



5500 NORTH ST. LOUIS AVENUE  
CHICAGO, ILLINOIS 60625-4699

## PROJECT MANUAL

**PROJECT NAME: CCICS Auditorium  
Renovation**

**PROJECT NO.: 61-0212-0113**

**AT:** NORTHEASTERN ILLINOIS UNIVERSITY  
5500 North St. Louis Avenue  
Chicago, Illinois 60625

**DATE:** **April 30, 2013**

**OWNER:** The Board of Trustees  
Northeastern Illinois University

**PROJECT  
MANAGER:** **Karl Tabor**  
**K-Tabor@neiu.edu**  
Northeastern Illinois University  
Tel: 773-442-5230 Fax: 773-442-5232

**PREPARED BY:** Northeastern Illinois University  
Facilities Management  
5500 North St. Louis Avenue  
Chicago, Illinois 60625  
Tel: 773-442-5230 Fax: 773-442-5280

**CONSULTANT:** **4240 Architecture**  
328 S. Jefferson, Suite 750  
Chicago, IL 60661  
Tel: 312-341-1155

**PROJECT MANUAL  
TABLE OF CONTENTS / INDEX OF DRAWINGS**

<u>DIVISION</u>	<u>SECTION</u>	<u>TITLE</u>	<u>PAGES</u>
<u>00</u>		<u>PROCUREMENT AND CONTRACTING REQUIREMENTS</u>	
	001113	ADVERTISEMENT FOR BIDS	001113-1-2
	002113	INSTRUCTIONS TO BIDDERS	002113-1-7
	004100	BID FORM	004100-1-6
	004105	BIDDER'S EMPLOYEE UTILIZATION - IDHR FORM	004105-1-2
	004106	CONTRACTOR/BIDDER QUALIFICATION FORM	004106-1-14
	004110	BIDDER APPLICATION FORM	004110-1-7
	004111	FINANCIAL DISCLOSURES AND CONFLICTS OF INTEREST	004111-1-8
	004112	STATE BOARD OF ELECTIONS INSTRUCTIONS AND CERTIFICATION	004112-1-2
	004113	CERTIFICATE AND STATUTORY REQUIREMENTS	004113-1-8
	004114	SUBCONTRACTOR ATTACHMENT FOR BIDS	004114-1-2
	004115	BUSINESS ENTERPRISE PROGRAM (BEP) UTILIZATION PLAN	004115-1-14
	004116	SMALL BUSINESS IDENTIFICATION	004116-1-1
	004123	BID OPENING & AWARD	004123-1-2
	005113	POST AWARD REQUIREMENTS	005113-1-1
	006000	REDUCTION IN RETAINAGE FORM	006000-1-1
	006100	BONDS AND INSURANCE	006100-1-3
	007200	GENERAL CONDITIONS	007200-1-19
	007300	SUPPLEMENTARY GENERAL CONDITIONS	007300-1-1
	007300.1	CERTIFIED PAYROLL FORM	007300.1-1-2
	009113	ADDENDA	009113-1-1
<u>01</u>		<u>GENERAL REQUIREMENTS</u>	
	011000	SUMMARY	011000-1-4
	011200	MULTIPLE CONTRACT SUMMARY	011200-1-5
	012300	ALTERNATES	012300-1-2
	012500	SUBSTITUTION PROCEDURES	012500-1-4
	012501	SUBSTITUTION REQUEST FORM	012501-1-2
	012600	CONTRACT MODIFICATION PROCEDURES	012600-1-3
	012900	PAYMENT PROCEDURES	012900-1-5
	013100	PROJECT MANAGEMENT AND COORDINATION	013100-1-10
	013200	CONSTRUCTION PROGRESS DOCUMENTATION	013200-1-9
	013233	PHOTOGRAPHIC DOCUMENTATION	013233-1-3
	013300	SUBMITTAL PROCEDURES	013300-1-10
	014000	QUALITY REQUIREMENTS	014000-1-9
	014200	REFERENCES	014200-1-2
	015000	TEMPORARY FACILITIES AND CONTROLS	015000-1-8
	016000	PRODUCT REQUIREMENTS	016000-1-5
	016116.00	VOLATILE ORGANIC COMPOUND CONTENT RESTRICTIONS	016116.00-1-2
	016116.01	ACCESSORY MATERIAL VOC CONTENT CERTIFICATION FORM	016116.01-1-1
	017300	EXECUTION	017300-1-9
	017419	CONSTRUCTION WASTE MANAGEMENT AND DISPOSAL	017419-1-9

	017700	CLOSEOUT PROCEDURES	017700-1-6
	017823	OPERATION AND MAINTENANCE DATA	017823-1-8
	017839	PROJECT RECORD DOCUMENTS	017839-1-4
	017900	DEMONSTRATION AND TRAINING	017900-1-5
<b><u>03</u></b>		<b><u>CONCRETE</u></b>	
	033000	CAST-IN-PLACE CONCRETE	033000-1-26
<b><u>04</u></b>		<b><u>MASONRY</u></b>	
	042000	UNIT MASONRY	042000-1-12
<b><u>05</u></b>		<b><u>METALS</u></b>	
	051200	STRUCTURAL STEEL	051200-1-14
	053100	METAL DECKING	053100-1-8
	057000	DECORATIVE METAL	057000-1-5
<b><u>06</u></b>		<b><u>WOOD, PLASTICS AND COMPOSITES</u></b>	
	061000	ROUGH CARPENTRY	061000-1-4
	064216	WOOD VENEER PANELING	064216-1-3
<b><u>07</u></b>		<b><u>THERMAL AND MOISTURE PROTECTION</u></b>	
	078400	FIRESTOPPING	078400-1-4
	079005	JOINT SEALERS	079005-1-4
<b><u>08</u></b>		<b><u>OPENINGS</u></b>	
	081113	HOLLOW METAL DOORS AND FRAMES	081113-1-4
	081416	FLUSH WOOD DOORS	081416-1-3
	087100	DOOR HARDWARE	087100-1-23
<b><u>09</u></b>		<b><u>FINISHES</u></b>	
	092116	GYPSON BOARD ASSEMBLIES	092116-1-6
	095100	ACOUSTICAL CEILINGS	095100-1-3
	096500	RESILIENT FLOORING	096500-1-4
	096800	CARPETING	096800-1-3
	096813	TILE CARPETING	096813-1-3
	098400	ACOUSTIC ROOM COMPONENTS	098400-1-2
	099000	PAINTING AND COATING	099000-1-5
<b><u>10</u></b>		<b><u>SPECIALTIES</u></b>	
	101400	SIGNAGE	101400-1-1
<b><u>11</u></b>		<b><u>EQUIPMENT</u></b>	

	116133	RIGGING, CURTAINS & TRACKS	116133-1-26
	116134	THEATRICAL LUMINAIRES AND ACCESSORIES	116134-1-23
<u>12</u>		<u>FURNISHINGS</u>	
	126100	FIXED THEATRE SEATING	126100-1-11
<u>22</u>		<u>PLUMBING</u>	
	221316	SANITARY WASTE AND VENT PIPING	221316-1-5
<u>23</u>		<u>HEATING, VENTILATING, AND AIR- CONDITIONING</u>	
	230503	GENERAL PROVISIONS FOR HVAC WORK	230503-1-7
	230505	BASIC HVAC MATERIALS AND METHODS	230505-1-17
	230515	MOTORS- VARIABLE FREQUENCY CONTROLLERS	230515-1-12
	230529	HANGERS AND SUPPORTS FOR PIPING AND EQUIPMENT	230529-1-8
	230593	TESTING, ADJUSTING, AND BALANCING FOR HVAC	230593-1-14
	230700	HVAC INSULATION	230700-1-21
	230920	BUILDING AUTOMATION SYSTEM- BAS	230920-1-23
	230920.01	BUILDING AUTOMATION SYSTEM- EXHIBITS	230920.01-1-20
	230921	BUILDING AUTOMATION SYSTEM- BASIC MATERIALS	230921-1-10
	230923	BUILDING AUTOMATION SYSTEM- FIELD PANELS	230923-1-12
	230924	BUILDING AUTOMATION SYSTEM- COMMUNICATION DEVICES	230924-1-3
	230925	BUILDING AUTOMATION SYSTEM- SOFTWARE- PROGRAMMING	230925-1-20
	230925.01	BUILDING AUTOMATION SYSTEM- SOFTWARE- EXHIBITS	230925.01-1-16
	232113	HYDRONIC PIPING	232113-1-8
	232300	REFRIGERANT PIPING	232300-1-12
	233113	METAL DUCTS	233113-1-9
	233300	AIR DUCT ACCESSORIES	233300-1-8
	233416	CENTRIFUGAL HVAC FANS	233416-1-5
	233713	DIFFUSERS, REGISTERS, AND GRILLES	233713-1-4
	238126	SPLIT-SYSTEM AIR-CONDITIONER	238126-1-6
<u>26</u>		<u>ELECTRICAL</u>	
	260503	GENERAL REQUIREMENTS FOR ELECTRICAL SYSTEMS	260503-1-11
	260505	BASIC ELECTRICAL MATERIALS AND METHODS	260505-1-8
	260511	CONDUCTORS AND CABLES FOR ELECTRICAL SYSTEMS	260511-1-4
	260526	GROUNDING AND BONDING FOR ELECTRICAL SYSTEMS	260526-1-5
	260529	HANGERS AND SUPPORTS FOR ELECTRICAL SYSTEMS	260529-1-10
	260533	RACEWAYS AND BOXES FOR ELECTRICAL	260533-1-8



	<b>SYSTEMS</b>	
260553	IDENTIFICATION FOR ELECTRICAL SYSTEMS	260553-1-6
260923	LIGHTING CONTROL DEVICES	260923-1-5
260961	THEATRE STAGE LIGHTING SYSTEMS	260961-1-25
262416	PANELBOARDS	262416-1-7
262726	WIRING DEVICES	262726-1-8
262813	FUSES	262813-1-4
262816	ENCLOSED SWITCHES AND CIRCUIT BREAKERS	262816-1-8
262913	ENCLOSED CONTROLLERS	262913-1-10

27

**COMMUNICATIONS**

274116	INTEGRATED AUDIOVISUAL SYSTEMS AND EQUIPMENT	274116-1-43
--------	---	-------------

**INDEX OF DRAWINGS**

<b>SHEET NO.</b>	<b>TITLE</b>
	Cover Sheet
G 001	Symbols, Abbreviations and Drawing Index
D 101	Demolition Plan
D 300	Demolition Sections
A 101	Floor Plans
A 201	Enlarged Auditorium Plan
A 202	Enlarged Corridor Plan
A 203	Second Floor Structural Plan
A 300	Interior Elevations
A 301	Interior Elevations
A 501	Details
A 502	Details
A 503	Details
A 601	Reflected Ceiling Plans
A 801	Schedules
E-001	Electrical Symbols, Abbreviations and Notes
E-102	Second Floor Electrical Demolition Plan
E-102A	Second Floor Upper Electrical Demolition Plan
E-103	Third Floor Electrical Demolition Plan
E-103A	Third Floor Upper Electrical Demolition Plan
E-202	Second Floor Power Plan
E-202A	Second Floor Upper Power Plan
E-203	Third Floor Power Plan
E-302	Second Floor Lighting Plan
E-302A	Second Floor Upper Lighting Plan
E-303	Third Floor Lighting Plan
E-303A	Third Floor Upper Lighting Plan
E-401	Electrical Riser Diagram
E-501	Electrical Schedules
E-502	Electrical Schedules

M-001	Mechanical Symbols, Abbreviations and Notes
M-102	Second Floor Mechanical Demolition Plan
M-102A	Second Floor Upper Mechanical Demolition Plan
M-103	Third Floor Mechanical Demolition Plan
M-103A	Third Floor Upper Mechanical Demolition Plan
M-202	Second Floor Mechanical Plan
M-202A	Second Floor Upper Mechanical Plan
M-203	Third Floor Mechanical Plan
M-203A	Third Floor Upper Mechanical Plan
M-501	Mechanical Schedules
M-601	Mechanical Details
M-701	Controls Architecture
M-702	Controls Architecture

TE-101	Stage Dimming – One Line Diagram
TE-102	Stage Dimming - Schedules
TE-201	Stage Dimming – Faceplate Details
TE-202	Stage Dimming – Faceplate Details
TE-301	Stage Dimming – Electrical Coordination Details
TR-101	Stage Rigging – Plan and Long Section
TR-201	Stage Rigging – Elevation and Details
TS-101	Seating Layout – Plan and Section

AV 001	Audiovisual Symbols and Legend
AV 002	Audiovisual Schedules
AV 101	Audiovisual Floor Plans
AV 301	Audiovisual Sections
AV 501	Audiovisual Details
AV 502	Audiovisual Details
AV 503	Audiovisual Details
AV 601	Audiovisual Conduit Riser
AV 701	Audiovisual Functional Diagrams
AV 702	Audiovisual Functional Diagrams
AV 703	Audiovisual Functional Diagrams
AV 704	Audiovisual Functional Diagrams

**DIVISION 00 – PROCUREMENT AND CONTRACTING REQUIREMENTS**

**SECTION 001113  
ADVERTISEMENT FOR BIDS**

Northeastern Illinois University (NEIU) at its bid receiving office, Purchasing Department, Building C, 4<sup>th</sup> Floor at 5500 N. St. Louis Ave. **(for personal or messenger delivery only)** will receive sealed bids for:

**CCICS Auditorium Renovation  
61-0212-0113**

Bids to be mailed shall be addressed to Purchasing Department, 5500 N. St. Louis Ave., Chicago, IL 60625-4699.

Bid opening on May 20, 2013 in the **Purchasing Department**, Building C, 4<sup>th</sup> Floor at 5500 N. St. Louis Ave. at 1:00 PM prevailing time for the following work:

**Project Description:**

Furnish and install all necessary labor, material and equipment required to complete the project known as **CCICS Auditorium Renovation** Project No. **61-0212-0113** consisting of the renovation of the existing Auditorium on the second floor of the building. The scope of work includes reconstruction of the stage and seating area floor; new seating; new interior finishes; refinishing of existing millwork; new millwork; new AV equipment; new theater equipment; and mechanical and electrical improvements.

**Separate Prime Contracts will be awarded for:**

- 1. General Construction – the Prime General Construction Contract includes the responsibility of coordinating contractor for the Prime Contracts listed below.**
- 2. Ventilating**
- 3. Electrical**

A **MANDATORY** pre-bid meeting will be held on **May 6, 2013 @ 11:30 AM**, in the first floor Conference Room at the Carruthers Center for Inner City Studies, 700 East Oakwood Avenue, Chicago, IL.

Bids shall include Bidder's Illinois DHR Identification Number for all bids. Project manual, drawings, and addenda will be available via the Illinois Public Higher Education Procurement Bulletin website: <http://www.procure.stateuniv.state.il.us/> . Bid opening dates and securities will be as follows:

<u>TRADE</u>	<u>BID SECURITY</u>	<u>BID DATE</u>	<u>TIME</u>
General	5% of the base bid	May 20, 2013	1:00 PM
Ventilating	5% of the base bid	May 20, 2013	1:00 PM
Electrical	5% of the base bid	May 20, 2013	1:00 PM

**BEP/MAFBE Contracting Goal**

Northeastern Illinois University strongly supports the participation of businesses owned by Minorities, Females and Persons with Disabilities (MAFBE) and has established a goal that 20% of its contracts be awarded to Business Enterprise Program (BEP)/MAFBE owned businesses. The University desires participation either on a direct basis or through sub-contracting efforts.

Information about the Bidder's BEP/MAFBE status must be included in the Bidder Application Form as part of its submission. The Bidder, if awarded a contract, agrees to notify the University of any change to its status as a BEP/MAFBE owned business within fifteen (15) business days of the occurrence of such a change.

The Bidder agrees to submit a Business Enterprise Program (BEP) Utilization Plan in accordance with Section 004115 of this bid document.

Sharon K. Hahs, President Northeastern Illinois University  
Board of Trustees of Northeastern Illinois University

**End of Section 001113**

## DIVISION 00 – PROCUREMENT AND CONTRACTING REQUIREMENTS

### **SECTION 002113 INSTRUCTIONS TO BIDDERS**

#### 00101 - IDHR CERTIFICATION

Illinois Department of Human Rights:

Prior to Bid opening, Bidder shall either be prequalified by the Illinois Department of Human Rights (IDHR) or have filed an application (IDHR Form PC-1) with the IDHR. For information regarding IDHR requirements, contact the Illinois Department of Human Rights, Public Contract Unit, 100 West Randolph Street, Suite 10-100, Chicago, Illinois 60601, 312-814-6200. Bidder shall comply with the IDHR requirements which appear in the General Conditions. Please be aware that, as of January 1, 2010, per Public Act 096-1786, all those filling for, or renewing an IDHR number will be charged a \$75.00 registration fee which will be valid for five years from the date issuance.

#### 00102 - CONTRACTOR/BIDDER QUALIFICATION

Northeastern Illinois University (NEIU) reserves the right to qualify bidders. All information must be provided on Contractor/Bidder Qualification Form (Section 004106) if included in bid document. Failure to provide all of the required information, or misrepresentations made in completing the form will be grounds to disqualify the bidder and reject their bid.

Contractors will be evaluated for their ability to complete the work based on the firm's physical and financial resources; prior work experience and performance; and experience working for governmental agencies and institution of higher education in the City of Chicago and regional area. Contractors must complete Section 004106 and receive acknowledgement from NEIU for eligibility to submit a bid. Contractors who have already received acknowledgement of prequalification from NEIU are not required to resubmit the qualification form. All bidders must submit all of the other required State certification forms.

#### 00103 - OBTAINING BIDDING DOCUMENTS

Bidding Documents may be obtained in accordance with the "Advertisement for Bids". There is no Bidding Document deposit when Bidding Documents have been prepared by NEIU's Technical Staff or can be downloaded directly from the Illinois public Higher Education Procurement Bulletin. The public web site is at <http://www.procure.stateuniv.state.il.us>. Username and password will be available at pre-bid meeting. Bid documents will be available no later than May 1, 2013.

Successful Bidder/Contractor (these words shall be used interchangeably throughout this document and are meant to be one and the same) will receive electronic copies of the Construction Documents.

#### 00104 - PRE-BID CONFERENCES

There will be a **MANDATORY Pre-Bid Meeting** on **May 6, 2013 at 11:30 AM** in the **Conference Room on the First Floor of 700 East Oakwood Blvd. Chicago, Illinois 60653.**

## 00105 - EXAMINATION OF BIDDING DOCUMENTS AND SITE

Bidder shall carefully examine Bidding Documents and inspect the project site to obtain first-hand knowledge of existing conditions. Contractor, by submitting Bid, represents that he has examined the Bidding Documents and inspected the site, that he understands the provisions of the Bidding Documents, and that he has familiarized himself with the local conditions under which the Work is to be performed. All inquires must be submitted in writing and emailed to [baaberg@4240arch.com](mailto:baaberg@4240arch.com) with a copy to [k-tabor@neiu.edu](mailto:k-tabor@neiu.edu). Process questions should be directed in writing to the Director of Purchasing. Both questions regarding the work and process questions must be submitted no later than 10:00 AM on Monday May 13, 2013. Bidder will not be given extra payment or contract time for conditions which could have been determined by such examinations.

## 00106 - BID PREPARATION

1. Bid shall be prepared on the enclosed Bid Form. The Bidder shall not make changes in the standard Bid Form provided by NEIU with the Bidding Documents. The Bidder shall fill in all relevant blank spaces including Alternate Bids and unit prices in ink or by typewriter only, pencil is not acceptable. When any Base Bid, Alternate Bid or unit price is omitted, NEIU will reject the entire Bid. Bids containing conditional or qualified statements will not be accepted. Show all amounts in both words and figures. In the case where words and figures are not identical in form or amount, the amount shown in words will govern, where such words are not ambiguous. When the intention and meaning are clear, omissions or misspellings of words will not render the words ambiguous. No conditional bids will be accepted. When a Bidder submits a Bid with spaces containing erasures or other changes, each erasure or change shall be initialed by the person signing the Bid. **Bidders are requested to submit the original bid form (noted on right edge "Required Bid Submittal Form") and two copies of the bid which can be obtained at the ftp site identified above. The bid is announced in the Illinois Public Higher Education Procurement Bulletin website: <http://www.procure.stateuniv.state.il.us/>**
2. Bidders shall be responsible for the delivery of their Bids during regular business hours, to NEIU's designated bid receiving office, prior to the bid closing time as stated in the Advertisement for Bids. Each Bid shall be submitted in a sealed opaque envelope, including express delivery envelopes, showing the name and address of the Bidder in the upper left-hand corner and addressed for direct delivery to **Purchasing Department, Northeastern Illinois University, 5500 N. St. Louis Ave, Chicago, IL 60625-4699**. The lower left-hand corner of the envelope shall be marked as follows:

**BID FOR: CCICS Auditorium Renovation  
PROJECT NO.: 61-0212-0113**

It shall not be sufficient to show that Bid was mailed in time to be received before scheduled closing time for receipt of Bids. Bid envelopes, including delivery envelopes, which are received unsealed or improperly identified as specified herein, will be rejected.

3. Modification or withdrawal of Bids shall be made in writing, including fax or e-mail and must be received at NEIU no later than one (1) day prior to the time of the bid opening. Modifications must not reveal the Bid price, but must provide an addition or subtraction so that the final Bid price can be determined only after the sealed Bid is opened. If the modification reveals the Bid price, the Bid will be rejected. When

modifications or withdrawals are made by fax or e-mail, a signed confirmation statement shall be sent to NEIU via registered or certified mail, bearing:

- A. A U.S. Post Office date stamp at least one (1) day prior to the time of the Bid opening date; or,
  - B. Evidence of time of processing by the U.S. Post Office, hand written and initialed by the postal clerk, indicating receipt by the U.S. Post Office one (1) day prior to the time of Bid opening.
4. All bids must include completed "Bid Form" (004100); "Bidder's Employee Utilization – IDHR Form (004105); "Bidder Application Form" (004110); "Financial Disclosures and Potential Conflicts of Interests" (004111); "State Board of Elections Certification" (004112); "Certifications and Statutory Requirements" (004113); "Subcontractor Attachment for Bids" (004114); "Business Enterprise Program (BEP) Utilization Plan (004115), and "Small Business Identification" (004116).

#### 00107 - ALTERNATE BIDS

Where Alternate Bids are included in the Bid Form, Bidders shall fill in each Alternate Bid with a Bid price. Failure to submit a Bid price for each Alternate Bid will result in rejection of the entire Bid. There will be no division of awards between base bid and accepted Alternate Bids.

#### 00108 - UNIT PRICE ITEMS

1. Definition: A fixed price for a specified unit of work.
2. Unit prices may be a component of the Base Bid. The Bidder shall multiply the unit Bid price times the specified quantity, and enter the extension, in figures in the column provided in the Bid Form. In case of a conflict between the unit price and the extension, the Unit Bid prices shall govern, and the Base Bid will be corrected. The acceptance of Base Bid Unit Prices shall be a condition of Contract award. When NEIU does not accept the Unit Price of the low Bidder, all Bids for that Contract will be rejected.

Quantities specified in the Bid Form, although approximate, are included in the Base or Alternate Bids. Payment to the Contractor will be made only for the actual work performed and accepted or materials furnished in accord with the Contract. NEIU may at any time, without invalidating the Contract, increase, decrease, or omit any of the Unit Price items in accord with specified change order procedures.

- A. Increased quantities will be paid for at the accepted Bid Price.
  - B. Decreased or omitted quantities will be deducted from the Contract sum at the accepted Unit Bid Price.
  - C. No payment will be made for any anticipated change in profit resulting from a change in the specified quantities.
3. Unit Prices may be a separate component outside the Base Bid. In these cases, the Bidder shall provide all requested Unit Prices as a condition of the Bid. NEIU reserves the right to accept or reject any or all Unit Prices. The award of the Base Bid is not conditional upon the acceptance of Unit Prices, outside the Base Bid.

NEIU also reserves the right to negotiate these Unit Prices prior to award. Unit Prices not specifically incorporated into the Contract shall not be binding upon NEIU or the Contractor. NEIU may formulate additive and deductive Unit Prices for the same item of work.

4. The acceptance of Unit Prices by NEIU does not alter the change order process. The Contractor may not increase, decrease, or omit work without a properly executed Change Order.

#### 00109 - SCHEDULE REQUIREMENTS

1. The current major milestone schedule for this Project is as follows:

Release of Project Manual:	April 30, 2013
Mandatory Pre-Bid Meeting:	May 06, 2013
Issue Addendum:	May 15, 2013
Bid Opening:	May 20, 2013
Board Approval (if required)	June 06, 2013
Pre-Construction Meeting:	June 17, 2013
Issue Letter of Intent:	June 10, 2013
Issue P.O. & Notice to Proceed:	June 17, 2013
On Site Construction Start Date:	July 01, 2013
Substantial Completion:	September 13, 2013
Final Completion:	September 27, 2013

#### 00110 - BID SECURITY

1. Submittal: Bids shall be accompanied by a Bid Security in the form of a certified check, cashier's check, bank draft or acceptable Bid Bond in favor of "Northeastern Illinois University". Failure to submit the Bid Security in full amount shown will result in rejection of the Bid. Bid Bonds shall be signed by the Contractor, Attorney-in-Fact, and Resident Agent.
2. Exchange: After the Bid opening, Bidders may replace other forms of Bid Security with an acceptable Bid Bond.
3. Default: If for any reason the Bidder withdraws his bid within ninety (90) calendar days after the Bid opening, or fails to comply with all post award requirements, such defaulting Bidder and Surety shall pay NEIU all costs incurred by NEIU for procuring the performance of the work required by the Bidding Documents which exceed the amount of his Bid. Such costs shall include, but not be limited to, the additional Contract price paid for the work and additional costs for advertising, Architect/Engineer and construction management services. If such costs are less than the Bid Security, the defaulting Bidder shall be entitled to the excess of his Bid Security. If the defaulting Bidder is the sole Bidder and after an attempt to secure other Bids by re-advertising none can be obtained, NEIU shall be entitled to the full amount of the Bid Security as liquidated damages.
4. Bid Security: NEIU reserves its rights in and to the Bid Securities of all Bidders until the lowest responsive Bidder has complied with all post award requirements at which time the Bid Securities other than the Bid Bonds will be returned to all Bidders.



## 00111 – BUILDER’S RISK INSURANCE

Builders Risk Insurance has been purchased and will be maintained by Northeastern Illinois University. A copy of the policy can be made available for review by contacting the Director of Procurement.

## 00112 - PRODUCT SUBSTITUTION

All Bids shall be based on providing all products exactly as required by the Bidding Documents. Substitutions may be permitted in accordance with this Section. NEIU reserves the right to reject any proposed substitution.

The Specifications provides the names of manufacturers of product which meet project specifications. The use of these names in this solicitation is for the purpose of describing the standard of quality, performance and characteristics desired and is not intended to limit or restrict competition. Substantially equivalent products to those cited may be considered for award, and the University encourages bidders to include these in their submittal, in accordance with this section.

For products specified only by reference or performance standards, select any product which meets or exceeds standards, by any manufacturer, subject to NEIU's approval. For products specified by naming several products or manufacturers, select any product and manufacturer named. Only those products or manufacturers named shall be acceptable except as provided below.

1. Prior to Bid Opening: The Director of Purchasing will consider written requests by prospective Bidders to amend the Bidding Documents to add products not specified. Such requests must be received at least ten (10) calendar days prior to Bid opening and include complete technical data and references for evaluation. If a request is approved, an Addendum will be issued no later than seventy-two (72) business hours prior to Bid opening.
2. With Bid: A Bidder may propose substitutions with a Bid by completing the Product Substitution Form included in the Project Manual, subject to the provisions stated thereon. Accepted substitutions will be so stated in the Contract. NEIU will review the Product Substitutions proposed by the low Bidder prior to award of Contract.
3. Substitutions by Change Order: After Notice of Award, substitutions may only be approved by written Change Order under one (1) of the following conditions:
  - A. Substitutions required for compliance with final interpretations of code requirements or insurance regulations.
  - B. Unavailability of specified products, through no fault of Contractor.
  - C. Subsequent information discloses inability of specified product to perform poorly or fit in designated space.
  - D. Manufacturer/fabricator refusal to certify or guarantee performance of specified product as specified.
  - E. When a substitution would be substantially to NEIU's best interests.

4. Procedure: Submit complete data substantiating compliance of proposed substitutions with Contract Documents:
  - A. An itemized comparison of proposed substitution with product or method specified.
  - B. Data relating to changes in construction schedule, coordination, other contract affected.
  - C. Accurate cost data on proposed substitution in comparison with product or method specified.
5. In making request for substitution, Bidder/Contractor represents that the proposed product is equal or superior to that specified; and,
  - A. Will provide an equal or superior guarantee for the substitution as was specified; and,
  - B. Will coordinate installation of accepted substitutions into work, making all changes for work to be complete; and,
  - C. Will pay all additional costs and expenses for NEIU and other contractors affected.
6. Substitutions will not be considered by Shop Drawing, informal request, or when acceptance will require substantial revision of Contract Documents.

#### 00113 - SIGNING BID SUBMITTAL

1. Original signatures on Bid Form & Bid Security are required. Rubber stamped or photo copied signatures are unacceptable.
2. All Bid Documents shall be signed by a person authorized to bind the business entity to a contract. The legal name of the business entity (sole proprietorship, corporation, partnership, joint venture, etc.) shall be stated. The name and title of the individual signing the documents shall be typed or printed below their signature.
  - A. The Owner shall sign for a sole proprietorship.
  - B. Corporations shall state the complete corporate name on the documents. The documents shall be signed by the president or vice-president, and the signature attested to by the corporate secretary, unless the corporation has, by written notice to NEIU, authorized representatives to sign the documents.
  - C. One of the authorized partners or joint venturers shall sign for a partnership, limited partnership or joint venture.
  - D. Individuals doing business under an assumed name shall sign in the name of the individual, "doing business as ..." (dba).
  - E. If signed by Attorney-in-Fact, there should be, attached to Bid, a Power of Attorney to sign Bid, dated same day as Bid and executed by authorized individuals.

00114 – VENDOR LEGAL AUTHORIZATION/REGISTRATION WITH ILLINOIS SECRETARY OF STATE

1. Vendor certifies that it is a properly formed and existing legal entity (30 ILCS 500/1.15.80, 20-43); and as applicable, has obtained an assumed name certificate from the appropriate authority, is registered to conduct business in Illinois, and is in good standing with the Illinois Secretary of State (30 ILCS 500/1.15.80).
2. Vendors may qualify to submit bids to State universities only if they are a legal entity authorized to do business in Illinois prior to submitting the bid, offer or proposal. This applies to both in-state and out-of-state firms.
3. A vendor/bidder must :
  1. A legal entity
  2. Registered to conduct business in Illinois
  3. In good standing with the Illinois Secretary of State
  4. Have an Illinois workplace for employees working on the contract
4. Specific information regarding compliance can be obtained from (30 ILCS 500/1.15.80, 20-43). Please contact the Illinois Secretary of State for additional information.

**End of Section 002113**

**DIVISION 00 – PROCUREMENT AND CONTRACTING REQUIREMENTS**

**SECTION 004100  
BID FORM**

BID TO: Northeastern Illinois University  
Purchasing Department  
5500 North St. Louis Avenue  
Chicago, Illinois 60625

PERSONAL DELIVERY TO:  
Northeastern Illinois University  
Purchasing Department, Building C, 4<sup>th</sup> Floor  
5500 North St. Louis Avenue  
Chicago, Illinois 60625

BID FROM: \_\_\_\_\_  
(Company)  
\_\_\_\_\_  
(Address)  
\_\_\_\_\_  
(City, State, Zip Code)  
Telephone: \_\_\_\_\_ Fax: \_\_\_\_\_

BID FOR: CCICS Auditorium Renovation

PROJECT NO.: 61-0212-0113

**THE UNDERSIGNED:**

1. Acknowledges receipt of:
  - 1.1 Project Manual and Drawings for: CCICS Auditorium Renovation
  - 1.2 Addenda: Note: If no Addenda have been received, write NONE

ADDENDUM NUMBER	DATE
_____	_____
_____	_____

2. Has examined the site and all bidding documents. He/she shall be responsible for performing all work specifically required of him/her by all parts of the bidding documents, including all drawings and specifications for the entire project even though such work may be included as related requirements specified in other Divisions or Sections.

NEIU  
P  
U  
R  
C  
H  
A  
S  
I  
N  
G  
D  
E  
P  
A  
R  
T  
M  
E  
N  
T  
B  
I  
D  
F  
O  
R  
M

NEIU  
GENERAL  
BIDDER  
BID  
SCHEDULE  
BIB  
DIB  
S  
B  
M  
H  
A  
F  
R  
M

3. Agrees:

- 3.1 To hold this bid open for ninety (90) calendar days after the opening date.
- 3.2 To accept the provisions of the Instructions to Bidders regarding disposition of bid security.
- 3.3 To enter into and execute a contract with NEIU, if awarded on the basis of his/her bid, and in connection therewith to:
  - 3.3.1 Furnish all bonds and insurance required by the bidding documents.
  - 3.3.2 Accomplish the work in accordance with the Contract.
  - 3.3.3 Complete the work within the Contract Time herein specified.

**CONTRACT TIME:**

The Contractor cannot commence work until receipt of Purchase Order and must provide Substantial Completion by September 13, 2013 and Final Completion by September 27, 2013.

**BASE BID GENERAL WORK:**

**THE BIDDER AGREES TO PERFORM ALL BASE BID WORK, EXCLUSIVE OF ALTERNATE BIDS, FOR THE SUM OF:**

\_\_\_\_\_ DOLLARS (\$) \_\_\_\_\_  
(Write Out Sum In Full)

**ALTERNATE WORK:**

**THE BIDDER PROPOSES TO EXECUTE THE WORK DESCRIBED IN THE DOCUMENTS FOR THE SUM IN ADDITION TO THE BASE BID, AS SHOWN BELOW:**

- 1. Alternate # G-1: Auditorium Lobby

ADD: \_\_\_\_\_ DOLLARS (\$) \_\_\_\_\_  
(Write Out Sum In Full)

**BASE BID ELECTRICAL WORK:**

**THE BIDDER AGREES TO PERFORM ALL BASE BID WORK, EXCLUSIVE OF ALTERNATE BIDS, FOR THE SUM OF:**

\_\_\_\_\_ DOLLARS (\$) \_\_\_\_\_  
(Write Out Sum In Full)

**ALTERNATE WORK:**



DIVISION 05: \_\_\_\_\_ DOLLARS (\$ \_\_\_\_\_).  
 DIVISION 06: \_\_\_\_\_ DOLLARS (\$ \_\_\_\_\_).  
 DIVISION 07: \_\_\_\_\_ DOLLARS (\$ \_\_\_\_\_).  
 DIVISION 08: \_\_\_\_\_ DOLLARS (\$ \_\_\_\_\_).  
 DIVISION 09: \_\_\_\_\_ DOLLARS (\$ \_\_\_\_\_).  
 DIVISION 10: \_\_\_\_\_ DOLLARS (\$ \_\_\_\_\_).  
 DIVISION 11: \_\_\_\_\_ DOLLARS (\$ \_\_\_\_\_).  
 DIVISION 12: \_\_\_\_\_ DOLLARS (\$ \_\_\_\_\_).  
 DIVISION 13: \_\_\_\_\_ DOLLARS (\$ \_\_\_\_\_).  
 DIVISION 14: \_\_\_\_\_ DOLLARS (\$ \_\_\_\_\_).  
 DIVISION 21: \_\_\_\_\_ DOLLARS (\$ \_\_\_\_\_).  
 DIVISION 22: \_\_\_\_\_ DOLLARS (\$ \_\_\_\_\_).  
 DIVISION 23: \_\_\_\_\_ DOLLARS (\$ \_\_\_\_\_).  
 DIVISION 26: \_\_\_\_\_ DOLLARS (\$ \_\_\_\_\_).  
 DIVISION 27: \_\_\_\_\_ DOLLARS (\$ \_\_\_\_\_).  
 DIVISION 28: \_\_\_\_\_ DOLLARS (\$ \_\_\_\_\_).  
 DIVISION 31: \_\_\_\_\_ DOLLARS (\$ \_\_\_\_\_).  
 DIVISION 32: \_\_\_\_\_ DOLLARS (\$ \_\_\_\_\_).  
 DIVISION 33: \_\_\_\_\_ DOLLARS (\$ \_\_\_\_\_).  
 Overhead and Profit: \_\_\_\_\_ DOLLARS (\$ \_\_\_\_\_).

**PROPOSED PRODUCT SUBSTITUTION LIST:**

The Base Bid and Alternate Bid(s) are to include only those products which are specified in the bidding documents. Following is a list of substitute products which the Bidder proposes to furnish on this project. If accepted by NEIU, the difference in price will be added to or deducted from the Base Bid or Alternate Bid(s).

Bidder understands that acceptance of any proposed substitution is at NEIU's option. Approval or rejection by NEIU of any substitution listed below will be indicated prior to executing the contract.

MANUFACTURER'S NAME AND PRODUCT	ADD +	DEDUCT -
_____	_____	_____
_____	_____	_____

NEIU  
#61-0212-0113  
004100-5  
Bid Form

**EVALUATION** of Contract award will be made in accordance with "Instructions to Bidders". Only the successful Bidder's proposed product substitution list will be evaluated.

**AFFIDAVIT OF AVAILABILITY**

**SUBMITTED FOR:**

I, being duly sworn, do hereby declare that the following is a true and correct statement relating to all uncompleted contracts of the undersigned for Federal, State, County, City, and private work, including all subcontract work and all pending low bids not yet awarded or rejected (**add sheets as necessary**):

LOCATION OF WORK	UNDER CONTRACT WITH	CONTRACT AMOUNT	DOLLAR VOLUME TO BE COMPLETED

**AWARDS PENDING**

TOTALS:

\_\_\_\_\_

**FAILURE TO SUBMIT CURRENT FACTUAL INFORMATION WILL RESULT IN NON-CONSIDERATION OF BID PROPOSAL.**

\_\_\_\_\_  
Bidder's Name (Print)

\_\_\_\_\_  
Signature



\_\_\_\_\_  
COMPANY

\_\_\_\_\_  
Address

Subscribed and sworn to before me this \_\_\_\_\_ day of \_\_\_\_\_, 20\_\_\_\_\_.

Notary Public: \_\_\_\_\_ SEAL:

**End of Section 004100**

FOR THE BIDDING PROCESS

**DIVISION 00 – PROCUREMENT AND CONTRACTING REQUIREMENTS**

**SECTION 004105  
 BIDDER'S EMPLOYEE UTILIZATION - IDHR FORM**

**MINORITIES/WOMEN GOALS**  
 When Total Workforce Employed Is

JOB CATEGORIES	TRADE CODES	1 - 3	4 - 10	10 or more
Sheet Metal	03	___	___	___
Equipment Optr.	04	___	___	___
Elevator Mechanic	05	___	___	___
Ironworker	06	___	___	___
Carpenter	07	___	___	___
Acoustical Tiler	08	___	___	___
Ceramic Tilesetter	09	___	___	___
Brick Mason	10	___	___	___
Cement Mason	11	___	___	___
Lather (Metal/Wood)	12	___	___	___
Taper	13	___	___	___
Plasterer	14	___	___	___
Painter	15	___	___	___
Glazier	16	___	___	___
Roofer	17	___	___	___
Metal Deck Roofer	18	___	___	___
Pipe/Sprnklr Fitter	19	___	___	___
Plumber	20	___	___	___
Insulator	21	___	___	___
Temp. Control	22	___	___	___
Laborer	23	___	___	___
Electrician	24	___	___	___
Fencing/ Grd.Rail	25	___	___	___
Landscaping	26	___	___	___
Truck Driver	28	___	___	___
Air Test & Balance	29	___	___	___
Sandblast/Water proofing/Caulkers	30	___	___	___
Asbestos Worker	31	___	___	___
Terrazzo	32	___	___	___
Carpet	33	___	___	___

10% through the 90% completion of the work of the trade. If Contractor fails to make a good faith effort to achieve these goals, NEIU may file a complaint against Contractor with the Illinois Fair Employment Practices Commission (IDHR). Sanctions resulting from a finding of noncompliance may include one or more of the following: (1) termination of Contract, (2) forfeiture of profit, (3) loss of prequalification status with NEIU.

BIDDER:

NAME \_\_\_\_\_

ADDRESS \_\_\_\_\_

CITY, STATE, ZIP CODE \_\_\_\_\_

TELEPHONE # \_\_\_\_\_

**ILLINOIS DEPARTMENT OF HUMAN RIGHTS**

NUMBER: \_\_\_\_\_

SIGNATURE: \_\_\_\_\_

(Company Officer)

SIGNATURE: \_\_\_\_\_

(Notary Public)

**NOTE:** Bidder's failure to complete IDHR Form and sign Bid Form 00310-1 & 2 shall result in rejection of the Bid. Bidder must set forth a projection of the total employee workforce to be hired or allocated to the Project in above table. Approval of the minority and female utilization projection shall be a post-award requirement.

Bidder/Contractor agrees to these goals for him/herself and their subcontractors in employing women and minorities for each category of work under the Contract from the





**SECTION 004106**  
**CONTRACTOR/BIDDER QUALIFICATIONS**

**Northeastern Illinois University**  
**CCICS Auditorium Renovation**  
**Contractor/Bidder Qualification Form**

Submit this form with bid to:

Northeastern Illinois University  
Purchasing Department  
4th Floor, C Building  
5500 N St Louis Ave  
Chicago, IL 60625  
Phone: 773-442-5308

**RETAIN A COPY OF YOUR COMPLETED APPLICATION.**

For qualification to be approved for the Northeastern Illinois University (NEIU) CCICS Auditorium Renovation project, these forms must be submitted with the Bid Form. An incomplete or rejected application will cause rejection of qualification.

M  
R  
O  
T  
F  
O  
R  
M  
A  
T  
H  
M  
E  
S  
D  
I  
D  
B  
D  
E  
M  
I  
C  
Q  
A  
R

**NORTHEASTERN ILLINOIS UNIVERSITY**  
**Contractor/Bidder Qualification Form**  
**This application may be returned with bid**

**Application Submittal**

The application should be completed by an individual able to answer questions regarding its content. **Retain a copy of the completed application for reference.** The application must be fully completed, as formatted. Applications that are incomplete or contain errors will be returned for corrections which will delay processing. If a question does not apply, insert "NA" for not applicable. Do not include "attachments" as replacements for our format. Do not attach supplemental information unless specifically requested on the application.

**Responsibility of Firm**

**It is the responsibility of each firm** to maintain current information regarding qualification. Firms are required to notify NEIU within five business days of ANY material changes to information contained in this application. Failure to do so may result in suspension of qualification and loss of bidding privilege.

**Licensing Requirement**

Copies of **current, valid licenses** relevant to trades identified in Item 20 **MUST be provided** with this application.

**APPRENTICESHIP TRAINING REQUIREMENT**

Effective June 1, 2004, all bidders and their subcontractors are required to certify, at time of bid, that they are participating in apprenticeship and training programs that are both approved by and registered with the US Department of Labor's Bureau of Apprenticeship and Training. The program(s) must be in the same trade(s) which the firm performs. See Item 15 in this application. Go to [www.doleta.gov/atels\\_bat/](http://www.doleta.gov/atels_bat/) or call Dave Wyatt at the US Department of Labor at 312/596-5508 for further information, or to inquire on how to participate or how a program complying with the new requirement can be set up in your area.

## DRUG FREE WORKPLACE ACT

**The Firm, by signing this application, agrees to comply with the provisions of the DRUG FREE WORKPLACE ACT.** Certification must be completed by all applicants; however, the requirements, specified in paragraphs (a) through (g), apply only when the firm performs a contract for \$5,000.00 or more and when, at the time of entering said contract, the firm has 25 or more employees (full or part-time).

This certification is required by the Drug Free Workplace Act (30 ILCS 580/1 et seq.). The Act requires certification by firms that it will maintain a drug free workplace.

The firm certifies that when it performs a contract in the amount of \$5,000 or more, and if it has 25 or more employees (full or part-time) at the time of entering a contract, it will provide a drug free workplace by:

- (a) Publishing a statement notifying employees that the unlawful manufacture, distribution, dispensing, possession or use of a controlled substance is prohibited in the firm's workplace and specifying the actions that will be taken against employees for violation of such prohibition.
- (b) Establishing a drug free awareness program to inform employees about:
  - (1) The dangers of drug abuse in the workplace;
  - (2) The firm's policy of maintaining a drug free workplace;
  - (3) Any available drug counseling, rehabilitation, and employee assistance programs; and
  - (4) The penalties that may be imposed upon employees for drug abuse violations occurring in the workplace.
- (c) Making it a requirement that each employee to be engaged in the performance of the contract be given a copy of the statement required by paragraph (a) and to post the statement in a prominent location in the workplace.
- (d) Notifying the employee in the statement required by paragraph (a) that, as a condition of employment under the contract, the employee will:
  - (1) Abide by the terms of the statement; and
  - (2) Notify the employer of any criminal drug statute conviction for a violation occurring in the workplace no later than five days after such a conviction.
- (e) Notifying the agency within ten days after receiving notice under subparagraph (d)(2) from an employee or otherwise receiving actual notice of such conviction.
- (f) Taking one of the following actions within 30 days of receiving notice under subparagraph (d)(2), with respect to any employee who is so convicted:
  - (1) Taking appropriate personnel action against such an employee, up to and including termination; or
  - (2) Requiring such employee to participate satisfactorily in a drug abuse assistance or rehabilitation program approved for such purposes by a Federal, State, or local health, law enforcement, or other appropriate agency.
- (g) Assisting employees in selecting a course of action in the event drug counseling, treatment, and rehabilitation is required and indicating that a referral team is in place.
- (h) Making a good faith effort to continue to maintain a drug free workplace through the implementation of paragraph (a), (b), (c), (d), (e), (f) and (g).

**NORTHEASTERN ILLINOIS UNIVERSITY  
Contractor/Bidder Qualification Form**

**(Please complete by typing or printing IN INK)**

1. **LEGAL** Firm Name \_\_\_\_\_

**COMMON** Firm Name \_\_\_\_\_

Doing Business As \_\_\_\_\_

Street Address \_\_\_\_\_

City, State, Zip \_\_\_\_\_

County \_\_\_\_\_

Contact Person \_\_\_\_\_

(List the person who can answer questions regarding information on this form.)

Business Phone \_\_\_\_\_

Fax Number \_\_\_\_\_

E-Mail Address \_\_\_\_\_

Parent Company     Division     Branch Office

Please complete Item 2 if the mailing address is different from above address.

If a mailing address is provided below, ALL CORRESPONDENCE will be sent to that address.

2. Mailing Address \_\_\_\_\_

City, State, Zip \_\_\_\_\_

3. Parent Company Name \_\_\_\_\_

(If applicable)

Address \_\_\_\_\_

City, State, Zip \_\_\_\_\_

4. Indicate below if a division or branch office, other than that listed in Item 1, is to be included with qualification and may be submitting a bid proposal. Attach a separate Page 1 for each. Bids **will not be accepted** from offices not included with this qualification. All questions in this application apply to offices listed in Items 1 - 4.

- Attached
- Not Applicable

5. Provide the firm's **IL Dept of Human Rights (IDHR)** number. \_\_\_\_\_  
5a. Expiration Date of **IL Dept of Human Rights (IDHA)** number. \_\_\_\_\_

To obtain an IDHR number, contact the IL Dept of Human Rights, Compliance Division, Public Contracts Unit, 100 West Randolph Street, 10th Floor, Chicago, Illinois 60601, 312/814-2432. All prospective contractors shall be registered or have an application pending (not subject to an Order of Noncompliance) with the IL Dept of Human Rights prior to a NEIU bid opening. Indicate below if an application is pending with the IL Dept of Human Rights. **Firms must notify NEIU of the assigned IDHR number.**

6. Provide the firm's **Taxpayer Identification Number**. \_\_\_\_\_  
(If sole proprietorship, provide owner's Social Security Number).

7. If the firm is a minority/female owned business enterprise, indicate the appropriate category(ies).

- Not Applicable
- African American
- Asian American
- Female
- Hispanic
- Native American

Indicate certification below. NEIU will only recognize firms as minority/female owned businesses when a copy of current certification from Central Management Services (CMS) is attached. Contact CMS at 312/814-4190 regarding procedures.

CMS Certified (**copy attached**)  Not Currently Certified with CMS

8. List the firm's Business Volume (dollar amount) for the last fiscal year. \_\_\_\_\_ \$

9. Number of full-time, non-labor employees. Include management, clerical, supervisory and technical people working for the firm. \_\_\_\_\_

10. How many years has the firm been in business? \_\_\_\_\_

11. How many years under present ownership? \_\_\_\_\_

12. Type of firm:  Corporation  Partnership  Sole Proprietorship  Ltd Liability Company  
**ALL CORPORATIONS, LIMITED LIABILITY PARTNERSHIPS AND LIMITED LIABILITY COMPANIES ARE REQUIRED TO ATTACH A CURRENT COPY OF THE FIRM'S CERTIFICATE OF GOOD STANDING FROM THE ILLINOIS SECRETARY OF STATE.**

For verbal confirmation of your firm's status of "good standing", call 217/782-7880. To order a certificate of "good standing" by credit card, call 217/782-6875. Firms requiring incorporation, call 217/782-9520. You may also write to the Illinois Secretary of State, Corporations Division, Third Floor, Howlett Building, Springfield, IL 62706.

13. List all key persons. **Key person** is defined as any individual who holds a 5% or more ownership



interest, regardless of position with the firm, **and** any officer or director, regardless of ownership in the firm. Also identify all other persons who have duties, responsibilities or authority delegated to owners, officers, partners or directors. If the firm is owned by another corporation, partnership, trust or business association, **identify all ultimate individuals who hold a 5% or more ownership interest in that company.** If percentage does not total 100, please explain. (i.e., "remaining ownership held by individuals with less than 5%".)

<u>Name of Person</u>	<u>Position/Title</u>	<u>% Ownership</u>
_____	_____	_____
_____	_____	_____
_____	_____	_____
_____	_____	_____

14. List names and titles of all individuals authorized to sign bids, proposals or contract documents.

<u>Name of Person</u>	<u>Position/Title</u>
_____	_____
_____	_____

15. House Bill 3048 amends the Illinois Procurement Code to make effective June 1, 2004, that all bidders and their subcontractors are required to certify, at time of bid, that they are participating in **apprenticeship and training programs** that are both approved by and registered with the US Department of Labor's Bureau of Apprenticeship and Training. The program(s) must be in the same trade(s) which the firm performs. Go to [www.doleta.gov/atels\\_bat/](http://www.doleta.gov/atels_bat/) or call Dave Wyatt at the US Department of Labor at 312/596-5508 for further information, or to inquire on how to participate or how a program complying with the new requirement can be set up in your area.

16. Identify all other names the firm or its predecessors have used in the past five years. Provide the dates that name was in effect.

\_\_\_\_\_

\_\_\_\_\_

18. Identify key persons and any **other** occupations or businesses (including **other** construction companies) in which they are currently engaged. Please explain below or attach a separate sheet.

\_\_\_\_\_

\_\_\_\_\_

19. Identify all firms by which key persons of this firm have been employed during the past five years and provide the dates of employment. Please explain below or attach a separate sheet.

---

---

20. Firms must be able to check at least one trade below. And, **for each trade checked**, provide recent (within the past three years), relevant construction experience in Item 31.

- General                       Electrical                       Heating
- Ventilating
- Other (Describe) \_\_\_\_\_

**In addition, copy(ies) of current and valid Illinois FIRM licenses MUST BE PROVIDED for each trade identified with an asterisk(\*) below.**

- Plumbing\*
- Fire Protection\*

**FOR A YES ANSWER TO ANY QUESTION 21-27  
ATTACH EXPLANATION ON A SEPARATE SHEET**

21. In the past five years, has the firm or its predecessor been cited for violating state or federal safety, sanitary or environmental laws which resulted in lawsuits filed against the firm, and/or were originally categorized as repeat or willful violations? If so, attach copies of citations issued and complaints filed in any lawsuits, and state whether the violations caused injuries.

Yes                       No

22. Has the firm or its predecessor or any key person with the firm or its predecessor ever been formally charged with or convicted of any state or federal crime (excluding traffic violations), including but not limited to the Illinois Procurement Code, embezzlement, theft, forgery, bribery, falsification or destruction of records, receipt of stolen property, criminal anti-trust violations, bid-rigging or bid-rotating? If a conviction or plea of nolo contendere was entered, include in your explanation documentation (such as a Court Order) when the sentence ended.

Yes                       No

23. Has the firm or its predecessor or any key person with the firm or its predecessor ever been charged with or convicted of a state or federal civil anti-trust violation or similar offense?

Yes                       No

24. Has the firm or its predecessor, any key person of the firm or its predecessor or any firm with which a key person was affiliated filed for bankruptcy within the past ten years?

Yes                       No

25. Has the firm or its predecessor or any key person of the firm or its predecessor ever been suspended or debarred by a state, federal or municipal agency, including but not limited to, the Illinois Department of Labor?

Yes                       No

26. Is any key person with the firm currently in default on a student loan?

Yes                       No

27. Is any owner, person with an interest in firm profits, or their spouse or minor child employed in any way by the State of Illinois? If your answer to this question is "yes" and you are the lowest responsive bidder, you will be required to obtain an exemption from the Governor prior to contract award. A conflict of interest may exist, as defined by the Illinois Procurement Code (30 ILCS 500/50-13).

Yes

No

**Surety Bonding**

28. Qualification is contingent upon the applicant having a surety (performance) bond capacity authorized only by a surety company acceptable to NEIU. Surety companies that are listed in Bests' Key Rating Guide with a rating of B or better and/or are listed in the Treasury Circular are considered acceptable. **Firms may forward this page by mail or fax to their local broker/agent for signature, then include signed page with application. Original signature is not required.**

Name of Firm Applying for Qualification

**Specific Surety Company Name**

Street Address

City, State, Zip

Telephone Number

Fax Number

**Local Broker/Agent**

Contact Person

Street Address

City, State, Zip

Telephone Number

Fax Number

Provide the current level of performance bonding (in dollar amount) authorized by the surety. The limits listed below will not prevent a firm from bidding on a larger project than the bond limit established at the time of qualification, so long as the bid amount falls within the bidding limit range authorized by NEIU.

Single Limit: \_\_\_\_\_

Aggregate Limit: \_\_\_\_\_

**BY SIGNING BELOW, THE LOCAL BROKER/AGENT CONFIRMS THE INFORMATION PROVIDED ABOVE. This page should be returned via fax to 773.442.5314**

\_\_\_\_\_  
Printed Name of Local Broker/Agent

\_\_\_\_\_  
Signature of Local Broker/Agent

\_\_\_\_\_  
Date

29. As. conditions of qualification, the firm:

a. Has read, understands and will comply with all instructions to this application.

FOR FATHOMING THE QUALITY OF THE WORK

- b. Will notify Northeastern Illinois University within five business days of any material changes to the information contained in this application.
- c. Will, upon request, provide Northeastern Illinois University with current audited financial statements within ten business days.
- d. Will adhere to all provisions of the Illinois Procurement Code.
- e. Swears that all information provided by it, to Northeastern Illinois University, is true.
- f. Will adhere to all provisions of the Drug Free Workplace Act.
- g. Agrees that if any of the above conditions are violated by the firm or if any responses are found to be materially untrue, the qualification of the firm will be suspended.
- h. Authorizes your firm's bank, as well as the surety and local broker/agent listed in Item 28 to provide any and all information regarding the firm to Northeastern Illinois University, as a condition of the firm's qualification.

30. This form must be **signed by** firm's **President, Vice-President or CEO** (if corporation or limited liability company), **Partner** (if partnership) **or Sole Owner** (if sole proprietorship).

*Under penalties of perjury, and the applicable statutes of the State of Illinois, I hereby swear, warrant and represent that the questions on this form have been personally answered by me, and that I have authority to execute this document on behalf of this firm.*

Signed \_\_\_\_\_

Printed Name \_\_\_\_\_

TITLE \_\_\_\_\_

SUBSCRIBED AND SWORN BEFORE ME

THIS \_\_\_\_\_ DAY OF \_\_\_\_\_, 20\_\_\_\_\_

\_\_\_\_\_  
Notary Public

My Commission expires: \_\_\_\_\_

**INSTRUCTIONS for completing Item 31 (next page)**

Complete the page in its entirety. Do not reformat. You may make copies of the page.

**REFERENCES WILL BE CONTACTED.**

**A minimum of five relevant references meeting requirements outlined (1-7) below must be provided.**

**Of those five references, firms must provide at least one relevant reference for each trade check marked in Item 20, if applying for multiple trades you may submit up to five references for each trade checked.**

**Each project listed as a reference must meet all of the following requirements.**

1. Project must have been completed or is now 90% complete and within the past 10 years.
2. Your firm's portion of the contract amount must be no less than \$75,000.
3. Neither residential projects nor projects where your firm performed as Construction Manager will be considered.
4. Only projects in which your firm completed at least 20% of the work utilizing your own forces will be considered.
5. Do not provide references for projects which are not yet complete.
6. All references must be relevant in size and type to those of the CCICS Auditorium Renovation Project.

Newly formed firms that may not have construction experience as a firm, or have fewer than five completed projects, may provide references reflecting experience of key personnel when that experience was within the past three years and meets all of the above requirements. In that case, provide the name of the key individual who has the experience and the name of the firm that employed them, then provide the reference data as formatted in Item 31.

**INSTRUCTIONS for completing reference questionnaires (required).**

Make at least five copies of the 2-page reference questionnaire.

After thorough execution of Item 31, complete the sections on BOTH PAGES of each questionnaire, as instructed below. DO NOT complete the section marked "THIS SECTION TO BE COMPLETED BY REFERENCE ONLY".

The information you provide on each questionnaire must reflect the references you listed in Item 31. Complete only one questionnaire for each project listed in Item 31.

1. On the REFERENCE QUESTIONNAIRE EMAIL TRANSMITTAL SHEET, complete Items 1 through 5. **Important: Be sure to confirm the Email address of all References.** If your firm performed as the Prime contractor, you may list EITHER the Project Owner OR the Architect/Engineer. If your firm performed as a Subcontractor, in most cases, the Prime contractor should be listed as the reference.
2. On the second page of the questionnaire, complete ONLY the section marked THIS SECTION TO BE COMPLETED BY CONTRACTOR APPLYING FOR QUALIFICATION. Provide ALL requested information.
3. After completing the questionnaires, include them with your application. **NEIU will send these questionnaires directly to your references, who are to return them to NEIU** (by email). DO NOT send the questionnaires to the references yourself.

We encourage firms to alert references that they will be receiving a questionnaire, and to confirm the email address of the reference. A sufficient number of positive responses, **at minimum three**, is required prior to proceeding with a qualification review.

31.

**REFERENCES**  
(Refer to Instructions on previous page)

<p><b>List:</b> 1. Name of Project 2. Description of Work Performed (List all trades performed by your firm.)</p>	<p><b>List:</b> 1. Prime or Subcontract 2. Your Contract Amount 3. Completion Date</p>	<p><b>List:</b> 1. Name of Project Owner OR Name of General Contractor 2. COMPLETE MAILING ADDRESS 3. Name of Contact Person 4. Phone <u>AND</u> EMAIL address</p>	<p><b>List:</b> 1. Name of Architect/Engineer (if applicable) 2. COMPLETE MAILING ADDRESS 3. Name of Contact Person 4. Phone <u>AND</u> EMAIL address</p>

Northeastern Illinois University  
**REFERENCE QUESTIONNAIRE (2 Pages)**  
EMAIL TRANSMITTAL SHEET

**Transmit to:**

1. REFERENCE Company Name \_\_\_\_\_
2. REFERENCE Contact Person \_\_\_\_\_
3. REFERENCE EMAIL Address \_\_\_\_\_
4. REFERENCE Phone Number \_\_\_\_\_
5. THE FIRM ( \_\_\_\_\_ ), has listed you as a reference on their Contractor Bidder Responsibility Qualification Application with Northeastern Illinois University ("NEIU"). NEIU is a State agency responsible for the construction of the CCICS Auditorium Renovation Project in Chicago, Illinois.

Our qualification process is responsibility based, and references are essential in confirming a trend of satisfactory construction performance. Information regarding the work performed, as indicated by the contractor, is described on the attached sheet. Feel free to include additional information which you may consider helpful. Please keep in mind that your response will be "on the record" and is available for the contractor's review.

Your prompt completion of this questionnaire is requested and appreciated. **Reference (NOT Bidding Contractor) - Please return both pages by email to my attention.**

**FROM: Jeff Schliesmann**

**EMAIL ADDRESS: J-Schliesmann@neiu.edu**  
**PHONE NUMBER: 773-442-5260**

There are two pages, including this sheet, being transmitted.



The contractor listed below has named you as a reference on a project completed within the past three years and/or is currently in progress. The work performed, as indicated by the contractor, is described below. Neither residential experience nor construction management experience is considered. Please so indicate if the work performed falls into either category. Please revise any incorrect data.

Your timely completion of Questions 1-10 below will assist NEIU in determining the responsibility of this contractor. Your response will be "on the record" and available for the contractor's review. The individual completing this questionnaire may be contacted to confirm their participation. Thank you for your assistance.

**Reference:** Upon completion, please return BOTH PAGES by email to [J-Schliesmann@neiu.edu](mailto:J-Schliesmann@neiu.edu)

**THIS SECTION TO BE COMPLETED BY CONTRACTOR APPLYING FOR QUALIFICATION**

Name of Firm Applying for Qualification: \_\_\_\_\_

Description of Project for Which Reference is Requested (Include type of work/trades performed):  
\_\_\_\_\_

Prime OR  Subcontractor Contract Amount: \_\_\_\_\_ (Dollar Value)

Project Completion Date: \_\_\_\_\_ (Month/Year)

**THIS SECTION TO BE COMPLETED BY REFERENCE ONLY**

1. Please provide the name of your company: \_\_\_\_\_

2. Did the applicant initiate unwarranted change orders or change order requests?  Yes  No

3. Did the applicant complete their portion of the project on time?  Yes  No

4. Were you pleased with the performance of the Superintendent/Project Manager?  Yes  No

5. Was the quality of the applicant's workmanship acceptable?  Yes  No

6. Was the applicant involved in any claims or litigation surrounding the project?  
If "Yes", please explain  Yes  No

7. Was the applicant's project coordination satisfactory throughout the project?  Yes  No

8. Were you pleased with the applicant's overall performance on the project?  Yes  No

9. Did applicant complete a minimum of 20% of the work utilizing its own forces?  Yes  No

10. Would you recommend the applicant for similar projects in the future?  Yes  No

Comments: \_\_\_\_\_

\_\_\_\_\_  
\_\_\_\_\_

Prepared by: \_\_\_\_\_ Date: \_\_\_\_\_ Phone: \_\_\_\_\_

Business Name \_\_\_\_\_

## Bidder Application Form

### Illinois Public Higher Education (IPHE)

This requested information is required to accomplish the statutory purpose of the Illinois Procurement Code [30 ILCS 500].

*Instructions: Please type or print. You must respond to all questions, sign the form, and submit it to the appropriate university. If your answer is "same," "not applicable," or "none," please write this to indicate no questions have been overlooked. It is your responsibility to notify the issuing university if the information in this application changes.*

Today's date \_\_\_\_\_ This application is:  Initial application  Revision of previously submitted application

Submit this completed form to the university closest to you or the university with whom you intend to do the most business. Check that university below:

<input type="checkbox"/> Director of Purchases Chicago State University 9501 King Drive Chicago, IL 60628-1598	<input type="checkbox"/> Director of Procurement Services Northern Illinois University B-113 Gilbert Hall DeKalb, IL 60115-2870	<input type="checkbox"/> Director of Purchases University of Illinois at Chicago Room 312 - M.A.B. (MC-560) 809 South Marshfield Avenue Chicago, IL 60612-7203
<input type="checkbox"/> Director of Purchases Eastern Illinois University Room 113 Old Main Charleston, IL 61920-3099	<input type="checkbox"/> Director of Purchasing Southern Illinois University Bldg 108 - Miles Hall Carbondale, IL 62901-6813	<input type="checkbox"/> University of Illinois at Springfield Purchasing BSB 106 PO Box 19243 4900 Shepherd Road Springfield, IL 62794
<input type="checkbox"/> Purchasing Office Governors State University University Park, IL 60466-0975	<input type="checkbox"/> Director of Purchasing Southern Illinois University Box 1012 Edwardsville, IL 62026-1012	<input type="checkbox"/> Director of Purchases University of Illinois at Urbana- Champaign Purchasing Division 616 E. Green, Suite 212 Champaign, IL 61820-5752
<input type="checkbox"/> Director of Purchases 1220 Illinois State University Normal, IL 61790-1220	<input type="checkbox"/> Director of Procurement Services SIU Medical School P.O. Box 19605 Springfield, IL 62794-9605	<input type="checkbox"/> Director of Purchases Western Illinois University One University Circle Room 227 Sherman Hall Macomb, IL 61455-1390
<input type="checkbox"/> Director of Purchasing Purchasing Department Northeastern Illinois University 5500 North St. Louis Avenue Chicago, IL 60625-4699		

If you wish to be included on the bid list for other universities, copy this form and submit it to the other universities.

1. Legal name/address to which solicitations are to be mailed:	2. Address to which purchase orders are to be mailed, if different:
3. Address to which payment is to be mailed, if different:	4. Contact person: Phone number: 800 number: FAX number: E-mail:
5. If a division of a corporation, show name and address of parent company:  State of incorporation _____	6. Years in business  U.S. owned business: <input type="checkbox"/> Yes <input type="checkbox"/> No

7. Legal and tax status – I certify, under penalty of perjury, that I/we do business as a (check one only):

- Individual
- Sole Proprietorship
- Partnership
- Corporation
- Not-for-Profit Corporation
- Medical Health Care Services Provider Corp.
- Real Estate Agent
- Government Entity
- Tax Exempt Organizations (IRC 501 (a) only)
- Trust or Estate
- Limited Liability Corporation

8. Enter your Taxpayer Identification Number (use Social Security Number if individual or sole proprietorship):

- FEIN \_\_\_\_\_
- SSN \_\_\_\_\_

9. Enter your Illinois Department of Human Rights (IDHR) number. Failure to do so will delay the processing of your application. If your IDHR number is 89999-00-0 or lower, you must re-register with the Illinois Department of Human Rights.

- IDHR Contractor Registration Number \_\_\_\_\_
- Exempt

If you employ 15 or more individuals and wish to bid on State of Illinois contracts, IDHR requires that you file an Employers Report Form - Form PC-1 before bid opening. You may obtain a PC-1 form through IDHR at (312) 814-2431, TDD (312) 263-1579, or [www.state.il.us/cms/purchase/download](http://www.state.il.us/cms/purchase/download). All persons (or firms) employing 14 or fewer individuals at all times during the past 365 days are exempt from the IDHR requirement and should check the "Exempt" box above.

10. Is your firm authorized to do business in the State of Illinois, as well as locally, with all necessary business licenses?

- Yes  No      If no, please explain

11. Net worth of business:

12. Bank reference - name and address:

13. Total sales and receipts (include amounts for all affiliated businesses) for most recent fiscal year:



**14. Special Programs – Complete all of 14 (A – D).**

The public higher education institutions of Illinois have various special programs that may be available to your company. Please check each category which applies, and complete the requested information. You may be requested to complete a more detailed form and provide additional documentation in order to ensure eligibility.

- (A) Small business.** See 30 ILCS 500/45-45. To participate as a small business you must qualify under the following definition and criteria:

“Small business” means a business that is independently owned and operated and is not dominant in its field of operation (that is, it does not exercise a controlling or major influence in a kind of activity in which a number of business concerns are primarily engaged). To compute your size status, include your (and your affiliates’) annual sales and receipts, subject to the following limitations:

**Wholesale business** – annual sales for the most recently completed fiscal year cannot exceed \$7,500,000

Submit a copy of the latest year’s Federal and State income tax return page(s) showing total annual gross sales for the company and an Illinois address. If both a wholesaler and retailer, the combined wholesale and retail annual sales for the latest year of tax filing shall not exceed \$9 million. The retail component shall not exceed \$1.5 million and the wholesale component shall not exceed \$7.5 million. Businesses desiring to qualify under the combined status must also submit a notarized statement delineating the retail and wholesale dollar components.

**Retail business or business selling services** – annual sales and receipts cannot exceed \$1,500,000

Submit a copy of the latest year’s Federal and State income tax return page(s) showing total annual gross sales for the company and an Illinois address. If both a wholesaler and retailer, the combined wholesale and retail annual sales for the latest year of tax filing shall not exceed \$9 million. The retail component shall not exceed \$1.5 million and the wholesale component shall not exceed \$7.5 million. Businesses desiring to qualify under the combined status must also submit a notarized statement delineating the retail and wholesale dollar components.

**Manufacturing business** – cannot employ more than 250 persons

Submit a copy of the latest year’s Federal or State income tax return page(s) showing an Illinois address and the latest year’s form IL-W-3 (Illinois Annual Withholding Income Tax Return) showing the number of Forms W-2, W-2G, and 1099-R issued (denotes number of employees at the company). If a manufacturing business has been in existence for less than a full fiscal year, its average employment shall be calculated for the period through one month prior to the bid or proposal due date. In such cases, a notarized statement to that effect and proof of when the business came into existence shall be submitted.

**Construction business** – annual sales and receipts cannot exceed \$10,000,000

Submit a copy of the latest year’s Federal and State income tax return page(s) showing total annual gross sales for the company and an Illinois address.

- (B) Minority, Female, Person with Disability.** See 30 ILCS 575. To participate in this you must qualify under the following criteria and be certified by one of the following:

- DCMS (Department of Central Management Services) Business Enterprise Program
- CMBDC (Chicago Minority Business Development Council)
- IDOT (Illinois Department of Transportation)
- WBDC (Women’s Business Development Center)

The business must be at least 51% owned and controlled by one or more individuals who are minority, female, or a person with disabilities. A business owned and controlled at least 51% by any combination of minorities, females, and persons with disabilities should be checked as a business owned and controlled by the eligible group that has the largest percentage of ownership. If this block is checked, also check each of the following which are applicable:

- |  |  |
|--|--|
| <input type="checkbox"/> African American  | <input type="checkbox"/> Female                  |
| <input type="checkbox"/> Hispanic  | <input type="checkbox"/> Native American/Alaskan |
| <input type="checkbox"/> Person with disability (must be severe mental or physical disabilities which substantially limit major life activities) | <input type="checkbox"/> Asian American          |

- (C) Not-for-profit, U.S. tax exempt agency for the disabled.** You must qualify under Section 501 of the Internal Revenue Code. See 30 ILCS 575/2A4.1.
- (D) State use – Not-for-profit agency for the severely handicapped.** Must meet requirements of U.S. Department of Labor and the Illinois Department of Rehabilitation Services. See 30 ILCS 500/45-35.

15. In compliance with the Illinois Procurement Code, state the name of each person or company having a beneficial interest of more than 7½% in the bidding enterprise and each person or company, who, together with spouse or minor children, has a beneficial interest of more than 15% in the bidding enterprise (attach additional sheets if necessary):

Name and Address	Percent Owned	Voting Percentage

If applicant is a corporation, please complete both columns:

Names of Corporate Officers	Names of Corporate Directors

16. List equipment, supplies, and/or services you can provide. Include brand and manufacturer names or other information that will help buyers to categorize your capabilities. (Additional items may be submitted on an attached sheet.) If the issuing university has provided a separate listing of equipment, supplies, and/or services, provide requested information and return it with this form. If the services available from your firm include professional and/or artistic services (see Item #17 for listing), and you wish to be pre-qualified so you can receive direct notification of opportunities, complete Items #17-24 of this application.

---



---



---



---



---



---

**Fill out this section to pre-qualify as a provider of  
Professional and Artistic Services**

If you do not offer such services, or do not wish to pre-qualify, proceed to Item #24.

**Completing this section does not guarantee that you will be pre-qualified. Being pre-qualified does not guarantee that you will be awarded a contract. You do not need to be pre-qualified to respond to a solicitation (Illinois Procurement Code [30 ILCS 500/35-15]).** Consult the universities' solicitations to determine specific qualification requirements for individual solicitations.

**Automatic notification** – Once you have been pre-qualified you will be entitled to receive an automatic notification of Procurement Bulletin solicitations for services for which you have pre-qualified if you have listed a FAX number and/or e-mail address as requested in Item #4.

**Do not use this section to pre-qualify for construction or construction-related professional services.** Contact the university with whom you wish to do business for information regarding specific requirements for these categories.

17. Please check the professional and artistic services for which you are requesting pre-qualification. For each service you check, provide the information requested in Items #17-23 of this application.

R  
E  
Q  
U  
I  
R  
E  
D  
I  
N  
F  
O  
R  
M  
A  
T  
I  
O  
N

<p><b>Accounting</b></p> <input type="checkbox"/> Accountant <input type="checkbox"/> Auditor <input type="checkbox"/> Billing Services <input type="checkbox"/> Collection Services	<p><b>Dentistry</b></p> <input type="checkbox"/> Dentist <input type="checkbox"/> Orthodontist <input type="checkbox"/> Periodontist	<p><b>Management/ Administrative Services</b></p> <input type="checkbox"/> Actuary <input type="checkbox"/> Banking Services <input type="checkbox"/> Consultant <input type="checkbox"/> Economist <input type="checkbox"/> Executive Search Services <input type="checkbox"/> Investment Services <input type="checkbox"/> Training and Development	<p><b>Medicine</b></p> <input type="checkbox"/> Audiologist <input type="checkbox"/> Chiropractor <input type="checkbox"/> Dietician <input type="checkbox"/> Medical Transcriber <input type="checkbox"/> Nurse <input type="checkbox"/> Occupational Therapist <input type="checkbox"/> Optometrist <input type="checkbox"/> Orthopedist <input type="checkbox"/> Pathologist <input type="checkbox"/> Pharmacist <input type="checkbox"/> Physical Therapist <input type="checkbox"/> Physician <input type="checkbox"/> Podiatrist <input type="checkbox"/> Radiologist <input type="checkbox"/> Surgeon <input type="checkbox"/> Temporary Medical Staffing <input type="checkbox"/> Veterinarian
<p><b>Artistic</b></p> <input type="checkbox"/> Artist <input type="checkbox"/> Entertainer <input type="checkbox"/> Musician <input type="checkbox"/> Sculptor	<p><b>Environmental/Land</b></p> <input type="checkbox"/> Cartographer <input type="checkbox"/> Environmental Analyst <input type="checkbox"/> Environmental Engineer <input type="checkbox"/> Geologist <input type="checkbox"/> Hydrologist <input type="checkbox"/> Land Appraiser <input type="checkbox"/> Land Use Planner <input type="checkbox"/> Meteorologist <input type="checkbox"/> Naturalist	<p><b>Marketing And Media Services</b></p> <input type="checkbox"/> Audio and Video Production <input type="checkbox"/> Commercial Photographer <input type="checkbox"/> Editor <input type="checkbox"/> Graphic Designer <input type="checkbox"/> Media Consultant <input type="checkbox"/> Public Relations	<p><b>Science/Research</b></p> <input type="checkbox"/> Archaeologist <input type="checkbox"/> Biologist <input type="checkbox"/> Botanist <input type="checkbox"/> Chemist <input type="checkbox"/> Educator <input type="checkbox"/> Entomologist <input type="checkbox"/> Historian <input type="checkbox"/> Other
<p><b>Clinical Psychology</b></p> <input type="checkbox"/> Psychotherapist <input type="checkbox"/> Psychiatrist	<p><b>Law</b></p> <input type="checkbox"/> Administrative Law Judge <input type="checkbox"/> Arbitrator <input type="checkbox"/> Attorney <input type="checkbox"/> Court Reporting <input type="checkbox"/> Hearing Officer <input type="checkbox"/> Law Clerk <input type="checkbox"/> Legal Services		

18. Licenses and/or professional registration – List names of each key person of the firm. If a requested service requires a licensed/registered practitioner, you may be required to provide a copy of such license/registration to the university before an award can be made or work begun.

Name	Capacity (Owner, Partner, Etc.)	Current Licenses/Registrations (Include Certificate # if Applicable)	License/Registration Exp. Date

19. Work experience – List contracts for similar services that have been completed within the last five years:

Project	Location	Type of Service	Total Amount of Contract	Start/Completion Dates	Name/Phone # of Owner or Other Reference

20. Resume' of key personnel – Provide the requested information for key personnel who would be assigned to work on contracts awarded or who would, at a minimum, supervise such work.

Name and Title	Primary Responsibilities	Years Experience (This Firm/Other Firms)	Education (Institutions, Years, Degrees, Certificates)	Other Relevant Experience and/or Qualifications

21. Judgments and claims – Are there any judgments, claims, or suits pending or outstanding against you or your organization that could affect the ability to complete any contract awarded?

Yes       No      If yes, please explain:

22. Receivership – Have you or your organization filed for bankruptcy, receivership, or reorganization within the last five years?

Yes       No      If yes, please provide details:

23. Statutory qualifications – Are you or your organization disqualified, ineligible, suspended, or otherwise barred from receiving solicitations and/or awards from any State of Illinois university or agency or any agency of the Federal Government?

Yes       No      If yes, please provide details:

**24. I understand that:**

Information provided in this application may be audited by any State university or verified by other means.

Provision of information in this application does not relieve me from providing the same or additional information as required in a response to a solicitation.

Submittal of this application does not guarantee pre-qualification. Pre-qualification will be given only if I meet all statutory or regulatory requirements, including any that may not be listed in this application.

I must update significant information changes within a reasonable amount of time. Significant changes include, but are not limited to: change of legal status, TIN, ownership, name, address, as well as loss of licensure or registration, filing of bankruptcy, or suspension or debarment by any Federal, state, or local governmental agency.

Failure to provide accurate and reliable information required by this form may, in accordance with any and all applicable laws, result in penalties including, but not limited to, suspension or debarment from doing business with any university and termination of contracts, and loss of profits in appropriate cases.

**Under penalty of perjury, I swear or affirm that:**

The information provided in this application is true and correct as of the time of signing.

I have not been barred from contracting with a unit of State or local government as a result of a violation of Section 33-E or 33E-4 of the Criminal Code of 1961.

I, along with other officers and employees, have not been convicted of bribery nor attempted bribery of an officer or employee of the State of Illinois, nor have made an admission of guilt of such conduct that is a matter of record.

I am an equal opportunity employer and in compliance with the equal opportunity requirements of applicable state and federal laws.

Signature \_\_\_\_\_ Name (type or print) \_\_\_\_\_

Date \_\_\_\_\_ Title \_\_\_\_\_

08/13/03

**END OF SECTION**

R  
E  
Q  
U  
I  
R  
E  
D  
B  
I  
D  
D  
S  
B  
B  
M  
T  
A  
F  
R  
O  
M



**SECTION 004111**  
**FINANCIAL DISCLOSURES AND CONFLICTS OF INTEREST**

Financial Disclosures and Conflicts of Interest forms ("forms") must be accurately completed and submitted by the vendor, any parent entity(ies) and any subcontractors. There are nine steps to this form and each must be completed as instructed in the step heading, unless otherwise provided. A bid, offer, or proposal that does not include this form shall be considered not responsive. The University will consider this form when evaluating the bid, offer, or proposal or awarding the contract.

The requirement of disclosure of financial interests and conflicts of interest is a continuing obligation. If circumstances change and the previously submitted form is no longer accurate, disclosing entities must provide an updated form.

**Separate forms are required for the vendor, any parent entity(ies) and any subcontractors.**

This disclosure is submitted for (check one):

- Vendor
- Vendor's Parent Entity(ies) (100% ownership)
- Subcontractor(s) >\$50,000
- Subcontractor's Parent Entity(ies) > \$50,000

Project Name and Reference #: \_\_\_\_\_

Vendor Name: \_\_\_\_\_

Doing Business As (DBA): \_\_\_\_\_

Parent Entity: \_\_\_\_\_

Subcontractor: \_\_\_\_\_

Instrument of Ownership or Beneficial Interest (check one):

- Sole Proprietorship
- Corporate Stock (C-Corporation, S-Corporation, Professional Corporation, Service Corporation)
- Limited Liability Company Membership Agreement (Series LLC, Low-Profit Limited Liability Partnership)
- Partnership Agreement (General Partnership, Limited Partnership, Limited Liability Partnership, Limited Liability Partnership)
- Not-for-Profit
- Trust Agreement (Beneficiary)
- Other

If you selected Other, please describe: \_\_\_\_\_

R  
E  
Q  
U  
I  
R  
E  
D  
B  
I  
D  
S  
B  
E  
M  
I  
T  
T  
A  
F  
O  
R  
M

**STEP 1**  
**SUPPORTING DOCUMENTATION SUBMITTAL**

(All vendors complete regardless of annual bid, offer, or contract value)  
(Subcontractors with subcontract annual value of more than \$50,000 must complete)

You must select one of the six options below and select the documentation you are submitting. You must provide the documentation the applicable section requires with this form.

Option 1 – Publicly Traded Entities

- 1.A.  Complete Step 2, Option A for each qualifying individual or entity holding any ownership or distributive income share in excess of 5% or an amount greater than 60% (\$106,447.20) of the annual salary of the Governor.  
OR  
1.B.  Attach a copy of the Federal 10-K, and I will skip to Step 3.

Option 2 – Privately Held Entities with more than 200 Shareholders

- 2.A.  Complete Step 2, Option A for each qualifying individual or entity holding any ownership or distributive income share in excess of 5% or an amount greater than 60% (\$106,447.20) of the annual salary of the Governor.  
OR  
2.B.  Complete Step 2, Option A each qualifying individual or entity holding any ownership share in excess of 5% and will attach the information Federal 10-K reporting companies are required to report under 17 CFR 229.401.

Option 3 – All other Privately Held Entities, not including Sole Proprietorships

- 3.A.  Complete Step 2, Option A for each qualifying individual or entity holding any ownership or distributive income share in excess of 5% or an amount greater than 60% (\$106,447.20) of the annual salary of the Governor.

Option 4 – Foreign Entities

- 4.A.  Complete Step 2, Option A for each qualifying individual or entity holding any ownership or distributive income share in excess of 5% or an amount greater than 60% (\$106,447.20) of the annual salary of the Governor.  
OR  
4.B.  Attach a copy of the Securities Exchange Commission Form 20-F or 40-F, and I will skip to Step 3.

Option 5 – Not-for-Profit Entities

- Complete Step 2, Option B.

Option 6 – Sole Proprietorships

- Skip to Step 3.

**STEP 2**

**DISCLOSURE OF FINANCIAL INTEREST OR BOARD OF DIRECTORS**

(All vendors, except sole proprietorships, must complete regardless of annual bid, offer, or contract value)  
(Subcontractors with subcontract annual value of more than \$50,000 must complete)

Complete either Option A (for all entities other than not-for-profits) or Option B (for not-for-profits). Additional rows may be inserted into the tables or an attachment may be provided if needed.

**OPTION A – Ownership Share and Distributive Income**

Ownership Share – If you selected Option 1.A., 2.A., 2.B., 3.A. or 4A. in Step 1, provide the name and address of each individual and entity and their percentage of ownership if said percentage exceeds 5%, or the dollar value of their ownership if said dollar value exceeds \$106,447.20.

Check here if including an attachment with requested information in a format substantially similar to the format below.

TABLE - X			
Name	Address	% of Ownership	\$ Value of Ownership

Distributive Income – If you selected Option 1.A., 2.A., 3.A., or 4A. in Step 1, provide the name and address of each individual and their percentage of the disclosing vendor’s total distributive income if said percentage exceeds 5% of the total distributive income of the disclosing entity, or the dollar value of their distributive income if said dollar value exceeds \$106,447.20.

Check here if including an attachment with requested information in a format substantially similar to the format below.

TABLE - Y			
Name	Address	% of Distributive Income	\$ Value of Distributive Income

Please certify that the following statements are true.

I have disclosed all individuals or entities that hold an ownership interest of greater than 5% or greater than \$106,447.20.  
 Yes  No

I have disclosed all individuals or entities that were entitled to receive distributive income in an amount greater than \$106,447.20 or greater than 5% of the total distributive income of the disclosing entity.  Yes  No

**OPTION B – Disclosure of Board of Directors (Not-for-Profits)**

If you selected Option 5 in Step 1, list members of your board of directors. Please include an attachment if necessary.

Name	Address

**STEP 3**  
**DISCLOSURE OF LOBBYIST OR AGENT**  
 (Complete only if bid, offer, or contract has an annual value over \$25,000)  
 (Subcontractors with subcontract annual value of more than \$50,000 must complete)

Yes  No. Is your company represented by or do you employ a lobbyist or other agent required to register under the Lobbyist Registration Act (lobbyist must be registered pursuant to the Act with the Secretary of State) or other agent who is not identified through Step 2, Option A above and who has communicated, is communicating, or may communicate with any University officer or employee concerning the bid or offer? If yes, please identify each lobbyist and agent, including the name and address below.

Name	Address	Relationship to Disclosing Entity

Describe all costs/fees/compensation/reimbursements related to the assistance provided by each representative lobbyist or other agent to obtain a State/University contract: \_\_\_\_\_

**STEP 4**  
**PROHIBITED CONFLICTS OF INTEREST**  
 (All vendors must complete regardless of annual bid, offer, or contract value)  
 (Subcontractors with subcontract annual value of more than \$50,000 must complete)

Step 4 must be completed for each person disclosed in Step 2, Option A and for sole proprietors identified in Step 1, Option 6 above. Please provide the name of the person for which responses are provided: \_\_\_\_\_

1. Do you hold or are you the spouse or minor child of any person who holds an elective office in the State of Illinois or hold a seat in the General Assembly?  Yes  No
2. Have you, your spouse, or minor child been appointed to or employed in any offices or agencies of State government and receive compensation for such employment in excess of 60% (\$106,447.20) of the salary of the Governor?  Yes  No
3. Are you or are you the spouse or minor child of an officer or employee of the Capital Development Board or the Illinois Toll Highway Authority?  Yes  No
4. Have you, your spouse, or an immediate family member who lives in your residence currently or who lived in your residence within the last 12 months been appointed as a member of a board, commission, authority, or task force authorized or created by State law or by executive order of the Governor?  Yes  No
5. If you answered yes to any question in 1-4 above, please answer the following: Do you, your spouse, or minor child receive from the vendor more than 7.5% of the vendor's total distributable income or an amount of distributable income in excess of the salary of the Governor (\$177,412.00)?  Yes  No
6. If you answered yes to any question in 1-4 above, please answer the following: Is there a combined interest of self with spouse or minor child more than 15% (\$354,824.00) in the aggregate of the vendor's distributable income or an amount of distributable income in excess of two times the salary of the Governor?  Yes  No

**STEP 5**

**POTENTIAL CONFLICTS OF INTEREST RELATING TO PERSONAL RELATIONSHIPS**

(Complete only if bid, offer, or contract has an annual value over \$25,000)

(Subcontractors with subcontract annual value of more than \$50,000 must complete)

Step 5 must be completed for each person disclosed in Step 2, Option A and for sole proprietors identified in Step 1, Option 6 above.

Please provide the name of the person for which responses are provided: \_\_\_\_\_

- 1. Do you currently have, or in the previous 3 years have you had State employment, including contractual employment of services?  Yes  No
- 2. Has your spouse, father, mother, son, or daughter, had State employment, including contractual employment for services, in the previous 2 years?  Yes  No
- 3. Do you hold currently or have you held in the previous 3 years elective office of the State of Illinois, the government of the United States, or any unit of local government authorized by the Constitution of the State of Illinois or the statutes of the State of Illinois?  Yes  No
- 4. Do you have a relationship to anyone (spouse, father, mother, son, or daughter) holding elective office currently or in the previous 2 years?  Yes  No
- 5. Do you hold or have you held in the previous 3 years any appointive government office of the State of Illinois, the United States of America, or any unit of local government authorized by the Constitution of the State of Illinois or the statutes of the State of Illinois, which office entitles the holder to compensation in excess of expenses incurred in the discharge of that?  Yes  No
- 6. Do you have a relationship to anyone (spouse, father, mother, son, or daughter) holding appointive office currently or in the previous 2 years?  Yes  No
- 7. Do you currently have or in the previous 3 years had employment as or by any registered lobbyist of the State government?  Yes  No
- 8. Do you currently have or in the previous 2 years had a relationship to anyone (spouse, father, mother, son, or daughter) that is or was a registered lobbyist?  Yes  No
- 9. Do you currently have or in the previous 3 years had compensated employment by any registered election or re-election committee registered with the Secretary of State or any county clerk in the State of Illinois, or any political action committee registered with either the Secretary of State or the Federal Board of Elections?  Yes  No
- 10. Do you currently have or in the previous 2 years had a relationship to anyone (spouse, father, mother, son, or daughter) who is or was a compensated employee of any registered election or reelection committee registered with the Secretary of State or any county clerk in the State of Illinois, or any political action committee registered with either the Secretary of State or the Federal Board of Elections?  Yes  No

**STEP 6**

**EXPLANATION OF AFFIRMATIVE RESPONSES**

(All vendors must complete regardless of annual bid, offer, or contract value)  
(Subcontractors with subcontract annual value of more than \$50,000 must complete)

If you answered "Yes" in Step 4 or Step 5, please provide on an additional page a detailed explanation that includes, but is not limited to the name, salary, State agency or university, and position title of each individual.

**STEP 7**

**POTENTIAL CONFLICTS OF INTEREST  
RELATING TO DEBARMENT & LEGAL PROCEEDINGS**

(Complete only if bid, offer, or contract has an annual value over \$25,000)  
(Subcontractors with subcontract annual value of more than \$50,000 must complete)

This step must be completed for each person disclosed through Step 2, Option A and Step 3, and for each entity and sole proprietor disclosed in Step 1.

Please provide the name of the person or entity for which responses are provided: \_\_\_\_\_

- 1. Within the previous ten years, have you had debarment from contracting with any governmental entity?  Yes  No
- 2. Within the previous ten years, have you had any professional licensure discipline?  Yes  No
- 3. Within the previous ten years, have you had any bankruptcies?  Yes  No
- 4. Within the previous ten years, have you had any adverse civil judgments and administrative findings?  Yes  No
- 5. Within the previous ten years, have you had any criminal felony convictions?  Yes  No

If you answered "Yes", please provide a detailed explanation that includes, but is not limited to the name, State agency or university, and position title of each individual and descriptive information regarding the nature of the debarment and/or legal proceeding.

**STEP 8**

**DISCLOSURE OF CURRENT AND PENDING CONTRACTS**

(Complete only if bid, offer, or contract has an annual value over \$25,000)  
(Subcontractors with subcontract annual value of more than \$50,000 must complete)

If you selected Option 1, 2, 3, 4 or 6 in Step 1, do you have any contracts, pending contracts, bids, proposals, or other ongoing procurement relationships with State of Illinois agencies or universities?  Yes  No

If "Yes", please specify below. Attach an additional page in the same format as provided below, if desired.

Agency/University	Project Title	Status	Value	Contract Reference/P.O./ Bulletin #

Please explain the procurement relationship: \_\_\_\_\_

MEMORANDUM FOR THE DIRECTOR

**STEP 9**  
**SIGN THE DISCLOSURE**

(All vendors must complete regardless of annual bid, offer, or contract value)  
(Subcontractors with subcontract annual value of more than \$50,000 must complete)

This disclosure is signed and made under penalty of perjury by an authorized officer or employee on behalf of the bidder or offeror pursuant to Sections 50-13 and 50-35 of the Illinois Procurement Code. This disclosure information is submitted on behalf of:

Name of Disclosing Entity: \_\_\_\_\_

Signature: \_\_\_\_\_ Date: \_\_\_\_\_

Printed Name: \_\_\_\_\_

Title: \_\_\_\_\_

Phone Number: \_\_\_\_\_

Email Address: \_\_\_\_\_

FOR FURTHER INFORMATION CONTACT THE BIDDING DIVISION



**DIVISION 00 – PROCUREMENT AND BIDDING REQUIREMENTS**

**SECTION 004112**

**STATE BOARD OF ELECTIONS CERTIFICATION INSTRUCTIONS AND CERTIFICATION**

**Compliance with Public Act 095-0971 (Registration with State Board of Elections)**

If you have not already reviewed Public Act 095-0971, which went into effect on January 1, 2009, we strongly recommend that you do so immediately. The Act is available at <http://www.ilga.gov/legislation/publicacts/fulltext.asp?Name=095-0971>.

The Act was amended by P.A. 097-0895 effective August 3, 2012, and the amendment is available at <http://www.ilga.gov/legislation/publicacts/97/097-0895.htm>

If you wish to submit a bid or proposal in response to this solicitation you must certify your compliance with the registration requirements of the Act by checking the appropriate box on the form below.

For any bid or proposal for a contract with a State agency by a business entity required to register under this Section, the chief procurement officer shall verify that the business entity is required to register under this Section and is in compliance with the registration requirements on the date the bid or proposal is due. A chief procurement officer shall not accept a bid or proposal if the business entity is not in compliance with the registration requirements as of the date bids or proposals are due.

**You must certify compliance with the Act, and if required, be registered with the Board of Elections prior to bid opening. THERE IS NO GRACE PERIOD ALLOWING FOR REGISTRATION WITH THE BOARD OF ELECTIONS AFTER BID OPENING.**

Note: vendors who registered with the State Board of Elections by mail or e-mail prior to August 1, 2009 must re-register on-line at <https://BEREP.elections.il.gov>.

**Vendor Certification of Compliance with Public Act 095-0971**  
**(Registration with State Board of Elections)**

Please read all of the following explanatory notes before completing the certification:

- If you are a for-profit vendor submitting a bid or proposal exceeding \$50,000, you must check Box #2, and register with the State Board of Elections, AND SUBMIT A COPY OF THE REGISTRATION CERTIFICATE ISSUED TO YOU BY THE BOARD OF ELECTIONS WITH YOUR BID OR PROPOSAL.
- If you are a for-profit vendor submitting a bid or proposal for less than \$50,000 but the annual total value of all of your contracts and offers with all State agencies (including all current State contracts, the bid or proposal you are submitting, any other pending offers, and offers you previously submitted this year where you were not awarded a contract) exceeds \$50,000, you must check Box #2, and register with the State Board of Elections, AND SUBMIT A COPY OF THE REGISTRATION

R  
E  
Q  
U  
I  
R  
E  
D  
B  
I  
D  
D  
E  
S  
B  
E  
R  
E  
P  
F  
O  
R  
M

CERTIFICATE ISSUED TO YOU BY THE BOARD OF ELECTIONS WITH YOUR BID OR PROPOSAL.

- If you are a for-profit vendor submitting a bid or proposal for less than \$50,000, and the annual total value of all of your contracts and offers with all State agencies is also less than \$50,000, you may check Box #1 indicating that you are not required to register.
- If you are a not-for-profit organization or governmental entity, you may check Box #1 indicating that you are not required to register regardless of the amount of your bid or proposal or the annual total value of all of your contracts and offers with all State agencies.
- There are no exceptions to the registration requirements for out-of-state or non-U.S. vendors.

**Certify your compliance with the Act by checking the appropriate box. If you fail to check any box, the University cannot accept your bid or proposal.**

1.  **The bidder/proposer certifies that they are not required to register as a business entity with the State Board of Elections pursuant to the Procurement Code (30 ILCS 500/20-160).** Further, the bidder/proposer acknowledges that all contracts between State agencies and a business entity that do not comply with this Section shall be voidable under Section 50-60 of the Procurement Code (30 ILCS 500/50-60).

OR

2.  **The bidder/proposer certifies that they have registered as a business entity with the State Board of Elections and acknowledges a continuing duty to update the registration pursuant to the Procurement Code (30 ILCS 500/20-160).** Further, the bidder/proposer acknowledges that all contracts between State agencies and a business entity that do not comply with this Section shall be voidable under Section 50-60 of the Procurement Code (30 ILCS 500/50-60).

**If you need to register with the State Board of Elections, please visit its website for specific information on the registration process:  
<https://BEREP.elections.il.gov>.**

If you are not required to register, check here

For confirmation purposes only, you may submit a copy of your registration certificate as part of your bid.

---

R  
E  
Q  
U  
I  
R  
E  
D  
B  
Y  
D  
I  
B  
D  
S  
B  
M  
H  
A  
F  
O  
R  
M

**DIVISION 00 – PROCUREMENT AND CONTRACTING REQUIREMENTS**

**SECTION 004113  
CERTIFICATIONS AND STATUTORY REQUIREMENTS**

*GENERAL TERMS:*

- “Vendor” is defined as any entity that is contractually obligated to perform work on behalf of or related to the Owner, regardless of whether the entity has a contract directly with the Owner. Certain provisions contained herein are only applicable to “Subcontractor(s)”. A Subcontractor is defined as a Vendor that has a contractual obligation with a prime vendor rather than directly with the Owner. “Owner” and “University” are used interchangeably within this document.
- Vendor will include these terms in any subcontract and acknowledges that this Contract may be declared void without penalty or obligation to pay additional compensation if Vendor or Subcontractors fail to fully and truthfully comply with the requirements of this Attachment or if this Contract has been made in violation of the Procurement Code or any other law.
- Vendor acknowledges that this Contract may be voided if any of the certifications made herein by the Vendor are false.
- Vendor certifies it is not legally barred from contracting with the State of Illinois and has no known conflicts of interest.
- In the event of a conflict between these contract certifications and a purchase order these contract certifications shall control.

*THE FOLLOWING CERTIFICATIONS AND STATUTORY REQUIREMENTS ARE APPLICABLE FOR ALL ENTITIES EXCEPT WHERE SPECIFICALLY NOTED:*

1. Vendor agrees that, if this is a multi-year contract, Vendor shall confirm compliance by July 1 of each year that this contract remains in effect. Vendor shall obtain from all Subcontractors a statement of compliance with these provisions. Should vendor or its subcontractor(s) fail to be or remain in compliance, the contract may be void by operation of law or the contract may be voidable at the option of the Owner without additional compensation. Violation of certain provisions may also be a civil or criminal offense.
2. Vendor, its employees and subcontractors will comply with applicable provisions of the U.S. Civil Rights Act, Section 504 of the Federal Rehabilitation Act, the Americans with Disabilities Act (42 U.S.C. § 12101 et seq.) and applicable rules in performance under this Contract.
3. This applies to individuals, sole proprietorships, partnerships and LLCs, but is not otherwise applicable. Vendor is not in default on an educational loan (5 ILCS 385/3).
4. Vendor has not been convicted of bribing or attempting to bribe an officer or employee of the State of Illinois or any other State, nor has Vendor made an admission of guilt of such conduct that is a matter of record (30 ILCS 500/50-5).
5. If Vendor has been convicted of a felony, at least five years have passed after the date of completion of the sentence for such felony, unless no person held responsible by a prosecutor’s office for the facts upon which the conviction was based continues to have any involvement with the business (30 ILCS 500/50-10).
6. If Vendor, or any officer, director, partner, or other managerial agent of Vendor, has been convicted of a felony under the Sarbanes-Oxley Act of 2002, or a Class 3 or Class 2 felony under the Illinois Securities Law of 1953, at least five years have passed since the date of the conviction. Vendor further certifies that it is not barred from being awarded a contract and acknowledges that the State shall declare the Contract void if this certification is false (30 ILCS 500/50-10.5).
7. Vendor and its affiliates are not delinquent in the payment of any debt to the State (or if delinquent has entered into a deferred payment plan to pay the debt), and Vendor and its affiliates

R  
E  
Q  
U  
I  
R  
E  
D  
B  
I  
D  
S  
B  
M  
T  
A  
L  
F  
O  
R  
M

acknowledge the State may declare the Contract void if this certification is false (30 ILCS 500/50-11) or if Vendor or an affiliate later becomes delinquent and has not entered into a deferred payment plan to pay off the debt (30 ILCS 500/50-60).

8. Vendor and all affiliates shall collect and remit Illinois Use Tax on all sales of tangible personal property into the State of Illinois in accordance with provisions of the Illinois Use Tax Act (30 ILCS 500/50-12) and acknowledges that failure to comply can result in the Contract being declared void.
9. Vendor certifies that it has not committed a willful or knowing violation of the Environmental Protection Act (relating to Civil Penalties under the Environmental Protection Act) within the last five years, and is therefore not barred from being awarded a contract. If the State later determines that this certification was falsely made by the Vendor, the Vendor acknowledges that the State may declare the Contract void (30 ILCS 500/50-14).
10. Vendor has not paid any money or valuable thing to induce any person to refrain from bidding on a State contract, nor has Vendor accepted any money or other valuable thing, or acted upon the promise of same, for not bidding on a State contract (30 ILCS 500/50-25).
11. Vendor is not in violation of the "Revolving Door" section of the Illinois Procurement Code (30 ILCS 500/50-30).
12. Vendor will report to the Illinois Attorney General and the Chief Procurement Officer any suspected collusion or other anti-competitive practice among any bidders, offerors, contractors, proposers or employees of the State (30 ILCS 500/50-40, 50-45, 50-50).
13. In accordance with the Steel Products Procurement Act, steel products used or supplied in the performance of a contract for public works shall be manufactured or produced in the United States, unless the executive head of the procuring agency grants an exception (30 ILCS 565).
14. If Vendor employs 25 or more employees and this Contract is worth more than \$5,000, Vendor certifies that it will provide a drug free workplace in accordance with the requirements of the Illinois Drug-Free Workplace Act (30 ILCS 580).
15. If Vendor is an individual and this Contract is worth more than \$5,000, Vendor shall not engage in the unlawful manufacture, distribution, dispensation, possession or use of a controlled substance during the performance of the Contract. (30 ILCS 580).
16. Neither Vendor nor any substantially owned affiliate is participating or shall participate in an international boycott in violation of the U.S. Export Administration Act of 1979 or the applicable regulations of the U.S. Department of Commerce. This certification applies to contracts that exceed \$10,000 (30 ILCS 582).
17. Vendor has not been convicted of the offense of bid rigging or bid rotating or any similar offense of any state or of the United States (720 ILCS 5/33 E-3, E-4).
18. Vendor complies with the Illinois Department of Human Rights Act, 775 ILCS 5/2-105 (2010), and rules applicable to public contracts, including equal employment opportunity, refraining from unlawful discrimination, and having written sexual harassment policies.

Responsibility for Subcontractors' Compliance: The Vendor shall be responsible for compliance with applicable provisions of the Act by all Subcontractors employed by the Vendor in connection with this contract and will promptly notify both the Owner and the Illinois Department of Human Rights in the event any Subcontractor fails or refuses to comply therewith. In addition, the Vendor shall not utilize any Subcontractor declared by the Illinois Human Rights Commission to be ineligible for contracts or subcontracts with the State of Illinois or any of its political subdivisions.

R  
E  
Q  
U  
I  
R  
E  
D  
B  
I  
D  
S  
C  
B  
M  
T  
T  
A  
L  
F  
O  
R  
M

R  
E  
Q  
U  
I  
R  
E  
D  
B  
I  
D  
S  
B  
M  
T  
T  
A  
L  
F  
O  
R  
M

Penalties for Noncompliance: In the event of the Vendor's noncompliance with any provision of the Illinois Human Rights Act or the Illinois Department of Human Rights' Rules and Regulations for Public Contracts, the Vendor may be declared ineligible for future contracts or subcontracts with the State of Illinois or any of its political subdivisions. In addition, this contract may be canceled or voided in whole or in part and such other sanctions, penalties, or remedies may be imposed as provided by statute or regulation.

Illinois Department of Human Rights (DHR) Public Contracts Number: If Vendor has (a) employed fifteen (15) or more full-time persons at the time of application for this contract; (b) employed 15 or more persons at any time during the 365-day period prior to the date of applying for this contract; or (c) is directed to file by a contracting agency of the State of Illinois, any political subdivision, or a municipal corporation, then Vendor must have a current Public Contract Number or have proof of having submitted a completed application. Please complete the appropriate sections below.

Name of Company (and D/B/A): \_\_\_\_\_  
DHR Public Contracts Number: \_\_\_\_\_  
Date of Expiration: \_\_\_\_\_  
 (check if applicable) The number is not required as the company has employed 14 or less full-time employees during the 365-day period immediately preceding the renewal period.

19. Vendor does not pay dues to, or reimburse or subsidize payments by its employees for any dues or fees to any "discriminatory club" (775 ILCS 25/2).
20. Vendor complies with the State Prohibition of Goods from Forced Labor Act, and certifies that no foreign-made equipment, materials, or supplies furnished to the State under the Contract have been or will be produced in whole or in part by forced labor, or indentured labor under penal sanction (30 ILCS 583).
21. Vendor certifies that no foreign-made equipment, materials, or supplies furnished to the State under the Contract have been produced in whole or in part by the labor or any child under the age of 12 (30 ILCS 584).
22. Vendor certifies that it has not committed a willful or knowing violation of the Lead Poisoning Prevention Act (410 ILCS 45) and acknowledges that it is prohibited from doing business with the State until the violation is mitigated. (30 ILCS 500/50-14.5).
23. Vendor (as "business entity" under 30 ILCS 500/50-37), certifies that it will not make a prohibited political contribution.
24. Vendor is required under 30 ILCS 500/20-65 to maintain, for a period of three (3) years after the later of the date of completion of this Contract or the date of final payment under the Contract, all books and records relating to the performance of the Contract and necessary to support amounts charged to the Owner under the Contract. The Contract and all books and records related to the Contract shall be available for review and audit by the Owner and the Illinois Auditor General. If this Contract is funded from contract/grant funds provided by the U.S. Government, the Contract, books, and records shall be available for review and audit by the Comptroller General of the U.S. and/or the Inspector General of the federal sponsoring agency. The Contractor agrees to cooperate fully with any audit and to provide full access to all relevant materials. Failure to maintain the required books and records shall establish a presumption in favor of the Owner for the recovery of any funds paid by the Owner under this Contract for which adequate books and records are not available.

25. Vendor is an existing legal entity, and as applicable, has obtained an assumed name certificate from the appropriate authority, is registered to conduct business in Illinois, and is in good standing with the Illinois Secretary of State. (30 ILCS 500/1.15.80)
26. Subcontractor certifies that it has not retained a person or entity to attempt to influence the outcome of a procurement decision for compensation contingent in whole or in part upon the decision or procurement. Subcontractor further certifies that it has not and will not, pursuant to this subcontract or otherwise, bill or otherwise cause the State of Illinois to pay for any of the lobbyist's costs, fees, compensation, reimbursement or other remuneration (30 ILCS 500/50-38).
27. Vendor has disclosed if required, on forms provided by the State, and agrees it is under a continuing obligation to disclose to the State, financial or other interests (public or private, direct or indirect) that may be a potential conflict of interest or that would prohibit Vendor from having or continuing the Contract. This includes, but is not limited to conflicts under the "Infrastructure Task Force Fee Prohibition" section of the State Finance Act (30 ILCS 105/8.40), Article 50 of the Illinois Procurement Code (30 ILCS 500/50), or those which may conflict in any manner with the Vendor's obligation under this Contract. Vendor shall not employ any person with a conflict to perform under this Contract. If any elected or appointed State officer or employee, or the spouse or minor child of same has any ownership or financial interest in the Vendor or the Contract, Vendor certifies it has disclosed that information to the State if required, on forms provided by the State, and any waiver of the conflict has been issued in accordance with applicable law and rule. A waiver is required if:
- a) the person intending to contract with the State, his/her spouse or child: (i) holds an elective office in Illinois; (ii) holds a seat in the Illinois General Assembly; (iii) is an officer or employee of the Capital Development Board or the Illinois Toll Highway Authority; or holds an appointed position or is employed in any of the offices or agencies of the State government and who receives compensation for such employment in excess of 60% of the salary of the Governor (currently \$106,447.20). (The conflict of interest threshold of 60% of the Governor's salary set forth in Section 50-13 does not apply to elective office holders, legislators, and officers or employees of the Capital Development Board or the Illinois Toll Highway Authority.);
  - b) the contract is with a firm, partnership, association or corporation in which a person referenced in a) above receives more than 7.5% of the total distributable income or an amount in excess of the salary of the Governor (currently \$177,412.00).
  - c) the contract is with a firm, partnership, association or corporation in which a person referenced in b) above, together with their spouse or minor child, receives more than 15% in the aggregate of the total distributable income or an amount in excess of 2 times the salary of the Governor (currently \$354,824.00) from the firm, partnership, association or corporation.
28. Vendor shall pay all current and applicable city, county, State and Federal taxes, licenses, assessments, including Federal Excise Taxes, due on his work, including without thereby limiting the foregoing, those required by the Federal Insurance Contributions Act and the Federal and State Unemployment Tax Acts.

Vendor shall accept exclusive liability for, and pay, all taxes, license fees, assessments, and excises, levied, assessed or imposed upon or on account of the execution of the contract or on the materials therefor, or on the manufacture, storage, sale, receipts from sale, transportation or delivery of the materials therefor, under any Federal, State, or local law or laws, and in the event said taxes, license fees, assessments and excises, or any part thereof, are in the first instance charged to the Owner, the Vendor shall, at the demand of the Owner, pay the Owner the amount thereof, plus any and all penalties which may have accrued thereon.

The Owner is exempted by Section 3-5 of the Illinois Use Tax Act (35 ILCS 105/3-5 (2000)) from paying any of the taxes imposed by that Act, and sales to Owner are exempt by Section 2-5 of the Illinois Retailer's Occupation Tax Act (35 ILCS 120/2-5 (2000)) from any of the taxes imposed by that Act. The Department of Revenue of the State of Illinois under Rule No. 15, issued August 9, 1961, has declared that sales of materials to construction contractors for conversion into real estate for schools, governmental bodies, agencies and instrumentalities, are not taxable retail sales.

29. This applies to information technology contracts and is otherwise not applicable. Vendor acknowledges that all information technology, including electronic information, software, systems and equipment, developed or provided under this Contract must be accessible to individuals with disabilities to the greatest extent possible, in accordance with the Illinois Information Technology Accessibility Act Standards published at [www.dhs.state.il.us/iitaa](http://www.dhs.state.il.us/iitaa) (30 ILCS 587).

30. This applies to service contracts and is otherwise not applicable. Vendor certifies (i) that it will offer to assume the collective bargaining obligations of the prior employer, including any existing collective bargaining agreement with the bargaining representative of any existing collective bargaining unit or units performing substantially similar work to the services covered by the contract subject to its bid or offer, and (ii) that it shall offer employment to all employees currently employed in any existing bargaining unit performing substantially similar work that will be performed under this contract (30 ILCS 500/25-80). This certification does not apply to heating and air-conditioning, plumbing and electrical service contracts.

31. The following certification is applicable for prime vendors only. In accordance with 30 ILCS 500/20-160, Vendor certifies that either:

Vendor is not required to register as a business entity with the State Board of Elections.

or

Vendor has registered as a business entity with the State Board of Elections and acknowledges a continuing duty to update the registration as required by the Act. **A copy of the official certificate of registration as issued by the State Board of Elections is attached.**

32. The following certification is applicable for prime vendors only. Disclosure of Business in Iran: You must respond to the following request for information. Failure to respond will disqualify your firm from consideration in this solicitation.

Within the 24 months before submission of the renewal offer the vendor, or any of its corporate parents or subsidiaries, has had business operations that involved contracts with or provision of supplies or services to

(a) the Government of Iran;

(b) companies in which the Government of Iran has any direct or indirect equity share;

(c) consortiums or projects commissioned by the Government of Iran; or

(d) companies involved in consortiums or projects commissioned by the Government of Iran;

**AND**

(1) more than 10% of the company's revenues produced in, or assets located in, Iran involve oil-related activities or mineral-extraction activities; less than 75% of the company's revenues produced in, or assets located in, Iran involve contracts with or provision of oil-related or mineral-extraction products or services to the Government of Iran or a project or consortium created exclusively by that government; and the company has failed to take substantial action;

**OR**





R  
E  
Q  
U  
I  
R  
E  
D  
B  
Y  
D  
S  
C  
B  
M  
T  
T  
A  
F  
O  
R  
M

performed. The records shall include each worker's name, address, telephone number when available, social security number, classification or classifications, hourly wages paid in each pay period, number of hours worked each day, and the starting and ending times of each work day. The certified payroll shall be accompanied by a statement signed by the vendor and statements signed by each subcontractor where appropriate which aver that: (1) such records are true and accurate, (2) the hourly rate paid to each worker is not less than the general prevailing rate of hourly wages required under the Act; and (3) the vendor acknowledges that filing a certified payroll that he or she knows to be false is a Class B misdemeanor.

- 39. The following certification is applicable for contractors and subcontractors only. Pursuant to the Employment of Illinois Workers on Public Works Act, Vendor shall employ Illinois laborers on all public works projects or improvements or for the clean-up and on-site disposal of hazardous waste whenever there is a period of excessive unemployment in Illinois, pursuant to the guidelines and exceptions in 30 ILCS 570/0.01 et. seq. (2010)
- 40. The following certification is applicable for contractors and subcontractors only. Pursuant to the Veterans Preference Act, Vendor shall give preference to veterans of the United States military and naval service in appointments and employment upon public works by, or for the use of, the State or its political subdivisions, pursuant to the guidelines in 330 ILCS 55/0.01 et. seq. (2010)
- 41. The following certification is applicable for contractors and subcontractors only. Pursuant to the Public Works Employment Discrimination Act (775 ILCS 10/0.01 et. seq. (2010)), Vendor shall not refuse or deny employment to any person in any capacity on the ground of unlawful discrimination, nor subject any person to unlawful discrimination in any manner, in connection with the Agreement
- 42. The following certification is applicable for contractors and subcontractors only. Pursuant to the Health and Safety Act, Vendor shall provide reasonable protection to the lives, health and safety of its employees and provide such employees with employment and a place of employment which are free from recognized hazards that are causing or are likely to cause death or serious physical harm, pursuant to the guidelines set forth in 820 ILCS 225/0.01 et. seq. (2010).
- 43. Domestic Products Act: If applicable, please check the statement below that applies to the articles you are offering in this contract. For the purposes of this question, "manufactured in the United States" means in the case of assembled articles that final assembly occurred in the United States.

\_\_\_\_\_ We certify that all offered articles were/will be manufactured in the United States. Contractor understands that, if it is awarded a contract based on a preference for US manufactured goods under the Procurement of Domestic Products Act (PA 93-0954), this certification will become part of the contract, and that if Contractor knowingly supplies non-US manufactured goods, it will be subject to penalties that include debarment for five years, voiding of the contract, and civil damages.

\_\_\_\_\_ We are unable to certify that all offered articles were/will be manufactured in the United States.

By signing this form, Vendor certifies that the above information is accurate and complete:

Company name: \_\_\_\_\_

Address: \_\_\_\_\_

Telephone number: \_\_\_\_\_

FTIN: \_\_\_\_\_

*(Do NOT provide Social Security number)*

Project Name/#: \_\_\_\_\_

Signature: \_\_\_\_\_

Printed name/Title: \_\_\_\_\_

Date: \_\_\_\_\_

MEMORANDUM FOR THE DIRECTOR

**DIVISION 00 – PROCUREMENT AND CONTRACTING REQUIREMENTS**

**SECTION 004114  
SUBCONTRACTOR ATTACHMENT FOR BIDS, RFPS**

**SUBCONTRACTORS:** Vendor will or may use subcontractors  yes  No

1. Vendor shall identify in this section the names and addresses of all subcontractors to be utilized by Vendor in the performance of the Contract, together with the anticipated amount of money each subcontractor is expected to receive pursuant to the Contract. For purposes of this section, "subcontractors" are those specifically hired to provide to the Vendor or another subcontractor some or all of the goods, services, property, remuneration, or other forms of consideration that are the subject of this Contract, including sublessees from a lessee of a State agency.
2. A copy of each subcontract issued pursuant to the Contract shall be provided to the State Purchasing Officer or Chief Procurement Officer within 20 days after the execution of the Contract or after execution of the subcontract, whichever is later. It is preferred that the subcontract be provided in PDF format and be sent to:

Buyer: \_\_\_\_\_  
Address: \_\_\_\_\_  
Phone: \_\_\_\_\_  
Email: \_\_\_\_\_

3. If at any time during the term of the Contract, Vendor adds or changes any subcontractors, Vendor will be required to promptly notify, by written amendment to the Contract, the State Purchasing Officer or the Chief Procurement Officer (care of the person identified in 2. Above) of the names and addresses and the expected amount of money that each new or replaced subcontractor will receive pursuant to the Contract.
4. Any subcontracts entered into prior to award of the Contract are done at the Vendor's and subcontractor's risk.
5. All subcontracts in the amount of \$50,000 or greater must include the **Standard Qualifications, Certifications, & Disclosures Attachment**, completed by the subcontractor. Contractors should copy these forms from this contract document and insure they are included and provided as part of all subcontracts
6. List all subcontractor information including name, address, phone, email, and anticipated amount to be paid on the following page.

R  
E  
Q  
U  
I  
R  
E  
D  
B  
I  
D  
S  
B  
E  
F  
O  
R  
M



## DIVISION 00 – PROCUREMENT AND CONTRACTING REQUIREMENTS

### SECTION 004115

#### **MINORITY, FEMALE, AND PERSONS WITH DISABILITY STATUS SUBCONTRACTING BUSINESS ENTERPRISE PROGRAM (BEP) UTILIZATION PLAN**

The State of Illinois Business Enterprise Program Act for Minorities, Females and Persons with Disabilities (BEP) (30 ILCS 575) establishes a goal for contracting with businesses that have been certified as owned and controlled by persons who are minority, female or who have disabilities.

**Contract Goal to be achieved by the Vendor:** This contract includes a specific Business Enterprise Program (BEP) utilization goal of 20% based on the availability of certified vendors to perform the anticipated direct subcontracting opportunities of this contract. In addition to the other award criteria established for this contract, NEIU will award this contract to a Vendor that meets the goal or makes good faith efforts to meet the goal. This goal is also applicable to change orders and allowances within the scope of work provided by the certified vendor.

Following are guidelines for the Vendor's response in the Utilization Plan. A format for the utilization plan is included in this section. Vendor should include any additional information that will add clarity to the Vendor's proposed utilization of certified vendors to meet the targeted goal. The Utilization Plan must demonstrate that the Vendor has either met the contract goal or that it has made good faith efforts to do so.

At the time of proposal submission, the Certified Vendor may not yet be certified with CMS Business Enterprise Program; **however, the Certified Vendor must meet the eligibility requirements and be fully certified in the BEP Program before contract award.** Visit [http://www.sell2.illinois.gov/bep/Business\\_Enterprise.htm](http://www.sell2.illinois.gov/bep/Business_Enterprise.htm) for complete requirements and to apply for certification in the Business Enterprise Program.

If applicable, the Plan should include an executed joint venture agreement specifying the terms and conditions of the relationship between the partners and their relationship and responsibilities to the contract. The joint venture agreement must clearly evidence that the certified vendor will be responsible for a clearly defined portion of the work and that its responsibilities, risks, profits and contributions of capital and personnel are proportionate to its ownership percentage. It must include specific details related to the parties' contributions of capital, personnel and equipment and share of the costs of insurance and other items; the scopes to be performed by the certified vendor's own forces and under its supervision; and the commitment of management, supervisory personnel and operative personnel employed by the certified vendor to be dedicated to the performance of the contract. Each joint venture partner must execute the proposal to NEIU.

An agreement between a vendor and a certified vendor in which the certified vendor promises not to provide subcontracting quotations to other vendors is prohibited. NEIU may request additional information to demonstrate compliance. The Vendor agrees to cooperate promptly with the designated NEIU representative in submitting to interviews, allowing entry to places of business, providing further documentation, or soliciting the cooperation of a proposed certified vendor. Failure to cooperate may render the proposal non-responsive. **The contract will not be finally awarded until the Vendor's Utilization Plan is approved.**

**Certified Vendor Locator References:** Vendors may consult CMS' BEP Certified Vendor Directory at [www.sell2.illinois.gov/bep/Small\\_and\\_Diverse\\_Businesses.htm](http://www.sell2.illinois.gov/bep/Small_and_Diverse_Businesses.htm), as well as the directories of other certifying agencies but subcontracting vendors must be certified by CMS as BEP vendors before the time of contract award.

**Vendor Assurance:** The Vendor shall not discriminate on the basis of race, color, national origin, sexual orientation or sex in the performance of this contract. Failure by the Vendor to carry out these requirements is a material breach of this contract, which may result in the termination of this contract or such other remedy, as NEIU deems appropriate. This assurance must be included in each subcontract that the Vendor signs with a subcontractor or supplier.

**Calculating Certified Vendor Participation:** The Utilization Plan documents work anticipated to be performed by all certified vendors and paid for upon satisfactory completion. Only the value of payments made for the work actually performed by certified BEP vendors is counted toward the contract goal. Counting guidelines are summarized below:

- 1) The value of the work actually performed by the certified vendor's forces shall be counted towards the goal. The entire amount of that portion of the contract that is performed by the certified vendor's forces, including supplies purchased or equipment leased by the BEP vendor shall be counted, except supplies purchased and equipment rented from the Vendor.
- 2) A joint venture shall count the portion of the total dollar value of the contract equal to the distinct, clearly defined portion of the work of the contract that the certified vendor performs with its forces toward the goal. A joint venture shall also count the dollar value of work subcontracted to other certified vendors. Work performed by the forces of a non-certified joint venture partner shall not be counted toward the goal.
- 3) When a certified vendor subcontracts part of the work of its contract to another firm, the value of the subcontracted work shall be counted toward the contract goal only if the certified vendor's subcontractor is a certified vendor. Work that a certified vendor subcontracts to a non-certified vendor will not count towards the goal.
- 4) A Vendor shall count towards the goal 100% of its expenditures for materials and supplies required under the contract and obtained from a certified vendor manufacturer, regular dealer or supplier.
- 5) A Vendor shall count towards the goal the following expenditures to certified vendors that are not manufacturers, regular dealers or suppliers:
  - (a) The fees or commissions charged for providing a bona fide service, such as professional, technical, consultant or managerial services and assistance in the procurement of essential personnel, facilities, equipment, materials or supplies required for performance of the contract, provided that the fee or commission is determined by NEIU to be reasonable and not excessive as compared with fees customarily allowed for similar services.
  - (b) The fees charged for delivery of materials and supplies required by the contract (but not the cost of the materials and supplies themselves) when the hauler, trucker, or delivery service is not also the manufacturer of or a regular dealer in the materials and supplies, provided that the fee is determined by NEIU to be reasonable and not excessive as compared with fees customarily allowed for similar services. The certified vendor

trucking firm must be responsible for the management and supervision of the entire trucking operation for which it is responsible on the contract, and must itself own and operate at least one fully licensed, insured and operational truck used on the contract.

- (c) The fees or commissions charged for providing any bonds or insurance specifically required for the performance of the contract, provided that the fee or commission is determined by NEIU to be reasonable and not excessive as compared with fees customarily allowed for similar services.
- 6) A Vendor shall count towards the goal only expenditures to firms that perform a commercially useful function in the work of the contract.
- (a) A firm is considered to perform a commercially useful function when it is responsible for execution of a distinct element of the work of a contract and carries out its responsibilities by actually performing, managing, and supervising the work involved. The certified vendor must also be responsible, with respect to materials or supplies used on the contract, for negotiating price, determining quality and quantity, ordering the materials or supplies, and installing the materials (where applicable) and paying for the material or supplies. To determine whether a firm is performing a commercially useful function, NEIU shall evaluate the amount of work subcontracted, whether the amount the firm is to be paid under the contract is commensurate with the work it is actually performing and the credit claimed for its performance of the work, industry practices, and other relevant factors.
  - (b) A certified vendor does not perform a commercially useful function if its role is limited to that of an extra participant in a transaction or contract through which funds are passed in order to obtain certified vendor participation. In determining whether a certified vendor is such an extra participant, NEIU shall examine similar transactions, particularly those in which certified vendors do not participate, and industry practices.
- 7) A Vendor shall not count towards the goal expenditures that are not direct, necessary and proximately related to the work of the contract. Only the amount of services or goods that are directly attributable to the performance of the contract shall be counted. Ineligible expenditures include general office overhead or other Vendor support activities.

**Good Faith Effort Procedures:** If the Vendor cannot meet the goal, the Vendor must document in the Utilization Plan its good faith efforts that could reasonably have been expected to meet the goal. NEIU will consider the quality, quantity, and intensity of the Vendor's efforts.

- 1) The following is a list of types of action that NEIU will consider as evidence of the Vendor's good faith efforts to meet the goal. Other factors or efforts brought to the attention of NEIU may be relevant in appropriate cases.
  - (a) Soliciting through all reasonable and available means (e.g., attendance at pre-bid meetings, advertising and/or written notices) the interest of all certified vendors that have the capability to perform the work of the contract. The Vendor must solicit this interest within sufficient time to allow the certified vendors to respond to the solicitation. The Vendor must determine with certainty if the certified vendors are interested by taking appropriate steps to follow up initial solicitations and encourage them to bid. The Vendor must provide interested certified

vendors with adequate information about the plans, specifications, and requirements of the contract in a timely manner to assist them in responding promptly to the solicitation.

- (b) Selecting portions of the work to be performed by certified vendors in order to increase the likelihood that the goal will be achieved. This includes, where appropriate, breaking out contract work items into economically feasible units to facilitate certified vendor participation, even when the Vendor might otherwise prefer to perform these work items with its own forces.
  - (c) Making a portion of the work available to certified vendors and selecting those portions of the work or material needs consistent with their availability, so as to facilitate certified vendor participation.
  - (d) Negotiating in good faith with interested certified vendors. Evidence of such negotiation includes the names, addresses, and telephone numbers of certified vendors that were considered; a description of the information provided regarding the plans and specifications for the work selected for subcontracting and evidence as to why additional agreements could not be reached for certified vendors to perform the work. A Vendor using good business judgment will consider a number of factors in negotiating with certified vendors and will take a firm's price and capabilities into consideration. The fact that there may be some additional costs involved in finding and using certified vendors is not in itself sufficient reason for a Vendor's failure to meet the goal, as long as such costs are reasonable. Vendors are not required to accept higher quotes from certified vendors if the price difference is excessive or unreasonable.
  - (e) Thoroughly investigating the capabilities of certified vendors and not rejecting them as unqualified without sound reasons. The certified vendor's memberships in specific groups, organizations, or associations and political or social affiliations are not legitimate causes for the rejection or non-solicitation of bids in the Vendor's efforts to meet the goal.
  - (f) Making efforts to assist interested certified vendors in obtaining lines of credit or insurance as required by NEIU, the Vendor or to perform the scope of work.
  - (g) Making efforts to assist interested certified vendors in obtaining necessary equipment, supplies, materials, or related assistance or services.
  - (h) Effectively using the services of available minority/women community organizations; minority/women vendors' groups; local, state, and federal minority/women business assistance offices; and other organizations that provide assistance in the recruitment and placement of certified vendors.
- 2) In evaluating the Vendor's good faith efforts, the good faith efforts of other vendors to meet the goal on this solicitation or similar contracts may be considered.
- 3) If NEIU determines that the Vendor has made good faith efforts to meet the goal, NEIU will award the contract provided that the Vendor is otherwise eligible for award. If NEIU determines that the Vendor has not made good faith efforts, NEIU will notify the Vendor of that preliminary determination. The preliminary determination shall include a statement of



reasons why good faith efforts have not been found, and may include additional good faith efforts that the Vendor could take. The Vendor shall have 5 business days to make the suggested good faith efforts and any other additional good faith efforts to meet the goal. The Vendor shall submit an amended Utilization Plan if additional certified vendor commitments to meet the goal are secured. If additional certified vendor commitments sufficient to meet the goal are not secured, the Vendor shall report the final good faith efforts made in the time allotted. All additional efforts taken by the Vendor will be considered. If NEIU determines that good faith efforts have not been made, the bid will be determined to be non-responsive.

**Contract Compliance:** Compliance with this section is an essential part of the contract. The following administrative procedures and remedies govern the Vendor's compliance with the contractual obligations established by the Utilization Plan. After approval of the Plan and award of the contract, the Utilization Plan becomes part of the contract. If the Vendor did not succeed in obtaining enough certified vendor participation to achieve the goal, and the Utilization Plan was approved and contract awarded based upon a determination of good faith, the total dollar value of certified vendor work calculated in the approved Utilization Plan as a percentage of the awarded contract value shall become the contract goal.

- 1) The Utilization Plan may not be amended without the NEIU's prior written approval.
- 2) The Vendor may not make changes to its contractual BEP certified vendor commitments or substitute BEP certified vendors without the prior written approval of NEIU. Unauthorized changes or substitutions, including performing the work designated for a certified vendor with the Vendor's own forces, shall be a violation of the utilization plan and a breach of the contract, and shall be cause to terminate the contract, and/or seek other contract remedies or sanctions. The facts supporting the request for changes must not have been known nor reasonably should have been known by the parties prior to entering into the subcontract. The Vendor must negotiate with the certified vendor to resolve the problem. Where there has been a mistake or disagreement about the scope of work, the certified vendor can be substituted only where agreement cannot be reached for a reasonable price or schedule for the correct scope of work.
- 3) Substitutions of a certified vendor shall be permitted under the following circumstances:
  - (a) Unavailability after receipt of reasonable notice to proceed;
  - (b) Failure of performance;
  - (c) Financial incapacity;
  - (d) Refusal by the certified vendor to honor the bid or proposal price or scope;
  - (e) Material mistake of fact or law about the elements of the scope of work of a solicitation where a reasonable price cannot be agreed;
  - (f) Failure of the certified vendor to meet insurance, licensing or bonding requirements;
  - (g) The certified vendor's withdrawal of its bid or proposal; or
  - (h) Decertification of the certified vendor.

- 4) If it becomes necessary to substitute a certified vendor or otherwise change the Utilization Plan, the Vendor must notify NEIU in writing of the request to substitute a certified vendor or otherwise change the Utilization Plan. The request must state specific reasons for the substitution or change. NEIU will approve or deny a request for substitution or other change in the Utilization Plan within 5 business days of receipt of the request.
- 5) Where the Vendor has established the basis for the substitution to NEIU's satisfaction, it must make good faith efforts to meet the contract goal by substituting a certified vendor. Documentation of a replacement vendor, or of good faith efforts to replace the certified vendor, must meet the requirements of the initial Utilization Plan. If the goal cannot be reached and good faith efforts have been made, the Vendor may substitute with a non-certified vendor.
- 6) If a Vendor plans to hire a subcontractor for any scope of work that was not previously disclosed in the Utilization Plan, the Vendor must obtain the approval of NEIU to modify the Utilization Plan and must make good faith efforts to ensure that certified vendors have a fair opportunity to bid on the new scope of work.
- 7) A new subcontract must be executed and submitted to NEIU within 5 business days of the Vendor's receipt of NEIU's approval for the substitution or other change.
- 8) The Vendor shall maintain a record of all relevant data with respect to the utilization of certified vendors, including but without limitation, payroll records, invoices, canceled checks and books of account for a period of at least 5 years after the completion of the contract. Full access to these records shall be granted by the Vendor upon 48 hours written demand by NEIU to any duly authorized representative thereof, or to any municipal, state or federal authorities. NEIU shall have the right to obtain from the Vendor any additional data reasonably related or necessary to verify any representations by the Vendor. After the performance of the final item of work or delivery of material by a certified vendor and final payment to the certified vendor by the Vendor, but not later than 30 calendar days after such payment, the Vendor shall submit a statement confirming the final payment and the total payments made to the BEP vendor under the contract.
- 9) NEIU will periodically review the Vendor's compliance with these provisions and the terms of its contract. Without limitation, the Vendor's failure to comply with these provisions or its contractual commitments as contained in the Utilization Plan, failure to cooperate in providing information regarding its compliance with these provisions or its Utilization Plan, or provision of false or misleading information or statements concerning compliance, certification status or eligibility of certified vendors, good faith efforts or any other material fact or representation shall constitute a material breach of this contract and entitle NEIU to declare a default, terminate the contract, or exercise those remedies provided for in the contract or at law or in equity.
- 10) NEIU reserves the right to withhold payment to the Vendor to enforce these provisions and the Vendor's contractual commitments. Final payment shall not be made on the contract until the Vendor submits sufficient documentation demonstrating compliance with its Utilization Plan.

**BEP UTILIZATION PLAN**

\_\_\_\_\_ (the Vendor) submits the following Utilization Plan as part of our proposal in accordance with the requirements of the Minority, Female, Persons with Disability Status and Subcontracting section of the solicitation for \_\_\_\_\_. We understand that compliance with this section is an essential part of this contract and that the Utilization Plan will become a part of the contract, if awarded.

\_\_\_\_\_ (the Vendor) makes the following assurance and agrees to include the assurance in each subcontract with a subcontractor or supplier utilized on this contract: We shall not discriminate on the basis of race, color, national origin, sexual orientation or sex in the performance of this contract. Failure to carry out these requirements is a material breach of this contract, which may result in the termination of this contract or such other remedy, as the NEIU deems appropriate.

We submit one (1) of the following statements:

- We are certified (or are eligible and have applied to be certified) with BEP and plan to fully meet the BEP utilization goal through self-performance.
- We attach Section I to demonstrate our Plan fully meets the BEP utilization goal of \_\_\_\_\_% through subcontracting
- We attach Section I to detail that we do not fully meet the BEP utilization goal. We also attach Section II, Demonstration of Good Faith Efforts.

Vendor's representative responsible for compliance:

Name: \_\_\_\_\_

Title: \_\_\_\_\_

Signature: \_\_\_\_\_

Telephone: (\_\_\_\_\_) \_\_\_\_\_ extension \_\_\_\_\_

Email: \_\_\_\_\_

RECEIVED  
BIBLIOTHECA  
FORM

FOR FILING

**SECTION I**

**UTILIZATION OF CERTIFIED VENDORS**

*Please submit a separate Section I for each proposed certified vendor.*

To achieve the BEP utilization goal through subcontracting, the following is proposed:

1) The proposed certified vendor's company name, address and phone number:

---

---

---

---

---

---

At the time of submission, the above certified vendor is:

- Certified with the CMS Business Enterprise Program (BEP)
  
- Meets the criteria and has submitted an application for certification with BEP  
(BEP certification must be completed before contract award)
  
- Certified as a disadvantaged, minority, or woman business enterprise with the following governmental agency or private organization (BEP certification must be completed before contract award):

---

---

2) A detailed description of the commercially useful work to be done by this certified vendor is as follows:

---

---

---

3) The total estimated cost to NEIU for this contract is \$\_\_\_\_\_.

The portion of the contract which will be subcontracted to this certified vendor is

\$\_\_\_\_\_.

or \_\_\_\_\_% of the total cost of the contract.

4) A notarized signed letter of intent between \_\_\_\_\_ the Vendor) and \_\_\_\_\_ (the certified vendor) detailing the work to be performed by the certified vendor and the agreed upon rates or prices, conforming to the Utilization Plan is included.

5) A joint venture agreement is not required, as the arrangement between \_\_\_\_\_ and \_\_\_\_\_ is that of contractor/sub-contractor and not a joint venture.

or,

A joint venture agreement between \_\_\_\_\_ and \_\_\_\_\_ is included in lieu of the letter of intent.

6) The Vendor has not prohibited or otherwise limited \_\_\_\_\_ (certified vendor) from providing subcontractor quotes to other potential respondents/vendors.

We understand that NEIU may require additional information to verify our compliance and we agree to cooperate immediately in submitting to interviews, allowing entry to any of our office locations, providing further documentation, or soliciting the cooperation of our proposed certified vendor. We will maintain appropriate records relating to our utilization of the certified vendor including: invoices, cancelled checks, books of account, and time records.

RE  
E  
Q  
U  
I  
R  
E  
D  
B  
I  
D  
S  
B  
E  
M  
I  
N  
I  
S  
T  
R  
I  
C  
T  
L  
Y  
F  
O  
R  
M

## SECTION II

### DEMONSTRATION OF GOOD FAITH EFFORTS TO ACHIEVE BEP SUBCONTRACTING GOAL

If the BEP subcontracting goal was not achieved, the Good Faith Efforts checklist (Section II A) and contacts log (Section II B) must be submitted with the solicitation response (or as otherwise specified by NEIU). **Failure to do so may render the Vendor's solicitation response non-responsive and cause it to be rejected, or render the Vendor ineligible for contract award, at NEIU's sole discretion.** The Vendor will promptly provide evidence in support of its Good Faith Efforts to NEIU upon request.

#### Section II A --Good Faith Efforts Checklist

Insert on each line below the initials of the authorized Vendor representative who is certifying on behalf of the Vendor that the Vendor has completed the activities described below. **If any of the items below were not completed, attach a detailed written explanation why each such item was not completed.** If any other efforts were made to obtain BEP participation in addition to the items listed below, attach a detailed written explanation.

\_\_\_\_\_ Identified portions of the project work capable of performance by available BEP vendors, including, where appropriate, breaking out contract work items into economically feasible units to facilitate BEP participation even when the Vendor could perform those scopes with its own forces.

\_\_\_\_\_ Solicited through reasonable and available means (e.g., written notices, advertisements) BEP vendors to perform the types of work that could be subcontracted on this project, within sufficient time to allow them to respond.

\_\_\_\_\_ Provided timely and adequate information about the plans, specifications and requirements of the contract. Followed up initial solicitations to answer questions and encourage BEP vendors to submit proposals or bids.

\_\_\_\_\_ Negotiated in good faith with interested BEP vendors that submitted proposals or bids and thoroughly investigated their capabilities.

\_\_\_\_\_ Made efforts to assist interested BEP vendors in obtaining bonding, lines of credit, or insurance as may be required for performance of the contract (if applicable).

\_\_\_\_ Utilized resources available to identify available certified vendors, including but not limited to BEP assistance staff; local, state and federal minority or women business assistance offices; and other organizations that provide assistance in the recruitment and placement of diverse businesses.

**Section II B -- Good Faith Efforts Contacts Log for Soliciting**

**BEP Sub-consultant, Subcontractor or Supplier Participation**

Use this form to document all contacts and responses (telephone, e-mail, fax, etc.) regarding the solicitation of BEP sub-consultants, subcontractors and suppliers. Duplicate as needed. (It is not necessary to show contacts with certified vendors with which the Vendor reached an agreement to participate on this project, as shown on Section I of this Plan.)

Name of certified vendor firm	Date and method of contact	Scope of work solicited	Reason agreement was not reached

**Letter of Intent (LOI)**

**Between Prime Vendor and Certified Vendor**

**Instructions:** The respondent is required to submit this signed and notarized Letter of Intent from each certified vendor identified on the Utilization Plan. LOIs must be submitted with the proposal and must be notarized by both parties. Submit a separate LOI for each proposed certified vendor. The amount and scope of work indicated on each LOI shall be the actual amount indicated on the Utilization Plan submitted with the proposal and approved by the NEIU.

Changes to the Utilization Plan including substitution of certified vendors are permitted only after award of the contract and only with prior written approval of NEIU. A request for changes to the Utilization Plan must be submitted on the *Request for Change of Utilization Plan Form* for all levels of subcontracting. LOIs must be submitted for all additions of certified vendors to the Utilization Plan prior to the start of work.

Project Name \_\_\_\_\_ Project/Solicitation

Number: \_\_\_\_\_

Name of Prime Vendor: \_\_\_\_\_

Address: \_\_\_\_\_  
Street City State Zip Code

Telephone: (\_\_\_\_) \_\_\_\_\_ Fax: (\_\_\_\_) \_\_\_\_\_ Email: \_\_\_\_\_

Name of Certified Vendor: \_\_\_\_\_

Address: \_\_\_\_\_  
Street City State Zip Code

Telephone: (\_\_\_\_) \_\_\_\_\_ Fax: (\_\_\_\_) \_\_\_\_\_ Email: \_\_\_\_\_



Type of agreement:  Services  Supplies  Both Services/Supplies

Type of payment:  Lump Sum \_\_\_\_\_  Hourly Rate \_\_\_\_\_  Unit Price \_\_\_\_\_

Period of Performance: \_\_\_\_\_ Proposed Subcontract Amount \$ \_\_\_\_\_ or Proposed % of Contract \_\_\_\_\_

Description of work to be performed by certified vendor:

---

---

List the governmental agency or private organization with whom the certified vendor is currently certified as a disadvantaged, minority, or woman business enterprise.

---

---

The prime vendor and the certified vendor above hereby agree that upon the execution of a contract for the above-named project between the prime vendor and the State of Illinois, the certified vendor will perform the scope of work for the price as indicated above.

**Prime Vendor** (Company Name and D/B/A):

**Certified Vendor** (Company Name and D/B/A):

\_\_\_\_\_  
Signature

\_\_\_\_\_  
Signature

\_\_\_\_\_  
Printed Name

\_\_\_\_\_  
Printed Name

Title: \_\_\_\_\_ Date: \_\_\_\_\_

Title: \_\_\_\_\_ Date: \_\_\_\_\_

Subscribed and sworn before me this  
\_\_\_\_\_ day of \_\_\_\_\_, 20\_\_\_\_.

Subscribed and sworn before me this  
\_\_\_\_\_ day of \_\_\_\_\_, 20\_\_\_\_.

\_\_\_\_\_  
Notary Public

\_\_\_\_\_  
Notary Public

My Commission expires: \_\_\_\_\_  
\_\_\_\_\_

My Commission expires: \_\_\_\_\_

FORMER DEDICATED BUSINESS DEVELOPER

**DIVISION 00 – PROCUREMENT AND CONTRACTING REQUIREMENTS**

**SECTION 004116**

**SMALL BUSINESS IDENTIFICATION**

If you are a small business as defined below please check the appropriate boxes. We are requesting this information in furtherance of Public Act 97-307, the Small Business Contracts Act, which establishes a goal of contracting with small businesses in Illinois.

“Small Business” means a business that (1) operates with an Illinois address, (2) pays Illinois income tax, (3) is independently owned and operated, (4) is not dominant in its field of operation, and (5) has annual sales and number of employees within the limits set below.

Please check the appropriate boxes.

- Wholesale business – annual sales for the most recently completed fiscal year cannot exceed \$10,000,000.
- Retail business or business selling services – annual sales and receipts cannot exceed \$6,000,000.
- Construction business – annual sales and receipts cannot exceed \$10,000,000.
- Combination business (any combination of a wholesale, retail or construction) - the annual sales for each type of business in the combination may not exceed the corresponding amounts shown above.
- Manufacturing business – cannot employ more than 250 persons and may not have annual sales and receipts that exceed the above criteria. If a manufacturing business has been in existence for less than a full fiscal year, its average employment shall be calculated for the period through one month prior to the bid or proposal due date.

I certify that the above information is true and correct and may be used and relied upon when making procurement decisions and awards.

Vendor Name: \_\_\_\_\_

Address: \_\_\_\_\_

Phone: \_\_\_\_\_

Officer's signature: \_\_\_\_\_

Printed Name: \_\_\_\_\_

Date: \_\_\_\_\_

RE  
E  
Q  
C  
I  
R  
E  
D  
B  
D  
S  
B  
M  
T  
A  
F  
R  
M

## DIVISION 00 – PROCUREMENT AND CONTRACTING REQUIREMENTS

### SECTION 004123 BID OPENING AND AWARD

#### 00410 - BID OPENING

1. At the time and address stated in the Advertisement for Bids, all Bids will be publicly opened and read. Noted errors, omissions and defects will be announced. All Bids received after that time will be returned unopened to the Bidder. Official time will be at NEIU.
2. Time For Acceptance: Bids shall be valid for 90 calendar days after Bid opening unless otherwise specified. NEIU and the Bidder may agree to extend the acceptance period beyond ninety (90) calendar days.
3. Reading of Bids: The public opening and reading of Bids is for informational purposes only, and is not to be construed as acceptance or rejection of any of the Bids submitted.

#### 00420 - REJECTION OF BIDS

1. Defective Bids: Defects or causes which will result in rejection include, but are not limited to:
  - A. Failure to be qualified in accordance with these documents.
  - B. Submission of a late Bid and Bid prepared in pencil.
  - C. Submission of a Bid that is not in substantial conformance with the Bidding Documents.
  - D. Submission of Bid Security in less than the amount stated in the Bidding Documents.
  - E. Failure to complete and sign the Bid Form.
  - F. Failure to complete and submit all, Section 004100 thru 004115 Bidding and Contract Requirements Forms marked "REQUIRED BID SUBMITTAL FORM" in margin.
  - G. All other errors, omissions and defects which are determined by NEIU to be technical deficiencies or acceptable irregularities may be waived by NEIU, including but not limited to the submission of Bid Security provided by a suspended Surety if, within five (5) business days after receipt of notification thereof, Bid Security acceptable to NEIU is supplied.
2. Cancellation of Advertisement: NEIU reserves the right to cancel all or any part of the Advertisement for Bids.
3. NEIU's Rights: Whenever, in its opinion, it is in the best interest of the State and not inconsistent with the competitive bidding process, NEIU reserves the right to:
  - A. Accept any Bid.

- B. Reject any or all bids.
- C. Waive technical deficiencies and irregularities.
- D. Rescind any Notice of Award if NEIU determines that the Notice of Award was issued in error.
- E. Rescind any Notice of Award for the convenience of the State per Sub-section 00720.
- F. Rebid any Contract.

00430 - AWARD

1. The issuance of a Notice of Award is based upon the expectation of the Contractor's timely compliance with all post award requirements.
2. The Contract will be awarded to the lowest responsible Bidder whose Bid produces the lowest combination of Base Bid and accepted Alternate Bids.

00440 – BID PROTEST

Protest Review Office:

Vendors may submit a written protest to the Protest Review Office following the requirements of the Higher Education Standard Procurement Rules 44 ILL.ADMIN.CODE 4.5550. For protests related to specifications, the Protest Review Office must physically receive the protest no later than 14 days after the solicitation or related addendum was posted to the Bulletin. For protests related to rejection of individual proposals or awards, the protest must be received by close of business no later than 14 days after the protesting party knows or should have known of the facts giving rise to the protest. The Protest Review Office's information is as follows:

Chief Procurement Office  
Attn: Protest Review Office  
Suite 513 Stratton Office Building  
401 South Spring Street  
Springfield, IL 62706

Phone (217) 558-3724  
Fax (217) 558-2164  
Illinois Relay (800) 526-0844

If the protest is submitted via email, it must be sent to both the following email addresses:

[Adam.Alstott@illinois.gov](mailto:Adam.Alstott@illinois.gov)

[EEC.CPOHE@illinois.gov](mailto:EEC.CPOHE@illinois.gov)

**End of Section 004123**

## DIVISION 00 – PROCUREMENT AND CONTRACTING REQUIREMENTS

### **SECTION 005113 POST AWARD REQUIREMENTS**

#### 00501 - GENERAL REQUIREMENTS

1. Submittals: Within fifteen (15) business days after date of the Notice of Award, the Contractor shall furnish, on NEIU forms, an A.I.A. or other form acceptable to NEIU, the following:

- A. Contract executed by the Contractor.
- B. Performance Bond.
- C. Labor and Material Payment Bond.
- D. Certificates of Insurance.
- E. Schedule of Values
- F. List of All Sub-Contractors:

The Contractor shall provide the names and addresses of all authorized subcontractors to be utilized by the Contractor in the performance of this contract, together with a description of the work to be performed by the subcontractor and the anticipated amount of money that each subcontractor is expected to receive pursuant to this contract.

The Contractor shall provide a copy of any subcontracts within 20 days of execution of this contract. All subcontracts in the amount of \$50,000 or greater must include the same certifications that vendor must make as a condition of this contract.

The Contractor shall notify the State of any additional or substitute subcontractors hired during the term of this contract. The Contractor shall provide to the State a copy of all such subcontracts within 20 days of execution of the subcontract.

2. Recertification: If the contract extends over multiple years, contractor and its subcontractors shall confirm compliance by July 1 of each year that this contract remains in effect. Contractor shall obtain from all Subcontractors a statement of compliance with these provisions. Should the contractor or subcontractor(s) fail to be or remain in compliance, the contract may be void by operation of law or the contract may be voidable at the option of NEIU without additional compensation. Violation of certain provisions may also be a civil or criminal offense.
3. Cancellation of Award: All post award requirements are mandatory. Noncompliance shall be cause for NEIU to cancel the Notice of Award.
4. Post Award Extensions: NEIU may extend the time limitations for good cause. No extension shall operate as a waiver of post award requirements, nor shall it extend the contract completion time.

**End of Section 005113**



## DIVISION 00 – PROCUREMENT AND CONTRACTING REQUIREMENTS

### SECTION 006100 BONDS AND INSURANCE

#### 00605 - GENERAL

1. Bonds and Insurance Required: The Contractor shall provide bonds and insurance specified in the Bidding Documents.

#### 00607 - QUALIFICATIONS OF SURETY COMPANIES

1. Bonds: The Contractor shall furnish a Performance Bond and a Labor Material Payment Bond covering the faithful performance of the Contract and the payment of all obligations arising there under. Each bond shall be in the full amount of the contract sum and executed by a Surety acceptable to NEIU.
2. Acceptability: Surety companies shall be acceptable to NEIU in accord with these documents. Surety company shall:
  - A. Be approved or listed in Treasury Circular 570; or
  - B. Have a policy holders rating of B or better and a financial rating of Class V or higher in Bests' Key Rating Guide (current edition) are acceptable; and,
  - C. Be duly licensed to transact business in Illinois; and,
  - D. Not be found unacceptable by NEIU for reasons of non-performance.
3. Signature Authority: Attorneys-in-Fact who sign bonds shall file with each bond a certified and effectively dated copy of their Power of Attorney and jurat (Notary's statement authenticating signature).
4. The Director of Purchasing is authorized to waive insurer and Surety prequalification standards established above in cases where the Director of Procurement determines that the standards create an extreme hardship on a Contractor desirous of submitting a Bid or obtaining an Authorization to Proceed for a NEIU project.

#### 00610 - PERFORMANCE BONDS

1. The Contractor and its Surety shall be bound by Sub-Section 00720 regarding NEIU's authority to carry out the work and terminate the Contract.
2. Surety shall waive notice of any changes in the Contract, including extensions of time for the performance thereof.
3. No right of actions shall accrue on the bond to or for the use of any person or corporation other than NEIU.

#### 00620 - LABOR AND MATERIAL PAYMENT BOND

1. The bond shall cover material used in the performance of the Contract and the labor at the prevailing wages established by the Illinois Department of Labor.



2. The Surety shall waive notice of any changes in the Contract, including extensions of time for the performance thereof.

00650 - INSURANCE

1. Qualifications of Insurance Companies:
  - A. An insurer's policy with a policy holders rating of B and a financial rating of Class V or higher in Bests' Key Rating Guide (current edition) are acceptable.
  - B. Insurance policies written by Lloyds of London are acceptable where in compliance with 1987 Ill. Rev. Ch. 73, Par. 698 et seq.
  - C. Policies from Risk Retention groups organized and operated under State or Federal laws will be acceptable in occurrence form only.
  - D. Insurance company duly licensed to transact business in Illinois.
2. Certificates of Insurance:
  - A. Contractor shall file with NEIU a Certificate of Insurance, showing complete coverage of all insurance required by this Section, signed by the insurance company's authorized agent.
  - B. NEIU shall be included as an additional insured for Commercial/Comprehensive General Liability, umbrella, and Builders' Risk policies or certificates.
  - C. Each policy, binder or certificate shall contain a provision that the policy will not be canceled, changed, or altered until at least thirty (30) calendar days prior written notice has been given to the named insured and NEIU.
3. Reconstruction: The prompt repair or reconstruction of the Work as a result of an insured loss or damage shall be the Contractor's responsibility and shall be accomplished at no additional cost to NEIU. The Contractor shall furnish proper assistance in the adjustment and settlement of all losses. Loss will be adjustable with and payable to the party purchasing the Builder's Risk Insurance, who shall be responsible for apportioning the loss proceeds to each and every entity involved in the loss to the extent of its interest.
4. Required Minimum Insurance Coverages:
  - A. Comprehensive Automobile Liability:
    1. \$ 500,000 Bodily Injury Per Person
    2. \$1,000,000 Bodily Injury Per Occurrence
    3. \$ 500,000 Property Damage Per Occurrence
    4. \$1,000,000 Combined Single Limit Coverage for bodily injury and property damage per occurrence in the same aggregate limit will be accepted in lieu of the separate limits specified above.
  - B. Workmen's Compensation: Statutory Limits
    1. Employer's Liability: \$500,000 Bodily Injury Per Person

2. The Contractor may use a Self-Insured Plan for Workmen's Compensation Insurance if the Plan is approved by the State of Illinois. For approval, the Contractor shall obtain a Certificate from the Illinois Industrial Commission, Office of Self-Insurance Administration, and Springfield Office.
  3. Certification of Carrier: The Worker's Compensation Insurance carrier, or self insurance service agency where applicable, shall certify that to the best of its knowledge, the contractor has properly reported wage and workforce data and made premium payments in compliance with Illinois rates and worker classifications.
- C. Commercial/Comprehensive General Liability (occurrence form). Include coverage for premises and operations, broad form property damage, products completed operations, independent contractor's personal injury liability, and contractual obligations. Coverage shall not be excluded because of the contractor's negligence. A Response Action Contractor may provide the Commercial Comprehensive General Liability Insurance on a claims made form. Where the hazard exists, the contractor shall purchase and maintain insurance to protect against claims due to explosion, collapse, or underground damage.
1. \$1,000,000 Bodily Injury Per Person
  2. \$1,000,000 Bodily Injury Aggregate Limit
  3. \$ 500,000 Property Damage Per Occurrence
  4. \$1,000,000 Property Damage Aggregate Limit
  5. \$1,000,000 Combined Single Limit Coverage for bodily injury and property damage per occurrence and in the same aggregate limit will be accepted in lieu of the separate limits specified above.
- D. Umbrella or Excess of Loss Coverage:
1. If the limits specified in Section 00650.4.A and C are not met, an Umbrella or Excess Liability policy of not less than \$1,000,000 for any one occurrence and subject to the same aggregate over the Comprehensive Automobile Liability and Commercial/Comprehensive General Liability coverages are acceptable. Umbrella coverage is subject to NEIU's approval as to form and amount of self insured retention.

#### 00655 - BUILDER'S RISK INSURANCE

1. Builder's Risk Insurance shall be purchased and maintained by Northeastern Illinois University. The policy can be made available for review by contacting the Director of Procurement.

**End of Section 006100**

## DIVISION 00 – PROCUREMENT AND CONTRACTING DOCUMENTS

### **SECTION 007200** **GENERAL CONDITIONS**

#### 00701 - DEFINITIONS

1. **Bidding Documents** include:
  - A. This "Project Manual." All contents listed in table of contents
  - B. Advertisement for Bids
  - C. Bid Forms
  - D. Bid Bond
  - E. Tables, Charts, Drawings which are listed in Index of Drawings
  - F. Addenda
  
2. **Contract Documents** include:
  - A. The Bidding Documents
  - B. Contractor's bid as accepted by NEIU
  - C. Contract
  - D. Approved IDHR forms
  - E. Performance Bond
  - F. Labor & Material Payment Bond
  - G. Required Insurance
  - H. Approved Change Orders
  
3. **Northeastern Illinois University** is a State agency created by the General Assembly in Illinois Revised Statutes, Ch. 144, par. 1151-1153, as amended, herein referred to as "NEIU".
  
4. **Owner** is the Board of Trustees of Northeastern Illinois University, a body politic and corporate of the State of Illinois, created and established under Illinois Revised Statutes, Ch. 144, Par. 1001, et seq., as amended, herein referred to as the "Board", acting by and through NEIU.
  
5. **Project** comprises the completed construction required by the contract documents and includes all labor necessary to produce such construction, and all materials and equipment incorporated or to be incorporated in such construction.
  
6. **NEIU** will designate a Project Manager for the project. The Project Manager shall act on its behalf. NEIU and its representatives shall at all times have access to the work. Orders and directions to Contractor shall be through the Project Manager.
  
7. **NEIU** will designate an Architect/Engineer to direct the work on its behalf in conjunction with the Project Manager.
  
8. **Contractor** is the individual partnership, firm, corporation, or other business entity entering into the contract with NEIU to perform the Work under the Contract Documents and is identified as such in the Contract.
  
9. **Substantial Completion** is a condition which occurs when NEIU accepts the certification of the Project Manager that construction is sufficiently complete in accordance with the Contract Documents so that the project or a designated portion thereof may be occupied or utilized for the use for which it is intended.

10. **Final Completion** is a condition which occurs when NEIU accepts the certification of the Project Manager that Contractor has complied with all requirements of the Contract including all punch list items, and that Contractor is authorized to receive final payment in full, including all retainage.

#### 00705 - CONTRACT DOCUMENTS

1. **Documents on Site:** Contractor shall keep a complete copy of the Contract Documents on the site and shall at all times give NEIU and its representatives access thereto.
2. **Conflicting Requirements:** The Contract Documents are complementary and what is required by any one shall be binding as if required by all. Specifications shall generally govern quality of materials and workmanship. Drawings shall generally govern dimensions, details and location of the work. It is not intended to mention every item of work in the Project Manual which can be adequately shown on the drawings nor to show on the drawings all items of work described or required by the Project Manual even if they are of such nature that they could have been shown thereon.
3. **Interpretations and Clarification:** All requests for interpretation of the Contract Documents and clarification to facilitate proper execution of the work shall be directed in writing to the Project Manager, who with reasonable promptness will furnish interpretations and supplemental instructions by means of drawings or otherwise. All such interpretations and instructions which constitute changes, pursuant to Sub-Section 00760, shall promptly be brought to the attention of NEIU.
4. **Ownership of Drawings, Project Manuals, and Models:** All copies of drawings and Project Manuals are the property of NEIU. Such copies are not to be used on any other work or project whatsoever.

#### 00710 - MISCELLANEOUS

1. **Governing Law:** This Contract shall be governed by the State of Illinois.
2. **Written Notice:** Written notice shall be deemed to have been duly given when delivered in person to the individual or member of the firm or to an officer of the corporation for whom it was intended, or when sent by certified mail to the last known business address of the addressee.
3. **Contractor Obligations Survive:** The obligations or duties imposed upon Contractor under the contract shall survive any termination of the Contract.
4. **Successors and Assigns:** NEIU and Contractor each binds itself, its partners, successors and assigns and legal representatives to other party hereto and the partners, successors, assigns and legal representatives of such other party in respect to all covenants, agreements and obligations contained in the Contract Documents.
5. **Building Codes:** Contractor shall perform all work in conformance with applicable building codes formally adopted by the unit of local government in which the Project is located; however, NEIU does not waive in any manner its exemption as a state agency from local laws or rules pertaining to the procurement of building permits. Contractor is responsible for investigating and determining which codes are in force at the project site and for designing and specifying accordingly. Contractor may submit written requests to NEIU, with full documentation, for deviations from the local

codes, or the substitution of more stringent codes, but shall not proceed with design or specifications based on deviations or other codes until receiving written authorization from NEIU.

6. **Regulatory Requirements:** Contractor shall comply with all laws, rules, and regulations, including those of the City of Chicago, applicable to installation of the work.
7. **Statutory Requirements:** All applicable Federal and State laws and the rules and regulations of all authorities having jurisdiction over construction of the Project shall apply to the Contract throughout, and they will be deemed to be included in the Contract the same as though written therein in full. The following Statutes among others govern the work:
  - A. Laws of Illinois:
    1. This contract shall be governed in all respects by the laws of the State of Illinois.
    2. The Contractor, subcontractors, etc. shall pay to all laborers, workmen, and mechanics performing work under the Contract, not less than the prevailing rate of wages as determined by the Illinois Department of Labor.
    3. Whenever there is a period of excessive unemployment in the State of Illinois (Ill. Rev. Stat., 1991, ch. 48, par. 2201 et seq.) the Contractor shall employ only Illinois laborers for this project.
    4. Certified Payroll. State law 820 ILCS 130/5 requires all contractors and sub-contractors working on University construction projects to submit certified payroll records to NEIU. Contractors must submit these records once a month or with their pay applications, whichever comes first.
    5. (30ILCS 500/20-65) requires that the Contractor shall maintain, for a minimum of 3 years after the completion of the contract, adequate books, records, and supporting documents to verify the amounts, recipients, and uses of all disbursements of funds passing in conjunction with the contract; the contract and all books, records, and supporting documents related to the contract shall be available for review and audit by the Auditor General; and the Contractor agrees to cooperate fully with any audit conducted by the Auditor General; and the Contractor agrees to cooperate fully with any audit conducted by the Auditor General and to provide full access to all relevant materials. Failure to maintain books, records, and supporting documents required by the Section shall establish a presumption in favor of the State for the recovery of any funds paid by the State under the contract for which adequate books, records, and supporting documentation are not available to support their purported disbursement.
    6. Contract Debt Certification: Contractor certifies that it, or any affiliate, is not barred from being awarded a contract under 30 ILCS 500. Section 50-11 prohibits a person from entering into a contract with a State agency if it knows or should know that it, or any affiliate, is delinquent in the payment of any debt to the State as defined by the Debt Collection Board. Section 50-12 prohibits a person from entering into a contract with a State agency if it, or any affiliate, has failed to collect and remit Illinois Use Tax on all sales of tangible personal property into the State of Illinois in accordance with the provisions of the Illinois Use Tax Act. The contractor further

acknowledges that the contracting State agency may declare the contract void if this certification is false or if the contractor, or any affiliate, is determined to be delinquent in the payment of any debt during the term of the contract.

7. Domestic Products Act: Contractor certifies that all articles to be provided under this contract have been or will be manufactured in the United States. Contractor understands that, if it knowingly supplies non-US manufactured goods, it will be subject to penalties under the Procurement of Domestic Products Act (PA 93-0954) that include debarment for five years, voiding of the contract, and civil damages.
  8. Lead Poisoning Prevention Act: Pursuant to P.A. 94-879, if Contractor is the owner of residential rental property in Illinois, Contractor certifies that it has not committed a willful or knowing violation of the Illinois Lead Poisoning Prevention Act that has not been mitigated.
  9. Substance Abuse Prevention on Public Works Project Act: Pursuant to P.A. 095-0635, the contractor certifies that it is in compliance with the Substance Abuse Prevention on Public Works Project Act. Prior to commencing work, the Contractor shall file with the University a written program meeting or exceeding the program requirements.
- B. Steel Products Procurement Act: It is understood and agreed by and between the Parties hereto that any contract for the construction, reconstruction, alteration, repair, improvement or maintenance contains the provision that steel products used or supplied in the performance of this contract or any subcontract thereto shall be manufactured or produced in the United States.
- C. The Contractor certifies that neither it nor any substantially-owned affiliated company is participating or shall participate in an international boycott in violation of the provisions of the U.S. Export Administration Act of 1979 or the regulations of the U.S. Department of Commerce promulgated under that Act.
- D. The Contractor certifies in accordance with Public Act 93-0307 that no foreign-made equipment, materials, or supplies furnished to the State under the contract have been produced in whole or in part by forced labor, convict labor, or indentured labor under penal sanction.
- E. The Contractor certifies in accordance with 30 ILCS 500/50-10.5 that no officer, director, partner, or other managerial agent of the contracting business has been convicted of a felony under the Sarbanes-Oxley Act of 2002 or a Class 3 or Class 2 felony under the Illinois Securities Law of 1953 for period of five years prior to the date of the bid or contract. The Contractor acknowledges that the contracting agency shall declare the contract void if this certification is false.
- F. Public Act 93-0575 adds Section 50-12 to the Illinois Procurement Code (30-ILCS 500/50-12). Section 50-12 prohibits the bidding or entering into contracts with the State of Illinois or a State agency by a person or business found by a court or the Pollution Control Board to have committed a willful or knowing violation of Section 42 of the Environmental Protection Act for a period of five years from the date of the order containing the finding or violation.

The Contractor certifies in accordance with 30 ILCS 500/50-12 that the bidder or contractor is not barred from being awarded a contract under this Section. The Contractor acknowledges that the contracting agency may declare the contract void if this certification is false.

- G. Under penalties of perjury, the undersigned certifies:
1. Employment Status: The Contractor certifies that if any of its personnel are an employee of the State of Illinois, they have permission from their employer to perform the service.
  2. Bribery Clause: The Contractor certifies it has not been convicted under the laws of Illinois or any other state of bribery or attempting to bribe an officer or employee of the State of Illinois or any other state in that officer's or employee's official capacity nor has the Contractor made any admission of guilt of such conduct which is a matter of public record.
  3. Loans: That is not in default on an educational loan as provided in Public Education Act 85-827 (105 ILCS 5/30-15. 12).
  4. Barred from Contracting/Bid-Rigging Rotating Law: Contractor certifies that it is not barred from contract with a unit of State or local government as a result of a violation of Section 33E-3 or 33E-4 of the Criminal Code of 1961 of the laws of the State of Illinois. These violations concern the criminal offenses of bid rigging, bid rotating, or kickback in regard to public contracts.
  5. Drug Free Workplace Act: Pursuant to the requirements of the Illinois Drug Free Workplace Act, the Contractor, if this agreement is in the amount of \$5,000 or more, certifies as follows:
    - a. That the Contractor, if an individual or sole proprietorship, will not engage in the unlawful manufacture, distribution, dispensation, possession or use of a controlled substance in the performance of this Agreement; or
    - b. That the Contractor, if a corporation, partnership, or other business entity having twenty-five (25) or more employees at the time of letting this Agreement, will provide a drug-free workplace by taking certain steps prescribed in the Act.
- H. The Illinois Steel Products Procurement Act, as amended (Ill. Rev. Stat., Ch. 48, Par. 1801 et seq.)
- I. The Illinois Roofing Industry Licensing Act, as amended (Ill. Rev. Stat., Ch. 111, Par. 7501 et seq.)
- J. The Illinois Asbestos Abatement Act, as amended (Ill. Rev. Stat., Ch. 122, Par. 1401 et seq.)
- K. The Illinois Response Action Contractor Indemnification Act, as amended (Ill. Rev. Stat., Ch. 111 1/2, Par. 7201 et seq.) referred to in all documents as the "Indemnification Act."
- L. When a project involves asbestos abatement in a public or private elementary or secondary school:

1. The Illinois Asbestos Abatement Act, as amended (Ill Rev. Stat, Ch122, Par. 1401 et seq.) referred to in all documents as the "Abatement Act."
2. Rules and Regulations for the Asbestos Abatement Act, as amended (77 Illinois Administrative Code, Sub ch. p. et seq.) referred to in all documents as the "Rules and Regulations."

M. Public Construction Bond Act (30 ILCS 550) requires each bond securing a contract between the University and any contractor shall be deemed to contain the following provisions whether such provisions are inserted in such bond or not:

"The principal and sureties on this bond agree that all the undertakings, covenants, terms, conditions and agreements of the contract or contracts entered into between the principal and the State or any political subdivision thereof will be performed and fulfilled and to pay all persons, firms and corporations having contracts with the principal or with subcontractors, all just claims due them under the provisions of such contracts for labor performed or materials furnished in the performance of the contract on account of which this bond is given, when such claims are not satisfied out of the contract price of the contract on account of which this bond is given, after final settlement between the officer, board, commission or agent of the State or of any political subdivision thereof and the principal has been made.

"Upon the default of the principal with respect to undertakings, covenants, terms, conditions, and agreements, the termination of the contractor's right to proceed with the work, and written notice of that default and termination by the State or any political subdivision to the surety ("Notice"), the surety shall promptly remedy the default by taking one of the following actions:

- (1) The surety shall complete the work pursuant to a written takeover agreement, using a completing contractor political subdivision; or
- (2) The surety shall pay a sum of money to the obligee, up to the penal sum of the bond, that represents the reasonable cost to complete the work that exceeds the unpaid balance of the contract sum.

The surety shall respond to the Notice within 15 working days of receipt indicating the course of action that it intends to take or advising that it requires more time to investigate the default and select a course of action. If the surety requires more than 15 working days to investigate the default and select a course of action or if the surety elects to complete the work with a completing contractor that is not prepared to commence performance within 15 working days after receipt of Notice, and if the State or any political subdivision determines it is in the best interest of the State to maintain the progress of the work, the State or any political subdivision may continue to work until the completing contractor is prepared to commence performance. Unless otherwise agreed to by the procuring agency, in no case may the surety take longer than 30 working days to advise the State or political subdivision on the course of action it intends to take. The surety shall be liable for reasonable costs incurred by the State or any political subdivision to maintain the progress to the extent the costs exceed the unpaid balance of the contract sum, subject to the penal sum of the bond."



- N. State Board of Elections Registration (P.A. 95-971)). By acceptance of award, the contractor certifies that either (1) it is not required to register as a business entity with the State Board of Elections pursuant to Section 20-160 of the Procurement Code (30 ILCS 500/20-160); or (2) (a) it has registered as a business entity with the State Board of Elections, (b) it acknowledges a continuing duty to update the registration. Any contracts entered into with contractor by the University are voidable under the Procurement Code if contractor fails to comply with the requirements of Section 20-160.
8. **Non-Asbestos Hazardous Materials:** For projects involving response action work other than asbestos abatement, the regulatory requirements are specified in the respective specification section of the Project Manual.
9. **Permits and Fees:** Contractor is responsible for any construction permits or inspection fees which might be assessed upon NEIU by State or local government.
10. **Taxes:** Purchases of building materials for incorporation into the project are exempt from the Illinois Retailer's Occupation and Use Tax (Sales tax). The Bidder shall therefore exclude such taxes in preparing their bid. The tax exempt number is **E9990-0981-04**. An exemption may also apply in regard to certain Federal excise taxes on materials and equipment used in connection with the Project.
11. **Royalties and Patents:** Contractor shall pay all royalties and license fees. The approval of any method of construction, invention, appliance, process, article, device, material, or equipment of any kind by NEIU or the Project Manager, will only be an approval of its adequacy for the work, and will not be an approval of the use thereof by Contractor in violation of any patent or other rights of any third person. Contractor shall indemnify NEIU in accordance with Sub-section 00741 against all suits and claims that may be based on an infringement of a patent.

#### 00715 - DISPUTES

1. Except as otherwise provided below, in the event of disputes or conflicts between the contracting parties, NEIU will solely resolve the matter and its decision will prevail unless otherwise removed to the Court of Claims.
2. **Not Cause for Delay:** NEIU shall have the authority to determine questions of fact that arise in relation to the interpretation of this Agreement and Contractor's performance hereunder. Unless the parties agree otherwise, such determinations procedures shall not be cause for delay of the work. Contractor shall proceed diligently with the performance of this Agreement and in accordance with NEIU's decision whether or not Contractor or anyone else has an active claim pending. Continuation of the work shall not be construed as a waiver of any rights accruing to Contractor.

#### 00720 - NEIU - RIGHTS AND RESPONSIBILITIES

1. **Authorized Representatives of NEIU**
- A. NEIU has the right to designate authorized representatives, including the Project Manager, to act on its behalf. NEIU and its representatives shall at all times have access to the work.
- B. NEIU will designate one or more Project Managers to act on its behalf. The extent of the Project Manager's authority will be defined in writing at the preconstruction meeting.

- C. NEIU may issue orders and directions to Contractor through the Project Manager.
2. **Right to Reject or Stop the Work:** NEIU may reject work which does not conform to the Contract Documents. If Contractor fails to correct defective work or fails to supply labor, materials or equipment in accordance with the contract, NEIU may order Contractor to stop work, or any portion thereof until the cause for such order has been eliminated. Notwithstanding the preceding, Contractor shall retain exclusive control over all duties and responsibilities imposed by the Structural Work Act.
3. **Right to Carry Out the Work:**
- A. If Contractor neglects or fails to carry out the work in accordance with the Contract or fails to perform any portion of the Contract, NEIU may make good such deficiencies after giving three (3) business days written notice to Contractor and its surety. This shall be without prejudice to any other remedy NEIU may have. NEIU may deduct from the payments then or thereafter due Contractor the cost of correcting such deficiencies, including, but not limited to, the cost of additional architectural/engineering services and construction management services made necessary by such neglect or failure. If the payments then or thereafter due to Contractor are not sufficient to cover such amount, Contractor shall be liable in such amount to NEIU.
- B. In case of emergencies (as determined by NEIU) involving public health or public safety or to protect against further loss or damage to State property or to prevent or minimize serious disruption of State services or to insure the integrity of State records, NEIU may cause such work to be performed without prior notice to Contractor or its surety.
4. **Right to Terminate the Contract:** If Contractor fails or refuses to prosecute the work with such diligence as to allow completion of performance in accordance with the current progress schedule or fails to complete the work at the time of completion in accordance with the documents or commits a breach of any other provision of the Contract Documents, NEIU may terminate Contractor's right to proceed with the work. In such case, NEIU will give Contractor and its Surety written notice of intention to terminate and the reason therefore and, unless within seven (7) business days the delay or violation shall cease or satisfactory arrangement of correction made, NEIU may issue a written termination notice for Contractor and its Surety. Thereupon, the Surety will be given opportunity to complete the work in accordance with the Contract Documents. Such completion may include, but not be limited to, the use of a completing contractor pursuant to a written takeover agreement, the payment of a sum of money required to allow NEIU to complete the work, or other arrangements agreed to by NEIU and Surety. If within seven (7) business days the surety fails to exercises its right to undertake the work, NEIU may take over the work, exclude Contractor from the site and take possession of all Contractor's tools, appliances, construction equipment and machinery at the site and use the same to the full extent they could have been used by Contractor (without liability for trespass or conversion), incorporate into the work all materials and equipment stored at the site or for which NEIU has paid Contractor but which are stored elsewhere, and finish the work as NEIU may deem expedient by contract publicly advertised or otherwise. If NEIU's expenses in completing the work exceed the unpaid balance of the contract sum, Contractor shall pay the difference to NEIU.
5. **Right to Terminate the Contract for Convenience of the State:** The Contract may be terminated whenever NEIU determines that such termination is in the best interest

of the State of Illinois. NEIU will give Contractor ten (10) days written notice of its intention to terminate the Contract. Upon the receipt of such notice, Contractor shall stop all work on the Contract except for work NEIU directs in writing to be completed. Contractor will be paid for all work completed under the Contract. In the event NEIU and Contractor cannot agree to the amount of payment due Contractor, Contractor will receive a percentage of the contract sum equal to the percentage of the work completed on the project prior to termination of the Contract.

6. **Termination for Funding:** NEIU's obligations hereunder shall cease immediately, without further payment being required, in any year for which the General Assembly of the State of Illinois or other legally applicable funding source fails to make an appropriation sufficient to pay such obligation. NEIU shall give Contractor notice of such termination for funding as soon as practicable after NEIU becomes aware of the failure of funding.
7. **Right to Order Acceleration:** If Contractor fails to prosecute the work in accordance with the Construction Schedule, as provided by Contractor pursuant to the terms of Division 1, NEIU may require Contractor to increase the number of shifts or overtime operations, days of work or the amount of construction plant or all of them, without additional compensation.
8. **Use and Possession Prior to Completion:** NEIU shall have the right to take possession or use any substantially completed part of the work upon the issuance of a Certificate of Substantial Completion in accordance with Sub-Section 00770. Such possession or use shall not be deemed acceptance of that part of the project being occupied except as stated in the Certificate and shall not constitute a waiver of existing claims by either party. Contractor will be relieved of responsibility for loss or damage to that portion of the work resulting from NEIU's use or possession.

#### 00730 - ARCHITECT/ENGINEER - RIGHTS AND RESPONSIBILITIES

1. **Duties Responsibility and Authority:** The Architect/Engineer employed by NEIU has assisted NEIU in the preparation of the Project Manual and Drawings for the project. When authorized to act on behalf of NEIU, the duties, responsibility and authority of the Architect/Engineer are set forth herein. Nothing contained herein shall create any contractual relationship between the Architect/Engineer and Contractor or any subcontractor, sub-subcontractor or supplier.
2. **General:** The Architect/Engineer shall consult with and advise NEIU and act as NEIU's representative as provided in these Standard Documents for Construction. NEIU's instructions to Contractor will be issued through the Architect/Engineer who shall have authority to act on behalf of NEIU in dealings with Contractor to the extent provided in the Standard Documents for Construction.
3. **Submittals:** The Architect/Engineer will review and monitor all required Contractor Submittals for conformance with the Contract Documents.
4. **Contractor's Payments:** The Architect/Engineer will review and certify Contractors' applications for payment; attend and assist in pay meetings; maintain records of payments, Contract balances, and all proposed and approved changes thereto. Review, reconcile, and maintain files for Contractor's Waivers of Liens and sworn statements.
5. **Interpretations:** The Architect/Engineer will provide, when requested, interpretation of Contract Documents; prepare and distribute supplementary Drawings, Specifications and instructions.

6. **Change Orders:** The Architect/Engineer will prepare "Requests for Proposals" for Contract changes; evaluate contractors' proposals; review and verify the cost of the change and recommend action.
7. **Observation of the Work:** The Architect/Engineer will observe the progress and quality of the work as is reasonably necessary to determine in general that it is proceeding in accordance with the Contract Documents. Monitor and acknowledge conformance of materials, finishes and workmanship to the quality standards established in the Contract Documents. Notify NEIU immediately if in the Architect/Engineer's opinion, work does not conform to the Contract Documents, requires special inspection or testing, or has been disapproved or rejected.
8. **Tests:** The Architect/Engineer will witness tests; review and evaluate test reports; notify NEIU and Contractor of deficiencies.
9. **Defective Work:** On the basis of tests and observations, the Architect/Engineer may disapprove of or reject Contractor's work while it is in progress. If the Architect/Engineer believes that such work will not produce a completed project that conforms generally to the Contract Documents or that it will prejudice the integrity of the design concept of the project as reflected in the Contract Documents.
10. **Systems Commissioning:** The Architect/Engineer will observe and assist in the refining and adjustment of any equipment or system.
11. **Closeout:** The Architect/Engineer shall certify that to the best of their knowledge, the reviewed work conforms to the requirements of the Contract Documents; conduct Substantial Completion and Final Completion inspections. Expedite and coordinate Substantial Completion, Final Completion, Contractors' Submittals, final payment and facility turnover in accordance with NEIU's procedures.
12. **Records:** The Architect/Engineer will maintain records, including correspondence, Submittals, Schedules, payment request, addresses of contractors, subcontractors, and major suppliers.
13. **Record Drawings:** The Architect/Engineer will observe Contractors' Record Drawings at intervals appropriate to the construction and notify NEIU and Contractor of any apparent failure to maintain up-to-date records. Prepare and submit revised Contract Documents as Record Drawings to show all changes reported to the Architect/Engineer by Contractor and all Change Orders and Addenda made during construction, including the location of all concealed systems installed during construction.
14. **Construction Supervision:** The Architect/Engineer shall not be responsible for construction means, methods, techniques, sequences, procedures or supervision or for safety precautions and programs in connection with the Project or work thereon and nothing hereunder shall relieve Contractor from his responsibility to carry out the work in accordance with the Contract Documents.
15. **On-Site Representative:** When included in its agreement, the Architect/Engineer will provide one or more on-site representatives to assist in carrying out the Architect/Engineer's construction phase responsibilities.
16. **Response Action Project:** When a project involves response action work as defined in the Response Action Contractor Indemnification Act, the

Architect/Engineer will have the properly trained personnel, approved by the State of Illinois, on the site at all times during the performance of the response action work.

17. **Claims and Disputes:** The Architect/Engineer will review the claim or dispute including documentation of any time, money, or other expenditure made in connection with it. While work is in progress, will observe, measure and verify costs incurred that are related to the dispute. Provide a written response, interpretation, and recommendation for resolution to the claimant and NEIU.
18. **Inspection:** After substantial completion, the Architect/Engineer will assist NEIU with an inspection of the project work. The Architect/Engineer will prepare a report of all observed defective material, equipment and workmanship which requires corrective work under the guarantees.
19. **Miscellaneous:** Other responsibilities and authority of the Architect/Engineer are set forth throughout the Contract Documents.

#### 00740 - CONTRACTOR - RIGHTS AND RESPONSIBILITIES

1. **Review of Contract Documents:** Contractor shall carefully study and compare the Contract Documents including all addenda, and shall promptly report to the Project Manager all errors, inconsistencies, or omissions it may discover. Contractor shall review the Drawings and Specifications relating to work to be performed by other contractors in connection with the Project. All work under the Contract which Contractor discovers may be in conflict with the work of such other contractors shall be brought to the attention of the Project Manager before the work is performed. If after the discovery of such conflict, Contractor fails to promptly notify the Project Manager, Contractor shall, upon written direction, remove all such work or portion thereof so conflicting, and rebuild it as directed at no additional cost to NEIU. Contractor shall not perform any work without documents bearing Project Manager signature and dated "Issued for Construction" stamp.
2. **Verification of Dimensions and Existing Conditions:** All dimensions and existing conditions shall be verified by Contractor by actual measurement and observation. All discrepancies between the requirements of the Contract Documents and the existing conditions or dimensions shall be reported to the Project Manager as soon as they are discovered. Failure to verify and report shall constitute Contractor's acceptance of existing conditions as fit for the proper execution of his work.
3. **Changed Conditions:** Should Contractor encounter subsurface or latent physical conditions at the site which differ materially from those indicated in the Contract Documents or from those ordinarily encountered and generally recognized as inherent in work of the character provided for in the Contract, Contractor shall give written notice to the Project Manager before any such condition is disturbed. No claim of Contractor under this provision will be allowed unless Contractor has given the required notice. The Project Manager will promptly investigate and, should the Project Manager determine that the conditions materially differ from those which should have been reasonably anticipated, will make such changes in the Contract Documents as may be necessary. If such conditions cause an increase or decrease in Contractor's cost or time of performance, the Contract Sum or Contract Time will be modified in accordance with Section 00700.
4. **Laying Out the Work:** Contractor shall be responsible for properly and accurately laying out the work, and for all lines, levels, elevations, and measurements for all the work under the contract.

5. **Supervision of the Work:**
- A. Contractor, using its best skill and judgment, shall efficiently supervise the work. Contractor shall be responsible for all site safety and for all construction means, methods, techniques, sequences, and procedures and for coordinating all portions of the work under the Contract.
  - B. Contractor shall furnish a competent and adequate staff as necessary for the proper administration, coordination, and supervision of the work; organize the procurement of all materials and equipment so that they will be available at the time they are needed for the work; and keep an adequate force of skilled work personnel on the job to complete the work in accordance with all requirements of the Contract.
  - C. Contractor shall employ at the site, satisfactory to the Project Manager, a competent superintendent who shall be in attendance at the site throughout the active performance of the work and at such other times as may be reasonably necessary, and who shall be authorized to commit Contractor with regard to personnel schedule, coordination, and cooperation. The superintendent shall not have less than two years documented experience in responsible field supervision for projects of comparable size and complexity. Contractor shall not change the superintendent unless it has given NEIU a written request for change thirty (30) days in advance of its proposed change, and NEIU has given authorization to do so. In the event the superintendent fails to perform his duties under the Contract requirements, NEIU may, in writing, require Contractor to remove the superintendent from the project, and Contractor shall provide a competent replacement.
  - D. When a project involves response action work as defined in the Response Action Contractor Indemnification Act, properly trained personnel, approved by the State of Illinois, shall be on the site at all times during the performance of the response action work.
6. **Responsibility for Damages:** Contractor shall be responsible for all loss or damage to the work, Project, site and improvements thereon and the work of other contractors caused by its operation during the performance of the Contract. The work shall be entirely at Contractor's risk and NEIU assumes no responsibility whatever for damage or loss to any of the work, adjacent property, or Contractor's equipment. Watchmen, if required, shall be retained at the expense of Contractor.
7. **Work of Other Contractors:** NEIU reserves the right to execute other contracts in connection with the Project. Contractor shall afford other contractors reasonable opportunity and storage of their materials and for the execution of their work, and shall properly connect and coordinate its work with theirs. Contractor shall not commit or permit any act which will interfere with the performance of work by any other contractor or by NEIU.
8. **Assignment of Claims:** NEIU shall not be bound by any assignment by Contractor to third parties of moneys due or become due or of any other claims it may have under its contract except where NEIU consents in writing to be so bound.
9. **Claims and Disputes:** Contractor shall promptly notify the Project Manager in writing of any claims or disputes. Any work performed, where the payment for same is in dispute, must be observed by the Project Manager while in progress. Failure to notify the Project Manager in such instances may result in rejection of any claim with NEIU.

10. **Notification:** No claim for a contract adjustment pursuant to any written order, verbal order, instruction, interpretation, clarification or changed condition will be allowed unless Contractor, within (thirty (30) calendar days of such occurrence furnishes a written notice setting forth the general nature and estimated monetary extent of such claim.
11. **Miscellaneous:** Other rights and responsibilities of Contractor are set forth throughout these Contract Documents and are included under other titles, articles, sections and headings for convenience. It is the responsibility of Contractor to familiarize itself with all provisions of these Contract Documents in order to understand fully the entirety of its rights and responsibilities hereunder.

#### 00741 - INDEMNIFICATION

1. **Duty to Indemnify:** Contractor shall defend, indemnify, keep, and save harmless the State of Illinois, Board, NEIU, the Project Manager, and their respective board members, representatives, agents and employees, in both individual and official capacities, against all suits, claims, damages, losses and expenses, including attorney's fees, caused by, growing out of, or incidental to, the performance of the work under the Contract by Contractor or its subcontractors to the full extent as allowed by the laws of the State of Illinois and not beyond any extent which would render these provisions void or unenforceable. This obligation includes but is not limited to: The Illinois laws regarding structural work (Ill. Rev. Stat. Ch. 48 par. et seq.) and regarding the protection of adjacent landowners (Ill. Rev. Stat. Ch. 111 1/2 par 3301 et seq.). In the event of any such injury (including death) or loss or damage, or claims therefore, Contractor shall give prompt notice to NEIU.
2. **Effect of Statutory Limitations:** In the event of any claim against the State of Illinois, Board, NEIU, or against any of their officials or employees, in either their personal or official capacities, made by any direct or indirect employee or agent of Contractor or of any subcontractor, Contractor's indemnification obligation shall not be affected by any limitation on the amount or type of damages, compensation, or benefits payable to said employee or agent contained in any other type of employee benefit act.
3. **NEIU/Architect/Engineer's Liability:** The obligations of Contractor shall not extend to the liability of NEIU's agents or employees or the Architect/Engineer, or their agents or employees.

#### 00742 - LABOR LEGISLATION

1. Contractor shall familiarize himself with all provisions of all Acts referred to in this paragraph and in addition shall make an investigation of labor conditions and all negotiated labor agreements which may exist or are contemplated at this time. Nothing in the Acts referred to in this paragraph shall be construed to prohibit the payment of more than the prevailing wage scale.
2. In the employment and use of labor, Contractor shall conform to all Illinois statutory requirements regarding labor, including but not limited to the following Acts:
  - A. The Human Rights Act, as amended (Ill Rev Stat. Ch. 68 par 1-101 et seq).
  - B. An Act to prohibit discrimination and intimidation on account of race, creed, color, sex or national origin in employment under contracts for public buildings or public works, as amended (Ill. Rev. Stat., Ch. 29, par. 17).
  - C. An Act to prohibit unjust discrimination in employment because of age and providing penalties, as amended (Ill. Rev. Stat., ch. 68, par. 1-101 et seq.).

- D. An Act to create the Minority and Female Business Enterprise Act, and to amend an Act named therein, as amended (Ill. Rev. Stat., Ch. 127, par. 132.601).
3. When project is classified as a Public Work, it is subject to all the provisions of the Prevailing Wage Law of the State of Illinois. Contractors and subcontractors shall conform to Illinois statutory requirements regarding prevailing wages, as defined in Chapter 48, section 39S-1-et. seq. Ill. Rev. Stat. which provides in part that Contractor, subcontractors, etc., shall pay to all laborers, workmen, and mechanics performing work under the Contract, not less than the prevailing rate of wages as determined by the Illinois Department of Labor. Contractor shall prominently post the current Schedule of Prevailing Wages at the project site, and shall notify immediately in writing all of its subcontractors, etc., of all changes in the Schedule of Prevailing Wages. Any increases in costs to Contractor due to changes in the prevailing rate of wages or labor law during the term of any Contract shall be at the expense of Contractor and not at the expense of NEIU. However, Change Orders shall be computed using the prevailing wage rates applicable at the time the Change Order work is scheduled to be performed.
  4. Equal Employment Opportunity - Applicable Laws: State of Illinois policy and law, set out in the Illinois Constitution, Article 1, Section 17, requires that employment opportunities be free from discrimination. The equal employment clause contained in Ch. 68, Par. 1-101 et seq. is incorporated into the Contract and is intended to insure compliance with the applicable laws and with the Illinois Department of Human Rights Rules and Regulations for Public Contracts. Contractor shall conform to all provisions of the Equal Employment Opportunity Clause (44 Illinois Administrative Code, Ch. X, Sec. 750, Appendix A), and shall include said clause, verbatim or by reference, in each of its subcontracts under which any portion of the Contract obligations will be undertaken or assumed, so that the provisions of the clause will be binding upon all such subcontractors.
  5. In no event shall minors be employed except as authorized under an Act to regulate the employment of children and to repeal an Act herein, named, as amended (Ill. Rev. Statutes, Ch. 48, Par. 31.1 et seq.).
  6. In no event shall convict labor be employed except as authorized under unified Code of Corrections, as amended (Ill. Rev. Statutes, Ch. 38, Par. 1001-1-1 et seq.)
  7. An Act requiring employment of Illinois Workers on public works project, as amended (Ill. Rev. Stat., Ch. 48, Par. 2201, et seq.).
  8. The Worker's Compensation Act, as amended (Ill. Rev. Stat., Ch. 48, Par. 138.1 et seq.).
  9. Certification required by the Drug-Free Workplace Act (Ill. Rev. Stat. Ch. 127, Pars. 132.311 et seq.).
  10. The bidder and all bidder's subcontractors must participate in applicable apprenticeship and training programs approved by and registered with the United States Department of Labor's Bureau of Apprenticeship and Training (30ILCS 500/30-22).

#### 00743 - RECORDS OF WAGES AND EXPENSES

1. Contractors and subcontractors shall keep or cause to be kept an accurate record of names, occupations and actual wages paid to each laborer, workman, and mechanic



employed by it in connection with the Contract. The record shall be open at all reasonable hours for inspection by any representative of NEIU or the Illinois Department of Labor and must be preserved for four years following completion of the Contract.

2. **Project Expenses:** In accordance with Public Act 87-991 (effective 1 September 92), Contractor shall maintain for a minimum of five (5) years after the completion of the Contract, adequate books, records, and supporting documents to verify the amounts, receipts, and uses of all disbursements of funds passing in conjunction with the Contract. These records shall be available for review and audit by the Auditor General. Contractor agrees to cooperate fully with any such audit and shall provide full access to all relevant materials. Failure to maintain the records required by this provision shall establish a presumption in favor of the State for the recovery of any funds paid by the State under the contract for which adequate records are not available to support their purported disbursement.

#### 00760 - CHANGES

1. NEIU may, at any time, without notice to the Sureties, order changes in the Contract Time or in work germane to the Contract. Contractor may initiate requests for changes. Upon issuance of a Change Order, Contractor shall promptly proceed with the work as changed. No work shall be changed without written approval of NEIU.
2. NEIU reserves the right not to proceed with a proposed change.
3. If a Change Order or an aggregate of Change Orders impact the critical items on the current construction schedule, Contractor may request a time extension. Time extensions requests will not be considered with the Change Order, but must be submitted separately. Time extension will be granted in accordance with Sub-section 01310.
4. **Value of Change:** If a change affects work covered by unit prices in the Contract, such unit prices shall be used as the basis for adjustments to the Contract Sum. Except as otherwise specified, in all other cases, adjustments to the Contract Sum shall be based on Contractor's direct costs, including costs of material, labor, Workmen's Compensation Insurance, equipment bonds and taxes as applicable, plus an amount of 10% for overhead and profit. If the changed work is performed by a subcontractor, 10% shall be added to that subcontractor's costs for overhead and profit an additional 5% shall be included for each intermediate subcontractor, if any, between Contractor and the subcontractor, performing the changed work.

#### 00765 - PAYMENT

1. **Progress Payments:** NEIU will make payments for materials and work incorporated into the Project as determined by NEIU in consultation with the Architect/Engineer. NEIU may require payment to be made on form, A.I.A. Document, G703. Such payments will be based on the approved Schedule of Values submitted fifteen (15) days prior to the first payment request. Applications for progress payments shall include an affidavit itemizing the principal portions of the work performed, and invoice-voucher and lien waivers from subcontractors and suppliers.
2. **Stored Material:** Progress payments will be made for materials and equipment not incorporated in the Work provided that:
  - A. Such materials and equipment have been delivered to and suitably stored at the site or some other location approved in writing by NEIU. Payment for

materials/equipment stored off-site will be permitted only NEIU's prior written authorization.

- B. Contractor submits evidence of title to such materials and equipment.
- C. The care and custody of such materials and equipment and all costs incurred for movement and storage shall be the responsibility of Contractor.
- D. Such materials and equipment are suitably insured by Contractor. Contractor shall submit a Certificate of Insurance showing NEIU as an additional insured and showing the amount of the insurance coverage.

4. **Retention and Retention Trusts:**

In making progress payments NEIU will retain 10% of each progress payment. After 50% of the work has been completed, if NEIU determines, upon the recommendation of the Project Manager, that the work is being performed in a satisfactory manner, NEIU will waive further retention.

5. **Lien Waivers:**

A. **Partial Lien Waivers:**

- 1. Contractor must submit lien waivers with each payment request.
- 2. Beginning with the second payment request, and with each succeeding payment request, Contractor shall submit to the Architect/Engineer partial lien waivers from them, each subcontractor, and supplier showing that the amount paid to date to each is at least equivalent to the total value of its work, less retainage, included on the previous month's invoice/voucher.
- 3. Lien waivers from Contractor and all subcontractors and suppliers shall accompany the first payment request if the amount of payment exceeds 50% of the total Contract sum.

B. **Final Lien Waivers:** Contractor's request for final payment shall include:

- 1. Contractor's final lien waivers which shall be for the full amount of its Contract including all change orders thereto.
- 2. Final lien waivers in the full amount of their contracts from all subcontractors and suppliers for which final lien waivers have not previously been submitted.

6. **Payments to Subcontractors and Suppliers:** Contractor shall pay each subcontractor and supplier, promptly upon receipt of payment from NEIU, an amount equal to the percentage of total contract completion allowed to Contractor on account of performance by the subcontractor or supplier, less the retainer and less amounts previously paid to the subcontractor or supplier. Contractor shall require that all subcontractors make similar payments to their subcontractors and suppliers. NEIU, the Project Manager may furnish to any subcontractor or supplier information regarding the percentage of work completed which was used as the basis for payment or the amount of payment on account of work by such subcontractors or suppliers.

7. **Title:** Title to all work, materials, and equipment covered by a progress payment shall pass to NEIU upon receipt of such payment by Contractor. This provision shall not relieve Contractor from sole responsibility under the Contract for all work materials and equipment upon which payments have been made or for the restoration of all damaged work or as waiving the right of NEIU to require fulfillment of all terms of the contract.

8. **Withholding of Payments:** NEIU may withhold payments, in whole or in part, if it reasonably determines:
1. Contractor's work is not progressing in accordance with the most current Construction Schedule.
  2. Work is not being performed in accordance with the Contract Documents.
  3. Contractor is failing to comply with any provisions of the Contract.
  4. Contractor or a subcontractor is under investigation by the Illinois Department of Labor for possible failure to pay prevailing wage benefits in accordance with the Contract Documents.
- B. NEIU will notify Contractor in writing when any such payments are withheld.
- C. Whenever NEIU receives notice in writing of a claim of money due from Contractor to any subcontractor, supplier, workmen, or employees for performance of work, NEIU may withhold the amount of such claim from Contractor provided that such withholding shall not be construed as conferring any rights on such subcontractor, suppliers, workmen, or employees nor as enlarging or altering the application or effect of existing lien laws.
- D. In the event of any withholding, NEIU will promptly investigate the facts and will make payments when the grounds for withholding have been removed.
- E. NEIU will notify Contractor in writing and in accordance with the Prompt Payment Act (if applicable) when any payments are withheld. In the event of any withholding, NEIU will promptly investigate the facts and will make payments when the grounds for withholding have been removed.
9. **Final Payment:** Upon acceptance of all work by NEIU the remaining balance of the Contract Sum, including retainage, will be paid upon presentation of:
- A. Final Invoice-Voucher
  - B. Contractor's Final Declaration
  - C. Final releases of Waivers of Liens for Contractor and all sub-contractors, suppliers, and others with lien rights against property of NEIU, together with complete list of those parties.
  - D. Copy of Certification of Systems Training
  - E. Final accounting statement, reflecting all adjustments to Contract Sum from Change Orders, unit prices, or liquidated damages.
  - F. Copy of transmittal letters to Project Manager for As-Built Drawings and Operating and Maintenance Manuals.

#### 00770 - INSPECTION AND ACCEPTANCE

1. **Inspection:** The work will be subject to inspection and testing by the Project Manager, at all reasonable times and at all places. All such inspections and testing will be conducted in such a manner as not to unreasonably delay the work or increase the cost of performance. Contractor shall provide, without additional compensation, all facilities, labor, and material reasonably necessary for such safe and convenient inspection and testing as is required.
2. **Notice:** When layouts of the building and site work are to be made or when the Contract, or Federal, or State laws require any work to be especially tested or

approved, or if work not yet inspected is to be covered, Contractor shall give the Project Manager timely notice of the work's readiness for inspection. If inspection is to be made by an authority other than the Project Manager, Contractor shall promptly notify the Project Manager of the date and time fixed for such inspection.

3. **Uncovering of Work:** Work covered without consent of the Project Manager shall, upon their request, be uncovered for examination and re-covered at Contractor's expense. Work covered with the consent of the Project Manager shall, upon their request, be uncovered for examination. If such work is found to be in accordance with the Contract, the contract sum and the contract time will be increased in accordance with Section 00700. If such work is found not in accordance with the Contract, the uncovering and re-covering shall be at Contractor's expense.
4. **Correction of Work:** Contractor shall, without additional compensation, promptly correct all work rejected by the Project Manager as defective or failing to conform to the Contract Documents unless NEIU agrees to accept such work with an appropriate reduction in the Contract Sum. If Contractor does not promptly correct rejected work, NEIU may repair or replace such work in accordance with Sub-section 00720.
5. **Acceptance:** When Contractor believes that the work or any part thereof is substantially complete, it shall give five (5) business days written notice to the Project Manager who will prepare a punch list of items remaining to be completed or corrected. When NEIU determines that the work is substantially complete, a Certificate of Substantial Completion will be submitted to Contractor for written acceptance. Such certificate will establish the date of Substantial Completion, state the responsibilities of NEIU and Contractor for security, maintenance, heat, utilities, and insurance and will fix the time within which Contractor shall complete or correct the items on the punch list. The Certificate of Substantial Completion will constitute acceptance of the Work except for items included on the punch list. Upon completion of punch list items, Contractor shall give five (5) business days written notice of final completion to the Project Manager who together with NEIU, will promptly inspect the work. When NEIU determines that all work, including all punch list items, is complete, a Certificate of Final Acceptance will be issued which will constitute acceptance of all work. Acceptance will not bar claims of NEIU under Sub-section 00780.

#### 00780 - WARRANTIES

1. Contractor warrants that all materials and equipment furnished under the Contract will be new, unless otherwise specified, and that all work will be in conformance with the Contract and free from defects in workmanship, materials and equipment for a period of one (1) year or such longer period as may be specified in the Contract Documents. Warranty time periods shall commence with the date of NEIU acceptance of the Certificate of Substantial Completion of the whole or any part of the project. The warranty time period for any incomplete or uncorrected work at the time of substantial completion shall commence with the date of final completion.
2. Contractor shall, at his own expense and without cost to NEIU, at any time within the Statute of Limitations, make good any defects in materials or workmanship which may develop, and any damage to other work caused by such defects or the repairing of same. Repair and replacement includes all defective or nonconforming work resulting from latent defects, fraud, fraudulent concealment or gross negligence. NEIU will give timely notice of such defects.
3. Upon notice from NEIU of such defect or nonconformity, Contractor shall promptly visit the site in the company of NEIU's representative to determine the extent of all

defects or nonconforming work, including all adjacent work not necessarily provided by Contractor but damaged as a result of such defect or nonconformity or as a result of remedying them. If Contractor does not promptly repair or replace defective or nonconforming work, NEIU may repair or replace such work and charge the cost thereof to Contractor. Work which is repaired or replaced by Contractor shall be inspected and accepted in accordance with this Section and shall be warranted by Contractor in accordance with Paragraph 1 of this Sub-section. The warranties set forth herein are in addition to all warranties or guarantees expressed or implied by operation of law, statute, or ordinance.

4. Contractor shall deliver all commercial warranties received from manufacturer to the Project Manager prior to final completion but this shall not reduce Contractor's obligations under this Section.

#### 00790 – VENDOR LEGAL AUTHORIZATION/REGISTRATION WITH ILLINOIS SECRETARY OF STATE

1. Vendor certifies that it is a properly formed and existing legal entity (30 ILCS 500/1.15.80, 20-43); and as applicable, has obtained an assumed name certificate from the appropriate authority, is registered to conduct business in Illinois, and is in good standing with the Illinois Secretary of State (30 ILCS 500/1.15.80).
2. Vendors may qualify to submit bids to State universities only if they are a legal entity authorized to do business in Illinois prior to submitting the bid, offer or proposal. This applies to both in-state and out-of-state firms.
3. A vendor/bidder must :
  1. A legal entity
  2. Registered to conduct business in Illinois
  3. In good standing with the Illinois Secretary of State
  4. Have an Illinois workplace for employees working on the contract
4. Specific information regarding compliance can be obtained from (30 ILCS 500/1.15.80, 20-43). Please contact the Illinois Secretary of State for additional information.

**End of Section 007200**

**DIVISION 00 – PROCUREMENT AND CONTRACTING REQUIREMENTS**

**SECTION 007300  
SUPPLEMENTARY GENERAL CONDITIONS**

00825 - PREVAILING WAGES

1. Pursuant to Public Act 86-799, the Project Manual includes the Prevailing Rate of wages for the county where the Work is being performed and for each craft or type of worker needed to execute the Contract.

Current Cook County Prevailing Wage Rates may be located at:

<http://www.state.il.us/agency/idol/rates/rates.HTM>

2. The Act regulates wages of laborers, mechanics, and other workmen employed in any public works by the State, county, city, or any public body or any political subdivision or by anyone under contract for public works, as amended (Ill. Rev. Stat., Ch. 48, Par. 39S-1 et seq.) which provides a part that Contractor, subcontractors, etc., shall pay to all laborers, workmen and mechanics performing work under the Contract, not less than the prevailing rate of wages as determined by the Illinois Department of Labor. Contractor shall prominently post the current Schedule of Prevailing Wages at the project site, and shall notify immediately in writing all its subcontractors, etc., of all changes in the Schedule of Prevailing Wages.
3. Prevailing wage rates, benefits and conditions will be those as provided in the Bid Documents. Any increase in costs to Contractor due to changes in the Prevailing Rate of wages or labor law during the term of any contract shall be at the expense of Contractor and not at the expense of NEIU.
4. Change Orders shall be computed using the prevailing wage rates applicable at the time the Change Order Work is scheduled to be performed.
5. Davis-Bacon Act

Any project authorized by the University and utilizing federal funding must follow the Davis-Bacon Act (the entire Act can be located within [www.dol.gov](http://www.dol.gov)). The requirements include the payment of prevailing wages and the submittal of certified payrolls to the Project Manager. Contractors must also post the scale of wages in a prominent and easily accessible place at the work site. Reports required by the University in order to ensure the payment of prevailing wage may be requested. No payment requests will be honored unless the certified payroll is attached. If any worker covered by the contract has been or is being paid a rate of wages less than the rate of wages required, the University may, by written notice to the contractor, terminate the work or such part of the work as to which there has been a failure to pay said required wages and to prosecute the work to completion by contract or otherwise, and the contractor and his/her sureties shall be liable to the University for any excess costs occasioned thereby.

Certified Payroll Form follows this section.

**End of Section 007300**

# NORTHEASTERN ILLINOIS UNIVERSITY

## CERTIFIED PAYROLL FORM

NEIU Purchase Order Number	
Company Name	
Address	
Pay Period	

The following statement is a part of the submission:

"The contractor certifies that (1) the payroll record is true and accurate; (2) the hourly rate paid to each worker is not less than the general prevailing rate of hourly wages required by the Illinois Prevailing Wage Act (820 ILCS 130/5); and (3) the contractor or subcontractor is aware that filing a certified payroll which he or she knows to be false is a Class B misdemeanor."

X \_\_\_\_\_  
Contractor's Signature and Date

X \_\_\_\_\_  
Printed Name and Title

This form must be signed by an authorized representative of the contractor's firm.

Submit paper records to: Project Manager, NEIU Facilities Management Department

Illinois state law requires all contractors working on University construction projects to submit certified payroll records to the University. The payroll records must include all workers employed by contractors on a University project.

Payroll records are to include: each worker's name, classification or classifications, hourly wage and paid in each pay period, number of hours worked each day and the starting and ending times of work each day. Also include hourly fringe benefit paid to each worker. You must submit a certified payroll only for employees working on a University project.

Failure to submit this form and a certified payroll may result in final payment being withheld by the University.

### What information do you have to supply?

For each project, contractors and sub-contractors must submit:

- For each employee:
  - o Name
  - o Classification or classifications
  - o Hourly wages paid in each pay period
  - o The number of hours worked each day in the pay period
  - o The starting and ending times of each work day in the pay period
  - o Hourly Fringe Benefit

- A statement signed by the contractor or sub-contractor certifying that the records are true and accurate; that the hourly wage paid each worker is not less than the general prevailing wage rate; and that the contractor is aware that knowingly filing a false certified payroll is a misdemeanor crime.

However, the form provided on the IDOL website is preferred. The NEIU project manager can direct you to this form when necessary.

**The University does not mandate that the information be provided in a certain way. The contractor must provide all the information required and must attach the University's cover sheet to each submittal.**

**You do not have to submit a certified payroll for all of your employees.** You must submit a certified payroll only for employees working on a University public works project. Existing state law defines these employees as: "Only such laborers, workers and mechanics as are directly employed by contractors or subcontractors in actual construction work on the site of the building or construction job, and laborers, workers and mechanics engaged in the transportation of materials and equipment to or from the site, but not including the transportation by sellers and suppliers or the manufacture or processing of materials or equipment, in the execution of any contract or contracts for public works shall be deemed to be employed upon public works."

**You do not have to submit the certified payrolls of your suppliers or their sub-contractors.** The legal definition of public works employees excludes the employees and subcontractors of suppliers and the manufacturers or processors of materials and equipment.

**Do sub-contractors submit their reports separately, or do prime contractors have to collect and submit the reports of all their sub-contractors?** It is the responsibility of each firm to submit certified payrolls every month. Prime contractors are not responsible for the submissions of sub-contractors. Prime contractors *may* collect certified payroll reports from their sub-contractors and submit them as one package if they so choose. These decisions should be made cooperatively by each prime contractor and sub-contractor.

**Failing to submit a certified payroll** or knowingly filing a false payroll is a Class B misdemeanor, punishable by up to six months in jail. A general contractor is not liable for false information supplied by a sub-contractor unless he knowingly submits a false certified payroll submitted by a sub-contractor.

Under the law, the University will retain these certified payroll records for three years. Most of the information is considered public record and will be available through the Freedom of Information Act. An employee's address, telephone number and social security number will not be released by the University.

The law was signed and became effective on August 10, 2005.

This requirement was the subject of House Bill 188, which was approved by the General Assembly in May, 2005. The bill amends Chapter 820 of the Illinois Compiled Statutes, Section 130/5. The law can be found on-line by visiting [www.ilga.gov](http://www.ilga.gov) and going to the "bill search" page.



**DIVISION 00 – PROCUREMENT AND CONTRACTING REQUIREMENTS**

**SECTION 009113**  
**ADDENDA**

All changes in or interpretations of Bidding Documents prior to the Bid Opening will be made by written Addenda issued by NEIU to each recipient of Bidding Documents recorded by NEIU. All Addenda will be issued via the Illinois Public Higher Education Procurement Bulletin website: <http://www.procure.stateuniv.state.il.us/> no later than three (3) business days prior to Bid Opening. When addenda are not timely issued, the bids will be returned unopened and the bid opening date will be extended. Failure to acknowledge all Addenda may result in Bid rejection.

**End of Section 009113**

## **DIVISION 01 - GENERAL REQUIREMENTS**

### **SECTION 011000 SUMMARY**

#### **PART 1 - GENERAL**

##### **1.1 SUMMARY**

###### **A. Section Includes:**

1. Project information.
2. Work covered by Contract Documents.
3. Work by Owner.
4. Access to site.
5. Coordination with occupants.
6. Work restrictions.
7. Specification and drawing conventions.
8. Miscellaneous provisions.

###### **B. Related Requirements:**

1. Section 015000 "Temporary Facilities and Controls" for limitations and procedures governing temporary use of Owner's facilities.

##### **1.2 PROJECT INFORMATION**

###### **A. Project Identification: CCICS Auditorium Renovation #61-0212-0113**

1. Project Location: 700 East Oakwood Blvd., Chicago, Illinois 60653.

###### **B. Owner: Northeastern Illinois University (NEIU), 5500 N. St. Louis Ave. Chicago, IL.**

###### **C. Architect: 4240 Architecture Inc, 328 South Jefferson Street, Suite 750, Chicago, IL 60661; 312.341.1155.**

###### **D. Coordinator for Multiple Contracts: General Contractor has been appointed by Owner to serve as Coordinating Contractor.**

##### **1.3 WORK COVERED BY CONTRACT DOCUMENTS**

###### **A. The Work of Project is defined by the Contract Documents and consists of the following:**

1. The renovation of the existing Auditorium on the second floor of the building. The scope of work includes selective demolition, reconstruction of the stage and seating area floor; installation of Owner furnished seating; new interior finishes; refinishing of existing millwork; new millwork; new AV equipment; new theater equipment; and mechanical and electrical improvements.

###### **B. Type of Contract:**

1. Project will be constructed under coordinated, concurrent multiple contracts. See Section 011200 "Multiple Contract Summary" for a description of work included under

each of the multiple contracts and for the responsibilities of Coordinating Contractor. Contracts for this Project include the following Prime Contractors:

- a. General.
- b. Ventilating.
- c. Electrical.

#### 1.4 ACCESS TO SITE

- A. General: Contractor shall have limited use of Project site for construction operations as indicated on Drawings by the Contract limits and as indicated by requirements of this Section.
- B. Use of Site: Limit use of Project site to areas within the Contract limits indicated. Do not disturb portions of Project site beyond areas in which the Work is indicated.
  1. Driveways, Walkways and Entrances: Keep driveways, parking lots, loading areas and entrances serving premises clear and available to Owner, Owner's employees, and emergency vehicles at all times. Do not use these areas for parking or storage of materials.
    - a. Schedule deliveries to minimize use of driveways and entrances by construction operations.
    - b. Schedule deliveries to minimize space and time requirements for storage of materials and equipment on-site.
- C. Condition of Existing Building: Maintain portions of existing building affected by construction operations in a weathertight condition throughout construction period. Repair damage caused by construction operations.

#### 1.5 COORDINATION WITH OCCUPANTS

- A. Partial Owner Occupancy: Owner will occupy the premises during entire construction period, with the exception of areas under construction. Cooperate with Owner during construction operations to minimize conflicts and facilitate Owner usage. Perform the Work so as not to interfere with Owner's operations. Maintain existing exits unless otherwise indicated.
  1. Maintain access to existing walkways, corridors, and other adjacent occupied or used facilities. Do not close or obstruct walkways, corridors, or other occupied or used facilities without written permission from Owner and authorities having jurisdiction.
  2. Provide not less than 72 hours' notice to Owner of activities that will affect Owner's operations.
- B. Owner Limited Occupancy of Completed Areas of Construction: Owner reserves the right to occupy and to place and install equipment in completed portions of the Work, prior to Substantial Completion of the Work, provided such occupancy does not interfere with completion of the Work. Such placement of equipment and limited occupancy shall not constitute acceptance of the total Work.
  1. Architect will prepare a Certificate of Substantial Completion for each specific portion of the Work to be occupied prior to Owner acceptance of the completed Work.
  2. Coordinating Contractor to obtain a Certificate of Occupancy from authorities having jurisdiction before limited Owner occupancy.
  3. Before limited Owner occupancy, mechanical and electrical systems shall be fully operational, and required tests and inspections shall be successfully completed. On

occupancy, Owner will operate and maintain mechanical and electrical systems serving occupied portions of Work.

4. On occupancy, Owner will assume responsibility for custodial service for occupied portions of Work. Each contractor is to continue to assume responsibility for security, maintenance, utilities, damage to work and insurance until final completion.

## 1.6 WORK RESTRICTIONS

- A. Work Restrictions, General: Comply with restrictions on construction operations.
  1. Comply with limitations on use of public streets and with other requirements of authorities having jurisdiction.
- B. On-Site Work Hours: Limit work in the existing building to normal working hours, unless otherwise indicated.
- C. Nonsmoking Building: Smoking is not permitted within the building or within 25 feet of entrances, operable windows, or outdoor-air intakes.
- D. Controlled Substances: Use of tobacco products and other controlled substances on Project site is not permitted.
- E. Employee Identification: Owner will provide identification tags for Contractor personnel working on Project site. Require personnel to use identification tags at all times. Identification tags will be picked up and returned daily to NEIU campus police office.
- F. Employee Screening: Comply with Owner's requirements for the Drug-Free Workplace Act (30 ILCS 580/1) for Contractor personnel working on Project site.
  1. Maintain list of personnel as required by above with Owner's representative.

## 1.7 SPECIFICATION AND DRAWING CONVENTIONS

- A. Specification Content: The Specifications use certain conventions for the style of language and the intended meaning of certain terms, words, and phrases when used in particular situations. These conventions are as follows:
  1. Imperative mood and streamlined language are generally used in the Specifications. The words "shall," "shall be," or "shall comply with," depending on the context, are implied where a colon (:) is used within a sentence or phrase.
  2. Specification requirements are to be performed by Contractor unless specifically stated otherwise.
- B. Division 01 General Requirements: Requirements of Sections in Division 01 apply to the Work of all Sections in the Specifications.
- C. Drawing Coordination: Requirements for materials and products identified on Drawings are described in detail in the Specifications. One or more of the following are used on Drawings to identify materials and products:
  1. Terminology: Materials and products are identified by the typical generic terms used in the individual Specifications Sections.
  2. Abbreviations: Materials and products are identified by abbreviations published as part of the U.S. National CAD Standard and scheduled on Drawings.

3. Keynoting: Materials and products are identified by reference keynotes referencing Specification Section numbers found in this Project Manual.

**PART 2 - PRODUCTS (NOT USED)**

**PART 3 - EXECUTION (NOT USED)**

END OF SECTION

## **DIVISION 01 - GENERAL REQUIREMENTS**

### **SECTION 011200 MULTIPLE CONTRACT SUMMARY**

#### **PART 1 - GENERAL**

##### **1.1 SUMMARY**

- A. Section includes a summary of each contract, including responsibilities for coordination and temporary facilities and controls.
- B. Specific requirements for Work of each contract are also indicated in individual Specification Sections and on Drawings.
- C. Related Requirements:
  - 1. Section 011000 "Summary" for the Work covered by the Contract Documents, restrictions on use of Project site, coordination with occupants, and work restrictions.
  - 2. Section 013100 "Project Management and Coordination" for general coordination requirements.

##### **1.2 DEFINITIONS**

- A. Permanent Enclosure: As determined by Architect, the condition at which roofing is insulated and weathertight; exterior walls are insulated and weathertight; and all openings are closed with permanent construction or substantial temporary closures equivalent in weather protection to permanent construction.

##### **1.3 COORDINATING CONTRACTOR**

- A. Project coordination shall be performed by the Prime General Contractor which will be responsible for coordination between all Prime Contractors on the Project.
- B. Each Prime Contractor shall be under the direction of the Coordinating Contractor for all issues of Project schedule and coordination for all aspects of the contracts and project completion.
  - 1. Prime General/Coordinating Contractor shall act on ventilating and electrical coordination.

##### **1.4 COORDINATION ACTIVITIES**

- A. Coordination activities of Coordinating Contractor include, but are not limited to, the following:
  - 1. Provide overall coordination of the Work.
  - 2. Coordinate shared access to workspaces.
  - 3. Coordinate product selections for compatibility.
  - 4. Provide overall coordination of temporary facilities and controls.

5. Coordinate, schedule, and approve interruptions of permanent and temporary utilities, including those necessary to make connections for temporary services.
  6. Coordinate construction and operations of the Work with work performed by each Contract.
  7. Prepare coordination drawings in collaboration with each contractor to coordinate work by more than one contract.
  8. Coordinate sequencing and scheduling of the Work. Include the following:
    - a. Initial Coordination Meeting: At earliest possible date, arrange and conduct a meeting with contractors for sequencing and coordinating the Work; negotiate reasonable adjustments to schedules.
    - b. Prepare a combined contractors' construction schedule for entire Project. Base schedule on preliminary construction schedule. Secure time commitments for performing critical construction activities from contractors. Show activities of each contract on a separate sheet. Prepare a simplified summary sheet indicating combined construction activities of contracts.
      - 1) Submit schedules for approval.
      - 2) Distribute copies of approved schedules to contractors.
  9. Provide photographic documentation.
  10. Provide quality-assurance and quality-control services specified in Section 014000 "Quality Requirements."
  11. Coordinate sequence of activities to accommodate tests and inspections, and coordinate schedule of tests and inspections.
  12. Provide information necessary to adjust, move, or relocate existing utility structures affected by construction.
  13. Locate existing permanent benchmarks, control points, and similar reference points, and establish permanent benchmarks on Project site.
  14. Provide field surveys of in-progress construction and site work and final property survey.
  15. Provide progress cleaning of common areas and coordinate progress cleaning of areas or pieces of equipment where more than one contractor has worked.
  16. Coordinate cutting and patching.
  17. Coordinate protection of the Work.
  18. Coordinate firestopping.
  19. Coordinate completion of interrelated punch list items.
  20. Coordinate preparation of Project record documents if information from more than one contractor is to be integrated with information from other contractors to form one combined record.
  21. Print and submit record documents if installations by more than one contractor are indicated on the same contract drawing or shop drawing.
  22. Collect record Specification Sections from contractors, collate Sections into numeric order, and submit complete set.
  23. Coordinate preparation of operation and maintenance manuals if information from more than one contractor is to be integrated with information from other contractors to form one combined record.
- B. Responsibilities of Coordinating Contractor for temporary facilities and controls include, but are not limited to, the following:
1. Provide common-use field office for use by all personnel engaged in construction activities.

2. Provide telephone service for common-use facilities.
- C. Heating, Ventilating, Plumbing, Electrical, and Fire Protection specific Coordination: Coordination activities include, but are not limited to, the following:
1. Schedule and sequence mechanical and electrical activities.
  2. Coordinate sharing access to workspaces by mechanical and electrical contractors.
  3. Coordinate integration of mechanical and electrical work into limited spaces.
  4. Coordinate protection of mechanical and electrical contractors' work.
  5. Coordinate cutting and patching for mechanical and electrical work.
  6. Prepare mechanical and electrical coordination drawings.
  7. Coordinate tests and inspections for mechanical and electrical work.
  8. Coordinate mechanical and electrical temporary services and facilities.

## 1.5 GENERAL REQUIREMENTS OF CONTRACTS

- A. Extent of Contract: Unless the Agreement contains a more specific description of the Work of each Contract, requirements indicated on Drawings and in Specification Sections determine which contract includes a specific element of Project.
1. Unless otherwise indicated, the work described in this Section for each contract shall be complete systems and assemblies, including products, components, accessories, and installation required by the Contract Documents.
  2. Trenches and other excavation for the work of each contract shall be the work of the General Construction Contract.
  3. Blocking, backing panels, sleeves, and metal fabrication supports for the work of each contract shall be the work of the General Construction Contract.
  4. Furnishing of access panels for the work of each contract shall be the work of each contract for its own work. Installation of access panels shall be the work of the General Construction Contract.
  5. Equipment pads for the work of each contract shall be the work of the General Construction Contract.
  6. Painting for the work of each contract shall be the work of the General Construction Contract.
  7. Cutting and Patching: Each contract shall perform its own cutting; patching shall be under the General Construction Contract.
  8. Through-penetration firestopping for the work of each contract shall be provided by the General Construction Contract.
  9. Contractors' Startup Construction Schedule: Within five working days after startup horizontal bar-chart-type construction schedule and preliminary network diagram submittal has been received from Project coordinator, submit a matching startup horizontal bar-chart schedule and startup network diagram showing construction operations sequenced and coordinated with overall construction.
- B. Substitutions: Each contractor shall cooperate with other contractors involved to coordinate approved substitutions with remainder of the work.
1. Coordinating Contractor shall coordinate substitutions.
- C. Temporary Facilities and Controls: In addition to specific responsibilities for temporary facilities and controls indicated in this Section and in Section 015000 "Temporary Facilities and Controls," each contractor is responsible for the following:



1. Installation, operation, maintenance, and removal of any additional temporary facility necessary for its own normal construction activity, and costs and use charges associated with each facility, except as otherwise provided for in this Section.
  2. Plug-in electric power cords and extension cords, supplementary plug-in task lighting, and special lighting necessary exclusively for its own activities.
  3. Its own field office, complete with necessary furniture, utilities, and telephone service, if needed or desired. See 011200, 1.4.B.1 for Coordinating Contractor responsibility.
  4. Its own storage and fabrication sheds.
  5. Temporary enclosures for its own construction activities.
  6. Staging and scaffolding for its own construction activities.
  7. General hoisting facilities for its own construction activities, up to 2 tons.
  8. Waste disposal facilities for the collection and legal disposal of its own hazardous, dangerous, unsanitary, or other harmful waste materials.
  9. Progress cleaning of work areas affected by its operations on a daily basis.
  10. Secure lockup of its own tools, materials, and equipment.
  11. Construction aids and miscellaneous services and facilities necessary exclusively for its own construction activities.
- D. Temporary Heating, Cooling, and Ventilation: Owner will pay utility-use charges.

## 1.6 GENERAL CONSTRUCTION CONTRACT

- A. Work in the General Construction Contract includes, but is not limited to, the following:
1. Remaining work not identified as work under other contracts.
  2. Selective demolition.
  3. Structural work, including sprayed fire-resistive materials and board fire protection.
  4. Interior construction, including partitions, doors, interior glazed openings, and fittings.
  5. Fire-protection specialties.
  6. Stairs, including railings and finishes.
  7. Interior finishes finish carpentry and architectural woodwork and built-in casework.
  8. Miscellaneous items, including concrete equipment bases and painting of mechanical and electrical work.
  9. Equipment, including the following:
    - a. Projection screen.
    - b. AV equipment
    - c. Stage rigging, lighting truss and support rails, and curtain.
  10. Furnishings, including installation of Owner purchased theater seating.
  11. Plumbing work, including piping, drinking fountain.
  12. Fire Protection work, including that with Alternate #1.
- B. Temporary facilities and controls in the General Construction Contract include, but are not limited to, the following:
1. Temporary facilities and controls that are not otherwise specifically assigned to the other Prime Contracts.
  2. Temporary enclosure for building exterior, except as indicated.
  3. Special or unusual hoisting requirements for construction activities, including hoisting loads in excess of 2 tons, hoisting material or equipment into spaces, and hoisting requirements outside building enclosure.

4. Project identification and temporary signs.
5. General waste disposal facilities.
6. Pest control.
7. Temporary fire-protection facilities.
8. Barricades, warning signs, and lights.
9. Security enclosure and lockup.
10. Environmental protection.
11. Restoration of Owner's existing facilities if used as temporary facilities.

#### 1.7 VENTILATING CONTRACT

- A. Work in the Ventilating Contract includes, but is not limited to, the following:
  1. Ventilating systems and equipment.
  2. Ventilating instrumentation and controls.
  3. Ventilating testing, adjusting, and balancing.
  4. Ventilating connections to equipment furnished by the General Construction Contract.
  5. Piping for mechanical equipment.
- B. Temporary facilities and controls in the Ventilating Contract include, but are not limited to, the following:
  1. Hoists and cranes for lifting and placing rooftop units.

#### 1.8 ELECTRICAL CONTRACT

- A. Work in the Electrical Contract includes, but is not limited to, the following:
  1. Electrical distribution.
  2. Interior lighting.
  3. Low-voltage systems.
  4. Fire alarm system.
  5. Special electrical systems, including the following:
  6. Electrical connections to equipment furnished by the General Construction Contract.
- B. Temporary facilities and controls in the Electrical Contract include, but are not limited to, the following:
  1. Electric power distribution.
  2. Lighting.
  3. Electrical connections to existing systems and temporary facilities and controls furnished by the General Construction Contract.

### **PART 2 - PRODUCTS (NOT USED)**

### **PART 3 - EXECUTION (NOT USED)**

END OF SECTION

## DIVISION 01 - GENERAL REQUIREMENTS

### SECTION 012300 ALTERNATES

#### PART 1 - GENERAL

##### 1.1 SUMMARY

- A. Section includes administrative and procedural requirements for alternates.

##### 1.2 DEFINITIONS

- A. Alternate: An amount proposed by bidders and stated on the Bid Form for certain work defined in the bidding requirements that may be added to or deducted from the base bid amount if Owner decides to accept a corresponding change either in the amount of construction to be completed or in the products, materials, equipment, systems, or installation methods described in the Contract Documents.
  - 1. Alternates described in this Section are part of the Work only if enumerated in the Agreement.
  - 2. The cost or credit for each alternate is the net addition to or deduction from the Contract Sum to incorporate alternate into the Work. No other adjustments are made to the Contract Sum.

##### 1.3 PROCEDURES

- A. Coordination: Revise or adjust affected adjacent work as necessary to completely integrate work of the alternate into Project.
  - 1. Include as part of each alternate, miscellaneous devices, accessory objects, and similar items incidental to or required for a complete installation whether or not indicated as part of alternate.
- B. Notification: Immediately following award of the Contract, notify each party involved, in writing, of the status of each alternate. Indicate if alternates have been accepted, rejected, or deferred for later consideration. Include a complete description of negotiated revisions to alternates.
- C. Execute accepted alternates under the same conditions as other work of the Contract.
- D. Schedule: A schedule of alternates is included at the end of this Section. Specification Sections referenced in schedule contain requirements for materials necessary to achieve the work described under each alternate.

## **PART 2 - PRODUCTS (NOT USED)**

## **PART 3 - EXECUTION**

### **3.1 SCHEDULE OF ALTERNATES**

#### **A. Alternate No. 1: Auditorium Lobby.**

1. Base Bid: Renovate the existing Corridor as indicated on Sheets A101 Floor Plans, E101 and V101.
2. Alternate: Demolish the existing offices and Corridor west of the Auditorium and provide a new Lobby, Vestibule and Storage Room as indicated on Sheets D101, A101, A202, A601, A801, E101 and V101.

END OF SECTION

## **DIVISION 01 - GENERAL REQUIREMENTS**

### **SECTION 012500 SUBSTITUTION PROCEDURES**

#### **PART 1 - GENERAL**

##### **1.1 SUMMARY**

- A. Section includes administrative and procedural requirements for substitutions.
- B. Related Requirements:
  - 1. Section 012300 "Alternates" for products selected under an alternate.
  - 2. Section 016000 "Product Requirements" for requirements for submitting comparable product submittals for products by listed manufacturers.

##### **1.2 DEFINITIONS**

- A. Substitutions: Changes in products, materials, equipment, and methods of construction from those required by the Contract Documents and proposed by Contractor.
  - 1. Substitutions for Cause: Changes proposed by Contractor that are required due to changed Project conditions, such as unavailability of product, regulatory changes, or unavailability of required warranty terms.
  - 2. Substitutions for Convenience: Changes proposed by Contractor or Owner that are not required in order to meet other Project requirements but may offer advantage to Contractor or Owner.

##### **1.3 ACTION SUBMITTALS**

- A. Substitution Requests: Each Contractor to submit three copies of each request for consideration to Coordinating Contractor. Coordinating Contractor to verify information submitted by Each Contractor is correct and complies with the information below prior to submitting to Architect. Identify product or fabrication or installation method to be replaced. Include Specification Section number and title and Drawing numbers and titles.
  - 1. Substitution Request Form: Use facsimile of form provided in Project Manual.
  - 2. Documentation: Show compliance with requirements for substitutions and the following, as applicable:
    - a. Statement indicating why specified product or fabrication or installation cannot be provided, if applicable.
    - b. Coordination information, including a list of changes or revisions needed to other parts of the Work and to construction performed by Owner and separate contractors that will be necessary to accommodate proposed substitution.
    - c. Detailed comparison of significant qualities of proposed substitution with those of the Work specified. Include annotated copy of applicable Specification Section. Significant qualities may include attributes such as performance, weight, size, durability, visual effect, sustainable design characteristics, warranties, and

specific features and requirements indicated. Indicate deviations, if any, from the Work specified.

- d. Product Data, including drawings and descriptions of products and fabrication and installation procedures.
- e. Samples, where applicable or requested.
- f. Certificates and qualification data, where applicable or requested.
- g. List of similar installations for completed projects with project names and addresses and names and addresses of architects and owners.
- h. Material test reports from a qualified testing agency indicating and interpreting test results for compliance with requirements indicated.
- i. Research reports evidencing compliance with building code in effect for Project, from ICC-ES.
- j. Detailed comparison of Contractor's construction schedule using proposed substitution with products specified for the Work, including effect on the overall Contract Time. If specified product or method of construction cannot be provided within the Contract Time, include letter from manufacturer, on manufacturer's letterhead, stating date of receipt of purchase order, lack of availability, or delays in delivery.
- k. Cost information, including a proposal of change, if any, in the Contract Sum.
- l. Contractor's certification that proposed substitution complies with requirements in the Contract Documents except as indicated in substitution request, is compatible with related materials, and is appropriate for applications indicated.
- m. Contractor's waiver of rights to additional payment or time that may subsequently become necessary because of failure of proposed substitution to produce indicated results.

3. Architect's Action: If necessary, Architect will request additional information or documentation for evaluation within seven days of receipt of a request for substitution. Architect will notify Contractor of acceptance or rejection of proposed substitution within 15 days of receipt of request, or seven days of receipt of additional information or documentation, whichever is later.

- a. Forms of Acceptance: Change Order, Construction Change Directive, or Architect's Supplemental Instructions for minor changes in the Work.
- b. Use product specified if Architect does not issue a decision on use of a proposed substitution within time allocated.

#### 1.4 QUALITY ASSURANCE

- A. Compatibility of Substitutions: Investigate and document compatibility of proposed substitution with related products and materials. Engage a qualified testing agency to perform compatibility tests recommended by manufacturers.

#### 1.5 PROCEDURES

- A. Coordination: Revise or adjust affected work as necessary to integrate work of the approved substitutions.

## **PART 2 - PRODUCTS**

### **2.1 SUBSTITUTIONS**

- A. Substitutions for Cause: Submit requests for substitution immediately on discovery of need for change, but not later than 15 days prior to time required for preparation and review of related submittals.
1. Conditions: Architect will consider Contractor's request for substitution when the following conditions are satisfied. If the following conditions are not satisfied, Architect will return requests without action, except to record noncompliance with these requirements:
- a. Requested substitution is consistent with the Contract Documents and will produce indicated results.
  - b. Requested substitution provides sustainable design characteristics that specified product provided for achieving LEED prerequisites and credits.
  - c. Substitution request is fully documented and properly submitted.
  - d. Requested substitution will not adversely affect Contractor's construction schedule.
  - e. Requested substitution has received necessary approvals of authorities having jurisdiction.
  - f. Requested substitution is compatible with other portions of the Work.
  - g. Requested substitution has been coordinated with other portions of the Work.
  - h. Requested substitution provides specified warranty.
  - i. If requested substitution involves more than one contractor, requested substitution has been coordinated with other portions of the Work, is uniform and consistent, is compatible with other products, and is acceptable to all contractors involved.
- B. Substitutions for Convenience: Architect will consider requests for substitution if received within ten (10) calendar days prior to bid opening. Requests received after that time will not be considered. When request is approved, Architect will issue an appropriate addendum not less than seven (7) days prior to bid opening dates.
1. Conditions: Architect will consider Contractor's request for substitution when the following conditions are satisfied. If the following conditions are not satisfied, Architect will return requests without action, except to record noncompliance with these requirements:
- a. Requested substitution offers Owner a substantial advantage in cost, time, energy conservation, or other considerations, after deducting additional responsibilities Owner must assume. Owner's additional responsibilities may include compensation to Architect for redesign and evaluation services, increased cost of other construction by Owner, and similar considerations.
  - b. Requested substitution does not require extensive revisions to the Contract Documents.
  - c. Requested substitution is consistent with the Contract Documents and will produce indicated results.
  - d. Requested substitution provides sustainable design characteristics that specified product provided for achieving LEED prerequisites and credits.
  - e. Substitution request is fully documented and properly submitted.
  - f. Requested substitution will not adversely affect Contractor's construction

- schedule.
- g. Requested substitution has received necessary approvals of authorities having jurisdiction.
  - h. Requested substitution is compatible with other portions of the Work.
  - i. Requested substitution has been coordinated with other portions of the Work.
  - j. Requested substitution provides specified warranty.
  - k. If requested substitution involves more than one contractor, requested substitution has been coordinated with other portions of the Work, is uniform and consistent, is compatible with other products, and is acceptable to all contractors involved.

**PART 3 - EXECUTION (NOT USED)**

END OF SECTION



**CCICS Auditorium Renovation  
Substitution Request**

TO: Behrnt Aaberg  
4240 Architecture Inc.  
328 S. Jefferson St. Suite 750  
Chicago, Illinois 60661

INSTALLER: \_\_\_\_\_ PHONE: \_\_\_\_\_  
Name of Installer

ADDRESS: \_\_\_\_\_  
\_\_\_\_\_

1. Specification Section: \_\_\_\_\_ Paragraph: \_\_\_\_\_

1. Reason for Substitution:

\_\_\_\_\_  
\_\_\_\_\_  
\_\_\_\_\_  
\_\_\_\_\_

2. Proposed Substitute:

A. Name and Model No. \_\_\_\_\_

B. Manufacturer: \_\_\_\_\_

Address: \_\_\_\_\_

Phone Number and Person to Contact: \_\_\_\_\_

B. Attach applicable performance and test data.

C. Numbers of applicable reference standards: \_\_\_\_\_

D. Attach a color chart, if applicable.

E. Attach installation instructions.

1. Manufacturer's Reputation: Attach evidence of manufacturer qualifications and reputation for prompt delivery and efficiency in servicing products, as applicable.

2. Comparison: Attach an itemized comparison of the proposed substitution with product specified, including test performance data.

3. Changes in Work: Attach data relating to changes required in other work to permit use of proposed substitution and changes required in construction schedule.

4. Previous Installation: Attach list of not less than 5 similar projects on which proposed substitution was used. List projects in the Los Angeles area. List name and address of project, date of installation, and name, address, and phone number of Architect.
5. Cost Data: Attach accurate cost data on proposed substitution in comparison with product specified.
6. In making request for substitution, Contractor represents that:
  - a. It has examined the Drawings and Specifications and has determined that, to the best of its knowledge, the proposed substitution is appropriate for the use intended in the Drawings and Specifications, and will perform as well as or better than the specified product.
  - b. It will provide the same warranties for substitution as for product specified.
  - c. It will coordinate installation of accepted substitution into Work, making such changes as may be required for Work to be complete in all respects.
  - d. It waives all claims for additional costs related to substitution which consequently become apparent.
  - e. Cost data is complete and includes all related costs under its Contract.

---

Name of Manufacturer, Signature of Manufacturer's Representative DATE

---

Name of Installer, Signature of Installer's Representative DATE

---

Name of Prime Contractor, Signature of Prime Contractor's Representative DATE

---

Name of Coordinating Contractor, Signature of Coordinating Contractor's Representative DATE

END OF SUBSTITUTION REQUEST FORM

## DIVISION 01 - GENERAL REQUIREMENTS

### SECTION 012600 CONTRACT MODIFICATION PROCEDURES

#### PART 1 - GENERAL

##### 1.1 SUMMARY

- A. Section includes administrative and procedural requirements for handling and processing Contract modifications.
- B. Related Requirements:
  - 1. Section 012500 "Substitution Procedures" for administrative procedures for handling requests for substitutions made after the Contract award.

##### 1.2 MINOR CHANGES IN THE WORK

- A. Architect will issue supplemental instructions authorizing minor changes in the Work, not involving adjustment to the Contract Sum or the Contract Time, on AIA Document G710, "Architect's Supplemental Instructions."

##### 1.3 PROPOSAL REQUESTS

- A. Owner-Initiated Proposal Requests: Architect will issue a detailed description of proposed changes in the Work that may require adjustment to the Contract Sum or the Contract Time. If necessary, the description will include supplemental or revised Drawings and Specifications.
  - 1. Work Change Proposal Requests issued by Architect are not instructions either to stop work in progress or to execute the proposed change.
  - 2. Within time specified in Proposal Request or 20 days, when not otherwise specified, after receipt of Proposal Request, submit a quotation estimating cost adjustments to the Contract Sum and the Contract Time necessary to execute the change.
    - a. Include a list of quantities of products required or eliminated and unit costs, with total amount of purchases and credits to be made. If requested, furnish survey data to substantiate quantities.
    - b. Indicate applicable taxes, delivery charges, equipment rental, and amounts of trade discounts.
    - c. Include costs of labor and supervision directly attributable to the change.
    - d. Include an updated Contractor's construction schedule that indicates the effect of the change, including, but not limited to, changes in activity duration, start and finish times, and activity relationship. Use available total float before requesting an extension of the Contract Time.
    - e. Quotation Form: Use forms acceptable to Architect.

- B. Contractor-Initiated Proposals: If latent or changed conditions require modifications to the Contract, Contractor may initiate a claim by submitting a request for a change to Architect.
1. Include a statement outlining reasons for the change and the effect of the change on the Work. Provide a complete description of the proposed change. Indicate the effect of the proposed change on the Contract Sum and the Contract Time.
  2. Include a list of quantities of products required or eliminated and unit costs, with total amount of purchases and credits to be made. If requested, furnish survey data to substantiate quantities.
  3. Indicate applicable taxes, delivery charges, equipment rental, and amounts of trade discounts.
  4. Include costs of labor and supervision directly attributable to the change.
  5. Include an updated Contractor's construction schedule that indicates the effect of the change, including, but not limited to, changes in activity duration, start and finish times, and activity relationship. Use available total float before requesting an extension of the Contract Time.
  6. Comply with requirements in Section 012500 "Substitution Procedures" if the proposed change requires substitution of one product or system for product or system specified.
  7. Proposal Request Form: Use form acceptable to Architect.

#### 1.4 ADMINISTRATIVE CHANGE ORDERS

- A. Unit-Price Adjustment: See Section 012200 "Unit Prices" for administrative procedures for preparation of Change Order Proposal for adjusting the Contract Sum to reflect measured scope of unit-price work.

#### 1.5 CHANGE ORDER PROCEDURES

- A. On Owner's approval of a Work Changes Proposal Request, Architect will issue a Change Order for signatures of Owner and Contractor on AIA Document G701.

#### 1.6 CONSTRUCTION CHANGE DIRECTIVE

- A. Construction Change Directive: Architect may issue a Construction Change Directive on AIA Document G714. Construction Change Directive instructs Contractor to proceed with a change in the Work, for subsequent inclusion in a Change Order.
1. Construction Change Directive contains a complete description of change in the Work. It also designates method to be followed to determine change in the Contract Sum or the Contract Time.
- B. Documentation: Maintain detailed records on a time and material basis of work required by the Construction Change Directive.
1. After completion of change, submit an itemized account and supporting data necessary to substantiate cost and time adjustments to the Contract.

**PART 2 - PRODUCTS (NOT USED)**

**PART 3 - EXECUTION (NOT USED)**

END OF SECTION

## **DIVISION 01 - GENERAL REQUIREMENTS**

### **SECTION 012900** **PAYMENT PROCEDURES**

#### **PART 1 - GENERAL**

##### **1.1 SUMMARY**

- A. Section includes administrative and procedural requirements necessary to prepare and process Applications for Payment.
- B. Related Requirements:
  - 1. Section 012200 "Unit Prices" for administrative requirements governing the use of unit prices.
  - 2. Section 012600 "Contract Modification Procedures" for administrative procedures for handling changes to the Contract.
  - 3. Section 013200 "Construction Progress Documentation" for administrative requirements governing the preparation and submittal of the Contractor's construction schedule.

##### **1.2 DEFINITIONS**

- A. Schedule of Values: A statement furnished by Contractor allocating portions of the Contract Sum to various portions of the Work and used as the basis for reviewing Contractor's Applications for Payment.

##### **1.3 SCHEDULE OF VALUES**

- A. Coordination: Coordinate preparation of the schedule of values with preparation of Contractor's construction schedule. Cost-loaded Critical Path Method Schedule may serve to satisfy requirements for the schedule of values.
  - 1. Coordinate line items in the schedule of values with other required administrative forms and schedules, including the following:
    - a. Application for Payment forms with continuation sheets.
    - b. Submittal schedule.
    - c. Items required to be indicated as separate activities in Contractor's construction schedule.
  - 2. Submit the schedule of values to Architect at earliest possible date, but no later than ten (10) business days before the date scheduled for submittal of initial Applications for Payment.
  - 3. Subschedules for Separate Elements of Work: Where the Contractor's construction schedule defines separate elements of the Work, provide subschedules showing values coordinated with each element.
  - 4. Subschedules for Separate Design Contracts: Where the Owner has retained design professionals under separate contracts who will each provide certification of payment

requests, provide subschedules showing values coordinated with the scope of each design services contract as described in Section 011000 "Summary."

**B. Format and Content:** Use Project Manual table of contents as a guide to establish line items for the schedule of values. Provide at least one line item for each Specification Section.

1. Identification: Include the following Project identification on the schedule of values:
  - a. Project name and location.
  - b. Name of Architect.
  - c. Architect's project number.
  - d. NEIU's project number.
  - e. Contractor's name and address.
  - f. Date of submittal.
  
2. Arrange schedule of values consistent with format of AIA Document G703.
3. Arrange the schedule of values in tabular form with separate columns to indicate the following for each item listed:
  - a. Related Specification Section or Division.
  - b. Description of the Work.
  - c. Name of subcontractor.
  - d. Name of manufacturer or fabricator.
  - e. Name of supplier.
  - f. Change Orders (numbers) that affect value.
  - g. Dollar value of the following, as a percentage of the Contract Sum to nearest one-hundredth percent, adjusted to total 100 percent.
    - 1) Labor.
    - 2) Materials.
    - 3) Equipment.
  
4. Provide a breakdown of the Contract Sum in enough detail to facilitate continued evaluation of Applications for Payment and progress reports. Coordinate with Project Manual table of contents. Provide multiple line items for principal subcontract amounts in excess of five percent of the Contract Sum.
  - a. Include separate line items under Contractor and principal subcontracts for Project closeout requirements in an amount totaling five percent of the Contract Sum and subcontract amount.
  - b. Itemize by name and amount all subcontractors and suppliers whose subcontracts will exceed \$500 unless otherwise approved by Project Manager.
  
5. Round amounts to nearest whole dollar; total shall equal the Contract Sum.
6. Provide a separate line item in the schedule of values for each part of the Work where Applications for Payment may include materials or equipment purchased or fabricated and stored, but not yet installed.
  - a. Differentiate between items stored on-site and items stored off-site. If required, include evidence of insurance.

7. Provide separate line items in the schedule of values for initial cost of materials, for each subsequent stage of completion, and for total installed value of that part of the Work.
8. Each item in the schedule of values and Applications for Payment shall be complete. Include total cost and proportionate share of general overhead and profit for each item.
  - a. Temporary facilities and other major cost items that are not direct cost of actual work-in-place may be shown either as separate line items in the schedule of values or distributed as general overhead expense, at Contractor's option.
9. Schedule Updating: Update and resubmit the schedule of values before the next Applications for Payment when Change Orders or Construction Change Directives result in a change in the Contract Sum.

#### 1.4 APPLICATIONS FOR PAYMENT

- A. Each Application for Payment following the initial Application for Payment shall be consistent with previous applications and payments as certified by Architect and paid for by Owner.
  1. Initial Application for Payment, Application for Payment at time of Substantial Completion, and final Application for Payment involve additional requirements.
- B. Payment Application Times: The date for each progress payment is indicated in the Agreement between Owner and Contractor. The period of construction work covered by each Application for Payment is the period indicated in the Agreement.
- C. Application for Payment Forms: Use AIA Document G702 and AIA Document G703 as form for Applications for Payment.
- D. Application for Payment Forms: Use forms acceptable to Architect and Owner for Applications for Payment. Submit forms for approval with initial submittal of schedule of values.
- E. Application Preparation: Complete every entry on form. Notarize and execute by a person authorized to sign legal documents on behalf of Contractor. Architect will return incomplete applications without action.
  1. Entries shall match data on the schedule of values and Contractor's construction schedule. Use updated schedules if revisions were made.
  2. Include amounts for work completed following previous Application for Payment, whether or not payment has been received. Include only amounts for work completed at time of Application for Payment.
  3. Include amounts of Change Orders and Construction Change Directives issued before last day of construction period covered by application.
  4. Indicate separate amounts for work being carried out under Owner-requested project acceleration.
- F. Stored Materials: Include in Application for Payment amounts applied for materials or equipment purchased or fabricated and stored, but not yet installed. Differentiate between items stored on-site and items stored off-site.
  1. Provide certificate of insurance, evidence of transfer of title to Owner, and consent of surety to payment, for stored materials.



2. Provide supporting documentation that verifies amount requested, such as paid invoices. Match amount requested with amounts indicated on documentation; do not include overhead and profit on stored materials.
  3. Provide summary documentation for stored materials indicating the following:
    - a. Value of materials previously stored and remaining stored as of date of previous Applications for Payment.
    - b. Value of previously stored materials put in place after date of previous Application for Payment and on or before date of current Application for Payment.
    - c. Value of materials stored since date of previous Application for Payment and remaining stored as of date of current Application for Payment.
- G. Transmittal: Submit three signed and notarized original copies of each Application for Payment to Architect by a method ensuring receipt within 24 hours. One copy shall include waivers of lien and similar attachments if required.
1. Transmit each copy with a transmittal form listing attachments and recording appropriate information about application.
- H. Waivers of Mechanic's Lien: With each Application for Payment, submit waivers of mechanic's lien from entities lawfully entitled to file a mechanic's lien arising out of the Contract and related to the Work covered by the payment.
1. Submit partial waivers on each item for amount requested in previous application, after deduction for retainage, on each item.
  2. When an application shows completion of an item, submit conditional final or full waivers.
  3. Owner reserves the right to designate which entities involved in the Work must submit waivers.
  4. Waiver Forms: Submit executed waivers of lien on forms acceptable to Owner.
- I. Initial Application for Payment: Administrative actions and submittals that must precede or coincide with submittal of first Application for Payment include the following:
1. List of subcontractors.
  2. Schedule of values.
  3. Contractor's construction schedule (preliminary if not final).
  4. Combined Contractor's construction schedule (preliminary if not final) incorporating Work of multiple contracts, with indication of acceptance of schedule by each Contractor.
  5. Products list (preliminary if not final).
  6. Schedule of unit prices.
  7. Submittal schedule (preliminary if not final).
  8. List of Contractor's staff assignments.
  9. List of Contractor's principal consultants.
  10. Copies of building permits.
  11. Copies of authorizations and licenses from authorities having jurisdiction for performance of the Work.
  12. Initial progress report.
  13. Report of preconstruction conference.
  14. Certificates of insurance and insurance policies.
  15. Performance and payment bonds.

16. Data needed to acquire Owner's insurance.
- J. Application for Payment at Substantial Completion: After Architect issues the Certificate of Substantial Completion, submit an Application for Payment showing 100 percent completion for portion of the Work claimed as substantially complete.
1. Include documentation supporting claim that the Work is substantially complete and a statement showing an accounting of changes to the Contract Sum.
  2. This application shall reflect Certificate(s) of Substantial Completion issued previously for Owner occupancy of designated portions of the Work.
- K. Final Payment Application: After completing Project closeout requirements, submit final Application for Payment with releases and supporting documentation not previously submitted and accepted, including, but not limited, to the following:
1. Evidence of completion of Project closeout requirements.
  2. Insurance certificates for products and completed operations where required and proof that taxes, fees, and similar obligations were paid.
  3. Updated final statement, accounting for final changes to the Contract Sum.
  4. AIA Document G706, "Contractor's Affidavit of Payment of Debts and Claims."
  5. AIA Document G706A, "Contractor's Affidavit of Release of Liens."
  6. AIA Document G707, "Consent of Surety to Final Payment."
  7. Evidence that claims have been settled.
  8. Final meter readings for utilities, a measured record of stored fuel, and similar data as of date of Substantial Completion or when Owner took possession of and assumed responsibility for corresponding elements of the Work.
  9. Final liquidated damages settlement statement.

**PART 2 - PRODUCTS (NOT USED)**

**PART 3 - EXECUTION (NOT USED)**

END OF SECTION

## **DIVISION 01 - GENERAL REQUIREMENTS**

### **SECTION 013100 PROJECT MANAGEMENT AND COORDINATION**

#### **PART 1 - GENERAL**

##### **1.1 SUMMARY**

- A. Section includes administrative provisions for coordinating construction operations on Project including, but not limited to, the following:
  - 1. General coordination procedures.
  - 2. Coordination drawings.
  - 3. Requests for Information (RFIs).
  - 4. Project meetings.
- B. Each contractor shall participate in coordination requirements. Certain areas of responsibility are assigned to a specific contractor.
- C. Related Requirements:
  - 1. Section 011200 "Multiple Contract Summary" for a description of the division of work among separate contracts and responsibility for coordination activities not in this Section.
  - 2. Section 013200 "Construction Progress Documentation" for preparing and submitting Contractor's construction schedule.
  - 3. Section 017300 "Execution" for procedures for coordinating general installation and field-engineering services, including establishment of benchmarks and control points.
  - 4. Section 017700 "Closeout Procedures" for coordinating closeout of the Contract.
  - 5. Section 019113 "General Commissioning Requirements" for coordinating the Work with Owner's Commissioning Authority.

##### **1.2 DEFINITIONS**

- A. RFI: Request from Owner, Architect, or Contractor seeking information required by or clarifications of the Contract Documents.

##### **1.3 INFORMATIONAL SUBMITTALS**

- A. Subcontract List: Prepare a written summary identifying individuals or firms proposed for each portion of the Work, including those who are to furnish products or equipment fabricated to a special design. Include the following information in tabular form:
  - 1. Name, address, and telephone number of entity performing subcontract or supplying products.
  - 2. Number and title of related Specification Section(s) covered by subcontract.
  - 3. Drawing number and detail references, as appropriate, covered by subcontract.

- B. Key Personnel Names: Within 15 days of starting construction operations, submit a list of key personnel assignments, including superintendent and other personnel in attendance at Project site. Identify individuals and their duties and responsibilities; list addresses and telephone numbers, including home, office, and cellular telephone numbers and e-mail addresses. Provide names, addresses, and telephone numbers of individuals assigned as alternates in the absence of individuals assigned to Project.
  - 1. Post copies of list in project meeting room, in temporary field office, and by each temporary telephone. Keep list current at all times.

#### 1.4 GENERAL COORDINATION PROCEDURES

- A. Coordination: Each contractor shall coordinate its construction operations with those of other contractors and entities to ensure efficient and orderly installation of each part of the Work. Each contractor shall coordinate its operations with operations, included in different Sections, that depend on each other for proper installation, connection, and operation.
  - 1. Schedule construction operations in sequence required to obtain the best results where installation of one part of the Work depends on installation of other components, before or after its own installation.
  - 2. Coordinate installation of different components with other contractors to ensure maximum performance and accessibility for required maintenance, service, and repair.
  - 3. Make adequate provisions to accommodate items scheduled for later installation.
- B. Prepare memoranda for distribution to each party involved, outlining special procedures required for coordination. Include such items as required notices, reports, and list of attendees at meetings.
  - 1. Prepare similar memoranda for Owner and separate contractors if coordination of their Work is required.
- C. Administrative Procedures: Coordinate scheduling and timing of required administrative procedures with other construction activities and activities of other contractors to avoid conflicts and to ensure orderly progress of the Work. Such administrative activities include, but are not limited to, the following:
  - 1. Preparation of Contractor's construction schedule.
  - 2. Preparation of the schedule of values.
  - 3. Installation and removal of temporary facilities and controls.
  - 4. Delivery and processing of submittals.
  - 5. Progress meetings.
  - 6. Preinstallation conferences.
  - 7. Project closeout activities.
  - 8. Startup and adjustment of systems.
- D. Conservation: Coordinate construction activities to ensure that operations are carried out with consideration given to conservation of energy, water, and materials. Coordinate use of temporary utilities to minimize waste.
  - 1. Salvage materials and equipment involved in performance of, but not actually incorporated into, the Work. See other Sections for disposition of salvaged materials that are designated as Owner's property.

## 1.5 COORDINATION DRAWINGS

- A. Coordination Drawings, General: Prepare coordination drawings according to requirements in individual Sections, and additionally where installation is not completely shown on Shop Drawings, where limited space availability necessitates coordination, or if coordination is required to facilitate integration of products and materials fabricated or installed by more than one entity.
1. Content: Project-specific information, drawn accurately to a scale large enough to indicate and resolve conflicts. Do not base coordination drawings on standard printed data. Include the following information, as applicable:
    - a. Use applicable Drawings as a basis for preparation of coordination drawings. Prepare sections, elevations, and details as needed to describe relationship of various systems and components.
    - b. Coordinate the addition of trade-specific information to the coordination drawings by multiple contractors in a sequence that best provides for coordination of the information and resolution of conflicts between installed components before submitting for review.
    - c. Indicate functional and spatial relationships of components of architectural, structural, civil, mechanical, and electrical systems.
    - d. Indicate space requirements for routine maintenance and for anticipated replacement of components during the life of the installation.
    - e. Show location and size of access doors required for access to concealed dampers, valves, and other controls.
    - f. Indicate required installation sequences.
    - g. Indicate dimensions shown on the Drawings. Specifically note dimensions that appear to be in conflict with submitted equipment and minimum clearance requirements. Provide alternate sketches to Architect indicating proposed resolution of such conflicts. Minor dimension changes and difficult installations will not be considered changes to the Contract.
- B. Coordination Drawing Organization: Organize coordination drawings as follows:
1. Floor Plans and Reflected Ceiling Plans: Show architectural and structural elements, and mechanical, plumbing, fire-protection, fire-alarm, and electrical Work. Show locations of visible ceiling-mounted devices relative to acoustical ceiling grid. Supplement plan drawings with section drawings where required to adequately represent the Work.
  2. Plenum Space: Indicate subframing for support of ceiling and wall systems, mechanical and electrical equipment, and related Work. Locate components within ceiling plenum to accommodate layout of light fixtures indicated on Drawings. Indicate areas of conflict between light fixtures and other components.
  3. Mechanical Rooms: Provide coordination drawings for mechanical rooms showing plans and elevations of mechanical, plumbing, fire-alarm, and electrical equipment.
  4. Structural Penetrations: Indicate penetrations and openings required for all disciplines.
  5. Slab Edge and Embedded Items: Indicate slab edge locations and sizes and locations of embedded items for metal fabrications, sleeves, anchor bolts, bearing plates, angles, door floor closers, slab depressions for floor finishes, curbs and housekeeping pads, and similar items.
  6. Mechanical and Plumbing Work: Show the following:

- a. Sizes and bottom elevations of ductwork, piping, and conduit runs, including insulation, bracing, flanges, and support systems.
  - b. Dimensions of major components, such as dampers, valves, diffusers, access doors, cleanouts and electrical distribution equipment.
  - c. Fire-rated enclosures around ductwork.
7. Electrical Work: Show the following:
- a. Runs of vertical and horizontal conduit 1-1/4 inches in diameter and larger.
  - b. Light fixture, exit light, emergency battery pack, smoke detector, and other fire-alarm locations.
  - c. Panel board, switch board, switchgear, transformer, busway, generator, and motor control center locations.
  - d. Location of pull boxes and junction boxes, dimensioned from column center lines.
8. Review: Architect will review coordination drawings to confirm that the Work is being coordinated, but not for the details of the coordination, which are Contractor's responsibility. If Architect determines that coordination drawings are not being prepared in sufficient scope or detail, or are otherwise deficient, Architect will so inform Contractor, who shall make changes as directed and resubmit.
- C. Coordination Digital Data Files: Prepare coordination digital data files according to the following requirements:
- 1. File Preparation Format: Same digital data software program, version, and operating system as original Drawings.
  - 2. File Submittal Format: Submit or post coordination drawing files using format same as file preparation format.
  - 3. Architect will furnish Contractor one set of digital data files of Drawings for use in preparing coordination digital data files.
    - a. Architect makes no representations as to the accuracy or completeness of digital data files as they relate to Drawings.
    - b. Digital Data Software Program: Coordinate requirements with Architect.
    - c. Contractor shall execute a data licensing agreement in the form of AIA Document C106.

## 1.6 REQUESTS FOR INFORMATION (RFIS)

- A. General: Immediately on discovery of the need for additional information or interpretation of the Contract Documents, Contractor shall prepare and submit an RFI in the form specified.
- 1. Architect will return RFIs submitted to Architect by other entities controlled by Contractor with no response.
  - 2. Coordinate and submit RFIs in a prompt manner so as to avoid delays in Contractor's work or work of subcontractors.
- B. Content of the RFI: Include a detailed, legible description of item needing information or interpretation and the following:
- 1. Project name.
  - 2. Project number.

3. Date.
  4. Name of Contractor.
  5. Name of Architect.
  6. RFI number, numbered sequentially.
  7. RFI subject.
  8. Specification Section number and title and related paragraphs, as appropriate.
  9. Drawing number and detail references, as appropriate.
  10. Field dimensions and conditions, as appropriate.
  11. Contractor's suggested resolution. If Contractor's suggested resolution impacts the Contract Time or the Contract Sum, Contractor shall state impact in the RFI.
  12. Contractor's signature.
  13. Attachments: Include sketches, descriptions, measurements, photos, Product Data, Shop Drawings, coordination drawings, and other information necessary to fully describe items needing interpretation.
    - a. Include dimensions, thicknesses, structural grid references, and details of affected materials, assemblies, and attachments on attached sketches.
- C. RFI Forms: Software-generated form with substantially the same content as indicated above, acceptable to Architect.
1. Attachments shall be electronic files in Adobe Acrobat PDF format.
- D. Architect's Action: Architect will review each RFI, determine action required, and respond. Allow seven working days for Architect's response for each RFI. RFIs received by Architect after 1:00 p.m. will be considered as received the following working day.
1. The following Contractor-generated RFIs will be returned without action:
    - a. Requests for approval of submittals.
    - b. Requests for approval of substitutions.
    - c. Requests for approval of Contractor's means and methods.
    - d. Requests for coordination information already indicated in the Contract Documents.
    - e. Requests for adjustments in the Contract Time or the Contract Sum.
    - f. Requests for interpretation of Architect's actions on submittals.
    - g. Incomplete RFIs or inaccurately prepared RFIs.
  2. Architect's action may include a request for additional information, in which case Architect's time for response will date from time of receipt of additional information.
  3. Architect's action on RFIs that may result in a change to the Contract Time or the Contract Sum may be eligible for Contractor to submit Change Proposal according to Section 012600 "Contract Modification Procedures."
    - a. If Contractor believes the RFI response warrants change in the Contract Time or the Contract Sum, notify Architect in writing within 10 days of receipt of the RFI response.
- E. RFI Log: Prepare, maintain, and submit a tabular log of RFIs organized by the RFI number. Submit log weekly. Software log with not less than the following:
1. Project name.

2. Name and address of Contractor.
  3. Name and address of Architect.
  4. RFI number including RFIs that were returned without action or withdrawn.
  5. RFI description.
  6. Date the RFI was submitted.
  7. Date Architect's response was received.
- F. On receipt of Architect's action, update the RFI log and immediately distribute the RFI response to affected parties. Review response and notify Architect within seven days if Contractor disagrees with response.
1. Identification of related Minor Change in the Work, Construction Change Directive, and Proposal Request, as appropriate.
  2. Identification of related Field Order, Work Change Directive, and Proposal Request, as appropriate.

## 1.7 PROJECT MEETINGS

- A. General: Schedule and conduct meetings and conferences at Project site unless otherwise indicated.
1. Attendees: Inform participants and others involved, and individuals whose presence is required, of date and time of each meeting. Notify Owner and Architect of scheduled meeting dates and times.
  2. Agenda: Prepare the meeting agenda. Distribute the agenda to all invited attendees.
  3. Minutes: Entity responsible for conducting meeting will record significant discussions and agreements achieved. Distribute the meeting minutes to everyone concerned, including Owner and Architect, within three days of the meeting.
- B. Preconstruction Conference: Owner will schedule and conduct a preconstruction conference before starting construction, but no later than 5 business days after Notice of Award.
1. Conduct the conference to review responsibilities and personnel assignments.
  2. Attendees: Authorized representatives of Owner, Safety Representative, Owner's Commissioning Authority, Architect, and their consultants; Contractor and its superintendent; major subcontractors; suppliers; and other concerned parties shall attend the conference. Participants at the conference shall be familiar with Project and authorized to conclude matters relating to the Work.
  3. Agenda: Discuss items of significance that could affect progress, including the following:
    - a. Tentative construction schedule.
    - b. Phasing.
    - c. Critical work sequencing and long-lead items.
    - d. Designation of key personnel and their duties.
    - e. Lines of communications.
    - f. Procedures for processing field decisions and Change Orders.
    - g. Procedures for RFIs.
    - h. Procedures for testing and inspecting.
    - i. Procedures for processing Applications for Payment.
    - j. Distribution of the Contract Documents.



- k. Submittal procedures.
- l. LEED requirements.
- m. Preparation of record documents.
- n. Use of the premises.
- o. Work restrictions.
- p. Working hours.
- q. Owner's occupancy requirements.
- r. Responsibility for temporary facilities and controls.
- s. Procedures for moisture and mold control.
- t. Procedures for disruptions and shutdowns.
- u. Construction waste management and recycling.
- v. Parking availability.
- w. Office, work, and storage areas.
- x. Equipment deliveries and priorities.
- y. First aid.
- z. Security.
- aa. Progress cleaning.

- 4. Minutes: Entity responsible for conducting meeting will record and distribute meeting minutes.

C. Preinstallation Conferences: Conduct a preinstallation conference at Project site before each construction activity that requires coordination with other construction.

- 1. Attendees: Installer and representatives of manufacturers and fabricators involved in or affected by the installation and its coordination or integration with other materials and installations that have preceded or will follow, shall attend the meeting. Advise Architect, and Owner's Commissioning Authority of scheduled meeting dates.
- 2. Agenda: Review progress of other construction activities and preparations for the particular activity under consideration, including requirements for the following:
  - a. Contract Documents.
  - b. Options.
  - c. Related RFIs.
  - d. Related Change Orders.
  - e. Purchases.
  - f. Deliveries.
  - g. Submittals.
  - h. LEED requirements.
  - i. Review of mockups.
  - j. Possible conflicts.
  - k. Compatibility requirements.
  - l. Time schedules.
  - m. Weather limitations.
  - n. Manufacturer's written instructions.
  - o. Warranty requirements.
  - p. Compatibility of materials.
  - q. Acceptability of substrates.
  - r. Temporary facilities and controls.

- s. Space and access limitations.
  - t. Regulations of authorities having jurisdiction.
  - u. Testing and inspecting requirements.
  - v. Installation procedures.
  - w. Coordination with other work.
  - x. Required performance results.
  - y. Protection of adjacent work.
  - z. Protection of construction and personnel.
3. Record significant conference discussions, agreements, and disagreements, including required corrective measures and actions.
  4. Reporting: Distribute minutes of the meeting to each party present and to other parties requiring information.
  5. Do not proceed with installation if the conference cannot be successfully concluded. Initiate whatever actions are necessary to resolve impediments to performance of the Work and reconvene the conference at earliest feasible date.
- D. Project Closeout Conference: Schedule and conduct a project closeout conference, at a time convenient to Owner and Architect, but no later than 90 days prior to the scheduled date of Substantial Completion.
1. Conduct the conference to review requirements and responsibilities related to Project closeout.
  2. Attendees: Authorized representatives of Owner, Owner's Commissioning Authority, Architect, and their consultants; Contractor and its superintendent; major subcontractors; suppliers; and other concerned parties shall attend the meeting. Participants at the meeting shall be familiar with Project and authorized to conclude matters relating to the Work.
  3. Agenda: Discuss items of significance that could affect or delay Project closeout, including the following:
    - a. Preparation of record documents.
    - b. Procedures required prior to inspection for Substantial Completion and for final inspection for acceptance.
    - c. Submittal of written warranties.
    - d. Requirements for completing LEED documentation.
    - e. Requirements for preparing operations and maintenance data.
    - f. Requirements for delivery of material samples, attic stock, and spare parts.
    - g. Requirements for demonstration and training.
    - h. Preparation of Contractor's punch list.
    - i. Procedures for processing Applications for Payment at Substantial Completion and for final payment.
    - j. Submittal procedures.
    - k. Coordination of separate contracts.
    - l. Owner's partial occupancy requirements.
    - m. Installation of Owner's furniture, fixtures, and equipment.
    - n. Responsibility for removing temporary facilities and controls.
  4. Minutes: Entity conducting meeting will record and distribute meeting minutes.
- E. Progress Meetings: Conduct progress meetings at regular intervals.

1. Coordinate dates of meetings with preparation of payment requests.
2. Attendees: In addition to representatives of Owner, Owner's Commissioning Authority and Architect, each contractor, subcontractor, supplier, and other entity concerned with current progress or involved in planning, coordination, or performance of future activities shall be represented at these meetings. All participants at the meeting shall be familiar with Project and authorized to conclude matters relating to the Work.
3. Agenda: Review and correct or approve minutes of previous progress meeting. Review other items of significance that could affect progress. Include topics for discussion as appropriate to status of Project.
  - a. Contractor's Construction Schedule: Review progress since the last meeting. Determine whether each activity is on time, ahead of schedule, or behind schedule, in relation to Contractor's construction schedule. Determine how construction behind schedule will be expedited; secure commitments from parties involved to do so. Discuss whether schedule revisions are required to ensure that current and subsequent activities will be completed within the Contract Time.
    - 1) Review schedule for next period.
  - b. Review present and future needs of each entity present, including the following:
    - 1) Interface requirements.
    - 2) Sequence of operations.
    - 3) Status of submittals.
    - 4) Deliveries.
    - 5) Off-site fabrication.
    - 6) Access.
    - 7) Site utilization.
    - 8) Temporary facilities and controls.
    - 9) Progress cleaning.
    - 10) Quality and work standards.
    - 11) Status of correction of deficient items.
    - 12) Field observations.
    - 13) Status of RFIs.
    - 14) Status of proposal requests.
    - 15) Pending changes.
    - 16) Status of Change Orders.
    - 17) Pending claims and disputes.
    - 18) Documentation of information for payment requests.
4. Minutes: Entity responsible for conducting the meeting will record and distribute the meeting minutes to each party present and to parties requiring information.
  - a. Schedule Updating: Revise Contractor's construction schedule after each progress meeting where revisions to the schedule have been made or recognized. Issue revised schedule concurrently with the report of each meeting.
- F. Coordination Meetings: Project Coordinator will conduct Project coordination meetings at regular intervals. Project coordination meetings are in addition to specific meetings held for other purposes, such as progress meetings and preinstallation conferences.

1. Attendees: In addition to representatives of Owner, Owner's Commissioning Authority and Architect, each contractor, subcontractor, supplier, and other entity concerned with current progress or involved in planning, coordination, or performance of future activities shall be represented at these meetings. All participants at the meetings shall be familiar with Project and authorized to conclude matters relating to the Work.
2. Agenda: Review and correct or approve minutes of the previous coordination meeting. Review other items of significance that could affect progress. Include topics for discussion as appropriate to status of Project.
  - a. Combined Contractor's Construction Schedule: Review progress since the last coordination meeting. Determine whether each contract is on time, ahead of schedule, or behind schedule, in relation to combined Contractor's construction schedule. Determine how construction behind schedule will be expedited; secure commitments from parties involved to do so. Discuss whether schedule revisions are required to ensure that current and subsequent activities will be completed within the Contract Time.
  - b. Schedule Updating: Revise combined Contractor's construction schedule after each coordination meeting where revisions to the schedule have been made or recognized. Issue revised schedule concurrently with report of each meeting.
  - c. Review present and future needs of each contractor present, including the following:
    - 1) Interface requirements.
    - 2) Sequence of operations.
    - 3) Status of submittals.
    - 4) Deliveries.
    - 5) Off-site fabrication.
    - 6) Access.
    - 7) Site utilization.
    - 8) Temporary facilities and controls.
    - 9) Work hours.
    - 10) Hazards and risks.
    - 11) Progress cleaning.
    - 12) Quality and work standards.
    - 13) Change Orders.
3. Reporting: Record meeting results and distribute copies to everyone in attendance and to others affected by decisions or actions resulting from each meeting.

**PART 2 - PRODUCTS (NOT USED)**

**PART 3 - EXECUTION (NOT USED)**

END OF SECTION

## **DIVISION 01 - GENERAL REQUIREMENTS**

### **SECTION 013200 CONSTRUCTION PROGRESS DOCUMENTATION**

#### **PART 1 - GENERAL**

##### **1.1 SUMMARY**

- A. Section includes administrative and procedural requirements for documenting the progress of construction during performance of the Work, including the following:
  - 1. Startup construction schedule.
  - 2. Contractor's construction schedule.
  - 3. Scheduled Community Event
  - 4. Construction schedule updating reports.
  - 5. Daily construction reports.
  - 6. Material location reports.
  - 7. Site condition reports.
  - 8. Special reports.
- B. Related Requirements:
  - 1. Section 011200 "Multiple Contract Summary" for preparing a combined Contractor's construction schedule.
  - 2. Section 013300 "Submittal Procedures" for submitting schedules and reports.
  - 3. Section 014000 "Quality Requirements" for submitting a schedule of tests and inspections.

##### **1.2 DEFINITIONS**

- A. Activity: A discrete part of a project that can be identified for planning, scheduling, monitoring, and controlling the construction project. Activities included in a construction schedule consume time and resources.
  - 1. Critical Activity: An activity on the critical path that must start and finish on the planned early start and finish times.
  - 2. Predecessor Activity: An activity that precedes another activity in the network.
  - 3. Successor Activity: An activity that follows another activity in the network.
- B. Cost Loading: The allocation of the schedule of values for the completion of an activity as scheduled. The sum of costs for all activities must equal the total Contract Sum unless otherwise approved by Architect.
- C. CPM: Critical path method, which is a method of planning and scheduling a construction project where activities are arranged based on activity relationships. Network calculations determine when activities can be performed and the critical path of Project.

- D. Critical Path: The longest connected chain of interdependent activities through the network schedule that establishes the minimum overall Project duration and contains no float.
- E. Event: The starting or ending point of an activity.
- F. Float: The measure of leeway in starting and completing an activity.
  - 1. Float time is not for the exclusive use or benefit of either Owner or Contractor, but is a jointly owned, expiring Project resource available to both parties as needed to meet schedule milestones and Contract completion date.
  - 2. Free float is the amount of time an activity can be delayed without adversely affecting the early start of the successor activity.
  - 3. Total float is the measure of leeway in starting or completing an activity without adversely affecting the planned Project completion date.
- G. Resource Loading: The allocation of manpower and equipment necessary for the completion of an activity as scheduled.

### 1.3 INFORMATIONAL SUBMITTALS

- A. Format for Submittals: Submit required submittals in the following format:
  - 1. Working electronic copy of schedule file, where indicated.
  - 2. PDF electronic file.
- B. Startup construction schedule.
  - 1. Approval of cost-loaded, startup construction schedule will not constitute approval of schedule of values for cost-loaded activities.
- C. Startup Network Diagram: Of size required to display entire network for entire construction period. Show logic ties for activities.
- D. Contractor's Construction Schedule: Initial schedule, of size required to display entire schedule for entire construction period.
  - 1. Submit a working electronic copy of schedule, using software indicated, and labeled to comply with requirements for submittals. Include type of schedule (initial or updated) and date on label.
- E. CPM Reports: Concurrent with CPM schedule, submit each of the following reports. Format for each activity in reports shall contain activity number, activity description, cost and resource loading, original duration, remaining duration, early start date, early finish date, late start date, late finish date, and total float in calendar days.
  - 1. Activity Report: List of all activities sorted by activity number and then early start date, or actual start date if known.
  - 2. Logic Report: List of preceding and succeeding activities for all activities, sorted in ascending order by activity number and then early start date, or actual start date if known.
  - 3. Total Float Report: List of all activities sorted in ascending order of total float.
  - 4. Earnings Report: Compilation of Contractor's total earnings from the Notice to Proceed until most recent Application for Payment.

- F. Construction Schedule Updating Reports: Submit with Applications for Payment.
- G. Daily Construction Reports: Submit at weekly intervals.
- H. Material Location Reports: Submit at weekly intervals.
- I. Site Condition Reports: Submit at time of discovery of differing conditions.
- J. Special Reports: Submit at time of unusual event.
- K. Qualification Data: For scheduling consultant.

#### 1.4 QUALITY ASSURANCE

- A. Prescheduling Conference: Conduct conference at Project site to comply with requirements in Section 013100 "Project Management and Coordination." Review methods and procedures related to the preliminary construction schedule and Contractor's construction schedule, including, but not limited to, the following:
  1. Review software limitations and content and format for reports.
  2. Verify availability of qualified personnel needed to develop and update schedule.
  3. Discuss constraints, including area separations, interim milestones, and partial Owner occupancy.
  4. Review delivery dates for Owner-furnished products.
  5. Review schedule for work of Owner's separate contracts.
  6. Review submittal requirements and procedures.
  7. Review time required for review of submittals and resubmittals.
  8. Review requirements for tests and inspections by independent testing and inspecting agencies.
  9. Review time required for Project closeout and Owner startup procedures, including commissioning activities.
  10. Review and finalize list of construction activities to be included in schedule.
  11. Review procedures for updating schedule.

#### 1.5 COORDINATION

- A. Coordinate Contractor's construction schedule with the schedule of values, list of subcontracts, submittal schedule, progress reports, payment requests, and other required schedules and reports.
  1. Secure time commitments for performing critical elements of the Work from entities involved.
  2. Coordinate each construction activity in the network with other activities and schedule them in proper sequence.

### **PART 2 - PRODUCTS**

#### 2.1 CONTRACTOR'S CONSTRUCTION SCHEDULE, GENERAL

- A. Time Frame: Extend schedule from date established for the Notice to Proceed to date of final completion.

1. Contract completion date shall not be changed by submission of a schedule that shows an early completion date, unless specifically authorized by Change Order.
- B. Activities: Treat each story or separate area as a separate numbered activity for each main element of the Work. Comply with the following:
1. Activity Duration: Define activities so no activity is longer than 20 days, unless specifically allowed by Architect.
  2. Procurement Activities: Include procurement process activities for the following long lead items and major items, requiring a cycle of more than 60 days, as separate activities in schedule. Procurement cycle activities include, but are not limited to, submittals, approvals, purchasing, fabrication, and delivery.
  3. Submittal Review Time: Include review and resubmittal times indicated in Section 013300 "Submittal Procedures" in schedule. Coordinate submittal review times in Contractor's construction schedule with submittal schedule.
  4. Startup and Testing Time: Include no fewer than 15 days for startup and testing.
  5. Substantial Completion: Indicate completion in advance of date established for Substantial Completion, and allow time for Architect's administrative procedures necessary for certification of Substantial Completion.
  6. Punch List and Final Completion: Include not more than 30 days for completion of punch list items and final completion.
- C. Constraints: Include constraints and work restrictions indicated in the Contract Documents and as follows in schedule, and show how the sequence of the Work is affected.
1. Owner-Furnished Products: Include a separate activity for each product. Include delivery date indicated in Section 011000 "Summary." Delivery dates indicated stipulate the earliest possible delivery date.
  2. Work Restrictions: Show the effect of the following items on the schedule:
    - a. Partial occupancy before Substantial Completion.
    - b. Use of premises restrictions.
    - c. Seasonal variations.
    - d. Environmental control.
    - e. Scheduled Community Event (Re: Paragraph 2.4).
  3. Work Stages: Indicate important stages of construction for each major portion of the Work, including, but not limited to, the following:
    - a. Subcontract awards.
    - b. Submittals.
    - c. Purchases.
    - d. Mockups.
    - e. Fabrication.
    - f. Sample testing.
    - g. Deliveries.
    - h. Installation.
    - i. Tests and inspections.
    - j. Adjusting.
    - k. Curing.
    - l. Building flush-out.
    - m. Startup and placement into final use and operation.



4. Construction Areas: Identify each major area of construction for each major portion of the Work. Indicate where each construction activity within a major area must be sequenced or integrated with other construction activities to provide for the following:
    - a. Structural completion.
    - b. Temporary enclosure and space conditioning.
    - c. Permanent space enclosure.
    - d. Completion of mechanical installation.
    - e. Completion of electrical installation.
    - f. Substantial Completion.
  
  - D. Milestones: Include milestones indicated in the Contract Documents in schedule, including, but not limited to, the Notice to Proceed, Substantial Completion, and final completion, and the following interim milestones:
    1. Temporary enclosure and space conditioning.
  
  - E. Cost Correlation: Superimpose a cost correlation timeline, indicating planned and actual costs. On the line, show planned and actual dollar volume of the Work performed as of planned and actual dates used for preparation of payment requests.
    1. See Section 012900 "Payment Procedures" for cost reporting and payment procedures.
  
  - F. Upcoming Work Summary: Prepare summary report indicating activities scheduled to occur or commence prior to submittal of next schedule update. Summarize the following issues:
    1. Unresolved issues.
    2. Unanswered Requests for Information.
    3. Rejected or unreturned submittals.
    4. Notations on returned submittals.
    5. Pending modifications affecting the Work and Contract Time.
  
  - G. Recovery Schedule: When periodic update indicates the Work is 14 or more calendar days behind the current approved schedule, submit a separate recovery schedule indicating means by which Contractor intends to regain compliance with the schedule. Indicate changes to working hours, working days, crew sizes, and equipment required to achieve compliance, and date by which recovery will be accomplished.
  
  - H. Computer Scheduling Software: Prepare schedules using current version of a program that has been developed specifically to manage construction schedules.
    1. Use Microsoft Project, for Windows XP operating system, unless otherwise agreed to by Owner.
- 2.2 STARTUP CONSTRUCTION SCHEDULE
- A. Bar-Chart Schedule: Submit startup, horizontal, bar-chart-type construction schedule to Owner within five business days of date pre-construction meeting.
  - B. Preparation: Indicate each significant construction activity separately. Identify first workday of each week with a continuous vertical line. Outline significant construction activities for first 90 days of construction. Include skeleton diagram for the remainder of the Work and a cash requirement prediction based on indicated activities.

## 2.3 CONTRACTOR'S CONSTRUCTION SCHEDULE (CPM SCHEDULE)

- A. General: Prepare network diagrams using AON (activity-on-node) format.
- B. Startup Network Diagram: Submit diagram within 14 days of date established for the Notice to Proceed. Outline significant construction activities for the first 90 days of construction. Include skeleton diagram for the remainder of the Work and a cash requirement prediction based on indicated activities.
- C. CPM Schedule: Prepare Contractor's construction schedule using a cost- and resource-loaded, time-scaled CPM network analysis diagram for the Work.
  - 1. Submit schedule to Architect within ten (10) business days after preconstruction meeting.
    - a. Failure to include any work item required for performance of this Contract shall not excuse Contractor from completing all work within applicable completion dates, regardless of Architect's approval of the schedule.
  - 2. Conduct educational workshops to train and inform key Project personnel, including subcontractors' personnel, in proper methods of providing data and using CPM schedule information.
  - 3. Establish procedures for monitoring and updating CPM schedule and for reporting progress. Coordinate procedures with progress meeting and payment request dates.
  - 4. Use "one workday" as the unit of time for individual activities. Indicate nonworking days and holidays incorporated into the schedule in order to coordinate with the Contract Time.
- D. CPM Schedule Preparation: Prepare a list of all activities required to complete the Work. Using the startup network diagram, prepare a skeleton network to identify probable critical paths.
  - 1. Activities: Indicate the estimated time duration, sequence requirements, and relationship of each activity in relation to other activities. Include estimated time frames for the following activities:
    - a. Preparation and processing of submittals.
    - b. Mobilization and demobilization.
    - c. Purchase of materials.
    - d. Delivery.
    - e. Fabrication.
    - f. Utility interruptions.
    - g. Installation.
    - h. Work by Owner that may affect or be affected by Contractor's activities.
    - i. Testing and commissioning.
    - j. Punch list and final completion.
    - k. Activities occurring following final completion.
  - 2. Critical Path Activities: Identify critical path activities, including those for interim completion dates. Scheduled start and completion dates shall be consistent with Contract milestone dates.
  - 3. Processing: Process data to produce output data on a computer-drawn, time-scaled network. Revise data, reorganize activity sequences, and reproduce as often as necessary to produce the CPM schedule within the limitations of the Contract Time.

4. Format: Mark the critical path. Locate the critical path near center of network; locate paths with most float near the edges.
  - a. Subnetworks on separate sheets are permissible for activities clearly off the critical path.
5. Cost- and Resource-Loading of CPM Schedule: Assign cost to construction activities on the CPM schedule. Do not assign costs to submittal activities. Obtain Architect's approval prior to assigning costs to fabrication and delivery activities. Assign costs under main subcontracts for testing and commissioning activities, operation and maintenance manuals, punch list activities, Project record documents, and demonstration and training (if applicable), in the amount of 5 percent of the Contract Sum.
  - a. Each activity cost shall reflect an appropriate value subject to approval by Architect.
  - b. Total cost assigned to activities shall equal the total Contract Sum.
- E. Contract Modifications: For each proposed contract modification and concurrent with its submission, prepare a time-impact analysis using a network fragment to demonstrate the effect of the proposed change on the overall project schedule.
- F. Initial Issue of Schedule: Prepare initial network diagram from a sorted activity list indicating straight "early start-total float." Identify critical activities. Prepare tabulated reports showing the following:
  1. Contractor or subcontractor and the Work or activity.
  2. Description of activity.
  3. Main events of activity.
  4. Immediate preceding and succeeding activities.
  5. Early and late start dates.
  6. Early and late finish dates.
  7. Activity duration in workdays.
  8. Total float or slack time.
  9. Average size of workforce.
  10. Dollar value of activity (coordinated with the schedule of values).
- G. Schedule Updating: Concurrent with making revisions to schedule, prepare tabulated reports showing the following:
  1. Identification of activities that have changed.
  2. Changes in early and late start dates.
  3. Changes in early and late finish dates.
  4. Changes in activity durations in workdays.
  5. Changes in the critical path.
  6. Changes in total float or slack time.
  7. Changes in the Contract Time.
- H. Value Summaries: Prepare two cumulative value lists, sorted by finish dates.
  1. In first list, tabulate activity number, early finish date, dollar value, and cumulative dollar value.
  2. In second list, tabulate activity number, late finish date, dollar value, and cumulative dollar value.

3. In subsequent issues of both lists, substitute actual finish dates for activities completed as of list date.
4. Prepare list for ease of comparison with payment requests; coordinate timing with progress meetings.
  - a. In both value summary lists, tabulate "actual percent complete" and "cumulative value completed" with total at bottom.
  - b. Submit value summary printouts one week before each regularly scheduled progress meeting.

## 2.4 SCHEDULE COMMUNITY EVENT

- A. Due to a community event, any exterior staging is required to be shut down and removed for the week of August 5-9, 2013, though contractors may work inside. The event itself will occur on Saturday, August 10, 2013. No work is to occur on this date.

## 2.5 REPORTS

- A. Daily Construction Reports: Prepare a daily construction report recording the following information concerning events at Project site:
  1. List of subcontractors at Project site.
  2. List of separate contractors at Project site.
  3. Approximate count of personnel at Project site.
  4. Equipment at Project site.
  5. Material deliveries.
  6. High and low temperatures and general weather conditions, including presence of rain or snow.
  7. Accidents.
  8. Meetings and significant decisions.
  9. Unusual events (see special reports).
  10. Stoppages, delays, shortages, and losses.
  11. Meter readings and similar recordings.
  12. Emergency procedures.
  13. Orders and requests of authorities having jurisdiction.
  14. Change Orders received and implemented.
  15. Construction Change Directives received and implemented.
  16. Services connected and disconnected.
  17. Equipment or system tests and startups.
  18. Partial completions and occupancies.
  19. Substantial Completions authorized.
- B. Material Location Reports: At weekly intervals, prepare and submit a comprehensive list of materials delivered to and stored at Project site. List shall be cumulative, showing materials previously reported plus items recently delivered. Include with list a statement of progress on and delivery dates for materials or items of equipment fabricated or stored away from Project site. Indicate the following categories for stored materials:
  1. Material stored prior to previous report and remaining in storage.
  2. Material stored prior to previous report and since removed from storage and installed.
  3. Material stored following previous report and remaining in storage.

- C. Site Condition Reports: Immediately on discovery of a difference between site conditions and the Contract Documents, prepare and submit a detailed report. Submit with a Request for Information. Include a detailed description of the differing conditions, together with recommendations for changing the Contract Documents.

## 2.6 SPECIAL REPORTS

- A. General: Submit special reports directly to Owner within one day(s) of an occurrence. Distribute copies of report to parties affected by the occurrence.
- B. Reporting Unusual Events: When an event of an unusual and significant nature occurs at Project site, whether or not related directly to the Work, prepare and submit a special report. List chain of events, persons participating, response by Contractor's personnel, evaluation of results or effects, and similar pertinent information. Advise Owner in advance when these events are known or predictable.

## PART 3 - EXECUTION

### 3.1 CONTRACTOR'S CONSTRUCTION SCHEDULE

- A. Contractor's Construction Schedule Updating: At monthly intervals, update schedule to reflect actual construction progress and activities. Issue schedule one week before each regularly scheduled progress meeting.
  - 1. Revise schedule immediately after each meeting or other activity where revisions have been recognized or made. Issue updated schedule concurrently with the report of each such meeting.
  - 2. Include a report with updated schedule that indicates every change, including, but not limited to, changes in logic, durations, actual starts and finishes, and activity durations.
  - 3. As the Work progresses, indicate final completion percentage for each activity.
- B. Distribution: Distribute copies of approved schedule to Architect Owner, separate contractors, testing and inspecting agencies, and other parties identified by Contractor with a need-to-know schedule responsibility.
  - 1. Post copies in Project meeting rooms and temporary field offices.
  - 2. When revisions are made, distribute updated schedules to the same parties and post in the same locations. Delete parties from distribution when they have completed their assigned portion of the Work and are no longer involved in performance of construction activities.

END OF SECTION

## **DIVISION 01 - GENERAL REQUIREMENTS**

### **SECTION 013233** **PHOTOGRAPHIC DOCUMENTATION**

#### **PART 1 - GENERAL**

##### **1.1 SUMMARY**

- A. Section includes administrative and procedural requirements for the following:
  - 1. Preconstruction photographs.
  - 2. Periodic construction photographs.
  - 3. Final completion construction photographs.
  - 4. Preconstruction video recording.
- B. Related Requirements:
  - 1. Section 013300 "Submittal Procedures" for submitting photographic documentation.
  - 2. Section 017700 "Closeout Procedures" for submitting photographic documentation as project record documents at Project closeout.
  - 3. Section 017900 "Demonstration and Training" for submitting video recordings of demonstration of equipment and training of Owner's personnel.
  - 4. Section 024119 "Selective Structure Demolition" for photographic documentation before selective demolition operations commence.

##### **1.2 INFORMATIONAL SUBMITTALS**

- A. Qualification Data: For Web-based photographic documentation service provider.
- B. Key Plan: Submit key plan of Project site and building with notation of vantage points marked for location and direction of each photograph and video recording. Indicate elevation or story of construction. Include same information as corresponding photographic documentation.
- C. Digital Photographs: Submit image files within three days of taking photographs.
  - 1. Digital Camera: Minimum sensor resolution of 8 megapixels.
  - 2. Format: Minimum 3200 by 2400 pixels, in unaltered original files, with same aspect ratio as the sensor, uncropped, date and time stamped, in folder named by date of photograph, accompanied by key plan file.
  - 3. Identification: Provide the following information with each image description in file metadata tag:
    - a. Name of Project.
    - b. Name and contact information for photographer.
    - c. Name of Architect.
    - d. Name of Contractor.
    - e. Date photograph was taken.
    - f. Description of vantage point, indicating location, direction (by compass point), and elevation or story of construction.



- C. Preconstruction Photographs: Before commencement of construction, take photographs of Project area and adjacent spaces, including existing items to remain during construction, from different vantage points, as directed by Architect.
  - 1. Take a minimum of 20 photographs to show existing conditions adjacent to project area before starting the Work.
- D. Periodic Construction Photographs: Take 20 photographs weekly, with timing each month adjusted to coincide with the cutoff date associated with each Application for Payment. Select vantage points to show status of construction and progress since last photographs were taken.
- E. Architect-Directed Construction Photographs: From time to time, Architect will instruct photographer about number and frequency of photographs and general directions on vantage points. Select actual vantage points and take photographs to show the status of construction and progress since last photographs were taken.
- F. Final Completion Construction Photographs: Take 20 color photographs after date of Substantial Completion for submission as project record documents. Architect will inform photographer of desired vantage points.
  - 1. Do not include date stamp.

### 3.2 CONSTRUCTION VIDEO RECORDINGS

- A. Video Recording Photographer: Engage a qualified videographer to record construction video recordings.
- B. Preconstruction Video Recording: Before starting construction, record video recording of Project site and adjacent spaces from different vantage points, as directed by Architect.
  - 1. Show existing conditions adjacent to Project area before starting the Work.
  - 2. Show protection efforts by Contractor.

END OF SECTION



## **DIVISION 01 - GENERAL REQUIREMENTS**

### **SECTION 013300** **SUBMITTAL PROCEDURES**

#### **PART 1 - GENERAL**

##### **1.1 SUMMARY**

- A. Section includes requirements for the submittal schedule and administrative and procedural requirements for submitting Shop Drawings, Product Data, Samples, and other submittals.
- B. Related Requirements:
  - 1. Section 012900 "Payment Procedures" for submitting Applications for Payment and the schedule of values.
  - 2. Section 013200 "Construction Progress Documentation" for submitting schedules and reports, including Contractor's construction schedule.
  - 3. Section 017823 "Operation and Maintenance Data" for submitting operation and maintenance manuals.
  - 4. Section 017839 "Project Record Documents" for submitting record Drawings, record Specifications, and record Product Data.
  - 5. Section 017900 "Demonstration and Training" for submitting video recordings of demonstration of equipment and training of Owner's personnel.

##### **1.2 DEFINITIONS**

- A. Action Submittals: Written and graphic information and physical samples that require Architect's responsive action. Action submittals are those submittals indicated in individual Specification Sections as "action submittals."
- B. Informational Submittals: Written and graphic information and physical samples that do not require Architect's responsive action. Submittals may be rejected for not complying with requirements. Informational submittals are those submittals indicated in individual Specification Sections as "informational submittals."
- C. File Transfer Protocol (FTP): Communications protocol that enables transfer of files to and from another computer over a network and that serves as the basis for standard Internet protocols. An FTP site is a portion of a network located outside of network firewalls within which internal and external users are able to access files.
- D. Portable Document Format (PDF): An open standard file format licensed by Adobe Systems used for representing documents in a device-independent and display resolution-independent fixed-layout document format.

##### **1.3 ACTION SUBMITTALS**

- A. Submittal Schedule: Each Contractor to submit a schedule of submittals to Coordinating Contractor arranged in chronological order by dates required by construction schedule. Coordinating Contractor to submit to Architect. Include time required for review, ordering,

manufacturing, fabrication, and delivery when establishing dates. Include additional time required for making corrections or revisions to submittals noted by Architect and additional time for handling and reviewing submittals required by those corrections.

1. Coordinate submittal schedule with list of subcontracts, the schedule of values, and Contractor's construction schedule.
2. Initial Submittal: Submit concurrently with startup construction schedule. Include submittals required during the first 60 days of construction. List those submittals required to maintain orderly progress of the Work and those required early because of long lead time for manufacture or fabrication.
3. Final Submittal: Submit concurrently with the first complete submittal of Contractor's construction schedule.
  - a. Submit revised submittal schedule to reflect changes in current status and timing for submittals.
4. Format: Arrange the following information in a tabular format:
  - a. Scheduled date for first submittal.
  - b. Specification Section number and title.
  - c. Submittal category: Action; informational.
  - d. Name of subcontractor.
  - e. Description of the Work covered.
  - f. Scheduled date for Architect's final release or approval.
  - g. Scheduled date of fabrication.
  - h. Scheduled dates for purchasing.
  - i. Scheduled dates for installation.
  - j. Activity or event number.

#### 1.4 SUBMITTAL ADMINISTRATIVE REQUIREMENTS

- A. Architect's Digital Data Files: Electronic digital data files of the Contract Drawings will be provided by Architect for Contractor's use in preparing submittals.
  1. Architect will furnish Contractor one set of digital data drawing files of the Contract Drawings for use in preparing Shop Drawings.
    - a. Architect makes no representations as to the accuracy or completeness of digital data drawing files as they relate to the Contract Drawings.
    - b. Digital Drawing Software Program: AutoCAD 2010.
    - c. Contractor shall execute a data licensing agreement in the form of AIA Document C106, Digital Data Licensing Agreement.
    - d. The following digital data files will be furnished for each appropriate discipline:
      - 1) Floor plans.
      - 2) Reflected ceiling plans.
- B. Coordination: Coordinate preparation and processing of submittals with performance of construction activities.
  1. Coordinate each submittal with fabrication, purchasing, testing, delivery, other submittals, and related activities that require sequential activity.

2. Submit all submittal items required for each Specification Section concurrently unless partial submittals for portions of the Work are indicated on approved submittal schedule.
  3. Submit action submittals and informational submittals required by the same Specification Section as separate packages under separate transmittals.
  4. Coordinate transmittal of different types of submittals for related parts of the Work so processing will not be delayed because of need to review submittals concurrently for coordination.
    - a. Architect reserves the right to withhold action on a submittal requiring coordination with other submittals until related submittals are received.
- C. Processing Time: Allow time for submittal review, including time for resubmittals, as follows. Time for review shall commence on Architect's receipt of submittal. No extension of the Contract Time will be authorized because of failure to transmit submittals enough in advance of the Work to permit processing, including resubmittals.
1. Initial Review: Allow 15 days for initial review of each submittal. Allow additional time if coordination with subsequent submittals is required. Architect will advise Contractor when a submittal being processed must be delayed for coordination.
  2. Intermediate Review: If intermediate submittal is necessary, process it in same manner as initial submittal.
  3. Resubmittal Review: Allow 15 days for review of each resubmittal.
  4. Sequential Review: Where sequential review of submittals by Architect's consultants, Owner, or other parties is indicated, allow 21 days for initial review of each submittal.
  5. Concurrent Consultant Review: Where the Contract Documents indicate that submittals may be transmitted simultaneously to Architect and to Architect's consultants, allow 15 days for review of each submittal. Submittal will be returned to Architect before being returned to Contractor.
- D. Electronic Submittals: Identify and incorporate information in each electronic submittal file as follows:
1. Assemble complete submittal package into a single indexed file incorporating submittal requirements of a single Specification Section and transmittal form with links enabling navigation to each item.
  2. Name file with submittal number or other unique identifier, including revision identifier.
    - a. File name shall use project identifier and Specification Section number followed by a decimal point and then a sequential number (e.g., CCICS-061000.01). Resubmittals shall include an alphabetic suffix after another decimal point (e.g., LNHS-061000.01.A).
  3. Provide means for insertion to permanently record Contractor's review and approval markings and action taken by Architect.
  4. Transmittal Form for Electronic Submittals: Use electronic form acceptable to Owner, containing the following information:
    - a. Project name.
    - b. Date.
    - c. Name and address of Architect.
    - d. Name of Construction Manager.
    - e. Name of Contractor.
    - f. Name of firm or entity that prepared submittal.

- g. Names of subcontractor, manufacturer, and supplier.
  - h. Category and type of submittal.
  - i. Submittal purpose and description.
  - j. Specification Section number and title.
  - k. Specification paragraph number or drawing designation and generic name for each of multiple items.
  - l. Drawing number and detail references, as appropriate.
  - m. Location(s) where product is to be installed, as appropriate.
  - n. Related physical samples submitted directly.
  - o. Indication of full or partial submittal.
  - p. Transmittal number, numbered consecutively.
  - q. Submittal and transmittal distribution record.
  - r. Other necessary identification.
  - s. Remarks.
5. Metadata: Include the following information as keywords in the electronic submittal file metadata:
- a. Project name.
  - b. Number and title of appropriate Specification Section.
  - c. Manufacturer name.
  - d. Product name.
- E. Options: Identify options requiring selection by Architect.
- F. Deviations and Additional Information: On an attached separate sheet, prepared on Contractor's letterhead, record relevant information, requests for data, revisions other than those requested by Architect on previous submittals, and deviations from requirements in the Contract Documents, including minor variations and limitations. Include same identification information as related submittal.
- G. Resubmittals: Make resubmittals in same form and number of copies as initial submittal.
- 1. Note date and content of previous submittal.
  - 2. Note date and content of revision in label or title block and clearly indicate extent of revision.
  - 3. Resubmit submittals until they are marked with approval notation from Architect's action stamp.
- H. Distribution: Furnish copies of final submittals to manufacturers, subcontractors, suppliers, fabricators, installers, authorities having jurisdiction, and others as necessary for performance of construction activities. Show distribution on transmittal forms.
- I. Use for Construction: Retain complete copies of submittals on Project site. Use only final action submittals that are marked with approval notation from Architect's action stamp.

## **PART 2 - PRODUCTS**

### **2.1 SUBMITTAL PROCEDURES**

- A. General Submittal Procedure Requirements: Each Contractor to prepare and submit submittals required by individual Specification Sections to Coordinating Contractor.

Coordinating Contractor to prepare and submit to Architect. Types of submittals are indicated in individual Specification Sections.

1. Submit electronic submittals via email as PDF electronic files.
    - a. Architect will return annotated file. Annotate and retain one copy of file as an electronic Project record document file.
  2. Action Submittals: Submit four paper copies of each submittal unless otherwise indicated. Architect will return three copies, one to owner for record
  3. Informational Submittals: Submit three paper copies of each submittal unless otherwise indicated. Architect will return one copy to owner for record.
  4. Certificates and Certifications Submittals: Provide a statement that includes signature of entity responsible for preparing certification. Certificates and certifications shall be signed by an officer or other individual authorized to sign documents on behalf of that entity.
    - a. Provide a digital signature with digital certificate on electronically submitted certificates and certifications where indicated.
    - b. Provide a notarized statement on original paper copy certificates and certifications where indicated.
- B. Product Data: Collect information into a single submittal for each element of construction and type of product or equipment.
1. If information must be specially prepared for submittal because standard published data are not suitable for use, submit as Shop Drawings, not as Product Data.
  2. Mark each copy of each submittal to show which products and options are applicable.
  3. Include the following information, as applicable:
    - a. Manufacturer's catalog cuts.
    - b. Manufacturer's product specifications.
    - c. Standard color charts.
    - d. Statement of compliance with specified referenced standards.
    - e. Testing by recognized testing agency.
    - f. Application of testing agency labels and seals.
    - g. Notation of coordination requirements.
    - h. Availability and delivery time information.
  4. For equipment, include the following in addition to the above, as applicable:
    - a. Wiring diagrams showing factory-installed wiring.
    - b. Printed performance curves.
    - c. Operational range diagrams.
    - d. Clearances required to other construction, if not indicated on accompanying Shop Drawings.
  5. Submit Product Data before or concurrent with Samples.
  6. Submit Product Data in the following format:
    - a. PDF electronic file.

- C. Shop Drawings: Prepare Project-specific information, drawn accurately to scale. Do not base Shop Drawings on reproductions of the Contract Documents or standard printed data, unless submittal based on Architect's digital data drawing files is otherwise permitted.
1. Preparation: Fully illustrate requirements in the Contract Documents. Include the following information, as applicable:
    - a. Identification of products.
    - b. Schedules.
    - c. Compliance with specified standards.
    - d. Notation of coordination requirements.
    - e. Notation of dimensions established by field measurement.
    - f. Relationship and attachment to adjoining construction clearly indicated.
    - g. Seal and signature of professional engineer if specified.
  2. Sheet Size: Except for templates, patterns, and similar full-size drawings, submit Shop Drawings on sheets at least 8-1/2 by 11 inches, but no larger than 30 by 42 inches.
  3. Submit Shop Drawings in the following format:
    - a. PDF electronic file.
- D. Samples: Submit Samples for review of kind, color, pattern, and texture for a check of these characteristics with other elements and for a comparison of these characteristics between submittal and actual component as delivered and installed.
1. Transmit Samples that contain multiple, related components such as accessories together in one submittal package.
  2. Identification: Attach label on unexposed side of Samples that includes the following:
    - a. Generic description of Sample.
    - b. Product name and name of manufacturer.
    - c. Sample source.
    - d. Number and title of applicable Specification Section.
    - e. Specification paragraph number and generic name of each item.
  3. For projects where electronic submittals are required, provide corresponding electronic submittal of Sample transmittal, digital image file illustrating Sample characteristics, and identification information for record.
  4. Disposition: Maintain sets of approved Samples at Project site, available for quality-control comparisons throughout the course of construction activity. Sample sets may be used to determine final acceptance of construction associated with each set.
    - a. Samples that may be incorporated into the Work are indicated in individual Specification Sections. Such Samples must be in an undamaged condition at time of use.
    - b. Samples not incorporated into the Work, or otherwise designated as Owner's property, are the property of Contractor.
  5. Samples for Initial Selection: Submit manufacturer's color charts consisting of units or sections of units showing the full range of colors, textures, and patterns available.
    - a. Number of Samples: Submit one full set(s) of available choices where color,

pattern, texture, or similar characteristics are required to be selected from manufacturer's product line. Architect will return submittal with options selected.

6. Samples for Verification: Submit full-size units or Samples of size indicated, prepared from same material to be used for the Work, cured and finished in manner specified, and physically identical with material or product proposed for use, and that show full range of color and texture variations expected. Samples include, but are not limited to, the following: partial sections of manufactured or fabricated components; small cuts or containers of materials; complete units of repetitively used materials; swatches showing color, texture, and pattern; color range sets; and components used for independent testing and inspection.
  - a. Number of Samples: Submit three sets of Samples. Architect will retain two Sample sets; remainder will be returned.
    - 1) Submit a single Sample where assembly details, workmanship, fabrication techniques, connections, operation, and other similar characteristics are to be demonstrated.
    - 2) If variation in color, pattern, texture, or other characteristic is inherent in material or product represented by a Sample, submit at least three sets of paired units that show approximate limits of variations.
- E. Product Schedule: As required in individual Specification Sections, prepare a written summary indicating types of products required for the Work and their intended location. Include the following information in tabular form:
  1. Type of product. Include unique identifier for each product indicated in the Contract Documents or assigned by Contractor if none is indicated.
  2. Manufacturer and product name, and model number if applicable.
  3. Number and name of room or space.
  4. Location within room or space.
  5. Submit product schedule in the following format:
    - a. PDF electronic file.
- F. Coordination Drawing Submittals: Comply with requirements specified in Section 013100 "Project Management and Coordination."
- G. Contractor's Construction Schedule: Comply with requirements specified in Section 013200 "Construction Progress Documentation."
- H. Application for Payment and Schedule of Values: Comply with requirements specified in Section 012900 "Payment Procedures."
- I. Test and Inspection Reports and Schedule of Tests and Inspections Submittals: Comply with requirements specified in Section 014000 "Quality Requirements."
- J. Closeout Submittals and Maintenance Material Submittals: Comply with requirements specified in Section 017700 "Closeout Procedures."
- K. Maintenance Data: Comply with requirements specified in Section 017823 "Operation and Maintenance Data."

- L. Qualification Data: Prepare written information that demonstrates capabilities and experience of firm or person. Include lists of completed projects with project names and addresses, contact information of architects and owners, and other information specified.
- M. Welding Certificates: Prepare written certification that welding procedures and personnel comply with requirements in the Contract Documents. Submit record of Welding Procedure Specification and Procedure Qualification Record on AWS forms. Include names of firms and personnel certified.
- N. Installer Certificates: Submit written statements on manufacturer's letterhead certifying that Installer complies with requirements in the Contract Documents and, where required, is authorized by manufacturer for this specific Project.
- O. Manufacturer Certificates: Submit written statements on manufacturer's letterhead certifying that manufacturer complies with requirements in the Contract Documents. Include evidence of manufacturing experience where required.
- P. Product Certificates: Submit written statements on manufacturer's letterhead certifying that product complies with requirements in the Contract Documents.
- Q. Material Certificates: Submit written statements on manufacturer's letterhead certifying that material complies with requirements in the Contract Documents.
- R. Material Test Reports: Submit reports written by a qualified testing agency, on testing agency's standard form, indicating and interpreting test results of material for compliance with requirements in the Contract Documents.
- S. Product Test Reports: Submit written reports indicating that current product produced by manufacturer complies with requirements in the Contract Documents. Base reports on evaluation of tests performed by manufacturer and witnessed by a qualified testing agency, or on comprehensive tests performed by a qualified testing agency.
- T. Research Reports: Submit written evidence, from a model code organization acceptable to authorities having jurisdiction, that product complies with building code in effect for Project. Include the following information:
  - 1. Name of evaluation organization.
  - 2. Date of evaluation.
  - 3. Time period when report is in effect.
  - 4. Product and manufacturers' names.
  - 5. Description of product.
  - 6. Test procedures and results.
  - 7. Limitations of use.
- U. Preconstruction Test Reports: Submit reports written by a qualified testing agency, on testing agency's standard form, indicating and interpreting results of tests performed before installation of product, for compliance with performance requirements in the Contract Documents.
- V. Compatibility Test Reports: Submit reports written by a qualified testing agency, on testing agency's standard form, indicating and interpreting results of compatibility tests performed before installation of product. Include written recommendations for primers and substrate preparation needed for adhesion.



- W. Field Test Reports: Submit written reports indicating and interpreting results of field tests performed either during installation of product or after product is installed in its final location, for compliance with requirements in the Contract Documents.
- X. Design Data: Prepare and submit written and graphic information, including, but not limited to, performance and design criteria, list of applicable codes and regulations, and calculations. Include list of assumptions and other performance and design criteria and a summary of loads. Include load diagrams if applicable. Provide name and version of software, if any, used for calculations. Include page numbers.

## 2.2 DELEGATED-DESIGN SERVICES

- A. Performance and Design Criteria: Where professional design services or certifications by a design professional are specifically required of Contractor by the Contract Documents, provide products and systems complying with specific performance and design criteria indicated.
  - 1. If criteria indicated are not sufficient to perform services or certification required, submit a written request for additional information to Architect.
- B. Delegated-Design Services Certification: In addition to Shop Drawings, Product Data, and other required submittals, submit digitally signed PDF electronic file and three paper copies of certificate, signed and sealed by the responsible design professional, for each product and system specifically assigned to Contractor to be designed or certified by a design professional.
  - 1. Indicate that products and systems comply with performance and design criteria in the Contract Documents. Include list of codes, loads, and other factors used in performing these services.

## **PART 3 - EXECUTION**

### 3.1 CONTRACTOR'S REVIEW

- A. Action and Informational Submittals: Review each submittal and check for coordination with other Work of the Contract and for compliance with the Contract Documents. Note corrections and field dimensions. Mark with approval stamp before submitting to Architect.
- B. Project Closeout and Maintenance Material Submittals: See requirements in Section 017700 "Closeout Procedures."
- C. Approval Stamp: Stamp each submittal with a uniform, approval stamp. Include Project name and location, submittal number, Specification Section title and number, name of reviewer, date of Contractor's approval, and statement certifying that submittal has been reviewed, checked, and approved for compliance with the Contract Documents.

### 3.2 ARCHITECT'S ACTION

- A. Action Submittals: Architect will review each submittal, make marks to indicate corrections or revisions required, and return it. Architect will stamp each submittal with an action stamp and will mark stamp appropriately to indicate action.

- B. Informational Submittals: Architect will review each submittal and will not return it, or will return it if it does not comply with requirements. Architect will forward each submittal to appropriate party.
- C. Partial submittals prepared for a portion of the Work will be reviewed when use of partial submittals has received prior approval from Architect.
- D. Incomplete submittals are unacceptable, will be considered nonresponsive, and will be returned for resubmittal without review.
- E. Submittals not required by the Contract Documents may be returned by the Architect without action.

END OF SECTION

## **DIVISION 01 - GENERAL REQUIREMENTS**

### **SECTION 014000 QUALITY REQUIREMENTS**

#### **PART 1 - GENERAL**

##### **1.1 SUMMARY**

- A. Section includes administrative and procedural requirements for quality assurance and quality control.
- B. Testing and inspecting services are required to verify compliance with requirements specified or indicated. These services do not relieve Contractor of responsibility for compliance with the Contract Document requirements.
  - 1. Specific quality-assurance and -control requirements for individual construction activities are specified in the Sections that specify those activities. Requirements in those Sections may also cover production of standard products.
  - 2. Specified tests, inspections, and related actions do not limit Contractor's other quality-assurance and -control procedures that facilitate compliance with the Contract Document requirements.
  - 3. Requirements for Contractor to provide quality-assurance and -control services required by Architect, Owner, Commissioning Authority, or authorities having jurisdiction are not limited by provisions of this Section.
  - 4. Specific test and inspection requirements are not specified in this Section.

##### **1.2 DEFINITIONS**

- A. **Quality-Assurance Services:** Activities, actions, and procedures performed before and during execution of the Work to guard against defects and deficiencies and substantiate that proposed construction will comply with requirements.
- B. **Quality-Control Services:** Tests, inspections, procedures, and related actions during and after execution of the Work to evaluate that actual products incorporated into the Work and completed construction comply with requirements. Services do not include contract enforcement activities performed by Architect.
- C. **Mockups:** Full-size physical assemblies that are constructed on-site. Mockups are constructed to verify selections made under Sample submittals; to demonstrate aesthetic effects and, where indicated, qualities of materials and execution; to review coordination, testing, or operation; to show interface between dissimilar materials; and to demonstrate compliance with specified installation tolerances. Mockups are not Samples. Unless otherwise indicated, approved mockups establish the standard by which the Work will be judged.
- D. **Preconstruction Testing:** Tests and inspections performed specifically for Project before products and materials are incorporated into the Work, to verify performance or compliance with specified criteria.

- E. Product Testing: Tests and inspections that are performed by an NRTL, an NVLAP, or a testing agency qualified to conduct product testing and acceptable to authorities having jurisdiction, to establish product performance and compliance with specified requirements.
- F. Source Quality-Control Testing: Tests and inspections that are performed at the source, e.g., plant, mill, factory, or shop.
- G. Field Quality-Control Testing: Tests and inspections that are performed on-site for installation of the Work and for completed Work.
- H. Testing Agency: An entity engaged to perform specific tests, inspections, or both. Testing laboratory shall mean the same as testing agency.
- I. Installer/Applicator/Erector: Contractor or another entity engaged by Contractor as an employee, Subcontractor, or Sub-subcontractor, to perform a particular construction operation, including installation, erection, application, and similar operations.
  - 1. Use of trade-specific terminology in referring to a trade or entity does not require that certain construction activities be performed by accredited or unionized individuals, or that requirements specified apply exclusively to specific trade(s).
- J. Experienced: When used with an entity or individual, "experienced" means having successfully completed a minimum of five previous projects similar in nature, size, and extent to this Project; being familiar with special requirements indicated; and having complied with requirements of authorities having jurisdiction.

### 1.3 CONFLICTING REQUIREMENTS

- A. Referenced Standards: If compliance with two or more standards is specified and the standards establish different or conflicting requirements for minimum quantities or quality levels, comply with the most stringent requirement. Refer conflicting requirements that are different, but apparently equal, to Architect for a decision before proceeding.
- B. Minimum Quantity or Quality Levels: The quantity or quality level shown or specified shall be the minimum provided or performed. The actual installation may comply exactly with the minimum quantity or quality specified, or it may exceed the minimum within reasonable limits. To comply with these requirements, indicated numeric values are minimum or maximum, as appropriate, for the context of requirements. Refer uncertainties to Architect for a decision before proceeding.

### 1.4 INFORMATIONAL SUBMITTALS

- A. Contractor's Quality-Control Plan: For quality-assurance and quality-control activities and responsibilities.
- B. Qualification Data: For Contractor's quality-control personnel.
- C. Testing Agency Qualifications: For testing agencies specified in "Quality Assurance" Article to demonstrate their capabilities and experience. Include proof of qualifications in the form of a recent report on the inspection of the testing agency by a recognized authority.
- D. Schedule of Tests and Inspections: Prepare in tabular form and include the following:

1. Specification Section number and title.
2. Entity responsible for performing tests and inspections.
3. Description of test and inspection.
4. Identification of applicable standards.
5. Identification of test and inspection methods.
6. Number of tests and inspections required.
7. Time schedule or time span for tests and inspections.
8. Requirements for obtaining samples.
9. Unique characteristics of each quality-control service.

#### 1.5 CONTRACTOR'S QUALITY-CONTROL PLAN

- A. Quality-Control Plan, General: Submit quality-control plan within 10 days of Notice to Proceed, and not less than five days prior to preconstruction conference. Submit in format acceptable to Architect. Identify personnel, procedures, controls, instructions, tests, records, and forms to be used to carry out Contractor's quality-assurance and quality-control responsibilities. Coordinate with Contractor's construction schedule.
- B. Quality-Control Personnel Qualifications: Engage qualified full-time personnel trained and experienced in managing and executing quality-assurance and quality-control procedures similar in nature and extent to those required for Project.
  1. Project quality-control manager shall not have other Project responsibilities.
- C. Submittal Procedure: Describe procedures for ensuring compliance with requirements through review and management of submittal process. Indicate qualifications of personnel responsible for submittal review.
- D. Testing and Inspection: In quality-control plan, include a comprehensive schedule of Work requiring testing or inspection, including the following:
  1. Contractor-performed tests and inspections including subcontractor-performed tests and inspections. Include required tests and inspections and Contractor-elected tests and inspections.
  2. Special inspections required by authorities having jurisdiction and indicated on the "Statement of Special Inspections."
  3. Owner-performed tests and inspections indicated in the Contract Documents, including tests and inspections indicated to be performed by the Commissioning Authority.
- E. Continuous Inspection of Workmanship: Describe process for continuous inspection during construction to identify and correct deficiencies in workmanship in addition to testing and inspection specified. Indicate types of corrective actions to be required to bring work into compliance with standards of workmanship established by Contract requirements and approved mockups.
- F. Monitoring and Documentation: Maintain testing and inspection reports including log of approved and rejected results. Include work Architect has indicated as nonconforming or defective. Indicate corrective actions taken to bring nonconforming work into compliance with requirements. Comply with requirements of authorities having jurisdiction.

#### 1.6 REPORTS AND DOCUMENTS

- A. Test and Inspection Reports: Prepare and submit certified written reports specified in other Sections. Include the following:

1. Date of issue.
  2. Project title and number.
  3. Name, address, and telephone number of testing agency.
  4. Dates and locations of samples and tests or inspections.
  5. Names of individuals making tests and inspections.
  6. Description of the Work and test and inspection method.
  7. Identification of product and Specification Section.
  8. Complete test or inspection data.
  9. Test and inspection results and an interpretation of test results.
  10. Record of temperature and weather conditions at time of sample taking and testing and inspecting.
  11. Comments or professional opinion on whether tested or inspected Work complies with the Contract Document requirements.
  12. Name and signature of laboratory inspector.
  13. Recommendations on retesting and reinspecting.
- B. Manufacturer's Technical Representative's Field Reports: Prepare written information documenting manufacturer's technical representative's tests and inspections specified in other Sections. Include the following:
1. Name, address, and telephone number of technical representative making report.
  2. Statement on condition of substrates and their acceptability for installation of product.
  3. Statement that products at Project site comply with requirements.
  4. Summary of installation procedures being followed, whether they comply with requirements and, if not, what corrective action was taken.
  5. Results of operational and other tests and a statement of whether observed performance complies with requirements.
  6. Statement whether conditions, products, and installation will affect warranty.
  7. Other required items indicated in individual Specification Sections.
- C. Factory-Authorized Service Representative's Reports: Prepare written information documenting manufacturer's factory-authorized service representative's tests and inspections specified in other Sections. Include the following:
1. Name, address, and telephone number of factory-authorized service representative making report.
  2. Statement that equipment complies with requirements.
  3. Results of operational and other tests and a statement of whether observed performance complies with requirements.
  4. Statement whether conditions, products, and installation will affect warranty.
  5. Other required items indicated in individual Specification Sections.
- D. Permits, Licenses, and Certificates: For Owner's records, submit copies of permits, licenses, certifications, inspection reports, releases, jurisdictional settlements, notices, receipts for fee payments, judgments, correspondence, records, and similar documents, established for compliance with standards and regulations bearing on performance of the Work.

## 1.7 QUALITY ASSURANCE

- A. General: Qualifications paragraphs in this article establish the minimum qualification levels required; individual Specification Sections specify additional requirements.

- B. **Manufacturer Qualifications:** A firm experienced in manufacturing products or systems similar to those indicated for this Project and with a record of successful in-service performance, as well as sufficient production capacity to produce required units.
- C. **Fabricator Qualifications:** A firm experienced in producing products similar to those indicated for this Project and with a record of successful in-service performance, as well as sufficient production capacity to produce required units.
- D. **Installer Qualifications:** A firm or individual experienced in installing, erecting, or assembling work similar in material, design, and extent to that indicated for this Project, whose work has resulted in construction with a record of successful in-service performance.
- E. **Professional Engineer Qualifications:** A professional engineer who is legally qualified to practice in jurisdiction where Project is located and who is experienced in providing engineering services of the kind indicated. Engineering services are defined as those performed for installations of the system, assembly, or product that are similar in material, design, and extent to those indicated for this Project.
- F. **Specialists:** Certain Specification Sections require that specific construction activities shall be performed by entities who are recognized experts in those operations. Specialists shall satisfy qualification requirements indicated and shall be engaged for the activities indicated.
  - 1. Requirements of authorities having jurisdiction shall supersede requirements for specialists.
- G. **Testing Agency Qualifications:** An NRTL, an NVLAP, or an independent agency with the experience and capability to conduct testing and inspecting indicated, as documented according to ASTM E 329; and with additional qualifications specified in individual Sections; and, where required by authorities having jurisdiction, that is acceptable to authorities.
  - 1. NRTL: A nationally recognized testing laboratory according to 29 CFR 1910.7.
  - 2. NVLAP: A testing agency accredited according to NIST's National Voluntary Laboratory Accreditation Program.
- H. **Manufacturer's Technical Representative Qualifications:** An authorized representative of manufacturer who is trained and approved by manufacturer to observe and inspect installation of manufacturer's products that are similar in material, design, and extent to those indicated for this Project.
- I. **Factory-Authorized Service Representative Qualifications:** An authorized representative of manufacturer who is trained and approved by manufacturer to inspect installation of manufacturer's products that are similar in material, design, and extent to those indicated for this Project.
- J. **Preconstruction Testing:** Where testing agency is indicated to perform preconstruction testing for compliance with specified requirements for performance and test methods, comply with the following:
  - 1. Contractor responsibilities include the following:
    - a. Provide test specimens representative of proposed products and construction.
    - b. Submit specimens in a timely manner with sufficient time for testing and analyzing results to prevent delaying the Work.

- c. Provide sizes and configurations of test assemblies, mockups, and laboratory mockups to adequately demonstrate capability of products to comply with performance requirements.
  - d. Build site-assembled test assemblies and mockups using installers who will perform same tasks for Project.
  - e. Build laboratory mockups at testing facility using personnel, products, and methods of construction indicated for the completed Work.
  - f. When testing is complete, remove test specimens, assemblies, and mockups; do not reuse products on Project.
2. Testing Agency Responsibilities: Submit a certified written report of each test, inspection, and similar quality-assurance service to Architect and Commissioning Authority, with copy to Contractor. Interpret tests and inspections and state in each report whether tested and inspected work complies with or deviates from the Contract Documents.
- K. Mockups: Before installing portions of the Work requiring mockups, build mockups for each form of construction and finish required to comply with the following requirements, using materials indicated for the completed Work:
- 1. Build mockups in location and of size indicated or, if not indicated, as directed by Architect.
  - 2. Notify Architect seven days in advance of dates and times when mockups will be constructed.
  - 3. Employ supervisory personnel who will oversee mockup construction. Employ workers that will be employed during the construction at Project.
  - 4. Demonstrate the proposed range of aesthetic effects and workmanship.
  - 5. Obtain Architect's approval of mockups before starting work, fabrication, or construction.
    - a. Allow seven days for initial review and each re-review of each mockup.
  - 6. Maintain mockups during construction in an undisturbed condition as a standard for judging the completed Work.
  - 7. Demolish and remove mockups when directed unless otherwise indicated.

## 1.8 QUALITY CONTROL

- A. Owner Responsibilities: Where quality-control services are indicated as Owner's responsibility, Owner will engage a qualified testing agency to perform these services.
- 1. Owner will furnish Contractor with names, addresses, and telephone numbers of testing agencies engaged and a description of types of testing and inspecting they are engaged to perform.
  - 2. Payment for these services will be made from testing and inspecting allowances, as authorized by Change Orders.
  - 3. Costs for retesting and reinspecting construction that replaces or is necessitated by work that failed to comply with the Contract Documents will be charged to Contractor, and the Contract Sum will be adjusted by Change Order.
- B. Contractor Responsibilities: Tests and inspections not explicitly assigned to Owner are Contractor's responsibility. Perform additional quality-control activities required to verify that the Work complies with requirements, whether specified or not.



1. Unless otherwise indicated, provide quality-control services specified and those required by authorities having jurisdiction. Perform quality-control services required of Contractor by authorities having jurisdiction, whether specified or not.
  2. Where services are indicated as Contractor's responsibility, engage a qualified testing agency to perform these quality-control services.
    - a. Contractor shall not employ same entity engaged by Owner, unless agreed to in writing by Owner.
  3. Notify testing agencies at least 24 hours in advance of time when Work that requires testing or inspecting will be performed.
  4. Where quality-control services are indicated as Contractor's responsibility, submit a certified written report, in duplicate, of each quality-control service.
  5. Testing and inspecting requested by Contractor and not required by the Contract Documents are Contractor's responsibility.
  6. Submit additional copies of each written report directly to authorities having jurisdiction, when they so direct.
- C. **Manufacturer's Field Services:** Where indicated, engage a factory-authorized service representative to inspect field-assembled components and equipment installation, including service connections. Report results in writing as specified in Section 013300 "Submittal Procedures."
- D. **Manufacturer's Technical Services:** Where indicated, engage a manufacturer's technical representative to observe and inspect the Work. Manufacturer's technical representative's services include participation in preinstallation conferences, examination of substrates and conditions, verification of materials, observation of Installer activities, inspection of completed portions of the Work, and submittal of written reports.
- E. **Retesting/Reinspecting:** Regardless of whether original tests or inspections were Contractor's responsibility, provide quality-control services, including retesting and reinspecting, for construction that replaced Work that failed to comply with the Contract Documents.
- F. **Testing Agency Responsibilities:** Cooperate with Architect, Commissioning Authority and Contractor in performance of duties. Provide qualified personnel to perform required tests and inspections.
  1. Notify Architect, Commissioning Authority, and Contractor promptly of irregularities or deficiencies observed in the Work during performance of its services.
  2. Determine the location from which test samples will be taken and in which in-situ tests are conducted.
  3. Conduct and interpret tests and inspections and state in each report whether tested and inspected work complies with or deviates from requirements.
  4. Submit a certified written report, in duplicate, of each test, inspection, and similar quality-control service through Contractor.
  5. Do not release, revoke, alter, or increase the Contract Document requirements or approve or accept any portion of the Work.
  6. Do not perform any duties of Contractor.
- G. **Associated Services:** Cooperate with agencies performing required tests, inspections, and similar quality-control services, and provide reasonable auxiliary services as requested. Notify agency sufficiently in advance of operations to permit assignment of personnel. Provide the following:

1. Access to the Work.
  2. Incidental labor and facilities necessary to facilitate tests and inspections.
  3. Adequate quantities of representative samples of materials that require testing and inspecting. Assist agency in obtaining samples.
  4. Facilities for storage and field curing of test samples.
  5. Delivery of samples to testing agencies.
  6. Preliminary design mix proposed for use for material mixes that require control by testing agency.
  7. Security and protection for samples and for testing and inspecting equipment at Project site.
- H. Coordination: Coordinate sequence of activities to accommodate required quality-assurance and -control services with a minimum of delay and to avoid necessity of removing and replacing construction to accommodate testing and inspecting.
1. Schedule times for tests, inspections, obtaining samples, and similar activities.
- I. Schedule of Tests and Inspections: Prepare a schedule of tests, inspections, and similar quality-control services required by the Contract Documents as a component of Contractor's quality-control plan. Coordinate and submit concurrently with Contractor's construction schedule. Update as the Work progresses.
1. Distribution: Distribute schedule to Owner, Architect, Commissioning Authority, testing agencies, and each party involved in performance of portions of the Work where tests and inspections are required.
- 1.9 SPECIAL TESTS AND INSPECTIONS
- A. Special Tests and Inspections: Conducted by a qualified testing agency or special inspector as required by authorities having jurisdiction, as indicated in individual Specification Sections, and as follows:
1. Verifying that manufacturer maintains detailed fabrication and quality-control procedures and reviews the completeness and adequacy of those procedures to perform the Work.
  2. Notifying Architect, Commissioning Authority, and Contractor promptly of irregularities and deficiencies observed in the Work during performance of its services.
  3. Submitting a certified written report of each test, inspection, and similar quality-control service to Architect and Commissioning Authority with copy to Contractor and to authorities having jurisdiction.
  4. Submitting a final report of special tests and inspections at Substantial Completion, which includes a list of unresolved deficiencies.
  5. Interpreting tests and inspections and stating in each report whether tested and inspected work complies with or deviates from the Contract Documents.
  6. Retesting and reinspecting corrected work.

## **PART 2 - PRODUCTS (NOT USED)**

## **PART 3 - EXECUTION**

### **3.1 TEST AND INSPECTION LOG**

- A. Test and Inspection Log: Prepare a record of tests and inspections. Include the following:
  - 1. Date test or inspection was conducted.
  - 2. Description of the Work tested or inspected.
  - 3. Date test or inspection results were transmitted to Architect.
  - 4. Identification of testing agency or special inspector conducting test or inspection.
- B. Maintain log at Project site. Post changes and revisions as they occur. Provide access to test and inspection log for Architect's, Commissioning Authority's, reference during normal working hours.

### **3.2 REPAIR AND PROTECTION**

- A. General: On completion of testing, inspecting, sample taking, and similar services, repair damaged construction and restore substrates and finishes.
  - 1. Provide materials and comply with installation requirements specified in other Specification Sections or matching existing substrates and finishes. Restore patched areas and extend restoration into adjoining areas with durable seams that are as invisible as possible. Comply with the Contract Document requirements for cutting and patching in Section 017300 "Execution."
- B. Protect construction exposed by or for quality-control service activities.
- C. Repair and protection are Contractor's responsibility, regardless of the assignment of responsibility for quality-control services.

END OF SECTION

## **DIVISION 01 - GENERAL REQUIREMENTS**

### **SECTION 014200 REFERENCES**

#### **PART 1 - GENERAL**

##### **1.1 DEFINITIONS**

- A. General: Basic Contract definitions are included in the Conditions of the Contract.
- B. "Approved": When used to convey Architect's action on Contractor's submittals, applications, and requests, "approved" is limited to Architect's duties and responsibilities as stated in the Conditions of the Contract.
- C. "Directed": A command or instruction by Architect. Other terms including "requested," "authorized," "selected," "required," and "permitted" have the same meaning as "directed."
- D. "Indicated": Requirements expressed by graphic representations or in written form on Drawings, in Specifications, and in other Contract Documents. Other terms including "shown," "noted," "scheduled," and "specified" have the same meaning as "indicated."
- E. "Regulations": Laws, ordinances, statutes, and lawful orders issued by authorities having jurisdiction, and rules, conventions, and agreements within the construction industry that control performance of the Work.
- F. "Furnish": Supply and deliver to Project site, ready for unloading, unpacking, assembly, installation, and similar operations.
- G. "Install": Unload, temporarily store, unpack, assemble, erect, place, anchor, apply, work to dimension, finish, cure, protect, clean, and similar operations at Project site.
- H. "Provide": Furnish and install, complete and ready for the intended use.
- I. "Project Site": Space available for performing construction activities. The extent of Project site is shown on Drawings and may or may not be identical with the description of the land on which Project is to be built.

##### **1.2 INDUSTRY STANDARDS**

- A. Applicability of Standards: Unless the Contract Documents include more stringent requirements, applicable construction industry standards have the same force and effect as if bound or copied directly into the Contract Documents to the extent referenced. Such standards are made a part of the Contract Documents by reference.
- B. Publication Dates: Comply with standards in effect as of date of the Contract Documents unless otherwise indicated.
- C. Copies of Standards: Each entity engaged in construction on Project should be familiar with industry standards applicable to its construction activity. Copies of applicable standards are not bound with the Contract Documents.

1. Where copies of standards are needed to perform a required construction activity, obtain copies directly from publication source.

### 1.3 ABBREVIATIONS AND ACRONYMS

- A. Industry Organizations: Where abbreviations and acronyms are used in Specifications or other Contract Documents, they shall mean the recognized name of the entities indicated in Gale's "Encyclopedia of Associations: National Organizations of the U.S." or in Columbia Books' "National Trade & Professional Associations of the United States."
- B. Code Agencies: Where abbreviations and acronyms are used in Specifications or other Contract Documents, they shall mean the recognized name of the entities in the following list. This information is believed to be accurate as of the date of the Contract Documents.
  1. IAPMO - International Association of Plumbing and Mechanical Officials; [www.iapmo.org](http://www.iapmo.org).
  2. ICC - International Code Council; [www.iccsafe.org](http://www.iccsafe.org).
  3. ICC-ES - ICC Evaluation Service, LLC; [www.icc-es.org](http://www.icc-es.org).
- C. Federal Government Agencies: Where abbreviations and acronyms are used in Specifications or other Contract Documents, they shall mean the recognized name of the entities in the following list. Information is subject to change and is up-to-date as of the date of the Contract Documents.
  1. EPA - Environmental Protection Agency; [www.epa.gov](http://www.epa.gov).
  2. OSHA - Occupational Safety & Health Administration; [www.osha.gov](http://www.osha.gov).
- D. Standards and Regulations: Where abbreviations and acronyms are used in Specifications or other Contract Documents, they shall mean the recognized name of the standards and regulations in the following list. This information is subject to change and is believed to be accurate as of the date of the Contract Documents.
  1. CFR - Code of Federal Regulations; Available from Government Printing Office; [www.gpo.gov/fdsys](http://www.gpo.gov/fdsys).
  2. FED-STD - Federal Standard; (See FS).
  3. FS - Federal Specification; Available from Department of Defense Single Stock Point; <http://dodssp.daps.dla.mil>.
    - a. Available from Defense Standardization Program; [www.dsp.dla.mil](http://www.dsp.dla.mil).
    - b. Available from General Services Administration; [www.gsa.gov](http://www.gsa.gov).
    - c. Available from National Institute of Building Sciences/Whole Building Design Guide; [www.wbdg.org/ccb](http://www.wbdg.org/ccb).
  4. USATBCB - U.S. Architectural & Transportation Barriers Compliance Board; (See USAB).

### **PART 2 - PRODUCTS (NOT USED)**

### **PART 3 - EXECUTION (NOT USED)**

END OF SECTION

## **DIVISION 01 - GENERAL REQUIREMENTS**

### **SECTION 015000** **TEMPORARY FACILITIES AND CONTROLS**

#### **PART 1 - GENERAL**

##### **1.1 SUMMARY**

- A. Section includes requirements for temporary utilities, support facilities, and security and protection facilities.
- B. Related Requirements:
  - 1. Section 011000 "Summary" for work restrictions and limitations on utility interruptions.

##### **1.2 USE CHARGES**

- A. General: Installation and removal of and use charges for temporary facilities shall be included in the Contract Sum unless otherwise indicated. Allow other entities to use temporary services and facilities without cost, including, but not limited to, Owner's construction forces, Architect, occupants of Project, testing agencies, and authorities having jurisdiction.
- A. Sewer Service: Owner will pay sewer-service use charges for sewer usage by all entities for construction operations.
- B. Water and Sewer Service from Existing System: Water from Owner's existing water system is available for use without metering and without payment of use charges. Provide connections and extensions of services as required for construction operations.
- C. Electric Power Service from Existing System: Electric power from Owner's existing system is available for use without metering and without payment of use charges. Provide connections and extensions of services as required for construction operations.

##### **1.3 INFORMATIONAL SUBMITTALS**

- A. Site Plan: Show temporary facilities, utility hookups, staging areas, and parking areas for construction personnel.
- B. Fire-Safety Program: Show compliance with requirements of NFPA 241 and authorities having jurisdiction. Indicate Contractor personnel responsible for management of fire-prevention program.
- C. Moisture-Protection Plan: Describe procedures and controls for protecting materials and construction from water absorption and damage.
  - 1. Describe delivery, handling, and storage provisions for materials subject to water absorption or water damage.

2. Indicate procedures for discarding water-damaged materials, protocols for mitigating water intrusion into completed Work, and replacing water-damaged Work.
  3. Indicate sequencing of work that requires water, such as sprayed fire-resistive materials, plastering, and terrazzo grinding, and describe plans for dealing with water from these operations. Show procedures for verifying that wet construction has dried sufficiently to permit installation of finish materials.
- D. Dust- and HVAC-Control Plan: Submit coordination drawing and narrative that indicates the dust- and HVAC-control measures proposed for use, proposed locations, and proposed time frame for their operation. Identify further options if proposed measures are later determined to be inadequate. Include the following:
1. Locations of dust-control partitions at each phase of work.
  2. HVAC system isolation schematic drawing.
  3. Location of proposed air-filtration system discharge.
  4. Waste handling procedures.
  5. Other dust-control measures.
- 1.4 QUALITY ASSURANCE
- A. Electric Service: Comply with NECA, NEMA, and UL standards and regulations for temporary electric service. Install service to comply with NFPA 70.
  - B. Tests and Inspections: Arrange for authorities having jurisdiction to test and inspect each temporary utility before use. Obtain required certifications and permits.
  - C. Accessible Temporary Egress: Comply with applicable provisions in the U.S. Architectural & Transportation Barriers Compliance Board's ADA-ABA Accessibility Guidelines.
- 1.5 PROJECT CONDITIONS
- A. Temporary Use of Permanent Facilities: Engage Installer of each permanent service to assume responsibility for operation, maintenance, and protection of each permanent service during its use as a construction facility before Owner's acceptance, regardless of previously assigned responsibilities.

## **PART 2 - PRODUCTS**

### 2.1 MATERIALS

- A. Polyethylene Sheet: Reinforced, fire-resistive sheet, 10-mil minimum thickness, with flame-spread rating of 15 or less per ASTM E 84 and passing NFPA 701 Test Method 2.
- B. Dust-Control Adhesive-Surface Walk-off Mats: Provide mats minimum 36 by 60 inches.

### 2.2 TEMPORARY FACILITIES

- A. Field Offices, General: Prefabricated or mobile units with serviceable finishes, temperature controls, and foundations adequate for normal loading.
- B. Common-Use Field Office: Of sufficient size to accommodate needs of Owner, Architect, and construction personnel office activities and to accommodate Project meetings specified

in other Division 01 Sections. Keep office clean and orderly. Furnish and equip offices as follows:

1. Furniture required for Project-site documents including file cabinets, plan tables, plan racks, and bookcases.
  2. Conference room of sufficient size to accommodate meetings of 10 individuals. Provide electrical power service and 120-V ac duplex receptacles, with no fewer than one receptacle on each wall. Furnish room with conference table, chairs, and 4-foot-square tack and marker boards.
  3. Drinking water and private toilet.
  4. Coffee machine and supplies.
  5. Heating and cooling equipment necessary to maintain a uniform indoor temperature of 68 to 72 deg F.
  6. Lighting fixtures capable of maintaining average illumination of 20 fc at desk height.
- C. Storage and Fabrication Sheds: Provide sheds sized, furnished, and equipped to accommodate materials and equipment for construction operations.
1. Store combustible materials apart from building.

## 2.3 EQUIPMENT

- A. Fire Extinguishers: Portable, UL rated; with class and extinguishing agent as required by locations and classes of fire exposures.
- B. HVAC Equipment: Unless Owner authorizes use of permanent HVAC system, provide vented, self-contained, liquid-propane-gas or fuel-oil heaters with individual space thermostatic control.
1. Use of gasoline-burning space heaters, open-flame heaters, or salamander-type heating units is prohibited.
  2. Heating Units: Listed and labeled for type of fuel being consumed, by a qualified testing agency acceptable to authorities having jurisdiction, and marked for intended location and application.
  3. Permanent HVAC System: If Owner authorizes use of permanent HVAC system for temporary use during construction, provide filter with MERV of 8 at each return-air grille in system and remove at end of construction and clean HVAC system as required in Section 017700 "Closeout Procedures".
- C. Air-Filtration Units: Primary and secondary HEPA-filter-equipped portable units with four-stage filtration. Provide single switch for emergency shutoff. Configure to run continuously.

## PART 3 - EXECUTION

### 3.1 INSTALLATION, GENERAL

- A. Locate facilities where they will serve Project adequately and result in minimum interference with performance of the Work. Relocate and modify facilities as required by progress of the Work.
1. Locate facilities to limit site disturbance as specified in Section 011000 "Summary."



- B. Provide each facility ready for use when needed to avoid delay. Do not remove until facilities are no longer needed or are replaced by authorized use of completed permanent facilities.

### 3.2 TEMPORARY UTILITY INSTALLATION

- A. General: Install temporary service or connect to existing service.
  - 1. Arrange with utility company, Owner, and existing users for time when service can be interrupted, if necessary, to make connections for temporary services.
- B. Water Service: Connect to Owner's existing water service facilities. Clean and maintain water service facilities in a condition acceptable to Owner. At Substantial Completion, restore these facilities to condition existing before initial use.
- C. Sanitary Facilities: Provide temporary toilets, wash facilities, and drinking water for use of construction personnel. Comply with requirements of authorities having jurisdiction for type, number, location, operation, and maintenance of fixtures and facilities.
  - 1. Toilets: Use of Owner's existing toilet facilities will be permitted, as long as facilities are cleaned and maintained in a condition acceptable to Owner. At Substantial Completion, restore these facilities to condition existing before initial use.
- D. Heating and Cooling: Provide temporary heating and cooling required by construction activities for curing or drying of completed installations or for protecting installed construction from adverse effects of low temperatures or high humidity. Select equipment that will not have a harmful effect on completed installations or elements being installed.
- E. Isolation of Work Areas in Occupied Facilities: Prevent dust, fumes, and odors from entering occupied areas.
  - 1. Prior to commencing work, isolate the HVAC system in area where work is to be performed according to coordination drawings.
    - a. Disconnect supply and return ductwork in work area from HVAC systems servicing occupied areas.
    - b. Maintain negative air pressure within work area using HEPA-equipped air-filtration units, starting with commencement of temporary partition construction, and continuing until removal of temporary partitions is complete.
  - 2. Maintain dust partitions during the Work. Use vacuum collection attachments on dust-producing equipment. Isolate limited work within occupied areas using portable dust-containment devices.
  - 3. Perform daily construction cleanup and final cleanup using approved, HEPA-filter-equipped vacuum equipment.
- F. Ventilation and Humidity Control: Provide temporary ventilation required by construction activities for curing or drying of completed installations or for protecting installed construction from adverse effects of high humidity. Select equipment that will not have a harmful effect on completed installations or elements being installed. Coordinate ventilation requirements to produce ambient condition required and minimize energy consumption.
  - 1. Provide dehumidification systems when required to reduce substrate moisture levels to level required to allow installation or application of finishes.

- G. Electric Power Service: Connect to Owner's existing electric power service. Maintain equipment in a condition acceptable to Owner.
- H. Lighting: Provide temporary lighting with local switching that provides adequate illumination for construction operations, observations, inspections, and traffic conditions.
  - 1. Install and operate temporary lighting that fulfills security and protection requirements without operating entire system.
  - 2. Install lighting for Project identification sign.
- I. Telephone Service: Provide temporary telephone service in common-use facilities for use by all construction personnel. Install one telephone line(s) for each field office.
  - 1. Provide additional telephone lines for the following:
    - a. Provide a dedicated telephone line for each facsimile machine in each field office.
  - 2. At each telephone, post a list of important telephone numbers.
    - a. Police and fire departments.
    - b. Ambulance service.
    - c. Contractor's home office.
    - d. Contractor's emergency after-hours telephone number.
    - e. Architect's office.
    - f. Engineers' offices.
    - g. Owner's office.
    - h. Principal subcontractors' field and home offices.
  - 3. Provide superintendent with cellular telephone or portable two-way radio for use when away from field office.
- J. Electronic Communication Service: Provide a desktop computer in the primary field office adequate for use by Architect and Owner to access Project electronic documents and maintain electronic communications.

### 3.3 SUPPORT FACILITIES INSTALLATION

- A. General: Comply with the following:
  - 1. Provide construction for temporary offices, shops, and sheds located within construction area or within 30 feet of building lines that is noncombustible according to ASTM E 136. Comply with NFPA 241.
  - 2. Maintain support facilities until Architect schedules Substantial Completion inspection. Remove before Substantial Completion. Personnel remaining after Substantial Completion will be permitted to use permanent facilities, under conditions acceptable to Owner.
- B. Traffic Controls: Comply with requirements of authorities having jurisdiction.
  - 1. Protect existing site improvements to remain including curbs, pavement, and utilities.

- 2. Maintain access for fire-fighting equipment and access to fire hydrants.
- C. Parking: Provide temporary parking areas for construction personnel.
- D. Project Signs: Provide Project signs as indicated. Unauthorized signs are not permitted. Refer to Section 015813 "Temporary Project Signage."
- E. Waste Disposal Facilities: Comply with requirements specified in Section 017419 "Construction Waste Management and Disposal."
- F. Lifts and Hoists: Provide facilities necessary for hoisting materials and personnel.
  - 1. Truck cranes and similar devices used for hoisting materials are considered "tools and equipment" and not temporary facilities.
- G. Existing Elevator Use: Use of Owner's existing elevators will be permitted, provided elevators are cleaned and maintained in a condition acceptable to Owner. At Substantial Completion, restore elevators to condition existing before initial use, including replacing worn cables, guide shoes, and similar items of limited life.
  - 1. Do not load elevators beyond their rated weight capacity.
  - 2. Provide protective coverings, barriers, devices, signs, or other procedures to protect elevator car and entrance doors and frame. If, despite such protection, elevators become damaged, engage elevator Installer to restore damaged work so no evidence remains of correction work. Return items that cannot be refinished in field to the shop, make required repairs and refinish entire unit, or provide new units as required.
- H. Existing Stair Usage: Use of Owner's existing stairs will be permitted, provided stairs are cleaned and maintained in a condition acceptable to Owner. At Substantial Completion, restore stairs to condition existing before initial use.
  - 1. Provide protective coverings, barriers, devices, signs, or other procedures to protect stairs and to maintain means of egress. If stairs become damaged, restore damaged areas so no evidence remains of correction work.

### 3.4 SECURITY AND PROTECTION FACILITIES INSTALLATION

- A. Protection of Existing Facilities: Protect existing vegetation, equipment, structures, utilities, and other improvements at Project site and on adjacent properties, except those indicated to be removed or altered. Repair damage to existing facilities.
- B. Environmental Protection: Provide protection, operate temporary facilities, and conduct construction as required to comply with environmental regulations and that minimize possible air, waterway, and subsoil contamination or pollution or other undesirable effects.
  - 1. Comply with work restrictions specified in Section 011000 "Summary."
- C. Security Enclosure and Lockup: Install temporary enclosure around partially completed areas of construction. Provide lockable entrances to prevent unauthorized entrance, vandalism, theft, and similar violations of security. Lock entrances at end of each work day.
- D. Barricades, Warning Signs, and Lights: Comply with requirements of authorities having jurisdiction for erecting structurally adequate barricades, including warning signs and lighting.

- E. Temporary Egress: Maintain temporary egress from existing occupied facilities as indicated and as required by authorities having jurisdiction.
- F. Temporary Enclosures: Provide temporary enclosures for protection of construction, in progress and completed, from exposure, foul weather, other construction operations, and similar activities. Provide temporary weathertight enclosure for building exterior.
  - 1. Where heating or cooling is needed and permanent enclosure is incomplete, insulate temporary enclosures.
- G. Temporary Fire Protection: Install and maintain temporary fire-protection facilities of types needed to protect against reasonably predictable and controllable fire losses. Comply with NFPA 241; manage fire-prevention program.
  - 1. Prohibit smoking in construction areas.
  - 2. Supervise welding operations, combustion-type temporary heating units, and similar sources of fire ignition according to requirements of authorities having jurisdiction.
  - 3. Develop and supervise an overall fire-prevention and -protection program for personnel at Project site. Review needs with local fire department and establish procedures to be followed. Instruct personnel in methods and procedures. Post warnings and information.
  - 4. Maintain existing standpipes and hoses for fire protection. Hang hoses with a warning sign stating that hoses are for fire-protection purposes only and are not to be removed. Match hose size with outlet size and equip with suitable nozzles.
- H. Temporary Partitions: Provide floor-to-ceiling dustproof partitions to limit dust and dirt migration and to separate areas occupied by Owner from fumes and noise.
  - 1. Construct dustproof partitions with two layers of 6-mil polyethylene sheet on each side. Cover floor with two layers of 6-mil polyethylene sheet, extending sheets 18 inches up the sidewalls. Overlap and tape full length of joints. Cover floor with fire-retardant-treated plywood.
    - a. Construct vestibule and airlock at each entrance through temporary partition with not less than 48 inches between doors. Maintain water-dampened foot mats in vestibule.
  - 2. Where fire-resistance-rated temporary partitions are indicated or are required by authorities having jurisdiction, construct partitions according to the rated assemblies.
  - 3. Insulate partitions to control noise transmission to occupied areas.
  - 4. Seal joints and perimeter. Equip partitions with gasketed dustproof doors and security locks where openings are required.
  - 5. Protect air-handling equipment.
  - 6. Provide walk-off mats at each entrance through temporary partition.

### 3.5 MOISTURE AND MOLD CONTROL

- A. Contractor's Moisture-Protection Plan: Avoid trapping water in finished work. Document visible signs of mold that may appear during construction.
- B. Controlled Construction Phase of Construction: After completing and sealing of the building enclosure but prior to the full operation of permanent HVAC systems, maintain as follows:

1. Control moisture and humidity inside building by maintaining effective dry-in conditions.
2. Use permanent HVAC system to control humidity.
3. Comply with manufacturer's written instructions for temperature, relative humidity, and exposure to water limits.
  - a. Hygroscopic materials that may support mold growth, including wood and gypsum-based products, that become wet during the course of construction and remain wet for 48 hours are considered defective.
  - b. Measure moisture content of materials that have been exposed to moisture during construction operations or after installation. Record readings beginning at time of exposure and continuing daily for 48 hours. Identify materials containing moisture levels higher than allowed. Report findings in writing to Architect.
  - c. Remove materials that cannot be completely restored to their manufactured moisture level within 48 hours.

### 3.6 OPERATION, TERMINATION, AND REMOVAL

- A. Supervision: Enforce strict discipline in use of temporary facilities. To minimize waste and abuse, limit availability of temporary facilities to essential and intended uses.
- B. Maintenance: Maintain facilities in good operating condition until removal.
  1. Maintain operation of temporary enclosures, heating, cooling, humidity control, ventilation, and similar facilities on a 24-hour basis where required to achieve indicated results and to avoid possibility of damage.
- C. Temporary Facility Changeover: Do not change over from using temporary security and protection facilities to permanent facilities until Substantial Completion.
- D. Termination and Removal: Remove each temporary facility when need for its service has ended, when it has been replaced by authorized use of a permanent facility, or no later than Substantial Completion. Complete or, if necessary, restore permanent construction that may have been delayed because of interference with temporary facility. Repair damaged Work, clean exposed surfaces, and replace construction that cannot be satisfactorily repaired.
  1. Materials and facilities that constitute temporary facilities are property of Contractor. Owner reserves right to take possession of Project identification signs.
  2. At Substantial Completion, repair, renovate, and clean permanent facilities used during construction period. Comply with final cleaning requirements specified in Section 017700 "Closeout Procedures."

END OF SECTION

## **DIVISION 01 - GENERAL REQUIREMENTS**

### **SECTION 016000 PRODUCT REQUIREMENTS**

#### **PART 1 - GENERAL**

##### **1.1 SUMMARY**

- A. Section includes administrative and procedural requirements for selection of products for use in Project; product delivery, storage, and handling; manufacturers' standard warranties on products; special warranties; and comparable products.
- B. Related Requirements:
  - 1. Section 012300 "Alternates" for products selected under an alternate.
  - 2. Section 012500 "Substitution Procedures" for requests for substitutions.
  - 3. Section 014200 "References" for applicable industry standards for products specified.

##### **1.2 DEFINITIONS**

- A. Products: Items obtained for incorporating into the Work, whether purchased for Project or taken from previously purchased stock. The term "product" includes the terms "material," "equipment," "system," and terms of similar intent.
  - 1. Named Products: Items identified by manufacturer's product name, including make or model number or other designation shown or listed in manufacturer's published product literature, that is current as of date of the Contract Documents.
  - 2. New Products: Items that have not previously been incorporated into another project or facility. Products salvaged or recycled from other projects are not considered new products.
  - 3. Comparable Product: Product that is demonstrated and approved through submittal process to have the indicated qualities related to type, function, dimension, in-service performance, physical properties, appearance, and other characteristics that equal or exceed those of specified product.
- B. Basis-of-Design Product Specification: A specification in which a specific manufacturer's product is named and accompanied by the words "basis-of-design product," including make or model number or other designation, to establish the significant qualities related to type, function, dimension, in-service performance, physical properties, appearance, and other characteristics for purposes of evaluating comparable products of additional manufacturers named in the specification.

##### **1.3 ACTION SUBMITTALS**

- A. Comparable Product Requests: Submit request for consideration of each comparable product. Identify product or fabrication or installation method to be replaced. Include Specification Section number and title and Drawing numbers and titles.

1. Include data to indicate compliance with the requirements specified in "Comparable Products" Article.
  2. Architect's Action: If necessary, Architect will request additional information or documentation for evaluation within one week of receipt of a comparable product request. Architect will notify Contractor of approval or rejection of proposed comparable product request within 15 days of receipt of request, or seven days of receipt of additional information or documentation, whichever is later.
    - a. Form of Approval: As specified in Section 013300 "Submittal Procedures."
    - b. Use product specified if Architect does not issue a decision on use of a comparable product request within time allocated.
- B. Basis-of-Design Product Specification Submittal: Comply with requirements in Section 013300 "Submittal Procedures." Show compliance with requirements.

#### 1.4 QUALITY ASSURANCE

- A. Compatibility of Options: If Contractor is given option of selecting between two or more products for use on Project, select product compatible with products previously selected, even if previously selected products were also options.
1. Each contractor is responsible for providing products and construction methods compatible with products and construction methods of other contractors.
  2. If a dispute arises between contractors over concurrently selectable but incompatible products, Architect will determine which products shall be used.

#### 1.5 PRODUCT DELIVERY, STORAGE, AND HANDLING

- A. Deliver, store, and handle products using means and methods that will prevent damage, deterioration, and loss, including theft and vandalism. Comply with manufacturer's written instructions.
- B. Delivery and Handling:
1. Schedule delivery to minimize long-term storage at Project site and to prevent overcrowding of construction spaces.
  2. Coordinate delivery with installation time to ensure minimum holding time for items that are flammable, hazardous, easily damaged, or sensitive to deterioration, theft, and other losses.
  3. Deliver products to Project site in an undamaged condition in manufacturer's original sealed container or other packaging system, complete with labels and instructions for handling, storing, unpacking, protecting, and installing.
  4. Inspect products on delivery to determine compliance with the Contract Documents and to determine that products are undamaged and properly protected.
- C. Storage:
1. Store products to allow for inspection and measurement of quantity or counting of units.
  2. Store materials in a manner that will not endanger Project structure.
  3. Store products that are subject to damage by the elements, under cover in a weathertight enclosure above ground, with ventilation adequate to prevent condensation.

4. Protect foam plastic from exposure to sunlight, except to extent necessary for period of installation and concealment.
5. Comply with product manufacturer's written instructions for temperature, humidity, ventilation, and weather-protection requirements for storage.
6. Protect stored products from damage and liquids from freezing.
7. Provide a secure location and enclosure at Project site for storage of materials and equipment by Owner's construction forces. Coordinate location with Owner.

## 1.6 PRODUCT WARRANTIES

- A. Warranties specified in other Sections shall be in addition to, and run concurrent with, other warranties required by the Contract Documents. Manufacturer's disclaimers and limitations on product warranties do not relieve Contractor of obligations under requirements of the Contract Documents.
  1. Manufacturer's Warranty: Written warranty furnished by individual manufacturer for a particular product and specifically endorsed by manufacturer to Owner.
  2. Special Warranty: Written warranty required by the Contract Documents to provide specific rights for Owner.
- B. Special Warranties: Prepare a written document that contains appropriate terms and identification, ready for execution.
  1. Manufacturer's Standard Form: Modified to include Project-specific information and properly executed.
  2. Specified Form: When specified forms are included with the Specifications, prepare a written document using indicated form properly executed.
  3. See other Sections for specific content requirements and particular requirements for submitting special warranties.
- C. Submittal Time: Comply with requirements in Section 017700 "Closeout Procedures."

## PART 2 - PRODUCTS

### 2.1 PRODUCT SELECTION PROCEDURES

- A. General Product Requirements: Provide products that comply with the Contract Documents, are undamaged and, unless otherwise indicated, are new at time of installation.
  1. Provide products complete with accessories, trim, finish, fasteners, and other items needed for a complete installation and indicated use and effect.
  2. Standard Products: If available, and unless custom products or nonstandard options are specified, provide standard products of types that have been produced and used successfully in similar situations on other projects.
  3. Owner reserves the right to limit selection to products with warranties not in conflict with requirements of the Contract Documents.
  4. Where products are accompanied by the term "as selected," Architect will make selection.
  5. Descriptive, performance, and reference standard requirements in the Specifications establish salient characteristics of products.



6. Or Equal: For products specified by name and accompanied by the term "or equal," or "or approved equal," or "or approved," comply with requirements in "Comparable Products" Article to obtain approval for use of an unnamed product.
- B. Product Selection Procedures:
1. Product: Where Specifications name a single manufacturer and product, provide the named product that complies with requirements. Comparable products or substitutions for Contractor's convenience will not be considered.
  2. Manufacturer/Source: Where Specifications name a single manufacturer or source, provide a product by the named manufacturer or source that complies with requirements. Comparable products or substitutions for Contractor's convenience will not be considered.
  3. Products:
    - a. Restricted List: Where Specifications include a list of names of both manufacturers and products, provide one of the products listed that complies with requirements. Comparable products or substitutions for Contractor's convenience will not be considered.
    - b. Nonrestricted List: Where Specifications include a list of names of both available manufacturers and products, provide one of the products listed, or an unnamed product, that complies with requirements. Comply with requirements in "Comparable Products" Article for consideration of an unnamed product.
  4. Manufacturers:
    - a. Restricted List: Where Specifications include a list of manufacturers' names, provide a product by one of the manufacturers listed that complies with requirements. Comparable products or substitutions for Contractor's convenience will not be considered.
    - b. Nonrestricted List: Where Specifications include a list of available manufacturers, provide a product by one of the manufacturers listed, or a product by an unnamed manufacturer, that complies with requirements. Comply with requirements in "Comparable Products" Article for consideration of an unnamed manufacturer's product.
  5. Basis-of-Design Product: Where Specifications name a product, or refer to a product indicated on Drawings, and include a list of manufacturers, provide the specified or indicated product or a comparable product by one of the other named manufacturers. Drawings and Specifications indicate sizes, profiles, dimensions, and other characteristics that are based on the product named. Comply with requirements in "Comparable Products" Article for consideration of an unnamed product by one of the other named manufacturers.
- C. Visual Matching Specification: Where Specifications require "match Architect's sample", provide a product that complies with requirements and matches Architect's sample. Architect's decision will be final on whether a proposed product matches.
1. If no product available within specified category matches and complies with other specified requirements, comply with requirements in Section 012500 "Substitution Procedures" for proposal of product.
- D. Visual Selection Specification: Where Specifications include the phrase "as selected by Architect from manufacturer's full range" or similar phrase, select a product that complies

with requirements. Architect will select color, gloss, pattern, density, or texture from manufacturer's product line that includes both standard and premium items.

## 2.2 COMPARABLE PRODUCTS

A. Conditions for Consideration: Architect will consider Contractor's request for comparable product when the following conditions are satisfied. If the following conditions are not satisfied, Architect may return requests without action, except to record noncompliance with these requirements:

1. Evidence that the proposed product does not require revisions to the Contract Documents, that it is consistent with the Contract Documents and will produce the indicated results, and that it is compatible with other portions of the Work.
2. Detailed comparison of significant qualities of proposed product with those named in the Specifications. Significant qualities include attributes such as performance, weight, size, durability, visual effect, and specific features and requirements indicated.
3. Evidence that proposed product provides specified warranty.
4. List of similar installations for completed projects with project names and addresses and names and addresses of architects and owners, if requested.
5. Samples, if requested.

## **PART 3 - EXECUTION (NOT USED)**

END OF SECTION

## **DIVISION 1 – GENERAL REQUIREMENTS**

### **SECTION 01 61 16 VOLATILE ORGANIC COMPOUND (VOC) CONTENT RESTRICTIONS**

#### **PART 1 GENERAL**

##### **1.01 SECTION INCLUDES**

- A. VOC restrictions for product categories listed below under "DEFINITIONS."
- B. All products of each category that are installed in the project must comply; Northeastern Illinois University's project goals do not allow for partial compliance.

##### **1.02 RELATED REQUIREMENTS**

- A. Section 01 33 00 - Submittal Procedures.
- B. Section 01 40 00 - Quality Requirements: Procedures for testing and certifications.
- C. Section 01 60 00 - Product Requirements: Fundamental product requirements, substitutions and product options, delivery, storage, and handling.
- D. Section 01 61 16.01 - Accessory Material VOC Content Certification Form.

##### **1.03 DEFINITIONS**

- A. VOC-Restricted Products: All products of each of the following categories when installed or applied on-site in the building interior:
  - 1. Adhesives, sealants, and sealer coatings.
  - 2. Carpet.
  - 3. Carpet cushion.
  - 4. Carpet tile.
  - 5. Resilient floor coverings.
  - 6. Paints and coatings.
  - 7. Gypsum board.
  - 8. Acoustical ceilings and panels.
  - 9. Wall coverings.
  - 10. Wood veneer paneling.
- B. Interior of Building: Anywhere inside the exterior weather barrier.
- C. Adhesives: All gunnable, trowelable, liquid-applied, and aerosol adhesives, whether specified or not; including flooring adhesives, resilient base adhesives, and pipe jointing adhesives.
- D. Sealants: All gunnable, trowelable, and liquid-applied joint sealants and sealant primers, whether specified or not; including firestopping sealants and duct joint sealers.

##### **1.04 REFERENCE STANDARDS**

- A. GreenSeal GS-36 - Commercial Adhesives; Green Seal, Inc.; 2011.
- B. SCAQMD 1168 - South Coast Air Quality Management District Rule No.1168; current edition; [www.aqmd.gov](http://www.aqmd.gov).

##### **1.05 SUBMITTALS**

- A. See Section 01 30 00 - Administrative Requirements, for submittal procedures.
- B. Evidence of Compliance: Submit for each different product in each applicable category.
- C. Product Data: For each VOC-restricted product used in the project, submit product data showing compliance, except when another type of evidence of compliance is required.

- D. Installer Certifications for Accessory Materials: Require each installer of any type of product (not just the products for which VOC restrictions are specified) to certify that either 1) no adhesives, joint sealants, paints, coatings, or composite wood or agrifiber products have been used in the installation of his products, or 2) that such products used comply with these requirements.
  - 1. Use the form following this section for installer certifications.

**1.06 QUALITY ASSURANCE**

- A. Testing Agency Qualifications: Independent firm specializing in performing testing and inspections of the type specified in this section.

**PART 2 PRODUCTS**

**2.01 MATERIALS**

- A. Adhesives and Joint Sealants: Provide only products having volatile organic compound (VOC) content not greater than required by South Coast Air Quality Management District Rule No.1168.
  - 1. Evidence of Compliance: Acceptable types of evidence are:
    - a. Report of laboratory testing performed in accordance with requirements.
    - b. Certification by manufacturer that product complies with requirements.
- B. Aerosol Adhesives: Provide only products having volatile organic compound (VOC) content not greater than required by GreenSeal GS-36.
  - 1. Evidence of Compliance: Acceptable types of evidence are:
    - a. Current GreenSeal Certification.
- C. Paints and Coatings: Provide products having VOC content as specified in Section 09 90 00.
- D. Carpet, Carpet Cushion, and Adhesive: Provide products having VOC content as specified in Section 09 68 00.
- E. Carpet Tile and Adhesive: Provide products having VOC content as specified in Section 09 68 13.
- F. Other Product Categories: Comply with limitations specified elsewhere.

**PART 3 EXECUTION**

**3.01 FIELD QUALITY CONTROL**

- A. Northeastern Illinois University reserves the right to reject non-compliant products, whether installed or not, and require their removal and replacement with compliant products at no extra cost to Northeastern Illinois University.
- B. All additional costs to restore indoor air quality due to installation of non-compliant products will be borne by Contractor.

**END OF SECTION**

**DIVISION 1 – GENERAL REQUIREMENTS**

**SECTION 01 61 16.01**  
**ACCESSORY MATERIAL VOC CONTENT CERTIFICATION FORM**

**1.01 FORM**

- A. Identification:
  - 1. Project Name: CCICS Auditorium Renovation
  - 2. Project No.: 61-0000-0000
  - 3. Architect: 4240 Architecture
  
- B. Use of This Form:
  - 1. Because installers are allowed and directed to choose accessory materials suitable for the applicable installation, there is a possibility that such accessory materials might contain VOC content in excess of that permitted, especially where such materials have not been explicitly specified.
  - 2. Contractor is required to obtain and submit this form from each installer of work on this project.
  - 3. For each product category listed, circle the correct words in brackets: either [HAS] or [HAS NOT].
  - 4. If any of these accessory materials has been used, attach to this form product data and MSDS sheet for each such product.
  
- C. VOC content restrictions are specified in Section 01 61 16.

**2.01 PRODUCT CERTIFICATION**

- A. I certify that the installation work of my firm on this project:
  - 1. [HAS] [HAS NOT] required the use of any ADHESIVES.
  - 2. [HAS] [HAS NOT] required the use of any JOINT SEALANTS.
  - 3. [HAS] [HAS NOT] required the use of any PAINTS OR COATINGS.
  - 4. [HAS] [HAS NOT] required the use of any COMPOSITE WOOD or AGRIFIBER PRODUCTS.
  
- B. Product data and MSDS sheets are attached.

**3.01 CERTIFIED BY: (Installer/Manufacturer/Supplier Firm)**

- A. Firm Name: \_\_\_\_\_
- B. Print Name: \_\_\_\_\_
- C. Signature: \_\_\_\_\_
- D. Title: \_\_\_\_\_ (officer of company)
- E. Date: \_\_\_\_\_

## **DIVISION 01 - GENERAL REQUIREMENTS**

### **SECTION 017300 EXECUTION**

#### **PART 1 - GENERAL**

##### **1.1 SUMMARY**

- A. Section includes general administrative and procedural requirements governing execution of the Work including, but not limited to, the following:
  - 1. Installation of the Work.
  - 2. Cutting and patching.
  - 3. Coordination of Owner-installed products.
  - 4. Progress cleaning.
  - 5. Starting and adjusting.
  - 6. Protection of installed construction.
- B. Related Requirements:
  - 1. Section 011000 "Summary" for limits on use of Project site.
  - 2. Section 013300 "Submittal Procedures" for submitting surveys.
  - 3. Section 017700 "Closeout Procedures" for submitting final property survey with Project Record Documents, recording of Owner-accepted deviations from indicated lines and levels, and final cleaning.
  - 4. Section 024119 "Selective Demolition" for demolition and removal of selected portions of the building.
  - 5. Section 078413 "Penetration Firestopping" for patching penetrations in fire-rated construction.

##### **1.2 DEFINITIONS**

- A. Cutting: Removal of in-place construction necessary to permit installation or performance of other work.
- B. Patching: Fitting and repair work required to restore construction to original conditions after installation of other work.

##### **1.3 INFORMATIONAL SUBMITTALS**

- A. Cutting and Patching Plan: Submit plan describing procedures at least 10 days prior to the time cutting and patching will be performed. Include the following information:
  - 1. Extent: Describe reason for and extent of each occurrence of cutting and patching.
  - 2. Changes to In-Place Construction: Describe anticipated results. Include changes to structural elements and operating components as well as changes in building appearance and other significant visual elements.
  - 3. Products: List products to be used for patching and firms or entities that will perform patching work.
  - 4. Dates: Indicate when cutting and patching will be performed.

5. Utilities and Mechanical and Electrical Systems: List services and systems that cutting and patching procedures will disturb or affect. List services and systems that will be relocated and those that will be temporarily out of service. Indicate length of time permanent services and systems will be disrupted.
  - a. Include description of provisions for temporary services and systems during interruption of permanent services and systems.
- B. Landfill Receipts: Submit copy of receipts issued by a landfill facility, licensed to accept hazardous materials, for hazardous waste disposal.

#### 1.4 QUALITY ASSURANCE

- A. Cutting and Patching: Comply with requirements for and limitations on cutting and patching of construction elements.
  1. Structural Elements: When cutting and patching structural elements, notify Architect of locations and details of cutting and await directions from Architect before proceeding. Shore, brace, and support structural elements during cutting and patching. Do not cut and patch structural elements in a manner that could change their load-carrying capacity or increase deflection
  2. Operational Elements: Do not cut and patch operating elements and related components in a manner that results in reducing their capacity to perform as intended or that results in increased maintenance or decreased operational life or safety.
  3. Other Construction Elements: Do not cut and patch other construction elements or components in a manner that could change their load-carrying capacity, that results in reducing their capacity to perform as intended, or that results in increased maintenance or decreased operational life or safety.
  4. Visual Elements: Do not cut and patch construction in a manner that results in visual evidence of cutting and patching. Do not cut and patch exposed construction in a manner that would, in Architect's opinion, reduce the building's aesthetic qualities. Remove and replace construction that has been cut and patched in a visually unsatisfactory manner.
- B. Cutting and Patching Conference: Before proceeding, meet at Project site with parties involved in cutting and patching, including mechanical and electrical trades. Review areas of potential interference and conflict. Coordinate procedures and resolve potential conflicts before proceeding.
- C. Manufacturer's Installation Instructions: Obtain and maintain on-site manufacturer's written recommendations and instructions for installation of products and equipment.

### **PART 2 - PRODUCTS**

#### 2.1 MATERIALS

- A. General: Comply with requirements specified in other Sections.
  1. For projects requiring compliance with sustainable design and construction practices and procedures, use products for patching that comply with requirements in Section 018113.13 "Sustainable Design Requirements - LEED for New Construction and Major Renovations."

- B. In-Place Materials: Use materials for patching identical to in-place materials. For exposed surfaces, use materials that visually match in-place adjacent surfaces to the fullest extent possible.
  - 1. If identical materials are unavailable or cannot be used, use materials that, when installed, will provide a match acceptable to Architect for the visual and functional performance of in-place materials.

### **PART 3 - EXECUTION**

#### **3.1 EXAMINATION**

- A. Existing Conditions: The existence and location of underground and other utilities and construction indicated as existing are not guaranteed. Before beginning sitework, investigate and verify the existence and location of underground utilities, mechanical and electrical systems, and other construction affecting the Work.
  - 1. Before construction, verify the location and invert elevation at points of connection of sanitary sewer, storm sewer, and water-service piping; underground electrical services, and other utilities.
  - 2. Furnish location data for work related to Project that must be performed by public utilities serving Project site.
- B. Examination and Acceptance of Conditions: Before proceeding with each component of the Work, examine substrates, areas, and conditions, with Installer or Applicator present where indicated, for compliance with requirements for installation tolerances and other conditions affecting performance. Record observations.
  - 1. Examine roughing-in for mechanical and electrical systems to verify actual locations of connections before equipment and fixture installation.
  - 2. Examine walls, floors, and roofs for suitable conditions where products and systems are to be installed.
  - 3. Verify compatibility with and suitability of substrates, including compatibility with existing finishes or primers.
- C. Written Report: Where a written report listing conditions detrimental to performance of the Work is required by other Sections, include the following:
  - 1. Description of the Work.
  - 2. List of detrimental conditions, including substrates.
  - 3. List of unacceptable installation tolerances.
  - 4. Recommended corrections.
- D. Proceed with installation only after unsatisfactory conditions have been corrected. Proceeding with the Work indicates acceptance of surfaces and conditions.

#### **3.2 PREPARATION**

- A. Existing Utility Information: Furnish information to local utility that is necessary to adjust, move, or relocate existing utility structures, utility poles, lines, services, or other utility appurtenances located in or affected by construction. Coordinate with authorities having jurisdiction.



- B. Field Measurements: Take field measurements as required to fit the Work properly. Recheck measurements before installing each product. Where portions of the Work are indicated to fit to other construction, verify dimensions of other construction by field measurements before fabrication. Coordinate fabrication schedule with construction progress to avoid delaying the Work.
- C. Space Requirements: Verify space requirements and dimensions of items shown diagrammatically on Drawings.
- D. Review of Contract Documents and Field Conditions: Immediately on discovery of the need for clarification of the Contract Documents caused by differing field conditions outside the control of Contractor, submit a request for information to Architect according to requirements in Section 013100 "Project Management and Coordination."

### 3.3 INSTALLATION

- A. General: Locate the Work and components of the Work accurately, in correct alignment and elevation, as indicated.
  - 1. Make vertical work plumb and make horizontal work level.
  - 2. Where space is limited, install components to maximize space available for maintenance and ease of removal for replacement.
  - 3. Conceal pipes, ducts, and wiring in finished areas unless otherwise indicated.
  - 4. Maintain minimum headroom clearance of 96 inches in occupied spaces and 90 inches in unoccupied spaces.
- B. Comply with manufacturer's written instructions and recommendations for installing products in applications indicated.
- C. Install products at the time and under conditions that will ensure the best possible results. Maintain conditions required for product performance until Substantial Completion.
- D. Conduct construction operations so no part of the Work is subjected to damaging operations or loading in excess of that expected during normal conditions of occupancy.
- E. Sequence the Work and allow adequate clearances to accommodate movement of construction items on site and placement in permanent locations.
- F. Tools and Equipment: Do not use tools or equipment that produce harmful noise levels.
- G. Templates: Obtain and distribute to the parties involved templates for work specified to be factory prepared and field installed. Check Shop Drawings of other work to confirm that adequate provisions are made for locating and installing products to comply with indicated requirements.
- H. Attachment: Provide blocking and attachment plates and anchors and fasteners of adequate size and number to securely anchor each component in place, accurately located and aligned with other portions of the Work. Where size and type of attachments are not indicated, verify size and type required for load conditions.
  - 1. Mounting Heights: Where mounting heights are not indicated, mount components at heights directed by Architect.
  - 2. Allow for building movement, including thermal expansion and contraction.

3. Coordinate installation of anchorages. Furnish setting drawings, templates, and directions for installing anchorages, including sleeves, concrete inserts, anchor bolts, and items with integral anchors, that are to be embedded in concrete or masonry. Deliver such items to Project site in time for installation.
- I. Joints: Make joints of uniform width. Where joint locations in exposed work are not indicated, arrange joints for the best visual effect. Fit exposed connections together to form hairline joints.
- J. Hazardous Materials: Use products, cleaners, and installation materials that are not considered hazardous.

### 3.4 CUTTING AND PATCHING

- A. Cutting and Patching, General: Employ skilled workers to perform cutting and patching. Proceed with cutting and patching at the earliest feasible time, and complete without delay.
  1. Cut in-place construction to provide for installation of other components or performance of other construction, and subsequently patch as required to restore surfaces to their original condition.
- B. Existing Warranties: Remove, replace, patch, and repair materials and surfaces cut or damaged during installation or cutting and patching operations, by methods and with materials so as not to void existing warranties.
- C. Temporary Support: Provide temporary support of work to be cut.
- D. Protection: Protect in-place construction during cutting and patching to prevent damage. Provide protection from adverse weather conditions for portions of Project that might be exposed during cutting and patching operations.
- E. Adjacent Occupied Areas: Where interference with use of adjoining areas or interruption of free passage to adjoining areas is unavoidable, coordinate cutting and patching according to requirements in Section 011000 "Summary."
- F. Existing Utility Services and Mechanical/Electrical Systems: Where existing services/systems are required to be removed, relocated, or abandoned, bypass such services/systems before cutting to prevent interruption to occupied areas.
- G. Cutting: Cut in-place construction by sawing, drilling, breaking, chipping, grinding, and similar operations, including excavation, using methods least likely to damage elements retained or adjoining construction. If possible, review proposed procedures with original Installer; comply with original Installer's written recommendations.
  1. In general, use hand or small power tools designed for sawing and grinding, not hammering and chopping. Cut holes and slots neatly to minimum size required, and with minimum disturbance of adjacent surfaces. Temporarily cover openings when not in use.
  2. Finished Surfaces: Cut or drill from the exposed or finished side into concealed surfaces.
  3. Concrete and Masonry: Cut using a cutting machine, such as an abrasive saw or a diamond-core drill.
  4. Excavating and Backfilling: Comply with requirements in applicable Sections where required by cutting and patching operations.

5. Mechanical and Electrical Services: Cut off pipe or conduit in walls or partitions to be removed. Cap, valve, or plug and seal remaining portion of pipe or conduit to prevent entrance of moisture or other foreign matter after cutting.
  6. Proceed with patching after construction operations requiring cutting are complete.
- H. Patching: Patch construction by filling, repairing, refinishing, closing up, and similar operations following performance of other work. Patch with durable seams that are as invisible as practicable. Provide materials and comply with installation requirements specified in other Sections, where applicable.
1. Inspection: Where feasible, test and inspect patched areas after completion to demonstrate physical integrity of installation.
  2. Exposed Finishes: Restore exposed finishes of patched areas and extend finish restoration into retained adjoining construction in a manner that will minimize evidence of patching and refinishing.
    - a. Clean piping, conduit, and similar features before applying paint or other finishing materials.
    - b. Restore damaged pipe covering to its original condition.
  3. Floors and Walls: Where walls or partitions that are removed extend one finished area into another, patch and repair floor and wall surfaces in the new space. Provide an even surface of uniform finish, color, texture, and appearance. Remove in-place floor and wall coverings and replace with new materials, if necessary, to achieve uniform color and appearance.
    - a. Where patching occurs in a painted surface, prepare substrate and apply primer and intermediate paint coats appropriate for substrate over the patch, and apply final paint coat over entire unbroken surface containing the patch. Provide additional coats until patch blends with adjacent surfaces.
  4. Ceilings: Patch, repair, or rehang in-place ceilings as necessary to provide an even-plane surface of uniform appearance.
  5. Exterior Building Enclosure: Patch components in a manner that restores enclosure to a weathertight condition and ensures thermal and moisture integrity of building enclosure.
- I. Cleaning: Clean areas and spaces where cutting and patching are performed. Remove paint, mortar, oils, putty, and similar materials from adjacent finished surfaces.

### 3.5 OWNER-INSTALLED PRODUCTS

- A. Site Access: Provide access to Project site for Owner's construction personnel.
- B. Coordination: Coordinate construction and operations of the Work with work performed by Owner's construction personnel.
  1. Construction Schedule: Inform Owner of Contractor's preferred construction schedule for Owner's portion of the Work. Adjust construction schedule based on a mutually agreeable timetable. Notify Owner if changes to schedule are required due to differences in actual construction progress.
  2. Preinstallation Conferences: Include Owner's construction personnel at preinstallation conferences covering portions of the Work that are to receive

Owner's work. Attend preinstallation conferences conducted by Owner's construction personnel if portions of the Work depend on Owner's construction.

### 3.6 PROGRESS CLEANING

- A. General: Clean Project site and work areas daily, including common areas. Enforce requirements strictly. Dispose of materials lawfully.
  - 1. Comply with requirements in NFPA 241 for removal of combustible waste materials and debris.
  - 2. Do not hold waste materials more than seven days during normal weather or three days if the temperature is expected to rise above 80 deg F.
  - 3. Containerize hazardous and unsanitary waste materials separately from other waste. Mark containers appropriately and dispose of legally, according to regulations.
    - a. Use containers intended for holding waste materials of type to be stored.
  - 4. Coordinate progress cleaning for joint-use areas where Contractor and other contractors are working concurrently.
- B. Site: Maintain Project site free of waste materials and debris.
- C. Work Areas: Clean areas where work is in progress to the level of cleanliness necessary for proper execution of the Work.
  - 1. Remove liquid spills promptly.
  - 2. Where dust would impair proper execution of the Work, broom-clean or vacuum the entire work area, as appropriate.
- D. Installed Work: Keep installed work clean. Clean installed surfaces according to written instructions of manufacturer or fabricator of product installed, using only cleaning materials specifically recommended. If specific cleaning materials are not recommended, use cleaning materials that are not hazardous to health or property and that will not damage exposed surfaces.
- E. Concealed Spaces: Remove debris from concealed spaces before enclosing the space.
- F. Exposed Surfaces in Finished Areas: Clean exposed surfaces and protect as necessary to ensure freedom from damage and deterioration at time of Substantial Completion.
- G. Waste Disposal: Do not bury or burn waste materials on-site. Do not wash waste materials down sewers or into waterways. Comply with waste disposal requirements in Section 017419 "Construction Waste Management and Disposal."
- H. During handling and installation, clean and protect construction in progress and adjoining materials already in place. Apply protective covering where required to ensure protection from damage or deterioration at Substantial Completion.
- I. Clean and provide maintenance on completed construction as frequently as necessary through the remainder of the construction period. Adjust and lubricate operable components to ensure operability without damaging effects.

- J. Limiting Exposures: Supervise construction operations to assure that no part of the construction, completed or in progress, is subject to harmful, dangerous, damaging, or otherwise deleterious exposure during the construction period. Where applicable, such exposure includes, but are not limited to, the following:
1. Excessive static or dynamic loading
  2. Excessive internal or external pressures
  3. Excessive high or low temperatures
  4. Thermal shock
  5. Excessively high or low humidity
  6. Air contamination or pollution
  7. Water or ice
  8. Solvents
  9. Chemicals
  10. Light
  11. Radiation
  12. Puncture
  13. Abrasion
  14. Heavy traffic
  15. Soiling, staining, and corrosion
  16. Bacteria
  17. Rodent and insect infestation
  18. Combustion
  19. Electrical current
  20. High-speed operation
  21. Improper lubrication
  22. Unusual wear or other misuse
  23. Contact between incompatible materials
  24. Destructive testing
  25. Misalignment
  26. Excessive
  27. Unprotected storage
  28. Improper shipping or handling
  29. Theft
  30. Vandalism

### 3.7 STARTING AND ADJUSTING

- A. Coordinate startup and adjusting of equipment and operating components with requirements in Section 019113 "General Commissioning Requirements."
- B. Start equipment and operating components to confirm proper operation. Remove malfunctioning units, replace with new units, and retest.
- C. Adjust equipment for proper operation. Adjust operating components for proper operation without binding.
- D. Test each piece of equipment to verify proper operation. Test and adjust controls and safeties. Replace damaged and malfunctioning controls and equipment.
- E. Manufacturer's Field Service: Comply with qualification requirements in Section 014000 "Quality Requirements."

3.8 PROTECTION OF INSTALLED CONSTRUCTION

- A. Provide final protection and maintain conditions that ensure installed Work is without damage or deterioration at time of Substantial Completion.
- B. Comply with manufacturer's written instructions for temperature and relative humidity.

END OF SECTION

## **DIVISION 01 - GENERAL REQUIREMENTS**

### **SECTION 017419 CONSTRUCTION WASTE MANAGEMENT AND DISPOSAL**

#### **PART 1 - GENERAL**

##### **1.1 SUMMARY**

- A. Section includes administrative and procedural requirements for the following:
  - 1. Salvaging nonhazardous demolition and construction waste.
  - 2. Recycling nonhazardous demolition and construction waste.
  - 3. Disposing of nonhazardous demolition and construction waste.

##### **1.2 DEFINITIONS**

- A. Construction Waste: Building and site improvement materials and other solid waste resulting from construction, remodeling, renovation, or repair operations. Construction waste includes packaging.
- B. Demolition Waste: Building and site improvement materials resulting from demolition or selective demolition operations.
- C. Disposal: Removal off-site of demolition and construction waste and subsequent sale, recycling, reuse, or deposit in landfill or incinerator acceptable to authorities having jurisdiction.
- D. Recycle: Recovery of demolition or construction waste for subsequent processing in preparation for reuse.
- E. Salvage: Recovery of demolition or construction waste and subsequent sale or reuse in another facility.
- F. Salvage and Reuse: Recovery of demolition or construction waste and subsequent incorporation into the Work.

##### **1.3 PERFORMANCE REQUIREMENTS**

- A. General: Achieve end-of-Project rates for salvage/recycling of 75 percent by weight of total non-hazardous solid waste generated by the Work. Practice efficient waste management in the use of materials in the course of the Work. Use all reasonable means to divert construction and demolition waste from landfills and incinerators. Facilitate recycling and salvage of materials, including the following:
  - 1. Demolition Waste:
    - a. Concrete.
    - b. Concrete reinforcing steel.
    - c. Brick.
    - d. Concrete masonry units.
    - e. Wood studs.

- f. Wood joists.
- g. Plywood and oriented strand board.
- h. Wood trim.
- i. Structural and miscellaneous steel.
- j. Doors and frames.
- k. Door hardware.
- l. Metal studs.
- m. Gypsum board.
- n. Acoustical tile and panels.
- o. Carpet.
- p. Carpet pad.
- q. Piping.
- r. Supports and hangers.
- s. Mechanical equipment.
- t. Refrigerants.
- u. Electrical conduit.
- v. Copper wiring.
- w. Lighting fixtures.
- x. Lamps.
- y. Ballasts.
- z. Electrical devices.

2. Construction Waste:

- a. Masonry and CMU.
- b. Lumber.
- c. Wood sheet materials.
- d. Wood trim.
- e. Metals.
- f. Carpet and pad.
- g. Gypsum board.
- h. Electrical conduit.
- i. Packaging: Regardless of salvage/recycle goal indicated in "General" Paragraph above, salvage or recycle 100 percent of the following uncontaminated packaging materials:
  - 1) Paper.
  - 2) Cardboard.
  - 3) Boxes.
  - 4) Plastic sheet and film.
  - 5) Polystyrene packaging.
  - 6) Wood crates.
  - 7) Plastic pails.

1.4 ACTION SUBMITTALS

- A. Waste Management Plan: Submit plan within 30 days of date established for the Notice to Proceed.



## 1.5 INFORMATIONAL SUBMITTALS

- A. Waste Reduction Progress Reports: Concurrent with each Application for Payment, submit report. Include the following information:
  - 1. Material category.
  - 2. Generation point of waste.
  - 3. Total quantity of waste in tons.
  - 4. Quantity of waste salvaged, both estimated and actual in tons.
  - 5. Quantity of waste recycled, both estimated and actual in tons.
  - 6. Total quantity of waste recovered (salvaged plus recycled) in tons.
  - 7. Total quantity of waste recovered (salvaged plus recycled) as a percentage of total waste.
- B. Waste Reduction Calculations: Before request for Substantial Completion, submit calculated end-of-Project rates for salvage, recycling, and disposal as a percentage of total waste generated by the Work.
- C. Records of Donations: Indicate receipt and acceptance of salvageable waste donated to individuals and organizations. Indicate whether organization is tax exempt.
- D. Records of Sales: Indicate receipt and acceptance of salvageable waste sold to individuals and organizations. Indicate whether organization is tax exempt.
- E. Recycling and Processing Facility Records: Indicate receipt and acceptance of recyclable waste by recycling and processing facilities licensed to accept them. Include manifests, weight tickets, receipts, and invoices.
- F. Landfill and Incinerator Disposal Records: Indicate receipt and acceptance of waste by landfills and incinerator facilities licensed to accept them. Include manifests, weight tickets, receipts, and invoices.
- G. Qualification Data: For waste management coordinator.
- H. Statement of Refrigerant Recovery: Signed by refrigerant recovery technician responsible for recovering refrigerant, stating that all refrigerant that was present was recovered and that recovery was performed according to EPA regulations. Include name and address of technician and date refrigerant was recovered.

## 1.6 QUALITY ASSURANCE

- A. Waste Management Coordinator Qualifications: Experienced firm, with a record of successful waste management coordination of projects with similar requirements, that employs a LEED-Accredited Professional, certified by the USGBC, as waste management coordinator. Waste management coordinator may also serve as LEED coordinator.
- B. Regulatory Requirements: Comply with hauling and disposal regulations of authorities having jurisdiction.
- C. Waste Management Conference: Conduct conference at Project site to comply with requirements in Section 013100 "Project Management and Coordination." Review methods and procedures related to waste management including, but not limited to, the following:

1. Review and discuss waste management plan including responsibilities of waste management coordinator.
2. Review requirements for documenting quantities of each type of waste and its disposition.
3. Review and finalize procedures for materials separation and verify availability of containers and bins needed to avoid delays.
4. Review procedures for periodic waste collection and transportation to recycling and disposal facilities.
5. Review waste management requirements for each trade.

## 1.7 WASTE MANAGEMENT PLAN

- A. General: Develop a waste management plan according to ASTM E 1609 and requirements in this Section. Plan shall consist of waste identification, waste reduction work plan, and cost/revenue analysis. Indicate quantities by weight or volume, but use same units of measure throughout waste management plan.
- B. Waste Identification: Indicate anticipated types and quantities of construction waste generated by the Work. Include estimated quantities and assumptions for estimates.
- C. Waste Reduction Work Plan: List each type of waste and whether it will be salvaged, recycled, or disposed of in landfill or incinerator. Include points of waste generation, total quantity of each type of waste, quantity for each means of recovery, and handling and transportation procedures.
  1. Salvaged Materials for Reuse: For materials that will be salvaged and reused in this Project, describe methods for preparing salvaged materials before incorporation into the Work.
  2. Salvaged Materials for Sale: For materials that will be sold to individuals and organizations, include list of their names, addresses, and telephone numbers.
  3. Salvaged Materials for Donation: For materials that will be donated to individuals and organizations, include list of their names, addresses, and telephone numbers.
  4. Recycled Materials: Include list of local receivers and processors and type of recycled materials each will accept. Include names, addresses, and telephone numbers.
  5. Disposed Materials: Indicate how and where materials will be disposed of. Include name, address, and telephone number of each landfill and incinerator facility.
  6. Handling and Transportation Procedures: Include method that will be used for separating recyclable waste including sizes of containers, container labeling, and designated location where materials separation will be performed.
- D. Cost/Revenue Analysis: Indicate total cost of waste disposal as if there was no waste management plan and net additional cost or net savings resulting from implementing waste management plan. Include the following:
  1. Total quantity of waste.
  2. Estimated cost of disposal (cost per unit). Include hauling and tipping fees and cost of collection containers for each type of waste.
  3. Total cost of disposal (with no waste management).
  4. Revenue from salvaged materials.
  5. Revenue from recycled materials.
  6. Savings in hauling and tipping fees by donating materials.
  7. Savings in hauling and tipping fees that are avoided.

8. Handling and transportation costs. Include cost of collection containers for each type of waste.
9. Net additional cost or net savings from waste management plan.

## **PART 2 - PRODUCTS (NOT USED)**

## **PART 3 - EXECUTION**

### **3.1 PLAN IMPLEMENTATION**

- A. General: Implement approved waste management plan. Provide handling, containers, storage, signage, transportation, and other items as required to implement waste management plan during the entire duration of the Contract.
  1. Comply with operation, termination, and removal requirements in Section 015000 "Temporary Facilities and Controls."
- B. Waste Management Coordinator: Engage a waste management coordinator to be responsible for implementing, monitoring, and reporting status of waste management work plan. Coordinator shall be present at Project site full time for duration of Project.
- C. Training: Train workers, subcontractors, and suppliers on proper waste management procedures, as appropriate for the Work.
  1. Distribute waste management plan to everyone concerned within three days of submittal return.
  2. Distribute waste management plan to entities when they first begin work on-site. Review plan procedures and locations established for salvage, recycling, and disposal.
- D. Site Access and Temporary Controls: Conduct waste management operations to ensure minimum interference with roads, streets, walks, walkways, and other adjacent occupied and used facilities.
  1. Designate and label specific areas on Project site necessary for separating materials that are to be salvaged, recycled, reused, donated, and sold.
  2. Comply with Section 015000 "Temporary Facilities and Controls" for controlling dust and dirt, environmental protection, and noise control.

### **3.2 SALVAGING DEMOLITION WASTE**

- A. Salvaged Items for Reuse in the Work: Salvage items for reuse and handle as follows:
  1. Clean salvaged items.
  2. Pack or crate items after cleaning. Identify contents of containers with label indicating elements, date of removal, quantity, and location where removed.
  3. Store items in a secure area until installation.
  4. Protect items from damage during transport and storage.
  5. Install salvaged items to comply with installation requirements for new materials and equipment. Provide connections, supports, and miscellaneous materials necessary to make items functional for use indicated.
- B. Salvaged Items for Sale and Donation: Not permitted on Project site.

- C. Salvaged Items for Owner's Use: Salvage items for Owner's use and handle as follows:
  - 1. Clean salvaged items.
  - 2. Pack or crate items after cleaning. Identify contents of containers with label indicating elements, date of removal, quantity, and location where removed.
  - 3. Store items in a secure area until delivery to Owner.
  - 4. Transport items to Owner's storage area designated by Owner.
  - 5. Protect items from damage during transport and storage.
- D. Doors and Hardware: Brace open end of door frames. Except for removing door closers, leave door hardware attached to doors.
- E. Equipment: Drain tanks, piping, and fixtures. Seal openings with caps or plugs. Protect equipment from exposure to weather.
- F. Lighting Fixtures: Separate lamps by type and protect from breakage.
- G. Electrical Devices: Separate switches, receptacles, switchgear, transformers, meters, panelboards, circuit breakers, and other devices by type.

### 3.3 RECYCLING DEMOLITION AND CONSTRUCTION WASTE, GENERAL

- A. General: Recycle paper and beverage containers used by on-site workers.
- B. Recycling Incentives: Revenues, savings, rebates, tax credits, and other incentives received for recycling waste materials shall be shared equally by Owner and Contractor.
- C. Preparation of Waste: Prepare and maintain recyclable waste materials according to recycling or reuse facility requirements. Maintain materials free of dirt, adhesives, solvents, petroleum contamination, and other substances deleterious to the recycling process.
- D. Procedures: Separate recyclable waste from other waste materials, trash, and debris. Separate recyclable waste by type at Project site to the maximum extent practical according to approved construction waste management plan.
  - 1. Provide appropriately marked containers or bins for controlling recyclable waste until removed from Project site. Include list of acceptable and unacceptable materials at each container and bin.
    - a. Inspect containers and bins for contamination and remove contaminated materials if found.
  - 2. Stockpile processed materials on-site without intermixing with other materials. Place, grade, and shape stockpiles to drain surface water. Cover to prevent windblown dust.
  - 3. Stockpile materials away from construction area. Do not store within drip line of remaining trees.
  - 4. Store components off the ground and protect from the weather.
  - 5. Remove recyclable waste from Owner's property and transport to recycling receiver or processor.

### 3.4 RECYCLING DEMOLITION WASTE

- A. Concrete: Remove reinforcement and other metals from concrete and sort with other metals.
  - 1. Pulverize concrete to maximum 4-inch size.
- B. Masonry: Remove metal reinforcement, anchors, and ties from masonry and sort with other metals.
  - 1. Pulverize masonry to maximum 4-inch size.
- C. Wood Materials: Sort and stack members according to size, type, and length. Separate lumber, engineered wood products, panel products, and treated wood materials.
- D. Metals: Separate metals by type.
  - 1. Structural Steel: Stack members according to size, type of member, and length.
  - 2. Remove and dispose of bolts, nuts, washers, and other rough hardware.
- E. Gypsum Board: Stack large clean pieces on wood pallets or in container and store in a dry location. Remove edge trim and sort with other metals. Remove and dispose of fasteners.
- F. Acoustical Ceiling Panels and Tile: Stack large clean pieces on wood pallets and store in a dry location.
- G. Metal Suspension System: Separate metal members including trim, and other metals from acoustical panels and tile and sort with other metals.
- H. Carpet and Pad: Roll large pieces tightly after removing debris, trash, adhesive, and tack strips.
  - 1. Store clean, dry carpet and pad in a closed container or trailer provided by Carpet Reclamation Agency or carpet recycler.
- I. Piping: Reduce piping to straight lengths and store by type and size. Separate supports, hangers, valves, sprinklers, and other components by type and size.
- J. Conduit: Reduce conduit to straight lengths and store by type and size.

### 3.5 RECYCLING CONSTRUCTION WASTE

- A. Packaging:
  - 1. Cardboard and Boxes: Break down packaging into flat sheets. Bundle and store in a dry location.
  - 2. Polystyrene Packaging: Separate and bag materials.
  - 3. Pallets: As much as possible, require deliveries using pallets to remove pallets from Project site. For pallets that remain on-site, break down pallets into component wood pieces and comply with requirements for recycling wood.
  - 4. Crates: Break down crates into component wood pieces and comply with requirements for recycling wood.
- B. Wood Materials:
  - 1. Clean Cut-Offs of Lumber: Grind or chip into small pieces.

2. Clean Sawdust: Bag sawdust that does not contain painted or treated wood.
- C. Gypsum Board: Stack large clean pieces on wood pallets or in container and store in a dry location.

1. Clean Gypsum Board: Grind scraps of clean gypsum board using small mobile chipper or hammer mill. Screen out paper after grinding.

### 3.6 DISPOSAL OF WASTE

- A. General: Except for items or materials to be salvaged, recycled, or otherwise reused, remove waste materials from Project site and legally dispose of them in a landfill or incinerator acceptable to authorities having jurisdiction.
1. Except as otherwise specified, do not allow waste materials that are to be disposed of accumulate on-site.
  2. Remove and transport debris in a manner that will prevent spillage on adjacent surfaces and areas.
- B. Burning: Do not burn waste materials.
- C. Disposal: Remove waste materials from Owner's property and legally dispose of them.

END OF SECTION

## **DIVISION 01 - GENERAL REQUIREMENTS**

### **SECTION 017700** **CLOSEOUT PROCEDURES**

#### **PART 1 - GENERAL**

##### **1.1 SUMMARY**

- A. Section includes administrative and procedural requirements for contract closeout, including, but not limited to, the following:
  - 1. Substantial Completion procedures.
  - 2. Final completion procedures.
  - 3. Warranties.
  - 4. Final cleaning.
  - 5. Repair of the Work.
- B. Related Requirements:
  - 1. Section 013233 "Photographic Documentation" for submitting final completion construction photographic documentation.
  - 2. Section 017300 "Execution" for progress cleaning of Project site.
  - 3. Section 017823 "Operation and Maintenance Data" for operation and maintenance manual requirements.
  - 4. Section 017839 "Project Record Documents" for submitting record Drawings, record Specifications, and record Product Data.
  - 5. Section 017900 "Demonstration and Training" for requirements for instructing Owner's personnel.

##### **1.2 ACTION SUBMITTALS**

- A. Product Data: For cleaning agents.
- B. Contractor's List of Incomplete Items: Initial submittal at Substantial Completion.
- C. Certified List of Incomplete Items: Final submittal at Final Completion.

##### **1.3 CLOSEOUT SUBMITTALS**

- A. Certificates of Release: From authorities having jurisdiction.
- B. Certificate of Insurance: For continuing coverage.

##### **1.4 MAINTENANCE MATERIAL SUBMITTALS**

- A. Schedule of Maintenance Material Items: For maintenance material submittal items specified in other Sections.

## 1.5 SUBSTANTIAL COMPLETION PROCEDURES

- A. Contractor's List of Incomplete Items: Prepare and submit a list of items to be completed and corrected (Contractor's punch list), indicating the value of each item on the list and reasons why the Work is incomplete.
- B. Submittals 60 Days Prior to Substantial Completion: Complete the following a minimum of 60 days prior to requesting inspection for determining date of Substantial Completion. List items below that are incomplete at time of request:
  - 1. Project Record Documents. Refer to Section 017839 for additional information.
  - 2. Operation and Maintenance Data: Refer to Section 017823 for additional information.
- C. Submittals Prior to Substantial Completion: Complete the following a minimum of 10 days prior to requesting inspection for determining date of Substantial Completion. List items below that are incomplete at time of request.
  - 1. Certificates of Release: Obtain and submit releases from authorities having jurisdiction permitting Owner unrestricted use of the Work and access to services and utilities. Include occupancy permits, operating certificates, and similar releases.
  - 2. Submit closeout submittals specified in other Division 01 Sections, including final completion construction photographic documentation, damage or settlement surveys, property surveys, and similar final record information.
  - 3. Submit closeout submittals specified in individual Sections, including specific warranties, workmanship bonds, maintenance service agreements, final certifications, and similar documents.
  - 4. Submit maintenance material submittals specified in individual Sections, including tools, spare parts, extra materials, and similar items, and deliver to location designated by Architect. Label with manufacturer's name and model number where applicable.
    - a. Schedule of Maintenance Material Items: Prepare and submit schedule of maintenance material submittal items, including name and quantity of each item and name and number of related Specification Section. Obtain Architect's signature for receipt of submittals.
  - 5. Submit test/adjust/balance records.
  - 6. Submit changeover information related to Owner's occupancy, use, operation, and maintenance.
- D. Procedures Prior to Substantial Completion: Complete the following a minimum of 10 days prior to requesting inspection for determining date of Substantial Completion. List items below that are incomplete at time of request.
  - 1. Advise Owner of pending insurance changeover requirements.
  - 2. Make final changeover of permanent locks and deliver keys to Owner. Advise Owner's personnel of changeover in security provisions.
  - 3. Complete startup and testing of systems and equipment.
  - 4. Perform preventive maintenance on equipment used prior to Substantial Completion.
  - 5. Instruct Owner's personnel in operation, adjustment, and maintenance of products, equipment, and systems. Submit demonstration and training video recordings specified in Section 017900 "Demonstration and Training."
  - 6. Advise Owner of changeover in heat and other utilities.
  - 7. Participate with Owner in conducting inspection and walkthrough with local emergency responders.



8. Terminate and remove temporary facilities from Project site, along with mockups, construction tools, and similar elements.
  9. Complete final cleaning requirements, including touchup painting.
  10. Touch up and otherwise repair and restore marred exposed finishes to eliminate visual defects.
- E. Inspection: Submit a written request for inspection to determine Substantial Completion a minimum of 10 days prior to date the work will be completed and ready for final inspection and tests. On receipt of request, Architect will either proceed with inspection or notify Contractor of unfulfilled requirements. Architect will prepare the Certificate of Substantial Completion after inspection or will notify Contractor of items, either on Contractor's list or additional items identified by Architect, that must be completed or corrected before certificate will be issued.
1. Reinspection: Request reinspection when the Work identified in previous inspections as incomplete is completed or corrected.
  2. Results of completed inspection will form the basis of requirements for final completion.

## 1.6 FINAL COMPLETION PROCEDURES

- A. Submittals Prior to Final Completion: Before requesting final inspection for determining final completion, complete the following:
1. Submit a final Application for Payment according to Section 012900 "Payment Procedures."
  2. Certified List of Incomplete Items: Submit certified copy of Architect's Substantial Completion inspection list of items to be completed or corrected (punch list), endorsed and dated by Architect. Certified copy of the list shall state that each item has been completed or otherwise resolved for acceptance.
  3. Certificate of Insurance: Submit evidence of final, continuing insurance coverage complying with insurance requirements.
  4. Submit pest-control final inspection report.
- B. Inspection: Submit a written request for final inspection to determine acceptance a minimum of 10 days prior to date the work will be completed and ready for final inspection and tests. On receipt of request, Architect will either proceed with inspection or notify Contractor of unfulfilled requirements. Architect will prepare a final Certificate for Payment after inspection or will notify Contractor of construction that must be completed or corrected before certificate will be issued.
1. Reinspection: Request reinspection when the Work identified in previous inspections as incomplete is completed or corrected.

## 1.7 LIST OF INCOMPLETE ITEMS (PUNCH LIST)

- A. Organization of List: Include name and identification of each space and area affected by construction operations for incomplete items and items needing correction including, if necessary, areas disturbed by Contractor that are outside the limits of construction.
1. Organize list of spaces in sequential order, starting with exterior areas first and proceeding from lowest floor to highest floor.
  2. Organize items applying to each space by major element, including categories for ceiling, individual walls, floors, equipment, and building systems.
  3. Include the following information at the top of each page:
    - a. Project name.

- b. Date.
  - c. Name of Architect.
  - d. Name of Contractor.
  - e. Page number.
4. Submit list of incomplete items in the following format:
- a. MS Excel electronic file. Architect will return annotated file.

## 1.8 SUBMITTAL OF PROJECT WARRANTIES

- A. Time of Submittal: Submit written warranties on request of Architect for designated portions of the Work where commencement of warranties other than date of Substantial Completion is indicated, or when delay in submittal of warranties might limit Owner's rights under warranty.
- B. Partial Occupancy: Submit properly executed warranties within 15 days of completion of designated portions of the Work that are completed and occupied or used by Owner during construction period by separate agreement with Contractor.
- C. Organize warranty documents into an orderly sequence based on the table of contents of Project Manual.
  - 1. Bind warranties and bonds in heavy-duty, three-ring, vinyl-covered, loose-leaf binders, thickness as necessary to accommodate contents, and sized to receive 8-1/2-by-11-inch paper.
  - 2. Provide heavy paper dividers with plastic-covered tabs for each separate warranty. Mark tab to identify the product or installation. Provide a typed description of the product or installation, including the name of the product and the name, address, and telephone number of Installer.
  - 3. Identify each binder on the front and spine with the typed or printed title "WARRANTIES," Project name, and name of Contractor.
  - 4. Warranty Electronic File: Scan warranties and bonds and assemble complete warranty and bond submittal package into a single indexed electronic PDF file with links enabling navigation to each item. Provide bookmarked table of contents at beginning of document.
- D. Provide additional copies of each warranty to include in operation and maintenance manuals.

## PART 2 - PRODUCTS

### 2.1 MATERIALS

- A. Cleaning Agents: Use cleaning materials and agents recommended by manufacturer or fabricator of the surface to be cleaned. Do not use cleaning agents that are potentially hazardous to health or property or that might damage finished surfaces.
  - 1. Use cleaning products that comply with Green Seal's GS-37, or if GS-37 is not applicable, use products that comply with the California Code of Regulations maximum allowable VOC levels.

## **PART 3 - EXECUTION**

### **3.1 FINAL CLEANING**

- A. General: Perform final cleaning. Conduct cleaning and waste-removal operations to comply with local laws and ordinances and Federal and local environmental and antipollution regulations.
- B. Cleaning: Employ experienced workers or professional cleaners for final cleaning. Clean each surface or unit to condition expected in an average commercial building cleaning and maintenance program. Comply with manufacturer's written instructions.
  - 1. Complete the following cleaning operations before requesting inspection for certification of Substantial Completion for entire Project or for a designated portion of Project:
    - a. Clean Project site, yard, and grounds, in areas disturbed by construction activities, including landscape development areas, of rubbish, waste material, litter, and other foreign substances.
    - b. Sweep paved areas broom clean. Remove petrochemical spills, stains, and other foreign deposits.
    - c. Rake grounds that are neither planted nor paved to a smooth, even-textured surface.
    - d. Remove tools, construction equipment, machinery, and surplus material from Project site.
    - e. Remove snow and ice to provide safe access to building.
    - f. Clean exposed exterior and interior hard-surfaced finishes to a dirt-free condition, free of stains, films, and similar foreign substances. Avoid disturbing natural weathering of exterior surfaces. Restore reflective surfaces to their original condition.
    - g. Remove debris and surface dust from limited access spaces, including roofs, plenums, shafts, trenches, equipment vaults, manholes, attics, and similar spaces.
    - h. Sweep concrete floors broom clean in unoccupied spaces.
    - i. Vacuum carpet and similar soft surfaces, removing debris and excess nap; clean according to manufacturer's recommendations if visible soil or stains remain.
    - j. Clean transparent materials, including mirrors and glass in doors and windows. Remove glazing compounds and other noticeable, vision-obscuring materials. Polish mirrors and glass, taking care not to scratch surfaces.
    - k. Remove labels that are not permanent.
    - l. Wipe surfaces of mechanical and electrical equipment, elevator equipment, and similar equipment. Remove excess lubrication, paint and mortar droppings, and other foreign substances.
    - m. Clean plumbing fixtures to a sanitary condition, free of stains, including stains resulting from water exposure.
    - n. Replace disposable air filters and clean permanent air filters. Clean exposed surfaces of diffusers, registers, and grills.
    - o. Clean ducts, blowers, and coils if units were operated without filters during construction or that display contamination with particulate matter on inspection.
      - 1) Clean HVAC system in compliance with NADCA Standard 1992-01. Provide written report on completion of cleaning.
    - p. Clean light fixtures, lamps, globes, and reflectors to function with full efficiency.
    - q. Leave Project clean and ready for occupancy.

- C. Pest Control: Comply with pest control requirements in Section 015000 "Temporary Facilities and Controls." Prepare written report.
- D. Construction Waste Disposal: Comply with waste disposal requirements in Section 017419 "Construction Waste Management and Disposal."

### 3.2 REPAIR OF THE WORK

- A. Complete repair and restoration operations before requesting inspection for determination of Substantial Completion.
- B. Repair or remove and replace defective construction. Repairing includes replacing defective parts, refinishing damaged surfaces, touching up with matching materials, and properly adjusting operating equipment. Where damaged or worn items cannot be repaired or restored, provide replacements. Remove and replace operating components that cannot be repaired. Restore damaged construction and permanent facilities used during construction to specified condition.
  - 1. Remove and replace chipped, scratched, and broken glass, reflective surfaces, and other damaged transparent materials.
  - 2. Touch up and otherwise repair and restore marred or exposed finishes and surfaces. Replace finishes and surfaces that that already show evidence of repair or restoration.
    - a. Do not paint over "UL" and other required labels and identification, including mechanical and electrical nameplates. Remove paint applied to required labels and identification.
  - 3. Replace parts subject to operating conditions during construction that may impede operation or reduce longevity.
  - 4. Replace burned-out bulbs, bulbs noticeably dimmed by hours of use, and defective and noisy starters in fluorescent and mercury vapor fixtures to comply with requirements for new fixtures.

END OF SECTION

## **DIVISION 01 - GENERAL REQUIREMENTS**

### **SECTION 017823 OPERATION AND MAINTENANCE DATA**

#### **PART 1 - GENERAL**

##### **1.1 SUMMARY**

- A. Section includes administrative and procedural requirements for preparing operation and maintenance manuals, including the following:
  - 1. Operation and maintenance documentation directory.
  - 2. Emergency manuals.
  - 3. Operation manuals for systems, subsystems, and equipment.
  - 4. Product maintenance manuals.
  - 5. Systems and equipment maintenance manuals.
- B. Related Requirements:
  - 1. Section 011200 "Multiple Contract Summary" for coordinating operation and maintenance manuals covering the Work of multiple contracts.
  - 2. Section 013300 "Submittal Procedures" for submitting copies of submittals for operation and maintenance manuals.
  - 3. Section 019113 "General Commissioning Requirements" for verification and compilation of data into operation and maintenance manuals.

##### **1.2 DEFINITIONS**

- A. System: An organized collection of parts, equipment, or subsystems united by regular interaction.
- B. Subsystem: A portion of a system with characteristics similar to a system.

##### **1.3 CLOSEOUT SUBMITTALS**

- A. Manual Content: Operations and maintenance manual content is specified in individual Specification Sections to be reviewed at the time of Section submittals. Submit reviewed manual content formatted and organized as required by this Section.
  - 1. Architect will comment on whether content of operations and maintenance submittals are acceptable.
  - 2. Where applicable, clarify and update reviewed manual content to correspond to revisions and field conditions.
- B. Format: Submit operations and maintenance manuals in the following format:
  - 1. PDF electronic file. Assemble each manual into a composite electronically indexed file. Submit on digital media acceptable to Architect.

- a. Name each indexed document file in composite electronic index with applicable item name. Include a complete electronically linked operation and maintenance directory.
  - b. Enable inserted reviewer comments on draft submittals.
2. One paper copies. Include a complete operation and maintenance directory. Enclose title pages and directories in clear plastic sleeves.
- C. Initial Manual Submittal: Submit draft copy of each manual at least 30 days before commencing demonstration and training. Architect will comment on whether general scope and content of manual are acceptable.
- D. Final Manual Submittal: Submit each manual in final form prior to requesting inspection for Substantial Completion and at least 15 days before commencing demonstration and training. Architect and Commissioning Authority will return copy with comments.
  1. Correct or revise each manual to comply with Architect's and Commissioning Authority's comments. Submit copies of each corrected manual within 15 days of receipt of Architect's and Commissioning Authority's comments and prior to commencing demonstration and training.

## **PART 2 - PRODUCTS**

### **2.1 OPERATION AND MAINTENANCE DOCUMENTATION DIRECTORY**

- A. Directory: Prepare a single, comprehensive directory of emergency, operation, and maintenance data and materials, listing items and their location to facilitate ready access to desired information. Include a section in the directory for each of the following:
  1. List of documents.
  2. List of systems.
  3. List of equipment.
  4. Table of contents.
- B. List of Systems and Subsystems: List systems alphabetically. Include references to operation and maintenance manuals that contain information about each system.
- C. List of Equipment: List equipment for each system, organized alphabetically by system. For pieces of equipment not part of system, list alphabetically in separate list.
- D. Tables of Contents: Include a table of contents for each emergency, operation, and maintenance manual.
- E. Identification: In the documentation directory and in each operation and maintenance manual, identify each system, subsystem, and piece of equipment with same designation used in the Contract Documents. If no designation exists, assign a designation according to ASHRAE Guideline 4, "Preparation of Operating and Maintenance Documentation for Building Systems."

## 2.2 REQUIREMENTS FOR EMERGENCY, OPERATION, AND MAINTENANCE MANUALS

- A. Organization: Unless otherwise indicated, organize each manual into a separate section for each system and subsystem, and a separate section for each piece of equipment not part of a system. Each manual shall contain the following materials, in the order listed:
1. Title page.
  2. Table of contents.
  3. Manual contents.
- B. Title Page: Include the following information:
1. Subject matter included in manual.
  2. Name and address of Project.
  3. Name and address of Owner.
  4. Date of submittal.
  5. Name and contact information for Contractor.
  6. Name and contact information for Construction Manager.
  7. Name and contact information for Architect.
  8. Name and contact information for Commissioning Authority.
  9. Names and contact information for major consultants to the Architect that designed the systems contained in the manuals.
  10. Cross-reference to related systems in other operation and maintenance manuals.
- C. Table of Contents: List each product included in manual, identified by product name, indexed to the content of the volume, and cross-referenced to Specification Section number in Project Manual.
1. If operation or maintenance documentation requires more than one volume to accommodate data, include comprehensive table of contents for all volumes in each volume of the set.
- D. Manual Contents: Organize into sets of manageable size. Arrange contents alphabetically by system, subsystem, and equipment. If possible, assemble instructions for subsystems, equipment, and components of one system into a single binder.
- E. Manuals, Electronic Files: Submit manuals in the form of a multiple file composite electronic PDF file for each manual type required.
1. Electronic Files: Use electronic files prepared by manufacturer where available. Where scanning of paper documents is required, configure scanned file for minimum readable file size.
  2. File Names and Bookmarks: Enable bookmarking of individual documents based on file names. Name document files to correspond to system, subsystem, and equipment names used in manual directory and table of contents. Group documents for each system and subsystem into individual composite bookmarked files, then create composite manual, so that resulting bookmarks reflect the system, subsystem, and equipment names in a readily navigated file tree. Configure electronic manual to display bookmark panel on opening file.
- F. Manuals, Paper Copy: Submit manuals in the form of hard copy, bound and labeled volumes.

1. Binders: Heavy-duty, three-ring, vinyl-covered, loose-leaf binders, in thickness necessary to accommodate contents, sized to hold 8-1/2-by-11-inch paper; with clear plastic sleeve on spine to hold label describing contents and with pockets inside covers to hold folded oversize sheets.
  - a. If two or more binders are necessary to accommodate data of a system, organize data in each binder into groupings by subsystem and related components. Cross-reference other binders if necessary to provide essential information for proper operation or maintenance of equipment or system.
  - b. Identify each binder on front and spine, with printed title "OPERATION AND MAINTENANCE MANUAL," Project title or name, and subject matter of contents, and indicate Specification Section number on bottom of spine. Indicate volume number for multiple-volume sets.
2. Dividers: Heavy-paper dividers with plastic-covered tabs for each section of the manual. Mark each tab to indicate contents. Include typed list of products and major components of equipment included in the section on each divider, cross-referenced to Specification Section number and title of Project Manual.
3. Protective Plastic Sleeves: Transparent plastic sleeves designed to enclose diagnostic software storage media for computerized electronic equipment.
4. Supplementary Text: Prepared on 8-1/2-by-11-inch white bond paper.
5. Drawings: Attach reinforced, punched binder tabs on drawings and bind with text.
  - a. If oversize drawings are necessary, fold drawings to same size as text pages and use as foldouts.
  - b. If drawings are too large to be used as foldouts, fold and place drawings in labeled envelopes and bind envelopes in rear of manual. At appropriate locations in manual, insert typewritten pages indicating drawing titles, descriptions of contents, and drawing locations.

### 2.3 EMERGENCY MANUALS

- A. Content: Organize manual into a separate section for each of the following:
  1. Type of emergency.
  2. Emergency instructions.
  3. Emergency procedures.
- B. Type of Emergency: Where applicable for each type of emergency indicated below, include instructions and procedures for each system, subsystem, piece of equipment, and component:
  1. Fire.
  2. Flood.
  3. Gas leak.
  4. Water leak.
  5. Power failure.
  6. Water outage.
  7. System, subsystem, or equipment failure.
  8. Chemical release or spill.
- C. Emergency Instructions: Describe and explain warnings, trouble indications, error messages, and similar codes and signals. Include responsibilities of Owner's operating personnel for notification of Installer, supplier, and manufacturer to maintain warranties.



D. Emergency Procedures: Include the following, as applicable:

1. Instructions on stopping.
2. Shutdown instructions for each type of emergency.
3. Operating instructions for conditions outside normal operating limits.
4. Required sequences for electric or electronic systems.
5. Special operating instructions and procedures.

## 2.4 OPERATION MANUALS

A. Content: In addition to requirements in this Section, include operation data required in individual Specification Sections and the following information:

1. System, subsystem, and equipment descriptions. Use designations for systems and equipment indicated on Contract Documents.
2. Performance and design criteria if Contractor has delegated design responsibility.
3. Operating standards.
4. Operating procedures.
5. Operating logs.
6. Wiring diagrams.
7. Control diagrams.
8. Piped system diagrams.
9. Precautions against improper use.
10. License requirements including inspection and renewal dates.

B. Descriptions: Include the following:

1. Product name and model number. Use designations for products indicated on Contract Documents.
2. Manufacturer's name.
3. Equipment identification with serial number of each component.
4. Equipment function.
5. Operating characteristics.
6. Limiting conditions.
7. Performance curves.
8. Engineering data and tests.
9. Complete nomenclature and number of replacement parts.

C. Operating Procedures: Include the following, as applicable:

1. Startup procedures.
2. Equipment or system break-in procedures.
3. Routine and normal operating instructions.
4. Regulation and control procedures.
5. Instructions on stopping.
6. Normal shutdown instructions.
7. Seasonal and weekend operating instructions.
8. Required sequences for electric or electronic systems.
9. Special operating instructions and procedures.

D. Systems and Equipment Controls: Describe the sequence of operation, and diagram controls as installed.

- E. Piped Systems: Diagram piping as installed, and identify color-coding where required for identification.

## 2.5 PRODUCT MAINTENANCE MANUALS

- A. Content: Organize manual into a separate section for each product, material, and finish. Include source information, product information, maintenance procedures, repair materials and sources, and warranties and bonds, as described below.
- B. Source Information: List each product included in manual, identified by product name and arranged to match manual's table of contents. For each product, list name, address, and telephone number of Installer or supplier and maintenance service agent, and cross-reference Specification Section number and title in Project Manual and drawing or schedule designation or identifier where applicable.
- C. Product Information: Include the following, as applicable:
  - 1. Product name and model number.
  - 2. Manufacturer's name.
  - 3. Color, pattern, and texture.
  - 4. Material and chemical composition.
  - 5. Reordering information for specially manufactured products.
- D. Maintenance Procedures: Include manufacturer's written recommendations and the following:
  - 1. Inspection procedures.
  - 2. Types of cleaning agents to be used and methods of cleaning.
  - 3. List of cleaning agents and methods of cleaning detrimental to product.
  - 4. Schedule for routine cleaning and maintenance.
  - 5. Repair instructions.
- E. Repair Materials and Sources: Include lists of materials and local sources of materials and related services.
- F. Warranties and Bonds: Include copies of warranties and bonds and lists of circumstances and conditions that would affect validity of warranties or bonds.
  - 1. Include procedures to follow and required notifications for warranty claims.

## 2.6 SYSTEMS AND EQUIPMENT MAINTENANCE MANUALS

- A. Content: For each system, subsystem, and piece of equipment not part of a system, include source information, manufacturers' maintenance documentation, maintenance procedures, maintenance and service schedules, spare parts list and source information, maintenance service contracts, and warranty and bond information, as described below.
- B. Source Information: List each system, subsystem, and piece of equipment included in manual, identified by product name and arranged to match manual's table of contents. For each product, list name, address, and telephone number of Installer or supplier and maintenance service agent, and cross-reference Specification Section number and title in Project Manual and drawing or schedule designation or identifier where applicable.

- C. **Manufacturers' Maintenance Documentation:** Manufacturers' maintenance documentation including the following information for each component part or piece of equipment:
  - 1. Standard maintenance instructions and bulletins.
  - 2. Drawings, diagrams, and instructions required for maintenance, including disassembly and component removal, replacement, and assembly.
  - 3. Identification and nomenclature of parts and components.
  - 4. List of items recommended to be stocked as spare parts.
- D. **Maintenance Procedures:** Include the following information and items that detail essential maintenance procedures:
  - 1. Test and inspection instructions.
  - 2. Troubleshooting guide.
  - 3. Precautions against improper maintenance.
  - 4. Disassembly; component removal, repair, and replacement; and reassembly instructions.
  - 5. Aligning, adjusting, and checking instructions.
  - 6. Demonstration and training video recording, if available.
- E. **Maintenance and Service Schedules:** Include service and lubrication requirements, list of required lubricants for equipment, and separate schedules for preventive and routine maintenance and service with standard time allotment.
  - 1. **Scheduled Maintenance and Service:** Tabulate actions for daily, weekly, monthly, quarterly, semiannual, and annual frequencies.
  - 2. **Maintenance and Service Record:** Include manufacturers' forms for recording maintenance.
- F. **Spare Parts List and Source Information:** Include lists of replacement and repair parts, with parts identified and cross-referenced to manufacturers' maintenance documentation and local sources of maintenance materials and related services.
- G. **Maintenance Service Contracts:** Include copies of maintenance agreements with name and telephone number of service agent.
- H. **Warranties and Bonds:** Include copies of warranties and bonds and lists of circumstances and conditions that would affect validity of warranties or bonds.
  - 1. Include procedures to follow and required notifications for warranty claims.

### **PART 3 - EXECUTION**

#### **3.1 MANUAL PREPARATION**

- A. **Operation and Maintenance Documentation Directory:** Prepare a separate manual that provides an organized reference to emergency, operation, and maintenance manuals.
- B. **Emergency Manual:** Assemble a complete set of emergency information indicating procedures for use by emergency personnel and by Owner's operating personnel for types of emergencies indicated.

- C. Product Maintenance Manual: Assemble a complete set of maintenance data indicating care and maintenance of each product, material, and finish incorporated into the Work.
- D. Operation and Maintenance Manuals: Assemble a complete set of operation and maintenance data indicating operation and maintenance of each system, subsystem, and piece of equipment not part of a system.
  - 1. Engage a factory-authorized service representative to assemble and prepare information for each system, subsystem, and piece of equipment not part of a system.
  - 2. Prepare a separate manual for each system and subsystem, in the form of an instructional manual for use by Owner's operating personnel.
- E. Manufacturers' Data: Where manuals contain manufacturers' standard printed data, include only sheets pertinent to product or component installed. Mark each sheet to identify each product or component incorporated into the Work. If data include more than one item in a tabular format, identify each item using appropriate references from the Contract Documents. Identify data applicable to the Work and delete references to information not applicable.
  - 1. Prepare supplementary text if manufacturers' standard printed data are not available and where the information is necessary for proper operation and maintenance of equipment or systems.
- F. Drawings: Prepare drawings supplementing manufacturers' printed data to illustrate the relationship of component parts of equipment and systems and to illustrate control sequence and flow diagrams. Coordinate these drawings with information contained in record Drawings to ensure correct illustration of completed installation.
  - 1. Do not use original project record documents as part of operation and maintenance manuals.
  - 2. Comply with requirements of newly prepared record Drawings in Section 017839 "Project Record Documents."
- G. Comply with Section 017700 "Closeout Procedures" for schedule for submitting operation and maintenance documentation.

END OF SECTION

## **DIVISION 01 - GENERAL REQUIREMENTS**

### **SECTION 017839 PROJECT RECORD DOCUMENTS**

#### **PART 1 - GENERAL**

##### **1.1 SUMMARY**

- A. Section includes administrative and procedural requirements for project record documents, including the following:
  - 1. Record Drawings.
  - 2. Record Specifications.
  - 3. Record Product Data.
  - 4. Miscellaneous record submittals.
- B. Related Requirements:
  - 1. Section 011200 "Multiple Contract Summary" for coordinating project record documents covering the Work of multiple contracts.
  - 2. Section 017300 "Execution" for final property survey.
  - 3. Section 017700 "Closeout Procedures" for general closeout procedures including timing for required submittal.
  - 4. Section 017823 "Operation and Maintenance Data" for operation and maintenance manual requirements.

##### **1.2 CLOSEOUT SUBMITTALS**

- A. Record Drawings: Comply with the following:
  - 1. Number of Copies: Submit one set(s) of marked-up record prints.
- B. Record Specifications: Submit one paper copy and annotated PDF electronic files of Project's Specifications, including addenda and contract modifications.
- C. Record Product Data: Submit one paper copy and annotated PDF electronic files and directories of each submittal.
  - 1. Where record Product Data are required as part of operation and maintenance manuals, submit duplicate marked-up Product Data as a component of manual.
- D. Miscellaneous Record Submittals: See other Specification Sections for miscellaneous record-keeping requirements and submittals in connection with various construction activities. Submit one paper copy and annotated PDF electronic files and directories of each submittal.
- E. Reports: Submit written report weekly indicating items incorporated into project record documents concurrent with progress of the Work, including revisions, concealed conditions, field changes, product selections, and other notations incorporated.

## **PART 2 - PRODUCTS**

### **2.1 RECORD DRAWINGS**

- A. Record Prints: Maintain one set of marked-up paper copies of the Contract Drawings and Shop Drawings, incorporating new and revised drawings as modifications are issued.
1. Preparation: Mark record prints to show the actual installation where installation varies from that shown originally. Require individual or entity who obtained record data, whether individual or entity is Installer, subcontractor, or similar entity, to provide information for preparation of corresponding marked-up record prints.
    - a. Give particular attention to information on concealed elements that would be difficult to identify or measure and record later.
    - b. Accurately record information in an acceptable drawing technique.
    - c. Record data as soon as possible after obtaining it.
    - d. Record and check the markup before enclosing concealed installations.
    - e. Cross-reference record prints to corresponding archive photographic documentation.
  2. Content: Types of items requiring marking include, but are not limited to, the following:
    - a. Dimensional changes to Drawings.
    - b. Revisions to details shown on Drawings.
    - c. Depths of foundations below first floor.
    - d. Locations and depths of underground utilities.
    - e. Revisions to routing of piping and conduits.
    - f. Revisions to electrical circuitry.
    - g. Actual equipment locations.
    - h. Duct size and routing.
    - i. Locations of concealed internal utilities.
    - j. Changes made by Change Order or Construction Change Directive.
    - k. Changes made following Architect's written orders.
    - l. Details not on the original Contract Drawings.
    - m. Field records for variable and concealed conditions.
    - n. Record information on the Work that is shown only schematically.
  3. Mark the Contract Drawings and Shop Drawings completely and accurately. Use personnel proficient at recording graphic information in production of marked-up record prints.
  4. Mark record sets with erasable, red-colored pencil. Use other colors to distinguish between changes for different categories of the Work at same location.
  5. Mark important additional information that was either shown schematically or omitted from original Drawings.
  6. Note Construction Change Directive numbers, alternate numbers, Change Order numbers, and similar identification, where applicable.
- B. Format: Identify and date each record Drawing; include the designation "PROJECT RECORD DRAWING" in a prominent location.

1. Record Prints: Organize record prints and newly prepared record Drawings into manageable sets. Bind each set with durable paper cover sheets. Include identification on cover sheets.
2. Format: Annotated PDF electronic file with comment function enabled.
3. Identification: As follows:
  - a. Project name.
  - b. Date.
  - c. Designation "PROJECT RECORD DRAWINGS."
  - d. Name of Architect.
  - e. Name of Contractor.

## 2.2 RECORD SPECIFICATIONS

- A. Preparation: Mark Specifications to indicate the actual product installation where installation varies from that indicated in Specifications, addenda, and contract modifications.
  1. Give particular attention to information on concealed products and installations that cannot be readily identified and recorded later.
  2. Mark copy with the proprietary name and model number of products, materials, and equipment furnished, including substitutions and product options selected.
  3. Record the name of manufacturer, supplier, Installer, and other information necessary to provide a record of selections made.
  4. For each principal product, indicate whether record Product Data has been submitted in operation and maintenance manuals instead of submitted as record Product Data.
  5. Note related Change Orders, record Product Data, and record Drawings where applicable.
- B. Format: Submit record Specifications as paper copy and scanned PDF electronic file(s) of marked-up paper copy of Specifications.

## 2.3 RECORD PRODUCT DATA

- A. Preparation: Mark Product Data to indicate the actual product installation where installation varies substantially from that indicated in Product Data submittal.
  1. Give particular attention to information on concealed products and installations that cannot be readily identified and recorded later.
  2. Include significant changes in the product delivered to Project site and changes in manufacturer's written instructions for installation.
  3. Note related Change Orders, record Specifications, and record Drawings where applicable.
- B. Format: Submit record Product Data as annotated PDF electronic file.
  1. Include record Product Data directory organized by Specification Section number and title, electronically linked to each item of record Product Data.

## 2.4 MISCELLANEOUS RECORD SUBMITTALS

- A. Assemble miscellaneous records required by other Specification Sections for miscellaneous record keeping and submittal in connection with actual performance of the Work. Bind or file miscellaneous records and identify each, ready for continued use and reference.

- B. Format: Submit miscellaneous record submittals as PDF electronic file.
  - 1. Include miscellaneous record submittals directory organized by Specification Section number and title, electronically linked to each item of miscellaneous record submittals.

### **PART 3 - EXECUTION**

#### **3.1 RECORDING AND MAINTENANCE**

- A. Recording: Maintain one copy of each submittal during the construction period for project record document purposes. Post changes and revisions to project record documents as they occur; do not wait until end of Project.
- B. Maintenance of Record Documents and Samples: Store record documents and Samples in the field office apart from the Contract Documents used for construction. Do not use project record documents for construction purposes. Maintain record documents in good order and in a clean, dry, legible condition, protected from deterioration and loss. Provide access to project record documents for Architect's reference during normal working hours.

END OF SECTION



## **DIVISION 01 - GENERAL REQUIREMENTS**

### **SECTION 017900** **DEMONSTRATION AND TRAINING**

#### **PART 1 - GENERAL**

##### **1.1 SUMMARY**

- A. Section includes administrative and procedural requirements for instructing Owner's personnel, including the following:
  - 1. Demonstration of operation of systems, subsystems, and equipment.
  - 2. Training in operation and maintenance of systems, subsystems, and equipment.
  - 3. Demonstration and training video recordings.

##### **1.2 INFORMATIONAL SUBMITTALS**

- A. Instruction Program: Submit outline of instructional program for demonstration and training, including a list of training modules and a schedule of proposed dates, times, length of instruction time, and instructors' names for each training module. Include learning objective and outline for each training module.
  - 1. Indicate proposed training modules using manufacturer-produced demonstration and training video recordings for systems, equipment, and products in lieu of video recording of live instructional module.
- B. Qualification Data: For facilitator, instructor, and videographer.
- C. Attendance Record: For each training module, submit list of participants and length of instruction time.
- D. Evaluations: For each participant and for each training module, submit results and documentation of performance-based test.

##### **1.3 CLOSEOUT SUBMITTALS**

- A. Demonstration and Training Video Recordings: Submit two copies within seven days of end of each training module.
  - 1. Identification: On each copy, provide an applied label with the following information:
    - a. Name of Project.
    - b. Name and address of videographer.
    - c. Name of Architect.
    - d. Name of Construction Manager.
    - e. Name of Contractor.
    - f. Date of video recording.

2. Transcript: Prepared in PDF electronic format. Include a cover sheet with same label information as the corresponding video recording and a table of contents with links to corresponding training components. Include name of Project and date of video recording on each page.
3. At completion of training, submit complete training manual(s) for Owner's use in PDF electronic file format on compact disc.

#### 1.4 QUALITY ASSURANCE

- A. Facilitator Qualifications: A firm or individual experienced in training or educating maintenance personnel in a training program similar in content and extent to that indicated for this Project, and whose work has resulted in training or education with a record of successful learning performance.
- B. Instructor Qualifications: A factory-authorized service representative, complying with requirements in Section 014000 "Quality Requirements," experienced in operation and maintenance procedures and training.
- C. Videographer Qualifications: A professional videographer who is experienced photographing demonstration and training events similar to those required.
- D. Preinstruction Conference: Conduct conference at Project site to comply with requirements in Section 013100 "Project Management and Coordination." Review methods and procedures related to demonstration and training including, but not limited to, the following:
  1. Inspect and discuss locations and other facilities required for instruction.
  2. Review and finalize instruction schedule and verify availability of educational materials, instructors' personnel, audiovisual equipment, and facilities needed to avoid delays.
  3. Review required content of instruction.
  4. For instruction that must occur outside, review weather and forecasted weather conditions and procedures to follow if conditions are unfavorable.

#### 1.5 COORDINATION

- A. Coordinate instruction schedule with Owner's operations. Adjust schedule as required to minimize disrupting Owner's operations and to ensure availability of Owner's personnel.
- B. Coordinate instructors, including providing notification of dates, times, length of instruction time, and course content.
- C. Coordinate content of training modules with content of approved emergency, operation, and maintenance manuals. Do not submit instruction program until operation and maintenance data has been reviewed and approved by Architect.

## **PART 2 - PRODUCTS**

### 2.1 INSTRUCTION PROGRAM

- A. Program Structure: Develop an instruction program that includes individual training modules for each system and for equipment not part of a system, as required by individual Specification Sections.

- B. Training Modules: Develop a learning objective and teaching outline for each module. Include a description of specific skills and knowledge that participant is expected to master. For each module, include instruction for the following as applicable to the system, equipment, or component:
1. Basis of System Design, Operational Requirements, and Criteria: Include the following:
    - a. System, subsystem, and equipment descriptions.
    - b. Performance and design criteria if Contractor is delegated design responsibility.
    - c. Operating standards.
    - d. Regulatory requirements.
    - e. Equipment function.
    - f. Operating characteristics.
    - g. Limiting conditions.
    - h. Performance curves.
  2. Documentation: Review the following items in detail:
    - a. Emergency manuals.
    - b. Operations manuals.
    - c. Maintenance manuals.
    - d. Project record documents.
    - e. Identification systems.
    - f. Warranties and bonds.
    - g. Maintenance service agreements and similar continuing commitments.
  3. Emergencies: Include the following, as applicable:
    - a. Instructions on meaning of warnings, trouble indications, and error messages.
    - b. Instructions on stopping.
    - c. Shutdown instructions for each type of emergency.
    - d. Operating instructions for conditions outside of normal operating limits.
    - e. Sequences for electric or electronic systems.
    - f. Special operating instructions and procedures.
  4. Operations: Include the following, as applicable:
    - a. Startup procedures.
    - b. Equipment or system break-in procedures.
    - c. Routine and normal operating instructions.
    - d. Regulation and control procedures.
    - e. Control sequences.
    - f. Safety procedures.
    - g. Instructions on stopping.
    - h. Normal shutdown instructions.
    - i. Operating procedures for emergencies.
    - j. Operating procedures for system, subsystem, or equipment failure.
    - k. Seasonal and weekend operating instructions.
    - l. Required sequences for electric or electronic systems.
    - m. Special operating instructions and procedures.

5. Adjustments: Include the following:
  - a. Alignments.
  - b. Checking adjustments.
  - c. Noise and vibration adjustments.
  - d. Economy and efficiency adjustments.
6. Troubleshooting: Include the following:
  - a. Diagnostic instructions.
  - b. Test and inspection procedures.
7. Maintenance: Include the following:
  - a. Inspection procedures.
  - b. Types of cleaning agents to be used and methods of cleaning.
  - c. List of cleaning agents and methods of cleaning detrimental to product.
  - d. Procedures for routine cleaning
  - e. Procedures for preventive maintenance.
  - f. Procedures for routine maintenance.
  - g. Instruction on use of special tools.
8. Repairs: Include the following:
  - a. Diagnosis instructions.
  - b. Repair instructions.
  - c. Disassembly; component removal, repair, and replacement; and reassembly instructions.
  - d. Instructions for identifying parts and components.
  - e. Review of spare parts needed for operation and maintenance.

### **PART 3 - EXECUTION**

#### **3.1 PREPARATION**

- A. Assemble educational materials necessary for instruction, including documentation and training module. Assemble training modules into a training manual organized in coordination with requirements in Section 017823 "Operation and Maintenance Data."
- B. Set up instructional equipment at instruction location.

#### **3.2 INSTRUCTION**

- A. Facilitator: Engage a qualified facilitator to prepare instruction program and training modules, to coordinate instructors, and to coordinate between Contractor and Owner for number of participants, instruction times, and location.
- B. Engage qualified instructors to instruct Owner's personnel to adjust, operate, and maintain systems, subsystems, and equipment not part of a system.
  1. Owner will furnish Contractor with names and positions of participants.

- C. Scheduling: Provide instruction at mutually agreed on times. For equipment that requires seasonal operation, provide similar instruction at start of each season.
  - 1. Schedule training with Owner with at least seven days' advance notice.
- D. Training Location and Reference Material: Conduct training on-site in the completed and fully operational facility using the actual equipment in-place. Conduct training using final operation and maintenance data submittals.
- E. Evaluation: At conclusion of each training module, assess and document each participant's mastery of module by use of an oral performance-based test.
- F. Cleanup: Collect used and leftover educational materials and give to Owner. Remove instructional equipment. Restore systems and equipment to condition existing before initial training use.

END OF SECTION

## DIVISION 3 – CONCRETE

### SECTION 033000

#### CAST-IN-PLACE CONCRETE

##### PART 1 - GENERAL

##### 1.1 RELATED DOCUMENTS

- A. Drawings and general provisions of the Contract, including General and Supplementary Conditions and Division 01 Specification Sections, apply to this Section.

##### 1.2 SUMMARY

- A. This Section specifies cast-in place concrete, including formwork, reinforcement, concrete materials, mixture design, placement procedures, and finishes, for the following:
  - 1. Superstructure.
  - 2. Concrete toppings.
- B. Related Sections include the following:
  - 1. Division 04 Section "Unit Masonry" for unit masonry construction.
  - 2. Division 05 Section "Structural Steel Framing" for steel framing and post-installed concrete anchors.
  - 3. Division 05 Section "Steel Decking" for metal decks.

##### 1.3 DEFINITIONS

- A. Cementitious Materials: Portland cement alone or in combination with one or more of the following: blended hydraulic cement, fly ash and other pozzolans, ground granulated blast-furnace slag, and silica fume; subject to compliance with requirements.

##### 1.4 SUBMITTALS

- A. General:
  - 1. Review of submittals is of a general nature only, and the responsibility for conformance with intent of drawings shall remain with the Contractor. Review does not imply or state that the fabricator has correctly interpreted the construction documents.
  - 2. All submissions shall be in accordance with the submission schedule developed and agreed between the Architect and Contractor at the commencement of the project. Submission shall include dates of order and delivery of materials to the shop and the site.
  - 3. Shop drawing schedule shall allow adequate time for reviews. Reinforcing steel shall not be fabricated or placed before the shop drawings have been reviewed by the Architect and returned.
- B. Product Data: For each type of product indicated, including ICC-ES for mechanical couplers.

- C. Design Mixtures: Each concrete mix design to be used on the project shall be reviewed and approved by the Testing Agency and Architect prior to concrete being delivered to site. Submit proposed mix designs for each class of concrete on the Mix Design submittal form included at the end of this specification. Submit alternate design mixtures when characteristics of materials, Project conditions, weather, test results, or other circumstances warrant adjustments.
1. For each concrete mixture, the following information shall be included: where the mix is to be used, all materials and admixtures including their source and proportions in the mix; Water content, water-to-cement ratio, slump, and aggregate grading; whether the mixture is appropriate for pumping; and total chloride content.
  2. Provide shrinkage test results for mixes with shrinkage criteria showing that mix meets performance criteria. The mix design number must match with the mix design number shown on the test data.
  3. Indicate compressive strength and method used to determine strength. The compressive strength of the concrete shall be proportioned per ACI. Include all calculations and tests required by ACI 318 Section 5.3 and 5.4. Laboratory test data must be submitted along calculations that show with each mix design meets the strength requirement. Mix design number must match the mix design number shown on the test data. Include all test results or past history back up data specific as part of the submittal. Test results within the past two years shall be used to indicate performance in accordance with past history.
  4. Indicate amounts of mixing water to be withheld for later addition at Project site.
  5. Each mix shall be stamped and signed by a Professional Engineer licensed in the State of Illinois.
- D. Steel Reinforcement Shop Drawings: Placing drawings in accordance with SP 66 that detail fabrication, bending, and placement. Direct copies of the contract documents are not acceptable as a submission from the Contractor.
1. Include bar sizes, lengths, material, grade, bar schedules, stirrup spacing, bent bar diagrams, bar arrangement, splices and laps, mechanical connections, tie spacing, hoop spacing, and supports for concrete reinforcement. Include any welding to be done.
  2. Shop drawings shall make it clear where each bar is located. Beams, grade beams and walls shall be shown in elevation. On elevations show locations of sleeves and penetrations.
  3. Check architectural, structural, mechanical, and electrical and other contract documents for anchor bolt schedules and locations, anchors, inserts, conduits, sleeves, and any other items which are required to be cast in concrete, and make necessary provisions as required so that reinforcing steel will not interfere with the placement of such embedded items.
  4. Show all areas of congestion. Identify where reinforcing steel will interfere with the placement of embedded items such as anchor bolts, anchors, inserts, conduits, sleeves and any other items which are required to be cast in concrete.
- E. Show on one or more plans and/or elevations, locations of construction, contraction and expansion of joints, slab edges, curbs, equipment pads, depressions, sleeves and openings.
- F. Mill Test Reports: Submit steel producer's certificates of mill analysis for each heat or melt of reinforcing steel, including steel source, description, heat number, yield point, ultimate tensile strength, elongation percent, bend test and the chemical composition of each heat as determined by ladle analysis, before delivery of steel to site. Where steel is required to be welded, mill reports shall be used to help verify the weldability of the steel.
- G. Material Test Reports: For the following, from a qualified testing agency, indicating compliance with requirements:
1. Lightweight aggregate (per ASTM C330).

Include service record data indicating absence of deleterious expansion of concrete due to alkali aggregate reactivity. Include evaluation of reactivity and the following:

- a. Abrasion Resistance: ASTM C131; Los Angeles Machine.
  - b. Cleanness Value: Test Method NO. C 227; coarse aggregate only.
  - c. Fineness: ASTM C117.
  - d. Organic Impurities: ASTM C40.
  - e. Potential Reactivity: ASTM C289.
  - f. Sand Equivalent: Test Method No. C 217.
  - g. Sieve Analysis: ASTM C136.
  - h. Soundness: ASTM C88.
  - i. Absorption for lightweight aggregate: Maximum 15%.
- H. Submit a complete description of the system proposed for meeting the specified floor slab flatwork tolerances. Submit survey data from a minimum of two previous slab installations to demonstrate capability to satisfy specified tolerances.
- I. Submit an affidavit identifying cementitious material used, including manufacturer's lot number, date of shipment by manufacturer, date of receipt by the concrete supplier, place of storage and date of use. If such information is not available, a sample of cementitious material used on the Project shall be taken for each day's pour and shall be tested as directed by the Architect.
- J. Transit-Mix Delivery Slips
1. Keep record at the Site showing time and place of each pour of concrete, together with transit mix delivery slip certifying contents of the pour per ASTM C94. Include the time water was added to dry mix.
  2. Make the record available for inspection at the Site and to the Architect for his review upon request.
  3. Upon completion of this portion of the Work, deliver the record and the delivery slips to the Architect.

## 1.5 QUALITY ASSURANCE

- A. Standards: Comply with the following unless modified by requirements in the Contract Documents:
1. ACI 117, "Specifications for Tolerances for Concrete Construction and Materials."
  2. ACI 301, "Specification for Structural Concrete," Sections 1 through 5 and Section 7, "Lightweight Concrete."
  3. ACI 318, "Building Code Requirements for Reinforced Concrete."
  4. ACI SP-66, "Detailing Manual"
  5. City of Chicago Building Code
- B. Installer Qualifications: A qualified installer who employs on Project personnel qualified as ACI-certified Flatwork Technician and Finisher and a supervisor who is an ACI-certified Concrete Flatwork Technician.
- C. Manufacturer Qualifications: A firm experienced in manufacturing ready-mixed concrete products and that complies with ASTM C 94/C 94M requirements for production facilities and equipment.
- D. Testing Agency Qualifications: An independent agency qualified according to ASTM C 1077 and ASTM E 329 for testing indicated, as documented according to ASTM E 548.



1. Personnel conducting field tests shall be qualified as ACI Concrete Field Testing Technician, Grade 1, according to ACI CP-01 or an equivalent certification program.
  2. Personnel performing laboratory tests shall be ACI-certified Concrete Strength Testing Technician and Concrete Laboratory Testing Technician - Grade I. Testing Agency laboratory supervisor shall be an ACI-certified Concrete Laboratory Testing Technician - Grade II.
- E. Testing Agency: Shall be selected and paid for by the Owner, unless otherwise specified; re-testing paid for by the Contractor.
- F. Contractor's Quality Control Plan: Quality Control includes the functions performed by the Contractor to ensure that the material and workmanship of concrete construction meets the project specifications and applicable standards. The Contractor shall submit a Quality Control Plan that addresses all inspection issues, including testing and inspection per ACI. The verification testing and inspection carried out by the Testing Agency does not relieve the contractor of the responsibility for conducting their own quality control/inspection program to ensure the requirements of the Contract Documents have been met. The Contractor's Quality Control Plan will be reviewed by the Testing Agency.
- G. Quality Control Inspector Qualifications: Along with Quality Control Plan, Contractor shall submit written qualifications for all inspectors to be assigned Quality Control functions for concrete work.
- H. Source Limitations: Obtain each type or class of cementitious material of the same brand from the same manufacturer's plant, obtain aggregate from one source, and obtain admixtures through one source from a single manufacturer.
- I. Unidentifiable Reinforcing Steel: Tested by testing agency; paid for by Contractor:
1. Test reinforcing delivered to site which cannot be properly identified by heat number and mill mark for compliance with ASTM A615 as follows:
    - a. No. 8 Bar and Smaller: One tensile test and one bend test of each size per 7-1/2 tons, or portion thereof.
    - b. No. 9 Bar and Larger: One tensile test of each size per 10 tons, or portion thereof.
- J. Concrete Testing Service: Engage a qualified independent testing agency to perform material evaluation tests and to test concrete mixtures. When mixes, are proportioned by trial batch method, engage a Laboratory conforming to ASTM E329 and under direction of a Professional Engineer licensed in the State of Illinois.
- K. Prefabrication and Preinstallation Conference: Conduct conference at Project site to comply with requirements in Division 01 Section "Project Management and Coordination."
1. Before submitting design mixtures, review concrete design mixture and examine procedures for ensuring quality of concrete materials. Require representatives of each entity directly concerned with cast-in-place concrete to attend, including the following:
    - a. Contractor's superintendent.
    - b. Independent testing agency responsible for concrete design mixtures.
    - c. Ready-mix concrete manufacturer.
    - d. Concrete subcontractor.
  2. Review special inspection and testing and inspecting agency procedures for field quality control, concrete finishes and finishing, cold- and hot-weather concreting procedures, curing procedures, construction contraction and isolation joints, and joint-filler strips, anchor rod and anchorage device installation tolerances, steel reinforcement installation,

floor and slab flatness and levelness measurement, concrete repair procedures, and concrete protection.

## 1.6 DELIVERY, STORAGE, AND HANDLING

### A. Steel Reinforcement:

1. Deliver, store, and handle steel reinforcement to prevent bending and damage.
2. Deliver reinforcing to Site properly bundled and tagged. Use tags that indicate bar size, lengths and marks corresponding to markings shown on shop drawings. Segregate so as to maintain identification after bundles are broken.
3. Store reinforcement in a manner that will prevent excessive rusting or fouling with/grease, oil, dirt, and other bond weakening materials.
4. Do not use damaged, reworked, or deteriorated material.

### B. Concrete Materials:

1. Protect cement from moisture and rotate stock to ensure fresh materials.
2. Protect aggregates as necessary to maintain saturated condition when batched.
3. Storage methods should comply with ACI 301 4.1.4.

## PART 2 - PRODUCTS

### 2.1 MANUFACTURERS

#### A. In other Part 2 articles where titles below introduce lists, the following requirements apply to product selection:

1. Available Products: Subject to compliance with requirements, products that may be incorporated into the Work include, but are not limited to, products specified.
2. Products: Subject to compliance with requirements, provide one of the products specified.
3. Available Manufacturers: Subject to compliance with requirements, manufacturers offering products that may be incorporated into the Work include, but are not limited to, manufacturers specified.
4. Manufacturers: Subject to compliance with requirements, provide products by one of the manufacturers specified.

### 2.2 FORM-FACING MATERIALS

#### A. Smooth-Formed Finished Concrete: Form-facing panels that will provide continuous, true, and smooth concrete surfaces. Furnish in largest practicable sizes to minimize number of joints.

1. Plywood, metal, or other approved panel materials.

#### B. Rough-Formed Finished Concrete: Plywood, lumber, metal, or another approved material. Provide lumber dressed on at least two edges and one side for tight fit.

#### C. For exposed surfaces not otherwise specified use Special exterior Type Douglas Fir, Grade AB plywood, conforming to NBS PS-1, minimum 3/4 in. thick and constructed so that finished concrete will be straight, smooth, dense, free from honeycombs, bulges, or depressions. Keep

joints between plywood sections to a minimum and make tight and strongly backed so that adjoining edges remain flush and true.

- D. Foam Filler or High Density Styrofoam Fill: Expanded polystyrene foam, ASTM C578, Type IX, 1.9 pounds per cubic foot density.
- E. Form-Release Agent: Commercially formulated form-release agent that will not bond with, stain, or adversely affect concrete surfaces and will not impair subsequent treatments of concrete surfaces.
  - 1. Formulate form-release agent with rust inhibitor for steel form-facing materials.
  - 2. Form release agents shall have a VOC content of 350 grams/liter or less.

## 2.3 STEEL REINFORCEMENT

- A. Recycled Content of Steel Products: Concrete reinforcement shall contain a minimum of 25% combined post-industrial and post-consumer recycled content where the percentage of recycled content is based on the weight of the component materials.
- B. Reinforcing Bars:
  - 1. ASTM A615, Grade 60, deformed, unless noted otherwise.
- C. Tie Wire: American Wire 16 gauge or heavier black annealed wire.
- D. Plain-Steel Welded Wire Reinforcement: ASTM A185, plain, fabricated from as-drawn steel wire into flat sheets.

## 2.4 REINFORCEMENT ACCESSORIES

- A. Bar Supports: Bolsters, chairs, spacers, and other devices for spacing, supporting, and fastening reinforcing bars and welded wire reinforcement in place. Manufacture bar supports from steel wire, plastic, or precast concrete according to CRSI's "Manual of Standard Practice," of greater compressive strength than concrete and as follows:

## 2.5 REINFORCEMENT FABRICATION

- A. Fabricate reinforcing in accordance with ACI 301, 315 or CRSI "Manual of Standard Practice."
- B. Bending:
  - 1. Do not bend or kink reinforcing except as shown on the Drawings.
  - 2. Minimum bend diameters and hook extensions as shown on the drawings or per ACI.
  - 3. In case of fabrication errors do not rebend or straighten reinforcement in a manner that will injure or weaken the material.
  - 4. Reinforcing bars are to be bent cold, do not preheat, unless approved by Architect.
  - 5. Do not rebend reinforcement that has previously been bent within 6 inches of new bend except as allowed in section 3.3.2.8 of ACI 301.
- C. Unacceptable Materials: Reinforcement with any of the following defects shall not be permitted in the Work and will be replaced without cost:
  - 1. Bar lengths, depths and bends exceeding specified fabrication tolerances.

2. Bend or kinks not shown on the Drawings or final shop drawings.
3. Bars with reduced cross-section due to rusting or other cause.
4. Bars with dirt, mud, grease or form release agent.

## 2.6 CONCRETE MATERIALS

- A. Cementitious Material: Use the following cementitious materials, of the same type, brand, and source, throughout Project:
1. Portland Cement: ASTM C150, Type II, unless noted otherwise.
  2. Supplement Portland Cement with the following Supplementary Cementitious Materials (SCM):
    - a. Fly Ash: ASTM C618, Class C.
    - b. Ground Granulated Blast-Furnace Slag: ASTM C989, Grade 100 or 120.
    - c. The SCM producer shall have a minimum of 5 years experience in the production of acceptable SCM and shall practice an effective quality control program to guard against contamination of the SCM.
  3. Cementitious material used shall have at least 2 years of use with proposed aggregates without detrimental reaction.
  4. Alkali content shall not exceed 0.6% when tested in accordance with ASTM C114.
  5. The temperature of cement delivered to the plant shall not exceed 150 degrees F.
- B. Lightweight Aggregate: ASTM C330, 1/2-inch nominal maximum aggregate size.
1. Lightweight cellular and granular inorganic materials, free from oil, organic matter, or other deleterious substances.
  2. Uniformly graded from 1/4-inch to maximum size. The combined grading shall be such that the percentage of weight of the combined aggregates shall fall within the limits established by ASTM C330.
  3. Dry weight of lightweight concrete shall not be greater than 115 pcf.
  4. Lightweight Aggregates Rotary Kiln Produced: Expanded shale slate, clay or slag aggregate, the maximum size used in a particular location shall be consistent with the form and dimensions of the section being placed, with the location and spacing of the reinforcing steel and with the method of vibration. The aggregate sizes shall be such as will produce dense, uniform concrete, free of honeycombs, or other irregularities.
- C. Water: ASTM C94, clean, free from deleterious matter.

## 2.7 ADMIXTURES

- A. General: Only if accepted by the Owner's Representative in accordance with ACI 318/318R 3.6 if they comply with requirements of ASTM C494. Where more than one is used, admixtures shall be compatible. Use of admixtures shall be consistent throughout Work.
1. Where specified herein do not use other admixtures without the written acceptance of the Architect.
  2. Prohibited Admixtures: Admixtures containing more than 0.05 percent chloride ions, fluorides, sulphites, thiocyanates, and/or nitrates are not permitted. Do not use admixtures that will negatively impact the visual finish of concrete exposed to view.
- B. Air-Entraining Admixture: ASTM C 260, certified by manufacturer to be compatible with other admixtures
1. Products:

- a. Grace Construction Materials; Darex AEA or Daravair
  - b. Master Builders, Inc.; MB-VR or Micro Air
  - c. Euclid Chemical Company (The); Air Mix
- C. Chemical Admixtures: Provide admixtures certified by manufacturer to be compatible with other admixtures and that will not contribute water-soluble chloride ions exceeding those permitted in hardened concrete. Do not use calcium chloride or admixtures containing calcium chloride.
- 1. Water-Reducing (Plasticizing) Admixture: ASTM C494, Type A. Products:
    - a. Grace Construction Products, W. R. Grace & Co.; "WRDA with Hycol"
    - b. Master Builders, Inc.; "Pozzolith 220N"
    - c. Euclid Chemical Company (The); "WR-75, WR-91 or Eucon MR"
  - 2. Retarding Admixture: ASTM C494, Type B.
  - 3. Water-Reducing and Retarding Admixture: ASTM C494, Type D. Products:
    - a. Sika Corporation; "Sikament 30,"
    - b. Euclid Chemical Company (The); "Eucon Retarder-75"
  - 4. High-Range, Water-Reducing (Superplasticizers) Admixture: ASTM C494, Type F. Products:
    - a. Grace Construction Products, W. R. Grace & Co.; "WRDA 19 or Daracem 100"
    - b. Sika Corporation; "Sikament 300"
    - c. BASF Construction Products; "Rheobuild 1000"
    - d. Euclid Chemical Company (The); "Eucon 37, 1037 or Plastol 5000"
  - 5. High-Range, Water-Reducing and Retarding Admixture: ASTM C494, Type G.
  - 6. Plasticizing and Retarding Admixture: ASTM C1017, Type II.
  - 7. Non-Chloride, Non-Corrosive Accelerating Admixture: ASTM C494, Type C or E. Manufacturer must have long-term non-corrosive test data from an independent testing laboratory (of at least a year's duration) using an acceptable accelerated corrosion test method. Products:
    - a. Euclid Chemical Company (The); "Accelguard 80, 90, or NCA"

## 2.8 CURING MATERIALS

- A. Absorptive Cover: AASHTO M182, Class 2, burlap cloth made from jute or kenaf, weighing approximately 9 oz./sq. yd. when dry.
- B. Moisture-Retaining Cover: ASTM C171, polyethylene film, fiber reinforced asphaltic vapor barrier building paper, or white burlap-polyethylene sheet.
  - 1. Provide in a thickness of 42 mils; standard weight of 53 lbs./1000 ft<sup>2</sup>; tensile strength (machine direction) of 36 lbs./in.; and puncture resistance of 70 lbs.
- C. Curing compounds shall have a VOC limit of 200 g/l.
- D. Clear, Waterborne, Membrane-Forming Curing Compound: ASTM C309, Type 1, Class B, dissipating. Sodium silicate compounds are prohibited.
- E. Clear, Waterborne, Membrane-Forming Curing Compound: ASTM C309, Type 1, Class B, nondissipating, certified by curing compound manufacturer to not interfere with bonding of floor covering. Sodium silicate compounds are prohibited.
- F. Clear, Waterborne, Membrane-Forming Curing Compound: ASTM C309, Type 1, Class B, 18 to 25 percent solids, nondissipating, certified by curing compound manufacturer to not interfere with bonding of floor covering. Sodium silicate compounds are prohibited.

## 2.9 RELATED MATERIALS

- A. Bonding Agent: ASTM C1059, Type II, non-redispersible, acrylic emulsion or styrene butadiene.
- B. Epoxy Bonding Adhesive: ASTM C881, two-component epoxy resin, capable of humid curing and bonding to damp surfaces, of class suitable for application temperature and of grade to suit requirements, and as follows:
  - 1. Types IV and V, load bearing, for bonding hardened or freshly mixed concrete to hardened concrete.
- C. Post-Installed Concrete Anchors:
  - 1. Expansion Anchors: Kwik Bolt by Hilti Inc, Trubolt Wedge by ITW Ramset/Red Head, Power-Stud by Powers-Rawl, or approved equal.
  - 2. Epoxy Dowels / Epoxy Anchors: HIT HY 150 by Hilti, Inc., CIA-Gel 7000 by Covert Operations, SET by Simpson Strong Tie, Power-Fast by Powers-Rawl, or approved equal.
  - 3. Grouted Dowels / Grouted Anchors: High strength non-shrink grout to anchor reinforcing steel or threaded rods in concrete shall be Masterflow 928 grout as manufactured by Master Builders, Sika Grout 212 as manufactured by Sika Corporation, or approved equal.

## 2.10 MORTARS AND GROUTS

- A. Bonding Grout: Approximately 1 part Portland cement to 1 part fine sand passing a no 30 sieve and a 50/50 mixture of approved bonding admixture and water, mixed to a consistency of thick paint and not exceeding the w/cm of the concrete to be bonded.
- B. Patching Mortar for exposed concrete shall be made of the same material and of approximately the same proportions as used for concrete, except that coarse aggregate shall be omitted and mortar shall consist of not more than 1 part Portland cement to 2-1/2 parts damp loose sand by volume.
  - 1. Combine white and gray Portland cement as necessary to match color specified by Architect. Use no more mixing water than necessary for handling and placing.
  - 2. Mix patching mortar in advance and allow to stand with frequent mixing with trowel without adding water until it has reached the stiffest consistency that will permit placing.
- C. High Flow Grout:
  - 1. Where high fluidity and/or increased placing time is required, use high flow grout.
  - 2. ASTM C1107, "Standard Specification for Packaged Dry, Hydraulic-Cement Grout (Non-Shrink)".
  - 3. When placed at a fluid consistency there shall be at least 95% bearing under an 18 inches x 36 inches base plate.
  - 4. "Hi-Flow Grout" manufactured by The Euclid Chemical Company or "Masterflow 928" manufactured by BASF Construction Products.
- D. Epoxy grout for anchor reinforcing steel or threaded rods in concrete shall be Masterflow MP as manufactured by BASF Construction Products, or Sikadur 32 Hi-Mod as manufactured by Sika Corporation, or Epoxy 452 or E3G by Euclid Chemical Company.

- E. Cementitious grout for anchor reinforcing steel or threaded rods in concrete shall be Masterflow 928 grout as manufactured by BASF Construction Products or Sika Grout 212 as manufactured by Sika Corporation, Hi-Flow grout by Euclid Chemical Company.
- F. Drypack Mortar for Form Holes at Non-Architectural Grade Surfaces: Composed of 1 part Portland cement and 2 parts of fine aggregate and water. Match color of adjacent surfaces.

## 2.11 REPAIR MATERIALS

- A. High Strength Flowing Repair Mortar: For forming and pouring structural members, or large horizontal repairs, provide the flowable one-part, high strength microsilica modified repair mortar with 3/8" aggregate. The product shall achieve 9000 psi @ 28-days at a 9-inch slump.
- B. Concrete Patching Mortar:
  - 1. Horizontal repairs, ASTM C1059, Type II. Products:
    - a. Euclid Chemical Co.; Euco Thin Coat, Concrete Coat
    - b. Sika Chemical Corp.; Sikatop 121 or 122
  - 2. Vertical or Overhead repairs, ASTM C1059, Type II. Products:
    - a. Euclid Chemical Co.; Verticoat
    - b. Sika Chemical Corp.; Sikatop 123
    - c. Master Builders; Emaco R300, 310 or R350
- C. Repair Underlayment: Cement-based, polymer-modified, self-leveling product that can be applied in thicknesses from 1/8 inch and that can be feathered at edges to match adjacent floor elevations.
  - 1. Cement Binder: ASTM C150, portland cement or hydraulic or blended hydraulic cement as defined in ASTM C219.
  - 2. Primer: Product of underlayment manufacturer recommended for substrate, conditions, and application.
  - 3. Aggregate: Well-graded, washed gravel, 1/8 to 1/4 inch or coarse sand as recommended by underlayment manufacturer.
  - 4. Compressive Strength: Not less than 5000 psi at 28 days when tested according to ASTM C109.
  - 5. Bond Strength: Not less than 1000 psi at 28 days when tested according to ASTM C1042.
  - 6. Products:
    - a. Euclid Chemical Co.; Flo-Top
    - b. Master Builders; UnderLayment 110
- D. Repair Overlayment: Cement-based, polymer-modified, self-leveling product that can be applied in thicknesses from 1/8 inch and that can be feathered at edges to match adjacent floor elevations.
  - 1. Cement Binder: ASTM C150, portland cement or hydraulic or blended hydraulic cement as defined in ASTM C219.
  - 2. Primer: Product of topping manufacturer recommended for substrate, conditions, and application.
  - 3. Aggregate: Well-graded, washed gravel, 1/8 to 1/4 inch or coarse sand as recommended by topping manufacturer.
  - 4. Compressive Strength: Not less than 5000 psi at 28 days when tested according to ASTM C109.
  - 5. Products:
    - a. Euclid Chemical Co.; Thin Top SL

- b. Master Builders; Topping 112
- 6. Product shall exhibit the following properties: Chaplin Abrasion Test – 0.0079-inches maximum at 28 days.

## 2.12 CONCRETE MIXTURES, GENERAL

- A. Prepare design mixtures for each type and strength of concrete, proportioned on the basis of laboratory trial mixture or field test data, or both, according to ACI 301.
  - 1. Procurement of concrete mix design is responsibility of Contractor.
  - 2. Use a qualified independent testing agency for preparing and reporting proposed mixture designs based on laboratory trial mixtures.
- B. Supplementary Cementitious Materials (SCM): Use fly ash, pozzolan, ground granulated blast-furnace slag, and silica fume as needed to reduce the total amount of portland cement, which would otherwise be used, by not less than 40 percent, or as noted otherwise within this specification, without exceeding the following limits:
  - 1. Fly Ash: 60.
  - 2. Ground granulated blast-furnace slag: 60 percent.
  - 3. Combined Fly Ash and Ground Granulated Blast-Furnace Slag: 80 percent, where neither component exceeds 50 percent.
- C. Limit water-soluble, chloride-ion content in hardened concrete to 0.06 percent by weight of cement.
- D. Admixtures: Use admixtures according to manufacturer's written instructions.
  - 1. Use water-reducing, high-range water-reducing, or plasticizing admixture in concrete, as required, for placement and workability.
  - 2. Use water-reducing and retarding admixture when required by high temperatures, low humidity, or other adverse placement conditions.
  - 3. Use water-reducing admixture in pumped concrete, concrete for heavy-use industrial slabs and parking structure slabs, concrete required to be watertight, and concrete with a water-cementitious materials ratio below 0.50.

## 2.13 CONCRETE MIXTURES

- A. Definition of Mix Properties:
  - 1. Concrete strength (f'c) is the minimum compressive strength at 28 days, tested in accordance with ASTM C39.
  - 2. Aggregate size is the largest of the coarse aggregate.
  - 3. Slump shall be measured at the point of delivery in accordance with ASTM C143 prior to the addition of superplasticizer (if used). Slump tolerance shall meet the requirements of ACI 117. Slump can be increased with use of a superplasticizer to improve workability of mix. After addition of superplasticizer, slump shall not exceed 8" at point of delivery.
  - 4. Air content is by volume and may be plus or minus 1.5 percent at point of delivery.
  - 5. Water/cement ratio is specified by weight.
  - 6. Drying shrinkage limit is percentage change in length after 21 days of drying when tested as per ASTM C157 with 4 inches x 4 inches x 11 inches specimen moist cured 7 days prior to drying.
- B. Lightweight Concrete Fill in Decking: Proportion lightweight concrete mixture as follows:



1. Minimum Compressive Strength (f'c): 4000 psi.
2. Maximum Water-Cementitious Materials Ratio: 0.45.
3. SCM Replacement ratio: 15 percent.
4. Maximum Aggregate Size: 1/2 inch.
5. Slump Limit: 4 inches, plus or minus 1 inch.
6. Air Content: 4.5 percent.
7. Shrinkage Limit: .045 percent.

#### 2.14 FABRICATING REINFORCEMENT

- A. Fabricate steel reinforcement according to CRSI's "Manual of Standard Practice."

#### 2.15 CONCRETE MIXING

- A. Ready-Mixed Concrete: Measure, batch, mix, and deliver concrete according to ASTM C 94/C 94M and furnish batch ticket information.
  1. The batching plant shall be equipped with an electric metering device capable of determining moisture content of sand.
  2. Begin the mixing operation within thirty minutes after the cement has been intermingled with the aggregates.
  3. When air temperature is between 85 and 90 deg F, reduce mixing and delivery time from 1-1/2 hours to 75 minutes; when air temperature is above 90 deg F, reduce mixing and delivery time to 60 minutes.
- B. Lightweight Concrete: Mix lightweight concrete in accordance with the directions of the approved lightweight aggregate manufacturer.

### PART 3 - EXECUTION

#### 3.1 PRECONSTRUCTION MEETING

- A. At least one week prior to commencement of concrete work, meet at the Project site to review methods and sequence of concrete construction, standard of workmanship, material selection, testing and quality control requirements, detailed requirements of the design mixes, placement procedures, off-site batching requirements, coordination of the work with other trades and other pertinent topics related to the Work. The meeting shall include the following:
  1. Owner's Representative
  2. Architect/Engineer
  3. Construction Manager/General Contractor
  4. Concrete Subcontractor
  5. Owner's Testing Laboratory
  6. Ready Mix Concrete Supplier
  7. Any other subcontractor and/or material supplier including plumbing, waterproofing and electrical supplier or manufacturer required
- B. The minutes shall include a statement by the concrete contractor indicating that the proposed mix design and placing techniques shall produce the concrete quality required by these specifications.

### 3.2 PREPARATION

- A. Prior to Work specified in this Section, carefully inspect the installed Work of other trades and verify that such Work is complete to the point where this installation may properly commence.
- B. Verify that forms may be constructed in accordance with all applicable codes and regulations, the referenced standards, and the design documents.
  - 1. Ensure Excavations are sufficient to permit placement, inspection, and removal of forms.
  - 2. Verify reinforcing steel has been inspected prior to concealing with formwork.
  - 3. Verify geotechnical engineer has approved all foundation excavations.
- C. The Contractor shall verify all dimensions prior to starting construction.
- D. Coordinate:
  - 1. Obtain necessary information for coordination of formwork with items to be embedded in concrete.
  - 2. Coordinate size and location of openings in concrete. Obtain Architects approval for openings not shown on Structural Drawings.
- E. Discrepancies:
  - 1. Notify the Architect of any discrepancies or inconsistencies.
  - 2. Do not proceed with installation in areas of discrepancy until such discrepancies have been fully resolved.

### 3.3 FORMWORK

- A. Design, erect, shore, brace, and maintain formwork, according to ACI 301, to support vertical, lateral, static, and dynamic loads, and construction loads that might be applied, until structure can support such loads and such that formwork can withstand excessive deflection when filled with wet concrete.
- B. Construct formwork so concrete members and structures are of size, shape, alignment, elevation, camber and position indicated, within tolerance limits of ACI 117. Make proper provision for all openings, offsets, recesses, anchorage, blocking, and other features of the Work as shown or required. Provide openings as required for vibrators and concrete placing.
- C. Limit concrete surface irregularities, designated by ACI 347R as abrupt or gradual, as follows:
  - 1. Class A, 1/8 inch for smooth-formed finished surfaces.
  - 2. Class B, 1/4 inch for rough-formed finished surfaces.
- D. Construct forms tight enough to prevent loss of concrete mortar. Tape all joints at forms for sandblasted finished concrete, including joints between plywood and trim strips.
- E. Fabricate forms for easy removal without hammering or prying against concrete surfaces. Provide crush or wrecking plates where stripping may damage cast concrete surfaces. Provide top forms for inclined surfaces steeper than 1.5 horizontal to 1 vertical.
  - 1. Install keyways, reglets, recesses, and the like, for easy removal.
  - 2. Do not use rust-stained steel form-facing material.

- F. Set edge forms, bulkheads, and intermediate screed strips for slabs to achieve required elevations and slopes in finished concrete surfaces. Provide and secure units to support screed strips; use strike-off templates or compacting-type screeds.
- G. Provide temporary openings for cleanouts and inspection ports where interior area of formwork is inaccessible. Close openings with panels tightly fitted to forms and securely braced to prevent loss of concrete mortar. Locate temporary openings in forms at inconspicuous locations.
- H. Do not chamfer exterior corners and edges of permanently exposed concrete.
- I. Form openings, chases, offsets, sinkages, keyways, reglets, blocking, screeds, and bulkheads required in the Work. Determine sizes and locations from trades providing such items.
- J. Clean forms and adjacent surfaces to receive concrete. Remove chips, wood, sawdust, dirt, and other debris just before placing concrete.
- K. Retighten forms and bracing before placing concrete, as required, to prevent mortar leaks and maintain proper alignment.
- L. Coat contact surfaces of forms with form-release agent, according to manufacturer's written instructions, before placing reinforcement. Do not allow excess form coating material to accumulate in forms or to come into contact with in-place concrete surfaces against which fresh concrete will be placed.

#### 3.4 EMBEDDED ITEMS

- A. Place and secure anchorage devices and other embedded items required for adjoining work that is attached to or supported by cast-in-place concrete. Use setting drawings, templates, diagrams, instructions, and directions furnished with items to be embedded. Ensure that embedded items are placed and held, during placing of concrete, to tolerances consistent with other items that will be attached to them.
- B. Provide pipe sleeves when pipes pass through concrete. Fill voids in sleeves, inserts and anchor slots with readily removable material to prevent entry of concrete into voids.
- C. Only Hearing Loop conduit shall be cast in concrete, coordinate location with subcontractor's drawings..
- D. Coring of concrete after placement is not permitted without prior approval by the Engineer of Record.

#### 3.5 VAPOR RETARDERS

- A. Plastic Vapor Retarders: Place, protect, and repair vapor retarders according to ASTM E 1643 and manufacturer's written instructions.
  - 1. Lap joints 6 inches and seal with manufacturer's recommended tape.

### 3.6 STEEL REINFORCEMENT

- A. General: Comply with CRSI's "Manual of Standard Practice" for placing reinforcement.
  - 1. Wherever embedded items interfere with placing of reinforcement notify the Architect and obtain approval before placing any concrete. Do not bend or field cut bars around openings or sleeves.
  - 2. Do not cut or puncture vapor retarder. Repair damage and reseal vapor retarder before placing concrete.
- B. Clean reinforcement of loose rust and mill scale, earth, ice, and other foreign materials that would reduce bond to concrete. Where there is a potential of rust staining adjacent finish surfaces, take necessary steps to prevent staining.
- C. Accurately position, support, and secure reinforcement against displacement, particularly under the weight of workmen and the placement of concrete. Use bar supports in sufficient number, size and location to prevent vertical displacement of the reinforcement and gouging of the formwork. Locate and support reinforcement with bar supports to maintain minimum concrete cover. Do not tack weld crossing reinforcing bars.
  - 1. Do not exceed the tolerances specified in ACI 117.
  - 2. Reinforcement shall be held in place by means of supports adequate to prevent displacement and to maintain reinforcement at proper distance from form face. The use of wood supports and spacers inside the forms is not permitted.
  - 3. Dowels shall be tied securely in place before concrete is deposited. In the event there are no bars in position to which dowel may be tied, No 3 bars (minimum) shall be added to provide proper support and anchorage.
  - 4. Do not place reinforcement in floor slabs or beams until concrete has been placed in columns and walls, except where bars extend down into columns or walls.
  - 5. Use templates for placement of column dowels.
  - 6. Where Drawings do not show the spacing of the reinforcing, the minimum clear spacing shall conform to ACI 318 Section 7.6.
  - 7. Reinforcing partially embedded in concrete shall not be field bent except as shown on the Drawings or accepted by the Architect.
  - 8. Wherever conduits, piping, inserts, sleeves, etc., interfere with placing of reinforcing steel, obtain acceptance of method of procedure before any concrete is placed. Bending of bars around openings or sleeves not permitted.
- D. Splicing: Make splices only at those locations shown on the Drawings or as accepted by the Architect. Splice locations not shown on the Drawings shall be approved in shop drawings before fabrication. Stagger splices in adjacent bars wherever possible.
- E. Reinforcing shall be rigidly and securely tied with steel tie wire. Set wire ties with ends directed into concrete, not toward exposed concrete surfaces.
- F. If allowed, field bending or straightening shall be in accordance with section 3.3.2.8 of ACI 301.
- G. Install welded wire reinforcement in longest practicable lengths on bar supports spaced to minimize sagging. Lap edges and ends of adjoining sheets at least one mesh spacing plus 2 inches or 6 inches, whichever is greater. Offset laps of adjoining sheet widths to prevent continuous laps in either direction. Lace overlaps with wire.

### 3.7 JOINTS

- A. General: Construct joints true to line with faces perpendicular to surface plane of concrete.
- B. Existing Concrete to New Concrete Joints
  - 1. Chip keys and roughen existing concrete surfaces where new concrete abuts. Roughen surface by bushhammering, chipping or sandblasting to remove surface mortar and expose clean aggregate.
  - 2. Drill and install dowels using epoxy grout in accordance with manufacturer's printed recommendations.
  - 3. Prime surface with 10-mil layer of epoxy adhesive using a stiff brush. Place concrete while the epoxy adhesive is still tacky. Re-prime if necessary.
- C. Construction Joints: Install so strength and appearance of concrete are not impaired, at locations indicated or as approved by Architect.
  - 1. Place joints perpendicular to main reinforcement. Continue reinforcement across construction joints, unless otherwise indicated. Do not continue reinforcement through sides of strip placements of floors and slabs.
  - 2. Locate joints for beams, slabs, joists, and girders in the middle third of spans. Offset joints in girders a minimum distance of twice the beam width from a beam-girder intersection.
  - 3. Roughen surface at all construction joints where key is not used and under baseplates. Roughen concrete surface while concrete is still green where possible. Do not leave laitance, loosened particles of aggregate or damaged concrete at surface. Forms and reinforcing shall be cleaned of drippings. Dampen contact surfaces of construction joints, leaving them free of standing water, before placing fresh concrete.
  - 4. Use a bonding agent at locations where fresh concrete is placed against hardened or partially hardened concrete surfaces.

### 3.8 CONCRETE PLACEMENT

- A. Before placing concrete, verify that installation of formwork, reinforcement, and embedded items is complete and that required inspections have been performed. Ensure that all foreign material has been removed from surfaces, including reinforcement and embedded items, against which concrete will be placed.
- B. The addition of water at the site is contingent upon full time inspection of the process by the owners testing laboratory and the acceptance of the Inspector. Comply with ACI 301, section 4.3.2.1.
- C. Before test sampling and placing concrete, water may be added at Project site, subject to limitations of ACI 301.
  - 1. Do not add water to concrete after adding high-range water-reducing admixtures to mixture.
- D. Method: Convey concrete as rapidly and directly as practicable to preserve quality and to prevent segregation.
  - 1. Do not deposit concrete that has initially set. Retempering of concrete, which has partially set, is not permitted.
  - 2. Maximum time for discharge of concrete shall be per ASTM C94.

- E. Placement: Deposit and consolidate concrete for floors and slabs in a continuous operation, within limits of construction joints, until placement of a panel or section is complete. Deposit concrete to avoid segregation.
1. When placing is once started, carry it on as a continuous operation until placement of the panel or section is complete. Construction joints to be made only where indicated on the Drawings or on approved shop drawings. Prevent the formation of cold joints at other locations.
  2. Deposit concrete in one layer or in horizontal layers of such thickness that no new concrete will be placed on concrete that has hardened enough to cause seams or planes of weakness. Deposit concrete in a manner to avoid inclined construction joints.
  3. Particular care shall be used when starting a concrete pour to maintain the continuity of appearance. Use all means necessary to avoid blemishes, imperfections, or changes in the finish.
  4. Maintain reinforcement in position on chairs during concrete placement.
- F. Consolidation: Consolidate concrete during placement operations so concrete is thoroughly worked around reinforcement and other embedded items and into corners.
1. Consolidate placed concrete with mechanical vibrating equipment according to ACI 301. Use and type of vibrator shall conform to ACI 309, Guide for Consolidation of Concrete.
  2. Do not use vibrators to transport concrete inside forms. Insert and withdraw vibrators vertically at uniformly spaced locations to rapidly penetrate placed layer and at least 6 inches into preceding layer. Do not insert vibrators into lower layers of concrete that have begun to lose plasticity. Place vibrating element directly in concrete and not attached to either inside or outside of forms or to reinforcing steel.
  3. At each insertion, limit duration of vibration to time necessary to consolidate concrete and complete embedment of reinforcement and other embedded items without causing mixture constituents to segregate. Do not over-vibrate concrete.
- G. Initial Finishing:
1. Screed slab surfaces with a straightedge and strike off to correct elevations.
  2. Where floor drains or floor slopes are indicated, slope slabs uniformly to provide even fall for drainage.
  3. Begin initial floating using bull floats or darbies to form a uniform and open-textured surface plane, before excess bleedwater appears on the surface. Do not further disturb slab surfaces before starting finishing operations.
- H. Fill Over Steel Deck:
1. At floor slabs, increase fill thickness as required to compensate for deflection of beams and deck at no additional cost to Owner. Obtain specified fill thickness at high, points of the deck. Finish floor to specified tolerances for floor flatness and levelness, including at suspended fill on steel deck floors
- I. Hot-Weather Placement: Comply with ACI 301 and as follows:
1. When concrete is expected to be placed at air temperatures of greater than 80 deg F, contractor shall review with Architect all special procedures that will be used including mix design modifications and methods of protection. This review shall occur prior to the expected extreme temperatures.
  2. Provide sufficient protection material and equipment on the Project site in advance of the time when the mean daily temperatures are expected to rise above 80 degrees F.
  3. When air temperature exceeds 80 deg F, take special precautions to prevent slump loss, rapid setting, and plastic shrinkage; including but not limited to:

- a. Maintain concrete temperature below 90 deg F at time of placement. Chilled mixing water or chopped ice may be used to control temperature, provided water equivalent of ice is calculated to total amount of mixing water. Using liquid nitrogen to cool concrete is Contractor's option.
  - b. Use set retarding admixture in accordance with previously accepted submittals.
  - c. Convey, deposit, finish and commence curing of concrete as rapidly as practicable.
4. Fog-spray forms, steel reinforcement, and subgrade just before placing concrete. Keep subgrade uniformly moist without standing water, soft spots, or dry areas.

### 3.9 FINISHING FLOORS AND SLABS

- A. Comply with ACI 302.1R recommendations for screeding, restraighening, and finishing operations for concrete surfaces. Do not wet concrete surfaces.
- B. Scratch Finish: While still plastic, texture concrete surface that has been screeded and bull-floated or darbied. Use stiff brushes, brooms, or rakes to produce a profile amplitude of 1/4 inch in 1 direction.
- C. Float Finish: Consolidate surface with power-driven floats or by hand floating if area is small or inaccessible to power driven floats. Restraighten, cut down high spots, and fill low spots. Repeat float passes and restraighening until surface is left with a uniform, smooth, granular texture.
- D. Trowel Finish: After applying float finish, apply first troweling and consolidate concrete by hand or power-driven trowel. Continue troweling passes and restraighten until surface is free of trowel marks and uniform in texture and appearance. Grind smooth any surface defects that would telegraph through applied coatings or floor coverings.
  - 1. Finish surfaces to the following tolerances, according to ASTM E 1155, for a randomly trafficked floor surface:
    - a. Specified overall values of flatness, F(F) 25; and of levelness, F(L) 20; with minimum local values of flatness, F(F) 17; and of levelness, F(L) 15. These values apply to all floors and slabs unless noted otherwise.
  - 2. Slabs supporting modular office partitions, adhered flooring systems, or compact storage shelving must also comply with the manufacturer's tolerance requirements.
  - 3. Slabs scheduled to receive wood flooring must also comply with tolerances required for installation of wood flooring. Finish and measure surface so gap at any point between concrete surface and an unleveled, freestanding, 10-foot long straightedge resting on 2 high spots and placed anywhere on the surface does not exceed 1/4 inch.
  - 4. Fill or grind completed floors as necessary to achieve specified finish tolerances. Fill shall be with a self-leveling cementitious product capable of being tapered to a feathered edge.
    - a. Repair any floor section measuring below either the minimum local F-number or the minimum local L-number.
- E. Trowel and Fine-Broom Finish: While concrete is still plastic, slightly scarify surface with a fine broom.
  - 1. Comply with flatness and levelness tolerances for trowel finished floor surfaces.
- F. Broom Finish: Immediately after float finishing, slightly roughen trafficked surface by brooming with fiber-bristle broom perpendicular to main traffic route. Coordinate required final finish with Architect before application.
- G. Schedule of Concrete Finish Types, unless otherwise indicated on Drawings:

1. Slabs to Receive:
  - a. Concrete Toppings: Float.
  - b. Mortar Setting Beds: Scratch.
  - c. Membrane Waterproofing: Float.
  - d. Fluid Applied Waterproofing: Trowel.
  - e. Resilient Flooring: Trowel.
  - f. Carpet: Trowel.
  - g. Tile (thin-set): Fine Broom.

### 3.10 CONCRETE PROTECTING AND CURING

- A. Protect freshly placed concrete from premature drying and excessive cold or hot temperatures. Comply with ACI 306.1 for cold-weather protection and ACI 301 for hot-weather protection during curing.
- B. Where supplementary cementitious materials are used, extra precautions shall be taken to prevent premature drying.
- C. Evaporation Retarder: Apply evaporation retarder to unformed concrete surfaces if hot, dry, or windy conditions cause moisture loss approaching 0.2 lb/sq. ft. x h before and during finishing operations. Apply according to manufacturer's written instructions after placing, screeding, and bull floating or darbying concrete, but before float finishing.
- D. Unformed Surfaces: Begin curing immediately after finishing concrete. Cure unformed surfaces, including floors and slabs, concrete floor toppings, and other surfaces.
- E. Cure concrete according to ACI 308.1, by one or a combination of the following methods:
  1. Moisture Curing: Keep surfaces continuously moist for not less than seven (7) days with the following materials:
    - a. Absorptive cover, water saturated, and kept continuously wet. Cover concrete surfaces and edges with 12-inch lap over adjacent absorptive covers.
  2. Moisture-Retaining-Cover Curing: Cover concrete surfaces with moisture-retaining cover for curing concrete, placed in widest practicable width, with sides and ends lapped at least 12 inches, and sealed by waterproof tape or adhesive. Cure for not less than seven (7) days. Immediately repair any holes or tears during curing period using cover material and waterproof tape.
    - a. Moisture cure or use moisture-retaining covers to cure concrete surfaces to receive floor coverings.
    - b. Moisture cure or use moisture-retaining covers to cure concrete surfaces to receive penetrating liquid floor treatments.
    - c. Cure concrete surfaces to receive floor coverings with either a moisture-retaining cover or a curing compound that the manufacturer certifies will not interfere with bonding of floor covering used on Project..
  3. Curing Compound: Apply uniformly in continuous operation by power spray or roller according to manufacturer's written instructions. Recoat areas subjected to heavy rainfall within three hours after initial application. Maintain continuity of coating and repair damage during curing period.
    - a. After curing period has elapsed, remove curing compound without damaging concrete surfaces by method recommended by curing compound manufacturer unless manufacturer certifies curing compound will not interfere with bonding of floor covering used on Project.
  4. Curing and Sealing Compound: Apply uniformly to floors and slabs indicated in a continuous operation by power spray or roller according to manufacturer's written



instructions. Recoat areas subjected to heavy rainfall within three hours after initial application. Repeat process 24 hours later and apply a second coat. Maintain continuity of coating and repair damage during curing period.

5. Interior slabs to receive resilient flooring: Cure only with moisture retaining cover. Do not cure with curing compound.
6. Interior slabs to receive thin set of tile: Cure only with moisture retaining cover. Do not cure with curing compound.

### 3.11 CONCRETE SURFACE REPAIRS

- A. Repair and patch defective areas when approved by Architect. Remove and replace concrete that cannot be repaired and patched to Architect's approval. Repair and replacement work will be done at Contractor's expense.
- B. Defective Concrete is defined as concrete which is under strength, out of line, level or plumb, or shows objectionable cracks, honeycombing, rock pockets voids, spalling, exposed reinforcement, that has any sawdust, wood, or debris embedded in it, or is otherwise defective, and in the Architect's judgment these defects impair the proper strength or appearance of the work. Any concrete work not in accordance with the Specification and Drawings will be deemed to be defective.
- C. Patching Mortar: Mix dry-pack patching mortar, consisting of one part portland cement to two and one-half parts fine aggregate passing a No. 16 sieve, using only enough water for handling and placing.
- D. Repairing Formed Surfaces: Surface defects include color and texture irregularities, cracks, spalls, air bubbles, honeycombs, rock pockets, fins and other projections on the surface, and stains and other discolorations that cannot be removed by cleaning.
  1. Immediately after form removal, cut out honeycombs, rock pockets, and voids more than 1/2 inch in any dimension in solid concrete, but not less than 1 inch in depth. Make edges of cuts perpendicular to concrete surface. Clean, dampen with water, and brush-coat holes and voids with bonding agent. Fill and compact with patching mortar before bonding agent has dried. Fill form-tie voids with patching mortar or cone plugs secured in place with bonding agent.
  2. Repair defects on surfaces exposed to view by blending white portland cement and standard portland cement so that, when dry, patching mortar will match surrounding color. Patch a test area at inconspicuous locations to verify mixture and color match before proceeding with patching. Compact mortar in place and strike off slightly higher than surrounding surface.
  3. Repair defects on concealed formed surfaces that affect concrete's durability and structural performance as determined by Architect.
- E. Repairing Unformed Surfaces: Test unformed surfaces, such as floors and slabs, for finish and verify surface tolerances specified for each surface. Correct low and high areas. Test surfaces sloped to drain for trueness of slope and smoothness; use a sloped template.
  1. Repair finished surfaces containing defects. Surface defects include spalls, popouts, honeycombs, rock pockets, crazing and cracks in excess of 0.01 inch wide or that penetrate to reinforcement or completely through unreinforced sections regardless of width, and other objectionable conditions.
  2. After concrete has cured at least 14 days, correct high areas by grinding.

3. Correct localized low areas during or immediately after completing surface finishing operations by cutting out low areas and replacing with patching mortar. Finish repaired areas to blend into adjacent concrete.
  4. Correct other low areas scheduled to receive floor coverings with a repair underlayment. Prepare, mix, and apply repair underlayment and primer according to manufacturer's written instructions to produce a smooth, uniform, plane, and level surface. Feather edges to match adjacent floor elevations.
  5. Correct other low areas scheduled to remain exposed with a repair topping. Cut out low areas to ensure a minimum repair topping depth of 1/4 inch to match adjacent floor elevations. Prepare, mix, and apply repair topping and primer according to manufacturer's written instructions to produce a smooth, uniform, plane, and level surface.
  6. Repair defective areas, except random cracks and single holes 1 inch or less in diameter, by cutting out and replacing with fresh concrete. Remove defective areas with clean, square cuts and expose steel reinforcement with at least a 3/4-inch clearance all around. Dampen concrete surfaces in contact with patching concrete and apply bonding agent. Mix patching concrete of same materials and mixture as original concrete except without coarse aggregate. Place, compact, and finish to blend with adjacent finished concrete. Cure in same manner as adjacent concrete.
  7. Repair random cracks and single holes 1 inch or less in diameter with patching mortar. Groove top of cracks and cut out holes to sound concrete and clean off dust, dirt, and loose particles. Dampen cleaned concrete surfaces and apply bonding agent. Place patching mortar before bonding agent has dried. Compact patching mortar and finish to match adjacent concrete. Keep patched area continuously moist for at least 72 hours.
- F. Perform structural repairs of concrete, subject to Architect's approval, using epoxy adhesive and patching mortar.
- G. Repair materials and installation not specified above may be used, subject to Architect's approval.

### 3.12 FIELD QUALITY CONTROL

- A. Testing and Inspecting: Owner will engage a qualified testing and inspecting agency to perform field tests and inspections and prepare test reports.
- B. Inspections:
1. Steel reinforcement placement.
  2. Post-installed concrete anchors, per ICC-ES recommendations.
  3. Verification of use of required design mixture.
  4. Concrete placement, including conveying and depositing.
  5. Curing procedures and maintenance of curing temperature.
- C. Concrete Tests: Testing of composite samples of fresh concrete obtained according to ASTM C 172 shall be performed according to the following requirements:
1. Testing Frequency: Obtain at one composite sample of the first 50 cu. yd. and one composite sample from each additional 100 cu. yd. or fraction thereof of each concrete mixture placed each day.
  2. Slump: ASTM C143; one test at point of placement for each composite sample, but not less than one test for each day's pour of each concrete mixture. Perform additional tests when concrete consistency appears to change.

3. Air Content: ASTM C173, volumetric method, for structural lightweight concrete; one test for each composite sample, but not less than one test for each day's pour of each concrete mixture.
4. Water Content: In accordance with AASHTO T318.
5. Concrete Temperature: ASTM C1064; one test hourly when air temperature is 40 deg F and below and when 80 deg F and above, and one test for each composite sample.
6. Unit Weight: ASTM C567, fresh unit weight of structural lightweight concrete; one test for each composite sample, but not less than one test for each day's pour of each concrete mixture.
7. Compression Test Specimens: ASTM C31.
  - a. Cast and laboratory cure two sets of two standard cylinder specimens for each composite sample.
8. Compressive-Strength Tests: ASTM C39; test one set of two laboratory-cured specimens at 7 days and one set of two specimens at 28 days.
  - a. Test one set of two field-cured specimens at 7 days and one set of two specimens at 28 days.
  - b. A compressive-strength test shall be the average compressive strength from a set of two specimens obtained from same composite sample and tested at age indicated.
9. Strength of each concrete mixture will be satisfactory if every average of any three consecutive compressive-strength tests equals or exceeds specified compressive strength and no compressive-strength test value falls below specified compressive strength by more than 500 psi.
10. Test results shall be reported in writing to Architect, concrete manufacturer, and Contractor within 48 hours of testing. Reports of compressive-strength tests shall contain Project identification name and number, date of concrete placement, name of concrete testing and inspecting agency, location of concrete batch in Work, design compressive strength at 28 days, concrete mixture proportions and materials, compressive breaking strength, and type of break for both 7- and 28- day tests.
11. Nondestructive Testing: Impact hammer, sonoscope, or other nondestructive device may be permitted by Architect but will not be used as sole basis for approval or rejection of concrete.
12. Additional Tests: Testing and inspecting agency shall make additional tests of concrete when test results indicate that slump, air entrainment, compressive strengths, or other requirements have not been met, as directed by Architect. Testing and inspecting agency may conduct tests to determine adequacy of concrete by cored cylinders complying with ASTM C42 or by other methods as directed by Architect.
  - a. If test results indicate that compressive strength requirements have not been met, the Contractor shall justify that the load carrying capacity of the structure has not been reduced. Carry out tests of cores drilled from the area in question as directed by the Architect in accordance with ASTM C43 and ACI 318 Section 5.6.5.
  - b. If the compressive tests of the core specimens fail to show the compressive strength specified, the concrete shall be deemed defective and shall be replaced or adequately strengthened in a manner acceptable to the Architect. Perform load tests as outlined in ASTM C39, as directed by the Architect, on the questionable portion of the Work.
13. Additional testing and inspecting, at Contractor's expense, will be performed to determine compliance of replaced or additional work with specified requirements.
14. Correct deficiencies in the Work that test reports and inspections indicate do not comply with the Contract Documents.

D. Reinforcing Steel

1. Notify the testing agency and the Architect at least 48 hours before concrete is to be poured or reinforcing is covered up.

2. Before any concrete is poured on any particular portion of the building, the reinforcing steel and form dimensions will be inspected by the Testing Agency. Any errors or discrepancies shall be corrected before concrete is placed.
  3. In addition to other required inspections, the following are subject to Controlled Inspection as per IBC Chapter 1704.4:
    - a. Placement of Reinforcing Steel
    - b. Welding of Reinforcing Steel
  4. A special inspector from the Testing Agency shall be present during all field bending of reinforcement.
  5. Installation of deformed bar anchors to be tested in accordance with Section 7.1 of AWS D1.1.
  6. Welding of Reinforcement: There shall be continuous inspection during all welding of reinforcement. All butt welds to be inspected using radiographic testing. At the Owners option recognized non-destructive tests such as resistance, Magnetic Particle Examination, and Liquid Penetrant Inspection may be used to inspect the welds.
  7. Comply with ICC-ES approvals with respect to special inspection required during installation.
  8. Testing and inspection of mechanical splices and reinforcing couplers to conform to manufacturer's recommendations and ICC-ES approval.
- E. Survey and Adjustment: Continuously observe formwork operations, record such observations on a daily basis, and submit reports of the results. Instrument check forms before and during concrete placement to assure no movement has taken place. Make appropriate corrections to reposition displaced forms.
1. Measure floor and slab flatness and levelness according to ASTM E1155 within 48 hours of finishing.

END OF SECTION 033000

**CONCRETE MIX DESIGN SUBMITTAL FORM**

**Project:** \_\_\_\_\_  
**City:** \_\_\_\_\_  
**General Contractor:** \_\_\_\_\_  
**Concrete Contractor:** \_\_\_\_\_  
**Concrete Strength (Class):** \_\_\_\_\_  
**Use (describe):** \_\_\_\_\_

**Design Mix Information**

*Please check one*

Based on Standard Deviation Analysis   
 Trial Mix Test Data

**Design Characteristics:**

Density  pcf  
 Strength  psi ([28][56] day)  
 Air  % specified

<b><u>MATERIALS</u></b>	<b><i>Type/ Source</i></b>	<b><i>Specific Gravity</i></b>	<b><i>Weight/lb.</i></b>	<b><i>Absolute Vol. cu.ft.</i></b>
<b>Cement</b>				
<b>Fly Ash</b>				
<b>Slag</b>				
<b>Coarse Aggregate</b>				
<b>Fine Aggregate</b>				
<b>Water</b>				
<b>Air</b>				
<b>Other</b>				
<b>TOTAL</b>				27.0 cu. ft.

\* Water/Cement Ratio (lbs. water/lbs. cement) = \_\_\_\_\_%

<u>ADMIXTURES</u>	Manufacturer	Dosage oz/cwt
Water Reducer		
Air Entraining Agent		
High Range Water Reducer		
Non-Corrosive Accelerator		
Other		

Slump before HRWR \_\_\_\_\_ inches

Slump after HRWR \_\_\_\_\_ inches

**Standard Deviation Analysis (from experience records):**

# of Test Cylinders Evaluated:	
Standard Deviation:	

USE THE LARGER VALUE:

$f'_{cr} = f'c + 1.34s$  or  $f'_{cr} = f'c + 2.33s - 500$  for 5000 PSI or less

$f'_{cr} = f'c + 1.34s$  or  $f'_{cr} = 0.90 f'c + 2.33\pm$  for higher strengths

(Refer to ACI 301 for increased deviation factor when less than 30 tests are available)

**LABORATORY TEST DATA**

*Compressive Strength*

Age (days)	Mix # 1	Mix #2	Mix #3
7	psi	psi	psi
7	psi	psi	psi
[28][56]	psi	psi	psi
[28][56]	psi	psi	psi
[28][56] average	psi	psi	psi

$F'_{cr} = f'c + 1200$  psi for 5000 psi or less

Or  $1.10 f'c + 700$  psi for strength higher than 5000 psi at [28][56] days

**REQUIRED ATTACHMENTS:**

Combined Aggregate Gradation Report

Standard Deviation Analysis of Compressive Strength Data or Trial Mixture Test Data

ADMIXTURE COMPATIBILITY CERTIFICATION LETTER

Please Check

<b>Submitted by:</b>
Name:
Address:
Phone #:
Main Plant Location:
Miles from Project:
Secondary Plant Location:
Miles from Project:
Date:

## **DIVISION 4 – MASONRY**

### **SECTION 042000**

#### **UNIT MASONRY**

#### **PART 1 GENERAL**

##### **1.1 GENERAL REQUIREMENTS**

- A. Work of this Section, as shown or specified, shall be in accordance with the requirements of the Contract Documents.

##### **1.2 SECTION INCLUDES**

- A. Work of this Section includes all labor, materials, equipment and services necessary to complete the unit masonry work as shown on the drawings and/or specified herein, including but not necessarily limited to the following:
  - 1. Concrete block walls and partitions.
  - 2. Metal joint reinforcing, anchors, ties, weeps, closures and related accessories for masonry.
  - 3. Control and expansion joints in masonry, filled with joint fillers.
  - 4. Chases, recesses, pockets and openings in masonry as required for installation of work by others.
  - 5. Grouting in of metal items built into masonry work.
  - 6. Protection, pointing and cleaning of masonry.
  - 7. Installation and sealing of masonry walls utilized for acoustical separation.

##### **1.3 RELATED SECTIONS**

- A. Division 03 Section "Cast-in-Place Concrete" for concrete construction
- B. Division 05 Section "Structural Steel Framing" for steel framing
- C. Division 05 Section "Steel Decking" for metal decks

##### **1.4 SUBMITTALS**

- A. Submit Shop Drawings for the following:
  - 1. Anchoring details.
  - 2. Control and expansion joint locations and details.
- B. Submit technical and installation information for the following:
  - 1. Mortar materials, each material and mortar type.



2. Certification of mortar mix.
3. Flashing material, descriptive literature.
4. Concrete block, joint reinforcing, anchors, ties and joint filler; submit manufacturer's technical and descriptive literature.
5. Block manufacturer shall submit certifications of compliance with ASTM C 90, C 331 and UL 618 prior to any job site delivery. Field sampling of concrete block may be tested by an Independent Testing Laboratory retained by the Owner according to the requirements of ASTM C 140.

C. Construction Procedures: Submit procedures and materials for cleaning masonry work; including certification that cleaner will not adversely affect stone, gaskets, sealants, etc.

## 1.5 QUALITY ASSURANCE

- A. Conform to the following non-cumulative tolerances (any masonry work not meeting these standards shall be re-built as directed by the Architect).
1. Variation from the plumb:
    - a. In lines and surfaces of columns, walls and arrises:
 

1).	In 10 feet	1/8"
2).	In any story of 25 feet maximum	1/4"
3).	In 40 feet or more	1/4"
    - b. For external corners, expansion joints and other conspicuous lines:
 

1).	In any story of 25 feet maximum	1/4"
2).	In 40 feet or more	3/8"
  2. Variation from the level or the grades indicated on the drawings; for exposed lintels, sills, parapets, horizontal grooves and other conspicuous lines:
 

a.	In any bay or 20 feet maximum	1/4"
b.	In 40 feet or more	1/4"
  3. Variation of the linear building lines from established position in plan related portion of columns and partitions:
 

a.	In any bay or 20 feet maximum	1/4"
b.	In 40 feet or more	1/2"
  4. Variation in cross-sectional dimensions of columns and in thickness of walls:
 

a.	Minus	1/8"
b.	Plus	1/8"
  5. Variation in dimensions of masonry openings:
 

a.	Horizontal dimension	-0" + 1/16"
b.	Vertical dimension	+0" - 1/16"

- B. Work of this Section shall conform to the requirements of the following:
1. 2005 ACI 530/ASCE 5/TMS 402 Building Code Requirements for Masonry Structures.
  2. 2005 ACI 530-1/ASCE 6/TMS 602 Specifications for Masonry Structures.
  3. L/600 deflection limitation for back-up framing.
- C. Pre-Construction Conference: Prior to installation of masonry and associated work, Contractor shall arrange a meeting with Masonry Subcontractor, installers of related work, and other entities concerned with masonry wall performance, including the Architect and Owner. Contractor shall record discussions and agreements and furnish copy to each participant. Provide at least seventy-two (72) hours' advance notice to participants prior to convening conference. Review methods and procedures related to masonry work, including, but not limited to, the following:
1. Review masonry requirements (drawings, specifications and other Contract Documents).
  2. Review required submittals, both completed and yet to be completed.
  3. Review and finalize construction schedule related to masonry work and verify availability of materials, installer's personnel, equipment and facilities needed to make progress and avoid delays.
  4. Review required inspection, testing, certifying and material usage accounting procedures.
  5. Review weather and forecasted weather conditions, and procedures for coping with unfavorable conditions.

#### 1.6 PRODUCT HANDLING

- A. General: Deliver, store, handle and protect all materials from damage, moisture, dirt and intrusion of foreign matter. Store all masonry units and mortar materials on raised platforms and under ventilated and waterproof cover. Store packaged materials in manufacturer's unopened containers, marked with manufacturer's name and product brand name. Immediately reseal containers after partial use. Remove and replace damaged materials.
- B. Masonry Units: Pack, deliver and store to prevent breakage, cracking, chipping, spalling or other damage. Store, protect and ventilate units at project site.
- C. Aggregate: Store with provisions for good drainage.
- D. Reinforcement and Anchors: Store and protect so that when placed, joint reinforcement and anchors will be free of soil, dirt, ice, loose rust, scale, or other coatings which would destroy or reduce bond with mortar, and will not be disfigured or bent out of shape.

#### 1.7 CODE REQUIREMENTS

- A. Work of this Section shall conform to all applicable requirements of the Chicago Building Code.

## 1.9 JOB CONDITIONS

- A. Hot-Weather Requirements: Protect unit masonry work when temperature and humidity conditions produce excessive evaporation of water from mortar and grout. Provide artificial shade and wind breaks and use cooled materials as required. Do not apply mortar to substrates with temperatures of 100 deg. F. and above.
- B. Protection of Masonry: During erection, cover tops of walls, projections, and sills with waterproof sheeting at end of each day's work. Cover partially completed masonry when construction is not in progress.
  - 1. Extend cover a minimum of 24" down both sides and hold cover securely in place.
  - 2. Where one wythe of multi-wythe masonry walls is completed in advance of other wythes, secure cover a minimum of 24" down face next to unconstructed wythe and hold cover in place.
- C. Stain Prevention: Prevent grout, mortar, and soil from staining the face of masonry to be left exposed or painted. Immediately remove grout, mortar, and soil that come in contact with such masonry.
  - 1. Protect base of walls from rain-splashed mud and mortar splatter by coverings spread on ground and over wall surface.
  - 2. Protect sills, ledges, and projections from mortar droppings.
  - 3. Protect surfaces of window and door frames, as well as similar products with painted and integral finishes, from mortar droppings.
  - 4. Turn scaffold boards near the wall on edge at the end of each day to prevent rain from splashing mortar and dirt on completed masonry.

## PART 2 PRODUCTS

### 2.1 MATERIALS

- A. Standard Concrete Block
  - 1. Portland cement, ASTM C 150, Type 1, one source.
  - 2. Aggregates, ASTM C 331, lightweight expanded shale, clay or slate aggregates, manufactured by the rotary kiln process equal to "Solite," "Norlite" or "Haydite."
    - a. All block shall be from one aggregate type and from one manufacturer.
  - 3. Concrete Masonry Units: Load bearing normal aggregate concrete masonry units conforming to the requirements of ASTM C 90, for walls less than 10" in thickness. For walls less than 10" in thickness provide lightweight CMU,
    - a. All other block may be hollow units.
  - 4. The producer of the concrete masonry units shall furnish certification from

an independent testing laboratory confirming that all 8" or larger masonry units meet all of the UL 618 requirements for two (2) hours or better (as required), referencing full scale fire test reports (ASTM E 119). All 4" and 6" units shall conform to "National Bureau of Standards" and "National Research Council" full scale fire tests.

5. Sizes and Shapes: Nominal face size 8" x 16" by thickness as indicated on drawings, with stretcher units, jamb units, header units, square corner units (at ends and corners of exposed or painted work), sash units (at control joints within masonry wall), lintel units and other special shapes and sizes required to complete the work. Provide 6", 10" and 12" x 16" units where noted on the drawings.
6. Finish: For exposed or painted block surfaces, in addition to ASTM requirements, block shall have uniformly dense, flat, fine grain texture, with no cracks, chips, spalls, or other defects which would impair appearance. For concealed CMU, surfaces shall be free from deleterious materials that would stain plaster or corrode metal.
7. Curing: All concrete block shall be steam cured, and air dried for not less than thirty (30) days before delivery.
8. Density of concrete block shall not exceed one hundred and twenty five (125) lbs. per cubic foot for 10" walls and one hundred and five (105) lbs. for less than 10".
9. Shrinkage: Shrinkage of concrete blocks shall not exceed 0.065% when tested in accordance with ASTM C 426-99.
10. Water Content
  - a. At the time of delivery to the job site, concrete masonry units shall have a value, in weight of contained water, of not more than thirty (30) percent of the fully saturated content for the unit tested.
  - b. Ship all units from the factory, and store at the job site, with all necessary protection to prevent increase of water content from rain and other sources.

#### B. Joint Reinforcing for Masonry Walls

1. For interior block walls and partitions, provide standard reinforcing fabricated of 9 ga. side and cross rods, truss or ladder design, no ties, spaced every other block course. Provide prefabricated pieces at corners and intersections of walls or partitions. Reinforcing shall be mill galvanized conforming to ASTM A 641, Class B-1, applied after fabrication.
2. Wire used in assemblies noted above shall be cold drawn steel wire conforming to ASTM A 82.
3. Approved Joint Reinforcing Manufacturers
  - a. Hohmann & Barnard
  - b. Dur-O-Wal
  - c. Heckmann Building Products
  - d. National Wire Products Industries, Inc.

E. Reinforcing Bars and Rods: ASTM A 615, Grade 60. See Drawings for

size. F. Control and Expansion Joint Fillers

1. Vertical Installation Within Concrete Masonry Wall: Extruded high grade neoprene rubber, cross shape, for use with concrete masonry sash units, which shall provide a force fit in the grooves of the sash block, and shall have 1/2" diameter tubular ends (compressed 25% when installed in 3/8" wide joint).
  - a. Provide the following sizes:
    - 1). 2-5/8" wide control joint fillers for 4" block walls.
    - 2). 4-5/8" wide for 6" block walls.
    - 3). 6-5/8" wide for 8", 10" and 12" block walls.
  - b. Provide backer rod and sealant joint over joint filler as per drawings and Section 079200 of these specifications.
2. Isolation Joint Filler at Abutting Construction and at Intersecting CMU Walls: Compressible and resilient closed cell neoprene gasket with pressure sensitive adhesive backing, thickness 30% greater than thickness of joint. Acceptable joint filler shall be "Everlastic, Type NN-1" by Williams Products, Inc., or approved equal. Recess joint filler and install backer rod and sealant as per drawings and Section 079200 of these specifications.
3. Within Face Brick: Provide "Emseal" installed to twenty-five (25) percent compression, as manufactured by Emseal or approved equal, behind filler rod and sealant installed by Section 079200. Filler depth shall be 2 x joint width.
  - a. Compressible filler between top of brick and bottom of shelf angle shall be "Soft Joint Sealant" made by Polytite.

## 2.2 MORTAR MATERIALS

- A. Portland Cement: ASTM C 150, Type 1, standard color, one source.
- B. Hydrated Lime: ASTM C 207, Type S, as manufactured by Corsons, or approved equal.
- C. Sand: Clean, washed, buff colored sand, graded per ASTM C144.
- D. Water: Clean, fresh and suitable for drinking.

## 2.3 MORTAR MIX

- A. Interior Masonry Construction: Provide Portland cement/lime mortar conforming to ASTM C 270, Type S, for load bearing conditions, mortar shall conform to ASTM C 270, Type M.
- B. Grout for Unit Masonry: Comply with ASTM C 476 for grout for use in construction of unit masonry. Use grout of consistency (fine or coarse) at time of placement which will completely fill all spaces intended to receive grout.
- C. Mixing

1. General: Add cement just before mixing and mix dry. Use sufficient amount of water as necessary to produce workable mix. Mix in small batches to make plastic mass.
2. Mixing: Machine mix all mortars in approved type mixer with device to accurately and uniformly control water. Add hydrated lime dry. Mix dry materials not less than two (2) minutes. Add water, then mix not less than three (3) minutes. Mix only amount of mortar that can be used before initial set. Do not use mortar which has reached its initial set or two (2) hours after initial mixing, whichever comes earlier. Mortar may not be re-tempered. Clean mixer for each batch, whenever mortar type is changed, and at end of each day's work.
3. Acceleration or other admixtures not permitted.
4. Mortar shall have a flow after suction of not less than seventy-five (75) percent of that immediately after mixing as determined by ASTM C 91.

D. Admixtures

1. No air-entraining admixtures or cementitious materials containing air-entraining admixtures shall be used in the mortar.
2. No antifreeze compounds or other substances shall be used in the mortar to lower the freezing point.
3. Calcium chloride or admixtures containing calcium chloride shall not be used in mortar.

## PART 3 EXECUTION

### 3.1 SURFACE CONDITIONS

A. Inspection

1. Prior to all work of this Section, carefully inspect the installed work of all other trades and verify that all such work is complete to the point where this installation may properly commence.
2. Verify that masonry may be completed in accordance with all pertinent codes and regulations, the referenced standards, and the original design.

B. Discrepancies

1. In the event of discrepancy, immediately notify the Architect in writing.
2. Do not proceed with installation in areas of discrepancy until all such discrepancies have been fully resolved.

### 3.2 COORDINATION

- A. Carefully coordinate with all other trades to ensure proper and adequate interface of the work of other trades with the work of this Section.

### 3.3 PREPARATION

- B. Concrete Block: Do not wet concrete block units.

### 3.4 INSTALLATION

#### A. General

1. Build walls to the full thickness shown. Build single wythe walls to the actual thickness of the masonry units, using units of nominal thickness shown.
2. Build chases and recesses as shown or required for the work of other trades.
3. Leave openings for equipment to be installed before completion of masonry work.  
After installation of equipment, complete masonry work to match work immediately adjacent to the opening.
4. Lay out walls in advance for accurate spacing of surface bond patterns with uniform joint widths and to properly locate openings, movement type joints, returns and off-sets. Avoid the use of less than half size units at corners, jambs and wherever possible.
5. Lay up walls plumb and true with courses level, accurately spaced and coordinated with other work.
6. Provide templates made of steel studs for plumbing of two story masonry openings.
7. Where possible, masonry walls and partitions shall be built after all overhead ducts, pipes and conduits are in place and tested. Masonry shall be neatly built around the items above. Walls and partitions shall be plumb, true to line and free from defects such as open cells, voids, dry joints and other similar defects. In rooms and spaces scheduled to have concrete block finish, all such surfaces including upper wall surfaces up to termination of structural ceiling in spaces without suspended ceilings, shall be made suitable for paint application. Cutting of openings in walls and partitions in place shall be done only with the approval of the Architect.

#### B. Mortar Bedding and Jointing

1. All joints between bricks shall be of equal width as indicated on the Drawings. and shall be completely filled with mortar. Bed joints shall be beveled per IMI recommendations, with the brick then shoved in place. At cavity wall construction, care shall be taken that no excess mortar goes into masonry cavity. Cross joints shall be formed by applying a full coat of mortar to the entire end or the entire side, as the case requires, and then shoving the mortar covered end and/or side of the brick tightly against the bricks previously laid; the practice of buttering the corners of brick and then throwing mortar scrapings into the empty joints will not be permitted. All brick shall be laid without disturbing the brick previously laid. Dry or butt joints will not be permitted. Grouting shall be done only as necessary. Do not slush head joints.
  - a. Horizontal joints of brick work shall be "weathered"; vertical joints shall be struck flush.
2. Lay concrete masonry units with full mortar coverage on horizontal and vertical face shells. Bed webs in mortar in starting course on exterior walls and in all courses of piers, columns and pilasters, where solid CMU is used and where adjacent to cells or cavities to be reinforced or filled with

concrete or grout.

a. To ensure alignment of brick and block coursing, adjust block back-up by cutting block to insure alignment of coursing or use adjustable anchorage.

3. Lay masonry walls with 3/8" joints unless otherwise shown on drawings.
4. Tool exposed joints of CMU slightly concave. Concealed joints shall be struck flush.
5. Remove masonry units disturbed after laying; clean and reset in fresh mortar. Do not pound corners at jambs to fit stretcher units which have been set in position. If adjustments are required, remove units, clean off mortar and reset in fresh mortar.

C. Stopping and Resuming Work: Rake back 1/2 brick length in each course; do not tooth.

Clean exposed surfaces of set masonry, wet units lightly (if required) and remove loose masonry units and mortar prior to laying fresh masonry.

D. Built-In Work

1. As the work progresses, build in items specified under this and other Sections of these specifications. Fill in solidly with masonry around built-in items.
2. Mortar in door frames, access doors, louvers and other metal items embedded or built into masonry work solidly with mortar as the masonry units are laid up.
3. Grout under lintels, bearing plates, and steel bearing on masonry with solid bed grout.
4. Sleeves, pipes, ducts and all other items which pass through masonry walls shall be caulked with interior grade sealant meeting requirements of Section 079200, so as to be air tight and prevent air leakage. Refer to Section 078413 for packing of voids in rated masonry walls.
5. Fill vertical cells of masonry units solid with grout which have anchoring, reinforcing rods, supporting or hanging devices embedded in the cell including stone anchors and window or curtain wall anchors.
6. Fill vertical cells of masonry units solid with mortar on each side of door frames to sixteen (16) inches beyond.
7. Unless otherwise noted, fill vertical cells of masonry units solid with grout which are below steel bearing plates, steel beams, and ends of lintels, to eight (8) inches beyond bearing and from floor to bearing.
8. Place wire mesh in horizontal joint below masonry unit cells to be filled with mortar, to prevent mortar from dropping into unfilled cells below.
9. Masonry indicated as being reinforced shall have all voids filled solid with grout.

Grout shall be consolidated in place by vibration or other methods which insure complete filling of cells. When the least clear dimension of the grouted cell is less than two (2) inches, the maximum height of grout pour shall not exceed



twelve (12) inches. When the least clear dimension is two (2) inches or more, maximum height of grout pour shall not exceed forty-eight (48) inches. When grouting is stopped for one (1) hour or longer, the grout pour shall be stopped 1-1/2" below the top of a masonry unit. Vertical bar reinforcing shall be accurately placed and held in position while being grouted, and shall be in place before grouting starts. All such reinforcing shall have a minimum clear cover of 5/8". Lap all bars a minimum of forty (40) bar diameters and provide steel spacer ties (not to exceed 192 bar diameter) to secure and position all vertical steel and prevent displacement during grouting. Provide continuous horizontal reinforcement embedded in mortar joints every second course.

#### E. Cutting and Patching

1. All exposed masonry which requires cutting or fitting shall be cut accurately to size with motorized carborundum or diamond saw, producing cut edges.
2. Do not saw cut any masonry openings in face brick construction without Architect's approval and after a procedure has been reviewed and approved.
3. Holes made in exposed masonry units for attachment of handrail brackets and similar items shall be neatly drilled to proper size.
4. All masonry which requires patching in exposed work, if approved by Architect, shall be patched neatly with mortar to match appearance of masonry as closely as possible and to the Architect's satisfaction. Rake back joints and use pointing mortar to match as required.

#### F. Interior Block Partitions

1. Build to full height unless otherwise shown on drawings. At non-rated partitions fill void between CMU and structural deck with continuous neoprene filler conforming to the requirements of Section 079210. At fire rated partitions, fill void with fire stop material meeting the requirements of Section 078413. Fasten to structure at top of partition using steel angles as specified herein. Coordinate head conditions with acoustical isolation requirements indicated in the drawings.
2. Provide continuous horizontal joint reinforcing every other block course, except as otherwise noted. Fully embed longitudinal side rods in mortar for their entire length with a minimum cover of 5/8". Lap reinforcement a minimum of six (6) inches at ends of units.
3. Provide continuity at corners and wall intersections by use of prefabricated "L" and "T" sections. Cut and bend units as directed by manufacturer for continuity at returns, offsets, column fireproofing, pipe enclosures and other special conditions.
4. Corners
  - a. Provide interlocking masonry unit bond in each course at corners.
  - b. Provide continuity at corners with prefabricated "L" reinforcement units, in addition to masonry bonding.

5. Intersecting and Abutting Walls

- a. Unless vertical control joints are shown as part of structural frame, provide interlocking masonry bond. Provide starters and special shapes as shown on the drawings to bond these horizontal reinforcement using prefabricated "T" units at interior partitions.

G. Control and Expansion Joints

1. Provide vertical expansion, control and isolation joints in masonry as shown.  
Build in related items as the masonry work progresses.
2. CMU Control Joint Spacing: If location of control joints is not shown, place vertical joints spaced not to exceed 20'-0" o.c. Location of control joints to be reviewed by Architect. In addition, locate joints at points of natural weakness in the masonry work, including the following:
  - a. At structural column or joint between bay.
  - b. Above control joints in the supporting structure.
  - c. Above major openings at end of lintels upward and below at ends of sills  
downward. Place at one side of jamb for openings not less than 7'-0" wide and at both sides for openings over 6'-0" wide.
  - d. At reduction of wall thickness.
  - e. Where masonry abuts supporting structure.
  - f. If additional joints are required, indicate same on approved shop drawings.
3. Brick Veneer Expansion Joint Spacing: Vertical expansion joints in brick veneer construction shall be located maximum 25'-0" o.c. unless otherwise noted in addition to expansion joints located within 2'-0" of each corner of the building.
4. Expansion joints in acoustic walls shall be filled using a resilient acoustical material as described in Section 079210. Joints shall not be bridged by any rigid material in contact with both sides, such as concrete, reinforcing bars or electrical conduit.

3.6 CLEANING, PROTECTION, ADJUSTMENT

A. Protection

1. The Contractor shall take adequate precautions for the protection of all surfaces against mortar spatter, and shall immediately remove any such spatter should it inadvertently occur, leaving no stain or discoloration.
2. Excess mortar shall be wiped off the masonry surfaces as the work progresses.
3. Wood coverings shall be placed over all such masonry surfaces as are likely to be damaged during the progress of the entire project.
4. Protective measures shall be performed in a manner satisfactory to the Architect.
5. Damaged masonry units shall be replaced to satisfaction of the Architect.

6. Exterior masonry walls shall be draped with waterproof covering until copings are in place, to prevent water penetration in cavity.

B. Clean-Up

1. Upon completion, all exposed masonry shall be thoroughly cleaned following recommendations of the IMI Technical Note No. 20. Before applying any cleaning agent to the entire wall, it shall be applied to a sample wall area of approximately 4' x 4' in a location approved by the Architect. No further cleaning work may proceed until the sample area has been approved by the Architect, after which time the same cleaning materials and method shall be used on the remaining wall area. If stiff brushes and water do not suffice, the surface shall be thoroughly saturated with clear water and then scrubbed with a solution of an approved detergent masonry cleaner, equal to "Vana Trol" made by ProSoCo Inc. or equal made by Diedrich or approved equal, mixed as per manufacturer's directions, followed immediately by a thorough rinsing with clear water. All lintels and other corrodible parts shall be thoroughly protected during cleaning.

- C. Pointing: Point any defective joint with mortar identical with that specified for that joint.

END OF SECTION

## DIVISION 5 – METALS

### SECTION 051200

#### STRUCTURAL STEEL

##### PART 1 - GENERAL

##### 1.1 RELATED DOCUMENTS

- A. Drawings and general provisions of the Contract, including General and Supplementary Conditions and Division 01 Specification Sections, apply to this Section.

##### 1.2 SUMMARY

- A. Section Includes:

1. Structural steel.
2. Bolts, washers, and other steel accessories
3. Shear studs.
4. Welded steel connections.
5. Grout.

- B. Related Sections:

1. Division 01 Section "Quality Requirements" for independent testing agency procedures and administrative requirements.
2. Division 03 Section "Cast-in-Place Concrete" for post-installed concrete anchors.
3. Division 05 Section "Steel Decking" for field installation of shear studs through deck.
4. Division 05 Section "Metal Fabrications" for other metal items not defined as structural steel.
5. Division 05 Section "Metal Stairs."
6. Division 05 Section "Decorative Metal".
7. Division 07 Section "Applied Fireproofing".

##### 1.3 DEFINITIONS

- A. Structural Steel: Elements of structural-steel frame, as classified by American Institute of Steel Construction (AISC) 303, "Code of Standard Practice for Steel Buildings and Bridges."

##### 1.4 SUBMITTALS

- A. General:

1. Review of submittals if of a general nature only, and responsibility for conformance with the intent of the Contract Documents shall remain with the Contractor. Review does not imply nor state that fabricator has correctly interpreted the Contract Drawings.
2. All submissions shall be in accordance with the submission schedule developed and agreed between the Architect and Contractor at the commencement of the project.

- Submission shall include dates of order and delivery of materials to the shop and the site.
3. Shop drawing schedule shall allow adequate time for reviews. Submittal shall include all related pieces in an assembled or area. The Contractor shall allow adequate time in shop drawing preparation stage for the dimensioning process and coordination with the Architectural Drawings and those of other disciplines. Submit a schedule for steel shop and erection drawings.
- B. Product Data: For each type of product indicated.
- C. Shop Drawings: Show fabrication of structural-steel components, including anchor rod setting plans, details of layout and connections, fabrication of all members, and element and erection plans. Direct copies of the Contract Documents are not acceptable as a submission from the Contractor.
1. Submit shop drawings to Architect for review and obtain Architect's acceptance prior to start of fabrication. Where shop drawings are resubmitted, the Contractor shall cloud and identify all changes made due to additions, deletions, and corrections to the shop drawing.
  2. Include layout, member size, and weights, materials used, and beam marks as well as orientation and relation of members to appropriate grid lines and setting elevations for column bases. Reference shop drawings to specific location and detail number on the Structural Drawings.
  3. Include details of cuts, connections, splices, camber, holes, openings, doubler plates, stiffeners and other pertinent data, including bolt hole sizes, connection materials, and welded joint designations.
  4. Include embedment drawings.
  5. Indicate welds by standard AWS symbols, distinguishing between shop and field welds, and show size, length, and type of each weld. Show backing bars that are to be removed and supplemental fillet welds where backing bars are to remain. Identify WPS applicable to each shop weld.
  6. Indicate type, size, and length of bolts, distinguishing between shop and field bolts. Identify pre-tensioned and slip-critical high-strength bolted connections.
  7. Indicate surface preparation and finishes.
  8. Submit plans of all levels locating the edge of slab at perimeter and at interior openings.
- D. Welding Procedure Specifications (WPSs) and Procedure Qualification Records (PQRs): Provide according to AWS D1.1, "Structural Welding Code - Steel" for each welded joint whether prequalified or qualified by testing, including items listed below. All submitted Procedures shall be reviewed by the Testing Agency prior to use on the project. The Procedures will be submitted to the Engineer for record only.
1. Power source (constant current or constant voltage).
  2. Electrode and flux manufacturer and trade name.
  3. Tolerances or the acceptable range of values, applicable to the various welding parameters.
  4. Where backgouging is required provide back gouging criteria (e.g. smoothness, grinding, gouge shape, inspection by the welder, etc.).
  5. For multi-pass welds define sequence and layering of passes.
  6. When the required effective throat thickness of flare groove welds is larger than allowed by Table J2.2 of AISC "Steel Construction Manual", submit data establishing by qualification the consistent production of such larger effective throat thickness. Qualification of effective throat thickness shall be as required by the AISC specification.
  7. For complete penetration butt or groove welds, include test records for the following only at locations specified on the drawings: toughness, (Charpy tests for weld metal), heat affected zone.

- E. Weld Shrinkage and Distortion Procedures: Submit weld shrinkage and distortion procedures for all welded connections where distortion due to weld shrinkage may cause damage to the steel material. The welding sequence and procedures are to minimize the effect of weld shrinkage, residual stresses, and to maintain erection tolerances. These procedures shall be reviewed by Testing Agency, and then used by Testing Agency to verify conformance. As a minimum, procedures shall be submitted for the following connections:
- F. Fastener Installation Procedures: Submit written procedures for the pre-installation testing, installation snugging, pre-tensioning, and post-installation inspection of fasteners. The procedures shall meet all requirements of the Research Council on Structural Connections (RCSC) "Specification for Structural Joints Using ASTM A325 or A490 Bolts" and the Contract Documents.
- G. Welding certificates.
- H. Mill test reports for structural steel, including chemical and physical properties, regardless of thickness or use. Reports shall comply with ASTM A6.
  - 1. Submit a mill report for each heat of steel used, and certified fastener reports for all fasteners, including nuts, washers and direct tension indicators prior to the start of fabrication. For unsatisfactory mill test report, retest steel.
  - 2. Include Charpy test results for heavy sections and for materials where Charpy values are specified.
  - 3. Mill test reports shall include ladle analysis and tensile elongation and bend tests.
  - 4. Mill reports shall be traceable to individual pieces of steel used.
- I. Product Test Reports and Certifications: Submit manufacturer's test reports and certifications as listed below. Test Reports and Certifications are submitted for record only and therefore will not be returned to the Contractor. A copy of the test reports and certifications shall be sent to the owners Quality Assurance Agency. The Contractor Certificate of Compliance letter shall accompany the Manufacturer's Certifications.
  - 1. Bolts, nuts, and washers including mechanical properties and chemical analysis. Certifications for high strength bolts shall conform to certification requirements contained in ASTM A325, A490, F1852, F959, F2280.
  - 2. Direct-tension indicators.
  - 3. Tension-control, high-strength bolt-nut-washer assemblies.
  - 4. Nonshrink grout.
  - 5. Welding electrodes, fluxes and shielded gas products. Certifications shall satisfy the applicable AWS A5 and project requirements.
- J. Submit fabricators identification mark system to Testing Agency prior to fabrication.

## 1.5 QUALITY ASSURANCE

- A. Testing Agency: Shop and field testing and inspection of steelwork specified in this document or requested by the Owner will be performed by an independent agency engaged by the Owner.
  - 1. The Testing Agency shall be furnished with the following:
    - a. One complete set of fabrication and erection drawings.
    - b. Material bills, cutting lists, order sheets and mill test reports.
    - c. Information regarding time, place of rolling and shipment of materials to shop.
    - d. If requested, representative sample pieces for testing.
    - e. Full and ample means and assistance for testing materials.

- f. Access and facilities, including scaffolding, temporary work platforms, etc., for testing and inspection at all places where materials or components are stored, fabricated or erected in the mill, shop or field.
  - g. Complete set of welding procedures.
  - h. Welder qualifications.
  - i. AISC fabricator certification documents, QA/QC manual and most recent AISC audit.
  - j. Reports for all Contractor tests and inspections.
2. In addition to the work specified elsewhere in the Contract Documents, the Testing Agency shall review the following for compliance with project specifications:
- a. Fastener Installation Procedures.
  - b. WPSs and WPQRs.
  - c. Manufacturer's Test Reports and Certifications .
  - d. Welder qualification.
- B. Comply with applicable provisions of the current edition of the following specifications and documents, except where more stringent requirements are shown or specified:
- 1. AISC 303 "Code of Standard Practice for Structural Steel Buildings and Bridges".
  - 2. AISC 360, "Specification for Structural Steel Buildings".
  - 3. AISC "Steel Construction Manual".
  - 4. RCSC's "Specification for Structural Joints Using ASTM A325 or A490 Bolts." with supplements.
  - 5. American Welding Society (AWS) D1.1.
  - 6. Chicago Building Code
- C. All work shall be performed by qualified operators experienced in their field of work and as otherwise required by these specifications.
- D. Shop-Painting Applicators: Qualified according to AISC's Sophisticated Paint Endorsement or SSPC-QP 3, "Standard Procedure for Evaluating Qualifications of Shop Painting Applicators."
- E. Welding Qualifications: Qualify procedures and personnel according to AWS D1.1 for each process, position and joint configuration. Each operator shall have been qualified as prescribed by AWS and shall be approved by the Chicago building department. Qualification performed more than six months prior to the start of the welding by the welder is acceptable, provided written documentation is submitted showing that the welder has continued to use the applicable welding process on an ongoing basis since the test was conducted, with no lapse in service exceeding six months.
- 1. Welder Certificates shall be submitted to Testing Agency prior to welding.
  - 2. Require welders to retake the qualification test if, as determined by the Architect or Testing Agency, there is a reasonable doubt as to the proficiency of the welder. If the welder does not requalify, he shall not perform any welding on the project.
  - 3. In addition to AWS D1.1 requirements on welder Qualification, qualify welders making welds with restricted access (such as welding the bottom flanges of girders to column flanges through cope or access holes in the girder webs) by using a mock-up assembly identical to the actual conditions of producing weldments in the field, using the approved WPS.
  - 4. Welder qualification shall include passing the bend test [and Charpy tests when Charpy values are specified for the electrode].
- F. Contractor's Quality Control Plan: Quality Control includes the functions performed by the Contractor to ensure that the material and workmanship of structural steel construction meets the project specifications and applicable standards. The Contractor shall submit a Quality

Control Plan that addresses all inspection issues, including fabrication/erection testing and inspection per AWS D1.1. The verification testing and inspection carried out by the Testing Agency does not relieve the contractor of the responsibility for conducting their own quality control/inspection program to ensure the requirements of the Contract Documents have been met. The Contractor's Quality Control Plan will be reviewed by the Testing Agency.

- G. Quality Control Inspector Qualifications: Along with Quality Control Plan, Contractor shall submit written qualifications for all inspectors to be assigned Quality Control functions for structural steel work, including general inspection, bolting inspection, welding inspection, and non-destructive testing. Qualifications for welding inspectors shall show evidence of ability to monitor all WPS variables, check weld sizes, and visually detect weld defects.
- H. Prefabrication and Preinstallation Conference: Prior to performing fabrication or erection work, there shall be a pre-fabrication and pre-erection meeting to review welding procedures, bolting procedures, and inspection requirements for all welding and bolting operations. The meeting shall include the following individuals: Owner's Representative, Testing Agency, Special Inspector, Steel Fabricator and Erector personnel supervising the shop, field and Quality Control work.

## 1.6 DELIVERY, STORAGE, AND HANDLING

- A. Do not handle structural steelwork until paint has thoroughly dried. Care shall be exercised to avoid abrasions and other damage.
- B. Store materials to permit easy access for inspection and identification. Keep steel members off ground and spaced by using pallets, dunnage, or other supports and spacers. Protect steel members and packaged materials from corrosion and deterioration. Material shall be kept free from dirt, grease, and other foreign matter.
  - 1. Do not store materials on structure in a manner that might cause distortion, damage, or overload to members or supporting structures. Repair or replace damaged materials or structures as directed, to the acceptance of the Architect, and at no additional cost to the Owner. Materials showing evidence of damage will be rejected and shall be immediately removed from the site.
- C. Store fasteners in a protected place in sealed containers with manufacturer's labels intact.
  - 1. Fasteners may be repackaged provided Owner's testing and inspecting agency observes repackaging and seals containers.
  - 2. Clean and re-lubricate bolts and nuts that become dry or rusty before use.
  - 3. Comply with manufacturers' written recommendations for cleaning and lubricating ASTM F1852 fasteners and for retesting fasteners after lubrication.
- D. Requirements for storage and handling of electrodes shall be per AWS D1.1. Additional requirements include:
  - 1. Long term storage of weld consumables shall be indoors, where moisture or dew does not collect, and in undamaged manufacturer's shipping bags, boxes, and containers.
  - 2. Open Flux Cored Arc Welding (FCAW) electrodes shall be completely covered during hours of non-use (i.e., weekends, nights of nonuse, days of nonuse, etc.). Where rain or dew could be expected to collect (i.e., open floors of erection site, open shop bays, etc.), electrodes shall also be covered.



## 1.7 COORDINATION

- A. Surveys: Contractor shall conduct field surveys and field verification as required to incorporate existing conditions from previous works, such as foundations and existing buildings, to the work before shop drawings are produced.
- B. Coordinate installation of anchorage items to be embedded in or attached to other construction without delaying the Work. Provide setting diagrams, templates, instructions, and directions for installation.
- C. Notify the Owner's Representative in sufficient time prior to shop or field fabrication or erection to permit testing and inspection without delaying work.
- D. Coordinate selection of shop primers with topcoats to be applied over them. Comply with paint and coating manufacturers' recommendations to ensure that shop primers and topcoats are compatible with one another.

## PART 2 - PRODUCTS

### 2.1 STRUCTURAL STEEL MATERIALS

- A. Recycled Content of Steel Products: Provide products with an average recycled content of steel products so post-consumer recycled content plus post-industrial recycled content is not less than 50 percent.
- B. Recycled Content of Steel Products: Provide products with an average recycled content of steel products so post-consumer recycled content plus post-industrial recycled content is not less than the following:
  - 1. W-Shapes: 60 percent.
  - 2. Channels, Angles: 60 percent.
  - 3. Plate and Bar: 25 percent.
  - 4. Steel Pipe: 25 percent.
  - 5. All Other Steel Materials: 50 percent.
- C. W-Shapes: ASTM A992, typical, and ASTM A572, Grade 50
- D. Channels, Angles: ASTM A36, ASTM A572, Grade 50
- E. Plate and Bar: ASTM A36, ASTM A572, Grade 50

### 2.2 WELDING MATERIALS

- A. Welding Material: Filler metal requirements shall conform to AWS D1.1 and AISC "Specification for Structural Steel Buildings". Minimum classified tensile strength of 70 ksi (E70). Use low hydrogen electrodes as defined by AWS D1.1, unless noted otherwise. For all CJP welds used on Heavy Structural Sections that are not part of the Seismic Load Resisting System the filler metal shall have a Charpy V-Notch (CVN) toughness of at least 20 ft-lb at 70 degrees F.

## 2.3 BOLTS, CONNECTORS, AND ANCHORS

- A. High-Strength Bolts, Nuts, and Washers: ASTM A325, Type 1, heavy-hex steel structural bolts unless noted otherwise; ASTM A563, Grade C, heavy-hex carbon-steel nuts; and ASTM F436, Type 1, hardened carbon-steel washers; all with plain finish. ASTM F1852 Twist-Off Type Torque Control Bolts are a suitable alternative to ASTM A325 bolts, although use of such bolts shall not negate the requirement that Direct Tension Indicators be used for inspection.
  - 1. Direct-Tension Indicators: ASTM F959, Type 325, compressible-washer type with plain finish. Use on all A325 bolts where noted 'slip-critical' or 'fully pre-tensioned' on Structural Drawings.
- B. Threaded Rods: ASTM A449.
  - 1. Nuts: ASTM A563 heavy-hex carbon steel.
  - 2. Washers: ASTM F436, Type 1, hardened carbon steel.
  - 3. Finish: Plain

## 2.4 PRIMER

- A. Comply with Division 09 Section "Paintings and Coatings"
- B. Primer Paint shall comply with all applicable SSPC requirements and shall be compatible with finish paints and spray-on fireproofing specified elsewhere.
- C. Primer:
  - 1. Typical Interior Primer: SSPC-Paint 25, Type II or SSPC-Paint 23. Primer shall comply with the requirements called out in the "Green Seal Standard for Anti-Corrosive Paints" (GC-03).

## 2.5 GROUT

- A. Grout shall have a minimum 2400 psi compressive strength in 48 hours and 6000 psi compressive strength at 28 days.
- B. Nonmetallic, Shrinkage-Resistant Grout: ASTM C1107, factory-packaged, nonmetallic aggregate grout, noncorrosive and nonstaining, mixed with water to consistency suitable for application and a 30-minute working time.

## 2.6 FABRICATION

- A. Structural Steel: Fabricate and assemble in shop to greatest extent possible. Fabricate according to AISC 303 and AISC 360.
  - 1. Camber structural-steel members where indicated. Fabricate beams and girders with natural camber upward, unless noted otherwise on the drawings. Camber stated in the drawings is the required camber after erection.
  - 2. Fabricate beams with rolling camber up.
  - 3. Identify high-strength structural steel according to ASTM A6 and maintain markings until structural steel has been erected.

4. Mark and match-mark materials for field assembly. Members shall be fabricated for delivery in a sequence that will expedite erection and minimize field handling of structural steel.
  5. Grind burrs, sharp arises and ragged edges that would prevent solid seating of the connected parts.
  6. Complete structural-steel assemblies, including welding of units, before starting shop-priming operations.
- B. Thermal Cutting: Perform thermal cutting by machine to greatest extent possible. An unguided torch may be used provided the cut is within 1/8 inch of the required line.
1. Plane thermally cut edges to comply with requirements in AWS D1.1.
- C. Bolt Holes: Cut, drill, or punch standard bolt holes perpendicular to metal surfaces.
1. Use standard holes unless otherwise indicated on the Drawings. Holes shall be drilled or punched at right angles to the surface of the metal. Making or enlarging holes by burning is prohibited.
  2. Flame cut holes for fasteners are not acceptable.
  3. Holes in column baseplates shall be no more than 3/8 inch larger than the nominal bolt size.
  4. For the following conditions holes shall be drilled (not punched), even where punching is allowed by referenced standards: a) material having a thickness in excess of 7/8 inch or the hole diameter; b) column base plates; c) holes less than 6-inches from an edge that requires a CJP weld; d) where holes are subjected to welding shrinkage stresses.
- D. Bending Steel Plate:
1. Bend plates perpendicular to the rolling direction.
  2. Grind flame cut plate edges transverse to the bend line.
  3. Grind out nicks in plate edges transverse to the bend line.
  4. Round sharp corners on plate edges transverse to the bend line.
- E. Heat Straightening: Will be permissible by the use of properly controlled heat, skilled personnel, proper equipment and in accordance with documents prepared by the fabricator and accepted. Reject materials that contain kinks or sharp angles. Material straightened prior to fabrication shall be rejected where it shows signs of distress or defects.
- F. Planing and Milling: Accurately finish ends of columns and other members transmitting bearing loads. Mill bearing surfaces to true planes. Mill ends of columns perpendicular to centerline axis connection mid-depth points at ends of member. Cut and fit column and bearing stiffeners in manner to provide bearing over entire cross section
1. Column Base Plates
    - a. From 2" Through 4" Thickness: Straighten by pressing.
    - b. Over 4" Thickness: Plane top for column bearing; plane bottom when bearing on steel.
- G. Cleaning: Clean and prepare steel surfaces that are to remain unpainted according to SSPC-SP 1, "Solvent Cleaning" and SSPC-SP 2, "Hand Tool Cleaning.
- H. Holes: Provide holes required for securing other work to structural steel and for other work to pass through steel framing members.
1. Provide holes, slots and openings together with necessary reinforcing as shown on the Drawings required for securing work of other trades to the work specified here. Where

- openings are shown on the Drawings no change shall be permitted without prior approval. Openings shall be done in the shop.
2. Cut, drill, or punch holes perpendicular to steel surfaces. Do not thermally cut bolt holes or enlarge holes by burning.
  3. Baseplate Holes: Cut, drill, or punch holes perpendicular to steel surfaces.
  4. Weld threaded nuts to framing and other specialty items indicated to receive other work.
- I. The Contractor shall cooperate fully with requests from inspection and testing personnel for access to the connections and joints to be inspected and tested. This includes beam and column turning in shop, weld backing removal when nondestructive examination indicates rejectable conditions, and access to platforms or scaffolding as required to perform the work safely.

## 2.7 SHOP CONNECTIONS

### A. General Bolting:

1. Product containers must be marked with lot numbers and traceability information so that correspondence with mill reports can be established. Manufacturer's symbol and grade markings shall appear on all bolts, nuts, through-hardened washers and direct tension indicators.
2. Bolts shall be of a length that will extend to a point at least flush with the surface of the nuts, though not more than a length equal to the height of the nut, beyond the nuts unless otherwise noted.
3. Bolts shall be installed with threads excluded from the shear plane.
4. Washers shall be used on all bolts. Use beveled washers where bolts bear on sloping surface.

### B. High-Strength Bolts: Shop install high-strength bolts according to RCSC's "Specification for Structural Joints Using ASTM A325 or A490 Bolts" for type of bolt and type of joint specified. Contact surfaces of bolted parts shall as a minimum comply with the Class A requirements.

1. Joint Type shall be as noted on drawings.
2. Direct tension indicator (load indicating washers or "Tension-Set" bolts) method shall be used at slip-critical connections. "Turn-of-Nut" methods are not an acceptable alternative.
3. When connection has bolts and welds, fully tighten bolts prior to welding with the exception that in moment connections the flange welds shall be completed prior to final tightening of high strength bolts.
4. When already tensioned bolts have had their tension relaxed, replace the bolt and tension indicator and re-tighten.

### C. Weld Connections: Comply with AWS D1.1 for tolerances, appearances, welding procedure specifications, weld quality, and methods used in correcting welding work.

1. Shop welds shall be inspected in the shop before the work is painted or shipped.
2. Weld sizes where shown shall be assumed to be effective weld sizes.
3. All groove or butt welds shall be full penetration unless noted otherwise on the Drawings.
4. Where structural steel members are to remain exposed in the finished work, welds exposed to view shall be uniformly made and ground smooth.
5. Weld tabs shall be in accordance with AWS D1.1. In addition, weld tabs shall extend beyond the edge of the joint a distance equal to the plate thickness but not less than 1-inch except at access holes in beam/girder webs and at continuity plate clips. Weld tabs shall be oriented parallel to the joint preparation and to the weld direction. Weld dams are not allowed.

6. Remove weld tabs and backup plates and grind surfaces smooth as required for inspection or testing. Where tabs or backup bars interfere with architectural treatment or are exposed to view in the final structure, remove and grind smooth. Backup bars and run-off tabs at Heavy Structural Sections shall be removed.
7. Splices of members in tension, all members of moment frames and all members of braced frames that are made from heavy steel sections shall be made in conformance with Section J1.5 of AISC 360.
8. Weld variables shall be consistent with the recommendations of the electrode manufacturer.
9. Do not weld into column flange-to-web intersection as defined the AISC "k" and "k1" distances except for the doubler plate to column welds. Continuity plate welds shall stay clear of this area as noted on the drawings.
10. Sequence the work as necessary to accommodate testing.
11. Welding Procedures:
  - a. Weld only in accordance with the Welding Procedure Specifications. WPS shall be readily available to all welders, inspectors, and supervisors during the production process.
  - b. Consider toughness and notch sensitivity of steel in formation of the welding procedures to prevent brittle and premature fracture during fabrication and erection. Toughness requirements are to match those of the parent metal.
  - c. Weld in a manner to minimize accumulation and concentration of through-thickness strains due to weld shrinkage. Sequence welds in a manner to reduce residual stresses (caused by welding) to a minimum value. Welding procedures shall incorporate measures necessary to eliminate cracking.
  - d. Do not mix different electrodes in the same weld joint unless the interactions have been shown not to cause problems.
  - e. Stringer passes only, no weaving or wash passes. Manipulation of the electrode for vertical welds (oscillation) shall be kept to a maximum movement of 4 to 5 electrode diameters.
  - f. Welding shall not begin until joint elements are bolted or tacked in intimate contact and adjusted to dimensions shown in the Drawings, with proper allowance for any weld shrinkage.
12. Refer to the Structural Drawings for additional requirements.

## 2.8 SOURCE QUALITY CONTROL

- A. Testing Agency: Testing Agency to perform shop tests and inspections as defined by AWS, AISC and these specifications. Testing Agency shall summarize their finding in inspection and testing reports. Reports shall identify any findings that are not in compliance with requirements of the project specifications.
  1. Provide testing agency with access to places where structural-steel work is being fabricated or produced to perform tests and inspections.
- B. See Part 1 of this specification for additional testing and inspection requirements. As a minimum the inspector will make all tests and inspections as required by the Chicago Building Code. Testing Agency will make all the tests and inspections indicated in the Contract Documents.
- C. Contractor shall correct deficiencies in Work that test reports and inspections indicate does not comply with the Contract Documents.
  1. Owner's Representative reserves right, at any time before final acceptance, to reject material not complying with requirements.

2. Any tests that may be necessary to reconfirm any noncompliance of original work, and as may be necessary to show compliance of corrected work, shall be at Contractor's expense.
- D. Each person installing connections shall be assigned an identifying symbol or mark and all shop and field connections shall be so identified so that the Inspector can refer back to the person making the connection.
- E. Bolted Connections: Shop-bolted connections will be inspected according to RCSC's "Specification for Structural Joints Using ASTM A325 or A490 Bolts."
1. High Strength Bolted Connections: High strength bolts specified as Snug-Tight (ST) need not be inspected for bolt tension. For high strength bolts specified as Slip-Critical (SC), verify that 10% or a minimum of 2 bolts per connection are tensioned in accordance with the RCSC Specification.
  2. Direct Tension Indicators: Observe all Direct Tension Indicators to see if proper tightness was achieved.
  3. Standard Bolted Connections: Testing Agency shall inspect the installation of A307 bolts to verify that 10% of all bolts or a minimum of 2 bolts per connection are installed properly and tightened to a Snug-Tight (ST) condition.
- F. Welded Connections:
1. Testing Agency shall be present during all welding operations. In addition to visual inspection, all shop-welded connections will be tested and inspected according to AWS D1.1 and this specification using the following inspection procedures:
    - a. Magnetic Particle Inspection (MT): ASTM E709; performed on root pass and on finished weld. Cracks or zones of incomplete fusion or penetration will not be accepted.
    - b. Ultrasonic Inspection (UT): ASTM E164.
  2. Visual Inspection of Welding: Testing Agency shall visually inspect all shop and field welding of structural steel accordance with the governing building code and AWS D1.1. Visual inspection of welds shall include but not be limited to the following:
    - a. Verify: Welding Procedure Specification (WPS) sheet has been provided and has been reviewed with each welder making the weld, welder qualification and identification, fit-up meets tolerances of WPS and mark joint prior to welding, welding consumables are per the Contract Documents and the WPS, amperage and voltage at the arc with hand-held meters, meters on welding equipment are functioning and accurate.
    - b. Observe preheat and interpass temperatures, weld pass sequence and size of weld bead.
    - c. Multi-pass shop and field welds shall be continuously inspected.
    - d. Visually inspect welds of heavy structural sections, or plates of 1-1/2 inch minimum thickness, at least 72 hours after completion of welding for the presence of cracks.
    - e. Visually inspect areas where backing bars and welds tabs are removed for conformance with the surface roughness criteria of the specifications.
    - f. Verify that the effective throat thickness of flare groove welds is consistently obtained when flush to bar or section. This verification shall be based on test sections where necessary.
  3. Nondestructive Testing Requirements: Testing Agency shall perform non-destructive testing of shop and field welding in accordance with the project specifications, governing building code, and AWS D1.1. Extent of non-destructive testing shall be as follows:
    - a. Complete Joint Penetration (CJP) welds: UT 100% CJP welds greater than 5/16-inch. MT 25% all CJP welds.

- b. Partial Penetration Joint (PPJ) welds: UT 100% of PJP welds greater than 5/16-inch. UT 100% PJP in column splices.
- c. Fillet Welds: Fillet welds of gusset plates to beams, columns and base plates - MT 10% of the following fillet welds and reduce to 5% if no significant cracks are found in the first 50 tested: a) gusset plate fillet welds to beam and columns; b) base plate fillet welds.

## PART 3 - EXECUTION

### 3.1 EXAMINATION

- A. Verify, with steel Erector present, elevations of concrete- and masonry-bearing surfaces and locations of anchor rods, bearing plates, and other embedments for compliance with requirements.
  - 1. Prepare a certified survey of bearing surfaces, anchor rods, bearing plates, and other embedments showing dimensions, locations, angles, and elevations.
- B. Discrepancies: In the event of discrepancy, immediately notify the Owner's Representative in writing. Do not proceed with construction in the region of the discrepancy until all such discrepancies have been resolved.
- C. Proceed with installation only after unsatisfactory conditions have been corrected.

### 3.2 PREPARATION

- A. Provide temporary shores, guys, braces, and other supports during erection to keep structural steel secure, plumb, and in alignment against temporary construction loads and loads equal in intensity to design loads. Remove temporary supports when permanent structural steel, connections, and bracing are in place unless otherwise indicated.
  - 1. The Contract Drawings indicate the completed structure. The Contractor is fully responsible for all temporary measures necessary for erection, except where specific sequences and requirements are specified on the Drawings.

### 3.3 ERECTION

- A. Set structural steel accurately in locations and to elevations indicated and according to AISC 303 and AISC 360. Check plumbness after erection of each tier.
- B. Dimensions shown on drawings are based on an assumed design temperature of 70 degree F. Fabrication and erection procedures shall take into account the ambient temperature range at the time of the respective operations.
- C. Where erection requires performing work of fabrication on site, comply with the applicable standards of Part 2 of this Specification.
- D. Care shall be taken to protect work already installed from damages resulting from structural steel erection.

- E. Items installed before concrete is placed shall be properly braced to prevent distortion by pressure of concrete. Watch and maintain bracing during concrete operations.
- F. Base Leveling Plates: Clean concrete- and masonry-bearing surfaces of bond-reducing materials, and roughen surfaces prior to setting plates. Clean bottom surface of plates. Remove any templates used for the setting of anchor bolts.
  - 1. Set plates for structural members on wedges, shims, or setting nuts as required.
  - 2. Weld plate washers to top of baseplate.
  - 3. Snug-tighten anchor rods after supported members have been positioned and plumbed. If used, do not remove wedges or shims but, if protruding, cut off flush with edge of plate before packing with grout.
  - 4. Promptly pack grout solidly between bearing surfaces and plates so no voids remain. Neatly finish exposed surfaces; protect grout and allow to cure. Comply with manufacturer's written installation instructions for shrinkage-resistant grouts.
- G. Maintain erection tolerances of structural steel within AISC 303.
- H. Align and adjust various members that form part of complete frame or structure before permanently fastening. Before assembly, clean bearing surfaces and other surfaces that will be in permanent contact with members. Perform necessary adjustments to compensate for discrepancies in elevations and alignment.
  - 1. Level and plumb individual members of structure.
- I. Do not use thermal cutting during erection.
- J. Do not enlarge unfair holes in members by burning or using drift pins. Ream holes that must be enlarged to admit bolts. Where a hole is required to be enlarged by more than 3/32-inch ream to and use next larger bolt size.
- K. Shear Studs: Prepare steel surfaces as recommended by manufacturer of shear studs. Use automatic end welding of headed-stud shear studs according to AWS D1.1 and manufacturer's written instructions.

### 3.4 FIELD CONNECTIONS

- A. Field connection requirements shall be as a minimum equal to those specified in Part 2 of this document.
- B. Erection bolts for welded connection shall be tightened securely and left in place, unless noted otherwise.
- C. High-Strength Bolts: Install high-strength bolts according to RCSC's "Specification for Structural Joints Using ASTM A325 or A490 Bolts" for type of bolt and type of joint specified.
- D. Weld Connections: Comply with AWS D1.1 for tolerances, appearances, welding procedure specifications, weld quality, and methods used in correcting welding work.
  - 1. Comply with AISC 303 and AISC 360 for bearing, alignment, adequacy of temporary connections, and removal of paint on surfaces adjacent to field welds.
  - 2. Weld in manner to prevent warping or distortion of finished product. Use jigs which will not restrain piece from moving during welding or cooling after welding. Sequence weld passes at a joint to prevent excessive heat build-up or cause shrinkage cracks to form.



3. Auxiliary Member Connections and Temporary Welds shall be per AWS provided that preheating may be omitted on ASTM A36 steel for single pass fillet welds with low hydrogen electrodes under the following conditions: Air temperature is 60° F. or over, steel is dry, and welds to structural base material are more than 1" away from corners or ends of plates.
4. Preheat and post-heat procedures for welded joints shall be utilized to prevent rapid cooling of welds, particularly in cold weather. Procedures are Contractor's responsibility.

### 3.5 FIELD QUALITY CONTROL

- A. Field quality control shall, as a minimum, conform to the requirements specified under Source Quality Control in Part 2.
- B. Erection Tolerances: Unless otherwise noted, level and plumb individual members of the structure within a tolerance of 1:500, but not to exceed 1/2" for full height of columns. Make exterior columns and columns adjacent to elevator beams accurate within tolerance of 1:1000, but not to exceed 1/2" for full column height. Make level and plumb based on the mean operating temperature of the structure, allowing for the difference in temperature at time of erection and the mean temperature of the structure when completed and in service. Base measurements relating to tolerances on the theoretical centerline of the columns.
  1. Columns: Gaps exceeding 1/8 inch between milled ends not permitted. Shim acceptable gaps with non-tapered mild steel shim stock.
- C. Bolted Connections: Bolted connections will be inspected according to RCSC's "Specification for Structural Joints Using ASTM A325 or A490 Bolts."
  1. The Inspector shall observe all Direct Tension Indicators to see if proper tightness is achieved.
- D. Welded Connections: Field welds will be visually inspected according to AWS D1.1, the governing building code, and Part 2 of this document, by the Testing Agency.
- E. Defective Work:
  1. Correct deficiencies in Work that test reports and inspections indicate does not comply with the Contract Documents. Work deemed defective will be removed from the site at the Contractor's expense.
  2. Any special tests not specifically covered by this specification that are proposed by the Contractor as a result of failure to comply with this Section shall be at the Contractor's expense. The Contractor shall be responsible for any consequential costs or delays.
  3. The results of those tests will be accepted, at the discretion of the Architect, as proof of adequate materials or workmanship.

### 3.6 REPAIRS AND PROTECTION

- A. Touchup Painting: Cleaning and touchup painting are specified in Division 09 painting Sections.

END OF SECTION 051200

## **DIVISION 5 METALS**

### **SECTION 053100**

#### **METAL DECKING**

##### **PART 1 - GENERAL**

###### **1.1 RELATED DOCUMENTS**

- A. Drawings and general provisions of the Contract, including General and Supplementary Conditions and Division 01 Specification Sections, apply to this Section.

###### **1.2 SUMMARY**

- A. This Section includes the following:
  - 1. Composite floor deck.
- B. Related Sections include the following:
  - 1. Division 03 Section "Cast-in-Place Concrete" for concrete fill.
  - 2. Division 05 Section "Structural Steel Framing" for shear studs.
  - 3. Division 05 Section "Metal Fabrications" for framing deck openings with miscellaneous steel shapes.
  - 4. Division 09 Section "Paintings and Coatings" for repair painting of primed deck.
  - 5. Division 07 Section "Applied Fireproofing".

###### **1.3 SUBMITTALS**

- A. General:
  - 1. Submit shop drawings for review and obtain acceptance prior to start of fabrication.
  - 2. Review of submittals if of a general nature only, and responsibility for conformance with the intent of the Contract Documents shall remain with the Contractor. Review does not imply nor state that fabricator has correctly interpreted the Contract Drawings.
- B. Product Data: For each type of deck, accessory, and product indicated.
- C. Shop Drawings:
  - 1. Prepare decking plans showing deck profile and gauge, sheet layout, supports, method of attachment, edge details, supplemental framing, openings and reinforcement, projections and accessories.
  - 2. Show type and location of welds and other fasteners.
  - 3. Show where shoring and supplemental framing of deck is needed. Shoring of deck is the responsibility of the Contractor. This includes determining whether shoring is needed, and if needed, the design of the shoring. Contractor shall consider concentrated loads from concrete and crews when investigating the need for shoring.

- D. Product Certificates:
  - 1. For each type of steel deck, submit to the Testing Agency the mill test certificate signed by product manufacturer.
  - 2. Welding electrodes.
- E. Welding:
  - 1. Welding Procedure Specifications (WPS) for all types of welds in this section.
  - 2. Certificate showing that welder has passed qualification tests.
  - 3. Welding electrodes certificate of compliance.
- F. Field quality-control test and inspection reports.
- G. Product Test Reports: Based on evaluation of comprehensive tests performed by a qualified testing agency, indicating that each of the following complies with requirements:
  - 1. Power-actuated mechanical fasteners.

#### 1.4 QUALITY ASSURANCE

- A. Testing Agency: Owner will engage a qualified independent testing and inspecting agency to perform field tests and inspections and prepare test reports. Testing Agency will be an independent agency qualified according to ASTM E 329 for testing indicated.
- B. Welding: Qualify procedures and personnel according to AWS D1.3, "Structural Welding Code - Sheet Steel."
- C. AISI Specifications: Comply with calculated structural characteristics of steel deck according to AISI's "North American Specification for the Design of Cold-Formed Steel Structural Members."
- D. Comply with applicable provisions of the following specifications and documents, except where more stringent requirements are shown or specified:
  - 1. SDI Publication No. 31, "Design manual for Composite Decks, Form Decks, and Roof Decks".
  - 2. American Welding Society (AWS) D1.3, "Structural Welding Code – Sheet Steel"
  - 3. Chicago Building code

#### 1.5 DELIVERY, STORAGE, AND HANDLING

- A. Protect steel deck from corrosion, deformation, and other damage during delivery, storage, and handling. Materials showing evidence of damage will be rejected and shall be immediately removed from the site.
- B. Store steel deck off of ground and provide drainage. Protect steel deck with a waterproof covering and ventilate to avoid condensation.

- C. Do not store materials on structure in a manner that might cause distortion or damage to members or supporting structures. Repair or replace damaged materials or structures as directed.
- D. Each bundle of fabricated elements shall be marked or tagged so as to note ASTM specification number, style, and grade.
- E. Do not overload decking during construction period and do not use decking for storage or working platform prior to welding in position.
- F. Where deck is exposed to view in the completed structure use special care to prevent damage to decking.

## PART 2 - PRODUCTS

### 2.1 GENERAL

- A. Fire-Test-Response Characteristics: Where indicated, provide steel deck units identical to those tested for fire resistance per ASTM E 119 by Underwriters Laboratories (UL) as part of an assembly used in the project.
  - 1. Fire-Resistance Ratings: Indicated by design designations of applicable testing and inspecting agency.
  - 2. Steel deck units shall be identified with appropriate markings of applicable testing and inspecting agency.
- B. All decking with concrete fill shall be provided with pre-punched vent tabs.

### 2.2 MANUFACTURERS

- A. Manufacturers: Subject to compliance with requirements, provide products by one of the following:
  - 1. Steel Deck:
    - a. Epic Metals Corporation.
    - b. Nucor Corp.; Vulcraft Division.
    - c. United Steel Deck, Inc.
    - d. Verco Manufacturing Co.
    - e. or approved equal

### 2.3 COMPOSITE FLOOR DECK

- A. Composite Steel Floor Deck: Fabricate panels, with integrally embossed or raised pattern ribs and interlocking side laps, to comply with "SDI Specifications and Commentary for Composite Steel Floor Deck," in SDI Publication No. 31, with the minimum section properties indicated, and with the following:
  - 1. Profile Depth and Uncoated-Steel Thickness: As indicated in the Structural Drawings.

## 2.4 ACCESSORIES

- A. Provide manufacturer's standard accessory materials for deck that comply with requirements indicated.
- B. Mechanical Fasteners: Corrosion-resistant, low-velocity, power-actuated or pneumatically driven carbon-steel fasteners; or self-drilling, self-threading screws.
- C. Side-Lap Fasteners: Corrosion-resistant, hexagonal washer head; self-drilling, carbon-steel screws, No. 10 minimum diameter.
- D. Miscellaneous Sheet Metal Deck Accessories: Steel sheet, minimum yield strength of 33,000 psi, not less than 16-gauge design uncoated thickness, of same material and finish as deck; of profile indicated or required for application.
- E. Pour Stops and Girder Fillers: As indicated in the Structural Drawings. Provide as a minimum steel sheet, minimum yield strength of 33,000 psi, of same material and finish as deck, and of thickness and profile as recommended by SDI Publication No. 31 for overhang and slab depth.
- F. Column Closures, End Closures, Z-Closures, and Cover Plates: Steel sheet, of same material, finish, and thickness as deck, unless otherwise indicated.
- G. Piercing Hanger Tabs: Provide UL approved hanger anchorage devices for composite deck, designed to receive wire hangers and to support not less than a 50 lb allowable load per hanger device. Provide either slots or clips or a combination of both so that devices are spaced not more than 12" o.c. in both directions, not over 9" from walls at ends of deck, and not more than 12" from walls at sides of deck. Integrally punch slots into the bottom surface of the deck ribs and stagger the pattern of slots by 6". Furnish non-piercing type of clips designed to fit over the side laps of deck.

## 2.5 FABRICATION

- A. Provide in lengths to be continuous for three spans and rest on a minimum of four supports, wherever steel layout permits. Where decking cannot be continuous for two spans, increase deck gauge as required to support temporary and permanent loads at acceptable deflections.
- B. Cantilevered units shall have the cantilever and at least the adjacent span in one length.
- C. Fabricate such that end joints occur over supporting members.
- D. Sheets parallel to and at the perimeter of the deck shall be full width sheets.
- E. Allowable Construction Load on Deck: Construction loads on deck shall not exceed carrying capacity of decks. Contractor is responsible for checking the adequacy of both steel decks and composite concrete filled decks for their ability to support all construction loads plus the wet weight of concrete.
- F. Tolerances:
  - 1. Panel length: Plus or minus ½ inch.

2. Thickness of deck units: Not less than 95 percent of the specified thickness.
3. Panel camber: ¼ inch in 10 foot length.

## PART 3 - EXECUTION

### 3.1 EXAMINATION

- A. Examine supporting frame and field conditions for compliance with requirements for installation tolerances and other conditions affecting performance:
  1. Check supporting members for correct layout and alignment.
  2. Verify that surfaces to receive floor deck are free of debris.
- B. Discrepancies
  1. In the event of discrepancy, immediately notify the Architect.
  2. Do not proceed with installation in areas of discrepancy until such discrepancies have been fully resolved

### 3.2 INSTALLATION, GENERAL

- A. Install deck panels and accessories according to Contract Documents and commentary in SDI Publication No. 31, manufacturer's written instructions, and requirements in this Section.
- B. Install temporary shoring before placing deck panels, if required to meet deflection limitations. Do not remove temporary shoring supporting composite deck construction until cast-in-place concrete has attained its design compressive strength.
- C. Locate deck bundles to prevent overloading of supporting members.
- D. Place deck panels on supporting frame and adjust to final position with ends accurately aligned and bearing on supporting frame before being permanently fastened. Do not stretch or contract side-lap interlocks.
- E. Place deck panels flat and square and fasten to supporting frame without warp or deflection.
- F. Cut and neatly fit deck panels and accessories around openings and other work projecting through or adjacent to deck.
- G. Provide supplemental miscellaneous steel to support metal deck where normal deck bearing is precluded by column flange plates or other framing members, and around minor openings where indicated. Design of this steel to support wet weight of concrete is the contractor's responsibility.
- H. Comply with AWS requirements and procedures for manual shielded metal arc welding, appearance and quality of welds, and methods used for correcting welding work.

- I. Where approved by the Architect, mechanical fasteners may be used in lieu of welding to fasten deck. Locate mechanical fasteners and install according to deck manufacturer's written instructions.

### 3.3 FLOOR-DECK INSTALLATION

- A. Fasten deck panels to steel supporting members as indicated in the Structural Drawings.
- B. Side-Lap and Perimeter Edge Fastening: Fasten side laps and perimeter edges of panels between supports as indicated in the Structural Drawings.
- C. End Bearing: Install deck ends over supporting frame with a minimum end bearing of 2 inches, with end joints as follows:
  - 1. End Joints: Butted
- D. Welding:
  - 1. Comply with AWS D1.3 requirements and procedures for welding sheet steel in structures.
  - 2. Wire brush all welds and touch-up with paint immediately after welding.
  - 3. Use weld washers when base metal thickness is less than 0.028 inch or where noted on Drawings.
- E. Pour Stops and Girder Fillers: Weld steel sheet pour stops and girder fillers to supporting wet concrete; provide closures of sufficient strength to remain in place without distortion according to SDI recommendations, unless otherwise indicated.
- F. Weld shear connectors to top flanges of beam through metal decking; quantities and spacing of stud as shown on the structural drawings. Welding of studs to decking per AWS procedures. Clean area to receive stud, remove rust, oil, grease and other foreign material that may inhibit fusion. Preheating not required if fusion tests meet AWS requirements. Fit metal deck tight against beam flange when welding.
- G. Immediately after welding deck in place, touch-up welds, burned areas, and surface coating damage with prime paint. Touch-up primer is not required for top side of deck that will be covered with concrete.
- H. Reinforce openings in decking as shown on Structural Drawings.
- I. When the underside of decking is exposed in the final structure, tape (or otherwise seal) joints to prevent leakage of concrete.

### 3.4 PROTECTION

- A. Construction Loads on Decking:
  - 1. Do not use deck units for storage or working platforms until permanently secured in position.

2. Construction loads shall not exceed carrying capacity of decks. Contractor is responsible for checking the adequacy of both steel decks and composite concrete filled decks for their ability to support all construction loads.
  3. Shoring of deck is the responsibility of the Contractor. This includes determining whether shoring is needed, and if needed, the design of the shoring. Contractor shall consider concentrated loads from concrete and crews when investigating the need for shoring.
  4. Concrete shall be placed with care to avoiding impact on deck by dropping or dumping. As a minimum, runways shall be planked if using buggies.
- B. Unless indicated in the Construction Documents, do not suspend ducts, piping, ceilings, light fixtures or other items from tabs in metal decking.
- C. Concrete admixtures containing chloride salts shall not be used with galvanized decking.

### 3.5 CLEAN-UP

- A. After erection, remove metal cuttings, and construction debris from cells for entire length.
- B. Remove grease, oil, and other foreign material from all surfaces.
- C. Leave deck and cells in proper condition for obtaining bond with concrete fill.

### 3.6 REPAIRS

- A. Repair Painting: Wire brush and clean rust spots, welds, and abraded areas on both surfaces of prime-painted deck immediately after installation, and apply repair paint.
  1. Apply repair paint, of same color as adjacent shop-primed deck, to bottom surfaces of deck exposed to view.
  2. Wire brushing, cleaning, and repair painting of bottom deck surfaces are included in Division 09 Section Paintings and Coatings.

### 3.7 FIELD QUALITY CONTROL

- A. Field welds will be subject to inspection as required by AWS D1.3. Perform welding of decking only in the presence of a full-time inspector employed by the Owner. Inspector shall be present during all welding operations and visually inspect all welds.
- B. Testing Agency will be provided with:
  1. A complete set of accepted "Submittals".
  2. Representative sample pieces as requested by the Testing Agency.
  3. Full and ample means and assistance for testing all material.
  4. Access and facilities, including scaffolding, temporary work platforms, etc., for testing and inspection at all places where materials or components are stored or fabricated, and also in their erected position.



- C. Scheduling of Tests and Inspections: The Contractor shall notify the Testing Agency in sufficient time prior to fabrication or erection work to allow testing and inspection without delaying the work.
- D. Testing Agency will:
  - 1. Inspect the steel deck installation as required by the building code and AWS D1.3.
  - 2. Review WPS for compliance with the project specifications.
  - 3. Review Manufacturer Test Reports and Certifications for compliance with the project specifications.
  - 4. Review welder qualifications in accordance with the project specifications.
  - 5. Report inspection results promptly and in writing to Contractor and Architect.
- E. Remove and replace work that does not comply with specified requirements.
- F. Additional inspecting, at Contractor's expense, will be performed to determine compliance of corrected work with specified requirements.

END OF SECTION 053100

## DIVISION 5 - METALS

### **SECTION 05 70 00** **DECORATIVE METAL**

#### **PART 1 GENERAL**

##### **1.01 SECTION INCLUDES**

- A. Railing and guardrail assemblies.
- B. Free-standing railings at steps.

##### **1.02 RELATED REQUIREMENTS**

- A. Section 01 74 19 - Construction Waste Management and Disposal: Additional requirements for cleaning.
- B. Section 05 50 00 - Metal Fabrications: Supports.

##### **1.03 REFERENCE STANDARDS**

- A. 16 CFR 1201 - Safety Standard for Architectural Glazing Materials; current edition.
- B. ASTM A36/A36M - Standard Specification for Carbon Structural Steel; 2008.
- C. ASTM A276 - Standard Specification for Stainless Steel Bars and Shapes; 2010.
- D. ASTM A307 - Standard Specification for Carbon Steel Bolts and Studs, 60 000 PSI Tensile Strength; 2010.
- E. ASTM A554 - Standard Specification for Welded Stainless Steel Mechanical Tubing; 2011.
- F. ASTM A666 - Standard Specification for Annealed or Cold-Worked Austenitic Stainless Steel Sheet, Strip, Plate, and Flat Bar; 2010.
- G. ASTM B221 - Standard Specification for Aluminum and Aluminum-Alloy Extruded Bars, Rods, Wire, Profiles, and Tubes; 2012.
- H. ASTM B221M - Standard Specification for Aluminum and Aluminum-Alloy Extruded Bars, Rods, Wire, Profiles, and Tubes (Metric); 2012.
- I. ASTM C1172 - Standard Specification for Laminated Architectural Flat Glass; 2009e1.
- J. ASTM E935 - Standard Test Methods for Performance of Permanent Metal Railing Systems and Rails for Buildings; 2000 (Reapproved 2006).
- K. AWI/AWMAC/WI (AWS) - Architectural Woodwork Standards; 2009.
- L. AWS C 3.4/C3.4M - Specification for Torch Brazing; 2007.
- M. AWS C 3.5/C 3.5M - Specification for Induction Brazing; 2007.
- N. AWS C 3.9/C 3.9M - Specification for Resistance Brazing; 2009.
- O. AWS D1.1/D1.1M - Structural Welding Code - Steel; 2010.
- P. AWS D1.6/D1.6M - Stainless Steel Welding Code; 2007.

##### **1.04 SUBMITTALS**

- A. See Section 01 33 00 - Submittal Procedures.
- B. Product Data: Submit manufacturer's product data including description of materials, components, finishes, fabrication details, glass, anchors, and accessories.

- C. Shop Drawings: Indicate railing system elevations and sections, details of profile, dimensions, sizes, connection attachments, anchorage, size and type of fasteners, and accessories. Indicate anchor and joint locations, brazed connections, transitions, and terminations.
- D. Test Reports: Submit test reports from an independent testing agency showing compliance with specified design and performance requirements.
- E. Maintenance Data: Manufacturer's instructions for care and cleaning.

### **1.05 QUALITY ASSURANCE**

- A. Installer Qualifications: Company specializing in installing decorative stairs and railing systems and acceptable to manufacturer.

### **1.06 DELIVERY, STORAGE, AND HANDLING**

- A. Deliver materials in factory provided protective coverings and packaging.
- B. Protect materials against damage during transit, delivery, storage, and installation at site.
- C. Inspect materials upon delivery for damage. Repair damage to be indistinguishable from undamaged areas; if damage cannot be repaired to be indistinguishable from undamaged parts and finishes, replace damaged items.
- D. Prior to installation, store materials and components under cover, in a dry location.

### **1.07 WARRANTY**

- A. Warranty: Manufacturer's standard one year warranty against defects in materials, fabrication, finishes, and installation commencing on Date of Substantial Completion.

## **PART 2 PRODUCTS**

### **2.01 MANUFACTURERS**

- A. Decorative Metal Railings:
  1. Architectural Railings and Grilles, Inc;: [www.stainless-railing.com](http://www.stainless-railing.com).
  2. Couturier Iron Craft, Inc;: [www.couturierironcraft.com](http://www.couturierironcraft.com).
  3. The Wagner Companies; [www.wagnercompanies.com](http://www.wagnercompanies.com).
  4. Ark Glass & Aluminum LLC; [www.arkglassaluminum.com](http://www.arkglassaluminum.com).
  5. Substitutions: See Section 01 60 00 - Product Requirements.
- B. Railing Components:
  1. Manufacturer/Fabricator specified for railings.

### **2.02 RAILING SYSTEMS**

- A. Railings - General: Factory- or shop-fabricated in design indicated, to suit specific project conditions, and for proper connection to building structure, and in largest practical sizes for delivery to site.
  1. Design Criteria: Design and fabricate railings and anchorages to resist the following loads without failure, damage, or permanent set; loads do not need to be applied simultaneously.
    - a. Lateral Force: 75 lb (333 N) minimum, at any point, when tested in accordance with ASTM E935.
    - b. Distributed Load: 50 pounds per foot (0.73 kN per m) minimum, applied in any direction at the top of the handrail, when tested in accordance with ASTM E935.
    - c. Concentrated Loads on Intermediate Rails: 50 pounds per square ft (0.22 per sq m), minimum.
    - d. Concentrated Load: 200 pounds (888 N) minimum, applied in any direction at any point along the handrail system, when tested in accordance with ASTM E935.

2. Assembly: Join lengths, seal open ends, and conceal exposed mounting bolts and nuts using slip-on non-weld mechanical fittings, flanges, escutcheons, and wall brackets.
  3. Joints: Tightly fitted and secured, machined smooth with hairline seams.
  4. Field Connections: Provide sleeves to accommodate site assembly and installation.
  5. Welded and Brazed Joints: Make exposed joints butt tight, flush, and hairline; use methods that avoid discoloration and damage of finish; grind smooth, polish, and restore to required finish.
    - a. Ease exposed edges to small uniform radius.
    - b. Welded Joints:
      - 1) Carbon Steel: Perform welding in accordance with AWS D1.1/D 1.1M.
      - 2) Stainless Steel: Perform welding in accordance with AWS D1.6/D1.6M.
    - c. Brass/Bronze Brazed Joints:
      - 1) Perform torch brazing in accordance with AWS C3.4/C3.4M.
      - 2) Perform induction brazing in accordance with AWS C3.5/C3.5M.
      - 3) Perform resistance brazing in accordance with AWS C3.9/C3.9M.
- B. Base Mount Railing System: Engineered, base supported railing system with structural glass.
1. Top Rail: None.
  2. Base Shoe, Aluminum: ASTM B221 or B221M, 6063 T5 alloy; 2-1/2 inch (64 mm) wide by 4-1/8 inch (105 mm) high, rectangular profile, clear anodized finish.
  3. Glass: As specified in this section.
  4. Fasteners:
    - a. Attachment to Steel: Provide 24 inch (610 mm) center-to-center hole spacing; 1/2 inch (13 mm), stainless steel, socket head cap screws for drilled and tapped or drilled and bolted attachment.

## 2.03 MATERIALS

- A. Steel Components:
1. Sections, Shapes, Plate and Bar: ASTM A36/A36M.
- B. Stainless Steel Components:
1. ASTM A666, Type 304.
  2. Stainless Steel Tubing: ASTM A554, Type 204, 16 gage (0.0625 inch) (1.59 mm), 1-1/2 inch (38 mm) diameter.
  3. Stainless Steel Bars, Shapes and Moldings: ASTM A276, Type 304.
  4. Stainless Steel Finish: No. 4 Satin.
- C. Glass: Laminated safety glass; ASTM C1172, unless otherwise indicated.
1. Plastic Interlayer: Minimum 0.060 inch (1.52 mm) thick.
  2. Impact Strength: Category II, tested in accordance with 16 CFR 1201.
  3. Thickness: 3/4 inch (19 mm).
  4. Configuration: As indicated on drawings.
  5. Edges: Ground smooth and polished.
  6. Color: Clear, no tint.
- D. Wood: Comply with AWI/AWMAC/WI (AWS).
1. Species: Manufacturer's standard red oak.
  2. AWI Grade: Premium.

## 2.04 ACCESSORIES

- A. Welding Fittings: Factory- or shop-welded from matching pipe or tube; joints and seams ground smooth.
- B. Anchors and Fasteners: Provide anchors and other materials as required to attach to structure, made of same materials as railing components unless otherwise indicated; where exposed fasteners are unavoidable provide flush countersunk fasteners.

1. For anchorage to concrete, provide inserts to be cast into concrete for bolting anchors.
  2. For anchorage to masonry, provide brackets to be embedded in masonry for bolting anchors.
  3. For anchorage to stud walls, provide backing plates for bolting anchors.
  4. Exposed Fasteners: No exposed bolts or screws.
- C. Carbon Steel Bolts and Nuts: ASTM A307.
- D. Bituminous Coating: Cold-applied asphalt mastic, noncorrosive compound free of asbestos, sulfur, and other deleterious impurities; 0.015 inch (0.4 mm) dry film thickness per coat.
- E. Sealant: Silicone; black.

## **PART 3 EXECUTION**

### **3.01 EXAMINATION**

- A. Verify that substrate and site conditions are acceptable and ready to receive work.
- B. Verify field dimensions of locations and areas to receive work.
- C. Notify 4240 Architecture immediately of conditions that would prevent satisfactory installation.
- D. Do not proceed with work until detrimental conditions have been corrected.
- E. Furnish components to be installed in other work to installer of that other work, including but not limited to blocking, sleeves, inserts, anchor bolts, embedded plates and supports for attachment of anchors.

### **3.02 PREPARATION**

- A. Protect existing work.
- B. Review installation drawings before beginning installation. Coordinate diagrams, templates, instructions and directions for installation of anchorages and fasteners.
- C. Clean surfaces to receive units. Remove materials and substances detrimental to the installation.

### **3.03 INSTALLATION**

- A. Comply with manufacturer's drawings and written instructions.
- B. Install components plumb and level, accurately fitted, free from distortion or defects and with tight joints, except where necessary for expansion.
- C. Anchor securely to structure.
- D. Conceal anchor bolts and screws whenever possible. Where not concealed, use flush countersunk fastenings.
- E. Isolate dissimilar materials with bituminous coating, bushings, grommets or washers to prevent electrolytic corrosion.

### **3.04 TOLERANCES**

- A. Maximum Variation From Plumb: 1/4 inch (6 mm) per floor level, non-cumulative.
- B. Maximum Offset From True Alignment: 1/4 inch (6 mm).
- C. Maximum Out-of-Position: 1/4 inch (6 mm).

### **3.05 CLEANING**

- A. Remove protective film from exposed metal surfaces.
- B. Metal: Clean exposed metal finishes with potable water and mild detergent, in accordance with

manufacturer recommendations; do not use abrasive materials or chemicals, detergents or other substances that may damage the material or finish.

- C. Glass and Glazing: Clean glazing surfaces; remove excess glazing sealant compounds, dirt, and other substances.
- D. See Section 01 74 19 - Construction Waste Management and Disposal for additional requirements.

### **3.06 PROTECTION**

- A. Protect installed components and finishes from damage after installation.
- B. Repair damage to exposed finishes to be indistinguishable from undamaged areas.
  - 1. If damage to finishes and components cannot be repaired to be indistinguishable from undamaged finishes and components, replace damaged items.

**END OF SECTION**

## **DIVISION 6 – WOOD, PLASTICS AND COMPOSITES**

### **SECTION 06 10 00 ROUGH CARPENTRY**

#### **PART 1 GENERAL**

##### **1.01 SECTION INCLUDES**

- A. Subflooring.
- B. Preservative treated wood materials.
- C. Fire retardant treated wood materials.
- D. Communications and electrical room mounting boards.
- E. Concealed wood blocking, nailers, and supports.

##### **1.02 RELATED REQUIREMENTS**

- A. Section 01 61 16 - Volatile Organic Compound (VOC) Content Restrictions.

##### **1.03 REFERENCE STANDARDS**

- A. ASTM E84 - Standard Test Method for Surface Burning Characteristics of Building Materials; 2012.
- B. AWPA U1 - Use Category System: User Specification for Treated Wood; American Wood Protection Association; 2010.
- C. PS 20 - American Softwood Lumber Standard; National Institute of Standards and Technology (Department of Commerce); 2005.
- D. SPIB (GR) - Grading Rules; Southern Pine Inspection Bureau, Inc.; 2002.

##### **1.04 SUBMITTALS**

- A. See Section 01 33 00 - Submittal Procedures.
- B. Product Data: Provide technical data on insulated sheathing, wood preservative materials, and application instructions.
- C. Manufacturer's Certificate: Certify that wood products supplied for rough carpentry meet or exceed specified requirements.

##### **1.05 DELIVERY, STORAGE, AND HANDLING**

- A. General: Cover wood products to protect against moisture. Support stacked products to prevent deformation and to allow air circulation.
- B. Fire Retardant Treated Wood: Prevent exposure to precipitation during shipping, storage, or installation.

#### **PART 2 PRODUCTS**

##### **2.01 GENERAL REQUIREMENTS**

- A. Dimension Lumber: Comply with PS 20 and requirements of specified grading agencies.
  - 1. If no species is specified, provide any species graded by the agency specified; if no grading agency is specified, provide lumber graded by any grading agency meeting the specified requirements.

2. Grading Agency: Any grading agency whose rules are approved by the Board of Review, American Lumber Standard Committee ([www.alsc.org](http://www.alsc.org)) and who provides grading service for the species and grade specified; provide lumber stamped with grade mark unless otherwise indicated.

B. Lumber fabricated from old growth timber is not permitted.

## **2.02 DIMENSION LUMBER FOR CONCEALED APPLICATIONS**

- A. Grading Agency: Southern Pine Inspection Bureau, Inc. (SPIB).
- B. Sizes: Nominal sizes as indicated on drawings, S4S.
- C. Moisture Content: S-dry or MC19.
- D. Miscellaneous Framing, Blocking, Nailers, Grounds, and Furring:
  1. Lumber: S4S, No. 2 or Standard Grade.
  2. Boards: Standard or No. 3.

## **2.03 CONSTRUCTION PANELS**

- A. Underlayment: APA Underlayment; plywood, Exposure 2, 3/4 inch (19 mm) thick. Fully sanded faces at resilient flooring.
- B. Communications and Electrical Room Mounting Boards: PS 1 A-D plywood, or medium density fiberboard; 3/4 inch (19 mm) thick; flame spread index of 25 or less, smoke developed index of 450 or less, when tested in accordance with ASTM E84.

## **2.04 FACTORY WOOD TREATMENT**

- A. Treated Lumber and Plywood: Comply with requirements of AWWA U1 - Use Category System for wood treatments determined by use categories, expected service conditions, and specific applications.
  1. Fire-Retardant Treated Wood: Mark each piece of wood with producer's stamp indicating compliance with specified requirements.
  2. Preservative-Treated Wood: Provide lumber and plywood marked or stamped by an ALSC-accredited testing agency, certifying level and type of treatment in accordance with AWWA standards.
- B. Fire Retardant Treatment:
  1. Interior Type A: AWWA U1, Use Category UCFA, Commodity Specification H, low temperature (low hygroscopic) type, chemically treated and pressure impregnated; capable of providing a maximum flame spread rating of 25 when tested in accordance with ASTM E84, with no evidence of significant combustion when test is extended for an additional 20 minutes.
    - a. Kiln dry wood after treatment to a maximum moisture content of 19 percent for lumber and 15 percent for plywood.
    - b. Treat rough carpentry items as indicated .
    - c. Do not use treated wood in applications exposed to weather or where the wood may become wet.
- C. Preservative Treatment:
  1. Preservative Pressure Treatment of Lumber Above Grade: AWWA U1, Use Category UC3B, Commodity Specification A using waterborne preservative to 0.25 lb/cu ft (4.0 kg/cu m) retention.
    - a. Kiln dry lumber after treatment to maximum moisture content of 19 percent.
    - b. Treat lumber in contact with masonry or concrete.



## **PART 3 EXECUTION**

### **3.01 INSTALLATION - GENERAL**

- A. Select material sizes to minimize waste.
- B. Reuse scrap to the greatest extent possible; clearly separate scrap for use on site as accessory components, including: shims, bracing, and blocking.
- C. Where treated wood is used on interior, provide temporary ventilation during and immediately after installation sufficient to remove indoor air contaminants.

### **3.02 BLOCKING, NAILERS, AND SUPPORTS**

- A. Provide framing and blocking members as indicated or as required to support finishes, fixtures, specialty items, and trim.
- B. In framed assemblies that have concealed spaces, provide solid wood fireblocking as required by applicable local code, to close concealed draft openings between floors and between top story and roof/attic space; other material acceptable to code authorities may be used in lieu of solid wood blocking.
- C. In metal stud walls, provide continuous blocking around door and window openings for anchorage of frames, securely attached to stud framing.
- D. In walls, provide blocking attached to studs as backing and support for wall-mounted items, unless item can be securely fastened to two or more studs or other method of support is explicitly indicated.
- E. Where ceiling-mounting is indicated, provide blocking and supplementary supports above ceiling, unless other method of support is explicitly indicated.

### **3.03 INSTALLATION OF CONSTRUCTION PANELS**

- A. Subflooring/Underlayment Combination: glue and screw to framing; staples are not permitted.
- B. Communications and Electrical Room Mounting Boards: Secure with screws to studs with edges over firm bearing; space fasteners at maximum 24 inches (610 mm) on center on all edges and into studs in field of board.
  - 1. At fire-rated walls, install board over wall board indicated as part of the fire-rated assembly.
  - 2. Where boards are indicated as full floor-to-ceiling height, install with long edge of board parallel to studs.
  - 3. Install adjacent boards without gaps.
  - 4. Size and Location: As indicated on drawings.

### **3.04 TOLERANCES**

- A. Framing Members: 1/4 inch (6 mm) from true position, maximum.
- B. Variation from Plane (Other than Floors): 1/4 inch in 10 feet (2 mm/m) maximum, and 1/4 inch in 30 feet (7 mm in 10 m) maximum.

### **3.05 CLEANING**

- A. Waste Disposal: Comply with the requirements of Section 01 74 19.
  - 1. Comply with applicable regulations.
  - 2. Do not burn scrap on project site.
  - 3. Do not burn scraps that have been pressure treated.
  - 4. Do not send materials treated with pentachlorophenol, CCA, or ACA to co-generation facilities or "waste-to-energy" facilities.
- B. Do not leave any wood, shavings, sawdust, etc. on the ground or buried in fill.

C. Prevent sawdust and wood shavings from entering the storm drainage system.

**END OF SECTION**

## **DIVISION 6 – WOOD, PLASTICS AND COMPOSITES**

### **SECTION 06 42 16 WOOD-VENEER PANELING**

#### **PART 1 GENERAL**

##### **1.01 SECTION INCLUDES**

- A. Custom wood veneer paneling.
- B. Solid wood panel trim.
- C. Shop finishing.

##### **1.02 RELATED REQUIREMENTS**

- A. Section 01 61 16 - Volatile Organic Compound (VOC) Content Restrictions.
- B. Section 06 10 00 - Rough Carpentry: Grounds and concealed blocking.

##### **1.03 REFERENCE STANDARDS**

- A. ASTM E84 - Standard Test Method for Surface Burning Characteristics of Building Materials; 2012.
- B. AWI/AWMAC/WI (AWS) - Architectural Woodwork Standards; 2009.
- C. PS 1 - Structural Plywood; 2009.
- D. PS 20 - American Softwood Lumber Standard; National Institute of Standards and Technology (Department of Commerce); 2005.

##### **1.04 SUBMITTALS**

- A. See Section 01 33 00 - Submittal Procedures.
- B. Shop Drawings: Indicate materials, component profiles, fastening methods, jointing details, and accessories.
  - 1. Provide the information required by AWI/AWMAC/WI Architectural Woodwork Standards.
- C. Samples: Submit four samples of finished plywood, 12 x 12 inch (300 x 300 mm) in size, illustrating wood grain and specified finish.
- D. Samples: Submit four samples of wood trim, 12 inch (300 mm) long.

##### **1.05 QUALITY ASSURANCE**

- A. Fabricator Qualifications: Company specializing in fabricating the products specified in this section with minimum five years of documented experience.
  - 1. Single Source Responsibility: Provide and install this work from single fabricator.

##### **1.06 REGULATORY REQUIREMENTS**

- A. Conform to applicable code for fire retardant requirements.

##### **1.07 DELIVERY, STORAGE, AND HANDLING**

- A. Protect work from moisture damage.
- B. Do not deliver wood materials to project site until building is fully enclosed and interior temperature and humidity are in accordance with recommendations of AWI/AWMAC/WI Architectural Woodwork Standards.

#### **PART 2 PRODUCTS**

##### **2.01 PANELING**

- A. Quality Grade: Unless otherwise indicated provide products of quality specified by AWI//AWMAC/WI Architectural Woodwork Standards for Premium Grade.
- B. Flat Paneling:
  - 1. Species: Red Oak.
  - 2. Cut: Quarter Sawn.
  - 3. Panels: Veneer of full width and balanced sequence matched.
  - 4. Visible Edges and Reveals: Match faces.
  - 5. Outside Corners: Mitered and splined.

## **2.02 WOOD-BASED MATERIALS - GENERAL**

- A. Wood fabricated from old growth timber is not permitted.
- B. Provide sustainably harvested wood, certified or labeled as specified in Section 01 60 00.
- C. Lumber: Maximum moisture content of 6 percent; with vertical grain, of quality suitable for transparent finish.

## **2.03 ADHESIVES AND FASTENERS**

- A. Adhesives: Type suitable for intended purpose, complying with applicable air quality regulations.

## **2.04 ACCESSORIES**

- A. Lumber for Shimming, Blocking: Softwood lumber of pine species.
- B. Primer: Alkyd primer sealer type.
- C. Wood Filler: Tinted to match surface finish color.

## **2.05 SHOP TREATMENT OF WOOD MATERIALS**

- A. Shop pressure treat wood materials requiring UL fire rating to concealed wood blocking.
- B. Provide UL approved identification on fire retardant treated material.
- C. Deliver fire retardant treated materials cut to required sizes. Minimize field cutting.
- D. Redry wood after pressure treatment to maximum 19 percent moisture content.

## **2.06 FABRICATION**

- A. Shop prepare and identify panels for grain matching during site erection.
- B. Prepare panels for delivery to site, permitting passage through building openings.
- C. Finish exposed edges of panels as specified by grade requirements.

## **2.07 SHOP FINISHING**

- A. Sand work smooth and set exposed nails and screws.
- B. Apply wood filler in exposed nail and screw indentations.
- C. Finish work in accordance with AWI/AWMAC/WI Architectural Woodwork Standards, Section 5 - Finishing for Grade specified and as follows:
  - 1. Transparent:
    - a. System - 1, Lacquer, Nitrocellulose.
    - b. Stain: As selected by 4240 Architecture.
    - c. Sheen: Flat.
- D. Prime paint surfaces that will be in contact with cementitious materials.

## **PART 3 EXECUTION**

### **3.01 EXAMINATION**

- A. Verify that field measurements are as indicated.
- B. Verify adequacy of backing and support framing.
- C. Verify mechanical, electrical, and building items affecting work of this section are placed and ready to receive this work.

### **3.02 INSTALLATION**

- A. Install work in accordance with AWI/AWMAC/WI Architectural Woodwork Standards requirements for grade indicated.
- B. Do not begin installation until wood materials have been fully acclimated to interior conditions.
- C. Set and secure materials and components in place, plumb and level, using concealed fasteners wherever possible.
- D. Where necessary to cut and fit on site, scribe work abutting other components. Do not use additional overlay trim to conceal gaps.
- E. Coordinate the installation of firestopping behind paneling.
- F. Set exposed fasteners, fill with wood filler, and finish to match panel finish.
- G. Touch up damaged finish to match original, using materials provided by fabricator; replace components that cannot be refinished like new.

### **3.03 TOLERANCES**

- A. Maximum Variation from True Position: 1/16 inch (1.5 mm).
- B. Maximum Offset from True Alignment with Abutting Materials: 1/32 inch (0.7 mm).

**END OF SECTION**

## DIVISION 7 – THERMAL AND MOISTURE PROTECTION

### SECTION 07 84 00 FIRESTOPPING

#### PART 1 GENERAL

##### 1.01 SECTION INCLUDES

- A. Firestopping systems.
- B. Firestopping of all joints and penetrations in fire-resistance rated and smoke-resistant assemblies, whether indicated on drawings or not, and other openings indicated.

##### 1.02 RELATED REQUIREMENTS

- A. Section 01 61 16 - Volatile Organic Compound (VOC) Content Restrictions.
- B. Section 01 73 00 - Execution: Cutting and patching.
- C. Section 09 21 16 - Gypsum Board Assemblies: Gypsum wallboard fireproofing.

##### 1.03 REFERENCE STANDARDS

- A. ASTM E119 - Standard Test Methods for Fire Tests of Building Construction and Materials; 2012.
- B. ASTM E814 - Standard Test Method for Fire Tests of Through-Penetration Fire Stops; 2011a.
- C. ITS (DIR) - Directory of Listed Products; Intertek Testing Services NA, Inc.; current edition.
- D. FM 4991 - Approval of Firestop Contractors; Factory Mutual Research Corporation; 2001.
- E. FM P7825 - Approval Guide; Factory Mutual Research Corporation; current edition.
- F. UL (FRD) - Fire Resistance Directory; Underwriters Laboratories Inc.; current edition.

##### 1.04 SUBMITTALS

- A. See Section 01 33 00 - Submittal Procedures.
- B. Schedule of Firestopping: List each type of penetration, fire rating of the penetrated assembly, and firestopping test or design number.
- C. Product Data: Provide data on product characteristics, performance ratings, and limitations.
- D. Manufacturer's Installation Instructions: Indicate preparation and installation instructions.

##### 1.05 QUALITY ASSURANCE

- A. Fire Testing: Provide firestopping assemblies of designs that provide the scheduled fire ratings when tested in accordance with methods indicated.
  - 1. Listing in the current-year classification or certification books of UL, FM, or ITS (Warnock Hersey) will be considered as constituting an acceptable test report.
  - 2. Valid evaluation report published by ICC Evaluation Service, Inc. (ICC-ES) at [www.icc-es.org](http://www.icc-es.org) will be considered as constituting an acceptable test report.
- B. Manufacturer Qualifications: Company specializing in manufacturing the products specified in this section with minimum three years documented experience.
- C. Installer Qualifications: Company specializing in performing the work of this section and:
  - 1. Approved by Factory Mutual Research under FM Standard 4991, Approval of Firestop Contractors, or meeting any two of the following requirements:
  - 2. With minimum 3 years documented experience installing work of this type.
  - 3. Able to show at least 5 satisfactorily completed projects of comparable size and type.
  - 4. Licensed by authority having jurisdiction.

## **1.06 FIELD CONDITIONS**

- A. Comply with firestopping manufacturer's recommendations for temperature and conditions during and after installation. Maintain minimum temperature before, during, and for 3 days after installation of materials.

## **PART 2 PRODUCTS**

### **2.01 FIRESTOPPING - GENERAL REQUIREMENTS**

- A. Manufacturers:
  - 1. A/D Fire Protection Systems Inc: [www.adfire.com](http://www.adfire.com).
  - 2. 3M Fire Protection Products: [www.3m.com/firestop](http://www.3m.com/firestop).
  - 3. Hilti, Inc: [www.us.hilti.com](http://www.us.hilti.com).
  - 4. Nelson FireStop Products: [www.nelsonfirestop.com](http://www.nelsonfirestop.com).
  - 5. Specified Technologies, Inc: [www.stifirestop.com](http://www.stifirestop.com).
  - 6. Substitutions: See Section 01 60 00 - Product Requirements.
- B. Firestopping: Any material meeting requirements.
- C. Primers, Sleeves, Forms, Insulation, Packing, Stuffing, and Accessories: Type required for tested assembly design.

### **2.02 FIRESTOPPING ASSEMBLY REQUIREMENTS**

- A. Head-of-Wall Firestopping at Joints Between Non-Rated Floor and Fire-Rated Wall: Use any system that has been tested according to ASTM E2837 to have fire resistance F Rating equal to required fire rating of floor or wall, whichever is greater.
  - 1. Movement: In addition, provide systems that have been tested to show movement capability as indicated.
- B. Through Penetration Firestopping: Use any system that has been tested according to ASTM E814 to have fire resistance F Rating equal to required fire rating of penetrated assembly.
  - 1. Temperature Rise: In addition, provide systems that have been tested to show T Rating as indicated.
  - 2. Listing by UL, FM, or Intertek in their certification directory will be considered evidence of successful testing.

### **2.03 FIRESTOPPING FOR FLOOR-TO-FLOOR, WALL-TO-FLOOR, AND WALL-TO-WALL JOINTS**

- A. Gypsum Board Walls:
  - 1. Top of Wall Joints at Underside of Steel Beam and Concrete Over Metal Deck Floor with Sprayed On Fireproofing:
    - a. 2 Hour Construction: UL System HW-D-0259; Hilti CFS-SP WB Firestop Joint Spray and CP 672.
    - b. 1 Hour Construction: UL System HW-D-0259; Hilti CFS-SP WB Firestop Joint Spray and CP 672.
  - 2. Top of Wall Joints at Underside of Flat Concrete:
    - a. 2 Hour Construction: UL System HW-D-1068; Hilti CFS-SP WB Firestop Joint Spray and CP 672.
    - b. 1 Hour Construction: UL System HW-D-1068; Hilti CFS-SP WB Firestop Joint Spray and CP 672.

### **2.04 FIRESTOPPING PENETRATIONS THROUGH CONCRETE AND CONCRETE MASONRY CONSTRUCTION**

- A. Blank Openings:
  - 1. In Floors or Walls:

- a. 2 Hour Construction: UL System C-AJ-0090; Hilti FS-ONE Intumescent Firestop Sealant.
- B. Penetrations Through Floors By:
  - 1. Multiple Penetrations in Large Openings:
    - a. 2 Hour Construction: UL System F-A-8012; Hilti CP 604 Self-Leveling Firestop Sealant.
  - 2. Uninsulated Metallic Pipe, Conduit, and Tubing:
    - a. 2 Hour Construction: UL System F-A-1016; Hilti CP 680-P/M Cast-In Device.
  - 3. Uninsulated Non-Metallic Pipe, Conduit, and Tubing:
    - a. 2 Hour Construction: UL System F-A-2058; Hilti FS-ONE Intumescent Firestop Sealant.
  - 4. Electrical Cables Not In Conduit:
    - a. 2 Hour Construction: UL System F-A-3033; Hilti CP 680-P/M Cast-In Device.
  - 5. Insulated Pipes:
    - a. 2 Hour Construction: UL System F-A-5015; Hilti CP 680-P/M Cast-In Device.
- C. Penetrations Through Walls By:
  - 1. Uninsulated Metallic Pipe, Conduit, and Tubing:
    - a. 2 Hour Construction: UL System W-J-1067; Hilti FS-ONE Intumescent Firestop Sealant.
    - b. 1 Hour Construction: UL System W-J-1067; Hilti FS-ONE Intumescent Firestop Sealant.
  - 2. Electrical Cables Not In Conduit:
    - a. 2 Hour Construction: UL System W-J-3060; Hilti FS-ONE Intumescent Firestop Sealant, CP 606 Flexible Firestop Sealant, CD 601S Elastomeric Firestop Sealant, or CP 618 Firestop Putty Stick.
  - 3. Insulated Pipes:
    - a. 2 Hour Construction: UL System W-J-5041; Hilti FS-ONE Intumescent Firestop Sealant.
    - b. 1 Hour Construction: UL System W-J-5041; Hilti FS-ONE Intumescent Firestop Sealant.
  - 4. HVAC Ducts, Uninsulated:
    - a. 2 Hour Construction: UL System W-J-7109; Hilti FS-ONE Intumescent Firestop Sealant or CP 606 Flexible Firestop Sealant.

## **2.05 FIRESTOPPING PENETRATIONS THROUGH GYPSUM BOARD WALLS**

- A. Blank Openings:
  - 1. 2 Hour Construction: UL System W-L-3334; Hilti CP 653 Speed Sleeve.
  - 2. 1 Hour Construction: UL System W-L-3334; Hilti CP 653 Speed Sleeve.
- B. Penetrations By:
  - 1. Multiple Penetrations in Large Openings:
    - a. 2 Hour Construction: UL System W-L-1389; Hilti FS-ONE Intumescent Firestop Sealant.
    - b. 1 Hour Construction: UL System W-L-1389; Hilti FS-ONE Intumescent Firestop Sealant.
  - 2. Uninsulated Metallic Pipe, Conduit, and Tubing:
    - a. 2 Hour Construction: UL System W-L-1054; Hilti FS-ONE Intumescent Firestop Sealant.
    - b. 1 Hour Construction: UL System W-L-1054; Hilti FS-ONE Intumescent Firestop Sealant.
  - 3. Uninsulated Non-Metallic Pipe, Conduit, and Tubing:
    - a. 2 Hour Construction: UL System W-L-2128; Hilti FS-ONE Intumescent Firestop Sealant.
    - b. 1 Hour Construction: UL System W-L-2128; Hilti FS-ONE Intumescent Firestop Sealant.



- Sealant.
4. Electrical Cables Not In Conduit:
    - a. 2 Hour Construction: UL System W-L-3065; Hilti FS-ONE Intumescent Firestop Sealant, CP 606 Flexible Firestop Sealant, CD 601S Elastomeric Firestop Sealant, or CP 618 Firestop Putty Stick.
    - b. 1 Hour Construction: UL System W-L-3065; Hilti FS-ONE Intumescent Firestop Sealant, CP 606 Flexible Firestop Sealant, CD 601S Elastomeric Firestop Sealant, or CP 618 Firestop Putty Stick.
  5. Insulated Pipes:
    - a. 2 Hour Construction: UL System W-L-5257; Hilti FS-ONE Intumescent Firestop Sealant, CP 606 Flexible Firestop Sealant, or CP 601S Elastomeric Firestop Sealant.
    - b. 1 Hour Construction: UL System W-L-5096; Hilti FS-ONE Intumescent Firestop Sealant, CP 606 Flexible Firestop Sealant, or CP 601S Elastomeric Firestop Sealant.
  6. HVAC Ducts, Insulated:
    - a. 2 Hour Construction: UL System W-L-7156; Hilti FS-ONE Intumescent Firestop Sealant.
    - b. 1 Hour Construction: UL System W-L-7156; Hilti FS-ONE Intumescent Firestop Sealant.

### **PART 3 EXECUTION**

#### **3.01 EXAMINATION**

- A. Verify openings are ready to receive the work of this section.

#### **3.02 PREPARATION**

- A. Clean substrate surfaces of dirt, dust, grease, oil, loose material, or other matter that could adversely affect bond of firestopping material.
- B. Remove incompatible materials that could adversely affect bond.

#### **3.03 INSTALLATION**

- A. Install materials in manner described in fire test report and in accordance with manufacturer's instructions, completely closing openings.
- B. Do not cover installed firestopping until inspected by authority having jurisdiction.
- C. Install labeling required by code.

#### **3.04 CLEANING**

- A. Clean adjacent surfaces of firestopping materials.

#### **3.05 PROTECTION**

- A. Protect adjacent surfaces from damage by material installation.

**END OF SECTION**

## **DIVISION 7 – THERMAL AND MOISTURE PROTECTION**

### **SECTION 07 90 05 JOINT SEALERS**

#### **PART 1 GENERAL**

##### **1.01 SECTION INCLUDES**

- A. Sealants and joint backing.

##### **1.02 RELATED REQUIREMENTS**

- A. Section 01 61 16 - Volatile Organic Compound (VOC) Content Restrictions.
- B. Section 07 84 00 - Firestopping: Firestopping sealants.
- C. Section 09 21 16 - Gypsum Board Assemblies: Acoustic sealant.

##### **1.03 REFERENCE STANDARDS**

- A. ASTM C834 - Standard Specification for Latex Sealants; 2010.
- B. ASTM C919 - Standard Practice for Use of Sealants in Acoustical Applications; 2012.
- C. ASTM C920 - Standard Specification for Elastomeric Joint Sealants; 2011.
- D. ASTM C1193 - Standard Guide for Use of Joint Sealants; 2011a.

##### **1.04 ADMINISTRATIVE REQUIREMENTS**

- A. Coordinate the work with other sections referencing this section.

##### **1.05 SUBMITTALS**

- A. See Section 01 30 00 - Administrative Requirements, for submittal procedures.
- B. Product Data: Provide data indicating sealant chemical characteristics.
- C. Samples: Submit two samples, 1/4 x 2 inch (6 x 51 mm) in size illustrating sealant colors for selection.

##### **1.06 QUALITY ASSURANCE**

- A. Manufacturer Qualifications: Company specializing in manufacturing the Products specified in this section with minimum three years documented experience.
- B. Applicator Qualifications: Company specializing in performing the work of this section with minimum 3 years experience.

##### **1.07 FIELD CONDITIONS**

- A. Maintain temperature and humidity recommended by the sealant manufacturer during and after installation.

##### **1.08 WARRANTY**

- A. See Section 01 78 00 - Closeout Submittals, for additional warranty requirements.
- B. Correct defective work within a five year period after Date of Substantial Completion.
- C. Warranty: Include coverage for installed sealants and accessories which fail to achieve airtight seal, exhibit loss of adhesion or cohesion, or do not cure.

#### **PART 2 PRODUCTS**

##### **2.01 MANUFACTURERS**

- A. Gunnable and Pourable Sealants:
  1. BASF Construction Chemicals-Building Systems: [www.buildingsystems.basf.com](http://www.buildingsystems.basf.com).
  2. Dow Corning Corporation: [www.dowcorning.com](http://www.dowcorning.com).
  3. Pecora Corporation: [www.pecora.com](http://www.pecora.com).
  4. Tremco Global Sealants: [www.tremcosealants.com](http://www.tremcosealants.com).
  5. W.R. Meadows, Inc: [www.wrmeadows.com](http://www.wrmeadows.com).

## 2.02 SEALANTS

- A. Sealants and Primers - General: Provide products having volatile organic compound (VOC) content as specified in Section 01 61 16.
- B. Type ES-1 - General Purpose Interior Sealant: Acrylic emulsion latex; ASTM C834, Type OP, Grade NF single component, paintable.
  1. Color: Match adjacent finished surfaces.
  2. Color: To be selected by 4240 Architecture from manufacturer's standard range.
  3. Applications: Use for:
    - a. Interior wall and ceiling control joints.
    - b. Other interior joints for which no other type of sealant is indicated.
  4. Products:
    - a. Pecora Corporation; AC-20 + Silicone Acrylic Latex Caulking Compound: [www.pecora.com](http://www.pecora.com).
    - b. Sherwin-Williams Company; 950A Siliconized Acrylic Latex Caulk: [www.sherwin-williams.com](http://www.sherwin-williams.com).
- C. Type ES-2 - Bathtub/Tile Sealant: White silicone; ASTM C920, Uses I, M and A; single component, mildew resistant.
  1. Applications: Use for:
    - a. Joints between plumbing fixtures and floor and wall surfaces.
    - b. Joints between kitchen and bath countertops and wall surfaces.
  2. Products:
    - a. Pecora Corporation; 898NST Sanitary Silicone Sealant - Class 50: [www.pecora.com](http://www.pecora.com).
    - b. Tremco Global Sealants; Tremsil 200\_\_\_\_: [www.tremcosealants.com](http://www.tremcosealants.com).
    - c. Dow Corning; 786\_\_\_\_\_.
    - d. Substitutions: See Section 01 60 00 - Product Requirements.
- D. Type ES-3 - Acoustical Sealant for Concealed Locations:
  1. Composition: Acrylic latex emulsion sealant.
  2. Applications: Use for concealed locations only:
    - a. Sealant bead between top stud runner and structure and between bottom stud track and floor.
  3. Products:
    - a. Pecora Corporation; AIS-919 Acoustical and Insulation Latex Sealant: [www.pecora.com](http://www.pecora.com).
    - b. Pecora Corporation; AC-20 FTR Acoustical and Insulation Sealant: [www.pecora.com](http://www.pecora.com).
    - c. BASF Construction Chemicals-Building Systems: [www.buildingsystems.basf.com](http://www.buildingsystems.basf.com).
    - d. Hilti, Inc.; CP 506 Smoke and Acoustical Sealant: [www.us.hilti.com](http://www.us.hilti.com).
    - e. Substitutions: See Section 01 60 00 - Product Requirements.
- E. Type ES-4 - Interior Floor Joint Sealant: Polyurethane, self-leveling; ASTM C920, Grade P, Class 25, Uses T, M and A; single component.
  1. Color: To be selected by 4240 Architecture from manufacturer's standard range.
  2. Products:
    - a. Pecora Corporation; NR-201 Self-Leveling Traffic and Loop Sealant: [www.pecora.com](http://www.pecora.com).
    - b. Sherwin-Williams Company; Stampede 1SL Polyurethane Sealant:



### **3.04 CLEANING**

- A. Clean adjacent soiled surfaces.

### **3.05 PROTECTION**

- A. Protect sealants until cured.

### **3.06 SCHEDULE**

- A. Interior Joints at ceramic, porcelain or stone tile: Type ES-4.
- B. Interior Joints for Which No Other Sealant is Indicated: Type ES-1; colors as shown on the drawings.
- C. Joints Between Plumbing Fixtures and Walls and Floors, and Between Countertops and Walls: Type ES-2.

**END OF SECTION**

## **DIVISION 8 - OPENINGS**

### **SECTION 08 11 13 HOLLOW METAL DOORS AND FRAMES**

#### **PART 1 GENERAL**

##### **1.01 SECTION INCLUDES**

- A. Non-fire-rated steel doors and frames.
- B. Steel frames for wood doors.
- C. Fire-rated steel doors and frames.
- D. Sound-rated steel doors and frames.

##### **1.02 RELATED REQUIREMENTS**

- A. Section 08 71 00 - Door Hardware.
- B. Section 09 90 00 - Painting and Coating: Field painting.

##### **1.03 REFERENCE STANDARDS**

- A. ANSI/ICC A117.1 - American National Standard for Accessible and Usable Buildings and Facilities; International Code Council; 2009.
- B. ANSI A250.8 - SDI-100 Recommended Specifications for Standard Steel Doors and Frames; 2003.
- C. ANSI A250.10 - Test Procedure and Acceptance Criteria for Prime Painted Steel Surfaces for Steel Doors and Frames; 1998 (R2011).
- D. ASTM E90 - Standard Test Method for Laboratory Measurement of Airborne Sound Transmission Loss of Building Partitions and Elements; 2009.
- E. ASTM E413 - Classification for Rating Sound Insulation; 2010.
- F. BHMA A156.115 - Hardware Preparation in Steel Doors and Steel Frames; 2006.
- G. NAAMM HMMA 840 - Guide Specifications for Installation and Storage of Hollow Metal Doors and Frames; The National Association of Architectural Metal Manufacturers; 2007.
- H. NFPA 80 - Standard for Fire Doors and Other Opening Protectives; 2013.
- I. UL (BMD) - Building Materials Directory; Underwriters Laboratories Inc.; current edition.
- J. UL 10C - Standard for Positive Pressure Fire Tests of Door Assemblies; Current Edition, Including All Revisions.
- K. UL 1784 - Standard for Air Leakage Tests of Door Assemblies; Current Edition, Including All Revisions.

##### **1.04 SUBMITTALS**

- A. See Section 01 33 00 - Submittal Procedures.
- B. Product Data: Materials and details of design and construction, hardware locations, reinforcement type and locations, anchorage and fastening methods, and finishes; and one copy of referenced grade standard.
- C. Shop Drawings: Details of each opening, showing elevations, glazing, frame profiles, and identifying location of different finishes, if any.

##### **1.05 QUALITY ASSURANCE**

- A. Manufacturer Qualifications: Company specializing in manufacturing the products specified in this section with minimum three years documented experience.

## **1.06 DELIVERY, STORAGE, AND HANDLING**

- A. Store in accordance with NAAMM HMMA 840.
- B. Protect with resilient packaging; avoid humidity build-up under coverings; prevent corrosion.

## **PART 2 PRODUCTS**

### **2.01 MANUFACTURERS**

- A. Steel Doors and Frames:
  - 1. Assa Abloy Ceco, Curries, or Fleming: [www.assaabloydss.com](http://www.assaabloydss.com).
  - 2. Republic Doors: [www.republicdoor.com](http://www.republicdoor.com).
  - 3. Steelcraft, an Ingersoll Rand brand: [www.steelcraft.com](http://www.steelcraft.com).
  - 4. Substitutions: See Section 01 60 00 - Product Requirements.

### **2.02 DOORS AND FRAMES**

- A. Requirements for All Doors and Frames:
  - 1. Accessibility: Comply with ANSI/ICC A117.1.
  - 2. Door Top Closures: Flush with top of faces and edges.
  - 3. Door Edge Profile: Beveled on both edges.
  - 4. Door Texture: Smooth faces.
  - 5. Hardware Preparation: In accordance with BHMA A156.115, with reinforcement welded in place, in addition to other requirements specified in door grade standard.
  - 6. Finish: Factory primed, for field finishing.
- B. Combined Requirements: If a particular door and frame unit is indicated to comply with more than one type of requirement, comply with all the specified requirements for each type; for instance, an exterior door that is also indicated as being sound-rated must comply with the requirements specified for exterior doors and for sound-rated doors; where two requirements conflict, comply with the most stringent.

### **2.03 STEEL DOORS**

- A. Interior Doors, Non-Fire-Rated:
  - 1. Grade: ANSI A250.8 Level 1, 16 gage, physical performance Level C, Model 1, full flush.
  - 2. Thickness: 1-3/4 inches (44 mm).
- B. Interior Doors, Fire-Rated:
  - 1. Grade: ANSI A250.8 Level 2, 16 gage, physical performance Level B, Model 1, full flush.
  - 2. Fire Rating: As indicated on Door and Frame Schedule, tested in accordance with UL 10C ("positive pressure").
    - a. Provide units listed and labeled by UL.
    - b. Attach fire rating label to each fire rated unit.
- C. Interior Smoke and Draft Control Doors (Indicated as "S" on Drawings): Same construction as fire-rated doors with indicated fire rating, plus:
  - 1. Maximum Air Leakage: 3.0 cfm per sq ft (0.01524 cu m/s/sq m) of door opening at 0.10 inch w.g. (24.9 Pa) pressure, when tested in accordance with UL 1784 at both ambient and elevated temperatures.
  - 2. Gasketing: No added gasketing or seals allowed.
  - 3. Label: UL "S" label.
- D. Interior Doors, Sound-Rated:
  - 1. Grade: ANSI A250.8 Level 2, 16 gage, physical performance Level B, Model 2, seamless.

2. STC Rating of Assembled Door, Frame, and Seals: 35, calculated in accordance with ASTM E413, tested in accordance with ASTM E90.
3. Sound Seals: Integral, concealed in door or frame.

#### **2.04 STEEL FRAMES**

- A. General:
  1. Comply with the requirements of grade specified for corresponding door, except:
    - a. ANSI A250.8 Level 3 Doors: 14 gage frames.
    - b. Frames for Wood Doors: Comply with frame requirements specified in ANSI 250.8 for Level 3, 14 gage
    - c. Frames for Sound-Rated Wood Doors: Comply with frame requirements specified in ANSI A250.8 for Level 3, 14 gage
  2. Finish: Same as for door.
- B. Interior Door Frames, Non-Fire-Rated: Fully welded type.
- C. Interior Door Frames, Fire-Rated: Fully welded type.
  1. Fire Rating: Same as door, labeled.
- D. Sound-Rated Door Frames: Fully welded type.
- E. Mullions for Pairs of Doors: Removable type, of profile similar to jambs, only at scheduled locations.

#### **2.05 ACCESSORY MATERIALS**

- A. Silencers: Resilient rubber, fitted into drilled hole; 3 on strike side of single door, 3 on center mullion of pairs, and 2 on head of pairs without center mullions.
- B. Temporary Frame Spreaders: Provide for all factory- or shop-assembled frames.

#### **2.06 FINISH MATERIALS**

- A. Primer: Rust-inhibiting, complying with ANSI A250.10, door manufacturer's standard.

### **PART 3 EXECUTION**

#### **3.01 EXAMINATION**

- A. Verify existing conditions before starting work.
- B. Verify that opening sizes and tolerances are acceptable.

#### **3.02 INSTALLATION**

- A. Install in accordance with the requirements of the specified door grade standard and NAAMM HMMA 840.
- B. In addition, install fire rated units in accordance with NFPA 80.
- C. Coordinate frame anchor placement with wall construction.
- D. Coordinate installation of hardware.

#### **3.03 TOLERANCES**

- A. Clearances Between Door and Frame: As specified in ANSI A250.8.
- B. Maximum Diagonal Distortion: 1/16 in (1.5 mm) measured with straight edge, corner to corner.

#### **3.04 ADJUSTING**

- A. Adjust for smooth and balanced door movement.



B. Adjust sound control doors so that seals are fully engaged when door is closed.

**END OF SECTION**

## **DIVISION 8 - OPENINGS**

### **SECTION 08 14 16 FLUSH WOOD DOORS**

#### **PART 1 GENERAL**

##### **1.01 SECTION INCLUDES**

- A. Flush wood doors; flush configuration; fire rated, non-rated, and acoustical.

##### **1.02 RELATED REQUIREMENTS**

- A. Section 08 12 13 - Hollow Metal Frames.
- B. Section 08 71 00 - Door Hardware.

##### **1.03 REFERENCE STANDARDS**

- A. AWI/AWMAC/WI (AWS) - Architectural Woodwork Standards; 2009.
- B. ITS (DIR) - Directory of Listed Products; Intertek Testing Services NA, Inc.; current edition.
- C. NFPA 80 - Standard for Fire Doors and Other Opening Protectives; 2013.
- D. NFPA 252 - Standard Methods of Fire Tests of Door Assemblies; National Fire Protection Association; 2012.
- E. UL (BMD) - Building Materials Directory; Underwriters Laboratories Inc.; current edition.
- F. UL 10B - Standard for Fire Tests of Door Assemblies; Current Edition, Including All Revisions.
- G. UL 1784 - Standard for Air Leakage Tests of Door Assemblies; Current Edition, Including All Revisions.

##### **1.04 SUBMITTALS**

- A. See Section 01 30 00 - Administrative Requirements for submittal procedures.
- B. Product Data: Indicate door core materials and construction; veneer species, type and characteristics.
- C. Shop Drawings: Show doors and frames, elevations, sizes, types, swings, undercuts, beveling, blocking for hardware, factory machining, factory finishing, cutouts for glazing and other details.
- D. Specimen warranty.
- E. Samples: Submit two samples of door veneer, 8 by 10 inch (204 x 254 mm) in size illustrating wood grain, stain color, and sheen.
- F. Manufacturer's Installation Instructions: Indicate special installation instructions.
- G. Warranty, executed in Northeastern Illinois University's name.

##### **1.05 QUALITY ASSURANCE**

- A. Manufacturer Qualifications: Company specializing in manufacturing the products specified in this section with minimum three years of documented experience.
- B. Installed Fire Rated Door Assembly: Conform to NFPA 80 for fire rated class as indicated.

##### **1.06 DELIVERY, STORAGE, AND HANDLING**

- A. Package, deliver and store doors in accordance with specified quality standard.
- B. Accept doors on site in manufacturer's packaging. Inspect for damage.
- C. Protect doors with resilient packaging sealed with heat shrunk plastic. Do not store in damp or

wet areas; or in areas where sunlight might bleach veneer. Seal top and bottom edges with tinted sealer if stored more than one week. Break seal on site to permit ventilation.

### **1.07 WARRANTY**

- A. See Section 01 78 00 - Closeout Submittals for additional warranty requirements.
- B. Interior Doors: Provide manufacturer's warranty for the life of the installation.
- C. Include coverage for delamination of veneer, warping beyond specified installation tolerances, defective materials, and telegraphing core construction.

## **PART 2 PRODUCTS**

### **2.01 MANUFACTURERS**

- A. Wood Veneer Faced Doors:
  - 1. Eggers Industries: [www.eggersindustries.com](http://www.eggersindustries.com).
  - 2. Haley Brothers: [www.haleybros.com](http://www.haleybros.com).
  - 3. Marshfield DoorSystems, Inc: [www.marshfielddoors.com](http://www.marshfielddoors.com).
  - 4. Substitutions: See Section 01 60 00 - Product Requirements.

### **2.02 DOORS AND PANELS**

- A. All Doors: See drawings for locations and additional requirements.
  - 1. Quality Level: Premium Grade, in accordance with AWI/AWMAC/WI Architectural Woodwork Standards.
  - 2. Wood Veneer Faced Doors: 5-ply unless otherwise indicated.
- B. Interior Doors: 1-3/4 inches (44 mm) thick unless otherwise indicated; flush construction.
  - 1. Provide solid core doors at all locations.
  - 2. Fire Rated Doors: Tested to ratings indicated on drawings in accordance with NFPA 252, UL 10B, or UBC Standard 7-2-94 ("neutral pressure"); UL or WH (ITS) labeled without any visible seals when door is open.
  - 3. Smoke and Draft Control Doors (Indicated as "S" on Drawings): In addition to required fire rating, provide door assemblies tested in accordance with UL 1784 with maximum air leakage of 3.0 cfm per sq ft (0.01524 cu m/s/sq m) of door opening at 0.10 inch w.g. (24.9 Pa) pressure at both ambient and elevated temperatures; with "S" label; if necessary, provide additional gasketing or edge sealing.
  - 4. Wood veneer facing with factory transparent finish.

### **2.03 DOOR AND PANEL CORES**

- A. Non-Rated Solid Core and 20 Minute Rated Doors: Type particleboard core (PC), plies and faces as indicated above.
- B. Fire Rated Doors: Mineral core, Type FD, plies and faces as indicated above; with core blocking as required to provide adequate anchorage of hardware without through-bolting.
- C. Sound Retardant Doors: Equivalent to Type PC construction with core as required to achieve rating specified; plies and faces as indicated above.

### **2.04 DOOR FACINGS**

- A. Wood Veneer Facing for Transparent Finish: Species as specified above, veneer grade as specified by quality standard, plain sliced, book veneer match, running assembly match; unless otherwise indicated.

### **2.05 ACCESSORIES**

- A. Astragals for Non-Rated Double Doors: Steel, T shaped, overlapping and recessed at face edge.

- B. Astragals for Fire Rated Double Doors: Steel, T shaped, overlapping and recessed at face edge, specifically for double doors.

## **2.06 DOOR CONSTRUCTION**

- A. Fabricate doors in accordance with door quality standard specified.
- B. Cores Constructed with stiles and rails:
  - 1. Provide solid blocks at lock edge for hardware reinforcement.
  - 2. Provide solid blocking for other throughbolted hardware.
- C. Factory machine doors for hardware other than surface-mounted hardware, in accordance with hardware requirements and dimensions.
- D. Factory fit doors for frame opening dimensions identified on shop drawings, with edge clearances in accordance with specified quality standard.
- E. Provide edge clearances in accordance with the quality standard specified.

## **2.07 FACTORY FINISHING - WOOD VENEER DOORS**

- A. Finish work in accordance with AWI/AWMAC/WI Architectural Woodwork Standards, Section 5 - Finishing for Grade specified and as follows:
- B. Factory finish doors in accordance with approved sample.

## **PART 3 EXECUTION**

### **3.01 EXAMINATION**

- A. Verify existing conditions before starting work.
- B. Verify that opening sizes and tolerances are acceptable.
- C. Do not install doors in frame openings that are not plumb or are out-of-tolerance for size or alignment.

### **3.02 INSTALLATION**

- A. Install doors in accordance with manufacturer's instructions and specified quality standard.
  - 1. Install fire-rated doors in accordance with NFPA 80 requirements.
- B. Factory-Finished Doors: Do not field cut or trim; if fit or clearance is not correct, replace door.
- C. Use machine tools to cut or drill for hardware.
- D. Coordinate installation of doors with installation of frames and hardware.

### **3.03 TOLERANCES**

- A. Conform to specified quality standard for fit and clearance tolerances.
- B. Conform to specified quality standard for telegraphing, warp, and squareness.

### **3.04 ADJUSTING**

- A. Adjust doors for smooth and balanced door movement.
- B. Adjust closers for full closure.

### **3.05 SCHEDULE - See Drawings**

**END OF SECTION**

## **DIVISION 08 - OPENINGS**

### **SECTION 08 71 00** **DOOR HARDWARE**

#### **PART 1 GENERAL**

##### **1.1 RELATED DOCUMENTS**

- A. Drawings and general provisions of the Contract, including General and Supplementary Conditions and Division 01 Specification Sections, apply to this Section.

##### **1.2 SUMMARY**

- A. Section includes:
  - 1. Mechanical door hardware for:
    - a. Swinging doors.
  - 2. Field verification, preparation and modification of existing doors and frames to receive new door hardware.
- B. Exclusions: Unless specifically listed in hardware sets, hardware is not specified in this section for:
  - 1. Windows
  - 2. Cabinets (casework), including locks in cabinets
  - 3. Signage
  - 4. Toilet accessories
  - 5. Overhead doors
- C. Related Sections:
  - 1. Division 01 Section "Alternates" for alternates affecting this section.
  - 2. Division 07 Section "Joint Sealants" for sealant requirements applicable to threshold installation specified in this section.
  - 3. Division 09 sections for touchup finishing or refinishing of existing openings modified by this section.

##### **1.3 REFERENCES**

- A. Fire/Life Safety
  - 1. NFPA - National Fire Protection Association
    - a. NFPA 80 - Standard for Fire Doors and Fire Windows
    - b. NFPA 101 - Life Safety Code
    - c. NFPA 105 - Smoke and Draft Control Door Assemblies

2. State Fire Safety Code.
- B. UL - Underwriters Laboratories
1. UL 10B - Fire Test of Door Assemblies
  2. UL 10C - Positive Pressure Test of Fire Door Assemblies
  3. UL 1784 - Air Leakage Tests of Door Assemblies
  4. UL 305 - Panic Hardware
- C. Accessibility
1. ADA - Americans with Disabilities Act.
  2. ANSI A117.1 - Accessible and Usable Buildings and Facilities.
- D. DHI - Door and Hardware Institute
1. Sequence and Format for the Hardware Schedule
  2. Recommended Locations for Builders Hardware
  3. Key Systems and Nomenclature
- E. ANSI - American National Standards Institute
1. ANSI/BHMA A156.1 - A156.29, and ANSI A156.31 - Standards for Hardware and Specialties

#### 1.4 SUBMITTALS

- A. General:
1. Submit in accordance with Conditions of Contract and Division 01 requirements.
  2. Highlight, encircle, or otherwise specifically identify on submittals deviations from Contract Documents, issues of incompatibility or other issues which may detrimentally affect the Work.
  3. Prior to forwarding submittal, comply with procedures for verifying existing door and frame compatibility for new hardware, as specified in PART 3, "EXAMINATION" article, herein.
- B. Action Submittals:
1. Product Data: Product data including manufacturers' technical product data for each item of door hardware, installation instructions, maintenance of operating parts and finish, and other information necessary to show compliance with requirements.
  2. Riser and Wiring Diagrams: After final approval of hardware schedule, submit details of electrified door hardware, indicating:
    - a. Wiring Diagrams: For power, signal, and control wiring and including:
      - 1) Details of interface of electrified door hardware and building safety and security systems.
      - 2) Schematic diagram of systems that interface with electrified door hardware.
      - 3) Point-to-point wiring.
      - 4) Risers.
  3. Samples for Verification: If requested by Architect, submit production sample or sample installations of each type of exposed hardware unit in finish indicated, and tagged with full description for coordination with schedule.

- a. Samples will be returned to supplier in like-new condition. Units that are acceptable to Architect may, after final check of operations, be incorporated into Work, within limitations of key coordination requirements.
4. Door Hardware Schedule: Submit schedule with hardware sets in vertical format as illustrated by Sequence of Format for the Hardware Schedule as published by the Door and Hardware Institute. Indicate complete designations of each item required for each door or opening, include:
- a. Door Index; include door number, heading number, and Architects hardware set number.
  - b. Opening Lock Function Spreadsheet: List locking device and function for each opening.
  - c. Type, style, function, size, and finish of each hardware item.
  - d. Name and manufacturer of each item.
  - e. Fastenings and other pertinent information.
  - f. Location of each hardware set cross-referenced to indications on Drawings.
  - g. Explanation of all abbreviations, symbols, and codes contained in schedule.
  - h. Mounting locations for hardware.
  - i. Door and frame sizes and materials.
  - j. Name and phone number for local manufacturer's representative for each product.
  - k. Operational Description of openings with any electrified hardware (locks, exits, electromagnetic locks, electric strikes, automatic operators, door position switches, magnetic holders or closer/holder units, and access control components). Operational description should include how door will operate on egress, ingress, and fire and smoke alarm connection.
    - 1) Submittal Sequence: Submit door hardware schedule concurrent with submissions of Product Data, Samples, and Shop Drawings. Coordinate submission of door hardware schedule with scheduling requirements of other work to facilitate fabrication of other work that is critical in Project construction schedule.
5. Key Schedule:
- a. After Keying Conference, provide keying schedule listing levels of keying as well as explanation of key system's function, key symbols used and door numbers controlled.
  - b. Use ANSI A156.28 "Recommended Practices for Keying Systems" as guideline for nomenclature, definitions, and approach for selecting optimal keying system.
  - c. Provide 3 copies of keying schedule for review prepared and detailed in accordance with referenced DHI publication. Include schematic keying diagram and index each key to unique door designations.
  - d. Index keying schedule by door number, keyset, hardware heading number, cross keying instructions, and special key stamping instructions.
  - e. Provide one complete bitting list of key cuts and one key system schematic illustrating system usage and expansion.
    - 1) Forward bitting list, key cuts and key system schematic directly to Owner, by means as directed by Owner.
  - f. Prepare key schedule by or under supervision of supplier, detailing Owner's final keying instructions for locks.
6. Templates: After final approval of hardware schedule, provide templates for doors, frames and other work specified to be factory prepared for door hardware installation.

C. Informational Submittals:

1. Qualification Data: For Supplier, Installer and Architectural Hardware Consultant.
2. Product Certificates for electrified door hardware, signed by manufacturer:
  - a. Certify that door hardware approved for use on types and sizes of labeled fire-rated doors complies with listed fire-rated door assemblies.
3. Certificates of Compliance:
  - a. Certificates of compliance for fire-rated hardware and installation instructions if requested by Architect or Authority Having Jurisdiction.
  - b. Installer Training Meeting Certification: Letter of compliance, signed by Contractor, attesting to completion of installer training meeting specified in "QUALITY ASSURANCE" article, herein.
4. Product Test Reports: For compliance with accessibility requirements, based on evaluation of comprehensive tests performed by manufacturer and witnessed by qualified testing agency, for door hardware on doors located in accessible routes.
5. Warranty: Special warranty specified in this Section.

D. Closeout Submittals:

1. Operations and Maintenance Data : Provide in accordance with Division 01 and include:
  - a. Complete information on care, maintenance, and adjustment; data on repair and replacement parts, and information on preservation of finishes.
  - b. Catalog pages for each product.
  - c. Name, address, and phone number of local representative for each manufacturer.
  - d. Parts list for each product.
  - e. Final approved hardware schedule, edited to reflect conditions as-installed.
  - f. Final keying schedule
  - g. Copies of floor plans with keying nomenclature
  - h. As-installed wiring diagrams for each opening connected to power, both low voltage and 110 volts.
  - i. Copy of warranties including appropriate reference numbers for manufacturers to identify project.

## 1.5 QUALITY ASSURANCE

- A. Product Substitutions: Comply with product requirements stated in Division 01 and as specified herein.
  1. Where specific manufacturer's product is named and accompanied by "No Substitute," including make or model number or other designation, provide product specified. (Note: Certain products have been selected for their unique characteristics and particular project suitability.)
    - a. Where no additional products or manufacturers are listed in product category, requirements for "No Substitute" govern product selection.
  2. Where products indicate "acceptable substitute" or "acceptable manufacturer", provide product from specified manufacturers, subject to compliance with specified requirements and "Single Source Responsibility" requirements stated herein.
- B. Supplier Qualifications and Responsibilities: Recognized architectural hardware supplier with record of successful in-service performance for supplying door hardware similar in quantity, type, and quality to that indicated for this Project and that provides certified Architectural



Hardware Consultant (AHC) available to Owner, Architect, and Contractor, at reasonable times during the Work for consultation.

1. Warehousing Facilities: In Project's vicinity.
  2. Scheduling Responsibility: Preparation of door hardware and keying schedules.
  3. Engineering Responsibility: Preparation of data for electrified door hardware, including Shop Drawings, based on testing and engineering analysis of manufacturer's standard units in assemblies similar to those indicated for this Project.
  4. Coordination Responsibility: Coordinate installation of electronic security hardware with Architect and electrical engineers and provide installation and technical data to Architect and other related subcontractors.
    - a. Upon completion of electronic security hardware installation, inspect and verify that all components are working properly.
- C. Installer Qualifications: Qualified tradesmen, skilled in application of commercial grade hardware with record of successful in-service performance for installing door hardware similar in quantity, type, and quality to that indicated for this Project.
- D. Architectural Hardware Consultant Qualifications: Person who is experienced in providing consulting services for door hardware installations that are comparable in material, design, and extent to that indicated for this Project and meets these requirements:
1. For door hardware, DHI-certified, Architectural Hardware Consultant (AHC).
  2. Can provide installation and technical data to Architect and other related subcontractors.
  3. Can inspect and verify components are in working order upon completion of installation.
  4. Capable of producing wiring diagrams.
  5. Capable of coordinating installation of electrified hardware with Architect and electrical engineers.
- E. Single Source Responsibility: Obtain each type of door hardware from single manufacturer.
1. Provide electrified door hardware from same manufacturer as mechanical door hardware, unless otherwise indicated.
  2. Manufacturers that perform electrical modifications and that are listed by testing and inspecting agency acceptable to authorities having jurisdiction are acceptable.
- F. Fire-Rated Door Openings: Provide door hardware for fire-rated openings that complies with NFPA 80 and requirements of authorities having jurisdiction. Provide only items of door hardware that are listed and are identical to products tested by Underwriters Laboratories, Intertek Testing Services, or other testing and inspecting organizations acceptable to authorities having jurisdiction for use on types and sizes of doors indicated, based on testing at positive pressure and according to NFPA 252 or UL 10C and in compliance with requirements of fire-rated door and door frame labels.
- G. Smoke- and Draft-Control Door Assemblies: Where smoke- and draft-control door assemblies are required, provide door hardware that meets requirements of assemblies tested according to UL 1784 and installed in compliance with NFPA 105.
1. Air Leakage Rate: Maximum air leakage of 0.3 cfm/sq. ft. (3 cu. m per minute/sq. m) at tested pressure differential of 0.3-inch wg (75 Pa) of water.
- H. Means of Egress Doors: Latches do not require more than 15 lbf (67 N) to release latch. Locks do not require use of key, tool, or special knowledge for operation.

- I. Accessibility Requirements: For door hardware on doors in an accessible route, comply with governing accessibility regulations cited in "REFERENCES" article, herein.
  - 1. Provide operating devices that do not require tight grasping, pinching, or twisting of wrist and that operate with force of not more than 5 lbf (22.2 N).
  - 2. Maximum opening-force requirements:
    - a. Interior, Non-Fire-Rated Hinged Doors: 5 lbf (22.2 N) applied perpendicular to door.
    - b. Sliding or Folding Doors: 5 lbf (22.2 N) applied parallel to door at latch.
    - c. Fire Doors: Minimum opening force allowable by authorities having jurisdiction.
  - 3. Bevel raised thresholds with slope of not more than 1:2. Provide thresholds not more than 1/2 inch (13 mm) high.
  - 4. Adjust door closer sweep periods so that, from open position of 70 degrees, door will take at least 3 seconds to move to 3 inches (75 mm) from latch, measured to leading edge of door.
  
- J. Keying Conference: Conduct conference at Project site to comply with requirements in Division 01.
  - 1. Attendees: Owner, Contractor, Architect, Installer, Owner's security consultant, and Supplier's Architectural Hardware Consultant.
  - 2. Incorporate keying conference decisions into final keying schedule after reviewing door hardware keying system including:
    - a. Function of building, flow of traffic, purpose of each area, degree of security required, and plans for future expansion.
    - b. Preliminary key system schematic diagram.
    - c. Requirements for key control system.
    - d. Requirements for access control.
    - e. Address for delivery of keys.
  
- K. Pre-installation Conference: Conduct conference at Project site.
  - 1. Review and finalize construction schedule and verify availability of materials, Installer's personnel, equipment, and facilities needed to make progress and avoid delays.
  - 2. Inspect and discuss preparatory work performed by other trades.
  - 3. Review required testing, inspecting, and certifying procedures.
  
- L. Coordination Conferences:
  - 1. Installation Coordination Conference: Prior to hardware installation, schedule and hold meeting to review questions or concerns related to proper installation and adjustment of door hardware.
    - a. Attendees: Door hardware supplier, door hardware installer, Contractor.
    - b. After meeting, provide letter of compliance to Architect, indicating when meeting was held and who was in attendance.

## **1.6 DELIVERY, STORAGE, AND HANDLING**

- A. Inventory door hardware on receipt and provide secure lock-up for hardware delivered to Project site.

- B. Tag each item or package separately with identification coordinated with final door hardware schedule, and include installation instructions, templates, and necessary fasteners with each item or package.
  - 1. Deliver each article of hardware in manufacturer's original packaging.
- C. Project Conditions:
  - 1. Maintain manufacturer-recommended environmental conditions throughout storage and installation periods.
  - 2. Provide secure lock-up for door hardware delivered to Project, but not yet installed. Control handling and installation of hardware items so that completion of Work will not be delayed by hardware losses both before and after installation.
- D. Protection and Damage:
  - 1. Promptly replace products damaged during shipping.
  - 2. Handle hardware in manner to avoid damage, marring, or scratching. Correct, replace or repair products damaged during Work.
  - 3. Protect products against malfunction due to paint, solvent, cleanser, or any chemical agent.
- E. Deliver keys to Owner by registered mail or overnight package service.

## **1.7 COORDINATION**

- A. Coordinate layout and installation of floor-recessed door hardware with floor construction. Cast anchoring inserts into concrete. Concrete, reinforcement, and formwork requirements are specified in Division 03.
- B. Installation Templates: Distribute for doors, frames, and other work specified to be factory prepared. Check Shop Drawings of other work to confirm that adequate provisions are made for locating and installing door hardware to comply with indicated requirements.
- C. Security: Coordinate installation of door hardware, keying, and access control with Owner's security consultant.
- D. Existing Openings: Where hardware components are scheduled for application to existing construction or where modifications to existing door hardware are required, field verify existing conditions and coordinate installation of door hardware to suit opening conditions and to provide proper door operation.
- E. Direct shipments not permitted, unless approved by Contractor.

## **1.8 WARRANTY**

- A. Special Warranty: Manufacturer's standard form in which manufacturer agrees to repair or replace components of door hardware that fail in materials or workmanship within specified warranty period.
  - 1. Warranty Period: Years from date of Substantial Completion, for durations indicated.
    - a. Closers:
      - 1) Mechanical: 10 years.

- b. Exit Devices:
    - 1) Mechanical: 3 years.
  - c. Locksets:
    - 1) Mechanical: 3 years.
  - d. Key Blanks: Lifetime
2. Warranty does not cover damage or faulty operation due to improper installation, improper use or abuse.

**1.9 MAINTENANCE**

- A. Maintenance Tools:
  - 1. Furnish complete set of special tools required for maintenance and adjustment of hardware, including changing of cylinders.

**PART 2 - PRODUCTS**

**2.1 MANUFACTURERS**

- A. The Owner requires use of certain products for their unique characteristics and particular project suitability to insure continuity of existing and future performance and maintenance standards. After investigating available product offerings Awarding Authority has elected to prepare proprietary specifications. These products are specified with the notation: "No Substitute."
  - 1. Where "No Substitute" is noted, submittals and substitution requests for other products will not be considered.
- B. Approval of manufacturers other than those listed shall be in accordance with QUALITY ASSURANCE article, herein.
- C. Approval of products from manufacturers indicated as "Acceptable Manufacturer" is contingent upon those products providing all functions and features and meeting all requirements of scheduled manufacturer's product.

Item	Scheduled Manufacturer	Acceptable Manufacturer
Continuous Hinges	Ives (IVE)	Marker, Stanley
Flush Bolts & Coordinators	Ives (IVE)	Burns, Trimco
Locksets & Deadlocks	Corbin-Russwin (COR)	No Substitute
Exit Devices & Mullions	Von Duprin (VON)	No Substitute
Cylinders & Keying	Corbin-Russwin (COR)	No Substitute
Door Closers	LCN (LCN)	No Substitute
Closer/Holder Unit	LCN (LCN)	Norton, Rixson
Door Trim	Ives (IVE)	Burns, Trimco
Protection Plates	Ives (IVE)	Burns, Trimco
Overhead Stops	Glynn-Johnson (GLY)	Rixson, Sargent
Stops & Holders	Ives (IVE)	Burns, Trimco
Thresholds & Weatherstrip	National Guard Products (NGP)	Reese, Zero

Silencers	Ives (IVE)	Burns, Trimco
Magnetic Holders	LCN (LCN)	Rixson, Sargent

- D. Hand of Door: Drawings show direction of slide, swing, or hand of each door leaf. Furnish each item of hardware for proper installation and operation of door movement as shown.
- E. Where specified hardware is not adaptable to finished shape or size of members requiring hardware, furnish suitable types having same operation and quality as type specified, subject to Architect's approval.

## 2.2 EXISTING MATERIALS

- A. Where existing door hardware is indicated to be removed and reinstalled:
  1. Carefully remove door hardware and components.
  2. Clean, protect and store existing door hardware in accordance with storage and handling requirements specified herein.
  3. Reinstall in accordance with installation requirements for new door hardware.

## 2.3 MATERIALS

- A. Fasteners
  1. Provide hardware manufactured to conform to published templates, generally prepared for machine screw installation.
  2. Furnish screws for installation with each hardware item. Finish exposed (exposed under any condition) screws to match hardware finish, or, if exposed in surfaces of other work, to match finish of this other work including prepared for paint surfaces to receive painted finish.
  3. Provide concealed fasteners for hardware units exposed when door is closed except when no standard units of type specified are available with concealed fasteners. Do not use thru-bolts for installation where bolt head or nut on opposite face is exposed in other work unless thru-bolts are required to fasten hardware securely. Review door specification and advise Architect if thru-bolts are required.
  4. Install hardware with fasteners provided by hardware manufacturer.
- B. Modification and Preparation of Existing Doors: Provide necessary fillers, Dutchmen, reinforcements, and fasteners, compatible with existing materials, as required for mounting new opening hardware and to cover existing door and frame preparations.
  1. Use materials which match materials of adjacent modified areas.
  2. When modifying existing fire-rated openings, provide materials permitted by NFPA 80 as required to maintain fire-rating.
- C. Provide screws, bolts, expansion shields, drop plates and other devices necessary for hardware installation.
  1. Where fasteners are exposed to view: Finish to match adjacent door hardware material.

## 2.4 CONTINUOUS HINGES

- A. Aluminum Geared

1. Manufacturers:
  - a. Scheduled Manufacturer: Ives.
  - b. Acceptable Manufacturers: Markar, Stanley.
2. Requirements:
  - a. Provide aluminum geared continuous hinges conforming to ANSI A156.25, Grade 2.
  - b. Provide aluminum geared continuous hinges, where specified in the hardware sets, fabricated from 6063-T6 aluminum, with 0.25-inch (6 mm) diameter Teflon coated stainless steel hinge pin.
  - c. Provide split nylon bearings at each hinge knuckle for quiet, smooth, self-lubricating operation.
  - d. Provide hinges capable of supporting door weights up to 450 pounds, and successfully tested for 1,500,000 cycles.
  - e. On fire-rated doors, provide aluminum geared continuous hinges that are classified for use on rated doors by testing agency acceptable to authority having jurisdiction.
  - f. Provide aluminum geared continuous hinges with electrified option where specified. Provide with sufficient number and gage of concealed wires to accommodate electric function of specified hardware.
  - g. Install hinges with fasteners supplied by manufacturer.
  - h. Provide hinges with symmetrical hole pattern.

## **2.5 FLUSH BOLTS**

- A. Manufacturers:
  1. Scheduled Manufacturer: Ives
  2. Acceptable Manufacturers: Burns, Trimco
- B. Requirements:
  1. Provide automatic, constant latching, and manual flush bolts with forged bronze or stainless steel face plates, extruded brass levers, and with wrought brass guides and strikes. Provide 12 inch (305 mm) steel or brass rods at doors up to 90 inches (2286 mm) in height. For doors over 90 inches (2286 mm) in height increase top rods by 6 inches (152 mm) for each additional 6 inches (152 mm) of door height. Provide dust-proof strikes at each bottom flush bolt.

## **2.6 COORDINATORS**

- A. Manufacturers:
  1. Scheduled Manufacturer: Ives
  2. Acceptable Manufacturers: Burns, Trimco
- B. Requirements:
  1. Where pairs of doors are equipped with automatic flush bolts, an astragal, or other hardware that requires synchronized closing of the doors, provide bar-type coordinating device, surface applied to underside of stop at frame head.

2. Provide filler bar of correct length for unit to span entire width of opening, and appropriate brackets for parallel arm door closers and surface vertical rod exit device strikes. Factory-prep coordinators for vertical rod devices if required.

## **2.7 MORTISE LOCKS**

- A. Manufacturers and Products:
  1. Scheduled Manufacturer and Product: Corbin-Russwin ML2000 Series, No Substitute
- B. Requirements:
  1. Provide mortise locks certified as ANSI A156.13, Grade 1 Operational, and manufactured from heavy gauge steel, containing components of steel with zinc dichromate plating for corrosion resistance. Provide multi-function lock case, field reversible for handing without opening case. Cylinders: Refer to "KEYING" article, herein.
  2. Provide locks with a standard 2-3/4 inches (70 mm) backset with full 3/4 inch (19 mm) throw stainless steel mechanical anti-friction latchbolt. Provide deadbolt with full 1 inch (25 mm) throw, constructed of stainless steel.
  3. Provide standard ASA strikes unless extended lip strikes are necessary to protect trim.
  4. Provide electrical options as scheduled. Provide electrified locksets with micro switch (RX) option that monitors retractor crank, and is actuated when rotation of inside or outside lever rotates retractor hub. Provide normally closed contacts or normally open contacts as required by security system.
  5. Lever Trim: Solid brass, bronze, or stainless steel, cast or forged in design specified, with wrought roses and external lever spring cages. Provide thru-bolted levers with 2-piece spindles.
    - a. Lever Design: Newport
    - b. Tactile Warning (Knurling): Where required by authority having jurisdiction. Provide on levers on exterior (secure side) of doors serving rooms considered to be hazardous.

## **2.8 CYLINDERS**

- A. Manufacturer:
  1. Scheduled Manufacturer: Corbin-Russwin, No Substitute
- B. Requirements: Provide cylinders/cores complying with the following requirements.
  1. Cylinders/cores compliant with ANSI/BHMA A156.5; latest revision, Section 12, Grade 1; permanent cylinders; cylinder face finished to match lockset, manufacturer's series as indicated.
- C. Provide cylinders to match owners existing system.
  1. Keying: As directed by the owner.
  2. Features: Cylinders/cores shall incorporate the following features.
- D. Nickel silver bottom pins.
  1. Identification:

- E. Mark permanent cylinders/cores and keys with applicable blind code per DHI publication "Keying Systems and Nomenclature" for identification. Blind code marks shall not include actual key cuts.
- F. Identification stamping provisions must be approved by the Architect and Owner.
- G. Failure to comply with stamping requirements shall be cause for replacement of cylinders/cores involved at no additional cost to Owner.
  - 1. Forward cylinders/cores to Owner, separately from keys, by means as directed by Owner.
- H. Construction Keying System.
- I. 3 construction control keys and extractor tool, if required.
- J. 12 construction change (day) keys.
  - 1. Owner or Owner's Representative will void operation of temporary construction keys.

## **2.9 KEYING**

- A. Keying system tied into existing system as directed by the Owner.
  - 1. Forward bitting list and keys separately from cylinders, by means as directed by Owner. Failure to comply with forwarding requirements shall be cause for replacement of cylinders/cores involved at no additional cost to Owner.
- B. Keys
  - 2. Material: Nickel silver; minimum thickness of .092-inch (2.3mm)
  - 3. Identification:
- C. Coordinate with cylinder/core and key identification requirements above.
- D. Stamp keys with Owner's unique key system facility code as established by the manufacturer; key symbol and embossed or stamped with "DO NOT DUPLICATE" along with the "PATENTED" or patent number to enforce the patent protection.
- E. Failure to comply with stamping requirements shall be cause for replacement of keys involved at no additional cost to Owner.
  - 4. Quantity: Furnish in the following quantities.
- F. Change (Day) Keys: 3 per cylinder/core.
- G. Permanent Control Keys: 3.
- H. Master Keys: 6.
- I. Unused balance of key blanks shall be furnished to Owner with the cut keys.



## 2.10 EXIT DEVICES

A. Manufacturer and Product: Von Duprin 98 series, No Substitute

B. Requirements:

1. Provide exit devices tested to ANSI/BHMA A156.3 Grade 1, and UL listed for Panic Exit or Fire Exit Hardware. Cylinders: Refer to "KEYING" article, herein.
2. Provide touchpad type exit devices, fabricated of brass, bronze, stainless steel, or aluminum, plated to standard architectural finishes to match balance of door hardware.
3. Quiet Operation: Incorporate fluid damper or other device that eliminates noise of exit device operation.
4. Touchpad: Extend minimum of one half of door width, but not the full length of exit device rail. Provide end-cap with two-point attachment to door. Match exit device finish, stainless steel for US26, US26D, US28, US32, and US32D finishes; and for all other finishes, provide compatible finish to exit device. Provide compression springs in devices, latches, and outside trims or controls; tension springs prohibited.
5. Provide exit devices with deadlatching feature for security and for future addition of alarm kits and/or other electrical requirements.
6. Provide exit devices with manufacturer's approved strikes.
7. Provide exit devices cut to door width and height. Locate exit devices at height recommended by exit device manufacturer, allowable by governing building codes, and approved by Architect.
8. Mount mechanism case flush on face of doors, or provide spacers to fill gaps behind devices. Where glass trim or molding projects off face of door, provide glass bead kits.
9. Provide cylinder dogging at non-fire-rated exit devices, unless specified less dogging.
10. Removable Mullions: 2 inches (51 mm) x 3 inches (76 mm) steel tube. Where scheduled as keyed removable mullion that is removed by use of a keyed cylinder, which is self-locking when re-installed.
11. Where lever handles are specified as outside trim for exit devices, provide heavy-duty lever trims with forged or cast escutcheon plates. Provide vandal-resistant levers that will travel to 90-degree down position when more than 35 pounds of torque are applied, and which can easily be re-set.
  - a. Lever Style: Match lever style of locksets.
  - b. Tactile Warning (Knurling): Where required by authority having jurisdiction. Provide on levers on exterior (secure side) of doors serving rooms considered to be hazardous.
12. Provide UL labeled fire exit hardware for fire rated openings.
13. Provide factory drilled weep holes for exit devices used in full exterior application, highly corrosive areas, and where noted in hardware sets.
14. Provide electrical options as scheduled.

## 2.11 DOOR CLOSERS

A. Manufacturer and Product: LCN 4040XP series. No Substitute

B. Requirements:

1. Provide door closers certified to ANSI/BHMA A156.4 Grade 1 requirements by BHMA certified independent testing laboratory. Certify surface mounted mechanical closers to exceed ten million (10,000,000) full load cycles. ISO 9000 certify closers. Stamp units with date of manufacture code.

2. Provide door closers with fully hydraulic, full rack and pinion action with high strength cast iron cylinder, and full complement bearings at shaft.
3. Cylinder Body: 1-1/2 inch (38 mm) diameter with 11/16 inch (17 mm) diameter double heat-treated pinion journal.
4. Hydraulic Fluid: Fireproof, passing requirements of UL10C, and requiring no seasonal closer adjustment for temperatures ranging from 120 degrees F to -30 degrees F.
5. Spring Power: Continuously adjustable over full range of closer sizes, and providing reduced opening force as required by accessibility codes and standards.
6. Hydraulic Regulation: By tamper-proof, non-critical valves, with separate adjustment for latch speed, general speed, and backcheck.
7. Provide closers with solid forged steel main arms and factory assembled heavy-duty forged forearms for parallel arm closers. When closers are parallel arm mounted, provide closers which mount within 6-inch (152 mm) top rail without use of mounting plate so that closer is not visible through vision panel from pull side.
8. Pressure Relief Valve (PRV) Technology: Not permitted.
9. Finish for Closer Cylinders, Arms, Adapter Plates, and Metal Covers: Powder coating finish which has been certified to exceed 100 hours salt spray testing as described in ANSI Standard A156.4 and ASTM B117, or has special rust inhibitor (SRI).
10. Provide special templates, drop plates, mounting brackets, or adapters for arms as required for details, overhead stops, and other door hardware items interfering with closer mounting.

## **2.12 ELECTRO-MECHANICAL CLOSER/HOLDERS**

### **A. Manufacturers and Products:**

1. Scheduled Manufacturer and Product: LCN 4040SE.
2. Acceptable Manufacturers and Products: Norton 7700PT/7210MPI, Rixson 4PUSH/4PULL.

### **B. Requirements:**

1. Provide single-point or multi-point hold-open electro-mechanical closer/holders as specified. Coordinate voltage requirements and provide transformer if necessary.
2. Provide multi-point electro-mechanical closer/holders with swing free arms.
3. Provide closer/holders that function as full rack and pinion door closer when current is interrupted or continuous hold-open is not engaged.
4. Provide door closers with fully hydraulic, full rack and pinion action with high strength cylinder and full complement bearings at shaft.
5. Cylinder Body: 1-1/2 inch (38 mm) diameter with 11/16 inch (17 mm) diameter double heat-treated pinion journal.
6. Hydraulic Fluid: Fireproof, passing requirements of UL10C, and requiring no seasonal closer adjustment for temperatures ranging from 120 degrees F to -30 degrees F.
7. Spring Power: Continuously adjustable over full range of closer sizes, and providing reduced opening force as required by accessibility codes and standards.
8. Hydraulic Regulation: By tamper-proof, non-critical valves, with separate adjustment for latch speed, general speed, and backcheck.
9. Pressure Relief Valve (PRV) Technology: Not permitted.
10. Provide special templates, drop plates, mounting brackets, or adapters for arms as required for details, overhead stops, and other door hardware items interfering with closer mounting.

## **2.13 DOOR TRIM**

### **A. Manufacturers:**

1. Scheduled Manufacturer: Ives.
2. Acceptable Manufacturers: Burns, Trimco.

### **B. Requirements:**

1. Provide push plates 4 inches (102 mm) wide by 16 inches (406 mm) high by 0.050 inch (1 mm) thick and beveled 4 edges. Where width of door stile prevents use of 4 inches (102 mm) wide plate, adjust width to fit.
2. Provide push bars of solid bar stock, diameter and length as scheduled. Provide push bars of sufficient length to span from center to center of each stile. Where required, mount back to back with pull.
3. Provide offset pulls of solid bar stock, diameter and length as scheduled. Where required, mount back to back with push bar.
4. Provide flush pulls as specified. Where required, provide back-to-back mounted model.
5. Provide pulls of solid bar stock, diameter and length as scheduled. Where required, mount back to back with push bar.
6. Provide pull plates 4 inches (102 mm) wide by 16 inches (406 mm) high by 0.050 inch (1 mm) thick, beveled 4 edges, and prepped for pull. Where width of door stile prevents use of 4 inches (102 mm) wide plate, adjust width to fit.
7. Provide wire pulls of solid bar stock, diameter and length as scheduled.

## **2.14 PROTECTION PLATES**

### **A. Manufacturers:**

1. Scheduled Manufacturer: Ives.
2. Acceptable Manufacturers: Burns, Trimco.

### **B. Requirements:**

1. Provide kick plates, mop plates, and armor plates minimum of 0.050 inch (1 mm) thick as scheduled. Furnish with sheet metal or wood screws, finished to match plates.
2. Sizes of plates:
  - a. Kick Plates: 10 inches (254 mm) high by 2 inches (51 mm) less width of door on single doors, 1 inch (25 mm) less width of door on pairs
  - b. Mop Plates: 4 inches (102 mm) high by 2 inches (51 mm) less width of door on single doors, 1 inch (25 mm) less width of door on pairs
  - c. Armor Plates: 36 inches (914 mm) high by 2 inches (51 mm) less width of door on single doors, 1 inch (25 mm) less width of door on pairs

## **2.15 OVERHEAD STOPS AND OVERHEAD STOP/HOLDERS**

### **A. Manufacturers:**

1. Scheduled Manufacturers: Glynn-Johnson
2. Acceptable Manufacturers: Rixson, Sargent

### **B. Requirements:**

1. Provide heavy duty concealed mounted overhead stop or holder as specified for exterior and interior vestibule single acting doors.
2. Provide heavy duty concealed mounted overhead stop or holder as specified for double acting doors.
3. Provide heavy or medium duty and concealed or surface mounted overhead stop or holder for interior doors as specified. Provide medium duty surface mounted overhead stop for interior doors and at any door that swings more than 140 degrees before striking wall, open against equipment, casework, sidelights, and where conditions do not allow wall stop or floor stop presents tripping hazard.
4. Where overhead holders are specified provide friction type at doors without closer and positive type at doors with closer.

## **2.16 DOOR STOPS AND HOLDERS**

### **A. Manufacturers:**

1. Scheduled Manufacturer: Ives.
2. Acceptable Manufacturers: Burns, Trimco.

### **B. Provide door stops at each door leaf:**

1. Provide wall stops wherever possible. Provide convex type where mortise type locks are used and concave type where cylindrical type locks are used.
2. Where a wall stop cannot be used, provide universal floor stops for low or high rise options.
3. Where wall or floor stop cannot be used, provide medium duty surface mounted overhead stop.

## **2.17 THRESHOLDS, SEALS, DOOR SWEEPS, AUTOMATIC DOOR BOTTOMS, AND GASKETING**

### **A. Manufacturers:**

1. Scheduled Manufacturer: National Guard Products.
2. Acceptable Manufacturers: Reese, Zero.

### **B. Requirements:**

1. Provide thresholds, weatherstripping (including door sweeps, seals, astragals) and gasketing systems (including smoke, sound, and light) as specified and per architectural details. Match finish of other items.
2. Size of thresholds::
  - a. Saddle Thresholds: 1/2 inch (13 mm) high by jamb width by door width
  - b. Bumper Seal Thresholds: 1/2 inch (13 mm) high by 5 inches (127 mm) wide by door width
3. Provide door sweeps, seals, astragals, and auto door bottoms only of type where resilient or flexible seal strip is easily replaceable and readily available.

## **2.18 SILENCERS**

### **A. Manufacturers:**

1. Scheduled Manufacturer: Ives.
2. Acceptable Manufacturers: Burns, Trimco.

B. Requirements:

1. Provide "push-in" type silencers for hollow metal or wood frames.
2. Provide one silencer per 30 inches (762 mm) of height on each single frame, and two for each pair frame.
3. Omit where gasketing is specified.

## 2.19 MAGNETIC HOLDERS

A. Manufacturers:

1. Scheduled Manufacturer: LCN.
2. Acceptable Manufacturers: Rixson, Sargent.

B. Requirements:

1. Provide wall or floor mounted electromagnetic door release as specified with minimum of 25 pounds of holding force. Coordination projection of holder and armature with other hardware and wall conditions to ensure that door sits parallel to wall when fully open. Wire magnetic holders on fire-rated doors into the fire control panel for fail-safe operation.

## 2.20 FINISHES

A. Finish: BHMA 626/652 (US26D); except:

1. Hinges at Exterior Doors: BHMA 630 (US32D)
2. Push Plates, Pulls, and Push Bars: BHMA 630 (US32D)
3. Protection Plates: BHMA 630 (US32D)
4. Overhead Stops and Holders: BHMA 630 (US32D)
5. Door Closers: Powder Coat to Match
6. Wall Stops: BHMA 630 (US32D)
7. Weatherstripping: Clear Anodized Aluminum
8. Thresholds: Mill Finish Aluminum

## PART 3 - EXECUTION

### 3.1 EXAMINATION

- A. Prior to installation of hardware, examine doors and frames, with Installer present, for compliance with requirements for installation tolerances, labeled fire-rated door assembly construction, wall and floor construction, and other conditions affecting performance.
- B. Existing Door and Frame Compatibility: Field verify existing doors and frames receiving new hardware and existing conditions receiving new openings. Verify that new hardware is compatible with existing door and frame preparation and existing conditions.
- C. Proceed with installation only after unsatisfactory conditions have been corrected.

### 3.2 PREPARATION

- A. Where on-site modification of doors and frames is required:
  - 1. Remove existing hardware being replaced, tag, and store according to contract documents.
  - 2. Field modify and prepare existing door and frame for new hardware being installed.
  - 3. When modifications are exposed to view, use concealed fasteners, when possible.
  - 4. Prepare hardware locations in accordance with:
    - a. Steel Doors and Frames: For surface applied door hardware, drill and tap doors and frames according to ANSI/SDI A250.6.
    - b. Wood Doors: DHI WDHS.5 "Recommended Hardware Reinforcement Locations for Mineral Core Wood Flush Doors."
    - c. Doors in rated assemblies: NFPA 80 for restrictions on on-site door hardware preparation.

### 3.3 INSTALLATION

- A. Mounting Heights: Mount door hardware units at heights to comply with the following, unless otherwise indicated or required to comply with governing regulations.
  - 1. Standard Steel Doors and Frames: ANSI/SDI A250.8.
  - 2. Custom Steel Doors and Frames: HMMA 831.
  - 3. Wood Doors: DHI WDHS.3, "Recommended Locations for Architectural Hardware for Wood Flush Doors."
- B. Install each hardware item in compliance with manufacturer's instructions and recommendations, using only fasteners provided by manufacturer.
- C. Do not install surface mounted items until finishes have been completed on substrate. Protect all installed hardware during painting.
- D. Set units level, plumb and true to line and location. Adjust and reinforce attachment substrate as necessary for proper installation and operation.
- E. Drill and countersink units that are not factory prepared for anchorage fasteners. Space fasteners and anchors according to industry standards.
- F. Install operating parts so they move freely and smoothly without binding, sticking, or excessive clearance.
- G. Hinges: Install types and in quantities indicated in door hardware schedule but not fewer than quantity recommended by manufacturer for application indicated or one hinge for every 30 inches (750 mm) of door height, whichever is more stringent, unless other equivalent means of support for door, such as spring hinges or pivots, are provided.
- H. Lock Cylinders: Install construction cores to secure building and areas during construction period.
  - 1. Replace construction cores with permanent cores as indicated in keying section.
- I. Key Control System: Tag keys and place them on markers and hooks in key control system cabinet, as determined by final keying schedule.

- J. Door Closers: Mount closers on room side of corridor doors, inside of exterior doors, and stair side of stairway doors from corridors. Closers shall not be visible in corridors, lobbies and other public spaces unless approved by Architect.
- K. Closer/holders: Mount closer/holders on room side of corridor doors, inside of exterior doors, and stair side of stairway doors.
- L. Thresholds: Set thresholds in full bed of sealant complying with requirements specified in Division 07 Section "Joint Sealants."
- M. Stops: Provide floor stops for doors unless wall or other type stops are indicated in door hardware schedule. Do not mount floor stops where they may impede traffic or present tripping hazard.
- N. Perimeter Gasketing: Apply to head and jamb, forming seal between door and frame.
- O. Meeting Stile Gasketing: Fasten to meeting stiles, forming seal when doors are closed.
- P. Door Bottoms: Apply to bottom of door, forming seal with threshold when door is closed.

### **3.4 FIELD QUALITY CONTROL**

- A. Architectural Hardware Consultant: Engage qualified independent Architectural Hardware Consultant to perform inspections and to prepare inspection reports.
  - 1. Architectural Hardware Consultant will inspect door hardware and state in each report whether installed work complies with or deviates from requirements, including whether door hardware is properly installed and adjusted.

### **3.5 ADJUSTING**

- A. Initial Adjustment: Adjust and check each operating item of door hardware and each door to ensure proper operation or function of every unit. Replace units that cannot be adjusted to operate as intended. Adjust door control devices to compensate for final operation of heating and ventilating equipment and to comply with referenced accessibility requirements.
  - 1. Spring Hinges: Adjust to achieve positive latching when door is allowed to close freely from an open position of 30 degrees.
  - 2. Electric Strikes: Adjust horizontal and vertical alignment of keeper to properly engage lock bolt.
  - 3. Door Closers: Adjust sweep period to comply with accessibility requirements and requirements of authorities having jurisdiction.
- B. Occupancy Adjustment: Approximately three six months after date of Substantial Completion, Installer's Architectural Hardware Consultant shall examine and readjust each item of door hardware, including adjusting operating forces, as necessary to ensure function of doors, door hardware, and electrified door hardware.

### **3.6 CLEANING AND PROTECTION**

- A. Clean adjacent surfaces soiled by door hardware installation.

- B. Clean operating items as necessary to restore proper function and finish.
- C. Provide final protection and maintain conditions that ensure door hardware is without damage or deterioration at time of Substantial Completion.

**3.7 DEMONSTRATION**

- A. Provide training for Owner's maintenance personnel to adjust, operate, and maintain door hardware and door hardware finishes. Refer to Division 01 Section "Demonstration and Training."

**3.8 DOOR HARDWARE SCHEDULE**

- A. Locksets, exit devices, and other hardware items are referenced in the following hardware sets for series, type and function. Refer to the above-specifications for special features, options, cylinders/keying, and other requirements.
- B. Hardware Sets:

**HARDWARE GROUP NO. 1**

FOR USE ON DOOR #(S):  
214A

PROVIDE EACH PR DOOR(S) WITH THE FOLLOWING:

QTY		DESCRIPTION	CATALOG NUMBER	FINISH	MFR
2	EA	CONT. HINGE	224HD	628	IVE
2	EA	FIRE EXIT HARDWARE	9847-EO-F-LBR	626	VON
2	EA	SURFACE CLOSER	4040XP EDA	689	LCN
4	EA	KICK PLATE	8400 10" X 2" LDW	630	IVE
2	EA	WALL STOP	WS407CVX	630	IVE
2	EA	FIRE/LIFE WALL MAG	SEM7840	689	LCN
1	SET	SEALS	5050B	BRN	NGP
1	SET	SEALS	5060B	BRN	NGP
2	EA	DOOR BOTTOM	112N	AL	NGP
1	EA	THRESHOLD	410	AL	NGP

\*WALL MAGS ARE TO BE TIED INTO THE EXISTING FIRE ALARM.



**HARDWARE GROUP NO. 2**

FOR USE ON DOOR #(S):

214B

PROVIDE EACH PR DOOR(S) WITH THE FOLLOWING:

QTY		DESCRIPTION	CATALOG NUMBER	FINISH	MFR
2	EA	CONT. HINGE	224HD	628	IVE
1	EA	FIRE EXIT HARDWARE	9847-L-F-LBR-996-06	626	VON
1	EA	FIRE EXIT HARDWARE	9875-L-F-996-06	626	VON
1	EA	MORTISE PRYAMID CYLINDER	AS REQUIRED	626	COR
1	EA	RIM PRYAMID CYLINDER	AS REQUIRED	626	COR
1	EA	COORDINATOR	COR X FL	628	IVE
2	EA	MOUNTING BRACKET	MB	689	IVE
1	EA	SURFACE CLOSER	4040XP CUSH	689	LCN
1	EA	SURFACE CLOSER	4040XP EDA	689	LCN
2	EA	KICK PLATE	8400 10" X 2" LDW	630	IVE
1	EA	WALL STOP	WS407CVX	630	IVE
1	EA	FIRE/LIFE HOLDER	4040SEH	689	LCN
1	EA	FIRE/LIFE WALL MAG	SEM7840	689	LCN
1	SET	SEALS	5050B	BRN	NGP
2	EA	DOOR BOTTOM	112N	AL	NGP
1	EA	THRESHOLD	410	AL	NGP

\*"T" ASTRAGAL BY DOOR MANUFACTURER.

\*CYLINDERS TO MATCH BUILDINGS EXISTING SYSTEM.

**HARDWARE GROUP NO. 3**

FOR USE ON DOOR #(S):

213A                      213B

PROVIDE EACH SGL DOOR(S) WITH THE FOLLOWING:

QTY		DESCRIPTION	CATALOG NUMBER	FINISH	MFR
1	EA	CONT. HINGE	224HD	628	IVE
1	EA	FIRE EXIT HARDWARE	98-L-F-996-06	626	VON
1	EA	RIM PRYAMID CYLINDER	AS REQUIRED	626	COR
1	EA	SURFACE CLOSER	4040XP EDA	689	LCN
1	EA	KICK PLATE	8400 10" X 2" LDW	630	IVE
1	EA	WALL STOP	WS407CVX	630	IVE
1	SET	SEALS	5050B	BRN	NGP
1	EA	DOOR BOTTOM	112N	AL	NGP
1	EA	THRESHOLD	410	AL	NGP

\*CYLINDERS TO MATCH BUILDINGS EXISTING SYSTEM.

**HARDWARE GROUP NO. 4**

FOR USE ON DOOR #(S):

291C

PROVIDE EACH SGL DOOR(S) WITH THE FOLLOWING:

QTY		DESCRIPTION	CATALOG NUMBER	FINISH	MFR
1	EA	CONT. HINGE	224HD	628	IVE
1	EA	FIRE EXIT HARDWARE	98-L-F-996-06	626	VON
1	EA	RIM PRYAMID CYLINDER	AS REQUIRED	626	COR
1	EA	SURFACE CLOSER	4040XP	689	LCN
1	EA	KICK PLATE	8400 10" X 2" LDW	630	IVE
1	EA	WALL STOP	WS407CVX	630	IVE
1	SET	SEALS	5050B	BRN	NGP
1	EA	DOOR BOTTOM	112N	AL	NGP
1	EA	THRESHOLD	410	AL	NGP
1	EA	DOOR CONTACT	679-05HM	BLK	SCE

\*DOOR POSITION SWITCH TO BE TIED INTO EXISTING FIRE ALARM SYSTEM.

\*CYLINDERS TO MATCH BUILDINGS EXISTING SYSTEM.

**HARDWARE GROUP NO. 5**

FOR USE ON DOOR #(S):

223

PROVIDE EACH PR DOOR(S) WITH THE FOLLOWING:

QTY		DESCRIPTION	CATALOG NUMBER	FINISH	MFR
2	EA	CONT. HINGE	224HD	628	IVE
1	SET	CONST LATCHING BOLT	FB51P	630	IVE
1	EA	DUST PROOF STRIKE	DP2	626	IVE
1	EA	MORTISE LOCK	ML2055 NSA	626	COR
1	EA	MORTISE PRYAMID CYLINDER	AS REQUIRED	626	COR
1	EA	COORDINATOR	COR X FL	628	IVE
2	EA	MOUNTING BRACKET	MB	689	IVE
1	EA	OH STOP	90S	630	GLY
2	EA	SURFACE CLOSER	4040XP EDA	689	LCN
2	EA	KICK PLATE	8400 10" X 2" LDW	630	IVE
1	EA	WALL STOP	WS407CVX	630	IVE
1	SET	SEALS	5050B	BRN	NGP
2	EA	DOOR BOTTOM	112N	AL	NGP
1	EA	THRESHOLD	410	AL	NGP

\*"T" ASTRAGAL BY DOOR MANUFACTURER.

\*CYLINDERS TO MATCH BUILDINGS EXISTING SYSTEM.

**HARDWARE GROUP NO. 6**

FOR USE ON DOOR #(S):

201

PROVIDE EACH SGL DOOR(S) WITH THE FOLLOWING:

QTY		DESCRIPTION	CATALOG NUMBER	FINISH	MFR
1	EA	CONT. HINGE	224HD	628	IVE
1	EA	MORTISE LOCK	ML2053 NSA	626	COR
1	EA	MORTISE PRYAMID CYLINDER	AS REQUIRED	626	COR
1	EA	FLOOR STOP	FS436	626	IVE

\*CYLINDERS TO MATCH BUILDINGS EXISTING SYSTEM.

## **DIVISION 9 - FINISHES**

### **SECTION 09 21 16 GYPSUM BOARD ASSEMBLIES**

#### **PART 1 GENERAL**

##### **1.01 SECTION INCLUDES**

- A. Performance criteria for gypsum board assemblies.
- B. Metal stud wall framing.
- C. Metal channel ceiling framing.
- D. Acoustic insulation.
- E. Gypsum wallboard.
- F. Joint treatment and accessories.

##### **1.02 RELATED REQUIREMENTS**

- A. Section 01 61 16 - Volatile Organic Compound (VOC) Content Restrictions.
- B. Section 06 10 00 - Rough Carpentry: Wood blocking product and execution requirements.

##### **1.03 REFERENCE STANDARDS**

- A. ASTM C475/C475M - Standard Specification for Joint Compound and Joint Tape for Finishing Gypsum Board; 2002 (Reapproved 2007).
- B. ASTM C645 - Standard Specification for Nonstructural Steel Framing Members; 2011a.
- C. ASTM C665 - Standard Specification for Mineral-Fiber Blanket Thermal Insulation for Light Frame Construction and Manufactured Housing; 2012.
- D. ASTM C754 - Standard Specification for Installation of Steel Framing Members to Receive Screw-Attached Gypsum Panel Products; 2011.
- E. ASTM C840 - Standard Specification for Application and Finishing of Gypsum Board; 2011.
- F. ASTM C954 - Standard Specification for Steel Drill Screws for the Application of Gypsum Panel Products or Metal Plaster Bases to Steel Studs From 0.033 in. (0.84 mm) to 0.112 in. (2.84 mm) in Thickness; 2011.
- G. ASTM C1002 - Standard Specification for Steel Self-Piercing Tapping Screws for the Application of Gypsum Panel Products or Metal Plaster Bases to Wood Studs or Steel Studs; 2007.
- H. ASTM C1047 - Standard Specification for Accessories for Gypsum Wallboard and Gypsum Veneer Base; 2010a.
- I. ASTM C1396/C1396M - Standard Specification for Gypsum Board; 2011.
- J. ASTM D3273 - Standard Test Method for Resistance to Growth of Mold on the Surface of Interior Coatings in an Environmental Chamber; 2012.
- K. ASTM E90 - Standard Test Method for Laboratory Measurement of Airborne Sound Transmission Loss of Building Partitions and Elements; 2009.
- L. ASTM E413 - Classification for Rating Sound Insulation; 2010.
- M. GA-216 - Application and Finishing of Gypsum Board; Gypsum Association; 2010.
- N. GA-600 - Fire Resistance Design Manual; Gypsum Association; 2009.

#### **1.04 SUBMITTALS**

- A. See Section 01 30 00 - Administrative Requirements, for submittal procedures.
- B. Product Data: Provide data on metal framing, gypsum board, accessories, and joint finishing system.
- C. Product Data: Provide manufacturer's data on partition head to structure connectors, showing compliance with requirements.

#### **1.05 QUALITY ASSURANCE**

- A. Installer Qualifications: Company specializing in performing gypsum board application and finishing, with minimum 5\_\_ years of documented experience.

### **PART 2 PRODUCTS**

#### **2.01 GYPSUM BOARD ASSEMBLIES**

- A. Provide completed assemblies complying with ASTM C840 and GA-216.
- B. Interior Partitions Indicated as Acoustic: Provide completed assemblies with the following characteristics:
  - 1. Acoustic Attenuation: STC of 45-49 calculated in accordance with ASTM E413, based on tests conducted in accordance with ASTM E90.
- C. Shaft Walls at HVAC Shafts: Provide completed assemblies with the following characteristics:
  - 1. Air Pressure Within Shaft: Sustained loads of 5 lbf/sq ft (0.24 kPa) with maximum mid-span deflection of L/240.
  - 2. Acoustic Attenuation: STC of 35-39 calculated in accordance with ASTM E413, based on tests conducted in accordance with ASTM E90.
- D. Fire Rated Assemblies: Provide completed assemblies with the following characteristics:

#### **2.02 METAL FRAMING MATERIALS**

- A. Manufacturers - Metal Framing, Connectors, and Accessories:
  - 1. Clarkwestern Dietrich Building Systems LLC: [www.clarkdietrich.com](http://www.clarkdietrich.com).
  - 2. MarinoWare: [www.marinoware.com](http://www.marinoware.com).
  - 3. Phillips Manufacturing Company: [www.phillipsmfg.com](http://www.phillipsmfg.com).
  - 4. Substitutions: See Section 01 60 00 - Product Requirements.
- B. Non-Loadbearing Framing System Components: ASTM C645; galvanized sheet steel, of size and properties necessary to comply with ASTM C754 for the spacing indicated, with maximum deflection of wall framing of L/240 at 5 psf (240 Pa).
  - 1. Studs: "C" shaped with flat or formed webs with knurled faces.
  - 2. Runners: U shaped, sized to match studs.
  - 3. Ceiling Channels: C shaped.
  - 4. Furring: Hat-shaped sections, minimum depth of 7/8 inch (22 mm).
  - 5. Resilient Furring Channels: 1/2 inch (12 mm) depth, for attachment to substrate through one leg only.
    - a. Manufacturers - Resilient Furring Channels:
      - 1) Same manufacturer as other framing materials.
- C. Shaft Wall Studs and Accessories: ASTM C645; galvanized sheet steel, of size and properties necessary to comply with ASTM C754 and specified performance requirements.
- D. Ceiling Hangers: Type and size as specified in ASTM C754 for spacing required.

- E. Partition Head To Structure Connections: Provide track fastened to structure with legs of sufficient length to accommodate deflection, for friction fit of studs cut short and fastened as indicated on drawings.

## 2.03 BOARD MATERIALS

- A. Manufacturers - Gypsum-Based Board:
  - 1. American Gypsum: [www.americangypsum.com](http://www.americangypsum.com).
  - 2. CertainTeed Corporation: [www.certainteed.com](http://www.certainteed.com).
  - 3. Georgia-Pacific Gypsum: [www.gpgypsum.com](http://www.gpgypsum.com).
  - 4. Lafarge North America Inc: [www.lafargenorthamerica.com](http://www.lafargenorthamerica.com).
  - 5. National Gypsum Company: [www.nationalgypsum.com](http://www.nationalgypsum.com).
  - 6. USG Corporation: [www.usg.com](http://www.usg.com).
  - 7. Substitutions: See Section 01 60 00 - Product Requirements.
- B. Gypsum Wallboard: Paper-faced gypsum panels as defined in ASTM C1396/C1396M; sizes to minimize joints in place; ends square cut.
  - 1. Application: Use for vertical surfaces and ceilings, unless otherwise indicated.
  - 2. Thickness:
    - a. Vertical Surfaces: 5/8 inch (16 mm).
    - b. Ceilings: 1/2 inch (13 mm).
    - c. Multi-Layer Assemblies: Thicknesses as indicated on drawings.
  - 3. Paper-Faced Products:
    - a. American Gypsum; EagleRoc Regular Gypsum Wallboard and FireBloc Type X Gypsum Wallboard.
    - b. CertainTeed Corporation; ProRoc Brand Gypsum Board.
    - c. Georgia-Pacific Gypsum; ToughRock, ToughRock Fireguard, and ToughRock FireGuard C Gypsum Wallboard.
    - d. Lafarge North America Inc; Regular Drywall and Firecheck Type X and Type C.
    - e. National Gypsum Company; Gold Bond Brand Gypsum Wallboard.
    - f. USG Corporation; Sheetrock Brand Gypsum Panels.
    - g. Substitutions: See Section 01 60 00 - Product Requirements.
- C. Backing Board For Non-Wet Areas: Water-resistant gypsum backing board as defined in ASTM C1396/C1396M; sizes to minimum joints in place; ends square cut.
  - 1. Application: Vertical surfaces behind thinset tile, except in wet areas.
  - 2. Mold Resistance: Score of 10, when tested in accordance with ASTM D3273.
  - 3. Type: Regular and Type X, in locations indicated.
  - 4. Type X Thickness: 5/8 inch (16 mm).
  - 5. Regular Board Thickness: 1/2 inch (13 mm).
  - 6. Edges: Tapered.
- D. Ceiling Board: Special sag-resistant gypsum ceiling board as defined in ASTM C1396/C1396M; sizes to minimize joints in place; ends square cut.
  - 1. Application: Ceilings, unless otherwise indicated.
  - 2. Thickness: 1/2 inch (13 mm).
  - 3. Edges: Tapered.
  - 4. Products:
    - a. American Gypsum; Interior Ceiling Board.
    - b. CertainTeed Corporation; ProRoc Interior Ceiling.
    - c. Georgia-Pacific Gypsum; ToughRock CD Ceiling Board.
    - d. Lafarge North America Inc; Sagcheck.
    - e. National Gypsum Company; High Strength Brand Ceiling Board.
    - f. USG Corporation; Sheetrock Brand Sag-Resistant Interior Gypsum Ceiling Board.
    - g. Substitutions: See Section 01 60 00 - Product Requirements.

- E. Shaftwall and Coreboard: Type X; 1 inch (25 mm) thick by 24 inches (610 mm) wide, beveled long edges, ends square cut.
  - 1. Paper Faced Type: Gypsum shaftliner board or gypsum coreboard as defined ASTM C1396/C1396M; water-resistant faces.

## **2.04 ACCESSORIES**

- A. Acoustic Insulation: ASTM C665; preformed glass fiber, friction fit type, unfaced. Thickness: 2 inches. (Thickness: 51 mm.)
- B. Acoustic Sealant: Non-hardening, non-skinning, for use in conjunction with gypsum board.
- C. Finishing Accessories: ASTM C1047, galvanized steel or rolled zinc, unless otherwise indicated.
  - 1. Types: As detailed or required for finished appearance.
  - 2. Special Shapes: In addition to conventional cornerbead and control joints, provide U-bead at exposed panel edges.
  - 3. Manufacturers - Finishing Accessories:
    - a. Same manufacturer as framing materials.
- D. Joint Materials: ASTM C475 and as recommended by gypsum board manufacturer for project conditions.
  - 1. Tape: 2 inch (50 mm) wide, creased paper tape for joints and corners, except as otherwise indicated.
  - 2. Ready-mixed vinyl-based joint compound.
- E. High Build Drywall Surfer: Vinyl acrylic latex-based coating for spray application, designed to take the place of skim coating and separate paint primer in achieving Level 5 finish.
- F. Screws for Attachment to Steel Members Less Than 0.03 inch (0.7 mm) In Thickness, to Wood Members, and to Gypsum Board: ASTM C1002; self-piercing tapping type; cadmium-plated for exterior locations.
- G. Screws for Attachment to Steel Members From 0.033 to 0.112 inch (0.8 to 2.8 mm) in Thickness: ASTM C954; steel drill screws for application of gypsum board to loadbearing steel studs.
- H. Anchorage to Substrate: Tie wire, nails, screws, and other metal supports, of type and size to suit application; to rigidly secure materials in place.

## **PART 3 EXECUTION**

### **3.01 EXAMINATION**

- A. Verify that project conditions are appropriate for work of this section to commence.

### **3.02 SHAFT WALL INSTALLATION**

- A. Shaft Wall Framing: Install in accordance with manufacturer's installation instructions.
  - 1. Install studs at spacing required to meet performance requirements.
- B. Shaft Wall Liner: Cut panels to accurate dimension and install sequentially between special friction studs.
  - 1. Seal perimeter of shaft wall and penetrations with acoustical sealant.

### **3.03 FRAMING INSTALLATION**

- A. Metal Framing: Install in accordance with ASTM C754 and manufacturer's instructions.
- B. Suspended Ceilings and Soffits: Space framing and furring members as indicated.
- C. Studs: Space studs as permitted by standard.
  - 1. Extend partition framing to structure where indicated and to ceiling in other locations.
  - 2. Partitions Terminating at Ceiling: Attach ceiling runner securely to ceiling track in

- accordance with manufacturer's instructions.
3. Partitions Terminating at Structure: Attach extended leg top runner to structure, maintain clearance between top of studs and structure, and brace both flanges of studs with continuous bridging.
- D. Openings: Reinforce openings as required for weight of doors or operable panels, using not less than double studs at jambs.
  - E. Acoustic Furring: Install resilient channels at maximum 24 inches (600 mm) on center. Locate joints over framing members.
  - F. Furring for Fire Ratings: Install as required for fire resistance ratings indicated and to GA-600 requirements.
  - G. Blocking: Install wood blocking for support of:
    1. Wall mounted cabinets.

### **3.04 ACOUSTIC ACCESSORIES INSTALLATION**

- A. Acoustic Insulation: Place tightly within spaces, around cut openings, behind and around electrical and mechanical items within partitions, and tight to items passing through partitions.
- B. Acoustic Sealant: Install in accordance with manufacturer's instructions.
  1. Place continuous bead at perimeter of each layer of gypsum board.
  2. In non-fire-rated construction, seal around all penetrations by conduit, pipe, ducts, and rough-in boxes.

### **3.05 BOARD INSTALLATION**

- A. Comply with ASTM C 840, GA-216, and manufacturer's instructions. Install to minimize butt end joints, especially in highly visible locations.
- B. Fire-Rated Construction: Install gypsum board in strict compliance with requirements of assembly listing.

### **3.06 INSTALLATION OF TRIM AND ACCESSORIES**

- A. Control Joints: Place control joints consistent with lines of building spaces and as indicated.
  1. Not more than 30 feet (10 meters) apart on walls and ceilings over 50 feet (16 meters) long.
- B. Corner Beads: Install at external corners, using longest practical lengths.
- C. Edge Trim: Install at locations where gypsum board abuts dissimilar materials and as indicated.

### **3.07 JOINT TREATMENT**

- A. Paper Faced Gypsum Board: Use paper joint tape, bedded with ready-mixed vinyl-based joint compound and finished with ready-mixed vinyl-based joint compound.
- B. Finish gypsum board in accordance with levels defined in ASTM C840, as follows:
  1. Level 4: Walls and ceilings to receive paint finish or wall coverings, unless otherwise indicated.
  2. Level 5: Walls and ceilings to receive semi-gloss or gloss paint finish and other areas specifically indicated.
  3. Level 1: Fire rated wall areas above finished ceilings, whether or not accessible in the completed construction.
  4. Level 0: Temporary partitions and surfaces indicated to be finished in later stage of project.
- C. Tape, fill, and sand exposed joints, edges, and corners to produce smooth surface ready to receive finishes.



1. Feather coats of joint compound so that camber is maximum 1/32 inch (0.8 mm).
- D. Where Level 5 finish is indicated, spray apply high build drywall surfacer over entire surface after joints have been properly treated; achieve a flat and tool mark-free finish.

### **3.08 TOLERANCES**

- A. Maximum Variation of Finished Gypsum Board Surface from True Flatness: 1/8 inch in 10 feet (3 mm in 3 m) in any direction.

**END OF SECTION**

## DIVISION 9 - FINISHES

### SECTION 09 51 00 ACOUSTICAL CEILINGS

#### PART 1 GENERAL

##### 1.01 SECTION INCLUDES

- A. Suspended metal grid ceiling system.
- B. Acoustical units.

##### 1.02 RELATED REQUIREMENTS

- A. Section 01 61 16 - Volatile Organic Compound (VOC) Content Restrictions.
- B. Section 07 90 05 - Joint Sealers: Acoustical sealant.
- C. Section 26 51 00 - Interior Lighting: Light fixtures in ceiling system.

##### 1.03 REFERENCE STANDARDS

- A. ASTM C635 - Standard Specification for the Manufacture, Performance, and Testing of Metal Suspension Systems for Acoustical Tile and Lay-in Panel Ceilings; 2007.
- B. ASTM E1264 - Standard Classification for Acoustical Ceiling Products; 2008e1.

##### 1.04 SUBMITTALS

- A. See Section 01 33 00 - Submittal Procedures.
- B. Product Data: Provide data on suspension system components.
- C. Samples: Submit two samples 6 x 12 inch (150 x 300 mm) in size illustrating material and finish of acoustical units.
- D. Samples: Submit two samples each, 12 inches (300 mm) long, of suspension system main runner.

##### 1.05 QUALITY ASSURANCE

- A. Suspension System Manufacturer Qualifications: Company specializing in manufacturing the products specified in this section with minimum three years documented experience.
- B. Acoustical Unit Manufacturer Qualifications: Company specializing in manufacturing the products specified in this section with minimum three years documented experience.

##### 1.06 FIELD CONDITIONS

- A. Maintain uniform temperature of minimum 60 degrees F (16 degrees C), and maximum humidity of 40 percent prior to, during, and after acoustical unit installation.

#### PART 2 PRODUCTS

##### 2.01 ACOUSTICAL UNITS

- A. Manufacturers:
  - 1. Armstrong World Industries, Inc: [www.armstrong.com](http://www.armstrong.com).
  - 2. Substitutions: See Section 01 60 00 - Product Requirements.
- B. Acoustical Units - General: ASTM E1264, Class A.
- C. Acoustical Panels Type CLG-1: Painted mineral fiber, ASTM E1264 Type III, with the following characteristics:
  - 1. Size: 24 x 24 inches (600 x 600 mm).

2. Thickness: 3/4 inches (19 mm).
  3. Composition: Wet felted.
  4. Light Reflectance: 90 percent, determined as specified in ASTM E1264.
  5. NRC Range:.6 to.7, determined as specified in ASTM E1264.
  6. Ceiling Attenuation Class (CAC): 35, determined as specified in ASTM E1264.
  7. Edge: Reveal edge to fit box grid.
  8. Surface Color: White.
  9. Surface Pattern: Perforated, regularly spaced large holes.
  10. Product: Ultima by Armstrong.
  11. Suspension System: Exposed grid Type CLG-1.
- D. Acoustical Panels Type CLG-3: Painted mineral fiber, ASTM E1264 Type III, with the following characteristics:
1. Size: 24 x 24 inches (600 x 600 mm).
  2. NRC Range:.55 to.60, determined as specified in ASTM E1264.
  3. Ceiling Attenuation Class (CAC): 30, determined as specified in ASTM E1264.
  4. Panel Edge: Square.
  5. Surface Pattern: Perforated.
  6. Surface Color: White.
  7. Product: 756A by Armstrong.
  8. Suspension System: Exposed grid Type CLG-3.

## 2.02 SUSPENSION SYSTEM(S)

- A. Manufacturers:
1. Armstrong World Industries, Inc: [www.armstrong.com](http://www.armstrong.com).
  2. Chicago Metallic Corporation: [www.chicagometallic.com](http://www.chicagometallic.com).
  3. USG: [www.usg.com](http://www.usg.com).
  4. Substitutions: See Section 01 60 00 - Product Requirements.
- B. Suspension Systems - General: ASTM C635; die cut and interlocking components, with stabilizer bars, clips, splices, perimeter moldings, and hold down clips as required.
- C. Exposed Steel Suspension System Type CLG-1: Formed steel, commercial quality cold rolled; intermediate-duty.
1. Profile: Box, for reveal edge panels, with screw slot; 9/16 inch (14 mm) wide face.
  2. Construction: Double web.
  3. Finish: White painted.
- D. Exposed Steel Suspension System Type CLG-3: Formed steel, commercial quality cold rolled; intermediate-duty.
1. Profile: Tee; 15/16 inch (24 mm) wide face.
  2. Construction: Double web.
  3. Finish: White painted.
  4. Product: 250 Series by Chicago Metallic.

## 2.03 ACCESSORIES

- A. Support Channels and Hangers: Galvanized steel; size and type to suit application and ceiling system flatness requirement specified.
- B. Perimeter Moldings: Same material and finish as grid.
1. At Exposed Grid: Provide L-shaped molding for mounting at same elevation as face of grid.
- C. Acoustical Sealant For Perimeter Moldings: Non-hardening, non-skinning, for use in conjunction with suspended ceiling system.
- D. Touch-up Paint: Type and color to match acoustical and grid units.

## PART 3 EXECUTION

### **3.01 INSTALLATION - SUSPENSION SYSTEM**

- A. Rigidly secure system, including integral mechanical and electrical components, for maximum deflection of 1:360.
- B. Lay out system to a balanced grid design with edge units no less than 50 percent of acoustical unit size.
- C. Install after major above-ceiling work is complete. Coordinate the location of hangers with other work.
- D. Hang suspension system independent of walls, columns, ducts, pipes and conduit. Where carrying members are spliced, avoid visible displacement of face plane of adjacent members.
- E. Where ducts or other equipment prevent the regular spacing of hangers, reinforce the nearest affected hangers and related carrying channels to span the extra distance.
- F. Do not support components on main runners or cross runners if weight causes total dead load to exceed deflection capability.
- G. Support fixture loads using supplementary hangers located within 6 inches (150 mm) of each corner, or support components independently.
- H. Do not eccentrically load system or induce rotation of runners.
- I. Perimeter Molding: Install at intersection of ceiling and vertical surfaces and at junctions with other interruptions.
  - 1. Use longest practical lengths.
  - 2. Overlap and rivet corners.

### **3.02 INSTALLATION - ACOUSTICAL UNITS**

- A. Install acoustical units in accordance with manufacturer's instructions.
- B. Fit acoustical units in place, free from damaged edges or other defects detrimental to appearance and function.
- C. Fit border trim neatly against abutting surfaces.
- D. Install units after above-ceiling work is complete.
- E. Install acoustical units level, in uniform plane, and free from twist, warp, and dents.
- F. Cutting Acoustical Units:
  - 1. Make field cut edges of same profile as factory edges.
  - 2. Double cut and field paint exposed reveal edges.
- G. Where round obstructions occur, provide preformed closures to match perimeter molding.

### **3.03 TOLERANCES**

- A. Maximum Variation from Flat and Level Surface: 1/8 inch in 10 feet (3 mm in 3 m).
- B. Maximum Variation from Plumb of Grid Members Caused by Eccentric Loads: 2 degrees.

**END OF SECTION**

## **DIVISION 9 - FINISHES**

### **SECTION 09 65 00 RESILIENT FLOORING**

#### **PART 1 GENERAL**

##### **1.01 SECTION INCLUDES**

- A. Resilient sheet flooring.
- B. Resilient tile flooring.
- C. Resilient base.
- D. Installation accessories.

##### **1.02 RELATED REQUIREMENTS**

- A. Section 01 61 16 - Volatile Organic Compound (VOC) Content Restrictions.
- B. Section 03 30 00 - Cast-in-Place Concrete: Restrictions on curing compounds for concrete slabs and floors.

##### **1.03 REFERENCE STANDARDS**

- A. ASTM F1066 - Standard Specification for Vinyl Composition Floor Tile; 2004 (Reapproved 2010)e1.
- B. ASTM F1861 - Standard Specification for Resilient Wall Base; 2008.
- C. ASTM F2034 - Standard Specification for Sheet Linoleum Floor Covering; 2008.
- D. BAAQMD 8-51 - Bay Area Air Quality Management District Regulation 8, Rule 51, Adhesive and Sealant Products; [www.baaqmd.gov](http://www.baaqmd.gov); 2002.
- E. GEI (SCH) - GREENGUARD "Children and Schools" Certified Products; GREENGUARD Environmental Institute; current listings at [www.greenguard.org](http://www.greenguard.org).
- F. RFCI - Recommended Work Practices for Removal of Resilient Floor Coverings; Resilient Floor Covering Institute; 1998.
- G. SCAQMD 1168 - South Coast Air Quality Management District Rule No.1168; current edition; [www.aqmd.gov](http://www.aqmd.gov).
- H. SCS (CPD) - SCS Certified Products; Scientific Certification Systems; current listings at [www.scs-certified.com](http://www.scs-certified.com).

##### **1.04 SUBMITTALS**

- A. See Section 01 33 00 - Submittal Procedures.
- B. Product Data: Provide data on specified products, describing physical and performance characteristics; including sizes, patterns and colors available; and installation instructions.
- C. Verification Samples: Submit two samples, 12 x 12 inch (300 x300 mm) in size illustrating color and pattern for each resilient flooring product specified.
- D. Maintenance Materials: Furnish the following for Northeastern Illinois University's use in maintenance of project.
  - 1. See Section 01 60 00 - Product Requirements, for additional provisions.

##### **1.05 DELIVERY, STORAGE, AND HANDLING**

- A. Protect roll materials from damage by storing on end.

## 1.06 FIELD CONDITIONS

- A. Maintain temperature in storage area between 55 degrees F (13 degrees C) and 90 degrees F (72 degrees C).
- B. Store materials for not less than 48 hours prior to installation in area of installation at a temperature of 70 degrees F (21 degrees C) to achieve temperature stability. Thereafter, maintain conditions above 55 degrees F (13 degrees C).

## PART 2 PRODUCTS

### 2.01 SHEET FLOORING

- A. Linoleum Sheet Flooring: Homogeneous wear layer bonded to backing, with color and pattern through wear layer thickness:
  - 1. Minimum Requirements: Comply with ASTM F2034, Type corresponding to type specified.
  - 2. VOC Content: Certified as Low Emission by one of the following :
    - a. GreenGuard Children and Schools; [www.greenguard.org](http://www.greenguard.org).
    - b. SCS Floorscore; [www.scs-certified.com](http://www.scs-certified.com).
  - 3. Backing: Jute fabric.
  - 4. Wear Layer Thickness: 0.080 inch (2.0 mm), minimum, excluding backing.
  - 5. Pattern: Solid color.
  - 6. Color: As shown on drawings.
  - 7. Seams: Heat welded.
  - 8. Manufacturers:
    - a. Forbo Linoleum, Inc; Product Walton Uni: [www.forbo-industries.com](http://www.forbo-industries.com).
    - b. Substitutions: See Section 01 60 00 - Product Requirements.
- B. Linoleum Welding Rod: Solid color linoleum produced by flooring manufacturer for heat welding seams, in color in color matching predominant flooring color.

### 2.02 TILE FLOORING

- A. Vinyl Composition Tile: Homogeneous, with color extending throughout thickness, and:
  - 1. Minimum Requirements: Comply with ASTM F1066, of Class corresponding to type specified.
  - 2. Size: 12 x 12 inch (305 x 305 mm).
  - 3. VOC Content: Certified as Low Emission by one of the following :
    - a. GreenGuard Children and Schools; [www.greenguard.org](http://www.greenguard.org).
    - b. SCS Floorscore; [www.scs-certified.com](http://www.scs-certified.com).
  - 4. Thickness: 0.125 inch (3.2 mm).
  - 5. Pattern: Marbleized.
  - 6. Manufacturers:
    - a. Armstrong World Industries, Inc; Product Excelon 51839 Fortress White: [www.armstrong.com](http://www.armstrong.com).
    - b. Substitutions: See Section 01 60 00 - Product Requirements.

### 2.03 RESILIENT BASE

- A. Resilient Base: ASTM F1861, Type TS rubber, vulcanized thermoset; top set Style B, Cove, and as follows:
  - 1. Height: 4 inch (100 mm).
  - 2. Thickness: 0.125 inch (3.2 mm) thick.
  - 3. Finish: Satin.
  - 4. Length: 4 foot (1.2 m) sections.
  - 5. Color: Color as selected from manufacturer's standards.
  - 6. Manufacturers:
    - a. Burke Flooring: [www.burkemercer.com](http://www.burkemercer.com).
    - b. Johnsonite, Inc: [www.johnsonite.com](http://www.johnsonite.com).

- c. Roppe Corp: [www.roppe.com](http://www.roppe.com).
- d. Substitutions: See Section 01 60 00 - Product Requirements.

## **2.04 ACCESSORIES**

- A. Subfloor Filler: White premix latex; type recommended by adhesive material manufacturer.
- B. Primers, Adhesives, and Seaming Materials: Waterproof; types recommended by flooring manufacturer.
  - 1. Provide only products having lower volatile organic compound (VOC) content than required by the more stringent of the South Coast Air Quality Management District Rule No.1168 and the Bay Area Air Quality Management District Regulation 8, Rule 51.
- C. Moldings, Transition and Edge Strips: Same material as flooring.

## **PART 3 EXECUTION**

### **3.01 EXAMINATION**

- A. Verify that surfaces are flat to tolerances acceptable to flooring manufacturer, free of cracks that might telegraph through flooring, clean, dry, and free of curing compounds, surface hardeners, and other chemicals that might interfere with bonding of flooring to substrate.
- B. Cementitious Sub-floor Surfaces: Verify that substrates are dry enough and ready for resilient flooring installation by testing for moisture and pH.
  - 1. Obtain instructions if test results are not within limits recommended by resilient flooring manufacturer and adhesive materials manufacturer.

### **3.02 PREPARATION**

- A. Remove existing resilient flooring and flooring adhesives; follow the recommendations of RFCI Recommended Work Practices for Removal of Resilient Floor Coverings.
- B. Prepare floor substrates as recommended by flooring and adhesive manufacturers.
- C. Remove sub-floor ridges and bumps. Fill minor low spots, cracks, joints, holes, and other defects with sub-floor filler to achieve smooth, flat, hard surface.
- D. Prohibit traffic until filler is cured.

### **3.03 INSTALLATION**

- A. Starting installation constitutes acceptance of sub-floor conditions.
- B. Install in accordance with manufacturer's instructions.
- C. Spread only enough adhesive to permit installation of materials before initial set.
- D. Fit joints tightly.
- E. Set flooring in place, press with heavy roller to attain full adhesion.
- F. Where type of floor finish, pattern, or color are different on opposite sides of door, terminate flooring under centerline of door.
- G. Install edge strips at unprotected or exposed edges, where flooring terminates, and where indicated.
- H. Scribe flooring to walls, columns, cabinets, floor outlets, and other appurtenances to produce tight joints.

### **3.04 SHEET FLOORING**

- A. Lay flooring with joints and seams parallel to longer room dimensions, to produce minimum number of seams. Lay out seams to avoid widths less than 1/3 of roll width; match patterns carefully at seams.

- B. Double cut sheet at seams.
- C. Lay flooring with tightly butted seams, without any seam sealer unless otherwise indicated.
- D. Finish seams in linoleum by heat welding.

### **3.05 TILE FLOORING**

- A. Mix tile from container to ensure shade variations are consistent when tile is placed, unless manufacturer's instructions say otherwise.
- B. Lay flooring with joints and seams parallel to building lines to produce symmetrical tile pattern.

### **3.06 RESILIENT BASE**

- A. Fit joints tightly and make vertical. Maintain minimum dimension of 18 inches (45 mm) between joints.
- B. Install base on solid backing. Bond tightly to wall and floor surfaces.

### **3.07 CLEANING**

- A. Remove excess adhesive from floor, base, and wall surfaces without damage.
- B. Clean in accordance with manufacturer's instructions.

### **3.08 PROTECTION**

- A. Prohibit traffic on resilient flooring for 48 hours after installation.

**END OF SECTION**



## **DIVISION 9 - FINISHES**

### **SECTION 09 68 00 CARPETING**

#### **PART 1 GENERAL**

##### **1.01 SECTION INCLUDES**

- A. Carpet, direct-glued.
- B. Removal of existing carpet.

##### **1.02 RELATED REQUIREMENTS**

- A. Section 01 61 16 - Volatile Organic Compound (VOC) Content Restrictions.
- B. Section 01 74 19 - Construction Waste Management and Disposal: Reclamation/Recycling of new carpet scrap, new cushion scrap, removed carpet, and removed carpet cushion.
- C. Section 03 30 00 - Cast-in-Place Concrete: Restrictions on curing compounds for concrete slabs and floors to receive adhesive-applied carpet.
- D. Section 09 68 13 - Tile Carpeting.

##### **1.03 REFERENCE STANDARDS**

- A. ASTM E648 - Standard Test Method for Critical Radiant Flux of Floor Covering Systems Using a Radiant Heat Energy Source; 2010e1.
- B. ASTM F710 - Standard Practice for Preparing Concrete Floors to Receive Resilient Flooring; 2011.
- C. CRI (CIS) - Carpet Installation Standard; Carpet and Rug Institute; 2009.
- D. CRI (GLA) - Green Label Testing Program - Approved Adhesive Products; Carpet and Rug Institute; Current Edition.
- E. CRI (GLP) - Green Label Plus Carpet Testing Program - Approved Products; Carpet and Rug Institute; Current Edition.
- F. NFPA 253 - Standard Method of Test for Critical Radiant Flux of Floor Covering Systems Using a Radiant Heat Energy Source; National Fire Protection Association; 2011.

##### **1.04 SUBMITTALS**

- A. See Section 01 33 00 - Submittal Procedures.
- B. Product Data: Provide data on specified products, describing physical and performance characteristics; sizes, patterns, colors available, and method of installation.
- C. Samples: Submit two samples 12 x 12 inch (300 x 300 mm) in size illustrating color and pattern for each carpet and cushion material specified.
- D. Maintenance Data: Include maintenance procedures, recommended maintenance materials, and suggested schedule for cleaning.
- E. Maintenance Materials: Furnish the following for Northeastern Illinois University's use in maintenance of project.
  - 1. See Section 01 60 00 - Product Requirements, for additional requirements.
  - 2. Extra Carpet: 100 sq ft (10 sq m) of each type, color, and pattern installed.

## **1.05 QUALITY ASSURANCE**

- A. Manufacturer Qualifications: Company specializing in manufacturing specified carpet with minimum three years documented experience.
- B. Installer Qualifications: Company specializing in installing carpet with minimum three years experience.

## **1.06 FIELD CONDITIONS**

- A. Store materials in area of installation for minimum period of 24 hours prior to installation.
- B. Maintain minimum 70 degrees F (21 degrees C) ambient temperature 24 hours prior to, during and 24 hours after installation.

## **PART 2 PRODUCTS**

### **2.01 MANUFACTURERS**

- A. Carpet:
  - 1. Tandus Flooring [www.tandus.com](http://www.tandus.com).
  - 2. Substitutions: See Section 01 60 00 - Product Requirements.

### **2.02 CARPET**

- A. Carpet Type CPT-1: Tufted, nylon, conforming to the following criteria:
  - 1. Critical Radiant Flux: Minimum of 0.22 watts/sq cm, when tested in accordance with ASTM E648 or NFPA 253.
  - 2. VOC Content: Provide CRI Green Label Plus certified product; in lieu of labeling, independent test report showing compliance is acceptable.
  - 3. Color: AWA Indigo 43707.
  - 4. Pattern: Curio 40021.
  - 5. Roll Width: 12'-6"
  - 6. Gage: 5/64"; 50.4 mm.
  - 7. Stitches: 13.2 per inch (5.2 per cm).
  - 8. Pile Weight: 32 oz/sq yd (1085 gm/sq m).
  - 9. Total Weight: 70.4 oz/sq yd (2387 g/sq m).

### **2.03 ACCESSORIES**

- A. Sub-Floor Filler: Type recommended by carpet manufacturer.
- B. Adhesives - General: Compatible with materials being adhered; maximum VOC content of 50 g/L; CRI Green Label certified; in lieu of labeled product, independent test report showing compliance is acceptable.
- C. Seam Adhesive: Recommended by manufacturer.
- D. Contact Adhesive: Compatible with carpet material; releasable type.

## **PART 3 EXECUTION**

### **3.01 EXAMINATION**

- A. Cementitious Sub-floor Surfaces: Verify that substrates are dry enough and ready for flooring installation by testing for moisture and pH.
  - 1. Test in accordance with ASTM F710.
  - 2. Obtain instructions if test results are not within limits recommended by flooring material manufacturer and adhesive materials manufacturer.

### **3.02 PREPARATION**

- A. Remove existing carpet and carpet cushion.
- B. Prepare floor substrates as recommended by flooring and adhesive manufacturers.

### **3.03 INSTALLATION - GENERAL**

- A. Starting installation constitutes acceptance of sub-floor conditions.
- B. Install carpet and cushion in accordance with manufacturer's instructions and CRI Carpet Installation Standard.
- C. Verify carpet match before cutting to ensure minimal variation between dye lots.
- D. Lay out carpet and locate seams in accordance with shop drawings:
  - 1. Locate seams in area of least traffic, out of areas of pivoting traffic, and parallel to main traffic.
  - 2. Do not locate seams perpendicular through door openings.
  - 3. Align run of pile in same direction as anticipated traffic and in same direction on adjacent pieces.
  - 4. Locate change of color or pattern between rooms under door centerline.
  - 5. Provide monolithic color, pattern, and texture match within any one area.
- E. Install carpet tight and flat on subfloor, well fastened at edges, with a uniform appearance.

### **3.04 DIRECT-GLUED CARPET**

- A. Double cut carpet seams, with accurate pattern match. Make cuts straight, true, and unfrayed. Apply seam adhesive to cut edges of woven carpet immediately.
- B. Apply contact adhesive to floor uniformly at rate recommended by manufacturer. After sufficient open time, press carpet into adhesive.
- C. Apply seam adhesive to the base of the edge glued down. Lay adjoining piece with seam straight, not overlapped or peaked, and free of gaps.
- D. Roll with appropriate roller for complete contact of adhesive to carpet backing.
- E. Trim carpet neatly at walls and around interruptions.

### **3.05 INSTALLATION ON STAIRS**

- A. Use one piece of carpet for each tread and the riser below. Apply seam adhesive to all cut edges.
- B. Install carpet with pile direction in the length of the stair.
- C. Adhere carpet tight to stair treads and risers.

### **3.06 CLEANING**

- A. Remove excess adhesive from floor and wall surfaces without damage.
- B. Clean and vacuum carpet surfaces.

**END OF SECTION**

## **DIVISION 9 - FINISHES**

### **SECTION 09 68 13 TILE CARPETING**

#### **PART 1 GENERAL**

##### **1.01 SECTION INCLUDES**

- A. Carpet tile, fully adhered.

##### **1.02 RELATED REQUIREMENTS**

- A. Section 01 61 16 - Volatile Organic Compound (VOC) Content Restrictions.
- B. Section 01 74 19 - Construction Waste Management and Disposal: Reclamation/Recycling of new carpet tile scrap.
- C. Section 09 68 00 - Carpeting: Broadloom carpet.

##### **1.03 REFERENCE STANDARDS**

- A. ASTM F710 - Standard Practice for Preparing Concrete Floors to Receive Resilient Flooring; 2011.
- B. CRI (CIS) - Carpet Installation Standard; Carpet and Rug Institute; 2009.
- C. CRI (GLA) - Green Label Testing Program - Approved Adhesive Products; Carpet and Rug Institute; Current Edition.
- D. CRI (GLP) - Green Label Plus Carpet Testing Program - Approved Products; Carpet and Rug Institute; Current Edition.

##### **1.04 SUBMITTALS**

- A. See Section 01 33 00 - Submittal Procedures.
- B. Product Data: Provide data on specified products, describing physical and performance characteristics; sizes, patterns, colors available, and method of installation.
- C. Samples: Submit two carpet tiles illustrating color and pattern design for each carpet color selected.
- D. Maintenance Materials: Furnish the following for Northeastern Illinois University's use in maintenance of project.
  - 1. See Section 01 60 00 - Product Requirements, for additional provisions.
  - 2. Extra Carpet Tiles: Quantity equal to 5 percent of total installed of each color and pattern installed.

##### **1.05 QUALITY ASSURANCE**

- A. Manufacturer Qualifications: Company specializing in manufacturing specified carpet tile with minimum three years documented experience.
- B. Installer Qualifications: Company specializing in installing carpet with minimum 3 years experience.

##### **1.06 FIELD CONDITIONS**

- A. Store materials in area of installation for minimum period of 24 hours prior to installation.

#### **PART 2 PRODUCTS**

##### **2.01 MANUFACTURERS**

## **2.02 MATERIALS**

- A. Carpet Tile Type CPT-2: Tufted, manufactured in one color dye lot.
  - 1. Thickness: 0.28 inch ( 7 mm).
  - 2. Color: 7492 Horizontal.
  - 3. VOC Content: Provide CRI Green Label Plus certified product; in lieu of labeling, independent test report showing compliance is acceptable.
  - 4. Static Control Fiber: Staticworx Helix 44 denier.
  - 5. Max. Electrostatic Charge: 3 Kv. at 20 percent relative humidity.
  - 6. Gage: 1/12 inch (2.1 mm).
  - 7. Stitches: 8.16 per inch (\_\_\_\_ per cm).
  - 8. Pile Weight: 18 oz/sq yd (\_\_\_\_ gm/sq m).

## **2.03 ACCESSORIES**

- A. Sub-Floor Filler: White premix latex; type recommended by flooring material manufacturer.
- B. Edge Strips: Embossed aluminum, color as selected.
- C. Adhesives: Acceptable to carpet tile manufacturer, compatible with materials being adhered; maximum VOC of 50 g/L; CRI Green Label certified; in lieu of labeled product, independent test report showing compliance is acceptable.

## **PART 3 EXECUTION**

### **3.01 EXAMINATION**

- A. Verify that sub-floor surfaces are smooth and flat within tolerances specified for that type of work and are ready to receive carpet tile.
- B. Verify that sub-floor surfaces are dust-free and free of substances that could impair bonding of adhesive materials to sub-floor surfaces.

### **3.02 PREPARATION**

- A. Prepare floor substrates as recommended by flooring and adhesive manufacturers.
- B. Remove sub-floor ridges and bumps. Fill minor or local low spots, cracks, joints, holes, and other defects with sub-floor filler.
- C. Apply, trowel, and float filler to achieve smooth, flat, hard surface. Prohibit traffic until filler is cured.
- D. Vacuum clean substrate.

### **3.03 INSTALLATION**

- A. Starting installation constitutes acceptance of sub-floor conditions.
- B. Install carpet tile in accordance with manufacturer's instructions and CRI Carpet Installation Standard.
- C. Blend carpet from different cartons to ensure minimal variation in color match.
- D. Cut carpet tile clean. Fit carpet tight to intersection with vertical surfaces without gaps.
- E. Lay carpet tile in square pattern, with pile direction parallel to next unit, set parallel to building lines.
- F. Fully adhere carpet tile to substrate.
- G. Trim carpet tile neatly at walls and around interruptions.
- H. Complete installation of edge strips, concealing exposed edges.

### **3.04 CLEANING**

- A. Remove excess adhesive without damage, from floor, base, and wall surfaces.
- B. Clean and vacuum carpet surfaces.

**END OF SECTION**

## **DIVISION 9 - FINISHES**

### **SECTION 09 84 00 ACOUSTIC ROOM COMPONENTS**

#### **PART 1 GENERAL**

##### **1.01 SECTION INCLUDES**

- A. Fabric-covered fiberglass core panels and mounting accessories.

##### **1.02 RELATED REQUIREMENTS**

- A. Section 01 61 16 - Volatile Organic Compound (VOC) Content Restrictions.
- B. Section 09 51 00 - Acoustical Ceilings.
- C. Section 09 90 00 - Painting and Coating.

##### **1.03 REFERENCE STANDARDS**

- A. ASTM C423 - Standard Test Method for Sound Absorption and Sound Absorption Coefficients by the Reverberation Room Method; 2009a.
- B. ASTM E84 - Standard Test Method for Surface Burning Characteristics of Building Materials; 2012.

##### **1.04 SUBMITTALS**

- A. See Section 01 30 00 - Administrative Requirements, for submittal procedures.
- B. Product Data: Manufacturer's printed data sheets for products specified.
- C. Shop Drawings: Fabrication and installation details, panel layout, and fabric orientation.
- D. Verification Samples: Fabricated samples of each type of panel specified; 12 x 12 in (305 x 305 mm), showing construction, edge details, and fabric covering.

##### **1.05 QUALITY ASSURANCE**

- A. Manufacturer Qualifications: Company with not less than 5 years of experience in manufacturing acoustical products similar to those specified.

##### **1.06 DELIVERY, STORAGE, AND HANDLING**

- A. Protect acoustical panels from moisture during shipment, storage, and handling. Deliver in factory-wrapped bundles; do not open bundles until panels are needed for installation.
- B. Store panels flat, in dry, well-ventilated space; do not stand panels on end.
- C. Protect panel edges from damage.

#### **PART 2 PRODUCTS**

##### **2.01 MANUFACTURERS**

- A. Acoustical Panels:
  - 1. Kinetics Noise Control; Product Hardside: [www.kineticsnoise.com](http://www.kineticsnoise.com).
- B.
- C. Substitutions: See Section 01 60 00 - Product Requirements.

##### **2.02 ACOUSTICAL WALL PANELS**

- A. Panels: Prefinished, factory assembled fabric-covered panels.

1. Surface Burning Characteristics: Flame spread index of 25 or less and smoke developed index of 450 or less, when tested in accordance with ASTM E84.
- B. Fiberglass Core Panels:
  1. Density: 6-7 lb/cu ft (\_\_\_\_\_ kg/cu m).
  2. Panel Width: 24 inches (610 mm).
  3. Panel Height: As detailed.
  4. Panel Thickness: 1 inch (25 mm).
  5. Corners: Mitred (Beveled).
  6. Mounting: z-clips.
- C. Fabric Covering: Seamless fabric facing material, for stretched covering of core material.
  1. Color: As scheduled.

### **2.03 FABRICATION**

- A. General: Fabricate panels to sizes and configurations indicated, with fabric facing installed without sagging, wrinkles, blisters, or visible seams.
  1. Where radiused or mitered corners are indicated, install fabric to avoid seams or gathering of material.
- B. Tolerances: Fabricate to finished tolerance of plus or minus 1/16 in (1.6 mm) for thickness, overall length and width, and squareness from corner to corner.

### **2.04 ACCESSORIES**

- A. Back-Mounting Accessories: Manufacturer's standard accessories for concealed support, designed to allow panel removal, and as follows:
  1. Two-part clip and base-support bracket system; brackets designed to support full weight of panels and clips designed for lateral support, with one part mechanically attached to back of panel and the other attached to substrate.

## **PART 3 EXECUTION**

### **3.01 EXAMINATION**

- A. Examine substrates for conditions detrimental to installation of acoustical panels. Proceed with installation only after unsatisfactory conditions have been corrected.

### **3.02 INSTALLATION**

- A. Install acoustical panels in locations indicated, following installation recommendations of panel manufacturer. Align panels accurately, with edges plumb and top edges level. Scribe to fit accurately at adjoining work and penetrations.

### **3.03 CLEANING**

- A. Clean fabric facing upon completion of installation from dust and other foreign materials, following manufacturer's instructions.
- B. Remove surplus materials, trimmed portions of panels, and debris resulting from installation.

### **3.04 PROTECTION**

- A. Provide protection of installed acoustical panels until completion of the work.
- B. Replace panels that cannot be cleaned and repaired to satisfaction of the 4240 Architecture.

**END OF SECTION**



## DIVISION 9 - FINISHES

### SECTION 09 90 00 PAINTING AND COATING

#### PART 1 GENERAL

##### 1.01 SECTION INCLUDES

- A. Surface preparation.
- B. Field application of paints, stains, varnishes, and other coatings.
- C. Materials for backpriming woodwork.
- D. Scope: Finish all interior and exterior surfaces exposed to view, unless fully factory-finished and unless otherwise indicated, including the following:
  - 1. Prime surfaces to receive wall coverings.
- E. Do Not Paint or Finish the Following Items:
  - 1. Items fully factory-finished unless specifically so indicated; materials and products having factory-applied primers are not considered factory finished.
  - 2. Items indicated to receive other finishes.
  - 3. Items indicated to remain unfinished.
  - 4. Fire rating labels, equipment serial number and capacity labels, and operating parts of equipment.
  - 5. Floors, unless specifically so indicated.
  - 6. Glass.
  - 7. Concealed pipes, ducts, and conduits.

##### 1.02 DEFINITIONS

- A. Conform to ASTM D16 for interpretation of terms used in this section.

##### 1.03 REFERENCE STANDARDS

- A. 40 CFR 59, Subpart D - National Volatile Organic Compound Emission Standards for Architectural Coatings; U.S. Environmental Protection Agency; current edition.
- B. ASTM D16 - Standard Terminology for Paint, Related Coatings, Materials, and Applications; 2012.
- C. ASTM D4442 - Standard Test Methods for Direct Moisture Content Measurement of Wood and Wood-Base Materials; 2007.
- D. SSPC (PM1) - Good Painting Practice: SSPC Painting Manual, Vol. 1; Society for Protective Coatings; Fourth Edition.

##### 1.04 SUBMITTALS

- A. See Section 01 33 00 - Submittal Procedures.
- B. Product Data: Provide complete list of all products to be used, with the following information for each:
  - 1. Manufacturer's name, product name and/or catalog number, and general product category (e.g. "alkyd enamel").
  - 2. MPI product number (e.g. MPI #47).
  - 3. Cross-reference to specified paint system(s) product is to be used in; include description of each system.
- C. Samples: Submit three paper "drop" samples, 8-1/2 by 11 inches (216 by 279 mm) in size, illustrating range of colors available for each finishing product specified.

1. Where sheen is specified, submit samples in only that sheen.
- D. Certification: By manufacturer that all paints and coatings comply with VOC limits specified.
- E. Maintenance Materials: Furnish the following for Northeastern Illinois University's use in maintenance of project.
  1. See Section 01 60 00 - Product Requirements, for additional provisions.
  2. Extra Paint and Coatings: 1 gallon (4 L) of each color; store where directed.
  3. Label each container with color in addition to the manufacturer's label.

#### **1.05 QUALITY ASSURANCE**

- A. Manufacturer Qualifications: Company specializing in manufacturing the products specified, with minimum three years documented experience.

#### **1.06 DELIVERY, STORAGE, AND HANDLING**

- A. Deliver products to site in sealed and labeled containers; inspect to verify acceptability.
- B. Container Label: Include manufacturer's name, type of paint, brand name, lot number, brand code, coverage, surface preparation, drying time, cleanup requirements, color designation, and instructions for mixing and reducing.
- C. Paint Materials: Store at minimum ambient temperature of 45 degrees F (7 degrees C) and a maximum of 90 degrees F (32 degrees C), in ventilated area, and as required by manufacturer's instructions.

#### **1.07 FIELD CONDITIONS**

- A. Do not apply materials when surface and ambient temperatures are outside the temperature ranges required by the paint product manufacturer.
- B. Follow manufacturer's recommended procedures for producing best results, including testing of substrates, moisture in substrates, and humidity and temperature limitations.
- C. Minimum Application Temperatures for Latex Paints: 45 degrees F (7 degrees C) for interiors; 50 degrees F (10 degrees C) for exterior; unless required otherwise by manufacturer's instructions.
- D. Minimum Application Temperature for Varnish Finishes: 65 degrees F (18 degrees C) for interior or exterior, unless required otherwise by manufacturer's instructions.
- E. Provide lighting level of 80 ft candles (860 lx) measured mid-height at substrate surface.

### **PART 2 PRODUCTS**

#### **2.01 MANUFACTURERS**

- A. Provide all paint and coating products used in any individual system from the same manufacturer; no exceptions.
- B. Paints:
  1. Duron, Inc: [www.duron.com](http://www.duron.com).
  2. Benjamin Moore & Co: [www.benjaminmoore.com](http://www.benjaminmoore.com).
  3. Sherwin-Williams Company: [www.sherwin-williams.com](http://www.sherwin-williams.com).
- C. Primer Sealers: Same manufacturer as top coats.
- D. Substitutions: See Section 01 60 00 - Product Requirements.

#### **2.02 PAINTS AND COATINGS - GENERAL**

- A. Paints and Coatings: Ready mixed, unless intended to be a field-catalyzed coating.
  1. Provide paints and coatings of a soft paste consistency, capable of being readily and uniformly dispersed to a homogeneous coating, with good flow and brushing properties,

- and capable of drying or curing free of streaks or sags.
  - 2. Supply each coating material in quantity required to complete entire project's work from a single production run.
  - 3. Do not reduce, thin, or dilute coatings or add materials to coatings unless such procedure is specifically described in manufacturer's product instructions.
- B. Primers: Where the manufacturer offers options on primers for a particular substrate, use primer categorized as "best" by the manufacturer.
- C. Volatile Organic Compound (VOC) Content:
- 1. Provide coatings that comply with the most stringent requirements specified in the following:
    - a. 40 CFR 59, Subpart D--National Volatile Organic Compound Emission Standards for Architectural Coatings.
  - 2. Determination of VOC Content: Testing and calculation in accordance with 40 CFR 59, Subpart D (EPA Method 24), exclusive of colorants added to a tint base and water added at project site; or other method acceptable to authorities having jurisdiction.
- D. Sheens: Provide the sheens specified; where sheen is not specified, sheen will be selected later by 4240 Architecture from the manufacturer's full line.
- E. Colors: As indicated on drawings

## **2.03 PAINT SYSTEMS - INTERIOR**

- A. Paint I-OP - All Interior Surfaces Indicated to be Painted, Unless Otherwise Indicated: Including gypsum board, concrete masonry, plaster, uncoated steel, and shop primed steel.
- 1. Two top coats and one coat primer.
  - 2. Top Coat(s): MPI Institutional Low Odor/VOC Interior Latex; MPI #143-148.
  - 3. Flat: MPI gloss level 1; use this sheen for ceilings and other overhead surfaces.
  - 4. Satin: MPI gloss level 4; use this sheen for items subject to frequent touch including metal doors, door frames and railings.
  - 5. Top Coat Product(s):
    - a. Sherwin-Williams ProMar 200 Zero VOC Interior Latex.
  - 6. Primer(s): As recommended by manufacturer of top coats.
- B. Paint I-OP-MD-DT - Medium Duty Door/Trim: For surfaces subject to frequent contact by occupants, including metals, wood, and \_\_\_\_\_:
- 1. Two top coats and one coat primer.
  - 2. Top Coat(s): MPI High Performance Architectural Interior Latex; MPI #139,140, 141.
  - 3. Semi-Gloss: MPI gloss level 5; use this sheen at all locations.

## **2.04 ACCESSORY MATERIALS**

- A. Accessory Materials: Provide all primers, sealers, cleaning agents, cleaning cloths, sanding materials, and clean-up materials required to achieve the finishes specified whether specifically indicated or not; commercial quality.
- B. Patching Material: Latex filler.
- C. Fastener Head Cover Material: Latex filler.

## **PART 3 EXECUTION**

### **3.01 EXAMINATION**

- A. Do not begin application of coatings until substrates have been properly prepared.
- B. Verify that surfaces are ready to receive work as instructed by the product manufacturer.
- C. Examine surfaces scheduled to be finished prior to commencement of work. Report any condition that may potentially affect proper application.

- D. If substrate preparation is the responsibility of another installer, notify 4240 Architecture of unsatisfactory preparation before proceeding.
- E. Test shop-applied primer for compatibility with subsequent cover materials.
- F. Measure moisture content of surfaces using an electronic moisture meter. Do not apply finishes unless moisture content of surfaces are below the following maximums:
  1. Gypsum Wallboard: 12 percent.
  2. Plaster and Stucco: 12 percent.
  3. Masonry, Concrete, and Concrete Unit Masonry: 12 percent.
  4. Interior Wood: 15 percent, measured in accordance with ASTM D4442.

### **3.02 PREPARATION**

- A. Clean surfaces thoroughly and correct defects prior to coating application.
- B. Prepare surfaces using the methods recommended by the manufacturer for achieving the best result for the substrate under the project conditions.
- C. Remove or mask surface appurtenances, including electrical plates, hardware, light fixture trim, escutcheons, and fittings, prior to preparing surfaces or finishing.
- D. Seal surfaces that might cause bleed through or staining of topcoat.
- E. Remove mildew from impervious surfaces by scrubbing with solution of tetra-sodium phosphate and bleach. Rinse with clean water and allow surface to dry.
- F. Concrete and Unit Masonry Surfaces to be Painted: Remove dirt, loose mortar, scale, salt or alkali powder, and other foreign matter. Remove oil and grease with a solution of tri-sodium phosphate; rinse well and allow to dry. Remove stains caused by weathering of corroding metals with a solution of sodium metasilicate after thoroughly wetting with water. Allow to dry.
- G. Gypsum Board Surfaces to be Painted: Fill minor defects with filler compound. Spot prime defects after repair.
- H. Plaster Surfaces to be Painted: Fill hairline cracks, small holes, and imperfections with latex patching plaster. Make smooth and flush with adjacent surfaces. Wash and neutralize high alkali surfaces.
- I. Aluminum Surfaces to be Painted: Remove surface contamination by steam or high pressure water. Remove oxidation with acid etch and solvent washing. Apply etching primer immediately following cleaning.
- J. Galvanized Surfaces to be Painted: Remove surface contamination and oils and wash with solvent. Apply coat of etching primer.
- K. Corroded Steel and Iron Surfaces to be Painted: Prepare using at least SSPC-PC 2 (hand tool cleaning) or SSPC-SP 3 (power tool cleaning) followed by SSPC-SP 1 (solvent cleaning).
- L. Uncorroded Uncoated Steel and Iron Surfaces to be Painted: Remove grease, mill scale, weld splatter, dirt, and rust. Where heavy coatings of scale are evident, remove by hand or power tool wire brushing or sandblasting; clean by washing with solvent. Apply a treatment of phosphoric acid solution, ensuring weld joints, bolts, and nuts are similarly cleaned. Prime paint entire surface; spot prime after repairs.
- M. Shop-Primed Steel Surfaces to be Finish Painted: Sand and scrape to remove loose primer and rust. Feather edges to make touch-up patches inconspicuous. Clean surfaces with solvent. Prime bare steel surfaces. Re-prime entire shop-primed item.

### **3.03 APPLICATION**

- A. Apply products in accordance with manufacturer's instructions.

- B. Do not apply finishes to surfaces that are not dry. Allow applied coats to dry before next coat is applied.
- C. Apply each coat to uniform appearance.
- D. Sand wood and metal surfaces lightly between coats to achieve required finish.
- E. Vacuum clean surfaces of loose particles. Use tack cloth to remove dust and particles just prior to applying next coat.
- F. Reinstall electrical cover plates, hardware, light fixture trim, escutcheons, and fittings removed prior to finishing.

#### **3.04 PROTECTION**

- A. Touch-up damaged coatings after Substantial Completion.

**END OF SECTION**

## DIVISION 10 - SPECIALTIES

### SECTION 10 14 00 SIGNAGE

#### PART 1 GENERAL

##### 1.01 SECTION INCLUDES

- A. Interior dimensional letter signage.

##### 1.02 SUBMITTALS

- A. See Section 01 33 00 - Submittal Procedures.
- B. Product Data: Manufacturer's printed product literature for each type of sign, indicating sign styles, font, foreground and background colors, locations, overall dimensions of each sign.
- C. Samples: Submit two samples of one letter, of size similar to that required for project, illustrating sign style, font, and method of attachment.

##### 1.03 QUALITY ASSURANCE

- A. Manufacturer Qualifications: Company specializing in manufacturing the products specified in this section with minimum three years of documented experience.

##### 1.04 DELIVERY, STORAGE, AND HANDLING

- A. Package signs as required to prevent damage before installation.

#### PART 2 PRODUCTS

##### 2.01 MANUFACTURERS

- A. Dimensional Letter Signs:
  1. Cosco Industries; Cast Aluminum: [www.coscoarchitecturalsigns.com](http://www.coscoarchitecturalsigns.com).
  2. InPro Corporation S600-060: [www.inprocorp.com](http://www.inprocorp.com).
  3. Substitutions: See Section 01 60 00 - Product Requirements.

##### 2.02 DIMENSIONAL LETTERS

- A. Metal Letters:
  1. Metal: Stainless steel sheet, flat.
  2. Finish: Brushed, satin.
  3. Font: Century Gothic.
  4. Mounting: Pin mounted.

#### PART 3 EXECUTION

##### 3.01 EXAMINATION

- A. Verify that substrate surfaces are ready to receive work.

##### 3.02 INSTALLATION

- A. Install in accordance with manufacturer's instructions.
- B. Install neatly, with horizontal edges level.
- C. Locate signs where indicated:
- D. Protect from damage until Substantial Completion; repair or replace damage items.

**END OF SECTION**

**SECTION 116133**  
**RIGGING, CURTAIN & TRACKS**

**1. GENERAL**

**1.1 DEFINITIONS**

- A. The term "Contractor" shall mean the contracting entity, also referred to herein as Rigging Contractor, as a Manufacturer or Manufacturer's agent, responsible for the fabrication, assembly, installation, testing, instruction and completion of all stage rigging work as covered in these Specifications and related Drawings.
- B. The terms "General Contractor" and "Electrical Contractor" are used herein to refer to organizations, individuals, and their representatives as typically defined for construction projects. These terms refer to parties other than the Rigging Contractor ("Contractor").
- C. Technical terms unique to stage rigging and related work shall be construed in the following order, in accordance with:
  - 1. Captions on related Drawings.
  - 2. Relevant usage and definitions of handbooks, guidebooks, or trade group recommendations by manufacturers' associations or professional and engineering societies, such as ASTM, ASME, ASHRAE, etc.
  - 3. Generally recognized theatrical usage.

**1.2 SCOPE**

All materials, components, and services necessary to provide a complete system indicated in this Section, as specified herein and shown on related Drawings, including:

- A. Preparation and submission of complete shop drawings and samples for review prior to fabrication.
- B. Verification of dimensions and conditions at the job site.
- C. Shipment of equipment to job site and the secured storage of all non-fixed equipment.
- D. Installation and completion, in accordance with these Specifications, related Drawings, the Equipment Manufacturer's recommendations, established trade criteria, and all applicable code requirements.
- E. The observation, demonstration, and necessary adjustment of the completed installation.
- F. Preparation and submission of complete record drawings and operational and maintenance data and certificates.

The systems described by this Specification and related Drawings are not designed or intended for use in human "flying" effects or for suspension of people in any manner.

### 1.3 WORK INCLUDED

- A. Theatrical Lighting Positions
- B. Theatrical Lighting Trusses
- C. Stage Curtains
- D. Motorized Curtain Operator Maintenance and Repair OR Replacement
- E. Curtain Track Adjustment/Repair OR Replacement
- F. Dead-Hung Scenery Pipes

The above is for reference only and is not intended to define the limits of the work for a complete installation.

### 1.4 WORK NOT INCLUDED

- A. Principal structural steel work, except as herein indicated.
- B. Electrical wiring, conduit, and connections.

The above is for reference only and is not intended to define the limits of the work for a complete installation.

### 1.5 RELATED WORK IN OTHER SECTIONS

- A. Structural steel.
- B. Concrete and masonry.
- C. Painting and finishing.
- D. Smoke vents and roof hatches.
- E. HVAC.
- F. Plumbing and sprinklers.
- G. General electrical work.
- H. Theatre stage lighting system.
- I. Theatre stage luminaires.
- J. Sound and communications systems.

### 1.6 QUALIFICATIONS

- A. All equipment and installation shall be the responsibility of a single contractor. The Contractor shall be responsible for the integration, operation, and performance of all elements of the systems described in this Section. This Contractor shall assume complete responsibility for the engineering, fabrication, transportation, and installation of the work in this Section, and shall hold the Owner, Architect, Theatre Consultant, and all their Employees and Consultants harmless for any costs for errors or omissions associated with the work of this Section and any action arising therefrom. The Contractor shall provide all warranty work and equipment upgrades as called for in this Section.



- B. Approved contractors may, at their option, arrange for sub-contract field and special shop work to be done by others. Bid submissions must identify such subcontractors and indicate the work they are to do.
- C. The Contractor shall have at least 10 years' experience in the installation of similar equipment and systems of a similar scope for university theatres. Contractor shall be a current Business member, accredited as a Dealer Retailer or Manufacturer, of the industry service organization, PLASA.
- D. Contractor shall employ only experienced stage riggers to direct the installation of work of this Section. A competent supervisor shall be maintained on this Project during the entire installation. The supervisor shall be certified as a Theater Rigger by the Entertainment Technician Certification Program. A change of supervisor shall not be acceptable unless by written authorization of the Architect.
- E. Subject to the above requirements, work performed under this Section may be by one of the following listed contractors:
  - 1. Chicago Flyhouse, Chicago, Illinois 773-533-1590
  - 2. Chicago Spotlight, Chicago Illinois 312-455-1171
  - 3. Grand Stage Company, Chicago Illinois 312-332-5611
  - 4. Inter-America Stage, Sanford, Florida, 877-302-4274
  - 5. I. Weiss, Fairview, New Jersey, 888-325-7192
  - 6. J. R. Clancy, Inc., Syracuse, New York, 315-451-3440
  - 7. Pook Diemont & Ohl, Inc., New York, New York, 718-402-2677
  - 8. SECOA, Champlin, Minnesota, 763-506-8800
  - 9. Stagecraft Industries, Portland, Oregon, 503-286-1600
  - 10. Texas Scenic, San Antonio, Texas, 210-684-0091
  - 11. Tiffin Scenic Studio, Tiffin, Ohio, 800-445-1546
- F. Contractors not having a qualified and experienced sewing room as an integral part of their operation shall employ the services of a qualified and experienced Sewing Sub-contractor for the fabrication of stage curtains. Sewing Sub-contractor shall have at least 10 years' experience in the fabrication of curtains for university theatres. If requested, the Rigging Contractor shall submit a representative list of university theatre projects performed by the Sewing Sub-contractor during the above period. Subject to the above requirements, work performed under this Section may be by one of the following Sewing Sub-contractors:
  - 1. Rose Brand, New York, New York
  - 2. Stage Decoration and Supplies, Greensboro, North Carolina
  - 3. Stagecraft Industries, Portland, Oregon
  - 4. Syracuse Scenery and Stage Lighting, Liverpool, New York

5. Tiffin Scenic Studios, Inc., Tiffin, Ohio
  6. Tru-Roll, a division of Advanced Entertainment Technology, Monrovia, California
  7. I. Weiss & Sons, Long Island City, New York
- G. Other contractors or sewing rooms may be considered with the prior review of the Theatre Consultant. Contractors seeking review must submit qualifications not later than 14 days prior to bid date.

## 1.7 SUBMITTALS

- A. With bid.
1. Proof that the contractor meets the qualification requirements as outlined in this Section.
  2. A list of at least three (3) university theatre stage rigging and drapery installations by the bidder comparable to this project in scope and completed in the past five (5) years.
  3. A list of any proposed deviations or exceptions from the Specifications. Any deviations or exceptions from the Specification proposed after bid shall not be accepted.
  4. A schedule for the anticipated completion of the following:
    - a. Shop drawings.
    - b. Delivery of all equipment.
    - c. Installation of all systems.
- B. Shop drawings. Within 30 days of contract award, the Contractor shall submit at least one set of drawings to the Architect for review prior to fabrication:
1. Floor plan, reflected ceiling plan and section of stage in scale equal to 1/4" = 1'-0".
  2. Elevation of each rigging and curtain set type, showing stage floor, mounting and arrangement, cable management, curtain travel, and curtain storage.
  3. Curtain schedule indicating fabric, finished size, fullness, top finish, construction details and special sewing requirements.
  4. Complete, fully dimensioned shop drawings of all major components.
  5. Requisite plans, sections, schematics, and details indicating assembly and installation of components.
  6. Load ratings of all load bearing components including, but not limited to, bearings, blocks, trim chains, lift lines, and purchase lines.
  7. Complete descriptions, including the manufacturer's catalog data sheets, of all components including, but not limited to, bearings, motors, transmissions, and items designated as "Deliver to Owner."

8. Complete descriptions, including manufacturer and model number, of all electrical components. All control panel switches and pilot lights shall be described by the manufacturer's catalog sheet.
  9. Certification by a recognized independent testing laboratory that all steel cable and rope meets the ASTM standards referenced in this Section.
  10. Details of all supplementary structural support to be supplied and installed as part of the work of this Section.
  11. Coordination Drawing(s) illustrating requirements for blocking, provided by others, necessary to support rigging system components.
  11. Power and control requirements and installation wiring diagrams for all electrical components.
  12. Quantities of each component and sub-assembly.
  13. Indication by boxed caption of any and all variations from the contract Drawings and Specifications, whether or not these variations have been formally or informally accepted by the Architect and Theatre Consultant.
  14. Prepare all shop drawings under the supervision of professional electrical and structural engineers so licensed by the State of Illinois. All shop drawings shall be stamped and certified by those engineers. Structural Engineer's review shall include all elements provided under the work of this section including the methods of attachment of said elements to the building. In lieu of an Electrical Engineer's stamp, a letter from the installing Electrical Contractor, verifying that all conductors, conduits and terminations will be installed in accordance with all applicable local and national codes shall be acceptable.
- C. Samples. Within 30 days of contract award, the Contractor shall submit to the Architect for review prior to fabrication:
1. Color lines for all curtain fabrics, for color selection by Architect.
  2. Sewn sample of curtain, demonstrating fabrication of top, bottom, and side hems. Finished size shall be 10 feet wide and 5 feet high. Fabric shall be identical to that specified, but fabric may be any color.
  3. 36-inch long sample of each type of curtain track, complete with (if applicable) live end pulley, dead end pulley, operating line, one (1) single carrier, and one (1) master carrier.
  4. Samples of any equipment component requested by the Theatre Consultant.
- Samples shall not be considered part of specified quantities but shall be returned.
- D. Final submittal. Within 30 days of final tests, and as a condition for final review, the Contractor shall submit to the Architect:
1. Receipts for delivery of all non-installed items, i.e., all items designated, "Deliver to Owner."

2. Three (3) sets to the Architect and one (1) set on electronic media to the Theatre Consultant, Format of sets shall be compliant with Division One of this Specification.
  - a. "As built and approved" drawings and wiring diagrams showing all systems and components as installed, including all field modifications. All field modifications shall be reviewed and stamped by professional engineers so licensed by the State of Illinois. The scope of this review shall be subject to the requirements noted above for Shop Drawing Submittals.
  - b. Operation and service manuals, schematics, and parts lists for each unit of equipment installed or provided.
  - c. Certificates of flame resistance.
  - d. Certificates of warranty, as set forth below.

#### 1.8 TESTING AND INSTRUCTION

- A. Upon completion of all installation work, the Contractor shall certify in writing to the Architect and Theatre Consultant that the work is complete and ready for final observation. Final observation shall be scheduled by the Owner, the Architect, and the Theatre Consultant to occur within 14 days following the Contractor's notice of completion.
- B. Final observation shall be conducted by a knowledgeable representative of the Contractor, in the presence of the Owner, the Architect, and the Theatre Consultant, and shall include the following:
  1. Operation of all components.
  2. Visual examination of all components.
  3. Sightline check of masking curtains.
- C. Necessary adjustments or modifications shall be made as required.
- D. As a condition of final completion, Contractor's representative shall instruct the Owner's staff or representatives, under the observation of the Architect and Theatre Consultant, in the operation and maintenance of the system including the storage and cleaning of all fabrics.
  1. Initial Instruction: This instruction session shall be scheduled for a minimum duration of four (4) hours. While it may be possible to schedule this instruction session to coincide with the system checkout, such coincidence shall not be assumed. Instruction shall be scheduled by the Owner, the Architect, and the Theatre Consultant to occur within 14 days following the Contractor's written notice.

#### 1.9 GENERAL REQUIREMENTS

- A. General Conditions of the project contract, work schedules, and site regulations apply to this work. Refer to Division One.

- B. This work shall comply with local codes and applicable NEC and UL standards, and all electrical components shall carry pertinent UL labels.
- C. For all requirements not otherwise addressed by this Specification, the work shall be at a minimum compliant with the requirements of ANSI E1.4-2009 – Entertainment Technology - Manual Counterweight Rigging Systems.
- D. All equipment shall be fully insured against loss or damage during shipment, job site storage, installation, and testing. The Contractor shall have and assume full responsibility for the safety of every unit of equipment, components and wiring during delivery, installation, and testing until acceptance by Owner. Certification of such coverage shall be furnished to the Architect within 30 days of award of contract.
- E. Warranty
  - 1. The Contractor shall unconditionally warrant all equipment and systems provided under this Section to be free from defects in materials and workmanship for a period of at least 12 months from the date of final acceptance of all work of this Section.
  - 2. All repairs and service during the warranty period shall be performed at the job site; labor, materials, and transportation of replacement material and parts and service personnel to and from the job site shall be included hereunder at the Contractor's expense.
  - 3. Appropriate additional equipment or draperies to replace equipment, devices, or draperies removed for repair, service, or cleaning shall be provided at the job site at no expense to the Owner to replace any and all equipment which must be removed for repair or service.
  - 4. Warranty service shall be performed by personnel in the employ of the Contractor and shall not be sub-contracted or assigned to another company, service, or individual unless the Owner has approved such assignment in writing, in which event the Contractor shall nevertheless be responsible to the Owner for such work.
- F. State-of-the-art assurance: No products shall be accepted if they have been discontinued or superseded at the time of shipment. Should the Rigging Contractor develop products of comparable function above and beyond the specification of the listed product, the Rigging Contractor shall make the newly developed product available to the project at no additional cost. The Rigging Contractor shall notify the Architect and the Theatre Consultant of any developments to the specified products, and shall note any change in the requirements of building infrastructure(s) to support the developments. The Architect and Theatre Consultant shall then determine whether upgraded products shall be accepted.

## 2. PRODUCTS

### 2.1 GENERAL

- A. All components shall be new and of first quality.

- B. Machinery and component parts shall comply with applicable trade practice, industry standards, and code requirements and bear appropriate labels of conformity and acceptability.
- C. All components shall bear UL labels and labels identifying the manufacturer, model number, serial number, and date of flameproofing. All such labels shall be permanently attached in a conspicuous location.
- D. Operating parts of all equipment shall be machine finished, and tolerances, finishes, fit, etc., where not specified, shall conform to good trade practices.
- E. All items necessary for a complete, operational, and safe system shall be provided, including bolts, nuts, washers, fittings, anchors, supports, hinges, and all other items required for completeness and operational safety. Where not specified elsewhere in this Section, all bolts shall be Grade 5 or better.
- F. Where not specifically called out in this Section, rope and wire rope shall be selected using a minimum safety factor of 8 to 1. All chain, shackles, and other hardware shall be selected using a minimum safety factor of 5 to 1.
- G. Where specification allows for "approved equal," substitutions shall be proposed to the Theatre Consultant at least 10 days prior to bid date.
- H. Equipment and hardware are specified on the basis of performance and minimum acceptable quality. Materials manufactured by any of the following companies that equal or surpass the performance and quality specified will be acceptable:
  - 1. Automatic Devices Company (ADC), Allentown, Pennsylvania
  - 2. Fisher Technical Services, Las Vegas, Nevada
  - 3. H & H Specialties, South El Monte, California
  - 4. J. R. Clancy, Syracuse, New York
  - 5. SECOA, Champlin, Minnesota
  - 6. Stage Technologies, Las Vegas, Nevada
  - 7. Tiffin Scenic Studios, Tiffin, Ohio
  - 8. Texas Scenic, San Antonio, Texas
  - 9. Rigging Innovators, San Antonio, Texas

## 2.2 ENGINEERING RESPONSIBILITY

- A. The engineering of all equipment, devices, machinery, and systems shall address the following considerations:
  - 1. Safety to personnel during operation, use, and maintenance.
  - 2. Adequate strength.
  - 3. Proper coordination of all systems and elements, including electrical insulation levels, interrupting capacities, protective relays, impact strength, breaking strength, emergency stopping distances, acceleration and

deceleration rates, and normal working stress capabilities of equipment and all components.

4. Reliability, with consideration for special or unusual requirements of the unit or installation.
  5. Ease of operation and maintenance.
  6. System operating sequences, including accounting for simultaneous as well as sequential operation of systems and sub-systems.
  7. Coordination with associated and/or adjacent systems provided by others, including system and sub-system status information, if required.
  8. Quiet operation.
- B. Provide all supplementary structural support necessary for safe and proper static and dynamic conditions of all systems and components required for the work of the Specification. Supplementary structural support required for access, support, enclosure, and service to all motors and motor control cabinets shall be supplied and installed as part of the work of this Section. All attachments, anchorages, connections, and miscellaneous steel additions to accommodate pulleys, blocks, etc., shall be designed, supplied, and installed by the Contractor and reviewed by the Architect. All methods of connection and imposed loads resulting from the Contractor's work shall be submitted to the Architect prior to fabrication.
- C. Provide all guards and other protective devices required to ensure protection of individuals associated with the operation of, or who may be near or adjacent to, equipment and devices provided as part of the work of this Section.
- D. Loading capacities of systems, where specified in the Drawings or the Specifications, refer to the net payload capacities exclusive of the dead loads—pipe battens, truss battens, sandbags, hooks, etc.—exactly as indicated on the Drawings and Specifications. Should the Contractor choose to suggest alternate methods that require heavier dead loads, the Contractor shall be responsible for increasing the capacities of the individual components, including the arbor capacities, accordingly. Any alternate methods must be approved specifically by the Theatre Consultant.

## 2.3 EQUIPMENT COMPONENTS

### A. Bearings

1. Unless otherwise noted, all bearings shall be of the tapered roller type. Precision sealed ball bearings and oil impregnated bronze bushings, or similar, shall not be used except in specific applications identified in this Specification, and where guidance or diverting of wire rope self-weight are the only loads carried. In all cases, such bearings and bushings may be used only when specifically approved in advance by the Architect and Theatre Consultant.

2. Selection of bearings or bushings shall meet the following performance criteria:
  - a. Silent operation at expected RPM
  - b. Low maintenance and lubrication
  - c. Ability to withstand long periods of static disuse under full design load without affecting performance
3. All bearings shall be pre-lubricated and sealed for life. For bearing types that cannot be sealed for life, easy means shall be provided for periodic lubrications via standard and common fittings. Such lubrication shall not require the disassembly of blocks or other extraordinary means. In all cases, such bearings may be used only when specifically approved in advance by the Architect and Theatre Consultant.

#### 2.4 STRUCTURAL AND MISCELLANEOUS METAL WORK

- A. Additional structural steel and other fittings required for installation, support, bracing, and/or operation of theatrical rigging in all areas of the Project are the responsibility of this Contractor and shall be in accordance with related Divisions of the Project Specifications. Excepted are supports which are erected behind finished surfaces. These supports shall be the responsibility of the General Contractor. The Rigging Contractor shall coordinate these locations and requirements with the General Contractor.
- B. Patented channel type structural steel shall accommodate the required load but shall equal Unistrut Series P1000 at minimum.
- C. Flame Cutting: Flame cutting is not acceptable, except for fabrication of counterweight.
- D. Miscellaneous steel shall be of suitable types and sizes. All straps, rods, anchors, clip anchors, clip angles and other hardware necessary for the attachment shall be supplied.

#### 2.5 ELECTRIC MOTOR DRIVE SYSTEMS

- A. Motor operated rigging sets
  1. All motorized equipment shall incorporate programmable solid state ramping, or mechanical flywheels, to ensure soft starts and stops.
  2. Minimum time to accelerate to full speed shall be 0.75 seconds. Deceleration time is variable and shall be without visually perceptible increments in normal operating mode so as to achieve noted positioning tolerance from any speed.
- B. Electrical Controls
  1. All electrically operated machinery and devices shall be fed from a disconnect device adjacent to the associated motor and controlled by dedicated motor starter control cabinet(s) as shown in the Drawings. All required motor starter control cabinets and associated disconnect devices shall be furnished as part of the Work of this Section.



## 2.6 ELECTRICAL EQUIPMENT

### A. General

1. Design and sizing of all equipment, including wire and cable installations, shall be based on a 60°C ambient temperature.
2. Equipment internal wiring shall be 600-volt, concentric stranded copper wire, at least 90°C MTW insulated, regardless of gauge. Minimum control wire size shall be #16 AWG except where shielded cable is required for position transducer data.
3. All wiring external to equipment shall be in accordance with Division 26 of the Project Specifications.
4. Provide all integral transformers and circuit protection for the proper operation of the work of this Specification.

## 2.7 SYSTEM SIGNAGE

- A. Provide placard(s), placed in conspicuous location(s) visible from the operating area(s), with information on stage rigging system.
- B. Sign shall be engraved lamincoid, filled with contrasting paint, with text as shown in the Drawings.
- C. Size, quantity and location(s) per Drawings.

## 2.8 STEEL CABLE

- A. All rope shall be impregnated with a dry lubricant. All cable shall meet the requirements of the ASTM Standard A 1023A-M, "Standard Carbon Steel Wire Ropes for General Purposes." Certification shall be provided from an independent testing laboratory.
- B. Multi-line set lift lines. 7x19 preformed galvanized aircraft cable of right regular lay. Minimum breaking strength shall be not less than indicated below: Cables larger than 3/8 inch diameter are permitted to be of 6x37 XIPS construction.

3/16 inch	=	4,200 pounds
1/4 inch	=	7,000 pounds
5/16 inch	=	9,800 pounds
3/8 inch	=	14,400 pounds
7/16 inch	=	17,600 pounds
1/2 inch	=	22,800 pounds
- C. Point hoist lift lines. XLT4 Stage Rope as manufactured by Union Rope, Kansas City, Missouri, USA. Diameter shall be as shown on the Drawings.
- D. Curtain guide lines. 3/16 inch 6x7 preformed improved plow steel cable of right regular lay.
- E. All wire rope connections shall employ thimbles of the proper size and compressed oval sleeve fittings as manufactured by National Telephone

("Nicopress"). All fittings shall be malleable copper. Aluminum fittings shall not be acceptable. All connections shall be selected and installed to develop the full tensile strength of the cable. Free ends shall extend above the fittings to an amount equal to the rope diameter. Rope ends shall be seized with a high-strength epoxy sealant. Contractor shall maintain and inspect all swaging equipment on a daily basis to ensure the integrity of swaged fittings.

- G. Drop-forged steel cable clips may not be used, except in specific locations as directed by this Specification, or in locations approved in advance by the Theatre Consultant. Clips shall meet or exceed Federal Specification FF-C-450 and shall produce a termination equal to at least 80 percent of the breaking strength of the wire rope. The saddles of the clips shall be in contact with the load end of the rope. One (1) clip shall be tight against the thimble to retain the cable in the thimble. Rope ends shall be seized with a high-strength epoxy sealant and secured to the standing line with nylon tension ties. Quantity and separation of the clips shall be according to the following:

cable diameter	quantity of clips	Inches of cable to turn back
3/16 inch	2	3-3/4 inches
1/4 inch	2	4-3/4 inches
5/16 inch	2	5-1/4 inches
3/8 inch	2	6-1/2 inches
7/16 inch	2	7 inches
1/2 inch	3	11-1/2 inches

- H. Sizes and connections per Drawings.

## 2.9 LIGHTING PIPES

- A. Pipe battens shall be nominal 1-1/2" I.D. black steel pipe, ASTM A53/A Strong (Schedule 40), stripped and painted with at least one coat of black primer and one coat of flat black paint.
- B. Splices shall be close-fitting internal steel sleeves with a wall thickness of not less than 0.1875 inch, and min. 24 inches long. One side of the splice shall be held in place with a minimum of two (2) plug welds. Other side shall be held with a minimum of two (2) 5/16" bolts and lock nuts; bolts shall be placed at right angles. For removable pipe sections, see Drawings for location of welded and bolted splice sides.
- C. Lighting Positions shall be constructed as shown in the Drawings.
- D. Lengths, quantities and locations as per Drawings and Schedules.

## 2.10 DEAD-HUNG SCENERY PIPES

- A. Pipe battens shall be nominal 1-1/2" I.D. black steel pipe, ASTM A53/A Strong (Schedule 40), stripped and painted with at least one coat of black primer and one coat of flat black paint.
- B. Splices shall be close-fitting internal steel sleeves with a wall thickness of not less than 0.1875 inch, and min. 24 inches long. One side of the splice shall be held in place with a minimum of two (2) plug welds. Other side shall be held with a minimum of two (2) 5/16" bolts and lock nuts; bolts shall be placed at right angles. For removable pipe sections, see Drawings for location of welded and bolted splice sides.
- C. Lighting Positions shall be constructed as shown in the Drawings.
- D. Lengths, quantities and locations as per Drawings and Schedules.

## 2.11 TRACKS

- A. Motorized Straight Tracks
  - 1. Tracks shall be of the heavy duty channel type, approximately 3 inch x 3 inch 14-gauge galvanized steel, entirely enclosed except for slot in bottom.
    - a. Approved Manufacturers:
      - i. ADC 2800 series
      - ii. H & H Specialties 400 series.
      - iii. Approved equal.
  - 2. Tracks shall be supported within 12 inches of the live and dead ends, at the center of the overlap, and no more than seven (7) feet O.C. in between, as shown in the Drawings.
  - 3. Carriers shall be constructed of steel bodies with a "hollow center" design to contain operating line, with nylon tired ball bearing wheels and six (6) inch trim chains on plated swivels.
    - a. Approved Carriers:
      - i. ADC 2851 (single) and 2852 (master).
      - ii. H & H 416 (single) and 417 (master)
      - iii. Approved equal.
  - 4. Live and dead end pulleys shall contain eight (8) inch diameter sheaves on ball bearings. For travelers mounted in rigging systems using lineset spacing of nine (9) inches or less, mount eight (8) inch dead-end pulleys at a 45 degree angle, with a total projection not greater than six (6) inches from lineset center line.
    - a. Approved Pulleys:
      - i. ADC 2863-A (live) and 2864-A (dead).

- ii. H & H 423M (live) and 424M (dead).
  - iii. Approved equal.
5. Operating line shall be 3/16 inch galvanized aircraft cable. For systems utilizing traction drive, the operating line shall be provided with an extruded nylon cover.

B. Finishes

- 1. All Steel Components shall be painted or powder coated flat black.
- 2. All Aluminum components shall be anodized flat black.
- 3. All plastic or nylon components shall be inherently colored black.
- 4. All operating line and tow ropes shall be black.

C. Every track segment shall be one (1) continuous piece of maximum catalog length, except where splicing clamps are required. Splicing clamps shall provide a flush, positive alignment of track sections.

D. All rope operated and motorized tracks shall be provided with rear fold devices to stack curtain only at offstage track ends. Rubber washers shall be placed on both sides of each rear fold tab.

E. All pulleys shall provide for positive retention of the operating line.

F. Quantities, sizes, and locations as per Drawings.

## 2.12 MOTORIZED RIGGING COMPONENTS

A. Motors

1. General

- a. Except as otherwise specified, all motors shall have minimum Class A winding insulation in accordance with NEMA Standard MG 1-12.40 rated for 15 to 20 minute intermittent duty cycle.
- b. All motors shall be equipped with grease lubricated anti-friction ball or roller bearings. Two (2) removable, threaded lubrication plugs shall be furnished for each bearing housing, both to be removed for lubrication with low-pressure grease tube applicator. Upper plug opening shall be for lubricant entrance, and lower plug opening shall permit simultaneous purging of spent lubricant from the bearing.
- c. Provide a drain plug in the bottom of the frame on the bearing brackets so as to permit periodic drainage of any possible accumulation of moisture.
- d. Conduit connection box shall be watertight, of cast iron, aluminum, or wrought iron construction, with neoprene gasket. A tapped hole shall be provided for conduit entrance and connection box shall be oriented and coordinated with associated equipment to provide full access to internal connections. Corrosion resistant, high melting point, non-flammable

sealing compound shall be used around motor leads where they pass through the motor frame.

## 2. AC Motors

- a. All AC motors shall be squirrel-cage type, of NEMA torque design B, with medium starting torque, normal breakdown torque, low slip, and low starting current.
- b. All AC motors shall be TEFC (totally enclosed, fan cooled) enclosures as defined by NEMA Standard MG 1-12.21.

## B. Gear Reducers

### 1. Right Angle and Helical Bevels

- a. Each right angle bevel or spiral bevel gear drive shall be selected to transmit twice required torque, horsepower, and impact. All ratings shall be AGMA mechanical ratings for load classification service factor equal to 2.0, except as otherwise noted.
- b. Each right angle bevel gear drive unit shall consist of the following:
  - i. One housing made of high tensile nickel cast iron, properly reinforced at all strain points for maximum rigidity, with precisely located gear set bearing supports. Each housing shall have sufficient capacity for lubricant, and surface area for adequate heat dissipation.
  - ii. Pinions, gears, and gear shafts manufactured from chromium, molybdenum alloy steel (AISI C-4150) and heat-treated to 32 Rockwell "C" scale minimum core hardness.
  - iii. Pinion and gear shafts supported by tapered roller or precision ball bearings of adequate capacity, properly mounted, and furnished with oil seals.
  - iv. All shaft diameters precisely ground, stepped, and radiused to minimize stress concentrations.

### 2. Helical Worm

- a. Gear reducers shall be combination helical-worm reducer, directly flange-mounted to the motor/brake assembly. The reducer shall have two (2) gear stages; the first stage shall be helical and the second stage shall consist of a worm and worm wheel. The worm shaft shall be milled, hardened, and ground to insure maximum efficiency and long life.
- b. Gear reducers shall be enclosed in high-strength gray cast iron housings with precisely located gear set bearing supports. Each housing shall have sufficient capacity for lubricant, and surface area for adequate heat dissipation.
- c. Gear reducer shall incorporate a high inertia flywheel at the motor stage for "soft start" and "soft stop" capability.

- d. Gear reducers shall be SEW-Eurodrive "Helical-Worm Gear", or approved equal.
- e. Gear reducers shall be of the worm gear type with compound helical bevel to single envelopment worm or double enveloping worm gears. Single stage 'Spirol' gearing is not acceptable equipment provided for the Work of this Specification.
- f. Worm gear reducers shall be selected to safely transmit specified torque and horsepower. Capacity and type shall be as required. Design of the power transmission train shall provide for gearing ratios of the worm gear stage to be greater than 40:1 wherever practical. Ratios less than 40:1 shall require approval of the Theatre Consultant. All ratings shall be AGMA Class 2 mechanical ratings with a load classification service factor equal to 1.3, except as otherwise noted or approved.
- e. Each worm gear reducer shall consist of essentially the following:
  - i. One housing made of high tensile nickel cast iron, properly reinforced at all strain points for maximum rigidity, with precisely located gear set bearing supports. Each housing shall have sufficient capacity for lubricant, and surface area for adequate heat dissipation.
  - ii. Worm gears manufactured from gear bronze with minimum tensile strength of 40,000 PSI and properly keyed or splined to the gear shaft. Gear shafts shall be manufactured from chromium, molybdenum alloy steel (AISI C-4150).
  - iii. Worm and worm shaft manufactured from chromium, molybdenum alloy steel (AISI C-4150) and heat-treated to 32 Rockwell "C" scale minimum core hardness.
  - iv. Each worm gear and shaft supported by two (2) tapered roller bearings of adequate capacity, properly mounted, and furnished with oil seals.
  - v. All shaft diameters precisely ground, stepped, and radiused to minimize stress concentrations.

#### C. Primary Brake

1. Except where indicated otherwise, all brakes shall operate from single-phase AC, and shall be electrically released/spring applied, designed to conform to applicable NEMA standards for intermittent duty. Springs shall be sized to limit brake release noise to comply with the noise requirement as outlined in this article. All brakes shall be furnished with means for manual release.
2. Brakes shall have drip-tight NEMA Type 2 enclosures.
3. All disc brakes, except primary shaft safety brakes, shall be designed for mounting directly to motor frame and bells.
4. All brakes shall stop and hold a minimum of 200 percent of motor full torque capacity.

#### D. Frames & Guards

1. All motors and associated gearboxes shall be installed on built-up frames, which contain all elements of the lifting system.
2. All motor units shall have drip pans of at least 16-gauge sheet steel to contain leakage of oil from motor, gearbox and/or pillow blocks.
3. All moving equipment, devices, and cables shall be guarded in a manner to prevent accidental contact with other machinery, devices, lines, or personnel. Guards shall not impede the operation of the protected device or adjacent devices.
4. All motor assemblies shall include shrouds to incorporate this protection.
  - a. Shroud construction shall be sufficient to resist incidental impact without deforming. Shroud material shall be open metal mesh with openings not to exceed 1/2 inch unless otherwise noted in the Drawings.
  - b. Shrouds shall be removable for maintenance
  - c. Overall shroud construction and attachment shall not produce additional noise when the motor is in operation.
  - d. Shroud construction must be designed so as to not impede cooling.

#### E. Grooved Cable Drums

1. Cable drums shall be grooved cast or welded steel, properly annealed. Minimum tread diameter shall be at least 30 times the diameter of the wire rope employed. Drums shall be grooved for cable and sized as noted in Drawings.
2. All cable drums shall have sufficient cable capacity in a single layer for maximum travel plus a minimum of three (3) dead wraps for each cable connection. One (1) hole shall be drilled through the root of the groove for each cable end. This hole shall have an axis which, in section, is angled 45 degrees from a radial line drawn from the shaft to the center of the hole. Hole shall be chamfered, free of burrs and of correct size to retain stop sleeve cable retainer.
3. Cable grooves shall be lathe turned and machined to the proper size for cable used, with groove diameter clearances to fit cable closely and prevent cable from assuming oval or elliptical shape under load. Groove diameter clearance shall be 10 percent for cables smaller than 3/8 inch diameter, and eight (8) percent for cables 3/8 inch diameter and larger. Minimum groove depth shall be 40 percent of the cable diameter.
4. Adjustable steel or UHMW plastic rollers or guards shall be provided to prevent cable from jumping out of grooves. These elements shall be adjusted so that they do not bear on the cable when the cable is correctly seated in the groove. Rollers shall be supported at both ends by precision ball bearings.
5. Fleet angles shall not exceed  $\pm 1.5$  degrees.

6. All cable drums shall be appropriately supported by shafting of sufficient size closely supported on both ends by bearings to minimize bending stresses in the shaft. Bearings shall be ball bearings with self-aligning, four-bolt, flange-mount style, cast iron housings, Peer UCF-200 series, or approved equal. Each bearing shall be selected to support at least three (3) times the total load of the respective drum.

F. Electrical Enclosures

1. Recessed panels shall be contained within code gauge, formed, and welded, steel back boxes or rack mount style enclosures. The operating panels shall be minimum 16-gauge steel or 6061-T6 aluminum plate, recessed within the back box to a depth sufficient to permit a locking hinged door to completely cover the panel without affecting any device within the enclosure. The front surface shall be flush with the finished wall surface.
2. Surface mounted control panels shall be contained within code gauge steel back boxes, with all seams and joints continuously welded and ground smooth. Surface mounted panels shall conform to NEMA 9 standards. Operating panel shall comprise the front cover of the enclosure.
3. Complete accessibility to internal components shall be provided by screw-down, hinged operating panels; a friction-lock or bar-lock shall be provided to hold the operating panel open for service. Panels shall have a minimum thickness of 16-gauge and shall incorporate internal bracing where required by panel size to prevent flexing of the panel.
4. All steel shall be zinc-phosphate treated, primed with a coat of zinc chromate, and finish painted with baked enamel. All aluminum panels shall be anodized and then be painted with a thermo setting epoxy paint. All finish colors shall be as selected by the Theatre Consultant.
5. All labels and legends shall be permanently engraved directly into the faceplate. Engravings shall be filled with contrasting color enamel. Micarta, lamicaid, and other types of engraved plastic labels shall not be used unless specifically noted. Dry transfer, decals, plastic "dymo," or other types of adhesive labels or silk screened legends shall not be used.
6. All control panel face plates shall have beveled edges and rounded corners.
7. Panel(s) shall have a nameplate in a conspicuous location identifying the Rigging Contractor, Project and Panel Designation.
8. Each panel shall be completely factory-wired internally, with permanently identified barrier type terminal strips provided for the connection of the external wiring. All panels shall be factory tested.

G. Motor control cabinets

1. Cabinet(s) shall be of steel framed construction with applied steel side, top and bottom panels, equal to a NEMA-9 rating. All components shall be factory primed and painted.



2. Cabinet(s) shall have a locking front door with an integral safety-interlock, which when the door is opened shall automatically disable the main electrical feed to the panel.
3. Cabinet(s) shall contain all motor control system electronics, starters, and power as shown in the Drawings.
  - a. All wires inside the cabinet(s) shall be identified at the jacket with separate numbers.
4. An engraved lamicoïd label shall be bolted or riveted to the front of the cabinet, to read:

Motor Control Cabinet (Number)

Set (Name #1)

Set (Name #2)

(Etc.)

Schuler Shook Theatre Planners, Chicago, IL

(Name, Location and Phone Number of Rigging Contractor)

(Year of Commissioning)

5. Install as shown in the Drawings.

#### H. Limit Switches

1. All linear motion monitoring switches shall be furnished with rotary lever arm, cam, or plunger style operators.
2. All adjustable linear motion monitoring limit switches shall include sufficient liquid-tight, flexible conduit and wire including grounding conductor, to permit at least ten (10) feet of movement for adjustment.
3. All motor-operated equipment shall be equipped with normal travel limit switches to stop motion at each end of travel and redundant over travel limits which shall remove power from the motor when actuated at each ultimate limit of travel. All ultimate limit switches, when struck, shall de-energize the corresponding motor, and all other affected motors until the assembly is manually re-set. Motor control cabinets shall be equipped with over travel bypass key switches to permit resetting the affected unit. Normal travel limit switches and redundant over travel limit switches shall each be individually enclosed devices with independent motion sensing.
4. Verify exact limit locations in field.

### 2.13 MOTORIZED RIGGING ASSEMBLIES

#### A. Horizontal Traversing motors

1. Curtain operator shall be equipped with either a ten (10) inch steel "pay-in/pay-out" grooved drum driven by roller chain and sprockets from the

output shaft of a gear reducer or a double V-groove eight (8) inch cast iron pulley mounted to the output shaft of a gear reducer. Curtain operating line speed shall be as shown in the Drawings.

2. Steel frame assembly shall include spring-loaded nylon pulley to keep proper tension on operating line.
3. Unit shall be driven by an instantly reversing motor coupled directly to a worm gear reducer.
4. For motors mounted on moving elements, provide a single multi-conductor cable for power and control. Cable shall be type SC or SO and shall be of sufficient length to allow track to be brought to within four (4) feet of the floor. Cable management shall be provided as shown in Drawings.
5. Approved Manufacturers
  - a. ADC.
  - b. H&H Specialties.
  - c. Approved equal.

#### 2.14 MOTORIZED RIGGING CONTROL SYSTEM

- A. The control system shall be specifically designed for the control of motorized theatrical rigging equipment. It shall provide a level of reliability, accuracy, and integrity appropriate for overhead lifting in places of public assembly.
- B. Emergency Stop
  1. The emergency stop system shall meet NFPA-79 (Electrical Standard for Industrial Machinery)
  2. The emergency stop circuit shall be a normally closed circuit or a supervised circuit that provides the same or greater level of reliability and security. Its operation shall not depend on software or semiconductors.
  3. Emergency Stop. There shall be a single emergency stop system that shall, when activated, stop all elements as shown in the Drawings.
    - a. Emergency stop actuators shall be rear-illuminated mushroom pushbutton switches. Operation shall be PUSH to engage and TWIST to release. Color: red.
  4. System shall function as noted below.
    - a. Category 0: Activation shall directly remove power by means of electromechanical components, using a UL580E Type 2, non-welding, positive break contactor(s).
    - b. Engagement of the system shall remove power from the motors, but not the control system electronics.
    - c. Feedback
      - i. When activated all pushbuttons described in this paragraph shall be illuminated and shall flash to indicate a "STOP" condition. Buttons

shall continue to flash until system has been taken out of "STOP" condition.

- d. When the system is taken out of the "STOP" condition no movement shall begin automatically.

5. Panel design and location as shown in the Drawings.

### C. User interface

1. The control system shall be comprised of individual control panels as shown in the Drawings. Each panel may contain one or more of the following control elements:

- a. Emergency Stop Button(s) as described in this section.
- b. One ON/OFF key switch. Provide five (5) keys. Switch shall not allow removal of key when in the ON position.
- c. Movement Controls: One set of two (2) momentary contact switches, labeled with the appropriate directional destination. It shall be necessary to maintain contact on the switch in order to maintain movement. A dedicated DEADMAN switch shall be acceptable as an alternative to push to run switches.
- d. Visual Feedback Indicators
  - i. Control Power Status shall indicate when illuminated that the control panel is active and communicating with the control system/software. Color: Green
  - ii. Motor Power Status shall indicate when illuminated that the motor(s) in the system are energized and within the acceptable amperage range. Color: Yellow

2. Local Control

- a. Provide local motor control in immediate proximity to each individual motor location.
- b. Control at motors shall be in NEMA Type 1 housings. In addition to pushbuttons for control of stop, up, down and overtravel limit bypass, control stations at motors shall include a three-position switch for delegating control of motor to local-off-normal. All STOP functions, whether local or remote, shall function regardless of the position of the local-off-normal selector switch.
  - i. Maintenance pendants may be provided for local control functions provided that the connection of a fixed speed style control pendant to a variable speed unit will not result in motion or damage to the connected units or vice versa. Connectors shall equal AMPHENOL MS or 97 series. When a maintenance pendant is plugged in the unit shall automatically switch from Normal to Local mode.

3. Push Button Motor Control Panel (MCP-X)
  - a. The Motor Control Panel shall be a surface mounted panel and completely wired internally. Design and configuration as shown in the Drawings.
  - b. The panel shall contain the following:
    - i. Control Panels as shown in the Drawings
    - ii. Receptacles for Portable Control Devices.
  - c. Install as shown in the Drawings.
4. All labels and legends shall be permanently engraved into the face of the panel and filled with a contrasting paint. No surface-mounted labels or tags of any kind will be permitted. No decals or silk-screened legends will be permitted.
5. Provide vinyl dust covers for all equipment components that are not wall-mounted.
- D. All components shall be UL listed and carry UL labels.
- E. Install as indicated in the Drawings.
- F. Quantities as per schedule.

2.15 LIGHTING TRUSS SYSTEM

A. Trusses

1. Trusses shall be rectangular, with an outside dimension of 18 inches by 12 inches.
2. Main chords shall be 2 inch O.D. aluminum tubing with a wall thickness of 0.125 inch.
3. Diagonal chords shall be 1 inch O.D. aluminum tubing with a wall thickness of 0.125 inch.
4. End plates shall be 3/8" and shall be pre-drilled to facilitate splicing sections into continuous lengths. Bolts shall be min. 5/8" Grade 8.
5. Trusses shall be fabricated by AWS certified welders.
6. Trusses shall be capable of supporting the following loads:

<u>Span</u>	<u>Max. uniform distributed load</u>	<u>Max. center point load</u>
20'	3,100 lb.	1,550 lb.
30'	1,726 lb.	864 lb.
40'	855 lb.	427 lb.
50'	425 lb.	214 lb.

7. Trusses shall be supplied in 10-foot and 5-foot long components, complete with all assembly hardware.
8. Quantity: (1) trusses at 35'-0" long.
9. Trusses shall be fabricated by one of the following approved manufacturers:
  - a. James Thomas Engineering, Knoxville, Tennessee
  - b. Tomcat USA, Midland, Texas
  - c. Other manufacturers may be considered with the prior approval of the Theatre Consultant. Manufacturers seeking approval must contact the Theatre Consultant not later than fourteen (14) days prior to bid date.

## 2.16 CURTAINS

### A. Fabrics

1. All fabrics not inherently flameproof shall be fully mill flameproofed by the immersion process to meet or exceed the minimum requirements set forth by NFPA "Small Scale 701." The Contractor shall submit certificates so stating.
2. All fabrics shall be produced from one (1) dye lot per color. Color quality shall be consistent throughout, with no visible streaking, striping, or spotting.
3. All curtain color selections shall be submitted to the Theatre Consultant following selection by Architect. Final color approval by the Theatre Consultant is required prior to ordering fabric.
4. Stage Curtain: 100 percent carded Inherently Flame Retardant velour, 54 inches wide, weighing 25 ounces per linear yard. "Prestige" as manufactured by KM Fabrics, Inc., Greenville, South Carolina, or approved equal by J. L. DeBall Fabrics or J. B. Martin Fabrics.
  - a. 45 backing ends per inch
  - b. 51 pile ends per inch
  - c. 48 picks per inch
  - d. 1148 pile tufts per square inch
  - e. Pile height: approximately .120 inch
5. Webbing
  - a. Heavy Weight Polypropylene. 3 inches tall, 1.7 mm thick. Rosebrand "Poly Pro Webbing" or equal. Color: Black.

### B. Fabrication

1. General
  - a. Unless otherwise noted, all pile fabrics shall have pile running up.

- b. All seams shall be vertical, unless otherwise specifically indicated. All fabric widths shall run full height, with no vertical piecing. All hems shall be sewn for the complete length of the hem.
  - c. Thread shall match face fabric in color and material.
  - d. The center of every curtain shall be indicated by a 1/2 inch wide fabric strip sewn to the back of the webbing. In addition, the center grommet of each border, backdrop, cyclorama and scrim shall be provided with a tie line in a color that is obviously different than the rest of the tielines.
  - e. All grommets shall be black in finish.
  - f. Every curtain shall contain two (2) permanent labels sewn to the off-stage end of the curtain. Labels shall be located at the top webbing and at 48 inches above the bottom hem. Stitches shall not penetrate the front face fabric of the curtain. This label shall indicate fabric, color, finished size, and method and date of flameproofing if applicable.
  - g. Sizes and quantities per Drawings.
2. Stage curtain.
- a. Fabric pile shall run down.
  - b. Top hem shall be single turned and reinforced with continuous 3-1/2 inch webbing. Fullness shall be sewn into the curtain by means of box pleats 12 inches O.C. Two (2) No. 3 brass grommets shall be provided at each top corner of each finished panel and one (1) grommet shall be provided at the center of each box pleat along the top hem. One heavy duty snap hook, Zoron Steel Bit Snap #421 1 3/4, or approved equal, shall be provided for each grommet for attachment to track.
  - c. Bottom hem shall be six (6) inches double turned and contain a continuous No. 6 plated jack chain held in a separate muslin pocket four (4) inches above bottom of curtain and tacked at each vertical seam to prevent bunching.
  - d. All vertical hems shall be faced back with 1/2 width of face fabric. The hem shall be continuously sewn to the selvage edge of the previous panel seam.
- C. Fabricate and install as shown in the Drawings and Schedules.

### 3. EXECUTION

#### 3.1 FABRICATION

- A. This Contractor is responsible for becoming familiar with and verifying all pertinent dimensions and conditions, both in the Drawings and in the field, before proceeding with any work.
- B. Coordinate the design, planning, and scheduling of the work of this Section with the work of all other trades. Notify the Architect of any difficulties in coordinating work with other contractors. Failure to do so shall constitute acceptance of construction as suitable in all ways to receive the work of this Section.
- C. All electrical components shall be fully assembled and internally wired, with terminals of the proper rating and clearly labeled, provided for external feeder and control wiring.
- D. All metal fabricated items shall be given at least one (1) coat of primer and one (1) coat of finish paint. Color: flat black.
- E. Where not specifically called out in the Drawings and Specifications, tracks and fittings shall be painted or anodized black.
- F. Verify curtain height dimensions after track installation is complete, prior to fabricating curtains.
- G. All curtain color selections shall be submitted to the Theatre Consultant following selection by Architect. Final color approval by the Theatre Consultant is required prior to ordering fabric.
- H. All equipment shall be fabricated and installed to facilitate maintenance and future replacement.

#### 3.2 INSTALLATION

- A. Contractor shall employ only experienced stage riggers for the installation of work of this Section. A competent supervisor shall be maintained on this Project during the entire installation. A change of supervisor shall not be acceptable unless by written authorization of the Architect.
- B. Coordinate installation with all other trades doing adjoining work.
- C. Examine all existing conditions at the jobsite prior to beginning installation. Report to Architect any conditions that vary from the Drawings that could prevent the correct installation of the specified system, including, but not limited to, out-of-plumb, out-of-square, out-of-true and out-of-level conditions. Failure to do so shall constitute acceptance of construction as suitable in all ways to receive the work of this Section.
- D. Provide protection for all stage flooring, regardless of whether flooring has been stained or sealed. Flooring shall be protected from both structural damage and cosmetic damage.
- E. Provide and install all supplementary structural support as required for the installation and safe operation of equipment and materials supplied under this Section.

- F. Do all required cutting, drilling, tapping, and welding necessary for proper installation. Cut no structural members unless specifically shown in the Drawings or indicated in the Contractor's shop drawings, or unless written approval is obtained from the Architect.
- G. Install all items in conformity with standard trade practices and manufacturers' recommendations. Position all items accurately and true to plumb line and level. Maintain maximum headroom and clearances at all locations.
- H. Ropes and cables shall enter rigging blocks and drums at a fleet angle not exceeding  $\pm 1.5$  degrees.
- I. All turnbuckles and screw-pin shackles shall be wired shut after adjustment.
- J. Install all traveler tracks with three (3) foot overlap at center.
- K. Install all curtain tracks with the turnbuckles at the mid-point of travel, to allow future adjustment in either direction. Install all curtains on tracks at the mid-point of the carrier trim chain, to allow future adjustment in either direction.
- L. No curtains shall be installed until construction and painting are complete and the building has been cleaned. Any curtains delivered to the job site prior to their installation shall be stored in a clean area in dustproof bags.

**END OF SECTION 116133**



**SECTION 11 61 34**  
**THEATRICAL LUMINAIRES AND ACCESSORIES**

**1. GENERAL**

**1.1 RELATED DOCUMENTS**

- A. Drawings and general provisions of the Contract, including General and Supplementary Conditions and Division 01 Specification Sections, apply to this Section.

**1.2 SCOPE**

All materials, components, and services necessary to provide a complete system indicated in this Section, as specified herein and shown on related Drawings, including:

- A. Drawings and general provisions of the Contract, including General and Supplementary Conditions and Division 1 Specification Sections, apply to this Section.
- B. Preparation and submission of complete shop drawings and samples for review prior to fabrication.
- C. Verification of dimensions and conditions at the job site.
- D. Shipment of equipment to the job site and the secured storage of all non-fixed equipment.
- E. Installation and completion in accordance with these Specifications, related Drawings, the Equipment Manufacturer's recommendations, established trade criteria, and all applicable code requirements.
- F. The inspection, demonstration, and necessary adjustment of the completed installation by the Manufacturer's engineering personnel.
- G. Preparation and submission of complete record drawings and operational and maintenance data and certificates.

**1.3 WORK INCLUDED**

- A. Theatrical Luminaires.
- B. Theatrical Followspots.
- C. Accessories.

The above is for reference only and is not intended to define the limits of the work for a complete installation.

**1.4 RELATED WORK IN OTHER SECTIONS**

- A. General requirements for all electrical work.
- B. Electrical service

- C. General lighting system.
- D. Theatrical rigging system.
- E. Theatrical sound and communications system.
- F. Theatre Stage Lighting System.

1.5 QUALIFICATIONS

- A. All equipment shall be provided by qualified Stage Lighting Dealers. All equipment provided under this Section shall be provided by the same Dealer for the Theatre and the TV Studio.
- B. The Manufacturers shall have at least ten (10) years experience in the fabrication of similar equipment.
- C. If requested, the Manufacturers shall submit a representative list of installations during the above period.
- D. Subject to the above requirements, the equipment indicated herein shall be by one of the following manufacturers:
  - 1. Altman Lighting, Yonkers, NY
  - 2. Colortran, a Division of Leviton, Portland, Oregon
  - 3. Electronic Theatre Controls, Middleton, Wisconsin
  - 4. LEX Products, Stamford, Connecticut
  - 5. Lighting and Electronics, Wappingers Falls, New York
  - 6. Lycian, Sugar Loaf, New York
  - 7. Phoebus Manufacturing, San Francisco, California
  - 8. Selecon Performance Lighting, Forest Hill, Maryland
  - 9. Strand Lighting, a Division of Genlyte, Cypress, California
  - 10. Strong Lighting, Omaha, Nebraska
  - 11. TMB, Carlstadt, New Jersey
  - 12. Union Connector, West Babylon, New York
- E. Other manufacturers may be considered with the prior review of the Theatre Consultant. Manufacturers seeking review must contact the Theatre Consultant not later than fourteen (14) days prior to bid date.
- F. The luminaire package shall be provided by a qualified theatrical dealer, who shall have at least five (5) years experience in the sales and installation of similar systems and who shall be factory certified to provide warranty service for all of the equipment in this Section. Dealer shall be a Business member, accredited as a Dealer/Retailer, of the entertainment service organization PLASA.
- G. Dealer shall be responsible for the integration, operation, and performance of all elements of the system described in this Section. Dealer shall provide all

warranty work and equipment upgrades as called for in this Section. The dealer shall be available for product service onsite within (24) hours of a call for service.

H. Subject to the above requirements, the equipment indicated herein shall be provided by one of the following dealers:

1. Barbizon Lighting, Chicago, Illinois 773-276-8500
2. Chicago Spotlight, Chicago, Illinois 312-455-1171
3. Designlab Chicago, Chicago, Illinois 773-265-1100
4. Grand Stage, Chicago, Illinois 312-332-5611
5. Intelligent Lighting Creations, Arlington Heights, Illinois 847-933-9792

Other dealers may be considered with the prior review of the Theatre Consultant. Dealers seeking review must contact the Theatre Consultant not later than fourteen (14) days prior to bid date.

## 1.6 SUBMITTALS

A. With bid.

1. Identification of qualified Theatrical Dealer providing package.
2. All deviations and exceptions from specification must be revealed with bid. Deviations and exceptions from specification submitted after this time shall not be accepted.
3. Shop drawings. Within thirty (30) days of receipt of order, the Manufacturer shall submit drawings and equipment data sheets to the Architect for distribution to the Theatre Consultant for review and action prior to fabrication:
  - a. Dimensions, components, and finishes of all equipment and accessories.
  - b. All system assemblies and major sub-assemblies, cabinets, and enclosures, including notation of type and manufacture of switches, pilot lights, locks, hardware, and electrical and electronic connectors.
  - c. Block schematics of system internal wiring and system element interconnection.
  - d. Quantities of each component and sub-assembly.
  - e. Indication by boxed caption of any and all variations from contract Drawings and Specifications, whether or not these variations have been formally or informally accepted by the Theatre Consultant.

B. Samples. Within thirty (30) days of receipt of order, the Manufacturer shall submit to the Architect for review prior to fabrication samples of any equipment component requested by the Theatre Consultant. Samples shall not be included in quantities of equipment specified but shall be returned.

- C. Final submittal. Within thirty (30) days of final tests, and as a condition for final review, the Manufacturer shall submit to the Architect:
1. Three (3) sets to the Architect and one (1) set on electronic media to the Theatre Consultant. Format of sets shall be compliant with Division One of this Specification.
    - a. Receipts for delivery of all non-installed items, i.e., all items designated, "deliver to Owner."
    - b. "As built and approved" drawings and equipment data sheets showing all systems and components as installed, including all field modifications.
    - c. Operating and maintenance manuals.
    - d. Parts lists.
    - e. Training videos as noted below.
    - f. Certificates of warranty, as set forth below.

#### 1.7 TESTING AND INSTRUCTION

- A. Upon completion of all installation work, the Contractor and Dealer shall certify in writing to the Architect that the work is complete and ready for final observation. Final observation shall be scheduled by the Owner, the Architect, and the Theatre Consultant within fourteen (14) days following the Contractor's notice of completion.
- B. As a condition of final completion, the Dealer's technician shall instruct the Owner's staff or representatives, under the observation of the Architect and Theatre Consultant, in the operation and maintenance of the equipment.
  1. Initial Instruction: This instruction session shall be scheduled for a minimum duration of four (4) hours. While it may be possible to schedule this instruction session to coincide with the system checkout, such coincidence shall not be assumed. Instruction shall be scheduled by the Owner, the Architect, and the Theatre Consultant to occur within fourteen (14) days following the Contractor's written notice.

#### 1.8 GENERAL REQUIREMENTS

- A. General Conditions of the project contract, work schedules, and site regulations apply to this work. Refer to Division 1.
- B. This work shall comply with local codes and applicable standards as established by NEC and approved testing agencies, and all components shall carry pertinent labels by approved testing agencies.
- C. The Contractor shall provide full insurance against loss or damage during shipment, storage, installation, and testing. Certification of such coverage shall be furnished to the Architect within thirty (30) days of award of contract.
- D. Warranty
  1. The Dealer shall unconditionally warrant all equipment and systems provided under this Section to be free from defects in materials and

workmanship for a period of at least twelve (12) months from the date of final acceptance of all work of this Section. Lamps and normal wear and tear are exempted.

2. Appropriate additional equipment to replace equipment removed for service shall be provided at the job site at no expense to the Owner to replace any and all equipment which must be removed for service.
  3. All warranty service shall be performed by technicians factory certified for the installed equipment.
- E. State-of-the-art assurance: All products specified shall be the Manufacturer's most recent iteration and most recent product. No products shall be accepted if they have been discontinued or superseded at the time of shipment. Should the Manufacturer develop products above and beyond the specification of the listed product, the Dealer shall make the newly developed product available to the project at no additional cost. The Dealer shall notify the Architect and the Theatre Consultant of any developments to the specified products, and shall note any change in the requirements of building infrastructure(s) to support the developments. The Architect and Theatre Consultant shall then determine whether upgraded products shall be accepted.

## 2. PRODUCTS

### 2.1 GENERAL

- A. All components shall be new, in good condition, and under warranty.
- B. All components shall bear UL labels and labels identifying the manufacturer, model number, and serial number. All such labels shall be permanently attached in a conspicuous location.
- C. Control signal protocol and connector types shall comply with "DMX-512" as established and published by the U. S. Institute for Theatre Technology.
- D. All control, signal, and video connectors shall be of substantial construction and shall be of the locking or latching type. All plate-mounted connectors shall be bolted to faceplates - rivets shall not be acceptable.
- E. All components requiring external electrical connections of more than eight (8) conductors shall include barrier-type terminal strips properly sized and permanently labeled.

### 2.2 STAGE LIGHTING CONNECTORS

- A. Two Pin and Ground
  1. 20-Ampere devices.
    - a. Connectors shall be 20-ampere slip pin, 2 wire plus ground, with integral strain relief.
    - b. Unless otherwise noted provide transparent plastic covers
    - c. The following manufacturer's devices shall be acceptable:
      - i. Union Connector

- ii. Marinco Bates® Plug

- iii. LEX Products

B. TWIST-LOCK

1. 20-Ampere devices

- a. Connectors shall be 20 ampere, 2 wire plus ground, locking, with nylon bodies and casings, and integral cable clamp. Configuration shall be NEMA L5-20.

- b. The following manufacturer's devices shall be acceptable:

- i. Hubbell

- ii. Leviton

D. 20-ampere 6-circuit multi-pin

1. A threaded coupling 19-pin cylindrical connector for theatrical lighting applications

2. All multi-conductor connectors shall be wired in accordance with the recommended practice RP-1 as published by the U. S. Institute for Theatre Technology.

3. The following manufacturer's devices shall be acceptable:

- i. Veam

- ii. Socapex

- iii. LEX Products

4. All products shall be compatible with Socapex 419 Series connectors.

2.3 FOLLOW SPOTS

A. Specifications

1. Lamp: Nominal 575w HMI, with an approximate color temperature of 5600 degrees K., and an average rated life of 250 hours.

2. Optical train: variable beam angle from 11 degrees to 22 degrees.

3. Optical performance: shall produce at least 220-foot candles (spot) at a throw distance of 40 feet.

4. Beam control: iris, horizontal shutters, and douser.

5. Color boom: six colors with automatic release.

6. Connector: 20 ampere, 2 wire plus ground, with nylon body and integral cable clamp. Type NEMA 5-15.

B. Acceptable units

1. Midget HP Model 1209, as manufactured by Lycian Stage Lighting, Sugar Loaf, New York.

2. Buxie, as manufactured by Robert Juliat, Wallingford, Connecticut.

3. Canto 575 MSR, as manufactured by LDR, Italy and distributed by Strong Lighting Omaha, NE.
  4. Or Approved Equal.
- C. Quantities per Schedule.
- D. Install at Front of House Lighting Position.
- E. As part of the work of this Section, experienced theatrical technicians shall provide the following assembly and alignment services at the job site prior to delivery to Owner:
1. Uncrating from factory containers and disposal of containers.
  2. Full assembly.
  3. Lamp alignment for maximum performance.

## 2.4 ELLIPSOIDAL REFLECTOR SPOTLIGHTS

### A. Specifications

1. Wattage: 575, 600, 750 watt.
2. Socket shall be mounted and shielded to withstand maximum lamp seal temperatures without substantial deterioration.
3. Reflector: Molded borosilicate, ellipsoidal, double flatted. Dichroic coatings to produce 95% minimum reflectance of visible light and 90% minimum transmission of infrared radiance.
4. Shutters: Four (4) stainless steel, operating in two (2) different planes. Shutter gate shall be rotating and locking, permitting flexible shutter cuts.
5. Pattern slot: accepts standard pattern (template) holder.
6. Iris: in addition to shutters, when specified.
7. Lenses: Aspheric, with anti-reflective coating to reduce light loss. Lenses shall be reasonably clear, with no perceptible discoloration or clouding.
8. Lamp adjustment: Vertical, horizontal, and axial adjustment.
9. Wiring: Three (3) 36 inch type SF-2 leads in fiberglass sleeve.
10. Connector shall be factory installed prior to shipment to job site.
11. Color frame: free of burrs and sharp edges; painted or anodized flat black.
12. Lamp: provide (1) per fixture, plus additional lamps. Lamp wattage, type, and total quantity shown in Schedule.
13. As part of the work of this Section, experienced theatrical technicians shall provide the following assembly and alignment services at the job site prior to delivery to Owner:
  - a. Uncrating from factory containers and disposal of containers.
  - b. Full assembly, including installation of C-clamps and lamps.

c. Lamp alignment to cosine (hot center) distribution.

B. Acceptable units (categorized by field angle)

1. 50 degree: ETC 450-B, 575w  
Selecon 18PACFB/6-L50  
Strand Leko Lite 11550C
2. 40 degree: ETC 436-B, 575w  
Selecon 18PACFB/6-L40  
Strand Leko Lite 11540C
3. 30 degree: ETC 426-B, 575w  
Selecon 18PACFB/6-L30  
Strand Leko Lite 11530C
4. 20 degree: ETC 419-B, 575w  
Selecon 18PACFB/6-L20  
Strand Leko Lite 11520C
5. 10/12 degree: ETC 410-B, 575w  
Strand Leko Lite 11510C
6. 5/10 degree: ETC 405-B, 575w  
Strand Leko Lite 11500C

C. Quantities per Schedule.

D. Deliver to Owner.

2.5 ELLIPSOIDAL REFLECTOR SPOTLIGHTS - SPARE LENS TUBES

A. Specifications

1. Lenses: Aspheric, with anti-reflective coating to reduce light loss. Lenses shall be reasonably clear, with no perceptible discoloration or clouding.
2. Lens tubes shall be interchangeable among all beam spreads, to fit same fixture body.
3. Provide complete spare lens tube assembly, to fully replace lens tube of ellipsoidal reflector spotlight

B. Acceptable units (categorized by field angle)

1. 50 degree: ETC 450-LT  
Selecon 18PACL50  
Strand Leko Lite 11550C
2. 36 degree: ETC 436-LT  
Selecon 18PACL40  
Strand Leko Lite 11540C
3. 26 degree: ETC 426-LT  
Selecon 18PACL30  
Strand Leko Lite 11530C



4. 19 degree: ETC 419-LT  
Selecon 18PACL20  
Strand Leko Lite 11520C
5. 10 degree: ETC 410-LT  
Strand Leko Lite 11510C

C. Quantities per Schedule.

D. Deliver to Owner.

## 2.6 PAR SPOTLIGHTS

### A. Specifications

1. Wattage: 575 watt.
2. Socket shall be mounted and shielded to withstand maximum lamp seal temperatures without substantial deterioration.
3. Reflector: Integral die-cast aluminum, faceted.
4. Lenses: Removable, rotating lenses fitting into fixture without the use of tools. Lenses shall be reasonably clear, with no perceptible discoloration or clouding. Each fixture complete with (4) lenses: Wide Flood, Medium Flood, Narrow Spot, and Very Narrow Spot.
5. Lamp adjustment: Vertical, horizontal, and axial adjustment.
6. Wiring: Three (3) 36 inch type SF-2 leads in fiberglass sleeve.
7. Connector shall be factory installed prior to shipment to job site.
8. Color frame: free of burrs and sharp edges; painted or anodized flat black.
9. Lamp: provide (1) per fixture, plus additional lamps. Lamp wattage, type, and total quantity shown in Schedule.
10. As part of the work of this Section, experienced theatrical technicians shall provide the following assembly and alignment services at the job site prior to delivery to Owner:
  - a. Uncrating from factory containers and disposal of containers.
  - b. Full assembly, including installation of C-clamps, lamps and lenses.

B. Acceptable units: ETC S4PAR-EA

C. Quantities per Schedule.

D. Deliver to Owner.

## 2.7 MINI-STRIP LIGHTS

### A. Specifications

1. Each unit shall consist of thirty (30) individual compartments, each containing lamp and color frame holder, and wired in three (3) series circuits. Each compartment shall include a neon lamp to indicate lamp burn-out.

2. Lamps: 12 volt. 50 MR16/WFL, 75 MR16/WFL.
  3. Wiring: Three (3) 36 inch type SF-2 leads in fiberglass sleeve, for each circuit.
  4. Connectors shall be factory installed prior to shipment to job site.
  5. Color frames: free of burrs and sharp edges; painted or anodized flat black.
  6. Mounting hardware: One (1) complete set of hanging trunions and one (1) complete set of floor trunions per unit.
  7. Lamp: provide (1) lamp per compartment, plus additional lamps. Lamp wattage, type, and total quantity shown in Schedule.
  8. As part of the work of this Section, experienced theatrical technicians shall provide the following assembly and alignment services at the job site prior to delivery to Owner:
    - a. Uncrating from factory containers and disposal of containers.
    - b. Full assembly, including installation of C-clamps, trunnions, and lamps.
- B. Acceptable units:           Altman "Zip Strip"  
  Times Square Lighting 716-30
- C. Quantities per Schedule.
- D. Deliver to Owner.

## 2.8 LED PAR SPOTLIGHTS

- A. General
1. The fixture shall be a color-mixing high-intensity LED illuminator with DMX control of intensity and color.
  2. All LED fixtures shall be provided by a single manufacturer to ensure compatibility
- B. Physical
1. The fixture shall be contained in an all-metal die-cast housing, free of burrs and pits.
  2. The housing shall have a black powdercoat finish
- C. Power supply, cooling and electronics shall be integral to each unit.
- D. Fixture housing shall provide two easy-access slots for secondary lenses and other accessories
1. Slots shall be equipped with locking retaining clip
- E. The unit shall be provided with :
1. Theatrical-style hanging yoke
  2. Five foot power lead with Power-Con to NEMA 5-15 male plug.
  3. 25 deg. secondary lens

F. Light output shall be via a round aperture

G. Thermal

1. Fixture shall be equipped with a cooling fan.
  - a. Fan speed control via a DMX channel shall be possible
  - b. Fan speed software shall permit the fixture to override DMX fan speed setting to prevent heat damage to the fixture
2. The fixture shall utilize advanced thermal management systems to maintain LED life to an average of 70% intensity after 50,000 hours of use
3. Thermal management shall include multiple temperature sensors within the housing to include:
  - a. LED array circuit board temperatures
  - b. Temperature sensors placed on each individual LED color circuit
  - c. Fixture ambient
  - d. CPU
    - 1). Fixture user shall permit monitoring of temperature sensors via a LCD multi-line backlit display
4. The fixture shall operate in an ambient temperature range of -20°C (-4°F) minimum, to 40° C (104°F) maximum ambient temperature.

H. Electrical

1. The fixture shall be equipped with 100V to 240V 50/60 Hz internal power supply
2. The fixture shall support power in and thru operation
  - a. Power in shall be via Neutrik® PowerCon™ input connector
  - b. Power thru shall be via Neutrik® PowerCon™ output connector
  - c. Fixture power wiring and accessory power cables shall be rated to support linking of multiple fixtures up to the capacity of a 15A breaker
3. The fixture requires power from non-dim source
4. Power supply outputs shall have self-resetting current limiting protection
5. Power supply shall have power factor correction

I. LED Emitters

1. The fixture shall contain a minimum of 5 different LED colors to provide color characteristics as described in Section G below.
2. All LEDs used in the fixture shall be high brightness and proven quality from established and reputable LED manufacturers.
3. Manufacturer of LED emitters shall utilize an advanced production LED binning process to maintain color consistency.

4. LED emitters should be rated for nominal 50,000 hour LED life to 70% intensity
5. All LED fixtures (100% of each lot) shall undergo a minimum eight-hour burn-in test during manufacturing.
6. LED system shall comply with all relevant patents

J. CALIBRATION

1. Fixture shall be calibrated at factory for achieve consistent color and intensity output between fixtures built at different times and/or from different LED lots or bins
  - a. Calibration data shall be stored on the LED array as a permanent part of on-board operating system
  - b. All arrays, including replacement arrays shall be calibrated to the same standard to insure consistency

K. COLOR

1. The fixture shall utilize an minimum of 40 LED emitters
2. The fixture shall be provided with the LED array as outlined below:
  - a. Red, Amber, Green, Cyan, Blue and Indigo and White LEDs in an array designed for broad spectrum color, light tints and variable colors.
  - b. Measured brightness of the array shall be greater than 2900 field lumens

L. DIMMING

1. The LED system shall use 15-bit nonlinear scaling techniques for high-resolution dimming.
2. At least four different dimming curve options shall be accessible at the fixture's User Interface
  - a. Incandescent
  - b. Standard
  - c. Linear
  - d. Quick
3. Dimming curves shall be optimized for smooth dimming over longer timed fades.
4. The LED system shall be digitally driven using high-speed pulse width modulation (PWM)
5. LED control shall be compatible with broadcast equipment in the following ways:
  - a. PWM control of LED levels shall be imperceptible to video cameras and related equipment

- b. PWM rates shall be adjustable by the user at the fixture if necessary to avoid any visible interference to video cameras and related equipment

M. CONTROL AND USER INTERFACE

1. The fixture shall be USITT DMX 512A-compatible via In and Thru 5-pin XLR connectors
2. The fixture shall be compatible with the ANSI RDM E1.20 standard
  - a. All fixture functions shall accessible via RDM protocol for modification from suitably equipped control console
  - b. Temperature sensors within the luminaire shall be viewable in real time via RDM
3. The fixture shall be equipped with multi-line LCD display for status reports and configuration changes
4. The fixture shall be equipped with a six-button user-interface
5. The fixture shall offer multiple DMX input profile options to include:
  - a. RGB - control of all individual LED colors via a three-channel profile
    - 1). Red, Green, Blue
  - b. HSI – control of all individual LED colors via a three-channel profile
    - 1). Hue, Saturation, Intensity
  - c. HSIC – control of all LED colors via a four-channel profile
    - 1). Hue, Saturation, Intensity and Color Point
  - d. Color point provides variable color temperature settings
  - e. Direct – control of each individual color channel via an independent channel
  - f. A variable-rate strobe channel shall be provided
6. The fixture shall offer three output settings
  - a. Boost mode - powers LEDs at maximum intensity and provides no compensation against LED 'droop' or intensity loss
  - b. Regulated mode – slightly restricts maximum LED intensity levels to compensate against LED droop
  - c. Protected mode – further restricts maximum LED intensity levels to compensate against LED droop and offer color consistency at highest permissible ambient temperatures (40C)
7. The fixture shall offer additional user-definable options to including but not limited to:
  - a. Display time out options
  - b. Loss of data behavior options

- c. White point settings
  - d. Red-shift option for tungsten dimming emulation
8. The fixture shall offer five Quick Set-Ups to allow user to rapidly select different combinations of the numerous user options based on the desired usage situation, to include:
- a. General – for most situations
  - b. Stage – when emulating incandescent fixtures is desired
  - c. High Impact – when maximum output and effect is desired
  - d. XT Arch – when color consistency and architectural characteristics are desired.
  - e. Studio - when DMX or stand-alone of white light output is required with intensity, color temperature and color tint control parameters
9. The fixture shall offer stand-alone functionality eliminating the need for a console
- a. Fixture shall ship with 24 preset colors accessible as a stand-alone feature
  - b. Fixture shall ship with 12 Sequences accessible as a stand-alone feature
  - c. Each color and sequence can be modified by the end user
  - d. Fixtures can be linked together with standard DMX cables and controlled from designated master fixture
  - e. Up to 32 fixtures may be linked
  - f. Fixtures in a stand-alone state shall restore to the settings present prior to power cycling, eliminating the need for reprogramming
- N. As part of the work of this Section, experienced theatrical technicians shall provide the following assembly and alignment services at the job site prior to delivery to Owner:
- 1. Uncrating from factory containers and disposal of containers.
  - 2. Full assembly, including installation of C-clamps and lamps.
- O. Acceptable units: ETC Desire D40-Lustr+
- P. Quantity per schedule.
- Q. Deliver to Owner.

## 2.9 PORTABLE MULTI-CONDUCTOR CABLE EXTENSION ASSEMBLIES

- A. Cables shall be rated at 600 volts, for six circuits, with two (2) #12 minimum AWG conductors for each 20-ampere circuit required plus one #12 minimum AWG grounding conductor for every three (3) circuits.

- B. Cables shall be cord type SC.
  - 1. Approved Manufacturers:
    - a. "Pro Cable" as manufactured by TMB, Burbank, CA.
    - b. "PowerFlex" as manufactured by LEX Products, Stamford, CT.
    - c. Coast Entertainment, a division of Coast Wire & Plastic Tech, Inc., Carson, CA
    - d, or approved equal.
- C. Connectors shall be 20 ampere, 6-circuit Multi-pin All connectors shall provide for positive ground wire connections through the connector to the chassis of the dimmer rack or plug box providing power.
- D. Each cable end shall be labeled at both ends, six inches from each connector, with 1/2 inch high black letters on a colored background indicating cable length. Labels shall be sealed to the cable with clear heatshrink tubing.
- E. Cable identification shall be in the following label background colors:
  - 1. 25' cables – red background.
  - 2. 10' cables – yellow background.
- F. Provide fully assembled product.
- G. Quantities and lengths per Schedule.
- H. Deliver to Owner.

#### 2.10 MULTI-CONDUCTOR CABLE BREAK-OUT ASSEMBLIES

- A. Multi-conductor connectors shall be 20 ampere, 6-circuit, multi-pin connectors.
- B. Pigtails shall include two (2) at 24" long, two (2) at 48" long, two (2) at 72" long and shall be cable type 12/3 SJO. Pigtails shall be labeled with the circuit number (1-6) near the receptacle end of the cables with 1/4" high black numbers on white background and sealed with clear shrink tubing.
- C. Receptacles shall be 20 ampere two pin and ground connectors as specified in this section.
- D. Provide fully assembled product.
- E. Deliver to Owner.

#### 2.11 AUTOMATED LUMINAIRES

- A. Lamp – Nominal 300-watt discharge lamp with an auto-ranging power supply.
- B. Fixture shall have motorized pan with at least 450 degrees of movement
- C. Fixture shall have motorized tile with at least 270 degrees of movement.
- D. Color shall be provided by color wheel(s).
- E. The fixture shall include a gobo wheel with at least 14 gobos.

- F. Fixture shall be able to communicate with the lighting console via the DMX-512 protocol.
- G. Provide pipe hanging hardware for each fixture.
- H. Approved Products:
  - 1. Legend 230 as manufactured by Chauvet Lighting
  - 2. Platinum Spot 5r as manufactured by Elation Lighting.
  - 3. Robin Pointe as manufactured by Robe Lighting

Other fixtures may be considered with the prior review of the Theatre Consultant not less than fourteen (14) days prior to bid date.

## 2.12 ACCESSORIES

- A. Pattern holders
  - 1. Stainless steel, with epoxy handle
  - 2. For holding standard "B" size theatrical "gobo" patterns within the designated slot in the lighting instrument.
- B. F-stop "donuts"
  - 1. Fabricated of min. 20 gauge steel, outside dimension to fit color frame holder of ellipsoidal spotlights, with diameter of circle to match the focal plane "gate" dimension for ellipsoidal spotlight served.
  - 2. Paint flat black with high-temperature paint.
- C. Drop-in iris assemblies
  - 1. Provides iris of beam size from 100% to 10% of rated beam.
- D. Top hats
  - 1. Square frame attached to cylinder. Cylinder length shall be equal to its diameter.
  - 2. Painted or anodized flat black.
- E. Stage cable
  - 1. 20-ampere cable shall be 12-3 type SO cord with male plug at one end and female connector at other end.
  - 2. 50-ampere cable shall be 6-3 type SO cord with male plug at one end and female connector at other end.
  - 3. Cable lengths shall be identified with the length near the receptacle end of the cables with 1/4" high black numbers on a colored background and sealed with clear shrink tubing. Colors as follows:
    - a. 25' cables – red
    - b. 10' cables – yellow
    - c. 5' cables – white



4. Each cable shall have (1) "Velcro" tiewrap permanently attached to the insulation near the female connector.
  5. Refer to Paragraph 2.2 for specification of connectors.
- F. Extension cords
1. 12-3 type SO cord with male plug at one end and female connector at other end.
  2. Connectors shall be NEMA 5-15 15A 125V, Hubbell 2311 (plug) and 2313 (connector), Leviton 5266-CB (plug) and 5269-CB (connector), or approved equal.
- G. Two-fers
1. Two-fers shall contain one male plug and two female connectors, wired in parallel with molded "Y" configuration.
  2. Cable shall be 12-3 type SO cord.
  3. Refer to Paragraph 2.2 for specification of connectors.
- H. Adapters
1. Adapters shall be constructed of 12-3 type SO cord, 18 inches long, with a male plug at one end and a female connector at other end.
  2. Connector types as per Schedule.
- I. Safety cables
1. Minimum 1/8" aircraft cable, with 2" diameter loops on each end, seized by swaged copper sleeves; one loop shall include an operable spring clip rated for 200 pounds breaking strength, Acco 2450-7 or approved equal. Finished cable length: 36 inches.
- J. Color media
1. 20" x 24" sheets of theatrical color media.
  2. Roscolux, Lee Filters, and Gamcolor media.
  3. Colors per Schedule.
- K. Color Filter Storage Cabinet
1. To accept 20" x 24" color media sheets.
  2. 10 shelves, with 50-sheet capacity per shelf.
  3. Modular Filter Storage Cabinet by Lee Filters, Totowa, New Jersey.
- L. Ghostlight
1. 72" stand with tripod base including locking casters, cable hook and lamp guard.
  2. 25' cable lead.
  3. Wiring: 12g three-conductor.

4. Connector: 15a parallel blade.
  5. Socket: medium screw base.
  6. Lamp: self-ballasted EFD Spiral compact fluorescent lamp, 13w: Panasonic 13w Spiral EFD13E28 or approved equal.
  7. UL Listing required.
  8. Altman Stage Lighting "GHOST," or approved equal.
- M. Tie Line
1. 1/8" Diameter, uncoated.
  2. Color: Black
- N. Gaffers Tape
1. 2" wide by 60 yards, each roll
  2. Colors: Black and White
  3. "Permacel" or "Pro-Gaff"
- O. Quantities, lengths, and types as per Schedule.
- P. Deliver to Owner.

## 2.13 THEATRE SCHEDULE OF QUANTITIES

<u>Section</u>	<u>Description</u>	<u>Quantity</u>
2.2	Connectors..... 1 for each unit, installed	
	Spare Connectors, Male.....	6
	Spare Connectors, Female .....	6
2.3	Followspots .....	2
2.4	Ellipsoidal Reflector spotlights:	
B1	50 degree.....	5
B2	36 degree.....	15
B3	26 degree.....	10
B4	19 degree.....	10
2.5	Ellipsoidal Reflector spotlights - Spare Lens tubes	
B1	50 degree.....	2
B2	36 degree.....	2
B3	26 degree.....	2
B4	19 degree.....	2
2.6	PAR Spotlights.....	40
2.7	Mini-Strip Lights .....	6
2.8	LED PAR Spotlights .....	6
2.9	Portable Multi-Conductor Cable Extension Assemblies .....	
E1	25-feet.....	6
E2	10-feet.....	6
2.10	Multi-Conductor Cable Break-out Assemblies .....	12
2.11	Automated Luminaires .....	4
2.15	A Pattern holders.....	40
	B F-stop "donuts".....	40
	C Drop-in iris assemblies.....	4
	D Top hats -for 50,36,26, and 19-degree ellipsoidal.....	20
	E Stage cable -	
	25 ft.....	10
	10 ft.....	10
	5 ft.....	10
	F Extension cords - 50 ft.....	10
	G Two-fers.....	24
	H Slip Pin / Parallel Blade.....	6
	H Parallel Blade / Slip Pin.....	6
	I Safety cables.....	140
	J Color Media ..... 100 sheets – See Schedule Below	
	K Color Media Storage cabinet.....	2
	L Ghostlight.....	1

2.13 THEATRE SCHEDULE OF QUANTITIES, PAGE 2

2.15	M	Tie-Line.....	1-600' foot spool
	N	Gaffers Tape - White.....	2 rolls
	N	Gaffers Tape – Black .....	24 rolls

Lamps -

Followspots..... 2

10°, 26°, 36°, and 50° Ellipsoidal Spotlights – as required plus 20% spares

PAR spotlights - 575 watt- .....as required plus 20% spares

Mini-Strip lights – 75 watt MR-16 EYC (wide), frosted - as required plus 20% spares

Color frames: One for each unit, plus 50% spares.

C-clamps: One for each unit, installed.

2.14 THEATRE SCHEDULE OF COLOR

<u>Manufacturer</u>	<u>Number &amp; Name</u>	<u>Quantity</u>
ROSCOLUX	01-Light Bastard Amber	4
	02-Bastard Amber	3
	08-Pale Gold	2
	17-Light Flame	2
	26-Light Red	6
	33-No Color Pink	3
	35-Light Pink	2
	52-Light Lavender	3
	58-Deep Lavender	5
	62-Booster Blue	3
	65-Daylight Blue	2
	68-Sky Blue	2
	76-Light Green Blue	2
	80-Primary Blue	6
	91-Primary Green	6
	94-Kelly Green	2
	97-Light Grey	2
	101-Light Frost	1
104-Tough Silk	3	
114-Hamburg Frost	3	
LEE FILTERS	HT 132-High temperature Medium Blue	2
	HT 141-High temperature Bright Blue	2
	136-Pale Lavender	2
	161-Slate Blue	3
	176-Loving Amber	4
	111-Dark Pink	3
	201-Full C.T. Blue	3

<u>Manufacturer</u>	<u>Number &amp; Name</u>	<u>Quantity</u>
GAMCOLOR	160-Chorus Pink	2
	290-Fire Orange	2
	540-Pale Green	2
	680-Kelly Green	2
	848-Bonus Blue	2
	950-Purple	3
	990-Dark Lavender	3
	65-Medium GAM Silk	1
	68-Light GAM Silk	1
	TOTAL SHEETS	100

### 3. EXECUTION

#### 3.1 FABRICATION

- A. Operating elements shall be mechanically safe and electrically "dead."
- B. All steel parts and panels shall be cleaned and primed with rust inhibiting primer. Exterior finishes shall be epoxy resin or baked enamel in matte black, or in Manufacturer's standard color where not specified.
- C. All internal wiring shall be factory completed. All wiring shall be in harnesses and bound. No loose or randomly routed wires shall be permitted.
- D. All wire sizes and insulation shall comply with NEC and UL meet or exceed electronics industry standards.

#### 3.2 PACKING AND SHIPPING

- A. Equipment shall be wrapped and sealed in polyethylene and substantially crated for shipment. Crates shall clearly indicate equipment contained, nature of components, and theatre site allocation.

#### 3.3 INSTALLATION

- A. Install all items in conformity with standard trade practices and Manufacturer's recommendations.
- B. Consult and coordinate work with trades doing adjoining work.
- C. Do not uncrate, unpack, unwrap, or install control console, video monitor(s), remote controls, or other auxiliary control components until construction is complete and environment is clean and dust-free.
- D. Align all ellipsoidal spotlights for cosine (hot center) alignment at jobsite, prior to delivery to Owner. Such alignment to be supervised by experienced representatives of theatrical Dealer Note: If union jurisdictions do not allow on-site work to be performed by theatrical Dealer, Dealer shall train and supervise union electrical workers in the alignment of ellipsoidal spotlights.

**END OF SECTION 11 61 34**

**SECTION 12 6100**  
**FIXED AUDIENCE SEATING**

**PART 1 GENERAL**

**1.1 DEFINITIONS**

- A. Technical terms unique to theatre seating and related work shall be construed in the following order, in accordance with:
1. Captions on related Drawings.
  2. Relevant usage and definitions of handbooks, guidebooks, or trade group recommendations by manufacturers' associations or professional societies, such as BIFMA, etc.
  3. Generally recognized theatrical usage

**1.2 SCOPE**

- A. All materials, components, and services necessary to provide a complete system indicated in this Section, as specified herein and shown on related Drawings, including:
1. Preparation and submission of complete shop drawings and samples for review prior to fabrication.
  2. Verification of dimensions and conditions at the job site.
  3. Shipment of equipment to job site and the secured storage of all non-fixed equipment.
  4. Installation and completion, in accordance with these Specifications, related Drawings, the Equipment Manufacturer's recommendations, established trade criteria, and all applicable code requirements.
  5. The inspection, demonstration, and necessary adjustment of the completed installation by the Contractor's engineering personnel.
  6. Preparation and submission of complete record drawings and operational and maintenance data and certificates.
  7. Seating specified in this Section is long lead. Manufacturer shall communicate with the Owner and General Contractor sufficiently in advance to ensure no delays in project completion

**B. WORK INCLUDED**

1. Furnish and install fixed seating as indicated on the drawings and as specified herein, in the following location(s):
  - a. Provide and install fixed audience seating in the Auditorium
2. Maintenance Materials
3. Coordination of Work
  - a. Coordinate installation of electrical wiring and transformer quantities and locations with seating layout. Ensure that junction boxes for aisle lights are located inboard of aisle light standards as shown in Drawings.
  - b. Coordinate seating layout as required with under-floor air distribution grille locations.

The above is for reference only and is not intended to define the limits of the work for a complete installation.

**C. WORK NOT INCLUDED**

1. Electrical wiring, conduit, and connections.



2. Concrete or other flooring finishes.
3. Handrails

The above is for reference only and is not intended to define the limits of the work for a complete installation.

### **1.3 RELATED WORK IN OTHER SECTIONS**

- A. Concrete and masonry.
- B. Painting and finishing.
- C. General electrical work.
- D. Mechanical Systems

### **1.4 QUALIFICATIONS**

- A. All equipment and installation shall be the responsibility of a single manufacturer who shall own and operate a full-time, staffed shop for the fabrication and assembly of fixed theatre seating. This Manufacturer shall assume complete responsibility for the design, fabrication, transportation, and installation of the work in this Section, and shall hold the Owner, Architect, Theatre Consultant, and all their Employees and Consultants harmless for any costs for errors or omissions associated with the work of this Section and any action arising there from.
- B. Approved manufacturers may, at their option, arrange for sub-contract field and special shop work to be done by others. Bid submissions must identify such subcontractors and indicate the work they are to do.
- C. Manufacturer shall engage a manufacturer-approved, locally based, experienced installer who regularly installs and services auditorium and theater seating similar in kind, quality, and extent to that indicated for Project. A competent supervisor shall be maintained on this Project during the entire installation. A change of supervisor shall not be acceptable unless by written authorization of the Architect.
- D. The Manufacturer and Installer shall have at least 10 years' experience in the installation of similar equipment and scope for university theatres. If requested, the Manufacturer shall submit a representative list of university theatre installations during the above period.
- E. Subject to the above requirements, work performed under this Section may be by one of the following listed manufacturers:
  1. American Seating Company, Grand Rapids, Michigan
  2. Ducharme Seating International, Montreal, Quebec, Canada
  3. Irwin Seating, Grand Rapids, Michigan

Other manufacturers may be considered with the prior review of the Theatre Consultant.

Manufacturers seeking review must contact the Theatre Consultant not later than 14 days prior to bid date.

### **1.5 SUBMITTALS**

- A. General: Submit in accordance with the General Conditions as described in the Project Manual.
- B. Submit Following with bid:
  1. Proof that the firm has been continuously engaged in the fabrication and installation of fixed theatre seating during the past 10 consecutive years.
  2. A list of at least three (3) installations by the bidder comparable to this project in scope including the same installation supervisor.

3. A list of any proposed deviations or exceptions from the Specifications. Any deviations or exceptions from the Specification proposed after bid shall not be accepted.
  4. A schedule for the anticipated completion of the following:
    - a. Shop drawings
    - b. Delivery of all equipment
    - c. Installation of all systems
- C. Shop drawings: Within 30 days of receipt of order, the Manufacturer shall submit at least one set of reproducible shop drawings and equipment data sheets to the Architect for distribution to the Theatre Consultant and Acoustics Consultant for review and action prior to fabrication:
1. Plan and section in scale equal to 1/4" = 1'-0".
  2. Complete, fully dimensioned shop drawings of all major components.
  3. Requisite plans, sections, schematics, and details indicating assembly and installation of components.
  4. Complete counts of every seat feature, including but not limited to:
    - a. End Standards
    - b. Aisle Lights
    - c. Transfer Arms
    - d. Row ID
    - e. Chair ID
  5. Quantities of each component and sub-assembly.
  6. Indication by boxed caption of any and all variations from the contract Drawings and Specifications, whether or not these variations have been formally or informally accepted by the Architect or Theatre Consultant.
  7. Product certificates signed by manufacturers certifying that their products comply with specified fire safety requirements as outlined in this Section.
  8. Product certificates signed by manufacturers certifying that their products comply with specified LEED requirements as outlined in Division One.
  9. Finish and fabric samples for architect selection.
  10. Two (2) 30-inch square "quality" sample of seating fabric for approval by Architect and Acoustical Consultant.
  11. A sample chair the same as to be supplied in the contract except for finishes and fabrics.
  12. Samples of any equipment component requested.
  13. Samples shall not be considered part of specified quantities but shall be returned.
  14. Provide acoustical testing data to the Acoustics Consultant. In addition, submit samples of cushion materials and fabrics used in the tests to the Architect and Acoustics Consultant.
- D. PROTOTYPES
1. Prior to fabrication of seating, provide for review by Owner, Architect and Theatre Consultant, a prototype as described below:
    - a. Build prototype as shown in Drawings
      - i. Include six-foot cord and 15A standard parallel blade and ground plug for both aisle lights.
      - ii. Aisle lights in prototype will be used to evaluate provided illumination levels. This will not relieve the manufacturer from responsibility to ensure seat-mounted aisle lights provide code required illumination levels for all interior aisles.

2. Deliver prototype to location as directed by Architect.
  3. Obtain Owner, Architect and Theatre Consultant acceptance of prototypes before beginning production of seating for Project.
  4. Prototype shall be retained at the site during construction in undisturbed condition as a standard for judging completed seating.
    - a. When directed, remove prototype from Project Site.
- E. Final submittal. Within 30 days of final tests, and as a condition for final review, the Contractor shall submit to the Architect:
1. Receipts for delivery of all non-installed items, i.e., all items designated, "Deliver to Owner."
  2. Three (3) sets to the Architect and one (1) set on electronic media to the Theatre Consultant, Format of sets shall be compliant with Division One of this Specification.
    - a. "As built and approved" drawings and wiring diagrams showing all systems and components as installed, including all field modifications.
    - b. Operation and service manuals, schematics, and parts lists for each unit of equipment installed or provided.
    - c. Certification that all components and assemblies comply with specified fire safety requirements as outlined in this Section.
    - d. Certification that all components and assemblies comply with specified LEED requirements as outlined in Division One.
    - e. Certificates of warranty, as set forth below.

#### **1.6 DELIVERY, STORAGE, AND HANDLING**

- A. Comply with requirements of the relevant sections of the General Conditions in the Project Manual.
- B. Deliver seating in manufacturer's unopened cartons clearly labeled with manufacturer's name and contents.
- C. Inspect deliveries upon arrival to verify no items are damaged. Immediately order replacement of damaged materials at no cost to Owner.
- D. Store seating in dry location protected from damage and soiling under environmental conditions acceptable to manufacturer.
- E. Handle seating in a manner to prevent damage.

#### **1.7 TESTING AND INSTRUCTION**

- A. Upon completion of all installation work, the Manufacturer shall certify in writing to the Architect and Owner that the work is complete and ready for final observation. Final observation shall be scheduled by the Owner, the Architect and Theatre Consultant to occur within 14 days following the Contractor's notice of completion. Costs of additional or repeat tests due to delay or negligence on the part of the Seating Manufacturer shall be borne by the Seating Manufacturer. These costs include the Architect and Theatre Consultant at their current hourly rates and the direct expenses resulting from this delay or negligence.
- B. Final observation shall be conducted by a knowledgeable representative of the Manufacturer, in the presence of the Owner, the Architect and Theatre Consultant, and shall include the following:
  1. Operation of all components.
  2. Visual examination of all components.
  3. Necessary adjustments or modifications shall be made as required.

- C. Manufacturer's representative shall instruct Owner's designated staff or representatives in the safe operation, maintenance and replacement of all components, including the storage and cleaning of all fabrics. This instruction session shall be scheduled to last a minimum of two (2) hours. While it may be possible to schedule this instruction session to coincide with the system checkout, such coincidence shall not be assumed.

**1.8 MAINTENANCE MATERIALS**

- A. Furnish extra materials described below matching products installed, packaged with protective covering for storage and identified with labels clearly describing contents. Provide sufficient material to provide two (2) percent, but not less than one of each component type and size for each seat back, pan, standard, fastener, aisle light and cushion.
- B. Upholstery fabric in size and quantity required to reupholster two (2) percent of each size of installed seats and backs.

**1.9 WARRANTY**

- A. The Manufacturer shall unconditionally warrant all components and installation provided under this Section to be free from defects in materials and workmanship for a period of at least 60 months from the date of final acceptance of all work of this Section.
- B. Appropriate additional equipment to replace equipment removed for service shall be provided at the job site at no expense to the Owner to replace any and all equipment which must be removed for service.
- C. All warranty service shall be performed by technicians certified by the manufacturer for the installed equipment.

**2. PRODUCTS**

**2.1 GENERAL**

- A. Seats shall use materials which are carefully selected to be free of defects, objectionable projections, or irregularities. Ease all corners and edges, and select exposed fasteners to prevent snagging and pinching hazards.

**2.2 ACOUSTICAL REQUIREMENTS**

- A. The acoustical testing shall demonstrate that the following sound absorption values are not exceeded:

- 1. Maximum Sound Absorption Values (Sabins/Seat):

	Octave Band Center Frequency (Hz)					
	125	250	500	1000	2000	4000
Occupied	4.0	4.5	6.5	7.2	7.2	7.2
Unoccupied	2.5	3.0	3.7	3.7	3.7	3.5

- B. Action of self-rising seat shall not produce an excessive amount of noise (squeaking or impact noise). . All springs shall be damped at all metal contact points. Hardware shall be permanently lubricated; stops shall be cushioned. The sound level of self-rising seats shall not exceed 30 dB-A when measured 3 feet from the seat using a precision sound level meter on the fast response.
- C. The Architect and Acoustics Consultant shall assess degree of noise produced

## 2.3 PERFORMANCE CHARACTERISTICS

- A. Chairs provided under this specification shall be compliant with all applicable codes. It shall be the Manufacturer's responsibility to provide documentation of compliance.
- B. Testing and Compliance
  - 1. The seats shall be certified to withstand a 600 pound static load, laterally distributed three inches from the leading edge of the seat.
  - 2. The seat shall also be certified to pass seat cycle oscillation testing, ASTM F851-87 and sandbag testing.
- C. Fire
  - 1. Such requirements shall include but may not be limited to the following standards:
    - a. Federal Motor Vehicle Safety Standard No. 302.
    - b. Class 1 requirements of U.S. Department of Commerce, CS 191-52.

## 2.4 MANUFACTURERS

- A. Acceptable Manufacturers:
  - 1. American Seating – “Stellar 220”
  - 2. Ducharme Seating – “Comfort”
  - 3. Irwin Seating – “Citation”
- B. Basis of Design:
  - 1. American Seating – “Stellar 220”

## 2.5 MATERIALS

- A. Fabrics:
  - 1. Fabric as selected by Architect from manufacturer's graded collections.
    - a. American Seating – Provide Grade 6 Fabric in bid pricing.
    - b. Ducharme Seating – Provide Grade 1 Fabric in bid pricing.
    - c. Irwin Seating – provide \$20 per yard allowance.
- B. Steel: Provide with smooth surfaces and be of sufficient gauge thickness and designed to withstand strains of normal use and abuse. ASTM A 36
- C. Electrolytic Zinc-Coated Steel Sheet: ASTM A 591, commercial and drawing quality, Coating Class C, chemically treated for baked-enamel finish and not less than 0.0396 inch thick.
- D. Padding Material: Seat and back padding material shall be of cold molded closed cell polyurethane foam.
- E. Wood
  - 1. Exposed plywood shall be hot press laminated using high frequency process. Interior plies shall be Class 3 or better. Exposed exterior plies shall be Class 1.
  - 2. Concealed plywood shall be hot press laminated using high frequency process. All plies shall be Class 3 or better.
  - 3. Exposed solid wood shall be grain matched hardwood, kiln dried, free from knots and blemishes. Species and appearance shall be consistent within each seat and from seat to seat.
  - 4. Surface applied wood veneers shall be Class 1.

F. Plastics

1. Plastic Seat backs shall be made of high-density polyethylene. Seat backs shall be one-piece injection molded shapes.

## 2.6 FINISHES

- A. Metal Parts: All ferrous metal parts, both exposed and non-exposed, shall be electrostatic powder coated. All coatings shall be consistent in appearance. All metal coatings shall have a dry film thickness of at least two millimeters and shall pass the 2H pencil hardness test.
- B. Wood Parts: All exposed surfaces shall be stained to color selected and finished with a clear plastic sealant of sufficient film depth to afford wear resistance of institutional quality.
- C. Hardware: All assembly hardware shall be rust resistant, black plated.

## 2.7 STANDARDS

- A. The standards shall be manufacturer's standard design made by a rectangular tube of sufficient gauge steel.
- B. A reinforced bracket for seat pan attachment shall be integrated into the standard.
- C. The seat pan shall be anchored to the standard by bolts.
- D. A support for attachment of the back shall be provided.
- E. The top of the column shall provide for armrest attachment.
- F. The standard shall each be attached to the concrete floor by 2-1/4 inch x 2 inch expansion bolts set in holes drilled to a depth of not less than 1-1/4 inches.
- G. The footplate shall be designed to follow the slope of the seating bowl floor.
- H. Standards shall be manufactured to conform to floor and riser conditions as shown in Drawings while maintaining seat and back dimensional and angular relationships throughout.

## 2.8 END PANELS

- A. Provide end panels, as selected by Architect from Manufacturer's catalog, securely attached to aisle standards with concealed fasteners.
- B. Exposed face shall be wood veneer, stain color as selected by Architect.
- C. Edges shall be finished with hardwood matching veneer edgebanding.

## 2.9 SEAT ASSEMBLIES

- A. Two-part seat assembly of arch-spring construction indicated below with upper part removable for reupholstering without removing pan from chair.
- B. Cushion shall be molded polyurethane foam padding tapered from 3 inches thick at the leading edge to 1-1/2 inches thick at the rear, over not less than five serpentine springs attached to reinforced steel frame; with weight-distributing and abrasion resisting sheeting separating padding from springs; upholstered with fabric sewn into box construction without welts and securely attached to frame to produce surfaces free of creases, stretch lines, or wrinkles. Fabric shall be removable without damaging any component.
- C. Seat pan shall be a single piece, sheet steel pan or molded polypropylene. Pan shall be reinforced at stress points and shall completely enclose the hinges and self-rising seat mechanisms.
- D. The seat shall rotate on two (2) hinge rods. Hinge rods shall be securely engaged in seat standard pivots. Bearing surfaces shall be low friction and permanently lubricated, requiring no maintenance. Seat-lift shall be accomplished by compression springs and self-lubricating plastic

cams. Seat shall automatically return to a full fold position. It shall be possible to rotate the seat to full-fold position with slight additional rearward pressure.

## **2.10. SEAT BACK ASSEMBLIES**

- A. Backs shall be of plywood construction with an upholstered front, and shall consist of two (2) parts; an upholstered panel and an exposed plastic rear panel.
- B. Cushion shall be high density closed cell cold cured sculpted non-skinning molded foam: density 3.5 pounds/cubic foot, padding measuring not more than 2 inches thick.
- C. Plywood base shall be a minimum of 5/8-inch thick. The cushion shall be securely cemented to plywood base with no voids occurring between the base and the foam.
- D. The exposed back panel shall be plastic, formed on the same radius as the upholstered panels. The exposed back panel shall not be less than 26 inches long and shall protect seat in raised position. Color shall be selected by Architect from manufacturer's standard colors.
- E. Exposed back panel shall be securely connected to the upholstery panel.
- F. Backs shall be designed and installed so as to achieve an even and consistent gap between seat back panels within each row except at aisle locations.
- G. Seat Back Assembly shall utilize steel back wings for connection to standards. Wings shall have provision for 12 degree, 16 degree and 20 degree pitch.

## **2.11 ARMRESTS**

- A. Armrests shall be provided at each aisle and between seats.
- B. Armrests shall be designed for concealed mounting to standards with all edges well rounded.
- C. Armrests shall be removable for repair or replacement.
- D. Armrests shall be at least 2-3/8 inches in width.
- E. Armrests shall be solid wood construction subject to the requirements noted above.

## **2.12 ACCESSORIES**

- A. Moveable Bases:
  - 1. Manufacturer's standard steel bases to provide for mobility of seats in multiple quantities as shown on Drawings.
  - 2. All components of the bases shall have rounded edges. Ends of components shall be ground smooth and finished to match.
  - 3. No part of the base assembly shall extend beyond the footprint of the seat when the pan is in the lowered position.
- B. Designated Aisle Access Standards: Manufacturer's ADA compliant tilt-up arm aisle standard in locations as shown on the Drawings. Standard shall include aisle light where indicated.
- C. Seat and Row Identification System:
  - 1. System shall utilize satin finish brass plates with etched characters.
  - 2. Seat identification plates:
    - a. Mount into vandal-resistant recess at front edge of seat pan, clearly viewable from above when seat pan is in folded position and secure with two rivets.
    - b. Rectangular with black characters not less than 3/8-inch in height.
    - c. Attachment hardware finish shall match plate faces.

3. Row identification plate
  - a. Mount at center of end panel in routed recess for flush, non-snagging, finish. Location shall place plate to ensure that the aisle lighting system illuminates the plate.
  - b. Round, 2 inch diameter, with black letters. Letters shall be at least 1 inch in height.
  - c. Attachment hardware finish shall match plate faces.

### **2.13 AISLE LIGHTING**

- A. Aisle Lights shall be LED and mounted on the seats as shown on the Drawings.
- B. Color Temperature of LED fixture shall be 3000 degrees Kelvin (Warm White).
- C. Wiring Harness shall be factory wired and routed through the end standard assembly. Harness shall be protected from sight and damage and shall terminate in an 18 inch long flexible whip for connection to the electrical junction box. Design wiring harness to operate with all ADA designated aisle seats, as required.
- D. Provide a complete working system including, if applicable, all required transformers and electrical requirements for installation by the Electrical Contractor. Transformers shall be installed outside the performance space.
- E. Seating manufacturer is responsible for ensuring that code-mandated illumination is provided by the seat-mounted aisle lights for all aisle conditions adjacent to end standards of installed seats.
- F. Fixture may not produce more than 0.1fc at 36 inches from the fixture above a line parallel to the floor at the elevation of the installed fixture.
- G. Surface mounted fixtures shall be a Tivoli "Beacon" or approved equal product mounted to the end panel as shown in the Drawings.

### **2.14 SPARE PARTS**

- A. Provide a quantity of seat and back component parts equal to two percent but not less than one each of each component in each size of the total amount installed. All spare components are to be labeled for size, venue and component type.
- B. Provide all fixed and removable seating units noted including removable seating units designed to fill all wheelchair locations.
- C. Provide 20 yards of upholstery fabric from the same dye lot as the installed seats. Extra fabric shall be wrapped, labeled and turned over to owner at completion.

## **3. EXECUTION**

### **3.1 PROJECT CONDITIONS**

- A. Environmental Requirements: Do not install seating until space is enclosed and weatherproof, wet-work in space is complete and nominally dry, installation of finishes including painting is complete, other units of Work adjacent or overhead are complete; and ambient temperature and humidity conditions will be continuously maintained at values near those indicated for final occupancy.

### **3.2 EXAMINATION**

- A. Examine conditions and proceed with work when substrates are ready.
- B. Examine substrates and conditions, with installer present, for compliance with requirements for construction tolerances, material properties as they affect anchors and fasteners, and location of junction boxes. Do not proceed with installation until unsatisfactory conditions have been corrected.



### 3.3 INSTALLATION

- A. Manufacturer shall engage a manufacturer-approved, locally based, experienced installer who regularly installs and services auditorium and theater seating similar in kind, quality, and extent to that indicated for Project. A competent supervisor shall be maintained on this Project during the entire installation. A change of supervisor shall not be acceptable unless by written authorization of the Architect.
- B. Seating Layout: Install seating to conform with Project Documentation in a manner that produces seating layouts with standards spaced laterally in each row so that end standards are in alignment from first to last row, regardless of whether aisles converge or are of constant width, and with backs and seats varied in width so that sightlines are optimized.
- C. General: Comply with Manufacturer's printed installation instructions applicable to products and application indicated.
- D. Locate all seats in locations indicated on approved shop drawings, with designed and required clearances, elevations, sight lines, aisles and aisle accessways.
- E. Install standards in locations conforming to seating layout, with each standard attached to substrate by not less than two (2) anchoring devices of size and type required to produce chairs free from rock or instability under conditions of actual use.
- F. Install chairs by mounting components to standards, or brackets mounted on standards, using manufacturer's recommended hardware and fasteners. Ensure that chairs in curved rows are installed at the specified radius, and verify that moving components operate smoothly and quietly.
- G. Installation review for compliance will include, but shall not be limited to the following:
  - 1. All end standards shall be plumb and shall be installed at a constant dimension from the aisle edge  $\pm$  1/4-inch variation allowed within a seating section with no more than 1/8-inch variation allowed between adjacent rows.
  - 2. All seat backs shall be aligned with a consistent back pitch angle. Allowable variation of not more than 0.25 degrees between adjacent seats and not more than 0.75 degrees across the length of a row.
  - 3. Gaps between seat backs shall be constant with no more than 1/4-inch variation between adjacent seats and no more than 1/2-inch variation between the largest gap and smallest gap within a seating section.
  - 4. Seat stagger shall be as shown in the drawings. Deviation is not allowed without approval of the Architect and Theatre Consultant.
  - 5. Seat Pans shall all automatically rise to a consistent position without noise as outlined in Paragraph 2.2 of this Specification. Position variation of no more than 1/8-inch between adjacent seats and not more than 1/4-inch within a row shall be allowed. Dimension shall be measured from the most projective portion of the seat pan to the front edge of the armrest.
  - 6. Coordination with in-floor electrical and mechanical devices shall be as drawn. Deviation shall require approval from the Architect. Unless noted otherwise, all in-floor air grilles shall be centered between seat standards and shall not project past the edge of the seat pan in its stored position. Aisle light junction boxes shall be not more than 10 inches from the seat standard and aligned with the seating layout line.
  - 7. Aisle lights shall be consistent in appearance. Appreciable variation in color temperature, output, distribution and alignment shall not be allowed.
  - 8. Seat and Row Identification plates shall be securely attached and free from scratches and blemishes. Design, location, font, and alignment shall be consistent throughout the project.
  - 9. Unless otherwise notified in writing by the General Contractor, responsibility for the condition of the seat fabric and all other seat finishes shall be the responsibility of the seating

manufacturer until substantial completion or review of the seating installation, whichever is later. Fabric and all other finishes shall be smooth, clean and unblemished.

10. All surfaces and edges shall be smooth to the touch and free of protrusions that will cause injury or damage to clothing.
11. Packaging and protective coverings shall be removed from the site and disposed of in accordance with jobsite protocol and mandated requirements.

### **3.4 ADJUSTING**

- A. Adjust self-rising seat mechanisms as required to ensure that seats in each row are aligned when in upright position.
- B. Touch-up minor abrasions and imperfections in painted finishes with coating which matches factory-applied finish.
- C. Replace upholstery which has been damaged in installation.

**END OF SECTION 12 6100**

## **DIVISION 22 - PLUMBING**

### **SECTION 22 13 16**

#### **SANITARY WASTE AND VENT PIPING**

##### **PART 1 - GENERAL**

###### **1.1 SUMMARY**

- A. Section includes the following for soil, waste, and vent piping inside the building:
  - 1. Pipe, tube, and fittings.
  - 2. Special pipe fittings.

###### **1.2 DEFINITIONS**

- A. EPDM: Ethylene-propylene-diene terpolymer rubber.
- B. NBR: Acrylonitrile-butadiene rubber.

###### **1.3 SUBMITTALS**

- A. Product Data: For pipe, tube, fittings, and couplings.
- B. Shop Drawings:
- C. Field quality-control inspection and test reports.

###### **1.4 QUALITY ASSURANCE**

- A. Piping materials shall bear label, stamp, or other markings of specified testing agency.

##### **PART 2 - PRODUCTS**

###### **2.1 MANUFACTURERS**

- A. Manufacturers: Subject to compliance with requirements, provide products by one of the manufacturers specified.
  - 1. Flexible, Nonpressure Pipe Couplings:
    - a. Fernco, Inc.
    - b. Logan Clay Products Company (The).
    - c. Mission Rubber Co.
    - d. NDS, Inc.
  - 2. Shielded Nonpressure Pipe Couplings:
    - a. Cascade Waterworks Mfg. Co.
    - b. Mission Rubber Co.

3. Rigid, Unshielded, Nonpressure Pipe Couplings:
  - a. ANACO.
4. Pressure Pipe Couplings:
  - a. Cascade Waterworks Mfg. Co.
  - b. Dresser, Inc.; DMD Div.
  - c. EBAA Iron Sales, Inc.
  - d. JCM Industries, Inc.
  - e. Romac Industries, Inc.

## **2.2 PIPING MATERIALS**

- A. Refer to PART 3 "Piping Applications" Article for applications of pipe, tube, fitting, and joining materials.

## **2.3 COPPER TUBE AND FITTINGS**

- A. Hard Copper Tube: ASTM B 88, Type L (ASTM B 88M, Type B), water tube, drawn temper.
  1. Copper Drainage Fittings: ASME B16.23, cast copper or ASME B16.29, wrought copper, solder-joint fittings.
  2. Copper Pressure Fittings: ASME B16.18, cast-copper-alloy or ASME B16.22, wrought-copper, solder-joint fittings. Furnish wrought-copper fittings if indicated.
  3. Copper Flanges: ASME B16.24, Class 150, cast copper with solder-joint end.
  4. Copper Unions: MSS SP-123, copper-alloy, hexagonal-stock body with ball-and-socket, metal-to-metal seating surfaces, and solder-joint or threaded ends.

## **PART 3 - EXECUTION**

### **3.1 PIPING APPLICATIONS**

- A. Flanges and unions may be used on aboveground pressure piping, unless otherwise indicated.
- B. Aboveground, soil and waste piping NPS 3 (DN 75) and smaller shall be any of the following:
  1. Copper tube, copper drainage fittings, and soldered joints.
  2. Dissimilar Pipe-Material Couplings: Rigid, unshielded, nonpressure pipe couplings for joining dissimilar pipe materials with small difference in OD.
- C. Aboveground, vent piping NPS 3 (DN 75) and smaller shall be any of the following:
  1. Copper tube, copper drainage fittings, and soldered joints.
  2. Dissimilar Pipe-Material Couplings: Rigid, unshielded, nonpressure pipe couplings for joining dissimilar pipe materials with small difference in OD.

### **3.2 PIPING INSTALLATION**

- A. Basic piping installation requirements are specified in Division 23 Section "Basic HVAC Materials and Methods."

- B. Make changes in direction for soil and waste drainage and vent piping using appropriate branches, bends, and long-sweep bends. Sanitary tees and short-sweep 1/4 bends may be used on vertical stacks if change in direction of flow is from horizontal to vertical. Use long-turn, double Y-branch and 1/8-bend fittings if 2 fixtures are installed back to back or side by side with common drain pipe. Straight tees, elbows, and crosses may be used on vent lines. Do not change direction of flow more than 90 degrees. Use proper size of standard increasers and reducers if pipes of different sizes are connected. Reducing size of drainage piping in direction of flow is prohibited.
- C. Install soil and waste drainage and vent piping at the following minimum slopes, unless otherwise indicated:
  - 1. Building Sanitary Drain: 2 percent downward in direction of flow for piping NPS 3 (DN 80) and smaller; 1 percent downward in direction of flow for piping NPS 4 (DN 100) and larger.
  - 2. Horizontal Sanitary Drainage Piping: 2 percent downward in direction of flow.
  - 3. Vent Piping: 1 percent down toward vertical fixture vent or toward vent stack.
- D. Install engineered soil and waste drainage and vent piping systems as follows:
  - 1. Combination Waste and Vent: Comply with standards of authorities having jurisdiction.
- E. Do not enclose, cover, or put piping into operation until it is inspected and approved by authorities having jurisdiction.

### **3.3 JOINT CONSTRUCTION**

- A. Basic piping joint construction requirements are specified in Division 23 Section "Basic HVAC Materials and Methods."
- B. Soldered Joints: Use ASTM B 813, water-flushable, lead-free flux; ASTM B 32, lead-free-alloy solder; and ASTM B 828 procedure, unless otherwise indicated.

### **3.4 HANGER AND SUPPORT INSTALLATION**

- 1. Pipe hangers and supports are specified in Division 23 Section "Hangers and Supports for Piping and Equipment." Install the following:
  - a. Vertical Piping: MSS Type 8 or Type 42, clamps.
- 2. Install individual, straight, horizontal piping runs according to the following:
  - a. 100 Feet (30 m) and Less: MSS Type 1, adjustable, steel clevis hangers.
- 3. Base of Vertical Piping: MSS Type 52, spring hangers.
- B. Install supports according to Division 23 Section "Hangers and Supports for Piping and Equipment."
- C. Rod diameter may be reduced 1 size for double-rod hangers, with 3/8-inch (10-mm) minimum rods.

- D. Install hangers for copper tubing with the following maximum horizontal spacing and minimum rod diameters:
  - 1. NPS 1-1/4 (DN 32): 72 inches (1800 mm) with 3/8-inch (10-mm) rod.
  - 2. NPS 1-1/2 and NPS 2 (DN 40 and DN 50): 96 inches (2400 mm) with 3/8-inch (10-mm) rod.
  - 3. NPS 2-1/2 (DN 65): 108 inches (2700 mm) with 1/2-inch (13-mm) rod.
- E. Install supports for vertical copper tubing every 10 feet (3 m).

### **3.5 CONNECTIONS**

- A. Drawings indicate general arrangement of piping, fittings, and specialties.
- B. Connect soil and waste piping to exterior sanitary sewerage piping. Use transition fitting to join dissimilar piping materials.
- C. Connect drainage and vent piping to the following:
  - 1. Plumbing Fixtures: Connect drainage piping in sizes indicated, but not smaller than required by plumbing code.
  - 2. Plumbing Fixtures and Equipment: Connect atmospheric vent piping in sizes indicated, but not smaller than required by authorities having jurisdiction.
  - 3. Plumbing Specialties: Connect drainage and vent piping in sizes indicated, but not smaller than required by plumbing code.

### **3.6 FIELD QUALITY CONTROL**

- A. During installation, notify authorities having jurisdiction at least 24 hours before inspection must be made. Perform tests specified below in presence of authorities having jurisdiction.
  - 1. Roughing-in Inspection: Arrange for inspection of piping before concealing or closing-in after roughing-in and before setting fixtures.
  - 2. Final Inspection: Arrange for final inspection by authorities having jurisdiction to observe tests specified below and to ensure compliance with requirements.
- B. Reinspection: If authorities having jurisdiction find that piping will not pass test or inspection, make required corrections and arrange for reinspection.
- C. Reports: Prepare inspection reports and have them signed by authorities having jurisdiction.
- D. Test sanitary drainage and vent piping according to procedures of authorities having jurisdiction or, in absence of published procedures, as follows:
  - 1. Test for leaks and defects in new piping and parts of existing piping that have been altered, extended, or repaired. If testing is performed in segments, submit separate report for each test, complete with diagram of portion of piping tested.
  - 2. Leave uncovered and unconcealed new, altered, extended, or replaced drainage and vent piping until it has been tested and approved. Expose work that was covered or concealed before it was tested.
  - 3. Roughing-in Plumbing Test Procedure: Test drainage and vent piping, except outside leaders, on completion of roughing-in. Close openings in piping system and fill with water to point of overflow, but not less than 10-foot head of water (30 kPa). From 15 minutes

before inspection starts to completion of inspection, water level must not drop. Inspect joints for leaks.

4. Finished Plumbing Test Procedure: After plumbing fixtures have been set and traps filled with water, test connections and prove they are gastight and watertight. Plug vent-stack openings on roof and building drains where they leave building. Introduce air into piping system equal to pressure of 1-inch wg (250 Pa). Use U-tube or manometer inserted in trap of water closet to measure this pressure. Air pressure must remain constant without introducing additional air throughout period of inspection. Inspect plumbing fixture connections for gas and water leaks.
5. Repair leaks and defects with new materials and retest piping, or portion thereof, until satisfactory results are obtained.
6. Prepare reports for tests and required corrective action.

### **3.7 PERFORMANCE REQUIREMENTS**

- A. Components and installation shall be capable of withstanding the following minimum working pressure, unless otherwise indicated:

1. Soil, Waste, and Vent Piping: 10-foot head of water (30 kPa).

### **3.8 CLEANING AND ADJUSTING**

- A. Clean interior of piping. Remove dirt and debris as work progresses.
- B. Protect drains during remainder of construction period to avoid clogging with dirt and debris and to prevent damage from traffic and construction work.
- C. Place plugs in ends of uncompleted piping at end of day and when work stops.

**End of Section 221316**

## **DIVISION 23 – HEATING, VENTILATING AND AIR CONDITIONING**

### **SECTION 23 05 03**

#### **GENERAL PROVISIONS FOR HVAC WORK**

##### **PART 1 - GENERAL**

###### **1.1 SUMMARY**

- A. The work under Division 23 "Heating, Ventilating, and Air Conditioning (HVAC)" shall include all labor, services, materials and equipment and performance of all work required for the installation of all mechanical work as shown on the Drawings and herein specified in the following Sections.
- B. Should there be any discrepancies or a question of intent, refer the matter to the Architect/Engineer for decision before ordering any equipment or materials or before starting any related work.
- C. Where work connects to that of another trade, or to piping or equipment in place, take measurements in the field to make connecting work come true and line up with the item being connected.
- D. Where work specified under other Divisions of the Specifications connects to equipment which is a part of Division 23, provide proper connection(s) to such equipment.
- E. Minor items and accessories or devices reasonably inferable as necessary, to the complete and proper installation and operation of any system, shall be provided by the Trade Contractor for such system whether or not they are specifically called for by the Specifications or Drawings.
- F. The Drawings and Specifications are to be taken together. Work specified and not shown or work shown and not specified shall be performed or furnished as though mentioned in both Specifications and Drawings. If there is a discrepancy between the Drawings and Specifications as to the quantity or quality to be provided, the greater quantity or the better quality shall be provided.

###### **1.2 DEFINITIONS**

- A. "Piping" includes, in addition to pipe, all fittings, valves, hangers, and other supports and accessories related to such piping.
- B. "Ductwork" includes, in addition to ducts, all fittings, transitions, dampers, hangers and other supports and accessories related to such ductwork.
- C. "Concealed" means hidden from sight in chases, furred spaces, shafts, hung ceilings, embedded in construction, in crawl spaces or buried.
- D. "Exposed" means not installed underground or "concealed" as defined above.
- E. "Invert Elevations" means the elevation of the inside bottom of pipe or duct.
- F. "HVAC Work" is all of the work in Division 23.



### 1.3 QUALITY ASSURANCE

- A. Each major component of equipment to have the manufacturer's name, address, model number and rating on a plate securely affixed in a conspicuous place.
- B. Code Ratings, labels or other data which are die-stamped or otherwise affixed to the surface of the equipment shall be in visible location.
- C. All equipment provided under Division 23 to perform with the least possible noise and vibration consistent with its duty. Quietness of operation of all equipment is a requirement. Any equipment, as determined by the Owner's Representative, Architect/Engineer or School Principal to be producing objectionable noise or transmitting noise or vibration to the building to be repaired or removed and replaced.
- D. All workmanship shall be first class in every respect and shall be performed only by skilled mechanics.
- E. Shutdown and Notifications:
  - 1. It is imperative that service interruptions on the various existing utilities be held to an absolute minimum. Wherever possible provide suitable temporary services or connections, where continuity of service for essential systems can be maintained by this means. It will be the Owner's final prerogative to decide which systems are to be considered as essential, and to establish the maximum allowable shutdown time, if any, for each system.
  - 2. Owner will require not less than 72 hours advance notice, in writing, that an interruption of service in any system is desired. Such notice shall identify the system or systems involved, and shall be submitted in duplicate, one copy of which will be signed and returned by the Owner's authorized representative stating whether the requested shutdown will be permitted or not.
- F. Existing Utilities:
  - 1. Location of utilities as shown on the drawings has been determined from the best available information and is given for convenience; however, Owner does not assume responsibility in the event that during construction, utilities other than those shown may be encountered, and that the actual location of those which are shown may be different from the location as shown on the plans.
  - 2. Assume responsibility for interference with or damage to any existing utilities, and repair or replace same with the least possible delay.
- G. Notify Architect of broken or open pipes discovered during construction.
- H. Layout and establish the lines and levels necessary for work.
- I. The following Standards shall be used where referenced by the following abbreviations:
  - 1. AABC: Associated Air Balance Council
  - 2. ADC: Air Diffusion Council
  - 3. AGA: American Gas Association
  - 4. AIA: American Institute of Architects
  - 5. AMCA: Air Moving and Conditioning Association
  - 6. ANSI: American National Standards Institute

7. ARI: Air Conditioning and Refrigeration Institute
8. ASE: Association of Safety Engineers
9. ASHRAE: American Society of Heating, Refrigeration and Air Conditioning Engineers
10. ASME: American Society of Mechanical Engineers
11. ASPE: American Society of Plumbing Engineers
12. ASTM: American Society of Testing and Materials
13. AWPB: American Wood Preserves Bureau
14. AWS: American Welding Society
15. AWWA: American Water Works Association
16. CSA: Canadian Standards Association
17. CISPI: Cast Iron Soil Pipe Institute
18. EIA: Electronic Industries Association
19. EPA: Environmental Protection Agency
20. FDA: Food and Drug Administration
21. FM: Factory Mutual Insurance Association
22. HIS: Hydraulic Institute Standards
23. IRI: Industrial Risk Insurers
24. IBR: Institute of Boiler and Radiator Manufacturers
25. IEEE: Institute of Electrical and Electronics Engineers
26. MCAA: Mechanical Contractors' Association of America
27. NIST: National Institute of Standards and Testing
28. NEBB: National Environmental Balancing Bureau
29. NEC: National Electric Code
30. NECA: National Electric Contractors Association
31. NEMA: National Electrical Manufacturers Association
32. NFPA: National Fire Protection Association
33. NSC: National Safety Council
34. NSF: National Sanitation Foundation
35. OSHA: Occupational Safety & Health Administration
36. SAE: Society of Automotive Engineers
37. SBI: Steel Boiler Institute Industry
38. SMACNA: Sheet Metal and Air Conditioning Contractors National Association
39. TIMA: Thermal Insulation Manufacturers Association
40. UL: Underwriters' Laboratories
41. USDA: United States Department of Agriculture

J. Project Certification:

1. Each trade shall submit a project certification, guaranteeing that this project was constructed and will operate in accordance with the performance requirements of the Drawings and Specifications. This certification shall be signed by a principal of the firm and shall be delivered to the Architect/Engineer prior to final payment.

K. Drawings:

1. The Drawings are essentially diagrammatic in nature and show general arrangement of the equipment, piping, ductwork, accessories, etc. Because of the small scale of the Drawings, it is not possible to show each offsets, fittings, and accessories, which may be required. Carefully investigate the structural conditions, Architectural Drawings, Equipment Drawings, and the finished conditions of the work and arrange such work

accordingly, furnish any fittings, pipe accessories that may be required to meet such conditions.

2. Any changes from the plans necessary to make the work conform to building as constructed and to fit work of other trades, or to conform to rules of the governing authorities and regulations, shall be met without extra cost to the Owner.
3. The layout of the piping, ductwork, equipment, etc., as shown on the Drawings shall be checked and exact locations shall be determined by the dimensions of equipment approved and Contractor shall obtain the Architect's approval for revised layout before the apparatus is installed. Consult the Architectural, Structural, and Equipment Drawings for the dimensions, locations of partitions, locations and sizes of structural supports, foundations, etc.
4. Refer to the Architectural Plans for details and large scale Drawings and to approved Shop Drawing of equipment furnished under other Contracts or Sections of the Specifications for exact location of service connections. The equipment Shop Drawings will be furnished to the Contractor before roughing in. Contractor shall not install any piping or ductwork for said equipment until they have received approved Coordination Drawings for same.

L. Minor Deviations:

1. The dimensions of equipment hereinafter specified or indicated on the Drawings are intended to establish the outlines and characteristics of such equipment in general. Minor deviations in dimensions will be permitted to allow the manufacturers specified to bid on their nearest stock equipment, provided the specified ratings are met or exceeded.
2. Where manufacturers' catalog numbers or types are mentioned in the Specifications or indicated on the Drawings, they are intended to be used as a guide only and shall not be interpreted as taking precedence over the basic rating and duty specified. In all cases, manufacturers shall verify the duty specified with particular characteristics of the equipment they intend to offer for approval and shall also pay the additional charges as may be required under other Divisions.

M. Interferences:

1. Before making any installation, the work of the trades must be coordinated and the necessary changes shall be made to avoid interferences or improper effect on work to be performed by any other Section. In the event that interferences develop, the Architect's decision will be final and no additional compensation will be allowed for moving of misplaced piping, ducts, conduit and/or equipment.

## **PART 2 - PRODUCTS**

### **2.1 MATERIALS AND EQUIPMENT**

- A. Unless otherwise specified, all material and equipment incorporated in the work under the contract shall be new.
- B. Material and equipment specified by one or more manufacturer's name, trade name and/or model number does not limit a bidder from bidding on other equipment providing the procedure set forth in the Conditions of the Contract and hereinafter specified is followed.
- C. The various mechanical systems have been engineered and designed on equipment name and catalog numbers specified or designated on the Drawings.

- D. A Contractor who intends to furnish equipment listed as approved equal shall proceed as follows:
1. Obtain Architect/Engineer's approval of said equipment.
  2. Be fully responsible for said equipment.
  3. Include in the Base Bid, all cost for any changes that may be required in his work and/or work of other trades for the proper installation and functioning of said equipment.

### **PART 3 - EXECUTION**

#### **3.1 ALTERATIONS IN PRESENT BUILDING AND SITE**

- A. Take particular note of the revisions and alterations of existing services, utilities, etc., due to the new construction as indicated on the Drawings and/or as required by alterations to the existing building.
1. Where necessary, reroute piping, ducts, etc. from within walls, floors, ceilings, etc. being removed. The Trade Contractor involved with the interrupted service shall be responsible for accomplishing the required work whether shown on the Drawings or not.
  2. Cap all abandoned or terminated piping, etc. below floor, behind wall surface, above ceiling, etc. as required to be completely concealed after new work is complete.
  3. In general, mechanical remodeling work is shown on the Mechanical Drawings but carefully study all Drawings for all contracts for "demolition" and "remodeling" work in the existing buildings and field check to verify locations where such work is being done to determine the exact extent of work required. No extra will be allowed for additional work required because of demolition or remodeling whether or not work is specifically noted, itemized or shown on the Drawings.
  4. Maintaining of Present Services: Maintain all services in the existing building. This shall include all temporary or permanent piping connections, etc., required to provide and maintain services to the present buildings and the equipment served. In the case of change over piping and ductwork or where new service connections are to be made to existing services and service interruptions can in no way be avoided, the service interruptions shall be with the minimum of inconvenience to the School. If the Owner's Representative directs that such work be performed during premium time hours then the Contractor shall be reimbursed for the premium time portion of the direct labor cost of the workmen actually performing the work. All costs (except for premium time portion of labor costs) incurred in order to comply with the foregoing shall be included in the Contractor's original bid for the work and without additional costs to the Board.
  5. Remove or reroute, as required, all services at existing buildings to be demolished.

#### **3.2 DISPOSITION OF REMOVED EQUIPMENT**

- A. Where existing materials or equipment are specified to be removed from service, the Trade Contractor shall take possession of same and remove them from the site promptly, except as specified below or unless otherwise noted on Drawings.
- B. All salvageable material and equipment, including but not necessarily limited to, electrical fixtures, conduit, wiring, plumbing fixtures, heating units, piping, valves, etc., shall be removed and maintained in as good condition as possible and turned over to the School. However, if the School decides any such materials are of no value, then they shall become the property of the Contractor who shall remove such discarded work from the premises and dispose of same.

- C. Existing equipment or systems, etc. which are specified to be replaced by new equipment, or systems, etc. shall not be removed from service until the new equipment, materials, systems, etc. have actually arrived at the project site.

### 3.3 INSTALLATION

- A. Each Trade Contractor shall be responsible for all of his work fitting into place in a satisfactory and neat workmanlike manner acceptable to the Architect/Engineer.
- B. Confer with other Trade Contractors regarding the location and size of pipes, equipment, fixtures, conduit, ducts, openings, switches, outlets, etc., in order that there may be no interference between the installation of the progress of the work of any Trade Contractor on the project. The Architectural Drawings shall take precedence over the Mechanical and Electrical Drawings.
- C. The Mechanical Drawings are diagrammatic and shall be followed as closely as actual construction of the building and the work of other trade contractors will permit. All changes from Drawings necessary to make the work of each Contractor conform to the building construction and the work of other trade contractors shall be done at the appropriate Trade Contractor's expense.
- D. Unless explicitly stated to the contrary, each Trade Contractor shall furnish and install each item of equipment or material hereinafter specified, complete with all necessary fittings, supports, trim, piping, insulation, etc., as required for a complete and operating installation.
- E. All equipment and materials shall be installed according to the manufacturer's instructions unless otherwise specifically directed by the Trade Contract Documents. All piping, valves, connections, and other like items recommended by the manufacturer or required for proper operation shall be provided without additional cost to the Board.
- F. All references to Contractors in Specifications and Drawings shall refer to the respective Trade Contractor performing that portion of the work.
- G. In general, all piping, ductwork and similar items shall be installed concealed from view above the ceiling, in partitions, shafts, chases, unless otherwise indicated.
- H. Locations of items not definitely fixed by dimensions are approximate only and exact locations necessary to secure the best conditions and results shall be determined at the site, subject to review.
- I. Where pipes are in partitions, furred out spaces and chases, obtain information as to their exact location and size and install work so as to be entirely concealed in the allotted space. If conflicts arise making this impossible, obtain instructions from the Architect/Engineer before proceeding with the work.
- J. Wherever two or more pipes are to be installed in parallel, or parallel to the piping of other trades, the piping shall be installed with sufficient space between pipes to allow for the proper application of pipe covering, painting and servicing.
- K. Furnish advance information on locations and sizes of frames, boxes, sleeves and openings needed for the work, and also furnish information and shop drawings necessary to permit installation of other work without delay.

- L. Where there is evidence that parts of the Mechanical Work will interfere with other work, assist in working out space conditions and/or the structure, make necessary adjustments to accommodate the work.
- M. Mechanical Work installed before coordinating with other work so as to cause interference with other work shall be changed to correct such condition without additional cost to the Board.
- N. In no case shall any pipe, conduit, duct, or item of equipment be installed where it is supported on or suspended from another pipe, conduit, duct or item of equipment.
- O. Where an item or task is specified to be provided "under this Section," it shall be understood that, that item or task is the responsibility of the trade responsible for that Section, but the work must be performed by qualified workmen of the appropriate trade.
- P. Accessibility:
  - 1. Install Mechanical work to permit removal (without damage to other parts) of coils, heat exchangers, pumps, fan shafts and wheels, belt guards, sheaves and drives, and other parts requiring periodic replacement or maintenance.
  - 2. Arrange pipes, ducts, and equipment to permit ready access to valves, cocks, traps, starters, motors, dampers, control components, and to clear the openings of swinging and overhead doors and of access panels.
  - 3. Change dimensions of ductwork when required to meet job conditions but maintain the same equivalent cross-sectional area.
  - 4. Provide access panels in equipment, ducts, and like items for inspection of interiors and proper maintenance.

**End of Section 230503**

## DIVISION 23 – HEATING, VENTILATING AND AIR CONDITIONING

### SECTION 23 05 05

#### BASIC HVAC MATERIALS AND METHODS

##### PART 1 - GENERAL

##### 1.1 SUMMARY

A. Section includes the following:

1. Piping materials and installation instructions common to most piping systems.
2. Concrete base construction requirements.
3. Escutcheons.
4. Dielectric fittings.
5. Mechanical sleeve seals.
6. Equipment nameplate data requirements.
7. Nonshrink grout for equipment installations.
8. Field-fabricated metal and wood equipment supports.
9. Installation requirements common to equipment specification sections.
10. Mechanical demolition.
11. Cutting and patching.
12. Touchup painting and finishing.
13. Access Panels
14. Bearings
15. Drives
16. Flashings
17. Cleaning

B. Pipe and pipe fitting materials are specified in Division 22.

##### 1.2 DEFINITIONS

- A. Finished Spaces: Spaces other than mechanical and electrical equipment rooms, furred spaces, pipe and duct shafts, unheated spaces immediately below roof, spaces above ceilings, unexcavated spaces, crawl spaces, and tunnels.
- B. Exposed, Interior Installations: Exposed to view indoors. Examples include finished occupied spaces and mechanical equipment rooms.
- C. Exposed, Exterior Installations: Exposed to view outdoors, or subject to outdoor ambient temperatures and weather conditions. Examples include rooftop locations.
- D. Concealed, Interior Installations: Concealed from view and protected from physical contact by building occupants. Examples include above ceilings and in duct shafts.
- E. Concealed, Exterior Installations: Concealed from view and protected from weather conditions and physical contact by building occupants, but subject to outdoor ambient temperatures. Examples include installations within unheated shelters.
- F. The following are industry abbreviations for rubber materials:

1. BS: Acrylonitrile-butadiene-styrene plastic.
2. CPVC: Chlorinated polyvinyl chloride plastic.
3. CR: Chlorosulfonated polyethylene synthetic rubber.
4. EPDM: Ethylene-propylene-diene terpolymer rubber.
5. NBR: Acrylonitrile-butadiene rubber.
6. PE: Polyethylene plastic.
7. PVC: Polyvinyl chloride plastic.

### 1.3 SUBMITTALS

- A. Refer to Division 01 Section "Submittal Procedures" for administrative and procedural requirements for submitting Shop Drawings, Product Data, Samples, and other miscellaneous submittals.
- B. Product Data: For dielectric fittings, flexible connectors, mechanical sleeve seals, access panels and identification materials and devices.
- C. Coordination Drawings: For access panel and door locations.
- D. Coordination Drawings: Detail major elements, components, and systems of mechanical equipment and materials in relationship with other systems, installations, and building components. Show space requirements for installation and access. Indicate if sequence and coordination of installations are important to efficient flow of the Work. Include the following:
  1. Planned piping layout, including valve and specialty locations and valve-stem movement.
  2. Planned duct systems layout, including elbow radii and duct accessories.
  3. Clearances for installing and maintaining insulation.
  4. Clearances for servicing and maintaining equipment, accessories, and specialties, including space for disassembly required for periodic maintenance.
  5. Equipment and accessory service connections and support details.
  6. Exterior wall and foundation penetrations.
  7. Fire-rated wall and floor penetrations.
  8. Sizes and location of required concrete pads and bases.
  9. Scheduling, sequencing, movement, and positioning of large equipment into building during construction.
  10. Floor plans, elevations, and details to indicate penetrations in floors, walls, and ceilings and their relationship to other penetrations and installations.
  11. Reflected ceiling plans to coordinate and integrate installation of air outlets and inlets, light fixtures, communication system components, sprinklers, and other ceiling-mounted items.
  12. Access panel locations in ceilings/walls/floors.

### 1.4 QUALITY ASSURANCE

- A. Requirements of Regulatory Agencies:
  1. American Society for Testing and Materials
    - a. ASTM A 53-98: Specification for Pipe, Steel, Black and Hot-Dipped, Zinc-Coated Welded and Seamless
    - b. ASTM B 32-96: Specification for Solder Metal
    - c. ASTM B 813-93: Specification for Liquid and Paste Fluxes for Soldering Applications of Copper and Copper Alloy Tube



- d. ASTM B 828-98: Practice for Making Capillary Joints by Soldering of Copper and Copper Alloy Tube and Fittings
  - e. ASTM C 1107-97: Specification for Packaged Dry, Hydraulic-Cement Grout (Nonshrink)
  - f. ASTM C 1173-97: Specification for Flexible Transition Couplings for Underground Piping Systems
  - g. ASTM D 1785-96b: Specification for Poly(Vinyl Chloride) (PVC) Plastic Pipe, Schedules 40, 80, and 120
  - h. ASTM D 2235-96a: Specification for Solvent Cement for Acrylonitrile-Butadiene-Styrene (ABS) Plastic Pipe and Fittings
  - i. ASTM D 2564-96a: Specification for Solvent Cements for Poly(Vinyl Chloride) (PVC) Plastic Piping Systems
  - j. ASTM D 2672-96a: Specification for Joints for IPS PVC Pipe Using Solvent Cement
  - k. ASTM D 2855-96: Practice for Making Solvent-Cemented Joints with Poly(Vinyl Chloride) (PVC) Pipe and Fittings
  - l. ASTM D 3139-98: Specification for Joints for Plastic Pressure Pipes Using Flexible Elastomeric Seals
  - m. ASTM F 402-93: Practice for Safe Handling of Solvent Cements, Primers, and Cleaners Used for Joining Thermostatic Pipe and Fittings
  - n. ASTM F 493-97: Specification for Solvent Cements for Chlorinated Poly(Vinyl Chloride) (CPVC) Plastic Pipe and Fittings
  - o. ASTM F 656-96a: Specification for Primers for Use in Solvent Cement Joints of Poly(Vinyl Chloride) (PVC) Plastic Pipe and Fittings
2. American Water Works Association
- a. AWWA C110-98: Ductile-Iron and Gray-Iron Fittings, 3 In. through 48 In. (76 mm through 1219 mm), for Water and Other Liquids
  - b. AWWA C219-97: Bolted, Sleeve-Type Couplings for Plain-End Pipe
3. American Welding Society
- a. AWS A5.8-92: Specification for Filler Metals for Brazing and Braze Welding
  - b. AWS D1.1-98: Structural Welding Code--Steel
  - c. AWS D10.12-89: Recommended Practices and Procedures for Welding Low Carbon Steel Pipe
  - d. Brazing Handbook. 1991.
4. ASME International
- a. ASME B1.20.1-83 (Reaffirmed 1992): Pipe Threads, General Purpose (Inch)
  - b. ASME B16.21-92: Nonmetallic Flat Gaskets for Pipe Flanges
  - c. ASME B18.2.1-96: Square and Hex Bolts and Screws--Inch Series
  - d. ASME B31 Series: Code for Pressure Piping
  - e. 1998 ASME Boiler and Pressure Vessel Code: Section IX, "Welding and Brazing Qualifications"
5. Copper Development Association Inc.
- a. Copper Tube Handbook. 1995.

6. Manufacturers Standardization Society of the Valve and Fittings Industry, Inc.
    - a. MSS SP-107-91: Transition Union Fittings for Joining Metal and Plastic Products
  - B. Steel Support Welding: Qualify processes and operators according to AWS D1.1, "Structural Welding Code--Steel."
  - C. Steel Pipe Welding: Qualify processes and operators according to ASME Boiler and Pressure Vessel Code: Section IX, "Welding and Brazing Qualifications."
    1. Comply with provisions in ASME B31 Series, "Code for Pressure Piping."
    2. Certify that each welder has passed AWS qualification tests for welding processes involved and that certification is current.
  - D. Equipment of higher electrical characteristics, physical dimensions, capacities, and ratings may be furnished provided such proposed equipment is approved in writing and connecting mechanical and electrical services, circuit breakers, conduit, motors, bases, and equipment spaces are increased. Additional costs shall be approved in advance by appropriate Contract Modification for these increases. If minimum energy ratings or efficiencies of equipment are specified, equipment must meet design and commissioning requirements.
- 1.5 DELIVERY, STORAGE, AND HANDLING
- A. Deliver pipes and tubes with factory-applied end caps. Maintain end caps through shipping, storage, and handling to prevent pipe-end damage and prevent entrance of dirt, debris, and moisture.
  - B. Protect stored pipes and tubes from moisture and dirt. Elevate above grade. Do not exceed structural capacity of floor, if stored inside.
  - C. Protect flanges, fittings, and piping specialties from moisture and dirt.
- 1.6 SEQUENCING AND SCHEDULING
- A. Coordinate phasing and sequencing of all work with the Owner and Building Engineer.
  - B. Coordinate mechanical equipment installation with other building components.
  - C. Arrange for pipe spaces, chases, slots, and openings in building structure during progress of construction to allow for mechanical installations.
  - D. Coordinate installation of required supporting devices and sleeves in poured-in-place concrete and other structural components, as they are constructed.
  - E. Sequence, coordinate, and integrate installations of mechanical materials and equipment for efficient flow of the Work. Coordinate installation of large equipment requiring positioning before closing in building.
  - F. Coordinate connection of mechanical systems with exterior underground and overhead utilities and services. Comply with requirements of governing regulations, franchised service companies, and controlling agencies.

- G. Coordinate requirements for access panels and doors if mechanical items requiring access are concealed behind finished surfaces. Access panels and doors are specified in Division 08 Section "Access Doors and Frames."
- H. Coordinate installation of identifying devices after completing covering and painting, if devices are applied to surfaces. Install identifying devices before installing acoustical ceilings and similar concealment.
- I. Coordinate connection of electrical services.

#### 1.7 WARRANTY

- A. Provide warranty on materials and labor for 18 months starting from date of delivery, or one year from date of substantial completion, whichever is longer.

### **PART 2 - PRODUCTS**

#### 2.1 MANUFACTURERS

- A. Manufacturers: Subject to compliance with requirements, provide products by one of the following manufacturers:
  - 1. Dielectric Unions: No preference.
  - 2. Dielectric Flanges: No preference.
  - 3. Dielectric-Flange Insulating Kits: No preference.
  - 4. Dielectric Couplings: No preference.
  - 5. Dielectric Nipples: No preference.
  - 6. Mechanical Sleeve Seals:
    - a. Calpico, Inc.
    - b. Metraflex Co.
    - c. Thunderline/Link-Seal.
  - 7. Metal, Flexible Connectors:
    - a. Grinnell Corp.; Grinnell Supply Sales Co..
    - b. Mercer Rubber Co.
    - c. Metraflex Co.
  - 8. Rubber, Flexible Connectors:
    - a. General Rubber Corp.
    - b. Metraflex Co.
    - c. Red Valve Co., Inc.
  - 9. Grooved Fittings:
    - a. Grinnell Corp.; Grinnell Supply Sales Co.
    - b. Victaulic Company of America.
    - c. Central Sprinkler.

## 2.2 PIPE, TUBE, AND FITTINGS

- A. Refer to individual Division 22 piping Sections for pipe, tube, and fitting materials and joining methods.
- B. Pipe Threads: ASME B1.20.1 for factory-threaded pipe and pipe fittings.

## 2.3 JOINING MATERIALS

- A. Refer to individual Division 22 piping Sections for special joining materials not listed below.
- B. Pipe-Flange Gasket Materials: Suitable for chemical and thermal conditions of piping system contents.
  - 1. ASME B16.21, nonmetallic, flat, 1/8-inch maximum thickness unless thickness or specific material is indicated.
    - a. Full-Face Type: For flat-face, Class 125, cast-iron and cast-bronze flanges.
    - b. Narrow-Face Type: For raised-face, Class 250, cast-iron and steel flanges.
  - 2. AWWA C110, rubber, flat face, 1/8 inch thick, unless otherwise indicated; and full-face or ring type, unless otherwise indicated.
- C. Flange Bolts and Nuts: ASME B18.2.1, carbon steel, unless otherwise indicated.
- D. Plastic, Pipe-Flange Gasket, Bolts, and Nuts: Type and material recommended by piping system manufacturer, unless otherwise indicated.
- E. Solder Filler Metals: ASTM B 32, lead-free alloys. Include water-flushable flux according to ASTM B 813.
- F. Brazing Filler Metals: AWS A5.8, BCuP Series, copper-phosphorus alloys for general-duty brazing, unless otherwise indicated; and AWS A5.8, BAg1, silver alloy for refrigerant piping, unless otherwise indicated.
- G. Welding Filler Metals: Comply with AWS D10.12 for welding materials appropriate for wall thickness and chemical analysis of steel pipe being welded.
- H. Solvent Cements for Joining Plastic Piping:
  - 1. PVC Piping: ASTM D 2564. Include primer according to ASTM F 656.

## 2.4 DIELECTRIC FITTINGS

- A. Description: Combination fitting of copper alloy and ferrous materials with threaded, solder-joint, plain, or weld-neck end connections that match piping system materials.
- B. Insulating Material: Suitable for system fluid, pressure, and temperature.
- C. Dielectric Unions: Factory-fabricated, union assembly, for 250-psig minimum working pressure at 180 deg F.

- D. Dielectric Flanges: Factory-fabricated, companion-flange assembly, for 150- or 300-psig minimum working pressure as required to suit system pressures.
- E. Dielectric-Flange Kits: Companion-flange assembly for field assembly. Include flanges, full-face- or ring-type neoprene or phenolic gasket, phenolic or polyethylene bolt sleeves, phenolic washers, and steel backing washers. Separate companion flanges and steel bolts and nuts shall have 150- or 300-psig minimum working pressure where required to suit system pressures.
- F. Dielectric Couplings: Galvanized-steel coupling with inert and noncorrosive, thermoplastic lining; threaded ends; and 300-psig minimum working pressure at 225 deg F.
- G. Dielectric Nipples: Electroplated steel nipple with inert and noncorrosive, thermoplastic lining; plain, threaded, or grooved ends; and 300-psig minimum working pressure at 225 deg F.

## 2.5 MECHANICAL SLEEVE SEALS

- A. Description: Modular sealing element unit, designed for field assembly, to fill annular space between pipe and sleeve.
  1. Sealing Elements: EPDM interlocking links shaped to fit surface of pipe. Include type and number required for pipe material and size of pipe.
  2. Pressure Plates: Carbon steel. Include two for each sealing element.
  3. Connecting Bolts and Nuts: Carbon steel with corrosion-resistant coating of length required to secure pressure plates to sealing elements. Include one for each sealing element.

## 2.6 FLEXIBLE CONNECTORS

- A. General: Fabricated from materials suitable for system fluid and that will provide flexible pipe connections. Include 125-psig minimum working-pressure rating, unless higher working pressure is indicated, and ends according to the following:
  1. 2-Inch NPS and Smaller: Threaded.
  2. 2-1/2-Inch NPS and Larger: Flanged.
  3. Option for 2-1/2-Inch NPS and Larger: Grooved for use with keyed couplings.
- B. Stainless-Steel-Hose/Steel Pipe, Flexible Connectors: Corrugated, stainless-steel, inner tubing covered with stainless-steel wire braid. Include steel nipples or flanges, welded to hose. Do not use for potable water.
- C. Stainless-Steel-Hose/Stainless-Steel Pipe, Flexible Connectors: Corrugated, stainless-steel, inner tubing covered with stainless-steel wire braid. Include stainless-steel nipples or flanges, welded to hose. Do not use for potable water.
- D. Couplings may be used to provide allowance for controlled pipe movement, expansion, contraction, and or deflection to absorb movement for thermal changes, settling or seismic action and also vibration attenuation.

## 2.7 SLEEVES

- A. Galvanized-Steel Sheet: 0.0239-inch minimum thickness; round tube closed with welded longitudinal joint.

- B. Steel Pipe: ASTM A 53, Type E, Grade B, Schedule 40, galvanized, plain ends.
- C. Cast Iron: Cast or fabricated "wall pipe" equivalent to ductile-iron pressure pipe, with plain ends and integral waterstop, unless otherwise indicated.
- D. Stack Sleeve Fittings: Manufactured, cast-iron sleeve with integral clamping flange. Include clamping ring and bolts and nuts for membrane flashing.
  - 1. Underdeck Clamp: Clamping ring with set screws.

## 2.8 ESCUTCHEONS

- A. Description: Manufactured wall and ceiling escutcheons and floor plates, with an ID to closely fit around pipe, tube, and insulation of insulated piping and an OD that completely covers opening.
- B. One-Piece, Deep-Pattern Type: Deep-drawn, box-shaped brass with polished chrome-plated finish.
- C. One-Piece, Cast-Brass Type: With set screw.
  - 1. Finish: Rough brass.
- D. Split-Casting, Cast-Brass Type: With concealed hinge and set screw.
  - 1. Finish: Rough brass.
- E. One-Piece, Stamped-Steel Type: With set screw and chrome-plated finish.
- F. Split-Plate, Stamped-Steel Type: With concealed hinge, set screw, and chrome-plated finish.
- G. One-Piece, Floor-Plate Type: Cast-iron floor plate.
- H. Split-Casting, Floor-Plate Type: Cast brass with concealed hinge and set screw.

## 2.9 ACCESS PANELS

- A. General: Refer to Division 08 Section, "Access Doors and Frames," for access panel manufacturers and other requirements.

## 2.10 BEARINGS (FAN REFURBISHMENT ONLY)

- A. Bearing shall be equal to Link Belt P300 ball bearings up to and including 1-11/16". Larger sizes to be Link Belt 6800 Series adaptor mounted and have split bearings. All bearings to be mounted in a split journal. Equipment manufacturer to determine whether oil or grease lubrication is required. Bearings to be doweled in place after 30 days of satisfactory running. Bearings to be selected for 100,000 hours minimum life and 200,000 hours average life, based on motor horsepower with a factor of 2.0 in accordance with the design standards set forth in the Anti-Friction Bearing Manufacturers Association, Design (B-10), and the published rating data. Upon request, bearing load calculations to be substantiated with submittal prints by attaching a copy of the fan manufacturer's computer run out.

## 2.11 DRIVES (FAN REFURBISHMENT ONLY)

- A. All drives shall be selected for a minimum of 1.4 service factor based on motor horsepower and including unit factors for length of belt, effective sheave diameter and arc of contact correction.
1. In no case will any driver with a 10 HP motor or larger have less than two (2) belts, nor will any drive be furnished with an arc of contact of less than 160 degrees at minimum effective sheave diameter.
  2. Adjustable drives shall be provided for fans having motors of 10 HP or less. Sheaves shall be selected to operate at mid-point of the fan curve to allow for adjustment in both directions. Fans having motors larger than 10 HP shall be provided with fixed sheaves after systems are balanced.
  3. It is the responsibility of the Trade to see that all fans deliver the design capacity at actual static pressures up to design static pressure. Fan sheaves shall be replaced as necessary to obtain desired results.
  4. All sheaves to be dynamically and statically balanced and multiple belts shall be machine matched in sets.
  5. Fan motors, shafts, pulleys and sheaves shall be provided with deep keyways and pulleys and sheaves shall be properly keyed and secured in place. The use of only set screws for securing pulley or sheaves to shafts is not acceptable.
  6. Each belt drive shall be provided a N.S.C. and O.S.H.A. approved belt guard. Guards shall be constructed of No. 12 USS gauge, 3/4" diamond mesh wire screens, or equivalent, welded to 1" structural steel, 1/8" thick angle frames and shall enclose all belts and sheaves. Tops and bottoms to be of substantial sheet metal not less than No. 18 USS gauge.
    - a. Guard shall be secured to the driven machines or to foundations or floors by heavy structural angle supports and anchor bolts. Braces or supports secured to motors will not be permitted and braces and/or supports must not "bridge" the sound and vibration isolators.
    - b. Guards shall be removable for maintenance.
    - c. Lubrication fittings shall be extended to point that will permit lubrication without removing guards.
- B. Guard shall be designed with adequate provision for movement of motor required to adjust belt tension. Means shall be provided to permit lubrication, use of speed counters, and other maintenance and testing operations with belt guard in place.
- C. For all direct drive equipment, provide a N.S.C. and O.S.H.A. approved coupling guard of formed metal or heavy wire mesh securely bolted in place.

## 2.12 GROUT

- A. Description: ASTM C 1107, Grade B, nonshrink and nonmetallic, dry hydraulic-cement grout.
1. Characteristics: Post-hardening, volume-adjusting, nonstaining, noncorrosive, nongaseous, and recommended for interior and exterior applications.
  2. Design Mix: 5000-psi, 28-day compressive strength.
  3. Packaging: Premixed and factory packaged.

## **PART 3 - EXECUTION**

### **3.1 MECHANICAL DEMOLITION**

- A. Refer to Division 01 Section "Cutting and Patching" and Division 02 Section "Selective Demolition" for general demolition requirements and procedures.
- B. Remove and cap all inactive or abandoned piping and ductwork in mechanical rooms. Larger duct and pipe located in accessible areas shall be removed and capped at the discretion of the contractor with concurrence of Owner and Building Engineer.
- C. Disconnect, demolish, and remove mechanical systems, equipment, and components indicated on the drawings to be removed.
  - 1. Piping to Be Removed: Remove portion of piping indicated to be removed and cap or plug remaining piping with same or compatible piping material.
  - 2. Piping to Be Abandoned in Place: Drain piping and cap or plug piping with same or compatible piping material.
  - 3. Ducts to Be Removed: Remove portion of ducts indicated to be removed and plug remaining ducts with same or compatible ductwork material.
  - 4. Ducts to Be Abandoned in Place: Cap or plug ducts with same or compatible ductwork material.
  - 5. Equipment to Be Removed: Disconnect and cap services and remove equipment.
  - 6. Equipment to Be Removed and Reinstalled: Disconnect and cap services and remove, clean, and store equipment; when appropriate, reinstall, reconnect, and make equipment operational.
  - 7. Equipment to Be Removed and Salvaged: Disconnect and cap services and remove equipment and deliver to Owner.
- D. If pipe, insulation, or equipment to remain is damaged in appearance or is unserviceable, remove damaged or unserviceable portions and replace with new products of equal capacity and quality.

### **3.2 PIPING SYSTEMS - COMMON REQUIREMENTS**

- A. Install piping according to the following requirements and Division 22 Sections specifying piping systems.
- B. Drawing plans, schematics, and diagrams indicate general location and arrangement of piping systems. Indicated locations and arrangements were used to size pipe and calculate friction loss, expansion, pump sizing, and other design considerations. Install piping as indicated unless deviations to layout are approved on Coordination Drawings.
- C. Install piping in concealed locations, unless otherwise indicated and except in equipment rooms and service areas.
- D. Install piping indicated to be exposed and piping in equipment rooms and service areas at right angles or parallel to building walls. Diagonal runs are prohibited unless specifically indicated otherwise.
- E. Install piping above accessible ceilings to allow sufficient space for ceiling panel removal.
- F. Install piping to permit valve servicing.



- G. Install piping at indicated slopes.
- H. Install piping free of sags and bends.
- I. Install fittings for changes in direction and branch connections.
- J. Install piping to allow application of insulation.
- K. Select system components with pressure rating equal to or greater than system operating pressure.
- L. Install escutcheons for penetrations of walls, ceilings, and floors according to the following:
  - 1. New Piping:
    - a. Piping with Fitting or Sleeve Protruding from Wall: One-piece, deep-pattern type.
    - b. Chrome-Plated Piping: One-piece, cast-brass type with polished chrome-plated finish.
    - c. Insulated Piping: One-piece, stamped-steel type with spring clips.
    - d. Bare Piping at Wall and Floor Penetrations in Finished Spaces: One-piece, stamped-steel type.
    - e. Bare Piping at Ceiling Penetrations in Finished Spaces: One-piece, stamped-steel type and set screw.
    - f. Bare Piping in Unfinished Service Spaces: One-piece, stamped-steel type with concealed hinge and set screw.
    - g. Bare Piping in Equipment Rooms: One-piece, stamped-steel type with set screw.
    - h. Bare Piping at Floor Penetrations in Equipment Rooms: One-piece, floor-plate type.
  - 2. Existing Piping: Use the following:
    - a. Chrome-Plated Piping: Split-casting, cast-brass type with chrome-plated finish.
    - b. Insulated Piping: Split-plate, stamped-steel type with concealed hinge and spring clips.
    - c. Bare Piping at Wall and Floor Penetrations in Finished Spaces: Split-plate, stamped-steel type with concealed hinge and spring clips.
    - d. Bare Piping at Ceiling Penetrations in Finished Spaces: Split-plate, stamped-steel type with concealed hinge and set screw.
    - e. Bare Piping in Unfinished Service Spaces: Split-plate, stamped-steel type with concealed hinge and set screw.
    - f. Bare Piping in Equipment Rooms: Split-plate, stamped-steel type with set screw or spring clips.
    - g. Bare Piping at Floor Penetrations in Equipment Rooms: Split-casting, floor-plate type.
- M. Sleeves are not required for core-drilled holes.
- N. Permanent sleeves are not required for holes formed by removable PE sleeves.
- O. Install sleeves for pipes passing through concrete and masonry walls, gypsum-board partitions, and concrete floor and roof slabs.

1. Cut sleeves to length for mounting flush with both surfaces.
    - a. Exception: Extend sleeves installed in floors of mechanical equipment areas or other wet areas 2 inches above finished floor level. Extend cast-iron sleeve fittings below floor slab as required to secure clamping ring if ring is specified.
  2. Install sleeves in new walls and slabs as new walls and slabs are constructed.
  3. Install sleeves that are large enough to provide 1/4-inch annular clear space between sleeve and pipe or pipe insulation. Use the following sleeve materials:
    - a. Steel Pipe Sleeves: For pipes smaller than NPS 6.
    - b. Steel Sheet Sleeves: For pipes NPS 6 and larger, penetrating gypsum-board partitions.
    - c. Stack Sleeve Fittings: For pipes penetrating floors with membrane waterproofing. Secure flashing between clamping flanges. Install section of cast-iron soil pipe to extend sleeve to 2 inches above finished floor level. Refer to Division 07 Section "Sheet Metal Flashing and Trim" for flashing.
      - 1) Seal space outside of sleeve fittings with grout.
  4. Except for underground wall penetrations, seal annular space between sleeve and pipe or pipe insulation, using joint sealants appropriate for size, depth, and location of joint. Refer to Division 07 Section "Joint Sealants" for materials and installation.
- P. Aboveground, Exterior-Wall Pipe Penetrations: Seal penetrations using sleeves and mechanical sleeve seals. Select sleeve size to allow for 1-inch (25-mm) annular clear space between pipe and sleeve for installing mechanical sleeve seals.
1. Install steel pipe for sleeves smaller than 6 inches in diameter.
  2. Install cast-iron "wall pipes" for sleeves 6 inches and larger in diameter.
  3. Mechanical Sleeve Seal Installation: Select type and number of sealing elements required for pipe material and size. Position pipe in center of sleeve. Assemble mechanical sleeve seals and install in annular space between pipe and sleeve. Tighten bolts against pressure plates that cause sealing elements to expand and make watertight seal.
- Q. Underground, Exterior-Wall Pipe Penetrations: Install cast-iron "wall pipes" for sleeves. Seal pipe penetrations using mechanical sleeve seals. Select sleeve size to allow for 1-inch annular clear space between pipe and sleeve for installing mechanical sleeve seals.
1. Mechanical Sleeve Seal Installation: Select type and number of sealing elements required for pipe material and size. Position pipe in center of sleeve. Assemble mechanical sleeve seals and install in annular space between pipe and sleeve. Tighten bolts against pressure plates that cause sealing elements to expand and make watertight seal.
- R. Fire-Barrier Penetrations: Maintain indicated fire rating of walls, partitions, ceilings, and floors at pipe penetrations. Seal pipe penetrations with firestop materials. Refer to Division 07 Section "Penetration Firestopping" for materials.
- S. Verify final equipment locations for roughing-in.

### 3.3 PIPING JOINT CONSTRUCTION

- A. Join pipe and fittings according to the following requirements and Division 22 Sections specifying piping systems.
- B. Ream ends of pipes and tubes and remove burrs. Bevel plain ends of steel pipe.
- C. Remove scale, slag, dirt, and debris from inside and outside of pipe and fittings before assembly.
- D. Soldered Joints: Apply ASTM B 813, water-flushable flux, unless otherwise indicated, to tube end. Construct joints according to ASTM B 828 or CDA's "Copper Tube Handbook," using lead-free solder alloy complying with ASTM B 32.
- E. Brazed Joints: Construct joints according to AWS's "Brazing Handbook," "Pipe and Tube" Chapter, using copper-phosphorus brazing filler metal complying with AWS A5.8.
- F. Threaded Joints: Thread pipe with tapered pipe threads according to ASME B1.20.1. Cut threads full and clean using sharp dies. Ream threaded pipe ends to remove burrs and restore full ID. Join pipe fittings and valves as follows:
  - 1. Note internal length of threads in fittings or valve ends, and proximity of internal seat or wall, to determine how far pipe should be threaded into joint.
  - 2. Apply appropriate tape or thread compound to external pipe threads unless dry seal threading is specified.
  - 3. Align threads at point of assembly.
  - 4. Tighten joint with wrench. Apply wrench to valve end into which pipe is being threaded.
  - 5. Damaged Threads: Do not use pipe or pipe fittings with threads that are corroded or damaged. Do not use pipe sections that have cracked or open welds.
- G. Welded Joints: Construct joints according to AWS D10.12, using qualified processes and welding operators according to Part 1 "Quality Assurance" Article.
- H. Flanged Joints: Align flange surfaces parallel. Select appropriate gasket material, size, type, and thickness for service application. Install gasket concentrically positioned. Assemble joints by sequencing bolt tightening to make initial contact of flanges and gaskets as flat and parallel as possible. Use suitable lubricants on bolt threads. Tighten bolts gradually and uniformly using torque wrench.
- I. Plastic Piping Solvent-Cement Joints: Clean and dry joining surfaces. Join pipe and fittings according to the following:
  - 1. Comply with ASTM F 402 for safe-handling practice of cleaners, primers, and solvent cements.
  - 2. PVC Pressure Piping: Join schedule number ASTM D 1785, PVC pipe and PVC socket fittings according to ASTM D 2672. Join other-than-schedule-number PVC pipe and socket fittings according to ASTM D 2855.
  - 3. PVC Nonpressure Piping: Join according to ASTM D 2855.
- J. Plastic Pressure Piping Gasketed Joints: Join according to ASTM D 3139.
- K. Plastic Nonpressure Piping Gasketed Joints: Join according to ASTM D 3212.

- L. PE Piping Heat-Fusion Joints: Clean and dry joining surfaces by wiping with clean cloth or paper towels. Join according to ASTM D 2657.
  - 1. Plain-End Pipe and Fittings: Use butt fusion.
  - 2. Plain-End Pipe and Socket Fittings: Use socket fusion.

### 3.4 PIPING CONNECTIONS

- A. Make connections according to the following, unless otherwise indicated:
  - 1. Install unions, in piping NPS 2 and smaller, adjacent to each valve and at final connection to each piece of equipment.
  - 2. Install flanges, in piping NPS 2-1/2 and larger, adjacent to flanged valves and at final connection to each piece of equipment.
  - 3. Dry Piping Systems: Install dielectric unions and flanges to connect piping materials of dissimilar metals.
  - 4. Wet Piping Systems: Install dielectric coupling and nipple fittings to connect piping materials of dissimilar metals

### 3.5 EQUIPMENT INSTALLATION - COMMON REQUIREMENTS

- A. Install equipment to provide maximum possible headroom, if mounting heights are not indicated.
- B. Install equipment according to approved submittal data. Portions of the Work are shown only in diagrammatic form. Refer conflicts to Architect.
- C. Install equipment level and plumb, parallel and perpendicular to other building systems and components in exposed interior spaces, unless otherwise indicated.
- D. Install mechanical equipment to facilitate service, maintenance, and repair or replacement of components. Connect equipment for ease of disconnecting, with minimum interference to other installations. Extend grease fittings to accessible locations.
- E. Install equipment giving right of way to piping installed at required slope.
- F. Install flexible connectors on equipment side of shutoff valves, horizontally and parallel to equipment shafts if possible.

### 3.6 PAINTING AND FINISHING

- A. Refer to Division 09 Section "Painting" for paint materials, surface preparation, and application of paint.
- B. Do not paint piping specialties with factory-applied finish.
- C. Damage and Touchup: Repair marred and damaged factory-painted finishes with materials and procedures to match original factory finish.

### 3.7 CUTTING AND PATCHING

- A. Cut, channel, chase, and drill floors, walls, partitions, ceilings, and other surfaces necessary for mechanical installations. Perform cutting by skilled mechanics of trades involved.

- B. Repair cut surfaces to match adjacent surfaces.

### 3.8 GROUTING

- A. Install nonmetallic, nonshrink, grout for mechanical equipment base bearing surfaces, pump and other equipment base plates, and anchors. Mix grout according to manufacturer's written instructions.
- B. Clean surfaces that will come into contact with grout.
- C. Provide forms as required for placement of grout.
- D. Avoid air entrapment during placing of grout.
- E. Place grout, completely filling equipment bases.
- F. Place grout on concrete bases to provide smooth bearing surface for equipment.
- G. Place grout around anchors.
- H. Cure placed grout according to manufacturer's written instructions.

### 3.9 CLEANING

- A. Coordinate general cleanup with the work as specified in Division 1.

### 3.10 ACCESS PANELS

- A. Where control valves, shut-off valves, drip traps, heating coils, dampers, pull boxes or other specialties, which require service or adjustment, are installed above inaccessible type furred ceilings or within furred walls, the Trade Contractor whose equipment is involved shall furnish and install access panels as required.
- B. Each Trade shall confer with other trades with respect to access panel locations, and shall wherever practical group valves, traps, dampers, etc. in such a way as to be accessible from a single panel and eliminate as many access panels as possible.

### 3.11 ERECTION

- A. Provide all necessary rigging, scaffolding, tools, tackle, labor and other like items necessary for the complete installation of the equipment.
- B. Adapt his work to job conditions and install his work to clear beams, joists and light fixtures, adjusting risers, avoiding interferences with windows and openings, raising or lowering work to permit the passing of ductwork or the work of other trades, all as required or as job conditions dictate, without additional costs to the Owner.
- C. Trade Contractor shall not rig, tie to, or rest weight upon any part of the building or make use of any stairway until specific permission is obtained.
  - 1. Permission to rig to or make use of any part of the building premises shall not relieve the contractor of responsibility for any damage.

- D. Cut, fit, and place miscellaneous metal supports accurately in location, alignment, and elevation to support and anchor mechanical materials and equipment.
- E. Field Welding: Comply with AWS D1.1, "Structural Welding Code--Steel."

### 3.12 ERECTION OF WOOD SUPPORTS AND ANCHORAGE

- A. Cut, fit, and place wood grounds, nailers, blocking, and anchorage to support and anchor mechanical materials and equipment.
- B. Select fastener sizes that will not penetrate members if opposite side will be exposed to view or will receive finish materials. Tighten connections between members. Install fasteners without splitting wood members.
- C. Attach to substrates as required to support applied loads.

### 3.13 FLASHINGS

- A. Openings in roof shall be flashed with 40 lb. sheet lead, in one piece, extending 24" under roofing in all directions from drains, pipes, or ducts, with upper edge at least 8" above the roof and turned over and down into increaser or sleeve or over curb for at least 1" and tightly bound with nonferrous wire.
  - 1. All lead flashings shall be entirely painted with a good coat of black asphaltum before installation.
  - 2. Roof flashing must be approved in writing by the Roofing Trade contractor to the effect that such flashing will not void guarantees or bonds pertaining to the roofing contract.
  - 3. Coordinate with the work under Division 07.

### 3.14 OPENINGS

- A. Where temporary openings are necessary thru walls and partitions of the building for the entry or installation of tanks, fans, or other machinery or apparatus, or for driveways and other facilities, the permanent work of the mechanical trades at said openings shall be temporarily omitted and installed after equipment is brought into the building or after temporary facilities are removed.
- B. Refer to other Sections of the Specifications for framing of openings for ducts, grilles, registers, etc., in walls, partitions, floors, roofs, etc. The trade for each service shall be responsible for locating and providing the proper dimensions for all required openings.
  - 1. Space between ducts and wall or floor openings shall be sealed as specified in Division 07 Section "Penetration Firestopping."
- C. No cutting or drilling of any building structural members will be permitted, unless the specific extent and limits are approved, in writing, by the Architect.
- D. All openings in the existing structure shall be core drilled with a diamond drill. The use of jackhammers will not be permitted.
- E. The Contractor shall notify the Architect if any existing openings are uncovered adjacent to location of a new opening. The new opening shall not be drilled if the existing can be used unless directed by the Architect.

**End of Section 230505**

**DIVISION 23 – HEATING, VENTILATING AND AIR CONDITIONING**

**SECTION 23 05 15**

**MOTORS - VARIABLE FREQUENCY CONTROLLERS**

**PART 1 - GENERAL**

**1.1 SUMMARY**

- A. Section includes solid-state, pulse-width modulated, variable frequency controllers and variable frequency drives for speed control of three-phase, squirrel-cage induction motors.

**1.2 DEFINITIONS**

- A. EMS: Energy Management System.
- B. IGBT: Integrated gate bipolar transistor.
- C. LAN: Local area network.
- D. PID: Control action, proportional plus integral plus derivative.
- E. PWM: Pulse-width modulated.
- F. VFC: Variable frequency controller and variable frequency drive.

**1.3 PERFORMANCE REQUIREMENTS**

- A. Design – Environmental: Equipment shall be rated for continuous operation, capable of driving full load without derating, under the following conditions, unless otherwise indicated:
  - 1. Temperature Range, Ambient: 32 deg F to 105 deg F.
  - 2. Relative Humidity: Less than 90 percent (noncondensing).
  - 3. Altitude: Not exceeding 3300 feet.
  - 4. Conditions: Winter: -10 deg F DB; Summer: 95 deg F DB / 75 deg F WB.
- B. Noise: The VFC shall not produce motor noise in excess of the manufacturers published noise standards for 60 Hz operation.

**1.4 SUBMITTALS**

- A. Product Data: For each type of VFC. Include dimensions, mounting arrangements, location for conduit entries, shipping and operating weights, and manufacturer's technical data on features, performance, electrical ratings, characteristics, and finishes.
- B. Shop Drawings:
  - 1. Include dimensioned plans, elevations, sections, and details, including required clearances and service space around equipment. Show tabulations of installed devices, equipment features, and ratings. Include the following:
    - a. Each installed unit's type and details.



- b. Nameplate legends.
    - c. Short-circuit current rating of integrated unit.
    - d. Listed and labeled for series rating of overcurrent protective devices in combination controllers by an NRTL acceptable to authorities having jurisdiction.
  - 2. Wiring Diagrams: Power, signal, and control wiring for VFCs. Provide schematic wiring diagram for each type of VFC.
  - C. Coordination Drawings: Floor plans, drawn to scale, showing dimensioned layout, required working clearances, and required area above and around VFCs where pipe and ducts are prohibited. Show VFC layout and relationships between electrical components and adjacent structural and mechanical elements. Show support locations, type of support, and weight on each support. Indicate field measurements.
  - D. Qualification Data: For manufacturer and testing agency.
  - E. Field Quality-Control Test Reports: Submit reports documenting the activities performed. These reports are to be submitted two weeks after startup is completed.
  - F. Operation and Maintenance Data: For VFCs, all installed devices, and components to include in emergency, operation, and maintenance manuals. Include the following:
    - 1. Routine maintenance requirements for VFCs and all installed components.
    - 2. Manufacturer's written instructions for testing and adjusting overcurrent protective devices.
    - 3. A table listing the installed VFC drives set up parameters, alarm and trip setting.
    - 4. Complete parts list with stock numbers, including spare parts.
  - G. Training Reports: Submit reports on training documenting dates and attendance.
- 1.5 QUALITY ASSURANCE
- A. Manufacturer Qualifications: Award the work to a single firm that specializes in the production of variable frequency drives, with not less than 5 years experience in the production of variable frequency drives similar in design and performance to those required for the Project, and whose work has resulted in a history of successful in-service performance. The manufacturer shall have sufficient production capacity, and have organized quality control and testing procedures, to be capable of producing the equipment required for the Project without causing a delay in the Work. The manufacturer shall maintain, within 100 miles of Project site, a service center capable of providing training, parts, and emergency maintenance and repairs.
  - B. Testing Agency Qualifications: An independent agency, with the experience and capability to conduct the testing indicated, that is a member company of the InterNational Electrical Testing Association and that is acceptable to authorities having jurisdiction.
    - 1. Testing Agency's Field Supervisor: Person currently certified by the InterNational Electrical Testing Association or the National Institute for Certification in Engineering Technologies to supervise on-site testing.
  - C. Source Limitations: Obtain all VFCs required for the Project through one source from a single manufacturer.
  - D. Electrical Components, Devices, and Accessories: Listed and labeled as defined in NFPA 70 by a testing agency acceptable to authorities having jurisdiction, and marked for intended use.

- E. Regulatory Requirements: Comply with the Chicago Building Code, including requirements for components and installation.
- F. Comply with IEEE 519-1992, "Recommended Practices and Requirements for Harmonic Control in Electrical Power Systems."

#### 1.6 DELIVERY, STORAGE, AND HANDLING

- A. Deliver and store VFCs in manufacturer's original protective packaging, with original labels detailing contents intact. Store VFCs indoors, off of ground, under cover, in clean, dry location with uniform temperature and humidity to prevent condensation. Protect VFCs from exposure to dirt, fumes, water, corrosive substances, and physical damage.

#### 1.7 COORDINATION

- A. Coordinate layout and installation of VFCs with other construction including conduit, piping, equipment, and adjacent surfaces. Maintain required workspace clearances, including clearances required for maintenance, and required clearances for equipment access doors and panels.
- B. Coordinate size and location of concrete bases. Deliver setting templates in time to allow casting of anchor-bolt inserts into bases. Concrete, reinforcement, and formwork requirements are specified in Division 03 Section "Cast-in-Place Concrete."
- C. Coordinate installation of roof curbs, equipment supports, and roof penetrations.
- D. Coordinate features of VFCs, installed units, and accessory devices with pilot devices and control circuits to which they connect.
- E. Coordinate features, accessories, and functions of each VFC and each installed unit with ratings and characteristics of supply circuit, motor, required control sequence, and duty cycle of motor and load.

#### 1.8 COORDINATION WITH ENERGY MANAGEMENT SYSTEM

- A. General: The equipment specified in this Section is required to be interfaced with the Energy Management System (EMS) as specified in Division 23 Section "Building Automation System." Provide all devices, hardware, programming, startup and commissioning required to establish the interface.
- B. Coordinate with EMS supplier for their review and acceptance of the communications interface to be provided. Include evidence of the coordination and review process with the required submittals for this Section.
- C. Provide a list of all read/write and read-only points available through the user interface. Provide software, hardware or paperwork that the contractor installing the EMS will require in order to accomplish the interface.
- D. The equipment supplier is solely responsible for the proper performance of their equipment provided the correct information is provided through the communications interface.
- E. Provide a prefunctional checklist, startup checklist and demonstration report to the Engineer, Commissioning Agent, or Board Authorized Representative for acceptance of system.

- F. Provide a startup technician on-site during the establishment of the interface. Coordinate this activity with the EMS installer.
- G. BACNet or LonWorks compliant manufacturer-provided controls
  - 1. Provide any information necessary to allow the BACNet compliant device to be directly connected to the existing network, and send/receive information to the system installed under Division 23 sections.
  - 2. The EMS shall then read and present the information made available by the equipment manufacturer, and transmit information receivable by the equipment manufacturer. This shall be accomplished by user configuration of point information, but shall not require recompiling or downloading of control programs.
- H. Non-BACNet or LonWorks compliant manufacturer-provided controls:
  - 1. Provide programming and hardware necessary to integrate information from the equipment into the EMS.
  - 2. Provide the owner and EMS installer with all documentation necessary to receive point information required by Division 23 sections in a communications method compatible with the EMS.

#### 1.9 WARRANTY

- A. Manufacturer's Warranty: Manufacturer agrees to repair or replace components or equipment that fail in materials or workmanship within the specified warranty period. Manufacturer's warranty shall include parts, labor, travel costs, and living expenses incurred by the manufacturer in providing onsite service and repair or replacement.
  - 1. Warranty Period: Three years from the date of Substantial Completion or Preliminary Acceptance.

#### 1.10 EXTRA MATERIALS

- A. Furnish extra materials that match products installed in the quantity indicated, in manufacturer's protective packaging, with manufacturer's original labels describing contents intact.
  - 1. Indicating Lights: Two of each type installed.

### **PART 2 - PRODUCTS**

#### 2.1 MANUFACTURERS

- A. Subject to compliance with requirements, provide products by one of the following:
  - 1. Yaskawa.
  - 2. ABB Power Distribution, Inc.; ABB Control, Inc. Subsidiary.
  - 3. Danfoss.
  - 4. Rockwell Automation; Allen-Bradley Co.; Industrial Control Group.
  - 5. Siemens Energy and Automation; Industrial Products Division.
  - 6. Toshiba International Corporation.

## 2.2 VARIABLE FREQUENCY CONTROLLERS

- A. Description: NEMA ICS 2, IGBT, PWM, VFC; listed and labeled as a complete unit and arranged to provide variable speed of an NEMA MG 1, Design B, 3-phase induction motor by adjusting output voltage and frequency.
1. Provide unit suitable for operation of premium-efficiency motor as defined by NEMA MG 1.
- B. All PWM AC Variable Frequency Drives of 40 hp and above shall be equipped with harmonic mitigation equipment to prevent power system problems resulting from high levels of reflected harmonic distortion. Provide harmonic mitigation for drives less than 40 hp where required to meet IEEE 519.
1. The harmonic mitigation equipment shall treat all of the characteristic low frequency harmonics generated by a 3-phase, diode bridge rectifier load (5th, 7th, 11th, 13th, etc.).
  2. The characteristic harmonics shall be suppressed without the need for individual tuning or the requirement to phase shift against other harmonic sources.
  3. Harmonic mitigation shall be by passive inductor/capacitor network or internal phase shifting transformer. Active electronic components shall not be used.
  4. Power factor shall be 0.98 lagging to 0.95 leading in operating range from full to half load.
  5. To ensure compatibility with engine generators, the harmonic mitigation equipment must never introduce a capacitive reactive power (KVAR) that is greater than 15% of its kVA rating.
  6. The harmonic mitigation equipment shall not resonate with system impedances or attract harmonic currents from other harmonic sources.
  7. The harmonic mitigation equipment in combination with the Variable Frequency Drive shall meet all requirements of IEEE 519 for individual and total harmonic voltage and current distortion. The Point of Common Coupling (PCC) for all voltage and current harmonic calculations and measurements shall be the input terminals to the harmonic mitigation equipment.
  8. Total Harmonic Voltage Distortion (THVD) shall meet the requirements of Table 10.2 of IEEE 519 by not exceeding 5% and by limiting the individual harmonic voltage distortion to less than 3%. These limits shall apply while operating on either utility supply or generator supply when applicable. The harmonic mitigation equipment vendor shall not be responsible for pre-existing voltage distortion caused by other harmonic sources.
  9. Total Demand Distortion (TDD) of the current at the input terminals of the harmonic mitigation equipment shall not exceed the limits as defined in Table 10.3 of IEEE 519. For  $I_{sc}/I_L$  ratio  $< 20$ , TDD must be less than 5%. For all other  $I_{sc}/I_L$  ratios, the TDD must not exceed 8% even when Table 10.3 allows for more relaxed limits. For single-phase applications, the TDD must not exceed 12%.
  10. The full load efficiency of the harmonic mitigation equipment / VFD combination shall be greater than 96%. The harmonic mitigation equipment itself shall have efficiency no less than 99%.
- C. Design and Rating: Match load type such as fans, blowers, and pumps, and type of connection used between motor and load, such as direct or through a power-transmission connection.
- D. Output Rating: 3-phase; 6 to 60 Hz, with voltage proportional to frequency throughout voltage range.
- E. Unit Operating Requirements:
1. Input ac voltage ranges of 208 V, plus or minus 10 percent or 480 V, plus or minus 10 percent as indicated on equipment schedules.

2. Input frequency tolerance of 50/60 Hz, plus or minus 6 percent.
  3. Minimum Efficiency: 96 percent at 60 Hz, full load.
  4. Minimum Displacement Primary-Side Power Factor: 96 percent.
  5. Overload Capability: 1.2 times the base load current for 60 seconds; 1.8 times the base load current for 3 seconds.
  6. Starting Torque: 100 percent of rated torque or as indicated.
  7. Speed Regulation: Plus or minus 1 percent.
- F. Isolated Control Interface: To allow controller to follow control signal over an 11:1 speed range.
1. Electrical Signal: 4 to 20 mA at 24 V.
- G. Internal Adjustability Capabilities:
1. Minimum Speed: 5 to 25 percent of maximum rpm.
  2. Maximum Speed: 80 to 100 percent of maximum rpm.
  3. Acceleration: 2 to a minimum of 22 seconds.
  4. Deceleration: 2 to a minimum of 22 seconds.
  5. Current Limit: 50 to a minimum of 110 percent of maximum rating.
- H. Self-Protection and Reliability Features:
1. Input transient protection by means of surge suppressors.
  2. Under- and overvoltage trips; inverter over-temperature, overload, and overcurrent trips.
  3. Motor Overload Relay: Adjustable and capable of NEMA ICS 2, Class 10 performance.
  4. Notch filter to prevent operation of the controller-motor-load combination at a natural frequency of the combination.
  5. Instantaneous line-to-line and line-to-ground overcurrent trips.
  6. Loss-of-phase protection.
  7. Reverse-phase protection.
  8. Short-circuit protection.
  9. Motor over temperature fault where motor is equipped with RTD.
- I. Multiple-Motor Capability: Controller suitable for service to multiple motors and having a separate overload relay and protection for each controlled motor. Overload relay shall shut off controller and motors served by it when overload relay is tripped.
- J. Automatic Reset/Restart: Attempts three restarts after controller fault or on return of power after an interruption and before shutting down for manual reset or fault correction. Bidirectional autospeed search shall be capable of starting into rotating loads spinning in either direction and returning motor to set speed in proper direction, without damage to controller, motor, or load.
- K. Power-Interruption Protection: To prevent motor from re-energizing after a power interruption until motor has stopped.
- L. Torque Boost: Automatically varies starting and continuous torque to at least 1.5 times the minimum torque to ensure high-starting torque and increased torque at slow speeds.
- M. Motor Temperature Compensation at Slow Speeds: Adjustable current fall-back based on output frequency for temperature protection of self-cooled, fan-ventilated motors at slow speeds.
- N. Input Line Conditioning: dc bus link reactors, isolation transformers, active and passive harmonic filters, and phase shifting transformers.

- O. VFC Output Filtering: Line inductors, output limit filters, sine wave filters, and motor termination filters shall be provided where the motor to drive conductor lengths exceed manufacturer's recommended lengths.
- P. Status Lights: Door-mounted LED indicators shall indicate the following conditions:
1. Power on.
  2. Run.
  3. Overvoltage.
  4. Line fault.
  5. Overcurrent.
  6. External fault.
- Q. Panel-Mounted Operator Station: Start-stop and auto-manual selector switches with manual speed control potentiometer and elapsed time meter.
- R. Indicating Devices: Meters or digital readout devices and selector switch, mounted flush in controller door and connected to indicate the following controller parameters:
1. Output frequency (Hz).
  2. Motor speed (rpm).
  3. Motor status (running, stop, fault).
  4. Motor current (amperes).
  5. Motor torque (percent).
  6. Fault or alarming status (code).
  7. PID feedback signal (percent).
  8. DC-link voltage (VDC).
  9. Set-point frequency (Hz).
  10. Motor output voltage (V).
- S. Control Signal Interface:
1. Electric Input Signal Interface: A minimum of 2 analog inputs (0 to 10 V or 0/4-20 mA) and 6 programmable digital inputs.
  2. Remote Signal Inputs: Capability to accept any of the following speed-setting input signals from the EMS or other control systems:
    - a. 0 to 10-V dc.
    - b. 0-20 or 4-20 mA.
    - c. Potentiometer using up/down digital inputs.
    - d. Fixed frequencies using digital inputs.
    - e. RS485.
    - f. Keypad display for local hand operation.
  3. Output Signal Interface:
    - a. A minimum of 1 analog output signal (0/4-20 mA), which can be programmed to any of the following:
      - 1) Output frequency (Hz).
      - 2) Output current (load).
      - 3) DC-link voltage (VDC).
      - 4) Motor torque (percent).
      - 5) Motor speed (rpm).

- 6) Set-point frequency (Hz).
4. Remote Indication Interface: A minimum of 2 dry circuit relay outputs (120-V ac, 1 A) for remote indication of the following:
    - a. Motor running.
    - b. Set-point speed reached.
    - c. Fault and warning indication (overtemperature or overcurrent).
    - d. PID high- or low-speed limits reached.
- T. Communications: Provide an RS485 interface allowing VFC to be used with an external system within a multidrop LAN configuration. Interface shall allow all parameter settings of VFC to be programmed via EMS control. Provide capability for VFC to retain these settings within the nonvolatile memory.
- U. Integral Disconnecting Means: NEMA AB 1, molded-case switch with lockable handle.
- V. Operation and Maintenance Features:
1. Current-Voltage-Frequency Indicating Devices: Mount meters or digital readout device and selector switch flush in controller door and connect to indicate controller output.
  2. Integral Main Disconnect: Circuit breaker connected to shut down all power to the controller. Interlock breaker with cabinet door.
  3. Auxiliary Motor Contactors: Electrically interlocked. One contactor connected between the controller output and the motor and controlled by the controller regulator. Provide motor overload protection under both modes of operation with control logic that allows common start-stop capability in either mode.
  4. Isolating Circuit Breaker: Arranged to electrically isolate the variable-speed controller to permit safe trouble-shooting and testing of the controller, both energized and de-energized, while the motor is operating in the bypass mode.
  5. Form C output contacts for run and fault conditions.
  6. Terminal strip for N.C. safety shutdown contacts.
  7. N.C. input for remote start/stop control in Auto mode.

## 2.3 ENCLOSURES

- A. Indoors: NEMA 250, Type 1.
- B. Outdoors: NEMA 3R.

## 2.4 ACCESSORIES

- A. Devices shall be factory installed in controller enclosure, unless otherwise indicated.
- B. Push-Button Stations, Pilot Lights, and Selector Switches: NEMA ICS 2, heavy-duty type.
- C. Stop and Lockout Push-Button Station: Momentary-break, push-button station with a factory-applied hasp arranged so padlock can be used to lock push button in depressed position with control circuit open.
- D. Standard Displayed information, display shall be interchangeable for all VFCs installed:
  1. Output frequency (Hz).
  2. Set-point frequency (Hz).

3. Motor current (amperes).
4. DC-link voltage (VDC).
5. Motor torque (percent).
6. Motor speed (rpm).
7. Motor output voltage (V).
8. Fault history with analytical data.

E. Historical Logging Information and Displays:

1. Real-time clock with current time and date.
2. Running log of total power versus time.
3. Total run time.
4. Fault log, maintaining last four faults with time and date stamp for each.

F. Nonshrink, Nonmetallic Grout: Factory-packaged, nonstaining, noncorrosive, nongaseous grout complying with ASTM C 1107.

2.5 FINISH

A. Finish: Manufacturer's standard paint finish, applied to factory-assembled and -tested VFCs.

**PART 3 - EXECUTION**

3.1 EXAMINATION

- A. Examine areas, surfaces, and substrates to receive VFCs for compliance with requirements, installation tolerances, and other conditions affecting performance.
- B. Examine roughing-in for conduit systems to verify actual locations of conduit connections before VFC installation.
- C. Proceed with installation only after unsatisfactory conditions have been corrected.

3.2 PREPARATION

- A. Harmonic Analysis: Obtain the electrical system one-line diagram from the contract document, provide a harmonic analysis demonstrating that the proposed VFDs (along with harmonic mitigation equipment provided) conform with IEEE 519-1992, "Recommended Practices and Requirements for Harmonic Control in Electrical Power Systems."

3.3 SELECTION

- A. Product Selection for Restricted Space: Drawings indicate maximum dimensions for VFCs, minimum clearances between VFCs, and adjacent surfaces and other items. Comply with indicated maximum dimensions and clearances.
- B. Select features of each VFC to coordinate with ratings and characteristics of supply circuit and motor; required control sequence; and duty cycle of motor, controller, and load.
- C. Select horsepower rating of controllers to suit motor controlled.



### 3.4 INSTALLATION

- A. Anchor each VFC assembly to steel-channel sills arranged and sized according to manufacturer's written instructions. Attach by bolting. Level and grout sills flush with mounting surface.
- B. Install VFCs on concrete bases.
- C. VFD's are not to be installed inside air handlers or air plenums due to the potentially high humidity or temperatures.

### 3.5 CONCRETE BASES

- A. Coordinate size and location of concrete bases. Verify structural requirements with structural engineer.

### 3.6 IDENTIFICATION

- A. Identify VFCs, components, and control wiring according to Division 23 Section "Mechanical Identification."
- B. Operating Instructions: Frame printed operating instructions for VFCs, including control sequences and emergency procedures. Fabricate frame of finished metal, and cover instructions with clear acrylic plastic. Mount on front of VFC units.

### 3.7 CONTROL WIRING INSTALLATION

- A. Install wiring between VFCs and remote devices according to Division 26 sections. Power and control wiring shall not be run in the same conduit, and shall follow manufacturer's recommendations.
- B. Bundle, train, and support wiring in enclosures.
- C. Connect hand-off-automatic switch and other automatic-control devices where applicable.
  - 1. Connect selector switches with control circuit in both hand and automatic positions for safety-type control devices such as low- and high-pressure cutouts, high-temperature cutouts, and motor overload protectors.

### 3.8 CONNECTIONS

- A. Install conduit and ground equipment in accordance with Division 26 sections.

### 3.9 ADJUSTING

- A. Set field-adjustable switches and circuit-breaker trip ranges.

### 3.10 DEMONSTRATION

- A. Engage a factory-authorized service representative to train Owner's maintenance personnel to adjust, operate, and maintain variable frequency controllers. Refer to Division 01 Section "Testing and Inspection."
- B. Conduct a minimum of 4 hours of training in operation and maintenance of equipment.

- C. Schedule training with at least seven days' advance notice.

### 3.11 CLEANING

- A. Remove paint splatters and other spots, dirt and debris. Touch up scratches and mars of finish to match original finish. Clean devices internally using methods and materials as recommended by manufacturer.

### 3.12 CONTRACTOR STARTUP AND REPORTING

- A. Prepare for acceptance tests as follows:

1. Test insulation resistance for each enclosed controller element, bus, component, connecting supply, feeder, and control circuit.
2. Test continuity of each circuit.

- B. Reports: Prepare written reports certified by testing organization of tests and observations. Report defective materials and workmanship and unsatisfactory test results. Include records of repairs and adjustments made. Harmonic compliance shall be verified with onsite field measurements of both the voltage and current harmonic distortion at the input terminals of the harmonic mitigating equipment with and without the equipment operating. A recording type Fluke 41 or equivalent harmonics analyzer displaying individual and total harmonic currents and voltages must be utilized.

- C. Manufacturer's Field Service: Engage a factory-authorized service representative to perform the following:

1. Inspect controllers, wiring, components, connections, and equipment installation. Test and adjust controllers, components, and equipment.
2. Assist in field testing of equipment including pretesting and adjusting of solid-state controllers.
3. Prepare written reports.

- D. Testing Agency: Engage a qualified testing and inspecting agency to perform the following field tests and inspections and prepare test reports:

1. Perform each electrical test and visual and mechanical inspection, except optional tests, stated in NETA ATS. Certify compliance with test parameters.
2. Correct malfunctioning units on-site, where possible, and retest to demonstrate compliance; otherwise, replace with new units and retest.

### 3.13 DEMONSTRATION AND COMMISSIONING

- A. Engage a factory-authorized service representative to train Owner's maintenance personnel to adjust, operate, and maintain air handling units.

1. Train Owner's maintenance personnel on procedures and schedules for starting up and shutting down, troubleshooting, servicing, and maintaining the equipment. The training will occur after the startup report has been provided to the owner and the trainer will provide two (2) Installation and Operations manuals for the use of the Owner's personnel during training.
2. Review data in maintenance manuals. Refer to Division 01 Section "Operation and Maintenance Data." All required and recommended maintenance will be reviewed as well

as operational troubleshooting. If the IOM does not include a written troubleshooting guide one shall be provided.

3. Schedule training with Owner, through Architect, with at least seven days' advance notice.
- B. Demonstrate proper operation of equipment to commissioning agent or Owner's designated personnel. The scope of the demonstration will include functional performance requirements under both local and building automation control as well as any commissioning requirements in Divisions 01 and 23 sections.

**End of Section 230515**

**DIVISION 23 – HEATING, VENTILATING AND AIR CONDITIONING**

**SECTION 23 05 29**

**HANGERS AND SUPPORTS FOR PIPING AND EQUIPMENT**

**PART 1 - GENERAL**

**1.1 SUMMARY**

- A. Section includes the following hangers and supports for mechanical system piping and equipment:
  - 1. Steel pipe hangers and supports.
  - 2. Trapeze pipe hangers.
  - 3. Metal framing systems.
  - 4. Thermal-hanger shield inserts.

**1.2 DEFINITIONS**

- A. MSS: Manufacturers Standardization Society for The Valve and Fittings Industry Inc.
- B. Terminology: As defined in MSS SP-90, "Guidelines on Terminology for Pipe Hangers and Supports."

**1.3 SUBMITTALS**

- A. Product Data: For the following:
  - 1. Steel pipe hangers and supports.
  - 2. Thermal-hanger shield inserts.
- B. Shop Drawings: Signed and sealed by a qualified professional engineer. Show fabrication and installation details and include calculations for the following:
  - 1. Trapeze pipe hangers. Include Product Data for components.
  - 2. Metal framing systems. Include Product Data for components.
  - 3. Equipment supports.

- C. Welding certificates.

**1.4 QUALITY ASSURANCE**

- A. Welding: Qualify procedures and personnel according to AWS D1.1, "Structural Welding Code-Steel." and ASME Boiler and Pressure Vessel Code: Section IX.

## 1.5 PERFORMANCE REQUIREMENTS

- A. Design supports for multiple pipes, including pipe stands, capable of supporting combined weight of supported systems, system contents, and test water.

## 1.6 WARRANTY

- A. Provide warranty on materials and labor for 18 months starting from date of delivery, or one year from date of substantial completion, whichever is longer.

## PART 2 - PRODUCTS

### 2.1 MANUFACTURERS

- A. Manufacturers: Subject to compliance with requirements, provide products by one of the following manufacturers:
  - 1. Steel Pipe Hangers and Supports:
    - a. Anvil
    - b. B-Line Systems, Inc.; a division of Cooper Industries.
    - c. Carpenter & Paterson, Inc.

### 2.2 TRAPEZE PIPE HANGERS

- A. Description: MSS SP-69, Type 59, shop- or field-fabricated pipe-support assembly made from structural-steel shapes with MSS SP-58 hanger rods, nuts, saddles, and U-bolts.

### 2.3 THERMAL-HANGER SHIELD INSERTS

- A. Description: 100 psig minimum, compressive-strength insulation insert encased in sheet metal shield.
- B. Insulation-Insert Material for Cold Piping: Water-repellent treated, ASTM C 533, Type I calcium silicate with vapor barrier.
- C. Insulation-Insert Material for Hot Piping: Water-repellent treated, ASTM C 533, Type I calcium silicate.
- D. For Trapeze or Clamped Systems: Insert and shield shall cover entire circumference of pipe.
- E. For Clevis or Band Hangers: Insert and shield shall cover lower 180 degrees of pipe.
- F. Insert Length: Extend 2 inches beyond sheet metal shield for piping operating below ambient air temperature.

## **PART 3 - EXECUTION**

### **3.1 HANGER AND SUPPORT APPLICATIONS**

- A. Specific hanger and support requirements are specified in Sections specifying piping systems and equipment.
- B. Comply with MSS SP-69 for pipe hanger selections and applications that are not specified in piping system Sections.
- C. Use hangers and supports with galvanized, metallic coatings for piping and equipment that will not have field-applied finish. Hangers installed outdoors shall have two coats of rust inhibitor paint after installation and adjustment.
- D. Use nonmetallic coatings on attachments for electrolytic protection where attachments are in direct contact with copper tubing.
- E. Use padded hangers for piping that is subject to scratching.
- F. Horizontal-Piping Hangers and Supports: Unless otherwise indicated and except as specified in piping system Sections, install the following types:
  - 1. Adjustable, Steel Clevis Hangers (MSS Type 1): For suspension of noninsulated or insulated stationary pipes, NPS 1/2 to NPS 30.
  - 2. U-Bolts (MSS Type 24): For support of heavy pipes, NPS 1/2 to NPS 30.
  - 3. Single Pipe Rolls (MSS Type 41): For suspension of pipes, NPS 1 to NPS 30, from 2 rods if longitudinal movement caused by expansion and contraction might occur.
  - 4. Adjustable Roller Hangers (MSS Type 43): For suspension of pipes, NPS 2-1/2 to NPS 20, from single rod if horizontal movement caused by expansion and contraction might occur.
- G. Vertical-Piping Clamps: Unless otherwise indicated and except as specified in piping system Sections, install the following types:
  - 1. Extension Pipe or Riser Clamps (MSS Type 8): For support of pipe risers, NPS 3/4 to NPS 20.
- H. Hanger-Rod Attachments: Unless otherwise indicated and except as specified in piping system Sections, install the following types:
  - 1. Steel Turnbuckles (MSS Type 13): For adjustment up to 6 inches for heavy loads.
  - 2. Steel Clevises (MSS Type 14): For 120 to 450 deg F piping installations.
  - 3. Swivel Turnbuckles (MSS Type 15): For use with MSS Type 11, split pipe rings.
  - 4. Malleable-Iron Sockets (MSS Type 16): For attaching hanger rods to various types of building attachments.
  - 5. Steel Weldless Eye Nuts (MSS Type 17): For 120 to 450 deg F piping installations.
- I. Building Attachments: Unless otherwise indicated and except as specified in piping system Sections, install the following types:
  - 1. Steel or Malleable Concrete Inserts (MSS Type 18): For upper attachment to suspend pipe hangers from concrete ceiling.

2. Side-Beam or Channel Clamps (MSS Type 20): For attaching to bottom flange of beams, channels, or angles.
  3. Center-Beam Clamps (MSS Type 21): For attaching to center of bottom flange of beams.
  4. Welded Beam Attachments (MSS Type 22): For attaching to bottom of beams if loads are considerable and rod sizes are large.
  5. Top-Beam Clamps (MSS Type 25): For top of beams if hanger rod is required tangent to flange edge.
  6. Side-Beam Clamps (MSS Type 27): For bottom of steel I-beams.
  7. Steel-Beam Clamps with Eye Nuts (MSS Type 28): For attaching to bottom of steel I-beams for heavy loads.
  8. Linked-Steel Clamps with Eye Nuts (MSS Type 29): For attaching to bottom of steel I-beams for heavy loads, with link extensions.
  9. Malleable Beam Clamps with Extension Pieces (MSS Type 30): For attaching to structural steel.
  10. Welded-Steel Brackets: For support of pipes from below, or for suspending from above by using clip and rod. Use one of the following for indicated loads:
    - a. Light (MSS Type 31): 750 lb (340 kg).
    - b. Medium (MSS Type 32): 1500 lb (680 kg).
    - c. Heavy (MSS Type 33): 3000 lb (1360 kg).
  11. Side-Beam Brackets (MSS Type 34): For sides of steel or wooden beams.
  12. Plate Lugs (MSS Type 57): For attaching to steel beams if flexibility at beam is required.
  13. Horizontal Travelers (MSS Type 58): For supporting piping systems subject to linear horizontal movement where headroom is limited.
- J. Saddles and Shields: Unless otherwise indicated and except as specified in piping system Sections, install the following types:
1. Steel Pipe-Covering Protection Saddles (MSS Type 39): To fill interior voids with insulation that matches adjoining insulation.
  2. Protection Shields (MSS Type 40): Of length recommended in writing by manufacturer to prevent crushing insulation.
  3. Thermal-Hanger Shield Inserts: For supporting insulated pipe.
- K. Comply with MSS SP-69 for trapeze pipe hanger selections and applications that are not specified in piping system Sections.
- L. Comply with MFMA-102 for metal framing system selections and applications that are not specified in piping system Sections.
- M. Use powder-actuated fasteners or mechanical-expansion anchors instead of building attachments where required in concrete construction.
- N. Use pipe positioning systems in pipe spaces behind plumbing fixtures to support supply and waste piping for plumbing fixtures.
- 3.2 HANGER AND SUPPORT INSTALLATION
- A. Trapeze Pipe Hanger Installation: Comply with MSS SP-69 and MSS SP-89. Arrange for grouping of parallel runs of horizontal piping and support together on field-fabricated trapeze pipe hangers.

1. Pipes of Various Sizes: Support together and space trapezes for smallest pipe size or install intermediate supports for smaller diameter pipes as specified above for individual pipe hangers.
2. Field fabricate from ASTM A 36/A 36M, steel shapes selected for loads being supported. Weld steel according to AWS D1.1.
3. Trapeze bars shall be tightly secured to structural members at two points with bolts or other similar mechanical fasteners. Hangers from bar joist and fabricated truss members shall be located at the panel points of the structural members. C-clamp type hangers attached to one side of double-angle bottom members are not allowed. Point loads shall not exceed the lesser of:
  - a. Manufacturer's certified recommendation for the component parts.
  - b. The following maximum point loads, and maximum hanger spacings as herein specified, for structural elements in any direction; except as specifically approved by the Structural Engineer of Record:

Structural Element Type	Maximum Hanger Point Load (lb)
Metal deck without concrete topping	50
Composite metal deck slab with concrete topping	50
Steel Beams:	
All channels, W4 through W8	100
W10 through W14	200
W16 through W24	400
W27 through W36	750
Built-up structural steel trusses	250
Reinforced post-tensioned concrete elements	
Slabs up to 6 inches thick	150
Slabs over 6 inches thick	250
Joists 8 inches wide	250
Beam/girders 8 inches wide	500

- B. Thermal-Hanger Shield Installation: Install in pipe hanger or shield for insulated piping.
  - a. Only workmen qualified by instructions of the manufacturers representative and/or licensed by the state and local authorities shall be assigned to use a powder actuated fastening tool.



- b. Where practical, tools of only one manufacturer shall be used on a project.
  - c. Only cartridges and fasteners supplied by the manufacturer of the tool shall be used to operate that tool.
  - d. Powder actuated fastening tools shall be handled with the same care as firearms.
  - e. All safety devices incorporated in the tool by the manufacturer shall be used at all times.
  - f. Acceptable types of powder actuated fastening tools are:
    - 1) Piston Tool - Low Velocity Type - is a tool utilizing a piston, activated by the power of a blank cartridge furnished by the manufacturer for use with it, to drive a stud, pin or fastener into a work surface.
    - 2) Powder Assisted Hammer Drive Tool - Low Velocity Type - is a tool utilizing a captive piston, activated by a blow from a 4 lb. hammer supplemented by the power of a blank cartridge furnished by the manufacturer for use with the tool, to drive a stud, pin or fastener into a work surface.
- C. Install hangers and supports complete with necessary inserts, bolts, rods, nuts, washers, and other accessories.
- D. Equipment Support Installation: Fabricate from welded-structural-steel shapes.
- E. Install hangers and supports to allow controlled thermal and seismic movement of piping systems, to permit freedom of movement between pipe anchors, and to facilitate action of expansion joints, expansion loops, expansion bends, and similar units.
- F. Install lateral bracing with pipe hangers and supports to prevent swaying.
- G. Install building attachments within concrete slabs or attach to structural steel. Install additional attachments at concentrated loads, including valves, flanges, and strainers, NPS 2-1/2 and larger and at changes in direction of piping. Install concrete inserts before concrete is placed; fasten inserts to forms and install reinforcing bars through openings at top of inserts.
- H. Load Distribution: Install hangers and supports so piping live and dead loads and stresses from movement will not be transmitted to connected equipment.
- I. Pipe Slopes: Install hangers and supports to provide indicated pipe slopes and so maximum pipe deflections allowed by ASME B31.1 (for power piping) and ASME B31.9 (for building services piping) are not exceeded.
- J. Insulated Piping: Comply with the following:
- 1. Attach clamps and spacers to piping.
    - a. Piping Operating above Ambient Air Temperature: Clamp may project through insulation.
    - b. Piping Operating below Ambient Air Temperature: Use thermal-hanger shield insert with clamp sized to match OD of insert.
    - c. Do not exceed pipe stress limits according to ASME B31.1 for power piping and ASME B31.9 for building services piping.
  - 2. Install MSS SP-58, Type 39, protection saddles if insulation without vapor barrier is indicated. Fill interior voids with insulation that matches adjoining insulation.

- a. Option: Thermal-hanger shield inserts may be used. Include steel weight-distribution plate for pipe NPS 4 and larger if pipe is installed on rollers.
- 3. Install MSS SP-58, Type 40, protective shields on cold piping with vapor barrier. Shields shall span an arc of 180 degrees.
  - a. Option: Thermal-hanger shield inserts may be used. Include steel weight-distribution plate for pipe NPS 4 and larger if pipe is installed on rollers.
- 4. Shield Dimensions for Pipe: Not less than the following:
  - a. NPS 1/4 to NPS 3-1/2: 12 inches long and 0.048 inch thick.
  - b. NPS 4: 12 inches long and 0.06 inch thick.
  - c. NPS 5 and NPS 6: 18 inches long and 0.06 inch thick.
  - d. NPS 8 to NPS 14: 24 inches long and 0.075 inch thick.
  - e. NPS 16 to NPS 24: 24 inches long and 0.105 inch thick.
- 5. Insert Material: Length at least as long as protective shield.
- 6. Thermal-Hanger Shields: Install with insulation same thickness as piping insulation.

### 3.3 EQUIPMENT SUPPORTS

- A. Fabricate structural-steel stands to suspend equipment from structure overhead or to support equipment above floor.
- B. Grouting: Place grout under supports for equipment and make smooth bearing surface.
- C. Provide lateral bracing, to prevent swaying, for equipment supports.

### 3.4 METAL FABRICATIONS

- A. Cut, drill, and fit miscellaneous metal fabrications for trapeze pipe hangers and equipment supports.
- B. Fit exposed connections together to form hairline joints. Field weld connections that cannot be shop welded because of shipping size limitations.
- C. Field Welding: Comply with AWS D1.1 procedures for shielded metal arc welding, appearance and quality of welds, and methods used in correcting welding work, and with the following:
  - 1. Use materials and methods that minimize distortion and develop strength and corrosion resistance of base metals.
  - 2. Obtain fusion without undercut or overlap.
  - 3. Remove welding flux immediately.
  - 4. Finish welds at exposed connections so no roughness shows after finishing and contours of welded surfaces match adjacent contours.

### 3.5 ADJUSTING

- A. Hanger Adjustments: Adjust hangers to distribute loads equally on attachments and to achieve indicated slope of pipe.

- B. Trim excess length of continuous-thread hanger and support rods to 1-1/2 inches.

**End of Section 230529**

**DIVISION 23 – HEATING, VENTILATING AND AIR CONDITIONING**

**SECTION 23 05 93**

**TESTING, ADJUSTING, AND BALANCING FOR HVAC**

**PART 1 - GENERAL**

**1.1 SUMMARY**

A. Section includes procedural requirements for testing, adjusting, and balancing (TAB) of new and existing systems to achieve the required flows within the limits of the fan and the motor HP. The testing, adjusting, and balancing work includes producing design objectives for the following:

1. Air Systems:

- a. Variable-air-volume systems.
- b. Multizone systems.
- c. Existing Systems.

2. DEFINITIONS

- B. AABC: Associated Air Balance Council.
- C. NEBB: National Environmental Balancing Bureau.
- D. TAB: Testing, Adjusting, and Balancing.
- E. TABB: Testing, Adjusting, and Balancing Bureau.
- F. TAB Firm: Entity responsible for performing and reporting TAB procedures.
- G. TAB Specialist: Entity engaged by TAB Firm to perform TAB work.

**1.2 SUBMITTALS**

- A. Qualification Data: Within **[30]** days of Notice to Proceed, submit documentation for the TAB contractor and the Project's TAB team members.
- B. Contract Documents Examination Report: Within **[30]** days of Notice to Proceed, submit the Contract Documents Examination Report.
- C. TAB Plan: Within **[30]** days of Notice to Proceed, submit TAB strategies and step-by-step procedures as specified in "Preparation" Article.
- D. Certified TAB reports. Submit two copies of the TAB reports prepared as specified in this specification on approved forms certified by the TAB contractor.
- E. Sample report forms. Submit two copies of the sample TAB report forms
- F. Instrument calibration reports, including the following:

1. Instrument type and make.
2. Serial number.
3. Application.
4. Dates of use.
5. Dates of calibration.

### 1.3 QUALITY ASSURANCE

- A. TAB Contractor Qualifications: Engage a TAB entity certified by AABC, NEBB, or TABB.
  1. TAB Field Supervisor: Employee of the TAB contractor and certified by AABC, NEBB or TABB.
  2. TAB Technician: Employee of the TAB contractor and who is certified by AABC, NEBB or TABB as a TAB technician.
- B. Certification of TAB Reports: Certify TAB field data reports and perform the following:
  1. Review field data reports to validate accuracy of data and to prepare certified TAB reports.
  2. Certify that the TAB team complied with the approved TAB plan and the procedures specified and referenced in this Specification.
- C. TAB Report Forms: Use standard TAB forms from NEBB, AABC or TABB as well as providing any additional information required by this specification.
- D. Instrumentation Type, Quantity, Accuracy, and Calibration: As described in ASHRAE 111, Section 5, "Instrumentation."
- E. Owner reserves the right to select at random 10% of the TAB report data for field verification witnessed by the commission agent. The TAB contractor will be given sufficient notice of the date of field verification. The same instruments that were used when the original test was recorded shall be used. A failure of more than 10% of the selected field verification items shall result in a repeat of the testing of the entire system at the TAB contractor's expense. The repeated work is also subject to field verification.

### 1.4 COORDINATION

- A. Coordinate the efforts of factory-authorized service representatives for systems and equipment, HVAC controls installers, and other mechanics to operate HVAC systems and equipment to support and assist TAB activities.
- B. Notice: Provide seven days' advance notice for each test. Include scheduled test dates and times.
- C. Perform TAB after leakage and pressure tests on air and water distribution systems have been satisfactorily completed.

### 1.5 WARRANTY

- A. Provide warranty in accordance with AABC, NEBB or TABB standards:
  1. National Project Performance Guarantee: Provide a guarantee on AABC's "National Standards for Testing and Balancing Heating, Ventilating, and Air Conditioning Systems"

- forms stating that AABC will assist in completing requirements of the Contract Documents if TAB firm fails to comply with the Contract Documents.
2. Special Guarantee: Provide a guarantee on NEBB forms stating that NEBB will assist in completing requirements of the Contract Documents if TAB firm fails to comply with the Contract Documents.
  3. Guarantee shall include the following provisions:
    - a. The certified TAB firm has tested and balanced systems according to the Contract Documents.
    - b. Systems are balanced to optimum performance capabilities within design and installation limits.

## **PART 2 - PRODUCTS (Not Used)**

## **PART 3 - EXECUTION**

### **3.1 EXAMINATION**

- A. Examine the Contract Documents and field conditions to become familiar with Project requirements and to discover conditions that may preclude proper TAB of systems and equipment.
- B. Examine systems for installed balancing devices, such as test ports, gage cocks, thermometer wells, flow-control devices, balancing valves and fittings, and manual volume dampers. Verify that locations of these balancing devices are accessible.
- C. Examine the approved submittals for HVAC systems and equipment.
- D. Examine design data including HVAC system descriptions, statements of design assumptions for environmental conditions and systems' output, and statements of philosophies and assumptions about HVAC system and equipment controls.
- E. Examine ceiling plenums used for return air to verify that they meet the leakage class of connected ducts as specified in Division 23 Section "Metal Ducts," and are properly separated from adjacent areas. Verify that penetrations in plenum walls are properly sealed or, as required, fire-stopped.
- F. Examine equipment performance data including fan and pump curves.
  1. Relate performance data to Project conditions and requirements, including system effects that can create undesired or unpredicted conditions that cause reduced capacities in all or part of a system.
  2. Calculate system-effect factors to reduce performance ratings of HVAC equipment when installed under conditions different from the conditions used to rate equipment performance. To calculate system effects for air systems, use tables and charts found in AMCA 201, "Fans and Systems," or in SMACNA's "HVAC Systems - Duct Design." Compare results with the design data and installed conditions.
- G. Examine system and equipment installations and verify that field quality-control testing, cleaning, and adjusting specified in individual Sections have been performed.

- H. Examine test reports specified in individual system and equipment Sections.
- I. Examine HVAC equipment and filters and verify that bearings are greased, belts are aligned and tight, and equipment with functioning controls is ready for operation.
- J.
- K. Examine equipment for installation and properly operating safety interlocks and controls.
- L. Report deficiencies discovered before and during performance of TAB procedures. Observe and record system reactions to changes in conditions. Record default set points if different from indicated values.

### 3.2 PREPARATION

- A. Prepare a TAB Plan that includes strategies and step-by-step procedures.
- B. Complete system-readiness checks and prepare reports. Verify the following:
  - 1. Permanent electrical-power wiring is complete.
  - 2. Automatic temperature-control systems are operational.
  - 3. Equipment and duct access doors are securely closed.
  - 4. Balance, smoke, and fire dampers are open.
  - 5.
  - 6. Ceilings are installed in critical areas where air-pattern adjustments are required and access to balancing devices is provided.
  - 7. Windows and doors can be closed so indicated conditions for system operations can be met.

### 3.3 GENERAL PROCEDURES FOR TESTING AND BALANCING

- A. Perform testing and balancing procedures on each system according to the procedures contained in AABC's "National Standards for Total System Balance," ASHRAE 111, NEBB's "Procedural Standards for Testing, Adjusting, and Balancing of Environmental Systems," or SMACNA's "HVAC Systems - Testing, Adjusting, and Balancing," and this Section.
  - 1. Comply with requirements in ASHRAE 62.1-2007, Section 7.2.2, "Air Balancing."
- B. Cut insulation, ducts, pipes, and equipment cabinets for installation of test probes to the minimum extent necessary for TAB procedures.
  - 1. After testing and balancing, patch probe holes in ducts with same material and thickness as used to construct ducts.
- C. Mark equipment and balancing devices, including damper-control positions, valve position indicators, fan-speed-control levers, and similar controls and devices, with paint or other suitable, permanent identification material to show final settings.
- D. Take and report testing and balancing measurements in inch-pound (IP) units.
- E. HVAC system lineup. The contractor will test the system in the normal system lineups.

1. Air systems will be balanced while aligned for minimum outside air flow and the position of the outside air dampers will be recorded for the minimum position.
2. It is not acceptable to balance air systems when the normal boundaries, doors, walls, or ductwork are not in their design configuration.

### 3.4 GENERAL PROCEDURES FOR BALANCING AIR SYSTEMS

- A. Prepare test reports for both fans and outlets. Obtain manufacturer's outlet factors and recommended testing procedures. Crosscheck the summation of required outlet volumes with required fan volumes.
- B. Prepare schematic diagrams of systems' "as-built" duct layouts.
- C. For variable-air-volume systems, develop a plan to simulate diversity.
- D. Determine the best locations in main and branch ducts for accurate duct-airflow measurements.
- E. Check airflow patterns from the outdoor-air louvers and dampers and the return- and exhaust-air dampers through the supply-fan discharge and mixing dampers.
- F. Locate start-stop and disconnect switches, electrical interlocks, and motor starters.
- G. Verify that motor starters are equipped with properly sized thermal protection.
- H. Check dampers for proper position to achieve desired airflow path.
- I. Check for airflow blockages.
- J. Check condensate drains for proper connections and functioning.
- K. Check for proper sealing of air-handling-unit components.
- L. Check for proper sealing of air duct system.

### 3.5 PROCEDURES FOR VARIABLE-AIR-VOLUME SYSTEMS

### 3.6 PROCEDURES FOR MULTIZONE SYSTEMS

- A. Set unit at maximum airflow through the cooling coil.
- B. Adjust fans to deliver total indicated airflows within the limits of the motor HP and maximum allowable fan speed listed by fan manufacturer. All fans shall deliver the design capacity at actual static pressures up to design static pressure. Fan sheaves shall be replaced as necessary to obtain desired results.
- C. Adjust each zone's balancing damper to achieve indicated airflow within the zone.

### 3.7 PROCEDURES FOR MOTORS

- A. Motors, 1/2 HP and Larger: Test at final balanced conditions and record the following data:
  1. Manufacturer's name, model number, and serial number.
  2. Motor horsepower rating.



3. Motor rpm.
4. Efficiency rating.
5. Nameplate and measured voltage, each phase.
6. Nameplate and measured amperage, each phase.
7. Starter thermal-protection-element rating.

- B. Motors Driven by Variable-Frequency Controllers: Test for proper operation at speeds varying from minimum to maximum. Test the manual bypass of the controller to prove proper operation. Record observations including name of controller manufacturer, model number, serial number, and nameplate data.

### 3.8 PROCEDURES FOR TESTING, ADJUSTING, AND BALANCING EXISTING SYSTEMS

- A. Perform a preconstruction inspection of existing equipment that is to remain and be reused.

1. Measure and record the operating speed, airflow, and static pressure of each fan.
2. Measure motor voltage and amperage. Compare the values to motor nameplate information.
3. Check the refrigerant charge.
4. Check the condition of filters.
5. Check the condition of coils.
6. Check the operation of the drain pan and condensate-drain trap.
7. Check bearings and other lubricated parts for proper lubrication.
8. Report on the operating condition of the equipment and the results of the measurements taken. Report deficiencies.

- B. Before performing testing and balancing of existing systems, inspect existing equipment that is to remain and be reused to verify that existing equipment has been cleaned and refurbished. Verify the following:

1. New filters are installed.
2. Coils are clean and fins combed.
3. Drain pans are clean.
4. Fans are clean.
5. Bearings and other parts are properly lubricated.
6. Deficiencies noted in the preconstruction report are corrected.

- C. Perform testing and balancing of existing systems. Adjust fans to deliver total indicated airflows within the maximum allowable fan speed listed by fan manufacturer and within the limits of the motor HP. All fans shall deliver the design air flow capacity at actual static pressure up to design static. Fan sheaves shall be replaced as necessary to obtain desired results.

1. Compare the indicated airflow of the renovated work to the measured fan airflows, and determine the new fan speed and the face velocity of filters and coils.
2. Verify that the indicated airflows of the renovated work result in filter and coil face velocities and fan speeds that are within the acceptable limits defined by equipment manufacturer.
3. Balance each air outlet.

### 3.9 TEMPERATURE-CONTROL VERIFICATION

- A. Verify that controllers are calibrated and commissioned.

- B. Check transmitter and controller locations and note conditions that would adversely affect control functions.
- C. Record controller settings and note variances between set points and actual measurements.
- D. Check the operation of limiting controllers (i.e., high- and low-temperature controllers).
- E. Check free travel and proper operation of control devices such as damper and valve operators.
- F. Check the sequence of operation of control devices. Note air pressures and device positions and correlate with airflow and water flow measurements. Note the speed of response to input changes.
- G. Check the interaction of electrically operated switch transducers.
- H. Check the interaction of interlock and lockout systems.
- I. Check main control supply-air pressure and observe compressor and dryer operations.
- J. Record voltages of power supply and controller output. Determine whether the system operates on a grounded or nongrounded power supply.
- K. Note operation of electric actuators using spring return for proper fail-safe operations.

### 3.10 TOLERANCES

- A. Set HVAC system air flow rates and water flow rates within the following tolerances:
  - 1. Supply, Return, and Exhaust Fans and Equipment with Fans: Plus or minus 10 percent.
  - 2. Air Outlets and Inlets: Plus or minus 10 percent.
  - 3. Heating-Water Flow Rate: Plus or minus 10 percent.
  - 4. Cooling-Water Flow Rate: Plus or minus 5 percent.

### 3.11 REPORTING

- A. Initial Construction-Phase Report: Based on examination of the Contract Documents as specified in "Examination" Article, prepare a report on the adequacy of design for systems' balancing devices. Recommend changes and additions to systems' balancing devices to facilitate proper performance measuring and balancing. Recommend changes and additions to HVAC systems and general construction to allow access for performance measuring and balancing devices.

### 3.12 FINAL REPORT

- A. General: Prepare a certified written report; tabulate and divide the report into separate sections for tested systems and balanced systems.
  - 1. Include a certification sheet at the front of the report's binder, signed and sealed by the certified testing and balancing engineer.
  - 2. Include a list of instruments used for procedures, along with proof of calibration.
- B. Final Report Contents: In addition to certified field-report data, include the following:

1. Pump curves.
2. Fan curves.
3. Manufacturers' test data.
4. Field test reports prepared by system and equipment installers.
5. Other information relative to equipment performance; do not include Shop Drawings and product data.

C. General Report Data: In addition to form titles and entries, include the following data:

1. Title page.
2. Name and address of the TAB contractor.
3. Project name.
4. Project location.
5. Architect's name and address.
6. Engineer's name and address.
7. Contractor's name and address.
8. Report date.
9. Signature of TAB supervisor who certifies the report.
10. Table of Contents with the total number of pages defined for each section of the report. Number each page in the report.
11. Summary of contents including the following:
  - a. Indicated versus final performance.
  - b. Notable characteristics of systems.
  - c. Description of system operation sequence if it varies from the Contract Documents.
12. Nomenclature sheets for each item of equipment.
13. Data for terminal units, including manufacturer's name, type, size, and fittings.
14. Notes to explain why certain final data in the body of reports vary from indicated values.
15. Test conditions for fans and pump performance forms including the following:
  - a. Settings for outdoor-, return-, and exhaust-air dampers.
  - b. Conditions of filters.
  - c. Cooling coil, wet- and dry-bulb conditions.
  - d. Face and bypass damper settings at coils.
  - e. Fan drive settings including settings and percentage of maximum pitch diameter.
  - f. Inlet vane settings for variable-air-volume systems.
  - g. Settings for supply-air, static-pressure controller.
  - h. Other system operating conditions that affect performance.

D. System Diagrams: Include schematic layouts of air and hydronic distribution systems. Present each system with single-line diagram and include the following:

1. Quantities of outdoor, supply, return, and exhaust airflows.
2. Water and steam flow rates.
3. Duct, outlet, and inlet sizes.
4. Pipe and valve sizes and locations.
5. Terminal units.
6. Balancing stations.
7. Position of balancing devices.

E. Air-Handling-Unit Test Reports: For air-handling units with coils, include the following:

1. Unit Data:
  - a. Unit identification.
  - b. Location.
  - c. Make and type.
  - d. Model number and unit size.
  - e. Manufacturer's serial number.
  - f. Unit arrangement and class.
  - g. Discharge arrangement.
  - h. Sheave make, size in inches, and bore.
  - i. Center-to-center dimensions of sheave, and amount of adjustments in inches.
  - j. Number, make, and size of belts.
  - k. Number, type, and size of filters.
  
2. Motor Data:
  - a. Motor make, and frame type and size.
  - b. Horsepower and rpm.
  - c. Volts, phase, and hertz.
  - d. Full-load amperage and service factor.
  - e. Sheave make, size in inches, and bore.
  - f. Center-to-center dimensions of sheave, and amount of adjustments in inches.
  
3. Test Data (Indicated and Actual Values):
  - a. Total air flow rate in cfm.
  - b. Total system static pressure in inches wg.
  - c. Fan rpm.
  - d. Discharge static pressure in inches wg.
  - e. Filter static-pressure differential in inches wg.
  - f. Preheat coil static-pressure differential in inches wg.
  - g. Cooling coil static-pressure differential in inches wg.
  - h. Heating coil static-pressure differential in inches wg.
  - i. Outdoor airflow in cfm.
  - j. Return airflow in cfm.
  - k. Outdoor-air damper position.
  - l. Return-air damper position.
  - m. Vortex damper position.
  
4. Test Data (Indicated and Actual Values):
  - a. Air flow rate in cfm.
  - b. Average face velocity in fpm.
  - c. Air pressure drop in inches wg.
  - d. Outdoor-air, wet- and dry-bulb temperatures in deg F.
  - e. Return-air, wet- and dry-bulb temperatures in deg F.
  - f. Entering-air, wet- and dry-bulb temperatures in deg F.
  - g. Leaving-air, wet- and dry-bulb temperatures in deg F.
  - h. Water flow rate in gpm.
  - i. Water pressure differential in feet of head or psig.
  - j. Entering-water temperature in deg F.
  - k. Leaving-water temperature in deg F.
  - l. Refrigerant expansion valve and refrigerant types.
  - m. Refrigerant suction pressure in psig.

- n. Refrigerant suction temperature in deg F.
- o. Inlet steam pressure in psig.

F. Fan Test Reports: For supply, return, and exhaust fans, include the following:

1. Fan Data:

- a. System identification.
- b. Location.
- c. Make and type.
- d. Model number and size.
- e. Manufacturer's serial number.
- f. Arrangement and class.
- g. Sheave make, size in inches, and bore.
- h. Center-to-center dimensions of sheave, and amount of adjustments in inches.

2. Motor Data:

- a. Motor make, and frame type and size.
- b. Horsepower and rpm.
- c. Volts, phase, and hertz.
- d. Full-load amperage and service factor.
- e. Sheave make, size in inches, and bore.
- f. Center-to-center dimensions of sheave, and amount of adjustments in inches.
- g. Number, make, and size of belts.

3. Test Data (Indicated and Actual Values):

- a. Total airflow rate in cfm.
- b. Total system static pressure in inches wg.
- c. Fan rpm.
- d. Discharge static pressure in inches wg.
- e. Suction static pressure in inches wg.

G. Round, Flat-Oval, and Rectangular Duct Traverse Reports: Include a diagram with a grid representing the duct cross-section and record the following:

1. Report Data:

- a. System and air-handling-unit number.
- b. Location and zone.
- c. Traverse air temperature in deg F.
- d. Duct static pressure in inches wg.
- e. Duct size in inches.
- f. Duct area in sq. ft.
- g. Indicated air flow rate in cfm.
- h. Indicated velocity in fpm.
- i. Actual air flow rate in cfm.
- j. Actual average velocity in fpm.
- k. Barometric pressure in psig.

2. Test Data (Indicated and Actual Values):

- a. Air flow rate in cfm

- b. Air velocity in fpm
  - c. Preliminary air flow rate as needed in cfm
  - d. Preliminary velocity as needed in fpm
  - e. Final air flow rate in cfm
  - f. Final velocity in fpm
  - g. Space temperature in deg F
3. Air-Cooled Condenser Test Data (Indicated and Actual Values):
- a. Refrigerant pressure in psig.
  - b. Refrigerant temperature in deg F.
  - c. Entering- and leaving-air temperature in deg F.
4. Evaporator Test Reports (Indicated and Actual Values):
- a. Refrigerant pressure in psig.
  - b. Refrigerant temperature in deg F.
  - c. Entering-water temperature in deg F.
  - d. Leaving-water temperature in deg F.
  - e. Entering-water pressure in feet of head or psig.
  - f. Water pressure differential in feet of head or psig.
5. Compressor Test Data (Indicated and Actual Values):
- a. Suction pressure in psig.
  - b. Suction temperature in deg F.
  - c. Discharge pressure in psig.
  - d. Discharge temperature in deg F.
  - e. Oil pressure in psig.
  - f. Oil temperature in deg F.
  - g. Voltage at each connection.
  - h. Amperage for each phase.
  - i. Kilowatt input.
  - j. Crankcase heater kilowatt.
  - k. Chilled-water control set point in deg F.
  - l. Condenser-water control set point in deg F.
  - m. Refrigerant low-pressure-cutoff set point in psig.
  - n. Refrigerant high-pressure-cutoff set point in psig.
6. Refrigerant Test Data (Indicated and Actual Values):
- a. Oil level.
  - b. Refrigerant level.
  - c. Relief valve setting in psig.
  - d. Unloader set points in psig.
  - e. Percentage of cylinders unloaded.
  - f. Bearing temperatures in deg F.
  - g. Vane position.
  - h. Low-temperature-cutoff set point in deg F.

H. Compressor and Condenser Reports: For refrigerant side of unitary systems, stand-alone refrigerant compressors, air-cooled condensing units, or water-cooled condensing units, include the following:

1. Unit Data:
  - a. Unit identification.
  - b. Location.
  - c. Unit make and model number.
  - d. Compressor make.
  - e. Compressor model and serial numbers.
  - f. Refrigerant weight in lb.
  - g. Low ambient temperature cutoff in deg F.
  
2. Test Data (Indicated and Actual Values):
  - a. Inlet-duct static pressure in inches wg.
  - b. Outlet-duct static pressure in inches wg.
  - c. Entering-air, dry-bulb temperature in deg F.
  - d. Leaving-air, dry-bulb temperature in deg F.
  - e. Condenser entering-water temperature in deg F.
  - f. Condenser leaving-water temperature in deg F.
  - g. Condenser-water temperature differential in deg F.
  - h. Condenser entering-water pressure in feet of head or psig.
  - i. Condenser leaving-water pressure in feet of head or psig.
  - j. Condenser-water pressure differential in feet of head or psig.
  - k. Control settings.
  - l. Unloader set points.
  - m. Low-pressure-cutout set point in psig.
  - n. High-pressure-cutout set point in psig.
  - o. Suction pressure in psig.
  - p. Suction temperature in deg F.
  - q. Condenser refrigerant pressure in psig.
  - r. Condenser refrigerant temperature in deg F.
  - s. Oil pressure in psig.
  - t. Oil temperature in deg F.
  - u. Voltage at each connection.
  - v. Amperage for each phase.
  - w. Kilowatt input.
  - x. Crankcase heater kilowatt.
  - y. Number of fans.
  - z. Condenser fan rpm.
  - aa. Condenser fan airflow rate in cfm.
  - bb. Condenser fan motor make, frame size, rpm, and horsepower.
  - cc. Condenser fan motor voltage at each connection.
  - dd. Condenser fan motor amperage for each phase.

I. Condenser Test Reports: For condensers, include the following:

1. Unit Data:
  - a. Unit identification.
  - b. Make and type.
  - c. Model and serial numbers.
  - d. Nominal cooling capacity in tons.
  - e. Refrigerant type and weight in lb.
  - f. Water-treatment chemical feeder and chemical.
  - g. Number and type of fans.

- h. Fan motor make, frame size, rpm, and horsepower.
  - i. Fan motor voltage at each connection.
  - j. Sheave make, size in inches, and bore.
  - k. Sheave dimensions, center-to-center, and amount of adjustments in inches.
  - l. Number of belts, make, and size.
  - m. Pump make and model number.
  - n. Pump manufacturer's serial number.
  - o. Pump motor make and frame size.
  - p. Pump motor horsepower and rpm.
2. Air Data (Indicated and Actual Values):
- a. Duct airflow rate in cfm.
  - b. Inlet-duct static pressure in inches wg.
  - c. Outlet-duct static pressure in inches wg.
  - d. Average entering-air, wet-bulb temperature in deg F.
  - e. Average leaving-air, wet-bulb temperature in deg F.
  - f. Ambient wet-bulb temperature in deg F.

### 3.13 INSPECTIONS

#### A. Initial Inspection:

1. After testing and balancing are complete, operate each system and randomly check measurements to verify that the system is operating according to the final test and balance readings documented in the final report.
2. Check the following for each system:
  - a. Measure airflow of at least 10 percent of air outlets.
  - b. Measure water flow of at least 5 percent of terminals.
  - c. Measure room temperature at each thermostat/temperature sensor. Compare the reading to the set point.
  - d. Verify that balancing devices are marked with final balance position.
  - e. Note deviations from the Contract Documents in the final report.

#### B. Final Inspection:

1. After initial inspection is complete and documentation by random checks verifies that testing and balancing are complete and accurately documented in the final report, request that a final inspection be made by Owner's Representative.
2. The TAB contractor's test and balance engineer shall conduct the inspection in the presence of the Board Authorized Representative.
3. The Board Authorized Representative shall randomly select measurements, documented in the final report, to be rechecked. Rechecking shall be limited to either 10 percent of the total measurements recorded or the extent of measurements that can be accomplished in a normal 8-hour business day.
4. If rechecks yield measurements that differ from the measurements documented in the final report by more than the tolerances allowed, the measurements shall be noted as "FAILED."
5. If the number of "FAILED" measurements is greater than 10 percent of the total measurements checked during the final inspection, the testing and balancing shall be considered incomplete and shall be rejected.



- C. TAB Work will be considered defective if it does not pass final inspections. If TAB Work fails, proceed as follows:
  - 1. Recheck all measurements and make adjustments. Revise the final report and balancing device settings to include all changes; resubmit the final report and request a second final inspection.
  - 2. If the second final inspection also fails, Owner may contract the services of another TAB contractor to complete TAB Work according to the Contract Documents and deduct the cost of the services from the original TAB contractor's final payment.
- D. Prepare test and inspection reports.

### 3.14 ADDITIONAL TESTS

- A. Within 90 days of completing TAB, perform additional TAB to verify that balanced conditions are being maintained throughout and to correct unusual conditions.
- B. Seasonal Periods: If initial TAB procedures were not performed during near-peak summer and winter conditions, perform additional TAB during near-peak summer and winter conditions.

**End of Section 230593**

## DIVISION 23 – HEATING, VENTILATING AND AIR CONDITIONING

### SECTION 23 07 00

#### HVAC INSULATION

#### PART 1 - GENERAL

##### 1.1 SUMMARY

- A. Section Includes:
  - 1. Insulation Materials:
    - a. Calcium silicate.
    - b. Flexible elastomeric.
    - c. Mineral fiber.
  - 2. Fire-rated insulation systems.
  - 3. Insulating cements.
  - 4. Adhesives.
  - 5. Mastics.
  - 6. Lagging adhesives.
  - 7. Sealants.
  - 8. Identification
  - 9. Tapes.
  - 10. Securements.
  - 11. Corner angles.

##### 1.2 DEFINITIONS

- A. Hot Surfaces: Normal operating temperatures of 100 deg F or higher.
- B. Dual-Temperature Surfaces: Normal operating temperatures that vary from hot to cold.
- C. Cold Surfaces: Normal operating temperatures less than 75 deg F.
- D. Thermal Resistivity: "R-values" represent the reciprocal of thermal conductivity (K-value). Thermal conductivity is the rate of heat flow through a homogeneous material exactly 1 inch thick. Thermal resistivities are expressed by the temperature difference in degrees F between two exposed faces required to cause one Btu to flow through one square foot of material, in one hour, at a given mean temperature.
- E. Density: Is expressed in lb/cu. ft.

##### 1.3 SUBMITTALS

- A. Product Data: For each type of product indicated. Include thermal conductivity, thermal resistivity (R-value), thickness, and jackets (both factory and field applied, if any).
- B. Shop Drawings:

1. Detail application of protective shields, saddles, and inserts at hangers for each type of insulation and hanger.
2. Detail attachment and covering of heat tracing inside insulation.
3. Detail insulation application at pipe expansion joints for each type of insulation.
4. Detail insulation application at elbows, fittings, flanges, valves, and specialties for each type of insulation.
5. Detail removable insulation at piping specialties, equipment connections, and access panels.
6. Detail application of field-applied jackets.
7. Detail application of Identification
8. Detail application at linkages of control devices.
9. Detail field application for each equipment type.
10. Detail outdoor duct insulation installation.

C. Samples: For each type of insulation jacket, and identification indicated. Identify each Sample, describing product and intended use.

1. Sample Sizes:

- a. Preformed Pipe Insulation Materials: 12 inches long by NPS 2.
- b. Sheet Form Insulation Materials: 12 inches square.
- c. Jacket Materials for Pipe: 12 inches long by NPS 2.
- d. Sheet Jacket Materials: 12 inches square.
- e. Manufacturer's Color Charts: For products where color is specified, show the full range of colors available for each type of finish material.

D. Material Test Reports: From a qualified testing agency acceptable to the authorities having jurisdiction indicating, interpreting, and certifying test results for compliance of insulation materials, sealers, attachments, cements, and jackets, with requirements indicated. Include dates of tests and test methods employed.

#### 1.4 QUALITY ASSURANCE

A. Installer Qualifications: Skilled mechanics who have successfully completed an apprenticeship program or another craft training program certified by the Department of Labor, Bureau of Apprenticeship and Training.

B. Fire-Test-Response Characteristics: Except where indicated otherwise, insulation and related materials shall have fire-test-response characteristics indicated, as determined by testing identical products per ASTM E 84, by UL or another testing and inspecting agency acceptable to the authorities having jurisdiction. Identify materials with appropriate markings of applicable testing and inspecting agency.

1. Insulation Installed Indoors:

- a. Flame-Spread Index: 25 or less.
- b. Smoke-Developed Index: 50 or less.

2. Insulation Installed Outdoors:

- a. Flame-Spread Index: 75 or less.
- b. Smoke-Developed Index: 150 or less.

## 1.5 DELIVERY, STORAGE, AND HANDLING

- A. Deliver materials to Project site in original packages and containers with seals unbroken and bearing manufacturer's original labels, including manufacturer's name, product name, and directions for storing, handling, and use.
- B. Store materials in a clean, dry, fully enclosed, conditioned space where they will be protected against damage from moisture, humidity, temperature extremes, direct sunlight, surface contamination, and other causes.
  - 1. Remove damaged or wet insulation from Project site.

## 1.6 COORDINATION

- A. Coordinate size and location of supports, hangers, and insulation shields specified in Division 23 Section "Hangers and Supports for Piping and Equipment."
- B. Coordinate clearance requirements with piping Installer for piping insulation application, duct Installer for duct insulation application, and equipment Installer for equipment insulation application. Before preparing piping and ductwork Shop Drawings, establish and maintain clearance requirements for installation of insulation and field-applied jackets and finishes and for space required for maintenance.
- C. Coordinate installation and testing of heat tracing.

## 1.7 SCHEDULING

- A. Schedule insulation application after pressure testing systems and, where required, after installing and testing heat tracing. Insulation application may begin on segments that have satisfactory test results.
- B. Complete installation and concealment of plastic materials as rapidly as possible in each area of construction.

## 1.8 WARRANTY

- A. Provide warranty on materials and labor for 18 months starting from date of delivery, or one year from date of Preliminary Acceptance or Substantial Completion, whichever is longer.

## **PART 2 - PRODUCTS**

### 2.1 MANUFACTURERS

- A. Manufacturers and Products: Subject to compliance with requirements, provide one of the following products for each of the products identified:
  - 1. Flexible Elastomeric Insulation:
    - a. Aeroflex USA Inc.; Aerocel.
    - b. Armacell LLC; AP Armaflex.
    - c. RBX Corporation; Insul-Sheet 1800 and Insul-Tube 180.
  - 2. Mineral-Fiber Blanket Insulation:

- a. CertainTeed Corp.; Duct Wrap.
  - b. Johns Manville; Microlite.
  - c. Owens Corning; All-Service Duct Wrap.
3. Mineral-Fiber Board Insulation:
- a. CertainTeed Corp.; Commercial Board.
  - b. Fibrex Insulations Inc.; FBX.
  - c. Johns Manville; 800 Series Spin-Glas.
  - d. Knauf Insulation; Insulation Board.
  - e. Manson Insulation Inc.; AK Board.
  - f. Owens Corning; Fiberglas 700 Series.
4. Fire-Rated Blanket Insulation:
- a. CertainTeed Corp.; FlameChek.
  - b. Johns Manville; Firetemp Wrap.
  - c. Nelson Firestop Products; Nelson FSB Flameshield Blanket.
  - d. Thermal Ceramics; FireMaster Duct Wrap.
  - e. 3M; Fire Barrier Wrap Products.
  - f. Unifrax Corporation; FyreWrap.
  - g. Vesuvius; PYROSCAT FP FASTR Duct Wrap.
5. Mineral-Fiber, Preformed Pipe Insulation:
- a. Fibrex Insulations Inc.; Coreplus 1200.
  - b. Johns Manville; Micro-Lok.
  - c. Knauf Insulation; 1000 Pipe Insulation.
  - d. Owens Corning; Fiberglas Pipe Insulation.
  - e. Insulco, Division of MFS, Inc.; Triple I.
  - f. P. K. Insulation Mfg. Co., Inc.; Super-Stik.
6. Flexible Elastomeric and Polyolefin Adhesive:
- a. Aeroflex USA Inc.; Aero seal.
  - b. Armacell LCC; 520 Adhesive.
  - c. Foster Products Corporation, H. B. Fuller Company; 85-75.
  - d. RBX Corporation; Rubatex Contact Adhesive.
7. Mineral-Fiber Adhesive:
- a. Childers Products, Division of ITW; CP-82.
  - b. Foster Products Corporation, H. B. Fuller Company; 85-20.
  - c. ITW TACC, Division of Illinois Tool Works; S-90/80.
8. ASJ Adhesive, and FSK Adhesive:
- a. Childers Products, Division of ITW; CP-82.
  - b. Foster Products Corporation, H. B. Fuller Company; 85-20.
  - c. ITW TACC, Division of Illinois Tool Works; S-90/80.
9. PVC Jacket Adhesive:
- a. Dow Chemical Company (The); 739, Dow Silicone.

- b. Johns-Manville; Zeston Perma-Weld, CEEL-TITE Solvent Welding Adhesive.
  - c. Speedline Corporation; Speedline Vinyl Adhesive.
10. Vapor-Barrier Mastic:
- a. Childers Products, Division of ITW; CP-35.
  - b. Foster Products Corporation, H. B. Fuller Company; 30-90.
  - c. ITW TACC, Division of Illinois Tool Works; CB-50.
  - d. Vimasco Corporation; 749.
11. Lagging Adhesives:
- a. Childers Products, Division of ITW; CP-52.
  - b. Foster Products Corporation, H. B. Fuller Company; 81-42.
  - c. Vimasco Corporation; 136.
12. ASJ Flashing Sealants and PVC Jacket Flashing Sealants:
- a. Childers Products, Division of ITW; CP-76.
13. PVC Jacket:
- a. Johns Manville; Zeston.
  - b. P.I.C. Plastics, Inc.; FG Series.
  - c. Proto PVC Corporation; LoSmoke.
  - d. Speedline Corporation; SmokeSafe.
14. Identification:
- a. Seton.
  - b. Brady.
  - c. Best.
  - d. Milwaukee.
15. ASJ Tape:
- a. Avery Dennison Corporation, Specialty Tapes Division; Fasson 0835.
  - b. Compac Corp.; 104 and 105.
  - c. Ideal Tape Co., Inc., an American Biltrite Company; 428 AWF ASJ.
  - d. Venture Tape; 1540 CW Plus, 1542 CW Plus, and 1542 CW Plus/SQ.
16. FSK Tape:
- a. Avery Dennison Corporation, Specialty Tapes Division; Fasson 0827.
  - b. Compac Corp.; 110 and 111.
  - c. Ideal Tape Co., Inc., an American Biltrite Company; 491 AWF FSK.
  - d. Venture Tape; 1525 CW, 1528 CW, and 1528 CW/SQ.
17. Bands:
- a. Childers Products; Bands.
  - b. IDC Corporation.
  - c. RPR Products, Inc.; Bands.

## 2.2 INSULATION MATERIALS

- A. Comply with requirements in PART 3 schedule articles for where insulating materials shall be applied.
- B. Products shall not contain asbestos, lead, mercury, or mercury compounds.
- C. Products that come in contact with stainless steel shall have a leachable chloride content of less than 50 ppm when tested according to ASTM C 871.
- D. Insulation materials for use on austenitic stainless steel shall be qualified as acceptable according to ASTM C 795.
- E. Foam insulation materials shall not use CFC or HCFC blowing agents in the manufacturing process.
- F. Flexible Elastomeric: Closed-cell, sponge- or expanded-rubber materials. Comply with ASTM C 534, Type I for tubular materials and Type II for sheet materials.
- G. Mineral-Fiber Blanket Insulation: Mineral or glass fibers bonded with a thermosetting resin. Comply with ASTM C 553, Type II and ASTM C 1290, Type III with factory-applied FSK jacket. Factory-applied jacket requirements are specified in "Factory-Applied Jackets" Article.
- H. Mineral-Fiber Board Insulation: Mineral or glass fibers bonded with a thermosetting resin. Comply with ASTM C 612, Type IB. For duct and plenum applications, provide insulation with factory-applied FSK jacket. For equipment applications, provide insulation with factory-applied ASJ. Factory-applied jacket requirements are specified in "Factory-Applied Jackets" Article.
  - 1. with appropriate markings of applicable testing and inspecting agency.
- I. Fire-Rated Blanket: High-temperature, flexible, blanket insulation with FSK jacket that is tested by UL, or another testing and inspecting agency acceptable to the authorities having jurisdiction, and certified to provide a 2-hour fire rating.
- J. Mineral-Fiber, Preformed Pipe Insulation:
- K. Mineral-Fiber, Pipe and Tank Insulation: Mineral or glass fibers bonded with a thermosetting resin. Semirigid board material with factory-applied FSK jacket complying with ASTM C 1393, Type II or Type IIIA Category 2. Nominal density is 2.5 lb/cu. ft. or more. Thermal conductivity (k-value) at 100 deg F is 0.29 Btu x in./h x sq. ft. x deg For less. Factory-applied jacket requirements are specified in "Factory-Applied Jackets" Article.

## 2.3 INSULATING CEMENTS

- A. Mineral-Fiber Insulating Cement: Comply with ASTM C 195.
- B. Mineral-Fiber, Hydraulic-Setting Insulating and Finishing Cement: Comply with ASTM C 449/C 449M.

## 2.4 ADHESIVES

- A. Adhesives, General: All adhesives and mastics installed within the building envelope shall be shown to comply either with the testing and product requirements of the California Department of Health Services' "Standard Practice for the Testing of Volatile Organic Emissions from

Various Sources Using Small-Scale Environmental Chambers," including 2004 Addenda, or with the VOC limits established in South Coast Air Quality Management District (SCAQMD) Rule #1168.

1. Aerosol adhesives shall comply with Green Seal Standard for Commercial Adhesives GS-36 (2000).
  - B. Compatibility: Materials shall be compatible with insulation materials, jackets, and substrates and for bonding insulation to itself and to surfaces to be insulated, unless otherwise indicated.
  - C. Polyisocyanurate Adhesive: Solvent-based resin adhesive, with a service temperature range of minus 75 to plus 300 deg F.
  - D. Flexible Elastomeric Adhesive: Comply with MIL-A-24179A, Type II, Class I.
  - E. Mineral-Fiber Adhesive: Comply with MIL-A-3316C, Class 2, Grade A.
  - F. ASJ Adhesive, and FSK Adhesive: Comply with MIL-A-3316C, Class 2, Grade A for bonding insulation jacket lap seams and joints.
  - G. PVC Jacket Adhesive: Compatible with PVC jacket.
  - H. Mastics: Comply with MIL-C-19565C, Type II. Materials shall be compatible with insulation materials, jackets, and substrates.
    1. Vapor-Barrier Mastic: Water based; suitable for indoor and outdoor use on below ambient services.
      - a. Water-Vapor Permeance: ASTM E 96, Procedure B, 0.013 permat 43-mildry film thickness.
      - b. Service Temperature Range: Minus 20 to plus 180 deg F
      - c. Solids Content: ASTM D 1644, 59 percent by volume and 71 percent by weight.
      - d. Color: White.
- 2.5 Lagging Adhesives: Comply with MIL-A-3316C Class I, Grade A. Materials shall be compatible with insulation materials, jackets, and substrates.
- a. Fire-resistant, water-based lagging adhesive and coating for use indoors to adhere fire-resistant lagging cloths over duct, equipment, and pipe insulation.
  - b. Service Temperature Range: Minus 50 to plus 180 deg F.
  - c. Color: White.
- 2.6 SEALANTS
- A. Sealants, General: All sealants installed within the building envelope shall be shown to comply either with the testing and product requirements of the California Department of Health Services' "Standard Practice for the Testing of Volatile Organic Emissions from Various Sources Using Small-Scale Environmental Chambers," including 2004 Addenda, or with the VOC limits established in South Coast Air Quality Management District (SCAQMD) Rule #1168.
  - B. Joint Sealants:
    1. Materials shall be compatible with insulation materials, jackets, and substrates.
    2. Permanently flexible, elastomeric sealant.



3. Service Temperature Range: Minus 100 to plus 300 deg F.
4. Color: White or gray.

C. ASJ Flashing Sealants:

1. Materials shall be compatible with insulation materials, jackets, and substrates.
2. Fire- and water-resistant, flexible, elastomeric sealant.
3. Service Temperature Range: Minus 40 to plus 250 deg F.
4. Color: White.

2.7 IDENTIFICATION

A. General: Products specified are manufacturer's standard products of categories and types required for each application as referenced in other Division 23 Sections. Where more than single type is specified for listed application, selection is Installer's option, but provide single selection for each product category.

B. Manufacturers: Subject to compliance with requirements, provide products by one of the following:

1. Seton.
2. Brady.
3. Best.
4. Milwaukee.

C. Snap-On Plastic Pipe Markers: Manufacturer's standard pre-printed, semi-rigid snap-on, color-coded pipe markers.

1. Lettering: Use piping system terms as indicated and abbreviate only as necessary for each application length.
2. Arrows: Either integrally with piping system service lettering (to accommodate both directions), or as separate unit, on each pipe marker to indicate direction of flow.

D. Lettering and Graphics: Coordinate names, abbreviations, and other designations used in mechanical identification, with corresponding designations indicated. Use numbers, letters, and terms indicated for proper identification, operation, and maintenance of mechanical systems and equipment.

1. Multiple Systems: Where multiple systems of same name are indicated, identify individual system number as well as service.

E. Color Coding:

	<u>Background</u>	<u>Lettering</u>
1. Domestic Cold Water	White	Black
2. Domestic Hot Water/ Hot Water Return	Blue	White
3. Non Potable Water/ Makeup Water	Purple	White
4. Condenser Water	Black	White
5. Storm Water	Grey	White
6. Rain Water Harvesting	Grey	White
7. Air Conditioning Condensate	Grey	White
8. Chilled Water	Green	White
9. Dual Temp. Water	Brown	White
10. Heating Hot Water	Orange	White
11. Steam/ Steam Condensate	Yellow	Black
12. Refrigerant Suction/ Hot Gas	Clear	Black

13.	Natural Gas	Yellow	Black
14.	Fire Protection	Red	White

## 2.8 TAPES

- A. ASJ Tape: White vapor-retarder tape matching factory-applied jacket with acrylic adhesive, complying with ASTM C 1136.
1. Width: 3 inches.
  2. Thickness: 11.5 mils.
  3. Adhesion: 90 ounces force/inch width.
  4. Elongation: 2 percent.
  5. Tensile Strength: 40 lbf/inch width.
  6. ASJ Tape Disks and Squares: Precut disks or squares of ASJ tape.
- B. FSK Tape: Foil-face, vapor-retarder tape matching factory-applied jacket with acrylic adhesive; complying with ASTM C 1136.
1. Width: 3 inches.
  2. Thickness: 6.5 mils.
  3. Adhesion: 90 ounces force/inch width.
  4. Elongation: 2 percent.
  5. Tensile Strength: 40 lbf/inch width.
  6. FSK Tape Disks and Squares: Precut disks or squares of FSK tape.

## 2.9 SECUREMENTS

- A. Bands:
1. Stainless Steel: ASTM A 167 or ASTM A 240/A 240M, Type 304; 0.020-inch thick, 3/4-inch wide with wing or closed seal.
  2. Springs: Twin spring set constructed of stainless steel with ends flat and slotted to accept metal bands. Spring size determined by manufacturer for application.
- B. Insulation Pins and Hangers:
1. Capacitor-Discharge-Weld Pins: Copper-coated steel pin, fully annealed for capacitor-discharge welding, 0.106-inch diameter shank, length to suit depth of insulation indicated.
  2. Cupped-Head, Capacitor-Discharge-Weld Pins: Copper- or zinc-coated steel pin, fully annealed for capacitor-discharge welding, 0.106-inch diameter shank, length to suit depth of insulation indicated with integral 1-1/2-inch galvanized carbon-steel washer.
  3. Metal, Adhesively Attached, Perforated-Base Insulation Hangers: Baseplate welded to projecting spindle that is capable of holding insulation, of thickness indicated, securely in position indicated when self-locking washer is in place. Comply with the following:
    - a. Baseplate: Perforated, galvanized carbon-steel sheet, 0.030 inch thick by 2 inches square.
    - b. Spindle: Copper- or zinc-coated, low carbon steel, fully annealed, 0.106-inch diameter shank, length to suit depth of insulation indicated.
    - c. Adhesive: Recommended by hanger manufacturer. Product with demonstrated capability to bond insulation hanger securely to substrates indicated without damaging insulation, hangers, and substrates.

4. Nonmetal, Adhesively Attached, Perforated-Base Insulation Hangers: Baseplate fastened to projecting spindle that is capable of holding insulation, of thickness indicated, securely in position indicated when self-locking washer is in place. Comply with the following:
    - a. Baseplate: Perforated, nylon sheet, 0.030 inch thick by 1-1/2 inches in diameter.
    - b. Spindle: Nylon, 0.106-inch- diameter shank, length to suit depth of insulation indicated, up to 2-1/2 inches.
    - c. Adhesive: Recommended by hanger manufacturer. Product with demonstrated capability to bond insulation hanger securely to substrates indicated without damaging insulation, hangers, and substrates.
  5. Self-Sticking-Base Insulation Hangers: Baseplate welded to projecting spindle that is capable of holding insulation, of thickness indicated, securely in position indicated when self-locking washer is in place. Comply with the following requirements:
    - a. Baseplate: Galvanized carbon-steel sheet, 0.030 inch thick by 2 inches square.
    - b. Spindle: Copper- or zinc-coated, low carbon steel, fully annealed, 0.106-inch-diameter shank, length to suit depth of insulation indicated.
    - c. Adhesive-backed base with a peel-off protective cover.
  6. Insulation-Retaining Washers: Self-locking washers formed from 0.016-inch- thick, galvanized-steel sheet, with beveled edge sized as required to hold insulation securely in place but not less than 1-1/2 inches in diameter.
    - a. Protect ends with capped self-locking washers incorporating a spring steel insert to ensure permanent retention of cap in exposed locations.
  7. Nonmetal Insulation-Retaining Washers: Self-locking washers formed from 0.016-inch-thick nylon sheet, with beveled edge sized as required to hold insulation securely in place but not less than 1-1/2 inches in diameter.
- C. Staples: Outward-clinching insulation staples, nominal 3/4-inch- wide, stainless steel or Monel.
- D. Wire: 0.062-inch soft-annealed, stainless steel.

### **PART 3 - EXECUTION**

#### **3.1 EXAMINATION**

- A. Examine substrates and conditions for compliance with requirements for installation and other conditions affecting performance of insulation application.
  1. Verify that systems and equipment to be insulated have been tested and are free of defects.
  2. Verify that surfaces to be insulated are clean and dry.
- B. Proceed with installation only after unsatisfactory conditions have been corrected.

#### **3.2 PREPARATION**

- A. Surface Preparation: Clean and dry surfaces to receive insulation. Remove materials that will adversely affect insulation application.

- B. Coordinate insulation installation with the trade installing heat tracing, if any. Comply with requirements for heat tracing that apply to insulation.
- C. Mix insulating cements with clean potable water; if insulating cements are to be in contact with stainless-steel surfaces, use demineralized water.

### 3.3 INSTALLATION – GENERAL

- A. Install insulation materials, accessories, and finishes according to the manufacturer's written instructions with smooth, straight, and even surfaces; free of voids throughout the length of equipment, ducts and fittings, and piping including fittings, valves, and specialties.
- B. Install insulation materials, forms, vapor barriers or retarders, jackets, and thicknesses required for each item of equipment, duct system, and pipe system as specified in insulation system schedules.
- C. Install accessories compatible with insulation materials and suitable for the service. Install accessories that do not corrode, soften, or otherwise attack insulation or jacket in either wet or dry state.
- D. Keep insulation materials dry during application and finishing.
- E. Install insulation with least number of joints practical.
- F. Install insulation with longitudinal seams at top and bottom of horizontal runs.
- G. Install insulation with tight longitudinal seams and end joints. Bond seams and joints with adhesive recommended by insulation material manufacturer.
- H. Install multiple layers of insulation with longitudinal and end seams staggered.
- I. Install vapor barriers on insulated pipes, ductwork, and equipment having surface operating temperatures below 60 deg F.
- J. Do not weld brackets, clips, or other attachment devices to piping, fittings, and specialties.
- K. Where vapor barrier is indicated, seal joints, seams, and penetrations in insulation at hangers, supports, anchors, and other projections with vapor-barrier mastic.
  - 1. Install insulation continuously through hangers and around anchor attachments.
  - 2. For insulation application where vapor barriers are indicated, extend insulation on anchor legs from point of attachment to supported item to point of attachment to structure. Taper and seal ends at attachment to structure with vapor-barrier mastic.
  - 3. Install insert materials and install insulation to tightly join the insert. Seal insulation to insulation inserts with adhesive or sealing compound recommended by insulation material manufacturer.
  - 4. Cover inserts with jacket material matching adjacent pipe insulation. Install shields over jacket, arranged to protect jacket from tear or puncture by hanger, support, and shield.
- L. Apply adhesives, mastics, and sealants at manufacturer's recommended coverage rate and wet and dry film thicknesses.
- M. Cut insulation in a manner to avoid compressing insulation more than 75 percent of its nominal thickness.

- N. Finish installation with systems at operating conditions. Repair joint separations and cracking due to thermal movement.
- O. Repair damaged insulation facings by applying same facing material over damaged areas. Extend patches at least 4 inches beyond damaged areas. Adhere, staple, and seal patches similar to butt joints.
- P. For above ambient services, do not install insulation to the following:
  - 1. Vibration-control devices.
  - 2. Testing agency labels and stamps.
  - 3. Nameplates and data plates.
  - 4. Manholes.
  - 5. Handholes.
  - 6. Cleanouts.

### 3.4 PIPE INSULATION INSTALLATION – GENERAL

- A. General: Requirements in this article apply to all insulation materials, unless more specific requirements are indicated for individual pipe insulation types.
- B. Insulation Installation on Fittings, Valves, Strainers, Flanges, and Unions:
  - 1. Install insulation over fittings, valves, strainers, flanges, unions, and other specialties with continuous thermal and vapor-retarder integrity, unless otherwise indicated.
  - 2. Pipe Elbows: Insulate pipe elbows using preformed fitting insulation or mitered fittings made from same material and density as adjacent pipe insulation. Each piece shall be butted tightly against adjoining piece and bonded with adhesive. Fill joints, seams, voids, and irregular surfaces with insulating cement finished to a smooth, hard, and uniform contour that is uniform with adjoining pipe insulation.
  - 3. Tee Fittings: Insulate tee fittings with preformed fitting insulation or sectional pipe insulation of same material and thickness as used for adjacent pipe. Cut sectional pipe insulation to fit. Butt each section closely to the next and hold in place with tie wire. Bond pieces with adhesive.
  - 4. Valves: Insulate valves using preformed fitting insulation or sectional pipe insulation of same material, density, and thickness as used for adjacent pipe. Overlap adjoining pipe insulation by not less than two times the thickness of pipe insulation, or one pipe diameter, whichever is thicker. For valves, insulate up to and including the bonnets, valve stuffing-box studs, bolts, and nuts. Fill joints, seams, and irregular surfaces with insulating cement.
  - 5. Strainers: Insulate strainers using preformed fitting insulation or sectional pipe insulation of same material, density, and thickness as used for adjacent pipe. Overlap adjoining pipe insulation by not less than two times the thickness of pipe insulation, or one pipe diameter, whichever is thicker. Fill joints, seams, and irregular surfaces with insulating cement. Insulate strainers so strainer basket flange or plug can be easily removed and replaced without damaging the insulation and jacket. Provide a removable reusable insulation cover. For below ambient services, provide a design that maintains vapor barrier.
  - 6. Fittings and Unions: Insulate flanges and unions using a section of oversized preformed pipe insulation. Overlap adjoining pipe insulation by not less than two times the thickness of pipe insulation, or one pipe diameter, whichever is thicker.
  - 7. Cover segmented insulated surfaces with a layer of finishing cement and coat with a mastic. Install vapor-barrier mastic for below ambient services and a breather mastic for above ambient services. Reinforce the mastic with fabric-reinforcing mesh. Trowel the mastic to a smooth and well-shaped contour.

8. For services not specified to receive a field-applied jacket except for flexible elastomeric, install fitted PVC cover over elbows, tees, strainers, valves, flanges, and unions. Terminate ends with PVC end caps. Tape PVC covers to adjoining insulation facing using PVC tape.
  9. Stencil or label the outside insulation jacket of each union with the word "UNION." Match size and color of pipe labels.
- C. Insulate instrument connections for thermometers, pressure gages, pressure temperature taps, test connections, flow meters, sensors, switches, and transmitters on insulated pipes, vessels, and equipment. Shape insulation at these connections by tapering it to and around the connection with insulating cement and finish with finishing cement, mastic, and flashing sealant.
- D. Install removable insulation covers at locations indicated on Drawings. Installation shall conform to the following:
1. Make removable flange and union insulation from sectional pipe insulation of same thickness as that on adjoining pipe. Install same insulation jacket as adjoining pipe insulation.
  2. When flange and union covers are made from sectional pipe insulation, extend insulation from flanges or union long at least two times the insulation thickness over adjacent pipe insulation on each side of flange or union. Secure flange cover in place with stainless-steel. Select band material compatible with insulation and jacket.
  3. Construct removable valve insulation covers in same manner as for flanges except divide the two-part section on the vertical center line of valve body.
  4. When covers are made from block insulation, make two halves, each consisting of mitered blocks wired to stainless-steel fabric. Secure this wire frame, with its attached insulation, to flanges with tie wire. Extend insulation at least 2 inches over adjacent pipe insulation on each side of valve. Fill space between flange or union cover and pipe insulation with insulating cement. Finish cover assembly with insulating cement applied in two coats. After first coat is dry, apply and trowel second coat to a smooth finish.
  5. Unless a PVC jacket is indicated in field-applied jacket schedules, finish exposed surfaces with a metal jacket.

### 3.5 FLEXIBLE ELASTOMERIC INSULATION INSTALLATION

- A. Seal longitudinal seams and end joints with manufacturer's recommended adhesive to eliminate openings in insulation that allow passage of air to surface being insulated.
- B. Insulation Installation on Pipe Flanges:
1. Install pipe insulation to outer diameter of pipe flange.
  2. Make width of insulation section same as overall width of flange and bolts, plus twice the thickness of pipe insulation.
  3. Fill voids between inner circumference of flange insulation and outer circumference of adjacent straight pipe segments with cut sections of sheet insulation of same thickness as pipe insulation.
  4. Secure insulation to flanges and seal seams with manufacturer's recommended adhesive to eliminate openings in insulation that allow passage of air to surface being insulated.
- C. Insulation Installation on Pipe Fittings and Elbows:
1. Install mitered sections of pipe insulation.
  2. Secure insulation materials and seal seams with manufacturer's recommended adhesive to eliminate openings in insulation that allow passage of air to surface being insulated.

D. Insulation Installation on Valves and Pipe Specialties:

1. Install preformed valve covers manufactured of same material as pipe insulation when available.
2. When preformed valve covers are not available, install cut sections of pipe and sheet insulation to valve body. Arrange insulation to permit access to packing and to allow valve operation without disturbing insulation.
3. Install insulation to flanges as specified for flange insulation application.
4. Secure insulation to valves and specialties and seal seams with manufacturer's recommended adhesive to eliminate openings in insulation that allow passage of air to surface being insulated.

3.6 MINERAL-FIBER INSULATION INSTALLATION

A. Insulation Installation on Straight Pipes and Tubes:

1. Secure each layer of preformed pipe insulation to pipe with wire or bands and tighten bands without deforming insulation materials.
2. Where vapor barriers are indicated, seal longitudinal seams, end joints, and protrusions with vapor-barrier mastic and joint sealant.
3. For insulation with factory-applied jackets on above ambient surfaces, secure laps with outward clinched staples at 6 inches o.c.
4. For insulation with factory-applied jackets on below ambient surfaces, do not staple longitudinal tabs but secure tabs with additional adhesive as recommended by insulation material manufacturer and seal with vapor-barrier mastic and flashing sealant.

B. Insulation Installation on Pipe Flanges:

1. Install preformed pipe insulation to outer diameter of pipe flange.
2. Make width of insulation section same as overall width of flange and bolts, plus twice the thickness of pipe insulation.
3. Fill voids between inner circumference of flange insulation and outer circumference of adjacent straight pipe segments with mineral-fiber blanket insulation.
4. Install jacket material with manufacturer's recommended adhesive, overlap seams at least 1 inch, and seal joints with flashing sealant.

C. Insulation Installation on Pipe Fittings and Elbows:

1. Install preformed sections of same material as straight segments of pipe insulation when available.
2. When preformed insulation elbows and fittings are not available, install mitered sections of pipe insulation, to a thickness equal to adjoining pipe insulation. Secure insulation materials with wire or bands.

D. Insulation Installation on Valves and Pipe Specialties:

1. Install preformed sections of same material as straight segments of pipe insulation when available.
2. When preformed sections are not available, install mitered sections of pipe insulation to valve body.
3. Arrange insulation to permit access to packing and to allow valve operation without disturbing insulation.
4. Install insulation to flanges as specified for flange insulation application.

E. Blanket Insulation Installation on Ducts and Plenums: Secure with adhesive and insulation pins.

1. Apply adhesives according to manufacturer's recommended coverage rates per unit area, for 100 percent coverage of duct and plenum surfaces.
2. Apply adhesive to entire circumference of ducts and to all surfaces of fittings and transitions.
3. Install either capacitor-discharge-weld pins and speed washers or cupped-head, capacitor-discharge-weld pins on sides and bottom of horizontal ducts and sides of vertical ducts as follows:
  - a. On duct sides with dimensions 18 inches and smaller, place pins along longitudinal centerline of duct. Space 3 inches maximum from insulation end joints, and 16 inches o.c.
  - b. On duct sides with dimensions larger than 18 inches place pins 16 inches o.c. each way, and 3 inches maximum from insulation joints. Install additional pins to hold insulation tightly against surface at cross bracing.
  - c. Pins may be omitted from top surface of horizontal, rectangular ducts and plenums.
  - d. Do not over compress insulation during installation.
  - e. Impale insulation over pins and attach speed washers.
  - f. Cut excess portion of pins extending beyond speed washers or bend parallel with insulation surface. Cover exposed pins and washers with tape matching insulation facing.
4. For ducts and plenums with surface temperatures below ambient, install a continuous unbroken vapor barrier. Create a facing lap for longitudinal seams and end joints with insulation by removing 2 inches from 1 edge and 1 end of insulation segment. Secure laps to adjacent insulation section with 1/2-inch outward-clinching staples, 1 inch o.c. Install vapor barrier consisting of factory- or field-applied jacket, adhesive, vapor-barrier mastic, and sealant at joints, seams, and protrusions.
  - a. Repair punctures, tears, and penetrations with tape or mastic to maintain vapor-barrier seal.
  - b. Install vapor stops for ductwork and plenums operating below 50 deg Fat 18-foot intervals. Vapor stops shall consist of vapor-barrier mastic applied in a Z-shaped pattern over insulation face, along butt end of insulation, and over the surface. Cover insulation face and surface to be insulated a width equal to 2 times the insulation thickness but not less than 3 inches
5. Overlap unfaced blankets a minimum of 2 inches on longitudinal seams and end joints. At end joints, secure with steel bands spaced a maximum of 18 inches o.c.
6. Install insulation on rectangular duct elbows and transitions with a full insulation section for each surface. Install insulation on round and flat-oval duct elbows with individually mitered gores cut to fit the elbow.
7. Insulate duct stiffeners, hangers, and flanges that protrude beyond insulation surface with 6-inch-wide strips of same material used to insulate duct. Secure on alternating sides of stiffener, hanger, and flange with pins spaced 6 inches o.c.
8. For ducts and plenums with surface temperatures below ambient, install a continuous unbroken vapor barrier. Create a facing lap for longitudinal seams and end joints with insulation by removing 2 inches from 1 edge and 1 end of insulation segment. Secure laps to adjacent insulation section with 1/2-inch outward-clinching staples, 1 inch o.c. Install vapor barrier consisting of factory- or field-applied jacket, adhesive, vapor-barrier mastic, and sealant at joints, seams, and protrusions.
  - a. Repair punctures, tears, and penetrations with tape or mastic to maintain vapor-barrier seal.



- b. Install vapor stops for ductwork and plenums operating below 50 deg F at 18-foot intervals. Vapor stops shall consist of vapor-barrier mastic applied in a Z-shaped pattern over insulation face, along butt end of insulation, and over the surface. Cover insulation face and surface to be insulated a width equal to 2 times the insulation thickness but not less than 3 inches.
    - 9. Install insulation on rectangular duct elbows and transitions with a full insulation section for each surface. Groove and score insulation to fit as closely as possible to outside and inside radius of elbows. Install insulation on round and flat-oval duct elbows with individually mitered gores cut to fit the elbow.
    - 10. Insulate duct stiffeners, hangers, and flanges that protrude beyond insulation surface with 6-inch-wide strips of same material used to insulate duct. Secure on alternating sides of stiffener, hanger, and flange with pins spaced 6 inches o.c.
  - F. Insulation Installation on Straight Pipes and Tubes:
    - 1. Secure single-layer insulation with stainless-steel bands at 12-inch intervals and tighten bands without deforming insulation materials.
    - 2. Install 2-layer insulation with joints tightly butted and staggered at least 3 inches. Secure inner layer with wire spaced at 12-inch intervals. Secure outer layer with stainless-steel bands at 12-inch intervals.
    - 3. Apply a skim coat of mineral-fiber, hydraulic-setting cement to insulation surface. When cement is dry, apply flood coat of lagging adhesive and press on one layer of glass cloth or tape. Overlap edges at least 1 inch. Apply finish coat of lagging adhesive over glass cloth or tape. Apply a thin finish coat to achieve smooth, uniform finish.
  - G. Insulation Installation on Pipe Flanges:
    - 1. Install preformed pipe insulation to outer diameter of pipe flange.
    - 2. Make width of insulation section same as overall width of flange and bolts, plus twice the thickness of pipe insulation.
    - 3. Fill voids between inner circumference of flange insulation and outer circumference of adjacent straight pipe segments with cut sections of block insulation of same material and thickness as pipe insulation.
    - 4. Finish flange insulation same as pipe insulation.
  - H. Insulation Installation on Pipe Fittings and Elbows:
    - 1. Install preformed sections of same material as straight segments of pipe insulation when available. Secure according to manufacturer's written instructions.
    - 2. When preformed insulation sections of insulation are not available, install mitered sections of calcium silicate insulation. Secure insulation materials with stainless-steel wire.
    - 3. Finish fittings insulation same as pipe insulation.
- 3.7 LABELING AND IDENTIFYING INSTALLATION
- A. Piping Systems: Install pipe markers on each system. Include arrows showing normal direction of flow.
    - 1. Plastic markers with application systems. Install on pipe insulation segment where required for hot non-insulated pipes.
      - a. Fasten markers on pipes smaller than 6-inch diameter by one of following methods:

- 1) Snap-on application of pre-tensioned semi-rigid plastic pipe marker.
  - 2) Adhesive lap joint in pipe marker overlap.
  - 3) Laminated or bonded application of pipe marker to pipe (or insulation).
  - 4) Taped to pipe (or insulation) with color-coded plastic adhesive tape, not less than 3/4-inch wide, lapped 1-1/2 inches minimum at both ends of pipe marker, and covering full circumference of pipe.
- b. Fasten markers on pipes 6-inch and larger diameter by one of following methods:
- 1) Laminated or bonded application of pipe marker to pipe (or insulation).
  - 2) Taped to pipe (or insulation) with color-coded plastic adhesive tape, not less than 1-1/2-inches wide, lapped 3 inches minimum at both ends of pipe marker, and covering full circumference of pipe.
  - 3) Strapped to pipe (or insulation) with manufacturer's standard stainless steel bands.
2. Locate pipe markers and color bands as follows wherever piping is exposed in finished spaces, machine rooms, accessible maintenance spaces (shafts, tunnels, plenums) and exterior non-concealed locations.
- a. Near each valve and control device.
  - b. Near each branch connection, excluding short take-offs for fixtures and terminal units. Mark each pipe at branch, where flow pattern is not obvious.
  - c. Near penetrations through walls, floors, ceilings, or enter non-accessible enclosures.
  - d. At access doors, manholes, and similar access points that permit view of concealed piping.
  - e. Near major equipment items and other points of origination and termination.
  - f. Spaced at a maximum of 50-feet o.c. along each run. Reduce intervals to 25 feet in congested areas of piping and equipment.
  - g. On piping above removable acoustical ceilings, except omit intermediately spaced markers.

### 3.8 FIRE-RATED INSULATION SYSTEM INSTALLATION

- A. Where fire-rated insulation system is indicated, secure system to ducts and duct hangers and supports to maintain a continuous fire rating.
- B. Insulate duct access panels and doors to achieve same fire rating as duct.
- C. Install firestopping at penetrations through fire-rated assemblies in accordance with Division 07 Section "Penetration Firestopping."

### 3.9 FIELD QUALITY CONTROL

- A. Testing Agency: Contractor shall engage a qualified testing agency to perform tests and inspections.
- B. Tests and Inspections:
  1. Inspect ductwork, randomly selected by Architect, by removing field-applied jacket and insulation in layers in reverse order of their installation. Extent of inspection shall be limited to one location for each duct system defined in the Article "Duct Insulation Schedule, General".

2. Inspect field-insulated equipment, randomly selected by Architect, by removing field-applied jacket and insulation in layers in reverse order of their installation. Extent of inspection shall be limited to one location for each type of equipment requiring insulation for this project. For large equipment, remove only a portion adequate to determine compliance.
3. Inspect pipe, fittings, strainers, and valves, randomly selected by Architect, by removing field-applied jacket and insulation in layers in reverse order of their installation. Extent of inspection shall be limited to three locations of straight pipe, three locations of threaded fittings, three locations of welded fittings, two locations of threaded strainers, two locations of welded strainers, three locations of threaded valves, and three locations of flanged valves for each pipe service defined in the Article "Piping Insulation Schedule, General".

C. All insulation applications will be considered defective Work if sample inspection reveals noncompliance with requirements. Architect may reject all work if sample work is found to be defective.

### 3.10 DUCT INSULATION PERFORMANCE , GENERAL

A. Plenums and Ducts Requiring Insulation:

1. Indoor, supply and outdoor air.
2. Indoor, concealed return located in non-conditioned space.
3. Indoor, return located in non-conditioned space.
4. Indoor, kitchen hood exhaust.
5. Indoor, exhaust between isolation damper and penetration of building exterior.
6. Outdoor, supply, return and outdoor air.

B. Items Not Insulated:

1. Factory-insulated flexible ducts.
2. Factory-insulated plenums and casings.
3. Flexible connectors.
4. Vibration-control devices.
5. Factory-insulated access panels and doors.

### 3.11 DUCT AND PLENUM INSULATION SCHEDULE

A. INSULATION APPLICATION SCHEDULE

1. General: Abbreviations used in the following schedules include:
  - a. Field-Applied Jackets: P - PVC, K - Foil and Paper, A - Aluminum, SS - Stainless Steel.

B. Indoor, Concealed duct insulation shall be mineral fiber blanket unless indicated otherwise.

C. DUCT SYSTEMS INSULATION SCHEDULE

DUCT LOCATION	OUTSIDE AIR, SUPPLY AIR, EXHAUST AIR (DOWNSTREAM OF DAMPER) INSULATION INSTALLED R-VALUE (H-Ft <sup>2</sup> ·deg F/BTU)	RETURN AIR INSULATION INSTALLED R-VALUE (H-Ft <sup>2</sup> ·deg F/BTU)
---------------	---	--

Exterior of Building (Notes 5, 6, 8)	8.0	8.0
Ventilated Attic (Notes 5, 7)	8.0	8.0
Unvented Attic Above Insulated Ceiling (Notes 5, 7)	8.0	8.0
Unvented Attic with Roof Insulation (Notes 1, 5, 7)	6.0	N/A
Unconditioned Space (Notes 2, 5, 6, 7)	8.0	8.0
Indirectly Conditioned Space (Notes 3, 7)	N/A	N/A
Ceiling Cavity / Shafts / Soffits / Me- chanical Spaces and Rooms (Notes 4, 5, 6, 7)	6.0	N/A
Exposed Locations within Conditioned Space	N/A	N/A
Buried	6.0	N/A

NOTE 1: INSULATION R-VALUES, MEASURED IN (H X FT<sup>2</sup> X F)/BTU, ARE FOR THE INSULATION AS INSTALLED AND DO NOT INCLUDE FILM RESISTANCE. WHERE EXTERIOR WALLS ARE USED AS PLENUM WALLS, WALL INSULATION SHALL BE AS REQUIRED BY THE MOST RESTRICTIVE CONDITION OF ASHRAE 90.1-2004 SECTION 5 OR 6.4.4.2. INSULATION RESISTANCE MEASURED ON A HORIZONTAL PLANE IN ACCORDANCE WITH ASTM C518 AT A MEAN TEMPERATURE OF 75F AT THE INSTALLED THICKNESS.

NOTE 2: INCLUDING CRAWL SPACES (BOTH VENTILATED/NON-VENTILATED), FRAMED CAVITIES IN WALLS, FLOOR AND CEILING ASSEMBLIES WHICH (A) SEPARATE CONDITIONED SPACE FROM UNCONDITIONED SPACE OR OUTSIDE AIR, AND (B) ARE UNINSULATED ON THE SIDE FACING AWAY FROM CONDITIONED SPACE.

NOTE 3: RETURN AIR PLENUMS WITH OR WITHOUT EXPOSED ROOFS ABOVE.

NOTE 4: CAVITY CONTAINED WITHIN THE INSULATED BUILDING ENVELOPE.

NOTE 5: VAPOR BARRIER REQUIRED.

NOTE 6: FIELD APPLIED JACKET (STAINLESS STEEL, OR ALUMINUM, FOR EXTERIOR APPLICATIONS, PVC FOR INTERIOR EXPOSED LOCATIONS).

NOTE 7: PROVIDE MINERAL FIBER BOARD WITH FIELD APPLIED JACKET (SS, OR A, EXTERIOR, ALL SERVICE INTERIOR) IN EXPOSED LOCATIONS IN LIEU OF MINERAL FIBER BLANKET.

NOTE 8: PROVIDE POLYISOCYANURATE BOARD INSULATION FOR OUTDOOR DUCTWORK

### 3.12 PIPING INSULATION SCHEDULE, GENERAL

A. Acceptable preformed pipe and tubular insulation materials and thicknesses are identified for each piping system and pipe size range. If more than one material is listed for a piping system, selection from materials listed is Contractor's option.

B. Items Not Insulated: Unless otherwise indicated, do not install insulation on the following:

1. Drainage piping located in crawl spaces.
2. Underground piping.
3. Chrome-plated pipes and fittings unless there is a potential for personnel injury.

3.13 PIPING INSULATION SCHEDULE

A. Abbreviations used in the following schedule include:

1. Pipe Sizes: NPS - Nominal Pipe Size.

B. Minimum HVAC Pipe Insulation Thickness Table:

HEATING SYSTEMS (Steam and Hot Water) (Note 1)	FLUID TEMPERATURE RANGE (deg F)	INSULATION TYPE / FIELD-APPLIED JACKET / IDENTIFICATION			PIPE SIZE AND INSULATION THICKNESS (INCHES) (Note 5, 6)				
		Glass Fiber	Polyisocyanurate	Flexible Elastomeric	<1" (Note 4)	1" to <1-1/2"	1-1/2" to <4"	4" to 6"	8" and Larger
High Pressure/ Temperature	306 – 450	X			2-1/2	3	3	4	4-1/2
Medium Pressure/ Temperature	251 – 305	X			2	2-1/2	3	3	3
Low Pressure/ Temperature	201 – 250	X			1-1/2	1-1/2	2	2	2
Low Temperature	106 – 200	X		X	1	1	1-1/2	1-1/2	1-1/2
Steam Condensate (for feed water)	Any	X		X	1	1-1/2	2	2	2
<b>COOLING SYSTEMS</b>									
Chilled Water, Refrigerant, and Brine	40 – 60	X (Note 2, 7)	X (Note 2, 3, 7)	X (Note 7)	1/2	3/4	1	1	1
	Below 40	X (Note 2, 7)	X (Note 2, 3, 7)	X (Note 7)	1	1-1/2	1-1/2	1-1/2	1-1/2
Indoor Air-Conditioning Condensate Drains	40 – 60	X		X	1	1	1	1	1

NOTE 1: GLASS-FIBER INSULATION ONLY FOR HYDRONIC PIPING.

NOTE 2: (P), (A), OR (SS) FIELD-APPLIED JACKET ON OUTDOOR INSTALLATIONS, EXPOSED AND CONCEALED.

NOTE 3: FOR OUTDOOR USE ONLY.

NOTE 4: PIPING INSULATION IS NOT REQUIRED BETWEEN THE CONTROL VALVE AND COIL ON RUNOUTS, WHEN THE CONTROL VALVE IS WITHIN 4-FEET OF THE COIL AND THE PIPE SIZE IS 1-INCH OR LESS.

NOTE 5: FOR PIPING EXPOSED TO OUTDOOR AIR, INCREASE INSULATION THICKNESS BY 1-INCH.

NOTE 6: INSULATION THICKNESS IS BASED ON INSULATION HAVING A THERMAL CONDUCTIVITY OF 0.22 – 0.25 BTU·INCH/(H·FT<sup>2</sup>·deg F)

NOTE 7: VAPOR BARRIER REQUIRED.

C. Piping, Exposed:

1. PVC, White – below 8 ft. height: 20 mils thick.

**End of Section 230700**

## **DIVISION 23 – HEATING, VENTILATING AND AIR CONDITIONING**

### **SECTION 23 09 20**

#### **BUILDING AUTOMATION SYSTEM (BAS)**

##### **PART 1 - GENERAL**

###### **1.1 SUMMARY**

- A. Section includes the installation of a building automation system (BAS) for control and monitoring of mechanical systems as indicated.

###### **1.2 SYSTEM DESCRIPTION**

- A. The distributed digital control (DDC) and building automation system (BAS) defined herein shall provide a complete LONMARK® or Native BACnet® Building Automation System (BAS) for all mechanical systems and other facility systems as included in the project documents. The contractor shall provide a complete and operational system to perform all sequences of operations stated in the Article "Sequence of Operation" or as shown on the control drawings.
- B. The BAS shall utilize electronic sensing, microprocessor-based digital control, and electronic actuation of dampers and valves to perform the control sequences and functions specified. The BAS for this project shall consist of monitoring and control of the systems indicated.
- C. The BAS system shall include a webserver (control system server CSS), a separate operator workstation (OWS), a laptop (portable operator terminal POT), all the software tools required to maintain or configure the server, OWS, and any local devices.
- D. All interlock wiring for mechanical system equipment shall be by this contractor unless specifically stated otherwise. This shall include, but not be limited to, items such as thermostats for unit heaters, interlock wiring to central boiler control panels, chiller flow switches, and duct smoke detectors.

###### **1.3 APPLICATION OF OPEN PROTOCOLS**

- A. Subject to the detailed requirements provided throughout the specification, the BAS and digital control and communications components installed, as work of this contract shall be an integrated distributed processing system utilizing one of the following standards:
  - 1. BACnet: System components shall communicate using native BACnet in accordance with ASHRAE Standard 135 and current addenda and annexes, including all workstations, all BACnet building controllers (B-BC), advanced application controllers (B-AAC) and all application specific controllers (B-ASC). Gateways to other communication protocols are not acceptable. All controllers must be BACnet Testing Labs listed for their required profile (B-BC, B-AAC or B-ASC).
  - 2. LonTalk: Provide control products and systems that comply with the latest version of the ANSI/EIA standard 709.1 and the LonTalk protocol of the Interoperability Standards as published by the LONMARK™ Association. All architectures involving tunneling the LonTalk protocol across an IP network must incorporate ISO Layer 3 transparent routing.

- B. Throughout these specifications, there are parallel requirements for BACnet or LonWorks systems. Such requirements shall be interpreted in light of whether the contractor is installing a BACnet, LonWorks, or a hybrid system.

#### **1.4 QUALITY ASSURANCE**

- A. Qualifications: The following companies are acceptable to install a web-based BAS system:
  - 1. Schneider Electric  
311 S Wacker Dr # 4550  
Chicago, IL 60606  
(312) 697-4770

#### **1.5 CODES AND STANDARDS**

- A. American Society of Heating, Refrigeration and Air Conditioning Engineers (ASHRAE) Standards:
  - 1. 90.1: Energy Standard for Buildings Except Low-Rise Residential Buildings.
  - 2. 62.1: Ventilation for Acceptable Indoor Air Quality.
  - 3. 135: BACnet - A Data Communication Protocol for Building Automation and Control Networks, current version including all annexes and addenda.
  - 4. 55: Thermal Environmental Conditions for Human Occupancy.
- B. Electronics Industries Alliance:
  - 1. EIA-709.1-A-99: Control Network Protocol Specification.
  - 2. EIA-709.3-99: Free-Topology Twisted-Pair Channel Specification.
  - 3. EIA-232: Interface Between Data Terminal Equipment and Data Circuit-Terminating Equipment Employing Serial Binary Data Interchange.
  - 4. EIA-458: Standard Optical Fiber Material Classes and Preferred Sizes.
  - 5. EIA-485: Standard for Electrical Characteristics of Generator and Receivers for use in Balanced Digital Multipoint Systems.
  - 6. EIA-472: General and Sectional Specifications for Fiber Optic Cable.
  - 7. EIA-475: Generic and Sectional Specifications for Fiber Optic Connectors and all Sectional Specifications.
  - 8. EIA-573: Generic and Sectional Specifications for Field Portable Polishing Device for Preparation Optical Fiber and all Sectional Specifications.
  - 9. EIA-590: Standard for Physical Location and Protection of Below-Ground Fiber Optic Cable Plant and all Sectional Specifications.
  - 10. EIA-852: Tunneling of Component Network Data over IP Channels.
- C. Underwriters Laboratories
  - 1. UL 916: Energy Management Systems.
- D. NEMA Compliance
  - 1. NEMA 250: Enclosure for Electrical Equipment.
  - 2. NEMA ICS 1: General Standards for Industrial Controls.
- E. NFPA Compliance



1. NFPA 90A: "Standard for the Installation of Air Conditioning and Ventilating Systems" where applicable to controls and control sequences.
2. NFPA 70: National Electrical Code (NEC).

F. Institute of Electrical and Electronics Engineers (IEEE)

1. IEEE 142: Recommended Practice for Grounding of Industrial and Commercial Power Systems.
2. IEEE 802.3: CSMA/CD (Ethernet – Based) LAN.
3. IEEE 802.4: Token Bus Working Group (ARCNET – Based) LAN.

## 1.6 DEFINITIONS

- A. Acknowledged: Data is broadcast repeatedly until an acknowledgement is received. Used for critical data using one to one bindings only. This type of service shall not be used for one to many bindings.
- B. Adjustable (ADJ): A characteristic of a control logic parameter such that it can be varied by the operator without downloading the program.
- C. Analog Calibration Offsets: For all analog input measured variables, with the exception of velocity pressure, the value measured by the hardware based analog input point shall be adjusted to match the value reported by a certified test instrument. An analog calibration offset is a parameter that can be added or subtracted from the raw value measured by the sensor to produce a calibrated value used by the control logic and reported to the operator workstations. The initial value of this parameter is set at zero and it is adjusted when the calibration process is executed. This adjustment is referred to as a single point calibration. These parameters are mandatory for all analog inputs except velocity pressure sensors. These offset values are configuration parameters and shall be written to EEPROM. It shall be possible to change the value of these parameters from a graphic page.
- D. Advanced Application Controller (AAC): A device with limited resources relative to the Building Controller (BC). It may support a level of programming and may also be intended for application specific applications. A fully programmable control module. This control module shall be capable of certain advanced features found in Building Controllers (e.g. storing trends, and initiating read and write requests) but it shall not serve as a master controller. Advanced Application Controllers may reside on either the Ethernet/IP backbone or on a subnet. A BACnet device to be used as an AAC will meet the requirements of ASHRAE 135, Annex L and will be listed as an AAC by BACnet Testing Labs. A BTL listed device will carry the BTL Mark.
- E. Application Programming Tool: A vendor unique software tool used to create applications for programmable controllers.
- F. Application Protocol Data Unit (APDU): A unit of data specified in an application protocol and consisting of application protocol control information and application user data (ISO 9545).
- G. Application Specific Controller (ASC): A device with limited resources relative to the Advanced Application Controller (AAC). A pre-programmed control module, intended for use in a specific application. ASCs shall have limited configurability, allowing the user to select various pre-programmed options, but it shall not be fully customizable. A BACnet device used as an ASC will meet the requirements of ASHRAE 135, Annex L and will be listed as an ASC by BACnet Testing Labs. A BTL listed device will carry the BTL Mark.

- H. BACnet/BACnet Standard: BACnet communication requirements, as defined by ASHRAE/ANSI 135, current version including all annexes and addenda.
- I. Bandwidth Utilization: The average utilization of the network capacity. Network loading is controlled by the use of event driven broadcast based data propagation and the use of appropriate binding services.
- J. Binding Services: When the network management tool within Niagara or Plexus is used to establish a binding, one of the following three types of binding services shall be selected:
  - 1. Unacknowledged: The data being broadcast is sent one time and an acknowledgement of receipt is not required. Used for non-critical data where there is no significant impact should the receiving device have to wait for the next broadcast.
  - 2. Unacknowledged Repeated: The data being broadcast is sent three times and an acknowledgement of receipt is not required. Used for most process control related data requiring timely receipt of the data.
  - 3. Acknowledged: The data is broadcast repeatedly until an acknowledgement is received. Used for critical data using one to one bindings only. This type of service shall not be used for one to many bindings.
- K. Binding: The concept of associating an output network variable from one device to the input network variable of a second device. There are three types of bindings:
  - 1. One to One: A single output network variable is bound to a single input network variable
  - 2. One to Many: A single output network variable is bound to input network variables on multiple devices.
  - 3. Many to One: Output network variables from multiple devices are bound to a single input network variable on a different device.
- L. Broadcasting: The propagation of data from a device to the control network. Software objects that broadcast data to the network shall include the following parameters:
- M. Building Automation System (BAS): The entire integrated energy management and control system.
- N. Building Controller (BC): A fully programmable control module capable of storing trends and schedules, serving as a router to devices on a subnet, and initiating read and write requests to other controllers. Typically this controller is located on the Ethernet/IP backbone of the BAS. A BACnet device to be used as a BC shall meet the requirements of ASHRAE 135, Annex L and will be listed as a BC by BACnet Testing Labs. A BTL listed device will carry the BTL Mark.
- O. Bus Topology: A term used to describe the sequential connection of devices on a LON segment. The communication cable runs from device to device with no tees or stubs from the main communication cable to a device.
- P. Change of Value (COV): An event that occurs when a measured or calculated analog value changes by a predefined amount (ASHRAE/ANSI 135-1995).
- Q. Channel: A LON network consisting of two segments connected by a physical layer repeater or router configured as a repeater. Each segment can support a theoretical limit of 64 connections.
- R. Client: A device that is the requestor of services from a server. A client device makes requests of, and receives responses from, a server device.

- S. Configuration Parameter: An input network variable to a controller that is written to the EEPROM.
- T. Connection: Made when a device is physically connected to the FTT-10 communication cable. Devices that count against the number of connections limit include LON Talk Adapters (PCLTA, PCC 10 etc.), any sensor, actuator, or controller with a FTT-10 transceiver and Neuron chip, and a router or repeater. Terminators are not considered to be a connection.
- U. Continuous Monitoring: Sampling and recording of a variable based on time or change of state (e.g. trending an analog value, monitoring a binary change of state).
- V. Control System Server (CSS), Web Server (WS): Provides access to the control system. This device will allow access to the control system with a web browser over the CPS WAN. As the BAS network devices are stand-alone, the CSS is not required for communications to occur. The webserver will have two NIC cards so that it functions as the bridge between the local supervisory LAN and the CPS LAN.
- W. Controller or Control Unit (CU): Intelligent stand-alone control panel. Controller is a generic reference and is a PCU.
- X. CPS WAN: Reference to Chicago Public Schools Information Technology network, used for normal business-related e-mail and Internet communication.
- Y. Direct Digital Control (DDC): Microprocessor-based control including Analog/Digital conversion and program logic
- Z. Enumerated SNVT: Defines the format of a single piece of data using a state description concept. The data will consist of a series of integers and each integer shall convey a defined condition or state. The list of available enumerated SNVT types is defined in the LonMark Standard Enumeration Master List, dated May 2002. This document is available on the Echelon.com web site.
- AA. Error Rate: A measurement of communication quality that assesses the number of defective data packets as a percentage of the total number of data packets. Defective data packets are generally the result of poor installation practices or improper cable selection.
- BB. Event Driven Communication: A term used to describe the propagation of data from a device to the network based on broadcasting rather than polling. The send on delta parameter is used to define the event and the data propagation is further controlled by the minimum and maximum send time parameters.
- CC. Free Topology: A data wiring topology that allows for loops, tees, y-connections etc. When this topology is used only one terminator of a specific design is required and allowable cable lengths are significantly reduced.
- DD. Functional Profile: A collection of variables required to define a the key parameters for a standard application. As this applies to the HVAC industry, this would include applications like VAV terminal, fan coil units, and the like.
- EE. Gateway (GTWY): A device, which contains two or more dissimilar networks/protocols, permitting information exchange between them (ASHRAE/ANSI 135-1995).
- FF. Hand Held Device (HHD): Manufacturer's microprocessor based device for direct connection to a Controller.

- GG. Host-Based Controller: Applicable only to Lon-based controllers where the on-board Neuron chip is used solely as the Communications Interface and a processor independent from the Neuron chip to is used to execute Application control and I/O processes.
- HH. JACE: Java Control Engine. Term used within the Niagara Framework to describe a component that serves several key functions:
1. Serve as the LANID.
  2. Collection of data from a FTT-10 LonTalk channel.
  3. Transmission of data to operator workstations on the TCP/IP network.
  4. Location for time schedules to support all of the devices on the LonTalk channel.
  5. Support for 1 LonTalk channel (two segments, 40 nodes each).
  6. Location for trend logs for all data to be trended from the devices on the LonTalk channel.
  7. Location for alarm handling software. The JACE shall process event broadcasted data from the devices (alarm indication) and enter the appropriate alarm information in the alarm reporting system at the TCP/IP level.
- II. Local Supervisory LAN Interface Device (LANID): Device used to facilitate communication and sharing of data throughout the BAS and CPS WAN
- JJ. LonMark Profile: To enhance interchangeability of control components at the sensor, actuator, terminal unit controller and package equipment controller level, the LonMark Association has created profiles that define the network image for these devices. These profiles define mandatory input and output variables and configuration parameters and a required format for each. Conformance to a LonMark profile provides to the facility owner the opportunity to replace a control component manufactured by one vendor with a similar component manufactured by a different vendor provided the embedded application of the replacement controller meets the sequence of control requirements.
- KK. Media Access Control address (MAC): Hardware address that uniquely identifies each node of a network. Each different type of network medium requires a different MAC layer.
- LL. Managed Communication: Transmission of data from a controller to a data manager, which in turn re-broadcasts the data to a second controller.
- MM. Manual Control: Where the operator takes control of an end device and forces a specific position or state. The manual mode and the desired manual position or states are parameters that are set by the operator.
- NN. Many to One: Output network variables from multiple devices are bound to a single input network variable on a different device.
- OO. Maximum Send Time Parameter: Parameter used to ensure the periodic update of network data. If a time period equal to the value of this parameter has expired without a broadcast of the variable, a re-broadcast of the current value shall be executed. See also "Send on Delta" and "Maximum Send Time."
- PP. Maximum Send Time: Adjustable parameter that defines the maximum time period between broadcasts of a software object's data to the network. Should the value of a software object remain constant over an extended period of time, the value will be rebroadcast once every maximum time period.
- QQ. Minimum Send Time Parameter: Parameter used to control unnecessary broadcasting of data onto the network. Broadcast of an updated value shall not occur unless a time period equal to

the value of this parameter has expired. The expiration of the time period does not mandate a re-broadcast. See also "Send on Delta" and "Maximum Send Time" definitions.

- RR. Minimum Send Time: Adjustable parameter that defines a mandatory time period during which no broadcasting of data will occur. Once this time period has been exceeded without a broadcast, the send on delta parameter or the maximum send time parameter shall determine when a broadcast is initiated.
- SS. Multiple Controller Integrated Control (MCIC): Where multiple controllers with I/O are used to control a single mechanical system, which is sub-divided into a collection of processes to be controlled. All primary measured variables and the end device associated with a single process along with the primary control logic for the process shall be contained within a single controller. Secondary data from one process that affects the control of another process may be sent from one controller to the primary controller controlling the process. When data is sent from one controller to another controller, broadcasting concepts as defined above must be used. If the data being received over the network only affects the general thermodynamic or psychometric performance of the process but does not have a significant affect on safety or equipment protection then unacknowledged repeated binding services shall be used. If the data being received over the network has a safety or equipment protection impact, then acknowledged repeated binding services shall be used. In both cases peer-to-peer communication is mandatory. All controllers must be on the same channel. Managed communication shall not be used to move data between the multiple controllers.
- TT. One to Many: A single output network variable is bound to input network variables on multiple devices.
- UU. One to One: A single output network variable is bound to a single input network variable.
- VV. Open Database Connectivity (ODBC): Open standard application-programming interface (API) for accessing a database, making access to any data, regardless of which database management system (DBMS) is handling the data, possible.
- WW. Operator Interface (OI): A device used by the operator to manage the BAS.
- XX. Operator Workstation (OWS): Used to interface with the BAS system via the internet or the Local Supervisory LAN.
- YY. Peer-to-Peer Communication: Data is broadcast from its origin and is received by the final device requiring the data without being received and retransmitted by a third device.
- ZZ. Polling Communication: The concept of a control device requesting a network variable from a second control device at a specified interval. Polling communication is typically used to populate dynamic data on an active graphic page and for temporary or short term trending of data where the trend data is not stored at the controller level.
- AAA. Portable Operators Terminal (POT): Laptop PC used both for direct connection to a controller and for remote dial up connection.
- BBB. Primary Control Unit (PCU): A fully programmable device capable of carrying out a number of tasks including control and monitoring via direct digital control (DDC) of specific systems.
- CCC. Protocol Implementation Conformance Statement (PICS): A written document, created by the manufacturer of a device, identifying the particular options specified by BACnet that are implemented in the device.

- DDD. Repeater: A physical device used to connect two segments and isolate physical problems. Typically required to allow the use of additional devices or additional cable length.
- EEE. Router: A device that connects two or more networks at the network layer.
- FFF. Segment: A single section of a LON network that contains no routers or repeaters.
- GGG. Send on Delta Parameter: A parameter used to control unnecessary broadcasting of data onto the network. For binary data the send on delta parameter is assumed to be a change of state.
- HHH. Send on Delta: Adjustable parameter that defines a requirement to broadcast when the data generated by the software object changes by an amount that exceeds this parameter's value. For binary data this parameters defaults to a change of state. The broadcast of data is initiated when this criteria and the minimum send time requirement have been met.
- III. Simple SNVT: Defines the format of a single piece of data. The definition of a simple SNVT in the master list of SNVTs will include the type of variable being measured (temperature, electric current, power etc.), the data type (signed integer, unsigned integer, floating point etc.), the data range, the resolution of the data and the engineering units.
- JJJ. Smart Device: A control I/O device such as a smart sensor (SS) or smart actuator (SA) that can directly communicate with the controller network to which it is connected rather than through a binary or analog signal.
- KKK. Standard Network Variable Type (SNVT): Data format statement for implicit (open) communication on a LonTalk network. The current master list of SNVTs is available from Echelon.com in a document defined as SNVT Master List, Version 11, Revision 2, dated May 2002.
- LLL. Standardized Query Language (SQL): Standardized means for requesting information from a database.
- MMM. Stand-Alone Controller: A stand-alone controller has provisions for all of the physical inputs and physical outputs associated with a single mechanical component such as a terminal unit, air handling unit, chiller or boiler. The controller shall also have embedded in it all of the control logic that associated the physical inputs to the physical outputs. A stand-alone controller may rely on other networked devices for time schedule inputs and trend data storage.
- NNN. Structured SNVT: Defines the format of a network variable that contains several different data elements. A simple SNVT or an enumerated SNVT may define each data element within a structured SNVT.
- OOO. Supervisory Logic: The concept of gathering performance data from multiple terminal units to determine if a specific condition exists within the family of terminal devices.
- PPP. Terminator: An electronic component that consists of a resistive and capacitive circuit specifically designed to enhance the quality of communications on a segment. On a bus topology, a terminator is connected to each end of a segment. For a channel consisting of two bus topology segments, a total of 4 terminators are required, one at each end of each segment.
- QQQ. Test Mode: A concept where the operator from the operator workstation can interrupt the flow of data from a sensor to the control logic and insert a mandatory test value or test state to be used by the control logic. The test mode and the desired test value or states are parameters that are set by the operator.

RRR. Unacknowledged Repeated: The data being broadcast is sent three times and an acknowledgement of receipt is not required. This type of service shall be used for most process control related data requiring timely receipt of the data.

SSS. Unacknowledged: The data being broadcast is sent one time and an acknowledgement of receipt is not required. This type of service shall be used for non-critical data where there is no significant impact should the receiving device have to wait for the next broadcast.

TTT. Web Server: Refer to "Control System Server."

UUU. XIF File: A file indicating the interface specifications for LonMark devices.

VVV. XML (Extensible Markup Language): A specification developed by the World Wide Web Consortium.

## **1.7 FUNCTIONAL INTENT**

A. Where detailed functional or performance requirements are specified, products intended for the Project, conforming to the specified requirements, must be submitted to, and approved by, CPS prior to shipment to the Project site.

## **1.8 SUBMITTALS**

A. Electronic Submittals: While all requirements for hard copy submittal apply, control submittals and O&M information shall also be provided in electronic format as follows.

1. Drawings and Diagrams: Shop drawings shall be provided on electronic media as an AutoCAD 2000 or later version drawing file and/or Adobe Portable Document Format file. All 'x reference' and font files must be provided with AutoCAD files.
2. Other Submittals: All other submittals shall be provided in Adobe Portable Document Format (PDF). Provide documents, such as Cheat Sheets and Trouble Shooting Guide, in rich text format (rtf) or Microsoft Word format as required.

B. Product Data: For each control device, panel, and accessory indicated or furnished. Include dimensions, capacities, performance and electrical characteristics, and material finishes. Include installation and start-up instructions. When manufacturer's cutsheets apply to a product series rather than a specific product, clearly indicate applicable data by highlighting or by other means. General catalogs shall not be accepted as cutsheets to fulfill submittal requirements.

C. Shop Drawings: Submit shop drawings for each control system, including a complete drawing for each air handling unit, system, pump, device, etc. with all point descriptors, addresses and point names indicated. Each shop drawing shall contain the following information:

1. System Architecture and System Layout:
  - a. One-line diagram indicating schematic locations of all control units, workstations, LAN interface devices, gateways, etc. Indicate network number, device ID, address, device instance, MAC address, drawing reference number, and controller type for each control unit. Indicate media, protocol, baud rate, and type of each LAN. For LonTalk systems indicate all LonTalk nodes, including Neuron ID and domain, sub-network and channel addresses. Indicate media, protocol, baud rate, and type of each LAN. All optical isolators, repeaters, end-of-line resistors, junctions, terminators, ground locations etc. shall be located on the diagram.

- b. Provide floor plans locating all control units, workstations, servers, LAN interface devices, gateways, etc. Include all WAN and LAN communication wiring routing, power wiring, power originating sources, and low voltage power wiring. Indicate network number, device ID, address, device instance, MAC address, drawing reference number, and controller type for each control unit. Indicate media, protocol, baud rate, and type of each LAN. For LonTalk systems provide as-built network architecture drawings showing all LonTalk nodes, including Neuron ID and domain, sub-network and channel addresses. All optical isolators, repeaters, end-of-line resistors, junctions, ground locations etc. shall be located on the floor plans. Wiring routing as-built conditions shall be maintained accurately throughout the construction period and the drawing shall be updated to accurately reflect accurate, actual installed conditions.
2. Schematic flow diagram of each air and water system showing fans, coils, dampers, valves, pumps, heat exchange equipment and control devices. Include contractor written description of sequence of operation.
  3. All physical points on the schematic flow diagram shall be indicated with names, descriptors, and point addresses identified as listed in the point summary table.
  4. With each schematic, provide a point summary table listing building number and abbreviation, system type, equipment type, full point name, point description, Ethernet backbone network number, network number, device ID, object ID (object type, instance number). See Division 23 Section " Building Automation System (BAS) - Software and Programming," PART 3 for additional requirements.
  5. Label each control device with setting.
  6. Label each input and output with the appropriate range.
  7. Provide a Bill of Materials with each schematic. Indicate device identification to match schematic and actual field labeling, quantity, actual product ordering number, manufacturer, description, size, voltage range, pressure range, temperature range, etc. as applicable. Also identify the specification section and specification reference.
  8. Provide a valve or damper and the associated actuator information including size, Cv, design flow, design pressure drop, manufacturer, model number, close off rating, etc. Indicate normal (fail) positions of spring return valves and dampers. This is the valve or damper position with no power to the actuator.
  9. Indicate all required electrical wiring. Electrical wiring diagrams shall include both ladder logic type diagram for motor starter, boiler burner, chiller, RTU, control, and safety circuits and detailed digital interface panel point termination diagrams with all wire numbers and terminal block numbers identified. Provide panel termination drawings on separate drawings. Ladder diagrams shall appear on system schematic. Clearly differentiate between portions of wiring, which are existing, factory-installed and portions to be field-installed. For all devices with safety circuits, including burners and chillers, field wiring will be labeled and all added devices will be properly mounted. Any internal wiring changes shall be approved by the manufacturer in writing. If for example a gas booster needs to be tied into the burner circuit the manufacturer shall identify the terminal points and provide an updated control diagram.
  10. Sample Operator Interface Graphic Screens for each unique type of system, with final screens to be received 60 days prior to system startup.
  11. Details of control panels, including controls, instruments, and labeling shown in plan or elevation indicating the installed locations.
  12. Sheets shall be consecutively numbered.
  13. Each sheet shall have a title indicating the type of information included and the HVAC system controlled.
  14. Table of Contents listing sheet titles and sheet numbers.
  15. Legend and list of abbreviations.



16. Provide an operating schedule for review. The schedule will have a schedule for each AHU/RTU and the associated equipment. Terminal units serving the principals office and associated administrative areas will have a separate schedule from the classrooms.
- D. Product Line Demonstrated History: The product line being proposed for the project must have an installed history of demonstrated satisfactory operation for a length of 1 year since date of final completion in at least 10 installations of comparative size and complexity. Submittals shall document this requirement with references.
  - E. Qualifications: For manufacturer, companies, Contractor and key personnel.
  - F. Checkout and Testing Forms: Submit a blank copy of the forms that will be used during Point-to-Point Checkout, Prefunctional Checkout, and Functional Performance Testing as outlined in Division 23 Section " Building Automation System (BAS) - Commissioning." Those forms should be structured to capture the following information at a minimum during each particular testing phase.
    1. Point-to-Point Checkout Form containing the following information:
      - a. Each point is addressed, labeled and that proper communication exists between the controller and the field device.
      - b. Documents that installed condition match the control drawings and that any changes or differences are noted on the drawings.
    2. Prefunctional Checkout Forms containing the following information:
      - a. Documents correct voltage and or current present as well as verifying circuits are free from grounds or faults for each control device.
      - b. Obtain and Record Test and Balance settings and incorporate into the BAS. Information from the TAB contractor shall include:
        - 1) Water and air system differential pressure and flow settings.
        - 2) AHU minimum outside air control point or damper setting.
      - c. Calibration data for all sensing and actuating devices recording final measured and displayed value. Record the type and model of the meter(s) that determined the measured value for analog inputs.
      - d. For analog outputs record both the displayed output as well state of the receiving device.
      - e. For digital input/outputs record the signal at the controller and the state of the sensing/control device.
      - f. For actuators:
        - 1) Check to ensure that actuated device moves smoothly and results are repeatable thru full range and seals tightly when the appropriate signal is applied to the operator.
        - 2) Check for appropriate fail position, and that the stroke and range is as required.
        - 3) For sequenced electronic actuators, calibrate in accordance with manufacturer's instructions to required ranges. Record final settings.
      - g. For all valves and actuators, verify the actual position against the Operator Interface readout. Set pumps to normal operating mode. With command valve

closed, verify that valve is closed, and adjust output zero signal as required. With command valve open, verify position is full open and adjust output signal as required. Command the valve to not less than three (3) intermediate positions. If actual valve position doesn't correspond correctly, replace actuator.

- h. Valve leak check: Verify proper close-off of the valves. Ensure the valve seats properly by simulating the maximum anticipated pressure difference across the circuit.
- i. For air and water flow measuring stations the data recorded will include the independent flow measurement, area, and the independently measured output of the flow station. The BAS input from the flow station and any factors used to calculate the flow including area and any constants used in the calculation of flow. Two sets of data shall be collected. The first at design flow and the second at 50% of design flow. It is not acceptable to simply add a correction factor to address differences between the flow station and the independent reading.
- j. For Operator Interfaces and Web accessible display:
  - 1) Verify that all elements on the graphics are functional and are properly bound to physical devices and/or virtual points, and that hot links or page jumps are functional and logical.
  - 2) Output all specified BAS reports for review and approval.
  - 3) Verify that the alarm pop ups, printing, and logging are functional and in accordance with requirements.
  - 4) Verify that all points are trended and are archiving to disk. Provide a sample to the Commissioning Authority and CPS for review.
  - 5) Verify that paging/dial-out alarm annunciation is functional.
  - 6) Verify the functionality of remote Operator Interfaces and that a robust connection can be established consistently.
  - 7) Verify that required third party software applications required with the bid are installed and are functional.
- k. For all actuating devices record final settings for device.
- l. Document verification of point to graphics binding for all points displayed on the workstation and that webserver display have been mapped correctly, and display the correct information.
- m. Document that the webserver is on the CPS LAN and can be viewed from off site (another school), that the modem is connected, and that the BAS is accessible via modem by the contractor.

3. Functional Performance Forms shall contain:

- a. List of all sequences, modes of operation and setpoint that initiates each sequence and/or mode. For each confirm that proper sequence of operation. Document any variance between designed sequence and actual condition.
- b. Record tuning parameters and response time for each control loop.
- c. Document all alarm and safeties test and final results.
- d. Results of trends including controlled points, setpoints, actual readings and other point defined by the Boards Authorized Representative.

G. Testing Plan:

- 1. Submit a plan for executing all phases of testing and completion of checkout forms. This includes the following: manufacturers' normal testing, point-to-point testing, pre-functional

testing, and functional performance testing. The testing plan shall show the overall milestones of the controls work and testing of the controls system.

2. Provide the schedule for completing each phase of testing for each system or set of equipment including, but not limited to, air handlers, chillers, boilers, unit-vents, VAV boxes, network wiring, and operator workstations. Schedules shall show the time frame needed to complete the tasks.
3. The testing plan shall identify other trade milestones that impact the successful completion of during each phase of testing.
4. This plan is not meant to take precedence over any other plan but is intended to provide coordination assistance to all trades as the project is scheduled.

H. Open Protocol Information:

1. General: Provide all information necessary for review of the proposed system, including information required by the authority maintaining the protocol standard to determine if the product selected for implementation complies with the protocol standards specified.
2. LonWorks Systems:

- a. Binding table indicating all Network Variables used in the project, Neuron ID and domain, subnet and channel address, and associated bound variables. Clearly indicate which parameters of a functional profile are bound and can be overridden.
- b. A point binding diagram shall be provided with each control schematic depicting all bound network variables along with the associated functional profiles.
- c. LonMark functional profile certifications.
- d. For Host-Based Controllers: Controller programming and configuration tool and or plug in required for all controllers with a minimum of 3 licenses as applicable.
- e. For non-host Controllers: LonTalk Neuron C source code and/or Neuron C application programming interface tool (3 licenses) and associated files required for all controllers.
- f. Backup of systems configuration database on CD. This shall be provided at Preliminary Acceptance and at the end of the warranty period.
- g. Documentation of all explicit messaging.
- h. XIF files for all LonMark components.

3. BACnet Systems:

- a. BACnet object description, object ID, and device ID, for each I/O point.
- b. Documentation for any non-standard BACnet objects, properties, or enumerations used detailing their structure, data types, and any associated lists of enumerated values.
- c. Submit PICS indicating the standardized BACnet device profile, functionality and configuration of each controller along with proof of BTL listing.

- I. Framed Control Drawings: After completion of installation and check out, but prior to training, laminated control drawings including system control schematics, sequences of operation, and panel termination drawings, shall be provided in panels for major pieces of equipment. Terminal unit drawings shall be located in the central plant equipment panel or mechanical room panel.

J. Control Logic Documentation (to be received and updated prior to training):

1. Submit control logic program listings (for graphical programming) and logic flow charts illustrating (for line type programs) to document the control software of all control units.

2. Control logic shall be annotated to describe how it accomplishes the sequence of operation. Annotations shall be sufficient to allow an operator to relate each program component (block or line) to corresponding portions of the specified Sequence of Operation.
3. Include written description of each control sequence.
4. Include control response, settings, setpoints, throttling ranges, gains, reset schedules, adjustable parameters, and limits.
5. Sheets shall be consecutively numbered.
6. Each sheet shall have a title indicating the controller designations and the HVAC system controlled.
7. Include Table of Contents listing sheet titles and sheet numbers
8. Submit one complete set of programming and operating manuals for all digital controllers concurrently with control logic documentation. This set will count toward the required number of Operation and Maintenance materials specified below.

K. Training Plan:

1. Training shall be provided in eight, four-hour sessions. A training plan is not required for opposite season or refresher training.
2. The material to be covered shall be further sub-divided into descriptions of the material to be covered in every 15 minutes. See Division 23 Section " Building Automation System (BAS) – Commissioning," for specific items to be addressed.
3. The descriptions shall include not only the material to be covered but also its location in the Operation and Maintenance Manual or the Training Manual including Section and page number.

L. Operation and Maintenance Manual: (All documentation to be received and updated prior to training)

1. In addition to other copies required, submit one copy of the materials directly to Chicago Public School's (CPS) operation staff.
2. Submit maintenance instructions and spare parts lists for each type of control device, control unit, and accessory.
3. Submit BAS User's Guides (Operating Manuals) for each controller type and for all workstation hardware and software and workstation peripherals.
4. Submit BAS advanced Programming Manuals for each controller type and for all workstation software.
5. Include all as built submittals (product data, shop drawings, control logic documentation, hardware manuals, software manuals, installation guides or manuals, maintenance instructions, and spare parts lists) in maintenance manual, in accordance with requirements of Division 01 Section "Operations and Maintenance Manual."

M. Training Manual: Submit training manual electronically for review. Once accepted, provide three hard copies and one electronic copy of the training manual at the start of training. Note only the initial 8 hours of training which include the Cheat Sheets will occur before the demonstration is completed. Include the following:

1. Cheat Sheets or quick reference section with step-by-step guidance with a level of detail that will allow someone with no experience with the control system to follow the instructions. The quick reference guidance can be provided one of two ways: screen prints with bubbled text describing the navigation required or written description of the steps to be taken with screen prints provided to facilitate the written explanation. The required cheat sheets shall include:
  - a. Logins and logoffs.

- b. Adjust and restore setpoints.
  - c. Overrides and releasing overrides. Include instructions for running a report to list all points currently overridden.
  - d. Start, group, plot and export Trends.
  - e. Adjust schedules and add holidays.
  - f. Processing of alarms including acknowledgement, review of alarm report, and clearing of alarm history.
  - g. Backup and restoration of system data.
  - h. Demonstrate how to clear/reset all field devices that may require manual intervention.
  - i. Demonstrate how to reset motor starter and the significance of Hand-Off-Auto switch position on motor starters.
  - j. Demonstration of each input and output device. Provide a picture of each input or output device with a brief narrative on its operation.
  - k. Demonstrate how to place the boiler or chiller system into manual control and boiler control, and how to restore the system to BAS control.
2. Operating instructions including system startup and shutdown, seasonal and emergency instruction.
  3. Trouble Shooting Guide. Include actions to be taken to trouble shoot problems with the OWS, PCU's CSS, and local control devices.
  4. Setpoint Table.
  5. Preventative maintenance instructions.
  6. Color print of each unique screen.
  7. Final Sequence of Operations. This document shall be printed but shall also be provided electronically in rich text format (rtf). The sequence shall provide not only the original design sequence from the specifications and drawings but also the any changes to the sequence.
  8. Complete set of the design control drawings (provided by the Architect on 11"x17" sheets). The manual will have a TAB for these drawings. The printed drawings will come from the Architect or Engineer.
  9. List of all alarm points and alarm priority.
- N. Video Training: The following training shall be recorded on a CD using screen capture software. Any files required to run the CD will be provided along with a file with the instruction on how to view the CD. The cadence of the video training shall be such that an inexperienced person can listen to the narrative and execute those steps on controls system while watching the CD. Include a screen view recording the actual video feed to the monitor for the work station penetration while narrating the associated steps.
1. Quick reference procedures. The taping of these procedures must include both a screen view preferably recording the actual video feed to the monitor while narrating the associated steps.
    - a. Login and logoff to control system as well as Microsoft XP login;
    - b. Adjust and restore setpoints.
    - c. Overrides and releasing overrides, as well as running a report to list all points currently overridden.
    - d. Start, group, plot and export Trends.
    - e. Adjust schedules and add holidays.
    - f. Processing of alarms including acknowledgement, review of alarm report and clearing of alarm history.
    - g. Backup and restoration of system data.

- h. Demonstrate workstation menu penetration and broad overview of the various workstation features.
  - i. Demonstrate all operations and functions that can be performed at the supervisory or local controllers as well as system display artifacts such as the indication that a point has failed or lost communication.
- O. Demonstration of portable operator interface device display capabilities.
  - P. Manufacturers Certificates: For all listed and/or labeled products, provide certificate of conformance. Include all LonMark functional profiles certifications for systems used on this project.
  - Q. Product Warranty Certificates: Submit manufacturers product warranty certificates covering the hardware provided.

### **1.9 PROJECT RECORD DOCUMENTS**

- A. The Project Record documents that have not already been submitted as part of the Operating and Maintenance Manual or Training Manual are to be submitted with the Record Documents. Any documents in the Operating and Maintenance Manual or Training Manual that have changed since they were submitted will need to be re-submitted as part of the Project record documents. All of these documents may be submitted electronically.
- B. Record copies of product data and control shop drawings updated to reflect the final installed condition.
- C. Record copies of approved control logic programming and database on CDs. The CDs will contain all information required to reinstall the control system program. It will include actual setpoints and settings of controls, final sequence of operation, including changes to programs made after submission and approval of shop drawings and including changes to programs made during specified testing. One set of CD's will be stored at the school in the main control panel and the second set will be provided to CPS Operations.
- D. Graphic Software: Record copies of approved project specific graphic software on CDs.
- E. For LonTalk systems provide as-built network architecture drawings showing all LonTalk nodes, including Neuron ID and domain, sub-network and channel addresses. For BACnet systems provide as-built network architecture drawings showing all BACnet nodes including a description field with specific controller identification, description and location information.
- F. Include individual floor plans with controller locations with all interconnecting wiring routing including space sensors, LAN wiring, power wiring, low voltage power wiring. Indicate device instance, MAC address and drawing reference number.
- G. Provide record riser diagram showing the location of all controllers.
- H. Maintain project record documents throughout the warranty period and submit final documents at the end of the warranty period

### **1.10 OPERATOR INTERFACE**

- A. The Operator Interface (OI) shall provide for overall system supervision, graphical user interface, management report generation, alarm annunciation, remote monitoring, and trend

reporting. . Refer to Division 23 Section " Building Automation System (BAS) - Operator Interfaces."

## 1.11 SYSTEM ARCHITECTURE

### A. Application of Open Protocols:

1. Subject to the detailed requirements provided throughout the specifications, the BAS and digital control and communications components installed, as work of this contract shall be an integrated distributed processing system utilizing the following standards:
  - a. LonTalk: Provide control products and systems that comply with the latest version of the ANSI/EIA standard 709.1 and the LonTalk protocol of the Interoperability Standards as published by the LONMARK™ Association. All architectures involving tunneling the LonTalk protocol across an IP network must incorporate ISO Layer 3 transparent routing.
  - b. BACnet or Hybrid System: The system architecture shall consist of a BACnet IP Router, a single Local Area Network (LAN) or two-level LANs that support BCs, AACs, ASCs, Operator Workstations (OWS), Smart Devices (SD), and Remote Communication Devices (RCDs) as applicable. In no event shall there be more than two levels of LAN topology within the system, excluding wiring to sensors with no control intelligence.

B. The system provided shall incorporate hardware resources sufficient to meet the functional requirements specified. The Contractor shall include all items not specifically itemized in these Specifications that are necessary to implement, maintain, and operate the system in compliance with the functional intent of these Specifications.

C. The system shall be configured as a distributed processing network(s) capable of expansion as specified below. Refer to the network architecture on the BAS drawings for other requirements and details.

D. The system architecture shall consist of an Ethernet-based, wide area network (WAN), a single Local Area Network (LAN) or multi-leveled LANs that support PCUs, Operator Workstations (OWS), and Remote Communication Devices (RCDs) as applicable. The following indicates a functional description of the BAS structure.

1. CPS WAN: Intranet-based network connecting multiple facilities with a central data warehouse and server, accessible via standard web-browser. This is an existing infrastructure and contractor is not required to configure any components of this WAN.
2. Local BAS Supervisory LAN: The Local BAS Supervisory LAN shall be an Ethernet-based, 100 Mbps LAN connecting Primary Control LANs and OWSs. The LAN serves as the inter-PCU gateway and OWS-to-PCU gateway and communications path and as the connection point for the CPS WAN. LAN shall be IEEE 802.3 Ethernet over Fiber or Category 5 cable with switches and routers that support 100 Mbps throughput. Power-line carrier communication shall not be acceptable for communications. The higher level layers of this network shall be the following:
  - a. LonWorks Supervisory LAN: Individual Primary Control LonTalk Networks routed over IP using LonTalk to IP routers.
  - b. BACnet Local Supervisory LAN: BACnet/IP as defined in Addendum A (Annex J) of the BACnet standard, and shall share a common network number for the Ethernet backbone, as defined in BACnet.

3. Primary Controller LAN ('Primary LAN'): High-speed, peer-to-peer communicating LAN used to connect and Primary Control (PCUs) and communicate exclusively control information. Acceptable technologies include:
  - a. LonTalk: The LonTalk standalone BAS shall be comprised of a network of PCUs supporting LonTalk protocol (EIA 709.1) and twisted pair, bus topology transceivers (EIA 709.3). The network shall communicate at 78 kbps. The network shall be installed utilizing the Bus Topology. The network shall consist of a single channel with 2 segments. Each segment shall be limited to a maximum of 40 nodes or as required to meet performance and standalone requirements, and to meet the requirements for response time, trending and bandwidth utilization as specified elsewhere in the specifications. A terminator shall be installed at both ends of each segment.
  - b. BACnet: Network used to connect AACs, ASCs or SDs. These can be Master Slave/ Token Passing or polling, or ARCnet in accordance with IEEE 802.4, in addition to those allowed for Primary Controller LANs. Network speed vs. the number of controllers on the LAN shall be dictated by the response time and trending requirements. The primary network shall communicate at a minimum of 38 kbps. Each secondary network may support up to 32 communicating devices without segmentation or repeaters subject to the requirements for response time, trending and bandwidth utilization.
  
- E. Dynamic Data Access: Any data throughout any level of the network shall be available to and accessible by all other devices, Controllers and OWS, whether directly connected or connected remotely.
  
- F. Remote Data Access: The system shall support the following methods of remote access to the building data.
  1. Dial-in via minimum of a 56k modem. The purpose of the remote access via phone is to allow for the contractor to access the control system. Dial-in connection shall allow access to all control system facilities and graphics with appropriate password. Chicago Public Schools shall provide and pay for the voice grade phone line to support this remote connection.
    - a. Browser-based access: A remote user, connecting via the CPS WAN and using a standard browser shall be able access all control system facilities and graphics with proper password. The remote access user will not need to load Java or other applications to view the web pages.
  
- G. Network Performance: The communication speed between the controllers, control LAN interface devices, and operator interface devices shall be sufficient to ensure fast system response time under any loading condition. Contractor shall submit guaranteed response times with shop drawings including calculations to support the guarantee. In no case shall delay times between an event, request, or command initiation and its completion be greater than those listed herein. Contractor shall reconfigure LAN as necessary to accomplish these performance requirements. The performance will also include the trending of all AI, AO and DI points at 15-minute intervals. Generally requirements do not apply when a remote connection must be established via modem:
  1. 5 seconds between a Level 1 (critical) alarm occurrence and annunciation at operator workstation.
  2. 10 seconds between a Level 2 alarm occurrence and annunciation at operator workstation.



3. 20 seconds between and a Level 3-5 alarm occurrence and annunciation at operator workstation.
  4. 10 seconds between an operator command via the operator interface to change a setpoint and the subsequent change in the controller.
  5. 5 seconds between an operator command via the operator interface to start/stop a device and the subsequent command to be received at the controller.
  6. 10 seconds between a change of value or state of an input and it being updated on the operator interface.
  7. Graphic Display, 10 seconds between an operator selection of a graphic and it completely painting the screen and updating all points.
  8. Graphic Refresh, every 15 seconds the graphic shall automatically refresh all graphic data.
- H. Control Systems Server (CSS) and Operator Work Station (OWS): These are two separate computers that maintain the systems configuration and programming database and is the operating platform for the operator interface (OI). It shall hold the backup files of the information downloaded into the individual controllers and as such support uploading and downloading that information directly to/from the controllers. It shall be located within each facility. It shall also act as a control information server to non-control system based programs. It shall allow secure multiple-access to the control information. Refer to Division 23 Section " Building Automation System (BAS) - Operator Interfaces," for requirements.
- I. The PCUs shall monitor, control, and provide the field interface for all points specified. Each PCU shall be capable of performing all specified energy management functions, and all DDC functions, independent of other PCUs and operator interface devices as more fully specified in Division 23 Section " Building Automation System (BAS) - Field Panels."
- J. Systems Configuration Database: The system architecture shall support maintaining the systems configuration database on a server or workstation on the Local Supervisory LAN. User tools provided to Chicago Public Schools shall allow configuring, updating, and maintaining current configurations and settings whether they are initiated at the server or the end device.
1. Database Schema shall be published and provided to Chicago Public Schools to facilitate easy access to the data.
  2. Database shall be ODBC compliant or a data access driver shall be provided to act as an ODBC or OLE DB data provider.
  3. For a LON system: The SCD and associated network services shall be Echelon LonWorks Network Services (LNS) (latest version) compliant, no exceptions allowed. The Network Management Application shall be LonMaker™ for Windows (latest released version) service tool (including hardware, software and any peripheral devices required) and is to be used for commissioning and management of the LonTalk control architecture, no exceptions allowed. The network management service tool shall remain on the project as the property of Chicago Public Schools. A copy of the LonTalk network database shall be archived on the service tool and the operator interface, documenting system bindings and node addressing. In addition all system variables shall have a plain English language description for each variable. This service tool shall be used for all system maintenance and expansion, so that the network database backup remains current
- K. Interruptions or fault at any point on any Primary Controller LAN shall not interrupt communications between other nodes on the network. If a LAN is severed, two separate networks shall be formed and communications within each network shall continue uninterrupted.
- L. All line drivers, repeaters, terminators, signal boosters, and signal conditioners shall be provided as necessary for proper data communication.

- M. Anytime any controller's database or program is changed in the field, the controller shall be capable of automatically uploading the new data to the OWS and CSS.

#### **1.12 WARRANTY MAINTENANCE**

- A. Contractor shall warrant all products and labor for a period of one (1) year after Final Acceptance.
- B. Chicago Public Schools reserves the right to make changes to the BAS during the warranty period. Such changes do not constitute a waiver of warranty. The Contractor shall warrant parts and installation work regardless of any such changes made by CPS, unless the Contractor provides clear and convincing evidence that a specific problem is the result of such changes to the BAS.
- C. At no cost to CPS, during the warranty period, the Contractor shall provide maintenance services for software and hardware components as specified below:
  - 1. Maintenance services shall be provided for all devices and hardware specified in Division 23 Section " Building Automation System (BAS)" Sections. Service all equipment per the manufacturer's recommendations. All devices shall be calibrated within the last month of the warranty period.
  - 2. Emergency Service: Any malfunction, failure, or defect in any hardware component or failure of any control programming that would result in property damage or loss of comfort control shall be corrected and repaired following telephonic notification by CPS to the Contractor.
    - a. Response by telephone to any request for service shall be provided within two (2) hours of the initial telephone request for service.
    - b. In the event that the malfunction, failure, or defect is not corrected through the telephonic communication, at least one (1) hardware and software technician, trained in the system to be serviced, shall be dispatched to the site within eight (8) hours of the initial telephone request for such services, as specified.
    - c. Emergency service shall be available on a 24-hour, 7-day-a-week basis.
  - 3. Normal Service: Any malfunction, failure, or defect in any hardware component or failure of any control programming that would not result in property damage or loss of comfort control shall be corrected and repaired following telephonic notification by CPS to the Contractor.
    - a. Response by telephone to any request for service shall be provided within eight (8) working hours (contractor specified 40 hr/week normal working period) of the initial telephone request for service.
    - b. In the event that the malfunction, failure, or defect is not corrected through the telephonic communication, at least one (1) hardware and software technician, trained in the system to be serviced, shall be dispatched to the site within three (3) working days of the initial telephone request for such services, as specified.
  - 4. Telephonic Request for Service: Contractor shall provide up to three telephone numbers for CPS to call in the event of a need for service. At least one of the lines shall be attended 24 hours a day, 7 days a week. Alternatively, pagers can be used for technicians trained in system to be serviced. A technician shall respond to every call within 15 minutes.
  - 5. Technical Support: Contractor shall provide technical support by telephone throughout the warranty period.

6. Preventive maintenance shall be provided throughout the warranty period in accordance with the hardware component manufacturer's requirements.

### **1.13 DELIVERY, STORAGE, AND HANDLING**

- A. Provide factory-shipping cartons for each piece of equipment and control device. Maintain cartons during shipping, storage and handling as required to prevent equipment damage, and to eliminate dirt and moisture from equipment. Store equipment and materials inside and protect from weather.

### **1.14 LISTING AND LABELING**

- A. The BAS and components shall be listed by Underwriters Laboratories (UL 916) as an Energy Management System.
- B. BACnet controllers, B-BC, B-AAC, B-ASC, etc. shall carry the BTL Mark for their device profile.

## **PART 2 - PRODUCTS**

### **2.1 MATERIALS AND EQUIPMENT**

- A. Materials shall be new, the best of their respective kinds without imperfections or blemishes, and not be damaged in any way. Used equipment shall not be used in any way for the permanent installation except where drawings or specs specifically allow existing materials to remain in place.

### **2.2 UNIFORMITY**

- A. To the extent practical, all equipment of the same type serving the same function shall be identical and from the same manufacturer.

## **PART 3 - EXECUTION**

### **3.1 INSPECTION**

- A. Examine areas and conditions under which control systems are to be installed. Do not proceed with work until unsatisfactory conditions have been corrected.

### **3.2 INSTALLATION OF CONTROL SYSTEMS**

- A. General: Install systems and materials in accordance with manufacturer's instructions, roughing-in drawings and details shown on drawings.

### **3.3 DIGITAL CONTROL STATIONS, CONTROLLER QUANTITY AND LOCATION**

- A. Individual Digital Control Stations (DCS) are referenced to indicate allocation of points to each DCS and DCS location. Digital control stations shall consist of one or multiple controllers to meet requirements specified.
- B. Where a DCS is referenced, Contractor shall provide at least one (1) controller, and additional controllers as required and in sufficient quantity to meet the requirements of this Specification. Restrictions in applying controllers are specified in Division 23 Section " Building Automation

System (BAS) - Field Panels." This Contractor shall extend power to the DCS from an acceptable power panel. If the contractor wishes to further distribute panels to other locations, contractor is responsible for extending power to that location also. Furthermore, contractor is responsible for ensuring adequate locations for the panels that do not interfere with other requirements of the project and maintain adequate clearance for maintenance access.

- C. Contractor shall locate DCSs as required. It is the Contractor's responsibility to provide enough controllers to ensure a completely functioning system, according to the point list, trending requirements and sequence of operations.
- D. Contractor shall provide the following, as a minimum:
  - 1. One DCS (including at least one controller) in each heating water and chilled water plant mechanical room.
  - 2. One DCS (including at least one controller) for each air handler located in an applicable mechanical room.
  - 3. One controller shall be provided for each terminal unit unless indicated otherwise.

### **3.4 SURGE PROTECTION**

- A. The Contractor shall furnish and install any power supply surge protection, filters, and other equipment as necessary for proper operation and protection of all PCUs, operator interfaces, printers, routers, gateways and other hardware and interface devices. All equipment shall be capable of handling voltage variations 10% above or below measured nominal value, with no affect on hardware, software, communications, and data storage.

### **3.5 CONTROL POWER SOURCE AND SUPPLY**

- A. Extend all power source wiring required for operation of all equipment and devices provided under Division 23 Building Automation System (BAS) Sections and Sequences of Operation.
  - 1. Control panels shall not share a power circuit. Power supplied to the panels shall have dedicated circuits and the circuit location shall be documented in the panel.

### **3.6 STARTUP, COMMISSIONING, AND TRAINING**

- A. Refer to Division 23 Section "Building Automation System (BAS) - Commissioning."

### **3.7 SEQUENCE OF OPERATION**

- A. Refer to Division 23 Section "Building Automation System (BAS) - Sequences of Operation."

### **3.8 IDENTIFICATION STANDARDS**

- A. Controller Identification. All controllers shall be identified by a plastic engraved nameplate securely fastened to the outside of the controller enclosure.
- B. Panel Identification. All local control panels shall be identified by a plastic engraved nameplate securely fastened to the outside of the controller enclosure.
- C. Field Devices. All field devices shall be identified by a typed (not handwritten) securely attached tag label.

- D. Panel Devices. All panel devices shall be identified by a typed label securely fastened to the backplane of the local control panel.
- E. Raceway Identification. All the covers to junction and pull boxes of the control system raceways shall be painted blue or have identification labels stating "Control System Wiring" affixed to the covers. Labels shall be typed, not hand written.
- F. Wire Identification. All low and line voltage control wiring shall be identified by a number, as referenced to the associated control diagram, at each end of the conductor or cable. Identification number shall be permanently secured to the conductor or cable and shall be typed

### **3.9 EXHIBITS**

- A. Exhibits A through E are attached.

**END OF SECTION**

**DIVISION 23 – HEATING, VENTILATING AND AIR CONDITIONING**

**SECTION 23 09 20.01**

**BUILDING AUTOMATION SYSTEM (BAS) – EXHIBITS**

- EXHIBIT A     Sample Cheat Sheet**
- EXHIBIT B     Sample Operating Instructions, Startup/Shutdown, Seasonal and Emergency**
- EXHIBIT C     Sample Setpoint Table**
- EXHIBIT D     Sample Preventative Maintenance Instructions**
- EXHIBIT E     Sample Trouble Shooting Instructions**
- EXHIBIT F     Sample Control Hardware Operation Instructions**

## EXHIBIT A – Sample Cheat Sheet

**SCHEDULING/OCCUPANCY:** From Windows Desktop:

- double click on Network Manager
- double click on Galileo Academy
- double click on Galileo HVAC

**Follow the same navigation directions as shown in the Set point adjust** , then select controller that operates device or equipment that will be adjusted for

Example for AHU 2

double click Z6400-12 AHU2 SOUTH SIDE

click on Configuration

On right side of screen

double click OCCPCxxC which is the number of the schedule you wish to modify

At the occupancy

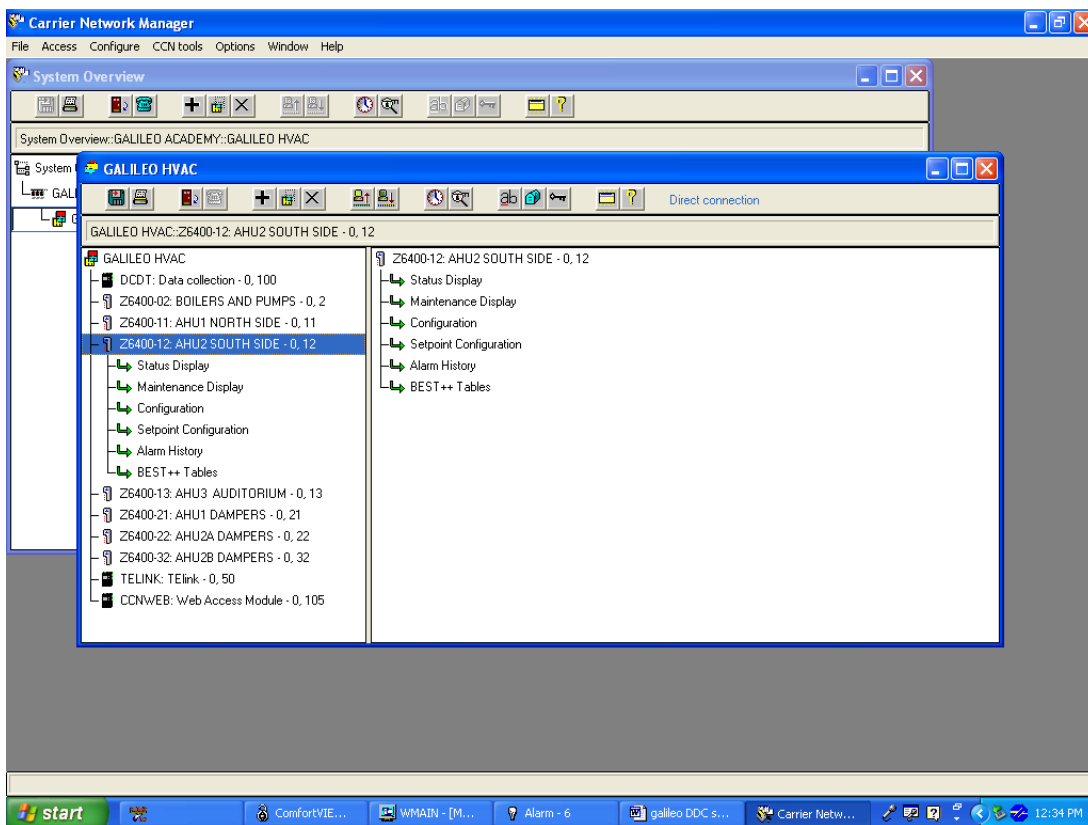

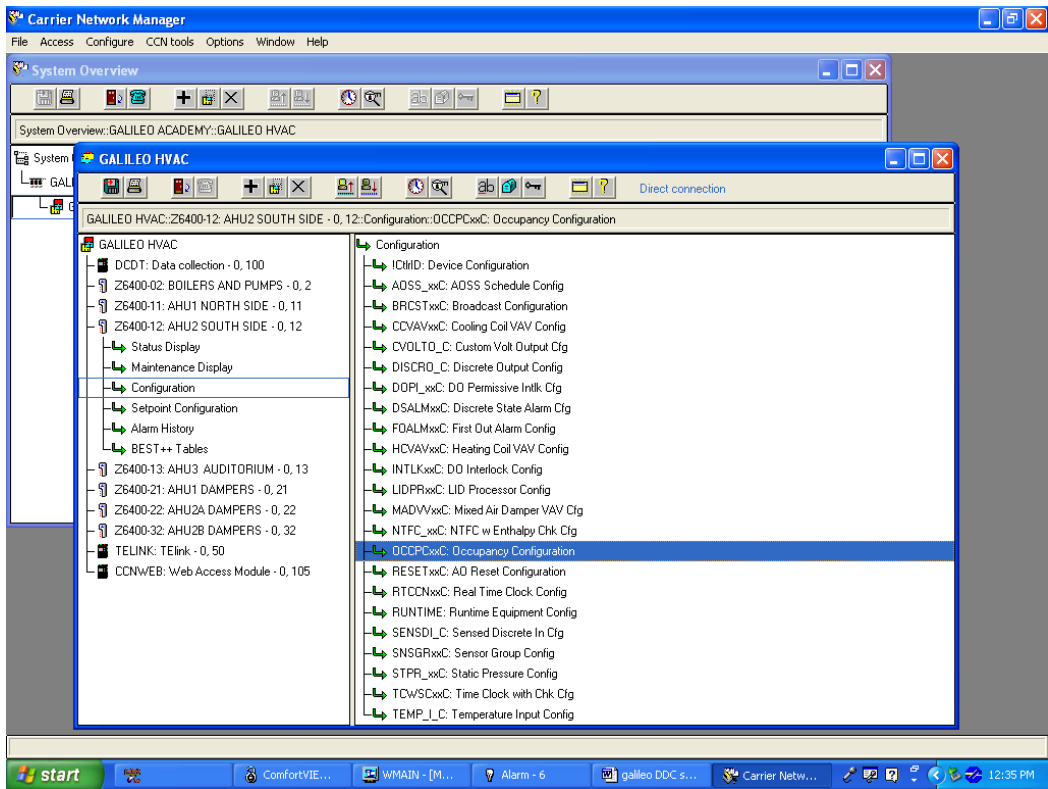
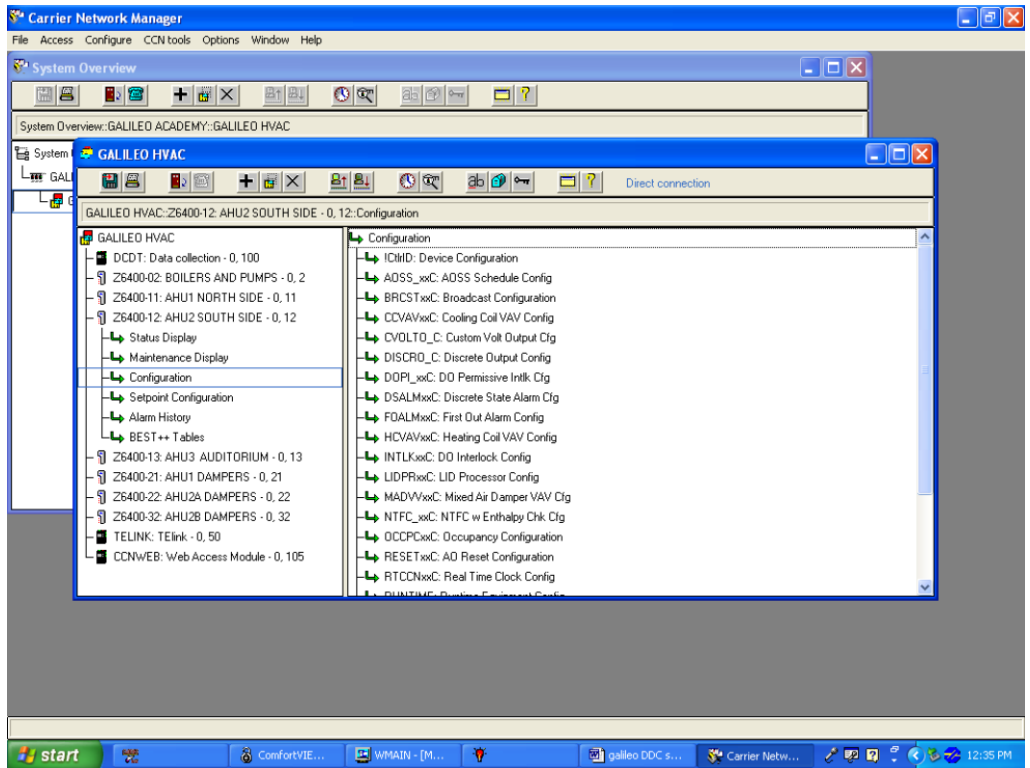



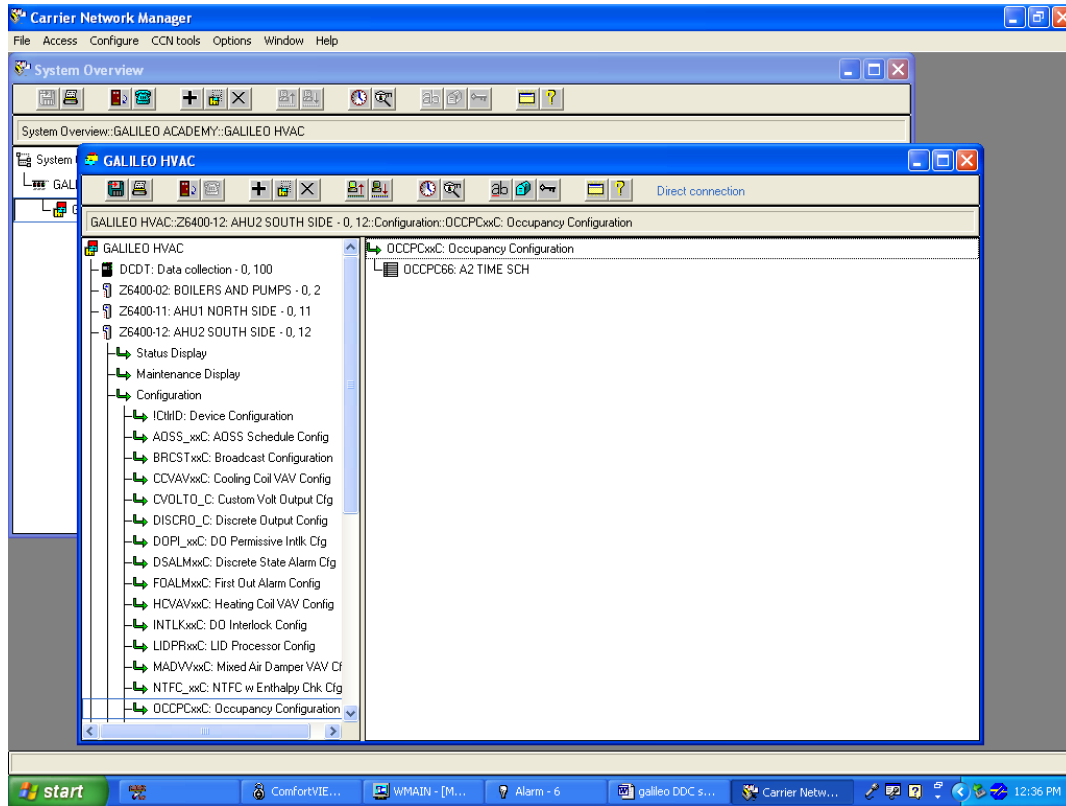

Period 1 is normal weekday schedule ensure that each weekday has a blue dot. The blue dot must be present for each day the schedule is to be active.

To modify start time click on the From box and input the new start time

To modify stop time click on the To box and input the new stop time

At tool bar, click on floppy disk icon to save the schedule

At tool bar click on the computer symbol with the down arrow. This will update the local controller.

To exit click lower X to close screen.

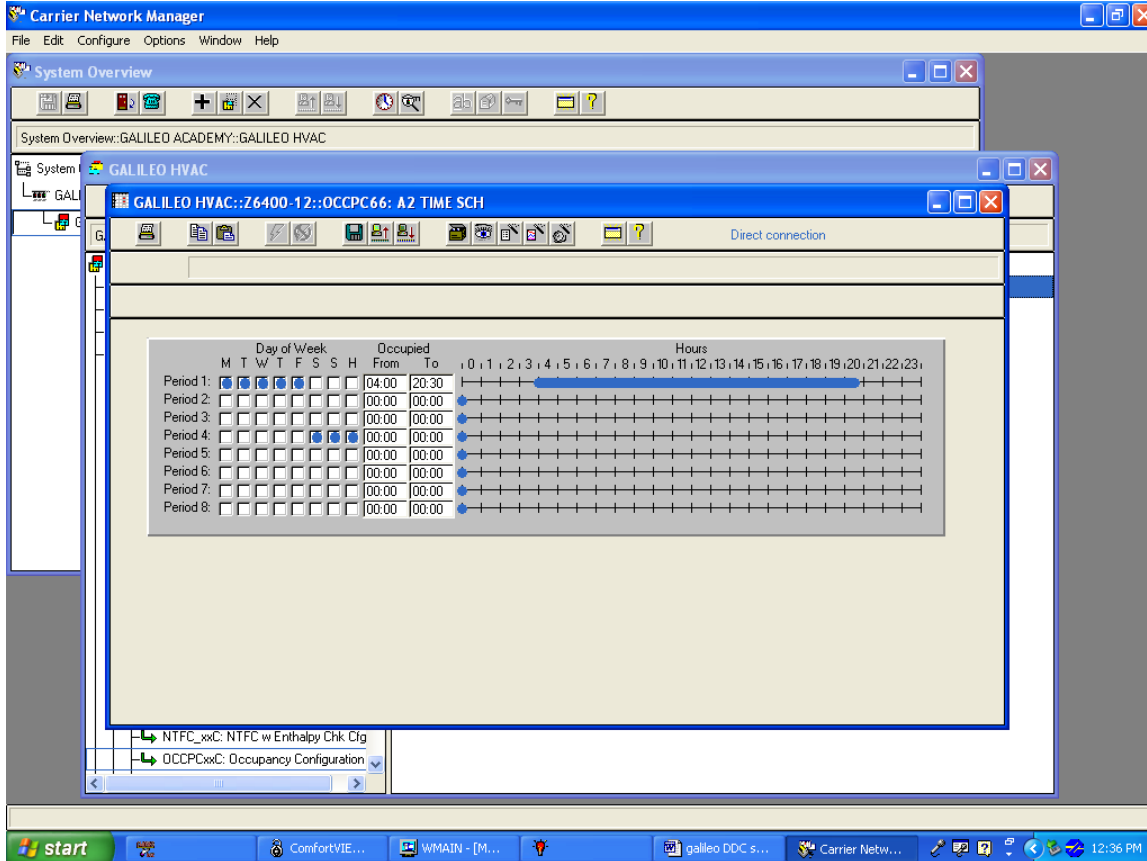

**EXHIBIT B**  
**Sample Operating Instructions, Startup/Shutdown, Seasonal and Emergency**

[Insert school name here]  
Startup/Shutdown and Seasonal Instructions

**Startup:** Defined as any time that the automation system has been disabled, whether due to power outage, manual disabling, or control program reboot.

- Prior to enabling the control system, place all equipment in the OFF or LOCAL mode of operation.
- The power to each of the control panels should be OFF at the circuit breaker.
- Verify that the latest version of each control program is available at the operator workstation.
- Starting with the control panel for the central plant (boilers then chillers), turn the circuit breaker that serves the control panel ON. Verify that the controller has power, is functioning properly, and is communicating. If this is verified, examine the outputs to see which are being enabled. Starting with pumps, then fans, then major mechanical pieces (boilers, chillers, etc.), enable each piece of equipment in the manual mode. Once everything has returned to automatic operation, verify the operation and stability of control loops.
- If the controller has no power once the circuit is turned ON, verify the fuses in the control panel. If they are failed, replace them; if they are fine, then confirm power at the power terminals of the controller. If there is no power, correct the wiring within the panel or call a service technician to do so. If the wiring is in tact, replace the controller or call a service technician to do so.
- If the controller has power, but no program loaded, or if a controller has been replaced, download the latest version of the program into the controller. Follow the rest of the startup procedure.
- Repeat the previous 3 steps for each control panel in the system.
- Once all systems are restored, verify that trend logs have been reestablished. If they have not, restore the trends as noted in the operations binder. After two hours, review the system status and trend reports. If fine, repeat every ½ day for the next 3 days to maintain system operation.
- If, after 2 hours, the system is unstable, note the issues with the trend logs. If temperature and pressure values are cycling, then adjust the control loop parameters to improve performance and review every hour until stable. If, instead, the system appears unresponsive, verify the status of the dial-in support system, and call a service technician to diagnose the issue.

**Shutdown:** Required for service work to system components, when emergencies require the system to be disabled, when work being performed in the building requires a power shutdown, or when the building power fails.

- Prior to shutting down each panel, make sure that there is a backup of each controller's program. If a backup of a program does not exist, and power is still available to the panel, upload the program and store for future download.
- Go to each control panel and pull the fuses that interrupt the 120 V power to the panel.
- Turn the circuit breaker feeding the panel to the OFF position.
- Place mechanical equipment in the OFF position for power outages, either voluntary or unexpected. Place mechanical equipment in the HAND/LOCAL mode if equipment needs to operate during a control system shutdown.

**Seasonal adjustments:**

- Changeover from summer to winter operation (or vice versa) is automatic in the building automation system.
- After performing all preventative maintenance on equipment to be operated for the seasonal changeover, place that system in the REMOTE/AUTO mode (ie. As summer approaches, make sure that chillers are in the position to be enabled).
- Establish trend logs for temperatures and pressures associated with the systems to be started. Once enabled, view trend logs on a daily basis to verify stable operation.
- Follow manufacturer's recommendations for seasonal tuning of control loops, clearing of trend logs and alarms (to free up storage and computing space). Make sure that before purging any

information, that the information has been uploaded to the workstation and stored on a disk for later retrieval.

- Once the new season has been firmly established, place the equipment that is no longer needed into the LOCAL/OFF mode for preventative maintenance.

## **FAILURE OF BUILDING AUTOMATION SYSTEM**

- Boilers should fail to control by their local aquastat (in winter mode) and pumps should fail on.
- Variable flow pumps will run at 60% of their maximum speed.
- Air handling units will have to be enabled manually
- Heating valves will fail open and chilled water valves closed. Actuators will have to be manually positioned until control power is restored.
- All other system heating valves will fail to supplying heat
- Once power and control are restored, equipment can be set to the automatic position

### **Failure of one boiler** on a design day (outside air less than 0°F)

- Monitor the discharge air temperature of the air handling systems. If they are still making setpoint, then monitor the preheat coil discharge temperature. If the preheat coil discharge temperature is sufficient to keep the coils from freezing, then the system has satisfactory capacity.
- If either the discharge air temperature or preheat coil discharge temperature are at a point where they cannot satisfy the load or protect the coils, then reduce the outside airflow rate to ½ of the system capacity. This condition will provide inadequate ventilation to the school, and should be used only when a boiler has failed and there is not enough system capacity to provide adequate heat. Once the boiler operation has been restored, or the outside air temperature rises above 0°F, the outside air should be restored to its minimum value.

### **Failure of temperature sensor** (either cut or shorted leads)

- An alarm condition at the BAS will notify the operator that the temperature value is out of range (too high or too low depending on the type of failure)
- Replace the sensor with the appropriate type, if available.
- If the appropriate type is not available, but another type is available, attempt to install the type available on a temporary basis. If successful, allow the system to operate automatically, but replace the sensor with the appropriate type within 48 hours.
- If there is no replacement available, view the trend history to determine the position of the valves and dampers on the system at the time of the failure. Manually override the software to place the valves and dampers in those positions. Monitor the operation of the system on a regular basis (every ½ hour for normal spaces, every ¼ hour for more critical spaces) and adjust the valve and damper positions accordingly. Replace the sensor with any type of useable sensor as soon as possible; replace with the appropriate type of sensor within 48 hours.

**EXHIBIT C**  
**Sample Setpoint Table**

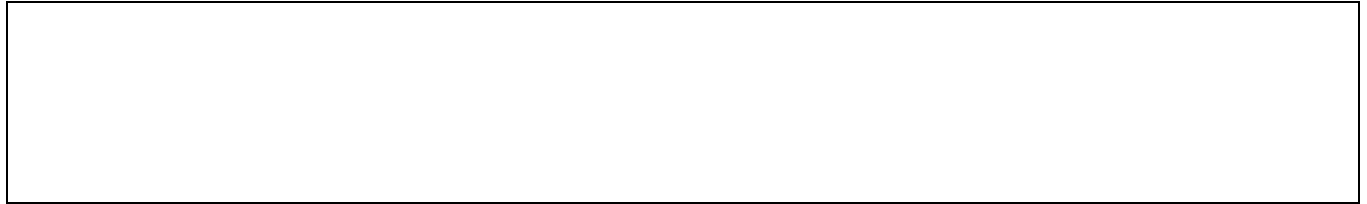

System	Description	Tag	Default	High Alarm	Low Alarm	What happens when changed
Boiler	Primary Hot Water Supply	PHWSTSP	180	205	165	The primary is designed for 180 degrees with reset on the secondary. Lowering the primary will prohibit heating during the coldest days and raising it will possibly trip the operating high limit or high limit safety on the boiler.
Chiller	Primary Chilled Water Supply	PCHWSTSP	45	55	42	The primary is designed for 45 and there is variable flow on the secondary. Raising the setpoint will reduce dehumidification and prohibit cooling during the warmest days, and lowering the limit will result in wasted energy and could cause the chiller to cycle on safeties.
Various	Space Temperature Setpoint	SPCSP	70W/ 74S	80	67	The system is designed to provide 70 in winter and 74 in summer. Changing significantly above or below these setpoints might provide little additional heating or cooling.
AHU	Discharge Air Temperature Setpoint	DATSP	Reset	75	52	The discharge air temperature setpoint is reset by the variance of space from its setpoint. This value will vary, and should not be overridden by the operator unless there is a problem with the space temperature sensor.

**EXHIBIT D**  
**Sample Preventative Maintenance Instructions**

Software preventative maintenance (performed once every 3 months):

- Review the software to look for things that may be in override or not performing properly.
- Review trend logs to look for control loops that need tuning.
- Review list of items that have been written in the issues log
- Add or modify graphics to meet their need.
- Back-up all files and do any maintenance on disks.

Hardware preventative maintenance (performed once every 6 months):

- Check calibration on sensors and transducers
  - Space temperature (¼ each session)
  - Duct temperature (all)
  - Water temperature (all, includes removing sensor and verifying the integrity of the conductive compound)
  - Humidity (all – replace sensor every 2 years)
  - Carbon Dioxide (all – replace sensor every 2 years)
  - Carbon Monoxide (all – replace sensor per manufacturer's recommendation)
  - Refrigerant (all – replace sensor per manufacturer's recommendation)
  - Freeze protection (all – verify correct positioning and security of contacts)
- Check out all damper and valve actuators for proper performance
  - For each, apply full control signal, apply zero control signal, remove power, manually operate, and restart
  - Inspect linkages and clamps for proper operation
  -
- Check batteries where applicable (UPS, etc.)
- Address any hardware items on the engineers issue log

## EXHIBIT E

### Sample Trouble Shooting Instructions

#### Basic Troubleshooting and Operations

- If the Front End PC is up and running but not displaying data for the HVAC Graphic Screens (showing “DOWN”): shutdown the PC using the standard Windows shutdown sequence and reboot it. If the data is still showing “DOWN” in the data fields, go to the UNC controller(s) (just outside the boiler room at north wall of boiler room) and check for power. Remove the black plastic cover using both hands (one hand on each side): once the cover is removed, check for power indicator lights. The heartbeat light should be flashing red. The Lon “RXD” and “TXD” lights should be flashing. If these lights are not on, chances are the 24VAC power to the unit is off. Check the transformer next to the control panel for power. It too has an indicator light. Try resetting the circuit breaker built into the transformer. If power to the UNC is on, you have the option of resetting the UNC. This should only be done in critical situations or when the building is generally unoccupied (certain equipment may shutdown during this procedure). To shutdown and reboot the UNC, pull out the hardwired plug connector at the top of the UNC. This kills power to the UNC and removes the battery backup also. Wait 5 seconds. Reconnect the connector. Check for status indicator lights. The heartbeat light should come immediately. The LON “TXD” and “RXD” lights should come on within 60 seconds. The Ethernet “DATA” light should come on within 30 seconds.
  
- If a piece of electrical equipment is commanded on and not running, it is probably locked out by a safety device or an electrical problem. Check for alarms at the Front End PC. If an alarm exists, correct the problem and reset the alarm device. If no alarms are present, check for electrical problems. **Warning, this should only be done by a trained qualified person.** If the piece of equipment has a motor starter, check for power. If there is a motor starter with a Hand-Off-Auto switch, make sure the switch is in “Auto” or “Hand” (usually “Auto”) Verify that the thermal overloads have not tripped. Verify that the fuses have not blown. Verify that all appropriate disconnects and service switches are in the correct position. Review the Precision Control shop drawings to see what connection if any the control system has to the piece of equipment.
  
- Low Temperature Switch Activation: these switches are typically installed on fan systems with hydronic coils. They have long (usually 20 feet) sensing tubes connected to the main electric switch chassis, which also has a setpoint adjustment and reset button. Once the temperature along any point of the sensing tube drops below the setpoint, the device trips. Manual reset is required by pressing a button on the cover. The reset button will only work if the temperature at the sensing tube rises above the setpoint. See the device data sheet for more information.
  
- Duct Smoke Detector Activation: If a duct smoke detector activates, wait for the environmental conditions to clear before attempting to reset the device. The device can be reset using the reset button on the front cover, or by removing and restoring power to the unit. See the device data sheet for more information.
  
- DDC Control Panels: make sure power to the control panel and all the DDC controllers contained inside is turned on. Transformer boxes next to the control panels have status indicator lights on them. Make sure the light is on. Make sure the power switch is on. If the circuit breaker is tripped, reset it. All DDC controllers in the panel will have blinking lights on them. All will have both red lights for power status, and yellow/green lights for communications status.
  
- Before manually overriding a motorized actuator, disconnect power.



- Always use caution when overriding outside air dampers, control valves, motors, etc, especially during the winter months. Leaving devices and/or equipment in an overridden state can lead to equipment malfunction and/or damage.
- Keep all HVAC control panels locked to prevent unauthorized tampering and damage from surrounding environments.
- Keep software backups for the HVAC control system in a known, accessible secured area. Anticipate the backup disc set will be needed at a future date.
- The Front End PC Server must remain on at all times. Various services and tasks run continuously and the system must stay up and running and connected to the network. Log off the Front End Graphics system when done using it. Do not shut the computer off. Logging off will prevent unauthorized use. It is recommended that no other customer installed application software be installed on the Front End PC Server. This will only result in reduced efficiency and slower operation and can ultimately lead to communications failure and system disruption.
- Keep the HVAC Control System manuals and shop drawings nearby. It is recommended that operating personnel regularly refer to the system manuals and drawings in an effort to familiarize themselves with their contents and to increase system knowledge and reduce downtime during crisis situations. Typically 1 set is kept in the Building Engineer's office. Another set is typically installed by the Front End PC. A third set is usually kept offsite in a known secured location or other location as preferred by the customer.

### **System Maintenance**

- The Front End PC Server should have the case opened up, and the interior blown out with compressed air annually. The power supply fans draw unfiltered air through the case on a continuous basis causing dust and dirt to buildup on the components inside the case. This should be done with care so as to not damage sensitive parts
- The Front End PC Server should have the hard drive defragmented annually. There is typically a utility provided under the Windows operating system that performs this function. This process should be run during unoccupied hours as a safety precaution against system disruption. It is not uncommon for the defrag process to take hours – depending on the size of the hard drive and the amount of data storage on it. Reference the below screen capture for locating the “Disk Defragmenter” utility under a typical Windows XP operating system.

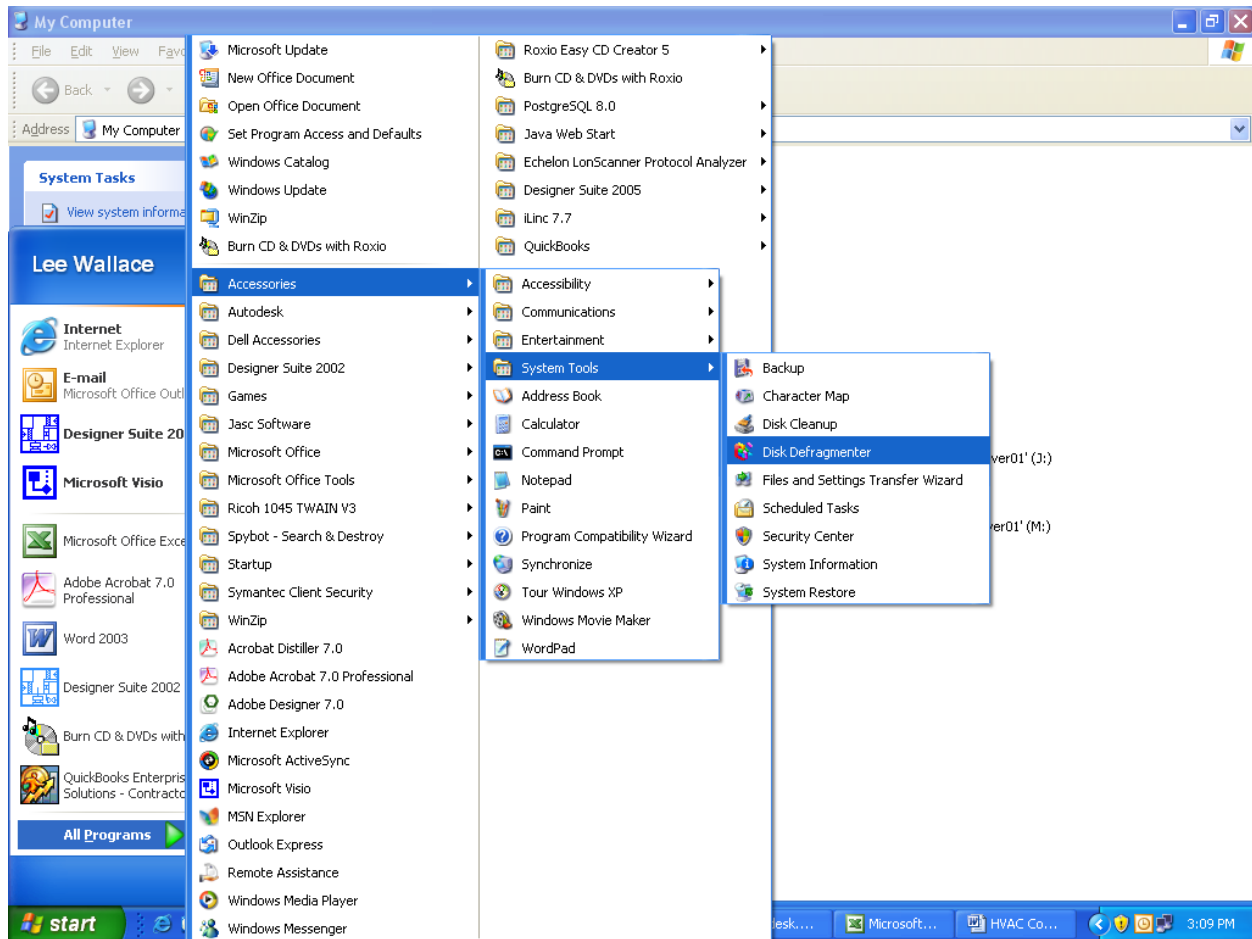

- System backups of the HVAC Control System software should be maintained on an ongoing basis. Backup discs were provided to the customer during system completion and turnover. However, as the system undergoes changes such as controller application changes, graphic screen modifications, controller binding table changes, address table changes, etc the system backups must be updated and kept current. System files reside in several locations. It is strongly recommended to have a trained authorized technician perform these backups as they are not always user friendly and at times require extensive knowledge and usage of specific software applications. In addition a strong knowledge of the DDC system software and hardware is necessary to know which software files need to be replaced after system changes are made. The building operator is typically not sufficiently qualified to perform system backups correctly.
- Anti-Virus and Spy ware software should be kept current on the Front End PC Server to protect the system from viruses, spy ware and other unwanted software that will negatively affect the performance of the system. It is recommended that the IT Manager get involved with this process as the Front End PC Server resides on the customers local area network and therefore should be treated as any other node on the network with respect to the requirements for Anti-Virus and Spy Ware software. It is also a good idea to remind the IT manager on an annual basis that the DDC Control system requires a fixed number of reserved static IP addresses and to make a note of those addresses so as to not assign those addresses to other nodes on the network. When two or more nodes on a network are assigned the same IP address, one or more nodes will experience communication failures over the network.

- Lubricate motorized dampers annually at the bearings. Clean all side seals with WD-40, Kroil, or similar cleaner/lubricant to prevent damper blades from binding. Inspect damper blades and linkages for abnormalities, damage, and wear. With the damper in the closed position, make sure the blades are closed well enough to prevent excessive leakage. With damper blades in the fully open position, checks to make sure all blades are positioned consistently with respect to one another. If not, make adjustments as necessary.
- Critical temperature, pressure, humidity, and gas sensors should be calibrated annually. These may include sensors such as outside air, chilled water supply, hot water supply, steam pressure, primary and secondary loop supply and return water, duct static pressure, hot/chilled water system differential pressure, carbon monoxide, refrigerant gas, etc. Typically a testing device known to be accurate will take a measurement of the sensed media and compare it to the reading of the installed sensor. If the two readings are not close enough to meet satisfactory system performance, and offset calibration is made either to the device itself or in the DDC controller via software.
- Reference pages 5-8 of the Duct Smoke Detector Installation and Maintenance Instructions for information as to detector maintenance and testing. Test and maintain smoke detectors per requirements of NFPA 72. Typically the sampling tube filters need to be cleaned annually and the detector chamber needs to be vacuumed and cleaned with compressed air. The detector should also be tested annually for proper operation per the manufacturer's instructions.

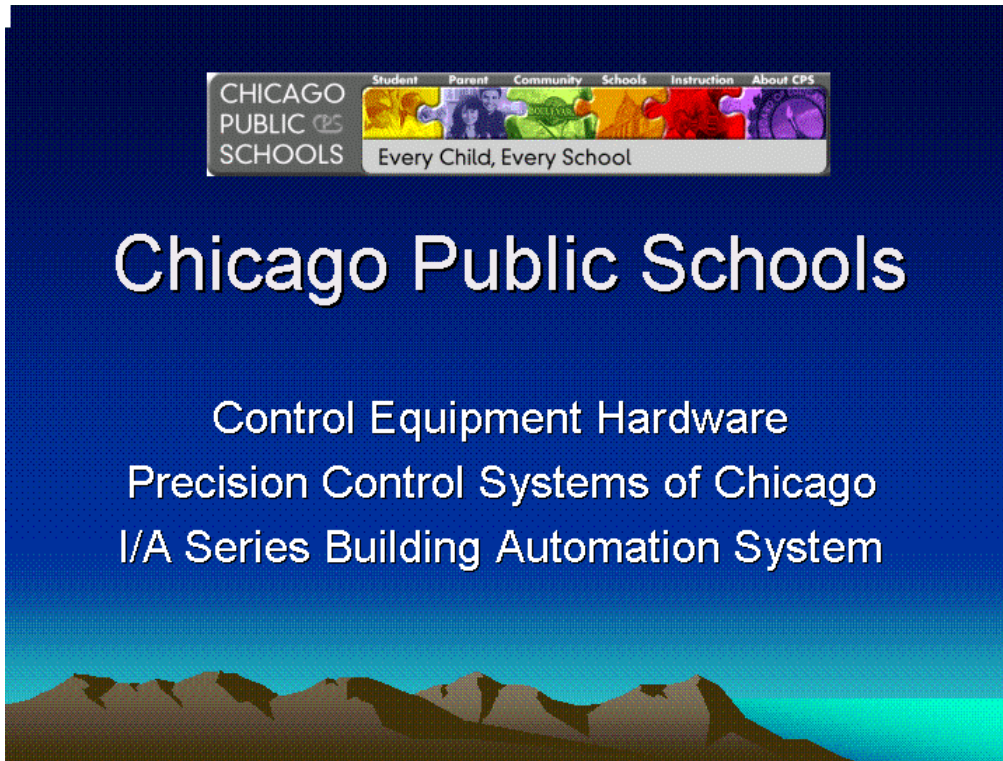

page 1

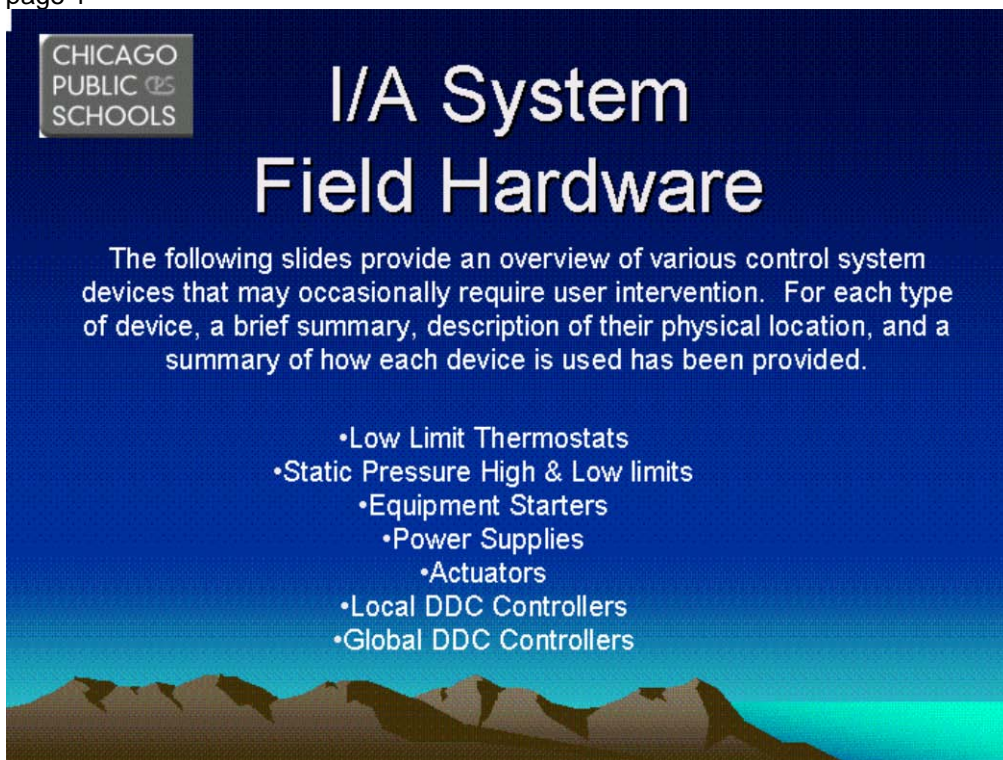

page 2



# Low Limit Thermostats

**Application:** Used to shut down equipment when internal temperatures reach a preset limit.

**Location:** Inside Unit-vents, after heating coil, mounted on the side of an air handler.

**Action:** Unit shuts down, control valves and dampers return to failsafe position (where applicable). Requires manual reset



Temperature Trip Setting

Push This Button To Reset Low Limit

# Static Pressure Limit

**Application:** Used to shut down equipment when exceeds preset high or low limits. For both high & low, two units are required.

**Location:** On supply air duct, usually mounted just down stream of air handler.

**Action:** Unit shuts down, control valves and dampers return to failsafe position (where applicable). Requires manual reset.

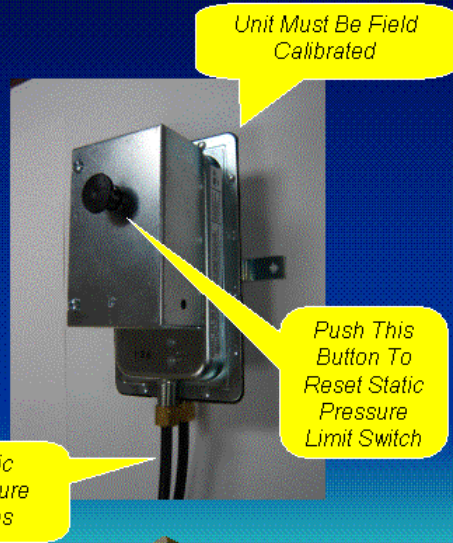

Unit Must Be Field Calibrated

Push This Button To Reset Static Pressure Limit Switch

Static Pressure Lines

# Magnetic Starter With Disconnect

**Application:** Used to start & stop 3-Phase & Single Phase motors over ½ Hp.

**Location:** Within close proximity of the motor.

**Action:** Starts & stops motor via some control voltage, typically 24vac or 120vac. Usually has a Hand-Off-Auto switch on front, holders for safety fuses, motor overloads with a manual reset button, and a safety disconnect switch.

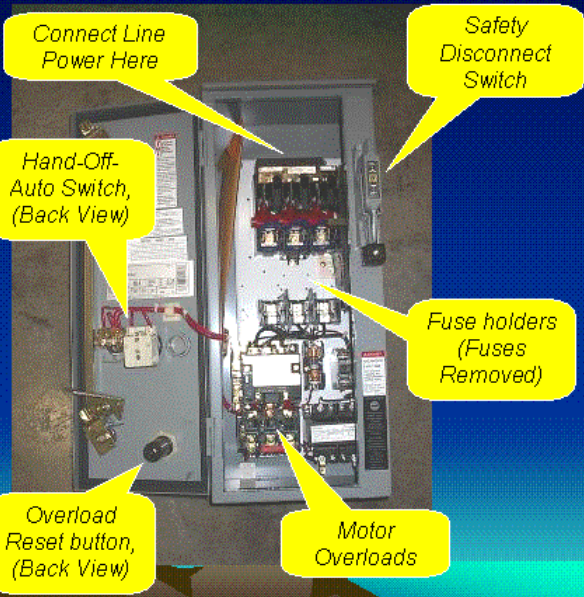

# 24 Volt AC Power Supply

**Application:** Used to power DDC controllers, transducers, relays, valve and/or damper actuators, etc. Most air handlers will have two or more power supplies.

**Location:** Adjacent to HVAC temperature control panels.

**Action:** Must remain on at all times. Status light indicates power. Includes Circuit Breaker for overload protection. 120V outlet rated at 4 amps max (for technicians use only)

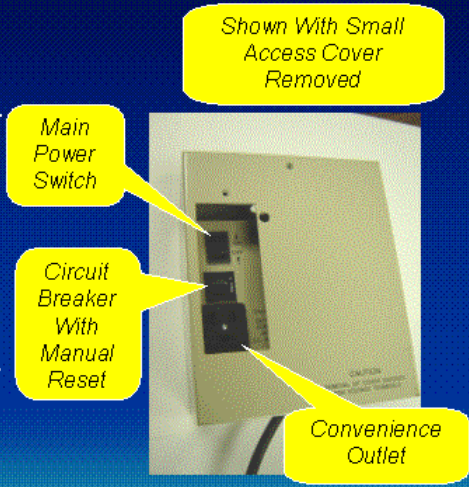



# Valve & Damper Actuator

**Application:** Used to operate control valves & motorized dampers.

**Location:** On chilled and hot water valves as well as outside, return, exhaust, face & bypass, and zone control dampers. Some applications may require multiple actuators for each valve or damper.

**Action:** Actuators can be two position, or modulating, as well as spring return, non-spring return, with either normally open, or normally closed fail safe positions.

Rotation Indicator

Damper or Valve shaft clamp, Use 10MM Wrench

Manual Override Hand Crank,  
**\*\* REMOVE POWER PRIOR TO OPERATING\*\***

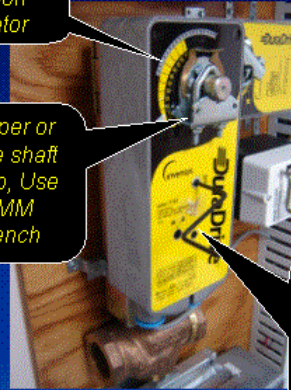

page 7

# MNL-200 DDC Controller

**Application:** Local DDC HVAC Controller with 2-Digital Inputs, 3-Universal Inputs, 6-Digital Outputs, & 2-Analog Outputs.

**Location:** Mounted inside temperature control panel within close proximity of mechanical equipment being controlled.

**Action:** Controls and monitors local equipment such as fan systems, heating/cooling plants, unit ventilators, lighting, etc.

24V AC Power

Digital Outputs

Power-Comm. Indicator Lights

Universal Inputs

Analog Outputs

Digital Inputs

LON, S-link Comm. Wiring

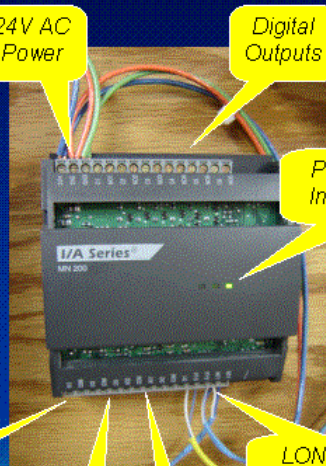

page 8

# MNL-800 DDC Controller

**Application:** Local DDC HVAC Controller with 8-Universal Inputs, 8-Digital Outputs, & 4-Analog Outputs.

**Location:** Mounted within close proximity of mechanical equipment being controlled.

**Action:** Controls and monitors local equipment such as fan systems, heating/cooling plants, unit ventilators, lighting, etc. Unit requires 24VAC Power.

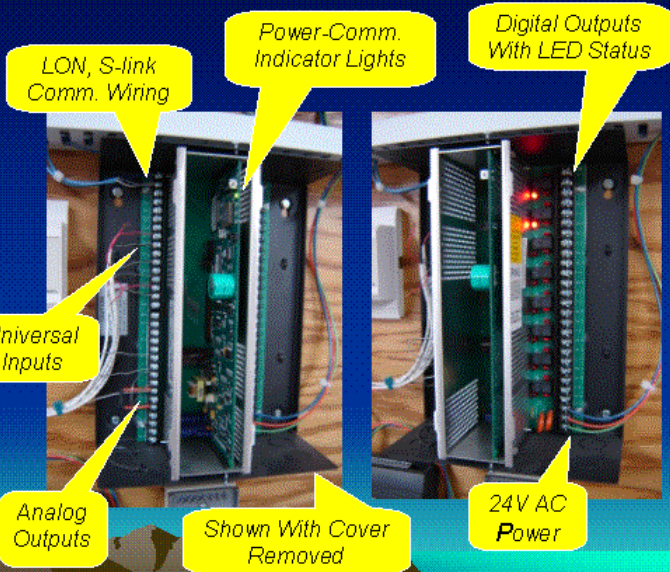

page 9

# UNC-510 DDC Controller

**Application:** Global DDC HVAC Controller. Does not have any I/O points.

**Location:** Typically mounted inside control panel.

**Action:** High Level DDC controller communicates with subordinate DDC controllers and with Front End PC.

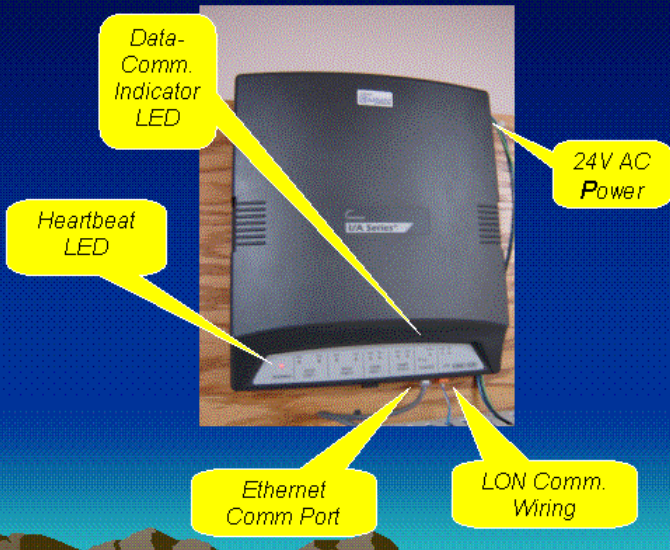

page 10



# Summary

This slide presentation has provided a brief overview of typical building automation system devices that may occasionally require user intervention. For a more detailed description, please refer to the individual O&M manual for each specific project.

## DIVISION 23 – HEATING, VENTILATING AND AIR CONDITIONING

### SECTION 23 09 21

#### BUILDING AUTOMATION SYSTEM (BAS) - BASIC MATERIALS, INTERFACE DEVICES, AND SENSORS

#### PART 1 - GENERAL

##### 1.1 SUMMARY

A. Section includes the following:

1. Wiring.
2. Field Panels.
3. Sensors.
4. Electric Control Components (Switches, EP Valves, Thermostats, Relays, Smoke Detectors, etc.).
5. Transducers.
6. Current Switches.
7. Nameplates.
8. Testing Equipment.

##### 1.2 DESCRIPTION OF WORK

- A. Refer to Division 23 Section "Building Automation System (BAS)" for general requirements.
- B. Refer to other Division 23 Sections for installation of instrument wells, valve bodies, and dampers in mechanical systems; not work of this Section.
- C. Provide the following electrical work as work of this Section, complying with requirements of Division 26 Sections:
1. Control wiring between field-installed controls, indicating devices, and unit control panels.
  2. Interlock wiring between electrically interlocked devices, sensors, and between a hand or auto position of motor starters as indicated for all mechanical and controls.
  3. Wiring associated with indicating and alarm panels (remote alarm panels) and connections to their associated field devices.
  4. All other necessary wiring for fully complete and functional control system as specified.
  5. Power wiring from spare circuits in electrical panels to Digital Control System Field Panels.

##### 1.3 WORK BY OTHERS

- A. Control Valves furnished under this Section shall be installed under the applicable piping Section under the direction of the Digital Control System Contractor who will be fully responsible for the proper operation of the valve.
- B. Control Dampers furnished under this Section shall be installed under the applicable air distribution or air handling equipment Section under the direction of the Digital Control System Contractor who will be fully responsible for the proper operation of the damper

- C. Water Pressure Taps, Thermal Wells, Flow Switches, Flow Meters, etc. that will have wet surfaces, shall be installed under the applicable piping Section under the direction of the Digital Control System Contractor who will be fully responsible for the proper installation and application.
- D. Controlled Equipment Power Wiring shall be furnished and installed under Division 26. Where control involves 120V control devices controlling 120V equipment, Division 26 Contractor shall extend power wiring to the equipment. Digital Control System Contractor shall extend it from the equipment to the control device.

## **PART 2 - PRODUCTS**

### **2.1 MATERIALS AND EQUIPMENT**

- A. General: Provide electronic control products in sizes and capacities indicated, consisting of valves, dampers, thermostats, clocks, controllers, sensors, and other components as required for complete installation. Except as otherwise indicated, provide manufacturer's standard materials and components as published in their product information; designed and constructed as recommended by manufacturer, and as required for application indicated.
- B. Instrument Pipe and Tube
  - 1. Hydronic and Instruments
    - a. Connection To Main Piping: Provide ½ inch minimum size threadolet, ½" x 2 inch brass nipple, and ½" ball valve for connection to welded steel piping. Provide tee fitting for other types of piping.
    - b. Remote Instruments: Adapt from ball valve to specified tubing and extend to remote instruments. Provide a union or otherwise removable fitting at ball valve so that connection to main can be cleaned with straight rod. Where manifolds with test ports are not provided for instrument, provide tees with ¼" FPT branch with plug for use as test port. Adapt from tubing size to instrument connection.
    - c. Line Mounted Instruments: Extend rigid piping from ball valve to instrument. Do not use close or running thread nipples. Adapt from ball valve outlet to instrument connection size. Provide a plugged tee if pipe makes 90 degree bend at outlet of valve to allow cleaning of connection to main with straight rod without removing instrument.
    - d. Instrument Tubing: Seamless copper tubing, Type K or L, ASTM B 88; with cast-bronze solder joint fittings, ANSI B1.18; or wrought-copper solder-joint fittings, ANSI B16.22; or brass compression-type fittings. Solder shall be 95/5 tin antimony, or other suitable lead free composition solder. Tubing OD size shall be not less than the larger of ¼" or the instrument connection size.
    - e. Rigid Piping For Line Mounted Instruments: Schedule 40 threaded brass, with threaded brass fittings.
  - 2. Low Pressure Air Instrument Sensing Lines
    - a. Connections: Use suitable bulkhead type fitting and static sensing tip for static pressure connections. Adapt tubing to instrument connection.
    - b. Tubing: Virgin polyethylene non-metallic tubing type FR, ASTM D 2737, and with flame-retardant harness for multiple tubing. Use compression or push-on brass fittings.

- C. Communication Wiring: All wiring shall be in accordance with National Electrical Codes and Division 26 of this specification.
1. Contractor shall supply all communication wiring between Building Controllers (BC), Routers, Gateways, Advanced Application Controllers (AAC), Application Specific Controllers (ASC) and local and remote peripherals (e.g., operator workstations, printers, and modems).
  2. Local Supervisory LAN: For any portions of this network required under this Section of the specification, contractor shall use Fiber or Category 5 of standard TIA/EIA 68 (10BaseT). Network shall be run with no splices and separate from any wiring over thirty (30) volts.
  3. Primary and Secondary Controller LANs: Communication wiring shall be individually 100% shielded pairs per manufacturers recommendations for distances installed, with overall PVC cover, Class 2, plenum-rated run with no splices and separate from any wiring over thirty (30) volts. Shield shall be terminated and wiring shall be grounded as recommended by BC manufacturer.
- D. Signal Wiring: Contractor shall run all signal wiring in accordance with National Electric Codes and Division 26 of this Specification.
1. Signal wiring to all field devices, including, but not limited to, all sensors, transducers, transmitters, switches, etc. shall be twisted, 100% shielded pair, minimum 18-gauge wire, with PVC cover. Signal wiring shall be run with no splices and separate from any wiring above thirty (30) volts.
  2. Signal wiring shield shall be grounded at controller end only unless otherwise recommended by the controller manufacturer.
- E. Low Voltage Analog Output Wiring: Contractor shall run all low voltage control wiring in accordance with National Electric Codes and Division 26 of this Specification.
1. Low voltage control wiring shall be minimum 16-gauge, twisted pair, 100% shielded, with PVC cover, Class 2 plenum-rated. Low voltage control wiring shall be run with no splices separate from any wiring above thirty (30) volts.
- F. Control Panels: Provide control panels with suitable brackets for wall mounting for each control system. Locate panel adjacent to systems served.
1. Fabricate panels of 16-gage furniture-grade steel, or 6063-T5 extruded aluminum alloy, totally enclosed on four sides, with hinged door and keyed lock, with manufacturer's standard shop-painted finish and color.
  2. Provide UL-listed cabinets for use with line voltage devices.
  3. All gauges and control components shall be identified by means of nameplates.
  4. All control tubing and wiring shall be run neatly and orderly in open slot wiring duct with cover.
  5. Complete wiring and tubing termination drawings shall be mounted in or adjacent to panel.

## 2.2 GENERAL FIELD DEVICES

- A. Provide field devices for input and output of digital (binary) and analog signals into controllers (BCs, AACs, ASCs). Provide signal conditioning for all field devices as recommended by field device manufacturers, and as required for proper operation in the system.

- B. It shall be the Contractor's responsibility to assure that all field devices are compatible with controller hardware and software.
- C. Field devices specified herein are generally 'two-wire' type transmitters, with power for the device to be supplied from the respective controller. If the controller provided is not equipped to provide this power, or is not designed to work with 'two-wire' type transmitters, or if field device is to serve as input to more than one controller, or where the length of wire to the controller will unacceptably affect the accuracy, the Contractor shall provide 'four-wire' type equal transmitter and necessary regulated DC power supply or 120 VAC power supply, as required.
- D. For field devices specified hereinafter that require signal conditioners, signal boosters, signal repeaters, or other devices for proper interface to controllers, Contractor shall furnish and install proper device, including 120V power as required. Such devices shall have accuracy equal to, or better than, the accuracy listed for respective field devices.
- E. Accuracy: As stated in this Section, accuracy shall include combined effects of nonlinearity, nonrepeatability and hysteresis.

### **2.3 TEMPERATURE SENSORS (TS)**

- A. Sensor range: When matched with A/D converter of BC, AAC/ASC, or Smart Sensor (SS), sensor range shall provide a resolution of no worse than 0.3°F (unless noted otherwise). Where thermistors are used, the stability shall be better than 0.25°F over 5 years.
- B. Room Temperature Sensor: Shall be a stainless steel wall plate sensor. An electronic thermostat with manual override will be provided in the principal and main office areas and in select administrative areas as approved by CPS. Provide ¼" medical grade closed cell foam insulating material. The following sensing elements are acceptable:
  - 1. Sensing element shall be platinum RTD, thermistor, or integrated circuit, +/- 0.3°F accuracy at calibration point.
- C. Single-Point Duct Temperature Sensor: Shall consist of sensing element, junction box for wiring connections and gasket to prevent air leakage or vibration noise. Temperature range as required for resolution indicated in paragraph A. Sensor probe shall be 316 stainless steel.
  - 1. Sensing element shall be platinum RTD, thermistor, or integrated circuit, +/- 0.3°F accuracy at calibration point

### **2.4 TEMPERATURE TRANSMITTERS**

- A. Where required by Controller, or where wiring runs are over 50 feet, sensors as specified above may be matched with transmitters outputting 4-20 mA linearly across the specified temperature range. Transmitters shall have zero and span adjustments, an accuracy of 0.1°F when applied to the sensor range.

### **2.5 DIFFERENTIAL PRESSURE SWITCHES (DPS)**

- A. General Service - Air: Diaphragm with adjustable setpoint and differential and snap acting form C contacts rated for the application. Provide manufacturer's recommended static pressure sensing tips and connecting tubing

## **2.6 PRESSURE SWITCHES (PS)**

- A. Diaphragm or bourdon tube with adjustable setpoint and differential and snap-acting Form C contacts rated for the application. Pressure switches shall be capable of withstanding 150% of rated pressure.
- B. Acceptable Manufacturers: Square D, ITT Neo-Dyn, ASCO, Penn, Honeywell, and Johnson Controls.

## **2.7 CURRENT SWITCHES (CS)**

- A. Clamp-On Design Current Operated Switch for Variable Speed Motor Status Indication
  - 1. Range: 1.5 to 135 Amps.
  - 2. Trip Point: Self-calibrating based on VA memory associated with frequency to detect loss of belt with subsequent increase of control output to 60 Hz.
  - 3. Switch: Solid state, normally open, 1 to 135 Vac or Vdc, 0.3 Amps. Zero off state leakage.
  - 4. Frequency Range: 5-75 Hz
  - 5. Trip Indication: LED
  - 6. Approvals: UL, CSA
  - 7. Max. Cable Size: 350 MCM
  - 8. Acceptable Manufacturers: Veris Industries, Inc. H-904.
- B. Clamp-On Wire Through Current Switch (CS/CR) (for Variable Speed Motors): Same as CS with 24v command relay rated at 5A @ 240 Vac resistive, 3A @ 240 Vac inductive, load control contact power shall be induced from monitored conductor (minimum conductor current required to energize relay 5A, max. rating of 135A). Acceptable manufacturer shall be Veris Industries, Inc., Model # H934.
- C. Variable Speed Status: Where current switches are used to sense the status for variable speed devices, the CT shall include on-board VA/Hz memory to allow distinction between a belt break and subsequent ramp up to 60 Hz, versus operation at low speed. The belt break scenario shall be indicated as a loss of status and the operation at low speed shall indicate normal status.

## **2.8 CURRENT TRANSFORMERS (CT)**

- A. Clamp-On Design Current Transformer (for Motor Current Sensing)
  - 1. Range: 1-10 amps minimum, 20-200 amps maximum
  - 2. Trip Point: Adjustable
  - 3. Output: 0-5 VDC.
  - 4. Accuracy:  $\pm 0.2\%$  from 20 to 100 Hz.
  - 5. Acceptable Manufacturers: KELE SA100, Veris Hawkeye 720.

## **2.9 CO<sub>2</sub> SENSORS/TRANSMITTERS (CARBON DIOXIDE)**

- A. CO<sub>2</sub> sensors shall use silicon based, diffusion aspirated, infrared single beam, dual-wavelength sensor.
- B. Range: 0-2000 ppm

- C. Accuracy:  $\pm 36$ ppm at 800 ppm and 68°F.
- D. Stability: 5% over 5 years.
- E. Output: 4-20 mA, 0-10 Vdc or relay.
- F. Mounting: Duct as indicated
- G. Acceptable Manufacturer: Vaisala, Inc. GMD20 (duct) or GMW20 (wall), MSA, Inc, Kele 8000 series.

## **2.10 ELECTRIC CONTROL COMPONENTS**

- A. Limit Switches (LS): Limit switches shall be UL listed, SPDT or DPDT type, with adjustable trim arm. Limit switches shall be as manufactured by Square D, Allen Bradley.
- B. Low Temperature Detector ('Freezestat') (FZ): Low temperature detector shall consist of a 'cold spot' element which responds only to the lowest temperature along any one foot of entire element, minimum bulb size of 1/8" x 20', junction box for wiring connections and gasket to prevent air leakage or vibration noise, DPST ( 4 wire, 2 circuit) with manual reset. Temperature range 15 to 55°F , factory set at 38°F.
- C. Surface-Mounted Thermostat: Surface-mounted thermostat shall consist of SPDT contacts, operating temperature range of 50 to 150°F , and a minimum 10°F fixed setpoint differential.
- D. Low Voltage Wall Thermostat: Wall-mounted thermostat shall consist of SPDT sealed mercury contacts, operating temperature range of 50 to 90°F , switch rating of 24 Vac (30 Vac max.), and both manual and automatic fan operation in both the heat and cool modes.
- E. Control Relays: All control relays shall be UL listed, with contacts rated for the application, and mounted in minimum NEMA-1 enclosure for indoor locations, NEMA-4 for outdoor locations.
  1. Control relays for use on electrical systems of 120 volts or less shall have, as a minimum, the following:
    - a. AC coil pull-in voltage range of +10%, -15% or nominal voltage.
    - b. Coil sealed volt-amperes (VA) not greater than four (4) VA.
    - c. Silver cadmium Form C (SPDT) contacts in a dustproof enclosure, with 8 or 11 pin type plug.
    - d. Pilot light indication of power-to-coil and coil retainer clips.
    - e. Coil rated for 50 and 60 Hz service.
    - f. Acceptable Manufacturers: Relays shall be Potter Brumfield, Model KRPA.
  2. Relays used for across-the-line control (start/stop) of 120V motors, 1/4 HP, and 1/3 HP, shall be rated to break minimum 10 Amps inductive load. Relays shall be IDEC.
  3. Relays used for stop/start control shall have low voltage coils (30 VAC or less), and shall be provided with transient and surge suppression devices at the controller interface.
- F. General Purpose Power Contactors: NEMA ICS 2, AC general-purpose magnetic contactor. ANSI/NEMA ICS 6, NEMA type 1 enclosure. Manufacturer shall be Square 'D', Cutler-Hammer or Westinghouse.

- G. Control Transformers: Furnish and install control transformers as required. Control transformers shall be machine tool type, and shall be US and CSA listed. Primary and secondary sides shall be fused in accordance with the NEC. Transformer shall be proper size for application, and mounted in minimum NEMA-1 enclosure.
  - 1. Transformers shall be manufactured by Westinghouse, Square 'D', or Jefferson.
- H. Time Delay Relays (TDR): TDRs shall be capable of on or off delayed functions, with adjustable timing periods, and cycle timing light. Contacts shall be rated for the application with a minimum of two (2) sets of Form C contacts, enclosed in a dustproof enclosure.
  - 1. TDRs shall have silver cadmium contacts with a minimum life span rating of one million operations. TDRs shall have solid state, plug-in type coils with transient suppression devices.
  - 2. TDRs shall be UL and CSA listed, Crouzet type.
- I. Pilot Light: Panel-mounted pilot light shall be NEMA ICS 2 oil tight, transformer type, with screw terminals, push-to-test unit, LED type, rated for 120 VAC. Unit shall be 800T type, as manufactured by Allen-Bradley.
- J. Alarm Horn: Panel-mounted audible alarm horn shall be continuous tone, 120 Vac Sonalert solid-state electronic signal, as manufactured by Mallory.
- K. Electric Selector Switch (SS): Switch shall be maintained contact, NEMA ICS 2, oil-tight selector switch with contact arrangement, as required. Contacts shall be rated for minimum 120 Vac operation. Switch shall be 800T type, as manufactured by Allen-Bradley.

## **2.11 NAMEPLATES**

- A. Provide engraved phenolic or micarta nameplates for all equipment, components, and field devices furnished. Nameplates shall be 1/8 thick, black, with white center core, and shall be minimum 1" x 3", with minimum 1/4" high block lettering. Nameplates for devices smaller than 1" x 3" shall be attached to adjacent surface.
- B. Each nameplate shall identify the function for each device.

## **2.12 TESTING EQUIPMENT**

- A. Contractor shall test and calibrate all signaling circuits of all field devices to ascertain that required digital and accurate analog signals are transmitted, received, and displayed at system operator terminals, and make all repairs and recalibrations required to complete test. Contractor shall be responsible for test equipment required to perform these tests and calibrations. Test equipment used for testing and calibration of field devices shall be at least twice as accurate as respective field device (e.g., if field device is +/-0.5% accurate, test equipment shall be +/-0.25% accurate over same range).



## **PART 3 - EXECUTION**

### **3.1 INSPECTION**

- A. Examine areas and conditions under which control systems are to be installed. Do not proceed with work until unsatisfactory conditions have been corrected in manner acceptable to Contractor.

### **3.2 INSTALLATION OF CONTROL SYSTEMS**

- A. General: Install systems and materials in accordance with manufacturer's instructions, roughing-in drawings and details shown on drawings. Install electrical components and use electrical products complying with requirements of National Electric Code and all local codes.
- B. Main Control Air Piping: All main air piping between the compressors and the control panels shall be copper, run per ASTM B88
- C. Branch Control Air Piping: Accessible tubing is defined as that tubing run in mechanical equipment rooms; inside mechanical equipment enclosures, such as heating and cooling units, instrument panels; across roofs, in pipe chases, etc. Inaccessible tubing is defined as that tubing run in concrete slabs; furred walls; or ceilings with no access.
  - 1. Provide copper tubing with maximum unsupported length of 3'-0", for accessible tubing run exposed to view. Polyethylene tubing may be used in lieu of above, when run within adequately supported, rigid enclosure, such as metallic raceways, or EMT. Terminal single-line connections less than 18 in length may be copper tubing, or polyethylene tubing run inside flexible steel protection. Accessible tubing run in concealed locations, such as pipe chases, suspended ceilings with easy access, etc. may be copper or polyethylene bundled and sheathed tubing.
  - 2. Provide copper or polyethylene tubing for inaccessible tubing, other than in concrete pour. If polyethylene tubing is used, install in EMT or vinyl-jacketed polyethylene tubing.
  - 3. Polyethylene piping may be used above suspended ceiling without conduit provided it is run in a neat and orderly fashion, bundled where applicable, and completely suspended (strapped to rigid elements or routed through wiring rings) away from areas of normal access. Tubing shall not be laid on the ceiling or duct.
  - 4. Pressure test control air piping at 30 psi (207 kPa) for 24 hours. Test fails if more than 2 psi loss occurs.
  - 5. Fasten flexible connections bridging cabinets and doors, neatly along hinge side, and protect against abrasion. Tie and support tubing neatly.
  - 6. Number-code or color-code tubing, except local individual room control tubing, for future identification and servicing of control system. Code shall be as indicated on approved installation drawings.
- D. Control Wiring: The term "control wiring" is defined to include providing of wire, conduit and miscellaneous materials as required for mounting and connection of electric control devices.
  - 1. Wiring System: Install complete wiring system for electric control systems. Install all control wiring external to panels in electric metallic tubing or raceway. On Renovation projects, wiring in finished areas shall be routed in wire mold. The routing of wiring in finished areas must be specifically approved by the AOR/EOR. Installation of wiring shall generally follow building lines. Install in accordance with National Electrical Code and Division 26 of this Specification. Fasten flexible conductors bridging cabinets and doors, neatly along hinge side, and protect against abrasion. Tie and support conductors neatly.

2. Control Wiring Conductors: Install control wiring conductors, without splices between terminal points, color-coded. Install in neat workmanlike manner, securely fastened. Install in accordance with National Electrical Code and Division 26 of this Specification.
  3. Communication wiring, signal wiring and low voltage control wiring shall be installed separate from any wiring over thirty (30) volts. Signal wiring shield shall be grounded at controller end only, unless otherwise recommended by the controller manufacturer.
  4. All WAN and LAN Communication wiring shield shall be terminated as recommended by controller manufacturer. All WAN and LAN Communication wiring shall be labeled with a network number, device ID at each termination and shall correspond with the WAN and LAN system architecture and floor plan submittals. All WAN and LAN cabling shall comply with applicable Division 26 requirements.
  5. Number-code or color-code conductors appropriately for future identification and servicing of control system. Code shall be as indicated on approved installation drawings.
- E. Control Valves: Install so that actuators, wiring, and tubing connections are accessible for maintenance. Where possible, install with valve stem axis vertical, with operator side up. Where vertical stem position is not possible, or would result in poor access, valves may be installed with stem horizontal. Do not install valves with stem below horizontal, or down.
- F. Freezestats: Install freezestats in a serpentine fashion where shown on drawing. Provide one foot of element for each square foot of coil face area. The length of element not just down stream of the coil will not be included in the coverage calculation. Where coil face area exceeds required length of element, provide multiple devices, wired in parallel for normally open close on trip application, wired in series for normally closed, open on trip application. Adequately support with coil clips such that sensor is not in direct contact with equipment. Coordinate the location of the switch such that it is normally accessible.
- G. Room Temperature Sensors: Install sensors as shown on the drawings. Provide approved security screws for mounting, matching those installed in other areas of the project. Provide 3 tools to the Owner for installation and removal of the security screws. Seal conduit penetrations at the wall box airtight. Install batt insulation in the wall box to completely fill the box. Electrical connections shall be made using a twist-on sealant filled connectors suitable for the installation.
- H. Averaging Temperature Sensors: Cover no more than three square feet per linear foot of sensor length except where indicated. Generally the sensor will be located where flow is sufficiently homogeneous/adequately mixed , consult AE for requirements.
- I. Airflow Measuring Stations: Install per manufacturer's recommendations in an unobstructed straight length of duct (except those installations specifically designed for installation in fan inlet). For installations in fan inlets, provide on both inlets of double inlet fans and provide inlet cone adapter as recommended by AFM station manufacturer.
- J. Fluid Flow Sensors: Install per manufacturer's recommendations in an unobstructed straight length of pipe.
- K. Relative Humidity Sensors: Provide element guard as recommended by manufacturer for high velocity installations. For high limit sensors, position remote enough to allow full moisture absorption into the air stream before reaching the sensor.
- L. Differential Pressure Transmitters: Provide valve bypass arrangement to protect against over pressure damaging the transmitter.

- M. Flow Switches: Where possible, install in a straight run of pipe at least 15 diameters in length to minimize false indications.
- N. Current Switches for Motor Status Monitoring: Adjust so that setpoint is below minimum operating current and above motor no load current.
- O. Supply Duct Pressure Transmitters:
  - 1. General: Install pressure tips with at least 4 'round equivalent' duct diameters of straight duct with no takeoffs upstream. Install pressure tips securely fastened with tip facing upstream in accordance with manufacturer's installation instructions. Locate the transmitter at an accessible location to facilitate calibration.
  - 2. VAV System 'Down-Duct' Transmitters: Locate pressure tips approximately 2/3 of the hydraulic distance to the most remote terminal in the air system.
- P. Cutting and Patching Insulation: Repair insulation to maintain integrity of insulation and vapor barrier jacket. Use hydraulic insulating cement to fill voids and finish with material matching or compatible with adjacent jacket material.

### **3.3 REFRIGERANT MONITOR**

- A. Install in accordance with the manufacturer's instructions. Place sensing tips in locations to maximize effectiveness.
- B. Hard wire interlocks to the emergency ventilation and shutdown of combustion devices.

**End of Section 230921**

## **DIVISION 23 – HEATING, VENTILATING AND AIR CONDITIONING**

### **SECTION 23 09 23**

#### **BUILDING AUTOMATION SYSTEM (BAS) - FIELD PANELS**

##### **PART 1 - GENERAL**

###### **1.1 SUMMARY**

- A. Section includes the following:
  - 1. Building Controllers (BC).
  - 2. Application Specific Controllers (ASC).
  - 3. Advanced Application Controllers (AAC).

###### **1.2 DESCRIPTION OF WORK**

- A. Furnish and install DDC Control units and/or Smart Devices required to support specified building automation system functions.
- B. Refer to Division 23 Section "Building Automation System (BAS)" for general requirements.

##### **PART 2 - PRODUCTS**

###### **2.1 STAND-ALONE FUNCTIONALITY**

- A. General: These requirements clarify the requirement for stand-alone functionality relative to packaging I/O devices with a controller. Stand-alone functionality is specified with the controller and for each Application Category specified in PART 3. This item refers to acceptable paradigms for associating the points with the processor.
- B. Functional Boundary: Provide controllers so that all points associated with and common to one unit or other complete system/equipment shall reside within a single control unit. The boundaries of a standalone system shall be as dictated in the contract documents. Generally systems specified for the Application Category will dictate the boundary of the standalone control functionality. See related restrictions below. When referring to the controller as pertains to the standalone functionality, reference is specifically made to the processor. One processor shall execute all the related I/O control logic via one operating system that uses a common programming and configuration tool.
- C. The following configurations are considered acceptable with reference to a controller's standalone functionality:
  - 1. Points packaged as integral to the controller such that the point configuration is listed as an essential piece of information for ordering the controller (having a unique ordering number).
  - 2. Controllers with processors and modular back planes that allow plug in point modules as an integral part of the controller.
  - 3. I/O point expander boards, plugged directly into the main controller board to expand the point capacity of the controller.

4. I/O point expansion devices connected to the main controller board via wiring and as such shall be remote from the controller and that communicate via a sub LAN protocol. These arrangements to be considered standalone shall have a sub LAN that is dedicated to that controller and include no other controller devices. All wiring to interconnect the I/O expander board shall be:
  - a. Contained in the control panel enclosure;
  - b. Or run in conduit. Wiring shall only be accessible at the terminations.
  
5. General purpose LonMark I/O devices or Smart Devices racked with a processor module in the same contiguous physical enclosure. The controller shall also include its own dedicated processor module and bridge or router making the controllers LAN communication a subnet or LAN segment dedicated to that controller as specified under Application Categories below. The following are additional requirements of this configuration:
  - a. Configuration must meet the requirements for battery back up.
  - b. If processor fails, the I/O devices shall go to their fail condition.
  - c. Contractor shall provide a network bandwidth analysis of the controller segment or subnet. The analysis shall document network bandwidth utilization does not exceed 30% for a continuous one hour period.
  - d. Logic must provide for orderly sequencing of I/O during a power interruption and restart of program logic upon restoration of power.
  - e. Programming must facilitate a robust uploading scheme using LONMark File Transfer Protocol and limit available bandwidth during upload.
  - f. Trending shall be buffered in the processor or dedicated data logging module and uploaded to the Tridium JACE, or buffered in the Tridium JACE.

## **2.2 BUILDING CONTROLLER (BC)**

### **A. General Requirements:**

1. The BC(s) shall provide fully distributed control independent of the operational status of the OWSs and CSS. All necessary calculations required to achieve control shall be executed within the BC independent of any other device. All control strategies performed by the BC(s) shall be both operator definable and modifiable through the Operator Interfaces.
2. BCs shall perform overall system coordination, accept control programs, perform automated HVAC functions, control peripheral devices and perform all necessary mathematical and logical functions. BCs shall share information with the entire network of BCs and AACs/ASCs for full global control. Each controller shall permit multi-user operation from multiple workstations and portable operator terminals connected either locally or over the Primary Controller LAN. Each unit shall have its own internal RAM, non-volatile memory, microprocessor, battery backup, regulated power supply, power conditioning equipment, ports for connection of operating interface devices, and control enclosure. BCs shall be programmable from an operator workstation, portable operator's terminal, or hand held operating device. BC shall contain sufficient memory for all specified global control strategies, user defined reports and trending, communication programs, and central alarming.
3. BCs shall be connected to a controller network that qualifies as a Primary Controlling LAN.
4. All BCs shall be protected from any memory loss due to a loss of power by one or a combination of the following:

- a. Volatile RAM shall have a battery backup using a lithium battery with a rated service life of fifty (50) hours, and a rated shelf life of at least five years. Self-diagnostic routine shall report an alarm for a low battery condition.
  - b. EEPROM, EPROM, or NOVRAM non-volatile memory
5. In addition BCs shall provide intelligent, standalone control of HVAC functions. Each BC shall be capable of standalone direct digital operation utilizing its own processor, non-volatile memory, input/output, wiring terminal strips, A/D converters, real-time clock/calendar and voltage transient and lightning protection devices. Refer to standalone functionality specified above.
  6. The BC shall provide for point mix flexibility and expandability. This requirement shall be met via either a family of expander boards, modular input/output configuration, or a combination thereof. Refer to stand alone functionality specified above.
  7. All BC point data, algorithms and application software shall be modifiable from the Operator Workstation.
  8. Each BC shall execute application programs, calculations, and commands via a microprocessor resident in the BC. The database and all application programs for each BC shall be stored in non-volatile or battery backed volatile memory within the BC and will be able to upload/download to/from the OWS and/or CSS.
  9. BC shall provide buffer for holding alarms, messages, trends etc.
  10. Each BC shall include self-test diagnostics, which allow the BC to automatically alarm any malfunctions, or alarm conditions that exceed desired parameters as determined by programming input.
  11. Each BC shall contain software to perform full DDC/PID control loops.
  12. For systems requiring end-of-line resistors those resistors shall be located in the BC, if it has I/O capability.
  13. Input-Output Processing
    - a. Digital Outputs (DO): Outputs shall be rated for a minimum 24 Vac or Vdc, 1 amp maximum current. Each shall be configurable as normally open or normally closed. Each output shall have an LED to indicate the operating mode of the output and Each DO shall be discrete outputs from the BC's board (multiplexing to a separate manufacturer's board is unacceptable). Provide suppression to limit transients to acceptable levels.
    - b. Analog Inputs (AI): AI shall be 0-5 Vdc, 0-10 Vdc, 0-20 Vdc, and 0-20 mA. Provide signal conditioning, and zero and span calibration for each input. Each input shall be a discrete input to the BC's board (multiplexing to a separate manufacturers board is unacceptable unless specifically indicated otherwise). A/D converters shall have a minimum resolution of 12 bits.
    - c. Digital Inputs (DI): Monitor dry contact closures. Accept pulsed inputs of at least one per second. Source voltage for sensing shall be supplied by the BC and shall be isolated from the main board. Software multiplexing of an AI and resistors shall only be done in non-critical applications and only with prior approval of Architect/Engineer.
    - d. Universal Inputs (UI-AI or DI): To serve as either AI or DI as specified above.
    - e. Electronic Analog Outputs (AO): Voltage mode: 0-5 Vdc and 0-10 Vdc; Current mode: 4-20 mA. Provide zero and span calibration and circuit protection. Pulse Width Modulated (PWM) analog via a DO and transducer is acceptable only with Chicago Public Schools (CPS) approval ( PWM will not be allowed on loops with a short time constant such as discharge temperature loops, economizer loops, pressure control loops and the like. They are generally acceptable for standard room temperature control loops). Where these are allowed, transducer/actuator shall be programmable for normally open, normally closed, or hold last position and shall allow adjustable timing. PWM controlled devices will have an

automatically initiated function that resets the device position tracking on a scheduled basis. The controllers shall initially be set up to perform this function once every 24 hours. The purpose of this required function is to recalibrate the position tracking to assure the device will open and close completely when commanded. Each AO shall be discrete outputs from the PCU's board (multiplexing to a separate manufacturers board is unacceptable). D/A converters shall have a minimum resolution of 10 bits.

- f. Analog Output Pneumatic (AOP), 0-20 psi: Pneumatic outputs via an I/P transducer, or digital to pneumatic transducer are acceptable. Multiplexed digital to pneumatic transducers are acceptable provided they are supplied as a standard product and part of the BC and provide individual feedback. Multiplexed pneumatic outputs of a separate manufacturer are unacceptable.
  - g. Pulsed Inputs: Capable of counting up to 8 pulses per second with buffer to accumulate pulse count. Pulses shall be counted at all times.
14. A communication port for operator interface through a terminal shall be provided in each BC. It shall be possible to perform all program and database back-up, system monitoring, control functions, and BC diagnostics through this port. Standalone BC panels shall allow temporary use of portable devices without interrupting the normal operation of permanently connected modems, printers, or workstations.
15. Each BC shall be equipped with loop tuning algorithm for precise proportional, integral, derivative (PID) control. Loop tuning tools provided with the Operator Workstation software is acceptable. In any case, tools to support loop tuning must be provided such that P, I, and D gains are automatically calculated.
16. Slope intercepts and gain adjustments shall be available on a per-point basis.
17. BC Power Loss:
- a. Upon a loss of power to any BC, the other units on the primary controlling network shall not in any way be affected.
  - b. Upon a loss of power to any BC, the battery backup shall ensure that the energy management control software, the Direct Digital Control software, the database parameters, and all other programs and data stored in the RAM are retained for a minimum of fifty (50) hours.
  - c. Upon restoration of power within the specified battery backup period, the BC shall resume full operation without operator intervention. The BC shall automatically reset its clock such that proper operation of any time dependent function is possible without manual reset of the clock. All monitored functions shall be updated.
  - d. Should the duration of a loss of power exceed the specified battery back-up period or BC panel memory be lost for any reason, the panel shall automatically report the condition (upon resumption of power) and be capable of receiving a download via the network, and connected computer. In addition, the owner shall be able to upload the most current versions of all energy management control programs, Direct Digital Control programs, database parameters, and all other data and programs in the memory of each BC to the operator workstation via the local area network, or via the telephone line dial-up modem where applicable, or to the laptop PC via the local RS-232C port.
18. BC Failure:
- a. Building Controller LAN Data Transmission Failure: BC shall continue to operate in stand-alone mode. BC shall store loss of communication alarm along with the time of the event. All control functions shall continue with the global values

programmable to either last value or a specified value. Peer BCs shall recognize the loss, report alarm and reconfigure the LAN.

- b. BC Hardware Failure: BC shall cease operation and terminate communication with other devices.
19. Each BC shall be equipped with firmware resident self-diagnostics for sensors and be capable of assessing an open or shorted sensor circuit and taking an appropriate control action (close valve, damper, etc.).
  20. BCs shall include LAN communications interface functions for controlling secondary controlling LANs Refer to Division 23 Section " Building Automation System (BAS) - Communications Devices" for requirements if this function is packaged with the BC.
  21. A minimum of four levels of password protection shall be provided at each BC.
  22. BCs shall be mounted on equipment, in packaged equipment enclosures, or locking wall mounted in a NEMA 1 enclosure.
- B. BACnet Building Controller Requirements:
1. The BC(s) shall support all BIBBs defined in the BACnet Building Controller (B-BC) device profile as defined in the BACnet standard.
  2. BCs shall communicate over the BACnet Building Controller LAN.
  3. Each BC shall be connected to the BACnet Building Controller LAN communicating to/from other BCs.
- C. LonTalk Building Controller Requirements:
1. All products shall be LonMark certified, and shall be designed according to the LonMark Interoperability Guidelines. Product documentation and devices shall display the LonMark symbol, indicating conformance to the LonMark Interoperability Standards.
    - a. In those instances in which LonMark devices are not available, the Network Integrator shall provide LonWorks devices with application source code, device resource files, and external interface definitions. The software tools required to install and commission the device shall be provided for non-LonMark devices.
  2. All products shall support and be certified to an appropriate LonMark functional profile. Where published profiles do not exist, use draft profile standards or submit a proposed draft as part of the submittal package. All drafts shall also be submitted simultaneously to the LonMark Interoperability Association for certification.
  3. An external interface file (\*.XIF) shall be provided for each LonTalk device describing network variables, configuration parameters and other parameters supported.
  4. All products shall utilize standard configuration parameter types for all product configuration parameters. Do not use network variables for this purpose.
  5. The use of manufacturer-defined network variables and configuration parameters shall be limited to factory-configured parameters. All data and configuration parameters that shall be required for field installation, service and maintenance shall be represented using standard LonMark network variables and configuration parameters. Modification of LonMark certified network variables and configuration parameters is unacceptable.
  6. Provide LonTalk bridge or routers and repeaters as required to combine different secondary (TP/FT-10) networks onto the primary Ethernet/IP network, or as required to segment groups of LonTalk devices to meet minimum throughput requirements.
  7. Provide all necessary bridge or routers and gateways in order to connect TP/FT-10 devices to the primary network, and to connect the primary network to the GEMnet.
  8. The network services for the BAS shall be the latest version of LonWorks Network Services (LNS).
  9. Device to device communication shall be event driven and peer to peer.



10. Propagation of data from a PCU to a Router for the execution of supervisory control logic shall be event driven at the device and not based on polling from the Router.
11. Propagation of data from a PCU to a Router to support non-alarm dynamic data display or for trending purposes shall be based on polling from the Router.
12. Propagation of data from a PCU to a Router to support the reporting of alarm conditions shall be event driven at the device and not based on polling from the Router.
13. The programming of all output network variables shall include the send on delta concept; minimum send time and maximum send time parameters.
  - a. Send on delta parameters shall be non-zero values selected to ensure efficient use of the available bandwidth but not exceeding the following:
    - 1) Temperatures: 0.36 Degrees Fahrenheit
    - 2) Pressures In Air Systems: 0.025 Inches Of Water
    - 3) Building Static Pressure: 0.0125 Inches Of Water
    - 4) Flow: Approximately 10 Cfm or 2% of the system operating range
    - 5) Relative Humidity: 3%
    - 6) Analog Position: 2%
    - 7) Enthalpy: Approximately 0.2 Btu Per Lb
    - 8) Binary Alarm Data: Change of State
  - b. If the minimum send time parameters can be set on a point by point basis, they shall not exceed the following:
    - 9) Alarms: 1 second
    - 10) Temperatures at Zone Level: 60 seconds
    - 11) Temperatures at Central Station Level: 10 seconds for data reporting, 5 seconds for control purposes
    - 12) Pressures: 5 seconds for data reporting, 1 second for control purposes.
  - c. If the minimum send time parameters can only be set on a controller basis, set the parameter at a value of 5 seconds.
14. The error rate for each channel shall be verified by a one hour test using the network analysis tool. The error rate shall not exceed 1%.
15. The bandwidth utilization for each channel shall be verified by a one hour test using the network analysis tool. The utilization shall not exceed 30%.
16. All products shall be LonMark certified, and shall be designed according to the LonMark Interoperability Guidelines. Product documentation and devices shall display the LonMark symbol, indicating conformance to the LonMark Interoperability Standards.
  - a. In those instances in which LonMark devices are not available, the Network Integrator shall provide LonWorks devices with application source code, device resource files, and external interface definitions. The software tools required to install and commission the device shall be provided for non-LonMark devices.
17. All products shall support and be certified to an appropriate LonMark functional profile. Where published profiles do not exist, use draft profile standards or submit a proposed

draft as part of the submittal package. All drafts shall also be submitted simultaneously to the LonMark Interoperability Association for certification.

18. An external interface file (\*.XIF) shall be provided for each LonTalk device describing network variables, configuration parameters and other parameters supported.
19. All products shall utilize standard configuration parameter types for all product configuration parameters. Do not use network variables for this purpose.
20. The use of manufacturer-defined network variables and configuration parameters shall be limited to factory-configured parameters. All data and configuration parameters that shall be required for field installation, service and maintenance shall be represented using standard LonMark network variables and configuration parameters. Modification of LonMark certified network variables and configuration parameters is unacceptable.
21. Provide LonTalk bridge or routers and repeaters as required to combine different secondary (TP/FT-10) networks onto the primary Ethernet/IP network, or as required to segment groups of LonTalk devices to meet minimum throughput requirements.
22. Provide all necessary bridge or routers and gateways in order to connect TP/FT-10 devices to the primary network, and to connect the primary network to the GEMnet WAN.
23. The network services for the BAS shall be the latest version of LonWorks Network Services (LNS), no exceptions allowed.
24. The Network Management Application shall be LonMaker™ for Windows (Latest Released Version) service tool (including hardware, software and any peripheral devices required) and is to be used for commissioning and management of the LonTalk control architecture, no exceptions allowed. The network management service tool shall remain on the project as the property of GSA. A copy of the LonTalk Network Database Shall Be Archived on the service tool and Site Control System Server (CSS)/ Operator Workstation (OWS), documenting system bindings and node addressing. In addition all system variables shall have a plain English language description for each variable. This service tool shall be used for all system maintenance and expansion, so that the network database backup remains current.

### **2.3 ADVANCED APPLICATION SPECIFIC CONTROLLER (AAC) AND APPLICATION SPECIFIC CONTROLLER (ASC)**

#### **A. General Requirements:**

1. AACs and ASCs shall provide intelligent, standalone control of HVAC equipment. Each unit shall have its own internal RAM, non-volatile memory and will continue to operate all local control functions in the event of a loss of communications on the ASC LAN or sub-LAN. Refer to standalone requirements by application specified in PART 3 of this Section. In addition, it shall be able to share information with every other BC and AAC /ASC on the entire network.
2. Each AAC and ASC shall include self-test diagnostics that allow the AAC /ASC to automatically relay to the BC, LAN Interface Device or workstation, any malfunctions or abnormal conditions within the AAC /ASC or alarm conditions of inputs that exceed desired parameters as determined by programming input.
3. AACs and ASCs shall include sufficient memory to perform the specific control functions required for its application and to communicate with other devices.
4. Each AAC and ASC must be capable of stand-alone direct digital operation utilizing its own processor, non-volatile memory, input/output, minimum 8 bit A to D conversion, voltage transient and lightning protection devices. All volatile memory shall have a battery backup of at least fifty- (50) hrs with a battery life of five years.
5. All point data; algorithms and application software within an AAC /ASC shall be modifiable from the Operator Workstation.
6. AAC and ASC Input-Output Processing

- a. Digital Outputs (DO): Outputs shall be rated for a minimum 24 VAC or VDC, 1 amp maximum current. Each shall be configurable as normally open or normally closed. Each output shall have an LED to indicate the operating mode of the output and Each DO shall be discrete outputs from the AAC/ASC's board (multiplexing to a separate manufacturer's board is unacceptable). Provide suppression to limit transients to acceptable levels.
- b. Analog Inputs (AI): AI shall be 0-5 Vdc, 0-10Vdc, 0-20Vdc, and 0-20 mA. Provide signal conditioning, and zero and span calibration for each input. Each input shall be a discrete input to the BC's board (multiplexing to a separate manufacturers board is unacceptable unless specifically indicated otherwise). A/D converters shall have a minimum resolution of 8-10 bits depending on application.
- c. Digital Inputs (DI): Monitor dry contact closures. Accept pulsed inputs of at least one per second. Source voltage for sensing shall be supplied by the BC and shall be isolated from the main board. Software multiplexing of an AI and resistors shall only be done in non-critical applications and only with prior approval of Architect/Engineer
- d. Universal Inputs (UI-AI or DI): To serve as either AI or DI as specified above.
- e. Electronic Analog Outputs (AO): Voltage mode: 0-5 Vdc and 0-10 Vdc; Current mode: 4-20 mA. Provide zero and span calibration and circuit protection. Pulse Width Modulated (PWM) analog via a DO and transducer is acceptable only with Chicago Public Schools (CPS) approval ( PWM will not be allowed on loops with a short time constant such as discharge temperature loops, economizer loops, pressure control loops and the like. They are generally acceptable for standard room temperature control loops). Where these are allowed, transducer/actuator shall be programmable for normally open, normally closed, or hold last position and shall allow adjustable timing. PWM controlled devices will have an automatically initiated function that resets the device position tracking on a scheduled basis. The controllers shall initially be set up to perform this function once every 24 hours. The purpose of this required function is to recalibrate the position tracking to assure the device will open and close completely when commanded. Each AO shall be discrete outputs from the PCU's board (multiplexing to a separate manufacturers board is unacceptable). D/A converters shall have a minimum resolution of 10 bits.
- f. Analog Output Pneumatic (AOP), 0-20 psi: Pneumatic outputs via an I/P transducer, or digital to pneumatic transducer are acceptable. Multiplexed digital to pneumatic transducers are acceptable provided they are supplied as a standard product and part of the AAC /ASC and provide individual feedback. Multiplexed pneumatic outputs of a separate manufacturer are unacceptable.

B. BACnet AAC(s) and ASC(s) Requirements:

- 1. The AAC(s) and ASC(s) shall support all BIBBs defined in the BACnet Building Controller (B-AAC and B-ASC) device profile as defined in the BACnet standard.
- 2. AAC(s) and ASC(s) shall communicate over the BACnet Building Controller LAN or the ASC LAN or sub-LAN.
- 3. Each BC shall be connected to the BACnet Building Controller LAN communicating to/from other BCs.

C. LonTalk AAC(s) and ASC(s) Requirements:

- 1. Refer to LonWorks requirements under BC. All apply also to the AACs and ASCs.

D. Terminal Box Controllers:

1. Terminal box controllers controlling damper positions to maintain a quantity of supply or exhaust air serving a space shall have an automatically initiated function that resets the volume regulator damper to the fully closed position on a scheduled basis. The controllers shall initially be set up to perform this function once every 24 hours. The purpose of this required function is to reset and synchronize the actual damper position with the calculated damper position and to assure the damper will completely close when commanded. The software shall select scheduled boxes randomly and shall not allow more than 5% of the total quantity of controllers in a building to perform this function at the same time. When possible the controllers shall perform this function when the supply or exhaust air system is not operating or is unoccupied.

### **PART 3 - EXECUTION**

#### **3.1 INSPECTION:**

- A. Examine areas and conditions under which control systems are to be installed. Do not proceed with work until unsatisfactory conditions have been corrected in manner acceptable to Contractor.

#### **3.2 SYSTEM ACCESS:**

- A. Provide an Ethernet connection and 5 port hub at each panel housing a controller or controllers, that provides access to the Local Supervisory LAN and to the Control System Server for all Controllers, other than an Application Category 1 Controllers. The user shall be able to access each controller on the system using this connection via the Control System Server database for graphics, schedules, programming, controller configuration etc.

#### **3.3 INSTALLATION OF CONTROL SYSTEMS:**

- A. General: Install systems and materials in accordance with manufacturer's instructions, specifications roughing-in drawings and details shown on drawings. Contractor shall install all controllers in accordance with manufacturer's installation procedures and practices.

#### **3.4 HARDWARE APPLICATION REQUIREMENTS**

- A. Here is where you assert your concept of optimal mix of power/quality/cost effectiveness. There are multiple levels of controller/application defined, the higher Category numbers being more powerful and expensive. The AE defines - within each category - what system(s) must be controlled (in standalone fashion) by controllers that meet that category. This item needs specific attention on every project.
- B. General: The functional intent of this specification is to allow cost effective application of manufacturers standard products while maintain the integrity and reliability of the control functions. Specific requirements indicated below are required for the respective application. Manufacturer shall apply the most cost-effective unit that meets the requirement of that application.
- C. Standalone Capability: Each Control Unit shall be capable of performing the required sequence of operation for the associated equipment. All physical point data and calculated values required to accomplish the sequence of operation shall originate within the associated CU with only the exceptions enumerated below. Refer to Item 2.01 above for physical limitations of standalone functionality. Listed below are functional point data and calculated values that shall be allowed to be obtained from or stored by other CUs or SDs via LAN.

D. Where associated control functions involve functions from different categories identified below, the requirements for the most restrictive category shall be met.

E. Application Category Type 0 (Distributed monitoring)

1. Applications in this category include the following:
  - a. Monitoring of variables that are not used in a control loop, sequence logic, or safety.
2. Points on BCs, AACs, and ASCs may be used in these applications as well as Ds and/or general-purpose I/O modules.
3. Where these points are trended, contractor shall verify and document that the network bandwidth is acceptable for such trends and is still capable of acceptable and timely control function.
4. LAN Restrictions: These points may reside on any controller

F. Application Category Type 1

1. Applications in this category include the following:
  - a. Fan Coil Units
  - b. Airflow Control Boxes (VAV and Constant Volume Terminal Units)
  - c. Terminal Control Dampers/Reheat Valves
  - d. Unitary equipment <15 tons (Package Terminal AC Units, Package Terminal Heat Pumps, Split-System AC Units, Split-System Heat Pumps, and Water-Source Heat Pumps)
  - e. Induction Units
2. Standalone Capability: Provide capability to execute control functions for the application for a given setpoint or mode, which shall generally be occupied mode control. Only the following data (as applicable) may be acquired from other controllers via LANs. In the event of a loss of communications with any other controller, or any fault in any system hardware that interrupts the acquisition of any of these values, the ASC shall use the last value obtained before the fault occurred. If such fault has not been corrected after the specified default delay time, specified default value(s) shall then be substituted until such fault has been corrected.

<u>Physical/Virtual Point</u>	<u>Default Value</u>
<u>Scheduling Period</u>	<u>Normal</u>
<u>Morning Warm-Up</u>	<u>Off (cold discharge air)</u>
<u>Load Shed</u>	<u>Off (no shedding)</u>
<u>Summer/Winter</u>	<u>Winter</u>
<u>Trend Data</u>	<u>N/A</u>

3. Mounting:
  - a. ASCs that control equipment located above accessible ceilings shall be mounted on the equipment in an accessible enclosure and shall be rated for plenum use.
  - b. ASCs that control equipment mounted in a mechanical room shall either be mounted in, on the equipment, or on the wall of the mechanical room at an adjacent, accessible location.
  - c. ASCs that control equipment mounted outside or in occupied spaces shall either be located in the unit or in a proximate mechanical/utility space.

- d. Contractor for this Section may furnish ASCs to the terminal unit manufacturer for factory mounting.
4. LAN Segment Restrictions:
- a. LonTalk systems: Limit the number of nodes servicing any one of these applications on the LAN Segment to 40. VAV terminals or zone dampers/reheat coils served by a single air handler are to be located on the same segment of the LAN with the AHU. Multiple AHU's may reside on a LAN segment if all the associated/served terminal boxes and zone dampers/reheat coils are located on the same LAN segment. If more than 40 VAV terminals or zone dampers/reheat coils are served by a single air handler, then one LAN segment shall be fully populated with the parent air handler and terminal unit Nodes with the balance of the served terminal units Nodes located on the other segment located on the single channel JACE.
  - b. BACnet Systems: Limit the number of AAC's/ASC's servicing any one of these applications on the LAN Segment to 32.
- G. Application Category Type 2
- 1. Applications in this category include the following:
    - a. Constant Volume Air Handlers
    - b. Unitary Equipment  $\geq$  15 tons (Air Conditioners, Heat Pumps, Packaged Heating/Cooling Units, and the like)
    - c. Constant Volume Pump Start/Stop
    - d. Misc. Equipment (Exhaust Fan) Start/Stop
    - e. Misc. Monitoring (not directly associated with a control sequence and where trending is not critical)
    - f. Variable Speed Drive (VSD) controllers not requiring safety shutdowns of the controlled device
    - g. Multizone Air handlers with fewer than 5 zones
  - 2. Standalone Capability: Only the following data (as applicable) may be acquired from other AACs via LANs. In the event of a loss of communications with any other AACs, or any fault in any system hardware that interrupts the acquisition of any of these values, the AAC shall use the last value obtained before the fault occurred. If such fault has not been corrected after the specified default delay time, specified default value(s) shall then be substituted until such fault has been corrected.
 

<u>Physical/Virtual Point</u>	<u>Default Delay Time</u>	<u>Default Value</u>
Outside Air Temperature	3 minutes	80°F
Outside Air Humidity	3 minutes	60%RH
Outside Air Enthalpy	3 minutes	30 Btu/lb
Trend Data		N/A
Cooling/Heating Requests	3 minutes	None
  - 3. Mounting:
    - a. AACs that control equipment located above accessible ceilings shall be mounted on the equipment in an accessible enclosure and shall be rated for plenum use.
    - b. AACs that control equipment mounted in a mechanical room may either be mounted in, on the equipment, or on the wall of the mechanical room at an adjacent, accessible location.

- c. AACs that control equipment mounted outside or in occupied spaces shall either be located in the unit or in a proximate mechanical/utility space.
4. LAN Segment Restrictions:
- a. LonTalk systems: Limit the number of nodes servicing any one of these applications on the LAN Segment to 40.
  - b. BACnet Systems: Limit the number of AAC's servicing any one of these applications on the LAN Segment to 32.
- H. Application Category Type 3
- 1. Applications in this category include the following:
    - a. VAV Air Handlers
    - b. Dual Duct Air Handlers
    - c. Multizone Air Handlers with 5 or more zones
    - d. Self Contained VAV Units
    - e. Central Cooling Plant
    - f. Central Heating Plant
    - g. Cooling Towers
    - h. Sequenced or Variable Speed Pump Control
    - i. Local Chiller Control (unit specific)
    - j. Local Free Cooling Heat Exchanger Control
  - 2. LAN Segment Restrictions:
    - a. LonTalk systems: Limit the number of PCU's servicing any one of these applications on the LAN Segment to 20. Only PCU's associated with equipment for the applications in this category shall reside on the LAN segment of this application category type, with the exception of Application Category Type 0 points.
  - 3. BACnet Systems: BCs shall be used in these applications.

### **3.5 CONTROL UNIT REQUIREMENTS**

- A. Refer to Division 23 Section "Building Automation System (BAS)" for requirements pertaining to control unit quantity and location.

**End of Section 230923**

## **DIVISION 23 – HEATING, VENTILATING AND AIR CONDITIONING**

### **SECTION 23 09 24**

#### **BUILDING AUTOMATION SYSTEM (BAS) - COMMUNICATION DEVICES**

##### **PART 1 - GENERAL**

###### **1.1 SUMMARY**

- A. Section includes network integration devices.

###### **1.2 DESCRIPTION OF WORK**

- A. Contractor shall provide all interface devices and software to provide an integrated system connecting Advanced Application Controllers, Application Specific Controllers, Building Controllers, Gateways, and Operator Work Station & Control System Server. The Control System Server will also be connected to the CPS's WAN.
- B. Refer to Division 23 Section "Building Automation System (BAS)," for general requirements.

##### **PART 2 - PRODUCTS**

###### **2.1 NETWORK CONNECTION**

- A. CPS WAN: Internet-based network connecting multiple facilities with a central data warehouse and server, accessible via standard web-browser. This is an existing infrastructure and Contractor is not required to configure any components of this WAN. Contractor is however required to provide data and services via BACnet over IP or LonTalk over IP to the CPS WAN.
- B. Refer Division 23 Section "BAS Software and Programming" for the naming convention.

###### **2.2 BUILDING CONTROLLER (BC), BACNET**

- A. The BC shall be a microprocessor-based communications device which acts as a router between the Primary LAN and Supervisory LAN
- B. The BC shall perform information translation between the Primary LAN and the Supervisory LAN, supervise communications on a polling supervisory LAN, and shall be applicable to systems in which the same functionality is not provided in the BC.
- C. BC shall support interrogation, full control, and all utilities associated with all AACs and ASCs under the Primary Controller LAN.
- D. All BACnet Interoperability Building Blocks (BIBBs) are required to be supported for each native BACnet device.

###### **2.3 LOCAL SUPERVISORY LAN INTERFACE DEVICE (LANID) LONTALK**

- A. Routers shall be a microprocessor-based communications device that provides for access and information translation between the Primary LAN and the Supervisory LAN, which is 100 Mbps



Ethernet TCP/IP and shall use LonTalk over IP. The Router shall be transparent to control functions and shall not be required to control information routing on the Primary LAN. Two routers shall be provided for each Primary LAN connection and shall be in parallel for dual access to the Primary LAN as follows:

1. LIP-3ECT routers as manufactured by LoyTec with the following features and capabilities, no exceptions will be allowed:
  - a. Provides routing for packets between ANSI/EIA-709 and the IP network.
  - b. Provides tunneling of ANSI/EIA-709 packets through the IP network.
  - c. Fully EIA-852 compliant.
  - d. Built-in EIA-852 configuration server.
  - e. Shall support the network analysis tool utilized for the project.
  - f. MD5 authentication.
  - g. Supports firmware update through serial port, Ethernet and EIA-709 channel.
  - h. Supports multiple transceivers: FT-10/LPT-10, TP-1250, RS-485, PLT-22.
  - i. Bit-rates between 300 bps and 2.5 Mbps.
  - j. May be used as L-Switch compatible collision-less, low-latency backbone.
  - k. Status, diagnostic, and activity LEDs for all LANs.
  - l. Built-in web server for configuration of the L-IP and the IP-852 channel.
  - m. Serial port for configuration.
  - n. Real-time clock with battery backup.
  - o. 9-35 VDC / 9-24 VAC supply voltage.
  - p. Network diagnostics and overview of the network status.
  - q. Status of the EIA-852 channel and EIA-709 network with the status LEDs.
  - r. Shall support the remote network analysis tool so the network can be analyzed from any OWS.
2. For LON systems, JACE 512 as manufactured by Tridium or NSX1000e as manufactured by Plexus, no exceptions will be allowed.

### **PART 3 - EXECUTION**

#### **3.1 INSPECTION:**

- A. Examine areas and conditions under which control systems are to be installed. Do not proceed with work until unsatisfactory conditions have been corrected in manner acceptable to Installer.

#### **3.2 INSTALLATION OF CONTROL SYSTEMS:**

- A. General: Install systems and materials in accordance with manufacturer's instructions, roughing-in drawings and details shown on drawings.
- B. Contractor shall fully configure and provide all interface devices and software to provide an integrated system.
- C. Contractor shall closely coordinate with CPS, or designated representative, to establish IP addresses and communications to assure proper operation of the building control system with the CPS WAN, CSS's/OWS's and OWSs.

**End of Section 230924**

## **DIVISION 23 – HEATING, VENTILATING AND AIR CONDITIONING**

### **SECTION 23 09 25**

#### **BUILDING AUTOMATION SYSTEM (BAS) - SOFTWARE AND PROGRAMMING**

##### **PART 1 - GENERAL**

###### **1.1 SUMMARY**

- A. Section includes the following:
  - 1. System Software.
  - 2. Programming Description.
  - 3. Control Algorithms.
  - 4. Energy Management Applications.
  - 5. Password Protection.
  - 6. Alarm Reporting.
  - 7. Trending.
  - 8. Data Acquisition and Storage.
  - 9. Point Structuring.
  - 10. Dynamic Color Graphics.

###### **1.2 DESCRIPTION OF WORK:**

- A. Fully configure systems and furnish and install all software, programming and dynamic color graphics for a complete and fully functioning system as specified.
- B. Refer to Division 23 Section "Building Automation System (BAS)" for general requirements.
- C. Refer to Division 23 Section "Building Automation System (BAS) - Sequence of Operation" for specific sequences of operation for controlled equipment.

###### **1.3 LICENSING**

- A. Include licensing for all software packages at all required Control System Server (CSS Operator Work Stations (OWS) and Portable Operator Terminal (POT).
- B. Any operator interface, programming environment, networking, database management and any other software used by the Contractor to install the system or needed to operate the system to its full capabilities shall be licensed and provided to Chicago Public Schools (CPS).
- C. Include licensing for all software packages at all required Web Server and OWS's and POT's. Licensing shall allow access to all aspects of the system including system access, workstations, points, programming, database management, graphics etc. No restrictions shall be placed on the licensing. All operator interfaces, programming environment, networking, database management and any other software used by the Contractor to install the system or needed to operate the system to its full capabilities shall be licensed and provided to Chicago Public Schools (CPS).
- D. All software should be available on all Web Servers and OWS's provided, and on all Portable Operator Terminals. Hardware and software keys to provide all rights shall be installed on all workstations. At least 2 sets of CDs shall be provided with backup software for all software

provided, so that CPS may reinstall any software as necessary. Include all licensing for workstation operating systems, and all required third-party software licenses. These backup disks will include a backup of all program data files, graphics etc. and shall allow the owner to completely restore the system in the case of a computer malfunction

- E. Provide evidence of licensing including version and original software copies for each WEB Server OWS's and POT's. Licenses shall allow for access to any site device and shall not be restricted to accessing, database management, configuring, etc. the LANs included in this project. The licensing and registration proof will be provided when the system is installed on site.
- F. Upgrade all software packages to the release (version) in effect at the end of the Warranty Period and provide a letter indicating the current release/version date at the end of the warranty.
- G. Refer to Division 23 Section "Building Automation System (BAS)" for further requirements.

## **PART 2 - PRODUCTS**

### **2.1 SYSTEM SOFTWARE-GENERAL**

- A. **Functionality and Completeness:** The Contractor shall furnish and install all software and programming necessary to provide a complete and functioning system as specified. The Contractor shall include all software and programming not specifically itemized in these Specifications, which is necessary to implement, maintain, operate, and diagnose the system in compliance with these Specifications.

### **2.2 CONTROLLER SOFTWARE**

- A. All bindings, SNVT's, configuration values, addresses, calibration values, parameters, variables, tuning values, gains, test values, etc. for all software, programs, network configurations etc. shall be exposed and be available for setup, manipulation, adjustment, calibration, testing, etc. at all workstations, CSS's/OWS's, POT's for use as allowed via applicable password protection for all controllers and devices throughout all networks and the entire BAS.
- B. **Building Controller (BC) Software Residency:** Each BC as defined below shall be capable of control and monitoring of all points physically connected to it. All software including the following shall reside and execute at the BC:
  - 1. Real-Time Operating System software
  - 2. Real-Time Clock/Calendar and network time synchronization
  - 3. BC diagnostic software
  - 4. LAN Communication software/firmware
  - 5. Direct Digital Control software
  - 6. Alarm Processing and Buffering software
  - 7. Energy Management software
  - 8. Data Trending, Reporting, and Buffering software
  - 9. I/O (physical and virtual) database
  - 10. Remote Communication software
- C. **Advanced Application Controller (AAC) Application Specific Controller (ASC) Software Residency:** Each AAC/ASC as defined below shall be capable of control and monitoring of all points physically connected to it. As a minimum, software including the following shall reside and execute at the AAC/ASC. Other software to support other required functions of the AAC/ASC may reside at the BC or LAN interface device (specified in Division 23 Section

"Building Automation System (BAS) - Communication Devices") with the restrictions/exceptions per application provided in Division 23 Section "Building Automation System (BAS) - Field Panels":

1. Real-Time Operating System software
  2. AAC/ASC diagnostic software
  3. LAN Communication software
  4. Control software applicable to the unit it serves that will support a single mode of operation
  5. I/O (physical and virtual) database to support one mode of operation
- D. Stand Alone Capability: BC shall continue to perform all functions independent of a failure in other BC/AAC/ASC or other communication links to other BCs/AACs/ASCs. Trends and runtime totalization shall be retained in memory. Runtime totalization shall be available on all digital input points that monitor electric motor status. Refer also to Division 23 Section "Building Automation System (BAS) - Field Panels" for other aspects of stand alone functionality..
- E. Operating System: Controllers shall include a real-time operating system resident in ROM. This software shall execute independently from any other devices in the system. It shall support all specified functions. It shall provide a command prioritization scheme to allow functional override of control functions. Refer also to Division 23 Section "Building Automation System (BAS) - Field Panels" for other aspects of the controller's operating system.
- F. Network Communications: Each controller shall include software/firmware that supports the networking of CUs on a common communications trunk that forms the respective LAN. Network support shall include the following:
1. Controller communication software shall include error detection, correction, and re-transmission to ensure data integrity.
  2. LonTalk - Provide a network bandwidth analysis tool. The tool for determining bandwidth utilization shall be the LoyTech protocol analyzer LPA-IP network analysis tool, no exceptions allowed. Turn the tool over to CPS as part of the Project Closeout requirements.
  3. Operator/System communication software shall facilitate communications between other BCs, all subordinate AACs/ASCs, Gateways and LAN Interface Devices or Operator Workstations. Gateways and LAN Interface Devices or CSS's/OWS's. Software shall allow point interrogation, adjustment, addition/deletion, and programming while the controller is on line and functioning without disruption to unaffected points. The software architecture shall allow networked controllers to share selected physical and virtual point information throughout the entire system.
- G. Point Database/Summary Table: All points included in the typical equipment point list must be represented in a common, open protocol format. Naming conventions for these points and network addressing are discussed in PART 3 of this Section. Point/system database creation and modification shall be via a user-friendly, menu-driven program. System software shall support virtual or logic point (points not representing a physical I/O) creation. Software shall support virtual points with all services specified herein. Database software shall support definition of all parameters specified in PART 3 of this Section for a given point type. If database does not support all these parameters, software module shall be created and attached to the points which accomplish the respective function.
- H. Diagnostic Software: Controller software shall include diagnostic software that checks memory and communications and reports any malfunctions

- I. Alarm/Messaging Software: Controller software shall support alarm/message processing and buffering software as more fully specified below.
- J. Application Programs: CUs shall support and execute application programs as more fully specified below:
  - 1. All Direct Digital Control software, Energy Management Control software, and functional block application programming software templates shall be provided in a 'ready-to-use' state, and shall not require (but shall allow) CPS programming.
  - 2. Line programs shall supply preprogrammed functions to support these energy management and functional block application algorithms. All functions shall be provided with printed narratives and/or flow diagrams to document algorithms and how to modify and use them.
- K. Security: Controller software shall support multiple level password access restriction as more fully specified below.
- L. Direct Digital Control: Controller shall support application of Direct Digital Control Logic. All logic modules shall be provided pre-programmed with written documentation to support their application. Provide the following logic modules as a minimum:
  - 1. Proportional-Integral-Derivative (PID) control with analog, PWM and floating output
  - 2. Two Position control (Hi or Low crossing with deadband)
  - 3. Single-Pole Double-Throw relay
  - 4. Delay Timer (delay-on-make, delay-on-break, and interval)
  - 5. Hi/Low Selection
  - 6. Reset or Scaling Module
  - 7. Logical Operators (And, Or, Not, Xor)
- M. Psychrometric Parameters: Controller software shall provide preprogrammed functions to calculate and present psychrometric parameters (given temperature and relative humidity) including the following as a minimum: Enthalpy, Wet Bulb Temperature.
- N. Updating/Storing Application Data: Site-specific programming residing in volatile memory shall be uploadable/downloadable from an OWS or CSS connected locally, to the Primary LAN, to the Local Supervisory LAN and remotely via the internet and modem and telephone lines as applicable but all must be available. Initiation of an upload or download shall include all of the following methods; Manually, Scheduled, and Automatically upon detection of a loss or change.
- O. Restart: System software shall provide for orderly shutdown upon loss of power and automatic restart upon power restoration. Volatile memory shall be retained; outputs shall go to programmed fail (open, closed, or last) position. Equipment restart shall include a user definable time delay on each piece of equipment to stagger the restart. Loss of power shall be alarmed at operator interface indicating date and time.
- P. Time Synchronization: Operators shall be able to set the time and date in any device on the network that supports time-of-day functionality. The operator shall be able to select to set the time and date for an individual device, devices on a single network, or all devices simultaneously. Automatic time synchronization shall be provided.
- Q. Misc. Calculations: System software shall automate calculation of psychrometric functions, calendar functions, kWh/kW, and flow determination and totalization from pulsed or analog inputs, curve-fitting, look-up table, input/output scaling, time averaging of inputs and A/D conversion coefficients.

## 2.3 APPLICATION PROGRAMMING DESCRIPTION

- A. The application software shall be user programmable.
- B. This specification generally requires a programming convention that is logical, easy to learn, use, and diagnose. General approaches to application programming shall be provided by one, or a combination, of the following conventions:
  - 1. Point Definition: provide templates customized for point type, to support input of individual point information. For LON systems use standard LonWorks SNVTs.
  - 2. Graphical Block Programming: Manipulation of graphic icon 'blocks', each of which represents a subroutine, in a functional/logical manner forming a control logic diagram. Blocks shall allow entry of adjustable settings and parameters via pop-up windows. Provide a utility that shall allow the graphic logic diagrams to be directly compiled into application programs. Logic diagrams shall be viewable either off-line, or on-line with real-time block output values.
  - 3. Functional Application Programming: Pre-programmed application specific programs that allow/require limited customization via 'fill-in-the-blanks' edit fields. Typical values would be setpoints gains, associated point names, alarm limits, etc.
  - 4. Line Programming: Textual syntax-based programming in a language similar to BASIC designed specifically for HVAC control. Subroutines or functions for energy management applications, setpoints, and adjustable parameters shall be customizable, but shall be provided preprogrammed and documented.
- C. Provide a means for testing and/or debugging the control programs both off-line and on-line.

## 2.4 ENERGY MANAGEMENT APPLICATIONS

- A. System shall have the ability to perform all of the following energy management routines via preprogrammed function blocks or template programs. As a minimum provide the following whether or not required in the software:
  - 1. Time-of-Day Scheduling
  - 2. Calendar-Based Scheduling
  - 3. Holiday Scheduling
  - 4. Temporary Schedule Overrides
  - 5. Optimal Start/Optimal Stop-based on space temperature offset, outdoor air temperature, and building heating and cooling capacitance factors as a minimum
  - 6. Night Setback and Morning Recovery Control, with ventilation only during occupancy
  - 7. Economizer Control (enthalpy or dry-bulb)
  - 8. Peak Demand Limiting and Load Shedding. The demand limiting function will use demand data as the basis for the function and the load shedding program will use space temperature adjustment or means acceptable to CPS to provide load shedding response. The function selected for a given school will be made by CPS.
  - 9. Dead Band Control
- B. All programs shall be executed automatically without the need for operator intervention, and shall be flexible enough to allow operator customization. For example the load shedding program will allow the operator to determine the spaces to be included in the load shed as well as the duration of the event. Programs shall be applied to building equipment as described in the Division 23 Section "Building Automation System (BAS) - Sequence of Operation."

## 2.5 PASSWORD PROTECTION

- A. Multiple-level password access protection shall be provided to allow the CPS's authorized BAS Administrator to limit workstation control, display and database manipulation capabilities as deemed appropriate for each user, based upon an assigned user name with a unique password.
- B. All passwords for the system shall be provided to CPS including administrator, dealer, or factory level passwords for the systems provided under this project.
- C. Passwords shall restrict access to all Control Units.
- D. Each user name shall be assigned to a discrete access level. A minimum of five levels of access shall be supported. Alternately, a comprehensive list of accessibility/functionality items shall be provided, to be enabled or disabled for each user.
- E. A minimum of 20 user names shall be supported and programmed per CPS's direction. Provide ability to deactivate passwords without removal of the login and password. CPS will be provided with the highest level login and password so that CPS controls the administrative passwords.
- F. Operators shall be able to perform only those commands available for the access level assigned to their user name.
- G. User-definable, automatic log-off timers of from 1 to 60 minutes shall be provided to prevent operators from inadvertently leaving interface device software on-line. This timer will not be the windows system screen saver feature.

## 2.6 ALARM AND EVENT MANAGEMENT REPORTING

- A. Alarm management shall be provided to monitor, buffer, and direct alarms and messages to operator devices and memory files. Each BC shall perform distributed, independent alarm analysis and filtering to minimize operator interruptions due to non-critical alarms, minimize network traffic, and prevent alarms from being lost. At no time shall a BC's ability to report alarms be affected by either operator activity at an Operator Workstation or local handheld device, or by communications with other panels on the network.
  - 1. Alarm Descriptor: Each alarm or point change shall include that point's English language description, and the time and date of occurrence. In addition to the alarm's descriptor and the time and date, the user shall be able to print, display and store an alarm message to more fully describe the alarm condition or direct operator response.
  - 2. Alarm Prioritization: The software shall allow users to define the handling and routing of each alarm by their assignment to discrete priority levels. A minimum of ten priority levels shall be provided. For each priority level, users shall have the ability to enable or disable an audible tone whenever an alarm is reported and whenever an alarm returns to normal condition. Users shall have the ability to manually inhibit alarm reporting for each individual alarm and for each priority level. Contractor shall coordinate with CPS on establishing alarm priority definitions.
  - 3. Alarm Report Routing: Each alarm priority level shall be associated with a unique user-defined list of operator devices including any combination of local or remote workstations, printers and workstation disk files. All alarms associated with a given priority level shall be routed to all operator devices on the user-defined list associated with that priority level. For each priority level, alarms shall be automatically routed to a default operator device in the event that alarms are unable to be routed to any operator device assigned to the priority level.



4. Auto-Dial Alarm Routing: For alarm priority levels that include a remote workstation (accessed by modem) as one of the listed reporting destinations, the BC shall initiate a call to report the alarm, and shall terminate the call after alarm reporting is complete. System shall be capable of multiple retries and buffer alarms until a connection is made. If no connection is made, system shall attempt connection to an alternate dial-up workstation. System shall also be able to dial multiple pagers upon alarm activation.
  5. Alarm Acknowledgment: For alarm priority levels that are directed to a workstation screen, an indication of alarm receipt shall be displayed immediately regardless of the application in use at the workstation, and shall remain on the screen until acknowledged by a user having a password that allows alarm acknowledgment. Upon acknowledgment, the complete alarm message string (including date, time, and user name of acknowledging operator) shall be stored in a selected file on the workstation hard disk.
  6. Alarm Display: All alarms will popup as described in Alarm Acknowledgment. The owner will have the option to limit the pop up alarms based on alarm priority.
- B. It shall be possible for any operator to receive a summary of all alarms, regardless of acknowledgement status; for which a particular recipient is enrolled for notification; based on current event state; based on the particular event algorithm (e.g., change of value, change of state, out of range, and so on); alarm priority; and notification class.
- C. Alarm Historical Database: The database shall store all alarms and events object occurrences in an ODBC or an OLE database-compliant relational database. Provide a commercially available ODBC driver or OLE database data provider, which would allow applications to access the data using standard Microsoft Windows Data Services.

## 2.7 TRENDING

- A. The software shall display historical data in both a tabular and graphical format. The requirements of this trending shall include the following:
1. Trends may be buffered in the BC as long as the trend data in the BC and the historical data stored on hard disk is displayed seamlessly.
  2. Provide trends for all physical points, virtual points and calculated variables.
  3. Trend data shall be stored in relational database format as specified in herein under Data Acquisition and Storage.
  4. In the graphical format, the trend shall plot at least 4 different values for a given time period superimposed on the same graph. The 4 values shall be distinguishable by using unique colors. In printed form the 4 lines shall be distinguishable by different line symbology. Displayed trend graphs shall indicate the engineering units for each trended value.
  5. The sample rate and data selection shall be selectable by the operator.
  6. The trended value range shall be selectable by the operator.
  7. Where trended values on one table/graph are COV, software shall automatically fill the trend samples between COV entries.
- B. Control Loop Performance Trends: Controllers incorporating PID control loops shall also provide high resolution sampling in less than six second increments for verification of control loop performance.
- C. Data Buffering and Archiving: Trend data may be buffered at the BC, and uploaded to hard disk storage for archiving as needed based on the BC's memory constraints. All archived trends shall be transmitted to the on-site OWS as applicable. Uploads shall occur based upon a user-defined interval, manual command, or automatically when the trend buffers become full.

- D. Time Synchronization: Provide a time master that is installed and configured to synchronize the clocks of all devices supporting time synchronization. Synchronization shall be done using Coordinated Universal Time (UTC). All trend sample times shall be able to be synchronized. The frequency of time synchronization message transmission shall be selectable by the operator.

## **2.8 DYNAMIC PLOTTING**

- A. Provide a utility to dynamically plot in real-time at least 4 values on a given 2-dimensional dynamic plot/graph with at least two Y-axes. At least 5 dynamic plots shall be allowed simultaneously.

## **2.9 DATA ACQUISITION AND STORAGE**

- A. All points included in the typical equipment point list must be represented in a common, open or accessible format. Naming conventions for these points and network addressing are discussed in the 'Point Naming Conventions' paragraph below.
- B. Data from the BAS shall be stored in relational database format. The format and the naming convention used for storing the database files shall remain consistent across the database and across time. The relational structure shall allow for storage of any additional data points, which are added to the BAS in future. The metadata/schema or formal descriptions of the tables, columns, domains, and constraints shall be provided for each database.
- C. The database shall allow applications to access the data while the database is running. The database shall not require shutting down in order to provide read-write access to the data. Data shall be able to be read from the database without interrupting the continuous storage of trend data being carried by the BAS.
- D. The database shall be ODBC or OLE database compliant. Provide a commercially-available ODBC driver or OLE database data provider, which would allow applications to access the data via Microsoft Windows standard data access services.

## **2.10 TOTALIZATION**

- A. The software shall support totalizing analog, digital, and pulsed inputs and be capable of accumulating, storing, and converting these totals to engineering units used in the documents. These values shall generally be accessible to the Operator Interfaces to support management-reporting functions.
- B. Totalization of electricity use/demand shall allow application of totals to different rate periods, which shall be user definable.
- C. When specified to provide electrical or utility Use/Demand, the Contractor shall obtain from the local utility all information required to obtain meter data, including k factors, conversion constants, and the like.

## **2.11 EQUIPMENT SCHEDULING**

- A. Provide a graphic utility for user-friendly operator interface to adjust equipment-operating schedules.

- B. Scheduling feature shall include multiple seven-day master schedules, plus holiday schedule, each with start time and stop time. Master schedules shall be individually editable for each day and holiday.
- C. Scheduling feature shall allow for each individual equipment unit to be assigned to one of the master schedules.
- D. Timed override feature shall allow an operator to temporarily change the state of scheduled equipment. An override command shall be selectable to apply to an individual unit, all units assigned to a given master schedule, or to all units in a building. Timed override shall terminate at the end of an operator selectable time, or at the end of the scheduled occupied/unoccupied period, whichever comes first. A password level that does not allow assignment of master schedules shall allow a timed override feature.
- E. A yearly calendar feature shall allow assignment of holidays, and automatic reset of system real time clocks for transitions between daylight savings time and standard time.

## 2.12 POINT STRUCTURING AND NAMING

- A. General: The intent of this Section is to require a consistent means of naming points across the CPS Enterprise. Contractor shall configure the systems from the perspective of the Enterprise, not solely the local project. The following requirement establishes a standard for naming points and addressing Buildings, Networks, Devices, Instances, and the like. The interface shall always use this naming convention. The naming convention shall be implemented as much as practical, and any deviations from this naming convention shall be approved by CPS.
- B. Point Summary Table
  1. The term 'Point' is a generic description for the class of object represented by analog and binary inputs, outputs, and values.
  2. With each schematic, Contractor shall provide a Point Summary Table listing:
    - a. Building number and abbreviation
    - b. System type
    - c. Equipment type
    - d. Point suffix
    - e. Full point name (see Point Naming Convention paragraph)
    - f. English language point description
    - g. Ethernet backbone network number,
    - h. Network number
    - i. Device ID
    - j. Device MAC address
    - k. Engineering units
  3. Point Summary Table shall be provided in both hard copy and in electronic format (ODBC-compliant).
  4. Point Summary Table shall also illustrate Network Variables/LonWorks Bindings.
  5. The Contractor shall coordinate with the CPS's representative and compile and submit a proposed Point Summary Table for review prior to any object programming or project startup.
  6. The Point Summary Table shall be kept current throughout the duration of the project by the Contractor as the Master List of all points for the project. Project closeout documents shall include an up-to-date accurate Point Summary Table. The Contractor shall deliver to CPS the final Point Summary Table prior to final acceptance of the system. The Point

Summary Table shall be used as a reference and guide during the commissioning process.

7. The Point Summary Table shall contain all data fields on a single row per point. The Point Summary Table is to have a single master source for all point information in the building that is easily sorted and kept up-to-date. Although a relational database of Device ID-to-point information would be more efficient, the single line format is required as a single master table that will reflect all point information for the building. The point description shall be an easily understandable English-language description of the point.
8. Point Summary Table shall also illustrate Network Variables/BACnet Data Links/LonWorks Bindings.

Point Summary Table Example

Row Headers and Examples

(Transpose for a single point per row format)

Building Number	0006 (CPS 4 digit Building Code)
System Type	Cooling
Equipment Type	Chiller
Point Suffix	CHLR1KW
*Point Name (Object Name)	0006.COOLING.CHILLER.CHLR1KW
*Point Description (Object Description)	Chiller 1 kW
Ethernet Network Number	600
Network Number	610
Device ID	1024006
Device MAC address	24
Point Type	AI
Instance Number	4
Engineering Units	KW
Network Variable?	True
Server Device	1024006
Client Devices	1028006

\* Represents information that shall reside in the property for the point

C. Point Naming Convention

1. All point names shall adhere to the format as established below. Said objects shall include all physical I/O points, calculated points used for standard reports, and all application program parameters. For each BAS point, a specific and unique name shall be required.
2. For each point, four (4) distinct descriptors shall be linked to form each unique object name: Building, System, Equipment, and Point. All keyboard characters except a space are allowable. Each of the four descriptors must be bound by a period to form the entire object name. Reference the paragraphs below for an example of these descriptors.
3. CPS shall designate the *Building* descriptor. The *System* descriptor shall further define the object in terms of air handling, cooling, heating, or other system. The *Equipment* descriptor shall define the equipment category; e.g., Chiller, Air Handler, or other equipment. The *Point* descriptor shall define the hardware or software type or function associated with the equipment; e.g., supply temperature, water pressure, alarm, mixed air temperature setpoint, etc. and shall contain any numbering conventions for multiples of equipment; e.g., CHLR1KW, CHLR2KW, BLR2AL (Boiler 2 Alarm), HWP1ST (Hot Water Pump 1 Status).
4. A consistent object (point) naming convention shall be utilized to facilitate familiarity and operational ease across the CPS WAN. Inter-facility consistency shall be maintained to ensure transparent operability to the greatest degree possible. The table below details the object naming convention and general format of the descriptor string.

Point Name Requirements

Descriptors		Comment
Building Number	0006	The Master Building List also has the correct number for each building.
System	AIRHANDLING EXHAUST HEATING COOLING UTILITY ENDUSE MISC	Boilers and ancillary equipment Chillers and ancillary equipment Main electrical and gas meters Specific building loads by type
Equipment	AHU-1 BOILERS CHILLERS FACILITY TOWERS WEATHER	Non-specific boiler system points Non-specific chiller system points
Point Suffix	See Input/Output point summary table for conventions	

5. Examples: Within each point name, the descriptors shall be bound by a period. Within each descriptor, words shall not be separated by dashes, spaces, or other separators as follows:
  - a. 0006.COOLING.CHILLERS.CHWP1ST
  - b. 0006.HEATING.BOILERS.BLR1CFH

D. Device Addressing Convention:

1. Lontalk - Network numbers and SNVT's shall be unique throughout the network.
2. BACnet - Network numbers and Device Object IDs shall be unique throughout the network.
3. BACnet - For each BAS object, a specific and unique BACnet object name shall be required.
4. All assignment of network numbers and Device Object IDs shall be coordinated with CPS.
5. Each Network number shall be unique throughout all facilities and shall be assigned in the following manner unless specified otherwise:
  - a. **BBBFF**, where: BBB = 1-655 assigned to each building, FF = 00 for building backbone network, 1-35 indicating floors or separate systems in the building.
6. Each Device Identifier property shall be unique throughout the system and shall be assigned in the following manner unless specified otherwise:
  - a. **XXFFBBB**, where: XX = number 0 to 40, FF = 00 for building backbone network, 1-35 indicating floors or separate systems in the building. BBB = 1-655 assigned to each building.
7. The Contractor shall coordinate with CPS or a designated representative to ensure that no duplicate Device Object IDs occur.
8. Alternative Device ID schemes or cross project Device ID duplication if allowed shall be approved before project commencement by CPS.

## 2.13 OPERATOR INTERFACE GRAPHIC SOFTWARE

- A. Graphic software shall facilitate user-friendly interface to all aspects of the System Software specified above. The intent of this specification is to require a graphic package that provides for intuitive operation of the systems without extensive training and experience. It shall facilitate logical and simple system interrogation, modification, configuration, and diagnosis.
- B. Graphic software shall support multiple simultaneous screens to be displayed and resizable in a 'Windows'-like environment. All functions excepting text entry functions shall be executable with a mouse.
- C. Graphic software shall provide for multitasking such that third-party programs can be used while the OWS software is on line. Software shall provide the ability to alarm graphically even when operator is in another software package.
- D. Operating system software shall be Microsoft Windows 2000 Professional or Microsoft Windows XP Professional.
- E. The software shall allow for CPS creation of user-defined, color graphic displays of geographic maps, building plans, floor plans, and mechanical and electrical system schematics. These graphics shall be capable of displaying all point information from the database including any attributes associated with each point (i.e., engineering units, etc.). In addition, operators shall be able to command equipment or change setpoints from a graphic through the use of the mouse.
- F. Screen Penetration: The operator interface shall allow users to access the various system graphic screens via a graphical penetration scheme by using the mouse to select from menus or 'button' icons. All screens will be accessible out the use of outline type selection screens. Each graphic screen shall be capable of having a unique list of other graphic screens that are directly linked through the selection of a menu item or button icon.
- G. Dynamic Data Displays: Dynamic physical point values shall automatically updated at a minimum frequency of 6 updates per minute without operator intervention. Point value fields shall be displayed with a color code depicting normal, abnormal, override and alarm conditions.
- H. Point Override Feature: Provide the following:
  - 1. An Operator from a work-station shall have the capability to place an end device under manual control, which shall prevent the control logic from making changes to the end device status, and provide the operator with the ability to position the end device. It must be possible to put a point under manual control and command the point to a specific state or value from a graphic page. Once under manual control the point will be able to be released to automatic operation from the same graphics page. See the definition of Manual Control in the definition of terms Article in this Section.
  - 2. An Operator from the operator work-station shall have the capability to place a sensor input into test mode. When in test mode, any changes from the physical sensor will no longer be recognized and the value reported to control logic shall take a value that is assigned to it by the operator from the operator work-station. It must be possible to put a point in test and assign a test value from a graphic page. See the definition of Test Mode in the definition of terms Article of this Section.
  - 3. Points that are overridden shall be reported as an alarm, and shall be displayed in a coded color. The alarm message shall include the operator's user name. A list of points that are currently in an override state shall be available through menu selection. Such overrides or changes shall occur in the control unit, not just in the workstation software. The graphic point override feature shall be subject to password level protection.

- I. Dynamic Symbols: Provide a selection of standard symbols that change in appearance based on the value of an associated point.
  - 1. Analog symbol: Provide a symbol that represents the value of an analog point as the length of a line or linear bar.
  - 2. Digital symbol: Provide symbols such as switches, pilot lights, rotating fan wheels, etc. to represent the value of digital input and output points.
  - 3. Point Status Color: Graphic presentations shall indicate different colors for different point statuses. (For instance, green = normal, red = alarm, gray (or '???') for non-response.
  
- J. Graphics Development Package: Graphic development and generation software shall be provided to allow the user to add, modify, or delete system graphic displays. The application of the graphic editing will be controlled by password level at the programmer level or higher.
  - 1. The Contractor shall provide libraries of pre-engineered screens and symbols depicting standard air handling unit components (e.g. fans, cooling coils, filters, dampers, etc.), mechanical system components (e.g., pumps, chillers, cooling towers, boilers, etc.), complete mechanical systems (e.g. constant volume-terminal reheat, VAV, etc.) and electrical symbols.
  - 2. The Graphic Development Package shall use a mouse or similar pointing device to allow the user to perform the following:
    - a. Define symbols
    - b. Position items on graphic screens
    - c. Attach physical or virtual points to a graphic
    - d. Define background screens
    - e. Define connecting lines and curves
    - f. Locate, orient and size descriptive text
    - g. Define and display colors for all elements
    - h. Establish correlation between symbols or text and associated system points or other displays.
    - i. Create hot spots or link triggers to other graphic displays or other functions in the software.

## **PART 3 - EXECUTION**

### **3.1 SYSTEM CONFIGURATION**

- A. Contractor shall thoroughly and completely configure the BAS software, supplemental software, network communications, CSS, OWS, printer, and remote communications for a fully complete operational system.

### **3.2 SITE-SPECIFIC APPLICATION PROGRAMMING**

- A. Provide all database creation and site-specific application control programming as required by these Specifications, national and local standards and for a fully functioning system. Contractor shall provide all initial site-specific application programming and thoroughly document programming. Generally meet the intent of the written sequences of operation. If a sequence is not clear, in the contractors opinion, it is the Contractor's responsibility to request clarification..
  
- B. All site-specific programming shall be fully documented and submitted for review and approval, both prior to downloading into the panel, at the completion of functional performance testing, and at the end of the warranty period.

- C. All programming, graphics and data files must be maintained in a logical system of directories with self-explanatory file names. All files developed for the project will be the property of CPS and shall remain on the workstation(s)/server(s) at the completion of the project.

### 3.3 PASSWORD SETUP

- A. Set up the following password levels to include the specified capabilities:
  - 1. Level 1: (CPS's BAS Administrator)
    - a. Level 2 capabilities
    - b. View, add, change and delete user names, passwords, password levels
    - c. All unrestricted system capabilities including all network management functions.
  - 2. Level 2: (Programmer)
    - a. Level 3 capabilities
    - b. Configure system software
    - c. Modify control unit programs
    - d. Modify graphic software
    - e. Essentially unrestricted except for viewing or modifying user names, passwords, password levels
  - 3. Level 3: (Chief Engineer)
    - a. Level 4 capabilities
    - b. Override output points
    - c. Change all setpoints and reset schedules.
    - d. Exit BAS software to use third party programs
  - 4. Level 4: (Assitant )
    - a. Level 5 capabilities
    - b. Acknowledge alarms
    - c. Change equipment schedules
    - d. Change room temperature setpoints
  - 5. Level 5: (Veiw only Access)
    - a. Display all graphic data
    - b. Trend point data
    - c. Unless otherwise directed the Login will the school name and the password will be "cpswebaccess".
- B. Contractor shall assist CPS's operators with assigning user names, passwords and password levels. There may be multiple login name and passwords for a given password level. The contractor will be responsible for changing BAS administrator and Programmer level passwords if those are accidentally provided to other contractors or the school engineer.

### 3.4 POINT PARAMETERS

- A. Provide the following minimum programming for each analog input:



1. Name
2. Address
3. Scanning frequency or COV threshold
4. Engineering units
5. Offset calibration and scaling factor for engineering units
6. High and low alarm values and alarm differentials for return to normal condition
7. High and low value reporting limits (reasonableness values), which shall prevent control logic from using shorted or open circuit values.
8. Default value to be used when the actual measured value is not reporting. This is required only for points that are transferred across the primary and/or secondary controlling networks and used in control programs residing in control units other than the one in which the point resides. Events causing the default value to be used shall include failure of the control unit in which the point resides, or failure of any network over which the point value is transferred. All default values will be provided in list format for evaluation by CPS.
9. Selectable averaging function that shall average the measured value over a user selected number of scans for reporting.

B. Provide the following minimum programming for each analog output:

1. Name
2. Address
3. Output updating frequency
4. Engineering units
5. Offset calibration and scaling factor for engineering units
6. Output Range
7. Default value to be used when the normal controlling value is not reporting.

C. Provide the following minimum programming for each digital input:

1. Name
2. Address
3. Engineering units (on/off, open/closed, freeze/normal, etc.)
4. Debounce time delay
5. Message and alarm reporting as specified
6. Reporting of each change of state, and memory storage of the time of the last change of state
7. Totalization of on-time (for all motorized equipment status points), and accumulated number of off-to-on transitions.

D. Provide the following minimum programming for each digital output:

1. Name
2. Address
3. Output updating frequency
4. Engineering units (on/off, open/closed, freeze/normal, etc.)
5. Direct or Reverse action selection
6. Minimum on-time
7. Minimum off-time
8. Status association with a DI and failure alarming (as applicable)
9. Reporting of each change of state, and memory storage of the time of the last change of state.
10. Totalization of on-time (for all motorized equipment status points), and accumulated number of off-to-on transitions.
11. Default value to be used when the normal controlling value is not reporting.

### 3.5 TRENDS

- A. Contractor shall establish and store trend logs. Trend logs shall be prepared for each physical input and output point. All dynamic virtual points such as setpoints subject to a reset schedule, intermediate setpoint values for cascaded control loops, and the like will be trended as directed by the CPS.
- B. CPS will analyze trend logs of the system operating parameters to evaluate normal system functionality. Contractor shall establish these trends and ensure they are being stored properly.
  - 1. Data shall include a single row of field headings and the data thereafter shall be contiguous. Each record shall include a date and time field or single date stamp. Recorded parameters for a given piece of equipment or component shall be trended at the same intervals and be presented in a maximum of two separate 2-dimensional formats with time being the row heading and field name being the column heading.
- C. Sample times indicated as COV ( $\pm$ ) or change-of-value mean that the changed parameter only needs to be recorded after the value changes by the amount listed. When outputting to the trending file, the latest recorded value shall be listed with any given time increment record. The samples shall be filled with the latest values also if the points include different time intervals. If the BAS does not have the capability to record based on COV, the parameter shall be recorded based on the interval common to the unit.
- D. Trending intervals or COV thresholds shall be dictated by CPS, or their representative, upon system start-up.
- E. The Contractor shall demonstrate functional trends as specified for a period of 30 days after successful system demonstration before final acceptance of the system. The trend limit is 1 year from demonstration for LEED projects that require trend data for M&V purposes. The limit on the length of trend data will be a function of the storage capacity of the computer.

### 3.6 TREND GRAPHS

- A. Prepare controller and workstation software to display graphical format trends. Trended values and intervals shall be the same as those specified
- B. Lines shall be labeled and shall be distinguishable from each other by using either different line types, or different line colors.
- C. Provide a legend identifying the line color and symbol along side the point noun name for each point in the trend. Also, indicate engineering units of the y-axis values; e.g. degrees F., inches w.g., Btu/lb, percent open, etc.
- D. The y-axis scales shall be chosen so that all trended values are in a readable range. Do not mix trended values on one graph if their unit ranges are incompatible.
- E. Trend outside air temperature, humidity, and enthalpy during each period in which any other points are trended except for control loop performance trends.
- F. Allow point groups to be saved for future trends. For example HW supply and return temperatures along with HX stm valve position and pump status.

### 3.7 ALARMS

- A. Override Alarms: Any point that is overridden through the override feature of the graphic workstation software shall be reported as a Level 3 alarm.
  
- B. Analog Input Alarms: For each analog input, program an alarm message for reporting whenever the analog value is outside of the programmed alarm limits. Report a 'Return-to-Normal' message after the analog value returns to the normal range, using a programmed alarm differential. The alarm limits shall be individually selected by the Contractor based on the following criteria:
  - 1. Space temperature, except as otherwise stated in sequence of operation: Level 3
    - a. Low alarm: 64°F
    - b. Low return-to-normal: 68°F
    - c. High alarm: 85°F
    - d. High return-to-normal: 80°F
  
  - 2. Controlled media temperature other than space temperature (e.g. AHU discharge air temperature, steam converter leaving water temperature, condenser water supply, chilled water supply, etc.): Level 3 (If controlled media temperature setpoint is reset, alarm setpoints shall be programmed to follow setpoint)
    - a. Low alarm: 3°F below setpoint
    - b. Low return-to-normal: 2°F below setpoint
    - c. High alarm: 3°F above setpoint
    - d. High return-to-normal: 2°F above setpoint.
  
  - 3. AHU mixed air temperature: Level 4
    - a. Low alarm: 45°F
    - b. Low return-to-normal: 46°F
    - c. High alarm: 90°F
    - d. High return-to-normal: 89°F
  
  - 4. Duct Pressure:
    - a. Low alarm: 0.5"w.g. below setpoint
    - b. Low return-to-normal: 0.25"w.g. below setpoint
    - c. High alarm: 0.5"w.g. above setpoint
    - d. High return-to-normal: 0.25"w.g. above setpoint
  
  - 5. Space humidity:
    - a) Low alarm: 35%
    - b) Low return-to-normal: 40%
    - c) High alarm: 75%
    - d) High return-to-normal: 70%
  
- C. Status versus Command Alarms: The Sequences of Operation are based on the presumption that motor starter Hand-Off-Auto (HOA) switches are in the 'Auto' position. BAS shall enunciate

the following Level 5 alarm message if status indicates a unit is operational when the run command is not present or vice versa:

1. *DEVICE XXXX FAILURE*: Status is indicated on *{the device}* even though it has been commanded to stop. Check the HOA switch, control relay, status sensing device, contactors, and other components involved in starting the unit. Acknowledge this alarm when the problem has been corrected.
- D. Maintenance Alarms: Enunciate Level 5 alarms when runtime accumulation exceeds a value specified by the operator.
1. *DEVICE XXXX REQUIRES MAINTENANCE*. Runtime has exceeded specified value since last reset.
- E. See requirements for additional equipment-specific alarms specified in Division 23 Section "Building Automation System (BAS) - Sequences of Operation."

### 3.8 GRAPHIC SCREENS

- A. Main Screen: The Main screen will be the first screen displayed after login, no navigation required to get to the main screen (see Exhibit A for sample screens). This screen will have the following features:
1. CPS will have the option of providing a picture of the school as background.
  2. There will be a link button to the floor plans, Summary screen, and system schematic screens. In the event that there are more 10 to 15 AHU, Boiler and Chiller screens a button to groups of AHU's will be provided.
  3. Manufacturer/Installer Logo or information is not to be included in the screen.
  4. Provide a global command to open heating or cooling valves to facilitate Test Adjust and Balance. The command will be grouped so that an AHU can be balanced as well as total system balancing. The same function will apply for VAV AHU's were all the boxes can be set at minimum or maximum flow.
- B. Floor Plan Screens: The contract document drawings will be made available to the Contractor in AutoCAD format upon request. These drawings may be used only for developing backgrounds for specified graphic screens; however CPS does not guarantee the suitability of these drawings for the Contractor's purpose (see Exhibit B for sample screens).
1. Provide graphic floor plan screens for each floor and/or wing of the building. Indicate the location of all equipment that is not located on the equipment room screens.
    - a. Indicate the location of temperature sensors associated with each temperature-controlled zone (i.e., VAV terminals, fan-coils, single-zone AHUs, etc.) on the floor plan screens.
    - b. Display the space temperature point adjacent to each temperature sensor symbol along with the room set point. Use a distinct line symbol to demarcate each terminal unit zone boundary. Use distinct background colors for each zone to demarcate the air-handling unit to which it is associated.
    - c. Indicate room numbers as provided by CPS. Verify final room number/name assignments, as these are often different than initially assigned room numbers on the contract drawings.
    - d. Provide a drawing link from each space temperature sensor symbol and equipment symbol shown on the graphic floor plan screens to each corresponding zone equipment schematic graphic screen. Because the area available for the floor

plans varies from system to system, the size of text used to display data such as room number and temperature will be at least 1/8" high on the screen when the entire floor plan section is displayed.

- e. The floor plan graphics will also indicate the location of control panels. For control devices such as duct smoke detectors, system pressure or differential pressure sensors (water or air), airflow stations that are located outside the equipment rooms. All of these devices will be linked to the associated system graphic. For terminal units the link to the associated system graphic is sufficient and the associated unit control devices do not need to be located on the floor plan.
2. Provide graphic floor plan screens for each mechanical equipment room and a plan screen of the roof. Indicate the location of each item of mechanical equipment. Provide a drawing link from each equipment symbol shown on the graphic plan view screen to each corresponding mechanical system schematic graphic screen.
  3. Provide a graphic building key plan that will allow navigation at a floor level or from floor to floor. Use elevation views and/or plan views as necessary to graphically indicate the location of all of the larger scale floor plans. Link graphic building key plan to larger scale partial floor plans. Provide links from each larger scale graphic floor plan screen to the building key plan and to each of the other graphic floor plan screens.
  4. When there is more than one building, provide a graphic site plan with links to and from each building plan.
- C. System Schematic Screens: Provide graphic system schematic screen for each HVAC subsystem (AHU) controlled with each I/O point in the project appearing on at least one graphic screen. System graphics shall have the same look as the submittal diagrams (do not use three dimensional graphics) with status, setpoints, current analog input and output values, operator commands, etc. as applicable. Input/output devices shall be shown in their schematically correct locations with the associated value, noun name and engineering units. The position of valves or dampers will be % OPEN. For three way valves it will be %OPEN to the device. The noun name (English language descriptors) shall be included for each point on all graphics; this may be accomplished by the use of a pop-up window accessed by selecting the displayed point with the mouse. Indicate all adjustable setpoints on the applicable system schematic graphic screen or, if space does not allow, on a supplemental linked-setpoint screen. Similar AHU's will have the same organization of information. For example a single zone AHU will not put all the set points across the top and multizone put them on the side or bottom (see Exhibit C for sample screens).
1. Provide graphic screens for each air handling system. Indicate outside air temperature and enthalpy, and mode of operation as applicable (i.e., occupancy mode and heating, cooling, economizer etc based on the sequence of operations). Link screens for air handlers to the heating system and cooling system graphics. Link screens for supply and exhaust systems if they are not combined onto one screen.
  2. Provide a graphic screen for each zone with the associated control devices or terminal unit with a link to the associated system schematic screen of the air handling unit that serves the zone.
  3. Provide a cooling system graphic screen showing all points associated with the chillers, cooling towers and pumps. Indicate outside air dry-bulb temperature and calculated wet-bulb temperature. Link the chilled water and condenser water systems screens if they cannot fit onto one cooling plant graphic screen.
  4. Link the heating and cooling system graphics to utility history reports showing current and monthly electric uses, demands, peak values, and other pertinent values.
  5. For each system schematic screen, including AHU, Boiler, Chiller and terminal unit screen, provide a button linked to a text version of the sequence of operation for the device or system. The sequence will be updated with the as-built sequence following completion of the demonstration.

- D. System Summary Screens: On each graphic System Screen, provide drawing links to the graphic air handling unit schematic screens (see Exhibit D for sample screens).
1. Provide a chilled water valve screen showing the analog output signal of all chilled water valves with signals expressed as percentage of fully open valve (percentage of full cooling). Indicate the discharge air temperature and setpoint of each air handling unit, cooling system chilled water supply and return temperatures and the outside air temperature and humidity on this graphic. Provide drawing links between the graphic cooling plant screen and this graphic screen.
  2. Provide a heating water valve screen showing the analog output signal of all air handling unit heating water valves with signals expressed as percentage of fully open valve (percentage of full heating). Indicate the temperature of the controlled medium (such as AHU discharge air temperature or zone hot water supply temperature) and the associated setpoint and the outside air temperature and humidity.
  3. When there are more than four AHU's on the system provide a summary screen with the following type of information for each AHU, each fan command, status, alarms (smoke, freeze, duct static), DAT and duct pressure if applicable. For the heating system provide status and supply water temp or steam pressure and for the chiller provide status and chilled water supply temperature.
  4. Provide a BAS system summary screen using the control system riser diagram to show the communication status of all controllers (BC, AAC and ASC's) on the BAS as well as all interface devices such as VFD's, chillers and boiler panels etcetera. Use green board concept, green means communicating, red is not communicating.
  5. Provide a terminal unit summary screen grouped by floor or AHU. If the summary is grouped by floor then the AHU will be shown for each terminal unit and vice versa. The points shown will depend on the type of terminal unit and will include room name, floor or AHU, room set point and temperature, DAT, valve position, command status, alarm and occupancy state.
  6. Exhaust fans will be show in a table format showing the command signal, the status, the alarm condition, and the occupancy state.
- E. Alarms: Each programmed alarm shall appear on at least one graphic screen. In general, alarms shall be displayed on the graphic system schematic screen for the system that the alarm is associated with (for example, chiller alarm shall be shown on graphic cooling system schematic screen). For all graphic screens, display analog values that are in a 'high alarm' condition in a red color, 'low alarm' condition in a blue color. Indicate digital values that are in alarm condition in a red color. When an alarm first occurs it shall "popup" over the current screen so that the operator is imediately aware of an alarm.
1. Maintenance Alarms
    - a. Runtime alarm screen will list all equipment with a BAS status. For each piece of equipment the screen will display the current run time (since the last reset), the runtime alarm limit (adj.), its alarm status (red / green) and the total accumulated runtime. The total accumulated runtime would only be zeroed out if the equipment were replaced. For equipment with internal runtime meters ensure that the total accumulative runtime is synchronized.
- F. Utility Metering: Provide a graphic for the gas, electric and water utility data required in the sequence of operations. This may entail multiple screens if submetering of the gas or electric usage is included in the project.

**End of Section 230925**

**DIVISION 23 – HEATING, VENTILATING AND AIR CONDITIONING**

**SECTION 23 09 25.01**

**BUILDING AUTOMATION SYSTEM (BAS) – SOFTWARE AND PROGRAMMING EXHIBITS**

**EXHIBIT A     Main Screen Example Graphics**

**EXHIBIT B     Floor Plan Example Graphics**

**EXHIBIT C     System Schematic Example Graphics**

**EXHIBIT D     System Summary Example Graphics**

The following graphic screens are provided as examples that incorporate most of the requirements of Division 23 Section "Building Automation System (BAS) – Software and Programming." While few graphic screens meet all the requirements they are illustrative of the quality of graphic screen that CPS expects on projects executed under this specification.

**EXHIBIT A Main Screen Example Graphics**

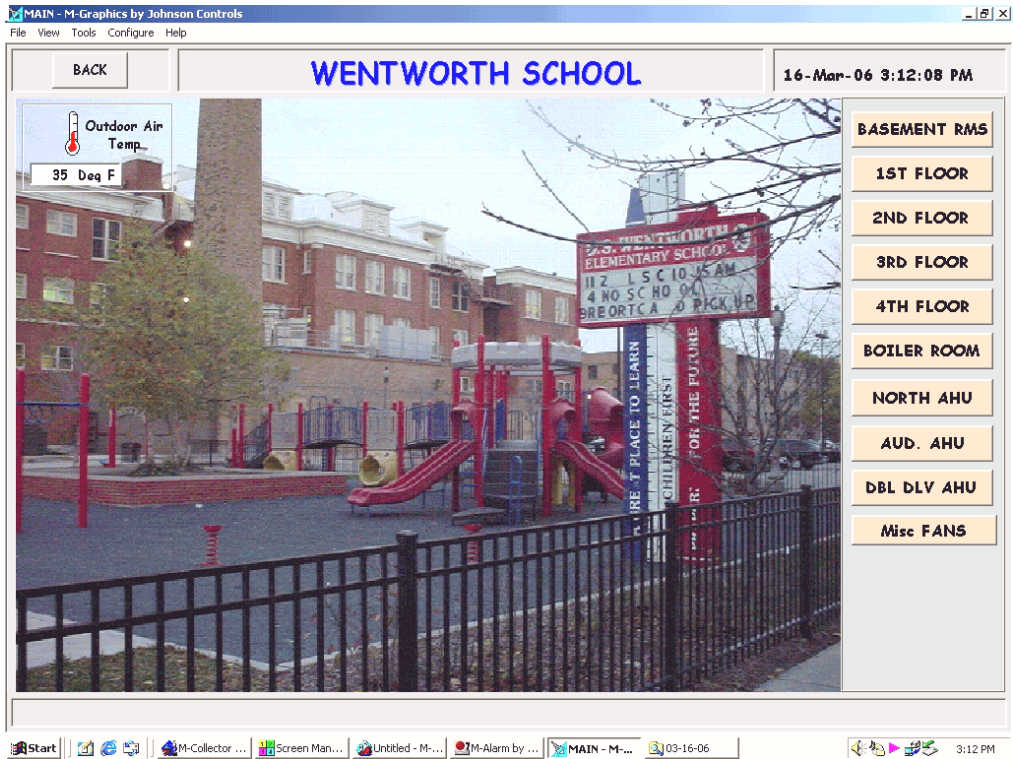
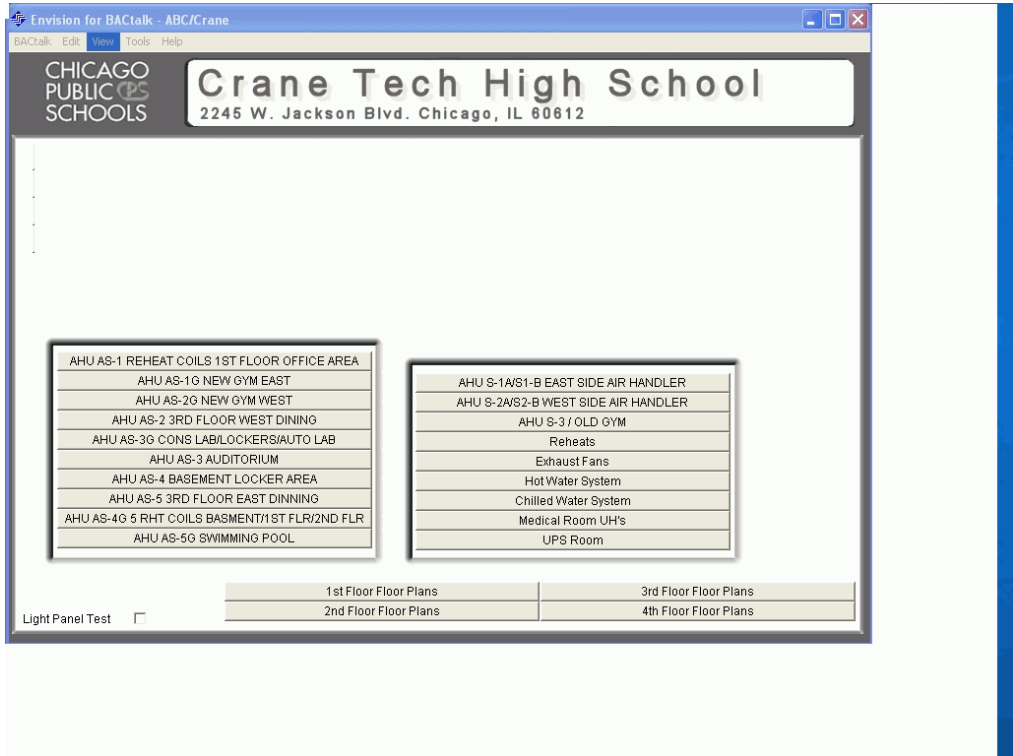



Tracer Summit - [Graphic - DePriest, DePriest]

File Connect Status View Go Setup Tools Window Help

CHICAGO PUBLIC SCHOOLS

# Oscar DePriest Elementary School

139 South Parkside Ave. Chicago, Illinois 60644 Outdoor Air Temp 49.0 °

Boilers 1st Floor FPB 1st Floor 2nd Floor FPB 2nd Floor 3rd Floor 3rd Floor FPB



Chiller  
Air Handler 1  
Ah 1 FPB  
Air Handler 2  
Ah 2 FPB  
Air Handler 3  
Air Handlers  
Air Handler 4  
Ah 4 FPB  
Air Handler 5  
Ah 5 FPB  
Hvu 1  
Exhaust  
Power Meter  
Riser  
Vav Summary

**EXHIBIT B Floor Plan Example Graphics**

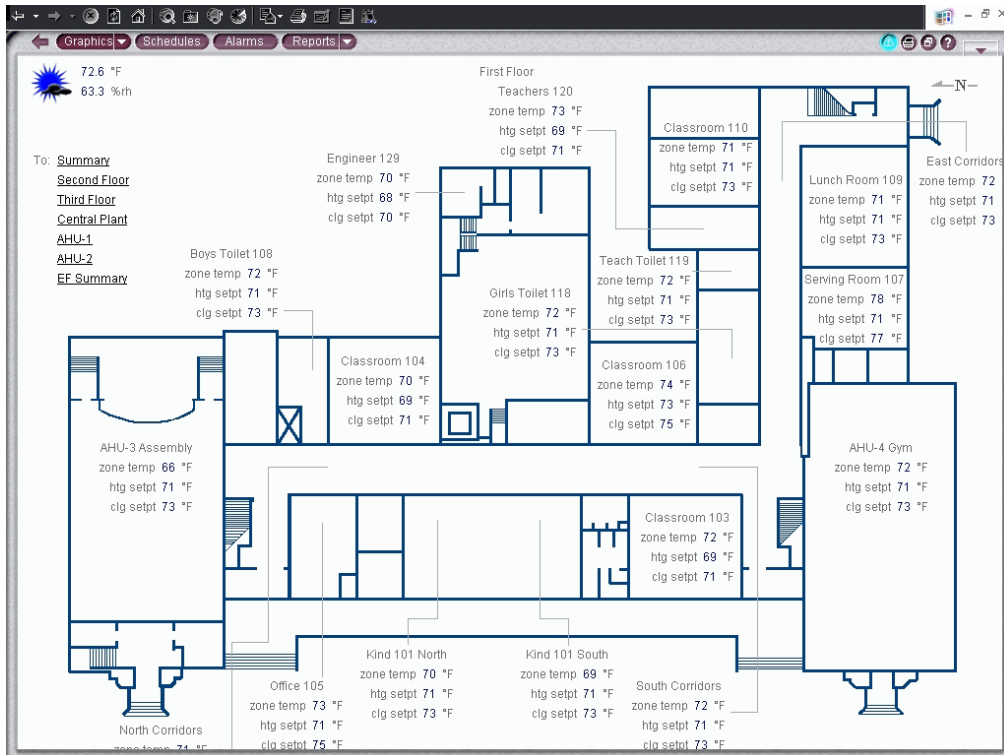
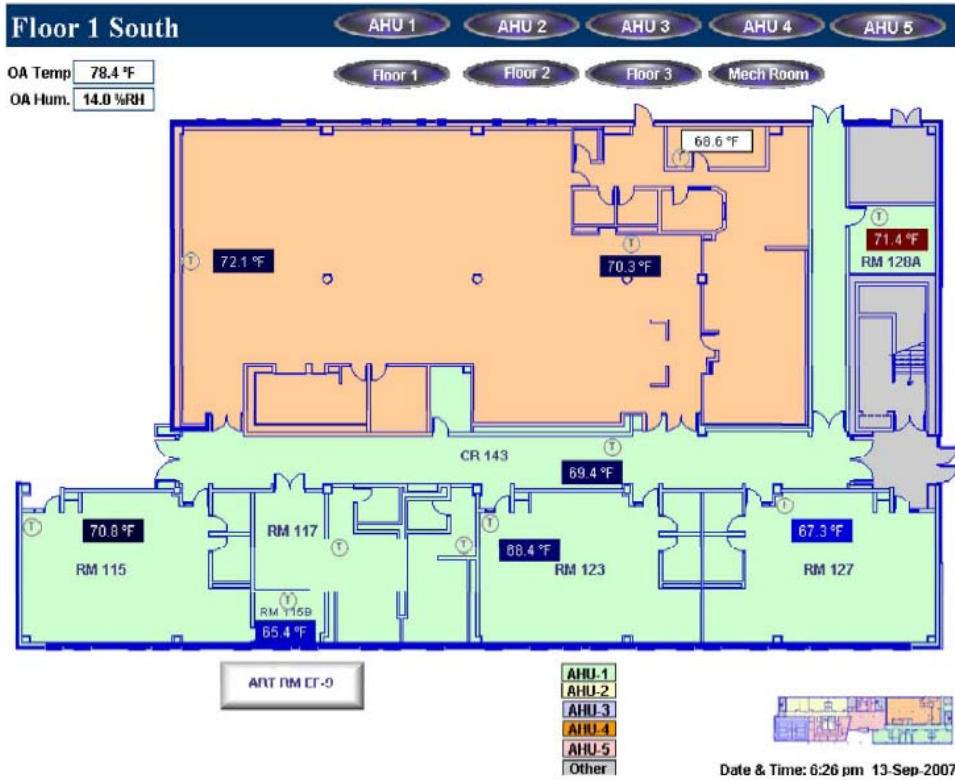

SpencerServer - Microsoft Internet Explorer

Address: http://10.13.255.12/stations/SpencerServer/tree/whole.html

**Spencer Academy**  
Chicago Public Schools

Outdoor Air Temp / Dew Point / Humidity  
37.90 °F / 31.05 °F / 77.19 %

Current Alarms In Bldg  
View Alarm History  
Clear Alarm History

Bldg Fire: Normal

Tree: AHU-1, AHU-2S, HW Sys, AHU-2N, AHU-3, Exhaust, Econo

Link to "/db/SpencerServer/FloorPlans/FloorPlan3South"

JFK - Microsoft Internet Explorer

Address: http://10.15.191.15/stations/JFKServer/tree/whole.html

**John F. Kennedy High School**  
3rd Floor West

Up / Down

S / N, E / W

When setting Heating and Cooling Set Points, Remember:  
All Cooling Set Points Must Be Higher Than The Heating Set Points.

Boys 321, Girls 320, EF-16 Boys & Girls Toilets

Room 321 73.29	Room 320 73.38	Room 318 72.01	Boys 321 70.27	Girls 320 72.01
Room 319E 73.09	Room 319W 72.14	Room 317 74.19	Corridor S 70.27	Room 316 72.19
Room 309E 72.34	Room 309W 72.61	Room 315 72.72	Room 314 72.18	Room 313A 71.98
Room 310 71.92	Room 311 74.17	Room 312 72.50	Room 312A 72.30	Room 313 72.32

Corridor N: 70.23

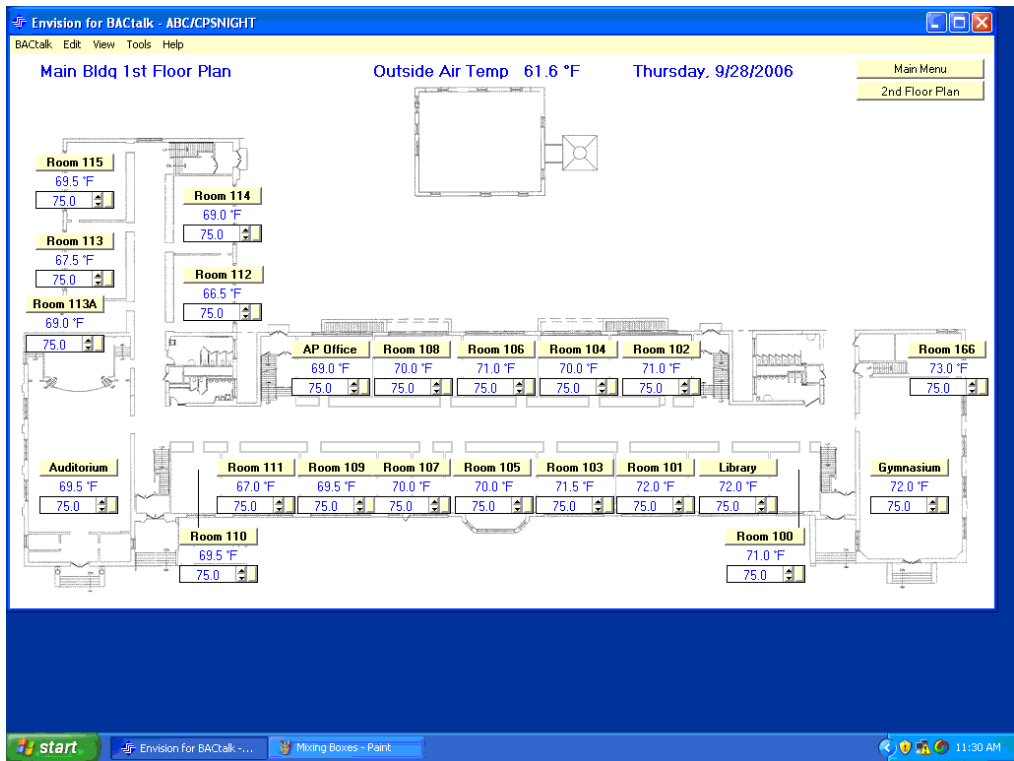
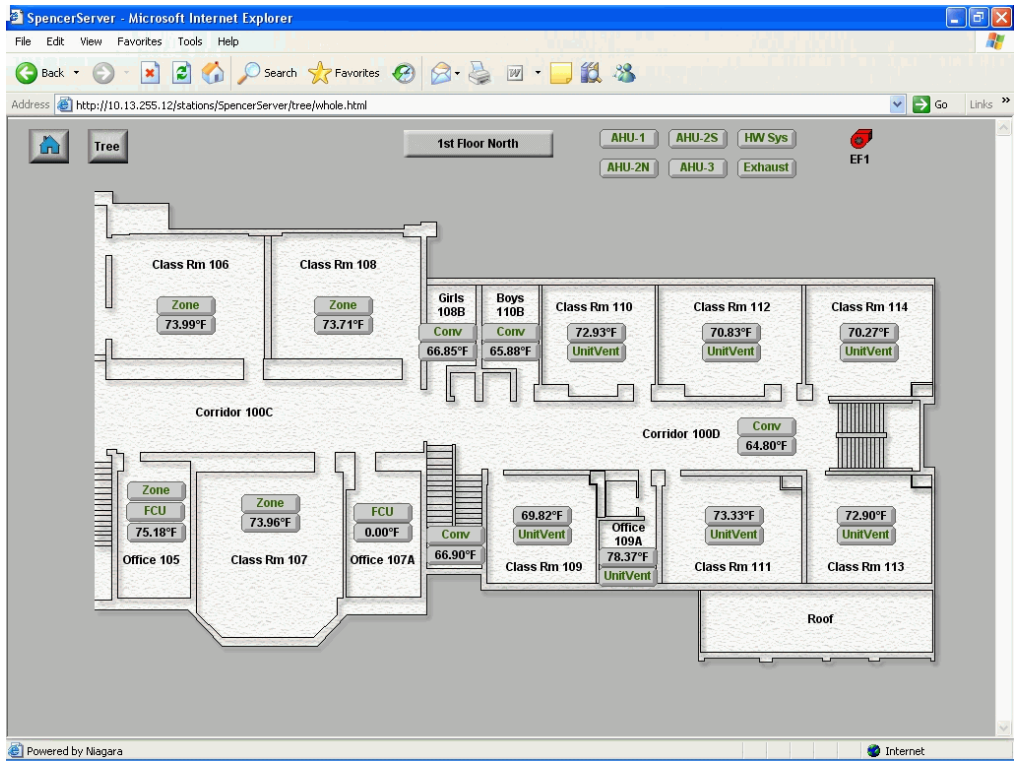

# EXHIBIT C System Schematic Example Graphics

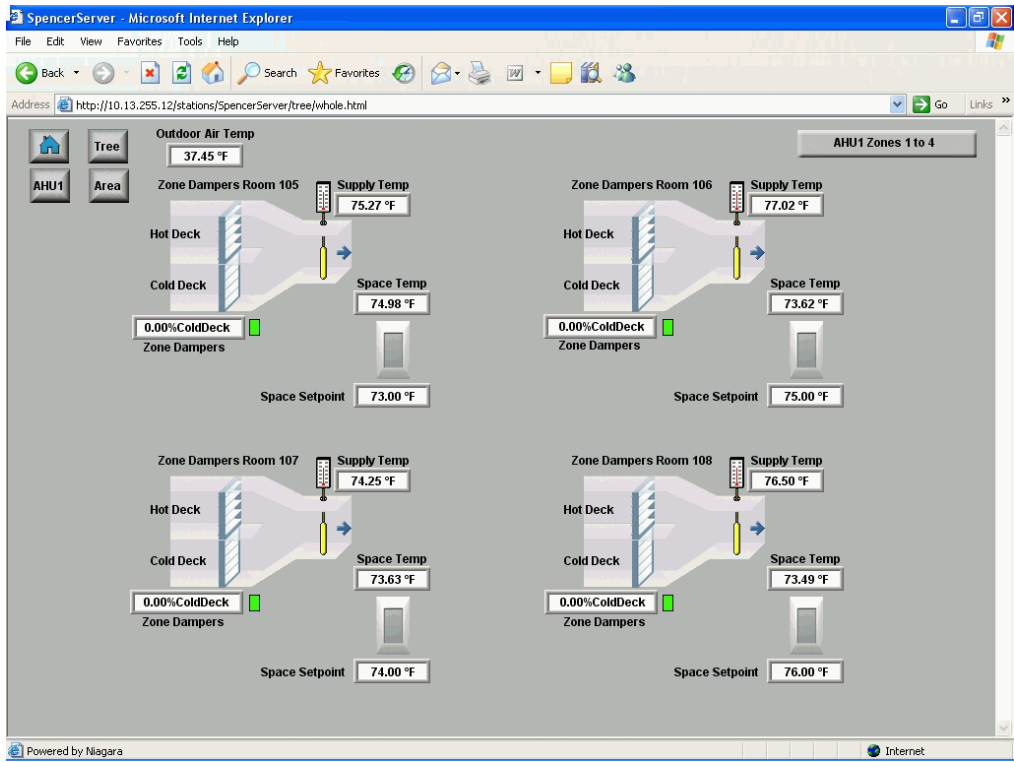
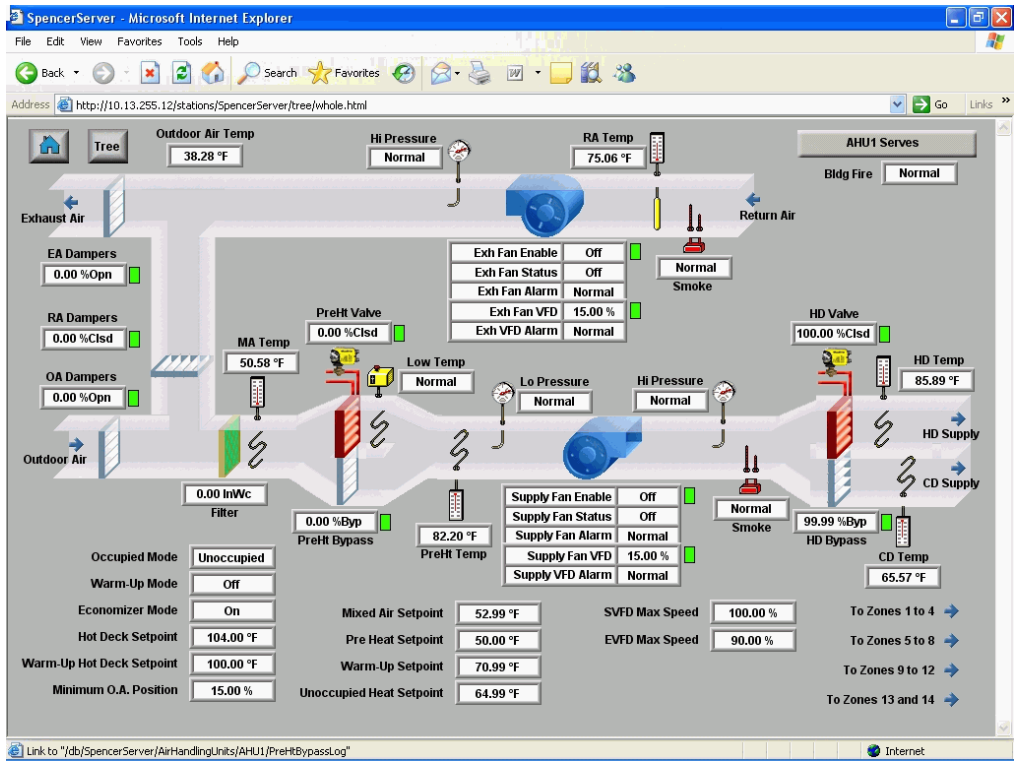



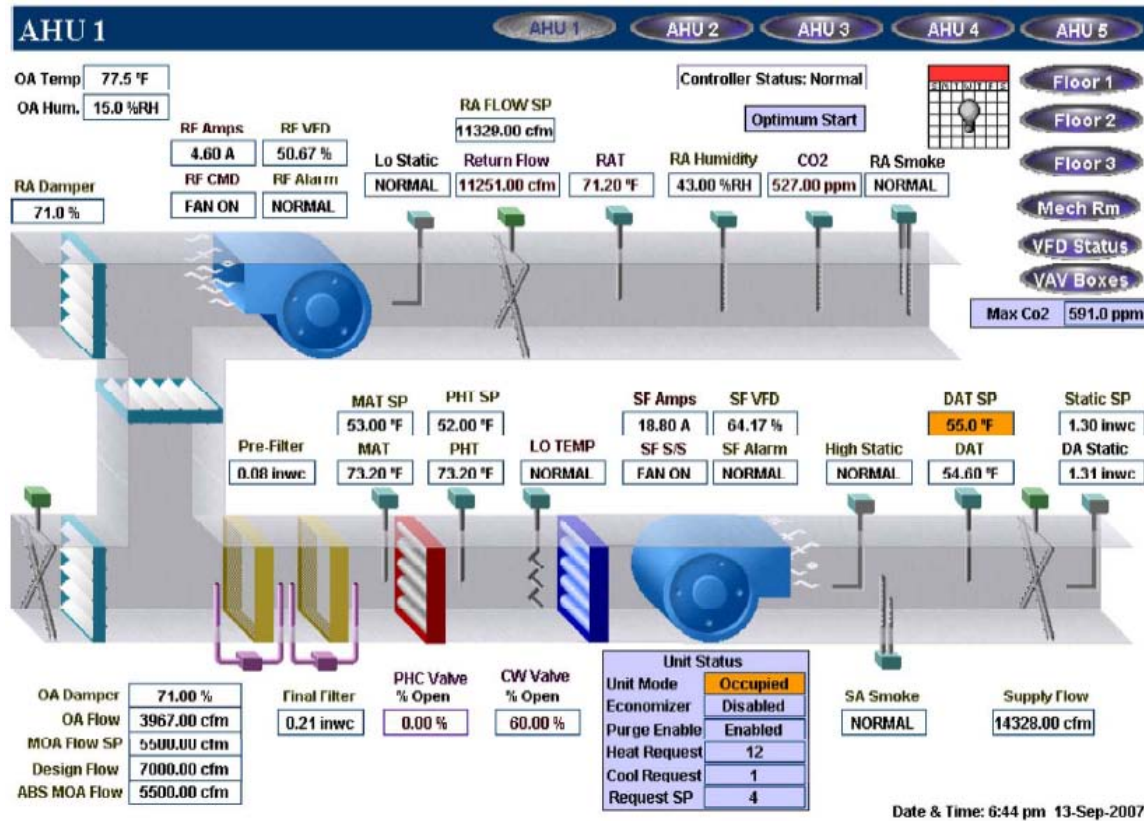
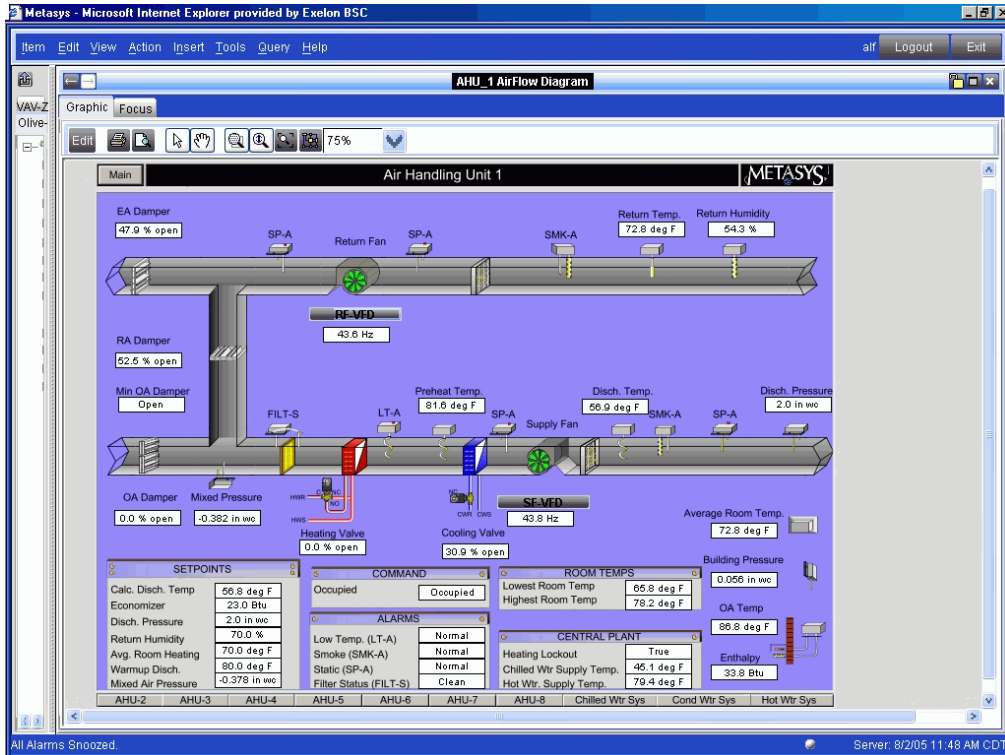

Additional Info pages

	SF VFD	RF VFD
Speed	64.17 %	50.67 %
Frequency	30.40 hz	29.00 hz
RPM	1135.00 rpm	887.00 rpm
Voltage	295.00 V	176.00 V
Run Hours	1636.00 hrs	1602.00 hrs
Power	6.30 kW	0.70 kW
Current	18.80 A	4.60 A
Fault	Normal	Normal
Running Status	Running	Running

Cool Down Setpoint	74.00	Optimal Start Status Scheduled Start: 6:00am 14-Sep-2007
Warm Up Setpoint	73.00	
Selected Rm Temp	73.90	
Oa Change Over	85.00	
Max Space Temp	73.90	
Min Space Temp	84.50	

Schedule

Weekly Schedule: /Albany\_Park/Albany/AHU\_1/Schedule

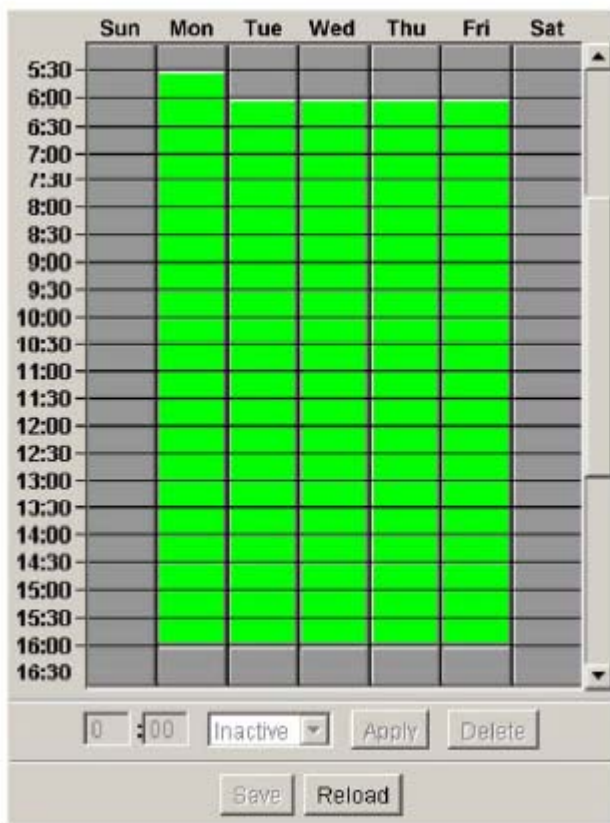

[Summary](#) [Weekly](#) [Holiday](#) [Special Events](#) [Calendar](#)

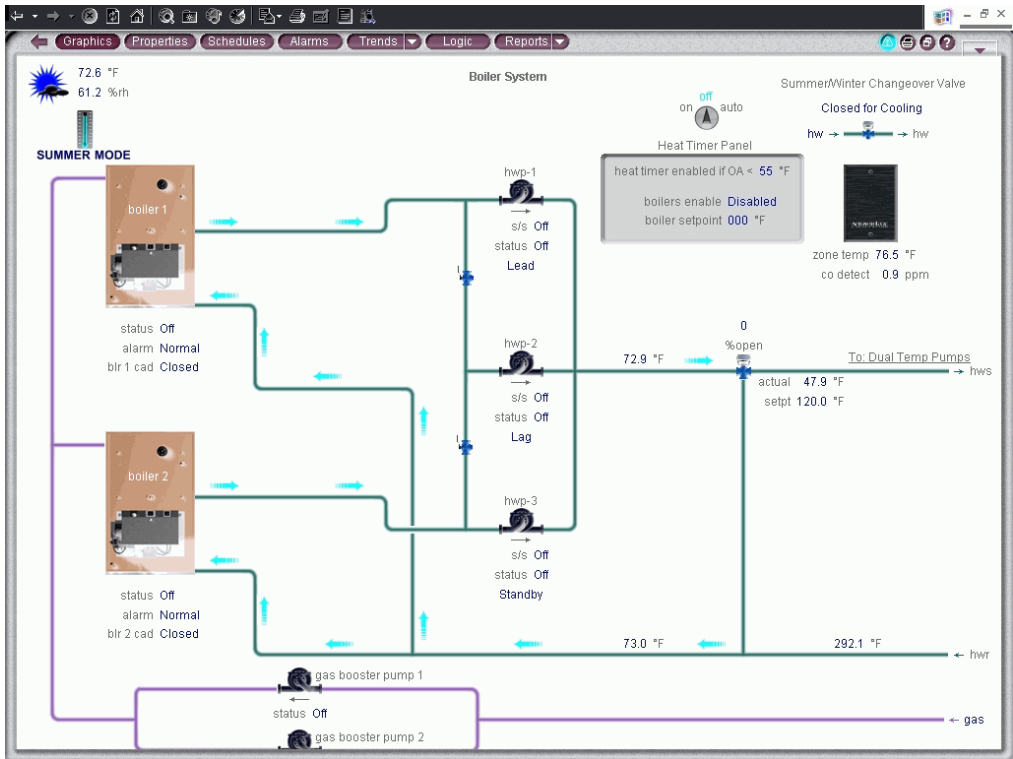
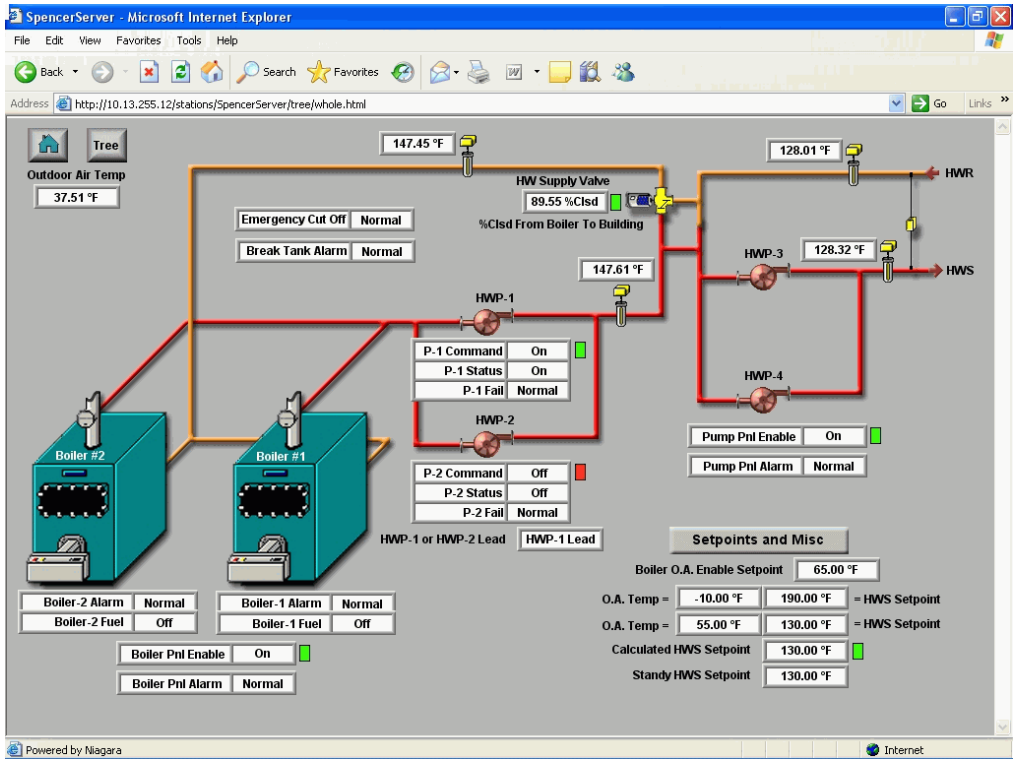



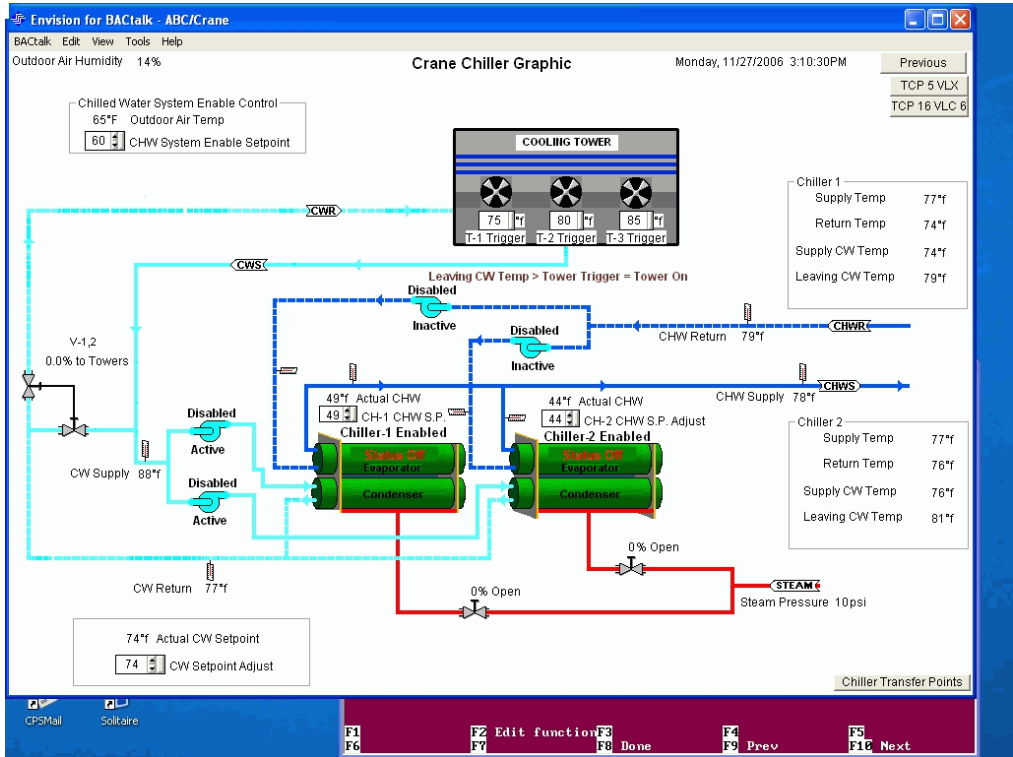
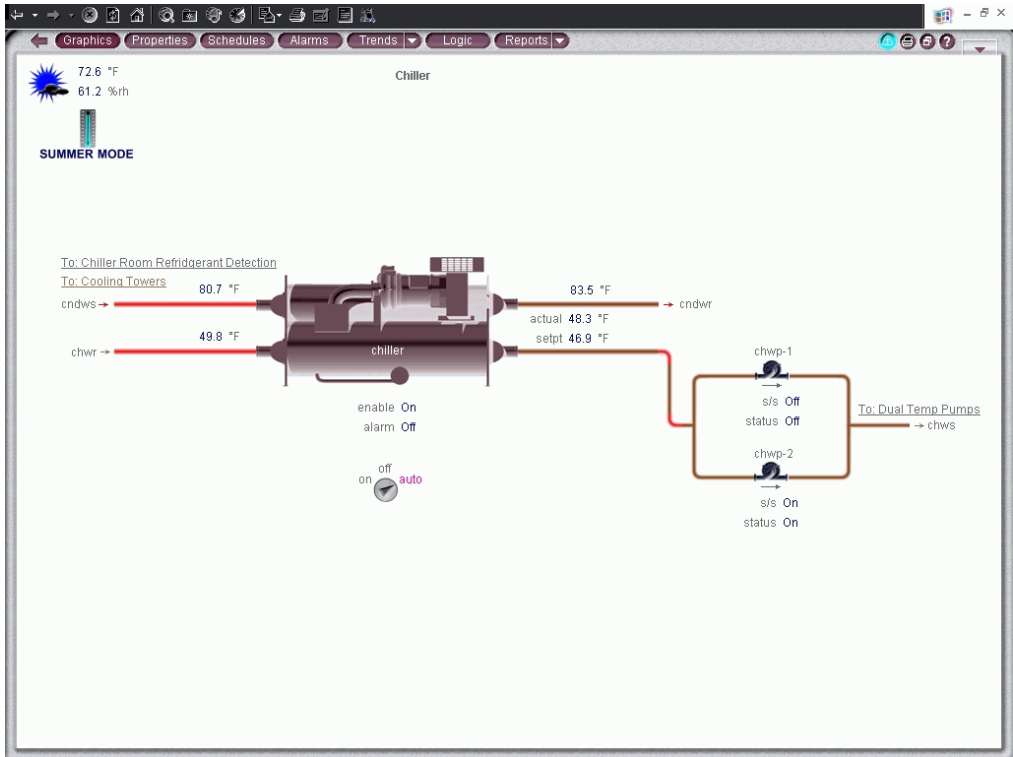

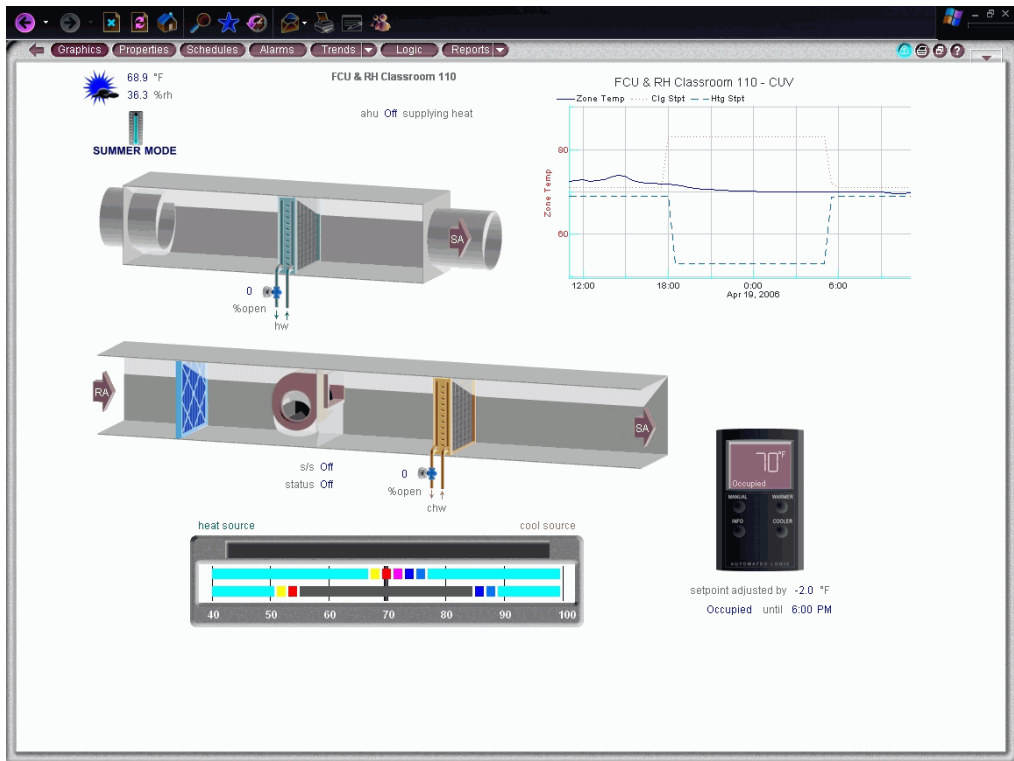

## EXHIBIT D System Summary Example Graphics

### Reheat summary

Envision for BACtalk - ABC/Crane

BACtalk Edit View Tools Help

Tuesday, 9/19/2006 12:40:00PM 1st Floor Reheats Previous 1st Flr Rht Pg 2 1st Flr Rht Pg 3

Outdoor Air Temp 55°F  
Outdoor Air Humidity 14%

Classroom ID	Reheat Coil ID	Room Setpoint	Room Temperature	Valve % Open	
Room 102	BC-101	72	69	100	■
Room 101	BC-103	72	68	100	■
Room 121	BC-105	72	72	0	■
121 - Conference	BC-105.10	72	70	7	■
120 - Transcript Office	BC-105.15	72	75	0	■
121 - Asst Principal	BC-105.6	72	70	7	■
121 - Principal	BC-105.8	72	70	7	■
Room 118	BC-107	50	76	0	■
Room 117	BC-108	65	72	0	■
Room 116	BC-109	72	75	0	■
Room 107	BC-114	72	79	0	■
100 - Choral Practice	BC-114.4	72	75	0	■
100 - Choral Faculty	BC-114.8	72	73	0	■
Instrumental Room	BC-115	72	74	0	■
Instrument Storage	BC-115.1	72	76	0	■
Room 100	BC-118	72	67	100	■
Music Library	BC-120	72	70	100	■

CPSMail BACtalk Alarm

### VAV Summary

Tracer Summit - [Graphic - 1st Floor FPB, DePriest]

File Connect Status View Go Setup Tools Window Help

#### First Floor Fan Powered and Vav Boxes

Serves	Room Temp	Cooling Setpt	Heat Active	Comm State	Air Flow Cfm	Supply Air Temp	Air Valve Position %	Served By	Unit Tag
F 1 065 Kitchen 123 South	71.3	70.0	Off	Up	1245	69.7	67.0	Ah 4	Fpb-E-1
F 1 066 Kitchen 123 North	73.6	70.0	Off	Up	2243	67.7	80.0	Ah 4	Fpb-F-1
V 1 067 Office 123A	70.3	70.0	Off	Up	130	65.8	58.0	Ah 4	Vav-A-1
F 1 068 Rooms 123,23B,23C	69.4	70.0	Off	Up	608	68.2	47.0	Ah 4	Fpb-E-2
F 1 069 Bldg Engineer 124	71.1	57.3	Off	Up	348	68.2	84.0	Ah 4	Fpb-A-1
V 1 070 Rooms 122A,122B	70.0	70.0	Off	Up	148	60.3	72.0	Ah 5	Vav-A-2
F 1 071 Conference 100D	69.8	70.0	Off	Up	117	68.6	53.0	Ah 5	Fpb-B-1
V 1 072 Off. 100C ,Corr. 111	70.9	70.0	Off	Up	343	71.0	71.0	Ah 5	Vav-B-1
V 1 073 Pantry 100H	68.5	72.0	Off	Up	0	21.0	21.0	Ah 5	Vav-A-3
F 1 074 Principal 100B	72.0	74.0	Off	Up	403	73.4	0.0	Ah 5	Fpb-C-1
F 1 075 Assist. Princ. 100A	71.1	72.0	Off	Up	111	70.1	47.0	Ah 5	Fpb-B-2
V 1 076 Business Office 100	72.7	75.0	On	Up	335	72.4	59.0	Ah 5	Vav-C-1
V 1 077 Lobby 101, Corr. 122	70.3	70.0	Off	Up	974	59.9	86.0	Ah 5	Vav-D-1
V 1 078 Nurse 101D	69.8	70.0	Off	Up	360	60.3	56.0	Ah 5	Vav-B-2
V 1 079 Counselor 101A	69.5	70.0	Off	Up	108	61.1	56.0	Ah 5	Vav-A-4
F 1 080 Corridor 188, Off. 101B	71.0	74.0	On	Up	108	72.0	25.0	Ah 5	Fpb-A-2
F 1 081 Offices 101C,101E	71.9	74.0	Off	Up	207	67.3	55.0	Ah 5	Fpb-B-3
V 1 082 Dishwash 121C, Stor.	71.3	74.0	On	Up	209	97.8	28.0	Ah 2	Vav-C-2
V 1 083 Corridors 149,150	73.9	74.0	Off	Up	312	62.4	25.0	Ah 2	Vav-D-2
F 1 084 Classroom 103	72.1	74.0	Off	Up	575	69.7	4.0	Ah 2	Fpb-F-2
F 1 085 Classroom 105	72.1	74.0	Off	Up	596	69.2	17.0	Ah 2	Fpb-F-3
F 1 086 Special Ed. 106	72.1	74.0	On	Up	310	72.0	47.0	Ah 2	Fpb-D-1
F 1 087 Special Ed. 108	73.7	76.0	On	Up	284	74.9	46.0	Ah 2	Fpb-D-2
F 1 088 Special Ed. 110	73.4	76.0	On	Up	289	69.7	40.0	Ah 2	Fpb-D-3
F 1 089 Classroom 109	72.2	74.0	Off	Up	592	68.7	17.0	Ah 2	Fpb-F-4
F 1 090 Classroom 113	72.2	74.0	Off	Up	622	68.7	18.0	Ah 2	Fpb-F-5
F 1 091 Classroom 112	72.4	74.0	Off	Up	422	69.6	17.0	Ah 2	Fpb-E-3
F 1 092 Classroom 114	72.2	74.0	Off	Up	432	68.7	17.0	Ah 2	Fpb-E-4
F 1 093 Classroom 117	71.8	74.0	On	Up	529	72.4	14.0	Ah 2	Fpb-F-6

04/12/05 17:04:04 Air Handler 4 Air Handler 5 Air Handler 2 Main Display

Room Numbers from Architects Plan Outdoor Air Temp 48.6 °

Envision for BACTalk - ABC/CPSNIGHT

BACTalk Edit View Tools Help

### 1st Floor Rooms

Room	Served By	Space Temp	Setpoint	Discharge	Fan Status	Sched Mode
Room 100	FC/AH-1-3N	71.0 °F	75.0	77.2 °F	Off	Occupied
Room 101	UV/AH-1-4N	72.0 °F	75.0	73.9 °F	Off	Occupied
Room 102	UV/AH-1-2N	71.0 °F	75.0	70.8 °F	Off	Occupied
Room 103	UV/AH-1-5N	71.5 °F	75.0	73.3 °F	Off	Occupied
Room 104	UV/AH-1-1N	70.0 °F	75.0	71.7 °F	Off	Occupied
Room 105	FC/AH-1-6N	70.5 °F	75.0	73.0 °F	Off	Occupied
Room 106	UV/AH-2-1S	71.0 °F	75.0	71.7 °F	Off	Occupied
Room 107	FC/AH-2-11S	70.0 °F	75.0	79.2 °F	Off	Occupied
Room 108	UV/AH-2-2S	70.0 °F	75.0	69.6 °F	Off	Occupied
Room 109	UV/AH-2-10S	69.5 °F	75.0	71.1 °F	Off	Occupied
Room 110	FC/AH-2-8S	69.5 °F	75.0	74.7 °F	Off	Occupied
Room 111	FC/AH-2-9S	67.5 °F	75.0	75.9 °F	Off	Occupied
Room 112	UV/AH-2-4S	66.5 °F	75.0	66.6 °F	Off	Occupied
Room 113	UV/AH-2-7S	67.5 °F	75.0	68.3 °F	Off	Occupied
Room 113A	FC/AH-2-7S	69.5 °F	75.0	79.0 °F	Off	Occupied
Room 114	UV/AH-2-5S	69.0 °F	75.0	69.7 °F	Off	Occupied
Room 115	UV/AH-2-6S	70.0 °F	75.0	70.7 °F	Off	Occupied
Room 116B/A. P. Office	FC/AH-2-3S	69.0 °F	75.0	72.0 °F	Off	Occupied
Room 166/Gym Office	FAN COIL	73.0 °F	75.0	72.0 °F	Off	Occupied
Auditorium	AHU-4	69.5 °F	75.0	69.5 °F	Running	Occupied
Gymnasium	AHU-3	72.0 °F	75.0	70.9 °F	Running	Occupied
Library	FC/AH-1-3N	72.0 °F	75.0	74.6 °F	Off	Occupied

start Envision for BACTalk - ... Floor Plan - 2nd Flr - ... 11:31 AM

SpencerServer - Microsoft Internet Explorer

File Edit View Favorites Tools Help

Address http://10.13.255.12/stations/SpencerServer/tree/whole.html

Outdoor Air Temp: 37.90 °F

Exhaust Fan	Command	Status	Alarm	Schedule
EF-1 N. Class Rm 1968 Addition	On	Off	Alarm	Occupied
EF-2 N. Class Rm 1968 Addition	On	Off	Alarm	Occupied
EF-3 N. Toilets 1968 Addition	On	Off	Alarm	Occupied
EF-4 N. Toilets 1968 Addition	On	Off	Alarm	Occupied
EF-5 Kitchen Hood	On	Off	Alarm	
EF-6 Dishwasher	On	Off	Alarm	
EF-7 Kitchen Toilet	On	Off	Alarm	Occupied
EF-8 Far North Storage Rm	On	Off	Alarm	Occupied
EF-9 Toilets 030A, 030B	On	On	Normal	Occupied
EF-10 Toilets 100A	On	On	Normal	Occupied
EF-11 Janitor Closets	On	On	Normal	Occupied
EF-12 Storage / Toilets	On	Off	Alarm	Occupied
EF-13 Toilets 020C, 107A	On	On	Normal	Occupied
EF-14 Basement Boys Toilet	On	Off	Alarm	Occupied
EF-15 Basement Girls Toilet	Off	Off	Normal	Occupied
EF-16 Principles Toilet	Off	Off	Normal	Occupied

Powered by Niagara Internet

# Fan Summary



# Control system summary

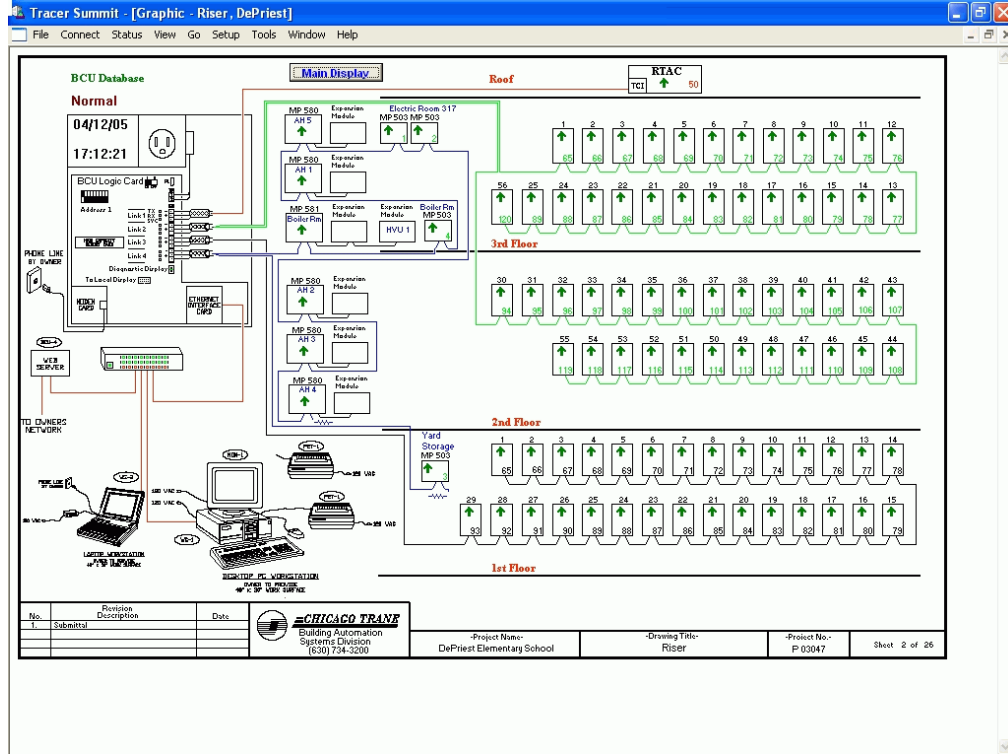

## Utility Data

Tracer Summit - [Graphic - Power Meter, DePriest]

File Connect Status View Go Setup Tools Window Help

### Power Meter

Elec_Meter_Current Phase A	???	Amps	Elec_Meter_Current Peak A	???	Amps
Elec_Meter_Current Phase B	???	Amps	Elec_Meter_Current Peak B	???	Amps
Elec_Meter_Current Phase C	???	Amps	Elec_Meter_Current Peak C	???	Amps
Elec_Meter_Voltage AB	???	Volts	Elec_Meter_Ph_A_pwr_real_KW	???	
Elec_Meter_Voltage BC	???	Volts	Elec_Meter_Ph_B_pwr_real_KW	???	
Elec_Meter_Voltage CA	???	Volts	Elec_Meter_Ph_C_pwr_real_KW	???	
Elec_Meter_Voltage AN	???	Volts	Elec_Meter_Ph_A_pwr_apparent_KVA	???	
Elec_Meter_Voltage BN	???	Volts	Elec_Meter_Ph_B_pwr_apparent_KVA	???	
Elec_Meter_Voltage CN	???	Volts	Elec_Meter_Ph_C_pwr_apparent_KVA	???	
Elec_Meter_pwr_real_KW	???		Elec_Meter_pf_Ph_A_displacement	???	
Elec_Meter_pwr_apparent_KVA	???		Elec_Meter_pf_Ph_B_displacement	???	
			Elec_Meter_pf_Ph_C_displacement	???	
Elec_Meter_peak_demand	???		Elec_Meter_pf_Ph_A_apparent	???	
Elec_Meter_KW/hr	???		Elec_Meter_pf_Ph_B_apparent	???	
Elec_Meter_KVahr	???		Elec_Meter_pf_Ph_C_apparent	???	
Elec_Meter_pf	???		Elec_Meter_KW/hr_forward	???	
Elec_Meter_freq	???		Elec_Meter_KW/hr_reverse	???	

[Main Display](#)

## Runtime graphic

Envision for BACTalk - CEC/MARSH

BACTalk Edit View Tools Help

### Equipment Runtimes

Device	Runtime	Alarm	Limit	Reset
S-1	27		1000	<input type="checkbox"/>
ER-1E	28		1000	<input type="checkbox"/>
HCP-S1	0		1000	<input type="checkbox"/>
S-2/3	49		1000	<input type="checkbox"/>
ER-2E	157		1000	<input type="checkbox"/>
HCP-S2	20		1000	<input type="checkbox"/>
ER-3E	51		1000	<input type="checkbox"/>
HCP-S3	20		1000	<input type="checkbox"/>
AHU-1	52		1000	<input type="checkbox"/>
ER-1	52		1000	<input type="checkbox"/>
PH-1	9		1000	<input type="checkbox"/>
AHU-2	51		1000	<input type="checkbox"/>
ER-2	52		1000	<input type="checkbox"/>
PH-2	1		1000	<input type="checkbox"/>
AHU-3	52		1000	<input type="checkbox"/>
ER-3	52		1000	<input type="checkbox"/>
PH-3	4		1000	<input type="checkbox"/>
CHP-1	39		1000	<input type="checkbox"/>
CHP-2	40		1000	<input type="checkbox"/>
PHP-W	0		1000	<input type="checkbox"/>
PHP-C	23		1000	<input type="checkbox"/>
PHP-E	0		1000	<input type="checkbox"/>
SHP-1	1		1000	<input type="checkbox"/>
SHP-2	354		1000	<input type="checkbox"/>

Main Menu

Previous

S-1

S-2

S-3

AHU-1

AHU-2

AHU-3

Chillers

Boilers

Device	Runtime	Alarm	Limit	Reset
TE-1 (Old)	0		1000	<input type="checkbox"/>
TE-2 (Old)	0		1000	<input type="checkbox"/>
TE-3 (Old)	0		1000	<input type="checkbox"/>
TE-1 (New)	0		1000	<input type="checkbox"/>
TE-2 (New)	0		1000	<input type="checkbox"/>

Key

No Runtime Alarm Present

Runtime Over Limit

## DIVISION 23 – HEATING, VENTILATING AND AIR CONDITIONING

### SECTION 23 21 13

#### HYDRONIC PIPING

##### PART 1 - GENERAL

###### 1.1 SUMMARY

- A. Section includes pipe and fitting materials, joining methods, special-duty valves, and specialties for the following:
  - 1. Condensate-drain piping.

###### 1.2 DEFINITIONS

- A. PTFE: Polytetrafluoroethylene.
- B. Concealed Locations: Spaces above ceilings, Spaces in Furred walls
- C. Finished Spaces: Spaces other than mechanical and electrical equipment rooms, furred spaces, pipe and duct shafts, unheated spaces immediately below roof, spaces above ceilings, unexcavated spaces, crawlspaces, and tunnels.
- D. Exposed, Interior Installations: Exposed to view indoors. Examples include finished occupied spaces and mechanical equipment rooms.

###### 1.3 SUBMITTALS

- A. Shop Drawings: Detail, at 1/4 scale, the piping layout, fabrication of pipe anchors, hangers, supports for multiple pipes, alignment guides, expansion joints and loops, and attachments of the same to the building structure. Detail location of anchors, alignment guides, and expansion joints and loops. Submittal shall be drawn in AutoCad latest edition. Copies of design drawings are not acceptable. Provide both AutoCad files and hard copies.”
- B. Field quality-control test reports.
  - 1. Submit written reports documenting the activities required to be performed in PART 3. These reports are to be submitted two weeks after the startup is completed.
- C. Record Drawings: Detail, at 1/4 scale, the actual piping installation layout, fabrication of pipe anchors, hangers, supports for multiple pipes, alignment guides, expansion joints and loops, and attachments of the same to the building structure. Detail location of anchors, alignment guides, and expansion joints and loops. Submittal shall be drawn in AutoCad latest edition. Provide both AutoCad files and hard copies.”

###### 1.4 QUALITY ASSURANCE

- A. Installer Qualifications:

1. Installers of Pressure-Sealed Joints: Installers shall be certified by the pressure-seal joint manufacturer as having been trained and qualified to join piping with pressure-seal pipe couplings and fittings.
- B. Steel Support Welding: Qualify processes and operators according to AWS D1.1/D1.1M, "Structural Welding Code - Steel."
- C. Welding: Qualify processes and operators according to ASME Boiler and Pressure Vessel Code: Section IX.
  1. Comply with provisions in ASME B31 Series, "Code for Pressure Piping."
  2. Certify that each welder has passed AWS qualification tests for welding processes involved and that certification is current.
  3. All welders certificates shall be on file at project site

#### 1.5 DELIVERY, STORAGE AND HANDLING

- A. Follow manufacturer's recommendations for handling, unloading and storage.
- B. Storage: Store per manufacturer's written recommendations. Store indoors in a warm, clean, dry place where pipe will be protected from weather, construction traffic, dirt, dust, water and moisture.

#### 1.6 WARRANTY

- A. Written manufacturers warranty covering parts and labor for a period of one year from substantial completion, or eighteen months from shipment, whichever is longer.

### PART 2 - PRODUCTS

#### 2.1 MANUFACTURERS

- A. Subject to compliance with requirements, provide products by one of the following manufacturers:
  1. Wrought Copper Tube and Fittings: No preference.
  2. Copper or Bronze Pressure-Seal Fittings:
    - a. Stadler-Viega.
    - b. Nibco

#### 2.2 COPPER TUBE AND FITTINGS

- A. Drawn-Temper Copper Tubing: ASTM B 88, Type L.
- B. Annealed-Temper Copper Tubing: ASTM B 88, Type K (below ground installations).
- C. Wrought-Copper Fittings: ASME B16.22.
- D. Copper or Bronze Pressure-Seal Fittings:



1. Housing: Copper.
2. O-Rings and Pipe Stops: EPDM.
3. Tools: Manufacturer's special tools.
4. Minimum 200-psig working-pressure rating at 250 deg F.

## 2.3 JOINING MATERIALS

- A. Brazing Filler Metals: AWS A5.8, BCuP Series, copper-phosphorus alloys for joining copper with copper; or BA9-1, silver alloy for joining copper with bronze or steel.

## PART 3 - EXECUTION

### 3.1 PIPING APPLICATIONS

- A. Condensate-Drain Piping: Type L, drawn-temper copper tubing, wrought-copper fittings, and soldered joints

### 3.2 PIPING INSTALLATIONS

- A. Drawing plans, schematics, and diagrams indicate general location and arrangement of piping systems. Indicate piping locations and arrangements if such were used to size pipe and calculate friction loss, expansion, pump sizing, and other design considerations. Install piping as indicated unless deviations to layout are approved on Coordination Drawings.
- B. Install piping in concealed locations, unless otherwise indicated and except in equipment rooms and service areas.
- C. Install piping indicated to be exposed and piping in equipment rooms and service areas at right angles or parallel to building walls. Diagonal runs are prohibited unless specifically indicated otherwise.
- D. Install piping above accessible ceilings to allow sufficient space for ceiling panel removal.
- E. Install piping to permit valve servicing.
- F. Install piping at indicated slopes.
- G. Install piping free of sags and bends.
- H. Install fittings for changes in direction and branch connections.
- I. Install piping to allow application of insulation.
- J. Select system components with pressure rating equal to or greater than system operating pressure.
- K. Grooved Joints: Assemble joints with coupling and gasket, lubricant, and bolts. Cut or roll grooves in ends of pipe based on pipe and coupling manufacturer's written instructions for pipe wall thickness. Use grooved-end fittings and rigid, grooved-end-pipe couplings.

- L. Install drains, consisting of a tee fitting, NPS 3/4 ball valve, and short NPS 3/4 threaded nipple with cap, at low points in piping system mains and elsewhere as required for system drainage.
- M. Install piping at a uniform grade of 0.2 percent upward in direction of flow.
- N.

### 3.3 HANGERS AND SUPPORTS

- A. Hanger, support, and anchor devices are specified in Division 23. Comply with the following requirements for maximum spacing of supports.
- B. Install the following pipe attachments:
  1. Adjustable steel clevis hangers for individual horizontal piping less than 20 feet long.
  2. Adjustable roller hangers and spring hangers for individual horizontal piping 20 feet or longer.
  3. Pipe Roller: MSS SP-58, Type 44 for multiple horizontal piping 20 feet or longer, supported on a trapeze.
  4. Spring hangers to support vertical runs.
  5. Provide copper-clad hangers and supports for hangers and supports in direct contact with copper pipe.
- C. Install hangers for drawn-temper copper piping with the following maximum spacing and minimum rod sizes:
  1. NPS 3/4: Maximum span, 5 feet; minimum rod size, 1/4 inch.
  2. NPS 1: Maximum span, 6 feet; minimum rod size, 1/4 inch.
  3. NPS 1-1/2: Maximum span, 8 feet; minimum rod size, 3/8 inch.
  4. NPS 2: Maximum span, 8 feet; minimum rod size, 3/8 inch.
  5. NPS 2-1/2: Maximum span, 9 feet; minimum rod size, 3/8 inch.
  6. NPS 3: Maximum span, 10 feet; minimum rod size, 3/8 inch.
  7. NPS 4: Maximum span, 10 feet; minimum rod size, 3/8 inch.

### 3.4 PIPE JOINT CONSTRUCTION

- A. Join pipe and fittings according to the following requirements and Division 22 Sections specifying piping systems.
- B. Ream ends of pipes and tubes and remove burrs. Bevel plain ends of steel pipe.
- C. Remove scale, slag, dirt, and debris from inside and outside of pipe and fittings before assembly.
- D. Soldered Joints: Apply ASTM B 813, water-flushable flux, unless otherwise indicated, to tube end. Construct joints according to ASTM B 828 or CDA's "Copper Tube Handbook," using lead-free solder alloy complying with ASTM B 32.
- E. Brazed Joints: Construct joints according to AWS's "Brazing Handbook," "Pipe and Tube" Chapter, using copper-phosphorus brazing filler metal complying with AWS A5.8.

- F. Welded Joints: Construct joints according to AWS D10.12/D10.12M, using qualified processes and welding operators according to Part 1 "Quality Assurance" Article.
- G. Flanged Joints: Select appropriate gasket material, size, type, and thickness for service application. Install gasket concentrically positioned. Use suitable lubricants on bolt threads.
- H. Pressure-Sealed Joints: Use manufacturer-recommended tool and procedure. Leave insertion marks on pipe after assembly.

### 3.5 HYDRONIC SPECIALTIES INSTALLATION

- A. Install automatic air vents at high points of system piping in mechanical equipment rooms only. Manual vents at heat-transfer coils and elsewhere as required for air venting.
- B. Install piping from boiler air outlet or air separator to expansion tank with a 2 percent upward slope toward tank.
- C. Install tangential air separator in pump suction. Install blowdown piping with gate or full-port ball valve; extend full size to nearest floor drain.

***RETAIN ONE OF TWO PARAGRAPHS AND ASSOCIATED SUBPARAGRAPHS BELOW. RENOVATION PROJECTS MAY REQUIRE TANK SUPPORT AT CEILING LEVEL. CPS PREFERENCE IS TO PROVIDE FLOOR MOUNTED BLADDER TANKS WHERE POSSIBLE.***

- D. Install bladder tanks per manufacturer's instructions. Install tank fitting and charge tank. Use manual vent for initial fill to establish proper water level in tank.
  - 1. Install tank fittings that are shipped loose.
  - 2. Support tank from floor or structure above with sufficient strength to carry weight of tank, piping connections, fittings, plus tank full of water. Do not overload building components and structural members.
- E. Install expansion tanks on the floor. Vent and purge air from hydronic system, and ensure tank is properly charged with air to suit system Project requirements.
- F. Provide 4" concrete pad beneath pressure fill systems. Install per manufacturers recommendations. Select associated pressure regulators for required system fill pressure in mid span of regulator range.

### 3.6 TERMINAL EQUIPMENT CONNECTIONS

- A. Sizes for supply and return piping connections shall be the same as or larger than equipment connections.
- B. Install control valves in accessible locations close to connected equipment.
- C. Install ports for pressure gages and thermometers at coil inlet and outlet connections according to Division 23.

### 3.7 CHEMICAL TREATMENT

- A. Perform an analysis of makeup water to determine type and quantities of chemical treatment needed to keep system free of scale, corrosion, and fouling, and to sustain the following water characteristics:
- B. Provide cleaning and chemical treatment per 15189 specification.
- C. Add initial chemical treatment and maintain water quality as recommended by chemical treatment company for the first year of operation.

***DELETE THE FOLLOWING PARAGRAPH AND ASSOCIATED PARAGRAPHS IF GLYCOL IS NOT USED. EDIT THE FOLLOWING PARAGRAPHS IF GLYCOL IS USED FOR GLYCOL TYPE AND % BY VOLUME MIX. 30% IS STANDARD. ETHYLENE GLYCOL MAY ONLY BE USED IN EXISTING SYSTEMS WHICH WERE ORIGINALLY DESIGNED WITH ETHYLENE GLYCOL.***

- D. Fill systems indicated to have antifreeze or glycol solutions with the following concentrations:
  - 1. Hot-Water Heating Piping: Minimum 30 percent propylene **[ethylene]** glycol.
  - 2. Chilled-Water Piping: Minimum 30 percent propylene **[ethylene]** glycol.
  - 3. Dual-Temperature Heating and Cooling Water Piping: Minimum 30 percent propylene **[ethylene]** glycol.

### 3.8 FIELD QUALITY CONTROL

- A. Prepare hydronic piping according to ASME B31.9 and as follows:
  - 1. Leave joints, including welds, uninsulated and exposed for examination during test.
  - 2. Provide temporary restraints for expansion joints that cannot sustain reactions due to test pressure. If temporary restraints are impractical, isolate expansion joints from testing.
  - 3. Flush hydronic piping systems with clean water; then remove and clean or replace strainer screens.
  - 4. Isolate equipment from piping. If a valve is used to isolate equipment, its closure shall be capable of sealing against test pressure without damage to valve. Install blinds in flanged joints to isolate equipment.
  - 5. Install safety valve, set at a pressure no more than one-third higher than test pressure, to protect against damage by expanding liquid or other source of overpressure during test.
- B. Perform the following tests on hydronic piping:
  - 1. Use ambient temperature water as a testing medium unless there is risk of damage due to freezing. Another liquid that is safe for workers and compatible with piping may be used (compressed air may not be used).
  - 2. While filling system, use vents installed at high points of system to release air. Use drains installed at low points for complete draining of test liquid.
  - 3. Isolate expansion tanks and determine that hydronic system is full of water.

4. Subject piping system to hydrostatic test pressure that is not less than 1.5 times the system's working pressure. Test pressure shall not exceed maximum pressure for any vessel, pump, valve, or other component in system under test. Verify that stress due to pressure at bottom of vertical runs does not exceed 90 percent of specified minimum yield strength or 1.7 times "SE" value in Appendix A in ASME B31.9, "Building Services Piping."
5. After hydrostatic test pressure has been applied for at least 10 minutes, examine piping, joints, and connections for leakage. Eliminate leaks by tightening, repairing, or replacing components, and repeat hydrostatic test until there are no leaks.
6. Prepare written report of testing.

C. Perform the following before operating the system:

1. Open manual valves fully.
2. Inspect pumps for proper rotation.
3. Set makeup pressure-reducing valves for required system pressure.
4. Inspect air vents at high points of system and determine if all are installed and operating freely (automatic type), or bleed air completely (manual type).
5. Set temperature controls so all coils are calling for full flow.
6. Inspect and set operating temperatures of hydronic equipment, such as boilers, chillers, cooling towers, to specified values.
7. Verify lubrication of motors and bearings.

### 3.9 COMMISSIONING AND DEMONSTRATION

- A. Engage a factory-authorized service representative to train Owner's maintenance personnel to adjust, operate, and maintain equipment. Refer to Division 01 Section "Demonstration and Training."
1. Train Owner's maintenance personnel on procedures and schedules for starting up and shutting down, troubleshooting, servicing, and maintaining the pressure fill system and other applicable equipment. The training will occur after the startup report has been provided to the owner and the trainer will provide two (2) Installation and Operations manuals for the use of the owner's personnel during training.
  2. Review data in maintenance manuals. Refer to Division 01 Section "Operation and Maintenance Data." All required and recommended maintenance will be reviewed as well as operational trouble shooting. If the IOM does not include a written trouble shooting guide one will be provided.
  3. Schedule training with Owner, through Architect, with at least seven days' advance notice.
  4. Training will occur in one (1) two (2) hour session.
- B. Demonstrate proper operation of equipment to commissioning agent or designated owners personnel. The scope of the demonstration will include functional performance requirements under both local and building automation control as well as any commissioning requirements in Division 01 and 23.
- C. Video record the training sessions. The manufacturer may submit a standard training video training CD for review as an alternate to videotaping of the training session. The standard video

must be reviewed and accepted by the owner/commissioning authority for the alternate to be acceptable.

END OF SECTION

## DIVISION 23 – HEATING, VENTILATING AND AIR CONDITIONING

### SECTION 23 23 00

#### REFRIGERANT PIPING

##### PART 1 - GENERAL

###### 1.1 SUMMARY

- A. Section includes refrigerant piping used for air-conditioning applications.

###### 1.2 SUBMITTALS

- A. Product Data: For each type of valve and refrigerant piping specialty indicated. Include pressure drop, based on manufacturer's test data, for the following:

1. Thermostatic expansion valves.
2. Solenoid valves.
3. Hot-gas bypass valves.
4. Filter dryers.
5. Strainers.
6. Pressure-regulating valves.

- B. Shop Drawings: Show layout of refrigerant piping and specialties, including pipe, tube, and fitting sizes, flow capacities, valve arrangements and locations, slopes of horizontal runs, oil traps, double risers, wall and floor penetrations, and equipment connection details. Show interface and spatial relationships between piping and equipment.

1. Shop Drawing Scale: 1/4 inch equals 1 foot.

- C. Welding certificates.

- D. Field quality-control test reports.

1. Submit written reports documenting the activities required to be performed in PART 3. These reports are to be submitted two weeks after the startup is completed.

- E. Operation and Maintenance Data: For refrigerant valves and piping specialties to include in maintenance manuals.

###### 1.3 QUALITY ASSURANCE

- A. Welding: Qualify procedures and personnel according to ASME Boiler and Pressure Vessel Code: Section IX, "Welding and Brazing Qualifications."

- B. Comply with ASHRAE 15, "Safety Code for Refrigeration Systems."

- C. Comply with ASME B31.5, "Refrigeration Piping and Heat Transfer Components."

#### 1.4 DELIVERY STORAGE AND HANDLING

- A. Store piping in a clean and protected area with end caps in place to ensure that piping interior and exterior are clean when installed.

#### 1.5 COORDINATION

- A. Coordinate size and location of roof curbs, equipment supports, and roof penetrations. These items are specified in Division 07 Section "Roof Accessories."

#### 1.6 PERFORMANCE REQUIREMENTS

- A. Line Test Pressure for Refrigerant R-410A:
  - 1. Suction Lines for Air-Conditioning Applications: 300 psig.
  - 2. Suction Lines for Heat-Pump Applications: 535 psig.
  - 3. Hot-Gas and Liquid Lines: 535 psig.

### **PART 2 - PRODUCTS**

#### 2.1 MANUFACTURERS:

- A. Subject to compliance with requirements, provide products by one of the following manufacturers:
  - 1. Refrigerants:
    - a. Atofina Chemicals, Inc.
    - b. DuPont Company; Fluorochemicals Div.
    - c. Honeywell, Inc.; Genetron Refrigerants.
    - d.

#### 2.2 COPPER TUBE AND FITTINGS

- A. Copper Tube: ASTM B 280, Type ACR or type K complying with ASTM B88 or ASTM B819.
- B. Wrought-Copper Fittings: ASME B16.22.
- C. Wrought-Copper Unions: ASME B16.22.
- D. Brazing Filler Metals: AWS A5.8.
- E. Flexible Connectors:
  - 1. Body: Tin-bronze bellows with woven, flexible, tinned-bronze-wire-reinforced protective jacket.
  - 2. End Connections: Socket ends.
  - 3. Offset Performance: Capable of minimum 3/4-inch (20-mm) misalignment in minimum 7-inch- (180-mm-) long assembly.
  - 4. Pressure Rating: Factory test at minimum 500 psig (3450 kPa).
  - 5. Maximum Operating Temperature: 250 deg F (121 deg C).



## 2.3 STEEL PIPE AND FITTINGS

- A. Steel Pipe: ASTM A 53/A 53M, black steel with plain ends; Type, Grade, and wall thickness as selected in PART 3 piping applications articles.
- B. Wrought-Steel Fittings: ASTM A 234/A 234M, for welded joints.
- C. Steel Flanges and Flanged Fittings: ASME B16.5, steel, including bolts, nuts, and gaskets, bevel-welded end connection, and raised face.
- D. Welding Filler Metals: Comply with AWS D10.12/D10.12M for welding materials appropriate for wall thickness and chemical analysis of steel pipe being welded.
- E. Flanged Unions:
  - 1. Body: Forged-steel flanges for NPS 1 to NPS 1-1/2 and ductile iron for NPS 2 to NPS 3. Apply rust-resistant finish at factory.
  - 2. Gasket: Fiber asbestos free.
  - 3. Fasteners: Four plated-steel bolts, with silicon bronze nuts. Apply rust-resistant finish at factory.
  - 4. End Connections: Brass tailpiece adapters for brazed-end connections to copper tubing.
  - 5. Offset Performance: Capable of minimum 3/4-inch (20-mm) misalignment in minimum 7-inch- long assembly.
  - 6. Pressure Rating: Factory test at minimum 400 psig.
  - 7. Maximum Operating Temperature: 330 deg F.
- F. Flexible Connectors:
  - 1. Body: Stainless-steel bellows with woven, flexible, stainless-steel-wire-reinforced protective jacket
  - 2. End Connections:
    - a. NPS 2 and Smaller: With threaded-end connections.
    - b. NPS 2-1/2 and Larger: With flanged-end connections.
  - 3. Offset Performance: Capable of minimum 3/4-inch misalignment in minimum 7-inch- long assembly.
  - 4. Pressure Rating: Factory test at minimum 500 psig.
  - 5. Maximum Operating Temperature: 250 deg F.

## 2.4 VALVES AND SPECIALTIES

- A. Diaphragm Packless Valves:
  - 1. Body and Bonnet: Forged brass or cast bronze; globe design with straight-through or angle pattern.
  - 2. Diaphragm: Phosphor bronze and stainless steel with stainless-steel spring.
  - 3. Operator: Rising stem and hand wheel.
  - 4. Seat: Nylon.
  - 5. End Connections: Socket, union, or flanged.
  - 6. Working Pressure Rating: 500 psig.
  - 7. Maximum Operating Temperature: 275 deg F.
- B. Packed-Angle Valves:

1. Body and Bonnet: Forged brass or cast bronze.
2. Packing: Molded stem, back seating, and replaceable under pressure.
3. Operator: Rising stem.
4. Seat: Nonrotating, self-aligning polytetrafluoroethylene.
5. Seal Cap: Forged-brass or valox hex cap.
6. End Connections: Socket, union, threaded, or flanged.
7. Working Pressure Rating: 500 psig.
8. Maximum Operating Temperature: 275 deg F.

C. Check Valves:

1. Body: Ductile iron, forged brass, or cast bronze; globe pattern.
2. Bonnet: Bolted ductile iron, forged brass, or cast bronze; or brass hex plug.
3. Piston: Removable polytetrafluoroethylene seat.
4. Closing Spring: Stainless steel.

D. Service Valves:

1. Body: Forged brass with brass cap including key end to remove core.
2. Core: Removable ball-type check valve with stainless-steel spring.
3. Seat: Polytetrafluoroethylene.
4. End Connections: Copper spring.
5. Working Pressure Rating: 500 psig.

E. Solenoid Valves: Comply with ARI 760 and UL 429; listed and labeled by an NRTL.

1. Body and Bonnet: Plated steel.
2. Solenoid Tube, Plunger, Closing Spring, and Seat Orifice: Stainless steel.
3. Seat: Polytetrafluoroethylene.
4. End Connections: Threaded.
5. Electrical: Molded, watertight coil in NEMA 250 enclosure of type required by location with 1/2-inch (16-GRC) conduit adapter, and 115-V ac coil.
6. Working Pressure Rating: 400 psig.
7. Maximum Operating Temperature: 240 deg F.
8. Manual operator.

F. Safety Relief Valves: Comply with ASME Boiler and Pressure Vessel Code; listed and labeled by an NRTL.

1. Body and Bonnet: Ductile iron and steel, with neoprene O-ring seal.
2. Piston, Closing Spring, and Seat Insert: Stainless steel.
3. Seat Disc: Polytetrafluoroethylene.
4. End Connections: Threaded.
5. Working Pressure Rating: 400 psig.
6. Maximum Operating Temperature: 240 deg F.

G. Thermostatic Expansion Valves: Comply with ARI 750.

1. Body, Bonnet, and Seal Cap: Forged brass or steel.
2. Diaphragm, Piston, Closing Spring, and Seat Insert: Stainless steel.
3. Packing and Gaskets: Non-asbestos
4. Capillary and Bulb: Copper tubing filled with refrigerant charge.
5. Suction Temperature: See Equipment Schedules
6. Superheat: Adjustable.
7. Reverse-flow option (for heat pump applications).

8. End Connections; Socket, flare, or threaded union.
9. Working Pressure Rating: 700 psig.

H. Hot-Gas Bypass Valves: Comply with UL 429, listed and labeled by NRTL.

1. Body, Bonnet, and Seal Cap: Ductile iron or steel.
2. Diaphragm, Piston, Closing Spring, and Seat Insert: Stainless steel.
3. Packing and Gaskets: Non-asbestos.
4. Solenoid Tube, Plunger, Closing Spring, and Seat Orifice: Stainless steel.
5. Seat: Polytetrafluoroethylene.
6. Equalizer: Internal or External.
7. Electrical: Molded, watertight coil in NEMA 250 enclosure of type required by location with 1/2-inch conduit adapter, and [24] [115] [208]-V ac coil.
8. End connections: Socket.
9. Set Pressure: As required.
10. Throttling Range: Maximum 5 psig.
11. Working Pressure Range: 500 psig.
12. Maximum Operating temperature: 240 deg F.

I. Straight-Type Strainers:

1. Body: Welded steel with corrosion-resistant coating.
2. Screen: 100-mesh stainless steel.
3. End Connections: Socket or flare.
4. Working Pressure Rating: 500 psig.
5. Maximum Operating Temperature: 275 deg F.

J. Angle-Type Strainers:

1. Body: Forged brass or cast bronze.
2. Drain Plug: Brass hex plug.
3. Screen: 100-mesh monel.
4. End Connections: Socket or flare.
5. Working Pressure Rating: 500 psig.
6. Maximum Operating Temperature: 275 deg F.

K. Moisture/Liquid Indicators:

1. Body: Forged brass.
2. Window: Replaceable, clear, fused glass window with indicating element protected by filter screen.
3. Indicator: Color coded to show moisture content in ppm.
4. Minimum Moisture Indicator Sensitivity: Indicate moisture above 60 ppm.
5. End Connections: Socket or flare.
6. Working Pressure Rating: 500 psig.
7. Maximum Operating Temperature: 240 deg F.

L. Replaceable-Core Filter Dryers: Comply with ARI 730.

1. Body and Cover: Painted-steel shell with ductile-iron cover, stainless-steel screws, and neoprene gaskets.
2. Filter Media: 10 micron, pleated with integral end rings; stainless-steel support.
3. Desiccant Media: Activated charcoal.
4. End Connections: Socket.

5. Access Ports: NPS 1/4 connections at entering and leaving sides for pressure differential measurement.
6. Maximum Pressure Loss: 2 psig.
7. Rated Flow: 1.5 tons
8. Working Pressure Rating: 500 psig.
9. Maximum Operating Temperature: 240 deg F.

M. Permanent Filter Dryers: Comply with ARI 730.

1. Body and Cover: Painted-steel shell.
2. Filter Media: 10 micron, pleated with integral end rings; stainless-steel support.
3. Desiccant Media: Activated charcoal.
4. End Connections: Socket.
5. Access Ports: NPS 1/4 connections at entering and leaving sides for pressure differential measurement.
6. Maximum Pressure Loss: 2 psig.
7. Rated Flow: 1.5 tons
8. Working Pressure Rating: 500 psig.
9. Maximum Operating Temperature: 240 deg F.

N. Mufflers:

1. Body: Welded steel with corrosion-resistant coating.
2. End Connections: Socket or flare.
3. Working Pressure Rating: 500 psig.
4. Maximum Operating Temperature: 275 deg F.

O. Receivers: Comply with ARI 495.

1. Comply with ASME Boiler and Pressure Vessel Code; listed and labeled by an NRTL.
2. Comply with UL 207; listed and labeled by an NRTL.
3. Body: Welded steel with corrosion-resistant coating.
4. Tappings: Inlet, outlet, liquid level indicator, and safety relief valve.
5. End Connections: Socket or threaded.
6. Working Pressure Rating: 500 psig.
7. Maximum Operating Temperature: 275 deg F.

P. Liquid Accumulators: Comply with ARI 495.

1. Body: Welded steel with corrosion-resistant coating.
2. End Connections: Socket or threaded.
3. Working Pressure Rating: 500 psig.
4. Maximum Operating Temperature: 275 deg F.

## 2.5 REFRIGERANTS

A. Manufacturers: Subject to compliance with requirements, provide products by one of the following:

1. Atofina Chemicals, Inc.
2. DuPont Company; Fluorochemicals Div.
3. Honeywell, Inc.; Genetron Refrigerants.
4. INEOS Fluor Americas LLC.

B. ASHRAE 34, R-22: Monochlorodifluoromethane.

- C. ASHRAE 34, R-134a: Tetrafluoroethane.
- D. ASHRAE 34, R-407C: Difluoromethane/Pentafluoroethane/1,1,1,2-Tetrafluoroethane.
- E. ASHRAE 34, R-410A: Pentafluoroethane/Difluoromethane.

## **PART 3 - EXECUTION**

### **3.1 REFRIGERANT PIPE SIZING:**

- A. All refrigerant pipe sizing shall be the responsibility of the Contractor in accordance with the equipment manufacturer's recommendations.
- B. Pipe sizing shall be in accordance with the recommendations in the 2010 ASHRAE Handbook – Refrigeration, Chapter 2 – System Practices for Halocarbon Refrigerants.
- C. Refrigerant piping indicated on Drawings is schematic only. Size piping and design actual piping layout, including oil traps, double risers, specialties, and pipe and tube sizes to accommodate, as a minimum, equipment provided, elevation difference between compressor and evaporator, and length of piping to ensure proper operation and compliance with warranties of connected equipment.

### **3.2 PIPING APPLICATIONS FOR REFRIGERANT R-410A**

- A. Suction Lines NPS 3-1/2 and Smaller for Conventional Air-Conditioning Applications: Copper, Type ACR, drawn-temper tubing and wrought-copper fittings with brazed or soldered joints.
- B. Hot-Gas and Liquid Lines: Copper, Type ACR, annealed- or drawn-temper tubing and wrought-copper fittings with brazed or soldered joints.
- C. Hot-Gas and Liquid Lines: Copper, Type ACR, drawn-temper tubing and wrought-copper fittings with 95-5 tin-antimony brazed joints.
- D. Safety-Relief-Valve Discharge Piping: Copper, Type ACR, annealed- or drawn-temper tubing and wrought-copper fittings with brazed joints.

### **3.3 VALVE AND SPECIALTY APPLICATIONS**

- A. Install packed-angle valves in suction and discharge lines of compressor.
- B. Install service valves for gage taps at inlet and outlet of hot-gas bypass valves and strainers if they are not an integral part of valves and strainers.
- C. Install a check valve at the compressor discharge and a liquid accumulator at the compressor suction connection.
- D. Except as otherwise indicated, install packed-angle valves on inlet and outlet side of filter dryers.
- E. Install a full-sized, three-valve bypass around filter dryers.
- F. Install solenoid valves upstream from each expansion valve and hot-gas bypass valve. Install solenoid valves in horizontal lines with coil at top.

- G. Install thermostatic expansion valves as close as possible to distributors on evaporators.
  - 1. Install valve so diaphragm case is warmer than bulb.
  - 2. Secure bulb to clean, straight, horizontal section of suction line using two bulb straps. Do not mount bulb in a trap or at bottom of the line.
  - 3. If external equalizer lines are required, make connection where it will reflect suction-line pressure at bulb location.
- H. Install safety relief valves where required by ASME Boiler and Pressure Vessel Code. Pipe safety-relief-valve discharge line to outside according to ASHRAE 15.
- I. Install moisture/liquid indicators in liquid line at the inlet of the thermostatic expansion valve or at the inlet of the evaporator coil capillary tube.
- J. Install strainers upstream from and adjacent to the following unless they are furnished as an integral assembly for device being protected:
  - 1. Solenoid valves.
  - 2. Thermostatic expansion valves.
  - 3. Compressor.
- K. Install filter dryers in liquid line between compressor and thermostatic expansion valve, and in the suction line at the compressor.
- L. Install receivers sized to accommodate pump-down charge.
- M. Install flexible connectors at compressors.

### 3.4 PIPING INSTALLATION

- A. Drawing plans, schematics, and diagrams indicate general location and arrangement of piping systems; indicated locations and arrangements were used to size pipe and calculate friction loss, expansion, pump sizing, and other design considerations. Install piping as indicated unless deviations to layout are approved on Shop Drawings.
- B. Install refrigerant piping according to ASHRAE 15.
- C. Install piping in concealed locations unless otherwise indicated and except in equipment rooms and service areas.
- D. Install piping indicated to be exposed and piping in equipment rooms and service areas at right angles or parallel to building walls. Diagonal runs are prohibited unless specifically indicated otherwise.
- E. Install piping above accessible ceilings to allow sufficient space for ceiling panel removal.
- F. Install piping adjacent to machines to allow service and maintenance.
- G. Install piping free of sags and bends.
- H. Install fittings for changes in direction and branch connections.
- I. Select system components with pressure rating equal to or greater than system operating pressure.

- J. Refer to Division 23 Sections "Building Automation System (BAS)" and "Building Automation System (BAS) - Sequence of Operation" for solenoid valve controllers, control wiring, and sequence of operation.
- K. Install piping as short and direct as possible, with a minimum number of joints, elbows, and fittings.
- L. Arrange piping to allow inspection and service of refrigeration equipment. Install valves and specialties in accessible locations to allow for service and inspection. Install access doors or panels as specified in Division 08 Section "Access Doors and Frames" if valves or equipment requiring maintenance is concealed behind finished surfaces.
- M. Install refrigerant piping in protective conduit where installed belowground.
- N. Install refrigerant piping in rigid or flexible conduit in locations where exposed to mechanical injury.
- O. Slope refrigerant piping as follows:
  1. Install horizontal suction lines with a uniform slope downward to compressor.
  2. Install traps and double risers to entrain oil in vertical runs.
  3. Liquid lines may be installed level.
- P. When brazing , remove solenoid-valve coils and sight glasses; also remove valve stems, seats, and packing, and accessible internal parts of refrigerant specialties. Do not apply heat near expansion-valve bulb.
- Q. Install pipe sleeves at penetrations in exterior walls and floor assemblies.
- R. Seal penetrations through fire and smoke barriers according to Division 07 Section "Penetration Firestopping."
- S. Install piping with adequate clearance between pipe and adjacent walls and hangers or between pipes for insulation installation.
- T. Install sleeves through floors, walls, or ceilings, sized to permit installation of full-thickness insulation.
- U. Seal pipe penetrations through exterior walls according to Division 07 Section "Joint Sealants" for materials and methods.
- V. Identify refrigerant piping and valves according to Division 23 Section "Identification for HVAC."

### 3.5 PIPE JOINT CONSTRUCTION

- A. Ream ends of pipes and tubes and remove burrs. Bevel plain ends of steel pipe.
- B. Remove scale, slag, dirt, and debris from inside and outside of pipe and fittings before assembly.
- C. Brazed Joints: Construct joints according to AWS's "Brazing Handbook," Chapter "Pipe and Tube."

1. Use Type BcuP, copper-phosphorus alloy for joining copper socket fittings with copper pipe.
  2. Use Type BAg, cadmium-free silver alloy for joining copper with bronze or steel.
- D. Threaded Joints: Thread steel pipe with tapered pipe threads according to ASME B1.20.1. Cut threads full and clean using sharp dies. Ream threaded pipe ends to remove burrs and restore full ID. Join pipe fittings and valves as follows:
1. Apply appropriate tape or thread compound to external pipe threads unless dry-seal threading is specified.
  2. Damaged Threads: Do not use pipe or pipe fittings with threads that are corroded or damaged. Do not use pipe sections that have cracked or open welds.
- E. Steel pipe can be threaded, but threaded joints must be seal brazed or seal welded.
- F. Welded Joints: Construct joints according to AWS D10.12/D10.12M.
- G. Flanged Joints: Select appropriate gasket material, size, type, and thickness for service application. Install gasket concentrically positioned. Use suitable lubricants on bolt threads.

### 3.6 HANGERS AND SUPPORTS

- A. Hanger, support, and anchor products are specified in Division 23 Section "Hangers and Supports for Piping and Equipment."
- B. Install the following pipe attachments:
1. Adjustable steel clevis hangers for individual horizontal runs less than 20 feet (6 m) long.
  2. Roller hangers and spring hangers for individual horizontal runs 20 feet (6 m) or longer.
  3. Pipe Roller: MSS SP-58, Type 44 for multiple horizontal piping 20 feet (6 m) or longer, supported on a trapeze.
  4. Spring hangers to support vertical runs.
  5. Copper-clad hangers and supports for hangers and supports in direct contact with copper pipe.
- C. Install hangers for copper tubing with the following maximum spacing and minimum rod sizes:
1. NPS 1/2: Maximum span, 60 inches; minimum rod size, 1/4 inch.
  2. NPS 5/8: Maximum span, 60 inches; minimum rod size, 1/4 inch.
  3. NPS 1: Maximum span, 72 inches; minimum rod size, 1/4 inch.
  4. NPS 1-1/4: Maximum span, 96 inches; minimum rod size, 3/8 inch.
  5. NPS 1-1/2: Maximum span, 96 inches; minimum rod size, 3/8 inch.
  6. NPS 2: Maximum span, 96 inches; minimum rod size, 3/8 inch.
  7. NPS 2-1/2: Maximum span, 108 inches; minimum rod size, 3/8 inch.
  8. NPS 3: Maximum span, 10 feet; minimum rod size, 3/8 inch.
  9. NPS 4: Maximum span, 12 feet; minimum rod size, 1/2 inch.
- D. Install hangers for steel piping with the following maximum spacing and minimum rod sizes:
1. NPS 2: Maximum span, 10 feet; minimum rod size, 3/8 inch.
  2. NPS 2-1/2: Maximum span, 11 feet; minimum rod size, 3/8 inch.
  3. NPS 3: Maximum span, 12 feet; minimum rod size, 3/8 inch.
  4. NPS 4: Maximum span, 14 feet; minimum rod size, 1/2 inch.



- E. Support multifloor vertical runs at least at each floor.

### 3.7 FIELD QUALITY CONTROL

- A. Perform tests and inspections and prepare test reports.
- B. Tests and Inspections:
  - 1. Comply with ASME B31.5, Chapter VI.
  - 2. Test refrigerant piping, specialties, and receivers. Isolate compressor, condenser, evaporator, and safety devices from test pressure if they are not rated above the test pressure.
  - 3. Test high- and low-pressure side piping of each system separately at not less than the pressures indicated in Part 1 "Performance Requirements" Article.
    - a. Fill system with nitrogen to the required test pressure.
    - b. System shall maintain test pressure at the manifold gage throughout duration of test.
    - c. Test joints and fittings with electronic leak detector or by brushing a small amount of soap and glycerin solution over joints.
    - d. Remake leaking joints using new materials, and retest until satisfactory results are achieved.

### 3.8 SYSTEM CHARGING

- A. Charge system using the following procedures:
  - 1. Install core in filter dryers after leak test but before evacuation.
  - 2. Evacuate entire refrigerant system with a vacuum pump to 500 micrometers (67 Pa). If vacuum holds for 12 hours, system is ready for charging.
  - 3. Break vacuum with refrigerant gas, allowing pressure to build up to 2 psig (14 kPa).
  - 4. Charge system with a new filter-dryer core in charging line.

### 3.9 ADJUSTING

- A. Adjust thermostatic expansion valve to obtain proper evaporator superheat.
- B. Adjust high- and low-pressure switch settings to avoid short cycling in response to fluctuating suction pressure.
- C. Adjust set-point temperature of air-conditioning or chilled-water controllers to the system design temperature.
- D. Perform the following adjustments before operating the refrigeration system, according to manufacturer's written instructions:
  - 1. Open shutoff valves in condenser water circuit.
  - 2. Verify that compressor oil level is correct.
  - 3. Open compressor suction and discharge valves.
  - 4. Open refrigerant valves except bypass valves that are used for other purposes.
  - 5. Check open compressor-motor alignment and verify lubrication for motors and bearings.
- E. Replace core of replaceable filter dryer after system has been adjusted and after design flow rates and pressures are established.

**End of Section 232300**

## DIVISION 23 – HEATING, VENTILATING AND AIR CONDITIONING

### SECTION 23 31 13

#### METAL DUCTS

#### PART 1 - GENERAL

##### 1.1 SUMMARY

- A. Section includes metal ducts for supply, return, outside, and exhaust air-distribution systems in pressure classes from minus four (4)- inch wg to plus ten (10)-inch wg. Metal ducts include the following:
1. Rectangular ducts and fittings.
  2. Single-wall, round, and flat-oval spiral-seam ducts and formed fittings.
  3. Double-wall, rectangular, round, and flat-oval spiral-seam ducts and formed fittings.

##### 1.2 DEFINITIONS

- A. Sealing Requirements Definitions: For the purposes of duct systems sealing requirements specified in this Section, the following definitions apply:
1. Seams: A seam is defined as joining of two longitudinally (in the direction of airflow) oriented edges of duct surface material occurring between two joints. All other duct surface connections made on the perimeter are deemed to be joints.
  2. Joints: Joints include girth joints; branch and sub-branch intersections; so-called duct collar tap-ins; fitting subsections; louver and air terminal connections to ducts; access door and access panel frames and jambs; duct, plenum, and casing abutments to building structures.

##### 1.3 PERFORMANCE REQUIREMENTS

- A. Delegated Hanger and Support Design: Hangers and supports shall comply with SMACNA's "HVAC Duct Construction Standards – Metal and Flexible."

##### 1.4 SUBMITTALS

- A. Shop Drawings: Drawn at a scale of not less than 1/4" = 1'-0". Show fabrication and installation details for metal ducts.
1. Fabrication, assembly, and installation, including plans, elevations, sections, components, and attachments to other work.
  2. Duct layout indicating sizes and pressure classes.
  3. Elevations of top and bottom of ducts.
  4. Dimensions of main duct runs from building grid lines.
  5. Fittings.
  6. Reinforcement and spacing.
  7. Seam and joint construction.
  8. Penetrations through fire-rated and other partitions.
  9. Equipment installation based on equipment being used on Project.
  10. Duct accessories, including access doors and panels.

11. Hangers and supports, including methods for duct and building attachment and vibration isolation.

B. Delegated-Design Submittal:

1. Spacing of hangers and supports.
2. Design calculations: Calculations, including analysis data, signed and sealed by the qualified professional engineer responsible for their preparation for selecting hangers and supports.

C. Coordination Drawings: Reflected ceiling plans, drawn to scale, on which the following items are shown and coordinated with each other, based on input from installers of the items involved:

1. Ceiling suspension assembly members.
2. Other systems installed in same space as ducts.
3. Ceiling- and wall-mounting access doors and panels required to provide access to dampers and other operating devices.
4. Ceiling-mounting items, including lighting fixtures, diffusers, grilles, speakers, sprinklers, access panels, and special moldings.

D. Field quality-control test reports.

1.5 QUALITY ASSURANCE

- A. Welding: Qualify procedures and personnel according to AWS D9.1, "Sheet Metal Welding Code," for duct joint and seam welding.

B. NFPA Compliance:

1. NFPA 90A, "Installation of Air Conditioning and Ventilating Systems."
2. NFPA 90B, "Installation of Warm Air Heating and Air Conditioning Systems."

- C. Comply with NFPA 96, "Ventilation Control and Fire Protection of Commercial Cooking Operations," Ch. 3, "Duct System," for range hood ducts, unless otherwise indicated.

1.6 DELIVERY, STORAGE AND HANDLING

- A. All materials shall be stored in a designated area and protected from inclement weather.
- B. All materials shall be secured so as not to be a hazard during the construction process.
- C. Store ductwork with tight-fitting seals on open ends to ensure ductwork is free of all dirt, debris and moisture during the installation process.

**PART 2 - PRODUCTS**

2.1 SHEET METAL MATERIALS

- A. Comply with SMACNA's "HVAC Duct Construction Standards--Metal and Flexible" for acceptable materials, material thicknesses, and duct construction methods, unless otherwise indicated. Sheet metal materials shall be free of pitting, seam marks, roller marks, stains, discolorations, and other imperfections.

- B. Galvanized Sheet Steel: Lock-forming quality; complying with ASTM A 653/A 653M and having G90 coating designation; ducts shall have mill-phosphatized finish for surfaces exposed to view.
- C. PVC-Coated Galvanized Steel: Acceptable by authorities having jurisdiction for use in fabricating ducts with UL 181, Class 1 listing. Lock-forming-quality, galvanized sheet steel complying with ASTM A 653/A 653M and having G90 coating designation. Factory-applied PVC coatings shall be 4 mils thick on sheet metal surfaces of ducts and fittings exposed to corrosive conditions and 2 mils thick on opposite surfaces.
- D. Carbon-Steel Sheets: ASTM A 366/A 366M, cold-rolled sheets; commercial quality; with oiled, matte finish for exposed ducts.
- E. Stainless Steel: ASTM A 480/A 480M, Type 304 & 316.
- F. Aluminum Sheets: ASTM B 209, alloy 3003, temper H14; with mill finish for concealed ducts and standard, 1-side bright finish for exposed ducts.
- G. Reinforcement Shapes and Plates: Galvanized-steel reinforcement where installed on galvanized sheet metal ducts.
- H. Tie Rods: Galvanized steel, 1/4-inch minimum diameter for lengths 36 inches or less; 3/8-inch minimum diameter for lengths longer than 36 inches.
- I. Insulated Flexible Ducts: Flexible ducts wrapped with flexible glass fiber insulation, enclosed by seamless aluminum pigmented plastic vapor barrier jacket; maximum 0.23 K value at 75 degrees F.

## 2.2 SEALANT MATERIALS

- A. Joint and Seam Sealants, General: The term "sealant" is not limited to materials of adhesive or mastic nature but includes combinations of open-weave fabric strips and mastics.
- B. Water-Based Joint and Seam Sealant: Flexible, adhesive sealant, resistant to UV light when cured, UL 723 listed, and complying with NFPA requirements for Class 1 ducts.
- C. Flanged Joint Mastic: One-part, acid-curing, silicone, elastomeric joint sealant complying with ASTM C 920, Type S, Grade NS, Class 25, Use O.
- D. Flange Gaskets: Butyl rubber or EPDM polymer with polyisobutylene plasticizer.

## 2.3 HANGERS AND SUPPORTS

- A. Building Attachments: Concrete inserts, powder-actuated fasteners, or structural-steel fasteners appropriate for construction materials to which hangers are being attached.
  - 1. Use powder-actuated concrete fasteners for standard-weight aggregate concretes or for slabs more than 4 inches thick.
  - 2. Exception: Do not use powder-actuated concrete fasteners for lightweight-aggregate concretes or for slabs less than 4 inches thick.
- B. Hanger Materials: Galvanized sheet steel or threaded steel rod.

1. Hangers Installed in Corrosive Atmospheres: All-thread rods used in pool areas, pool equipment rooms, and pool supporting spaces shall be aluminum if the ducts are aluminum and stainless steel if the ducts are stainless steel.
  2. Strap and Rod Sizes: Comply with SMACNA's "HVAC Duct Construction Standards--Metal and Flexible" for steel sheet width and thickness and for steel rod diameters.
  3. Galvanized-steel straps attached to aluminum ducts shall have contact surfaces painted with zinc-chromate primer.
- C. Duct Attachments: Sheet metal screws, blind rivets, or self-tapping metal screws; compatible with duct materials.
- D. Trapeze and Riser Supports: Steel shapes complying with ASTM A 36/A 36M.
1. Supports for Galvanized-Steel Ducts: Galvanized-steel shapes and plates.
  2. Supports for Stainless-Steel Ducts: Stainless-steel support materials.
  3. Supports for Aluminum Ducts: Aluminum support materials..

#### 2.4 RECTANGULAR DUCT FABRICATION

- A. Fabricate ducts, elbows, transitions, offsets, branch connections, and other construction according to SMACNA's "HVAC Duct Construction Standards--Metal and Flexible" and complying with requirements for metal thickness, reinforcing types and intervals, tie-rod applications, and joint types and intervals.
1. Lengths: Fabricate rectangular ducts in lengths appropriate to reinforcement and rigidity class required for pressure class.
  2. Deflection: Duct systems shall not exceed deflection limits according to SMACNA's "HVAC Duct Construction Standards--Metal and Flexible."
- B. Transverse Joints: Prefabricated slide-on joints and components constructed using manufacturer's guidelines for material thickness, reinforcement size and spacing, and joint reinforcement.
- C. Formed-On Flanges: Construct according to SMACNA's "HVAC Duct Construction Standards--Metal and Flexible," Figure 1-4, using corner, bolt, cleat, and gasket details.
1. Duct Size: Maximum 30 inches wide and up to 2-inch wg pressure class.
  2. Longitudinal Seams: Pittsburgh lock sealed with noncuring polymer sealant.
- D. Cross Breaking or Cross Beading: Cross break or cross bead duct sides 19 inches and larger and 0.0359 inch thick or less, with more than 10 sq. ft. of nonbraced panel area unless ducts are lined.

#### 2.5 ROUND AND FLAT-OVAL DUCT AND FITTING FABRICATION

- A. Manufacturers: applicable to factory-fabricated duct and fittings:
- B. Subject to compliance with requirements, provide products by one of the following manufacturers:
1. Ductmate Industries, Inc.
  2. Lindab.
  3. Lockformer.

- C. Diameter as applied to flat-oval ducts in this Article is the diameter of a round duct with a circumference equal to the perimeter of a given size of flat-oval duct.
- D. Round, Longitudinal- and Spiral Lock-Seam Ducts: Fabricate supply ducts of galvanized steel according to SMACNA's "HVAC Duct Construction Standards--Metal and Flexible."
- E. Flat-Oval, Longitudinal- and Spiral Lock-Seam Ducts: Fabricate supply ducts according to SMACNA's "HVAC Duct Construction Standards--Metal and Flexible. Fabricate ducts larger than 72 inches in diameter with butt-welded longitudinal seams.
- F. Duct Joints:
  - 1. Ducts up to 20 Inches in Diameter: Interior, center-beaded slip coupling, sealed before and after fastening, attached with sheet metal screws.
  - 2. Ducts 21 to 72 Inches in Diameter: Three-piece, gasketed, flanged joint consisting of two internal flanges with sealant and one external closure band with gasket.
  - 3. Ducts Larger Than 72 Inches in Diameter: Companion angle flanged joints per SMACNA "HVAC Duct Construction Standards--Metal and Flexible," Figure 3-2.
  - 4. Round Ducts: Prefabricated connection system consisting of double-lipped, EPDM rubber gasket. Manufacture ducts according to connection system manufacturer's tolerances.
  - 5. Flat-Oval Ducts: Prefabricated connection system consisting of two flanges and one synthetic rubber gasket.
- G. 90-Degree Tees and Laterals and Conical Tees: Fabricate to comply with SMACNA's "HVAC Duct Construction Standards--Metal and Flexible," with metal thicknesses specified for longitudinal-seam straight ducts.
- H. Diverging-Flow Fittings: Fabricate with reduced entrance to branch taps and with no excess material projecting from fitting onto branch tap entrance.
- I. Fabricate elbows using die-formed, gored, pleated, or mitered construction. Bend radius of die-formed, gored, and pleated elbows shall be 1-1/2 times duct diameter. Unless elbow construction type is indicated, fabricate elbows as follows:
  - 1. Mitered-Elbow Radius and Number of Pieces: Welded construction complying with SMACNA's "HVAC Duct Construction Standards--Metal and Flexible," unless otherwise indicated.
  - 2. Round Mitered Elbows: Welded construction with the following metal thickness for pressure classes from minus 2- to plus 2-inch wg:
    - a. Ducts 3 to 36 Inches in Diameter: 0.034 inch.
    - b. Ducts 37 to 50 Inches in Diameter: 0.040 inch.
    - c. Ducts 52 to 60 Inches in Diameter: 0.052 inch.
    - d. Ducts 62 to 84 Inches in Diameter: 0.064 inch.
  - 3. Round Mitered Elbows: Welded construction with the following metal thickness for pressure classes from 2- to 10-inch wg:
    - a. Ducts 3 to 26 Inches in Diameter: 0.034 inch.
    - b. Ducts 27 to 50 Inches in Diameter: 0.040 inch.
    - c. Ducts 52 to 60 Inches in Diameter: 0.052 inch.
    - d. Ducts 62 to 84 Inches in Diameter: 0.064 inch.

4. Flat-Oval Mitered Elbows: Welded construction with same metal thickness as longitudinal-seam flat-oval duct.
5. 90-Degree, 2-Piece, Mitered Elbows: Use only for supply systems or for material-handling Class A or B exhaust systems and only where space restrictions do not permit using radius elbows. Fabricate with single-thickness turning vanes.
6. Round Elbows 8 Inches and Less in Diameter: Fabricate die-formed elbows for 45- and 90-degree elbows and pleated elbows for 30, 45, 60, and 90 degrees only. Fabricate nonstandard bend-angle configurations or nonstandard diameter elbows with gored construction.
7. Round Elbows 9 through 14 Inches in Diameter: Fabricate gored or pleated elbows for 30, 45, 60, and 90 degrees unless space restrictions require mitered elbows. Fabricate nonstandard bend-angle configurations or nonstandard diameter elbows with gored construction.
8. Round Elbows Larger Than 14 Inches in Diameter and All Flat-Oval Elbows: Fabricate gored elbows unless space restrictions require mitered elbows.
9. Die-Formed Elbows for Sizes through 8 Inches in Diameter and All Pressures 0.040 inch thick with 2-piece welded construction.
10. Flat-Oval Elbow Metal Thickness: Same as longitudinal-seam flat-oval duct specified above.
11. Pleated Elbows for Sizes through 14 Inches in Diameter and Pressures through 10-Inch wg: 0.022 inch.

### **PART 3 - EXECUTION**

#### **3.1 DUCT APPLICATIONS**

- A. Static-Pressure Classes: Unless otherwise indicated, construct ducts according to the following:
  1. Supply Ducts (constant volume units): +2".
  2. Supply Ducts (before Air Terminal Units): +4".
  3. Supply Ducts (after Air Terminal Units): +2".
  4. Supply Ducts (between fan and first system fire damper): +8".
  5. Return Ducts (Negative Pressure): -2".
  6. Return Ducts (between nearest fire damper and return fan inlet): -4".
  7. Return Ducts (return fan discharge and AHU intake / exhaust damper): -4".
  8. Exhaust Ducts (Negative Pressure): -2".

#### **3.2 DUCT INSTALLATION**

- A. Construct and install ducts according to SMACNA's "HVAC Duct Construction Standards--Metal and Flexible," unless otherwise indicated.
- B. Install round and flat-oval ducts in lengths not less than 12 feet unless interrupted by fittings.
- C. Install ducts with fewest possible joints.
- D. Install fabricated fittings for changes in directions, size, and shape and for connections.
- E. Install couplings tight to duct wall surface with a minimum of projections into duct. Secure couplings with sheet metal screws. Install screws at intervals of 12 inches, with a minimum of 3 screws in each coupling.



- F. Install ducts, unless otherwise indicated, vertically and horizontally and parallel and perpendicular to building lines; avoid diagonal runs.
- G. Install ducts close to walls, overhead construction, columns, and other structural and permanent enclosure elements of building.
- H. Install ducts with a clearance of 1 inch, plus allowance for insulation thickness.
- I. Conceal ducts from view in finished spaces. Do not encase horizontal runs in solid partitions unless specifically indicated.
- J. Coordinate layout with suspended ceiling, fire- and control dampers, lighting layouts, and similar finished work.
- K. Seal all joints and seams. Apply sealant to male end connectors before insertion, and afterward to cover entire joint and sheet metal screws.
- L. Electrical Equipment Spaces: Route ducts to avoid passing through transformer vaults and electrical equipment spaces and enclosures.
- M. Non-Fire-Rated Partition Penetrations: Where ducts pass through interior partitions and exterior walls and are exposed to view, conceal spaces between construction openings and ducts or duct insulation with sheet metal flanges of same metal thickness as ducts. Overlap openings on 4 sides by at least 1-1/2 inches.
- N. Fire-Rated Partition Penetrations: Where ducts pass through interior partitions and exterior walls, install appropriately rated fire dampers, sleeves, and firestopping sealant. Fire and smoke dampers are specified in Division 23 Section "Air Duct Accessories." Firestopping materials and installation methods are specified in Division 07.
- O. Protect duct interiors from moisture, construction debris and dust, and other foreign materials. Comply with SMACNA's "IAQ Guidelines for Occupied Buildings Under Construction," Appendix G, "Duct Cleanliness for New Construction Guidelines."

### 3.3 PVC-COATED DUCT, SPECIAL INSTALLATION REQUIREMENTS

- A. Repair damage to PVC coating with manufacturer's recommended materials.

### 3.4 UNDERSLAB DUCTS, SPECIAL INSTALLATION REQUIREMENTS

- A. Verify undamaged condition of ducts before enclosure with fill or encasement.
- B. Protect ducts from damage by equipment used in placing fill materials and concrete on or around ducts.
- C. Protect duct openings from damage and prevent entrance of foreign materials.

### 3.5 RANGE HOOD EXHAUST DUCTS, SPECIAL INSTALLATION REQUIREMENTS

- A. Install ducts to allow for thermal expansion through 2000 deg F temperature range.
- B. Install ducts without dips or traps that may collect residues unless traps have continuous or automatic residue removal.

- C. Install access panels at each change in direction and at intervals defined by NFPA 96; locate on sides of duct a minimum of 1-1/2 inches from bottom; and fit with grease-tight covers of same material as duct.
- D. Do not penetrate fire-rated assemblies except as permitted by applicable building codes.

### 3.6 SEAM AND JOINT SEALING

- A. Seal all duct seams and joints to the most severe requirement between the latest Chicago Building Code and SMACNA's "HVAC Duct Construction Standards--Metal and Flexible" for duct pressure class indicated.
- B. Utilize sealant designed for outdoor use with ductwork exposed to the outdoors.
- C. Seal ducts before external insulation is applied.

### 3.7 HANGING AND SUPPORTING

- A. Support horizontal ducts within 24 inches of each elbow and within 48 inches of each branch intersection.
- B. Support vertical ducts at maximum intervals of 16 feet and at each floor.
- C. Install upper attachments to structures with an allowable load not exceeding one-fourth of failure (proof-test) load.
- D. For concrete structure installations: Install concrete inserts before placing concrete.
- E. For concrete structure installations: Install powder-actuated concrete fasteners after concrete is placed and completely cured.
  - 1. Do not use powder-actuated concrete fasteners for lightweight-aggregate concretes or for slabs less than 4 inches thick.

### 3.8 CONNECTIONS

- A. Make connections to equipment with flexible connectors according to Division 23 Section "Air Duct Accessories."
- B. Comply with SMACNA's "HVAC Duct Construction Standards--Metal and Flexible" for branch, outlet and inlet, and terminal unit connections.

### 3.9 FIELD QUALITY CONTROL

- A. Perform the following field tests and inspections according to SMACNA's "HVAC Air Duct Leakage Test Manual" and prepare test reports:
  - 1. Disassemble, reassemble, and seal segments of systems to accommodate leakage testing and for compliance with test requirements.
  - 2. Conduct tests at static pressures equal to maximum design pressure of system or section being tested. If pressure classes are not indicated, test entire system at maximum system design pressure. Do not pressurize systems above maximum design operating pressure. Give seven days' advance notice for testing.

3. Maximum Allowable Leakage: Comply with requirements for Leakage Class 3 for round and flat-oval ducts, Leakage Class 12 for rectangular ducts in pressure classes lower than and equal to 2-inch wg (both positive and negative pressures), and Leakage Class 6 for pressure classes from 2- to 10-inch wg.
4. Remake leaking joints and retest until leakage is equal to or less than maximum allowable.

**End of Section 233113**

**DIVISION 23 – HEATING, VENTILATING AND AIR CONDITIONING**

**SECTION 23 33 00**

**AIR DUCT ACCESSORIES**

**PART 1 - GENERAL**

**1.1 SUMMARY**

A. Section includes the following:

1. Backdraft dampers.
2. Volume dampers.
3. Fire dampers.
4. Turning vanes.
5. Duct-mounting access doors.
6. Flexible connectors.
7. Duct accessory hardware.

**1.2 SUBMITTALS**

A. Product Data: For the following:

1. Backdraft dampers.
2. Volume dampers.
3. Fire dampers.
4. Turning vanes.
5. Duct-mounting access doors.
6. Flexible connectors.
7. Flexible ducts.

B. Shop Drawings: Detail equipment assemblies and indicate dimensions, weights, loads, required clearances, method of field assembly, components, and location and size of each field connection.

1. Special fittings.
2. Backdraft dampers.
3. Manual-volume damper installations.
4. Motorized-control damper installations.
5. Fire-damper and combination fire- and smoke-damper installations, including sleeves and duct-mounting access doors.
6. Duct mounted access doors.
7. Flexible connectors.
8. Wiring Diagrams: Power, signal, and control wiring.

C. Coordination Drawings: Reflected ceiling plans, drawn to scale and coordinating penetrations and ceiling-mounting items. Show ceiling-mounting access panels and access doors required for access to duct accessories.

### 1.3 QUALITY ASSURANCE

- A. Comply with NFPA 90A, "Installation of Air Conditioning and Ventilating Systems," and NFPA 90B, "Installation of Warm Air Heating and Air Conditioning Systems."

### 1.4 DELIVERY, STORAGE AND HANDLING

- A. Materials delivered to the site must be coordinated with the site supervisor prior to delivery.
- B. All materials shall be stored in a designated area and protected from the environment.
- C. All materials shall be secured so as not to be a hazard during the construction process.
- D. All materials must be free of all dirt, debris and moisture during the installation process.

## **PART 2 - PRODUCTS**

### 2.1 MANUFACTURERS

- A. Subject to compliance with requirements, provide products by one of the following manufacturers:

- 1. Backdraft Dampers:

- a. Greenheck.
- b. Ruskin.
- c. Vent Products Company.

- 2. Volume Dampers

- a. Nailor.
- b. Ruskin.
- c. Vent Products Company.

- 3. Fire Dampers:

- a. Greenheck.
- b. Ruskin.
- c. Vent Products Company.

- 4. Duct-Mounting Access Doors:

- a. CESCO Products.
- b. Ductmate Industries.
- c. Greenheck.

- 5. Flexible Connectors:

- a. Ductmate Industries.
- b. Ventfabrics, Inc.
- c. Ward Industries.

- 6. Flexible Ducts:

- a. Flexmaster USA.
- b. Hart & Cooley, Inc.
- c. McGill Airflow Corp.

## 2.2 SHEET METAL MATERIALS

- A. Comply with SMACNA's "HVAC Duct Construction Standards--Metal and Flexible" for acceptable materials, material thicknesses, and duct construction methods, unless otherwise indicated.
- B. Galvanized Sheet Steel: Lock-forming quality; complying with ASTM A 653/A 653M and having G90coating designation; ducts shall have mill-phosphatized finish for surfaces exposed to view.
- C. Stainless Steel: ASTM A 480/A 480M Type 304 (specify Type 314 as required by the application).
- D. Aluminum Sheets: ASTM B 209 alloy 3003, temper H14; with mill finish for concealed ducts and standard, 1-side bright finish for exposed ducts.
- E. Extruded Aluminum: ASTM B 221, alloy 6063, temper T6.
- F. Reinforcement Shapes and Plates: Galvanized-steel reinforcement where installed on galvanized sheet metal ducts; compatible materials for aluminum and stainless-steel ducts.
- G. Tie Rods: Galvanized steel, 1/4-inch minimum diameter for lengths 36 inches or less; 3/8-inch minimum diameter for lengths longer than 36 inches.

## 2.3 BACKDRAFT DAMPERS

- A. Description: Multiple-blade, parallel action gravity balanced, with center-pivoted blades of maximum 6-inch width, with sealed edges, assembled in rattle-free manner with 90-degree stop, steel ball bearings, and axles; adjustment device to permit setting for varying differential static pressure.
- B. Frame: 0.063-inch thick extruded aluminum, with welded corners and mounting flange.
- C. Blades: 0.050-inch thick aluminum sheet.
- D. Blade Seals: Neoprene.
- E. Blade Axles: Galvanized steel.
- F. Tie Bars and Brackets: Galvanized steel.
- G. Return Spring: Adjustable tension.

## 2.4 VOLUME DAMPERS

- A. General Description: Factory fabricated, with required hardware and accessories. Stiffen damper blades for stability. Include locking device to hold single-blade dampers in a fixed position without vibration. Close duct penetrations for damper components to seal duct consistent with pressure class.

1. Pressure Classes of 3-Inch wg or Higher: End bearings or other seals for ducts with axles full length of damper blades and bearings at both ends of operating shaft.
- B. Standard Volume Dampers: Multiple- or single-blade, parallel- or opposed-blade design as indicated, standard leakage rating, with linkage outside airstream and suitable for horizontal or vertical applications.
1. Steel Frames (For use in steel ductwork): Hat-shaped, galvanized sheet steel channels, minimum of 0.064 inch thick, with mitered and welded corners; frames with flanges where indicated for attaching to walls and flangeless frames where indicated for installing in ducts.
  2. Roll-Formed Steel Blades (For use with steel frames): 0.064-inch- thick, galvanized sheet steel.
  3. Aluminum Frames (For use in stainless steel or aluminum ductwork): Hat-shaped, 0.10-inch- thick, aluminum sheet channels; frames with flanges where indicated for attaching to walls; and flangeless frames where indicated for installing in ducts.
  4. Roll-Formed Aluminum Blades (For use with aluminum frames): 0.10-inch- thick aluminum sheet.
  5. Extruded-Aluminum Blades (For use with aluminum frames): 0.050-inch- thick extruded aluminum.
  6. Blade Axles: Galvanized steel. Drive shaft will be the full length of the blade.
  7. Bearings: Stainless-steel sleeve.
  8. Tie Bars and Brackets: Aluminum (aluminum or stainless steel ductwork applications), Galvanized steel (galvanized steel ductwork applications).
- C. Low-Leakage Volume Dampers: Multiple- or single-blade, parallel- or opposed-blade design as indicated, low-leakage rating, with linkage outside airstream, and suitable for horizontal or vertical applications.
1. Steel Frames (For use in steel ductwork) : galvanized sheet steel channels, minimum of 0.064 inch thick, with mitered and welded corners; frames with flanges where indicated for attaching to walls and flangeless frames where indicated for installing in ducts.
  2. Roll-Formed Steel Blades (For use with steel frames): 0.064-inch- thick, galvanized sheet steel.
  3. Aluminum Frames (For use in stainless steel or aluminum ductwork) : 0.10-inch- thick, aluminum sheet channels; frames with flanges where indicated for attaching to walls and flangeless frames where indicated for installing in ducts.
  4. Roll-Formed Aluminum Blades (For use with aluminum frames): 0.10-inch- thick aluminum sheet.
  5. Extruded-Aluminum Blades (For use with aluminum frames): 0.050-inch- thick extruded aluminum.
  6. Blade Axles: Galvanized steel. Drive shaft will be the full length of the blade.
  7. Bearings: Stainless-steel sleeve thrust or ball.
  8. Blade Seals: Neoprene.
  9. Jamb Seals: Cambered stainless steel.
  10. Tie Bars and Brackets: Aluminum (aluminum or stainless steel ductwork applications), Galvanized steel (galvanized steel ductwork applications).
- D. Jackshaft: 1-inch- diameter, galvanized-steel pipe rotating within pipe-bearing assembly mounted on supports at each mullion and at each end of multiple-damper assemblies.
1. Length and Number of Mountings: Appropriate to connect linkage of each damper in multiple-damper assembly.

- E. Damper Hardware: Zinc-plated, die-cast core with dial and handle made of 3/32-inch- thick zinc-plated steel, and a 3/4-inch hexagon locking nut. Include center hole to suit damper operating-rod size. Include elevated platform for insulated duct mounting.

## 2.5 FIRE DAMPERS

- A. Fire dampers shall be labeled according to UL 555.
- B. Fire Rating: Insert rating as required by application hours.
- C. Frame: Curtain type with blades outside airstream fabricated with roll-formed, 0.034-inch- thick galvanized steel; with mitered and interlocking corners.
- D. Mounting Sleeve: Factory- or field-installed, galvanized sheet steel.
  - 1. Minimum Thickness: 0.052 or 0.138 inch thick as indicated and of length to suit application.
  - 2. Exceptions: Omit sleeve where damper frame width permits direct attachment of perimeter mounting angles on each side of wall or floor, and thickness of damper frame complies with sleeve requirements.
- E. Mounting Orientation: Vertical or horizontal as indicated.
- F. Blades: Roll-formed, interlocking, 0.034-inch- thick, galvanized sheet steel. In place of interlocking blades, use full-length, 0.034-inch- thick, galvanized-steel blade connectors.
- G. Horizontal Dampers: Include blade lock and stainless-steel closure spring.
- H. Fusible Links: Replaceable, 165 deg F rated.

## 2.6 TURNING VANES

- A. Fabricate to comply with SMACNA's "HVAC Duct Construction Standards--Metal and Flexible" for vanes and vane runners. Vane runners shall automatically align vanes.
- B. Manufactured Turning Vanes: Fabricate 1-1/2-inch- wide, single-vane, curved blades of galvanized sheet steel set 3/4 inch o.c.; support with bars perpendicular to blades set 2 inches o.c.; and set into vane runners suitable for duct mounting.
- C. Acoustic Turning Vanes: Fabricate airfoil-shaped aluminum extrusions with perforated faces and fibrous-glass fill.

## 2.7 DUCT-MOUNTING ACCESS DOORS

- A. General Description: Fabricate doors airtight and suitable for duct pressure class.
- B. Door: Double wall, duct mounting, and rectangular; fabricated of galvanized sheet metal with insulation fill and thickness as indicated for duct pressure class. Include vision panel where indicated. Include piano hinge and cam latches.
  - 1. Frame: Galvanized sheet steel, with bend-over tabs and foam gaskets.
  - 2. Provide number of hinges and locks as follows:
    - a. Less than 12 Inches Square: Secure with two sash locks.



- b. Up to 18 Inches Square: Continuous hinge and two sash locks.
  - c. Larger than 18 inches square: Continuous hinge and two compression latches with outside and inside handles.
- C. Door: Double wall, duct mounting, and round; fabricated of galvanized sheet metal with insulation fill and 1-inch thickness. Include cam latches.
  - 1. Frame: Galvanized sheet steel, with spin-in notched frame.
- D. Pressure Relief Access Door: Double wall and duct mounting; fabricated of galvanized sheet metal with insulation fill and thickness as indicated for duct pressure class. Include vision panel where indicated, latches, and retaining chain.
  - 1. Frame: Galvanized sheet steel, with bend-over tabs and foam gaskets.
- E. Seal around frame attachment to duct and door to frame with neoprene or foam rubber.
- F. Insulation: 1-inch- thick, fibrous-glass or polystyrene-foam board.

## 2.8 FLEXIBLE CONNECTORS

- A. General Description: Flame-retardant or noncombustible fabrics, coatings, and adhesives complying with UL 181, Class 1.
- B. Metal-Edged Connectors: Factory fabricated with a fabric strip 5-3/4 inches wide attached to two strips of 2-3/4-inch- wide, 0.028-inch- thick, galvanized sheet steel or 0.032-inch- thick aluminum sheets. Select metal compatible with ducts.
- C. Indoor System, Flexible Connector Fabric: Glass fabric double coated with neoprene.
  - 1. Minimum Weight: 26 oz./sq. yd..
  - 2. Tensile Strength: 480 lbf/inch in the warp and 360 lbf/inch in the filling.
  - 3. Service Temperature: Minus 40 to plus 200 deg F.
- D. Outdoor System, Flexible Connector Fabric: Glass fabric double coated with weatherproof, synthetic rubber resistant to UV rays and ozone.
  - 1. Minimum Weight: 24 oz./sq. yd..
  - 2. Tensile Strength: 530 lbf/inch in the warp and 440 lbf/inch in the filling.
  - 3. Service Temperature: Minus 50 to plus 250 deg F.

## 2.9 DUCT ACCESSORY HARDWARE

- A. Instrument Test Holes: Cast iron or cast aluminum to suit duct material, including screw cap and gasket. Size to allow insertion of pitot tube and other testing instruments and of length to suit duct insulation thickness.
- B. Adhesives: High strength, quick setting, neoprene based, waterproof, and resistant to gasoline and grease.

## **PART 3 - EXECUTION**

### **3.1 APPLICATION AND INSTALLATION**

- A. Install duct accessories according to applicable details in SMACNA's "HVAC Duct Construction Standards--Metal and Flexible" for metal ducts and in NAIMA AH116, "Fibrous Glass Duct Construction Standards," for fibrous-glass ducts.
- B. Provide duct accessories of materials suited to duct materials; use galvanized-steel accessories in galvanized-steel and fibrous-glass ducts, stainless-steel accessories in stainless-steel ducts, and aluminum accessories in aluminum ducts.
- C. Install backdraft dampers on exhaust fans or exhaust ducts nearest to outside and where indicated.
- D. Provide balancing dampers at points on supply, return, and exhaust systems where branches lead from larger ducts as required for air balancing. Install at a minimum of two duct widths from branch takeoff.
- E. Provide test holes at fan inlets and outlets and elsewhere as indicated.
- F. Install fire dampers, with fusible links, according to manufacturer's UL-approved written instructions.
- G. Install duct silencers rigidly to ducts.
- H. Install duct access doors to allow for inspecting, adjusting, and maintaining duct accessories, control devices - sensors and terminal units as follows:
  - 1. On both sides of duct coils. On terminal units coordinate upstream coil access door with equipment supplier.
  - 2. Downstream from volume dampers, turning vanes, and duct mounted equipment.
  - 3. Adjacent to fire dampers, providing access to reset or reinstall fusible links.
  - 4. To interior of ducts for cleaning; before and after each change in direction, at maximum 50-foot spacing.
  - 5. On sides of ducts where adequate clearance is available.
  - 6. Where indicated on plans.
  - 7. Upstream and downstream of ducted fans.
- I. Label access doors according to Division 23 Section "Identification for HVAC."
- J. Install flexible connectors immediately adjacent to equipment in ducts associated with fans and motorized equipment supported by vibration isolators.
- K. For fans developing static pressures of 5-inch wg and higher, cover flexible connectors with loaded vinyl sheet held in place with metal straps.
- L. Connect terminal units to supply ducts directly or with maximum 12-inch lengths of flexible duct. Do not use flexible ducts to change directions.
- M. Connect diffusers or light troffer boots to low pressure ducts directly or with maximum 60-inch lengths of flexible duct clamped or strapped in place.
- N. Connect flexible ducts to metal ducts with adhesive plus sheet metal screws.

- O. Install duct test holes where indicated and required for testing and balancing purposes.
- P. Provide turning vanes in all short radius / square elbows (>45 degrees) and tees.

### 3.2 ADJUSTING

- A. Adjust duct accessories for proper settings.
- B. Adjust fire dampers for proper action.
- C. Final positioning of manual-volume dampers is specified in Division 23 Section "Testing, Adjusting, and Balancing for HVAC."

### 3.3 DEMONSTRATION AND COMMISSIONING

- A. Engage a factory-authorized service representative to train Owner's maintenance personnel to adjust, operate, and maintain the duct accessories.
  - 1. Train Owner's maintenance personnel on troubleshooting, servicing, and maintaining duct accessories. The training will occur after all devices are installed including all access doors. The trainer will provide two (2) Installation and Operations manuals for the use of the owners personnel during training.
  - 2. Review data in maintenance manuals. Refer to Division 01 Section "Operation and Maintenance Data." All required and recommended maintenance will be reviewed as well as operational trouble shooting. If the IOM does not include a written trouble shooting guide one will be provided.
  - 3. Schedule training with Owner, through Architect, with at least seven days' advance notice.
  - 4. Training will occur in one (1) two (2) hour session and will include the dropping and resetting of 3 fire dampers selected by the owner. This portion of the training may not take longer than 30 minutes of the training session.
- B. Demonstrate proper operation of equipment to commissioning agent or designated owners personnel. The scope of the demonstration will include functional performance requirements under both local and building automation control as well as any commissioning requirements in Division 01 or 23.
  - 1. For all fire dampers or access doors for fire dampers installed on this project the Contractor will demonstrate that any fire dampers selected by the owner can be dropped and reset using the provided access doors.

**END OF SECTION**

## DIVISION 23 – HEATING, VENTILATING AND AIR CONDITIONING

### SECTION 23 34 16

#### CENTRIFUGAL HVAC FANS

##### PART 1 - GENERAL

###### 1.1 SUMMARY

A. Section includes the following:

1. Forward-curved centrifugal fans.

###### 1.2 SUBMITTALS

A. Product Data: Include rated capacities, furnished specialties, and accessories for each type of product indicated and include the following:

1. Certified fan performance curves with system operating conditions indicated.
2. Certified fan sound-power ratings.
3. Motor ratings and electrical characteristics, plus motor and electrical accessories.
4. Material thickness and finishes, including color charts.
5. Dampers, including housings, linkages, and operators.

B. Shop Drawings: Detail equipment assemblies and indicate dimensions, weights, loads, required clearances, method of field assembly, components, and location and size of each field connection.

1. Wiring Diagrams: Power, signal, and control wiring.
2. Design Calculations: Calculate requirements for selecting vibration isolators and seismic restraints and for designing vibration isolation bases.
3. Vibration Isolation Base Details: Detail fabrication, including anchorages and attachments to structure and to supported equipment. Include auxiliary motor slides and rails, and base weights.

C. Coordination Drawings: Show fan room layout and relationships between components and adjacent structural and mechanical elements. Show support locations, type of support, and weight on each support. Indicate and certify field measurements.

D. Field quality-control test reports.

E. Operation and Maintenance Data: For centrifugal fans to include in emergency, operation, and maintenance manuals.

###### 1.3 QUALITY ASSURANCE

A. Electrical Components, Devices, and Accessories: Listed and labeled as defined in NFPA 70, Article 100, by a testing agency acceptable to authorities having jurisdiction, and marked for intended use.

B. AMCA Compliance: Products shall comply with performance requirements and shall be licensed to use the AMCA-Certified Ratings Seal.

- C. NEMA Compliance: Motors and electrical accessories shall comply with NEMA 1.

#### 1.4 DELIVERY, STORAGE, AND HANDLING

- A. Deliver fans as factory-assembled units, to the extent allowable by shipping limitations, with protective crating and covering.
- B. Disassemble and reassemble units, as required for moving to the final location, according to manufacturer's written instructions.
- C. Lift and support units with manufacturer's designated lifting or supporting points.

#### 1.5 PERFORMANCE REQUIREMENTS

- A. Project Altitude: Base fan performance ratings on sea level.
- B. Operating Limits: Classify according to AMCA 99.

#### 1.6 COORDINATION

- A. Coordinate size and location of structural-steel support members.
- B. Coordinate size and location of concrete bases. Cast anchor-bolt inserts into bases. Concrete, reinforcement, and formwork requirements are specified in Division 03.
- C. Coordinate installation of roof curbs, equipment supports, and roof penetrations. These items are specified in Division 07 Section "Roof Accessories."

#### 1.7 EXTRA MATERIALS

- A. Furnish extra materials described below that match products installed and that are packaged with protective covering for storage and identified with labels describing contents. Provide one set of belts for each belt-driven unit.

#### 1.8 WARRANTY

- A. Provide manufacturer's standard form in which manufacturer agrees to replace components of fans that fail in materials or workmanship within one year after date of substantial completion or 18 months from date of delivery, whichever is longer.

### **PART 2 - PRODUCTS**

#### 2.1 MANUFACTURERS

- A. Forward-Curved Centrifugal Fans:
  - 1. Howden Fan Co.
  - 2. Loren Cook Company.
  - 3. New York Blower Company (The).

## 2.2 FORWARD-CURVED CENTRIFUGAL FANS

- A. Description: Factory-fabricated, -assembled, -tested, and -finished, belt-driven centrifugal fans consisting of housing, wheel, fan shaft, bearings, motor and disconnect switch, drive assembly, and support structure.
- B. Housings: Formed panels to make curved-scroll housings with shaped cutoff; with doors or panels to allow access to internal parts and components.
  - 1. Panel Bracing: Steel angle- or channel-iron member supports for mounting and supporting fan scroll, wheel, motor, and accessories.
  - 2. Spun inlet cone with flange.
  - 3. Outlet flange.
- C. Forward-Curved Wheels: Black-enameled or galvanized steel construction with inlet flange, backplate, shallow blades with inlet and tip curved forward in direction of airflow, mechanically secured to flange and backplate; cast-steel hub swaged to backplate and fastened to shaft with set screws.
- D. Shafts: Statically and dynamically balanced and selected for continuous operation at maximum rated fan speed and motor horsepower, with final alignment and belt adjustment made after installation.
  - 1. Turned, ground, and polished hot-rolled steel with keyway. Ship with protective coating of lubricating oil.
  - 2. Designed to operate at no more than 70 percent of first critical speed at top of fan's speed range.
- E. Grease-Lubricated Shaft Bearings: Self-aligning, pillow-block-type, ball or roller bearings with adapter mount and two-piece, cast-iron housing.
  - 1. Ball-Bearing Rating Life: ABMA 9, L50 in excess of 200,000 hours.
  - 2. Roller-Bearing Rating Life: ABMA 11, L50 at 200,000 hours.
- F. Belt Drives: Factory mounted, with final alignment and belt adjustment made after installation.
  - 1. Service Factor Based on Fan Motor Size: 1.5.
  - 2. Fan Pulleys: Cast iron or cast steel with split, tapered bushing; dynamically balanced at factory.
  - 3. Motor Pulleys: Adjustable pitch for use with motors through 5 hp; fixed pitch for use with larger motors. Select pulley so pitch adjustment is at the middle of adjustment range at fan design conditions.
  - 4. Belts: Oil resistant, nonsparking, and nonstatic; matched sets for multiple belt drives.
  - 5. Belt Guards: Fabricate to comply with OSHA and SMACNA requirements of diamond-mesh wire screen welded to steel angle frame or equivalent, prime coated. Secure to fan or fan supports without short circuiting vibration isolation. Include provisions for adjustment of belt tension, lubrication, and use of tachometer with guard in place.
  - 6. Motor Mount: Adjustable for belt tensioning.
- G. Accessories:

1. Scroll Access Doors: Shaped to conform to scroll, with quick-opening latches and gaskets.
  2. Cleanout Door: Bolted gasketed door allowing access to fan scroll, of same material as housing.
  3. Scroll Drain Connection: NPS 1 steel pipe coupling welded to low point of fan scroll.
  4. Companion Flanges: Rolled flanges for duct connections of same material as housing.
  5. Discharge Dampers: Assembly with parallel blades constructed of two plates formed around and to shaft, channel frame, and sealed ball bearings; with blades linked outside of airstream to single control lever of same material as housing.
  6. Shaft Cooler: Metal disk between bearings and fan wheel, designed to dissipate heat from shaft.
  7. Shaft Seals: Airtight seals installed around shaft on drive side of single-width fans.
  8. Weather Cover: Enameled-steel sheet with ventilation slots, bolted to housing.
- H. Motors: Comply with requirements in Division 23 Section " Common Motor Requirements for HVAC Equipment."
1. Enclosure Type: Totally enclosed, fan cooled.

### **PART 3 - EXECUTION**

#### **3.1 INSTALLATION**

- A. Install centrifugal fans level and plumb.
- B. Support floor-mounting units using spring isolators having a static deflection of 1 inch. Vibration- and seismic-control devices are specified in Division 23 Section "Vibration Controls for HVAC."
  1. Secure vibration controls to concrete bases using anchor bolts cast in concrete base.
- C. Install floor-mounting units on concrete bases.
- D. Install floor-mounting units on concrete bases designed to withstand, without damage to equipment, the seismic force required by authorities having jurisdiction.
- E. Support suspended units from structure using threaded steel rods and spring hangers having a static deflection of 1 inch. Vibration-control devices are specified in Division 23 Section "Vibration Controls for HVAC."
- F. Install units with clearances for service and maintenance.
- G. Label fans according to requirements specified in Division 23 Section "Identification for HVAC."

#### **3.2 CONNECTIONS**

- A. Duct installation and connection requirements are specified in other Division 23 Sections. Drawings indicate general arrangement of ducts and duct accessories. Make final duct connections with flexible connectors. Flexible connectors are specified in Division 23 Section "Air Duct Accessories."
- B. Install ducts adjacent to fans to allow service and maintenance.

- C. Ground equipment according to Division 26 Section "Grounding and Bonding for Electrical Systems."
- D. Connect wiring according to Division 26 Section "Conductors and Cables for Electrical Systems."

### 3.3 CLEANING

- A. After completing installation, inspect exposed finish. Remove burrs, dirt, and construction debris, and repair damaged finishes including chips, scratches, and abrasions.
- B. Clean fan interiors to remove foreign material and construction debris. Vacuum clean fan wheel and cabinet.

### 3.4 CONTRACTOR STARTUP AND REPORTING

- A. Perform the following field tests and inspections and prepare test reports:
  - 1. Verify that shipping, blocking, and bracing are removed.
  - 2. Verify that unit is secure on mountings and supporting devices and that connections to ducts and electrical components are complete. Verify that proper thermal-overload protection is installed in motors, starters, and disconnect switches.
  - 3. Verify that cleaning and adjusting are complete.
  - 4. Disconnect fan drive from motor, verify proper motor rotation direction, and verify fan wheel free rotation and smooth bearing operation. Reconnect fan drive system, align and adjust belts, and install belt guards.
  - 5. Adjust belt tension.
  - 6. Adjust damper linkages for proper damper operation.
  - 7. Verify lubrication for bearings and other moving parts.
  - 8. Verify that manual and automatic volume control and fire and smoke dampers in connected ductwork systems are in fully open position.
  - 9. Refer to Division 23 Section "Testing, Adjusting, and Balancing for HVAC" for testing, adjusting, and balancing procedures.
  - 10. Remove and replace malfunctioning units and retest as specified above.
- B. Test and adjust controls and safeties. Replace damaged and malfunctioning controls and equipment. Refer to Division 23 Section "Building Automation System (BAS)."

### 3.5 DEMONSTRATION AND COMMISSIONING

- A. Engage a factory-authorized service representative to train Owner's maintenance personnel to adjust, operate, and maintain centrifugal fans. Refer to Division 01 Section "Demonstration and Training."

**END OF SECTION**



## DIVISION 23 – HEATING, VENTILATING AND AIR CONDITIONING

### SECTION 23 37 13

#### DIFFUSERS, REGISTERS, AND GRILLES

##### PART 1 - GENERAL

##### 1.1 SUMMARY

- A. Section includes ceiling- and wall-mounted diffusers, registers, and grilles.

##### 1.2 DEFINITIONS

- A. Diffuser: Circular, square, or rectangular air distribution outlet, generally located in the ceiling and comprised of deflecting members discharging supply air in various directions and planes and arranged to promote mixing of primary air with secondary room air.
- B. Grille: A louvered or perforated covering for an opening in an air passage, which can be located in a sidewall, ceiling, or floor.
- C. Register: A combination grille and damper assembly over an air opening.

##### 1.3 SUBMITTALS

- A. Product Data: For each product indicated, include the following:
  - 1. Data Sheet: Indicate materials of construction, finish, and mounting details; and performance data including throw and drop, static-pressure drop, and noise ratings.
  - 2. Diffuser, Register, and Grille Schedule: Indicate Drawing designation, room location, quantity, model number, size, and accessories furnished.
- B. Coordination Drawings: Reflected ceiling plans, drawn to scale, on which the following items are shown and coordinated with each other, based on input from installers of the items involved:
  - 1. Ceiling suspension assembly members.
  - 2. Method of attaching hangers to building structure.
  - 3. Size and location of initial access modules for acoustical tile.
  - 4. Ceiling-mounted items including lighting fixtures, diffusers, grilles, speakers, sprinklers, access panels, and special moldings.
  - 5. Duct access panels.

##### 1.4 QUALITY ASSURANCE

- A. ARI Compliance: Test and rate diffusers, registers, and grilles in accordance with ARI 650 "Standard for Diffusers, registers, and grilles".
- B. ASHRAE Compliance: Test and rate diffusers, registers, and grilles in accordance with ASHRAE 70 "Method of Testing for Rating the Air Flow Performance of Outlets and Inlets".

- C. ADC Compliance: Test and rate diffusers, registers, and grilles in certified laboratories under requirements of ADC 1062 "Certification, Rating and Test Manual".
- D. ADC Seal: Provide diffusers, registers, and grilles bearing ADC Certified Rating Seal.
- E. NFPA Compliance: Install diffusers, registers, and grilles in accordance with NFPA 90A "Standard for the Installation of Air Conditioning and Ventilating Systems".

#### 1.5 DELIVERY, STORAGE AND HANDLING

- A. Deliver diffusers, registers, and grilles wrapped in factory-fabricated fiber-board type containers. Identify on outside of container type of outlet or inlet and location to be installed. Avoid crushing or bending and prevent dirt and debris from entering and settling in devices.
- B. Store diffusers, registers, and grilles in original cartons and protect from weather and construction work traffic. Where possible, store indoors; when necessary to store outdoors, store above grade and enclose with waterproof wrapping.

#### 1.6 WARRANTY

- A. Provide warranty on materials and labor for 18 months starting from date of delivery, or one year from date of substantial completion, whichever is longer.

### **PART 2 - PRODUCTS**

#### 2.1 MANUFACTURERS

- A. Subject to compliance with requirements, provide diffusers by one of the following:
  - 1. Ceiling Air Diffusers:
    - a. Nailor.
    - b. Titus Products Div.; Philips Industries, Inc.
    - c. Tuttle & Bailey; Div. of Interpace Corp.
    - d. Price Industries.
  - 2. Wall Registers and Grilles
    - a. Nailor.
    - b. Titus Products Div.; Philips Industries, Inc.
    - c. Tuttle & Bailey; Div. of Interpace Corp.
    - d. Price Industries.

#### 2.2 CEILING AIR DIFFUSERS

- A. General: Except as otherwise indicated, provide manufacturer's standard ceiling air diffusers where shown; of size, shape, capacity and type indicated; constructed of materials and components as indicated, and as required for complete installation.
- B. Performance: Provide ceiling air diffusers that have, as minimum, temperature and velocity traverses, throw and drop, and noise criteria ratings for each size device as listed in manufacturer's current data.

- C. Ceiling Compatibility: Provide diffusers with border styles that are compatible with adjacent ceiling systems, and that are specifically manufactured to fit into ceiling module with accurate fit and adequate support. Refer to general construction drawings and specifications for types of ceiling systems which will contain each type of ceiling air diffuser.
- D. Types: Provide ceiling diffusers of type, capacity, and with accessories and finishes as listed on diffuser schedule.

### 2.3 WALL REGISTERS AND GRILLES

- A. General: Except as otherwise indicated, provide manufacturer's standard wall registers and grilles where shown; of size, shape, capacity and type indicated; constructed of materials and components as indicated, and as required for complete installation.
- B. Performance: Provide wall registers and grilles that have, as minimum, temperature and velocity traverses, throw and drop, and noise criteria ratings for each size device as listed in manufacturer's current data.
- C. Wall Compatibility: Provide registers and grilles with border styles that are compatible with adjacent wall systems, and that are specifically manufactured to fit into wall construction with accurate fit and adequate support. Refer to general construction drawings and specifications for types of wall construction which will contain each type of wall register and grille.
- D. Types: Provide wall registers and grilles of type, capacity, and with accessories and finishes as listed on schedule.

### 2.4 DOOR AND TRANSFER GRILLES

- A. General: Except as otherwise indicated, provide manufacturer's standard wall registers and grilles where shown; of size, shape, capacity and type indicated; constructed of materials and components as indicated, and as required for complete installation.
- B. Performance: Provide wall registers and grilles that have, as minimum, temperature and velocity traverses, throw and drop, and noise criteria ratings for each size device as listed in manufacturer's current data.
- C. Construction: Outer borders shall be constructed of heavy extruded aluminum and shall have countersunk screw holes for a neat appearance. Border shall be interlocked at the four corners and mechanically staked to form a rigid frame. Extruded aluminum inverted V-blades with a deflection shall be used to create a sight proof design and provide additional stiffness to the grille.
- D. Types: Provide wall grilles of type, capacity, and with accessories and finishes as listed on schedule.

### 2.5 SOURCE QUALITY CONTROL

- A. Verification of Performance: Rate diffusers, registers, and grilles according to ASHRAE 70, "Method of Testing for Rating the Performance of Air Outlets and Inlets."

## **PART 3 - EXECUTION**

### **3.1 EXAMINATION**

- A. Examine areas where diffusers, registers, and grilles are to be installed for compliance with requirements for installation tolerances and other conditions affecting performance of equipment.
- B. Proceed with installation only after unsatisfactory conditions have been corrected.

### **3.2 INSTALLATION**

- A. Install diffusers, registers, and grilles level and plumb.
- B. Ceiling-Mounted Outlets and Inlets: Drawings indicate general arrangement of ducts, fittings, and accessories. Air outlet and inlet locations have been indicated to achieve design requirements for air volume, noise criteria, airflow pattern, throw, and pressure drop. Make final locations where indicated, as much as practicable. For units installed in lay-in ceiling panels, locate units in the center of panel. Where architectural features or other items conflict with installation, notify Architect for a determination of final location.
- C. Install diffusers, registers, and grilles with airtight connections to ducts and to allow service and maintenance of dampers, air extractors, and fire dampers.

### **3.3 CLEANING**

- A. After installation of diffusers, registers, and grilles, inspect exposed finish. Clean exposed surfaces to remove burrs, dirt, and smudges. Replace diffusers, registers, and grilles that have damaged finishes.

### **3.4 CONTRACTOR STARTUP AND REPORTING**

- A. After installation, adjust diffusers, registers, and grilles to air patterns indicated, or as directed, before starting air balancing.

**End of Section 233713**

## DIVISION 23 – HEATING, VENTILATING AND AIR CONDITIONING

### SECTION 23 81 26

#### SPLIT-SYSTEM AIR-CONDITIONERS

##### PART 1 - GENERAL

###### 1.1 SUMMARY

- A. Section includes split-system air-conditioning units consisting of separate evaporator-fan and compressor-condenser components.

###### 1.2 SUBMITTALS

- A. Product Data: For each type of product indicated. Include rated capacities, operating characteristics, and furnished specialties and accessories. Include performance data in terms of capacities, outlet velocities, static pressures, sound power characteristics, motor requirements, and electrical characteristics.
  - 1. Include documentation on refrigerants, including printed statement that refrigerants are free of HCFCs.
- B. Shop Drawings: Include plans, elevations, sections, details, and attachments to other work.
  - 1. Detail equipment assemblies and indicate dimensions, weights, loads, required clearances, method of field assembly, components, and location and size of each field connection.
  - 2. Wiring Diagrams: For power, signal, and control wiring.
- C. Field quality-control reports.
- D. Operation and Maintenance Data: For split-system air-conditioning units to include in emergency, operation, and maintenance manuals.
- E. Recording(s) of training session(s).
- F. Warranty: Sample of special warranty.

###### 1.3 QUALITY ASSURANCE

- A. Electrical Components, Devices, and Accessories: Listed and labeled as defined in Chicago Electric Code, by a qualified testing agency, and marked for intended location and application.
- B. ASHRAE Compliance:
  - 1. Fabricate and label refrigeration system to comply with ASHRAE 15, "Safety Standard for Refrigeration Systems."
  - 2. ASHRAE Compliance: Applicable requirements in ASHRAE 62.1-latest edition, Section 4 - "Outdoor Air Quality," Section 5 - "Systems and Equipment," Section 6 - "Procedures," and Section 7 - "Construction and System Start-Up."

- C. ASHRAE/IESNA Compliance: Applicable requirements in ASHRAE/IESNA 90.1-most current version.

#### 1.4 COORDINATION

- A. Ground-Mounted Remote Condensing Units: Coordinate sizes and locations of concrete bases with actual equipment provided.
- B. Roof-Mounted Remote Condensing Units: Coordinate sizes and locations of roof curbs, equipment supports, and roof penetrations with actual equipment provided.

#### 1.5 WARRANTY

- A. Special Warranty: Manufacturer's standard form in which manufacturer agrees to repair or replace components of split-system air-conditioning units that fail in materials or workmanship within specified warranty period.
  - 1. Warranty Period:
    - a. Compressor: Six years from date of Preliminary Acceptance or Substantial Completion.
    - b. Parts: One year from date of Preliminary Acceptance or Substantial Completion.

#### 1.6 EXTRA MATERIALS

- A. Furnish extra materials that match products installed and that are packaged with protective covering for storage and identified with labels describing contents.
  - 1. Filters: One set for each air-handling unit.

### **PART 2 - PRODUCTS**

#### 2.1 MANUFACTURERS

- A. Manufacturers: Subject to compliance with requirements, provide products by one of the following:
  - 1. Carrier Corporation; Home Comfort and HVAC Building & Industrial Systems.
  - 2. Mitsubishi Electric & Electronics USA, Inc.; HVAC Advanced Products Division.
  - 3. SANYO North America Corporation; SANYO Fisher Company.
  - 4. Trane; a business of Ingersoll Rand.
  - 5. YORK; a Johnson Controls company.

#### 2.2 INDOOR UNITS (5 TONS OR LESS)

- A. Wall-Mounted, Evaporator-Fan Components:
  - 1. Cabinet: Enameled steel with removable panels on front and ends in color selected by Architect, and discharge drain pans with drain connection.
  - 2. Refrigerant Coil: Copper tube, with mechanically bonded aluminum fins and thermal-expansion valve. Comply with ARI 210/240.
  - 3. Fan: Direct drive, centrifugal.

4. Fan Motors:
  - a. Comply with NEMA designation, temperature rating, service factor, enclosure type, and efficiency requirements specified in Division 23.
  - b. Multi-tapped, multi-speed with internal thermal protection and permanent lubrication.
  - c. Enclosure Type: Totally enclosed, fan cooled.
  - d. NEMA Premium (TM) efficient motors as defined in NEMA MG 1.
  - e. Controllers, Electrical Devices, and Wiring: Comply with requirements for electrical devices and connections specified in Division 26 Sections.
  - f. Mount unit-mounted disconnect switches on exterior or interior of unit.
  
5. Airstream Surfaces: Surfaces in contact with the airstream shall comply with requirements in ASHRAE 62.1-latest edition.
6. Condensate Drain Pans:
  - a. Fabricated with one or two percent slope in at least two planes to collect condensate from cooling coils (including coil piping connections, coil headers, and return bends) and humidifiers, and to direct water toward drain connection.
    - 1) Length: Extend drain pan downstream from leaving face to comply with ASHRAE 62.1-latest edition.
    - 2) Pan Depth: 1 inch, minimum.
  - b. Single-wall, non-corrosive non-condensing with moisture tight seal.
  - c. Drain Connection: Located at lowest point of pan and sized to prevent overflow. Terminate with threaded nipple on one end of pan.
    - 1) Minimum Connection Size: NPS 1.
  
7. Air Filtration Section:
  - a. Comply with NFPA 90A.
  - b. Minimum Arrestance: According to ASHRAE 52.1 and MERV according to ASHRAE 52.2.
  - c. Filter-Holding Frames: Arranged for flat or angular orientation, with access doors on both sides of unit. Filters shall be removable from one side or lifted out from access plenum.
  - d. Disposable Panel Filters:
    - 1) Thickness: 1 inch.
    - 2) Frame: Galvanized steel, with metal grid on outlet side, steel rod grid on inlet side, and hinged; with pull and retaining handles.

## 2.3 OUTDOOR UNITS (5 TONS OR LESS)

### A. Air-Cooled, Compressor-Condenser Components:

1. Casing: Steel, finished with baked enamel, in color selected by Architect, with removable panels for access to controls, weep holes for water drainage, and mounting holes in base. Provide brass service valves, fittings, and gage ports on exterior of casing.
2. Compressor: Hermetically sealed with crankcase heater and mounted on vibration isolation device. Compressor motor shall have thermal- and current-sensitive overload devices, start capacitor, relay, and contactor.

- a. Compressor Type: Scroll.
  - b. Two-speed compressor motor with manual-reset high-pressure switch and automatic-reset low-pressure switch.
  - c. Refrigerant Charge: R-407C or R-410A as scheduled.
  - d. Refrigerant Coil: Copper tube, with mechanically bonded aluminum fins and liquid sub-cooler. Comply with ARI 210/240.
- 3. Fan: Aluminum-propeller type, directly connected to motor.
  - 4. Motor: Permanently lubricated, with integral thermal-overload protection.
  - 5. Low Ambient Kit: Permits operation down to -20 deg F.
  - 6. Mounting Base: Polyethylene.

## 2.4 ACCESSORIES

- A. Thermostat: Low voltage with sub-base to control compressor and evaporator fan.
  - 1. Compressor time delay.
  - 2. 24-hour time control of system stop and start.
  - 3. Liquid-crystal display indicating temperature, set-point temperature, time setting, operating mode, and fan speed.
  - 4. Fan-speed selection including auto setting.
- B. Automatic-reset timer to prevent rapid cycling of compressor.
- C. Refrigerant Line Kits: Soft-annealed copper suction and liquid lines factory cleaned, dried, pressurized, and sealed; factory-insulated suction line with flared fittings at both ends.
- D. Drain Hose: For condensate.

## PART 3 - EXECUTION

### 3.1 INSTALLATION

- A. Install units level and plumb.
- B. Install evaporator-fan components using manufacturer's standard mounting devices securely fastened to building structure.
- C. Install ground-mounted, compressor-condenser components on 4-inches thick, reinforced concrete base that is 4 inches larger, on each side, than unit, with cast-in anchor-bolt inserts. Concrete, reinforcement, and formwork are specified in Division 03 Section "Cast-In-Place Concrete."
- D. Install roof-mounted, compressor-condenser components on equipment supports specified in Division 07 Section, "Roof Accessories." Anchor units to supports with removable, cadmium-plated fasteners.
- E. Install and connect pre-charged refrigerant pipes to component's quick-connect fittings. Install pipes to allow access to unit.



### 3.2 PIPE CONNECTIONS

- A. Pipe installation requirements are specified in other Division 22 Sections. Drawings indicate general arrangement of piping, fittings, and specialties.
- B. Pipe installations shall allow space for service and maintenance of system components.

### 3.3 FIELD QUALITY CONTROL

- A. Manufacturer's Field Service: Engage a factory-authorized service representative to inspect components, assemblies, and equipment installations, including connections, and to assist in testing.
- B. Tests and Inspections:
  - 1. Leak Test: After installation, charge system and test for leaks. Repair leaks and repeat test until no leaks exist.
  - 2. Operational Test: After electrical circuitry has been energized, start units to confirm proper motor rotation and unit operation.
  - 3. Controls and Safeties: Test and adjust controls and safeties. Replace damaged and malfunctioning controls and equipment.
- C. Remove and replace malfunctioning units and retest as specified above.

### 3.4 STARTUP SERVICE

- A. Engage a factory-authorized service representative to perform startup service.
  - 1. Complete installation and startup checks according to manufacturer's written instructions.

### 3.5 TRAINING AND DEMONSTRATION

- A. Engage a factory-authorized service representative to train Owner's maintenance personnel to adjust, operate, and maintain unit as specified below:
  - 1. Train Owner's maintenance personnel on procedures and schedules for starting up and shutting down, troubleshooting, servicing, and maintaining system components. The training will occur after the startup report has been provided to the Owner and the trainer will provide four Installation and Operation manuals for the use of the Owner's personnel during training.
  - 2. Review data in maintenance manuals. Refer to Division 01 Section "Operation and Maintenance Data." All required and recommended maintenance will be reviewed as well as operational troubleshooting. If the IOM does not include a written troubleshooting guide, one will be provided.
  - 3. Schedule training with Owner, through Architect, with at least seven days advance notice.
- B. Demonstrate proper operation of equipment to commissioning agent, if one, and designated Owner's personnel. The scope of the demonstration shall include functional performance requirements under local control as well as any commissioning requirements in Division 01 and 23.
- C. Video record the training session(s). The manufacturer may submit a standard training video or training CD for review as an alternate to recording of the training session. The standard video

must be reviewed and accepted by the Owner and Commissioning Authority, if one, for the alternate to be acceptable.

**End of Section 238126**

## DIVISION 26 – ELECTRICAL

### SECTION 26 05 03

#### GENERAL REQUIREMENTS FOR ELECTRICAL SYSTEMS

##### PART 1 - GENERAL

##### 1.1 SUMMARY

- A. Section includes general administrative, material, and procedural requirements for electrical installations. The following administrative and procedural requirements are included in this Section to expand the requirements specified in Division 01.
1. Electrical product general requirements and accesses.
  2. Substitutions.
  3. Submittals.
  4. Alternates.
  5. Coordination drawings.
  6. Record documents.
  7. Maintenance manuals.
  8. Rough-ins.
  9. Electrical installations.
  10. Cutting and patching.

##### 1.2 DEFINITIONS

- A. Definitions:
1. Listed: Equipment or materials included in a list published by an organization acceptable to the authority having jurisdiction and concerned with product evaluation, that maintain periodic inspection of production of listed equipment or materials, and whose listing states either that the equipment or material meets appropriate designated standards or has been tested and found suitable for use in a specified manner.
  2. Labeled: Equipment or materials to which has been attached a label, symbol, or other identifying mark of an organization that is acceptable to the authority having jurisdiction and concerned with product evaluation that maintains periodic inspection of production of labeled equipment or materials and by whose labeling the manufacturer indicates compliance with appropriate standards or performance in a specified manner.
  3. General Explanation: A substantial amount of specification language consists of definitions of terms found in other Contract Documents, including Drawings. (Drawings are recognized as being diagrammatic in nature and not completely descriptive of the requirements indicated thereon). Certain terms used in Contract Documents are defined in this article. Definitions and explanations contained in this Section are not necessarily either complete or exclusive but are general for the Work to the extent that they are not stated more explicitly in another element of the Contract Documents.
  4. General Requirements: The provisions or requirements of other Division 01 Sections apply to entire work of the Contract and where so indicated, to other elements which are included in the project.
  5. Indicated: The term "indicated" is a cross-reference to graphic representations, notes or schedules on drawings, to other paragraphs or schedules in the specifications, and to similar means of recording requirements in the Contract Documents. Where terms such as "shown," "noted," "scheduled," and "specified" are used in lieu of "indicated," it is for

purpose of helping the reader locate cross- references, and no limitation of location is intended except as specifically noted.

6. Directed, Requested, etc: Where not otherwise explained, terms such as "directed", "requested", "authorized", "selected", "reviewed", "required", "accepted", and "permitted" mean "directed by Architectural/Engineer", and similar phrases. However, no such implied meaning will be interpreted to extend the Architect/Engineer's responsibility into the Contractor's area of construction supervision.
7. Furnish: Except as otherwise defined in greater detail, the term "furnish" is used to mean supply and deliver to the project site, ready for unloading, unpacking, assembly, installation, and similar operations, as applicable in each instance.
8. Install: Except as otherwise defined in greater detail, the term "install" is used to describe operations at the job site, including unloading, unpacking, assembly, erection, placing, anchoring, mounting, connecting, testing, protecting and cleaning, placing in working condition and similar operations, as applicable in each instance.
9. Provide: Except as otherwise defined in greater detail, the term "provide" means to furnish and install, complete and ready for intended use, as applicable in each instance.
10. Installer: The term "installer" is defined as the entity (person or firm) engaged by the contractor, its subcontractor or sub-subcontractor for performance of a particular unit of work at the project site. It is a general requirement that such entities (installers) be expert in the operation they are engaged to perform.
11. Connect: The term "connect" means to provide power sources, overcurrent devices, raceway, conductors, terminations, insulation and other materials required for the operation and control of the equipment noted by the term.
12. Wiring: The term wiring means all raceways, fittings, conductors, connectors, tape, junction and outlet boxes, connectors, splices, and all other items necessary and/or required in connection with such work.
13. Conduit: The term conduit means the inclusion of all fittings, hangers, supports, sleeves, etc.
14. Concealed: The term concealed means embedded in masonry or other construction, installed behind wall furring or within partitions, or installed within suspended ceilings.
15. Exposed: The term exposed means not installed underground or concealed as defined above.
16. Accessible: The term accessible means being capable of being reached without the use of ladders or without climbing or crawling under, through or over obstacles such as other mechanical or electrical equipment, building members or structure, piping, ductwork or going through doors.

### **1.3 SUBMITTALS**

- A. General: Follow the procedures specified in Division 01 Section "Submittal Procedures." If submittals include any deviations from specified equipment/materials, these deviations must be clearly identified. The reason for the deviation must also be indicated.
- B. Prepare shop drawings and obtain approvals from inspection authorities for fire alarm and life systems, and other electrical installations requiring specific approval.
- C. Submit coordination drawings for areas specified and those areas defined as "problem" coordination areas during construction.
- D. Submit 1/4" scale drawings drawing of electrical room equipment layouts with distribution equipment submittal. Layout shall be based on equipment being submitted for approval.
- E. Electronic drawing files in AutoCad 2004 or velum copies of the electrical drawings for use in preparing submittals may be purchased from the engineer. These drawings will not be provided without charge to the contractor or any of the subcontractors.

- F. Documents will not be accepted for review unless:
1. They comply as to number of copies and type of paper indicated in the General Requirements.
  2. They include complete information pertaining to appurtenances and accessories.
  3. They are submitted as a package where they pertain to related items.
  4. Where they consist of standard catalog sheets displaying other items which are not applicable, they are properly marked with the electrical data, product identification and accessories as related to this specific project.
  5. They indicate the project and address along with the Contractor's name, address and phone number.
  6. Where they consist of standard factory assembly or field installation drawings, they are properly marked with external connection identification as related to this specific project.
- G. Any materials, fixtures, apparatus, or equipment that are not in accordance with specification requirements can and will be rejected for use in this installation and construction.
- H. Any materials, fixtures, apparatus or equipment installed without stamped or written review will be removed by the Contractor and replaced with specified equipment at the direction of the Architect/Engineer and without recourse for additional compensation.
- I. Prepare and submit all shop drawings to governmental agencies and utility companies which are required by these agencies for their approval.

#### **1.4 QUALITY ASSURANCE**

- A. Carefully examine the contract documents, visit the site, and become thoroughly familiar with the local conditions relating to the work. Failure to do so will not relieve the contractor of the obligations of the Contract.
- B. Discovery of any conflicting design information or any design intentions which are not readily interpreted shall be referred to the Architect/Engineers for further description or illustration prior to any product selection or execution of work.
- C. Discovery of any materials or equipment which are damaged, unsuitable, incompatible, or non-compliant with any applicable codes, laws, ordinances or other regulations shall be brought to the direct attention of the Architect/Engineer.
- D. Should there be any discrepancies or question of intent, refer the matter to the Architect/Engineer for a final decision before ordering any equipment or materials and before starting any relating work.
1. In case of conflict between project specifications and drawings, the Contractor shall assume the more expensive method for purposes of bidding, unless the Architect/Engineer rules otherwise.
- E. Manufacturers of equipment shall be firms regularly engaged in manufacturing factory fabricated systems and equipment whose products have been in satisfactory use in similar service for not less than 5 years.

## **1.5 DELIVERY, STORAGE, AND HANDLING**

- A. Delivery product to the project properly identified with names, model numbers, types grades, compliance labels, and other information needed for identification.

## **1.6 RULES AND REGULATIONS**

- A. Work and materials shall conform to and be execute, inspected and tested in accordance with the latest edition of the City of Chicago Electrical Code and the governing rules and regulations of Federal, State and Local governmental agencies.
- B. Other codes which will apply to this installation include the current editions of:
  - 1. ANSI C2 – National Electrical Safety Code.
  - 2. ASME/ANSI A17.1 - Safety Code for Elevators and Escalators.
  - 3. ASTM - American Society for Testing and Materials.
  - 4. ICEA - Standards for Wire and Cable.
  - 5. IEEE Standards.
  - 6. IESNA Standards.
  - 7. NEMA Standards.
  - 8. NFPA 20 - Standards.
  - 9. OSHA Regulations.
  - 10. Underwriters Laboratories.
- C. Where governing codes indicate the Drawings and Specifications do not comply with the minimum requirements of applicable codes, the Contractor shall either notify the Architect/Engineer in writing during the bidding period identifying the revisions required to meet code requirements or provide an installation which will comply with the code requirements.
- D. Where regulations of electric utility and telephone companies apply, conformance with their regulations is mandatory and any costs involved shall be included in the Contract, with the exception of extra facility and other charges which are directly paid by the Owner.
- E. Where any materials, equipment or installation is not in compliance with the more stringent of the applicable codes, laws, ordinances, regulations and contract documents, they shall be entirely removed, replaced, modified or otherwise corrected at no additional cost to the Owner.

## **1.7 SUBSTITUTIONS**

- A. The materials, products and equipment described in the Bidding Documents establish a standard of required functions, dimensions, appearance and quality to be met by any proposed substitutions.
- B. No substitution will be considered prior to receipt of Bids unless written request for approval has been received by the Architect/Engineer at least ten (10) days prior to the date for receipt of Bids. Each such request shall include the name of the material or equipment for which it is to be substituted and a complete description of the proposed substitute including drawings, cuts, performance, test data and warranties, and any other information necessary for an evaluation. A statement setting forth any changes in other materials, equipment or other work than incorporation of the substitute would require shall be included. The burden of proof of the merit of the proposed substitute is upon the proposer. The Architect's decision of approval or disapproval of a proposed substitution shall be final.

- C. If the Architect approved any proposed substitution prior to receipt of Bids, such approval will be set forth in an Addendum. This Addendum shall then be issued to all Bidders.
- D. Requests for substitution shall be made only by a Bidder. Request for substitution received by the Architect from Sales representative, vendors, suppliers etc., are not acceptable.
- E. Refer to Division 01 Section "Substitution Procedures" for additional instructions on substitution.

#### **1.8 RELATED WORK SPECIFIED IN OTHER SECTIONS**

- A. Openings: Wall, floor, ceiling, and roof openings specifically shown and identified on the Architectural and Structural or Electrical Drawing shall be provided.
- B. Roof Sleeves: Roof sleeves shown as furnished and installed shall be incorporated into the finished roofing and made watertight.
- C. Painting: Painting of all exposed-to-view conduit, pipes, unfinished hangers, supports, and equipment, insulated or not, in finished and unfinished areas, shall be provided. Furnish all manufactured equipment in factory-finished baked enamel, unless otherwise specified.

#### **1.9 WIRING AND CONTROLS**

- A. Wiring and controls associated with equipment shall be furnished, installed, and wired in accordance with the manufacturer's recommendations and applicable standards and codes. Provide installation instructions, locating dimensions, and wiring diagrams for the other trades. Supervise the installation and start-up and test the equipment unless otherwise specified.
- B. Equipment Furnished by Other Divisions: Equipment specified in other Divisions and requiring electrical supply shall be erected, aligned, leveled, and prepared for operation. Provided required controls and accessories along with installation instructions, diagrams, dimensions and supervision of installation and start-up. Provide the required electrical rough-ins, and confirm the electrical controls and accessories furnished under the specifications for the other Divisions. Install those controls and accessories not located in the mechanical piping and ductwork. Provide additional electrical controls, accessories, fittings, and devices not specified under the equipment but required for a finished, operating job. Make final electrical connections. Participate in the start-up and test services.

#### **1.10 PERMIT AND INSPECTIONS**

- A. Permits: Obtain and pay for all permits, bonds, licenses, tap-in fees, etc., required by the City, State, or other authority having jurisdiction over the work, as a part of the work of the affected Section.
- B. Inspections: Arrange and pay for all inspections required by the above when they become due as part of the work of the Sections affected. Conceal no work until approved by these governing authorities. Present the Contractor, Architect/Engineer with properly signed certificate of final inspection.

#### **1.11 REVIEW OF MATERIALS**

- A. Within 21 calendar days after award of this Contract, submit a typewritten list of all items of equipment and material proposed for installation on this Project to the Architect/Engineer for review for design conformance. Set forth the specification page number, manufacturer's name,

model number, size, nonstandard accessories specified or required, and any other information required to identify each item.

#### **1.12 PROJECT SITE CONDITIONS**

- A. Inspect and examine the site before submitting the proposal. Note the location of any existing facilities, existing services or interference with other trades. Immediately contact Architect/Engineer indicating discrepancies. Failure to do so will not relieve the Contractor of the obligations of the Contract.
- B. Visit the site or premises in order to become familiar with job conditions. No extras will be allowed for work which could have been foreseen by an examination of the site or premises.
- C. Adjust work to meet actual conditions existing at the job.
- D. Inspect and examine the site to determine how equipment will be transported to final mounting locations. No extra charges will be allowed for moving, hoisting or otherwise transporting equipment to final mounting location.

### **PART 2 - PRODUCTS**

#### **2.1 MATERIALS**

- A. All materials, unless otherwise specified, shall be new and be the standard products of the manufacturer. Seconds, rejects, or damaged materials will be rejected.
- B. The equipment to be provided under these Specifications shall be essentially the standard commercial grade product of the manufacturer. Where two or more units of the same class of equipment are required, these units shall be products of a single manufacturer.
- C. The listing of a manufacturer for certain equipment and systems does not indicate acceptance of a standard or catalogued item of equipment. All equipment and systems shall conform to the Specifications.

#### **2.2 U.L. LISTING & LABELING**

- A. All equipment shall bear the Underwriter's Laboratories (U.L.), or other approved agency, listing label.
- B. Wherein an item of equipment is specified to be U.L. Listed, the entire assembly shall be listed by Underwriters laboratories, Inc. Any modifications to suit the intent of the Specifications, shall be performed in accordance with the City of Chicago Electrical Code.

### **PART 3 - EXECUTION**

#### **3.1 ROUGH-IN**

- A. Verify final locations for rough-ins with field measurements and with the requirements of the actual equipment to be connected.



- B. Refer to equipment specifications in Divisions 02 through 14, 22, 23, and 26 for rough-in requirements.

### **3.2 ELECTRICAL INSTALLATIONS**

- A. General: Sequence, coordinate, and integrate the various elements of electrical systems, materials, and equipment. Comply with the following requirements:

1. The Architect shall control the placement of wall and ceiling mounted electrical devices, fixtures, and outlets. The intent is to aesthetically locate fixtures/outlets by providing rough-in hardware, boxes and/or mounting plates, as required, when stud or furring may not be readily available for direct mounting. When drawing details are not available, consult with Architect's representative for actual placement.
2. Coordinate electrical systems, equipment, and materials installation with other building components. Be responsible for any changes in openings and locations necessitated by the equipment installed.
3. Verify all dimensions by field measurements.
4. Arrange for chases, slots, and openings in other building components during progress of construction, to allow for electrical installations.
5. Coordinate the installation of required supporting devices and sleeves to be set in poured-in-concrete and other structural components, as they are constructed.
6. Sequence, coordinate, and integrate installations of electrical materials and equipment for efficient flow of the Work. Give particular attention to large equipment requiring positioning prior to closing in the building.
7. Where mounting heights are not detailed or dimensioned, install systems, materials, and equipment to provide the maximum headroom possible.
8. Install systems, materials, and equipment to conform with approved submittal data, including coordination drawings, to greatest extent possible. Conform to arrangements indicated by the Contract Documents, recognizing that portions of the Work are shown only in diagrammatic form. Where coordination requirements conflict with individual system requirements, refer conflict to the Architect.
9. Switchgear/Switchboard/Motor Control Center Assembly Selection: The drawings indicate sizes, profiles, and dimensional requirements of assembly equipment. Equipment having equal performance characteristics and complying with indicated maximum dimensions and profiles may be considered, provided deviations do not change the design concept, intended performance, or code/future extension provision clearances. The burden of proof of equality is on the proposer a minimum of 10 days prior to bid.
10. Protect all equipment and materials from the elements, dirt and other damage from the time it is removed from the point of storage until final acceptance.
11. Equipment shall include the component parts thereof such as disconnect switches, motor starters, motors, drives, and guards necessary to the satisfactory and safe operation of the equipment.
12. Installation shall include setting equipment to accurate line and grade, leveling equipment, aligning equipment components, providing and installing couplings, bolts, guards and anchor bolts.
13. All tolerances in alignment and leveling, and the quality of workmanship for each class and stage of work shall be subject to manufacturer's installation instructions.
14. All manufacturers' finished equipment surfaces damaged during construction shall be brought to an "as new" condition by touch up or repairing. Any rust shall be completely removed and the surface primed prior to repainting.
15. Workmanship shall conform to the "Standard of Installation" published by the National Electrical Contractors Association.
16. Prior to start of utility trench work, notify the Architect of utilities that require excavations lower than the building foundations. Do not proceed with trench work without direction

from the Architect to ensure the building foundations will not be compromised by the utility installation.

17. Provide all scaffolding, rigging, hoisting and services necessary for erection and delivery of equipment and apparatus furnished into the premises. These items shall be removed from the premises when no longer required.
18. No electrical equipment, raceways or other work of any kind shall be covered up or hidden from view before it has been examined and approved. Any unsatisfactory work or materials shall be removed and corrected immediately.
19. Install systems, materials, and equipment level and plumbing, parallel and perpendicular to other building systems and components.
20. Install electrical equipment to facilitate servicing, maintenance, and repair or replacement of equipment components. As much as practical, connect equipment for ease of disconnecting, with minimum of interference with other installations.
21. Install access panels or doors where units are concealed behind finished surfaces. Access panels and doors are specified in Division 26 Section "Basic Electrical Materials and Methods."
22. Install systems, materials, and equipment giving right-of-way priority to systems required to be installed at a specified slope.

### **3.3 MANUFACTURER'S DIRECTIONS AND SUPERVISION**

- A. Where supervision by a manufacturer is specified, follow all instructions, recommended manufacturer and specified field tests, and other recommendations of the manufacturer. The manufacturer shall supervise the installation, connection, start-up, testing, and adjustment, instruction of the Owner and final tests of such equipment or system. Where two or more manufacturer's equipment are interrelated, take responsibility to coordinate their work and provide supervision.
- B. Have the manufacturer instruct the Owner in the proper operation and maintenance techniques of all equipment, systems, etc., at the time of completion of all work.
- C. Prior to final acceptance by the Owner prepare and submit to the Architect for review 3 copies of operation and maintenance (O and M) instructions in printed form for each item of equipment or system installed in the building. Complete instructions for each system shall be assembled and bound in a brochure. Detailed contents of the O and M manuals are as hereinafter specified. Refer to appropriate Division 01 Sections for general requirements affecting this work.

### **3.4 PAINTING**

- A. Provide the prime painting of all equipment and materials furnished under Division 26 specifications, unless specifically stated otherwise. In general, all equipment except raceways and galvanized boxes that are not provided with a factory-applied final finish shall be delivered to the job site with a shop-applied prime coat of paint.

### **3.5 TEST AND INSPECTION**

- A. Upon completion of the work, notify the Architect in writing, that the entire electrical installation has been examined, inspected, tested, calibrated or adjusted as specified and that it is ready for final inspection. Work to be connected prior to final inspection and also to include all of the work specified for "Manufacturers' Directions and Supervision." Include documentation of specified testing and inspection.

- B. Prior to each inspection, provide a written certification that each system or piece of equipment to be operated during that test has been tested and does meet design performance criteria of the Contract Documents.
- C. On completion of work, obtain Certificates of Compliance, and approval or acceptance from all authorities having jurisdiction over the work, and deliver these certificates to the Architect. The work shall not be deemed to have reached a state of completion until the certificates have been delivered.

### **3.6 LOOSE EQUIPMENT**

- A. Provide four keys for every different piece of electrical equipment which is equipped with a lock.
- B. Provide all other loose equipment specified/supplied for use with all systems.

### **3.7 SHOP DRAWINGS**

- A. Refer to Division 01 for quantities and types of shop drawings.
- B. Required shop drawings shall be submitted in groups by systems. For example, all lighting fixtures, lamps, ballasts and accessories shall be submitted simultaneously in one package.
- C. Refer to individual Division 26 Sections for required shop drawings.
- D. Shop drawings submitted for other than those specifically required in the appropriate Specification Section will not be reviewed or returned.

### **3.8 OPERATION AND MAINTENANCE MANUALS**

- A. Prepare maintenance manuals in accordance with Division 01 Section "Operating and Maintenance Data". In addition to the requirements specified in Division 01, include specific Division 26 Section requirements, and the following information for equipment items:
  - 1. Description of function, normal operating characteristics and limitations, performance curves, engineering data and tests, and complete nomenclature and commercial numbers of replacement parts.
  - 2. Manufacturer's printed operating procedures to include start-up, break-in, and routine and normal operating instructions; regulation, control, stopping, shutdown, and emergency instructions; and summer and winter operating instructions.
  - 3. Maintenance procedures for routine preventative maintenance and troubleshooting; disassembly, repair, and reassembly; aligning and adjusting instructions.
  - 4. Servicing instructions and lubrication charts and schedules.
- B. The minimum information that shall be furnished in the maintenance manual shall include the following:
  - 1. Individual Characteristics for trouble shooting sequences for each item of:
    - a. Branch circuit panel.
    - b. Fire alarm system.
    - c. Individual motor starter.
  - 2. Catalog cut sheets for every item for which a shop drawing is required.

3. Schedule of loads served for each:
  - a. Branch circuit panel.
4. Overload element schedule for each motor starter whether individual or in a motor control center.
5. Bolt tightening torques and inspection intervals on each:
  - a. Bolted bus connection.
  - b. Cable connection.
  - c. Miscellaneous bolted electrical connections.
6. Manufacturers' recommended cleaning intervals and special procedures for each:
  - a. Cooling fins.
  - b. Electrical equipment interior.
  - c. Electrical equipment ventilation opening.
  - d. Lighting fixture lenses, louvers and reflectors.
7. Main and arcing contact adjustment and replacement for each:
  - a. Contactor.
  - b. Circuit breaker.
  - c. Fused switch.
  - d. Interrupter switch.
  - e. Motor starter.
8. Calibration and exercise procedures and intervals for each:
  - a. Control system.
  - b. Emergency battery.
  - c. Molded case breaker.
  - d. Relay.
9. "As designed" and "as left" relay settings.
10. Testing interval and target values for ground fault protection circuit relays.
11. Testing and trouble shooting procedures unique to special systems.
12. Approved special construction details that differ from the details shown on Drawings.

### **3.9 COORDINATION DRAWINGS**

- A. Prepare coordination drawings to a scale of  $\frac{1}{4}" = 1'-0"$  or larger; detailing major elements, components, and systems of electrical equipment and materials in relationship with other systems, installations, and building components. Indicate locations where space is limited to installation and access and where sequencing and coordination of installations are of importance to the efficient flow of the Work, including (but not necessarily limited to) the following:
  1. Indicate the proposed locations of major raceway systems, equipment, and materials. Include the following:
    - a. Clearances for servicing equipment, including space for equipment disassembly required for periodic maintenance.

- b. Exterior wall and foundation penetrations.
  - c. Fire-rated wall and floor penetrations.
  - d. Equipment connections and support details.
  - e. Sizes and location of required concrete pads and bases.
2. Coordination drawings shall be provided by Division 26 for the following:
- a. Access door locations.
  - b. Communication rooms.
  - c. Electrical equipment rooms.
  - d. Mechanical equipment rooms.
  - e. Power factor correction capacitor locations.
3. Indicate scheduling, sequencing, movement, and positioning of large equipment into the building during construction.
4. Prepare floor plans, elevations, and details to indicate penetrations in floors, walls, and ceilings and their relationship to other penetrations and installations.

### **3.10 RECORD DOCUMENTS**

- A. Prepare record documents in accordance with the requirements in Division 01 Section "Project Closeout." In addition to the requirements specified in Division 01, indicate installed conditions for:
- 1. Major raceway systems, size and location, for both exterior and interior, locations of control devices; distribution and branch electrical circuitry; and fuse and circuit breaker size and arrangements.
  - 2. Major equipment locations (exposed and concealed), dimensioned from prominent building lines.
  - 3. Contract Modifications and actual equipment and materials installed.
- B. Engage the services of a Land Surveyor or Professional Engineer registered in the State of Illinois to record the locations and invert elevations of underground installations.

**END OF SECTION**

## DIVISION 26 – ELECTRICAL

### SECTION 26 05 05

#### BASIC ELECTRICAL MATERIALS AND METHODS

##### PART 1 - GENERAL

##### 1.1 SUMMARY

- A. Section includes the limited scope construction materials and methods for application with electrical installations as follows:
1. Excavation for underground utilities and services, including underground raceways, vaults, and equipment.
  2. Miscellaneous materials for support of electrical materials and equipment.
  3. Concrete equipment bases.
  4. Cutting and patching for electrical construction.
  5. Touchup painting.
  6. Mounting heights.
  7. Electrical equipment coordination and installation.
  8. Sleeves for raceways and cables.
  9. Sleeve seals.
  10. Common electrical installation requirements.

##### 1.2 DEFINITIONS

- A. The following definitions apply to excavation operations:
1. Additional Excavation: Where excavation has reached required subgrade elevations, if unsuitable bearing materials are encountered, continue excavation until suitable bearing materials are reached. The Contract Sum may be adjusted by an appropriate Contract Modification
  2. Subbase: As used in this Section refers to the compacted soil layer used in pavement systems between subgrade and the pavement base course material.
  3. Subgrade: As used in this Section refers to the compacted soil immediately below the slab or pavement system.
  4. Unauthorized excavation consists of removal of materials beyond indicated subgrade elevations or dimensions without specific direction from the Architect.

##### 1.3 SUBMITTALS

- A. Shop drawings are not required for material and equipment specified under this Section of the specifications.

##### 1.4 QUALITY ASSURANCE

- A. Electrical Components, Devices, and Accessories: Listed and labeled as defined in City of Chicago Electrical Code, Article 100, by a testing agency acceptable to authorities having jurisdiction, and marked for intended use.
- B. Comply with City of Chicago Electrical Code.

- C. Installer Qualifications: Engage an experienced installer for the installation and application of joint sealers, ~~access panels,~~ and doors.
- D. Qualify welding processes and welding operators in accordance with AWS D1.1 "Structural Welding Code – Steel."
  - 1. Certify that welder has satisfactorily passed AWS qualification tests for welding processes involved and, if pertinent, has undergone recertification.

## 1.5 PROJECT CONDITIONS

- A. Conditions Affecting Excavations: The following project conditions apply:
  - 1. Maintain and protect existing building services which transit the area affected by selective demolition.
  - 2. Protect structures, utilities, sidewalks, pavements, and other facilities from damage caused by settlement, lateral movement, undermining, washout, and other hazards created by excavation operations.
  - 3. Site Information: Subsurface conditions were investigated during the design of the Project. Reports of these investigations are available for information only; data in the reports are not intended as representations or warranties of accuracy or continuity of conditions. The Owner will not be responsible for interpretations or conclusions drawn from this information.
  - 4. Existing Utilities: Locate existing underground utilities in excavation areas. If utilities are indicated to remain, support and protect services during excavation operations.
  - 5. Remove existing underground utilities indicated to be removed.
    - a. Uncharted or Incorrectly Charted Utilities: Contact utility owner immediately for instructions.
    - b. Provide temporary utility services to affected areas. Provide minimum of 48-hour notice to Architect prior to utility interruption.
  - 6. Use of explosives is not permitted.
- B. Environmental Conditions: Apply joint sealers under temperature and humidity conditions within the limits permitted by the joint sealer manufacturer. Do not apply joint sealers to wet substrates.

## 1.6 COORDINATION

- A. Coordinate chases, slots, inserts, sleeves, and openings with general construction work and arrange in building structure during progress of construction to facilitate the electrical installations that follow.
  - 1. Set inserts and sleeves in poured-in-place concrete, masonry work, and other structural components as they are constructed.
- B. Sequence, coordinate, and integrate installing electrical materials and equipment for efficient flow of the Work. Coordinate installing large equipment requiring positioning before closing in the building.
  - 1. Coordinate installation and connection to exterior underground and overhead utilities and services, including provision for electricity-metering components.

2. Comply with requirements of authorities having jurisdiction and of utility company providing electrical power and other services.
- C. Coordinate location of access panels and doors for electrical items that are concealed by finished surfaces. Access doors and panels are specified in Division 08 Section "Access Doors and Frames."

## **PART 2 - PRODUCTS**

### **2.1 MANUFACTURERS**

- A. Manufacturers: Subject to compliance with requirements, provide products by one of the following manufacturers:
1. Manufacturers:
    - a. Advance Products & Systems, Inc.
    - b. Calpico, Inc.
    - c. Metrafex Co.
    - d. Pipeline Seal and Insulator, Inc.

### **2.2 MISCELLANEOUS MATERIALS**

- A. Material: Cold-formed steel, with corrosion-resistant coating acceptable to authorities having jurisdiction.
- B. Metal Items for Use Outdoors or in Damp Locations: Hot-dip galvanized steel.
- C. Pipe Sleeves: ASTM A 53, Type E, Grade A, Schedule 40, galvanized steel, plain ends.
- D. Expansion Anchors: Carbon-steel wedge or sleeve type.
- E. Toggle Bolts: All-steel springhead type.
- F. Powder-Driven Threaded Studs: Heat-treated steel.

### **2.3 CONCRETE BASES**

- A. Concrete Forms and Reinforcement Materials: As specified in Division 03 Section "Cast-in-Place Concrete."
- B. Concrete: 3000 psi, 28 day compressive strength as specified in Division 03 Section "Cast-in-Place Concrete."

### **2.4 TOUCHUP PAINT**

- A. For Equipment: Equipment manufacturer's paint selected to match installed equipment finish.
- B. Galvanized Surfaces: Zinc-rich paint recommended by item manufacturer.



## **2.5 SLEEVES FOR RACEWAYS**

- A. Steel Pipe Sleeves: ASTM A 53/A 53M, Type E, Grade B, Schedule 40, galvanized steel, plain ends.
- B. Cast-Iron Pipe Sleeves: Cast or fabricated "wall pipe," equivalent to ductile-iron pressure pipe, with plain ends and integral waterstop, unless otherwise indicated.
- C. Sleeves for Rectangular Openings: Galvanized sheet steel with minimum 0.052 inch or 0.138 inch thickness as indicated and of length to suit application.
- D. Coordinate sleeve selection and application with selection and application of firestopping specified in Division 07 Section "Penetration Firestopping."

## **2.6 SLEEVE**

- A. Description: Modular sealing device, designed for field assembly, to fill annular space between sleeve and raceway.
  - 1. Sealing Elements: EPDM interlocking links shaped to fit surface of conduit. Include type and number required for material and size of raceway.
  - 2. Pressure Plates: Carbon steel. Include two for each sealing element.
  - 3. Connecting Bolts and Nuts: Carbon steel with corrosion-resistant coating of length required to secure pressure plates to sealing elements. Include one for each sealing element.

## **PART 3 - EXECUTION**

### **3.1 EXAMINATION**

- A. Examine substrates, areas, and conditions, with Installer present, for compliance with requirements for installation tolerances. Do not proceed with installation until unsatisfactory conditions have been corrected.

### **3.2 EXCAVATION**

- A. Slope sides of excavations to comply with local codes and ordinances. Shore and brace as required for stability of excavation.
- B. Shoring and Bracing: Establish requirements for trench shoring and bracing to comply with local codes and authorities. Maintain shoring and bracing in excavations regardless of time period excavations will be open.
  - 1. Remove shoring and bracing when no longer required. Where sheeting is allowed to remain, cut top of sheeting at an elevation of 30 inches below finished grade elevation.
- C. Install sediment and erosion control measures in accordance with local codes and ordinances.
- D. Dewatering: Prevent surface water and subsurface or ground water from flowing into excavations and from flooding project site and surrounding area.

1. Do not allow water to accumulate in excavations. Remove water to prevent softening of bearing materials. Provide and maintain dewatering system components necessary to convey water away from excavations.
  2. Establish and maintain temporary drainage ditches and other diversions outside excavation limits to convey surface water to collecting or run-off areas. Do not use trench excavations as temporary drainage ditches.
- E. Material Storage: Stockpile satisfactory excavated materials where directed, until required for backfill or fill. Place, grade, and shape stockpiles for proper drainage.
1. Locate and retain soil materials away from edge of excavations. Do not store within drip-line of trees indicated to remain.
  2. Remove and legally dispose of excess excavated materials and materials not acceptable for use as backfill or fill.

### **3.3 ELECTRICAL EQUIPMENT INSTALLATION**

- A. Headroom Maintenance: If mounting heights or other location criteria are not indicated, arrange and install components and equipment to provide the maximum possible headroom.
- B. Materials and Components: Install level, plumb, and parallel and perpendicular to other building systems and components, unless otherwise indicated.
- C. Equipment: Install to facilitate service, maintenance, and repair or replacement of components. Connect for ease of disconnecting, with minimum interference with other installations.
- D. Right of Way: Give to raceways and piping systems installed at a required slope.

### **3.4 FIRESTOPPING**

- A. Apply firestopping to cable and raceway penetrations of fire-rated floor and wall assemblies to achieve fire-resistance rating of the assembly. Firestopping materials and installation requirements are specified in Division 07 Section "Penetration Firestopping."

### **3.5 CONCRETE BASES**

- A. Construct concrete bases of dimensions indicated, but not less than 4 inches larger, in both directions, than supported unit. Follow supported equipment manufacturer's anchorage recommendations and setting templates for anchor-bolt and tie locations, unless otherwise indicated. Use 3000 psi, 28 day compressive-strength concrete and reinforcement as specified in Division 03 Section "Cast-in-Place Concrete."

### **3.6 SLEEVE INSTALLATION FOR ELECTRICAL PENETRATIONS**

- A. Electrical penetrations occur when raceways penetrate concrete slabs, concrete or masonry walls, or fire-rated floor and wall assemblies.
- B. Coordinate sleeve selection and application with selection and application of firestopping specified in Division 07 Section "Penetration Firestopping."
- C. Concrete Slabs and Walls: Install sleeves for penetrations unless core-drilled holes or formed openings are used. Install sleeves during erection of slabs and walls.
- D. Use pipe sleeves unless penetration arrangement requires rectangular sleeved opening.

- E. Rectangular sleeve Minimum Metal Thickness:
  - 1. For sleeve cross-section rectangle perimeter less than 50 inches and no side greater than 16 inches, thickness shall be 0.052 inch.
  - 2. For sleeve cross-section rectangle perimeter equal to or greater than 50 inches, and 1 or more sides equal to or greater than 16 inches, thickness shall be 0.138 inch.
- F. Fire-Rated Assemblies: Install sleeves for penetrations of fire-rated floor and wall assemblies unless openings compatible with firestop system used are fabricated during construction of floor or wall.
- G. Cut sleeves to length for mounting flush with both surfaces of walls.
- H. Extend sleeves installed in floors 2 inches above finished floor level.
- I. Seal space outside of sleeves with grout for penetrations of concrete and masonry with approved joint compound for gypsum board assemblies.
- J. Interior Penetrations of Non-Fire-Rated Walls and Floors: Seal annular space between sleeve and raceway or cable, using joint sealant appropriate for size, depth, and location of joint. Refer to Division 07 Section "Joint Sealants" for materials and installation.
- K. Fire-Rated-Assembly Penetrations: Maintain indicated fire rating of walls, partitions, ceilings, and floors at raceway and cable penetrations. Install sleeves and seal raceway penetration sleeves with firestop materials. Comply with Division 07 Section "Penetration Firestopping."
- L. Roof-Penetration Sleeves: Seal penetration of individual raceways with flexible boot-type flashing units applied in coordination with roofing work.
- M. Aboveground, Exterior-Wall Penetrations: Seal penetrations using sleeves and mechanical sleeve seals. Select sleeve size to allow for 1-inch annular clear space between pipe and sleeve for installing mechanical sleeve seals.
- N. Underground, Exterior-Wall Penetrations: Install cast-iron "wall pipes" for sleeves. Size sleeves to allow for 1-inch annular clear space between raceway or cable and sleeve for installing mechanical sleeve seals.

### **3.7 CUTTING AND PATCHING**

- A. General: Perform cutting and patching in accordance with Division 01 Section "Cutting and Patching." In addition to the requirements specified in Division 01, the following requirements apply:
  - 1. Perform cutting, fitting, and patching of electrical equipment and materials required to:
    - a. Uncover Work to provide for installation of ill-timed Work.
    - b. Remove and replace defective Work.
    - c. Remove and replace Work not conforming to requirements of the Contract Documents.
    - d. Remove samples of installed Work as specified for testing.
    - e. Upon written instructions for the Architect, uncover and restore Work to provide for Architect observation of concealed work.
    - f.

2. Cut, remove, and legally dispose of electrical equipment, components, and materials as indicated, including but not limited to removal of electrical items indicated to be removed and items made obsolete by the new Work.
3. Protect the structure, furnishings, finishes, and adjacent materials not indicated or scheduled to be removed.
4. Provide and maintain temporary partitions or dust barriers adequate to prevent the spread of dust and direct to adjacent areas.
5. Protection of Installed Work: During cutting and patching operations, protect adjacent installations.
6. Patch finished surfaces and building components using new materials matching materials and experienced Installers. Installers' qualifications refer to the materials and methods required for the surface and building components being patched.

### **3.8 FIELD QUALITY CONTROL**

- A. Inspect installed components for damage and faulty work, including the following:
  1. Excavation for underground utilities.
  2. Concrete bases.
  3. Cutting and patching for electrical construction.
  4. Touchup painting.
- B. Inspect installed sleeve and sleeve-seal installations and associated firestopping for damage and faulty work.

### **3.9 REFINISHING AND TOUCHUP PAINTING**

- A. Refinish and touch up paint. Paint materials and application requirements are specified in Division 09 Section "Painting."
  1. Clean damaged and disturbed areas and apply primer, intermediate, and finish coats to suit the degree of damage at each location.
  2. Follow paint manufacturer's written instructions for surface preparation and for timing and application of successive coats.
  3. Repair damage to galvanized finishes with zinc-rich paint recommended by manufacturer.
  4. Repair damage to PVC or paint finishes with matching touchup coating recommended by manufacturer.

### **3.10 MOUNTING HEIGHTS**

- A. Mounting heights of electrical items shall be as listed below, unless otherwise specified, or by the Architect/Engineer's field instructions. Dimensions are above finished floor, unless otherwise indicated. In areas where code requires different mount heights, as in hazardous areas, comply with code requirements.

- |  |              |
|--|--------------|
| 1. General Receptacles                 | -18" to C.L. |
| 2. General Tele and Data Outlets       | -18" to C.L. |
| 3. General Toggle Switches             | -48" to C.L. |
| 4. Fire Alarm Pull Stations            | -48" to C.L. |
| 5. Fire Alarm Audio Visual Devices     | -80" to C.L. |
| 6. General Wall Mounted Lights         | -90" to C.L. |
| 7. Exit Signs                          | -90" to C.L. |
| 8. Individual Disconnects and Starters | -60" to C.L. |
| 9. Grouped Disconnects and Starters    | >12" to C.L. |

>72" to C.L.

10. Panelboard Overcurrent Devices

>12" to C.L.

>72" to C.L.

### **3.11 CLEANING AND PROTECTION**

- A. On completion of installation, including outlets, fittings, and devices, inspect exposed finish. Remove burrs, dirt, paint spots, and construction debris.
- B. Protect equipment and installations and maintain conditions to ensure that coatings, finishes, and cabinets are without damage or deterioration at time of Substantial Completion.

**End of Section 260505**

## DIVISION 26 – ELECTRICAL

### SECTION 26 05 11

#### CONDUCTORS AND CABLES FOR ELECTRICAL SYSTEMS

##### PART 1 - GENERAL

##### 1.1 SUMMARY

- A. Section includes the following:
  - 1. Building wires and cables rated 600 V and less.
  - 2. Connectors, splices, and terminations rated 600 V and less.
  - 3. Sleeves and sleeve seals for cables.

##### 1.2 DEFINITIONS

- A. PDM: Ethylene-propylene-diene terpolymer rubber.
- B. NBR: Acrylonitrile-butadiene rubber.

##### 1.3 SUBMITTALS

- A. Product Data: For each type of product indicated.
- B. Field quality-control test reports.

##### 1.4 QUALITY ASSURANCE

- A. Electrical Components, Devices, and Accessories: Listed and labeled as defined in City of Chicago Electrical Code, Article 100, by a testing agency acceptable to authorities having jurisdiction, and marked for intended use.
- B. Comply with City of Chicago Electrical Code.

##### 1.5 DELIVERY, STORAGE AND HANDLING

- A. Deliver wire and cables according to NEMA WC26.

##### 1.6 COORDINATION

- A. Set sleeves in cast-in-place concrete, masonry walls, and other structural components as they are constructed.
- B. Coordinate layout and installation of cables with other contractors.

## **PART 2 - PRODUCTS**

### **2.1 MANUFACTURERS**

A. Manufacturers: Subject to compliance with requirements, provide products by one of the following manufacturers:

1. Conductors and Cables
  - a. American Insulated Wire Corp.; a Leviton Company.
  - b. General Cable Corporation.
  - c. Senator Wire & Cable Company.
  - d. Southwire Company.
2. Connectors and Splices
  - a. AFC Cable Systems, Inc.
  - b. Hubbell Power Systems, Inc.
  - c. O-Z/Gedney; EGS Electrical Group LLC.
  - d. 3M; Electrical Products Division.
  - e. Tyco Electronics Corp.

### **2.2 CONDUCTORS AND CABLES**

- A. Copper Conductors: Comply with NEMA WC 70.
- B. Conductor Insulation: Comply with NEMA WC 70 for Types THW, THHN-THWN, and XHHW.

### **2.3 CONNECTORS AND SPLICES**

- A. Description: Factory-fabricated connectors and splices of size, ampacity rating, material, type, and class for application and service indicated.

## **PART 3 - EXECUTION**

### **3.1 CONDUCTOR MATERIAL APPLICATIONS**

- A. Feeders: Copper. Solid for No. 10 AWG and smaller; stranded for No. 8 AWG and larger.
- B. Branch Circuits: Copper. Solid for No. 10 AWG and smaller; stranded for No. 8 AWG and larger.

### **3.2 CONDUCTOR INSULATION AND MULTICONDUCTOR CABLE APPLICATIONS AND WIRING METHODS**

- A. Service Entrance: Type THHN-THWN, single conductors in raceway or Type XHHW, single conductors in raceway.
- B. Exposed Feeders: Type THHN-THWN, single conductors in raceway.
- C. Feeders Concealed in Ceilings, Walls, Partitions, and Crawlspace: Type THHN-THWN, single conductors in raceway.

- D. Feeders Concealed in Concrete, below Slabs-on-Grade, and Underground: Type THHN-THWN, single conductors in raceway.
- E. Exposed Branch Circuits, Including in Crawlspace: Type THHN-THWN, single conductors in raceway.
- F. Branch Circuits Concealed in Ceilings, Walls, and Partitions: Type THHN-THWN, single conductors in raceway.
- G. Branch Circuits Concealed in Concrete, below Slabs-on-Grade, and Underground: Type THHN-THWN, single conductors in raceway.
- H. Class 1 Control Circuits: Type THHN-THWN, in raceway.
- I. Class 2 Control Circuits: Type THHN-THWN in raceway.
- J. Fire Alarm Circuits: Red conductors, type THHN-THWN in raceway.

### **3.3 INSTALLATION OF CONDUCTORS AND CABLES**

- A. Conceal cables in finished walls, ceilings, and floors, unless otherwise indicated.
- B. Use manufacturer-approved pulling compound or lubricant where necessary; compound used must not deteriorate conductor or insulation. Do not exceed manufacturer's recommended maximum pulling tensions and sidewall pressure values.
- C. Use pulling means, including fish tape, cable, rope, and basket-weave wire/cable grips, that will not damage cables or raceway.
- D. Install exposed cables parallel and perpendicular to surfaces of exposed structural members, and follow surface contours where possible.
- E. Identify and color-code conductors and cables according to Division 26 Section "Identification for Electrical Systems."
- F. Install wires and cables according to manufacturer's written instructions and NECA's "Standard of Care".
- G. Remove existing abandoned wires from raceway before pulling in new conductors.

### **3.4 CONNECTIONS**

- A. Tighten electrical connectors and terminals according to manufacturer's published torque-tightening values. If manufacturer's torque values are not indicated, use those specified in UL 486A and UL 486B.
- B. Make splices and taps that are compatible with conductor material and that possess equivalent or better mechanical strength and insulation ratings than unspliced conductors.
- C. Wiring at Outlets: Install conductor at each outlet, with at least 6 inches of slack.
- D. Keep conductor splices to a minimum.



- E. Connect conductors to outlets and components as indicated and as instructed by manufacturers.

### **3.5 CONTRACTOR STARTUP AND REPORTING**

- A. Perform tests and inspections and prepare test reports.
- B. Tests and Inspections:
  - 1. After installing conductors and cables and before electrical circuitry has been energized, test service entrance and feeder conductors, and conductors feeding the following critical equipment and services for compliance with requirements.
  - 2. Perform each visual and mechanical inspection and electrical test stated in NETA Acceptance Testing Specification. Certify compliance with test parameters.
- C. Test Reports: Prepare a written report to record the following:
  - 1. Test procedures used.
  - 2. Test results that comply with requirements.
  - 3. Test results that do not comply with requirements and corrective action taken to achieve compliance with requirements.
- D. Remove and replace malfunctioning units and retest as specified above.

**End of Section 260511**

## DIVISION 26 – ELECTRICAL

### SECTION 26 05 26

#### GROUNDING AND BONDING FOR ELECTRICAL SYSTEMS

##### PART 1 - GENERAL

##### 1.1 SUMMARY

- A. Section includes methods and materials for grounding systems and equipment for electrical.
- B. Furnish and install complete grounding and bonding system as shown or as implied in the Contract Documents:
  - 1. Equipment grounding.
  - 2. Wiring device grounding.
  - 3. Panelboard grounding.
  - 4. Isolated grounding.
  - 5. Grounding/Earthing System
- C. Furnish and install a complete equipotential ground system for data processing systems in strict conformance with City of Chicago Electrical Code, Section 250.

##### 1.2 DEFINITIONS

- A. Equipment Grounding Conductor: (EGC):
  - 1. The conductor that connects the non-current-carrying metal parts of equipment to the grounding electrode conductor or ground bus.
- B. Grounding Electrode Conductor: (GEC)
  - 1. The conductor that connects the grounding electrodes to the grounded circuit conductor and/or the equipment grounding conductor.
- C. Grounded Circuit Conductor: (GCC)
  - 1. A circuit conductor, usually the neutral that is intentionally connected to ground.
- D. Made Electrode: (ME)
  - 1. Any item, such as a ground rod, which is used to provide a ground connection.
- E. Isolated Ground: (IE)
  - 1. A conductor or system that connects equipment directly to the grounding electrode. Also referred to as single point ground.

##### 1.3 SUBMITTALS

- A. Product Data: For each type of product indicated.

- B. Other Informational Submittals: Plans showing dimensioned as-built locations of grounding features, including the following:
  - 1. Grounding arrangements and connections for separately derived systems.
  - 2. Grounding for sensitive electronic equipment.
- C. Field quality-control test reports. Indicate overall resistance to ground.
- D. Operation and Maintenance Data: For grounding to include the following in emergency, operation, and maintenance manuals:
  - 1. Instructions for periodic testing and inspection of grounding features at grounding connections for separately derived systems based on NETA MTS.
    - a. Tests shall be to determine if ground resistance or impedance values remain within specified maximums, and instructions shall recommend corrective action if they do not.
    - b. Include recommended testing intervals.

#### **1.4 QUALITY ASSURANCE**

- A. Electrical Components, Devices, and Accessories: Listed and labeled as defined in the Chicago Electrical Code, Article 100, by a testing agency acceptable to authorities having jurisdiction, and marked for intended use.
- B. Manufacturer's Qualifications: Company specializing in manufacturing the products specified in this Section with minimum three years documented experience.
- C. Comply with UL 467 for grounding and bonding materials and equipment.
- D. Comply with City of Chicago Electrical Code.
- E. Comply with ANSI-T-STD-607-A for grounding and bonding of Telecommunication Systems.
- F. A licensed electrical contractor shall perform installation and termination of the main bonding conductor to the building service entrance ground. The contractor must also be approved by the Chicago Public Schools.
- G. Listing and Labeling: Provide products specified in this Section that are listed and labeled.
  - 1. The Terms "Listed" and "Labeled": As defined in the National Electrical Code, Article 100.
  - 2. Listing and Labeling Agency Qualifications: A "Nationally Recognized Testing Laboratory" (NRTL) as defined in OSHA Regulation 1910.7.

#### **1.5 REFERENCES**

- A. IEEE 1100 - Recommend Practice for Powering and Grounding Electronic Equipment (IEEE Emerald Book).
- B. TIA/EIA-606 – Administration Standard for the Telecommunications Infrastructure.
- C. TIA J-STD-607 – Commercial Building Grounding (Earthing) and Bonding Requirements for Telecommunications; Rev A. 2002.

- D. TIA-942 – Telecommunications Infrastructure Standard for Data Centers.

## **PART 2 - PRODUCTS**

### **2.1 MANUFACTURERS**

- A. Manufacturers: Subject to compliance with requirements, provide products by one of the following manufacturers:
1. Electrodes:
    - a. Burndy.
    - b. Harger.
    - c. NSI Industries.
    - d. Thomas and Betts.
  2. Mechanical Connectors: Bronze
    - a. Burndy.
    - b. Harger.
    - c. NSI Industries.
    - d. Thomas and Betts.
  3. Exothermic Connections:
    - a. Burndy.
    - b. Cadweld.
    - c. Ultraweld (Harger).

### **2.2 CONDUCTORS**

- A. Equipment Grounding Conductors: Insulated with green color insulation.
- B. Insulated Conductors: wire or cable insulated for 600 V unless otherwise required by applicable Code or authorities having jurisdiction.
- C. Bare Copper Conductors:
1. Solid Conductors: ASTM B 3.
  2. Stranded Conductors: ASTM B 8.
  3. Tinned Conductors: ASTM B 33.
  4. Bonding Cable: 28 kcmil, 14 strands of No. 17 AWG conductor, 1/4 inch (6 mm) in diameter.
  5. Bonding Conductor: No. 4 or No. 6 AWG, stranded conductor.
  6. Bonding Jumper: Copper tape, braided conductors, terminated with copper ferrules; 1-5/8 inches (41 mm) wide and 1/16 inch (1.6 mm) thick.
- D. Grounding Bus: Rectangular bars of annealed copper, 1/4 by 2 inches in cross section, unless otherwise indicated; with insulators.
- E. Bonding Straps: Soft copper, 0.05 inch thick and 2 inches wide, except as indicated.

- F. Cable assemblies shall be UL Listed and CSA Certified. Cables shall be a distinctive green (equipment ground) or green/yellow tracer (isolated ground) in color, and all jackets shall be UL, VW-1 flame rated.

## **2.3 CONNECTORS**

- A. Listed and labeled by a nationally recognized testing laboratory acceptable to authorities having jurisdiction for applications in which used, and for specific types, sizes, and combinations of conductors and other items connected.
- B. Bolted Connectors for Conductors and Pipes: Copper or copper alloy, bolted pressure-type, with at least two bolts.
  - 1. Heavy duty Pipe Clamps: Pipe clamps shall be high copper alloy or cast bronze with silicon bronze threaded fasteners; saddle type designed for the size of conductor indicated or required by Contract Documents.
  - 2. Beam Clamps: Beam clamps shall be compression type; heavy duty bronze construction; provide a minimum of 8 square inches of bonding surface; and designed for copper rope-lay cable.
  - 3. Grounding Bushings: Groundings bushings shall be malleable iron, threaded, with insulated liner and solderless lug.
- C. Welded Connectors: Exothermic-welding kits of types recommended by kit manufacturer for materials being joined and installation conditions.
- D. Pressure Connectors: High –conductivity plated units.
- E. Terminating Lugs:
  - 1. Crimp compression type.

## **PART 3 - EXECUTION**

### **3.1 APPLICATIONS**

- A. Conductors: Install solid conductor for No. 8 AWG and smaller, and stranded conductors for No. 6 AWG and larger, unless otherwise indicated.
- B. Grounding Bus: Install in electrical and telephone equipment rooms, in rooms housing service equipment, and elsewhere as indicated.
  - 1. Install bus on insulated spacers 1 inch minimum, from wall 6 inches above finished floor, unless otherwise indicated.
  - 2. Where indicated on both sides of doorways, route bus up to top of door frame, across top of doorway, down to specified height above floor, and connect to horizontal bus.
- C. Conductor Terminations and Connections:
  - 1. Pipe and Equipment Grounding Conductor Terminations: Bolted connectors.
  - 2. Underground Connections: Welded connectors, except at test wells and as otherwise indicated.
  - 3. Connections to Ground Rods at Test Wells: Bolted connectors.
  - 4. Connections to Structural Steel: Welded connectors.

### **3.2 EQUIPMENT GROUNDING**

- A. Install insulated equipment grounding conductors with all feeders and branch circuits.
- B. Air-Duct Equipment Circuits: Install insulated equipment grounding conductor to duct-mounted electrical devices operating at 120 V and more, including air cleaners, heaters, dampers, humidifiers, and other duct electrical equipment. Bond conductor to each unit and to air duct and connected metallic piping.
- C. Water Heater and Heat-Tracing: Install a separate insulated equipment grounding conductor to each electric water heater and heat-tracing cable. Bond conductor to heater units, piping, connected equipment, and components.
- D. Isolated Grounding Receptacle Circuits: Install an insulated equipment grounding conductor connected to the receptacle grounding terminal. Isolate conductor from raceway and from panelboard grounding terminals. Terminate at equipment grounding conductor terminal of the applicable derived system or service, unless otherwise indicated.
- E. Metal Poles Supporting Outdoor Lighting Fixtures: Install grounding electrode and a separate insulated equipment grounding conductor in addition to grounding conductor installed with branch-circuit conductors.

### **3.3 CONTRACTOR STARTUP AND REPORTING**

- A. Perform the following tests and inspections and prepare test reports:
  - 1. After installing grounding system but before permanent electrical circuits have been energized, test for compliance with requirements.
  - 2. Test completed grounding system at each location where a maximum ground-resistance level is specified, at service disconnect enclosure grounding terminal, at ground test wells and at individual ground rods. Make tests at ground rods before any conductors are connected.
    - a. Measure ground resistance not less than two full days after last trace of precipitation and without soil being moistened by any means other than natural drainage or seepage and without chemical treatment or other artificial means of reducing natural ground resistance.
    - b. Perform tests by fall-of-potential method according to IEEE 81.
- B. Report measured ground resistances that exceed the following values:
  - 1. Power Distribution Units or Panelboards Serving Electronic Equipment: 3 ohm(s).
- C. Excessive Ground Resistance: If resistance to ground exceeds specified values, notify Architect promptly and include recommendations to reduce ground resistance.

**END OF SECTION**

## **DIVISION 26 – ELECTRICAL**

### **SECTION 26 05 29**

#### **HANGERS AND SUPPORTS FOR ELECTRICAL SYSTEMS**

##### **PART 1 - GENERAL**

###### **1.1 SUMMARY**

- A. This Section includes the following:
  - 1. Hangers and supports for electrical equipment and systems.
  - 2. Construction requirements for concrete bases.

###### **1.2 DEFINITIONS**

- A. EMT: Electrical metallic tubing.
- B. IMC: Intermediate metal conduit.
- C. RMC: Rigid metal conduit.

###### **1.3 QUALITY ASSURANCE**

- A. Welding: Qualify procedures and personnel according to AWS D1.1/D1.1M, "Structural Welding Code - Steel."
- B. Manufacturer's Qualifications: Company specializing in manufacturing Products specified in this Section with minimum three years experience.
- C. Listing and Labeling: Provide products specified in this Section that are listed and labeled:
  - 1. Listing and labeling Agency Qualifications: A "Nationally Recognized Testing Laboratory" as defined in OSHA Regulation 1910.7.
- D. Comply with City of Chicago Electrical Code.

###### **1.4 DELIVERY, STORAGE AND HANDLING**

- A. Material delivered to jobsite shall be stored in original packaging per manufacturer's requirements.

###### **1.5 COORDINATION**

- A. Provide steel supports, anchor bolts, inserts, etc., for all equipment specified under this section of the specifications.
- B. Floor-mounted electrical equipment shall be installed on a minimum of 4 inch concrete housekeeping pads with a minimum of 4 inch equipment inset on all sides. Concrete shall be in accordance with referenced concrete specification section.

- C. Provide formed steel support channels extending from and solidly anchored to the floor and ceiling slabs and mount the designated equipment thereto.
- D. Coordinate installation of roof curbs, equipment supports, and roof penetrations. These items are specified in Division 7 Section "Roof Accessories."

**1.6 PROVIDE STEEL SUPPORT CHANNELS FOR:**

- A. Communication and special systems cabinets.
- B. Disconnect switches.
- C. Individual motor starters.
- D. Individual circuit breakers.
- E. Panelboards.

**1.7 WARRANTY - NOT APPLICABLE**

**PART 2 - PRODUCTS**

**2.1 MANUFACTURERS**

- A. Manufacturers: Subject to compliance with requirements, provide products by one of the following manufacturers:
  - 1. Steel Slotted Support Systems:
    - a. Allied Tube & Conduit.
    - b. Cooper B-Line, Inc.; a division of Cooper Industries.
    - c. GS Metals Corp.
    - d. Thomas & Betts Corporation.
    - e. Unistrut; Tyco International, Ltd.
  - 2. Powder Actuated Fasteners
    - a. Hilti Inc.
    - b. ITW Ramset/Red Head; a division of Illinois Tool Works, Inc.
    - c. MKT Fastening, LLC.
    - d. Simpson Strong-Tie Co., Inc.; Masterset Fastening Systems Unit.
  - 3. Mechanical-expansion Anchors
    - a. Cooper B-Line, Inc.; a division of Cooper Industries.
    - b. Empire Tool and Manufacturing Co., Inc.
    - c. Hilti Inc.
    - d. ITW Ramset/Red Head; a division of Illinois Tool Works, Inc.
    - e. MKT Fastening, LLC.
  - 4. Conduit Sealing Bushings:
    - a. Bridgeport Fittings, Inc.



- b. Cooper Industries, Inc.
- c. Killark Electric Mfg. Co.
- d. O-Z/Gedney
- e. Raco, Inc.
- f. Spring City Electrical Mfg. Co.

5. Vibration Isolators:

- a. California Dynamics Company
- b. Mason Industries

## 2.2 SUPPORT, ANCHORAGE, AND ATTACHMENT COMPONENTS

- A. Steel Slotted Support Systems: Comply with MFMA-4, factory-fabricated components for field assembly.
  - 1. Products for outdoor use shall be hot-dip galvanized after fabrication and applied according to MFMA-4.
  - 2. Other supports, support hardware, and fasteners shall be protected with zinc coating or with treatment of equivalent corrosion resistance using approved alternative treatment, finish, or inherent material characteristic.

## 2.3 MANUFACTURERD SUPPORTING DEVICES

- A. Raceway Supports: Clevis hangers, riser clamps, conduit straps, threaded C-clamps with retainers, ceiling trapeze hangers, wall brackets, and spring steel clamps as described in NECA 1 and NECA 101.
- B. Conduit Sealing Bushings: Factory-fabricated watertight conduit sealing bushing assemblies suitable for sealing around conduit, or tubing passing through concrete floors and walls. Construct seals with steel sleeve, malleable iron body, neoprene sealing grommets or rings, metal pressure rings, pressure clamps, and cap screws.
- C. Cable Supports for Vertical Conduit: Factory-fabricated assembly consisting of threaded body and insulating wedging plug for non-armored electrical cables in riser conduits. Plugs shall have number and size of conductor gripping holes as required to suit individual risers. Construct body of malleable-iron casting with hot-dip galvanized finish. Provide OZ/Gedney type "S" cable support or equal.
- D. U-Channel Systems: 12-gauge steel channels, with 9/16 inch diameter holes, at a minimum of 2 inches on center, in top surface. Provide fittings and accessories that mate and match with U-channel and are of the same manufacturer.
- E. Structural Steel for Fabricated Supports and Restraints: ASTM A 36/A 36M, steel plates, shapes, and bars; black and galvanized.
- F. Mounting, Anchoring, and Attachment Components: Items for fastening electrical items or their supports to building surfaces include the following:
  - 1. Powder-Actuated Fasteners: Threaded-heat-treated steel stud, for use in hardened Portland cement concrete, steel, or wood, with tension, shear, and pullout capacities appropriate for supported loads and building materials where used.

2. Mechanical-Expansion Anchors: Insert-wedge-type, zinc-coated steel, for use in hardened Portland cement concrete with tension, shear, and pullout capacities appropriate for supported loads and building materials in which used.
3. Concrete Inserts: Steel or malleable-iron, slotted support system units similar to MSS Type 18; complying with MFMA-4 or MSS SP-58.
4. Clamps for Attachment to Steel Structural Elements: MSS SP-58, type suitable for attached structural element.
5. Through Bolts: Structural type, hex head, and high strength. Comply with ASTM A 325.
6. Toggle Bolts: All-steel springhead type.
7. Hanger Rods: Threaded steel.

## 2.4 VIBRATION ISOLATORS

- A. General: Provide vibration isolators with either known undeflected heights or other markings so that, after adjustment, when carrying their load, the deflection under load can be verified, thus determining that the load is within the proper range of the device and that the correct degree of vibration isolation is being provided according to the design.
  1. Provide isolators that operate in the linear portion of their load versus deflection curve. Furnish load versus deflection curves from the manufacturer that are linear, over a deflection range 50% above the design deflection.
- B. Vibration Isolator Types
  1. General Properties:
    - a. The ratio of lateral to vertical stiffness shall be not less than 0.9 or greater than 1.5.
    - b. The theoretical vertical natural frequency for each support point, based upon the load per isolator and isolator stiffness, shall not differ from the design objectives for the equipment as a whole by more than (+/-) 10%.
    - c. Wave motion through the isolator shall be reduced to the following extent: Isolation above the primary vertical system resonance frequency shall follow the theoretically predicted isolation curve for single degree of freedom systems with 1-dB to 50 dB at all frequencies above the 150 Hz.
    - d. All neoprene mountings shall have a shore hardness of 40 –65 after minimum aging of 30 days, or corresponding open-aging.
  2. Isolator Description:
    - a. Type MS shall be spring type, without housings or snubbers, equipped with leveling bolts and with two layers of ribbed or waffled neoprene pads, separated by a 1/16" galvanized steel plate under the base plate. Neoprene sleeves and washer shall be installed at all anchor bolts.
    - b. Type HS shall be suspension hangers having a steel frame and spring element, in series with a neoprene pad, cut or washer. The isolator shall be designed so that hanger rod may be misaligned 15 degrees in any direction relative to the vertical, without contacting hanger box frame.
    - c. Type MN shall be neoprene isolator support type unit having a minimum static deflection of ¼".
    - d. Type HN shall be a suspension hanger type employing a neoprene isolator unit having a minimum static deflection of ¼".
- C. Equipment Frames

1. Mounting frames and brackets shall be provided to carry the load of the equipment without causing mechanical distortion or stress to the equipment.
2. The mounting frames shall consist of welded, wide flange or channel structural steel, with welder brackets to accept the isolators. The section depth of any frame member shall be not less than 1/10th of the length of the longest frame member, and not less than 1/10th of the greatest span between support points. All frame members shall have the same depth.

## **2.5 FABRICATED METAL EQUIPMENT SUPPORT ASSEMBLIES**

- A. Description: Welded or bolted, structural-steel shapes, shop or field fabricated to fit dimensions of supported equipment.
- B. Materials: Comply with requirements in Division 5 Section "Metal Fabrications" for steel shapes and plates.
- C. Pipe Sleeves: Provide pipe sleeves of one of the following:
  1. Sheet Metal: Fabricate from galvanized sheet metal; round tube closed with snaplock joint, welded spiral seams, or welded longitudinal joint. Fabricate sleeves from the following gage metal for sleeve diameter noted:
    - a. 3 inch and smaller: 2 gauge.
    - b. 4 inch to 6 inch: 16 gauge.
    - c. Over 6 inch: 14 gauge.
  2. Steel Pipe: Fabricate from Schedule 40 galvanized steel pipe.
  3. Plastic Pipe: Fabricate from Schedule 80 PVC plastic pipe.

## **PART 3 - EXECUTION**

### **3.1 APPLICATION**

- A. Comply with NECA 1 and NECA 101 for application of hangers and supports for electrical equipment and systems except if requirements in this Section are stricter.
- B. Maximum Support Spacing and Minimum Hanger Rod Size for Raceway: Space supports for EMT, IMC, and RMC as scheduled in Table 1 at the end of this Section. Minimum rod size shall be 1/4 inch in diameter.
- C. Multiple Raceways or Cables: Install trapeze-type supports fabricated with steel slotted support system, sized so capacity can be increased by at least 25 percent in future without exceeding specified design load limits.
  1. Secure raceways and cables to these supports with single-bolt conduit clamps single-bolt conduit clamps using spring friction action for retention in support channel.
- D. Spring-steel clamps designed for supporting single conduits without bolts may be used for 1-1/2-inch and smaller raceways serving branch circuits and communication systems above suspended ceilings and for fastening raceways to trapeze supports.
- E. Damp Locations and Outdoors: Hot-dip galvanized materials or nonmetallic, U-channel system components.

- F. Dry Locations: Steel materials.

### **3.2 SUPPORT INSTALLATION**

- A. Comply with NECA 1, NECA 101 and manufacturer's instructions for installation requirements except as specified in this Article.
- B. Raceway Support Methods: In addition to methods described in NECA 1, RMC EMT, IMC, and RMC may be supported by openings through structure members, as permitted in the Chicago Electrical Code.
- C. Strength of Support Assemblies: Where not indicated, select sizes of components so strength will be adequate to carry present and future static loads within specified loading limits. Minimum static design load used for strength determination shall be weight of supported components plus 200 lb.
- D. Mounting and Anchorage of Surface-Mounted Equipment and Components: Anchor and fasten electrical items and their supports to building structural elements by the following methods unless otherwise indicated by code:
  - 1. To Wood: Fasten with lag screws or through bolts.
  - 2. To New Concrete: Bolt to concrete inserts.
  - 3. To Masonry: Approved toggle-type bolts on hollow masonry units and expansion anchor fasteners on solid masonry units.
  - 4. To Existing Concrete: Expansion anchor fasteners.
  - 5. Instead of expansion anchors, powder-actuated driven threaded studs provided with lock washers and nuts may be used in existing standard-weight concrete 4 inches thick or greater. Do not use for anchorage to lightweight-aggregate concrete or for slabs less than 4 inches thick.
  - 6. To Steel: Welded threaded studs complying with AWS D1.1/D1.1M, with lock washers and nuts Spring-tension clamps.
  - 7. To Light Steel: Sheet metal screws.
  - 8. Items Mounted on Hollow Walls and Nonstructural Building Surfaces: Mount cabinets, panelboards, disconnect switches, control enclosures, pull and junction boxes, transformers, and other devices on slotted-channel racks attached to substrate.
  - 9. Welding to steel structure may be used only for threaded studs, not for conduits, pipe straps, or other items.
  - 10. Fasteners: Select so the load applied to each fastener does not of its proof test load.
  - 11. Holes cut to depth of more than 1-1/2" in reinforced concrete beams or to depth of more than 3/4 inch in concrete shall not cut the main reinforcing bars. Fill holes that are not used.
  - 12. Ensure that the load applied to any fastener does not exceed 25 percent of the proof test load. Use vibration and shock-resistant fasteners for attachments to concrete slabs.
- E. Vibration Isolators:
  - 1. All floor supported transformers in excess of 300 kVA located within the building shall be mounted on isolation units utilizing type MS springs, appropriately secured to the transformer housing. Spring units shall be selected for a minimum static deflection of 1.5 inch.
  - 2. All floor supported transformers equal to or less than 300 kVA located within the building shall be mounted on vibration isolation rails utilizing type MN neoprene mounts selected to deflect a minimum of 0.25 inch.
  - 3. Suspended transformers 45 kVA and less shall be supported on an appropriate steel frame from Type HS hangers, selected for a minimum static deflection of 0.75 inch.

### 3.3 INSTALLATION

- A. Where equipment supports are on concrete construction, take care not to weaken concrete or penetrate waterproofing.
- B. Obtain prior approval for installation method of structural steel required to frame into building structural members for the support of equipment, conduit, etc. Welding shall be permitted only when approved by Architect.
- C. Coordinate dimensions of concrete housekeeping pads with requirements for equipment supplied.
- D. Install supporting devices to fasten electric components securely and permanently in accordance with CEC requirements.
- E. Coordinate with the building structural system and with other electrical installation.
- F. In wet and damp locations use steel channel supports to stand cabinets and panelboards one inch off wall.
- G. Raceway Supports: Comply with the CEC and the following requirements:
  - 1. Conform to manufacturer's recommendations for selection and installation of supports.
  - 2. Install individual and multiple (trapeze) raceway hangers and riser clamps as necessary to support raceways. Provide U-bolts, clamps, attachments, and other hardware necessary for hanger assembly and for securing hanger rods and conduits.
  - 3. Support parallel runs of horizontal raceways together on trapeze-type hangers.
  - 4. Support individual horizontal raceways by separate pipe hangers. Spring steel fasteners may be used in lieu of hangers only for 1-1/2 inch and smaller raceways serving lighting and receptacle branch circuits above suspended ceilings only. For hanger rods with spring steel fasteners, use ¼ inch diameter or larger threaded steel. Use spring steel fasteners that are specifically designed for supporting single conduits or tubing.
  - 5. Space supports for raceways in accordance with Table I of this section. Space supports for raceway types not covered by the above in accordance with CEC.
- H. Vertical Conductors Supports: Install simultaneously with installation of conductors.
- I. Do not fasten supports to pipes, ducts, mechanical equipment and conduit.
- J. Do not use ceiling system components for support.
- K. Provide weight-distributing facilities, where required, so as not to exceed the load-bearing capabilities of floors or walls that bear the weight of, or support, electrical systems.
- L. Exposed part of hangers and supports shall be painted with one coat of rust-inhibiting primer.
- M. Equipment shall not be held in place by its own dead weight. Provide base anchor fasteners in each case.
- N. Miscellaneous Supports: Support miscellaneous electrical components as required to provide the same structural safety factors as specified for raceway supports. Install metal channel or angle iron racks for mounting cabinets, panelboards, disconnects, control enclosures, pull boxes, junction boxes, transformers, and other devices.

- O. In overhead spaces, boxes shall be supported independently of raceways. Support boxes directly from the building structure or by bar hangers. Where bar hangers are used for boxes, attach the bar to raceways on opposite side of the box and support the raceway with an approved type of fasteners not more than 2 inches from the box.
- P. Sleeves: Install in concrete slabs and walls and all other fire-rated floors and walls for raceways and cable installations. For sleeves through fire-rated wall or floor construction, see Division 8 Section "Firestopping" for appropriate UL listed firestopping system.
- Q. Conduit Seals: Install seals for conduit penetrations of slabs on grade and exterior walls below grade and where indicated. Tighten sleeve seal screws until sealing grommets have expanded to form watertight seal.
- R. Fastening: Unless otherwise indicated, fasten electrical items and their supporting hardware securely to the building structure, including but not limited to conduits, raceways, cables, cable trays, busways, cabinets, panelboards, transformers, boxes, disconnect switches, and control components in accordance with the following:
  - 1. Wood: Fasten with wood screws or screw-type nails.
  - 2. Masonry: Toggle bolts on hollow masonry units and expansion bolts on solid masonry units.
  - 3. New Concrete: Concrete inserts with machine screws and bolts.
  - 4. Existing Concrete: Expansion bolts.
  - 5. Instead of expansion bolts, threaded studs or nails driven by a power charge may be used in existing concrete.
  - 6. Steel: Welded threaded studs or spring-tension clamps on steel.
    - a. Field Welding: Comply with AWS D1.1.
  - 7. Welding to steel structure may be used only for threaded studs, not for conduits, pipe straps, or other items.
  - 8. Light Steel: Sheet-metal screws.
  - 9. Fasteners: Select so the load applied to each fastener does not exceed 25 percent of its proof-test load or the manufacturer's published allowable load capacity. For electrical cable or premises wire hangers for communications. Select nail, screw, or anchor suitable for base material. Space hangers according to cable bundle weight and sagging requirements.
  - 10. Holes cut to depth of more than 1-1/2" in reinforced concrete beams or to depth of more than 3/4 inch in concrete shall not cut the main reinforcing bars. Fill holes that are not used.
  - 11. Use vibration and shock-resistant anchors for vibratory equipment or support attachments to concrete slabs.
- S. Install metal channel racks for mounting cabinets, panelboards, disconnect switches, control enclosures, pull and junction boxes, transformers, and other devices unless components are mounted directly to structural elements of adequate strength.
- T. Vibration Isolators:
  - 1. All floor supported transformers in excess of 300 kVA located within the building shall be mounted on isolation units utilizing type MS springs, appropriately secured to the transformer housing. Spring units shall be selected for a minimum static deflection of 1.5 inch.

2. All floor supported transformers equal to or less than 300 kVA located within the building shall be mounted on vibration isolation rails utilizing type MN neoprene mounts selected to deflect a minimum of 0.25 inch.
3. Suspended transformers 45 kVA and less shall be supported on an appropriate steel frame from Type HS hangers, selected for a minimum static deflection of 0.75 inch.

### **3.4 INSTALLATION OF FABRICATED METAL SUPPORTS**

- A. Install metal channel racks for mounting cabinets, panelboards, disconnect switches, control enclosures, pull and junction boxes, transformers, and other devices unless components are mounted directly to structural elements of adequate strength.
- B. Comply with installation requirements in Division 5 Section "Metal Fabrications" for site-fabricated metal supports.
- C. Cut, fit, and place miscellaneous metal supports accurately in location, alignment, and elevation to support and anchor electrical materials and equipment.
- D. Field Welding: Comply with AWS D1.1/D1.1M.

### **3.5 CONCRETE BASES**

- A. Construct concrete bases of dimensions indicated but not less than 4 inches larger in both directions than supported unit, and so anchors will be a minimum of 10 bolt diameters from edge of the base.
- B. Use 3000-psi, 28-day compressive-strength concrete. Concrete materials, reinforcement, and placement requirements are specified in Division 3 Section "Cast-in-Place Concrete."
- C. Anchor equipment to concrete base.
  1. Place and secure anchorage devices. Use supported equipment manufacturer's setting drawings, templates, diagrams, instructions, and directions furnished with items to be embedded.
  2. Install anchor bolts to elevations required for proper attachment to supported equipment.
  3. Install anchor bolts according to anchor-bolt manufacturer's written instructions.

### **3.6 PAINTING**

- A. Touchup: Clean field welds and abraded areas of shop paint. Paint exposed areas immediately after erecting hangers and supports. Use same materials as used for shop painting. Comply with SSPC-PA 1 requirements for touching up field-painted surfaces.
  1. Apply paint by brush or spray to provide minimum dry film thickness of 2.0 mils.

### **3.7 CLEANING**

- A. The Contractor shall at all times, keep the site free from accumulations of waste material or rubbish caused by its employees or work. Remove all crates, cartons, and other waste materials or trash from the working areas at the end of each working day. Flammable waste material must be removed from the working areas at the time of generation. All rubbish and debris, combustible or not, shall be discarded in covered metal containers daily and removed from the premises at least weekly and legally disposed of.

- B. The Contractor shall be responsible for the general cleaning and maintenance of the premises and for the coordination and direction of the cleanup work of all trades. Each trade shall clean and maintain its portion of the work as required and as directed by the General Contractor. In case of a dispute, the Owner may remove rubbish and charge the Contractor as shall be determined to be just.
- C. Clean all electronic equipment per manufacturer's requirements as it relates to the project.
- D. Clean interior and exterior of concentrator enclosures.
- E. All equipment shall be cleaned prior to final acceptance.

**3.8 SCHEDULES**

TABLE I: SPACING FOR RACEWAY SUPPORTS

Raceway Size (Inches)	No. of Conductors in Run		Maximum Spacing of Supports (Feet)	
			RGS & IMC*	EMT
<u>Horizontal Runs</u>				
1/2, 3/4	1 or 2	Flat ceiling or wall.	5	5
1/2, 3/4	1 or 2	Where it's difficult to provide support except at intervals fixed by the building construction.	7	7
1/2, 3/4	3 or more	Any location.	7	7
1/2 - 1	3 or more	Any location.	7	7
1 & larger	1 or 2	Flat ceiling or wall.	6	6
1 & larger	1 or 2	Where it is difficult to provide support except as intervals fixed by the building construction.	10	10
1 & larger	3 or more	Any location.	10	10
Any	--	Concealed.	10	10
<u>Vertical Runs</u>				
1/2, 3/4	--	Exposed	7	7
1, 1 1/4	--	Exposed	8	8
1 1/2 and larger	--	Exposed	10	10
Up to 2	--	Shaftway	14	10
2 1/2	--	Shaftway	16	10
3 & larger	--	Shaftway	20	10
Any	--	Concealed	10	10

\* Maximum spacings for IMC above apply to straight runs only. Otherwise the maximums for EMT apply.

Abbreviations:  
 EMT Electrical metallic tubing.  
 IMC Intermediate metallic conduit.  
 RGS Rigid galvanized steel conduit.

**End of Section 260529**



## **DIVISION 26 – ELECTRICAL**

### **SECTION 26 05 33**

#### **RACEWAYS AND BOXES FOR ELECTRICAL SYSTEMS**

##### **PART 1 - GENERAL**

###### **1.1 SUMMARY**

- A. Section includes raceways, fittings, boxes, enclosures, and cabinets for electrical wiring.

###### **1.2 DEFINITIONS**

- A. EMT: Electrical metallic tubing.
- B. EPDM: Ethylene-propylene-diene terpolymer rubber.
- C. FMC: Flexible metal conduit.
- D. IMC: Intermediate metal conduit.
- E. LFMC: Liquidtight flexible metal conduit.
- F. RNC: Rigid nonmetallic conduit.

###### **1.3 SUBMITTALS**

- A. Product Data: For surface raceways, wireways and fittings, floor boxes, hinged-cover enclosures, and cabinets.
- B. Shop Drawings: For custom enclosures and cabinets. Include plans, elevations, sections, details, and attachments to other work.

###### **1.4 QUALITY ASSURANCE**

- A. Listing and Labeling: Provide raceways and boxes specified in this Section that are listed and labeled.
  - 1. The Terms "Listed and Labeled": As defined in City of Chicago Electrical Code.
  - 2. Listing and Labeling Agency Qualifications: A "Nationally Recognized Testing Laboratory" as defined in OSHA Regulation 1910.7.
- B. Comply with NECA's "Standard of Installation."
- C. Comply with City of Chicago Electrical Code.

## **1.5 DELIVERY, STORAGE AND HANDLING – NOT APPLICABLE**

- A. Effectively protect all materials, accessories, and components from any damage or injury from the time of fabrication until final Owner acceptance.
- B. Deliver equipment in fully enclosed vehicles after specified environmental conditions have been permanently established in spaces where equipment is to be placed.
- C. Store equipment in spaces with environments controlled within manufacturer's ambient temperature and humidity tolerances for non-operating equipment.

## **1.6 COORDINATION**

- A. Coordinate layout and installation of raceways and boxes with other construction elements to ensure adequate headroom, working clearance, and access.

## **PART 2 - PRODUCTS**

### **2.1 MANUFACTURERS**

- A. Manufacturers: Subject to compliance with requirements, provide products by one of the following:
  - 1. Metal Conduit and Tubing
    - a. Allied Tube & Conduit; a Tyco International Ltd. Co.
    - b. Maverick Tube Corporation.
    - c. O-Z Gedney; a unit of General Signal.
    - d. Wheatland Tube Company.
  - 2. Nonmetallic Conduit
    - a. CertainTeed Corp.; Pipe & Plastics Group.
    - b. Electri-Flex Co.
    - c. RACO; a Hubbell Company.
  - 3. Metal Wireways
    - a. Cooper B-Line, Inc.
    - b. Hoffman.
    - c. Square D; Schneider Electric
  - 4. Surface Metal Raceways:
    - a. Wiremold Company (The); Electrical Sales Division
    - b. Hubbell Incorporated
  - 5. Boxes, Enclosures, and Cabinets
    - a. Cooper Crouse-Hinds; Div. of Cooper Industries, Inc.
    - b. EGS/Appleton Electric.
    - c. Hoffman.

- d. Hubbell Incorporated; Killark Electric Manufacturing Co. Division.
- e. O-Z/Gedney; a unit of General Signal.
- f. RACO; a Hubbell Company.
- g. Walker Systems, Inc.; Wiremold Company (The).
- h. Woodhead, Daniel Company; Woodhead Industries, Inc. Subsidiary.

## **2.2 METAL CONDUIT AND TUBING**

- A. Rigid Steel Conduit: ANSI C80.1.
- B. IMC: ANSI C80.6.
- C. EMT: ANSI C80.3.
- D. FMC: Zinc-coated steel.
- E. LFMC: Flexible steel conduit with PVC jacket.
- F. Fittings for Conduit (Including all Types and Flexible and Liquidtight), EMT, and Cable: NEMA FB 1; listed for type and size raceway with which used, and for application and environment in which installed.
  - 1. Conduit Fittings for Hazardous (Classified) Locations: Comply with UL 886.
  - 2. Fittings for EMT: compression type with insulated throat.
  - 3. Coating for Fittings for PVC-Coated Conduit: Minimum thickness, 0.040 inch, with overlapping sleeves protecting threaded joints.
- G. Joint Compound for Rigid Steel Conduit or IMC: Listed for use in cable connector assemblies, and compounded for use to lubricate and protect threaded raceway joints from corrosion and enhance their conductivity.

## **2.3 METAL WIREWAYS**

- A. Description: Sheet metal sized and shaped as indicated, NEMA 250, Type [1] [12] [3R], unless otherwise indicated.
- B. Fittings and Accessories: Include couplings, offsets, elbows, expansion joints, adapters, hold-down straps, end caps, and other fittings to match and mate with wireways as required for complete system.
- C. Wireway Covers: Screw-cover type.
- D. Finish: Manufacturer's standard enamel finish.

## **2.4 SURFACE RACEWAYS**

- A. Surface Metal Raceways: Galvanized steel with snap-on covers. Manufacturer's standard enamel finish in color selected by Architect.

## **2.5 BOXES, ENCLOSURES, AND CABINETS**

- A. Sheet Metal Outlet and Device Boxes: NEMA OS 1.

- B. Cast-Metal Outlet and Device Boxes: NEMA FB 1, ferrous alloy, Type FD, with gasketed cover.
- C. Nonmetallic Outlet and Device Boxes: NEMA OS 2.
- D. Metal Floor Boxes: Cast metal, fully adjustable rectangular.
- E. Small Sheet Metal Pull and Junction Boxes: NEMA OS 1.
- F. Cast-Metal Access, Pull, and Junction Boxes: NEMA FB 1, cast aluminum with gasketed cover.
- G. Hinged-Cover Enclosures: NEMA 250, Type 1, with continuous-hinge cover with flush latch, unless otherwise indicated.
  - 1. Metal Enclosures: Steel, finished inside and out with manufacturer's standard enamel.
- H. Cabinets:
  - 1. NEMA 250, Type 1, galvanized-steel box with removable interior panel and removable front, finished inside and out with manufacturer's standard enamel.
  - 2. Hinged door in front cover with flush latch and concealed hinge.
  - 3. Key latch to match panelboards.
  - 4. Metal barriers to separate wiring of different systems and voltage.
  - 5. Accessory feet where required for freestanding equipment.

## **PART 3 - EXECUTION**

### **3.1 RACEWAY APPLICATION**

- A. Outdoors: Apply raceway products as specified below, unless otherwise indicated:
  - 1. Exposed Conduit: IMC.
  - 2. Concealed Conduit, IMC.
  - 3. Underground Conduit: RNC, Type EPC 80-PVC, encased in concrete.
  - 4. Connection to Vibrating Equipment (Including Transformers and Hydraulic, Pneumatic, Electric Solenoid, or Motor-Driven Equipment): LFMC.
  - 5. Boxes and Enclosures, Aboveground: NEMA 250, Type 3Ror4.
- B. Indoors: Apply raceway products as specified below, unless otherwise indicated:
  - 1. Exposed: EMT in mechanical rooms, crawl spaces, mechanical tunnels, and other unfinished areas; Surface Metal Raceway in corridors, classrooms, offices, toilets, and all other finished spaces.
  - 2. Exposed and Subject to Severe Physical Damage: Rigid steel conduit. Includes raceways in the following locations:
    - a. Loading dock.
    - b. Mechanical rooms.
  - 3. Concealed in Ceilings and Interior Walls and Partitions: EMT
  - 4. Connection to Vibrating Equipment (Including Transformers and Hydraulic, Pneumatic, Electric Solenoid, or Motor-Driven Equipment): FMC, except use LFMC in damp or wet locations.

5. Damp or Wet Locations: Rigid steel conduit.
  6. Boxes and Enclosures: NEMA 250, Type 1, except use NEMA 250, Type 4, stainless steel in damp or wet locations.
  7. Embedded in or below concrete slab: Rigid Steel Conduit.
- C. Minimum Raceway Size: 3/4-inch trade size.
- D. Raceway Fittings: Compatible with raceways and suitable for use and location.
1. Rigid and Intermediate Steel Conduit: Use threaded rigid steel conduit fittings.
  2. PVC Externally Coated, Rigid Steel Conduits: Use only fittings listed for use with that material. Patch and seal all joints, nicks, and scrapes in PVC coating after installing conduits and fittings. Use sealant recommended by fitting manufacturer.

### **3.2 INSTALLATION**

- A. Comply with NECA 1 for installation requirements applicable to products specified in Part 2 except where requirements on Drawings or in this Article are stricter.
- B. Keep raceways at least 6 inches away from parallel runs of flues and steam or hot-water pipes. Install horizontal raceway runs above water and steam piping.
- C. Complete raceway installation before starting conductor installation.
- D. Support raceways as specified in Division 26 Section "Hangers and Supports for Electrical Systems."
- E. Install raceways level and square and at proper elevations. Insure adequate headroom.
- F. Protect stub-ups from damage where conduits rise through floor slabs. Arrange stub-ups so curved portions of bends are not visible above the finished slab.
- G. Install no more than the equivalent of three 90-degree bends in any conduit run except for communications conduits, for which fewer bends are allowed.
- H. Conceal conduit and EMT within finished walls, ceilings, and floors, unless otherwise indicated.
- I. Install raceway sealing fittings at suitable, approved, and accessible locations and fill them with listed sealing compound. For concealed raceways, install each fitting in a flush steel box with a blank cover plate having a finish similar to that of adjacent plates or surfaces. Install raceway sealing fittings at the following points:
1. Where conduits pass from warm to cold locations, such as boundaries of refrigerated spaces.
  2. Where otherwise required by the City of Chicago Electrical Code.
- J. Recessed Boxes in Masonry Walls: Saw-cut opening for box in center of cell of masonry block, and install box flush with surface of wall.
- K. Set metal floor boxes level and flush with finished floor surface.
- L. Use temporary closures to prevent foreign matter from entering raceways.

- M. Make bends and offsets so ID is not reduced. Keep legs of bends in the same plane and straight legs of offsets parallel, unless otherwise indicated.
- N. Use raceway fittings compatible with raceways and suitable for use and location.
- O. Run concealed raceways, with a minimum of bends, in the shortest practical distance considering the type of building construction and obstructions, unless otherwise indicated.
- P. Raceways Embedded in Slabs: Install in middle third of slab thickness, and leave at least 3/4-inch concrete cover. Install conduit below the slab reinforcing.
  - 1. Secure raceways to reinforcing rods to prevent sagging or shifting during concrete placement.
  - 2. Space raceways laterally 18 inches on center to prevent voids in concrete.
  - 3. Conduit larger than 1-inch trade shall not be installed in the slab.
  - 4. Transition to rigid steel conduit before rising above floor.
  - 5. Conduits penetrating the slab shall be spaced a minimum of 4 inches apart.
  - 6. Conduits shall not cross within the slab.
- Q. Install exposed raceways parallel to or at right angles to nearby surfaces or structural members, and follow the surface contours as much as practical.
  - 1. Run parallel or banked raceways together, on common supports where practical.
  - 2. Make bends in parallel or banked runs from same centerline to make bends parallel. Use factory elbows only where elbows can be installed parallel; otherwise, provide field bends for parallel raceways.
- R. Join raceways with fittings designed and approved for the purpose and make joints tight.
  - 1. Make raceway terminations tight. Use bonding bushings or wedges at connections subject to vibration. Use bonding jumpers where joints cannot be made tight.
  - 2. Use insulating bushings to protect conductors.
- S. Terminations: Where raceways are terminated with locknuts and bushings, align raceways to enter squarely and install locknuts with dished part against the box. Where terminations are not secure with 1 locknut, use 2 locknuts: 1 inside and 1 outside the box.
- T. Where raceways are terminated with threaded hubs, screw raceways or fittings tightly into the hub so the end bears against the wire protection shoulder. Where chase nipples are used, align raceways so the coupling is square to the box and tighten the chase nipple so no threads are exposed.
- U. Install pull wires in empty raceways. Use No. 14 AWG zinc-coated steel or monofilament plastic line with not less than 200-lb tensile strength. Leave at least 12 inches of slack at each end of the pull wire.
- V. Voice and Data System Raceways, 2-Inch Trade Size and Smaller: In addition to the above requirements, install raceways in maximum lengths of 100 feet and with a maximum of two 90-degree bends or equivalent. Separate lengths with pull or junction boxes where necessary to comply with these requirements. Provide insulating bushings at all terminations. Comply with EIA/TIA-569, Commercial Building Standards for Telecommunications Pathways and Spaces.

- W. Install raceway sealing fittings according to manufacturer's written instructions. Locate fittings at suitable, approved, and accessible locations and fill them with UL-listed sealing compound. For concealed raceways, install each fitting in a flush steel box with a blank cover plate having a finish similar to that of adjacent plates or surfaces. Install raceway sealing fittings at the following points:
1. Where conduits pass from warm to cold locations, such as the boundaries of refrigerated spaces.
  2. Where otherwise required by CCBC.
- X. Stub-up Connections: Extend conduits through concrete floor for connection to freestanding equipment. Install with an adjustable top or coupling threaded inside for plugs set flush with the finished floor. Extend conductors to equipment with rigid steel conduit; FMC may be used 6 inches above the floor. Install screwdriver-operated, threaded flush plugs flush with floor for future equipment connections.
- Y. Flexible Connections: Use maximum of 6 feet of flexible conduit for recessed and semirecessed lighting fixtures; for equipment subject to vibration, noise transmission, or movement; and for all motors. Use liquidtight flexible conduit in wet or damp locations. Install separate ground conductor across flexible connections.
- Z. Surface Raceways: Install a separate, green, ground conductor in raceways from junction box supplying the raceways to receptacle or fixture ground terminals.
1. Select each surface raceway outlet box, to which a lighting fixture is attached, of sufficient diameter to provide a seat for the fixture canopy.
  2. Where a surface raceway is used to supply a fluorescent lighting fixture having central-stem suspension with a backplate and a canopy (with or without extension ring), no separate outlet box is required.
  3. Provide surface metal raceway outlet box, and the backplate and canopy, at the feed-in location of each fluorescent lighting fixture having end-stem suspension.
  4. Where a surface metal raceway extension is made from an existing outlet box on which a lighting fixture is installed, no additional surface-mounted outlet box is required. Provide a backplate slightly smaller than the fixture canopy.
- AA. Install hinged-cover enclosures and cabinets plumb. Support at each corner.
- BB. Installation of Combination Device Wall Enclosures:
1. In each instance where two or more device boxes are generally located in the same vicinity and at the same mounting height, mount those devices in a common multi-gang barriered box appropriate for the device types.
  2. Combination receptacle and communications devices (i.e. television, data and receptacle) shall be installed in minimum 2 gang boxes with barriers to segregate the systems.
  3. Combination devices (i.e. data/voice outlet and normal and IG receptacle) installed in minimum 3 gang box under common wall plate. Provide barriers to segregate systems.

### **3.3 CLEANING**

- A. Provide final protection and maintain conditions that ensure coatings, finishes, and cabinets are without damage or deterioration at time of Preliminary Acceptance.
1. Repair damage to galvanized finishes with zinc-rich paint recommended by manufacturer.

2. Repair damage to PVC or paint finishes with matching touchup coating recommended by manufacturer.

### **3.4 PROTECTION**

- A. Provide final protection and maintain conditions, in a manner acceptable to manufacturer and Installer, that ensure coatings, finishes, and cabinets are without damage or deterioration at the time of Preliminary Acceptance.
  1. Repair damage to galvanized finishes with zinc-rich paint recommended by manufacturer.
  2. Repair damage to PVC or paint finishes with matching touchup coating recommended by manufacturer.

**End of Section 260533**



## **DIVISION 26 – ELECTRICAL**

### **SECTION 26 05 53**

#### **IDENTIFICATION FOR ELECTRICAL SYSTEMS**

##### **PART 1 - GENERAL**

###### **1.1 SUMMARY**

- A. Section includes the following:
  - 1. Identification for raceway.
  - 2. Identification for conductors and communication and control cable.
  - 3. Underground-line warning tape.
  - 4. Warning labels and signs.
  - 5. Instruction signs.
  - 6. Equipment identification labels.
  - 7. Miscellaneous identification products.

###### **1.2 DEFINITIONS**

- A. ANSI – American National Standards Institute.
- B. UL – Underwriter's Laboratories.

###### **1.3 SUBMITTALS**

- A. Product Data: For each electrical identification product indicated.
- B. Identification Schedule: An index of nomenclature of electrical equipment and system components used in identification signs and labels.
- C. Samples: For each type of label and sign to illustrate size, colors, lettering style, mounting provisions, and graphic features of identification products.

###### **1.4 QUALITY ASSURANCE**

- A. Comply with ANSI A13.1 and ANSI C2.
- B. Comply with the City of Chicago Electrical Code.
- C. Comply with 29 CFR 1910.145.

###### **1.5 COORDINATION**

- A. Coordinate identification names, abbreviations, colors, and other features with requirements in the Contract Documents, Shop Drawings, manufacturer's wiring diagrams, and the Operation and Maintenance Manual, and with those required by codes, standards, and 29 CFR 1910.145. Use consistent designations throughout Project.

- B. Coordinate installation of identifying devices with completion of covering and painting of surfaces where devices are to be applied.
- C. Coordinate installation of identifying devices with location of access panels and doors.
- D. Install identifying devices before installing acoustical ceilings and similar concealment.

## **1.6 REFERENCES**

- A. American National Standards Institute (ANSI): ANSI A 13.1 – Identification of Piping Systems.
- B. Manufacturer's catalogs: Specification manufacturers' catalogs are incorporated by reference to same force and effect as if repeated herein in full.

## **PART 2 - PRODUCTS**

### **2.1 MANUFACTURERS**

- A. Manufacturers: Subject to compliance with requirements, provide products by one of the following manufacturers:
  - 1. Equipment Identification Plates:
    - a. Quentin D.Schwab, 606 E. Dodson Drive, Urbana, IL 61801.
    - b. Joe Halm Building Specialties, Box 525, LaGrange, IL.
    - c. Mechanical Tag Systems, Box 1565, Cedar Rapids, IA 52406.
    - d. Seton Name Plate Corp., 592 Boulevard, New Haven, CT 06505.
    - e. N&E Specialty Co., Box 3518, Peoria, IL 61614.

### **2.2 RACEWAY IDENTIFICATION MATERIALS**

- A. Comply with ANSI A13.1 for minimum size of letters for legend and for minimum length of color field for each raceway and cable size.
- B. Color for Printed Legend:
  - 1. Power Circuits: Black letters on an orange field.
  - 2. Legend: Indicate system or service and voltage, if applicable.
- C. Snap-Around, Color-Coding Bands: Slit, pretensioned, flexible, solid-colored acrylic sleeves, 2 inches long, with diameter sized to suit diameter of raceway or cable it identifies and to stay in place by gripping action.
- D. Self-Adhesive Vinyl Tape: Colored, heavy duty, waterproof, fade resistant; 2 inches wide; compounded for outdoor use.

### **2.3 CONDUCTOR AND COMMUNICATION- AND CONTROL-CABLE IDENTIFICATION MATERIALS**

- A. Color-Coding Conductor Tape: Colored, self-adhesive vinyl tape not less than 3 mils thick by 1 to 2 inches wide.

- B. Metal Tags: Brass or aluminum, 2 by 2 by 0.05 inch, with stamped legend, punched for use with self-locking nylon tie fastener.

## **2.4 WARNING LABELS AND SIGNS**

- A. Comply with the City of Chicago Electrical Code and 29 CFR 1910.145.
- B. Self-Adhesive Warning Labels: Factory printed, multicolor, pressure-sensitive adhesive labels, configured for display on front cover, door, or other access to equipment, unless otherwise indicated.
- C. Baked-Enamel Warning Signs: Preprinted aluminum signs, punched or drilled for fasteners, with colors, legend, and size required for application. 1/4-inch grommets in corners for mounting. Nominal size, 7 by 10 inches.
- D. Metal-Backed, Butyrate Warning Signs: Weather-resistant, nonfading, preprinted, cellulose-acetate butyrate signs with 0.0396-inch galvanized-steel backing; and with colors, legend, and size required for application. 1/4-inch grommets in corners for mounting. Nominal size, 10 by 14 inches.
- E. Warning label and sign shall include, but are not limited to, the following legends:
  - 1. Multiple Power Source Warning: "DANGER - ELECTRICAL SHOCK HAZARD - EQUIPMENT HAS MULTIPLE POWER SOURCES."
  - 2. Workspace Clearance Warning: "WARNING - OSHA REGULATION - AREA IN FRONT OF ELECTRICAL EQUIPMENT MUST BE KEPT CLEAR FOR 36 INCHES."

## **2.5 INSTRUCTION SIGNS**

- A. Engraved, laminated acrylic or melamine plastic, minimum 1/16 inch thick for signs up to 20 sq. in. and 1/8 inch thick for larger sizes.
  - 1. Engraved legend with black letters on white face.
  - 2. Punched or drilled for mechanical fasteners.
  - 3. Framed with mitered acrylic molding and arranged for attachment at applicable equipment.

## **2.6 EQUIPMENT IDENTIFICATION LABELS**

- A. Self-Adhesive, Engraved, Laminated Acrylic or Melamine Label: Permanent adhesive backed, with white letters on a dark-gray background. Minimum letter height shall be 3/8 inch.
- B. Engraved, Laminated Acrylic or Melamine Label: Punched or drilled for screw mounting. White letters on a dark-gray background. Minimum letter height shall be 3/8 inch.

## **2.7 MISCELLANEOUS IDENTIFICATION PRODUCTS**

- A. Fasteners for Labels and Signs: Self-tapping, stainless-steel screws or stainless-steel machine screws with nuts and flat and lock washers.

## **PART 3 - EXECUTION**

### **3.1 APPLICATION**

- A. Accessible Raceways and Cables of Auxiliary Systems: Identify the following systems with color-coded, self-adhesive vinyl tape applied in bands:
  - 1. Fire Alarm System: Red.
  - 2. Fire-Suppression Supervisory and Control System: Red and yellow.
  - 3. Security System: Blue and yellow.
  - 4. Mechanical and Electrical Supervisory System: Green and blue.
  - 5. Telecommunication System: Green and yellow.
  - 6. Control Wiring: Green and red.
  
- B. Branch-Circuit Conductor Identification: Where there are conductors for more than three branch circuits in same junction or pull box, use metal tags. Identify each ungrounded conductor according to source and circuit number.
  
- C. Conductors to Be Extended in the Future: Attach write-on tags to conductors and list source and circuit number.
  
- D. Auxiliary Electrical Systems Conductor Identification: Identify field-installed alarm, control, signal, sound, intercommunications, voice, and data connections.
  - 1. Identify conductors, cables, and terminals in enclosures and at junctions, terminals, and pull points. Identify by system and circuit designation.
  - 2. Use system of marker tape designations that is uniform and consistent with system used by manufacturer for factory-installed connections.
  - 3. Coordinate identification with Project Drawings, manufacturer's wiring diagrams, and Operation and Maintenance Manual.
  
- E. Locations of Underground Lines: Identify with underground-line warning tape for power, lighting, communication, and control wiring and optical fiber cable. Install underground-line warning tape for both direct-buried cables and cables in raceway.
  
- F. Warning Labels for Indoor Cabinets, Boxes, and Enclosures for Power and Lighting: Comply with 29 CFR 1910.145 and apply baked-enamel warning signs. Identify system voltage with black letters on an orange background. Apply to exterior of door, cover, or other access.
  - 1. Equipment with Multiple Power or Control Sources: Apply to door or cover of equipment including, but not limited to, the following:
    - a. Power transfer switches.
    - b. Controls with external control power connections.
  - 2. Equipment Requiring Workspace Clearance According to the City of Chicago Electrical Code: Unless otherwise indicated, apply to door or cover of equipment but not on flush panelboards and similar equipment in finished spaces.
  
- G. Instruction Signs:
  - 1. Operating Instructions: Install instruction signs to facilitate proper operation and maintenance of electrical systems and items to which they connect. Install instruction

- signs with approved legend where instructions are needed for system or equipment operation.
2. Emergency Operating Instructions: Install instruction signs with white legend on a red background with minimum 3/8-inch- high letters for emergency instructions at equipment used for power transfer .
- H. Equipment Identification Labels: On each unit of equipment, install unique designation label that is consistent with wiring diagrams, schedules, and Operation and Maintenance Manual. Apply labels to disconnect switches and protection equipment, central or master units, control panels, control stations, terminal cabinets, and racks of each system. Systems include power, lighting, control, communication, signal, monitoring, and alarm systems unless equipment is provided with its own identification.
1. Labeling Instructions:
    - a. Indoor Equipment: Self-adhesive, engraved, laminated acrylic or melamine label. Unless otherwise indicated, provide a single line of text with 1/2-inch- high letters on 1-1/2-inch- high label; where 2 lines of text are required, use labels 2 inches high.
    - b. Outdoor Equipment: Engraved, laminated acrylic or melamine label with non-corroding screws.
    - c. Elevated Components: Increase sizes of labels and letters to those appropriate for viewing from the floor.
  2. Equipment to Be Labeled:
    - a. Panelboards, electrical cabinets, and enclosures.
    - b. Access doors and panels for concealed electrical items.
    - c. Emergency system boxes and enclosures.
    - d. Disconnect switches.
    - e. Enclosed circuit breakers.
    - f. Motor starters.
    - g. Push-button stations.
    - h. Voice and data cable terminal equipment.
    - i. Master clock and program equipment.
    - j. Intercommunication and call system master and staff stations.
    - k. Television/audio components, racks, and controls.
    - l. Fire-alarm control panel and annunciators.
    - m. Security and intrusion-detection control stations, control panels, terminal cabinets, and racks.
    - n. Monitoring and control equipment.
    - o. Terminals, racks, and patch panels for voice and data communication and for signal and control functions.

### **3.2 INSTALLATION**

- A. Verify identity of each item before installing identification products.
- B. Location: Install identification materials and devices at locations for most convenient viewing without interference with operation and maintenance of equipment.
- C. Apply identification devices to surfaces that require finish after completing finish work.

- D. Self-Adhesive Identification Products: Clean surfaces before application, using materials and methods recommended by manufacturer of identification device.
- E. Attach nonadhesive signs and plastic labels with screws and auxiliary hardware appropriate to the location and substrate.
- F. System Identification Color Banding for Raceways and Cables: Each color band shall completely encircle cable or conduit. Place adjacent bands of two-color markings in contact, side by side. Locate bands at changes in direction, at penetrations of walls and floors, at 50-foot maximum intervals in straight runs, and at 25-foot maximum intervals in congested areas.
- G. Color-Coding for Phase and Voltage Level Identification, 600 V and Less: Use the colors listed below for ungrounded service, feeder, and branch-circuit conductors.
  - 1. Color shall be factory applied.
  - 2. Colors for 208/120-V Circuits:
    - a. Phase A: Black.
    - b. Phase B: Red.
    - c. Phase C: Blue.
    - d. Neutral – White.
    - e. Ground – Green.
- H. Aluminum Wraparound Marker Labels and Metal Tags: Secure tight to surface of conductor or cable at a location with high visibility and accessibility.
- I. Underground-Line Warning Tape: During backfilling of trenches install continuous underground-line warning tape directly above line at 6 to 8 inches below finished grade. Use multiple tapes where width of multiple lines installed in a common trench exceeds 16 inches overall.
- J. Painted Identification: Prepare surface and apply paint according to Division 09 Section "Painting."
- K. Provide on device plates for local toggle switches, toggle switch type manual starters, pilot lights, and other electrical items, whose function is not readily apparent, engraved suitable inscriptions or plastic laminate nameplates describing the equipment controlled or indicated.
- L. For exterior installations, conduits, except branch lighting circuit conduits, shall be tagged at the ends and in intermediate boxes, chambers, manholes, handholes, and other enclosures in accordance with the same inscriptions as shown on the Drawings.
- M. In each switchboard room, electrical closet, or other space containing electrical equipment, provide a vitreous enameled metal sign, red on white, reading "Electrical Equipment Room – No Storage Permitted". Signs shall be mounted a clearly visible locations within the rooms or on the inside of doors where wall space within the room is not available.

**END OF SECTION**

## **DIVISION 26 – ELECTRICAL**

### **SECTION 26 09 23**

#### **LIGHTING CONTROL DEVICES**

##### **PART 1 - GENERAL**

###### **1.1 SUMMARY**

- A. Section includes the following lighting control devices:
  - 1. Indoor occupancy sensors.

###### **1.2 DEFINITIONS**

- A. LED: Light-emitting diode.
- B. PIR: Passive infrared.

###### **1.3 SUBMITTALS**

- A. Product Data: For each type of product indicated.
- B. Shop Drawings: Show installation details for occupancy and light-level sensors.
  - 1. Interconnection diagrams showing field-installed wiring.
- C. Field quality-control test reports.
- D. Operation and Maintenance Manuals: Provide a collection of manufacturer recommended operation and maintenance practices for each type of product including, but not limited to:
  - 1. Tools required.
  - 2. Acceptable cleaners and recommended cleaning practices.
  - 3. Replacement parts list.
  - 4. Manufacturer service department contact information.
  - 5. Submittal data.
  - 6. Intended operation narrative.

###### **1.4 QUALITY ASSURANCE**

- A. Electrical Components, Devices, and Accessories: Listed and labeled as defined in the Chicago Electrical Code, by a testing agency acceptable to authorities having jurisdiction, and marked for intended use.
- B. Comply with City of Chicago Building Code.

###### **1.5 DELIVERY, STORAGE AND HANDLING**

- A. Effectively protect all materials, accessories, and components from any damage or injury from the time of fabrication until final Owner acceptance.

- B. Deliver equipment in fully enclosed vehicles after specified environmental conditions have been permanently established in spaces where equipment is to be placed.
- C. Store equipment in spaces with environments controlled within manufacturer's ambient temperature and humidity tolerances for non-operating equipment.

## **1.6 COORDINATION**

- A. Coordinate layout and installation of ceiling-mounted devices with other construction that penetrates ceilings or is supported by them, including light fixtures, HVAC equipment, smoke detectors, fire-suppression system, and partition assemblies.

## **PART 2 - PRODUCTS**

### **2.1 MANUFACTURERS**

- A. Manufacturers: Subject to compliance with requirements, provide products by one of the following manufacturers:
  - 1. Indoor Occupancy Sensors
    - a. Hubbell Lighting
    - b. Leviton Mfg. Company, Inc.
    - c. Lutron Electronics, Inc.
    - d. Novitas, Inc.
    - e. Sensor Switch, Inc.

### **2.2 INDOOR OCCUPANCY SENSORS**

- A. General:
  - 1. Operation: Unless otherwise indicated, turn lights on when covered area is occupied and off when unoccupied; with a time delay for turning lights off, adjustable over a minimum range of 1 to 15 minutes. Where multiple occupancy sensors occur within the same space, connect sensors together to control the lights as a unit.
  - 2. Coordination:
    - a. Coordinate sensor load rating to load controlled. Provide any power-packs, relays and control components necessary for a fully functional complete system.
    - b. Provide occupancy sensors compatible with high-inrush electronic ballasts, compact fluorescent lamps, and low-voltage relay control systems.
    - c. For dual-technology sensors, coordinate both technologies within the same sensor to have the same coverage area.
  - 3. Sensitivity: Provide either self-adjusting occupancy sensors or provide all necessary contractor start-up (adjustments and fine tuning) of each occupancy sensor prior to Owner Acceptance.
  - 4. Mounting:



- a. Sensor: Suitable for mounting in any position on a standard outlet box. Suitably enclose sensor for return air plenum conditions where applicable.
  - b. Protection: Provide a vandal resistant coated-steel wire cage around occupancy sensors used in areas subject to damage or vandalism.
  - c. Obstructions: Provide ceiling mounted sensors anywhere there is likely to be permanent or temporary obstructions (i.e., stalls, bookcases, coat racks) that limit the sensor's ability to detect movement.
  - d. Time-Delay and Sensitivity Adjustments: Recessed and concealed behind hinged door.
5. Indicator: LED, to show when motion is being detected during testing and normal operation of the sensor.
  6. Bypass Switch: Override the on function in case of sensor failure.
  7. Automatic Light-Level Sensor: Adjustable from 2 to 200 fc; keep lighting off when selected lighting level is present.
- B. PIR Type: Detect occupancy by sensing a combination of heat and movement in area of coverage.
1. Detector Sensitivity: Detect occurrences of 6-inch- minimum movement of any portion of a human body that presents a target of not less than 36 sq. in..
  2. Detection Coverage (Room): Detect occupancy anywhere in a circular area of 1000 sq. ft. when mounted on a 96-inch- high ceiling.
  3. Detection Coverage (Corridor): Detect occupancy within 90 feet when mounted on a 10-foot- high ceiling.
- C. Ultrasonic Type: Detect occupancy by sensing a change in pattern of reflected ultrasonic energy in area of coverage.
1. Detector Sensitivity: Detect a person of average size and weight moving not less than 12 inches in either a horizontal or a vertical manner at an approximate speed of 12 inches/s.
  2. Detection Coverage (Small Room): Detect occupancy anywhere within a circular area of 600 sq. ft. when mounted on a 96-inch- high ceiling.
  3. Detection Coverage (Standard Room): Detect occupancy anywhere within a circular area of 1000 sq. ft. when mounted on a 96-inch- high ceiling.
  4. Detection Coverage (Large Room): Detect occupancy anywhere within a circular area of 2000 sq. ft. when mounted on a 96-inch- high ceiling.
  5. Detection Coverage (Corridor): Detect occupancy anywhere within 90 feet when mounted on a 10-foot- high ceiling in a corridor not wider than 14 feet.
  6. Provide sensors operating at a minimum of 32 kHz and a maximum of 98dB.
  7. Locate sensors away from areas with strong air currents such as adjacent to HVAC diffusers.
  8. Layout shall account for sensitivity adjustments below maximum and any absorptive materials such as carpeting or material covered partitions.
- D. Microphonic Type: Detect occupancy by sensing noise level changes in the space.
1. Detector Sensitivity: Detect a person of average size and weight moving not less than 12 inches in either a horizontal or a vertical manner at an approximate speed of 12 inches/s.
  2. Detection Coverage (Small Room): Detect occupancy anywhere within a circular area of 600 sq. ft. when mounted on a 96-inch- high ceiling.
  3. Detection Coverage (Standard Room): Detect occupancy anywhere within a circular area of 1000 sq. ft. when mounted on a 96-inch- high ceiling.

4. Detection Coverage (Large Room): Detect occupancy anywhere within a circular area of 2000 sq. ft. when mounted on a 96-inch- high ceiling.
5. Detection Coverage (Corridor): Detect occupancy anywhere within 90 feet when mounted on a 10-foot- high ceiling in a corridor not wider than 14 feet.
6. Do not use the microphonic sensing technology to initiate an ON sequence.
7. Provide automatic gain control.
8. .

## **PART 3 - EXECUTION**

### **3.1 SENSOR INSTALLATION**

- A. Install and aim sensors in locations to achieve not less than 95 percent coverage of areas indicated. Do not exceed coverage limits specified in manufacturer's written instructions.

### **3.2 WIRING INSTALLATION**

- A. Wiring Method: Comply with Division 26 Section "Conductors and Cables for Electrical Systems." Minimum conduit size shall be 1/2 inch.
- B. Wiring within Enclosures: Comply with NECA 1. Separate power-limited and nonpower-limited conductors according to conductor manufacturer's written instructions.
- C. Size conductors according to lighting control device manufacturer's written instructions, unless otherwise indicated.
- D. Splices, Taps, and Terminations: Make connections only on numbered terminal strips in junction, pull, and outlet boxes; terminal cabinets; and equipment enclosures.

### **3.3 IDENTIFICATION**

- A. Identify components and power and control wiring according to Division 26 Section "Identification for Electrical Systems."
  1. Identify controlled circuits in lighting contactors.
  2. Identify circuits or luminaries controlled by photoelectric and occupancy sensors at each sensor.
- B. Label time switches and contactors with a unique designation.

### **3.4 FIELD QUALITY CONTROL**

- A. Perform the following field tests and inspections and prepare test reports:
  1. After installing time switches and sensors, and after electrical circuitry has been energized, adjust and test for compliance with requirements.
  2. Operational Test: Verify operation of each lighting control device, and adjust time delays.
- B. Lighting control devices that fail tests and inspections are defective work.

### **3.5 ADJUSTING**

- A. Occupancy Adjustments: When requested within 12 months of date of Substantial Completion, provide on-site assistance in adjusting sensors to suit occupied conditions. Provide up to two visits to Project during other-than-normal occupancy hours for this purpose.

### **3.6 CLEANING**

- A. The contractor shall remove all paint spatters and other spots, dirt and debris from the equipment. Clean equipment and devices internally and externally using methods and materials recommended by the manufacturer.

### **3.7 CONTRACTOR STARTUP AND REPORTING**

- A. Contractor shall prepare and submit a complete set of record drawings, operation and maintenance data and certificates as outlined in this Section.
- B. Install any necessary initial lighting controls settings into the field devices. Coordinate schedules with the Owner so that a complete schedule is available at the time of commissioning. Electrical Contractor shall be responsible for schedule updates until panels are turned over to the Owner. Provide final system programming documents including final operating schedules, wiring documentation and programmable device and system switch operation data.
- C. Train Owner's maintenance personnel to adjust, operate, and maintain lighting control devices. Training shall last a minimum of 4 hours and at the end of the session, the owner's maintenance personnel shall be thoroughly instructed in the proper operation of the system.

### **3.8 COMMISSIONING AND DEMONSTRATION**

- A. After system checkout and adjustment, the contractor shall operate the system for the review of the owner and architect. Necessary adjustments or modifications shall be made as required by the owner or architect.

**End of Section 260923**

## DIVISION 26 – ELECTRICAL

### SECTION 26 09 61

#### THEATRE STAGE LIGHTING SYSTEM

##### 1. GENERAL

###### 1.1 SCOPE

All materials, components, and services necessary to provide a complete system indicated in this Section, as specified herein and shown on related Drawings, including:

- A. Preparation and submission of complete shop drawings and samples for review prior to fabrication.
- B. Verification of dimensions and conditions at the job site.
- C. Shipment of equipment to the job site and the secured storage of all non-fixed equipment.
- D. Installation and completion in accordance with these Specifications, related Drawings, the Equipment Manufacturer's recommendations, established trade criteria, and all applicable code requirements.
- E. The observation, demonstration, and necessary adjustment of the completed installation by the Manufacturer's engineering personnel.
- F. Preparation and submission of complete record drawings and operational and maintenance data and certificates.

###### 1.2 WORK INCLUDED

- A. Stage lighting control consoles and control accessories.
- B. Remote control panels and receptacles.
- C. Network data system.
- D. Dimmers.
- E. Wiring devices.

The above is for reference only and is not intended to define the limits of the work for a complete installation.

###### 1.3 RELATED WORK IN OTHER SECTIONS

- A. General requirements for all electrical work.
- B. Electrical service
- C. General lighting system.
- D. Theatrical rigging system.
- E. Theatrical sound and communications system.
- F. Theatrical luminaires and accessories.

#### 1.4 QUALIFICATIONS

- A. All dimming and control system equipment shall be provided by qualified StageLighting Manufacturers.
- B. The Manufacturers shall have at least ten (10) years experience in the fabrication of similar equipment.
- C. If requested, the Manufacturers shall submit a representative list of installations during the above period.
- D. Subject to the above requirements, the equipment indicated herein shall be by one of the following manufacturers:
  - 1. Dimming and control
    - a. Electronic Theatre Controls, Middleton, Wisconsin
  - 2. Wiring devices
    - a. Electronic Theatre Controls, Middleton, Wisconsin
    - b. LEX Products, Stamford, Connecticut
    - c. Performance Electric, Greer, South Carolina
    - d. Rigging Innovators, San Antonio, Texas
    - e. SECOA, Minneapolis, Minnesota
    - f. Southeast Stage Rigging & Curtains, Greenville, South Carolina
    - g. TMB, Carlstadt, New Jersey
    - h. Union Connector, West Babylon, New York
- E. Other manufacturers may be considered with the prior review of the Theatre Consultant. Manufacturers seeking review must contact the Theatre Consultant not later than fourteen (14) days prior to bid date.
- F. The dimming and control system shall be provided by a qualified theatrical dealer, who shall have at least five (5) years experience in the sales and installation of similar systems and who shall be factory certified to provide warranty service for all of the equipment in this Section. Dealer shall be a Business member, accredited as a Dealer/Retailer, of the entertainment service organization PLASA.
- G. Dealer shall be responsible for the integration, operation, and performance of all elements of the system described in this Section. Dealer shall provide all warranty work and equipment upgrades as called for in this Section. The dealer shall be available for product service onsite within (24) hours of a call for service.
- H. Subject to the above requirements, the equipment indicated herein shall be provided by one of the following dealers:
  - 1. Chicago Spotlight, Chicago, Illinois 312-455-1171
  - 2. Designlab Chicago, Chicago, Illinois 773-265-1100
  - 3. Intelligent Lighting Creations, Arlington Heights, Illinois 847.933.9792

Other dealers may be considered with the prior review of the Theatre Consultant. Dealers seeking review must contact the Theatre Consultant not later than fourteen (14) days prior to bid date.

## 1.5 SUBMITTALS

### A. With bid.

1. Identification of qualified Theatrical Dealer providing system.
2. All deviations and exceptions from specification must be revealed with bid. Deviations and exceptions from specification submitted after this time shall not be accepted.
3. Manufacturer shall indicate any additional infrastructure that is not shown in the Drawings and is required to install Manufacturer's system.
4. Shop drawings. Within thirty (30) days of receipt of order, the Manufacturer shall submit drawings and equipment data sheets to the Architect for distribution to the Theatre Consultant for review and action prior to fabrication:
  - a. Dimensions, components, and finishes of all equipment and accessories.
  - b. All system assemblies and major sub-assemblies, cabinets, and enclosures, including notation of type and manufacture of switches, pilot lights, locks, hardware, and electrical and electronic connectors.
  - c. Block schematics of system internal wiring and system element interconnection.
  - d. Full size samples of labeling styles for all wiring device types.
  - e. Quantities of each component and sub-assembly.
  - f. Indication by boxed caption of any and all variations from contract Drawings and Specifications, whether or not these variations have been formally or informally accepted by the Theatre Consultant.

### B. Samples. Within thirty (30) days of receipt of order, the Manufacturer shall submit to the Architect for review prior to fabrication samples of any equipment component requested by the Theatre Consultant. Samples shall not be included in quantities of equipment specified but shall be returned.

### C. Final submittal. Within thirty (30) days of final tests, and as a condition for final review, the Manufacturer shall submit to the Architect:

1. Three (3) sets to the Architect and one (1) set on electronic media to the Theatre Consultant. Format of sets shall be compliant with Division One of this Specification.
  - a. Receipts for delivery of all non-installed items, i.e., all items designated, "deliver to Owner."
  - b. "As built and approved" drawings and equipment data sheets showing all systems and components as installed, including all field modifications.
  - c. Documentation of Data Network system, noting system layout, all panel locations, and all wire lengths. Documents shall indicate the device IP

address, MAC/NIC address, Hub Number, and Port number, where applicable. Subnet Masks and Subnet documentation shall be provided where applicable.

- d. Operating and maintenance manuals.
- e. Parts lists.
- f. Training videos as noted below.
- g. Certificates of warranty, as set forth below.

## 1.6 TESTING AND INSTRUCTION

- A. Upon completion of all installation work, the Contractor and Dealer shall certify in writing to the Architect that the work is complete and ready for final observation. Final observation shall be scheduled by the Owner, the Architect, and the Theatre Consultant within fourteen (14) days following the Contractor's notice of completion.
- B. System testing shall include testing of control data network, documenting traffic utilization within the Network Data System requirements noted below in this Section. Testing shall also include verification of Wireless Handheld Remotes operational range as required in Part 2 of this Section.
- C. After system checkout and adjustment, the Dealer's factory certified technician shall operate the system for the review of the Owner, the Architect, and the Theatre Consultant.
- D. Necessary adjustments or modifications shall be made as required.
- E. As a condition of final completion, the Dealer's factory certified technician shall instruct the Owner's staff or representatives, under the observation of the Architect and Theatre Consultant, in the operation and maintenance of the system.
  - 1. Initial Instruction: This instruction session shall be scheduled for a minimum duration of six (6) hours. While it may be possible to schedule this instruction session to coincide with the system checkout, such coincidence shall not be assumed. Instruction shall be scheduled by the Owner, the Architect, and the Theatre Consultant to occur within fourteen (14) days following the Contractor's written notice.
    - a. Provide to Users at time of training a copy of the circuit termination schedule that has been revised by the Dealer and Electrical Contractor to reflect the installed circuit terminations for the Owner's use and reference. This document shall not supplant any other requirements contained in this Specification.
  - 2. Follow-up Instruction: This instruction session shall take place not less than thirty (30) days nor more than six (6) months from the initial instruction. This instruction shall be scheduled by the Owner, shall be scheduled for a minimum duration of four (4) hours and will cover topics requested by the Owner.
- F. The Dealer shall provide to the Owner video instructions on the operation and maintenance of the system. Information contained in video will cover all points

of operation and maintenance covered in the instruction session with Owner's staff. A videotaped recording of the actual instruction session is acceptable. Provide four (4) full copies of video instruction. Video format shall be DVD.

## 1.07 GENERAL REQUIREMENTS

- A. General Conditions of the project contract, work schedules, and site regulations apply to this work. Refer to Division One
- B. This work shall comply with local codes and applicable standards as established by NEC and approved testing agencies, and all components shall carry pertinent labels by approved testing agencies.
- C. The Contractor shall provide full insurance against loss or damage during shipment, storage, installation, and testing. Certification of such coverage shall be furnished to the Architect within thirty (30) days of award of contract.
- D. Warranty
  - 1. The Dealer shall unconditionally warrant all equipment and systems provided under this Section to be free from defects in materials and workmanship for a period of at least twelve (12) months from the date of final acceptance of all work of this Section. Lamps and normal wear and tear are exempted.
  - 2. Appropriate additional equipment to replace equipment removed for service shall be provided at the job site at no expense to the Owner to replace any and all equipment which must be removed for service. Replacement control console(s) must of the same model as those removed for service.
  - 3. All warranty service shall be performed by technicians factory certified for the installed equipment.
  - 4. For a period of two (2) years following acceptance, the Dealer shall provide and install, at no cost to the Owner, all control system upgrades. Thereafter the Dealer shall notify the Owner of all system upgrades for the life of the control system. The Dealer shall keep system user's name and address in a database for this purpose. All upgrades shall include a full written description of operational modifications. System upgrades shall be designed so as to allow existing data to be accessed and upgraded.
- E. State-of-the-art assurance: All products specified shall be the Manufacturer's most recent iteration and most recent product. No products shall be accepted if they have been discontinued or superseded at the time of shipment. Should the Manufacturer develop products of comparable function above and beyond the specification of the listed product, the Dealer shall make the newly developed product available to the project at no additional cost. The Dealer shall notify the Architect and the Theatre Consultant of any developments to the specified products, and shall note any change in the requirements of building infrastructure(s) to support the developments. The Architect and Theatre Consultant shall then determine whether upgraded products shall be accepted.

## 2. PRODUCTS

### 2.1 GENERAL



- A. All components shall be new, in good condition, and under warranty.
- B. All components shall bear labels from approved testing agencies and labels identifying the manufacturer, model number, and serial number. All such labels shall be permanently attached in a conspicuous location.
- C. All control and receptacle faceplates not otherwise described in this Specification shall be black anodized aluminum or black painted steel, and all labels and legends shall be permanently engraved directly into the faceplate. Engravings shall be filled with white paint. Minimum text height if not specified elsewhere: 1/4" inch. Micarta, lamicaid, and other types of engraved plastic labels shall not be used. Dry transfer, decals, plastic "dymo," or other types of adhesive labels shall not be used. Silk-screened legends shall not be used except where specifically noted. All faceplates shall have beveled edges and rounded corners.
- D. Control signal protocols and connector types
  - 1. All control signal protocol and connector types shall comply with the following Standards:
    - a. ANSI E1.11 – 2004 / Entertainment Technology USITT DMX-512-A Asynchronous Serial Digital Data Transmission Standard for Controlling Lighting Equipment and Accessories.
    - b. ANSI E1.17 – 2006 Entertainment Technology – Architecture for Control Networks.
    - c. ANSI E1.20 – 2006 Entertainment Technology – RDM Remote Device Management over DMX512 Networks.
    - d. ANSI E1.30 Series of Documents level equipment interoperability for control of commonly encountered entertainment technology devices using E1.17.
  - 2. All components shall be compatible within the Stage Lighting Manufacturer's network data system.
  - 3. All control, signal, and video connectors shall be of substantial construction and shall be of the locking or latching type. All plate-mounted connectors shall be bolted to faceplates. Rivets shall not be acceptable.
- E. Provide a total of (2) keys for each keyed device.
- F. Where specification allows for "approved equal," substitutions shall be proposed to the Theatre Consultant at least ten (10) days prior to bid date.

## 2.2 NETWORK DATA SYSTEM

- A. The Network Data System shall provide for the interconnection of devices used solely for stage lighting and special effects.
- B. A dedicated network is required for each performance space in the project. The network shall consist of receptacle panels, connecting wiring, patch bay(s), patch cables, hub devices, routers, switches, and receptacle panels for portable node devices.

- C. Provide all materials, components, and services necessary to provide a complete network data system indicated in this Section. Dealer shall be responsible for performance of the complete system.
- D. The network shall provide for the connection of the following devices:
  - 1. Control Consoles
  - 2. Remote video displays
  - 3. Designer's remote control consoles
  - 4. Wireless Handheld remote controls
  - 5. Automated spotlights
  - 6. Color changers
  - 7. Moving yoke devices
  - 8. DMX-controlled special effects
- E. Dry Lines/Redundant Networks
  - 1. A multiplexed signal from the control console locations to the dimmer racks which is not be part of the network and shall use dedicated multiplexed signal wiring conforming to the DMX-512/1990 standard. All other control devices shall operate as part of the network. If the manufacturer's system requires devices that are not network compatible, manufacturer shall provide all required hardware to accommodate those devices to meet the intent of this specification. Contractor shall provide and install conduits, boxes, and conductors to accommodate these devices, as part of the work of this Section.
- F. Network capacity shall be determined by the following simultaneous usage criteria. System shall allow all the data below to be sent simultaneously, within the traffic and collision maximums noted in Item L below.
  - 1. Control Consoles – quantity one (1)
    - a. Control signal to dimmers
    - b. Dimmer feedback information
  - 2. Remote video displays – quantity two (2) in use, in two separate locations
  - 3. Designer's remote control consoles – quantity one (1)
  - 4. Wireless Handheld remote controls
    - a. Network signal for one (1) unit
  - 5. Distributed DMX signal – two (2) 512-dimmer universes6.

- G. The system shall utilize unshielded twisted pair (UTP) wiring. UTP wiring shall be 4 pair #24 AWG unshielded twisted pair wiring. Fiber optic wiring is permissible for "backbone" wiring runs. Fiber optic wiring shall be 62.5/125/900 Micron Fiber Optic wiring. All elements of the system shall meet the following requirements:
1. Institute of Electrical & Electronic Engineers Standard 802.3: 1996 (E), ANSI/IEEE Standard 802.3, 1993 Edition
  2. Electronic Industries Association/Telecommunications Industries Association Standard 568-1995
  3. TIA/EIA Bulletin TSB67 for field-testing of unshielded twisted-pair cabling systems
  4. ESTA CP/96-1057r1 Recommended Practice for Ethernet Cabling Systems in Entertainment Lighting Applications and CP/98-1005r3, Supplement to the Recommended Practice.
- H. All system elements shall be provided from a qualified network hardware manufacturer. The manufacturer shall have at least five (5) years experience in the fabrication of network hardware. Subject to the above requirements, the equipment indicated herein shall be by one of the following manufacturers:
1. Allied Telesyn
  2. Bay Networks
  3. Cisco Systems
  4. 3Com Corporation
  5. Hubbell Premise
  6. Panduit
- I. Panels
1. Network terminations shall be provided at the following panels as shown in the Drawings and Schedules:
    - a. Control Receptacle Panel(s) (CRP-xx)
    - b. Rehearsal Panel(s) (RP-XX)
    - c. Signal Processing Rack(s) (SPR-XX)
- J. Wiring methods
1. All permanent network wiring shall terminate in receptacles in panels. All equipment shall be connected to receptacles via "patch cables" with RJ45 plugs. No installed wire shall terminate directly to network equipment. The use of male RJ45 pigtailed shall not be permitted.
  2. Cable shall be pulled in conduits, meeting the minimum-bending radius permitted by the cable manufacturer. All cable shall be pulled with no more than the maximum pulling tension permitted by the cable manufacturer.
  3. Riser rated or Plenum rated cable shall be used where required under local codes.

K. Electrical requirements

1. All UTP wiring segments shall be of continuous runs of not more than 250 feet. The Contractor shall coordinate and submit all conduit runs for review, verifying the maximum length of each wiring run. If a wiring run exceeds the noted maximum footage, Contractor shall notify the Architect of all issues and coordinate with Manufacturer to bring the segment wiring to the stated maximum run. Manufacturer shall provide required repeaters and system elements as necessary. Contractor shall provide and install such elements as part of the work of this Section.
2. All cable shall meet the standards for TIA/EIA-568-B Category 6, or highest rated category wiring then in use at the time of installation. The Contractor shall use a current generation 100Mhz or higher network/cable analyzer to perform testing on the cable plan and shall test all data pairs. All cable shall be tested for continuity, attenuation, near end crosstalk, mutual capacitance, cable impedance, cable resistance, cable length, structural return loss and pair mapping. All testing will be performed by certified cable technicians. As part of the final submittal, provide cable analyzer printouts of all test performed, labeled by cable number.
3. All wiring shall meet the TIA/EIA-586-B wiring standard.
4. All cable and installation shall accommodate 100Mbs transmission rate.
5. The system shall be designed for maximum 40% traffic utilization and maximum 10% collisions within the same collision domain. The use of switches is acceptable to manage network traffic.
6. All Layer 2 switches shall provide for IGMP Layer 3 snooping to accommodate IP multicast events.

L. Portable Node Devices

1. Node devices shall be portable, for the connection of equipment at receptacle panels
2. Nodes shall have receptacles for connection of network cables.
3. Nodes shall be provided with a C-Clamp and a safety cable.
4. Nodes shall have black enclosure.
5. Unless noted otherwise the Dealer shall configure all nodes to have DMX out receptacles.
6. Quantities per schedule. Note: scheduled nodes are portable, for use at receptacles. Provide scheduled quantity in addition to any nodes required for basic system operation.
7. Deliver to Owner.

M. Network cables

1. Cables shall have a Category rating to match wiring of installed wiring.
2. Cables shall include RJ45 plugs at each end, for proper mating to receptacle panels and node devices.

3. Cables shall be of type "ProPlex" as manufactured by TMB, Carlstadt, NJ or approved equal.
4. Connectors shall be Neutrik "Ethercon" type connectors or approved equal.
5. Quantities per schedule.
6. Deliver to Owner.

N. Patch cables

1. Cables shall be rated Category 5 to match wiring of installed wiring.
2. Cables shall include RJ45 plugs at each end, for proper mating to receptacle panels and node devices. Each cable shall be protected by a rubber boot of a diameter sufficient to extend beyond the plug connection tab.
3. Provide an equal quantity of at least five (5) different colors for all cables and boots.
4. Quantities as sufficient to fully patch the network.
5. Deliver to Owner.

O. Uninterruptable power supply.

1. Capable of sustaining operating voltage to supported devices for a minimum of ten (10) minutes in the event of a loss of power.
2. Capable of filtering spikes, surges, and noise from power source.
3. Conditioner shall provide continuity of earth ground from source to the console.
4. Shall include test switch to confirm battery charge.
5. Shall include battery end-of-life indicator.
6. Shall be rack mounted.
7. UPS shall be sized to provide rated power supply for supported devices.
8. Eaton Powerware Series 5 or approved equal.

2.3 SIGNAL PROCESSING RACK

- A. The Signal Processing Rack shall be 19" equipment mounting rack(s) with a hinged front door.
- B. The Rack shall be surface wall mounted and completely wired internally. Rack shall include hinged "swing-away" mounting for rear access. Design and configuration as shown in the Drawings.
- C. Patch panel(s) shall include sufficient patching for all network receptacles, plus (12) spare receptacles.
  1. The Panel(s) shall include wire management panel(s) as manufactured by Panduit or approved equal.
  2. The Panel(s) shall include engraved labeling of each port. Port labeling shall refer to Control Receptacle Panel designation.

- D. System to incorporate for Power over Ethernet. Provide one of the following systems:
  - 1. IEEE 802.3af compliant Power over Ethernet 24-48VDC 10/100 Base T Switches as required

OR

- 1. IEEE 802.3af compliant Power Injector and 10/100 Base T network switches as required. Injector(s) must have sufficient ports to simultaneously service to all network taps.
- E. All wires shall be identified at the jacket with separate numbers.
- F. The rack shall contain the following elements as shown in the Drawings:
  - 1. Network Patch Bay
  - 2. Network Switch
  - 3. Power Over Ethernet (POE) Power Injector.
  - 4. Cable Management.
  - 5. Signal Translation node, if required.
  - 6. Uninterruptable Power Supply.
  - 7. Architectural Lighting Processor.
- G. Install as shown in the Drawings.

#### 2.4 CONTROL RECEPTACLE PANELS

- A. The Control Receptacle Panels shall be mounted as indicated in the Drawings, and completely wired internally, with terminal strips of the proper rating for all external connections.
- B. The face of each panel shall contain receptacles as indicated in the Drawings. These receptacles shall be of the locking type and shall be sized for the proper number and capacity of conductors as indicated in the Drawings.
  - 1. Receptacles for device connection.
    - a. All Category 6 connectors shall be RJ45. All female RJ45 connectors shall be individual connectors of matching catalog number.
    - b. All fiber optic connectors shall be ST style connectors.
    - c. Control connectors shall be equal to 4-pin or 5-pin XLR, Switchcraft D4M or D5M. Smaller or less substantial connectors shall not be acceptable.
  - 2. Engraved Lamicoid label(s) with the following information:
    - a. Designation of wire destination
    - b. Maximum length of patch cable permissible from the receptacle.
  - 3. Faceplate engraving of device name and receptacles as shown in Drawings.
- C. Install as shown in the Drawings.

## 2.5 REHEARSAL PANEL

- A. The Rehearsal Panel shall be flush floor mounted, with a hinged access cover. Cover plate shall be 3/8" thick cast iron, with cast-in non-skid gridding in the top and at least three (3) cable notches. The back box shall be constructed of 20-gauge steel, with knockouts provided in the bottom and on sides. Terminal strips, of the proper rating and clearly labeled, shall be provided for all external connections.
- B. The face of the panel shall contain the following as shown in the Drawings:
  - 1. Lighting Control Receptacles for operation of control console and auxiliary console.
  - 2. Network Data System Receptacles.
  - 3. Two (2) specification grade 110V duplex convenience outlets.
- C. Provide dust flap of min. 1/16" sheet neoprene, commercial grade, 55/65 Duro. Flap shall be sized to cover all receptacles completely and shall be permanently attached to the top of the faceplate. Dust flap shall be designed and constructed to protect the receptacles from dust when not in use and to be peeled back to allow cords to be plugged into receptacles. Dust flap shall be separated into two pieces as shown in Drawings.
- D. All labels and legends shall be permanently engraved directly into the faceplate. Engravings shall be filled with white paint.
- E. Install as shown in the Drawings.

## 2.6 THEATRE LIGHTING CONTROL SYSTEM

- A. The Theatre Lighting Control System shall be a comprehensive lighting control system designed to control all dimming and relay panels as shown in the Schedules.
- B. The system shall be comprised of individual control panels as shown in the Drawings. Each panel shall contain one or more of the following control elements:
  - 1. Master Lighting Control
    - a. Controls, quantities and labeling as noted in the Drawings.
    - b. Rear-illuminated liquid crystal display screen shall display available presets and programming information.
      - i. It shall be possible to limit control and access to the screen through the use of password controls.
      - ii. It shall be possible to program fade times for each preset
      - iii. The panel shall be capable of addressing all dimmers in the system.
      - iv. Control zone numbers and names as noted in the Drawings.
    - c. Panic switch. Rear-illuminated pushbutton switch. Color: red. Operation: Push On / Lock. Panic switch shall bring designated architectural lighting circuits on to full power overriding all other dimmer

controls. The dimmer racks shall be locked at this state until released by the Normal Switch. This switch shall function regardless of the operating status of other control system elements.

- d. Normal switch. Rear-illuminated pushbutton switch. Color: green. Operation: Push On / Lock. Normal Switch shall release the dimmer override and shall return the dimmers to the last state prior to the activation of the Panic Switch.
  - e. Night Light switch. Rear-illuminated pushbutton switch. Color: White. Operation: Push On / Push Off. Night Light switch shall activate a preset of house lights and work lights for use when the theatre is unoccupied. The Night Light preset shall only be activated and deactivated with this switch. All other houselight controls and worklight switches, including Entry Panels, will continue to operate while the Night Light preset is engaged, but their action shall not affect any channels being controlled by the Night Light preset.
  - f. Entry Panel Lockout Switch. Recessed rear-illuminated pushbutton switch. Color: White. Lockout switch shall address all designated Entry Panels. Switch shall be able to lock out local control.
2. Houselight Controls
    - a. One Master (1) linear slider for house light dimmers.
    - b. Linear sliders for individual control of house light dimmers. Quantity and Label per drawings.
  3. Work light controls.
    - a. Manufacturer standard pushbuttons. Operation: Push On / Push Off. Each button shall incorporate or have associated with it a status indicating LED.
    - b. One (1) Kill/Restore switch. Switch function shall be:  
Switch Up - Restore (non-locking)  
Switch – Center – HELD  
Switch – Down – Kill (non-locking).  
Kill position shall take all work light circuits to zero. Restore position shall restore last state of all circuits, including status indicators.
    - c. Controls, quantities and labeling as noted in the Drawings.
  4. Specialty Lighting.
    - a. Programmable Buttons.
      - i. Pushbuttons to activate separate presets.
      - ii. UP and DOWN pushbuttons to raise and lower channel levels, and to program presets in setup mode.
      - iii. Buttons shall not be labeled specifically, but shall include a write-on area for labeling.
      - iv. Quantity and Label per drawings.



- C. The following systems shall be acceptable:
  - 1. ETC "Paradigm"
- D. Auxiliary Control Console
  - 1. The Auxiliary Control Console shall be a separate console, totally enclosed, portable, and completely wired internally.
  - 2. The face of the panel shall contain the control Panels as shown in the Drawings
  - 3. The console elements shall retain their memory regardless of connection status to system power.
  - 4. Design and configuration as shown in the Drawings.
  - 5. The Auxiliary Control Console shall include a vinyl dust cover or case lid as appropriate, and one (1) 25-foot multi-conductor cable terminating in a locking connector appropriate for mating with Control Receptacle Panels as required by the Drawings.
- E. Entry Panels
  - 1. All panels shall employ a multiplexed control signal.
  - 2. Panels shall be mounted as shown in the Drawings and Schedules, and completely wired internally, with terminals of the proper rating for all external wiring.
  - 3. The face of the panel shall contain momentary contact pushbutton switches or faders. Quantity, labeling, and circuits controlled per Drawings.
  - 4. Enclosed entry panels.
    - a. The face of the panel shall be recessed and covered by a hinged latching cover with a clear view panel.
    - b. All entry panel enclosures mounted in audience areas shall be custom color per the Architect's specifications. All faceplates to complement enclosure color with a color from manufacturer's standard finish selections.
  - 5. The panels shall retain their memory regardless of connection status to system power.
  - 6. Install as shown in the Drawings.
- F. All labels and legends shall be permanently engraved directly into the faceplate, or the surrounding faceplate of the panel's enclosure. Engravings shall be filled with paint of a contrasting color.

## 2.7 STAGE LIGHTING CONSOLES

- A. Specifications
  - 1. DMX Outputs: 1024
  - 2. Control Channels: 10,000
  - 3. Encoders: 4

4. Removable Media recording for show file storage
5. 40 Submaster Faders with bump buttons and status-indicating LEDs

B. Console shall include:

1. Two (2) high-resolution 19" LCD flat screen, DVI Monitors, color.
2. Two (2) Removable Media for show file storage.
3. One (1) set of 25-foot control cables terminating in locking connectors appropriate for mating with the Control Receptacle Panel.
  - a. Connectors shall be Neutrix EtherCon or equivalent.
4. Vinyl dust covers for the console and video displays.

C. Acceptable products.

1. ETC "Ion" with 2x20 Universal Fader Wing

No other system shall be considered unless specifically approved by the Theatre Consultant at least 10 days prior to bid date.

D. Install in the Control Room as shown in the Drawings.

## 2.8 CONTROL ACCESSORIES

A. Uninterruptable power supply.

1. Capable of sustaining operating voltage to control console and video display(s) for a minimum of ten (10) minutes in the event of a loss of power.
2. Capable of filtering spikes, surges, and noise from power source.
3. Conditioner shall provide continuity of earth ground from source to the console.
4. Shall include test switch to confirm battery charge.
5. Shall include battery end-of-life indicator.
6. Shall be sized to provide rated power supply for control console, external display(s), and any console-mounted work light.
7. Eaton Powerware Series 5 or approved equal.

B. Wireless Handheld Remotes.

1. Unit(s) shall be capable of calling up channels, adjusting levels, calling up cues, running cues, and performing dimmer check.
2. Provide all portable transmitter(s)/access point(s) required for a complete and functioning system.
  - a. System shall provide for continuous operation from all points within the auditorium chamber and stage house including but not limited to the gridiron, stage floor, dimmer room, auditorium catwalks, control rooms, and auditorium.
3. The following transmission protocol methodologies shall be acceptable:
  - a. IEEE 802.11 b/g, commonly known as Wi-Fi technology.

- b. UHF radio transmission. Systems utilizing UHF radio transmission shall be in compliance with the limits for a Class A digital device, pursuant to Part 15 of the FCC Rules.
- 4. Systems requiring line-of-sight technology shall not be accepted.
- 5. Units shall be capable of four (4) hours of continuous use on a single battery charge.
- C. Offline Editing Software. Software for off-line editing of show information from main control console. Software shall enable user to load show information directly from main control console, view, edit, and print all show data, and re-load information back into main control console for playback.
- D. Extension control cable. Two (2) 25'-0" extension cable for control console, neoprene outer jacket.
- E. Install in Control Room.

## 2.9 DIMMER RACKS

### A. Physical requirements

- 1. The Dimmer Racks shall be floor supported, substantially framed, and enclosed with sheet metal panels. Access for installation and maintenance shall be provided through the front of the rack. All parts shall be properly cleaned prior to painting and then painted with a rust inhibiting primer. The finish paint shall be baked enamel. Each rack section shall not exceed 25" wide, 26" deep, and 86" high.
- 2. The racks shall be mounted using one of the vibration isolation methods noted below and as shown in the Drawings:
  - a. Waffle type neoprene vibration padding, Mason Industries type WSW, with a hardness of 40-50 Duro, consisting of two (2) pads mounted on the sides of a metal shim. Each corner of each rack shall contain one (1) WSW pad mounted to the frame to distribute the load from the corner of the frame.

OR

- a. Cone type neoprene vibration padding, Mason Industries type ND-B, with a hardness of 40-50 Duro. Each corner of each rack shall contain (1) pad bolted to the rack. The racks shall be braced laterally by a cone type neoprene deflection mounting, Mason Industries type BR, with a hardness of 40-50 Duro. Rack shall be bolted to deflection mounting. Deflection mount shall be bolted to a support at the dimmer room wall.
- 3. No portion of the dimmer rack shall contact any part of the building structure or walls except through resilient connections specifically approved by the theatre consultant. All load, feed, and control conduit connections to the dimmer racks shall be isolated through the use of flexible conduit connections as shown in the Drawings.
- 4. Each dimmer space and control module space shall have guides for ease of insertion and withdrawal of the dimmer and control modules for maintenance.

5. Each dimmer space shall be clearly labeled with circuit/dimmer number and channel number such as "HL-xx."
6. All connections and test points shall be accessible through the front of the rack.
7. The rack shall incorporate a front locking door to cover all user-operable portions of its components.
8. An engraved lamicooid label shall be bolted or riveted to the front of the rack, to read:

DIMMER RACK (Number)  
DIMMERS (Beginning no.)—(End no.)/  
CHANNEL NUMBER (Beginning no.)-(End no.)  
Schuler Shook Theatre Planners, Chicago, IL  
(Year of Commissioning)

**B. Electrical requirements**

1. The Dimmer Racks shall be designed to operate at a voltage of 120/208 volts, 60 Hz, 3-phase 4-wire, with the main busses of each rack sized for maximum full loading of all contained dimmers.
2. The Dimmer Racks shall be completely wired internally, and terminals of the proper rating shall be provided for all external connections. Each terminal shall be clearly and permanently marked and numbered.
3. Each dimmer space shall include factory wired, heavy duty, free floating female power and control jacks to ensure proper seating of the dimmer module male pins when the dimmer is inserted.
4. In order to protect control components from a catastrophic failure of voltage isolation at the dimmer module, the Dimmer rack shall incorporate isolation between control voltage of all control devices and line voltage of dimmers. Isolation shall be in excess of 2500 volts RMS. This isolation shall be in addition to any isolation provided in each dimmer.

**C. Electronic requirements**

1. Each rack shall include a solid-state interface system capable of translating the multiplexed information format from the Control Console, to a signal for driving the Dimmer Modules.
2. Each rack shall include control electronics to govern the output voltage of the dimmers. The Dealer shall adjust the output voltage to provide 115 volts at each stage circuit receptacle supplied by that rack.
3. Each rack shall include storage of a minimum of thirty-two (32) user-defined dimmer states for backup. Backup states shall be activated by user at the rack.

- D. Thermal requirements
  - 1. Forced air ventilation shall be provided by low-noise fans in each rack. These fans shall keep the dimmers within safe operating temperature.
  - 2. Each rack shall contain an electronic system to monitor the temperature within the rack. This system shall shut down the rack and activate a warning light on or near the Control Console should the safe operating temperature of the rack be exceeded.
- E. Install as shown in the Drawings.
- F. Provide and deliver to Owner spare modules of each module type in the rack. See Schedule of Quantities.
- G. To ensure proper air ventilation, provide and install blank filler modules in all unfilled dimmer module spaces. Provide placard on inner face of each dimmer rack door, reading, "CAUTION—FILL ALL EMPTY RACK SLOTS WITH BLANK MODULES. DO NOT OPERATE DIMMERS UNLESS ALL SLOTS ARE FILLED."

## 2.10 RACK MOUNTED DIMMERS

- A. Acoustical requirements
  - 1. 500 $\mu$ s SCR DIMMERS
    - a. Dimmers shall be equipped with firing circuitry and filtering designed to reduce "filament sing" attributable to rapid SCR switching of the AC waveform. Rise time shall not be less than 500 microseconds measured at 90-degree conduction angle, at the dimmer's full rated load.
    - b. Acoustical performance criteria: accumulated filament noise levels measured at a distance of 10'-0" from any fixture shall not exceed 20 dBA with any loading and at any dimming level.
- B. Physical requirements
  - 1. Dimmer Modules shall be of the plug-in drawer type, designed for insertion into and removal from the Dimmer Rack without the use of tools. A substantial handle shall be provided in the face of each module.
  - 2. Each Dimmer shall be plainly identified with the Manufacturer's name and address, dimmer rating in amperes and volts, and catalog identification. Dimmers shall each bear an individual serial number for identification.
- C. Electrical requirements
  - 1. The Dimmer Module shall be designed to operate at a nominal line voltage of 120 volts, 60 Hz.
  - 2. The faceplate of each module shall include fully magnetic circuit breakers to serve as disconnecting devices and to provide branch circuit protection.
  - 3. Each module shall be completely factory wired, with power and control connections between the Dimmer Module and the Dimmer Rack provided through permanently installed, oversized, self-aligning connectors located at the rear of the module.

D. Electronic requirements

1. SCR Dimmers

- a. Dimmers shall be solid state, utilizing two silicon-controlled rectifiers (SCR) in a back-to-back electrical configuration, which provides, at all times, a symmetrical alternating current output. The full load of the circuit shall be carried and controlled solely by the SCRs.
- b. Each dimmer shall include an integral inductive toroidal filter to reduce the rate of current rise resulting from the SCR switching, to isolate the dimmer from the AC line to prevent interaction with other dimmers, and to limit conducted radio frequency interference.
- c. Power efficiency shall exceed 90% at any voltage and at any load.

E. Thru-Power Modules

1. The module shall provide a single module which allows the choice between dimmed, non-dim or hot power on each circuit in the module.
2. Module, when in dimmer mode, shall provide 500 $\mu$ s rise time response subject to the requirements of this article.
3. Module shall provide two air gap relay switches outputs controlled by the control system
4. Module shall provide two manual bypass constant power circuits controlled manually.

2.11 LED DRIVER CONTROL CARDS

- A. The control card(s) shall be mounted in the Signal Processing Rack as shown in Drawings
- B. The card(s) shall be a multi-purpose LED dimming controller and solid-stage DC drive. It shall decode control signals from the lighting control system to switched or pulse-width modulated DC outputs.
- C. The card(s) shall provide at least six (6) outputs, with each output controlled by a discrete control channel in double precision mode. Starting control channel shall be user-selectable.
- D. The card(s) shall have at least four (4) operating modes:
  1. Default LED Control. The module shall translate the DMX 8-bit signal to 16-bit control by means of a high-resolution software fade algorithm to ensure even, step-free fading of LED intensity. The linear DMX control signal shall be translated to an LED-specific output curve so that, to the human eye, the LEDs appear to fade linearly from zero to full. Straight linear outputs shall not be acceptable.
  2. Double Precision Control with Fade Curve. Each output shall be controlled by two sequential DMX channels to produce a true 16-bit value for calculating intensity. The linear DMX control signal shall be translated to an LED-specific output curve so that, to the human eye, the LEDs appear to fade linearly from zero to full. Straight linear outputs shall not be acceptable.

3. Double Precision Control without Fade Curve. Each output shall be controlled by two sequential DMX channels to produce a true 16-bit value for calculating intensity. The linear DMX control signals shall determine the output PWM values in a straight linear fashion, without use of any curve to compensate for human eye response.
  4. Non-Dim Control. This mode shall switch, not dim, the outputs. When the DMX value for an output is below 50%, the output shall be off (open). When the DMX value is above 50%, the output shall be on (closed). This mode shall efficiently drive solenoid coils or solid state relays.
- E. A dry contact closure input shall be provided as a panic override. When the input is shorted (closed), all outputs shall be forced to full, regardless of DMX input values.
- F. Electrical
1. Multiple modules, up to the RS485 limitation of 32, may be daisy-chained on the same DMX input data line.
  2. The power input shall accept a range of 9 to 30 volts DC and shall consume no more than 5 watts.
  3. The DMX input port shall be capable of withstanding the continuous application of up to 250V without damage to internal components.
  4. Input protection shall be of the self-resetting type, rated for 250V. Replaceable fuses shall not be acceptable.
  5. The DMX input port shall provide 1500-volt opto-isolation between the DMX signal and module electronics.
  6. The module shall support any LED fixture which operates within a range of 5 to 30 volts DC.
  7. Each output shall be capable of driving up to 4 amperes at 30VDC of connected load.
  8. Each output shall be fully electrically isolated to 2500V and fuse-protected from all other outputs to eliminate the possibility of system malfunction or damage due to accidental grounding or other electrical faults. One spare fuse shall be securely attached to each board.
  9. DMX connections, DC output and power connections shall all utilize pluggable Phoenix-type screw terminal blocks, capable of accepting solid or stranded wire sizes from #26 to #14 AWG.
- G. Acceptable systems:
1. "eDin 6 channel LED Dimmer/DC Driver", by Pathway Connectivity, Calgary, Alberta, Canada
  2. "Unison 4-Wire Fluorescent Option Card" by Electronic Theatre Controls, Middleton, Wisconsin
  3. Or approved equal.

## 2.12 STAGE LIGHTING CONNECTORS

- A. Two Pin and Ground
  - 1. 20-Ampere devices.
    - a. Connectors shall be 20-ampere slip pin, 2 wire plus ground, with integral strain relief.
    - b. Unless otherwise noted provide transparent plastic covers
    - c. The following manufacturer's devices shall be acceptable:
      - i. Union Connector
      - ii. Maringo Bates® Plug
      - iii. LEX Products
- B. TWIST-LOCK
  - 1. 20-Ampere devices
    - a. Connectors shall be 20 ampere, 2 wire plus ground, locking, with nylon bodies and casings, and integral cable clamp. Configuration shall be NEMA L5-20.
    - b. The following manufacturer's devices shall be acceptable:
      - i. Hubbell
      - ii. Leviton
- C. 20-ampere 6-circuit multi-pin
  - 1. A threaded coupling 19-pin cylindrical connector for theatrical lighting applications
  - 2. All multi-conductor connectors shall be wired in accordance with the recommended practice RP-1 as published by the U. S. Institute for Theatre Technology.
  - 3. The following manufacturer's devices shall be acceptable:
    - i. Veam
    - ii. Socapex
    - iii. LEX Products
  - 4. All products shall be compatible with Socapex 419 Series connectors.
- D. Quantities per Drawings & Schedules.

## 2.13 WIRING DEVICES

- A. General Requirements
  - 1. All device number and letter labeling shall be provided with matching character fonts.
  - 2. 20-ampere pigtails shall be 12-3 type S cord, length per Drawings, secured by cushioned strain reliefs or nylon "Heyco" bushings.



3. Connectors for circuits other than standard 20-amp stage circuits shall have covers that correspond to the label color.
  4. Device labeling
    - a. Plug Strips circuit numbers shall be permanent die-cut letters not less than 1-1/2 inches high, using white letters for standard 20-amp stage circuit numbers and yellow letters for all other numbers.
    - b. Circuit numbers on all other devices shall be engraved into the face plate and filled with epoxy paint, or engraved onto black plastic lamicaid labels permanently attached with epoxy cement and a minimum of two (2) steel rivets. Letters shall be not less than one inch high and shall be white for standard 20-amp stage circuit numbers and yellow for all other numbers.
  5. All multi-pin receptacles shall include a removable threaded cover with retaining chain.
  6. Receptacle configuration as shown in the Drawings.
  7. Exterior finish shall be flat black baked enamel (for steel) or black anodized (for aluminum) unless noted otherwise.
  8. Devices with multiple voltages shall provide continuous voltage barriers separating each voltage.
  9. All components requiring external electrical connections of more than eight (8) conductors shall include barrier-type terminal strips properly sized and permanently labeled.
    - a. For all devices the terminal strips shall be sized to accept a range of wire from #12 to #6
  10. Units shall be UL listed and carry a UL label.
- B. Plug boxes
1. Plug boxes shall be constructed of 16-gauge steel or extruded aluminum. Knockouts shall be provided on all sides of the back box.
- D. Floor pockets
1. Floor pockets shall be flush floor mounted, with a hinged access cover. Cover plate shall be 3/8" thick cast iron, with cast-in non-skid gridding in the top and at least one cable notch for each receptacle. The back box shall be constructed of 20-gauge steel, with knockouts provided in the bottom and on all sides. . Receptacles shall be mounted on a 20 gauge steel plate angled for visibility and access.
  2. Provide a dust flap for each faceplate. Dust flap shall be min. 1/8" sheet neoprene, commercial grade. Flap shall be sized to completely cover all receptacles, shall be permanently attached to the top of the faceplate, and shall be slit once between each receptacle. Dust flap shall be designed and constructed to protect the receptacles from dust when not in use and to be peeled back to allow a cord to be plugged into a receptacle. Paint circuit numbers onto dust flap segments in letters not less than 1 inch high.
- E. Multi-conductor cables

1. Cables shall be rated at 600 volts, minimum 90 degrees Celsius, with two (2) conductors for each 20-ampere circuit required plus one grounding conductor for every three (3) circuits.
2. Permanently installed cables shall be cord type SC or SO.
3. Portable cables shall be cord type SC.
  - a. Approved Manufacturers:
    - i. "Pro Cable" as manufactured by TMB, Burbank, CA.
    - ii. "PowerFlex" as manufactured by LEX Products, Stamford, CT.
    - iii. Coast Entertainment, a division of Coast Wire & Plastic Tech, Inc., Carson, CA
    - iv. or approved equal.
4. Wire size shall be minimum #12 AWG, or larger as code requirements dictate.
5. Sizes and lengths as indicated in the Drawings and schedules.
- F. Locations, quantities, sizes and circuits as shown in the Drawings.
- G. Install as shown in the Drawings.

2.14 SCHEDULE OF QUANTITIES

Section	Description	Quantity
2.2	Network Data system	as required
L	Portable Node devices: DMX translation	2
M	Network cables: 10'	4
	25'	4
	50'	2
N	Network patch cables	8 additional
2.3	Signal Processing Rack	per Drawings
2.4	Control Receptacle Panels	per Drawings
2.5	Rehearsal Panel	per Drawings
2.6	D Auxiliary Control Console, cable, and dust cover	1
E	Entry Panels	per Drawings
2.7	Control Console	1
B1	LCD Monitor	2
B2	Removable Storage Media	2
B3	Control Cables	1 set
B4	Dust covers, console and monitor(s)	1 set
2.8	A Uninterruptible Power Supply	1
B	Hand-held remote control and cable	1
C	Off-line Editing Software	1
D	Extension control cable	1 set
2.9	Dimmer Racks	as required
F	Spare dimmer rack components:	
	Control Electronics Module	1 set
	Dual 2.4kW dimmer module	1 set
2.10	Dimmers	per Drawings
E	Thru-Power module	6
2.11	LED Driver Control Cards	per Drawings
2.13	Wiring Devices	per Drawings

### 3. EXECUTION

#### 3.1 FABRICATION

- A. Racks and cabinets shall be welded assemblies of sheet steel or aluminum or bar size angles, channels, and tees or aluminum extrusions forming rigid enclosures to support internal components.
- B. Operating elements shall be mechanically safe and electrically "dead."
- C. All steel parts and panels shall be cleaned and primed with rust inhibiting primer. Exterior finishes shall be epoxy resin or baked enamel in matte black, or in Manufacturer's standard color where not specified.
- D. All internal wiring shall be factory completed. All wiring shall be in harnesses and bound. No loose or randomly routed wires shall be permitted.
- E. All wire sizes and insulations shall comply with NEC, UL, and local codes and meet or exceed electronics industry standards.

#### 3.2 PACKING AND SHIPPING

- A. Equipment shall be wrapped and sealed in polyethylene and substantially crated for shipment. Crates shall clearly indicate equipment contained, nature of components, and theatre site allocation.
- B. Electronics shall be packaged and shipped in dust and static proof packaging.
- C. All materials shall be delivered to the site in clean, undamaged operational condition.

#### 3.3 INSTALLATION

- A. Install all items in conformity with Project Documents, standard trade practices and Manufacturer's recommendations.
- B. Consult and coordinate work with trades doing adjoining work.
- C. Position all items accurately as indicated in the Drawings, and true to plumb line and level. Maintain maximum headroom and clearance at all points.
- D. Do not uncrate, unpack, unwrap, or install control console, video monitor(s), remote controls, or other auxiliary control components until construction is complete and environment is clean and dust-free.

END OF SECTION 26 0961

## DIVISION 26 – ELECTRICAL

### SECTION 26 24 16

#### PANELBOARDS

##### PART 1 - GENERAL

##### 1.1 SUMMARY

- A. Section includes the following:
  - 1. Lighting and appliance branch-circuit panelboards 600V and less.

##### 1.2 DEFINITIONS

- A. EMI: Electromagnetic interference.
- B. GFCI: Ground-fault circuit interrupter.
- C. RFI: Radio-frequency interference.
- D. RMS: Root mean square.
- E. SPDT: Single pole, double throw.

##### 1.3 SUBMITTALS

- A. Product Data: For each type of panelboard, overcurrent protective device, transient voltage suppression device, accessory, and component indicated. Include dimensions and manufacturers' technical data on features, performance, electrical characteristics, ratings, and finishes.
- B. Shop Drawings: For each panelboard and related equipment.
  - 1. Dimensioned plans, elevations, sections, and details. Show tabulations of installed devices, equipment features, and ratings. Include the following:
    - a. Enclosure types and details for types other than NEMA 250, Type 1.
    - b. Bus configuration, current, and voltage ratings.
    - c. Short-circuit current rating of panelboards and overcurrent protective devices.
    - d. Features, characteristics, ratings, and factory settings of individual overcurrent protective devices and auxiliary components.
  - 2. Wiring Diagrams: Power, signal, and control wiring.
- C. Field quality-control test reports including the following:
  - 1. Test procedures used.
  - 2. Test results that comply with requirements.
  - 3. Results of failed tests and corrective action taken to achieve test results that comply with requirements.

- D. Panelboard Schedules: For installation in panelboards. Submit final versions after load balancing.
- E. Operation and Maintenance Data: For panelboards and components to include in emergency, operation, and maintenance manuals. In addition to items specified in Division 01 Sections "Closeout Procedures" and "Operation and Maintenance Data," include the following:
  - 1. Manufacturer's written instructions for testing and adjusting overcurrent protective devices.
  - 2. Time-current curves, including selectable ranges for each type of overcurrent protective device.

#### **1.4 QUALITY ASSURANCE**

- A. Source Limitations: Obtain panelboards, overcurrent protective devices, components, and accessories through one source from a single manufacturer.
- B. Product Options: Drawings indicate size, profiles, and dimensional requirements of panelboards and are based on the specific system indicated. Refer to Division 01 Section "Product Requirements."
- C. Electrical Components, Devices, and Accessories: Listed and labeled as defined in the City of Chicago Electrical Code, Article 100, by a testing agency acceptable to authorities having jurisdiction, and marked for intended use.
- D. Comply with NEMA PB 1.
- E. Comply with the City of Chicago Electrical Code.

#### **1.5 PROJECT CONDITIONS**

- A. Environmental Limitations: Rate equipment for continuous operation under the following conditions, unless otherwise indicated:
  - 1. Ambient Temperature: Not exceeding 104 deg F.
  - 2. Altitude: Not exceeding 6600 feet.
- B. Service Conditions: NEMA PB 1, usual service conditions, as follows:
  - 1. Ambient temperatures within limits specified.
  - 2. Altitude not exceeding 6600 feet.
- C. Interruption of Existing Electric Service: Do not interrupt electric service to facilities occupied by Owner or others unless permitted under the following conditions and then only after arranging to provide temporary electric service according to requirements indicated:
  - 1. Notify Architect and Owner's representative no fewer than seven working days in advance of proposed interruption of electrical service.
  - 2. Do not proceed with interruption of electrical service without Architect's and Owner's representative written permission.

## **1.6 COORDINATION**

- A. Coordinate layout and installation of panelboards and components with other construction that penetrates walls or is supported by them, including electrical and other types of equipment, raceways, piping, and encumbrances to workspace clearance requirements.
- B. Coordinate size and location of concrete bases. Cast anchor-bolt inserts into bases. Concrete, reinforcement, and formwork requirements are specified in Division 03.

## **1.7 EXTRA MATERIALS**

- A. Furnish extra materials described below that match products installed and that are packaged with protective covering for storage and identified with labels describing contents.
  - 1. Keys: Six spares for each type of panelboard cabinet lock.

## **1.8 DELIVERY, STORAGE AND HANDLING**

- A. Store enclosed panelboards indoors in clean and dry space with uniform temperature to prevent condensation. Protect panelboards from exposure to dirt, fumes, water, corrosive substances, and physical damage.
- B. If stored in areas subject to weather, cover panelboards to protect them from weather, dirt, dust, corrosive substances, and physical damage. Remove loose packing and flammable materials from inside panelboards; install electric heating of sufficient wattage to prevent condensation.
- C. Deliver in factor shipping cartons.
- D. Handle panelboards to avoid damage.

## **PART 2 - PRODUCTS**

### **2.1 MANUFACTURERS**

- A. Manufacturers: Subject to compliance with requirements, provide products by one of the following manufacturers:
  - 1. Panelboards, Overcurrent Protective Devices, Controllers, Contactors, and Accessories:
    - a. Eaton Corporation; Cutler-Hammer Products.
    - b. General Electric Co.; Electrical Distribution & Protection Div.
    - c. Siemens Energy & Automation, Inc.
    - d. Square D.

### **2.2 MANUFACTURED UNITS**

- A. Enclosures: Flush- and surface-mounted cabinets. NEMA PB 1, Type 1.
  - 1. Rated for environmental conditions at installed location.
    - a. Outdoor Locations: NEMA 250, Type 3R.
    - b. Kitchen Areas: NEMA 250, Type 4X, stainless steel.
    - c. Other Wet or Damp Indoor Locations: NEMA 250, Type 4.

2. Hinged Front Cover: Entire front trim hinged to box and with standard door within hinged trim cover.
  3. Skirt for Surface-Mounted Panelboards: Same gage and finish as panelboard front with flanges for attachment to panelboard, wall, and ceiling or floor.
  4. Gutter Extension and Barrier: Same gage and finish as panelboard enclosure; integral with enclosure body. Arrange to isolate individual panels.
  5. Finish: Manufacturer's standard enamel finish over corrosion-resistant treatment or primer coat.
  6. Directory Card: With transparent protective cover, mounted in metal frame, inside panelboard door.
- B. Phase and Ground Buses:
1. Material: Hard-drawn copper, 98 percent conductivity.
  2. Equipment Ground Bus: Adequate for feeder and branch-circuit equipment ground conductors; bonded to box.
  3. Isolated Equipment Ground Bus: Adequate for branch-circuit equipment ground conductors; insulated from box.
  4. Extra-Capacity Neutral Bus: Neutral bus rated 200 percent of phase bus and UL listed as suitable for nonlinear loads.
  5. Split Bus: Vertical buses divided into individual verticals.
  6. Integral TVSS or provision for the connection of the remote TVSS.
- C. Conductor Connectors: Suitable for use with conductor material.
1. Main and Neutral Lugs: Compression type.
  2. Ground Lugs and Bus Configured Terminators: Compression type.
  3. Extra-Capacity Neutral Lugs: Rated 200 percent of phase lugs mounted on extra-capacity neutral bus.
- D. Service Equipment Label: UL labeled for use as service equipment for panelboards with main service disconnect switches.
- E. Future Devices: Mounting brackets, bus connections, and necessary appurtenances required for future installation of devices.

### **2.3 PANELBOARD SHORT-CIRCUIT RATING**

- A. Fully rated to interrupt symmetrical short-circuit current available at terminals.

### **2.4 LIGHTING AND APPLIANCE BRANCH-CIRCUIT PANELBOARDS**

- A. Branch Overcurrent Protective Devices: Bolt-on circuit breakers, replaceable without disturbing adjacent units.
- B. Doors: Concealed hinges; secured with flush latch with tumbler lock; keyed alike.

### **2.5 OVERCURRENT PROTECTIVE DEVICES**

- A. Molded-Case Circuit Breaker: UL 489, with interrupting capacity to meet available fault currents.
1. Thermal-Magnetic Circuit Breakers: Inverse time-current element for low-level overloads, and instantaneous magnetic trip element for short circuits. Adjustable magnetic trip setting for circuit-breaker frame sizes 250 A and larger.



2. Adjustable Instantaneous-Trip Circuit Breakers: Magnetic trip element with front-mounted, field-adjustable trip setting.
  3. Electronic trip-unit circuit breakers shall have RMS sensing; field-replaceable rating plug; and with the following field-adjustable settings:
    - a. Instantaneous trip.
    - b. Long- and short-time pickup levels.
    - c. Long- and short-time time adjustments.
    - d. Ground-fault pickup level, time delay, and  $I^2t$  response.
  4. GFCI Circuit Breakers: Single- and two-pole configurations with [5] [30]-mA trip sensitivity.
- B. Molded-Case Circuit-Breaker Features and Accessories: Standard frame sizes, trip ratings, and number of poles.
1. Lugs: Mechanical style, suitable for number, size, trip ratings, and conductor materials.
  2. Application Listing: Appropriate for application; Type SWD for switching fluorescent lighting loads; Type HACR for heating, air-conditioning, and refrigerating equipment.
  3. Ground-Fault Protection: Integrally mounted relay and trip unit with adjustable pickup and time-delay settings, push-to-test feature, and ground-fault indicator.
  4. Shunt Trip: 120-V trip coil energized from separate circuit, set to trip at 75 percent of rated voltage where indicated on drawings..
  5. Undervoltage Trip: Set to operate at 35 to 75 percent of rated voltage with field-adjustable 0.1- to 0.6-second time delay.
  6. Auxiliary Contacts: Two SPDT switches with "a" and "b" contacts; "a" contacts mimic circuit-breaker contacts, "b" contacts operate in reverse of circuit-breaker contacts.
  7. Zone-Selective Interlocking: Integral with electronic trip unit; for interlocking ground-fault protection function.
  8. Multipole units enclosed in a single housing or factory-assembled to operate as a single unit.
- C. Fused Switch: NEMA KS 1, Type HD; clips to accommodate specified fuses; lockable handle.
- D. Fuses are specified in Division 26 Section "Fuses."

## 2.6 ACCESSORY COMPONENTS AND FEATURES

- A. Furnish accessory set including tools and miscellaneous items required for overcurrent protective device test, inspection, maintenance, and operation.
- B. Furnish portable test set to test functions of solid-state trip devices without removal from panelboard.

## PART 3 - EXECUTION

### 3.1 INSTALLATION

- A. Install panelboards and accessories according to NEMA PB 1.1.
- B. Mount top of trim 74 inches above finished floor, unless otherwise indicated.
- C. Mount plumb and rigid without distortion of box. Mount recessed panelboards with fronts uniformly flush with wall finish.

- D. Install overcurrent protective devices and controllers.
  - 1. Set field-adjustable switches and circuit-breaker trip ranges.
- E. Install filler plates in unused spaces.
- F. Stub four 1-inch empty conduits from panelboard into accessible ceiling space or space designated to be ceiling space in the future. Stub four 1-inch empty conduits into raised floor space or below slab not on grade.
- G. Arrange conductors in gutters into groups and bundle and wrap with wire ties after completing load balancing.

### **3.2 IDENTIFICATION**

- A. Identify field-installed conductors, interconnecting wiring, and components; provide warning signs as specified in Division 26 Section "Identification for Electrical Systems."
- B. Create a directory to indicate installed circuit loads after balancing panelboard loads. Obtain approval before installing. Use a computer or typewriter to create directory; handwritten directories are not acceptable.
- C. Panelboard Nameplates: Label each panelboard with engraved metal or laminated-plastic nameplate mounted with corrosion-resistant screws.

### **3.3 CONNECTIONS**

- A. Ground equipment according to Division 26 Section "Grounding and Bonding for Electrical Systems."
- B. Connect wiring according to Division 26 Section "Conductors and Cables for Electrical Systems."

### **3.4 GROUNDING**

- A. Make equipment grounding connections for panelboards as indicated.
- B. Provide ground continuity to main electrical ground bus as indicated.

### **3.5 ADJUSTING**

- A. Set field-adjustable switches and circuit-breaker trip ranges as indicated.

### **3.6 DEMONSTRATION AND TRAINING**

- A. Training: Arrange and pay for the services of factory-authorized service representatives to demonstrate Panelboards and OCPD's and train Owner's maintenance personnel.
- B. Conduct a minimum of one half day of training in operation and maintenance as specified in Division 01 Section "Closeout Procedures". Include both classroom training and hands on equipment operation and maintenance procedures.
- C. Schedule training with at least seven days' advance notice.

### **3.7 CLEANING**

- A. On completion of installation, inspect interior and exterior of panelboards. Remove paint splatters and other spots. Vacuum dirt and debris; do not use compressed air to assist in cleaning. Repair exposed surfaces to match original finish.

### **3.8 CONTRACTOR STARTUP AND REPORTING**

- A. Prepare for acceptance tests as follows:
  - 1. Test insulation resistance for each panelboard bus, component, connecting supply, feeder, and control circuit.
  - 2. Test continuity of each circuit.
- B. Perform the following field tests and inspections and prepare test reports:
  - 1. Perform each electrical test and visual and mechanical inspection stated in NETA ATS, Section 7.5 for switches and Section 7.6 for molded-case circuit breakers. Certify compliance with test parameters.
  - 2. Correct malfunctioning units on-site, where possible, and retest to demonstrate compliance; otherwise, replace with new units and retest.

### **3.9 COMMISSIONING AND DEMONSTRATION**

- A. Balancing Loads: After Substantial Completion, but not more than 2 months after Final Acceptance, conduct load-balancing measurements and make circuit changes as follows:
  - 1. Perform measurements during period of normal working load as advised by Owner.
  - 2. Perform load-balancing circuit changes outside normal occupancy/working schedule of the facility. Make special arrangements with owner to avoid disrupting critical 24-hour services such as fax machines and on-line data processing, computing, transmitting, and receiving equipment.
  - 3. Recheck loads after circuit changes during normal load period. Record all load readings before and after changes and submit test records.
  - 4. Tolerance: Difference exceeding 20 percent between phase loads, within a panelboard, is not acceptable. Rebalance and recheck as required to meet this minimum requirement.

**END OF SECTION**

## DIVISION 26 – ELECTRICAL

### SECTION 26 27 26

#### WIRING DEVICES

#### PART 1 - GENERAL

##### 1.1 SUMMARY

A. Section includes the following:

1. Receptacles, receptacles with integral GFCI, and associated device plates.
2. Twist-locking receptacles.
3. Receptacles with integral surge suppression units.
4. Wall-box motion sensors.
5. Isolated-ground receptacles.
6. Snap switches
7. Wall-switch.
8. Communications outlets.
9. Pendant cord-connector devices.
10. Cord and plug sets.
11. Floor service outlets, poke-through assemblies, service poles, and multioutlet assemblies.

##### 1.2 DEFINITIONS

- A. EMI: Electromagnetic interference.
- B. GFCI: Ground-fault circuit interrupter.
- C. MMTV: Media Management TV System
- D. Pigtail: Short lead used to connect a device to a branch-circuit conductor.
- E. RFI: Radio-frequency interference.
- F. TVSS: Transient voltage surge suppressor.
- G. UTP: Unshielded twisted pair.

##### 1.3 SUBMITTALS

- A. Product Data: For each type of product indicated.
- B. Shop Drawings: List of legends and description of materials and process used for premarking wall plates.
- C. Field quality-control test reports.
- D. Operation and Maintenance Data: Wiring devices shall be provided with all manufacturers' packing label warnings and instruction manuals that include labeling conditions. Provide a

collection of manufacturer recommended operation and maintenance practices for each type of product including, but not limited to:

1. Tools required.
2. Acceptable cleaners and recommended cleaning practices.
3. Replacement parts list.
4. Manufacturer service department contact information.
5. Submittal data.
6. Intended operation narrative.

#### **1.4 QUALITY ASSURANCE**

- A. Source Limitations: Obtain each type of wiring device and associated wall plate through one source from a single manufacturer. Insofar as they are available, obtain all wiring devices and associated wall plates from a single manufacturer and one source.
- B. Electrical Components, Devices, and Accessories: Listed and labeled as defined in the City of Chicago Electrical Code, by a testing agency acceptable to authorities having jurisdiction, and marked for intended use.
- C. Comply with NFPA 101.
- D. Comply with City of Chicago Electrical Code.

#### **1.5 DELIVERY, STORAGE AND HANDLING**

- A. Effectively protect all materials, accessories, and components from any damage or injury from the time of fabrication until final Owner acceptance.
- B. Deliver equipment in fully enclosed vehicles after specified environmental conditions have been permanently established in spaces where equipment is to be placed.
- C. Store equipment in spaces with environments controlled within manufacturer's ambient temperature and humidity tolerances for non-operating equipment.

#### **1.6 COORDINATION**

- A. Receptacles for Owner-Furnished Equipment: Match plug configurations.

#### **1.7 EXTRA MATERIALS**

- A. Furnish extra materials described in subparagraphs below that match products installed and that are packaged with protective covering for storage and identified with labels describing contents.
  1. Service/Power Poles: One for every 10, but no less than one.
  2. Floor Service Outlet Assemblies: One for every 10, but no less than one.
  3. Poke-Through, Fire-Rated Closure Plugs: One for every five floor service outlets installed, but no less than two.
  4. TVSS Receptacles: One for every 10 of each type installed, but no less than two of each type.

## **PART 2 - PRODUCTS**

### **2.1 MANUFACTURERS**

- A. Manufacturers: Subject to compliance with requirements, provide products by one of the following manufacturers:
1. Wiring Devices:
    - a. Cooper Wiring Devices; a division of Cooper Industries, Inc.
    - b. Hubbell Incorporated; Wiring Device-Kellems
    - c. Leviton Mfg. Company Inc.
    - d. Pass & Seymour/Legrand; Wiring Devices & Accessories
  2. Poke-Through, Floor Service Outlets, and Telephone/Power Poles:
    - a. Hubbell, Inc.
    - b. Pass & Seymour/Legrand; Wiring Devices & Accessories
    - c. Square D Co.
  3. Wiremold Co. Multi-Outlet Assemblies:
    - a. Hubbell Incorporated; Wiring Device-Kellems.
    - b. Wiremold Co.

### **2.2 STRAIGHT BLADE RECEPTACLES**

- A. Convenience Receptacles, 125 V, 20 A: Comply with NEMA WD 1, NEMA WD 6 configuration 5-20R, and UL 498.
- B. Isolated-Ground, Duplex Convenience Receptacles, 125 V, 20 A: Comply with NEMA WD 1, NEMA WD 6 configuration 5-20R, and UL 498.
1. Description: Straight blade; equipment grounding contacts shall be connected only to the green grounding screw terminal of the device and with inherent electrical isolation from mounting strap. Isolation shall be integral to receptacle construction and not dependent on removable parts.

### **2.3 GFCI RECEPTACLES**

- A. General Description: Straight blade, non-feed-through type. Comply with NEMA WD 1, NEMA WD 6, UL 498, and UL 943, Class A, and include indicator light that is lighted when device is tripped. Units shall fit in a 2-3/4" deep outlet box without an adapter.
- B. Duplex GFCI Convenience Receptacles, 125 V, 20 A:
- C. Duplex TVSS Convenience Receptacles:
1. Description: Straight blade, 125 V, 20 A; NEMA WD 6 configuration 5-20R.
- D. Isolated-Ground, Duplex Convenience Receptacles:

1. Description: Straight blade, 125 V, 20 A; NEMA WD 6 configuration 5-20R. Equipment grounding contacts shall be connected only to the green grounding screw terminal of the device and with inherent electrical isolation from mounting strap. Isolation shall be integral to receptacle construction and not dependent on removable parts.

## **2.4 TWIST-LOCKING RECEPTACLES**

- A. Single Convenience Receptacles, 125 V, 20 A: Comply with NEMA WD 1, NEMA WD 6 configuration L5-20R, and UL 498.
- B. Isolated-Ground, Single Convenience Receptacles, 125 V, 20 A:
  1. Description: Comply with NEMA WD 1, NEMA WD 6 configuration L5-20R, and UL 498. Equipment grounding contacts shall be connected only to the green grounding screw terminal of the device and with inherent electrical isolation from mounting strap. Isolation shall be integral to receptacle construction and not dependent on removable parts.

## **2.5 PENDANT CORD-CONNECTOR DEVICES**

- A. Description: Matching, locking-type plug and receptacle body connector; NEMA WD 6 configurations L5-20P and L5-20R, heavy-duty grade.
  1. Body: Nylon with screw-open cable-gripping jaws and provision for attaching external cable grip.
  2. External Cable Grip: Woven wire-mesh type made of high-strength galvanized-steel wire strand, matched to cable diameter, and with attachment provision designed for corresponding connector.

## **2.6 SNAP SWITCHES**

- A. Comply with NEMA WD 1 and UL 20.
- B. Switches, 120/277 V, 20 A:
- C. Pilot Light Switches, 20 A:
  1. Description: Single pole, with neon-lighted handle, illuminated when switch is "ON."
- D. Key-Operated Switches, 120/277 V, 20 A:
  1. Description: Single pole, with factory-supplied key in lieu of switch handle.
- E. Single-Pole, Double-Throw, Momentary Contact, Center-Off Switches, 120/277 V, 20 A; for use with mechanically held lighting contactors.
- F. Key-Operated, Single-Pole, Double-Throw, Momentary Contact, Center-Off Switches, 120/277 V, 20 A; for use with mechanically held lighting contactors, with factory-supplied key in lieu of switch handle.

## **2.7 COMMUNICATIONS OUTLETS**

- A. Category 5e Outlet:

1. Comply with requirements of Division 27 Section "Data Communications Horizontal Cabling" for Category 5e UTP components.

B. Category 6 Outlet:

1. Comply with requirements of Division 27 Section "Data Communications Horizontal Cabling" for Category 6 UTP components.

C. Media Management TV System Outlet:

1. Comply with requirements of Division 27 Section "Distributed Audio-Video Communication Systems" for MMTV Category 6 UTP and coaxial cabling components.

## 2.8 WALL PLATES

A. Single and combination types to match corresponding wiring devices.

1. Plate-Securing Screws: Metal with head color to match plate finish.
2. Material for Finished Spaces: 0.035-inch thick, satin-finished stainless steel except as noted otherwise on drawings.
3. Material for Unfinished Spaces: Galvanized steel.
4. Material for Damp Locations: Cast aluminum with spring-loaded lift cover, and listed and labeled for use in "wet locations."

B. Wet-Location, Weatherproof Cover Plates: NEMA 250, complying with type 3R weather-resistant, die-cast aluminum with lockable cover.

## 2.9 FLOOR SERVICE FITTINGS

A. Type: Modular, flush-type, dual-service units suitable for wiring method used.

B. Compartments: Barrier separates power from voice and data communication cabling.

C. Service Plate: Rectangular, die-cast aluminum with satin finish.

D. Power Receptacle: NEMA WD 6 configuration 5-20R, gray finish, unless otherwise indicated.

E. Communications Outlet: Modular, color-coded RJ45 jacks for UTP cable. Coordinate jack type with drawing requirements and Division 27 Section "Data Communications Horizontal Cabling".

## 2.10 POKE-THROUGH ASSEMBLIES

A. Description: Factory-fabricated and -prewired assembly of below-floor junction box with multichanneled, through-floor raceway/firestop unit and detachable matching floor service outlet assembly as specified above.

1. Service Outlet Assembly: Flush type with devices coordinated with drawings and Division 27 Section "Data Communications Horizontal Cabling".
2. Size: Selected to fit nominal 3-inch cored holes in floor and matched to floor thickness.
3. Fire Rating: Unit is listed and labeled for fire rating of floor-ceiling assembly.
4. Closure Plug: Arranged to close unused 3-inch cored openings and reestablish fire rating of floor.
5. Wiring Raceways and Compartments: Sized for a minimum of four No. 12 AWG conductors and a minimum of four (4) 4-pair Category 6 UTP communication cables.



Comply with requirements of Division 27 Section "Data Communications Horizontal Cabling" for Category 6 UTP components.

6. Communications Outlets: Modular, color-coded RJ45 jacks for UTP cable. Coordinate jack type with drawing requirements and Division 27 Section "Data Communications Horizontal Cabling".

## **2.11 MULTIOUTLET ASSEMBLIES**

- A. Components of Assemblies: Products from a single manufacturer designed for use as a complete, matching assembly of raceways and receptacles.
- B. Raceway Material: Metal, with manufacturer's standard corrosion-resistant finish.
- C. Wire: No. 12 AWG.

## **2.12 FINISHES**

- A. Color:
  1. Wiring Devices Connected to Normal Power System: Ivory, unless otherwise indicated or required by Chicago Electrical Code or device listing.
  2. Wiring Devices Connected to Emergency Power System: Solid Red.
  3. TVSS Devices: Solid Blue.
  4. Isolated-Ground Receptacles: Solid Orange.

## **PART 3 - EXECUTION**

### **3.1 INSTALLATION**

- A. Comply with NECA 1, including the mounting heights listed in that standard, unless otherwise noted.
- B. Coordination with Other Trades:
  1. Take steps to insure that devices and their boxes are protected. Do not place wall finish materials over device boxes and do not cut holes for boxes with routers that are guided by riding against outside of the boxes.
  2. Keep outlet boxes free of plaster, drywall joint compound, mortar, cement, concrete, dust, paint, and other material that may contaminate the raceway system, conductors, and cables.
  3. Install device boxes in brick or block walls so that the cover plate does not cross a joint unless the joint is troweled flush with the face of the wall.
  4. Install wiring devices after all wall preparation, including painting, is complete.
- C. Conductors:
  1. Do not strip insulation from conductors until just before they are spliced or terminated on devices.
  2. Strip insulation evenly around the conductor using tools designed for the purpose. Avoid scoring or nicking of solid wire or cutting strands from stranded wire.
  3. The length of free conductors at outlets for devices shall meet provisions of Chicago Electrical Code, without pigtails.
  4. Existing Conductors:

- a. Cut back and pigtail, or replace all damaged conductors.
- b. Straighten conductors that remain and remove corrosion and foreign matter.
- c. Pigtailling existing conductors is permitted provided the outlet box is large enough.

D. Device Installation:

1. Replace all devices that have been in temporary use during construction or that show signs that they were installed before building finishing operations were complete.
2. Keep each wiring device in its package or otherwise protected until it is time to connect conductors.
3. Do not remove surface protection, such as plastic film and smudge covers, until the last possible moment.
4. Connect devices to branch circuits using pigtails that are not less than 6 inches in length.
5. When there is a choice, use side wiring with binding-head screw terminals. Wrap solid conductor tightly clockwise, 2/3 to 3/4 of the way around terminal screw.
6. Use a torque screwdriver when a torque is recommended or required by the manufacturer.
7. When conductors larger than No. 12 AWG are installed on 15- or 20-A circuits, splice No. 12 AWG pigtails for device connections.
8. Tighten unused terminal screws on the device.
9. When mounting into metal boxes, remove the fiber or plastic washers used to hold device mounting screws in yokes, allowing metal-to-metal contact.

E. Device Plates: Do not use oversized or extra-deep plates. Repair wall finishes and remount outlet boxes when standard device plates do not fit flush or do not cover rough wall opening.

F. Dimmers:

1. Install dimmers within terms of their listing.
2. Verify that dimmers used for fan speed control are listed for that application.
3. Install unshared neutral conductors on line and load side of dimmers according to manufacturers' device listing conditions in the written instructions.

G. Arrangement of Devices: Unless otherwise indicated, mount flush, with long dimension vertical and with grounding terminal of receptacles on top. Group adjacent switches under single, multigang wall plates.

H. Adjust locations of floor service outlets and service poles to suit arrangement of partitions and furnishings. Isolated Ground Receptacles: Connect to isolated grounding conductor routed to designated isolated equipment ground terminal of electrical system.

### 3.2 IDENTIFICATION

A. Comply with Division 26 Section "Identification for Electrical Systems."

1. Receptacles: Identify panelboard and circuit number from which served. Use hot, stamped or engraved machine printing with black-filled lettering on face of plate, and durable wire markers or tags inside outlet boxes.
2. Switches: Where 3 or more switches are ganged, and elsewhere where indicated, identify each switch with approved legend engraved with black-filled lettering on face of wall plate.

### 3.3 FIELD QUALITY CONTROL

A. Perform tests and inspections and prepare test reports.

1. Test Instruments: Use instruments that comply with UL 1436.
2. Test Instrument for Convenience Receptacles: Digital wiring analyzer with digital readout or illuminated LED indicators of measurement.
3. Test Wiring Devices: Test wiring devices for proper polarity and ground continuity. Operate each operable device at least 6 times.

B. Tests for Convenience Receptacles:

1. Line Voltage: Acceptable range is 105 to 132 V.
2. Percent Voltage Drop under 15-A Load: A value of 6 percent or higher is not acceptable.
3. Ground Impedance: Values of up to 2 ohms are acceptable.
4. GFCI Trip: Test for tripping values specified in UL 1436 and UL 943.
5. Using the test plug, verify that the device and its outlet box are securely mounted.
6. The tests shall be diagnostic, indicating damaged conductors, high resistance at the circuit breaker, poor connections, inadequate fault current path, defective devices, or similar problems. Correct circuit conditions, remove malfunctioning units and replace with new ones, and retest as specified above.

C. Replace damaged or defective components.

### 3.4 CLEANING

- A. The contractor shall remove all paint spatters and other spots, dirt and debris from the equipment. Clean equipment and devices internally and externally using methods and materials recommended by the manufacturer. Replace stained or improperly painted wall plates or devices.

### 3.5 CONTRACTOR STARTUP AND REPORTING

- A. Contractor shall prepare and submit a complete set of record drawings, test reports, operation and maintenance data and certificates as outlined in this Section.

### 3.6 COMMISSIONING AND DEMONSTRATION

- A. After system checkout and adjustment, the contractor shall operate the system for the review of the owner and architect. Necessary adjustments or modifications shall be made as required by the owner or architect.

**End of Section 262726**

## DIVISION 26 – ELECTRICAL

### SECTION 26 28 13

#### FUSES

##### PART 1 - GENERAL

##### 1.1 SUMMARY

- A. Section includes the following:
  - 1. Cartridge fuses rated 600 V and less for use in switches, panelboards and controllers.
  - 2. Spare-fuse cabinets.

##### 1.2 SUBMITTALS

- A. Product Data: Include the following for each fuse type indicated:
  - 1. Dimensions and manufacturer's technical data on features, performance, electrical characteristics, and ratings.
  - 2. Let-through current curves for fuses with current-limiting characteristics.
  - 3. Time-current curves, coordination charts and tables, and related data.
  - 4. Fuse size for elevator feeders and elevator disconnect switches.
- B. Operation and Maintenance Data: For fuses to include in emergency, operation, and maintenance manuals.
  - 1. In addition to items specified in Division 01 Sections "Closeout Procedures" and "Operation and Maintenance Data," include the following:
    - a. Let-through current curves for fuses with current-limiting characteristics.
    - b. Time-current curves, coordination charts and tables, and related data.
    - c. Ambient temperature adjustment information.

##### 1.3 QUALITY ASSURANCE

- A. Source Limitations: Obtain fuses from a single manufacturer.
- B. Electrical Components, Devices, and Accessories: Listed and labeled as defined in the City of Chicago Electrical Code, Article 100, by a testing agency acceptable to authorities having jurisdiction, and marked for intended use.
- C. Comply with NEMA FU 1.
- D. Comply with NFPA 70 and City of Chicago Electrical Code.

##### 1.4 DELIVERY, STORAGE AND HANDLING

- A. Deliver fuses in original manufacturer packaging and store them in dry and clean location at the temperature and relative humidity as required by the manufacturer's installation instructions.

## **1.5 PROJECT CONDITIONS**

- A. Where ambient temperature to which fuses are directly exposed is less than 40 deg F or more than 100 deg F, apply manufacturer's ambient temperature adjustment factors to fuse ratings.

## **1.6 COORDINATION**

- A. Coordinate fuse ratings with utilization equipment nameplate limitations of maximum fuse size.

## **1.7 EXTRA MATERIALS**

- A. Furnish extra materials described below that match products installed and that are packaged with protective covering for storage and identified with labels describing contents.
  - 1. Fuses: Quantity equal to twenty percent of each fuse type and size, but no fewer than one set of three of each type and size.

## **PART 2 - PRODUCTS**

### **2.1 MANUFACTURERS**

- A. Manufacturers: Subject to compliance with requirements, provide products by one of the following manufacturers:
  - 1. Cooper Bussman, Inc.
  - 2. Littlefuse.
  - 3. Ferraz Shawmut, Inc.

### **2.2 CARTRIDGE FUSES**

- A. Characteristics: NEMA FU 1, nonrenewable cartridge fuse; class and current rating indicated; voltage rating consistent with circuit voltage.

### **2.3 SPARE-FUSE CABINET**

- A. Cabinet: Wall-mounted, 0.05-inch- thick steel unit with full-length, recessed piano-hinged door and key-coded cam lock and pull.
  - 1. Size: Adequate for storage of spare fuses specified with 15 percent spare capacity minimum.
  - 2. Finish: Gray, baked enamel.
  - 3. Identification: "SPARE FUSES" in 1-1/2-inch- high letters on exterior of door.
  - 4. Fuse Pullers: For each size of fuse.

### **2.4 APPLICATION OF FUSES**

- A. General: Apply current limiting fuses as indicated and as follows:
  - 1. New general purpose fusible switches: Apply for the following class types:
    - a. 0-600 Amperes: Class RK1, dual element time delay; LPN-RK, LPS-RK.
  - 2. Bolted Pressure Switches: Class L, time delay.

3. Switches in Switchboards: Apply the following classes and types:
  - a. 60-600 Amperes: Class RK1, dual element time delay; LPN-RK, LPS-RK.
  - b. 601 Amperes and Above: Class L, time delay; Lo-Peak KRPC.
4. Existing General-Purpose Switches:
5. 30-600 Amperes: Class RK1, dual element time delay; LPN-RK, LPS-RK.
6. 601-1,200 Amperes: Class L, time delay; Lo-Peak KRPC.

## **2.5 FUSEHOLDERS**

- A. Provide fuseholders to accommodate the fuses specified. Coordinate installation with assembly manufacturers as applicable. Provide pins or other physical rejection features when current limiting fuses are specified, and non-current limiting fuses of the same dimensions are available.

## **2.6 ACCESSORIES**

- A. Provide fuse accessories for general operation and maintenance of specified fuses. Include items listed below and items recommended by manufacturer.
  1. Fuse pullers.
  2. Fuse pull rings.
  3. Handling poles with extensions.
  4. Pole grapplers, prongs, clamps, etc.

## **PART 3 - EXECUTION**

### **3.1 EXAMINATION**

- A. Examine utilization equipment nameplates and installation instructions. Install fuses of sizes and with characteristics appropriate for each piece of equipment.
- B. Evaluate ambient temperatures to determine if fuse rating adjustment factors must be applied to fuse ratings.
- C. Proceed with installation only after unsatisfactory conditions have been corrected.

### **3.2 FUSE APPLICATIONS**

- A. Service Entrance: Class L, fast acting.
- B. Feeders: Class J, fast acting.
- C. Motor Branch Circuits: Class RK1, time delay.
- D. Other Branch Circuits: Class RK5, fast acting .

### **3.3 INSTALLATION**

- A. Install fuses in fusible devices. Arrange fuses so rating information is readable without removing fuse.

- B. Furnish and install all fuses including fuses for equipment furnished by other trades.
- C. Fuses shall not be installed in the equipment until the installation is complete, tested and ready to be energized. Paralleling of fuses will not be permitted.
- D. All fuses shall be of the same manufacture to insure retention of selective coordination as designed.
- E. All fuses shall be sized as indicated on the Contract Drawings. Where fuse ratings are not indicated for fuses used to provide motor backup protection or as short circuit protection, such fuses shall be sized in accordance with the heavy service recommendations of the fuse manufacturer.
- F. All low voltage fuses are sized based on the results of short circuit and coordination study as specified in Division 26 Section "Overcurrent Protective Device Coordination Study"
- G. The Contractor shall affix to the inside of the door of each fuse enclosure a label or sticker indicating the proper type and rating of fuse. The fuse manufacturer's labels shall be used where such are furnished with fuses.
- H. Install spare-fuse cabinet(s).

### **3.4 IDENTIFICATION**

- A. Install typewritten labels indicating fuse replacement information on inside door of each fused switch.

### **3.5 DEMONSTRATION AND TRAINING**

- A. Training: Arrange and pay for the services of factory-authorized service representatives to demonstrate OCPD's and train Owner's maintenance personnel.
- B. Conduct a minimum of one half day of training in operation and maintenance as specified in the Division 01 Sections "Closeout Procedures" and "Demonstration and Training". Include both classroom training and hands on equipment operation and maintenance procedures.
- C. Schedule training with at least seven days' advance notice.

### **3.6 CLEANING**

- A. Clean devices using methods and materials as recommended by manufacturer.

**END OF SECTION**

## DIVISION 26 – ELECTRICAL

### SECTION 26 28 16

#### ENCLOSED SWITCHES AND CIRCUIT BREAKERS

##### PART 1 - GENERAL

###### 1.1 SUMMARY

- A. Section includes the following individually mounted, enclosed switches and circuit breakers rated 600V AC and less:
  - 1. Fusible switches.
  - 2. Nonfusible switches.
  - 3. Bolted-pressure contact switches.
  - 4. Molded-case circuit breakers.
  - 5. Molded-case switches.
  - 6. Enclosures.

###### 1.2 DEFINITIONS

- A. GD: General duty.
- B. GFCI: Ground-fault circuit interrupter.
- C. HD: Heavy duty.
- D. RMS: Root mean square.
- E. SPDT: Single pole, double throw.

###### 1.3 REFERENCES

- A. International Electrical Testing Association
  - 1. NETA, ATS – 1999; Electrical Testing Specifications for Electrical Power Distribution Equipment and Systems
- B. National Electrical Manufacturers Association
  - 1. NEMA 250-97: Enclosures for Electrical equipment (1000V Maximum)
  - 2. NEMA 1-99: Molded Case Circuit Breakers and Molded Case Switches
  - 3. NEMA FU 1-86: Low Voltage Cartridge Fuses
  - 4. NEMA KS 1-01: Enclosed and Miscellaneous Distribution Equipment Switches (600Volts Maximum)
  - 5. NEMA PB 1.1-96: General Instructions for proper Installation, Operation and Maintenance of Panelboards Rated 600 Volts or Less
  - 6. NEMA PB 2.1-96: General Instructions for proper Installation, Operation and Maintenance of Deadfront Distribution Switchboards Rated 600 Volts or Less



C. Underwriters Laboratories

1. UL 486A: Wire connectors and soldering lugs for use with copper conductors
2. UL 98: Enclosed and Dead-Front Switches.
3. UL 489: Molded-Case Circuit Breakers, Molded-Case Switches, and Circuit-Breaker Enclosures
4. UL 977: Fused Power Circuit Devices
5. UL 1053: Ground Fault Sensing and Relaying Equipment

#### 1.4 SUBMITTALS

- A. Product Data: For each type of enclosed switch, circuit breaker, accessory, and component indicated. Include dimensioned elevations, sections, weights, and manufacturers' technical data on features, performance, electrical characteristics, ratings, and finishes.
1. Enclosure types and details for types other than NEMA 250, Type 1.
  2. Current and voltage ratings.
  3. Short-circuit current rating.
  4. Features, characteristics, ratings, and factory settings of individual overcurrent protective devices and auxiliary components.
  5. Time current curves.
  6. Let-through current curves for circuit breakers with current limiting characteristics.
  7. Coordination charts, tables and related data.
- B. Shop Drawings: Wiring Diagrams detailing power, signal, and control wiring and differentiating between manufacturer-installed and field-installed wiring.
- C. Field quality-control test reports including the following:
1. Test procedures used.
  2. Test results that comply with requirements.
  3. Results of failed tests and corrective action taken to achieve test results that comply with requirements.
- D. Manufacturer's field service report.
- E. Operation and Maintenance Data: For enclosed switches and circuit breakers to include in emergency, operation, and maintenance manuals. In addition to items specified in Division 01 Sections "Closeout Procedures" and "Operation and Maintenance Data," include the following:
1. Manufacturer's written instructions for testing and adjusting enclosed switches and circuit breakers.
  2. Time-current curves, including selectable ranges for each type of circuit breaker.

#### 1.5 QUALITY ASSURANCE

- A. Electrical Components, Devices, and Accessories: Listed and labeled as defined in the City of Chicago Electrical Code, Article 100, by a testing agency acceptable to authorities having jurisdiction, and marked for intended use.
- B. Comply with the City of Chicago Electrical Code.

- C. Product Selection for Restricted Space: Drawings indicate maximum dimensions for enclosed switches and circuit breakers, including clearances between enclosures, and adjacent surfaces and other items. Comply with indicated maximum dimensions.

## **1.6 DELIVERY, STORAGE AND HANDLING**

- A. Store enclosed switches and circuit breakers indoors in clean and dry space with uniform temperature to prevent condensation. Protect enclosed switches and circuit breakers from exposure to dirt, fumes, water, corrosive substances, and physical damage.
- B. If stored in areas subject to weather, cover enclosed switches and circuit breakers to protect them from weather, dirt, dust, corrosive substances, and physical damage. Remove loose packing and flammable materials. Install electric heating of sufficient wattage to prevent condensation.
- C. Deliver in factory shipping cartons.
- D. Handle enclosed switches and circuit breakers to avoid damage.

## **1.7 COMPATIBILITY**

- A. All protective devices in new assemblies shall be of the same manufacturer except for special applications of proprietary types to maximize single-source responsibility.
- B. Protective devices added to existing assemblies shall have compatible interrupting ratings with the existing assembly and shall be of the original manufacturer. If not available, modify or extend the assembly to accept compatible protective devices of same manufacturer as supplied in new assemblies.

## **1.8 PROJECT CONDITIONS**

- A. Environmental Limitations: Rate equipment for continuous operation under the following conditions, unless otherwise indicated:
  - 1. Ambient Temperature: Not less than minus 22 deg F and not exceeding 104 deg F .
  - 2. Altitude: Not exceeding 6600 feet.

## **1.9 COORDINATION**

- A. Coordinate layout and installation of switches, circuit breakers, and components with other construction, including conduit, piping, equipment, and adjacent surfaces. Maintain required workspace clearances and required clearances for equipment access doors and panels.

## **1.10 EXTRA MATERIALS**

- A. Furnish extra materials described below that match products installed and that are packaged with protective covering for storage and identified with labels describing contents.
  - 1. Spares: For the following:
    - a. Potential Transformer Fuses: Three of each type installed.
    - b. Control-Power Fuses: Three of each type installed.

- c. Fuses and Fusible Devices for Fused Circuit Breakers: Three of each type installed.
  - d. Fuses for Fusible Switches: Three of each type installed.
2. Spare Indicating Lights: Three of each type installed.

## **PART 2 - PRODUCTS**

### **2.1 MANUFACTURERS**

- A. Manufacturers: Subject to compliance with requirements, provide products by one of the following manufacturers:
- 1. Eaton Corporation; Cutler-Hammer Products.
  - 2. General Electric Co.; Electrical Distribution & Control .
  - 3. Siemens Energy & Automation, Inc.
  - 4. Square D/Group Schneider.
  - 5. Boltswitch, Inc.
  - 6. Pringle Electrical Mfgr. Co.

### **2.2 FUSIBLE AND NONFUSIBLE SWITCHES**

- A. Fusible Switch, 600 or 1200 A and Smaller: NEMA KS 1, Type HD, with clips or bolt pads to accommodate specified fuses, lockable handle with capability to accept two padlocks, and interlocked with cover in closed position.
- B. Nonfusible Switch, 600 or 1200 A and Smaller: NEMA KS 1, Type HD, lockable handle with capability to accept two padlocks, and interlocked with cover in closed position.
- C. Accessories:
- 1. Equipment Ground Kit: Internally mounted and labeled for copper and aluminum ground conductors.
  - 2. Neutral Kit: Internally mounted; insulated, capable of being grounded, and bonded; and labeled for copper and aluminum neutral conductors.
  - 3. Auxiliary Contact Kit: Auxiliary set of contacts arranged to open before switch blades open.

### **2.3 FUSED POWER CIRCUIT DEVICES**

- A. Bolted-Pressure Contact Switch: UL 977; operating mechanism shall use a rotary-mechanical-bolting action to produce and maintain high-clamping pressure on the switch blade after it engages the stationary contacts.
- 1. Auxiliary Switches: Factory installed, SPDT, with leads connected to terminal block, and including one set more than quantity required for functional performance indicated.
  - 2. Service-Rated Switches: Labeled for use as service equipment.
  - 3. Ground-Fault Relay: Comply with UL 1053. Self-powered type with mechanical ground-fault indicator, test function, tripping relay with internal memory, and three-phase current transformer/sensor.

- a. Configuration: Integrally mounted relay and trip unit with adjustable pickup and time-delay settings, push-to-test feature, and ground fault indicator.
  - b. Internal Memory: Integrates the cumulative value of intermittent arcing ground-fault currents and uses the effect to initiate tripping.
  - c. No-Trip Relay Test: Operation of "no-trip" test control permits ground-fault simulation test without tripping switch.
  - d. Test Control: Simulates ground fault to test relay and switch (or relay only if "no-trip" mode is selected).
4. Open-Fuse Trip Device: Arranged to trip switch open if a phase fuse opens.

## 2.4 MOLDED-CASE CIRCUIT BREAKERS AND SWITCHES

- A. Molded-Case Circuit Breaker: NEMA AB 1, with interrupting capacity to meet available fault currents.
- 1. Thermal-Magnetic Circuit Breakers: Inverse time-current element for low-level overloads and instantaneous magnetic trip element for short circuits. Adjustable magnetic trip setting for circuit-breaker frame sizes 250 A and larger.
  - 2. Adjustable Instantaneous-Trip Circuit Breakers: Magnetic trip element with front-mounted, field-adjustable trip setting.
  - 3. Electronic Trip-Unit Circuit Breakers: RMS sensing; field-replaceable rating plug; with the following field-adjustable settings:
    - a. Instantaneous trip.
    - b. Long- and short-time pickup levels.
    - c. Long- and short-time time adjustments.
    - d. Ground-fault pickup level, time delay, and  $I^2t$  response.
  - 4. Current-Limiting Circuit Breakers: Frame sizes 400 A and smaller and let-through ratings less than NEMA FU 1, RK-5.
  - 5. Integrally Fused Circuit Breakers: Thermal-magnetic trip element with integral limiter-style fuse listed for use with circuit breaker and trip activation on fuse opening or on opening of fuse compartment door.
  - 6. GFCI Circuit Breakers: Single- and two-pole configurations with [5] [30]-mA trip sensitivity.
- B. Molded-Case Circuit-Breaker Features and Accessories:
- 1. Standard frame sizes, trip ratings, and number of poles.
  - 2. Lugs: Mechanical style with compression lug kits suitable for number, size, trip ratings, and conductor material.
  - 3. Application Listing: Type SWD for switching fluorescent lighting loads; Type HACR for heating, air-conditioning, and refrigerating equipment.
  - 4. Ground-Fault Protection: Integrally mounted relay and trip unit with adjustable pickup and time-delay settings, push-to-test feature, and ground-fault indicator.
  - 5. Communication Capability: Integral communication module with functions and features compatible with power monitoring and control system specified in 16 "Electrical Power Monitoring and Control."
  - 6. Shunt Trip: 120-V trip coil energized from separate circuit, set to trip at 75 percent of rated voltage.

7. Undervoltage Trip: Set to operate at 35 to 75 percent of rated voltage with field-adjustable 0.1- to 0.6-second time delay.
  8. Auxiliary Switch: Two SPDT switches with "a" and "b" contacts; "a" contacts mimic circuit-breaker contacts, "b" contacts operate in reverse of circuit-breaker contacts.
  9. Key Interlock Kit: Externally mounted to prohibit circuit-breaker operation; key shall be removable only when circuit breaker is in off position.
  10. Zone-Selective Interlocking: Integral with electronic trip unit; for interlocking ground-fault protection function.
- C. Molded-Case Switches: Molded-case circuit breaker with fixed, high-set instantaneous trip only, and short-circuit withstand rating equal to equivalent breaker frame size interrupting rating.
- D. Molded-Case Switch Accessories:
1. Lugs: Mechanical style with compression lug kits suitable for number, size, trip ratings, and material of conductors.
  2. Application Listing: Type HACR for heating, air-conditioning, and refrigerating equipment.
  3. Shunt Trip: 120-V trip coil energized from separate circuit, set to trip at 75 percent of rated voltage. Provide "dummy" trip unit where required for proper operation.
  4. Undervoltage Trip: Set to operate at 35 to 75 percent of rated voltage with field-adjustable 0.1- to 0.6-second time delay. Provide "dummy" trip unit where required for proper operation.
  5. Auxiliary Switch: Two SPDT switches with "a" and "b" contacts; "a" contacts mimic circuit-breaker contacts, "b" contacts operate in reverse of circuit-breaker contacts.
  6. Key Interlock Kit: Externally mounted to prohibit operation; key shall be removable only when switch is in off position.
  7. Test kit for each type of solid state breaker.
  8. Handle extensions.
- E. Additional accessories:
1. Provide breaker accessories for general operation and maintenance of specified breakers. Include items listed below and items recommended by manufacturer:
    - a. Handle extensions for devices not mounted in panelboards.
    - b. Special adjustment tools.
  2. Provide quantities of circuit protective accessories in locations necessary for effective general operation.

## 2.5 ENCLOSURES

- A. NEMA AB 1 and NEMA KS 1 to meet environmental conditions of installed location.
1. Outdoor Locations: NEMA 250, Type 3R.
  2. Kitchen Areas: NEMA 250, Type 4X, stainless steel.
  3. Other Wet or Damp Indoor Locations: NEMA 250, Type 4.

## **PART 3 - EXECUTION**

### **3.1 EXAMINATION**

- A. Examine elements and surfaces to receive enclosed switches and circuit breakers for compliance with installation tolerances and other conditions affecting performance.
- B. Proceed with installation only after unsatisfactory conditions have been corrected.

### **3.2 CONCRETE BASES**

- A. Coordinate size and location of concrete bases. Verify structural requirements with structural engineer.
- B. Concrete materials and installation requirements are specified in Division 03.

### **3.3 INSTALLATION**

- A. Comply with applicable portions of NECA 1, NEMA PB 1.1, and NEMA PB 2.1 for installation of enclosed switches and circuit breakers.
- B. Mount individual wall-mounting switches and circuit breakers with tops at uniform height, unless otherwise indicated. Anchor floor-mounting switches to concrete base. Support enclosures independent from stud partitions.
- C. Temporary Lifting Provisions: Remove temporary lifting eyes, channels, and brackets and temporary blocking of moving parts from enclosures and components. Provide quantities of the circuit protective devices accessories in locations necessary for the effective general operations of the facility.
- D. Install new circuit protective devices to existing assemblies when shown on drawings. Rearrange existing circuit protective devices and provide bus extensions, hardware, enclosure modifications, etc., to accomplish the installations. Modify assemblies, directories or add nameplates to match existing.

### **3.4 IDENTIFICATION**

- A. Identify field-installed conductors, interconnecting wiring, and components; provide warning signs as specified in Division 26 Section "Identification for Electrical Systems."
- B. Enclosure Nameplates: Label each enclosure with engraved metal or laminated-plastic nameplate as specified in Division 26 Section "Identification for Electrical Systems."

### **3.5 CONTROL WIRING INSTALLATION**

- A. Install wiring between OCPDs and control/indication devices as specified in Division 26 Section "Conductors and Cables for Electrical Systems."

### **3.6 ADJUSTING**

- A. Set field-adjustable switches and circuit-breaker trip ranges.
- B. Adjust operating mechanisms for free mechanical movement.

### **3.7 DEMONSTRATION**

- A. Training: Arrange and pay for the services of factory-authorized service representative to demonstrate OCPDs and train Owner's maintenance personnel.
- B. Conduct a minimum of one half day of training in operation and maintenance as specified in the Division 01 Sections "Closeout Procedures" and "Demonstration and Training." Include both classroom training and hands on equipment operation and maintenance procedures.
- C. Schedule training with at least seven days' advance notification.

### **3.8 CLEANING**

- A. On completion of installation, vacuum dirt and debris from interiors; do not use compressed air to assist in cleaning.
- B. Inspect exposed surfaces and repair damaged finishes.

### **3.9 CONTRACTOR STARTUP AND REPORTING**

- A. Manufacturer's Field Service: Engage a factory-authorized service representative to inspect, test, and adjust field-assembled components and equipment installation, including connections, and to assist in field testing. Report results in writing.
- B. Prepare for acceptance testing as follows:
  - 1. Inspect mechanical and electrical connections.
  - 2. Verify switch and relay type and labeling verification.
  - 3. Verify rating of installed fuses.
  - 4. Inspect proper installation of type, size, quantity, and arrangement of mounting or anchorage devices complying with manufacturer's certification.
- C. Perform the following field tests and inspections and prepare test reports:
  - 1. Perform each electrical test and visual and mechanical inspection stated in NETA ATS, Section 7.5 for switches and Section 7.6 for molded-case circuit breakers. Certify compliance with test parameters.
  - 2. Correct malfunctioning units on-site, where possible, and retest to demonstrate compliance; otherwise, replace with new units and retest.

**END OF SECTION**

## **DIVISION 26 – ELECTRICAL**

### **SECTION 26 29 13**

#### **ENCLOSED CONTROLLERS**

##### **PART 1 - GENERAL**

###### **1.1 SUMMARY**

- A. Section includes enclosed controllers rated 600 Vac and less, of the following types:
  - 1. Across-the-line, manual and magnetic controllers.
  - 2. Reduced-voltage controllers.
  - 3. Multispeed controllers.

###### **1.2 DEFINITIONS**

- A. Motor Controller: A device that controls, protects, and energizes an electric motor, and where required, controls its speed or the torque or power delivered by it.

###### **1.3 REFERENCES**

- A. International Electrical Testing Association
  - 1. NETA ATS: Acceptance Testing Specifications for Electric Power Distribution Equipment and Systems
- B. National Electrical Manufacturers Association
  - 1. NEMA 250: Enclosures for Electrical Equipment (1000 volts maximum)
  - 2. NEMA AB 1: Molded Case Circuit Breakers and Molded Case Switches
  - 3. NEMA ICS 2: Industrial Control Devices, Controllers and Assemblies
  - 4. NEMA KS 1: Enclosed and Miscellaneous Distribution Equipment Switches (600 Volts Maximum)
  - 5. NEMA MGG 1: Motors and Generators (Including Rev.1)

###### **1.4 SUBMITTALS**

- A. Product Data: For each type of enclosed controller. Include dimensions and manufacturer's technical data on features, performance, electrical characteristics, ratings, and finishes.
- B. Shop Drawings: For each enclosed controller.
  - 1. Include dimensioned plans, elevations, sections, and details, including required clearances and service space around equipment. Show tabulations of installed devices, equipment features, and ratings. Include the following:
    - a. Each installed unit's type and details.
    - b. Nameplate legends.
    - c. Short-circuit current rating of integrated unit.



- d. Listed and labeled for series rating of overcurrent protective devices in combination controllers by an NRTL acceptable to authorities having jurisdiction.
  - e. Features, characteristics, ratings, and factory settings of individual overcurrent protective devices in combination controllers.
2. Wiring Diagrams: Power, signal, and control wiring.
- C. Coordination Drawings: Floor plans, drawn to scale, showing dimensioned layout, required working clearances, and required area above and around enclosed controllers where pipe and ducts are prohibited. Show enclosed controller layout and relationships between electrical components and adjacent structural and mechanical elements. Show support locations, type of support, and weight on each support. Indicate field measurements.
  - D. Qualification Data: For manufacturer.
  - E. Field quality-control test reports.
  - F. Operation and Maintenance Data: For enclosed controllers to include in emergency, operation, and maintenance manuals. In addition to items specified in Division 01 Sections "Closeout Procedures" and "Operation and Maintenance Data," include the following:
    - 1. Routine maintenance requirements for enclosed controllers and all installed components.
    - 2. Manufacturer's written instructions for testing and adjusting overcurrent protective devices.
  - G. Load-Current and Overload-Relay Heater List: Compile after motors have been installed and arrange to demonstrate that selection of heaters suits actual motor nameplate full-load currents.
  - H. Load-Current and List of Settings of Adjustable Overload Relays: Compile after motors have been installed and arrange to demonstrate that dip switch settings for motor running overload protection suit actual motor to be protected.

## 1.5 QUALITY ASSURANCE

- A. Manufacturer Qualifications: A qualified manufacturer. Maintain, within 50 miles of Project site, a service center capable of providing training, parts, and emergency maintenance and repairs.
- B. Installer's Qualifications: Firm with at least 5 years of successful installation experience on projects utilizing motor controllers similar to that required for this project.
- C. Source Limitations: Obtain enclosed controllers of a single type through one source from a single manufacturer.
- D. Electrical Components, Devices, and Accessories: Listed and labeled as defined in the City of Chicago Electrical Code, Article 100, by a testing agency acceptable to authorities having jurisdiction, and marked for intended use.
- E. Comply with the City of Chicago Electrical Code.
- F. Product Selection for Restricted Space: Drawings indicate maximum dimensions for enclosed controllers, minimum clearances between enclosed controllers, and for adjacent surfaces and other items. Comply with indicated maximum dimensions and clearances.

## **1.6 DELIVERY, STORAGE, AND HANDLING**

- A. Store enclosed controllers indoors in clean, dry space with uniform temperature to prevent condensation. Protect enclosed controllers from exposure to dirt, fumes, water, corrosive substances, and physical damage.
- B. If stored in areas subject to weather, cover enclosed controllers to protect them from weather, dirt, dust, corrosive substances, and physical damage. Remove loose packing and flammable materials from inside controllers; install electric heating of sufficient wattage to prevent condensation.
- C. Deliver in factory shipping cartons.
- D. Handle motor controllers to avoid damage.

## **1.7 PROJECT CONDITIONS**

- A. Interruption of Existing Electrical Service: Do not interrupt electrical service to facilities occupied by Owner or others unless permitted under the following conditions and then only after arranging to provide temporary electrical service according to requirements indicated:
  - 1. Notify Architect and owner's representative no fewer than seven days in advance of proposed interruption of electrical service.
  - 2. Indicate method of providing temporary utilities.
  - 3. Do not proceed with interruption of electrical service without Architect's and owner's representative written permission.

## **1.8 COORDINATION**

- A. Coordinate layout and installation of enclosed controllers with other construction including conduit, piping, equipment, and adjacent surfaces. Maintain required workspace clearances and required clearances for equipment access doors and panels.
- B. Coordinate size and location of concrete bases. Cast anchor-bolt inserts into bases. Concrete, reinforcement, and formwork requirements are specified in Division 03 Section "Cast-in-Place Concrete."
- C. Coordinate installation of roof curbs, equipment supports, and roof penetrations. These items are specified in Division 07 Section "Roof Accessories."
- D. Coordinate features of enclosed controllers and accessory devices with pilot devices and control circuits to which they connect.
- E. Coordinate features, accessories, and functions of each enclosed controller with ratings and characteristics of supply circuit, motor, required control sequence, and duty cycle of motor and load.

## **1.9 EXTRA MATERIALS**

- A. Furnish extra materials described below that match products installed and that are packaged with protective covering for storage and identified with labels describing contents.
  - 1. Spare Fuses: Furnish one spare for every five installed, but no fewer than one set of three of each type and rating.
  - 2. Indicating Lights: Two of each type installed.

## **PART 2 - PRODUCTS**

### **2.1 MANUFACTURERS**

- A. Manufacturers: Subject to compliance with requirements, provide products by one of the following manufacturers:
1. Eaton Corporation; Cutler-Hammer Products.
  2. General Electrical Company; GE Industrial Systems.
  3. Square D.

### **2.2 ACROSS-THE-LINE ENCLOSED CONTROLLERS**

- A. General:
1. Starters shall be manual type for motors 1/3 HP and smaller and magnetic type motors ½ HP and larger.
  2. Contacts shall open each ungrounded connection to the motor.
  3. Starter contacts shall be twin-break, silver-to-silver, renewable contacts with one set of contacts for each phase.
- B. Manual Controller: NEMA ICS 2, general purpose, Class A, with "quick-make, quick-break" toggle action, and marked to show whether unit is "OFF," "ON," or "TRIPPED."
1. Single phase motor starting switches (thermal switches) for fractional horse power motors. Single pole for 120 Volt, two pole for 208 Volt operation.
  2. Trip-free, toggle operated with on-off-reset position clearly indicated with neon pilot light for run indication.
  3. Thermal overload shall be melting alloy or bimetallic type element with heater rating clearly indicated. Ambient-compensated type with inverse-time-current characteristics and NEMA ICS 2, Class 20 tripping characteristics. Provide one overload for single pole switch and two overloads for two pole switch. Sensor shall match to nameplate, full-load current of specific motor to which they connect and shall have appropriate adjustment for duty cycle.
  4. Where the motor is interlocked and controlled by another device, the motor starter shall be marked "Hand-Off-Auto".
- C. Magnetic Controller: NEMA ICS 2, Class A, full voltage, nonreversing, across the line, unless otherwise indicated.
1. Control Circuit: 120 V; obtained from integral control power transformer with a control power transformer of sufficient capacity to operate connected pilot, indicating and control devices, plus 100 percent spare capacity.
  2. Overload Relay: Ambient-compensated type with inverse-time-current characteristic and NEMA ICS 2, Class 20 tripping characteristic. Provide with heaters or sensors in each phase matched to nameplate full-load current of specific motor to which they connect and with appropriate adjustment for duty cycle.
  3. Adjustable Overload Relay: Dip switch selectable for motor running overload protection with NEMA ICS 2, Class 20 tripping characteristic, and selected to protect motor against voltage and current unbalance and single phasing. Provide relay with Class II ground-fault protection, with start and run delays to prevent nuisance trip on starting.
  4. Pilot lights:
    - a. Green light to indicate motor running.
    - b. Red light to indicate motor off.

- D. Combination Magnetic Controller: Factory-assembled combination controller and disconnect switch.
  - 1. Fusible Disconnecting Means: NEMA KS 1, heavy-duty, fusible switch with rejection-type fuse clips rated for fuses. Select and size fuses to provide Type 2 protection according to IEC 947-4-1, as certified by an NRTL.
  - 2. Nonfusible Disconnecting Means: NEMA KS 1, heavy-duty, nonfusible switch.
  - 3. Circuit-Breaker Disconnecting Means: NEMA AB 1, motor-circuit protector with field-adjustable, short-circuit trip coordinated with motor locked-rotor amperes.

### **2.3 COMBINATION 2-SPEED MAGNETIC MOTOR CONTROLLERS**

- A. General: Match controller to motor type, application, and to number of speeds. The starter shall serve the purpose of starting a 2-speed motor at the pre-selected speed and to provide complete overload, overcurrent, and undervoltage protection at each speed.
- B. NEMA ICS 2, Class A, full voltage, nonreversing, across the line, unless otherwise indicated.
  - 1. Control Circuit: 120 V; obtained from integral control power transformer with a control power transformer of sufficient capacity to operate connected pilot, indicating and control devices, plus 100 percent spare capacity.
  - 2. Overload Relay: Ambient-compensated type with inverse-time-current characteristic and NEMA ICS 2, Class 20 tripping characteristic. Provide with heaters or sensors in each phase matched to nameplate full-load current of specific motor to which they connect and with appropriate adjustment for duty cycle.
  - 3. Adjustable Overload Relay: Dip switch selectable for motor running overload protection with NEMA ICS 2, Class 20 tripping characteristic, and selected to protect motor against voltage and current unbalance and single phasing. Provide relay with Class II ground-fault protection, with start and run delays to prevent nuisance trip on starting. Pilot lights:
    - a. Green light to indicate motor high speed.
    - b. Amber light to indicate motor low speed.
    - c. Red light to indicate motor off.
    - d. The 2-speed starter shall be an assembly of two magnetic across-the-line starters, one for each motor speed, mechanically and electrically interlocked and wired for automatic control through a cover mounted control switch. Include single phase protection.
    - e. Decelerating Relay: Provide selection of lower than current operating speed by push-button or pilot device as indicated with deceleration automatically timed through any intervening speeds.

### **2.4 REDUCED-VOLTAGE ENCLOSED CONTROLLERS**

- A. Solid-State, Reduced-Voltage Controller: NEMA ICS 2, suitable for use with NEMA MG 1, Design B, polyphase, medium induction motors.
  - 1. Adjustable acceleration rate control utilizing voltage or current ramp, and adjustable starting torque control with up to 500 percent current limitation for 20 seconds.
  - 2. Surge suppressor in solid-state power circuits providing 3-phase protection against damage from supply voltage surges 10 percent or more above nominal line voltage.
  - 3. LED indicators showing motor and control status, including the following conditions:
    - a. Control power available.
    - b. Controller on.
    - c. Overload trip.

- d. Loss of phase.
  - e. Shorted silicon-controlled rectifier.
4. Automatic voltage-reduction controls to reduce voltage when motor is running at light load.
  5. Motor running contactor operating automatically when full voltage is applied to motor.
  6. Shorting contactor:
    - a. A microprocessor shall control the operation of the shorting contactor via an output relay.
    - a. The shorting contactor shall close, shorting the thyristors after the
    - b. Motor current is below 130% of motor FLA and voltage is below nominal voltage (indicating ramp complete), and open on a stop command to allow deceleration ramp.
  7. Motor must be automatically protected from solid state component failure by one of the following means:
    - a. Shunt trip coil to trip disconnect in the event of a controller fault condition including a shorted thyristor.
    - b. Isolation contactor that opens when the motor is stopped or when the controller detects a fault condition including a shorted thyristor.

## **2.5 MULTISPEED ENCLOSED CONTROLLERS**

- A. Multispeed Enclosed Controller: Match controller to motor type, application, and number of speeds; include the following accessories:
  1. Compelling relay to ensure that motor will start only at low speed.
  2. Accelerating relay to ensure properly timed acceleration through speeds lower than that selected.
  3. Decelerating relay to ensure automatically timed deceleration through each speed.

## **2.6 ENCLOSURES**

- A. Description: Flush- or surface-mounting cabinets as indicated. NEMA 250, Type 1, unless otherwise indicated to comply with environmental conditions at installed location.
  1. Outdoor Locations: NEMA 250, Type 3R.
  2. Kitchen Areas: NEMA 250, Type 4X, stainless steel.
  3. Other Wet or Damp Indoor Locations: NEMA 250, Type 4.
  4. Hazardous Areas Indicated on Drawings: NEMA 250, Type 7C.

## **2.7 ACCESSORIES**

- A. Devices shall be factory installed in controller enclosure, unless otherwise indicated.
- B. Push-Button Stations and Pilot Lights: NEMA ICS 2, heavy-duty type.
- C. Hand-Off-Automatic selector switches: NEMA ICS 2, heavy-duty type.
- D. Other selector switches as required: NEMA ICS 2, heavy-duty type.

- E. Stop and Lockout Push-Button Station: Momentary-break, push-button station with a factory-applied hasp arranged so padlock can be used to lock push button in depressed position with control circuit open.
- F. Control Relays: Auxiliary and adjustable time-delay relays.
- G. Elapsed Time Meters: Heavy duty with digital readout in hours.
- H. Phase-Failure and Undervoltage Relays: Solid-state sensing circuit with isolated output contacts for hard-wired connection. Provide adjustable undervoltage setting.

## **2.8 FACTORY FINISHES**

- A. Finish: Manufacturer's standard paint applied to factory-assembled and -tested enclosed controllers before shipping.

## **PART 3 - EXECUTION**

### **3.1 EXAMINATION**

- A. Examine areas and surfaces to receive enclosed controllers for compliance with requirements, installation tolerances, available clearances and other conditions affecting performance.
  - 1. Proceed with installation only after unsatisfactory conditions have been corrected.

### **3.2 APPLICATIONS**

- A. Select features of each enclosed controller to coordinate with ratings and characteristics of supply circuit and motor; required control sequence; duty cycle of motor, controller, and load; and configuration of pilot device and control circuit affecting controller functions.
- B. Select horsepower rating of controllers to suit motor controlled.
- C. Use fractional-horsepower manual controllers for single-phase motors, unless otherwise indicated.
- D. Push-Button Stations: In covers of magnetic controllers for manually started motors where indicated, start contact connected in parallel with sealing auxiliary contact for low-voltage protection.
- E. Hand-Off-Automatic Selector Switches: In covers of manual and magnetic controllers of motors started and stopped by automatic controls or interlocks with other equipment.

### **3.3 INSTALLATION**

- A. For control equipment at walls, bolt units to wall or mount on lightweight structural-steel channels bolted to wall. For controllers not at walls, provide freestanding racks.
- B. Install freestanding equipment on concrete bases.
- C. Enclosed Controller Fuses: Install fuses in each fusible switch. Comply with requirements in Division 26 Section "Fuses."

### **3.4 CONCRETE BASES**

- A. Coordinate size and location of concrete bases. Verify structural requirements with structural engineer.

### **3.5 IDENTIFICATION**

- A. Identify enclosed controller, components, and control wiring according to Division 26 Section "Identification for Electrical Systems."

### **3.6 CONTROL WIRING INSTALLATION**

- A. Install wiring between enclosed controllers according to Division 26 Section "Conductors and Cables for Electrical Systems."
- B. Bundle, train, and support wiring in enclosures.
- C. Connect hand-off-automatic switch and other automatic-control devices where applicable.
  - 1. Connect selector switches to bypass only manual- and automatic-control devices that have no safety functions when switch is in hand position.
  - 2. Connect selector switches with enclosed controller circuit in both hand and automatic positions for safety-type control devices such as low- and high-pressure cutouts, high-temperature cutouts, and motor overload protectors.

### **3.7 CONNECTIONS**

- A. Conduit installation requirements are specified in other Division 26 Sections. Drawings indicate general arrangement of conduit, fittings, and specialties.
- B. Ground equipment according to Division 26 Section "Grounding and Bonding for Electrical Systems."

### **3.8 DEMONSTRATION**

- A. Training: Engage a factory-authorized service representative to demonstrate solid-state controllers and train Owner's maintenance personnel to adjust, operate and maintain enclosed controllers. Refer to Division 01 Section "Demonstration and Training".
  - 1. Conduct a minimum of 4 hours of training in operation and maintenance as specified in Division 01 Section "Closeout Procedures." Include training relating to equipment operation and maintenance procedures.
  - 2. Schedule training with at least 7 days' advance notice.

### **3.9 CLEANING**

- A. Remove paint splatters and other spots, dirt, and debris. Touch up scratches and mars of finish to match original finish. Clean devices internally, using methods and materials recommended by manufacturer.

### **3.10 CONTRACTOR STARTUP AND REPORTING**

- A. Prepare for acceptance tests as follows:

1. Test insulation resistance for each enclosed controller element, bus, component, connecting supply, feeder, and control circuit.
  2. Test continuity of each circuit.
- B. Manufacturer's Field Service: Engage a factory-authorized service representative to perform the following:
1. Assist in field testing of equipment including pretesting and adjusting of solid-state controllers.
  2. Report results in writing.
- C. Perform the following field tests and inspections and prepare test reports:
1. Perform each electrical test and visual and mechanical inspection, as stated in NETA ATS, "Motor Control - Motor Starters." Certify compliance with test parameters.
  2. Correct malfunctioning units on-site, where possible, and retest to demonstrate compliance; otherwise, replace with new units and retest.
- D. Pretesting: On completing installation of the system, perform the following preparations for tests:
1. Make insulation resistance tests of conducting parts of motor control components; and of connecting supply, feeder, and control circuits. For devices containing solid-state components, use test equipment and methods recommended by the manufacturer.
  2. Make continuity tests of circuits.
  3. Provide set of Contract Documents to test personnel. Include full updating on final system configuration and parameters where they supplement or differ from those indicated in original Contract Documents.
  4. Provide manufacturer's instructions for installation and testing of motor control devices to test personnel.
- E. Visual and mechanical inspection: Include the following inspections and related work:
1. Motor-Control Device Ratings and Settings: Verify that ratings and settings as installed are appropriate for final loads and final arrangement and parameters. Recommend final protective-device ratings and settings where differences are found. Use accepted revised ratings or settings to make the final system adjustments. Prepare and submit load current and overload relay heater list.
  2. Inspect for defects and physical damage, NRTL labeling, and nameplate compliance with current project drawings.
  3. Exercise and perform operational tests of mechanical components and other devices in accordance with manufacturer's instructions.
  4. Check tightness of electrical connections of devices with calibrated torque wrench. Use manufacturer's recommended torque values.
  5. Clean devices using manufacturer's approved methods and materials.
  6. Verify proper fuse types and ratings in fusible devices.
- F. Electrical Tests: Perform the following in accordance with manufacturer's instructions:
1. Insulation resistance test of motor control devices conducting parts to the extent permitted by the manufacturer's instructions. Insulation resistance less than 10 megohms is not acceptable.
  2. Use primary current injection to check performance characteristics of motor-circuit protectors and for overload relays of controllers for motors 15 horsepower and larger.



Trip characteristics not within manufacturer's published time-current tolerances are not acceptable.

3. Make adjustments for final settings of adjustable-trip devices.
  4. Test auxiliary protective features such as loss of phase, phase unbalance and undervoltage to verify operation.
  5. Check for improper voltages at terminals in controllers that have external control wiring when controller disconnect is opened.
- G. Correct deficiencies and retest motor control devices. Verify by the system tests that specified requirements are met.
- H. Set field-adjustable switches and circuit-breaker trip ranges.

**END OF SECTION**

**DIVISION 27 – COMMUNICATIONS**

**SECTION 274116**

**INTEGRATED AUDIOVISUAL SYSTEMS AND EQUIPMENT**

**PART 1 - GENERAL**

**1.1 SUMMARY**

- A. Provide complete systems in compliance with drawings, general provisions of contract, including General and Supplementary Conditions, Division 1 Specifications, and Instructions to Bidders.
- B. System refers to the complete and functional assemblage of equipment required to achieve the specified functionality, performance, and design intent. This shall include, but not be limited to, ancillary items such as power supplies, interfaces, transformers, cable, and connectors.
- C. Scope of Work: This specification section defines certain audio and audiovisual systems to be installed in the Caruthers Center for Inner City Studies (CCICS) auditorium at North Eastern Illinois University (NEIU).
- D. Section Includes:
  - 1. Supply and install a turnkey audio and audiovisual system, to include equipment and materials, whether specifically mentioned herein or not, to ensure a complete and operating system.
  - 2. Generate submittal information for the complete fabrication, installation and wiring of the system. Provide (or sub-contract for) the on-site installation and wiring, and provide on-going supervision and coordination during implementation.
  - 3. Provide for the initial adjustment of the systems as herein prescribed and provide test equipment for the system checkout and acceptance tests. Prior to the systems acceptance tests, submit an initial testing and tuning report showing methods and results for tests performed.
  - 4. Provide on-the-job training in the operation and maintenance of the systems for personnel designated by the Owner.
  - 5. Provide one-year warranty from date of system acceptance for systems installed.
- E. Related Requirements: Comply with the following:
  - 1. Section 012500 – Substitution Procedures.
  - 2. Section 013300 – Submittal Procedures.
  - 3. Section 014000 – Quality Requirements.
  - 4. Section 014200 – References.

5. Section 016000 – Product Requirements.
6. Section 017329 – Cutting and Patching.
7. Section 017800 – Closeout Submittals.
8. Section 078400 – Firestopping.

F. Related Documents and Sections:

1. Section 270528.29 – Hanger and Supports for Communications Systems
2. Document 00200 – Instructions to Bidders.
3. Document 00210 – Supplementary Instructions to Bidders.
4. Document 00700 – General Conditions.
5. Document 00800 – Supplementary Conditions.
6. Division 01 – General Requirements Sections.
7. Division 12 – Furnishings
8. Division 23 – Heating, Ventilation and Air Conditioning (HVAC)
  
9. Division 26 - Electrical

## 1.2 REFERENCES

- A. Reference Standards: See Section 014200 – References. In addition to requirements shown or specified, comply with applicable provisions of the following for design, materials, fabrication, and installation of component parts:
1. BICSI/InfoComm, Audiovisual Design Reference Manual.
  2. InfoComm, AV Installation Handbook.
  3. InfoComm, Audiovisual Best Practices.
  4. Maltese, AV 9000: Defining Quality in Engineered Audio Visual Systems, 2006.
  5. City and State or District Ordinances, as applicable to location.
  6. IEEE C2, National Electrical Safety Code®.

7. NFPA-70, National Electrical Code®.
  8. NFPA-72, National Fire Alarm Code®.
  9. NFPA-101, Life Safety Code®.
  10. *NFPA-255, Standard Method of Test of Surface Burning Characteristics of Building Materials.*
  11. American National Standards Institute (ANSI).
  12. Federal Communications Commission (FCC).
  13. National Electrical Manufacturers Association (NEMA).
  14. Occupational Safety and Health Administration (OSHA).
  15. Uniform Building Code (UBC).
  16. City and other local codes and requirements.
- B. Work shall comply with the latest edition of applicable criteria, standards, and codes including subsequent addendums.
- C. In the event of conflicts, the more stringent provisions shall be applied.

### 1.3 DEFINITIONS

- A. Definitions: See Section 014200 – References for additional definitions.
1. Code Requirements: Minimum requirements.
  2. Final Acceptance: Owner's Representative's acceptance of project from Contractor.
  3. Furnished by Others: Receive delivery at job site or where called for and install.
  4. Owner's Representative: Architect or Engineer having contract directly with Owner for professional services.
  5. Relocate: Disassemble, disconnect, and transport equipment to new locations, then clean, test, and install ready to use.
  6. Replace: Remove and provide new item.
  7. Rough-in: Pipe, duct, conduit, equipment layout and installation.
  8. Provide: Furnish and install.
  9. Authority Having Jurisdiction (AHJ): Federal, state, local, or other regional department, or individual having statutory authority.

10. Systems Contract Documents: These specifications and drawings referred to herein are furnished with and are integral parts of this system construction document. The specifications and drawings shall remain the property of the Owner and shall be returned by unsuccessful bidders.
11. Specification Information Requests: Direct requests for clarification, substitution, or changes in these specifications or drawings to the Owner.
12. Custom: Indicates systems or components that shall be fabricated by the Contractor based on these specifications and drawings.
13. Owner Furnished Equipment (OFE): Provide for removal, relocation and testing prior to installation. Coordinate the integration of existing components or new components, provided by the Owner into the audiovisual system. Provide required mounting hardware, rack panels, cable, connectors, etc. to ensure proper operation of the OFE systems as specified.
14. Not In Contract (NIC): Refers to work or equipment that is not in contract covered in this section.
15. Future Equipment: Indicates equipment that will be added to the systems by the Owner or Owner representative at a later date. Provisions shall be made for this equipment.
16. Or Equal: Indicates equal in materials, size, color, design, function, and performance of specified and conforming with base bid manufacturer/model.

#### 1.4 CONTRACTOR QUALIFICATIONS

- A. Be a licensed dealer for equipment described in these documents and maintain a service department within 75 miles of the project site capable of maintaining those systems both on a component and a complete systems level.
- B. Have direct experience on 5 recent projects of similar type and size.
- C. Own and maintain the tools and equipment necessary for successful installation and testing of systems as detailed herein and have personnel who are adequately trained in the use of such tools and equipment.
- D. Employ at least one control system programmer certified by the manufacturer of the control system utilized in the project.
- E. Employ at least one engineer holding a current Certified Technology Specialist – Design (CTS-D) certification by InfoComm International. The engineer shall be assigned to oversee technical aspects of the project and shall stamp all drawing submittals with a current CTS-D stamp.
- F. Employ at least one technician holding a current Certified Technology Specialist – Installation (CTS-I) certification by InfoComm International. The technician shall be assigned as the lead field technician overseeing the installation.

## 1.5 SYSTEM DESCRIPTION

### A. Auditorium

#### 1. Audio

- a. The sound reinforcement system shall provide high quality live sound reinforcement and playback of pre-recorded sound program within the auditorium.
- b. Audio coverage will be provided by a Left-Right steerable column loudspeakers at the front edges of the stage
- c. Provide subwoofers recessed into the stage front for low frequency extension of the sound reinforcement system.
- d. Provide a UHF wireless microphone system (handheld and laveliers), using diversity antenna systems. The wireless receivers will be located in the Control Booth with antennae remotely connected to maximize the signal reception and minimize dropouts.
- e. Provide hard-wired microphone position in receptacle plates for the stage via wall mounted or floor box receptacle plates.
- f. Provide a wired gooseneck microphone integrated on the lectern for speech reinforcement. The lectern microphone shall have the ability to be muted by the control system and direct touch with visual indication of state.
- g. Provide termination for the previously mentioned inputs at a patch panel in the Control Booth where they may be routed to audio mixing, processing and recording devices.
- h. Provide audio monitoring of signals in the Control Booth at the audio mix position.
- i. Provide system-wide audio signal processing (equalization, delay, matrix mixing and distribution) of the audio signals using digital signal processing (DSP) equipment, to be located within the system equipment racks located within the Control Booth.
- j. Provide receptacles throughout the auditorium for connection of portable loudspeakers to a dedicated loudspeaker patching panel. The patching and head-end equipment will be located in the Control Booth.
- k. Provide left-right near field loudspeakers for control room monitoring, with related amplifier, switching, and control.

#### 2. Video and Display

- a. Provide a digital video projector with native 16:9 High Definition resolution mounted in the Control Booth. The projector shall have a minimum brightness of 8,000 ANSI lumens. Projectors shall be mounted to minimize lens shift and keystone correction. Mounting shall incorporate vibration isolation.

- b. Provide one motorized projection screen, 16:9 aspect ratio (wide-screen format, 220-inch diagonal) to provide detailed viewing capability.
- c. Provide a video/program audio matrix switcher that shall transmit and receive digital video/program audio via UTB cabling. The UTP video receiver box shall have integral scaler for scaling of all sources to a native system resolution in a digital format.
- d. Provide permanently installed cameras as follows:
  - 1) Two High Definition color cameras with remote pan, tilt zoom, focus and iris control shall be located on the Control Booth technical niche to provide an image of the stage.
  - 2) The video signal from these shall be connected to the video patchbay in the Control Booth equipment rack. From there, the video signal may be distributed as required to the video production switcher and other devices for recording and distribution.
  - 3) The control surface for these cameras shall be in the Control Booth.

### 3. Control

- a. Provide sound control via an audio mix console and associated equipment including microphone and line level patching located in the control room.
- b. Provide a 32-input Left-Center-Right pannable multi-bus digital mixing console with digital audio processing and an external stage box as per the equipment list (or approved equal).
- c. Monitor mixing for the stage performers can take place at the main control console utilizing one or more of the auxiliary busses or groups.
- d. Provide virtual automatic microphone mixing via a programmed present in the DSP system.
- e. Provide a touch panel control system to control audio, video and lighting system functionality. See drawings for touch panel control locations.
  - 1) The control system shall include the following system presets and functionality for each.
    - a) Lecture Mode
      - (1) Automatic mixing of microphone level inputs via a programmed preset in the DSP.
      - (2) Volume control of the auto mixed outputs .
      - (3) Selection of the video source input device.
        - (a) Blu-Ray / DVD

- (b) Control Room Video Input
  - (c) Lectern Video Input
- (4) Sub-page for transport and power control of Blu-Ray / DVD player.
- (5) Digital projector power control
- (6) Projection Screen Up/Down
- (7) House lighting presets and controls
- b) Performance Mode
  - (1) Bypass of automatic mixing of microphone level inputs via a programmed preset in the DSP. The primary mixing device will be the digital mixing console.
  - (2) Selection of the video source input device.
    - (a) Blu-Ray / DVD
    - (b) Control Room Video Input
    - (c) Lectern Video Input
  - (3) Sub-page for transport and power control of Blu-Ray / DVD player.
  - (4) Digital projector power control
  - (5) Projection Screen Up/Down
  - (6) House lighting presets and controls
- c) Video Playback Mode –
  - (1) Automatic mixing of microphone level inputs via a programmed preset in the DSP.
  - (2) Routing of surround sound audio signals to the installed Left-Right and subwoofer loudspeakers and to temporary center and rear channel loudspeakers.
  - (3) Separate volume control of the auto mixed microphone level inputs and the Blu-Ray audio.
  - (4) Selection of the video source input device.
    - (a) Blu-Ray / DVD



- (b) Control Room Video Input
    - (c) Lectern Video Input
  - (5) Sub-page for transport and power control of Blu-Ray / DVD player.
  - (6) Digital projector power control
  - (7) Projection Screen Up/Down
  - (8) House lighting presets and controls
- 4. Tieline distribution
  - a. Provide local interconnectivity of audio, HD-SDI video, and UTP with the use of tie-line panels in the auditorium that terminate to an audio, video or RJ-45 data patch bay in the Control Room.
  - b. The Control Room shall serve as the hub for all audio, HD-SDI video and RJ-45 connectivity for the auditorium and adjacent Lobby.
- 5. Assistive Listening – Induction Loop
  - a. Provide an induction-loop system comprised of multi-zone loop areas within the auditorium for wireless assistive listening for individuals with hearing impairments and telecoil hearing aids, and to comply with the pertinent disabilities codes.
  - b. Loops shall be defined covering all of the auditorium seating areas. The loop amplifiers shall be located in the equipment racks in the Control Room.
  - c. Proposed loop coverage zones and induction loop cable layouts are shown on the drawings. Field strength in these zones shall meet the requirements of BSA IEC 60118-4 version 2, 2006.
  - d. Provide induction loop signage indicating where induction loops are available. Coordinate signage size and mounting location with the architect.
- 6. Portable Speakers
  - a. Provide custom loudspeaker terminal cabinet patch panel in the Control Room, allowing patched audio, amplified by dedicated power amplifiers in the rack, to be sent to the auditorium by individually patching pre-wired cables into the panel.
  - b. Provide portable loudspeakers and cables to be connected to the audio system at the loudspeaker receptacles.

## 1.6 SUBMITTALS

### A. General:

1. Comply with section 013300 – Submittal Procedures
2. In addition to requirements specified in section 013300, submit electronic copies of submittals in PDF format.

**B. BID SUBMITTAL**

1. Schedule of Values: Provide a Schedule of Values and quantities for equipment to be supplied. Each piece of equipment shall be individually priced. Equipment costs shall reflect required modifications and accessories. Equipment schedules in Part 3 should be used for bid submission.
2. Non-Equipment Costs: Furnish the total non-equipment and Service cost and separately a list of non-equipment costs for each area, by the following categories:
  - a. Engineering: Including required design, drawings, run sheets, instruction manuals, etc.
  - b. Pre-Installation: Including fabrication, modification, assembly, rack wiring, etc., performed on the Contractor's premises.
  - c. Installation: Including on-site installation and wiring, coordination and supervision, testing, checkout, Owner training, etc., performed on the Owner's premises.
  - d. Software Development: Including required design, testing, debugging, documentation, etc.
  - e. Documentation: Including equipment manuals, as-built drawings, software instruction manuals and program listings, user instruction panels, etc.
  - f. Training: Including training sessions with owner staff as noted in this specification.
  - g. General and Administrative: Including G & A expenses, shipping, insurance, and guarantees.
  - h. Project Management: Including weekly written reports, project schedule management, and resource management.
  - i. Warranty and first years' service.
  - j. Taxes: Including applicable Local, State, and Federal taxes.
3. Service Contract:
  - a. Submit cost for a separate one-year service contract for the second year maintenance, covering installed systems, new and Owner-furnished. Include in this contract quarterly site visits to inspect, repair, and adjust systems to restore them to as-new operation. Parts and shop labor are assumed to be additional charges beyond the scope of this contract. This service contract shall commence immediately after expiration of the warranty period. The cost for this service contract shall not be commingled with the costs for the systems base bid.

- b. Submit separate costs for "on-call" service, both in-house and in-shop.
4. Substitutions:
- a. Comply with Section 012500 – Substitution Procedures.
  - b. Submit bids on the basis of the specified equipment. Submit proposals for substitutions with associated equipment costs, separate and apart from the costs of the equipment as specified.
  - c. Proposals for substitutions will receive careful and equitable consideration if the differences do not depart from the overall intent of the design and operation of the system, and are in the best interests of the Owner.
  - d. Proposals for substitutions shall be accompanied by full technical information, and specifications for the equipment so proposed.
  - e. Under no circumstances shall the Owner's Representative be required to prove that an item proposed for substitution is not equal to the specified item. The Contractor shall submit to the Owner's Representative evidence to support the contention that the item proposed for substitution is equal to the contract specified item. The Owner's Representative's decision as to the equality of substitution shall be final.
5. System Enhancements:
- a. Submit recommendations that will enhance the performance of the system, or reduce costs without loss of performance, in the bid submission. Suggestions that are of value to the Owner will be taken into consideration in the evaluation of the bid returns.
  - b. Such proposals shall be made as "alternates", with the appropriate cost modifications shown separate and apart from the costs of the system "as specified".
6. Contractor Resume:
- a. A list of five recently completed projects of similar type and size with contact names and telephone numbers for each.
  - b. A technical resume of experience for the Contractor's Engineer, Project Manager, Control System Programmer, Lead Field Technician and any other relevant personnel who will be assigned to this project.
  - c. A list of technical product training attended by the Contractor's personnel that will install the systems.
  - d. A list of subcontractors providing services under this scope of work. Provide description of work to be performed by each subcontractor and their qualifications.
7. Exceptions: Make exceptions to these specifications and related drawings with the bid submission. In the absence of exceptions, these specifications and related drawings

shall be binding in letter and intent. It will further be assumed that the design and specifications have been examined in detail, and full responsibility for the performance of the complete installation as designed and specified is accepted.

8. Project Approach:

- a. An outline of the project approach and availability of resources.
- b. A scheduling plan with the bid return indicating the various pertinent terminal dates after award of contract for completion of design, pre-installation work, on-site installation work, and testing and acceptance.

9. Test Equipment: A list of test equipment, giving make and model numbers to be used for tests and acceptance testing.

C. Installation Submittal

1. Provide after the award of contract, but prior to equipment procurement and installation

2. Shop drawings and data sheets shall be provided as a single comprehensive package. Partial submittals shall not be accepted with prior consent from the Owner's Representative.

3. Shall include, but not be limited to, the following:

- a. System wiring diagrams for video, audio, and control systems showing manufacturer and model numbers, connectivity, cable types and cable identifiers including ancillary devices. Clearly label each item of equipment shown on the drawing with the manufacturer's terminal number or input/output designation.
- b. Plate and Panel drawings showing finish, color, exact lettering, connectors and other pertinent fabrication instructions for all custom plates and panels in the systems. Include physical samples of engraving, finish and color.
- c. Rack Elevation drawings showing equipment layout within each rack, rack accessories, and power/grounding layout within each rack.
- d. Floor Plans, Reflected Ceiling Plans, Elevation and Sectional View drawings showing the layout for audiovisual devices within the facility.
- e. Run sheets or field wiring drawings: Clearly show at each terminal point the type of connector to be used and include typical wiring details of each connector. Note where shields are connected and where they will float to ensure the integrity of the grounding system. Call out wire types and color codes where appropriate. Assign wire numbers and patchbay locations to every wire and patch point in the drawing.
  - a. Detail drawings including:
    - 1) Custom furniture and millwork.
    - 2) Custom components, assemblies and circuitry.

- 3) Custom equipment mounting.
  - 4) Patch Panel Layout drawings.
  - 5) Unusual equipment modifications
- b. Drawing Index and Title Page
- c. Symbols Legend
- d. Binder containing product data sheets for equipment
- 1) Should be organized logically by system
  - 2) Where a product data sheet includes more than one item, indicate model being proposed.
  - 3) Provide an index for reference
- e. Project schedule including the following milestones:
- 1) Submittal packages.
  - 2) Equipment procurement, indicate equipment with long lead times.
  - 3) Rack fabrication.
  - 4) Installation.
  - 5) Substantial completion.
  - 6) Acceptance testing.
  - 7) Owner/user training.
- f. Test Equipment: Provide a list of test equipment, including manufacturer, description, and model number, of equipment that is expected to be employed in the test and adjustment of the systems specified.
- g. Control System Touch Panel Submittal:
- 1) Preliminary layouts of all remote control devices (touch panels, remote controls, etc.), submitted on disk and hardcopy.
  - 2) Touch Panel layouts must be done in software supplied by control system manufacturer, such as VisionTools Pro-e. AutoCAD or similar graphics file formats are not acceptable.
  - 3) Descriptions of each button with functionality. Buttons with “trivial” functions, such as help buttons, may be omitted.

- 4) For each piece of equipment, lists of functions under control of the remote control system.
- 5) For each piece of equipment, a list of all inputs (feedback) to the remote control system.

D. Substantial Completion Submittal:

1. Shall be provided a minimum of 2 weeks prior to scheduled acceptance testing by the Owner's Representative and shall include the following:
  - a. A draft version of Record Drawings for systems depicting the current state of the systems to be tested.
  - b. A draft version of the Operation and Maintenance manuals which shall include the following:
    - 1) Detailed operation instructions that can be easily understood by non-technical users. Include normal settings for equalizer, amplifier, signal processing, and user-operated controls. Include pictures of touch panel screens when appropriate.
    - 2) A troubleshooting guide for the most common problems that might arise.
    - 3) Equipment list for each room with manufacturer, model number, serial number, client tracking number (if applicable), and other unique equipment numbers for installed equipment in spreadsheet format.
    - 4) A list of fixed or static IP addresses, ISDN numbers and telephone numbers used for audiovisual equipment.
    - 5) A list of frequencies and/or channels used for wireless microphone systems.
    - 6) Recommended maintenance schedule with reference to the applicable pages in the manufacturer's maintenance manuals. Where inadequate information is provided by the manufacturer, provide the information necessary for proper maintenance.
    - 7) A list of necessary and recommended replacement parts for a normal maintenance period of one year.
    - 8) Software files for graphical user interface, source code, DSP, and equipment settings on CD-ROM. Provide electronic copies of compiled and un-compiled programming files.
    - 9) Include the terms of the warranty and the appropriate contact phone numbers for service.
    - 10) Equipment manufacturer's operation and maintenance manuals for each piece of equipment.
  - c. Test and Measurement Data consisting of:

- 1) Documentation of the tools and the manner in which the performance tests were taken.
- 2) Documentation of the performance test results.
- 3) Documentation of the system settings prior to and after the system set-up.

E. Closeout Submittal

1. Comply with Section 017800 – Closeout Submittals.
2. The Closeout Submittal shall be provided within 30 days of systems acceptance and shall include:
  - a. Final Project Record Drawings: Submit on CD-ROM in AutoCAD and PDF format. Final Project Record Drawings shall include drawings associated with the systems. The locations of installed conduits shall be shown on floor plan drawings.
  - b. Two copies of the Final Operation and Maintenance manuals as described in Substantial Completion Submittal.
  - c. A systems information packet shall be mounted in each equipment rack and shall consist of the system drawings associated with the rack, important telephone numbers and a list of equipment in the rack with serial numbers.
  - d. Manufacturers' instruction manuals for items of equipment, incorporating or followed by manufacturers' warranty statements.
    - 1) Where manufacturer's registration is required, register warranty in Owner's name at an address determined by Owner. Provide copy of registration.

1.7 PERFORMANCE STANDARDS

- A. Meet the following performance standards with each system, unless restricted by the published specifications of a particular piece of equipment:
- B. Audio Signal:
  1. Signal-to-Noise Ratio (including crosstalk): 55 dB minimum.
  2. Total Harmonic Distortion: 0.1% maximum from 20 Hz to 20,000 Hz.
  3. Frequency Response:  $\pm 1.0$  dB, 20 Hz to 20,000 Hz.
- C. Audio Reproduction:
  1. Signal-to-Noise Ratio (including crosstalk): 55 dB minimum.
  2. Total Harmonic Distortion: 1% maximum from 30 Hz to 15,000 Hz.
  3. Frequency Response:

- a. Program Reproduction System Loudspeakers:  $\pm 2$  dB, a flat response from 63 Hz to 6 kHz, decreasing uniformly from a relative level of 0 dB at 6 kHz to a relative level of -5 dB at 20 kHz as measured on axis of loudspeakers.
  - 4. Sound Output Capability: Provide program levels of not less than 95 dB and speech reinforcement levels of not less than 85dB in the seating area without objectionable distortion, rattles, or buzzes, employing as test signals several different samples of recorded music and microphones applied at each system input.
  - 5. Hum and Noise: Hum and noise shall be inaudible (below the background noise level of the space) under normal operation and as observed in normal seat locations.
- D. Video Signal:
  - 1. Signal-to-Noise Ratio (peak to RMS) Unweighted DC to 4.2 MHz: 55 dB minimum
  - 2. Crosstalk: Crosstalk (unweighted DC to 4.2 MHz): 45 dB minimum
  - 3. Frequency Response: Within plus-or-minus 0.5 dB to 4.2 MHz.
  - 4. Line and Field Tilt: 2% minimum
  - 5. Differential Gain: 3% maximum
  - 6. Differential Phase:  $2^\circ$  maximum
- E. Video Timing:
  - 1. System Timing: Sync coincidence within 50 nanoseconds
  - 2. Color Timing: Within  $2^\circ$  at 3.58 MHz
- F. Optical: Optical projection systems shall meet the following performance standards:
  - 1. The total averaged light output from a projector, in lumens, shall be within plus-or-minus 15% of that specified by the projector manufacturer.
  - 2. The light fall-off from the center of the projected image to four corners, as measured at the projected image plane, shall not exceed 50% for video projector images nor 35% for slide projector images.
  - 3. Projectors, lenses, and mirrors shall be mounted and braced so that there will be no observable movement in the image induced by vibration or other mechanical operations or structural conditions.

#### 1.8 DELIVERY, STORAGE AND HANDLING

- A. Bear costs of shipping to the site, and of unusual storage requirements. Make appropriate arrangements, and coordinate with authorized personnel at the site, for the proper acceptance, handling, protection, and storage of equipment so delivered.



## 1.9 ADDITIONAL ENGINEERING SERVICES

- A. In the event that the Owner's Representative is required to provide additional engineering services as a result of substitution of equivalent materials or equipment by the Contractor, or changes by the Contractor in dimension, weight, power requirements, etc., of the equipment and accessories furnished, or if the Owner's Representative is required to examine and evaluate changes proposed by the Contractor for the convenience of the Contractor, then the Owner's Representative's expenses in connection with such additional services shall be paid by the Contractor and may be deducted from monies owed to the Contractor.
- B. In the event that the Owner's Representative is required to provide additional engineering services as a result of Contractor's errors, omissions or failure to conform to the requirements of the Contract Documents, or if the Owner's Representative is required to examine and evaluate changes proposed by the Contractor solely for the convenience of the Contractor, then the Owner's Representative's expense in connection with such additional services shall be paid by the Contractor and may be deducted from monies owed to the Contractor.
- C. In the event that the Owner's Representative is scheduled to visit the project site to validate proper system performance before the Contractor has tested and setup all systems in accordance with this document, then the Owner's Representative's expense in connection with such additional services shall be paid by the Contractor and may be deducted from monies owed to the Contractor.

## 1.10 WARRANTY

- A. Comply with Section 017800 – Closeout Submittals.
- B. For a period of one year from completion of the project, affect replacement or substitutions of equipment within 24 hours of first notification. Complete repairs to equipment within 72 hours. If repairs cannot be completed during this time period, or if ordering of parts is required, forward to the Owner every 72 hours documentation of progress of repairs. This repair capability is mandatory. Include costs anticipated to comply with this requirement in the bid.
- C. Contractor shall be responsible for and make good, without expense to the Owner defects arising during this warranty period that are due to imperfect materials, equipment, improper installation or poor workmanship.
- D. Activate manufacturer's equipment warranties in Owner's name to commence on the date of acceptance. In the case of Contractor- modified equipment, the manufacturer's warranty is normally voided. In such cases, provide the Owner with a warranty equivalent to that of the original manufacturer.
- E. Provide and include in the warranty quarterly site visits to check and adjust equipment and restore systems to original performance standards.
- F. Provide a service visit one month prior to the warranty expiration to confirm the correct working condition of the system and to make necessary adjustments to bring the system back to optimal working condition. Include costs anticipated to comply with this requirement in the bid.

## PART 2 - PRODUCTS

### 2.1 GENERAL

- A. Potential discrepancies among the contract documents shall be highlight and described to the Owner's Representative or the most stringent case shall be assumed.

### 2.2 SPECIFIC EQUIPMENT

- A. Reference Schedule A, "Equipment List"
- B. Schedule A presents the major components of the systems and quantities of equipment and systems to be installed. Provide additional equipment and accessories as required to produce a complete and functional system consistent with the design intent.
- C. At the time of installation supply the latest model of the product which is available for each piece of equipment.
- D. Should there be a difference in pricing between the equipment model cost at the time of bid and the pricing for the latest equipment model to be provided at the time of installation, the price differential will be compensated accordingly.
- E. Materials: Supply materials and equipment that shall be new and shall meet or exceed the latest published specifications of the manufacturer.

### 2.3 CABLES

- A. Cables must be manufactured and installed in compliance with local and state codes.
- B. Cable Passing through two or more floors: Rated, listed and marked for use in riser application.
  - 1. Riser Cable: CMR or OFNR rated per NEC and comply with other applicable codes.
- C. Cable in Plenums: Rated, listed and marked for use in plenum application.
  - 1. Plenum Cable: CMP rated per NEC and comply with other applicable codes.
- D. Contractor shall verify all spaces as plenum or non-plenum with the architect/mechanical engineer prior to purchasing or installing any cable. Contractor shall be aware of any owner or AHJ requirements for plenum cable or other cable types.
- E. Twisted Pair Horizontal Cabling:
  - 1. Refer to Section 271500 – Communications Copper Horizontal Cabling.
  - 2. Microphone and Line Level Cables: Provide #22 AWG Shielded Twisted Pair Cable.
  - 3. High-Impedance Loudspeaker Cables: Provide #16 AWG Unshielded Twisted Pair Cable.
  - 4. DC Power Cables: Provide #16 AWG Unshielded Twisted Pair Cable.

5. Low-Impedance Loudspeaker Cables: Provide #12 AWG Unshielded Twisted Pair Cable.
  6. RS-232/RS-422/RS-485 Control Cables: Provide Shielded Data Cable.
  7. Data/Power Cables: Provide Data/Power Cable.
  8. UTP Cable: Provide Category 6 UTP Cable.
  9. Induction Loop System Feeder Cable: Provide 4 core, #12 AWG stranded wire in star quad configuration.
- F. Digital Cabling:
1. HDMI Cables: Provide HDMI specification 1.4 compliant cables.
- G. Coaxial Horizontal Cabling:
1. Comply with Section 271500 – Communications Coaxial Horizontal Cabling.
  2. The following distance guidelines shall be used for baseband video cable selection:
    - a. Series 11/U where lengths between active devices are between 45.72 m [(150 feet)] and 91.5 m [(300 feet)].
    - b. Series 11/U or Series 6/U where lengths between active devices are between 15.24 m [(50 feet)] and 45.72 m [(150 feet)].
    - c. Series 11/U, Series 6/U, or Series 59/U where lengths between active devices are 15.25 m [(50 feet)] or less.
  3. Video Cables (Series 59/U): Provide Series 59/U – Coaxial Video Cable.
  4. Video Cables (Series 6/U): Provide Series 6/U – Coaxial Video Cable.
  5. Video Cables (Series 11/U): Provide Series 11/U – Coaxial Video Cable.
  6. Induction Loop Cabling
    - a. Direct burial grade cable with an EPR-CSP HOFR (heat and oil resistant, flame retardant) rating, #14 AWG stranded wire.

## 2.4 CONNECTORS

- A. Audio connectors of XLR, 3.5 mm [(1/4 inch)], and RCA types shall be solder type and incorporate metal shells and bodies. Acceptable manufacturers: Switchcraft or Neutrik.
- B. Video connectors of BNC and RCA shall be:
  1. Dual crimp or compression style nickel plated brass connector utilizing a gold plated center contact.

2. Connector and pin appropriately selected based on the specified cable as part of a manufacturer's approved assembly.
  3. Crimp or compression tool and die sets utilized shall be approved by the manufacturer for the assembly.
  4. Color coded via strain relief boot, isolation bushing or O-ring to designate video type. Color designations shall be as follows:
    - a. SDI/HD-SDI: Orange
  5. Acceptable manufacturers: ADC, Extron, Tyco, Kings, Bomar, Canare, or Trompeter.
- C. Use only rosin core solder or approved mechanical connectors for joints and connections within the system. Twist-on wire-nuts are not acceptable.
- D. Terminator: Provide 75Ω terminators where required.
- E. UTP Connectors: Refer to Section 271500 – Communications Horizontal Cabling.

## 2.5 EQUIPMENT RACKS

- A. Locate equipment to allow proper airflow and ventilation. At the rack, provide ventilation to manage rack temperatures, that do not exceed 90 degree Fahrenheit after 5 hours of continuous operation.
- B. Provide passive ventilation when racks are open to work areas.
- C. Cable lacing bars shall be used for horizontal cable management.
- D. Use only rack screws with nylon anti-scuff washers.
- E. Key locking doors identically.
- F. Fill empty rack spaces with flanged, 0.125 inch thick aluminum, standard rack size, brushed black anodized finish blank panels, unless otherwise noted.
- G. Provide and install security covers to restrict access to equipment with front panel controls that do not require adjustment by the end user.
- H. Provide a custom rack panel recognizing both the design firm and the integration firm. The panel shall have the firms' logos and contact information on it. Provide a logo panel at each separate location in the project.
- I. Panels mounted on the rear rack rails shall not block access to front mounted components or conflict with vertical cable management.
- J. Provide rack shelves for ancillary equipment.

## 2.6 INTERFACES

- A. Audio: Provide line level interfaces for sources not having nominal plus 4dBu, balanced inputs and outputs.
- B. Auxiliary Interfaces:
  - 1. Provide one cable with molded connectors for each auxiliary audio, video, and control interface location provided as specified herein, unless noted otherwise on the Drawings.
  - 2. Cables shall be flexible.
  - 3. Where multiple formats are typically utilized together cables shall include all formats within a single jacket, included but not limited to, VGA with mini-TRS, Composite Video with Stereo Audio, and Component Video with Stereo Audio.
  - 4. Provide the following length cables, unless noted otherwise on the Drawings:
    - a. Rack Mounted Interface: 3.6 m [(12 feet)].
    - b. Wall Mounted Interface: 3.6 m [(12 feet)].
    - c. Floor Mounted Interface: 3.6m [(12 feet)].
    - d. Table Mounted Interface: 1.8 m [(6 feet)].
  - 5. Provide manufacturer's adapter plates for pass-through connections as indicated on the Drawings.
  - 6. Extra Materials:
    - a. Furnish extra materials described below that match products installed and that are packaged with protective covering for storage and identified with labels describing contents.
    - b. Provide one of each type for every ten required, but not less than one.

## 2.7 CUSTOM FABRICATION

- A. Electrical Power Connections: Electrical power junction boxes and circuits will be provided by others. Provide required interconnections to the power system from these junction boxes to the equipment and equipment racks.
- B. Equipment Rack: Provide power receptacle strips, with "U" ground outlets. Power receptacle strips shall be mounted on the rear interior of the rack space on the left side as viewed from the rear. Insulate power receptacle strips from the rack. Power receptacle strips shall be SGL Waber Company or approved equal. Provide UL-approved incandescent work light mounted on the upper left interior panel of each equipment rack.
- C. Project Information Label: Permanently mount, at the top facing edge of each equipment rack, an engraved plastic laminate plate, with filled lettering on contrasting background. Plate shall identify "Design by Arup. Installation by: Contractor, City, ST."

- D. Audio Transformers: Provide appropriate impedance ratio and power handling capacity for the function intended of audio transformers specified in the system.
- E. Labeling: Provide permanently mounted 1/32" thick by 1/4" high black lamicaid or anodized, brushed aluminum labels with 1/8" engraved lettering for each piece of equipment and every user-adjustable control and input on the audiovisual equipment.
- F. Rack Mount Adapters and Security Covers: Provide the appropriate factory or custom rack mount adapters for equipment installed in the audiovisual equipment rack, whether specifically itemized or not. Provide security covers for equalizers, crossovers, signal delays, and other adjustable signal processors.
- G. System Functional Diagrams: Provide reduced-size as-built functional diagram for the control, audio and video system. Frame with acrylic cover, or laminate drawing, and mount adjacent to equipment rack.
- H. Seismic Safety: Mount and brace permanently installed equipment to the building structure to minimize potential damage to personnel or equipment from foreseeable seismic events. Physically bolt audiovisual equipment rack base or bottom rails to the floor to prevent toppling. Brace hanging equipment such as loudspeakers, et cetera both to minimize sway and to prevent detachment from the overhead structure.

## 2.8 OPEN-TOP CABLE SUPPORT (J-SUPPORT)

- A. Comply with Section 270528.29 – Hanger and Supports for Communications Systems

## 2.9 MISCELLANEOUS EQUIPMENT

- A. Provide screws, anchors, clamps, tie wraps, wire molding, miscellaneous grounding and support hardware necessary to facilitate installation of the system.
- B. Furnish special installation equipment or tools necessary to properly complete system. This may include, but is not limited to, tools for terminating cables, test equipment for audiovisual devices, jack stands for cable reels, and cable winches.
- C. Furnish scaffolding, rigging, hoisting and services necessary for erection and delivery of equipment and apparatus furnished into the premises. These items shall be removed from premises when no longer required.
- D. Project Information Label: Permanently mount, at the top facing edge of each equipment rack, an engraved plastic laminate plate, with filled lettering on contrasting background. Plate shall identify "Design by Arup, Chicago, IL Installation by: Contractor, City, ST."
- E. Audio Transformers: Provide appropriate impedance ratio and power handling capacity for the function intended of audio transformers specified in the system.
- F. Networks and Pads: Provide networks and pads as shown on the drawings or as required to achieve proper impedance matching and levels. Networks and pads shall be balanced. 0.5 watt, 5% composition resistors shall be soldered to fixed connection points at each end.
- G. Rack Mount Adapters and Security Covers: Provide the appropriate factory or custom rack mount adapters for equipment installed in the audiovisual equipment rack, whether specifically

itemized or not. Provide security covers for equalizers, crossovers, signal delays, and other adjustable signal processors.

- H. Coordinate return or recycling of removed and/or replaced equipment with Owner. Existing equipment not reused shall be returned to the Owner. The Contractor is required to properly recycle or dispose of equipment at no additional charge at Owner's request.

## PART 3 - EXECUTION

### 3.1 GENERAL

- A. Installation shall include:
  - 1. Delivery, unloading and setting in place of equipment.
  - 2. Fastening equipment to walls, floors, ceilings, or other structure as required.
  - 3. Interconnecting wiring of the system components.
  - 4. Equipment alignment and adjustment.
  - 5. Other work required to result in complete and operational systems.
- B. If in the opinion of the Contractor, an installation practice is desired or required, which is contrary to these specifications or drawings, a request for modification shall be made in writing to the Owner's Representative. Modifications shall not commence without written approval from the Owner's Representative.
- C. Prevent and guard against electromagnetic and electrostatic interference, and install the equipment to provide safety for the operator.
- D. Coordinate ordering and installation of equipment with long lead times or having a major impact on work by other trades so as not to delay the job or impact the schedule.
- E. Provide access to equipment and components requiring operation, service or maintenance within the life of the system.
- F. Verify correctness of parts list and equipment model numbers and conformance of each component with manufacturer's specifications.
- G. No equipment shall be hidden or covered up prior to inspection by the Owner's Representative. Work that is determined to be unsatisfactory shall be corrected immediately.
- H. The contractor shall be responsible for damage to surface or work disrupted as a result of contractor's work. Repair of surfaces, including painting, and patching, shall be included as necessary.
- I. Edges of holes which cables pass through shall be covered with rubber or nylon grommets.
- J. Equipment and enclosures shall be mounted plumb and square.

### 3.2 WORKMANSHIP

- A. Materials and standards shall meet or exceed industry standards and be fully guaranteed for one full year from final acceptance.
- B. Cable integrity and associated terminations shall be thoroughly inspected, fully tested and guaranteed as free from defects, transpositions, opens-shorts, tight kinks, and damaged jacket insulation.
- C. Labor must be thoroughly competent and skilled, and work shall be executed in strict accordance with the best practices of the trade.
- D. All equipment shall be installed in accordance with manufacturer's instructions.
- E. Installation shall be done in conformance with the manufacturers' design and installation guidelines. Failure to follow the appropriate guidelines will require the Contractor to provide in a timely fashion the additional material and labor necessary to properly rectify the situation.

### 3.3 EXAMINATION

- A. General: Examine conditions and proceed with work in accordance with Section 014000 – Quality Requirements.
- B. Examination of Premises: Visit Site to become familiar with local conditions under which work is to be performed and correlate observations with requirements of Contract Documents. No allowance shall be made for claims for concealed conditions which Contractor, in exercise of reasonable diligence in observations of site and local conditions, should have learned of.
- C. Verify that electrical requirements including junction boxes, floor boxes, ceiling loudspeaker enclosures, empty conduit and power circuits and receptacles are in place as shown on the drawings.
- D. Inspect and review related electrical work to verify correct voltage, polarity, and grounding prior to interfacing power with audiovisual equipment.
- E. Before ordering materials or doing work, verify measurements and be responsible for correctness of same.
  - 1. No extra charge or compensation allowed for duplicate work or material required because of unverified difference between actual dimension and measurement indicated on Drawings.
  - 2. Submit discrepancies found in writing to Owner's Representative for consideration before proceeding with Work.
- F. Facility Review: Conduct walk through with Owner's Representative of work areas, describing specific work methods and proposed schedules, before commencing work, enabling Owner's Representative to identify areas of concern, desired installation timetables and review important procedural and safety precautions.



- G. Prior to start of installation, meet at project site with Owner's Representative and other trades performing related work to coordinate efforts. Review areas of potential interference and resolve conflicts before proceeding with work.
- H. Examine areas and conditions under which system is to be installed. Do not proceed with work until satisfactory conditions have been achieved. Notify Owner's Representative if conditions are unacceptable and schedule will be affected.
- I. The Drawings are diagrammatic in nature and, unless explicitly dimensioned, indicate approximate locations of equipment and components. Changes in the location, and offsets of equipment and components which are not shown on the Drawings but are necessary in order to accommodate building conditions and coordination with the work of other trades, shall be made prior to installation, without additional cost.

#### 3.4 ROUGH-IN

- A. Before construction work commences, visit site and identify exact routing for pathways. Identify required core locations.
  - 1. Notify Owner's Representative of core locations that will require asbestos containment prior to proceeding with work.
- B. Equipment Locations: Coordinate with other trades, other renovation projects, and existing conditions to eliminate interference with required clearances for equipment maintenance and inspections.
  - 1. Provide code mandated clearances at equipment racks and enclosures, and other equipment requiring maintenance and operation. If it is determined that ample maintenance and passage space has not been provided, rearrange work and/or provide other equipment as required for maintenance space.
  - 2. Coordinate work with other trades and existing conditions to determine exact routing of cable tray, hangers, conduit, etc., before fabrication and installation. Where more than one trade is involved in area, space, or chase, coordinate to utilize space appropriately in relation to their individual requirements.
  - 3. Coordinate work in open ceilings. Where cable tray, hangers, conduits, cables are exposed route infrastructure perpendicular to finishes and other building systems. Route infrastructure to reduce locations where trade work transition from/to exposed areas.
  - 4. Bring changes in size or location of material or equipment necessary to meet field conditions or in order to avoid conflicts between trades to immediate attention of Owner's Representative before such alterations are made.
  - 5. Verify with Owner's Representative exact location and mounting height of equipment in finished areas, such as equipment racks, communication, and electrical devices.

#### 3.5 MOUNTING REQUIREMENTS

- A. Work shall be installed level and plumb, parallel and perpendicular to other building systems and components.

- B. Permanently attach equipment to the building structure with a minimum safety factor of 5. Suspended components that move or are otherwise subjected to continuous wear or friction shall be supported with a minimum safety factor of 8. When a higher safety factor is recommended by an equipment manufacturer or required by the AHJ, the more stringent requirement shall be met.
- C. Do not attach equipment in a manner that weakens or overloads the building structure.
- D. Attain the stamped approval of a licensed Structural Professional Engineer for equipment that is attached in a manner or location that could impact the integrity of the building structure or cause personal injury.
- E. Install equipment with the ability for minor adjustment as required for optimization.
- F. Loudspeaker enclosures shall be supported from the building structure, or from the ceiling suspension system in acoustical tile ceilings with a safety wire fastened to the building structure.
- G. Seismic bracing shall be installed on appropriate equipment where local codes require such installation.
- H. Give consideration, not only to operational efficiency, but also to overall aesthetic factors in the installation of equipment and cable.

### 3.6 PENETRATIONS

- A. Conduit and Sleeve Openings: Shall be waterproofed and fireproofed in compliance with applicable codes and regulations.
- B. Firestopping: Fire-stop openings and penetrations through fire and smoke rated wall and floor assemblies in accordance with Section 078400 - Firestopping.
  - 1. Fire-stop System Inside of Conduits:
    - a. Use only dielectric, water resistant, non-hardening, permanently pliable/re-enterable putty along with appropriate damming or backer materials.
    - b. Use sealant capable of being removed and reinstalled.
    - c. Sealant shall adhere to penetrants and common construction materials and be capable of allowing normal wire/cable movement without being displaced.
  - 2. Add fire-stop pillows rated for sealing existing cable tray penetrations through firewall.
  - 3. Patch openings remaining around and inside conduit, sleeves, and cable penetrations to maintain integrity of fire rated assembly.

### 3.7 ELECTRICAL POWER, GROUNDING AND BONDING

- A. Provide a ground bus bar bonded to each equipment rack. Terminate the bus bar to the audiovisual technical ground. Ground the chassis of each piece of equipment not utilizing a 3-prong power cord to the bus bar.

- B. For active equipment, float the ground wire at the output side of balanced audio lines other than microphone lines or intercom and where required by manufacturer.
- C. Carry audio shields straight through passive devices such as patch panels and terminal strips.
- D. Arrange inner-rack power distribution so that no circuit exceeds 80% of full power.
- E. When the electrical service to a rack is hardwired, the Contractor shall terminate inner-rack power wiring to a j-box at the top or bottom of the rack for field connection of the electrical service.
- F. Ground control lines in compliance with the manufacturer's specification for the appropriate equipment.
- G. No power cord from equipment shall have its third prong (ground) removed or defeated.
- H. Label each outlet within each rack to reflect which circuit is feeding it.
- I. Establish only one ground connection path between equipment in the system.
- J. Do not place audiovisual distribution cabling alongside power lines or share the same conduit, channel or sleeve with electrical apparatus.
- K. Provide cable service loops at devices for inspection, minor adjustment, and future flexibility.
- L. Grounding Procedures: In order to minimize problems resulting from improper grounding, and to achieve maximum signal-to-noise ratios, adhere to the following grounding procedures:
  - 1. General: Because of the great number of possible variations in grounding systems, follow good engineering practice, as outlined above, and deviate from these practices only when necessary to minimize crosstalk and to maximize signal-to-noise ratios in the audio, video, and control systems.
  - 2. System Grounds: Establish a single primary "system ground" for the systems in each particular area. Connect grounding conductors in that area to this primary system ground. Provide the system ground in the audio equipment rack for the area. The ground shall consist of a copper bar of sufficient size to accommodate secondary ground conductors.
  - 3. Rack Ground:
    - a. Connect the No.6 insulated copper wire connected to the earth ground to the primary system ground busbar in the Equipment Rack.
    - b. Bond a No.12 TW stranded wire from the Equipment Rack frame to the primary system ground bus bar.
  - 4. Equipment Grounds: Grounding methods used will be dependent upon individual equipment interconnection of chassis ground, circuit common, and power supply common within the units. Provide ground method for equipment types as follows:

- a. Equipment having a 3-wire power cord with green wire of the power cord connected to chassis (Signal common is not internally connected to chassis): Make no connection from chassis ground to primary systems ground busbar in Equipment Rack.
  - b. Equipment having a 3-wire power cord with green wire of the power cord connected to chassis: Make no connection from chassis ground to primary system busbar, but do make connection with 14AWG insulated wire from circuit common to primary system ground busbar in Equipment Rack. Separate circuit common from chassis ground.
  - c. Equipment having a 2-wire power cord, no green wire, neutral is not tied to chassis, and circuit common is tied to chassis: Make connection from chassis to primary system ground busbar using 14AWG insulated wire.
5. Audio Cable Shields: Ground audio cable shields at one point only. There are no exceptions. For inter- and intra-rack wiring connect the shield at one end only, this shall be at the input to a device. The shield shall be lifted at the device output. For ungrounded portable equipment, such as microphones, the shield shall be connected at both ends but grounded at only one end.
6. Video Receptacles: Insulate video receptacles from the panel, outlet box, or wireway. Unless otherwise detailed herein, use insulated-from-panel type receptacles.

### 3.8 CABLE INSTALLATION:

- A. Comply with Section 271500– Communications Copper Horizontal Cabling.
- B. Mark cables, regardless of length, with permanent, non-handwritten number or letter cable markers within six inches of both ends. There shall be no unmarked cables in the system. Marking codes used on cables shall correspond to codes shown on drawings and/or run sheets.
- C. Furnish screw-type terminal blocks, boards, strips, or connectors, for cables which interface with racks, cabinets, consoles, or equipment modules. Terminate wires terminating at screw-type terminals with crimp-on lugs. "Telephone-style" punch-down blocks are not acceptable for signal or data wiring.
- D. Group cables according to the signals being carried. In order to reduce signal contamination, form separate groups for the following cables:
  1. Power cables
  2. Video/Control/Data cables
  3. Audio cables carrying signals less than minus 20 dBm.
  4. Audio cables carrying signals between minus 20 dBm and plus 30 dBm.
  5. Audio cables carrying signals above plus 30 dBm.
  6. Broadband RF cables.

7.

- E. Cut cables (except video and camera cables that must be cut to an electrical length) to the length dictated by the run. For equipment mounted in drawers or on slides, provide the interconnecting cables with a service loop of appropriate length.
- F. Install cable with a bend radius not less than that recommended by the cable manufacturer.
- G. Clearly identify cable terminated in a floor pocket with permanent, indelible labels within 6" of the cable connector. Provide strain relief for cables. Provide connectors with metal shell/casing. Provide a minimum of 3' of free cable coiled in the floor pocket. Use spiral wrap to group similar cable types.

### 3.9 EQUIPMENT RACKS

- A. Perform rack fabrication before delivering the racks to the job site. Only wiring and terminations dependant on external devices shall be done at the job site.
- B. Test equipment power and functionality to the fullest extent possible prior to delivering the racks to the job site.
- C. Equip the rack with sufficient AC power distribution to support equipment as well as two spare, non-switched, convenience outlets. One convenience outlet is to be readily accessible from the front and one readily accessible from the rear of the rack.
- D. Provide service loops within the equipment rack for cables connected to external devices.
- E. Locate equipment in racks to comply with ADA guidelines.
- F. Install equipment racks level and plumb with the room and with adjacent racks.
- G. Organize inner-rack cables in an orthogonal manner and organized into neat harnesses by cable type. The rear of equipment shall be fully visible without an array of cables in the way.
- H. As a general practice, run power cables, control cables, and high level cables on the left side of an equipment rack as viewed from the rear. Run other cables on the right side of an equipment rack, as viewed from the rear.
- I. Horizontal cable management in rack shall be tied in bundles with cable lengths cut to minimize excessive cable slack, but allowing for service and testing.
- J. Provide horizontal support bars if cable bundles sag.
- K. Adhesive backed cable tie anchors shall not be used.
- L. Velcro style cable wraps shall be used in vertical wire management. Plastic cable ties shall not be acceptable.
- M. Arrange unlike signal types in separate harnesses maintaining adequate separation distances to avoid interference.

- N. Package spare parts for each device in a clear plastic pouch and attach it to the rear of that device.
- O. Allow the Owner's Representative to inspect the racks for approval prior to delivery to the job site.
- P. Receptacle Plate Designation: Clearly engrave wall-mounted receptacle plates with alphanumeric identification of input type (i.e., mic, line, speaker, video etc) and corresponding audio or video patch field designation.
- Q. Patch Panel Assignments: Wire patch panels so that signal "sources" (outputs from) appear on the upper row of a row pair; and "loads" (inputs to) appear on the lower row of a row pair.
- R. Patch Panel Designation Strips: Utilize alphanumeric identifications and descriptive information on audio and video patch panel designation strips. Number the jack positions in each horizontal row sequentially from left to right. Letter the horizontal jack rows sequentially from top to bottom. Include the alphanumeric identification of each jack on the functional block drawings, as well as on reproductions of these drawings which shall be mounted in an appropriate location near the patch bays.

### 3.10 SYSTEM SETUP AND PERFORMANCE VERIFICATION

#### A. Preparation:

1. Interior finishes and furnishings shall be in place for these tests.
2. HVAC system is to be balanced and in operation.
3. Confirm complete and proper labeling of system components.
4. Attach reduced-size Block Drawings to a rack in each location.
5. Remove boxes and debris from the project site.
6. Deliver portable and spare equipment to the premises, tested and stored as directed.
7. Tests and adjustments shall be performed in the sequence specified herein.

#### B. General Setup:

1. Verify that audiovisual related components are free from rough or jagged edges.
2. Verify that rack ventilation is working properly.
3. Verify that systems are free from oscillation and stray RF interference.
4. Test and verify continuity and proper termination of every cable in the system.
5. Following final acceptance of system set-up and performance, equipment with front panel controls, not normally adjusted by the operator shall have the controls disabled or be mounted behind blank panels or be furnished with security panels.

C. Audio System Setup and Testing:

1. Impedance

- a. Measure and document the impedance of each loudspeaker circuit at 63 Hz, 250 Hz, 1 kHz and 4 kHz.
- b. Measure at the circuit's entry point to the equipment rack.
- c. Measurement shall be taken prior to the loudspeaker circuit being connected to the amplifier.
- d. Reject and correct measurements that differ significantly from calculated values or fall outside of amplifier specifications.
- e. Measure and document the magnitude of impedance at 1 kHz.

2. Polarity

- a. Perform polarity checks of loudspeaker lines by means of a polarity tester or use DC source at one end of each line and a voltmeter at the other end. Loudspeaker lines shall be identically polarized with respect to color-coding.
- b. Test polarity of the loudspeakers using a sine-wave test signal warbled about 500 Hz. The listener shall be located on axis of the loudspeaker. Switch the loudspeakers from nominally in polarity to nominally out of polarity with respect to the selected loudspeaker. With the loudspeakers in proper polarity, the quality and clarity of the music or speech should be greater, and the warble test signal should clearly come to the surrounding space from the loudspeaker.

3. Ambient Noise

- a. Measure and document the unweighted octave band ambient noise level ( $L_{90}$ ) in each loudspeaker zone in the system under normal operating conditions at seated listener height (4 ft AFF).
- b. Ensure that the minimal loudspeaker level is at least 25 dB(A) above the ambient noise level at the furthest listener. At the direction of the Owner's Representative, make additional level adjustments that the space requires.

4. Hum and Noise Level:

- a. Measure the hum and noise levels of the overall system for each microphone input channel and line-level input channel.
- b. Adjust gain controls for optimum signal-to-noise ratio so that full amplifier output will be achieved with 0 dBm at a line-level input.
- c. Terminate line-level inputs with shielded resistors of 150 and 600 ohms, respectively, for these measurements.

- d. Disconnect the loudspeaker lines and terminate the power-amplifier outputs with power resistors for these measurements. The value of the load resistor shall be within 5% of the nominal load impedance of the amplifier under test. The power rating of the resistor shall equal the power rating of the amplifier.
5. Wireless Microphones and Accessories:
  - a. Arrange wireless microphone antennas to provide drop-out free performance over the entire area being served.
  - b. Set wireless microphone channels for minimum interference from external RF sources and maintain proper channel separation to eliminate adjacent channel interference.
6. Unity Gain:
  - a. Bring the system to a unity gain level of plus 4 dBu.
  - b. Verify proper gain structure throughout system.
7. Delay:
  - a. Using an impulse response measure the arrival time for each loudspeaker zone.
  - b. Set-up delay as required providing localization based on the Haas effect. Realizing localization based on level differences will not be accepted.
8. Uniform Coverage: Using pink noise at the nominal operating level as the source and measuring in dBA with a sound pressure level meter at the typical listening height, verify that there is a variance of no more than a plus or minus 3 dB within the listening area.
9. Frequency Response:
  - a. Using a dual channel FFT, adjust equalizers to achieve a system frequency response described in PART 1.
  - b. Take an average of measurements performed at a variety of locations in the room.
  - c. Perform this measurement and setup only after furniture and floor, wall, and ceiling treatments have been installed.
  - d. Re-take the uniform coverage test and make adjustments as required.
  - e. Document both the un-equalized and equalized average frequency response curves of the room and include the graphs in the Project Record documentation.
  - f. Properly adjust processing equipment, such as compressors, limiters and feedback eliminators for typical operation.
10. Assistive Listening Systems:
  - a. Set gain so that normal speech or music does not over modulate the transmitter.



- b. Adjust induction loop output level so that the field strength meets the requirements of BSA IEC 60118-4 version 2, 2006.
11. Power-Output and Signal-Level Adjustment within System:
- a. Measure the electrical distortion of the overall system for each line-level input channel.
  - b. Adjust gain control as for the tests specified herein.
  - c. Apply a 1-kHz sine-wave signal from an oscillator having less than 0.5% total harmonic distortion at the input tested, at a level required to produce full amplifier output. Note that a pad with 150-ohm output impedance is required for driving the microphone-level input in accordance with the EIA standard.
  - d. Use a distortion analyzer to measure the output level and the total harmonic distortion of the amplification and control equipment. In the absence of a distortion analyzer, a high input impedance-measuring device such as a DMM may be used to measure the output level. Lack of clipping or apparent deformation of a sine-wave input signal at the power-amplifier output, as seen on the oscilloscope, may serve as evidence that distortion of amplification and control equipment is within acceptable limits.
  - e. Make measurements with loads actually incurred in the system operation. Power-amplifier loads shall be power resistors equal to the nominal load impedance of the output terminals used in the system.

D. Video System Setup and Testing:

- 1. Motorized Projection Screens: Properly set projection screen travel limits.
- 2. Video Projectors:
  - a. Properly align, and focus video projectors.
  - b. Verify image fills entire screen with proper image geometry.
  - c. Comply with video displays below.
- 3. Video Displays:
  - a. Allow video display to warm up for a minimum of thirty minutes with moving images prior to testing and adjustments.
  - b. Video display adjustments shall be performed using the native resolution at each utilized input of the display.
  - c. Image sizing:
    - 1) Using a crosshair or crosshatch pattern, adjust the display devices to show a full non-scaled image at the system resolution with appropriate aspect ratio settings.

- d. Clock Setting:
  - 1) Using an alternating pixel test pattern, adjust the clock setting until the pixels appear to stand still.
  - 2) Document the value of the onscreen display.
- e. Black Level:
  - 1) Properly adjust using a picture line up generating equipment (PLUGE) test pattern.
  - 2) Adjust the brightness control slowly until the black than black bar is just fully extinguished, the remaining vertical bar should be dimly visible.
  - 3) Document the appropriate value of the onscreen display.
- f. Gain:
  - 1) Properly adjust using a PLUGE test pattern on the display to be adjusted.
  - 2) Adjust the contrast control until the 100% white bar is at the threshold of maximum brightness without blooming.
  - 3) Document the value of the onscreen display.
  - 4) Perform Black Level and System Gain tests until there is no additional interaction between contrast and brightness control adjustments and document the final onscreen values for contrast and brightness. Document the values of the onscreen display.
- g. Color Level:
  - 1) Properly adjust using a SMPTE color bars test pattern.
  - 2) While viewing the blue information only, adjust the color level until the first and last large bar blends with the small patch underneath.
  - 3) Document the onscreen value for color level.
- h. Color Phase:
  - 1) Use a signal generator to provide a SMPTE color bars test pattern on the display to be adjusted.
  - 2) While viewing the blue channel information only, adjust the tint control until the large internal bars blend with their patch below.
  - 3) Perform Color Level and Color Phase tests until there is no additional color or tint control interaction and document the final onscreen values for color and tint.

- i. Gray Scale:
  - 1) Set the proper black level (bias) and gain settings for each of the three color channels independently using the "window" test patterns.
- 4. Cameras and camera equipment:
  - a. Adjust and set reference black.
  - b. Adjust and set white balance.
  - c. Adjust and set chroma level and phase.
  - d. Camera images shall be free of visible vibration.
  - e. Adjust and set pan/tilt limit switches.
  - f. Set camera presets in accordance with the design intent and Owner's requirements.
- 5. Timing: Properly calibrate video timing and genlock to ensure seamless switching and alignment.
- 6. Signal Processing Equipment:
  - a. Configure and adjust signal processing equipment to produce a properly aligned and centered image at the native resolution of the relative display for each potential source resolution.
- 7. Computer Interfaces:
  - a. Adjust gain.
  - b. Adjust peaking using H pattern.
  - c. Adjust horizontal and vertical position for the native resolution of the relative display.
- 8. System Calibration:
  - a. Properly calibrate individual system components. Verify signal continuity and quality throughout the signal path.
  - b. Document adjusted values of individual components.
  - c. Video images shall be free of anomalies, including, but not limited to, banding, bending, ghosting, reflections, video roll, visible jitter and double images.
- E. Control Equipment Setup and Testing:
  - 1. Test all hardwired and wireless network connections connected to the audiovisual system.

2. Verify proper operation of all equipment and devices connected to the audiovisual control system.
3. Verify correct function of all control system operations, including, but not limited to:
  - a. Equipment powers on and off correctly and in the proper order.
  - b. User is locked out of the system during system start-up and shutdown, timers are provided if this is an excessive period.
  - c. When system is "shutdown" all appropriate audio and video has stopped playing.
  - d. Gauges and feedback are registering correctly.
  - e. Automated functions are sequencing properly.
  - f. Interfaces are registering the same feedback.
4. Verify installed GUI complies with approved design.
5. Provide and verify system password protection and backdoor password at designated control interface locations.

### 3.11 ACCEPTANCE TESTING

- A. Before Acceptance Tests are scheduled, perform a system checkout. Furnish all required test equipment and perform all work necessary to determine and/or modify performance of the system to meet the requirements of this specification. This work shall include the following:
  1. Submission of the test and measurement data.
  2. Test all audio, video and related systems for compliance with the System Setup and Performance Verification as specified herein.
  3. Check all control functions, from all controlling devices to all controlled devices, for proper operation.
  4. Adjust, balance, and align all equipment for optimum quality and to meet the manufacturer's published specifications. Establish and mark normal settings for all level controls, and document these settings in the Operation and Maintenance Manual.
  5. Unless otherwise specified, use tamper-proof security covers on all controls affecting overall system level balance and signal-to-noise ratio, such as power amplifier input level control, and input-output level controls for equalizers, mixers, amplifiers, etc. Some controls may require re-adjustment as the result of Acceptance Testing.
  6. Maintain documentation of all performance tests for reference by the Owner's Representative during the System Acceptance Tests.
    - a. Upon completion of the tests and necessary adjustments, submit a digital copy of a written report presenting test results, including numerical values of all

measurements, for review by the Owner's Representative prior to demonstration and System Acceptance testing.

- b. With the above report, submit written certification that the installation conforms to specifications, is complete, and is ready for inspection and testing by the Owner's Representative.
7. Meet with the Owner and the Owner's Representative and make system changes as directed.
- B. Upon completion of the Contractor's system checkout and performance verification, demonstrate the proper operation of all audiovisual systems in the project to the Owner's Representative.
- C. Provide a qualified technician knowledgeable with the system and the installation to assist the Owner's Representative with the acceptance procedure.
- D. The Contractor shall provide all labor, materials, tools, and measurement equipment necessary for these demonstrations, tests and adjustments.
- E. System Acceptance Tests will not be performed until the Contractor's system checkout has been completed. The System Acceptance Tests will be supervised by the Owner's Representative and will consist of the following:
  1. A physical inventory will be taken of all equipment on site.
  2. The operation of all system equipment shall be demonstrated by the Contractor.
  3. Both subjective and objective tests will be required to determine compliance with the specifications.
  4. Acceptance Tests may include speech intelligibility surveys and subjective evaluations by observers listening at various positions under various operating conditions, using speech, music, and live or recorded effects material. Acceptance tests shall include viewing of monitor images for sharpness, contrast, brightness, and color.
  5. Measurement of frequency response, distortion, noise, wave form, color vector, or other characteristics may be performed (or a demonstration test requested) by the Owner's Representative on any item, or group of items, deemed necessary to determine conformity with criteria.
  6. All final Record Drawings, run sheets, manuals, and other required documents, as detailed herein, shall be on hand. Two complete sets of these documents shall be delivered to the Owner's Representative at this time. (One complete set shall have been delivered to the Owner's Representative prior to the scheduling of Acceptance Tests).
  7. In the event further adjustment is required, or defective equipment must be repaired or replaced, tests may be suspended or continued at the option of the Owner's Representative.
    - a. If the need for further adjustments becomes evident during the demonstration and testing, continue work until the installation operates properly. Included in the

continued work shall include, but not be limited to, changes to or installation of resistive pads, readjustment of loudspeaker aiming, adjustment of system equalizers, programming changes to the control system, convergence of the video projector, if these adjustments are required.

- b. If acceptance of the system is delayed because of defective equipment or because the equipment does not fulfill this specification, reimburse the Owner for time and expenses for these tests during extensions of the acceptance-testing period.

### 3.12 DEMONSTRATION AND INSTRUCTION

- A. Upon completion of the system installation and acceptance procedure, provide system training and orientation for the Owner's personnel (see bid return form for training time). An individual intimately familiar with the equipment in the system and qualified to explain it in detail should conduct the training. When an employee capable of providing such training is not available, retain the services of someone qualified to do so at no additional fee.
- B. Conduct the training prior to the owner using the system for the first time to ensure proper usage. If necessary, conduct the training at a time outside of normal business hours at no additional fee.
- C. Shall include, but not be limited to:
  - 1. Physical review of installed systems.
  - 2. Review of systems documentation and test results.
  - 3. Instructions on standard care and maintenance methods to enable Owner's personnel to successfully maintain system.
  - 4. Additional Owner requirements defined during project.

### 3.13 CLEANUP AND REPAIR

- A. Upon completion of the work, remove refuse and rubbish from and about the premises, and shall leave the relevant areas and equipment clean and in an operational state. Repair damage caused to the premises by the installation activities, at no cost to the Owner.

### 3.14 PROTECTION OF WORK

- A. During the installation, and up to the date of final acceptance, protect finished and unfinished work against damage and loss. In the event of such damage or loss, replace or repair such work at no cost to the Owner.

END OF SECTION

**NEIU CCICS Auditorium Renovation**

**AV Equipment List & Bid Form**

Description	Device Type	Preferred Make	Preferred Model	Qty	Unit Cost	Extended System Equipment Cost
<b>AUDIO</b>						
Goosneck microphone on Lectern	MIC-1	Shure	MX-418	1		
Wireless Microphone - Body Pack Trasmitter with Battery	MIC-2A	Shure	ULXD1 + SB900	2		
Wireless Microphone - Lavelier	MIC-2B	Shure	SM11	2		
Wireless Microphone - Handheld	MIC-3	Shure	ULXD2, SM58	4		
Wireless Microphone Receiver (2-channel)	WMR-1	Shure	ULXD4Q	1		
Wireless Microphone - Charging Station		Shure	SBC800	1		
Wired Microphone	MIC-4	Shure	SM58	4		
Audio DSP Frame	DSP-1	Biamp	Tesira Server-I/O	1		
Audio DSP Input Cards (14 channels input)		Biamp	Input Cards (SIC-4)	6		
Audio DSP Output Cards (10 channels output)		Biamp	Output Cards (SOC-4)	6		
Digital Audio Mixing Console	AC-1	Soundcraft	Si Expression 3	1		
Digital Audio Mixing Console - Expansion Card		Soundcraft	CAT5 MADI i/o Card	1		
Digital Audio Mixing Console - Stage Box	SB-1	Soundcraft	32 Channel Mini Stagebox Cat 5 (32 in x 8 analog out x 8 digital out)	1		
Digital Audio Mixing Console - Stage Box Expansion Card		Soundcraft	CAT5 MADI i/o Card	1		
Audio Patchbays	PB-1/PB-2	Bitree	2x48 Channel Bantam, Programmable, 1 RU	2		
Digital Audio Extractor	DAE-1	Atlona	AV-HD570	1		
Surround Sound Processor	SSP-1	Extron	SSP 7.1	1		
Monitor/Surround Amplification	AMP-1	QSC	RMX4050 - 2 channel, 850 watts/ch at 8-ohms	3		
Monitor Loudspeakers - Control Room	S-6	JBL	LSR2325P	2		
Monitor Loudspeakers - Stage	S-5	JBL	PRX412M - 2-way full range monitor wedge loudspeaker	4		

NEIU #61-0212-0113

**NEIU CCICS Auditorium Renovation**

**AV Equipment List & Bid Form**

Description	Device Type	Preferred Make	Preferred Model	Qty	Unit Cost	Extended System Equipment Cost
Main Loudspeakers - Left/Right (self powered)	S-1	Renkus Heinz	ICL-FR Digitally Steerable Array	2		
Main Loudspeakers - Left/Right Mounting Hardware		Renkus Heinz	HK-ICL-F Hinge Kit	2		
Main Loudspeakers - Subwoofers (self powered)	S-2	Renkus Heinz	CF18S-5 Powered 18" subwoofer	2		
Main Loudspeakers - Center Channel	S-3	Renkus Heinz	TRX151/9, 90 x 40, 2-way, Full Range Loudspeaker	1		
Surround Loudspeakers - Rear Surround Channels	S-4	Renkus Heinz	TRX81/9, 90 x 60, 2-way, Full Range Loudspeaker	2		
Assistive Listening Phase Shifter	SP-1	Listen	SP5 Phase Shifter with Rackmount tray	1		
Assistive Listening Amplifier	ILA-1	Listen	ILD100G Loop Driver with Rackmount Kit	2		
Assistive Listening Hearing Loop Receiver		Listen	LR-IL-1 Loop Receiver	8		
Assistive Listening Stereo Headphones for Loop Receivers		Listen	LA-165	8		
			<b>Total AUDIO Costs</b>			



**NEIU CCICS Auditorium Renovation**

**AV Equipment List & Bid Form**

Description	Device Type	Preferred Make	Preferred Model	Qty	Unit Cost	Extended System Equipment Cost
<b>DISPLAY</b>						
Motorized front projection screen (16-ft W by 9-ft H viewing area)	PS-220	DaLite	Tensioned Cosmopolitan Electrol Large, HD 1.1 screen material	1		
Digital video projector, 16:9 native, WXGA	PJ-1	Christie	DHD800 (8,000 Lumens, Single Chip DLP, )	1		
Digital video projector lens (1.8:2.8)		Christie	103-120104-01	1		
			<b>Total DISPLAY Costs</b>			
<b>VIDEO</b>						
Video Transmitter - Lectern	TX-1	Crestron	DM-TX-401-C	1		
Video Transmitter - Control Booth	TX-2	Crestron	DM-TX-201-C	1		
Video Transmitter - Loose	TX-3	Crestron	DM-TX-201-C	3		
Video Receiver - Projector	RX-1	Crestron	DM-RMC-SCALER-C	1		
Video Receiver - Loose	RX-1	Crestron	DM-RMC-SCALER-C	1		
Video Matrix Switcher - Main Frame	MX-1	Crestron	DM-MD8X8	1		
Video Matrix Switcher - Input Card, HD-BaseT		Crestron	DMC-C-DSP	5		
Video Matrix Switcher - Input Card, HDMI		Crestron	DMC-HD-DSP	3		
Video Matrix Switcher - Output Card, HD-BaseT		Crestron	DMCO-55	1		
Video Matrix Switcher - Output Card, HDMI		Crestron	DMCO-33	1		
DVD/Blu-Ray Player	BR-1	Pioneer	BDP-V6000	1		
Pan/Tilt/Zoom Camera	CAM-1	Panasonic	AW-HE50 S	2		
Pan/Tilt/Zoom Controller	CCU-1	Panasonic	AW-RP50	1		
Video Production Switcher	SWR-1	Panasonic	AW-HS50N	1		
Control Booth LCD Display	DS-1	NEC	PA231W-BK	2		
Lecture capture system	LC-1	Crestron	Capture HD	1		
HDMI to HD-SDI Converter	CNV-1	AJA	HA5 Converter	1		
HD-SDI to HDMI Converter w/ Audio Embedder	CNV-2	Extron	DSC 3G-HD A	1		
Lectern PC	PC-1	TBC	Owner Furnished	1		
			<b>Total VIDEO Costs</b>			

NEIU #61-0212-0113

CCICS Auditorium Renovation

274116-A3

Advertisement for Bid

25 April 2013

**NEIU CCICS Auditorium Renovation**

**AV Equipment List & Bid Form**

Description	Device Type	Preferred Make	Preferred Model	Qty	Unit Cost	Extended System Equipment Cost
<b>CONTROL</b>						
Wall Mount Touch Panel	TP-1	Crestron	TSW-750-B-S	1		
Control Booth Touch Panel	TP-1	Crestron	TSW-750-B-S	1		
Table Top Kit		Crestron	TSW-750-TTK-B-S	1		
Central Control Processor	CPU-1	Crestron	CP3	1		
Wireless Intercom - Base Station and Battery Charger	WIC-1	Clearcom	MB100 Base Station, AC40A Charger	1		
Wireless Intercom - Beltpacks and Batteries		Clearcom	BP200 Beltpack + Pouch, BAT41 Battery	4		
Wireless Intercom - Headsets		Clearcom	HS15 Headset	4		
Wireless Intercom - Antenna Extension Kit, 30-ft		Clearcom	G26671-1	2		
AV Network Switch - 16 Port	NSW-1	Netgear	JGS516	1		
AV Network Switch - PoE 4 Port	NSW-2	Crestron	CEN-SE-POE-5	1		
AV Wireless Network Router	NSW-3	Linksys	WRT-54gs	1		
			<b>Total CONTROL Costs</b>			
<b>MISC</b>						
Wall mounted AV panel - Type I1		Custom		2		
Wall mounted AV panel - Type I2		Custom		2		
Wall mounted AV panel - Type I3		Custom		1		
Wall mounted AV panel - Type I4		Custom		1		
Wall mounted AV panel - Type S1		Custom		2		
Wall mounted AV panel - Type S2		Custom		2		
Wall mounted AV panel - Type S3		Custom		1		
Rack mounted AV panel - Type PP-V1		Custom		1		
Rack mounted AV panel - Type PP-V2		Custom		1		
Rack mounted AV panel - Type PP-A1		Custom		1		
Rack mounted AV panel - Type PP-A2		Custom		1		
Floor box AV Panel - Type F1		Custom		2		
Floor box AV Panel - Type F2		Custom		1		

NEIU #61-0212-0113

CCICS Auditorium Renovation

274116-A4

Advertisement for Bid

25 April 2013

**NEIU CCICS Auditorium Renovation**

**AV Equipment List & Bid Form**

Description	Device Type	Preferred Make	Preferred Model	Qty	Unit Cost	Extended System Equipment Cost
Equipment Rack, Slide Out, 26-inch depth	RK-1, RK-2	Middle Atlantic	MRK-4431AXS-26	2		
Equipment Rack Extra Components (Screws, Blanks, Rails)						
Equipment Rack, Half height w/casters		Middle Atlantic	Slim 5-8-26 (8 RU Rack) + 5WLR	1		
Power Conditioning / Distribution		SurgeX		4		
Cable (LOT)		Various	Various	1		
Microphone Stands (LOT)		Various	Various	1		
Misc Equipment		Various	Various	1		
			<b>Total MISC Equipment Costs</b>			

**NEIU CCICS Auditorium Renovation**

**AV Equipment List & Bid Form**

Description	Device Type	Preferred Make	Preferred Model	Qty	Unit Cost	Extended System Equipment Cost
<b>Non-Equipment</b>						
Engineering						
Pre-Installation						
Installation						
Software Development						
Programming						
Documentation						
Training (3 Days)						
General and Administrative						
Project Management/Field Supervision						
Warranty and First Year Service						
Taxes						

<b>System Totals</b>	
Total Equipment Cost	
Total Non-Equipment Cost	
<b>Total Costs</b>	