

General Description

Poppet Type, Check Valve Insert.

Features

- For inserting inside manifold blocks
- High flow capacity
- Minimal leakage - less than 3 drops/min.
- Simple construction - extremely cost effective
- Range of cracking pressures available
- Good contamination tolerance
- All external parts zinc plated

Performance Curve

Pressure Drop vs. Flow (Through cartridge only)

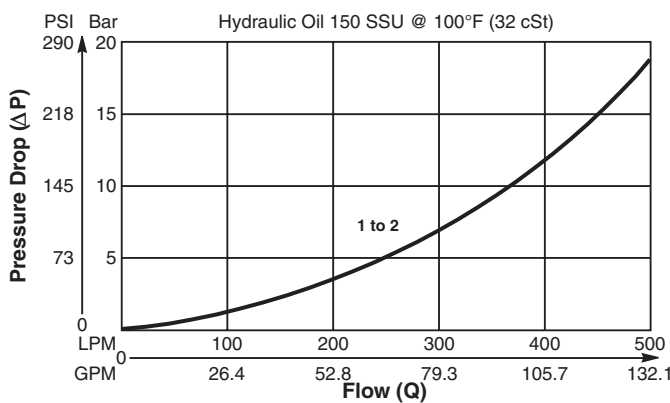

Specifications

Rated Flow	500 LPM (132 GPM)
Nominal Flow @ 7 Bar (100 PSI)	300 LPM (79 GPM)
Maximum Inlet Pressure	420 Bar (6000 PSI)
Leakage at 150 SSU (32 cSt)	Less than 3 drops/min.
Cartridge Material	Steel operating parts, hardened steel poppet.
Operating Temp. Range/Seals	-34°C to +121°C (Nitrile, Buna-N) (-30°F to +250°F) -26°C to +204°C (Fluorocarbon) (-15°F to +400°F)
Fluid Compatibility/Viscosity	Mineral-based or synthetic with lubricating properties at viscosities of 45 to 2000 SSU (6 to 420 cSt)
Filtration	ISO-4406 18/16/13, SAE Class 4
Approx. Weight	.06 kg (.13 lbs.)
Cavity	2C (See BC Section for more details)

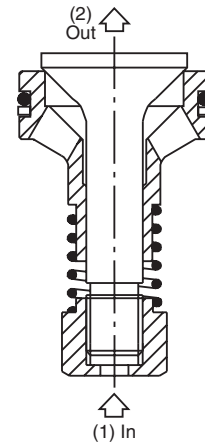
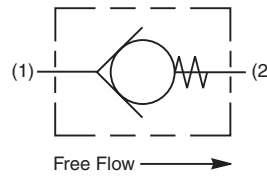

Dimensions Millimeters (Inches)

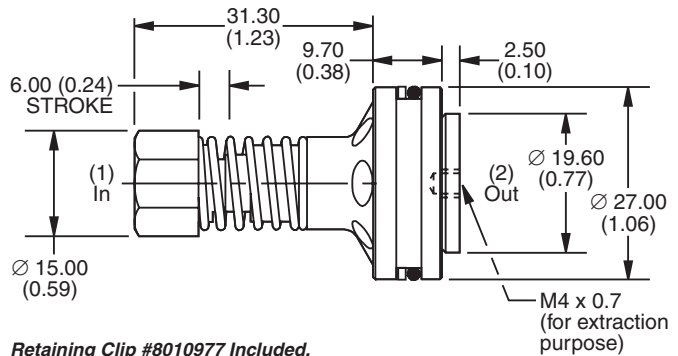

Retaining Clip #8010977 Included.

Ordering Information

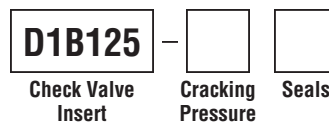

Code	Cracking Pressure
0.0	0 Bar (0 PSI)
0.1	0.1 Bar (1.5 PSI)
0.2	0.2 Bar (3 PSI)
1.0	1.0 Bar (15 PSI) Std.
2.0	2.0 Bar (30 PSI)
3.0	3.0 Bar (45 PSI)
5.0	5.0 Bar (72 PSI)

Code	Seals / Kit No.
N	Nitrile, Buna-N / (SK30014N-1)
V	Fluorocarbon / (SK30014V-1)

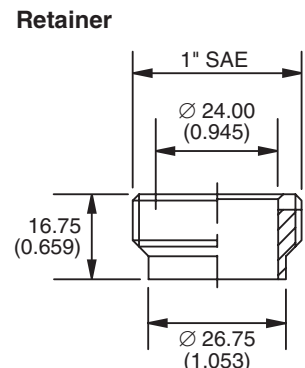

Note: Valve is supplied with retention round wire circlip. As an alternative to circlip retention of the check valve insert, the threaded retainer shown here can be used to lock the insert beneath 1" SAE ports and should be ordered separately. For 1" SAE order as RT10002. Torque to 85 Nm (63 lb. ft.)

CV
Check Valves

SH
Shuttle Valves

LM
Load/Motor Controls

FC
Flow Controls

PC
Pressure Controls

LE
Logic Elements

DC
Directional Controls

MV
Manual Valves

SV
Solenoid Valves

PV
Proportional Valves

CE
Coils & Electronics

BC
Bodies & Cavities

TD
Technical Data