



# SHURFLO BLASTER™ II

## MARINE WASHDOWN PUMP – PRODUCT TECHNICAL DATA SHEET

OEM: 4238-121-A07  
 AFTERMARKET: 4238-121-E07



### APPLICATION:

Marine fresh or salt water wash-down installation.  
 This pump may be used for general water transfer.

### PUMP DESIGN:

Type: 4 Chamber Diaphragm pump  
 Ports: ½”-14 NPSM-Male  
 Liquid: 130°F [54°C] Max  
 Dry-Prime: 6 feet [1.82 M]  
 Run Dry: Yes  
 Inlet Pressure: 30 PSI Max. [2.06 Bar]

### ELECTRICAL:

Motor: 12V DC Permanent Magnet, Intermittent Duty.  
 Protection: Thermal Overload, Automatic Restart  
 Leads: 14 AWG, 14 ¾” [37 cm] Red +, 15” [38 cm] Black  
 Fuse: 10 Amp Recommended  
 Control: Shut-Off 45 PSI [3.1 Bar] ± 2 PSI [0.13 Bar]  
 Re-start 30 PSI [2.0 Bar] ± 2 PSI [0.13 Bar]

### MATERIALS OF CONSTRUCTION:

Housings: Polypro  
 Valves/Seals: EPDM  
 Diaphragm: Santoprene  
 Hardware: Stainless Steel

### AGENCY APPROVALS:

Ignition Protection 8846, CE, IMCI Certified

### SHIPPING INFORMATION:

Approx. Net Weight: 5.2 lbs. [2.4 Kg] ea.  
 Carton Qty.: 6  
 Approx. Carton Weight: 31.2 lbs. [14.1 Kg]  
 Approx. Carton Size: 24”L X 18”W X 6”H [61cm x 46cm x 15cm]  
 Retail (individual) box: 11”L X 6”W X 5”H [28cm x 15cm x 13cm]

### Aftermarket model includes:

- Pistol grip plastic spray nozzle
- Fittings: swivel straight adapter ½-14 NPT (hex-wing nut) x ¾ barb (Qty. 2)
- Fitting: swivel straight adapter ½-14 NPT (hex-wing nut) x ¾ NHR (Male) (Qty. 1)

### REPAIR KITS

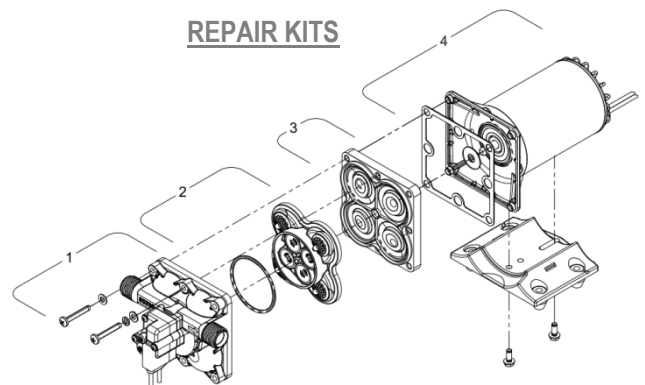

Number	Description	Part Number
1	Upper Assembly	94-800-13
2	Valve Assembly	94-800-01
3	Drive Assembly	94-800-15
4	Motor/Gasket	94-71-002-07
1,2,3	Pump Head	94-800-17
Not Shown	Check Valve	94-800-03

**RELATED DOCUMENTS:**

Catalog: MS-030-140  
 App Guide Sheet : MS-020-005  
 Installation Manual: 911-1047  
 Aftermarket Warranty: 911-1045

**TYPICAL PERFORMANCE AT 12V**

PRESSURE		FLOW		CURRENT
BAR	PSI	GPM	LPM	AMPS
0	0	3.7	14.0	3.0
0.7	10	2.7	10.2	3.9
1.4	20	2.3	8.7	4.9
2.1	30	2.0	7.5	5.8
2.8	40	1.8	6.8	7.5

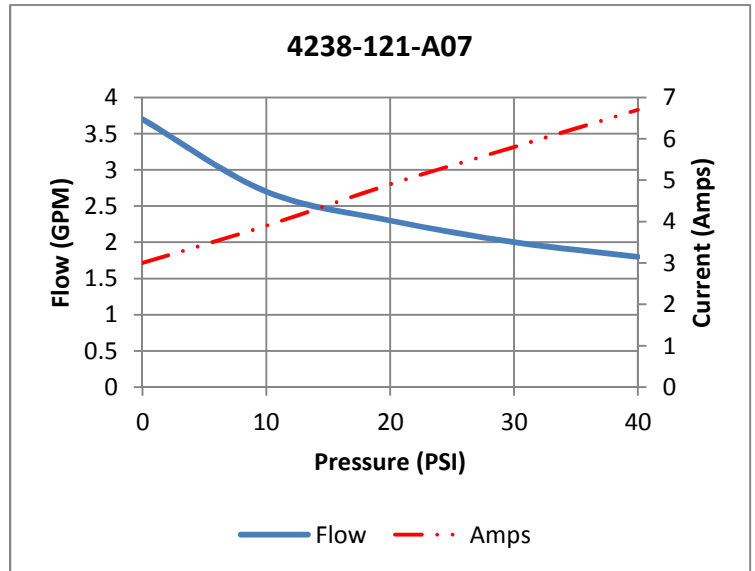

**DIMENSIONS:**

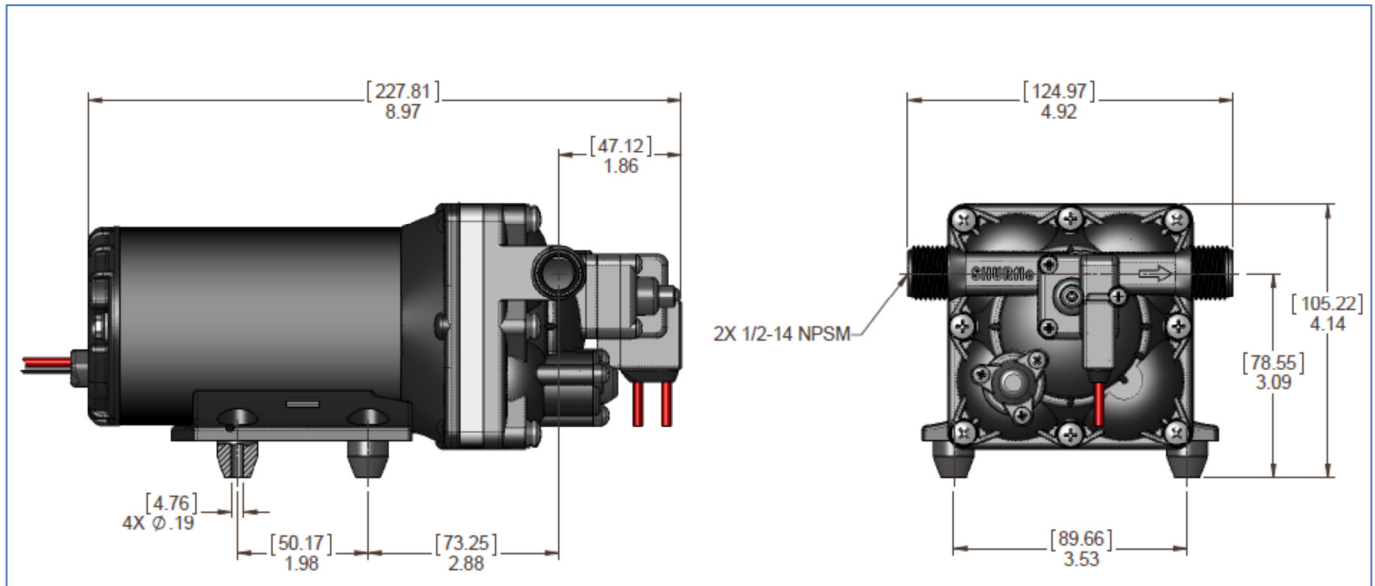

3545 Harbor Gateway South, Suite 103, Costa Mesa, CA 92626, (800) 854-3218 www.SHURFLO.com

All Pentair trademarks and logos are owned by Pentair, Inc. All other brand or product names are trademarks or registered marks of their respective owners. Because we are continuously improving our products and services, Pentair reserves the right to change specifications without prior notice. Pentair is an equal opportunity employer.