

TEST REPORT

for
STATIC TESTING
of
TRAIN C BEAM CLAMPS AND UNISTRUT HANGERS
for
COMANCHE PEAK STEAM ELECTRIC STATION (CPSES) ✓

CCL TEST PROCEDURE
1903.23-01, Revision 0

Report Date: July 10, 1986
CCL Report Number: A-720-86
CCL Project Number: 85-1903.23/24
TUGCO P.O. Number: CPF-11167-S
SUPPLEMENT Number: 25

By Jeffrey H. Bond
Jeffrey H. Bond, P.E.

Checked By Keith F. Armstrong
Keith F. Armstrong

Approved By D. Gary Hughes
D. Gary Hughes, P.E.
CORPORATE CONSULTING AND
DEVELOPMENT COMPANY, LTD.

Approved By _____
TEXAS UTILITIES GENERATING
COMPANY

Prepared By
CORPORATE CONSULTING & DEVELOPMENT COMPANY, LTD.
P.O. Box 12728
Research Triangle Park, North Carolina 27709-9998

for
TEXAS UTILITIES GENERATING COMPANY
P.O. BOX 1002 - GLEN ROSE, TEXAS 76043

Report Prepared By: Jeffrey H. Bond
Technical Editor: Darlene H. Rachal
Technical Typist: Beverly J. Williams
Q.A. Review: *A. Hatmaker*
Original Issue: July 10, 1986

REVISION(S)

Number	Issue Date	Revision By	Checked By	Q.A. By	Description and Pages Revised

Copyright 1986
CORPORATE CONSULTING AND DEVELOPMENT COMPANY, LTD.
Research Triangle Park, North Carolina

TABLE OF CONTENTS

	<u>Page</u>
LIST OF TABLES	ii
1. INTRODUCTION	1
2. TEST OBJECTIVES	2
3. TEST SETUPS	3
3.1 Threaded Rod Beam Clamps	3
3.2 Beam Clamps	3
3.3 UNISTRUT Hangers	3
4. TEST RESULTS SUMMARY	5
4.1 Threaded Rod Beam Clamp Test Results	5
4.2 Beam Clamp Test Results	5
4.3 UNISTRUT Hanger Test Results	5
5. TEST DATA	13
6. REFERENCES	16
APPENDIX A CCL TEST PROCEDURE NUMBER 1903.23-01, REVISION 0	
APPENDIX B RECORDS OF DEVIATION FROM TEST PROCEDURE, NUMBERS 1 THROUGH 10	
APPENDIX C TUGCO CONCRETE PLACEMENT SUMMARY TSG-13,916	
APPENDIX D PROJECT 1903.23/24 MASTER TEST MONITOR LOG	
APPENDIX E TEST SETUP FIGURES, PLOTS, DATA, AND PHOTOGRAPHS	

LIST OF TABLES

	<u>Page</u>
Table 4.1 Threaded Rod Beam Clamp Test Data	6
Table 4.2 Beam Clamp Test Data	7
Table 4.3 UNISTRUT Hanger Test Data	11
Table 5.1 Summary of Calibrated Equipment	14

1. INTRODUCTION

This report documents the results of testing of beam clamps and UNISTRUT® hangers used to support Train C conduit for Texas Utilities Generating Company (TUGCO) at Comanche Peak Steam Electric Station (CPSES) in Glen Rose, Texas.

Static testing was performed to determine the ultimate load carrying capacity of the test items. The test items included:

- UNISTRUT P2785 and P2786 beam clamps
- Appleton PC-200-RA beam clamp
- UNISTRUT P254x series welded foot hanger
- UNISTRUT P1026 hanger fittings

Cyclic testing was performed to determine the fatigue life of CPSES threaded rod when used in conjunction with UNISTRUT P1651S beam clamps.

Testing was performed at the laboratory facilities of Corporate Consulting and Development Company, Ltd. (CCL) near Research Triangle Park, North Carolina during the months of May and June, 1986. The test program was performed in accordance with CCL Test Procedure Number 1903.23-01, Revision 0 (Reference 1, included in this report as Appendix A), and the procedures and instructions of CCL's Quality Assurance (QA) program. CCL's QA program complies with the applicable requirements of ANSI N45.2-1972; 10CFR50, Appendix B; and 10CFR21.

2. TEST OBJECTIVES

The test procedure used to assemble and test the items described in the previous section was written to incorporate the requirements given by Impell Corporation (Impell) in Report Number 01-0210-1514, Revision 0 (Reference 2, included in this report as part of Appendix A).

During the course of the test program it was necessary to add, delete, or otherwise modify several of the test configurations. To adequately document and approve such changes, Record of Deviation from Test Procedure (RDTP) forms were implemented to augment the Reference 1 test procedure. Appendix B of this report presents RDTP numbers 1 through 10.

The results of testing, including plots, data, test log entries, and photographs are presented for use in evaluation of this data.

3. TEST SETUPS

The test samples are intended to simulate typically installed conditions at CPSES. The test samples are assembled as indicated in the sketches contained in References 1 and 2 in accordance with instructions from the UNISTRUT Catalog 10R (Reference 2) and CPSES DCA 5106, Revision 9 (Reference 3, included in this report as part of Appendix A).

The following sections describe the test setup used for each general category of test.

3.1 Threaded Rod Beam Clamps

The cyclic tests of UNISTRUT P1651S beam clamps were intended to simulate typically installed conditions for threaded rod attachments to wide-flange (WF) structural members. The purpose of the tests was to determine the fatigue life of the rod/clamp assembly when assembled and installed on a WF member.

The threaded rod beam clamp test setups are schematically illustrated in Figures 6.1 and 6.2 of Reference 1.

3.2 Beam Clamps

The static tests performed on UNISTRUT P2785, P2786, and Appleton PC-200-RA beam clamps were intended to simulate typically installed conditions for attachment of UNISTRUT channel and conduit to a WF member. The purpose of the tests was to determine the stiffness, ultimate load capacity, and modes of failure of the beam clamp assemblies.

The beam clamp test setups are schematically illustrated in Figures 6.3 through 6.22 of Reference 1 and are further addressed in RDTP numbers 1, 8, 9, and 10.

3.3 UNISTRUT Hangers

The static tests performed on cantilever hangers assembled from UNISTRUT P1000 channel, P1001 channel, P254x series welded foot hangers,

and P1026 angle brackets were intended to simulate typically installed conditions, including concrete attachments. The purpose of the tests was to determine stiffness and ultimate load characteristics, and modes of failure of the cantilever hanger assemblies.

The cantilever hanger test setups are schematically illustrated in Figures 6.23 and 6.24 of Reference 1 and are further addressed in RDTP numbers 5 and 7. These concrete-mounted test setups were installed with HILTI® bolts in accordance with CEI-20, Installation of HILTI Drilled-In Bolts (Reference 5). The bolts were installed into a reinforced concrete block that was fabricated by TUGCO at CPSES. The block was fabricated in accordance with TUGCO Drawing Number FSC-0905, Revision 2, and TUGCO concrete mix and placement procedures. The concrete placement summary for the reinforced concrete block used during the test is documented in TUGCO letter number TSG-13,916 (included in this report as Appendix C).

The HILTI bolts were set in concrete with the appropriate test sample and torqued in accordance with Section 3.1.4 of Reference 5. The date and time of torquing were recorded to document the start of bolt relaxation. Testing of each HILTI bolt did not commence until the bolt had relaxed for a minimum of 48 hours.

4. TEST RESULTS SUMMARY

The master test monitor log, included in this report as Appendix D, presents the test sequence and includes general descriptions of test sample modes of failure. The actual test results are included in this report as Appendix E. The following sections describe the test results for the samples.

4.1 Threaded Rod Beam Clamp Test Results

Each beam clamp, with a 2-foot length of threaded rod, was cycled separately in both principal horizontal directions in accordance with test procedure requirements and direction from the TUGCO representative witnessing the test.

For each test configuration, three samples were tested. The first sample was cycled as shown in Figures 6.1 and 6.2 in Reference 1. The next two samples were cycled with the threaded rod placed in tension with a one thousand pound preload. All test samples successfully met the requirement of 100 cycles of deflection-controlled input at $\pm 4\text{-}1/2$ inches. Table 4.1 summarizes the test inputs and results.

4.2 Beam Clamp Test Results

The beam clamps described in Section 3.2 were tested in accordance with the test procedure and all applicable RDTP's. Table 4.2 summarizes the test setups and ultimate loads obtained during testing.

4.3 UNISTRUT Hanger Test Results

The UNISTRUT hangers described in Section 3.3 were tested in accordance with the test procedure and all applicable RDTP's. Table 4.3 summarizes the test setups and ultimate loads obtained during testing.

Table 4.1 Threaded Rod Beam Clamp Test Data

Test Sample Number	Preload (pounds)	Cycle Stroke (inches)	Load Required to Impose Deflection (pounds)	
			After 1 Cycle	After 100 Cycles
1a-01	0	$\pm 4-1/2$	40	40
1a-02	1000	$\pm 4-1/2$	285	280
1a-03	1000	$\pm 4-1/2$	295	295
1b-01	0	$\pm 4-1/2$	40	40
1b-02	1000	$\pm 4-1/2$	290	280
1b-03	1000	$\pm 4-1/2$	285	270

Table 4.2 Beam Clamp Test Data

Test Configuration Number	Beam Clamp Description	Ultimate Load (pounds)		
		Test Number One	Test Number Two	Test Number Three
2a-12	Two P2785's with a 12-inch extension of P1000 channel on a WF test fixture	3,532	5,639	5,470
2b-12	Two P2785's with a 12-inch extension of P1000 channel on a WF test fixture	2,385 ⁽⁰²⁾	2,200 ⁽⁰³⁾	2,012 ⁽⁰⁴⁾
2c-12	Two P2785's with a 12-inch extension of P1000 channel on a WF test fixture	1,381 ⁽⁰⁴⁾	1,387 ⁽⁰⁵⁾	1,399 ⁽⁰⁶⁾
2d-12	Two P2785's with a 12-inch extension of P1000 channel on a WF test fixture	1,948	1,863	1,705
2b-24	Two P2785's with a 24-inch extension of P1000 channel on a WF test fixture	470	738	602
2c-24	Two P2785's with a 24-inch extension of P1000 channel on a WF test fixture	721	757	818

(Continued)

() Upper right-hand corner number is actual test number, if other than column heading

Table 4.2 Beam Clamp Test Data

Test Configuration Number	Beam Clamp Description	Ultimate Load (pounds)		
		Test Number One	Test Number Two	Test Number Three
2d-24	Two P2785's with a 24-inch extension of P1000 channel on a WF test fixture	848	829	801
3a-12	Two P2786's with a 12-inch extension of P5000 channel on a WF test fixture	4,541	5,588	3,725
3b-12	Two P2786's with a 12-inch extension of P5000 channel on a WF test fixture	2,214	2,426	2,164
3c-12	Two P2786's with a 12-inch extension of P5000 channel on a WF test fixture	1,944	1,734	1,864
3d-12	Two P2786's with a 12-inch extension of P5000 channel on a WF test fixture	2,062	2,370	2,022
3b-24	Two P2786's with a 24-inch extension of P5000 channel on a WF test fixture	565	917	798

(Continued)

() Upper right-hand corner number is actual test number, if other than column heading

Table 4.2 Beam Clamp Test Data

Test Configuration Number	Beam Clamp Description	Ultimate Load (pounds)		
		Test Number One	Test Number Two	Test Number Three
3c-24	Two P2786's with a 24-inch extension of P5000 channel on a WF test fixture	948	970	851
3d-24	Two P2786's with a 24-inch extension of P5000 channel on a WF test fixture	1,012	866	905
5a	A single Appleton PC-200-RA with a 12-inch extension of 2-inch diameter conduit on a WF test fixture	1,445 ⁽⁰²⁾	1,489 ⁽⁰⁴⁾	1,752 ⁽⁰⁵⁾
5b	A single Appleton PC-200-RA with a 12-inch extension of 2-inch diameter conduit on a WF test fixture	952	1,146	1,121
5c	A single Appleton PC-200-RA with a 12-inch extension of 2-inch diameter conduit on a WF test fixture	5,930	6,532	5,254
10c-12	Two P2786's with a 12-inch extension of P5500 channel on a WF test fixture	1,611	1,758	1,756

(Continued)

() Upper right-hand corner number is actual test number, if other than column heading

Table 4.2 Beam Clamp Test Data

Test Configuration Number	Beam Clamp Description	Ultimate Load (pounds)		
		Test Number One	Test Number Two	Test Number Three
11a	A single P2785 with a 12-inch extension of P1000 channel on a WF test fixture	231	238	251
11b	A single P2785 with a 12-inch extension of P1000 channel on a WF test fixture	208	167	201

(Concluded)

() Upper right-hand corner number is actual test number, if other than column heading

Table 4.3 UNISTRUT Hanger Test Data

Test Configuration Number	Hanger Description	Ultimate Load (pounds)		
		Test Number One	Test Number Two	Test Number Three
6	A P2546 bolted to a 16-inch P1000 channel header, which is HILTI bolted (3/8-inch diameter, 4-inch embed) to a concrete test fixture	863	1,456	1,489
7	P1000 attached with two P1026 brackets to a 16-inch P1000 channel header, which is HILTI bolted (3/8-inch diameter, 4-inch embed) to a concrete test fixture	1,885 ⁽⁰¹⁾	1,649 ⁽⁰²⁾	1,900 ⁽⁰⁴⁾
9a	Two P254x bolted to a 16-inch P1000 channel header which is HILTI bolted (3/8-inch diameter, 4-inch embed) to a concrete test fixture	567	1,281	1,315
9b	Two P254x bolted to a 16-inch P1000 channel header which is HILTI bolted (3/8-inch diameter, 4-inch embed) to a concrete test fixture	2,258 ⁽⁰²⁾	2,485 ⁽⁰³⁾	2,534 ⁽⁰⁴⁾

(Continued)

() Upper right-hand corner number is actual test number, if other than column heading

Table 4.3 UNISTRUT Hanger Test Data

Test Configuration Number	Hanger Description	Ultimate Load (pounds)		
		Test Number One	Test Number Two	Test Number Three
9c	Two P254x bolted to a 16-inch P1000 channel header which is HILTI bolted (3/8-inch diameter, 4-inch embed) to a concrete test fixture	5,940 ⁽⁰⁵⁾	6,708 ^(06a)	6,155 ⁽⁰⁷⁾

(Concluded)

() Upper right-hand corner number is actual test number, if other than column heading

5. TEST DATA

All test setup figures, plots, data, and photographs relating to this test program are included in this report in Appendix E. Appendix E presents results relating to threaded rod beam clamps, beam clamps, and UNISTRUT hangers.

The test results for the threaded rod beam clamps include:

- Test setup figures
- Force-versus-deflection hysteresis plots
- Photographs of pre- and post-test results

The test results for beam clamps and UNISTRUT hangers include:

- Test setup figures
- Force-versus-deflection plots
- Printout of force-versus-deflection data
- Photographs of pre- and post-test results

Table 5.1 presents a summary of all calibrated equipment used in this test program. Calibration records are maintained by CCL.

Table 5.1 Summary of Calibrated Equipment

Instrument/ Description	CCL No.	Manufacturer	Model No.	Serial No.	Range	Accuracy	Calibration	
							Last Done	Next Done
Load Cell	7007	Lebow	3124	1692	5K lbs	± 0.2%	5/31/86	5/31/87
Load Cell	7012	Lebow	3124	1735	15K lbs	± 0.32%	7/29/85	7/29/86
Load Cell	7015	Lebow	3132	5770	3K lbs	± 0.07%	7/26/85	7/26/86
Load Cell	7018	Lebow	3124	2217	10K lbs	± 0.1%	5/25/86	5/25/87
Load Cell	7023	Lebow	3174	265	10K lbs	± 0.408%	6/13/86	6/13/87
Load Cell	7038	Lebow	3174	209	5K lbs	± 0.15%	6/16/86	6/16/87
LVDT	1083	Schaevitz	2000HR	10590	± 2 inch	± 0.22%	Prior to use	
Load Cell Indicator	1069	Daytronic	3270	6165	0-±20K Cts	± 0.05% FS	9/17/85	9/17/86
Load Cell Indicator	1062	Daytronic	3270	6761	5K Cts	± 0.05% FS	3/5/86	3/5/87
LVDT Indicator	1078	Daytronic	3330	497	5K Cts	± 0.1% FS	7/3/86	7/3/87
Linear Potentiometer	1060	Bourns	12820-0- 10.0-0- 503	4-5933	0-10"	± 0.0625"	Prior to use	
Linear Potentiometer	1098	Waters	PR-242	1002	0-12"	± 1%	Prior to use	
Linear Potentiometer	1103	Waters	LFS-12/ 300-0A5	8538	0-12"	± 1%	Prior to use	
Cal. Resistor Box	1012	CCL	N/A	N/A	40,60,120KΩ	± 0.038%	2/12/86	2/12/87
Cal. Resistor Box	1081	CCL	N/A	N/A	60KΩ	± 0.1%	9/12/85	9/12/86
X-Y Plotter	3008	Esterline/ Angus	575-LAB S.O. #M12989A	978972	X 100 Mv/in Y 100 Mv/in	± 0.35% FS	Prior to use	

(Continued)

Table 5.1 Summary of Calibrated Equipment

Instrument/ Description	CCL No.	Manufacturer	Model No.	Serial No.	Range	Accuracy	Calibration	
							Last Done	Next Done
Rule	9032	Starrett	1-C #607 R36	N/A	0-36"	± 0.0156"	1/3/86	1/3/87
Torque Wrench	9030	Utica	TCI-150 FRD	DD 2673	0-150 ft/lbs	± 4% CW	4/3/86	9/3/86
Digital Voltmeter	6005	Keithly	179	1174	0-20 VDC	± 0.04% Plus one digit	7/19/85	7/19/86
Digital Voltmeter	6048	Keithly	197	310470	0-20 VDC	± 0.015% Plus two digits	5/31/85	6/30/86
Digital Voltmeter	6049	Fluke	8024B	3715179	0-20 VDC	± 0.1% Reading + 1 digit	5/20/86	11/20/86
Torque Transducer	7026	GSE	1052	008	0-50 ft/lbs	± 0.25% FS	8/19/85	8/12/86
Michead	9027	Starrett	63	N/A	2"	0.0001 in.	2/28/86	2/28/88
ACRO/LABTECH DATA ACQUISITION SYSTEM 900								
Gen I/O P.S.	3015	Acro	901	N/A	N/A	N/A	N/A	N/A
Gen I/O CPU	3017	Acro	991	N/A	N/A	N/A	N/A	N/A
Gen I/O A/D	3022	Acro	912	N/A	± 2/20 VDC	± 0.03% Input ± 0.1% Range	Prior to use	

(Concluded)

6. REFERENCES

1. Corporate Consulting and Development Company, Ltd. Test Procedure Number 1903.23-01, Revision 0, dated May 9, 1986, Test Procedure for Static and Cyclic Testing of Train C Conduit Beam Clamps and UNISTRUT Hangers for Comanche Peak Steam Electric Station.
2. Impell Corporation Report Number 01-0210-1514, Revision 0, dated April 22, 1986, Specification for Testing Beam Clamps and UNISTRUT Hangers.
3. UNISTRUT General Engineering Catalog, Number 10R, 1984.
4. Comanche Peak Steam Electric Station Design Change Authorization (DCA) Number 5106, Revision 9, dated January 3, 1983.
5. Brown & Root, Inc. Procedure Number CEI-20, Revision 9, dated December 16, 1983, including Document Change Notice (DCN) Numbers 1 and 2, Installation of HILTI Drilled-In Bolts.

APPENDIX A

CCL TEST PROCEDURE NUMBER 1903.23-01, REVISION 0

TEST PROCEDURE

for

STATIC AND CYCLIC TESTING

of

TRAIN C CONDUIT BEAM CLAMPS AND UNISTRUT HANGERS

for

COMANCHE PEAK STEAM ELECTRIC STATION (CPSES)

DMPELL REPORT NUMBER:

01-0210-1514, Revision 0

Procedure Date:

May 9, 1986

CCL Procedure Number:

1903.23-01

CCL Project Number:

85-1903.23

By



Jeffrey W. Bond, P.E.

Checked By

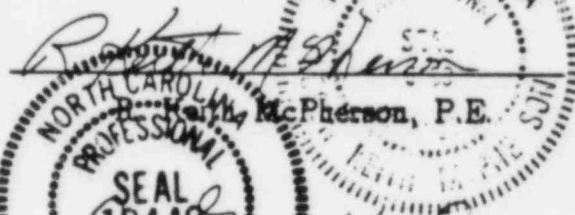

Robert A. McPherson, P.E.

Approved By

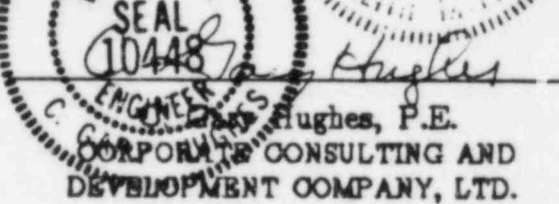

C. S. Hughes, P.E.

CORPORATE CONSULTING AND
DEVELOPMENT COMPANY, LTD.

Approved By

TEXAS UTILITIES GENERATING
COMPANY

Prepared By

CORPORATE CONSULTING & DEVELOPMENT COMPANY, LTD.

P.O. Box 12728

Research Triangle Park, North Carolina 27709-9928

for

TEXAS UTILITIES GENERATING COMPANY

P.O. BOX 1002 - GLEN ROSE, TEXAS 76043

Report Prepared By: Jeffrey H. Bond
Technical Editor: Darlene H. Rachal
Technical Typist: Wanda W. Stephenson
Q.A. Review: *[Signature]*
Original Issue: May 9, 1986

REVISION(S)

Number	Issue Date	Revision By	Checked By	Q.A. By	Description and Pages Revised

Copyright 1986
CORPORATE CONSULTING AND DEVELOPMENT COMPANY, LTD.
Research Triangle Park, North Carolina



Corporate Consulting
& Development Company, Ltd.

Research Triangle Park NC 27709
P.O. Box 12725 • 919-362-8800

TEST PROCEDURE

PROCEDURE No. 1903.23-1, Rev. 0
 ISSUE DATE 5/9/86 PAGE 1 OF 87
 PREPARED BY [Signature] DATE 5-9-86
 APPROVED BY C. [Signature] DATE 9 May 86
 APPROVED BY [Signature] DATE 5/9/86
 QA REVIEW BY [Signature] DATE 5/9/86

TABLE OF CONTENTS

	PAGE
LIST OF FIGURES.....	2
LIST OF TABLES.....	5
1.0 INTRODUCTION.....	6
1.1 Test Program Contents.....	6
1.2 Personnel Certification.....	7
1.3 Test Monitor.....	7
1.4 Test Equipment and System Calibration.....	7
2.0 TEST ITEMS.....	9
2.1 UNISTRUT P1651S Beam Clamp Cyclic Tests.....	9
2.2 UNISTRUT P2785 and P2786 Beam Clamp Static Tests.....	9
2.3 Appleton PC-200-RA Conduit Clamp Static Tests.....	10
2.4 Cantilever Hanger Static Tests.....	10
3.0 TEST FIXTURING.....	17
3.1 Fixturing for Beam Clamps.....	17
3.2 Fixturing for Cantilever Hanger.....	17
4.0 INSTRUMENTATION.....	19
5.0 TEST SEQUENCE.....	22
6.0 TEST SETUP.....	24
7.0 TEST REPORT.....	50
8.0 REFERENCES.....	51
APPENDIX 1 IMPELL TEST SPECIFICATION NUMBER 01-0210-1514.....	52
APPENDIX 2 TUGCO DCA NUMBER 5106, REV. 9.....	71
APPENDIX 3 RECORD OF DEVIATION.....	86



Corporate Consulting
& Development Company, Ltd.

Research Triangle Park NC 27709
P.O. Box 12728 • 919-362-8800

PROCEDURE No. 1903.23-1, Rev. 0
ISSUE DATE 5/9/86 PAGE 2 OF 87
PREPARED BY _____ DATE _____
APPROVED BY _____ DATE _____
APPROVED BY _____ DATE _____
QA REVIEW BY _____ DATE _____

TEST PROCEDURE

LIST OF FIGURES (Continued)

	PAGE
Figure 2.1 Illustration of Test Numbers 1a and 1b.....	13
Figure 2.2 Illustration of Test Numbers 2a through 2d, and 3a through 3d.....	14
Figure 2.3 Illustration of Test Numbers 5a through 5d.....	15
Figure 2.4 Illustration of Test Numbers 6, 7, and 8.....	16
Figure 4.1 Sample Static Test Load-Versus-Deflection Curve.....	21
Figure 6.1 Test Sample Number 1a: UNISTRUT P1651S Beam Clamp Cyclic Test in the 1 Direction.....	25
Figure 6.2 Test Sample Number 1b: UNISTRUT P1651S Beam Clamp Cyclic Test in the 2 Direction.....	26
Figure 6.3 Test Sample Number 2a-12: UNISTRUT P2785 Beam Clamp Static Test in the 1 Direction with a 12-inch Moment Arm.....	27
Figure 6.4 Test Sample Number 2b-12: UNISTRUT P2785 Beam Clamp Static Test in the 2 Direction with a 12-inch Moment Arm.....	28
Figure 6.5 Test Sample Number 2c-12: UNISTRUT P2785 Beam Clamp Static Test in the 3 Direction with a 12-inch Moment Arm.....	29
Figure 6.6 Test Sample Number 2d-12: UNISTRUT P2785 Beam Clamp Static Test in the -3 Direction with a 12-inch Moment Arm.....	30



Corporate Consulting
& Development Company, Ltd.

Research Triangle Park, NC 27709
PO Box 12728 • 919-362-8800

TEST PROCEDURE

PROCEDURE No. 1903.23-1, Rev. 0
ISSUE DATE 5/9/86 PAGE 3 OF 87
PREPARED BY _____ DATE _____
APPROVED BY _____ DATE _____
APPROVED BY _____ DATE _____
QA REVIEW BY _____ DATE _____

LIST OF FIGURES (Continued)

	PAGE
Figure 6.7 Test Sample Number 2a-24: UNISTRUT P2785 Beam Clamp Static Test in the 1 Direction with a 24-inch Moment Arm.....	31
Figure 6.8 Test Sample Number 2b-24: UNISTRUT P2785 Beam Clamp Static Test in the 2 Direction with a 24-inch Moment Arm.....	32
Figure 6.9 Test Sample Number 2c-24: UNISTRUT P2785 Beam Clamp Static Test in the 3 Direction with a 24-inch Moment Arm.....	33
Figure 6.10 Test Sample Number 2d-24: UNISTRUT P2785 Beam Clamp Static Test in the -3 Direction with a 24-inch Moment Arm.....	34
Figure 6.11 Test Sample Number 3a-12: UNISTRUT P2786 Beam Clamp Static Test in the 1 Direction with a 12-inch Moment Arm.....	35
Figure 6.12 Test Sample Number 3b-12: UNISTRUT P2786 Beam Clamp Static Test in the 2 Direction with a 12-inch Moment Arm.....	36
Figure 6.13 Test Sample Number 3c-12: UNISTRUT P2786 Beam Clamp Static Test in the 3 Direction with a 12-inch Moment Arm.....	37
Figure 6.14 Test Sample Number 3d-12: UNISTRUT P2786 Beam Clamp Static Test in the -3 Direction with a 12-inch Moment Arm.....	38
Figure 6.15 Test Sample Number 3a-24: UNISTRUT P2786 Beam Clamp Static Test in the 1 Direction with a 24-inch Moment Arm.....	39
Figure 6.16 Test Sample Number 3b-24: UNISTRUT P2786 Beam Clamp Static Test in the 2 Direction with a 24-inch Moment Arm.....	40



Corporate Consulting
& Development Company, Ltd.

Research Triangle Park, NC 27709
P.O. Box 12728 • 919-362-8800

TEST PROCEDURE

PROCEDURE No. 1903.23-1, Rev. 0
 ISSUE DATE 5/9/86 PAGE 4 OF 87
 PREPARED BY _____ DATE _____
 APPROVED BY _____ DATE _____
 APPROVED BY _____ DATE _____
 QA REVIEW BY _____ DATE _____

LIST OF FIGURES (Concluded)

	PAGE
Figure 6.17 Test Sample Number 3c-24: UNISTRUT P2786 Beam Clamp Static Test in the 3 Direction with a 24-inch Moment Arm.....	41
Figure 6.18 Test Sample Number 3d-24: UNISTRUT P2786 Beam Clamp Static Test in the -3 Direction with a 24-inch Moment Arm.....	42
Figure 6.19 Test Sample Number 5a: Appleton PC-200-RA Beam Clamp Static Test in the 1 Direction.....	43
Figure 6.20 Test Sample Number 5b: Appleton PC-200-RA Beam Clamp Static Test in the 2 Direction.....	44
Figure 6.21 Test Sample Number 5c: Appleton PC-200-RA Beam Clamp Static Test in the 3 Direction.....	45
Figure 6.22 Test Sample Number 5d: Appleton PC-200-RA Beam Clamp Static Test in the -3 Direction.....	46
Figure 6.23 Test Sample Number 6: UNISTRUT P2546 Cantilever Hanger Static Test in the Weak Direction.....	47
Figure 6.24 Test Sample Number 7: UNISTRUT P1026 Cantilever Hanger Static Test in the Weak Direction.....	48
Figure 6.25 Test Sample Number 8: UNISTRUT P2546/P2348 Cantilever Hanger Static Test in the Weak Direction.....	49



Corporate Consulting
& Development Company, Ltd.

Research Triangle Park, NC 27709
P.O. Box 12728 • 919-362-8800

TEST PROCEDURE

PROCEDURE No. 1903.23-1, Rev. 0
ISSUE DATE 5/9/86 PAGE 5 OF 87
PREPARED BY _____ DATE _____
APPROVED BY _____ DATE _____
APPROVED BY _____ DATE _____
QA REVIEW BY _____ DATE _____

LIST OF TABLES

	PAGE
Table 2.1 Summary of Tests.....	11
Table 4.1 Sample Load-Versus-Deflection Table.....	20



Corporate Consulting
& Development Company, Ltd.

Research Triangle Park, NC 27709
P.O. Box 12728 • 919-362-8800

TEST PROCEDURE

PROCEDURE No. 1903.23-1, Rev. 0
 ISSUE DATE 5/9/86 PAGE 6 OF 87
 PREPARED BY _____ DATE _____
 APPROVED BY _____ DATE _____
 APPROVED BY _____ DATE _____
 QA REVIEW BY _____ DATE _____

1.0 INTRODUCTION

This test procedure describes the requirements for static and cyclic testing of beam clamps and UNISTRUT® hangers used to support Train C conduit for Texas Utilities Generating Company (TUGCO) at Comanche Peak Steam Electric Station (CPSES) in Glen Rose, Texas. Testing will be performed at the laboratory facilities of CCL Laboratories, Inc. (CCL) near Research Triangle Park, North Carolina. Testing shall be in accordance with the Impell Corporation Specification Number 01-0210-1514, Revision 0, Specification for Testing Beam Clamps and UNISTRUT Hangers (Reference 1), included as Appendix 1, TUGCO's Design Change Authorization concerning installation of Train C conduit (Reference 2), included as Appendix 2, and this test procedure.

The test program will be performed in accordance with the procedures and instructions of CCL's Quality Assurance (QA) program. This fully documented QA program complies with the applicable requirements of ANSI N45.2-1972, 10CFR50 Appendix B, and 10CFR21.

1.1 Test Program Contents

This test program consists of the following tests:

<u>Description</u>	<u>Type of Test</u>
UNISTRUT P1651S beam clamp	Cyclic
UNISTRUT P2785 and P2786 beam clamps	Static
Appleton PC-200-RA beam clamp	Static
UNISTRUT P2546 welded foot hanger	Static
UNISTRUT P1026 hanger fittings	Static
UNISTRUT P2546 welded foot hanger with P2348 fittings	Static

TEST PROCEDURE

1.2 Personnel Certification

All personnel assigned to this test program will be certified as qualified for the tasks assigned. Personnel certification is achieved through personnel education level, vocational training, and practical experience as outlined in CCL Operating Procedure (OP) 02-002.

1.3 Test Monitor

The appointed and approved test monitor, who serves as an extension to the QA Department, shall ensure that all tests are properly executed in accordance with the requirements and procedures specified herein and CCL OP 10-002.

1.4 Test Equipment and System Calibration

All test equipment and instruments used during this test program will have a decal affixed to indicate the next calibration due date. All calibrated devices used are calibrated in accordance with CCL OP 12-001 and have calibrations traceable to the National Bureau of Standards.

1.5 Deviations in Test Procedures

During the course of the overall test program, it may become necessary to deviate from the procedures specified herein. Reasons for deviations include but are not limited to:

- increased accuracy of data
- modifications to boundary conditions
- additional data (or less data) is required
- changes in methodology
- changes in test specimen configuration and hardware



Corporate Consulting
& Development Company, Ltd.

Research Triangle Park, NC 27709
P.O. Box 12728 • 919-362-8800

TEST PROCEDURE

PROCEDURE No. 1903.23-1, Rev. 0
ISSUE DATE 5/9/86 PAGE 8 OF 87
PREPARED BY _____ DATE _____
APPROVED BY _____ DATE _____
APPROVED BY _____ DATE _____
QA REVIEW BY _____ DATE _____

When the need for deviations arises, the form shown in Appendix 3 will be completed and filed in the project file. Signatures from appropriate CCL and Impell personnel will be required prior to proceeding with the stated changes. All deviations will be fully documented in the final test report.



Corporate Consulting
& Development Company, Ltd.

Research Triangle Park NC 27709
P O Box 12728 • 919-362-8800

TEST PROCEDURE

PROCEDURE No. 1903.23-1, Rev. 0
ISSUE DATE 5/9/86 PAGE 9 OF 87
PREPARED BY _____ DATE _____
APPROVED BY _____ DATE _____
APPROVED BY _____ DATE _____
QA REVIEW BY _____ DATE _____

2.0 TEST ITEMS

Table 2.1 summarizes the test items in this program. The following sections describe the test setups.

2.1 UNISTRUT P1651S Beam Clamp Cyclic Tests

Figure 2.1 illustrates test numbers 1a and 1b. The beam clamps will be subjected to cyclic loads in each of the two horizontal directions indicated in the figure.

The cyclic load will be delivered under deflection control. The threaded rod end will be cycled through an Impell-specified deflection. Each test will continue for either 100 cycles or until failure occurs in the test sample. Examples of failure are separation of the beam clamp from the wide-flange support structure, fracture of the threaded rod, or fracture of the clamp at the threaded hole where the threaded rod mates with the clamp.

2.2 UNISTRUT P2785 and P2786 Beam Clamp Static Tests

Figure 2.2 illustrates test numbers 2a through 2d, and 3a through 3d. The beam clamps will be subjected to static loads in the directions indicated in the figure and Table 2.1.

The static load will be placed on each test sample and increased gradually. Load will be continually increased until failure occurs. Examples of failure are separation of the beam clamp from the wide-flange support structure or deformations exceeding 12 inches.



Corporate Consulting
& Development Company, Ltd.

Research Triangle Park NC 27709
PO Box 12726 • 919-362-8800

TEST PROCEDURE

PROCEDURE No. 1903.23-1, Rev. 0
 ISSUE DATE 5/9/86 PAGE 10 OF 87
 PREPARED BY _____ DATE _____
 APPROVED BY _____ DATE _____
 APPROVED BY _____ DATE _____
 QA REVIEW BY _____ DATE _____

2.3 Appleton PC-200-RA Conduit Clamp Static Tests

Figure 2.3 illustrates test numbers 5a through 5d. The conduit clamps will be subjected to static loads in the directions indicated in the figure and Table 2.1.

The static load will be placed on each test sample and increased gradually. Load will be continually increased until failure occurs. An example of failure is separation of the beam clamp from the wide-flange support structure.

2.4 Cantilever Hanger Static Tests

Figure 2.4 illustrates test samples 6, 7, and 8. These are concrete-mounted supports that are to be loaded in the direction of the weak axis of the cantilevered UNISTRUT channel.

The static load will be placed on each test sample and increased gradually. Load will be continually increased until failure occurs. Examples of failure are pull-out of the attachment bolts, fracture of the weld or fitting at the base connection, fracture of UNISTRUT hardware at the channel attachment, and fracture of the UNISTRUT channel lips.



Corporate Consulting
& Development Company, Ltd.

Research Triangle Park NC 27709
P.O. Box 12728 • 919-362-8800

TEST PROCEDURE

PROCEDURE No. 1903.23-1, Rev. 0
ISSUE DATE 5/9/86 PAGE 11 OF 87
PREPARED BY _____ DATE _____
APPROVED BY _____ DATE _____
APPROVED BY _____ DATE _____
QA REVIEW BY _____ DATE _____

Table 2.1 Summary of Tests

Test Number	Test Item	Type of Test	Direction of Load	Number of Tests	Type of Attachment
1a	UNISTRUT P1651S	Cyclic	1	3	To 4-inch wide flange
1b	UNISTRUT P1651S	Cyclic	2	3	To 4-inch wide flange
2a	UNISTRUT P2785 (pair)	Static	1	6	To 4-inch wide flange, holding UNISTRUT P1000 channel
2b	UNISTRUT P2785 (pair)	Static	2	6	To 4-inch wide flange, holding UNISTRUT P1000 channel
2c	UNISTRUT P2785 (pair)	Static	3	6	To 4-inch wide flange, holding UNISTRUT P1000 channel
2d	UNISTRUT P2785 (pair)	Static	-3	6	To 4-inch wide flange, holding UNISTRUT P1000 channel
3a	UNISTRUT P2786 (pair)	Static	1	6	To 4-inch wide flange, holding UNISTRUT P5500 or P5000 channel
3b	UNISTRUT P2786 (pair)	Static	2	6	To 4-inch wide flange, holding UNISTRUT P5500 or P5000 channel
3c	UNISTRUT P2786 (pair)	Static	3	6	To 4-inch wide flange, holding UNISTRUT P5500 or P5000 channel

(Continued)

TEST PROCEDURE

PROCEDURE No. 1903.23-1, Rev. 0
 ISSUE DATE 5/9/86 PAGE 12 OF 87
 PREPARED BY _____ DATE _____
 APPROVED BY _____ DATE _____
 APPROVED BY _____ DATE _____
 QA REVIEW BY _____ DATE _____

Table 2.1 Summary of Tests

Test Number	Test Item	Type of Test	Direction of Load	Number of Tests	Type of Attachment
3d	UNISTRUT P2786 (pair)	Static	-3	6	To 4-inch wide flange, holding UNISTRUT P5500 or P5000 channel
5a	Appleton PC-200-RA	Static	1	3	To 4-inch wide flange, holding 2 inch conduit
5b	Appleton PC-200-RA	Static	2	3	To 4-inch wide flange, holding 2 inch conduit
5c	Appleton PC-200-RA	Static	3	3	To 4-inch wide flange, holding 2 inch conduit
5d	Appleton PC-200-RA	Static	-3	3	To 4-inch wide flange, holding 2 inch conduit
6	UNISTRUT P2546	Static	Lateral (Weak Direction)	3	Attached to concrete with 3/8-inch diameter HILTI® bolts with 2-inch embedment
7	UNISTRUT P1026	Static	Lateral (weak direction)	3	Attached to concrete with 3/8-inch diameter HILTI bolts with 2-inch embedment
8	UNISTRUT P2546/2348	Static	Lateral (weak direction)	3	Attached to concrete with 3/8-inch diameter HILTI bolts with 2-inch embedment

(Concluded)



Corporate Consulting
& Development Company, Ltd.

Research Triangle Park, NC 27709
P.O. Box 12728 • 919-362-8800

TEST PROCEDURE

PROCEDURE No. 1903.23-1, Rev. 0
ISSUE DATE 5/9/86 PAGE 13 OF 87
PREPARED BY _____ DATE _____
APPROVED BY _____ DATE _____
APPROVED BY _____ DATE _____
QA REVIEW BY _____ DATE _____

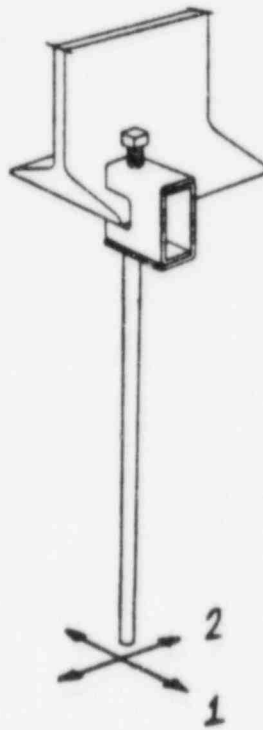

Figure 2.1 Illustration of Test Numbers 1a and 1b



Corporate Consulting
& Development Company, Ltd.

Research Triangle Park, NC 27709
P.O. Box 12728 • 919-362-8800

TEST PROCEDURE

PROCEDURE No. 1903.23-1, Rev. 0
ISSUE DATE 5/9/86 PAGE 14 OF 87
PREPARED BY _____ DATE _____
APPROVED BY _____ DATE _____
APPROVED BY _____ DATE _____
QA REVIEW BY _____ DATE _____

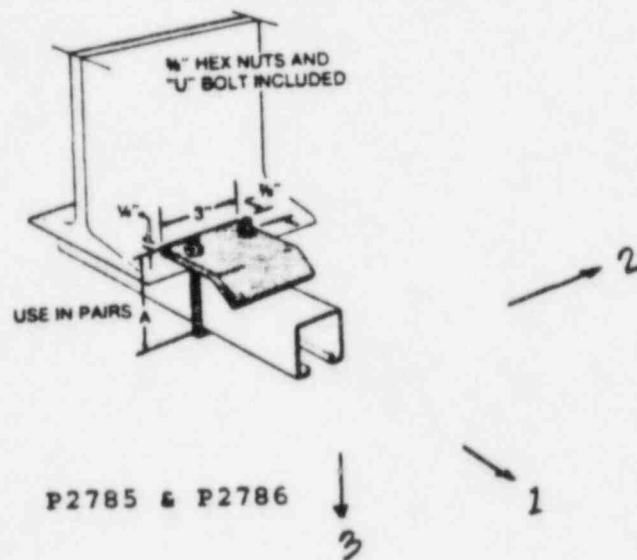

Figure 2.2 Illustration of Test Numbers 2a through 2d,
and 3a through 3d



Corporate Consulting
& Development Company, Ltd.

Research Triangle Park NC 27709
P.O. Box 12728 • 919-362-8800

TEST PROCEDURE

PROCEDURE No. 1903.23-1, Rev. 0
ISSUE DATE 5/9/86 PAGE 15 OF 87
PREPARED BY _____ DATE _____
APPROVED BY _____ DATE _____
APPROVED BY _____ DATE _____
QA REVIEW BY _____ DATE _____

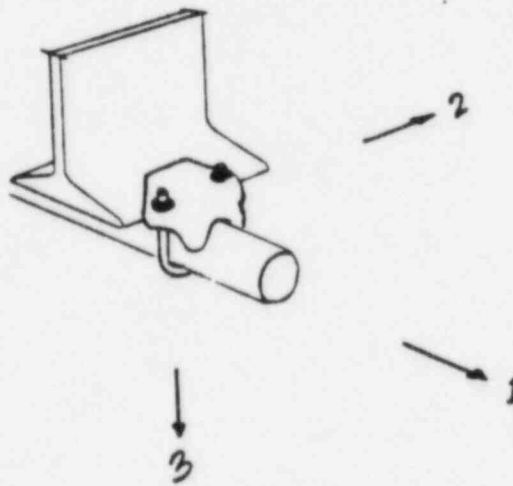

Figure 2.3 Illustration of Test Numbers 5a through 5d



Corporate Consulting
& Development Company, Ltd.

Research Triangle Park, NC 27709
P.O. Box 12728 • 919-362-8800

PROCEDURE No. 1903.23-1, Rev. 0

ISSUE DATE 5/9/86 PAGE 16 OF 87

PREPARED BY _____ DATE _____

APPROVED BY _____ DATE _____

APPROVED BY _____ DATE _____

QA REVIEW BY _____ DATE _____

TEST PROCEDURE

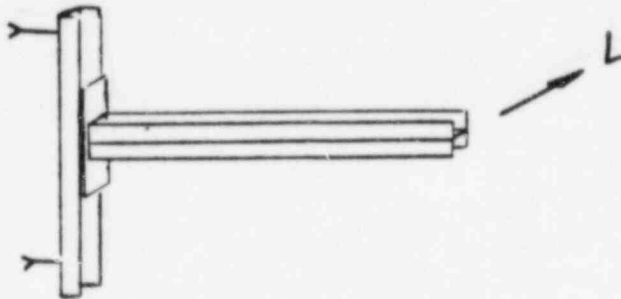

Test Sample Number 6

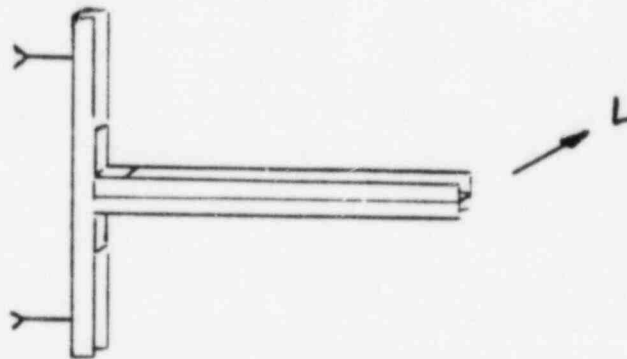

Test Sample Number 7

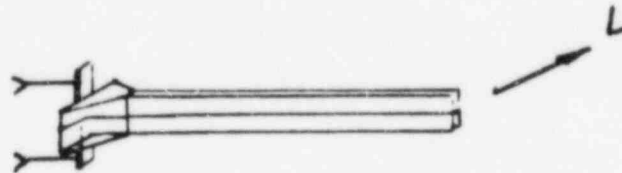

Test Sample Number 8

Figure 2.4 Illustration of Test Numbers 6, 7, and 8



Corporate Consulting
& Development Company, Ltd.

Research Triangle Park, NC 27709
P.O. Box 12728 • 919-362-8800

TEST PROCEDURE

PROCEDURE No. 1903.23-1, Rev. 0
ISSUE DATE 5/9/86 PAGE 17 OF 87
PREPARED BY _____ DATE _____
APPROVED BY _____ DATE _____
APPROVED BY _____ DATE _____
QA REVIEW BY _____ DATE _____

3.0 TEST FIXTURING

The following sections describe the fixturing required for the test samples.

3.1 Fixturing for Beam Clamps

The items associated with test numbers 1a, 1b, 2a through 2d, 3a through 3d, and 5a through 5d require attachment to a wide-flange (WF) beam. The beam section will be 4 inches deep, up to 18 inches long (as required to perform a specific test), and stiffened on the ends to inhibit torsion and flexure of the WF section. This beam section will be attached to a rigid test fixture to complete the required setup.

3.2 Fixturing for Cantilever Hangers

The items associated with test numbers 6, 7, and 8 will be attached to concrete blocks with HILTI bolts to simulate typical as-installed conditions with UNISTRUT P1000 channel headers. The HILTI bolts will be 3/8-inch diameter and 2-3/4 inches long, installed to an embedment of 2 inches.

The bolts will be installed in reinforced concrete blocks fabricated by TUGCO at CPSES. Each block is fabricated in accordance with TUGCO Drawing Number FSC-0905, Revision 2, and TUGCO concrete mix and placement procedures. Additional information concerning the concrete blocks is contained in CCL's Conduit Clamp Test Procedure (Reference 3).



Corporate Consulting
& Development Company, Ltd.

Research Triangle Park NC 27709
P.O. Box 12728 • 919-362-8800

TEST PROCEDURE

PROCEDURE No. 1903.23-1, Rev. 0
 ISSUE DATE 5/9/86 PAGE 18 OF 87
 PREPARED BY _____ DATE _____
 APPROVED BY _____ DATE _____
 APPROVED BY _____ DATE _____
 QA REVIEW BY _____ DATE _____

The bolt holes for each HILTI bolt will be drilled and marked prior to installation of any bolts. The installed center-to-center and edge distances will be recorded and verified to be in accordance with the requirements of TUGCO's HILTI Bolt Installation Procedure (Reference 4).

The HILTI bolts will be set and torqued in accordance with Section 3.1.4 of Reference 4. The date and time of torquing will be recorded to document the point at which bolt relaxation starts. Testing of HILTI bolts will not commence until each bolt has relaxed for a minimum of 48 hours. The basis for this relaxation period is documented in Section 9.0 of CCL's Conduit Clamp Test Report (Reference 5).



Corporate Consulting
& Development Company, Ltd.

Research Triangle Park, NC 27709
P.O. Box 12728 • 919-362-8800

TEST PROCEDURE

PROCEDURE No. 1903.23-1, Rev. 0
 ISSUE DATE 5/9/86 PAGE 19 OF 87
 PREPARED BY _____ DATE _____
 APPROVED BY _____ DATE _____
 APPROVED BY _____ DATE _____
 QA REVIEW BY _____ DATE _____

4.0 INSTRUMENTATION

The static and cyclic loads will be applied by hydraulic cylinder. The test data, consisting of forces and deflections, will be measured with force transducers (load cells) and linear variable differential transducers (LVDT's) or linear potentiometers. Displacements will be measured in the direction of load application.

The static test data will be collected and recorded using CCL's personal computer-based data acquisition system (PC-DAS). Cyclic test data will also be collected and recorded with the PC-DAS; however, a strip chart recorder will also be employed to directly record the test results.

Table 4.1 presents a sample data table for presentation of load-versus-deflection data. Figure 4.1 presents a sample static test load-versus-deflection curve.



Corporate Consulting
& Development Company, Ltd.

PROCEDURE No. 1903.23-1, Rev. 0

ISSUE DATE 5/9/86 PAGE 20 OF 87

PREPARED BY _____ DATE _____

APPROVED BY _____ DATE _____

APPROVED BY _____ DATE _____

QA REVIEW BY _____ DATE _____

Research Triangle Park NC 27709
P.O. Box 12728 • 919-362-8800

TEST PROCEDURE

----- A:\DATA\TRAINC2\A3101.PRN
Current date is Fri 11-08-1985
Current time is 13:58:43.89

5	"AD bd"	0.0000	0.0010	0.0410
5	"AD bd"	0.0000	0.0010	0.0616
2	"AD bd"	0.0000	0.0010	0.0410
5	"AD bd"	0.0000	0.0020	0.0410
		-10.0409	0.0020	0.0616
		-10.0409	0.0030	0.0616
		0.0000	0.0040	0.0616
1	"AD ch"	0.0000	0.0040	0.0410
3	"AD ch"	0.0000	0.0050	0.0410
4	"AD ch"	0.0000	0.0060	0.0410
1	"AD ch"	0.0000	0.0070	0.0410
		0.0000	0.0080	0.0616
5.000000E+00	"rate"	0.0000	0.0100	0.0410
2.000000E+00	"rate"	0.0000	0.0110	0.0821
5.000000E+00	"rate"	0.0000	0.0120	0.0821
2.000000E+00	"rate"	0.0000	0.0140	0.0410
5.000000E+00	"rate"	0.0000	0.0150	0.0821
2.000000E+00	"rate"	0.0000	0.0180	0.0821
5.000000E+00	"rate"	0.0000	0.0200	0.0821
2.000000E+00	"rate"	0.0000	0.0230	0.0821
		0.0000	0.0261	0.0821
2	"AD gain c"	0.0000	0.0301	0.0616
1	"AD gain c"	0.0000	0.0341	0.1026
2	"AD gain c"	0.0000	0.0381	0.0821
2	"AD gain c"	0.0000	0.0421	0.1026
		10.0409	0.0461	0.1026
0.000000E+00	"AD offs"	10.0409	0.0541	0.1026
0.000000E+00	"AD offs"	30.1228	0.0681	0.1436
0.000000E+00	"AD offs"	40.1638	0.0812	0.1231
0.000000E+00	"AD offs"	50.2047	0.0912	0.1231
		50.2047	0.1022	0.1436
1.004094E+03	"AD scale"	70.2866	0.1202	0.1847
1.002024E+00	"AD scale"	80.3275	0.1473	0.2462
2.052000E+00	"AD scale"	100.4094	0.1734	0.2257
1.004094E+03	"AD scale"	110.4503	0.1944	0.2872
"SAMPLE NO. A-31-01"		130.5322	0.2114	0.2668
"TRAIN C"		140.5732	0.2255	0.2872
"11-09-85"		140.5732	0.2365	0.3078
"CCL 1903.11"		150.6141	0.2445	0.2872
" FORCE " "	"DISPLACEMENT" "DISPLACEMENT"	160.6550	0.2515	0.3078
" LBS. " "	" INCHES " "	160.6550	0.2575	0.3078
-10.0409	0.0000	170.6960	0.2625	0.3287
-10.0409	0.0000	180.7369	0.2675	0.3488
-10.0409	0.0000	180.7369	0.2715	0.3078
-10.0409	0.0000	190.7778	0.2766	0.3488
-10.0409	0.0000	190.7778	0.2806	0.3287
0.0000	0.0000	200.8188	0.2846	0.3694
-10.0409	0.0000	200.8188	0.2876	0.3287
-10.0409	0.0000	210.8597	0.2916	0.3287
-10.0409	0.0000	210.8597	0.2946	0.3694
-10.0409	0.0000	210.8597	0.2986	0.3694
-10.0409	0.0000	220.9007	0.3016	0.3899
-10.0409	0.0000	220.9007	0.3046	0.3488
-10.0409	0.0000	230.9416	0.3086	0.3899
-10.0409	0.0000	230.9416	0.3106	0.3899
-10.0409	0.0000	230.9416	0.3136	0.3488
-10.0409	0.0000	230.9416	0.3156	0.3899
0.0000	0.0000	230.9416	0.3176	0.3694
-10.0409	0.0000	240.9825	0.3206	0.3899
-10.0409	0.0000	240.9825	0.3227	0.3694
0.0000	0.0000	240.9825	0.3247	0.3694
-10.0409	0.0000	240.9825	0.3257	0.4104
		240.9825	0.3267	0.3694
		240.9825	0.3277	0.4104

Table 4.1 Sample Load-Versus-Deflection Table



Corporate Consulting
& Development Company, Ltd.

Research Triangle Park NC 27709
P.O. Box 12728 • 919-362-8800

TEST PROCEDURE

PROCEDURE No. 1903.23-1, Rev. 0
ISSUE DATE 5/9/86 PAGE 21 OF 87
PREPARED BY _____ DATE _____
APPROVED BY _____ DATE _____
APPROVED BY _____ DATE _____
QA REVIEW BY _____ DATE _____

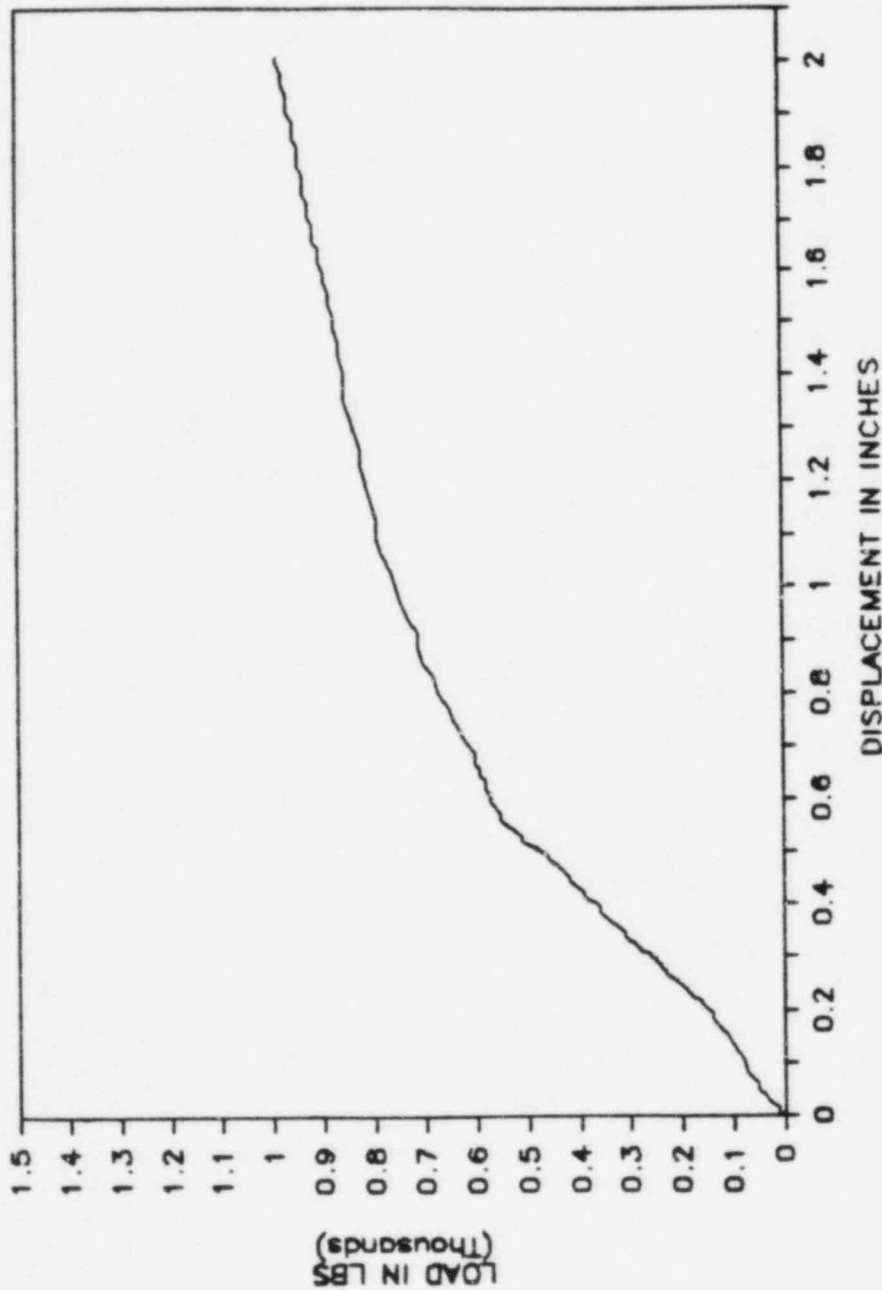

Figure 4.1 Sample Static Test Load-Versus-Deflection Curve



Corporate Consulting
& Development Company, Ltd.

Research Triangle Park NC 27709
P.O. Box 12728 • 919-362-8800

PROCEDURE No. 1903.23-1, Rev. 0
ISSUE DATE 5/9/86 PAGE 22 OF 87
PREPARED BY _____ DATE _____
APPROVED BY _____ DATE _____
APPROVED BY _____ DATE _____
QA REVIEW BY _____ DATE _____

TEST PROCEDURE

5.0 TEST SEQUENCE

- Each test sample will be assembled in accordance with the figures in Section 6 and fastened to the applicable test fixture.
- Where applicable, HILTI bolts will be torqued and allowed to relax in accordance with Section 3.2.
- Load application fixturing will be attached for the direction to be tested.
- The test configuration and sample number will be identified on a note card, and the setup will be photographed.
- Pertinent information required for the test file will be manually recorded or keyed into the computer, where applicable. This information will include, as a minimum:
 - Test sample identification number
 - Instrumentation list
 - Test date
 - Person conducting the test
 - Critical dimensions relating to displacement measurement locations
- Test monitor reviews will be performed as required by the test monitor log.
- The PC-DAS will be initiated for the test and a data file created.
- Test samples will be tested in accordance with Sections 2.1 through 2.4 as applicable.
- A photograph will be taken after failure to document the mode and extent of failure.



Corporate Consulting
& Development Company, Ltd.

Research Triangle Park, NC 27709
P.O. Box 12728 • 919-362-8800

TEST PROCEDURE

PROCEDURE No. 1903.23-1, Rev. 0
ISSUE DATE 5/9/86 PAGE 23 OF 87
PREPARED BY _____ DATE _____
APPROVED BY _____ DATE _____
APPROVED BY _____ DATE _____
QA REVIEW BY _____ DATE _____

- The test data will be stored on the magnetic disk file and a hard copy will be printed for inclusion in the sample file folder.
- The master test monitor log entry of time, date, and general test results will be made.



Corporate Consulting
& Development Company, Ltd.

Research Triangle Park, NC 27709
P.O. Box 12728 • 919-362-8800

TEST PROCEDURE

PROCEDURE No. 1903.23-1, Rev. 0
ISSUE DATE 5/9/86 PAGE 24 OF 87
PREPARED BY _____ DATE _____
APPROVED BY _____ DATE _____
APPROVED BY _____ DATE _____
QA REVIEW BY _____ DATE _____

6.0 TEST SETUP

The following figures will serve as test sample assembly figures.

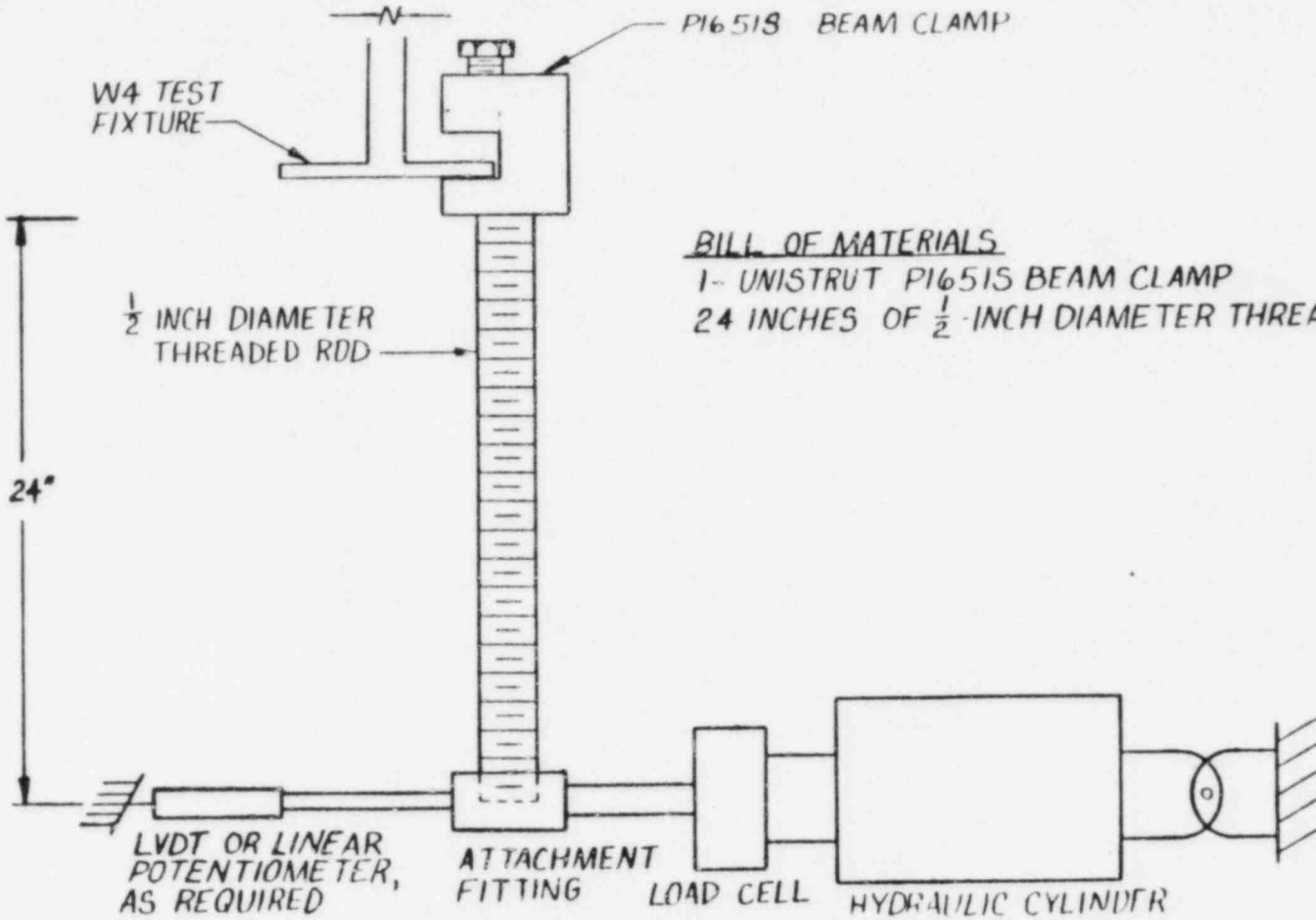

BILL OF MATERIALS

- 1- UNISTRUT P1651S BEAM CLAMP
- 24 INCHES OF 1/2 INCH DIAMETER THREADED ROD

Figure 6.1 Test Sample Number 1a: UNISTRUT P1651S Beam Clamp
Cyclic Test in the 1 Direction



Corporate Consulting
& Development Company, Ltd.

Research Triangle Park, NC 27709
P.O. Box 12128 • 919-362-8800

TEST PROCEDURE

PROCEDURE No. 1903.23-1, Rev. 0
 ISSUE DATE 5/9/86 PAGE 25 OF 87
 PREPARED BY _____ DATE _____
 APPROVED BY _____ DATE _____
 QA REVIEW BY _____ DATE _____



Corporate Consulting
& Development Company, Ltd.

Research Triangle Park NC 27709
P.O. Box 12728 • 919-362-8800

PROCEDURE No. 1903.23-1, Rev. 0
 ISSUE DATE 5/9/86 PAGE 26 OF 87
 PREPARED BY _____ DATE _____
 APPROVED BY _____ DATE _____
 APPROVED BY _____ DATE _____
 QA REVIEW BY _____ DATE _____

TEST PROCEDURE

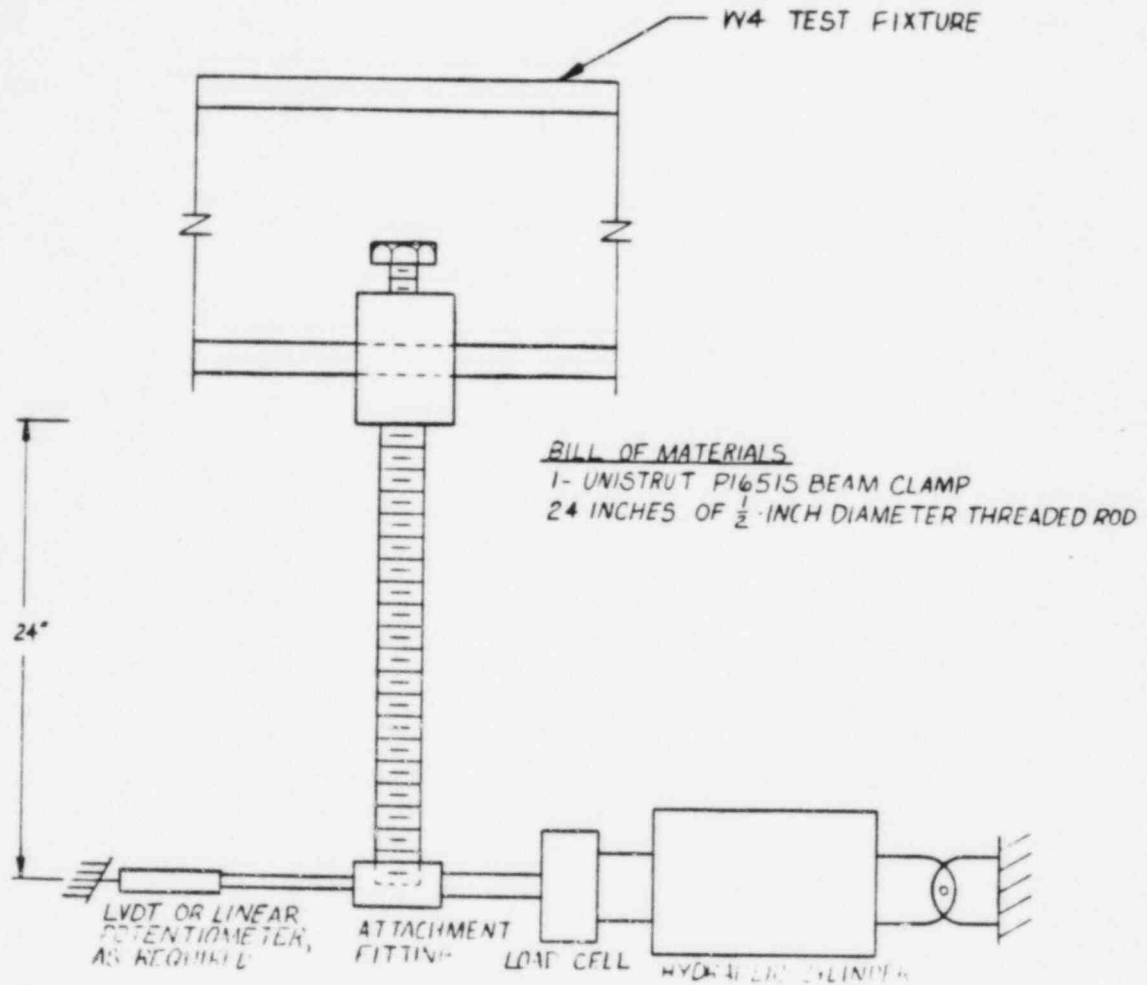

Figure 6.2 Test Sample Number 1b: UNISTRUT P1651S Beam Clamp Cyclic Test in the 2 Direction



TEST PROCEDURE

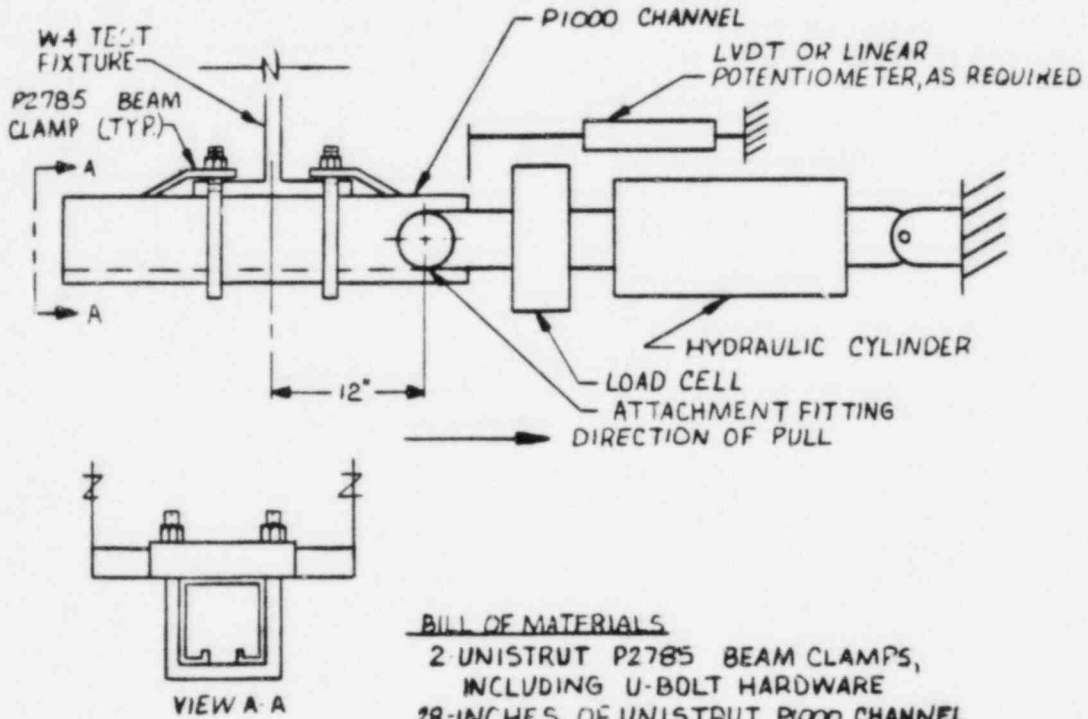

Figure 6.3 Test Sample Number 2a-12: UNISTRUT P2785 Beam Clamp Static Test in the 1 Direction with a 12-inch Moment Arm



Corporate Consulting
& Development Company, Ltd.

Research Triangle Park NC 27709
P.O. Box 12728 • 919-362-8800

PROCEDURE No. 1903.23-1, Rev. 0

ISSUE DATE 5/9/86 PAGE 28 OF 87

PREPARED BY _____ DATE _____

APPROVED BY _____ DATE _____

APPROVED BY _____ DATE _____

QA REVIEW BY _____ DATE _____

TEST PROCEDURE

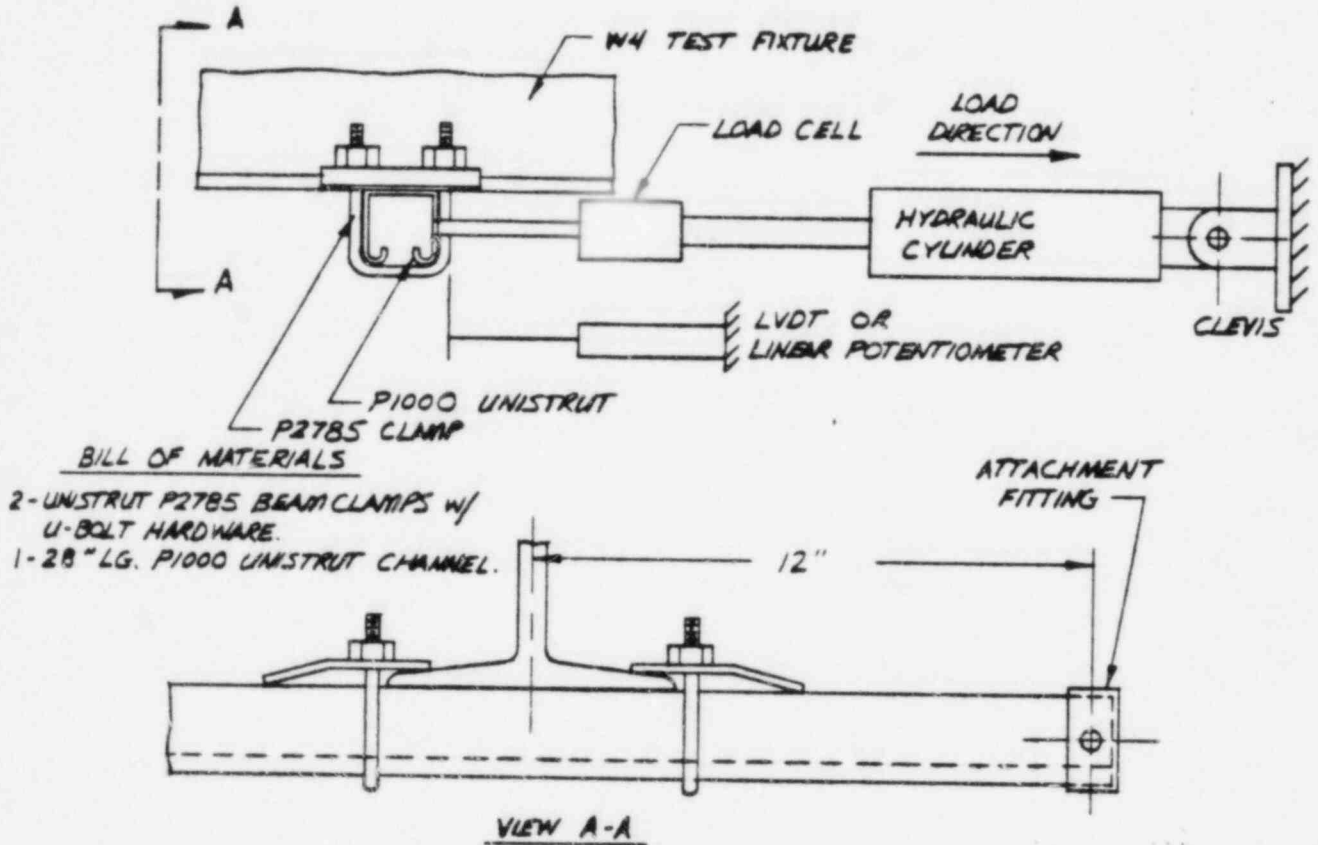

Figure 6.4 Test Sample Number 2b-12: UNISTRUT P2785 Beam Clamp Static Test in the 2 Direction with a 12-inch Moment Arm



Corporate Consulting
& Development Company, Ltd.

Research Triangle Park, NC 27709
P.O. Box 12728 • 919-362-8800

PROCEDURE No. 1903.23-1, Rev. 0

ISSUE DATE 5/9/86 PAGE 29 OF 87

PREPARED BY _____ DATE _____

APPROVED BY _____ DATE _____

APPROVED BY _____ DATE _____

QA REVIEW BY _____ DATE _____

TEST PROCEDURE

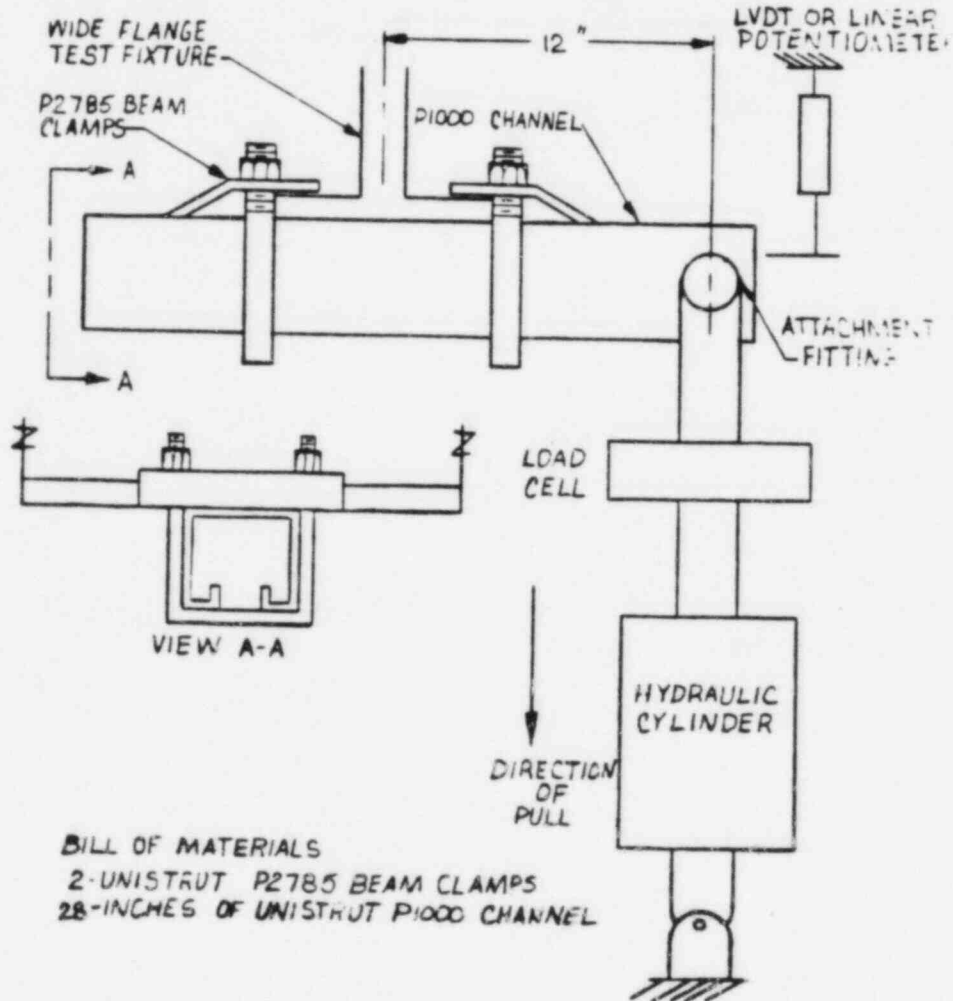

Figure 6.5 Test Sample Number 2c-12: UNISTRUT P2785 Beam Clamp Static Test in the 3 Direction with a 12-inch Moment Arm



Corporate Consulting
& Development Company, Ltd.

Research Triangle Park NC 27709
P.O. Box 12728 • 919-362-8800

PROCEDURE No. 1903.23-1, Rev. 0
 ISSUE DATE 5/9/86 PAGE 30 OF 87
 PREPARED BY _____ DATE _____
 APPROVED BY _____ DATE _____
 APPROVED BY _____ DATE _____
 QA REVIEW BY _____ DATE _____

TEST PROCEDURE

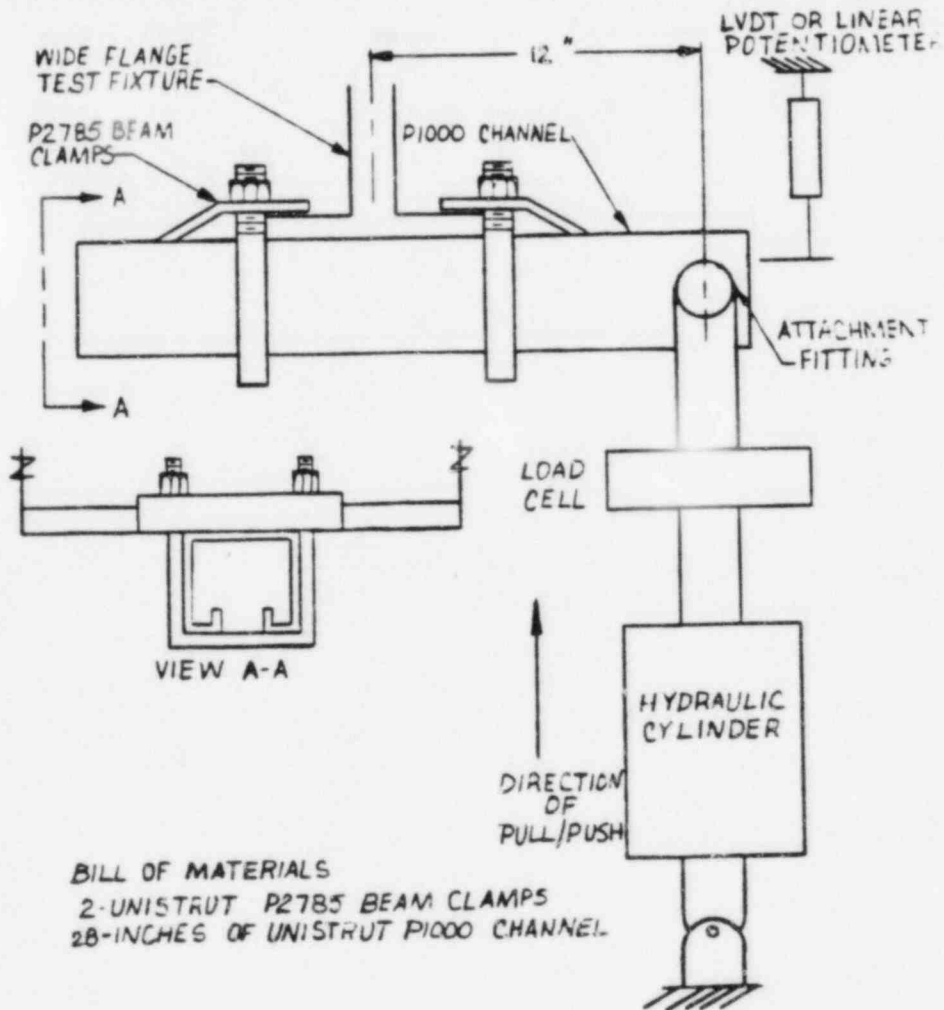

Figure 6.6 Test Sample Number 2d-12: UNISTRUT P2785 Beam Clamp Static Test in the -3 Direction with a 12-inch Moment Arm

TEST PROCEDURE

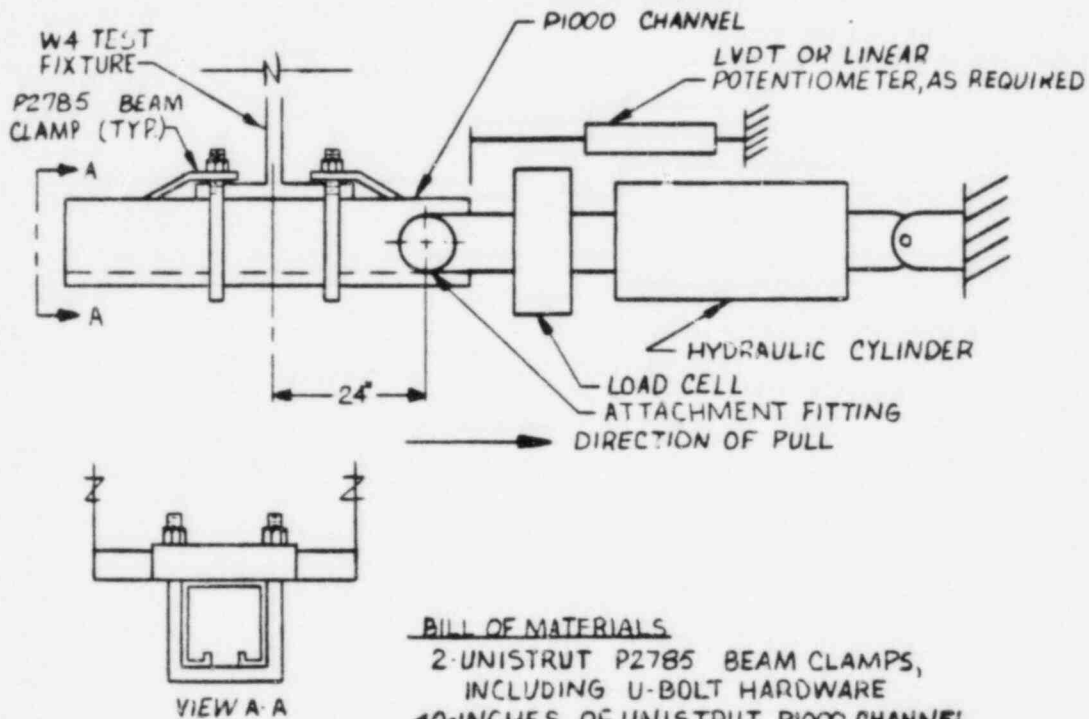

Figure 6.7 Test Sample Number 2a-24: UNISTRUT P2785 Beam Clamp Static Test in the 1 Direction with a 24-inch Moment Arm



Corporate Consulting
& Development Company, Ltd.

Research Triangle Park, NC 27709
P.O. Box 12728 • 919-362-8800

TEST PROCEDURE

PROCEDURE No. 1903.23-1, Rev. 0

ISSUE DATE 5/9/86 PAGE 32 OF 87

PREPARED BY _____ DATE _____

APPROVED BY _____ DATE _____

APPROVED BY _____ DATE _____

QA REVIEW BY _____ DATE _____

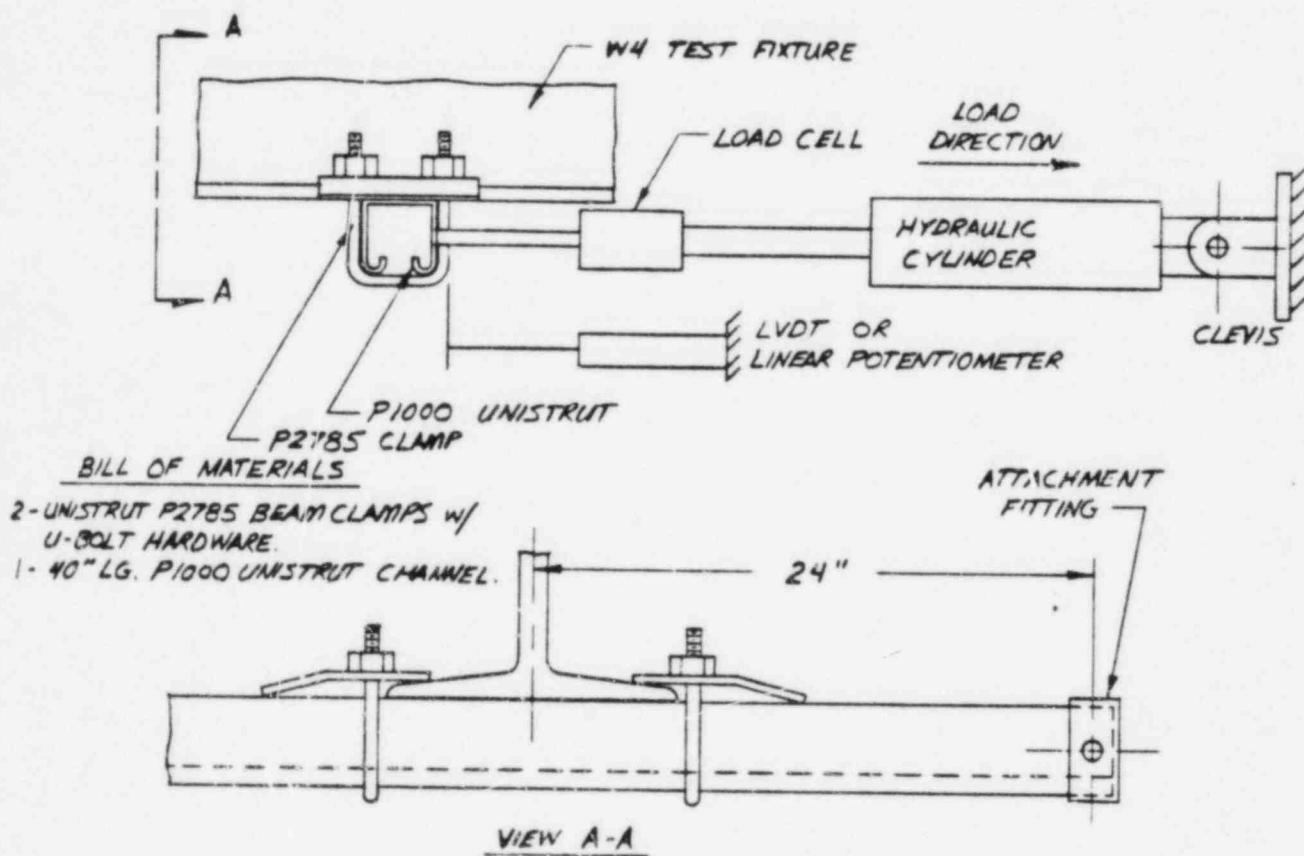

Figure 6.8 Test Sample Number 2b-24: UNISTRUT P2785 Beam Clamp Static Test in the 2 Direction with a 24-inch Moment Arm

TEST PROCEDURE

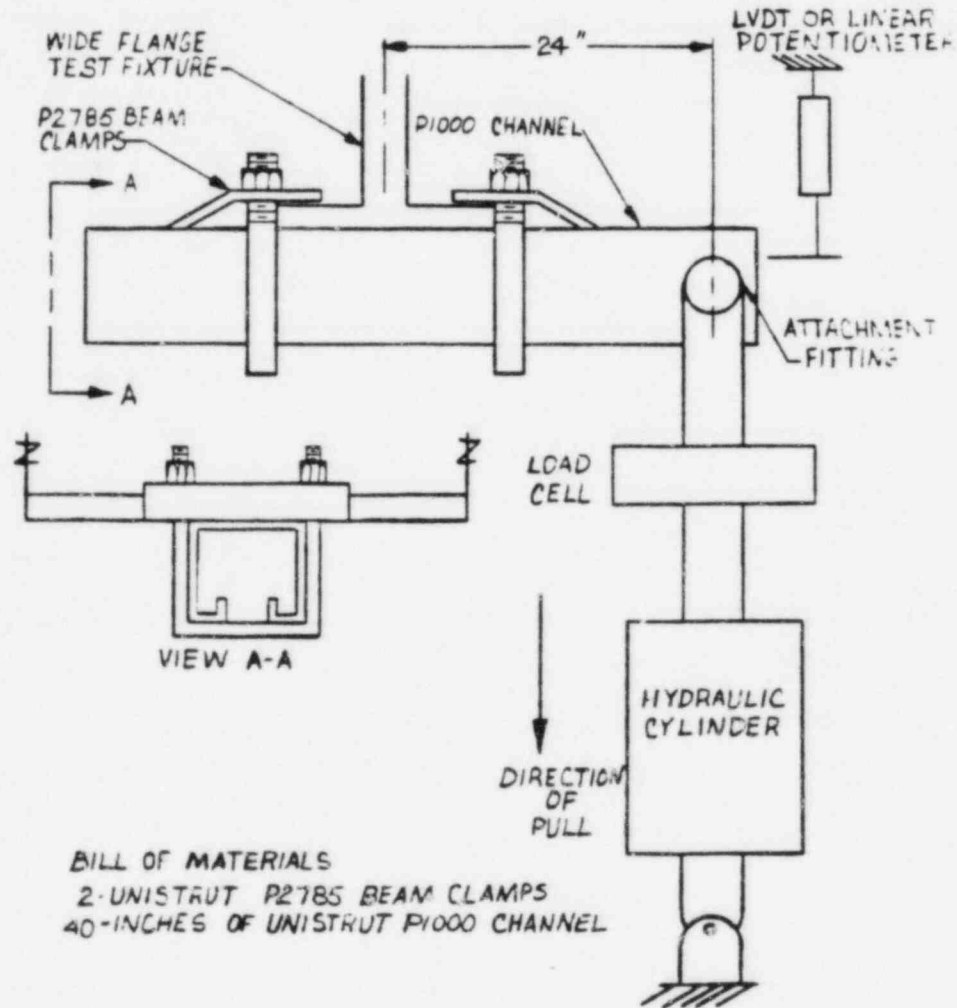
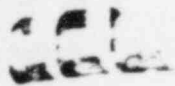

Figure 6.9 Test Sample Number 2c-24: UNISTRUT P2785 Beam Clamp Static Test in the 3 Direction with a 24-inch Moment Arm



Corporate Consulting
& Development Company, Ltd.

Research Triangle Park NC 27709
P.O. Box 12128 • 919-362-8800

PROCEDURE No. 1903.23-1, Rev. 0

ISSUE DATE 5/9/86 PAGE 34 OF 87

PREPARED BY _____ DATE _____

APPROVED BY _____ DATE _____

APPROVED BY _____ DATE _____

QA REVIEW BY _____ DATE _____

TEST PROCEDURE

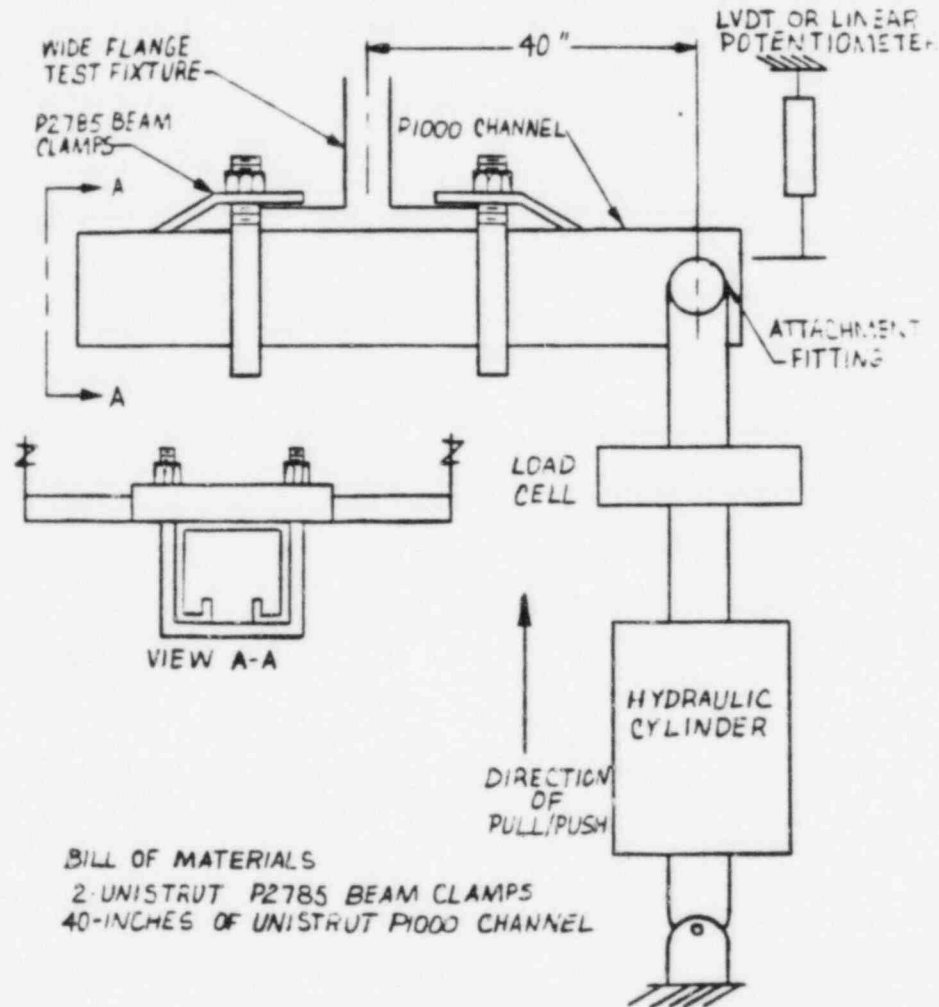

Figure 6.10 Test Sample Number 2d-24: UNISTRUT P2785 Beam Clamp Static Test in the -3 Direction with a 24-inch Moment Arm



TEST PROCEDURE

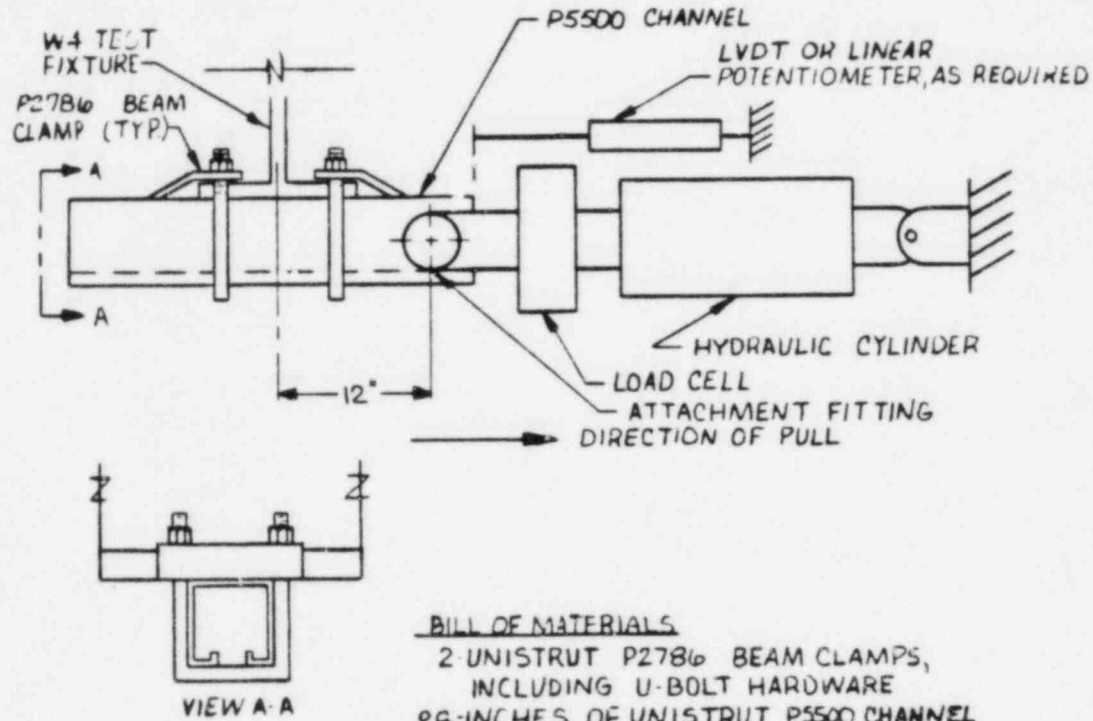

Figure 6.11 Test Sample Number 3a-12: UNISTRUT P2786 Beam Clamp Static Test in the 1 Direction with a 12-inch Moment Arm



Corporate Consulting
& Development Company, Ltd.

Research Triangle Park NC 27709
PO Box 12728 • 919-362-8800

PROCEDURE No. 1903_23-1, Rev. 0
 ISSUE DATE 5/9/86 PAGE 36 OF 87
 PREPARED BY _____ DATE _____
 APPROVED BY _____ DATE _____
 APPROVED BY _____ DATE _____
 QA REVIEW BY _____ DATE _____

TEST PROCEDURE

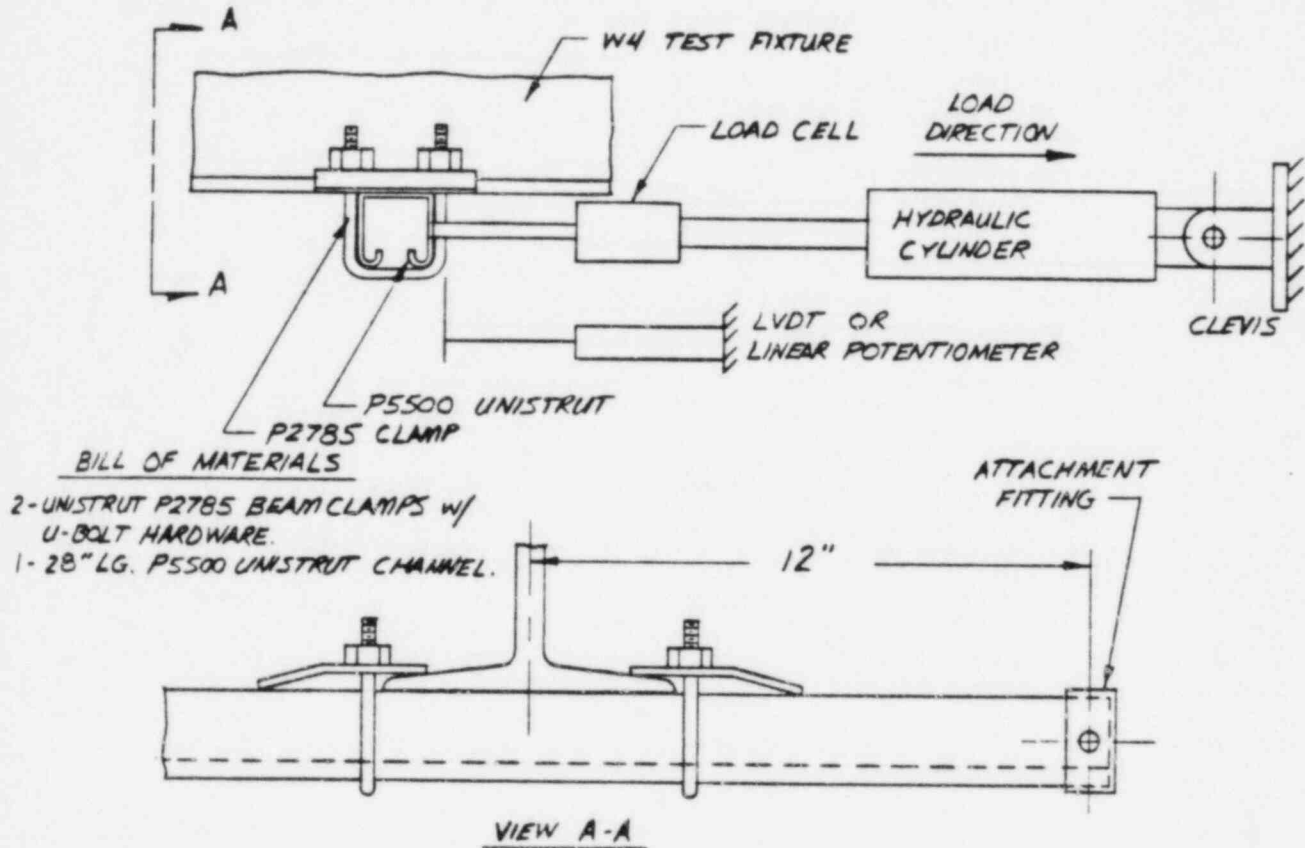

Figure 6.12 Test Sample Number 3b-12: UNISTRUT P2786 Beam Clamp Static Test in the 2 Direction with a 12-inch Moment Arm



Corporate Consulting
& Development Company, Ltd.

Research Triangle Park, NC 27709
P.O. Box 12728 • 919-362-8800

PROCEDURE No. 1903.23-1, Rev. 0
 ISSUE DATE 5/9/86 PAGE 37 OF 87
 PREPARED BY _____ DATE _____
 APPROVED BY _____ DATE _____
 APPROVED BY _____ DATE _____
 QA REVIEW BY _____ DATE _____

TEST PROCEDURE

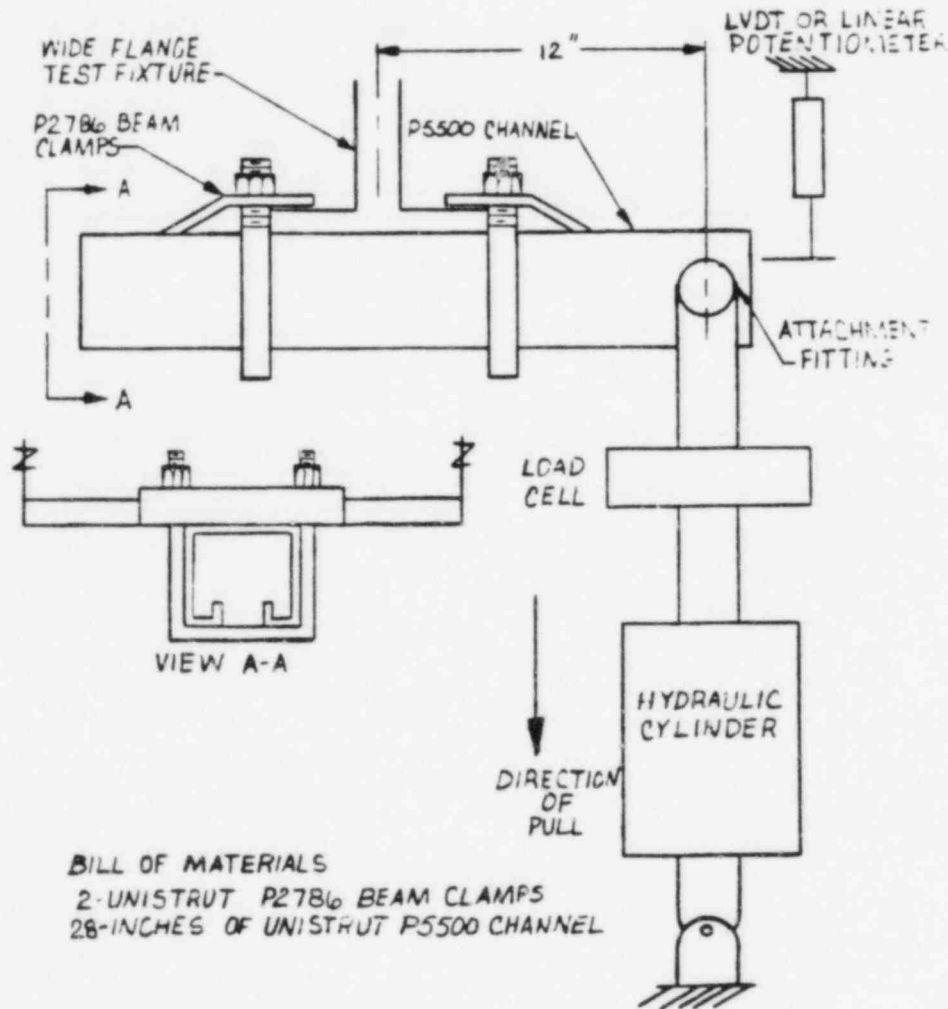

Figure 6.13 Test Sample Number 3c-12: UNISTRUT P2786 Beam Clamp Static Test in the 3 Direction with a 12-inch Moment Arm



Corporate Consulting
& Development Company, Ltd.

Research Triangle Park, NC 27709
P.O. Box 12728 • 919-362-8800

TEST PROCEDURE

PROCEDURE No. 1903.23-1, Rev. 0
 ISSUE DATE 5/9/86 PAGE 38 OF 87
 PREPARED BY _____ DATE _____
 APPROVED BY _____ DATE _____
 APPROVED BY _____ DATE _____
 QA REVIEW BY _____ DATE _____

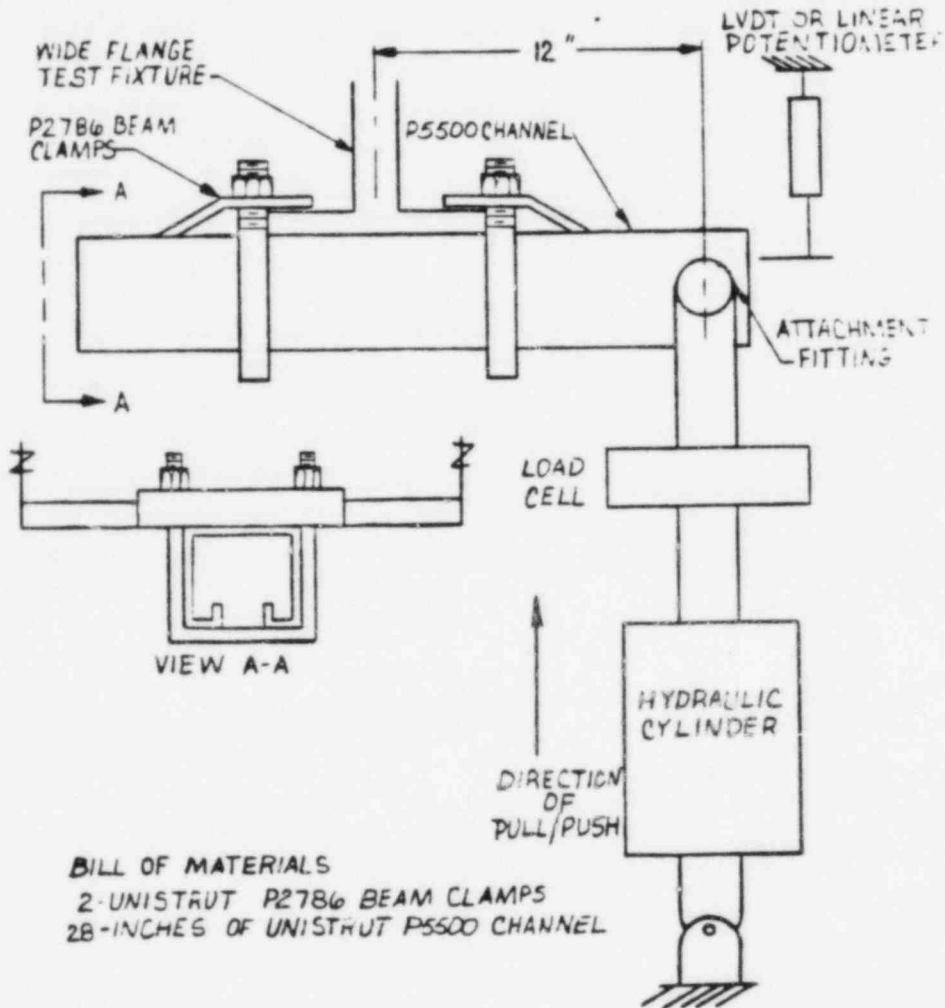

Figure 6.14 Test Sample Number 3d-12: UNISTRUT P2786 Beam Clamp Static Test in the -3 Direction with a 12-inch Moment Arm



Corporate Consulting
& Development Company, Ltd.

Research Triangle Park, NC 27709
P.O. Box 12728 • 919-362-8800

TEST PROCEDURE

PROCEDURE No. 1903.23-1, Rev. 0
 ISSUE DATE 5/9/86 PAGE 39 OF 87
 PREPARED BY _____ DATE _____
 APPROVED BY _____ DATE _____
 APPROVED BY _____ DATE _____
 QA REVIEW BY _____ DATE _____

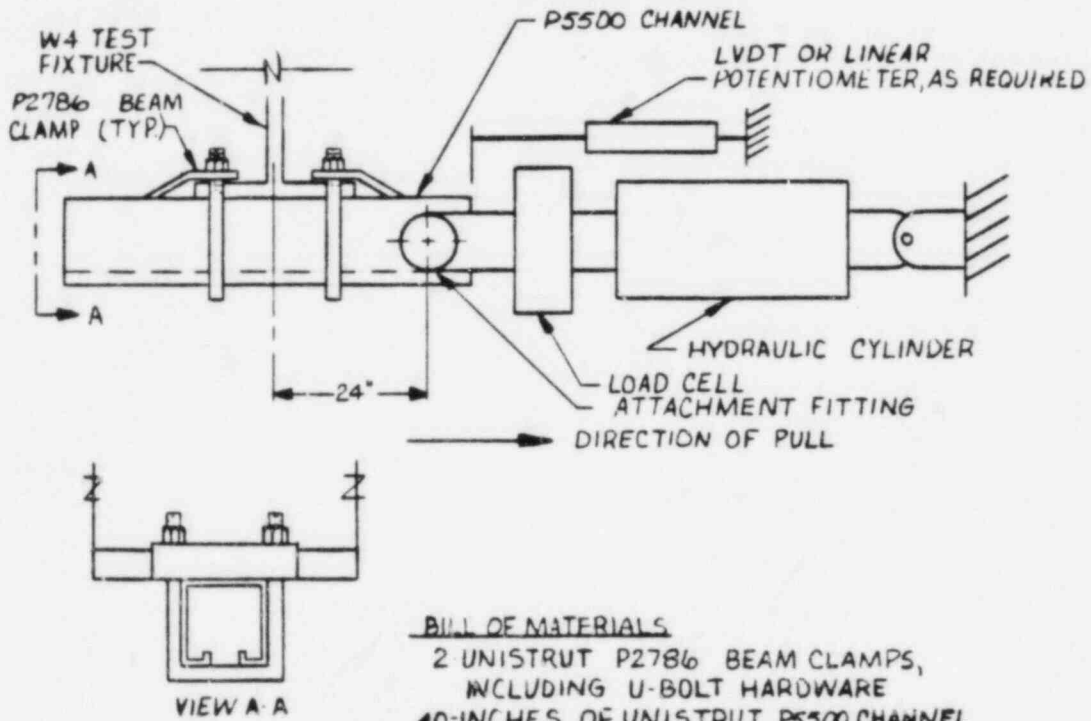
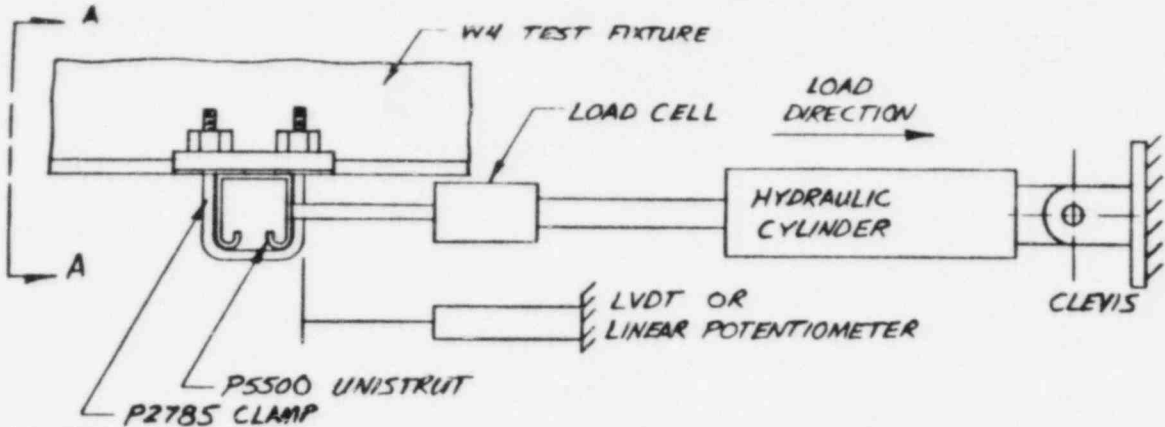

Figure 6.15 Test Sample Number 3a-24: UNISTRUT P2786 Beam Clamp Static Test in the 1 Direction with a 24-inch Moment Arm



BILL OF MATERIALS

- 2 - UNISTRUT P2785 BEAM CLAMPS w/
U-BOLT HARDWARE.
- 1 - 40" LG. P5500 UNISTRUT CHANNEL.

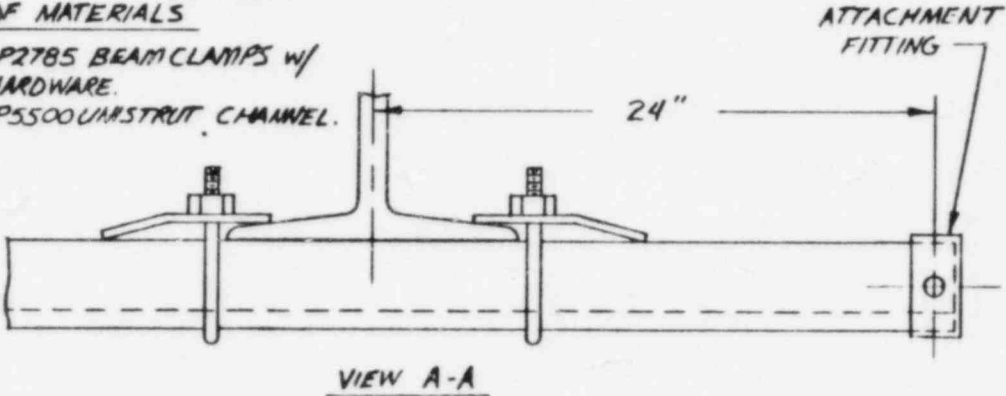

Figure 6.16 Test Sample Number 3b-24: UNISTRUT P2786 Beam Clamp Static Test in the 2 Direction with a 24-inch Moment Arm

Corporate Consulting
& Development Company Ltd.

Research Triangle Park NC 27709
P.O. Box 12728 • 919-362-8800

TEST PROCEDURE

PROCEDURE No. 1903.23-1, Rev. 0
 ISSUE DATE 5/9/86 PAGE 40 OF 87
 PREPARED BY _____ DATE _____
 APPROVED BY _____ DATE _____
 QA REVIEW BY _____ DATE _____

TEST PROCEDURE

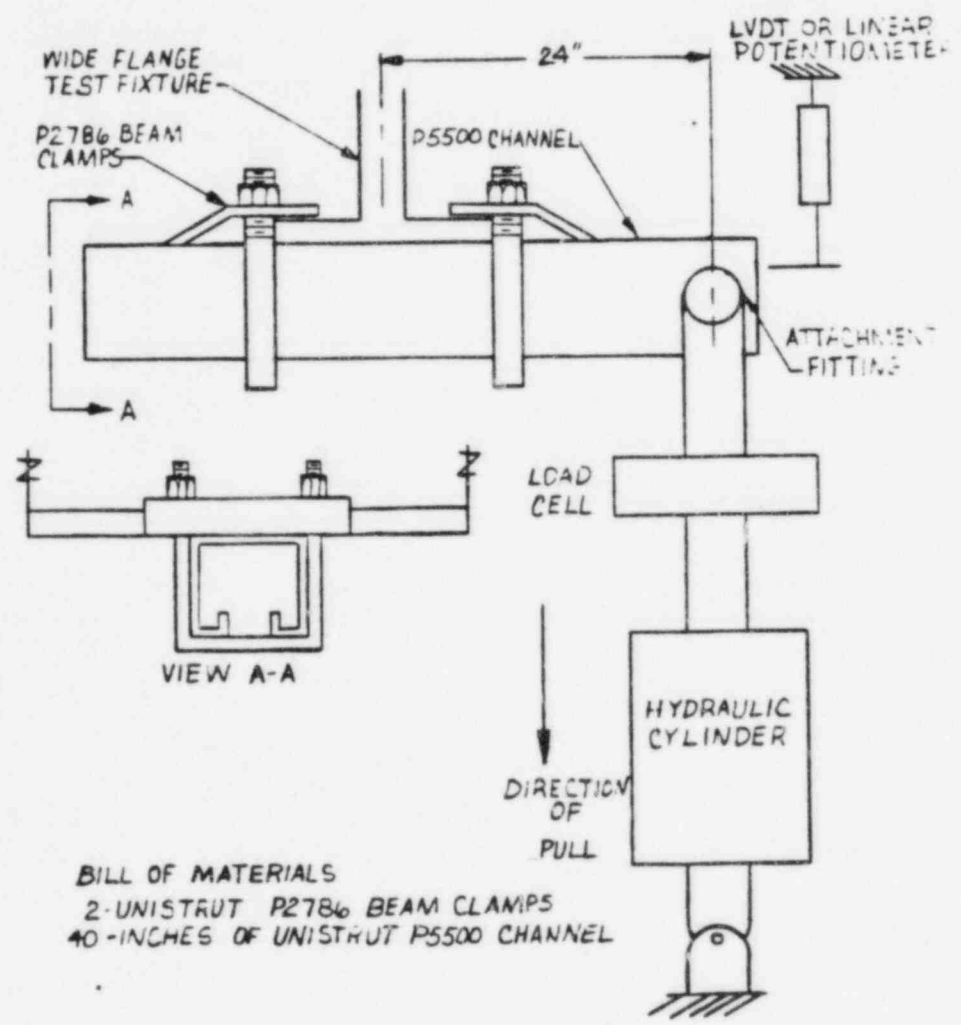

Figure 6.17 Test Sample Number 3c-24: UNISTRUT P2786 Beam Clamp Static Test in the 3 Direction with a 24-inch Moment Arm



Corporate Consulting
& Development Company, Ltd.

Research Triangle Park, NC 27709
P.O. Box 12728 • 919-362-8800

TEST PROCEDURE

PROCEDURE No. 1903.23-1, Rev. 0
 ISSUE DATE 5/9/86 PAGE 42 OF 87
 PREPARED BY _____ DATE _____
 APPROVED BY _____ DATE _____
 APPROVED BY _____ DATE _____
 QA REVIEW BY _____ DATE _____

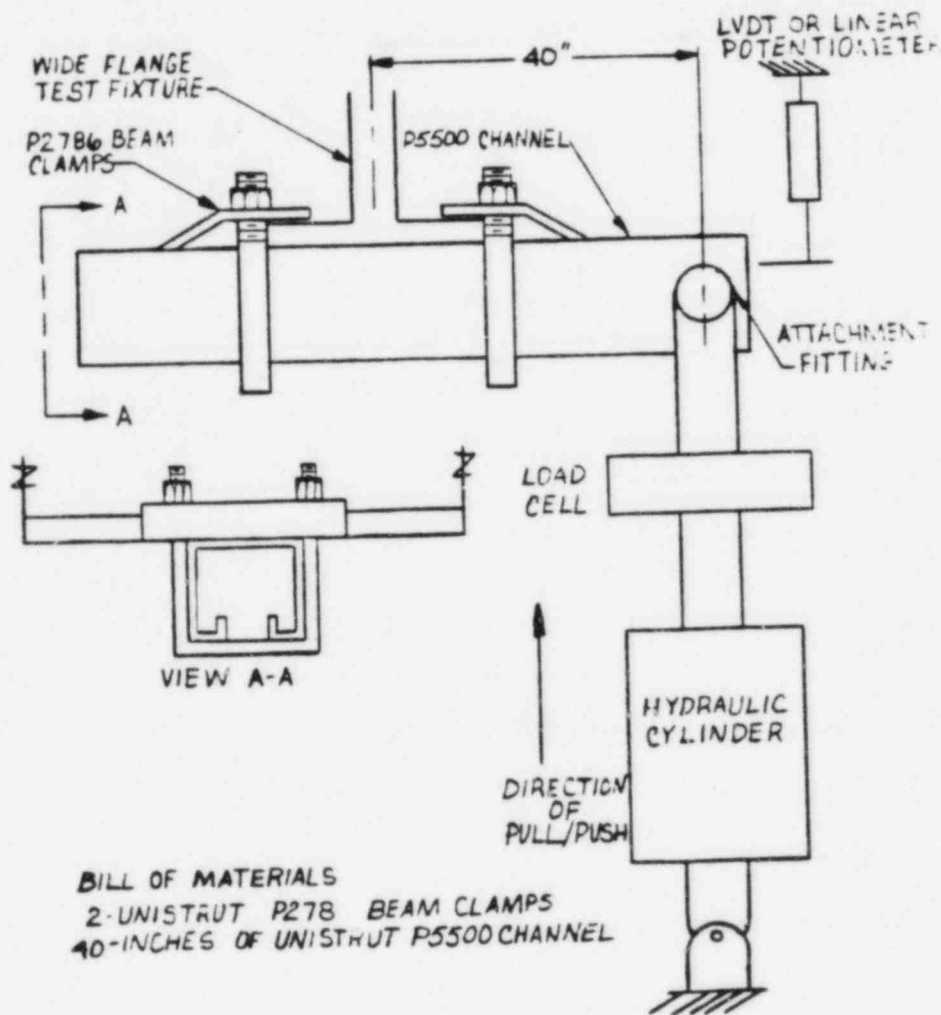
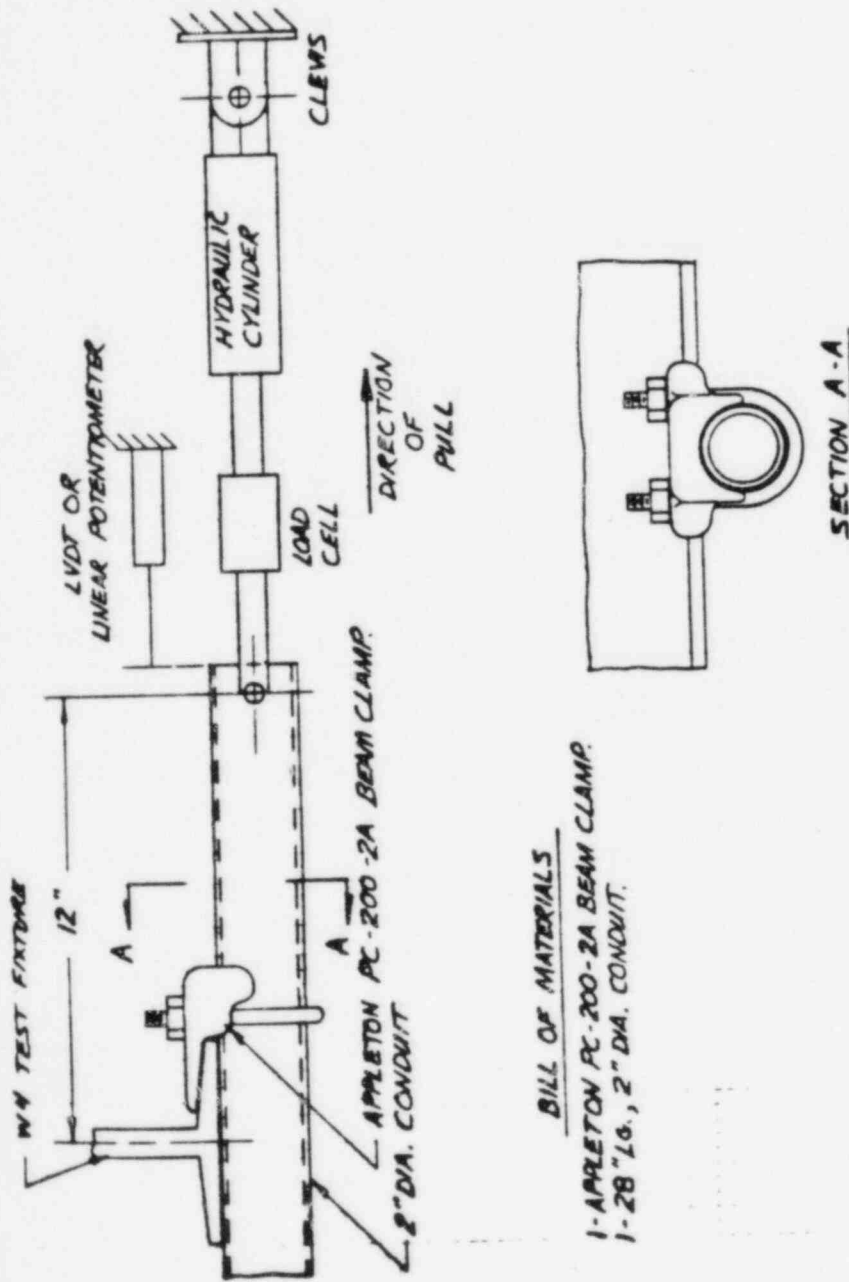

Figure 6.18 Test Sample Number 3d-24: UNISTRUT P2786 Beam Clamp Static Test in the -3 Direction with a 24-inch Moment Arm

TEST PROCEDURE

PROCEDURE No. 1903.23-1, Rev. 0
ISSUE DATE 5/9/86 PAGE 43 OF 87
PREPARED BY _____ DATE _____
APPROVED BY _____ DATE _____
APPROVED BY _____ DATE _____
QA REVIEW BY _____ DATE _____



- BILL OF MATERIALS
- 1-APPLETON PC-200-2A BEAM CLAMP.
 - 1-28" Lg., 2" DIA. CONDUIT.

Figure 6.19 Test Sample Number 5a: Appleton PC-200-RA Beam Clamp Static Test in the 1 Direction

TEST PROCEDURE

PROCEDURE No. 1903.23-1, Rev. 0
 ISSUE DATE 5/9/86 PAGE 44 OF 87
 PREPARED BY _____ DATE _____
 APPROVED BY _____ DATE _____
 APPROVED BY _____ DATE _____
 QA REVIEW BY _____ DATE _____

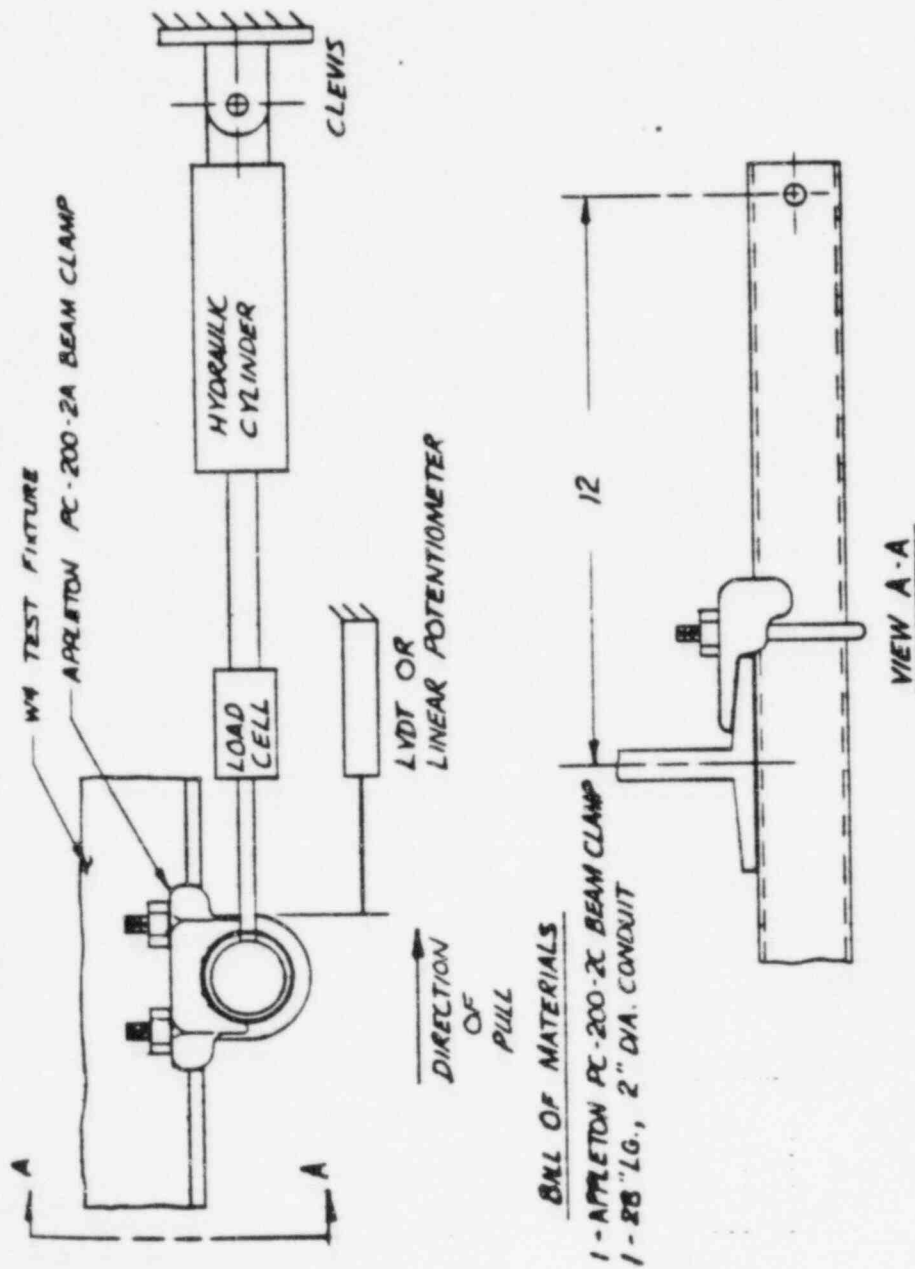
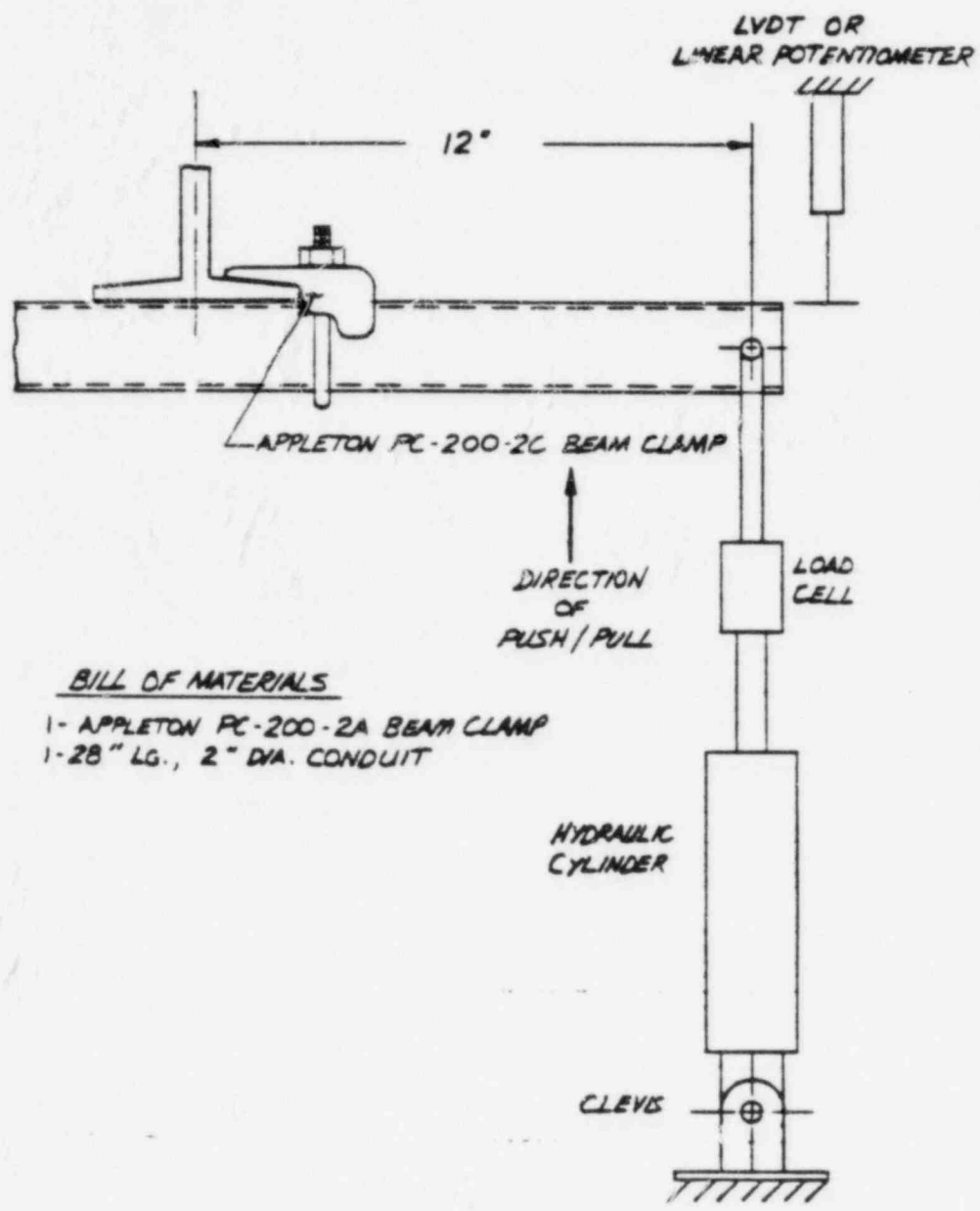

Figure 6.20 Test Sample Number 5b: Appleton PC-200-RA Beam Clamp Static Test in the 2 Direction

TEST PROCEDURE



BILL OF MATERIALS

- 1- APPLETON PC-200-2A BEAM CLAMP
- 1- 28" LG., 2" DIA. CONDUIT

Figure 6.21 Test Sample Number 5c: Appleton PC-200-RA Beam Clamp Static Test in the 3 Direction

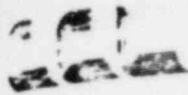

Corporate Consulting
& Development Company, Ltd.

Research Triangle Park NC 27709
PC Box 12728 • 919-362-8800

PROCEDURE No. 1903.23-1, Rev. 0
ISSUE DATE 5/9/86 PAGE 46 OF 87
PREPARED BY _____ DATE _____
APPROVED BY _____ DATE _____
APPROVED BY _____ DATE _____
QA REVIEW BY _____ DATE _____

TEST PROCEDURE

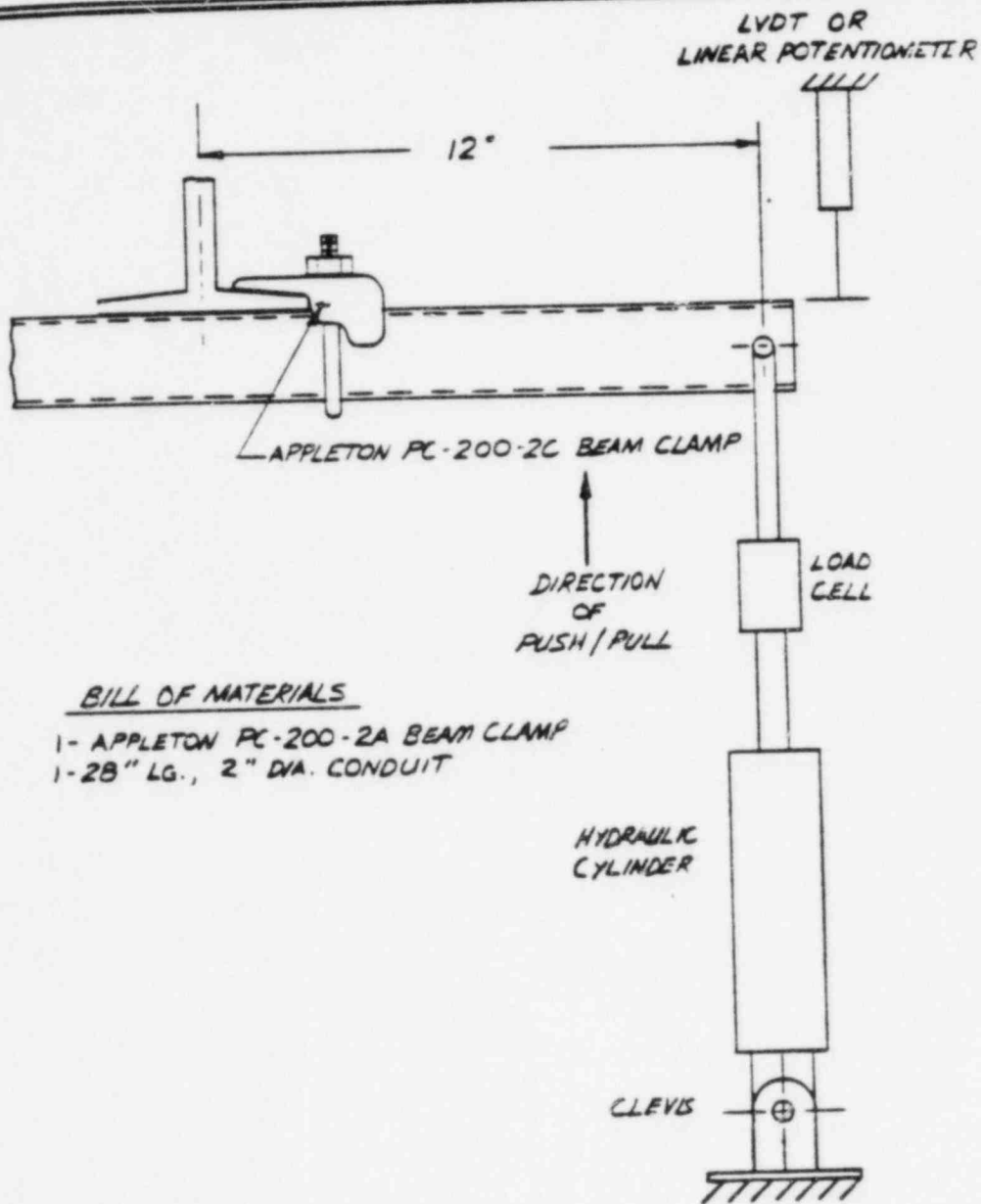

Figure 6.22 Test Sample Number 5d: Appleton PC-200-RA Beam Clamp Static Test in the -3 Direction



Corporate Consulting
& Development Company, Ltd.

Research Triangle Park NC 27709
P.O. Box 12728 • 919-362-8800

TEST PROCEDURE

PROCEDURE No. 1903.23-1, Rev. 0

ISSUE DATE 5/9/86 PAGE 47 OF 87

PREPARED BY _____ DATE _____

APPROVED BY _____ DATE _____

QA REVIEW BY _____ DATE _____

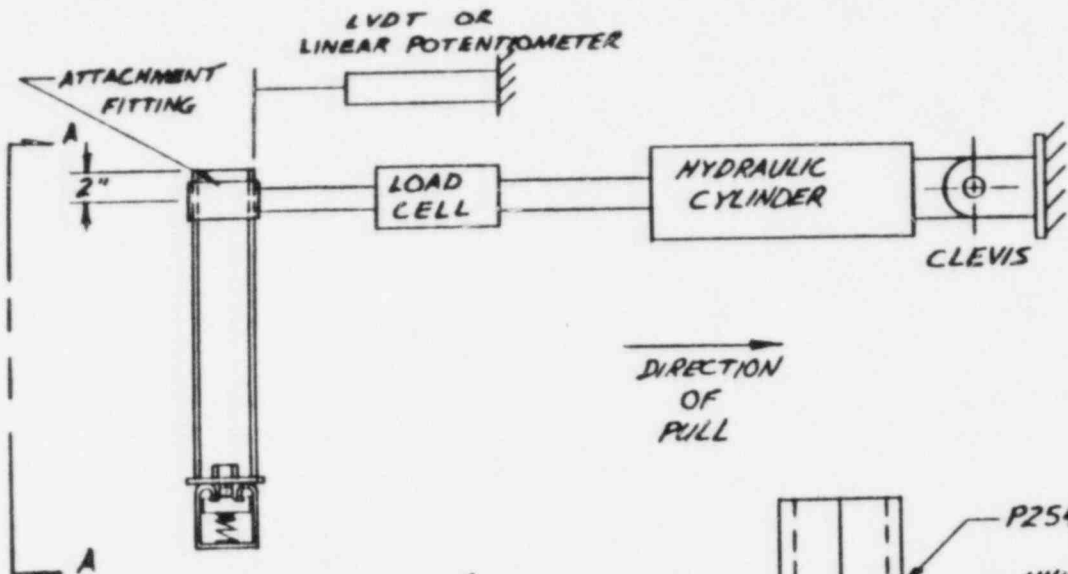

- NOTE: 1. HILTI BOLT EMBEDMENT IS 2".
2. DRILL 2 - 7/16" DIA. HOLES IN P1000 FOR HILTI BOLTS.

BILL OF MATERIALS

- 1- P2546 UNISTRUT WELDED FOOT HANGER.
- 2- SETS OF UNISTRUT SPRING NUTS & BOLTS.
- 2- 3/8" DIA., 2 3/4" LG. HILTI BOLTS.
- 1- 16" LG. P1000 UNISTRUT CHANNEL.

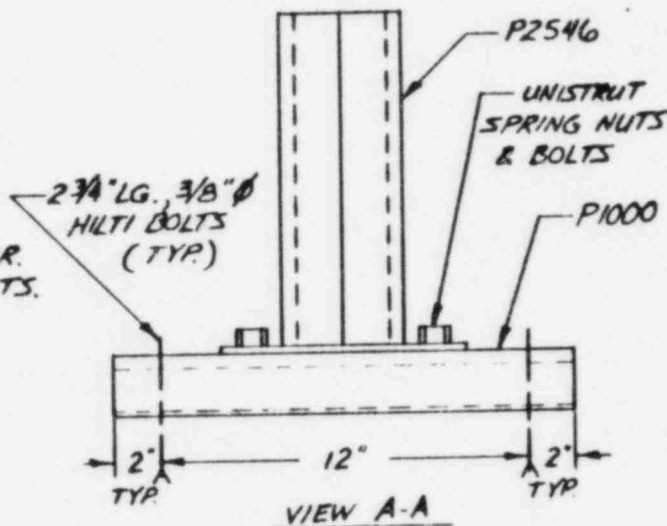

Figure 6.23 Test Sample Number 6: UNISTRUT P2546 Cantilever Hanger Static Test in the Weak Direction



Corporate Consulting
& Development Company, Ltd.

Research Triangle Park NC 27709
P.O. Box 12728 • 919-362-8800

TEST PROCEDURE

PROCEDURE No. 1903.23-1, Rev. 0
 ISSUE DATE 5/9/86 PAGE 48 OF 87
 PREPARED BY _____ DATE _____
 APPROVED BY _____ DATE _____
 APPROVED BY _____ DATE _____
 QA REVIEW BY _____ DATE _____

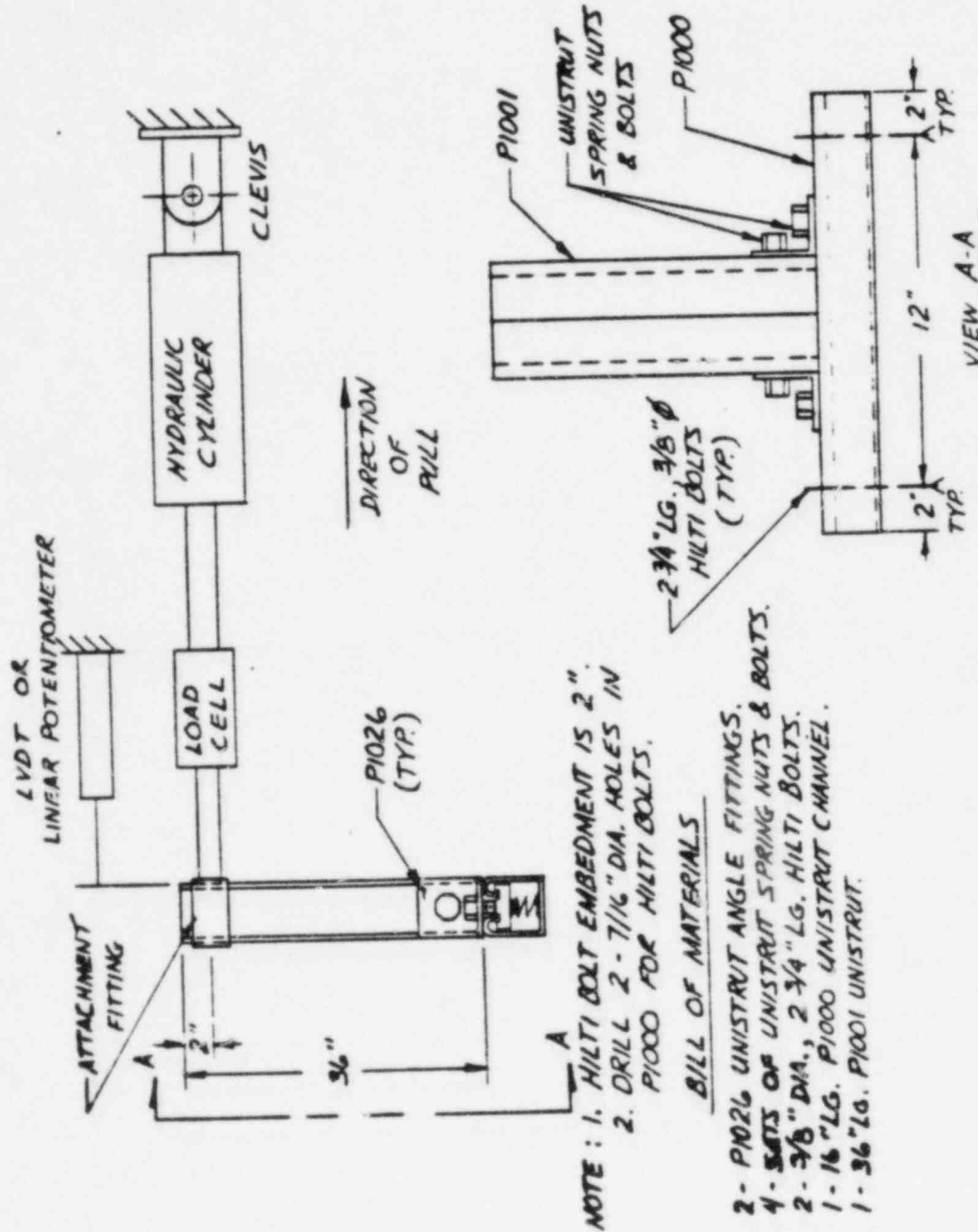

Figure 6.24 Test Sample Number 7: UNISTRUT PI026 Cantilever Hanger Static Test in the Weak Direction



Corporate Consulting
& Development Company, Ltd.

Research Triangle Park, NC 27709
P.O. Box 12728 • 919-362-8800

PROCEDURE No. 1903.23-1, Rev. 0

ISSUE DATE 5/9/86 PAGE 49 OF 87

PREPARED BY _____ DATE _____

APPROVED BY _____ DATE _____

APPROVED BY _____ DATE _____

QA REVIEW BY _____ DATE _____

TEST PROCEDURE

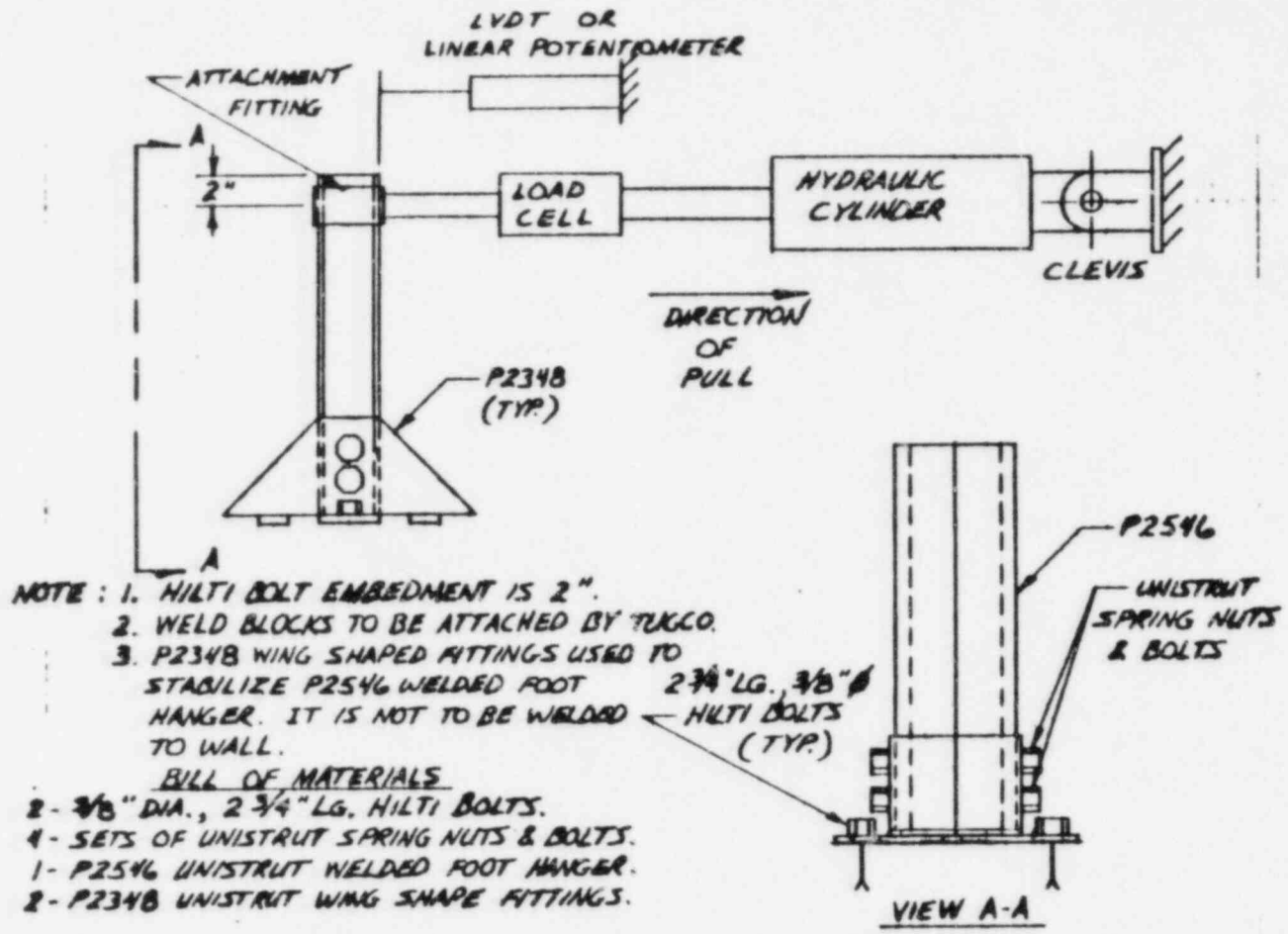

Figure 6.25 Test Sample Number 8: UNISTRUT P2546/P2348
Cantilever Hanger Static Test in the
Weak Direction

TF-067



Corporate Consulting
& Development Company, Ltd.

Research Triangle Park NC 27709
P.O. Box 12728 • 919-362-8800

PROCEDURE No. 1903.23-1, Rev. 0
ISSUE DATE 5/9/86 PAGE 50 OF 87
PREPARED BY _____ DATE _____
APPROVED BY _____ DATE _____
APPROVED BY _____ DATE _____
QA REVIEW BY _____ DATE _____

TEST PROCEDURE

7.0 TEST REPORT

A test report, signed by a registered professional engineer, will be published for the items tested in accordance with this procedure. The test report will include, as a minimum, the following information:

- Test fixture and loading apparatus descriptions
- Test instrumentation descriptions
- Load-versus-deflection curves
- A summary of yield (where identifiable) and maximum loads and corresponding deflections
- Discussion of test results, including the number of cycles sustained in test numbers 1a and 1b.
- Pre- and post-test specimen photographs, including test apparatus
- Description of corrective actions or anomalies occurring during the test program.



Corporate Consulting
& Development Company, Ltd.

Research Triangle Park, NC 27709
P.O. Box 12728 • 919-362-8800

TEST PROCEDURE

PROCEDURE No. 1903.23-1, Rev. 0
ISSUE DATE 5/9/86 PAGE 51 OF 87
PREPARED BY _____ DATE _____
APPROVED BY _____ DATE _____
APPROVED BY _____ DATE _____
QA REVIEW BY _____ DATE _____

8.0 REFERENCES

1. Impell Corporation Report Number 01-0210-1514, Revision 0, dated April 22, 1986, Specification for Testing Beam Clamps and UNISTRUT Hangers.
2. Comanche Peak Steam Electric Station (CPSES) Design Change Authorization (DCA) Number 5106, Revision 9, dated January 3, 1983.
3. Corporate Consulting and Development Company, Ltd. Test Procedure Number 1903.07-1, Revision 3, dated November 8, 1985, Test Procedure for Conduit Systems Design Adequacy Program; Component Testing of Conduit Clamps for Comanche Peak Steam Electric Station.
4. Brown & Root, Inc. Procedure Number CEI-20, Revision 9, dated December 16, 1983, Including Document Change Notice (DCN) Numbers 1 and 2, Installation of HILTI Drilled-In Bolts.
5. Corporate Consulting and Development Company, Ltd. Report Number A-699-85, dated December 17, 1985, Conduit Clamp Test Report, Phase 1 for Texas Utilities Generating Company.



Corporate Consulting
& Development Company, Ltd.

Research Triangle Park, NC 27709
P.O. Box 12726 • 919-362-8800

TEST PROCEDURE

PROCEDURE No. 1903.23-1, Rev. 0
ISSUE DATE 5/9/86 PAGE 52 OF 87
PREPARED BY _____ DATE _____
APPROVED BY _____ DATE _____
APPROVED BY _____ DATE _____
QA REVIEW BY _____ DATE _____

APPENDIX 1

IMPELL TEST SPECIFICATION NUMBER 01-0210-1514



Corporate Consulting
& Development Company, Ltd.

Research Triangle Park, NC 27709
P.O. Box 12728 • 919-362-8800

TEST PROCEDURE

PROCEDURE No. 1903.23-1, Rev. 0
ISSUE DATE 5/9/86 PAGE 53 OF 87
PREPARED BY _____ DATE _____
APPROVED BY _____ DATE _____
APPROVED BY _____ DATE _____
QA REVIEW BY _____ DATE _____

SPECIFICATION FOR TESTING BEAM CLAMPS AND UNISTRUT HANGERS

Prepared for:

Texas Utilities Generating Company
P. O. Box 1002
Glen Rose, Texas 76043

Prepared by:

Impell Corporation
350 Lennon Lane
Walnut Creek, California 94598

Impell Report No. 01-0210-1514
Revision 0

April 1986



Corporate Consulting
& Development Company, Ltd.

Research Triangle Park, NC 27709
P.O. Box 12728 • 919-362-8800

TEST PROCEDURE

PROCEDURE No. 1903.23-1, Rev. 0
 ISSUE DATE 5/9/86 PAGE 54 OF 87
 PREPARED BY _____ DATE _____
 APPROVED BY _____ DATE _____
 APPROVED BY _____ DATE _____
 QA REVIEW BY _____ DATE _____

IMPELL CORPORATION REPORT APPROVAL COVER SHEET

Client: Texas Utilities Generating Company
 Project: Train C Conduit Job Number: 0210-052-1355
 Report Title: Specification for Testing Beam Clamps and Unistrut Hangers
 Report Number: 01-0210-1514 Rev. 0

The work described in this Report was performed in accordance with the Impell Quality Assurance Program. The signatures below verify the accuracy of this Report and its compliance with applicable quality assurance requirements.

Prepared By: Andrew D. Howell Date: 4/22/86
 Reviewed By: Karen Korman Date: 4/22/86
 Approved By: M. Swartz Date: 4/22/86

REVISION RECORD

Rev. No.	Prepared	Reviewed	Approved	Approval Date	Revision



Corporate Consulting
& Development Company, Ltd.

Research Triangle Park, NC 27709
P.O. Box 12728 • 919-362-8800

TEST PROCEDURE

PROCEDURE No. 1903.23-1, Rev. 0
 ISSUE DATE 5/9/86 PAGE 55 OF 87
 PREPARED BY _____ DATE _____
 APPROVED BY _____ DATE _____
 APPROVED BY _____ DATE _____
 QA REVIEW BY _____ DATE _____

TABLE OF CONTENTS

	<u>Page</u>
1.0 INTRODUCTION	1-1
2.0 SCOPE OF WORK	2-1
3.0 TEST SPECIMENS	3-1
4.0 TEST PROCEDURES	4-1
5.0 TEST REPORT	5-1
6.0 PURCHASER SUPPLIED ITEMS	6-1
7.0 QUALITY ASSURANCE REQUIREMENTS	7-1
8.0 REFERENCES	8-1
Table	
Figures	



Corporate Consulting
& Development Company, Ltd.

Research Triangle Park NC 27709
P.O. Box 12728 • 919-362-8800

TEST PROCEDURE

PROCEDURE No. 1903.23-1, Rev. 0
 ISSUE DATE 5/9/86 PAGE 56 OF 87
 PREPARED BY _____ DATE _____
 APPROVED BY _____ DATE _____
 APPROVED BY _____ DATE _____
 QA REVIEW BY _____ DATE _____

1.0 INTRODUCTION

This specification outlines the requirements for testing of beam clamps and UNISTRUT hangers for Comanche Peak Steam Electric Station. These tests shall provide the necessary information for assessing the design adequacy of these components.

Tests will be provided to determine the behavior of the following types of clamps and hangers:

1. UNISTRUT P1651S beam clamp
2. UNISTRUT P2785 and P2786 beam clamps
3. Appleton PC-200-RA beam clamp
4. UNISTRUT P2546 welded foot hanger
5. UNISTRUT P1026 hanger fittings
6. UNISTRUT 2546 welded foot hanger with P2348 fittings

The objective of these tests are as follows:

1. Determine the suitability for cyclic loading of a P1651S beam clamp.
2. Determine the monotonic capacities for P2785 and P2786 beam clamp pairs.
3. Determine the monotonic capacities for single Appleton PC-200-RA beam clamps.
4. Determine the monotonic capacity in the conduit longitudinal direction of: a P2546 welded foot hanger; a hanger consisting of P1026 fittings attached to a P1001 member; a P2546 welded foot hanger with a pair of P2348 fittings.



Corporate Consulting
& Development Company, Ltd.

Research Triangle Park NC 27709
P.O. Box 12728 * 919-362-8800

TEST PROCEDURE

PROCEDURE No. 1903.23-1, Rev. 0
 ISSUE DATE 5/9/86 PAGE 57 OF 87
 PREPARED BY _____ DATE _____
 APPROVED BY _____ DATE _____
 APPROVED BY _____ DATE _____
 QA REVIEW BY _____ DATE _____

2.0 SCOPE OF WORK

The Testing Laboratory shall perform the following tasks:

1. Prepare detailed test procedures for all tests in accordance with the requirements of this specification.
2. Fabricate all necessary test fixtures and provide test instrumentation to measure the response of the test specimens.
3. Assemble test specimens from materials provided by purchaser, in accordance with the referenced procedures.
4. Perform the specified tests.
5. Prepare a comprehensive schedule for performing and completing the specified tests.
6. Prepare a test report that provides all measured and observed test results.



TEST PROCEDURE

PROCEDURE No. 1903.23-1, Rev. 0
 ISSUE DATE 5/9/86 PAGE 58 OF 87
 PREPARED BY _____ DATE _____
 APPROVED BY _____ DATE _____
 APPROVED BY _____ DATE _____
 QA REVIEW BY _____ DATE _____

3.0 TEST SPECIMENS

The test specimens shall consist of the following types:

1. A single UNISTRUT P1651S beam clamp, as shown in the UNISTRUT General Engineering Catalog (Ref. 5), will be mounted on a W4 section and fitted with a 24-inch length of one-half inch threaded rod.
2. A set of UNISTRUT P2785 beam clamps, as shown in Ref. 5, will be mounted on a W4 section, and will be holding a P1000 channel of appropriate length.
3. A set of UNISTRUT P2786 beam clamps, as shown in Ref. 5, will be holding a P5500 channel of appropriate length.
4. A single Appleton PC-200-RA beam clamp, as shown in Ref. 6, will be mounted on a W4 section, and will be attached to 1-1/2 inch diameter conduit of appropriate length.
5. A UNISTRUT P2546 welded foot hanger will be connected to a P1000 header and attached to a reinforced concrete surface with two 3/8-inch diameter HILTI bolts that are embedded to a depth of two inches.
6. UNISTRUT P1026 fittings will be attached to a P1001 channel member of 36-inch length and the fittings shall be connected to a P1000 header that is attached to a reinforced concrete surface with two 3/8-inch diameter HILTI bolts that are embedded to a depth of two-inches.
7. A UNISTRUT P2546 welded foot hanger with a pair of P2348 wing shape fittings shall be attached to a reinforced concrete surface with two 3/8-inch diameter HILTI bolts that are embedded to a depth of two inches.



Corporate Consulting
& Development Company, Ltd.

Research Triangle Park, NC 27709
P.O. Box 12728 • 919-362-8800

TEST PROCEDURE

PROCEDURE No. 1903.23-1, Rev. 0
 ISSUE DATE 5/9/86 PAGE 59 OF 87
 PREPARED BY _____ DATE _____
 APPROVED BY _____ DATE _____
 APPROVED BY _____ DATE _____
 QA REVIEW BY _____ DATE _____

3.0 TEST SPECIMENS

The W4 section to which a beam clamp is attached shall be no longer than 18-inches, shall be stiffened at the ends and shall be rigidly attached to the test fixture. The cantilever hanger (P2546 and P1026) and header may be attached to a rigid test fixture if the Test Laboratory can demonstrate that there is no significant difference when compared with the tested behavior of a hanger attached to concrete.

A listing of all test specimens is given in Table 1.



TEST PROCEDURE

4.0 TEST PROCEDURES

The various test procedures are outlined below. The Purchaser reserves the right to alter the test program upon review of interim test results.

4.1 Beam Clamps

4.1.1 Cyclic Suitability

The P1651S beam clamp shall be subjected to cycles of load reversals in the horizontal directions shown in Figure 1. The horizontal force applied at the end of the threaded rod shall be equal to or greater than the force necessary to yield the rod when deflected in that direction. The actual displacement shall be specified by the Purchaser. One hundred cycles of horizontal load shall be applied in each direction. A new specimen shall be used for each direction of load. Moreover, there shall be three virgin samples for each direction. Cycling will be discontinued only if there is separation between clamp and beam. All cycling shall be conducted at a rate of 1 Hertz or less.

4.1.2 Monotonic Capacity

Clamp types P2785 and P2786 shall be similarly tested by a gradual application of load to the UNISTRUT channel in one of the directions shown in Figure 2. The tests will be conducted until failure (separation of clamp from beam or deformations exceeding 12 inches). Each direction of load will be tested separately and three new samples will be tested for each direction of load. For loading in the vertical direction, separate tests will be performed for upwards and for downwards load. Two separate loading locations shall be tested: 12 inches from the web of the beam and 24 inches from the web.

Clamp type PC-200-RA shall be monotonically tested by applying load to the conduit, as shown in Figure 3. Separate tests will be conducted for the three loading directions indicated, and three samples shall be done in each direction.

4.2 Cantilever Hangers

The three types of cantilever hangers shall be tested monotonically to failure (loss of load carrying capacity or separation of members) in the direction shown in Figure 4. Three samples of each cantilever type shall be tested for the one direction of loading.



Corporate Consulting
& Development Company, Ltd.

Research Triangle Park, NC 27709
P.O. Box 12728 • 919-362-8800

TEST PROCEDURE

PROCEDURE No. 1903.23-1, Rev. 0
 ISSUE DATE 5/9/86 PAGE 61 OF 87
 PREPARED BY _____ DATE _____
 APPROVED BY _____ DATE _____
 APPROVED BY _____ DATE _____
 QA REVIEW BY _____ DATE _____

4.0 TEST PROCEDURES

4.3 Test Data Monitoring

Applied load and deflection in the loaded direction shall be continuously monitored. Care should be taken in that displacement measuring devices have sufficient range to measure the displacement at failure and that they have sufficient resolution to accurately define the load-deflection curve.



Corporate Consulting
& Development Company, Ltd.

Research Triangle Park NC 27709
P.O. Box 12726 • 919-362-8800

PROCEDURE No. 1903.23-1, Rev. 0
 ISSUE DATE 5/9/86 PAGE 62 OF 87
 PREPARED BY _____ DATE _____
 APPROVED BY _____ DATE _____
 APPROVED BY _____ DATE _____
 QA REVIEW BY _____ DATE _____

TEST PROCEDURE

5.0 TEST REPORT

Upon conclusion of testing a test report shall be prepared by the Testing Laboratory. The report shall contain, at a minimum, the following items:

1. A description of test fixture and loading apparatus.
2. A description of instrumentation used to control and monitor test behavior.
3. Load-deflection curves for each test.
4. A summary of ultimate, yield and maximum loads as well as yield and maximum displacements.
5. A description of test procedures.
6. A description of test results.
7. Photographs of test specimens before and after testing.
8. Photographs of the testing apparatus.
9. Description of any anomalies, installation errors, or deviations from the stated test procedure.

In addition, interim test reports will be required on an as-requested basis by the Purchaser, which shall consist of results to date.



Corporate Consulting
& Development Company, Ltd.

Research Triangle Park, NC 27709
P.O. Box 12728 • 919-362-8800

TEST PROCEDURE

PROCEDURE No. 1903.23-1, Rev. 0
ISSUE DATE 5/9/86 PAGE 63 OF 87
PREPARED BY _____ DATE _____
APPROVED BY _____ DATE _____
APPROVED BY _____ DATE _____
QA REVIEW BY _____ DATE _____

6.0 PURCHASER SUPPLIED ITEMS

The Purchaser shall supply all beam clamps, channel sections, conduit, fittings, welded foot hangers, and associated hardware necessary for performing the tests. Tests items shall be verified by the Purchaser to be representative of that type of item found in Unit 1 of Comanche Peak Steam Electric Station.



Corporate Consulting
& Development Company, Ltd.

Research Triangle Park, NC 27709
P.O. Box 12728 • 919-362-8800

TEST PROCEDURE

PROCEDURE No. 1903.23-1, Rev. 0
 ISSUE DATE 5/9/86 PAGE 64 OF 87
 PREPARED BY _____ DATE _____
 APPROVED BY _____ DATE _____
 APPROVED BY _____ DATE _____
 QA REVIEW BY _____ DATE _____

7.0 QUALITY ASSURANCE REQUIREMENTS

The testing Laboratory shall establish and implement a quality assurance program which conforms to the applicable rules and standards as imposed by NRC, 10 CFR 50 Appendix B and this specification.

The Testing Laboratory shall submit all installation and test procedures to TUGCO for review and approval prior to implementation. This right of review and approval shall also extend to any changes made to the Testing Laboratory's quality assurance program and procedures during the course of work.

The Testing Laboratory shall not commence test until TUGCO project approves the test procedure. TUGCO reserves the right to witness all testing.

The Testing Laboratory shall provide right of access to his plant facilities, and records for inspection or audit purposes by TUGCO, TUGCO's designated representative, or other authorized parties such as regulatory agencies.

The Testing Laboratory shall agree to stop work at the request of TUGCO or TUGCO's representative until resolution of any major quality assurance or quality control deficiencies.

The Testing Laboratory shall establish procedures to assure that all inspection tools, instruments, gauges and other measuring and testing devices are in calibration and traceable to the standards of the National Bureau of Standards. When inspection and testing equipment is found to be out of calibration, all items inspected, tested, or measured with that equipment since the latest valid calibration shall be considered unacceptable. Resolution of these cases shall be determined on a case-by-case basis.



Corporate Consulting
& Development Company, Ltd.

Research Triangle Park NC 27709
P.O. Box 12728 • 919-362-8800

TEST PROCEDURE

PROCEDURE No. 1903.23-1, Rev. 0
ISSUE DATE 5/9/86 PAGE 65 OF 87
PREPARED BY _____ DATE _____
APPROVED BY _____ DATE _____
APPROVED BY _____ DATE _____
QA REVIEW BY _____ DATE _____

8.0 REFERENCES

1. DCA 5106, Rev. 9
2. CPPA-2142
3. DCA-4693
4. CPPA-4865
5. UNISTRUT General Engineering Category, No. 10R,
1984
6. Appleton Catalog



Corporate Consulting
& Development Company, Ltd.

Research Triangle Park NC 27709
P.O. Box 12728 • 919-362-8800

TEST PROCEDURE

PROCEDURE No. 1903.23-1, Rev. 0
 ISSUE DATE 5/9/86 PAGE 66 OF 87
 PREPARED BY _____ DATE _____
 APPROVED BY _____ DATE _____
 APPROVED BY _____ DATE _____
 QA REVIEW BY _____ DATE _____

Table 1

Summary of Tests (75 Tests Total)

Test No.	Item Tested	Loading Type	Direction of Load	Purpose	No. of Tests
1a	P1651S	Cyclic	1	Cyclic Suitability	3
1b	P1651S	Cyclic	2	Cyclic Suitability	3
2a	P2785	Monotonic	1	Ultimate Capacity	6
2b	P2785	Monotonic	2	Ultimate Capacity	6
2c	P2785	Monotonic	3	Ultimate Capacity	6
2d	P2785	Monotonic	-3	Ultimate Capacity	6
3a	P2786	Monotonic	1	Ultimate Capacity	6
3b	P2786	Monotonic	2	Ultimate Capacity	6
3c	P2786	Monotonic	3	Ultimate Capacity	6
3d	P2786	Monotonic	-3	Ultimate Capacity	6
5a	PC-200-RA	Monotonic	1	Ultimate Capacity	3
5b	PC-200-RA	Monotonic	2	Ultimate Capacity	3
5c	PC-200-RA	Monotonic	3	Ultimate Capacity	3
5d	PC-200-RA	Monotonic	-3	Ultimate Capacity	3
6	P2546	Monotonic	L	Ultimate Capacity	3
7	P1026	Monotonic	L	Ultimate Capacity	3
8	P2546/2348	Monotonic	L	Ultimate Capacity	3

Impell Report 01-0210-1514
Revision 0



Corporate Consulting
& Development Company, Ltd.

Research Triangle Park NC 27709
P.O. Box 12728 • 919-362-8800

PROCEDURE No. 1903.23-1, Rev. 0
ISSUE DATE 5/9/86 PAGE 67 OF 87
PREPARED BY _____ DATE _____
APPROVED BY _____ DATE _____
APPROVED BY _____ DATE _____
QA REVIEW BY _____ DATE _____

TEST PROCEDURE

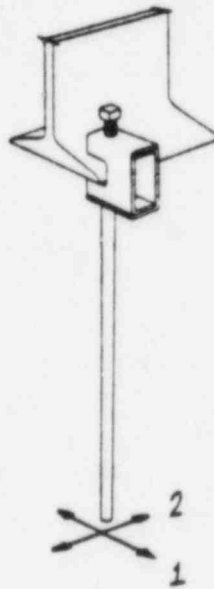

FIGURE 1. P1651S Beam Clamp.

Impell Report 01-0210-1514
Revision 0



Corporate Consulting
& Development Company, Ltd.

Research Triangle Park, NC 27709
P.O. Box 12726 • 919-362-8800

PROCEDURE No. 1903.23-1, Rev. 0
ISSUE DATE 5/9/86 PAGE 68 OF 87
PREPARED BY _____ DATE _____
APPROVED BY _____ DATE _____
APPROVED BY _____ DATE _____
QA REVIEW BY _____ DATE _____

TEST PROCEDURE

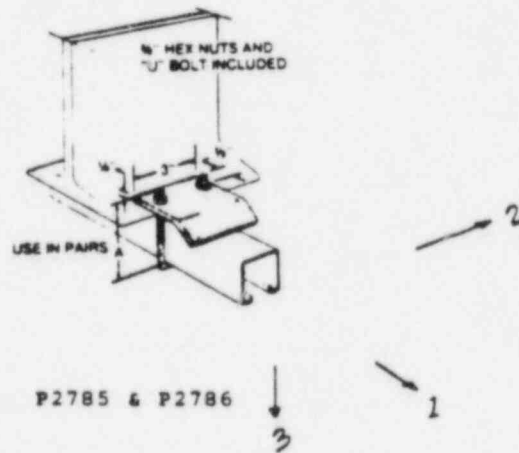

FIGURE 2. Beam Clamps P2785, P2786

Impell Report 01-0210-1514
Revision 0



Corporate Consulting
& Development Company, Ltd.

Research Triangle Park, NC 27709
P.O. Box 12728 • 919-362-8800

TEST PROCEDURE

PROCEDURE No. 1903.23-1, Rev. 0
ISSUE DATE 5/9/86 PAGE 69 OF 87
PREPARED BY _____ DATE _____
APPROVED BY _____ DATE _____
APPROVED BY _____ DATE _____
QA REVIEW BY _____ DATE _____

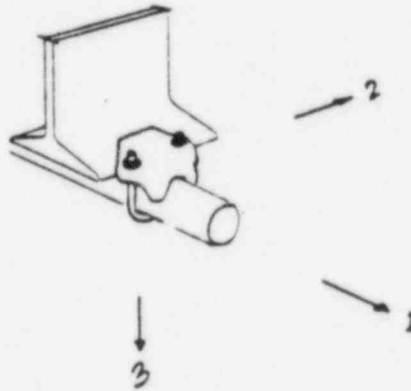

Figure 3. Beam Clamp PC-200-RA.

Impell Report 01-0210-1514
Revision 0



Corporate Consulting
& Development Company, Ltd.

Research Triangle Park, NC 27709
P.O. Box 12726 • 919-362-8800

TEST PROCEDURE

PROCEDURE No. 1903.23-1, Rev. 0
ISSUE DATE 5/9/86 PAGE 70 OF 87
PREPARED BY _____ DATE _____
APPROVED BY _____ DATE _____
APPROVED BY _____ DATE _____
QA REVIEW BY _____ DATE _____

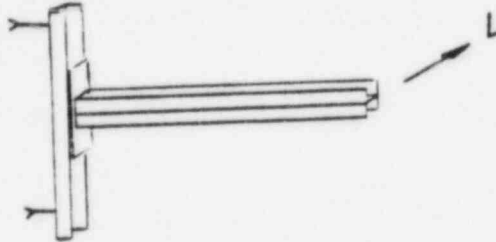

P2546

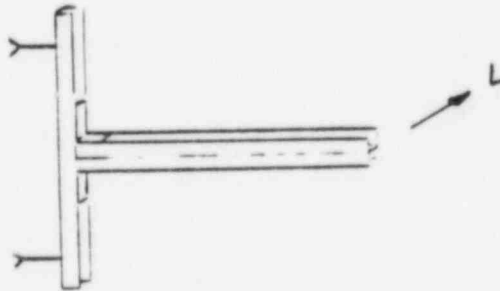

P1026 Fittings



FIGURE 4. Cantilever Hangers.



Corporate Consulting
& Development Company, Ltd.

Research Triangle Park, NC 27709
P.O. Box 12728 • 919-362-8800

TEST PROCEDURE

PROCEDURE No. 1903.23-1, Rev. 0
ISSUE DATE 5/9/86 PAGE 71 OF 87
PREPARED BY _____ DATE _____
APPROVED BY _____ DATE _____
APPROVED BY _____ DATE _____
QA REVIEW BY _____ DATE _____

APPENDIX 2

TUGCO DCA NUMBER 5106, REV. 9



Corporate Consulting
& Development Company, Ltd.

Research Triangle Park, NC 27709
PO Box 12726 • 919-362-8800

PROCEDURE No. 1903.23-1, Rev. 0
ISSUE DATE 5/9/86 PAGE 72 OF 87
PREPARED BY _____ DATE _____
APPROVED BY _____ DATE _____
APPROVED BY _____ DATE _____
QA REVIEW BY _____ DATE _____

TEST PROCEDURE

RAB, TUGCO(2) AM(4) CW, JB

CONTROLLED DOCUMENT

DO NOT COPY

PAGE 1 OF 13

COMANCHE PEAK STEAM/ELECTRIC STATION
DESIGN CHANGE AUTHORIZATION

CHANGE INDEX: OEI _____
: II _____
: III _____

C

(WILL) (WILL NOT) BE INCORPORATED IN DESIGN DOCUMENT DCA NO. 5106 Rev. 9

1. SAFETY RELATED DOCUMENT: YES XX NO

2. ORIGINATOR: CPPE XX ORIGINAL DESIGNER

**FOR OFFICE AND
ENGINEERING USE ONLY**

3. DESCRIPTION:

A. APPLICABLE SPEC/DWG/DOCUMENT 2323-E1-1705 REV. 4

B. DETAILS "THIS REVISION VOIDS AND SUPERSEDES DCA #5106 REV. 8"

Non-safety related conduits can be supported according to typical details attached hereto. Construction shall refer to the owner's guideline defined in CPPA-3417 to select areas where non-seismic conduit support can be installed in safety related structures.

REV. 1, 3, 5, 8, & 9 are issued for clarification of notes as indicated.

REV. 2: Adds Containment Bldg. liner supports.

REV. 4: Adds alternate attachments to embedded steel weld plates of sh. 11 of 13. REV. 5: Adds page 12 of 13.

REV. 6: Adds page 12 of 13.

REV. 7: Adds page 13 of 13.

4. SUPPORTING DOCUMENTATION:

CPPA-2142; DCA-4693; CPPA-4865

JOB NO. 37-1000
RECEIVED
JAN 10 1983
RECEIVED

5. APPROVAL SIGNATURES: SGM/PP/cw

January 3, 1983

A. ORIGINATOR: Shawn A. Mc...

DATE 1-3-83

B. DESIGN REPRESENTATIVE: Paul...

DATE 1-5-83

6. VENDOR TRANSMITTAL REQUIRED: YES _____ NO XX

7. STANDARD DISTRIBUTION:

- ARMS (Original) (1)
- Quality Engineering (1)
- TS for Orig. Design (1)
- Westinghouse-site (1)
- Civil Engineering (1)
- Tim Stewart - EE (1)

DCA FORM 11-80
Admin. Rev 7-82



Corporate Consulting
& Development Company, Ltd.

Research Triangle Park NC 27709
PO Box 12728 • 919-362-8800

PROCEDURE No. 1903.23-1, Rev. 0
 ISSUE DATE 5/9/86 PAGE 73 OF 87
 PREPARED BY _____ DATE _____
 APPROVED BY _____ DATE _____
 APPROVED BY _____ DATE _____
 QA REVIEW BY _____ DATE _____

TEST PROCEDURE

Page 2 of 13
DCA 5106 Rev. 9

NOTES

- 1) SUPPORT DESIGN IS BASED ON EIGHT FT. (8'-0") SPACING FOR CONDUIT 3/4"Ø TO 1 1/2"Ø AND TEN FT. (10'-0") FOR 2"Ø AND LARGER.
- 2) WHERE BENDS OCCUR IN CONDUIT SUPPORT TO BE LOCATED FROM TANGENT 2'-6" (MAX.).
- 3) WHERE CONDUIT TERMINATES AT EQUIPMENT, JUNCTION BOX, ETC. THE SUPPORT SHALL BE LOCATED AT 3'-0" (MAX) FROM BOX OR EQUIP.
- 4) SUPPORT DETAILS SHOWN ARE SUGGESTED ONLY. DEVIATION BASED ON SOUND ENGINEERING AND CONSTRUCTION TECHNIQUES MAY BE ALLOWED, INCLUDING BUT NOT LIMITED TO THE USE OF DETAILS AS SHOWN IN S-910.
- 5) REFER TO CPPA-2142 TO DETERMINE THE AREA WHERE NON SEISMIC SUPPORTS FOR CONDUIT, JUNCTION & PULL BOXES AND CONDULETS CAN BE USED.
- 6) MILTI KWIK BOLTS SHALL BE INSTALLED AS PER CIVIL ENGR. PROCEDURE CE1-20, INCLUDING THE MINIMUM EMBEDMENT REQUIREMENTS FOR THE BOLTS. EMBEDMENTS SHOWN ELSEWHERE IN THIS DCA ARE NOT MANDATORY, BUT ONLY SUGGESTED.
- 7) WHEN BOTH ENDS OF CONDUIT TERMINATE AT EQUIPMENT, JUNCTION BOX, ETC., THE CONDUIT MAY SPAN A MAXIMUM OF 3'-0" WITHOUT ANY SUPPORT.
- 8) WHEN FITTINGS ARE USED IN SPANS (LB, LBD, C, BC, ETC.), SUPPORT SPACING SHALL BE MAINTAINED PER NOTE 1, MEASURING THRU THE FITTING.

△



Corporate Consulting
& Development Company, Ltd.

Research Triangle Park NC 27709
P.O. Box 12728 • 919-362-8800

TEST PROCEDURE

PROCEDURE No. 1903.23-1, Rev. 0
 ISSUE DATE 5/9/86 PAGE 74 OF 87
 PREPARED BY _____ DATE _____
 APPROVED BY _____ DATE _____
 APPROVED BY _____ DATE _____
 QA REVIEW BY _____ DATE _____

Page 3 of 13
DCA 5106 Rev. 2

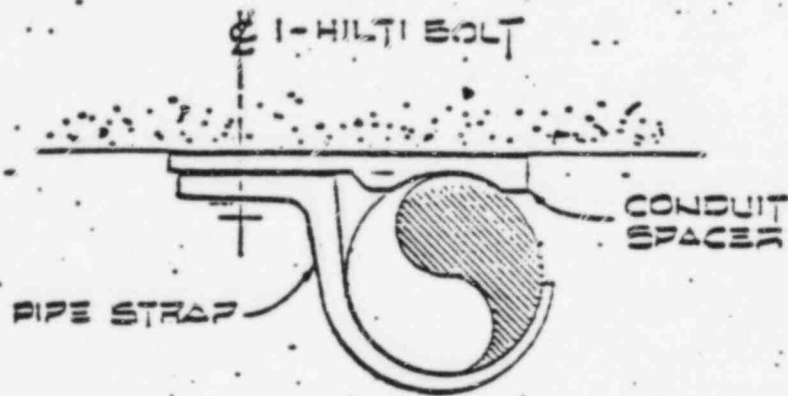

1-HOLE PIPE STRAP

SCHEDULE

CONDUIT SIZE	3/4"	1"	1 1/2"	2"	3"	4"	5"
HILTI KINK BOLT (DIA x MIN. EMB'D)	1/2" x 2"	1/2" x 2"	3/8" x 2 1/2"	1/2" x 2 1/2"	X	X	X

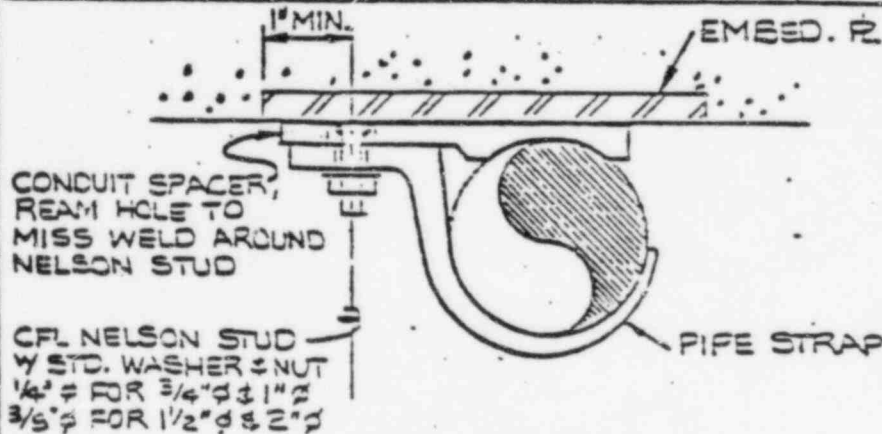

TEST PROCEDURE

Page 4 of 13
DCA 5125 Rev 9

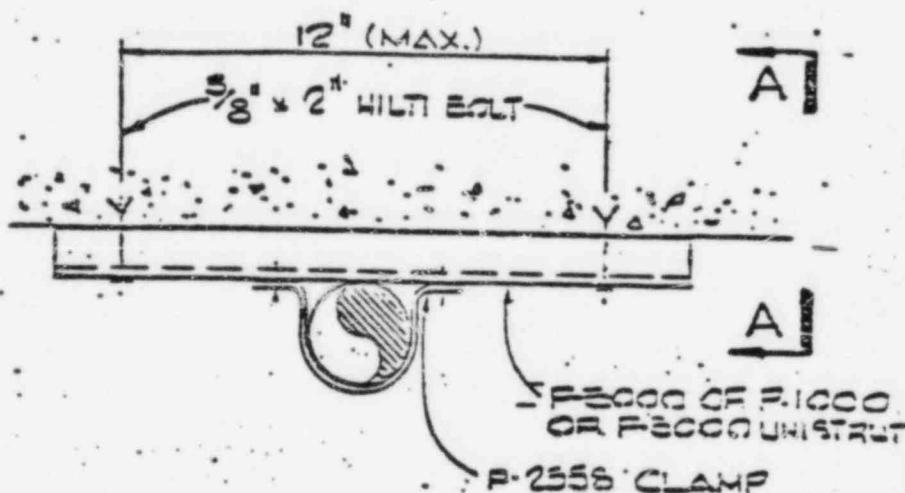

SUPPORT FOR CONDUIT
- AGAINST WALL OR CEILING

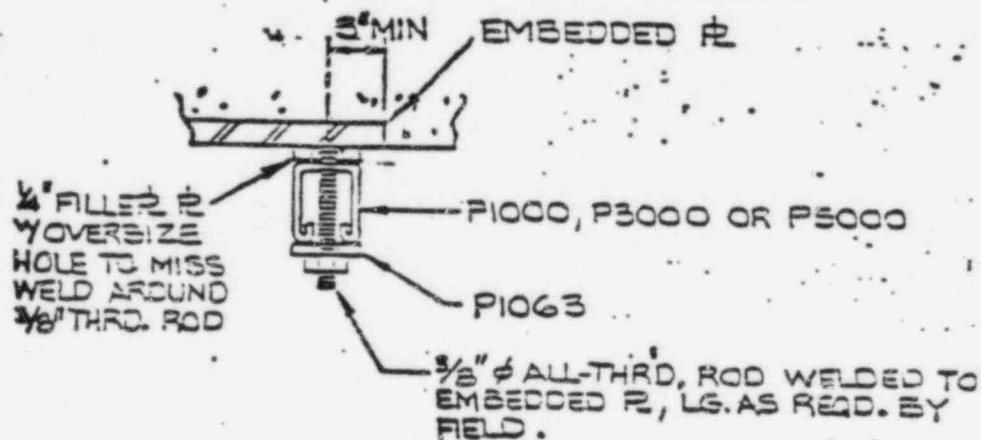

ALTERNATE SECTION A-A

TEST PROCEDURE

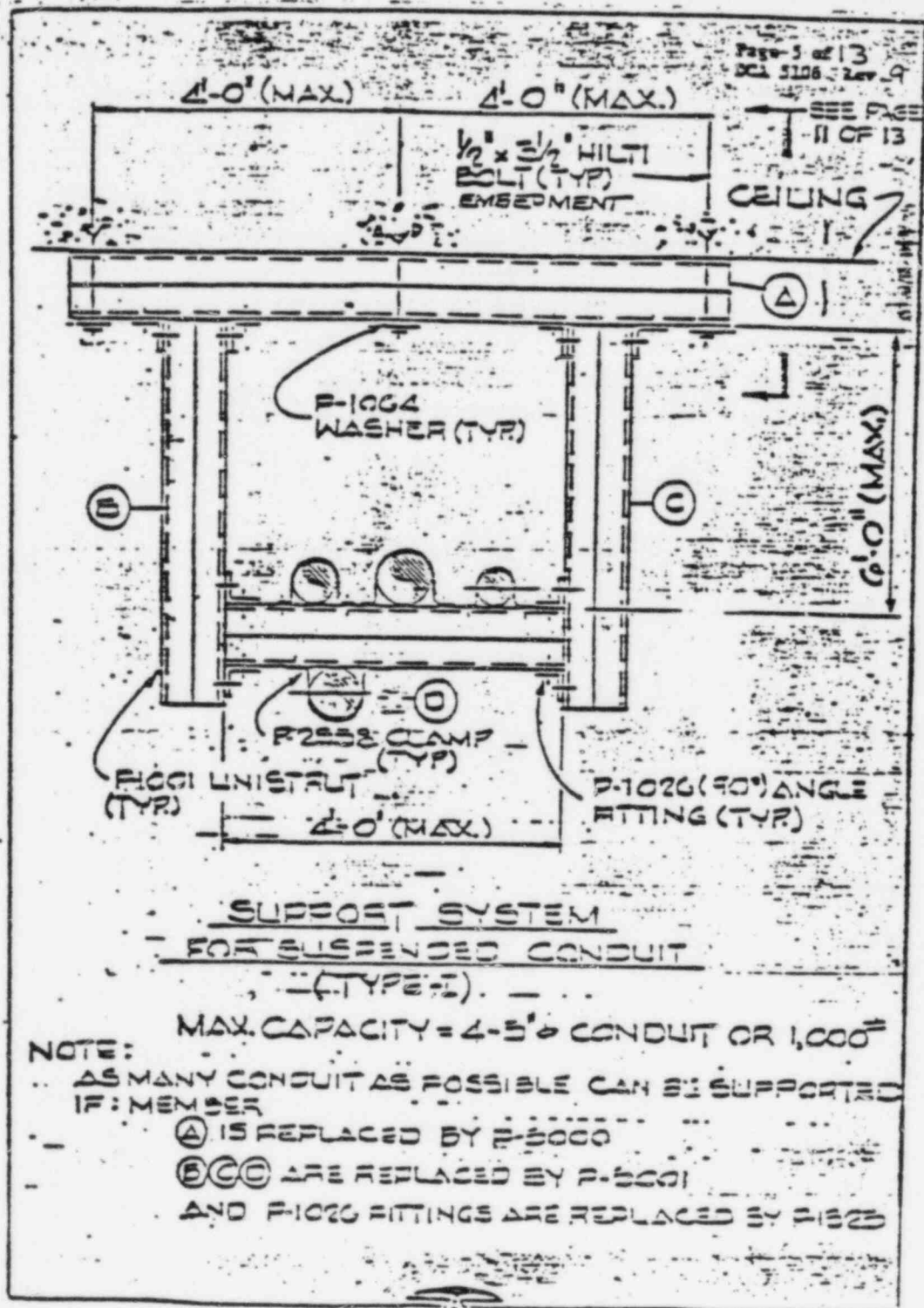



Corporate Consulting
& Development Company, Ltd.

Research Triangle Park NC 27709
PO Box 12728 • 919-362-8800

TEST PROCEDURE

PROCEDURE No. 1903.23-1, Rev. 0
 ISSUE DATE 5/9/86 PAGE 77 OF 87
 PREPARED BY _____ DATE _____
 APPROVED BY _____ DATE _____
 APPROVED BY _____ DATE _____
 QA REVIEW BY _____ DATE _____

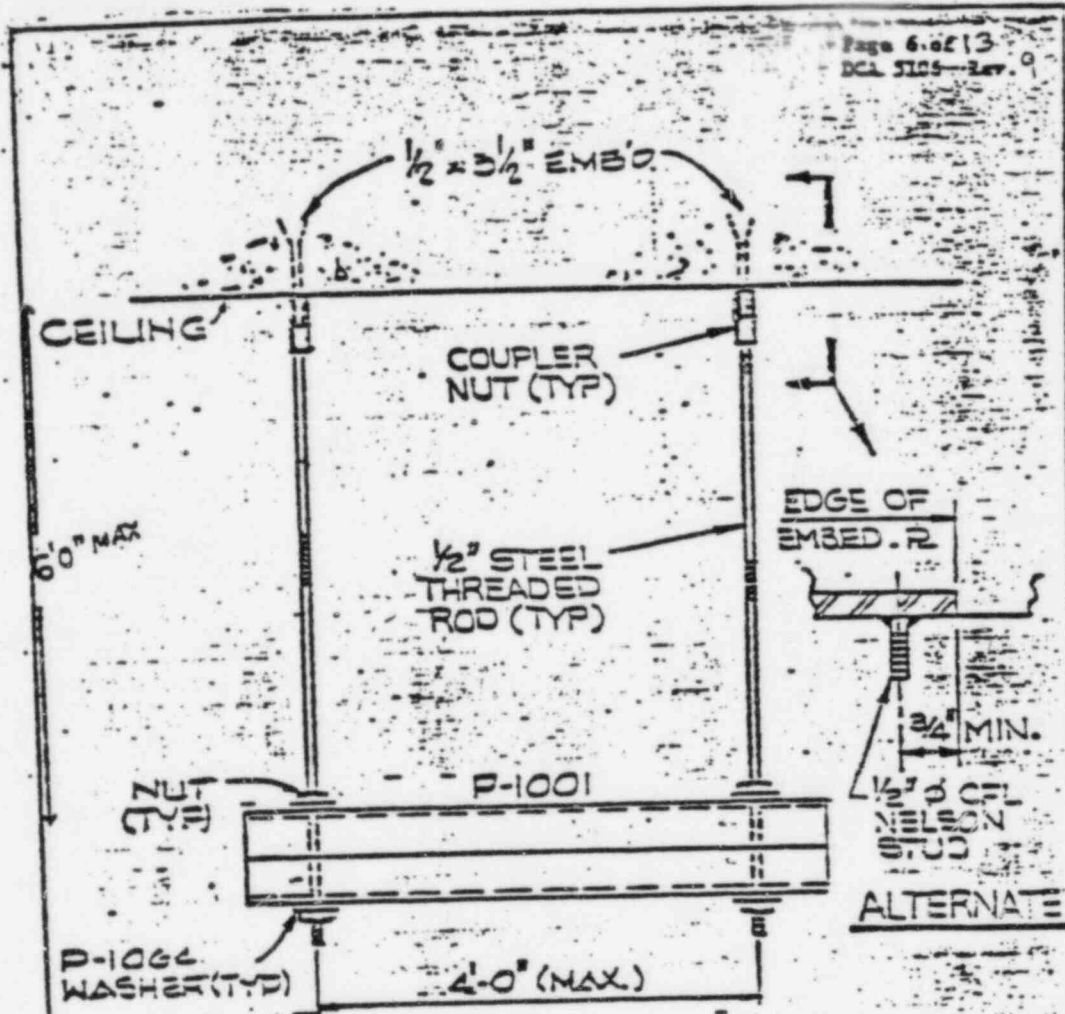

Page 6 of 13
DCI 5105-Rev. 0

SUPPORT SYSTEM FOR
SUSPENDED CONDUIT
(TYPE-I) (ALTERNATE)

MAX. CAPACITY:
4-3" Ø CONDUIT OR 1,000 LBS.



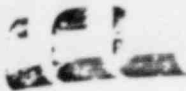

Corporate Consulting
& Development Company, Ltd.

Research Triangle Park NC 27709
PO Box 12728 • 919-362-8800

TEST PROCEDURE

PROCEDURE No. 1903.23-1, Rev. 0
 ISSUE DATE 5/9/86 PAGE 78 OF 87
 PREPARED BY _____ DATE _____
 APPROVED BY _____ DATE _____
 APPROVED BY _____ DATE _____
 QA REVIEW BY _____ DATE _____

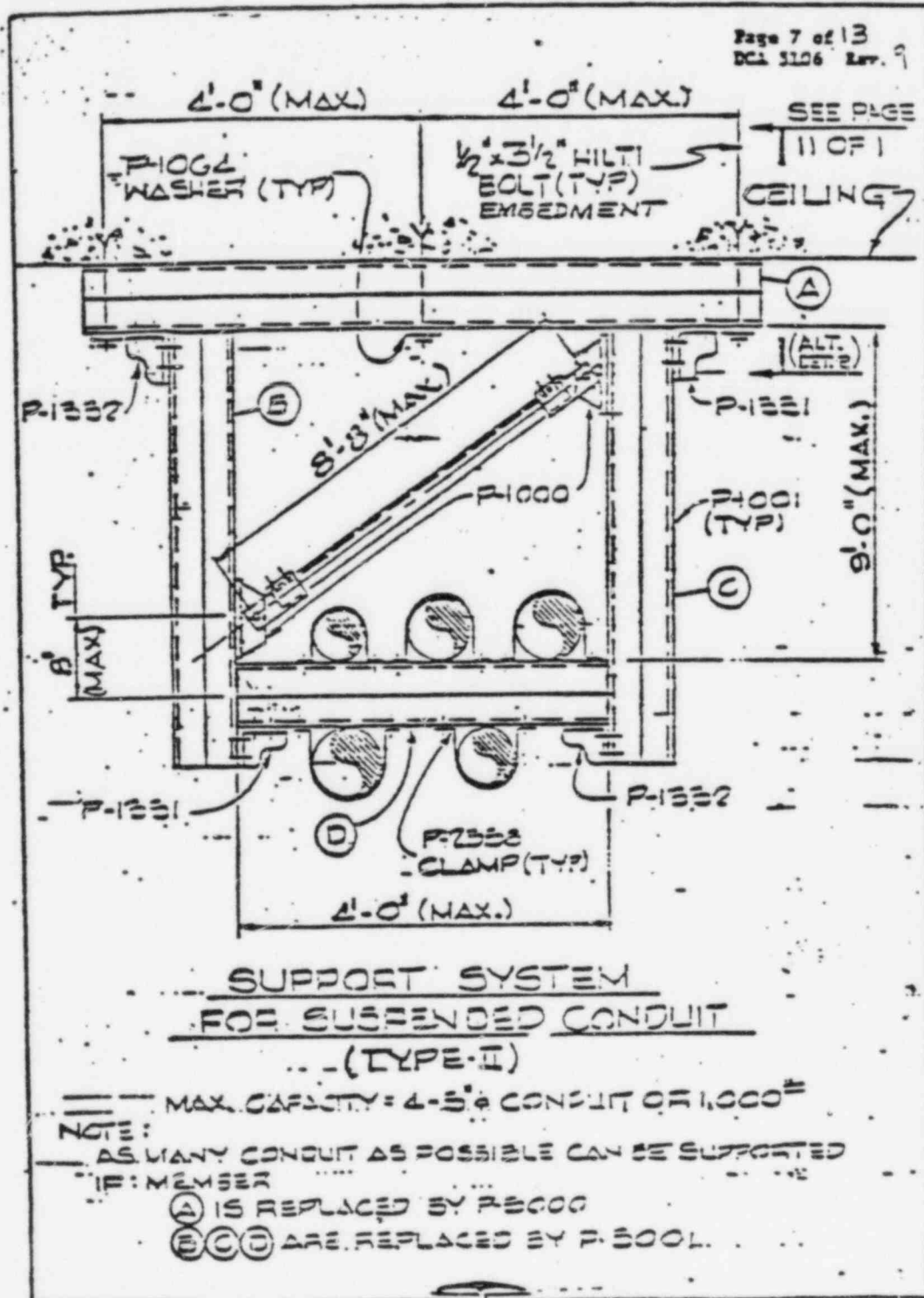



Corporate Consulting
& Development Company Ltd.

Research Triangle Park, NC 27709
P.O. Box 12728 • 919-362-8800

PROCEDURE No. 1903.23-1, Rev. 0
 ISSUE DATE 5/9/86 PAGE 79 OF 87
 PREPARED BY _____ DATE _____
 APPROVED BY _____ DATE _____
 APPROVED BY _____ DATE _____
 QA REVIEW BY _____ DATE _____

TEST PROCEDURE

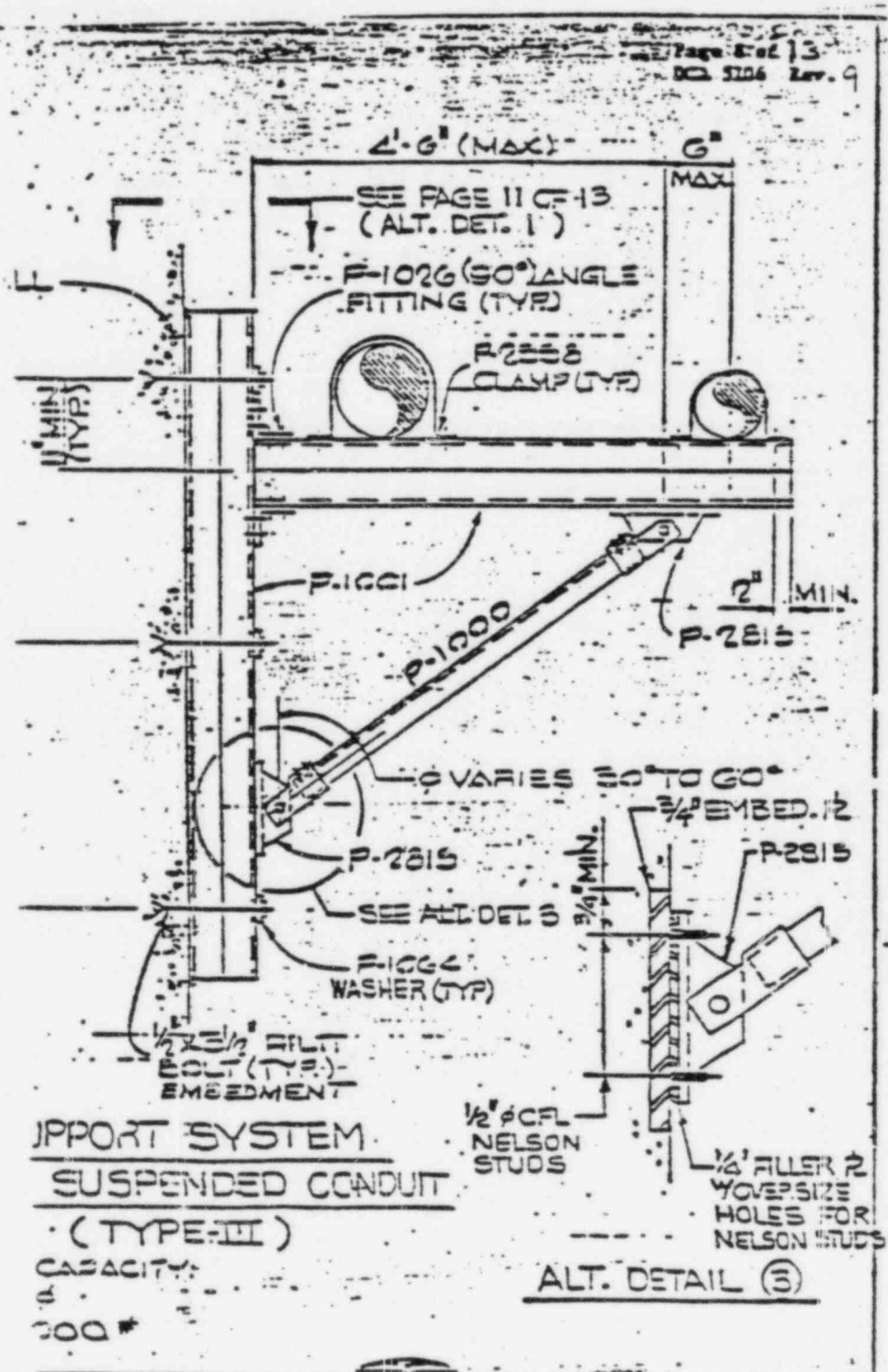



Corporate Consulting
& Development Company, Ltd.

Research Triangle Park NC 27709
P.O. Box 12726 • 919-362-8600

PROCEDURE No. 1903.23-1, Rev. 0
 ISSUE DATE 5/9/86 PAGE 80 OF 87
 PREPARED BY _____ DATE _____
 APPROVED BY _____ DATE _____
 APPROVED BY _____ DATE _____
 QA REVIEW BY _____ DATE _____

TEST PROCEDURE

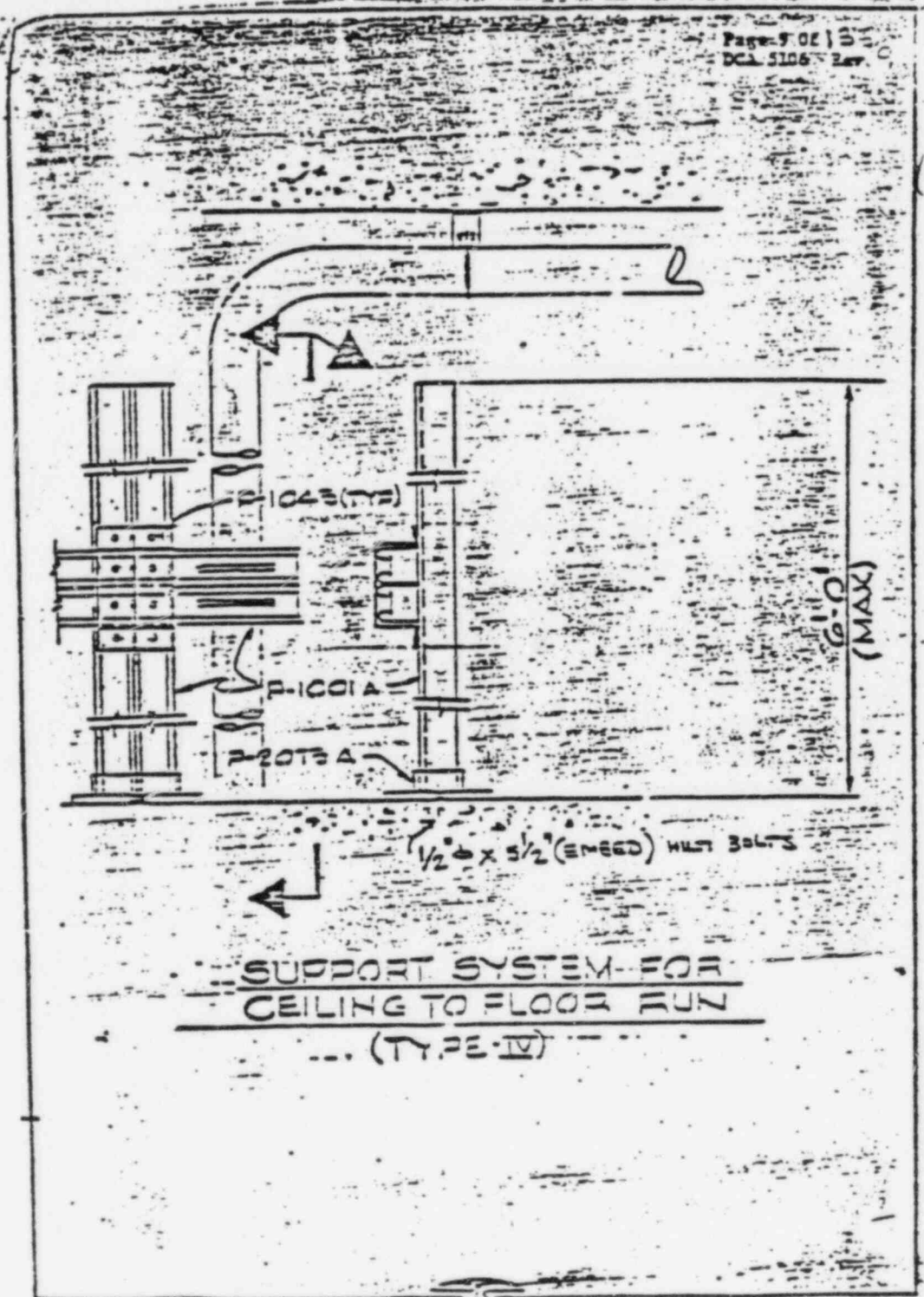

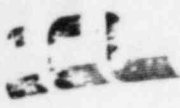

Corporate Consulting
& Development Company, Ltd.

Research Triangle Park, NC 27709
P.O. Box 12728 • 919-362-8800

1903.23-1, Rev. 0

PROCEDURE No. _____
 ISSUE DATE 5/9/86 PAGE 81 OF 87
 PREPARED BY _____ DATE _____
 APPROVED BY _____ DATE _____
 APPROVED BY _____ DATE _____
 QA REVIEW BY _____ DATE _____

TEST PROCEDURE

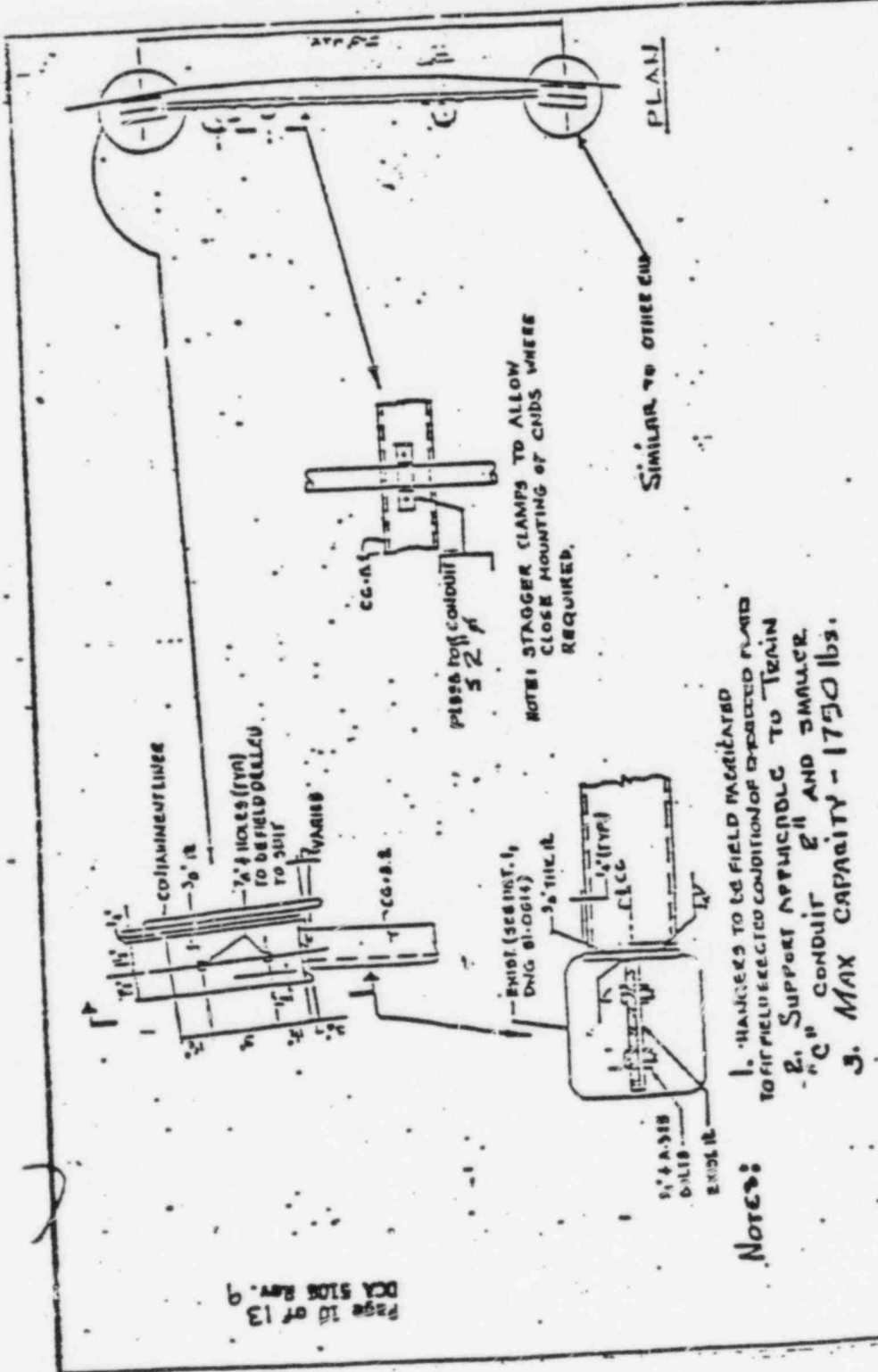

SUPPORT SYSTEM FOR
SUSPENSION RAILS (NAIL-2)

- Notes:
1. HANGERS TO BE FIELD FACILITATED TO FIT FIELD SELECTED CONDITION OF EXISTING RAIL
 2. SUPPORT APPROPRIATE TO TRAIN
 3. MAX CAPACITY - 1750 lbs.



Corporate Consulting
& Development Company, Ltd.

Research Triangle Park, NC 27709
P.O. Box 12728 • 919-362-8800

TEST PROCEDURE

PROCEDURE No. 1903.23-1, Rev. 0
ISSUE DATE 5/9/86 PAGE 82 OF 87
PREPARED BY _____ DATE _____
APPROVED BY _____ DATE _____
APPROVED BY _____ DATE _____
QA REVIEW BY _____ DATE _____



Corporate Consulting
& Development Company, Ltd.

Research Triangle Park NC 27709
P.O. Box 12728 • 919-362-8800

TEST PROCEDURE

PROCEDURE No. 1903.23-1, Rev. 0
 ISSUE DATE 5/9/86 PAGE 83 OF 87
 PREPARED BY _____ DATE _____
 APPROVED BY _____ DATE _____
 APPROVED BY _____ DATE _____
 QA REVIEW BY _____ DATE _____

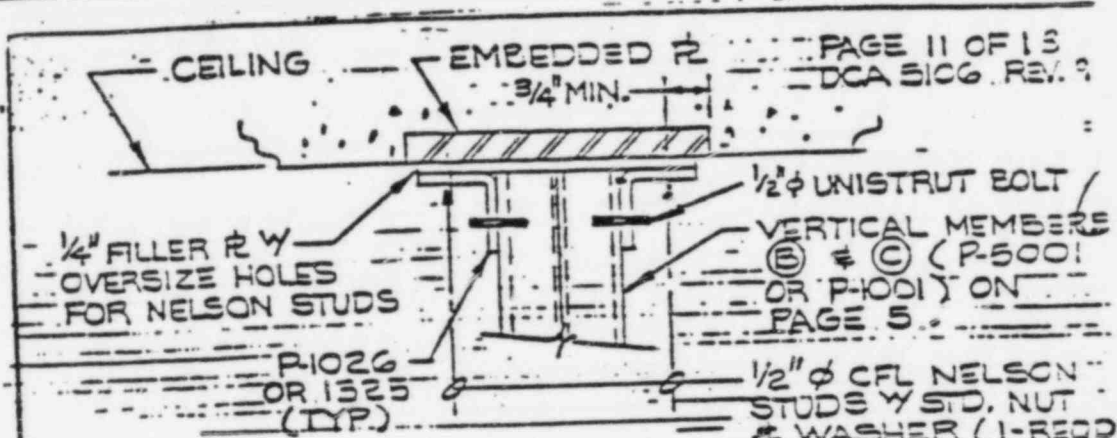

ALTERNATE DETAIL ① FOR P1026 & 2 FOR P-1325

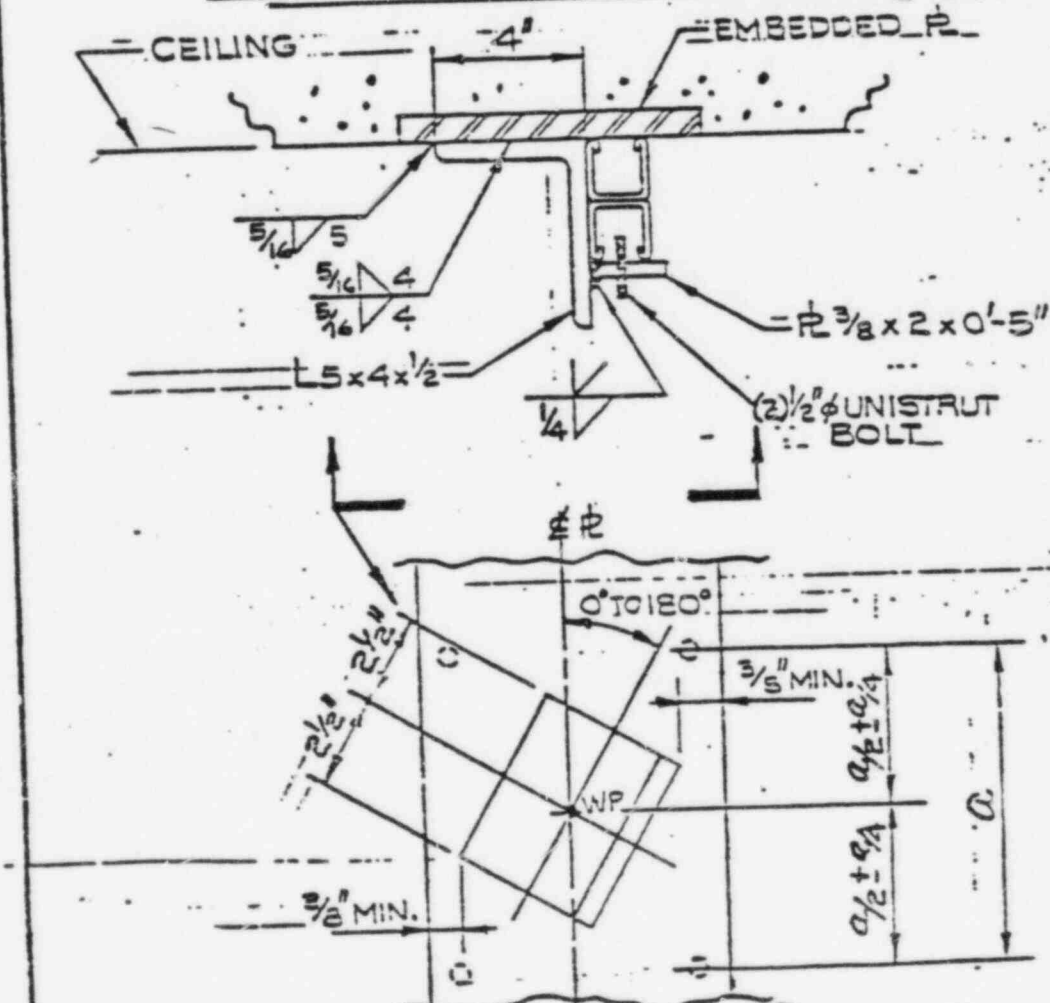

ALTERNATE DETAIL ②

TEST PROCEDURE

PROCEDURE No. 1903.23-1, Rev. 0
 ISSUE DATE 5/9/86 PAGE 84 OF 87
 PREPARED BY _____ DATE _____
 APPROVED BY _____ DATE _____
 APPROVED BY _____ DATE _____
 QA REVIEW BY _____ DATE _____

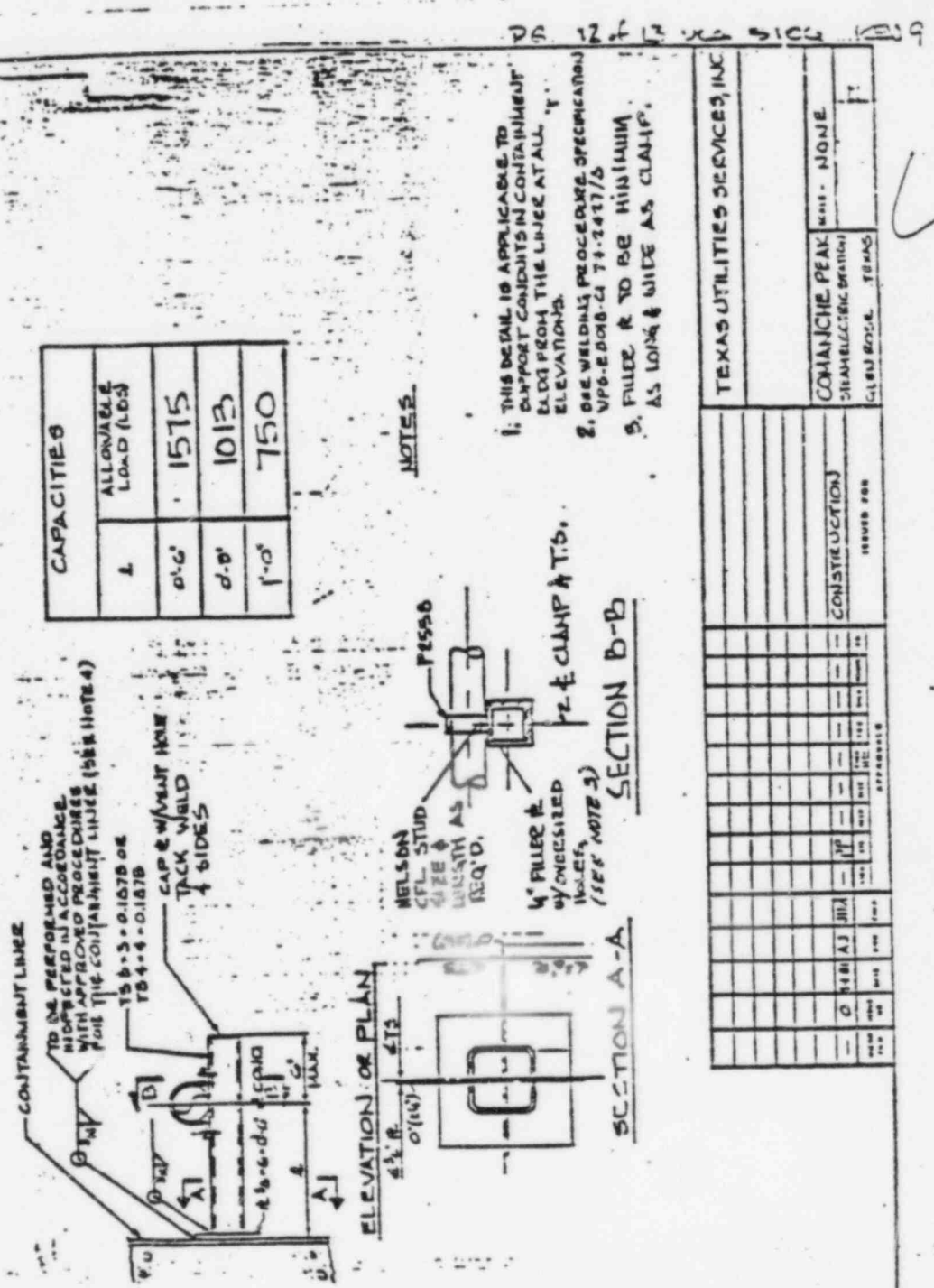

CAPACITIES

ALLOWABLE LOAD (LBS)
1575
1013
750

TEXAS UTILITIES SERVICES, INC.	
CONSTRUCTION	ISSUES FOR
COMANCHE PEAK	MISS - NONE
CLEAR ELECTRIC SERVICE	T5-B-A3



Corporate Consulting
& Development Company, Ltd.

Research Triangle Park, NC 27709
P.O. Box 12728 • 919-362-8800

PROCEDURE No. 1903.23-1, Rev. 0
 ISSUE DATE 5/9/86 PAGE 85 OF 87
 PREPARED BY _____ DATE _____
 APPROVED BY _____ DATE _____
 APPROVED BY _____ DATE _____
 QA REVIEW BY _____ DATE _____

TEST PROCEDURE

CAPACITIES				
WALL			CEILING	
BRACKET	A	1/2" Ø H.K.B. W/ 2" MIN. EMB'T	3/8" Ø H.K.B. W/ 2" MIN. EMB'T	1/2" Ø OR 3/8" Ø HILTI-KWIK BOLT
P-2542	12"	230#	190#	230#
P-2543	18"	230#	150#	230#
P-2544	24"	230#	80#	230#
P-2545	30"	230#	80#	230#
P-2546	36"	190#	50#	230#

NOTES:

APPLICATION	
SUPPLEMENTARY TO COND. SURF. SURFACE (HORIZ. OR VERT.)	
WALL OR CEILING	HORIZONTAL

THIS DETAIL IS APPLICABLE
TO SUPPORT C-TRAIN
CONDUITS ONLY, AT ALL DEVS.

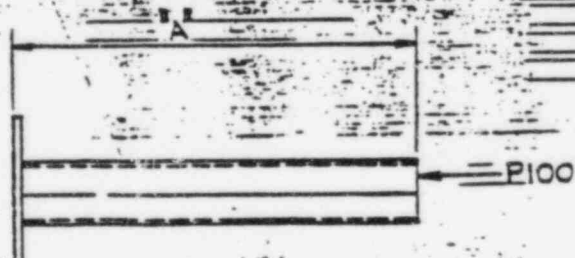

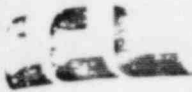

Corporate Consulting
& Development Company, Ltd.

Research Triangle Park NC 27709
P.O. Box 12728 • 919-362-8800

TEST PROCEDURE

PROCEDURE No. 1903.23-1, Rev. 0
ISSUE DATE 5/9/86 PAGE 86 OF 87
PREPARED BY _____ DATE _____
APPROVED BY _____ DATE _____
APPROVED BY _____ DATE _____
QA REVIEW BY _____ DATE _____

APPENDIX 3
RECORD OF DEVIATION

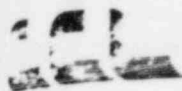

Corporate Consulting
& Development Company, Ltd.

Research Triangle Park, NC 27709
P.O. Box 12728 • 919-362-8800

TEST PROCEDURE

PROCEDURE No. 1903.23-1, Rev. 0
 ISSUE DATE 5/9/86 PAGE 87 OF 87
 PREPARED BY _____ DATE _____
 APPROVED BY _____ DATE _____
 APPROVED BY _____ DATE _____
 QA REVIEW BY _____ DATE _____

Record of Deviation from Test Procedure

Page _____ of _____

Test Procedure No. _____ CCL Project No. _____

Client _____ Date of Deviation _____

Section of Procedure Affected _____

Reason for Deviation: _____

(Continued on additional pages)

Description of Deviation: _____

(Continued on additional pages)

Prepared by: _____ Date _____

Principal Test Engineer: _____ Date _____

Project Manager: _____ Date _____

CCL QA Manager: _____ Date _____

Client Approval: _____ Date _____

APPENDIX B

RECORDS OF DEVIATION FROM TEST PROCEDURE, NUMBERS 1 THROUGH 10

CONTROLLED DOCUMENT

DO NOT COPY

Record of Deviation from Test Procedure #1

Page 1 of 1

Test Procedure No. 1903.23-01, Rev. 0 CCL Project No. 85-1903.23/24

Client TUGCO Date of Deviation May 30, 1986

Section of Procedure Affected 6.0 and Table 2.1

Reason for Deviation: Test numbers 2a-24 and 3a-24 will duplicate test numbers 2a-12 and 3a-12.

(Continued on additional pages)

Description of Deviation: Test numbers 2a-24 and 3a-24 are deleted. Test numbers 2a-12 and 3a-12 adequately test the longitudinal strength capacity of UNISTRUT P2785 and P2786 beam clamps.

(Continued on additional pages)

Prepared by: [Signature] Date JUNE 6, 1986
Principal Test Engineer: R. Keith M. [Signature] Date 6/6/86
Project Manager: [Signature] Date JUNE 6, 1986
CCL QA Manager: [Signature] Date 6/6/86
Client Approval: [Signature] Date 6/6/86

CONTROLLED DOCUMENT

DO NOT COPY

Record of Deviation from Test Procedure #2

Page 1 of 1

Test Procedure No. 1903.23-01, Rev. 0 CCL Project No. 85-1903.23/24

Client TUGCO Date of Deviation May 30, 1986

Section of Procedure Affected 6.0

Reason for Deviation: TUGCO did not ship nuts with the UNISTRUT P2786 beam clamps.

(Continued on additional pages)

Description of Deviation: Nuts that normally are used with SUPERSTRUT U-501 beam clamps will be substituted for the missing nuts. The SUPERSTRUT U-501 beam clamp nuts were supplied by TUGCO.

(Continued on additional pages)

Prepared by: Henry H Bond Date JUNE 6, 1986
Principal Test Engineer: R. Keith McPherson Date 6/6/86
Project Manager: Henry H Bond Date JUNE 6, 1986
CCL QA Manager: Blair J Date 6/6/86
Client Approval: A. Stowell Date 6/6/86

CONTROLLED DOCUMENT

DO NOT COPY

Record of Deviation from Test Procedure #3

Page 1 of 1

Test Procedure No. 1903.23-01, Rev. 0 CCL Project No. 85-1903.23/24

Client TUGCO Date of Deviation May 30, 1986

Section of Procedure Affected 5.0

Reason for Deviation: TUGCO Train C installation procedures do not provide a specific torque requirement for installation of clamps and fittings.

(Continued on additional pages)

Description of Deviation: The torque values specified for UNISTRUT hardware on page 29 of UNISTRUT General Engineering Catalog Number 10R will be used for clamp and fitting installation to maintain a nominal, consistent assembly methodology.

(Continued on additional pages)

Prepared by: <u>Alfred H. Bond</u>	Date <u>JUNE 6, 1986</u>
Principal Test Engineer: <u>R. Keith McPherson</u>	Date <u>6/6/86</u>
Project Manager: <u>Alfred H. Bond</u>	Date <u>JUNE 6, 1986</u>
CCL QA Manager: <u>[Signature]</u>	Date <u>6/6/86</u>
Client Approval: <u>A. S. Currell</u>	Date <u>6/6/86</u>

CONTROLLED DOCUMENT

DO NOT COPY

Record of Deviation from Test Procedure #3

Page 1 of 1

Test Procedure No. 1903.23-01, Rev. 0 CCL Project No. 85-1903.23/24

Client TUGCO Date of Deviation May 30, 1986

Section of Procedure Affected 5.0

Reason for Deviation: TUGCO Train C installation procedures do not provide a specific torque requirement for installation of clamps and fittings.

(Continued on additional pages)

Description of Deviation: The torque values specified for UNISTRUT hardware on page 29 of UNISTRUT General Engineering Catalog Number 10R will be used for clamp and fitting installation to maintain a nominal, consistent assembly methodology.

(Continued on additional pages)

Prepared by:	<u>[Signature]</u>	Date	<u>JUNE 6, 1986</u>
Principal Test Engineer:	<u>[Signature]</u>	Date	<u>6/6/86</u>
Project Manager:	<u>[Signature]</u>	Date	<u>JUNE 6, 1986</u>
CCL QA Manager:	<u>[Signature]</u>	Date	<u>6/6/86</u>
Client Approval:	<u>[Signature]</u>	Date	<u>6/6/86</u>

CONTROLLED DOCUMENT

DO NOT COPY

Record of Deviation from Test Procedure #4

Page 1 of 1

Test Procedure No. 1903.23-01, Rev. 0 CCL Project No. 85-1903.23/24

Client TUGCO Date of Deviation May 30, 1986

Section of Procedure Affected 6.0

Reason for Deviation: Correction of a typographical error

(Continued on additional pages)

Description of Deviation: Figures 6.10 and 6.18 illustrate a 40-inch long moment arm that should be a 24-inch long moment arm.

(Continued on additional pages)

Prepared by: *W. H. Bond* Date JUNE 6, 1986
Principal Test Engineer: *A. Kurt Johnson* Date 6/6/86
Project Manager: *W. H. Bond* Date JUNE 6, 1986
CCL QA Manager: *E. Blantyn* Date 6/6/86
Client Approval: *A. S. Cowell* Date 6/6/86

CONTROLLED DOCUMENT

DO NOT COPY

Record of Deviation from Test Procedure #5

Page 1 of 4

Test Procedure No. 1903.23-01, Rev. 0 CCL Project No. 85-1903.23/24

Client TUGCO Date of Deviation May 30, 1986

Section of Procedure Affected 6.0 and Table 2.1

Reason for Deviation: Change in method of load application.

(Continued on additional pages)

Description of Deviation: Figures 6.23, 6.24, and 6.25 illustrate test configurations 6, 7, and 8. Impell has requested that:

1. The load be applied through 2-inch diameter conduit and a UNISTRUT P2558-20 clamp, and

2. Longer HILTI bolts be used (4-inch minimum embedment) on test configurations 6 and 7.

The attached 3 figures provide updated test figures.

(Continued on additional pages)

Prepared by:	<u>Jeffrey H Bond</u>	Date	<u>JUNE 6, 1986</u>
Principal Test Engineer:	<u>R. Kurt Johnson</u>	Date	<u>6/6/86</u>
Project Manager:	<u>Jeffrey H Bond</u>	Date	<u>JUNE 6, 1986</u>
CCL QA Manager:	<u>Blanch</u>	Date	<u>6/6/86</u>
Client Approval:	<u>A. Lowell</u>	Date	<u>6/6/86</u>

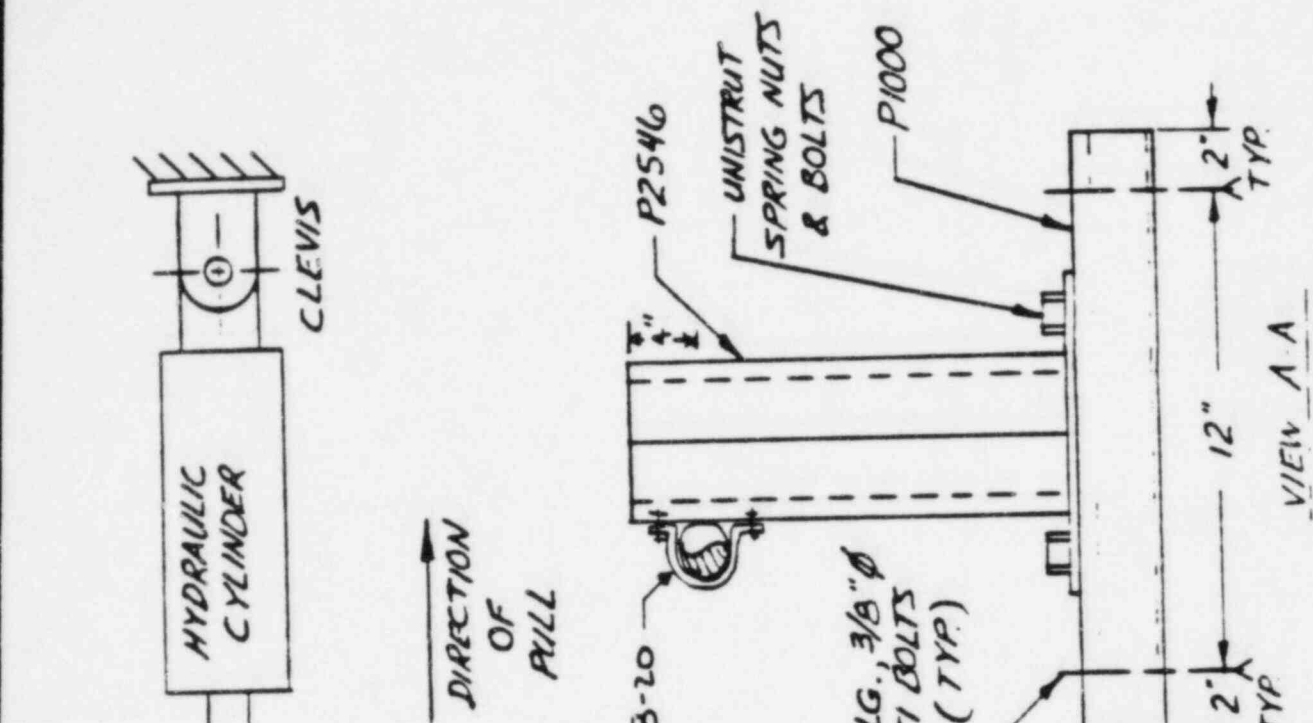

NOTE : 1. HILTI BOLT EMBEDMENT IS 4"
 2. DRILL 2 - 7/16" DIA. HOLES IN P1000 FOR HILTI BOLTS.

BILL OF MATERIALS

- 1 - P2546 UNISTRUT WELDED FOOT HANGER.
- 2 - SETS OF UNISTRUT SPRING NUTS & BOLTS (1/2")
- 2 - 3/8" DIA., 5" LG. HILTI BOLTS.
- 1 - 16" LG. P1000 UNISTRUT CHANNEL.
- 1 - P2558-20 CLAMP w/ 3/8" UNISTRUT SPRING NUTS AND BOLTS
- 12" LG. 2" ϕ CONDUIT

Test Configuration 6

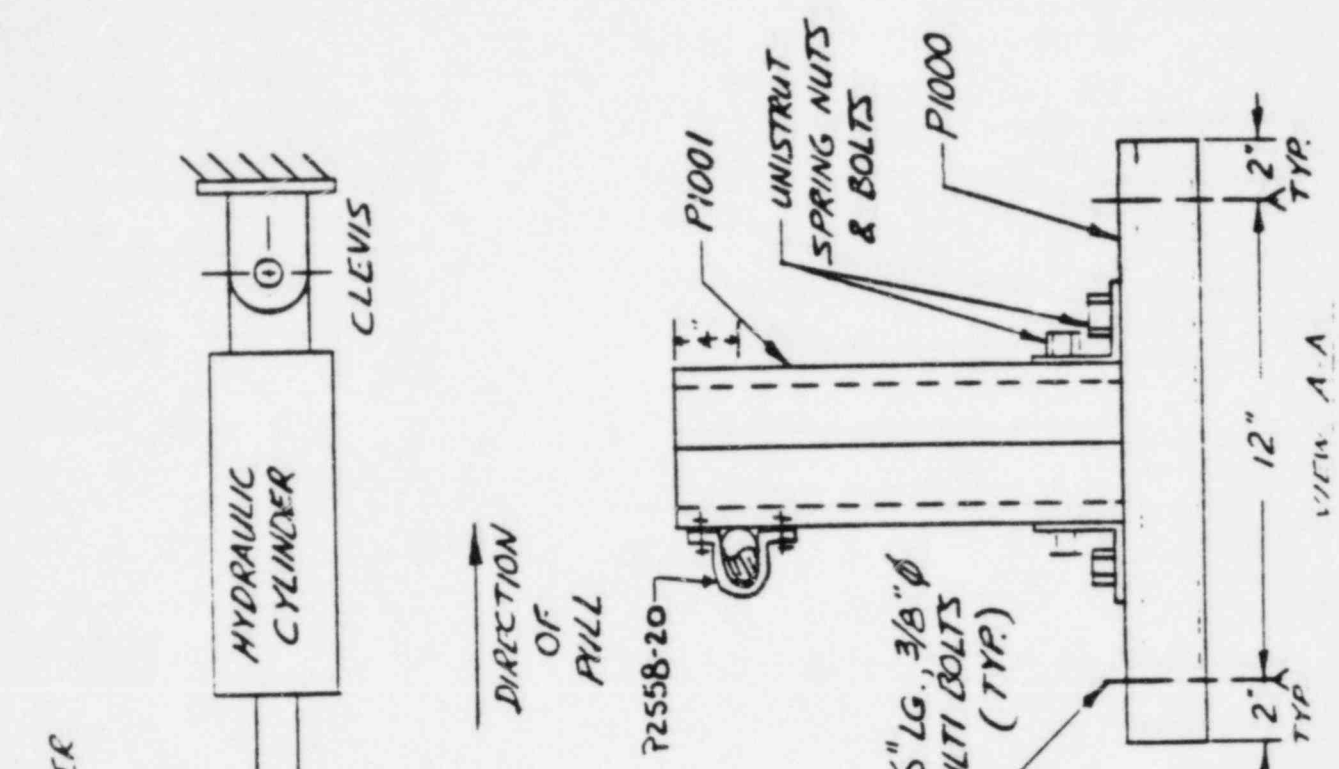

NOTE: 1. HILTI BOLT EMBEDMENT IS 4"
2. DRILL 2-7/16" DIA. HOLES IN
P1000 FOR HILTI BOLTS.

BILL OF MATERIALS

- 2- P1026 UNISTRUT ANGLE FITTINGS.
- 4- SETS OF UNISTRUT SPRING NUTS & BOLTS (1/2")
- 2- 3/8" DIA., 5" LG. HILTI BOLTS.
- 1- 16" LG. P1000 UNISTRUT CHANNEL.
- 1- 36" LG. P1001 UNISTRUT.
- 1- P2558-20 CLAMP w/ 3/8" UNISTRUT SPRING NUTS AND BOLTS
- 12" LG. 2" Ø CONDUIT

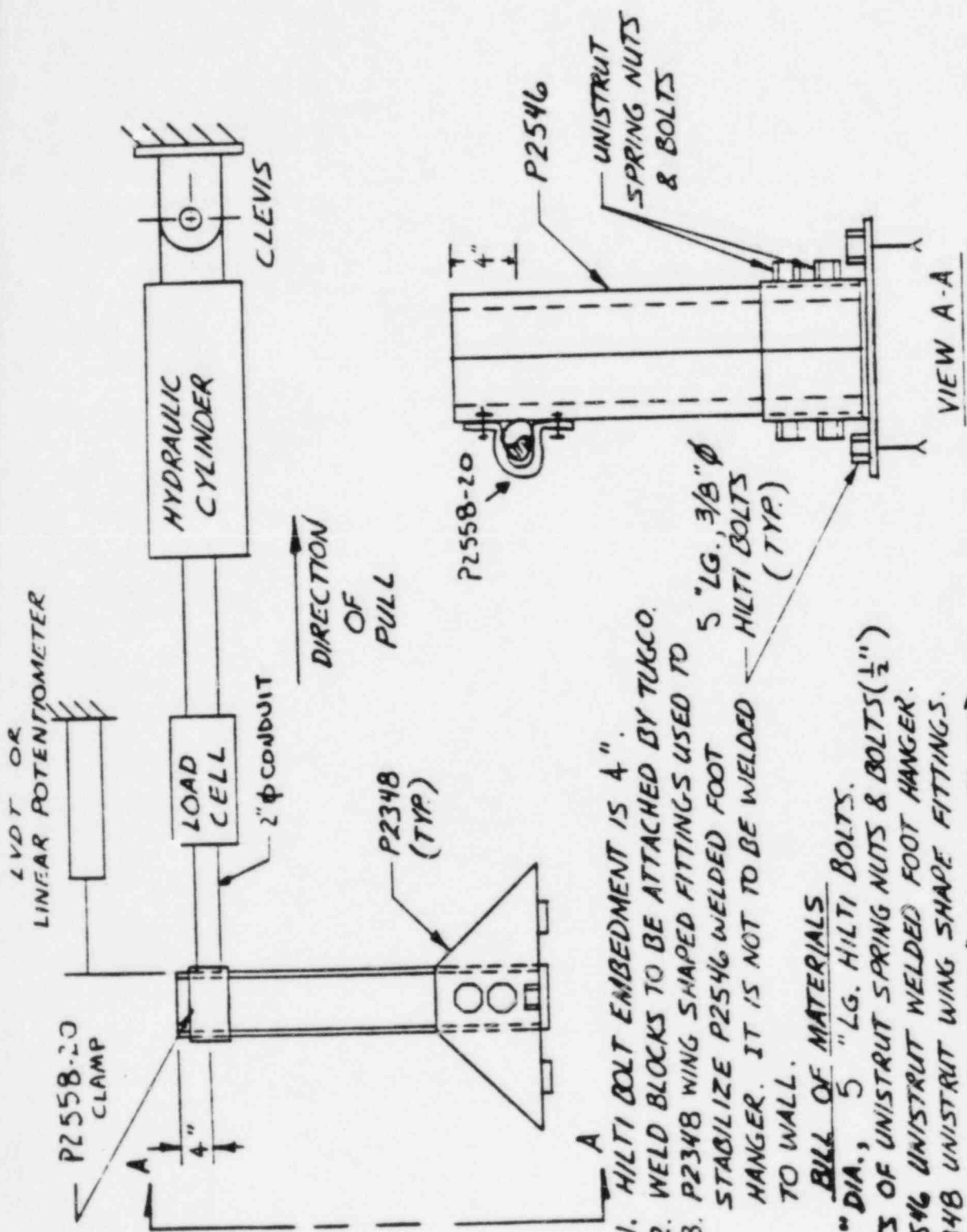

- NOTE : 1. HILTI BOLT EMBEDMENT IS 4".
 2. WELD BLOCKS TO BE ATTACHED BY TUGCO.
 3. P2348 WING SHAPED FITTINGS USED TO STABILIZE P2546 WELDED FOOT HANGER. IT IS NOT TO BE WELDED TO WALL.
BILL OF MATERIALS
 2- 3/8" DIA., 5" LG. HILTI BOLTS.
 4- SETS OF UNISTRUT SPRING NUTS & BOLTS (1/2")
 1- P2546 UNISTRUT WELDED FOOT HANGER.
 2- P2348 UNISTRUT WING SHAPE FITTINGS.
 1- P2558-20 CLAMP w/ 3/8" SPRING NUTS AND BOLTS
 12" LG. 2" φ CONDUIT

DO NOT COPY

Record of Deviation from Test Procedure #6

Page 1 of 1

Test Procedure No. 1903.23-01, Rev. 0 CCL Project No. 85-1903.23/24

Client TUGCO Date of Deviation May 30, 1986

Section of Procedure Affected 6.0 and Table 2.1

Reason for Deviation: To perform additional tests.

(Continued on additional pages)

Description of Deviation: Figures 6.11 through 6.18 illustrate test configuration numbers 3a-12 through 3d-12, and 3a-24 through 3d-24 (see Record of Deviation from Test Procedure #1 concerning the deletion of test configuration number 3a-24). These tests will be performed with UNISTRUT P5000 channel rather than the indicated P5500 channel.

(Continued on additional pages)

Prepared by: W. H. Bond Date JUNE 6, 1986

Principal Test Engineer: R. Kent M. Jones Date 6/6/86

Project Manager: W. H. Bond Date JUNE 6, 1986

CCL QA Manager: Blair Date 6/6/86

Client Approval: A. Stowell Date 6/6/86

CONTROLLED DOCUMENT

DO NOT COPY

Record of Deviation from Test Procedure #7

Page 1 of 4

Test Procedure No. 1903.23-01, Rev. 0 CCL Project No. 85-1903.23/24

Client TUGCO Date of Deviation May 30, 1986

Section of Procedure Affected 6.0 and Table 2.1

Reason for Deviation: To perform additional tests.

(Continued on additional pages)

Description of Deviation: Test configuration numbers 9a, 9b, and 9c have been added as static tests. The attached 3 figures illustrate the test configuration and the direction of loads to be applied.

(Continued on additional pages)

Prepared by: <u>Henry H Bond</u>	Date <u>JUNE 6, 1986</u>
Principal Test Engineer: <u>R. Keith Maherson</u>	Date <u>6/6/86</u>
Project Manager: <u>Henry H Bond</u>	Date <u>JUNE 6, 1986</u>
CCL QA Manager: <u>Blentz</u>	Date <u>6/6/86</u>
Client Approval: <u>ad Cowell</u>	Date <u>6/6/86</u>

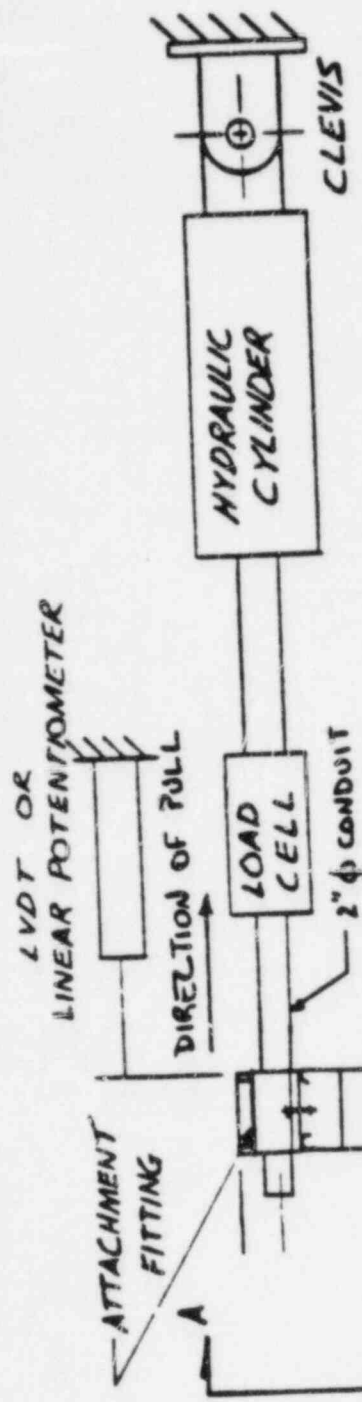

DIRECTION OF PULL IS OUT OF THE PAGE

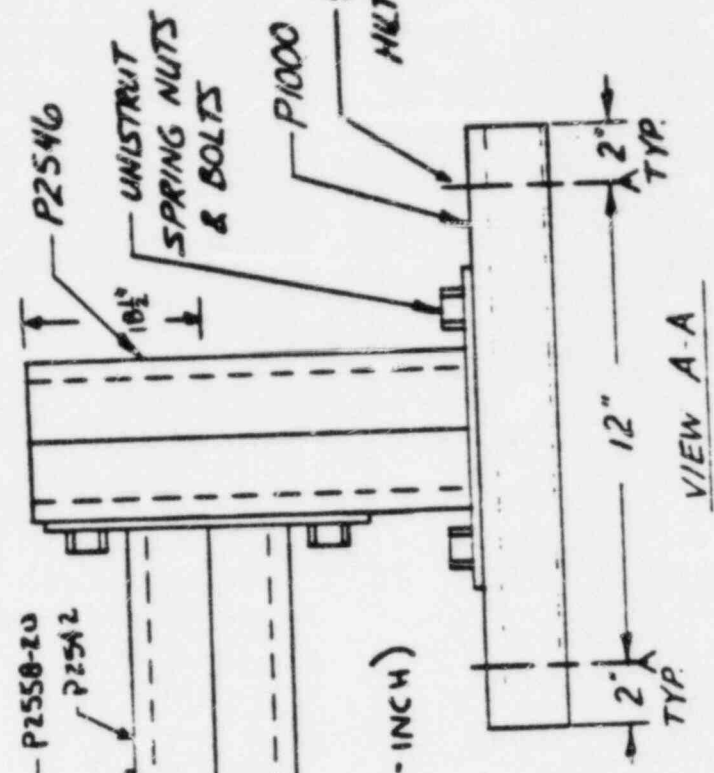

NOTE : 1. MULTI BOLT EMBEDMENT IS 4".
2. DRILL 2 - 7/16" DIA. HOLES 1/4" P1000 FOR MULTI BOLTS.

BILL OF MATERIALS

- 2 - P2546 UNISTRUT WELDED FOOT HANGER.
- 4 SETS OF UNISTRUT SPRING NUTS & BOLTS. (1/2" INCH)
- 2 3/8" DIA., 5" LG. MULTI BOLTS.
- 1 16" LG. P1000 UNISTRUT CHANNEL.
- 1 P2558-20 CLAMP w/3/8" UNISTRUT SPRING NUTS AND BOLTS
- 12" LG. 2" φ CONDUIT

BILL OF MATERIALS

- 2 - P2546 UNISTRUT WELDED FOOT HANGER.
- 4 SETS OF UNISTRUT SPRING NUTS & BOLTS. (1/2" INCH)
- 2 3/8" DIA., 5" LG. HILTI BOLTS.
- 1 16" LG. P1000 UNISTRUT CHANNEL.
- 1 P2558-20 CLAMP 1/2" LG. UNISTRUT SPRING NUTS AND BOLTS
- 12" LG. 2" φ CONDUIT

DIRECTION OF PULL

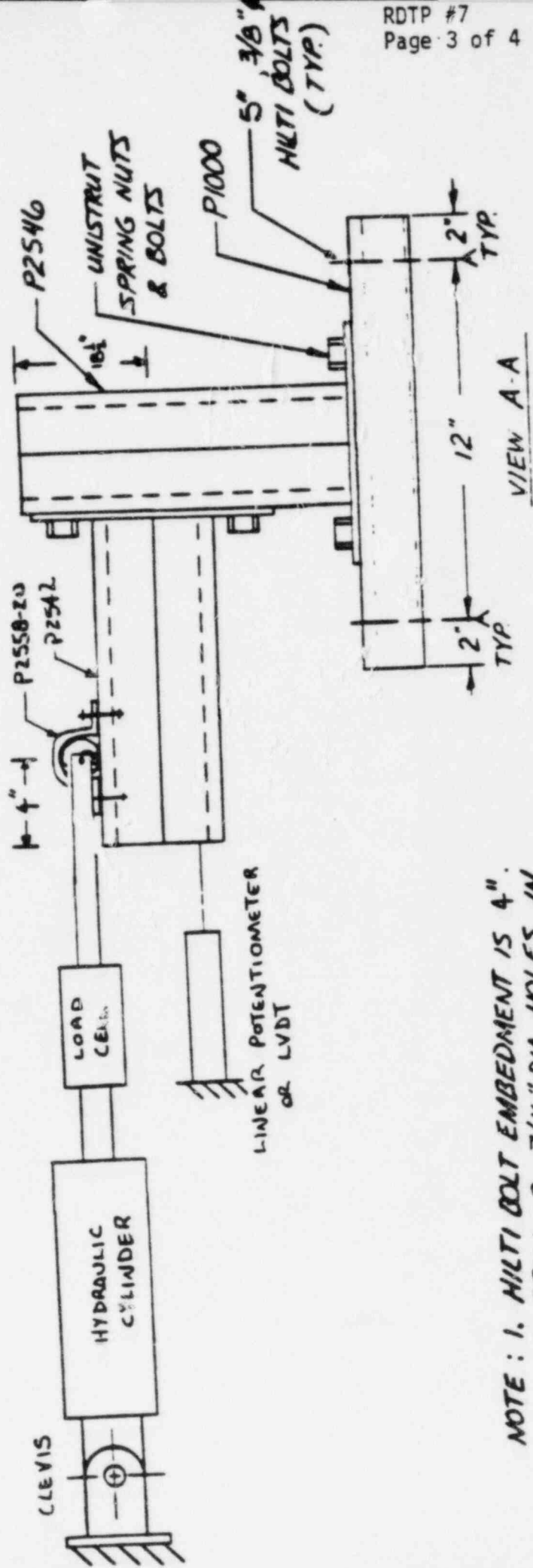

NOTE: 1. HILTI BOLT EMBEDMENT IS 4".
2. DRILL 2 - 7/16" DIA. HOLES IN P1000 FOR HILTI BOLTS.

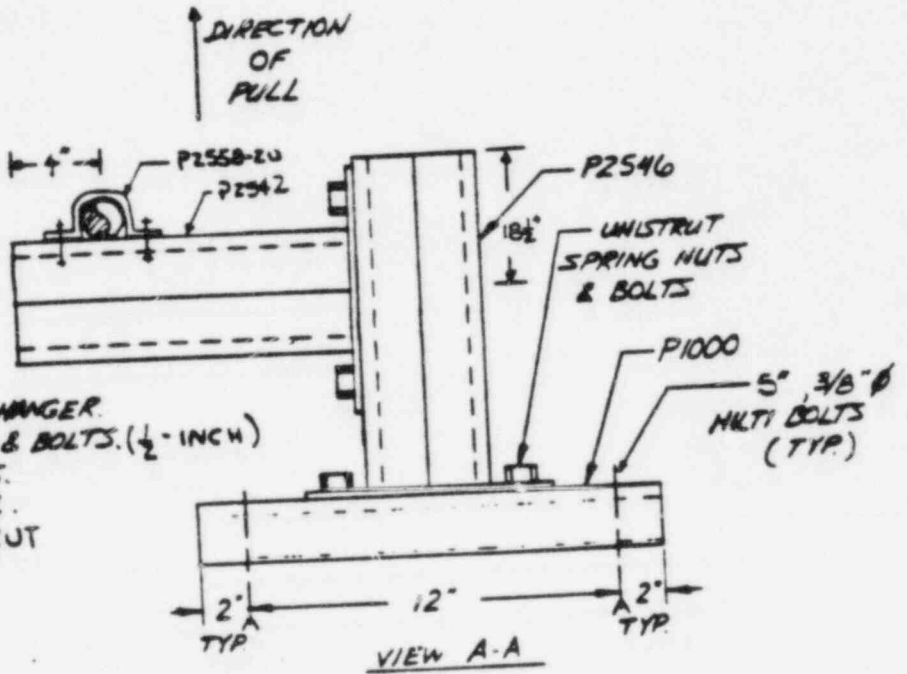
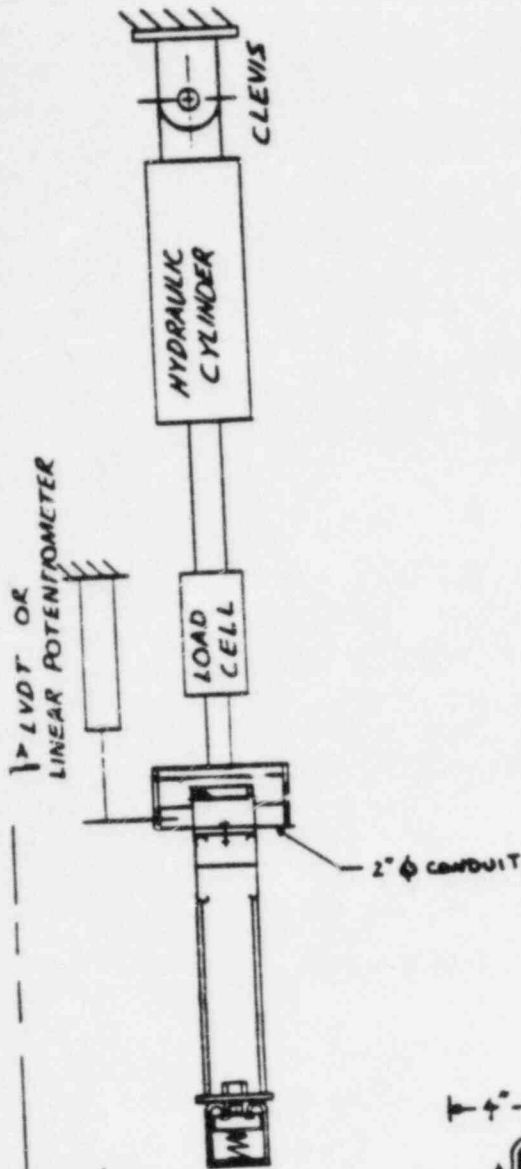

1. HILTI BOLT EMBEDMENT IS 4".
2. DRILL 2-7/16" DIA. HOLES IN P1000 FOR HILTI BOLTS.

BILL OF MATERIALS

- 2- P2546 UNISTRUT WELDED FOOT HANGER.
- 4 SETS OF UNISTRUT SPRING NUTS & BOLTS. (1/2" INCH)
- 2 3/8" DIA., 5" LG. HILTI BOLTS.
- 16" LG. P1000 UNISTRUT CHANNEL.
- 1 P2558-20 CLAMP 1/2" UNISTRUT SPRING NUTS AND BOLTS
- 12" LG. 2" ϕ CONDUIT

Test Configuration 9c

CONTROLLED DOCUMENT

DO NOT COPY

Record of Deviation from Test Procedure #8

Page 1 of 1

Test Procedure No. 1903.23-01, Rev. 0 CCL Project No. 85-1903.23/24

Client TUGCO Date of Deviation May 30, 1986

Section of Procedure Affected 6.0 and Table 2.1

Reason for Deviation: To perform additional tests.

(Continued on additional pages)

Description of Deviation: Record of Deviation from Test Procedure #6
discussed the substitution of UNISTRUT P5000 channel for P5500 channel in
figures 6.11 through 6.18 (test configuration numbers 3a-12 through 3d-12
and 3a-24 through 3d-24). The test shown in figure 6.13 will be run as-
is. The test number will be 10c-12.

(Continued on additional pages)

Prepared by: <u>[Signature]</u>	Date <u>June 6, 1986</u>
Principal Test Engineer: <u>[Signature]</u>	Date <u>6/6/86</u>
Project Manager: <u>[Signature]</u>	Date <u>June 6, 1986</u>
CCL QA Manager: <u>[Signature]</u>	Date <u>6/6/86</u>
Client Approval: <u>[Signature]</u>	Date <u>6/6/86</u>

CONTROLLED DOCUMENT

DO NOT COPY

Record of Deviation from Test Procedure #9

Page 1 of 3

Test Procedure No. 1903.23-01, Rev. 0 CCL Project No. 85-1903.23/24

Client TUGCO Date of Deviation June 3, 1986

Section of Procedure Affected 6.0, Table 2.1, and Figure 2.2

Reason for Deviation: To perform additional tests.

(Continued on additional pages)

Description of Deviation: Add test numbers 11a and 11b as shown in the following figures.

(Continued on additional pages)

Prepared by: <u>Walter Bond</u>	Date <u>JUNE 6, 1986</u>
Principal Test Engineer: <u>R. J. M. Mahan</u>	Date <u>6/6/86</u>
Project Manager: <u>Walter Bond</u>	Date <u>JUNE 6, 1986</u>
CCL QA Manager: <u>Blair J.</u>	Date <u>6/6/86</u>
Client Approval: <u>a. D. Schwell</u>	Date <u>6/6/86</u>

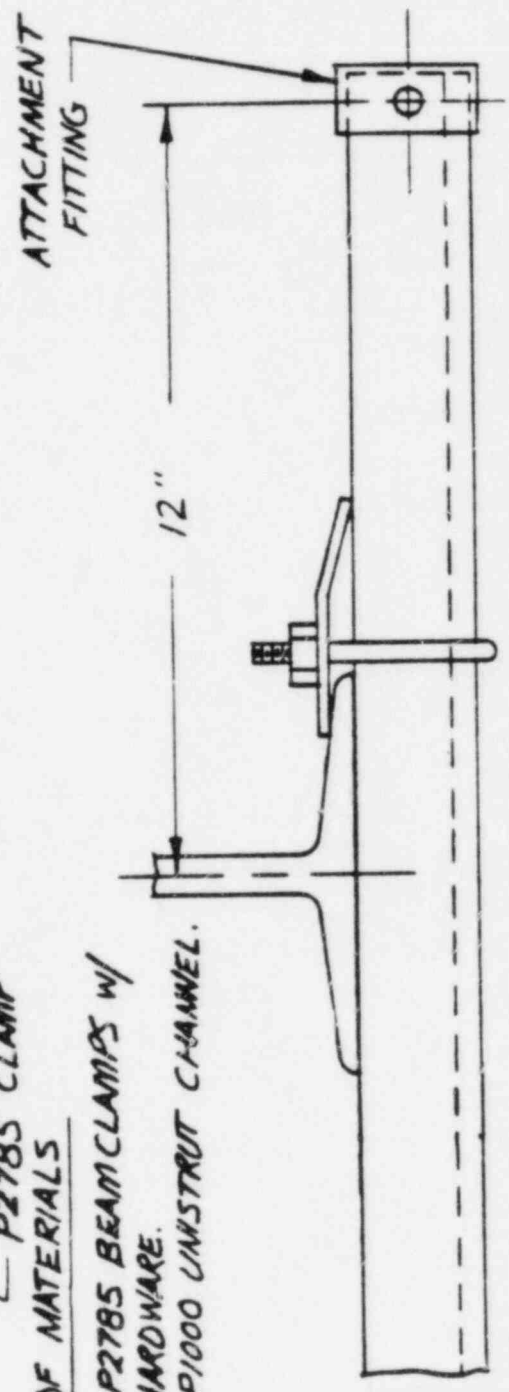
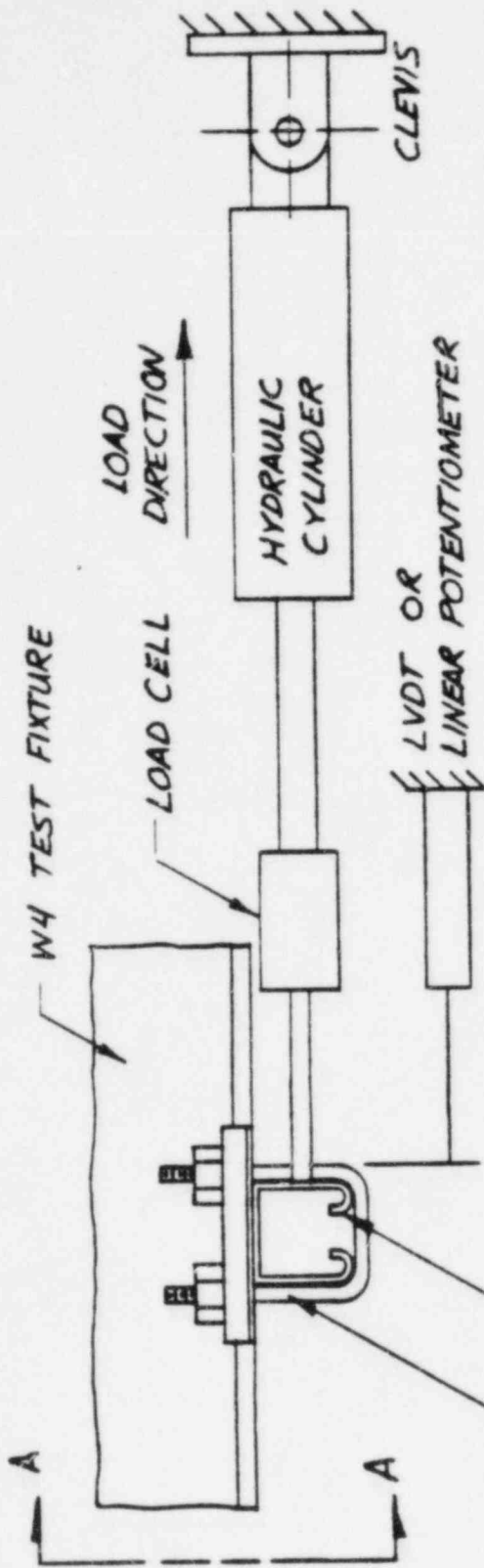

- BILL OF MATERIALS**
- 1 - UNISTRUT P2785 BEAM CLAMPS w/ U-BOLT HARDWARE.
 - 1 - 20" LG. P1000 UNISTRUT CHANNEL.

VIEW A-A

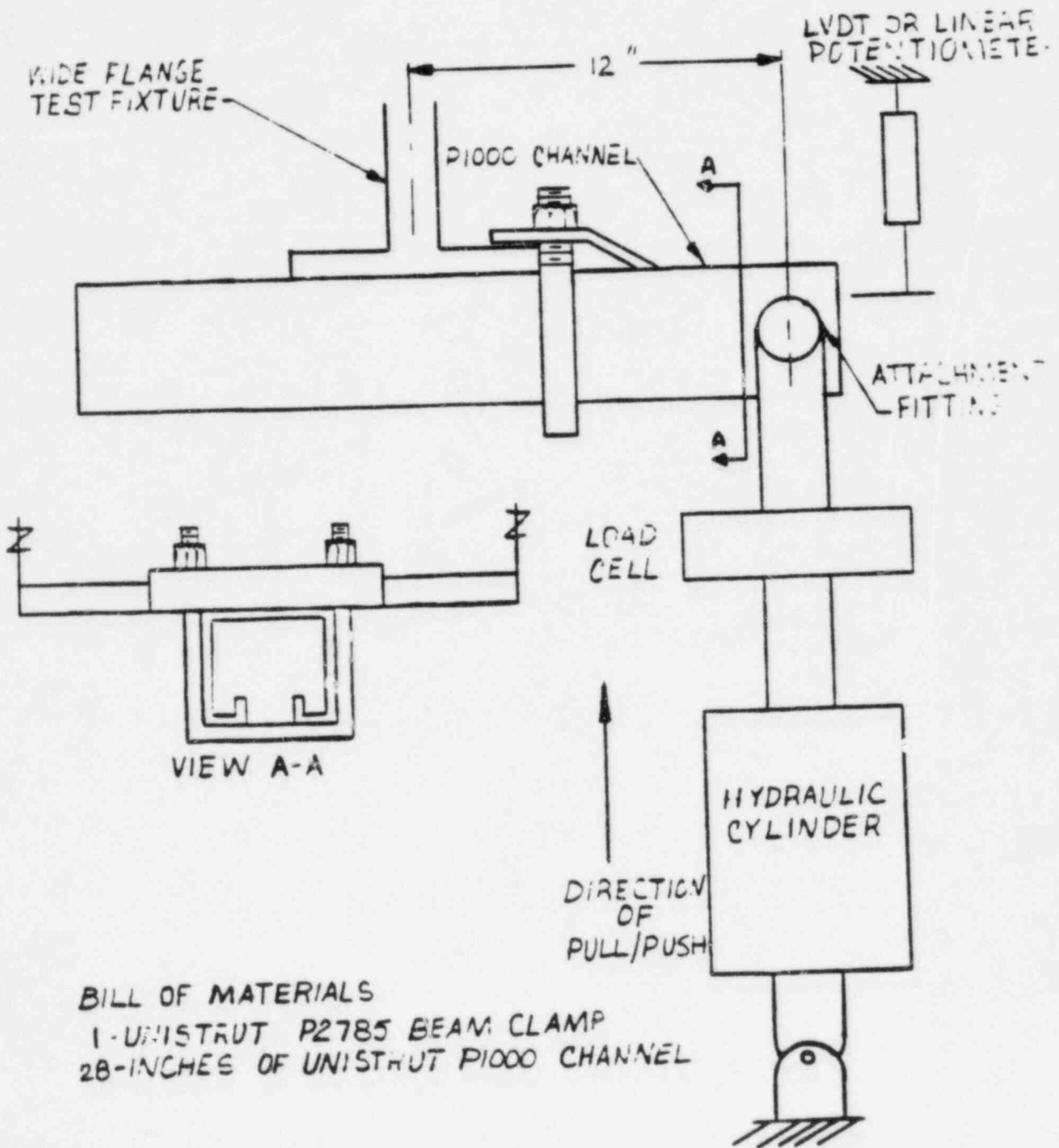

Test Configuration 11b

CONTROLLED DOCUMENT

DO NOT COPY

RECEIVED

JUN 26 1986

Record of Deviation from Test Procedure #10

Page 1 of 3

Test Procedure No. 1903.23-01, Rev. 0 CCL Project No. 85-1903.23/24

Client TUGCO Date of Deviation June 19, 1986

Section of Procedure Affected 6.0 and Table 2.1

Reason for Deviation: To modify test setups and delete a test.

(Continued on additional pages)

Description of Deviation: Figures 6.20 through 6.22 illustrate test configuration numbers 5b, 5c, and 5d. The test setups for configurations 5b and 5c are revised to obtain translational restraint stiffness rather than rotational restraint stiffness. Test configuration 5d is deleted since it would be a test of the conduit bearing strength against the W4 test fixture, and not involve the clamp. The attached two figures illustrate the revised test setups for configurations 5b and 5c.

(Continued on additional pages)

Prepared by: <u><i>Jeffrey H Bond</i></u>	Date <u>JUNE 25, 1986</u>
Principal Test Engineer: <u><i>Justin M. Johnson</i></u>	Date <u>6-25-86</u>
Project Manager: <u><i>Jeffrey H Bond</i></u>	Date <u>JUNE 25, 1986</u>
CCL QA Manager: <u><i>W. H. Hutmaker</i></u>	Date <u>6/25/86</u>
Client Approval: <u><i>A. D. Caswell</i></u>	Date <u>6/26/86</u>

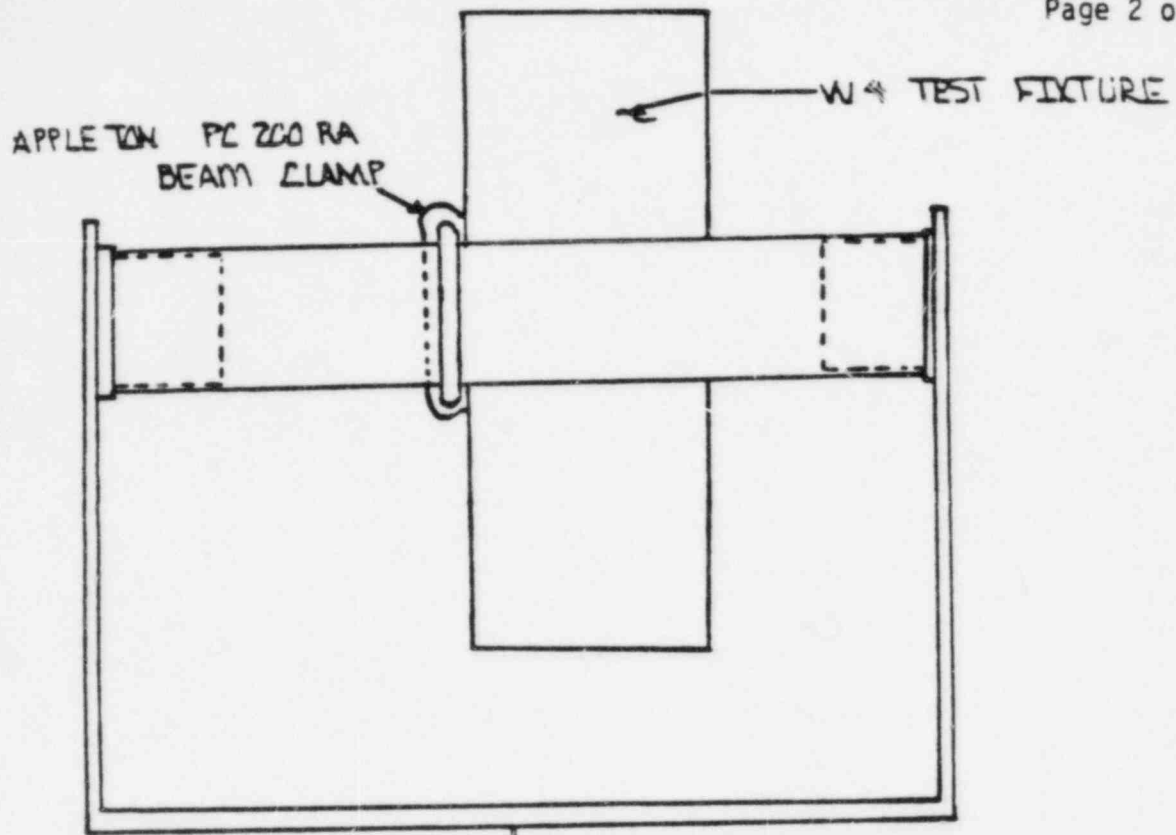

LEAD
CELL

BILL OF MATERIAL.

- 1. APPLETON PC 200-RA BEAM CLAMP
- 1. 28" LG; 2" DIA. CONDUIT

LINEAR POTENTIOMETER

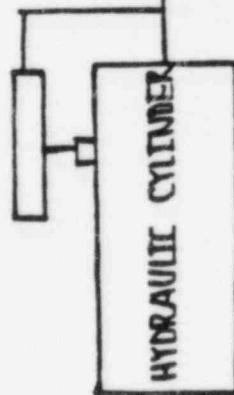

CLEVIS

Test Configuration 5b

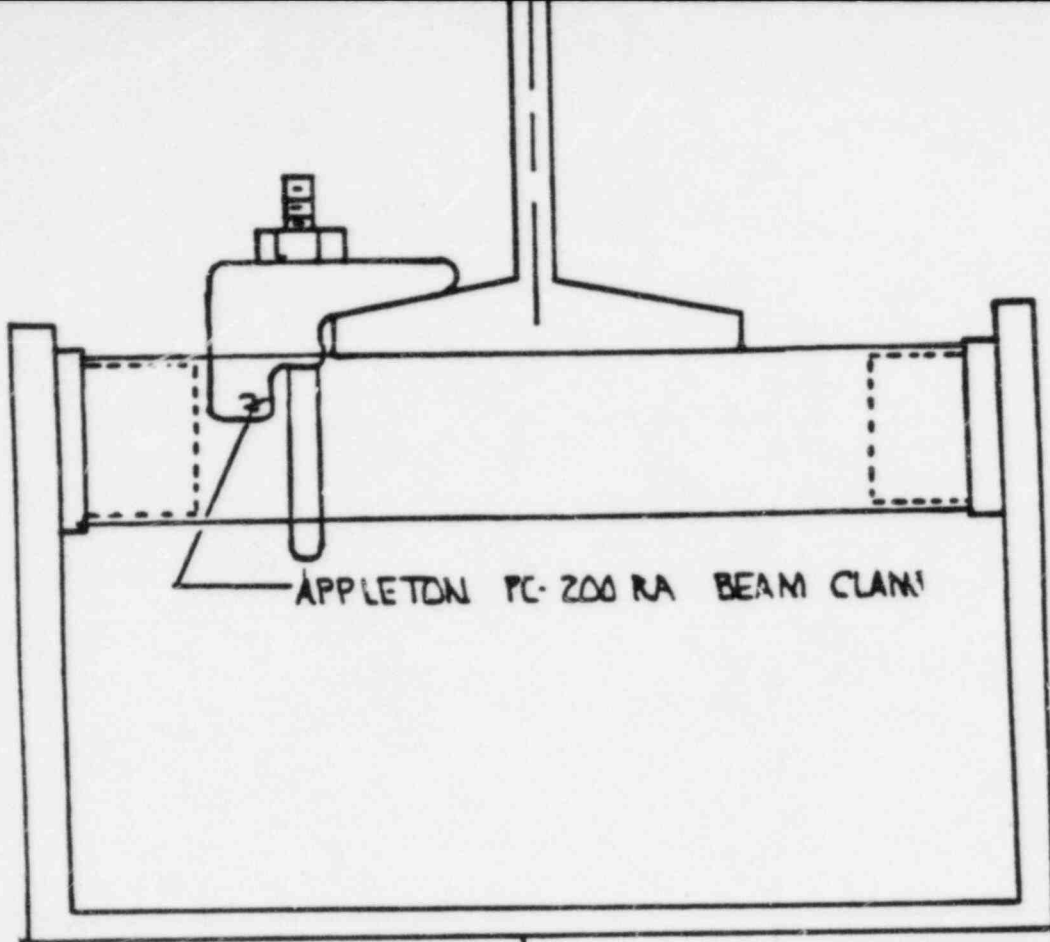

APPLETON PC-200 RA BEAM CLAMP

BILL OF MATERIAL

APPLETON PC 200 RA BEAM CLAMP
28" LG: 2" DIA. CONDUIT

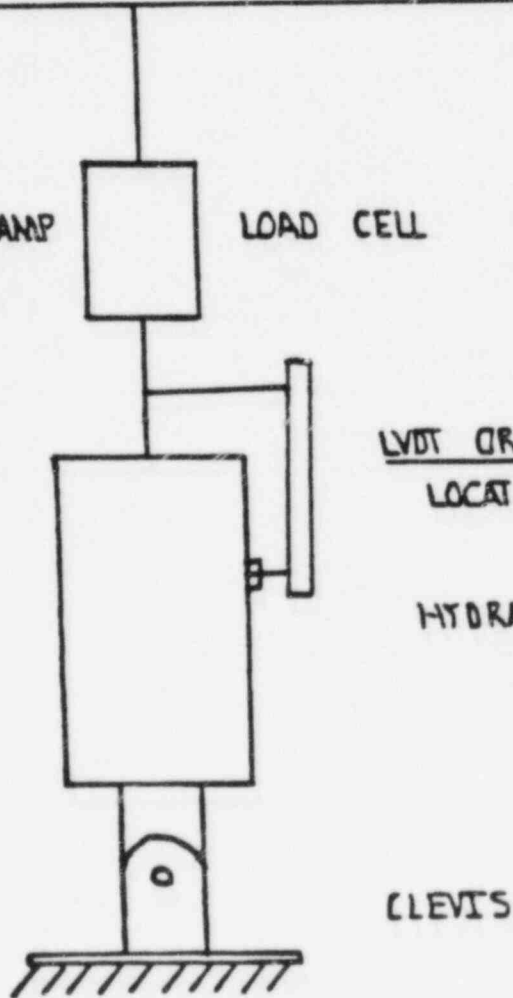

LOAD CELL

LVDT OR LINEAR POTENTIOMETER
LOCATED ON CYLINDER

HYDRAULIC CYLINDER

CLEVIS

Test Configuration 5c

APPENDIX C

TUGCO CONCRETE PLACEMENT SUMMARY TSG-13,916

100 Yds - 041 1319
1/24/68

TEXAS UTILITIES GENERATING COMPANY
P. O. BOX 1002 · GLEN ROSE, TEXAS 76043

December 02, 1985

Corporate Consulting & Development Co., Ltd.
P. O. Box 12728
Research Triangle Park, NC 27709

ATTN: R. Keith McPherson

COMANCHE PEAK STEAM ELECTRIC STATION
CONCRETE PLACEMENT SUMMARY
COMPONENT TESTING OF CONDUIT CLAMPS

Dear Mr. McPherson:

Enclosed please find a copy of the Concrete Placement Summary for the following pours:

- A Pour No. 017-9810-119 dated 08-02-85
- B Pour No. 017-9810-121 dated 08-07-85
- C Pour No. 017-9810-129 dated 08-12-85

These pours are for the concrete test blocks which have been previously shipped to you.

Please call me or S. Guha-Majumdar (ext. 8926) if you need any clarification.

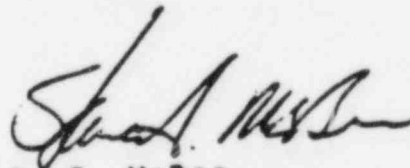

S. G. McBee
Lead Civil/Structural Engineer
Conduit Design Adequacy

BGM: SM. kms

Enclosures

cc: ARMS (1L, 1E)
Roland Yow - CCL (1L)
Peter Chang (1L)

CONCRETE PLACEMENT SUMMARY

8-2-85

Pour No. 017-9810-119

Admixture Used:

Total Yds. Placed: 2 cy

Compressor(s): MTE-1900

Slump Rg. (In.): 3 1/4 to N/A

Tester(s): MTE-836-C

Air Cont. Rg. %: 3.7 to N/A

Temperature(s): 2418

Temp. Rg. (F): 91 to N/A

Mix I.D.: 132

Unit Weight: 144.54

Temp Failure

Ticket No.	Slump In.	Air %	Concrete Temp.	Rebar Temp.	Add Water Gals.	Remarks
64216	3 1/4	3.7	91	N/A	N/A	5/5 cy Adm (S)
N/A	N/A	N/A	N/A			N/A

Bob Hork
Inspector/Technician

Joe Scoggin HG-01
TUGCO Lab Supervisor/Designee

CONCRETE PLACEMENT INSPECTION

Equipment Used:

Compressor(s) MTC-1800

Pump Meter(s) MTC-836-C

Scale(s) 2418

Wet + Temp. Feistwee

Batch No.	Ticket No.	Slump In.	Air %	Concrete Temp.	Rebar Temp.	Add Water Gals.	Remarks
41	64216	3 1/4	3.7	91	N/A	N/A	5/5 used
N/A	N/A	N/A	N/A	N/A			N/A

CONCRETE CYLINDER TEST DATA

Agg. No. #	Coarse Agg. #	Total H ₂ O on Ticket #	Air Temp. of	Total Air	
107	8460	1074		45 1/2oz.	
Batch #	Hour Sampled	Weather	Plant #	Sample #	Spic. Taken By:
107	900 AM	Clear	1	1075	DW
Sample Taken At:			Moisture Content Setting	Time Batched	
Central Mixer <input type="checkbox"/> Forms <input type="checkbox"/> Pt. of Discharge <input checked="" type="checkbox"/>			2.5	0817 AM	

Method of Placing Pump Bucket
 Buggies Belt Chute

[Signature]
 INSPECTOR/TECHNICIAN

Texas Utilities Generating Co.
Comanche Peak Steam Electric Station
1981-83 Units 1 & 2

Date: 8-2-85

TEST: Unit Weight of Fresh Concrete, ASTM C-138, Instruction No. QI-QP-11.1-13

MATERIAL DESCRIPTION: 132 DATE SAMPLED: 8-2-85

MATERIAL SOURCES: ticket # 64216 DATE TESTED: 8-2-85

- a. MEASURE WEIGHT (LBS.) + COVER = 27.68
- b. FILLED MEASURE WEIGHT (LBS.) + COVER = 99.95
- c. WEIGHT OF CONCRETE (LBS.) 72.27
- d. VOLUME OF MOLD (cu.ft.) .50
- e. $\frac{c}{d}$ = UNIT WEIGHT 144.54 LB./CU.FT.

TESTED BY: [Signature]

CHECKED BY: [Signature]

CONTROL NO. MTE-1053 Scale
L-151 Measure

[Signature] HQ-01
TUGCO Laboratory Supervisor/Designee

FOR INFORMATION ONLY

DATE 8-20-85
 POUR NO 017-9810-119
 CYL SET NO NA

PEAK STEAM ELECTRIC STATION

COMPRESSIVE TESTS OF CONCRETE

SPECIAL

MI-OP-11.1-41 R/1

COMPLETE S'AS MIXABLE BATCH TICKET	(W) MOST AGGR	F.A 6150 LBS	H ₂ O F.A 150 LBS	C.A 8460 LBS	H ₂ O C.A 0 LBS	TOTAL WATER/BATCH 1224 LBS	TYPE OF CURING M+W
CEMENT / CU YD 3157 LBS	H ₂ O ADDED 0 GAL	H ₂ O/CEMENT RATIO .388	AIR CU. % 9.0	TOTAL W.P. 45 OZ	SPECIFIED DESIGN STRENGTH 4000 PSI 28 DAYS		
BRAND OF CEMENT G-H	TYPE OF CEMENT II	BRAND OF AIR ENTRAINING ADMIXTURE MBUR		BRAND OF WATER REDUCING ADMIXTURE NA		MAX SIZE C.A. 3/4	
SOURCE C.A. TI-TIN Top	SP GR C.A. 2.64	SOURCE F.A. TKI-TIN Top		SP GR F.A. 2.62	FINENESS MODULES F.A. 2.66		

NO. OF MIXING PLANT 1	BATCH LOAD 5 C.Y.	TICKET NO. 64216	SAMPLE TAKEN AT: <input type="checkbox"/> CENTRAL MIXER <input type="checkbox"/> FORMS <input checked="" type="checkbox"/> POINT OF DISCHARGE			
METHOD OF PLACING <input type="checkbox"/> PUMP <input type="checkbox"/> BUCKET	DATE SAMPLED 8-2-85	HOUR 9:00 AM	WEATHER HOT	AIR TEMP 92 °F	CONC. TEMP 91 °F	SLUMP 3 1/4 IN
<input type="checkbox"/> BUGGIES <input type="checkbox"/> BELT <input checked="" type="checkbox"/> CHUTE						

NO. OF MIXING AT CENTRAL PLANT 70 Rev	UNIT WT CU FT 144.54 LBS	MIX ID. 132	SPECIMEN TAKEN BY OSBORNE	SPECIMEN CAST BY DO-DW	AIR 3.7%
---	-----------------------------	----------------	------------------------------	---------------------------	-------------

NO. ID	AGE	MEASURED DIA IN	AVG DIA IN	DATE CAPPED	CAPPED BY	TIME TESTED	DATE TESTED	MAX. LOAD LB.	COMPRESSIVE STRENGTH	CAP CHECKED BY	CYLINDER TESTED BY	TYPE OF BREAK
1-A	3	6.003 5.995	6.002	8-5-85	DW	1250	8-5-85	95500	3380	DW	DW	REG
1-B	3	6.012 6.007	6.011	8-5-85	DW	1252	8-5-85	102000	3590	DW	DW	REG
1-C	3	6.020 6.014	6.017	8-5-85	DW	1254	8-5-85	99500	3500	DW	DW	REG
2-A	7	6.015 6.009	6.012	8-9-85	DW	0732	8-9-85	112000	3950	DW	DW	REG
2-B	7	6.020 6.016	6.011	8-9-85	DW	0730	8-9-85	115500	4070	DW	DW	REG
2-C	7	6.015 6.012	6.014	8-9-85	DW	0734	8-9-85	116000	4080	DW	DW	REG
3-A	28	5.970 6.010	5.990	8-29-85	DW	0718	8-30-85	150000	5320	DW	DW	REG
3-B	28	5.970 5.998	5.994	8-29-85	DW	0721	8-30-85	145000	5140	DW	DW	REG

DATE & TIME STRIPPED: 8-3-85 0800 AM
 REMARKS: SPECIMENS MADE AT ENGINEERS REQUEST

CURING CONTROL TEST RESULTS FOR 28 DAY BREAK

LABORATORY CURED CYLINDER(S)	FIELD CURED CYLINDERS
STRENGTH (P.S.I.) <u>NA</u> (C)	STRENGTH (P.S.I.) <u>NA</u> (D)
<u>L</u> (D)	<u>L</u> (D)
L (C) + (D) + (C) + (D) = <u>L</u>	2 (D) + (D) + 2 = <u>L</u>

* NOTE (1) ABOVE MUST BE EQUAL TO OR GREATER THAN 0.85; OR (2) ABOVE NEED NOT EXCEED THE DESIGN STRENGTH BY MORE THAN 500 PSI EVEN THOUGH THE 0.85 CRITERION IS NOT MET.

WORMETER OR
 SUPERS NO 2116 1392
 COMPRESSION MACHINE NO. 2116 9031
 TAPPING MOLD NO. 6101, 6102

3 DAY PREPARED BY DW HG-20 CHECKED BY PHORGE
 7 DAY PREPARED BY DW HG-20 CHECKED BY PHORGE
 28 DAY PREPARED BY DW HG-20 CHECKED BY PHORGE

ENGINEERS COMMENTS (IF APPLICABLE)

De Luzzio HG-01

ON COMPRESSIVE TESTS OF CONCRETE
 TYPE CI-QP-11.1-41 R/1

SPECIAL

COMPLETE S.A. AS APPLICABLE FROM BATCH TICKET	(M) MOST AGGR.	F.A. 6150 LBS	H ₂ O FA 150 LBS	C.A. 8460 LBS	H ₂ O CA 0 LBS	TOTAL WATER/BATCH 1224 LBS	TYPE OF CURING M+N
CEMENT / CU YD.	H ₂ O ADDED	H ₂ O/CEMENT RATIO	AIR CU YD	TOTAL #2	SPECIFIED DESIGN STRENGTH		
3157 LBS	0 GAL	.388	9.0 %	45 OZ	4000 PSI 28 DAYS		
BRAND OF CEMENT	TYPE OF CEMENT	BRAND OF AIR ENTRAINING ADMIXTURE		BRAND OF WATER REDUCING ADMIXTURE		MAX SIZE C.A.	
G-H	II	MBUR		NA		2.66	
SOURCE C.A.	SP GR C.A.	SOURCE F.A.		SP GR F.A.	FINENESS MODULUS F.A.		
TXI-TIN Top	2.64	TXI-TIN Top		2.62	2.66		

PLANT	BATCH LOAD	TICKET NO.	SAMPLE TAKEN AT:					
1	5 CY	64216	<input type="checkbox"/> CENTRAL MIXER	<input type="checkbox"/> FORMS	<input checked="" type="checkbox"/> POINT OF DISCHARGE			
METHOD OF PLACING	RUMP	BUCKET	DATE SAMPLED	HOUR	WEATHER	AIR TEMP	CONC. TEMP	SLUMP
<input type="checkbox"/> BUGGIES <input type="checkbox"/> BELT <input checked="" type="checkbox"/> CHUTE			8-2-85	9:00 AM	HOT	92 °F	91 °F	3 1/4 IN

TIME OF MIXING AT CENTRAL PLANT	UNIT WT. CU. FT.	MIX ID	SPECIMEN TAKEN BY	SPECIMEN CAST BY	AIR
70 REV MIN	144.54 LBS	132	OSBORNE	DO-DW	3.7 %

PAGER ID	AGE	MEASURED DIA IN	AVG DIA IN	DATE CAPPED	CAPPED BY	TIME TESTED	DATE TESTED	MAX LOAD LB.	COMPRESSIVE STRENGTH	CAP CHECKED BY	CYLINDER TESTED BY	TYPE OF BREAK
3-C	28	6.002	6.002	8-29-85	JW	0723	8-30-85	151000	5340	JW	JW	RESG
4-A	56	6.023	6.023	9-27-85	JW	1415	9-27-85	171000	6000	JW	JW	RESG
4-B	56	6.014	6.007	9-27-85	JW	1417	9-27-85	165000	5820	JW	JW	RESG
4-C	56	6.017	6.012	9-27-85	JW	1419	9-27-85	178500	6290	JW	JW	RESG
5-A	90	6.014	6.003	10-30-85	JW	0844	10-31-85	164000	6570	JW	JW	RESG
5-B	90	6.012	5.999	10-30-85	JW	0838	10-31-85	155200	6550	JW	JW	RESG
5-C	90	6.012	5.998	10-30-85	JW	0852	10-31-85	145000	6550	JW	JW	RESG
EXTRA	90	6.033	6.031	10-30-85	JW	0840	10-31-85	145000	6480	JW	JW	RESG

DATE & TIME STRIPPED: 8-3-85 0900 REMARKS: SPECIMENS MADE AT ENGINEERS REQUEST

CURING CONTROL TEST RESULTS FOR 28 DAY BREAK

LABORATORY CURED CYLINDER(S)	FIELD CURED CYLINDERS
STRENGTH (P.S.I.) <u>NA</u> (C)	STRENGTH (P.S.I.) <u>NA</u> (D)
<u>L</u> (D)	<u>L</u> (D)
1 (C)+(D) - (C)+(D) = <u>L</u> *	2. 801+(D) + 2 = <u>L</u> *

* NOTE (1) ABOVE MUST BE EQUAL TO OR GREATER THAN 0.85; OR (2) ABOVE NEED NOT EXCEED THE DESIGN STRENGTH BY MORE THAN 500 PSI EVEN THOUGH THE 0.85 CRITERION IS NOT MET.

DIAMETER OR GAUGES NO. WITE 1392
 COMPRESSION MACHINE NO. WITE 3031
 CAPPING MOLD NO. L101, L102
 28 DAY PREPARED BY JW HG-22 CHECKED BY HQ26
 90 DAY PREPARED BY JW HG-22 CHECKED BY HQ26

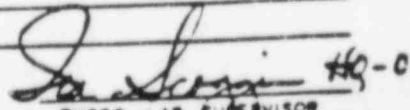
ENGINEERS COMMENTS (IF APPLICABLE)

 TUGCO LAB SUPERVISOR

Las Utilities Generat., Co.
Sanche Peak Steam Electric Station

Page 1 of 1
Date 8-7-55
Pour No. 017-9810-121
Mix I.D. No. 132

CONCRETE PLACEMENT INSPECTION

Equipment Used
Crownmeter(s) 777E 1800
Meter(s) 777E 536C
Trip(s) 418

Ticket No.	Ticket No.	Slump In.	Air %	Concrete Temp.	Rebar Temp.	Add Water Gals.	Remarks
41	641219	4	5.0	67	n/a	n/a	8/8 mon
41	641219	3 3/4	4.8	69			8/8 rec
n/a	n/a	n/a	n/a	n/a			

CONCRETE CYLINDER TEST DATA

Agg.	Coarse Agg.	Total H ₂ O on Ticket	Air Temp.	Total Air	
220 #	13560 #	1761 #	96 °F	75 1/2oz.	
Lot/Batch	Hour Sampled	Weather	Plant #	Sample #	Splic. Taken By:
254 #	1320 ^{PM}	St Cloudy	1	148	JW
Where Taken At:	Moisture Content Setting		Time Batched		
Central Mixer <input type="checkbox"/> Forms <input type="checkbox"/> Pt. of Discharge	1.0		1259 ^{PM}		

Method of Placing Pump Bucket
 Buggies Belt Chute

[Signature]
INSPECTOR/TECHNICIAN

000009

Texas Utilities Generating Co.
Comanche Peak Steam Electric Station
1981-83 Units 1 & 2

Date: 8-7-85

TEST: Unit Weight of Fresh Concrete, ASTM C-138. Instruction No. QI-QP-11.1-13

MATERIAL DESCRIPTION: 132 DATE SAMPLED: 8-7-85
MATERIAL SOURCES: ticket # 64219 DATE TESTED: 8-7-85

- a. MEASURE WEIGHT (LBS.) + COVER = 27.68
- b. FILLED MEASURE WEIGHT (LBS.) + COVER = 100.12
- c. WEIGHT OF CONCRETE (LBS.) 72.44
- d. VOLUME OF MOLD (cu.ft.) .50
- e. $\frac{c}{d}$ = UNIT WEIGHT 144.88 LB./CU.FT.

TESTED BY: [Signature] #9-23

CHECKED BY: [Signature]

CONTROL NO. WTE-1053 Scale
L-151 Measure

[Signature] HQ-01
TUGCO Laboratory Supervisor/Designee

CONFIDENTIAL ONLY

COMPRESSIVE TESTS OF CONCRETE

BT-OP-11.1-41 R/1

(SPECIAL)
 # 2

COMPLETE DIAL AS UNCALIBRATED MIX BATCH TICKET	(W) MOIST AGGR	F.A.	H ₂ O F.A.	C.A.	H ₂ O C.A.	TOTAL WATER/BATCH	TYPE OF CURING
	9660 LBS	96	LBS 13560 LBS	0	LBS 1857 LBS	M+W	
	CEMENT / CU YD	H ₂ O ADDED	H ₂ O/CEMENT RATIO	AIR CU YD	TOTAL H ₂ O	SPECIFIED DESIGN STRENGTH	
	5054 LBS	0 GAL	.367	9.4 OZ	75 OZ	NA PSI NA DAYS	
TYPE OF CEMENT	TYPE OF CEMENT	BRAND OF AIR ENTRAINING ADMIXTURE		BRAND OF WATER REDUCING ADMIXTURE		MAX SIZE C.A.	
G-H	II	M B V R		NA		3/4	
FINENESS C.A.	SP GR C.A.	SOURCE F.A.	SP GR F.A.	FINENESS MODULUS F.A.			
Tx1-TIN TOP	2.64	Tx1-TIN TOP	2.62	2.50			

NO. OF MIXING	BATCH LOAD	TICKET NO.	SAMPLE TAKEN AT:					
PLANT 1	8 C.Y.	64219	<input type="checkbox"/> CENTRAL MIXER	<input type="checkbox"/> FORMS	<input checked="" type="checkbox"/> POINT OF DISCHARGE			
METHOD OF PLACING	<input type="checkbox"/> PUMP	<input type="checkbox"/> BUCKET	DATE SAMPLED	HOUR	WEATHER	AIR TEMP	CONC. TEMP	SLUMP
<input type="checkbox"/> BUCKIES	<input type="checkbox"/> BELT	<input checked="" type="checkbox"/> CHUTE	8-7-85	13 ²⁰	HOT	96 °F	69 °F	3 3/4 IN

NO. OF MIXING AT CENTRAL PLANT	UNIT WT CU FT	MIX ID.	SPECIMEN TAKEN BY	SPECIMEN CAST BY	AIR
70 REV MIN	144.88 LBS	132	WOOD	IBS-RG	4.8%

AGE ID	MPZ	MEASURED DIA IN	AVG DIA IN	DATE CAPPED	CAPPED BY	TIME TESTED	DATE TESTED	MAX LOAD LB	COMPRESSIVE STRENGTH	CAP CHECKED BY	CYLINDER TESTED BY	TYPE OF BREAK
6A	3	5.957 5.992	5.975	8-9-85	RW	0910	8-10-85	83,500	2980	R.G.	R.G.	REG.
6B	3	5.965 5.990	5.973	8-9-85	RW	0915	8-10-85	85,500	3050	R.G.	R.G.	REG.
6C	3	6.002 5.933	5.993	8-9-85	RW	0918	8-10-85	87,000	3080	R.G.	R.G.	REG.
7A	7	6.004 6.012	6.008	8-13-85	RW	1245	8-14-85	105,500	3700	RW	RW	REG.
7B	7	6.001 5.988	6.000	8-13-85	RW	1247	8-14-85	105,500	3730	RW	RW	REG.
7C	7	6.019 6.001	6.010	8-13-85	RW	1250	8-14-85	110,000	3880	RW	RW	REG.
8A	28	5.976 6.000	5.983	9-4-85	(C)	1258	9-4-85	148,500	5270	(C)	(C)	REG.
8B	28	5.970 5.993	5.980	9-4-85	(C)	1255	9-4-85	148,000	5270	(C)	(C)	REG.

DATE & TIME STRIPPED: 8-8-85 730 AM
 REMARKS: SPECIMENS MADE AT ENGINEERS REQUEST

CURING CONTROL TEST RESULTS
 FOR 28 DAY BREAK

LABORATORY CURED CYLINDER(S)	FIELD CURED CYLINDERS
STRENGTH (PSI) <u>NA</u> (C)	STRENGTH (PSI) <u>NA</u> (C)
<u>1</u> (D)	<u>1</u> (D)
1. (C)+(D) = <u>1</u> *	2. (C)+(D) + 2 = <u>1</u> *

* NOTE: (1) ABOVE MUST BE EQUAL TO OR GREATER THAN 0.85; OR (2) ABOVE NEED NOT EXCEED THE DESIGN STRENGTH BY MORE THAN 500 PSI EVEN THOUGH THE 0.85 CRITERION IS NOT MET.

W/OMETER OR
 CALIBERS NO 7AE139Z
 COMPRESSION MACHINE NO 1976 3031
 CAPPING MOLD NO 6101, 6102

3 DAY PREPARED BY RW HSA-22 CHECKED BY RW HSA-22
 7 DAY PREPARED BY RW HSA-22 CHECKED BY RW HSA-22
 28 DAY PREPARED BY RW HSA-22 CHECKED BY RW HSA-22

ENGINEERS COMMENTS (IF APPLICABLE)

J. S. ...
 TUGCO LAB SUPERVISOR

(SPECIAL)
#2

DATE 8-7-85
POUR NO 017-9810-121
CYL. SET NO NA
Page 2 of 2

COMPRESSIVE TESTS OF CONCRETE
GT-QP-11.1-41 R/1

COMPLETE S'X AS APPLICABLE CON BATCH TICKET	(W) MOIST AGGR.	F.A.	H ₂ O F.A.	C.A.	H ₂ O C.A.	TOTAL WATER/BATCH	TYPE OF CURING
	9660 LBS	96 LBS	135 LBS	0 LBS	1857 LBS	M & W	
	CEMENT / CU. YD	H ₂ O ADDED	H ₂ O/CEMENT RATIO	AIR CU. %	TOTAL	SPECIFIED DESIGN STRENGTH	
	5054 LBS	0 GAL	.367	9.4 OZ	75 OZ	NA PSI NA DAYS	
NAME OF CEMENT	TYPE OF CEMENT	BRAND OF AIR ENTRAINING ADMIXTURE		BRAND OF WATER REDUCING ADMIXTURE		MAX SIZE C.A.	
G-H	II	MBUR		NA		3/4	
GRADE C.A.	SP GR. C.A.	SOURCE F.A.	SP GR. F.A.	FINENESS MODULES F.A.			
TXI-TIN TOP	2.64	TXI-TIN TOP	2.62	2.50			

PLANT	BATCH LOAD	TICKET NO.	SAMPLE TAKEN AT:					
PLANT 1	8 C.Y.	64219	<input type="checkbox"/> CENTRAL MIXER	<input type="checkbox"/> FORMS	<input checked="" type="checkbox"/> POINT OF DISCHARGE			
METHOD OF PLACING	<input type="checkbox"/> PUMP	<input type="checkbox"/> BUCKET	DATE SAMPLED	HOUR	WEATHER	AIR TEMP.	CONC. TEMP.	SLUMP
<input type="checkbox"/> BUCKIES	<input type="checkbox"/> BELT	<input checked="" type="checkbox"/> CHUTE	8-7-85	13 ⁰⁰ AM	HOT	96 °F	69 °F	3 3/4 IN.

NAME OF MIXING AT CENTRAL PLANT	UNIT WT. CU. FT	MIX ID.	SPECIMEN TAKEN BY	SPECIMEN CAST BY	AIR
70 REV	144.88 LBS	132	WOOD	RG-IAS	4.8%

CYLINDER ID	AGE	MEASURED DIA IN	AVG DIA IN	DATE CAPPED	CAPPED BY	TIME TESTED	DATE TESTED	MAX LOAD (LBS)	COMPRESSIVE STRENGTH	CAP CHECKED BY	CYLINDER TESTED BY	TYPE OF BREAK
9C	28	6.005	6.005	9-4-85	W	1301	9-4-85	151000	5330	W	W	REG
9A	56	6.012	6.011	10-2-85	W	1430	10-2-85	167000	5280	W	W	REG
9B	56	6.004	6.008	10-2-85	W	1432	10-2-85	162000	5710	W	W	REG
9C	56	6.005	6.010	10-2-85	W	1434	10-2-85	167000	5290	W	W	REG
10A	90	5.976	5.974	11-4-85	W	0800	11-5-85	177000	6320	W	W	REG
10B	90	5.979	5.993	11-4-85	W	0802	11-5-85	182500	6470	W	W	REG
10C	90	6.007	6.010	11-4-85	W	0804	11-5-85	187000	6591	W	W	REG
NA												

SITE & TIME STRIPPED 8-8-85 7:30 AM
REMARKS: SPECIMENS MADE AT ENGINEER'S REQUEST

CURING CONTROL TEST RESULTS
FOR 28 DAY BREAK

LABORATORY CURED CYLINDER(S)	FIELD CURED CYLINDERS
STRENGTH (P.S.I.) NA (C)	STRENGTH (P.S.I.) NA (1)
_____ (D)	_____ (2)
1. (C)+(D) = (C)+(D) = _____ *	2. (1)+(2) + 2 = _____ *

* NOTE (1) ABOVE MUST BE EQUAL TO OR GREATER THAN 0.85; OR (2) ABOVE NEED NOT EXCEED THE DESIGN STRENGTH BY MORE THAN 500 PSI EVEN THOUGH THE 0.85 CRITERION IS NOT MET.

KROMETER OR
METERS NO. TATE 1372
IMPRESSION MACHINE NO. TATE 3031
SPRING MOLD NO. L101, L102

28 DAY PREPARED BY W JG-22 CHECKED BY H0126
90 DAY PREPARED BY W JG-22 CHECKED BY H0126

ENGINEER'S COMMENTS (IF APPLICABLE)

FOR INFORMATION ONLY
TUGCO LAB SUPERVISOR
H0-01

Texas Utilities Generating Co.
Comanche Peak Steam Electric Station
1981-83 Units 1 & 2

Date: 8-12-85

TEST: Unit Weight of Fresh Concrete, ASTM C-138, Instruction No. QI-QP-11.1-13

MATERIAL DESCRIPTION: 132 DATE SAMPLED: 8-12-85
MATERIAL SOURCES: ticket # 64228 DATE TESTED: 8-12-85

a. MEASURE WEIGHT (LBS.) + COVER = 27.68
b. FILLED MEASURE WEIGHT (LBS.) + COVER = 99.71
c. WEIGHT OF CONCRETE (LBS.) 72.03
d. VOLUME OF MOLD (cu.ft.) .50
e. $\frac{c}{d}$ = UNIT WEIGHT 144.06 LB./CU.FT.

TESTED BY: Jan Scoggin

CHECKED BY: Robert Johnson

CONTROL NO. MTE-1053

Scale

L-151

Measure

Jan Scoggin HQ-01
TUGCO Laboratory Supervisor/Designee

CONCRETE PLACEMENT INSPECTION

Equipment Used:

Protractor(s) 7775 180

Ruler(s) 7773 236

Scale(s) 66112

Tick No.	Ticket No.	Slump In.	Air %	Concrete Temp.	Rebar Temp.	Add Water Gals.	Remarks
10	64228	4	5.1	64	N/A	N/A	N4 sec
N/A	N/A	N/A	N/A	N/A	N/A	N/A	N/A

CONCRETE CYLINDER TEST DATA

Agg.	Coarse Agg.	Total H ₂ O on Ticket	Air Temp.	Total Air	
100	6780	879	97 OF	37 1/2oz.	
Lot/Batch	Hour Sampled	Weather	Plant #	Sample #	Spic. Taken By:
27	1348	Clear	1	N4	DW
Sample Taken At:	Moisture Content Setting		Time Batched		
Central Mixer <input type="checkbox"/> Forms <input type="checkbox"/> P.T. of Discharge	20		1321 AM PM		

Method of Placing Pump Bucket
 Buggies Belt Chute

[Signature]
 INSPECTOR/TECHNICIAN

CONFIDENTIAL ONLY

PEAK STEAM ELECTRIC STATION

(SPECIAL #3)

DATE 8-12-85
POUR NO 017-9810-129
CYL SET NO NA
Page 1 of 2

COMPRESSIVE TESTS OF CONCRETE
RI-QP-11.1-41 R/I

COMPLETE DATA AS APPLICABLE FROM BATCH TICKET	(W) MOIST AGGR	F.A.	M ₂ O F.A.	C.A.	M ₂ O C.A.	TOTAL WATER/BATCH	TYPE OF CURING
	4830 LBS	45	6780 LBS	0	974 LBS	M+W	
	CEMENT / CU YD	M ₂ O ADDED	M ₂ O/CEMENT RATIO	AIR CL. %	TOTAL W/B	SPECIFIED DESIGN STRENGTH	
	2527 LBS	0 GAL	.385	9.3 1/2	37 1/2	4100 PSI 28 DAYS	
BRAND OF CEMENT	TYPE OF CEMENT	BRAND OF AIR ENTRAINING ADMIXTURE		BRAND OF WATER REDUCING ADMIXTURE		MAX SIZE C.A.	
G-H	II	M BUR		NA		3/4	
SOURCE C.A.	SP GR. C.A.	SOURCE F.A.	SP GR. F.A.	FINENESS MODULES F.A.			
TXI-TIN TOP	2.64	TXI-TIN TOP	2.62	2.59			

TYPE OF MIXING	BATCH LOAD	TICKET NO	SAMPLE TAKEN AT:					
PLANT 1	4	64228	<input type="checkbox"/> CENTRAL MIXER	<input type="checkbox"/> FORMS	<input checked="" type="checkbox"/> POINT OF DISCHARGE			
METHOD OF PLACING	<input type="checkbox"/> PUMP	<input type="checkbox"/> BUCKET	DATE SAMPLED	HOUR	WEATHER	AIR TEMP	CONC. TEMP	SLUMP
<input type="checkbox"/> BUGGIES	<input type="checkbox"/> BELT	<input checked="" type="checkbox"/> CHUTE	8-12-85	13:48 AM	HOT	99°	64°	4

TIME OF MIXING AT CENTRAL PLANT	UNIT WT. CU FT	MIX ID.	SPECIMEN TAKEN BY	SPECIMEN CAST BY	AIR
70 REV MIN	144.06 LBS	132	OSBORNE	DO-IAS	5.1%

NUMBER	AGE	MEASURED DIA IN	AVG DIA IN	DATE CAPPED	CAPPED BY	TIME TESTED	DATE TESTED	MAX LOAD LB	COMPRESSIVE STRENGTH	CAP CHECKED BY	CYLINDER TESTED BY	TYPE OF BREAK
11A	3	6.026	6.010	8-14-85	DEW	0740	8-15-85	80000	2820	DEW	DEW	REG
11b	3	5.982	5.961	8-14-85	DEW	0730	8-15-85	85000	3030	DEW	DEW	REG
11c	3	6.006	6.011	8-14-85	DEW	0734	8-15-85	81500	2870	DEW	DEW	REG
12A	7	5.976	5.988	8-16-85	DEW	0801	8-19-85	98000	3480	DEW	DEW	REG
12B	7	5.973	5.985	8-16-85	DEW	0804	8-19-85	102000	3630	DEW	DEW	REG
12C	7	5.984	5.989	8-16-85	DEW	0759	8-19-85	104000	3690	DEW	DEW	REG
13A	28	5.999	5.999	9-9-85	DEW	1308	9-9-85	146000	5170	DEW	DEW	REG
13B	28	5.992	5.992	9-9-85	DEW	1312	9-9-85	147000	5210	DEW	DEW	REG

DATE & TIME STRIPPED: 8-13-85 7:00 PM
REMARKS: SPECIMENS MADE AT ENGINEER'S REQUEST

CURING CONTROL TEST RESULTS FOR 28 DAY BREAK

LABORATORY CURED CYLINDERS:	FIELD CURED CYLINDERS:
STRENGTH (PSI) <u>NA</u> (C)	STRENGTH (PSI) <u>NA</u> (G)
<u>↓</u> (D)	<u>↓</u> (H)
1 (G)+(D) + (C)+(D) = <u>↓</u> *	2. (H)+(D) + 2 = <u>↓</u> *

* NOTE: (1) ABOVE MUST BE EQUAL TO OR GREATER THAN 0.85; OR (2) ABOVE NEED NOT EXCEED THE DESIGN STRENGTH BY MORE THAN 500 PSI EVEN THOUGH THE 0.85 CRITERION IS NOT MET.

SCHEMATIC OR CALIBERS NO TYPE 1392
 COMPRESSION MACHINE NO TYPE 3031
 CAPPING MOLD NO L101, L102

7 DAY PREPARED BY DEW HAZZ CHECKED BY Q HQ126
 28 DAY PREPARED BY DEW HAZZ CHECKED BY Q HQ126
 5 DAY PREPARED BY DEW HAZZ CHECKED BY Q HQ126

ENGINEER'S COMMENTS (IF APPLICABLE)
 I. Lewis HQ-01

COMPRESSIVE TESTS OF CONCRETE
01-QP-11.7-41 R/T

SPECIMEN # 3

WATER/BATCH 974 LBS TYPE OF CURING M+W
CEMENT / CU YD. 2527 LBS H₂O ADDED 0 GAL H₂O/CEMENT RATIO .385 AIR CU. YD. 9.372 OZ TOTAL AIR 37 1/2 OZ SPECIFIED DESIGN STRENGTH 4000 PSI 28 DAYS
TYPE OF CEMENT II BRAND OF AIR ENTRAINING ADMIXTURE MBUR BRAND OF WATER REDUCING ADMIXTURE NA MAX SIZE C.A. 3/4
SOURCE F.A. 2.64 TXI-TIN TOP SP. GR. F.A. 2.62 FINENESS MODULUS F.A. 2.59

BATCH LOAD 4 C.Y. 64228 TICKET NO. 64228 SAMPLE TAKEN AT: CENTRAL MIXER FORMS POINT OF DISCHARGE
METHOD OF PLACING PUMP BUCKET CHUTE DATE SAMPLED 8-12-85 13:48 AM WEATHER HOT AIR TEMP 97 °F CONC. TEMP 64 °F WIND 4 IN
SPECIMEN TAKEN BY OSBORNE SPECIMEN CAST BY DO-1AS AIR 5.1%

AGE	MEASURED DIA IN	AVG DIA IN	DATE CAPPED	CAPPED BY	TIME TESTED	DATE TESTED	MAX LOAD LB	COMPRESSIVE STRENGTH	CAP CHECKED BY	CYLINDER TESTED BY	TYPE OF BREAK
3C 28	6.000	6.007	9-9-85	DW	1310	9-9-85	142000	5010	DW	DW	REG
4A 56	5.997	5.974	10-4-85	DW	0924	10-7-85	161500	5720	DW	DW	REG
4B 56	6.000	6.006	10-4-85	DW	0926	10-7-85	175000	6180	DW	DW	REG
4C 56	6.010	6.010	10-4-85	DW	0917	10-7-85	172000	6060	DW	DW	REG
5A 90	5.991	5.989	11-11-85	DW	1313	11-10-85	182000	6460	DW	DW	REG
5B 90	6.014	6.014	11-11-85	DW	1319	11-10-85	185000	6510	DW	DW	REG
5C 90	5.965	5.963	11-11-85	DW	1324	11-10-85	177000	6300	DW	DW	REG
NA											

DATE & TIME STRIPPED 8-13-85 7:00 PM REMARKS SPECIMENS MADE AT ENGINEER'S REQUEST

CURING CONTROL TEST RESULTS FOR 28 DAY BREAK

LABORATORY CURED CYLINDER(S) STRENGTH (P.S.I.) NA (C)
FIELD CURED CYLINDER(S) STRENGTH (P.S.I.) NA (D)
1. (C)+(D) - (C)+(D) = \downarrow *
2. (C)+(D) + 2 * \downarrow *

* NOTE: (1) ABOVE MUST BE EQUAL TO OR GREATER THAN 0.85; OR (2) ABOVE NEED NOT EXCEED THE DESIGN STRENGTH BY MORE THAN 500 PSI EVEN THOUGH THE 0.85 CRITERION IS NOT MET.

MOOMETER OR GAUGES NO. TIME 1392
IMPRESSION MACHINE NO. 207E 3051
DIPPING MOLD NO. L101, L102

56 DAY PREPARED BY DW H822 CHECKED BY H826
90 DAY PREPARED BY DW H822 CHECKED BY H826

ENGINEER'S COMMENTS (IF APPLICABLE)

J. Logan H8-01
TUCCO LAB SUPERVISOR

APPENDIX D

PROJECT 1903.23/24 MASTER TEST MONITOR LOG

MASTER LOG
CYCLIC AND STATIC TESTING OF TRAIN C CONDUIT BEAM CLAMPS AND UNISTRUT® HANGERSClient: Texas Utilities Generating Company CCL Project Number: 85-1903.23/24

Entries are to be made for the following items as a minimum:

1. Upon completion of each test, technician in charge should enter test sample number, date and time of test, a brief description of test sample behavior, and any deviations or ROA's. Test monitor must verify all test data and QA logs are complete to that point before proceeding.
2. Scale factor verifications for ACRO 900 System should be performed at the beginning and ending of each week and noted in Master Log.
3. Any changes in instrumentation and transducers should be noted. Include test sample number, instrumentation/transducer change, verification of scale factor (as required), etc.
4. LVDT's and Linear Potentiometers, should be verified at the beginning and ending of each week and noted in the Master Log.
5. Load cells should be within their normal calibration cycle at the start of the test program and verified at full scale capacity only at the end of the test program. Note starting calibration dates and verification data.
6. If the test sample fails, a description of the mode of failure for the test sample is required in addition to a description of the progression to failure.

Form Prepared By:

Mark H. BondDate: 5-21-86

Form Approved By:

C. BlankDate: 5-21-86

MASTER TEST MONITOR LOG
 CYCLIC AND STATIC TESTING OF TRAIN C CONDUIT
 BEAM CLAMPS AND UNISTRUT® HANGERS

Client: Texas Utilities Generating Company

CCL Project Number: 85-1903.23/24

DATE	TIME	TASK DESCRIPTION	TECH	TEST MON
5-22-86	1500	LVDT'S, LOAD CELLS (TO BE USED), WITH DATRONICS AMPS. HAVE HAD A PRE-TEST SCALE FACTOR RUN/CALCULATIONS MADE. LVDT'S & LINEAR POT. HAVE BEEN CALIBRATED PRIOR TO USE TO BE POST/PRE CALIBRATED ON A WEEKLY BASIS.	ODP -	

Form Prepared By: [Signature]
 Form Approved By: [Signature]

Date: 5-21-86
 Date: 5-21-86

MASTER TEST MONITOR LOG
 CYCLIC AND STATIC TESTING OF TRAIN C CONDUIT
 BEAM CLAMPS AND UNISTRUT® HANGERS

Client: Texas Utilities Generating Company

CCL Project Number: 85-1903.23/24

DATE	TIME	TASK DESCRIPTION	TECH	TEST MON
5-22-86	17:00	2A12-01 TEST COMPLETE. UNISTRUT SECTION SLIPPED OUT OF CLAMPS.	RHL	EAB
5-22-86	17:53	2A-12-02 TEST COMPLETE. UNISTRUT SECTION SLIPPED OUT OF CLAMPS. "CHANNELS" PAGE FOR LOAD LOAD CELL WAS SET FOR 2.0V RANGE ON BASIS OF FAILURE LOAD FOR LAST TEST. LABTECH NOTEBOOK DATA ACQUISITION TIME REDUCED TO 3 MINS.	RHL	EAB
5-22-86	19:09	2A-12-03 TEST COMPLETE. UNISTRUT SECTION SLIPPED OUT OF CLAMPS.	RHL	EAB
5-22-86	20:59	2C-12-01 TEST COMPLETE. U-CLAMP NEAREST VERTICAL LOAD CAUSED UNISTRUT FLANGES TO BEND INWARD. WHEN FLANGES MET IN MIDDLE OF STRUT, BOLTS BELOW BEARING PLATE BEND OUTWARD, ALLOWING PLATE TO SLIP OFF OF FIXTURE.	RHL	EAB

Form Prepared By: *Jeffrey H. Bond*
 Form Approved By: *[Signature]*

Date: 5-21-86
 Date: 5-21-86

MASTER TEST MONITOR LOG
 CYCLIC AND STATIC TESTING OF TRAIN C CONDUIT
 BEAM CLAMPS AND UNISTRUT HANGERS

Client: Texas Utilities Generating Company

CCL Project Number: 85-1903.23/24

DATE	TIME	TASK DESCRIPTION	TECH	TEST MON
5-23-86	11:32	2C-12-02 TEST COMPLETE. DATA ACQUISITION RANGE RESET TO 2 VOLTS FOR THIS TEST (FROM 20 VOLTS FOR LAST TEST.). UNISTRUT SECTION FLANGES BY NEAREST LOAD ATTACHMENT POINT BENT INWARD. WHEN FLANGES MET, BOLTS ON U-BOLT BENT; ALLOWING BEARING PLATE TO SLIP OFF OF TEST FIXTURE.	RHC	KAT
5-23-86	15:00	2C-12-03 TEST COMPLETE. FLANGES ON UNISTRUT SECTION BENT INWARD. WHEN BY FLANGES MET, U-BOLT BENT BELOW BEARING PLATE, ALLOWING PLATE TO SLIP OFF OF TEST FIXTURE.	RHC	EAB
5-23-86	18:02	CALIBRATED LINEAR POT. # 1098 FOR USE ON TRAIN C TESTS 2B-12. ALSO CALIBRATED LOAD CELL # 7015 FOR USE ON SAME TEST CONFIGURATIONS. CALIBRATIONS APPROVED BY KEITH MCPHERSON.	RHC	-

Form Prepared By: [Signature]
 Form Approved By: [Signature]

Date: 5-21-86

Date: 5-21-86

MASTER TEST MONITOR LOG
 CYCLIC AND STATIC TESTING OF TRAIN C CONDUIT
 BEAM CLAMPS AND UNISTRUT HANGERS

Client: Texas Utilities Generating Company

CCL Project Number: 85-1903.23/24

DATE	TIME	TASK DESCRIPTION	TECH	TEST MON
5-23-86	18:36	2B-12-01 TEST COMPLETE. BEARING PLATES SLIPPED ON TEST FIXTURE UNTIL 4 BOLTS OF SAMPLE CONTACTED FIXTURE. BOLTS DEFORMED UNTIL UNISTRUT SECTION BENT. LOAD ATTACHMENT POINT WAS APPROXIMATELY 4 1/2" FROM CENTER OF UNISTRUT SECTION. ATTACHMENT POINT WILL BE RELOCATED FOR SUBSEQUENT TESTS TO CENTERLINE OF UNISTRUT. AMPLIFIER OUTPUT EXCEEDED 2 VOLT DATA ACQUISITION RANGE. LOADS IN EXCESS OF 2400 LBS. WERE OBSERVED BY TECHNICIAN.	12HC	UMP UMP
5-24-86	747	BECAUSE 2B-12-01 OVER RANGED LOAD CELL/CONTROLLER OUTPUT A SAMPLE No. ⁰⁰² X. 2B-12-04 WILL BE RAN.	ODB	KFA

Form Prepared By: [Signature]
 Form Approved By: [Signature]

Date: 5-21-86
 Date: 5-21-86

MASTER TEST MONITOR LOG
 CYCLIC AND STATIC TESTING OF TRAIN C CONDUIT
 BEAM CLAMPS AND UNISTRUT HANGERS

Client: Texas Utilities Generating Company

CCL Project Number: 85-1903.23/24

DATE	TIME	TASK DESCRIPTION	TECH	TEST MON
5-24-86	9:55	ZB-12-02 TEST COMPLETE. BEARING PLATES SLIPPED ON TEST FIXTURE UNTIL U-BOLTS CONTACTED FIXTURE. U-BOLTS BENT UNTIL UNISTRUT SECTION BENT. LOAD ATTACHMENT POINT WAS RELOCATED TO CENTER LINE OF UNISTRUT SECTION.	RHL	<i>WV</i>
5-24-86	11:22	ZB-12-03 TEST COMPLETE. BEARING PLATES SLIPPED ON TEST FIXTURE UNTIL U-BOLTS CONTACTED FIXTURE. U-BOLTS DEFORMED UNTIL UNISTRUT SECTION BENT.	RHL	EAB
5-24-86	13:30	ZB-12-04 TEST COMPLETE. BEARING PLATES SLIPPED ON TEST FIXTURE UNTIL U-BOLTS CONTACTED FIXTURE. U-BOLTS BENT UNTIL UNISTRUT SECTION DEFORMED.	RHL	EAB

Form Prepared By: *Johnny H. Bond*
 Form Approved By: *[Signature]*

Date: 5-21-86
 Date: 5-21-86

MASTER TEST MONITOR LOG
 CYCLIC AND STATIC TESTING OF TRAIN C CONDUIT
 BEAM CLAMPS AND UNISTRUT® HANGERS

Client: Texas Utilities Generating Company

CCL Project Number: 85-1903.23/24

DATE	TIME	TASK DESCRIPTION	TECH	TEST MON
5-24-86	16:38	2D-12-01 TEST COMPLETE. UNISTRUT SECTION'S FLANGES DEFLECTED TOWARDS CENTERLINE OF STRUT, THEN WEB OF STRUT BEND IN DIRECTION OF LOAD. LINEAR POT. DATA MUST BE BIASED BY .2607 FOR INITIAL DEFLECTION TO BE ZERO.	RHL	EAB
6-24-86		RAN POST-TEST CALIBRATIONS FOR THE TRAIN C LOAD CELL/LVDT/ACRA/ LINEAR POTENTIOMETER SYSTEM. SEE PROJECT CALIBRATION FILES.	RHL	—
5-26-86	11:19	2D-12-02 TEST COMPLETE. UNISTRUT SECTION WEB WEB BENT AT EDGE OF TEST FIXTURE, THEN FLANGES DEFLECTED TOWARDS CENTER OF WEB.	RHL	CEK
5-26-86	11:56	2D-12-03 TEST COMPLETE. UNISTRUT SECTION WEB BENT AT EDGE OF TEST FIXTURE, THEN FLANGES DEFORMED TOWARDS CENTER OF WEB.	RHL	CEK

Form Prepared By: *Jeffrey H. Bond*
 Form Approved By: *Blair J.*

Date: 5-21-86

Date: 5-21-86

MASTER TEST MONITOR LOG
CYCLIC AND STATIC TESTING OF TRAIN C CONDUIT
BEAM CLAMPS AND UNISTRUT® HANGERS

Client: Texas Utilities Generating Company

CCL Project Number: 85-1903.23/24

DATE	TIME	TASK DESCRIPTION	TECH	TEST MON
5-26-86	14:04	2D-24-01 TEST COMPLETE. UNISTRUT SECTION BENT AT TEST FIXTURE EDGE. WEBS BY UNDER CLAMP BY FARTHEST FROM LOAD DEFLECTED TOWARDS CENTER OF SECTION.	RWC	CEK
5-26-86	14:04	DUE TO PREVIOUS COMPUTER OPERATIONS, THE BATCH PROGRAM "RUNLTH.BAT." DID NOT COMPLETE ITS EXECUTION. THE DATA FILE HARDCOPY DOES NOT CONTAIN THE FOLLOWING INFORMATION; FOR TEST ^{2D-24-01} 2D-12 RWC 5-26-86 CURRENT DATE: MON 5-26-1986 CURRENT TIME: 14:04 3 "AD Bd" 3 "AD Bd" 1 "AD Ch" 4 "AD Ch" 1.0000E+00 "RATE" 1.0000E+00 "RATE"	RWC	—

Form Prepared By: [Signature]
Form Approved By: [Signature]

Date: 5-21-86
Date: 5-21-86

MASTER TEST MONITOR LOG
 CYCLIC AND STATIC TESTING OF TRAIN C CONDUIT
 BEAM CLAMPS AND UNISTRUT® HANGERS

Client: Texas Utilities Generating Company

CCL Project Number: 85-1903.23/24

DATE	TIME	TASK DESCRIPTION	TECH	TEST MON
5-26-86	14:04	Z "AD GAIN C" Z "AD GAIN C" 0.0000+E00 "AD OFFS" 0.0000+E00 "AD OFFS" 9.996808E+02 "AD SCALE" 2.396500E+00 "AD SCALE" BATCH PROGRAM EXECUTION PROBLEM CORRECTED BY REBOOTING COMPUTER.	RHC	COIL
5-26-86	14:57	DATA FOR TEST 2D-24-01 WAS NOT COPIED TO A DATA FILE FOR PERMANENT STORAGE OR LOTUS DATA REDUCTION. DATA WILL HAVE TO BE ENTERED INTO LOTUS MANUALLY.	RHC	—

Form Prepared By: *Jeffrey H. Bond*
 Form Approved By: *Blair J.*

Date: 5-21-86
 Date: 5-21-86

MASTER TEST MONITOR LOG
CYCLIC AND STATIC TESTING OF TRAIN C CONDUIT
BEAM CLAMPS AND UNISTRUT HANGERS

Client: Texas Utilities Generating Company

CCL Project Number: 85-1903.23/24

DATE	TIME	TASK DESCRIPTION	TECH	TEST MON
5-26-86	14:57	2D-24-02 TEST COMPLETE. UNI-STRUT WEB BENT AT TEST FIXTURE.	RHL	CE/L
5-26-86	15:27	2D-24-03 TEST COMPLETE. UNISTRUT SECTION WEB BENT AT TEST FIXTURE.	RHL	CE/L
5-26-86	16:16	2C-24-01 TEST COMPLETE. UNISTRUT SECTION FLANGES NEAREST LOAD ATTACHMENT POINT DEFORMED TOWARDS CENTER OF SECTION, W-BOLTS BENT AS UNISTRUT SECTION BENT.	RHL	CEK
5-26-86	16:47	2C-24-02 TEST COMPLETE. UNISTRUT SECTION FLANGES NEAREST LOAD UNDER W-BOLT NEAREST LOAD ATTACHMENT POINT DEFORMED TO CENTER OF SECTION. W-BOLTS BENT AS UNISTRUT SECTION BENT.	RHL	CEK

Form Prepared By: [Signature]
Form Approved By: [Signature]

Date: 5-21-86
Date: 5-21-86

MASTER TEST MONITOR LOG
CYCLIC AND STATIC TESTING OF TRAIN C CONDUIT
BEAM CLAMPS AND UNISTRUT® HANGERS

Client: Texas Utilities Generating Company

CCL Project Number: 85-1903.23/24

DATE	TIME	TASK DESCRIPTION	TECH	TEST MON
5-26-86	1726	2C-24-03 COMPLETE. BENT UNISTRUT, BENT CLAMP "U" BOLT, CLAMP SLIPPED.	ODB	CEK
5-26-86	1916	VERIFIED ALL DATA BACKUP, " " " " " " " "	ODB	—
5-26-86	23:30	CREATED DATA FILE FOR TEST 2D-24-01, FROM FILE 2D-24-02. HEADER (DATA ACQUISITION) IS IDENTICAL FOR BOTH TESTS. PRINTOUT OF 2D-24-01 TEST DATA USED TO INPUT LOAD/DEFLECTION DATA.	RHL	—
5-27-86	1050	2b-24-01 COMPLETE. "U" BOLT SCRATCHED UNISTRUT SLIGHTLY BENT "U" BOLT BOTH CLAMPS SLIPPED. FOR 2b-24-02 & -03 VOLTAGE RANGE FOR LOAD CELL DATA ACQUISITION WILL BE REDUCED FROM 2.0V TO 2.0V.	ODB	KFA
			ODB	KAL

Form Prepared By: *Jeffrey H. Bond*
Form Approved By: *Blair J.*

Date: 5-21-86
Date: 5-21-86

MASTER TEST MONITOR LOG
 CYCLIC AND STATIC TESTING OF TRAIN C CONDUIT
 BEAM CLAMPS AND UNISTRUT® HANGERS

Client: Texas Utilities Generating Company

CCL Project Number: 85-1903.23/24

DATE	TIME	TASK DESCRIPTION	TECH	TEST MON
5-27-86	12:04	2b-24-02 COMPLETE. GREATER SCARRING OF BEAM & UNISTRUT [®] BENT "U" BOLT, SLIPPED, BOTH CLAMPS.	ODB	KFA
5-27-86	14:03	2B-24-03 COMPLETE. BEARING PLATES 5 HOLDING UNISTRUT SECTION TO TEST FIXTURE SLIPPED. 4-BOLTS BENT SLIGHTLY BENT. UNISTRUT SECTION DID NOT DEFORM. RHL	RHL	CEK
5-27-86	18:00	3D-24-01 TEST COMPLETE. UNISTRUT SECTION FLANGES DEFORMED TO CENTER OF SECTION AT U-BOLT FASTENEST FROM LOAD ATTACHMENT POINT AND CAUSED SQUARED OFF SECTION OF U-BOLT TO "ROUND". U-BOLTS BEHIND BEARING PLATE DEFORMED. (SEE SYSTEM) (SEE FILE) RHL 5.27.86 (PHOTO.) RHL 5.27.86	RHL	CEK



Form Prepared By: J. H. Bond
 Form Approved By: Blair J.

Date: 5-21-86
 Date: 5-21-86

MASTER TEST MONITOR LOG
CYCLIC AND STATIC TESTING OF TRAIN C CONDUIT
BEAM CLAMPS AND UNISTRUT® HANGERS

Client: Texas Utilities Generating Company

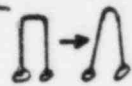
CCL Project Number: 85-1903.23/24

DATE	TIME	TASK DESCRIPTION	TECH	TEST MON
5-27-86	18:00	3D-24-01 (CONTINUED) SUBSEQUENT 3D ^{EM} 3D-24 TESTS WILL BE PERFORMED USING ^{RHL} 12" STROKE HYDRAULIC CYLINDER AND 3K LBS. LOAD CELL.	RHL	CEX
5-28-86	807	BR FOR SAMPLES 3D-24-02/03 L.C. VOLTAGE RANGE WILL BE 2 VOLT. 999. LBS/U. SWL.	ODB	
5-28-86	826	3d-24-02 COMPLETE. OUTSIDE "U" BOLT: COLASPED UNISTRUT WITHIN TURN COLASPED "U" BOLT  BENT OUTSIDE "U" BOLT / CLAMP  FAILURE: OUTSIDE "U" BOLT & CLAMP SLIPPED OFF I" BEAM.	ODB	KFA

Form Prepared By: J. H. Bond
Form Approved By: [Signature]

Date: 5-21-86
Date: 5-21-86

MASTER TEST MONITOR LOG
CYCLIC AND STATIC TESTING OF TRAIN C CONDUIT
BEAM CLAMPS AND UNISTRUT® HANGERS

Client: Texas Utilities Generating Company

CCL Project Number: 85-1903.23/24

DATE	TIME	TASK DESCRIPTION	TECH	TEST MON
5-20-86	1030	RAN A SCALE FACTOR/CALIBRATION OF 10K LOAD CELL #7018, AMP. 1069 ODS SEE CALIBRATION FILES.	CDB	—
5-28-86	1052	3A-12-01 COMPLETE. TORQUE OF "U" BOLTS WARPED INWARD UNISTRUT. FAILURE: BENT BACK 'U' BOLT (OPP. END FROM CYLINDER) TOWARDS CYLINDER; UNISTRUT SLIPPED; FRONT CLAMP SLIPPED FROM 'I' BEAM.	ODB	KA
5-28-86	12:04	3A-12-02 TEST COMPLETE. U-BOLT FARTHEST FROM LOAD ATTACHMENT POINT BENT AT TEST FIXTURE AND DUG INTO UNISTRUT SECTION. WHEN UNISTRUT SECTION SLIPPED, FORWARD U-BOLT AND BEARING PLATE SLIPPED OFF OF TEST FIXTURE. AS UNISTRUT SECTION WAS SLIPPING, BACK U-BOLT INTERMITTENTLY GRABBED AND RELEASED UNISTRUT.	RHC	CGK

Form Prepared By: [Signature]
Form Approved By: [Signature]

Date: 5-21-86

Date: 5-21-86

MASTER TEST MONITOR LOG
CYCLIC AND STATIC TESTING OF TRAIN C CONDUIT
BEAM CLAMPS AND UNISTRUT® HANGERS

Client: Texas Utilities Generating Company

CCL Project Number: 85-1903.23/24

DATE	TIME	TASK DESCRIPTION	TECH	TEST MON
5-28-86	1319	3d-24-03 COMPLETE. SAME FAILURE MODE AS 3d-24-02, TECH. KNOWTISTED UNISTRUT, BETWEEN "U" BOLTS, CLOSED DURING END OF TEST.	ODB	CEK
5-28-86	1340	3a-12-03 COMPLETE. SAME FAILURE MODE AS 3a-12-01.	ODB	CEK
5-28-86	14:00	3d-24-01 ^{REV 5-28-86} 3c-24-01 TEST COMPLETE. UNISTRUT SECTION FLANGES UNDER CLAMP NEAREST LOAD ATTACHMENT POINT DEFLECTED TOWARDS CENTER OF SECTION. U-BOLT BENT AND CLAMP SLIPPED OFF OF TEST FIXTURE.	PLAL	CEK

Form Prepared By: J. H. Bond
Form Approved By: Blant J.

Date: 5-21-86

Date: 5-21-86

MASTER TEST MONITOR LOG
CYCLIC AND STATIC TESTING OF TRAIN C CONDUIT
BEAM CLAMPS AND UNISTRUT® HANGERS

Client: Texas Utilities Generating Company

CCL Project Number: 85-1903.23/24

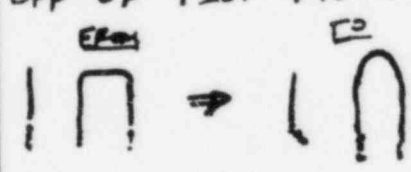
DATE	TIME	TASK DESCRIPTION	TECH	TEST MON
5.28.86	14:36	^{2.4} ^{0.00} ★ <u>3C-24-02</u> TEST COMPLETE. FAILURE MODE SAME AS 3C-24-01.	RHL	CEK
5.28.86	15:04	3C-24-03 TEST COMPLETE. FAILURE MODE SAME AS 3C-24-01.	RHL	CEK
5.28.86	16:24	3C-12-01 TEST COMPLETE. FLANGES OF UNISTRUT SECTION DEFLECTED TO CENTER OF SECTION, UNDER U-BOLT CLOSEST TO TO LOAD ATTACHMENT POINT. SAME U-BOLT DEFORMED (SEE SKETCH). CLAMP ON U-BOLT SLIPPED OFF OF TEST FIXTURE. 	RHL	CEK

Form Prepared By: [Signature]
Form Approved By: [Signature]





Date: 5-21-86

Date: 5-21-86

MASTER TEST MONITOR LOG
 CYCLIC AND STATIC TESTING OF TRAIN C CONDUIT
 BEAM CLAMPS AND UNISTRUT® HANGERS

Client: Texas Utilities Generating Company

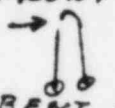
CCL Project Number: 85-1903.23/24

DATE	TIME	TASK DESCRIPTION	TECH	TEST MON
5-28-86	16:54	3C-12-02 TEST COMPLETE. SAME FAILURE MADE AS 3C-12-01.	ROAL	CEL
5-28-86	1752	3C-12-03 COMPLETE. U-BOLT BENT UNISTRUT CLOSED.  FRONT "U" BOLT BENT  CLAMP OF FRONT BOLT STARTED TO SLIP OFF "I" BEAM. BROKE FRONT "U" BOLT  AT 90° BENT AREA.	ODS	CEL
5-28-86	1906	3d-12-01 COMPLETE. OUTER "U" BOLT BENT.  BENT CLAMP, CLAMP SLIPPED. DURING TEST UNISTRUT COLLAPSED SIDE TO SIDE TOUCHING. INNER "U" BOLT SLIGHTLY BENT. 		

CONT. NEXT PAGE

Form Prepared By: [Signature]
 Form Approved By: [Signature]

Date: 5-21-86

Date: 5-21-86

MASTER TEST MONITOR LOG
CYCLIC AND STATIC TESTING OF TRAIN C CONDUIT
BEAM CLAMPS AND UNISTRUT® HANGERS

Client: Texas Utilities Generating CompanyCCL Project Number: 85-1903.23/24



DATE	TIME	TASK DESCRIPTION	TECH	TEST MON
5-28-86		3d-12-01 CONTINUED, FROM PREVIOUS PAGE. AFTER DISMANTLING SAMPLE, FIXTURE "I" BEAM HAD BEEN BENT BY INNER "U" BOLT & CLAMP.	ODB	EAB
5-28-86	20:40	3D-12-02 TEST COMPLETE. UNISTRUT SECTION FLANGES DEFORMED TOWARDS CENTER OF SECTION, BENT W-BOLT BEARING AREA. (SEE SKETCHS). ^{FOR} FROM LOAD BENT W-BOLT FURTHER FROM LOAD ATTACHMENT POINT AND ASSOCIATED CLAMP. I-BEAM OF TEST FIXTURE WAS WARPED DURING HIGHER LOADS. CLAMP WHICH BENT SLIPPED OFF OF TEST FIXTURE FIRST, FOLLOWED BY OTHER (UNDEFORMED) CLAMP.	IML	EAB

Form Prepared By: [Signature]Date: 5-21-86Form Approved By: [Signature]Date: 5-21-86

MASTER TEST MONITOR LOG
 CYCLIC AND STATIC TESTING OF TRAIN C CONDUIT
 BEAM CLAMPS AND UNISTRUT® HANGERS

Client: Texas Utilities Generating Company

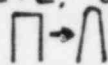
CCL Project Number: 85-1903.23/24

DATE	TIME	TASK DESCRIPTION	TECH	TEST MON
5-29-86	1108	3d-12-03 COMPLETE. OUTER U' BOLT BENT  COLASPED UNISTRUT. BENT 'I' BEAM, BENT OUTER U' BOLT  CLAMP SLIPPED & BENT. OUTER U' BOLT BROKE AT BEND.	ODB	CEK
5-29-86	16:15	3B-12-01 TEST COMPLETE. FORWARD LEG OF U-BOLT CLOSEST TO LOAD ATTACHMENT POINT SHEARED AFTER BEING PINCHED BETWEEN TEST FIXTURE AND UNISTRUT SECTION.	RHL	EAB
5-29-86	16:59	3B-12-02 TEST COMPLETE. FAILURE MODE SAME AS FOR TEST 3B-12-01.	RHL	EAB

Form Prepared By: 

Date: 5-21-86

Form Approved By: 

Date: 5-21-86

MASTER TEST MONITOR LOG
 CYCLIC AND STATIC TESTING OF TRAIN C CONDUIT
 BEAM CLAMPS AND UNISTRUT® HANGERS

Client: Texas Utilities Generating Company

CCL Project Number: 85-1903.23/24

DATE	TIME	TASK DESCRIPTION	TECH	TEST MON
5-29-86	19:32	^{RAC 5-29-86} A-38 <u>38-12-03</u> TEST COMPLETE. FAILURE MODE SAME AS 38-12-01.	RAC	WJ
5-29-86	22:40	38-24-01 TEST COMPLETE. SAMPLE CLAMPS SLIPPED ON TEST FIXTURE BUT DID NOT BREAK. TESTING ON THIS CONFIGURATION POSTPONED PENDING CONSULTATION WITH ENGINEERING PERSONNEL. HYDRAULIC CYLINDER RAN OUT OF STROKE BEFORE W-BOLT SHEARED.	RAC	EAB
5-30-86	1048	5a-01 COMPLETE. "U" BOLT OF CLAMP LEANED TOWARDS CYLINDER, CONDUIT DIPPED, CONDUIT SLIPPED. KNIFE OF CLAMP DUG INTO CONDUIT $\approx 1"$ SCRATCH. SHOULDERS OF CLAMP DUG IN $\approx 1"$. FOR NEXT, 5a-02 3K LOAD CELL 7015 WILL BE USED, SAMPLE RATE UP FROM 1HZ TO 3HZ.		
5-30-86	1058	DO NOT USE LOAD CELL 7007 UNTIL TESTED/CALIB.	ODB ODB	KJA KPA

Form Prepared By: Johnny H. Bond
 Form Approved By: Blair J.

Date: 5-21-86
 Date: 5-21-86

MASTER TEST MONITOR LOG
CYCLIC AND STATIC TESTING OF TRAIN C CONDUIT
BEAM CLAMPS AND UNISTRUT® HANGERS

Client: Texas Utilities Generating CompanyCCL Project Number: 85-1903.23/24

DATE	TIME	TASK DESCRIPTION	TECH	TEST MON
5-30-86	1345	FOR SAMPLE 5a-01 "I" BEAM DUG INTO CONDUIT, NOT KNIFE.	ODB	CEK
5-30-86	1346	5a-01 ⁰² COMPLETE. "U" BOLT LEANED TOWARDS CYLINDER, CONDUIT SLIPPED. "I" BEAM SCRATCHED CONDUIT THE LENGTH OF PULL, BUT DEEP FOR THE FIRST 3/4 INCH. SHOULDERS OF CLAMP DUG IN TO CONDUIT ≈ 1 ".	ODB	CEK
5-30-86	1450	5a-03 COMPLETE. RAN OUT OF ACQUISITION TIME, SHORT ≈ 10 SEC. AT 850 LBS. "U" BOLT LEANED TOWARDS CYLINDER. FAILED ≈ 2000 LBS. CONDUIT SLIPPED. CLAMP/KNIFE SLIPPED FROM "I" BEAM, KNIFE PULLED OUT OF CLAMP, A SAMPLE, 5a-04, WILL BE RAN.	ODB	CEK

Form Prepared By: J. H. BondDate: 5-21-86Form Approved By: [Signature]Date: 5-21-86

MASTER TEST MONITOR LOG
CYCLIC AND STATIC TESTING OF TRAIN C CONDUIT
BEAM CLAMPS AND UNISTRUT HANGERS

Client: Texas Utilities Generating CompanyCCL Project Number: 85-1903.23/24

DATE	TIME	TASK DESCRIPTION	TECH	TEST MON
5-30-86	1530	5a-04 COMPLETE. "U" BOLT LEANED TWARD CYLINDER, CONDUIT SLIPPED ≈ 1/2 INCH. CLAMP SLIPPED FROM "I" BEAM. KNIFE OF CLAMP ROTATED, SLIGHTLY.	ODB	CEK
5-30-86	1733	5a-05 COMPLETE. THIS SAMPLE WAS RAN BECAUSE OF THE LACK OF A PROP UNDER THE CONDUIT OF SAMPLE 5a-01. "U" BOLT LEANED TOWARDS THE CYLINDER. CONDUIT SLIPPED. CLAMP STAYED ON "I" BEAM.	ODB	CEK
5-30-86	21:44	3B-24-02 TEST COMPLETE. CLAMPS SLIPPED ON TEST FIXTURE UN- TIL HYDRAULIC CYLINDER RAN OUT OF STROKE.	RHL	WJG

Form Prepared By:

Jeffrey H. Bond

Date:

5-21-86

Form Approved By:

Blair J.

Date:

5-21-86

MASTER TEST MONITOR LOG
CYCLIC AND STATIC TESTING OF TRAIN C CONDUIT
BEAM CLAMPS AND UNISTRUT® HANGERS

Client: Texas Utilities Generating Company

CCL Project Number: 85-1903.23/24

DATE	TIME	TASK DESCRIPTION	TECH	TEST MON
5.30.86	22:21	BB-24-03 TEST COMPLETE. FAILURE MODE SAME AS FOR BB-24-02.	RHL	WMP
5.31.86	9:40	TEST DATA FROM 5.30.86 TRANSFERRED TO LOTUS WORK DISKS.	RHL	—
5.31.86	10:36	5C-01 TEST COMPLETE. LOAD CAUSED EYE OF CLAMP HOLDING U-BOLT TO BREAK.	RHL	WMP
5.31.86	11:02	5C-02 TEST COMPLETE. CLAMP BROKE ON A LINE BETWEEN EYES FOR U-BOLT. (SEE SKETCH)	RHL	KFT



Form Prepared By: J. H. Bond

Date: 5-21-86

Form Approved By: [Signature]

Date: 5-21-86

MASTER TEST MONITOR LOG
CYCLIC AND STATIC TESTING OF TRAIN C CONDUIT
BEAM CLAMPS AND UNISTRUT® HANGERS

Client: Texas Utilities Generating CompanyCCL Project Number: 85-1903.23/24

DATE	TIME	TASK DESCRIPTION	TECH	TEST MON
5-31-86	11:36	5C-03 TEST COMPLETE. FAILURE MODE SAME AS FOR 5C-02 PLUS KEY FELL OUT OF CLAMP.	RHL	KFA
5-31-86	14:36	5B-01 TEST COMPLETE. CLAMP SLID ON TEST FIXTURE. LOAD CELL 7015 WILL BE USED IN PLACE OF LOAD CELL 7018.	RHL	KFA
5-31-86	17:01	5B-02 TEST COMPLETE. CLAMP SLID ON TEST FIXTURE.	RHL	KFA
5-31-86	2141	RAN POST CALIBRATION/SCALE FACTORS FOR ALL TRANSDUCERS, USED/INBOX, & AMPS. SEE CALIB. LOG.	ODB	—
6-2-86	1010	RAN POST CHECK ON LUBRICANTS	ODB	—

Form Prepared By:

Johnny H. Bond

Date:

5-21-86

Form Approved By:

Blair J.

Date:

5-21-86

MASTER TEST MONITOR LOG
 CYCLIC AND STATIC TESTING OF TRAIN C CONDUIT
 BEAM CLAMPS AND UNISTRUT® HANGERS

Client: Texas Utilities Generating Company

CCL Project Number: 85-1903.23/24

DATE	TIME	TASK DESCRIPTION	TECH	TEST MON
6-28-86	14:25	SB-03 TEST COMPLETE. CLAMP SLIPPED ON TEST FIXTURE.	RHL	EAB
6-3-86	15:42	11A-01 TEST COMPLETE. CLAMP SLIPPED ON TEST FIXTURE.	RHL	EAB
6-3-86	16:08	11A-02 TEST COMPLETE. FAILURE MODE SAME AS TEST 11A-01. LOAD CELL DATA ACQUISITION VOLTAGE RANGE CHANGED TO 2 VOLTS FOR THIS TEST.	RHL	EAB
6-3-86	16:42	11A-03 TEST COMPLETE. FAILURE MODE SAME AS TEST 11A-01.	RHL	EAB

Form Prepared By: Jerry H. Bond
 Form Approved By: [Signature]

Date: 5-21-86
 Date: 5-21-86

MASTER TEST MONITOR LOG
CYCLIC AND STATIC TESTING OF TRAIN C CONDUIT
BEAM CLAMPS AND UNISTRUT® HANGERS

Client: Texas Utilities Generating Company

CCL Project Number: 85-1903.23/24

DATE	TIME	TASK DESCRIPTION	TECH	TEST MON
6.3.86	17:31	11B01 TEST COMPLETE. CLAMP BENT NEAR U-BOLT HOLES, SLIPPED OFF OF CHANNEL. VOLTAGE RANGE FOR SUBSEQUENT 11B- TESTS WILL BE REDUCED TO THE 2 VOLT RANGE FOR LOAD CELL DATA.	RWC	KFA
6.3.86	17:52	11B-02 TEST COMPLETE. FAILURE MODE SAME AS TEST 11B-01. DISREGARD LOAD DATA AFTER TEST SAMPLE FAILURE; SPAN READING FOR LOAD CELL INADVERTENTLY TAKEN BEFORE COMPUTER HAD DATA ^{DATA} CLOSED TAKING DATA. 6.3.86	RWC	KFA
6.3.86	18:33	11B-03 ^{11B-05} TEST COMPLETE. FAILURE MODE SAME AS FOR 11B-01.	RWC	EA13

Form Prepared By: John H. Bond

Date: 5-21-86

Form Approved By: [Signature]

Date: 5-21-86

MASTER TEST MONITOR LOG
 CYCLIC AND STATIC TESTING OF TRAIN C CONDUIT
 BEAM CLAMPS AND UNISTRUT HANGERS

Client: Texas Utilities Generating Company

CCL Project Number: 85-1903.23/24

DATE	TIME	TASK DESCRIPTION	TECH	TEST MON
6.3.86	19:28	2C-12-04 TEST COMPLETE. FLANGES OF UNISTRUT SECTION COLLAPSED TO MIDDLE OF CHANNEL. SQUARED OFF END OF U-BOLT WAS ROUNDED OUT BY FLANGES. CLAMP BENT ALONG LINE BETWEEN U-BOLT HOLES AND SLIPPED OFF OF TEST FIXTURE. U-BOLT BENT ON CLAMP NEAREST LOAD ATTACHMENT POINT. SEE TESTS 2C-12-01 THROUGH 2C-12-03, 6-23-86.	RHL	EAB
6.3.86	20:20	2C-12-05 TEST COMPLETE. FAILURE MODE SAME AS TEST 2C-12-04. DATA ACQUISITION VOLTAGE RANGE REDUCED FROM 20VOLTS TO 2 VOLTS FOR THIS AND SUBSEQUENT 2C-12 TEST.	RHL	EAB
6.3.86	21:00	2C-12-06 TEST COMPLETE. FAILURE MODE SAME AS TEST 2C-12-04.	RHL	EAB

Form Prepared By: [Signature]
 Form Approved By: [Signature]

Date: 5-21-86
 Date: 5-21-86

MASTER TEST MONITOR LOG
 CYCLIC AND STATIC TESTING OF TRAIN C CONDUIT
 BEAM CLAMPS AND UNISTRUT HANGES

Client: Texas Utilities Generating Company

CCL Project Number: 85-1903.23/24

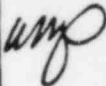
DATE	TIME	TASK DESCRIPTION	TECH	TEST MON
6.5.86	17:19	9C-01 TEST COMPLETE. VERTICAL UNISTRUT SECTION TWISTED CLOCKWISE AS LOAD INCREASED. THIS TWIST ^{WAS} PULLED THE HILT BOLTS UP ^{FROM} FROM THEIR ORIGINAL POSITION. LOWER BOLT ON CANTILEVER SECTION PULLED SPRING NUT THROUGH UNISTRUT SECTION FLANGES, THEN FOOT OF CANTILEVER BENT AT UPPER CANTILEVER BOLT. JEFF BOND RECOMMENDED GUIDES TO RESTRAINT THE SAMPLE IN ONE VERTICAL PLANE FOR SUBSEQUENT '9C' TESTS.	EMC	

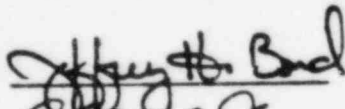
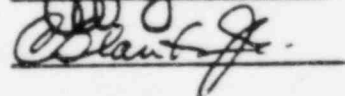
Form Prepared By: 
 Form Approved By: 

Date: 5-21-86

Date: 5-21-86

MASTER TEST MONITOR LOG
CYCLIC AND STATIC TESTING OF TRAIN C CONDUIT
BEAM CLAMPS AND UNISTRUT® HANGERS

Client: Texas Utilities Generating CompanyCCL Project Number: 85-1903.23/24

DATE	TIME	TASK DESCRIPTION	TECH	TEST MON
6-5-86	21:34	<p>9C-02 TEST COMPLETE. UNISTRUT FEA SECTION MOUNTED TO CONCRETE 6-5-86 DEFORMED; SECTION FLANGES BY HILTI BOLT NEAREST LOAD DIRECTION DISTORTED INWARD, SECTION WAS BENT BY HILTI BOLT. SAME HILTI BOLT PULLED OUT OF CONCRETE ABOUT 1/4". FOOT OF VERTICAL SECTION BENT. FOOT OF CANTILEVER SECTION BENT BEFORE LOWER SPRING NUT BAR THROUGH LIPS OF VERTICAL SECTION FLANGES. WELD BETWEEN FOOT AND TENSIONED SIDE OF VERTICAL MEMBER CRACKED. ALSO, THERE WAS SEPARATION OF THE P100 CHANNELS OF PART P2546 WHERE THE LOWER CANTILEVER SPRING NUT PULLED OUT. TEST WAS RUN USING GUIDES TO RESTRAIN SAMPLE TO ONE VERTICAL PLANE. CANTILEVER WAS BEARING ON RIGHT GUIDE (AS SEEN LOOKING AT SAMPLE WITH CANTILEVER FREE END CLOSEST TO OBSERVER)</p>		

Form Prepared By: Jeffrey H. BondDate: 5-21-86Form Approved By: Blair J.Date: 5-21-86

MASTER TEST MONITOR LOG
CYCLIC AND STATIC TESTING OF TRAIN C CONDUIT
BEAM CLAMPS AND UNISTRUT® HANGERS

Client: Texas Utilities Generating Company

CCL Project Number: 85-1903.23/24

DATE	TIME	TASK DESCRIPTION	TECH	TEST MON
6-5-86	21:26	<p>9C-02 (CONTINUED)</p> <p>UNTIL ROTATION OF CANTILEVER HAD DISPLACED CANTILEVER LENGTH ENOUGH FROM BETWEEN GUIDES TO ALLOW MORE TORSIONAL ROTATION IN CLOCKWISE DIRECTION. (CLOCKWISE ROTATION FROM PLAN VIEW.)</p> <p>LOWER CANTILEVER SPRING NUT PULLED ^{OUT} AFTER MAXIMUM ROTATION.</p>	IZAL	EAB
6-6-86	1039	<p>9C-03 COMPLETE. DEFORMED FAILURE STARTED AT POINT ① GRIPPING & BENDING OF LIPOF UNISTRUT. THEN PULLING AT POINTS ② & ②B. PULLED NUTS SLIGHTLY & DEFORMED UNISTRUT HOLE AT ②B.</p> <p>CONT. NEXT PAGE</p>		

Form Prepared By: Jeffrey H. Bond
Form Approved By: Blair J.

Date: 5-21-86
Date: 5-21-86

MASTER TEST MONITOR LOG
CYCLIC AND STATIC TESTING OF TRAIN C CONDUIT
BEAM CLAMPS AND UNISTRUT® HANGERS

Client: Texas Utilities Generating Company

CCL Project Number: 85-1903.23/24

DATE	TIME	TASK DESCRIPTION	TECH	TEST MON
6-6-86	CONT	9C-03 CONT. THEN COLLAPSED UNISTRUT AT POINT ③. THEN DEFORMED UNISTRUT AT POINT ④. (UNISTRUT NUT). FAILURE TORE UNISTRUT LIPS AT POINT ⑤/①. PULLED SPRING NUT THROUGH. BENT FOOT OF HANGER AT POINT ⑥. AT BOLT.	CDB	KFA
6-6-86	15:28	<p>CALL 6-9-86</p> <p>9B-01</p> <p>9B-01 TEST COMPLETE. SAMPLE WAS SHOCK LOADED - TEST DATA IS INVALID. SAMPLE WAS RUN TO FAILURE AFTER DATA ACQUISITION SYSTEM WAS OUT OF ^{THE} THE SAMPLING TIME.</p> <p>APPROXIMATE LOAD AT FAILURE WAS 2400 LBS. UNISTRUT SECTION ^{CALL} WAS ATTACHED TO CONCRETE FAILED WHERE REINFORCED BOLT AND SPRING NUT HOLDING</p>		

Form Prepared By: [Signature]
Form Approved By: [Signature]

Date: 5-21-86
Date: 5-21-86

MASTER TEST MONITOR LOG
CYCLIC AND STATIC TESTING OF TRAIN C CONDUIT
BEAM CLAMPS AND UNISTRUT® HANGERS

Client: Texas Utilities Generating CompanyCCL Project Number: 85-1903.23/24

DATE	TIME	TASK DESCRIPTION	TECH	TEST MON
6.6.86	(CONT.)	(QB-01 CONTINUED) VERTICAL FOOT HANGER WAS ATTACHED. SPRING NUT PULLED THROUGH FLANGE LIPS. A QB-04 WILL BE RUN.	RHL	KFA
6.6.86	16:39	QB-02 TEST COMPLETE. UNISTRUT SECTION ATTACHED TO CONCRETE BLOCK LIFTED UP, PULLING REARWARD HILTI BOLT OUT OF CONCRETE ABOUT 1/4". WELDS ON FOOT OF VERTICAL SECTION FIPPED, ^{OR} NEAR SEPARATION EXTENDING ALMOST TO CENTERLINE OF VERTICAL SECTION.	RHL	KFA
6.6.86	16:50	HYDRAULIC CYLINDER IS RIGIDLY ATTACHED TO TEST SAMPLE CONDUIT FOR ^{RHL} QB QB-02 AND SUBSEQUENT 'QB' TESTS.	RHL	KFA

Form Prepared By:

John H. Bond
Plant

Date: 5-21-86

Form Approved By:

Date: 5-21-86

MASTER TEST MONITOR LOG
 CYCLIC AND STATIC TESTING OF TRAIN C CONDUIT
 BEAM CLAMPS AND UNISTRUT® HANGERS

Client: Texas Utilities Generating Company

CCL Project Number: 85-1903.23/24

DATE	TIME	TASK DESCRIPTION	TECH	TEST MON
6-6-86	17:44	9D-03 TEST COMPLETE. FAILURE MODE SAME AS TEST 9B-02. LOAD CELL 7007 (5K LBS) WAS SUBSTITUTED FOR LOAD CELL 7012 (15K LBS.).	RAL	KFA
6-6-86	18:19	9B-04 TEST COMPLETE. UNISTRUT SECTION ATTACHED TO CONCRETE PULLED UP REARWARD HILT BOLT ABOUT 3/8". LIPS ON UNISTRUT FLANGES WERE RIPPED OUT BY SPRING NUT HOLDING VERTICAL SECTION TO HORIZONTAL SECTION.	RAL	KFA

Form Prepared By: [Signature]
 Form Approved By: [Signature]

Date: 5-21-86
 Date: 5-21-86

MASTER TEST MONITOR LOG
 CYCLIC AND STATIC TESTING OF TRAIN C CONDUIT
 BEAM CLAMPS AND UNISTRUT® HANGERS

Client: Texas Utilities Generating Company

CCL Project Number: 85-1903.23/24

DATE	TIME	TASK DESCRIPTION	TECH	TEST MON
6-7-86	10:50	PERFORMED CALIBRATION ON LOAD CELL 7038 FOR USE ON TEST 6-01. LTN SCALE FACTOR = 999.72238 LBS/V.	RHL	KFD
6-7-86	11:08	TEST 6-01 COMPLETE. CANTILEVER SECTION LEANED ⁸⁴⁶ 846 IN LOAD DIRECTION, DEFORMING CONDUIT CLAMP AND ROLLING OVER UNISTRUT SECTION ATTACHED TO CONCRETE. HILT BOLTS PULLED OUT OF CONCRETE ABOUT 1/4".	RHL	KFD

Form Prepared By: J. H. Bond
 Form Approved By: [Signature]

Date: 5-21-86
 Date: 5-21-86

MASTER TEST MONITOR LOG
CYCLIC AND STATIC TESTING OF TRAIN C CONDUIT
BEAM CLAMPS AND UNISTRUT® HANGERS

Client: Texas Utilities Generating Company

CCL Project Number: 85-1903.23/24

DATE	TIME	TASK DESCRIPTION	TECH	TEST MON
6-7-86	13:05	6-02 TEST COMPLETE. CONDUIT CLAMP DEFORMED, GAPS BETWEEN FEET OF CLAMP AND CANTILEVER DEVELOPED DURING PULL. UNISTRUT SECTION ATTACHED TO CONCRETE ^{RHC} CONCRETE BENT AT BT ^{RHC} MULTI BOLT 6-7-86 HOLE. HOLTE BOLTS SNAPPED OFF AT FAILURE. CONDUIT CLAMP ATTACHMENT POINT REDUCED TO 12 1/2" ABOVE CONCRETE SURFACE FROM 22 3/4" (FOR TEST 6-01).	RHC	KAT
6-7-86	14:14	7-01 TEST COMPLETE. CONDUIT CLAMP DEFORMATION SIMILAR TO TEST 6-01 AND 6-02. UNISTRUT SECTION ATTACHED TO CONCRETE ^{RHC} CONCRETE 6-7-86. ROLLED, SNAPPED ONE HILTI BOLT, PULLED OTHER HILTI OUT OF CONCRETE ABOUT 1/4". CANTILEVER TURNED IN CLAMPS SLIGHTLY.	RHC	KAT

Form Prepared By: [Signature]
Form Approved By: [Signature]

Date: 5-21-86
Date: 5-21-86

MASTER TEST MONITOR LOG
CYCLIC AND STATIC TESTING OF TRAIN C CONDUIT
BEAM CLAMPS AND UNISTRUT® HANGERS

Client: Texas Utilities Generating CompanyCCL Project Number: 85-1903.23/24

DATE	TIME	TASK DESCRIPTION	TECH	TEST MON
6-7-86	14:52	6-03 TEST COMPLETE. FAILURE MODE AND TEST SETUP SAME AS 6-02, EXCEPT ONLY ONE HILTI BOLT SNAPPED OFF FOR 6-03.	RHC	KFA
6-7-86	16:06	9A-01 TEST COMPLETE. UNISTRUT CONNECTED TO CONCRETE BOLDED, PULLING HILTI BOLTS UP ABOUT 1/4". P2542 WAS TWISTED AS SAMPLE WAS PULLED; HYDRAULIC CYLINDER WAS RIGIDLY ATTACHED TO CONDUIT.	RHC	KFA

Form Prepared By: J. H. BondDate: 5-21-86Form Approved By: [Signature]Date: 5-21-86

MASTER TEST MONITOR LOG
CYCLIC AND STATIC TESTING OF TRAIN C CONDUIT
BEAM CLAMPS AND UNISTRUT® HANGERS

Client: Texas Utilities Generating CompanyCCL Project Number: 85-1903.23/24

DATE	TIME	TASK DESCRIPTION	TECH	TEST MON
6-9-86	12:00	9A-02 TEST COMPLETE. CONDUIT CLAMP DEFORMED, TWISTED CANTILEVERED ARM, ROLLED OVER UNISTRUT SECTION ATTACHED TO CONCRETE. BOLT HOLES IN UNISTRUT SECTION DEFORMED, ^{RAC} HILTI BOLT SNAPPED. MOMENT ^{6.9.2} ARM DECREASED 10 1/2 INCHES FROM TEST 9A-01.	RAC	WJ
6-9-86	13:50	7-02 TEST COMPLETE. CONDUIT CLAMP DEFORMED, UNISTRUT ATTACHED TO CONCRETE PULLED, PULLED BOTH HILTI BOLTS UP ABOUT 1/4", SNAPPED BOLTS OFF.	RAC	COX

Form Prepared By: *Jeffrey H. Bond*Date: 5-21-86Form Approved By: *Blair J.*Date: 5-21-86

MASTER TEST MONITOR LOG
CYCLIC AND STATIC TESTING OF TRAIN C CONDUIT
BEAM CLAMPS AND UNISTRUT® HANGERS

Client: Texas Utilities Generating Company

CCL Project Number: 85-1903.23/24

DATE	TIME	TASK DESCRIPTION	TECH	TEST MON
6-9-86	14:46	7-03 TEST COMPLETE. TEST PROCEEDED NORMALLY UNTIL WELD BETWEEN CONDUIT AND TEST FIXTURE MOUNTED ON HYDRAULIC CYLINDER FAILED. TEST DECLARED INVALID. A FOURTH TEST CONFIGURATION WILL BE RUN.	RNL	CEL
6-9-86	1801	9a-03 COMPLETE. CONDUIT SLIGHTLY SLIPPED. THE HOLE SAMPLE LEANED AT HILTIES TOWARD CYLINDER. CONDUIT REMAINING \pm STRAIGHT. HILTIE FAILURE UNDER CANTILEVERED ARM, BROKE AT CONCRETE. BENT/TWISTED CANTILEVERED ARM & BENT CONDUIT CLAMP BOLTS.	ODB	CEL

Form Prepared By: *Johnny H. Bond*
 Form Approved By: *Blair J.*

Date: 5-21-86
 Date: 5-21-86

MASTER TEST MONITOR LOG
CYCLIC AND STATIC TESTING OF TRAIN C CONDUIT
BEAM CLAMPS AND UNISTRUT® HANGERS

Client: Texas Utilities Generating CompanyCCL Project Number: 85-1903.23/24

DATE	TIME	TASK DESCRIPTION	TECH	TEST MON
6-9-86	21:05	<p>9C-04 TEST COMPLETE. SAMPLE TWISTED, UNISTRUT ATTACHED TO CONCRETE. LIFTED HULTI BOLT OUT OF CONCRETE ABOUT 1/4", HORIZONTAL CANTILEVER'S ^{TOP} SP ₆₋₉₋₈₆ LOWER SPRING NUT DEFORMED LIPS OF UNISTRUT CHANNEL. SEPARATION OF VERTICAL CANTILEVER'S SECTION NEAR SPRING NUTS OF HORIZONTAL CANTILEVER. ALSO DEFORMATION OF LIPS OF UNISTRUT ATTACHED TO CONCRETE. NO REDUCTION OF LOAD BEFORE TEST STOPPED TO PREVENT DAMAGE TO LINEAR POT. LOAD CELL WENT PASS ^{OVER} _{WITH} 5K LOAD.</p> <p>TEST FIXTURE WILL BE MODIFIED TO PREVENT ROTATION OF SAMPLE FOR SUBSEQUENT TESTS. LOAD CELL 7023 WILL BE PUT IN PLACE OF LOAD CELL 7038. 7023 HAS 10K LBS. RANGE. <u>TEST INVALID</u>.</p>	RHL	EAB

Form Prepared By:

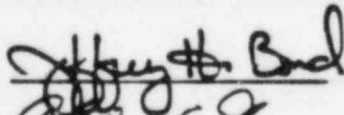
Date: 5-21-86

Form Approved By:

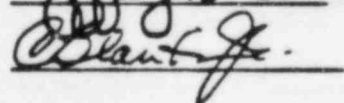
Date: 5-21-86

MASTER TEST MONITOR LOG
 CYCLIC AND STATIC TESTING OF TRAIN C CONDUIT
 BEAM CLAMPS AND UNISTRUT® HANGERS

Client: Texas Utilities Generating Company

CCL Project Number: 85-1903.23/24

DATE	TIME	TASK DESCRIPTION	TECH	TEST MON
6-9-86 <i>6-10-86</i>	23:18	9C-05 TEST COMPLETE. WELDED FOOT OF HORIZONTAL CANTILEVER BENT, WELD BETWEEN FOOT AND STRUT RIPPED. HORIZONTAL CANTILEVER BEGAN BEARING ON UNISTRUT GUIDES 1 MINUTE, 28 SECONDS INTO TEST. SAMPLE CONTINUED TO TWIST UNTIL FAILURE.	RAL	EAB
6-9-86 <i>6-10-86</i>	22:50	RAN CALIBRATION ON LOAD CELL 7023 FOR USE IN TEST 9C-05.	RAL	—
6-10-86	940	9C-06 TEST ABORTED, INNER SPRING NUT OF P2546 NOT ENGAGED INTO UNISTRUT, TORQUED. P2546 FOOT SLIGHTLY BENT. SAMPLE WILL CONTINUE WITH SPRING NUT REPOSITIONED FILE NAME (DATA) 9C06A.	ODB	KFA

Form Prepared By: *Jeffrey H. Bond*
 Form Approved By: *Blair J.*

Date: 5-21-86
 Date: 5-21-86

MASTER TEST MONITOR LOG
 CYCLIC AND STATIC TESTING OF TRAIN C CONDUIT
 BEAM CLAMPS AND UNISTRUT® HANGERS

Client: Texas Utilities Generating Company

CCL Project Number: 85-1903.23/24

DATE	TIME	TASK DESCRIPTION	TECH	TEST MON
6-10-86	10:16	9C-06A COMPLETE. REUSED P2542 FROM 9A-01. SAMPLE LEANED, PULLED/BOWED UP UNISTRUT FROM CONCRETE. COLLAPSED UNISTRUT ON CONCRETE, PULLED MILTI. SAMPLE TWISTED BENDING P2542 FOOT. UNISTRUT P2546 SPRING NUT PULLED LIPS OF UNISTRUT. P2546 SPRING NUT PULLED LIPS OF P2542. RIPPED WELDS OF FOOT OF P2542.	ODB	KFA
6-11-86	13:24	1a-01 complete: sample completed 100 cycles with no apparent visible damage. The 2 nd & 100 th cycles were recorded on x-y plotter. Little if any change in the load vs. displacement curve was noticed. In the future, each curve will be recorded on separate sheets of paper	unf	KFA

Form Prepared By: J. H. Bond
 Form Approved By: Blantje

Date: 5-21-86
 Date: 5-21-86

MASTER TEST MONITOR LOG
 CYCLIC AND STATIC TESTING OF TRAIN C CONDUIT
 BEAM CLAMPS AND UNISTRUT HANGERS

Client: Texas Utilities Generating Company

CCL Project Number: 85-1903.23/24

DATE	TIME	TASK DESCRIPTION	TECH	TEST MON
6-11-86	16:25	1a-02 complete: sample completed 100 cycles with 1004 lbs. of vertical load. No visible signs of damage. The 1 st , 50 th and 100 th cycles were recorded on x-y platter, on separate pieces of paper.	RWB	UMP
6-11-86	18:16	1a-03 complete: sample completed 100 cycles with 1004 lbs. of vertical load. No signs of damage. 1 st , 50 th and 100 th cycles recorded on x-y platter, on separate pieces of paper. Test ran at 10 m ^y /in.	RWB	KFA

Form Prepared By:

Wayne H. Bond

Date: 5-21-86

Form Approved By:

Blair J.

Date: 5-21-86

MASTER TEST MONITOR LOG
CYCLIC AND STATIC TESTING OF TRAIN C CONDUIT
BEAM CLAMPS AND UNISTRUT® HANGERS

Client: Texas Utilities Generating CompanyCCL Project Number: 85-1903.23/24

DATE	TIME	TASK DESCRIPTION	TECH	TEST MON
6-12-86	1444	PAN CALIB./SCALE FACTOR FOR LOAD CELL 7007 SEE CALIB. FILE ²	ODB	CEL
6-12-86	15:01	1b-01 complete: sample completed 100 cycles with no signs of damage. No vertical load was attached to sample 1 st and 100 th cycle were recorded on separate pieces of paper. Test ran at 10 ^{mv} /in.	RMB	KA
6-12-86	1515	9C-07 COMPLETE. SAMPLE LEANED BACK. PICKED-UP UNISTRUT FROM CONCRETE (BOND) SAMPLE TWISTED TO SIDE. COLLAPSED UNISTRUT & PULLED, SLIGHTLY, HILT. P2542 PULLED SPRING NUT (LOWER) OUT OF P2546 CHANNEL. P2546 BENT & SEPARATED. CONTROL/STOP BUTTON WAS RELEASED AT FIRST SIGN OF SPRING NUT/CHANNEL FAILURE THEN PRESSED BY ACCIDENT.	ODB	CEK

Form Prepared By: Henry H. BondDate: 5-21-86Form Approved By: Clayton J.Date: 5-21-86

MASTER TEST MONITOR LOG
 CYCLIC AND STATIC TESTING OF TRAIN C CONDUIT
 BEAM CLAMPS AND UNISTRUT® HANGERS

Client: Texas Utilities Generating Company

CCL Project Number: 85-1903.23/24

DATE	TIME	TASK DESCRIPTION	TECH	TEST MON
6-12-86	16:54	16-02 complete: sample completed 100 cycles with 1004 lbs. of vertical load. 1st, 50th and 100th cycles were recorded on separate pieces of paper. After disassembling test sample the jaws of the clamp had spread apart approx. 1/8". Test ran at 10 mv/in.	EBB	KFA
6-12-86	1740	7-04 COMPLETE. SAMPLE LEANED TOWARDS CYLINDER. BENT/BOWED UNISTRUT FROM CONCRETE. BROKE HILT1, BENT OTHER HILT1. TWISTED CLAMP.	ODB	CEC

Form Prepared By: Jeffrey H. Bond
 Form Approved By: Blair J.

Date: 5-21-86

Date: 5-21-86

MASTER TEST MONITOR LOG
CYCLIC AND STATIC TESTING OF TRAIN C CONDUIT
BEAM CLAMPS AND UNISTRUT® HANGERS

Client: Texas Utilities Generating Company

CCL Project Number: 85-1903.23/24

DATE	TIME	TASK DESCRIPTION	TECH	TEST MON
6-12-86	18:32	16-03 complete. Sample completed 100 cycles with 1004 lbs of vertical load. 1 st , 50 th , and 100 th cycles were recorded on separate pieces of paper. after 100 cycle, jaws of clamp had spread open about 1/16". Test ran at 10mV/in.	RHB	WMP
6-12-86	11:51	10C-12-01 TEST COMPLETE. UNISTRUT PS500 SECTION'S FLANGES DEFLECTED ^{RHC 6-13-86} TOWARDS CENTER OF SECTION UNDER U-BOLT CLOSEST TO LOAD ATTACHMENT POINT. CLAMP ATTACHED TO SAME U-BOLT SLIPPED OFF OF TEST FIXTURE. U-BOLT NUTS TORQUED USING TORQUE TRANSDUCER 7026, DATRONIC 1062. TORQUE WRENCH ^{RHC 6-12-86} 9030 USUALLY USED TO TORQUE NUTS ^{OUT OF SERVICE.} _{RHC 6-12-86}	RHC	CEK

Form Prepared By: [Signature]
Form Approved By: [Signature]

Date: 5-21-86

Date: 5-21-86

MASTER TEST MONITOR LOG
 CYCLIC AND STATIC TESTING OF TRAIN C CONDUIT
 BEAM CLAMPS AND UNISTRUT® HANGERS

Client: Texas Utilities Generating Company

CCL Project Number: 85-1903.23/24

DATE	TIME	TASK DESCRIPTION	TECH	TEST MON
6-13-86	13:41	<p>10C-12-02 TEST COMPLETE. FLANGES OF UNISTRUT SECTION DEFLECTED TOWARDS CENTER OF SECTION UNDER U-BOLT CLOSEST TO LOAD ATTACHMENT POINT. CLAMP ON SAME U-BOLT BENT AND SLIPPED OFF OF TEST FIXTURE. U-BOLT BENT BEHIND CLAMP. (SEE SKETCH).</p> <div style="text-align: center;">  <p>U-BOLT</p> </div>	RHZ	CEK

Form Prepared By: [Signature]
 Form Approved By: [Signature]

Date: 5-21-86
 Date: 5-21-86

MASTER TEST MONITOR LOG
 CYCLIC AND STATIC TESTING OF TRAIN C. CONDUIT
 BEAM CLAMPS AND UNISTRUT® HANGERS

Client: Texas Utilities Generating Company

CCL Project Number: 85-1903.23/24

DATE	TIME	TASK DESCRIPTION	TECH	TEST MON
6-13-86	14:07	100-12-03 TEST COMPLETE. FAILURE MODE SAME AS 100-12-02.	RHL	CEK
7-9-86	852	ALL LVDT'S AND LINEAR POT.'S HAVE BEEN "POST TEST CALIBRATED". ALL LOAD CELL'S HAVE HAD ALL POST SCALE FACTOR RUNS VERIFIED, (FOR LTN USE), COMPARED TO LAST USED SCALE FACTOR.	ODB	—

Form Prepared By: J. H. Bond
 Form Approved By: Diante J.

Date: 5-21-86
 Date: 5-21-86

APPENDIX E

TEST SETUP FIGURES, PLOTS, DATA, AND PHOTOGRAPHS

(UNDER SEPARATE COVER)

2 Volumes