

ANALYSIS OF INTERMEDIATE COVER
SIZE 3", TYPE JHF, 11 STAGE PACIFIC PUMP
SAFETY INJECTION SERVICE
SHOP ORDERS J-49738 AND J-49871
SERIAL NUMBERS 51667/668 AND 51928/929
TEXAS UTILITIES - COMANCHE PEAK 1 AND 2

By:



Lloyd D. Hanson, P.E.
Senior Design Engineer
Pacific Pumps Division
Dresser Industries, Inc.

Date:

January 11, 1983

8406130111 830201
PDR ADOCK 0500044J
S PDR

TABLE OF CONTENTS

<u>Section 1:</u>	Contents
<u>Section 2:</u>	Discussion
<u>Section 3:</u>	Stress Analysis
<u>Section 4:</u>	Phase I Metallurgical Report (June 15, 1982)
<u>Section 5:</u>	Phase II Metallurgical Report (November 18, 1982)
<u>Section 6:</u>	Reference Material <ul style="list-style-type: none">- Assembly Drawing- Outline Drawing- Pump Photo (typical)- Intermediate Cover Photo- Performance Curves
<u>Section 7:</u>	- Indication Survey
<u>Section 8:</u>	- Installation Lists
<u>Section 9:</u>	- Field Recommendations

DISCUSSION OF LINEAR INDICATIONS AND THEIR EFFECT ON PUMP OPERABILITY

Visible linear indications on the shroud separating and supporting the diffuser vanes and return guide vanes have been found in the JHF type pumps supplied to Texas Utilities - Comanche Peak Station. These indications exceeded the inspection maximum of 1/16" (beyond which an internal rejected material report (RMR) and engineering disposition is required) and ranged in surface size from 1/8 inch to in excess of 1 inch*. It is our opinion that these indications resulted from casting processes and have always been present in the castings and in no way affect the operability of the pumps. They are merely more visible now due to the operational testing and subsequent cleaning operations of the pumps.

Since we now know of these inspection findings, an RMR has been written on the element from pump serial number 51667 and others and given the engineering disposition "USE AS IS". The purpose of this document is to support that disposition and show that these indications do not effect the operation of the pumps. The specific considerations are as follows:

1. The cause of the indications is well understood.
2. The stress levels in the part are quite low.
3. These parts are designed and manufactured the same way as thousands of nearly identical parts used in similar pumps without failure.
4. The arrangement of the pump is such that even should a shroud be broken in two, the pieces are constrained so that they would continue to function in channeling the fluid flow and would not interfere with the operation of the pump.

*NOTE: The dimensions given above are the lengths as they appear on the curved surface. The depth as discussed in the Field Recommendations never exceeded 1/2" in the radial direction. (See Section 9.)

DISCUSSION OF LINEAR INDICATIONS AND THEIR EFFECT ON PUMP OPERABILITY

-1-

The indications seen on these intercovers are examples of casting process effects. As such, they are associated with the original solidification and cooling of the casting. Our experience in the use of castings of these alloys is that such indications are common and are quite often seen during receiving inspection of raw castings. Once the parts have cooled and are properly heat treated, no driving force remains to cause new or extend the existing indications. Included in Section 4 of this report is a report by our metallurgical consultant which presents evidence to support the conclusion drawn above.

-2-

The complex geometry in the region of the part where the indications are found necessitated the use of the finite element method to calculate the stresses. A discussion of this analysis and the results are presented in Section 3 of this report. Basically, it is our opinion that these low stresses cannot cause crack initiation or propagation in these parts. Section 5 of this report is a second report by our metallurgical consultant which uses the stresses we have calculated along with load history data obtained from the N.S.S.S. supplier to analyze crack propagation and life projections using the methods of fracture mechanics. This analysis supports the opinion expressed above and the resulting conclusion that the integrity of these parts is not affected by the presence of the indications. One additional consideration is that the primary stress causing load, the hydrostatic end force, varies from a minimum at the 11th stage and is maximum at the 1st stage. Assuming that the indications are caused or made worse by operating stress, then the parts having the greatest number of indications would be in the first few stages. This is not the case. Instead, the list in Section 7 shows a random distribution of indications.

-3-

Pacific Pumps has designed and built pumps having essentially identical diffuser/intercover design for more than 30 years. The materials used for these pump parts have included cast iron, bronze, and various steels including the martensitic stainless steel used for these parts. No failure has occurred in these pumps due to material failure in the diffuser intercover shroud. Section 8 of this report includes lists of operating pumps with similar internal construction.

DISCUSSION OF LINEAR INDICATIONS AND THEIR EFFECT ON PUMP OPERABILITY

-4-

As discussed in the stress calculations, during operation these parts are pressed together by hydrostatic forces so that the end face of each diffuser blade is loaded in compression. Fractures in the shrouds yielding pieces that included diffuser vanes would be held in place by these compressive loads and the return passage vane which is integrally cast between the shroud and the thick section of the intercover. It is not plausible that a piece could break off between blades since such a piece would have a negligibly small load on it.

It is our opinion that the above discussion and associated attachments are sufficient to justify the use of these parts as is. We recommend that these elements be reassembled and returned to service. In addition, Section 9 of this report presents some recommendations for field inspection and criteria for further action.

SECTION III

STRESS ANALYSIS

In this section we will review the loads carried by the 3" JHF pump intermediate cover and present the results of a finite element stress analysis. The purpose of this work was both to show the generally low condition of stress in the area of the indications and to provide data which could be used in a fracture mechanics analysis. This analysis is documented in Mettek Report #220431-2, dated November 18, 1982, with the results that it is likely that the indications are below the threshold for propagation and are conservatively below any failure criterion over the service life of the pump.

The next page is a sketch of the intermediate cover. Referring to this sketch and the pump assembly drawing included in Section 6, we can discuss the loads on the part. These covers are assembled at the same time as the impellers to form an internal element bundle which is then placed between the upper and lower halves of the pump case.

The water enters the first stage impeller (part #C001 on the left side of the assembly drawing) and is pumped to higher pressure levels at each stage. As a result each "cover" (see sketch) has one stage of differential pressure across it. It becomes, in effect, a piston hydrostatically loaded by the pressure buildup of the pump. This load is carried by the return guide vane, shroud, and diffuser vane into the next lower stage cover (or into the case at the first stage).

This is the only significant source of load on these parts; however, we have considered this load to be made up of two superimposed components. First, is a "static" component represented by the required design pressure increase in each stage of approximately 145 psi. Second, is a high frequency dynamic component caused by the blade passage of the impeller. Experience shows this to be typically 1% of the developed pressure but for our purposes we used an upper bound of 3%. Since the loads accumulate from stage to stage, we have performed the finite element analysis assuming that the full pump differential pressure of 1590 psi acts across one cover. Other sources of stress such as hydrodynamic forces or thermal cycling have been considered to be much less than the pressure forces discussed above. In particular, the possibility of significant thermal stresses and thermal fatigue are precluded by the fact that the section is flooded on all sides and is relatively thin. In addition, the pump goes through very few significant thermal cycles.

For the actual analysis, the equivalent pressure load was applied to the cover end of the part with the diffuser vane end fixed in the axial direction. Three models were run to see if any significant redistribution of local stresses occurs due to the presence of the indication in the part. The indication was simulated by removing thin elements to create a notch-type void in two of the models. The third model includes the complete section.

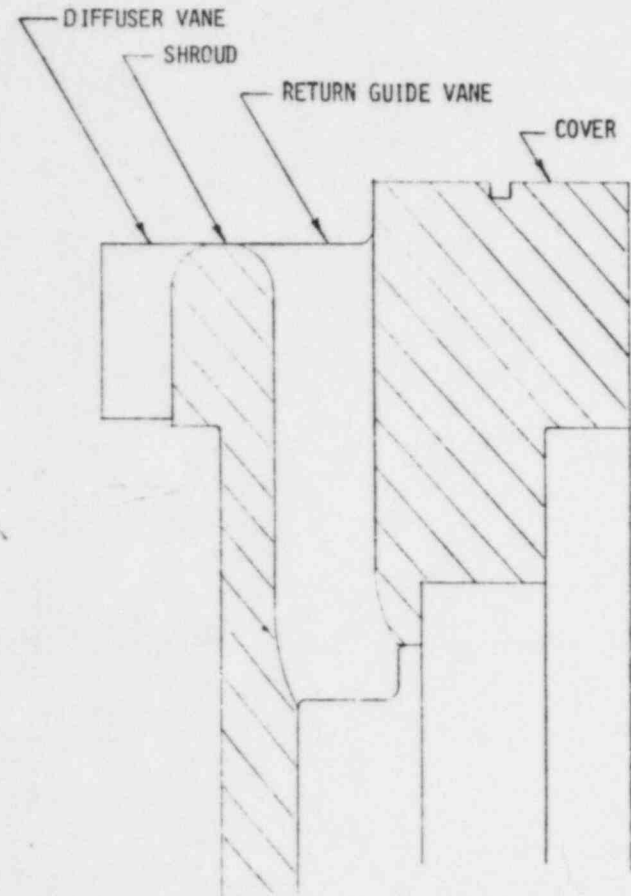
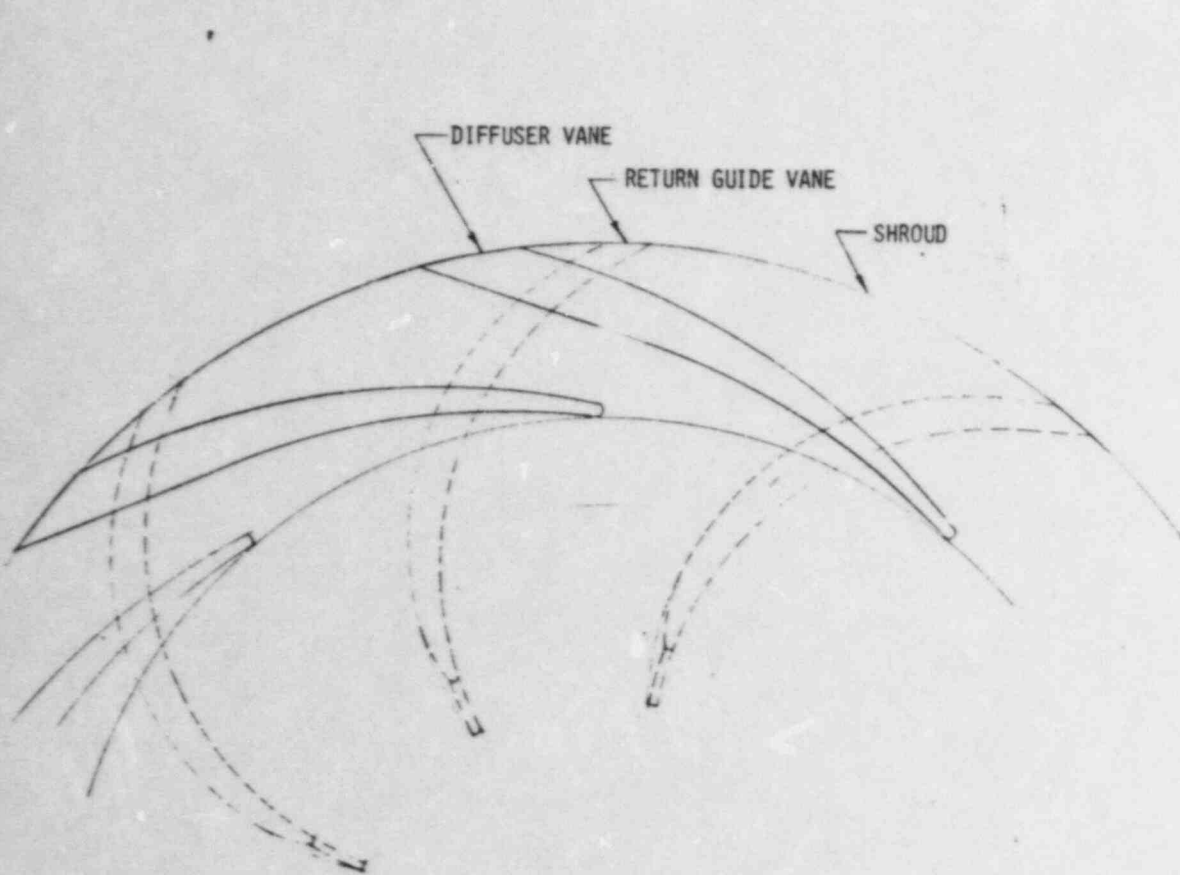

NO	REVISION	BY	DATE	CKD

LIMITS ON ALL FINISH DIMENSIONS
UNLESS OTHERWISE SPECIFIED:
FRACTIONAL $\pm 1/64$
ANGULAR $\pm 1/4^\circ$
PARALLEL $\pm .002$ IN 10°
CONCENTRIC WITHIN .002 F.I.R.
BREAK OR BURR ALL MACHINED
SHARP CORNERS APPROX. $0.10 \times 45^\circ$
UNLESS OTHERWISE SPECIFIED

PACIFIC PUMPS		
DIVISION OF DRESSER INDUSTRIES		
3" JHF INTERMEDIATE COVER		
DWN. 6/82	DATE	TYPE
CKD.	APPROVED	SHEET OF
SCALE		B

SECTION III

STRESS ANALYSIS

On the next three pages we see the relevant results of these analyses. In each sketch the element number is shown in parenthesis and the stress as either a positive or negative number. We have used the standard convention of positive numbers representing tension and negative numbers representing compression.

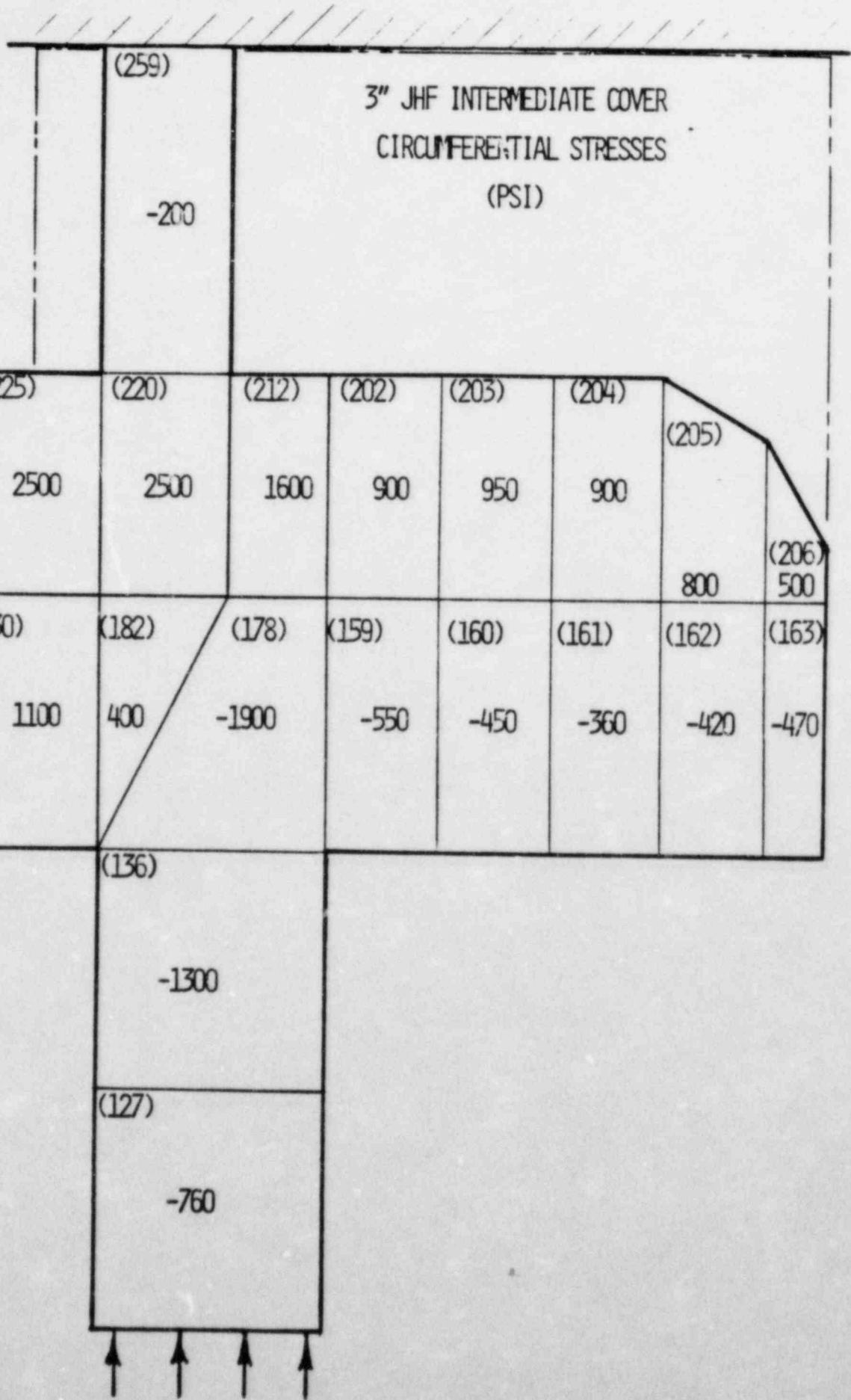

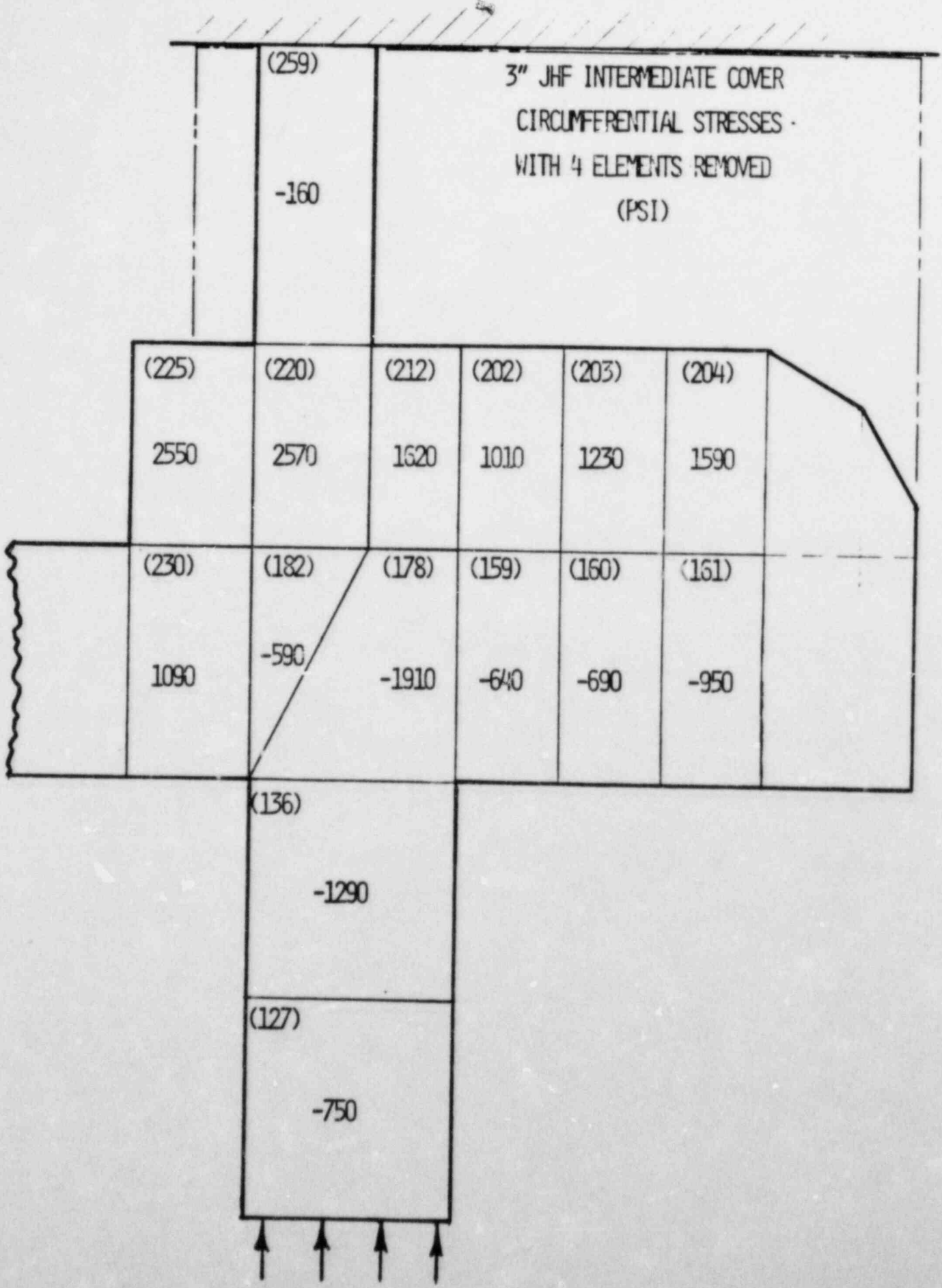

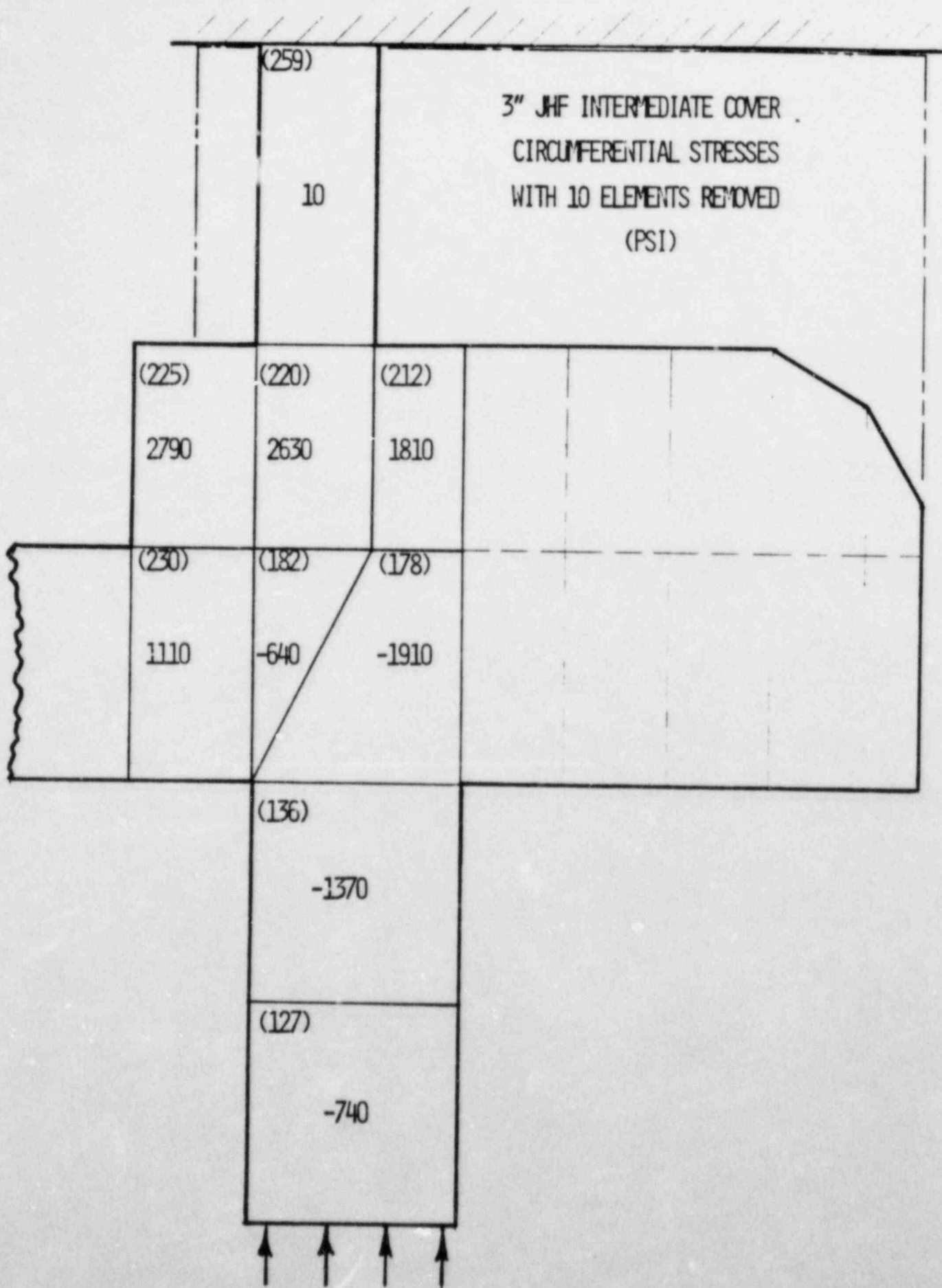

SECTION III

STRESS ANALYSIS

As can be seen from these sketches, the stress distribution in the shroud is mostly due to a bending load acting across the section. This agrees with what we expect since the load path is predominantly from the return vane to the diffuser vane and is introduced into the shroud as bending from the forces applied by adjacent vanes. In addition, we see that absence or presence of the indication does not significantly alter the stresses. The magnitude of the stresses are quite small especially when we consider that we are dealing with an alloy (CA6NM) having a minimum yield strength of 80000 psi and minimum ultimate tensile of 110000 psi. For reference, the ASME B&PV allowable for this alloy is 27500 psi.

In summary, we have calculated stresses of approximately 2000 psi. For purpose of further analysis, we will add conservatism by using 3000 psi for the "static" component and 100 psi (approximately 3% of 3000) for the "dynamic" component. The "static" component is really not static since it is applied many times over the life of the plant; specifically, each time the pump is started. From the N.S.S.S. vendor (Westinghouse) we have data that indicates that a reasonable upper bound for the starts and stops is 2500 cycles. The cycles for the "dynamic" component has been similarly determined by considering the expected maximum operating time of the pump and the total number of blade passings that would occur. This number turned out to be 2×10^{10} cycles. The above data was given to Mettek and was used in the fracture mechanics analysis to show that the presence of the indication will not lead to part failure.

METTEK

MATERIALS ENGINEERING TECHNOLOGY LABORATORIES

PACIFIC PUMP P.O. 74450

ANALYSIS OF LINEAR INDICATIONS
ON SHROUD SECTION OF INTERMEDIATE COVER-9th STAGE
S.I. PUMP SERIAL NO. 51928
SIZE 3", MODEL JHF, 11 STAGE

Prepared by:

L. Raymond, Ph.D.

METTEK Report #220431-1

FINAL REPORT

15 JUNE 1982

Prepared for:

PACIFIC PUMP DIVISION
DRESSER INDUSTRIES, INC.
HUNTINGTON PARK, CA 90255

METTEK

MATERIALS ENGINEERING TECHNOLOGY LABORATORIES

15 June 1982

Pacific Pumps
5715 Bickett Street
Huntington Park, CA 90255

Attention: George Morrisey

SUBJECT: ANALYSIS OF LINEAR INDICATIONS ON SHROUD SECTION
OF INTERMEDIATE COVER (Ref. Pattern Drawing
C-17519)

PURPOSE: To determine whether or not linear indications in the shroud section of the intermediate cover were due to hot tearing in the casting processes rather than some time delay cracking phenomenon.

An intermediate cover from a safety pump was submitted for analysis because recently, linear indications were visually detected in the shroud section. The part was cast in 1977 by Quali-Cast Corp., Chehalis, Washington (S.O. 2820/1-19-77). The material was specified as ASTM A296 GR CA-6NM. Any required weld repair was by shielded manual metal arc per ASME Section IX. The weld electrode was AWS E410 Ni Mo-16. The casting was austenitized at 1750F, air cooled and tempered at 1100F. At Quali-Cast, the intermediate cover was tested after fabrication and was accepted after 100% visual inspection of accessible areas and 100% magnetic particle inspection of excavations.

Linear indications were visually detected on the surface near the edge of the shroud and near the base of the diffuser vane. Generally, the length of the indications did not exceed 0.25-inch and only on two occasions did the indication extend along the side of the shroud. Typical indications are illustrated on sketches appended to this report. These indications are similar in nature to those found on the first pump that was inspected; but were fewer in number, with one indication being somewhat longer.

IRVINE INDUSTRIAL COMPLEX

1805 E. Carnegie Avenue • Santa Ana, CA 92705 • (714) 549-1083

TEST PLAN

The test plan was to remove the shroud and vanes from the diffuser section using an horizontal band saw. The shroud was radiographically inspected to delineate the internal profile of the surface indications. Concurrently, the diffuser cover was cut into segments at 90° intervals (See Fig. 15) that were used to produce four subsized (R3) tensile coupons, four standard Charpy V-notched impact specimens per ASTM A3704 on mechanical testing of steel products, and one chemical analysis. Other segments of the diffuser section were macroetched to identify the grain structure and the extent of weld repair.

The shroud section had each vane identified sequentially from position 1 to position 9. The most pronounced indications from x-ray radiography were saw cut and removed to be characterized metallographically with the scanning electron microscope (SEM) after the pieces were broken open along the plane of the indications. Two additional Charpy specimens were machined with their fracture plane oriented parallel to the plane of the indications. These CVN specimens were then fatigue pre-cracked and used to measure the fracture toughness (K_{Ic}) per ASTM E399. From the remaining segments of the shroud section two standard R1 tensile coupons per ASTM A370 were used to determine the tensile properties in compliance with ASTM A296, the specification for the CA-6NM casting alloy.

RESULTS

Sectioning of Intermediate Pump Each vane on the shroud section was identified with scribe marks 1-9 as shown on the Figures 1 through 12. The indications at the base of the vanes are highlighted in Figures 5 through 12. The separation of the cover from the diffuser prior to cutting test coupons is shown in Figures 13 and 14. After the saw cuts, the remaining pieces were re-

assembled and illustrated in Figures 17 through 20.

X-ray Radiography The attempt to delineate the internal profile of the linear indication was not successful. Only a direct shot of the entire diffuser section was used to identify the extent of the depth of the linear indication by the contrast noted at the respective positions; i.e., a definitive dark line on the x-ray film implied a deep crack as compared to a very faint line on the x-ray film which suggested a shallow surface crack. On this basis, five of the 9 vane locations were identified as having cracks. Location 6 (Fig. 6) was interpreted to be most severe, and positions 3 and 8 were interpreted to be less severe and the remaining 4 and 5 were interpreted to be surface indications. Position 2 was not detected by x-ray although noted visually.

Tensile Properties The results of tensile tests are listed in Table 1. The minimum values taken from ASTM A 296 are also listed for comparison. As noted, the minimum yield strength and tensile strength are exceeded. In all cases the ductility parameters of elongation in 2 inches and reduction in area are only met by sample B from the R1 specimen. The other samples appear to be slightly below the minimum specified 15% elongation. These values also compared well with the original test report by Quali-Cast Corp.

Charpy Impact Test The results from the Charpy Impact Tests (Type A) at room temperature measured 20, 26, 16 and 18 ft-lbs with the corresponding lateral expansion in mils of 17, 18, 11 and 12 respectively. No impact are specified in ASTM A296, but numbers from Climax Molybdenum's literature suggest that

impact energy at room temperature could be as high as 60 ft-lbs.

Chemical Analysis The spectrochemical analysis shows the composition as listed in Table 2 and compared to the requirements in ASTM A296. As noted, the chemistry is within specification and again compares favorably to the Quali-Cast material test report for these castings.

Fracture Toughness is not a requirement for the casting alloy CA-6NM but an attempt was made to measure the fracture toughness in order to estimate the damage tolerances of the casting by other means than the Charpy Impact energy. As noted in Table 3, the material was extremely tough because a valid brittle fracture toughness test could not be produced in the 3-point, slow bend test. The significance of the measurement is that a minimum value for fracture toughness can be estimated. This minimum value, in turn, can be used to calculate the critical stresses required for rapid crack propagation. This stress, in turn, can be compared to the anticipated stresses that the part will see in service. This approach shows the critical stress to exceed 80 ksi, for an 0.25-inch edge defect through the tip of the shroud.

Metallography Three metallographic mounts were taken from the piece shown in Figure 21 which is from vane #6 after it was broken open at the position of the linear indication. The depth profile of the defect can be seen in Figure 22 and is delineated by comparing the dark area to the bright region that has metallic lustre. Mount #1 is shown in Figure 23 and it represents a transverse section through the fracture face previously shown. As noted, the grain flow is typical of the corner of a casting and at high magnifications, the microstructure was seen to be tempered martensite as anticipated. Figures 23 through 28 show the fracture face both in the dark region and

the freshly formed surface. The dark region was caused by an oxide film as shown in Figure 25, where secondary cracking was also found to exist (Fig. 24). The decarburization located along the secondary cracks suggest that the cracks existed prior to heat treatment. The oxide film being black in coloring also suggests a high temperature oxide. These features are typical of all phenomenon described as a hot tear which is commonly observed in the 400 series of casting alloys. A second mount was taken at a section parallel to the fracture face and, again, the grain flow and microstructure was as normally expected. The third mount was taken from the fracture pieces of a Charpy specimen and again shows the consistency of the grain flow and microstructure throughout the casting. The indications at #2 and #8 are exposed in Figures 33 and 34.

SEM/Fractography Figures 29 and 30 show the surface of the dark area and bright metallic area as examined with the SEM. As noted, the dark area has many products of high temperature oxidation as compared to the fracture area which shows the classic features of dimple rupture. No slow growth crack extension was noted beyond the dark zone. A typical surface weld repair is shown in Figures 31 and 32. The inclusion was identified by x-ray microprobe (XRM) analysis.

SEM/XRM A series of x-ray spectra were obtained by scanning the different regions of the fracture face and weld repair nugget area. Trace 1 shows the peaks typical of the base metal consistent with the CA-6NM alloy. Trace 3 shows a comparison of the x-ray spectra of the black oxide area in order to identify any surface contamination. Other than potassium (K), calcium (Ca), and phosphorus (P), no unusual contamination was observed, consistent with the discoloration being caused by oxidation instead of corrosion. The

remaining spectra are of the weld repair nugget (Traces 5-7) and they identify the inclusion to be titanium (Ti), probably a cutting on the weld repair electrode.

CONCLUSIONS/RECOMMENDATIONS

1. The linear indications are generally superficial in nature except for the one located at vane #6 which was almost 1/4 of an inch deep and through the tip of the shroud.
2. CA-6NM casting material meets the requirements of ASTM specification A296 with regard to chemistry and tensile tests. Additional Charpy impact and fracture toughness tests showed the material to be extremely damage tolerant.
3. No indications of slow crack growth by any time delay mechanism is suggested. The residual stresses as noted by opening of the diffuser shroud during the cutting operation was found to be non-existent; i.e., no changes in dimensions were observed with cutting.
4. The linear indications were caused by hot tear cracks introduced during the original casting operation.
5. A fracture analysis might be performed to convincingly establish that the existing hot tear cracks are not a potential safety hazard. This would require better stress analysis of the part and definition of anticipated service loads.

Respectfully submitted,

METTEK Laboratories

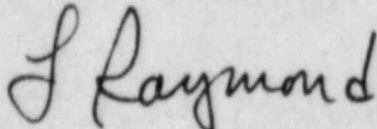

L. Raymond, Ph.D.
Consulting Engineer

dr

TABLE 1
TENSILE PROPERTIES PER ASTM A370

Source	Y.S.* (ksi)	T.S.* (ksi)	Elongation (%)	Reduction of Area (%)
ASTM A296	80 min.	110 min.	15 min.	35 min.
Quali-Cast Test Report 3659	99.9	126.8	15.7	40.7
R3 (0.25-in)	89.6	122.0	10.5	50.4
	91.6	120.2	10.0	53.7
	89.6	122.2	11.5	50.4
	90.7	120.9	11.5	43.8
R1 (0.50-in)	97.0	120.6	10.0	24.5
	98.2	121.5	18.5	45.1

*Y.S. = Yield Strength

*T.S. = Tensile Strength

TABLE 2
 CHEMICAL ANALYSIS

Source	C	Mn	Si	P	S	Cr	Ni	Mo
ASTM A296	0.06 max	1.0 max	1.0 max	.04 max	.04 max	11.5/14.0	3.5/4.5	0.4/1.0
Quali-Cast Test Report 3659	0.05	.40	.75	.020	.024	12.5	4.0	0.65
METTEK	0.06	.60	.71	.017	.023	12.7	4.5	0.74

TABLE 3
FRACTURE TOUGHNESS ESTIMATES

Location	B (in)	W (in)	A (in)	S (in)	P _{max} (kips)	P _{eq} (kips)	K _{eq} (ksi $\sqrt{\text{in}}$)
Vane #2	.395	.395	.201	1.9	1.21	2.44	140
Vane #8	.395	.393	.198	1.9	1.20	2.57	146
Type of Test: Slow bend precracked Charpy per ASTM E399-81 Temp = 74F Rel Hum = 51% K _f (max) = 28 ksi $\sqrt{\text{in}}$ B _{1c} = 5-inches							
*K _{Ic} Test Invalid per E399; therefore, equivalent energy estimate of fracture toughness (K _{eq}) based on assumption of crack initiation at max load.							

KILOVOLTS 27.5
FULL SCALE 8530
SECONDS OF COUNT 100
JOB ORDER NUMBER 220431
MAGNIFICATION 250x

METTEK

Materials Engineering Technology Laboratories
1805 E. Carnegie Ave. Santa Ana, CA 92705 (714) 549-1083

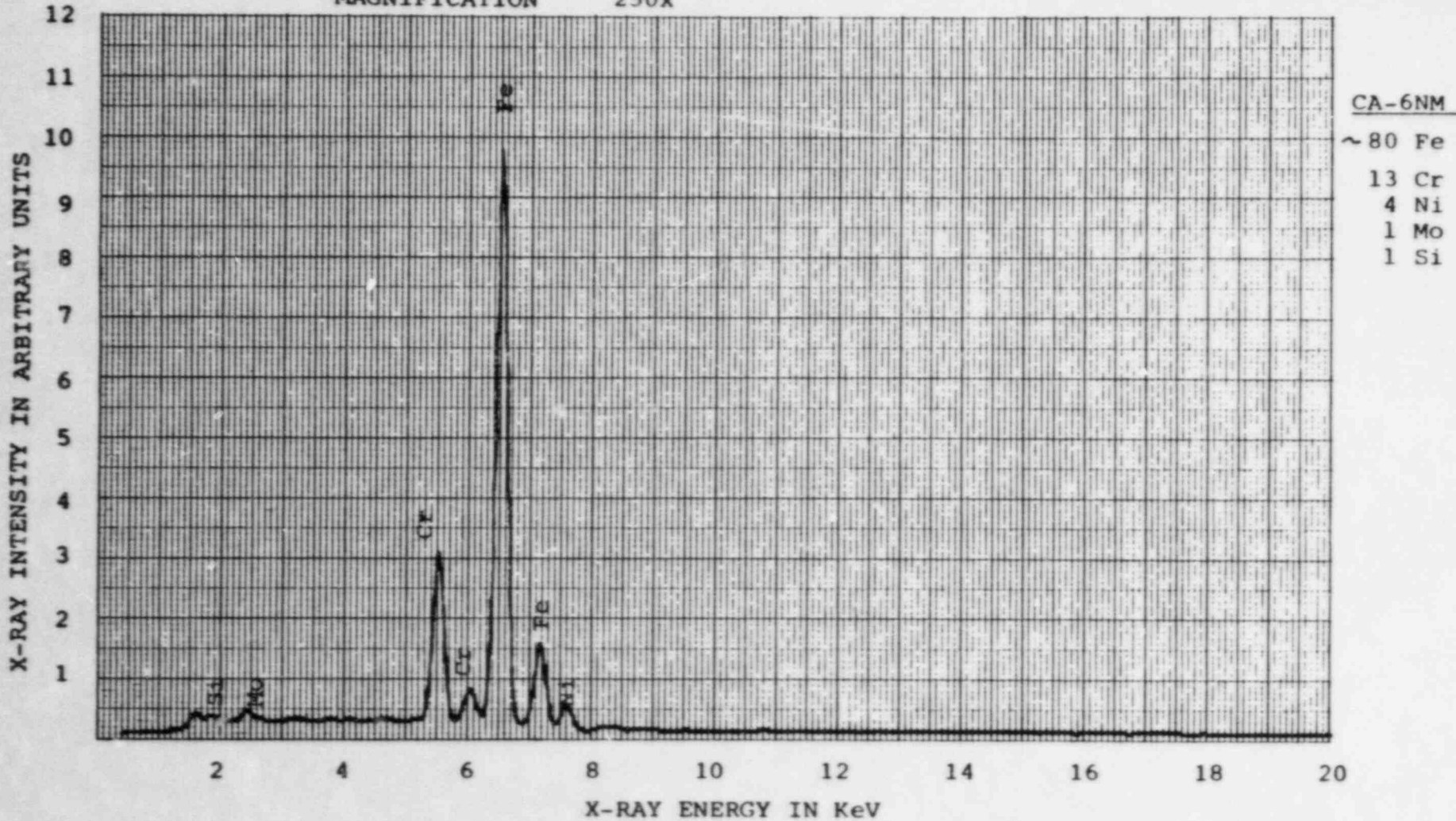

Trace 1 X-ray spectrum of bright area on fracture face of Fig. 2., Location Vane #6, consistent with the chemistry in CA-6NM.

KILOVOLTS 27.5
FULL SCALE 1030
SECONDS OF COUNT 100
JOB ORDER NUMBER 220431
MAGNIFICATION 250x

METTEK

Materials Engineering Technology Laboratories
1805 E. Carnegie Ave. Santa Ana CA 92705 (714) 549-1083

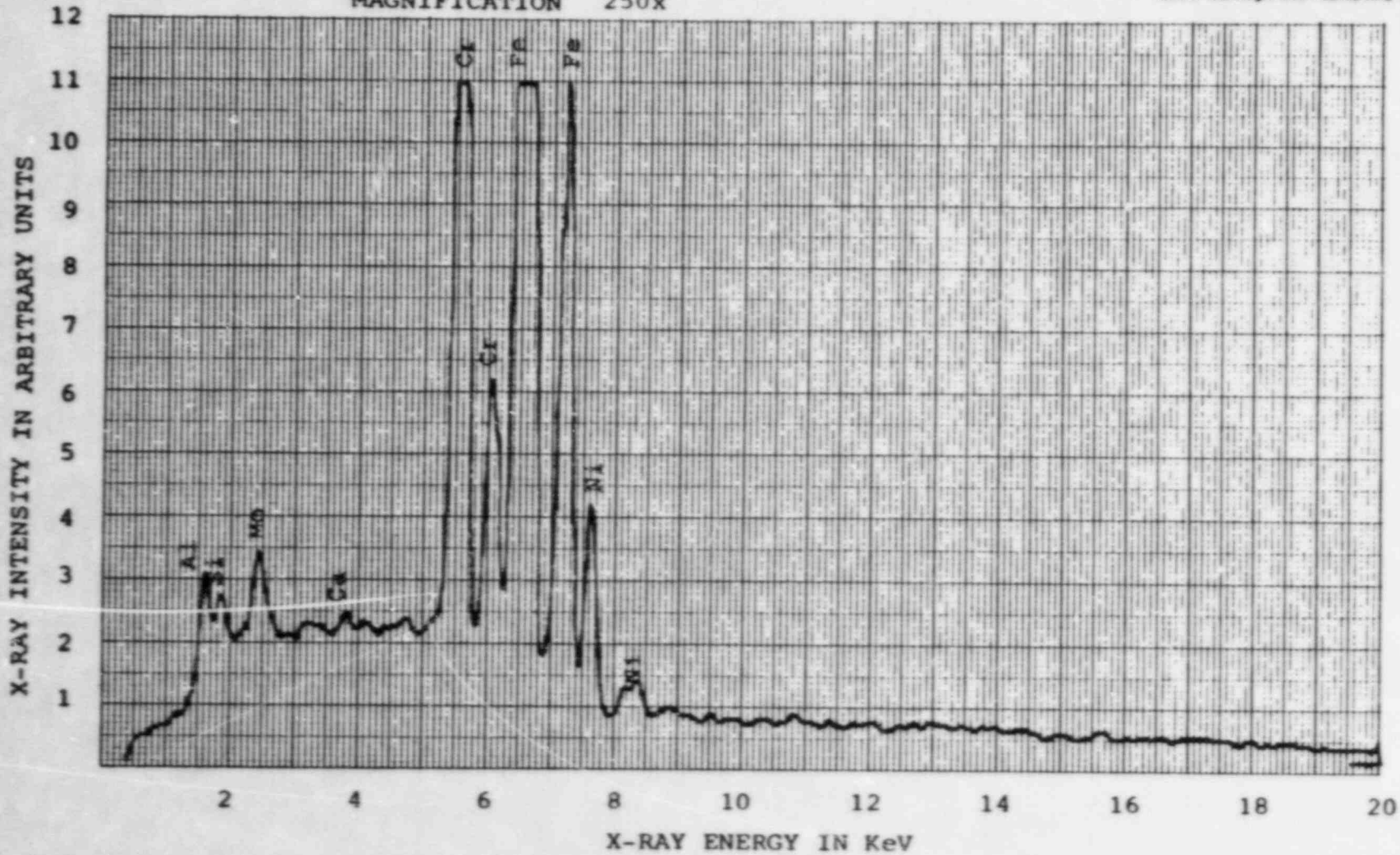

Trace 2 Same as Trace 1, but with scale expanded to show minor contaminated peaks of aluminum (Al) and calcium (Ca).

METTEK
Materials Engineering Technology Laboratories
1805 E Carnegie Ave. Santa Ana CA 92705 (714) 549-1083

KILOVOLTS 27.5
FULL SCALE 8530
SECONDS OF COUNT 100
JOB ORDER NUMBER 220431
MAGNIFICATION 250x

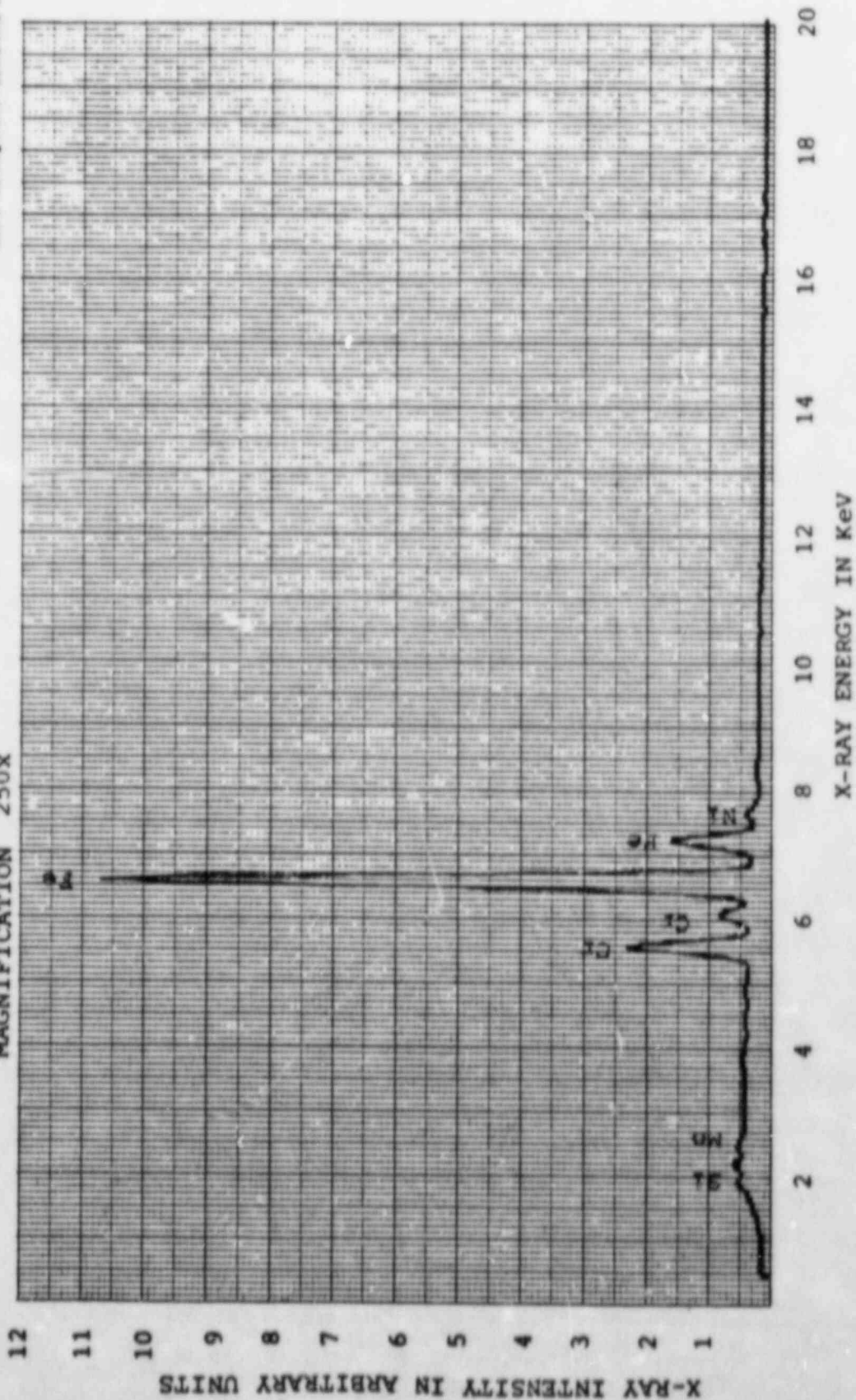

Trace 3 X-ray spectrum of dark area on fracture face of defect from location at Vane #6.

KILOVOLTS 27.5
FULL SCALE 1030
SECONDS OF COUNT 100
JOB ORDER NUMBER 220431
MAGNIFICATION 250x

METTEK

Materials Engineering Technology Laboratories
1805 E. Carnegie Ave. Santa Ana CA 92705 (714) 549-1083

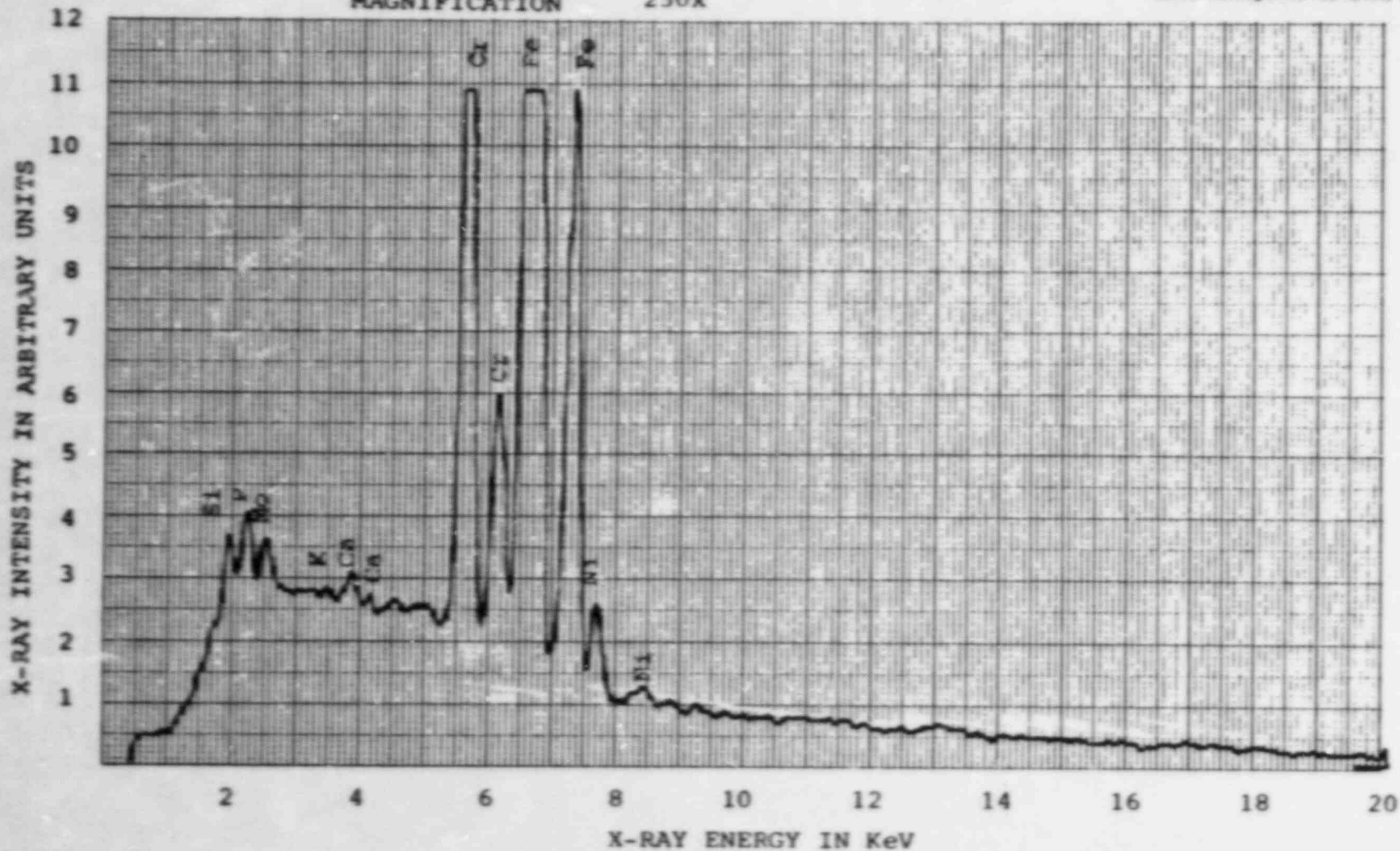

Trace 4 Same as Trace 3 but with scale expanded to show minor peaks of phosphorous (P), calcium (Ca), and potassium (K).

KILOVOLTS 27.5
FULL SCALE 8440
SECONDS OF COUNT 100
JOB ORDER NUMBER 220431
MAGNIFICATION 250x

METTEK

Materials Engineering Technology Laboratories
1805 E. Carnegie Ave. Santa Ana, CA 92705 (714) 549-1083

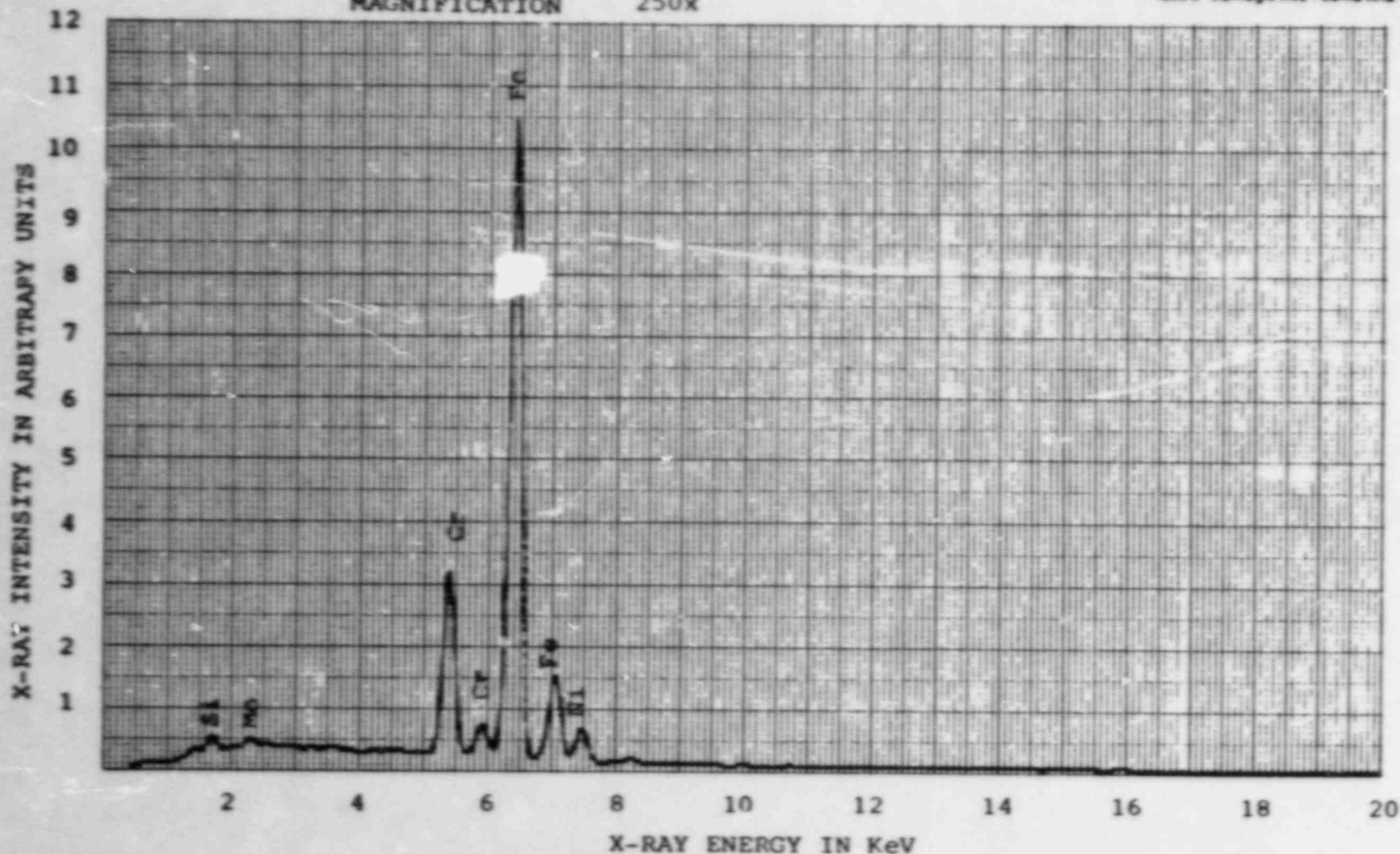

Trace 5 X-ray spectrum of base metal adjacent to weld repair. Identical to Trace 1, complying with CA-6NM chemistry.

KILOVOLTS 27.5
FULL SCALE 8440
SECONDS OF COUNT 100
JOB ORDER NUMBER 220431
MAGNIFICATION 250x

METTER

Materials Engineering Technology Laboratories
1805 E. Carnegie Ave. Santa Ana, CA 92705 (714) 549-1083

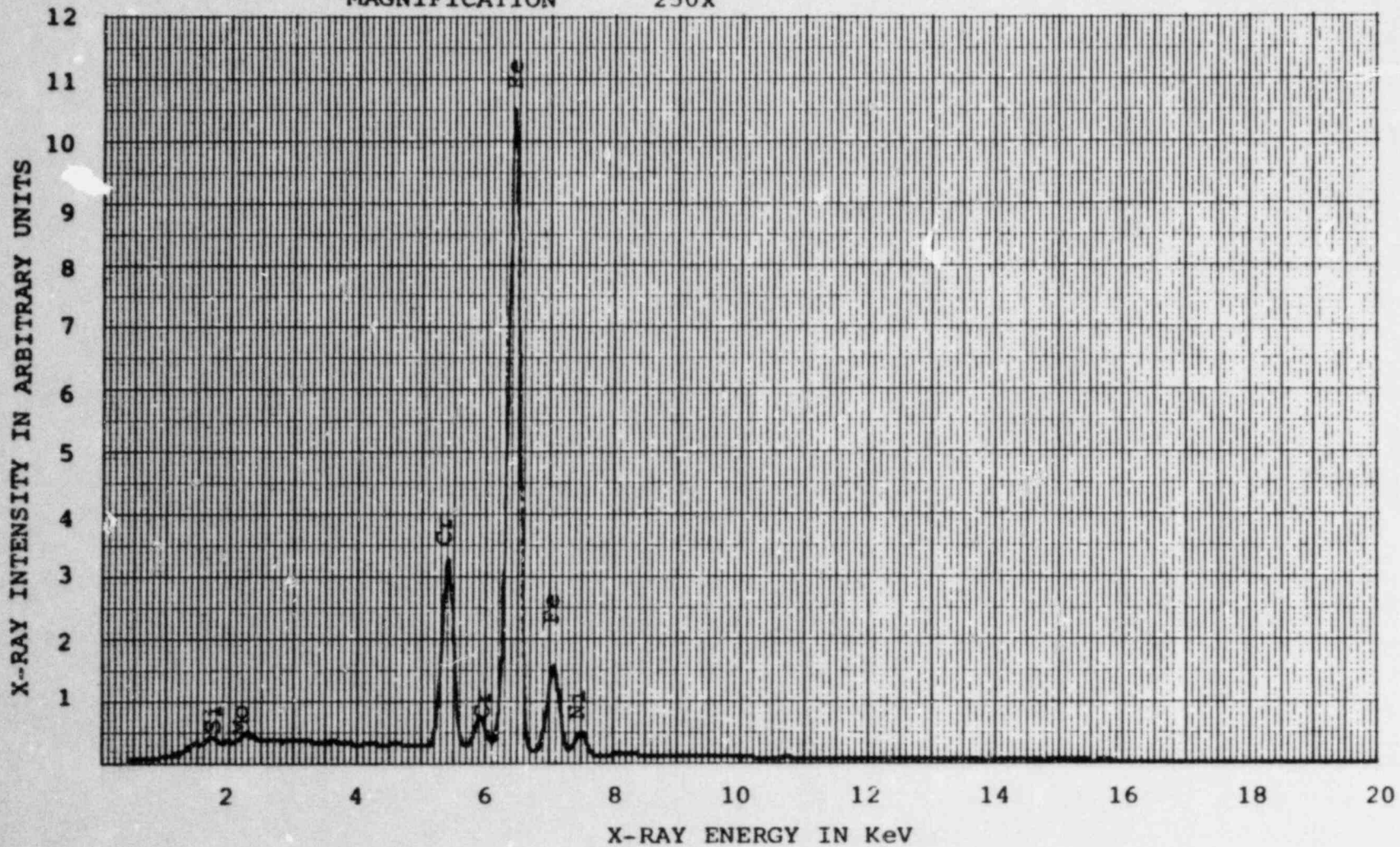

Trace 6 X-ray spectrum of weld metal in weld repair area seen to be identical to base metal.

KILOVOLTS 27.5
FULL SCALE 8440
SECONDS OF COUNT 100
JOB ORDER NUMBER 220431
MAGNIFICATION 500x

METTEK

Materials Engineering Technology Laboratories
1805 E. Carnegie Ave. Santa Ana, CA 92705 (714) 549-1083

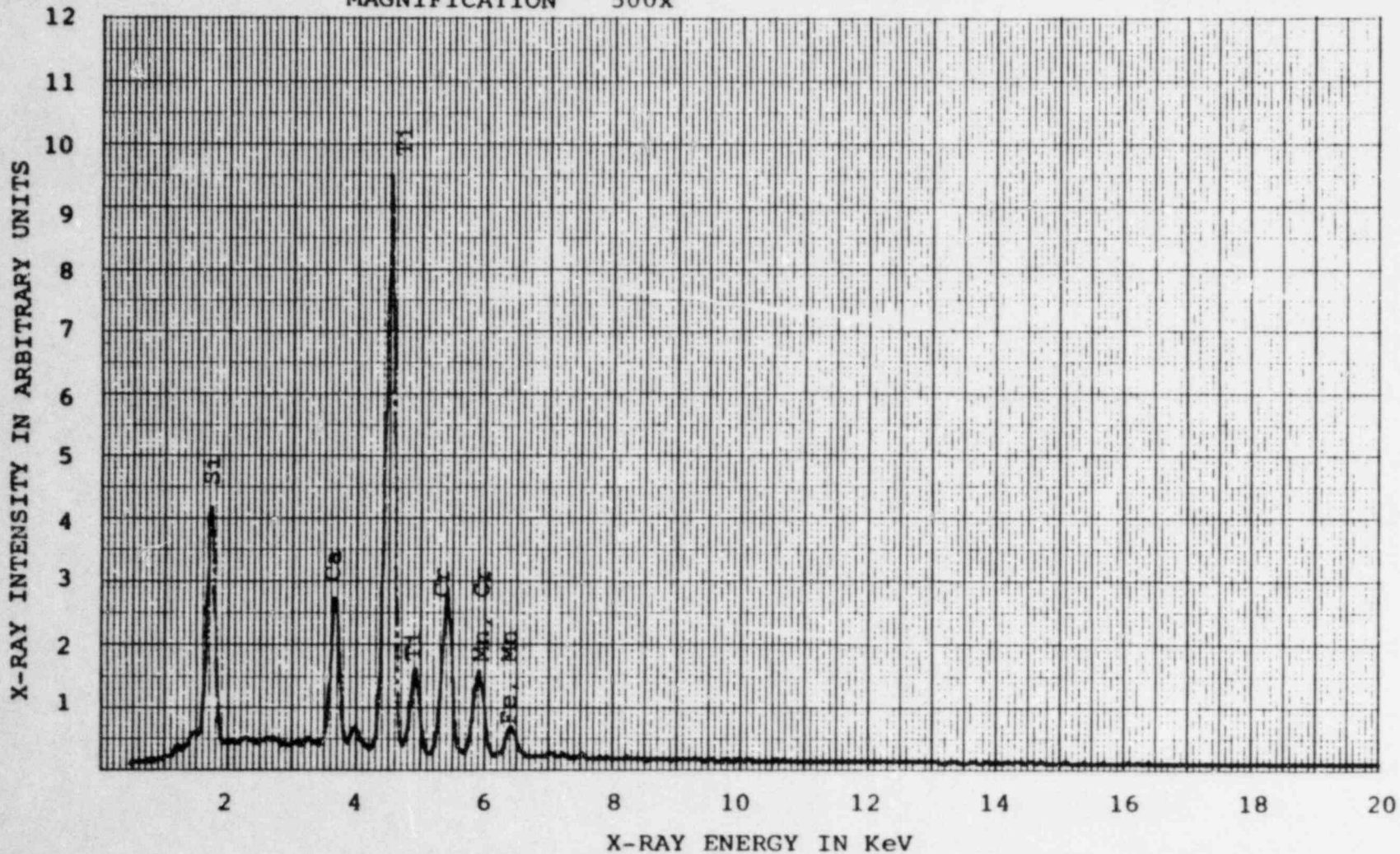

Trace 7 X-ray spectrum of inclusion between weld repair and base metal. Inclusion consists of titanium (Ti), silicon (Si), and calcium (Ca). Particles shown in Figures 31 and 32.

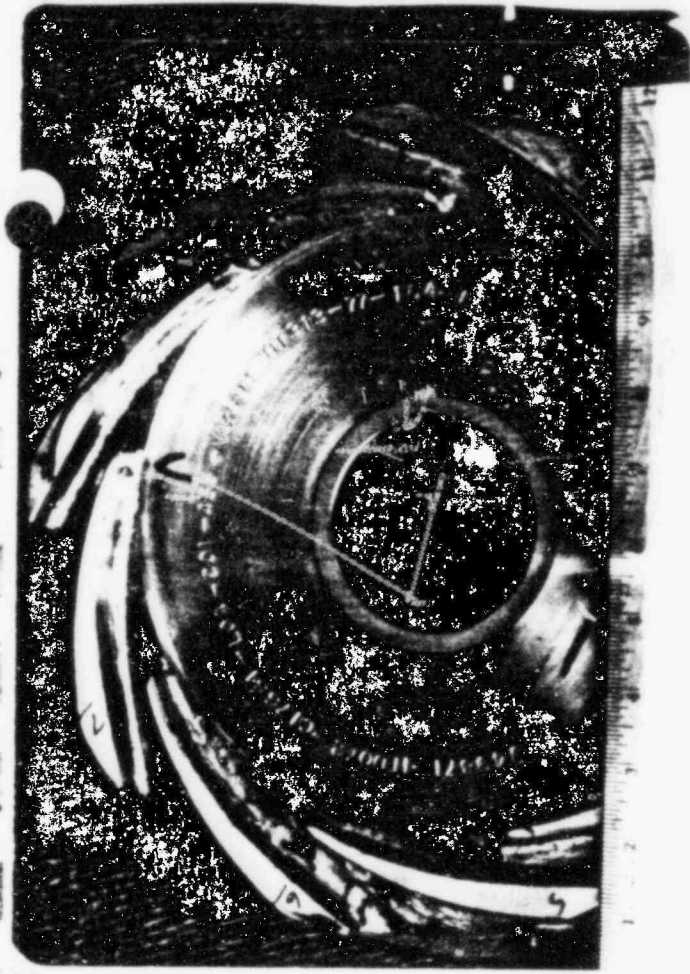

Fig. 2 Diffuser vanes



Fig. 1 Intermediate Cover



Fig. 4 Side View



Fig. 3 Cover and diffuser section including vanes.



Fig. 6 Indications/vanes 5 & 6



Fig. 8 Indications/Vanes 7 & 8



Fig. 5 Indications/Vanes 3 & 4



Fig. 7 Indications/ Vanes 1 & 2



Fig. 10 Indication Vane 5



Fig. 12 Indication Vane 8

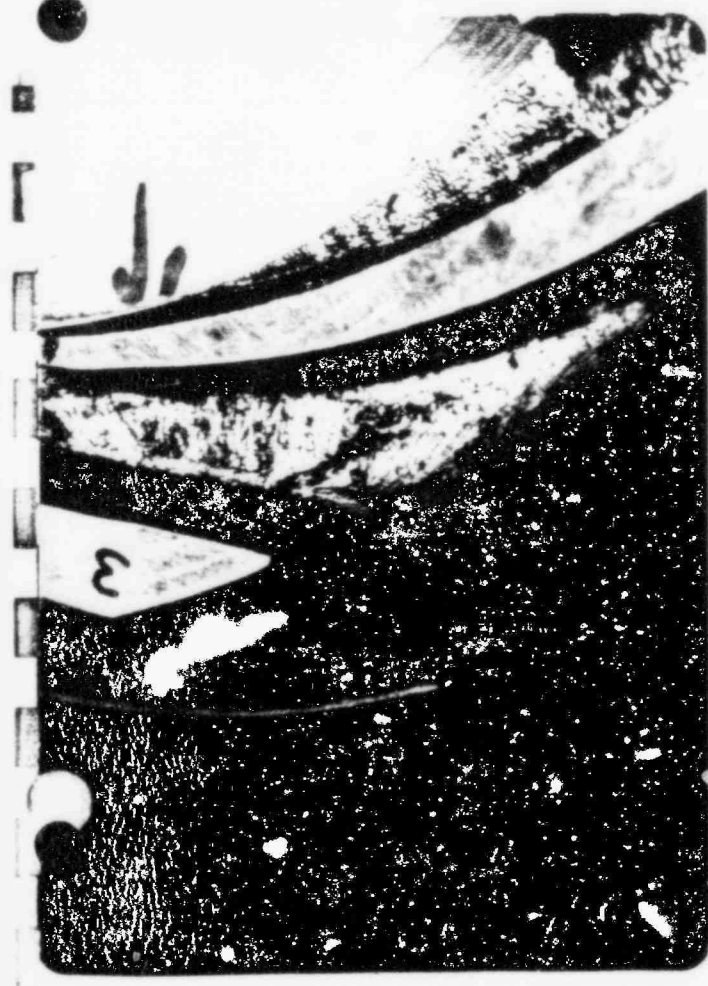

Fig. 9 Indication Vane 3

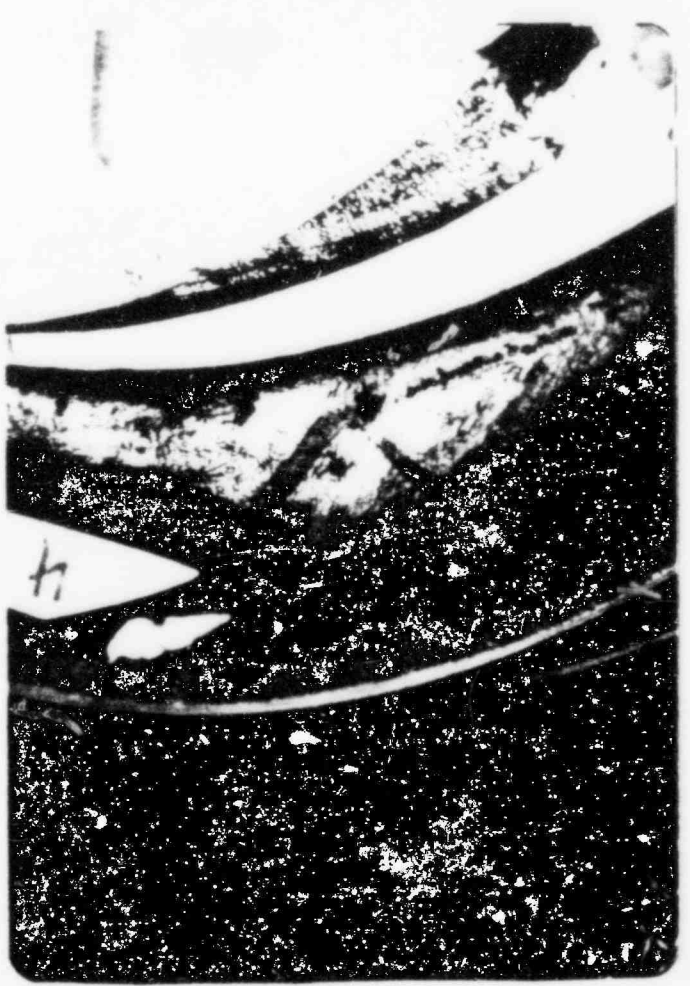

Fig. 11 Indication Vane 4



Fig. 13 Intermediate cover-bottom after separation.

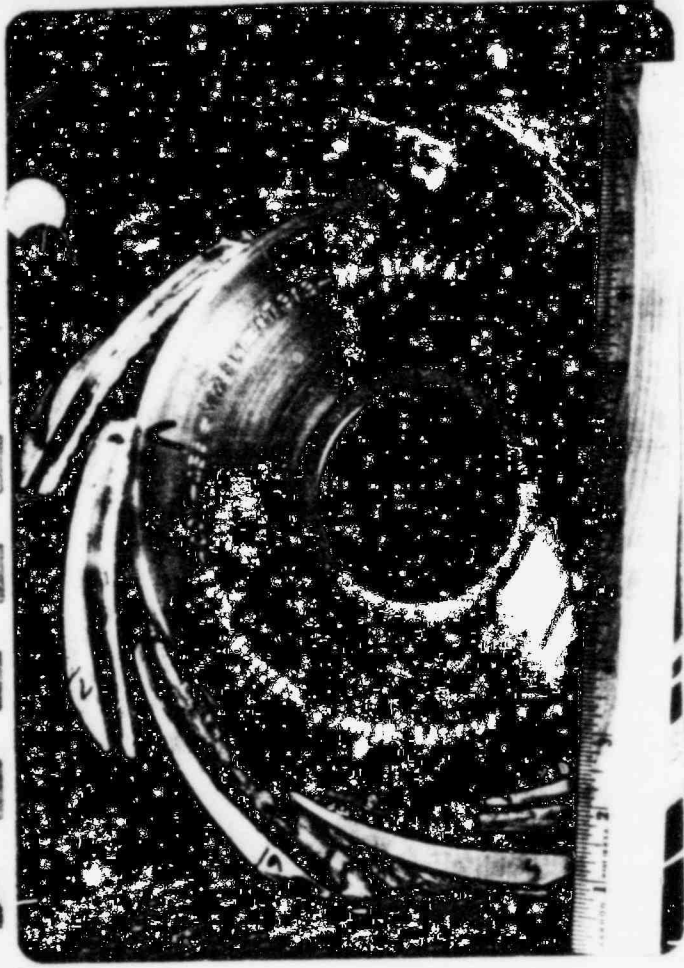

Fig. 14 Intermediate cover-top after separation.

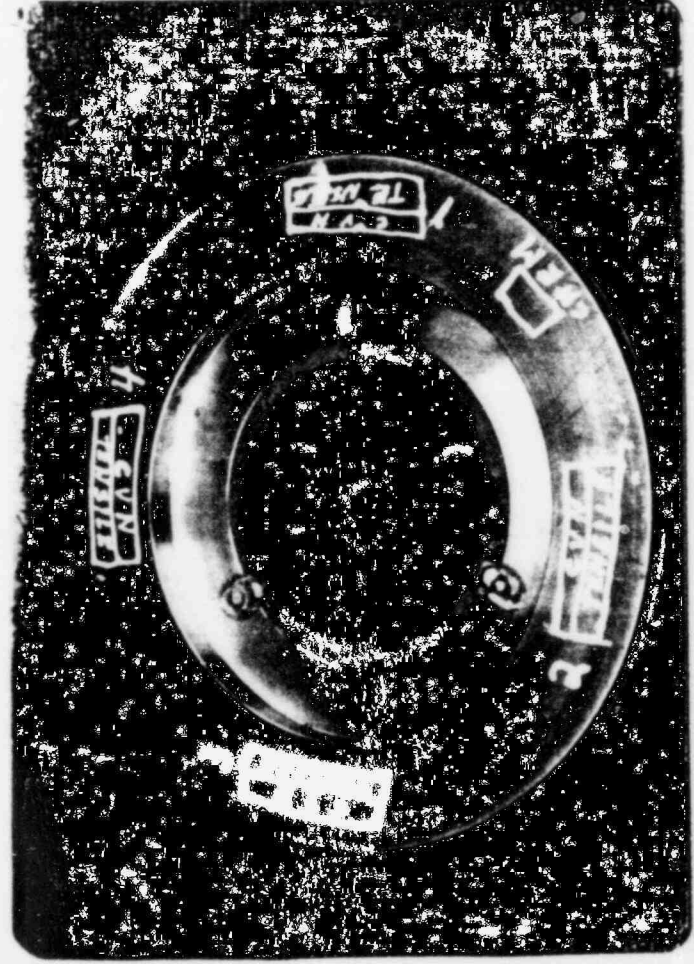

Fig. 15 Location of test coupons.

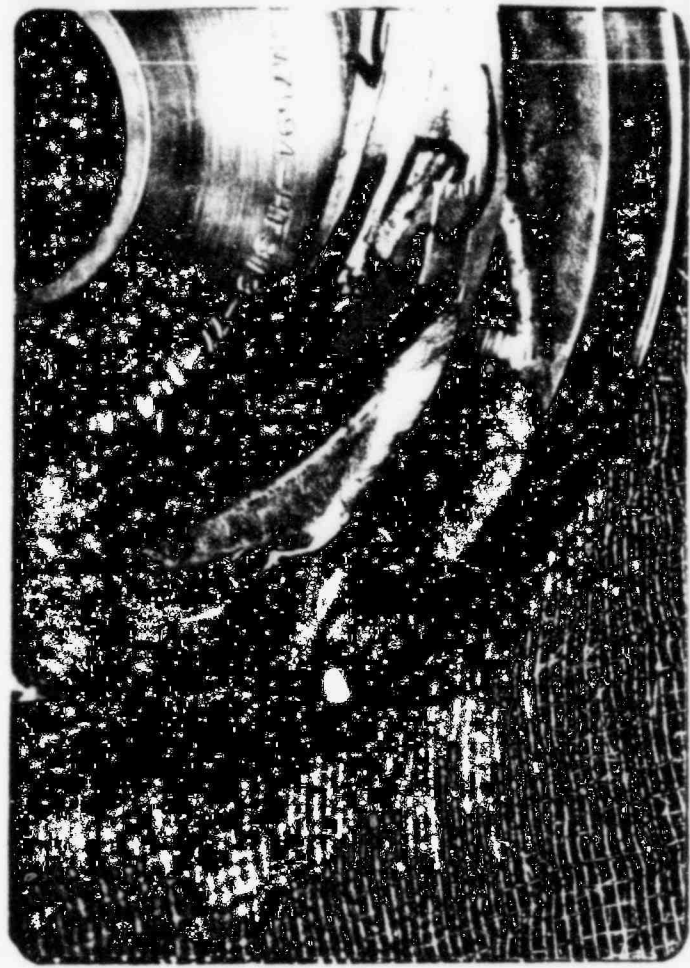

Fig. 16 Machining mark, tip of vanes.

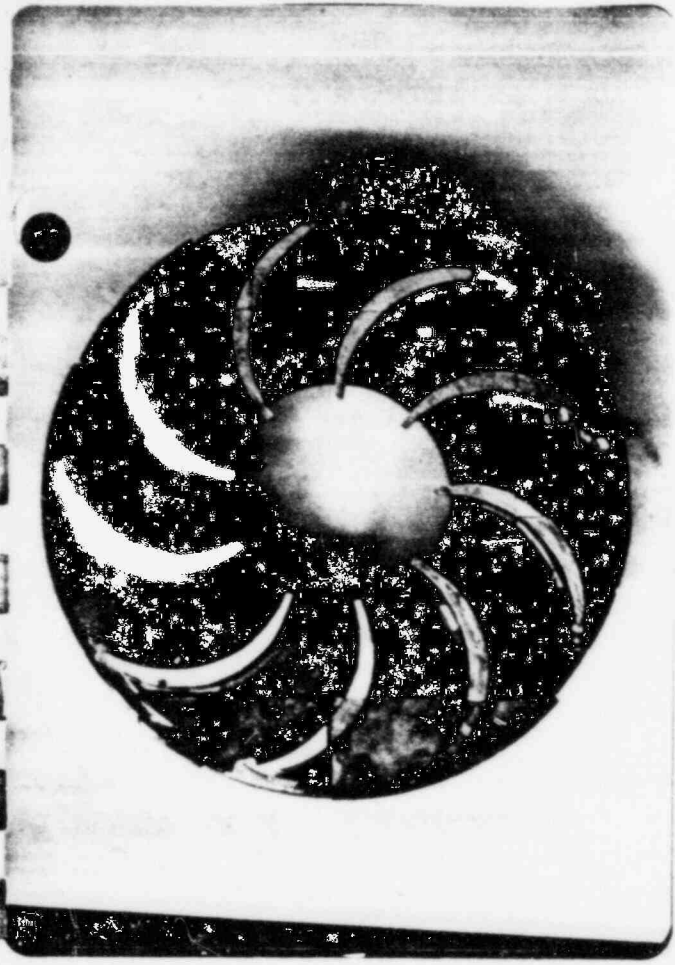

Fig. 18 Cover after cutting.



Fig. 20 Shroud after cutting.



Fig. 17 Cover CVN location



Fig. 19 Vane #6 defect exposed.

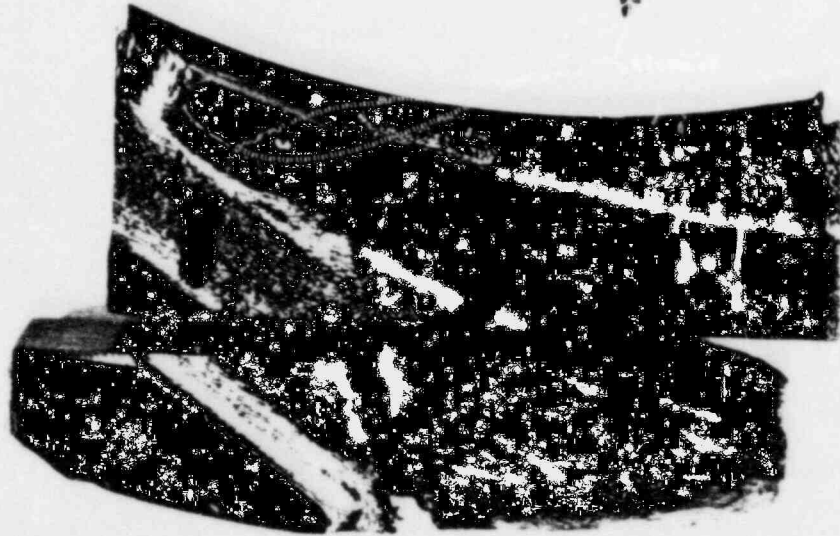

FIGURE 21. Defect at vane location #6, broken open to expose surface.



FIGURE 22. Fracture surface of segment including defect at vane location #6.



FIGURE 23. Transverse section through defect located at vane #6.



FIGURE 24. Decarburization layer along secondary crack in transverse section of dark area. 200x



FIGURE 25. Oxide on dark area exposed at vane location #6.

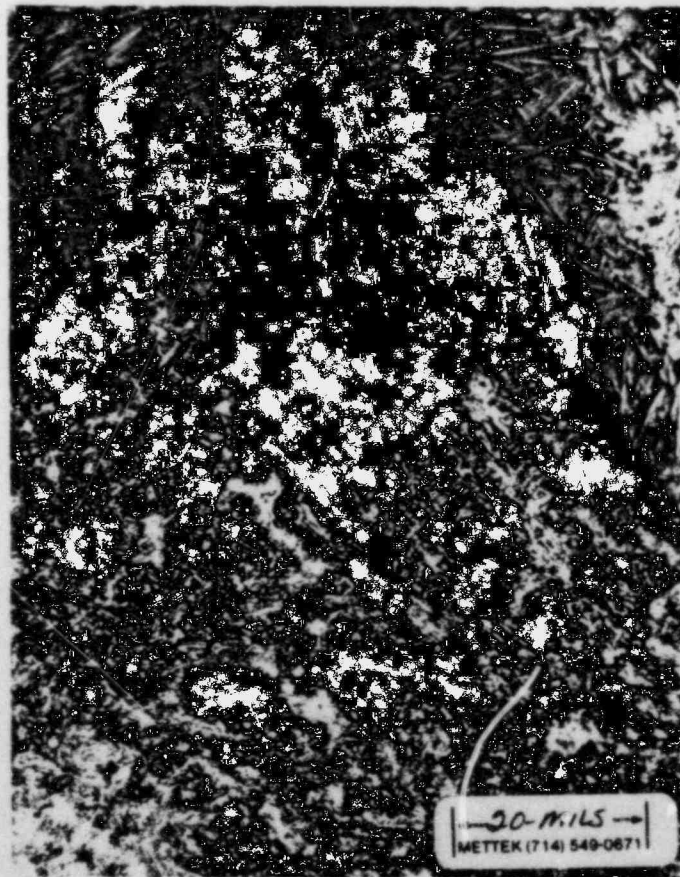

FIGURE 26. Transverse section through light zone at vane location #6

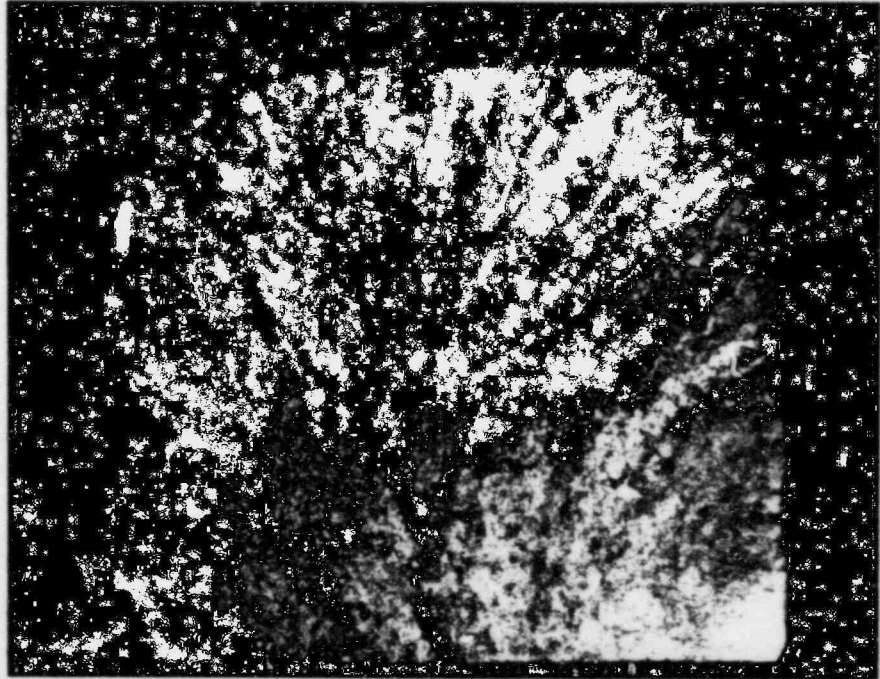

FIGURE 27. Macro section of plane parallel to fracture face shown in Fig. 22.

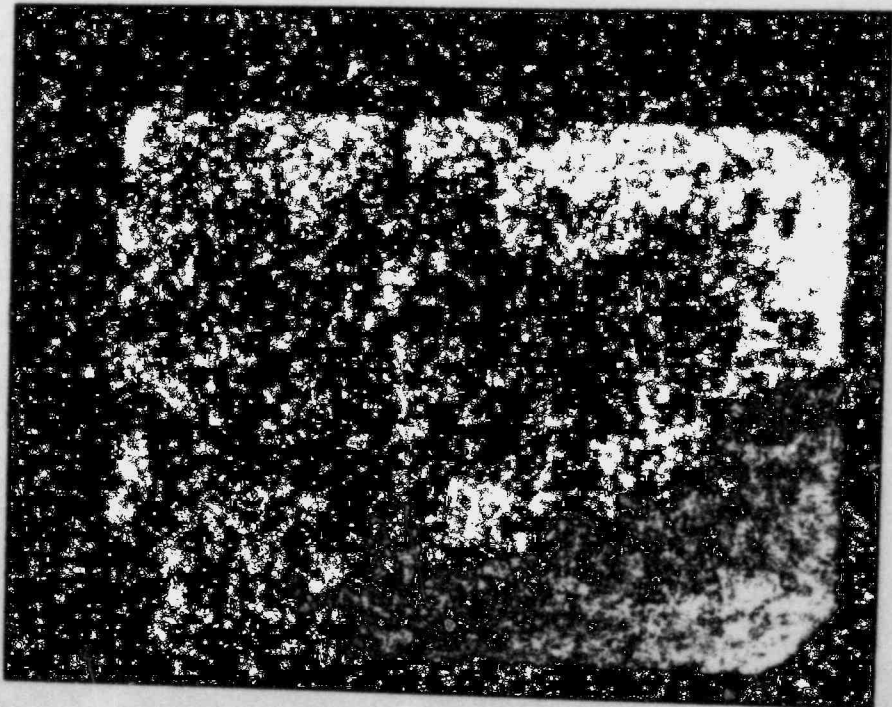

FIGURE 28. Macro section taken from CVN specimen.

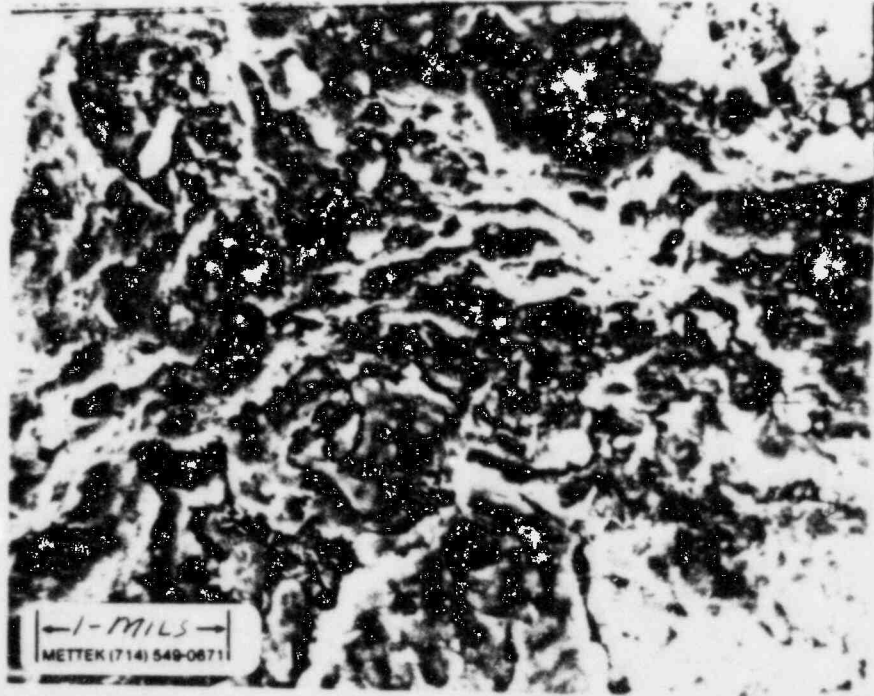

FIGURE 29. SEM photograph of oxides found on surface of dark area, top view of Fig. 25

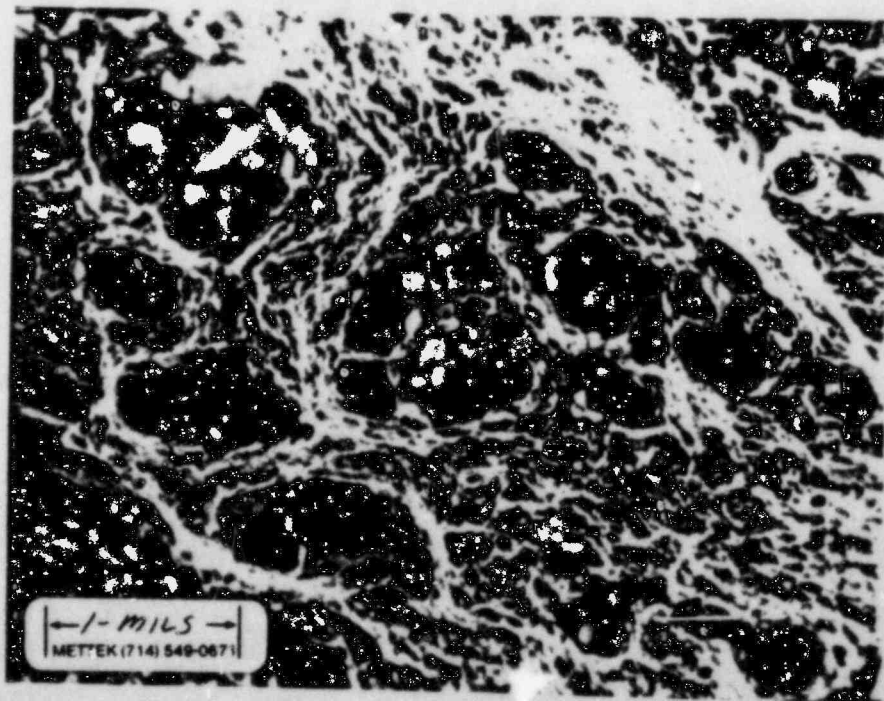

FIGURE 30. SEM photograph of dimples found on surface of light area, top view of Fig. 26.

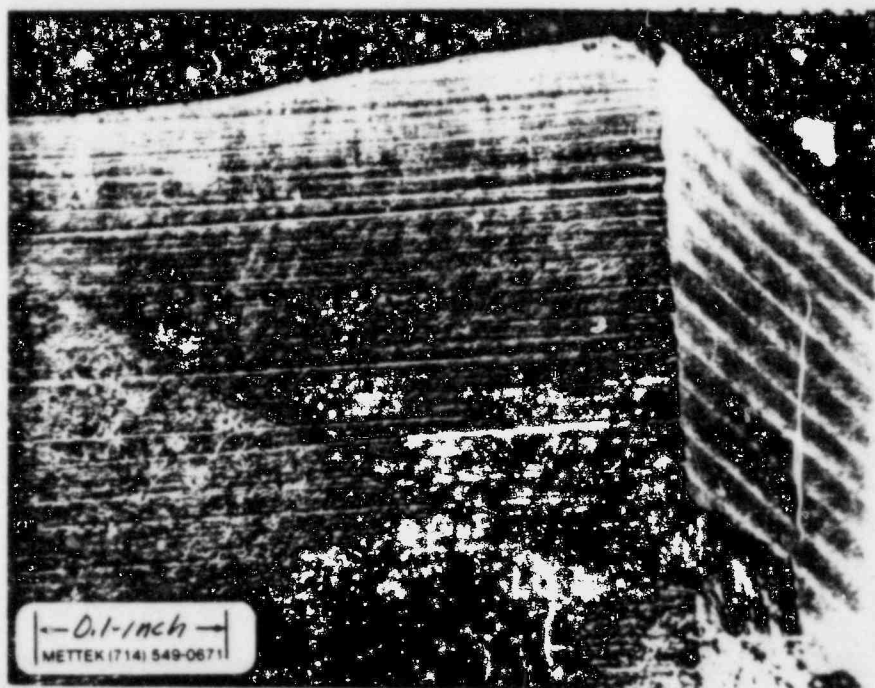

FIGURE 31. Inclusion noted at bottom of surface weld repair

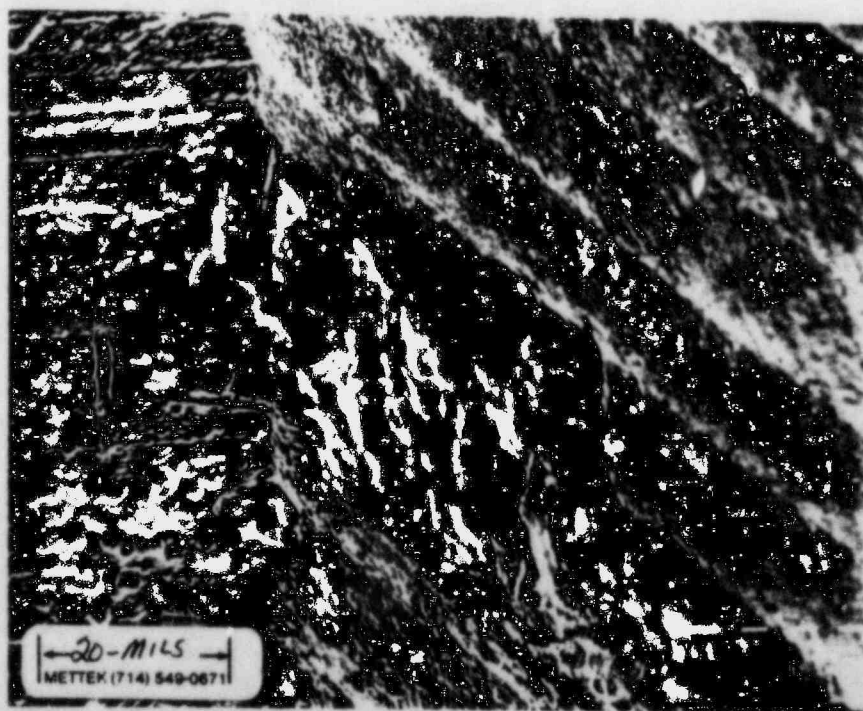

FIGURE 32. Inclusion at higher magnification identified by XRM as titanium (Ti), possibly due from coating on welding electrode.

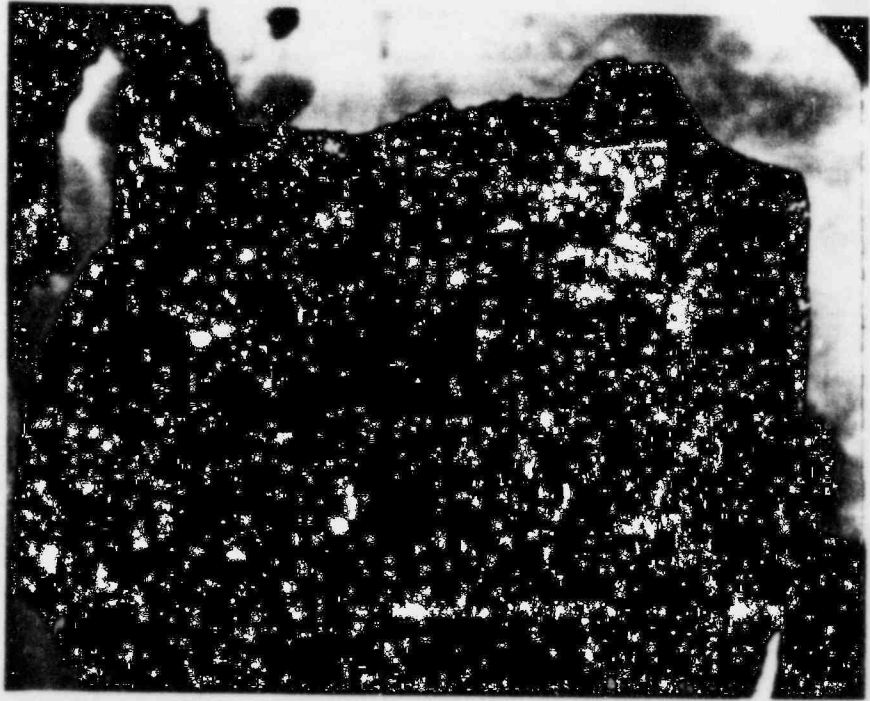

FIGURE 33. Fracture surface of segment including defect at vane location #2.

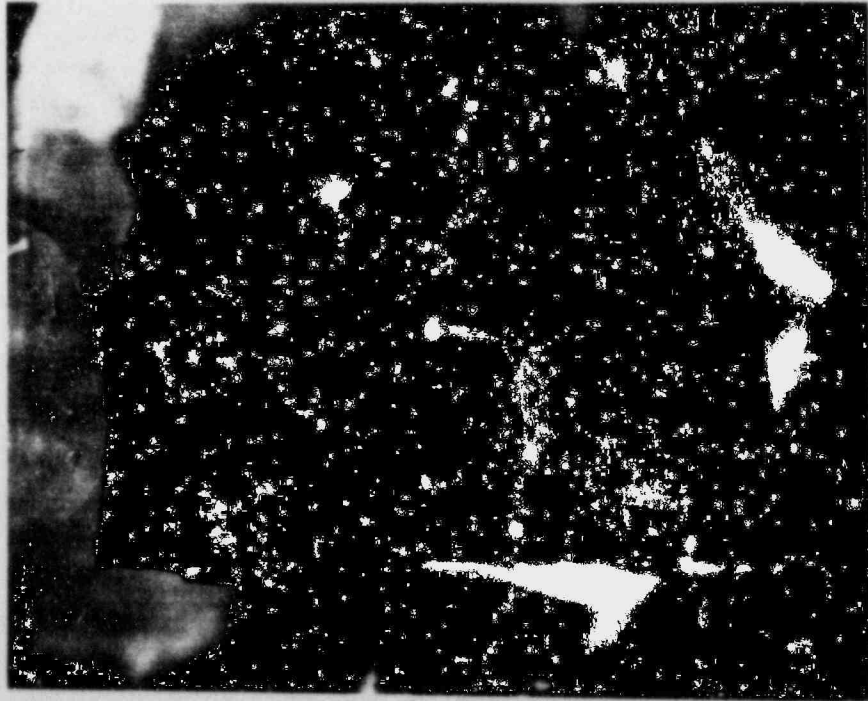
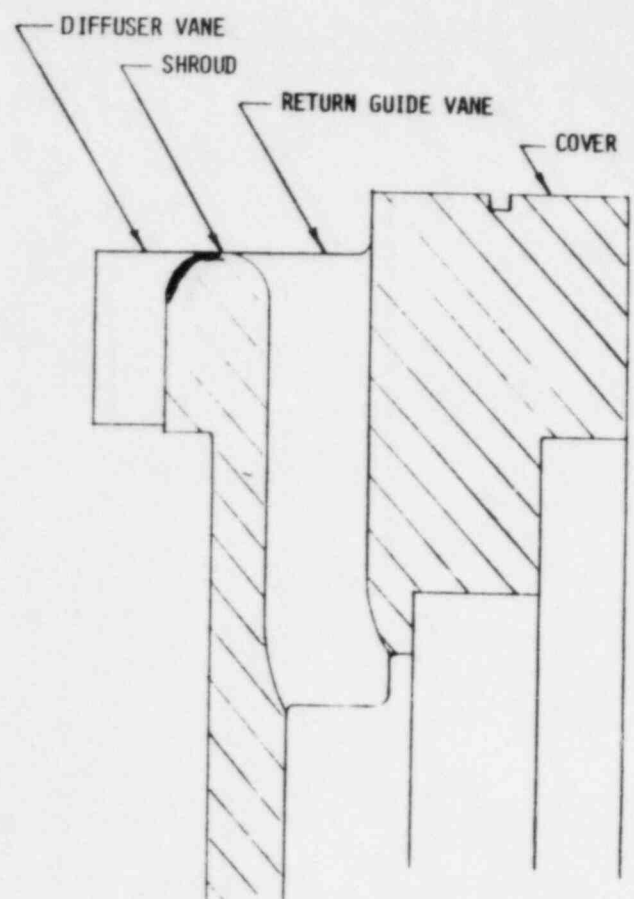
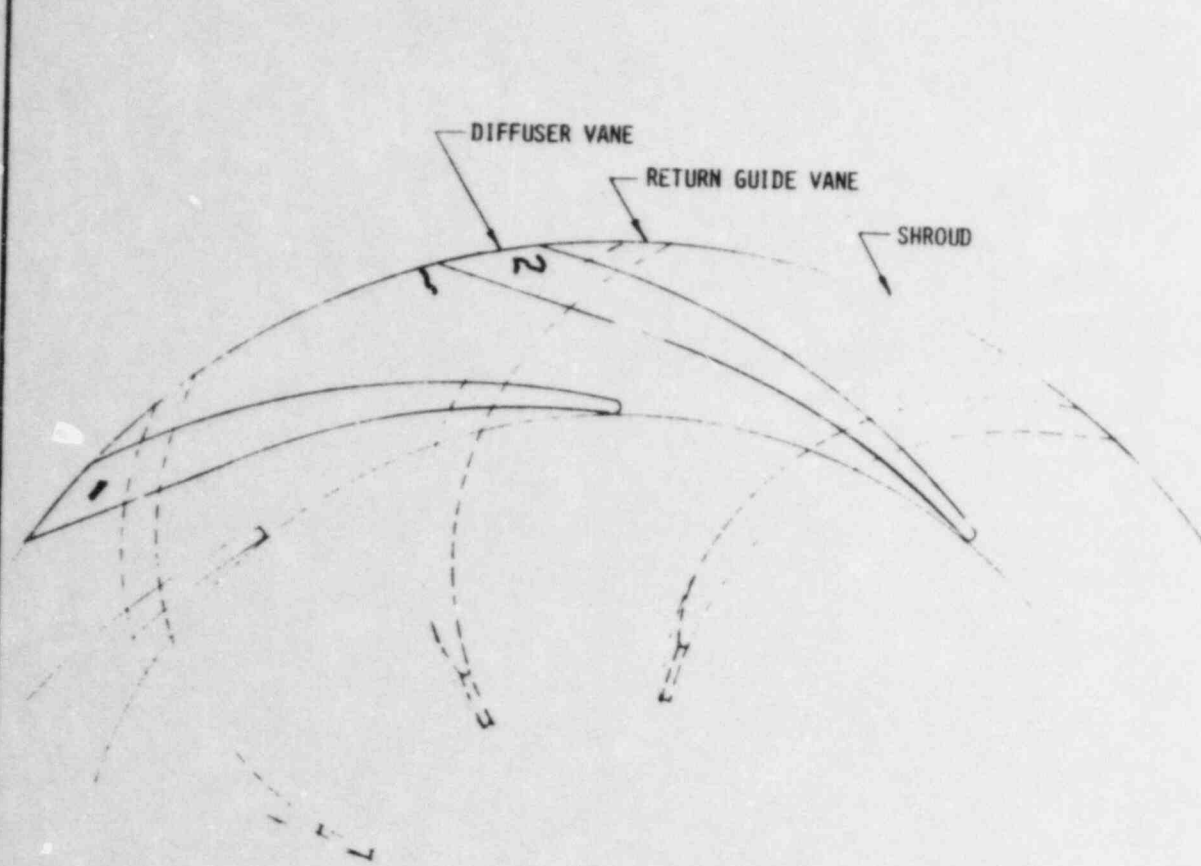

FIGURE 34. Fracture surface of segment including defect at vane location #8.



						LIMITS ON ALL FINISH DIMENSIONS UNLESS OTHERWISE SPECIFIED: FRACTIONAL $\pm 1/64$ ANGULAR $\pm 1/4^\circ$ PARALLEL $\pm .002$ IN 10" CONCENTRIC WITHIN .002 F.I.R. BREAK OR BURR ALL MACHINED SHARP CORNERS APPROX. $10 \times 45^\circ$ UNLESS OTHERWISE SPECIFIED	PACIFIC PUMPS DIVISION OF DRESSER INDUSTRIES		
							3" JHF INTERMEDIATE COVER		
							DWN 6/82	DATE	TYPE
							CKD.	APPROVED	SHEET OF
							SCALE		B
NO.	REVISION	BY	DATE	CKD	PART NO.				

BRUNING 40 21

Sketch of indication at edge of shroud near base of diffuser vane #2, blades number sequentially clockwise 1 through 9. Profile of hot tear crack is sketched to illustrate appearance after piece was broken open at indication (2/3 scale).

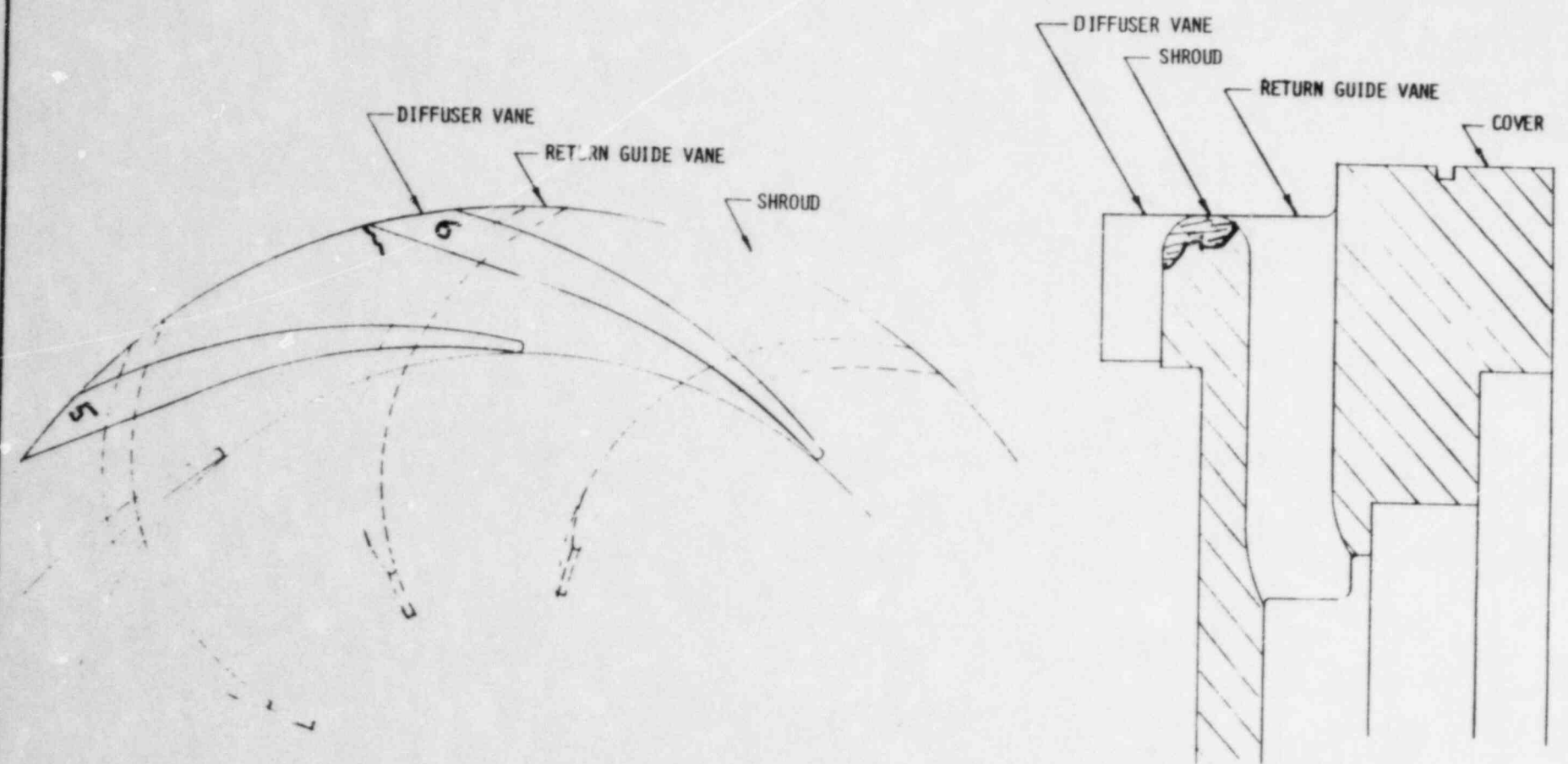

					LIMITS ON ALL FINISH DIMENSIONS UNLESS OTHERWISE SPECIFIED: FRACTIONAL ± 1/84 ANGULAR ± 1/4° PARALLEL ± .002 IN 10" CONCENTRIC WITHIN .002 F.I.R. BREAK OR BURR ALL MACHINED SHARP CORNERS APPROX. D10 x 45° UNLESS OTHERWISE SPECIFIED	PACIFIC PUMPS		
						DIVISION OF DRESSER INDUSTRIES		
						3" JHF INTERMEDIATE COVER		
						OWN 5/82	DATE	TYPE
						CKD.	APPROVED	SHEET OF
NO.	REVISION	BY	DATE	CHKD.	PART NO.	SCALE	B	

BRUNING 40 21

Sketch of indication at edge of shroud near base of diffuser vane #6, blades number sequentially clockwise 1 through 9. Profile of hot tear crack is sketched to illustrate appearance after piece was broken open at indication (2/3 scale).

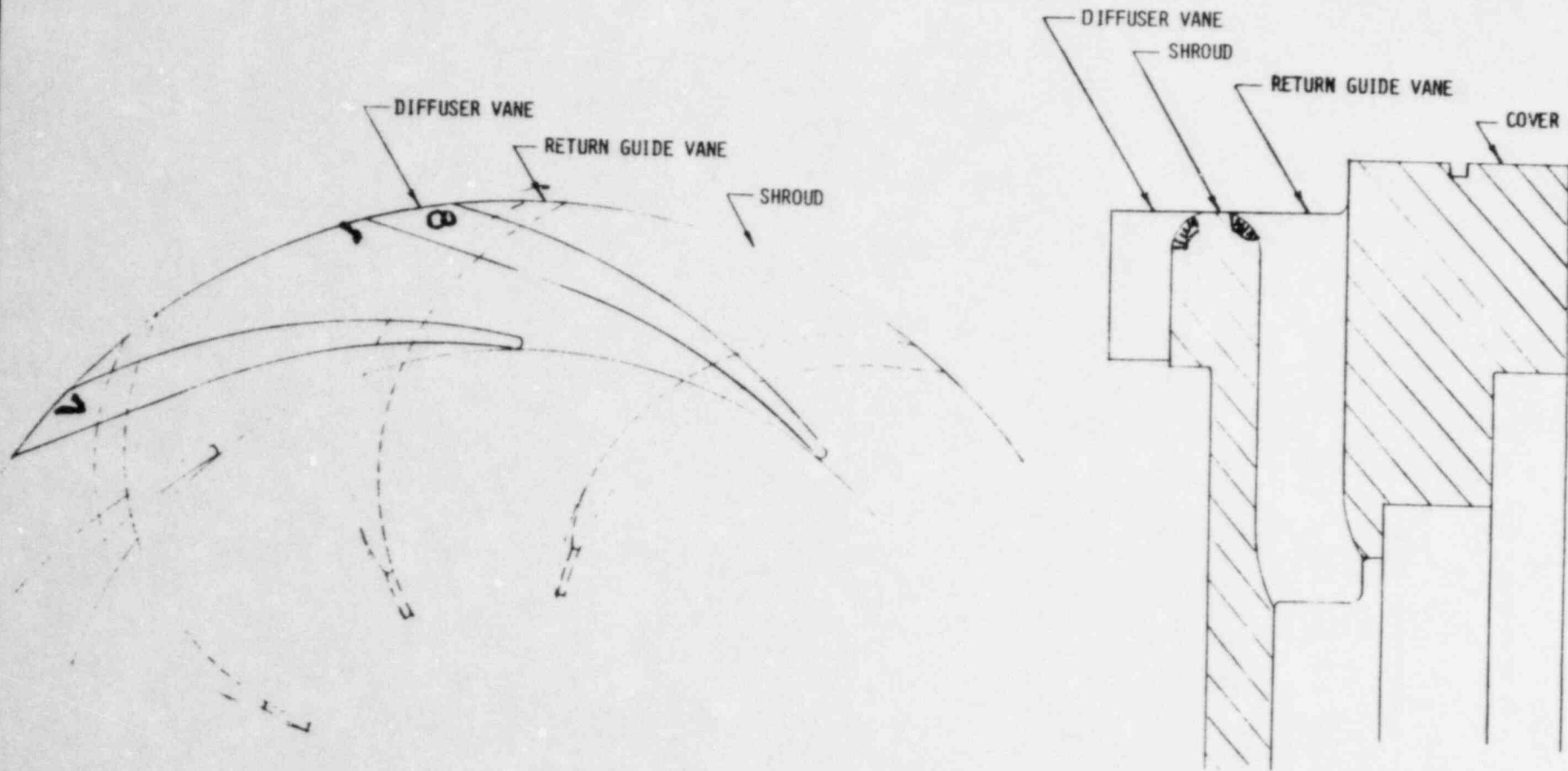

						PACIFIC PUMPS DIVISION OF BREXER INDUSTRIES 3" JHF INTERMEDIATE COVER	OWN	DATE	TYPE
							6/82		
							APPROVED	SHEET OF	
								B	
NO.	REVISION	BY	DATE	CKD	PART NO.	SCALE			

LIMITS ON ALL FINISH DIMENSIONS
 UNLESS OTHERWISE SPECIFIED:
 FRACTIONAL $\pm 1/64$
 ANGULAR $\pm 1/4^\circ$
 PARALLEL $\pm .002$ IN 10°
 CONCENTRIC WITHIN .002 F.I.R.
 BREAK OR BURR ALL MACHINED
 SHARP CORNERS APPROX. $DN \times 45^\circ$
 UNLESS OTHERWISE SPECIFIED

Sketch of indication at edge of shroud near base of diffuser vane #8, blades number sequentially clockwise 1 through 9. Profile of hot tear crack is sketched to illustrate appearance after piece was broken open at indication (2/3 scale).

BRUNING 40 21

METTEK

MATERIALS ENGINEERING TECHNOLOGY LABORATORIES

PACIFIC PUMP P.O. 74450

DEVELOP ACCEPTANCE CRITERIA BASED ON FRACTURE MECHANICS
ANALYSIS OF LINEAR SURFACE INDICATIONS ON SHROUD
SECTION OF INTERMEDIATE COVER 9TH-STAGE // S.I. PUMP
SERIAL NO. 51928 SIZE 3-INCH, MODEL JHF, 11 STAGE

Prepared by:

L. Raymond, Ph.D.

METTEK Report #220431-2

SUPPLEMENT/PHASE II

18 November 1982

Prepared for:

PACIFIC PUMP DIVISION

DRESSER INDUSTRIES, INC.

HUNTINGTON PARK, CA 90255

IRVINE INDUSTRIAL COMPLEX

1805 E. Carnegie Avenue • Santa Ana, CA 92705 • (714) 549-1083

METTER

MATERIALS ENGINEERING TECHNOLOGY LABORATORIES

18 November 1982

Pacific Pumps
5715 Bickette Street
Huntington Park, CA 92055

Attention: G. Morrissy

SUBJECT: DEVELOP ACCEPTANCE CRITERIA BASED ON FRACTURE
MECHANICS ANALYSIS OF LINEAR SURFACE INDICATIONS
ON SHROUD SECTION OF INTERMEDIATE COVER
(Ref. Pattern Drawing C-17519)

ABSTRACT

An initial investigation identified linear surface indications on the shroud section of an intermediate cover to be hot tears and not due to any time delay cracking phenomenon. The tears were essentially superficial, located radially near the edge at the tip of vanes. This phase of the study was used to characterize a CA-6NM casting alloy by machining test specimens from an actual intermediate pump cover and measure the material properties within the framework of fracture mechanics. The test results were used to perform a safe-life cycle analysis from which it was concluded from the most conservative analysis that took into account the worst case operating conditions, the safety of the pump was not being jeopardized, primarily because of the low operating stresses producing a below threshold operating fatigue stress intensity range.

A previous METTEK Report #220431-1 (PHASE I) identified the source of the linear surface indications to be hot tears or a surface separation occurring during solidification because of tensile stresses in the skin produced when the surface begins to solidify and contract ahead of the remainder of the section. CA-6NM is an alloy modification to the widely used CA-15. One purpose for the modifications is to decrease the sensitivity of commonly detected surface separations that occur during solidification; thereby minimizing the cost of weld repair, which is a common and an acceptable practice for this family of casting alloys.

This report covers the additional work performed at METTEK Labs in order to develop an acceptance criteria for the intermediate covers found to contain the linear surface indications. The approach was to:

- characterize the CA-6NM casting alloy with regard to the size, shape and location of the hot tears found in the intermediate covers, specifically in the shroud section;
- characterize the Ca-6NM casting alloy from an intermediate cover by selectively sectioning

an actual cover and machining test specimens for determination of the yield strength (YS), tensile strength (UTS), fracture toughness (K_{Ic}), fatigue crack growth rate (da/dN) in air and a boric acid solution (corrosion fatigue), and the threshold stress intensity for sustained load crack growth rate in a boric acid solution (K_{Isc}).

- determine the load history profile for start-up and on-line pressure pulses for a projected 40-year life;
- analyze for the safe design life employing fracture mechanics.

The entire approach throughout this phase of the program was to take a WORST-CASE approach to the analysis. ALL values selected in the safe-life design analysis were to be selected to provide an extremely conservative approach to the analysis; i.e., maximum anticipated stresses, lowest fracture toughness, highest crack growth rates, largest possible size and shape of the hot tear, located radially to the circularly shaped shroud section.

The results of the safe-life prediction analysis are presented graphically in order to visually illustrate the relative location of the maximum anticipated operating stresses in the intermediate cover relative to the safe-life design envelope.

It is the intention of this study to analytically and graphically illustrate the margin of safety existing in the current design of the intermediate cover when linear surface indications are located radially at the edge of the shroud section, near the tip of the diffuser. The approach was to use finite element analysis to establish the operating stresses and fracture mechanics test methods to measure the important parameters that can cause subcritical crack growth or crack extension. Then, a fracture mechanics analysis employing the current state-of-the-art techniques and incorporating an extremely conservative approach was used to predict the safe-life operating conditions. It is within this framework that any potential hazard of operating the pump with the existing linear surface indications was evaluated.

2.0

BACKGROUND

As previously shown in the first (PHASE I) METTEK report #220431-1, the CA-6NM casting did satisfy the chemical, tensile, and hardness requirements of ASTM STD A296-74 for corrosion-resistant, iron-chromium-nickel-molybdenum alloy castings.

The workmanship and quality, which specifies visual examination of the surfaces to locate adhering "sand, scale, cracks, and hot-tears", satisfied all requirements. Magnetic particle inspection of this alloy casting is only upon agreement between the manufacturer and purchaser. During the original manufacture of the intermediate pump covers, only visual examination was required.

Of the parts in question, the diffuser with the largest number, size, and density of surface indications was selected for destructive examination. On metallurgical examination, no microstructural anomalies were found and internal shrinkage cavities were few in number and were well within acceptable limits. X-ray radiographs suggested that the linear indications were primarily surface indications except for the vane labelled #6. All indications were located at the edge of the shroud cover, near the tip of the vane, essentially radially oriented.

Weld repairs were found on the surface of the cover section and were considered minor, which per ASTM STD A296 means that the depth of the cavity after preparation for repair does not exceed 20% of the actual thickness or 0.16-inch for the shroud. Minor weld repairs can be made by the manufacturer without prior approval of the purchaser.

Since the linear indications in question were not detected during any previous inspection, one question addressed in the first phase of this study was if the linear surface indications were due to some time delay cracking phenomenon. Residual stresses were found to be non-existent by selective cutting techniques. No indication of slow growth by any time delay mechanism was suggested by examination with the scanning electron microscope; therefore, the only remaining conclusion was that the linear indications existed from time of manufacture. A possible reason that they were overlooked was the presence of smeared metal on the surface that was introduced during the routine surface cleaning operation of the intermediate cover prior to visual inspection.

3.0 APPROACH

Every reasonable attempt was made to orient the test specimens such that they are representative of the material in the location and direction that a hot tear might extend by fatigue or stress corrosion. For example, the Charpy impact specimens were machined from pieces taken directly behind the region containing the linear surface indication at the radial edge of the shroud with the fracture plane of the Charpy specimen defined by the notch, located parallel to the plane defined by the linear surface indication. In retrospect, the mechanical properties established the fact that the casting is homogeneous throughout, both within the shroud and cover sections.

For completeness, the results of the chemical analysis and tensile properties taken from the Phase I report are again included as Tables 1 and 2, respectively. The chemistry is seen to meet ASTM STD 296 from all aspects. The tensile properties show the tensile strength to be the same in both the shroud and cover sections. A lower yield strength is obtained with the sub-size R3-tensile specimens machined from the cover section. In all cases, the minimum yield and tensile strength are exceeded; but the ductility parameters of elongation and reduction in area are only satisfied by one standard sized (R1) tensile specimen machined from the shroud section. No serious violations of the mechanical property

TABLE 1. CHEMICAL ANALYSIS

SOURCE	C	Mn	Si	P	S	Cr	Ni	Mo
ASTM A296	0.06 max	1.0 max	1.0 max	.04 max	.04 max	11.5/14.0	3.5/4.5	0.4/1.0
Quali-Cast Test Report 3659	0.05	.40	.75	.020	.024	12.5	4.0	0.65
METTEK	0.06	.60	.71	.017	.023	12.7	4.5	0.74

TABLE 2. TENSILE PROPERTIES PER ASTM STD A370

Source	Y.S.* (ksi)	T.S.* (ksi)	Elongation (%)	Reduction of Area (%)
ASTM A296	80 min.	110 min.	15 min.	35 min.
Quali-Cast Test Report 3659	99.9	126.8	15.7	40.7
R3 (0.25-in)	89.6	122.0	10.5	50.4
COVER	91.6	120.2	10.0	53.7
	89.6	122.2	11.5	50.4
	90.7	120.9	11.5	43.8
R1 (0.50-in)	97.0	120.6	10.0	24.5
SHROUD	98.2	121.5	18.5	45.1

*Y.S. = Yield Strength

*T.S. = Tensile Strength

measurements are noted and the variations are to be expected in comparison to a separately cast test bar commonly used to verify the mechanical properties of a casting.

The remainder of this report will present the Laboratory test program results obtained during this phase of the investigation and the resulting analysis. Mechanical properties that were measured for safe-life design analysis were:

- FRACTURE TOUGHNESS
 - three point bend per ASTM STD E399 @ OF & RT
 - dynamic, instrumented impact per ASTM STD 819-81 @ OF, 30F, 60F, & 90F
 - correlation with STD-CVN per ASTM STD E23-81 @ OF, 30F, 60F, 90F, 200F & 400F
- FATIGUE CRACK GROWTH RATE per ASTM STD E647-81
 - Air @ RT
 - Boric Acid Solution @ RT
- STRESS CORROSION THRESHOLD
 - Boric Acid Solution @ RT

4.0 RESULTS

4.1 FRACTURE TOUGHNESS

4.1.1 Three Point Bend per ASTM STD E399

Charpy-sized fatigue precracked specimens were tested per ASTM STD E399-81@ 0F and RT. The displacement was monitored both by load-line and clip-gage-opening-displacement (COD) techniques. The purpose for these measurements was the possible utilization of non-linear fracture mechanics estimates of fracture toughness such as the J-intergral, the British COD, or the equivalent energy methods in case a valid, linear-elastic solution could not be obtained. The load-displacement traces are shown on Fig. 1. The two room temperature samples were machined from the shroud directly behind the linear indications at the base of vane #2 and vane #8. The exceptionally high ductility is apparent. The fracture toughness per E399 is invalid, suggesting an absolute minimum of $K_{Ic} > \sqrt{B/2.5} \cdot YS = 40 \text{ Ksi} \sqrt{\text{in.}}$; but implying a much higher toughness because of the large amount of plasticity exhibited during the fracture process.

The two 0F samples were machined from the cover section. They were again fatigue precracked and tested with a COD-gage to monitor displacement. Because of smaller span (S) between supports, a variation in the load-displacement curve was observed (Figure 1). A computer printout for the analysis per ASTM STD E399-81 is attached.

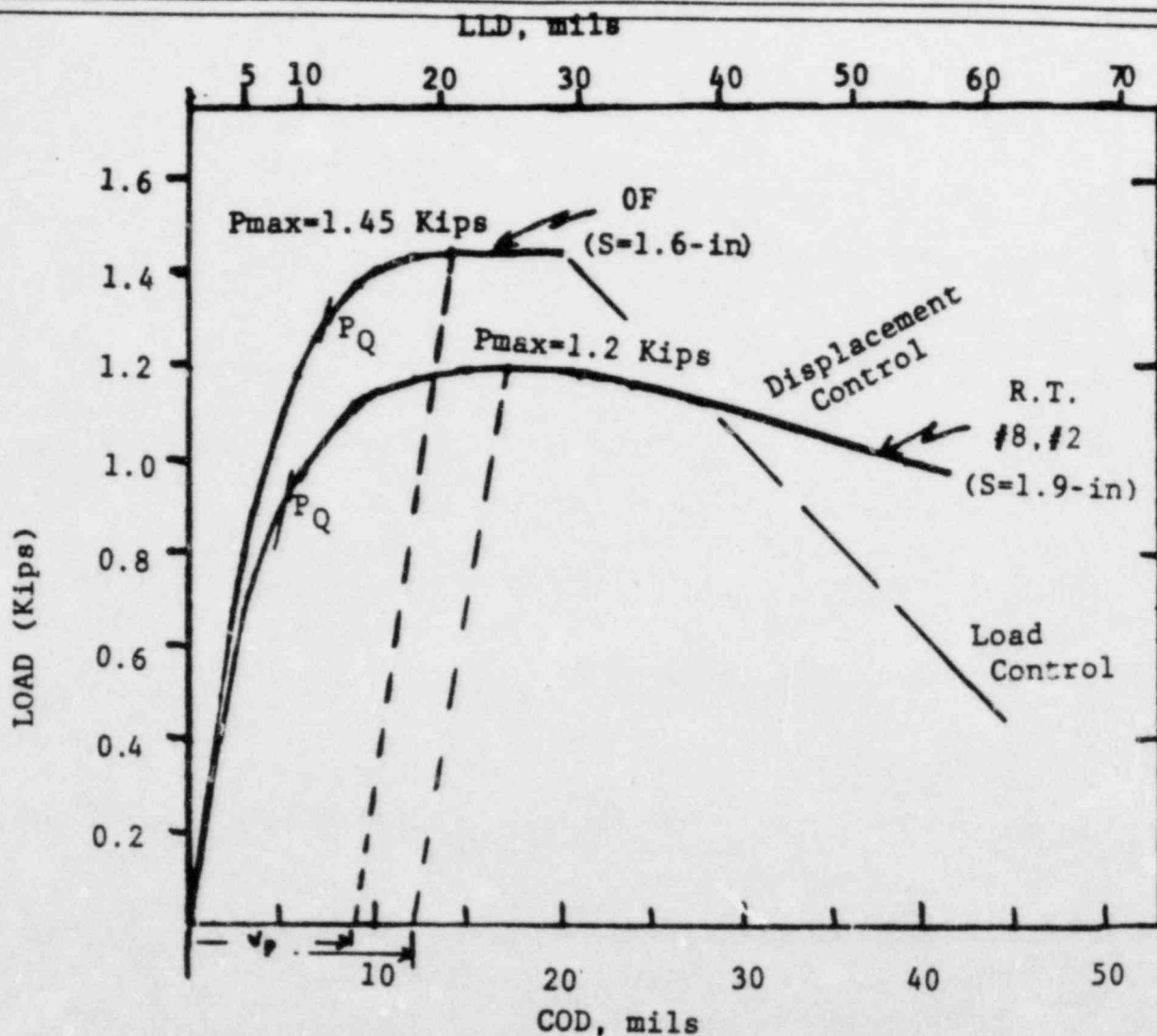

Figure 1. Load-displacement traces of 3-point bend fracture toughness tests per ASTM E399-81 using precracked Charpy-sized specimens. The load-displacement curves vary because the span (S) between supports varied. Also, the room temperature (R.T.) tests were conducted under displacement control whereas the OF specimens were tested under load control.

SAMPLE COMPUTER PRINT OUT OF BEND E399-81 TEST RESULTS- R.T.

BEND E399-81 TEST RESULTS

INPUT DATA

ID NO: #2
 ORIENTATION: 2
 TEMPERATURE: 74F
 LOADING RATE: SLOW
 REL HUMIDITY: 51%

DIMENSIONS (INCH)

(S) SPAN: 1.9
 (B) THICKNESS: .395
 (W) DEPTH: .395
 (F) RATIO BF/B: 1

CRACK LENGTH (INCH)

(M1) -MIDWAY 1: .202
 (C) -CENTER: .202
 (M2) -MIDWAY 2: .198
 (A) AVERAGE: .201
 O.9AVERAGE: .181
 (S1) SURFACE 1: .190
 (S2) SURFACE 2: .184

YS(KSI): 98
 E(KSI): 30000
 PF(KIPS): .4
 PQ(KIPS): .92
 PMAX(KIPS): 1.21

SUCCESS CRITERIA

(M1-C)/0.05A < 1 : 0
 (M2-C)/0.05A < 1 : .4
 (M2-M1)/0.05A < 1 : .4
 .9A / S1 < 1 : .95
 .9A / S2 < 1 : .98
 (0.45W) / A < 1 : .89
 A / (0.55W) < 1 : .92
 KF/0.6KQ < 1 : .72
 KF/0.002E < 1 : .35

BIC/B < 1 : 1.56
 PMAX/1.1PQ < 1 : 1.2

CALCULATIONS

KQ(KSI.IN^{0.5}): 48.7
 RSB : 2
 BIC(INCH) : .6

FRACTURE APPEARANCE
 % OBLIQUE: 0

BEND E399-81 TEST RESULTS

INPUT DATA

ID NO: #8
 ORIENTATION: 8
 TEMPERATURE: 74F
 LOADING RATE: SLOW
 REL HUMIDITY: 51%

DIMENSIONS (INCH)

(S) SPAN: 1.9
 (B) THICKNESS: .395
 (W) DEPTH: .393
 (F) RATIO BF/B: 1

CRACK LENGTH (INCH)

(M1) -MIDWAY 1: .201
 (C) -CENTER: .199
 (M2) -MIDWAY 2: .195
 (A) AVERAGE: .198
 O.9AVERAGE: .179
 (S1) SURFACE 1: .192
 (S2) SURFACE 2: .181

YS(KSI): 98
 E(KSI): 30000
 PF(KIPS): .4
 PQ(KIPS): .895
 PMAX(KIPS): 1.2

SUCCESS CRITERIA

(M1-C)/0.05A < 1 : .2
 (M2-C)/0.05A < 1 : .4
 (M2-M1)/0.05A < 1 : .61
 .9A / S1 < 1 : .93
 .9A / S2 < 1 : .99
 (0.45W) / A < 1 : .89
 A / (0.55W) < 1 : .92
 KF/0.6KQ < 1 : .74
 KF/0.002E < 1 : .35

BIC/B < 1 : 1.49
 PMAX/1.1PQ < 1 : 1.22

CALCULATIONS

KQ(KSI.IN^{0.5}): 47.5
 RSB : 1.9
 BIC(INCH) : .6

FRACTURE APPEARANCE
 % OBLIQUE: 0

SAMPLE COMPUTER PRINT OUT OF BEND E399-81 TEST RESULTS- OF.

BEND E399-81 TEST RESULTS

BEND E399-81 TEST RESULTS

INPUT DATA

INPUT DATA

ID NO: #1A
ORIENTATION: 1
TEMPERATURE: OF
LOADING RATE: SLOW
REL HUMIDITY: 20%

ID NO: #2A
ORIENTATION: 2
TEMPERATURE: OF
LOADING RATE: SLOW
REL HUMIDITY: 20%

DIMENSIONS (INCH)

DIMENSIONS (INCH)

(S) SPAN: 1.6
(B) THICKNESS: .395
(W) DEPTH: .395
(F) RATIO BF/B: 1

(S) SPAN: 1.6
(B) THICKNESS: .395
(W) DEPTH: .395
(F) RATIO BF/B: 1

CRACK LENGTH (INCH)

CRACK LENGTH (INCH)

(M1) -MIDWAY 1: .205
(C) -CENTER: .211
(M2) -MIDWAY 2: .201
(A) AVERAGE: .206
0.9AVERAGE: .185
(S1) SURFACE 1: .195
(S2) SURFACE 2: .188

(M1) -MIDWAY 1: .208
(C) -CENTER: .207
(M2) -MIDWAY 2: .202
(A) AVERAGE: .206
0.9AVERAGE: .185
(S1) SURFACE 1: .198
(S2) SURFACE 2: .188

YS(KSI): 100
E(KSI): 30000
PF(KIPS): .4
PQ(KIPS): 1.2
PMAX(KIPS): 1.45

YS(KSI): 100
E(KSI): 30000
PF(KIPS): .4
PQ(KIPS): 1.3
PMAX(KIPS): 1.44

SUCCESS CRITERIA

SUCCESS CRITERIA

(M1-C)/0.05A < 1 : .58
(M2-C)/0.05A < 1 : .97
(M2-M1)/0.05A < 1 : .39
.9A / S1 < 1 : .95
.9A / S2 < 1 : .98
(0.45W) / A < 1 : .86
A / (0.55W) < 1 : .95
KF/0.6KQ < 1 : .56
KF/0.002E < 1 : .31

(M1-C)/0.05A < 1 : .1
(M2-C)/0.05A < 1 : .47
(M2-M1)/0.05A < 1 : .58
.9A / S1 < 1 : .93
.9A / S2 < 1 : .98
(0.45W) / A < 1 : .86
A / (0.55W) < 1 : .95
KF/0.6KQ < 1 : .51
KF/0.002E < 1 : .31

BIC/B < 1 : 1.97
PMAX/1.1PQ < 1 : 1.1

BIC/B < 1 : 2.31
PMAX/1.1PQ < 1 : 1.01

CALCULATIONS

CALCULATIONS

KQ(KSI.IN^0.5): 55.7
RSB : 2.4
BIC(INCH) : .8

KQ(KSI.IN^0.5): 60.4
RSB : 2.4
BIC(INCH) : .9

FRACTURE APPEARANCE
% OBLIQUE: 0

FRACTURE APPEARANCE
% OBLIQUE: 0

One estimate of fracture toughness is based on the specimen strength ratio R_{sb}^* or $K_{Ic} \cong 0.3 R_{sb} \cdot YS = 60 \text{Ksi} \sqrt{\text{in.}}$. Another estimate based on a single specimen COD test, assuming that crack initiation occurs at maximum load, is calculated to be between 139 and 150 $\text{Ksi} \sqrt{\text{in.}}$. The difference in the two estimates is that the COD approach takes the additional plasticity into account. Dynamic fracture toughness, measured subsequently, is also based only on the maximum load and therefore ignores the additional plasticity during local yielding as the specimen approaches maximum load.

Finally, an equivalent energy method proposed by Witt is used to estimate K_{Ic} . The results of which are listed in Table 3 and found to agree quite well with the elastic-plastic COD analysis.

Since the estimates of fracture toughness are not used in subsequent calculations, the accuracy of the estimate is academic other than serving the purpose of suggesting a margin of safety on toughness. In this report, only a lower limit or minimum value of fracture toughness is used to calculate critical stresses and predict safe-life cycles.

A computer print out of the COD analysis per British Standards are attached.

* Rapid Inexpensive tests for determining fracture toughness
NMAB-328.

 SAMPLE COMPUTER PRINT OUT OF COD ANALYSIS PER BRITISH STANDARD

KCOD 3-PT TEST

SAMPLE NO : #2
 TEMP : 74F
 A/W : .509
 BN/B : 1
 YS (KSI) : 98
 CODP (MILS) : 10
 PMAX (KIPS) : 1.21
 S : 1.6
 B : .394
 W : .394
 Z : .06
 (Y OR N) : N
 S : 1.9
 B : .395
 W : .395
 Z : .05
 K (COD) : 139.2

KCOD 3-PT TEST

SAMPLE NO : #8
 TEMP : 74F
 A/W : .501
 BN/B : 1
 YS (KSI) : 98
 CODP (MILS) : 12
 PMAX (KIPS) : 1.2
 S : 1.6
 B : .394
 W : .394
 Z : .06
 (Y OR N) : N
 S : 1.9
 B : .395
 W : .393
 Z : .05
 K (COD) : 150.3

KCOD 3-PT TEST

SAMPLE NO : #1A
 TEMP : 0F
 A/W : .505
 BN/B : 1
 YS (KSI) : 100
 CODP (MILS) : 8.75
 PMAX (KIPS) : 1.450
 S : 1.6
 B : .394
 W : .394
 Z : .06
 (Y OR N) : N
 S : 1.6
 B : .395
 W : .395
 Z : .05
 K (COD) : 133.6

KCOD 3-PT TEST

SAMPLE NO : #2A
 TEMP : 0F
 A/W : .510
 BN/B : 1
 YS (KSI) : 100
 CODP (MILS) : 12
 PMAX (KIPS) : 1.440
 S : 1.6
 B : .394
 W : .394
 Z : .06
 (Y OR N) : N
 S : 1.6
 B : .395
 W : .395
 Z : .05
 K (COD) : 150.9

TABLE 3. FRACTURE TOUGHNESS ESTIMATES
USING EQUIVALENT ENERGY ANALYSIS

Location	B (in)	W (in)	A (in)	S (in)	P _{max} (kips)	P _{eq} (kips)	K _{eq} (ksi $\sqrt{\text{in}}$)
Vane #2	.395	.395	.201	1.9	1.21	2.44	140
Vane #8	.395	.393	.198	1.9	1.20	2.57	146
Type of Test: Slow bend precracked Charpy per ASTM E399-81							
Temp = 74F Rel Hum = 51% K _f (max) = 28 ksi $\sqrt{\text{in}}$ B _{Ic} = 5-inches							
*K _{Ic} Test Invalid per E399; therefore, equivalent energy estimate of fracture toughness (K _{eq}) based on assumption of crack initiation at max load.							

4.1.2 Dynamic Fracture Toughness

In order to determine the effects of strain or loading rate, instrumented impact tests per ASTM STD E812-81 and conventional Charpy Impact Tests per ASTM STD E23-81 were conducted. The samples were all machined from the cover section. Typical results are attached (pp 11A-11D) Table 4 summarizes the test data and compares the results and two loading rates and over a range of temperatures. The data is plotted on Fig. 2. From these results the minimum value of toughness at the upper shelf was conservatively estimated to be 75 Ksi $\sqrt{\text{in}}$ and the minimum fracture toughness on the lower shelf was 45 K $\sqrt{\text{in}}$ * with a transition temperature at about 100F. These minimum values were used in all subsequent analysis.

4.1.3 STANDARD CHARPY IMPACT

The standard Charpy impact tests were correlated to the fatigue precracked, dynamic fracture toughness tests by using a correlation* where:

$$KId^2 = 5E \bullet CVN$$

where E=30 Msi and CVN is in units of ft-lbs; then, KI d is in units of Ksi $\sqrt{\text{in}}$.

The relationship appears to be quite good on examining Figure 2 and Table 4.

*Barsom/Rolfe "Fracture and Fatigue Control in Structures" 1977

K 3-PT TEST T-0F

SAMPLE NO : 1
A/W : 0.51
BN/B : 1.0
YS(KSI) : 98
PD(KIPS) : 1.45
PM(KIPS) : 1.45
S: 1.6
B: .394
W: .394

(Y OR N): Y

KQ : 65.4
RSB : 2.3
K(RSB) : 65.4
BIC/BN : 2.8
KIC MAX VALID : 38.9
KRSB MAX VALID : 73.5

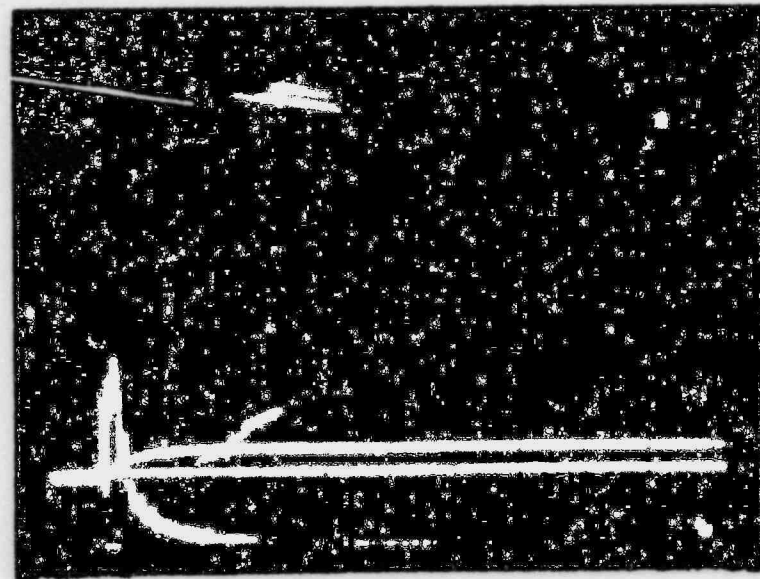
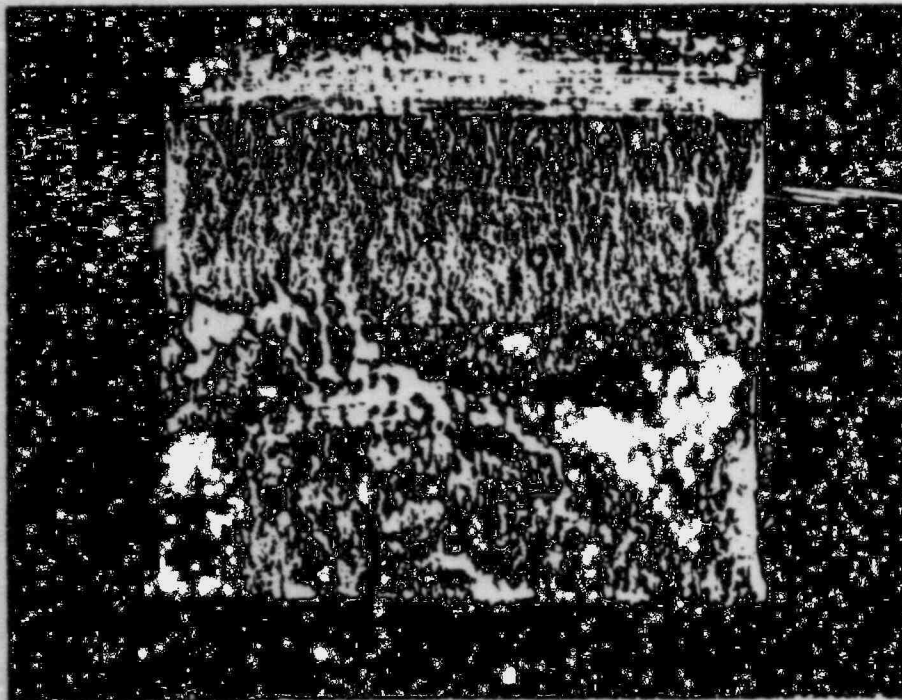

K 3-PT TEST T=30F

SAMPLE NU :2
A/W :0.55
BN/B :1.0
YS(KSI) :98
PD(KIPS) :1.58
PM(KIPS) :1.58
S:1.6
B: .394
W: .394

(Y OR N):Y

KD :81.5

RSB :3

K(RSB) :81.5

BIC/BN :4.3

KIC MAX VALID :38.9

KRSB MAX VALID :73.5

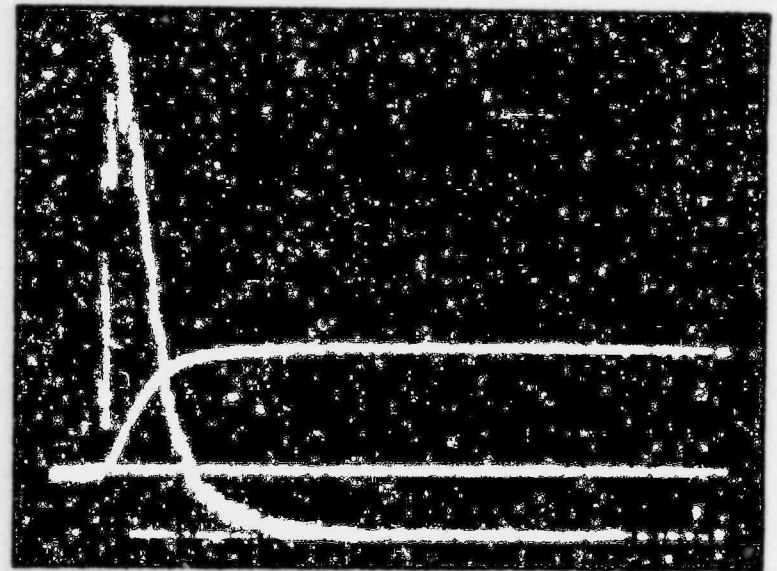
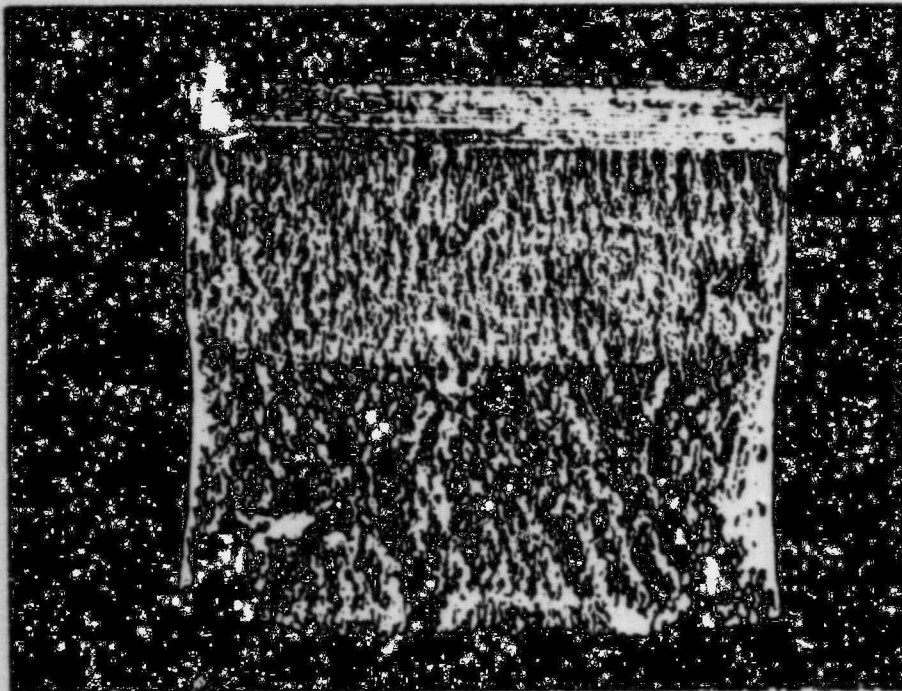

K 3-PT TEST T=60F

SAMPLE NO : 3
A/W : 0.54
BN/B : 1.0
YS (KSI) : 98
PD (KIPS) : 1.625
PM (KIPS) : 1.625
S : 1.6
B : .394
W : .394

(Y OR N) : Y

KQ : 81
RSB : 3
K (RSB) : 81
BIC/BN : 4.3
KIC MAX VALID : 38.9
KRSD MAX VALID : 73.5

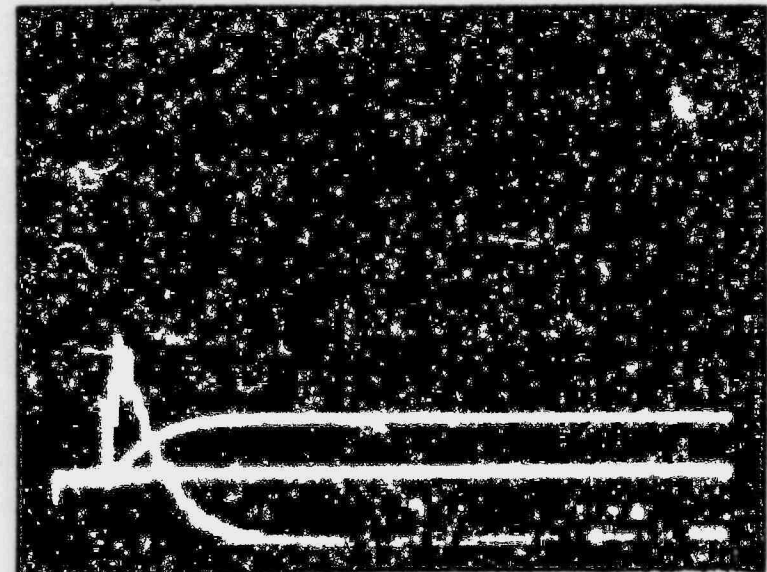
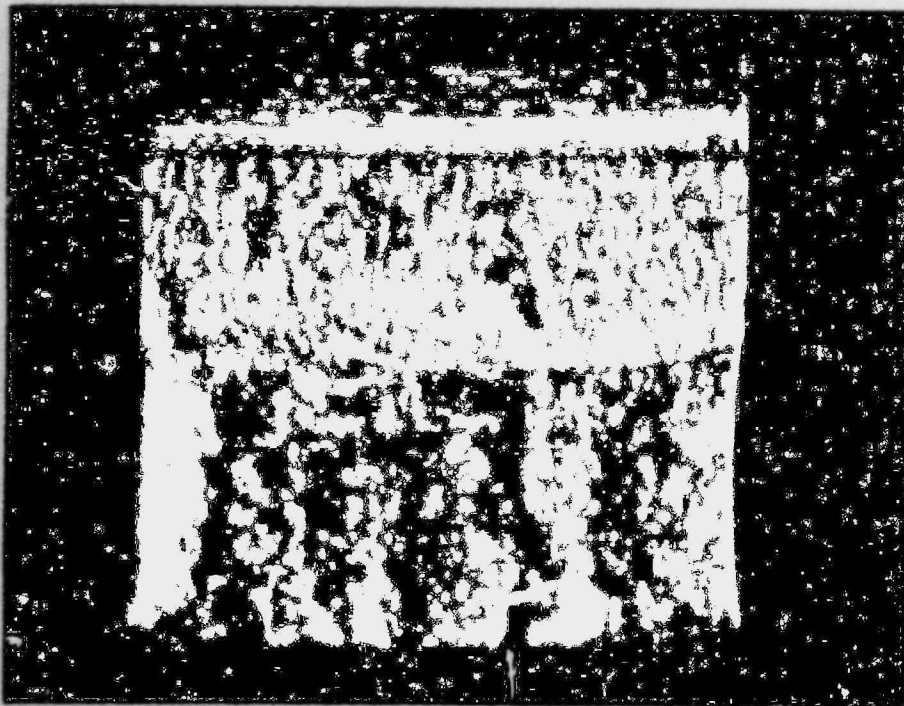

K 3-PT TEST T=90F

SAMPLE NO : 4
A/W : 0.53
BN/B : 1.0
YS(KSI) : 98
PD(KIPS) : 1.75
PM(KIPS) : 1.75
S : 1.6
B : .394
W : .394

(Y OR N): Y

KQ : 84.3
RSB : 3.1
K(RSB) : 84.3
BIC/BN : 4.7
KIC MAX VALID : 38.9
KRSB MAX VALID : 73.5

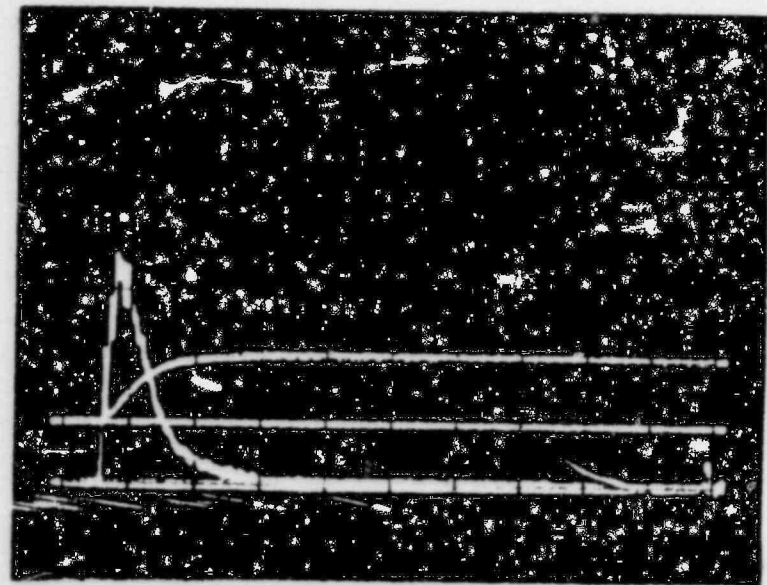
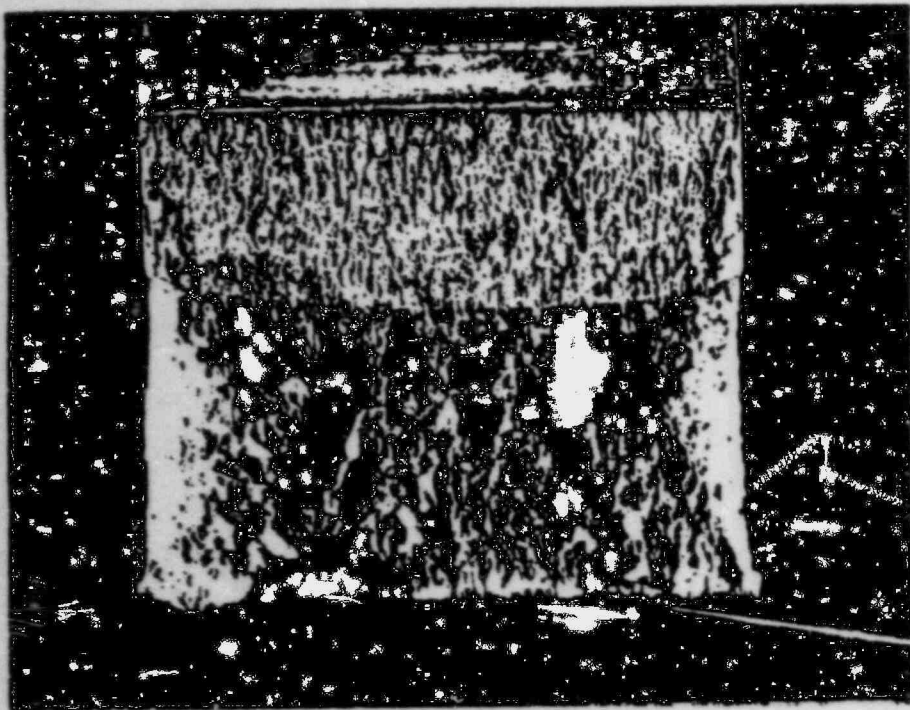

Table 4., SUMMARY OF FRACTURE TOUGHNESS DATA.

METHOD	0		30		60		RT		90		200		400	
	--	KIc	--	--	--	--	--	KIc	--	--	--	--	--	--
Precracked - E399 Charpy Slow Bend	K(Rsb)	72,72	--	--	--	--	--	60.58	--	--	--	--	--	--
	K(COD)	133,151	--	--	--	--	--	139,150	--	--	--	--	--	--
	K(Eq)							140,146						
DYNAMIC	CVN	KId	CVN	KId	CVN	KId	CVN	KId	CVN	KId	CVN	KId	CVN	KId
Precracked E812 Charpy Impact	--	65.4	--	81.5	--	81	--	--	--	84.3	--	--	--	--
Standard E23 Charpy Impact	24	60.0*	30	67.1*	26	62.4*	26 20 18 16	62.4* 54.8* 52.0* 49.0*	41	78.4*	40	77.5*	43	80.3*

CVN = Charpy V-Notched impact energy in ft-lbs.

KId = Estimated by equivalent energy, COD technique -- $Ksi \sqrt{in.}$

KID = dynamic KIc, either measured or *calculated from $KId^2 = 5E \cdot CVN$ ($Ksi \sqrt{in.}$)

E = Elastic Modulus = 30 Msi

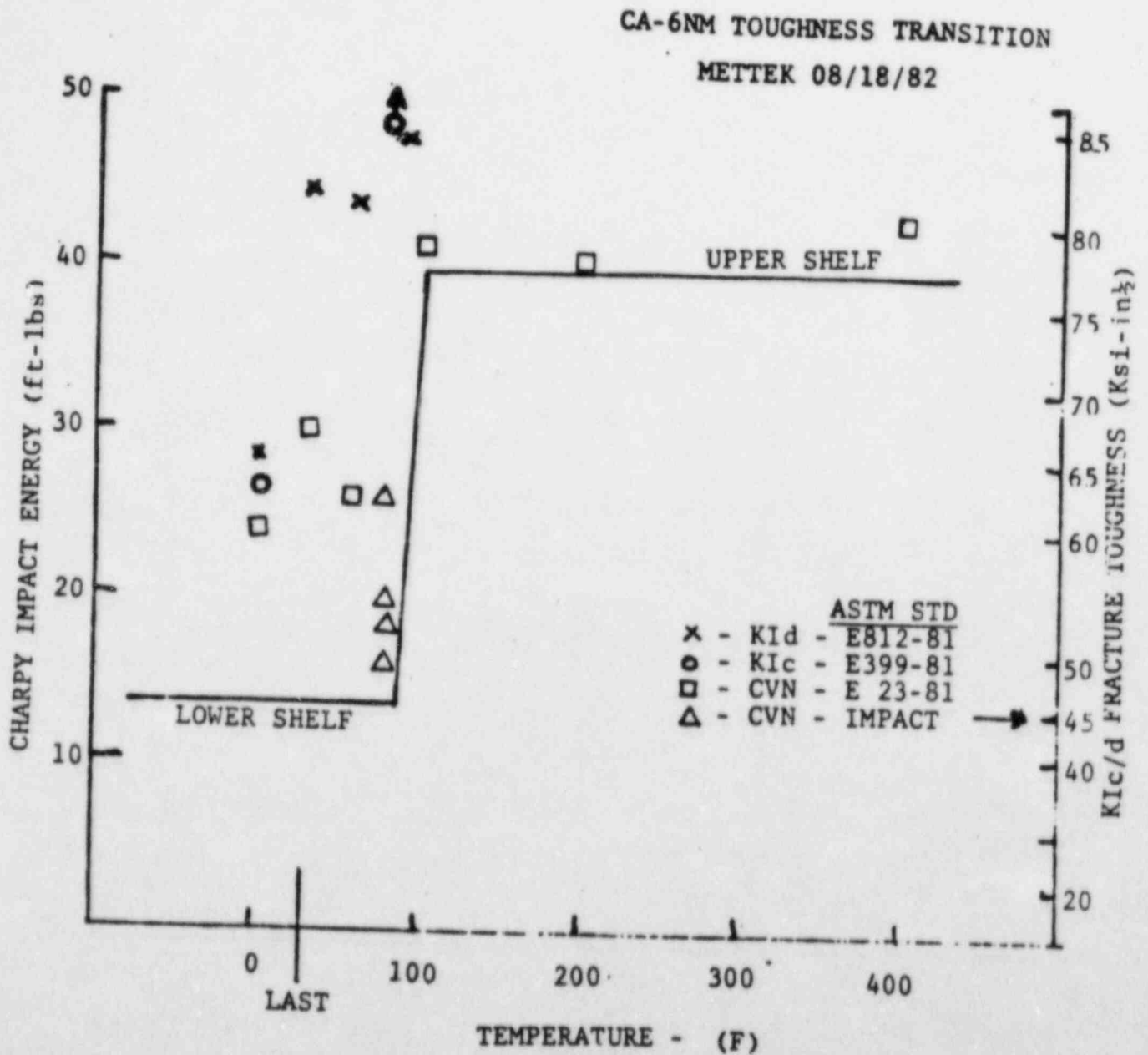

FIGURE 2. Summary of fracture toughness data, plotted to delineate transition temperature behavior in addition to providing absolute minimum fracture toughness used for subsequent safe-life cycle analysis.

4.2

FATIGUE CRACK GROWTH RATE

Fatigue testing for crack growth rates as a function of the crack-tip stress intensity range (ΔK) was done according to ASTM STD E647-81 using a compact type specimen with the thickness (B) equal to 0.5-inches and the width (W) equal to 1.5-inches. During tests the crack length was measured optically from both sides with a travelling microscope. The average crack length (a) was used in calculating the rates. Testing was at a frequency range of 10-60Hz depending on the applied stress intensity range. The stress ratio (R) was 0.1 and the temperature was ambient or about 80F.

Fatigue crack extension was monitored as a function of the number of fatigue cycles (N). The incremental polynomial method, a recommended curve smoothing technique described in the Appendix of ASTM E647-81 was used to analyze the data and calculate the slope or rate of crack extension. An Apple computer was used to perform the analysis and plot the results as shown on Figure 3.

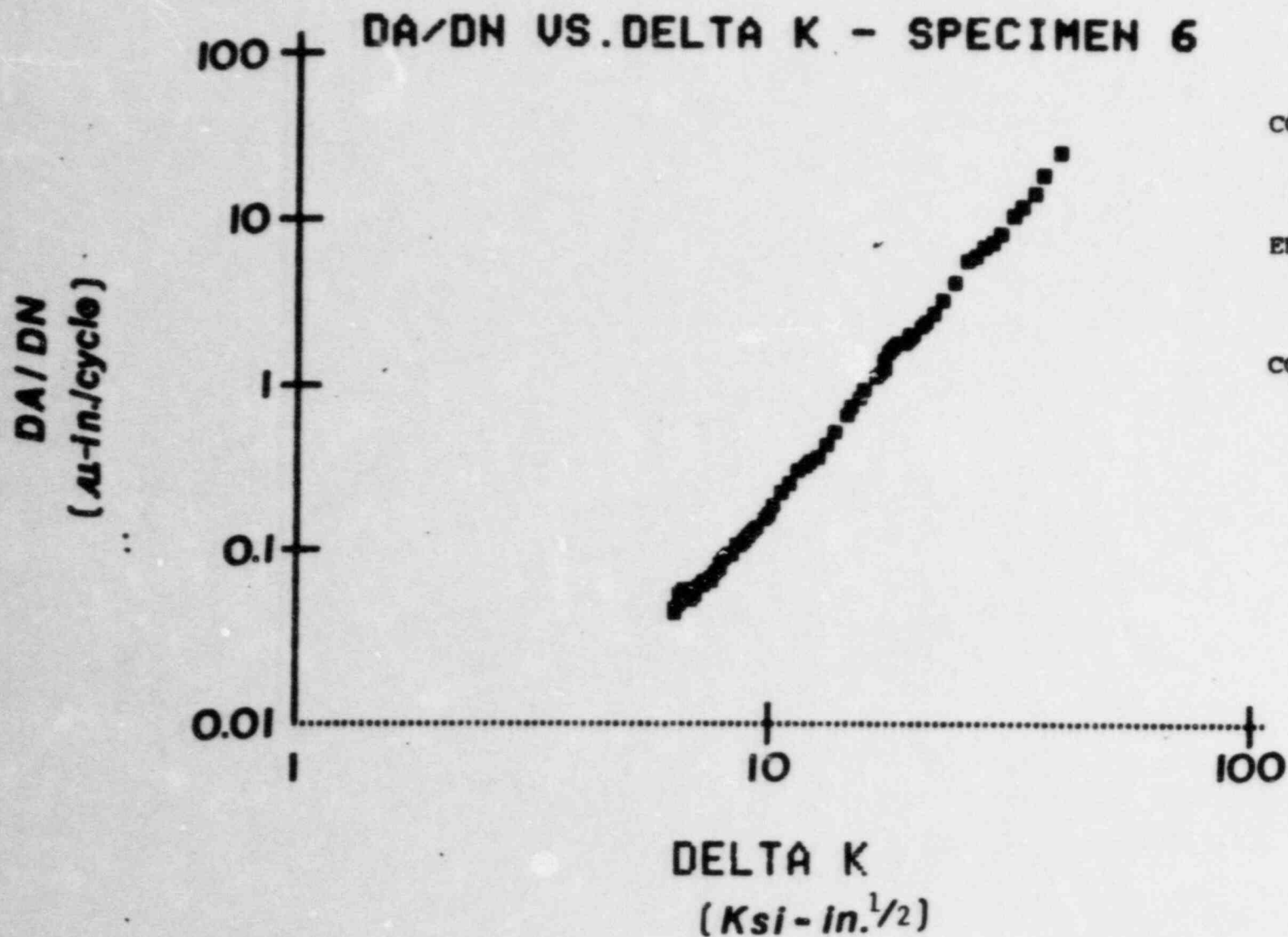
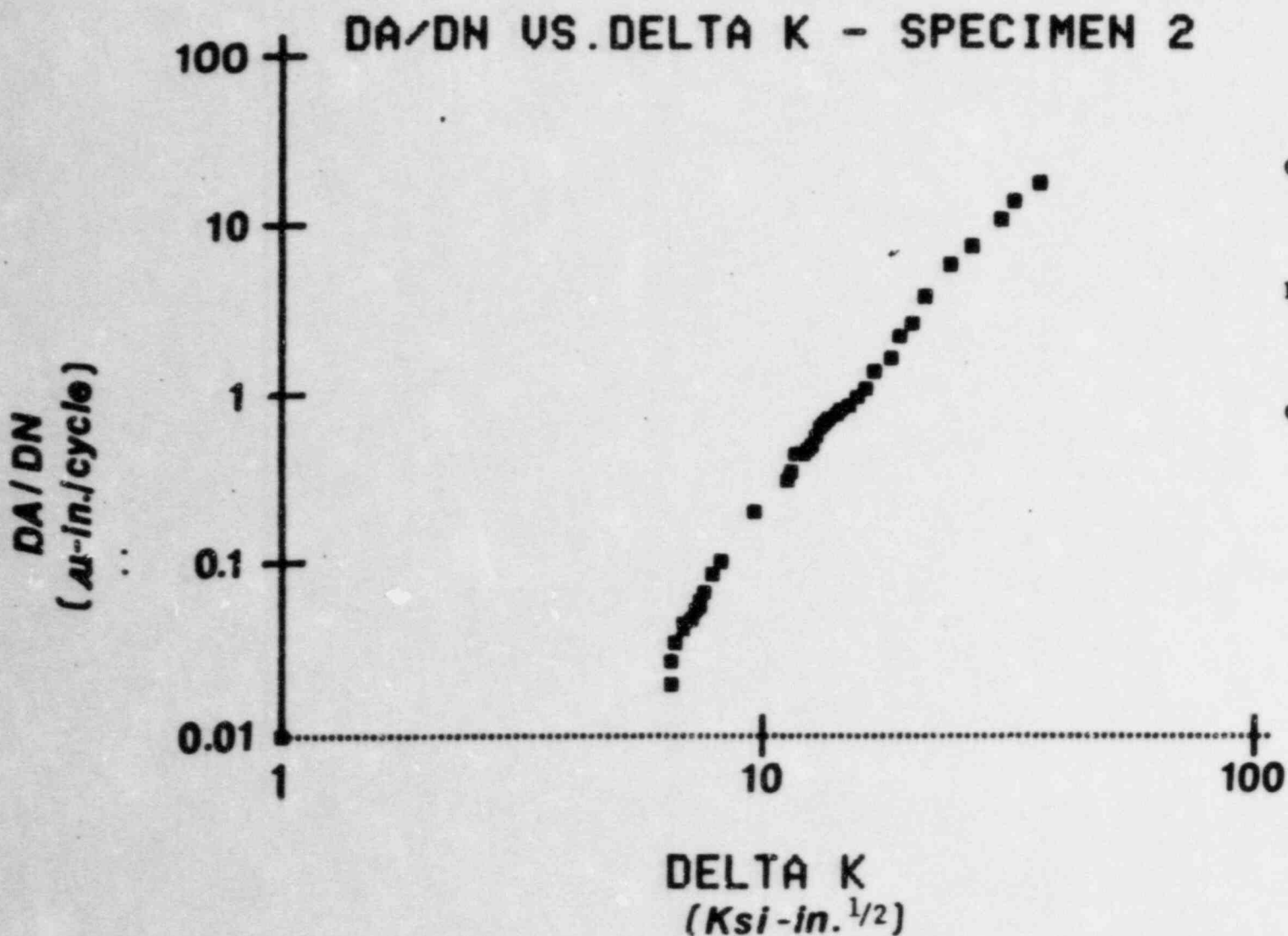

FIGURE 3. Measured fatigue-crack growth rate in air per ASTM STD E64 -81 of CA-6NM Casting Alloy.

In addition to conducting the test in air, a corrosion-fatigue study in a boric acid solution representing the refueling water in the storage tank. The purity of the water was maintained by using distilled water and adding boric acid to provide 2000-4000ppm of boron. The pH of the solution was between 4.0 and 4.7 as called for in the specification supplied by Westinghouse. The oxygen was not controlled during test thereby again representing worst-case condition by using a system that was not de-oxygenated. The test results are plotted on Figure 4. On comparison, they are seen to overlay the test results in air (Fig. 3). Therefore, it can be concluded that the boric acid refueling water solution does not represent a more aggressive corrosion-fatigue environment. Both sets of data are represented by a conservative upper-limit curve given by:

$$\boxed{da/dN \text{ (Micro-inches)} = 2.57 \times 10^{-4} \cdot (\Delta K)^{3.0}} \quad \text{Eqn. 1}$$

with ΔK in units of $\text{Ksi} \sqrt{\text{in}}$



COMPACT SPECIMEN

B = .500 in.
W = 1.500 in.

ENVIRONMENT

Boric Acid Solution
Temp = 80°F

CONDITIONS

10 Hz
1 Kip = Pmax

FIGURE 4. Measured corrosion fatigue-crack growth rates per ASTM STD E647-81 in a boric acid solution (pH4-4.7) of CA -6NM casting

4.3

STRESS CORROSION/BORIC ACID

An accelerated stress corrosion testing method developed at METTEK* was used to determine the threshold stress intensity for sustained load crack growth in a boric acid solution. Again, the system was not de-oxygenated, representing the most aggressive environment. One test specimen was broken in air for comparison. The results showed no environmentally assisted crack growth; i.e., $K_{Isc}c/K_{Ic} \geq 0.9$.

The test method employs a Charpy-sized specimen, loaded by a rising step method. A potential @ -1.2V vs SCE is used to generate an aggressive hydrogen environment that has been shown to induce stress corrosion cracking in the high toughness HY-140 ship steels. This same method of testing could not produce any environmentally assisted cracking in the CA-6NM casting alloy.

*Accelerated, Low-Cost Test Method for Measuring the Susceptibility of HY-Steel to Hydrogen Embrittlement. By L. Raymond, Ph.D. ASM Conference, Washington, D.C. November 1982

5.0 SAFE-LIFE ANALYSIS

A conservative analysis for safe-life operating cycles of the intermediate cover of the S.I. Pump requires knowledge of the largest possible size of hot tear and the operational stresses in addition to the data obtained in this test program.

5.1 HOT TEAR CHARACTERIZATION

The size and shape of the hot-tears were carefully identified in the PHASE I report. The radial location of the hot tear near the tip of the blade and the superficial, shallow surface shape is indicated in Figure 5 for vane #2. Figure 6 shows the worst tear that was found and coincidentally, it is identified as vane #6. Again consistent with the worst case analysis, the largest imaginable tear would be represented by a 0.5-inch deep, through the thickness (13/16-inch) radially oriented edge crack. Because of the geometry of the diffuser vanes in the shroud section, whereby they cross at about 1-inch from the edge of the shroud, it is not anticipated that extension of the hot-tear would exceed this value. These observations are consistent with the stress

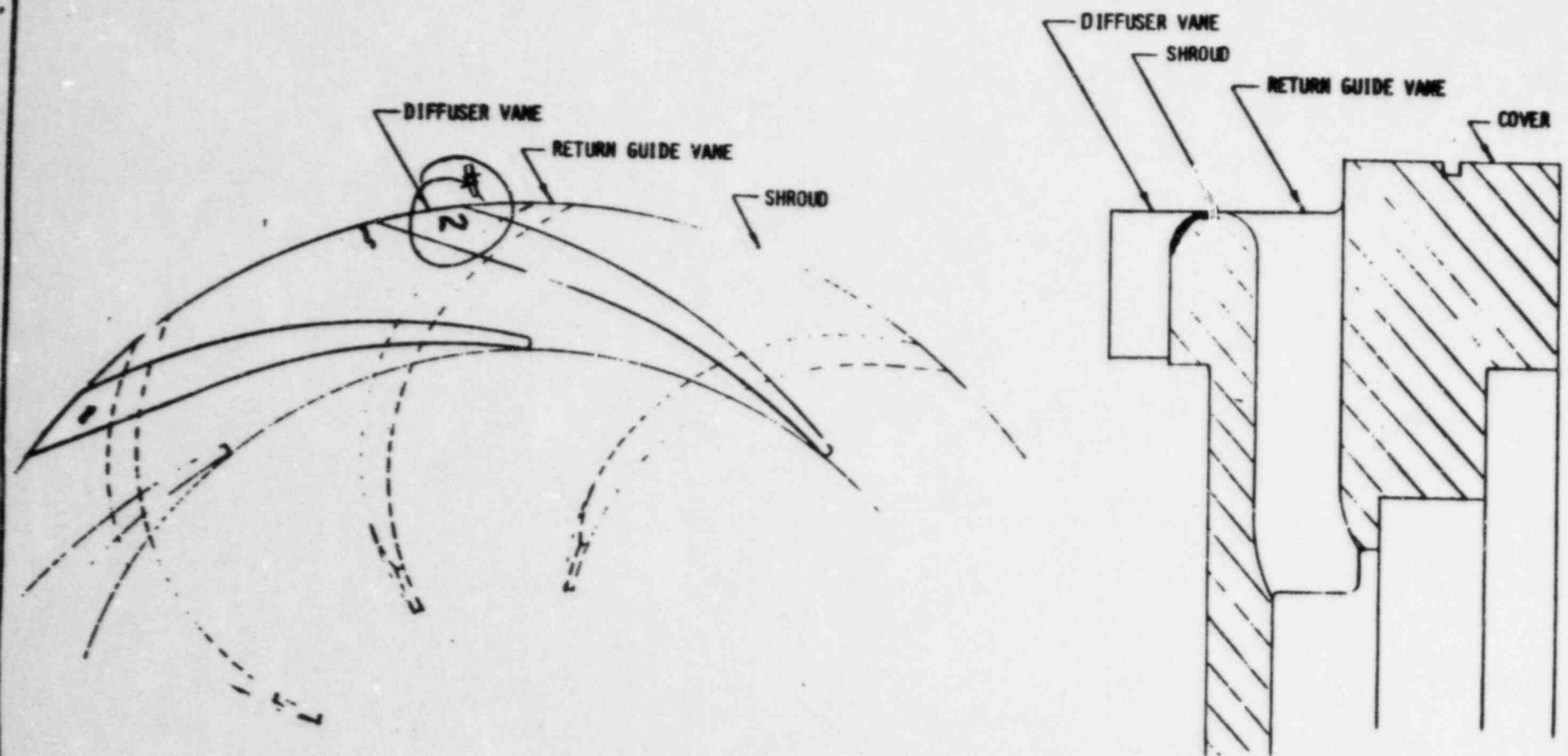

				LIMITS ON ALL FINISH DIMENSIONS UNLESS OTHERWISE SPECIFIED: FRACTIONAL 2 / 64 ANGULAR 2 / 16° PARALLEL 2 .002 IN 10" CONCENTRIC WITHIN .002 P.I.R. BREAK OR BURN ALL MACHINED SHARP CORNERS APPROX 10°-45° UNLESS OTHERWISE SPECIFIED	PACIFIC PUMPS	
					DIVISION OF SPENCER INDUSTRIES	
					3" JHF INTERMEDIATE COVER	
		DRAWN 6/82	DATE		TYPE	
		CHKD.	APPROVED		SCALE	B
NO.	REVISION	BY	DATE		APP.	PART NO.

FIGURE 5. Sketch of indication at edge of shroud near base of diffuser vane #2, blades number sequentially clockwise 1 through 9. Profile of hot tear crack is sketched to illustrate appearance after piece was broken open at indication (2/3 scale).

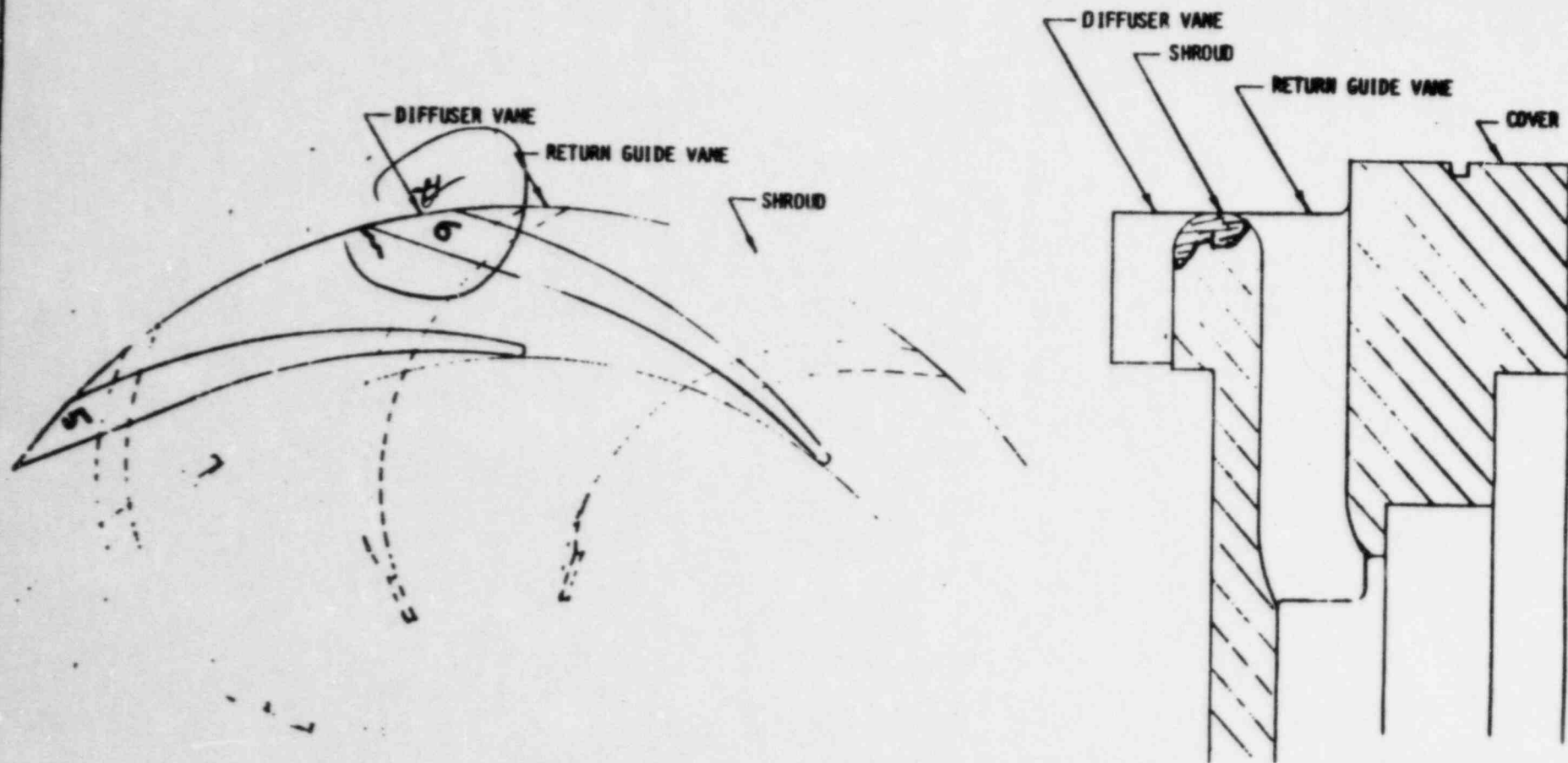

				LIMITS ON ALL FINISH DIMENSIONS UNLESS OTHERWISE SPECIFIED:		PACIFIC PUMPS DIVISION OF INTEGRAL INDUSTRIES	
				FRACTIONAL 2/1000			
				ANGULAR 2/10°		3° JMF INTERMEDIATE COVER	
				PARALLEL 2.002 IN 10"		DATE 6/82	
				CONCENTRIC WITHIN .002 F.I.R.		BY	
				BREAK OR BURR ALL MACHINES		TYPE	
				SHARP CORNERS APPROX. 60° ± 45°		SHEET	
				UNLESS OTHERWISE SPECIFIED		APPROVED	
NO.	REVISION	BY	DATE	FIG.	PART NO.	SCALE	B

FIGURE 6. Sketch of indication at edge of shroud near base of diffuser vane #6, blades number sequentially clockwise 1 through 9. Profile of hot tear crack is sketched to illustrate appearance after piece was broken open at indication (2/3 scale).

analysis. Therefore, for the safe-life analysis, the hot tear will be analyzed in fracture mechanics jargon as a single edge notch specimen with the initial depth of crack not exceeding 0.5-inches.

5.2 CRITICAL STRESS CALCULATIONS

Based on the conservative estimates of fracture toughness on both the upper and lower shelves, the fracture strength curve of the CA-6NM alloy are shown in Figure 7. The curves are derived from a fracture mechanics relationship for a single edge notch specimen where,

$$K_{Ic} = 1.1 \sigma \sqrt{\pi a}$$

or

$$K_{Ic} \cong 2 \sigma \sqrt{a}$$

Eqn. 2

where K_{Ic} \cong plane strain fracture toughness
per ASTM E399-81

σ \cong applied far field or gross stress

a \cong depth of crack from edge

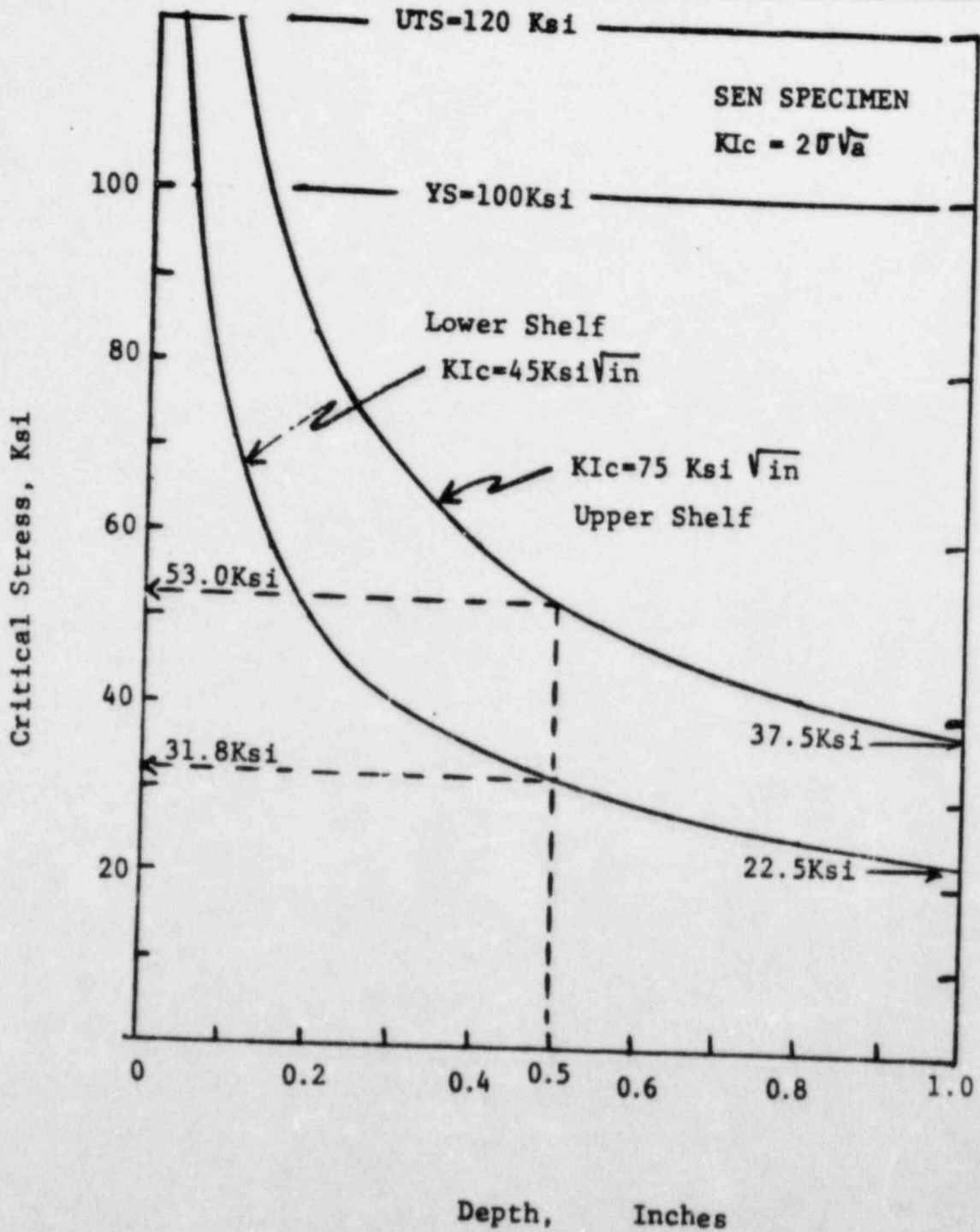

FIGURE 7. Estimated strength of the shroud section of the diffuser with a radially oriented edge crack.

Examining Figure 7 shows the critical stress to be 31.8 Ksi and 53 Ksi for the lower and upper shelf, respectively. If the tear were to extend to one-inch, the critical stresses would then be lowered to 22.5 and 37.5 Ksi, respectively.

5.3 OPERATING STRESSES

The actual stresses the shroud experiences under operating conditions has been carefully detailed in another section of this report. Finite element analysis has shown that the stress history profiles can be characterized as shown in Figure 8. Two aspects of the analysis are considered, start-up and on-line pressure pulses. Conservatively, the start-up stresses can be described as $\Delta\sigma = 3\text{Ksi}$ and $R = 0$; whereas the on-line stresses are $\Delta\sigma = 0.1\text{ Ksi}$ and $R = 0.97$. In essence, a tensile stress component of 3 Ksi is never exceeded. Immediately, it should be noted that this stress level is far below the critical stresses described in the previous section; i.e., for the worst case the critical stress exceeds the operating stress by a factor of 7; i.e., $22.5/3$.

START - UP

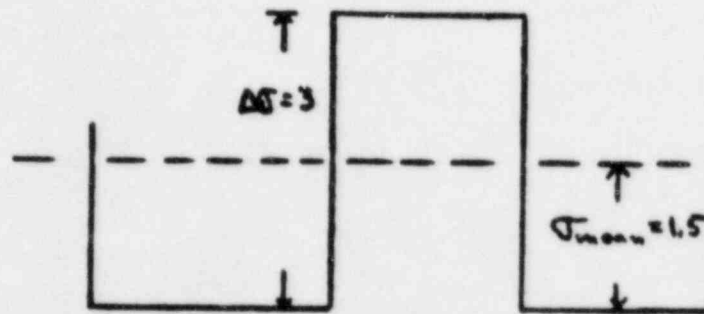

FREQUENCY :

MAXIMUM=2500 Cycles/40yr

R= 0

ON - LINE

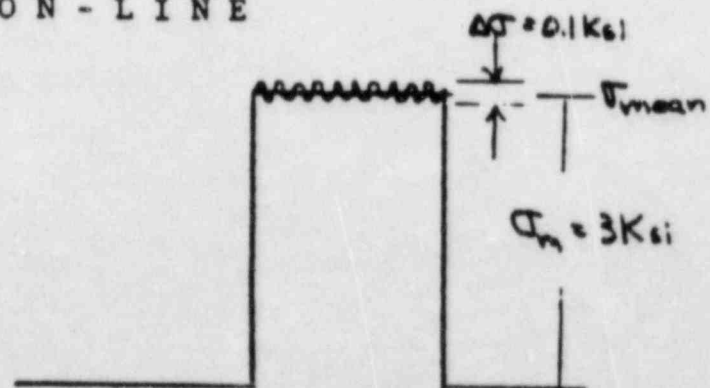

FREQUENCY:

MAXIMUM= 2×10^{10} Cycles/40yr

R= 0.97

FIGURE 8. Stress history profile intermediate pump.

5.4

FATIGUE THRESHOLD

From the data of Figure 3 and 4, a fatigue-crack growth threshold stress intensity $K_{\text{threshold}}$ for crack growth is suggested to be about $\Delta K = 8 \text{ Ksi}\sqrt{\text{in}}$. Figure 9A shows an ideal fatigue-crack growth curve that identifies various regions. Figure 9B provides some data on other steels supporting the fact that the value of $8 \text{ Ksi}\sqrt{\text{in}}$ is reasonable considering the fact that we are working with a CA-6NM casting alloy and the data of Figure 9B is for both low-strength and high-strength low alloy carbon steels.

Examining equation 2, the following is derived:

$$\Delta K = 2\Delta\sigma\sqrt{a}$$

Eqn. 3

or for $\Delta\sigma = 3 \text{ Ksi}$ and $a = 0.5\text{-inches}$

$$\Delta K = 4.2 \text{ Ksi}\sqrt{\text{in}} \leq K_{\text{th}}$$

Max-operational \leq threshold;

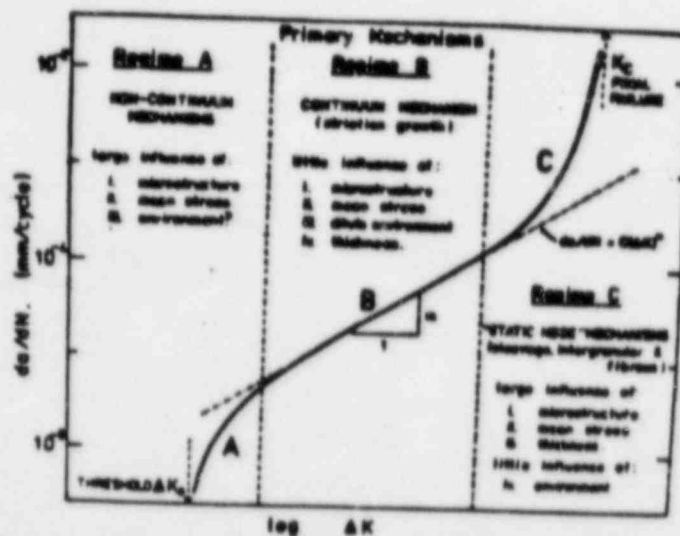

Figure 9A. Schematic variation of fatigue-crack growth rates (da/dN) with alternating stress intensity (ΔK).

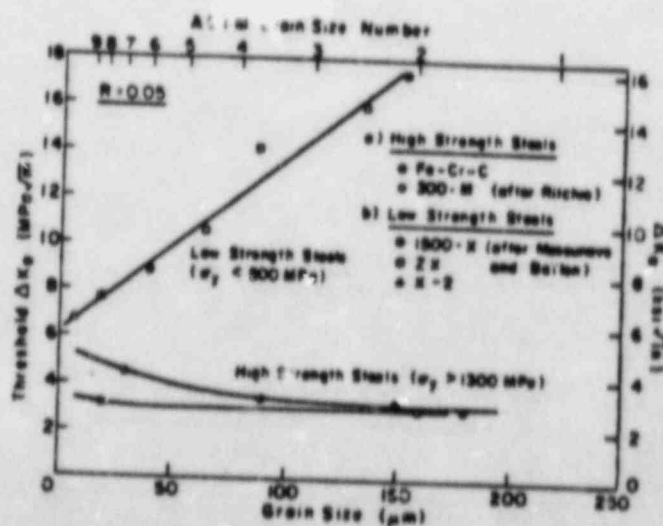

Figure 9B. Variation of threshold ΔK_{th} with grain size for steels. Compositions of low-strength steels are between AISI 1007 and 1080; compositions of high-strength steels are approximately AISI 4340.

Leading to the conclusion that the max-operational driving force or stress intensity for fatigue-crack extension of the largest possible hot-tear is below the threshold stress intensity for fatigue-crack extension. This means that no crack extension of the hot tear will occur in fatigue because the driving force is too low, similar to operating below the endurance limit in a classical fatigue S-N curve analysis.

5.5 SAFE-LIFE CYCLE DIAGRAMS

Continuing in a very conservative vein, if it is assumed that a threshold stress intensity range does not exist, but instead, the measured crack growth rate of Figures 3 and 4 can be extrapolated along the straight line on the log (da/dN) vs log (ΔK) plot; i.e.,

$$(da/dN) = A (\Delta K)^m \tag{Eqn. 4}$$

applies; then the conditions for safe-life cycles can be calculated by substituting Eqn. 3 into Eqn. 4 and integrating or;

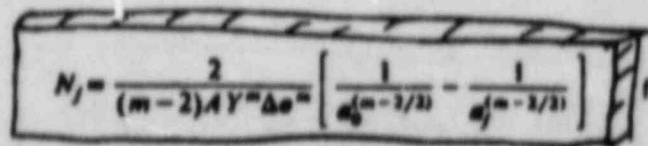

$$N_f = \frac{2}{(m-2)AY^m \Delta \sigma^m} \left[\frac{1}{a_0^{(m-2/2)}} - \frac{1}{a_f^{(m-2/2)}} \right] \text{ for } m \neq 2 \tag{Eqn. 5}$$

where

N_f = number of cycles to failure

a_0 = initial crack size

a_f = final crack size at failure = $[K_{Ic} / (2 \sigma_{max})]^2$

$\Delta \sigma$ = stress range

A, m = material constants $\left\{ \begin{array}{l} 2.57 \times 10^{-10} \cdot A \\ 2.0 = m \end{array} \right\}$ VPPRE UNIT CHANGE

W = specimen width

$K_{Ic} = 4.5 \text{ ksi} \cdot \text{in}^{1/2}$

Using the safe-life cycle or requirement specified by the contractor,

$$N_{\text{(start-up)}} = 2500 \text{ cycles/40 yrs}$$

$$N_{\text{(operational)}} = 2 \times 10^{10} \text{ cycles/40 yrs}$$

and calculating the number of cycles for a hot-tear to extend to 1-inch; i.e., $a_f = 1\text{-inch}$ where for the material constants

$$N_f = (4A \Delta\sigma^3)^{-1} \cdot (a_0^{-\frac{1}{2}} - 1) \quad \text{Eqn. 6}$$

where $A = 2.57 \times 10^{-10}$ and
 $\Delta\sigma = 3 \text{ Ksi (start-up) and } 0.1 \text{ Ksi (on-line)}$

Then the number of cycles to extend the hot tear to 1-inch is shown on Figures 10 and 11. As noted over 100 yrs of projected on-line pressure pulses would be required and over 40,000 years of projected start-up cycles would be required to extend the hot tear to 1-inch radial length.

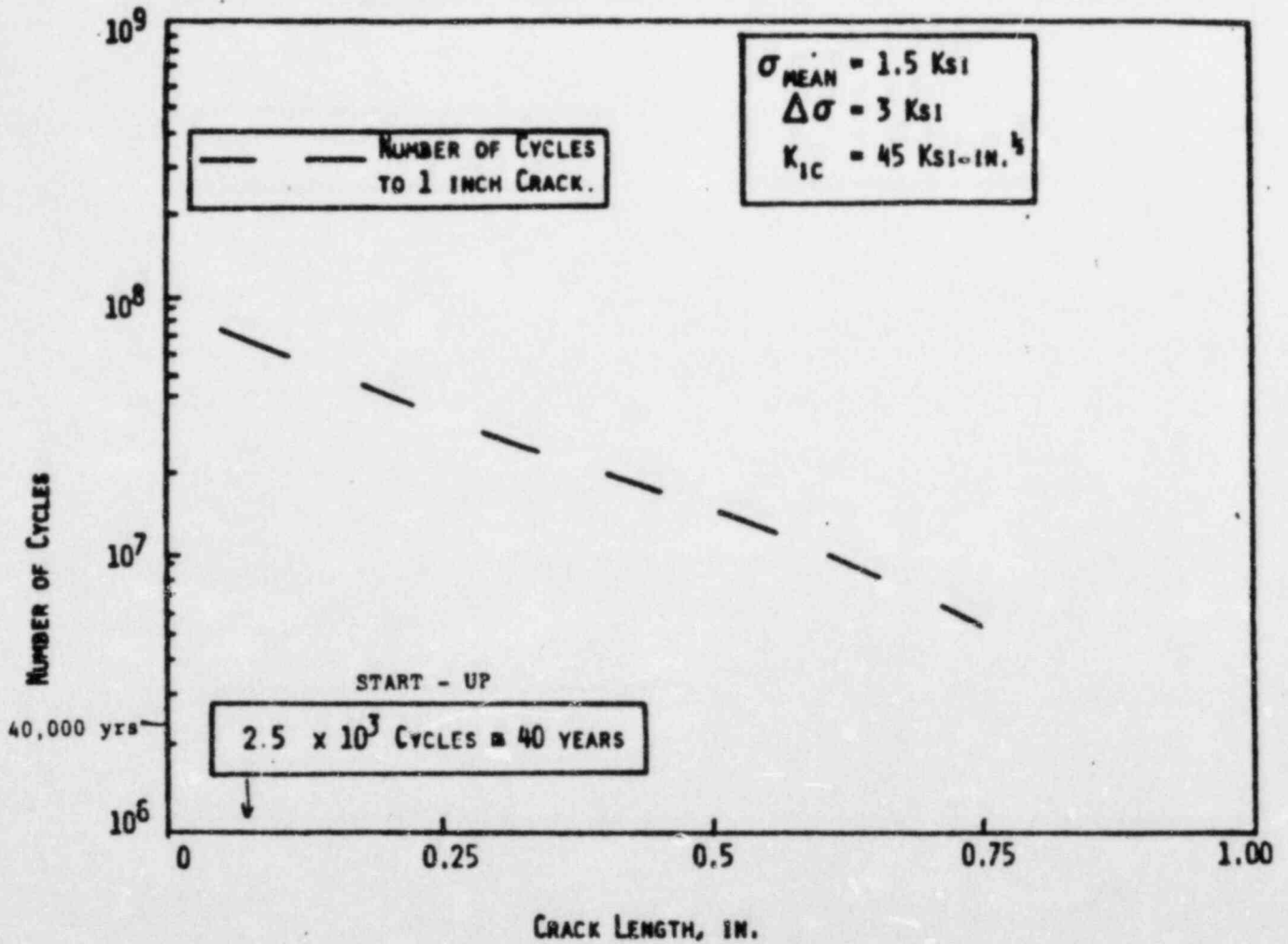

FIGURE 10. Predicted number of start-up fatigue cycles required to extend a radially oriented edge crack to 1-inch in length. Initial size or depth of hot tear is indicated on horizontal axis.

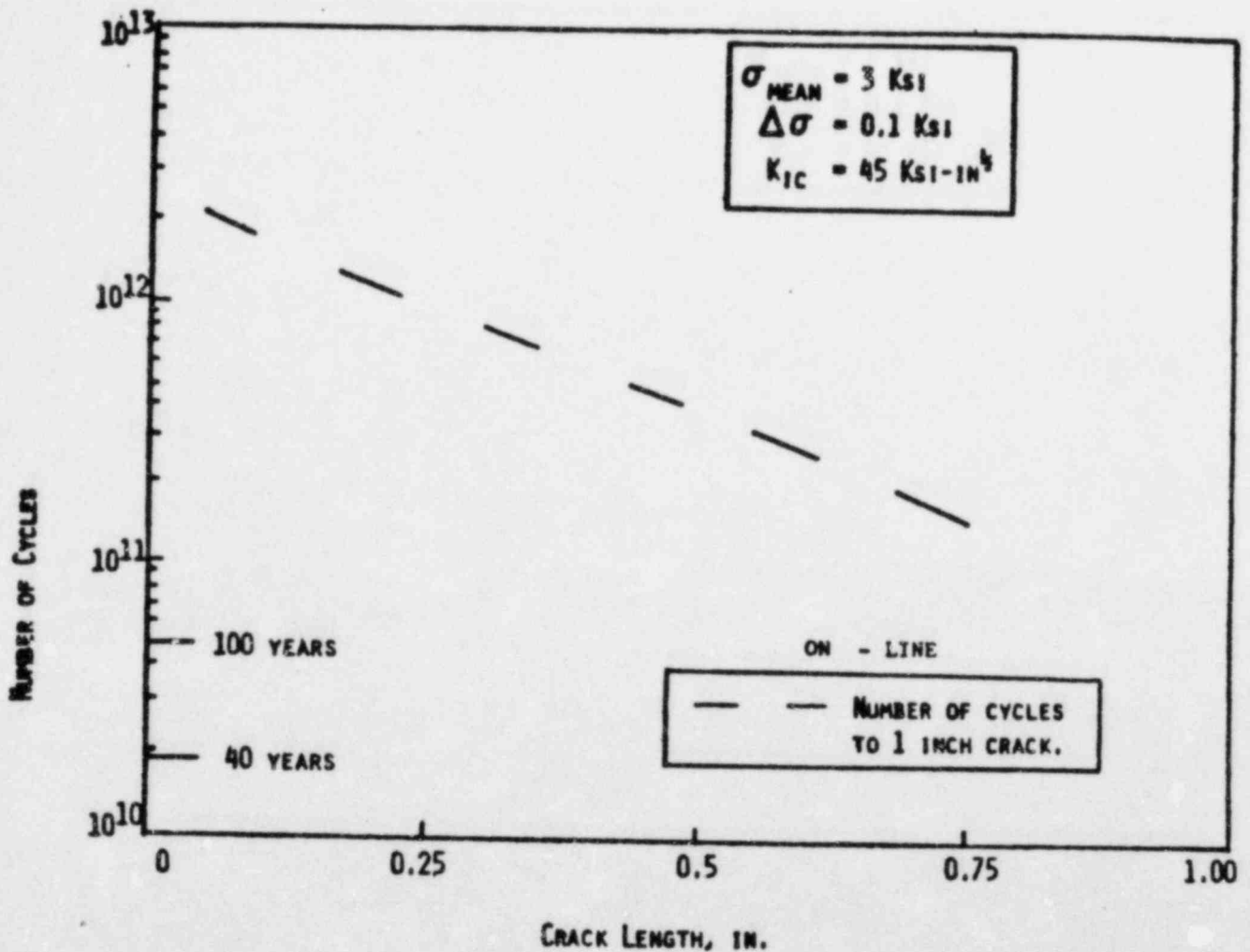

FIGURE 11. Predicted number of on-line fatigue cycles required to extend a radially oriented edge crack to 1-inch in length. Initial size or depth of hot tear is indicated on horizontal axis.

A design envelope similar to the modified Goodman diagram can also be calculated, although further modified to incorporate initial size of the hot tear. The Goodman diagram is essentially a constant finite-life diagram, plotting the stress range ($\Delta\sigma$) vs. σ_{mean} . If values of 1×10^4 or a factor of safety of 4 is used on the start-up cycles over the 40 yr period and 2×10^{10} cycles are used for the on-line pressure pulses, then the following may be calculated by rearranging Eqn. 5 and incorporating Eqn. 2.

$$\sigma_{mean} = (0.5 K_{Ic}) a_0^{-\frac{1}{2}} - (2N \cdot K_{Ic} \cdot A \cdot \Delta\sigma^3 + \Delta\sigma/2) \quad \text{Eqn. 7}$$

where for $a_0 = 0.25, 0.5$ or 1.0 -inch
 $K_{Ic} = 45 \text{ Ksi } \sqrt{\text{in}}$
 $N = 1 \times 10^4$ or 2×10^{10}
 and $A = 2.57 \times 10^{-10}$,

The stress range $\Delta\sigma$ and σ_{mean} can be delineated as shown in the fracture mechanics modified Goodman diagrams of Figures 12 and 13.

As observed on studying Figures 11 and 12, the operational stresses are far below any combination of mean and alternating stress range that would exceed the safe-life zone delineated by the lines for $a_0 = 0.25, 0.50,$ or 1.0 -inches. Obviously these zones decrease in size as the assumed initial size of the hot tear increases.

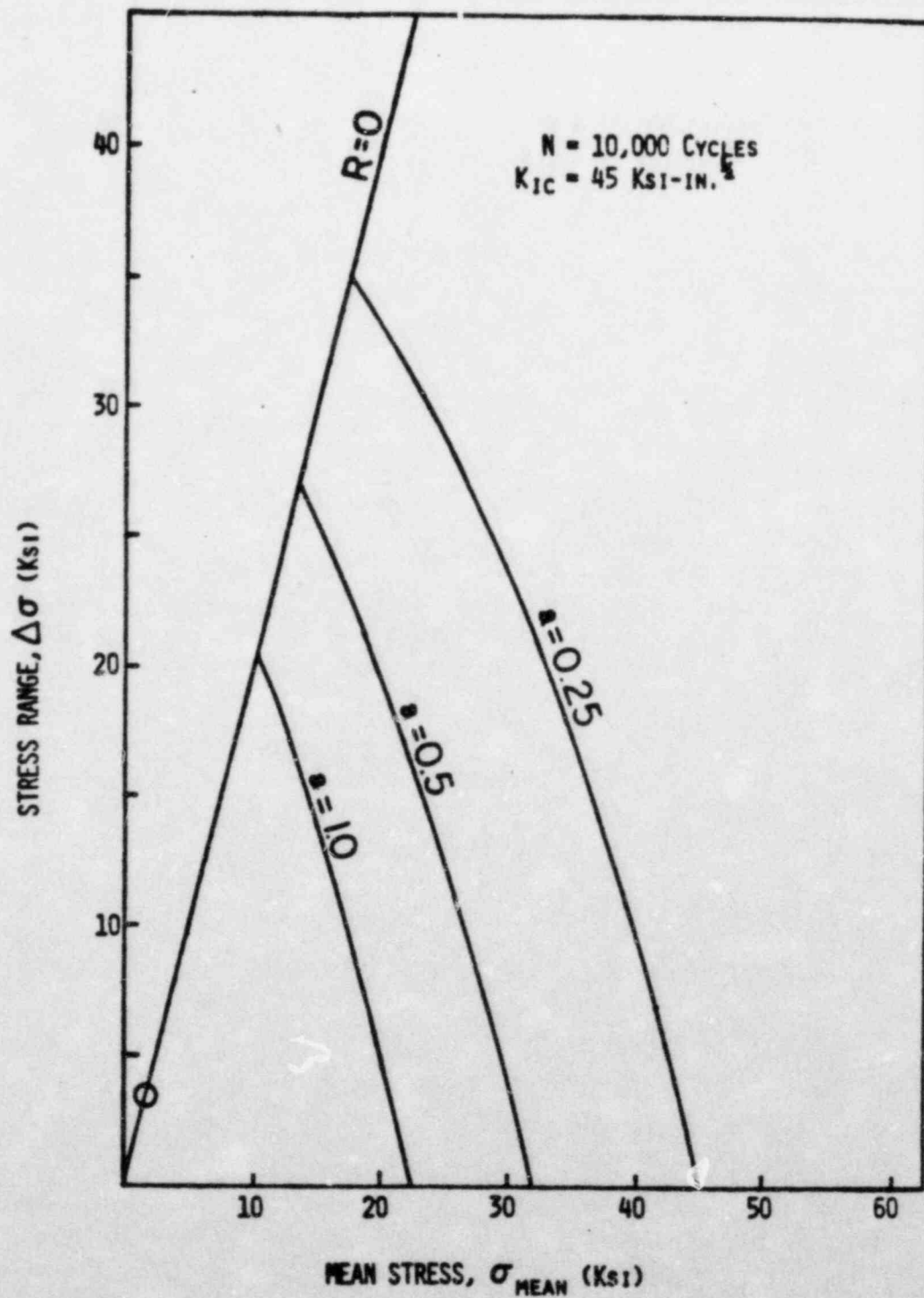

FIGURE 12. Safe-life design envelope for a projected 10,000 start-up cycles. Circle indicates actual operating conditions.

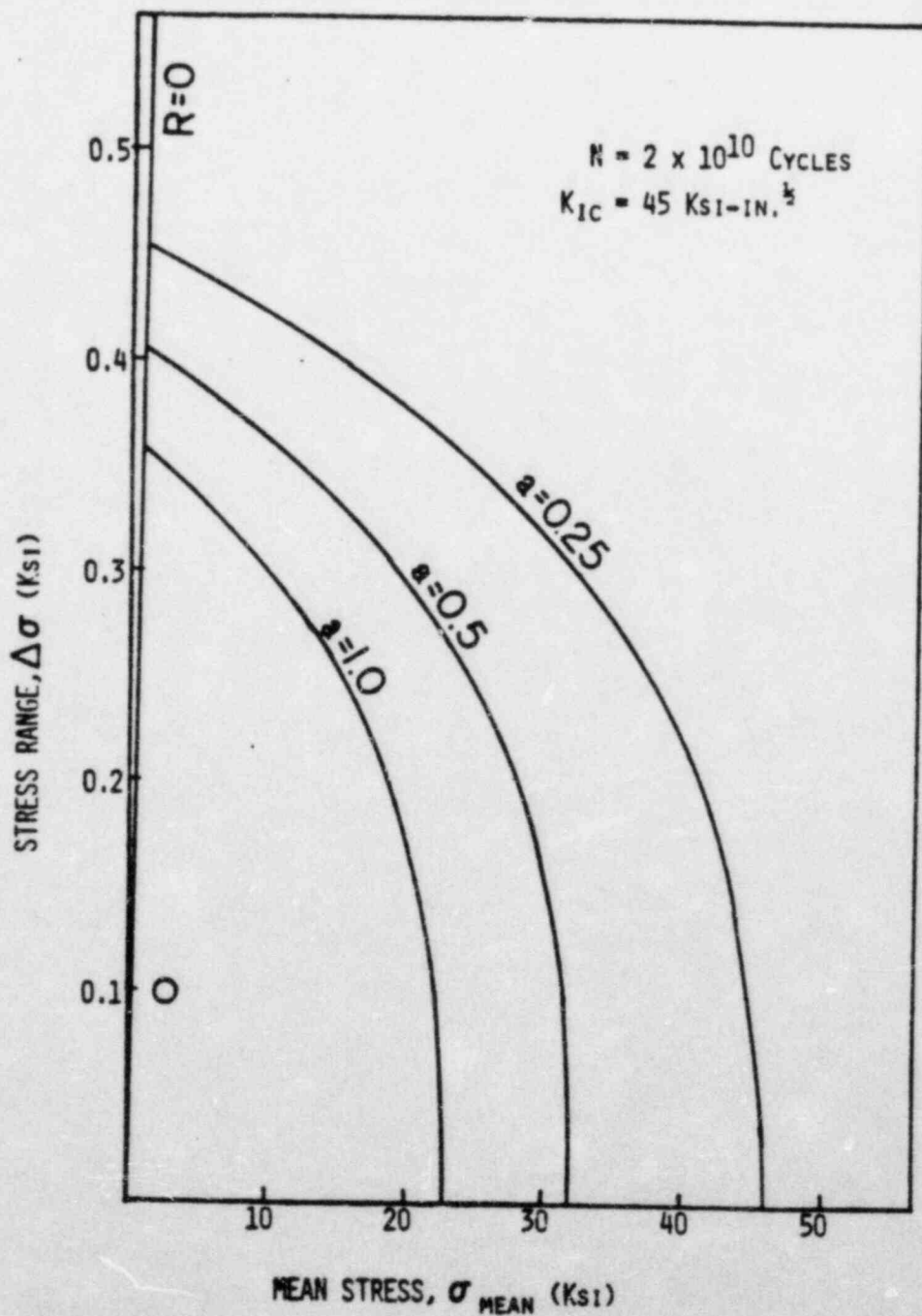

FIGURE 13. Safe-life design envelope for a projected 20,000 million cycles of on-line pressure pulses. Circle indicates actual operating conditions.

6.0 CONCLUSIONS

6.1 Under the worst possible operating conditions, the largest observed hot tear would not extend to near critical values within the projected 40 year operational conditions of the intermediate pump cover.

6.2 Because of the low projected operating stresses, the operating stress intensity range is below threshold for fatigue-crack extension. Even assuming no threshold exists, extension from 0.5-inch to 1-inch would take over 100 years for on-line pressure pulse conditions and even longer for the other considerations.

6.3 The storage tank refueling water would not aggravate the conditions by causing accelerated conditions of corrosion-fatigue or stress corrosion crack, even without de-oxygenation of the boric acid solution.

6.4 The minimum conceivable fracture toughness under low-temperature, high-loading rate conditons would not produce fracture unless the tear extended radially to 1-inch and the operating stresses exeeded 20 Ksi; whereas it is calculated that the actual operating stresses do not exceed 3 Ksi.

LEGEND: ○ - NAMES CIRCLED INDICATES WELD FACILITIES.
 SEE WELD TABLE ON SHEET 2.
A - A NUMBER BOXED INDICATES NOTE FOR INFO SEE SHEET 2.
 ADD - A LETTER FOLLOWED BY THREE OR MORE NUMBERS INDICATES "PART NUMBER" FOR INFO SEE SHEET 2.

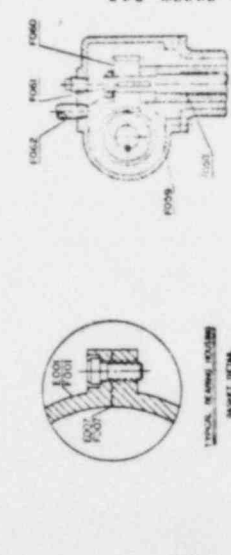
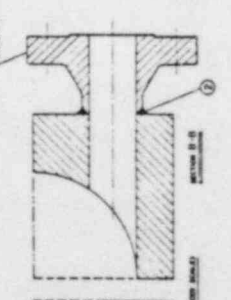
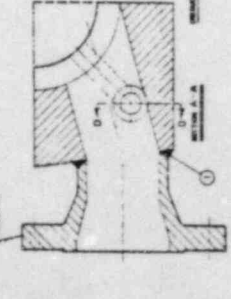
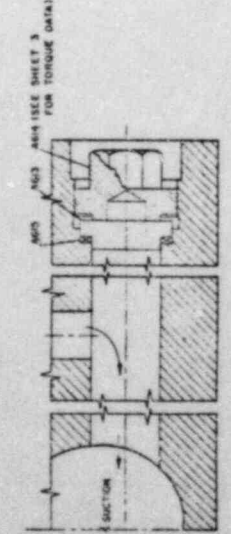
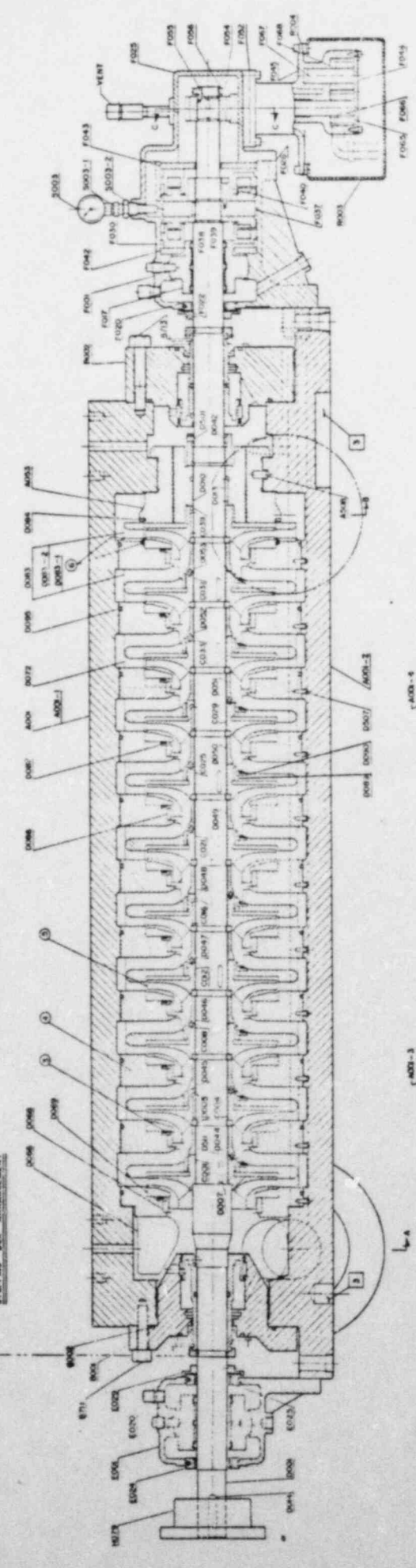
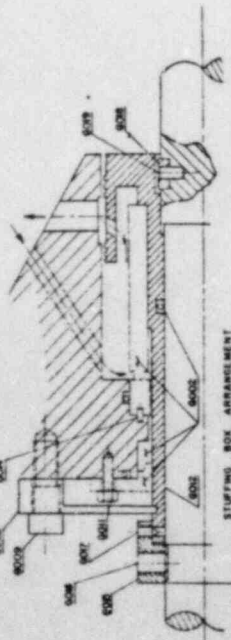

327212	327213	327214	327215	327216	327217	327218	327219	327220	327221	327222	327223	327224	327225	327226	327227	327228	327229	327230	327231	327232	327233	327234	327235	327236	327237	327238	327239	327240	327241	327242	327243	327244	327245	327246	327247	327248	327249	327250
--------	--------	--------	--------	--------	--------	--------	--------	--------	--------	--------	--------	--------	--------	--------	--------	--------	--------	--------	--------	--------	--------	--------	--------	--------	--------	--------	--------	--------	--------	--------	--------	--------	--------	--------	--------	--------	--------	--------

CONTRACTOR: SAUNDERS & BROS. INC.
 SERVICE: 1 SAFETY INJECTION PUMP
 SIZE/TYPE: 3" JET - II STAGES

PACIFIC PUMPS DIVISION
 GREASER INDUSTRIES, INC.
 PUMP ASSEMBLY
 SHEET 2 OF 6
 500-549728

REV.	DATE	BY	CHKD.	ZONE
1	4-11-79			ALL

REVISED AND REDRAWN
 REV 3 DATE 6-28-79 BY MC EVOLEK FOR PUMPS
 SHEET 2 OF 6 AND 5-23-79
 PART FROM OLD DRAWING 5-10-79/3-79
 REVISED WAS WASHER SPRING AND NOTE #14
 ADD NOTE #15 IN COLUMN 10 TO WOODS
 REVISED (DROPPED DATA)
 SHEET 4 REVISED AND REDRAWN.
 ALL SHEET 4 REVISED 8 REDRAWN.

REVISED DATE 6-28-79 BY MC EVOLEK FOR PUMPS
 SHEET 2 OF 6 AND 5-23-79
 PART FROM OLD DRAWING 5-10-79/3-79
 REVISED WAS WASHER SPRING AND NOTE #14
 ADD NOTE #15 IN COLUMN 10 TO WOODS
 REVISED (DROPPED DATA)
 SHEET 4 REVISED AND REDRAWN.
 ALL SHEET 4 REVISED 8 REDRAWN.

REVISED DATE 6-28-79 BY MC EVOLEK FOR PUMPS
 SHEET 2 OF 6 AND 5-23-79
 PART FROM OLD DRAWING 5-10-79/3-79
 REVISED WAS WASHER SPRING AND NOTE #14
 ADD NOTE #15 IN COLUMN 10 TO WOODS
 REVISED (DROPPED DATA)
 SHEET 4 REVISED AND REDRAWN.
 ALL SHEET 4 REVISED 8 REDRAWN.

REVISED DATE 6-28-79 BY MC EVOLEK FOR PUMPS
 SHEET 2 OF 6 AND 5-23-79
 PART FROM OLD DRAWING 5-10-79/3-79
 REVISED WAS WASHER SPRING AND NOTE #14
 ADD NOTE #15 IN COLUMN 10 TO WOODS
 REVISED (DROPPED DATA)
 SHEET 4 REVISED AND REDRAWN.
 ALL SHEET 4 REVISED 8 REDRAWN.

PART NUMBER	NAME OF PART	MATERIAL	PART NUMBER	NAME OF PART	MATERIAL
[1] [2] [4] A001	CASE ASSEMBLY		[3] D046	IMPLR SPACER SLV, 3RD STG	A582 416
[1] [4] A001-1	CASE - UPPER HALF	SAI82 F304	[3] D047	IMPLR SPACER SLV, 4TH STG	A582 416
[1] [4] A001-2	CASE - LOWER HALF	SAI82 F304	[3] D048	IMPLR SPACER SLV, 5TH STG	A582 416
[1] [4] A001-3	CASE - SUCTION FLANGE	SAI82 F304	[3] D049	IMPLR SPACER SLV, 6TH STG	A582 416
[1] [4] A001-4	CASE - DISCHARGE FLANGE	SAI82 F304	[3] D050	IMPLR SPACER SLV, 7TH STG	A582 416
[3] A053	PRESSURE REDUCING BUSHING	A276 440A	[3] D051	IMPLR SPACER SLV, 8TH STG	A582 416
A508	DOWEL	A276 304	[3] D052	IMPLR SPACER SLV, 9TH STG	A582 416
A521	PIN, TAPER		[3] D053	IMPLR SPACER SLV, 10TH STG	A582 416
[10] A522	ALIGNING DOWEL	A434 BC (CODE CASE 1644-4)	D066	SUCTION SPACER	A296 CA6NM
[10] A524	ALIGNING KEY	SA36	[3] D068	SUCTION SPACER WEARING RING	A276 440A
A55	PARTING FLANGE GASKET	[5]	D069	LOCKING KEY	A276 304
[1] A613	COVER	SAI82 F304	D072	INTERMEDIATE COVER	A296 CA6NM
[1] A614	PLUG-LEAKOFF PASSAGE	SAI93 B7	[4] D083	COVER-DIFFUSER ASSEMBLY	
A615	GASKET	[6]	[4] D083-1	INTERMEDIATE COVER-DISCHARGE	A296 CA6NM
[1] A721	CASE STUD	SAI93 B7	[4] D083-2	DIFFUSER-DISCHARGE	A296 CA6NM
[1] A722	CASE STUD	SAI93 B7	D084	SPACER RING	A276 304 OR A182 F304
[1] A751	CASE CAP NUT	SAI94 7	[3] D086	INTMD COVER WEARING RING	A276 440A
[1] A752	CASE CAP NUT	SAI94 7	D087	LOCKING KEY	A276 304
A771	SLUG		[3] D089	INTMD COVER BUSHING	A276 440A
A772	SLUG		D090	LOCKING KEY	A276 304
A780	WASHER		D095	O-RING	[7]
A781	WASHER		D501	SET SCREW	A276 304
[1] B001	SEAL HOUSING, INBOARD	SAI82 F304	D507	DOWEL	A276 304
[1] B002	SEAL HOUSING, OUTBOARD	SAI82 F304	D508	DOWEL	A276 304
[1] B711	SEAL HSG BOLTING, INBOARD	SAI93 B6	D511	DOWEL	A276 304
[1] B713	SEAL HSG BOLTING, OUTBOARD	SAI93 B6	E001	BEARING HOUSING, INBOARD	A216 WCB
[14] C001	IMPELLER, 1ST STAGE	A296 CA40	E007	SHEET GASKET, BRG HOUSING	
[14] C004	IMPELLER, 2ND STAGE	A296 CA40	E020	BEARING SLEEVE, INBOARD	
[14] C008	IMPELLER, 3RD STAGE	A296 CA40	E024	OIL BAFFLE - OUTER	
[14] C012	IMPELLER, 4TH STAGE	A296 CA40	E025	OIL BAFFLE - INNER	
[14] C016	IMPELLER, 5TH STAGE	A296 CA40	E029	DEFLECTOR RING	
[14] C021	IMPELLER, 6TH STAGE	A296 CA40	F001	BEARING HOUSING, OUTBOARD	A216 WCB
[14] C025	IMPELLER, 7TH STAGE	A296 CA40	F007	SHEET GASKET, BRG HOUSING	
[14] C029	IMPELLER, 8TH STAGE	A296 CA40	F017	BEARING SLEEVE, OUTBOARD	
[14] C033	IMPELLER, 9TH STAGE	A296 CA40	F020	OIL BAFFLE	
[14] C037	IMPELLER, 10TH STAGE	A296 CA40	F022	DEFLECTOR RING	
[14] C039	IMPELLER, 11TH STAGE	A296 CA40	F025	END COVER	A216 WCB
[22] D001	PUMP SHAFT	A276 414	F026	SHEET GASKET-END COVER	
D005	SPLIT RING	A582 416 OR A276 410 OR 414	F030	BEARING, THRUST, OUTBOARD	
D007	IMPELLER KEY	A276 304	F037	THRUST COLLAR	
[12] [14] D010	PRESSURE REDUCING SLV	A276 420	F038	THRUST COLLAR KEY	
D013	PRESSURE RDCG SLEEVE KEY	A276 304	F039	THRUST COLLAR SPACER	
D014	FLEXIBLE COUPLING KEY		F040	THRUST NUT	
[22] D042	PRESS RDCG SLEEVE LOCKNUT	A276 410	F042	RETAINER PLATE - INNER	
[13] D044	IMPLR SPACER SLV, 1ST STG	A582 416	F043	RETAINER PLATE - OUTER	
[13] D045	IMPLR SPACER SLV, 2ND STG	A582 416	F045	GEAR PUMP HOUSING	

PACIFIC PUMPS DIVISION
DRESSER INDUSTRIES, INC.

TITLE PUMP ASSEMBLY

SIZE	PRODUCT ENG DWG NO	SHEET	REV
D	500-J49708	2 OF 6	

38

37

36

35

34

33

32

31

WELD TABLE

PART NUMBER	NAME OF PART	MATERIAL	JOINT NUMBER	PROCEDURE SPECIFICATION	WELD TECHNIQUE		INSPECTION				REMARKS	
					SHEET	NUMBER	VISUAL	PT	MT	RT		
F046	GEAR PUMP COVER											
F052	SHEET GASKET - GEAR PUMP		①	042-2-6000-2	6000-2	REV I	X	X		X		SUCTION NOZZLE
F054	WORM		②	042-2-6000-2	6000-2	REV I	X	X		X		DISCHARGE NOZZLE
F055	WORM KEY		③	042-2-6005-1		NOT REQ'D	X	X				LOCKING KEYS
F056	LOCKNUT & WASHER		④	042-2-5440-2		NOT REQ'D	X	X				PWHT } REPAIR COVERS
F058	GEAR PUMP SHAFT			042-2-5920-2		NOT REQ'D	X	X				NO PWHT } AND DIFFUSERS.
F059	GEAR PUMP THRUST COLLAR		⑤	042-2-5230-1		NOT REQ'D	X	X				IMPELLER REPAIR
F060	WORM GEAR		⑥	042-2-5440-2	5440-3	REV O	X					PWHT-DISCH DIFFUSER TO DISCH INT COVER
F061	WORM GEAR KEY											
F062	LOCKNUT & WASHER		⑦	042-2-6000-2	6000-7	REV I	X	X				ORIFICE PLATES
F065	GEAR PUMP											(SHOWN ON SHEET 5)
F066	GEAR PUMP KEY		⑧	042-2-6000-2	6000-10	REV O	X	X				ORIFICE PLATES TO TUBE
4) F067	IDLER GEAR SHAFT											(SHOWN ON SHEET 5)
4) F068	IDLER GEAR		⑨	042-2-5810-0	5810-6	REV O	X	X	X			PWHT } COMPONENT SUPPORT
8) G002	SEAL			W/5810-1								DETAILS SHOWN
G008	RETAINER PLATE		⑩	042-2-5170-2	5170-1	REV O	X	X	X			NO PWHT } ON SHEET 6.
G009	SOCKET HEAD CAP SCREW											
G011	SOCKET HEAD CAP SCREW											
G012	SEAL SHAFT SLEEVE	[9]										
G014	PIN											
G015	SHAFT SLV COLLAR											
G016	SET SCREW - CUP POINT											
G017	SET SCREW - HALF DOG POINT											
G018	SHAFT SLEEVE KEY	A276 304										
G019	SPRING PIN											
10) H001-1	BASE CRADLE	SA36										
10) H002	HEX HEAD CAPSCREW	SAI93 B7										
H003	WASHER - PLAIN											
H030	CENTERING PIN	SA36										
H031	ALIGNING DOWEL LUG	SA36										
H079	COUPLING - PUMP HALF											
R003	OIL RESERVOIR											
R004	SHEET GASKET - OIL RESERVOIR											
10) R019	HEX HEAD CAPSCREW	SAI93 B7										
R020	WASHER - PLAIN											
S003	THERMOMETER											
S003-1	THERMOMETER WELL											
S003-2	THERMOMETER ADAPTER											
11) 4) V005	MINIMUM FLOW ORIFICE	SA479 304L 304 OR 316										
11) 4) V005-1	ORIFICE PLATES											
11) 4) V005-2	ORIFICE TUBE	SA312 304 OR 316, OR SA479 304 OR 316										

PACIFIC PUMPS DIVISION
DRESSER INDUSTRIES, INC.

TITLE PUMP ASSEMBLY

SIZE	PRODUCT ENG DWG NO	SHEET	REV
D	500-J49728	3 OF 6	5

NOTES:

- 1 PRESSURE RETAINING ITEM.
- 2 HORIZONTALLY SPLIT CASE, TOP VIEW, BOLTING AND PARTING FLANGE GASKET ARE SHOWN ON SHEET 5.
- 3 FOR PUMP ALIGNING ARRANGEMENT SEE SHEET 6.
- 4 MUST BE ORDERED AS AN ASSEMBLY WITH MATING PART(S).
- 5 COMPRESSED ASBESTOS SHEET.-CHLORIDE AND/OR FLUORIDE CONTENT SHALL NOT EXCEED 200 PPM.
- 6 SPIRAL WOUND ASBESTOS/304SS (FLEXITALLIC).-CHLORIDE AND/OR FLUORIDE CONTENT SHALL NOT EXCEED 200 PPM.
- 7 ETHYL PROPYLENE "O" RINGS.-ASTM D-2000 2BA,810,C12,F17 CHLORIDE AND/OR FLUORIDE CONTENT SHALL NOT EXCEED 200 PPM.
- 8 SEE SEAL DRAWING FOR SEAL DETAIL AND MATERIAL OF PARTS FURNISHED BY J. CRANE CO.
- 9 A276 4H0 (ANNEALED) WITH 0.003/0.005 CR OXIDE PER LINDE PROCESS LC-4.
- 10 COMPONENT SUPPORT (ASME CODE SECT III, SUB SECT NF).
- 11 JOINT 9 AND 10 ARE SUBSECTION NF WELDS. EITHER PT OR MT WILL BE PERFORMED.
- 12 TEMPERED AT A TEMPERATURE GREATER THAN 1100°.
- 13 TEMPERED AT A TEMPERATURE LESS THAN 1100°.
- 14 FLAME HARDENED.

S O NO

5J50032
5J50031
5J50030
5J49728
5J49729
5J49730
5J49731
5J49732
5J49735
5J49736
5J49738
5J49869
5J49870
5J49871

SERIAL NO

52231/32
52229/30
52227/28
51647/48
51649/50
51651/52
51653/54
51655/56
51661/62
51663/64
51667/68
51924/25
51926/27
51928/29

PLANT & SPIN NO

GAE-SIAPSI-OI/02
GBE-SIAPSI-OI/02
LMP-SIAPSI-OI/02
SAP-SIAPSI-OI/02
SEP-SIAPSI-OI/02
SCP-SIAPSI-OI/02
SDP-SIAPSI-OI/02
SFP-SIAPSI-OI/02
NAH-SIAPSI-OI/02
NCH-SIAPSI-OI/02
TBX-SIAPSI-OI/02
LLP-SIAPSI-OI/02
NEU-SIAPSI-OI/02
TCX-SIAPSI-OI/02

CONTRACTOR: WESTINGHOUSE N.E.S.
SERVICE: SAFETY INJECTION PUMP
SIZE/TYPE: 3"-JHF-II STAGES

PACIFIC PUMPS DIVISION DRESSER INDUSTRIES, INC.			
TITLE PUMP ASSEMBLY			
SIZE D	PRODUCT ENG DWG NO 500-J49728	SHEET 4 OF 6	REV

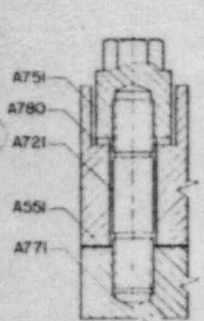

SECTION A-A
(32 PLACES)

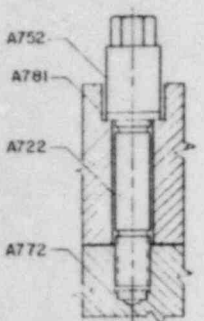

SECTION B-B
(6 PLACES)

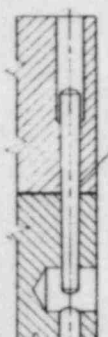

SECTION C-C
(2 PLACES)

1-BNC-3 TAP
FOR JACKSCREWS
(JACKSCREWS BY PURCHASER)

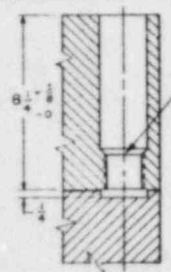

SECTION D-D
(2 PLACES)

LEGEND: ○ - A NUMBER CIRCLED INDICATES
"WELD PROCEDURE"
SEE WELD TABLE ON SHEET 2.
A521-A LETTER FOLLOWED BY THREE
OR MORE NUMBERS INDICATES
"PART NUMBER"
FOR INFO SEE SHEET 2.

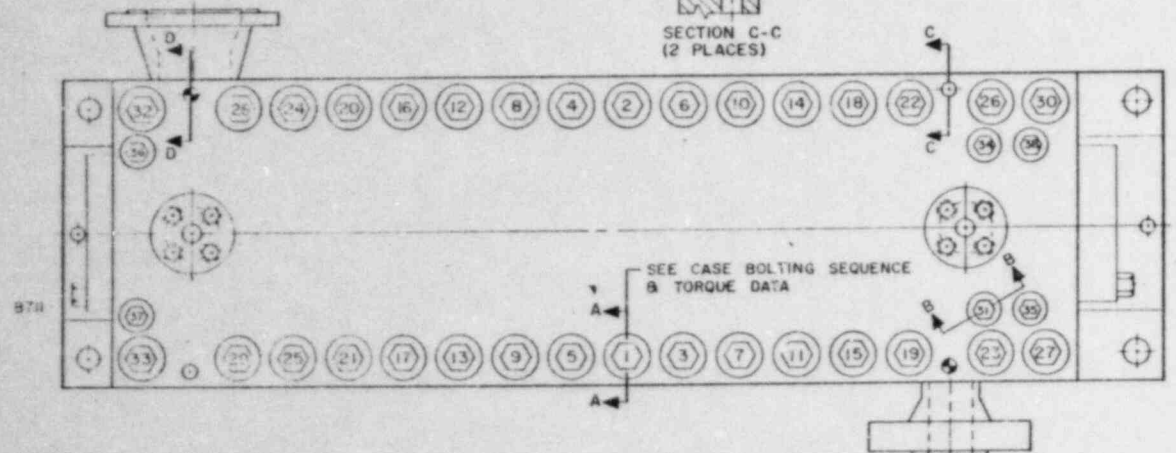

SEE CASE BOLTING SEQUENCE
& TORQUE DATA

CASE BOLTING SEQUENCE &
TORQUE DATA

1. NUMBERS 1 TO 38 REPRESENT THE
TIGHTENING SEQUENCE OF CASE
BOLTING.

2. INDIVIDUAL NUTS AND BOLTS TO
BE TIGHTENED IN A SERIES OF 4
PROGRESSIVE STEPS OF 25%, 50%,
75% AND 100% OF FINAL TORQUE
LOAD.

3. WRENCH TORQUE LOAD:
A751 - 2 1/4"-12N-3 CAP NUT 5000 FT.LB.
A752 - 1 1/2"-12N-3 CAP NUT 1600 FT.LB.
B711 } 1-BNC-3 CAP SCR 200 FT.LB.
B713 }
A614 - 2"-12N-3 CAP SCR 175 FT.LB. (A614 SHOWN ON SHEET 1)

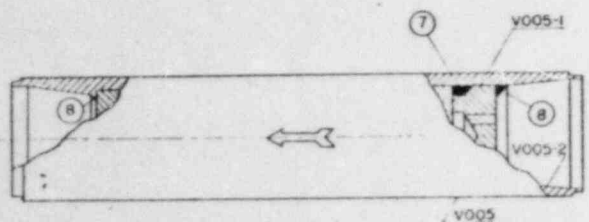

MINIMUM FLOW ORIFICE

S.O. NO.	SERIAL NO.	PLANT & SPIN NO.
5J50032	52231/32	GAE-SIAPSI-01/02
5J50031	52229/30	GBE-SIAPSI-01/02
5J50030	52227/28	LMP-SIAPSI-01/02
5J49728	51647/48	SAP-SIAPSI-01/02
5J49729	51649/50	SEP-SIAPSI-01/02
5J49730	51651/52	SCP-SIAPSI-01/02
5J49731	51653/54	SDP-SIAPSI-01/02
5J49732	51655/56	SFP-SIAPSI-01/02
5J49735	51661/62	NAH-SIAPSI-01/02
5J49736	51663/64	NCH-SIAPSI-01/02
5J49738	51667/68	TBX-SIAPSI-01/02
5J49869	51924/25	LLP-SIAPSI-01/02
5J49870	51926/27	NEU-SIAPSI-01/02
5J49871	51928/29	TCX-SIAPSI-01/02

CONTRACTOR : WESTINGHOUSE N.E.S.
SERVICE : SAFETY INJECTION PUMP
SIZE/TYPE : 3"-JHF-II STAGES

PACIFIC PUMPS DIVISION DRESSER INDUSTRIES, INC.				
TITLE PUMP ASSEMBLY				
SIZE	PRODUCT	ENG DWG NO	SHEET	REV
D	500-J49728		5 of 6	(

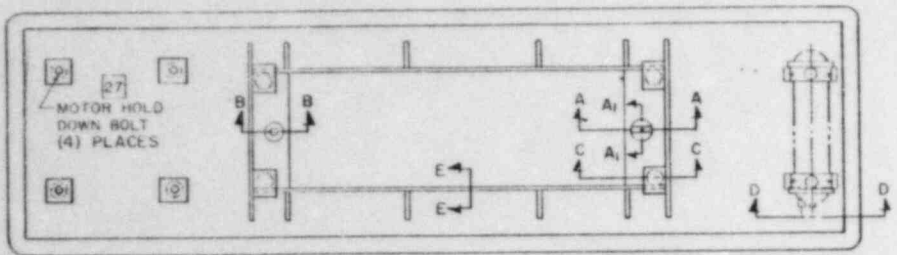

LEGEND: A001 - A LETTER FOLLOWED BY THREE OR MORE NUMBERS INDICATES PART NUMBER FOR DESCRIPTION AND MATERIAL SEE SHEET 2.
 □ - A NUMBER BOXED INDICATES NOTE.
 ○ - A NUMBER CIRCLED INDICATES WELD PROCEDURE, SEE WELD TABLE ON SHEET 2.

- NOTES:
- 21 - COMPONENT SUPPORT (ASME CODE SECTION III, SUBSECTION NF)
 - 22 - PART A522 IS A TIGHTLY FITTED DOWEL TO SECURE POSITIVE ALIGNMENT AT PUMP INBOARD END.
 - 23 - PART A524 IS A KEY DESIGNED TO SECURE PUMP AXIAL ALIGNMENT AND AT THE SAME TIME TO ALLOW FOR CASE THERMAL EXPANSION.
 - 24 - SCREWS ARE FOR ASSEMBLY PURPOSE ONLY AND DO NOT CARRY ANY STRESS LOADS.
 - 25 - DRIP POCKET DRAIN CONNECTION P-D4 ON PUMP AND MOTOR OUTLINE DRAWING.
 - 26 - THIS PLATE IS NON-NF, HOWEVER MATERIAL IS NF LISTED AND COMPLIES WITH THE MATERIAL SPECIFICATIONS.
 - 27 - FOR BOLTING TIGHTENING TORQUE DATA SEE PUMP AND MOTOR OUTLINE DRAWING.
 - 28 - FOR CORRECT LOCATION OF LUBO COOLER CONNECTIONS SEE PUMP AND MOTOR OUTLINE DRAWING.

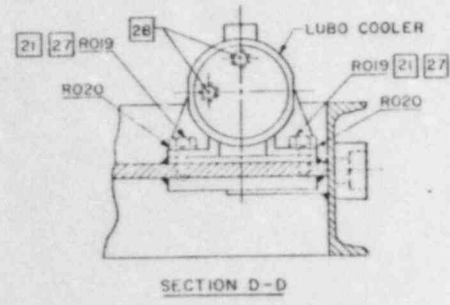
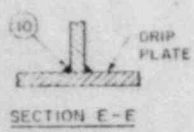
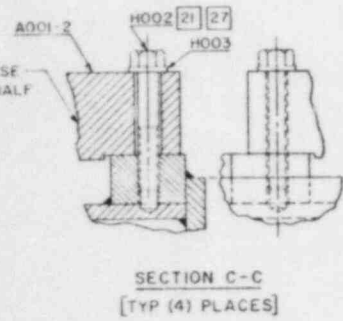
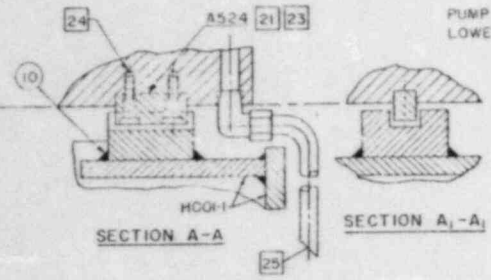
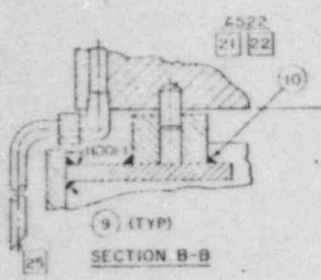
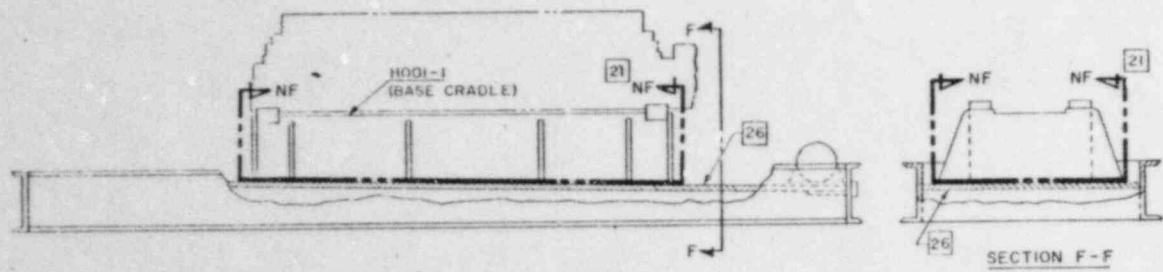

CONTRACTOR WESTINGHOUSE N.E.S.
 SERVICE SAFETY INJECTION PUMP
 SIZE/TYPE 3" - JHF - II STAGES

5J50032	52231/32	GAE - SIAPSI - 01/02
5J50031	52229/30	GBE - SIAPSI - 01/02
5J50030	52227/28	LMP - SIAPSI - 01/02
5J49728	51647/48	SAP - SIAPSI - 01/02
5J49729	51649/50	SEP - SIAPSI - 01/02
5J49730	51651/52	SCP - SIAPSI - 01/02
5J49731	51653/54	SDP - SIAPSI - 01/02
5J49732	51655/56	SFP - SIAPSI - 01/02
5J49735	51661/62	N4H - SIAPSI - 01/02
5J49736	51663/64	NCH - SIAPSI - 01/02
5J49738	51667/68	TBX - SIAPSI - 01/02
5J49809	51924/25	LLP - SIAPSI - 01/02
5J49870	51916/27	NEU - SIAPSI - 01/02
5J49871	51928/29	TCX - SIAPSI - 01/02

PACIFIC PUMPS DIVISION DRESSER INDUSTRIES INC.			
TITLE PUMP ASSEMBLY			
SIZE	PRODUCT ENG DWG NO	SHEET	REV
D	500-J49728	6 OF 6	

1. PUMP

1.1 PUMP CONNECTIONS:
 P-A1 SUCT NOZZLE - 6" ISO LBS ANSI STD RF FLANGE
 P-B1 DISCH NOZZLE - 3" 1500 LBS ANSI STD RF FLANGE
 P-D4 DRIP SOCKET DRAIN - 0.75" NPT (ONE EACH END) PIPED TO DRIP PLATE.
 P-W1 CASE VENT - 0.82" DIA HOLE (ONE EACH END) FINISHED WITH (4) 0.82" INCH - 3 X 0.14" DEEP TAPS ON 3.25" DBC - TO FIT 0.75" 300 LBS ANSI STD RF FLANGE.
 P-X1 FLANGE AND BOLTING FURNISHED BY PURCHASER.
 P-Y1 THREADED HOLES FOR EXHAUSTS - 2 PLACES
 0.75" - 0.82" X 1.00" DEEP - FOR LIFTING THE CASE UPPER HALF AND THE CASE ASSEMBLY (EXHAUSTS FURNISHED BY PURCHASER).

NOTE 1.1.1 SUCT AND DISCH FLANGES AND THE CASE VENT OPENINGS ARE COVERED WITH WOODEN DISCS FOR SHIPMENT.
 NOTE 1.1.2 FLANGE BOLTING TORQUE DATA:
 P-A1 3/4" BOLT - 65 FT/LB TORQS AND CONNECTING P-B1 1/2" BOLTS - 22" - 1/2 LB FLANGES FURNISHED BY PURCHASER)

1.2 HYDRAULIC DATA (PROPOSED)

FLOW, US GPM	DESIGN	RUN OUT
DIFF HEAD, MAX, FT	440	660
DIFF HEAD, MIN, FT	375	465
NPSH REQ'D, FT	3545	1560
POWER, MAX HP	NA	23

SP GRAVITY: 1.0 NORMAL
 MINIMUM FLOW: SEE SECTION 4.
 DESIGN PRESSURE: 1750 PSIG MAX.
 DESIGN TEMPERATURE: 300°F MAX.
 NOM SPEED: 3600 RPM

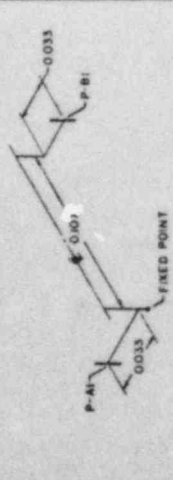

1.3 LUBE OIL SYSTEM
 MAIN L.O.P. MAIN SHAFT DRIVEN GEAR PUMP
 LUBO RS/W LUBE OIL RESERVOIR
 CAPACITY APPROX. 3 US GAL.
 LUBO CLR LUBE OIL COOLER
 MAKE AMERICAN STANDARD
 MODEL #08023-35C7-C

MAX ALLOWABLE DESIGN LUBO COOLER NOZZLE LOADS:
 PIPING LOADS SHALL BE LIMITED TO FOLLOWING LOADS:
 AXIAL = 75 LBS
 BENDING = 200 INCH-LBS
 SHEAR = 75 LBS
 TORSIONAL = 400 INCH-LBS

CONNECTIONS:
 L-D LUBO RS/W DRAIN - 0.50" NPT
 L-M LUBO CLR CLG WATER INLET - 1.00" NPT
 L-N LUBO CLR CLG WATER OUTLET - 1.00" NPT
 L-O LUBE OIL INLET TO CLR - 1.00" NPT
 L-P LUBE OIL OUTLET FROM CLR - 1.00" NPT
 PIPED BY PACIFIC PUMPS DIV.

1.5 COOLING

COOLING WATER REQUIRED TO LUBO CLR CONNECTION 1.1-1.12 10 GPM AT 105°F NORMAL, 60°F MINIMUM AND 120°F MAXIMUM.
 COOLING WATER DESIGN PRESSURE: 150 PSIG
 PRESSURE DROP: 1.1 PSI (MAX) HEAT LOAD: 24,000 BTU/HR

1.6 COUPLINGS AND GUARDS

CP16 - FLEXIBLE COUPLING
 MAKE: ZUKIN INDUSTRIES, INC
 TYPE/SIZE: SPECIAL FE-102-1/2, BALANCED, WITH 3/16" LIMITED END FLOAT
 NOTE 1.6.1 THIS COUPLING HAS LIMITED END FLOAT (LEFT) TO PREVENT MOTOR SHAF T THRUST COLLAR FROM CONTACTING AND DAMAGING MOTOR SLEEVE BEARING IT IS NECESSARY TO POSITION THE MOTOR SO THAT WHEN THE MOTOR SHAFT IS PULLED ALL THE WAY TOWARD DRIVEN EQUIPMENT, THE DISTANCE BETWEEN BOTH SHAFT ENDS IS 0.12" LESS THAN SPACING INDICATED.
 GRD - COUPLING GUARD - HINGED TYPE

1.7 ASME CODE, CODE DATE, AGENCIES AND CLASS
 THE PUMPS ARE CLASS 2, PER SECTION III OF THE ASME BOILER & PRESSURE VESSEL CODE, 1974 EDITION INCLUDING SUMMER ADDENDA
1.8 PUMP WGT WEIGHT 6200 LBS
PUMP (BY WEIGHT) 6100 LBS
INTERNAL VOLUME 1.8 CU.FT.

2. MOTOR

2.1 DATA:
 MAKE: WESTINGHOUSE ELECTRIC CORP.
 HP : 450
 FRAME SIZE: 3810H
 NOM RPM : 5700
 VOLTAGE : 6600
 HERTZ : 60
 PHASE : 3
 END PLAY : 0.50 MINIMUM (SEE NOTE 1.6.1)

2.2 CONNECTIONS:
 HM-E1 MAIN MOTOR CONDUIT BOX (SEE NOTE 2.2.1)
 BOX SUPPLIED UNDRILLED - USEABLE DRILLING AREA 11.0 X 6.0.
 SEQUENCE CONNECTIONS: VOLTAGE SEQUENCE T1, T2, T3
 HM-E2 AUXILIARY CONDUIT BOX (SEE NOTE 2.2.1)
 BOX SUPPLIED UNDRILLED - USEABLE DRILLING AREA 6.50 X 6.00
 [04, 05, 06] - TERMINAL BOARD MARKING STRIPS FOR [04, 05, 06] COPPER CONSTANTAN THERMOCOUPLES (SEE NOTE 2.2.2)

HM-E3 GROUNDING PADS
 0.50" - 15 UNC - 28 X 0.50 DEEP X 1.75 APART
 TWO HOLES ON EACH SIDE.
 HM-T1 BEARING TEMPERATURE DETECTOR (SEE NOTE 2.2.1)
 0.75 NPT CONNECTION FOR COOLANT.
 HM-X1 MAIN CONDUIT BOX SUP-DRT - (SEE NOTE 2.2.1)
 HM-H1 (4) LIFTING LUGS (FOR MOTOR ONLY)
 HM-H2 LOUVERED AIR EXHAUST - BOTH SIDS (SEE NOTE 2.2.3)
 HM-H3 LOUVERED AIR INLET - BOTH ENDS (SEE NOTE 2.2.3)
 HM-E4 SPACE HEATER COUOLET BOX
 AREA 3.75 X 4.25
 [05, 05, 05] - TERMINAL BOARD MARKING STRIP FOR SPACE HEATERS. (SEE NOTE 2.2.2)

NOTE 2.2.1 CONDUIT BOXES MAY BE ROTATED IN STEPS OF 90° BECAUSE OF INTERFERENCE WITH BASE THE MAIN CONDUIT CANNOT BE LOCATED FACING DOWN BEFORE RELOCATING MAIN COOLANT BOX. SEE MOTOR SUPPORT FOR INSTRUCTIONS HOW TO HANDLE BOX SUPPORTS HM - X1.

NOTE 2.2.2 MOTOR ACCESSORIES:
 1. SPACE HEATERS - W/AMP REGARDING TYPE - 270/110V, 0.9/1/82 A, 260W
 2. WINDING TEMP DEVICE - COPPER CONSTAN THERMOCOUPLES, ALARM TEMP 135°C
 3. BEARING TEMP DEVICE - RTD
 4. OHMS AT 25°C, ALARM TEMP 85°C
NOTE 2.2.3 CAUTION: WHEN INSTALLING THE UNIT, AVOID LOCATING MOTOR SO THAT ADJACENT STRUCTURES ARE CLOSER THAN 6.0 INCHES TO THE MOTOR ENDS AND SIDES.
 ALSO MAKE CERTAIN THAT NO ADJACENT STRUCTURES CAUSE EXHAUST AIR TO BE DIRECTED INTO INLET OPENINGS.

NOTE 2.2.4 STATION MAIN LEAD TERMINAL:
 0.115/0.025" ±
 1-3/4" Ø/16 DIA HOLES
 1-3/4"
 1-3/4"
 0.232/0.232

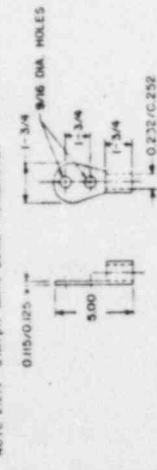

3. BASE PLATE

3.1 CONNECTIONS:
 H-X1 (Ø1.132 DIA. HOLES FOR FOUNDATION ANCHOR BOLTS. RECOMMENDED: BOLT SIZE 1/2"
 H-X2 4.0 DIA (MIN) GROUT HOLES.
 (Ø2) SHOWN, BASE HAS A MINIMUM OF (18) GROUT HOLES.
 H-X3 LIFTING LUGS: 2.0" DIA. HOLE - (4) PLACES FOR LIFTING THE PUMP - MOTOR - BASE ASSEMBLY.
 H-B1 BASE DRAIN - SOCKET WELD CONNECTION FOR 2" SCHED 80 PIPE.

4. MINIFLOW ORIFICE

4.1 HYDRAULIC DATA:
 CAPACITY: 45 GPM (INCLUDED IN PUMP CAPACITY)
 DESIGN PRESSURE: 1750 PSIG MAX.
 DESIGN TEMPERATURE: 300°F MAX.
4.2 MATERIALS:
 SEE PUMP ASSEMBLY DRAWING FOR MATERIALS
NOTE 4.1.1 ORIFICE FLOW CAPACITY MAY VARY 10%.
NOTE 4.1.2 ORIFICE DESIGN BASED ON 50 PSI PRESSURE LOSS AT 45 GPM FOR THE ASSOCIATED PIPING.

5. MISC INFO AND NOTES

5.1 WEIGHTS:
 PUMP 6200 LBS
 BASE 3210 LBS
 MOTOR 4800 LBS
 TOTAL WEIGHT 15,310 LBS

5.2 REFERENCE DRAWINGS:
 PACIFIC PUMPS DWG NO
 PUMP ASSEMBLY 500 - J49728
 MECH SEAL ASST: J. CHANE
 MOTOR OUTLINE: W 9502020, 240 - J49738
 OF SP - 43449, 276 - J49728

5.3 HOLD-DOWN BOLTING TORQUE DATA:
 PUMP (4) 1-1/2" UNF HEX HD CAPSCREW 80 FT/LB
 MOTOR (4) 7/8" 9HC HEX HD CAPSCREW 300 FT/LB
 LUBO COOLER: (4) 3/4" - 0.82" HEX HD CAPSCREW 200 FT/LB

5.4 THE BEARING SYSTEM WILL OPERATE 40 SECONDS (MAX) WITHOUT COOLING WATER, PROVIDED THE COOLING WATER TEMPERATURE WAS NOT MORE THAN 100°F BEFORE LOSS OF WATER.

5449-271 51928/29 TCC-SI8P81-01/02
 5449-738 51677/68 TCC-SI8P81-01/02
 5449-739 51677/68 TCC-SI8P81-01/02
 L-TRACTOR: WESTINGHOUSE N.E.S
 SERVICE : SAFETY INJECTION
 M/F/TYPE : 3" - JHF - II STAGES

PACIFIC PUMPS DIVISION DUCESBER INDUSTRIES, INC	
TITLE	PUMP AND MOTOR OUTLINE
SHEET	300 - J49738
REV	





CONTRACTOR WESTINGHOUSE NEC.

TEST PERFORMANCE CURVE NO. 37739A

CUSTOMER TEXAS

ITEM NO. IBX-01 P.O. 546- CAV 23604-BPE

SIZE 3" TYPE IHF STAGES 11

INPELLER PATTERN M-7844 M-7592

R.P.M. FIELD DATE 10-4-77

MAXIMUM DIAMETER 8 9/16 8 9/16

PUMP NUMBER 51667

RATED DIAMETER 8 9/16 8 9/16 8 5/16

PERFORMANCE ALSO APPLIES TO PUMP

MINIMUM DIAMETER 7 9/16 7 9/16

NUMBER _____

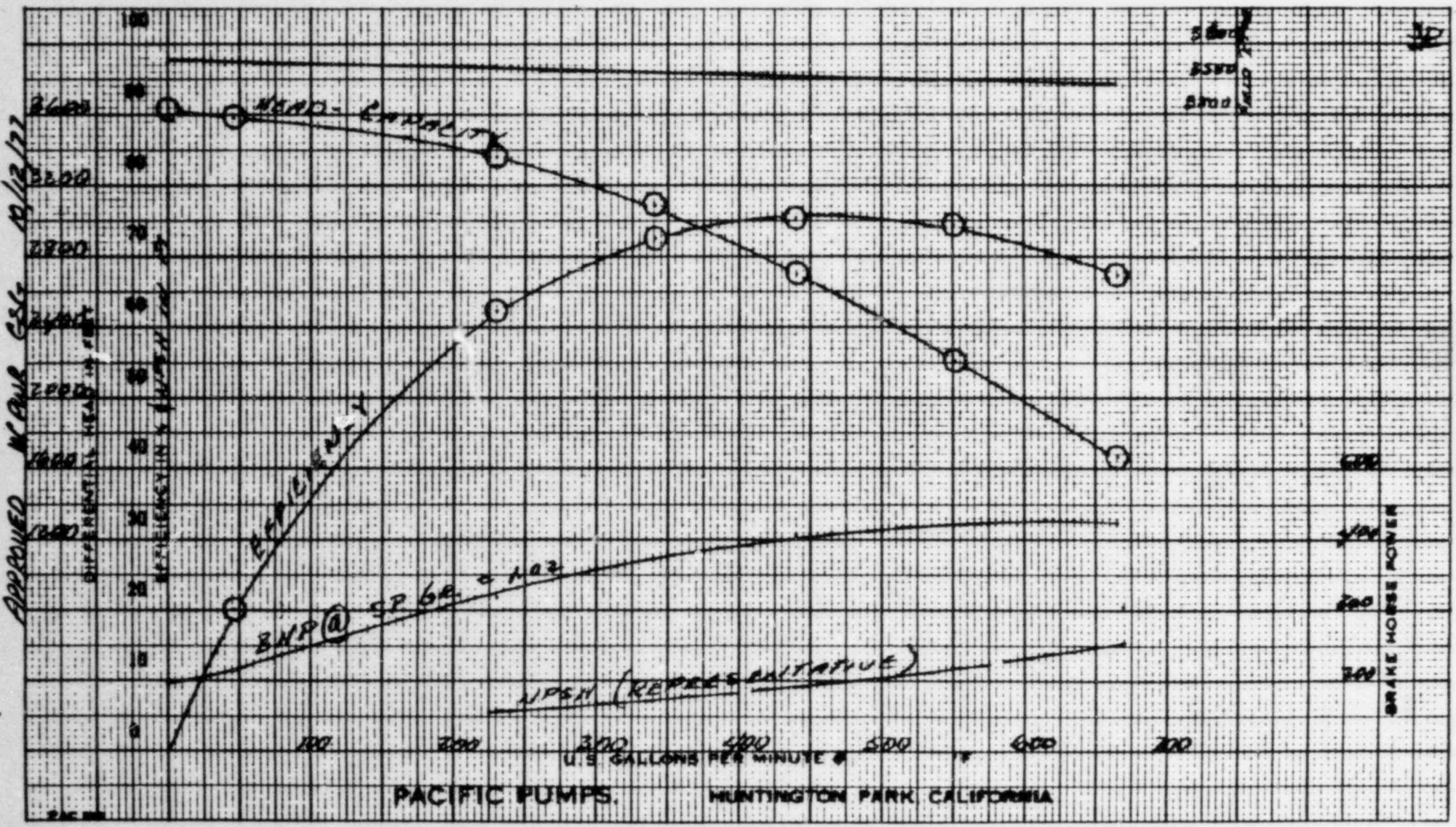

CONTRACTOR WESTINGHOUSE NES

TEST PERFORMANCE CURVE NO. 37739B

CUSTOMER TEXAS

ITEM NO. TBX-0 P.O. 546-CAN-236954-BPE

SIZE 3" TYPE JMF STAGES 11

IMPELLER PATTERN M-7844 M-7392

R.P.M. FIELD DATE 9-22-77

MAXIMUM DIAMETER 8 9/16 8 9/16

PUMP NUMBER 51668

RATED DIAMETER 8 9/16 8 9/16

PERFORMANCE ALSO APPLIES TO PUMP

MINIMUM DIAMETER 7 9/16 7 9/16

NUMBER _____

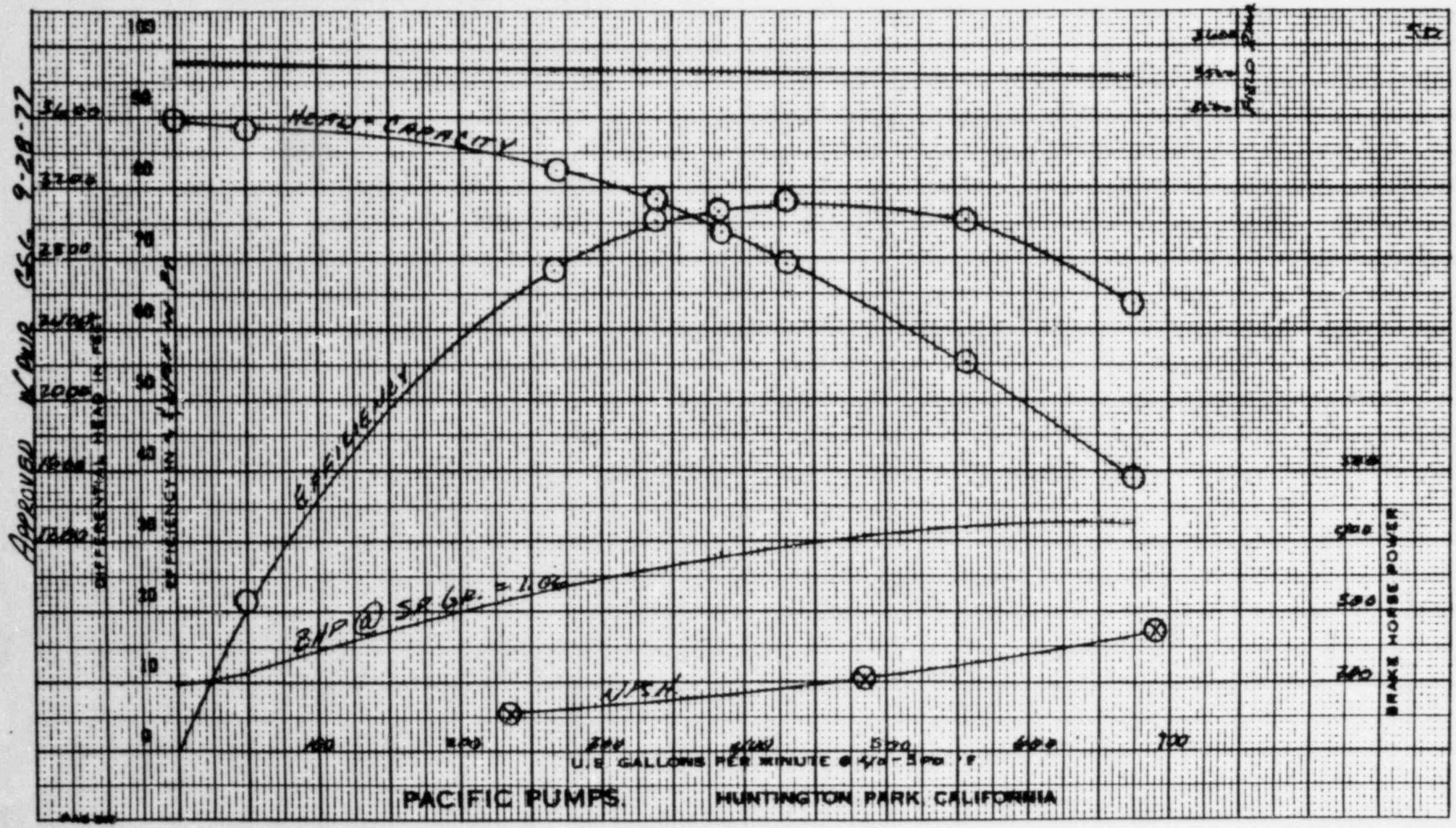

TEST PERFORMANCE CURVE NO. 27 / 1

SIZE 3" TYPE IHF STAGES 11

R.P.M. FIELD DATE 11-28-77

PUMP NUMBER 51928

PERFORMANCE ALSO APPLIES TO PUMP NUMBER _____

CONTRACTOR WESTING HOUSE AFS

CUSTOMER TEXAS UTILITIES CO

ITEM NO. TLX-01 P.O. 546 - C.A.V. 256159-BPI

IMPELLER PATTERN 1A-774 14-7592

MAXIMUM DIAMETER 8 9/16 8 9/16

RATED DIAMETER 8 9/16 8 3/16

MINIMUM DIAMETER 7 9/16 7 9/16

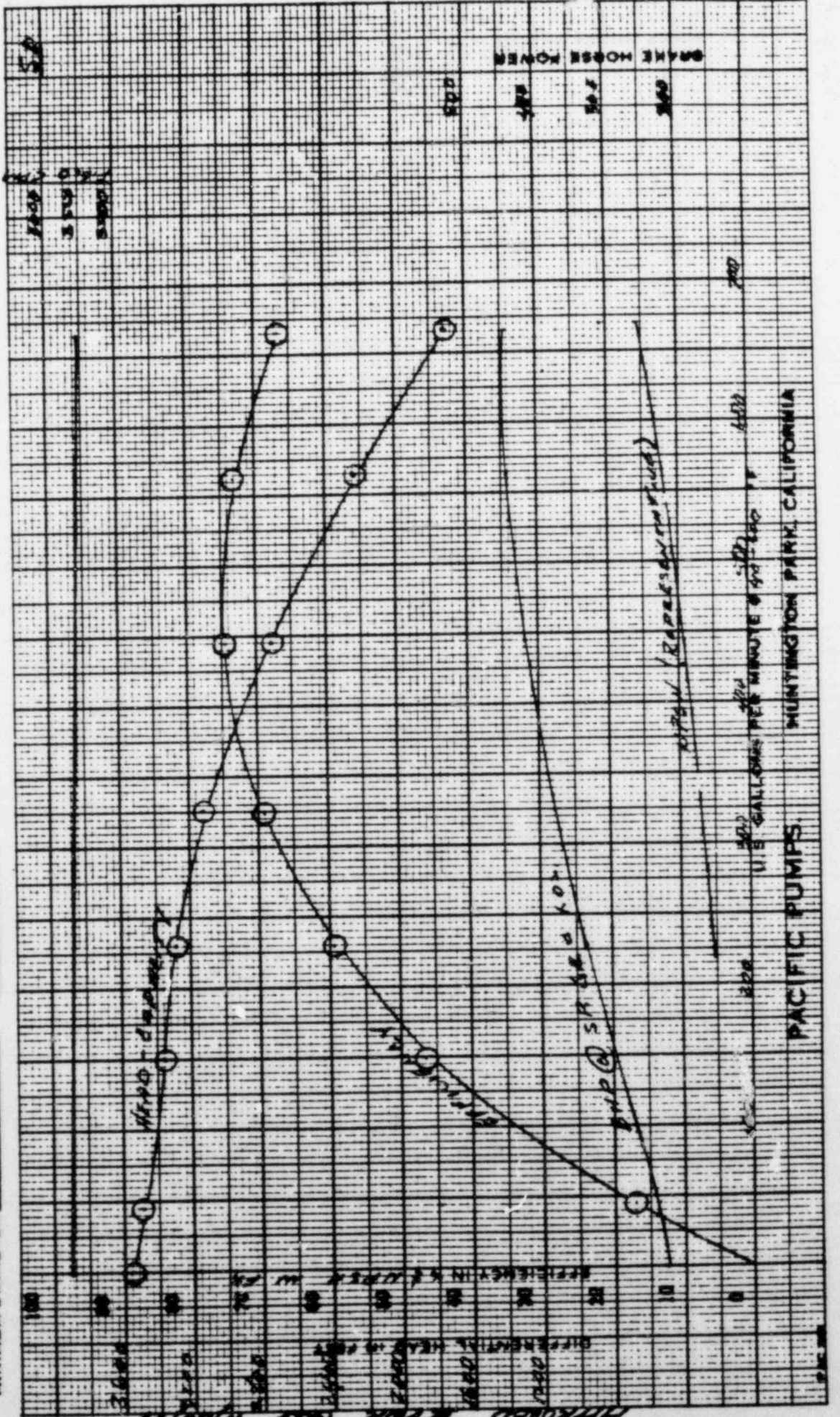

APPROVED NRDR EST. 11/2/77

PACIFIC PUMPS, MOUNTINGTON PARK, CALIFORNIA

U.S. GALLONS PER MINUTE @ 1725 RPM

APPROX. DIAMETER

PUMP @ 5700 RPM

TEST PERFORMANCE CURVE NO. 371716

SIZE 3" TYPE IMF STAGES 11

R.P.M. FIELD DATE 12-19-77

PUMP NUMBER 51929

PERFORMANCE ALSO APPLIES TO PUMP NUMBER _____

CONTRACTOR WESTINGHOUSE ALES

CUSTOMER TEXAS UTILITIES CO

ITEM NO. TX-02 P.O. 546 - CAU-236959-BPE

IMPELLER PATTERN M-7344 17-759L

MAXIMUM DIAMETER 8 9/16" 8 9/16"

RATED DIAMETER 8 9/16" 8 9/16"

MINIMUM DIAMETER 7 9/16" 7 9/16"

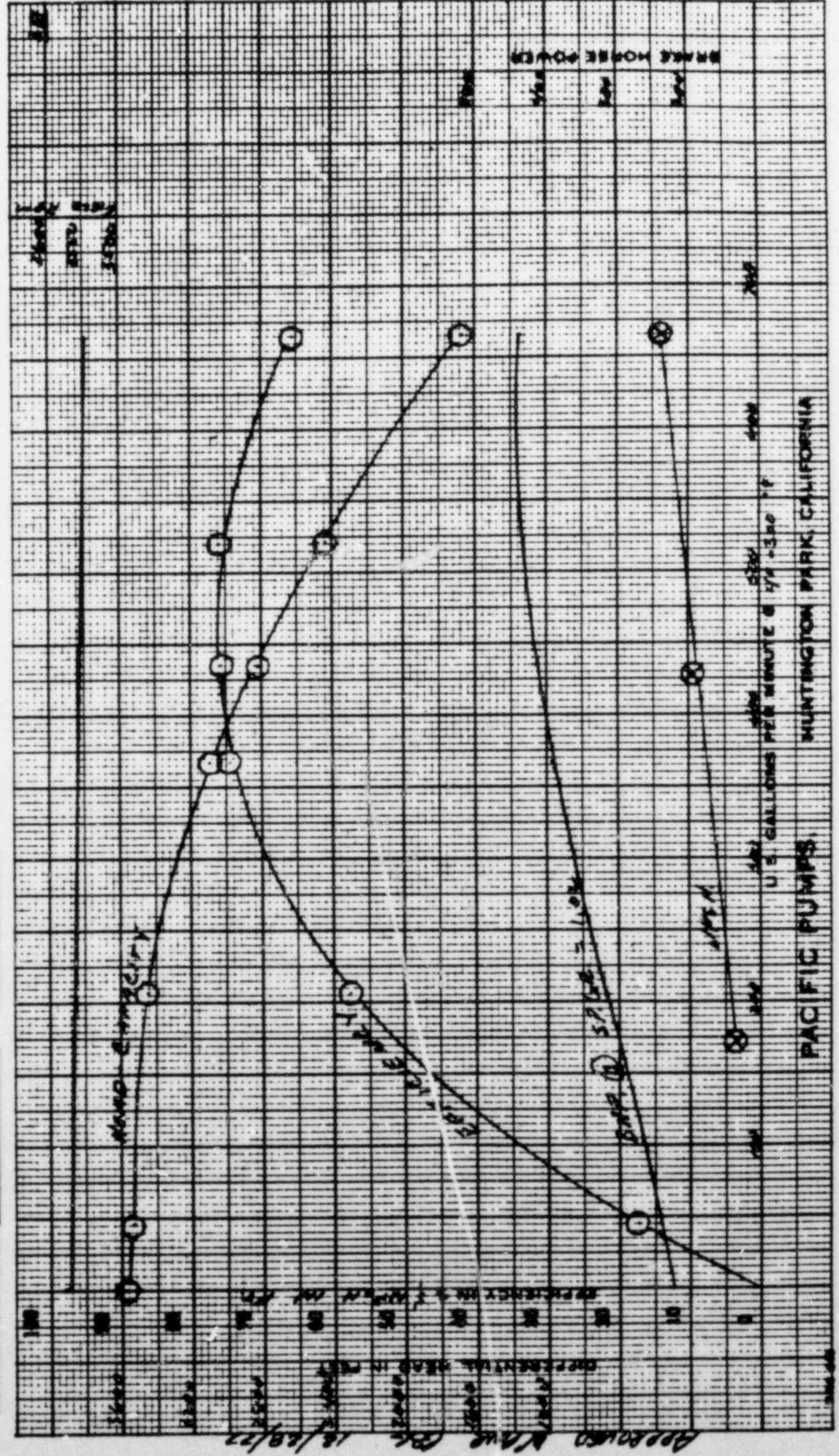

PACIFIC PUMPS HUNTINGTON PARK, CALIFORNIA

Approved Name: _____ Date: 12/29/77

SECTION VII

INDICATION SURVEY

Following is a list, by stage number, of the number and size of linear indications in the area of concern. For comparison, two other elements are shown. Since inspection results vary with the surface treatment of the material, one should not use these results as a measure of the condition of one pump to a different one; however, any given pump will be consistent from stage to stage and the point of these lists is to demonstrate that there is no correlation between the stage location and the number and size of the indications. Since the stress is much higher in the low number stages, this helps to show that the indications are not created or aggravated by any stress load on the part.

PUMP SERIAL NUMBER - 51667 (TEXAS)

<u>STAGE NO.</u>	<u>NO. INDIC.</u>	<u>LENGTH</u>
2	0	
3	3	3/16 - 5/16
4	4	1/8 - 1/2
5	0	
6	2	3/16 - 1
7	7	1/8 - 1/2
8	6	1/4 - 1-3/8
9	5	1/8 - 1/2
10	3	1/8 - 3/4
11	3	3/16 - 3/4

PUMP SERIAL NUMBER - 51650

<u>STAGE NO.</u>	<u>NO. INDIC.</u>	<u>LENGTH</u>
2	2	1/8 - 3/8
3	4	1/8 - 1/4
4	8	3/16 - 3/4
5	3	1/8 - 3/8
6	4	1/8 - 1-1/4
7	10	1/8 - 1-1/4
8	1	3/8
9	0	
10	14	1/8 - 1
11	14	1/8 - 3

NOTE: The dimensions given above are the lengths as they appear on the curved surface. The depth as discussed in the Field Recommendations never exceeded 1/2" depth in the radial direction. (See Section 9.)

SECTION VII
INDICATION SURVEY

PUMP SERIAL NUMBER - 51649

<u>STAGE NO.</u>	<u>NO. INDIC.</u>	<u>LENGTH</u>
2	0	
3	3	3/16 - 1/4
4	0	
5	2	3/16 - 5/8
6	4	1/8 - 1/4
7	0	
8	3	1/4 - 3/8
9	1	5/16
10	7	1/8 - 5/8
11	0	

INSTALLATION LISTS

The second list is of the Pacific type JTC, which is the modern cast horizontally split case multistage pump. The significant difference is the back-to-back impeller arrangement to reduce thrust bearing loads. These pumps use an essentially identical diffuser/cover arrangement to the type JHF; however, the static load is only half that of the JHF for the same total developed pressure due to the back-to-back construction.

JTC MULTISTAGE PUMPS

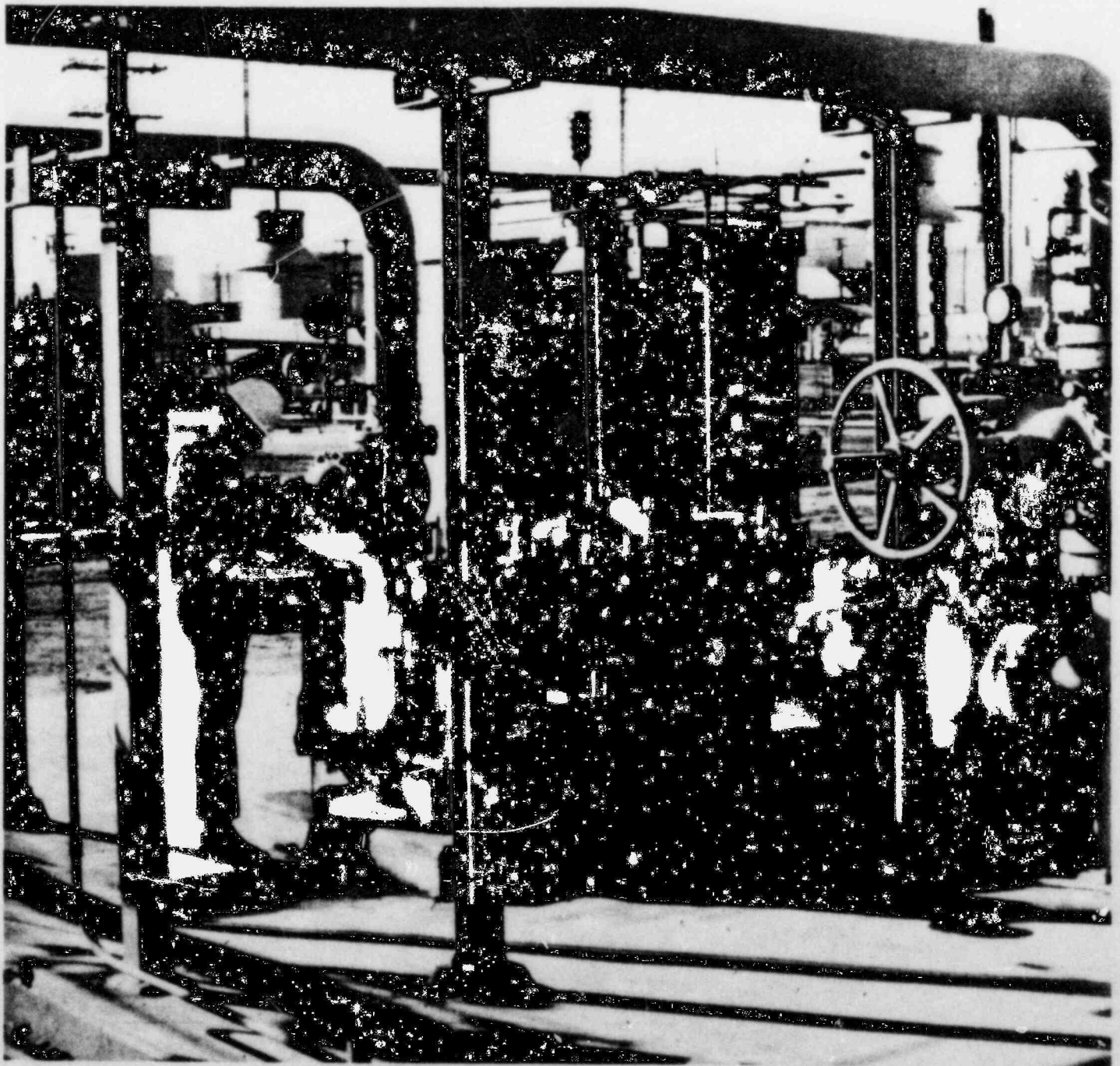

CUSTOMER AND LOCATION	PUMP NO.	NO. UNITS	SIZE	NO. STGS	RPM	GPM	SUCT. PRESS. PSIG	DISCH. PRESS. PSIG	PUMP TEMP. °F	SP. GR.	PRODUCT
CITY OF GRAND HAVEN GRAND HAVEN, MICHIGAN	29165/66	4	2"	8	3570	250	45	820	270	.933	Feedwater
CITY OF GARLAND GARLAND, TEXAS	29179/80	2	2½"	10	3560	395	82	1132	312	.912	Feedwater
LEA COUNTY ELEC. COOP. LOVINGTON, N. M.	29181/82	2	2½"	10	3560	390	70	1120	302	.917	Feedwater
MEDINA ELECTRIC COOP. PEARSALL, TEXAS	29186-94	9	2"	10	3560	276	70	1140	302	.917	Feedwater
TIDEWATER OIL CO. SAN PEDRO, CALIF.	29259	1	4"X	6	3585	650	-	535	88	.75	Gasoline
ATLANTIC REFINING CO. PHILADELPHIA, PA.	29301/02	2	2"	6	3550	220	-	540	105	1.01	20% DEA
ATLANTIC PIPELINE CO. GARDEN CITY STATION GLASSCOCK, TEXAS	29308 29309	1 1	6"X 6"X	4 4	3580 3580	1350 1350	20 650	467 1150	55-98 55-98	.855 .855	34° API Sour Crude 34° API Sour Crude
FIBER INDUSTRIES, INC. SHILBY, N.C.	29313/14	2	1½"	8	3565	117	30	720	267	.934	Feedwater
GENERAL PETROLEUM CO. TORRANCE, CALIF.	29330/31	2	1½"	6	3575	55	24	590	228	.952	Feedwater
CITIES SERVICE OIL CO. E. CHICAGO, INDIANA	29363/64	2	2½"	4	3570	250/386	35	280/330	50	.557	Alkylate
SHELL OIL COMPANY DOMINGUEZ, CALIF.	29374	1	3"	8	3580	525	85	817	60-90	.7-82	Av. Gas
SUN OIL COMPANY TWIN OAKS, PA.	29448	1	3"	10	3580	525	13	965	400	.739	Furance
U.S. AIR FORCE HILL AIR FORCE BASE OGDEN, UTAH	29476	1	2½"	8	3570	300	20	650	90	.72	JP-4
STANDARD VACUUM REFIN. BATAAN, PHILIPPINES	29577/78679	3	2"	8	3570	304	8	744	212	.96	Feedwater
ODESSA BUTADIENE CO. ODESSA, TEXAS	29591	1	3"	8	3575	658	15	765	250	.943	Feedwater
PAN AMERICAN PETRO CORP. SWIFTY, TEXAS	29647/48	2	1½"	8	3600	160	145	555	96	.545	Still Prod.
WOODLAWN CORP. WOODLAWN, TEXAS	29672	1	2½"	6	3550	600	(Outlet) 350	(Inlet) 950	100	.70	Rich Oil (H.T.)
BAY PETROLEUM CORP. CHALMERTT, LA.	29690/91	2	2½"	6	3580	240/420	10	755/715	220	.957	Feedwater
ACADIA CORP. RAYNE, LA.	29699	1	2"	6	3600	146	-	475	100	.735	H.C.
JONES & LAUGHLIN STEEL CO. PITTSBURGH, PA.	29710/11/12	3	6"X	4	3570	1600	5	575	228	.953	Feedwater
SKILLY OIL COMPANY LOCO HILLS, N.M.	29784/85	2	1½"	8	3570	153	40	640	85	.795	Lean Oil
GOLIAD CORP. GOLIAD, LA.	29809	1	4"X	6	3430/ 3820	730	473/ 300	1030/ 1030	-45	.69	H.C.
COW ISLAND, LA.	29814/15	2	2"	6	4070	360	60	710	307	.916	Feedwater
ACADIA CORP. EGAN, LA.	29835	1	1½"	8	3570	153	10	563	120	.734	H.C.
TEXACO, INC. PORT ARTHUR, TEXAS	29841	1	2"	4	3570	350/175	-7.7	168/358	40-60	.805	Lubricating Oil
WARREN PETROLEUM CORP. MAYSVILLE, OKLAHOMA	29853 29854	1 1	2" 3"	8 4	3600 3600	185 990	45 310 (Outlet)	845 630 (Inlet)	175 105	.80 .72	Lean Oil Rich Oil
OHIO OIL COMPANY MARKHAM, TEXAS	29857	1	1½"	6	3650	146	20	600	Amb.	1.03	Salt Water
GOLIAD CORPORATION COW ISLAND, LOUISIANA	29810	1	4"X	6	3430 3820 3660 2890	730 765 694	473 300 83 95	1030 1030 547 372	-45/ -38/ -44	.69/ .768 .77	HC
DAIKYO OIL COMPANY JAPAN	29967	1	1½"	8	3570	108	-	610	100	.76	Oil
CONTINENTAL OIL CO. PONCA CITY, OKLAHOMA	29968	1	1½"	8	3565	105	114	800	80	.8613	Wax Distillate
PARKE, DAVIS & CO. HOLLAND, MICHIGAN	29994/95	2	1½"	8	3570	125	14	712	228	.952	Feedwater
IDEMITSU KOSAN CO., LTD. TOKUYAMA, JAPAN	30046/47	2	2"	6	3565	200	200	550	100	.51	Deethanizer Feed
CITY OF VIRGINIA VIRGINIA, MINNESOTA	30147	1	2½"	8	3560	340	24	906	240	.947	Feedwater

CUSTOMER AND LOCATION	PUMP NO.	NO. UNITS	SIZE	NO. STGS	RPM	GPM	SUCT. PRESS. PSIG	DISCH. PRESS. PSIG	PUMP TEMP. °F	SP. GR.	PRODUCT
EL PASO NATURAL GAS TERRELL CTY., TEXAS	30180/81 30188-92	2 5	6"X 4"X	4 6	4100 3600	1500 800	16 16	955 955	10 10	1.24 1.24	Organic Liquid Organic Liquid
ACADIA CORP. EGAN, LOUISIANA	30215	1	2"	6	3600	145	0	475	100	.735	HC
CONSUMERS COOP. REF., LTD. REGINA, SASK., CANADA	30368 30369 30370	1 1 1	1½" 1½" 2"	10 8 10	3565 3570 3575	100 100 190	0 100 0	650 650 900	100 255 125	.74 .67 .86	Naphtha Oil Oil
TRANSWESTERN PIPINI KERMIT, TEXAS	30374/75	2	2"	8	4060	186/75	0/6.37	637/1037	100	.99	12" MFA (5th step bleed-off nozzle)
FSSO STD., DIV. OF HUMBLE OIL & REFINING CO. BATON ROUGE, LOUISIANA	30477	1	2½"	8	3585	410	8	835/1004	100	99/1.21	Fresh Water & Brine
UNION OIL CO. OF CALIF. WILMINGTON, CALIFORNIA	30484 30487	1 1	4"X 4"X	8 4	3580 3570	665 595	5 13	855 410	236 290	.67 .655	Naphtha Naphtha
CONTINENTAL OIL CO. PONCA CITY, OKLAHOMA	30590/91	2	1½"	8	3570	110	40	550	105	.745	Lean Oil
NAPH-SOL REFINING CO. MUSKEGON, MICHIGAN	30656	1	2"	8	3580	175	0	840	100	.825	API 55° 35°
STANDARD OIL CO. OF INDIANA WHITING, INDIANA	30698/99	2	6"X	6	3580	960	33	830	240	.95	Feedwater
CITIES SERVICE OIL CO. EAST CHICAGO, INDIANA	30730	1	2"	6	3570	220	245	535	90	.526	HC
CITIES SERVICE OIL CO. EAST CHICAGO, INDIANA	30774	1	2½"	8	3550	350	10	660	75	.75	Naphtha
ASHLAND OIL & REF. CO. CATLETTSBURG, KENTUCKY	30802/03	2	2½"	6	3570	400	50	540	90	.73	57.6° API
CALIFORNIA COMPANY RANGELY, COLORADO	30908 30909	1 1	3" 3"	6 8	3680 4150 4020 3780	500 487 487	0 550 450 550	475 1200 1200	160 190 90	.77 .799 .795	Lean Oil Lean Oil
AUSTRALIAN OIL REF. PTY. KURNELL NEW SOUTH WALES, AUSTRALIA	27971/72	2	2"	6	4200	260	0	650	260	.88	Vacuum Residum
CITY OF VERO BEACH VERO BEACH, FLORIDA	30822/23	2	2½"	10	3560	300	70	1720	300	.9183	Feedwater
PETROLEOS MEXICANOS MEXICO	31905/96 31098 31099-106 31107-10 31111 31112/13 31114	2 1 8 4 1 2 1	1½" 1½" 2½" 1½" 2½" 2½" 1½"	10 10 8 10 8 8 10	3570 3570 3580 3570 3580 3580 3570	110 70 350 100 350 350 100	30 0 10 0 0 10 0	860 900 830 830 830 800 800	150 100 80 80 100 80 100	.83 .86 .84 .84 .85 .87 .88	Waxy Crude Crude Crude Crude Crude Crude Crude
ASHLAND OIL & REFINING CATLETTSBURG, KENTUCKY	31153/54 31160	2 1	4"X 4"X	6 6	3580 3580	600 635	100 25	600 610	440 332	.51 .63	Naphtha Naphtha
ALUMINUM CO. OF AMERICA POINT COMFORT, TEXAS	31208/09	2	3"	8	3580	655	150	850	-20	.79	Lean Oil
CHEMSTRAND CORPORATION GONZALEZ, FLORIDA	3120/11	2	4"X	6	3820	900	33	944	267	.935	Feedwater
CITY OF CHELLE ROCHELLE, ILLINOIS	31241/2/3	3	3"	10	3565	240	12	115	227	.952	Feedwater
PHILLIPS PETROLEUM CO. SWEENEY, TEXAS	31250/51	2	1½"	6	3570	160	2	586	100	1.023	20" DEA
MARUZEN OIL CO., LTD. SHIMOTSU, JAPAN	31256	1	2"	8	3570	250	10	490	270	.647	Reactor Charge
SOUTHERN CALIFORNIA EDISON LONG BEACH, CALIFORNIA	31324/5/6	3	2½"	10	3570	425	50	1170	270	.975	Fuel Oil
SIGNAL OIL & GAS HOUSTON, TEXAS	31396/97	2	1½"	8	3570	90	65	580	225	.663	Lean Oil
SHELL CHEMICAL COMPANY VENTURA, CALIFORNIA	31428/29	2	1½"	6	3570	75	38	625	120	.93	Carbonat. Solution
DOW CHEMICAL COMPANY FREEPORT, TEXAS	31439/40 31446	2 1	1½" 1½"	8 8	3570 3560	110 90	0 0	660 535	100 100	.85 .858	Reactor Charge 29.3° API
CITY OF COLORADO SPRINGS COLORADO SPRINGS, COLO.	31470/71	2	2½"	10	3580	400	27	1127	250	.94	Feedwater
SHELL OIL COMPANY SORRENTO, LOUISIANA	31551	1	2½"	10	3570	350	50	890	70	1.0	Fresh Water
HUMBLE OIL & REFINING	31582	1	6" S	4	3580	1600	40 600 Max)	635	90	.86	Sour Crude
INDIAN ALUMINUM CO., LTD. CALCUTTA, INDIA	31586/87	2	2"	10	2960	185	12	782	250	.94	Feedwater

CUSTOMER & LOCATION	PUMP NO.	NO. UNITS	SIZE	NO. STGS	RPM	GPM	SUCT. PRESS. PSIG	DISCH. PRESS. PSIG	PUMP TEMP. °F	SP. C.G.	PRODUCT
ASIA OIL CO., LTD. OHAMA, JAPAN	31591/92	2	2"	10	3570	150	0	925	100	78	Reactor Charge
	32593/94	2	2"	10	2970	180	10	500	100	74	Unitining Charge
	31595/96	2	2"	10	2970	205	250	655	290	66	Platforming Charge
SHOWA OIL COMPANY JAPAN	31615	1	2"	8	2960	220	70	490	100	74	Unitining Charge
	31616/17	2	2"	10	2970	250	95	635	240	66	Platforming Charge
U.S. ATOMIC ENERGY COM RINCON, PUERTO RICO	31621/22	2	.	10	3570	195	50	1060	290	925	Feedwater
POWERINE OIL COMPANY SANTA FE SPRINGS, CALIF	31685	1	1½"	8	3570	125	0	650	100	746	53.9° API
MITSUBISHI OIL COMPANY JAPAN	31691	1	1½"	10	3550	135	140	650	250	655	59.6° API
CITY OF BROWNSVILLE BROWNSVILLE, TEXAS	31713/14	2	2½"	8	3570	350		959	291	923	Feedwater
CITY OF NATCHITOCHE LOUISIANA	31777/78	2	1½"	8	3570	175	40	653	275	93	Feedwater
ATAS MERSIN, TURKEY	31807	1	2½"	10	2960	315	145	670	105	73	HC
	31808/09	2	2½"	10	2960	324	40	555	105	77	HC
MITSUBISHI OIL COMPANY KAWASAKI, JAPAN	31836	1	2"	6	2980	221	21.3	305	100	625	Li. SRG
CITY OF ANTHONY ANTHONY, KANSAS	31849	1	1½"	6	3555	105	5	520	227	95	Feedwater
STANDARD OIL CO. - OHIO CLEVELAND, OHIO	31861	1	4"X	4	3550	686	0	375	80/200	88	HC
GOVERNMENT OF THE REPUBLIC OF INDONESIA	31878/83	6	3"	10	2970	275	72	990	330	902	Feedwater
COSDEN PETROLEUM CORP. BIG SPRINGS, TEXAS	31969	1	2"	10	3560	250	62	617	120	52	Li. HC
UNION CARBIDE CHEMICALS SLADRIIT, TEXAS	31973	1	6"X	4	3920	1140	15	780	250	94	Feedwater
	31974	1	6"X	6	3570	1140	15	780	250	94	Feedwater
CROWN CENTRAL PETROLEUM HOUSTON, TEXAS	32014/15	2	1½"	10	3570	72	0	975	125	842	Toluene
REPESA CARTAGENA, SPAIN	32056/57	2	1½"	6	3570	55	17.6	543	212	958	Condensate
	32061/62	2	3"	6	2970	454	14.7	449	155	982	1:1 MEA
	32082/83	2	2"	6	2970	166	18	318	110	61	Naphtha
	32088/89	2	2½"	8	2970	260	26	560	230	95	Water
	32090	1	2½"	8	2970	260	15	570	100	1.0	Water
STANDARD OIL OF CALIFORNIA PITTSBURG, CALIFORNIA	32154	1	4"X	4	3570	730	13	413	50 (413 Max.)	905	Crude Oil
EL PASO NATURAL GAS ODISSA, TEXAS	32163/4/5	3	2½"	8	3570	360	18	818	225	953	Feedwater
REPESA CARTAGENA, SPAIN	32177/8/9	3	4"X	8	2950	718	34	679	250	943	Feedwater
AURORA GASOLINE CO DETROIT, MICHIGAN	32192	1	2½"	10	3570	365	35	995	150	88	HC
	32193	1	2"	4	3570	365	250 (Outlet)	800 (Inlet)	150	80	HC (HT)
CLARK OIL & RIPPING BLU ISLAND, ILLINOIS	32201	1	2"	6	3575	240	0	470	100	73	Naphtha
EL PASO NATURAL GAS ODISSA, TEXAS	32279/80	2	1½"	6	3570	120	0	635	105	995	MEA
AMERICAN OIL COMPANY TEXAS CITY, TEXAS	37429	1	1½"	10	3570	66	2.36	822.64	60	86	HC (70% Aromatics)
STANDARD OIL OF CALIFORNIA LA HABRA, CALIFORNIA	37471	1	6"X	6	3580	930	15	1015	105	1.006	Oilfield Brine-Water
STANDARD OIL OF CALIFORNIA LA HABRA, CALIFORNIA	37501/02	2	2½"	10	3570	440	35	1250	100	1.006	Oilfield Brine-Water
CHEMSTRAND CO. DICATUR, ALABAMA	37504/06	2	3"	8	3750	500	29	894	228	0.952	Feedwater
CITY OF NEW ULM NEW ULM, MINNESOTA	37538/39	2	2½"	10	3575	360	37	1200	270	0.933	Feedwater
MONOCHEM INC. GLISMAR, LOUISIANA	37562	1	4"X	6	3580	890	20	790	227	951	Water
MONSANTO CHEM CO. CHOCOLATE BAYOU, TEXAS	37571-73	3	6"X	4	3580	1120	74	600	297	92	Water
U.S. STEEL CORP. DUQUESNE, PENNSYLVANIA	37595	1	6"X	2	3560	900	0	352	210	955	Feedwater
LANESE CORPORATION AMPA, TEXAS	37600/01	2	2"	8	3550	218	170	646	105	55	Butane
W. R. GRACE COMPANY MEMPHIS, TENNESSEE	37606/07	2	1½"	6	3565	139	20	534	250	94	Water

CUSTOMER & LOCATION	PUMP NO.	NO. UNITS	SIZE	NO. STGS	RPM	GPM	SUCT. PRESS. PSIG	DISCH. PRESS. PSIG	PUMP TEMP. °F	SP. GR.	PRODUCT
BETTIS ATOMIC POWER LAB. SCOVILLE, IDAHO	37613	1	3"	10	3580	100	0	1550	120	0.989	Water
SOUTHERN NITROGEN CO. SAVANNAH, GEORGIA	37615/16	2	3"	4	3570	430	0	300	210	.959	Water
POWERINE OIL COMPANY SANTA FE SPRINGS, CA	37634	1	6"X	6	3580	1750	60	610	AMB	0.75	Gasoline
CELANESE CHEMICAL CO. BAY CITY, TEXAS	37659/60	2	1½"	8	3560	35	0	550	110	.70	Lean Oil
FINCH PRUYN CO. GLEN FALLS, NEW YORK	37685/86	2	6"X	6	3575	1200	41.4	240	255	0.94	Feedwater
AM. POTASH & CHEM. CORP. TRONA, CALIFORNIA	37696/97	2	2"	6	3570	269	35	550	281	0.93	Condensate
PHILLIPS PETROLEUM CO. SWEENEY, TEXAS	37759/60	2	1½"	6	3550	60	-1.7	545	100	.875	Benzene & Cyclohexane
MOBIL OIL COMPANY KAPLAN, LOUISIANA	37781	1	2"	6	4050	360	60	710	307	.916	Water
SUNTIDE REFINING CO. CORPUS CHRISTI, TEXAS	37808/09	2	1½"	4	3570	125	0	305	60	0.87	Xylenes
SOUTHERN PERU COPPER CORP. ILO, PERU	37839/40	2	4"X	8	3565	735	98	1075	324	0.907	Deaerated Condensate
PURE OIL COMPANY LEMONT, ILLINOIS	37841/42	2	2½"	8	3570	224	0	867	100	.857	Hydrocarbon w/1.5% Wt. Sulfur
REPUBLIC STEEL CO. WARREN, OHIO	37854/55	2	2"	10	3570	200	10	450	153	0.981	Condensate
INDUSTRIA DEL ALCALI MEXICO	37892/93	2	3"	4	4140	676	15	615	221	.955	Boilerfeed Water
CHEMSTRAND CO. GONZALEZ, FLORIDA	37896	1	4"X	6	3880	900	33	944	267	.935	Boiler Water
PHILLIPS PETROLEUM CO. PHILLIPS, TEXAS	37902	1	2"	6	3550	220	195	510	92	.533	HC
CONTINENTAL OIL COMPANY PONCA CITY, OKLAHOMA	37954	1	3"	8	3570	510	0	675	105	0.741	Naphtha
HUMBLE OIL & REFINING CO. BAYTOWN, TEXAS	37978	1	2½"	8	3570	330	10	645	265	0.695	Varsol
COMMONWEALTH PETROCHEMICALS PONCE, PUERTO RICO	37984/85	2	2½"	10	3570	295	0	970	105	.855	Toluene
HUDSON'S BAY OIL & GAS CO. SYLVAN LAKE GAS PROC. CAN.	38000	1	2½"	8	3570	379	79	992	110	0.998	20% Wt. Mea-Water Solution
HYDSON'S BAY OIL & GAS CO. ALBERTA, CANADA	38001	1	2½"	8	3570	379	79	992	110	0.998	20% Wt. Mea-Water Solution
COMBINED LOCKS PAPER CO. COMBINED LOCKS, WISCONSIN	38012/13	2	2½"	10	3570	360	28.54	1075	240	.947	Boiler Feedwater
WESTERN ILLINOIS POWER COOP. PEARL, ILLINOIS	38014/15	2	3"	10	3565	567	68	1093	302	0.917	Feedwater
COMMONWEALTH PETROCHEMICAL PONCE, PUERTO RICO	38023/24	2	4"X	6	3570	875	45	780	287	.92	Boiler Feedwater
GETTY OIL COMPANY PERSIAN GULF, ARABIA	38068	1	1½"	6	3420	126	10	465	240	0.95	Water
EMPRESA NACIONAL DEL PETROLEO CONCEPCION, CHILE	38151	1	2½"	10	2970	230	25	525	340	0.77	Hvy-naphtha
EMPRESA NACIONAL DEL PETROLEO CONCEPCION, CHILE	38158/59	2	6"X	6	2970	1250	0	420	50	0.85	Crude 45% Gregorio 25% Clarence
ROHN & HAAS DEER PARK, TEXAS	38210/11	2	1½"	6	3560	125	25	536	260	0.938	Deaerated BF Water
CAROLINA POWER & LIGHT ROXBORO, N. CAROLINA	38310	1	4"X	4	3570	1115	133.11	552.11	350	0.89	Condensate
EL PASO NATURAL GAS JAL, NEW MEXICO	38337/38	2	1½"	8	3560	80	550	900	75	0.825	Lean Oil
REFINERIA DE PETROLEOS DE ESCOMBRENAS - SPAIN	38344	1	3"	6	3550	500	15	510	100	0.713	Naphtha
CITY OF MARQUETTE MARQUETTE, MICHIGAN	38351/52	2	2½"	10	3565	350	70	1120	302	0.917	Feedwater
STANDARD OIL COMPANY INGLEWOOD, CALIF.	38356/57	2	4"X	8	3570	730	15	1215	100	1.025	Salt Water
HUMBLE OIL & REFINING CO. VENICE, CALIFORNIA	38383/84	2	2"	6	3565	180	5	700	230	.951	Water
FORCA E LUZ DO PARA BELEM, BRAZIL	38386-89	4	3"	10	3580	600	90	1150	321.2	.9086	Water

CUSTOMER & LOCATION	PUMP NO.	NO. UNITS	SIZE	NO. STGS	RPM	GPM	SUCT. PRESS. PSIG.	DISCH. PRESS. PSIG.	PUMP TEMP. °F	SP. GR.	PRODUCT
NAS LASTMAN CO. WAGGON, TEXAS	38437-39	3	3"	6	3780	575	24	749	250	0.944	B.F. Water
PHILLIPS PETROLEUM CO. KANSAS CITY, KANSAS	38461	1	6"X	6	3570	825	20	885	259	0.937	Feedwater
PHILLIPS PETROLEUM CO. KANSAS CITY, KANSAS	38462/63	2	6"X	6	3570	825	20	885	259	0.937	Feedwater
PHILLIPS PETROLEUM CO. KANSAS CITY, KANSAS	38464-65	2	1½"	4	3560	80	230	416	100	0.461	Propane
SHELL OIL COMPANY WASHINGTON, CALIFORNIA	38478/79	2	2"	6	3560	234	11	694	100	1.016	Dichloro-Mine
TENNCO OIL COMPANY CHALMERS, LOUISIANA	38486	1	2½"	6	3565	240	10	755	220	0.957	Boiler Feedwater
PHILLIPS PETROLEUM CO. KENNEWICK, WASHINGTON	38590/91	2	1½"	6	3560	116	20	540	250	.94	B.F. Water
ACU, INC. BONNIE, FLORIDA	38676/77	2	2½"	6	3560	290	5	725	228	0.95	Water
HERCULES POWDER COMPANY LA. MISSOURI	38692/93	2	1½"	8	3550	148	20	649	250	.94	Boiler Feedwater
SUNRAY OIL COMPANY TULSA, OKLAHOMA	38700/01	2	3"	6	3880	600	0	775	210	.96	Water
ACU, INC. BARTON, FLORIDA	38724/25	2	2"	6	3560	240	5.6	550	220	0.955	Water
ACU, INC. BONNIE, FLORIDA	38676/77	2	2½"	6	3560	290	5	725	228	0.95	Water
HERCULES POWDER CO. LOUISIANA, MISSOURI	38692/93	2	1½"	8	3550	148	20	649	250	.94	Boiler Feedwater
SUNRAY OIL COMPANY TULSA, OKLAHOMA	38700/01	2	3"	6	3880	600	0	775	210	.96	Water
CARIBBEAN REFINING CO. SAN JUAN, PUERTO RICO	38755	1	2"	8	3550	225	15	625	304	0.665	Hydro-Carbons
THE DE NAUFLOTHS SAHIBBOCHS, LOUISIANA	40153/54	2	2"	8	3570	290	70	720	310	.913	Water
THE DE NAUFLOTHS SAHIBBOCHS, LOUISIANA	40155/56	2	3"	8	3570	315	72	742	300	.918	Water
COASTAL STATES PETROCHEM. CORP. CHRISTI, TEXAS	40166	1	2"	6	3560	285	30	330	315	0.545	H.C.
TEXACO, INC. SERRINE, LOUISIANA	40168/69	2	2½"	10	3560	410	0	865	60	1.0	Water
TEXACO, INC. SERRINE, LOUISIANA	40170	1	4"X	6	3560	820	0	500	60	1.2	Brine
WARREN PETROLEUM MONTE BELVIEU, TEXAS	40171	1	2½"	4	3860	425	15	550	250	0.9431	Feedwater
NAT. ORGANIC CHEMICAL IND. BOMBAY, INDIA	40172/73	2	2"	10	4000	230	37.5	1402.5	250	0.944	Water
NAT. ORGANIC CHEMICAL IND. BOMBAY, INDIA	40174-76	3	4"X	10	3328	655	42.1	484	250	0.945	Water
SHAMROCK OIL & GAS AMARILLO, TEXAS	40253/54	2	2"	6	3550	210	5	660	210	0.96	Water
AMOCO CHEMICALS DECATUR, ALABAMA	40259/60	2	2"	10	3575	120	40	1190	258	0.938	Feedwater
RUST ENGINEERING CO. ORANGE, TEXAS	42809	1	1½"	10	3550	60	102.67	1045	212	0.96	Water
COMPANIA ESPANOLA DE PET. ALGERIAS, SPAIN	40355	1	6"X	6	2960	850	35	490	310	0.622	Unifining Charge
COMPANIA ESPANOLA DE PETRO. ALGERIAS, SPAIN	40382-84	3	3"	10	2900	385	15	810	250	.94	Boiler feed
COMPANIA ESPANOLA DE PETRO. ALGERIAS, SPAIN	40393/94	2	3"	4	2900	350	50	370	298	.92	Water
CORP. DIFOMENTO DE LA PROD. QUINTARO, CHILE	40411/12	2	2"	4	2965	200	150	448	60	.84	Diesel, Kerosene
SHELL OIL CO. FREEPORT, TEXAS	40413	1	6"X	4	3570	992	570	900	-40	.69	Hydrocarbon
SHELL OIL CO. FREEPORT, TEXAS	40414	1	6"X	4	3565	1015	570	900	119	.69	Hydrocarbon
SHELL OIL CO. FREEPORT, TEXAS	40417	1	6"X	4	3565	1015	100	545	119	.65	Hydrocarbons
SOUTHWESTERN OIL & REF. CO. CORPUS CHRISTI, TEXAS	40456	1	3"	4	3565	600	0	482	250	.94	Feed water

CUSTOMER & LOCATION	PUMP NO.	NO. UNITS	SIZE	NO. STGS	RPM	GPM	SUCT. PRESS. PSIG	DISCH. PRESS. PSIG	PUMP TEMP. °F	SP. GR.	PRODUCT
STAUFFER CHEMICAL CO. LONG BEACH, CALIF.	40524	1	3"	6	3570	433	0	619	100	1.06	Dea Solution
ATLANTIC REFINING CO. PHILADELPHIA, PENN.	40556/57	2	4"X	4	3560	655	3	518	222	.956	H ₂ O
DOUGLAS OIL COMPANY PARAMOUNT, CALIFORNIA	40559	1	2"	6	3570	130	15	480	105	.858	Diesel Oil
UNION BAG-CAMP PAPER CORP. PRATTVILLE, ALABAMA	40565/66	2	6"XB	6	4400	1900	75	1200	298	.92	
UNION BAG-CAMP PAPER CORP. PRATTVILLE, ALABAMA	40567	1	2½"	4	35	200	75	605	298	1.0	Water
CITY OF WILLMAR, MINN. WILLMAR, MINNESOTA	40568	1	2½"	10	3580	400	58	1245	300	.954	Boiler Feedwater
TEXACO, INC. SORRENTO, LOUISIANA	40576	1	4"X	4	3560	820	0	500	110	1.2	Brine
MOBIL OIL CO. TORRANCE, CALIFORNIA	40606/07	2	6"X	4	3570	1500	13	685.5	110	1.066	Richamine
PHILLIPS PETROLEUM CO. BORGER, TEXAS	40613	1	2"	10	3570	250	0	625	AMB.	.58	Butane
CITY OF AMES AMES, IOWA	40614/15	2	4"X	8	3570	730	90	1240	303	.92	Water
G.E.A.P.E.D. OSWEGO, NEW YORK	40631/32	2	1½"	10	3570	420	80	1225	140	1.0	Reactor Water
G.E.A.P.E.D. Forked River, New Jersey	40635/36	2	2½"	10	3570	420	80	1225	140	1.0	Reactor Water
CELANESE CHEMICAL CO. BISHOP, TEXAS	40658	1	1½"	6	3800	120	15	547	100	.89	Methanol
SEQUOIA REFINING CO. HERCULES, CALIF.	40695	1	2½"	6	3570	325	70	625	120	.73	Hydrocarbon
SEQUOIA REFINING CO. HERCULES, CALIF.	40699	1	2½"	8	3565	485	70	650	255	.68	Hydrocarbon
COMPANIA ESPANOLA DE PET. ALGECIRAS, SPAIN	40721/22	2	1½"	8	2950	105	0	470	220	.957	Water
MOBIL OIL CO. TORRANCE, CALIFORNIA	40776/77	2	1½"	6	3560	104	40	540	212	.965	Condensate
NASA MANNED SPACECRAFT CENTER CLEAR LAKE, TEXAS	40729	1	6"X	4	3420	1350	0	600	120	1.0	High Purity Water
CHINESE PETROLEUM CO. TAIWAN, FORMOSA	40799	1	2"	4	3570	200	7.5	414.5	85	1.0	Plant Water
FIRST NITROGEN CORP. DONALDSONVILLE, LA	40804	1	2"	6	3560	100	25	700	250	.942	Boiler Feedwater
ATLANTIC REFINING CO. PHILADELPHIA, PA	40820	1	6"X	8	3550	1956	325	1385	250	.692	HC w/H ₂ S
COASTAL STATES PETROCHEMICAL CORPUS CHRISTI, TEXAS	40835	1	1½"	6	3560	115	125	575	100	.852	Oil
COASTAL STATES PETROCHEMICAL CORPUS CHRISTI, TEXAS	40836	1	1½"	8	3570	85	50	660	93	.847	HC
SHELL OIL COMPANY WILMINGTON, CALIF.	40870	1	2½"	-	3570	280	2.02	1095.02	AMB.	.78	Gasoline
SHELL OIL CO. LOS ANGELES, CALIF.	40871	1	2½"	-	3570	280	50	1143	AMB.	.78	Gasoline
AMERICAN OIL CO. SALT LAKE CITY, UTAH	40892	1	2"	8	3575	216	19	370	350	.614	Heart Cut Naptha
MURPHY OIL CO. MIRAUX, LOUISIANA	40907	1	1½"	6	3570	125	0	525	212	.96	Steam Condensate
MURPHY OIL CORP. MIRAUX, LOUISIANA	40908	1	1½"	6	3570	125	0	525	212	.96	
COMPANIA ESPANOLA DE PET. ALGECIRAS, SPAIN	40912	1	2"	10	2950	100	0	675	95	.86	Aromatic H.C.
COMPANIA ESPANOLA DE PET. ALGECIRAS, SPAIN	40913	1	8"X	6	2900	1900	0	550	97	.86	Aromatic H.C.
SEQUOIA REFINING CO. HERCULES, CALIFORNIA	40978	1	2½"	-	-	-	-	-	-	-	Hydrocarbon
MOBIL OIL COMPANY TORRANCE, CALIFORNIA	40993	1	4"X	8	3570	700	0	800	100	.743	Gasoline & Distillate
SEQUOIA REFINING CO. HERCULES, CALIFORNIA	490995/96	2	4"X	4	3570	885	-9	341	60	.765	Crude Oil
SEQUOIA REFINING CO. HERCULES, CALIFORNIA	41001	1	1½"	4	3350	35	1.25	325	80	.756	Unstable Platformate

CUSTOMER & LOCATION	PUMP NO.	NO. UNITS	SIZE	NO. STGS	RPM	GPM	SUCT. PRESS. PSIG	DISCH. PRESS. PSIG	PUMP TEMP. °F	SP. GR.	PRODUCT
SEQUOIA REFINING CO. HERCULES, CALIFORNIA	41019-21	3	4"X	8	2550	640	80	925	80	.733	Gasoline
TENNECO MFG. CO. PASADENA, TEXAS	41030/31	2	4"X	6	3570	700	15	750	250	.94	Feed Water
MOBIL CHEMICAL CO. BEAUMONT, TEXAS	41066	1	1½"	10	3565	87.5	35	765		.776	Hydrocarbon
TERRA CHEMICAL INT'L INC. FORT NIAL, IOWA	4114/15	2	2½"	6	3570	315	20	760	240	.96	B.F. Water
UNION CARBIDE CORP. GARY, INDIANA	41126/27	2	2"	6	3550	244	15	500	250	1.0	B.F. Water
SEQUOIA REFINING HERCULES, CALIFORNIA	41138/39	2	1½"	4	3550	135	0	325	228	.95	Treated Water
HESS OIL VIRGIN ISLANDS CORP. ST. CROIX, VIRGIN ISLANDS	41154	1	2½"	8	3570	435	35	620	165	.694	Hydrocarbon
HESS OIL VIRGIN ISLANDS CORP. ST. CROIX, VIRGIN ISLANDS	41155	1	2"	8	3570	222	10	620	275	.638	Hydrocarbon
HESS OIL VIRGIN ISLANDS CORP. ST. CROIX, VIRGIN ISLANDS	41156	1	2½"	10	3570	435	35	850	440	.723	Hydrocarbon
HESS OIL VIRGIN ISLANDS CORP. ST. CROIX, VIRGIN ISLANDS	41157	1	2½"	10	3570	280	0	850	440	.723	Hydrocarbon
DOW CHEMICAL CO. FREEPORT, TEXAS	41199-200	2	4"X	4	3570	755	111	554	230	.95	Water
STANDARD OIL OF KENTUCKY PASCAGOULA, MISSISSIPPI	41207	1	4"X	10	3570	930	51	1161	250	.944	Boiler Feedwater
STANDARD OIL OF CALIF. LA HABRA, CALIFORNIA	41211	1	2½"	12	3580	350	0	1650	100	1.006	Salt Water
STANDARD OIL OF CALIF. LA HABRA, CALIFORNIA	41210	1	2½"	10	3570	400	0	1125	100	1.006	Salt Water
HUMBLE OIL & REF. CO. BATON ROUGE, LOUISIANA	41260/61	2	1½"	8	3570	142	15	700	125	.852	Aromatic Hydrocarbon
EL PASO PRODUCTS CO. ODESSA, TEXAS	41317	1	4"X	8	3800	800	700	1300	80	.57	Butane
PHILLIPS PETROLEUM PUERTO RICO	41374/75	2	2"	6	3550	225	14.7	590	100	.855	To Luene
PHILLIPS PETROLEUM PUERTO RICO	41376/77	2	1½"	6	3570	85	0	520	100	.86	Benzene
WYCON CHEMICAL CHEYENNE, WYOMING	41402/03	2	2"	6	3560	224	5	495	244	.953	Feed Water
MOBIL OIL CO. BEAUMONT, TEXAS	41434/35	2	6"X	4	3570	1495	60	545	110	.71	Naptha Charge
KUWAIT NATIONALPET. CO. SHUAIBA, KUWAIT	41477/78	2	3"	8	2970	465	70	535	110	1.0	Lean Amine
CALTEX OIL RAUNHEIM, GERMANY	41488-90	3	6"X	6	-	-	-	-	-	-	Water
STANDARD OIL OF CALIF. WHITTIER, CALIFORNIA	41527	1	2½"	10	3570	400	0	1125	100	1.006	Brine Water
ASHLAND OIL & REF. CO. CANTON, OHIO	41535/36	2	2½"	6	3550	580	234	800	300	.745	Gas Oil
ASHLAND OIL & REF. CO. CANTON, OHIO	41541/42	2	3"	10	3550	575	85	850	330	.60	Naphtha
ASHLAND OIL & REF. CO. CANTON, OHIO	41543/44	2	2"	6	3550	430	237	790	100	.71	Naphtha
STAUFFER CHEMICALS CO. HOUSTON, TEXAS	41581/82	2	4"X	4	3570	840	Flooded	600	228	.952	Water
AMERICAN ENKA CORP. LOWLAND, TENNESSEE	41600/01	2	4"	4	3900	630	Flooded	545	240	.946	Feed Water
CITIES SERVICE OIL CO. LAKE CHARLES, LA.	41605	1	2"	6	3570	210	67	600	304	.92	Water
WARREN PETROLEUM MONT BELVIEW, TEXAS	41646	1	2½"	4	3860	425	15	550	250	.9431	Hot Water
DRESSER ENGR. CO. FT. STOCKTON, TEXAS	46148/49	2	4"X	8	3550	700	10	1210	90	1.06	Diaglycol Amine or MEA
DRESSER ENGR. CO. FT. STOCKTON, TEXAS	46150/51	2	3"	6	3550	750	1170	230	170	1.07	Diaglycol Amine or MEA
DRESSER ENGR. CO. FT. STOCKTON, TEXAS	41652	1	2½"	8	3820	350	10	1210	70	1.06	Diaglycol Amine or MEA
KUWAIT NATIONAL PETROLEUM SHUAIBA, KUWAIT	41659	1	3"	10	2950	524	20	490	110	.705	Light Naphtha

CUSTOMER & LOCATION	PUMP NO.	NO. UNITS	SIZE	NO. STGS.	RPM	GPM	SUCT. PRESS. PSIG	DISCH. PRESS. PSIG	PUMP TEMP. °F	SP. GR.	PRODUCT
KUWAIT NATIONAL PETROLEUM SHUAIBA, KUWAIT	41661/62	2	6"X	8	2950	847	25	706	110	.685	Naphtha
NATIONAL IRANIAN OIL CO' TEHRAN, IRAN	41680/81	2	1½"	6	2950	50	10	247	100	.65	HC
PHILLIPPS PETROLEUM SEENY, TEXAS	41781/82	2	1½"	6	3570	75	13	525	125	.987	Water
SHELL OIL CO. WOOD RIVER, ILLINOIS	47193	1	6"X	8	3570	1210	115	1185	50	.785	Lean Oil 49.4" API
SHELL OIL CO. WOOD RIVER, ILLINOIS	41794	1	4"X	8	3570	1196	225	1150	72	.74	Hydrocarbon
CAROLINA EASTMAN COLUMBIA, S. C.	41856-58	3	2½"	8	3550	440	24	835	267	.935	Boiler Feed Water
SUNTIDE REFINING CO. CORPUS CHRISTI, TEXAS	41866	1	2½"	6	3570	200	260	640	345	.656	HC
SUNTIDE REFINING CO. CORPUS CHRISTI, TEXAS	41867/68	2	2½"	6	3570	200	10	660	105	.828	Benzene
KOREA OIL CORP. LISAN CITY, KOREA	41944/45	2	2"	8	3570	215	0	585	100	.709	Hydrocarbon
AMONACO ESPANOL S.A. MALAGA, SPAIN	41992	1	1½"	6	3600	6	2.4	425.7	150	.682	Naphtha
MOBIL OIL CO. BEAUMONT, TEXAS	42027/28	2	4"X	8	3550	800	312	750	110	.47	Propane
TEXACO, INC. ENGLE POINT, NEW JERSEY	42031/32	2	1½"	10	3550	85	0	702	100	.854	Toluene
NATIONAL IRANIAN OIL CO. TEHRAN, IRAN	42102-04	3	6"X	8	2950	900	6	810	225	.95	Water
TRANSWESTERN PIPELINE PYOTE, TEXAS	42182/83	2	4"X	6	3700	700	0	1050	130	1.07	Sulfinol
EL PASO NATURAL GAS CO. FARMINGTON, NEW MEXICO	42191/92	2	6"X	6	3800	1600	50	960	90	.815	HC Lean Oil
TENNECO OIL COMPANY CHALMETTE, LOUISIANA	42221/22	2	2½"	6	3570	247	10	780	228	.95	Hot Water
CELANESE CHEMICAL CO. BISHOP, TEXAS	42225/26	2	4"X	6	3600	900	5	832	220	.955	Water
COMPANIA ESPANOLA DE PETRO. ALGECIRAS, SPAIN	42262/63	2	3"	10	2900	385	15	810	250	.94	Water
SHELL OIL CO. WOOD RIVER, ILLINOIS	42268/69	2	2½"	8	3550	290	12	796	225	.953	Water
AMERICAN MESSER CORP. BROOKLYN, NEW YORK	42271/72	2	1½"	6	3550	120	5.6	500	100	.88	Methanol
TEXACO, INC. WILMINGTON, CALIFORNIA	42287/88	2	3"	6	3570	470	2.85	563	-94	.91	Methanol & Dissolved
TEXACO, INC. WILMINGTON, CALIFORNIA	42295/96	2	4"X	6	3570	640	21.4	631.4	95	.782	Methanol
HUMBLE OIL CO. GARDEN CITY, LOUISIANA	42320	1	6"X	4	3600	800	25	676	267	.92	Boiler Feed Water
AMERICAN OIL COMPANY TEXAS CITY, TEXAS	42321	1	1½"	8	3560	70	0	712	190	.9667	Condensate
CONTINENTAL OIL CO. LAKE CHARLES, LOUISIANA	42347/48	2	3"	8	3570	530	16	776	240	.95	BI Water
ASIATIC PETROLEUM DURBAN, SOUTH AFRICA	42360/61	2	2½"	8	2960	332	66	578	446	.91	H.G.O. & Asphalt
COMBINED LOCKS PAPER CO. COMBINED LOCKS, WISCONSIN	42368	1	2½"	10	3570	400	28.54	1128.54	250	.947	Boiler Feed Water
AMERICAN POTASH & CHEM CORP. TRONA, CALIFORNIA	42369/70	2	4"X	6	3570	750	62	880	280	.93	Water
STANDARD OIL CO. OF CALIF. INGLEWOOD, CALIF.	42379	1	4"X	8	3570	730	15	1215	100	1.025	Brine Water
ASHLAND OIL & REFINING CO. LOUISVILLE, KENTUCKY	42385	1	1½"	10	3570	144	50	650	100	.735	Naphtha
ASHLAND OIL & REFINING CO. LOUISVILLE, KENTUCKY	42386	1	2"	10	3570	180	80	700	400	.57	Naphtha
ASHLAND OIL & REFINING CO. LOUISVILLE, KENTUCKY	42387	1	2"	10	3570	180	80	700	400	.735	Naphtha
CONTAINER CORP. OF AMER. CALI, COLOMBIA	42477/78	2	2"	10	3550	235	60	1000	298	.92	Feedwater
UN OIL COMPANY PHILADELPHIA, PENNSYLVANIA	42479/80	2	3"	10	3550	410	10	800	300	.664	Light Naphtha

CUSTOMER & LOCATION	PUMP NO.	NO. UNITS	SIZE	NO. STGS	RPM	GPM	SUCT. PRESS. PSIG	DISCH. PRESS. PSIG	PUMP TEMP. °F	SP. GR.	PRODUCT
TEXACO, INC. ANGELES, CALIF.	42485/86	2	2½"	6	3550	405	6.6	658	250	.958	Water
TEXACO, INC. ANGELES, CALIF.	42507	1	1½"	8	3570	153	5	725	210	.96	Steam Condensate
CITY OF HENDERSON HENDERSON, KENTUCKY	42588/89	2	3"	10	3580	635	10	972	338.7	.887	Water
POWERLINE OIL CO. SANTA FE SPRINGS, CALIF.	42601	1	2"	10	3550	200	0	920	100	.775	Naphtha
TENNECO OIL CO. CHALMETTE, LOUISIANA	42604	1	3"	10	3550	420	5	1200	110	1.11	Caustic Solution
MOBIL OIL CO. BEAUMONT, TEXAS	42644/45	2	4"X	6	3570	850	24	655	250	.94	Boiler Feedwater
UNION CARBIDE CORP. TEXAS CITY, TEXAS	42648/49	2	3"	6	3570	800	965	150	291	1.0	Water 92 WT/Diss. Gas & Liq. 8%
UNION CARBIDE CORP. TEXAS CITY, TEXAS	42650/51	2	4"X	8	3570	1000	12	1086	221	.95	Water Ph8-9 / 0.04% Alcohol
STANDARD OIL CO. OF CALIF. WHITTIER, CALIFORNIA	42652	1	2½"	10	3570	440	100	1200	100	1.006	Brine Water
BROWN & ROOT, INC. ASHDOWN, ARKANSAS	42746/47	2	6"X	8	3570	1350	400	1170	280	.92	Feedwater
SOUTHERN CALIF EDISON SAN ONO RE NUCLEAR GEN. STA	42768	1	2"	10	3570	235	15	1050	90	1.0	Water
COASTAL STATES PET. CHEM. CORPUS CHRISTI, TEXAS	40836	1	1½"	8	3570	85	50	660	93	.847	HC
GOODYEAR TIRE & RUBBER CO. BEAUMONT, TEXAS	42821-23	3	4"X	6	3565	910	10	575	240	.95	Feedwater-Ph8
GULF REFINING CO. DALLAS, TEXAS	42858	1	4"X	6	3580	700	0	590	AMB.	.735	Hydrocarbon
TEXACO, INC. LOS ANGELES, CALIFORNIA	42859	1	2½"	8	3570	416	4.8	759.8	210	.96	Steam Condensate
NORTHWESTERN REF. CO. ST. PAUL PARK, MINNESOTA	42870	1	2½"	6	3570	345	0	350	100	.75	Hydrocarbon
NORTHWESTERN REF. CO. ST. PAUL PARK, MINNESOTA	42872	1	2"	10	3550	170	0	865	100	.84	Hydrocarbon
STANDARD OIL CO. OF CALIF. INGLWOOD, CALIFORNIA	42910	1	4"X	8	3570	730	15	1215	120	1.03	Oil Field Brine Water
STANDARD OIL CO. OF CALIF. INGLWOOD, CALIFORNIA	42911/12	2	4"X	8	3570	730	15	1215	120	1.03	Oil Field Brine Water
TRANS-ESTERN PIPELINE PYOTI, TEXAS	42926/27	2	2½"	10	3570	440	0	1074	100	1.0	15-18% Amine
UNION CARBIDE CORP. TEXAS CITY, TEXAS	42932/33	2	3"	6	3550	480	0	710	101	1.024	75% Water 25% Diethanolamin
AMERICAN OIL CO. TEXAS CITY, TEXAS	42936/37	2	1½"	6	3570	150	-1	474	150	.98	Water
GREAT NORTHERN OIL CO. PINE BLND, MINNESOTA	42999/00	2	4"X	6	3575	713	0	575	225	.956	Water
SUN OIL CO. TOLLEDO, OHIO	43017/18	2	6"X	4	3570	1000	12	564	216	.96	Water
ASHLAND OIL & REFINING CO. CATLETTSBURG, KENTUCKY	43053/54	2	2½"	6	3550	350	100	675	100	.75	Cyclohexane
MONSANTO CO. F. GREENWOOD, S.C.	43061	1	1½"	6	3570	148	5.3	510.3	228	.952	Water
UNION TEXAS PETROLEUM RAYNE, LOUISIANA	43101	1	2"	8	3550	160	60	775	307	.916	Deaerated Water
SOUTHERN CALIF. EDISON WATSON PUMPING & HTG STA	43120-23	4	6"X	4	3570	1750	800	1400	200	.978	High Visc. Fuel Oil "C" Fuel - Displ. Oil
COLUMBIAN CARBON LAKE CHARLES, LOUISIANA	43217	1	2"	8	3575	250	30	775	267	.93	Boiler Feedwater
SUN OIL CO. MC ALLEN, TEXAS	43140	1	2½"	6	3550	589	360	930	13	.615	HC
MILLSTONE POINT CO. WATERFORD, CONNECTICUT	43159/60	2	3"	10	3570	540	80	1190	150	.980	Water
ASIATIC PETROLEUM DURBAN, SO. AFRICA	43168	1	2½"	8	2960	332	66	578	446	.91	H.G.O. & Asphalt
COLLIER CARBON & CHEM. LASKA	43245/46	2	4"X	6	3570	685	25	750	230	.955	Boiler Feedwater
VIRGIN ISLANDS WATER & PWR ST. THOMAS, VIRGIN ISLANDS	43255/56	2	3"	8	3570	630	23	885	263.7	.94	Water

CUSTOMER & LOCATION	PUMP NO.	NO. UNITS	SIZE	NO. STGS	RPM	GPM	SUCT. PRESS. PSIG	DISCH. PRESS. PSIG	PUMP TEMP. °F	SP. GR.	PRODUCT
SO. SERVICES BARRY STEAM PLANT	43261	1	4"X	6	3570	750	83	753	250	.942	Water
SAN JACINO GAS PROCESSING ACADIA PARISH, LOUISIANA	43275/76	2	1½"	6	3550	162	280	480	51	.482	HC
SAN JACINO GAS PROCESSING ACADIA PARISH, LOUISIANA	43281/82	2	1½"	6	3560	95	5	425	225	.953	Feedwater
COLUMBIA NITROGEN CORP. AUGUSTA, GEORGIA	43299	1	3"	4	3550	690	40	420	266	.94	Treated Water
KANSAS CITY POWER & LIGHT KANSAS CITY, MISSOURI	43300	1	6"X	4	3550	1788	160	678	350	.95	Water
HERCULES INC. OF WILMINGTON PLAQUEMINE, LOUISIANA	43304/05	2	6"X	8	3570	1000	15	1300	250	.94	Feedwater
PAN AMERICAN PETROLEUM FOX CREEK, ALBERTA, CANADA	43313-16	4	2"	10	3570	466	300	1075	115	1.08	Lean Solvent
STANDARD OIL CO. OF CALIF. WHITIER, CALIFORNIA	43341	1	2½"	10	3570	440	100	1200	100	1.006	Brine Water
PETROBRAS RIO DE JANEIRO, BRAZIL	43364-66	3	4"X	6	3575	650	15	805	250	.942	Water
ABADAN PETROCHEMICAL ABADAN, IRAN	43367/68	2	2"	10	2950	125	200	625	90	.49	Light Hydrocarbon
ABADAN PETROCHEMICAL ABADAN, IRAN	43369	1	1½"	10	3550	830	30	750	228	.952	Light Hydrocarbon
PHILLIPS PETROLEUM CO. AVON, CALIFORNIA	43445/46	2	4"X	6	3550	830	30	750	228	.952	Water
HUMBLE OIL & REFINING BATON ROUGE, LOUISIANA	43451/52	2	2"	6	3570	298	124	660	212	.958	Steam Condensate
C. PFIZER & COMPANY TERRA HAUTE, INDIANA	43453/54	2	2"	8	3550	180	5	950	228	.45	Feedwater
SUN OIL COMPANY MARCUS HOOK, PA.	43459/60	2	4"X	6	3550	750	13	640	240	.947	Water
WESTINGHOUSE APD BELL GARDENS, CALIF.	43461-78	18	2½"	10	3570	650	80	-	300	.918	Water
COASTAL STATES PETRO. CORPUS CHRISTI, TEXAS	43483	1	1½"	8	3570	165	50	700	100	.842	HC
STAUFFER CHEMICAL CO. HENDERSON, NEVADA	43525/26	2	4"X	8	3550	720	21	1135	229.5	.951	Feedwater
AMERICAN OIL CO. TEXAS CITY, TEXAS	43582	1	6"X	8	4600	1301	105	2145	100	.86	Oil
AMERICAN OIL CO. TEXAS CITY, TEXAS	43583	1	6"X	8	4600	2488	1874	417	105	.606	HC
AMERICAN OIL CO. TEXAS CITY, TEXAS	43608/09	2	4"X	4	3570	700	90	471	45	.831	Lean Oil
MORGAN CITY LOUISIANA MORGAN, LOUISIANA	43635/36	2	2½"	10	3570	450	78	1004	313	.910	Water
TENNECO MFG. CO. PASADENA, TEXAS	43667	1	4"X	6	3570	700	15	750	250	.94	Feedwater
BIG THREE INDUSTRIAL GAS & EQUIP. BAYPORT, TEXAS	43691	1	2½"	8	3570	315	20	1000	260	.938	Water
ALLIED CHEMICAL BATON ROUGE, LOUISIANA	43730-32	3	3"	10	3550	500	21	1111	260	.938	Boiler Feedwater
AMERICAN OIL COMPANY TEXAS CITY, TEXAS	43769/70	2	2½"	6	3550	327	5	550	240	.945	Water
STANDARD OIL CO. OF TEXAS EL PASO, TEXAS	43785/86	2	2½"	6	3550	400	62	565	287	.928	Feedwater
IMPERIAL OIL REDWATER, ALBERTA, CANADA	43813/14	2	4"X	6	3570	700	24.6	842	254	.94	Bl' water
SOUTHWESTERN OIL & REFINING CORPUS CHRISTI, TEXAS	43817	1	3"	4	3570	600	0	482	250	.94	Treated Water
HILL CHEMICAL COMPANY BORGER, TEXAS	43837/38	2	1½"	8	3570	120	24.5	734.5	250	.944	Boiler Feedwater
CONSOLIDATED EDISON CO. OF N.Y. NEW YORK CITY, N.Y.	43848	1	1½"	10	3550	130	5	927	220	.955	Water
TRANSWESTERN PIPELINE CO. WARD COUNTY, TEXAS	43854/55	2	4"X	6	3700	950	0	925	.30	1.07	Sulfinol
SASOL SOUTH AFRICA	43856/57	2	3"	10	2950	360	254.2	654.2	103	.49	HC
SASOL SOUTH AFRICA	43858-60	3	4"X	8	2950	550	274.2	654.2	100	.476	HC

CUSTOMER & LOCATION	PUMP NO.	NO. UNITS	SIZE	NO. STGS	RPM	GPM	SUCT. PRESS. PSIG	DISCH. PRESS. PSIG	PUMP TEMP. °F	SP. GR.	PRODUCT
MONTECATINI EDISON NAPOLI, ITALY	43893	1	1½"	10	2960	65	63	640	120	.89	Hydrocarbons
NIPPON PET. & REF. CO. JAPAN	43913	1	6"X	8	2950	1290	255	1205	140	.833	Hydrocarbon
COLUMBIA NITROGEN CORP. AUGUSTA, GEORGIA	43914	1	3"	4	3550	700	40	420	266	.94	Boiler Feedwater
GULF OIL CORP. PURVIS, MISSISSIPPI	43921	1	4"X	6	3570	800	0	585	90	.844	HC
GULF OIL CORP. SANTA FE SPRINGS, CALIF.	43961	1	2"	10	3500	450	1230	250	190	.695	HC
NITROGEN INC. DONALDSONVILLE, LOUISIANA	43981	1	2"	8	3550	190	29	709	250	.944	Boiler Feedwater
HAI'A REFINERIES HAI'A, ISRAEL	43985/86	2	4"X	10	2970	630	0	670	250	.63	Naptha
CITY OF OWATONNA OWATONNA, MINNESOTA	44008	1	3"	10	3570	480	100	1150	310	.913	Feedwater
CITIES SERVICE LAKI CHARLES, LOUISIANA	44019	1	3"	6	3570	460	0	600	200	.94	-
SINCLAIR KOPPERS PORT ARTHUR, TEXAS	44055	1	2½"	6	3570	300	15	665	200	.955	Feedwater
OXIRANI CHEMICAL CO. BAYPORT, TEXAS	44056/57	2	2"	10	3570	240	12.5	955	120	.80	Organics
SOUTHWESTERN OIL & REF. CO. CORPUS CHRISTI, TEXAS	44059/60	2	3"	4	3760	490	0	470	80	.734	Naptha
EL PASO NATURAL GAS CO. COYANOSA, TEXAS	44069/70	2	4"X	8	3570	677	100	1200	95	1.052	Diaglyco- lamine
EL PASO NATURAL GAS CO. COYANOS, TEXAS	44071/72	2	3"	6	3570	788	1170	240	172	1.056	Diaglyco- lamine
EL PASO NATURAL GAS CO. CAYNOSA, TEXAS	44073	1	2½"	8	3880	372	10	1200	95	1.052	Diaglyco- lamine
SAHRAIN PET. CO. SAHRAIN, ARABIAN GULF	44092	1	2½"	10	4000	455	30	1215	150	.875	Gas Oil
CAROLINA POWLR & LIGHT HARTSVILLE, SO. CAROLINA	44097/87	2	2½"	10	3550	300	23	1313	100	.994	Condensate
HESS OIL VIRGIN ISLANDS CORP. ST. CROIX, VIRGIN ISLANDS	44099	1	2½"	8	3570	500	150	765	350	.66	Hydrocarbon
TENNECO OIL COMPANY CHALMETTE, LOUISIANA	44105	1	2½"	8	3570	338	40	700	200	.70	Naptha
CENTRAL FARMERS FERTILIZER CO. DONALDSONVILLE, LOUISIANA	44115	1	2"	8	3570	190	29	709	250	.944	Boiler Feedwater
UNION CARBIDE BRAZIL	44164-66	3	3"	6	3570	480	15	743	220	.96	Feedwater
OWENS-ILLINOIS TOMAHAWK, WISCONSIN	44198	1	1½"	4	3570	80	15	423	250	.983	Condensate
EL PASO NATURAL GAS TERRELL COUNTY, TEXAS	44199	1	6"X	4	4100	1500	16	955	10	1.24	Organic Solvent
EL PASO NATURAL GAS TERRELL COUNTY, TEXAS	44200	1	4"X	6	3600	800	16	955	10	1.24	Organic Solvent
HESS OIL VIRGIN ISLANDS CORP. ST. CROIX, VIRGIN ISLANDS	44268/69	2	2½"	10	3570	350	0	850	440	.723	Hydrocarbons
AGIP USA INC. GROTTOLE, ITALY	44270	1	3"	10	3050	530	15.1	918	212	1.024	MEA
TELLPSEN PETRO CHEM. TEXAS CITY, TEXAS	44278-80	3	4"X	4	3570	1000	18	507	230	.95	Feedwater
WESTINGHOUSE PAD PITTSBURGH, PENN.	44288-95	7	1½"	6	3570	85	-	-	200	1.0	Water
COMMONWEALTH PETROCHEMICAL PENUELAS, PUERTO RICO	44330/31	2	1½"	8	3570	120	0	625	120	.841	Toluene
HESS OIL ST. CROIX, VIRGIN ISLANDS	44338-40	1	2"	4	3550	270	15	440	250	.942	Feedwater
AMERICAN OIL COMPANY TEXAS CITY, TEXAS	44389/90	2	2½"	10	4900	475	535	1535	84	.430	Ethane- Propane
UNION OIL COMPANY LEMONT, ILLINOIS	44401	1	4"X	6	3570	710	138	695	289	.65	Hydrocarbons
UNION OIL COMPANY LEMONT, ILLINOIS	44402	1	6"X	6	3570	880	112	720	330	.64	Hydrocarbons
U.S. CHEMICALS HAVER HILL, OHIO	44442/43	2	4"X	6	3570	750	10	700	227	.952	Feedwater

CUSTOMER & LOCATION	PUMP NO.	NO. UNITS	SIZE	NO. STGS.	RPM	GPM	SUCT. PRESS. PSIG	DISCH. PRESS. PSIG	PUMP TEMP. °F	SP. GR.	PRODUCT
COMMONWEALTH PETROCHEMICALS PENUELAS, PUERTO RICO	44478/79	2	2"	6	3570	250	185	490	100	.524	Pentane & Lighter
HUMBLE OIL & REFINING BAYTOWN, TEXAS	44494/95	2	6"X	4	3570	1100	20	647	90	.82	Kerosene
COMMONWEALTH PETROCHEMICALS PENUELAS, PUERTO RICO	44599-601	3	6"X	6	3570	1100	15	780	250	.94	Feedwater
STANDARD OIL OF OHIO TOLEDO, OHIO	44602	1	2½"	10	3570	457	25	750	130	.69	Crude Tower Naphtha
VIRGIN ISLANDS WATER & POWER ST. CROIX, VIRGIN ISLANDS	44678/79	2	3"	8	3570	630	37	893	265	.93	Water
HESS OIL VIRGIN ISLANDS CORP. ST. CROIX, VIRGIN ISLANDS	44592/93	2	6"X	4	3570	900	65	765	250	.942	Water
CREOLE PETROLEUM CORP. AMUAY, VENEZUELA	44785-87	3	4"X	6	3550	850	0	680	120	.83	Middle Distillate Hydrotiner
FARMER CHEMICAL ASSOC. TUNIS, NORTH CAROLINA	44788/89	2	2½"	6	3570	350	33	653	240	.947	Feedwater
SIGNAL OIL & GAS CO. HOUSTON, TEXAS	44801	1	2½"	8	3570	300	0	727	100	.87	Hydrocarbon
MOBIL OIL DE VENEZUELA VENEZUELA	44817	1	2"	8	3570	254	38	648	100	.735	Hydrocarbon
MOBIL OIL CORP. DURBAN, SOUTH AFRICA	44826/27	2	4"X	4	2950	475	13	350	60	.85	Crude Oil
CITIES SERVICE OIL CO. LAKE CHARLES, LA	44907/08	2	3"	10	3570	458	4	832	105	.794	Mid-Distillate
CENTRAL TERMICA DE ACECA SPAIN	44911-14	4	2½"	10	2950	343	350	1150	220	.925	Fuel Oil
ATLANTIC PIPELINE CO. ALTOONA, PENNSYLVANIA	44915	1	6"X	8	3570	830	37	1147	ATM	.856	Gasoline & Furnace Oil
FARMERS UNION CENTRAL EX LAUREL, MONTANA	44927	1	2½"	10	3950	450	0	1205	100	.87	Fuel Oils
CARIBBEAN GULF REFINING SAN JUAN, PUERTO RICO	44950	1	2"	8	3550	225	15	625	350	.665	Hydrocarbons
EL PASO NATURAL GAS CO. PUCKETT COUNTY, TEXAS	44953	1	6"X	4	4100	1500	16	986	-10	1.25	Organ Solvent
EL PASO NATURAL GAS CO. PUCKETT COUNTY, TEXAS	44954	1	4"X	6	3940	800	16	986	-10	1.25	Organic Solvent
MARATHON OIL CO. ROBINSON, ILLINOIS	44957/58	2	2½"	8	3570	425	21	836	254	.94	Condensate
TEXAS EASTMAN CO. LONGVIEW, TEXAS	44978-80	3	3"	6	3780	575	24	749	250	.944	Boiler Feedwater
STANDARD OIL OF OHIO LIMA, OHIO	45028/29	2	4"X	6	3570	740	25	825	265	.915	Water
STANDARD OIL OF OHIO LIMA, OHIO	45057	1	4"X	6	3570	570	15	494	304	.646	Isocera. kate 555.5- 59.6° API
MONSANTO COMPANY EVERETT, MASS.	45064/65	2	1½"	8	3570	96	15	680	228	.955	Treated Deaerated Water
GULF OIL CORPORATION SANTA FE SPRINGS, CALIF.	45070	1	4"X	4	3600	600	20	600	240	.95	Feedwater
MARATHON OIL COMPANY ROBINSON, ILLINOIS	45086/87	2	2½"	6	3570	328	246	818	219	.96	Boiler Feed Water
CITY OF WILLMAR WILLMAR, MINNESOTA	45108	1	2½"	10	3550	400	13	1213	225	.954	Feedwater
ENJAY CHEMICAL LINDEN, NEW JERSEY	45119/20	2	2½"	6	3570	360	71	450	40	.53	H.C. Liquid
OXOCHEM ENTERPRISE PUERTO RICO	45139/40	2	3"	6	3570	550	20	597	239	.947	Boiler Feed Water
OXOCHEM ENTERPRISE PUERTO RICO	45141/42	2	1½"	8	3570	151	10	605	240	.947	Boiler Feed Water
UNION ELECTRIC FRANKLIN COUNTY, MISSOURI	45161/62	2	1½"	4	3570	80	140	600	100	1.0	Water
UNION ELECTRIC CO. FRANKLIN COUNTY, MISSOURI	45168/69	2	1½"	4	3570	80	140	600	100	1.0	Water
HESS OIL ST. CROIX, VIRGIN ISLAND	45179	1	2"	4	3550	270	15	440	250	.942	Feedwater
CELANESE CHEMICAL PAMPA, TEXAS	45187	1	2"	8	3550	218	170	646	105	.55	Butane
VISTRON CORP. LIMA, OHIO	45217	1	4"X	10	3570	930	51	1161	250	.94	Boiler Feed Water

CUSTOMER AND LOCATION	PUMP NO.	NO. UNITS	SIZE	NO. STGS	RPM	GPM	SUCT. PRESS. PSIG	DISCH. PRESS. PSIG	PUMP TEMP. °F	SP. GR.	PRODUCT
AMOCO CHEMICALS CORP. CHOCOLATE BAYOU, TEXAS	45226/27 & 45342	3	4"X	4	3570	650	36	548	270	.945	Water
ERIKSBERG MEK VERKSTADS AB GOTEBORG, SWEDEN	45341	1	2½"	8	3500	285	43	995	261	.9375	Condensate
NORTHWESTERN REFINING CO. ST. PAUL PARK, MINN. SOTA	45343	1	2½"	6	3570	380	145	621	240	.75	Hydrocarbon
SIGNAL OIL & GAS CO. BAKERSFIELD, CALIFORNIA	45359	1	2"	6	3550	250	0	466	100	.773	Naphtha
STANDARD OIL OF CALIF. HONOLULU, HAWAII	45417	1	2½"	6	3550	350	5	448	77	.82	Kerosene
UTAH CONST. & MINING CO. SAN JUAN, PERU	45418/19	2	3"	10	3570	550	40	1138	309	.92	Boiler Feed Water
HUMBLE OIL & REI CO. LINDEN, NEW JERSEY	45425	1	2½"	6	3570	325	37	520	90	.79	Acetone & H ₂ O
OFFICE OF SALINE WATER ROSWELL, NEW MEXICO	45433	1	2"	8	3570	175	0	800	75	1.008	Seawater
OFFICE OF SALINE WATER ROSWELL, NEW MEXICO	45434	1	2½"	10	3570	175	0	1500	75	1.025	Seawater
WYANDOTTE CHEM. GEISMAR, LOUISIANA	45501/02	2	2"	8	3550	118	52	580	150	.906	Ethylene/Oxide/ H ₂ O Solution
MOBIL OIL CORP. COYANOSA, TEXAS	45545	1	2"	10	3570	252	8	1150	132	.985	15WT% MEA Solution
TEXAS EASTMAN LONGVIEW, TEXAS	45565-67	3	2½"	6	3570	365	22	720	250	.94	Boiler Feed Water
CELLANESI CHEMICAL CO. BISHOP, TEXAS	45628	1	4"	6	3800	900	5	830	220	.956	Deaerated Condensate
CITY OF LAKEWORTH LAKEWORTH, FLORIDA	45645/46	2	4"X	8	3570	765	129	1115	346	.894	Boiler Feed Water
WESTINGHOUSE ELECTRIC CORP. VARIOUS NUCLEAR SITES	45648-55	8	2½"	10	3570	400	-	-	300	1.0	Borated Water
TEXACO PORT ARTHUR, TEXAS	45658/59	2	4"X	6	3570	810	9	710.7	60	.814	Kerosene
ECOPETROL BARRANCABERMEJA, COLOMBIA	45665	1	4"X	4	3700	810	27	612	260	.94	Boiler Feed Water
CAROLINA POWER & LIGHT SKYLAND, NORTH CAROLINA	45700	1	3"	6	3560	625	110	466	350	.89	Condensate
MOBIL OIL CORP. BEAUMONT, TEXAS	45706/07	2	6"X	4	3570	910	0	500	180	.92	H.C.
COMMONWEALTH EDISON ZION STATION	45796/97	2	3"	10	3580	495	1	1343	80	1.0	Water
COMMONWEALTH EDISON ZION STATION	45798/99	2	3"	10	3580	495	1	1343	80	1.0	Water
COMMONWEALTH EDISON ZION STATION	45800	1	4"X	10	3580	990	1	1343	80	1.0	Water
COMMONWEALTH EDISON ZION STATION	45801	1	4"X	10	3580	990	1	1343	80	1.0	Water
MAGMA COPPER SAN MANUEL, ARIZONA	45812-14	3	2½"	6	3560	422	36	652	240	.948	Deaerated Condensate
FARMERS CHEMICAL ASSOC. TUNIS, NORTH CAROLINA	45857	1	2½"	6	3570	350	33	653	240	.947	Feedwater
GULF OIL CORPORATION SANTA FE SPRINGS, CALIF.	45873/74	2	6"X	6	3570	1600	65	750	AMB	.86	Gasoline or Diesel
HESS OIL VIRGIN SIALDNS ST. CROIX, VIRGIN ISLANDS	45961	1	6"X	4	3570	900	65	765	250	.942	Water
THERMAL SYSTEMS, INC. OKLAHOMA CITY, OKLAHOMA	45964/65	2	2"	8	3550	200	14	690	250	.943	Water
TENNECO OIL CO. CHALMETTE, LOUISIANA	45995	1	3"	10	3550	475	0	805	145	.699	Naphtha
KYUNG IN ENERGY CO. S. KOREA	46254-57	4	2½"	8	3570	215	-2.2	830	215	.915	Fuel Oil
STANDARD OIL OF CALIF. HONOLULU, HAWAII	46022	1	2½"	6	3550	365	5	488	77	.82	Kerosene
GEORGIA PACIFIC LAQUEMINE, LOUISIANA	46143-45	3	4"X	8	3570	800	13	1253	227	.95	Feedwater
GULF OIL CO. ALLIANCE, LOUISIANA	46166	1	4"X	8	3550	830	100	710	380	.706	Light Furnace Oil
UNION OIL CO. OF CALIF. RODLO, CALIFORNIA	46169/70	2	4"X	6	3570	720	28	800	258	.94	Boiler Feedwater

CUSTOMER & LOCATION	PUMP NO.	NO. UNITS	SIZE	NO. STGS	RPM	GPM	SUCT. PRESS. PSIG	DISCH. PRESS. PSIG	PUMP TEMP. °F	SP. GR.	PRODUCT
PHILLIPS PETROLEUM CO. SAN ROQUE, VENEZUELA	46171/72	2	2½"	8	3450	323	120	850	90	.84	Lean Oil
NORTHERN PETROCHEMICAL CO. MORRIS, ILLINOIS	46183-85	3	6"X	6	3550	1100	9.3	850	228	.953	Feedwater
SUN OIL COMPANY YABUCAO, PUERTO RICO	46197-99	3	3"	6	3570	592	16	590	219	.950	Feedwater
CITY OF VIRGINIA VIRGINIA, MINNESOTA	46239	1	2½"	8	3560	340	24	906	240	.947	Condensate & Make Up
GULF OIL CO. ALLIANCE, LOUISIANA	46240-43	4	4"	6	3570	750	0	795	220	.955	Feedwater
GULF OIL CO. ALLIANCE, LOUISIANA	46252/53	2	2"	10	3550	228	13	750	267	.755	Recycle Aromatics
HESS OIL VIRGIN ISLANDS ST. CROIX, VIRGIN ISLANDS	46291	1	2½"	10	3570	250	0	850	490	.723	Hydrocarbon
SHELL CHEMICAL HOUSTON, TEXAS	46292/93	2	2"	4	3550	265	35	382	274	.93	Condensate
HARVEY ALUMINUM CO. ST. CROIX, VIRGIN ISLANDS	46314	1	3"	8	3880	590	27.2	1073	260	.938	Feedwater
ATLANTIC RICHFIELD WHATCOM COUNTY, WASHINGTON	46324/25	2	3"	10	3570	418	69	1068	300	.78	Diesel or Stone Oil
ATLANTIC RICHFIELD WHATCOM COUNTY, WASHINGTON	46326/27	2	2"	10	3570	184	155	966	115	1.01	Lean D1 A
SOUTH CAROLINA INDUSTRIES FLORENCE, SOUTH CAROLINA	46335	1	4"X	8	3550	980	20	950	250	.943	Feedwater
CONTINENTAL OIL CO. WRENSHALL, MINNESOTA	46349	1	3"	6	3570	583	0	450	40.7	.81	Crude Condensate & H ₂ O
WESTINGHOUSE ELECTRIC CORP. PORTLAND GEN. ELECT. CO.	46368/69	2	2½"	10	3570	400			300	1.0	Borated Water
AKERGRUPPEN STORD, NORWAY	46380/81	2	2"	10	3550	264	58	1103	280	.928	Feedwater
ENAP CONCEPCION REFINERY, CHILE	46413	1	2½"	10	2980	230	25	525	340	.635	Naptha
UNION CARBIDE CORP. GARY, INDIANA	46429	1	2"	6	2550	244	15	500	250	1.0	Boiler Feedwater
FARMERS CHEMICAL TUNIS, NORTH CAROLINA	46459 46475	2	4"X	10	4000	770			240	.947	Boiler Feedwater
CHINESE PETROLEUM CO. TAOUFEN, TAIWAN	46472/73	2	2"	6	4500	280	22	1062	240	.948	Feedwater
ATLANTIC RICHFIELD E. CHICAGO, INDIANA	46499/500	2	4"X	8	2570	928	30	960	125	.89	Furnace Oil w/ 15% Sulphur
S & Q CONSTRUCTION SAN ARDO, CALIFORNIA	46517/18	2	2½"	8	3570	425	10	855	280	.947	Feedwater
HESS OIL VIRGIN ISLANDS CORP. ST. CROIX, VIRGIN ISLANDS	46520/21	2	4"X	6	3570	600	50	750	250	.94	Feedwater
PUERTO RICO OLEFINS CO. PUERTO RICO	46414/15	2	2"	10	3570	243	25	1000	190	.785	Dripolene
DOUGLAS OIL COMPANY FARAMOUNT, CALIFORNIA	46606	1	2"	8	3550	265	5	649	100	.898	Diesel
BATAAN REFINING CORP. BATAAN, PHILIPPINES	46610	1	2½"	8	3550	325	0	575	110	.71	Hydrocarbon
AIR PRODUCTS & CHEMICALS PACE, FLORIDA	46725/26	2	2"	8	3550	220	5	755	250	.942	Boiler Feedwater
GETTY OIL CO. DELAWARE CITY	46705/06	2	4"X	6	3570	580	18	849	230	.95	Boiler Feedwater
AGRICO CHEMICAL CO. BLYTHEVILLE, ARKANSAS	46722	1	6"X	4	3570	1300	27	683	248	.94	Feed Water
AIR PRODUCTS & CHEMICALS CO. PACE, FLORIDA	46725/26	2	2"	8	3550	180	5	755	250	.942	Boiler Feedwater
BELL OIL & GAS CO. ARDMORE, OKLAHOMA	46839/40	2	2"	8	3550	214	5	508	100	.738	Hydrocarbon
ATLANTIC RICHFIELD CO. WATSON, CALIFORNIA	46863/64	2	2"	6	3550	205	0	455	121	0.64	Hydrocarbon
ATLANTIC RICHFIELD CO. WATSON, CALIFORNIA	46878/79	2	2"	8	3550	232	30	498	157	0.592	N-Pentane
ATLANTIC RICHFIELD CO. WATSON, CALIFORNIA	46880/81	2	2"	6	3550	286	243	491	333	0.45	Hydrocarbon
ATLANTIC RICHFIELD CO. HOUSTON, TEXAS	46886/87	2	6"X	6	3570	920	4	661	216	0.68	Hydrocarbon

CUSTOMER & LOCATION	PUMP NO.	NO. UNITS	SIZE	NO. STGS	RPM	GPM	SUCT. PRESS. PSIG	DISCH. PRESS. PSIG	PUMP TEMP. °F	SP. GR.	PRODUCT
ATLANTIC RICHFIELD CO. HOUSTON, TEXAS	46892/93	2	6"X	4	3570	1385	238	595	200	0.71	Hydrocarbon
ATLANTIC RICHFIELD CO. HOUSTON, TEXAS	46894/95	2	3"	6	3570	466	301	660	100	0.76	Rich Abs Oil
ATLANTIC RICHFIELD CO. HOUSTON, TEXAS	46914/15	2	3"	6	3570	350	120	470	100	0.565	Light HC
ATLANTIC RICHFIELD CO. E. CHICAGO, INDIANA	46922/23	2	4"X	6	3570	720	15	510	100	0.738	Naptha
ATLANTIC RICHFIELD CO. E. CHICAGO, INDIANA	46928/29	2	2"	6	3550	226	116	622	235	0.95	Boiler Feedwater
GREAT NORTHERN OIL CO. PINE BEND, MINNESOTA	46948	1	3"	10	3570	445	10	860	350	0.77	No. 2 Fuel Oil
ATLANTIC RICHFIELD CO. PHILADELPHIA, PENN.	46957/58	2	6"X	6	3570	1310	33	638	100	0.725	Hydrocarbon
ATLANTIC RICHFIELD CO. PHILADELPHIA, PENN.	46959/60	2	6"X	6	3570	1095	24	585	289	0.672	Hydrocarbon
ATLANTIC RICHFIELD CO. E. CHICAGO, INDIANA	46989/90	2	4"X	6	3570	690	190	570	200	0.70	Naptha
HESS OIL VIRGIN ISLANDS ST. CROIX, VIRGIN ISLANDS	46998	1	2½"	8	3570	467	35	627	275	0.69	Hydrocarbon Liquid
AB GOTAVERKEN GÖTEBORG, SWEDEN	47005	1	2½"	8	3550	264	78	1080	297	0.920	Feedwater
AKERGRUPPEN STORD, NORWAY	47006	1	2"	10	3550	265	63	1195	280	0.928	Feedwater
STANDARD OIL CO OF CALIF. PASCAGOULA, MISSISSIPPI	47023/24	2	4"X	8	3570	575	7.3	936.3	100	0.765	Naptha
STANDARD OIL CO OF CALIF. EL PASO, TEXAS	47025/26	2	4"	8	3570	575	7.3	936.3	100	0.765	Naptha
STANDARD OIL CO OF CALIF. EL SEGUNDO	47027/28	2	4"	8	3570	575	154.8	936.7	100	0.72	Naptha
U.S.I. CHEMICALS CO. TUSCOLA, ILLINOIS	47029-31	1	2½"	10	3570	226	27.3	1153	225	0.95	Process Water
U.S.I. CHEMICAL CO. TUSCOLA, ILLINOIS	47032/33	2	1½"	10	3570	122	140.8	999	135	0.985	Scrubber Water
U.S.I. CHEMICAL CO. TUSCOLA, ILLINOIS	47034/35	2	2"	10	3570	220	69.5	1005.7	135	0.887	120 Proof Ethanol
STANDARD OIL OF CALIF. INGLEWOOD, CALIFORNIA	47036-38	3	4"X	8	3570	575	15	1215	120	1.02	Oilfield Brine Water
FALCONBRIDGE DOMINICANA TYLER, TEXAS	47047/48	2	2½"	8	3550	220	0	646	150	0.736	Naptha
QUAKER STATE OIL REF. CORP. CONGO, W. V.	47054/55	2	1½"	10	3570	119	0	575	100	0.722	Hydrocarbon
HUMBLE OIL & REFINING CO. BILLINGS, MONTANA	47069/70	2	2½"	6	3570	356	16	485	370	0.68	Kerosene
ATLANTIC RICHFIELD CO. CHERRY POINT REF., WASH.	47081	1	4"X	8	3570	782	10	897	220	0.957	Boiler Feedwater
EL PASO PRODUCTS ODESSA, TEXAS	47088/89	2	2½"	8	3570	400	18	780	230	0.953	Water
ATLANTIC RICHFIELD CO. CHERRY POINT REF., WASH.	47082	1	4"X	8	3570	782	10	897	220	0.957	Boiler Feedwater
CARIBBEAN GULF REF. CO. BAYAMON, PUERTO RICO	47104	1	2"	6	3550	250	30.2	458	300	0.66	Naptha
CARIBBEAN GULF REF. CO. BAYAMON, PUERTO RICO	47105/06	2	3"	8	3570	420	95.7	835	250	0.744	Distillate
REYNOLDS METALS CO. GREGORY, TEXAS	47110/11	2	3"	8	3570	628	60	815	298	0.921	Boiler Feedwater
LIQUID CARBONIC GEISMER, LOUISIANA	47117/18	2	2½"	10	3570	138	5	953	228	0.952	Deaerated Boiler Feedwater
OXIRANE BAYPORT, TEXAS	47120/21	2	3"	10	3550	510	14.3 PSIA	952 PSIA	120	0.8	Organics
STANDARD OIL OF CALIF. LA HABRA, CALIFORNIA	47153	1	6"X	6	3580	1020	30 PSIA	1030 PSIA	105	1.006	Oilfield Brine Water
PHELPS-DODGE CORP. MORENCI, ARIZONA	47154/55	2	2½"	8	3550	352	2 PSIA	1002 PSIA	230	0.953	Condensate
TEXACO, INC. BERWICK, LOUISIANA	47173/74	2	3"	6	3570	480	5	720	230	0.952	Water
CITIES SERVICE HELEX, INC. HICKOK, KANSAS	47193	1	4"X	6	3840	1050	15	765	236	0.95	Feedwater

CUSTOMER AND LOCATION	PUMP NO.	NO. UNITS	SIZE	NO. STGS	RPM	GPM	SUCT. PRESS. PSIG	DISCH. PRESS. PSIG	PUMP TEMP. °F	SP. GR.	PRODUCT
CONTINENTAL OIL CO. LAKE CHARLES, LOUISIANA	47231	1	4"X	8	3570	650	6	706	110	0.74	Naphtha
PETROLEO BRASILEIRO S.A. BRASIL	47303-06	4	4"X	8	3570	675	14.9	1054	104	0.95	Gasoline/Diesel Oil
JONE & LAUGHLIN ALIQUIPPA, PENNA.	47310-12	3	6"	8	3570	900	-	1150	267	0.947	Water
MOBIL OIL CORP. TORRANCE, CALIF.	47313	1	3"	6	3570	500	7	657	220	0.965	Water
MOBIL OIL CORP. TORRANCE, CALIF.	47314	1	3"	6	3570	600	7	635	220	0.965	Water
HESS OIL VIRGIN ISLAND ST. CROIX, VIRGIN ISLAND	47315-18	4	2"	4	3570	290	15	440	250	0.942	Feedwater
CITIES SERVICE OIL CO. LAKE CHARLES, LOUISIANA	47325/26	2	6"	4	3570	1001	0	475	120	0.74	Hydrocarbon
ASHLAND OIL & REFINING CANTON, OHIO	47359	1	2"	10	3570	500	120	1430	375	0.70	Gas Oil
ASHLAND OIL & REFINING CANTON, OHIO	47360	1	2"	10	3570	500	160	1415	100	0.67	Naphtha
PHILLIPS PETROLEUM CO. BORGES, TEXAS	47381/82	2	3"	6	3570	575	60	513	150	0.715	Hydrocarbon
VINICLOR S.A. BARCELONA, SPAIN	47383-85	3	2½"	10	3550	444	41.8	999.8	280	0.93	Condensate Feedwater
VINICLOR S.A. BARCELONA, SPAIN	47394/95	2	1½"	8	2950	44	107	513	212	0.956	Condensate Feedwater
INSTITUTO VENEZOLANO DE PETROQUIMICA EL TABLAZO, VENEZUELA	47410-13	4	2½"	8	3550	486	-	-	284	0.926	Feedwater
MONTECATINI EDISON SPA PORTO-MARGHERA	47427/28	2	1½"	8	2950	53	82.5	452	104	0.784	Hydrocarbon
ROCK ISLAND REFINING CORP. INDIANAPOLIS, INDIANA	47459/60	2	2½"	8	3570	320	20	565	100	0.70	Naptha
INSTITUTO VENEZOLANO PETROQUIMICA EL TABLAZO, VENEZUELA	47512-14	3	3"	8	3570	480	20.8	845.8	240	0.94	Water
PACIFIC PWR & LIGHT & IDAHO PWR CO., JIM BRIDGER PWR PLANT/ WYOMING (UNIT 1)	47549/50	2	1½"	4	3570	60	180	637	130	1.0	Water
PACIFIC PWR & LIGHT & IDAHO PWR CO., JIM BRIDGER PWR PLANT/WOMING (UNIT 2)	47555/56	2	1½"	4	3570	60	180	637	130	1.0	Water
PACIFIC PWR & LIGHT IDAHO PWR CO., JIM BRIDGER PWR PLANT/WOMING (UNIT 3)	47561/62	2	1½"	4	3570	60	180	637	130	1.0	Water
SUN OIL CO. TULSA, OKLAHOMA	47603	1	2"	8	3490	245	0	650	120	0.76	Unifined Naptha
STANDARD OIL CO OF CALIF. INGLEWOOD, CALIF.	47620	1	4"X	8	3570	575	15	1215	120	1.03	Oilfield Brine Water
UNION OIL CO. OF CALIF. WILMINGTON, CALIFORNIA	47636	1	6"X	8	3570	1213	135	1000	85	0.81	Turbine Fuel
HUDSON BAY OIL & GAS EDSON, ALBERTA	47672	1	6"	4	4100	1710	41	1007	110	1.02	Treating Solution
SHELL OIL CO. VENTURA, CALIFORNIA	47683/84	2	3"	4	3550	500	-	-	90	0.88	29° API Crude
HARVEY ALUMINA CORP. ST. CROIX, VIRGIN ISLANDS	47703	1	3"	8	3880	590	27	1073	260	0.938	Feedwater
AMERICAN OIL CO. WHITING, INDIANA	47724/25	2	4"X	10	3550	524	58	1598	241	0.95	Hydrocarbon
AMERICAN OIL CO. WHITING, INDIANA	47730/31	2	2½"	10	3570	400	136	1178	110	1.0	Lean Amine
MURPHY OIL CORP. MERAUX, LOUISIANA	47745	1	3"	8	3570	590	-2	593	100	0.699	Hydrocarbon
MURPHY OIL CORP. MERAUX, LOUISIANA	47746/47	2	2½"	6	3570	410	250	560	100	0.505	Hydrocarbon
MURPHY OIL CORP. MERAUX, LOUISIANA	47748/49	2	2½"	6	3570	335	250	560	100	0.503	Hydrocarbon
THERMAL SYSTEMS INC. OKLAHOMA CITY, OKLAHOMA	47750	1	2"	8	3550	200	15	690	250	0.943	Water
DRESSER-CLARK DIV. OLEAN, NEW YORK	47761/62	2	1½"	8	3570	165	-	-	228	0.952	Feedwater

CUSTOMER AND LOCATION	PUMP NO.	NO. UNITS	SIZE	NO. STGS	RPM	GPM	SUCT. PRESS. PSIG	DISCH. PRESS. PSIG	PUMP TEMP. °F	SP. GR.	PRODUCT
TEXACO OIL CO. SAN ARDO, CALIFORNIA	47763	1	2½"	8	3570	425	10	855	280	0.947	Feedwater
CRA INC. COFFEYVILLE, KANSAS	47778	1	4"X	6	3570	365	8	608	130	0.684	Hydrocarbon
CHINESE PETROLEUM CORP. KAOHSIUNG, TAIWAN	47816/17	2	2½"	4	3570	420	14	399	230	0.95	Water
ST. OIL CO. OF CALIF. EL SEGUNDO, CALIFORNIA	47828/29	2	2"	8	3550	200	20	714	218	0.956	Boiler Feedwater
GETTY OIL CO. DELAWARE CITY, DELAWARE	47849/50	2	6"X	6	3570	1152	40	900	280	0.93	Feedwater
UNION OIL CO. LIMONT, ILLINOIS	47856	1	6"	6	3550	880	112	720	330	0.64	Hydrocarbon Saturated w/H ₂
UNION OIL CO. BLAUMONT, TEXAS	47857	1	4"X	6	3570	660	65	739	140	0.758	Hydrocarbon
INDIAN FARMERS FERT. INDIA	47863	1	2"	10	2900	190	29	709	250	0.944	Feedwater
EL PASO PRODUCTS CO. ODISSA, TEXAS	47865	1	4"X	8	3550	800	700	1300	80	0.57	Butane
SANDIA CORPORATION ALBUQUERQUE, N. MEXICO	47875	1	2"	10	3550	250	0	1000	120	1.0	Media-De-ionized Water
KYUNG IN ENERGY KOREA	47885	1	1½"	10	3570	135	24	650	365	0.634	Hydrocarbon
KYUNG IN ENERGY KOREA	47886	1	1½"	10	3570	125	28	692	225	0.697	Naphtha
KYUNG IN ENERGY KOREA	47887	1	1½"	8	3570	106	45	660	170	0.782	Naphtha
CHINESE PETROLEUM KAOHSIUNG, TAIWAN	47888/89	2	3"	4	3510	600	300	600	85	.75	JP-4
UNION OIL CO. OF CALIF. WILMINGTON, CALIF.	47920	1	2"	10	3550	248	2.5	785.5	80	0.825	Hydrocarbon Distillate
PUBLIC UTILITIES BOARD BROWNSVILLE, TEXAS	47925	1	1½"	6	3550	160	19	519	225	.96	Water
AMOCO CHEMICALS CORP. TEXAS CITY, TEXAS	47939/40	2	2"	10	3550	205	113	613	57	.515	Propylene
AMOCO CHEMICALS CORP. TEXAS CITY, TEXAS	47943/44	2	2½"	8	3570	351	95	515	50	.529	Propane-Propylene
E. I. DUPONT DENEMOURS BELLE, WEST VIRGINIA	47963/64	2	2"	6	3550	200	-	-	200	.963	Water
GETTY OIL CO. BAKERSFIELD, CALIF.	47977	1	4"	6	3560	775	20	855	240	0.947	Boiler Feedwater
GETTY OIL CO. BAKERSFIELD, CALIF.	47978/79	2	4"X	6	3560	775	20	855	240	0.947	Boiler Feedwater
AMERICAN OIL CO. TEXAS CITY, TEXAS	47993	1	1½"	8	3560	70+20 Min. Fl.	0	712	190	.9667	Water Condensate
PEMCA - IVP CARACAS, VENEZUELA	48033-36	4	3"	6	3550	570	45	552	234	0.951	Water
TENNECO OIL CO. CHALMETTE, LOUISIANA	48139/40	2	3"	8	3570	600	50	725	240	0.951	Boiler Feedwater
EL PASO NATURAL GAS CO. JAL, NEW MEXICO	48141/42	2	1½"	4	3550	125	250	618	273	0.93	Water
DOUGLAS OIL CO. PARAMOUNT, CALIF.	48157	1	4"X	6	3550	600	0	750	150	0.895	Gas Oil
MOBIL OIL CORP. AUGUSTA, KANSAS	48158/59	2	2½"	8	3570	335	52	585	130	0.725	Hydrocarbon
CRA INC. COFFEYVILLE, KANSAS	48218	1	2½"	6	3570	307	90	527	250	0.655	Naphtha
MOBIL OIL CORPORATION FERNDALE, WASHINGTON	48222	1	2½"	8	3570	335	2 55 Max.	585	130	.725	Hydrocarbon
PETROLEOS MEXICANOS AGUA DULCE, VER. AGUA-DULCE, VER.	48237/38	2	2"	8	3550	200	18 30	700	68	.90	Crude Oil
NATIONAL IRANIAN OIL CO TEHRAN, IRAN	48239	1	6"X	8	2950	900	6	810	225	.95	Water
CONSUMERS POWER MARYSVILLE, MICHIGAN	48248/49	2	2"	10	3570	245	5 50 Max.	800	135	.797	Hydrocarbon
PHILLIPS PETROLEUM CO. KANSAS CITY, KANSAS	48280	2	6"X	6	3550	825	20	885	259	.937	Boiler Feed Water

CUSTOMER AND LOCATION	PUMP NO.	NO. UNITS	SIZE	NO. STGS	RPM	GPM	SUCT. PRESS. PSIG	DISCH. PRESS. PSIG	PUMP T. HP Y	SP. GR.	PRODUCT
COASTAL STATES PETRO. CORPUS CHRISTI, TEXAS	48283	1	2"	8	3550	220	0	700	100	.92	Scrub Gas Oil
CONSOLIDATED EDISON LONG ISLAND CITY, NEW YORK	48303-05	3	2 1/2"	4	3570	360	50	462	228	.95	Water
PETROLIUS MEXICANOS AGUA DULCE, VER	48307	1	2"	8	3550	200	18 30	770	68	.90	Crude Oil
ASHLAND OIL & REF CO. ST. PAUL PARK, MINNESOTA	48346	1	2"	10	3570	500	120	1430	375	.70	Gas Oil
ASHLAND OIL & REF CO. ST. PAUL PARK, MINNESOTA	48347	1	2"	10	3570	500	160	1415		.67	Naphtha
GULF STATES UTILITIES SAN GABRIEL, LOUISIANA	48354-56	3	2 1/2"	12	3570	350	50	1100	170 235	.78 .91	Low Sulphur
AMERICAN PET CO. OF TEXAS MOUNT PLEASANT, TEXAS	48359/60	2	2"	10	3550	195	0	881	60 100	.94 .834	Diesel Fuel
AMERICAN PET CO. OF TEXAS MOUNT PLEASANT, TEXAS	48361/62	2	1 1/2"	8	3570	105	5	769	110	.997	18" Mez Solution
HUMBLE OIL & REF CO. BATON ROUGE, LA	48369	1	2 1/2"	6	3570	350	100 150	705 755	212 300	.958	Steam Condensate
ILLINOIS POWER DECATUR, ILLINOIS	48410-12	3	1 1/2"	8	3570	150	0 123 Max	550	20 80	.825	No. 2 Fuel Oil
PUBLIC SERVICE ELECTRIC GAS LINDEN, NEW JERSEY	48416/17	2	4"X	6	3570	675	5	815	228	.95	Feed Water
CALTEX (R. M. PARSONS U.K. LTD) BAHRAIN	48420/21	2	3"	8	3570	563	141.6	967.6	150	1.005	Lean Dea
CALTEX (R. M. PARSONS U.K. LTD) BAHRAIN	48433/34	2	2 1/2"	8	3570	400	34	717	235	.95	Water
SOUTHERN CALIF. EDISON CO. LONG BEACH GEN. STA.	48462/63	2	6"X	4	3570	1680 1680	50 50	671.0 667.5	200	.902 .948	Fuel Oil
SOUTHERN CALIF. EDISON CO. HUNTINGTON BEACH GEN STA	48464/65	2	6"X	4	3570	1680 1680	50 50	671.0 667.5	200	.902 .972	Fuel Oil
AMERICAN OIL COMPANY WOOD RIVER, ILLINOIS	48493	1	3"	6	3570	480	200	750	100	.75	Heavy Naphtha
WESTINGHOUSE PAD/ U.S.N. Y1 NX-27	48532	1	1 1/2"	6	3570	85			110	.82 1.09	Water Solution
ST. JOE PAPER CO./SIMONS-EASTERN CO. PORT ST JOE, FLORIDA	48541/42	2	1 1/2"	10	3550	98	0	922	130	1.0	Condensate
MOBIL OIL CORPORATION ABBEVILLE, LOUISIANA	48563	1	2"	6	3900	280			300	.916	Steam Condensate
NORTHERN PETRO CHEM CO. MORRIS, ILLINOIS	48568	1	6"X	6	3550	1100	9.3	850	228	.953	Feedwater
COASTAL STATES GAS PRODUCING CO. CORPUS CHRISTI, TEXAS	48571	1	6"X	8	3550	900	00	1050	100	.90	Gas Oil
COASTAL STATES GAS PRODUCING CO. CORPUS CHRISTI, TEXAS	48572/73	2	3"	8	3550	500	100	1000	120	1.01	20" Dea
HESS OIL - VIRGIN ISLANDS ST. CROIX, VIRGIN ISLANDS	48596	1	4"	6	3570	600	50	750	250	.94	Feed Water
GULF OIL COMPANY SANTA FE SPRINGS, CALIF.	48645	1	2"	10	3570	300	1200	200	100	.83	Hydrocarbon
SINCLAIR RODGERS PORT ARTHUR, TEXAS	48670/71	2	2 1/2"	6	3570	400	15	665	220	.995	Boiler Feed Water
ASHLAND OIL, INC. TONAWADA, NEW YORK	48699/700	2	2 1/2"	10	3570	390	7.5	733	100	.69	Naphtha
PHELPS-DODGE CORP. LARAMORE, OPHAM & DOUGLAS - MORENCI, ARIZ	48726	1	2 1/2"	8	3550	382			230	.953	Condensate
NATIONAL IRANIAN OIL CO. TEHRAN, IRAN	48727-29	3	6"X	8	2950	900	6	810	225	.95	Water
GEORGIA PACIFIC PLAQUEMINE, LOUISIANA	48742	1	4"X	8	3570	800	13	118	227	.95	Feed Water
PEMEX COSOLEACAQUE, MEXICO	48745	1	2"	8	3550	198	21.1	726.1	250	.944	Boiler Feed Water
NORTHERN ILLINOIS GAS CO. MORRIS, ILLINOIS	49779/80	2	4"X	8	3570	405	0	901	60	.678	Naphtha
B.P.O.C. MARCUS HOOK, PA	48833	1	2 1/2"	10	3570	371	150	1045	180	.995	22" Dea Lean
B.P.O.C. MARCUS HOOK, PA	48835/36	2	6"X	8	3570	1220	45	1235	175 148 Max	.88	Vacuum Gas Oil
B.P.O.C. MARCUS HOOK, PA	48837	1	4"X	8	3570	1300	125	950	165	.81	Vac. Gas Oil & Light HC 7" H2O

CUSTOMER AND LOCATION	PUMP NO.	NO. UNITS	SIZE	NO. STGS	RPM	GPM	SUCT. PRESS. PSI	DISCH. PRESS. PSIG	PUMP TEMP. °F	SP. GR.	PRODUCT
MEX MEXICO	48845/46	2	1½"	4	3570	120	0	375	180	.974	Water Condensate
PEMEX MEXICO	48847/48	2	2"	8	3570	180	0	825	180	.974	Water Condensate
MOBIL OIL BEAUMONT, TEXAS	48866/67	2	1½"	6	3570	175		225	150	.82	Hydrocarbon
CONTINENTAL OIL CO BILLINGS, MONTANA	48873	1	2½"	8	3570	400	10 20 Max.	660	300 325 Max.	.708	Distillate
CLARK DIV - DRESSER IND OLEAN, NEW YORK TEST FAC	48811/12	2	2½"	6	3580	360	15	726	228	.953	Boiler Feed Water
MOBIL OIL CORP COW ISLAND GAS PLANT, KAPLAN, LOUISIANA	48919	1	4"X	6	3570	690	100	568	450 83	.679 .697	Lean Oil
B.P.O.C. MARCUS HOOK, PA	48934	1	2½"	10	3570	713	205 1600 Max.	1400 1600 Max.	140	.78	Hydrotreated Oil 0.8 Wt. %H2S
N.I.O.C. - FLUOR TEHRAN, IRAN	48965/66	2	4"X	6	2970	690	75	550	380	.89	Hydrocarbon
SINCLAIR-RODGERS PORT ARTHUR, TEXAS	48983	1	4"X	6							
GASCO, INC. HONOLULU, HAWAII	48993/94	2	1½"	10	3570	125	8 28 Max.	849	230	.95	Water
GASCO, INC. HONOLULU, HAWAII	48995/96	2	1½"	10	3570	93	0 10 Max.	725	68	.77	Naphtha
COLLIER CARBON & CHEMICAL CORP KENAI, ALASKA	48999	1	2½"	6	3570	359	25	750	230	.955	boiler Feed Water
HERCULES, INC. PLAQUEMINE, LOUISIANA	49031	1	6"X	8	3570	1177	22	1400	248	.94	Feed Water
MALLARD EXPLORATION, INC. FLOMATON, ALABAMA	49038/39	2	3"	4	3570	600	5	450	228	.951	Boiler Feed Water
N.I.O.C. - FLUOR TEHRAN, IRAN	49050	1	2½"	10	2950	395	5	515	100	.720	Hc Liquid
PHILLIPS PETROLEUM CO. WYLER, TEXAS	49058	1	3"	6	3570	360	60	664	120	.85	Light Cycle Oil
UNION OIL COMPANY - FLUOR LOS ANGELES REF, CALIF	49062	1	3"	10	3570	494	23	685	100 120 Max.	.715	Light Naphtha
TAMPA ELECTRIC TAMPA, FLORIDA	49067-69	3	2"	6	3550	255 255	575 580	958 950	220 100	1.0 0.9	No. 6 Fuel Oil Low Sulfur
PHILLIPS PETROLEUM CORPORATION CHATOM, ALABAMA	49078/79	2	1½"	6	3570	150	15	500	250	.953	Water w/PH = 7.5%
DRESSER CLARK (TEST FACILITY) OLEAN, NEW YORK	39389	1	2"	4	4420	130	5	600	100 200	.964	Water
STANDARD OIL CO. PASCAGOULA, MISSISSIPPI	49138	1	6"X	8	3570	1600	1425	305	350	.67	Hydrocarbon
CONSUMERS POWER CO.	49147/48	2	2½"	10	3570	350	25	850	Amb. 40° to 108	.77 .77	Lift HC
CONSUMERS POWER CO.	49199 49202	4	3"								
GOTAAS LARSEN, INC. NEW YORK, NEW YORK	49292	1	1½"	4	3570	95	88	430	315	.912	B.F. Water
GOTAAS-LARSEN, INC. NEW YORK, NEW YORK	49293	1	1½"	4	3570	95	88	430	315	.912	B.F. Water
GOTAAS-LARSEN, INC. NEW YORK, NEW YORK	49294	1	1½"	4	3570	95	88	430	315	.912	B.F. Water
HESS OIL VIRGIN ISLANDS CORP. ST. CROIX, VIRGIN ISLANDS	49295/96	2	6"X	4	3570	1200 1350	20	530	110	.727	Hydrocarbon
HESS OIL VIRGIN ISLANDS CORP. ST. CROIX, VIRGIN ISLANDS	49297/98	2	6"X	4	3570	1200 1350	20	530	110	.727	Hydrocarbon
COLUMBIA NITROGEN CORP. AUGUSTA, GEORGIA	49343/44	2	3"	4	3550	400	17.3	480	242	1.235	30K2CO ₃
UNION CAM CORP SAVANNAH, GEORGIA	49345/56	2	2"	8	3550	200	15-50 150 Max.	791 826	256 300	.943 .918	Desuperheater Water
HESS OIL (G.E.) VIRGIN ISLANDS	49376/77	2	2"	4	3570	260	15	440	250	.942	Water
TEX PETRO. CORP. PIPPINES	49396	1	4"X	6	3570	730	39.15	782	244	.943	BF Water
ATLANTIC CITY ELECTRIC/U.E. NEW JERSEY	49402-04	3	1½"	8	3570	135	16.4 218	452.4	50 250	.84 .94	Crude No. 6 Residual
COLUMBIA NITROGEN CORP. AUGUSTA, GEORGIA	49435/36	2	3"	4	3550	506	-0.5	393	140	1.22	K ₂ CO ₃

CUSTOMER AND LOCATION	PUMP NO.	NO. UNITS	SIZE	NO. STGS	RPM	GPM	SUCT. PRESS. PSIG	DISCH. PRESS. PSIG	PUMP TEMP. °F	SP. GR.	PRODUCT
STANDARD OIL COMPANY PASCAGOULA, MISSISSIPPI	49462/63	2	2½"	8	3570	330	80	885	150	1.01	Lean Dea
PHILLIPS PETROLEUM CORP. WOOD CROSS, UTAH	49474	1	2½"	6	3570	380	105	545	235	.655	HC
KOCH REFINING CO. (R. M. PARSONS) PINE BLND, MINN.OTA	49476	1	4"X	6	3570	820	185.6 300 Max	285.6	110	.945	18% Mea Solution
CLIX LAUREL	49490	1	2½"	6	3570	245	20	365	317	.64	Hydrocarbon
GETTY OIL DELAWARE	49513	1	4"X	6	3580	1170	750	50	AMB	.75	Naphtha
MURPHY OIL	49542	1	3"	8	-	-	-	-	-	-	-
CLIX FORD BACON & DAVIS MONTANA	49491	1	2½"	6	3570	475	20	365	317	.64	Hydrocarbon
HESS OIL VIRGIN ISLANDS CORP. ST. CROIX, VIRGIN ISLANDS	49552/53	2	6"X	6	3570	1350	50 100 Max	750	250	.94	B.F. Water
HESS OIL VIRGIN ISLANDS CORP. ST. CROIX, VIRGIN ISLANDS	49554	1	6"X	6	3570	1350	50 100 Max	750	250	.94	B.F. Water
CHEVRON OIL PERT AMBOY, TEXAS	49559/60	2	2½"	6	3620	422	233	750	250 275 Max	.94	Condensate
HAWAIIAN INDEPENDENT REF. OAHU, HAWAII	49589/90	2	2½"	6	3570	363	-4	435	110	.732	Naphtha
PETROLEO BRAZILEIRO SAO PAULO, BRAZIL	49603-06	4	2½"	12	3570	580	50	1300	170 194	.95 .954	Fuel Oil
COMMONWEALTH PETROCHEM. PENEELAS, PUERTO RICO	49651-53	3	6"X	6	3570	1100	15	780	250	.94	B.F. Water
WYANDOTTE CORP FORD, BACON & DAVIS GEISMAR, LOUISIANA	49656/57	2	3"	10	3570	500	37	1044	340	.895	B.F. Water
MOBIL OIL CO. BEAUMONT, TEXAS	49660/61	-	4"X	6	3700	800	52 Abs	930 Abs	260	.938	Lean Dea
BASI WYANDOTTE CORP.	49657	1	3"	10	-	-	-	-	-	-	-
MOBIL OIL CO (A. C. MCKEE) BEAUMONT, TEXAS	49709/10	2	3"	6	3570	465	155	772	125	.87	Lean Dea
PETROLEO BRAZILEIRO BRAZIL	49740	1	4"X	-	-	-	-	-	-	-	-
SUN OIL TULSA	49782	1	2"	6	-	-	-	-	-	-	-
CHINA PETROCHEMICAL	49794/95	2	2½"	6	-	-	-	-	-	-	-
STANDARD OIL OF OHIO	49839	1	4"X	-	3570	1300	150 1000	860 1000	140	.853	Desulfur UGO & DESDL UED
STANDARD OIL OF OHIO	49840/41	2	4"X	-	3570	790	150	1575	180	.99	22% Lean Dea

SECTION IX

FIELD RECOMMENDATIONS

Although the preceding report clearly demonstrates the usability of these parts "as is", it is our opinion that the following field program would be prudent but not so burdensome as to distract from other important activities.

Whenever the pumps are opened up due to some operating problem or normal maintenance, the intermediate cover in the shroud section should be visually inspected to determine the extent of the indications. Note that we do not recommend scheduling a special disassembly for the purpose of inspecting these parts. The reason for this is that we feel the above report eliminates all concern for failure and that the cost and risk of doing damage to a good pump during disassembly and reassembly cannot be justified. However, we do recommend intermediate covers be inspected on at least a ten year cycle. Since this is generally advisable for plant reasons other than these intercover indications, we feel this is a prudent maximum inspection cycle.

The actual visual inspection should be made to a controlled procedure since individual interpretation can be very misleading when dealing with this type of indication. We would suggest that Article 9 of Section 5 of the ASME Boiler & Pressure Vessel Code would serve as a good guide in this area. Other non-destructive methods such as Magnetic Particles (MT) or Dye Penetrant or radiographic examination are not recommended since they require special preparation of the part or technique to be used and would probably not be useful. Our own factory trials using MT on these parts shows that good visual inspection is more than adequate to detect significant indications of the type we are considering.

A log should be kept of the findings. This should include at least the quantity and size of indications found on each intermediate cover. In addition, we recommend that all indications which extend more than 1 inch radially towards the center of the part be referred to Pacific Pumps for possible further analysis. Note that this is roughly double the depth of any indications we have so far seen so we do not anticipate any problem with this criterion. The actual length of 1 inch is based upon the depth of the shroud in a radial direction before a vane is encountered. It is also approximately the same as the notch depth introduced into the finite element model. A higher level of complexity in the stress field is introduced if the indication extends into or along a vane. However, even in this case, we believe the stress levels to not be significantly increased in the plane causing opening of any crack.

SECTION IX

FIELD RECOMMENDATIONS

We can summarize our recommendations as follows:

- 1) Visually inspect the shroud section of the intermediate cover during normal or emergency maintenance or every 10 years (but do not open pump only for intercover inspection).
- 2) Log all indications found in the shroud for each part. A map is not recommended. Overall statistics are the key.
- 3) Report to Pacific all indication having a radial depth greater than 1". (See sketch.)

Again, we suggest the above program even though we are convinced that the indications pose no threat to the integrity of the intercover or operability of the pump.

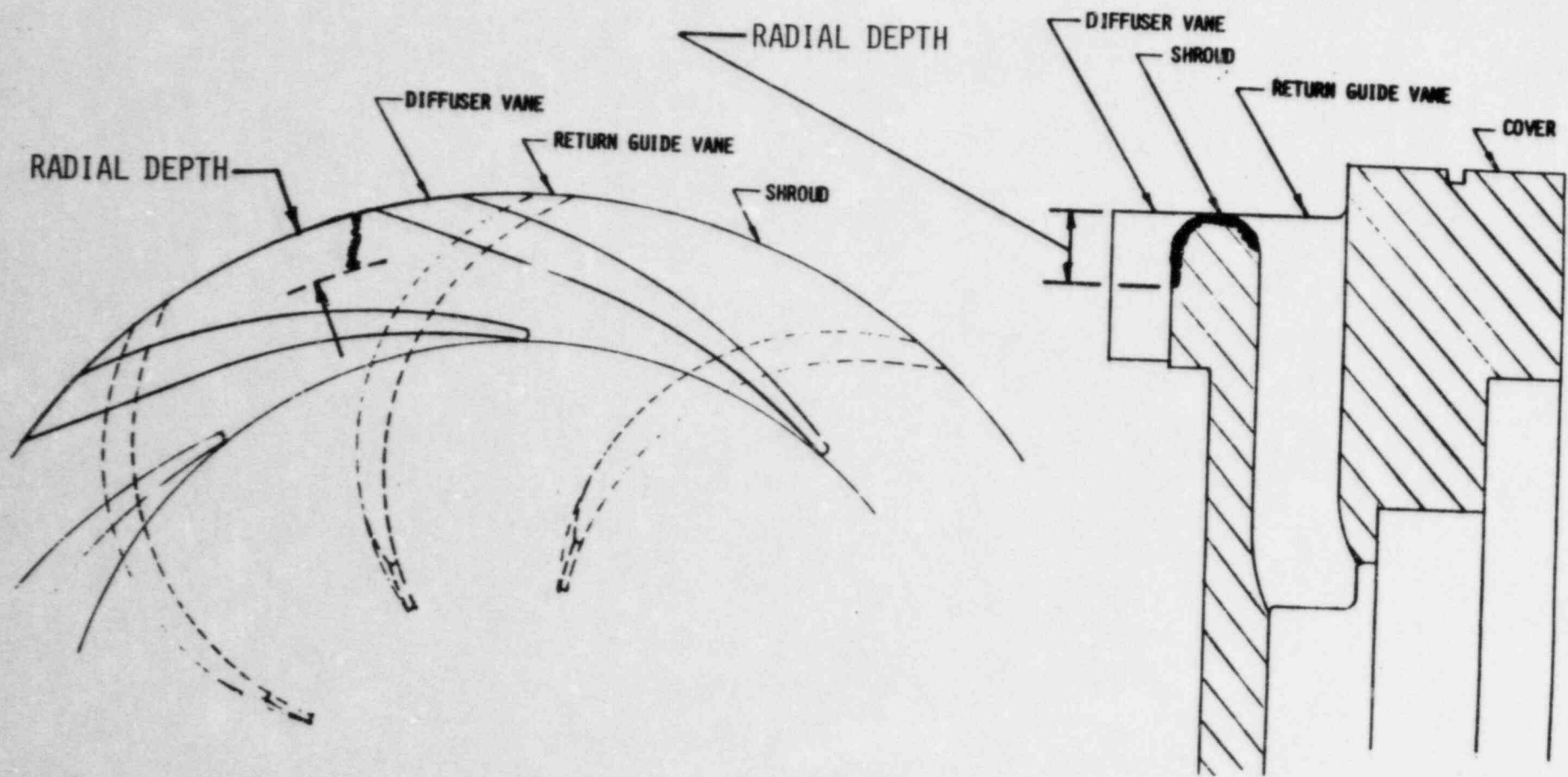

SKETCH OF RADIAL MEASUREMENT TECHNIQUE