

TECHNICAL EVALUATION REPORT

WIND AND TORNADO LOADINGS (SEP, III-2)

JERSEY CENTRAL POWER AND LIGHT COMPANY
OYSTER CREEK NUCLEAR GENERATING STATION

NRC DOCKET NO. 50-219

FRC PROJECT C5257

NRC TAC NO. 41606

FRC ASSIGNMENT 14

NRC CONTRACT NO. NRC-03-79-118

FRC TASK 402

Prepared by

Franklin Research Center
20th and Race Street
Philadelphia, PA 19103

Author: D. J. Barrett
R. Agarwal

FRC Group Leader: D. J. Barrett

Prepared for

Nuclear Regulatory Commission
Washington, D.C. 20555

Lead NRC Engineer: D. Persinko

June 8, 1982

This report was prepared as an account of work sponsored by an agency of the United States Government. Neither the United States Government nor any agency thereof, or any of their employees, makes any warranty, expressed or implied, or assumes any legal liability or responsibility for any third party's use, or the results of such use, of any information, apparatus, product or process disclosed in this report, or represents that its use by such third party would not infringe privately owned rights.



Franklin Research Center

A Division of The Franklin Institute

The Benjamin Franklin Parkway, Phila. Pa. 19103 (215) 448-1000

See also Appendix 9.5

TECHNICAL EVALUATION REPORT

WIND AND TORNADO LOADINGS (SEP, III-2)

JERSEY CENTRAL POWER AND LIGHT COMPANY
OYSTER CREEK NUCLEAR GENERATING STATION

NRC DOCKET NO. 50-219

FRC PROJECT C5257

NRC TAC NO. 41606

FRC ASSIGNMENT 14

NRC CONTRACT NO. NRC-03-79-118

FRC TASK 402

Prepared by

Franklin Research Center
20th and Race Street
Philadelphia, PA 19103

Author: D. J. Barrett
R. Agarwal

FRC Group Leader: D. J. Barrett

Prepared for

Nuclear Regulatory Commission
Washington, D.C. 20555

Lead NRC Engineer: D. Persinko

June 8, 1982

This report was prepared as an account of work sponsored by an agency of the United States Government. Neither the United States Government nor any agency thereof, or any of their employees, makes any warranty, expressed or implied, or assumes any legal liability or responsibility for any third party's use, or the results of such use, of any information, apparatus, product or process disclosed in this report, or represents that its use by such third party would not infringe privately owned rights.



Franklin Research Center

A Division of The Franklin Institute

The Benjamin Franklin Parkway, Phila., Pa. 19103 (215) 448-1000

CONTENTS

<u>Section</u>	<u>Title</u>	<u>Page</u>
1	INTRODUCTION	1
	1.1 Purpose of Review	1
	1.2 Generic Issue Background	1
	1.3 Plant-Specific Background	1
2	REVIEW CRITERIA.	4
3	TECHNICAL EVALUATION	7
	3.1 General Information	7
	3.2 Reactor Building	10
	3.3 Ventilation Stack	12
4	CONCLUSIONS	14
5	REFERENCES	16

APPENDIX A - REACTOR BUILDING DESIGN REVIEW CALCULATIONS

APPENDIX B - VENTILATION STACK DESIGN REVIEW CALCULATIONS

FOREWORD

This Technical Evaluation Report was prepared by Franklin Research Center under a contract with the U.S. Nuclear Regulatory Commission (Office of Nuclear Reactor Regulation, Division of Operating Reactors) for technical assistance in support of NRC operating reactor licensing actions. The technical evaluation was conducted in accordance with criteria established by the NRC.

1. INTRODUCTION

1.1 PURPOSE OF REVIEW

In the Systematic Evaluation Program (SEP), licensees are required to establish the ability of Class I structures to safely withstand a high wind or tornado strike. After conducting an appropriate investigation, licensees report the conclusions in a safety analysis report (SAR). The purpose of the present review is to provide a technical evaluation of the SAR prepared by the Jersey Central Power and Light Company (JCP&L) for the Oyster Creek Nuclear Generating Station [1].

1.2 GENERIC ISSUE BACKGROUND

Some operating nuclear plants were designed on the basis of local building codes which did not consider the effects of the high wind speeds of tornadoes. Since the construction of these plants, research has led to an understanding of the various phenomena that occur during a tornado strike, and this knowledge has been incorporated into the definition of a design basis tornado (DBT) in Nuclear Regulatory Guide 1.76 [2]. Due to the concern regarding the extent to which older nuclear plants can satisfy DBT licensing criteria, the Nuclear Regulatory Commission (NRC), as part of the SEP, initiated Topic III-2, "Wind and Tornado Loadings," to investigate and assess the structural safety of existing designs against current requirements.

Licensees are required to prepare an SAR addressing the concern of SEP Topic III-2. The SAR should identify the limiting elements of the structural design and specify the loading conditions and threshold wind speeds at which buildings and components fail. As part of Assignment 14, Franklin Research Center (FRC) is assessing the adequacy and accuracy of the SARs. Typical items that are reviewed are the tornado load calculations and combinations, the structural acceptance criteria, and the method of analysis. In order to verify the conclusions on structural strength, an independent tornado analysis on a sample of Class I structures and components is also conducted.

1.3 PLANT-SPECIFIC BACKGROUND

The review of the Oyster Creek SAR was begun in April 1982. Prior to that time, JCP&L responded to NRC requests for information by providing architectural-engineering structural drawings. Additional sources of information were a JCP&L letter on the SEP structural topics [3] and the plant final safety analysis report [4]. The conclusions stated by JCP&L in the SAR are summarized in Table 1. Correspondence with NRC [5] established the reactor building and ventilation stack as the priority review structures.

The original wind loading criteria of the Oyster Creek structural systems were the structural load provisions of the American Standard Association codes that were in effect at the time of plant design. These provisions called for a graded wind load of 30 psf at a 30 ft elevation, to 45 psf at elevations above 100 ft. The structural acceptance criteria permitted stress levels at a 33-1/3% increase over code allowables. The criteria for this review are stated in Section 2 of this report.

Table 1. Summary of Conclusions from Oyster Creek Topic III-2 SAR*

<u>Class I Structures</u>	<u>Wind (mph)</u>	<u>Pressure (psi)</u>
Reactor Building Exterior Concrete Walls	300	2.0
Reactor Building Insulated Metal Siding	160	0.53
Reactor Building Roof Decking	280	0.96
Reactor Building Steel for Craneway Enclosure	190**	0.68
Control Room - North Wall	160	0.53
Remainder	300	2.0
Intake Structure	300	2.0
Ventilation Stack	180	2.0
Battery Room (interior room)		
Diesel Generator and Oil Tank Vaults	300	2.0

*The table lists the various Class I structures with their respective maximum permissible wind velocity and depressurization values. The allowable stresses do not exceed 90% of yield for reinforcing steel and 85% of the ultimate concrete strength and include the combined effect of dead loads plus normal operating loads.

**Based on siding drag - without siding steelwork can withstand 300 mph.

2. REVIEW CRITERIA

The intent of code regulations is to ensure the safety of systems vital to the safe shutdown of a reactor. The General Design Criteria (GDC) of 10CFR50, Appendix A [6] regulate the designs of these safety systems; in particular, GDC 2 requires that structures housing safety-related equipment be able to withstand the effects of natural phenomena such as tornadoes. The design basis must consider the most severe postulated tornado as well as the combined effects of tornado, normal, and accident conditions.

Regulatory Guide 1.76 defines a DET in terms of the parameters of maximum wind speed, maximum differential pressure, rate of pressure drop, and core radius, given with respect to geographical location. The specified magnitudes of these regional parameters are the acceptable regulation levels, but additional analysis may be performed where appropriate to justify the selection of a less conservative DBT. In Reference 7, the NRC established the tornado parameters to be used in the SEP study of the Oyster Creek plant.

Regulatory Guide 1.117 [8] assists in the identification of structures and systems that should be protected from the effects of a DBT. This regulatory position is elaborated in the Standard Review Plan (SRP), Section 3.3.2 (NUREG-0800) [9]. The analysis presented in this report is of a representative sample of safety-related structural systems at the Oyster Creek plant.

With the dynamic pressure and air flow assumptions from the SRP, Section 3.3.2, and with the aid of Reference 10, a velocity-pressure distribution model can be constructed from the DBT characteristics. The actual forces acting on a structure can be calculated from this model augmented by the experimental data reported in References 11 and 12. These forces arise from wind-induced positive and negative pressures as well as from differential pressures.

An additional tornado load is the impact of wind-borne missiles against structures. The potential missiles are identified in the missile spectrum of the SRP, Section 3.5.1.4 [13], while the particular missiles to be included

in this study were identified by the NRC as part of the SEP assignment [7]. References 14 and 15 assist in the determination of the structural effects of missile impact, while the guidelines of the SRP, Section 3.3.2 indicate acceptable combinations of impact effects with the loads resulting from wind and differential pressures.

Since the DBT is considered an extreme environmental event, tornado-induced loads are part of the loading combinations to be used in extreme environmental design (see Article CC-3000 in the ASME Boiler and Pressure Vessel Code [16] and the SRP, Section 3.8.4 [17]). The structural effects of these loading combinations are determined by analysis; stresses are calculated either by a working stress or ultimate strength method, whichever is appropriate for the structure under consideration. The ASME Code specifications for an extreme environmental event permit the application of reserve strength factors to allowable working stress design limits, and also permit local strength capacities to be exceeded by missile loadings (concentrated loads) provided that this causes no loss of function in any safety-related systems.

The sources of criteria described above and other source documents used in the evaluation are listed below:

- NRC Regulatory Guide 1.76, "Design Basis Tornado for Nuclear Power Plants" [2]
- NRC Regulatory Guide, 1.117, "Tornado Design Classification" [8]
- NUREG-0800, Standard Review Plan
 - Section 3.3.2, "Tornado Loadings" [9]
 - Section 3.5.1.4, "Missiles Generated by Natural Phenomena" [13]
 - Section 3.5.3, "Barrier Design Procedures" [18]
 - Section 3.8.1, "Concrete Containment" [19]
 - Section 3.8.4, "Other Seismic Category I Structures" [17]
 - Section 3.8.5, "Foundations" [20]
- AISC Specification for Design, Fabrication and Erection of Structural Steel for Buildings [21]
- ACI-318-77, "Building Code Requirements for Reinforced Concrete" [22]
- ASME Boiler and Pressure Vessel Code, Section III, Division 2 (ACI-359), "Standard Code for Concrete Reactor Vessels and Containments" [16]

NRC/SEB, "Criteria for Safety-Related Masonry Wall Evaluation,"
Structural Engineering Branch (1981) [23]

ACI-307-79, "Specification for the Design and Construction of Reinforced
Concrete Chimneys" [24].

3. TECHNICAL EVALUATION

3.1 GENERAL INFORMATION

The structures included in this review are the ventilation stack and the reactor building. These structures are classified seismically as Category I Nuclear Safety Related. The plan of the building arrangement and an isometric drawing of the Oyster Creek site are shown in Figures 1 and 2.

The DBT characteristics taken as a basis for analysis are (unit abbreviations are from the SRP, Section 3.3.2):

Maximum wind speed	250 mph
Maximum pressure drop	1.5 psi
Rate of pressure drop	0.6 psi/sec
Core radius	150 ft.

These characteristics yield a dynamic pressure of 160 psf. For application of this pressure to external flat surfaces of structures, the shape coefficients are 0.80 for windward walls (positive pressure), 0.50 for leeward walls (suction), and 0.70 for roofs (suction). The shape coefficient for the cylindrical ventilation stack is 0.70. Gust factors for tornado loadings are taken as unity.

The design basis missiles are C and F from the Standard Review Plan, Section 3.5.1.4 missile spectrum.

Missile C: Steel rod: 1-in diameter, 3-ft length, 8-lb weight, 220 ft/sec velocity; strikes at all elevations.

Missile F: Utility pole: 13.5-in diameter, 35-ft length, 1490-lb weight, 147 ft/sec velocity; strikes in a zone limited to 30 ft above grade.

The full effects of a tornado are experienced by the main structural members only if the skin of the building (walls, panels, roof decks, etc.) can properly transmit the associated loadings. For the purpose of analysis, the most conservative circumstances of integrity or failure of these elements are assumed. For instance, a steel roof deck may fail when subjected to the DBT differential pressure. However, even though the roof deck failure provides

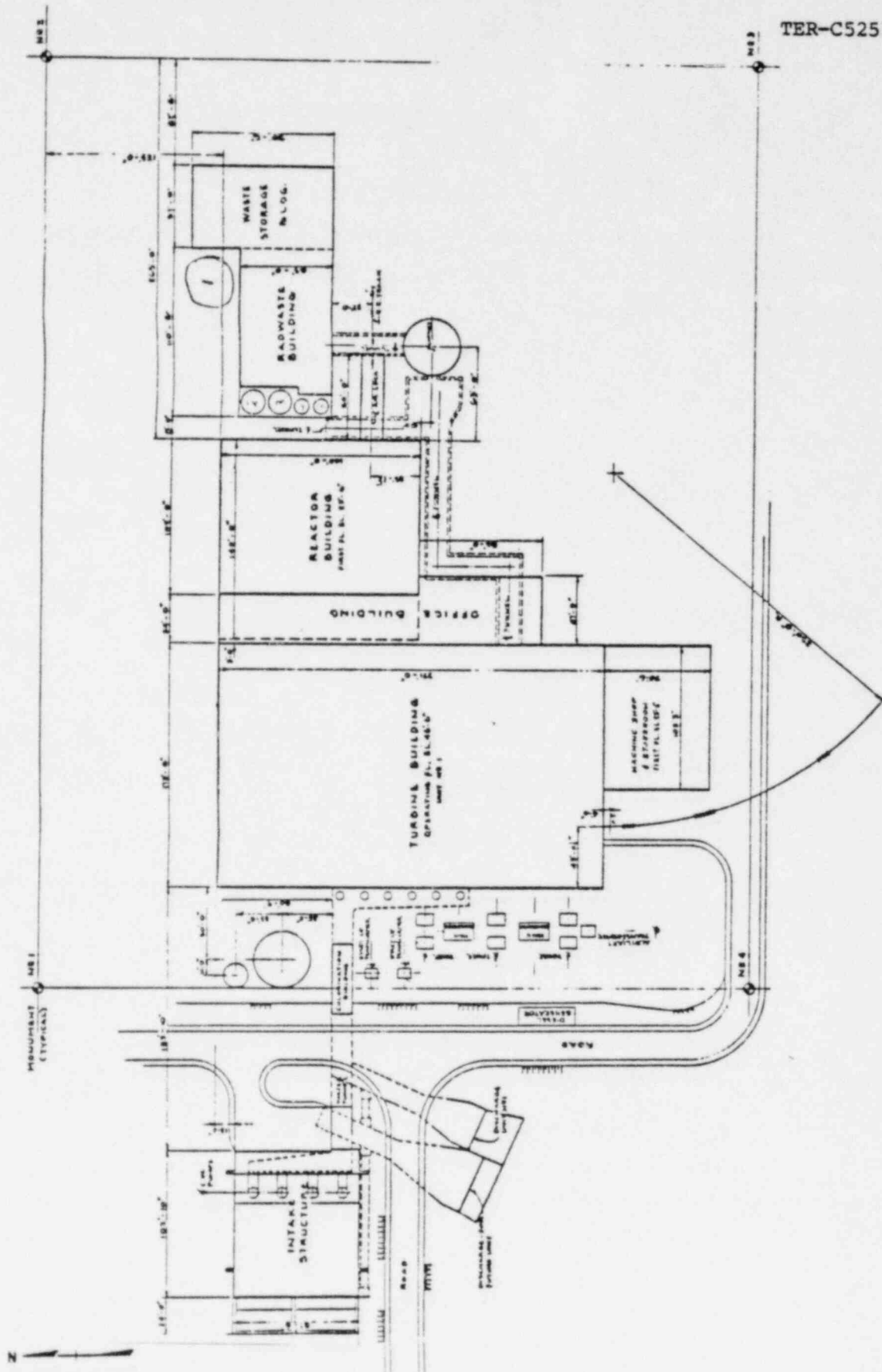

Figure 1. Site Plot Plan

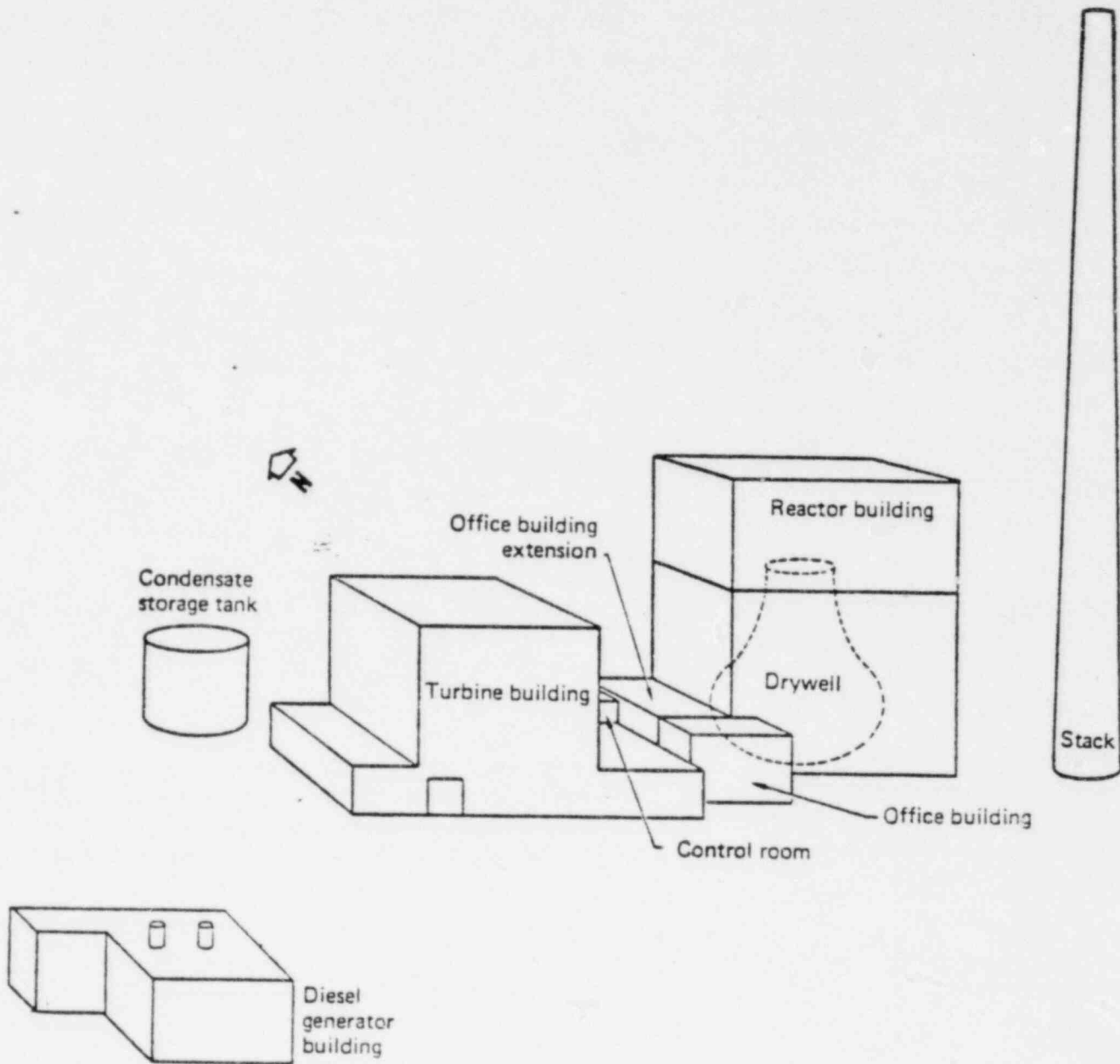

Figure 2. Isometric of Oyster Creek Plant Showing Major Structures

venting, the tornado loads are still assumed to exist so that the strength of other, stronger structural elements can be analyzed.

For most structures, a wind flow field acting at an angle to the surfaces of a building is not as demanding as a frontal attack because the elements resisting lateral forces are oriented and framed so that the effects of adjacent wall loadings are uncoupled. Likewise, the action of windward face pressure and leeward face suction are uncoupled when their actions are resisted by separate structural elements. The most conservative loading cases are chosen accordingly.

The goal of analysis is to identify a structure's weakest members and to establish the threshold wind speed at which these members fail the structural acceptance criteria [17]. This wind speed limit rating depends on the postulated loading conditions. Once a limiting member is identified, the loading conditions used to determine subsequent limiting members are in some cases modified to account for failure of the weaker member. Therefore, conclusions about the strength of structural components are based on a supposition of sequential failure.

The following are typical assumptions for the structural modeling in this report:

1. No snow load exists during a tornado strike.
2. Thickened floor slabs can be used to transmit lateral loads.
3. Connections are designed in accordance with good engineering practice.
4. Unless noted otherwise, steel roof decking is assumed to remain intact.

Additional assumptions are identified on the calculation sheets (see appendices).

3.2 REACTOR BUILDING

3.2.1 Evaluation

The reactor building is primarily a reinforced concrete structure with the exception of a steel roof deck, which is supported by structural steel framing. The high point of this building is at elevation 169 ft 3 in, while

adjacent grade is at elevation 23 ft. The reactor building can be divided into two sections: the main section, which is below the service floor level (elevation 119 ft 3 in), and the service floor enclosure (above elevation 119 ft 3 in).

The exterior of the main section consists of thick reinforced concrete walls framing into the concrete floor slabs, beams, and columns. These elements were examined for the critical load case of differential pressure loads. Each panel is assumed to transfer loads in the horizontal direction to the nearest columns and in the vertical direction to the adjacent thickened floor slabs. The analysis of the panels can be found on pages A-12 through A-14 of Appendix A. Since the vertical section showed adequate reserve moment capacity, the capacity of a horizontal section was not calculated.

The concrete columns of the main section were checked for stability and capacity. The critical members were chosen on the basis of the smallest section and least reinforcement. The members selected were columns A-1 and A-4 (see building plan on page A-2). The dead and live loads on the columns were taken as those values reported in Reference 4. The wind loads acting on the wall panels adjacent to the columns are transferred to the columns as reactions, producing moments in the columns. The columns are taken as supported between successive beam and floor slabs. The column analysis and calculation are given on pages A-1 through A-11.

The service floor enclosure consists of insulated metal wall panels and UK 16-16 Q roof sections supported by a framework of columns and trusses. To analyze the capacity of the roof steel, the steel deck is assumed to remain intact. Also, when examining the capacity of the columns, it is assumed that the metal panels do not fail. The analysis of the structural steel elements of the service floor enclosure are presented on pages A-15 through A-21.

3.2.2 Conclusion

The reinforced concrete elements of the main section can safely withstand the tornado loadings. The limiting elements of the roof steel are the 12B19 beams, which have limit ratings of 0.131 psi (61 mph) for differential

pressure, 26.7 psf (102 mph) for tornado dynamic pressure, and 16.8 psf (68 mph) for high wind dynamic pressure. The limiting elements of the roof supports are the north and south side steel columns which have a limit rating of 1.07 psi (174 mph) for differential pressure, but can withstand the full tornado and high wind dynamic pressures.

3.3 VENTILATION STACK

3.3.1 Evaluation

The ventilation stack is an unlined, free-standing axisymmetric reinforced concrete structure. The top of the stack is at elevation 391 ft with grade at elevation 23 ft. The outer diameter at the top is 9 ft 6 in with 6-in-thick concrete. The outer diameter at the top of the foundation (elevation -3 ft) is 31 ft 8-3/4 in with 18-in-thick concrete. For calculation of the diameter of the stack at intermediate sections, it is assumed that the outer surface is smooth. In the event of a tornado strike, the stack can be subjected to pressure as high as 112 psf, corresponding to a 250 mph tornado and 0.7 shape factor.

The stack has been analyzed by a working stress design technique. This method is given in the American Concrete Institute Code (ACI) 307-79 [24]. Two sections, one at 233 ft and the other at 278.1 ft below the top of stack, were found to be the most critical. These sections were reanalyzed by increasing the allowable stresses in reinforcing steel to its yield strength (f_y) and in concrete to 0.85 times the compressive strength (f'_c). The stack analysis is given on pages B-1 through B-4 in Appendix B.

The section at 338.2 ft below the top of stack has three openings. For the purpose of analysis, the openings were grouped to form one equivalent opening, with an opening angle of $\beta = 49.8^\circ$. Also, the section at 386.5 ft below the top of stack, which is below grade, has two openings. These two openings were also grouped for the purpose of analysis yielding an equivalent opening angle of $\beta = 42.1^\circ$. Additional reinforcement is provided around each opening. Analysis shows that even under the conservative assumption of grouping the openings together, these sections are not the most critical.

The foundation pedestal is hexagonal in shape with each side measuring 18 ft 7-1/2 in. The pedestal is a reinforced concrete block 7 ft thick, and rests on a soil with a bearing capacity of 13 ksf. To determine the resistance to overturning moment, the axial stress due to the dead weight of the stack and concrete pedestal, plus the flexural stresses due to the wind forces, were balanced against the soil bearing capacity. These calculations are shown on pages B-5 to B-6.

3.3.2 Conclusion

It was found that the stack cannot withstand the full tornado dynamic pressure. Using the allowable stresses in reinforcement and concrete, according to ACI 307-79 [24], it was found that the sections at 233 ft and 278.1 ft below the top of stack were limiting and can withstand a tornado dynamic pressure of only 48.8 psf at a 138 mph wind speed. The section at 278.1 ft below the top of the stack was found to be the limiting section when the code allowable stress was increased to 0.85 f'c in concrete and yield stress in reinforcing steel. For these increased stress levels, this section can withstand tornado dynamic pressure of 68.6 psf at a 164 mph wind speed.

The equilibrium model for the stack foundation shows that the foundation was not the limiting design component. The stack foundation can resist an overturning movement due to a dynamic pressure of 93.7 psf at a 191 mph wind speed.

4. CONCLUSIONS

The results of the tornado structural analysis for the reactor building and ventilation stack are summarized in Table 2.

Table 2. Strength Summary of the Structural Components Analyzed

<u>Structure</u>	<u>Element*</u>	<u>Cause of Failure**</u>	<u>Wind Speed (mph)</u>
Reactor Building	12B19 Roof Beams	3	68
		2	61
		1	102
	North and South Side Steel Columns	2	174
	Concrete Walls and Columns	-	-
Ventilation Stack***	Concrete Shaft (When analyzed by ACI 307-79 allowables)	1	138
		1	164
		1	191
	Concrete Foundation	1	191

*The first element identified for each structure is the limiting element. Additional elements that have been found to be inadequate are subsequently listed. Note that this table does not imply that all inadequate elements have been identified or that entries are listed with respect to the most critical loading combination. Structural details not included in this review are windows, doors, and roof decks.

**Key: 1 = tornado dynamic pressure; 2 = differential pressure; 3 = high wind dynamic pressure. Tangential wind speeds are listed for differential pressure failures.

***The resistance of the stack to circumferential stresses cannot be determined because the placement of the hoop reinforcement is not known.

It is pointed out that the roof deck itself was not analyzed but that the underlying structural support, the 12B19 roof beams, were included in this study. Also, while the wall panels were not analyzed, the panel fasteners, girts, and panels of a comparable siding system reviewed in a previous study [25] were found to have limited tornado loading resistance (limiting element failed at 48 mph wind speed for tornado differential pressure).

While not specifically reviewed, an additional area of concern is the control room, which is located on the east side of the turbine building (see Figure 2). The north and south walls of the control room are exposed to the atmosphere. The south wall and part of the north wall are constructed of reinforced concrete block, a structural component which typically has limited tornado resistance. The common wall (west) between the turbine building and the control room is also constructed of concrete block and has glass panels that will be subjected to differential pressure loadings with failure of the skin of the turbine building.

A comparison of Table 1 with Table 2 and the above comments shows that for other than the concrete structures, the strengths claimed for structural components in the Oyster Creek SAR are in conflict with and greater than the strengths found by the analysis presented herein.

5. REFERENCES

1. I. R. Finrock (JCP&L)
Letter with Attachments to W. Paulson (NRC)
Subject: Oyster Creek Nuclear Generating Station Systematic Evaluation Program
May 7, 1981
Docket No. 50-219
2. "Design Basis Tornado for Nuclear Power Plants"
NRC, April 1974
Regulatory Guide 1.76
3. I. R. Finrock (JCP&L)
Letter with Attachments to D. L. Ziemann (NRC)
Subject: SEP Structural Topics
December 7, 1979
Docket No. 50-219
4. Oyster Creek Nuclear Generating Station
Final Safety Analysis Report
5. D. J. Barrett (FRC)
Informal Technical Communication to D. Persinko (NRC)
Subject: Comments of the Change of Scope: Tasks 401 and 402
April 7, 1981
6. Code of Federal Regulations, Title 10, Part 50
Appendix A, "General Design Criteria"
7. E. J. Butcher (NRC)
Letter to S. P. Carfagno (FRC)
Subject: Tentative Work Assignment P
April 23, 1981
8. "Tornado Design Classification"
NRC, Rev. 1, April 1978
Regulatory Guide 1.117
9. Standard Review Plan
Section 3.3.2, "Tornado Loadings"
NRC, July 1981
NUREG-0800
10. McDonald, J. R., Mehta, K. C., and Minor, J. E.
"Tornado-Resistant Design of Nuclear Power Plant Structures"
Nuclear Safety, Vol. 15, No. 4, July-August 1974

11. "Wind Forces on Structures"
New York: Transactions of the American Society of Civil Engineers,
Vol. 126, Part II, 1962
ASCE Paper No. 3269
12. "Building Code Requirements for Minimum Design Loads in Buildings and
Other Structures"
New York: American National Standards Institute, 1972
ANSI A58.1-1972
13. Standard Review Plan
Section 3.5.1.4, "Missiles Generated by Natural Phenomena"
NRC, July 1981
NUREG-0800
14. Williamson, R. A. and Alvy, R. R.
"Impact Effect of Fragments Striking Structural Elements"
Holmes and Narver, Inc.
Revised November 1973
15. "Full-Scale Tornado-Missile Impact Tests"
Palo Alto, CA: Electric Power Research Institute, July 1977
Final Report NP-440, Project 399
16. ASME Boiler and Pressure Vessel Code, Section III, Division 2
"Standard Code for Concrete Reactor Vessels and Containments"
New York: American Society of Mechanical Engineers, 1973
ACI-359
17. Standard Review Plan
Section 3.8.4, "Other Seismic Category I Structures"
NRC, July 1981
NUREG-0800
18. Standard Review Plan
Section 3.5.3, "Barrier Design Procedures"
NRC, July 1981
NUREG-0800
19. Standard Review Plan
Section 3.8.1, "Concrete Containment"
NRC, July 1981
NUREG-0800
20. Standard Review Plan
Section 3.8.5, "Foundations"
NRC, July 1981
NUREG-0800

21. Specification for Design, Fabrication and Erection of Structural Steel for Buildings
New York: American Institute of Steel Construction, 1978
22. "Building Code Requirements for Reinforced Concrete"
Detroit: American Concrete Institute, 1977
ACI 318-71
23. Criteria for Safety-Related Masonry Wall Evaluation
NRC, Structural Engineering Branch, 1981
24. "Specification for the Design and Construction of Reinforced Concrete Chimneys"
American Concrete Institute, 1979
ACI 307-79
25. FRC Technical Evaluation Report
"Wind and Tornado Loadings, Robert Emmett Ginna Nuclear Power Plant"
December 2, 1981
TER-C5257-400

APPENDIX A

REACTOR BUILDING DESIGN REVIEW CALCULATIONS



Franklin Research Center

A Division of The Franklin Institute

The Benjamin Franklin Parkway, Phila., Pa. 19103 (215) 448-1000



Franklin Research Center
A Division of The Franklin Institute
The Benjamin Franklin Parkway, Phila. Pa. 19103

Project 02G - C5257 - 01

Page A-1

By RA

Date APRIL '82

Ch'k'd B

Date 5/5

Rev. Date

Title REACTOR BUILDING - OYSTER CREEK CROSS-SECTION

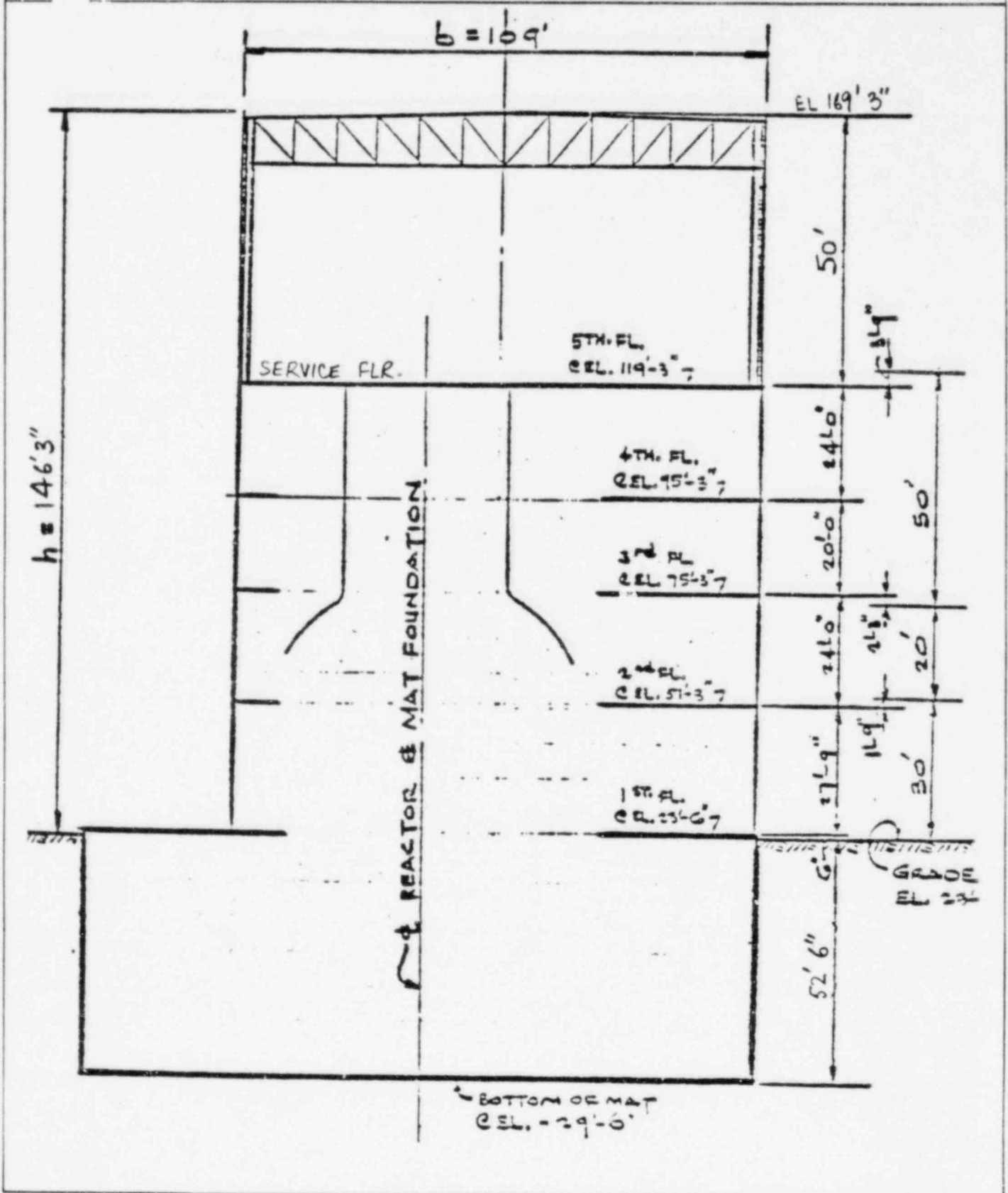



Franklin Research Center
 A Division of The Franklin Institute
 The Benjamin Franklin Parkway, Phila., Pa. 19103

Project 02G - C5257 - 01

Page A-2

By RA

Date APRIL '82

Chk'd CB 5/5

Rev. Date

Title REACTOR BUILDING - OYSTER CREEK - COL. LINE PLAN

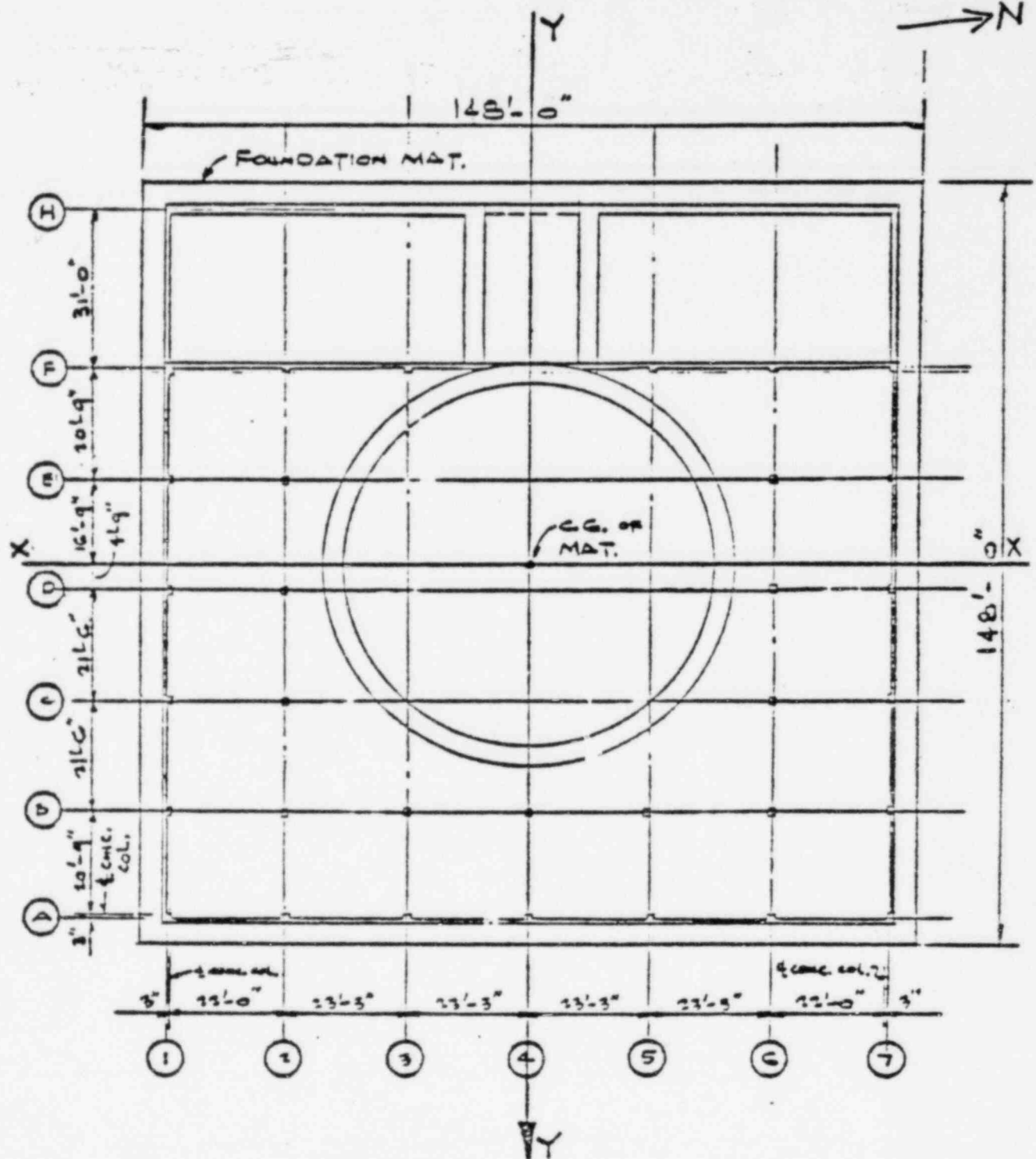

PLAN



Franklin Research Center
A Division of The Franklin Institute
The Benjamin Franklin Parkway, Phila. Pa. 19103

Project 02G - CS257-01

Page A-3

By RA

Date APRIL '82

Ch'k'd LB 5/5

Rev. Date

Title

REACTOR BUILDING — REINFORCED CONCRETE BELOW SERVICE FL. ELEV 119'3"

THE CRITICAL CASE WILL BE THE PRESSURE DROP CASE. A PRESSURE OF 216 PSF WILL ACT ON CONCRETE WALLS AND COLUMNS.

WE ANALYZE THE COLUMNS (A-1) AND (A-4) ASSUMING ALL LOAD IN LATERAL DIRECTION IS TRANSFERRED ONTO THE COLUMNS. WE ALSO CHECK THE EAST WALL SECTION FOR TRANSFER OF MOMENT IN VERTICAL DIRECTION.

COLUMN (A-1) AND (A-4) ARE ASSUMED TO BE SIMPLY SUPPORTED BETWEEN TWO FLOORS. IT IS ASSUMED THAT ALL SHEAR IS TRANSFERRED THROUGH FLOOR SLABS AND OTHER CONCRETE CONSTRUCTION.

CONSIDER 1FT. WIDE STRIP OF THE WALL IN VERTICAL DIRECTION

$l = 24'$ Between 4th & 5th Floor

$$M = \frac{wl^2}{8}$$

$$w = 216 \text{ psf} \times 1 \text{ ft} \\ = 216$$

$$= \frac{216}{1500} \times \frac{(24)^2}{8}$$

$$\therefore M_{w45} = 15.552 \text{ K-ft}$$

$l = 27'9''$ Between 1st & 2nd Floor

$$M = 0.216 \frac{(27.75)^2}{8}$$

$$\therefore M_{w12} = 20.792 \text{ K-ft}$$

WE ALSO ASSUME THAT ALL FLOOR LOADS ARE TRANSFERRED AS AXIAL LOADS ON THE COLUMNS.



Franklin Research Center
A Division of The Franklin Institute
The Benjamin Franklin Parkway, Phila., Pa. 19103

Project 02G-C5257-01

Page A-4

By RA

Date

APRIL '82

Ch'k'd

Date

LB 5/5

Rev.

Date

Title

REACTOR BUILDING - REINF. CONC. - BELOW SERVICE FL. ELEV 119'3"

NOW FIND THE ACTUAL MOMENTS ON THE COLUMNS

THE COLUMNS ARE SPACED 23'3" APART ON EAST SIDE OF THE REACTOR BLDG.

FOR COLUMN A-4 $W = 216 \times 23.25$
 $= 5022 \text{ lbs/ft}$

$$W = 5.022 \text{ K/ft}$$

$l = 27'9''$ Between 1st & 2nd flr.

$$\therefore M_{c12} = 5.022 \left(\frac{27.75}{8} \right)^2$$

$$M_{c12} = 483.407 \text{ K-ft}$$

$l = 24'$ Between 4th & 5th flr.

$$\therefore M_{c45} = 5.022 \left(\frac{24}{8} \right)^2$$

$$M_{c45} = 361.584 \text{ K-ft}$$



Title

REACTOR BLDG - CAPACITY OF COL (A-1) WEAKEST SECTION

BALANCE CONDITION

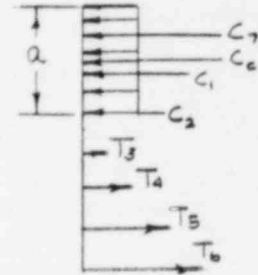
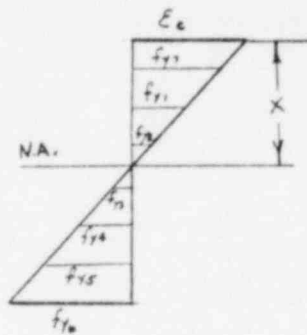
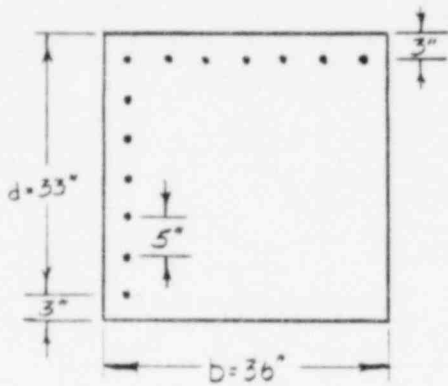

Assume 3" cover on both sides for balanced condition

STEEL $f_y = 40 \text{ ksi}$

$E_y = 1.379 \times 10^{-3}$

CONCRETE $f'_c = 3 \text{ ksi}$

$E_c = 0.003$

First we find the balanced condition case

Balance Neutral Axis $x_b = \left(\frac{E_c}{E_c + E_y} \right) d$

$d = 33"$

$x_b = \left(\frac{0.003}{0.003 + 1.379 \times 10^{-3}} \right) 33$

$x_b = 22.61 \text{ inches}$



Title REACTOR BLDG. - CAP. OF COL WEAKEST SECTION

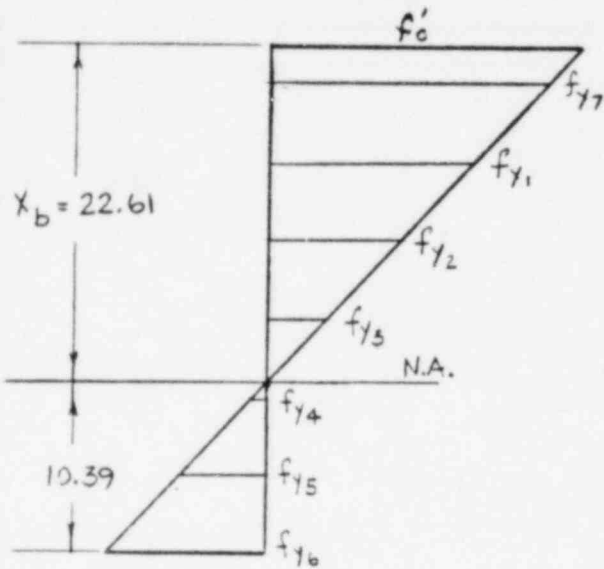

From strain geometry:

$$f_{y6} = 40 \text{ ksi}$$

$$\frac{f_{y5}}{5.39} = \frac{40}{10.39} \quad f_{y5} = 20.75 \text{ ksi}$$

$$\frac{f_{y4}}{.39} = \frac{40}{10.39} \quad f_{y4} = 1.5 \text{ ksi}$$

$$\frac{f_{y3}}{4.61} = \frac{40}{10.39} \quad f_{y3} = 17.75 \text{ ksi}$$

$$\frac{f_{y2}}{9.61} = \frac{40}{10.39} \quad f_{y2} = 37.0 \text{ ksi}$$

$$\frac{f_{y1}}{14.61} = \frac{40}{10.39} \quad f_{y1} > f_y$$

$\therefore f_{y1} = 40 \text{ ksi}$
 $\therefore f_{y7} = 40 \text{ ksi}$

Now we find the allowable axial load P_o for balanced condition

Compression $C_c = 0.85 f'_c (0.85 x_b) b$
 $= (0.85)(3)(0.85)(22.61)(36)$
 $= 1764.26 \text{ KIPS}$

STEEL

Tension = (7 of #11 bars) f_{y6} + (2 bars) f_{y5} + (2 bars) f_{y4}
 $= (7 \times 1.56)(40) + (2 \times 1.56)(20.75) + (2 \times 1.56)(1.5)$
 $T = 506.22 \text{ kips}$



Title REACTOR BLDG. - CAPACITY OF COL. WEAKEST SECTION

Compression =

$$C_s = (7 \text{ bars} + 2 \text{ bars})(40 - (.85)(3)) + (2 \text{ bars})(37 - (.85)(3)) + (2 \text{ bars})(17.75 - (.85)(3))$$

$$= (9 \times 1.56)(40 - 2.55) + (2 \times 1.56)(37 - 2.55) + (2 \times 1.56)(17.75 - 2.55)$$

$$C_s = 680.71 \text{ kips}$$

$$P_b = C_c + C_s \quad T$$

$$= 1764.26 + 680.71 = 506.22$$

$$P_b = 1938.75 \text{ kips}$$

since $0.8 \text{ L.L.} = 115 \Rightarrow \text{L.L.} = 143.75$
 $\text{D.L.} = 775.0$
918.75 LOAD

Design column for axial load $P_a = 920 \text{ kips}$

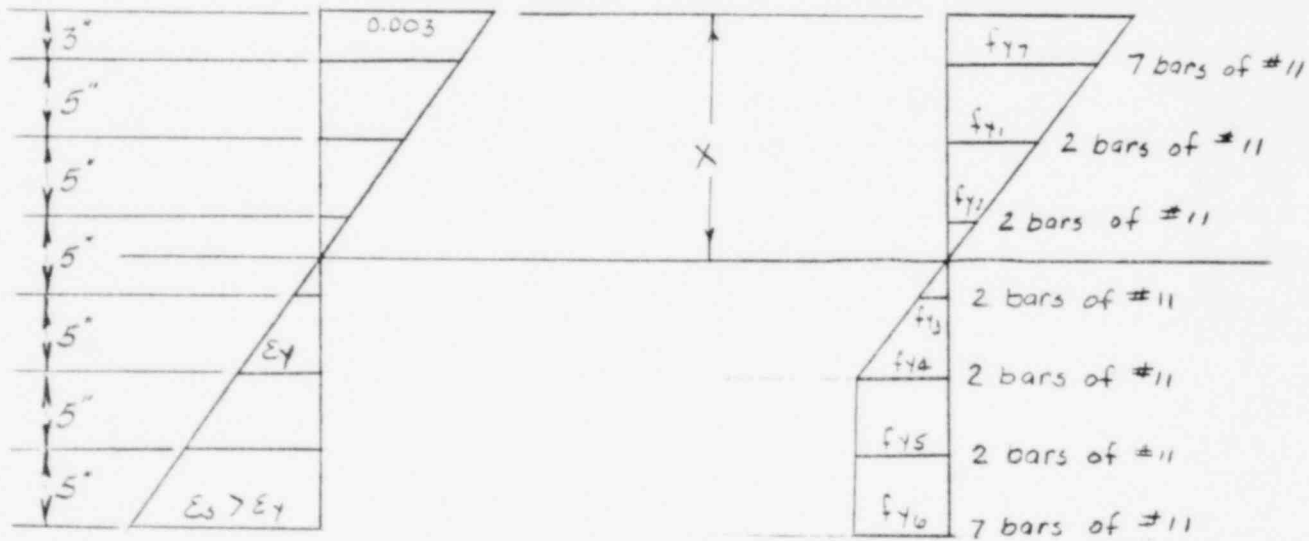

Assume $f_{y1} = f_{y7} = 40 \text{ ksi}$
 $f_{y2} = f_{y3} = f_{y4} = f_{y5} = f_{y6} = 40 \text{ ksi}$



Title REACTOR BLDG. - CAPACITY OF COL. WEAKEST SEC.

from strain geometry:

$$\frac{\epsilon_{y_3}}{(18-x)} = \frac{0.003}{x}$$

$$\epsilon_{y_3} = \frac{0.003(18-x)}{x} \quad f_{y_3} = \frac{87(18-x)}{x}$$

$$\epsilon_{y_2} = \frac{0.003(x-13)}{x} \quad f_{y_2} = \frac{87(x-13)}{x}$$

$$\epsilon_{y_1} = \frac{0.003(x-8)}{x} \quad f_{y_1} = \frac{87(x-8)}{x}$$

STEEL

$$\begin{aligned} \text{Tension} &= (7 \text{ bars}) f_{y_6} + (2 \text{ bars}) f_{y_5} + (2 \text{ bars}) f_{y_4} + (2 \text{ bars}) f_{y_3} \\ &= [(7+2+2) \times 1.56] 40 + (2 \times 1.56) \left[\frac{87(18-x)}{x} \right] \\ &= 686.4 + \frac{271.44(18-x)}{x} \end{aligned}$$

Compression

$$\begin{aligned} C_s &= (2 \text{ bars}) f_{y_2} + (2 \text{ bars}) f_{y_1} + (7 \text{ bars}) f_{y_7} \\ &= (2 \times 1.56) \left[\frac{87(x-13)}{x} + \frac{87(x-8)}{x} \right] + (7 \times 1.56) \times 40 \\ &= 271.44 \left(\frac{2x-21}{x} \right) + 436.8 \end{aligned}$$

$$\begin{aligned} C_c &= 0.85 f'_c (0.85 x) (36) \\ &= 78.03 x \end{aligned}$$



Title REACTOR BUILDING - REINF. CONC. COL. WEAKEST SECTION CAPACITY

$$P = 920 \text{ kips}$$

$$P = C_c + C_s - T$$

$$920 = \frac{271.44}{x}(2x-21) + 436.8 + 78.03x - 686.4 - \frac{271.44}{x}(18-x)$$

$$920 = 78.03x - 249.6 + \frac{271.44}{x}(2x-21-(18-x))$$

$$0 = 78.03x^2 - 1169.6x + 271.44(3x-39)$$

$$0 = 78.03x^2 - 1169.6x + 814.32x - 10586.16$$

$$0 = 78.03x^2 - 355.28x - 10586.16$$

$$x = \frac{355.28 \pm \sqrt{(355.28)^2 + 4(78.03)(10586.16)}}{2(78.03)}$$

$$x = \frac{355.28 \pm 1852.13}{156.06}$$

$$x = 14.14 \text{ inches}$$

$$\therefore C_c = 78.03x = 78.03(14.14) = \underline{1103.7 \text{ kips}}$$

$$\begin{aligned} \therefore C_s &= \frac{271.44}{x}(2x-21) + 436.8 = \frac{271.44}{14.14}(2(14.14)-21) + 436.8 \\ &= \underline{576.68 \text{ kips}} \end{aligned}$$

$$\begin{aligned} \therefore T &= 686.4 + \frac{271.44}{x}(18-x) = 686.4 + \frac{271.44}{14.14}(18-14.14) \\ &= \underline{760.39 \text{ kips}} \end{aligned}$$



Franklin Research Center
A Division of The Franklin Institute
The Benjamin Franklin Parkway, Phila. Pa. 19103

Project 02G-C5257-01

Page A-10

By RA

Date APRIL '82

Ch'k'd MLP

Date 4-82

Rev.

Date

Title REACTOR BLDG. - CAPACITY OF COL. WEAKEST SECTION

Assume that the plastic centroid is at mid-depth of section.

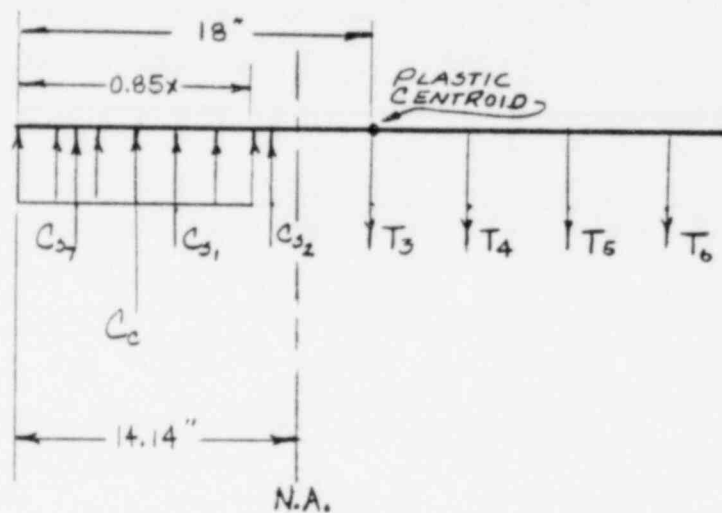

$$C_{37} = 7 \cdot 1.56 \cdot 40 = 436.8$$

$$C_{31} = 2 \cdot 1.56 \cdot 31.79 = 117.92$$

$$C_{32} = 2 \cdot 1.56 \cdot 7.04 = 21.96$$

$$T_4 = 2 \cdot 1.56 \cdot 40 = 124.8$$

$$T_5 = 2 \cdot 1.56 \cdot 40 = 124.8$$

$$T_6 = 2 \cdot 1.56 \cdot 40 = 436.8$$

Moment Capacity, by taking moment about plastic centroid.

$$\begin{aligned} \bar{C}M &= C_c \left(18 - \frac{0.85x}{2} \right) + 15(C_{37} + T_6) + 10(C_{31} + T_5) + 5(C_{32} + T_4) \\ &= 1103.7 \left(18 - \frac{0.85(14.14)}{2} \right) + 15(436.8 + 436.8) + 10(117.92 + 124.8) + 5(21.96 + 124.8) \\ &= 13231.76 + 13104 + 2427.2 + 733.8 \end{aligned}$$

$$M = 29,496.76 \text{ k-inch}$$

$$M = 2,458.1 \text{ k-ft}$$

$$\triangleright M_{col} = 483.407 \text{ k-ft}$$

NO FURTHER INVESTIGATION RECD.

∴ O.K



Franklin Research Center
A Division of The Franklin Institute
The Benjamin Franklin Parkway, Phila., Pa. 19103

Project

02G-C5257-01

Page

A-11

By RA

Date

APRIL '82

Ch'k'd

MLP

Date

4-82

Rev.

Date

Title REACTOR BLDG. - CAPACITY OF COL.

SAME COLUMN SECTION, HAS INCREASED REINFORCEMENT.
FOR 28 bars of #11 (9 bars instead of 7)

$$T = (2 \times 1.56 \times 40) + 686.4 + \frac{271.44}{x} (18-x)$$

$$= 811.2 + \frac{271.44}{x} (18-x)$$

$$C_2 = \frac{271.44}{x} (2x-21) + 436.8 + (2 \times 1.56 \times 40)$$

$$= \frac{271.44}{x} (2x-21) + 561.6$$

\therefore x remains the same

$$T = 760.39 + (2 \times 1.56 \times 40)$$

$$= 760.39 + 124.8$$

$$= 885.19$$

$$C_2 = 576.68 + 124.8$$

$$= 701.48$$

$$M = 29496.76 + 15(2 \times 124.8) = 33240.76 \text{ k.inch}$$

$$M = 2770.1 \text{ k.ft} > M_{col} = 483.407 \text{ k.ft}$$

\therefore O.K.



Title REACTOR BUILDING - EAST SIDE WALL SEC CAPACITY.

THE WALL SECTION CAPACITY IS FOUND FOR SECTION IN FLEXURE ONLY.

TAKE 1 FT WIDE WALL SECTION VERTICALLY

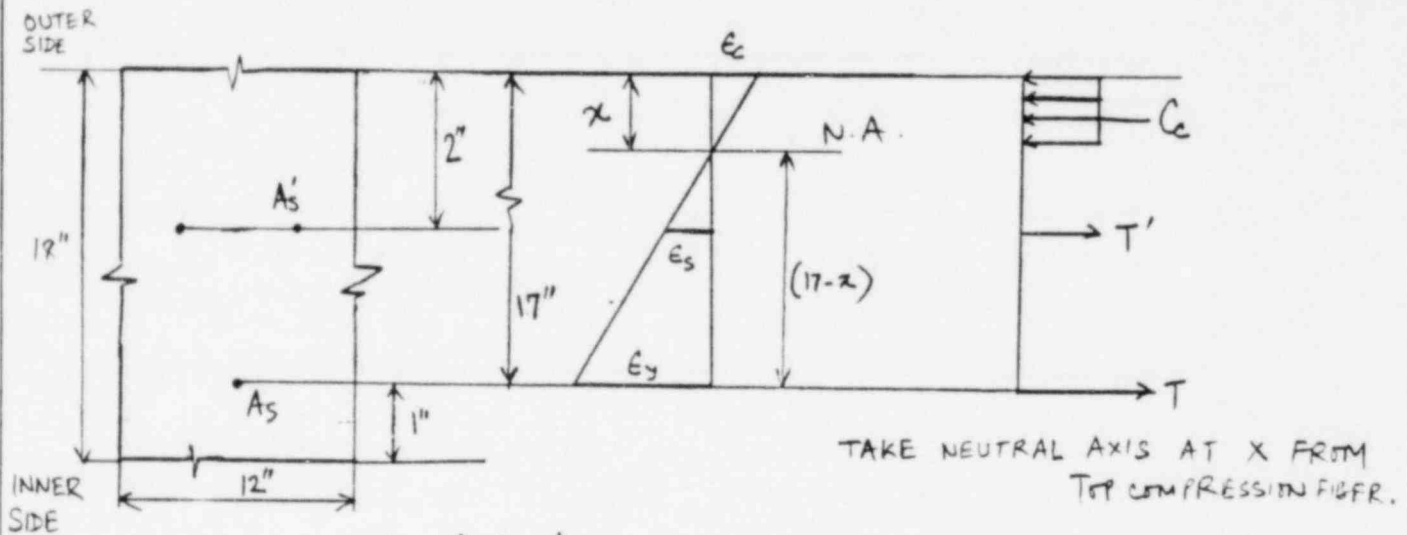

TAKE NEUTRAL AXIS AT X FROM TOP COMPRESSION FIBER.

All steel bars are #8

$$A_s' = 2 \times 0.79 = 1.58 \text{ in}^2$$

$$A_s = 0.79 \text{ in}^2$$

$f_c' = 3 \text{ ksi}$ Concrete
 $f_y = 40 \text{ ksi}$ Steel

COMPRESSION

$$C_c = 0.85 f_c' (0.85x) b$$

$$= 0.85 \times 3 \times 0.85x \times 12$$

$$\therefore C_c = 26.01x$$

TENSION

$$T = A_s f_y$$

$$= 0.79 \times 40$$

$$\therefore T = 31.6 \text{ k}$$



Title

REACTOR BUILDING - EAST SIDE WALL SEC. CAPC.

FROM THE STRAIN GEOMETRY

$$\epsilon_y = 1.37931 \times 10^{-3}$$

$$\frac{\epsilon_y}{(17-x)} = \frac{\epsilon_s}{(2-x)}$$

$$\Rightarrow \epsilon_s = \left(\frac{2-x}{17-x} \right) 1.37931 \times 10^{-3}$$

$$f_s = 29,000 \epsilon_s$$

$$\therefore f_s = 40 \frac{(2-x)}{(17-x)}$$

$$T' = A_s' f_y$$

$$= 1.58 \times 40 \frac{(2-x)}{(17-x)}$$

$$\therefore T' = 63.2 \frac{(2-x)}{(17-x)}$$

FOR EQUILIBRIUM $T' + T = C_c$

$$\therefore 31.6 + 63.2 \frac{(2-x)}{(17-x)} = 26.01x$$

$$\Rightarrow 26.01x^2 - 536.97x + 663.6 = 0$$

$$\therefore x = 1.32025''$$

$$\therefore T' = 63.2 \frac{(2-x)}{(17-x)}$$

$$T' = 2.7398 \text{ kips}$$



Title

REACTOR BUILDING - EAST SIDE WALL SEC. CAPACITY

$$\therefore C_c = 26.01x$$

$$C_c = 34.3398 \text{ kips}$$

Now the Moment Capacity

$$M = T \left(d - \frac{a}{2} \right) + T' \left(2 - \frac{a}{2} \right)$$

$$a = 0.85x$$

$$= 31.6 \left(17 - \frac{1.12222}{2} \right) + 2.7398 \left(2 - \frac{1.1222}{2} \right)$$

$$\therefore M = 523.4113 \text{ k-inch}$$

$$= 43.618 \text{ k-ft.}$$

CAPACITY OF WALL WHEN INNER FACE
IN TENSION

$$M = 43.618 \text{ k-ft} > M_w = 20.792 \text{ k-ft}$$

\therefore WALL ALSO O.K.

THUS WE FIND THAT REINFORCED CONCRETE SECTION OF REACTOR BUILDING HAS HIGHER MOMENT CAPACITY (WALLS IN VERTICAL DIRECTION & THE COLUMNS) COMPARED TO ACTUAL MOMENT DUE TO PRESSURE DROP OUTSIDE LOADING OF 216 PSF INSIDE THE BUILDING, FOR THE TORNADO CASE.



Franklin Research Center
A Division of The Franklin Institute
The Benjamin Franklin Parkway, Phila. Pa. 19103

Project 02G-C5257-01

Page A-15

By RA

Date APRIL 82

Ch'k'd MLP

Date 482

Rev.

Date

Title REACTOR BUILDING - STEEL ABOVE SERVICE FLOOR ELEV 119.5'

STEEL COLUMN ANALYSIS

[East & West Side More Critical
Higher Axial Load.]

- All columns are 14WF158 -
TO FIND THE AXIAL LOAD ON COLUMNS, TAKE WT OF STEEL INTRUSS

Dead Weight of Steel in Half Truss

Member	Length	Wt/Unit Length	Weight
JL 6x4x3/4	53' 6"	47.2	2525.2
JL 6x4x3/4	53' 6"	47.2	2525.2
JL 5x3 1/2 x 3/8	10.5' x 2	20.8	436.8
JL 5x3 1/2 x 5/16	10.5' x 2	17.4	365.4
JL 4x3x1/4	10.5' x 2	11.6	243.6
JL 5x3x7/16	13.8' x 2	22.6	623.8
JL 4x3x3/8	13.8' x 2	17.0	469.2
JL 4x3x1/4	13.8' x 2	11.6	320.2
14 WF 61	23' 3"	61.0	1418.2
6x 12 B 19	23' 3"	19.0	2650.5
6x JL 5x3 1/2 x 5/16	23' 3"	17.4	2427.3
6x JL 3 1/2 x 2 1/2 x 1/4	25.5'	4.9	749.7
3x 8 WF 17	2.5'	17	127.5

TOTAL = 14882.6 lbs.

= 14.9 kips

TO ACCOUNT FOR ROOF DECKING ALSO ADD ABOUT 5 kips
FOR AXIAL LOAD, USE 20 kips



Franklin Research Center
A Division of The Franklin Institute
The Benjamin Franklin Parkway, Phila., Pa. 19103

Project 02G-C5257-01

Page A-16

By RA

Date APRIL '82

Ch'k'd Date MLP 4-82

Rev. Date

Title REACTOR BUILDING - STEEL ABOVE SERVICE FL. ELEV. 119.5'

UNBRACED HEIGHT

Unbraced height of column $\lambda = 141'-1" - 119'-5" = 21'-8" > 12 b_f = 16.5'$

$$\frac{k\lambda}{r_y} = \frac{21'-8"}{4} = \frac{260}{4} = 65.$$

for A36 STEEL $C_c = 126.1$
 $F_y = 36 \text{ ksi}$

$$\left(\frac{k\lambda}{r/C_c}\right) = \frac{65}{126.1} = 0.515$$

$$F_a = \frac{\left[1 - \frac{1}{2}\left(\frac{k\lambda}{r/C_c}\right)^2\right] F_y}{\frac{5}{3} + \frac{3}{8}\left(\frac{k\lambda}{r/C_c}\right) - \frac{1}{8}\left(\frac{k\lambda}{r/C_c}\right)^3} = \frac{31.217}{1.843}$$

$$F_a = 16.94 \text{ ksi}$$

$$\frac{\lambda}{r} = \frac{260}{4.36} = 59.63$$

$$F_b = \left[\frac{2}{3} - \frac{F_y (\lambda/r)^2}{1530 \times 10^3}\right] F_y$$

$$F_b = 20.99 \text{ ksi}$$



Title

REACTOR BUILDING - STEEL ABOVE SERVICE FL. ELEV. 119.5'

$$\text{Axial Load} = 20 \text{ kips}$$

$$f_a = 0.43 \text{ ksi}$$

$$\frac{f_a}{F_a} = \frac{.43}{16.94} = 0.025 < 0.15$$

$$\text{Use } \frac{f_a}{F_a} + \frac{f_b}{F_b} \leq 1.0$$

$$f_b = F_b (1 - f_a/F_a)$$

$$f_b = 20.99 (1 - 0.025) = 20.46$$

$$f_b = \frac{M}{I} \cdot y$$

$$M = \frac{f_b \cdot I}{y} = \frac{(20.46)(1900)}{(15/2)} = 5184.53 \text{ k.inch}$$

$$= 432.0 \text{ k.ft}$$

$$M = \frac{wL^2}{8}$$

$$w = 8(432)/(21.667)^2 = 7.36 \text{ k/ft} = 7360 \text{ lb/ft}$$

PANEL WIDTH ON EAST & WEST SIDE = 23' 3"

$$\text{pressure } p = \frac{w}{23.25} = \frac{7360}{23.25} = 316.6 \text{ psf}$$

ASSUMPTION: THIS IS ASSUMING THAT THE SIDING DOES NOT FAIL AND CAN TRANSFER THE ABOVE LOAD TO THE COLUMNS.



Title

REACTOR BUILDING - STEEL ABOVE SERVICE FLR. ELEV 119.5'

NOW CHECK STEEL COLUMNS ON NORTH & SOUTH SIDE.

14WF158

Unbraced height = 37' 9"

$$\frac{KL}{r_{xx}} = \frac{37.75 \times 12}{6.4} = 70.78125 < C_c = 126.1$$

For $F_y = 36$ ksi

$$F_a = \frac{\left[1 - \frac{1}{2} \left(\frac{KL/r}{C_c}\right)^2\right] F_y}{\frac{5}{3} + \frac{3}{8} \left(\frac{KL/r}{C_c}\right) - \frac{1}{8} \left(\frac{KL/r}{C_c}\right)^3}$$

$$F_a = \frac{(0.84246) 36}{1.8551}$$

$$\therefore F_a = 16.349232 \text{ ksi} \quad \checkmark$$

Assume Axial load about 10 kips

$$f_a = \frac{10}{A_{gr}} = \frac{10}{46.5} = 0.2151 \text{ ksi} \quad \checkmark$$

$$\therefore \frac{f_a}{F_a} = 0.013154 < 0.15 \quad \checkmark$$

Unbraced height $l = 37.75 \text{ ft} > 12b_f = 16.5'$

$$\therefore \text{Use } F_b = \frac{12 \times 10^3 C_b}{l d / A_f} = 32.623 > 0.6 F_y$$

Take $C_b = 1.0$

$$\therefore \text{Use } F_b = 0.6 F_y = 22 \text{ ksi}$$

$$\frac{f_a}{F_a} + \frac{f_b}{F_b} \leq 1.0 \quad \text{can be used here}$$



Franklin Research Center
A Division of The Franklin Institute
The Benjamin Franklin Parkway, Phila. Pa. 19103

Project 02G - C5257 - 01

Page A-19

By RA

Date

MAY '82

Ch'k'd

Date

CB 5/5

Rev.

Date

Title REACTOR BUILDING - STEEL ABOVE SERVICE FLR. ELEV 119.5'

$$\therefore f_b = \left(1 - \frac{f_a}{F_{cr}}\right) f_b$$

$$= 0.98685 \times 22$$

$$\therefore f_b = 21.710619 \text{ ksi}$$

$$M = \frac{f_b I}{y} = \frac{21.710619 \times 19000}{(15/2)} = 5500.0234 \text{ k-inch}$$

$$\therefore M = 458.33528 \text{ k-ft}$$

$$M = \frac{wl^2}{8}$$

$$\Rightarrow w = \frac{8M}{l^2} = \frac{8 \times 458.33528}{(37.75)^2}$$

$$w = 2.5729975 \text{ k/ft}$$

This takes load laterally of 26' 9"

$$\therefore \text{pressure } p = \frac{w}{26.75}$$

$$= \frac{2572.9975}{26.75}$$

$$\therefore p = \underline{\underline{96.187 \text{ psf}}}$$



Title

REACTOR BUILDING - STEEL ABOVE SERVICE FL. ELEV 119.5'

ROOF STEEL *

Critical Member 12B19 Supports 8'11" x 23'3" area

A36 steel

Area = 5.59 in²

d = 12.16 in

I_{xx} = 130 in⁴

I_{yy} = 3.76 in⁴

r_T = 1.01 in.

r_{xx} = 4.82 in.

r_{yy} = 0.82 in.

$$\left(\frac{KL}{r}\right)_{\min.} = \frac{(23.25)(12)}{0.82} = 340.24$$

TAKE K=1

$$\frac{KL}{r_T} = \frac{(23.25)(12)}{1.01} = 276.24$$

TAKE C_b=1

$$> 119\sqrt{C_b} = 119$$

$$\text{USE } F_b = \frac{170 \times 10^3 \times C_b}{(1/r_T)^2} = \frac{170 \times 10^3}{(276.24)^2}$$

$$F_b = 2.23 \text{ ksi}$$

$$F_b = \frac{M}{I} \cdot y$$

$$M = \frac{F_b \cdot I}{y} = \frac{(2.23)(130)}{(12.16/2)} = 47.68 \text{ k-inch}$$

$$= 3.97 \text{ k-ft}$$

* ROOF STEEL CONSISTS OF MAIN TRUSSES IN EAST-WEST DIRECTION AND SUPPORTING SWAY TRUSSES IN NORTH-SOUTH DIRECTION. ROOF DECKING UK 16-16 & DECK IS WELD TO TOP CHORD OF ROOF STEEL. NOW IF ROOF DECKING DOES NOT FAIL, ALL LOAD IS TRANSFERRED TO TOP CHORD IN WHICH 12B19 IS CRITICAL MEMBER.



Title REACTOR BUILDING - STEEL ABOVE SERVICE FL. ELEV 119.5'

$$M = \frac{wL^2}{8}$$

$$W = \frac{8M}{L^2} = \frac{8(3.97)}{(23.25)^2} = .059 \text{ k/ft}$$

$$= 59 \text{ lb/ft}$$

$$\text{pressure} \frac{w}{8'11"} = \frac{59}{8.917} = 6.62 \text{ psf}$$

ASSUMPTION : THIS IS TRUE IF WE ASSUME THAT ROOF DECKING DOES NOT FAIL AND ALL LOAD IS TRANSFERRED TO 12B19

FOR ALLOWABLE PRESSURE ADD THE SELF WT OF BEAM & ROOF DECK

ASSUME WT. OF ROOF DECKING = 3 psf

SELF WT. OF BEAM = 19 lbs/ft.

CONVERT THIS TO PRESSURE = $\frac{19}{8.917}$

= 2.13084 psf

∴ TOTAL ALLOWABLE PRESSURE FOR

$$\text{UPLIFT} = 6.62 + 3 + 2.131$$

$$= \underline{11.751 \text{ psf}}$$

APPENDIX B

VENTILATION STACK DESIGN REVIEW CALCULATIONS



Franklin Research Center

A Division of The Franklin Institute

The Benjamin Franklin Parkway, Phila., Pa. 19103 (215) 447-1000



Title

CONCRETE STACK - OYSTER CREEK.

FOR THE DESIGN CALCULATIONS ACI 307-79 WAS USED. THIS USES WORKING STRESS DESIGN. FOR THE CONCRETE WE USED ALLOWABLE STRESSES ACCORDING TO CODE ACI 307-79.

FOR WIND AND DEAD LOAD STRESSE ALLOWABLES:

a) STRESS IN CONCRETE, AT OUTSIDE DIAMETER

$$f_{cw} \leq 0.25 f'_c$$

FOR STACK $f'_c = 5000 \text{ psi}$

b) STRESS IN THE VERTICAL REINFORCEMENT ON THE WINDWARD SIDE

$$f_{sw} \leq 12.5 \text{ ksi FOR } F_y = 40 \text{ ksi STEEL}$$

THE STACK IS BETWEEN ELEV -3'0" AND ELEV 391'0"

THE GRADE IS AT ELEV 23'0"

THE TOP HAS OUTER DIAMETER OF 9'6" AND HAS 6" THICK CONCRETE.

AT GRADE O.D IS 30' 3 1/8" AND AT BASE AT ELEV -3' O.D. IS 31' 8 3/4", 18" THICK CONCRETE

WE ASSUME THE OUTER SURFACE OF STACK GRADUALLY AND SMOOTHLY CHANGES



Title CONCRETE STACK - OYSTER CREEK

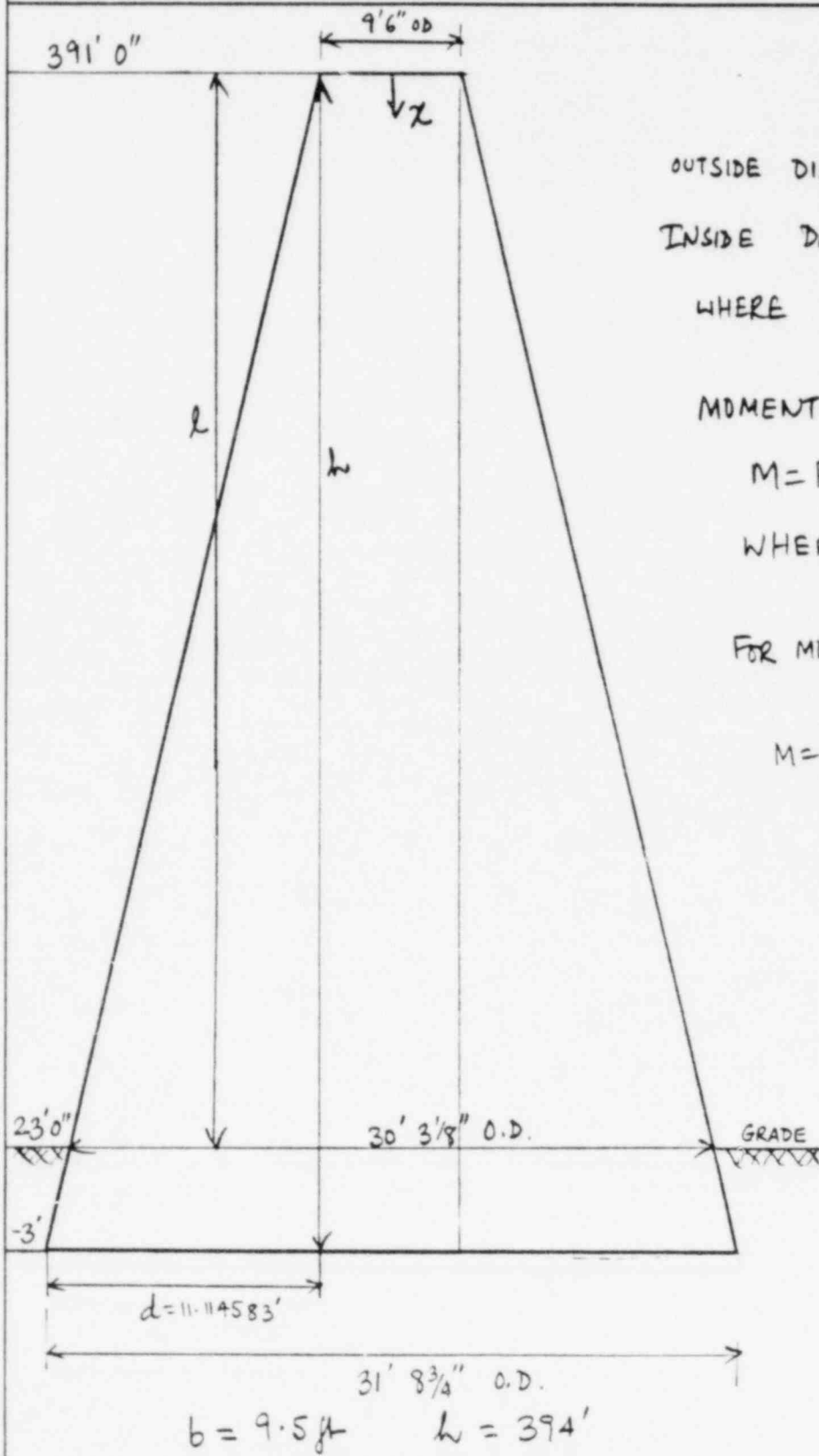

OUTSIDE DIA. $D_o = b + (2d/h)x$

INSIDE DIA. $D_I = D_o - 2T$

WHERE T = THICKNESS

MOMENT FOR ABOVE GRADE

$$M = P \left[b \frac{x^2}{2} + \frac{L}{3} \frac{dx^3}{h} \right]$$

WHERE P = DYNAMIC PRESSURE.

FOR MOMENT BELOW GRADE

$$M = P \left[bl \left(x - \frac{l}{2} \right) + \frac{dl^2}{h} \left(x - \frac{2}{3}l \right) \right]$$



Franklin Research Center
A Division of The Franklin Institute
The Benjamin Franklin Parkway, Phila., Pa. 19103

Project 02G - CS257-01

Page 8-3

By RA

Date APRIL '82

Ch'k'd B

Date 5/5

Rev. Date

Title CONCRETE STACK - OYSTER CREEK

DISTANCE FROM TOP IN FT.	THICKNESS OF SECTION INCHES	DIAMETERS IN FT.		STEEL AREA IN ²	MOMENT CAPACITY K-FT.	α	EQUIVALENT PRESSURE lb/ft ²
		OUTER	INNER				
112.7344	6.00	15.8604	14.8604	40.2	4602.2	62.0°	62.33 ✓
142.7969	7.00	17.5565	16.3898	35.48	5804.21	61.25°	46.72
172.8594	8.00	19.2526	17.9193	32.12	7508.277	61.25°	39.413
202.922	9.00	20.9487	19.4487	30.10	9836.6708	61.75°	35.88
233.0	10.00	22.6448	20.9781	28.52	12853.374	62.5°	34.12 ✓
278.1	12.00	25.1889	23.1889	29.45	19503.219	63.5°	34.25 ✓
315.6563	13.00	27.3091	25.1424	55.12	29028.458	66.0°	37.74 ✓
323.1719	19.00	27.7331	24.5664	63.6	32135.550	60.7°	39.51
353.1719	20.00	29.4257	26.0923	66.0	42717.943	63.25°	42.44
338.1719 ^(A)	25.00	28.5794	24.4127	79.0	104983.98	88°	115.77
386.50 ^(B)	18.00	31.3060	28.3060	73.2	105371.54	95.75°	84.484

α & β ARE DEFINED IN ACI 307-79 CODE

(A) THIS SECTION HAS THREE OPENINGS WHICH ARE EQUIVALENT TO OPENING ANGLE $\beta = 49.812^\circ$. THE THREE OPENINGS WERE SUMMED UP TO BE ASSUMED EQUIVALENT TO ONE OPENING.

(B) THIS SECTION IS BELOW GRADE. HAS TWO OPENINGS WHICH ARE EQUIVALENT TO $\beta = 42.0995^\circ$. TWO OPENINGS SUMMED-UP AND ASSUMED EQUIVALENT TO ONE OPENING. IN THIS SECTION ONLY CONCRETE REACHES ALLOWABLE FIRST.

IN ALL OTHER SECTIONS REINFORCING STEEL REACHES ALLOWABLE STRESS BEFORE CONCRETE.



Title

CONCRETE STACK - OYSTER CREEK.

FOR A SECTION 233' BELOW FROM THE TOP, FOR

- 1) ANGLE $\alpha = 62.5^\circ$ WITH STEEL REACHING ALLOWABLE STRESS OF 12.5 ksi BEFORE CONCRETE ALLOWABLE 1.25 ksi

MOMENT CAPACITY $M = 12853.374 \text{ K-ft}$.

THIS WHEN CONVERTED BACK PRESSURE $P = 34.12 \text{ psf}$.

- 2) BUT IF WE INCREASE ALLOWABLE STRESSES TO:

IN REINFORCEMENT (USE YIELD STRESS $f_{sw} = f_y = 40 \text{ ksi}$)

IN CONCRETE USE $0.85 f_c'$ AS ALLOWABLE

THEN ALSO STEEL REACHES YIELD FIRST FOR $\alpha = 47.5^\circ$

MOMENT CAPACITY $M = 19342.361 \text{ K-ft}$

EQUIVALENT PRESSURE = 51.34 psf .

FOR SECTION 278.1' BELOW FROM THE TOP FOR

- 1) ANGLE $\alpha = 63.5^\circ$ WITH STEEL REACHING ALLOWABLE OF 12.5 ksi BEFORE CONCRETE ALLOWABLE 1.25 ksi

MOMENT CAPACITY $M = 19503.219 \text{ K-ft}$

EQUIVALENT PRESSURE = 34.25 psf

- 2) ALLOWABLE IN REINFORCEMENT $f_{sw} = f_y = 40 \text{ ksi}$ AND IN CONCRETE ALLOWABLE = $0.85 f_c'$ $\alpha = 47.375^\circ$

MOMENT CAPACITY $M = 27328.402 \text{ K-ft}$

EQUIVALENT PRESSURE = 47.986 psf



Title CONCRETE STACK FOUNDATION - OYSTER CREEK

CONCRETE STACK FOUNDATION IS A OCTOGNAL SHAPED 7 FT. THICK REINFORCED CONCRETE SECTION

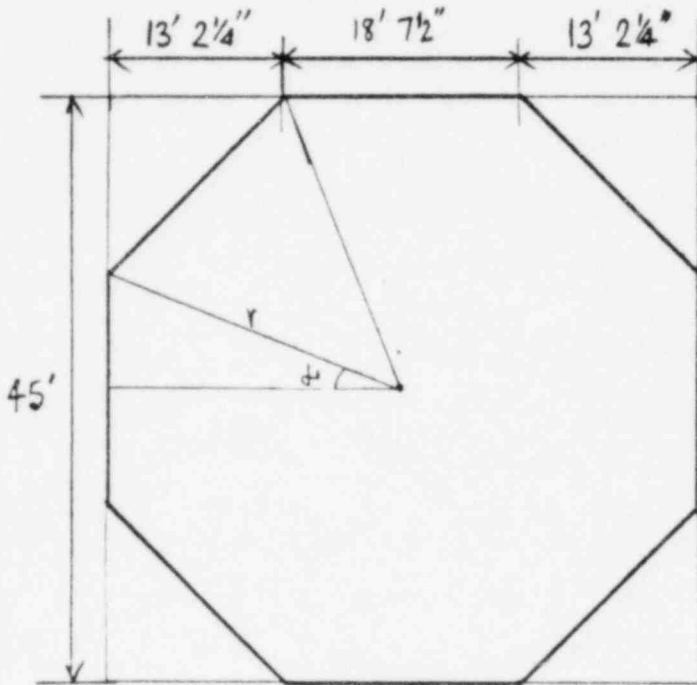

Number of Sides $n=8$

AREA $A = \frac{a^2 n}{4 \tan \alpha}$

$a = 18.625'$
 $\alpha = 22.5^\circ$

$\therefore A = \frac{(18.625)^2 \cdot 8}{4 \tan 22.5}$

$A = 1674.9361 \text{ ft}^2 \checkmark$

INERTIA ABOUT ANY AXIS

$I = \frac{A}{24} (6r_1^2 - a^2)$

$r_1 = \frac{a}{2 \sin \alpha} = \frac{18.625}{2 \sin 22.5}$

$\therefore r_1 = 24.3347 \checkmark$

$r = 24.354 \text{ ft.}$

$I = \frac{1674.9361}{24} (6 \times (24.3347)^2 - (18.625)^2)$

$\therefore I = 223756.49 \text{ ft}^4 \checkmark$

DEAD WT OF FOUNDATION = $0.15 \times 1674.9361 \times 7.0$
 $= 1758.6829 \text{ kips}$



Title

CONCRETE STACK FOUNDATION - OYSTER CREEK.

$$\text{TOTAL WT. OF CHIMNEY} = 3578.6345 \text{ kips}$$

$$\therefore \text{TOTAL DEAD WT } W = 3578.6345 + 1758.6829$$

$$W = 5337.3175 \text{ kips.}$$

$$\text{USE } \sigma = \frac{P}{A} + \frac{M}{I} \cdot y$$

$$y = r = 24.354 \text{ ft}$$

FOR σ USE SOIL BEARING CAPACITY

OF 13 KSF AS GIVEN ON DNG. # 4049-7

$$\therefore 13 = \frac{5337.3175}{1674.9361} + \frac{M(24.354)}{223756.49}$$

$$\therefore M = 90163.106 \text{ k-ft.}$$

CONVERT THIS TO PRESSURE p BY FORMULA

$$M = p \left[bl \left(x - \frac{l}{2} \right) + \frac{dl^2}{6} \left(x - \frac{2l}{3} \right) \right]$$

$$l = 368 \text{ ft}$$

$$x = 404 \text{ ft}$$

$$b = 9.5 \text{ ft}$$

$$d = 11.114583 \text{ ft}$$

$$h = 394 \text{ ft}$$

$$90163.106 = p \left[(9.5) 368 \left(404 - \frac{368}{2} \right) + \frac{11.114583^2 (368)^2}{394} \left(404 - \frac{368 \times 2}{3} \right) \right]$$

$$= p (1375267.5)$$

$$\therefore p = 0.0655604 \text{ ksi}$$

$$\therefore P = 65.561 \text{ psf}$$

FOR 0.7 SHAPE FACTOR THIS IS EQUIVALENT TO 191.33 psf