



**Weiler**<sup>®</sup>  
Solutions Resource Guide

▶ Providing Surface Conditioning Solutions To Countless Industries Worldwide

# Providing Solutions Worldwide



Weiler Corporation,  
Cresco, PA U.S.A

Weiler facility in  
Suzhou, China

*The Weiler tradition of quality and commitment to excellence dates back to 1898 when my great-grandfather began manufacturing brushes for the jewelry industry in Pforzheim, Germany. This tradition has fostered a continued commitment to superior quality and service, teamwork, innovation and continuous improvement, enabling Weiler Corporation to become a leading global manufacturer of surface conditioning solutions.*

*At Weiler Corporation, we believe that our ability to develop and manufacture compelling product and service solutions is critical for continued success. We make it a priority to work closely with our end-user customers, observe their processes and understand their challenges so we can develop improved tools to solve their most difficult deburring, cleaning or surface finishing problems.*

*This Solutions Resource Guide not only has information on our products, but also on how to safely and effectively apply our solutions. All Weiler co-workers are committed to providing our end user-customers with the most cost-effective solution for their specific application needs. We support this commitment with an experienced and responsive Sales, Customer Service and Application Engineering team, and a 100% satisfaction guarantee.*

*Contact Customer Service at (800) 835-9999 or Application Engineering at (888) 299-APPS (2777) for assistance in selecting the right product for your application. You can also visit us on-line at [www.weilercorp.com](http://www.weilercorp.com) where you will find additional product and technical information, case studies, downloadable literature and newly added products. All of us at Weiler, along with our network of distributor-partners, stand ready to provide you with world-class service and value-added solutions that will help you remain competitive in a global market.*



Sincerely,

Chris Weiler, President/C.E.O.

# For Countless Industries In Over 50 Countries

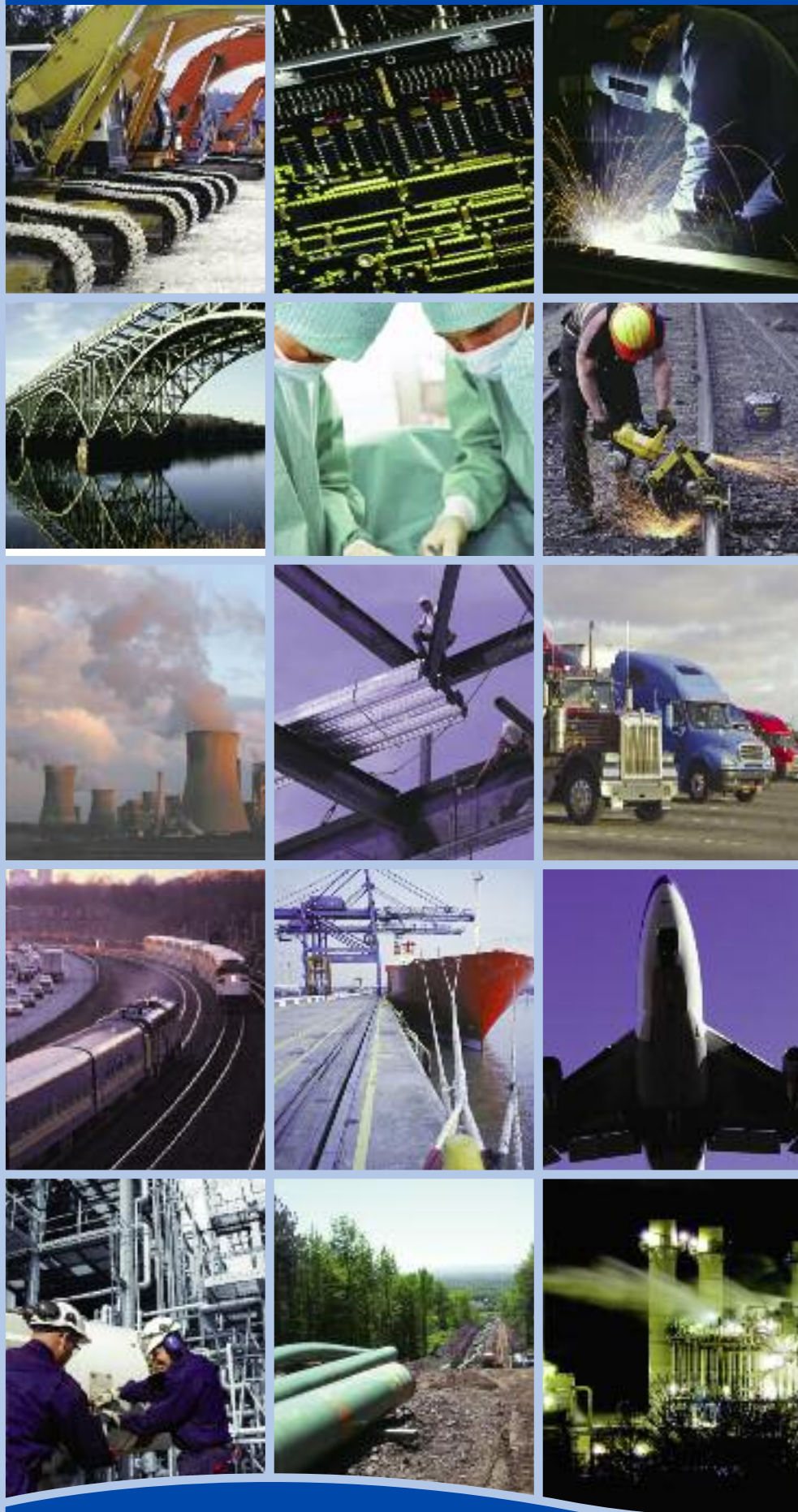

Weiler is committed to manufacturing high quality surface conditioning products, including Power Brushes, Nylox® Nylon Abrasive Filament Brushes, Abrasives and Maintenance Products for a wide variety of applications in industries, such as:

- Electronics
- Railway
- Steel
- Aircraft
- Construction
- Painting
- Food Processing
- Pipeline
- Transportation
- Heavy Equipment
- Welding
- Pharmaceutical
- Nuclear
- Trucking
- Ship Building
- Petroleum
- Farming
- Automotive
- Biomedical
- Aerospace
- Building Products
- Recreational Vehicles
- Agricultural Equipment
- Machining
- Fabricating

# Table of Contents

New Products .....	4
Our Commitment to the Environment .....	5
General Information .....	6
Safety Information .....	7
Application Assistance .....	8-9
<b>Power Brushes .....</b>	<b>10-65</b>
Solutions Showcase .....	13-14
Technical Information .....	15-21
Knot Wire Wheels .....	22-28
Weld Cleaning Brushes .....	27-28
Crimped Wire Wheels .....	29-36
Small Diameter Wire Wheels .....	33-34
Nylon & Tampico Wheels .....	37
Cup Brushes .....	38-40
Brushes for Small Angle Grinders .....	41-44
End Brushes .....	45-48
Crosshole Deburring Brushes .....	49
Power & Hand Tube Brushes .....	50-54
Miniature Brushes .....	55-56
Non-Sparking Brushes .....	57-58
Strip Brushes .....	59-62
Wide Face Brushes .....	63-65
<b>Nylox® Nylon Abrasive Filament Brushes .....</b>	<b>66-93</b>
Solutions Showcase .....	69-70
Technical Information .....	71-76
Engineered Products & Solutions .....	77
Wheel Brushes .....	78-83
Crosshole Deburring Brushes .....	84
Disc Brushes .....	85-87
Cup Brushes .....	87
End Brushes .....	88
Tube Brushes .....	89
Adapters & Drive Arbors .....	90-91
FME Area Product Solutions .....	92-93
<b>Tiger® Abrasives .....</b>	<b>94-133</b>
Solutions Showcase .....	97-98
<b>Coated Abrasives .....</b>	<b>99-120</b>
Technical Information .....	99-101
Abrasive Flap Discs .....	102-111
Resin Fiber Discs .....	112
AL-tra CUT™ Discs .....	113
Blending Discs .....	114
Trim-Kut® Discs .....	115
Flap Wheels .....	116-117
Belts .....	118-120
Shop Rolls .....	120
<b>Bonded Abrasives .....</b>	<b>121-127</b>
Technical Information .....	121-123
Cutting Wheels .....	124-125, 127
Grinding Wheels .....	126
<b>Non-Woven Abrasives .....</b>	<b>128-133</b>
Technical Information .....	128
Unitized Wheels .....	128
Convolute Wheels .....	129
Surface Conditioning Discs .....	130-131
Hand Pads .....	132
Flap Wheels .....	133

<b>Maintenance Products .....</b>	<b>134-173</b>
Technical Information .....	137-138, 165
Green Works™ Maintenance Products .....	139-140
Pro-Flex™ Sweeps .....	141
Specialty Floor Brushes .....	142
Floor Brushes .....	143-144
Garage Brushes .....	145
Street and Wire Brooms .....	146
Handles, Braces & Tips .....	147-148
Upright & Whisk Brooms .....	149
Dusters & Dust Pans .....	150
Squeegees & Window Brushes .....	151
Vehicle Care Products .....	152
Scrub & Utility Brushes .....	153-155
Mops & Accessories .....	156-157
Masonry & Applicator Brushes .....	158-159
Scratch Brushes .....	160-162
Flue Brushes .....	163
Tube Fitting Brushes .....	164
Professional Paint, Varnish & Sash Brushes .....	166
Professional Sash & Parts Cleaning Brushes .....	167
Industrial Paint Brushes .....	168
Chip & Oil Brushes .....	169
Marking Brushes .....	170
Glue & Acid Brushes .....	171
Paint Rollers & Accessories .....	172-173
<b>Display Packaged Product .....</b>	<b>174-176</b>
<b>Alphabetical Product Index .....</b>	<b>177-178</b>
<b>Item No. Index .....</b>	<b>179-186</b>

## How To Order

Weiler has an extensive network of local distributors throughout the country to assist you with product recommendations and support. To place an order or locate a distributor in your area, contact our Customer Service Team at 800-835-9999. For custom products, our Application Engineering Department will work with you to design and manufacture the best product **and** recommend the best process for your specific requirements. Call 888-299-APPS (2777).

You can also check out our website which features a Distributor Locator! Visit us at: [www.weilercorp.com](http://www.weilercorp.com) for the distributor in your area; electronic catalog; available literature, videos, technical papers; MSDS sheets; new product information; product cross reference and more!



[www.weilercorp.com](http://www.weilercorp.com)



[info@weilercorp.com](mailto:info@weilercorp.com)

## Power Brushes

### Roughneck® 76 Knot Wheel - See page 27

Our Roughneck 76 knot wheel cleans welds over 50% faster than competitor's. Roughneck's trimmed knot ends are more aggressive than untrimmed 76 knot wheel brushes and also feature 25% more wire per tuft. Our rigid side plate construction provides superior side load resistance to prevent premature wire breakage and stops knot movement for better balance and less vibration. When Performance Counts, Count on Weiler! Made in the U.S.A.

### Roughneck® Jr. 4-1/2" Stringer Bead Wheels - See page 27

A line of weld cleaning brushes designed specifically for the most popular size of small angle grinder. These new wheels feature a high knot count and short trim length to deliver the greatest cleaning action and longest life on this tool.

### Dually® Weld Cleaning Brushes - See page 28

Featuring a unique dual-hex nut which simplifies periodic flipping of the brush and maintains full use of the tool guard, these "Flip 'N Fast" wheels are the most cost-effective cleaning tools for multi-pass welding applications.

### High Filament Retention (HFR™) Brushes - See page 28

Featuring a patent-pending film coating which minimizes wire loss when used within the usage guidelines established by the Electrical Power Research Institute, the Weiler HFR stringer bead wheel is the first choice for hot-pass weld cleaning within Foreign Material Exclusion areas of nuclear power plants.

## Nylox® Nylon Abrasive Filament Brushes

### Expanded Burr-Rx® Product Offering - See pages 78-80

With the addition of power tube brushes, small diameter wheels and Bore-Rx™ internal brushing tools, Weiler now offers a comprehensive line of specialty nylon abrasive filament deburring tools featuring advanced ceramic grain technology.

### FME Solutions Program - See pages 92-93

Developed for cleaning and surface preparation within Foreign Material Exclusion areas of nuclear power plants, this tooling system features a full range of products manufactured with our Black Nylox ceramic grain filament to provide an alternative to wire brushes for routine maintenance and repair activities.

## Abrasives

### Tiger Paw Abrasive Flap Discs - See pages 107-108

Tiger Paws are designed for aggressive performance on tough edge grinding applications. These 100% zirconia alumina flap discs last 30-40% longer than competitive standard zirconia alumina flap discs due to both a high performance grain and special poly cotton backing that provides superior grain retention. This unique combination gets the job done faster and more efficiently.

## Maintenance

### Green Works™ Product Line - See pages 139-140

Environmentally-friendly maintenance products made from recycled or sustainable materials.

### Pro-Flex™ Sweeps - See page 141

Features a virtually unbreakable connector; fast, 1 minute assembly with no tools; comfort grip handle; and is packaged ready to display.



# Our Commitment To The Environment

## Our Logo May Be Red, White & Blue, but Weiler is Committed To Going GREEN!

Weiler Corporation is dedicated to sustainable business development. We recognize the importance of protecting the environment through the use of recyclable materials, elimination of waste, and the efficient use of resources. We encourage the combined efforts of protection, conservation and recycling to safeguard our natural resources.

As part of our commitment to a sustainable future, Weiler has implemented a variety of programs and initiatives.



### Heat Reclamation

Our air compressor rooms have reclamation systems for processing waste heat, which is used to help heat our buildings in the winter.

### Reducing Energy Use

Throughout much of our facility, we have replaced existing lighting with high efficiency fluorescent lighting and motion sensors. In 2008, Weiler utilized a green design for the construction of a 21,000 sq. ft. office building addition which included a demand control ventilation system, energy star appliances, highly efficient motors in the mechanical HVAC equipment and exterior lighting fixtures controlled by a time clock or photocell.

### Environment

Our co-workers are committed to our pledge to protect the environment. The Weiler team has been participating in the Adopt-a-Highway and Keep America Beautiful programs since 1991. A large portion of our 100 acres is a preserved natural habitat for plants and wildlife. Environmental landscaping features a man-made pond with re-oxygenating fountain, footbridge, waterfall, walking paths, and plants. Algae and weeds in our pond are controlled using aeration and grass carp, no chemicals. In the winter, we use organic antifiskid material and only minimum ice melt. We have also upgraded our outside lighting to meet Dark Skies Lighting requirements (visual pollution).



### Water Conservation

We utilize pressure-assist, low consumption toilets and water restrictors, and automatic sensor controls on faucets.

Printed on Recycled Paper



### Recycling

Weiler has been recycling since the early eighties. We currently recycle cardboard, paper, plastics, aluminum cans, oils, wood pallets, and all metals (including process scrap). Cardboard boxes and metal barrels are returned to our suppliers for reuse until they are no longer acceptable, then they are recycled. Fiber drums are recycled for reuse through our supplier.

### Paper Products

Weiler purchases paper products made from recycled materials. Our printers are set to print double-sided to save paper. And we installed air-wave hand dryers that uses up to 80% less energy than conventional hot air hand dryers. In addition, much of our literature is available on our website for download. This *Solutions Resource Guide* is printed on recycled stock.



One of our most recent green initiatives was the introduction of our new Green Works™ line of environmentally-friendly maintenance products made from recycled or sustainable raw materials. For instance, the fill material is made from recycled plastic bottles, and the handles are made from bamboo – an abundant and fast growing substitute for wood. See pages 139-140 to learn more about our entire line of eco-friendly products.

Weiler Corporation invites you to join us in building a better future and finding ways to "Go Green".

# General Information

## How To Use This Catalog

Our goal is to make it as easy as possible to do business with Weiler. We have done our best in providing valuable technical information, product specifications and application solutions in the most "user-friendly" manner possible.

This Resource Guide is divided into four main sections represented by a different color for easy indexing:

**Power Brushes - Blue**

**Nylox® Nylon Abrasive Filament Brushes - Purple**

**Abrasives - Red**

**Maintenance Products - Green**

Application Solutions are featured throughout this Resource Guide to provide examples of the types of deburring, finishing, cleaning and other surface conditioning challenges that our products can solve.

**Blue Charts** - Indicates Weiler Industrial Grade product. Engineered for superior performance in high production areas.

**Red Charts** - Indicates Vortec Pro Professional Grade product. Engineered for cost-effective use in less demanding environments.

Table Example:

Product Group name and description.

The tool icon indicates the most commonly used tools for the products within the table. (See icon reference guide below.)

### Standard Twist Wheels - Non-Sparking Bronze Wire

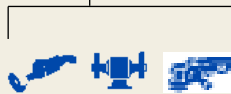

Dia.	Wire Size	Arbor Hole	No. of Knots	Face Width	Trim Length	Max. AH Avail.	Thickness at Face Plates	Max. RPM	Standard Pack	Item Number
3"	.020	1/2"- 3/8"	20	3/8"	5/8"	1/2"	7/16"	25,000	10	08271

The Item No. (or EDP number) is the number used when placing your order.

### Vortec Pro® Knot Wire Wheel Brushes - Standard Twist - Heavy-duty brushing action.



Dia.	Wire Size	Wire Type	Arbor Hole	Face Width	Max. RPM	Display Pack Item No.	Boxed Qty. Item No.
3"	.014" Fine	Carbon	1/2"-3/8"	Wide	25,000	-	36290

## Tool Icons

These icons illustrate some of the common power tools that can be used to drive Weiler brushes and abrasives. Many products within this Resource Guide can also be used on other types of tools and machines, including automated equipment.

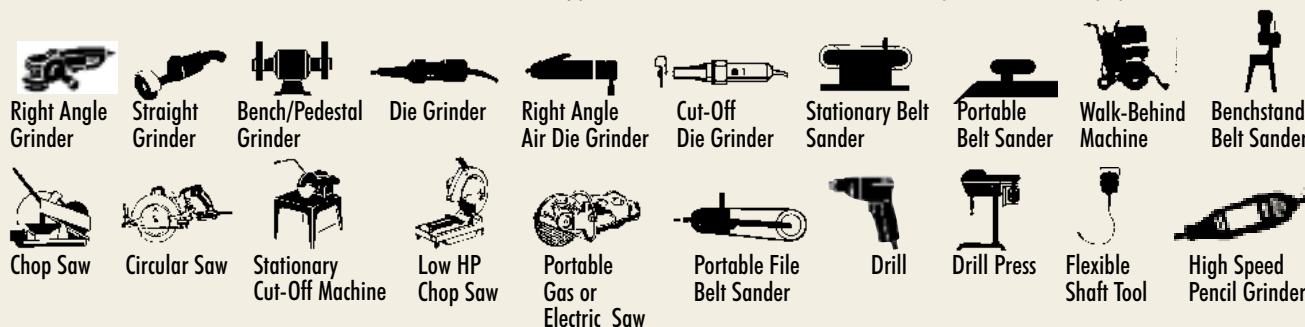

## Weiler's Satisfaction Guarantee

Weiler Corporation hereby warrants that its Power Brush, Nylox®, Abrasive and Maintenance products shall be free from defects in material and workmanship under normal use and service, for a period of one year from the date of purchase. In the event the customer reasonably becomes dissatisfied with the performance of any of Weiler's products, Weiler will repair or replace the product at no cost to the customer. This repair or replacement is contingent upon prompt written notice and compliance by the customer with instructions given by Weiler regarding the return of the product for evaluation.

This warranty is expressly in lieu of all other warranties, expressed or implied, including the warranties of merchantability and fitness for a particular purpose. Correction in the manner provided hereinabove shall be the extent of Weiler's liability, and no other entity is authorized to extend that liability.

# Safety Information

**All of Weiler's products are made to the strictest quality standards and specifications and are designed to provide superior work performance and safe operation when used properly.**



**Warning:** Failure to observe safety precautions may result in injury.

Many manufacturers mark some safety warnings, recommendations and usage restrictions directly on the product. However, it is not always practical to include even the most limited safety information on the product itself. Therefore, the operator **MUST READ** and **FOLLOW** all instructions supplied in or on the product container as well as those marked on the product. The operator should also refer to the safety and operating information printed in this catalog and other literature.



## Safety Standards - Established by the American National Standards Institute:

Weiler power brushes and abrasives conform to the ANSI standards listed below. All operators of power brushes and abrasives must comply with these safety standards.

- ANSI B165.1 "Safety Requirements - Power Brushes"
- ANSI B7.1 "Safety Requirements - For the Use, Care and Protection of Abrasive Wheels".

## Safety Goggles

Safety goggles or full face shields worn over safety glasses with side shields **MUST BE WORN BY ALL OPERATORS AND OTHERS IN THE AREA OF BRUSH AND ABRASIVE OPERATIONS.** Comply with the requirements of ANSI Z87.1 "Occupational Eye and Face Protection".



## Protective Clothing

Appropriate protective clothing must be used where there is a possibility of injury that can be prevented by such clothing.



## Hearing Protection

Use of these products may create elevated sound levels. Hearing protection must be worn where required.



## Safety Gloves

Grinding applications are conducted in harsh environments. The use of safety gloves is recommended.



## Respiratory Protection

Wear respiratory protection against dust and fumes (see ANSI Z88.2).



## Speeds

Observe all speed restrictions indicated on brushes, abrasives, containers, labels, or printed in pertinent literature. MSFS means Maximum Safe Free Speed (RPM) - spinning free with no work applied. For reasons of safety, MSFS or Maximum RPM should not be exceeded under any circumstances.



## Tool Guards

Guards must be kept in place at all times when product is running.

## Tool/Work Rest

On bench grinders, tool/work rests should be used to support the work-piece during use. It should have a maximum opening of 1/8" to the product face. Only adjust the rest when the product is not in motion.

## Availability of ANSI Standards

Based on the collective experience of the American Brush Manufacturers Association Industrial Division members (ANSI B165.1) and the United Abrasives Manufacturers Association's Bonded Division (ANSI B7.1) both ANSI Standards are referenced and provided solely as a public service for the guidance of the users of the members' products. All Brush and Abrasive recommendations are not necessarily complete with respect to any particular application and common sense safety considerations should generally be followed. Any applicable federal, state, local law or regulation must be strictly adhered to and is controlling over any recommendation contained herein.



## Before Starting Product:

Use eye protection and safety equipment. Inspect product for rust, damage, etc. If the RPM marked on the power tool is higher than the RPM marked on the product, do not mount the product onto the tool.

## And Don't Forget:

Inspect and jog the machine to ensure that the product is mounted properly and securely, machine guards are in place, no vibration, etc. Run machine at operating speed for at least one minute before applying work. Do not stand in front of or in line with product.



# Need a Solution?

## Product Selection Guide: By Surface Finish

Weiler offers a wide range of brushes and abrasives for cleaning, deburring and finishing. The chart below will help you determine the most effective brush or abrasive product type based on surface finish and degree of aggression required for your application. As indicated, Coated and Bonded Abrasives will remove base material. Wire Brushes, Nylox® Brushes and Non-Woven Abrasives will not typically remove base material and are used for jobs requiring surface refinement.

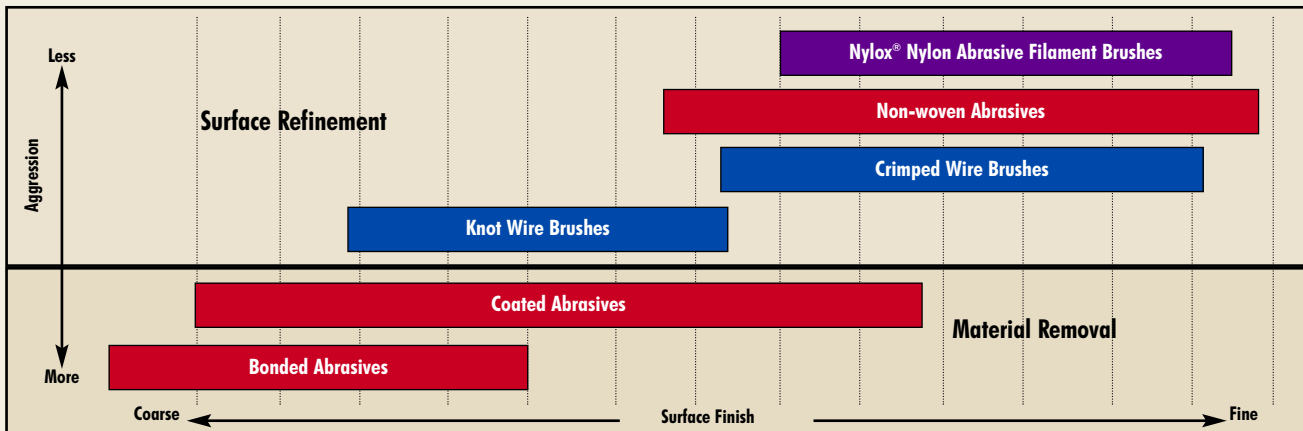

**Note:** If you need assistance in choosing the correct product for your specific application, contact our Application Engineering Team at 888-299-APPS (2777).

## Application Engineering Solutions

Weiler Corporation is *the* source for surface conditioning solutions. Our goal is to provide solutions that will help you lower costs by increasing productivity. By combining our broad product offering with the support of our Application Engineering Team, you can count on Weiler to provide solutions to your specific application.

### Have An Application Problem?

#### Option 1 - Application Hotline:

Call our Application Engineering Hotline at 888-299-APPS (2777) with all your deburring, cleaning and finishing challenges. If your question cannot be answered on the phone...

#### Option 2 - In-House Part Evaluation:

Send your component parts to our in-house lab for evaluation and product recommendation. This enables Weiler to evaluate and process parts in a controlled environment without interrupting your production schedule. We will address issues such as cycle time, finish required and product life, providing the most cost-effective solution. Weiler's in-house lab is also equipped with a Hurco VSX-40 vertical machining center, giving us the capability to perform technical viability analysis on your parts. The availability of the Hurco permits recommendations concerning speeds, feeds and tool paths to be extremely precise. This virtually eliminates technical uncertainty for customers interested in implementing in-machine deburring.

#### Option 3 - On-Site Evaluation:

If it is determined that an on-site visit is required, a Weiler Application Engineer will visit your facility to review the current production process. Weiler will determine the best product and process to meet your specific application requirements.

**Turn to Weiler for assistance with product selection and application solutions.**



Visit [www.weilercorp.com](http://www.weilercorp.com) to view our Solutions Showcase, featuring real-life case studies.

Need A Solution?

# Need a Solution?

## Application Engineering Assistance Form

If you are having an application problem, complete the following form and fax or mail it to Weiler's Application Engineering Department. This form is also available on Weiler's website at [www.weilercorp.com](http://www.weilercorp.com). E-mail the form to [info@weilercorp.com](mailto:info@weilercorp.com) or see below for return information.

Date: \_\_\_\_\_

Company Name: \_\_\_\_\_

Address: \_\_\_\_\_

Phone: ( \_\_\_\_\_ ) \_\_\_\_\_ Fax: ( \_\_\_\_\_ ) \_\_\_\_\_

Your Name: \_\_\_\_\_ Title: \_\_\_\_\_

E-mail: \_\_\_\_\_

Part Name: \_\_\_\_\_

Material: \_\_\_\_\_ Annual Production: \_\_\_\_\_

Describe Application: *(Surface Finishing/Deburring/Edge Blending/Roughening/Cleaning)*

Application Status: \_\_\_\_\_ Existing \_\_\_\_\_ New

If Existing: A: Describe Current Process: \_\_\_\_\_

B: Reason for Changing Process: \_\_\_\_\_

Desired Cycle Time: \_\_\_\_\_

Equipment To Be Used: *(Grinder, Lathe, Custom Designed, etc.)*

\_\_\_\_\_ Off-hand \_\_\_\_\_ Semi-Automatic \_\_\_\_\_ Fully Automatic

Equipment RPM: \_\_\_\_\_ Variable? \_\_\_ Yes \_\_\_ No Range: \_\_\_\_\_

Will Coolant be used? \_\_\_ Yes \_\_\_ No

Additional Specifications: \_\_\_\_\_

Fax: 800-635-3615, call toll-free: 888-299-APPS (2777) or e-mail us at: [info@weilercorp.com](mailto:info@weilercorp.com)

Weiler Corporation  
One Weiler Drive  
Cresco, PA 18326-0149  
Attn: Application Engineering Department

# Power Brushes

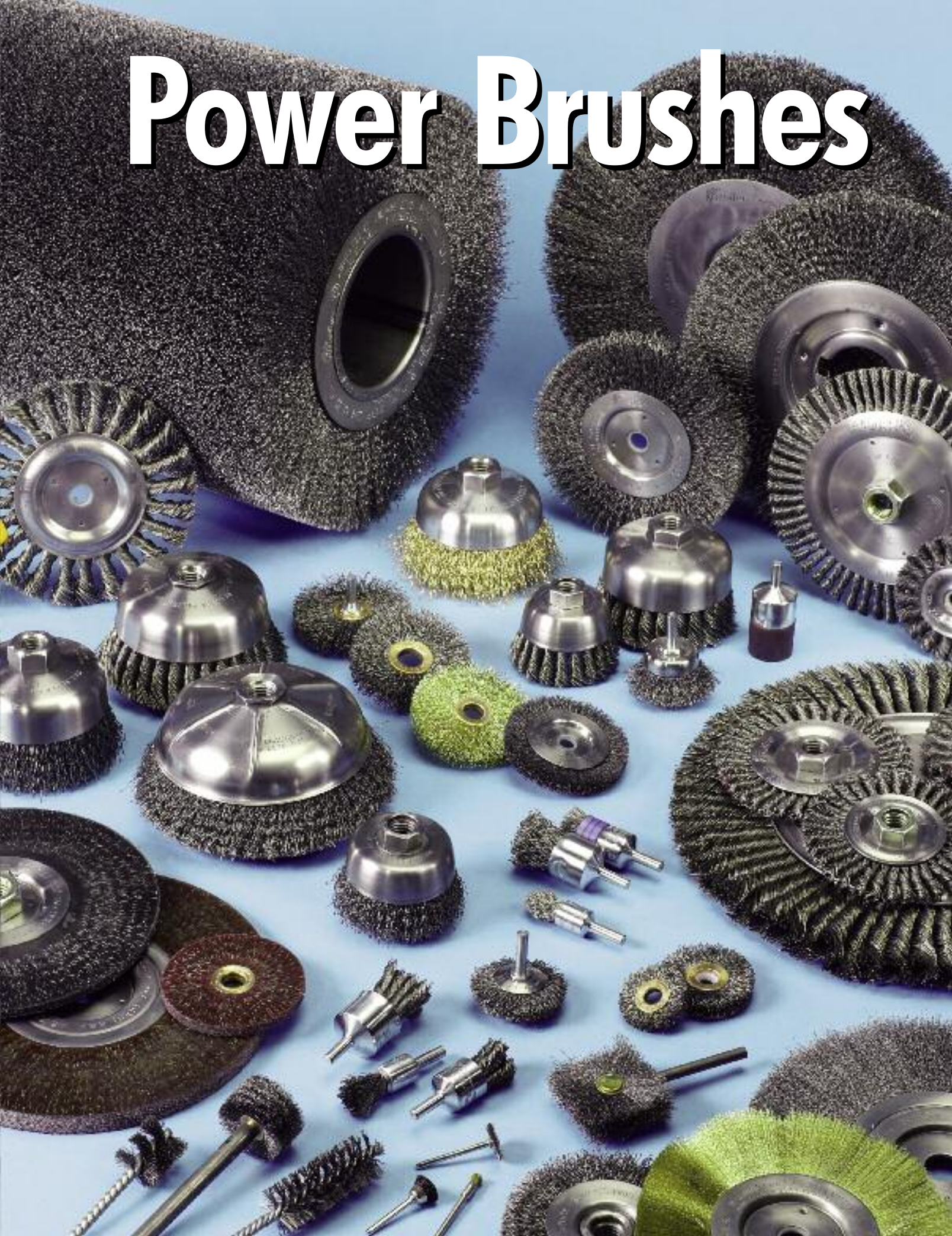



# Weiler® Power Brushes

Power Brushes

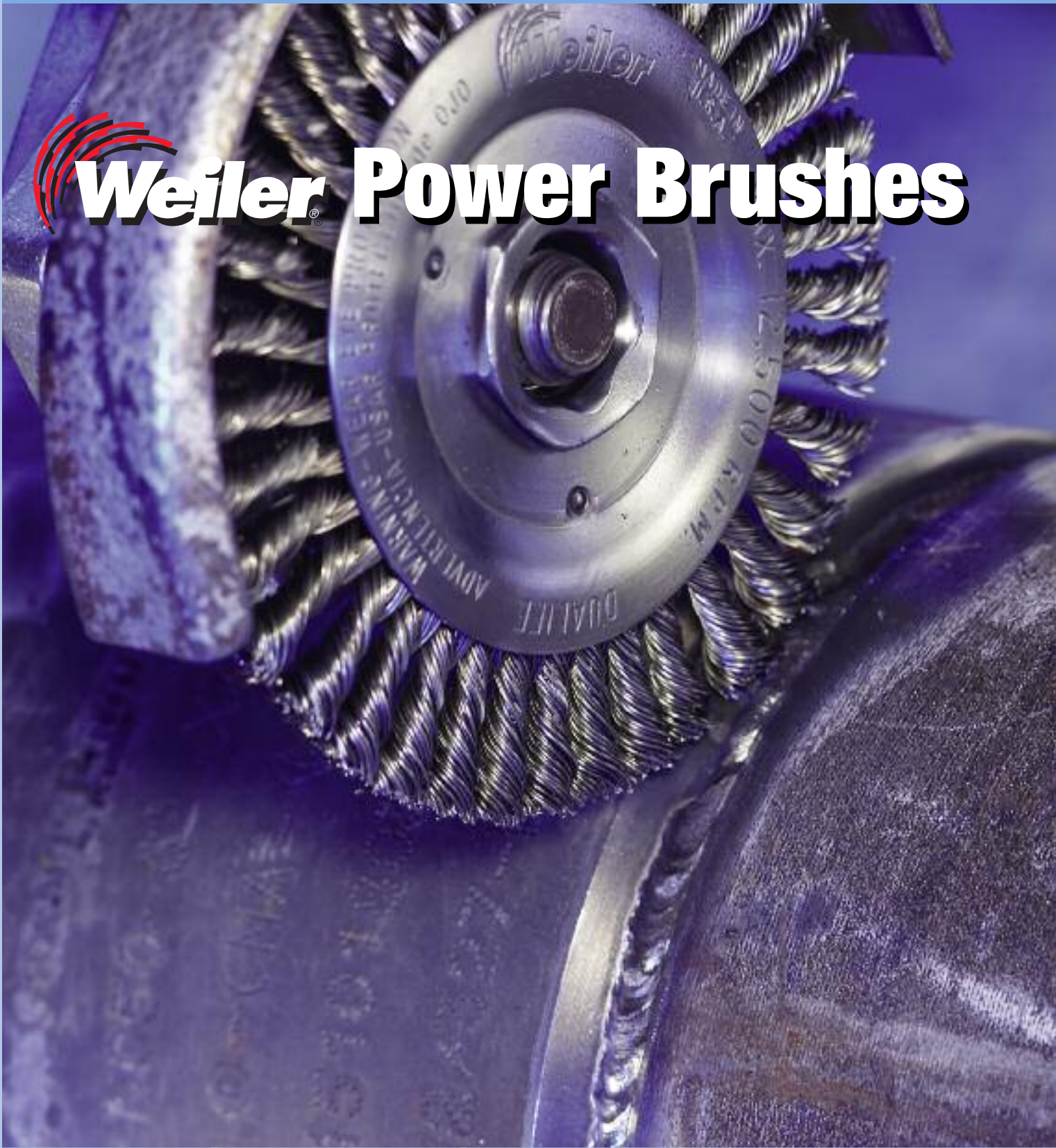



- Knot Wire Wheels

**New!**

- Weld Cleaning Brushes

*Dually® Line of Flip 'N Fast Wheels!*

- Crimped Wire Wheels

- Nylon and Tampico Wheels

- Cup Brushes

**New!**

- Small Angle Grinder Brushes

*Roughneck® Jr. 4-1/2" Stringer Bead  
& 2-3/4" Hurricane Twist Cups!*

- End Brushes

- Miniature Brushes

- Crosshole Deburring Brushes

*Exclusive Bore-Rx™ Internal Deburring  
Tools for Automated Use!*

- Power and Hand Tube Brushes

- Non-Sparking Brushes

- Strip Brushes

- Wide Face Brushes

**Knowledgeable and Responsive  
Customer Service Team:**

**800-835-9999**

**Application Engineering Support:  
888-299-APPS (2777)**

**Interactive Website: [www.weilercorp.com](http://www.weilercorp.com)**



# Solutions Showcase

## Tube End Deburring

**Problem:** Structural tubing is fabricated into an abundance of different forms. In order to facilitate safer handling and proper fit, the ends of the tubing must frequently be deburred.

**Solution:** Wide face crimped wire wheel brushes are an extremely effective solution for tube end deburring. Brushes can deburr the OD and ID of tubing at an extremely high rate and produce a media-cost-per-part of considerably less than \$0.01 per part.



## Gear Deburring

**Problem:** Power transmission components like gears cannot function properly when burrs prevent correct engagement. Further, burrs which become detached from gears can become lodged in critical transmission components causing premature wear and potential failure.

**Solution:** Knot wire wheel brushes with surface speed in excess of 6000 SFPM are an excellent solution for deburring gears prior to heat treatment. The high energy filament tips are able to separate burrs from base material and produce a uniform edge break, which protects the edge of the gear.



Photos courtesy of On-Line Services.

## Removal of Mill Scale

**Problem:** Mill processing of steel often involves heat treating and oil quenching operations that produce an adherent scale which must be removed prior to joining or finishing operations.

**Solution:** Wire brushes are capable of quickly cleaning material to white metal and producing varying degrees of surface roughening to promote adhesion. Brushing operations are often preferred over blasting and chemical processes which generate an expensive waste stream and can be costly to operate and maintain.



# Solutions Showcase

## Inter-Pass Pipeline Weld Cleaning



Before



After

**Problem:** To prevent voids and inclusions when welding multi-pass joints, the surface of each bead must be completely cleaned of slag and other residuals. Performing inter-pass weld cleaning as quickly and as thoroughly as possible is critical to avoiding costly repair work and delays.

**Solution:** Weiler's Roughneck® and Dually® stringer bead wheels have been engineered to maximize efficiency and minimize costs and are the preferred choice of welders' helpers on the pipeline. From hot pass to cap pass, these premium weld cleaning brushes excel at quickly and thoroughly removing slag, spatter, and oxidation without damaging the filler material.

## Cleaning Threaded Connections



Before



After

**Problem:** The box ends of drill string and other oilfield tubular goods are examples of connections that must be periodically cleaned without altering the geometry of the threads. Abrasive products all remove base material to some extent, and are capable of damaging threads, resulting in unreliable connections and the risk of potential failures.

**Solution:** The conformability and impact action of small diameter crimped wire wheels make them ideal tools for cleaning threads without fear of damage. When used on a high-speed die grinder, these radial wheel brushes quickly remove residual dope as well as rust, corrosion and scale from male or female thread ends.

## Removal of Excess Molded Rubber



Before



After

**Problem:** Mechanical rubber components such as motor mounts are produced through a process that commonly leaves flash and excess rubber on critical surfaces. In order for the component to function properly, this unwanted material must be removed.

**Solution:** The non-loading nature of wire brushes makes them the best available solution in the marketplace for removal of rubber from targeted surfaces. This solution can be implemented off-hand or using automated equipment.

# Power Brush Technical Information

## Operational Advantages of Power Brushes

### Power Brushes Do Not Remove Base Material

Unlike bonded and coated abrasive products, power brushes have the ability to clean hard surfaces without removing base material. The impact action of the sharp, hardened wire tips of a rotating brush behave in the same manner as the media in a blasting operation and they have the same ability to separate surface contaminants without damaging the substrate.

Grinding Wheel



Wire Wheel



Due to its compliant nature, a power brush focuses more of this mechanical energy on edges. This makes it an ideal tool for removing burrs and blending sharp edges without changing overall part dimensions after sawing, cutting, grinding and machining operations.

### Power Brushes Do Not Load

Unlike bonded, coated and non-woven abrasive products, power brushes will not load when used on softer materials or when removing paint or similar coatings from a harder surface. Because a power brush consists of a collection of individual wire filaments, there is no place for debris to accumulate and prevent the sharp wire tips from striking the work.

Resin Fiber Disc



Cup Brush



As a power brush is used, the wire tips will naturally tend to wear to a point due to contact with the working surface. It is possible to take advantage of this self-sharpening action by periodically switching the mounting position of wheel brushes to maintain their speed and effectiveness.

## Construction Advantages of Weiler Power Brushes



### Weiler's Solid Ring Construction

Our crimped wire brushes are constructed using solid rings to retain the fill material and our manufacturing process results in an even, consistent distribution of wire strands around the entire brush diameter. This ensures that our crimped wire products run smoother and last longer than the competition – even in the toughest applications.



### Weiler's Individual Knot Hole Construction

Weiler's knot wheels are constructed with an internal steel plate that has equally spaced individual holes around the perimeter. Wire is inserted through each hole and twisted into a knot. Each hole has precisely the same wire count, thereby assuring perfect balance. This eliminates vibration, reduces operator fatigue and increases brush life.

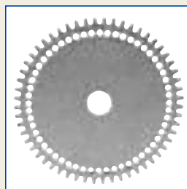

### Weiler's Roughneck® Weld Cleaning Brushes Construction

Each knot is twisted through its own hole and locked into an individual sprocket tooth. This prevents the knots from moving, providing a stronger striking action on the work surface, longer brush life and less operator fatigue. This results in the most aggressive weld cleaning in the market with the lowest cost-per-piece brushed.



# Power Brush Technical Information

## Product Attributes

### Wheel Brush

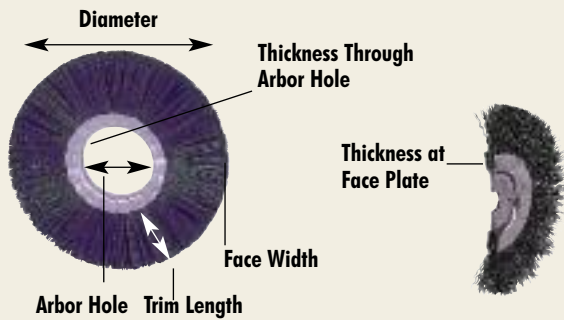

### Cup Brush

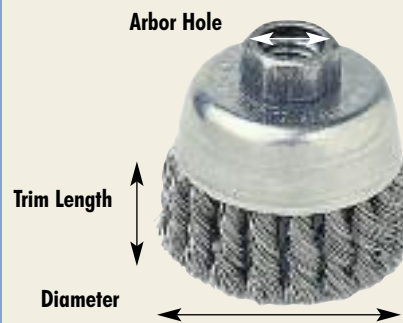

### Stem-Mounted End Brush

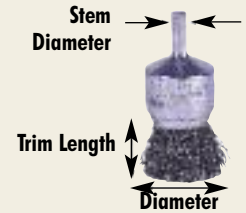

### Tube Brush

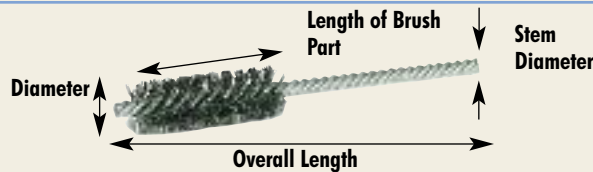

## Fill Materials

**Steel Wire** - Carbon steel wire is typically the most durable power brush fill material for metalworking and heavy-duty cleaning applications. **Weiler industrial grade brushes** utilize heat treated, high tensile steel wire that has been drawn to the most exacting industry standards for superior fatigue resistance and aggressive brushing action. **Vortec Pro® professional grade brushes** utilize more cost-effective grades of steel wire to deliver reliable performance in less demanding applications.

**Stainless Steel Wire** - Stainless steel wire is only recommended when brushing corrosion-resistant or non-ferrous metals such as stainless or aluminum or when the brush is being used in a wet environment. Stainless steel wire is not any more durable or aggressive than the highest grades of steel wire. All Weiler stainless steel brushes are manufactured with Type 302 stainless wire, but select items are also available with Type 316 wire by special order.

**Non-Ferrous Wire** - Brass, bronze and aluminum wire are available in assorted Weiler industrial grade power brush items. These non-ferrous materials will not generate a spark in use, but they lack the durability of carbon steel and stainless steel wire. Due to their soft brushing action, these materials may also be used in special applications such as decorative finishing.

**Animal Hair** - Natural hair bristle is used primarily in miniature power brushes for scratch-free cleaning and polishing. Depending on the animal species and type of hair, this fill material can range from relatively stiff to relatively soft, making it suitable for a variety of applications from removing dust from optical lenses to buffing precious metals using abrasive compounds.

**Vegetable Fiber** - Tampico, a natural fiber produced from the Mexican agave plant, is a common natural fill material used in wet scrubbing and cleaning applications as well as buffing and polishing metals. It is heat, alkali and acid resistant. Its natural color is off-white but it may be dyed or bleached.

**Synthetic** - Nylon is typically the most durable synthetic bristle material for use in power brushes and can be used in a variety of applications due to its flexibility, high fatigue strength and resistance to abrasion, heat, acids and alkalis. Polypropylene is less durable and used primarily in strip brushes.

## Special Information On Stainless Steel Brushes

As noted above, Weiler's complete offering of stainless steel wire brushes is manufactured using wire drawn from Type 302 stainless steel. Although 302 stainless is typically a non-magnetic material, it is important to remember that the amount of cold-working that it experiences during the wire-drawing process causes it to become magnetic. For this reason, proper storage and handling of stainless steel brushes is critical to prevent cross-contamination and "after rust" issues.

Type 302 is widely used in the manufacture of power brushes for its relative durability and aggressive action as well as for its austenitic properties which insure the corrosion resistance of the materials on which it is applied. The use of a different grade of stainless steel wire is typically required in critical weld preparation and cleaning applications, but it will not address "after rust" and other cross-contamination issues. To insure the corrosion resistance of any stainless steel surface after brushing, passivating it with a 10-20% solution of nitric acid is recommended.

# Power Brush Technical Information

## Product Selection

### Weiler Industrial Grade Products

Engineered and manufactured to maximize performance and minimize operating costs in the most demanding surface conditioning applications. The use of superior construction, the highest quality materials and the most stringent manufacturing processes deliver the lowest cost-of-use and most consistent performance in heavy production environments.

### Weiler Vortec Pro® Professional Grade Products

Manufactured using similar product construction and to the same exacting standards as other Weiler power brushes, but engineered to provide cost-effective use in less demanding environments. Vortec Pro brushes are an economical choice for the construction trades, low volume production shops and light duty industrial MRO use.

### Crimped vs. Knot Wire Brushes

#### Crimped Wire Brushes:

- Made with wire that is crimped to allow individual filaments to support each other.
- Provide flexibility for light to medium duty brushing action.
- Use on parts that could be damaged by the impact of a knot brush.
- Use for a broad range of applications.

#### Knot Wire Brushes:

- Made with straight wire filaments that are twisted as a single unit like a piece of cable or wire rope.
- Provide less flexibility and more aggressive brushing action in heavy-duty applications.
- Use on parts requiring high-impact action.
- Use to remove large burrs and heavy contamination, such as multiple layers of rust, scale, paint or oxides.

### Trim Length and Fill Density

**Longer trim, lower density brushes** offer a greater degree of flexibility that is ideal for applications such as cleaning surfaces which are somewhat irregular. However, the lower fill density can result in shorter brush life and less consistent performance in production environments.

**Shorter trim, higher density brushes** are less flexible and work with a faster action which requires less applied pressure or engagement with the brush face. This produces more consistent performance and longer life in applications such as edge deburring.

**To maximize brush life and reduce costs**, always use the shortest trim, highest density brush that will adequately conform to the surface or part edges.

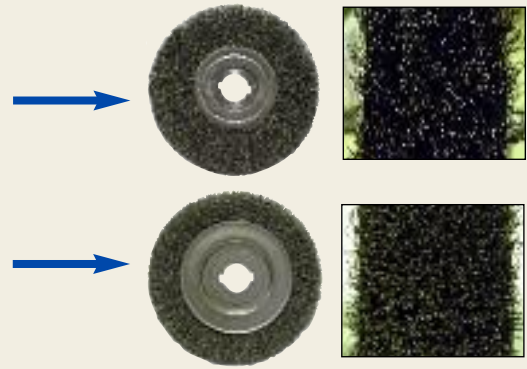

### Knot Configurations



**Standard Twist:** A slight tuft at the end of the wire knot provides some flexibility for use on irregular surfaces.



**Cable Twist:** The wire is tightly twisted to the end of the knot, providing very aggressive brushing action.



**Stringer Bead Twist:** The wire is very tightly twisted to the end of the knot, creating a narrow face with high-impact action, primarily used for weld cleaning.



**Hurricane Twist:** A flattened, dull knot end allows the brush to last longer and provide smoother operation but sacrifices much of the cutting action of the other knot types.



# Power Brush Technical Information

## Wire Size

Wire	Coarse		Medium to Coarse		Medium		Fine		Very Fine	
Gauge #	20	24	25	30	33	34	35	38	43	47
Dia. in Inches	.035	.023	.020	.014	.0118	.0104	.0095	.008	.006	.005
Dia. in Millimeters	0,89	0,58	0,51	0,36	0,30	0,26	0,24	0,20	0,15	0,13

Wire sizes in decimals of an inch are shown in all tables throughout this catalog. American Steel Wire Equivalent Gauge (Formerly Washburn & Moen)

**Larger diameter wire** produces a more aggressive brushing action due to its stiffness, but it also fatigues and breaks much more quickly.

**Smaller diameter wire** can resist fatigue and breakage longer, but it produces a less aggressive and more flexible brushing action.

**To maximize brush life and reduce costs**, always use the finest wire that will accomplish the job without requiring excessive applied pressure or engagement with the brush face.

**Polyflex® Encapsulated Brushes** are suitable for extremely demanding applications which do not require a high degree of conformability. They are especially well-suited for users with the following types of requirements:

- **Extreme brushing pressure** - Encapsulation protects wires from over-flexing and extends brush life relative to conventional knot and crimped wire brushes.
- **Severe cleaning operations** - Encapsulation holds the wire tips rigidly in place and creates the most aggressive brushing action that can be achieved with a wire brush.

In order to optimize the performance of encapsulated brushes, selection of the correct elastomer is critical. The following is a description of the three types of elastomers and their performance attributes.

### Burgundy (Standard)

General purpose elastomer; suitable for most manufacturing applications.



### Orange (Heavy-Duty)

A more heavy-duty elastomer than burgundy; used for more demanding applications.



### Black (Extra Heavy-Duty)

A heat stabilized elastomer that does not wear easily; used primarily for cleaning welds.



## Product Selection Chart:

	Cleaning Surface Prep Roughening Weld Cleaning Remove Oxides & Rust	Surface Finishing (Functional, Aesthetic, Decorative, Satin)	Heavy Deburring	Light Deburring & Edge Blending	Deflashing
Crimped Wheels	● ● ●	● ●		● ● ●	
Knot Wheels	● ● ●		● ● ●		● ● ●
Crimped Cups	●	●		●	
Knot Cups	●		●		
Crimped Stem-Mounted	● ●			● ●	
Knot Stem-Mounted	● ●		● ●		● ●
Encapsulated	● ● ● ● ●		● ● ● ● ●		● ● ● ● ●
Power & Hand Tube	●	●		●	
Miniature	●	●		●	

## Product & Application Key

- Right Angle Grinder 
- Bench/Pedestal Grinder 
- Die Grinder 
- High Speed Pencil Grinder 
- Straight Grinder 
- Right Angle Die Grinder 
- Hand Drill/Drill Press 

# Power Brush Technical Information

## Power Brush Operating Information

### Brushing Speeds

- Power brushes, like cutting tools, operate most effectively when the speed and pressure of the operation are properly matched to the demands of the application. In most operations, the highest speed and lightest pressure will ensure the fastest brushing action and longest brush life.
- Increasing brush speed increases the face hardness and brushing action; therefore, a fine wire brush rotating at a higher speed will often produce the same results as a coarser wire brush rotating at a slower speed. Finer wire operating at a higher speed is generally preferred and will provide a longer brush life.

- MSFS - Maximum Safe Free Speed (RPM) is the maximum speed at which the brushes may be used safely but is not necessarily the optimum speed for a given application. Operating speed should be determined by the application. When running a wire brush, a rule of thumb is to run it a "mile a minute" or a minimum of 5,000 Surface Feet Per Minute (SFPM). However, never exceed the Maximum Safe Free Speed of the brush.
- Make sure spindle size and motor of machine are large enough to accommodate the diameter of brush to be used (see table on pg. 20).

### Recommended Surface Speeds For Brushing Applications

$$SFPM = \frac{\pi \text{ Dia. (Inches)} \times RPM}{12}$$

### Surface Feet Per Minute (SFPM)

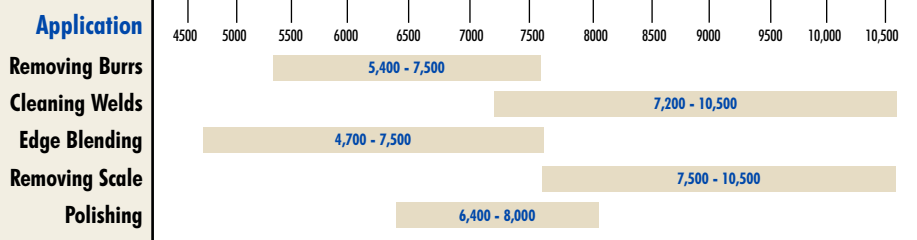

Table of Surface Speeds (Peripheral Speed in Ft./Min.)

RPM	Diameter (Inches)							
	2	3	4	6	8	10	12	15
1000	525	785	1,050	1,575	2,100	2,625	3,150	3,925
1500	785	1,175	1,575	2,350	3,150	3,925	4,725	5,900
1750	915	1,375	1,850	2,750	3,650	4,550	5,500	6,800
2500	1,300	1,950	2,625	3,925	5,250	6,550	7,850	9,825
3000	1,575	2,350	3,125	4,725	6,275	7,850	9,425	11,775
3450	1,800	2,700	3,600	5,400	7,200	9,000	11,000	13,500
4000	2,100	3,150	4,175	6,275	8,375	10,475	-	-
6000	3,125	4,700	6,275	9,425	-	-	-	-
10,000	5,250	7,850	10,500	-	-	-	-	-
15,000	7,850	11,775	15,750	-	-	-	-	-
20,000	10,450	15,700	20,950	-	-	-	-	-

**Example:** A 6" diameter wheel running at 3,450 RPM has a surface speed of 5,400 SFPM.

### Brushing Pressure

Avoid excessive pressure when using a wire brush. Excessive pressure causes over-bending of the filaments and heat build-up resulting in filament breakage, rapid dulling and reduced brush life.

Instead of greater pressure, try the following:

1. A brush with more aggressive action (increase filament diameter, decrease trim length, different brush type, i.e., knot type instead of crimped type)
2. Higher surface speed (increase RPM or brush diameter)

Important Note: Never exceed the recommended Maximum Safe Free Speed or RPM rating of the brush.

**Correct**  
Wire Tips Doing the Work



**Incorrect**  
Excessive Pressure Causes Wire Breakage



# Power Brush Technical Information

## Power Brush Operating Information

### Minimum Recommended Spindle Diameter (from ANSI Standard B165.1)

Outside Dia. of Wheel Brush	Maximum Face Width of Wheel Brush	Minimum Outside Dia. of Spindle (Shaft)
2"	1/4"	1/4"
3"	3/4"	1/4"
3" (heavy-duty)	1"	3/8"
4"	1"	3/8"
6"	1-1/4"	1/2"
8"	1-1/4"	5/8"
10"	2"	3/4"
12"	3"	1"
14"	3"	1-1/4"
15"	3"	1-1/4"
16"	3"	2"

Note: These diameters are based on the wheel brush being mounted next to the supported end of the shaft rather than the unsupported end in order to minimize overhang.

### Recommended Motor Sizes

Brush Diameter	Motor Size	RPM
4"	1/4 HP	3,450
6"	1/2 HP	3,450
8"	3/4 HP	3,450
10"	1 HP	1,750
12"	1 HP	1,750
15"	1-1/2 HP	1,750

Note: This chart is based on 1" brush face.

### Arbor Hole Variation Table - For Weiler Industrial Grade Wheels

If an arbor hole size other than the size listed in the product table is required, change the last digit of the Item Number as indicated in the Table.

Arbor Hole Diameter	Change Last Digit of Item Number to:	Arbor Hole Features
1/2"-3/8"	4	Plastic Snap-Out Adapter
5/8"-1/2"	5	Plastic Snap-Out Adapter
5/8"-11 UNC	6	Threaded Nut (6", 7" & 8" Wheels Only)
5/8"	7	3", 4" & 6" Wheels Only
3/4"	8	—
7/8"	0 - 11	—
1"	0 - 12	1/4"*x 1/8"+ double keyway
1-1/4"	9	5/16"*x 5/32"+ double keyway
1-1/2"	0 - 13	3/8"*x 3/16"+ double keyway
1-3/4"	0 - 16	3/8"*x 3/16"+ double keyway
2"	0 - 14	1/2"*x 1/4"+ double keyway
2-1/4"	0 - 17	3/4"*x 3/8"+ double keyway
2-1/2"	0 - 15	1/2"*x 1/4"+ double keyway

\* Width of keyway      + Depth of keyway

**Example:** Item Number 01228 has a listed, standard size arbor hole of 3/4". If an 1-1/4" arbor hole is desired, drop the 8 from 01228 and add 9. The Item Number becomes 01229. If a 2" arbor hole is desired, drop the 8 from 01228 and add 0-14. The Item Number becomes 01220-14.

### Self-Sharpening of Wire Wheel Brushes

When using wire wheel brushes without nuts, periodically reverse the direction of rotation to take advantage of the self-sharpening action that will result. Remove the brush from the spindle, flip the wire brush 180° and remount the brush securely.



Remove



Flip 180°



Remount Securely

# Power Brush Technical Information

## Power Brush Troubleshooting Guide

There are many variables in power brush applications. If the power brush you are using does not accomplish the desired results, select a solution from the suggestions below for your specific application or call Weiler's **Application Engineering Hotline at 888-299-2777**.

Problem	Recommended Solutions
Brush works too fast	<ul style="list-style-type: none"> <li>• Select a brush with longer filaments and/or lower fill density</li> <li>• Select a brush with a smaller diameter wire</li> <li>• Select a brush with a narrower face and/or lower fill density</li> <li>• Select a brush with a smaller outside diameter</li> <li>• Operate the brush at a slower RPM</li> </ul>
Brush works too slowly	<ul style="list-style-type: none"> <li>• Select a brush with shorter filaments and/or higher fill density</li> <li>• Select a brush with a larger diameter wire</li> <li>• Select a brush with a wider face and/or higher fill density</li> <li>• Select a brush with a larger outside diameter</li> <li>• Operate the brush at a faster RPM</li> </ul>
Brushing action rolls or peens the burr over instead of removing burr	<ul style="list-style-type: none"> <li>• Select a brush with a larger diameter wire</li> <li>• Select a brush with shorter filaments and/or higher fill density</li> <li>• Operate the brush at a faster RPM</li> <li>• Replace the crimped wire brush with a knot wire brush</li> </ul>
Finer final finish required	<ul style="list-style-type: none"> <li>• Select a brush with longer filaments</li> <li>• Select a brush with a smaller diameter wire</li> <li>• Operate the brush at a higher RPM</li> <li>• Replace the wire brush with a nylon abrasive brush (Nylox®)</li> </ul>
Coarser final finish required	<ul style="list-style-type: none"> <li>• Select a brush with shorter filaments</li> <li>• Select a brush with a larger diameter wire</li> <li>• Operate the brush at a slower RPM</li> </ul>
Non-uniform brushing action	<ul style="list-style-type: none"> <li>• Select a brush with longer filaments</li> <li>• Select a brush with a larger diameter wire</li> <li>• Automate the operation to reduce human variables</li> </ul>
Filaments break off	<ul style="list-style-type: none"> <li>• Reduce applied pressure or engagement</li> <li>• Select a brush with a smaller diameter wire</li> <li>• Select a brush with a lower fill density</li> </ul>
Short brush life	<ul style="list-style-type: none"> <li>• Reduce applied pressure or engagement</li> <li>• Select a brush with a smaller diameter wire</li> <li>• Select a brush with a higher fill density</li> </ul>



Call our Application Engineering Hotline at 888-299-APPS (2777). If the problem is too complex to be solved over the phone, we will determine if an evaluation should be conducted at our in-house lab or your facility. Either way, Weiler will provide the most cost-effective solution for your specific application.

# Knot Wire Wheels with Arbor Hole

**Knot Wire Wheels with Arbor Hole** - Knot wire wheels with an arbor hole are intended for use on straight grinders and stationary machines such as bench or pedestal grinders and buffing lathes. Featuring Weiler's individual knot hole construction, these radial brushes are available in heat-treated steel, Type 302 stainless steel, and bronze wire for use in a wide variety of applications.

## Applications

- Removing rust, scale and heavy corrosion
- Surface roughening and preparation
- Coating removal
- Removing excess molded rubber or plastic
- Heavy deburring

**Standard Twist Wheels** - Provide heavy-duty brushing action with some flexibility; Ideal for demanding cleaning applications on somewhat irregular surfaces.



Dia.	Wire Size	Arbor Hole	No. of Knots	Face Width	Trim Length	Max. AH Avail.	Thickness at Face Plates	Max. RPM	Std. Pack	Item Number	
										Steel	Stainless
3"	.0118	1/2"-3/8"	20	3/8"	5/8"	1/2"	7/16"	25,000	10	08004	08254
	.014									08014 ■	08264
	.020									08024*	08274
4"	.0118	1/2"-3/8"	24	1/2"	7/8"	1/2"	7/16"	20,000	10	08034	08284
	.014									08044 ■	08294
	.020									08064	08314
4"	.014	5/8"-1/2"	24	1/2"	7/8"	7/8"	7/16"	20,000	10	08045	-
6"	.0118	5/8"-1/2"	24	1/2"	1-3/8"	1-1/4"	9/16"	9,000	10	08075	08325
	.014									08085 ■	-
	.016									08095	08345
	.023									08105	-
6"	.016	5/8"-1/2"	30	5/8"	1-1/4"	1-1/4"	5/8"	9,000	5	08975	-
7"	.014	5/8"	24	5/8"	1-7/8"	1-1/4"	9/16"	9,000	2	08835	-
8"	.0118	5/8"	38	5/8"	1-5/8"	2"	1/2"	6,000	2	08125	08375
	.014									08135	-
	.016									08145	08395
	.023									08155	-
8"	.014	3/4"	38	5/8"	1-5/8"	2"	1/2"	6,000	2	08138	-
10"	.014	3/4"	52	3/4"	1-3/4"	2-1/2"	3/4"	4,500	2	08178	-
10"	.0118	1-1/4"★	52	3/4"	1-3/4"	2-1/2"	3/4"	4,500	2	08169	-
	.014									08179	-
	.016									08189	-
12"	.0118	1-1/4"★	52	3/4"	2-3/4"	2-1/2"	11/16"	3,600	1	08199	-
	.014									08209	-
	.016									08219	-
12"	.014	2"◆	52	3/4"	2-3/4"	2-1/2"	11/16"	3,600	1	08200-14	-
12"	.020	1-1/4"★	56	5/8"	2-3/4"	3"	13/16"	4,500	2	09719	-
12"	.023	2"◆	66	3/4"	2-1/4"	3"	13/16"	5,000	2	09870	-
15"	.016	1-1/4"★	52	7/8"	4-1/4"	2-1/2"	3/4"	3,600	2	08249	-

★ 5/16" x 5/32" Double Keyway ◆ 1/2" x 1/4" Double Keyway

\* Available in non-sparking bronze wire, see page 57 for details.

■ Available in Display Packaging. Add "P" to end of Item Number when placing order. See page 170 for details.

**Vortec Pro® Standard Twist Wheels** - Provide an aggressive brushing action for general-purpose surface cleaning applications.



Dia.	Wire Size	Wire Type	Arbor Hole	Face Width	Max. RPM	Display Pack Item No.	Boxed Qty. Item No.
3"	.014" Fine	Carbon	1/2"-3/8"	Wide	25,000	-	36290
	.014" Fine					-	36291
4"	.014" Fine	Carbon	1/2"-3/8"	Wide	20,000	36026	36226
	.014" Fine					-	36293
	.020" Coarse					-	36294
6"	.014" Fine	Carbon	5/8"-1/2"	Wide	9,000	36027	36227
	.023" Coarse					-	36278
8"	.014" Fine	Carbon	5/8"	Wide	6,000	36028	36228
	.023" Coarse					-	36279



Removing rubber coating from a hydraulic hose.



08014

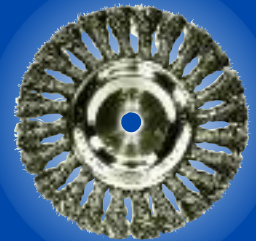

08085



08189



36228

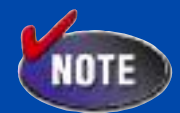

**NOTE**  
If a different arbor hole is required (than listed in the tables) refer to Arbor Hole Table shown on Pg. 20.

Knot Wire Wheels with Arbor Hole

# Knot Wire Wheels with Arbor Hole

**Standard Twist Wheels - High Density & Extra High Density** - Engineered for maximum performance in production applications; for use on automated equipment such as dedicated gear deburring machines.

Automotive gear deburring using heavy-duty knot wheel brushes.

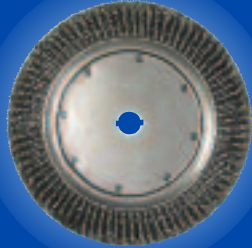

08339



09020

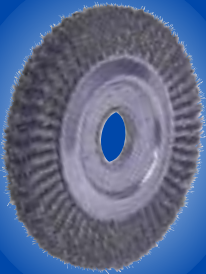

09480



94000

Knot Wire Wheels with Arbor Hole

Dia.	Wire Size	Arbor Hole	Face Width	Trim Length	Thickness at Face Plates	Max. RPM	Standard Pack	Item No. Steel
<b>80 Knots</b>								
14"	.0118	1-1/4"★	3/4"	2-1/2"	5/8"	5,000	2	08309
	.0118	2"◆						08300
	.014	1-1/4"★						08319
	.014	2"◆						08310
	.020	1-1/4"★						08339
.020	2"◆	08330						
15"	.0118	1-1/4"★	3/4"	3"	5/8"	5,000	2	09969
	.0118	2"◆						09960
	.014	1-1/4"★						09989
	.014	2"◆						09980
	.020	1-1/4"★						09999
.020	2"◆	09990						
<b>90 Knots</b>								
14"	.014	2"◆	3/4"	1-1/2"	5/8"	5,000	2	09020*
	.014	1-1/4"★						09029*
	.016	2"◆						09790
	.016	1-1/4"★						09799
	.020	2"◆						09800
	.020	1-1/4"★						09809
	.020	2"◆						09040*
.020	1-1/4"★	09049*						
15"	.020	2"◆	3/4"	2"	5/8"	5,000	2	09840
	.020	2"◆						09080*
	.020	1-1/4"★						09089*

★ 5/16" x 5/32" Double Keyway

◆ 1/2" x 1/4" Double Keyway

\* Economy

**Standard Twist Wheels - Two Section** - Provide heavy-duty brushing action with some flexibility; feature a double row of knotted wire for a wider brush face.



Dia.	Wire Size	Arbor Hole	No. of Knots	Face Width	Trim Length	Thickness at Face Plates	Max. RPM	Standard Pack	Item No. Steel
3"	.0118	1/2"-3/8"	40	3/4"	5/8"	3/4"	22,000	5	09104
4"	.0118	1/2"-3/8"	48	3/4"	7/8"	3/4"	20,000	5	09134
6"	.0118	2"	60	7/8"	1-3/8"	7/8"	8,000	5	09160
	.016								09180
8"	.0118	2"	76	1"	1-5/8"	1"	6,000	1	09410
	.016								09430
	.023								09440
10"	.0118	2"	104	1-1/4"	1-3/4"	1-1/4"	4,500	1	09460
	.016								09480
	.023								09490
12"	.0118	2"	104	1-1/4"	2-3/4"	1-1/4"	3,600	1	09510
	.016								09530
	.023								09540

See Metal Adapters on page 31 for brushes with 2" arbor holes.

**Standard Twist Wheels - Four Section** - Featuring four rows of knotted wire; for use in automated cleaning processes such as removing light mill scale from metal rod and wire.

Dia.	Wire Size	Arbor Hole	No. of Knots	Face Width	Trim Length	Thickness at Face Plates	Max. RPM	Standard Pack	Item Number Steel
12"	.0118	2"	208	2"	2-3/4"	1-3/4"	3,600	4	94098
	.014								94000

See Metal Adapters on page 31 for brushes with 2" arbor holes.



# Knot Wire Wheels with Arbor Hole

**Cable Twist Wheels** - Provide maximum brushing action with minimal flexibility; ideal for demanding cleaning and coating removal applications on relatively smooth surfaces.



Dia.	Wire Size	Arbor Hole	No. of Knots	Face Width	Trim Length	Max. AH Avail.	Thickness at Face Plates	Max. RPM	Std. Pack	Item Number	
										Steel	Stainless
4"	.020	1/2"-3/8"	24	1/4"	7/8"	1/2"	7/16"	20,000	10	08534	—
6"	.023	5/8"-1/2"	24	3/8"	1-3/8"	1-1/4"	9/16"	9,000	10	08565	08695*
8"	.023	5/8"	38	1/2"	1-5/8"	2"	1/2"	6,000	2	08615	—
10"	.023	3/4" 1-1/4"★	52	1/2"	1-3/4"	2-1/2"	3/4"	4,500	2	08878 08879	— —
12"	.023	1-1/4"★	52	7/16"	2-3/4"	3"	3/4"	3,600	2	09379	—

If a different arbor hole is required (than listed) refer to the Arbor Hole Table on page 20.

★ 5/16" x 5/32" Double Keyway \*Standard Pack 2

**Joint & Crack Cleaning Wheels** - Featuring heavy-duty construction and an extra long trim length for cleaning expansion joints and cracks in concrete and asphalt; for use on walk-behind machines.

Dia.	Wire Size	Arbor Hole	No. of Knots	Face Width	Trim Length	Thickness at Face Plates	Max. RPM	Std. Pack	Item Number
									Steel
10"	.035	1" with two drive holes*	38	3/8"	2-5/8"	1/2"	5,000	2	94199
12"	.035	1" with two drive holes*	38	3/8"	3-5/8"	1/2"	5,000	2	94224
12"	.035	1" with two drive holes*	52	3/8"	2-3/4"	3/4"	5,000	2	94026

\* Drive holes are 3/8" diameter with 1/4" x 1/8" double keyway.

**Adapter** - For mounting Joint & Crack Cleaning Wheels onto a 20mm arbor.

For Brush Arbor Hole Size	Adapted Arbor Hole Size	Standard Pack	Item Number
1"	20mm	10	04455

**Cable Twist Wheel - Four Section** - Featuring four rows of tightly knotted wire; for use in demanding automated applications such as cleaning the OD of drill pipe and other oilfield tubular goods.

Dia.	Wire Size	Arbor Hole	No. of Knots	Face Width	Trim Length	Max. AH Avail.	Thickness at Face Plates	Max. RPM	Std. Pack	Item Number
										Steel
10"	.023	2"	208	1-3/4"	1-3/4"	2"	1-7/8"	4,500	1	94008



In addition to the products featured in this catalog, Weiler can custom-design brushes to meet your specific needs.



Cleaning a crack on an airport runway prior to filling.



08534



94224



04455

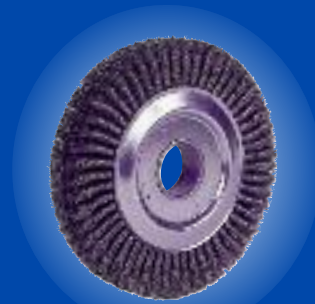

94008

Knot Wire Wheels with Arbor Hole

# Knot Wire Wheels with Nut



Prepping a machine guard for on-site welding and repair.

**Knot Wire Wheels with Nut** - Knot wire wheels with a threaded nut are intended for use primarily on small and large right angle grinders. Featuring Weiler's individual knot hole construction, these radial brushes are available in heat-treated steel, Type 302 stainless steel and bronze wire for use in a wide variety of applications.

## Applications

- Removing powder-coating, epoxy-based paints, and rubberized coatings
- Weld preparation and cleaning
- Cleaning scale and heavy corrosion
- Removing heavy burrs from large pieces after cutting

**Standard Twist Wheels** - Provide heavy-duty brushing action with some flexibility; ideal for deburring and demanding cleaning applications on somewhat irregular surfaces.



13106

Dia.	Wire Size	Arbor Hole	No. of Knots	Face Width	Trim Length	Max. AH Avail.	Thickness at Face Plates	Max. RPM	Std. Pack	Item Number	
										Steel	Stainless
3"	.014	M10 x 1.25	20	3/8"	5/8"	-	7/16"	25,000	5	13201	13208
4"	.014	M10 x 1.25	24	1/2"	7/8"	-	7/16"	20,000	5	13100	13107
		M10 x 1.50								13101	13108
		M14 x 2.0								13102	13109
		3/8"-24 UNF								13103	13110
		1/2"-13 UNC								13105	-
5/8"-11 UNC	13106 ■	13113 ■									
4"	.020	M10 x 1.25	24	1/2"	7/8"	-	7/16"	20,000	5	13114	-
		M10 x 1.50								13115	-
		M14 x 2.0								13116	-
		3/8"-24 UNF								13117	-
		1/2"-13 UNC								13119	-
		5/8"-11 UNC								13120*	-
6"	.016 .023	5/8"-11 UNC	24	1/2"	1-3/8"	-	9/16"	9,000	2 5	-	08346
										08106	-

- Available in Display Packaging. Add "P" to end of Item Number when placing order. See page 170 for details.
- \* Available in non-sparking bronze wire, see page 57 for details.

**Vortec Pro® Standard Twist Wheels** - Provide an aggressive brushing action for general purpose deburring, cleaning, and surface preparation applications.



13266

Dia.	Wire Size	Wire Type	Arbor Hole	Face Width	Max. RPM	Display Pack Item No.	Boxed Qty. Item No.
4"	.014" Coarse	Carbon	5/8"-11	Wide	20,000	36012	36212
		Stainless	5/8"-11			36013	36213
		Carbon	M10 x 1.25	36015		36215	
		Carbon	M10 x 1.50	36016		36216	
		Carbon	M14 x 2.0	36017		36217	
6"	.025" Extra Coarse	Carbon	5/8"-11	Wide	11,000	36024	36224

**Cable Twist Wheels** - Provide maximum brushing action with minimal flexibility; ideal for demanding cleaning and surface preparation applications on relatively smooth surfaces.



36055

Dia.	Wire Size	Arbor Hole	No. of Knots	Face Width	Trim Length	Max. AH Avail.	Thickness at Face Plates	Max. RPM	Std. Pack	Item Number	
										Steel	Stainless
4"	.020	M10 x 1.25	24	1/4"	7/8"	1/2"	7/16"	20,000	5	13261	-
		M10 x 1.50								-	13272
		5/8"-11 UNC								13266 ■	13276

- Available in Display Packaging. Add "P" to end of Item Number when placing order. See page 170 for details.

**Vortec Pro® Cable Twist Wheels** - Provide the most aggressive brushing action for general purpose cleaning and surface preparation applications.



Dia.	Wire Size	Wire Type	Arbor Hole	Face Width	Max. RPM	Display Pack Item No.	Boxed Qty. Item No.
4"	.020" Coarse	Carbon	5/8"-11	Medium	20,000	36055	36255
			M10 x 1.50			36057	36257
			M10 x 1.25			36058	36258

# Knot Wire Wheels with Nut or Stem

**Standard Twist Bevel Brushes** - Saucer-shaped radial wheels which provide a heavy-duty brushing action with some flexibility; ideal for cleaning fillet welds and into corners.



Dia.	Wire Size	Arbor Hole	No. of Knots	Face Width	Trim Length	Max. RPM	Std. Pack	Item Number	
								Steel	Stainless
4"	.014	M10 x 1.25	20	3/8"	3/4"	12,500	1	13401	-
		M10 x 1.50						13402	13412
		5/8"-11 UNC						13406	13416
4"	.020	M14 x 2.0	20	3/8"	3/4"	12,500	1	13423	-
		5/8"-11 UNC						13426	13436
4-1/2"	.014	5/8"-11 UNC	20	3/8"	1"	12,500	1	13456	13466
4-1/2"	.020	5/8"-11 UNC	20	3/8"	1"	12,500	1	13476	13486



Cleaning a corner weld with a bevel brush.

**Knot Wire Wheels with Stem** - Knot wire wheels with a permanently attached 1/4" stem or shank are primarily intended for use on high-speed die grinders. Although they can also be mounted onto a drill, the speed and power of that tool will limit the effectiveness of the brush. Featuring Weiler's individual knot hole construction, these radial wheels are available in heat-treated steel and Type 302 stainless steel wire.

## Applications

- Removing powder-coating, epoxy-based paints, and rubberized coatings
- Weld preparation and cleaning
- Cleaning scale and heavy corrosion
- Removing heavy burrs from large pieces after cutting

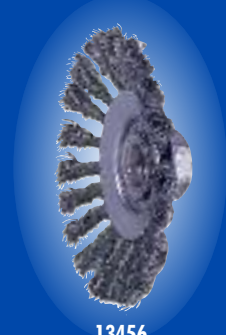

13456

**Standard Twist Wheels** - Permanently mounted on a 1/4" stem to provide heavy-duty brushing action with some flexibility; ideal for deburring and demanding cleaning applications on somewhat irregular surfaces.



Dia.	Wire Size	No. of Knots	Face Width	Trim Length	Max. RPM	Standard Pack	Item Number	
							Steel	Stainless
3-1/4"	.0118	20	3/8"	5/8"	25,000	5	17680	-
	.014						17681	17684
	.020						17682	-
4"	.0118	24	1/2"	7/8"	20,000	5	17686	-
	.014						17687	17691
	.020						17689	-

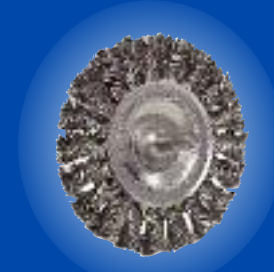

17681



In a year, we use 240,000 miles of our most popular wire sizes. The circumference of the Earth is 24,901 miles, so you can circle the Earth 9.6 times. Or, you can go to the moon but not make it back. The distance to the moon is 238,857 miles.

Knot Wire Wheels with Nut or Stem

# Weld Cleaning Brushes

**Made in the U.S.A.**, the performance-engineered construction of Weiler's stringer bead wheels makes them the most effective weld cleaning tools for the most demanding users.

Identifiable by their gold nuts, our premium weld cleaning brushes are designed and manufactured to the most stringent quality standards in the industry. Weiler stringer bead wheels utilize the highest quality wire available and feature a twist that puts all of the sharp tips at the very end of the knots, making them the fastest, most aggressive weld cleaning tools on the market.

For example, the construction of Weiler's original Roughneck® brush virtually eliminates knot movement resulting in the most effective cleaning action, smoothest operation, and longest wheel life. Offered in a variety of widths for efficient use in inter-pass weld cleaning operations, our entire line of cleaning brushes excel at removing slag, spatter, and oxidation without damaging the filler material. They are engineered to maximize your efficiency and minimize your costs.

**Roughneck® Stringer Bead Wheels** - The standard for high-performance weld cleaning brushes. Narrow face brushes are suitable for cleaning root and hot passes and reaching into corners; wider face wheels can be used for cleaning filler and cap passes as well as for other surface prep and cleaning applications.



Removing weld slag before the next weld pass.

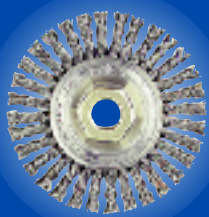

13131



09000

**New!**

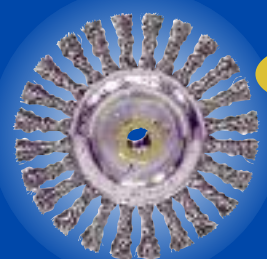

08776

**New!**



35800

Dia.	Wire Size	Arbor Hole	No. of Knots	Face Width	Trim Length	Thickness at Face Plates	Max. RPM	Std. Pack	Item Number	
									Steel	Stainless
<b>Root Pass Brushes</b>										
4"	.020	1/2"-3/8" M10 x 1.25 M10 x 1.50 M14 x 2.0 3/8"-24 UNF 1/2"-13 UNC 5/8"-11 UNC	32	3/16"	7/8"	7/16"	20,000	5	13124 13125 ■ 13126 13127 13128 13130 13131 ■	08954* 13132 13133 13134 13135 13137 13138 ■
4-1/2"	.020	5/8"-11 UNC M14 x 2.0 7/8"	38	3/16"	13/16"	3/8"	12,500	5	13232 13233 13234	13238 13239 13249
5"	.020	5/8"-11 UNC	38	3/16"	7/8"	3/8"	12,500	5	08756	08806
	.020	7/8"	38	3/16"		08750			-	
6"	.020	5/8"-11 UNC	48	3/16"	1-1/8"	3/8"	12,500	10	08766†	-
	.020	5/8"-11 UNC	38	3/16"	1-3/8"	3/8"			-	08786†•
	.020	5/8"-11 UNC	56	3/16"	1-1/8"	7/16"			09400 ■	09500
6-7/8"	.020	5/8"-11 UNC	56	3/16"	1-1/8"	7/16"	9,000	10	09000 ■	09200
			76						09100	-
<b>Filler Pass Brushes</b>										
5"	.023	5/8"-11 UNC	24	1/2"	7/8"	3/8"	12,500	5	09856	09866
6"	.023	5/8"-1/2"	24	1/2"	1-3/8"	9/16"	12,500	10	08775	-
	.023	5/8"-11 UNC	24	1/2"	1-3/8"	9/16"	12,500	10	08776 ■	08796•
	.023	5/8"-11 UNC	30	1/2"	1-1/4"	5/8"	12,500	10	08916	08926•
	.023	5/8"-11 UNC	30	5/16"	1-3/8"	1/2"	12,500	10	09386	09396•

† Light Duty • Standard Pack 5 \* Standard Pack 10

■ Available in Display Packaging. Add "P" to end of Item Number when placing order. See page 170 for details.

**Polyflex™ Encapsulated Stringer Bead Wheels** - Black Elastomer\* - Feature a heat-stabilized encapsulation that gradually wears away to expose a consistent short trim for higher aggression, controlled brushing action, and longer life; suitable for cleaning hot welds.

Dia.	Wire Size	Arbor Hole	No. of Knots	Face Width	Trim Length	Thickness at Face Plates	Max. RPM	Standard Pack	Item Number
									Steel
4"	.020	5/8"-11 UNC	32	3/16"	7/8"	7/16"	20,000	5	35800
6"	.014	5/8"-11 UNC	-	3/16"	1-7/16"	3/8"	9,000	5	35206 ▲
6-7/8"	.020	5/8"-11 UNC	56	3/16"	1-1/8"	7/16"	9,000	10	35600
7"	.014	5/8"-11 UNC	-	3/16"	1-15/16"	3/8"	9,000	5	35216 ▲

\* See Elastomer Color Code Chart on page 18 for more information.

▲ Crimped wire

# Weld Cleaning Brushes

**Featuring a new patent-pending design,** the Dually line of cleaning brushes is the choice for the most demanding inter-pass welding applications such as pipeline construction, boiler and pressure vessel fabrication, and shipbuilding.

Welders' assistants on the pipeline were among the first to realize the value in periodically switching the mounting position of a wheel in order to maintain cleaning speed and effectiveness. The Dually utilizes a nut design that features a hex on each side of the wheel which is high enough to insure adequate tool clearance in either mounting position. Now all users can realize the benefits of the "Flip" without compromising safety by removing the guard from their grinder.



**CHECK OUT THE VIDEO**



**New!** **Dually® Stringer Bead Wheels** - Feature a dual-hex nut design\* that simplifies periodic flipping of the wheel for maximum cleaning action, long life, and safer use.

Dia.	Wire Size	Arbor Hole	No. of Knots	Face Width	Trim Length	Thickness at Face Plates	Max. RPM	Std. Pack	Item Number	
									Steel	Stainless
<b>Root Pass Brushes</b>										
4-1/2"	.020	5/8"-11 UNC	38	3/16"	13/16"	3/8"	12,500	5	79801	79811
5"	.020	5/8"-11 UNC	38	3/16"	7/8"	3/8"	12,500	5	79802	79812
6"	.020	5/8"-11 UNC	56	3/16"	1-1/8"	7/16"	12,500	5	79805	79815
7"	.020	5/8"-11 UNC	56	3/16"	1-1/8"	7/16"	9,000	5	79800	79810
<b>Filler Pass Brushes</b>										
5"	.023	5/8"-11 UNC	24	1/2"	7/8"	3/8"	12,500	5	79803	79813
6"	.023	5/8"-11 UNC	30	1/2"	1-1/4"	5/8"	12,500	5	79804	79814

**New!** **HFR™ Stringer Bead Wheels** - Feature a patent-pending film coating to minimize wire loss when used within recommended operating guidelines for hot-pass weld cleaning in FME areas of nuclear power plants. Weiler HFR Brushes have been engineered and tested to meet the requirements for a High Filament Retention power brush as defined by the Electrical Power Research Institute.

Dia.	Wire Size	Arbor Hole	No. of Knots	Face Width	Trim Length	Thickness at Face Plates	Max. RPM	Std. Pack	Item Number	
									Steel	Stainless
4"	.020	5/8"-11 UNC	32	3/16"	7/8"	7/16"	13,500	1	13381	13388

**Vortec Pro® Stringer Bead Wheels** - Manufactured using similar product construction and to the same exacting standards as other Weiler weld cleaning brushes; they have been engineered for cost-effective use in less demanding applications.

Dia.	Wire Size	Wire Type	Arbor Hole	Face Width	Max. RPM	Display Pack Item No.	Boxed Qty. Item No.
4"	.020" Coarse	Carbon	5/8"-11	Narrow	20,000	36018	36218
		Carbon	5/8"-11			-	36308*
		Stainless	5/8"-11			36019	36219
		Carbon	M10 x 1.25			36021	36221
		Carbon	M10 x 1.50			36022	36222
5"	.020" Coarse	Carbon	5/8"-11	Narrow	12,500	-	36295
		Stainless	5/8"-11			-	36296
		Carbon	5/8"-11			36025	36225
6"	.020" Coarse	Carbon	5/8"-11	Narrow	12,500	-	36307*
		Carbon	5/8"-11			-	36297
6-7/8"	.020" Coarse	Carbon	5/8"-11	Narrow	9,000	-	36298
		Stainless	5/8"-11			-	36298

\*Light Duty



Weiler's Cable Twist Wheels were used by NASA on its booster rockets.



Removing slag and spatter before the cap pass.



79802



13381

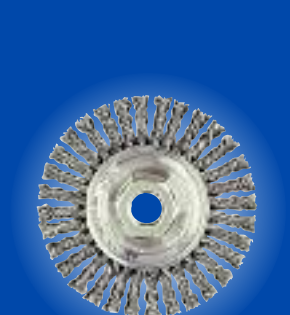

36218

Weld Cleaning Brushes

# Crimped Wire Wheels with Arbor Hole



Removing heat discoloration from a stainless steel canister.

**Crimped Wire Wheels with Arbor Hole** - Are intended for use on straight grinders and stationary machines such as bench or pedestal grinders and buffing lathes. Featuring Weiler's solid ring construction, these radial brushes are available in heat-treated steel, Type 302 stainless steel and brass wire for use in a wide variety of applications.

## Applications

- Removing rust and light corrosion
- Removing heat discoloration
- Paint removal and surface cleaning
- Light deburring
- Decorative finishing

**Crimped Wire Wheels** - Provide a flexible brushing action and consistent performance for demanding light-duty cleaning and deburring applications.



Crimped Wire Wheels with Arbor Hole



00184



01238



If a different arbor hole is required (than listed in the tables) refer to Arbor Hole Table shown on Pg. 20.

Dia.	Wire Size	Arbor Hole	Face Width	Trim Length	Max. AH Avail.	Thickness at Face Plates	Max. RPM	Std. Pack	Item Number	
									Steel	Stainless
3"	.006	1/2"-3/8"	7/16"	1/2"	3/4"	7/16"	12,500	2	00204	00244
	.008								-	
	.0118								00234	00264
	.014								00274	-
4"	.006	1/2"-3/8"	1/2"	7/8"	3/4"	7/16"	12,500	2	00104	00154
	.008								-	
	.0095	5/8"-1/2"	1/2"-3/8"	3/4"	7/16"	6,000	10	00105	-	
	.0118	-								
	.0118	1/2"-3/8"	00114	-						
	.014	5/8"-1/2"	00124	-						
	.014	1/2"-3/8"	00134	00184						
.014	1/2"-3/8"	00135	-							
.014	1/2"-3/8"	00144	-							
6"	.006	5/8"-1/2"	3/4"	1-7/16"	1-1/4"	7/16"	6,000	10	01035 ▲	01675*
	.008								-	
	.008	1-1/4"★	3/4"	1-7/16"	1-1/4"	7/16"	6,000	10	01045	-
	.0104	5/8"-1/2"							01049	-
	.0118	-	01055	01695*						
	.014	-	01065 ▲	01705*						
.014	-	01075 ■	-							
.014	-	01068	-							
8"	.006	5/8"	3/4"	2-1/16"	1-1/4"	1/2"	6,000	2	01135	01775
	.008								-	
	.0104	3/4"	3/4"	2-1/16"	1-1/4"	1/2"	6,000	2	01145	-
	.0118								01155	01795
	.014	01165	01805							
	.014	01175 ■	-							
	.006	3/4"	3/4"	2-1/16"	1-1/4"	1/2"	6,000	2	01138	-
.008	01148								-	
.0104	01158	-								
.0118	01168	-								
.014	01178	-								
.0118	1-1/4"★	3/4"	2-1/16"	1-1/4"	1/2"	6,000	2	-	01809	
.014	-	01179	-							
10"	.006	3/4"	3/4"	2-1/2"	2"	5/8"	4,000	2	01228	-
	.0104								01238	-
	.0118	01248	-							
	.014	01258	01898							
	.014	1" •	01250-12	-						
.014	1-1/4"★	3/4"	2-1/2"	2"	5/8"	4,000	2	01259	-	
12"	.006	1-1/4"★	3/4"	2-15/16"	2-1/2"	1/2"	3,000	2	01299	01939
	.0104								01309	01949
	.0118	01319	-							
	.014	01329	-							
.014	2"◆	3/4"	2-15/16"	2-1/2"	1/2"	3,000	2	01320-14	-	
15"	.0118	1-1/4"★	3/4"	4-7/16"	2-1/2"	1/2"	3,000	2	01339	-
	.014								01349	-

- ◆ 1/2" x 1/4" Double Keyway      ★ 5/16" x 5/32" Double Keyway      • 1/4" x 1/8" Double Keyway
- ▲ Available in non-sparking bronze wire, see page 57 for details.      \* Standard Pack 2
- Available in Display Packaging. Add "P" to end of Item Number when placing order. See page 170 for details.

**DID YOU KNOW?** Crimped wire narrow face wheels can be made with nylon or abrasive nylon fill, up to 20" in diameter.

# Crimped Wire Wheels with Arbor Hole

**Vortec Pro® Crimped Wire Wheels** - Provide a flexible brushing action and cost-effective performance in general purpose cleaning and deburring applications.



Dia.	Wire Size	Wire Type	Arbor Hole	Face Width	Max. RPM	Display Pack Item No.	Boxed Qty. Item No.
4"	.014" Coarse	Carbon	1/2"-3/8"	Narrow	6,000	36062	36262
6"	.008" Fine	Carbon	5/8"-1/2"	Narrow	6,000	36002	36202
	.014" Coarse	Carbon		Narrow		36000	36200
	.014" Coarse	Stainless		Narrow		36001	36201
8"	.014" Coarse	Carbon	5/8"	Narrow	6,000	36005	36205

**Polyflex™ Encapsulated Crimped Wire Wheels - Burgundy Elastomer\*** - Feature an encapsulation that gradually wears away to expose a consistent short trim for higher aggression, controlled brushing action, and longer life.



Dia.	Wire Size	Arbor Hole	Face Width	Trim Length	Max. AH Avail.	Thickness at Face Plates	Max. RPM	Std. Pack	Item Number
4"	.0095	1/2"-3/8"	3/8"	7/8"	3/4"	7/16"	6,000	2	35084
6"	.0104	5/8"-1/2"	1/2"	1-7/16"	1-1/4"	7/16"	6,000	2	35105
	.014								35117
8"	.014	5/8"	1/2"	2-1/16"	1-1/2"	1/2"	6,000	2	35135
<b>Orange Elastomer* - Heavy-Duty</b>									
6"	.0104	5/8"-1/2"	1/2"	1-7/16"	1-1/4"	7/16"	6,000	2	35520

\* See Elastomer Color Code chart on page 18 for more information.

**Bench Grinder Wheels** - Feature a shorter trim length, narrower face width, and the same durable construction as other Weiler crimped wire wheels; designed specifically for use on small bench grinders for reduced flaring and long life in a broad range of applications.



Dia.	Wire Size	Arbor Hole	Face Width	Trim Length	Max. AH Avail.	Thickness at Face Plates	Max. RPM	Std. Pack	Item Number
6"	.006	5/8"-1/2"	1/2"	1-1/16"	1-1/4"	7/16"	6,000	10	01085
	.008								01095
	.0118								01115
	.014								01125

**Crimped Wire Wheels - High Density** - Feature an increased fill density for greater brushing action, more consistent performance, and longer life in the most demanding applications requiring the flexibility of a crimped wire wheel.



Dia.	Wire Size	Arbor Hole	Face Width	Trim Length	Max. AH Avail.	Thickness at Face Plates	Max. RPM	Std. Pack	Item Number	
									Steel	Stainless
4-1/4"	.0118	5/8"-1/2"	3/4"	5/8"	3/4"	9/16"	6,000	1	01501	-
	.014								01502	
6"	.008	5/8"-1/2"	3/4"	1-1/8"	1"	9/16"	6,000	1	01503	-
	.0118								01504	01508
	.014								01505	01509
	.020								01506	-
7"	.014	5/8"	7/8"	1-5/8"	1"	9/16"	6,000	1	01511	-
8"	.006	5/8"	7/8"	1-1/2"	1-1/4"	11/16"	4,500	1	01512	-
	.0104								01513	-
	.0118								01514	-
	.014								01515	-
10"	.0118	3/4"	1"	2-1/2"	1-1/4"	11/16"	4,500	2	01517	-
	.014								01518	-
12"	.014	1-1/4"★	1-1/8"	3-1/8"	2"	3/4"	3,000	1	01521	-

★5/16" x 5/32" Double Keyway



If a different arbor hole is required (than listed in the tables) refer to Arbor Hole Table shown on Pg. 20.



Removing heavy break-off burrs from saw-cut tube.

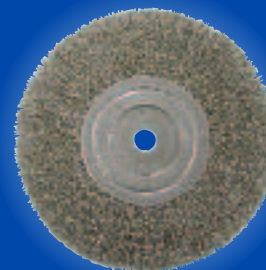

36205



35105



01115

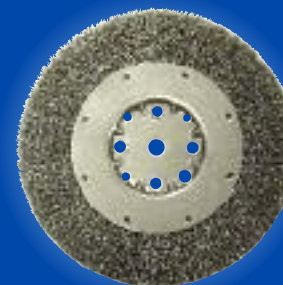

01515

Crimped Wire Wheels with Arbor Hole

# Crimped Wire Wheels with Arbor Hole

**Crimped Wire Wheels - Medium Face** - Provide a flexible brushing action and consistent performance for demanding light-duty cleaning and deburring applications; feature a wider face width to cover more area.



Dia.	Wire Size	Arbor Hole	Face Width	Trim Length	Thickness at Face Plates	Max. RPM	Std. Pack	Item Number	
								Steel	Stainless
4-1/2"	.0118	2"	15/16"	3/4"	7/8"	6,000	1	06020	-
6"	.006	2"	1"	1-1/8"	15/16"	6,000	1	06040	-
	.008							06050	-
	.0104							06060	06440
	.0118							06070	06450
	.014							06080	-
8"	.006	2"	1"	1-3/8"	1"	4,500	1	06090	-
	.0104							06100	-
	.0118							06110	06490
	.014							06120	-
	.020							06620	-
10"	.0118	2"◆	1-1/8"	2"	1"	3,600	1	06150	06530
	.014							06160	-
	.020							06170	-
12"	.0118	2"◆	1-1/4"	3"	1"	3,600	1	06180	-
	.014							06190	-
	.020							06200	-

◆ 1/2" x 1/4" Double Keyway

For arbor hole reducing adapters, see Metal Adapter Table below.

Cleaning an exhaust manifold for a small gasoline engine.

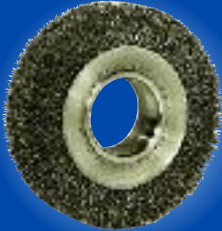

06080



06150



02325



03809

**Vortec Pro® Crimped Wire Wheels - Medium Face** - Provide a flexible brushing action and cost-effective performance in general purpose cleaning and deburring applications; feature a wider face width to cover more area.



Dia.	Wire Size	Arbor Hole	Face Width	Trim Length	Thickness at Face Plates	Max. RPM	Display Pack Item No.	Boxed Qty. Item No.
6"	.014 Coarse	5/8"-1/2"	5/8"	1-1/16"	1/2"	6,000	-	02325
			3/4"	1-7/16"	7/16"			
7"	.014 Coarse	5/8"	3/4"	1-9/16"	1/2"	6,000	-	02335

**Metal Adapters** - For Medium & Wide Face Brushes. Used in pairs & priced per pair.

For Brush Arbor Hole Size	Adapted Arbor Hole Size	Item Number
2"	1/2"	03809
	5/8"	03810
	3/4"	03811
	7/8"	03824
	1"	03812
	1-1/4"	03813
	1-1/2"	03814



# Crimped Wire Wheels with Arbor Hole

**Crimped Wire Wheels - Wide Face** - Provide a flexible brushing action and consistent performance for demanding light-duty cleaning and deburring applications; feature a wider face width to cover more area.



Dia.	Wire Size	Arbor Hole	Face Width	Trim Length	Thickness at Face Plates	Max. RPM	Std. Pack	Item Number	
								Steel	Stainless
4-1/2"	.006	2"	1-1/4"	3/4"	7/8"	6,000	1	03000	-
	.0118							03010	-
	.014							03020	-
6"	.006	2"	1-1/4"	1-1/8"	1"	6,000	1	03030	03480
	.008							03040	-
	.0104							03050	-
	.0118							03060	03510
	.014							03070	03520
7"	.0118	2"	1-1/4"	1-5/8"	1"	6,000	1	03090	-
	.014							03100	-
8"	.006	2"	1-1/2"	1-3/8"	1-3/8"	4,500	1	03110	-
	.0095							03130	-
	.0118							03140	03590
	.014							03150	-
	.020							03160	-
10"	.0104	2"	2"	1-7/8"	1-5/8"	4,000	1	03180	-
	.0118							03190	-
	.014							03200	-
	.020							03210	-
12"	.0118	2"	2"	2-7/8"	1-9/16"	3,000	1	03220	-
	.014							03230	03680
	.020							03240	-

For arbor hole reducing adapters, see Metal Adapter Table on page 31.

**Vortec Pro® Crimped Wire Wheels - Wide Face** - Provide a flexible brushing action and cost-effective performance in general purpose cleaning and deburring applications; feature a wider face width to cover more area.



Dia.	Wire Size	Arbor Hole	Face Width	Trim Length	Thickness at Face Plates	Max. RPM	Display Pack Item No.	Boxed Qty. Item No.
6"	.014" Coarse	5/8"-1/2"	7/8"	1-1/8"	7/8"	6,000	- 36004	06645 36204
7"	.014" Coarse	5/8"	7/8"	1-5/8"	7/8"	6,000	-	06655
8"	.014" Coarse	5/8"	1"	1-3/8"	1"	4,000	36006	36206
10"	.014" Coarse	3/4"	1-1/8"	2"	1"	3,600	36065	36265

**Polyflex™ Encapsulated Crimped Wire Wheel - Wide Face** - Burgundy Elastomer\* - Feature an encapsulation that gradually wears away to expose a consistent short trim for higher aggression, controlled brushing action, and longer life. Wider face width covers more area.



Dia.	Wire Size	Arbor Hole	Face Width	Trim Length	Thickness at Face Plates	Max. RPM	Std. Pack	Item Number
								Steel
6"	.0118	2"	1"	1-1/8"	1"	6,000	1	35160

\* See Elastomer Color Code Chart on page 18 for more information.

For arbor hole reducing adapters, see Metal Adapter Table on page 31.

**Crimped Wire Wheels - Extra High Density** - Engineered for maximum performance in production processes requiring the flexibility of a crimped wire wheel; for use on automated equipment for applications such as gear deburring, flash removal, and rubber buffing.

Dia.	Wire Size	Arbor Hole	Face Width	Trim Length	Thickness at Face Plates	Max. RPM	Std. Pack	Item Number
								Steel
12"	.006 .0118	2"◆	1-1/8"	1-5/8"	3/4"	3,000	1	01531 01532

◆ 1/2" x 1/4" Double Keyway



Removing carbon build-up from an automotive valve.

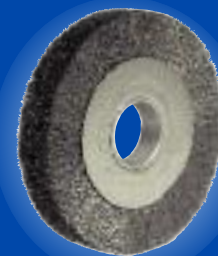

03110



06655

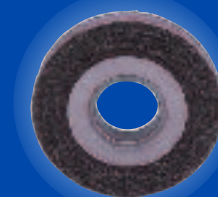

35160



01533

Crimped Wire Wheels with Arbor Hole

# Crimped Wire Wheels with Arbor Hole



Producing an antique finish on a brass door knob rose.

**Plater's Wire Wheels** - Feature a longer trim length and very small diameter fill material for producing fine satin and antique finishes on non-ferrous and precious metals.



Dia.	Wire Size	Arbor Hole	Face Width	Trim Length	Number of Rows	Max. RPM	Std. Pack	Item Number
								Brass*
3"	.003	1/4"	1/2"	1"	2	6,000	12	22021
4"	.004	1/4"	1"	1-1/4"	4	4,000	5	22061
6"	.005	1/4"	1"	1-7/8"	4	3,600	1	22241

\* Also available in carbon steel, stainless steel and nickel silver wire.

**Small Diameter Crimped Wire Wheels** - Identifiable by their copper center, Weiler's small diameter crimped wire wheels feature a plain arbor hole for use on a variety of portable tools and stationary machines. Featuring Weiler's solid ring construction for high-speed use, these radial brushes are available in heat-treated steel, Type 302 stainless steel, and brass wire.

## Applications

- Cleaning threads
- Removing rust and light corrosion
- Cleaning and finishing ID's and recessed areas
- Wire stripping
- Light deburring
- Cleaning boiler tubes and internal passages
- Removing carbon build-up and deposits

**Small Diameter Wheels** - Provide a flexible brushing action and consistent performance for light-duty cleaning and deburring applications requiring a small wheel.



Dia.	Wire Size	Arbor Hole	Face Width	Trim Length	Max. RPM	Standard Pack	Item Number						
							Steel	Stainless					
1"	.003	1/4"	3/16"	1/4"	20,000	10	-	16461					
	.005						-	16471					
	.006						15071	-					
1-1/4"	.003	1/4"	1/4"	3/8"	20,000	10	15101	-					
	.006						15111	16511					
	.008						-	16521					
	.008						15732	-					
1-3/8"	.006	1/4"	1/4"	3/8"	20,000	10	15131	-					
	.008						15141	-					
	.008						15272	-					
	.0104						15151	-					
	.0104						15302 ▲	16702					
1-1/2"	.006	3/8"	1/4"	7/16"	20,000	10	15312	16712					
	.008			7/16"			-						
	.008			1/4"			15753	-					
	.0104			3/8"			15322	-					
	.0118			3/8"			15332	-					
	.0118			3/8"			15322	-					
	.014			3/8"			15762	-					
2"	.003	1/4"	3/8"	3/4"	20,000	10	99307	-					
	.003			1/2"			15863	15973					
	.005			1/2"			-	16833					
	.006			1/2"			15433 ▲	-					
	.008			1/2"			15443	16843					
	.0104			1/2"			15453	16853					
	.0118			1/2"-3/8"			15463 ▲	16863					
	.0118			9/16"			15770	-					
	.014			1/2"-3/8"			15473	16873					
	2-1/2"			.0118			1/2"-3/8"	1/2"	3/4"	20,000	10	15513	16913
				.014								15523	-
.003		1/2"	5/8"	1"	20,000	10						99551	-
3"	.006	1/2"-3/8"	5/8"	1"	20,000	10	15533	16933					
	.006			5/8"			15/16"	-					
	.008			1/2"-3/8"			1"	15543	16943				
	.008			5/8"			15/16"	-					
	.0104			1/2"			1"	15553	-				
	.0118			1/2"-3/8"			1"	15563	16963				
	.0118			5/8"			15/16"	-					
	.014			1/2"-3/8"			1"	15573 ▲	16973				
	.014			5/8"			15/16"	-					
	4"			.006			1/2"	1/2"	1-1/2"	20,000	10	99553	-

▲ Available in non-sparking brass wire, see page 57 for details.

Crimped Wire Wheels with Arbor Hole

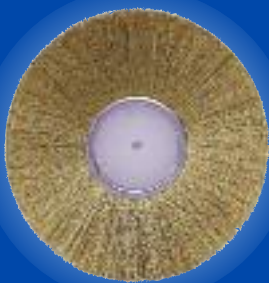

22241



15433

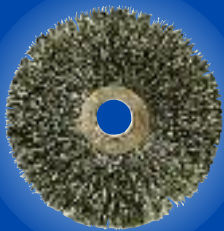

15563

# Crimped Wire Wheels with Arbor Hole

**Polyflex™ Encapsulated Small Diameter Wheels - Burgundy Elastomer\* - Feature an encapsulation that gradually wears away to expose a consistent short trim for higher aggression, controlled brushing action, and longer life.**



Dia.	Wire Size	Arbor Hole	Face Width	Trim Length	Max. RPM	Standard Pack	Item Number
							Steel
1-1/4"	.008	3/8"	3/16"	5/16"	20,000	10	35293
	.014						35294
2"	.0104	1/2"	1/4"	1/2"	20,000	10	35240
	.014						35070
3"	.008	1/2"	1/4"	1"	20,000	10	35808
	.0118						35250
	.014						35260

\* See Elastomer Color Code chart on page 18 for more information.

## Wire Stripping Brushes

Used for removing insulation from electrical wire. These brushes are made to order according to the specifications needed for the specific application.

When ordering, please specify:

- Brush diameter
- Brush face width
- Arbor hole size
- Wire size

For application assistance, call our Application Engineering Hotline toll-free at: 888-299-APPS (2777)



- The adapters and drive arbors listed on this page are for use with small diameter wheel brushes only; do not attempt to use them with cutting or grinding wheels, buffing wheels, or any type of abrasive wheel or disc.
- Do not adapt a wheel brush for use on a shaft diameter less than that specified by ANSI B165.1 (see page 20) or exceed the maximum wheel diameter specified for a drive arbor.
- Never mount a drive arbor onto a tool which operates above the maximum RPM rating of either the arbor or the brush (whichever may be lower) and be sure that the stem of the arbor is properly secured in the collet or chuck before use.

**Drive Arbors - For mounting small diameter wheels into a collet or chuck.**



Arbor Dia.	Stem Dia.	Stem Length	Length of Shaft	For Brushes with Max. Dia. of	Max. RPM	Standard Pack	Item Number
<b>Unthreaded Shaft</b>							
1/4"	1/4"	1-1/8"	3/16"	2"	20,000	5	07723
3/8"	1/4"	1-1/8"	3/16"	4"	20,000	5	07722
<b>Threaded Shaft</b>							
1/2"	1/4"	3/4"	3/4"	3"	25,000	5	07724
3/8"	1/4"	3/4"	3/4"	3"	25,000	5	07727
5/8"	1/4"	3/4"	3/4"	3"	25,000	5	07729
1/2"	1/4"	7/8"	3/4"	3"	20,000	5	07721
1/4"	1/4"	1-1/16"	1-1/8"	2"	20,000	5	07725
3/8"	1/4"	1"	1-1/8"	3"	20,000	5	07726

**Plastic Adapters - For mounting small diameter wheels onto various arbor sizes.**

Fixed Arbor Hole Size	Adapted Arbor Hole Size	Standard Pack	Item Number
1/2"	1/4"	10	04400
1/2"	3/8"	10	04401
5/8"	1/2"	10	04402
3/8"	1/4"	10	04403



Removing casting flash from ductile-iron housing with an encapsulated brush.



35070

## DID YOU KNOW?

Small diameter wheels can be manufactured with different diameters than what appears in this catalog.

Crimped Wire Wheels with Arbor Hole

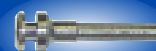

07723



07722



07727



07724



07721



07729



07726



04401, 04402

# Crimped Wire Wheels with Nut or Stem



Removing flash from a sand-cast iron engine block.

Crimped Wire Wheels with Nut or Stem

**Crimped Wire Wheels with Nut** - Crimped wire wheels with a threaded nut are intended for use primarily on small angle grinders. Featuring Weiler's solid ring construction, these radial brushes are available in heat-treated steel and Type 302 stainless steel wire.

## Applications

- Removing rust and light corrosion
- Removing heat discoloration and welding residuals
- Surface prep prior to welding

**Crimped Wire Wheels** - Provide a flexible brushing action and consistent performance for demanding light-duty cleaning and deburring applications.



Dia.	Wire Size	Arbor Hole	Face Width	Trim Length	Thickness at Face Plates	Max. RPM	Std. Pack	Item Number	
								Steel	Stainless
4"	.006	5/8"-11 UNC	1/2"	7/8"	7/16"	14,000	5	-	00156
4"	.014	M10 x 1.50 M14 x 2.0 3/8"-24 UNF 5/8"-11 UNC	1/2"	7/8"	7/16"	14,000	5	13076	-
								13077	-
								13078	-
								13081	13085
4"	.014	5/8"-11 UNC	1/2"	7/8"	7/16"	14,000	5	35416*	-

\* Polyflex™ encapsulated - Burgundy elastomer. See Elastomer Color Code Chart on page 18 for more information.

**Vortec Pro® Crimped Wire Wheel Brushes** - Provide a flexible brushing action and cost-effective performance in general purpose cleaning and deburring applications.



Dia.	Wire Size	Wire Type	Arbor Hole	Face Width	Max. RPM	Display Pack Item No.	Boxed Qty. Item No.
4"	.014" Coarse	Carbon	5/8"-11	Narrow	14,000	36007	36207

**Crimped Wire Bevel Brushes** - Saucer-shaped radial wheels which provide a flexible brushing action for cleaning fillet welds and into corners.



Dia.	Wire Size	Arbor Hole	Face Width	Trim Length	Max. RPM	Standard Pack	Item Number
							Steel
3-3/8"	.0118	M10 x 1.25 5/8"-11 UNC	1/2"	1/2"	12,500	1	13091 13095

**Crimped Wire Wheels with Stem** - Crimped wire wheels with a permanently attached 1/4" stem or shank are primarily intended for use on high-speed die grinders. Although they can also be mounted onto a drill, the speed and power of that tool will limit the effectiveness of the brush. Featuring Weiler's solid ring construction, these radial wheels are available in heat-treated steel, Type 302 stainless steel, and brass wire.

## Applications

- Cleaning threads
- Cleaning and finishing ID's and recessed areas
- Paint removal and surface cleaning
- Light deburring

**Conflex Brushes** - Small diameter copper center wheels permanently mounted onto a 1/4" stem to provide a very flexible brushing action.



Dia.	Wire Size	Face Width	Trim Length	Max. RPM	Standard Pack	Item Number		
						Steel	Stainless	Brass
2"	.006	3/8"	1/2"	20,000	10	17609	-	-
	.0118					17610	17611	-
2-1/2"	.006	3/8"	3/4"	20,000	10	17612	-	-
	.014					17614	-	-
3"	.008	1/2"	1"	20,000	10	17615 ■	-	-
	.0118					17616 ■	-	17641
	.014					17617 ■	17618	-

■ Available in Display Packaging. Add "P" to end of Item Number when placing order. See page 171 for details.

**Polyflex® Encapsulated Conflex Brushes - Burgundy Elastomer\*** - Feature an encapsulation that gradually wears away to expose a consistent short trim for higher aggression, controlled brushing action, and longer life. 1/4" Stem.



Dia.	Wire Size	Face Width	Trim Length	Max. RPM	Standard Pack	Item Number
						Steel
2"	.0118	1/4"	1/2"	20,000	10	35305
3"	.008	1/4"	1"	20,000	10	35310
	.0118					35315

\* See Elastomer Color Code Chart on page 18 for more information.



13085



13095



17616

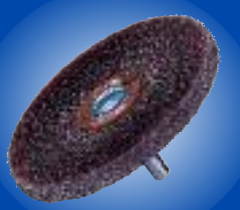

35310

# Crimped Wire Wheels with Stem

**Conflex Brushes - Wide Face** - Provide a flexible brushing action and consistent performance for demanding light-duty cleaning and deburring applications; feature a wider face width to cover more area. 1/4" Stem.



Dia.	Wire Size	Face Width	Trim Length	Max. RPM	Standard Pack	Item Number	
						Steel	Stainless
1-1/4"	.006	1/2"	3/8"	20,000	10	17600	-
	.008					17601	-
1-1/2"	.006	1/2"	1/2"	20,000	10	17602	-
	.008					17603	-
	.0118					17604	-
1-3/4"	.006	1/2"	5/8"	20,000	10	17605	-
	.008					-	17608
2"	.0118	3/4"	7/16"	20,000	10	17619	-
2-1/2"	.014	3/4"	11/16"	20,000	10	17620	-
3"	.008	1"	15/16"	20,000	10	17621	17637
	.0118					17622	-
	.014					17623	-

**Crimped Wire Radial Wheels** - Feature side plates for a shorter trim length and more controlled brushing action in a stem-mounted crimped wire wheel. 1/4" Stem



Dia.	Wire Size	Trim Length	Max. RPM	Standard Pack	Item Number	
					Steel	Stainless
1-1/2"	.006	3/8"	20,000	10	17950	17971
	.008				17951	17972
	.0118				17952	17973
	.014				17953	-
2"	.006	7/16"	20,000	10	17954	-
	.008				17955	17974
	.0118				17956	-
	.014				17957	17975
	.020				17958	-
2-1/2"	.008	9/16"	20,000	10	17959	17976
	.0118				17961	-
	.014				17962	17977
	.020				17963	-
3"	.008	13/16"	20,000	10	17964	17978
	.0118				17965	-
	.014				17966	17979
	.020				17967	-
4"	.008	1-5/16"	15,000	10	17968	17981
	.014				17969	17982

**Vortec Pro® Crimped Wire Radial Wheels** - Designed to be a flexible and economic small diameter brushing tool for a broad range of general purpose applications. 1/4" Stem.



Dia.	Wire Size	Wire Type	Trim Length	Max. RPM	Display Pack Item #	Boxed Qty. Item #
1-1/2"	.0118" Coarse	Carbon	3/8"	20,000	36008	36208
2"	.014" Coarse	Carbon	7/16"	20,000	36009	36209
3"	.008" Fine	Carbon	13/16"	20,000	36059	36259
	.014 Coarse	Carbon			36011	36211

**Concave Brushes** - Saucer-shaped radial wheels permanently mounted on a 1/4" stem to provide flexible brushing action for addressing corners and hard-to-reach areas.



Dia.	Wire Size	Trim Length	Max. RPM	Standard Pack	Item Number	
					Steel	Stainless
1-1/2"	.006	3/8"	20,000	10	17901	17930
	.008				17902	-
	.0118				17903	17931
2"	.008	1/2"	20,000	10	17906	-
	.014				17907	17933
2-1/2"	.006	5/8"	20,000	10	17909	-
	.014				17912	17935
3"	.006	15/16"	20,000	10	17914	17936
	.008				17915	-
	.014				17917	17937
4"	.008	1-1/4"	20,000	10	17922	-
	.014				17923	-



Removing carbon build-up from an engine.



17603



17971



36211



17907

Crimped Wire Wheels with Stem

# Nylon and Tampico Wheels



Deburring a plastic part using a nylon brush.



17233

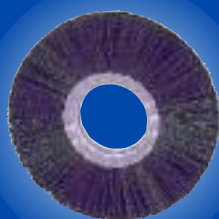

20490



17453



20180



03809

Nylon and Tampico Wheels

**Nylon Wheels** - Wheel brushes filled with non-metallic filaments are primarily intended for light-duty surface cleaning and scrubbing applications as well as scratch-free finishing and polishing. Synthetic filaments such as nylon are durable and provide a very flexible brushing action in applications requiring less aggression than a wire brush. The softer fill material allows them to be used on materials that a wire brush would scratch or gouge.

## Applications

- Wet or dry cleaning and scrubbing
- Sweeping loose chips and debris
- Removing burrs and die flash from plastic parts

**Nylon Wheels** - Feature a chemical-resistant synthetic fill material with excellent bend recovery for use in applications requiring a soft, durable fill material.



Dia.	Fill Dia.	Arbor Hole	Face Width	Trim Length	Max. RPM	Standard Pack	Item Number
1-1/2"	.010	3/8"	1/4"	7/16"	20,000	10	29025
2"	.010 .014	1/2"	3/8"	1/2"	20,000	10	17223 17233
2-1/2"	.022	5/8"	3/8"	11/16"	20,000	10	99346
3"	.010 .016	1/2"	3/8"	1"	20,000	10	29070 17263
6"	.016	2"	3/4"	1-1/2"	6,000	2	20490
8"	.020	2"	3/4"	2-1/2"	5,000	2	20510

For arbor hole reducing adapters, see Metal Adapter Table below and plastic adapters on page 34.

**Tampico Wheels** - Wheel brushes filled with non-metallic filaments are primarily intended for light-duty surface cleaning and scrubbing applications as well as scratch-free finishing and polishing. Natural vegetable fibers such as Tampico hold abrasive compounds well and can be used for deburring, edge blending, and polishing applications.

## Applications

- Wet or dry cleaning and scrubbing
- Removing burrs and blending edges with abrasive compounds
- Buffing and polishing non-ferrous and precious metals

**Tampico Wheels** - Feature a durable vegetable fiber fill material that is chemical and heat resistant and also holds abrasive compounds well.



Dia.	Arbor Hole	Face Width	Trim Length	Max. RPM	Standard Pack	Item Number
2-1/2"	1/2"	1/2"	3/4"	20,000	10	17443
3"	1/2"	1/2"	1"	20,000	10	17453
6"	2"	5/8"	1-1/2"	6,000	10	20180
8"	2"	5/8"	2-1/2"	5,000	5	20190

For arbor hole reducing adapters, see Metal Adapter Table below and plastic adapters on page 34.

**Metal Adapters** - For 6" & 8" Brushes. Used in pairs & priced per pair.

For Brush Arbor Hole Size	Adapted Arbor Hole Size	Item Number
2"	1/2"	03809
	5/8"	03810
	3/4"	03811
	7/8"	03824
	1"	03812
	1-1/4"	03813
	1-1/2"	03814

# Knot Wire Cup Brushes

**Wire Cup Brushes** - Wire cup brushes are intended primarily for use on portable power tools for addressing larger surface areas more efficiently than a wheel brush. Cup brushes featuring a threaded nut are designed for smooth, efficient operation on angle grinders to make quick work of large jobs. Utility cup brushes featuring a permanently-attached 1/4" stem are more suitable for smaller jobs and are recommended for use on high-speed air tools for the most effective brushing action and longest life.

Cup brushes are available in a variety of knot wire and crimped wire configurations for use in a broad range of surface cleaning applications, and they are manufactured with individual knot hole and solid ring construction for high performance and long life. Weiler's cup brushes are available in heat-treated steel, Type 302 stainless steel, and bronze or brass wire.

## Applications

- Removing paint and coatings
- Cleaning rust, scale, and corrosion
- Deburring
- Weld prep and cleaning
- Removal of slag from the edges of plasma-cut or flame-cut plates

**Knot Wire Cup Brushes - Single Row** - Provide heavy-duty brushing action with some flexibility; ideal for demanding cleaning applications on relatively flat surfaces.



Dia.	Wire Size	Arbor Hole	Trim Length	Max. RPM	Standard Pack	Item Number		
						Steel	Stainless	Bronze
2-3/4"	.014	M10 x 1.25	1"	14,000	1	13015	-	-
		M10 x 1.50				13016	-	-
		M14 x 2.0				13020	-	-
		3/8"-24 UNF				13021	-	-
		5/8"-11 UNC				13025	-	-
						13025 ■	-	-
2-3/4"	.020	M10 x 1.25	1"	14,000	1	13281 ■	13253	-
		M10 x 1.50				13282	13254	-
		M14 x 2.0				13283	13255	-
		3/8"-24 UNF				13284	13256	-
		1/2"-13 UNC				13285	13257	-
		5/8"-11 UNC				13286 ■	13258	13299
3-1/2"	.023	M10 x 1.25	7/8"	13,000	1	13150	-	-
		M10 x 1.50				13151	-	-
		M14 x 2.0				13152	13159	-
		3/8"-24 UNF				13153	13160	-
		1/2"-13 UNC				13155	-	-
		5/8"-11 UNC				13156 ■	13163	-
3-1/2"	.014 .020	5/8"-11 UNC	1-1/4"	9,000	1	12736	-	-
						12746	-	-
4"	.014 .020 .023 .035	5/8"-11 UNC	1-1/4"	10,200	1	12306	12406	-
						-	-	12776
						12316 ■	12416	-
						12326	-	-
4"	.023	5/8"-11 UNC	1-1/4"	10,200	1	12206 ❖	-	-
4"	.023	5/8"-11 UNC	1-1/4"	10,200	1	12826*	-	-
5"	.014 .023	5/8"-11 UNC	1-3/8"	9,000	1	12256*	-	-
						12276 ■*	-	-
6"	.014 .023 .035	5/8"-11 UNC	1-3/8"	6,600	1	12356	12456	-
						12376 ■	12476	-
						12396	-	-
6"	.023	5/8"-11 UNC	1-3/8"	6,600	1	12816*	-	-
6"	.014 .023 .035	5/8"-11 UNC	1-5/8"	6,000	1	12846	-	-
						12856	12886	-
						12866	-	-

\* With internal nut ❖ Cable Twist

■ Available in Display Packaging. Add "P" to end of Item Number when placing order. See page 171 for details.



Most Weiler wire brushes are 100% recyclable.



Removing slag from a flame-cut steel plate.



13016



13156



12276

Knot Wire Cup Brushes

# Knot Wire Cup Brushes

**Vortec Pro® Knot Wire Cup Brushes - Single Row** - Provide an aggressive brushing action for general-purpose surface cleaning applications.



Dia.	Wire Size	Wire Type	Arbor Hole	Max. RPM	Display Pack Item No.	Boxed Qty. Item No.
3"	.020" Coarse	Carbon	5/8"-11	14,000	36038	36238
		Stainless	5/8"-11		36039	36239
		Carbon	M10 x 1.25		36041	36241
		Carbon	M10 x 1.50		36042	36242
		Carbon	M14 x 2.0		36043	36243
3-1/2"	.020" Coarse	Carbon	5/8"-11	13,000	36066	-
4"	.025" Coarse	Carbon	5/8"-11	10,200	36044	36244
5"	.023" Coarse	Carbon	5/8"-11	7,000	36070	-
6"	.025" Coarse	Carbon	5/8"-11	6,600	36045	36245

Cleaning a weld joint and removing surrounding spatter with a banded knot wire cup brush.

**Knot Wire Cup Brushes - Banded - Single Row** - Feature a removable metal band around fill material to reduce the exposed trim length and limit brush flaring at operating speed to provide a very aggressive, controlled brushing action.



Dia.	Wire Size	Arbor Hole	Trim Length	Max. RPM	Standard Pack	Item Number	
						Steel	Stainless
2-3/4"	.014	5/8"-11 UNC	5/8"	12,500	1	13300	-
	.020					13301	13302
4"	.023	5/8"-11 UNC	7/8"	10,200	1	12301	-
5"	.023	5/8"-11 UNC	7/8"	6,600	1	12120	-

**Knot Wire Cup Brush - 1-1/2 Rows** - Features an internal nut for use on dedicated equipment such as line traveling machines that clean and prep OD of pipe prior to coating.

Dia.	Wire Size	Arbor Hole	Trim Length	Max. RPM	Std. Pack	Item Number - Steel
4"	.023	5/8"-11 UNC	1-1/4"	7,000	1	94012

**Knot Wire Cup Brushes - Double Row** - Provide very aggressive brushing while still maintaining some flexibility; ideal for severe cleaning applications.



Dia.	Wire Size	Arbor Hole	Trim Length	Max. RPM	Standard Pack	Item Number	
						Steel	Stainless
4"	.014	5/8"-11 UNC	1-1/4"	9,000	1	12756	-
	.020					12766	12726
6"	.014	5/8"-11 UNC	1-3/8"	6,600	1	12536	-
	.023					12556	12636
	.035					12576	-
6"	.014	5/8"-11 UNC	1-1/2"	6,000	1	12906	-
	.023					12916	-
	.035					12926	-

**Knot Wire Cup Brushes - Banded - Double Row** - Feature a removable metal band around fill material to reduce the exposed trim length and limit brush flaring to provide an extremely aggressive, controlled brushing action for the most severe applications.



Dia.	Wire Size	Arbor Hole	Trim Length	Max. RPM	Std. Pack	Item Number - Steel
4"	.020	5/8"-11 UNC	7/8"	9,000	1	12796
6"	.023	5/8"-11 UNC	7/8"	6,600	1	12676
	.035					12686

**Polyflex™ Encapsulated Crimped Wire Cup Brushes** - Feature fill material that has been encapsulated in an elastomer which gradually wears away to keep only the wire tips exposed; ideal for applications on flat surfaces that require maximum aggression but no flexibility in the brushing action.



Dia.	Wire Size	Arbor Hole	Trim Length	Max. RPM	Std. Pack	Item Number - Steel
3-1/2"	.014	5/8"-11 UNC	7/8"	12,000	1	35406
4"	.020	5/8"-11 UNC	1-1/8"	9,000	1	35186
6"	.020	5/8"-11 UNC	1-1/4"	6,000	1	35006
<b>Orange Elastomer* - Heavy-Duty</b>						
6"	.020	5/8"-11 UNC	1-1/4"	6,000	1	35530
<b>Black Elastomer* - Extra Heavy-Duty</b>						
6"	.020	5/8"-11 UNC	1-1/4"	6,000	1	35760

\* See Elastomer Color Code Chart on page 18 for more information.

Knot Wire Cup Brushes



36244



13301



12556



12676



35406



# Crimped Wire Cup Brushes

**Crimped Wire Cup Brushes** - Very flexible brushing action and the most consistent performance for demanding light-duty cleaning applications; feature a threaded nut for use on angle grinders.



Dia.	Wire Size	Arbor Hole	Trim Length	Max. RPM	Standard Pack	Item Number	
						Steel	Stainless
3"	.014	M10 x 1.25	1"	14,000	1	13240 ■▲	—
		M10 x 1.50				13241	—
		M14 x 2.0				13242	—
		3/8"-24 UNF				13243	—
		1/2"-13 UNC				13244	—
		5/8"-11 UNC				13245 ■	—
3-1/2"	.014	M10 x 1.25	7/8"	12,000	1	13175	13182
		M10 x 1.50				13176	13183
		M14 x 2.0				13177	13184
		3/8"-24 UNF				13178	13185
		1/2"-13 UNC				—	13187
		5/8"-11 UNC				13181	13188
4"	.0118 .014 .020	5/8"-11 UNC	1-3/8"	10,200	1	14016	—
						14026	—
						14036 ■▲	14126
						—	—
5"	.014 .020	5/8"-11 UNC	1-1/4"	9,000	1	14206 ▲	—
						14216	14256
6"	.014 .020	5/8"-11 UNC	1-1/4"	6,600	1	14066 ▲*	—
						14076 ■*	14166*

\* With internal nut   ▲ Available in non-sparking brass & bronze wire, see page 57 for details.  
 ■ Available in Display Packaging. Add "P" to end of Item Number when placing order. See page 170 for details.

**Vortec Pro® Crimped Wire Cup Brushes** - Provide flexible brushing action and cost-effective performance in general purpose cleaning applications.



Dia.	Wire Size	Wire Type	Arbor Hole	Max. RPM	Display Pack Item No.	Boxed Qty. Item No.
3"	.014" Coarse	Carbon	5/8"-11	14,000	36031	36231
			1/2"-13		36032	36232
			M10 x 1.25		36033	36233
			M10 x 1.50		36034	36234
			M14 x 2.0		36035	36235
3-1/2"	.014" Coarse	Carbon	5/8"-11	12,000	36068	—
4"	.020" Coarse	Carbon	5/8"-11	9,000	36036	36236
5"	.020" Coarse	Carbon	5/8"-11	9,000	36061	36261
6"	.020" Coarse	Carbon	5/8"-11	6,600	36037	36237

**Cup Brushes with Stem** - Designed primarily for use on high speed die grinders, cup brushes with permanently attached stems can also be used on drills.

**Utility Crimped Wire Cup Brushes** - Smaller diameter cup brushes which provide flexible brushing action and consistent performance for more demanding light-duty cleaning applications; featuring a 1/4" stem for use on air tools.



Dia.	Wire Size	Trim Length	Max. RPM	Standard Pack	Item Number		
					Steel	Stainless	Brass
1-3/4"	.006	3/4"	13,000	10	14300	14303	14310
	.0118				14301	14304	14314
2"	.008	5/8"	13,000	10	14313	14318	—
	.0118				14306	14319	—
2-1/2"	.008	7/8"	13,000	10	14315	14320	—
	.014				14317	14321	—
2-3/4"	.0118	7/8"	6,000	1	14302	—	14311

**Vortec Pro® Utility Crimped Wire Cup Brushes** - Designed to be a flexible and economic small diameter brushing tool for a broad range of general purpose applications using air tools or drills. 1/4" Stem.



Dia.	Wire Size	Wire Type	Trim Length	Max. RPM	Display Pack Item #	Boxed Qty. Item #
2"	.008" Fine	Carbon	5/8"	13,000	36060	36260
	.014" Coarse	Carbon			36029	36229
3"	.014" Coarse	Carbon	7/8"	13,000	36030	36230



Removing paint from a steel surface with a crimped wire cup brush.



13245



14301



36230

Crimped Wire Cup Brushes

# Small Angle Grinder Brushes



Cleaning a weld with a stringer bead wheel brush.

**Small Angle Grinder Brushes** - These industrial grade brushes are specifically designed to provide the smoothest, most efficient brushing action on 4" and 4-1/2" mini-grinders. Featuring Weiler's individual knot hole and solid ring product construction, these perfectly balanced brushes produce minimal vibration in use, reducing operator fatigue and providing longer life.

Weiler's wide selection of thread sizes and assortment of threaded adapters permit these high performance brushes to be used on all popular brands of mini-grinders. See the Small Angle Grinder Reference Chart on page 44 for help in selecting the right product for use on your specific grinder.

## Applications

- Removing paint and coatings
- Cleaning rust, scale and corrosion
- Light deburring
- Weld prep and cleaning
- Removal of slag from the edges of plasma-cut or flame-cut plates

**CHECK OUT THE VIDEO**



**Knot Wire Wheels - Standard Twist** - Provide heavy-duty brushing action with some flexibility; ideal for demanding cleaning applications on somewhat irregular surfaces.



Dia.	Wire Size	Arbor Hole	No. of Knots	Face Width	Trim Length	Thickness at Face Plates	Max. RPM	Std. Pack	Item Number	
									Steel	Stainless
3"	.014	3/8"-24 UNF	20	3/8"	5/8"	7/16"	25,000	5	13201	13208
4"	.014	M10 x 1.25	24	1/2"	7/8"	7/16"	20,000	5	13100	13107
		M10 x 1.50							13101	13108
		M14 x 2.0							13102	13109
		3/8"-24 UNF							13103	13110
		1/2"-13 UNC							13105	-
		5/8"-11 UNC							13106 ■	13113 ■
4"	.020	M10 x 1.25	24	1/2"	7/8"	7/16"	20,000	5	13114	-
		M10 x 1.50							13115	-
		M14 x 2.0							13116	-
		3/8"-24 UNF							13117	-
		1/2"-13 UNC							13119	-
		5/8"-11 UNC							13120	-

■ Available in Display Packaging. Add "P" to end of Item Number when placing order. See page 170 for details.

**Knot Wire Wheels - Cable Twist** - Provide maximum brushing action with minimal flexibility; ideal for demanding cleaning and coating removal applications on relatively smooth surfaces.



Dia.	Wire Size	Arbor Hole	No. of Knots	Face Width	Trim Length	Thickness at Face Plates	Max. RPM	Std. Pack	Item Number	
									Steel	Stainless
4"	.020	M10 x 1.25 M10 x 1.50 5/8"-11 UNC	24	1/4"	7/8"	7/16"	20,000	5	13261	-
									-	13272
									13266 ■	13276

■ Available in Display Packaging. Add "P" to end of Item Number when placing order. See page 170 for details.

**Knot Wire Wheels - Stringer Bead Twist** - Provide maximum impact action for fast removal of slag, spatter, and oxidation. The 4" Mini Roughneck and the 4-1/2" Roughneck Jr. feature a narrow face width suitable for cleaning welds and reaching into corners



Dia.	Wire Size	Arbor Hole	No. of Knots	Face Width	Trim Length	Thickness at Face Plates	Max. RPM	Std. Pack	Item Number	
									Steel	Stainless
4"	.020	1/2"-3/8" M10 x 1.25 M10 x 1.50 M14 x 2.0 3/8"-24 UNF 1/2"-13 UNC 5/8"-11 UNC	32	3/16"	7/8"	7/16"	20,000	5	13124	08954*
									13125 ■	13132
									13126	13133
									13127	13134
									13128	13135
									13130	13137
									13131 ■	13138 ■
									4-1/2"	.020
13233	13239									
13234	13249									

■ Available in Display Packaging. Add "P" to end of Item Number when placing order. See page 170 for details.

\*Standard Pack 10

13106

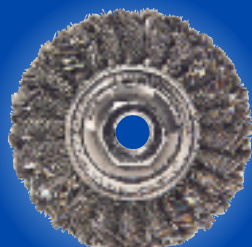

13266



13138

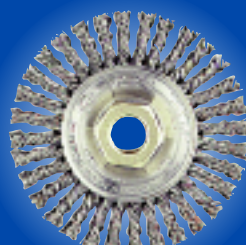

# Small Angle Grinder Brushes

**Polyflex™ Encapsulated Knot Wire Wheels - Stringer Bead Twist. Black Elastomer\*** - Feature a heat-stabilized encapsulation that gradually wears away to keep only the wire tips exposed for maximum aggression; suitable for cleaning hot welds.



Dia.	Wire Size	Arbor Hole	No. of Knots	Face Width	Trim Length	Thickness at Face Plates	Max. RPM	Std. Pack	Item Number	
									Steel	
4"	.020	5/8"-11 UNC	32	3/16"	7/8"	7/16"	20,000	5	35800	

\* See Elastomer Color Code Chart on page 18 for more information.

**Crimped Wire Wheels -** Provide flexible brushing action and consistent performance for demanding light-duty cleaning and deburring applications.



Dia.	Wire Size	Arbor Hole	Face Width	Trim Length	Thickness at Face Plates	Max. RPM	Std. Pack	Item Number	
								Steel	Stainless
4"	.014	M10 x 1.50 M14 x 2.0 3/8"-24 UNF 5/8"-11 UNC	1/2"	7/8"	7/16"	14,000	5	13076	-
								13077	-
								13078	-
								13081	13085

**Polyflex™ Encapsulated Crimped Wire Wheel - Burgundy Elastomer\*** - Feature fill material that has been encapsulated in an elastomer which gradually wears away to keep only the wire tips exposed; ideal for applications that require maximum aggression but no flexibility to the brushing action.



Dia.	Wire Size	Arbor Hole	Face Width	Trim Length	Thickness at Face Plate	Max. RPM	Std. Pack	Item Number	
								Steel	
4"	.014	5/8"-11 UNC	1/2"	7/8"	7/16"	14,000	5	35416	

\* See Elastomer Color Code Chart on page 18 for more information.

**Knot Wire Bevel Brushes -** Saucer-shaped radial wheels which provide a heavy-duty brushing action with some flexibility; ideal for cleaning fillet welds and into corners.



Dia.	Wire Size	Arbor Hole	No. of Knots	Face Width	Trim Length	Max. RPM	Std. Pack	Item Number	
								Steel	Stainless
4"	.014	M10 x 1.25 M10 x 1.50 5/8"-11 UNC	20	3/8"	3/4"	12,500	1	13401	-
								13402	13412
								13406	13416
4"	.020	M14 x 2.0 5/8"-11 UNC	20	3/8"	3/4"	12,500	1	13423	-
								13426	13436
4-1/2"	.014 .020	5/8"-11 UNC	20	3/8"	1"	12,500	1	13456	13466
								13476	13486

**Crimped Wire Bevel Brushes -** Saucer-shaped radial wheels which provide a more flexible brushing action for cleaning fillet welds and into corners.



Dia.	Wire Size	Arbor Hole	Face Width	Trim Length	Max. RPM	Standard Pack	Item Number	
							Steel	
3-3/8"	.0118	M10 x 1.25 5/8"-11 UNC	1/2"	1/2"	12,500	1	13091	13095

**Threaded Adapters -** For mounting brushes with a 5/8"-11 UNC nut to other threaded spindles.

Fixed Thread Size	Adapted Thread Size	Standard Pack	Item Number
5/8" - 11 UNC	M10 x 1.25	10	07771 ■
5/8" - 11 UNC	M10 x 1.50	10	07772 ■
5/8" - 11 UNC	3/8" - 16 UNC	10	07769
5/8" - 11 UNC	3/8" - 24 UNF	10	07746

■ Available in Display Packaging. Add "P" to end of Item Number when placing order. See page 170 for details.



Prepping the bevel end of a stainless pipe for welding.



35800



13085



35416

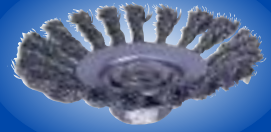

13456



13095



07771

Small Angle Grinder Brushes

# Small Angle Grinder Brushes



Removing paint from a metal surface with a crimped wire cup brush.



13016

**Knot Wire Cup Brushes** - Provide heavy-duty brushing action with some flexibility; ideal for demanding cleaning applications on relatively flat surfaces.



Dia.	Wire Size	Arbor Hole	Trim Length	Max. RPM	Standard Pack	Item Number	
						Steel	Stainless
2-3/4"	.014	M10 x 1.25	1"	14,000	1	13015	-
		M10 x 1.50				13016	-
		M14 x 2.0				13020	-
		3/8"-24 UNF				13021	-
		5/8"-11 UNC				13025 ■	-
2-3/4"	.020	M10 x 1.25	1"	14,000	1	13281 ■	13253
		M10 x 1.50				13282	13254
		M14 x 2.0				13283	13255
		3/8"-24 UNF				13284	13256
		1/2"-13 UNC				13285	13257
		5/8"-11 UNC				13286 ■	13258
3-1/2"	.023	M10 x 1.25	7/8"	13,000	1	13150	-
		M10 x 1.50				13151	-
		M14 x 2.0				13152	13159
		3/8"-24 UNF				13153	13160
		1/2"-13 UNC				13155	-
		5/8"-11 UNC				13156 ■	13163

■ Available in Display Packaging. Add "P" to end of Item Number when placing order. See page 171 for details.

**Knot Wire Cup Brushes - Hurricane Twist** - Provide very smooth brushing action and extended life with reduced cleaning action.



13711

Dia.	Wire Size	Arbor Hole	Trim Length	Max. RPM	Std. Pack	Item Number	
						Steel	Stainless
2-3/4"	.014	M10 x 1.25	3/4"	14,000	1	13715	-
		M10 x 1.50				13716	-
		M14 x 2.0				13717	-
		5/8"-11 UNC				13718	-
2-3/4"	.020	M10 x 1.25	3/4"	14,000	1	13709	13719
		M10 x 1.50				13710	13720
		M14 x 2.0				13711	13721
		5/8"-11 UNC				13712	13722

**Crimped Wire Cup Brushes** - Provide very flexible brushing action and the most consistent performance for lighter-duty cleaning applications on somewhat irregular surfaces.



13245

Dia.	Wire Size	Arbor Hole	Trim Length	Max. RPM	Std. Pack	Item Number	
						Steel	Stainless
3"	.014	M10 x 1.25	1"	14,000	1	13240 ■	-
		M10 x 1.50				13241	-
		M14 x 2.0				13242	-
		3/8"-24 UNF				13243	-
		1/2"-13 UNC				13244	-
		5/8"-11 UNC				13245 ■	-
3-1/2"	.014	M10 x 1.25	7/8"	12,000	1	13175	13182
		M10 x 1.50				13176	13183
		M14 x 2.0				13177	13184
		3/8"-24 UNF				13178	13185
		1/2"-13 UNC				-	13187
		5/8"-11 UNC				13181	13188

■ Available in Display Packaging. Add "P" to end of Item Number when placing order. See page 170 for details.

**Polyflex® Encapsulated Crimped Wire Cup Brush - Burgundy Elastomer\*** - Features fill material that has been encapsulated in an elastomer which gradually wears away to keep only the wire tips exposed; ideal for applications on flat surfaces that require maximum aggression but no flexibility to the brushing action.



35406

Dia.	Wire Size	Arbor Hole	Trim Length	Max. RPM	Standard Pack	Item Number
						Steel
3-1/2"	.014	5/8"-11 UNC	7/8"	12,000	1	35406

\*See Elastomer Color Code Chart on page 18 for more information.

Small Angle Grinder Brushes

# Small Angle Grinder Brushes

**Small Angle Grinder Reference Chart** - Lists the thread size of popular mini-grinders to help you select the appropriate Weiler brush for your tool.

Manufacturer	Model Numbers	Male Thread Size	Grinder Size	Max. RPM	
AEG	WS601	5/8-11	4-1/2"	10,000	
Black & Decker	6246	M10 x 1.50	4"	10,000	
	2750/2750G	5/8-11	4-1/2"	10,000	
	4252	5/8-11	5"	10,000	
	7750	5/8-11	4-1/2"	10,000	
	G750/G850	5/8-11	4-1/2"	10,000	
	FS6500AG	5/8-11	4-1/2"	10,000	
	G950	5/8-11	4-1/2"	10,000	
Bosch	1347A	5/8-11	4-1/2"	11,000	
	1375/1375A	5/8-11	4-1/2"	11,000	
	1700/1710D	5/8-11	4-1/2"	11,000	
	1800/1810PS	5/8-11	4-1/2"	11,000	
	1701/1711D	5/8-11	5"	11,000	
	1703EVS	5/8-11	5"	11,000	
	1711/1801	5/8-11	5"	11,000	
	1811PS	5/8-11	5"	11,000	
	1803EVS	5/8-11	5"	11,000	
	1347	M14 x 2.0	4-1/2"	11,000	
	1348/1348E	M14 x 2.0	5"	11,000	
	1347A/1348AE	5/8-11	5"	11,000	
	7352-111 Air	M14 x 2.0	5"	12,000	
	DeWalt	DW831	5/8-11	5"	10,000
DW802G		5/8-11	4-1/2"	10,000	
D28110		5/8-11	4-1/2"	11,000	
D28402/D28112		5/8-11	4-1/2"	11,000	
D28114		5/8-11	4-1/2" / 5"	11,000	
D28131		5/8-11	4-1/2" / 5"	11,000	
DW402/DW400		5/8-11	4-1/2"	10,000	
Hilti		AG 125-SE	M14	5"	11,000
	AG 125-S	M14	5"	11,000	
	DEG 500-D	5/8-11	5"	11,000	
	HG 500-D	5/8-11	5"	11,000	
	DC 500-S	5/8-11	5"	11,000	
	DAG 450-S	5/8-11	4-1/2"	11,000	
	DAG 451-S	5/8-11	4-1/2"	11,000	
	HG450	5/8-11	4-1/2"	11,000	
	HG500/DC500	5/8-11	5"	11,000	
	Hitachi	G10SR2	M10 X 1.25	4"	11,000
G12SA3/G12SE2		5/8-11	4-1/2"	10,000	
G12SR2		M10 X 1.25	4-1/2"	11,000	
G13SC2		5/8-11	5"	10,000	
G10SD1		M10 x 1.50	4"	11,000	
G12SA		5/8-11	4-1/2"	10,000	
G12S1		5/8-11	4-1/2"	11,000	
G13SC		5/8-11	5"	11,000	
Ingersoll-Rand		AG230P64	3/8-24	4"	12,000
		AG230P1045	5/8-11	4-1/2"	12,000
	AG230P105	5/8-11	5"	12,000	
	3445	5/8-11	4-1/2"	12,000	
	TA120RP64	3/8-24	4"	12,000	
	HA120RP64	3/8-24	4"	12,000	
	HA120RP1045	5/8-11	4-1/2"	12,000	
IR344	3/8 - 24	4"	13,500		
Jepson	4601	M10 X 1.25	4"	11,000	
	4205	5/8-11	5"	10,000	
	4105N	M14	5"	10,000	
	4045	5/8-11	4-1/2"	11,000	
	4050	M14	5"	11,000	
Jet	JSM-619	3/8-24	4"	11,000	
	JSM-6195B	5/8-11	5"	11,000	
	JEG-400HD	3/8-16	4"	11,500	
	JEG-450	5/8-11	4-1/2"	11,500	
	JEG-500	5/8-11	5"	9,800	

Manufacturer	Model Numbers	Male Thread Size	Grinder Size	Max. RPM
Makita	9553NB	M10 X 1.25	4"	11,000
	9564	5/8-11	4-1/2"	10,500
	9527PB/9557PB	5/8-11	4-1/2"	10,000
	9557NB	5/8-11	4-1/2"	11,000
	9554NB	5/8-11	4-1/2"	10,000
	9558NB	5/8-11	5"	11,000
	9565	5/8-11	5"	10,500
	9015A/9558PB	5/8-11	5"	10,000
	9005B	5/8-11	5"	10,000
	9514B	M10 x 1.25	4"	11,000
	9501BZ	M10 x 1.25	4"	10,000
	9501BKW	M10 x 1.25	4"	10,000
	9526PB	M10 x 1.50	4"	10,000
	9503BHZ	5/8-11	4-1/2"	10,000
	9527PB	5/8-11	4-1/2"	10,000
	9505BHZ/9528PB	5/8-11	5"	10,000
	Metabo	W 7-115	5/8-11	4-1/2"
W 7-125		5/8-11	5"	9,000
WE 9-125		5/8-11	5"	10,000
W 10-125		5/8-11	5"	10,000
WE 14-125		5/8-11	5"	10,500
W14-125		5/8-11	5"	10,000
7010		M14 x 2.0	4-1/2"	10,000
6014/7015		5/8-11	4-1/2"	10,000
EWE9125S		5/8-11	4-1/2"	1,750-8,000
11025		5/8-11	4-1/2"/5"	10,000
7026/10125		5/8-11	5"	8,500
9023	5/8-11	5"	10,000	
9025	5/8-11	5"	10,000	
11050	5/8-11	6"	8,500	
7016	5/8-11	4-1/2"	1,700-8,500	
Milwaukee Electric Tool	6140-6	5/8-11	4-1/2"	10,000
	6145	1/2-13	4-1/2"	10,000
	6148-6	5/8-11	4-1/2"	10,000
	6141	5/8-11	5"	10,000
	6149-20	5/8-11	5"	10,000
	6151	5/8-11	4-1/2"	10,000
	6153-20	5/8-11	4-1/2"	11,000
	6154-20	5/8-11	4-1/2"	11,000
	6155-20	5/8-11	5"	11,000
	6156-20	5/8-11	5"	11,000
	6140/6142	5/8-11	4-1/2"	10,000
	6145	1/2-13	4-1/2"	10,000
6146	1/2-13	5"	10,000	
Porter Cable	749/8749	M14 x 2.0	4-1/2"	12,000
	7406	5/8-11	4-1/2"	10,000
	7405	5/8-11	5"	10,000
Ryobi	AG401	5/8-11	4"	11,000
	AG450	5/8-11	4-1/2"	11,000
	SG-1000K	3/8-16	4"	11,000
	G-1155-C	5/8-11	4-1/2"	11,000
	G-1125-C	5/8-11	5"	10,000
Sioux	1240	M10 x 1.50	4-1/2"	11,000
	1240A	M10 x 1.25	4-1/2"	11,000
	1245	5/8-11	5"	10,000
Skil	9290-01	5/8-11	4-1/2"	11,500
	9330-01	5/8-11	4-1/2"	11,000
	9325-01	5/8-11	4-1/2"	11,000
	9410/(9410:02)	M10 x 1.50	4-1/2"	12,000
	9310/9415	5/8-11	4-1/2"	11,000
	9611/(9611:02)	5/8-11	4-1/2"	12,000
HD9611	5/8-11	4-1/2"	12,000	

Small Angle Grinder Brushes

# Knot Wire End Brushes



Cleaning hard-to-reach fillet welds on a gusseted base plate.



10026



36251



11141



**Stem-Mounted End Brushes** - Wire end brushes are intended primarily for use on high-speed portable power tools for addressing smaller surfaces and recessed areas. End brushes feature an integral 1/4" steel stem for safe operation at high speed and quick mounting into the collet or chuck of either electric or pneumatic die grinders.

End brushes are available in a variety of knot wire and crimped wire configurations for use in a broad range of applications, and they are manufactured with the highest quality construction for smooth, efficient performance and long life. Weiler's end brushes are available in heat-treated steel, Type 302 stainless steel, and bronze or brass wire.

## Applications

- Cleaning ID's, internal passages and recessed areas
- Deburring internal edges and crosshole intersections
- Removal of die flash and excess molded material
- Spot facing

**Knot Wire End Brushes** - Feature a hollow end and heavy-duty brushing action with some flexibility; ideal for more demanding cleaning applications in recessed areas.



Dia.	Wire Size	Trim Length	Max. RPM	Standard Pack	Item Number		
					Steel	Stainless	Bronze
1/2"	.006	1-1/8"	20,000	10	-	10215	-
	.0104				10208	10216	-
	.014				10217	10218	-
3/4"	.006	1-1/8"	20,000	10	-	10220	-
	.0104				10210	10211	-
	.014	7/8"	22,000	10025 ■	10029	-	
	.014			-	10387 ♦	-	
	.020			10026 ■	10030	-	
	.020			-	10388 ♦	-	
1-1/8"	.006	1"	20,000	10	10141	10142 •	-
	.0104				10212	10213	-
	.0118	7/8"	22,000	10187	-	-	
	.014			10027 ■	10031	-	
	.014			-	10392 ♦	-	
	.020			10028 ■	10032	10067	
	.020			-	10393 ♦	-	
	.020			-	-	-	

♦ Nickel-plated Cup compliant with DOD MIL STD 2041D(SH)

• Coated Cup

■ Available in Display Packaging. Add "P" to end of Item Number when placing order. See page 171 for details.

**Vortec Pro® Knot Wire End Brushes** - Feature similar hollow-end construction and heavy-duty brushing action, but they have been engineered to provide cost-effective use for less demanding applications.



Dia.	Wire Size	Wire Type	Trim Length	Max. RPM	Display Pack Item No.	Boxed Qty. Item No.
3/4"	.014" Fine	Carbon	7/8"	22,000	-	36286
	.014" Fine	Stainless			-	36287
	.020" Coarse	Carbon			36050	36250
1"	.014" Fine	Carbon	7/8"	22,000	-	36288
	.014" Fine	Stainless			-	36289
	.020" Coarse	Carbon			36051	36251

**Knot Wire End Brushes - Banded** - Feature a pair of bands around the fill to reduce the exposed trim length and limit brush flaring at operating speed to provide a very aggressive, controlled brushing action.



Dia.	Wire Size	Trim * Length	Max. RPM	Standard Pack	Item Number
					Steel
1-1/8"	.014	3/8"	18,000	10	11140
	.020				11141

\* Trim length from bands



**Mount End Brushes Safely** - When mounting end brushes, the amount of overhang from the tool should be minimized by clamping on as much of the straight portion of the stem as possible. However, the collet or chuck should NOT clamp on the radius at the base of the stem to insure a secure hold before use. See photo on left for the correct brush orientation.

# Crimped Wire End Brushes

**Crimped Wire End Brushes** - Feature a solid end construction and very flexible brushing action ideal for more demanding light-duty cleaning applications in corners and hard-to-reach areas.



Cleaning the exhaust port of a gasoline engine.

Dia.	Wire Size	Trim Length	Max. RPM	Standard Pack	Item Number							
					Steel	Brass	Stainless					
3/8"	.006	7/8"	20,000	10	10186	-	-					
	.0118				10188	-	-					
1/2"	.005	7/8"	25,000	10	-	10158	-					
	.006				-		10013					
	.006				-		11010 •					
	.006				-		10370 ♦					
	.0104				-		10014					
	.0104				-		11011 •					
	.0104				-		10371 ♦					
	.014				-		10015					
	.014				-		10372 ♦					
	.020				-		10016					
	.020				-		10373 ♦					
	3/4"				.006		7/8"	22,000	10	10005	-	10017
					.006					-	11013 •	
.006		-	10374 ♦									
.0104		-	10018									
.0104		-	11014 •									
.0104		-	10375 ♦									
.014		-	10019									
.014		-	10376 ♦									
.020		-	10020									
.020		-	10377 ♦									
1"		.005	7/8"	20,000	10	-				10128	-	
		.006	1"			10009					-	10021
		.006	7/8"			11006 •					-	11016 •
	.006	1"	-			-	10378 ♦					
	.0104	-	10010			-	10022					
	.0104	-	11007 •			-	11017 •					
	.0104	-	-			-	10379 ♦					
	.0118	7/8"	20,000			-	10091	-				
	.014	1"	22,000			-	10011	-	10023			
	.014	-	-			-	-	-	10380 ♦			
	.020	1-1/8"	-			-	10012 ■	-	10024			
	.020	-	-			-	-	-	10381 ♦			

♦ Nickel-plated Cup compliant with DOD MIL STD 2041D(SH)

• Coated Cup

■ Available in Display Packaging. Add "P" to end of Item Number when placing order. See page 171 for details.

**Vortec Pro® Crimped Wire End Brushes** - Feature similar solid end construction and flexible brushing action, but they have been engineered to provide cost-effective use for less demanding applications.



Dia.	Wire Size	Wire Type	Trim Length	Max. RPM	Display Pack Item #	Boxed Qty. Item #
1/2"	.006" Fine	Carbon	7/8"	25,000	-	36280
	.006" Fine	Stainless			-	36281
	.0104" Medium	Carbon			-	36282
3/4"	.006" Fine	Stainless	7/8"	22,000	-	36283
	.0104" Medium	Carbon			36047	36247
	.014" Coarse	Carbon			36046	36246
1"	.006" Fine	Carbon	7/8"	22,000	-	36284
	.006" Fine	Stainless			-	36285
	.0104" Medium	Carbon			36049	36249
	.014" Coarse	Carbon			36048	36248



11013



10009



36247



1. Insert Brush



2. Apply Power



3. Shut-Off Power



4. Remove Brush

When brushing a recessed area or the inside diameter of a tube, use an End Brush in the following manner: Insert the brush, start the brush rotating. Turn off the power before removing the brush. This will prevent the brush from flaring out and enable it to fit into the recessed area again.

Crimped Wire End Brushes

# Crimped Wire End Brushes

**Crimped Wire End Brushes - Banded** - Feature a pair of bands around the fill to reduce the exposed trim length and limit brush flaring at operating speed to provide an aggressive, controlled brushing action.



Dia.	Wire Size	Trim * Length	Max. RPM	Standard Pack	Item Number		
					Steel	Stainless	Aluminum
1/2"	.006	9/16"	20,000	10	11100	11110	-
	.0104		11101		-	-	
3/4"	.006	7/16"	20,000	10	11102	11112	-
	.0104	3/8"			11103	11113	-
		1"			3/8"	-	11114
1"	.0104	3/4"	10,000	10	11105	11115	-
1"	.008	3/4"	20,000	10	-	-	10160

\* Trim length from bands

**\*Controlled Flare End Brushes** - Feature uniquely trimmed crimped wire fill for more effective brushing action and greatly enhanced durability when cleaning corners and fillet welds.



Dia.	Wire Size	Trim Length	Max. RPM	Standard Pack	Item Number	
					Steel	Stainless
1/2"	.0104	7/8"	25,000	10	10301	10313
	.014				10302	10314
	.020				10303	10315
	3/4"				.0104	7/8"
3/4"	.014	7/8"	22,000	10	10306	-
	.020				10307	10319
	1"				.0104	1"
1"	.014	1-1/8"	22,000	10	10310	10322
	.020				10311	10323

\*Patent #8,186,000 B2

The unique trim of a controlled flare end brush is designed specifically to address hard-to-reach areas, reducing filament fatigue and breakage typically associated with a standard end brush when cleaning corners and fillet welds.



Standard Crimped Wire End Brush      Controlled Flare End Brush

**Pilot Bonding Brushes** - Banded to expose a short 3/8" trim length of crimped stainless wire and feature a pilot in the center of their solid end. They were originally designed to clean around rivet holes in aluminum aircraft panels but may be used in other similar applications.



Dia.	Wire Size	Pilot Dia.	Max. RPM	Standard Pack	Item Number
					Stainless
1/2"	.005	3/32"	20,000	10	10056
		1/8"			10057
		5/32"			10058
		3/16"			10059

**Polyflex® Encapsulated Crimped Wire End Brushes - Burgundy Elastomer\*** - Feature fill material that has been encapsulated in an elastomer which gradually wears away to keep only the wire tips exposed; ideal for applications such as spot facing which may require maximum aggression and no flaring.



Dia.	Wire Size	Trim Length	Max. RPM	Standard Pack	Item Number	
					Steel	Stainless
1/2"	.0104	7/8"	18,000	10	35340	35500
3/4"	.0104	7/8"	16,000	10	35345	35505
1"	.0104	7/8"	14,000	10	35350	-
<b>Orange Elastomer* - Heavy-Duty</b>						
1/2"	.0104	7/8"	18,000	10	35535	-
3/4"	.0104	7/8"	16,000	10	35540	-
1"	.0104	7/8"	14,000	10	35545	-

\* See Elastomer Color Code Chart on page 18 for more information.

Cleaning a fillet weld on aluminum using a controlled flare end brush.



11112



10310



10059



35350

Crimped Wire End Brushes



# Crimped Wire End & Square Brushes

**Circular Flared End Brushes** - Feature crimped wire fill which has been "pre-flared" to match the working angle of the brush at operating speed; suited for addressing broad and slightly contoured surfaces.



Dia.	Wire Size	Max. RPM	Standard Pack	Item Number	
				Steel	Stainless
1"	.006	25,000	1	10033	10042
	.008			10034	10043
	.020			10099	-
1-1/4"	.006	20,000	1	10076	-
	.008			10035	-
	.020			-	-
1-1/2"	.006	20,000	1	10044	10045
	.008			10037	10046
	.020			10038	10047
2"	.014	25,000	2	11142	-
	.008			10039	10048
2-3/4"	.008	16,000	2	10040	-
	.020			10150	10151
	.014			10041	10050
3"	.006	16,000	2	10134	-
	.008			10073	10074
	.014			-	-
	.020			-	-
4"	.008	15,000	1	-	96705

Cleaning the sides and bottom of a deep drawn part using a square brush.

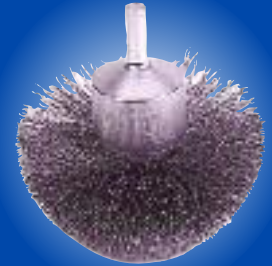

10041

**Polyflex® Encapsulated Circular Flared End Brushes - Black Elastomer\*** - Crimped wire fill that has been encapsulated in a heavy-duty elastomer which gradually wears away to keep only the wire tips exposed. Their saucer-shape, narrow face, and aggressive brushing action make them suitable for addressing edges, corners, and confined areas.



O.D. Dia.	Wire Size	Cup Size	Max. RPM	Standard Pack	Item Number	
					Steel	Stainless
1-3/4"	.006	3/4"	25,000	2	35222	-
	.0104				35223	35226
	.020				35224	-
2"	.0104	3/4"	20,000	2	35233	-
	.020				35234	-
	.006				35296	-
2-3/4"	.0104	1"	16,000	2	35297	35299
	.020				35298	-
	.020				-	-

\* See Elastomer Color Code Chart on page 18 for more information.

**Pencil End Brushes** - Contains straight wire fill material retained in a small diameter steel tube. They provide a light-duty brushing actions suitable for very small recessed areas.



Tube Dia.	Wire Size	Trim Length	Overall Length	Max. RPM	Standard Pack	Item Number	
						Steel	Stainless
1/4"	.0104	3/4"	3-3/4"	8,000	10	99825	99823

**Square Brushes** - Wire-filled square brushes are designed to simultaneously clean the side and bottom of blind bores or circular recesses. Square brushes feature an integral 1/4" steel stem for safe operation and quick mounting into the chuck of a drill or drill press.

## Applications

- Removing light rust and carbon build-up from ID's
- Deburring internal edges and crosshole intersections

**Square Brushes** - Feature crimped wire construction for a very flexible brushing action for light-duty cleaning and deburring of ID's and passages.



Sq. Dia.	Wire Size	Overall Length	Max. RPM	Standard Pack	Item Number
					Steel
1"	.006	3-5/8"	4,500	10	33000
1-1/16"	.006	3-11/16"	4,500	10	33002
1-1/2"	.006	3-7/8"	4,500	10	33005
1-7/8"	.006	4-1/16"	4,500	10	33009



99825

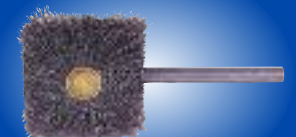

33009

Crimped Wire End & Square Brushes

# Crosshole Deburring Brushes



Deburring intersecting oil passages in an engine block.

**Bore-Rx™ Brushes** - Weiler's crimped wire Bore-Rx brushes are designed for automated use in CNC machining centers and dedicated equipment. They are densely filled for high aggression and long tool life and feature a 3/8" diameter steel stem with a flat for use in a collet or end-mill holder.

Bore-Rx brushes are ideal tools for removing burrs from internal edges. Since they can eliminate manual deburring operations, these internal brushing tools help to improve part-to-part consistency and reduce direct labor costs. Bore-Rx brushes are available in sizes ranging from 3/4" to 4" in diameter, and they are designed to be interpolated within bore sizes that are larger than the brush diameter.

**Bore-Rx Brushing Tools - Wire Fill** - Feature dense crimped wire fill for aggressive deburring action on ductile metals and other hard-to-deburr materials.

Dia.	Wire Size	Face Width	Overall Length	Max. RPM	Standard Pack	Item Number
3/4"	.005	3/8"	4-3/8"	8,000	1	17202
		3/4"	4-3/4"			17203
7/8"	.006	3/4"	4-3/4"	8,000	1	17205
1"	.006	3/4"	5"	8,000	1	17207
1-1/4"	.006	3/4"	4-3/4"	8,000	1	17209
1-1/2"	.006	1"	5"	8,000	1	17211
2"	.006	1"	4-1/4"	6,000	1	17214
2-1/2"	.008	1"	4-3/4"	6,000	1	17216
3"	.008	1"	5-1/4"	6,000	1	17218
4"	.0118	1"	6-1/4"	6,000	1	17219

\* Stainless Steel fill is available by special order.

Note: All Bore-Rx brush stems have a 2" long flat for use in end mill holders. Alternatively, they can be mounted in 3/8" collets. Bore-Rx extension holder is available. Contact Application Engineering at 888-299-APPS (2777).

## Replacement Bore-Rx Brush Heads and Reusable Bore-Rx Arbors

In high production applications, reusable arbors reduce manufacturing costs by allowing the use of inexpensive brush head replacements. Brush heads are made-to-order in diameters ranging from 3/4" to 1-1/2" with face widths of 1/4" to 1". They are available on 3/16" and 1/4" pins. The pin diameter is based on the application and determines brush density. Contact Application Engineering at 888-299-APPS (2777) for more information.



## Operating Parameters For Wire Bore-Rx Brushes

Brush Diameter	Recommended RPM	Recommended Feed Rate
5/8" - 7/8"	8,000	20"/min
1" - 1-1/2"	8,000	20"/min
2" - 2-1/2"	6,000	20"/min
3" - 4"	3,000	20"/min

### Tool Paths for Crosshole Deburring

An effective tool path for most crosshole deburring jobs is circular interpolation using the following guidelines to determine diameter of interpolation. The interpolation should be performed at a depth where the center of the brush face is at the center of the intersecting hole.

■ Diameter of Interpolation = Hole Diameter - Brush Diameter

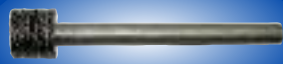

17205

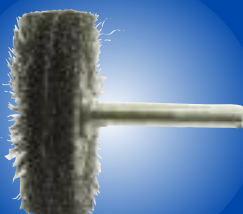

17218



Replacement Head



Reusable Arbor

# Power and Hand Tube Brushes

**Power and Hand Tube Brushes** - Weiler offers a comprehensive line of power and hand tube brushes for internal cleaning and deburring applications in tubing, pipe, drilled-and-tapped holes, and machined bores and passages. Due to their twisted-in-wire construction, the use of power tube brushes is limited to low-speed power tools such drills and drill presses and to CNC and manual machine tools in which the RPM can be precisely programmed or set. In addition, they should not be used in reverse rotation to prevent unraveling of the stem wire. Available in a wide variety of brush configurations and fill materials, Weiler can supply a tube brush for any application. If you do not see what you need in this catalog, see the Special Tube Brush Design Specification Sheet on page 54, or call our toll-free Application Engineering Hotline at 888-299-APPS(2777) for assistance.

## Applications

- Deburring and cleaning drilled-and-tapped holes and other internal threads
- Cleaning and finishing the ID of tubing and pipe
- Crosshole deburring
- Removing burrs and chips from internal keyways, slots, and grooves
- Removing paint, coatings, and build-up other foreign material from the surfaces of bores and passages

**Double Stem, Double Spiral** - Feature four stem wires and a double spiral of straight wire fill material to provide aggressive cleaning and deburring action.



Dia.	Wire Size	Brush Part	Stem Dia.	Overall Length	Standard Pack	Item Number		
						Steel	Stainless	Brass
3/8"	.003	1-1/2"	1/8"	4"	10	21342	-	-
	.006	2-1/8"		6"		21232	-	-
1/2"	.004	2"	5/32"	5"	10	21106	21116	-
	.006					21107	21117	21178
	.0104					21252	-	-
5/8"	.005	2"	7/32"	5"	10	21108	21118	-
	.008					21109	21119	21219
	.0104					21184	-	-
3/4"	.006	2-1/2"	1/4"	5-1/2"	10	21110	21120	21179
	.008					21247	-	-
	.0104					21111	21121	-
7/8"	.006	2-1/2"	1/4"	5-1/2"	10	21112	21122	-
	.0104					21113	21123	-
1"	.006	2-1/2"	1/4"	5-1/2"	10	21114	21124	21218
	.0104					21115	21125	-
1-1/4"	.006	2-1/2"	1/4"	5-1/2"	10	21164	21245	-
	.0104					21167	21236	-
1-1/2"	.014	2-1/2"	1/4"	5-1/2"	10	-	21413	-

## Tube Brush Operating Recommendations



The stems in power tube brushes are not as strong as the stems in most other brushes. Therefore, it is very important to avoid any load conditions and brush speeds that can cause excessive stem deflections and destructive bending.

A suggested guideline to avoid this unsafe condition is minimizing the overhang of the stem to under an inch, and running the brush at speeds below 2,000 RPM.

Increasing overhang could decrease the safe speed at which the brush can operate. To reach into deeper holes, use drill extension rods instead of increasing stem overhang.

### Before Starting the Brush:

- Secure brush in chuck
- Ensure clockwise brush rotation (running the brush counter-clockwise could cause the brush to fall apart.)
- Clamp work securely.
- Position all guards in place.
- Align brush with the work so the brush rotates on its true centerline to prevent any stem deflections.
- Guide the brush into the hole before starting the brush rotation.
- Always wear eye protection.



Removing zinc coating from holes in a brake bracket.



21178



21110

Correct Mounting in Chuck



Incorrect Mounting in Chuck



Power and Hand Tube Brushes

# Power and Hand Tube Brushes

**Polyflex® Encapsulated Double Stem, Double Spiral - Burgundy Elastomer\* -**  
 Encapsulated with an elastomer that leaves only the sharp wire tips exposed for maximum aggression and a very rigid brushing action.



Dia.	Wire Size	Brush Part	Stem Dia.	Overall Length	Standard Pack	Item Number	
						Steel	Brass
1/2"	.006	2"	5/32"	5"	10	35821	
5/8"	.0104	2"	7/32"	5"	10	35822	
3/4"	.0104	2-1/2"	1/4"	5-1/2"	10	35823	
1"	.0104	2-1/2"	1/4"	5-1/2"	10	35825	

\* See Elastomer Color Chart on page 20 for more information.





**Round -** Feature a single continuous length of stainless steel stem wire and a single spiral of crimped wire fill for a more flexible brushing action; for use on smooth or threaded blind holes.



Dia.	Wire Size	Brush Part	Stem Dia.	Overall Length	Standard Pack	Item Number		
						Steel	Stainless	Brass
1/4"	.004	1"	1/8"	3-1/2"	10	21072	21081	21332
5/16"	.005	1"	1/8"	3-1/2"	10	21175	-	-
3/8"	.004	1"	1/8"	3-1/2"	10	21073	21082	-
	.006					-	-	
	.008					-	-	
						21264	21240	-
7/16"	.005	1"	1/8"	3-1/2"	10	21142	21181	-
1/2"	.005	1"	3/16"	3-1/2"	10	21074	21083	21182
9/16"	.005	1"	3/16"	3-1/2"	10	21143	-	-
	.0104					-	21404	-
5/8"	.005	1"	3/16"	3-1/2"	10	21075	21084	-
	.008					-	-	
11/16"	.005	1"	3/16"	3-1/2"	10	21144	-	-
3/4"	.006	1"	7/32"	3-1/2"	10	21076	21085	-
	.008					-	-	
13/16"	.005	1"	7/32"	3-1/2"	10	21146	-	-
7/8"	.006	1"	7/32"	3-1/2"	10	21077	21086	-
	.008					-	-	
15/16"	.005	1"	7/32"	3-1/2"	10	21148	-	-
1"	.005	1"	1/4"	3-1/2"	10	21149	21340	-
	.008					21078	21087	-
1-1/8"	.005	1"	1/4"	3-1/2"	10	21150	-	-
	.008					21079	21088	-
1-1/4"	.008	1"	1/4"	3-1/2"	10	21080	21089	-
1-1/2"	.008	1"	1/4"	3-1/2"	10	21203	-	21152
	.0104					-	-	
2-1/4"	.008	1"	1/4"	3-1/2"	10	21322	-	-



## Power and Hand Tube Brush Selection Tips

- A flat burrite style tube brush is most effectively used with a holder on blind, threaded holes. 
- A round tube brush is most effectively used fully chucked on smooth or threaded blind holes. 
- A single stem, single spiral tube brush is most effectively used for manual or hand cleaning applications. 
- A double stem, double spiral tube brush is most effectively used with power tools for heavy-duty cleaning and deburring. 
- A polyflex encapsulated double stem, double spiral tube brush is most effectively used on power tools for very aggressive cleaning and deburring applications. 

Cleaning the threads on the I.D. of a mortar shell.



35825



21074

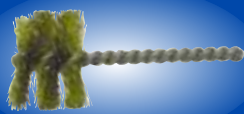

21152

## DID YOU KNOW?

Weiler manufactures more "special" power & hand tube brushes than the standard products in this catalog.

# Power and Hand Tube Brushes

**Burrite Type** - Feature a single continuous length of stainless steel stem wire and filled with a tuft of crimped wire to provide an aggressive flat side action; ideal for cleaning and deburring internal threads.



Dia.	Wire Size	Brush Part	Stem Dia.	Overall Length	Standard Pack	Item Number	
						Steel	Stainless
1/4"	.003	9/16"	3/32"	2-1/8"	10	21000	-
	.005					21001	21050
5/16"	.003	9/16"	3/32"	2-1/8"	10	21004	-
	.005					21005	-
3/8"	.003	9/16"	3/32"	2-1/8"	10	21008	-
	.005					21009	21051
	.005					21023	-
7/16"	.003	9/16"	3/32"	2-1/8"	10	21014	-
	.005					21015	-
	.005					21020	-
1/2"	.003	9/16"	3/32"	2-1/8"	10	21021	21053
	.005					21025	-
	.005					21027	-
9/16"	.003	5/8"	1/8"	2-1/4"	10	21028	-
	.005					21030	-
	.005					21031	21055
5/8"	.003	5/8"	1/8"	2-1/4"	10	21034	21056
	.005					21035	-
	.008					21036	21057
3/4"	.005	5/8"	1/8"	2-1/4"	10	21040	21058
	.008					21041	-
	.008					21044	-
1-1/8"	.005	5/8"	1/8"	2-1/4"	10	-	-

Deburring the threads of a tapped hole using a burrite brush in a holder.



21014

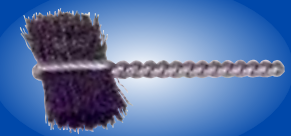

21040

**Burrite Type Holders** - Feature a 1/4" stem for convenient mounting into the chuck of a drill or the collet of a machine tool and allow the brush to be used in either direction of rotation. They allow the brush to be used in a standard tapping cycle for deburring threaded holes in CNC machining centers.



For Brush Stem Dia.	Holder Dia.	Overall Length	Standard Pack	Item Number
3/32"	1/4"	3-1/8"	5	95202
1/8"	3/8"	3-3/8"	5	95203



95203

**Single Stem, Single Spiral** - Feature a single continuous length of galvanized steel stem wire with a formed eye loop for convenient hand use. The single spiral of straight wire fill allows for easy manual insertion into the ID.

Dia.	Wire Size	Brush Part	Stem Dia.	Overall Length	Standard Pack	Item Number		
						Steel	Stainless	Brass
1/8"	.003	1"	3/32"	6"	10	21246	21249	-
3/16"	.003	1-1/2"	3/32"	7"	10	21090	21098	21221
	.005					21091	21099	-
1/4"	.003	1-1/2"	3/32"	7"	10	21092	21100	21270
	.005					21093	21101	21139
	.006					21161	-	-
	.006					21094	21414	21191
3/8"	.004	2"	1/8"	8"	10	21095	21103	-
	.006					21096	21104	21165
1/2"	.004	2"	1/8"	8"	10	21097	21105	-
	.006					21162	-	-
	.008					-	-	-
9/16"	.005	2-1/2"	5/32"	9"	10	21233	-	-



21095

Power and Hand Tube Brushes

# Power and Hand Tube Brushes

**Nylon Hand Tube Brushes** - Feature a single continuous length of galvanized steel stem wire with a formed eye loop for convenient hand use. The single spiral of straight nylon fill allows for easy manual insertion and scratch-free cleaning of the ID.

Dia.	Fill Dia.	Brush Part	Stem Dia.	Overall Length	Standard Pack	Item Number Nylon
1/4"	.005	2"	3/32"	6-1/4"	36	44110
3/8"	.005	2"	3/32"	6-1/4"	36	44213
1/2"	.010	3"	1/8"	8-1/2"	36	44111
3/4"	.012	3"	1/8"	8-1/2"	36	44112
1"	.014	4"	5/32"	12-1/4"	36	44113
1-1/4"	.014	4"	5/32"	13"	36	44114
2"	.014	5"	3/16"	16-3/4"	36	44115

Removing flash from the I.D. of an aluminum casting.



44113

**Percolator Brush** - Features single stem, single spiral construction with an eye loop and straight white nylon fill. Intended for cleaning the internal passages in coffee percolators, this brush can be also be used in other similar manual cleaning applications.

Dia.	Fill Dia.	Brush Part	Stem Dia.	Overall Length	Standard Pack	Item Number Nylon
7/16"	.010	3-1/2"	5/32"	11-1/2"	10	44316



44316

**Valve Guide Brushes** - Are made with single stem, single spiral construction and have a permanently-attached long steel handle for convenient hand use or for mounting into a chuck. Intended for removing heavy deposits from valve guides in gas and diesel engines, these brushes can also be used in a range of other similar applications.



Dia.	Fill Dia./Material	Brush Part	Overall Length	Standard Pack	Item Number
1/4"	.0104 Steel	2"	10"	10	95563
5/16"					95027
11/32"					95566
3/8"					95028
7/16"					95665
1/2"	95029				
11/32"	.008 Nylon	2-1/2"	10"	10	95660
3/8"	.012 Nylon				95567



95567

**Gun Cleaning Brushes - Rifle Brushes**

Constructed using a continuous piece of stem wire and fine bronze wire fill for a scratch-free cleaning action in gun barrels, these flexible tube brushes are designed to be attached to extension rods using the 8-32 male coupling.

Caliber	Brush Part	Overall Length	Coupling Size	Standard Pack	Item Number Bronze
22	2-1/4"	3-1/4"	8-32	10	95301
30	2-1/4"	3-1/4"	8-32	10	99786
35	2-1/4"	3-1/4"	8-32	10	99788
45	2-1/4"	3-1/4"	8-32	10	99791



95301

**Gun Cleaning Brushes - Shotgun Brushes**

Constructed using a continuous piece of stem wire and fine bronze wire fill for a scratch-free cleaning action in gun barrels, these flexible tube brushes are designed to be attached to extension rods using the 5/16"-27 male coupling.

Gauge	Brush Part	Overall Length	Coupling Size	Standard Pack	Item Number Bronze
12	1-5/8"	2-7/8"	5/16-27	10	99714
16	1-5/8"	2-7/8"	5/16-27	10	99694
20	1-5/8"	2-7/8"	5/16-27	10	95084
410	1-5/8"	2-7/8"	5/16-27	10	95129



99714

Power and Hand Tube Brushes

# Power and Hand Tube Brushes

**Special Brush Designs** - Design a power tube brush for your specific application.

## Special Tube Brush Specification Sheet:

(Use the illustration on this page as a guide)

1. Brush diameter \_\_\_\_\_
2. Length of brush part \_\_\_\_\_
3. Overall brush length \_\_\_\_\_
4. Special stem diameter (if required) \_\_\_\_\_
5. Stem material:  
 Galvanized Steel     Stainless     Other
6. Application \_\_\_\_\_
7. Brush fill material:  
 Steel wire     Stainless wire  
 Nylon Abrasive Filament (Nylox®)  
 Brass wire     Other \_\_\_\_\_
8. Fill material diameter \_\_\_\_\_
9. Special tip style (if required) \_\_\_\_\_
10.  Single stem     Double stem
11. Order Quantity \_\_\_\_\_

**\* Special tube brushes are not returnable, as they are manufactured to order.**

Name: \_\_\_\_\_  
 Company Name: \_\_\_\_\_  
 Address: \_\_\_\_\_  
 Phone: (\_\_\_\_\_) \_\_\_\_\_  
 Fax: (\_\_\_\_\_) \_\_\_\_\_  
 E-mail: \_\_\_\_\_

End-User Name: \_\_\_\_\_  
 City: \_\_\_\_\_  
 State: \_\_\_\_\_ Zip: \_\_\_\_\_

**For additional information call:**

Weiler's Application Engineering  
 Hotline toll free at:  
**888-299-APPS (2777)**

**Mail or fax specification sheet to:**

Application Engineering  
 Weiler Corporation  
 One Weiler Drive  
 Cresco, PA 18326-0149  
**Fax: 800-635-3615**

**Or visit our website at:**

**www.weilercorp.com**  
**E-mail: info@weilercorp.com**

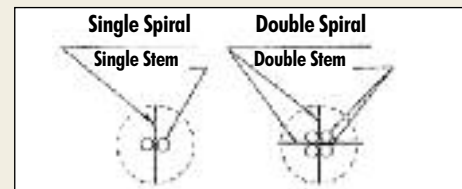
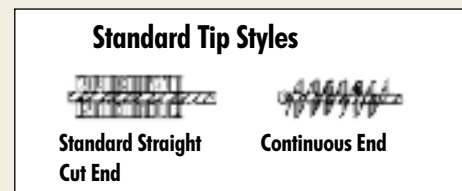
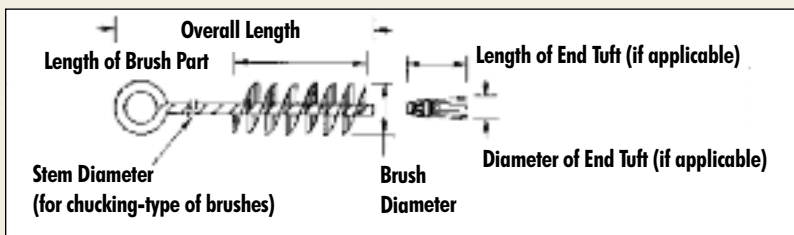

Power and Hand Tube Brushes

# Miniature Brushes



Removing galled spots from a metal forming die.



99554

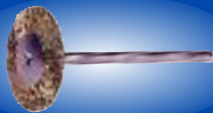

26144

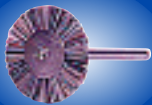

26041



26074



26095

Miniature Brushes

**Miniature Brushes** - The Weiler family began producing miniature brushes for the jewelry industry in 1898, and their tradition of providing the highest quality, most cost-effective products continues to this day.

Weiler's line of miniature brushes are designed for precision cleaning, light deburring, and finishing applications in variety of crafts, trades, and industries. In addition to use in jewelry production and in dental and optical labs, miniature brushes have many applications in modern industries such as electronics and instrumentation production, aerospace and aircraft manufacture, and precision tool and die shops. They are permanently mounted on 1/8" or 3/32" stems for quick mounting and efficient use on high-speed electric rotary tools and air-powered pencil die grinders.

## Applications

- Decorative finishing
- Buffing and polishing of small parts
- Light deburring and edge blending
- Light-duty cleaning

## Wire Wheel Brushes -

Fine crimped wire fill for light-duty cleaning and deburring.



Dia.	Wire Size	Trim Length	Stem Size	Max. RPM	Standard Pack	Item Number		
						Steel	Stainless	Brass
5/8"	.005	1/8"	1/8"	37,000	144	-	99554	-
3/4"	.003 .005	3/16"	1/8"	37,000	144	26000	-	26001
						26003	26005	26004
3/4"	.003 .005	3/16"	3/32"	37,000	144	26140	-	26141
						26143	-	26144
1"	.003 .005 .005	5/16"	1/8"	37,000	144	26012	26014	-
						26015	26017	26016
						26155	-	-
1-1/4"	.005	3/8"	1/8"	37,000	144	26021	-	-
1-1/2"	.005	1/2"	1/8"	25,000	144	26296	26294	-

**Bristle Wheel Brushes** - Natural hair fill for scratch-free cleaning of small parts or for buffing and polishing of features such as slots and grooves using abrasive compounds.



Dia.	Fill Type	Trim Length	Stem Size	Max. RPM	Standard Pack	Item Number
3/4"	Stiff Hair	3/16"	3/32"	37,000	144	26041
	Soft Hair					26042
	Stiff Hair*					26043
	Stiff Hair					26059
			1/8"			

\* Double thick

## Wire Cup Brushes -

Fine crimped wire fill for light-duty cleaning or deburring in confined areas.



Dia.	Wire Size	Trim Length	Stem Size	Max. RPM	Standard Pack	Item Number		
						Steel	Stainless	Brass
5/8"	.003 .005	1/4"	1/8"	37,000	144	26071	-	26072
						26074	26076	26075

**Bristle Cup Brushes** - Natural hair fill for scratch-free cleaning of confined areas or for buffing and polishing of small recessed surfaces using abrasive compounds.



Dia.	Fill Type	Trim Length	Stem Size	Max. RPM	Standard Pack	Item Number
1/2"	Stiff Hair	7/32"	3/32"	37,000	144	26091
9/16"	Stiff Hair	1/4"	1/8"	37,000	144	26093
	Soft Hair					26094
1"	Stiff Hair	7/16"	1/8"	25,000	144	26095
	Soft Hair					26096



# Miniature Brushes

**Wire End Brushes** - Fine crimped wire fill for light-duty cleaning or deburring in very small recessed areas or ID's.



Dia.	Wire Size	Trim Length	Stem Size	Max. RPM	Standard Pack	Item Number		
						Steel	Stainless	Brass
3/16"	.003	1/4"	1/8"	37,000	144	-	-	26097
			3/32"			26098	26099	-
						26101	-	-
1/4"	.005	7/16"	1/8"	37,000	144	-	-	26106
						26107	26108	-
5/16"	.005	9/16"	1/8"	25,000	144	26113	26114	-

**Bristle End Brushes** - Natural hair fill for scratch-free cleaning or for buffing and polishing of very small recesses using abrasive compounds.



Dia.	Fill Type	Trim Length	Stem Size	Max. RPM	Standard Pack	Item Number
3/16"	Stiff Hair	1/4"	1/8"	37,000	144	26115
	Soft Hair		3/32"			26122
	Stiff Hair					26116
1/4"	Stiff Hair	3/8"	1/8"	37,000	144	26119
5/16"	Stiff Hair	9/16"	1/8"	25,000	144	26121

**Bristle End Brushes - Plastic Ferrule**  
Feature a plastic ferrule or cup to protect internal surfaces during use.



Dia.	Fill Type	Trim Length	Stem Size	Max. RPM	Standard Pack	Item Number
3/16"	Stiff Hair	1/4"	1/8"	37,000	144	26128
1/4"	Stiff Hair	3/8"	1/8"	37,000	144	26131
5/16"	Stiff Hair	9/16"	1/8"	25,000	144	26133

**Abrasive Nylon End Brushes - Plastic Ferrule**  
Nylox® abrasive nylon fill for buffing and polishing without compounds. They can also be used in automated applications for precision deburring and finishing of small part features.



Dia.	Filament Dia./Grit	Trim Length	Stem Size	Max. RPM	Standard Pack	Item Number
3/16"	.018/500	1/4"	1/8"	37,000	144	26136
1/4"	.018/500	3/8"	1/8"	37,000	144	26138
5/16"	.018/500	9/16"	1/8"	25,000	144	26146

**DID YOU KNOW?** Weiler Corporation is the largest manufacturer of miniature brushes in the world.



Deburring the I.D. of a small machined part.



26114



26121



26133

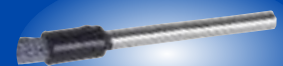

26136

Miniature Brushes

# Non-Sparking Brushes



Creating an antique finish on a brass plate.



13121



01475



29078



17641



13299

Non-Sparking Brushes

**Non-Sparking Brushes** - Weiler offers an assortment of wire power brushes featuring high-quality bronze or brass wire which offer a very soft brushing action in comparison to steel and stainless steel and which will not generate a spark when used on metal surfaces. They are frequently used for cleaning molds and dies in the injection-molding and extrusion of plastics, and in maintenance activities in areas where flammable or potentially explosive materials are present, such as refineries and petrochemical plants.

Non-sparking brushes are available in a variety of knot wire and crimped wire configurations for use in a broad range of surface cleaning applications, and they are manufactured with individual knot hole and solid ring construction for high performance and long life. Weiler's non-sparking power brushes are available with plain arbor holes, nuts, and permanently-attached stems for use on a variety of tools.

## Applications

- Light to medium duty cleaning of surfaces, recesses, and ID's
- Deburring component parts machined from soft, non-ferrous metals

**Standard Twist Wheels** - Provide a heavy-duty brushing action with some flexibility; ideal for more demanding cleaning applications.



Dia.	Wire Size	Arbor Hole	No. of Knots	Face Width	Trim Length	Max. AH Avail.	Thickness at Face Plates	Max. RPM	Std. Pack	Item Number Bronze
3"	.020	1/2" - 3/8"	20	3/8"	5/8"	1/2"	7/16"	25,000	10	08271
4"	.020	5/8" - 11	24	1/2"	7/8"	-	7/16"	20,000	5	13121

**Crimped Wire Wheels** - Provide a flexible brushing action and consistent performance for light-duty cleaning and deburring applications.



Dia.	Wire Size	Arbor Hole	Face Width	Trim Length	Max. AH Avail.	Thickness at Face Plates	Max. RPM	Std. Pack	Item No. Brass
6"	.005 .0118	5/8"-1/2"	1/2"	1-7/16"	1-1/4"	7/16"	6,000	2	01415 01475

For other available arbor holes, see Arbor Hole Table pg 20.

**Small Diameter Crimped Wire Wheels** - Provide a flexible brushing action and consistent performance for light-duty cleaning and deburring applications requiring a small wheel.



Dia.	Wire Size	Arbor Hole	Face Width	Trim Length	Max. RPM	Std. Pack	Item Number Brass
1-1/2"	.005	3/8"	1/4"	7/16"	20,000	10	29178
2"	.005 .0118	1/2"	3/8"	1/2"	20,000	10	29059 29086
3"	.014	1/2"	5/8"	1"	20,000	10	29078

**Conflex Brush** - Small diameter copper-center wheels permanently mounted onto a 1/4" stem to provide a very flexible brushing action.



Dia.	Wire Size	Face Width	Trim Length	Max. RPM	Standard Pack	Item Number Brass
3"	.0118	1/2"	1"	20,000	10	17641

**Knot Wire Cup Brushes** - Provide heavy-duty brushing action with some flexibility for more demanding cleaning applications on relatively flat surfaces.



Dia.	Wire Size	Arbor Hole	Trim Length	Max. RPM	Standard Pack	Item Number Bronze
2-3/4"	.020	5/8"-11 UNC	1"	14,000	1	13299
4"	.020	5/8"-11 UNC	1-1/4"	10,200	1	12776

# Non-Sparking Brushes

**Crimped Wire Cup Brushes** - Provide a very flexible brushing action for light-duty cleaning applications on somewhat irregular surfaces.



Dia.	Wire Size	Arbor Hole	Trim Length	Max. RPM	Standard Pack	Item Number	
						Bronze	Brass
3"	.020	5/8"-11 UNC	7/8"	14,000	1	13231	—
4"	.020	5/8"-11 UNC	1-3/8"	10,200	1	14616	—
5"	.014	5/8"-11 UNC	1-1/4"	8,000	1	—	14606
6"	.020	5/8"-11 UNC	1-1/4"	6,600	1	14316*	—

\* With internal nut

**Utility Crimped Wire Cup Brushes** - Smaller diameter cup brushes which provide a flexible brushing action for light-duty cleaning applications.



Dia.	Wire Size	Trim Length	Stem Diameter	Max. RPM	Standard Pack	Item Number
						Brass
1-3/4"	.006	3/4"	1/4"	13,000	10	14310
	.0118					14314
2-3/4"	.0118	7/8"	1/4"	6,000	1	14311

**Knot Wire End Brushes** - Feature a hollow end and heavy-duty brushing action with some flexibility; ideal for more demanding cleaning applications in recessed areas.



Dia.	Wire Size	Trim Length	Stem Diameter	Max. RPM	Standard Pack	Item Number
1-1/8"	.020	7/8"	1/4"	22,000	10	10067

**Crimped Wire End Brushes** - Feature a solid end and very flexible brushing action ideal for light-duty cleaning applications in corners and hard-to-reach areas.



Dia.	Wire Size	Trim Length	Stem Diameter	Max. RPM	Standard Pack	Item Number
						Brass
1/2"	.005	7/8"	1/4"	25,000	10	10158
1"	.005	7/8"	1/4"	20,000	10	10128
1"	.0118	1"	1/4"	22,000	10	10091

**Double Stem, Double Spiral Power Tube Brushes** - Constructed with four stem wires and a double spiral of straight wire fill material to provide a more aggressive internal cleaning action.



Dia.	Wire Size	Brush Part	Stem Dia.	Overall Length	Standard Pack	Item Number
						Brass
1/2"	.006	2"	5/32"	5"	10	21178
5/8"	.008	2"	7/32"	5"	10	21219
3/4"	.006	2-1/2"	1/4"	5-1/2"	10	21179
1"	.006	2-1/2"	1/4"	5-1/2"	10	21218

**Round Power Tube Brushes** - Feature a single continuous length of stainless steel stem wire and a single spiral of crimped wire fill for a more flexible brushing action; suitable for use on smooth or threaded blind holes.



Dia.	Wire Size	Brush Part	Stem Dia.	Overall Length	Standard Pack	Item Number
						Brass
1/4"	.004	1"	1/8"	3-1/2"	10	21332
1/2"	.005	1"	3/16"	3-1/2"	10	21182
1-1/2"	.008	1"	1/4"	3-1/2"	10	21152

**Single Stem, Single Spiral Hand Tube Brushes** - Constructed using a single continuous length of galvanized steel stem wire and feature a formed eye loop for convenient hand use. The single spiral of straight wire fill allows for easy manual insertion into the ID.

Dia.	Wire Size	Brush Part	Stem Dia.	Overall Length	Standard Pack	Item Number
						Brass
3/16"	.003	1-1/2"	3/32"	7"	10	21221
1/4"	.003	1-1/2"	3/32"	7"	10	21270
	.005					21139
3/8"	.004	2"	1/8"	8"	10	21191
1/2"	.004	2"	1/8"	8"	10	21165



Removing labels from a compressed-gas storage cylinder.



14316



14314



10067



10158



21178



21332



21191

Non-Sparking Brushes

# Strip Brushes



Straight strip brush used as a guard to prevent chips from flying.

**Metal Channel Strip Brushes** - Consist of natural, synthetic or wire bristles, held securely in place by a U-shaped metal channel and center wire, as illustrated. All Weiler brushes are first manufactured into a straight strip brush. The strip can then be coiled into cylinder brushes, or other shapes such as discs and cups. There is a variety of brush fill and virtually an infinite number of brush specifications within each metal channel size. All strip brushes are manufactured to our customers' individual requirements. This provides the proper filament stiffness, and allows for customers' unique modification of length and trim, enabling us to provide the ideal brush for the application.

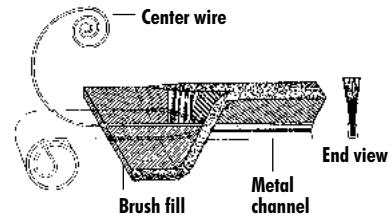

## Applications

- Spreading powdered materials
- Lag brushes
- Dusting tires, tile, paper, etc.
- Eliminating static electricity
- Splash guard on grinders and machine tools
- Curtains to prevent chips from flying
- Conveyor belt cleaning - assembled on hubs to form rotary brushes



## DID YOU KNOW?

Weiler Strip Brushes are used to apply wax to apples.

## General Fiber Characteristics

	6.6 Nylon	6.12 Nylon	Polypropylene	Horse Hair	Tampico
Heat Distortion (° F)	300	250	225	370	283
Melting Point	500	405	330	-	-
Bend Recovery (%)	90	90	70-80	excellent	poor
Shelf Life	excellent	excellent	good	poor	fair
Abrasion Resistance	excellent	excellent	good	good	poor
Specific Gravity (G/CC)	1.13-4	1.04-5	.90-1	1.3	.6
Tensile Strength (PSI)	60-70M	50-60M	50-80M	-	-

## Chemical and Environmental Resistance

	6.6 Nylon	6.12 Nylon	Polypropylene	Horse Hair	Tampico
Dilute Alkalis	excellent	excellent	excellent	poor	good
Dilute Acids	good	good	excellent	poor	good
Strong Acids	fair	good	good	good-poor	good-poor
Alcohols	good	good	excellent	poor	good
Petroleum Distillates	excellent	excellent	good	poor	good
Hot Water	good	good	fair	poor	good
Alcohols, Vegetable Oils	good	good	excellent	poor	good

# Strip Brushes - Straight

## Strip Brushes - Straight

Can be mounted on metal or wood back-up plates or on rotary hubs with machine or wood screws.

### Fill Materials

- Hair (horse, goat, etc.)
- Carbon steel
- Type 302 stainless steel
- Non-ferrous metals (brass, bronze, etc.)
- Nylon abrasive filament (Nylox®)
- Natural fibers (tampico)
- Synthetics (nylon, polypropylene)



## Strip Brushes - Straight

Metal Channel Size	Before Forming	After Forming (width x height)	Channel Materials			Max. OAH	Max. Bristle Dia. (nylon)	Max. Bristle Dia. (wire)
			Galv. Steel	Stainless Steel				
				400 Series	300 Series			
#2.5	5/16" x .025	1/8 (.125) x 1/8" (.125)	XXX	XXX	-	1-1/2"	.012	.006*
#3	3/8" x .025	5/32" (.156) x 5/32" (.156)	XXX	XXX	-	3-1/2"***	.014	.006*
#4	1/2" x .030	3/16" (.187) x 3/16" (.187)	XXX	XXX	XXX	4"	.025	.010
#5	5/8" X .040	7/32" (.218) X 1/4" (.250)	XXX	XXX	-	4-1/2"	.030	.014
#7	7/8" X .040	5/16" (.312) X 5/16" (.312)	XXX	XXX	XXX	6"	.050	.020
#10	1-1/4" X .050	7/16" (.437) X 7/16" (.437)	XXX	XXX	-	6"	.060	.020

### Straight Strip Brushes Specification Sheet - Use illustration as guide

\* Available in brass or bronze only.  
\*\* Max. wire OAH 1-1/2".

1. Overall brush height \_\_\_\_\_
2. Overall brush length \_\_\_\_\_
3. Channel size:
  - #2.5     #3     #4
  - #5     #7     #10
4. Channel material:
  - Galvanized Steel     Stainless Steel
5. Brush fill material:
  - Horsehair     Nylon
  - Carbon Steel     Bronze
  - Polypropylene     Brass
  - 302 Stainless     Tampico
  - Nylon Abrasive Filament (Nylox)
  - Other \_\_\_\_\_
6. Fill material:
  - Crimped     Straight
  - Diameter \_\_\_\_\_
  - Color (if applicable) \_\_\_\_\_
7. Application:  Wet     Dry  
Operating Temp. \_\_\_\_\_ °F
8. Quantity required \_\_\_\_\_

**\* Straight strip brushes are not returnable, as they are manufactured to order.**

Name: \_\_\_\_\_

Company Name: \_\_\_\_\_

Address: \_\_\_\_\_

Phone: (\_\_\_\_) \_\_\_\_\_

Fax: (\_\_\_\_) \_\_\_\_\_

E-mail: \_\_\_\_\_

End-User Name: \_\_\_\_\_

City \_\_\_\_\_ State \_\_\_\_\_ Zip \_\_\_\_\_

**For additional information call:** Weiler's Application Engineering Hotline toll free at: **888-299-APPS (2777)**

**Mail or fax specification sheet to:** Application Engineering  
Weiler Corporation  
One Weiler Drive  
Cresco, PA 18326-0149  
Fax: **800-635-3615**

**Or visit our website:** [www.weilercorp.com](http://www.weilercorp.com)  
E-mail: [info@weilercorp.com](mailto:info@weilercorp.com)

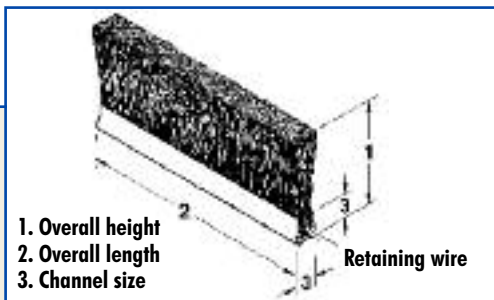

# Strip Brushes - Discs, Cups & Holders

**Strip Brushes - Coil Wound** - Can be supplied as an unmounted refill coil, mounted on disposable tubing or wound on a customer's shaft.

## Fill Materials

- Hair (horse, goat, etc.)
- Carbon steel
- Type 302 stainless steel
- Non-ferrous metals (brass, bronze, etc.)
- Nylon abrasive filament (Nyxox®)
- Natural fibers (tampico)
- Synthetics (nylon, polypropylene)

**Alligator Clips** - Use on #7 channel only. Coil Wound Strip Brushes can be supplied with Alligator Clips that have tabs at each end to be attached to customers' mandrel.



## Strip Brushes - Coil Wound

Metal Channel Size	Before Forming	After Forming (width x height)	Channel Materials			Min. I.D.	Max. O.D.	Max. Bristle Dia. (nylon)	Max. Bristle Dia. (wire)
			Galv. Steel	Stainless Steel					
				400 Series	300 Series				
#2.5	5/16" x .025	1/8 (.125) x 1/8" (.125)	XXX	XXX	-	3/8"	3-3/8"	.012	.006*
#3	3/8" x .025	5/32" (.156) x 5/32" (.156)	XXX	XXX	-	3/8"	7"	.014	.006*
#4	1/2" x .030	3/16" (.187) x 3/16" (.187)	XXX	XXX	XXX	1/2"	7"	.025	.008
#7	7/8" x .040	5/16" (.312) x 5/16" (.312)	XXX	XXX	XXX	1"	11"	.050	.020

\* Available in brass or bronze only.

## Coil Wound Strip Brushes Specification Sheet - Use illustrations as guide

<p>1. Outside diameter size _____</p> <p>2. Inside diameter size _____</p> <p>3. Brush face _____</p> <p>4. Channel size:  <input type="checkbox"/> #2.5   <input type="checkbox"/> #3   <input type="checkbox"/> #4   <input type="checkbox"/> #7</p> <p>5. Channel material:  <input type="checkbox"/> Galvanized Steel  <input type="checkbox"/> Stainless Steel</p> <p>6. Brush fill material:  <input type="checkbox"/> Horsehair   <input type="checkbox"/> Nylon  <input type="checkbox"/> Carbon Steel   <input type="checkbox"/> Bronze  <input type="checkbox"/> Polypropylene   <input type="checkbox"/> 302 Stainless  <input type="checkbox"/> Tampico   <input type="checkbox"/> Brass  <input type="checkbox"/> Nylon Abrasive Filament (Nyxox)  <input type="checkbox"/> Other _____</p> <p>7. Fill material:   <input type="checkbox"/> Crimped   <input type="checkbox"/> Straight          Diameter _____          Color (if applicable) _____</p> <p>8.   <input type="checkbox"/> Close wound   <input type="checkbox"/> Open wound          Specify pitch between spirals _____</p> <p>9. Mounting Clips:   <input type="checkbox"/> Yes   <input type="checkbox"/> No</p> <p>10. Application:   <input type="checkbox"/> Wet   <input type="checkbox"/> Dry          Operating Temperature _____ °F</p>	<p>11. Quantity required _____</p> <p><b>* Coil wound strip brushes are not returnable, as they are manufactured to order.</b></p> <p>Name: _____</p> <p>Company Name: _____</p> <p>Address: _____</p> <p>Phone: (_____) _____</p> <p>Fax: (_____) _____</p> <p>E-mail: _____</p> <p>End-User Name: _____</p> <p>City: _____ State: _____</p> <p>Zip: _____</p> <p><b>For additional information call:</b>          Weiler's Application Engineering Hotline          toll free at: <b>888-299-APPS (2777)</b></p> <p><b>Mail or fax specification sheet to:</b>          Application Engineering          Weiler Corporation          One Weiler Drive          Cresco, PA 18326-0149  <b>Fax: 800-635-3615</b></p> <p><b>Or visit our website:</b>  <a href="http://www.weilercorp.com">www.weilercorp.com</a>  <b>E-mail: info@weilercorp.com</b></p>
--	--

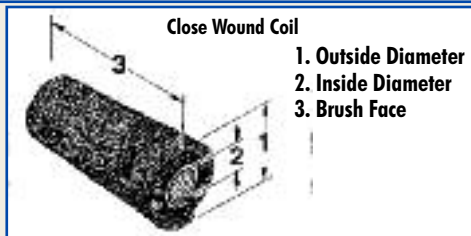
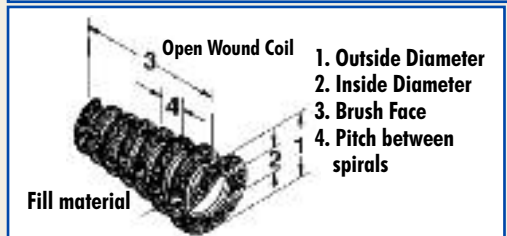

# Strip Brushes - Discs, Cups & Holders



## Strip Brushes - Disc Brushes

**Outside Disc:** A circular single loop brush with the bristles facing OUTWARD, and the metal channel on the inside.

**Inside Disc:** A circular single loop brush with the bristles facing INWARD, and the metal channel on the outside.



## Strip Brushes - Formed Cups

These strip brushes are formed into a circle with the bristles facing down, commonly found in vacuum cleaning applications.

### Holders for Metal Channel Size #2.5 - Max. length 12'

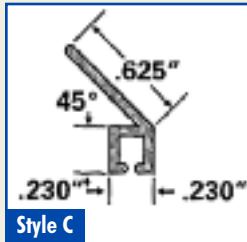
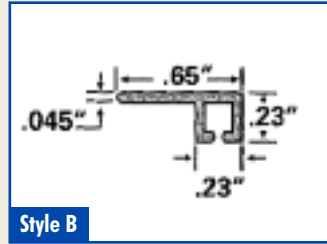
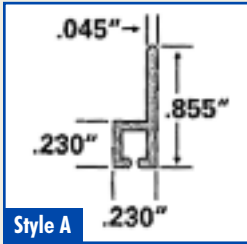

### Holders for Metal Channel Size #4 - Max. length 12'

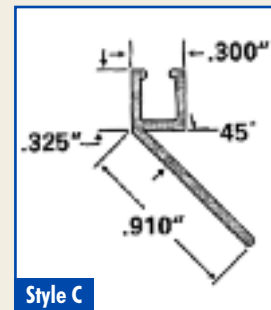
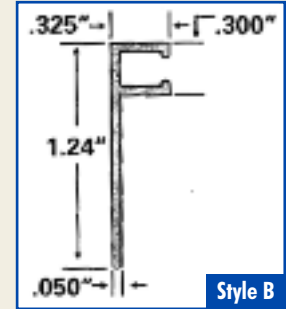
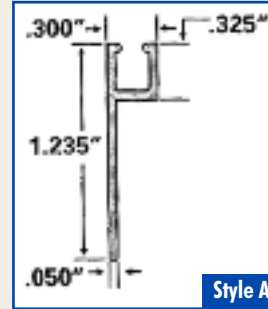

### Holders for Metal Channel Size #7 - Max. length 12'

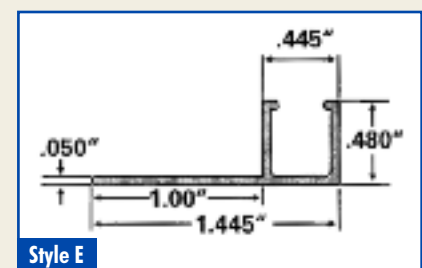
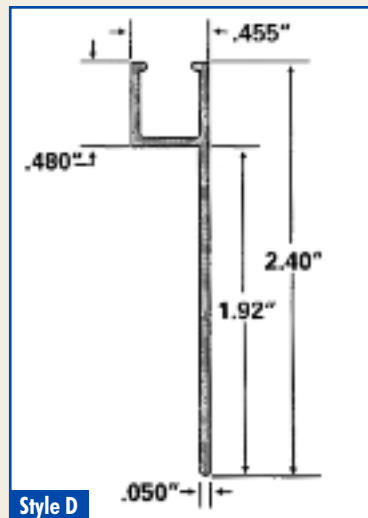
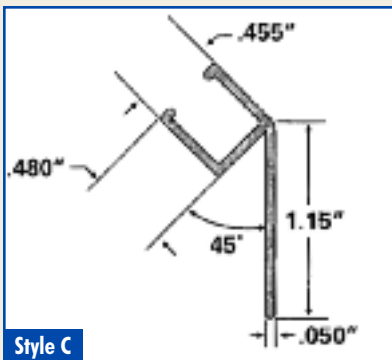
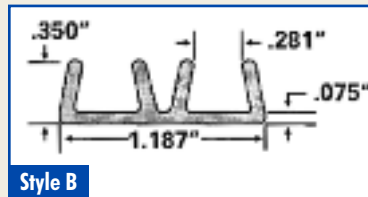
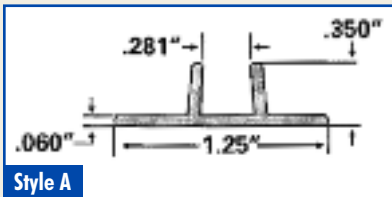

# Wide Face Brushes



Removing light corrosion and mill scale from coiled steel.

**Wide Face Brushes** - Cylindrical brush assemblies have proven to be reliable and economical tools for a wide variety of industrial surface conditioning applications. In addition to gang-mounting a series of individual wheel brushes onto a shaft or reusable arbor, one-piece wide face brush units can be manufactured to cover broad surfaces or provide maximum brushing action in a minimum amount of space.

Cylindrical brushes can be manufactured using several different styles of construction, and the characteristics of each style of construction can significantly affect brush performance. Weiler will custom-design a wide face brush in the most appropriate type of construction for your specific application. Please call our Application Engineering Team at 888-299-APPS (2777) to discuss your requirements.

## Applications

- Scrubbing debris from the surface of material during processing
- Removing corrosion, surface contamination, mill scale, or heat discoloration
- Roughening surfaces to promote adhesion or bonding
- Removing applied finishes and coatings
- Producing decorative surface finishes
- Deburring or finishing cylindrical parts
- Deburring the cut ends of tubing and extrusions



**Disposable Brush Assemblies** - Wide face assemblies for brushing flat surfaces can be manufactured as disposable units with a variety of available fill materials depending on the specific application. Available fills include; metallic filaments such as steel, stainless steel, or brass crimped wire; Nylox® nylon abrasive filaments; synthetic filaments such as nylon or heat-stabilized polypropylene; or natural fibers such as tampico.

Disposable mountings can be constructed of carbon steel or stainless steel components, and "flow-through" mountings which allow coolant to be circulated through the core and out the face of the brush are available for wet applications.



**Refillable Brush Assemblies** - Wide face assemblies for brushing flat surfaces can also be manufactured as a replaceable brush unit wound onto a permanent and reusable arbor. Depending on the specific application and production environment, the refilling of reusable arbors may be a more economical option than using disposable units. Reusable mountings can be designed by Weiler or supplied by the customer.

In addition to the secondary operations such as nibbling and grinding of the brush face and dynamic balancing of the completed unit, Weiler also offers maintenance services on mounting hardware like collars and bearings.



Call our Application Engineering Hotline at 888-299-APPS (2777). If the problem is too complex to be solved over the phone, we will determine if an evaluation should be conducted at our in-house lab or your facility. Either way, Weiler will provide the most cost-effective solution for your specific application.



# Wide Face Brushes

**Tube End Deburring Brushes** - Cylindrical rotary brushes are an ideal media for production applications involving the batch deburring of the ends of tubing that has been cut-to-length. Automated brushing systems are readily available and considerably less expensive to purchase and operate than chamfering machines.

Brush deburring machines can be integrated with cut-off operations to eliminate work-in-process and increase throughput, and they are flexible enough to be quickly adjusted for various shapes, sizes, and lengths of tubing. Unlike chamfering operations, brush deburring does not leave secondary burrs, brushing equipment is more tolerant of slight variations in machine set-up and tube length, and quality brushes last much longer than cutting inserts on double-end finishers.

Tube end deburring brushes are most commonly manufactured as disposable assemblies which are then mounted onto keyed shafts. High-tensile steel, hard-drawn steel, and Type 302 stainless steel wire are the most common fill materials used in tube end deburring brushes. Weiler offers high quality brushes with wire sizes from .006 to .020 and four available levels of fill density so that the brushing performance can be tailored to the material, burr condition, and budget of the end-user.

**Replacement Tube End Deburring Brushes** - The brushes in the chart below are a few of the popular Weiler replacement brushes that are available for the most common tube end deburring machines.

Dia.	Face Width	Arbor Hole	Wire Size	Brush Density	Standard Pack	Item No. Steel
10"	18"	3-1/4"	.014	General Purpose High Performance	1	07340 07341
12"	18"	3-1/4"	.014	General Purpose High Performance	1	07286 07342
12"	18"	3-1/4"	.020	General Purpose High Performance	1	07343 07344

\* The most common arbor hole sizes are 3-1/4" and 2" with 1/2" x 1/4" keyways. Other arbor holes are available upon request.

Contact your Weiler Sales Rep. or our Customer Service Department for price and availability.

**Custom Tube End Deburring Brushes** - Please use the appropriate specification sheet on the next page when requesting a quotation on a custom tube end deburring brush.



## Brush-Tube Orientation

Brush-tube orientation determines which edges of the tube are deburred. The illustrations below show three orientations and the target edge.

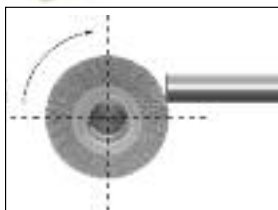

Deburring Tube I.D.

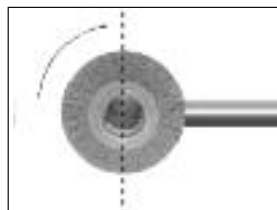

Deburring Tube I.D. and O.D.

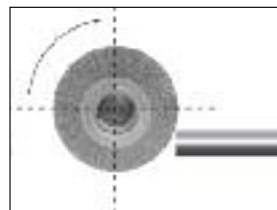

Deburring Tube O.D.



Deburring steel tubing on an automated machine.

**DID YOU KNOW?**

The largest wide face brush we manufacture weighs 152 pounds.

Wide Face Brushes

# Wide Face Brushes

## Wide Face Brush Specification Sheet - For 8" to 16" brushes

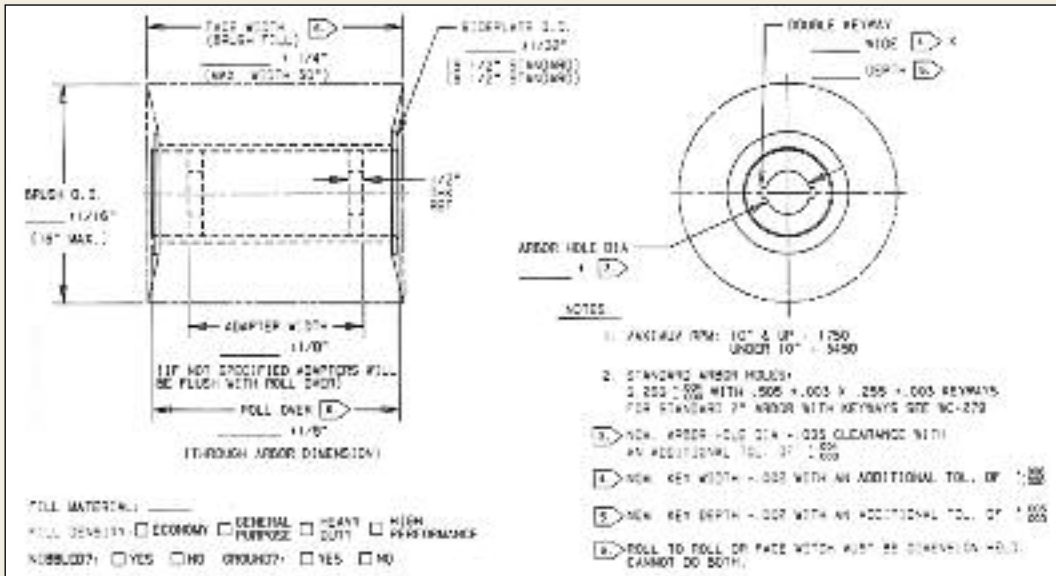

Name: \_\_\_\_\_  
 Company Name: \_\_\_\_\_  
 Address: \_\_\_\_\_  
 Phone: (\_\_\_\_) \_\_\_\_\_ Fax: (\_\_\_\_) \_\_\_\_\_  
 E-mail: \_\_\_\_\_  
 End-user Name: \_\_\_\_\_  
 City \_\_\_\_\_ State \_\_\_\_\_ Zip \_\_\_\_\_

**For additional information call:**  
 Weiler's Application Engineering Hotline  
 toll free at: **888-299-APPS (2777)**

**Mail or fax specification sheet to:**

Application Engineering  
 Weiler Corporation  
 One Weiler Drive  
 Cresco, PA 18326-0149  
**Fax: 800-635-3615**

**Or visit our website:**  
[www.weilercorp.com](http://www.weilercorp.com)  
**E-mail: info@weilercorp.com**

## Wide Face Brush Specification Sheet (2" I.D.) - For 6" & 8" brushes with a 2" I.D.

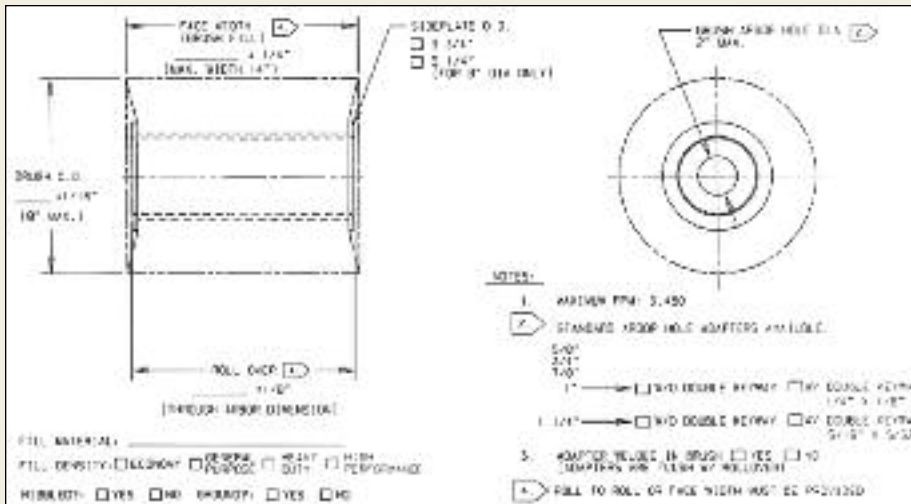

Name: \_\_\_\_\_  
 Company Name: \_\_\_\_\_  
 Address: \_\_\_\_\_  
 Phone: (\_\_\_\_) \_\_\_\_\_ Fax: (\_\_\_\_) \_\_\_\_\_  
 E-mail: \_\_\_\_\_  
 End-user Name: \_\_\_\_\_  
 City \_\_\_\_\_ State \_\_\_\_\_ Zip \_\_\_\_\_

**For additional information call:**  
 Weiler's Application Engineering Hotline  
 toll free at: **888-299-APPS (2777)**

**Mail or fax specification sheet to:**

Application Engineering  
 Weiler Corporation  
 One Weiler Drive  
 Cresco, PA 18326-0149  
**Fax: 800-635-3615**

**Or visit our website:**  
[www.weilercorp.com](http://www.weilercorp.com)  
**E-mail: info@weilercorp.com**

# Nylox® Brushes

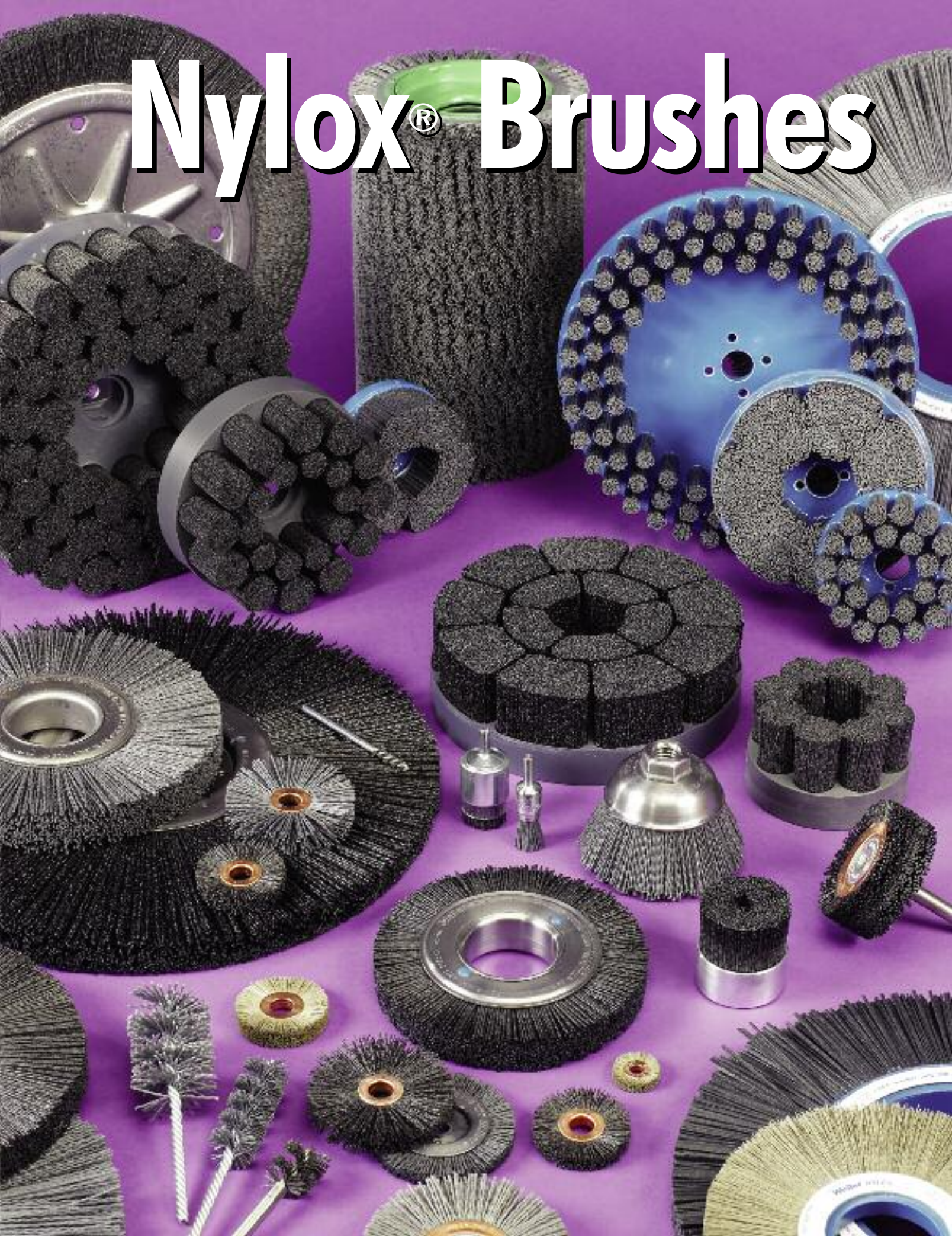

# **Weiler Nylox<sup>®</sup> Brushes**

**Nylox<sup>®</sup> Brushes**

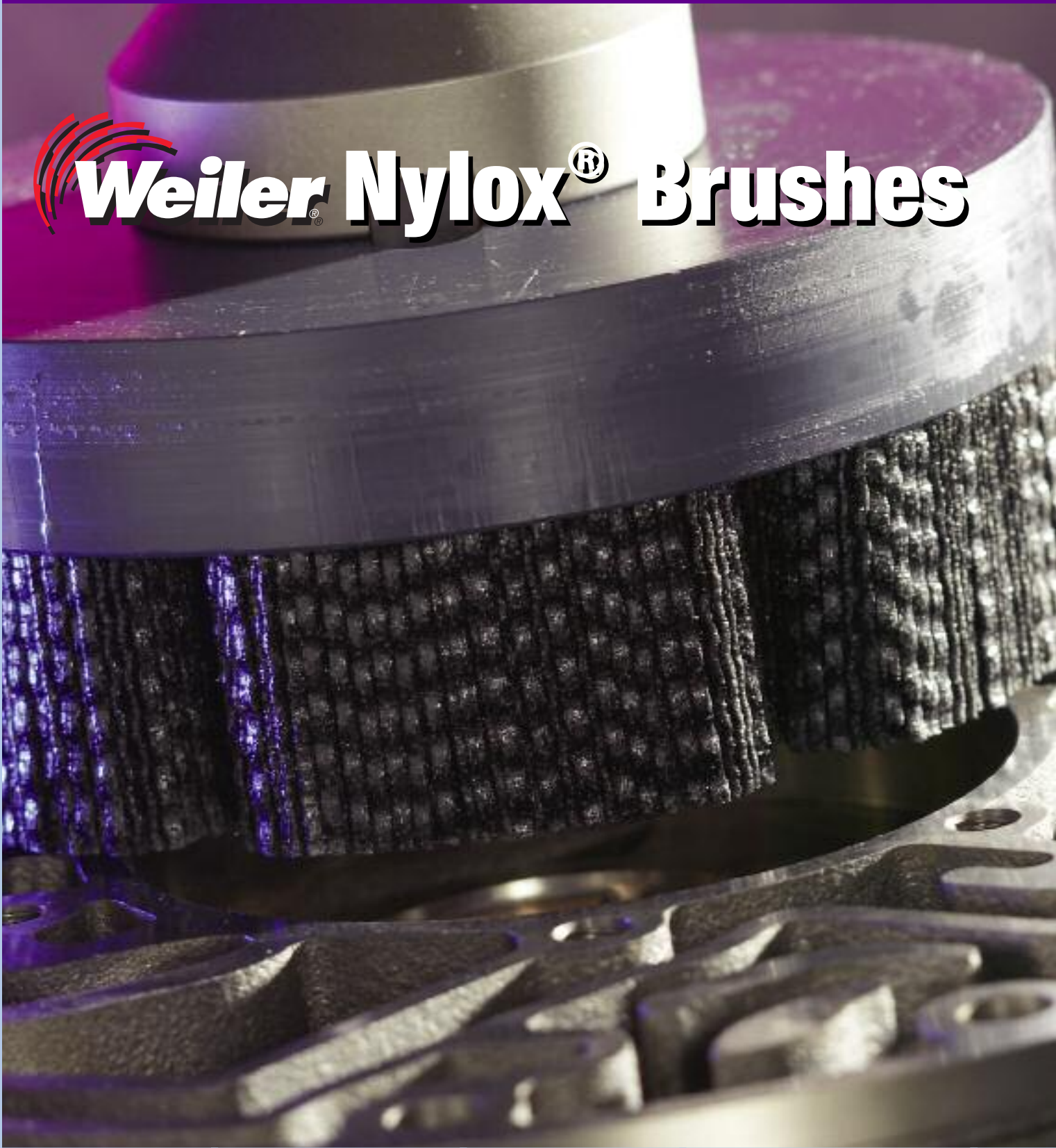



## ■ Engineered Products & Equipment

**New!**

### ■ Wheel Brushes

*Including an Expanded Offering of Burr-Rx® Ceramic Filament Brushes!*

**New!**

### ■ Disc Brushes

*Featuring Burr-Rx® Shell Mill Holder Brushes - No Drive Arbor Required!*

### ■ Cup Brushes

### ■ End Brushes

**New!**

### ■ Crosshole Deburring Brushes

*Now with Advanced Burr-Rx® Ceramic Filament Technology!*

**New!**

### ■ Tube Brushes

*Including Burr-Rx® Ceramic Filament Power Tube Brushes!*

**New!**

### ■ FME Area Product Solutions

### ■ Adapters & Drive Arbors

**Knowledgeable and Responsive  
Customer Service Team:  
800-835-9999**

**Application Engineering Support:  
888-299-APPS (2777)**

**Interactive Website:  
[www.weilercorp.com](http://www.weilercorp.com)**



# Solutions Showcase

## Transmission Valve Body

**Problem:** Burrs on transmission components can break away from parent components during use and cause transmission wear and eventual failure. Therefore, fluid passages must be completely burr-free.

**Solution:** A 10" Nylox® disc brush operating at 825 RPM in a vertical CNC machining center is an ideal solution for deburring this component. Since all of the burrs are on a single plane, the non-directional nature of a Nylox disc brush produces a part on which all edges have been uniformly deburred.



## Steering Component

**Problem:** Manual deburring can be costly in many respects. Hard deburring tools and aggressive abrasive wheels do not allow much margin for operator error and the result is often high scrap rates.

**Solution:** Nylox brushes produce a flexible filing action which concentrates all of the abrasive cutting action on sharp edges, giving them the ability to remove burrs without altering overall part dimensions. For example, a 6" Burr-Rx wheel mounted onto a 1,725 RPM pedestal buffer is capable of deburring this steering component just as quickly as a convolute wheel but without the fear of over-radiusing the edges of the teeth or producing flat spots.



## Aluminum Wheel

**Problem:** Sharp burrs cause safety concerns due to handling issues. In the production of aluminum wheels, burrs and sharp edges can also contribute to problems with painting and powder coating.

**Solution:** Weiler designs Nylox disc brushes that are tailored to match the specific geometric features of each aluminum wheel. The customized design and use of next-generation filament technology ensures wheels that are thoroughly deburred at the minimal cost-per-part.



# Solutions Showcase

## Pump Gear

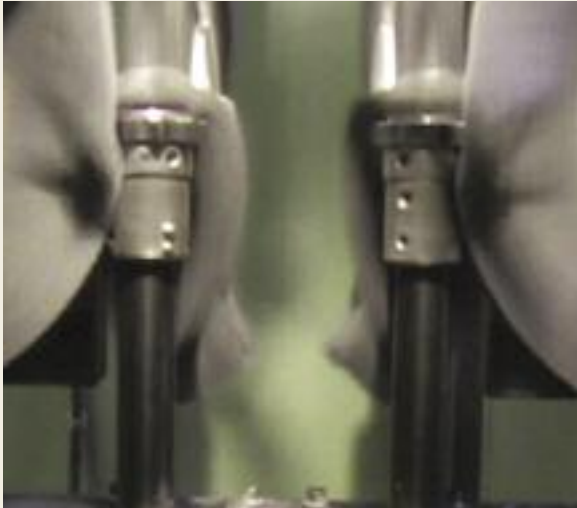

**Problem:** Pumps are extremely susceptible to failure due to burrs. Due to the tight fit between components, all edges must be deburred and radiused to ensure proper function. Proper deburring of rotating pump gears is especially important.

**Solution:** A dedicated machine running 14" Nylox wheel brushes at 900 RPM was a low-cost solution for deburring these gears. By using dedicated equipment, cycle time was minimized and an acceptable edge condition was achieved.

## Cast Aluminum Housing



**Problem:** Although deburring the face-milled surfaces of castings is a very straight forward application for Nylox disc brushes, the limited availability of valuable machine time can be a perceived obstacle that prevents users from reaping the many benefits of implementing in-machine deburring operations.

**Solution:** The advanced ceramic grain technology of Weiler's Burr-Rx tools offer a deburring action that is up to 400% greater than traditional abrasive nylon brushes which contain silicon carbide or aluminum oxide filaments. This allows Burr-Rx deburring tools to be used at feed rates which dramatically reduce the amount of additional machine time required to perform a brushing operation.

## Turbine Blade

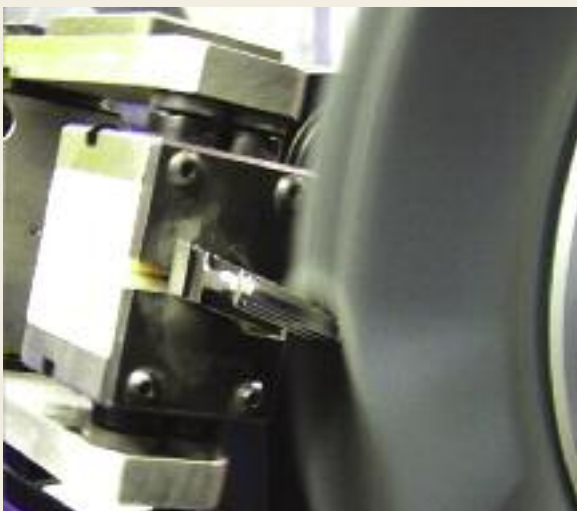

**Problem:** Protecting turbine engine components against high-temperature fatigue is critical to ensure safe, reliable engine operation. Component edges must be burr-free and generally require an edge radius in the range of 0.005" to 0.060".

**Solution:** Robots are extremely well-suited for this application because they can manipulate the component in many orientations in relation to the brush. Weiler works closely with users and robot integrators to develop products and process programs which maximize brush life while generating exceptional part quality and consistency.

Photo courtesy of ACME Manufacturing.

# Nylox® Technical Information

## Operational Advantages of Nylox® Brushes

### Aggressive Yet Compliant



Nylon filaments co-extruded with an abrasive grain act like flexible files precisely deburring and radiusing edges as they wipe across them. Because the cutting pressure with which the abrasive grains are applied against a broad surface is limited by the compliant nature of the filaments, Nylox brushes tend not to alter the overall dimensions or geometry of a part. This high degree of compliance allows them to conform to complex part shapes and reduces the need for ultra-precise programming and fixturing that is typically required with other deburring and finishing tools.

### Enhanced Surface Finishes



The compliant cutting action of Nylox brushes not only limits their ability to alter part dimensions, but it makes them an effective tool for refining surface texture characteristics without removing significant amounts of base material. Although they contain the same abrasive grain sizes, Nylox brushes will **not** generate the same prominent scratch pattern as a comparable coated abrasive product. Their limited aggression and flexible filing action also make them suitable for deburring a wider range of materials in comparison to wire filled power brushes.

### Ideal For Automation



Because the abrasive grain is evenly distributed throughout the durable nylon filament, Nylox brushes offer extremely consistent performance throughout their product life. Coupled with their extremely compliant nature, this makes them an ideal media for use in automated deburring and finishing processes involving either dedicated production equipment or flexible solutions such as robotic cells. Their use can also be directly integrated into the cycle of CNC machining centers to improve part quality and consistency while reducing direct labor costs.

## Construction Advantages of Weiler Nylox Brushes

### Metal Hub Construction

- Metal hub components are assembled under high pressure, potentially damaging the filaments and causing premature breakage.
- Retaining ring displaces filament material creating a void in the center of the brush face.
- Lower fill density can result in shorter life and less consistent performance.



### Weiler's Composite Hub Construction

- Molded hub construction eliminates filament breakage.
- Uniform distribution of fill material and superior balance.
- Higher fill density provides more aggressive brushing and longer life.
- Consistent performance as the brush wears.



### Weiler's Composite Metal Hub Construction

- Filaments retained using the latest polymer technology to prevent filament breakage.
- Metal components add impact resistance and dimensional stability.
- The highest filament density in the market ensures lowest cost-per-part.



### Monofilament Construction

This construction is less aggressive due to lack of filament density. This hinders processing of severe burrs or generating larger edge radii in shorter cycle times. The short trim length results in less conformability and decreased brush life, resulting in fewer parts-per-brush.

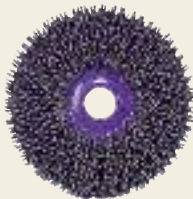

### Weiler's Tufted Construction

Weiler's construction offers increased aggression due to added filament density. This enables processing of severe burrs or generating larger edge radii in shorter cycle times. Our longer trim length allows for greater conformability and longer tool life.

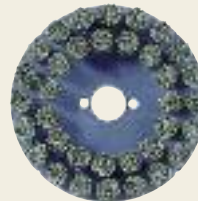

### Weiler's Maximum Density Construction

Maximum density brushes are uniquely suited for demanding applications characterized by large burrs and rapid feed rates.

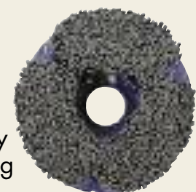



## Product Attributes

### Brush Terminology

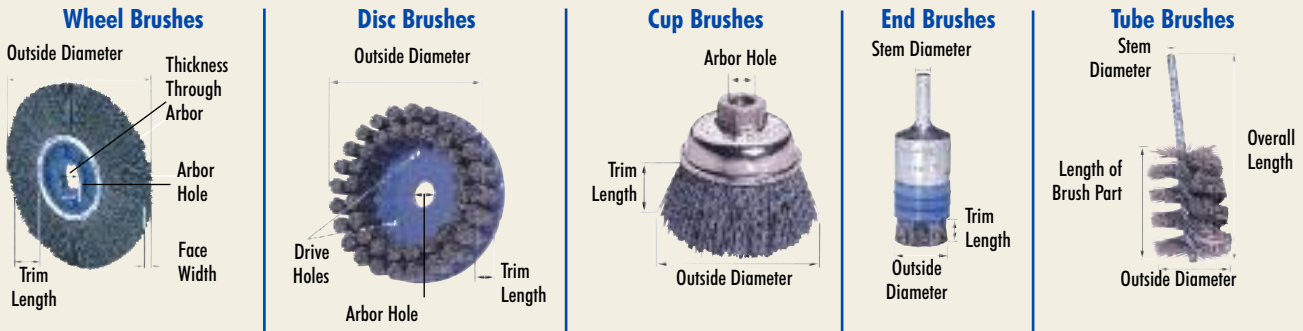

### Nylox Filaments

Abrasive brush filaments are manufactured by extruding a mixture of liquefied polymer and abrasive grain. Unlike the filaments used in DIY grade abrasive brushes, industrial grade products like Weiler's Nylox and Burr-Rx brushes feature the highest grade of abrasive filament manufactured using a Type 6.12 nylon polymer. Industrial grade filaments also feature the highest quality abrasive materials which have been sifted and sorted to insure that the grains are consistent in size. These grains may be one of three different types of abrasive:

- **Silicon Carbide (SiC)** - Is a sharp-edged grain which produces an effective cutting action. It is the most common grain used in industrial grade brushes.
- **Aluminum Oxide (AO)** - Is a duller, less aggressive grain typically used in finishing applications requiring a less pronounced scratch line pattern or deburring applications on materials where the use of SiC may be prohibited.
- **Burr-Rx Ceramic (CG)** - An engineered abrasive grain that produces a superior cutting action and is compatible with the widest range of materials. It is the most effective grain available today!

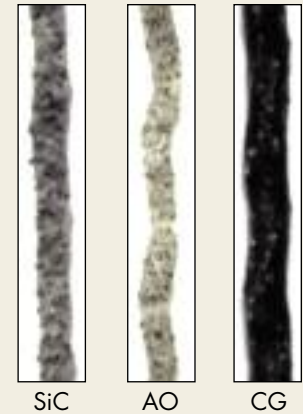

### Material Removal vs. Time

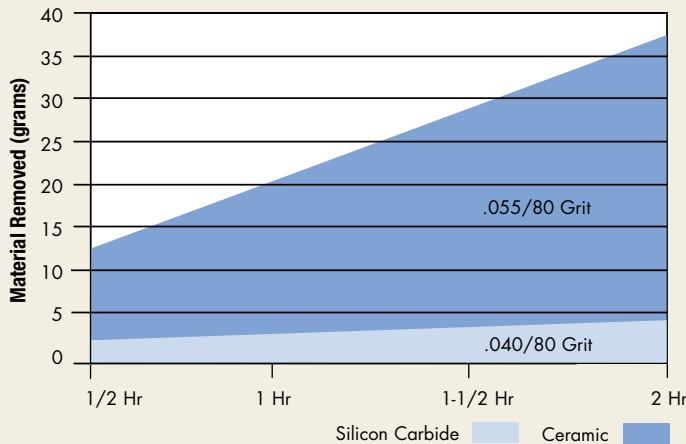

Nylox brushes containing the Burr-Rx black ceramic filament are the most cost-effective choice for a brush deburring tool because the engineered abrasive grain produces a cutting action up to 400% greater than equivalent SiC and AO filaments. This not only allows Burr-Rx brushes to remove burrs that traditional nylon abrasive filament products cannot, but it also minimizes cycle times by allowing the use of much higher feed rates and much shorter dwell times.

Burr-Rx brushes are especially well-suited for use on hard-to-deburr metals such as Inconel, stainless steel and titanium, but with proper selection of the product and operating parameters, they can be used on virtually any material.

**Round Filaments** - Due to their cross-sectional shape and the reduced contact with the work surface or part edges that result, round filaments provide a more compliant brushing action for less aggression and enhanced conformability.

**Rectangular Filaments** - Due to their shape, larger cross-sectional area and increased contact with the work, rectangular filaments provide a less compliant brushing action for much greater aggression and reduced conformability.

Crimping either type of filament along its length enhances conformability, allowing greater penetration of part edges into the brush face, often increases aggression. Crimped filaments are especially beneficial in maximum density disc brush designs.

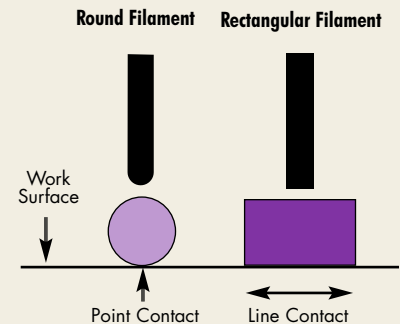

# Nylox® Technical Information

## Product Selection

### Trim Length and Fill Density

**Longer Trim, lower density brushes** offer a greater degree of flexibility that is ideal for applications requiring a high degree of brush conformability. However, the lower fill density can result in shorter brush life and less consistent performance.

**Shorter Trim, higher density brushes** work with a faster action and less engagement with the brush face. This produces shorter cycle times, more consistent performance and longer life in applications that do not require a high degree of brush conformability.

**To maximize brush life and reduce costs**, always use the shortest trim, highest density brush that will adequately conform to the surface or part edges.

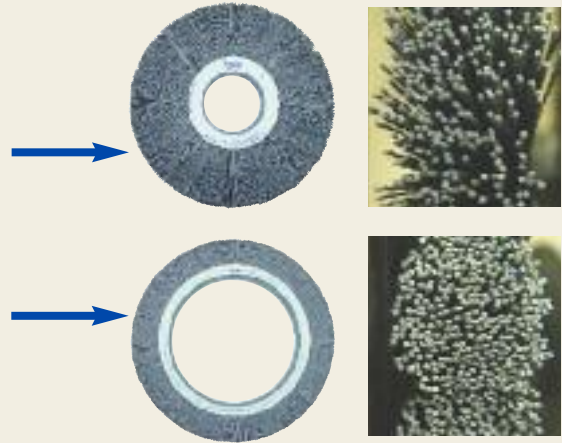

### Nylox® Brush Selection Chart

	Surface Finishing (Functional, Aesthetic, Decorative, Satin)	Deburring & Edge Blending	Automated Equipment Applications
Wheel	● ● ●	● ● ●	●
Disc	●	●	●
Cup	●	●	●
Stem-Mounted	●	●	●
Tube			

### Product & Application Key

- Right Angle Grinder \*
- Hand Drill/Drill Press
- CNC's, Milling & Automatic Machines
- Straight Grinder \*
- Bench/Pedestal Grinder \*

\* Due to the low recommended operating speeds of Nylox products, they typically cannot be used on standard power tools. However, they are suitable for use on low or variable-speed tools.



## Lubricut™ Lubricant

Prevents Smearing. Improves the Finish. Lowers Costs.

Lubricut™ is a lubricant that can be used with Nylox wheels operating above the recommended surface speed. Directing a light spray of Lubricut into the face of the wheel permits the wheel to be operated at higher surface speeds and up to twice the normal load **without smearing** - while improving the finish.



1. Turn off machine.



2. Slowly rotate wheel by hand.



3. While rotating, direct a light spray of Lubricut into the wheel face.

## Nylox<sup>®</sup> Brush Operating Information

### Operating Speed

Nylox<sup>®</sup> abrasive brushes work with a wiping and filing action. Think of them as flexible files. They work best when operated at speeds that allow fairly deep penetration of the work-piece into the brush filaments. Usually, faster speeds do not work as well as slower speeds. The maximum RPM marked on the brush is not the optimum working speed. A good rule of thumb is to stay under 2,500 SFPM in dry applications and 3,500 SFPM in wet applications.

### Operating Speeds - Wheel Brushes

Diameter	RPM
2"	3,450 - 5,000
3"	2,500 - 3,450
4"	1,750 - 2,500
6"	1,350 - 1,750
8"	1,150 - 1,350
10"	950 - 1,150
12"	750 - 950
14"	650 - 850

### Operating Speeds - Disc Brushes

Diameter	RPM
1-3/4" & 2"	1,750 - 2,000
3"-4"	1,500 - 1,750
5" - 6"	1,250 - 1,500
8"	800 - 1,000
10"	700 - 800
12"	600 - 700
14"	500 - 600

### Wheel Brush Penetration

When using nylon abrasive wheel brushes, optimum aggression is obtained and wheel life maximized when the work-piece penetrates into the face of the brush approximately 10% of the trim length. The sides of the Nylox filament actually do the work. To achieve a maximum edge radius and complete burr removal, parts should be buried into a slow running brush face.



### Disc Brush Penetration

When using nylon abrasive disc brushes, a good starting point for a depth of penetration between the brush face and work surface is 0.075"-0.100". This depth of interference produces the best compromise between aggression and brush life.



### Feed Rate Recommendations

Feed rate is determined by the amount of deburring, edge radiusing or surface finishing required, and the type of material that is being processed. It is generally application specific. Slower feeds result in a more aggressive brushing action. Based on the brushing action desired for a specific application, the feed rate can be increased or decreased.

Material	SiC and AO Grain Feed Rate	Burr-Rx Grain Feed Rate
Non-Ferrous	50 in./min.	80 in./min.
Cast Iron	30 in./min.	60 in./min.
Mild Steel and Ductile Iron	25 in./min.	50 in./min.
Stainless and Alloy Steels	15 in./min.	30 in./min.
Titanium and High Nickel Alloys	10 in./min.	30 in./min.

## Nylox Brush Operating Information

### Tool Path

The ideal tool path for a Nylox® Disc brush is very similar to the path of the face mill that produced the burr. However, three differences exist:

- The rotation direction of the brush should be opposite of the cutting tool that created the burr.
- The length of the path must be longer than the part. Unlike a cutter path that can stop when the leading edge of the cutter reaches the end of the part, the tool path of a brush should continue until the trailing edge of the brush reaches the end of the part.
- The centerline of the brush may need to be off-set from the center of the part in order to maximize the number of filaments that strike the part at a perpendicular angle. This is especially important when the diameter of the brush is similar to the width of the part.

**A** The part is deburred in the shortest cycle time with the lowest consumable cost-per-part.

**B** The part is deburred, but requires a longer cycle time. When a large brush will not fit in the tool changer, this method is recommended.

**C** Produces less deburring than A & B.

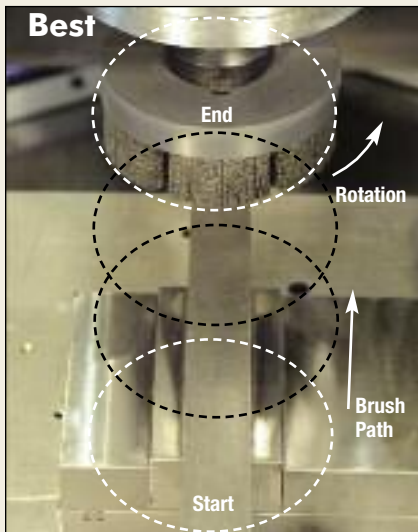

If a large diameter brush can be used, the centerline of the brush should be positioned on the center of the part. Ideally, the brush should be 3-4" wider than the part.

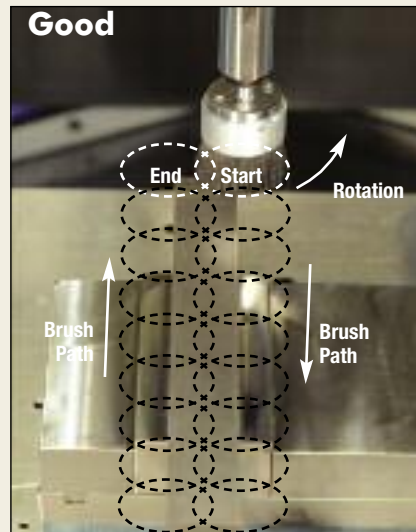

If a small diameter brush must be used, the centerline of the brush should be positioned on the edge of the part. This maximizes aggression by increasing the amount of perpendicular contact between the brush filaments and the burred edge.

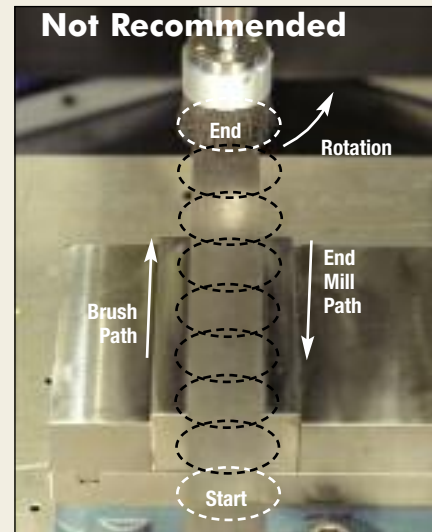

Positioning a small diameter brush with its centerline on the center of the part is not recommended. This configuration will not allow perpendicular contact of the filaments against the burred edge.

### Coolants

Nylox® brushes can be run dry, without coolants. However, certain deburring conditions, such as higher speeds, material properties and greater depth of penetration can create excessive heat buildup, causing the nylon filaments to melt and smear on the work surface. If the speed or depth of penetration cannot be changed, coolants are recommended to overcome heat smear. Coolants will also help produce finer finishes.

### Wear Compensation

On dedicated equipment, it is possible to automate wear compensation by using electronic controls to monitor the load on drive motors and adjust the position of the brushing tool to maintain a relatively consistent amount of interference or pressure. Since this is typically not possible with standard CNC machine tools, there are three other possible methods of compensating for tool wear for "in-machine" implementations of Nylox brushes.

#### Automatic Indexing:

Most CNC controllers allow tool wear compensation to be accomplished by programming a "macro" - routine to periodically adjust the position of the tool based upon the number of parts produced. Some experimentation may be required to determine the frequency and the amount of adjustment that will result in the most consistent performance and maximum brush life.

#### Probing:

If the machining center has the capability to probe the face of the brush, this feature can be used to gauge the true position of the filament tips. Adjustments to the brush position can then be made to maintain a consistent amount of interference between the tool and the part.

#### Manual:

If the other methods cannot possibly be used, machine operators can adjust the brush position based on either statistical process control data or visual inspection of completed parts.

## Nylox Brush Operating Information

**Spindle Diameter Requirements:** The minimum Spindle Diameter standards of ANSI B165.1 for Power Brushes should also be used for Nylox Brushes. See pg. 20 for more information.

### Recommended Motor Sizes

Brush Diameter	Motor Size	RPM*
8"-4"	1/4 HP	3,450
6"	1/2 HP	1,725
8"	3/4 HP	1,725
10"	1 HP	1,140
12"	1 HP	1,140
14"	1-1/2 HP	900

Note: This chart is based on 1" brush face.

\* A variable-speed motor control may be required to achieve optimum operating RPM; see charts on page 74.

## Nylox Brush Troubleshooting Guide

There are many variables in Nylox applications. If the Nylox brush you are using does not accomplish the desired results, select a solution from the suggestions below for your specific application or call Weiler's Application Engineering Hotline at 888-299-2777.

Problem	Recommended Solutions
Brush not aggressive enough	<ul style="list-style-type: none"> <li>• Increase filament diameter and/or grit size</li> <li>• Increase filament density by using round straight rather than round crimped</li> <li>• Increase surface contact by using rectangular rather than round</li> <li>• Increase pressure/depth of interference</li> <li>• Increase surface speed by increasing spindle RPM</li> <li>• Use a larger diameter brush</li> <li>• Reduce trim length or feed rate</li> </ul>
Brush too aggressive	<ul style="list-style-type: none"> <li>• Reduce filament diameter and/or grit size</li> <li>• Reduce filament density by using round crimped rather than round straight</li> <li>• Reduce surface contact by using round rather than rectangular</li> <li>• Reduce pressure/depth of interference</li> <li>• Reduce surface speed by reducing spindle RPM</li> <li>• Use a smaller diameter brush</li> <li>• Increase trim length or feed rate</li> </ul>
Brush not conformable enough	<ul style="list-style-type: none"> <li>• Increase trim length</li> <li>• Reduce filament diameter</li> <li>• Reduce filament density by using round crimped rather than round straight or rectangular</li> <li>• Reduce surface speed by reducing spindle RPM</li> <li>• Reduce feed rate</li> </ul>
Finer final finish required	<ul style="list-style-type: none"> <li>• Increase surface speed by increasing spindle RPM</li> <li>• Decrease grit size</li> <li>• Use brush with a coolant</li> </ul>
Coarser final finish required	<ul style="list-style-type: none"> <li>• Reduce surface speed by reducing spindle RPM</li> <li>• Increase grit size</li> <li>• Use brush without a coolant</li> </ul>
Filaments melt/smear on workpiece	<ul style="list-style-type: none"> <li>• Reduce surface speed by reducing spindle RPM</li> <li>• Use a smaller diameter brush</li> <li>• Use brush with a coolant</li> </ul>
Short brush life	<ul style="list-style-type: none"> <li>• Increase filament density</li> <li>• Reduce pressure/depth of interference</li> </ul>



Two members of our Application Engineering Team discuss the results after testing an engineered product.

**Nylox® Engineered Products** - In order to provide you with the most cost-effective media for your particular surface conditioning application, it is sometimes necessary to design and manufacture a unique, custom tailored product to meet your requirements. Although Weiler offers such engineered solutions in all of our product lines, the innovative construction and value-added nature of the Nylox line of nylon abrasive filament brushes showcases the creativity and expertise of our Application Engineering Team in designing products that have been tailored to the needs of the customer.



Custom-engineered Nylox brushes can be designed and manufactured as variations on standard product configurations such as wheel, disc, cup, end, or tube brushes. In addition, Weiler's exclusive Burr-Rx® and Bore-Rx™ brushing tools can be engineered to meet the demands of a specific application.

Wide face brush assemblies for applications such as finishing flat surfaces or deburring cylindrical parts can also be designed and manufactured using Nylox nylon abrasive filaments. For more information on Weiler's wide face brushes, see pages 63 and 64.

For solutions to difficult applications, call our Application Engineering Hotline at 888-299-APPS.

If the problem is too complex to be solved over the phone, we will determine if an evaluation should be conducted at our in-house lab or the user's facility.

## Application Engineering Solutions

Weiler Corporation is *the* source for surface conditioning solutions. Our goal is to provide solutions that will help you lower costs by increasing productivity. By combining our broad product offering with the support of our Application Engineering Team, you can count on Weiler to provide solutions to your specific application.

### Have An Application Problem?

#### Option 1 - Application Hotline:

Call our Application Engineering Hotline at 888-299-APPS (2777) with all your deburring, cleaning and finishing challenges. If your question cannot be answered on the phone...

#### Option 2 - In-House Part Evaluation:

Send your component parts to our in-house lab for evaluation and product recommendation. This enables Weiler to evaluate and process parts in a controlled environment without interrupting your production schedule. We will address issues such as cycle time, finish required and product life, providing the most cost-effective solution. Weiler's in-house lab is also equipped with a Hurco VSX-40 vertical machining center, giving us the capability to perform technical viability analysis on your parts. The availability of the Hurco permits recommendations concerning speeds, feeds and tool paths to be extremely precise. This virtually eliminates technical uncertainty for customers interested in implementing in-machine deburring.

#### Option 3 - On-Site Evaluation:

If it is determined that an on-site visit is required, a Weiler Application Engineer will visit your facility to review the current production process. Weiler will determine the best product and process to meet your specific application requirements.



**When Performance Counts, Turn to Weiler for assistance with product selection and application solutions!**

# Nylox<sup>®</sup> Wheel Brushes



Deburring a vane section for a jet engine.

## Nylox<sup>®</sup> Composite Metal Hub and Composite Hub Wheels -

Weiler's Nylox abrasive nylon wheel brushes featuring composite metal hub and composite hub construction are manufactured using a molded polymer material to retain the filaments. In comparison to traditional metal hub construction which folds the fill material around an internal retaining ring or wrap wire, these techniques result in a significant increase in fill density and the elimination of filament breakage offering the lowest cost-of-use and greatest consistency of performance in production applications.

Weiler's composite metal hub wheels marry the high density and superior filament retention of composite hub wheels with the dimensional stability and shock resistance of metal hub construction, and they feature 2" arbor holes which allows for convenient mounting on many pieces of equipment.

Burr-Rx wheels feature Weiler's advanced black ceramic grain filament which delivers up to a 400% greater edge cutting action in comparison to traditional silicon carbide and aluminum oxide filaments for the fastest, most aggressive deburring action to minimize cycle times and maximize media life.

## Applications

- Precision deburring of component parts after machining or grinding
- Honing cutting tools and generating specific edge profiles and radii
- Improving texture characteristics on machined or ground surfaces
- Light duty cleaning and finishing of metals; Light sanding of woods and composites

## Burr-Rx<sup>®</sup> Crimped Filament Wheels - Composite Metal Hub\* - Crimped Round Black Ceramic Filament

Dia.	Filament Dia./Grit	Arbor Hole	Face Width	Trim Length	Thickness At Face Plates	Max. RPM	Standard Pack	Item Number
6"	.026/120	2"	3/4"	1"	15/16"	4,000	1	86123
	.035/80							86181
	.043/120							86124
	.055/80							86120
8"	.026/120	2"	7/8"	2"	15/16"	4,000	1	86126
	.043/120							86127
	.055/80							86128
10"	.026/120	2"★	1-1/8"	2"	7/8"	1,800	2	86129
	.035/80							86182
	.043/120							86130
	.055/80							86131
12"	.026/120	2"★	1-1/4"	3"	7/8"	1,800	2	86132
	.043/120							86133
	.055/80							86134
14"	.026/120	2"★	1"	1-3/4"	3/4"	1,800	2	86135
	.035/80							86108
	.043/120							86136
	.055/80							86137
14"	.026/120	2"★	1-1/4"	4"	7/8"	1,800	2	86138
	.043/120							86139
	.055/80							86140

\*Patent Pending

★ 1/2" x 1/4" Double Keyway

## Burr-Rx<sup>®</sup> Crimped Filament Wheels - Composite Hub - Round Black Ceramic Filament

O.D. x I.D.	Filament Dia./Grit	Face Width	Trim Length	Thickness Through Arbor	Max. RPM	Standard Pack	Item Number
8" x 3-1/4"	.043/120	1"	1-5/16"	13/16"	1,800	2	83394
14" x 7-1/4"	.026/120	1"	2-3/4"	15/16"	1,800	2	84926
	.043/120						84941
	.035/80						84925
	.055/80						83405



86123



86131



86135



**NOTE**

See adapters on page 90.

Nylox<sup>®</sup> Wheel Brushes

# Nylox® Wheel Brushes

## Crimped Filament Wheels - Composite Metal Hub\* - Round Silicon Carbide Filament

Dia.	Filament Dia./Grit	Arbor Hole	Face Width	Trim Length	Thickness Through Arbor	Max. RPM	Standard Pack	Item Number
6"	.018/500	2"	1"	1-1/4"	1-1/16"	3,600	1	83000
	.022/320							83010
	.022/120							83011
	.035/180							83030
	.040/120							83040
	.040/80							83050
.060/46	83070							
8"	.018/500	2"	1"	2-1/4"	3/4"	3,600	2	83100
	.022/320							83110
	.022/120							83111
	.035/180							83130
	.040/120							83140
	.040/80							83150
10"	.022/320	2"★	1-1/8"	2"	7/8"	1,800	2	83513
	.035/180							83514
	.040/120							83515
	.040/80							83516
12"	.022/320	2"★	1-1/4"	3"	7/8"	1,800	2	83715
	.035/180							83716
	.040/120							83717
	.040/80							83718
12"	.050/80	2"★	1-1/4"	3"	7/8"	1,800	2	83719•

\*Patent Pending  
 ★ 1/2" x 1/4" Double Keyway  
 • High Aggression

Removing burrs from an aluminum heat sink.



83075



83516



85014

## Rectangular Filament Wheel - Composite Metal Hub\* - Straight Silicon Carbide Filament

Dia.	Grit Size	Arbor Hole	Face Width	Trim Length	Thickness Through Arbor	Max. RPM	Standard Pack	Item Number
12"	80	2"★	1-1/4"	3"	7/8"	1,800	2	85014

\*Patent Pending  
 ★ 1/2" x 1/4" Double Keyway

**DID YOU KNOW?**

The largest special order Nylox composite hub wheel that we have manufactured was over 40" in diameter.

**Lubricut™**  
**Lubricant**

**Prevents Smearing.**  
**Improves the Finish.**  
**Lowers Costs.**

Lubricut™ is a lubricant that can be used with Nylox® wheels operating above the recommended surface speed. Directing a light spray of Lubricut into the face of the wheel permits the wheel to be operated at higher surface speeds and up to twice the normal load **without smearing** - while improving the finish. *See page 73 for recommended usage.*

83999





# Nylox® Wheel Brushes

## Crimped Filament Wheels - Composite Hub - Round Silicon Carbide Filament

O.D. x I.D.	Filament Dia./Grit	Face Width	Trim Length	Thickness Through Arbor	Max. RPM	Standard Pack	Item Number
6" x 2"	.040/80	1/2"	1-1/4"	9/16"	3,600	1	83116
8" x 2"*	.040/120 .040/80	7/8"	2-1/8"	13/16"	3,600	2	83190 83180
8" x 3-1/4"	.040/80	1"	1-5/16"	13/16"	1,800	2	83393
10" x 2"	.018/500 .022/320 .035/180 .040/120 .040/80	1"	3"	1-1/16"	3,600	2	83300 83310 83330 83340 83350
10" x 3-1/4"	.035/180 .040/120 .040/80	1"	2-5/16"	13/16"	1,800	2	83430 83440 83450
10" x 5-1/4"	.040/80	1"	1-5/8"	15/16"	1,800	2	83550
12" x 3-1/4"	.035/180 .040/120	1-1/8"	3-5/16"	13/16"	1,800	2	83630 83640
12" x 4-1/4"	.022/320 .035/180 .040/120 .040/80	1"	3-1/8"	15/16"	1,800	2	84710 84730 84740 84750
12" x 5-1/4"	.040/120 .040/80	1-1/8"	2-3/4"	15/16"	1,800	2	83740 83750
12" x 5-1/4"-2"*	.022/320	1-1/8"	2-3/4"	1-1/16"	1,800	2	85156 •
14" x 5-1/4"	.022/320 .035/180 .040/120 .040/80	1-1/8"	3-3/4"	15/16"	1,800	2	83910 83930 83940 83950
14" x 5-1/4"-2"*	.022/320 .040/80	1-1/8"	3-3/4"	1-1/16"	1,800	2	85150 • 85153 •
20" x 12"	.035/180	1-1/4"	3-1/4"	1-1/16"	1,000	1	85440

• Same density as our standard 5-1/4" I.D. brushes, but requires no adapters for mounting on a 2" diameter shaft.

\* 1/2" x 1/4" Double Keyway

## Rectangular Filament Wheel - Composite Hub - Straight Silicon Carbide Filament

O.D. x I.D.	Grit Size	Face Width	Trim Length	Thickness Through Arbor	Max. RPM	Standard Pack	Item Number
14" x 5-1/4"	120	1-1/8"	3-3/4"	1-1/16"	1,800	2	84640

Other diameters and grit sizes available upon request.

**Nylox® Metal Hub Basic Sections** - Weiler also offers abrasive nylon wheels featuring traditional metal hub construction for light duty deburring and finishing in non-production applications.

### Applications

- Low volume manual deburring
- General use in a tool room or shop

## Crimped Filament Basic Sections - Metal Hub - Round Silicon Carbide Filament

O.D. x I.D.	Filament Dia./Grit	Face Width	Trim Length	Thickness Through Arbor	Max. RPM	Standard Pack	Item Number
6" x 2"	.022/320 .035/180 .040/120	5/8"	1-1/2"	9/16"	6,000	2	20600 20610 20620
8" x 2"	.022/320 .040/120	5/8"	2-1/2"	9/16"	5,000	2	20630 20650
10" x 3-1/4"	.035/180	9/16"	2-7/8"	17/32"	4,500	2	20661
14" x 5-1/4"	.035/180	9/16"	3-7/8"	9/16"	3,000	2	20730



Deburring the tip of a turbine blade.



83190



85150

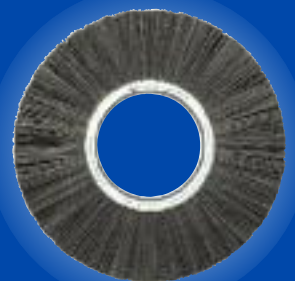

84640

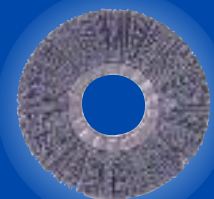

20620



**NOTE**

See adapters on page 90.

Nylox® Wheel Brushes

# Nylox® Wheel Brushes

**Nylox® Narrow Face Wheels** - Featuring a high density metal hub construction, Weiler's narrow face wheels are designed and manufactured to be the most cost-effective tool for applications requiring a 3" or 4" radial brush.

Deburring threads on a CNC lathe with live tooling.



31110



86165



31255



31124

## Burr-Rx® Heavy-Duty Narrow Face Wheels - Metal Hub - Crimped Round Black Ceramic Filament

Dia.	Filament Dia./Grit	Arbor Hole	Face Width	Trim Length	Thickness Through Arbor	Max. RPM	Standard Pack	Item Number
3"	.026/120	5/8"-1/2"	9/16"	1/2"	7/16"	6,000	2	31240
	.035/80							31241
	.043/120							31242
	.055/80							31246
4"	.026/120	5/8"-1/2"	5/8"	1"	7/16"	6,000	2	31110
	.035/80							31270
	.043/120							31280
	.055/80							31290

## Burr-Rx® Narrow Face Wheels - Metal Hub - Crimped Round Black Ceramic Filament

Dia.	Filament Dia./Grit	Arbor Hole	Face Width	Trim Length	Thickness Through Arbor	Max. RPM	Standard Pack	Item Number
3"	.026/120	1/2"-3/8"	3/8"	1/2"	7/16"	6,000	2	86164
	.035/80							31102
	.043/120							31101
4"	.026/120	1/2"-3/8"	1/2"	7/8"	7/16"	6,000	2	86165
	.035/80							31103
	.043/120							31100
	.055/80							31105
6"	.026/120	5/8"-1/2"	5/8"	7/8"	11/16"	4,500	2	31134
	.043/120							31135
	.035/80							31136
	.055/80							31137

## Heavy-Duty Narrow Face Wheels - Metal Hub - Crimped Round Silicon Carbide Filament

Dia.	Filament Dia./Grit	Arbor Hole	Face Width	Trim Length	Thickness Through Arbor	Max. RPM	Standard Pack	Item Number
3"	.040/80	5/8"-1/2"	9/16"	1/2"	7/16"	6,000	2	31245
4"	.022/320	5/8"-1/2"	5/8"	1"	7/16"	6,000	2	31255
	.035/180							31265
	.040/120							31275
	.040/80							31285

## Narrow Face Wheels - Metal Hub - Crimped Round Silicon Carbide Filament

Dia.	Filament Dia./Grit	Arbor Hole	Face Width	Trim Length	Thickness Through Arbor	Max. RPM	Standard Pack	Item Number
3"	.022/320	1/2"-3/8"	3/8"	1/2"	7/16"	6,000	2	31074
	.035/180							31084
	.040/120							31094
4"	.022/320	1/2"-3/8"	1/2"	7/8"	7/16"	6,000	2	31104
	.035/180							31114
	.040/120							31124
6"	.022/320	5/8"-1/2"	5/8"	7/8"	11/16"	4,500	1	31121
	.035/180							31122
	.040/120							31123

# Nylox® Wheel Brushes

**Nylox® Small Diameter Wheels** - Weiler offers the widest assortment of small diameter radial wheels for addressing recesses and internal features, or delivering a targeted brushing action to a specific area on a part.

Small diameter Burr-Rx® wheels feature Weiler's advanced black ceramic grain filament which delivers up to a 400% greater edge cutting action in comparison to traditional silicon carbide and aluminum oxide filaments for the fastest, most aggressive deburring action for minimum cycle times and maximum media life.

## Applications

- Deburring keyways, slots and crosshole intersections
- Honing and finishing of cylindrical bores

### Burr-Rx® Small Diameter Wheels - Metal Hub - Crimped Round Black Ceramic Filament

Diameter	Filament Dia./Grit	Arbor Hole	Face Width	Trim Length	Max. RPM	Standard Pack	Item Number
1-1/4"	.026/120	1/4"	5/16"	5/16"	10,000	10	17551
1-1/2"	.026/120	1/2"	3/8"	1/4"	10,000	10	17541
2"	.026/120	1/2"	3/8"	1/2"	10,000	10	17548
	.035/80						17555
	.055/80						17542
2-1/2"	.026/120	5/8"	1/2"	11/16"	10,000	10	17556
	.035/80						17557
3"	.026/120	1/2"	1/2"	1"	10,000	10	17565
	.035/80						17567
	.043/120						17568
	.055/80						16000

Other diameters and grit sizes available upon request.

### Small Diameter Wheels - Metal Hub - Crimped Round Silicon Carbide Filament

Diameter	Filament Dia./Grit	Arbor Hole	Face Width	Trim Length	Max. RPM	Standard Pack	Item Number
1-1/8"	.022/120	1/4"	5/16"	1/4"	10,000	10	17532
1-1/4"	.022/120	1/4"	5/16"	5/16"	10,000	10	17535
1-3/8"	.018/500 ▲	1/4"	5/16"	3/8"	10,000	10	16310
1-1/2"	.022/120	1/2"	3/8"	1/4"	10,000	10	17628
	.035/180						29353
	.018/500						17533
2"	.022/320	1/2"	3/8"	1/2"	10,000	10	17543
	.040/120						17633
	.022/120						17629
2"	.022/120	5/8"	7/16"	7/16"	10,000	10	17629
	.022/320						29356
2-1/2"	.022/120	5/8"	1/2"	11/16"	10,000	10	29123
	.035/180						29280
	.035/180						29088
3"	.022/320	1/2"	1/2"	1"	10,000	10	17563
	.022/120						16315
	.040/120						16263

▲ Aluminum Oxide

Other diameters and grit sizes available upon request.



Weiler's Application Engineering Team is available to recommend the best product and process to meet your specific application requirements.



Deburring the edges of a machined aluminum component.



16000



17533



**NOTE**

See adapters on page 90.

Nylox® Wheel Brushes

# Nylox® Wheel Brushes



A diamond abrasive disc brush creates a small radius on a ceramic part.



83005

**Diamond Filament Wheel Brushes** - Weiler's diamond filament wheels utilize composite hub construction for high performance in precision applications. Our wheel brushes are made-to-order in a wide range of diameters and thicknesses. Additional configurations are available such as; tube brushes, composite hub disc brushes and end brushes. Common wheel configurations are listed below. Other sizes and pricing are available on request. Additional product configurations are available. Please contact Customer Service at 800-835-9999.

## Applications

Ideal for producing edge radii on hard materials:

- Diamond
- Ceramic
- CBN
- Glass

## Diamond Filament Wheels - Composite Hub - Round Diamond Filament

O.D. x I.D.	Filament Diam. /Grit	Face Width	Trim Length	Thickness Through Arbor	Max. RPM	Standard Pack	Item Number
6" x 2"	.024/200	5/16"	1-1/4"	1/4"	3,600	1	83002
	.014/600						83003
	.012/1000						83004
8" x 2"	.024/200	5/16"	2-1/4"	1/4"	3,600	1	83005
	.014/600						83006
	.012/1000						83007

Nylox® Wheel Brushes

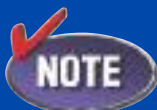

See adapters on page 90.



**Operating Speeds - Wheels** - Nylox® abrasive brushes work with a wiping and filing action. Think of them as flexible files. They work best when operated at speeds that allow penetration of the work-piece into the brush filaments. The maximum RPM marked on the brush is not the optimum working speed. A good rule of thumb is to stay under 2,500 SFPM in dry applications and 3,500 SFPM in wet applications.

Diameter	RPM
2"	3,450 - 5,000
3"	2,500 - 3,450
4"	1,750 - 2,500
6"	1,350 - 1,750
8"	1,150 - 1,350
10"	950 - 1,150
12"	750 - 950
14"	650 - 850

Note: See parameter summary on page 74 for additional information.



Weiler was the first manufacturer of Composite Hub Nylox® Brushes.

# Nylox<sup>®</sup> Crosshole Deburring Brushes

**Bore-Rx<sup>™</sup> Brushes** - These brushes are designed for automated applications in CNC machining centers and dedicated machines. They are ideal for removing burrs from internal edges and finishing bores. Since they eliminate off-hand deburring, they improve part-to-part consistency and reduce direct labor content. Bore-Rx brushes are available in sizes ranging from 7/8" to 4" and can be readily adapted into a machining center's tool changer using an end-mill holder or 3/8" collet.

## Bore-Rx Brushes - 3/8" stems - Crimped Round Black Ceramic Filament

Diameter	Filament Dia./Grit	Face Width	Overall Length	Max. RPM	Standard Pack	Item Number
7/8"	.026"/120	3/4"	4-3/4"	8,000	1	17206
1"	.026"/120	3/4"	4-3/4"	8,000	1	17208
1-1/4"	.026"/120	3/4"	4-3/4"	8,000	1	17210
1-1/2"	.026"/120	1"	5"	8,000	1	17212
2"	.026"/120	1"	3-1/4"	6,000	1	17215
2-1/2"	.055"/80	1"	3-1/4"	6,000	1	17217
3"	.026"/120	1"	3-1/4"	6,000	1	86150
	.043/120					86151
	.055/80					86152
4"	.026/120	1"	3-1/4"	6,000	1	86154
	.043/120					86155
	.055/80					86156

Note: All Bore-Rx brush stems have a 2" long flat for use in end mill holders. Alternatively, they can be mounted in 3/8" collets.

## Replacement Bore-Rx Brush Heads and Reusable Bore-Rx Arbors

In high production applications, reusable arbors reduce manufacturing costs by allowing the use of inexpensive brush head replacements. Brush heads are made-to-order in diameters ranging from 7/8" to 1-1/2" with face widths of 1/4" to 1". They are available on 3/16" and 1/4" pins. The pin diameter is based on the application and determines brush density. Contact Application Engineering at 888-299-APPS (2777) for more information.



## Operating Parameters For Bore-Rx Brushes

Brush Diameter	Recommended RPM	Recommended Feed Rate
5/8" - 7/8"	3000	20"/min
1" - 1-1/2"	3000	20"/min
2" - 2-1/2"	2000	20"/min
3" - 4"	1500	20"/min

### Tool Paths for Crosshole Deburring

An effective tool path for most crosshole deburring jobs is circular interpolation using the following guidelines to determine diameter of interpolation. The interpolation should be performed at a depth where the center of the brush face is at the center of the intersecting hole.

■ Diameter of Interpolation = Hole Dia. - 0.975 x Brush Dia.

### Tool Paths for Bore Finishing

Nylox brushes can be used to improve the surface finish of bores. The best tool path normally involves helically interpolating the bore. The above recommendations for speed, feed and diameter of interpolation are also valid for bore finishing. The use of coolant is highly recommended in order to achieve maximum surface finish improvement.



Deburring the internal bores of an air-cooled cylinder head.

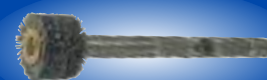

17208

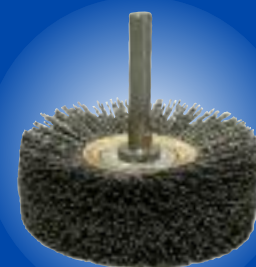

86155

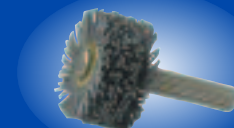

Replacement Head



Reusable Arbor

Nylox<sup>®</sup> Crosshole Deburring Brushes

# Nylox® Disc Brushes

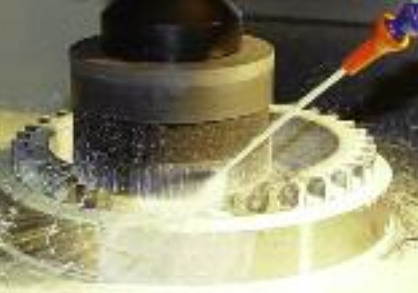

Deburring a bearing cage in a CNC machining center.



86112



86143

Nylox® Disc Brushes

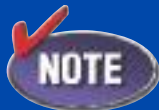

See page 72 for more information about applying Nylox disc brushes in CNC applications.

**Nylox® Disc Brushes** - Weiler's Nylox disc brushes are manufactured using a tufted filament configuration and longer trim length for increased aggression, greater conformability and longer product life in comparison to monofilament disc brushes which feature a distribution of short individual bristles.

Burr-Rx® disc brushes feature Weiler's advanced black ceramic grain filament which delivers up to a 400% greater edge cutting action in comparison to traditional silicon carbide and aluminum oxide filaments for the fastest, most aggressive deburring action for minimum cycle times and maximum media life.

All of our Burr-Rx disc brushes are manufactured using a new process which results in a very consistent, flat brush face in comparison to traditional construction which utilizes a molded backing. The high dimensional precision of these tools means that the brushes are suitable for the most critical applications and perform more consistently from first part to last. In addition, the machined polymer backings are designed to mount directly onto a standard shell mill holder for convenient use in CNC machining centers.

## Applications

- Deburring flat surfaces on machined components
- Improving texture characteristics on machined or ground surfaces
- Deburring face-milled castings or forgings
- Blending tool marks after machining or grinding

## Burr-Rx® Shell Mill Holder Disc Brushes - Crimped Black Ceramic Filament

Diameter	Filament Diameter/Grit	Arbor Hole	Trim Length	Max. RPM	Standard Pack	Item Number
<b>Round Filament</b>						
4"	.026/120	1-1/4"	1-1/2"	1,800	1	86112
	.043/120					86113
	.043/120					86204*
	.055/80					86114*
6"	.026/120	1-1/4"	1-1/2"	1,800	1	86115
	.043/120					86116
	.043/120					86117*
	.055/80					86117*
8"	.026/120	1-1/4"	1-1/2"	1,800	1	86141
	.043/120					86142
	.043/120					86143*
	.055/80					86143*
10"	.026/120	1-1/4"	1-1/2"	1,800	1	86125
	.043/120					86121
	.043/120					86122*
	.055/80					86122*
<b>Rectangular Filament</b>						
4"	80	1-1/4"	1-1/2"	1,800	1	86167*
6"	80	1-1/4"	1-1/2"	1,800	1	86198*
8"	80	1-1/4"	1-1/2"	1,800	1	86199*

\* Maximum Density



Note: See parameter summary on page 74 for additional information.

**Operating Speeds - Discs** - Nylox® abrasive brushes work with a wiping and filing action. Think of them as flexible files. They work best when operated at speeds that allow penetration of the work-piece into the brush filaments. The maximum RPM marked on the brush is not the optimum working speed. A good rule of thumb is to stay under 2,500 SFPM in dry applications and 3,500 SFPM in wet applications.

Diameter	RPM
1-3/4"	1,750 - 2,000
3"-4"	1,500 - 1,750
5" - 6"	1,250 - 1,500
8"	800 - 1,000
10"	700 - 800
12"	600 - 700
14"	500 - 600

# Nylox<sup>®</sup> Disc Brushes

## Composite Hub Disc Brushes - Silicon Carbide Filament

Diameter	Filament Dia./Grit	Arbor Hole	Trim Length	Max. RPM	Standard Pack	Item Number
<b>Crimped Round Filament</b>						
3"	.035/180 .040/120	7/8"	1-1/2"	2,500	1	85776 85778
3-1/2"	.022/320 .035/180 .040/80	7/8"	1-1/2"	2,500	1	85792 85794 85798
4"	.022/320 .035/180 .040/120 .040/80	7/8"	1-1/2"	2,500	1	85812 85814 85816 85818
5"	.035/180 .040/80	7/8"	1-1/2"	2,500	1	85832 85836
6"	.035/180 .040/120 .040/80	7/8"	1-1/2"	2,000	1	85850 85852 85854
8"	.035/180 .040/120 .040/80	7/8"	1-1/2"	2,000	1	85908 85912 85914
10"	.040/120 .040/80	7/8"	1-1/2"	1,750	1	85930 85932
12"	.035/180 .040/120	7/8"	1-1/2"	1,750	1	85946 85948
<b>Rectangular Filament</b>						
3"	120 80	7/8"	1-1/2"	2,500	1	85786 85788
3-1/2"	320 80	7/8"	1-1/2"	2,500	1	85800 85806
4"	180 120 80 80 80	7/8"	1-1/2"	2,500	1	85822 85824 85826 85995 • 85900* •
5"	120 80 80	7/8"	1-1/2"	2,500	1	85842 85844 85978 •
6"	120 80 80 80	7/8"	1-1/2"	2,000	1	85860 85862 85996 • 85901* •
8"	120 80	7/8"	1-1/2"	2,000	1	85920 85922
9"	80	7/8"	1-1/2"	2,000	1	85997 •
10"	120 80	7/8"	1-1/2"	1,750	1	85938 85940

\* Banded for extra aggression

• Maximum density



### Arbor & Drive Hole Specifications for Composite Hub Disc Brushes

Brush Diameter	Arbor Hole Diameter	Drive Holes
3"-5", 6" Max. Density	7/8"	(2) 1/4" dia. on a 1-1/4" dia. bolt circle
6"	7/8"	(3) 1/4" dia. on a 3" dia. bolt circle
8"	7/8"	(4) 1/4" dia. on a 3" dia. bolt circle
10"	7/8"	(4) 1/4" dia. on a 1.625" dia. bolt circle
12"	7/8"	(4) 1/4" dia. on a 1.625" dia. bolt circle
14"	5"	N.A.



Deburring the edges of an aluminum engine cover.

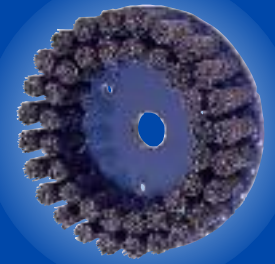

85852

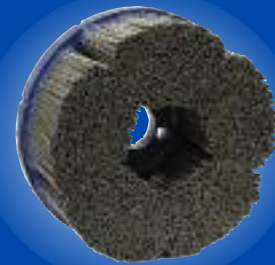

85978

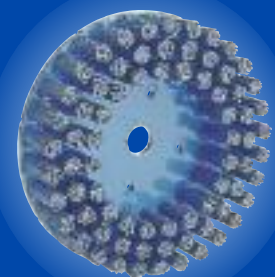

85920



See adapters & drive arbors on pages 90-91.

Nylox<sup>®</sup> Disc Brushes

# Nylox® Disc and Cup Brushes



Removing burrs and breaking sharp edges on a transmission component.



85733



85753



85752



85981



14413

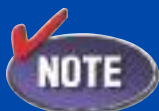

See adapters & drive arbors on pages 90-91.

**Nylox Mini-Disc Brushes** - Featuring a precision machined aluminum cup, Weiler's mini-disc brushes are designed to be the most cost-effective media for applications requiring a smaller brushing tool.

## Applications

- Deburring flat surfaces on machined components
- Improving texture characteristics on machined or ground surfaces
- Deburring face-milled castings or forgings
- Blending tool marks after machining or grinding

## Burr-Rx® Mini Disc Brushes - Maximum Density - Crimped Black Ceramic Filament

Diameter	Filament Diameter/Grit	Trim Length	Max. RPM	Standard Pack	Item Number
<b>Round Filament</b>					
2"	.026/120	1-1/4"	4,500	1	86106
	.035/80				85738
	.043/120				86107
3"	.055/80	1-1/4"	4,500	1	85733
	.026/120				86109
	.035/80				86013
	.043/120				86110
	.055/80				86111
<b>Rectangular Filament</b>					
2"	80	1-1/4"	4,500	1	85736
3"	80	1-1/4"	4,500	1	86014

## Mini Disc Brushes - Silicon Carbide Filament

Diameter	Filament Dia./Grit	Trim Length	Max. RPM	Standard Pack	Item Number
<b>Round Filament</b>					
1-3/4"	.035/180	1-1/4"	6,000	2	85753
	.022/120				85751
	.040/80				85750
<b>Rectangular Filament</b>					
1-3/4"	80	1-1/4"	6,000	2	85752
2"	80	1-1/4"	4,500	2	85773*
3"	80	1-1/4"	4,500	1	85981*

\* Maximum Density

**Nylox Cup Brushes** - Weiler also offers an assortment of Nylox tools featuring traditional cup brush construction for deburring and finishing use in lighter duty applications. These brushing tools can be used on dedicated machines in automated processes or on low speed/high torque handheld tools for manual applications.

## Applications

- Deburring and finishing complex or contoured parts



## Cup Brushes - Crimped Round Silicon Carbide Filament

Diameter	Filament Dia./Grit	Arbor Hole	Trim Length	Max. RPM	Standard Pack	Item Number
2-3/4"	.022/320	1/4" Stem	1-1/4"	6,000	1	14401
	.035/180					14403
	.040/120					14404
3-1/2"	.035/180	5/8"-11	1-1/2"	12,000	1	14413
	.040/120					14414
5"	.040/120	5/8"-11	1-1/4"	8,000	1	14576
6"	.040/120	5/8"-11	1-1/4"	6,600	1	14516*
	.040/80					14506*

\* With internal nut



# Nylox® End Brushes

**Nylox® End Brushes and Miniature End Brushes** - Featuring an integral stem for convenient mounting into a toolholder or collet, Nylox end brushes and miniature end brushes are suitable for addressing recesses and internal features, or delivering a targeted brushing action to a specific area on a part.

## Applications

- Deburring small recessed areas and internal part features
- Finishing slots and recessed surfaces on machined parts

## Burr-Rx® End Brushes - Banded - Crimped Round Black Ceramic Filament - Mounted on 1/4" Stems

Diameter	Filament Diameter/Grit	Trim Length*	Max. RPM	Standard Pack	Item Number
3/8"	.026/120	1/4"	10,000	10	86098
	.043/120				86099
1/2"	.026/120	1/4"	10,000	10	86100
	.043/120				86101
3/4"	.026/120	1/4"	10,000	10	86102
	.043/120				86103
1"	.026/120	1/4"	10,000	10	86104
	.043/120				86105

\* Trim length from bands

## End Brushes - Banded - Crimped Round Silicon Carbide Filament - Mounted on 1/4" Stems

Diameter	Filament Dia./Grit	Trim Length*	Max. RPM	Standard Pack	Item Number
1/2"	.022/320	3/8"	10,000	10	11160
	.035/180				11161
	.040/120				11162
3/4"	.035/180	3/8"	10,000	10	11165
	.040/120				11166
1"	.022/320	3/8"	10,000	10	11168
	.035/180				11169
	.040/120				11170

\* Trim length from bands

## End Brushes - Crimped Round Silicon Carbide Filament - Mounted on 1/4" Stems

Diameter	Filament Dia./Grit	Trim Length	Max. RPM	Standard Pack	Item Number
1/2"	.022/320	7/8"	10,000	10	10172
	.035/180				10173
	.040/120				10174
3/4"	.022/320	7/8"	10,000	10	10152
	.035/180				10153
	.040/120				10154
1"	.022/320	7/8"	10,000	10	10155
	.035/180				10156
	.040/120				10157

## Miniature End Brushes - Crimped Round Silicon Carbide Filament

Plastic Ferrule - Mounted on 1/8" stems

Diameter	Filament Dia./Grit	Trim Length	Max. RPM	Standard Pack	Item Number
3/16"	.018/500	1/4"	37,000	144	26136
1/4"	.018/500	3/8"	37,000	144	26138
5/16"	.018/500	9/16"	25,000	144	26146



Blending tool marks on a hydraulic component.



86104



11166



10154



26136

Nylox® End Brushes

# Nylox® Tube Brushes

**Nylox® Power Tube Brushes** - Weiler offers a comprehensive line of Nylox power tube brushes for internal deburring and finishing applications in tubular component parts, drilled and tapered holes, and machined bores and passages. Power tube brushes are suitable for use in drill presses and manual and CNC machine tools. See pages 50-51 for operating guidelines.

## Burr-Rx® Tube Brushes - Crimped Black Ceramic Filament - 1/4" Cadmium Plated Stems

Diameter	Filament Dia./Grit	Length of Brush Part	Stem Diameter	Overall Length	Standard Pack	Item Number
3/8"	.026/120	1"	1/4"	3-1/2"	10	21758
1/2"	.026/120	1"	1/4"	3-1/2"	10	21759
5/8"	.026/120	1"	1/4"	3-1/2"	10	21761
3/4"	.026/120	1"	1/4"	3-1/2"	10	21762
7/8"	.026/120	1"	1/4"	3-1/2"	10	21763
1"	.026/120	1"	1/4"	3-1/2"	10	21764
1-1/4"	.026/120	1"	1/4"	3-1/2"	10	21765

## Tube Brushes - Crimped Round Silicon Carbide Filament - Double Stem, Single Spiral

Diameter	Filament Dia./Grit	Length of Brush Part	Stem Diameter	Overall Length	Standard Pack	Item Number
1/4"	.022/320	2"	5/32"	5"	10	21126
3/8"	.022/320	2"	5/32"	5"	10	21128
1/2"	.022/320 .040/80	2"	3/16"	5"	10	21130 21325
5/8"	.022/320 .040/80	2"	7/32"	5"	10	21132 21326
11/16"	.022/320	2"	7/32"	5"	10	21133
3/4"	.022/320 .040/80	2-1/2"	1/4"	5-1/2"	10	21134 21327
7/8"	.022/320 .040/80	2-1/2"	1/4"	5-1/2"	10	21136 21976
1"	.022/320 .040/80	2-1/2"	1/4"	5-1/2"	10	21138 21328
1-1/4"	.022/320 .022/120 .035/180 .040/80	2-1/2"	1/4"	5-1/2"	10	21306 21304 21305 21329
1-1/2"	.022/320 .035/180 .040/80	2-1/2"	1/4"	5-1/2"	10	21309 21308 21330
1-3/4"	.040/80 .035/180	2-1/2"	1/4"	5-1/2"	10	21311 21312
2"	.022/320 .040/80	2-1/2"	1/4"	5-1/2"	10	21473 21345

## Tube Brushes - Micro Abrasive - For ultra-fine deburring and finishing of small internal holes.

Diameter	Length of Brush Part	Stem Diameter	FOR HOLE DIAMETERS		Overall Length	Standard Pack	Item Number
			Decimal	Fraction			
<b>Silicate Filament</b>							
.030"	1/2"	.015	.031"	1/32"	4"	10	26900
.050"	1/2"	.022	.047"	3/64"	4"		26901
.075"	3/4"	.033	.063"	1/16"	4"		26902
.090"	3/4"	.041	.078"	5/64"	4"		26903
.105"	1"	.041	.094"	3/32"	4"		26904
.125"	1"	.064	.109"	7/64"	4"		26905
.135"	1"	.075	.125"	1/8"	4"		26906
<b>600 Grit Aluminum Oxide Filament</b>							
.165"	1"	.087	.156"	5/32"	5"	10	26907
.190"	1"	.087	.188"	3/16"	5"		26908
.260"	1"	.115	.250"	1/4"	5"		26909
.325"	1"	.115	.313"	5/16"	5"		26910
.385"	1"	.147	.375"	3/8"	5"		26911
.515"	1"	.194	.500"	1/2"	5"		26912
.640"	1"	.194	.625"	5/8"	5"		26913
.765"	1"	.212	.750"	3/4"	5"		26914
.890"	1"	.212	.875"	7/8"	5"		26915

Crosshole deburring an aluminum manifold.



21759



21128



21138

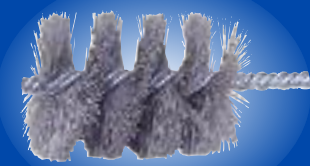

21473



26904



26908



26915

Nylox® Tube Brushes

# Nylox<sup>®</sup> Adapters and Drive Arbors

**Metal Adapters - Reusable** - Used in pairs and priced per pair.

Diameter	Arbor Hole Size	Used With	Standard Pack	Item Number
2"	1/2"	All 2" I.D. Wheels	1	03809
	5/8"			03810
	3/4"			03811
	7/8"			03824
	1"			03812
	1-1/4"			03813
	1-1/2"			03814
3-1/4"	3/4"	3-1/4" I.D. Wheels (When mounting only one wheel)	1	03910
	7/8"			03911
	1"			03912
	1-1/4"			03913
	2"			03915
5-1/4"	3/4"	5-1/4" I.D. Wheels (When mounting only one wheel)	1	03920
	7/8"			03921
	1"			03922
	1-1/4"			03923
	2"			03925

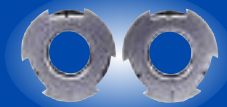

03809



03923

**Steel Flanges - Reusable** - Used on the ends of a gang mount. Used in pairs and priced per pair. Must be used in conjunction with Pressboard Adapters in chart below.

Flange O.D.	Arbor Hole Size	Used With	Standard Pack	Item Number
5-5/8"	3/4"	3-1/4" & 4-1/4" I.D. Wheels	1	03931
	1"			03933
	1-1/4"			03934
	2"			03936
6-1/2"	1-1/4"	5-1/4" I.D. Wheels	1	03944
	1-1/2"			03945
	2"			03946
8-3/4"	1-1/4"	7-1/4" I.D. Wheels	1	03954
	1-1/2"			03955
	2"			03956

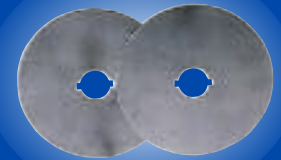

03944

**Pressboard Adapters** - Used for centering 10", 12" and 14" Nylox<sup>®</sup> Wheels when gang mounting. Must be used in conjunction with Steel Flanges in chart above.

Brush I.D.	Arbor Hole Size	Standard Pack	Item Number
3-1/4"	3/4"	1	03890
	1"		03892
	1-1/4"		03893
	2"		03895
	3/4"		03960
4-1/4"	1-1/4"	1	03963
	2"		03965
	3/4"		03403
5-1/4"	1-1/4"	1	03404
	1-1/2"		03405
	2"		03973
7-1/4"	1-1/4"	1	03974
	1-1/2"		03975
	2"		03975

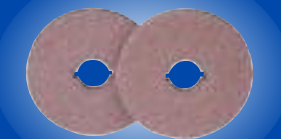

03403

Nylox<sup>®</sup> Adapters and Drive Arbors

# Nylox<sup>®</sup> Adapters and Drive Arbors



04401

04402



89029



89033



07700



07701



07718

## Plastic Adapters

Fixed Arbor Hole Size	Adapted Arbor Hole Size	Used With	Standard Pack	Item Number
1/2"	1/4"	Small Dia. Wheels	10	04400
1/2"	3/8"	Small Dia. Wheels	10	04401
5/8"	1/2"	Small Dia. Wheels	10	04402

## Miniature & Burr-Rx™ Disc Brush Drive Arbors - Includes drive arbor, set screw and hex key.

For Brush Diameter	Stem Diameter	Stem Length	Max. RPM	Standard Pack	Item Number
1-3/4"-3"	1/4"	1-3/4"	6,000	1	89023*
1-3/4"-3"	3/8"	1-3/4"	6,000	1	89024*
1-3/4"-3"	1/2"	1-3/4"	6,000	1	89029*

\* For use with Burr-Rx Mini Disc brushes on page 87 only. Products supplied with set screw and wrench.

## Miniature & Burr-Rx™ Disc Brush Drive Arbors - Includes drive arbor, set screw and hex key. Recommended for operations in which brush rotation alternates between forward and reverse.

For Brush Diameter	Stem Diameter	Stem Length	Max. RPM	Standard Pack	Item Number
2"-3"	1/2"	1-3/4"	6,000	1	89033*

\* For use with Burr-Rx Mini Disc brushes on page 87 only. Products supplied with set screw and wrench.

## Disc Brush Drive Arbors - Mounts Weiler disc brushes to any type of milling machine or CNC machine.

Fits	Arbor Hole	Drive Studs	Bolt Circle	Plate O.D.	Shaft Dia.	Stem Length	Std. Pack	Item Number
3", 4" and 5" Disc Brushes	7/8"	2	1-1/4"	2-7/8"	3/4"	2-3/4"	1	07700*
6" Std. Tuft Disc Brushes NOT Max. Density	7/8"	3	3"	5-7/8"	3/4"	2-1/2"	1	07701*
6" Max. Density Disc Brushes, also 5" Std. Tuft	7/8"	2	1-1/4"	4-7/8"	3/4"	2-1/2"	1	07715*
8" and 9" Disc Brushes	7/8"	4	3"	7-7/8"	3/4"	2-1/2"	1	07702*
10" and 12" Disc Brushes	7/8"	4	1-5/8"	9-7/8"	3/4"	2-1/2"	1	07703*
<b>Replacement kit includes:</b> (1) 1/2"-13 locking flow-through bolt and (1) Belleville spring washer	-	-	-	-	-	-	1	07718*

\* Flow-through drive arbor.



- The adapters and drive arbors listed on this page are for use with small diameter wheel brushes only; do not attempt to use them with cutting or grinding wheels, buffing wheels, or any type of abrasive wheel or disc.
- Do not adapt a wheel brush for use on a shaft diameter less than that specified by ANSI B165.1 (see page 20) or exceed the maximum wheel diameter specified for a drive arbor.
- Never mount a drive arbor onto a tool which operates above the maximum RPM rating of either the arbor or the brush (whichever may be lower) and be sure that the stem of the arbor is properly secured in the collet or chuck before use.

**DID YOU KNOW?**

Weiler's Black Ceramic Nylon Abrasive Filament Brushes are being used on key parts of the United States Navy's newest warships.

# Nylox<sup>®</sup> FME Area Product Solutions

In nuclear power plants, Foreign Material Exclusion (FME) programs may limit or even exclude the use of wire brushes in some areas during the performance of routine maintenance, repair or shut-down activities. Weiler has developed a FME-compliant tooling system to address the needs of plant operators and maintenance contractors working in these facilities as well as other industries where the potential introduction of broken wire filaments may be of concern.

Weiler's FME Solutions program is a complete system consisting of non-wire brushing tools designed to perform a broad range of surface cleaning and preparation applications as well as the power tools required to drive them. For cleaning hot welds in FME-controlled areas, Weiler offers the HFR stringer bead wire wheel (see page 28) which can be used on a standard right angle grinder.

**Black Nylox Ceramic Brushes** - The engineered ceramic grain in Weiler's Black Nylox filament is up to 400% more aggressive than the silicon carbide and aluminum oxide grain in other abrasive filaments, making it much more effective in surface cleaning applications. The efficient cutting action of the Black Nylox filament also generates less heat and makes it much more resistant to "smearing" than traditional nylon abrasive filaments.

**Narrow Face Wheels - Crimped Ceramic Filament**  
Used on edge for weld prep and cold weld cleaning.

Diameter	Filment Dia./Grit Size	Face Width	Arbor Hole	Max. RPM	Standard Pack	Item Number
4"	.055/80	1/2"	5/8"-11 Nut	4,800	5	31112
4"	.043/120	1/2"	5/8"-11 Nut	4,800	5	31111

**Cup Brush - Rectangular Ceramic Filament**  
Used on its face for heavy-duty cleaning of broad surfaces.

Diameter	Filment Dia./Grit Size	Arbor Hole	Max. RPM	Standard Pack	Item Number
4"	.049 x .098 - 80 Grit	5/8"-11 Nut	4,800	1	86160

**Bevel Brush - Rectangular Ceramic Filament**  
For aggressive cleaning in corners and confined areas.

Diameter	Filment Dia./Grit Size	Face Width	Arbor Hole	Max. RPM	Standard Pack	Item Number
4"	.049 x .098 - 80 Grit	3/4"	5/8"-11 Nut	4,800	1	31113



Nylon abrasive filament brushes require a lower operating RPM than most other power tool accessories and they cannot be used effectively on standard grinders.

**Weiler Grinders By Metabo<sup>®</sup>** - Engineered by Metabo exclusively for Weiler, these grinders operate at the optimum speed required to make the most effective use of the Black Nylox brushes. The critical mechanisms of these industrial grade electric grinders are sealed to protect them from the accumulation of dust and swarf. In addition, the housing and case of these virtually indestructible power tools are designed to insure optimum air flow over the motors for reliable performance and long service life. Grinders feature an extended-slide "Deadman" switch design which insures that the tool shuts off if dropped.



## Model 60012 4-1/2" Right Angle Grinder

### Features:

- Double insulation
- 4,800 RPM
- Deadman switch
- Current interruption protection
- Spindle lock
- Tool-free guard adjustment
- 2-position side handle
- 12.2 Amp
- 5/8"-11 Spindle
- Spanner wrench included



Removing gasket material from a pipe flange.

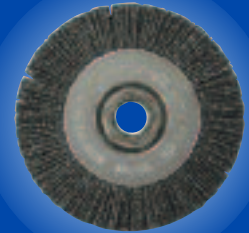

31112

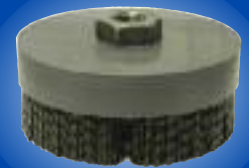

86160



31113

Nylox<sup>®</sup> FME Area Product Solutions

# Nylox® FME Area Product Solutions



Cleaning internal threads inside a valve.

Nylox® FME Area Product Solutions



86148



86159



86171



44144



95016

## End Brush - Crimped Ceramic Filament - 1/4" Stem For spot-facing or cleaning in tight areas.



Diameter	Filment Dia./Grit Size	Trim Length	Max. RPM	Standard Pack	Item Number
1"	.055/80	3/4"	4,800	10	86148

## Controlled Flare End Brush - Crimped Ceramic Filament - 1/4" Stem For cleaning corners and tight areas.



Diameter	Filment Dia./Grit Size	Trim Length	Max. RPM	Standard Pack	Item Number
1"	.035/80	1-1/8"	4,800	10	86159

## Conflex Brushes - Crimped Ceramic Filament - 1/4" Stem For O.D. and I.D. cleaning in confined areas.



Diameter	Filment Dia./Grit Size	Face Width	Trim Length	Max. RPM	Standard Pack	Item No.
3"	.043/120	1"	15/16"	4,800	10	86171
3"	.055/80	1"	15/16"	4,800	10	86172



**Tech Note**  
Nylon abrasive filament brushes require a lower operating RPM than most other power tool accessories and they cannot be used effectively on standard grinders.

## Model 60006 Die Grinder



### Features:

- Double insulation
- 4,800 RPM
- Deadman switch
- Spindle lock
- Side handle included
- 7.5 Amp
- 1/4" Collet
- Extended spindle for working in confined areas

## Hand Scratch Brushes - Crimped Ceramic Filament - For general purpose, light-duty cleaning.

Overall Length	Block Type	Brush Part	Grit Size	Trim Length	Standard Pack	Item No.
10"	Wood	5"	80	3/4"	12	44144
8-3/4"	Wood	2 x 9 Rows	120	5/8"	36	95016



Weiler's Nylox and Burr-Rx brushes are used by all three of the major jet engine manufacturers to deburr critical component parts.

# Tiger® Abrasives

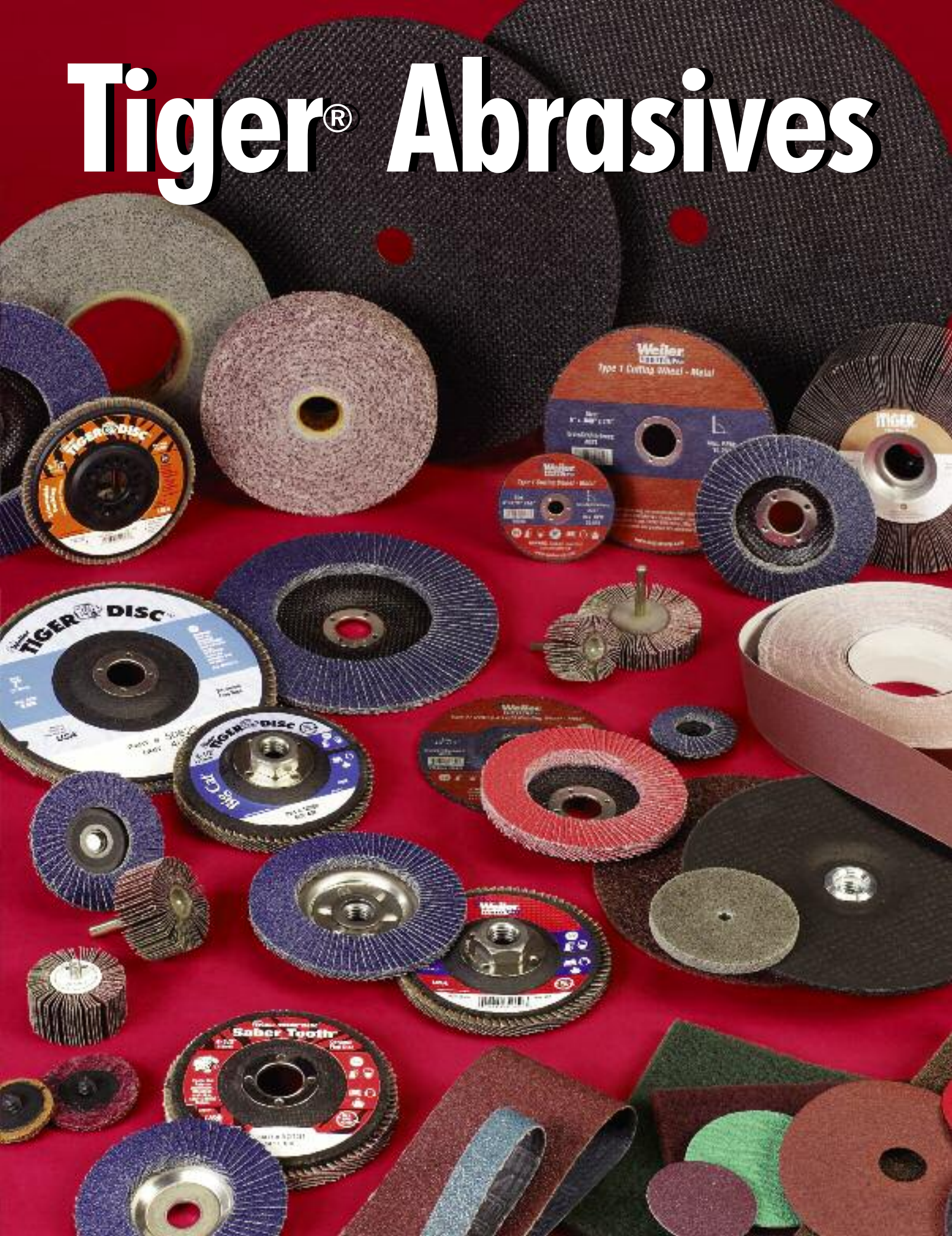

# **Weiler® Abrasives**

**Abrasives**

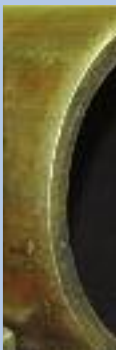





- **Flap Discs**  
*Market Leader!*
- **Resin Fiber Discs**
- **AL-tra CUT™ Discs**  
*Best for Aluminum*
- **Blending Discs**
- **TRIM-KUT® Discs**
- **Flap Wheels**
- **Belts**
- **Shop Rolls**
- **Grinding & Cutting Wheels**  
*New Vortec Pro® General Purpose Bonded Program*
- **Unitized Wheels**
- **Convolute Wheels**
- **Surface Conditioning Discs**
- **Hand Pads**
- **Interleaf Flapwheels**

**New!**

**Knowledgeable and Responsive  
Customer Service Team:  
800-835-9999**

**Application Engineering Support:  
888-299-APPS (2777)**

**Interactive Website:  
[www.weilercorp.com](http://www.weilercorp.com)**



## Steel Piping

**Problem:** A clean bevel end free of any surface imperfections is critical to a strong joint when welding heavy-wall piping. Unfortunately, lengths of steel pipe can sit in yards for significant periods of time, and pitting of the bevel ends is usually the result.

**Solution:** Coated abrasive flap discs like Weiler's original Tiger Disc are ideal tools for quickly removing heavy corrosion and blending pitting from bevel ends. The chatter-free, compliant grinding action and smooth, consistent finish produced by these discs make them the preferred choice for this application.

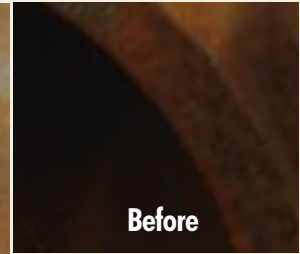

## Steel Channel

**Problem:** Burrs produced by cut-off operations are dangerous and can prevent parts from fitting together properly which can cause potential structural weak points.

**Solution:** Weiler's coated abrasive flap wheels are flexible grinding products which are ideal for light stock removal applications. A 60 grit wheel can be used to remove a large burr and produce a smooth blended edge.



Photos courtesy of On-Line Services.

## Aluminum Frames

**Problem:** Aluminum welds are particularly difficult to blend due to the tendency of the chips to become welded to the abrasive media. This causes the cut rate of the abrasive to fall rapidly and generates an expensive grinding operation.

**Solution:** Weiler's AL-tra Cut™ discs are specially formulated to prevent loading by lowering the grinding temperature. A 60 grit AL-tra Cut disc can blend an aluminum weld bead much faster than a conventional disc without loading.

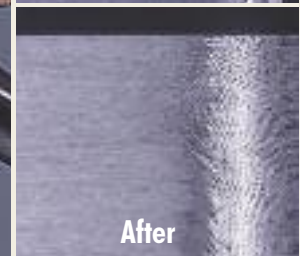

# Solutions Showcase

## Snow Plow Blade



**Problem:** Grinding fillet welds is a difficult, time-consuming process that is often expensive to perform.

**Solution:** Weiler's Trimmable Tiger® flap disc offers the ability to create a flexible grinding media that can easily blend fillet welds. The disc's trimmable design also extends the life of the disc, resulting in lower grinding and finishing costs.

## Steel Handle



**Problem:** The removal of parting lines is a common application in the foundry business.

**Solution:** Weiler's selection of coated abrasive belts includes high performance and value products that help users control their production costs. Belts with 36 and 40 grit are commonly used for parting line removal.

## Steel Rack Braces



**Problem:** To prevent weldments used in the construction of offshore oil platforms from "racking" under load, lengths of steel bar stock are added as braces during the fabrication of these structural members. Beveling or chamfering the ends of the bars increases weld penetration and strengthens the joint.

**Solution:** The requirement for fast stock removal and long wheel life makes this an ideal application for a good quality Type 27 grinding wheel like those in Weiler's Vortec Pro® line of general-purpose bonded abrasives.

# Coated Abrasive Flap Disc Technical Information

## PREMIUM PERFORMANCE



### Saber Tooth™

**Use:** Cool, fast cutting on SS, AL & hard-to-grind metals  
**Cloth Type:** Top coated ceramic alumina poly-backed  
**Styles:** Type 27 HD or type 29 standard  
**Backing:** Phenolic

**PAGE 102**



### Big Cat®

**Use:** Conformable with superior life; industrial applications on steel and stainless  
**Cloth Type:** Premium zirconia alumina or aluminum oxide  
**Style:** Type 27 high density  
**Backing:** Phenolic

**PAGE 103**



### Trimmable

**Use:** Trimmable and flexible; for extended life and fillet welds on steel and stainless  
**Cloth Type:** Premium zirconia alumina or top coated ceramic alumina poly-backed  
**Style:** Type 29 standard  
**Backing:** Non-marking composite

**PAGE 104**



### Original Tiger®

**Use:** Premium performance; industrial applications on steel and stainless  
**Cloth Type:** Premium zirconia alumina or aluminum oxide  
**Styles:** Type 29 or 27 standard  
**Backings:** Phenolic or aluminum

**PAGE 105-106**

## Flap Disc Product Tiers

### Weiler Tiger®

#### Premium Industrial Grade Products -

Engineered and manufactured to maximize performance and minimize operating costs in all surface grinding applications. The use of superior construction, the highest quality materials and the most stringent manufacturing processes deliver consistent performance and the lowest cost-of-use.

- Saber Tooth™ Ceramic Alumina Flap Discs
- Big Cat® High Density Flap Discs
- Original Tiger® Abrasive Flap Discs
- Trimmable Tiger® Flap Discs
- BobCat™ Mini Flap Discs

### BobCat™ Mini Flap Discs



**Use:** Fast grinding in tight areas on steel and stainless  
**Cloth Type:** Premium zirconia alumina  
**Mounting:** Threaded arbor, drive mandrel or Norton Speed-Lok®  
**Styles:** Type 29 or 27 standard  
**Backing:** Non-marking composite

**PAGE 111**

## HIGH PERFORMANCE



**New!**



### Tiger Paw™

**Use:** Aggressive performance and long life; heavy-duty edge-grinding applications on steel and stainless  
**Cloth Type:** 100% zirconia alumina poly cotton-backed  
**Styles:** Type 29 or 27 standard  
**Backing:** Phenolic

**PAGE 107**

### Tiger Paw™ Super HD

**Use:** Conformable with extended life; heavy-duty edge-grinding applications on steel and stainless  
**Cloth Type:** 100% zirconia alumina poly cotton-backed  
**Style:** Type 27 high density  
**Backing:** Phenolic

**PAGE 108**

### Weiler Tiger Paw™

#### High Performance Industrial Grade Products -

Engineered and manufactured to maximize performance on heavy-duty edge grinding applications such as pipe beveling and breaking the edge on plasma torch cut materials. The combination of 100% Zirconia Alumina grain, poly-cotton cloth and superior grain retention ensures long life and a consistent material removal rate over the life of the disc, increasing production throughput and lowering overall grinding costs.

- Tiger Paw™ Abrasive Flap Discs
- Tiger Paw™ Super High Density Flap Discs

## FAST CUT



### Vortec Pro®

**Use:** Standard performance on steel and stainless  
**Cloth Type:** Zirconia alumina cotton-backed  
**Styles:** Type 29 or 27 standard  
**Backing:** Phenolic or aluminum

**PAGE 109**



### Vortec Pro® HD

**Use:** Conformable with long life; applications on steel and stainless  
**Cloth Type:** Zirconia alumina cotton-backed  
**Style:** Type 27 high density  
**Backing:** Phenolic

**PAGE 110**

### Weiler Vortec Pro®

#### Fast Cut Professional Grade Products -

Manufactured using similar product construction and to the same exacting standards as other Weiler flap discs, but engineered to provide cost-effective use. Vortec Pro Abrasives are an economical choice for the construction trades, low volume production shops and the professional contractor.

- Vortec Pro® Abrasive Flap Discs
- Vortec Pro® High Density Flap Discs

# Coated Abrasive Flap Disc Technical Information

## Flap Disc Product Construction

**Grind and Finish in One Step!** Weiler's Coated Abrasive Flap Discs save you time and money. There's no need to switch from a Type 27 Grinding Wheel to a Resin Fiber Disc because flap discs grind and finish in one step. This results in fewer changeovers and increased productivity.

### Flap Disc Construction Styles:



#### Angled Style - Type 29

- Maximum aggression
- Long life
- Ideal working angle of 15-35°



#### Flat Style - Type 27

- Smooth grinding action
- Long life
- Ideal working angle of less than 15°



#### High Density Style - Type 27

- Thicker disc with longer flaps
- Conforms to curved & irregular surfaces
- Maximum life
- Ideal working angle of less than 15°

## Why Choose Flap Discs?

Flap discs replace grinding wheels and resin fiber discs by grinding and finishing in ONE step!

### Flap Discs vs. Grinding Wheels:



- Rapid stock removal
- Smooth finish without gouging
- Cool cutting and less glazing
- Lightweight
- Less vibration reduces operator fatigue
- Reduced noise

### Flap Discs vs. Resin Fiber Discs:



- Last 20 times longer
- Fewer changeovers reduce overall grinding and finishing costs
- Consistent finish
- No back-up pad needed
- Easy to store, no curling
- Reduced loading

## Grain Selection

Grain Type	Grain Features	Application
Ceramic Alumina	<ul style="list-style-type: none"> <li>• Numerous crystals</li> <li>• Cut rate constant for 75% of grinding life</li> <li>• Self-sharpening grain - consistent sharp edge</li> <li>• Long life - dissipates heat</li> </ul>	High cut rate and long life on stainless, aluminum and other hard-to-grind metals.
Zirconia Alumina	<ul style="list-style-type: none"> <li>• Multi-Crystal</li> <li>• Fast cut rate</li> <li>• Self-sharpening</li> <li>• Stands up to heavy pressure &amp; high temps.</li> </ul>	High rate of stock removal and long life in demanding applications.
Aluminum Oxide	<ul style="list-style-type: none"> <li>• Single Crystal</li> <li>• Cut rate declines at start of grinding</li> <li>• Fracturing - dulling</li> </ul>	General purpose metalworking applications.

## Grit Size Selection

**Coarser Grits: 24, 36, 40**  
Maximum material removal.

**Finer Grits: 60, 80, 120**  
Achieve desired finishes.

**For Best Results:**  
Use 1 grit size coarser than resin fiber disc. 36 grit, use same size.



Weiler's Ceramic Alumina and Zirconia Alumina Flap Discs are contaminant-free, which means Iron, Sulfur and Chlorine are ≤ 0.1%.

## Backing Selection

### Aluminum:



Rigid support for maximum aggression; recyclable.

### Composite\*:



Trimnable, non-marking backing; allows access to hard-to-reach angles.

\*BobCat Discs are not trimmable.

### Phenolic:



Prevents backing from scratching the workpiece.

# Coated Abrasive Flap Disc Technical Information

Coated Abrasive Flap Disc Technical Information

## Flap Disc Product Features



## Lab Testing Results

### Item(s) Tested: 4-1/2" x 7/8" Flap Discs - 40 Grit Zirconia Alumina

The following are the results of an automated test comparing the Weiler 4-1/2" Type 29 standard Flap Disc vs. two major manufacturers of flap discs products. The test involved grinding for up to 80 minutes (only the Tiger made it that long) on mild steel bar stock.

**Reciprocating Flap Disc Machine** - The angle grinder is mounted at a 15° angle and applies 15 pounds of weight to the 1/8" thick workpiece. The grinder moves back & forth over an 8" path and the flap disc and workpiece weights are taken every minute.

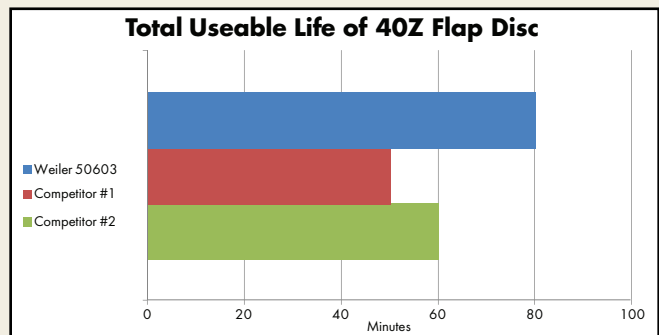
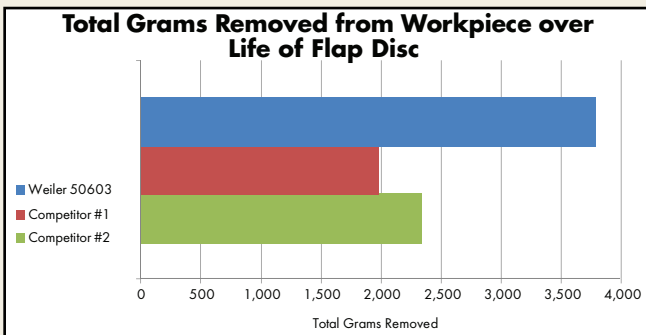

The 50603 flap disc outperformed the competition in both material removal and life. More work and fewer changeovers increases productivity and reduces overall grinding & finishing costs.

## Important Safety Information

Read and comply with the Safety Standards of the American National Standards Institute - ANSI B7.1 "Safety Requirements - For the Use, Care and Protection of Abrasive Wheels".

 Observe all speed restrictions indicated on products, containers, labels or printed in literature. NEVER exceed the Maximum RPM!

 Safety goggles and face shields worn over safety glasses with side shields MUST BE WORN BY ALL OPERATORS AND OTHERS IN AREA OF ABRASIVE OPERATIONS. Comply with the requirements of ANSI Z87.1 "Occupational Eye and Face Protection".



Appropriate clothing must be used where there is a possibility of injury that can be prevented.



Safety gloves must be worn.



Hearing protection must be worn where required.



Keep all guards in place.



Wear respiratory protection against dust and fumes (see ANSI Z88.2).

# Saber Tooth™ Ceramic Alumina Flap Discs

## Saber Tooth™ Ceramic Alumina Flap Discs

provide cool, fast cutting action on hard-to-grind metals, resulting in lower grinding and finishing costs.

- Fast cut and long life due to the aggressive self-sharpening ceramic alumina grain.
- Specially formulated grinding aid prevents dulling and glazing of grain and allows for "cool-cutting" protecting high value parts from heat discoloration.
- Designed to work with heat sensitive materials such as Aluminum, Stainless Steel, Inconel, Titanium and other hard-to-grind metals.

Bright Red Grinding Aid Dissipates Heat



CHECK OUT THE VIDEO

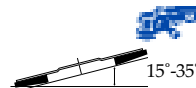

## Saber Tooth™ Flap Disc - Angled Style (Type 29) -

Cool, fast cutting on hard-to-grind metals.

Diameter	Arbor Hole	Grit Size	Max. RPM	Standard Pack	Item Number
4-1/2"	7/8"	36	13,000	10	50100
		40			50101
		60			50102
		80			50103
4-1/2"	5/8"-11 Nut	36	13,000	10	50104*
		40			50105*
		60			50106*
		80			50107*
7"	7/8"	36	8,600	10	50108
		40			50109
		60			50110
		80			50111
7"	5/8"-11 Nut	36	8,600	10	50112*
		40			50113*
		60			50114*
		80			50115*

\*Patent # 6,945,863

## Trimable Back Saber Tooth™ - Angled Style (Type 29) -

Cool, fast cutting on hard-to-grind metals. High stock removal, long life and flexibility.

Diameter	Arbor Hole	Grit Size	Max. RPM	Standard Pack	Item Number
4 1/2"	7/8"	40	13,000	10	50117
		60			50118
		80			50119
4 1/2"	5/8"-11 Nut	40	13,000	10	50121*
		60			50122*
		80			50123*

\*Patent # 6,945,863

## Saber Tooth™ Phenolic Back - High Density - Flat Style (Type 27) -

Cool, fast cutting on hard-to-grind metals. Increased conformability and 30-40% longer life than standard flap discs.

Diameter	Arbor Hole	Grit Size	Max. RPM	Standard Pack	Item Number
4-1/2"	7/8"	40	13,000	10	50130
		60			50131
		80			50132
4-1/2"	5/8"-11 Nut	40	13,000	10	50133*
		60			50134*
		80			50135*
7"	7/8"	40	8,600	10	50136
		60			50137
		80			50138
7"	5/8"-11 Nut	40	8,600	10	50139*
		60			50140*
		80			50141*

\*Patent # 6,945,863



Weld blending on stainless steel with a Saber Tooth Abrasive Flap Disc.



50109

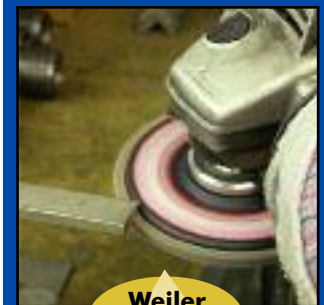

Weiler Innovation!

Weiler's Ceramic Alumina Flap Discs were the first line in the marketplace to include a trimmable backed disc, providing:

- Extended disc life.
- High flexibility which enables access to hard-to-reach areas such as right angles and irregular shapes.
- Non-marking backing will not damage the workpiece, resulting in less rework and scrap.

Saber Tooth™ Ceramic Alumina Flap Discs

# High Density Abrasive Flap Discs



Blending and finishing edges of a flame-cut steel part.

**22%  
MORE CLOTH**  
than competitors'  
high density  
flap discs!

**High Density Flap Discs** - Due to their thickness and larger flaps, Weiler's made in the U.S.A., high density flap discs conform to curved and irregular surfaces while producing a consistent finish and a 30-40% longer life than standard flap discs.

## Applications

Provides increased conformability and long life when:

- Grinding and finishing in one step
- Weld blending
- Deburring
- Deflashing
- Edge chamfering
- Stock removal

**Weiler  
Big Cat Flap Disc**

Larger flaps ensure more contact with the work surface, providing smoother grinding action and longer life.

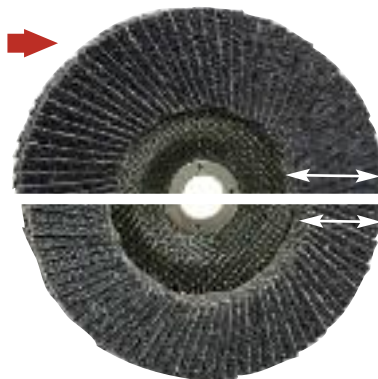

**Competitor  
High Density Flap Disc**

## Features And Benefits

- **Enhanced conformability** helps reduce gouging and undercutting.
- **Thicker phenolic back** (more layers of fiberglass) than competitors, provides more stability for thicker cloth configuration.
- **Most flap area in the industry** – unique combination of flap count, height and width.
- **Longest lasting high density disc** – as much as 20% over top competitors discs.
- **Big Cat is well known in the industry** – ask for it by name for increased productivity, reduced operating costs and maximum disc life.
- **Weiler's 20 years of experience** producing flap discs has yielded our proprietary cloth which has a unique combination of grain, grain placement, size, make coats and woven backing material.
- **Made in the U.S.A.** – satisfaction guaranteed!

**Big Cat® - High Density Flat Style (Type 27)**  
Increased conformability and maximum life.

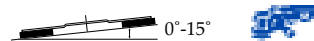

Diameter	Arbor Hole	Grit Size	Max. RPM	Standard Pack	Item Number Phenolic Backing	
					Zirconia Alumina	Aluminum Oxide
4-1/2"	7/8"	40	12,000	10	50803	50763
		60			50804	50764
		80			50805	50765
		120			50806	50766
4-1/2"	5/8"-11 Nut	40	12,000	10	50808*	50768*
		60			50809*	50769*
		80			50810*	50770*
7"	7/8"	40	8,600	10	50823	50783
		60			50824	50784
		80			50825	50785
		120			50826	50786
7"	5/8"-11 Nut	40	8,600	10	50843*	50833*
		60			50844*	50834*
		80			50845*	50835*
		120			50846*	50836*

\*Patent # 6,945,863

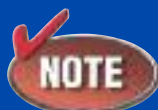

See adapters on page 106.

High Density Abrasive Flap Discs



50804



50765

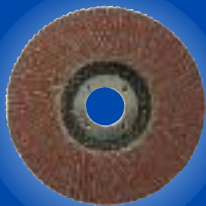



# Trimmable Abrasive Flap Discs

**Trimmable Tiger® Flap Discs** - Durable and efficient, Weiler's made in the U.S.A., Trimmable Tiger is designed for hard-to-reach angles and increased life!

- The unique composite backing can be trimmed, exposing more abrasive material and extending disc life, resulting in lower grinding and finishing costs.
- The trimmable backing also allows for high flexibility, enabling the operator to access hard-to-reach areas such as right angles and irregular shapes, and grind on-edge without changing tools, increasing productivity.
- The non-marking backing will not damage the workpiece, resulting in less re-work and scrap.
- Like all Tiger Discs, the Trimmable Tiger aggressively removes stock while providing excellent finish consistency - all in one step.

## Applications

- Grinding and finishing in one step
- Deburring
- Deflashing
- Edge chamfering
- Stock removal
- Weld blending

**Trimmable Tiger Disc - Angled Style (Type 29)**  
High stock removal, long life and flexibility.

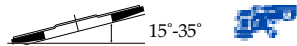

Diameter	Arbor Hole	Grit Size	Max. RPM	Standard Pack	Item Number
					Zirconia Alumina
4-1/2"	7/8"	40	13,000	10	50002
		60			50003
		80			50004
		120			50005
4-1/2"	5/8"-11 Nut	40	13,000	10	50006*
		60			50007*
		80			50008*
		120			50009*
5"	7/8"	40	12,000	10	50010
		60			50011
		80			50012
		120			50013
5"	5/8"-11 Nut	40	12,000	10	50014
		60			50015
		80			50016
		120			50017

**Weiler Innovation!**

\*Patent # 6,945,863

1st in the market to offer trimmable backed flap discs with Metal 5/8"-11 Nuts!

(Eliminates the possibility of cross-threading or nut sticking to spindle after use.)

**Tech Note**

## Trimmable Backing For Extended Disc Life.

The Trimmable Tiger Disc's innovative design enables the operator to reduce the diameter of the backing to extend disc life. To trim backing, run against a sharp metal edge until desired backing diameter is achieved as shown at right.



Trimmable Tigers are packaged in a convenient display box with a window and perforated sides for quick, easy opening and display.

**DID YOU KNOW?**

Trimmable Flap Discs are used in the construction and fabrication of the "Up-Armored" Humvees used by the United States Military.



Grinding in corners just got easier with the flexibility of the Trimmable Tiger Disc!

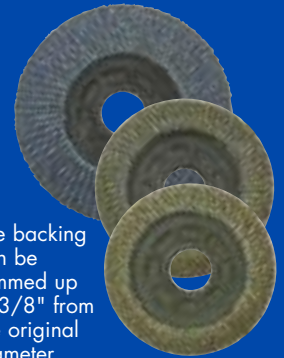

The backing can be trimmed up to 3/8" from the original diameter, dramatically extending the life of the disc.



50002

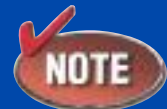

Visit [www.weilercorp.com](http://www.weilercorp.com) to see a video demonstrating applications and advantages of our Trimmable Tiger Disc.

Trimmable Abrasive Flap Discs

# Tiger® Disc Abrasive Flap Discs

#1 Seller

**Original Tiger® Disc** - Weiler's "made in U.S.A." Tiger Discs are the benchmark of the industry. They are designed for the serious industrial user who values both a high cut rate and long life.

## Applications

- Grinding and finishing in one step
- Weld blending
- Deburring
- Deflashing
- Edge chamfering
- Stock removal

**Tiger Disc - Angled Style (Type 29).** Maximum aggression and long life.



Removing rust, corrosion and pitting from the bevel end of pipe.



50603



50513



50543

Tiger® Disc Abrasive Flap Discs

Diameter	Arbor Hole	Grit Size	Max. RPM	Standard Pack	Item Number		
					Phenolic Backing		Aluminum Backing
					Zirconia Alumina	Alum. Oxide	Zirconia Alumina
4"	5/8"	36	15,000	10	50592	50552	50502
		40			50593	50553	50503
		60			50594	50554	50504
		80			50595	50555	50505
		120			50596	50556	50506
4-1/2"	7/8"	★24	13,000	10	50601	50561	50511
		36			50602	50562	50512
		40			50603	50563	50513
		60			50604	50564	50514
		80			50605	50565	50515
		120			50606	50566	50516
4-1/2"	5/8"-11 Nut	★24	13,000	10	-	-	50510*
		36			-	-	50517*
		40			50608*	-	50518*
		60			50609*	-	50519*
		80			50610*	-	50520*
		120			-	-	50509*
5"	7/8"	★24	12,000	10	50611	50571	50521
		36			50612	50572	50522
		40			50613	50573	50523
		60			50614	50574	50524
		80			50615	50575	50525
		120			50616	50576	50526
6"	7/8"	40	10,200	10	50649	-	-
		60			50650	-	-
		80			50651	-	-
6"	5/8"-11 Nut	40	10,200	10	50659	-	-
		60			50660	-	-
		80			50661	-	-
		-			-	-	-
7"	7/8"	★24	8,600	10	50621	50581	50531
		36			50622	50582	50532
		40			50623	50583	50533
		60			50624	50584	50534
		80			50625	50585	50535
		120			50626	50586	50536
7"	5/8"-11 Nut	★24	8,600	10	50641*	50631*	50541*
		36			50642*	50632*	50542*
		40			50643*	50633*	50543*
		60			50644*	50634*	50544*
		80			50645*	50635*	50545*
		120			50646*	50636*	50546*

\*Patent # 6,945,863

★ When grinding steel and other ferrous materials, a 36 grit Tiger Disc is more productive than a 24 grit. 24 grit Tiger Discs are most productive when used on aluminum and other soft materials.

**Weiler Innovation!**

1st in the market to offer aluminum backed flap discs! (Strongest in the industry)

**NOTE**

See adapters on page 106.



## Grit Size Selection

**For Best Results:**

Use 1 grit size coarser than resin fiber disc.

**Exception:**

36 grit, use same size.

# Tiger<sup>®</sup> Disc Abrasive Flap Discs

**Tiger Disc - Flat Style (Type 27).** Smooth grinding action and long life.



Diameter	Arbor Hole	Grit Size	Max. RPM	Standard Pack	Item Number Phenolic Backing	
					Zirconia Alumina	Aluminum Oxide
4"	5/8"	40	15,000	10	50693	50653
		60			50694	50654
		80			50695	50655
		120			50696	50656
4-1/2"	7/8"	40	13,000	10	50703	50663
		60			50704	50664
		80			50705	50665
		120			50706	50666
4-1/2"	5/8"-11 Nut	40	13,000	10	50708*	50668*
		60			50709*	50669*
		80			50710*	50670*
		120			50699*	50671*
5"	7/8"	40	12,000	10	50713	50673
		60			50714	50674
		80			50715	50675
		120			50716	50676
7"	7/8"	40	8,600	10	50723	50683
		60			50724	50684
		80			50725	50685
		120			50726	50686
7"	5/8"-11 Nut	40	8,600	10	50743*	50733*
		60			50744*	50734*
		80			50745*	50735*
		120			50746*	50736*

\*Patent # 6,945,863

**Adapting Nuts & Spanner Wrench - For use with Tiger, Vortec Pro and High Density Flap Discs.**

Description	Thread Size	For Use With	Standard Pack	Item Number
Adapting Nuts	3/8" - 24	4" Flap Disc with 5/8" arbor hole (Can be used with an adjustable or combination wrench.)	1	56484
Adapting Nuts	5/8"-11	4-1/2", 5" & 7" Flap Discs with 7/8" arbor hole	1	56494
Spanner Wrench	-	Item No. 56494 only	1	56495

When mounting, adapters must be nested, see illustration below.



## Flap Disc Adapting Nut Assembly



Removing heavy weld spatter while prepping surface for painting.



50664



50708



56494

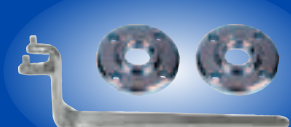

56495

Tiger<sup>®</sup> Disc Abrasive Flap Discs

# Tiger Paw™ Abrasive Flap Discs

**Tiger Paw™ Flap Discs** are designed for the user looking for aggressive performance and long life in heavy-duty applications like edge grinding.

**CHECK OUT THE VIDEO**



*Got The EDGE*

- **100% zirconia alumina grain** is fast cutting with long life, resulting in fewer changeovers and increased productivity.
- **Superior grain retention** - lasts longer and maintains perfect cutting angle to provide excellent performance and sustained stock removal when grinding on-edge.
- **Engineered poly/cotton cloth** features excellent grain retention for maximum disc life.

**New!**

**Tiger Paw - Phenolic Back - Angled Style (Type 29) - Aggressive action and long life; for heavy-duty applications on steel and stainless.**

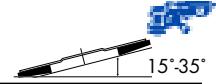

Diameter	Arbor Hole	Grit Size	Max. RPM	Standard Pack	Item Number
					Zirconia Alumina
4"	5/8"	40	15,000	10	51104
		60			51105
4-1/2"	7/8"	36	13,000	10	51118
		40			51119
		60			51120
		80			51121
4-1/2"	5/8"-11 Nut	36	13,000	10	51123*
		40			51124*
		60			51125*
		80			51126*
5"	7/8"	40	12,000	10	51129
		60			51130
5"	5/8"-11 Nut	36	12,000	10	51153*
		40			51132*
		60			51133*
		80			51154*
7"	7/8"	40	8,600	10	51145
		60			51150
7"	5/8"-11 Nut	36	8,600	10	51149*
		40			51146*
		60			51147*
		80			51148*

\*Patent # 6,945,863

**Tiger Paw - Phenolic Back - Flat Style (Type 27) - Smooth action and long life; for heavy-duty applications on steel and stainless.**

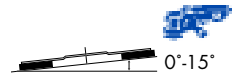

Diameter	Arbor Hole	Zirconia Alumina Grit Size	Max. RPM	Standard Pack	Item Number
4"	5/8"	40	15,000	10	51101
		60			51102
4-1/2"	7/8"	36	13,000	10	51107
		40			51108
		60			51109
		80			51110
4-1/2"	5/8"-11 Nut	36	13,000	10	51112*
		40			51113*
		60			51114*
		80			51115*
5"	7/8"	40	12,000	10	51134
		60			51135
5"	5/8"-11 Nut	36	12,000	10	51155*
		40			51156*
		60			51157*
		80			51158*
7"	7/8"	40	8,600	10	51137
		60			51138
7"	5/8"-11 Nut	36	8,600	10	51139*
		40			51140*
		60			51142*
		80			51143*

\*Patent # 6,945,863

Beveling a pipe edge with a Tiger Paw Flap Disc.



51118



51147



51115

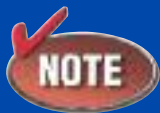

See adapters on page 106.

Tiger Paw™ Abrasive Flap Discs

# Tiger Paw™ Abrasive Flap Discs



Weld blending on the corner of a security gate with a Tiger Paw XHD.

**Tiger Paw™ Super High Density Flap Discs** feature thicker and larger flaps that conform to curved and irregular shapes while producing a consistent finish. These high density flap discs are designed for the user looking for extended life and conformability in heavy-duty applications.

- **40% more abrasive cloth** than a standard flap disc.
- **100% zirconia alumina grain** provides superior edge grinding.
- **Engineered poly/cotton cloth** features excellent grain retention for maximum disc life.

**Tiger Paw XHD - Super High Density - Phenolic Back - Flat Style (Type 27) - Extended life and conformability; for heavy-duty applications on steel and stainless steel.**

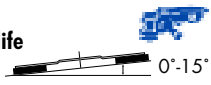

Diameter	Arbor Hole	Grit Size	Max. RPM	Standard Pack	Item Number Zirconia Alumina
4-1/2"	7/8"	36	12,000	10	51160
		40			51161
		60			51162
		80			51163
4-1/2"	5/8"-11 Nut	36	12,000	10	51164*
		40			51165*
		60			51166*
		80			51167*
7"	7/8"	40	8,600	10	51170
		60			51171
7"	5/8"-11 Nut	40	8,600	10	51168*
		60			51169*

\*Patent # 6,945,863

## When Performance Counts, Count On Weiler!

The following are the results of automated testing comparing the Weiler Tiger Paw 4-1/2" Type 29 standard density Flap Disc vs. five major manufacturers of flap disc products.

**Reciprocating Flap Disc Machine** - The angle grinder is mounted at a 15° angle and applies 15 pounds of weight to the 1/8" thick workpiece. The grinder moves back & forth over an 8" path and the flap disc and workpiece weights are taken every minute.

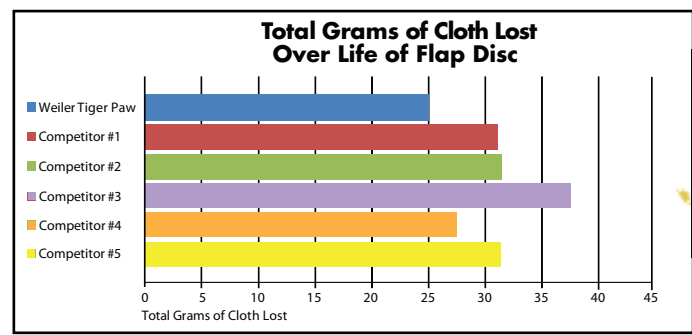
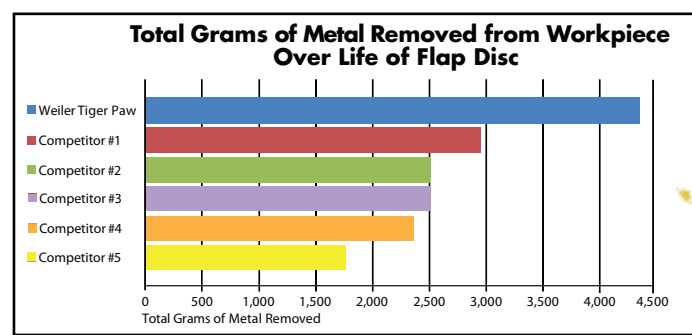

**The Weiler Tiger Paw flap disc outperformed the competition in both material removal and life. More work and fewer changeovers increases productivity and reduces overall grinding and finishing costs.**



Tiger Paw™ Abrasive Flap Discs

# Vortec Pro® Abrasive Flap Discs

**Vortec Pro® Flap Discs** - Made in the U.S.A., these flap discs are designed for the user looking for a high cut rate at a value price (maintains similar cut rate as original Tiger® Discs).

**Vortec Pro® - Angled Style (Type 29) - High cut rate at a value price.**

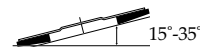

Diameter	Arbor Hole	Grit Size	Max. RPM	Standard Pack	Item Number	
					Phenolic Backing	Aluminum Backing
					Zirconia Alumina	Zirconia Alumina
4"	5/8"	36	15,000	10	31337 ■	31301 ■
		40			31338	31302
		60			31339 ■	31303 ■
		80			31340 ■	31304 ■
		120			31341	31305
4-1/2"	7/8"	★24	13,000	10	31342	31306
		36			31343 ■	31307 ■
		40			31344	31308
		60			31345 ■	31309 ■
		80			31346 ■	31310 ■
120	31347	31311				
4-1/2"	5/8"-11 Nut	★24	13,000	10	31348*	31312*
		36			31349*	31313*
		40			31350*	31314*
		60			31351*	31315*
		80			31352*	31316*
120	31353*	31317*				
5"	7/8"	★24	12,000	10	31354	31318
		36			31355	31319
		40			31356	31320
		60			31357	31321
		80			31358	31322
120	31359	31323				
7"	7/8"	★24	8,600	10	31360	31324
		36			31361 ■	31325 ■
		40			31362	31326
		60			31363 ■	31327 ■
		80			31364 ■	31328 ■
120	31365	31329				
7"	5/8"-11 Nut	★24	8,600	10	31366*	31330*
		36			31367*	31331*
		40			31368*	31332*
		60			31369*	31333*
		80			31370*	31334*
120	31371*	31335*				

\*Patent # 6,945,863    ★ When grinding steel and other ferrous materials, a 36 grit Vortec Pro flap disc is more productive than a 24 grit. 24 grit Vortec Pro flap discs are most productive when used on aluminum and other soft materials.

■ Available in display pack. See page 172 for details.

**Vortec Pro® - Flat Style (Type 27) - Smooth grinding action at a value price.**



Diameter	Arbor Hole	Grit Size	Max. RPM	Standard Pack	Item Number
					Phenolic Backing
					Zirconia Alumina
4-1/2"	7/8"	36	13,000	10	31401
		40			31402
		60			31403
		80			31404
4-1/2"	5/8"-11 Nut	36	13,000	10	31407*
		40			31408*
		60			31409*
		80			31410*
7"	7/8"	36	8,600	10	31413
		40			31414
		60			31415
		80			31416
7"	5/8"-11 Nut	36	8,600	10	31419*
		40			31420*
		60			31421*
		80			31422*

\*Patent # 6,945,863

Grinding welds on a fabricated steel part.



31350



31369



31402

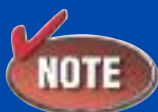

See adapters on page 106.

Vortec Pro® Abrasive Flap Discs

# High Density Abrasive Flap Discs



**Vortec Pro® - High Density Flat Style (Type 27)**  
Increased conformability at a value price.



Diameter	Arbor Hole	Grit Size	Max. RPM	Standard Pack	Item Number	
					Phenolic Backing	Zirconia Alumina
4-1/2"	7/8"	40	12,000	10		31387
		60			31388	
		80			31389	
4-1/2"	5/8"-11 Nut	40	12,000	10		31390*
		60			31391*	
		80			31392*	

\*Patent # 6,945,863

Blending and finishing edges of a flame-cut steel part.



31390

**Vortec Pro® - Display Packaged - Angled Style (Type 29) -**  
Standard performance on steel and stainless.

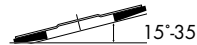

Diameter	Arbor Hole	Grit Size	Max. RPM	Item Number	
				Phenolic Backing	Aluminum Backing
				Zirconia Alumina	Zirconia Alumina
4"	5/8"	36	15,000	30822	-
		40		30825	-
		60		30826	-
4"	5/8"-11 Nut	36	15,000	-	30821
		60		-	30823
		80		-	30824
4-1/2"	7/8"	36	13,000	30828	-
		60		30831	-
		80		30832	-
4-1/2"	5/8"-11 Nut	36	13,000	-	30827
		40		-	30829
		60		-	30830



30831

High Density Abrasive Flap Discs

**DID YOU KNOW?**

Weiler was the first manufacturer of Abrasive Flap Discs in the U.S.A.

# BobCat™ Mini Flap Discs

**BobCat™ Mini Flap Discs** - Weiler's made in the U.S.A. BobCats are designed for use on right angle die grinders, providing smooth grinding and enhanced conformability in tight areas.

## Applications

- Grinding and finishing in one step
- Grinding, deburring and blending on steel, stainless steel and other metals
- Jobs requiring high aggression and rapid stock removal
- Metal fabrication requiring light weld blending or edge chamfering

**Outlasts Blending Discs 19 to 1!**

**BobCat Mini Flap Discs - Zirconia Alumina Grain - Plastic Backing**  
Ideal for tight spaces and in heavy-duty applications where blending discs do not hold up.



Diameter	Grit Size	Max. RPM	Standard Pack	Item Number	
				Type 29	Type 27
2"	36	30,000	10	50922	50932
	40			50923	50933
	60			50924	50934
	80			50925	50935
	120			50926	50936
3"	36	20,000	10	50902	50912
	40			50903	50913
	60			50904	50914
	80			50905	50915
	120			50906	50916

Patent #5,951,389

**BobCat Drive Mandrel - For mounting BobCat Discs without a backing pad.**

Description	Standard Pack	Item Number
For mounting 2" & 3" BobCats on tools with 1/4" collets	1	07766

3" BobCats can also be mounted on Norton Speed-Lok® TS back-up pads and Weiler metal hub pad #60509. Speed-Lok® TS is a registered trademark of Norton Co.

**DID YOU KNOW?**

Our website features a Distributor Locator to make it easy to find Weiler products in your area.

Surface blending with a BobCat disc in a tight area.

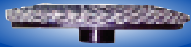

Type 29

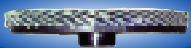

Type 27



50914

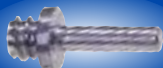

07766



# Resin Fiber Discs

**Resin Fiber Discs** - These fiber backed, coated abrasive discs are for use on right angle grinders. Weiler's line of premium resin fiber discs are suitable for light grinding, blending, surface preparation and finishing on a variety of materials.

## Applications

### ■ Saber Tooth™

**Ceramic Alumina:**  
Cool, fast cutting action on aluminum, stainless steel and other hard-to-grind metals.

### ■ Zirconia Alumina:

High performance grinding of stainless steel, tool steel and hard-to-grind materials.

### ■ Aluminum Oxide:

All purpose weld blending, grinding, surface preparation and finishing of metals, plastic, wood and fiberglass.

**Saber Tooth Resin Fiber Discs - Ideal for aluminum and stainless steel.**

Dissipates Heat



Diameter	Arbor Hole	Grit Size	Standard Pack	Item No. - Ceramic Alumina
4-1/2"	7/8"	24	25	59550
		36		59551
		50		59552
		60		59553
		80		59554
5"	7/8"	24	25	59557
		36		59558
		50		59559
		60		59560
		80		59561
7"	7/8"	24	25	59564
		36		59565
		50		59566
		60		59567
		80		59568

**Resin Fiber Discs - Ideal for blending, finishing and surface preparation.**



Diameter	Arbor Hole	Grit Size	Standard Pack	Item Number	
				Zirconia Alumina	Aluminum Oxide
4"	5/8"	24	25	-	59491
		36		-	59492
		50		-	59493
		60		-	59494
		80		-	59495
		120		-	59497
4-1/2"	7/8"	24	25	59731	59571
		36		59732	59573
		50		59733	59575
		60		-	59576
		80		59735	59577
		100		-	59578
5"	7/8"	120	25	-	59579
		16		-	59500
		24		59701	59501
		36		59702	59503
		50		59703	59505
		60		-	59506
7"	7/8"	80	25	59705	59507
		100		-	59508
		120		-	59509
		16		59710	59520
		24		59711	59521
		36		59712	59523
9"	7/8"	50	25	59713	59525
		60		59714	59526
		80		59715	59527
		100		-	59528
		120		-	59529
		16		-	59540
9"	7/8"	24	25	-	59541
		36		59722	59543
		50		-	59545
		60		-	59546

Do not exceed maximum RPM of back-up pad.



Blending welds on the corner of a steel furniture frame.



59557



59732

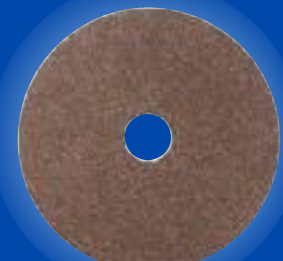

59503

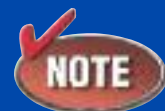

See back-up pads on page 113.

Resin Fiber Discs

# AL-tra CUT™ Discs - For Grinding Aluminum

**AL-tra CUT™ Discs** - Specially formulated for superior grinding performance on aluminum, **AL-tra CUTs improve grinding on aluminum 400-800%!** These revolutionary discs resist loading, ensure higher cut rates, prolong disc life and achieve a superior finish compared to conventional sanding/grinding discs in the market. AL-tra CUT Discs replace conventional resin fiber discs 5 to 1 or more.

## Applications

For aluminum applications such as:

- Weld blending
- Grinding
- Deburring
- Finishing

## AL-tra CUT Performance



Weiler's exclusive AL-tra CUT Discs resist loading when grinding aluminum, ensuring constant grain contact with the work surface.



Conventional resin fiber discs load when grinding aluminum. This prevents the abrasive grain from contacting the work surface and dramatically decreases performance.

## 2" & 3" AL-tra CUT Discs - Aluminum Oxide

Diameter	Grit Size	Standard Pack	Item Number	
			Plastic Button*	Metal Hub <sup>+</sup>
2"	36	50	59806	59869
	60		59807	59870
	80		59808	59871
	120		59809	59872
3"	36	25	59811	59874
	60		59812	59875
	80		59813	59876
	120		59814	59877
<b>2" &amp; 3" Back-up Pads - 1/4" stem</b>				
Diameter	Max. RPM	Std. Pack	Plastic Button	Metal Hub
2"	25,000	1	51551	60508
3"	20,000	1	51552	60509

Do not exceed maximum RPM of back-up pad.

Do not store AL-tra CUT Discs above 120° F.

\* Compatible with 3M Roloc™ back-up pads. (Roloc™ is a trademark of 3M.)

+ Compatible with Norton Speed-Lok® TS back-up pads. (Speed-Lok® TS is a registered trademark of Norton Co.)

## 4-1/2" & 7" AL-tra CUT Discs - Aluminum Oxide

Diameter	Arbor Hole	Grit Size	Standard Pack	Item Number
4-1/2"	7/8"	36	25	59821
		60		59823
		80		59824
		120		59826
7"	7/8"	36	25	59862
		60		59864
		80		59865
		120		59867

Do not exceed maximum RPM of back-up pad.

Do not store AL-tra CUT Discs above 120° F.

## Accessories for Resin Fiber & AL-tra CUT Discs

Description	Thread Size	Max. RPM	Standard Pack	Item Number
4" Back-up Pad	5/8"-11*	12,000	1	59605
4-1/2" Back-up Pad	5/8"-11*	11,000	1	59611
5" Back-up Pad	5/8"-11*	10,000	1	59600
7" Back-up Pad	5/8"-11	8,500	1	59601
9" Back-up Pad	5/8"-11	6,500	1	59602
Spanner Wrench	-	-	1	59603
Disc Nut	5/8"-11	-	1	59604

\*Other thread sizes available on special orders.

Blending welds and saw marks on a mounting bracket.



59806



59875

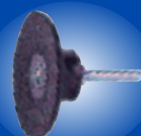

51552



60508

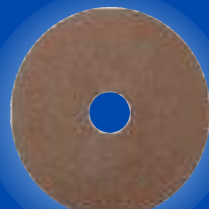

59821

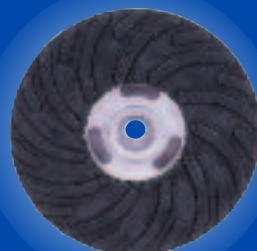

59601



59604



59603

AL-tra CUT™ Discs - For Grinding Aluminum

# Blending Discs

**Blending Discs** - These cloth backed, coated abrasive discs are for use on right angle air tools. Available with either a metal hub or a plastic button fastening system, the flexible back-up pads give the discs a great deal of conformability. Weiler's blending discs are suitable for a wide range of light fabrication, repair and maintenance applications.

## Applications

- **Saber Tooth™ Ceramic Alumina:**  
Cool, fast cutting action on aluminum, stainless steel and other hard-to-grind metals.
- **Zirconia Alumina:**  
High performance blending of stainless steel, tool steel and hard-to-grind materials.
- **Aluminum Oxide:**  
All purpose blending or finishing metal surfaces, light weld removal, removing handling marks, surface imperfections and mill marks.

## Saber Tooth™ Ceramic Alumina Blending Discs -

For aluminum, stainless and other hard-to-grind metal applications.

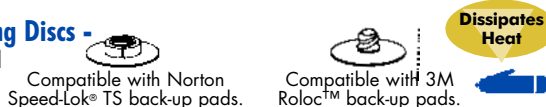

Diameter	Grit Size	Standard Pack	Item Number	
			Metal Hub	Plastic Button
2"	36	100	60150	60170
	60		60151	60171
	80		60152	60172
3"	36	50	60155	60175
	60		60156	60176
	80		60157	60177

## Blending Discs - Metal Hub Style - Compatible with Norton Speed-Lok® TS back-up pads.

Diameter	Grit Size	Standard Pack	Item Number	
			Zirconia Alumina	Aluminum Oxide
2"	36	100	60378	60040
	60		60381	60043
	80		60382	60044
	120		60384	60046
3"	36	50	60391	60053
	60		60394	60056
	80		60395	60057
	120		60397	60059

## Blending Discs - Plastic Button Style - Compatible with 3M Roloc™ back-up pads.

Diameter	Grit Size	Standard Pack	Item Number
			Aluminum Oxide
2"	36	100	60118
	60		60121
	80		60122
	120		60124
3"	36	50	60131
	60		60134
	80		60135
	120		60137

## Back-up Pads - 1/4" Stem

Diameter	Max. RPM	Standard Pack	Metal Hub Style	Plastic Button Style
2"	25,000	1	60508	51551
3"	20,000	1	60509	51552

Do not exceed maximum RPM of back-up pad.  
(Speed-Lok® TS is a registered trademark of Norton Co.) (Roloc™ is a trademark of 3M.)



Blending surface imperfections prior to painting.

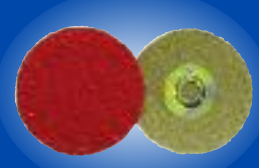

60150

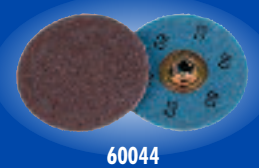

60044

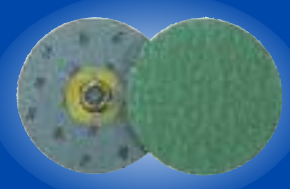

60391

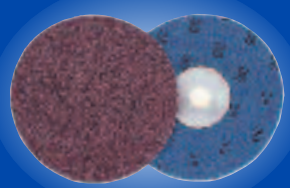

60131

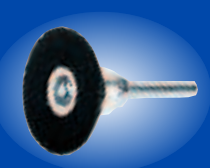

60508

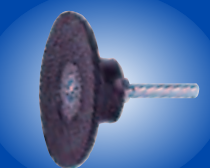

51552

Blending Discs

# TRIM-KUT® Discs

**TRIM-KUT® Discs** - Trim-Kuts are abrasive discs designed for light grinding and blending applications on a variety of materials. The abrasive grains are fused directly onto a wearable polymer backing, resulting in a disc that requires no back-up pad. The polymer backing trims during use to expose new grains to the work surface. 3" discs are designed for use on right angle air die grinders, and 4-1/2" discs are for use on right angle grinders.

Deburring and chamfering a section of pipe after cutting.



59300



59403



59327



59326

56485



56496

## NOTE

If you are using a blending disc or TRIM-KUT Disc, ask our Application Engineering Department if Weiler's BobCat Abrasive Flap Discs can enhance your productivity. BobCats dramatically outperform blending and TRIM-KUT Discs by reducing changeovers and providing consistently high cut rates and extended life. See page 107 for more information.

## Applications

- Edge blending
- Light weld and stock removal
- Preparation for painting and surface finishing
- Deburring

## TRIM-KUT Discs - Aluminum Oxide

Diameter	Arbor Hole	Grit Size	Max. RPM	Standard Pack	Item Number
3"	5/16" - 18	36	21,000	25	59300
		60			59305
		120			59315

Do not use TRIM-KUT discs in temperatures lower than 48° fahrenheit. Store at 50% relative humidity.

## TRIM-KUT Discs - Aluminum Oxide

Diameter	Arbor Hole	Grit Size	Max. RPM	Standard Pack	Item Number
4-1/2"	7/8"	36	13,000	25	59403
		60			59404
		120			59405

Do not use TRIM-KUT discs in temperatures lower than 48° fahrenheit. Store at 50% relative humidity.

## TRIM-KUT Adapters

Description	For Use With	Standard Pack	Item Number
1/4" Mandrel	3" TRIM-KUT Discs	25	59327
3/8"-24 UNF Adapter	3" TRIM-KUT Discs	25	59326
Adapting Nuts	4-1/2" TRIM-KUT Discs	1	56485
Spanner Wrench	Item No. 56485 only	1	56496



Extend disc life 2-3 times.  
Renew TRIM-KUT's sharp cutting edge by running the edge against a clamped piece of steel scrap.

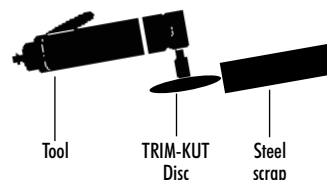

# Coated Abrasive Flap Wheels

**Flap Wheels** are designed with a solid hub construction that:

- Enables flap wheels to be rated at higher RPM's, providing more aggressive cutting action and increased productivity.
- Provides perfect balance leading to smooth, chatter-free finishing.

## Applications

- Final finishing metal surfaces
- Blending and finishing dies, molds, tools, tubing, and channels
- Finish prior to painting or plating
- Deburring and mis-match removal on machined parts
- Smoothing metal, plastics and wood
- Cleaning
- Edge blending

**Tiger® Mounted Flap Wheels - 1/4" Stem - Aluminum Oxide.** A premium line designed to provide long life. Ideal for medium to high production environments.

Diameter	Width	Grit Size	Max. RPM	Standard Pack	Item Number
1"	1"	60	30,000	10	52003
		80			52004
		120			52005
1-1/2"	1/2"	60	25,000	10	52226
		80			52227
		120			52229
1-1/2"	1"	60	25,000	10	52009
		80			52010
		120			52011
2"	1/2"	60	25,000	10	52366
		80			52367
		120			52369
2"	1"	60	25,000	10	52015
		80			52016
		120			52017
2-1/2"	1"	60	23,000	10	52486
		80			52487
		120			52489
3"	1/2"	60	23,000	10	52024
		80			52025
		120			52026
3"	1"	60	23,000	10	52027
		80			52028
		120			52029

**Tiger® Mounted Flap Wheels - 1/4"-20 Threaded Stem - Aluminum Oxide**

Diameter	Width	Grit Size	Max. RPM	Standard Pack	Item Number
1"	1"	60	30,000	10	52601
		80			52603
		120			52605
2"	1"	60	25,000	10	52611
		80			52613
		120			52615
3"	1"	60	20,000	10	52621
		80			52623
		120			52625

**Drive Arbor - For 1/4"-20 Mounted Flap Wheels**

Thread Size	Adapted Size	Standard Pack	Item Number
1/4"-20	1/4"	5	07756



Deburring perforated steel channel after saw-cut.



52010



52027

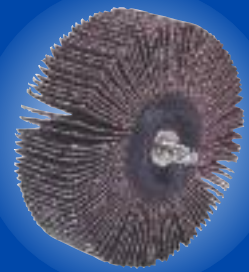

52621



07756

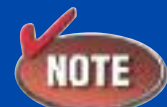

- Drive arbor is used individually and must be ordered individually.
- Drive arbor is to be used with Weiler flap wheels only.
- Stems must be fully chucked before using and should not be run above the maximum RPM listed.

Coated Abrasive Flap Wheels

# Coated Abrasive Flap Wheels



Removing burrs from the inside diameter of a cut tube.



30726



53166



53286



03834

Coated Abrasive Flap Wheels

## Vortec Pro® Mounted Flap Wheels - 1/4" Stem - Aluminum Oxide

Provide fast cutting action at a value price. Ideal for low to medium production environments.

Diameter	Width	Grit Size	Max. RPM	Standard Pack	Item Number
1"	1"	60	30,000	10	30720
		80			30721
		120			30722
2"	1"	60	25,000	10	30723
		80			30724
		120			30725
3"	1"	60	23,000	10	30726
		80			30727
		120			30728

## Tiger® Unmounted Flap Wheels - Aluminum Oxide

Diameter	Width	Arbor Hole	Grit Size	Max. RPM	Standard Pack	Item Number
4"	1"	5/8"	60	9,000	10	53166
			80			53167
			120			53169
6"	1"	1"	50	6,000	5	53285
			60			53286
			80			53287
			120			53289
6"	1-1/2"	1"	50	5,700	4	53305
			60			53306
			80			53307
			120			53309
6"	2"	1"	50	5,700	3	53325
			60			53326
			80			53327
			120			53329

## Metal Adapters - For Unmounted Flap Wheels. Used in pairs and priced per pair.

Wheel Arbor Hole Size	Adapted Arbor Hole Size	Standard Pack	Item Number
1"	1/2"	1	03833
	5/8"		03834
	3/4"		03835

**DID YOU KNOW?**

Weiler products were used in the construction of the 'Oasis of the Sea', the world's largest ocean liner.

# Coated Abrasive Belts

**Coated Abrasive Belts** - Enhance productivity and lower operating costs with our wide assortment of coated abrasive belts in sizes ranging from 1/4" x 18" to 6" x 132". We also have the ability to provide custom made belts in sizes, backings and grains for specialized applications.

## Portable File Belts



Size (Width x Length)	Grit Size	Standard Pack	Item Number	
			Zirconia Alumina	Aluminum Oxide
1/4" x 18"	80	10	68524	67023
1/4" x 24"	60	10	68541	67040
	80		68542*	67041
	120		-	67043
3/4" x 18"	40	10	68575	67074
	60		68577	67076
	80		68578	67077
	120		-	67079
1/2" x 24"	36	10	68592	67091
	40		68593	67092
	50		68594	67093
	60		68595	67094
	80		68596	67095
	100		-	67096
	120		-	67097
3/4" x 20-1/2"	40	10	68629	67128
	50		68630	67129
	60		68631	67130
	80		68632	67131
	100		-	67132
	120		-	67133
1" x 12"	60	10	68649	67148
	80		68650	67149
	120		-	67151
1" x 30"	60	10	68667	67166
	80		68668	67167
	120		-	67169

## Portable Belts



Size (Width x Length)	Grit Size	Standard Pack	Item Number	
			Zirconia Alumina	Aluminum Oxide
3" x 18"	60	10	-	67488
	80		-	67489
	120		-	67491
3" x 21"	40	10	69005	67504
	50		69006	67505
	60		69007	67506
	80		69008	67507
	100		-	67508
	120		-	67509
3" x 24"	36	10	69040	67539
	40		69041	67540
	50		69042	67541
	60		69043	67542
	80		69044	67543
	100		-	67544
	120		-	67545
3-1/2" x 15-1/2"	60	10	-	67614
	80		-	67615
	120		-	67617
4" x 21-3/4"	60	10	-	67632
	80		-	67633
	100		-	67634
	120		-	67635
4" x 24"	36	10	69148	67647
	40		69149	67648
	50		69150	67649
	60		69151	67650
	80		69152	67651
	100		-	67652
	120		-	67653

\*Standard Pack 50



Blending a weld using a portable file belt.



68524



67091



68650



69008



67614



69152

Coated Abrasive Belts

# Coated Abrasive Belts

## Applications

- Decorative finishing of metal surfaces
- Smoothing metal, plastic & wood
- Grinding, deburring and flash removal on saw-cut parts
- Removing tool marks & forging scale
- Edge blending
- Finishing prior to painting or plating
- Grinding gates off castings



Blending parting lines on a grey iron casting.



68828



69166

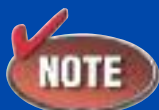

**NOTE**

Saber Tooth™ Ceramic Belts also available! Contact Customer Service at 800-835-9999 for available sizes and grits.

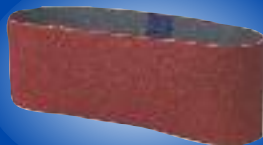

## Benchstand/Backstand Belts

Size (Width x Length)	Grit Size	Standard Pack	Item Number		
			Zirconia Alumina	Aluminum Oxide	
1" x 42"	40	10	68683	67182	
	60		68685	67184	
	80		68686	67185	
	100		-	67186	
	120		-	67187	
	-		-	-	-
1" x 132"	36	10	68718	67217	
	40		68719	67218	
	60		68721	67220	
	80		68722	67221	
	100		-	67222	
	-		-	-	-
2" x 60"	60	10	68828	67327	
	80		68829	67328	
	120		-	67330	
2" x 118"	40	10	68879	67378	
	60		68881	67380	
2" x 132"	24	10	68895	67394	
	36		68896	67395	
	40		68897	67396	
	50		68898	67397	
	60		68899	67398	
	80		68900	67399	
	100		-	67400	
	120		-	67401	
	-		-	-	-
	-		-	-	-
2-1/2" x 60"	36	10	68950	67449	
	40		68951	67450	
	50		68952	67451	
	60		68953	67452	
	80		68954	67453	
	100		-	67454	
	120		-	67455	
	-		-	-	-
	-		-	-	-
	3" x 132"		24	10	69075
36		69076	67575		
40		69077	67576		
50		69078	67577		
60		69079	67578		
80		69080	67579		
100		-	67580		
120		-	67581		
150		-	67582		
180		-	67583		
220		-	67584		
240		-	67585		
320		-	67586		
-		-	-		-
4" x 36"	36	10	69166	67665	
	40		69167	67666	
	50		69168	67667	
	60		69169	67668	
	80		69170	67669	
	100		-	67670	
	120		-	67671	
	-		-	-	-
4" x 132"	24	10	69291	67790	
	36		69292	67791	
	40		69293	67792	
	50		69294	67793	
	60		69295	67794	
	80		69296	67795	
	100		-	67796	
	120		-	67797	
	-		-	-	-
	-		-	-	-

Note: Other belt sizes available by special order.



# Coated Abrasive Belts & Shop Rolls



## Benchstand/Backstand Belts

Size (Width x Length)	Grit Size	Standard Pack	Item Number	
			Zirconia Alumina	Aluminum Oxide
6" x 48"	36	10	69346	67845
	40		69347	67846
	50		69348	67847
	60		69349	67848
	80		69350	67849
	100		-	67850
	120		-	67851
	150		-	67852
6" x 60"	36	10	69382	67881
	40		69383	67882
	50		69384	67883
	60		69385	67884
	80		69386	67885
6" x 132"	36	10	69400	67899
	40		69401	67900
	50		69402	67901
	60		69403	67902
	80		69404	67903
	120		-	67905

Polishing the O.D. of a part turning in a lathe.



67845

**Shop Rolls** - Weiler's Shop Rolls are resin over resin bonded - providing a stronger, heat and moisture resistant bond that better utilizes the abrasive grains. The cotton cloth provides a tougher, durable backing for longer life. J-flex cloth provides a higher degree of flexibility to conform to contoured parts.

### Applications

- Off-hand polishing of metal surfaces
- General purpose machine shop use
- Off-hand deburring
- Cleaning stock that is being turned in a lathe

**Shop Rolls - Aluminum Oxide - 50 Yards. One roll per box.**

Roll Width	Grit Size	Standard Pack	Item Number		
1"	50	1	65204		
	60		65205		
	80		65206		
	100		65207		
	120		65208		
	150		65209		
	180		65210		
	240		65212		
	320		65213		
	1-1/2"		50	1	65217
			60		65218
80		65219			
100		65220			
120		65221			
150		65222			
180		65223			
240		65225			
320		65226			
2"		50	1		65230
		60			65231
	80	65232			
	100	65233			
	120	65234			
	150	65235			
	180	65236			
	240	65238			
	320	65239			



65204



Use light machine oil with shop rolls as a lubricant for finer finishes and quicker cut.

Coated Abrasive Belts & Shop Rolls

# Bonded Abrasive Technical Information

**Vortec Pro® Bonded Abrasives** - Specifically designed for general purpose grinding & cutting applications requiring heavy material removal such as rough grinding, weld removal, snagging, cutting and parting. All product is resin bond formulated for aggressive stock removal and fast cutting and are reinforced with fiberglass webbing for stability.



## Grinding

### Type 27 Products:

These products range from 4" to 9" diameter and are available in 1/4" thick for grinding and 1/8" thick for light grinding. Type 27 Wheels are offered in aluminum oxide, silicon carbide or zirconia alumina grain with a 5/8"-11 hub option.

## Cutting

### Type 27 Products:

Type 27 Wheels are offered in .045", .060", 3/32" and 1/8" wheel thicknesses. Diameters range from 4" to 9" and are available in aluminum oxide, silicon carbide or zirconia alumina grain, with an option of a 5/8"-11 hub.

### Type 1 Products:

This product category includes wheels ranging from 2" to 14" diameter in various thicknesses and grit sizes in aluminum oxide, silicon carbide or zirconia alumina grain. Type 1 Wheels are for use on right angle grinders, electric or air die grinders, tool room grinders, circular saws, stationary saws, chop saws and high speed portable gas and electric saws and walk-behind machines.



## Safety



Abrasive users and others in area must wear goggles or face shields over safety glasses. Safety guards must be used. Do not exceed maximum RPM.

### Bonded Abrasives Safety Guide - For complete and detailed safety information see ANSI safety code B7.1.

#### — DO —

1. ALWAYS handle and store wheels in a careful manner.
2. ALWAYS visually inspect all wheels before mounting for possible damage.
3. ALWAYS make sure operation speed established for machine does not exceed wheel speed.
4. ALWAYS check mounting flanges for equal and correct diameter.
5. ALWAYS use mounting blotters when supplied with wheels.
6. ALWAYS keep grinder work rest properly adjusted within 1/8" of wheel face.
7. ALWAYS wear safety glasses or some type of eye protection equipment.
8. ALWAYS use a safety guard covering at least one-half of the wheel diameter.
9. ALWAYS allow newly mounted wheels to run at operation speed, with guard in place, for at least one minute before applying to workpiece.

1. DON'T use a wheel that has been dropped.
2. DON'T force a wheel onto the spindle or alter the hole size of the wheel.
3. DON'T use a wheel that fits the arbor too loosely.
4. DON'T exceed maximum operation speed established for the wheel.
5. DON'T use dirty, nicked, warped or sprung mounting flanges.
6. DON'T tighten the mounting nut excessively.
7. DON'T grind on the side of the wheel unless the wheel is specifically designed for that purpose.
8. DON'T start machine without safety guard in place.
9. DON'T jam work into the wheel.
10. DON'T stand directly in front of a grinding wheel whenever a grinder is started.
11. DON'T grind or cut material for which the wheel is not designed.
12. DON'T grind or cut without proper ventilation.

#### — DON'T —

# Bonded Abrasive Technical Information

## Bonded Wheel General Operating Recommendations

### Fixture the work-piece

to minimize wheel contact area for a faster, cooler cut.



**Incorrect**  
(Wide contact point)



**Correct**  
(Two small contact points)

### Use an oscillating head

when cutting thicker cross sections (over 3"). This reduces arc of contact and permits larger sections to be cut with a given diameter wheel.



### Counter rotation of the work-piece

is recommended for cutting large cross sections (over 8") and when cutting tubular stock.



■ To maximize performance, run at or close to the Maximum Safe Free Speed or RPM. NEVER EXCEED the MSFS or RPM.

■ For maximum wheel life, select the coarsest, hardest wheel that will perform the cut.

■ How to determine proper wheel wear:

Convex wheel wear is a sign of proper wheel usage.

Pointed wheel wear is a sign of improper usage. Wheel is too hard for application or feed rate is too slow for application.

## Bonded Wheel Product Selection

### Grain/Grit/Grade Guide

Grain	WA	White Aluminum Oxide: Longer wheel life on all metals except titanium & ductile iron
	A	Aluminum Oxide: for use on all metals except titanium and ductile iron
	C	Silicon Carbide: for use on non-metallics, titanium, ductile iron & stone
	Z	Zirconia Alumina: for higher cut rates in high pressure applications (Type 27 only)
Grit	16	Extra Coarse: for fast, aggressive cutting and maximum wheel life
	24	Coarse: for fast, aggressive cutting and maximum wheel life
	30	Medium/Coarse: for fast cutting and long wheel life
	36	Medium/Coarse: excellent for general purpose cutting
	46	Fine/Medium: for a smoother finish and reduced burr
	60	Fine: for a burr-free cut
Grade	S-V	Hard: for maximum wheel life
	R	Medium/Hard: for cutting large cross sections; improved stock removal rate
	N	Soft: for maximum cut rate

### Thickness Guide

1/4"	Grinding Only
1/8"	Light Grind & Cut
3/32"	Cutting Only
1/16"	Cutting Only
.045"	Cutting Only
.040"	Cutting Only
.035"	Cutting Only

### Application Guide

A24N	Aluminum Oxide - Fast Cut - Ideal for use on hard welds and steel, stainless steel, and in low pressure, large contact grinding where the harder wheel grade (R) dulls or glazes.
A24R	Aluminum Oxide - Long Life - Offers longer life than the softer wheel grade (N). Ideal for all general purpose grinding on structural steel, or in foundries or heavy fabrication applications.
Z24T	High Performance Zirconia Alumina - Offers improved cut rate in high pressure applications. Ideal when grinding or cutting stainless steel, high carbon steel, cast iron and other metals.
C24R	High Performance Silicon Carbide - Offers an excellent cut rate on concrete, stone and non-ferrous metals.

# Bonded Abrasive Technical Information

## Application Solutions Guide

There are many variables in using Cut-Off Wheels. If the product you are using does not accomplish the desired results, select a solution from the suggestions below for your specific application or call Weiler's **Application Engineering Hotline at 888-299-2777**.

Problem	Possible Cause	Recommended Solution
Slow cut rate	• Insufficient power being used	• Increase feed rate; run machine at full power
	• Contact area too large	• Reduce contact area
	• Side run out	• Check for spindle run out
	• Wheel binding	• Provide relief under part
Workpiece burn	• Insufficient feed rate	• Increase feed rate
	• Wheel speed too slow	• Check for wheel slippage
	• Wheel too coarse	• Use finer grit or increase power
Non-square cuts	• Work not properly fixtured	• Support both sides and fixture properly
	• Worn spindle bearings	• Check spindle
Too much burr	• Improper fixturing	• Check part fixturing
	• Grit too coarse	• Use a finer grit

## Lab Testing Results

### Item(s) Tested: 4-1/2" x 1/4" x 7/8" Bonded Grinding/Cutting Wheels in A24R

The following are the results of an automated test comparing the Weiler Vortec Pro Type 27 4-1/2 X 1/4" general purpose grinding wheel vs. two major manufacturers of general purpose bonded products. The test involved grinding for 30 minutes on mild steel bar stock.

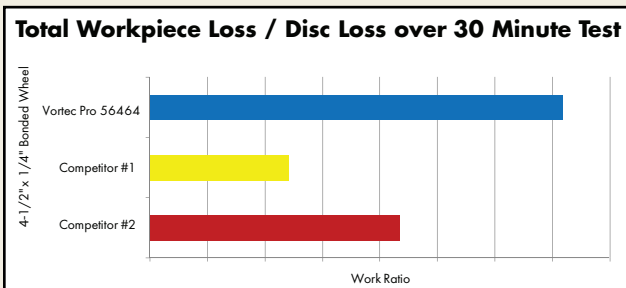
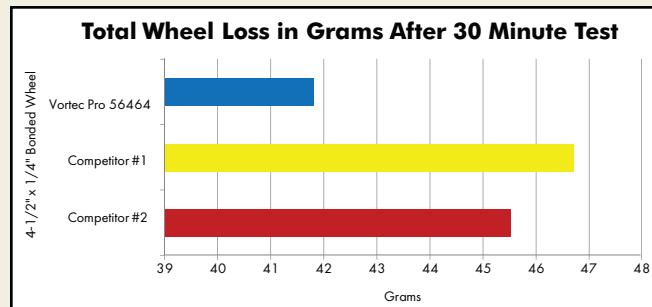
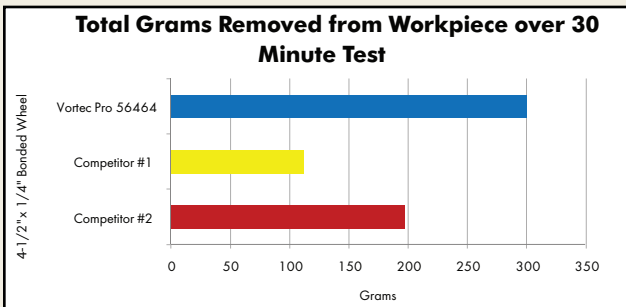

As you can see from this data, the Vortec Pro #56464 Grinding Wheel removed more total material from the workpiece while losing less gram mass than the competition. Combining the higher workpiece removal with the least disc loss makes the Vortec Pro product the obvious choice for your bonded abrasive applications.

**Tech Note**

### Storage and Handling:

- Handle bonded product in a manner to prevent dropping or bumping.
- Do not roll wheels
- Use trucks or other appropriate conveyances to provide support and protection in transporting all bonded products that cannot be carried by hand.
- Store in suitable racks, bins or drawers.
- Store in a dry area not subject to extreme temperature changes. Some bonded product may be affected by excessive humidity and temperature changes.
- Locate racks as near as practical to the grinding location, but never where there is damage from passing trucks, crane handling equipment or excessive vibration.

**Tech Note**

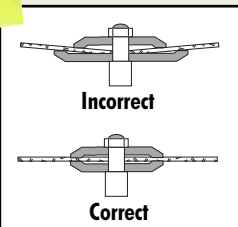

Flanges should be of equal diameter, recessed and at least one-third the diameter of the wheel.

# Vortec Pro® Bonded Abrasives

**Cutting & Grinding Wheels** - The Vortec Pro® bonded abrasive line is specifically designed for general purpose cutting and grinding applications on steel, iron, and other ferrous metals. All product is resin-bond formulated for aggressive stock removal and fast cutting, and are reinforced with fiberglass webbing for stability.

## Applications

- Weld removal
- Cutting and parting
- Rough Grinding
- Notching

## Vortec Pro® Small Type 1 Reinforced Cut-Off Wheels -

General purpose cutting applications in toolrooms and machine shops.

Diameter	Wheel Thickness	Arbor Hole	Type	Max. RPM	Standard Pack	Item Number	
2"	.035"	1/4"	WA60T - Metal	30,000	100	56013*	
	1/16"	1/4"	A36T - Metal		50	56015	
	1/4"	3/8"	A36T - Metal		25	56131	
3"	.035"	1/4"	WA60T - Metal	25,000	100	56061*	
	.035"	3/8"	WA60T - Metal		100	56062*	
	1/16"	1/4"	A36T - Metal		100	56065	
	1/16"	3/8"	A36T - Metal		100	56068	
	1/16"	1/4"	A60T - Metal		100	56067	
	1/16"	3/8"	A60T - Metal		100	56070	
	1/8"	3/8"	A36T - Metal		50	56076	
	1/8"	1/4"	A36T - Metal		50	56270	
	1/4"	3/8"	A36T - Metal		23,000	25	56147
	4"	.035"	5/8"		WA60T - Metal	19,000	50
.035"		1/4"	WA60T - Metal	50	56079*		
.035"		3/8"	WA60T - Metal	50	56080*		
1/16"		1/4"	A36T - Metal	50	56083		
1/16"		3/8"	A36T - Metal	50	56086		
1/16"		1/4"	A60T - Metal	50	56085		
1/16"		3/8"	A60T - Metal	50	56088		
1/16"		5/8"	A60T - Metal	50	56272		
1/4"		3/8"	A36T - Metal	25	56163		
1/8"		3/8"	A36T - Metal	50	56099		
4-1/2"	.045"	7/8"	WA60T - Metal	13,500	50	56281*	
	1/16"	7/8"	A60T - Metal		50	56103	
5"	.035"	3/8"	WA60T - Metal	12,200	100	56106*	
	.035"	5/8"	WA60T - Metal		100	56108*	
	1/16"	5/8"	A36T - Metal		25	56115	
	1/16"	5/8"	A60T - Metal		25	56117	
	1/16"	7/8"	A36T - Metal		100	56118	

\*Contaminant-free.

## Vortec Pro® Type 1 Reinforced Cut-Off Wheels -

General purpose metal applications in toolrooms and machine shops.

Diameter	Wheel Thickness	Arbor Hole	Type	Max. RPM	Standard Pack	Item Number
6"	.035"	1/2"	WA60T - Metal	10,200	25	56170*
	.035"	5/8"	WA60T - Metal			56171*
	.040"	7/8"	WA60T - Metal			56282*
	.045"	7/8"	WA60T - Metal			56273*
	1/16"	5/8"	A60T - Metal			56274
7"	.035"	5/8"	WA60T - Metal	8,740	25	56183*
	.045"	7/8"	WA60T - Metal			56275*
	1/16"	5/8"	A36T - Metal			56188
	1/16"	1-1/4"	A60T - Metal			56193
7"	1/8"	5/8"/DIA.	A24T - Metal	8,740	15	56208
			C24T - Concrete			56209

\*Contaminant-free.

DIA. = 5/8" arbor with diamond knockout adapter for circular saws.

## Mounting Mandrels - 1/4" Stem. For Type 1 Wheels only

Arbor Size	Wheel Thickness	Standard Pack	Item Number
1/4"	.035" to 1/4"	10	56489
3/8"	.035" to 1/4"	10	56490
1/4", 3/8" *	.035" to 1/4"	10	56491*
1/4", 3/8"+	.035" to 1/4"	1	36512+

\*Combination pack +Display packaged



Cutting a piece of steel tubing to length.



56013



56103



All Weiler grinding and cutting wheels are resin bonded and contain at least 2-layers of fiberglass reinforcement.



56282



56489

Vortec Pro® Bonded Abrasives

# Vortec Pro® Bonded Abrasives



Notching a steel bar prior to welding.

## Vortec Pro® Type 27 Thin Cutting Wheels - Aluminum Oxide

For general purpose, burr-free cutting with less resistance on various metals.

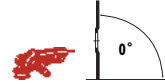

Diameter	Wheel Thickness	Arbor Hole	Type	Max. RPM	Standard Pack	Item Number
4-1/2"	.045"	7/8"	WA60S - Metal	13,300	25	56393*
5"	.045"	7/8"	WA60S - Metal	12,200	100	56392*
6"	.045"	7/8"	WA60S - Metal	10,200	25	56283*
7"	.060"	7/8"	WA60S - Metal	8,500	25	56391*

\*Contaminate-free.

## Type 27 Thin Cutting Wheels - Zirconia Alumina

For fast, burr-free cutting with longer life and less resistance on various metals.

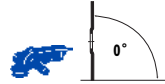

Diameter	Wheel Thickness	Arbor Hole	Type	Max. RPM	Standard Pack	Item Number
4-1/2"	.045"	7/8"	Z46T - Metal	13,300	25	56389
5"	.045"	7/8"	Z46T - Metal	12,200	50	56388
7"	.060"	7/8"	Z36T - Metal	8,500	25	56387

## Vortec Pro® Type 27 Cutting Wheels - For general purpose cutting on ferrous metals.



Diameter	Wheel Thickness	Arbor Hole	Type	Max. RPM	Standard Pack	Item Number
4"	3/32"	5/8"	A24T - Metal	15,200	25	56474
4-1/2"	3/32"	5/8"-11 7/8"	A24T - Metal	13,300	10 25	56385 56475
5"	3/32"	5/8"-11 7/8"	A24T - Metal	12,200	10 25	56384 56476
6"	3/32"	5/8"-11 7/8"	A24R - Metal	10,200	10 25	56278 56277
7"	3/32"	5/8"-11 7/8"	A24R - Metal	8,500	10 25	56477 56383

## Vortec Pro® Type 27 - Pipeline Cutting & Light Grinding Wheels -

General purpose light grinding and cutting. For root pass cutting and light grinding.

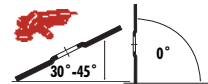

Diameter	Wheel Thickness	Arbor Hole	Type	Max. RPM	Standard Pack	Item Number
4"	1/8"	5/8"	A24R - Metal	15,200	25	56431
4-1/2"	1/8"	5/8"-11 7/8"	A24R - Metal	13,300	10 25	56429 56430
5"	1/8"	5/8"-11 7/8"	A24T - Metal	12,200	10 25	56427 56428
7"	1/8"	5/8"-11 7/8"	A24T - Metal	8,500	10 25	56425 56426
9"	1/8"	5/8"-11 7/8"	A24T - Metal	6,600	10 20	56423 56424

### Tech Note

■ All Weiler Vortec Pro bonded Thin Cutting wheels (.060 and thinner) contain White AO for a longer life vs the standard brown AO other manufactures use to save cost.

■ All Weiler Vortec Pro bonded Thin Cutting wheels (.060 and thinner) are contaminant free, which means Iron, Sulfur and Chlorine is ≤ 0.1% - they will not rust stainless steel.

56283



56385



56430

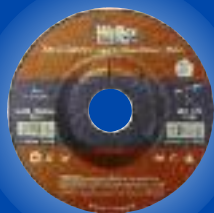

Vortec Pro® Bonded Abrasives

# Vortec Pro® Bonded Abrasives

Vortec Pro® Type 27 Grinding Wheels - For general purpose, rough grinding.



Diameter	Wheel Thickness	Arbor Hole	Type	Max. RPM	Standard Pack	Item Number
<b>Silicon Carbide - For Stone/Concrete Applications</b>						
4-1/2"	1/4"	5/8"-11 7/8"	C24R Stone/Concrete	13,300	10 25	56482 56483
7"	1/4"	5/8"-11 7/8"	C24R Stone/Concrete	8,500	10 20	56486 56487
9"	1/4"	5/8"-11 7/8"	C24R Stone/Concrete	6,600	10 20	56492 56493
<b>Aluminum Oxide - For General Purpose Steel Applications</b>						
4"	1/4"	5/8"	A24R - Metal	15,200	25	56473
4-1/2"	1/4"	5/8"-11 7/8"	A24R - Metal	13,300	10 25	56454 56464
4-1/2"	1/4"	5/8"-11 7/8"	A24N - Metal	13,300	10 25	56455 56457
5"	1/4"	5/8"-11 7/8"	A24R - Metal	12,200	10 25	56449 56466
6"	1/4"	5/8"-11 7/8"	A24R - Metal	10,200	10 25	56279 56280
7"	1/4"	5/8"-11 7/8"	A24R - Metal	8,500	10 20	56468 56467
9"	1/4"	5/8"-11 7/8"	A24R - Metal	6,600	10 20	56470 56442



Grinding out weld defects for repair.



56464

Type 27 Grinding Wheels - For general purpose, rough grinding.

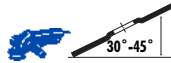

Diameter	Wheel Thickness	Arbor Hole	Type	Max. RPM	Standard Pack	Item Number
<b>Zirconia Alumina - High Performance Grain That Cuts Faster with Long Life</b>						
4-1/2"	1/8"	5/8"-11 7/8"	Z24T - Metal	13,300	10 25	56420 56421
4-1/2"	1/4"	5/8"-11 7/8"	Z24T - Metal	13,300	10 10	56453 56456
7"	1/8"	5/8"-11 7/8"	Z24T - Metal	8,500	10 20	56416 56417
7"	1/4"	5/8"-11 7/8"	Z24T - Metal	8,500	10 10	56444 56446



56468

Vortec Pro® Type 1 Vitrified Grinding Wheels - For general purpose rough grinding and heavy stock removal.

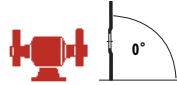

Diameter	Wheel Thickness	Arbor Hole	Type	Max. RPM	Standard Pack	Item Number
6"	3/4"	1"	36AO - Metal 60AO - Metal	4,100	5	36459 36460
8"	1"	1"	36AO - Metal 60AO - Metal	3,600	5	33052 33053



Adapting Nut Assembly



56494

Adapting Nut

Grinding Wheel

Adapting Nut

Right Angle Grinder

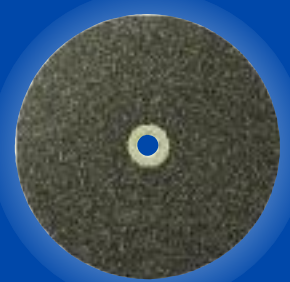

33052

Adapting Nuts - For 4-1/2" & 5" Angle Grinders.

Adapts To	Min. Wheel Thickness	Standard Pack	Item Number
7/8" to 5/8"-11	1/16"	1	56494
5/8" to 3/8"-24	1/16"	1	56484

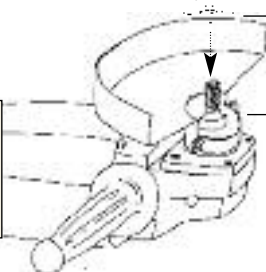

When mounting, adapters must be nested, see illustration at right.

Vortec Pro® Bonded Abrasives

# Vortec Pro® Bonded Abrasives

## Vortec Pro® Large Type 1 Reinforced Cut-Off Wheels -

General purpose - For stationary machines.



Diameter	Wheel Thickness	Arbor Hole	Type	Max. RPM	Standard Pack	Item Number
12"	1/8"	1"	C24T - Stone/Concrete	5,100	10	56234
14"	1/8"	1"	A30R - Metal	4,400	10	56230
14"	1/8"	1"	C20R - Stone/Concrete	4,400	10	56246

## Vortec Pro® Large Type 1 Reinforced Cut-Off Wheels -

General purpose - For portable gas or electric saws.



Diameter	Wheel Thickness	Arbor Hole	Type	Max. RPM	Standard Pack	Item Number
12"	1/8"	1"	A24T - Metal	6,300	10	56241
12"	1/8"	1"	C24T - Stone/Concrete	6,300	10	56242
12"	1/8"	20mm	A24T - Metal	6,300	10	56254
12"	1/8"	20mm	C24T - Stone/Concrete	6,300	10	56255
14"	1/8"	1"	A24T - Metal	5,400	10	56250
14"	1/8"	1"	C24T - Stone/Concrete	5,400	10	56251
14"	1/8"	20mm	A24T - Metal	5,460	10	56263
14"	1/8"	20mm	C24T - Stone/Concrete	5,460	10	56264

## Vortec Pro® Large Type 1 Reinforced Cut-Off Wheels -

General purpose - For low horsepower chop saws.



Diameter	Wheel Thickness	Arbor Hole	Type	Max. RPM	Standard Pack	Item Number
12"	3/32"	1"	A46T - Metal	5,100	10	56239
12"	3/32"	1"	A46S - Metal	5,100	10	56238
14"	3/32"	1"	A46T - Metal	4,400	10	56240
14"	3/32"	1"	A46S - Metal	4,400	10	56244

## Vortec Pro® Large Type 1 Reinforced Cut-Off Wheels -

General purpose - For walk behind machines.



Diameter	Wheel Thickness	Arbor Hole	Type	Max. RPM	Standard Pack	Item Number
14"	3/16"	1"	C16T - Stone/Concrete	4,400	10	56268
			C16R - Stone/Concrete			56267

**Plastic Adapters -** Allows Type 1 wheels to work on machines with a 20mm arbor hole.

Wheel Arbor Hole Size	Adapted Arbor Hole Size	Standard Pack	Item Number
1"	20mm	10	04455

Cutting angle iron with a chopsaw.



56264



56238



04455

**Tech Note**

The following factors can cause wheel breakage:

- Excessive speed
- Excessive wheel feed rate
- Improper mounting
- Improper machine conditions
- Work improperly clamped
- Misuse

**DID YOU KNOW?**

All Weiler Vortec Pro Cutting Wheels have a metal reinforcement ring around the arbor hole.



# Non-Woven Unitized Wheels

## Non-Woven Abrasives Technical Information

Non-woven abrasive products can be used in a broad range of surface-conditioning applications from cleaning and finishing to deburring and light blending. Unlike bonded and coated abrasives, they cannot be used for applications requiring heavy stock removal such as grinding and weld blending.

All non-woven products are fabricated from base materials that are composed of a random "web" of nylon fibers that have been bonded together with synthetic resins and impregnated with abrasive grains. Although these materials vary in fiber density, their three dimensional nature results in specialty abrasive products that are pliable, conformable to the work surface, and limited in their ability to remove base stock.

Non-woven products resist loading and perform consistently as new, fresh abrasive grains are exposed as the nylon fibers wear away from the product during use. Non-woven abrasives can be used either wet or dry on a range of materials including ferrous and non-ferrous metals, ceramics, plastics, composites, and wood. Non-woven products are designed for use where stock removal is not required. Non-wovens begin where coated abrasives leave off.

**Unitized Wheels** - Designed for use on die grinders and are ideal for a variety of cleaning, finishing, deburring and edge blending applications.

### Applications

- Deburring machined surfaces
- Blending saw and machine marks
- Removing heat discoloration, rust and oxidation

### Unitized Wheels

Diameter	Face Width	Arbor Hole	Grain	Grade	Max. RPM	Standard Pack	Item Number
<b>Series 2 - Cleaning &amp; Finishing - Hardness: Soft</b>							
2"	1/4"	1/4"	Silicon Carbide	Fine	18,000	10	55511
3"	1/4"	1/4"	Aluminum Oxide	Fine	12,000	10	55512
			Silicon Carbide	Fine			55513
<b>Series 4 - General Purpose - Hardness: Medium</b>							
2"	1/4"	1/4"	Aluminum Oxide	Fine	18,000	10	55520
			Aluminum Oxide	Fine			55481
3"	1/4"	1/4"	Aluminum Oxide	Fine	12,000	10	55522
			Aluminum Oxide	Fine			55487
<b>Series 6 - Deburring - Hardness: Medium/Hard</b>							
1"	1"	3/16"	Aluminum Oxide	Fine	30,000	10	55531
2"	1/4"	1/4"	Aluminum Oxide	Fine	22,000	10	54488
3"	1/4"	1/4"	Aluminum Oxide	Fine	18,000		54492
			Aluminum Oxide	Fine			55530
<b>Series 8 - HD Deburring &amp; Polishing - Hardness: Hard (Heavy-Duty)</b>							
1"	1"	3/16"	Aluminum Oxide	Medium	30,000	10	55543
2"	1/8"	1/4"	Aluminum Oxide	Coarse	22,000	10	55545
			Aluminum Oxide	Medium			55540
3"	1/8"	1/4"	Aluminum Oxide	Coarse	18,000	10	55546
			Aluminum Oxide	Medium			55541
			Aluminum Oxide	Medium			55542

### Mandrels

Stem Diameter	For Wheel Diameter	For Wheel Thickness	Standard Pack	Item Number
1/4"	2" - 3"	1/2"	1	07761
	1"	1"	1	07764
	2" - 3"	1/8" - 1/4"	10	56489



A unitized wheel deburring a ring gear.

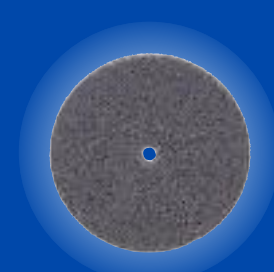

55512

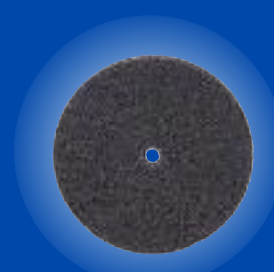

55541



56489

Non-Woven Unitized Wheels

# Non-Woven Convolute Wheels

**Convolute Wheels** - Weiler's Convolute Wheels are designed for a wide variety of cleaning, finishing, deburring and edge blending needs on straight shaft tools and bench/pedestal grinders.

## Applications

- Cleaning and polishing metal surfaces
- Polishing and finishing machined parts
- Deburring stamped metal parts
- Removing parting lines
- Blending edges
- Removing coated abrasive grind lines

## Convolute Wheels



Dia.	Face Width	Arbor Hole	Grain	Grade	Density	Max. RPM	Standard Pack	Item Number
<b>MRO/General Purpose - For general cleaning and finishing</b>								
6"	1/2"	1"	Silicon Carbide	Fine	7	6,000	4	54450
	1"		Silicon Carbide	Fine			3	54455
	1"		Silicon Carbide	Medium			3	54456
8"	1"	3"	Silicon Carbide	Fine	7	4,500	3	54460
			Silicon Carbide	Medium			7	54461
<b>Deburring Wheels - For deburring and edge blending</b>								
6"	1/2"	1"	Silicon Carbide	Fine	8	6,000	4	54300
	1/2"		Silicon Carbide	Fine			4	54301
	1/2"		Silicon Carbide	Medium			4	54401
	1"		Silicon Carbide	Fine			3	54303
	1"		Silicon Carbide	Fine			3	54304
	1"		Silicon Carbide	Medium			3	54050
	2"		Silicon Carbide	Fine			2	54307
8"	1"	3"	Silicon Carbide	Fine	8	4,500	3	54309
			Silicon Carbide	Fine			3	54310
			Silicon Carbide	Medium			3	54052

## Adapters

Wheel Inside Diameter	Arbor Hole	Standard Pack	Item Number
<b>Telescoping Plastic Adapter</b>			
1"	3/4" - 5/8" - 1/2"	1	04440
<b>Metal Adapters</b>			
3"	1/2"	1	03804
	5/8"		03805
	3/4"		03806
	1"		03807
	1-1/4"		03808

## Tech Note

### Suggested Wheel Dressing Method

The initial dressing is most important to achieve maximum cutting and face uniformity. This process takes less than one minute.

- Step 1:** Mount a 36 grit abrasive cloth strip to a solid backing (plywood).
- Step 2:** Run the wheel at a high RPM (not to exceed Maximum Safe Free Speed). Apply the abrasive strip to the wheel face using light, uniform pressure.
- Step 3:** Move the abrasive strip across the wheel face until the wheel face is uniform.
- Step 4:** Use a piece of hardwood to burn away the excess nylon fiber. Hold the wood against the face until the wheel cuts the wood, exposing fresh grain and eliminating excess nylon.



Wheel that needs to be dressed.

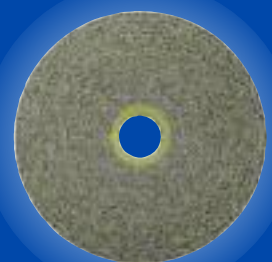

Illustration of Step 2.

Polishing a stainless steel door handle.



54455



54303

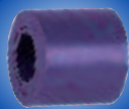

04440



03804

## NOTE

Lubricut™ Lubricant is available for use on Convolute Wheels. See page 73 for usage recommendations.

# Non-Woven Surface Conditioning Discs



**Surface Conditioning Discs** - Have an open construction, scrim reinforcement and a superior resin system. These features minimize loading, heat build-up, fraying of disc edges, grain shedding and extend disc life, providing superior performance.

## Applications

- Light deburring
- Surface preparation
- Blending light scratches
- Removing rust and corrosion
- Removing rust and oxidation
- Cleaning and removing stains from stainless steel
- Producing satin finishes on aluminum and stainless steel

## Plastic Button Style Discs - Compatible with 3M Roloc™ back-up pads.



Diameter	Grade	Standard Pack	Item Number	
			General Purpose	High Performance
1-1/2"	Very Fine (Blue)	50	51527	-
	Medium (Maroon)		51528	-
	Coarse (Brown)		51529	-
2"	Very Fine (Blue)	50	51530	57324
	Medium (Maroon)		51531	57323
	Coarse (Brown)		51532	57322
3"	Very Fine (Blue)	25	51533	57327
	Medium (Maroon)		51534	57326
	Coarse (Brown)		51535	57325
4"	Very Fine (Blue)	10	51536	-
	Medium (Maroon)		51537	-
	Coarse (Brown)		51538	-

Roloc™ is a trademark of 3M.

## Plastic Button Style Back-up Pads - 1/4" Stem

Diameter	Max. RPM	Standard Pack	Item Number
1-1/2"	30,000	1	51550
2"	30,000	1	51551
3"	20,000	1	51552
4"	12,000	1	51553

Do not exceed maximum RPM of back-up pad.



- The flexible, open style construction of non-wovens makes them conformable, non-loading and ideal for finishing non-ferrous metals such as aluminum and brass.
- Unlike steel wool, the non-metallic construction of non-wovens will not contaminate metals and cause surface rust.

Finishing the surface for a stainless steel part for the food service industry.

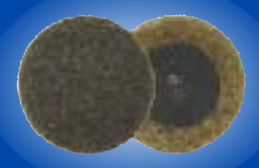

51532

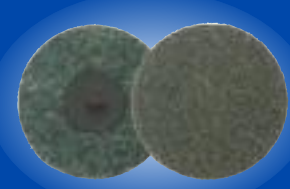

51533

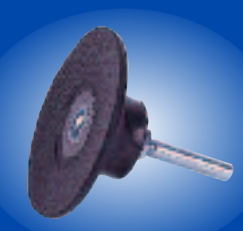

51552

Non-Woven Surface Conditioning Discs

# Non-Woven Surface Conditioning Discs

## Hook & Loop Style Discs



Putting a decorative satin finish on a stainless steel door.



51508

Diameter	Grade	Standard Pack	Item Number
2"	Very Fine (Blue)	50	51503
	Medium (Maroon)		51504
	Coarse (Brown)		51505
3"	Very Fine (Blue)	25	51506
	Medium (Maroon)		51507
	Coarse (Brown)		51508
4"	Very Fine (Blue)	10	51509
	Medium (Maroon)		51510
	Coarse (Brown)		51511
4-1/2"	Very Fine (Blue)	10	51512
	Medium (Maroon)		51513
	Coarse (Brown)		51514
5"	Very Fine (Blue)	10	51515
	Medium (Maroon)		51516
	Coarse (Brown)		51517
6"	Very Fine (Blue)	10	51518
	Medium (Maroon)		51519
	Coarse (Brown)		51520
7"	Very Fine (Blue)	10	51521
	Medium (Maroon)		51522
	Coarse (Brown)		51523
8"	Medium (Maroon)	10	51525
	Coarse (Brown)		51526

## Hook & Loop Style Back-up Pads



51561

Diameter	Arbor Hole or Stem Size	Max. RPM	Standard Pack	Item Number
2"	1/4" Stem	16,000	1	51561
3"	1/4" Stem	18,000	1	51562
4"	1/4" Stem	16,000	1	51563
4-1/2"	5/8" -11 Arbor	13,000	1	51569
5"	5/8" -11 Arbor	10,000	1	51575
6"	5/8" -11 Arbor	8,000	1	51577
7"	5/8" -11 Arbor	6,000	1	51578
8"	5/8" -11 Arbor	4,500	1	51579

Do not exceed maximum RPM of back-up pad.



Weiler operates 6 warehouses in the U.S.A., Canada & Mexico.

# Non-Woven Hand Pads



Cleaning a restaurant sink with a commercial hand pad.

**Hand Pads** - For cleaning and conditioning surfaces by hand. Unlike steel wool, hand pads are non-metallic, and do not produce "after-rust" on work surfaces. Hand pads can be used in wet applications.

## Applications

- |  |   |
|--|---|
| <p><b>Industrial Grade:</b></p> <ul style="list-style-type: none"> <li>■ Producing satin finishes on aluminum and stainless steel</li> <li>■ Light deburring</li> <li>■ Surface preparation</li> <li>■ Blending light scratches</li> </ul> | <p><b>Commercial Grade:</b></p> <ul style="list-style-type: none"> <li>■ Cleaning and removing stains from stainless steel</li> <li>■ Removing rust, corrosion and oxidation</li> </ul> |
|--|---|

## Hand Pads - Industrial Grade

Size	Grain	Grade	Description	Standard Pack	Item Number
6" x 9"	Silicon Carbide	Ultra Fine	Finishing (Grey)	60	51434
6" x 9"	Aluminum Oxide	Medium	Economy General Purpose (Maroon)	60	51460
6" x 9"	Aluminum Oxide	Med/ Coarse	General Purpose (Maroon)	60	51444
6" x 9"	Aluminum Oxide	Heavy-Duty	Heavy-Duty (Tan)	40	51454



51460

## Hand Pads - Commercial Grade

Size	Grain	Grade	Description	Standard Pack	Item Number
6" x 9"	Aluminum Oxide	Fine	Economy (Green)	400	51456
6" x 9"	Aluminum Oxide	Medium	Standard-Duty (Green)	60	51457
6" x 9"	Aluminum Oxide	Heavy-Duty	Heavy-Duty (Green) 20% thicker than Standard Duty	60	51458



51457

## Hand Pad Holder

Description	Standard Pack	Item Number
For 3" x 6" Pad	1	59616



Although denser non-woven abrasive products are suitable for applications requiring light stock removal such as removing large, well-attached burrs and blending minor tool marks and imperfections, the strength of these products is producing decorative finishes ranging from satin to near-mirror polish. The various grades of non-woven products produce scratch patterns which can be compared to those produced by coated abrasive products. However, their pliable nature results in a softer, less pronounced scratch-line pattern.

Grade	Grit Range
Ultra Fine	600
Very Fine	240-360
Fine	180-220
Medium	100-150
Coarse	50-80



59616

Non-Woven Hand Pads

# Non-Woven Interleaf Flap Wheels



Deburring the I.D. of a steel pipe with an interleaf flap wheel.

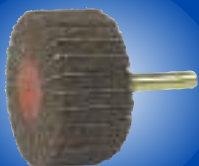

54500

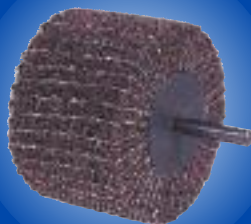

54510

**Interleaf Flap Wheels** - Provide a combination of non-woven and coated abrasive material to produce a very conformable product compared to a standard coated abrasive flap wheel. They are designed to be a finishing and surface blending tool as compared to a material-removing coated abrasive flap wheel. They are ideal for producing satin or decorative finishes on irregular or contoured surfaces.

## Applications

- General decorative finishing
- Applying satin finishes
- Producing antique finishes
- Final sandings
- Soft metal finishing
- Removing oxides from precious metals
- Fine burr removal

## Stem-Mounted Interleaf Flap Wheels - Aluminum Oxide



Diameter	Face Width	Grit Size	Stem Size	Max. RPM	Standard Pack	Item Number
2"	1"	120	1/4"	13,700	10	54500
		180				54501
		320				54502
3"	1"	120	1/4"	8,600	5	54506
		180				54507
		320				54508
3"	2"	120	1/4"	8,600	5	54509
		180				54510
		320				54511

**DID YOU KNOW?**

Defuzzing coconuts, finishing casket hardware and cleaning blades used for lasik surgery are all applications in which Weiler products are used.

# Maintenance

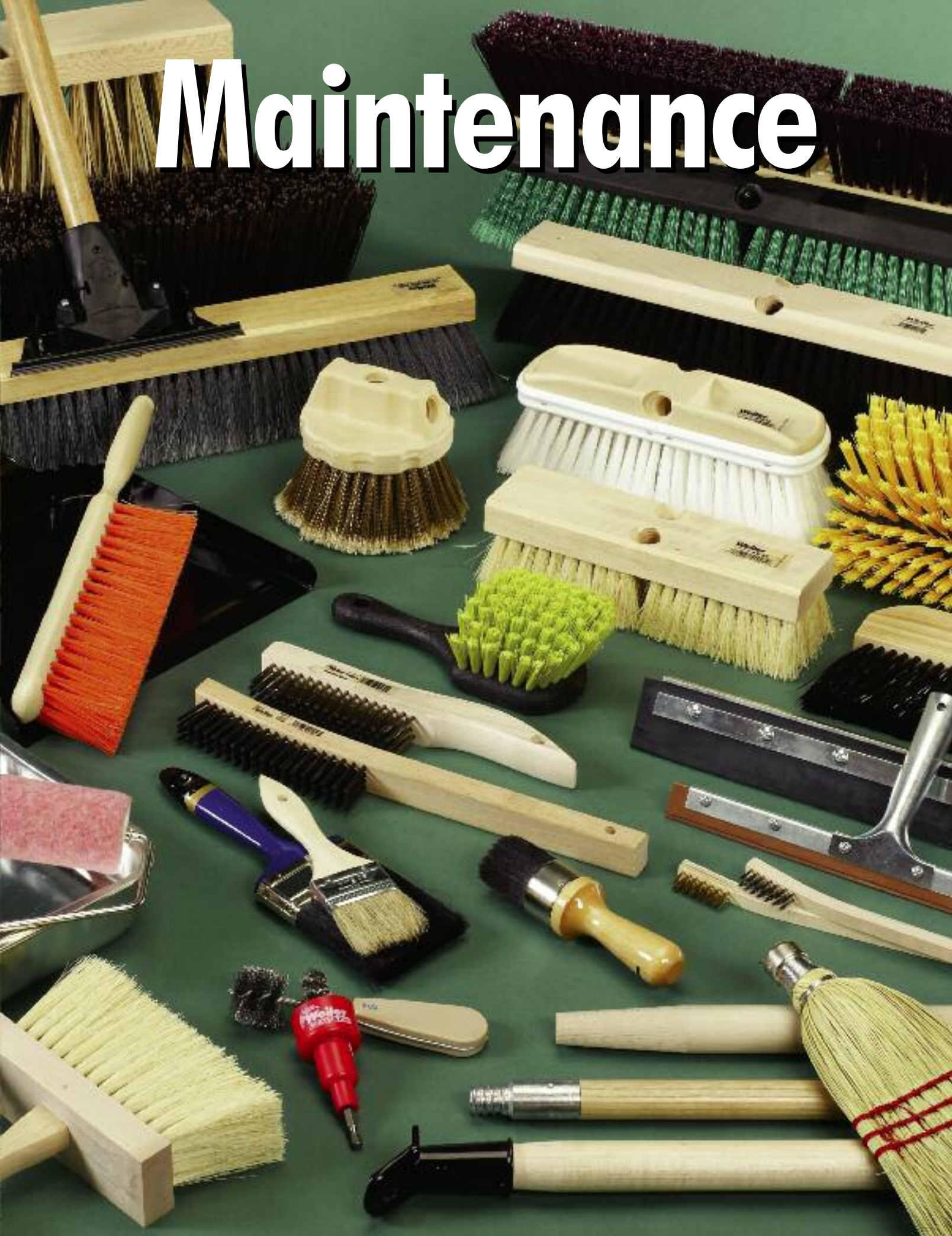

# Weiler® Maintenance

Maintenance

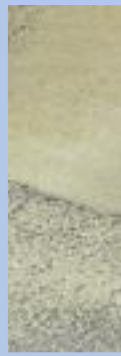
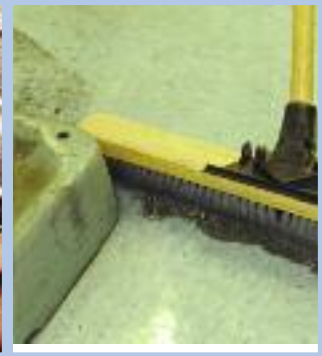





**New!**

## ■ Green Works™ Maintenance Products

*Environmentally-friendly!*

**New!**

## ■ Pro-Flex™ Sweeps

*Ships complete with handle, ready to assemble - no tools!*

## ■ Floor, Garage and Street Brushes

## ■ Handles

## ■ Upright and Whisk Brooms

## ■ Dusters and Dust Pans

## ■ Squeegees & Window Brushes

## ■ Vehicle Care Products

## ■ Scrub & Utility Brushes

## ■ Mops & Accessories

## ■ Masonry & Applicator Brushes

## ■ Scratch Brushes

## ■ Flue Brushes

## ■ Tube Fitting Brushes

## ■ Paint Brushes, Rollers & Accessories

**Knowledgeable and Responsive  
Customer Service Team:  
800-835-9999**

**Application Engineering Support:  
888-299-APPS (2777)**

**Interactive Website:  
[www.weilercorp.com](http://www.weilercorp.com)**



# Maintenance Product Technical Information

## Maintenance Brush Terminology and Features

**Block:** Fill material is set into this part of the sweep.

**Synthetic Foam Block:**

- Made with a synthetic cellular core surrounded by a solid skin.
- Will not crack, split, warp or house contaminating bacteria.
- Water, solvent and mild acid resistant
- Lighter weight than hardwood blocks

**Lacquered Hardwood Block:**

- Made of natural, kiln-dried hardwood
- Resists moisture
- Helps prevent cracking, increasing brush life.

**Dense Fill:**

- Set into the block and serves as the actual working part of the brush.
- More efficient sweeping
- Longer brush life

**Reorder Number:**

- Shown on block

**Two Handle Holes:**

- Allows user to change sweeping direction to prevent the fill material from setting in one direction. Periodically changing sweeping direction increases the life of the brush.

**Flagged Tips:**

- Each synthetic filament end is mechanically split, forming multiple tips which "pick up" fine dust and dirt particles.
- Horsehair has naturally tapered or flagged tips.

**Solid Brush Face with Flared Ends:**

- The tufts of fill material on each end of a contractor, floor, garage or street brush are flared outward.
- Flared ends allow the brushing material to get into corners without marking or scraping the wall with the block.
- Prevents a gap in the middle of the brush.

**Staggered Hole Pattern:**

- Prevents gaps in the fill material so brush sweeps up all the dirt in its path.

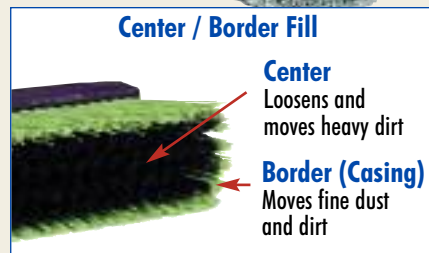
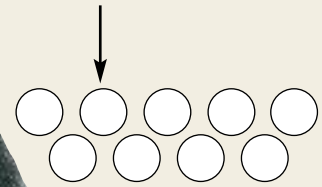
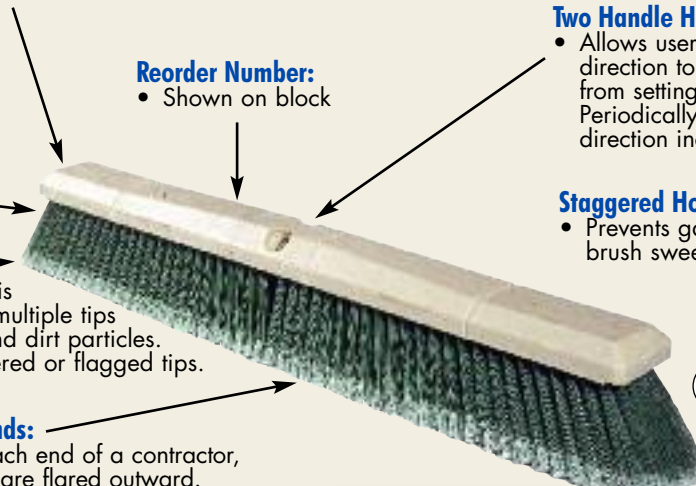

## Care of Floor Brushes

**Storage -** Floor brushes should be hung when not in use so no weight is against the fill material. This will help keep the shape and prolong the life of the brush.

**Handles -** The handle should be periodically re-positioned from one staff hole to the other to prevent fill material from setting in one position. The use of a brace will help prevent handle breakage. Perma-Flex™ (#44301) handles are guaranteed to outlast the life of the brush.

**Blocks -** Avoid knocking a wood block against the floor to remove imbedded material, as this will damage the end of the block.

**Cleaning -** Synthetic filled brushes can be cleaned with detergent and water. Fiber filled brushes should be combed to remove dirt and other foreign material. Dip coarse natural fiber brushes in water to help prevent breakage due to dry fiber.

## Product Selection

### Floor Brush Selection Guide

Surface Type	Debris	Recommended Brush
Tile, linoleum, highly polished	Fine dust	#42001 black horsehair
Smooth wood	Fine to medium dirt	#42041 flagged silver polystyrene
Smooth concrete	Fine to medium dirt	#42035 black polypropylene
Uneven or rough floors, heavy traffic areas	Medium to heavy dirt and debris	#42007 black tampico
Rough concrete, asphalt	Heavy, caked dirt, grease, litter	#42134 black tampico - inner row of steel wire #42023 palmyra

# Maintenance Product Technical Information

**Weiler Industrial Grade Products** - Engineered and manufactured to maximize performance and minimize operating costs in all cleaning applications. The use of superior construction, the highest quality materials and the most stringent manufacturing processes deliver the lowest cost of use and most consistent performance available in a maintenance product.





**Weiler Vortec Pro® Professional Grade Products** - Manufactured using similar product construction and to the same exacting standards as other Weiler Maintenance products, but engineered to provide cost-effective use specifically designed for the professional, providing a cost effective price. Vortec Pro Maintenance products are an economical choice for the construction trades, low volume production shops and the professional contractor.

## Fill Materials Used In Maintenance Brushes





### Animal

Type	Advantages	Applications	Notes
 <p><b>Horsehair</b></p>	<ul style="list-style-type: none"> <li>• Very durable and resilient</li> <li>• Naturally flagged tips</li> <li>• Resistant to high temperatures (to 370° F)</li> <li>• Can be blended with other materials</li> <li>• Fine texture</li> </ul>	<ul style="list-style-type: none"> <li>• Fine particles</li> <li>• Ideal for polished and smooth surfaces</li> <li>• Scratch-free sweeping</li> </ul>	<ul style="list-style-type: none"> <li>• Not for use on oily or wet surfaces</li> </ul>

### Natural

Type	Advantages	Applications	Notes
 <p><b>Tampico</b></p>	<ul style="list-style-type: none"> <li>• Material holds water very well</li> <li>• Heat, alkali and acid resistant (to 283° F)</li> <li>• Soft to medium texture</li> <li>• Good durability</li> </ul>	<ul style="list-style-type: none"> <li>• Polishing, buffing and cleaning</li> <li>• Scrubbing and washing</li> <li>• Ideal for wet and dry applications</li> </ul>	<ul style="list-style-type: none"> <li>• Natural color is off white</li> <li>• Can be dyed or bleached</li> </ul>
 <p><b>Palmyra</b></p>	<ul style="list-style-type: none"> <li>• Softer and finer texture than Bassine</li> <li>• More economical than Bassine</li> <li>• Medium to coarse texture</li> <li>• Good durability</li> </ul>	<ul style="list-style-type: none"> <li>• Used in garage, scrub, deck and patio brushes</li> <li>• Ideal for wet and dry applications</li> </ul>	<ul style="list-style-type: none"> <li>• Brown in color</li> </ul>
 <p><b>Bassine</b></p>	<ul style="list-style-type: none"> <li>• Coarse, tough fibers</li> <li>• Excellent durability</li> </ul>	<ul style="list-style-type: none"> <li>• Heavy scrubbing and cleaning</li> <li>• Tasks requiring a tough, long lasting natural fiber</li> </ul>	<ul style="list-style-type: none"> <li>• Dark brown in color</li> </ul>
 <p><b>Bass</b></p>	<ul style="list-style-type: none"> <li>• Good flexibility</li> <li>• Very coarse, tough fibers</li> <li>• Excellent durability</li> </ul>	<ul style="list-style-type: none"> <li>• Heavy-duty cleaning applications</li> <li>• Use on rough surfaces</li> </ul>	<ul style="list-style-type: none"> <li>• Dark brown in color</li> </ul>

### Synthetic

Type	Advantages	Applications	Notes
 <p><b>Nylon</b></p>	<ul style="list-style-type: none"> <li>• Excellent durability</li> <li>• Resistant to most acids &amp; alkalis</li> <li>• High water absorbency</li> <li>• Resistant to high temperatures (to 350° F)</li> <li>• Best man-made fiber to resist fatigue</li> </ul>	<ul style="list-style-type: none"> <li>• Heavy-duty industrial</li> <li>• Scrubbing and cleaning</li> <li>• Wet and dry applications</li> </ul>	<ul style="list-style-type: none"> <li>• May be level or crimped</li> </ul>
 <p><b>Polypropylene</b></p>	<ul style="list-style-type: none"> <li>• Very durable</li> <li>• Acid, oil, bacteria and fungus resistant</li> <li>• Versatile</li> <li>• Resistant to high temperatures (to 225° F)</li> <li>• Will not absorb moisture</li> </ul>	<ul style="list-style-type: none"> <li>• Variety of medium to coarse industrial applications</li> <li>• Wet and dry applications</li> </ul>	<ul style="list-style-type: none"> <li>• May be level or crimped</li> </ul>
 <p><b>Polystyrene</b></p>	<ul style="list-style-type: none"> <li>• Extremely durable</li> <li>• Liquid and oil resistant</li> <li>• Resistant to temperatures (to 180° F)</li> <li>• Ends can be flagged</li> </ul>	<ul style="list-style-type: none"> <li>• Used in vehicle care brushes</li> <li>• Used in fruit and vegetable wash brushes</li> <li>• Wet and dry applications</li> </ul>	<ul style="list-style-type: none"> <li>• May be level or crimped</li> <li>• Not for use with sweeping compounds</li> </ul>
 <p><b>Recycled PET</b></p>	<ul style="list-style-type: none"> <li>• Environmentally-friendly</li> <li>• Less landfill waste</li> </ul>	<ul style="list-style-type: none"> <li>• Fine, Medium &amp; Coarse for a variety of applications</li> </ul>	<ul style="list-style-type: none"> <li>• Fill made from recycled water bottles</li> </ul>



# Green Works™ Maintenance Products

**Green Works™ Maintenance Products** - Sustainable, recyclable, environmentally-friendly, **Green** - all of these come to mind with the new Green Works line from Weiler. Made from recycled or sustainable raw materials, the Green Works line is manufactured in a LEED (Leadership in Energy & Environmental Design) approved facility to insure that even the production environment is environmentally-friendly. All of this, plus the same great performance! Every product is made to the quality levels you expect when you hear the name Weiler.

## Green Works Product Construction

- **Fill material** is made out of recycled water bottles, giving a second life to these waste products and helping to clean up the environment.
- **Rubberwood blocks** are made from the wood of rubber trees that have ended their life cycle in the rubber production industry. We are putting the waste product of that industry to good use.
- **Foam blocks** are made from recycled plastics.
- **Handles** are made from bamboo - a very strong and durable natural resource that replenishes at a very rapid rate in the environment.

## Floor Sweeps -

Choose from flagged tips that pick-up fine dust and dirt to durable fibers that sweep heavy, caked dirt and debris.

Block Size	Block Type	Fill Material	Trim Length	Standard Pack	Item Number
<b>Fine Sweeping - For fine dust and dirt on smooth surfaces</b>					
24"	Recycled Black Foam	Recycled Grey Fill	3"	12	42352
24"	Renewable Rubberwood	Recycled Grey Fill	3"	12	42355
<b>Medium Sweeping - For general purpose sweeping on semi-smooth surfaces</b>					
24"	Recycled Black Foam	Recycled Blue Fill	3"	12	42353
24"	Renewable Rubberwood	Recycled Blue Fill	3"	12	42356
<b>Coarse Sweeping - For heavy dirt and debris on very rough surfaces</b>					
24"	Recycled Black Foam	Recycled Maroon Fill	3"	12	42354
24"	Renewable Rubberwood	Recycled Maroon Fill	3"	12	42357

Handle #42380 or #42381 are recommended for use with these sweeps. See page 136 for details.

## Street Broom - Ideal for wet or dry sweeping on streets, parking lots, loading docks and driveways.

Block Size	Block Type	Fill Material	Trim Length	Standard Pack	Item Number
16"	Renewable Rubberwood	Recycled Black Fill	6"	6	42360

Handle #42382 is recommended for use with this broom. See page 136 for details.

## Duo Sweep - Heavy-duty upright with two handle holes - one straight and one angled.

Size	Block Type	Fill Material	Trim Length	Standard Pack	Item Number
9"	Recycled Black Foam	Recycled Yellow Fill	7"	12	42365

Handle #42383 is recommended for use with this sweep. See page 143 for details.

42352



42357



42360



42365



# Green Works™ Maintenance Products



36 billion water bottles end up in landfills every year. Help us make a difference!

Green Works™ Maintenance Products

**Counter Duster** - Ideal for quick clean-ups. Features a comfortable grip handle.

Block Size	Block Type	Fill Material	Trim Length	Standard Pack	Item Number
8"	Recycled Black Foam	Recycled Grey Fill	2-1/2"	12	42368



**Scrub Brushes** - Designed to provide the most effective brushing and cleaning action.

Block Size	Type	Block Type	Fill Material	Standard Pack	Item Number
8"	Utility	Recycled Black Foam	Recycled Yellow Fill	12	42375
9"	Pointed Deck	Renewable Rubberwood	Recycled Yellow Fill	12	42373
10"	Deck	Renewable Rubberwood	Recycled Yellow Fill	12	42371
10"	Bi-Level	Recycled Black Foam	Recycled Yellow Fill	12	42372
20"	Utility	Recycled Black Foam	Recycled Yellow Fill	12	42376



Handle #42380 or #42381 are recommended for use with these scrub brushes.

**Solid Bamboo Handles** - Very strong, abundant source material.

Length	Diameter	Tip Type	Std. Pack	Item Number
5'	7/8"	Threaded Wood	12	42380
5'	7/8"	Threaded Metal	12	42381
5'	1-1/8"	Tapered Wood	12	42382



Weiler's 76,000 sq. ft. distribution center was specifically designed with energy conservation in mind.

# Pro-Flex™ Sweeps

## Weiler Pro-Flex™ Sweep Quick Assembly & Unbreakable!

- **Easy-to-Assemble:** The convenient and easy-to-assemble T-knob construction of the Pro-Flex Sweep **takes less than 1 minute to assemble.** The handle connects easily and securely to the broom head, and there's no need for a brace!
- **Unbreakable:** Utilizing an advanced polymer technology, the Pro-Flex Sweep's unique handle/sweep connector flexes on impact, providing unbelievable shock absorbency...and it's unbreakable! Ideal for the most demanding applications on a construction site.
- **More Maneuverable:** Without the need for a brace, the Pro-Flex Sweep is lighter, easy to maneuver and eliminates potential damage to low surface areas.
- The Pro-Flex Sweep... the strongest sweep on the market AND the easiest to assemble!



The Pro-Flex Sweep's indestructible design will make it the last sweep you will ever buy!



Flexible connection makes these sweeps the strongest on the market!



Foam grip handle is strategically placed for users' comfort during long periods of sweeping.

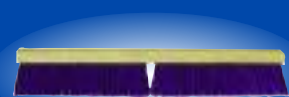

44606

**DID YOU KNOW?**

This is how the Pro-Flex Sweep looks straight out of the box, ready to display.

### Pro-Flex™ Sweeps - Hardwood Block

Includes comfort grip Pro-Flex handle and scraper for removal of heavy, caked dirt and debris.

Block Size	Fill Material	Trim Length	Standard Pack	Item Number
<b>Convenient scraper attaches handle to sweep head for display and shipping purposes</b>				
24"	Flagged Grey Polystyrene Border with Stiff Black Polypropylene Center	3"	1	44600
24"	Palmyra	4"	1	44601
24"	Medium Maroon Polypropylene	3-1/4"	1	44604
24"	Stiff Blue Polypropylene	3-1/4"	1	44606



### Pro-Flex Sweep Assembly - No Tools Required!



Remove nuts from broom assembly



Flip scraper and place over bolts



Place handle connector over bolts and tighten nuts securely

# Specialty Floor Brushes

**Contractor Brooms** - Designed to withstand rugged, every day use. The 1-1/8" bolt-on handle design combined with a lacquered hardwood block and 12-gauge steel brace makes the Contractor Broom the most durable sweep in our product line.

**Contractor Brooms - Hardwood Block - Heavy-duty brace included with all brooms.**  
Ideal for construction sites and other heavy use environments.

Block Size	Fill Material	Trim Length	Standard Pack	Item Number
<b>Fine Sweeping - For fine dust and dirt on smooth surfaces</b>				
24"	Flagged Silver Polystyrene	3"	1	44553
<b>Medium Sweeping - For general purpose sweeping on semi-smooth surfaces</b>				
18"	Flagged Grey Polystyrene Border with Stiff Black Polypropylene Center	3"	1	44580
24"				44581
30"				44582
<b>Coarse Sweeping - For heavy dirt and debris on very rough surfaces</b>				
24"	Palmyra	4"	1	44584
24"	Medium Maroon Polypropylene	3-1/4"	1	44587
24"	Stiff Blue Polypropylene	3-1/4"	1	44590
30"				44591



- For Contractor Brooms, use Handle No. 44635 (1-1/8" x 60").
- Handle not included in price - order handle separately. See page 147.
- Bolt to assemble broom is included with the broom, not with the handle.

**Perma-Sweep™ Floor Brushes** - Weiler offers color-coded floor sweeps to make product selection and identification easier. Constructed with foam blocks and synthetic filaments, these materials are durable, resist acid and bacteria and can be used in wet or dry sweeping applications.

**Perma-Sweep™ - Synthetic Foam Block - Made of durable materials designed to resist acid and bacteria.**

Block Size	Fill Material	Trim Length	Standard Pack	Item Number
<b>Fine Sweeping - For fine dust and dirt on smooth surfaces</b>				
18"	Flagged Green Polystyrene	3"	1	42163
24"				42164
<b>Medium Sweeping - For general purpose sweeping on semi-smooth surfaces</b>				
18"	Yellow Polypropylene	3"	1	42165
24"				42166
<b>Coarse Sweeping - For heavy dirt and debris on very rough surfaces</b>				
18"	Maroon Polypropylene	3"	1	42167
24"				42168



- For Perma-Sweep Floor Brushes, use Perma-Flex Handle No. 44301 (15/16" x 60") Guaranteed for the life of the brush!
- Handle not included in price - order handle separately. See page 147.



Sweeping leaves from a garage floor.



44553



44584

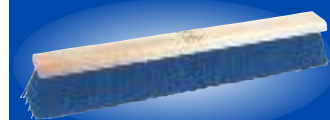

44590



42164



42165



42167

# Floor Brushes

**Floor Brushes** - Weiler offers a broad array of floor brushes in various sizes and fill materials for fine, medium and coarse sweeping applications. Choose from flagged tips that pick up fine dust and dirt to durable fibers that sweep heavy-caked dirt and debris. The lacquered hardwood blocks resist moisture and help prevent cracking, thereby increasing brush life.

## Fine Sweeps - Lacquered Hardwood Block

For dust and fine dirt on smooth surfaces: Tile, Wood, Linoleum, Marble, Ceramic Tile and Smooth Concrete.

Block Size	Fill Material	Trim Length	Standard Pack	Item Number	★ Combo Qty. Item Number
18" 24"	Black Horsehair	3"	1	42001 42002	44855 44856
18" 24"	Black Horsehair and Black Polypropylene Blend	3"	1	42013 42014	- -
10" 18" 24" 36"	Flagged Silver Polystyrene	3"	1	70312 42041 42042 42098*	- 44857 44858 -

\* Brace included      ★ Combo Packs include 12 sweeps per pack and 12 #44300 handles (not assembled).

## Vortec Pro® Fine Sweeps - Lacquered Hardwood Block

Reliable and efficient sweeps at a value price.

Block Size	Fill Material	Trim Length	Standard Pack	Item Number
18" 24"	Flagged Grey Polystyrene	3"	12	77013 77014

## Medium Sweeps - Lacquered Hardwood Block

General purpose sweeping on semi-smooth surfaces: Wood, Smooth Concrete, Asphalt and Factory/Shop Floors.

Block Size	Fill Material	Trim Length	Standard Pack	Item Number	★ Combo Qty. Item Number
12" 14" 16" 18" 24" 36"	Black Tampico	3"	1	70112 42114 42006 42007 42008 42047*	- - - 44859 44860 -
24" 36"	Horsehair Border with Black Tampico Center	3"	1	42017 42049*	- -
18" 24"	Horsehair and Polystyrene Border with Black Polypropylene Center	3"	1	70067 70068	- -
18" 24" 36"	Black Polypropylene	3"	1	42035 42037 42095*	44861 44862 -

\* Brace included      ★ Combo Packs include 12 sweeps per pack and 12 #44300 handles (not assembled).

## Vortec Pro® Medium Sweeps - Lacquered Hardwood Block

Reliable and efficient sweeps at a value price.

Block Size	Fill Material	Trim Length	Standard Pack	Item Number	★ Combo Qty. Item Number
18" 24"	Dark Grey Polystyrene Border with Black Polypropylene Center	3"	1	25234 25235	44851 44852
18" 24"	Black Tampico	3"	1	25231 25232	44853 44819

★ Combo Packs include 12 sweeps per pack and 12 #44300 handles (not assembled).



- Handle No. 44300 (15/16" x 60") recommended for use with all Floor Brushes.
- Handle not included in price - order handle separately. See pages 147-148 for additional options.

Sweeping saw dust on a smooth surface.



42001



42042



77013



42007



25234



Sweeping Center available.  
See page 176.



# Floor Brushes

## Coarse Sweeps - Lacquered Hardwood Block

For heavy dirt and debris on rough surfaces: Wood, Concrete, Asphalt and Brick.

Block Size	Fill Material	Trim Length	Standard Pack	Item Number	★ Combo Qty. Item Number
18"	Black Tampico with 1 row Tempered Steel Wire in Center	3"	1	42134	44871
24"				42135	44872

★ Combo Packs include 12 sweeps per pack and 12 #44300 handles (not assembled).



- Handle No. 44300 (15/16" x 60") recommended for use with all Floor Brushes.
- Handle not included in price - order handle separately. See pages 147-148 for additional options.

**Strip Brooms** - The corrosion-resistant frame is lightweight, resulting in less user fatigue! Efficient and economical, Strip Brooms make quick work of dirt and debris on all types of surfaces.

**Vortec Pro® Strip Brooms** - Economy brushes provide lasting, efficient service at minimal cost.

Block Size	Fill Material	Trim Length	Standard Pack	Item Number
<b>Fine Sweeping - For smooth surfaces</b>				
24"	Green Polypropylene	3"	12	25299
<b>Medium Sweeping - For semi-rough surfaces</b>				
18" 24"	Red Polypropylene	3"	12	25290 25291
<b>Coarse Sweeping - For rough surfaces</b>				
18" 24"	Brown Polypropylene	3"	12	25294 25295



- For Strip Brooms, use Handle No. 25297 (15/16" x 60").
- Handle not included in price - order handle separately. See page 147.

**DID YOU KNOW?**

Weiler scrubs, handles and sweeps were used in the BP oil spill clean-up.



Sweeping cinders from the surface of a parking lot.



42134



42135



25299



25290



25294

Floor Brushes

# Garage Brushes



Sweeping metal shavings from a shop floor.

## Garage Brushes - Palmyra Fill - Lacquered Hardwood Block

For sweeping heavy, caked dirt and debris on rough surfaces: Concrete, Garage/Factory Floors, Rough Wood, Sidewalks, Barns and Brick Surfaces.

Block Size	Fill Material	Trim Length	Standard Pack	Item Number	★ Combo Qty. Item Number
16"	Wet or dry sweeping	4"	1	42021	-
18"				42022	44867
24"				42023	44868
36"				42138*	-

\* Brace included      ★ Combo Packs include 12 brushes per pack and 12 #44300 handles (not assembled).



42023



42149



25241



73180



73182

## Garage Brushes - Maroon Polypropylene Fill - Lacquered Hardwood Block

For sweeping heavy, caked dirt and debris on rough surfaces: Concrete, Garage/Factory Floors, Rough Wood, Sidewalks, Barns and Brick Surfaces.

Block Size	Fill Material	Trim Length	Standard Pack	Item Number	★ Combo Qty. Item Number
18"	Wet or dry sweeping Solvent, oil, chemical & liquid resistant	3-1/4"	1	42025	44869
24"				42026	44870
36"				42149*	-

\* Brace included      ★ Combo Packs include 12 brushes per pack and 12 #44300 handles (not assembled).

## Vortec Pro® Garage Brushes - Lacquered Hardwood Block

Reliable and efficient brushes at a value price.

Block Size	Fill Material	Trim Length	Standard Pack	Item Number	★ Combo Qty. Item Number
18"	Palmyra	4"	1	25241	44865
24"				25242	44866
18"	Maroon Polypropylene	3-1/4"	1	25238	44863
24"				25239	44864

\* Combo Packs include 12 brushes per pack and 12 #44300 handles (not assembled).

## Driveway Coaters - For applying blacktop driveway and parking lot dressings; asphalt, sealers or roof coatings.

Block Size	Fill Material	Trim Length	Standard Pack	Item Number	★ Combo Qty. Item Number
10"	Black Tampico	2-5/8"	12	73180	-
18"	Palmyra	2"	12	73182*	44885

\* With squeegee      ★ Combo Packs include 12 brushes per pack and 12 #75527 handles (not assembled).



- Handle No. 44019 (1-1/8" x 60") recommended for use with all Garage Brushes.
- Handle No. 75527 (7/8" x 48") recommended for Driveway Coaters.
- Handle not included in price - order handle separately. See pages 147-148 for additional options.

# Street and Wire Brooms

**Street Brooms - Hardwood Block - Wide flared ends for sweeping close to curbs and walls. For heavy-duty wet or dry sweeping: Streets, Sidewalks, Loading Docks, Parking Lots, Driveways and all Asphalt Surfaces.**

Block Size	Fill Material	Trim Length	Standard Pack	Item Number	★ Combo Qty. Item Number
16"	Natural Palmyra	6-1/4"	6	70208	-
16"	Dyed Palmyra	6-1/4"	6	70209	-
16"	Bass & Palmyra Blend	6-1/4"	6	42032	44873
16"		7-1/4"		42099	-
16"	Brown Polypropylene	5-1/4"	6	42033	44874
18"				42173	-
24"				42174	-
16"	Orange Polypropylene	5-1/4"	6	70212	-
18"				42054	-
24"				42055	-
14"	White Polypropylene Fill Orange Block	4"	6	70210	-
16"				70211	-

★ Combo Packs include 12 brooms per pack and 12 #44020 handles (not assembled).

## Wire Brooms - Hardwood Block

For sweeping or scrubbing concrete or stone floors, driveways, etc. Ideal for sweeping heavy chips and debris.

Block Size	Fill Material	Trim Length	Standard Pack	Item Number
16"	Round Wire	3-3/4"	6	70215
14"	Flat Wire	5"	1	42030



- All sweeps on this page require a tapered tip handle.
- Handle No. 44020 (1-1/8" x 60") recommended for use with all Street & Wire Brooms.
- Use Spring-Loc Adapter to keep tapered wood handle securely fastened to the block.
- Handle not included in price - order handle separately. See pages 147-148 for adapter and handle.



Weiler now has a line of environmentally-friendly maintenance products. See pages 139-140 for details.



Sweeping debris in a parking lot.



70209



42032

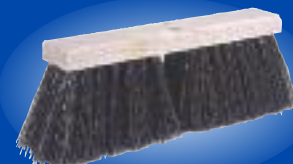

42033

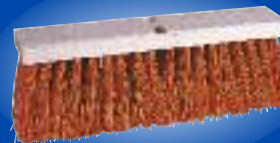

42054



70210



42030

# Handles

**Handles** - Weiler's wood and metal handles are constructed for long life. Handles are available in a large variety of styles and tips to fit a wide selection of block types. The following charts provide recommended uses for each style handle.

The Perma-Flex tip is guaranteed not to break when used with a Perma-Sweep.

## Wood Handles - Quality hardwood handles.

Length	Diameter	Tip	Description	Std. Pack	Item No.	
48"	7/8"	Threaded Wood	Use with floor and garage brushes.	12	75527	
48"	15/16"				44571	
54"	15/16"				44572	
60"	15/16"				44018	
60"	1-1/8"				44019	
72"	15/16"				44303	
11"	3/4"	Tapered Wood	Use with masonry and roof brushes, street brooms, floor and deck scrubs and squeegees.	36	75528	
48"	7/8"				12	44574
54"	1-1/8"				12	44573
60"	1-1/8"				12	44020
72"	1-1/8"				12	44306
48"	15/16"	Threaded Metal	Heavy-duty metal tip provides additional strength.	12	75525	
60"	15/16"				44300	
60"	1-1/8"				44435	
72"	15/16"				44302	
48"	15/16"	Perma-Flex™	Durable threaded plastic tip guaranteed not to break when used with Perma-Sweep™ Floor Brushes.	12	75516	
60"	15/16"				44301	
60"	15/16"	-	Use with Strip Brooms.	12	25297	
60"	1-1/8"	-	Use with Contractor Brooms.	12	44635	

## Metal Handles - Reinforced, heavy-duty metal handles are available in two colors and optional foam cover.

Length	Diameter	Tip	Description	Std. Pack	Item No.
48"	3/4"	Threaded Plastic	Black metal with plastic hang cap.	12	42383
60"	15/16"	Threaded Metal	Yellow plastic coat with plastic hang cap.	12	44577
60"	15/16"	Threaded Metal	Black plastic coat with black foam cover and plastic hang cap.	12	44578

## Vortec Pro® Metal Handles - Reliable and efficient handles at a value price.

Length	Diameter	Tip	Description	Std. Pack	Item No.
60"	15/16"	Threaded Plastic	Black plastic coat with convenient hang-up cap.	12	75555



44018



44020



44300



44301



25297



44635



42383



44577

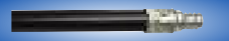

44578



75555

# Handles, Braces and Tips

**Metal Telescoping and Fountain Tube Handles** - Use telescoping handles to shorten or extend the reach of the handle. Use fountain tube handles when a continuous flow of water is needed, i.e. car/truck washing.

Length	Diameter	Type	Use	Standard Pack	Item No.
6' extends to 12'	—	Telescoping	Window, wall and Vehicle wash brushes	6	44499
5'	7/8"	Fountain Tube	Vehicle wash brushes	12	44319

**Fiberglass Handles** - Fiberglass handles are stronger than wood or metal. Virtually indestructible.

Length	Diameter	Tip	Description	Std. Pack	Item No.
60"	1"	Tapered/Threaded	Hollow handle	12	44561*
60"	1"	Threaded	Honeycomb core	12	44562
60"	1"	Threaded	All white	12	44563+

\* For use with both tapered and threaded holes  
+ Approved for the food service industry



Fiberglass with polyethylene reinforced honeycomb core



Fiberglass hollow handle.

## Handle Accessories

Description	Use	Std. Pack	Item No.
Steel brace. Fits all handle sizes.	Reinforces & locks handle to block. (Standard with sweeps 30" and larger)	12	44021
Heavy-duty steel brace attaches to block with wood screws and wraps around handle. Fits all handle sizes.	Increases life of the brush by providing extra support for handle and block.	12	44290
Replacement handle thread. Made of heavy-duty fiberglass. For any 15/16" diameter handle.	Cut off damaged threads and slip this tip in place for a new handle.	12	44317
Tapered Adapter to tapered ends.	Converts threaded handle ends	12	75505
Spring Loc Adapter for any 1-1/8" diameter tapered wood handle for street brooms and window brushes.	Keeps tapered wood handles from separating from the block.	6	44624



Weiler handles are sanded to avoid splinters.



Heavy-duty steel brace (Item #44290) provides extra support.



44499



44319



44561



44562



44563



44021



44290



44317



75505



44624

Handles, Braces and Tips

# Upright and Whisk Brooms

**Upright & Whisk Brooms** - Made of fine quality broom corn, fiber or synthetic material, Weiler's upright brooms and whisks are durable enough to meet all industrial and commercial applications.

**Upright Brooms** - Ideal for sweeping floors, reaching into corners, cleaning ceilings, etc.

Description	Fill Material	Trim Length	Overall Length	Standard Pack	Item Number
<b>Household Broom - Good Quality</b>					
4 sews - 7/8" handle	Corn & Fiber	15"	54"	12	44547
<b>Light Industrial Brooms - Better Quality</b>					
5 sews - 7/8" handle	Corn & Fiber	17"	57"	12	44548
5 sews - 7/8" handle	100% Corn	15"	56"	12	44009
6 sews - 1-1/8" handle	100% Black Corn	16"	56"	12	70304
<b>Janitor's Broom - Best Quality</b>					
5 sews - 1-1/8" handle Wire banded	Corn & Fiber	17"	57"	12	70308
<b>Warehouse Broom - Heavy-Duty</b>					
4 sews - 1-1/8" handle Wire banded	Corn & Fiber	18"	57"	12	44008

**Angle Broom** - Angled trim allows access to corners, under low cabinets and other hard-to-reach areas.

Description	Fill Material	Trim Length	Overall Length	Standard Pack	Item Number
Large Plastic - 12" sweep face	Flagged Plastic	7-1/2"-6"	54"	12	44305

**Vortec Pro® Angle Broom** - Reliable and efficient broom at a value price.

Description	Fill Material	Trim Length	Overall Length	Standard Pack	Item Number
Small Plastic - 8" sweep face	Flagged Plastic	3-3/4"-5"	54"	6	75160

**Cap Brooms** - Metal top for added durability. Ideal for wet or dry applications.

Description	Fill Material	Trim Length	Overall Length	Standard Pack	Item Number
Metal Cap - Wire banded 12" sweep face	Palmyra	10"	55"	6	44007
Metal Cap - Wire banded 12" sweep face	Brown Poly	10"	55"	6	70325
Track & Switch - Steel chisel point on handle end	Palmyra	8"	55"	6	70324

**Lobby Broom** - For light-duty spot sweeping.

Description	Fill Material	Trim Length	Overall Length	Standard Pack	Item Number
Lobby Broom - 3 sews	Black Synthetic	10"	38"	12	70327

**Vortec Pro® Lobby Brooms** - Reliable and efficient brooms at a value price.

Description	Fill Material	Trim Length	Overall Length	Standard Pack	Item Number
Plastic Cap - 8" sweep face	Flagged Plastic	5"	36"	12	44546
Toy/Lobby - 3 sews, 7/8" handle	Corn & Fiber	11"	40"	12	70300

**Whisk Brooms** - For fast, efficient clean-up.

Use	Number of Sews	Fill Material	Trim Length	Standard Pack	Item Number
General purpose - all applications	3	Corn & Fiber	10"	12	44266
Sweeping coarse & heavy material	2	Palmetto	7"	12	44099
Course sweeping of hot chips	-	Bassine	5-1/4"	12	44103

Sweeping plastic and metal chips in a tool room



44009



44305



70325



70300



44266

# Dusters and Dust Pans

**Dusters & Dust Pans** - Whether cleaning fine particles or heavy debris, Weiler has a Counter Duster to do the job. These brushes are available in a wide selection of fill materials and have comfortably shaped blocks in wood or foam. Also choose from an array of Dust Pans to meet the application requirements.

## Counter Dusters - For clean up in hard-to-reach areas.

Fill Material	Trim Length	Brush Length	Block Type	Standard Pack	Item Number
<b>Horsehair</b>					
Horsehair	2-1/4"	8"	Wood	12	44003
	2-1/4"	9"			44351
Black Horsehair and Fiber Mix	2-1/2"	8"	Wood	12	71019
<b>Synthetic</b>					
Flagged Silver Polystyrene	2-1/2"	8"	Wood	12	44354
Black Polystyrene	2-1/2"	8"	Wood	12	25252
Orange Polystyrene	2"	9"	Foam	12	42213
<b>Natural Fiber</b>					
Black Tampico	2-1/2"	8"	Wood	12	25251
Tri-colored Tampico	2-1/2"	8"	Wood	12	44004

## Dust Pans - Durable, industrial grade - For quick clean-ups.

Description	Height	Width	Depth	Standard Pack	Item Number
Heavy-duty 20 gauge steel Black enamel finish	-	12"	13-1/2"	12	71078
Extra wide - Heavy-duty 20 gauge steel Black enamel finish	-	16"	15"	12	71079
Lobby Dust Pan Black enamel metal hopper Aluminum handle	39-1/2"	12"	9"	6	71081

## Vortec Pro® Dust Pans - Reliable and efficient pans at a value price.

Description	Height	Width	Depth	Standard Pack	Item Number
Molded plastic	-	12-1/4"	12"	12	71077
Lobby Dust Pan Molded plastic hopper Aluminum handle	39-1/2"	12"	11"	6	71080

## Radiator Brushes - 24" Overall Length. Ideal for cleaning radiators and narrow, hard-to-reach places.

Fill Material	Type	Brush Part	Trim Length	Standard Pack	Item Number
Black Horsehair	Foam Handle	9-1/2"	2-1/2"	12	73050
Black Horsehair	Twisted-in-Wire Handle	7-1/2"	2-1/2"	12	73055

## Wall Dusting Brush - For dusting ceilings, valances, high moldings and other hard-to-reach places. Twisted-in-wire construction with plastic handle.

Fill Material	Overall Length	Trim Length	Standard Pack	Item Number
Horsehair	12" x 5"	2-3/4"	2	71076



Cleaning up oil absorbent from a shop floor.



44003

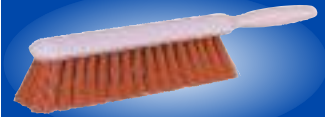

42213



44004

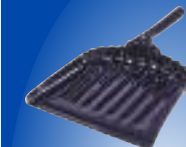

71078



71077



71080



73050



73055



71076

Dusters and Dust Pans

# Squeegees & Window Brushes

**Squeegees** - For fast, efficient cleaning, Weiler provides a variety of non-scratching floor and window squeegees and window brushes. Designed for high durability.

## Floor Squeegees - Heavy-duty construction, iron handle socket.

Description	Length	Type	Standard Pack	Item Number	Standard Pack	Refill Blade Item No.
Black rubber blade for rough, heavy use	18"	Straight	6	45506	12	45508
	24"			45507		45512
	30"			45534		45536
	36"			75202		45513
Black rubber blade for rough, heavy use	18"	Curved	12	75206	12	75225
	24"		6	45510	6	45512
	30"		6	45535	6	45536
	36"		6	45511	6	45513
Stainless steel scraper	8"	-	12	75242	-	-

## Window Squeegees - Rust-proof handle socket and frame.

Description	Length	Standard Pack	Item Number	Standard Pack	Refill Blade Item No.
One piece frame with hard rubber section joined with a soft, red rubber blade.	6"	12	45537	12	75233
	12"		45500	24	45503
	14"		45538	24	75228
	16"		45501	24	45504
	18"		45502	24	45505



- All squeegees require a tapered tip handle.
- Handle No. 44020 (1-1/8" x 60") recommended for use with all Squeegees.
- Use Spring-Loc Adapter to keep tapered wood handle securely fastened to the block.
- Handle not included in price - order handle separately. See pages 147-148 for adapter and handle.

## Window Brushes - Two threaded handle holes

High quality, non-scratching brushes used for industrial window washing.

Description	Block Size	Block	Trim Length	Standard Pack	Item Number
Round Style					
Flagged Gold Polystyrene	4-1/2"	Plastic	2-1/2"	12	25271
Stiff Black Horsehair and Polypropylene Mix	4-1/2"	Plastic	2-3/4"	12	73003



- Handle No. 44019 (1-1/8" x 60") recommended for use with #25271 & #73003 Window Brushes.
- Handle not included in price - order handle separately. See page 147 for handle.

Cleaning a window with a window squeegee.



45507



45510

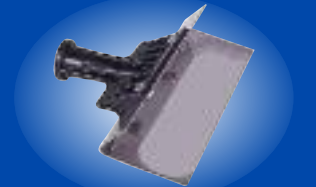

75242

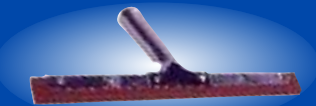

45500



45503



25271



# Vehicle Care Products

**Vehicle Care Brushes** - Weiler's line of vehicle care brushes meets the cleaning needs of car and truck fleets. Brushes are also popular in the marine industry. All products are designed to provide professional results.

**Vehicle Wash Brushes** - Protective bumper - Foam block with two handle holes. Can be used with flow-through handle #44319 on page 148.

Block Size	Fill Material	Trim Length	Standard Pack	Item Number	★ Combo Qty. Item Number
9-1/2" x 2-3/4"	Grey Fiber	2-1/2"	12	44318*	-
9-1/2" x 2-3/4"	Flagged White Polystyrene	2-1/2"	12	44510	44875
9-1/2" x 2-3/4"	Flagged Orange Polystyrene	2-1/2"	12	42210	-
9-1/2" x 2-3/4"	Flagged Green Polystyrene	2-1/2"	12	73146	-

\*May scratch smooth or high gloss surfaces, use polystyrene filled products for these surfaces.

★ Combo Packs include 12 brushes per pack and 12 #44319 handles (not assembled).

**School Bus Brush** - Easily sweeps between school bus seats. Lacquered hardwood block with one threaded handle hole. Use handle #44571 on page 147.

Block Size	Fill Material	Trim Length	Standard Pack	Item Number
10" x 2-1/2"	Flagged Silver-grey Polystyrene	3"	12	70312

**Bi-Level Scrub Brushes** - Foam Block - The bi-level design allows the brush to stay in contact with the surface at various working angles. Can be used with flow-through handle #44319 on page 148.

Block Size	Fill Material	Trim Length	Standard Pack	Item Number
10"	Flagged White Polystyrene	2-3/4"	6	44699
10"	Fine Green Nylex	2-3/4"	12	44693

**Upholstery/Spotting Brush** - Wet & dry cleaning, prespotting, carpet touch-up, etc. Shaped plastic handle.

Block Size	Fill Material	Trim Length	Number of Rows	Standard Pack	Item Number
8-1/2" x 2-9/16"	.016 Crimped Polypropylene	5/8"	8 x 9	12	44307

**Spoke Brushes** - Ideal for cleaning spokes or confined spaces.

Length of Brush Part	Fill Material	Brush Part	Overall Length	Standard Pack	Item Number
6"	Polypropylene	2" tapered to 3/4"	11"	12	44482
10"	White Tampico	2-7/8" tapered to 1-1/4"	15"	12	44315

**Tire Cleaning Brushes** - Foam block - Used for cleaning sidewalls of tires.

Block Size	Fill Material	Trim Length	Number of Rows	Standard Pack	Item Number
8-1/2" x 2-9/16"	.008 Brass	5/8"	8 x 9	12	99593
7" x 1-9/16"	.008 Brass	5/8"	6 x 8	12	73156



Washing a car with a vehicle wash brush and fountain tube handle.



44510



70312



44699

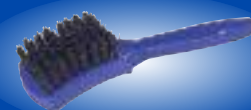

44307



44315



99593

Vehicle Care Products

# Scrub Brushes



Scrubbing a stainless steel sink.

**Scrub & Utility Brushes** - A broad range of high quality scrub and utility brushes are available from Weiler. From quick cleaning to heavy-duty scrubbing, Weiler's brushes are designed to provide the most effective brushing and cleaning action.

## Hand Scrub Brushes - Heavily filled for heavy-duty scrubbing.

Block Size	Fill Material	Trim Length	Block Type	Standard Pack	Item Number
7-1/2"	Light Blue Polypropylene	1"	Contoured Plastic w/Rubber Insert	24	43999
6"	White Polypropylene	1-1/8"	Iron Style - Plastic	12	44395
7-1/4"	Palmyra	1"	Square - Wood	24	72034
8"	White Tampico	1-1/8"	Square - Wood	12	44024
	White Tampico	1"			72058*
	Palmyra	1-1/8"			44025
8-1/4"	White Tampico	1-1/8"	Square - Wood	12	73111
9"	White Tampico	1-1/8"	Pointed - Wood	12	44023

\* Threaded handle hole

## Deck Scrub Brushes - Excellent for scrubbing decks or floors. One threaded and one tapered handle hole. Can be used with threaded handle #44018 or tapered handle #44020 on page 147.

Block Size	Fill Material	Trim Length	Number of Rows	Block Type	Standard Pack	Item Number	★ Combo Qty. Item Number
9"	Palmyra	2"	5 x 14	Wood	12	44428	-
	Tampico					44429	-
10"	Palmyra	2"	6 x 18	Wood	12	44026	44876
	Tampico					44028	44877
	Polypropylene					44434	44878
10"	Polypropylene	2"	5 x 14	Foam	12	44728*	-
12"	Palmyra	2"	6 x 20	Wood	12	44027	-
	Tampico					44029	-
	Polypropylene					44438	-

\* Threaded handle hole

★ Combo Packs include 12 scrubs per pack and 12 #44018 handles (not assembled).

## Bi-Level Scrub Brushes - The bi-level design allows the brush to stay in contact with the surface. Can be used with flow-through handle #44319 on page 148 or the Perma-Flex handle #44301 on page 147.

Block Size	Fill Material	Trim Length	Block Type	Standard Pack	Item Number
10"	Stiff Crimped Blue Polypropylene	1-3/4"	Foam	6	44692
10"	Flagged White Polystyrene	2-3/4"	Foam	6	44699
10"	Fine Green Nylex	2-3/4"	Foam	12	44693

## Baseboard Brush - Can be used with threaded handle #44018 on page 147.

Block Size	Fill Material	Trim Length	Standard Pack	Item Number
5-1/2" x 2-7/8"	Black Polypropylene	1-3/4"	12	73075

## Vortec Pro® Boot Brush - Reliable and efficient brush at a value price.

Size	Description	Item Number
9" x 6"	Boot Cleaning Brush - Metal Frame - Wood Block - Black Nylon Fill	44391

Scrub Brushes

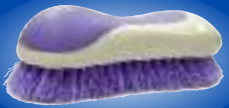

43999



44395



44024



44023



44026



44434

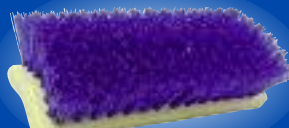

44692



73075



44391

# Scrub Brushes & Utility Brushes

**Utility Scrub Brushes - Wood Block.** For general scrubbing in factories, kitchens, institutions, etc.

Overall Length	Fill Material	Trim Length	Block Type	Standard Pack	Item Number
8"	Palmyra Yellow Polypropylene White Tampico	2"	Wood	12	72086 44013 44014
20"	Palmyra Yellow Polypropylene White Tampico	2"	Wood	12	72101 44016 44017

**Utility Scrub Brushes - Foam Block.** Chemical and water resistant, will not warp or crack.

Overall Length	Fill Material	Trim Length	Block Type	Standard Pack	Item Number
8"	Palmyra Yellow Polypropylene White Tampico	2"	Foam	12	79101 79120 79100
20"	Palmyra Yellow Polypropylene White Tampico	2"	Foam	12	79107 79109 44663

**Utility Scrub Brushes - Plastic Block.** Designed for high temperature cleaning, ideal for food service.

Overall Length	Fill Material	Trim Length	Block Type	Standard Pack	Item Number
8"	White Nylon	2"	Plastic	12	44416
20"	White Nylon	2"	Plastic	12	44418

**Vortec Pro® Utility Scrub Brushes - Ideal for general purpose cleaning.**

Overall Length	Fill Material	Trim Length	Block Type	Standard Pack	Item Number
8"	Tampico	2"	Foam	12	25262
20"	Tampico	2"	Foam	12	25263

**Vortec Pro® Dish/Sink Brush - Plastic Block - Reliable and efficient brush at a value price.**

Overall Length	Fill Material	Trim Length	Standard Pack	Item Number
8-3/4"	White Plastic with Blue Polypropylene Border	1"	12	75002

**Grout Detail Brush - Use for removing stubborn dirt, grime and mildew from tiled surfaces.**

Block Size	Fill Material	Trim Length	Standard Pack	Item Number
8-1/2"	Stiff Black Nylon	7/8"	24	73233

**Bowl Brushes - 2" Trim Length - For thorough, efficient cleaning.**

Brush Part	Fill Material	Handle	Overall Length	Standard Pack	Item Number
3-1/2" x 3-3/4"	White Plastic	Plastic	14-1/2"	12	75001
4-1/2" x 4"	White Plastic	Plastic	16"	12	75070
5-3/4" x 4-3/4"	Black Nylon	Plastic	21"	12	75068
6-1/2" x 4"	Black Saran	Wood	21"	12	75071



Removing stubborn dirt, grime and mildew from a tiled surface with a grout detail brush.



44014



44016



79120



79107



44418



25262



75002

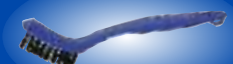

73233



75071

Scrub Brushes and Utility Brushes

# Utility Brushes



Cleaning a toilet with a Weiler Bowl Brush.



44001



75000



44314



75003



99594



75085



44111



44115



44316



75570

## Professional Bowl Brushes - Hardwood handle and natural fiber - For thorough cleaning.

Brush Part	Fill Material	Diameter	Overall Length	Standard Pack	Item Number
6" x 5"	White Tampico	2"	20"	12	44001*
6-1/2"	Tampico	3-1/4"	23"	12	75060
7-1/4" x 6"	Marble Union Fiber	2-1/2"	22"	12	75072

\* Foam handle

## Vortec Pro® Bowl Brush Set - 2" Trim Length - Reliable and efficient brushes at a value price.

Brush Part	Fill Material	Handle	Overall Length	Standard Pack	Item Number
3-1/2" x 3-3/4"	White Plastic	Plastic	14-1/2"	6	75000

## Vortec Pro® Nail Brushes - Great for use in shop or industrial settings.

Brush Part	Fill Material	Block Type	Trim Length	Number of Rows	Standard Pack	Item Number
4-3/4" x 1-1/2"	Plastic	Wood	3/4"	4 x 15	36	44314
3-1/2" x 1-1/4"	Poly-propylene	Plastic	3/8"	6 x 18 • 4 x 17 (double-sided)	24	75003
4-3/4" x 1-1/2"	White Tampico	Wood	11/16"	4 x 15	12	75021

## Bottle Washing Brush - Brush shape enables access to hard-to-reach areas when cleaning.

Length of Brush Part	Fill Material	Handle	Overall Length	Standard Pack	Item Number
6"	Black Horsehair	Wood	16"	12	99594

## Vortec Pro® Bottle Washing Brush - Reliable and efficient brush at a value price.

Length of Brush Part	Fill Material	Handle	Overall Length	Standard Pack	Item Number
5-1/2" x 2-3/8"	White Nylon	Twisted-in-wire	17"	24	75085

## Nylon Tube Brushes - Loop handle, Straight black nylon fill.

Diameter	Fill Diameter	Brush Part	Stem Diameter	Overall Length	Standard Pack	Item Number
1/4"	.005	2"	3/32"	6-1/4"	36	44110
3/8"	.005	2"	3/32"	6-1/4"	36	44213
1/2"	.010	3"	1/8"	8-1/2"	36	44111
3/4"	.012	3"	1/8"	8-1/2"	36	44112
1"	.014	4"	5/32"	12-1/4"	36	44113
1-1/4"	.014	4"	5/32"	13"	36	44114
2"	.014	5"	3/16"	16-3/4"	36	44115

## Percolator Brush - Straight white nylon fill

Ideal for internal cleaning in industrial, laboratory and food service.

Diameter	Fill Diameter	Brush Part	Stem Diameter	Overall Length	Standard Pack	Item Number
7/16"	.010	3-1/2"	5/32"	11-1/2"	10	44316

## Vat Brush - For valves, outlets, small tanks, beverage dispensers & coffee urns.

Can be used with the Perma-Flex handle #44301 on page 147.

Fill Material	Block Type	Overall Length	Standard Pack	Item Number
White Nylon	White Nylon	8"	1	75570

# Mops & Accessories

**Industrial Grade Mops** - Our wet and dry mops are made with industrial grade cotton and can be laundered. They will not scratch floors or unravel.

**Wet Mop Heads** - Durable, ideal for all-purpose cleaning. Can be laundered.

Weight	Material	Standard Pack	Item Number
<b>Cut End</b>			
12 oz.	8-ply tight twist cotton	12	75100
16 oz.			75102
20 oz.			75103
24 oz.			75104
32 oz.			75105
Small Medium Large X-Large	4-ply high bulk cotton economy	12	75170 75171 75172 75173
<b>Loop End</b>			
Small Medium Large X-Large	4-ply tight twist cotton	12	75180 75181 75182 75183
Small Medium Large X-Large	4-ply tight twist rayon finishing candy striped	12	75190 75191 75192 75193

**Wet Mop Handles** - Industrial Grade. Hardwood handle with plated metal heads.

Description	Size	Standard Pack	Item Number
Quick-Change Plastic Head	54" x 15/16"	12	75140
Screw Type	54" x 1-1/8"	12	75131
Spring Type	54" x 1-1/8"	12	75132
Jaw Type	54" x 1-1/8"	12	75130

**Professional Dust Mops** - Tie-on style, 4-ply cotton. Can be laundered.

Mop Size	Frame Size	Standard Pack	Item Number
18"	5" x 18"	12	75116
24"	5" x 24"	12	75117
36"	5" x 36"	12	75118

**Professional Dust Mop Frames** - Heavy-duty full swivel frame.

Mop Size	Frame Size	Standard Pack	Item Number
18"	5" x 18"	12	75136
24"	5" x 24"	12	75137
36"	5" x 36"	12	75138

**Professional Dust Mop Handle** - Heavy-duty clamp-on style.

Length	Diameter	Standard Pack	Item Number
60"	15/16"	12	75133



Cleaning a corner with a dust mop.



75102



75171



75190



75140



75131



75116



75136



75133

# Mops & Accessories



Use the Combo Bucket with 12 to 32 oz. mop heads



75127



75126



36666



75150

Mops and Accessories

**Wedge-Style Dust Mop** - Tie-on style, 4-ply cotton  
Durable, ideal for all-purpose cleaning. Can be laundered.

Size	Frame Size	Standard Pack	Item Number
8" wedge	5" x 8"	12	75127

**Wedge-Style Frame and Handle**

Length	Diameter	Standard Pack	Item Number
60"	15/16"	12	75126

**One-Piece Cotton Deck Mops** - Industrial grade. Mop head securely tied to handle.

Description	Weight	Standard Pack	Item Number
#10	10 oz.	12	75096
#12	12 oz.	12	75097
#16	16 oz.	12	75109
#20	20 oz.	12	75098
#24	24 oz.	12	75110

**Vortec Pro® Combo Bucket** - One-piece construction that will not rust, fade, crack, peel, chip, dent or warp. Wringer fits all sizes of plastic or metal buckets.

Bucket Size	Wringer	Standard Pack	Item Number
36 qt.	12-32 oz.	1	36666

**Wax Applicators** - 100% lambswool. Washes easily and dries quickly. Pads are easily changed. Can be used with threaded handle #44018 on page 147.

Block and Pad Size	Pad Refill Number	Standard Pack	Item Number
6" x 10"	75155	1	75150
6" x 12"	75156	12	75151
6" x 14"	75157	12	75152
6" x 16"	75158	12	75153
6" x 18"	75159	12	75154

# Masonry & Applicator Brushes

**Masonry & Applicator Brushes** - Weiler's full line of Masonry & Applicator Brushes covers everything from the ground up - cement finishing and stippling brushes for texturing and applying cement and asphalt; whitewashing and masonry brushes for applying cement, water paints and liquid waterproofing materials on concrete block and masonry walls; smoothing brushes for applying wallpaper; and roof brushes for spreading roofing tar and coatings.

**Knot-Type Roof Brushes** - For application of roof coatings.  
Can be used with tapered handle #44574 on page 147.

Block Size	Fill Material	Trim Length	Number of Knots	Standard Pack	Item Number	★ Combo Qty. Item Number
6-1/4"	Tampico	3-1/4"	3	12	44010	44883
8-3/4"	Tampico	3-1/4"	4	12	73177	-

★ Combo Packs include 12 brushes per pack and 12 #44574 handles (not assembled).

**Block-Type Roof Brushes** - For application of roof coatings.  
Can be used with tapered handle #44574 or threaded handle #75527 on page 147.

Block Size	Fill Material	Trim Length	Number of Knots	Standard Pack	Item Number	★ Combo Qty. Item Number
7"	White Tampico One tapered handle hole	2"	5	12	44011	44884
7"	Cream Colored Polypropylene One tapered handle hole	2"	5	12	73171	-
7"	White Tampico One threaded handle hole	2"	5	12	73195	-

★ Combo Packs include 12 brushes per pack and 12 #44574 handles (not assembled).

**Masonry Brushes** - Useful tools for applying cement, waterpaints and liquid waterproofing materials on masonry walls. Handle attached.

Block Size	Fill Material	Trim Length	Number of Rows	Standard Pack	Item Number
7"	White Tampico	3-1/4"	2	12	44032
6"	Solvent Resistant Polypropylene	3-1/4"	3	12	74020
4"	White Tampico	3"	4	12	74004
6-1/2"	White Tampico	3-1/2"	4	12	44031
6"	White Tampico	3"	5	12	74002
6-1/2"	White Tampico	4"	5	12	44448

**Whitewash Brushes** - Two tapered handle holes allow user to choose the correct brush angle needed.  
Can be used with tapered handle #75528 on page 147.

Block Size	Fill Material	Trim Length	Number of Rows	Standard Pack	Item Number
6"	White Tampico	2-5/8"	2	12	74048
7"	White Tampico	2-5/8"	2	12	44034 74053*

\* Includes a 12" tapered wood handle.



Applying waterproofing material with a masonry brush.



44010



44011



44031



44448



44034

Masonry and Applicator Brushes

# Masonry & Applicator Brushes



Creating texture on newly poured concrete.



74015



73111



79251



74078

Masonry and Applicator Brushes

## Acid Brush - Detachable handle.

For the application of Kalsomine, cold water, acid and water repellents to concrete and other rough surfaces.

Block Size	Fill Material	Trim Length	Number of Rows	Standard Pack	Item Number
7"	White Tampico	3-1/2"	3	12	74015

## Acid Scrub Brush - Hardwood block- Tapered handle hole

Recommended for applying sealcoating, cement slurry, water-proofing, etc.

Block Size	Fill Material	Trim Length	Standard Pack	Item Number
8-1/4" x 2-3/4"	White Tampico	1-1/8"	12	73111

NOTE: Handle not included - can be used with tapered handle #44574 on page 147.

## Cement Finishing Brushes - Hardwood block. Ideal for creating texture to newly poured cement and for applying coatings on asphalt or concrete. Use handle #44303 on page 147.

Block Length	Fill Material	Trim Length	No. of Rows	Standard Pack	Item Number	★ Combo Qty. Item Number
24"	Black Polypropylene	2-1/4"	3	6	79251	-
24"	Black Polypropylene	3-1/4"	3	6	79252	44879
36"	Black Polypropylene	3-1/4"	3	6	79253	44880
24"	Horsehair	2-1/2"	3	6	79255	44881
36"	Horsehair	2-1/2"	3	6	79256	44882

★ Combo Packs include 12 brushes per pack and 12 #44303 handles (not assembled).

## Smoothing Brush - Hardwood block. For smoothing wallpaper.

Block Length	Fill Material	Trim Length	Standard Pack	Item Number
12"	White Tampico	2"	12	74078



Weiler scrubs and sweeps were used to help with the clean-up after Hurricane Katrina.



# Scratch Brushes

**Scratch Brushes** - Weiler's extensive Scratch Brush offering includes many block and handle types and sizes. The wide variety of fill materials available assures the right brush for the right job. Common applications are cleaning dirt, rust, scale, chips and paint; plating and welding operations.

## Curved Handle Scratch Brushes - Hardwood block - Ideal for cleaning and prepping surfaces.

Block Size	Brush Length	Number of Rows	Trim Length	Standard Pack	Item Number
<b>.012 Steel Wire</b>					
13-3/4" x 1-1/8"	5-1/4"	3 x 14	1-1/4"	12	44594*
14" x 7/8"	5-1/2"	3 x 19	1-3/16"	12	44053
14" x 1-1/8"	6"	4 x 18	1-3/16"	12	44056
<b>.012 Steel Wire with Scraper</b>					
14" x 7/8"	5-1/2"	3 x 19	1-3/16"	12	44055
14" x 1-1/8"	6"	4 x 18	1-3/16"	12	44058
<b>.012 Stainless Steel Wire</b>					
13-3/4" x 1-1/8"	5-1/4"	3 x 14	1-1/4"	12	44432*
14" x 7/8"	5-1/2"	3 x 19	1-3/16"	12	44054
14" x 1-1/8"	6"	4 x 18	1-3/16"	12	44057

\* V-Groove

## Vortec Pro® Curved Handle Scratch Brushes - Reliable and efficient brushes at a value price.

Block Size	Brush Length	Number of Rows	Trim Length	Standard Pack	Item Number
<b>.012 Steel Wire</b>					
13-1/2" x 1"	6"	3 x 19	1"	12	25150
14" x 1-1/8"	6"	4 x 18	1"	12	25201
<b>.012 Stainless Steel Wire</b>					
13-1/2" x 1"	6"	3 x 19	1"	12	25154
14" x 1-1/8"	6"	4 x 18	1"	12	25202

## Shoe Handle Scratch Brushes - Hardwood blocks - Ideal for cleaning and prepping surfaces.

Block Size	Brush Length	Number of Rows	Trim Length	Standard Pack	Item Number
<b>.012 Steel Wire</b>					
10" x 3/8"	5"	1 x 17	1-1/16"	12	44100
10" x 5/8"	5"	2 x 17	1-3/16"	12	44061
10" x 1-1/8"	5"	4 x 16	1-3/16"	12	44063
11"	5"	4 x 16	1-3/16"	12	73217•
<b>.012 Steel Wire with Scraper</b>					
10" x 1-1/8"	5"	4 x 16	1-3/16"	12	44065
<b>.012 Stainless Steel Wire</b>					
10" x 3/8"	5"	1 x 17	1-1/16"	12	44101
10" x 3/8"	5"	1 x 17	3/4"	12	44235
10" x 5/8"	5"	2 x 17	1-3/16"	12	44062
10" x 1-1/8"	5"	4 x 16	1-3/16"	12	44064
11"	5"	4 x 16	1-3/16"	12	44299•
<b>.012 Brass Wire</b>					
11"	5"	4 x 16	1-1/4"	12	73218•

• Plastic block

## Vortec Pro® Shoe Handle Scratch Brushes - Reliable and efficient brushes at a value price.

Block Size	Brush Length	Number of Rows	Trim Length	Standard Pack	Item Number
<b>.012 Steel Wire</b>					
10" x 1"	5"	4 x 16	1"	12	25100
<b>.012 Stainless Steel Wire</b>					
10" x 1"	5"	4 x 16	1"	12	25104



Removing excess concrete from the surface of a steel support plate.



44594  
Top View



44053



44055



25150



44063



44065



73218



25100

Scratch Brushes

# Scratch Brushes



Removing dirt and oil from a lathe.

Scratch Brushes



44069



44076



44116

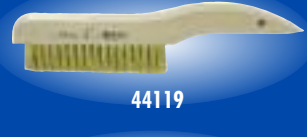

44119



44075



44551



44189



44619



95151



99383



44732

## Heavy-Duty Scratch Brush with Scraper - .012 Steel Wire - Ideal for cleaning and prepping surfaces.

Block Size	Brush Length	Number of Rows	Trim Length	Standard Pack	Item Number
11-1/2" x 1-1/2"	5-1/2"	4 x 11	1-1/2"	12	44069

## Vortec Pro® Heavy-Duty Scratch Brush with Scraper - .012 Steel Wire - Reliable and efficient brushes at a value price.

Block Size	Brush Length	Number of Rows	Trim Length	Standard Pack	Item Number
11-1/2" x 1-1/2"	5"	4 x 11	1-5/8"	12	25211

## Plater's Brushes - Hardwood block. For general cleaning in the plating, metal finishing, aircraft and missile industries. Also used with inert arc aluminum welding.

Block Size	Brush Length	Number of Rows	Trim Length	Standard Pack	Item Number
<b>Tampico</b>					
13" x 1-1/4"	5-1/4"	4 x 18	1"	12	44076
<b>Nylon</b>					
13" x 1-1/8"	5-1/4"	4 x 19	1"	12	44077
<b>.006 Steel Wire</b>					
10" x 1-1/8"	5"	4 x 16	1"	12	44117
13" x 7/8"	5-1/2"	3 x 19	1"	12	44116
<b>.006 Stainless Steel Wire</b>					
10" x 1-1/8"	5"	4 x 18	1"	12	44240
13" x 7/8"	5-1/2"	3 x 19	1"	12	44660
13" x 1-1/8"	5-1/2"	4 x 19	1"	12	44232
<b>.006 Brass Wire</b>					
10" x 1-1/8"	5"	4 x 18	1"	12	44119
13" x 7/8"	5-1/2"	3 x 19	1"	12	44118

## Small Hand Scratch Brushes - Ideal for cleaning and prepping surfaces.

Block Size	Block	No. of Rows	Wire Size	Trim Length	Standard Pack	Item Number
<b>Stainless Steel Wire</b>						
7-1/2" x 1/2"	Plastic	3 x 7	.006	1/2"	36	44075
7-1/2" x 1/2"	Wood	3 x 7	.006	1/2"	36	44167+
7-3/4" x 3/8"	Wood	3 x 7	.006	1/2"	36	44551*
8-3/4" x 1/2"	Wood	2 x 9	.006	5/8"	36	95013
<b>Straight Brass Wire</b>						
7-1/2" x 1/2"	Wood	3 x 7	.006	1/2"	36	44189
<b>Crimped Brass Wire</b>						
6" x 1/2"	Wood	3 x 10	.005	5/8"	72	44619
8-3/4" x 1/2"	Wood	2 x 9	.008	5/8"	36	95014
<b>Crimped Aluminum</b>						
6-3/4" x 1-5/8"	Wood	6 x 9	.008	5/8"	12	95151
8-3/4" x 1/2"	Wood	2 x 9	.008	5/8"	36	44251
<b>Straight Black Nylon</b>						
6-1/2" x 1/2"	Plastic	4 x 15	.010	1/2"	24	99383
7-1/2" x 1/2"	Wood	3 x 7	.012	1/2"	36	44637
<b>White Nylon</b>						
7-1/2" x 1/2"	Plastic	3 x 7	.016	1/2"	36	44609
<b>Double-Sided Brass/White Nylon</b>						
7-1/2" x 1/2"	Plastic	3 x 7	.006/.016	1/2"	24	44731
<b>Double-Sided Brass/Stainless Steel</b>						
7-1/2" x 1/2"	Plastic	3 x 7	.006/.016	1/2"	24	44732
<b>Double-Sided Stainless Steel/White Nylon</b>						
7-1/2" x 1/2"	Plastic	3 x 7	.006/.016	1/2"	24	44733

+ Countertop display available. See page 176.

\*Wire drawn

# Scratch Brushes

**Vortec Pro® Small Hand Scratch Brushes** - Reliable and efficient brushes at a value price.

Block Size	Handle	No. of Rows	Wire Size	Trim Length	Standard Pack	Item Number
<b>Stainless Steel Wire</b>						
7-1/2" x 1/2"	Wood	3 x 7	.006	1/2"	36	44805
7-1/2" x 1/2"	Plastic	3 x 7	.006	1/2"	36	44806
<b>Straight Brass Wire</b>						
7-1/2" x 1/2"	Wood	3 x 7	.006	1/2"	36	44810

**Block Type Scratch Brushes** - For rugged cleaning on bricks, stone and similar large flat areas.

Block Size	Fill Material	Brush Part	No. of Rows	Trim Length	Standard Pack	Item Number
7-1/4" x 2-5/8"	.012 Round Wire Curved Face	7"	9 x 21	1-3/16"	12	44066
7-1/4" x 2-1/4"	.014 Round Wire Flat Face	7"	6 x 19	1-5/8"	12	44067

**Vortec Pro® Block Type Scratch Brush** - Reliable and efficient brushes at a value price.

Block Size	Fill Material	Brush Part	No. of Rows	Trim Length	Standard Pack	Item Number
7-1/4" x 2-1/4"	.012 Steel	7"	6 x 19	1-5/8"	12	25212

**Butcher Block Brush** - For cleaning concrete forms and green concrete after forms have been removed.

Block Size	Fill Material	Brush Part	No. of Rows	Trim Length	Standard Pack	Item Number
7-1/2" x 2-3/4"	.017 x .110 Flat Wire	7"	5 x 10	1-1/4"	12	44073

**Chipping Hammer Refill** - A refill brush for most chipping hammers. Used for weld cleaning.

Block Size	Fill Material	Brush Part	No. of Rows	Trim Length	Standard Pack	Item Number
4-5/8" x 7/8"	.012 Steel	4-1/2"	3 x 15	1-1/8"	12	44070

**Wire Duster** - For cleaning chips, borings, solder, rust, dirt & corrosion from castings.

Block Size	Fill Material	Handle Length	No. of Rows	Trim Length	Standard Pack	Item Number
3" x 1-1/8"	.012 Steel	5-3/4"	4 x 8	2-1/2"	12	44451

**File Card Brush** - Waxed hardwood block. Use for file cleaning or to roughen and prepare surface material prior to sweating and soldering.

Overall Length	Fill Material	Brush Part	Trim Length	Standard Pack	Item Number
8-1/4"	.012 Steel	1-5/8" x 4"	1/4"	12	44260

**Metal Chip Brush** - Small stiff wire brush for brushing hot metal. Can be exposed to flames without burning.

Overall Length	Fill Material	Trim Length	Face Width	Standard Pack	Item Number
5-1/2"	.012 Steel	1-1/2"	1-1/4"	12	44074



Removing chips from the slots of a milling machine.



Scratch Brushes

# Flue Brushes



Cleaning boiler pipes with a flue brush.

**Flue Brushes** - Designed and engineered from black oil-tempered wire. Flue brushes are available in single spiral and double spiral construction. Other fill materials and sizes available by special order. Contact Customer Service for details.

## Applications

- Pipe cleaning
- Flue cleaning
- Boiler tube cleaning

**Flue Brushes** - Filled with .012 round wire and fitted with 1/4" x 2" NPT pipe nipple. For internal cleaning of pipes and flues.

Brush Diameter	Brush Length	Overall Length	Standard Pack	Item Number
<b>Single Spiral</b>				
7/8"	4-1/2"	7-1/2"	1	44124
1"	4-1/2"	7-1/2"	1	44125
1-1/4"	4-1/2"	7-1/2"	1	44047
1-1/2"	4-1/2"	7-1/2"	1	44128
1-3/4"	4-1/2"	7-1/2"	1	44048
2"	4-1/2"	7-1/2"	1	44131
2-1/2"	4-1/2"	7-1/2"	1	44133
3"	4-1/2"	7-1/2"	1	44135
3-1/2"	4-1/2"	7-1/2"	1	44137
4"	4-1/2"	7-1/2"	1	44139
<b>Double Spiral</b>				
1"	4-1/2"	7-1/2"	1	44149
1-1/4"	4-1/2"	7-1/2"	1	44035
1-1/2"	4-1/2"	7-1/2"	1	44150
1-3/4"	4-1/2"	7-1/2"	1	44036
2"	4-1/2"	7-1/2"	1	44152
2-1/4"	4-1/2"	7-1/2"	1	44037
2-1/2"	4-1/2"	7-1/2"	1	44154
2-3/4"	4-1/2"	7-1/2"	1	44038
3"	4-1/2"	7-1/2"	1	44156
4"	4-1/2"	7-1/2"	1	44169
4-7/8"	4-1/2"	7-1/2"	1	44159

**Flue Brush Extension Rod** - One 1/4" male pipe nipple and one 1/4" female pipe coupling allows user to extend flue brush.

Description	Standard Pack	Item Number
36" Fiberglass Extension Rod	1	95925



"Pipeline" Flue Brushes By Special Order Only.

- Heavy-duty. Exact size diameter. Rugged double stem, single spiral.
- Fitted with 1/4" pipe nipple. Available in diameters of 1-5/8" - 15".



Flue Brushes are available in additional sizes and fill materials.

44131

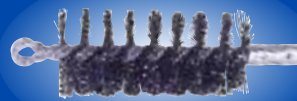

44154



95925

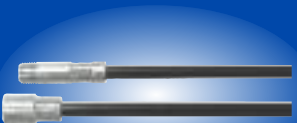

# Tube Fitting Brushes

**Tube Fitting Brushes** - Several configurations and sizes of Tube Fitting Brushes are available for cleaning and deburring copper, internal and external tube fittings. The handy 4-in-1 tube fitting brush cleans both outside and inside diameters of multiple tube sizes.

**Internal Tube Fitting Brushes - Wire Fill** - For internal cleaning and deburring of copper tube fittings. Also used in trucking and marine industries as a light socket cleaning brush.

Tube Diameter	Actual Diameter	Brush Length	Overall Length	Handle Length	Standard Pack	Item Number
1/8"	1/4"	1"	6-1/2"	3-1/4"	12	44078
1/4"	3/8"	1"	6-1/2"	3-1/4"	12	44079
3/8"	1/2"	1"	6-1/2"	3-1/4"	12	44080
1/2"	5/8"	1"	6-1/2"	3-1/4"	12	44081
5/8"	3/4"	1"	6-1/2"	3-1/4"	12	44082
3/4"	7/8"	1"	6-1/2"	3-1/4"	12	44083
7/8"	1"	1"	6-1/2"	3-1/4"	12	44084
1"	1-1/8"	1"	6-1/2"	3-1/4"	12	44085
1-1/4"	1-3/8"	1"	6-1/2"	3-1/4"	12	44086
1-1/2"	1-5/8"	1-1/2"	6-1/2"	3-1/4"	6	44087

**External Tube Fitting Brushes - 1/4" Stem**

Ideal for cleaning tube ends. Mount to a hand drill for fast results.

Outside Diam.	Standard Pack	Item Number
3/8"	40	44734
1/2"	40	44735
5/8"	40	44736
3/4"	40	44737
7/8"	40	44738
1"	40	44739

**4-in-1 Tube Fitting Brush**

**One Brush Replaces Four!** - Steel Wire

Cleans the outside and inside diameters of 1/2" and 3/4" tubes and fittings.

Use for soldering prep, deburring, drill hole cleaning and cleaning battery terminals.

Tube Inside Diameter	Tube Outside Diameter	Standard Pack	Item Number
3/4" and 1/2"	7/8" and 5/8"	1	44690

**Turbo Tube™ Brushing Tool** - The Turbo Tube Brushing Tool is two brushes in one, so fittings and copper tubing can be easily cleaned without changing tools!

## Applications

- Fitting brush cleans outside diameter
- Ideal for plumbing and HVAC projects
- Tube brush cleans inside diameter

**Vortec Pro® Turbo Tube Brushes** - Clean I.D. and O.D. with the same tool.

Rust-proof stainless steel bristles. Reliable and efficient brushes at a value price.



I.D. Size	O.D. Size	Wire Type	Standard Pack	Item Number
1/2"	5/8"	Stainless	1	36303
3/4"	7/8"	Stainless	1	36304
1"	1-1/8"	Stainless	1	36305



Cleaning the inside of a copper fitting prior to soldering.



44079



44734



44690



36303

Tube Fitting Brushes

# Paint & Varnish Brush Technical Information

## General Information

### Brush Types:

Weiler brushes are designed for industrial use. These quality brushes are made with the finest materials, yet priced to give the lowest cost-per-use.

- Wall Paint
- Varnish
- Flat Sash
- Angular Sash
- Oval Sash
- Chip & Oil
- Acid
- Glue
- Stencil
- Parts Cleaning
- Marking
- Round Sash

## Paint Brush Terminology

**Fill Material:** The part of the brush that actually does the work. Weiler brushes are filled with Natural China Bristle or Tapered Polyester. Various sizes of fill material are blended together to create the proper taper.

### Flagged Ends:

A split at the end of each tapered fiber of fill material. Bristle is naturally tapered with a flagged tip. Polyester fibers are made tapered and then mechanically processed to form a flagged tip. Flagging allows each tip to pick up more paint and spread it more evenly.

**Thickness:** The thickness of the brush, measured at the ferrule, will determine the quality level of the brush. The thicker the brush, the more paint pick-up and release.

**Ferrule:** The metal band that holds the fill material and handle together. All Weiler paint and varnish brushes are made with plated metal ferrules which will not rust or corrode.

**Handle:** Weiler handles are made of quality wood or synthetics. Wood handles are sanded and lacquered. Synthetic handles are not affected by paints, varnishes or solvents. All handles provide a comfortable grip for hours of fatigue-free use.

**Trim Length:** The length of the fill material extending from the ferrule. The longer the trim, the more paint is picked up and released for a quicker, easier job.

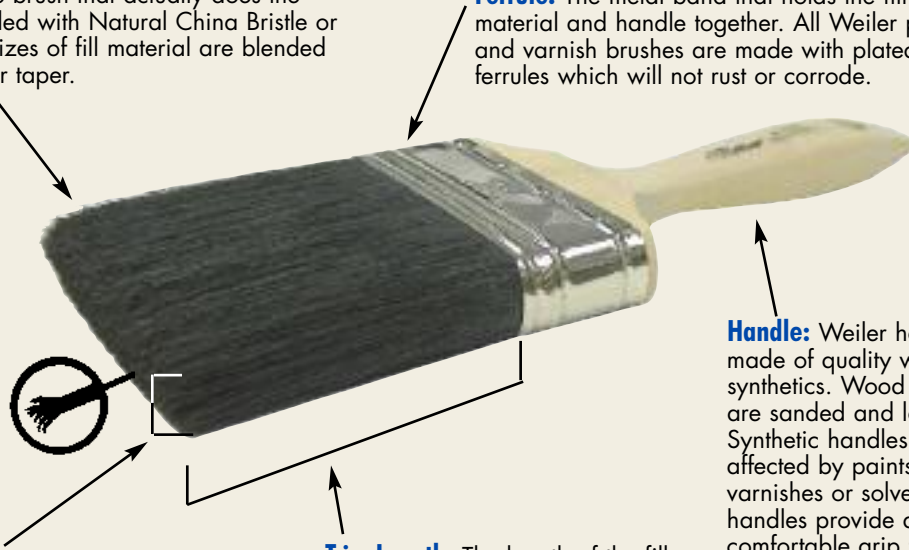

## Paint & Varnish Brush Selection Guide

The chart below provides information on paint brush fill types to allow you to recommend the correct brush for the job.

Brush Fill	Recommended For	Benefits
China Bristle	All oil based and alkyd paints, stains, varnish urethane & shellac	<ul style="list-style-type: none"> <li>• Softest tip for fewest brush marks</li> <li>• Natural fibers hold paint better than synthetics</li> </ul>
Polyester/Nylon blend	All paints and coatings	<ul style="list-style-type: none"> <li>• Most durable material</li> <li>• Precise tipping</li> <li>• Cleans up easily</li> </ul>
Polyester	All paints and coatings	<ul style="list-style-type: none"> <li>• Low cost</li> <li>• Does not absorb water</li> </ul>

## Paint & Varnish Brush Care

Brushes Used In	Clean With
<ul style="list-style-type: none"> <li>• Oil base paint</li> <li>• Latex paint</li> <li>• Water base paint</li> <li>• Varnish</li> <li>• Shellac</li> </ul>	<ul style="list-style-type: none"> <li>• Turpentine or mineral spirits</li> <li>• Warm soapy water</li> <li>• Warm soapy water</li> <li>• Turpentine or mineral spirits</li> <li>• Alcohol</li> </ul>

Note: After cleaning, shake out, comb bristles and hang by handle.

## Special Paint Brushes

The brushes listed in this catalog will cover the major requirements of industry. However, if an application requires another type, size or style of brush, contact your nearest Weiler distributor or Weiler's Customer Service Team.

# Professional Paint, Varnish & Sash Brushes

**Professional Wall, Varnish and Sash Brushes** - These high quality brushes are available in a wide variety of sizes and materials to fill all applications. The Professional Wall Brushes have a sanded wooden handle, the preferred standard among professional users. The Professional Varnish and Sash Brushes are color coded - Blue for Bristle and Red for Polyester/Nylon Blend, and feature painted foam handles in the "beaver tail" style. These handles are attractive and easier to grip, reducing user fatigue.

**Wall Paint Brushes** - For interior/exterior painting of large flat surfaces.

Width	Thickness	Bristle Length	Standard Pack	Item Number
<b>Black China Bristle - Sanded Wood Handle</b>				
3"	7/8"	3-1/4"	6	40022
4"	7/8"	3-3/4"	6	40023
<b>Poly/Nylon - Sanded Wood Handle</b>				
3"	7/8"	3"	6	40061
4"	7/8"	3"	6	40062

**Varnish Brushes** - Comfortable foam grip handle; smooth paint flow.

Width	Thickness	Bristle Length	Standard Pack	Item Number
<b>Black China Bristle - Blue Foam Handle</b>				
1"	7/16"	2"	12	40000
1-1/2"	1/2"	2-1/4"	12	40001
2"	9/16"	3"	12	40002
2-1/2"	5/8"	3"	12	40003
3"	11/16"	3"	12	40004
4"	11/16"	3"	12	40010
<b>Poly/Nylon - Red Foam Handle</b>				
1"	7/16"	2-1/4"	12	40058
2"	3/4"	2-3/4"	12	40059
3"	7/8"	3"	12	40060
4"	7/8"	3"	6	40106

**Angled Sash Brushes** - For trim or cut work like window sills, door frames, etc.

Width	Thickness	Bristle Length	Standard Pack	Item Number
<b>Black China Bristle - Blue Foam Handle</b>				
1-1/2"	7/16"	2-1/4"	12	40041
2"	1/2"	2-1/4"	12	40008
<b>Poly/Nylon - Red Foam Handle</b>				
1-1/2"	7/16"	2-1/2"	12	40011
2"	1/2"	2-1/2"	12	40040

**Flat Sash Brushes** - For trim or cut work like window sills, door frames, or other narrow, flat surfaces.

Width	Thickness	Bristle Length	Standard Pack	Item Number
<b>Black China Bristle - Blue Foam Handle</b>				
1"	3/8"	2"	12	40113
1-1/2"	7/16"	2-1/4"	12	40114
2"	9/16"	3"	12	40115
<b>Poly/Nylon - Red Foam Handle</b>				
1"	3/8"	2-1/4"	12	40014
1-1/2"	7/16"	2-1/4"	12	40017
2"	9/16"	2-1/2"	12	40018



Applying paint to clap board siding.



40022



40061



40002



40059



40041



40040



40115



40017

Professional Paint, Varnish & Sash Brushes

# Professional Sash & Parts Cleaning Brushes



Cleaning an oil pan with a parts cleaning brush.

Professional Sash & Parts Cleaning Brushes



40056



40121



40035



25222

**Oval Sash Brushes** - Ideal for cleaning parts, crevices and painting hard-to-reach areas.

Size	Thickness	Bristle Length	Standard Pack	Item Number
<b>Black China Bristle - Plain Foam Handle - Chisel Trim</b>				
#2	7/16"	1-3/4"	24	40116
#4	11/16"	1-3/4"	12	40019
#6	13/16"	1-3/4"	12	40056
#8	15/16"	3"	12	40020
#10	1-1/16"	3"	12	40021
#12	1-3/16"	3"	12	40057

**Round Sash Brushes** - Ideal for cleaning parts, crevices and painting hard-to-reach areas.

Size	Thickness	Bristle Length	Standard Pack	Item Number
<b>Grey Bristle - Plain Foam Handle - Flat Trim</b>				
#2	7/16"	1-3/4"	24	40118
#4	11/16"	2"	12	40119
#6	13/16"	2"	12	40120
#8	15/16"	2-1/4"	12	40121
#10	1-1/16"	2-1/4"	12	40122
#12	1-3/16"	2-1/4"	12	40123

**Parts Cleaning Brushes** - Ideal for applications such as cleaning carburetors, transmission components, applying adhesives and lubricants.

**Parts Cleaning Brushes** - Stainless steel ferrule - Heavily filled.

Thickness	Fill Material	Bristle Length	Standard Pack	Item Number
<b>Plain Foam Handle - Chisel Trim</b>				
1"	Synthetic	2-1/2"	12	40035
1"	Tampico	2-3/4"	12	40036

**Vortec Pro® Parts Cleaning Brushes** - Reliable and efficient brushes at a value price.

Thickness	Fill Material	Bristle Length	Standard Pack	Item Number
<b>Plain Foam Handle - Chisel Trim</b>				
15/16"	Nylon	2-1/2"	12	25221
1"	Tampico	2-3/4"	12	25222



# Industrial Paint Brushes

**Industrial Paint Brushes** - The Industrial line features color coded plastic handles to provide quality paint brushes at competitive prices.

**Industrial Varnish Brushes** - Heavily-filled brush with comfortable handle in a variety of sizes.

Width	Thickness	Bristle Length	Standard Pack	Item Number
<b>Black Bristle - Black Plastic Handle</b>				
1/2"	1/4"	1-3/4"	48	40088*
1"	3/8"	1-3/4"	36	40089
1-1/2"	7/16"	2"	24	40101
2"	7/16"	1-3/4"	12	40074
2-1/2"	1/2"	2-1/4"	12	40102
3"	1/2"	2"	12	40103
4"	5/8"	2-3/4"	12	40104
<b>Black Polyester - Red Plastic Handle</b>				
1/2"	1/4"	1-3/4"	48	40112
1"	3/8"	2"	36	40107
1-1/2"	7/16"	2"	24	40108
2"	7/16"	2"	12	40109
3"	1/2"	2"	12	40110
4"	11/16"	2-3/4"	12	40111

\*Grey Bristle

**Bent Radiator Brush** - Black Bristle - Wood Handle  
Ideal for painting radiators and other hard-to-reach areas.

Width	Thickness	Bristle Length	Standard Pack	Item Number
2"	9/16"	2-1/4"	12	95502

**Detail Brushes** - Grey Bristle - Plastic Handle

Width	Thickness	Bristle Length	Standard Pack	Item Number
1-1/2"	5/16"	5/8"	24	40012
1-1/2"	5/16"	1"	24	40013

**Vortec Pro® Foam Applicator Brushes** - Wood Handle  
Reliable and efficient brushes at a value price. Not recommended for use with lacquer, shellac or solvents.

Width	Thickness	Foam Length	Standard Pack	Item Number
1"	5/8"	2-5/8"	50	99801
2"	5/8"	2-5/8"	50	99805
3"	7/16"	2-5/8"	40	99806
4"	7/16"	2-5/8"	30	40199



Flagged tips on synthetic and bristle style brushes help them carry more paint to the work surface.



Painting inside the fins of a radiator with a Radiator brush.



40074



40109

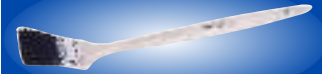

95502



40013

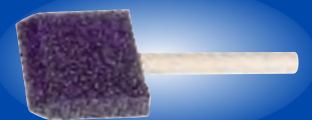

99806

Industrial Paint Brushes

# Chip and Oil Brushes

**Chip And Oil Brushes** - Chip and Oil brushes are inexpensive, multi-purpose brushes for use in applications requiring disposable brushes.

## Chip and Oil Brushes - White Bristle - Wood Handle

Width	Thickness	Bristle Length	Standard Pack	Item Number
1/2"	5/16"	1-1/2"	30	40065
1"	5/16"	1-1/2"	30	40066
1-1/2"	5/16"	1-1/2"	30	40067
2"	5/16"	1-1/2"	20	40068 +
2-1/2"	3/8"	1-1/2"	20	40069
3"	3/8"	1-1/2"	10	40070 +
4"	5/8"	1-5/8"	10	40071
	3/8"	2"		40076

+ Countertop display available. See page 176.

## Vortec Pro® Chip and Oil Brushes - Reliable and efficient brushes at a value price.

Width	Thickness	Bristle Length	Standard Pack	Item Number
<b>White Bristle - Wood Handle</b>				
1/2"	5/16"	1-1/2"	36	40177
1"	5/16"	1-1/2"	36	40179
1-1/2"	5/16"	1-1/2"	24	40180
2"	5/16"	1-1/2"	24	40181
2-1/2"	3/8"	1-1/2"	12	40182
3"	3/8"	1-1/2"	12	40183
4"	5/8"	1-3/4"	12	40184
	3/8"			40185
<b>Black Bristle - Plastic Handle</b>				
1/2"	1/4"	1-5/8"	30	40160
1"	5/16"	1-5/8"	30	40161
1-1/2"	5/16"	1-5/8"	30	40162
2"	5/16"	1-5/8"	20	40163
2-1/2"	3/8"	1-3/4"	20	40164
3"	3/8"	1-3/4"	10	40165
4"	11/16"	2"	10	40166
<b>Grey China Bristle - Plastic Handle</b>				
1/2"	1/4"	1-1/2"	48	40026
1"	5/16"	1-1/2"	36	40027
1-1/2"	5/16"	1-1/2"	24	40028
2"	3/8"	1-1/2"	24	40029
2-1/2"	1/2"	1-1/2"	12	40030
3"	1/2"	1-1/2"	12	40031
4"	11/16"	1-1/2"	12	40032
<b>Grey China Bristle - Plastic Handle</b>				
1/2"	1/4"	1-3/4"	48	40129
1"	5/16"	1-3/4"	36	40130
1-1/2"	5/16"	1-3/4"	24	40131
2"	3/8"	1-3/4"	24	40132
2-1/2"	1/2"	1-3/4"	12	40133
3"	1/2"	1-3/4"	12	40134
4"	11/16"	1-3/4"	12	40135
<b>Black Synthetic - Red Plastic Handle</b>				
1/2"	1/4"	1-3/4"	48	40136
1"	5/16"	1-3/4"	36	40137
1-1/2"	5/16"	1-3/4"	24	40138
2"	3/8"	1-3/4"	24	40139
3"	1/2"	1-3/4"	12	40140
4"	11/16"	2-3/4"	12	40141

Removing chips from the ways of a lathe.



40068



40181



40161

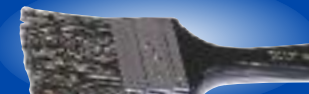

40029

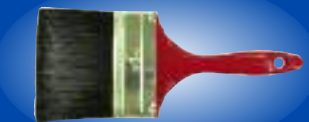

40141

# Marking Brushes

**Marking Brushes** - Weiler's high quality Marking Brushes come in a variety of animal, natural and synthetic bristles in numerous handle styles for many applications such as fine artwork, pin striping and sign painting.

## Red Sable Watercolor Brushes - Seamless ferrule. Pointed tip - Round black handle

Size	Diameter	Trim Length	Standard Pack	Item Number
3/0	3/64"	1/4"	12	41000
0	1/16"	5/16"	12	41001
2	3/32"	7/16"	12	41002
4	1/8"	5/8"	12	41003

## Black Bristle Marking Brushes - Long, lacquered handle

Size	Diameter	Trim Length	Standard Pack	Item Number
1	1/8"	3/4"	12	41004
2	5/32"	15/16"	12	41005
4	7/32"	1-1/8"	12	41007
5	1/4"	1-1/4"	12	41008
6	9/32"	1-3/8"	12	41009

## Flat Marking Brushes - Ox hair - Single stroke - Round black handle

Width	Trim Length	Standard Pack	Item Number
1/4"	7/8"	12	41018
1/2"	1"	12	41019
3/4"	1-1/4"	12	41020
1"	1-3/8"	12	41021

## Sign Brushes - Ox hair - Flat red handle

Width	Trim Length	Standard Pack	Item Number
1/4"	3/4"	12	41014
1/2"	1"	12	41015
3/4"	1-1/8"	12	41016
1"	1-1/4"	12	41017

## Fitch Brushes - Black china bristle - Chiseled edge - Clear lacquered handle

Width	Trim Length	Standard Pack	Item Number
1/4"	13/16"	12	41022
1/2"	1-1/16"	12	41023
3/4"	1-5/16"	12	41024
1"	1-9/16"	12	41025

## Lacquering Brushes - Seamless aluminum ferrule. Camel hair - Round black handle

Size	Diameter	Trim Length	Standard Pack	Item Number
1	5/32"	11/16"	12	41010
3	7/32"	13/16"	12	41011
5	1/4"	1-1/8"	12	41012
6	5/16"	1-3/16"	12	41013



Painting a tight area on a steel door with a Marking Brush.



41003



41009



41021



41015



41024



41011

Marking Brushes

# Glue and Acid Brushes

**Glue And Acid Brushes** - Weiler's Glue and Acid Brushes come in multiple sizes, ferrule types, handles and fill materials for a wide variety of cleaning and coating applications.

## Bridled Glue Brushes - Grey china bristle - Steel ferrule - Long foam handle

Diameter	Trim Length	Standard Pack	Item Number
7/16"	1-1/4"	36	40077
13/16"	1-3/4"	24	40078
15/16"	1-3/4"	24	40079

## Acid/Flux Brushes - Horsehair - Tin ferrule

Width	Trim Length	Overall Length	Standard Pack	Item Number
5/16"	3/4"	5-3/4"	144	44088
3/8"	3/4"	5-3/4"	144	44089
1/2"	3/4"	5-3/4"	144	44090

## Stylus Brush - Stiff grey horsehair. Aluminum tube with cork to hold cleaning fluid. For cleaning electrical contact points.

Width	Trim Length	Overall Length	Standard Pack	Item Number
1/2"	3/8"	5"	100	44097

## Stencil Brushes - China bristle - Seamless steel ferrule - Lacquered wood handle

Diameter	Bristle Length	Standard Pack	Item Number
1"	1-3/8"	12	40080
1-1/2"	1-5/8"	12	40081
2"	1-3/4"	12	40082

## Dope Brushes - With hanger for coating applications in drilling operations.

Brush Part	Fill Material	Diameter	Overall Length	Standard Pack	Item Number
4"	Mixed Tampico	2"	16"	12	44261
		2-1/2"			44262
		3"			44263

## Dauber Brush - For applying dope to the thread ends of drill pipe.

Brush Size	Fill Material	Overall Length	Standard Pack	Item Number
4"	White Tampico	16"	12	44259

Applying flux to a copper tube prior to soldering.



40078



44089



44097



40082



44262



44259

# Paint Rollers and Accessories

**Paint Rollers And Accessories** - Paint Rollers can be used almost anywhere including walls, ceilings, floors, decks, fences, metal surfaces, concrete, and brick walls. Weiler carries a wide variety of rollers for the professional painter, industrial use and those weekend DIY projects. Accessories include roller frames, paint trays, bucket grids and painter's mitts.

## Paint Roller Selection Guide

Work Surface	Coating	Recommended Nap
Metal, Smooth Wood, Smooth Concrete	Enamels, Epoxies Adhesives, Paint	3/16", 3/8" (Low nap)
Rough Wood, Drywall, Cement Block	All Paint	1/2", 3/4" (Medium nap)
Stucco, Brick, Concrete	All Paint	1" (High nap)

## Professional Grade Rollers - Poly blend with phenolic core.

Size	Nap	Painting Surface	Standard Pack	Item Number
9"	3/16"	Smooth Semi-smooth Rough	12	49050
	1/2"			49051
	3/4"			49052

## Industrial Grade Rollers - Poly blend with PVC core.

Size	Nap	Painting Surface	Standard Pack	Item Number
3"	3/8"	Semi-smooth	24	49046
4"	3/8"	Semi-smooth Rough	12	49044
	3/4"			49045
9"	3/16"	Smooth Semi-smooth Rough Extra Rough	12	49061
	1/2"			49062
	3/4"			49063
	1"			49053
18"	3/8"	Smooth Rough	1	49082
	3/4"			49086

## Vortec Pro® Rollers - Poly blend with PVC core. Reliable and efficient rollers at a value price.

Size	Nap	Painting Surface	Standard Pack	Item Number
9"	3/8"	Semi-smooth Semi-smooth	12	49070
	1/2"			49071

## Specialty Rollers - Can be used with all paints. Ideal for trim and touch-up.

Description	Standard Pack	Item Number
3" Roller with 3/8" nap. Standard duty frame	24	49016
3" Roller with 3/8" nap. Wire frame with two tin end caps. Bent wire handle	12	49015
4" Micro Perlon Roller Reach	24	49025
4" Micro Perlon Twin Pack Cover	24	49066



Applying primer to new drywall.



49050



49045



49063



49070



49016



49015



49025

Paint Rollers and Accessories

# Paint Rollers and Accessories



The bucket grid is a must for every painting project!



49021



49020



49010

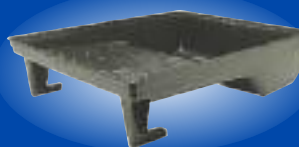

49011

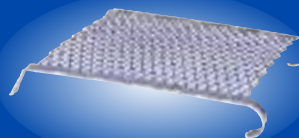

49007

**Frames** - All metal with two plastic caps. Solid plastic handle with threaded grip. Can be used with threaded handle #44300 on page 147.

Size	Description	Standard Pack	Item Number
3"	Standard-duty 1/4" dia. frame with 4 wire cage	24	49019
4"	Standard-duty 1/4" dia. frame with 4 wire cage	24	49018
9"	Heavy-duty 5/16" dia. frame with 5 wire cage	12	49022
12"-18"	Adjustable frame fits 12"-18" rollers	1	49021

**Vortec Pro® Frame** - Reliable and efficient frame at a value price.

Size	Description	Standard Pack	Item Number
9"	Standard-duty 1/4" dia. frame with 4 wire cage	24	49020

**Paint Trays** - A variety of trays available to meet users' specific needs.

Description	Paint Capacity	Standard Pack	Item Number
4" Plastic tray	1 Quart	24	49008
9" Galvanized steel tray; Rust resistant	1 Quart	24	49010
9" Deluxe plastic tray; Rust proof	1 Quart	20	49012
9" Paint tray liner	1 Quart	24	96702

**Vortec Pro® Paint Tray** - Reliable and efficient tray at a value price.

Description	Paint Capacity	Standard Pack	Item Number
9" Economy plastic tray; Rust proof	1 Quart	20	49011

**Bucket Grid** - Permits use of paint roller directly from a 5-gallon pail.

Description	Standard Pack	Item Number
Heavy steel - 5 gallon size	12	49007

# Display Packaged Product

**Display Packaged Product** - In order to generate impulse purchases, a variety of our most popular Weiler industrial grade items are available in highly visible display packaging to stimulate impulse sales. Customers can easily view the product and assess its high quality. Package labeling includes key technical information and UPC barcodes. A multi-lingual safety slip is included with all products, providing comprehensive information on the safe use of the product.

**Standard Twist Wheels** - Provide heavy-duty brushing action with some flexibility; Ideal for demanding cleaning applications on somewhat irregular surfaces.



Dia.	Wire Size	Arbor Hole	No. of Knots	Face Width	Trim Length	Max. AH Avail.	Thickness at Face Plates	Max. RPM	Std. Pack	Item Number	
										Steel	Stainless
3"	.014	1/2"-3/8"	20	3/8"	5/8"	1/2"	7/16"	25,000	1	08014P	-
4"	.014	1/2"-3/8"	24	1/2"	7/8"	1/2"	7/16"	20,000	1	08044P	-
4"	.014	5/8"-11	24	1/2"	7/8"	-	7/16"	20,000	1	13106P	13113P
6"	.014	5/8"-1/2"	24	1/2"	1-3/8"	1-1/4"	9/16"	9,000	1	08085P	-



13106P

**Cable Twist Wheel** - Maximum brushing action with minimal flexibility; ideal for demanding cleaning and surface prep applications on relatively smooth surfaces.



Dia.	Wire Size	Arbor Hole	No. of Knots	Face Width	Trim Length	Max. AH Avail.	Thickness at Face Plates	Max. RPM	Standard Pack	Item No. Steel
4"	.020	5/8"-11	24	1/4"	7/8"	1/2"	7/16"	20,000	1	13266P



13266P

**Roughneck® Stringer Bead Wheels** - Maximum impact action for fast removal of slag, spatter, oxidation as well as other surface prep and cleaning applications.



Dia.	Wire Size	Arbor Hole	No. of Knots	Face Width	Trim Length	Thickness at Face Plates	Max. RPM	Standard Pack	Item Number	
									Steel	Stainless
4"	.020	M10 x 1.25 5/8"-11	32	3/16"	7/8"	7/16"	20,000	1	13125P	-
									13131P	13138P
6"	.020	5/8"-11	56	3/16"	1-1/8"	7/16"	12,500	1	09400P	-
	.023			1/2"	1-3/8"	9/16"			08776P	-
6-7/8"	.020	5/8"-11	56	3/16"	1-1/8"	7/16"	9,000	1	09000P	-



13131P

**Crimped Wire Wheels** - Provide a flexible brushing action and consistent performance for demanding light-duty cleaning and deburring applications.



Dia.	Wire Size	Arbor Hole	Face Width	Trim Length	Max. AH Avail.	Thickness at Face Plates	Max. RPM	Standard Pack	Item Number Steel
6"	.014	5/8"-1/2"	3/4"	1-7/16"	1-1/4"	7/16"	6,000	1	01075P
6"	.014	5/8"-1/2"	5/8"	1-1/16"	-	1/2"	6,000	1	02325P
6"	.014	5/8"-1/2"	7/8"	1-1/8"	-	7/8"	6,000	1	06645P
7"	.014	5/8"-1/2"	3/4"	1-9/16"	-	1/2"	6,000	1	02335P
8"	.014	5/8"	3/4"	2-1/16"	1-1/4"	1/2"	6,000	1	01175P



01075P

**Conflex Brushes** - Small diameter copper center wheels permanently mounted onto a 1/4" stem to provide a very flexible brushing action.



Dia.	Wire Size	Face Width	Trim Length	Max. RPM	Standard Pack	Item Number Steel
3"	.008	1/2"	1"	20,000	1	17615P
	.014					17617P



17617P

**Threaded Adapters** - For mounting brushes with a 5/8"-11UNC nut to other threaded spindles.

Fixed Thread Size	Adapted Thread Size	Standard Pack	Item No.
5/8" - 11 UNC	M10 x 1.25	1	07771P
5/8" - 11 UNC	M10 x 1.50	1	07772P



07771P

# Display Packaged Product

Display Packaged Product

**Knot Wire Cup Brushes - Single Row** - Provide heavy-duty brushing action with some flexibility; ideal for demanding cleaning applications on relatively flat surfaces.



12316P

Dia.	Wire Size	Arbor Hole	Trim Length	Max. RPM	Standard Pack	Item Number Steel
2-3/4"	.014	5/8"-11 UNC	1"	14,000	1	13025P
2-3/4"	.020	M10 x 1.25 5/8"-11 UNC	1"	14,000	1	13281P 13286P
3-1/2"	.023	5/8"-11 UNC	7/8"	13,000	1	13156P
4"	.023	5/8"-11 UNC	1-1/4"	10,200	1	12316P
5"	.023	5/8"-11 UNC	1-3/8"	7,000	1	12276P*
6"	.023	5/8"-11 UNC	1-3/8"	6,600	1	12376P

\* With internal nut



13245P

**Crimped Wire Cup Brushes** - Very flexible brushing action and the most consistent performance for demanding light-duty cleaning applications; featuring a threaded nut for use on angle grinders.



Dia.	Wire Size	Arbor Hole	Trim Length	Max. RPM	Standard Pack	Item Number Steel
3"	.014	M10 x 1.25 5/8"-11 UNC	1"	14,000	1	13240P 13245P
4"	.020	5/8"-11 UNC	1-3/8"	9,000	1	14036P
6"	.020	5/8"-11 UNC	1-1/4"	6,600	1	14076P*

\* With internal nut

**Knot Wire End Brushes** - Feature a hollow end and heavy-duty brushing action with some flexibility; ideal for more demanding cleaning applications in recessed areas.



10012P



10028P

Dia.	Wire Size	Trim Length	Max. RPM	Standard Pack	Item Number Steel
3/4"	.014 .020	1-1/8"	22,000	1	10025P 10026P
1-1/8"	.014 .020	7/8"	22,000	1	10027P 10028P

**Crimped Wire End Brush** - Feature a solid end construction and very flexible brushing action ideal for more demanding light-duty cleaning applications in corners and hard-to-reach areas.



13001

Dia.	Wire Size	Trim Length	Max. RPM	Standard Pack	Item Number Steel
1"	.020	1-1/8"	20,000	1	10012P

**Mini-Grinder Kit** - For use on small right angle grinders. All products have a 5/8"-11 Arbor Hole



Kit Contains	Item No.
4-1/2" Abrasive Flap Disc (Zirconium Grain, 60 Grit); Item #50519: For grinding and finishing in one step.	13001
2-3/4" Knot Wire Cup Brush (.020 Steel Wire); Item #13286: For cleaning large surface areas.	
4" Stringer Bead Knot Wire Wheel (.020 Steel Wire); Item #13131 For weld cleaning, deburring and surface preparation.	



13002

**Air Tool/Drill Accessory Kit** -

All products have a 1/4" Stem and are ideal for general purpose cleaning and deburring in recessed or confined areas.



Kit Contains	Item No.
3" Crimped Wire Wheel (.0118 Steel Wire); Item #17616	13002
1-3/4" Crimped Wire Cup Brush (.0118 Steel Wire); Item #14301	
3/4" Crimped Wire End Brush (.020 Steel Wire); Item #10008	
3" Abrasive Flap Wheel (Aluminum Oxide Grain, 80 Grit); Item #52028	



# Display Packaged Product

## Vortec Pro® - Display Packaged Flap Discs- Angled Style (Type 29)

Convenient hang-card makes increasing point-of-purchase sales easy!



Diameter	Grit Size	Max. RPM	Phenolic Back - Zirconium			Aluminum Back - Zirconium		
			Arbor Hole	Standard Pack	Item Number	Arbor Hole	Standard Pack	Item Number
4"	36	15,000	5/8"	6	30822	5/8"-11	6	30821
	60				30825			30823
	80				30826			30824
4-1/2"	36	13,000	7/8"	6	30828	5/8"-11	6	30827
	60				30831			30829
	80				30832			30830



30828

## Multi-Purpose Brush Countertop Display -

Economical brushes provide lasting, efficient service at minimal cost.

Display Contains	Item No.
(20) 2" Multi-Purpose Brushes, White Bristle - Wood Handle; Item #40068	61011
(10) 3" Multi-Purpose Brushes, White Bristle - Wood Handle; Item #40070	



61011

## Stainless Steel Scratch Brush Countertop Display -

Ideal for removing rust, scale and paint from metal surfaces.

Display Contains	Item No.
(36) Stainless Steel Small Hand Scratch Brushes, 7-1/2" x 1/2" Block Wood Handle; Item #44167	61012



61012

## FREE Sweeping Center Rack And Header with Qualifying Order - Rack #44901 and Header #44902

Contact Customer Service at 800-835-9999 for details on how to receive a FREE rack and header to use when displaying Weiler maintenance products.

A Qualifying Order is required. Below is an example of a Qualifying Order.

### Recommended List of Product for Sweeping Center Display

Description	Item No.
6 each: 24" Contractor Broom, Flagged Grey Polystyrene Border with Stiff Black Polypropylene Center, 3" Trim	44581
24" Contractor Broom, Palmyra, 4" Trim	44584
24" Contractor Broom, Medium Maroon Polypropylene, 3-1/4" Trim	44587
24" Contractor Broom, Stiff Blue Polypropylene, 3-1/4" Trim	44590
12 each: 57" Light Industrial Corn Broom, 17" Trim	44548
24 each: 5' x 1-1/8" Contractor Broom Handle with Free Brace	44635

Item #s 44901 & 44902 must appear on purchase order.



42300

## FREE Pro-Flex™ Display Box with Qualifying Order - Display Box #44625

Contact Customer Service at 800-835-9999 for details on how to receive your FREE display box to use when displaying Weiler Pro-Flex products.

A Qualifying Order is required. Below is an example of a Qualifying Order.

### Recommended List of Product for Pro-Flex™ Display Box

Description	Item No.
3 each: 24" Flagged Grey Polystyrene Border with Stiff Black Polypropylene Center, 3" Trim	44600
24" Palmyra, 4" Trim	44601
24" Medium Maroon Polypropylene, 3-1/4" Trim	44604
24" Stiff Blue Polypropylene, 3-1/4" Trim	44606

Each sweep comes with handle attached and ready to display.

Item #44625 must appear on purchase order.



44625

Display Packaged Product

# Alphabetical Product Index

Description	Page	Description	Page	Description	Page
4-in-1 Tube Fitting Brushes	164	Brushes for Small Angle Grinders	41-44	Non-Sparking	58
<b>A</b>		Bucket Grid	173	Nylon Abrasive Filament (Nylox)	56, 88, 93
Abrasive Flap Disc Selection Guide	99	Burr-Rx® Brushes	78, 81-82	Pencil	48
Abrasive Flap Disc Technical Information	99-101	Butcher Block Brushes	162	Pilot Bonding	47
Abrasive Flap Discs	99-111	Bus Brush	152	Engineered Product (Nylox)	77
Angled, Type 29 (Tiger Discs)	105	<b>C</b>		External Tube Fitting Brushes	164
Angled, Type 29 (Vortec Pro)	109	Cement Finishing Brushes	159	<b>F</b>	
BobCat Mini Discs	111	Chip & Oil Brushes	169	File Card Brush	162
Display Packaged (Vortec Pro)	110, 176	Chipping Hammer Refill	162	Fitch Brushes	170
Flat, Type 27 (Tiger Discs)	106	Circular Flared End Brushes	48	Flap Wheels	116-117, 133
Flat, Type 27 (Vortec Pro)	109	Coated Abrasive Belts	118-120	Floor Brush Selection Guide	137
High Density Flap Discs	103	Coated Abrasive Flap Wheels	116-117	Floor Brushes	139, 141-144
Saber Tooth Ceramic Flap Discs	102	Coated Abrasive Shop Rolls	120	Floor Squeegees	151
Tiger Paw™ Flap Discs	107-108	Coated Abrasives	100-120	Flue Brushes	163
Trimmable Tiger Discs	104	Combo Bucket	157	Flux Brushes	171
Vortec Pro® Flap Discs	109-110	Concave Brushes	36	FME Area Products	92-93
Abrasives	94-133	Conflex Brushes	35-36, 93	<b>G</b>	
Abrasive Nylon Filament Brushes	66-93	Contractor Brooms	142	Garage Brushes	145
Acid Brushes	171	Controlled Flare End Brushes	47, 93	General Information	6
Adapters		Convolute Wheels	129	Glue Brushes	171
Adapters, Small Angle Grinder Brushes	42	Copper Center Wheels	33, 35-37, 57	Green Works™ Maintenance Products	139-140
Metal	31, 37, 90, 117, 129	Counter Dusters	140, 150	Grinding Wheels	126
Plastic Adapters	34, 91, 127, 129	Crack Cleaning Brushes	24	Grout Detail Brush	154
Pressboard Adapters	90	Crimped Wire Wheels	29-36	Gun Cleaning Brushes	53
Telescoping Plastic	129	Crosshole Deburring Brushes	49, 84	<b>H</b>	
Threaded	42	Cup Brushes		Hand Pads	132
TRIM-KUT Adapters	115	Crimped Wire	40, 43	Hand Scratch Brushes	93, 160-162
Adapting Nuts	106, 115, 126	Crimped Wire-Non-Sparking	58	Hand Scrub Brushes	153
AL-tra CUT™ Discs	113	For Small Right Angle Grinders	43	Handles	140, 147-148, 156-157
Application Solution Guides		Knot Wire	38-39, 43	<b>I</b>	
Cut-Off Wheels	123	Miniature	55	Industrial Paint Brushes	168
Nylon Abrasive Filament Brushes (Nylox)	76	Nylon Abrasive Filament (Nylox)	87, 92	Industries Served	2
Power Brushes	17-18	Stem-Mounted	40	Internal Tube Fitting Brushes	164
Arbor Hole Table	20	Cutting Wheels	125	Item No. Index	179-186
Artist Brushes	170	Cut-Off Wheel Selection Guide	122	<b>J</b>	
Acid Scrub Brushes	159	Cut-Off Wheel Technical Information	121-123	Joint/Crack Cleaning Brushes	24
Application Engineering Information	8	Cut-Off Wheels	124, 127	<b>K</b>	
Applicator Brushes	158, 159	<b>D</b>		Knot Wire	
<b>B</b>		Dauber Brush	171	Wheels	22-28
Baseboard Brush	153	Deck Scrub Brushes	153	Cup Brushes	38-39, 43
Bamboo Handles	140	Deck Mops	157	End Brushes	45
Belts	118-120	Detail Brushes	168	<b>L</b>	
Bent Radiator Brush	168	Diamond Filament Wheels	83	Lacquering Brushes	170
Bevel Brushes		Die Grinder	93	Lubricant (Lubricut)	73, 79
Crimped Wire	35, 42	Disc Brushes	85-87	<b>M</b>	
Knot Wire	26, 42	Display Packaged Product	174-176	Maintenance Products Overview	134-138
Nylox®	92	Dope Brushes	171	Maintenance Products	134-173
Big Cat® High Density Flap Discs	103	Drive Arbors	91	Maintenance Product Technical Information	137-138
Bi-Level Scrubs	140, 152-153	Driveway Coaters	145	Mandrels	111, 124, 128
Blending Discs	114	Dually® Weld Cleaning Brushes	28	Marking Brushes	170
Block Type Scratch Brushes	162	Duo Sweep	139	Masonry Brushes	158-159
Bob Cat™ Mini Flap Discs	111	Dust Mops	156	Metal Adapters	31, 37, 90, 117, 129
Bonded Abrasives (Vortec Pro)	121-127	Dust Pans	150	Metal Chip Brush	162
Bonded Abrasive Technical Information	121-123	<b>E</b>		Miniature Brushes	
Bonded Abrasive Safety Information	121	Encapsulated Brushes (Polyflex)		Cup	55
Bore-Rx™ Brushes	49, 84	Stem-Mounted Wheels (Conflex)	35	End	56
Bottle Washing Brush	155	Crimped Wire Wheels	30, 32, 34, 42	Nylon Abrasive Filament End (Nylox)	56, 88, 91, 93
Bowl Brushes	154-155	Cup Brushes	39, 43	Wheel	55
Braces and Tips	148	End Brushes	47, 48	Mop Handles	156-157
Brooms		Flared End Brushes	48	Mops	156-157
Contractor	142	Knot Wire Wheels	27, 42, 45	<b>N</b>	
Floor	139, 141-144	Small Diameter Wire Wheels	34	Nail Brushes	155
Garage	145	Tube Brushes	51	Need A Solution Form	9
Handles	147-148	End Brushes		New Products	4
Selection Guide	137-138	Circular Flared	48	Non-Sparking Brushes	57-58
Street	146	Controlled Flare	47, 93		
Strip	144	Crimped Wire	46		
Upright	149	Encapsulated	47-48		
Whisk	149	Knot Wire	45		
Wire	146	Miniature	56		

# Alphabetical Product Index

Description	Page	Description	Page	Description	Page
Non-Woven Discs	130-131	Scratch Brushes	93, 160-162	Non-Sparking	58
Non-Woven Flap Wheels	133	Block Type	162	Nylon	53, 155
Non-Woven Hand Pads	132	Butcher Block	162	Nylon Abrasive Filament (Nylox)	89
Nylon Abrasive Filament Brushes (Nylox)	66-93	Chipping Hammer Refill	162	Wire	50-54
Adapters	90-91	Curved Handle	160	Tube Fitting Brushes	164
Bore-Rx	49, 84	File Card	162	Type 1 Cut-Off Wheels	124, 127
Brush Selection Guide	73	Metal Chip	162	Type 27 Abrasive Flap Discs	102-111
Brushing Machine	77	Nylox	93	Type 27 Cutting Wheels	125
Burr-Rx	78, 81-82	Plater's	161	Type 27 Grinding Wheels	126
Cup Brushes	87, 92	Shoe Handle	160	Type 29 Abrasive Flap Discs	102-111
Disc Brushes	85-87	Small Hand	161-162		
Drive Arbors	91	Wire Duster	160-161	<b>U</b>	
End Brushes	56, 88, 93	With Scraper	160-161	Unitized Wheels	128
Engineered Products	77	Scrub Brushes	140, 152-154	Upholstery/Spotting Brush	152
Overview	66-70	Shop Rolls	120	Upright Brooms	149
Technical Information	71-76	Sign Brushes	170	Utility Brushes	155
Tube Brushes	89	Small Angle Grinder Reference Chart	44	Utility Scrub Brushes	154
Wheel Brushes	78-83, 92	Smoothing Brush	159		
Nylon Tube Brushes	151	Solutions Showcases		<b>V</b>	
Nylon Wheels	37	Abrasives	97-98	Valve Guide Brushes	53
Nylox Nylon Abrasive Filament Brushes	66-93	Nylon Abrasive Filament Brushes (Nylox)	69-70	Varnish Brushes	166-168
Nylox Overview	66-70	Power Brushes	13-14	Vat Brush	155
Nylox Brush Selection Guide	73	Spoke Brush	152	Vehicle Care Brushes	152
Nylox Technical Information	71-76	Square Brushes	48	Vehicle Wash Brushes	152
		Squeegees	151	Video	
<b>O</b>		Steel Flanges	90	4-1/2" Grinder Products	41
Ordering Information	3	Stem-Mounted Brushes		Dually® Weld Cleaning Brushes	28
		Circular Flared	48	Saber Tooth™ Flap Discs	102
<b>P</b>		Concave	36	Tiger Paw™ Flap Discs	107
Paint Brushes	165-168	Conflex Brushes	35	Vitrified Grinding Wheels	126
Paint and Varnish Brush Selection Guide	165	Controlled Flare	47	Vortec Pro® Abrasive Flap Discs	109-110
Paint and Varnish Brush Technical Information	165	Crimped Wire Cup	40	Vortec Pro Bonded Abrasives	124-127
Paint Rollers and Frames	172-173	Crimped Wire End	46-47		
Paint Trays	173	Crimped Wire Wheels (Conflex)	36	<b>W</b>	
Parts Cleaning Brushes	167	Encapsulated	35, 47-48	Wall Dusting Brush	150
Pencil End Brushes	48	Knot Wire End	45	Wall Paint Brushes	166
Percolator Brushes	155	Knot Wire Wheels	26	Watercolor Brushes	170
Perma-Sweep Floor Brushes	142	Miniature	55-56	Wax Applicators	157
Pilot Bonding Brushes	47	Nylon Abrasive Filament (Nylox)	88	Weiler Die Grinder	93
Plastic Adapters	34, 91, 127, 129	Pencil End	48	Weiler Right Angle Grinder	92
Plater's Brushes	161	Pilot Bonding	47	Weld Cleaning Brushes	27-28
Plater's Brass Wire Wheels	33	Radial Wheels	36	Wet Mops	156
Power Brushes	10-65	Square	48	Wheel Brushes	
Power Brush Overview	10-14	Stencil Brushes	171	Abrasive Flap	113, 116-117
Power Brush Selection Guide	17-18	Street Brooms	146	Crimped Wire-Bench Grinder	30
Power Brush Technical Information	15-21	Stringer Bead Brushes	27-28, 41-42	Crimped Wire-Bevel Brushes	35-42
Pressboard Adapters	90	Strip Brooms	144	Crimped Wire-Encapsulated	30, 32, 42, 47
Pro-Flex™ Sweeps	141	Strip Brushes	59-62	Crimped Wire-Medium Face	31
Product Selection Guides		Stylus Brush	171	Crimped Wire-Non-Sparking	57
Abrasive Flap Discs	99	Surface Conditioning Discs	130-131	Crimped Wire-Wide Face	32
Bonded Abrasives	122			For Small Angle Grinders	41-42
Cut-Off Wheels	122	<b>T</b>		Knot Wire-Bevel Brushes	26, 42
Floor Brushes	137	Table of Contents	3	Knot Wire-Cable Twist	24-25, 41
General (By Surface Finish)	8	Tampico Wheels	37	Knot Wire-Encapsulated	27, 42
Nylon Abrasive Filament Brushes (Nylox)	73	Technical Information		Knot Wire-Non-Sparking	57
Paint & Varnish Brushes	165	Abrasive Flap Discs	99-101	Knot Wire-Standard Twist	25-26, 41, 57
Power Brushes	17-18	Bonded Abrasives	121-123	Knot Wire-Stringer Bead Twist	27-28, 41-42
Professional Paint Brushes	166-167	Maintenance Products	137-138, 165	Miniature	55
Push Brooms	139-146	Non-Woven Abrasives	128	Nylon	37
Push Broom Handles	147-148	Nylon Abrasive Filament Brushes (Nylox)	71-76	Nylon Abrasive Filament (Nylox)	78-83, 92
		Paint & Varnish	165	Plater's	33
<b>R</b>		Power Brushes	15-21	Small Diameter (Copper Center)	33, 35-37, 57
Radiator Brush	150, 168	Telescoping Plastic Adapter	129	Stem-Mounted	26, 36
Resin Fiber Discs	112	Testing Lab Results (Cutting/Grinding Wheels)	123	Tampico	37
Right Angle Grinder	92	Tiger® Disc Abrasive Flap Discs	105-106	Whisk Brooms	149
Roof Brushes	158	Tiger Paw™ Abrasive Flap Discs	107-108	Whitewash Brush	158
Roughneck® Weld Cleaning Brushes	27-28, 41	Tire Cleaning Brush	152	Wide Face Brushes	63-65
		Tool Icon Reference Guide	6	Window Brushes	151
<b>S</b>		TRIM-KUT Adapters	115	Window Squeegees	151
Saber Tooth™ Abrasive Flap Discs	102	TRIM-KUT Discs	115	Wire Brooms	146
Safety Information	7	Trimmable Abrasive Flap Discs	104	Wire Descaling Brushes	23
Sash Brushes	166-167	Tube Brushes		Wire Duster	162
Satisfaction Guarantee	6			Wire Stripping Brushes	34

# Item Number Index

Item No.	Page	Item No.	Page	Item No.	Page	Item No.	Page	Item No.	Page
00104	29	02325P	174	06020	31	08264	22	10004	46
00105	29	02335	31	06040	31	08271	57	10005	46
00114	29	02335P	174	06050	31	08274	22	10006	46
00124	29	03000	32	06060	31	08284	22	10007	46
00134	29	03010	32	06070	31	08294	22	10008	46
00135	29	03020	32	06080	31	08300	23	10009	46
00144	29	03030	32	06090	31	08309	23	10010	46
00154	29	03040	32	06100	31	08310	23	10011	46
00156	35	03050	32	06110	31	08314	22	10012	46
00184	29	03060	32	06120	31	08319	23	10012P	175
00204	29	03070	32	06150	31	08325	22	10013	46
00214	29	03090	32	06160	31	08330	23	10014	46
00234	29	03100	32	06170	31	08339	23	10015	46
00244	29	03110	32	06180	31	08345	22	10016	46
00264	29	03130	32	06190	31	08346	25	10017	46
00274	29	03140	32	06200	31	08375	22	10018	46
01035	29	03150	32	06440	31	08395	22	10019	46
01045	29	03160	32	06450	31	08534	24	10020	46
01049	29	03180	32	06490	31	08565	24	10021	46
01055	29	03190	32	06530	31	08615	24	10022	46
01065	29	03200	32	06620	31	08695	24	10023	46
01068	29	03210	32	06645	32	08750	27	10024	46
01075	29	03220	32	06645P	174	08756	27	10025	45
01075P	174	03230	32	06655	32	08766	27	10025P	175
01085	30	03240	32	07286	64	08775	27	10026	45
01095	30	03403	90	07340	64	08776	27	10026P	175
01115	30	03404	90	07341	64	08776P	174	10027	45
01125	30	03405	90	07342	64	08786	27	10027P	175
01135	29	03480	32	07343	64	08796	27	10028	45
01138	29	03510	32	07344	64	08806	27	10028P	175
01145	29	03520	32	07700	91	08835	22	10029	45
01148	29	03590	32	07701	91	08878	24	10030	45
01155	29	03680	32	07702	91	08879	24	10031	45
01158	29	03804	129	07703	91	08916	27	10032	45
01165	29	03805	129	07715	91	08926	27	10033	48
01168	29	03806	129	07718	91	08954	27, 41	10034	48
01175	29	03807	129	07721	34	08975	22	10035	48
01175P	174	03808	129	07722	34	09000	27	10037	48
01178	29	03809	31, 37, 90	07723	34	09000P	174	10038	48
01179	29	03810	31, 37, 90	07724	34	09020	23	10039	48
01228	29	03811	31, 37, 90	07725	34	09029	23	10040	48
01238	29	03812	31, 37, 90	07726	34	09040	23	10041	48
01248	29	03813	31, 37, 90	07727	34	09049	23	10042	48
01250-12	29	03814	31, 37, 90	07729	34	09080	23	10043	48
01258	29	03824	31, 37, 90	07746	42	09089	23	10044	48
01259	29	03833	117	07756	116	09100	27	10045	48
01299	29	03834	117	07761	128	09104	23	10046	48
01309	29	03835	117	07764	128	09134	23	10047	48
01319	29	03890	90	07766	111	09160	23	10048	48
01320-14	29	03892	90	07769	42	09180	23	10050	48
01329	29	03893	90	07771	42	09200	27	10056	47
01339	29	03895	90	07771P	174	09379	24	10057	47
01349	29	03910	90	07772	42	09386	27	10058	47
01415	57	03911	90	07772P	174	09396	27	10059	47
01475	57	03912	90	08004	22	09400	27	10067	45, 58
01501	30	03913	90	08014	22	09400P	174	10073	48
01502	30	03915	90	08014P	174	09410	23	10074	48
01503	30	03920	90	08024	22	09430	23	10076	48
01504	30	03921	90	08034	22	09440	23	10091	46, 58
01505	30	03922	90	08044	22	09460	23	10099	48
01506	30	03923	90	08044P	174	09480	23	10128	46, 58
01508	30	03925	90	08045	22	09490	23	10134	48
01509	30	03931	90	08064	22	09500	27	10141	45
01511	30	03933	90	08075	22	09510	23	10142	45
01512	30	03934	90	08085	22	09530	23	10150	48
01513	30	03936	90	08085P	174	09540	23	10151	48
01514	30	03944	90	08095	22	09719	22	10152	88
01515	30	03945	90	08105	22	09790	23	10153	88
01517	30	03946	90	08106	25	09799	23	10154	88
01518	30	03954	90	08125	22	09800	23	10155	88
01521	30	03955	90	08135	22	09809	23	10156	88
01531	32	03956	90	08138	22	09840	23	10157	88
01532	32	03960	90	08145	22	09856	27	10158	46, 58
01675	29	03963	90	08155	22	09866	27	10160	47
01695	29	03965	90	08169	22	09870	22	10172	88
01705	29	03973	90	08178	22	09960	23	10173	88
01775	29	03974	90	08179	22	09969	23	10174	88
01795	29	03975	90	08189	22	09980	23	10186	46
01805	29	04400	34, 91	08199	22	09989	23	10187	45
01809	29	04401	34, 91	08200-14	22	09990	23	10188	46
01898	29	04402	34, 91	08209	22	09999	23	10208	45
01939	29	04403	34	08219	22	10001	46	10210	45
01949	29	04440	129	08249	22	10002	46	10211	45
02325	31	04455	24, 127	08254	22	10003	46	10212	45



# Item Number Index

Item No.	Page	Item No.	Page	Item No.	Page	Item No.	Page	Item No.	Page
17684	26	21041	52	21175	51	25291	144	30720	117
17686	26	21044	52	21178	50, 58	25294	144	30721	117
17687	26	21050	52	21179	50, 58	25295	144	30722	117
17689	26	21051	52	21181	51	25297	147	30723	117
17691	26	21053	52	21182	51, 58	25299	144	30724	117
17901	36	21055	52	21184	50	26000	55	30725	117
17902	36	21056	52	21191	52, 58	26001	55	30726	117
17903	36	21057	52	21203	51	26003	55	30727	117
17906	36	21058	52	21218	50, 58	26004	55	30728	117
17907	36	21072	51	21219	50, 58	26005	55	30821	110, 176
17909	36	21073	51	21221	52, 58	26012	55	30822	110, 176
17912	36	21074	51	21232	50	26014	55	30823	110, 176
17914	36	21075	51	21233	52	26015	55	30824	110, 176
17915	36	21076	51	21236	50	26016	55	30825	110, 176
17917	36	21077	51	21240	51	26017	55	30826	110, 176
17922	36	21078	51	21245	50	26021	55	30827	110, 176
17923	36	21079	51	21246	52	26041	55	30828	110, 176
17930	36	21080	51	21247	50	26042	55	30829	110, 176
17931	36	21081	51	21249	52	26043	55	30830	110, 176
17933	36	21082	51	21252	50	26059	55	30831	110, 176
17935	36	21083	51	21264	51	26071	55	30832	110, 176
17936	36	21084	51	21265	51	26072	55	31074	81
17937	36	21085	51	21266	51	26074	55	31084	81
17950	36	21086	51	21267	51	26075	55	31094	81
17951	36	21087	51	21269	51	26076	55	31100	81
17952	36	21088	51	21270	52, 58	26091	55	31101	81
17953	36	21089	51	21282	51	26093	55	31102	81
17954	36	21090	52	21304	89	26094	55	31103	81
17955	36	21091	52	21305	89	26095	55	31104	81
17956	36	21092	52	21306	89	26096	55	31105	81
17957	36	21093	52	21308	89	26097	56	31110	81
17958	36	21094	52	21309	89	26098	56	31111	92
17959	36	21095	52	21311	89	26099	56	31112	92
17961	36	21096	52	21312	89	26101	56	31113	92
17962	36	21097	52	21322	51	26106	56	31114	81
17963	36	21098	52	21325	89	26107	56	31121	81
17964	36	21099	52	21326	89	26108	56	31122	81
17965	36	21100	52	21327	89	26113	56	31123	81
17966	36	21101	52	21328	89	26114	56	31124	81
17967	36	21103	52	21329	89	26115	56	31134	81
17968	36	21104	52	21330	89	26116	56	31135	81
17969	36	21105	52	21332	51, 58	26119	56	31136	81
17971	36	21106	50	21340	51	26121	56	31137	81
17972	36	21107	50	21342	50	26122	56	31240	81
17973	36	21108	50	21345	89	26128	56	31241	81
17974	36	21109	50	21404	51	26131	56	31242	81
17975	36	21110	50	21413	50	26133	56	31245	81
17976	36	21111	50	21414	52	26136	56, 88	31246	81
17977	36	21112	50	21473	89	26138	56, 88	31255	81
17978	36	21113	50	21758	89	26140	55	31265	81
17979	36	21114	50	21759	89	26141	55	31270	81
17981	36	21115	50	21761	89	26143	55	31275	81
17982	36	21116	50	21762	89	26144	55	31280	81
20180	37	21117	50	21763	89	26146	56, 88	31285	81
20190	37	21118	50	21764	89	26155	55	31290	81
20490	37	21119	50	21765	89	26294	55	31301	109
20510	37	21120	50	21976	89	26296	55	31302	109
20600	80	21121	50	22021	33	26900	89	31303	109
20610	80	21122	50	22061	33	26901	89	31304	109
20620	80	21123	50	22241	33	26902	89	31305	109
20630	80	21124	50	25100	160	26903	89	31306	109
20650	80	21125	50	25104	160	26904	89	31307	109
20661	80	21126	89	25150	160	26905	89	31308	109
20730	80	21128	89	25154	160	26906	89	31309	109
21000	52	21130	89	25201	160	26907	89	31310	109
21001	52	21132	89	25202	160	26908	89	31311	109
21004	52	21133	89	25211	161	26909	89	31312	109
21005	52	21134	89	25212	162	26910	89	31313	109
21008	52	21136	89	25221	167	26911	89	31314	109
21009	52	21138	89	25222	167	26912	89	31315	109
21014	52	21139	52, 58	25231	143	26913	89	31316	109
21015	52	21142	51	25232	143	26914	89	31317	109
21020	52	21143	51	25234	143	26915	89	31318	109
21021	52	21144	51	25235	143	29025	37	31319	109
21023	52	21146	51	25238	145	29059	57	31320	109
21025	52	21148	51	25239	145	29070	37	31321	109
21027	52	21149	51	25241	145	29078	57	31322	109
21028	52	21150	51	25242	145	29086	57	31323	109
21030	52	21152	51, 58	25251	150	29088	82	31324	109
21031	52	21161	52	25252	150	29123	82	31325	109
21034	52	21162	52	25262	154	29178	57	31326	109
21035	52	21164	50	25263	154	29280	82	31327	109
21036	52	21165	52, 58	25271	151	29353	82	31328	109
21040	52	21167	50	25290	144	29356	82	31329	109

# Item Number Index

Item No.	Page	Item No.	Page	Item No.	Page	Item No.	Page	Item No.	Page
31330	109	35234	48	36059	36	36297	28	40123	167
31331	109	35240	34	36060	40	36298	28	40129	169
31332	109	35250	34	36061	40	36303	164	40130	169
31333	109	35260	34	36062	30	36304	164	40131	169
31334	109	35293	34	36063	30	36305	164	40132	169
31335	109	35294	34	36064	30	36307	28	40133	169
31337	109	35296	48	36065	32	36308	28	40134	169
31338	109	35297	48	36066	39	36459	126	40135	169
31339	109	35298	48	36068	40	36460	126	40136	169
31340	109	35299	48	36070	39	36512	124	40137	169
31341	109	35305	35	36200	30	36666	157	40138	169
31342	109	35310	35	36201	30	40000	166	40139	169
31343	109	35315	35	36202	30	40001	166	40140	169
31344	109	35340	47	36203	31	40002	166	40141	169
31345	109	35345	47	36204	32	40003	166	40160	169
31346	109	35350	47	36205	30	40004	166	40161	169
31347	109	35406	39, 43	36206	32	40008	166	40162	169
31348	109	35416	35, 42	36207	35	40010	166	40163	169
31349	109	35500	47	36208	36	40011	166	40164	169
31350	109	35505	47	36209	36	40012	168	40165	169
31351	109	35520	30	36211	36	40013	168	40166	169
31352	109	35530	39	36212	25	40014	166	40177	169
31353	109	35535	47	36213	25	40017	166	40179	169
31354	109	35540	47	36215	25	40018	166	40180	169
31355	109	35545	47	36216	25	40019	167	40181	169
31356	109	35600	27	36217	25	40020	167	40182	169
31357	109	35760	39	36218	28	40021	167	40183	169
31358	109	35800	27, 42	36219	28	40022	166	40184	169
31359	109	35808	34	36221	28	40023	166	40185	169
31360	109	35821	51	36222	28	40026	169	40199	168
31361	109	35822	51	36223	28	40027	169	41000	170
31362	109	35823	51	36224	25	40028	169	41001	170
31363	109	35825	51	36225	28	40029	169	41002	170
31364	109	36000	30	36226	22	40030	169	41003	170
31365	109	36001	30	36227	22	40031	169	41004	170
31366	109	36002	30	36228	22	40032	169	41005	170
31367	109	36003	31	36229	40	40035	167	41007	170
31368	109	36004	32	36230	40	40036	167	41008	170
31369	109	36005	30	36231	40	40040	166	41009	170
31370	109	36006	32	36232	40	40041	166	41010	170
31371	109	36007	35	36233	40	40056	167	41011	170
31387	110	36008	36	36234	40	40057	167	41012	170
31388	110	36009	36	36235	40	40058	166	41013	170
31389	110	36011	36	36236	40	40059	166	41014	170
31390	110	36012	25	36237	40	40060	166	41015	170
31391	110	36013	25	36238	39	40061	166	41016	170
31392	110	36015	25	36239	39	40062	166	41017	170
31401	109	36016	25	36241	39	40065	169	41018	170
31402	109	36017	25	36242	39	40066	169	41019	170
31403	109	36018	28	36243	39	40067	169	41020	170
31404	109	36019	28	36244	39	40068	169	41021	170
31407	109	36021	28	36245	39	40069	169	41022	170
31408	109	36022	28	36246	46	40070	169	41023	170
31409	109	36023	28	36247	46	40071	169	41024	170
31410	109	36024	25	36248	46	40074	168	41025	170
31413	109	36025	28	36249	46	40076	169	42001	143
31414	109	36026	22	36250	45	40077	171	42002	143
31415	109	36027	22	36251	45	40078	171	42006	143
31416	109	36028	22	36255	25	40079	171	42007	143
31419	109	36029	40	36257	25	40080	171	42008	143
31420	109	36030	40	36258	25	40081	171	42013	143
31421	109	36031	40	36259	36	40082	171	42014	143
31422	109	36032	40	36260	40	40088	168	42017	143
33000	48	36033	40	36261	40	40089	168	42021	145
33002	48	36034	40	36262	30	40101	168	42022	145
33005	48	36035	40	36265	32	40102	168	42023	145
33009	48	36036	40	36278	22	40103	168	42025	145
33052	126	36037	40	36279	22	40104	168	42026	145
33053	126	36038	39	36280	46	40106	166	42030	146
35006	39	36039	39	36281	46	40107	168	42032	146
35070	34	36041	39	36282	46	40108	168	42033	146
35084	30	36042	39	36283	46	40109	168	42035	143
35105	30	36043	39	36284	46	40110	168	42037	143
35117	30	36044	39	36285	46	40111	168	42041	143
35135	30	36045	39	36286	45	40112	168	42042	143
35160	32	36046	46	36287	45	40113	166	42047	143
35186	39	36047	46	36288	45	40114	166	42049	143
35206	27	36048	46	36289	45	40115	166	42054	146
35216	27	36049	46	36290	22	40116	167	42055	146
35222	48	36050	45	36291	22	40118	167	42095	143
35223	48	36051	45	36293	22	40119	167	42098	143
35224	48	36055	25	36294	22	40120	167	42099	146
35226	48	36057	25	36295	28	40121	167	42114	143
35233	48	36058	25	36296	28	40122	167	42134	144









# Item Number Index

Item No.	Page	Item No.	Page	Item No.	Page	Item No.	Page	Item No.	Page
69347	120	75100	156	83003	83	85798	86	86138	78
69348	120	75102	156	83004	83	85800	86	86139	78
69349	120	75103	156	83005	83	85806	86	86140	78
69350	120	75104	156	83006	83	85812	86	86141	85
69382	120	75105	156	83007	83	85814	86	86142	85
69383	120	75109	157	83010	79	85816	86	86143	85
69384	120	75110	157	83011	79	85818	86	86148	93
69385	120	75116	156	83030	79	85822	86	86150	84
69386	120	75117	156	83040	79	85824	86	86151	84
69400	120	75118	156	83050	79	85826	86	86152	84
69401	120	75126	157	83070	79	85832	86	86154	84
69402	120	75127	157	83100	79	85836	86	86155	84
69403	120	75130	156	83110	79	85842	86	86156	84
69404	120	75131	156	83111	79	85844	86	86159	93
70067	143	75132	156	83116	80	85850	86	86160	92
70068	143	75133	156	83130	79	85852	86	86164	81
70112	143	75136	156	83140	79	85854	86	86165	81
70208	146	75137	156	83150	79	85860	86	86167	85
70209	146	75138	156	83180	80	85862	86	86171	93
70210	146	75140	156	83190	80	85900	86	86172	93
70211	146	75150	157	83300	80	85901	86	86181	78
70212	146	75151	157	83310	80	85908	86	86182	78
70215	146	75152	157	83330	80	85912	86	86198	85
70300	149	75153	157	83340	80	85914	86	86199	85
70304	149	75154	157	83350	80	85920	86	86204	85
70308	149	75160	149	83393	80	85922	86	89023	91
70312	143, 152	75170	156	83394	78	85930	86	89024	91
70324	149	75171	156	83405	78	85932	86	89029	91
70325	149	75172	156	83430	80	85938	86	89033	91
70327	149	75173	156	83440	80	85940	86	94000	23
71019	150	75180	156	83450	80	85946	86	94008	24
71076	150	75181	156	83513	79	85948	86	94012	39
71077	150	75182	156	83514	79	85978	86	94026	24
71078	150	75183	156	83515	79	85981	87	94098	23
71079	150	75190	156	83516	79	85995	86	94199	24
71080	150	75191	156	83550	80	85996	86	94224	24
71081	150	75192	156	83630	80	85997	86	95013	161
72034	153	75193	156	83640	80	86013	87	95014	161
72058	153	75202	151	83715	79	86014	87	95016	93
72086	154	75206	151	83716	79	86098	88	95027	53
72101	154	75225	151	83717	79	86099	88	95028	53
73003	151	75228	151	83718	79	86100	88	95029	53
73050	150	75233	151	83719	79	86101	88	95084	53
73055	150	75242	151	83740	80	86102	88	95129	53
73075	153	75505	148	83750	80	86103	88	95151	161
73111	153, 159	75516	147	83910	80	86104	88	95202	52
73146	152	75525	147	83930	80	86105	88	95203	52
73156	152	75527	147	83940	80	86106	87	95301	53
73171	158	75528	147	83950	80	86107	87	95502	168
73177	158	75555	147	83999	79	86108	78	95563	53
73180	145	75570	155	84640	80	86109	87	95566	53
73182	145	77013	143	84710	80	86110	87	95567	53
73195	158	77014	143	84730	80	86111	87	95660	53
73217	160	79100	154	84740	80	86112	85	95665	53
73218	160	79101	154	84750	80	86113	85	95925	163
73233	154	79107	154	84925	78	86114	85	96702	173
74002	158	79109	154	84926	78	86115	85	96705	48
74004	158	79120	154	84941	78	86116	85	99307	33
74015	159	79251	159	85014	79	86117	85	99346	37
74020	158	79252	159	85150	80	86120	78	99383	161
74048	158	79253	159	85153	80	86121	85	99551	33
74053	158	79255	159	85156	80	86122	85	99553	33
74078	159	79256	159	85440	80	86123	78	99554	55
75000	155	79800	28	85733	87	86124	78	99593	152
75001	154	79801	28	85736	87	86125	85	99594	155
75002	154	79802	28	85738	87	86126	78	99694	53
75003	155	79803	28	85750	87	86127	78	99714	53
75021	155	79804	28	85751	87	86128	78	99786	53
75060	155	79805	28	85752	87	86129	78	99788	53
75068	154	79810	28	85753	87	86130	78	99791	53
75070	154	79811	28	85773	87	86131	78	99801	168
75071	154	79812	28	85776	86	86132	78	99805	168
75072	155	79813	28	85778	86	86133	78	99806	168
75085	155	79814	28	85786	86	86134	78	99823	48
75096	157	79815	28	85788	86	86135	78	99825	48
75097	157	83000	79	85792	86	86136	78		
75098	157	83002	83	85794	86	86137	78		

Item Number Index

