



**Hewlett Packard  
Enterprise**

# **THE RUGGED EDGE IS NOW A COMMERCIAL DOMAIN**

**Key to an Edge to Core to Cloud Architecture**



Bill Burnham  
US Federal CTO  
Hewlett Packard Enterprise

August 2020



# HPE TODAY...

Hybrid IT

Products

HPE  
Pointnext  
Services

Intelligent Edge



Supercomputing



Data Platform for  
AI & Analytics



High Performance  
Computing



Big Data / Fast Data  
Analytics Software



All-Flash and Hybrid  
Flash Storage



Software Defined  
Network Data Fabric



Hyperconverged Platform



Datacenter Management  
Software



Cloud Consulting Practice  
AWS and US Focus



Cloud Consulting Practice  
Azure and UK Focus



Service Authentication  
Edge to Core to Cloud



Cloud Consumption  
Analytics Software



Wireless Network  
Solution Provider



Wireless Network  
Analytics



User and Entity Behavior  
Analytics



Sensor Based Network  
Performance & Monitoring



SD WAN  
Solution Provider

# THE FUTURE IS EDGE CENTRIC, CLOUD ENABLED AND DATA DRIVEN

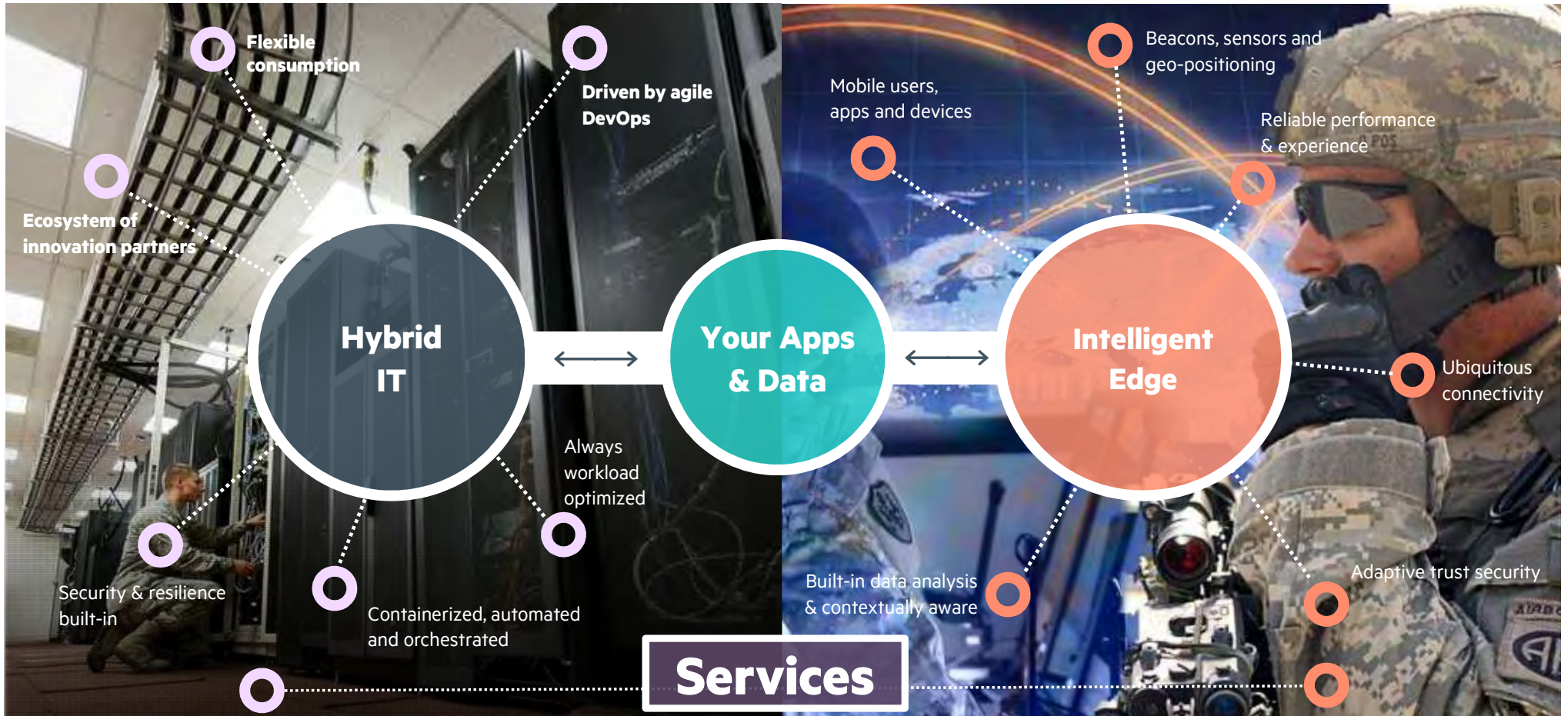

# **FOUR KEY CHALLENGES TO ADOPTING HYBRID IT**

---

- Application Rationalization
- Data availability between environments
- Workload Orchestration and management
- Security and Authentication between environments



# GLOBALY DISTRIBUTED GOVERNMENT COMMUNICATIONS CHALLENGES

---

- Space, power and air conditioning challenges overseas
- Shipping challenges (Diplomatic Courier Service limits delivery frequency)
- Increased Cyber threats – Insider and external
- Secure remote access for remote operation/trouble-shooting



# THE EDGE IS A PLACE...



Sports arenas

Electrical power grid

Planes, trains, automobiles

Medical facility

Residences

People, animals, nature

Manufacturing floor

Buildings, Branch Office

Wind farm

Energy power plant

Ships, boats, submarines

Crop fields

Why compute  
at the Edge?



Latency



Bandwidth



Cost



Threats



Duplication



Reliability



Compliance

# **HPE EDGELINE PRODUCT OVERVIEW**

---

Built for the rugged edge in the commercial sector



# HPE EDGELINE CONVERGED EDGE SYSTEMS

One platform serving the spectrum of Edges

1. **Size, Weight & Power (SWaP) optimized**
2. **Commercial Off the Shelf (COTS)**
3. **Industry leading security and manageability**
4. **Open Standards-based**
5. **Purpose built for the edge**

Extreme Level  
Converged Edge System

EL8000



High Level  
Converged Edge System

EL4000



Mid-High Level  
Converged Edge System

EL1000



Mid Level  
Converged Edge System

EL300



Converged  
Edge Systems  
OT + IT

GL20

Mid Level  
Gateway

GL20



Basic  
Gateways

Entry Level  
Gateway

GL10





# HPE EDGELINE CONVERGED SERVER FAMILY

## EL1000 (3.5”H x 14”W x 9”D)



Single node Xeon-D (65W)  
LP Accelerator and SFF SSD support

## EL300 (7.5”H x 9”W x 4”D)



Single node i5 (15W)  
Fanless, IP50 rated  
-30°C to 70°C

## EL8000 (8.6”H x 8.7”W x 17”D)



Four node **Cascade Lake (205W)**  
**Full Size** Accelerator support  
**NVMe and SFF storage** options  
Integrated **4x10Gb** networking  
**Enterprise Security and Management**  
**0°C to 55°C Operating Temperature**

## EL4000 (1.75”H x 17”W x 20”D)

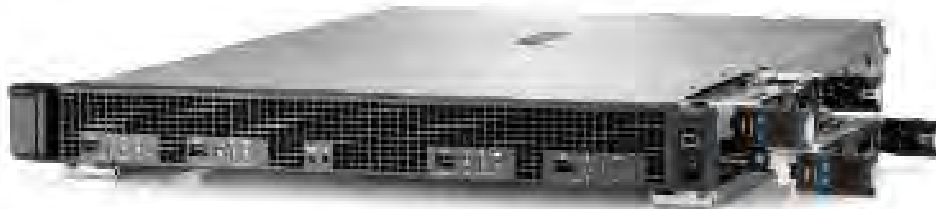

Four node Xeon-D (65W)  
LP Accelerator support  
NVMe support

## **EDGE LINE EL8000 ~ THE NEW STANDARD FOR THE INTELLIGENT EDGE**

---



**Up to four Data Center quality server blades, capable of running Artificial Intelligence, Machine Learning and Data Analytic workloads. Commercial Airline carry-on size means compute can travel with you.**



## **THE STORY WE'VE TOLD FOR YEARS HAS COME TRUE**

---

**Commercial companies partner and spend \$1 billion  
Over two and a half years  
To Design, Engineer and Produce a product  
That by chance meets a critical DoD requirement.**

**The HPE Edgeline EL8000 Converged Server Platform  
Built for the 5G Telco community is perfect for  
The Department of Defense Rugged Edge Mission.**



## EDGE IN THE FY20 NDAA

On December 20, 2019, President Trump signed into law the National Defense Authorization Act (NDAA) for Fiscal Year (FY) 2020

### SEC. 259. COMMERCIAL EDGE COMPUTING TECHNOLOGIES AND BEST PRACTICES FOR DEPARTMENT OF DEFENSE WARFIGHTING SYSTEMS.

(a) REPORT REQUIRED.—Not later than 120 days after the date of the enactment of this Act, the Under Secretary of Defense for Acquisition and Sustainment shall submit to the congressional defense committees a report on commercial edge computing technologies and best practices for Department of Defense warfighting systems.

(b) CONTENTS.—The report submitted under subsection (a) shall include the following:

(1) Identification of initial warfighting system programs of record that will benefit most from accelerated insertion of commercial edge computing technologies and best practices, resulting in significant near-term improvement in system performance and mission capability.

(2) The plan of the Department of Defense to provide additional funding for the systems identified in paragraph (1) to achieve fielding of accelerated commercial edge computing technologies before or during fiscal year 2021.

(3) The plan of the Department to identify, manage, and provide additional funding for commercial edge computing technologies more broadly over the next four fiscal years where appropriate for—

(A) command, control, communications, and intelligence systems;

(B) logistics systems; and

(C) other mission-critical systems.

(4) A detailed description of the policies, procedures, budgets, and accelerated acquisition and contracting mechanisms of the Department for near-term insertion of commercial edge computing technologies and best practices into military mission-critical systems.

# HPE EDGELINE EL8000

## Chassis:

- Small Size: 8.6" x 8.7" x 17"
- 5U. Half rack width.
- All I/O on the same side. Chassis is reversible.
- Variety of power supply options

## Configurations per 5U half width block:

- Up to 4 high-power compute blades (Scalable Cascade Lake processors, up to 28 Core 205W TDP Xeon per blade, plus accelerator options – GPU, FPGA, etc.)
- Storage Chassis (June 2020): Compute node w/ >120TB raw capacity (8SFF SSDs w/ HW RAID)

## Ruggedized

- 0-55C operational temperature specification
- Tested to higher levels of shock and vibration vs. typical server

## Superior Management and Security

- iLO5 Silicon root of Trust
- Backed by HPE's Secure Supply Chain

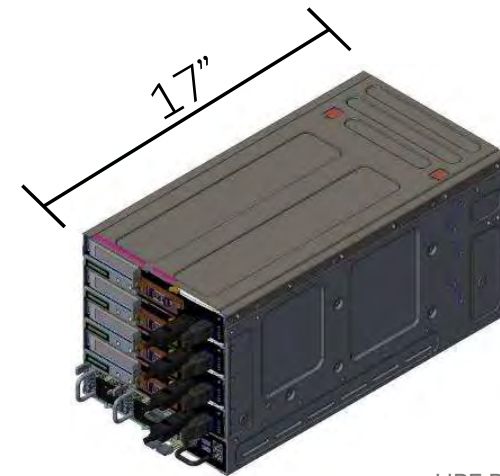
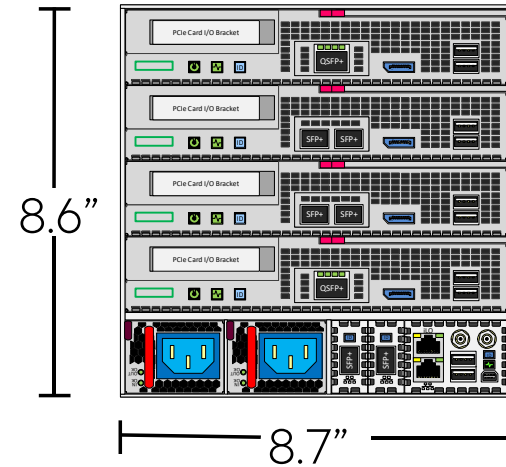

# EDGELINE EL8000 CREATES INCREDIBLE DENSITY

- Built for the Edge, but data center capable --with Zero-U shelf, two EL8000 chassis can be mounted side by side
- Twelve chassis in 30 RU provides 48 server nodes totaling up to:
  - 1,344 cores of Cascade Lake compute (using Platinum 8280M 28 core Xeon 205W TDP )
  - 72TB DDR4 RAM
  - 960TB NVMe Storage
  - 48 PCIe Gen3 slots available for GPU, FPGA, high speed networking
  - Integrated 10Gb switches for dual uplink to top of rack switches



## GETTING TO THE EDGE CAN BE TOUGH ~ SIZE AND WEIGHT MATTER

Which would you rather ship? Which would you rather receive?



Three normal data center servers with one top of rack switch, requiring assembly upon arrival and no switch redundancy.

One HPE Edgeline EL8000 with four data center server blades and two integrated 10Gb/s switches. Plug it in and turn it on.

# EDGELINE EL8000 VALIDATIONS & CERTIFICATIONS

## VMware Compatibility Guide

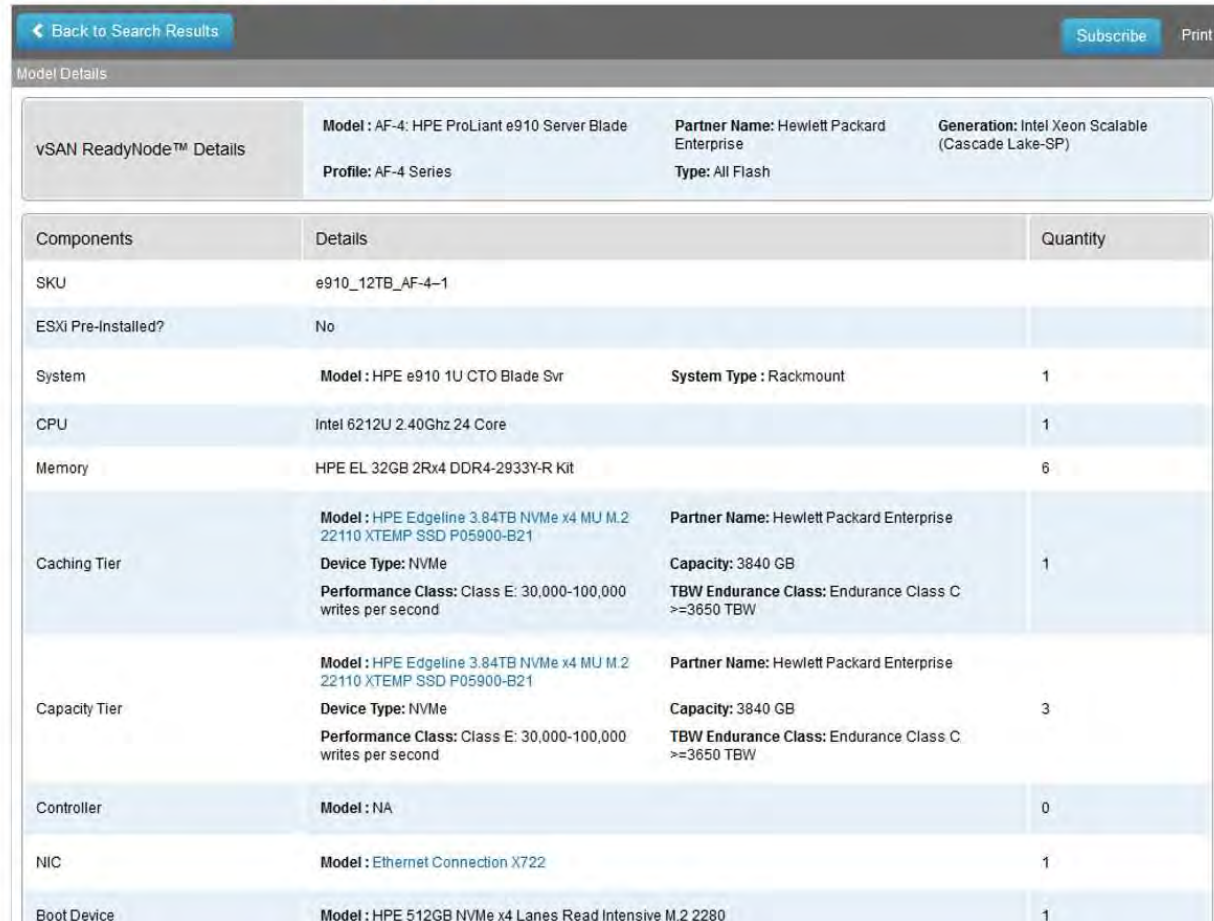

Model Details

Model : AF-4: HPE ProLiant e910 Server Blade    Partner Name: Hewlett Packard Enterprise    Generation: Intel Xeon Scalable (Cascade Lake-SP)  
Profile: AF-4 Series    Type: All Flash

Components	Details	Quantity
SKU	e910_12TB_AF-4-1	
ESXi Pre-Installed?	No	
System	Model : HPE e910 1U CTO Blade Svr    System Type : Rackmount	1
CPU	Intel 6212U 2.40Ghz 24 Core	1
Memory	HPE EL 32GB 2Rx4 DDR4-2933Y-R Kit	6
Caching Tier	Model : HPE Edgeline 3.84TB NVMe x4 MU M.2 22110 XTEMP SSD P05900-B21    Partner Name: Hewlett Packard Enterprise Device Type: NVMe    Capacity: 3840 GB Performance Class: Class E: 30,000-100,000 writes per second    TBW Endurance Class: Endurance Class C >=3650 TBW	1
Capacity Tier	Model : HPE Edgeline 3.84TB NVMe x4 MU M.2 22110 XTEMP SSD P05900-B21    Partner Name: Hewlett Packard Enterprise Device Type: NVMe    Capacity: 3840 GB Performance Class: Class E: 30,000-100,000 writes per second    TBW Endurance Class: Endurance Class C >=3650 TBW	3
Controller	Model : NA	0
NIC	Model : Ethernet Connection X722	1
Boot Device	Model : HPE 512GB NVMe x4 Lanes Read Intensive M.2 2280	1

- vSAN ReadyNode
- Nutanix (DX8000)
- Azure Stack HCI
- Azure Stack Hub (in progress)
- HPE Container Platform
- Red Hat OpenShift





# HPE PROLIANT E910 SERVER

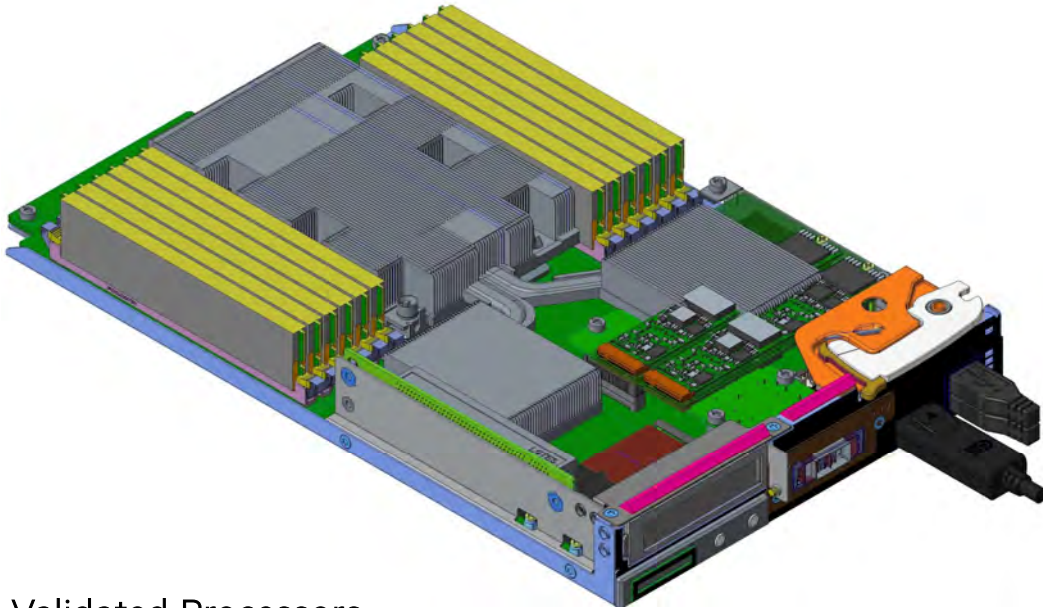

## e910 Server Networking Options

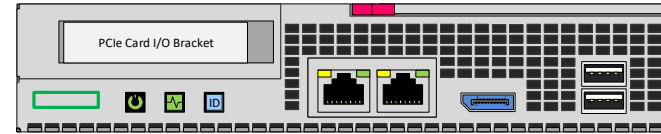

- Dual RJ45
- 10/100/1000BaseT

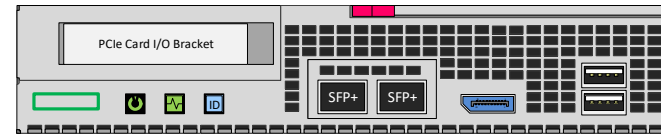

- Dual SFP+
- Dual 10Gb

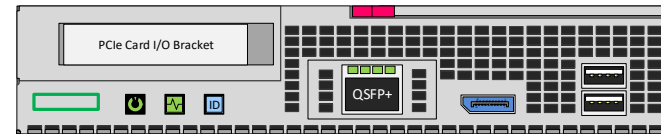

- QSFP+
- Quad 10Gb
  - Four separate 10GbE

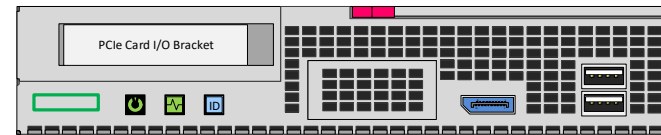

No Network

## Validated Processors

2nd Generation Intel® Xeon® Scalable Processor Family							
Intel® Xeon® SP	Frequency	Cores	L3 Cache	Power	UPI	DDR4 MHz	Max Memory
Platinum 8280M Processor	2.7Ghz	28	38.5	205W	3 UPI links	2933MT/s	2TB
Gold 6254 Processor	3.1Ghz	18	24.75	200W	3 UPI links	2933MT/s	1TB
Gold 6244 Processor	3.6Ghz	8	24.75	150W	3 UPI Links	2933MT/s	1TB
Gold 6230N Processor	2.3Ghz	20	27.5	125W	3 UPI links	2933MT/s	1TB
Gold 6212U Processor	2.4GHz	24	35.75	165W	n/a	2933MT/s	1TB
Silver 4210 Processor	2.2Ghz	10	13.75	85W	2 UPI links	2400MT/s	1TB



# 1U AND 2U E910 BLADE PCIE LAYOUT

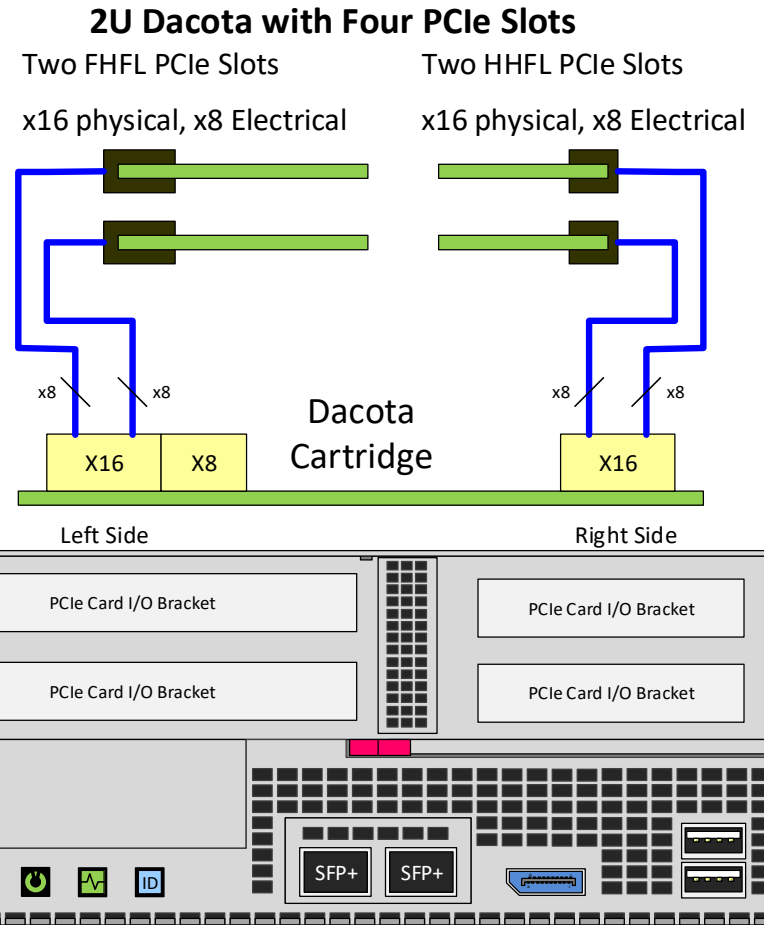
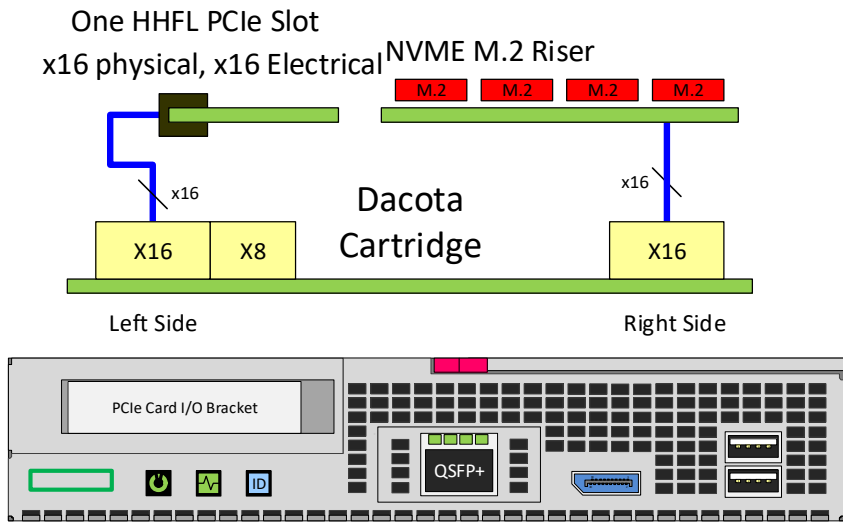

## **UNMATCHED “SWAP-C3” = DATA CENTER IN A GYM BAG**

Size: 8.6” x 8.7” x 16.9”

Weight: 50lbs

Power: 110v/15amp AC; 24 to 48 volt DC



Compute: Four Servers (Up to 28 Core Cascade Lake procs, 20TB Storage, 1.5TB RAM, 10Gb Switches)

Cooling: 0 to 55C (131F)

Cost: Significantly less than existing, less capable, rugged edge servers

Nothing in the market can match EL8000 metrics across SWaP-C3

# HPE EDGELINE EL8000 COMPONENTS

Plug and Play ~ reconfigurable



**1U and 2U Compute Nodes**



**1U / 2U Compute Nodes w/ blank**



**2U Compute w/ Storage Shelf**



ProLiant e910 1U Blade



ProLiant e910 2U Blade



Edgeline 2U Storage Tray

# MILSPEC RUGGEDIZATION

Ultralife 6U EL8000-MCS Ruggedized Enclosure

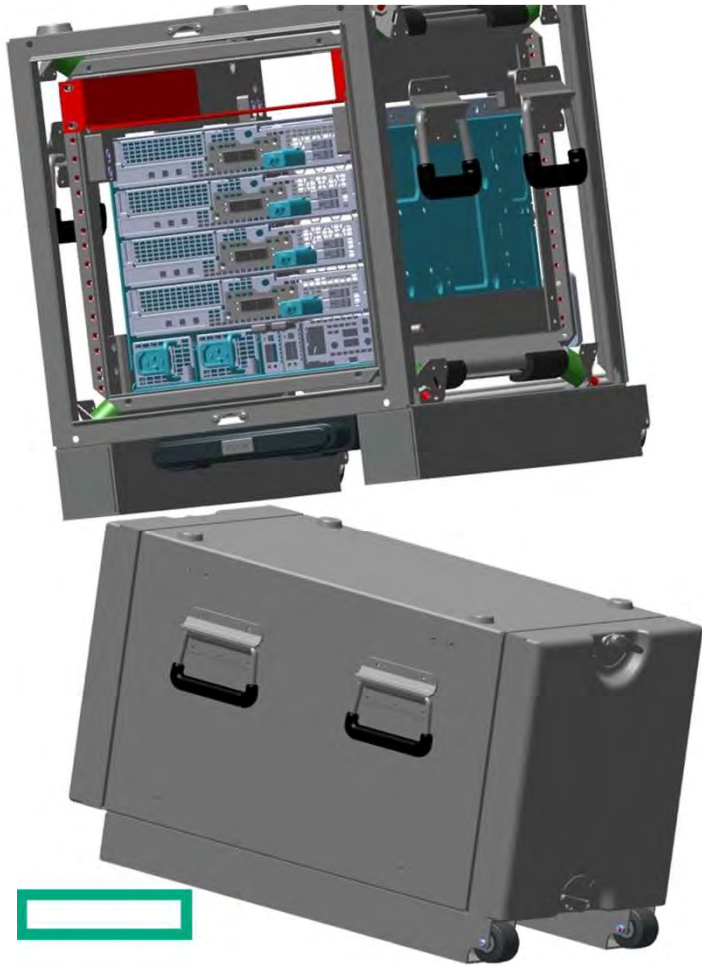

HPE StoreFabric Switch with rail kit

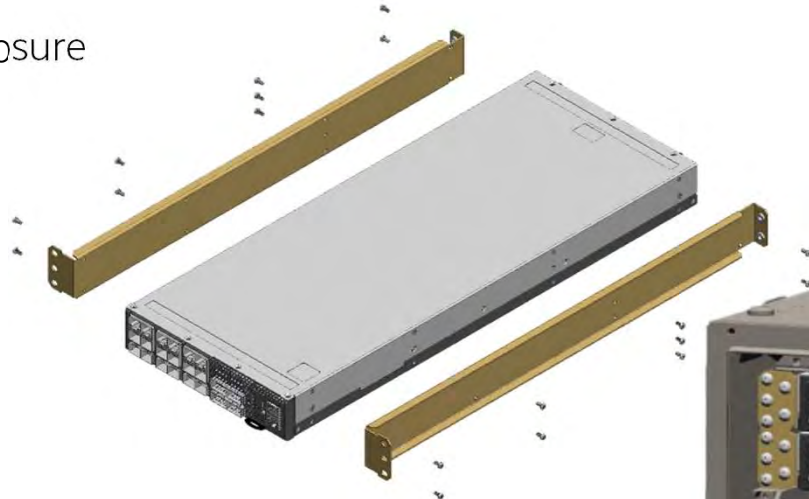

EL8000 Accessory Case



Ultralife UPS (Jan/Feb 2021)



# HPE/MELLANOX SN2010M 1/2 RACK WIDTH SWITCH



## HPE StoreFabric M-Series SN2010M (18 x SFP28 + 4 x QSFP28) Front

- |                 |                                       |
|-----------------|---------------------------------------|
| 1. Console Port | 5. Inventory Information Pull-out Tab |
| 2. USB Port     | 6. System Status LEDs                 |
| 3. MGMT Port    | 7. QSFP Ports (19-22)                 |
| 4. Reset Button | 8. SFP Ports (1-18)                   |

ROP77A: HPE StoreFabric SN2010M 25GbE 18SFP28 4QSFP28 Power to Connector Airflow Half Width TAA Switch

ROP78A: HPE SKHPE StoreFabric SN2010M 25GbE 18SFP28 4QSFP28 Connector to Power Airflow Half Width TAA Switch

# ULTRALIFE COMMERCIAL CARRY-ON CASE

Dimensions: 9" x 14" x 22"



Easily fits in small overhead



Under Seat  
In First Class



## EDGE LINE EL8000 TEMPEST LEVEL 1

- Partner CIS Secure is designing lids to attach to the Ultralife Commercial Airline Carry-on travel case that will create a TEMPEST Level 1 certified solution. Expected completion Sep 2020.

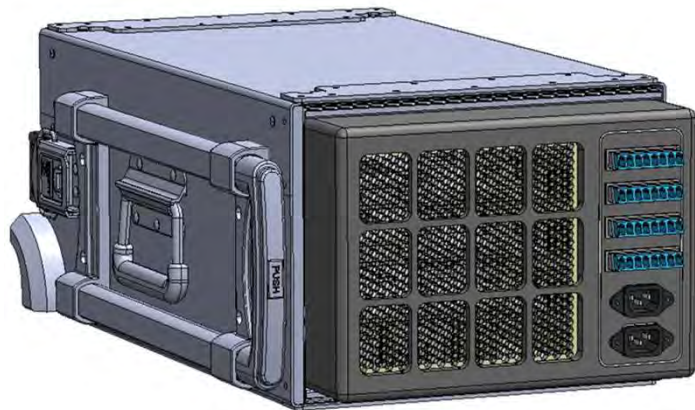

TEMPEST Lid Front

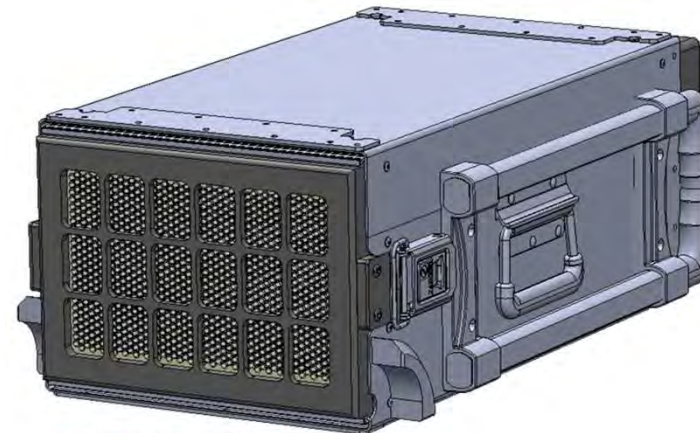

TEMPEST Lid back





# HPE EDGELINE EL8000 LIST PRICE EXAMPLE

## HPE Edgeline EL8000 Converged Server with 96 Cascade Lake Cores, 768GB RAM, 20TB NVMe Storage, 10Gb/s int switch

Qty	Product #	Product Description	Unit Price (USD)	Extended List Price (USD)
<b>Edgeline EL8000 Chassis</b>				
1	P12379-B21	HPE Edgeline EL8000 5U Configure-to-order Front Cabling Chassis	5765.00	5765.00
2	P17297-B21	HPE Edgeline EL8000 10GbE SFP+ Switch	995.00	1990.00
2	P11290-B21	HPE EL8000 1500W 264VAC PS Kit	750.00	1500.00
2	Q7F42A	HPE C15 US 125V 15Amp 2.5m Black Power Cord	69.00	138.00
1	H7J33A3	HPE EL8000 Chassis Support	258.00	258.00
			<b>Chassis Cost:</b>	<b>\$9,651.00</b>

<b>e910 Server Blade: 24 Core Cascade Lake, 192GB DDR4 RAM, 512GB NVMe boot/cache drives, 4TB NVMe Storage</b>				
1	P12381-B21	HPE ProLiant e910 1U Node Configure-to-order Blade Server	1850.00	1850.00
1	P12395-B21	Intel Xeon-Gold 6212U (2.4GHz/24-core/165W) Processor Kit for HPE ProLiant e910	3365.00	3365.00
12	P12401-B21	HPE EL 16GB 2Rx4 DDR4-2933Y-R Kit	622.00	7464.00
2	880264-B21	HPE 512GB NVMe x4 Lanes Read Intensive M.2 2280 1yr Wty Extended Temperature SSD	1214.00	2428.00
4	P05892-B21	HPE Edgeline 960GB NVMe x4 Lanes Mixed Use M.2 22110 3yr Wty Extended Temperature SSD	1519.00	6076.00
1	P12384-B21	HPE ProLiant e910 1U x16 HHHL Left Riser Kit	110.00	110.00
1	P12386-B21	HPE ProLiant e910 4-slot NVMe M.2 Enablement Kit	299.00	299.00
1	P17296-B21	HPE ProLiant e910 2-port 10GbE SFP+ Module	325.00	325.00
1	BD505A	HPE iLO Advanced 1-server License with 3yr Support on iLO Licensed Features	469.00	469.00
1	H7J33A3	HPE EL8000 e910 1U Blade Support	734.00	734.00
			<b>Single Blade Total</b>	<b>\$23,120.00</b>
			<b>4 ea Total</b>	<b>\$92,480.00</b>

**Chassis with Four Server Blades Total List Price** **\$102,131.00**

# HPE EL8000 USE CASES

---



# EDGE LINE EL8000 RUGGED ENOUGH FOR SPACE

## One Giant Step Towards Launch

July 1, 2020 | Blog, High Performance Computing, Partners



OrbitsEdge has reached a significant milestone in our quest to put a high-performance data center in orbit, a cloud above the clouds, with the testing of the Hewlett Packard Enterprise (HPE) EL 8000s. These are the actual systems that will be aboard our SatFrame™ during our initial launch in late 2021.

Unlike the satellites in orbit today, they will feature processing speeds that are competitive with what is available on Earth. The EL-8000s will provide 1000 times more computing power than current space-grade systems. *(Most satellites have "radiation-hardened processors" but their processing capabilities are similar to a 2000-era flip phone.)*

The SatFrame is designed to provide a robust, protective approach, allowing OrbitsEdge to introduce state-of-the-art processing in space without having to compromise years of development to generate space-ready hardware and software. Leveraging the EL-8000 offers strategic benefits as an already ruggedized hardware and software solution for the OrbitsEdge SatFrame proprietary system, further improving the mitigation of harsh radiation, thermal, and power requirements in space.

# EDGELINE EL8000 OCEUS CSfC SMART GATEWAY

- CSfC NIAP validation of Aruba OS 8.6 on the EL8000 on-going at Gossamer Labs
- Partner OCEUS has designed a CSfC Smart Gateway to support their Private LTE solution on the EL8000 with Joint Staff J6 advocacy

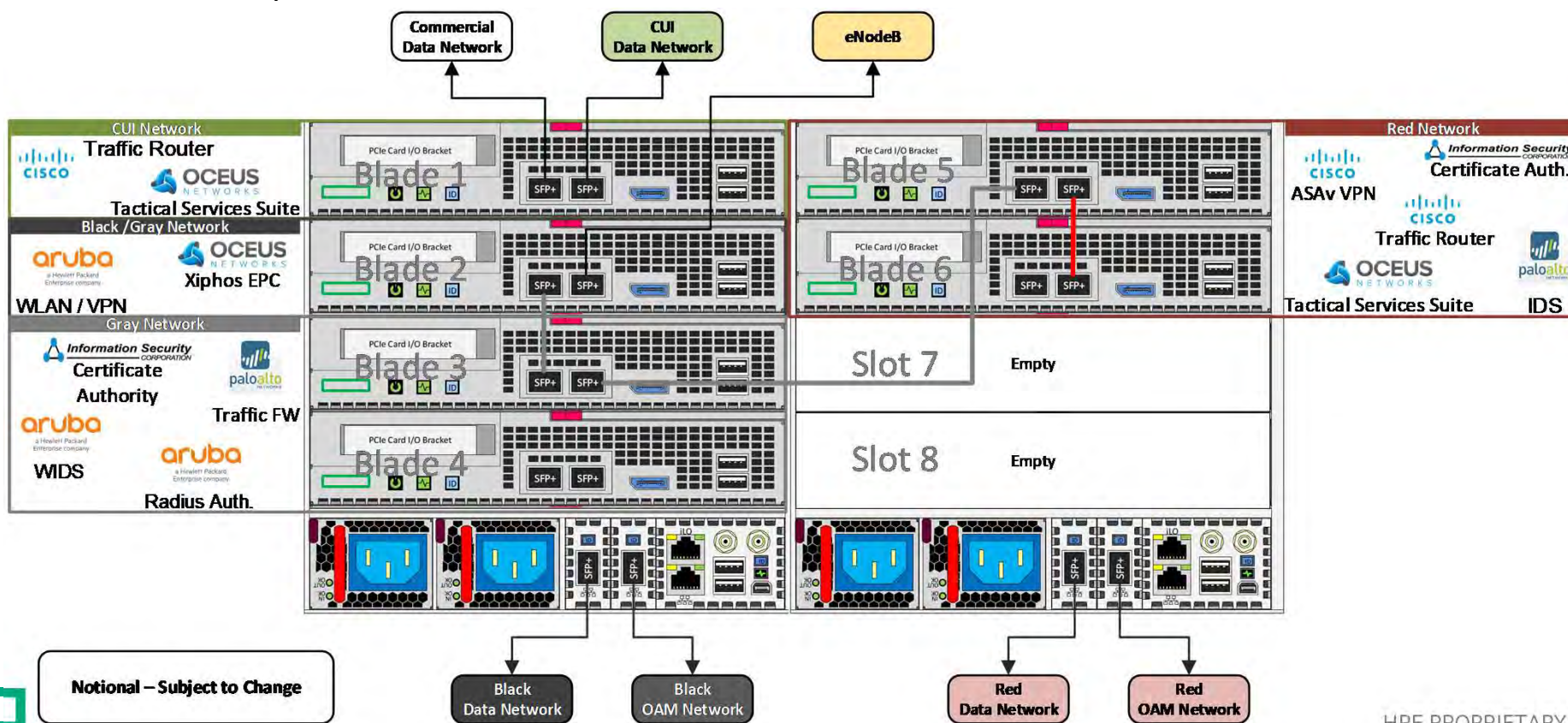

# OCEUS CSFC PRIVATE LTE PROJECT ON EDGELINE EL8000

- CSfC Private LTE solution for installation on Air Force Special Operations Command (AFSOC) bases

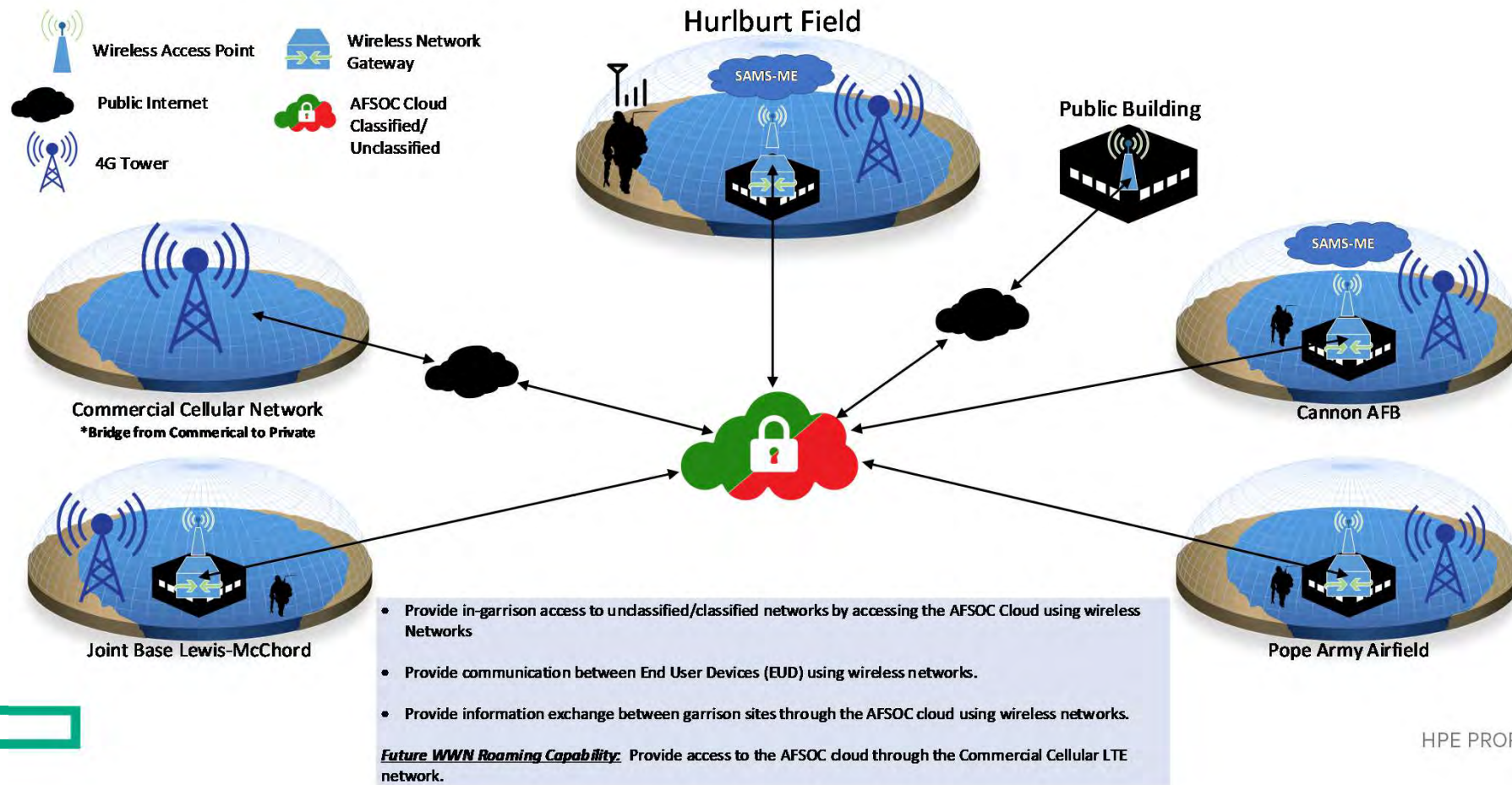

# OCEUS MULTI-DOMAIN AIR-GROUND OPERATIONS NETWORK (M-DRAGON)

- The OCEUS Smart Gateway enables their M-Dragon solution architecture

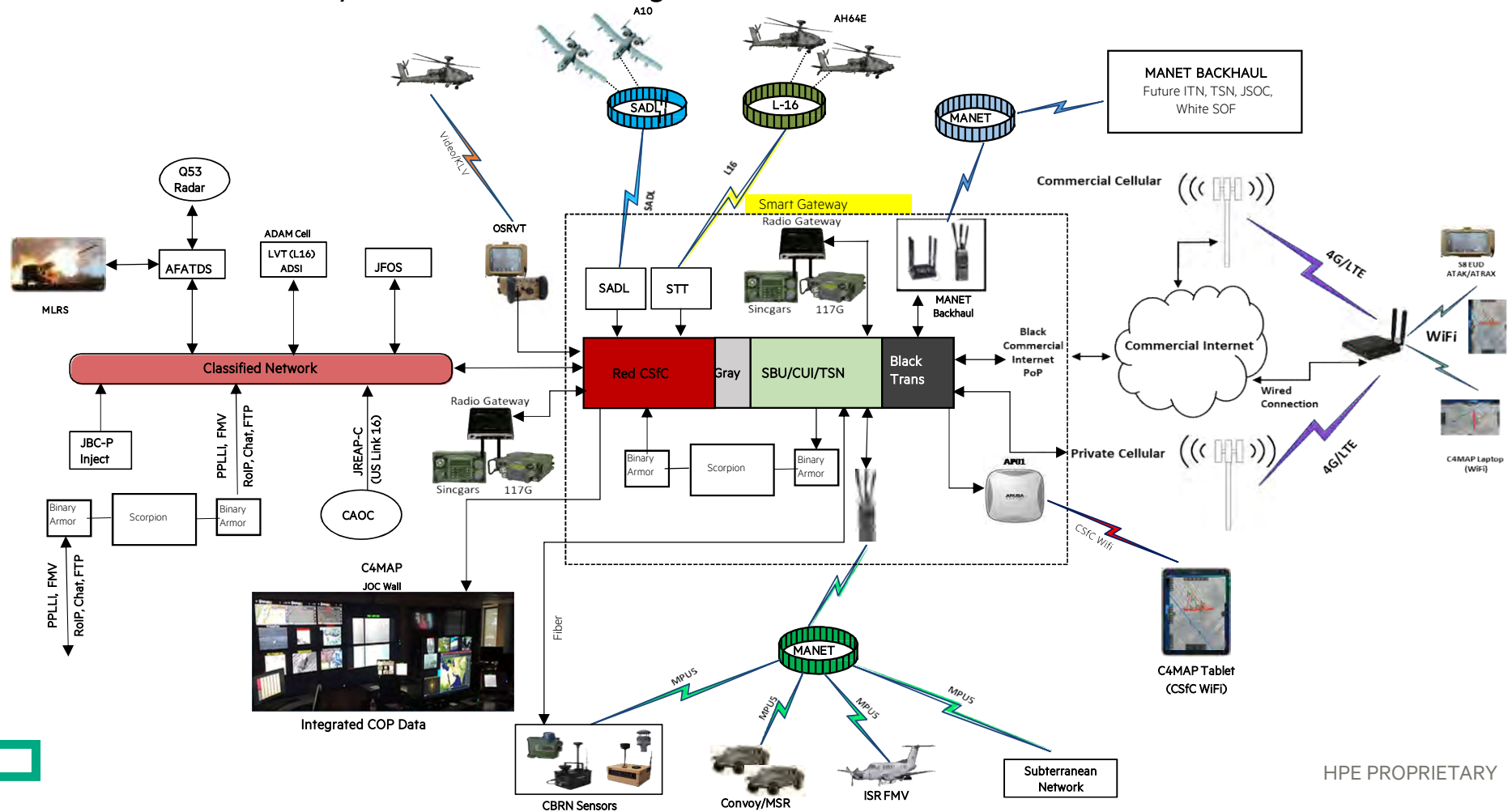

## HPE and RedHat introduce KubeStack for AI-Edge

- Red Hat and HPE have partnered to provide a best-of-breed solution, combining the Red Hat OpenShift Container Platform and Edgeline EL8000 as a turnkey offering. This appliance-like solution provides GPU-enabled compute on the industry-leading Kubernetes-based OpenShift Platform.
- KubeStack for AI-Edge provides a single bundled SKU containing all of the necessary components for a successful data science at the edge experience:
  - **Engineering recommended hardware.** KubeStack for AI-Edge provides Red Hat engineering recommended purpose-built hardware from HPE and NVIDIA designed to execute high-performance GPU-enabled AI/ML tasks in a form factor appliance that fits in an airline's overhead compartment. The hardware components are built upon the HPE EL8000 outfitted with a complement of NVIDIA T4 GPUs – in a SWaP optimized package (8.6”x8.7”x17”).
  - **Red Hat Subscriptions.** KubeStack for AI-Edge provides Red Hat validated software, access to the Red Hat knowledge base and escalation support for 1, 3 and 5-year periods. Bundle includes OpenShift Container Platform (OCP), OpenShift Container Storage (OCS), Advanced Cluster Manager (ACM), Middleware Integration and Red Hat Enterprise Linux (RHEL).
  - **Single SKU and Pre-Installed Software:** KubeStack for AI-Edge has been packaged by Carahsoft as a single SKU for ease of procurement and comes pre-installed to allow for quick integration into a customer's environment.
- Development information can be found at [faros.dev](https://faros.dev) and has been shared with the Open Source community. Currently KubeStack for AI-Edge is in tech preview with a few select US Public Sector customers.
- Press release, Datasheet and other collateral will be available soon (September 2020).

# OMNISIG REAL-TIME SPECTRUM SENSING

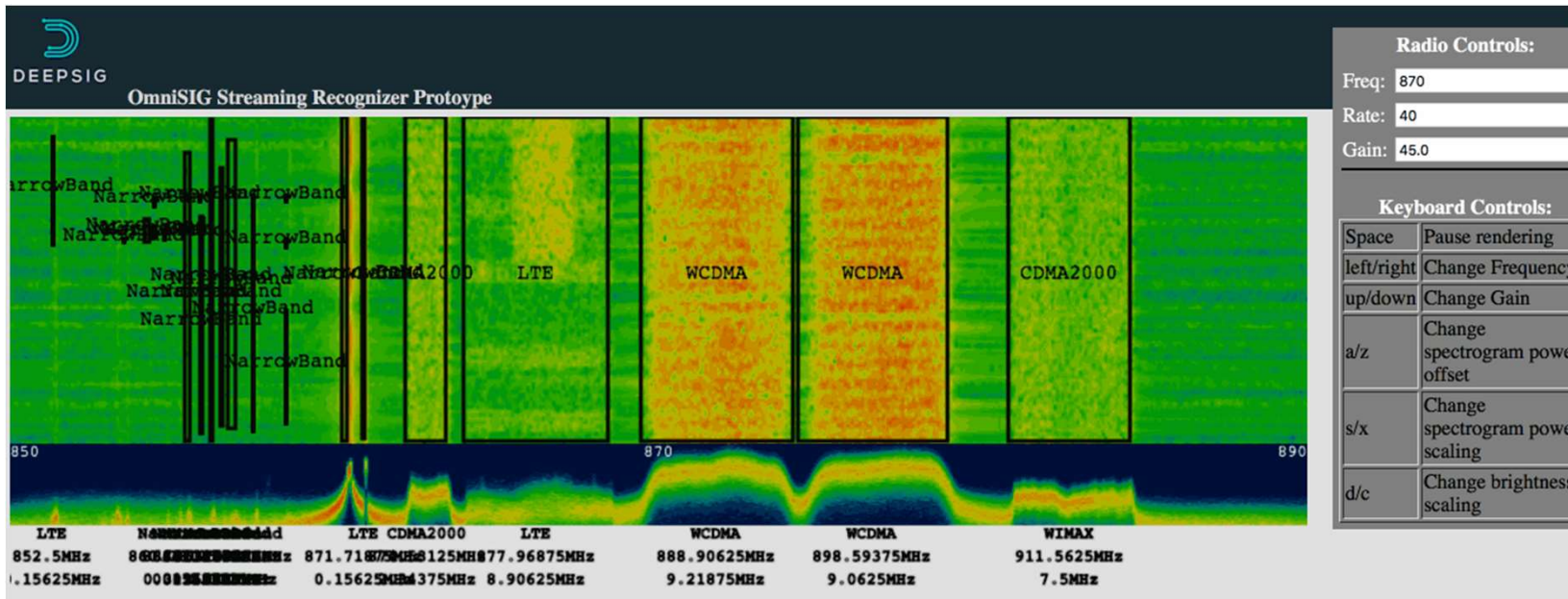

- Scans 50 MHz in 6 msec with one processor
  - Bandwidth and/or speed increased with additional processors
- Labeled waterfall spectrum and JSON streaming data
  - JSON can indicate new signal / threat detection or wireless cyber intrusion



# **HPE IS BECOMING AN EDGE TO CORE TO CLOUD PLATFORM-AS-A-SERVICE COMPANY**









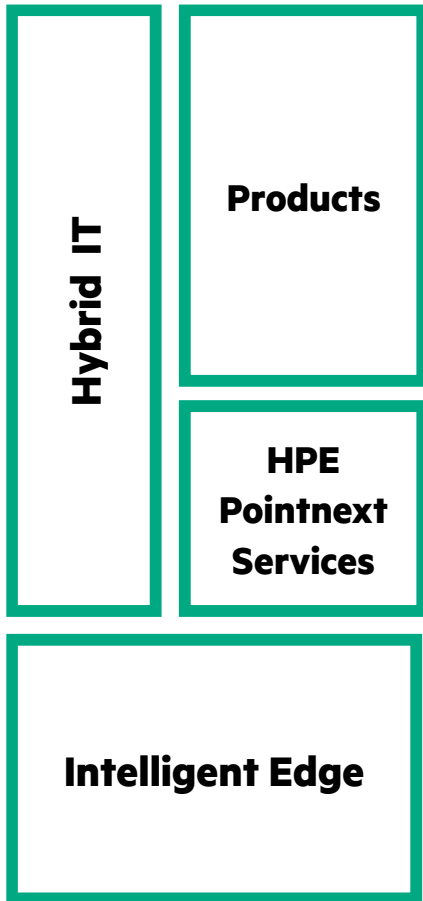







---

Adding industry leading technologies to the team



# HPE TODAY...



 Supercomputing	 Data Platform for AI & Analytics	 High Performance Computing	 Big Data / Fast Data Analytics Software
 All-Flash and Hybrid Flash Storage	 Software Defined Network Data Fabric	 Hyperconverged Platform	 Datacenter Management Software
 Cloud Consulting Practice AWS and US Focus	 Cloud Consulting Practice Azure and UK Focus	 Service Authentication Edge to Core to Cloud	 Cloud Consumption Analytics Software
 Wireless Network Solution Provider	 Wireless Network Analytics	 User and Entity Behavior Analytics	 Sensor Based Network Performance & Monitoring
 SD WAN Solution Provider			

# ANALYTICS DATA PIPELINE - EDGE TO CORE TO CLOUD

A simple view

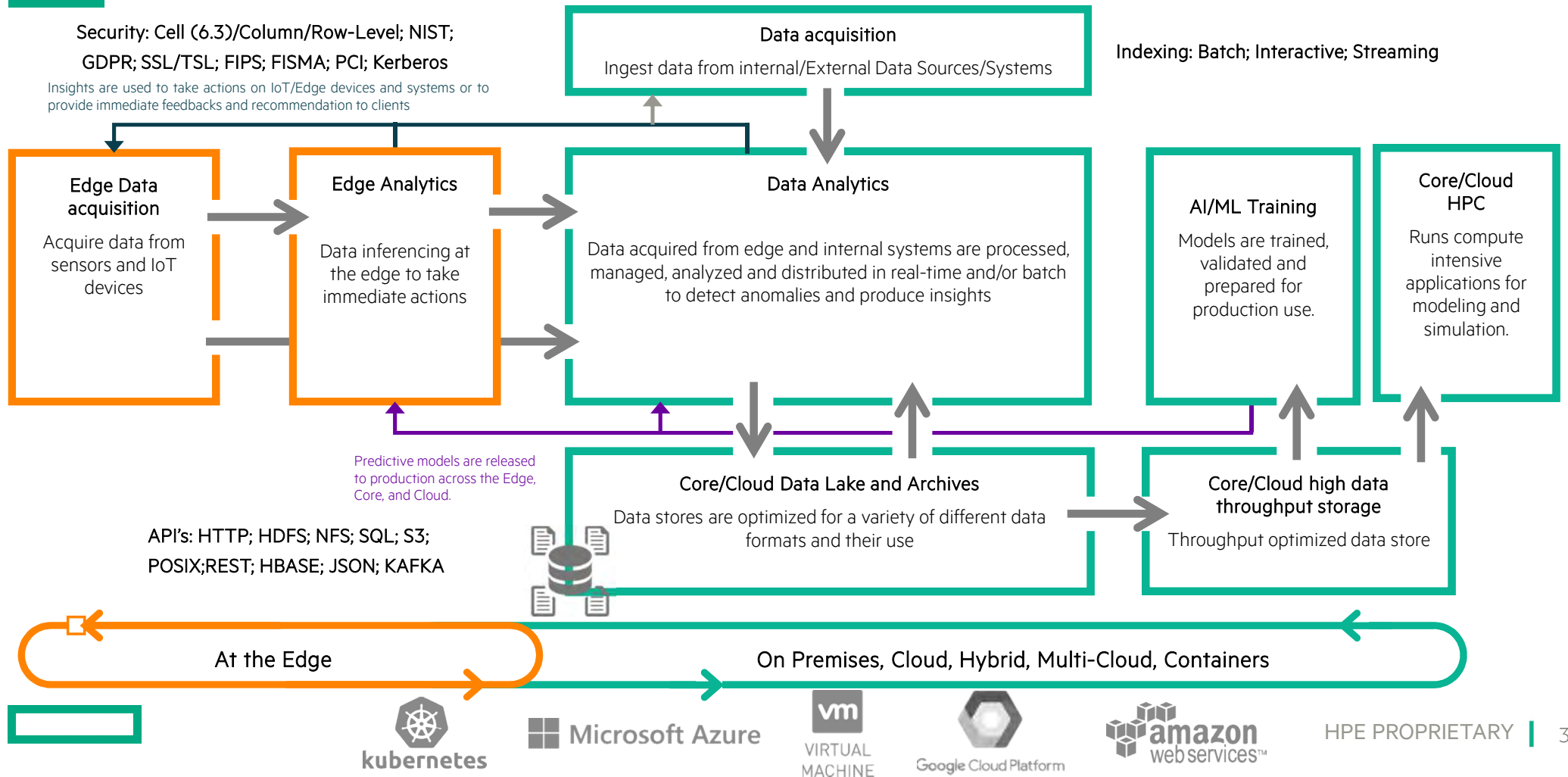

# MAPR DATA PLATFORM OVERVIEW

- MapR is a patented data platform for advanced AI / ML and analytics that runs on commodity hardware across deployment models
- Unique to MapR is a set of core services designed to ensure exabyte scale and high performance while providing unmatched data protection, disaster recovery, security and easy management
- Open APIs and container support ensure broad distributed application access and portability across disparate environments running MapR

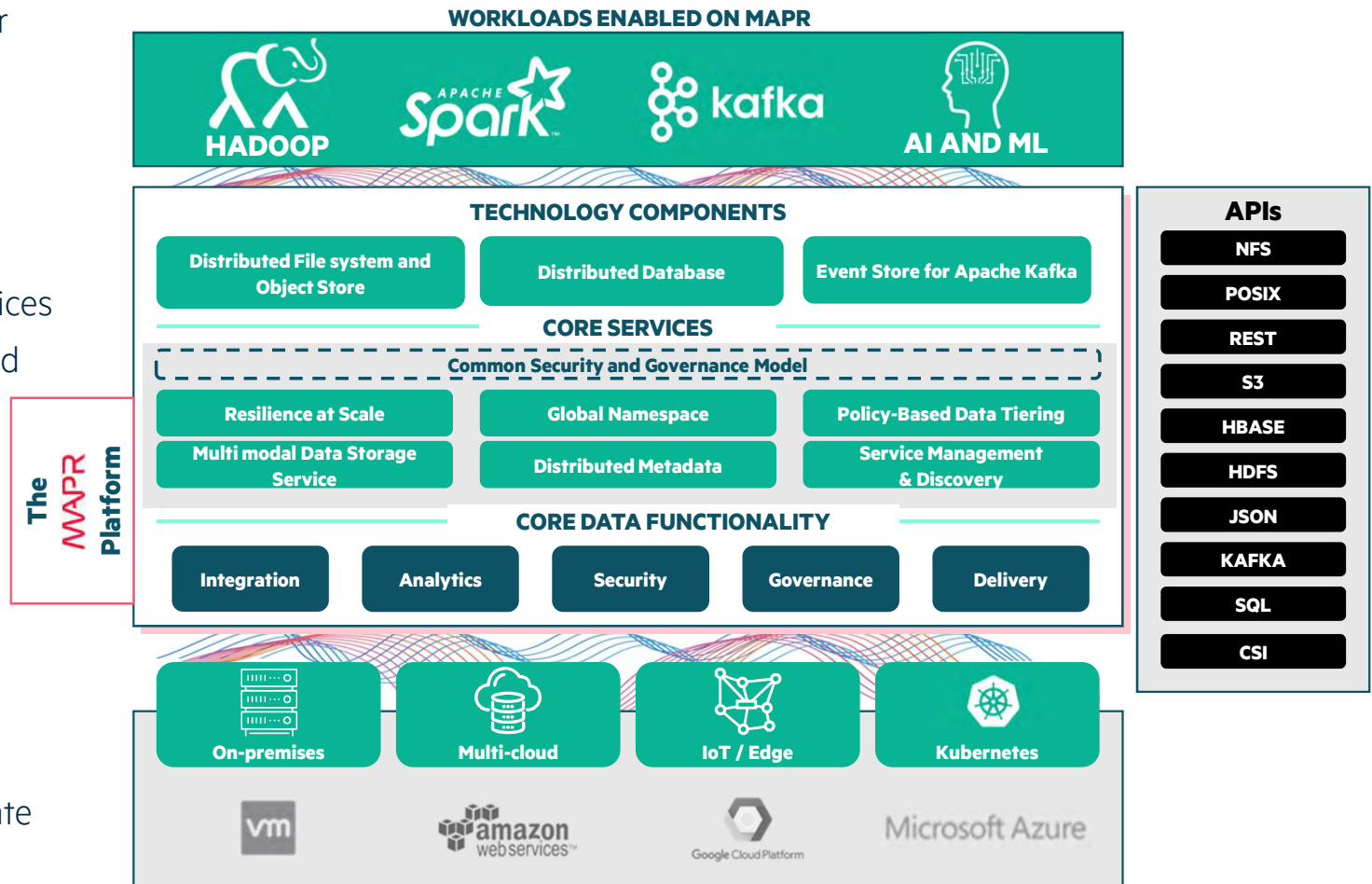

# MAPR DATA FABRIC FEATURES



## Global Namespace

Ability to view and run globally deployed multiple clusters as a single, logical, local cluster



## Distributed Metadata Service

Provides unlimited scale a) cluster with 100s of nodes b) 10s of billions of files c) 10s of millions of tables and message topics without any special hardware and software



## Resilience at Scale

Automatic services failover, container replication and mirroring to meet stringent business SLAs



## Multi modal data persistence service

Single distributed data fabric that can store files, tables, and message topic with data portability across APIs



## Policy-Based Data Tiering Service

Balance performance, cost, and capacity tradeoffs by storing, managing, and analyzing data in different hot, warm, cold data tiers



## Service Management & Discovery

Cohesive set of APIs to manage services on the cluster – essential when operating multiple multi-node clusters



**Common Security and Governance Model:** Unified platform-level security across all data including built-in auditing, expressive authorization, and flexible authentication supporting any username/password registry and Kerberos

# DOD EXAMPLE GLOBAL NAMESPACE

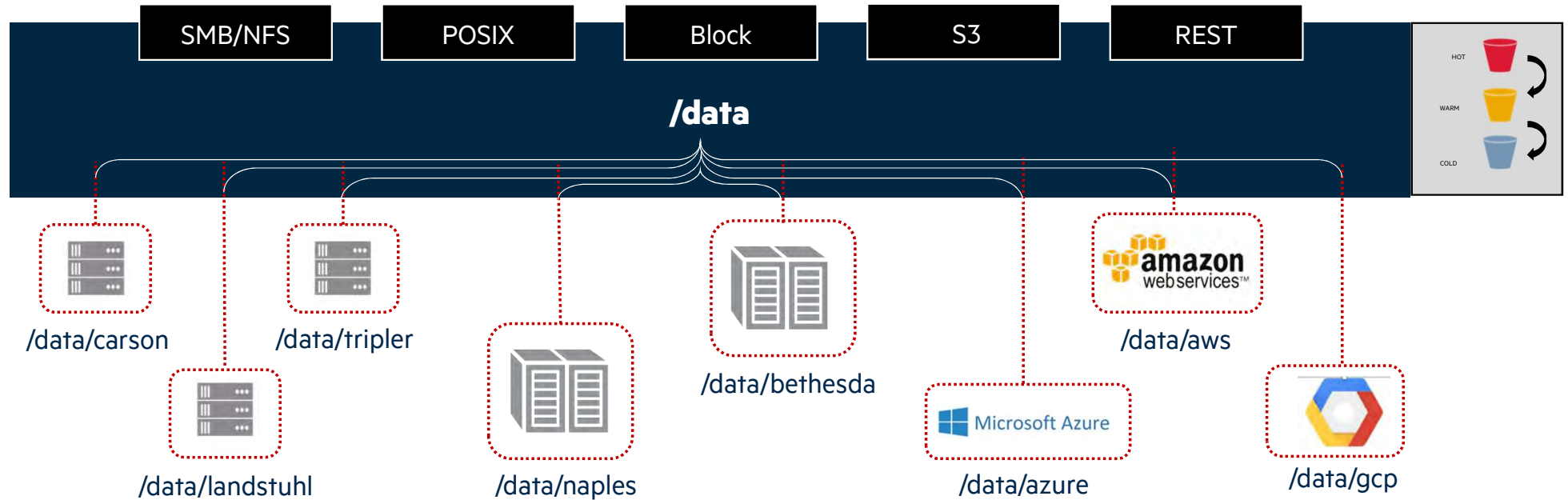

MapR Data Fabric converges edge, on-premises and cloud environments into a single global namespace to deliver ubiquitous seamless access to data across geo-distributed clusters

# ONE PLATFORM – HISTORICAL, OPERATIONAL AND REAL TIME DATA

## Distributed File and Object Store



Industry's only exabyte scale data store for building intelligent applications

- **Easy access to any type of data** – NFS, S3 and HDFS based access for AI or Analytics
- **Massive scalability** – hundreds of petabytes of data across multiple locations
- **Automated data placement** – maintain different data temperatures and optimize performance
- **Deploy data anywhere** – infrastructure agnostic
- **Reliability and high availability** – in-built machine learning to automate data copies across nodes, clusters and racks

## Multi-Modal Database



High performance NoSQL database for operational analytics and applications

- **One database, multiple data models** – build innovative apps using Documents, Key Value, Wide column data models
- **Performance at scale** – Faster: 2x Cassandra & 5x Hbase with immediate global data replication of any writes
- **Strong Data Consistency** – for System of Record with no data loss or corruption
- **Data level access controls** – down to specific data or document elements
- **Flexible & fast data access** – sophisticated data indexing strategies with secondary indexes

## Event Store for Apache Kafka

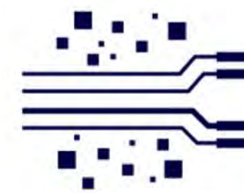

Global IOT scale event streaming system for real-time intelligent applications

- **Persistent store** – eliminate data copies as the store supports both batch and interactive technologies
- **Integrated processing technologies** – Spark Streaming, Storm, Flink and Apex
- **Kafka API** – easily build or migrate real-time Kafka producers and consumers
- **Flexible global deployment** – replicating streams in any globally distributed model
- **Reliability and high availability** – with global replication of metadata

DESCRIPTION

KEY CAPABILITIES

# POTENTIAL FAILURE SCENARIOS

What can go wrong?

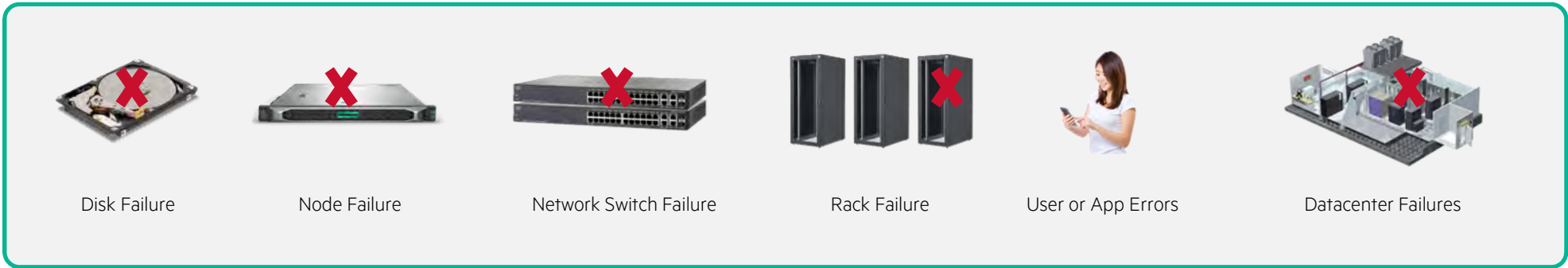

How we protect it?

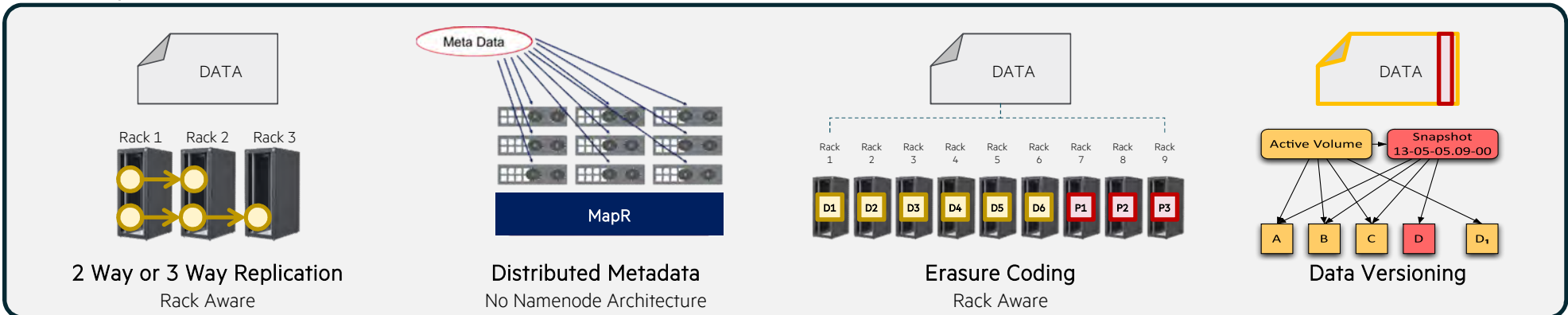



# DATA FLOW IS SEAMLESS WITH MAPR FOR REPLICATION AND DATA TIERING

MapR provides seamless & uncomplicated Hot, Warm, and Cold data Tiering

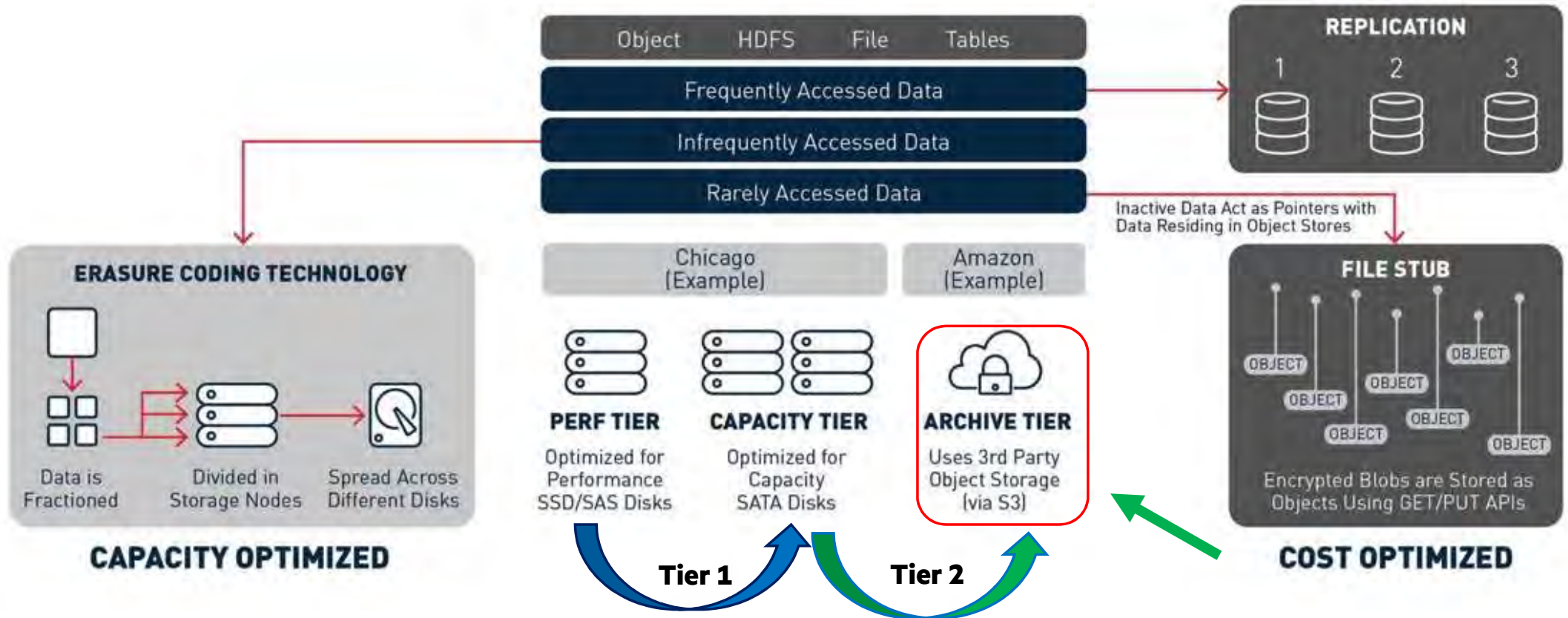

# CONVERGED DATA FABRIC

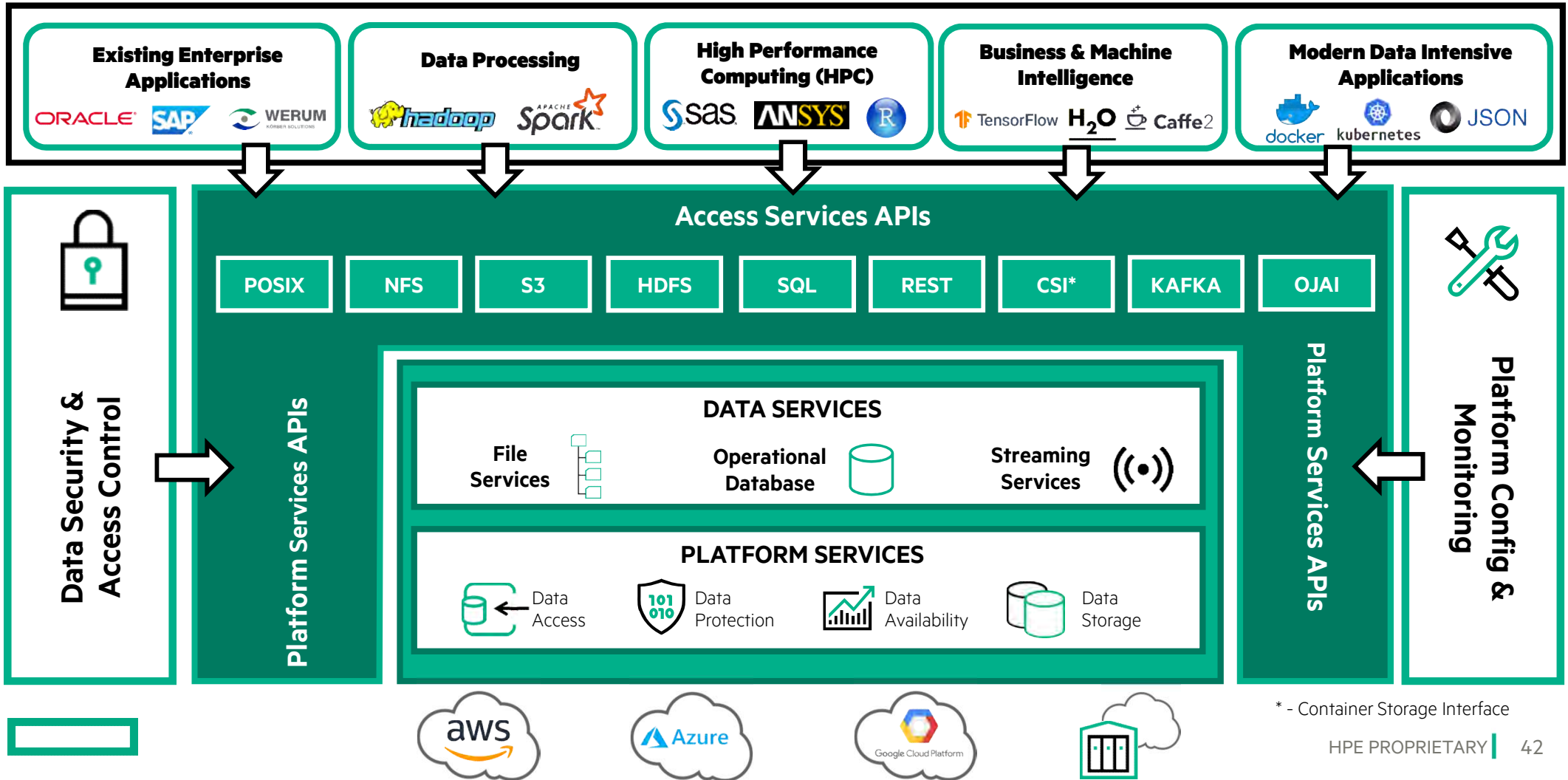

\* - Container Storage Interface

# **HPE'S CONTAINER VISION AND STRATEGY**

---

Containerize all applications and enable Enterprise-wide orchestration



# LEVERAGING DIFFERENTIATED IP FROM RECENT HPE ACQUISITIONS

Open source Kubernetes plus software innovations from BlueData and MapR



Open source standard for container orchestration – with rapidly growing adoption



Enterprise container-based software platform – initially focused on AI / ML and analytics



Data fabric for Kubernetes – with persistent storage and universal data access for containers

The HPE Container Platform is a turnkey solution representing the next generation of the BlueData software platform pre-integrated with MapR data fabric for persistent storage, with the ability to deploy and manage open source Kubernetes clusters at scale

# HPE EZMERAL CONTAINER PLATFORM

Turnkey enterprise-grade container management for both cloud native and non-cloud native applications

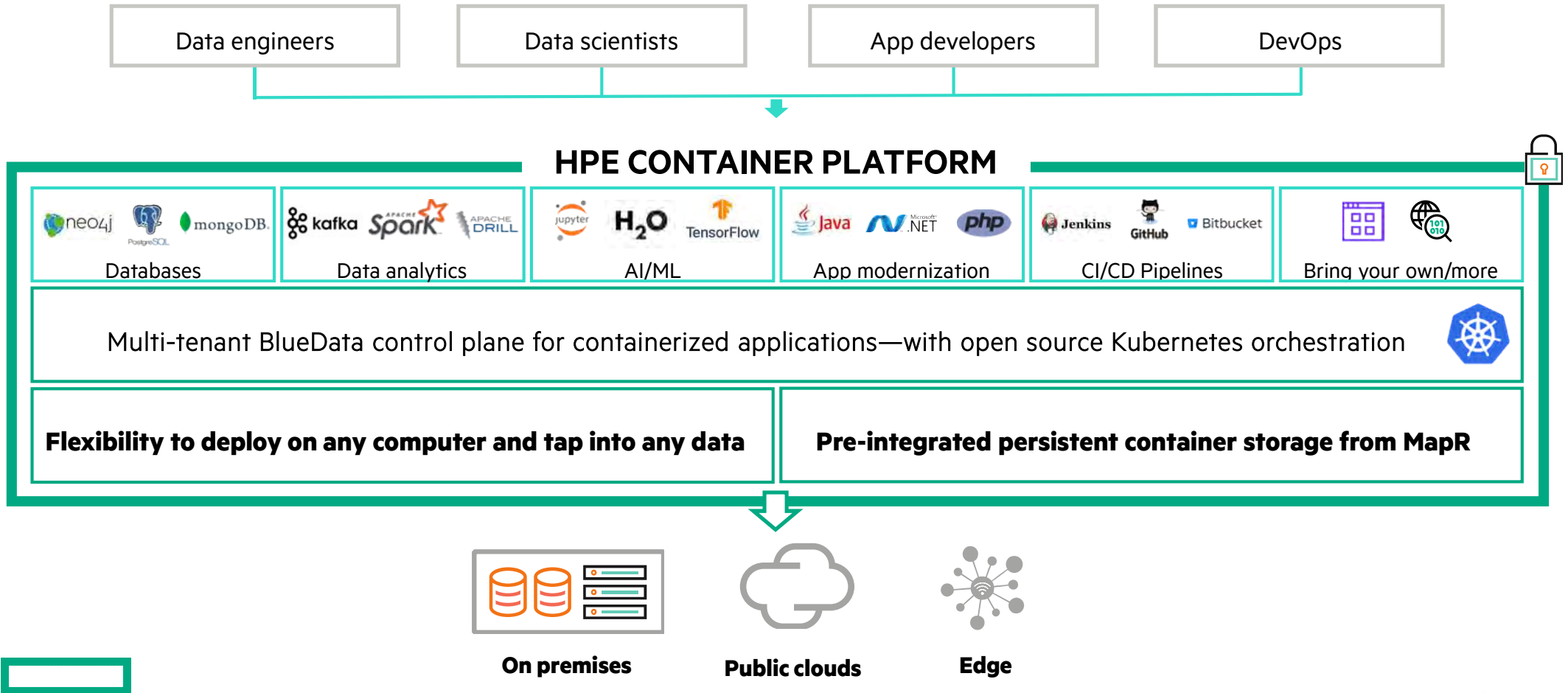

# PRE-BUILT CATALOG OF READY TO RUN APP TEMPLATES

An App Store experience for developers, data scientists, and other users

The image displays two overlapping screenshots of the HPE Container Platform App Store interface. The top screenshot shows the main App Store view with a sidebar on the left containing navigation options: Dashboard, Users, Data Sources, App Store (highlighted), and Service Endpoints. The main area features a 'Categories' list (Analytics, Big Data, Cloud Services, Database, Developer Tools, Machine Learning, Integration) and a grid of application cards. Two cards are visible: 'Airflow Operator' and 'MongoDB'. The bottom screenshot shows the 'Launch Application: Tomcat' form, which includes fields for Name (myTomcat), Description (My first web app), Resource Template (small - 4 VCPU, 8192 MB RAM), Namespace (<Default>), and Deployment Type (<helm>). A 'Submit' button is located at the bottom right of the form.

# PRE-BUILT CATALOG OF READY TO RUN APP TEMPLATES

An App Store experience for developers, data scientists, and other users

The screenshot displays an 'App Store' interface with a grid of application templates. A modal dialog titled 'Create New Cluster' is overlaid on the center. The dialog is divided into three sections: 'Cluster Detail', 'Node Roles', and 'Advanced Settings'. In the 'Cluster Detail' section, there are input fields for 'Cluster Name' and 'Cluster Description'. The 'Node Roles' section shows 'Select Cluster Type' set to 'DataScience' and 'Distribution' set to 'Rstudio-Server with Spark 2.1.1'. Below this, 'Controller' and 'Worker' roles are both set to 'Small - 4 VCPU, 8192 MB RAM', with a quantity of '4' for the workers. A 'Create Cluster' button is at the bottom of the dialog. The background shows templates for Cloudera (CDH 5.14.4 and 6.1.0), Cassandra (3.11), CentOS (6.x and 7.x), Confluent (Kafka 5.0), Couchbase (Server 5.5.1), Databricks (Databricks Server), and Hortonworks (DataFlow Nifi and DataFlow with Ambari 2.5). A MySQL template is also partially visible.

# INTRODUCING THE EZMERAL CONTAINER PLATFORM

The industry's first enterprise-grade container platform designed to deploy both cloud-native and non-cloud-native applications using open source Kubernetes – running on bare-metal or virtualized infrastructure, on any public cloud, and at the edge

Cloud-Native and Non-Cloud-Native Apps



**Kubernetes Distribution**



Any Hardware



Any Cloud

- Bring the speed and efficiency of containers to both cloud-native microservices apps and non-cloud-native monolithic apps
- Lower costs with bare-metal containers and reduce risk with enterprise-grade security
- Deliver new code releases faster with on-demand container deployment
- Build once and run anywhere (on-premises, public clouds, and the edge), providing hybrid cloud portability



## WHY'D WE BUY SCYTALE?

Authenticating applications or software services across platforms requires a tremendous effort and hinders cloud or container migration efforts and development velocity.

Key contributor to the CNCF Open Source Projects: The SPIFFE (Secure Production Identity Framework For Everyone) specification defines a standard to authenticate software services in cloud native environments through the use of platform-agnostic, cryptographic identities. SPIRE (the SPIFFE Runtime Environment) is the code that implements the SPIFFE specification on a wide variety of platforms and enforces multi-factor attestation for the issuance of identities. In practice, this reduces the reliance on hard-coded secrets when authenticating application services.



A Scytale: <https://en.wikipedia.org/wiki/Scytale>

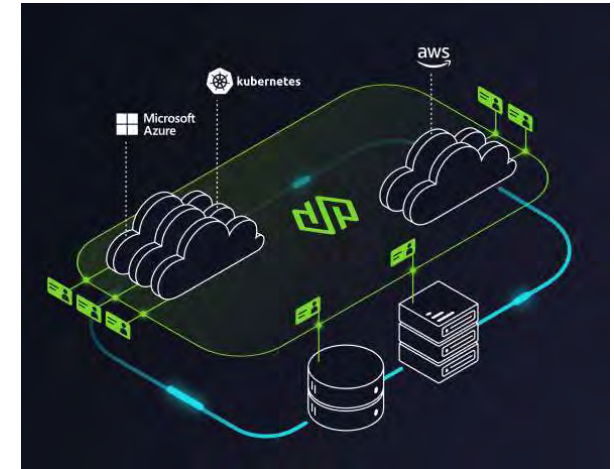

Standardize, scale, and accelerate service authentication across cloud, container, and on-premise platforms

# EZMERAL CONTAINER PLATFORM ON APOLLO, SYNERGY, AND EDGELINE

Initial Reference Configurations and Reference Architectures, with more to come

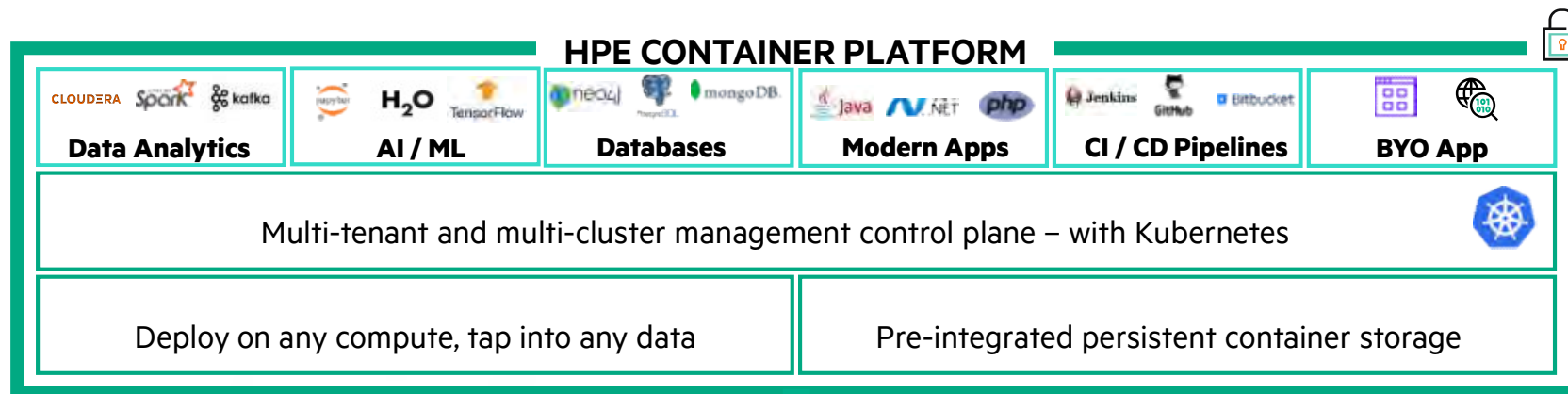

## Apollo

AI / ML/ DL and Data Analytics  
 RC available @ Launch  
 RA available post-Launch



## Synergy

DevOps, CI/CD, App Modernization, Hybrid Cloud  
 RC available @ Launch  
 RA available post-Launch



## Edgeline

Edge Analytics and IoT  
 RC available April 2020  
 RA available post-Launch



# DATA PIPELINE WITH HPE MAPR

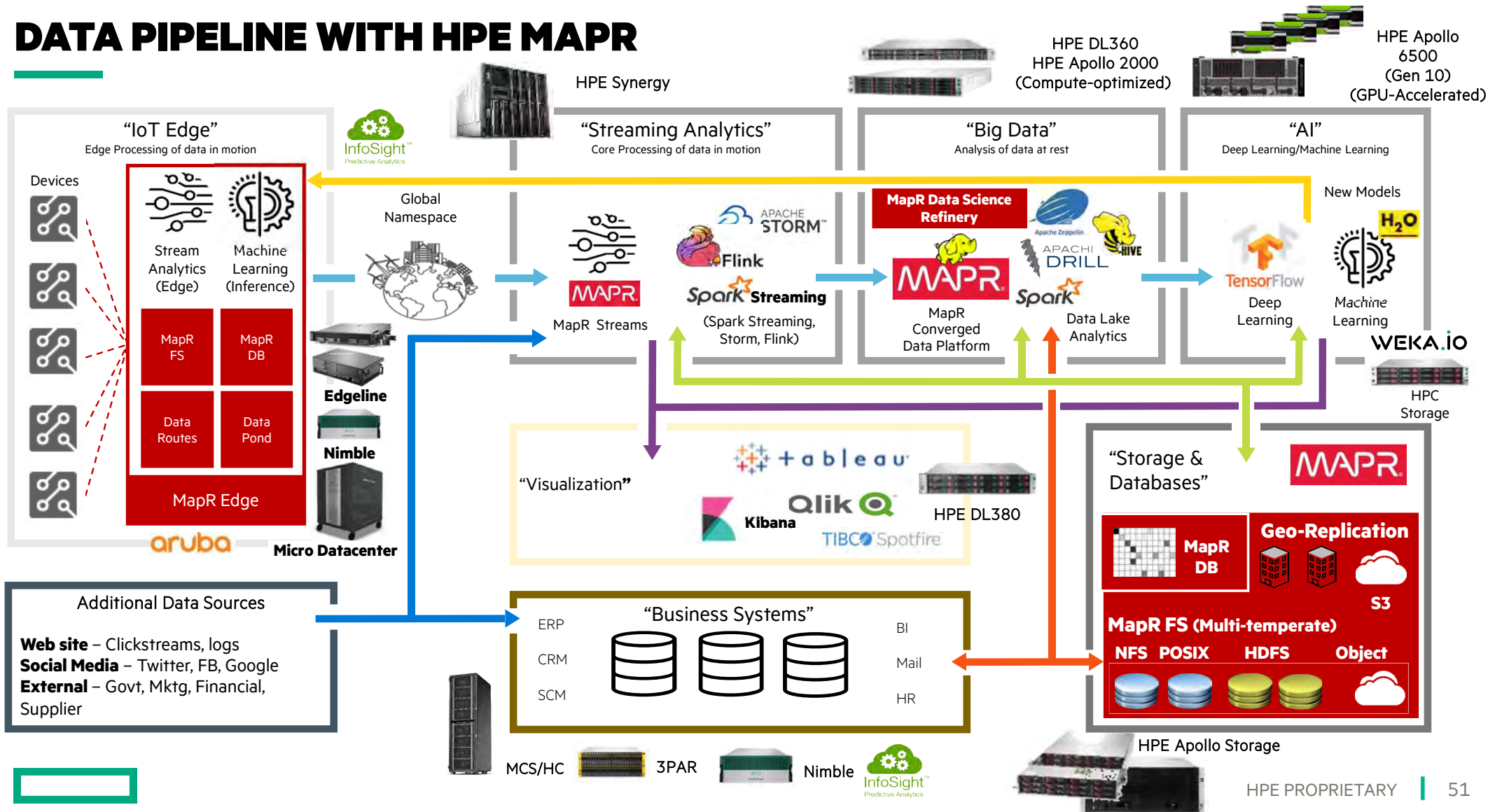

# WHAT IS EZMERAL?

HPE rebranded software portfolio

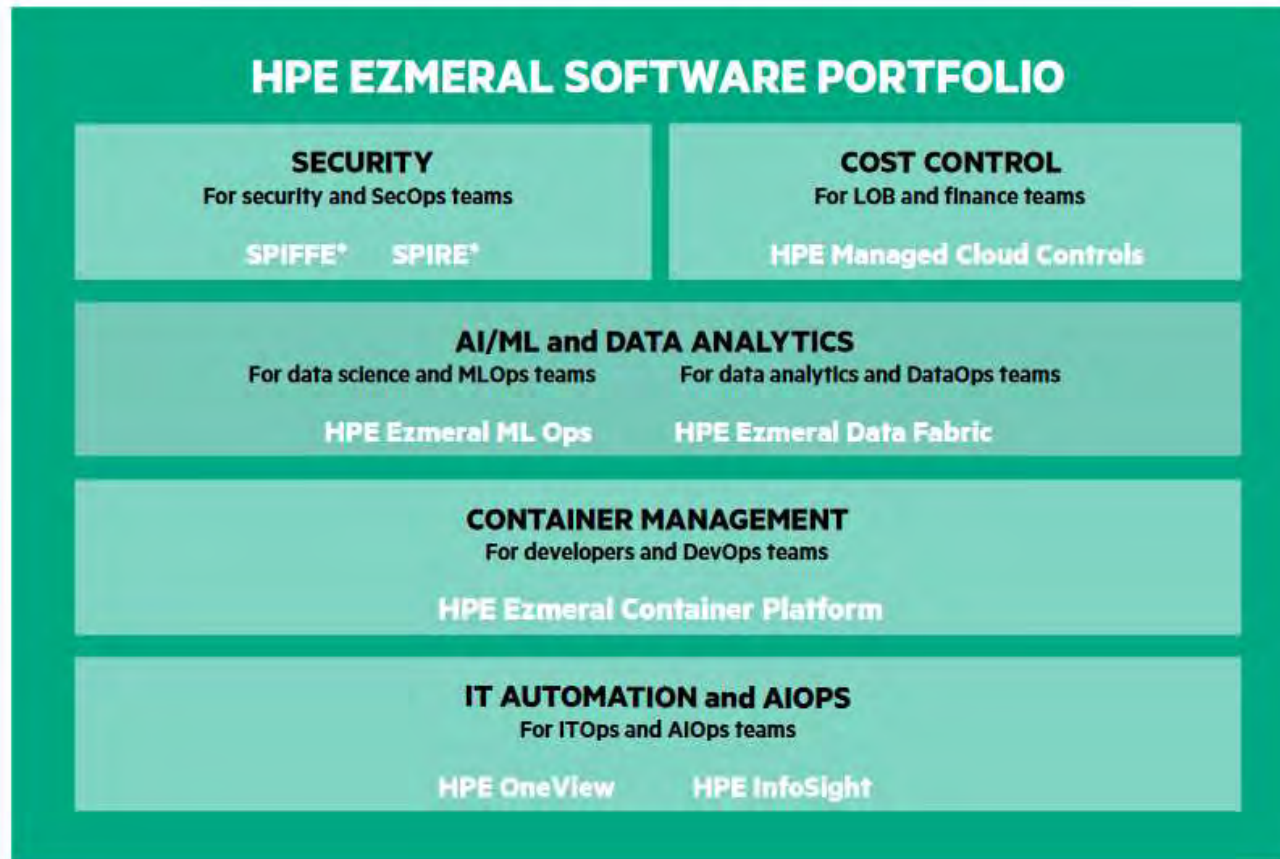

# FOUR KEY CHALLENGES TO ADOPTING HYBRID IT

- Application Rationalization



- Data availability between environments



- Workload Orchestration and management



- Security and Authentication between environments



# END TO END DATA PIPELINE (EDGE TO CORE TO CLOUD)

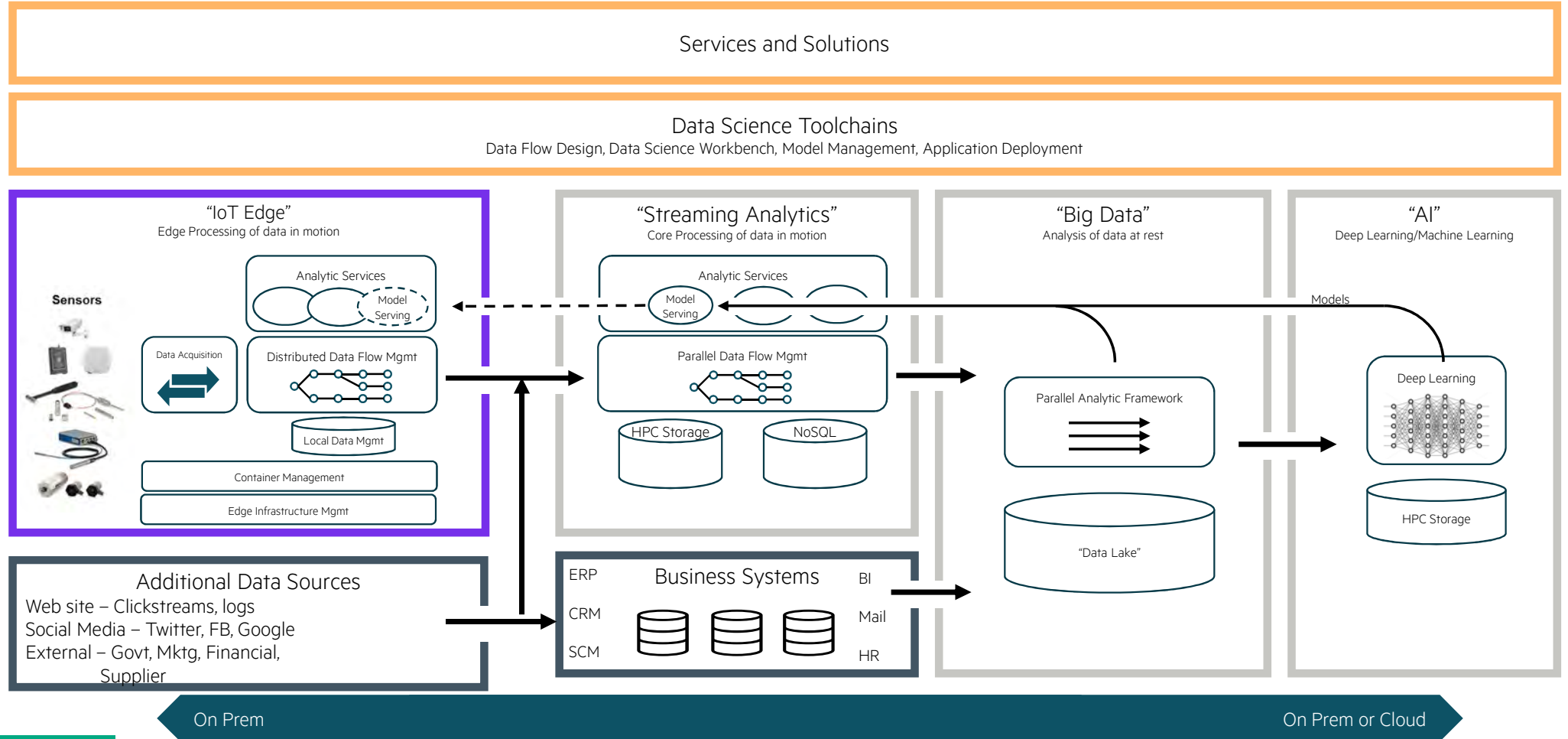

# **RUNTIME FIRMWARE VALIDATION**

---

Hardware Silicon Root of Trust backed with auto-recovery



# MOST SECURE - HPE SILICON ROOT OF TRUST FIRMWARE VALIDATION

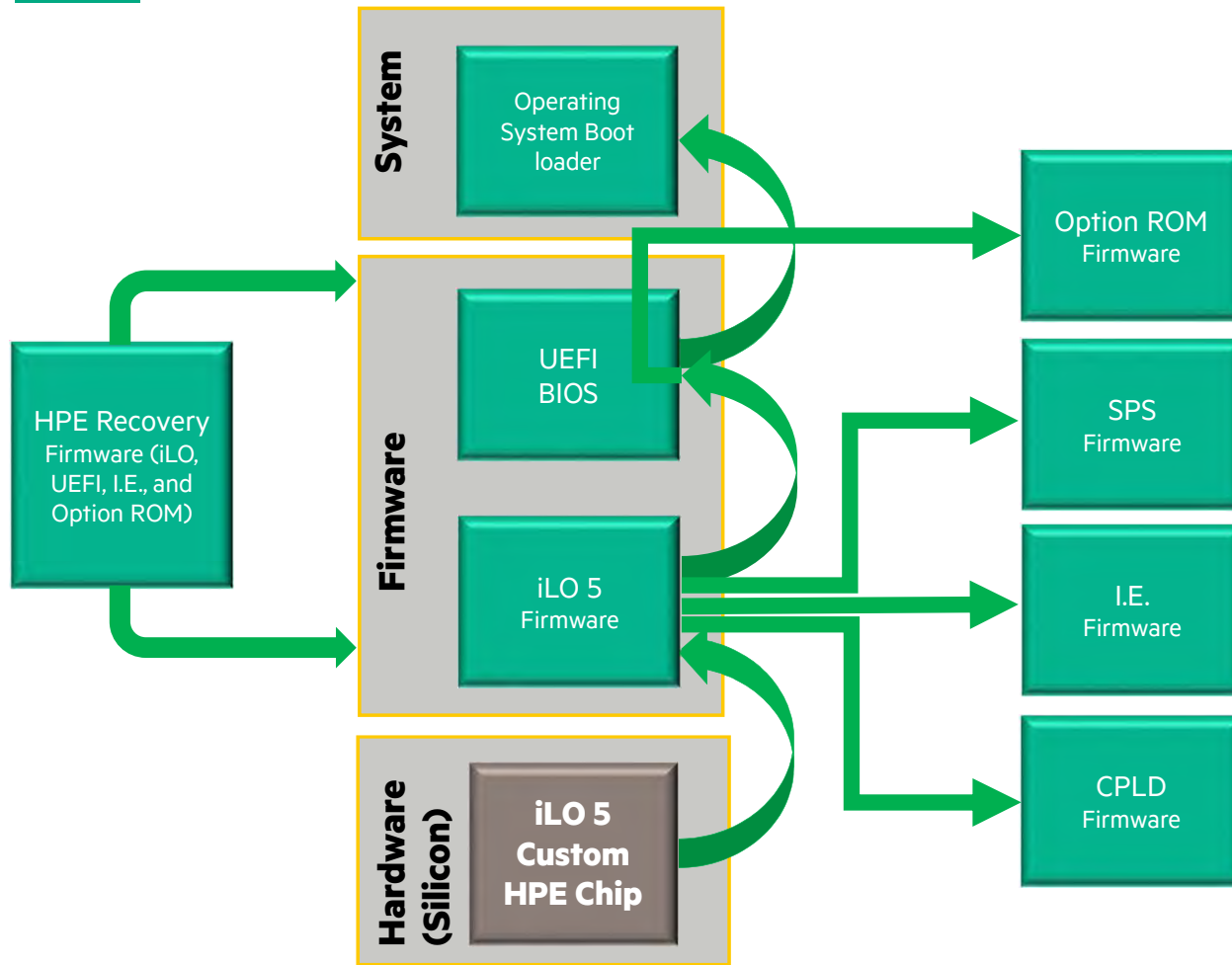

<b>Option ROM</b>	Option ROM verified for authenticity and validity
<b>Secure Boot</b>	If all firmware is good, server will allow the OS to Secure Boot
<b>SPS Firmware</b>	iLO firmware also checks the server platform services (SPS)
<b>I.E. Firmware</b>	iLO firmware also checks the innovation engine firmware (I.E.)
<b>CPLD Firmware</b>	Next, the iLO firmware checks the system programmable logic device (CPLD)
<b>iLO5 HPE Firmware</b>	When a server is powered-on, the HPE iLO silicon chip immediately checks the iLO5 firmware
<b>BMC/iLO5 Silicon Chip</b>	HPE designs & develops, our own iLO silicon chip. Competitors don't do this



# YOU WANT TO TALK SECURITY- SILICON ROOT OF TRUST

You may qualify for enhanced terms and conditions when negotiating individual cyber insurance policies with participating insurers



## Silicon Root of Trust

Available in HPE Gen10 Server<sup>1</sup>

Products Include:

- HPE ProLiant (DL, ML, BL)
- HPE Synergy
- HPE Apollo
- HPE SimpliVity
- Edgeline 8000

<sup>1</sup>iLO 5 with Silicon Root of Trust



## iLO Advanced License

Ensure that the firmware runtime verification is activated, to scan firmware every 30 days, at a minimum.

- Alerts for compromised firmware
- Automatic recovery to last known trusted state



## Review Policy

HPE customers with silicon root of trust enabled may engage with participating cyber security insurers for enhanced terms and conditions on individually negotiated cyber insurance policies.



## Win with HPE

Start taking advantage Cyber Catalyst<sup>SM</sup> accepted silicon root of trust and negotiate individual cyber insurance policies from participating insurers.



## **ON-RAMP 4 PROPOSED EXERCISE**

---



# HPE EDGELINE EL8000 DEMONSTRATING KEY ABMS CAPABILITIES

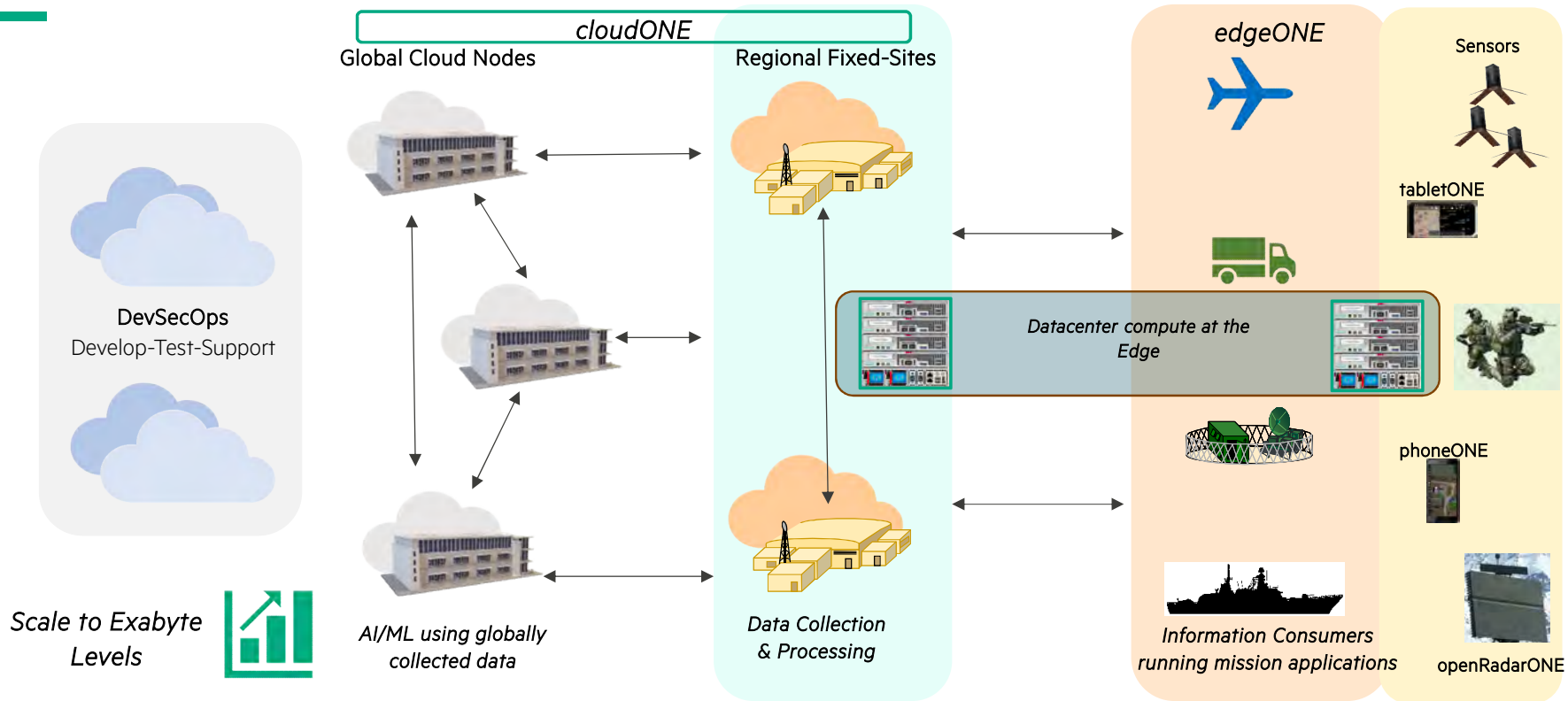

Scale to Exabyte Levels 

DevSecOps	dataONE	Global Namespace
1:1, 1:Many, or Many:Many	Connected & Disconnected Operations	
Act	Decide	Sense
Scale and move data securely, efficiently across ABMS ecosystem		

# THE FUTURE IS EDGE CENTRIC, CLOUD ENABLED AND DATA DRIVEN

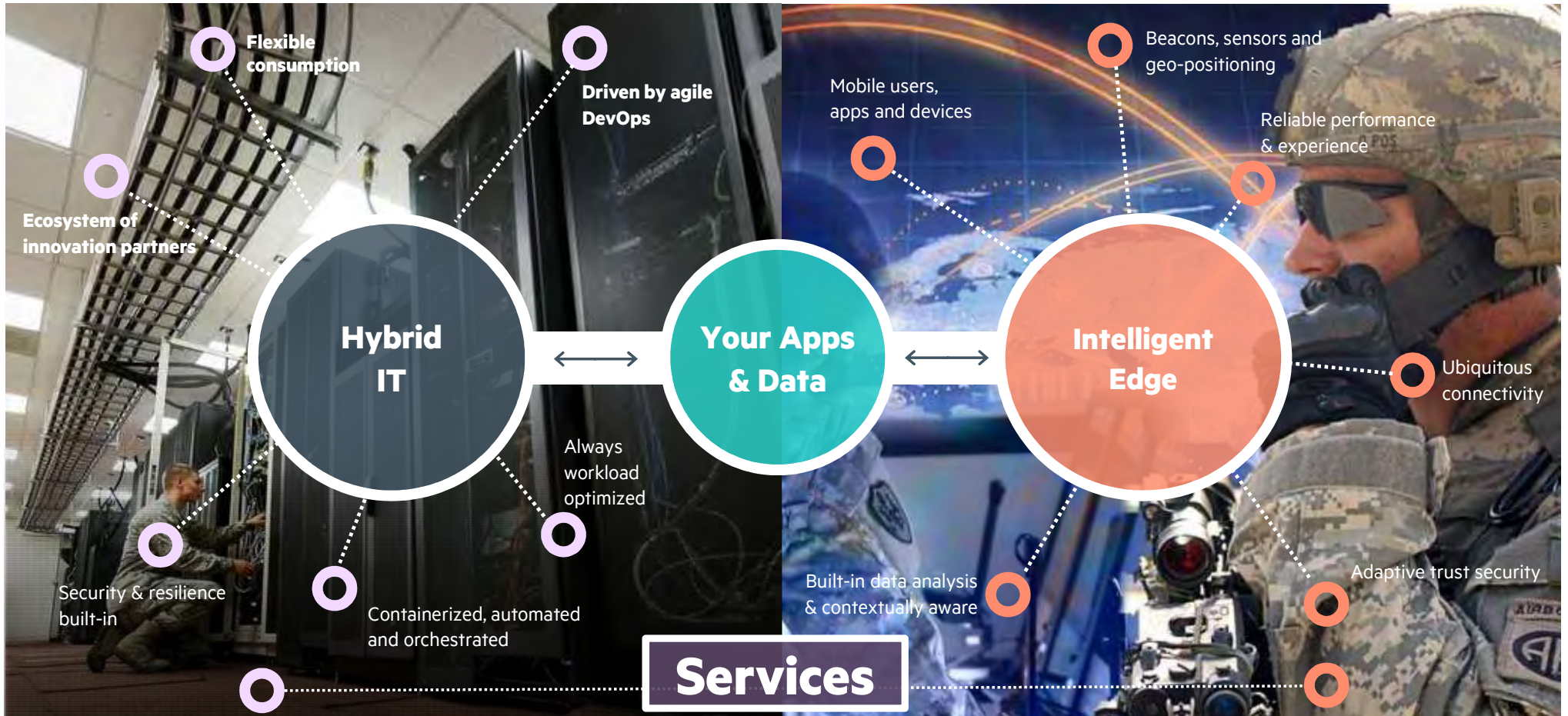

**THANK YOU**

