

BALL SPLINE ROTARY BALL SPLINE STROKE BALL SPLINE BALL SCREW SPLINE

BALL SPLINE

STRUCTURE AND ADVANTAGES	B-2
TYPES	B-3
ACCURACY	B-5
PRELOAD AND CLEARANCE IN ROTATIONAL DIRECTION	B-6
STRENGTH OF SPLINE SHAFT	B-7
LOAD RATING	B-8
CALCULATION OF DEFLECTION AND DEFLECTION ANGLE OF SPLINE SHAFT	B-9
ALLOWABLE ROTATIONAL SPEED OF SPLINE SHAFT	B-10
LIFE CALCULATION	B-11
OPERATING CONDITIONS	B-11
LUBRICATION	B-12
HOLLOW SPLINE SHAFT	B-12
SPECIAL REQUIREMENTS	B-12
USE AND HANDLING PRECAUTIONS	B-13
MOUNTING	B-14
DIMENSION TABLE	B-18~

ROTARY BALL SPLINE

STRUCTURE AND ADVANTAGES	B-32
ACCURACY OF SPR TYPE	B-33
ACCURACY OF SPB TYPE	B-34
PRELOAD AND CLEARANCE IN ROTATIONAL DIRECTION	B-35
HOLLOW SPLINE SHAFT	B-36
SPECIAL REQUIREMENTS	B-36
MOUNTING	B-37
LUBRICATION	B-38
OPERATING CONDITIONS	B-39
APPLICATION EXAMPLES	B-39
DIMENSION TABLE	B-40~

STROKE BALL SPLINE

STRUCTURE AND ADVANTAGES	B-46
ACCURACY	B-47
PRELOAD AND CLEARANCE IN ROTATIONAL DIRECTION	B-48
COMPARISON OF DYNAMIC FRICTIONAL RESISTANCE	B-48
USE AND HANDLING PRECAUTIONS	B-49
DIMENSION TABLE	B-50~

BALL SCREW SPLINE

STRUCTURE AND ADVANTAGES	B-52
PRELOAD	B-52
USE AND HANDLING PRECAUTIONS	B-52
ACCURACY	B-53
SPBR TYPE MOTION PATTERN	B-54
SPBF TYPE MOTION PATTERN	B-55
DIMENSION TABLE	B-56~

BALL SPLINE

The NB ball spline is a linear motion mechanism utilizing the rolling motion of ball elements that can sustain loads and transfer torque simultaneously. It can be used in a wide variety of applications including robotics and transport type equipment.

STRUCTURE AND ADVANTAGES

The NB ball spline consists of a spline shaft with raceway grooves and a spline nut. The spline nut consists of an outer cylinder (main body), retainer, side rings, and ball elements that is designed and manufactured to achieve a reliably smooth motion.

High Load Capacity and Long Travel Life

The raceway grooves are machined to a radius close to that of the ball elements. The large ball contact area results in high load capacity and long travel life.

Wide Variety of Configurations

Spline shaft sizes with diameters from 4mm to 100mm are available. Several types of Spline nut are available: cylindrical types (SSP/SSPM), and flange types (SSPF/SSPT). Material option of Stainless steel (SUS440C or equivalent) is also available. They can be specified to suit various applications.

High Accuracy Torque Transmission

Due to the effective contact angle between the raceway grooves and the balls, the NB ball spline can transfer large torque. By adjusting preload it is possible to obtain a higher rigidity and a higher positioning accuracy.

Ease of Additional Custom Machining

Since a round shaft with raceway grooves is used, NB ball spline shafts can be easily machined to customized specifications.

High-Speed Motion and High-Speed Rotation

The outer cylinder is compact and well balanced, resulting in good performance at high speed.

LIGHT WEIGHT and COMPACTNESS

The NB ball spline SSP-AM type has a smaller spline-nut diameter compared to the conventional SSP type nut on the same shaft diameter. The SSP-AM type is best suited for the chip-mounter head device and the multi-axial applications. Anti-corrosion type is also available.

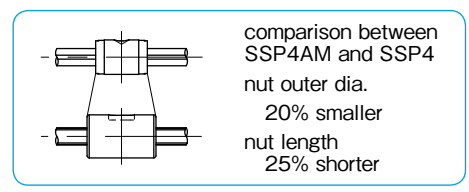
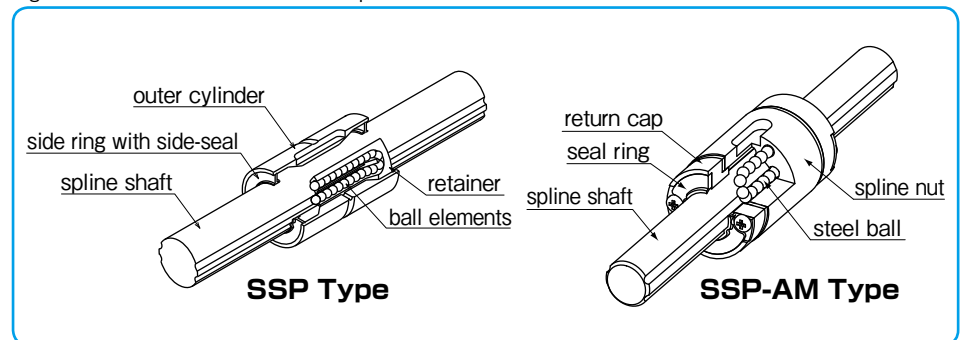

Figure B-1 Basic Structure of NB Ball Spline



TYPES

TYPES OF SPLINE NUT

A wide variety of spline nut designs are available and all spline nuts come with side-seals as a standard feature.



Table B-1 Types of Spline Nut

type of nut		shape and advantage	page
cylindrical type	SSP SSPS	<ul style="list-style-type: none"> cylindrical spline nut with key groove with special key nominal diameter: SSP4-100 : SSPS4-25 	P.B-18
	SSP-AM SSPS-AM	<ul style="list-style-type: none"> light and compact nut countersink for fixing (SSP4AM) with special key nominal diameter: 4-10 	P.B-20
	SSPM	<ul style="list-style-type: none"> cylindrical spline nut without key groove with two lock plates for fixing nominal diameter: 6-10 	P.B-22
flange type	SSPF SSPFS	<ul style="list-style-type: none"> spline nut with flange nominal diameter: SSPF6-60 : SSPFS6-25 	P.B-24
	SSPT	<ul style="list-style-type: none"> spline nut with a two side cut flange nominal diameter: 6-10 	P.B-26
	SSPT-AM SSPK-AM SSPTS-AM SSPKS-AM	<ul style="list-style-type: none"> light and compact nut with flange nominal diameter: 4-10 	P.B-28

TYPES OF SPLINE SHAFT

Depending on the application requirements, either a ground spline shaft or a non-ground (commercial grade) spline shaft is available.

Table B-2

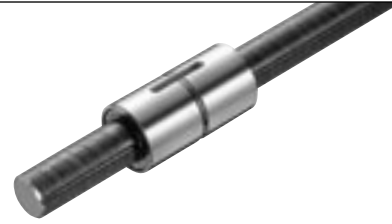
type of spline shaft	shape and advantage
ground spline shaft	 <ul style="list-style-type: none"> • precision ground and precision machined surface finish • high precision • possible to machine ends of spline shaft and surface treatment • nominal diameter: 4-100
standard spline shaft	 <ul style="list-style-type: none"> • standard dimension and shape • accuracy grade: high grade • short lead time • nominal diameter: 4-60 (refer to page B-30)
commercial shaft (non-ground)	 <ul style="list-style-type: none"> • for general industrial use • cost effective • possible to machine ends of spline shaft and surface treatment • nominal diameter: 20-50 • maximum length: 5000mm (refer to page B-31)

ACCURACY

The NB ball spline is measured for accuracy at the points shown in Figure B-2 and categorized as either high-grade (blank) or precision-grade (P). Contact NB for accuracy information on the commercial type ball spline. Figure B-2 Accuracy Measurement Points

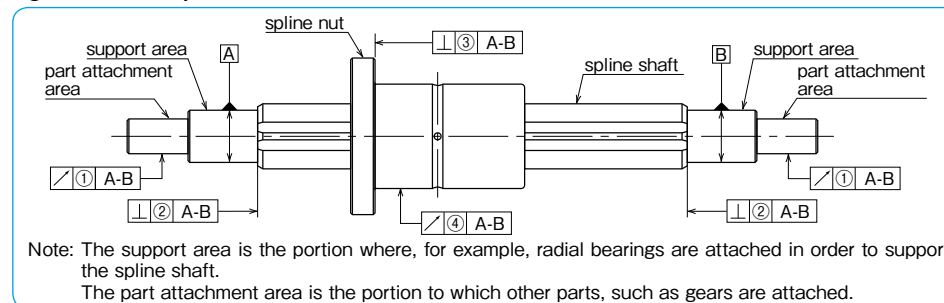

Tolerance of Spline Shaft Groove Torsion (Max.)

The groove torsion is indicated per 100mm, arbitrarily set as the effective length of the spline shaft section.

Table B-3
Tolerance of Spline Shaft Groove Torsion (Max.)

type of shaft	ground shaft	
	high	precision (P)
accuracy grade		
tolerance	13μm/100mm	6μm/100mm

Table B-4 Tolerance Relative to Spline Support Area (Max.)

unit : μm

part number	radial runout of part attachment area ①		perpendicularity of the end of the spline shaft section ② (when grinding is requested on the drawing)		perpendicularity of the flange ③	
	high-grade	precision-grade	high-grade	precision-grade	high-grade	precision-grade
SSP 4·4AM	14	8	9	6	—	—
SSP 5AM					11	8
SSP 6·6AM						
SSP 8·8AM						
SSP 10·10AM	17	10	11	8	13	9
SSP 13A	19	12				
SSP 16A						
SSP 20A						
SSP 25A	22	13	13	9	16	11
SSP 30A						
SSP 40A						
SSP 50A						
SSP 60A	29	17	19	13	22	15
SSP 80						
SSP 80L						
SSP100						
SSP100L	34	20	22	15	—	—
SSP 20	19	12	11	8	13	9
SSP 25	22	13	13	9	16	11
SSP 30						
SSP 40						
SSP 50	25	15	16	11	19	13
SSP 60	29	17	19	13	22	15

Table B-5 ④ Radial Runout of Outer Surface of Spline Nut Relative to Spline Shaft Support Area (Max.) unit: μm

total length of spline shaft (mm)	greater than	or less	SSP4 SSP4AM		SSP5AM SSP6 SSP6AM		SSP8 SSP8AM		SSP10 SSP10AM		part number SSP13A SSP16A		SSP20A·20 SSP25A·25 SSP30A·30		SSP40A·40 SSP50A·50		SSP60A·60 SSP80 SSP80L		SSP100 SSP100L		
			high-grade	precision grade	high-grade	precision grade	high-grade	precision grade	high-grade	precision grade	high-grade	precision grade	high-grade	precision grade	high-grade	precision grade	high-grade	precision grade	high-grade	precision grade	high-grade
—	200	46	26	46	26	46	26	36	20	34	18	32	18	32	16	30	16	30	16	30	16
200	315	89	—	89	57	89	57	54	32	45	25	39	21	36	19	34	17	32	17	32	17
315	400	—	—	126	—	126	82	68	41	53	31	44	25	39	21	36	19	34	17	34	17
400	500	—	—	—	—	163	—	82	51	62	38	50	29	43	24	38	21	35	19	35	19
500	630	—	—	—	—	—	—	102	65	75	46	57	34	47	27	41	23	37	20	37	20
630	800	—	—	—	—	—	—	—	—	92	58	68	42	54	32	45	26	40	22	40	22
800	1,000	—	—	—	—	—	—	—	—	115	75	83	52	63	38	51	30	43	24	43	24
1,000	1,250	—	—	—	—	—	—	—	—	153	97	102	65	76	47	59	35	48	28	48	28
1,250	1,600	—	—	—	—	—	—	—	—	195*	127*	130	85	93	59	70	43	55	33	55	33
1,600	2,000	—	—	—	—	—	—	—	—	—	—	171	116	118	77	86	54	65	40	65	40

★ SSP13A, 16A maximum length: 1500mm
 ★★ Please contact NB for shaft lengths exceeding 2000mm.

PRELOAD AND CLEARANCE IN ROTATIONAL DIRECTION

Both the clearance and preload are expressed in terms of clearance in the rotational direction. The preload is categorized into three different levels: standard, light (T1), and medium (T2). A preload cannot be specified with the commercial grade spline shaft.

Table B-6 Preload and Clearance in Rotational Direction unit: μm

part number	standard	light (T1)	medium (T2)
SSP 4·4AM	0~+3	-3~-0	-
SSP 5AM			
SSP 6·6AM			
SSP 8·8AM			
SSP 10·10AM	-3~+1	-8~-3	-13~-8
SSP 13A			
SSP 16A			
SSP 20A·20			
SSP 25A·25	-4~+2	-12~-4	-20~-12
SSP 30A·30			
SSP 40A·40			
SSP 50A·50			
SSP 60A·60	-6~+3	-18~-6	-30~-18
SSP 80			
SSP 80L			
SSP100			
SSP100L	-8~+4	-24~-8	-40~-24
SSP100L			

Table B-7 Preload and Operating Condition

preload	preload symbol	operating conditions
standard	blank	minute vibration is applied. a precise motion is required. a torque in a given direction is applied.
light	T1	slight vibration is applied. slight torsional load is applied. cyclic torque is applied.
medium	T2	shock/vibration is applied. over-hang load is applied. torsional load is applied.

* Frictional resistance may be affected by preload.

STRENGTH OF SPLINE SHAFT

The ball spline has larger load ratings compared to ball bush. Also, the ball spline can sustain radial load, moment (bending moment) and torque (twisting moment) at the same time. Thus, it is necessary to consider the strength of ball spline shaft.

Using the following equations, select the size of ball spline.

$$\sigma \geq \frac{M}{Z} \dots\dots\dots (1)$$

σ : permissible bending stress of spline shaft (98N/mm²)
 M: bending moment onto spline shaft (N·mm)
 Z: modulus of section (mm³)
 (refer to Table B-8 on page B-8)

Twisting Moment Only

$$\tau_a \geq \frac{T}{Z_p} \dots\dots\dots (2)$$

τ_a : permissible twisting stress of spline shaft (49N/mm²)
 T: twisting moment onto spline shaft (N·mm)
 Z_p: polar modulus of section (mm³)
 (refer to Table B-8 on page B-8)

Bending Moment and Twisting Moment Combined

Calculate equivalent bending moment (Me) by using equation (3). Then, substitute Me into equation (1) for shaft size selection.

$$M_e = \frac{1}{2} \{ M + \sqrt{M^2 + T^2} \} \dots\dots\dots (3)$$

Me: equivalent bending moment (N·mm)
 M: bending moment onto spline shaft
 T: twisting moment onto spline shaft

Rigidity of Spline Shaft

The rigidity of spline shaft is expressed in the torsional angle (θ) caused by twisting moment. For high accuracy smooth motion, it is necessary to keep the torsional angle within 0.25° per 1,000mm.

$$\theta = \frac{T \cdot L}{G \cdot I_p} \cdot \frac{360}{2\pi} \dots\dots\dots (4)$$

$$\text{Rigidity} = 0.25 \geq \frac{1,000}{L} \theta \dots\dots\dots (5)$$

θ : torsional angle (°)
 T: twisting moment onto spline shaft (N·mm)
 L: spline shaft length (mm)
 G: shearing modulus (SUJ2) 7.9×10⁴ (N/mm²)
 (SUS) 7.69×10⁴ (N/mm²)
 I_p: polar moment of inertia of area (mm⁴)
 (refer to Table B-8 on page B-8)

Figure B-3 Bending Moment

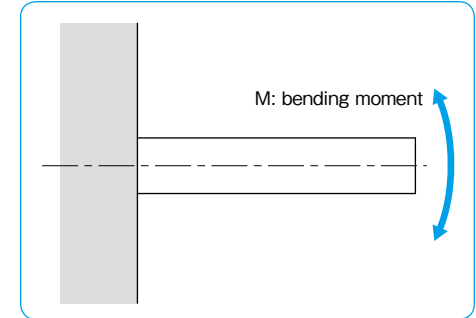

Figure B-4 Twisting Moment

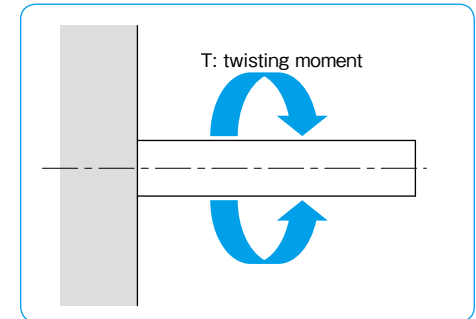
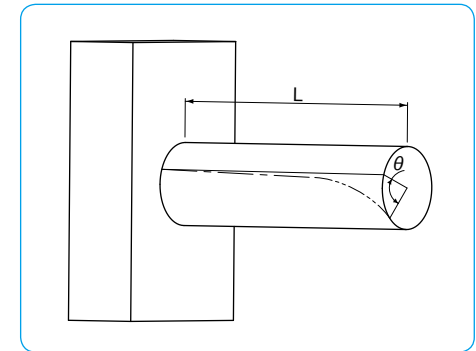

Figure B-5 Deformation of Spline Shaft by Twisting Moment



BALL SPLINE

Table B-8 Cross-sectional Characteristics of Spline Shaft

part number	I moment of inertia of area mm ⁴	Z modulus of section mm ³	I _p polar moment of inertia of area mm ⁴	Z _p polar modulus of section mm ³	C=1/48EI	
					SUJ2 1/N·mm ²	SUS440C
SSP 4	1.18×10	5.90	2.41×10	1.20×10	8.57×10 ⁻⁹	8.83×10 ⁻⁹
SSP 6	5.91×10	1.97×10	1.21×10 ²	4.04×10	1.71×10 ⁻⁹	1.76×10 ⁻⁹
SSP 8	1.90×10 ²	4.76×10	3.88×10 ²	9.69×10	5.32×10 ⁻¹⁰	5.47×10 ⁻¹⁰
SSP 10	4.61×10 ²	9.22×10	9.42×10 ²	1.88×10 ²	2.19×10 ⁻¹⁰	2.26×10 ⁻¹⁰
SSP 13A	1.32×10 ³	2.03×10 ²	2.70×10 ³	4.16×10 ²	4.16×10 ⁻¹¹	7.89×10 ⁻¹¹
SSP 16A	2.98×10 ³	3.73×10 ²	6.15×10 ³	7.68×10 ²	3.39×10 ⁻¹¹	3.49×10 ⁻¹¹
SSP 20A	7.35×10 ³	7.35×10 ²	1.51×10 ⁴	1.51×10 ³	1.38×10 ⁻¹¹	1.42×10 ⁻¹¹
SSP 25A	1.79×10 ⁴	1.43×10 ³	3.68×10 ⁴	2.94×10 ³	5.65×10 ⁻¹²	5.82×10 ⁻¹²
SSP 30A	3.63×10 ⁴	2.42×10 ³	7.57×10 ⁴	5.05×10 ³	2.79×10 ⁻¹²	—
SSP 40A	1.15×10 ⁵	5.73×10 ³	2.39×10 ⁵	1.20×10 ⁴	8.83×10 ⁻¹³	—
SSP 50A	2.81×10 ⁵	1.12×10 ⁴	5.86×10 ⁵	2.34×10 ⁴	3.60×10 ⁻¹³	—
SSP 60A	5.91×10 ⁵	1.97×10 ⁴	1.22×10 ⁶	4.08×10 ⁴	1.71×10 ⁻¹³	—
SSP 80	1.93×10 ⁶	4.83×10 ⁴	3.92×10 ⁶	9.81×10 ⁴	5.24×10 ⁻¹⁴	—
SSP 80L						
SSP100	4.69×10 ⁶	9.38×10 ⁴	9.55×10 ⁶	1.91×10 ⁵	2.16×10 ⁻¹⁴	—
SSP100L						
SSP 20	5.03×10 ³	5.53×10 ²	1.04×10 ⁴	1.14×10 ³	2.01×10 ⁻¹¹	2.07×10 ⁻¹¹
SSP 25	1.27×10 ⁴	1.10×10 ³	2.63×10 ⁴	2.29×10 ³	7.97×10 ⁻¹²	8.21×10 ⁻¹²
SSP 30	2.74×10 ⁴	1.96×10 ³	5.73×10 ⁴	4.10×10 ³	3.69×10 ⁻¹²	—
SSP 40	8.71×10 ⁴	4.66×10 ³	1.82×10 ⁵	9.75×10 ³	1.16×10 ⁻¹²	—
SSP 50	2.16×10 ⁵	9.19×10 ³	4.53×10 ⁵	1.93×10 ⁴	4.69×10 ⁻¹³	—
SSP 60	4.50×10 ⁵	1.59×10 ⁴	9.46×10 ⁵	3.35×10 ⁴	2.25×10 ⁻¹³	—
SSP 4AM	1.18×10	6.01	2.44×10	1.23×10	8.56×10 ⁻⁹	8.82×10 ⁻⁹
SSP 5AM	2.77×10	1.11×10	5.77×10	2.31×10	3.65×10 ⁻⁹	3.76×10 ⁻⁹
SSP 6AM	5.89×10 ²	1.96×10	1.22×10 ²	4.05×10	1.72×10 ⁻⁹	1.77×10 ⁻⁹
SSP 8AM	1.88×10 ²	4.71×10	3.86×10 ²	9.66×10	5.37×10 ⁻¹⁰	5.53×10 ⁻¹⁰
SSP 10AM	4.53×10 ²	9.06×10	9.35×10 ²	1.87×10 ²	2.23×10 ⁻¹⁰	2.30×10 ⁻¹⁰

LOAD RATING

The load rating for SSP-AM type depends on the direction of load.

Table B-9 LOAD RATING

		SSP4AM	SSP5AM~10AM
basic dynamic load rating	vertical	C	C
	horizontal	1.73×C	1.22×C
basic static load rating	vertical	C ₀	C ₀
	horizontal	1.73×C ₀	1.22×C ₀

Figure B-6 Load Direction

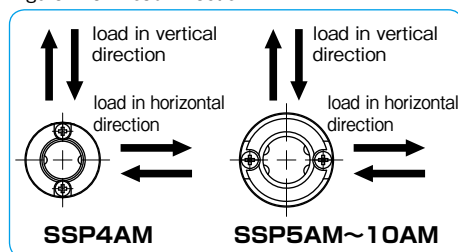

CALCULATION OF DEFLECTION AND DEFLECTION ANGLE OF SPLINE SHAFT

The following formulas are used to obtain the deflection and its angle of the ball spline shaft. Typical conditions are listed in Table B-10.

Table B-10 Formulas for Calculating Deflection and Deflection Angle

support method	specification	formula for deflection	formula for deflection angle
1 support support		$\delta_{max} = \frac{P\ell^3}{48EI} = P\ell^3C$	$i_1 = 0$ $i_2 = \frac{P\ell^2}{16EI} = 3P\ell^2C$
2 fixed fixed		$\delta_{max} = \frac{P\ell^3}{192EI} = \frac{1}{4}P\ell^3C$	$i_1 = 0$ $i_2 = 0$
3 support support		$\delta_{max} = \frac{5p\ell^4}{384EI} = \frac{5}{8}p\ell^4C$	$i_2 = \frac{p\ell^3}{24EI} = 2p\ell^3C$
4 fixed fixed		$\delta_{max} = \frac{p\ell^4}{384EI} = \frac{1}{8}p\ell^4C$	$i_2 = 0$
5 support support		$\delta_1 = \frac{Pa^3}{6EI} \left(2 + \frac{3b}{a}\right) = 8Pa^3 \left(2 + \frac{3b}{a}\right)C$ $\delta_{max} = \frac{Pa^3}{24EI} \left(\frac{3\ell^2}{a^2} - 4\right) = 2Pa^3 \left(\frac{3\ell^2}{a^2} - 4\right)C$	$i_1 = \frac{Pab}{2EI} = 24PabC$ $i_2 = \frac{Pa(a+b)}{2EI} = 24Pa(a+b)C$
6 fixed fixed		$\delta_1 = \frac{Pa^3}{6EI} \left(2 - \frac{3a}{\ell}\right) = 8Pa^3 \left(2 - \frac{3a}{\ell}\right)C$ $\delta_{max} = \frac{Pa^3}{24EI} \left(2 + \frac{3b}{a}\right) = 2Pa^3 \left(2 + \frac{3b}{a}\right)C$	$i_1 = \frac{Pa^2b}{2EI\ell} = \frac{24Pa^2bC}{\ell}$ $i_2 = 0$
7 fixed free		$\delta_{max} = \frac{P\ell^3}{3EI} = 16P\ell^3C$	$i_1 = \frac{P\ell^2}{2EI} = 24P\ell^2C$ $i_2 = 0$
8 fixed free		$\delta_{max} = \frac{p\ell^4}{8EI} = 6p\ell^4C$	$i_1 = \frac{p\ell^3}{6EI} = 8p\ell^3C$ $i_2 = 0$
9 support support		$\delta_{max} = \frac{\sqrt{3}Mo\ell^2}{216EI} = \frac{2\sqrt{3}}{9}Mo\ell^2C$	$i_1 = \frac{Mo\ell}{12EI} = 4Mo\ell C$ $i_2 = \frac{Mo\ell}{24EI} = 2Mo\ell C$
10 fixed fixed		$\delta_{max} = \frac{Mo\ell^2}{216EI} = \frac{2}{9}Mo\ell^2C$	$i_1 = \frac{Mo\ell}{16EI} = 3Mo\ell C$ $i_2 = 0$

δ_1 : deflection at the concentrated load point (mm) δ_{max} : maximum deflection (mm) i_1 : deflection angle at the concentrated load point (rad) i_2 : deflection angle at the support point (rad) Mo : moment (N·mm) P : concentrated load (N) p : uniformly distributed load (N/mm) a, b : concentrated load point distance (mm) ℓ : span (mm) I : moment of inertia of area (mm⁴) (refer to Table B-8 on page B-8) E : modulus of longitudinal elasticity (SUJ2) 2.06×10^5 (N/mm²) (SUS) 2.0×10^5 (N/mm²) C : $1/48EI$ (1/N·mm²)

ALLOWABLE ROTATIONAL SPEED OF SPLINE SHAFT

When the rotational speed is increased and approaches the spline shaft resonant frequency, the spline shaft is disabled from further operation. This speed is called the critical speed and can be obtained by the following equations. In order to leave a sufficient safety margin, the allowable operating speed should be set at about 80% of the calculated value.

Using the following equations, select the size of ball spline shaft. First, calculate λ and A by equation (8) and (9) then, substitute the values into equation (7).

$$N_c = 60 \cdot \frac{\lambda^2}{2\pi \cdot L^2} \cdot \sqrt{\frac{E \cdot I_d \times 10^3}{\gamma \cdot A}} \dots\dots\dots (7)$$

N_c : critical speed (rpm)
 L : support distance (mm)
 E : modulus of longitudinal elasticity (SUJ2) 2.06×10^5 (N/mm²)
 (SUS) 2.0×10^5 (N/mm²)
 γ : density (SUJ2) 7.85×10^{-6} (kg/mm³)
 (SUS) 7.75×10^{-6} (kg/mm³)

I_d : Minimum Moment of Inertia of Area (mm⁴)

$$I_d = \frac{\pi \cdot d^4}{64} \dots\dots\dots (8)$$

d : maximum machined-down diameter with no spline grooves left (refer to Table B-11)

A: Minimum Cross-sectional Area of the Spline Shaft (mm²)

$$A = \frac{\pi \cdot d^2}{4} \dots\dots\dots (9)$$

d : maximum machined-down diameter with no spline grooves left (refer to Table B-11)

λ : coefficient of mounting method (refer to Figure B-7)

- fixed-free $\lambda = 1.875$
- supported-supported $\lambda = 3.142$
- fixed-supported $\lambda = 3.927$
- fixed-fixed $\lambda = 4.730$

Table B-11 Spline Shaft Profile

part number	d: maximum diameter with no spline grooves left mm	part number	d: maximum diameter with no spline grooves left mm
SSP 4	3.5	SSP20	16.4
SSP 6	5.3	SSP25	20.6
SSP 8	7.2	SSP30	24.8
SSP 10	9	SSP40	33.1
SSP 13A	11.7	SSP50	41.4
SSP 16A	14.2	SSP60	49.7
SSP 20A	17.9		
SSP 25A	22.4	SSP 4AM	3.4
SSP 30A	26.8	SSP 5AM	4.3
SSP 40A	35.5	SSP 6AM	5.2
SSP 50A	44.6	SSP 8AM	7.1
SSP 60A	54	SSP10AM	8.8
SSP 80			
SSP 80L	73.9		
SSP100			
SSP100L	92		

The maximum diameter (d) is recommended as the shaft diameter of the support area leaving no spline grooves after end-machining.

Figure B-7 Mounting Method

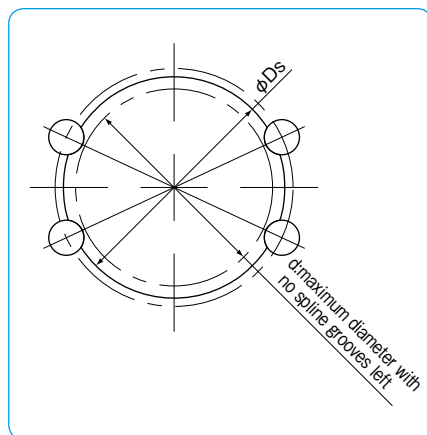
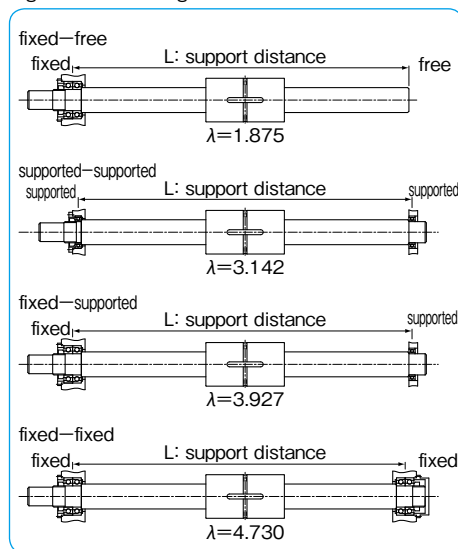

RATED LIFE CALCULATION

When the ball elements are used as the rolling elements in ball splines, the following equations are used to calculate the life of ball spline:

For radial load

$$L = \left(\frac{f_c \cdot C}{f_w \cdot P} \right)^3 \cdot 50$$

For torque load

$$L = \left(\frac{f_c \cdot C_T}{f_w \cdot T} \right)^3 \cdot 50$$

L : rated life (km) f_c : contact coefficient f_w : load coefficient
 C : basic dynamic load rating (N) P : applied load (N)
 C_T : basic dynamic torque rating (N·m) T : applied torque (N·m)
 * Refer to page Eng-5 for the coefficients
 ** The load rating of the commercial spline is approximately 70% of the standard ball spline.

$$L_h = \frac{L \cdot 10^3}{2 \cdot \ell_s \cdot n_1 \cdot 60}$$

L_h : life time (hr) ℓ_s : stroke length (m)
 L : rated life (km) n_1 : number of cycles per minute (cpm)

OPERATING CONDITIONS

The performance of the ball spline is affected by the operating conditions of the application. The operating conditions should, therefore be carefully taken into consideration.

Dust Prevention

Foreign particles or dust in the ball spline nut affects the motion accuracy and shortens the life time. Standard seals will perform well against dust prevention under normal operating conditions; however, in a harsh environment, it is necessary to attach bellows or protective covers. (refer to Figure B-9)

Operating Temperature

Since the retainer is made of resin, the operating temperature should never exceed 80°C.

Figure B-8 Radial Load and Torque Load

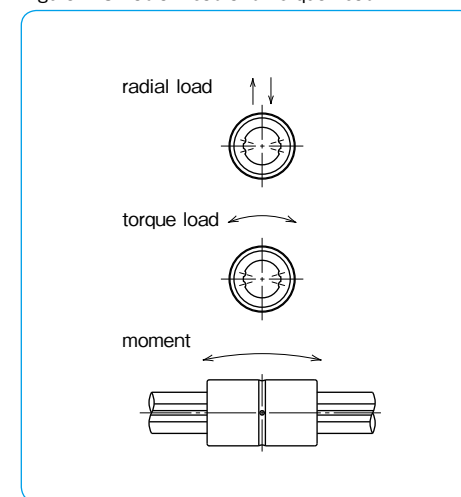
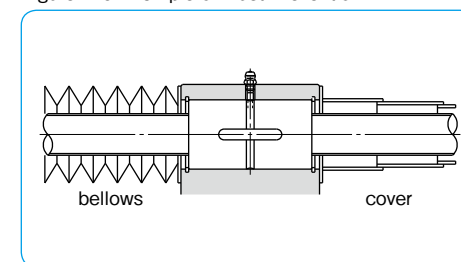

Figure B-9 Example of Dust Prevention



LUBRICATION

The spline nut is prelubricated with lithium soap based grease prior to shipment for immediate use. Please relubricate with a similar type of grease periodically depending on the operating conditions. Low dust generation grease is available from NB standard grease. (refer to page Eng-39)
The NB spline nut has seals as standard. The seals work well to contain the grease inside the nut especially for the ground shaft, since the seal shape approximates the spline shaft profile.

Figure B-10 Example of Lubrication Mechanism

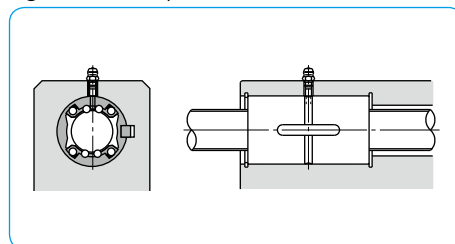

HOLLOW SPLINE SHAFT

NB provides hollow shafts. It can be used for running cable, air piping, and weight reduction. Table B-12 shows a list of recommended inner diameter for hollow spline shaft (SUJ2).

Table B-12 Recommended Inner Diameter for Hollow Spline Shaft

part number	shaft diameter Ds mm	inner diameter d mm	cross-sectional coefficient Z mm ³	second moment of inertia I mm ⁴
SSP 4	4	1.5	11.5	5.6
SSP 6	6	2	58.3	18.9
SSP 8	8	3	186	44.9
SSP10	10	4	448	85.9
SSP13A	13	6	1,260	182
SSP16A	16	8	2,780	323
SSP20A	20	10	6,860	637
SSP25A	25	15	15,400	1,100
SSP 4AM	4	1.5	11.6	5.7
SSP 5AM	5	2	26.9	10.3
SSP 6AM	6	2	58.1	18.8
SSP 8AM	8	3	184	44.4
SSP10AM	10	4	440	84.2

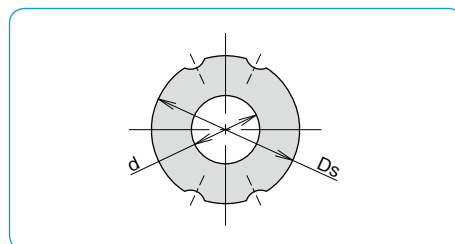
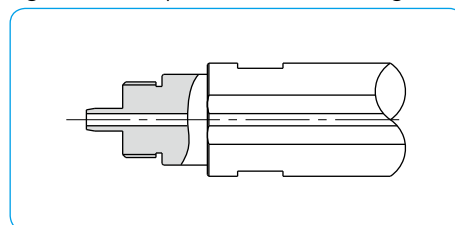

Figure B-11 Example of Shaft-end Machining



USE AND HANDLING PRECAUTIONS

NB ball spline must be handled with care as it is a precise component. Please note the following points.

A Set of Spline Nut and Spline Shaft

The ball spline's accuracy and preload is guaranteed when spline nut and shaft are aligned as shown in Figure B-12. Please make sure to align the NB marks when reinserting the shaft.

When inserting the spline shaft into the spline nut, ensure that the ball elements do not drop out. This is done by aligning the raceway grooves of the shaft with the rows of ball elements and the seal lip of the nut. Then, carefully insert the spline shaft through the spline nut. In case that the nut is preloaded, please exercise additional care.

Figure B-12 NB mark Alignment

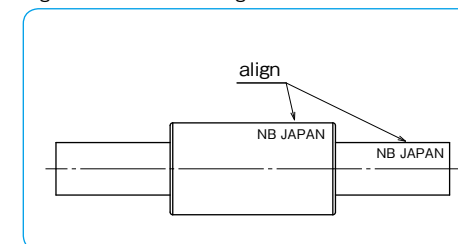

Fit between Spline Nut and Housing

A transition fit is used for the SSP/SSPM-type spline nut and its housing bore to minimize the clearance. If high accuracy is not required, then a clearance fit can be used. Regarding the SSPT/SSPF type spline nut, for a light load and little torque application a hole slightly larger than the outer diameter of the nut can suffice. The mounting surface for the flange influences the perpendicularity and parallelism. Please make sure that the accuracy of the mounting surface is correct.

Table B-13 Fit for the Spline Nut

type of spline nut	clearance fit	transition fit
SSP	H7	J6
SSP-AM		
SSPM		

Insertion of Spline Nut

When inserting a spline nut into the housing, use a jig like the one shown in Figure B-13. Carefully insert the nut so as to not hit the side ring and seal.

Figure B-13 Insertion of Spline Nut into Housing

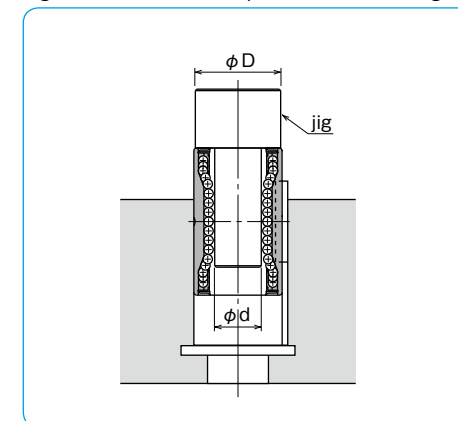

Table B-14 Recommended Jig Dimensions unit: mm

part number	D	d	part number	D	d
SSP 4	9.5	3.5	SSP20	31.5	16.5
SSP 6	13.5	5	SSP25	36.5	20.5
SSP 8	15.5	7	SSP30	44.5	25
SSP 10	20.5	8.5	SSP40	59.5	33
SSP 13A	23.5	12	SSP50	74	41
SSP 16A	30.5	14.5	SSP60	89	50
SSP 20A	34.5	18			
SSP 25A	41.5	22.5	SSP 4AM	7.5	3
SSP 30A	46.5	27	SSP 5AM	9.5	4
SSP 40A	63.5	35.6	SSP 6AM	11.5	5
SSP 50A	79	44	SSP 8AM	14.5	7
SSP 60A	89	53.5	SSP10AM	18.5	8.5
SSP 80					
SSP 80L	119	74			
SSP100					
SSP100L	149	92			

Excessive Moment

One spline nut can sustain high moments, however, excessive moment makes the spline nut unbalanced and unstable during motion. Please use more than one spline nut for high moment or high accuracy applications.

MOUNTING

Mounting of SSP Type

Examples of installing the SSP type are shown in Figures B-14 and B-15.

Figure B-14 Using a Retaining Ring

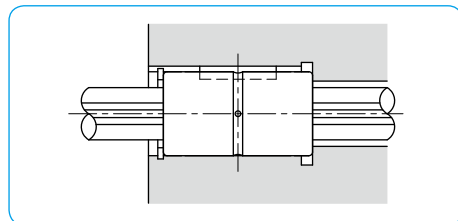
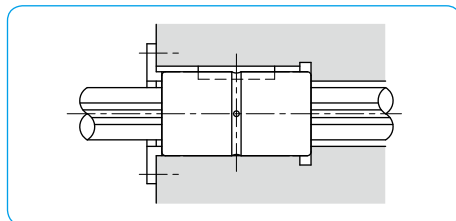

Figure B-15 Using a Push Plate



Key

The SSP type spline nut comes with a key shown in Figure B-16.

Figure B-16 Key for SSP Type

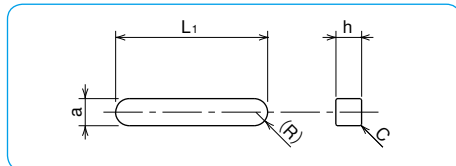

Table B-15 Major Dimensions of Key

part number	a	tolerance μm	h	tolerance μm	L ₁	C	
	mm		mm		mm	mm	
SSP 4	2	+16 + 6	2	0 -25	6	0.2	
SSP 6	2.5		2.5		10.5		
SSP 8	2.5		2.5		10.5		
SSP 10	3		3		13		
SSP 13A	3		3		15		
SSP 16A	3.5	+24 +12	3.5	0 -30	17.5	0.5	
SSP 20A	4		4		29		
SSP 25A	4		4		36		
SSP 30A	4		4		42		
SSP 40A	6		6		52		
SSP 50A	8	+30/+15	7	0 -36	58	0.5	
SSP 60A	12		8		67		
SSP 80	16		+36 +18		10		76
SSP 80L							110
SSP100	20		+43 +22		13		0
SSP100L		-43		160			
SSP 20	4	+24	4	0	26	0.2	
SSP 25	5	+12	5	-30	33	0.3	
SSP 30	7	+30	7	0	41	0.3	
SSP 40	10	+15	8	-36	55	0.5	
SSP 50	15	+36	10	0/-43	60	0.5	
SSP 60	18	+18	11		68	0.5	
SSP 5AM	2	+16 + 6	2	0 -25	6	0.2	
SSP 6AM	2		2		8		
SSP 8AM	2.5		2.5		8.5		
SSP 10AM	3		3		11		

For SSPs and SSP AM type, the material of key is stainless steel.

Mounting of SSP4AM Type

Example of installing the SSPM type are shown in Figure B-17.

Figure B-17 Using SSP4AM Lock Plates

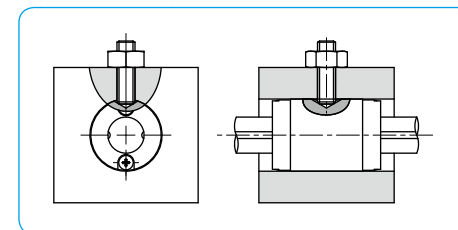

Mounting of SSPM Type

Examples of installing the SSPM type are shown in Figures B-18,19,22 and 23.

Figure B-18 Using F Type Lock Plates

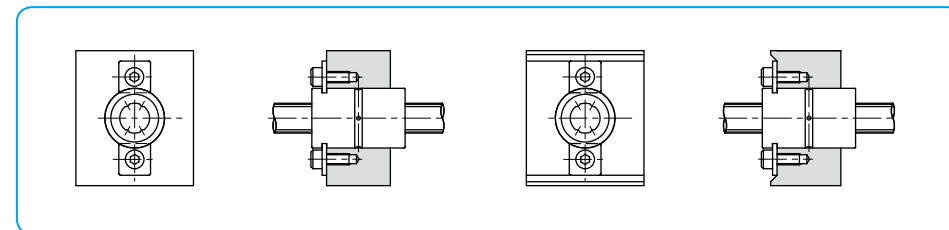

F Type Lock Plate (Standard Plate)

The lock plate shown in Figure B-19 is provided with the SSPM spline nut.
Material: SUS304CSP

Table B-16 F Type Lock Plate

part number	K mm	G mm	t mm	R mm	applicable spline nut
FP 6	6.8	2.9	1.0	0.5	SSPM 6
FP 8	8.5	3.5	1.2	0.5	SSPM 8
FP10	8.5	3.5	1.2	0.5	SSPM10

Figure B-19 F Type Lock Plate

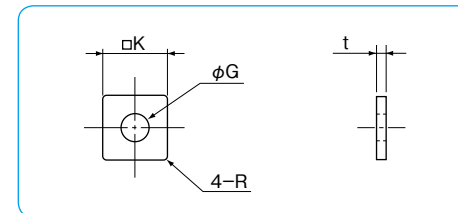
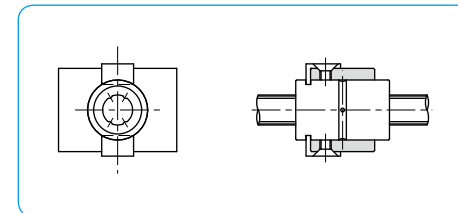

Figure B-20 Using LP Type Lock Plates



LP Type Lock Plate (Optional Plate)

The LP type lock plate is also available for purchase with the SSPM spline nut.

Material: SUS304CSP

Figure B-21 LP Type Lock Plate

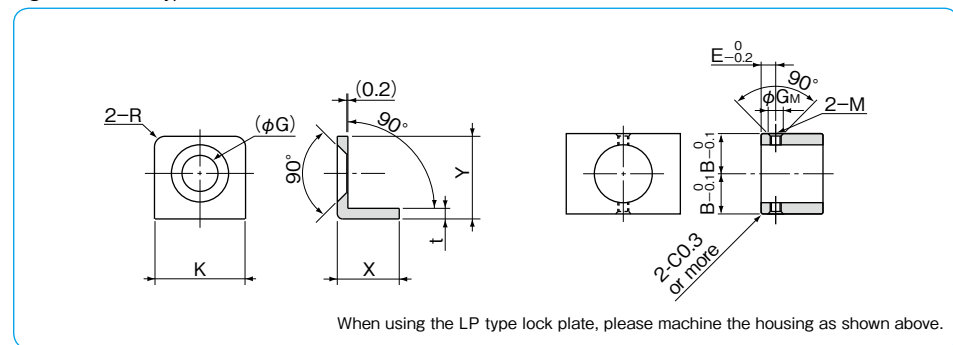

Table B-17 LP Type Lock Plate

part number	lock plate major dimensions						machined housing dimensions				applicable spline nut
	K mm	G mm	t mm	R mm	X mm	Y mm	B mm	E mm	G _M mm	M	
LP 6	8.6	3.8	1.0	1	5.85	7.8	11.1	3.3	3.5	M2.5	SSPM 6
LP 8	9.15	4.5	1.2	1	6.45	9.2	12.3	4.0	4.2	M3	SSPM 8
LP10	9.15	4.5	1.2	1	6.45	9.2	14.8	4.0	4.2	M3	SSPM10

Figure B-22 Using Special Lock Plates (1)

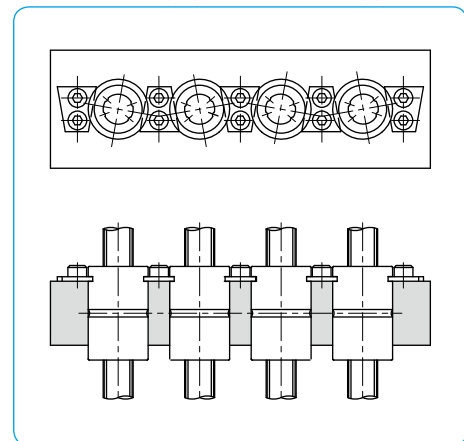
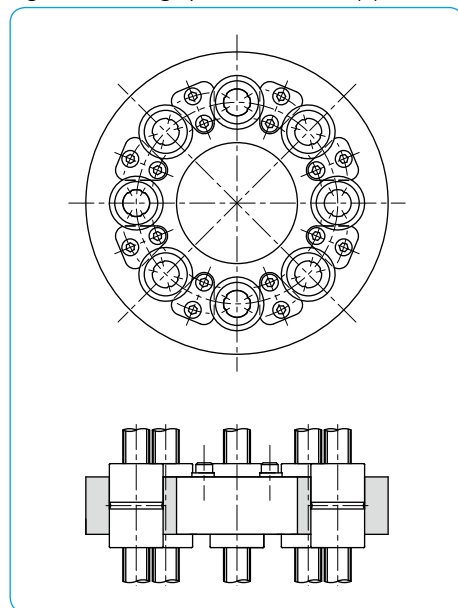

Figure B-23 Using Special Lock Plates (2)



Mounting of SSPF Type

Examples of installing the SSPF type are shown in Figure B-24.

Figure B-24 Examples of installing SSPF Type

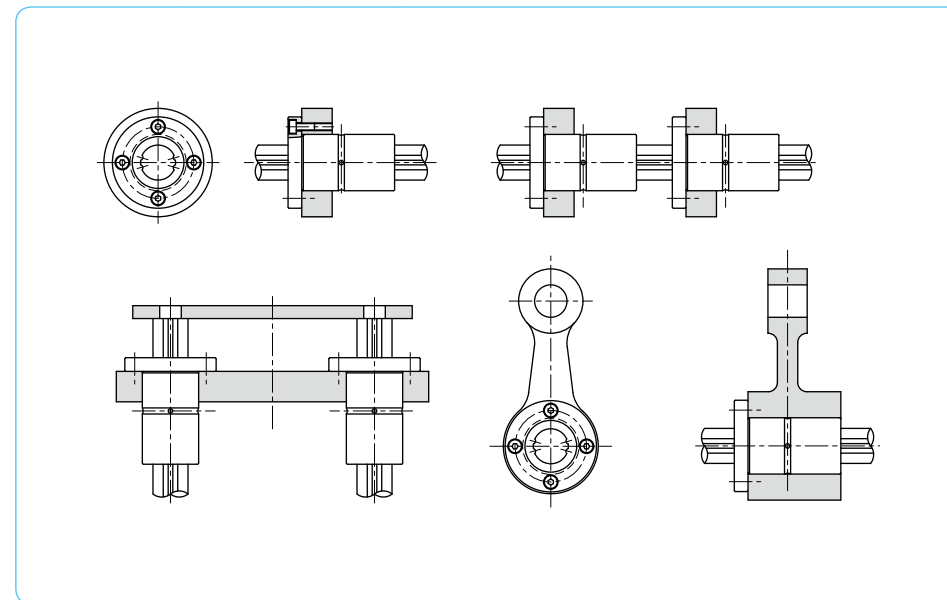

Mounting of SSPT Type

Examples of installing SSPT type are shown in Figure B-25.

Figure B-25 Examples of installing SSPT Type

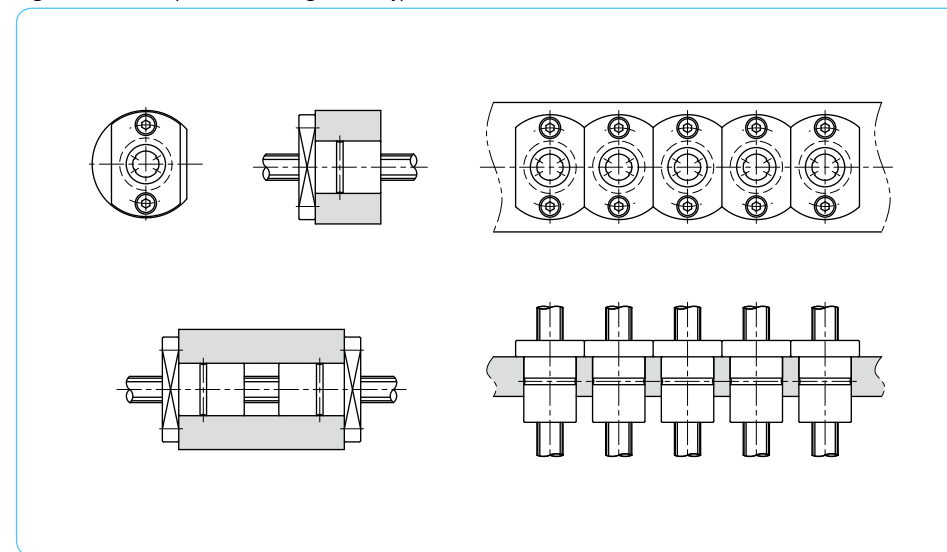

SSP TYPE

– Cylindrical Spline Nut –

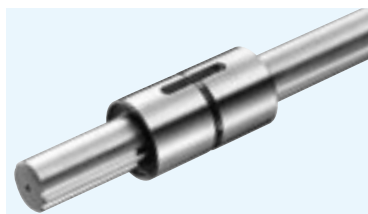

part number structure

example **SSP 80 L-2-T1-600-P/CU**

specification
SSP: standard
SSPS: anti-corrosion

nominal diameter

nut length
blank: standard
L: long

number of nuts attached to one shaft

Note: retainer material is resin.

with special specification

accuracy grade
blank: high
P: precision

spline shaft total length

preload symbol
blank: standard
T1: light
T2: medium

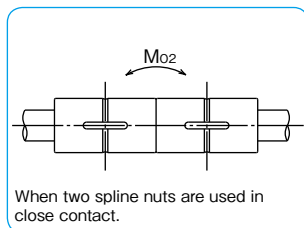

When two spline nuts are used in close contact.

part number		D mm	tolerance μm	L mm	tolerance mm	B mm	major dimensions				
standard	anti-corrosion						b mm	tolerance μm	t +0.05 0 mm	L ₁ mm	d mm
SSP 4	SSPS 4	10	0/-9	16	0 -0.2	-	2	1.2	6	-	
SSP 6	SSPS 6	14	0	25			2.5	+14	1.2	10.5	1
SSP 8	SSPS 8	16	-11	25			2.5	0	1.2	10.5	1.5
SSP 10	SSPS10	21	0	33			3	1.5	13	1.5	
SSP 13A	SSPS13A	24	-13	36			3	1.5	15	1.5	
SSP 16A	SSPS16A	31	0	50			3.5	2	17.5	2	
SSP 20A	SSPS20A	35	0	63			4	+18	2.5	29	2
SSP 25A	SSPS25A	42	-16	71			4	0	2.5	36	3
SSP 30A	—	47	0	80			4	0	2.5	42	3
SSP 40A	—	64	0	100			6	-0.3	3.5	52	4
SSP 50A	—	80	-19	125	8	+22/0	4	58	4		
SSP 60A	—	90	0	140	12	+27	5	67	4		
SSP 80	—	120	-22	160	-	118.2	16	0	6	76	5
SSP 80L	—	120	0	217					175.2	110	
SSP 100	—	150	0	185					132.6	110	
SSP100L	—	150	-25	248	195.6	20	+33	7	110	5	
									160		
SSP 20	SSPS20	32	0	60	0/-0.2	-	4	+18	2.5	26	2
SSP 25	SSPS25	37	-16	70	0 -0.3		5	0	3	33	3
SSP 30	—	45	0	80			7	+22	4	41	3
SSP 40	—	60	0	100			10	0	4.5	55	4
SSP 50	—	75	-19	112			15	+27	5	60	4
SSP 60	—	90	0/-22	127			18	0	6	68	4

SSP type spline nut comes with a key (refer to page B-14).

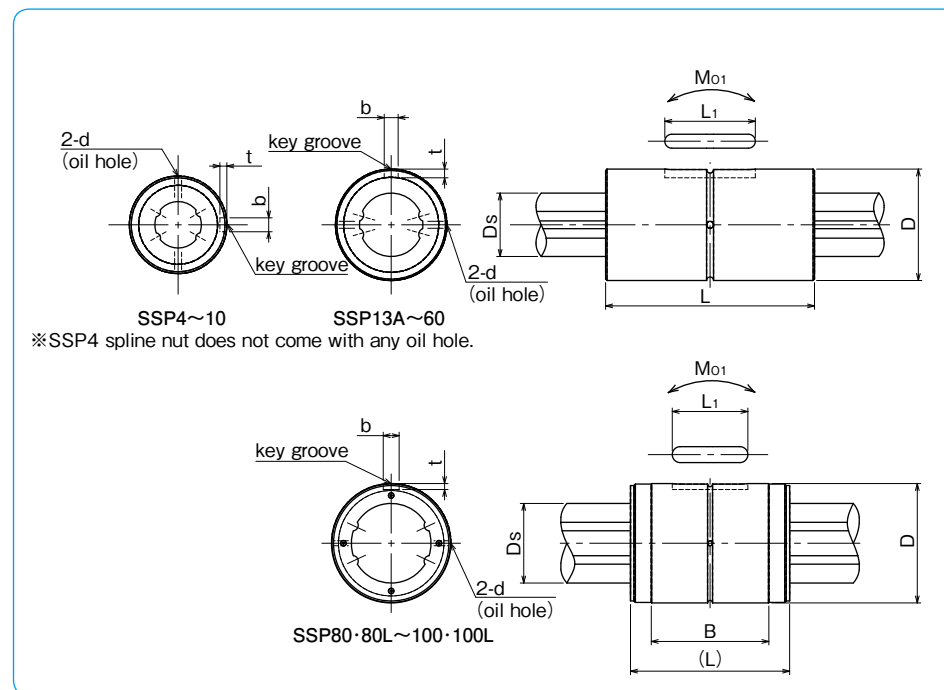

SSP4~10 SSP13A~60
 ※SSP4 spline nut does not come with any oil hole.

SSP80~80L~100~100L

Ds mm	tolerance μm	basic torque rating		basic load rating		allowable static moment		mass		size
		dynamic C _T N·m	static C _{0T} N·m	dynamic C kN	static C ₀ kN	M ₀₁ N·m	M ₀₂ N·m	nut kg	shaft kg/m	
4	0	0.74	1.05	0.86	1.22	1.97	10.3	0.0065	0.10	4
6	-12	1.5	2.4	1.22	2.28	5.1	40	0.019	0.21	6
8	0	2.1	3.7	1.45	2.87	7.4	50	0.023	0.38	8
10	-15	4.4	8.2	2.73	5.07	18.0	116	0.054	0.60	10
13	0	21	39.2	2.67	4.89	13.7	109	0.07	1.0	13A
16	-18	60	110	6.12	11.2	46	299	0.15	1.5	16A
20	0	105	194	8.9	16.3	110	560	0.22	2.4	20A
25	-21	189	346	12.8	23.4	171	1,020	0.33	3.7	25A
30	0	307	439	18.6	23.2	181	1,470	0.36	5.38	30A
40	0	674	934	30.8	37.5	358	2,940	0.95	9.55	40A
50	-25	1,290	2,950	40.3	64.9	690	4,080	1.9	15.0	50A
60	0	1,570	2,620	47.7	79.5	881	5,470	2.3	21.6	60A
80	-30	3,860	6,230	83.1	134	2,000	11,100	5.1	39	80
		5,120	9,340	110	201	4,410	21,100	7.6		80L
100	0	6,750	11,500	135	199	3,360	19,300	9.7	61	100
	-35	8,960	17,300	179	298	7,340	37,700	13.9		100L
18.2	0	83	133	7.84	11.3	63	500	0.2	2.0	20
23	-21	162	239	12.3	16.1	104	830	0.22	3.1	25
28	0	289	412	18.6	23.2	181	1,470	0.35	4.8	30
37.4	0	637	882	30.8	37.5	358	2,940	0.81	8.6	40
47	-25	1,390	3,180	46.1	74.2	696	4,400	1.5	13.1	50
56.5	0/-30	2,100	4,800	58.0	127	1,300	8,800	2.5	19	60

1kN ≅ 102kgf 1N · m ≅ 0.102kgf · m

SSP-AM TYPE

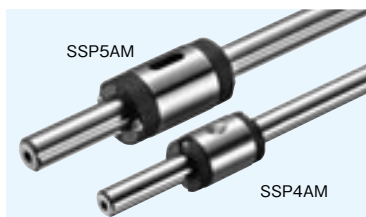

part number structure

example **SSP 4 AM-2 T1 -200 -P /CU**

specification
SSP AM : standard
SSPS AM : anti-corrosion

nominal diameter

number of nuts attached to one shaft

with special specification
 accuracy grade
blank : high
P : precision

spline shaft total length

preload symbol
blank : standard
T1 : light

Note: SSP(S)4AM does not come with side-seals.
 Material of return cap is resin.

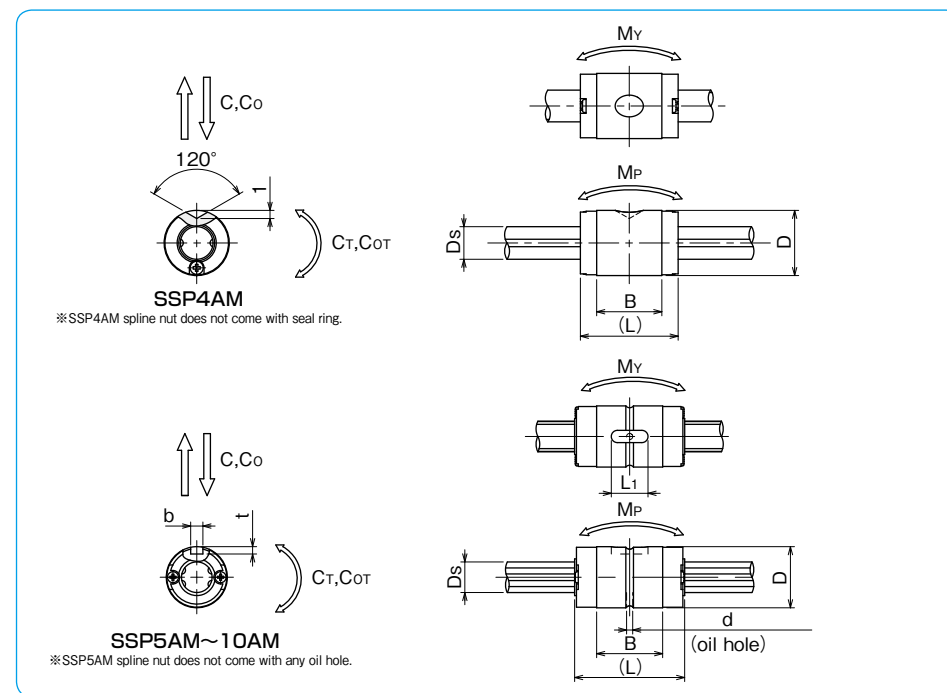
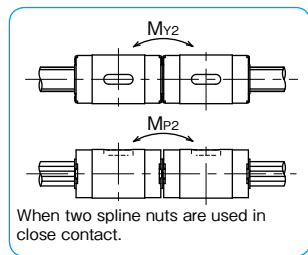

part number		major dimensions										
standard	anti-corrosion	D tolerance	L	B	b tolerance	t +0.05 0	L ₁	d	D _s h7 tolerance			
		mm	mm	mm	mm	mm	mm	mm	mm	mm	mm	
SSP 4AM	SSPS 4AM	8	12	8	-	-	-	-	4			
SSP 5AM	SSPS 5AM	10	18	10.8	2	1.2	6	-	5	0	-12	
SSP 6AM	SSPS 6AM	12	21	13	2	1.2	8	1	6			
SSP 8AM	SSPS 8AM	15	25	14.9	2.5	1.5	8.5	1.2	8	0		
SSP10AM	SSPS10AM	19	30	18	3	1.8	11	1.5	10	-15		

SSP (S) 5AM-10AM type spline nut come with a key (refer to page B-14).

basic torque rating		basic load rating		allowable static moment		mass		size
dynamic C _T	static C _{oT}	dynamic C	static C _o	M _P M _{P2}	M _Y M _{Y2}	nut	shaft	
N · m	N · m	N	N	N · m	N · m	g	g/100mm	
0.72	1.00	314	438	0.59 3.36	1.03 5.82	2.5	9.7	4AM
2.33	4.05	825	1,160	2.10 13.4	2.56 16.3	5.1	14.9	5AM
2.95	5.27	890	1,290	2.55 16.5	3.11 20.1	9.2	21.6	6AM
5.85	9.83	1,330	1,810	4.11 27.8	5.00 33.8	15.8	38.4	8AM
12.4	19.4	2,270	2,870	7.84 52.5	9.53 63.9	30.7	59.8	10AM

Allowable static moment M_{P2} and M_{Y2} are the values when two spline nuts are used on close contact.

1kN≒102kgf 1N · m≒0.102kgf · m

SSPM TYPE

– Keyless Spline Nut –

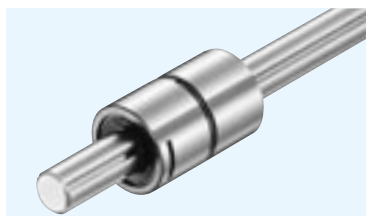

part number structure

example **SSPM 10-2-T1-200-P/CU**

SSPM type

nominal diameter

number of nuts attached to one shaft

Note: retainer material is resin.

spline shaft total length

with special specification

accuracy grade
blank: high
P: precision

preload symbol
blank: standard
T1: light

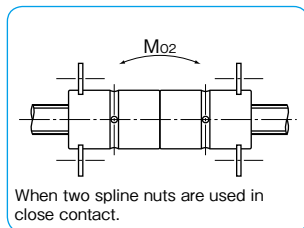

When two spline nuts are used in close contact.

part number	major dimensions											
	D mm	tolerance μm	L mm	tolerance mm	F mm	W mm	C mm	A mm	d mm	B mm	H mm	K mm
SSPM 6	14	0	25	0	2.2	1.1	1.0	12.0	1	9.4	25.6	6.8
SSPM 8	16	-11	25	-0.2	2.7	1.3	1.2	13.6	1.5	11	30.6	8.5
SSPM10	21	0/-13	33	-0.2	2.7	1.3	1.2	18.6	1.5	13.5	35.6	8.5

Two F type lock plates per SSPM type spline nut are provided (refer to page B-15).

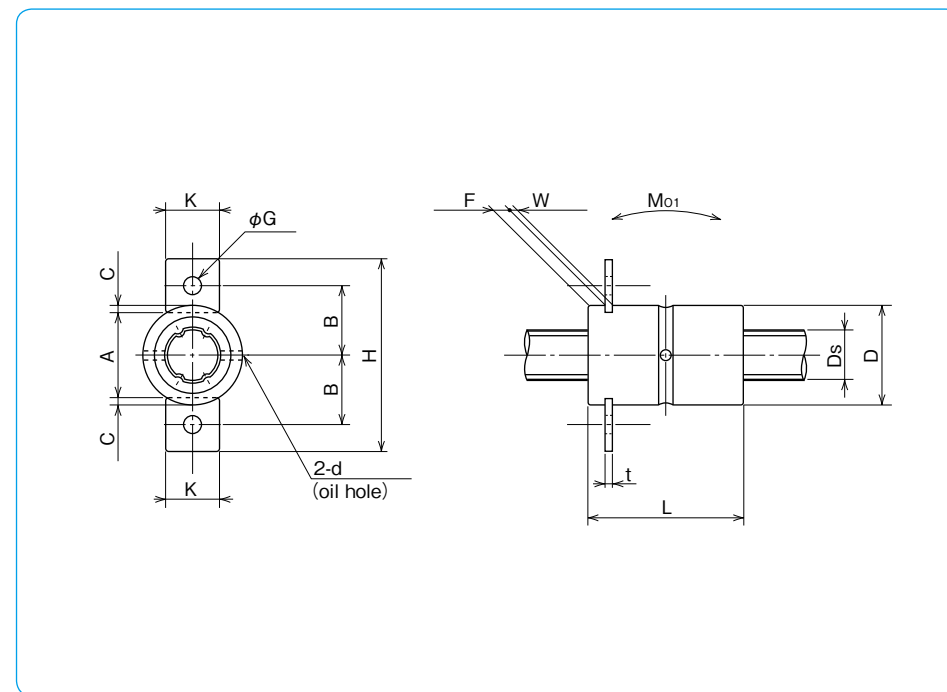

G mm	t mm	Ds mm	tolerance μm	basic torque rating		basic load rating		allowable static moment		mass		
				dynamic C _T N·m	static Co _T N·m	dynamic C kN	static Co kN	Mo ₁ N·m	Mo ₂ N·m	nut kg	shaft kg/m	size
2.9	1.0	6	0/-12	1.5	2.4	1.22	2.28	5.1	40	0.019	0.21	6
3.5	1.2	8	0	2.1	3.7	1.45	2.87	7.4	50	0.023	0.38	8
3.5	1.2	10	-15	4.4	8.2	2.73	5.07	18.0	116	0.054	0.60	10

1kN≒102kgf 1N·m≒0.102kgf·m

SSPF TYPE

— Flange Type Nut —



part number structure

example **SSPF 25 - 2 - T1 - 436 - P / CU**

specification
SSPF: standard
SSPFS: anti-corrosion

nominal diameter

number of nuts attached to one shaft

Note: retainer material is resin.

with special specification

accuracy grade
blank: high
P: precision

spline shaft total length

preload symbol
blank: standard
T1: light
T2: medium

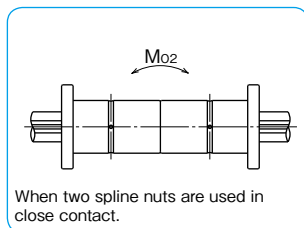

When two spline nuts are used in close contact.

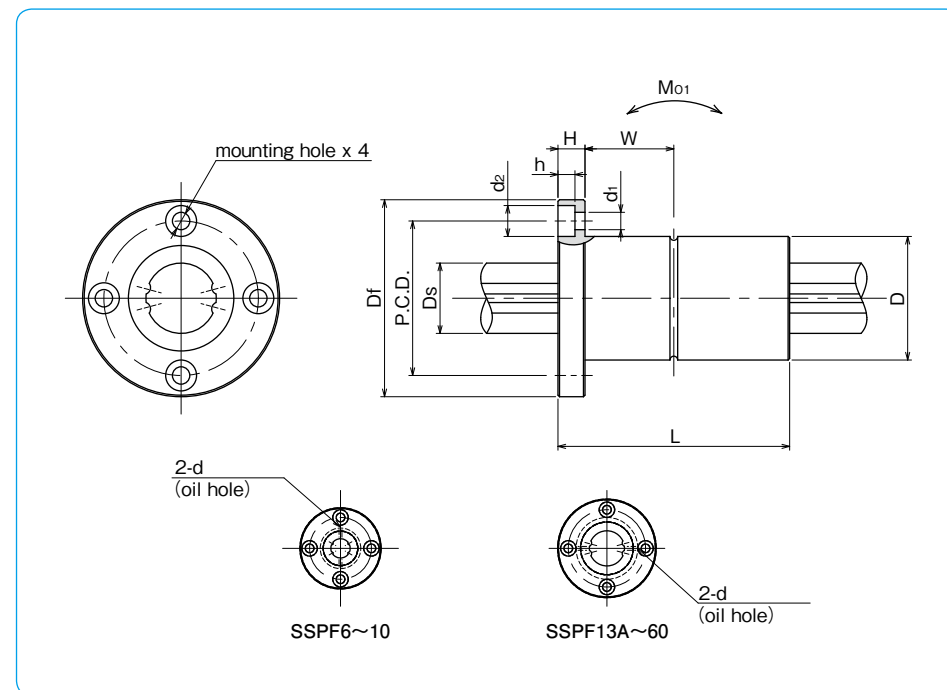

part number		D		L		major dimensions				
standard	anti-corrosion	mm	tolerance μm	mm	tolerance mm	Df mm	H mm	P.C.D. mm	$d_1 \times d_2 \times h$ mm	W mm
SSPF 6	SSPFS 6	14	0	25		30	5	22	3.4×6.5×3.3	7.5
SSPF 8	SSPFS 8	16	-11	25		32	5	24	3.4×6.5×3.3	7.5
SSPF10	SSPFS10	21	0	33	0	42	6	32	4.5×8×4.4	10.5
SSPF13A	SSPFS13A	24	-13	36	-0.2	43	7	33	4.5×8×4.4	11
SSPF16A	SSPFS16A	31		50		50	7	40	4.5×8×4.4	18
SSPF20A	SSPFS20A	35	0	63		58	9	45	5.5×9.5×5.4	22.5
SSPF25A	SSPFS25A	42	-16	71		65	9	52	5.5×9.5×5.4	26.5
SSPF30A	—	47		80		75	10	60	6.6×11×6.5	30
SSPF40A	—	64	0	100	0	100	14	82	9×14×8.6	36
SSPF50A	—	80	-19	125	-0.3	124	16	102	11×17.5×11	46.5
SSPF60A	—	90	0/-22	140		129	18	107	11×17.5×11	52
SSPF20	SSPFS20	32		60	0/-0.2	51	7	40	4.5×8×4.4	23
SSPF25	SSPFS25	37	0	70		60	9	47	5.5×9.5×5.4	26
SSPF30	—	45	-16	80		70	10	54	6.6×11×6.5	30
SSPF40	—	60	0	100	0	90	14	72	9×14×8.6	36
SSPF50	—	75	-19	112	-0.3	113	16	91	11×17.5×11	40
SSPF60	—	90	0/-22	127		129	18	107	11×17.5×11	45.5

d	Ds	tolerance μm	basic torque rating		basic load rating		allowable static moment		mass		size
			dynamic C_T N·m	static C_{0T} N·m	dynamic C kN	static C_0 kN	M_{O1} N·m	M_{O2} N·m	nut kg	shaft kg/m	
1	6	0/-12	1.5	2.4	1.22	2.28	5.1	40	0.037	0.21	6
1.5	8	0	2.1	3.7	1.45	2.87	7.4	50	0.042	0.38	8
1.5	10	-15	4.4	8.2	2.73	5.07	18.0	116	0.094	0.6	10
1.5	13	0	21	39.2	2.67	4.89	13.7	109	0.1	1	13A
2	16	-18	60	110	6.12	11.2	46	299	0.2	1.5	16A
2	20		105	194	8.9	16.3	110	560	0.33	2.4	20A
3	25	0	189	346	12.8	23.4	171	1,020	0.45	3.7	25A
3	30	-21	307	439	18.6	23.2	181	1,470	0.55	5.38	30A
4	40	0	674	934	30.8	37.5	358	2,940	1.41	9.55	40A
4	50	-25	1,290	2,950	40.3	64.9	690	4,080	2.73	15.0	50A
4	60	0/-30	1,570	2,620	47.7	79.5	881	5,470	3.2	21.6	60A
2	18.2		83	133	7.84	11.3	63	500	0.22	2	20
3	23	0	162	239	12.3	16.1	104	830	0.32	3.1	25
3	28	-21	289	412	18.6	23.2	181	1,470	0.51	4.8	30
4	37.4	0	637	882	30.8	37.5	358	2,940	1.15	8.6	40
4	47	-25	1,390	3,180	46.1	74.2	696	4,400	2.1	13.1	50
4	56.5	0/-30	2,100	4,800	58.0	127	1,300	8,800	3.3	19	60

1kN=102kgf 1N·m=0.102kgf·m

SSPT TYPE

– Two Side Cut Flange Type –

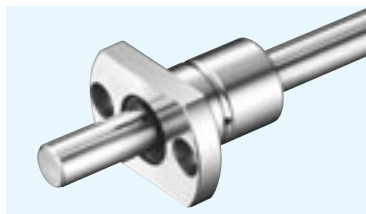

part number structure

example **SSPT 10-2-T1-436-P/CU**

SSPT type

nominal diameter

number of nuts attached to one shaft

Note: retainer material is resin.

spline shaft total length

preload symbol
blank: standard
T1: light

accuracy grade
blank: high
P: precision

with special specification

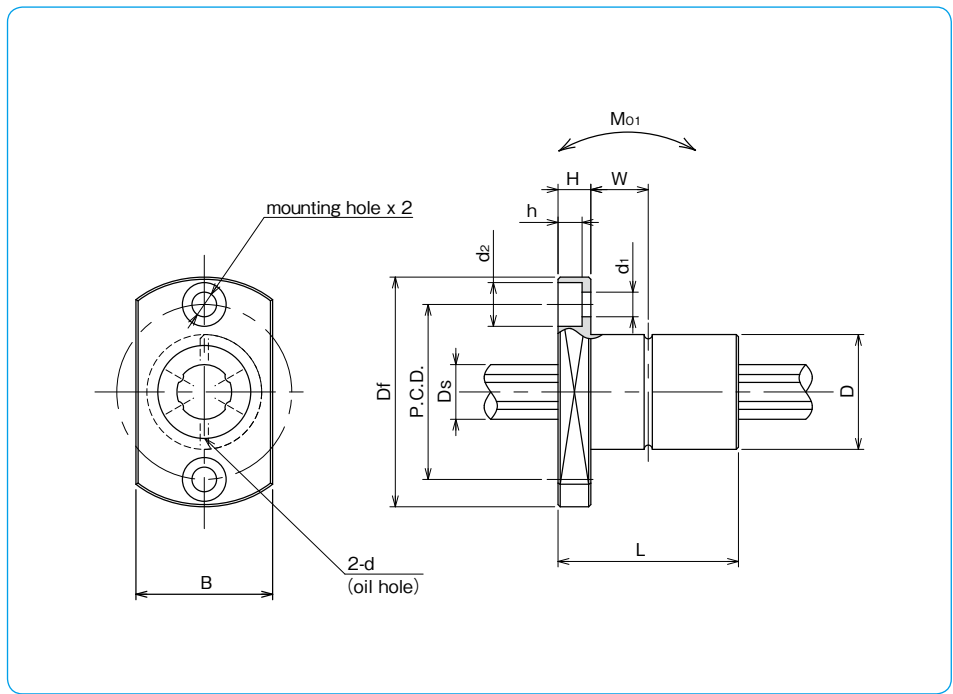
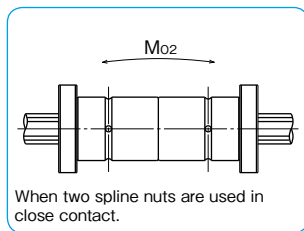

part number	D		L		major dimensions					W
	mm	tolerance μm	mm	tolerance mm	Df mm	B mm	H mm	P.C.D. mm	d ₁ × d ₂ × h mm	
SSPT 6	14	0	25	0	30	18	5	22	3.4 × 6.5 × 3.3	7.5
SSPT 8	16	-11	25	-0.2	32	21	5	24	3.4 × 6.5 × 3.3	7.5
SSPT 10	21	0/-13	33	-0.2	42	25	6	32	4.5 × 8 × 4.4	10.5

d mm	D _s mm	tolerance μm	basic torque rating		basic load rating		allowable static moment		mass		size
			dynamic C _T N · m	static Co _T N · m	dynamic C kN	static Co kN	Mo ₁ N · m	Mo ₂ N · m	nut kg	shaft kg/m	
1	6	0/-12	1.5	2.4	1.22	2.28	5.1	40	0.029	0.21	6
1.5	8	0	2.1	3.7	1.45	2.87	7.4	50	0.035	0.38	8
1.5	10	-15	4.4	8.2	2.73	5.07	18.0	116	0.075	0.6	10

1kN ≒ 102kgf 1N · m ≒ 0.102kgf · m

SSPT-AM TYPE SSPK-AM TYPE

— Light and Compact Flange Type —

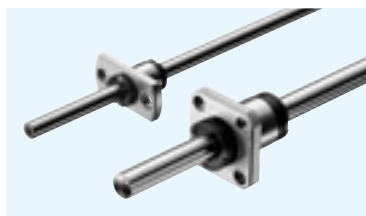

part number structure

example **SSPK 10 AM-2 T1 400 P/CU**

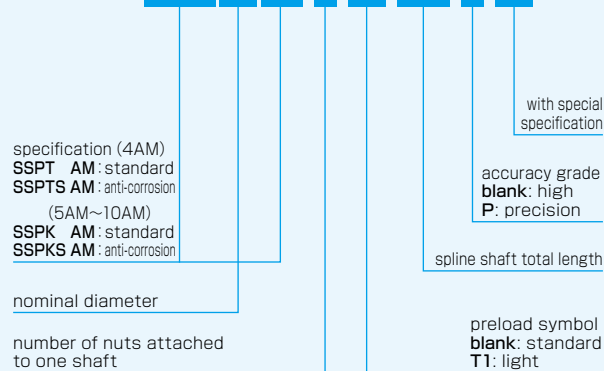

Note: Nut material of SSPT-AM and SSPK-AM is stainless steel.

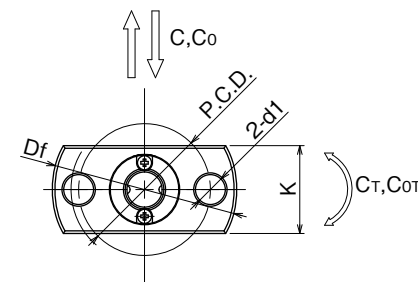

SSPT4AM
*SSPT4AM spline nut does not come with seal ring.

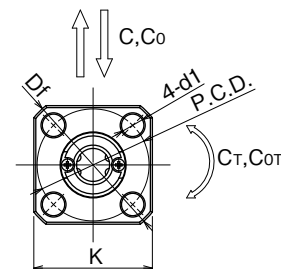

SSPK5AM~10AM
*SSPK5AM spline nut does not come with oil groove.

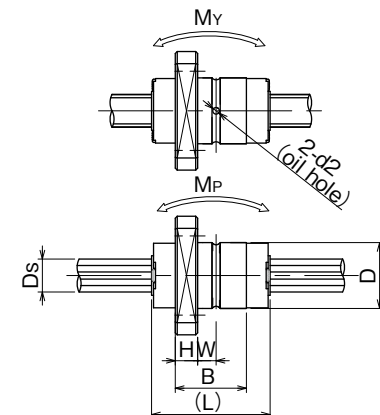
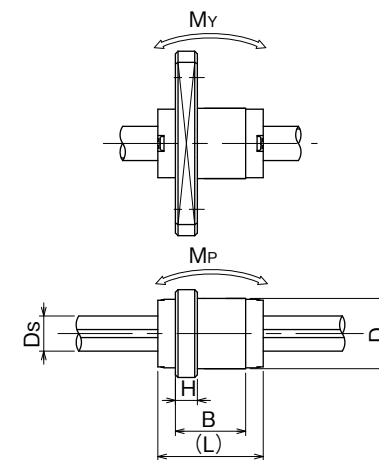

part number		major dimensions									
standard	anti-corrosion	D h6 tolerance	L	B	Df	K	H	P.C.D.	d1	W	
		mm	mm	mm	mm	mm	mm	mm	mm	mm	mm
SSPT 4AM	SSPTS 4AM	8	12	8	21	10	2.5	15	3.4	—	
SSPK 5AM	SSPKS 5AM	10	18	10.8	23	18	3.4	17	3.4	2.8	
SSPK 6AM	SSPKS 6AM	12	21	13	25	20	3	19	3.4	3.5	
SSPK 8AM	SSPKS 8AM	15	25	14.9	28	22	3.95	22	3.4	3.5	
SSPK10AM	SSPKS10AM	19	30	18	36	28	4	28	4.5	5	

d2	Ds h7 tolerance	basic torque rating		basic load rating		allowable static moment		mass		size	
		dynamic C _T	static Co _T	dynamic C	static Co	static moment M _P	static moment M _{V2}	nut	shaft		
mm	mm	μm	N · m	N · m	N	N	N · m	N · m	g	g/100mm	
—	4	0	0.72	1.00	314	438	0.59	1.03	5.0	9.7	4AM
1	5	-9	2.33	4.05	825	1,160	2.10	2.56	10.7	14.9	5AM
1	6	-12	2.95	5.27	890	1,290	2.55	3.11	14.7	21.6	6AM
1.2	8	-11	5.85	9.83	1,330	1,810	4.11	5.00	23.9	38.4	8AM
1.5	10	-15	12.4	19.4	2,270	2,870	7.84	9.53	44.0	59.8	10AM

Allowable static moment M_{P2} and M_{V2} are the values when two spline nuts are used in close contact. 1N = 102gf 1N · m = 102gf · m

STANDARD BALL SPLINE

part number structure

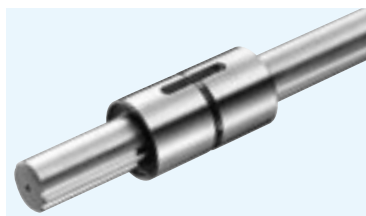

example **SSP 10 S -2- T1 -400**

nut shape
SSP: cylindrical type
SSPM: keyless type
SSPF: flange type
SSPT: two side cut flange type

nominal diameter: 10

S: standard spline shaft

number of nuts attached to one shaft: 2

preload symbol
blank: standard
T1: light
T2: medium

standard length L: 400

example **SSP 4 AM S -2- T1 -300**

nut shape
SSP AM: cylindrical type

nominal diameter: 4

S: standard spline shaft

number of nuts attached to one shaft: 2

preload symbol
blank: standard
T1: light

standard length L: 300

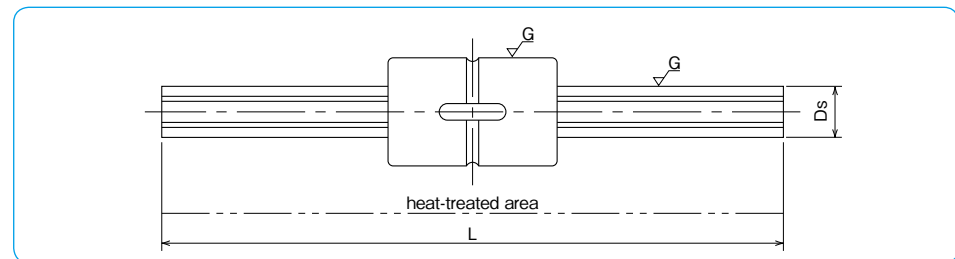

nominal diameter	Ds		major dimensions						applicable nut				
	mm	tolerance μm	standard length L mm						SSP	SSPM	SSPF	SSPT	SSP-AM
4	4	0	100	150	200	300	—	○	○	○	○	○	
6	6	-12	150	200	300	400	—	○	○	○	○	○	
8	8	0	150	200	300	400	500	○	○	○	○	○	
10	10	-15	200	300	400	500	600	○	○	○	○	○	
13A	13	0	200	300	400	500	600	○	—	○	—	—	
16A	16	-18	200	300	400	500	600	○	—	○	—	—	
20A	20	0	300	500	1,000	—	—	○	—	○	—	—	
25A	25	—	300	500	1,000	—	—	○	—	○	—	—	
30A	30	-21	300	500	1,000	—	—	○	—	○	—	—	
40A	40	0	500	1,000	—	—	—	○	—	○	—	—	
50A	50	-25	500	1,000	—	—	—	○	—	○	—	—	
60A	60	0/-30	500	1,000	—	—	—	○	—	○	—	—	
20	18.2	0	300	500	1,000	—	—	○	—	○	—	—	
25	23	-21	300	500	1,000	—	—	○	—	○	—	—	
30	28	0	300	500	1,000	—	—	○	—	○	—	—	
40	37.4	0	500	1,000	—	—	—	○	—	○	—	—	
50	47	-25	500	1,000	—	—	—	○	—	○	—	—	
60	56.5	0/-30	500	1,000	—	—	—	○	—	○	—	—	
4AM	4	0	100	150	200	300	—	—	—	—	—	○	
5AM	5	-12	150	200	300	400	—	—	—	—	—	○	

• Tolerance of standard length L: JIS B0405 coarse grade. ○ yes — none
 • Please refer to dimension tables for nut shape and dimensions.

COMMERCIAL BALL SPLINE

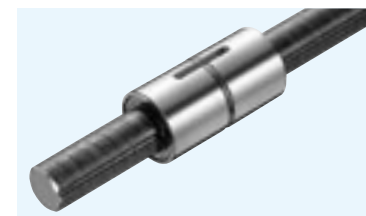

part number structure

example **SSPF 25 C -2- 436/ CU**

nut shape
SSP: cylindrical type
SSPF: flange type

nominal diameter: 25

commercial spline shaft: C

number of nuts attached to one shaft: 2

spline shaft total length: 436

with special specification: CU

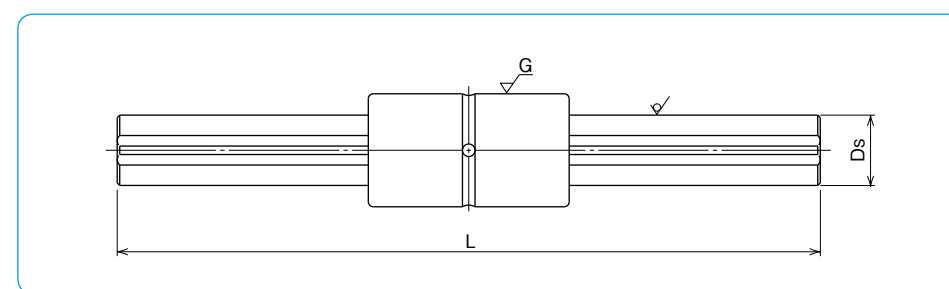

nominal diameter	Ds		major dimensions						applicable nut	
	mm	tolerance μm	standard length L mm						SSP	SSPF
20	18.2	0	500	1,000	2,000	3,000	4,000	5,000	○	○
25	23	-12	500	1,000	2,000	3,000	4,000	5,000	○	○
30	28	0	500	1,000	2,000	3,000	4,000	5,000	○	○
40	37.4	0	500	1,000	2,000	3,000	4,000	5,000	○	○
50	47	-25	500	1,000	2,000	3,000	4,000	5,000	○	○

• Tolerance of total length
 total length up to 4,000: JIS B0405 coarse grade
 total length greater than 4,000: ±5.0mm
 Please specify tolerances when required.
 • Please refer to dimension tables for nut shape and dimensions.
 • When a commercial shaft is used, the load rating of the nut is approximately 70% of indicated rating in the dimension tables.

ROTARY BALL SPLINE

The NB rotary ball spline can be used for both rotational motion and linear motion. The applications include SCARA robots, vertical shaft of assembly equipment, tool changers, and loaders, etc.

STRUCTURE AND ADVANTAGES

The NB Rotary Ball Spline nut consists of a spline nut and a rotating portion using either cross rollers for SPR or balls for SPB.

High Accuracy

Ball Splines transfer torque and achieve accurate positioning in the linear direction. By adding the rotating portion, Rotary Ball Splines can achieve accurate positioning in the linear and rotational directions.

Half the Parts, Reduction in Installation Cost

The Spline nut and rotary bearing are combined in order to significantly reduce the number of parts, compared to conventional system. The combination also reduces the housing thickness to a minimum, resulting in light weight and easy installation.

Figure B-26 Structure of SPR type

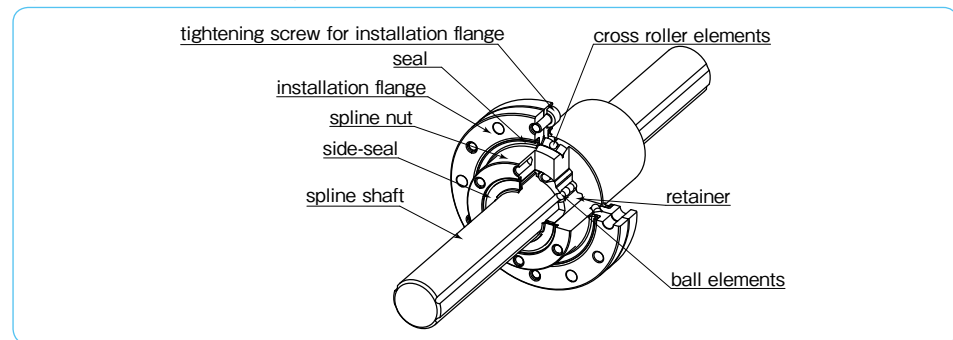
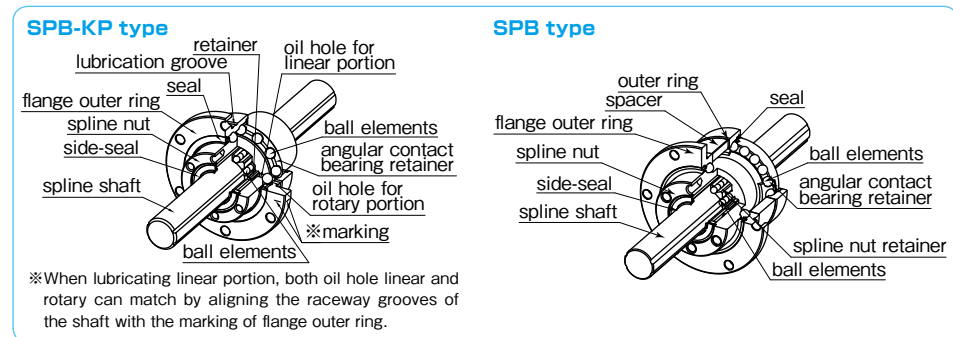

Figure B-27 Structure of SPB-KP type and SPB type



ACCURACY OF SPR TYPE

The accuracy of SPR type is measured at the points shown in Figure B-28.

Figure B-28 Accuracy Measurement Points

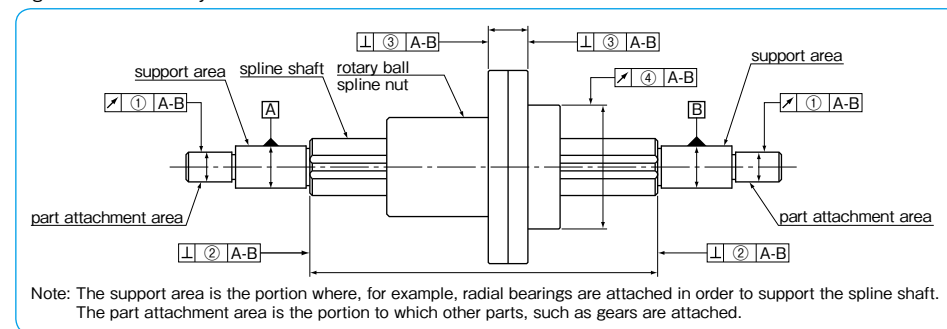

Tolerance of Spline Shaft Groove Torsion (Max.)

The groove torsion is indicated per 100mm, arbitrarily set as the effective length of the spline shaft section.

Table B-18 Tolerance of Spline Shaft Groove Torsion (Max.)

tolerance
13 μm/100mm

Table B-19 Tolerance Relative to Spline Support Area (Max.)

unit : μm

part number	①radial runout of part attachment area	②perpendicularity of the end of the spline shaft section (when grinding is requested on the drawing)	③perpendicularity of the flange
SPR 6	14	9	14
SPR 8			
SPR10			
SPR13			
SPR16	19	11	18
SPR20A			
SPR25A			
SPR30A			
SPR40A	25	16	25
SPR50A			
SPR60A			
SPR20			
SPR25			
SPR30			
SPR40			
SPR50	25	16	25
SPR60			
SPR60A	29	19	29
SPR20			
SPR25	22	13	21
SPR30			
SPR40	25	16	25
SPR50			
SPR60	29	19	29
SPR20			

Table B-20 ④Radial Runout of Outer Surface of Rotary Spline Nut Relative to Spline Support Area (Max.)

unit : μm

spline shaft total length (mm) greater than or less	part number							
	SPR 6, 8	SPR 10	SPR 13, 16	SPR 20A, 20, 25A, 25, 30A, 30	SPR 40A, 40, 50A, 50	SPR 60A, 60	SPR 60A, 60	SPR 60A, 60
200	46	36	34	32	32	30	30	30
200 315	89	54	45	39	36	34	34	34
315 400	126	68	53	44	39	36	36	36
400 500	163*	82	62	50	43	38	38	38
500 630	—	102	75	57	47	41	41	41
630 800	—	—	92	68	54	45	45	45
800 1,000	—	—	115	83	63	51	51	51
1,000 1,250	—	—	153	102	76	59	59	59
1,250 1,600	—	—	195*	130	93	70	70	70
1,600 2,000	—	—	—	171	118	86	86	86

※Please contact NB for spline shafts exceeding 2000mm. * SPR6 shaft Max. length: 400mm SPR13, SPR16 Max.length: 1500mm

ACCURACY OF SPB TYPE

The accuracy of SPB type is measured at the points shown in Figure B-29.

Figure B-29 Accuracy Measurement Points

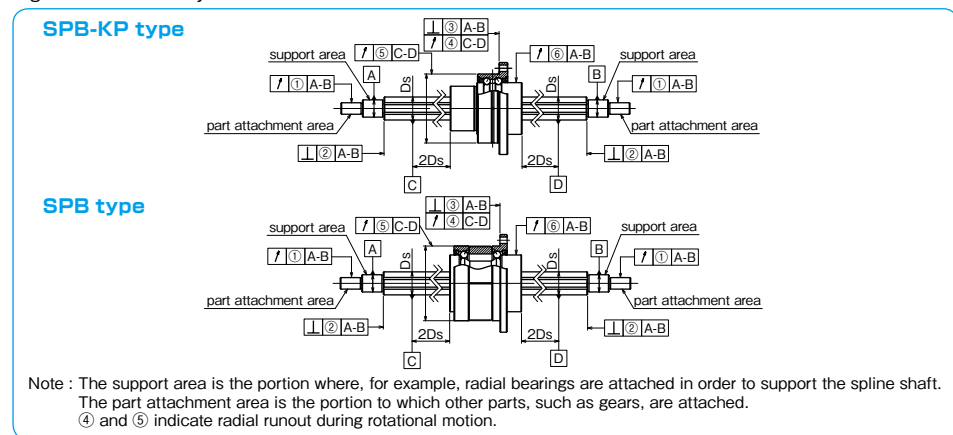

Tolerance of Spline Shaft Groove Torsion (Max.)

The groove torsion is indicated per 100mm, arbitrarily set as the effective length of the spline shaft section.

Table B-21 Tolerance of Spline Shaft Groove Torsion (Max.)

accuracy grade	high	precision (P)
tolerance	13 μm/100mm	6 μm/100mm

Table B-22 Tolerance Relative to Spline Support Area (Max.)

unit : μ m

part number	①radial runout of part attachment area		②perpendicularity of the end of the spline shaft section (when grinding is requested on the drawing)		③perpendicularity of the flange	
	high-grade	precision-grade (P)	high-grade	precision-grade (P)	high-grade	precision-grade (P)
SPB 6KP	14	8	9	6	14	10
SPB 8KP						
SPB10KP	17	10	11	8	18	13
SPB13KP	19	12				
SPB16KP,16						
SPB20KP,20						
SPB25KP,25	22	13	13	9	21	16

Table B-23 Tolerance of Angular Contact Bearing Rotation (Max.)

unit : μ m

part number	④lateral runout of flange mounting side		⑤radial runout of outer ring	
	high-grade	precision-grade (P)	high-grade	precision-grade (P)
SPB 6KP	6	6	8	8
SPB 8KP				
SPB10KP				
SPB13KP	8	8	9	9
SPB16KP,16				
SPB20KP,20			10	10
SPB25KP,25				

Table B-24 ⑥Radial Runout of Spline Nut Relative to Spline Support Area (Max.)

unit : μ m

spline shaft total length (mm)	size	size									
		6		8		10		13,16		20,25	
greater than	or less	high-grade	precision-grade (P)	high-grade	precision-grade (P)	high-grade	precision-grade (P)	high-grade	precision-grade (P)	high-grade	precision-grade (P)
-	200	46	26	46	26	36	20	34	18	32	18
200	315	89	57	89	57	54	32	45	25	39	21
315	400	126	-	126	82	68	41	53	31	44	25
400	500	-	-	163	-	82	51	62	38	50	29
500	630	-	-	-	-	102	65	75	46	57	34
630	800	-	-	-	-	-	92	58	68	42	
800	1,000	-	-	-	-	-	-	115	75	83	52
1,000	1,250	-	-	-	-	-	-	153	97	102	65
1,250	1,600	-	-	-	-	-	-	195	127	130	85
1,600	2,000	-	-	-	-	-	-	-	-	171	116

*SPB16, 13KP, and 16KP shaft maximum length : 1,500mm
 **Please contact NB for spline shafts exceeding 2,000mm.

PRELOAD AND CLEARANCE

The amount of clearance and preload for the spline portion and the cross roller portion are expressed in terms of the clearance in the rotational direction and the clearance in the radial direction, respectively. Three levels of preload are available: standard, light (T1), and medium (T2).

Table B-25 Preload and Clearance in Rotational and Radial Direction unit : μ m

	part number	standard	light (T1)	medium (T2)
linear motion	SPR 6	-2~+1	-6~-2	-
	SPR 8			
	SPR10	-3~+1	-8~-3	-13~-8
	SPR13			
	SPR16			
	SPR20A	-4~+2	-12~-4	-20~-12
	SPR25A			
	SPR30A			
	SPR40A			
	rotational motion	SPR50A	-6~+3	-18~-6
SPR60A				
SPR20		-4~+2	-12~-4	-20~-12
SPR25				
SPR30				
SPR40		-6~+3	-18~-6	-30~-18
SPR50				
SPR60				
rotational motion	SPR 6 ~ SPR60	-1~+3		

Table B-26 Preload and Clearance in Rotational Direction (Linear Motion) unit : μ m

part number	standard	light (T1)	medium (T2)
SPB 6KP	0 ~ +3	-3 ~ 0	-
SPB 8KP			
SPB10KP			
SPB13KP	-3 ~ +1	-8 ~ -3	-13 ~ -8
SPB16KP,16			
SPB20KP,20			
SPB25KP,25	-4 ~ +2	-12 ~ -4	-20 ~ -12

Please contact NB for other than preload standards above.

Table B-27 Preload and Operating Conditions

preload	symbol	operating conditions
standard	blank	minute vibration is applied. a precise motion is required. moment is applied in a given direction.
light	T1	light vibration is applied. light torsional load is applied. cyclic torque is applied.
medium	T2	shock/vibration is applied. over-hang load is applied. torsional load is applied.

**Frictional resistance may be affected by preload.

HOLLOW SPLINE SHAFT

NB provides hollow shafts. It can be used for running cable, air piping, and weight reduction. Table B-28 shows a list of recommended inner diameter for hollow spline shaft (SUJ2).

Table B-28 Recommended Inner Diameter for Hollow Spline Shaft

part number		outer diameter Ds mm	inner diameter d mm	second moment of inertia I mm ⁴	cross-sectional coefficient Z mm ³
SPR 6	SPB 6KP	6	2	58.3	18.9
SPR 8	SPB 8KP	8	3	186	44.9
SPR10	SPB10KP	10	4	448	85.9
SPR13	SPB13KP	13	6	1,260	182
SPR16	SPB16KP,16	16	8	2,780	323
SPR20A	SPB20KP,20	20	10	6,860	637
SPR25A	SPB25KP,25	25	15	15,400	1,100

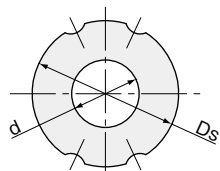

SPECIAL REQUIREMENTS

NB provides customization such as shaft-end machining, spline nut machining, and surface treatment per customer requests. Please contact NB for the inner diameter of SPR20~SPR60.

Figure B-30 Examples of Shaft-end Machining

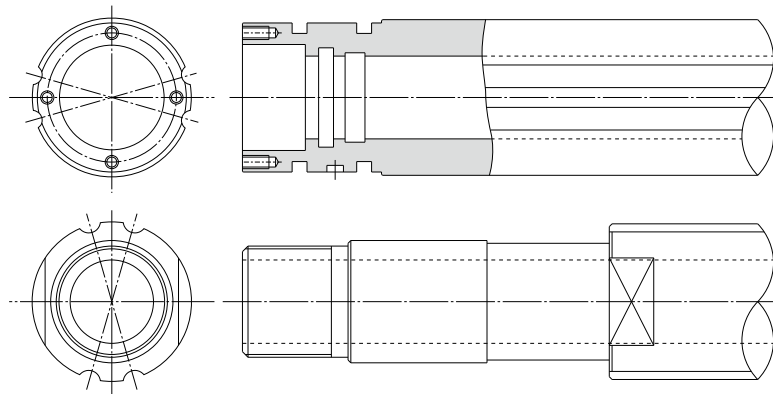

MOUNTING

The flange attachment screws of SPR type have been pre-adjusted for smooth rotary movement and should never be loosened. Shock loading to the flange assembly should be avoided as this can degrade the accuracy of movement and deteriorate the overall performance. The spacer of SPB type is properly adjusted to produce the best preload condition. Shock loading to the spacer should be avoided as this can change the preload condition and deteriorate the accuracy. Please fix the mounting screws diagonally. The recommended torque values for medium-hardness steel screws are listed in Table B-29.

SPR Type

When the flange of SPR type is to be used with a faucet joint (as shown in Figure B-31) the housing bore should be machined to a tolerance of H7 and to a minimum depth of 60% of the flange thickness. If only a light load is applied to the SPR in operation, the flange can be used without a pilot end.

Figure B-31 SPR type Mounting Method

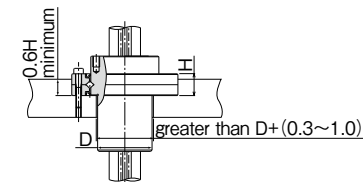

SPB-KP Type

The housing bore for the SPB-KP type should be matched to a tolerance of H7 and keep enough depth (as shown in Figure B-32) so that the outer ring is inside the housing.

Figure B-32 SPB-KP type Mounting Method

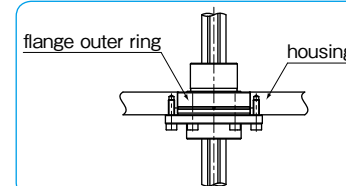

SPB Type

The housing bore for the SPB type should be machined to a tolerance of H7 and contain enough depth so that the outer ring is inside the housing. If not, the outer ring may fall off.

Figure B-33 SPB type Mounting Method

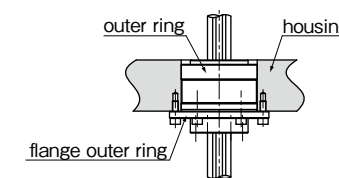

Insertion of Spline Shaft

When inserting the spline shaft into the rotary ball spline nut, ensure that the ball elements do not drop out. This is done by aligning the raceway grooves of the shaft with the rows of ball elements and seal lip of the nut. Then, carefully insert the spline shaft through the spline nut.

Table B-29 Recommended Torque unit : N·m

mounting screw	M2	M2.5	M3	M4	M5	M6	M8
recommended torque	0.4	0.9	1.4	3.2	6.6	11.2	27.6

(for alloy steel screw)

LUBRICATION

Since NB rotary ball spline nuts are equipped with seals at both the spline portion and the rotational portion, the lubricant is retained for an extended period of time. The spline nut is prelubricated with lithium soap based grease prior to shipment for immediate use. Please relubricate with a similar type of grease periodically depending on the operating conditions.

Low dust generation grease is available from NB standard grease. (refer to page Eng-39) However, an oil lubricant is recommended for high-speed applications. A grease fitting or machining oil holes is optional (Figure B-34-37), please contact NB for details.

SPR Type

A grease fitting for rotational portion and machining oil hole for spline portion are optional.

Figure B-34 Example of Installed Grease Fitting

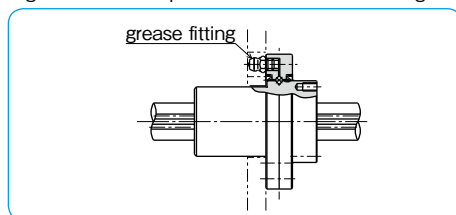
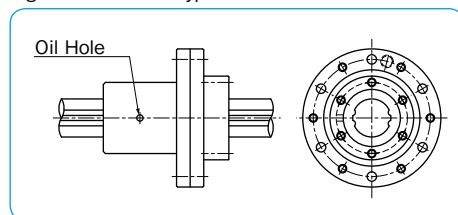

Figure B-35 SPR type Oil Hole



SPB-KP Type

Lubrication is done through oil hole on the outer ring. It is applied the spline portion and the cross roller portion simultaneously.

Figure B-36 SPB-KP type Oil Hole

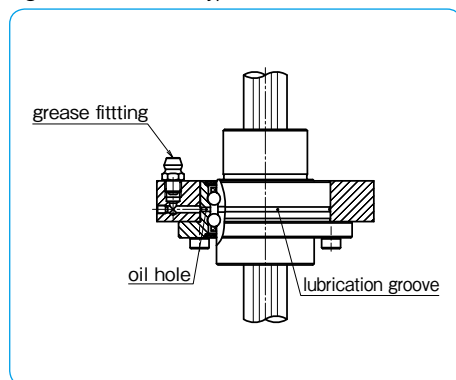

SPB Type

Rotational portion has an oil hole as a standard. For lubrication, it is recommended to mount a grease fitting or oil hole to housing. Machining oil hole for spline portion is available. Please contact NB.

Figure B-37 SPB type Oil Hole

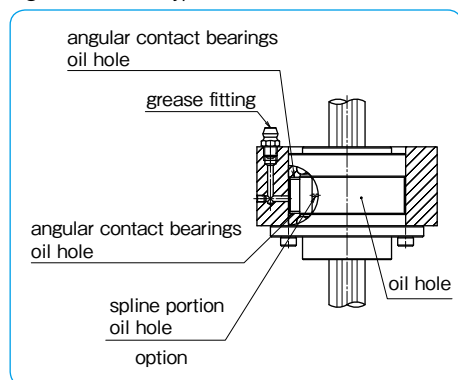

OPERATING CONDITIONS

The performance of the rotary ball spline is affected by the operating conditions of the application. The operating conditions should therefore be carefully taken into consideration.

Operating Temperature

Resin retainers are used in the rotary ball spline, since the operating temperature should never exceed 80°C.

Dust Prevention

Foreign particles or dust in the rotary ball spline nut affect the motion accuracy and shorten the lifetime. Standard seals will perform well for dust prevention under normal operating conditions; however, in a harsh environment, it is necessary to attach bellows or protective covers.

APPLICATION EXAMPLES

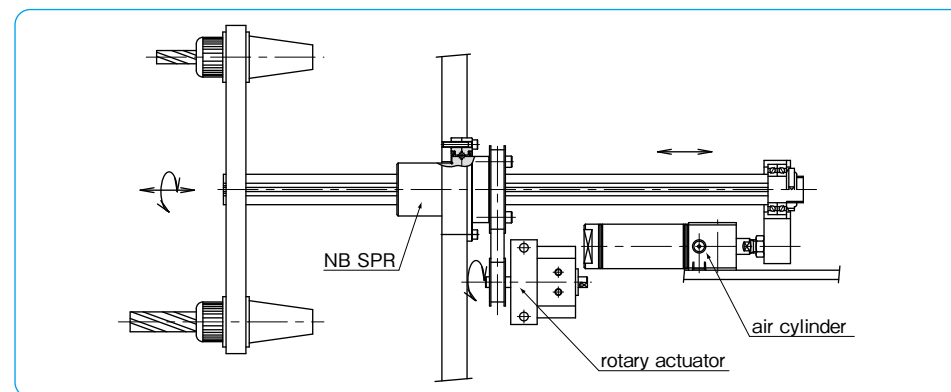
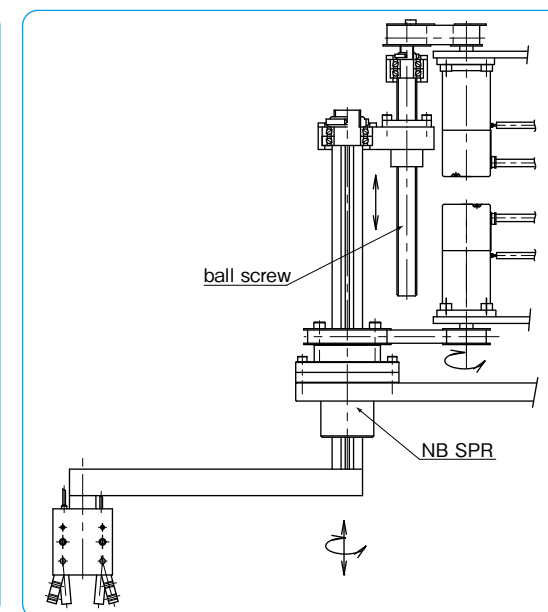
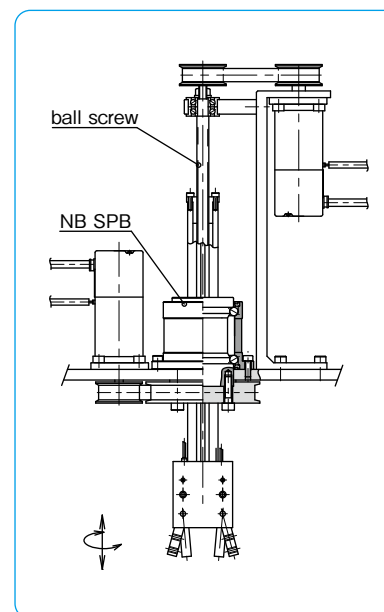

SPR TYPE

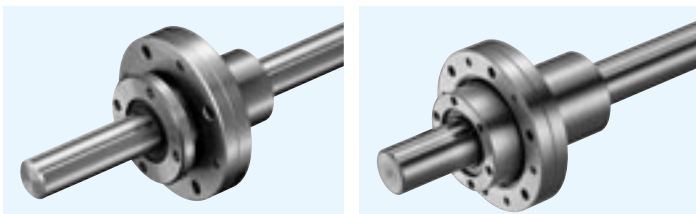

part number structure

example **SPR 25 - 2 - T1 - 436 / CU**

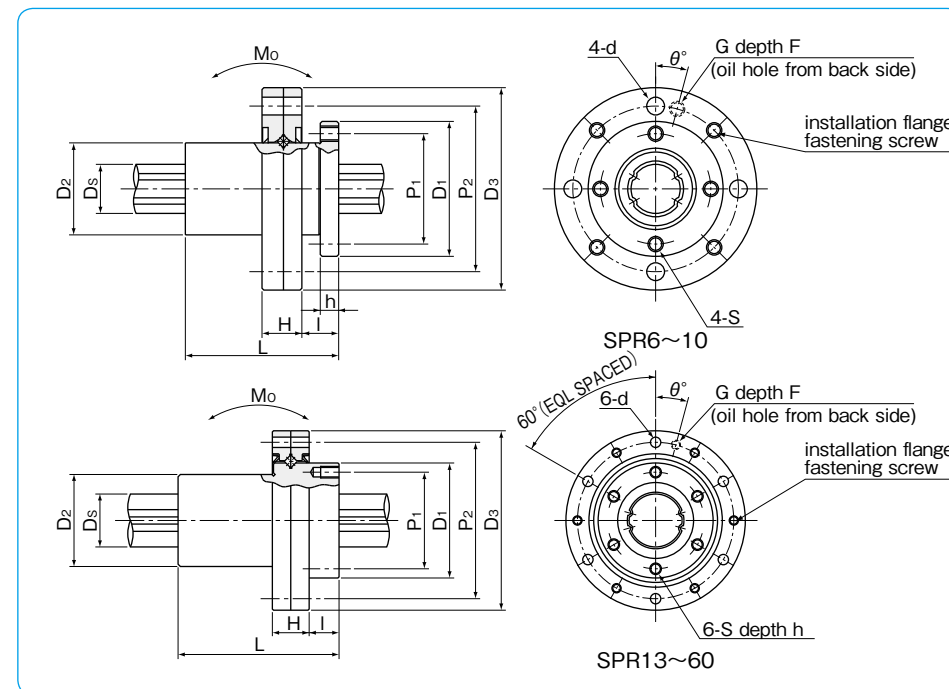
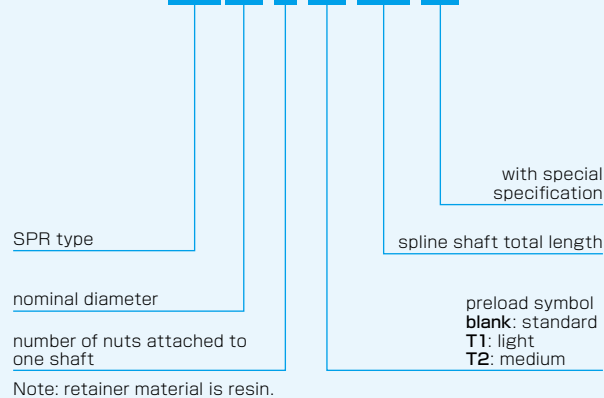

part number	major dimensions					major dimensions of cross roller bearing									
	D ₁	D ₂	L	P ₁	S	h	I	H	D ₃	P ₂	d	G	F	θ	
	mm	mm	mm	mm	mm	mm	mm	mm	mm	mm	mm	mm	mm	mm	°
SPR 6	20	13	25	16	M2	2.5	5	6.5	30	24	2.4	M3	2.6	20°	
SPR 8	22	15	25	18	M2.5	3	6	6.5	33	27	2.9	M3	2.6	20°	
SPR10	27	19	33	22	M3	4	8	7	40	33	3.4	M3	2.8	20°	
SPR13	29	24	36	24	M3	5	8	9	50	42	3.4	M3	3.6	15°	
SPR16	36	31	50	30	M4	6	10	11	60	50	4.5	M3	4.4	15°	
SPR20A	44	35	63	38	M4	7	12	13	72	62	4.5	M6×0.75	5.2	15°	
SPR25A	55	42	71	47	M5	8	13	16	82	72	4.5	M6×0.75	6.4	15°	
SPR30A	61	47	80	52	M6	10	17	17	100	86	6.6	M6×0.75	6.8	15°	
SPR40A	76	64	100	66	M6	10	23	20	120	104	9	M6×0.75	8	15°	
SPR50A	92	80	125	80	M8	13	24	22	134	118	9	M6×0.75	8.8	15°	
SPR60A	107	90	140	95	M8	13	25	25	155	137	9	M6×0.75	10	15°	
SPR20	40	34	60	34	M4	7	12	13	66	56	4.5	M6×0.75	5.2	15°	
SPR25	50	40	70	42	M5	8	13	16	78	68	4.5	M6×0.75	6.4	15°	
SPR30	61	47	80	52	M6	10	17	17	100	86	6.6	M6×0.75	6.8	15°	
SPR40	76	64	100	64	M6	10	23	20	120	104	9	M6×0.75	8	15°	
SPR50	88	75	112	77	M8	13	24	22	130	114	9	M6×0.75	8.8	15°	
SPR60	102	90	127	90	M8	13	25	25	150	132	9	M6×0.75	10	15°	

Please contact NB for the grease fitting and relubrication method.

spline shaft	ball spline				cross roller bearing		allowable static moment Mo	mass		*maximum revolutions	size	
	Ds	basic torque rating dynamic C _T	basic torque rating static Co _T	basic load rating dynamic C	basic load rating static Co	basic load rating dynamic C _R		basic load rating static Co _R	nut			shaft
mm	μm	N · m	N · m	kN	kN	kN	kN	kg	kg/m	rpm		
6	0/-12	1.5	2.4	1.22	2.28	0.6	0.5	5.1	0.04	0.21	2,940	6
8	0	2.1	3.7	1.45	2.87	1.2	1.10	7.4	0.05	0.38	2,580	8
10	-15	4.4	8.2	2.73	5.07	2.4	2.45	18.0	0.09	0.60	2,060	10
13	0	21	39.2	2.67	4.89	2.9	3.70	13.7	0.17	1.0	1,350	13
16	-18	60	110	6.12	11.2	5.6	6.70	46	0.33	1.5	1,080	16
20	0	105	194	8.9	16.3	6.55	8.79	110	0.57	2.4	890	20A
25	-21	189	346	12.8	23.4	9.63	12.7	171	0.81	3.7	700	25A
30	0	307	439	18.6	23.2	11.8	17.1	181	1.19	5.38	640	30A
40	0	674	934	30.8	37.5	23.0	32.3	358	2.25	9.55	510	40A
50	-25	1,290	2,950	40.3	64.9	27.8	44.0	690	3.57	15.0	430	50A
60	0/-30	1,570	2,620	47.7	79.5	29.0	48.8	881	5.03	21.6	370	60A
18.2	0	83	133	7.84	11.3	5.90	7.35	63	0.45	2.0	980	20
23	-21	162	239	12.3	16.1	9.11	11.5	104	0.75	3.1	770	25
28	0	289	412	18.6	23.2	11.8	17.1	181	1.25	4.8	640	30
37.4	0	637	882	30.8	37.5	23.0	32.3	358	2.30	8.6	510	40
47	-25	1,390	3,180	46.1	74.2	27.2	42.1	696	3.10	13.1	450	50
56.5	0/-30	2,100	4,800	58.0	127	26.5	42.6	1,300	4.70	19	400	60

*Maximum revolutions for grease lubrication.

Contact NB for further information in case oil lubrication is required.

1kN=102kgf 1N · m=0.102kgf · m

SPB-KP TYPE

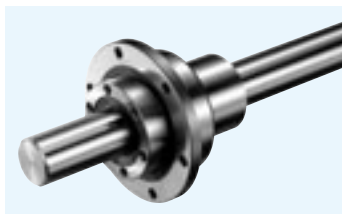

part number structure

example **SPB 16 KP-2-T1-600-P/CU**

- SPB**: SPB KP type
- 16**: nominal diameter
- KP-2**: number of nuts attached to one shaft
- T1**: preload symbol for linear portion (T1: light, T2: medium)
- 600**: spline shaft total length
- P**: accuracy grade (blank: high, P: precision)
- CU**: with special specification

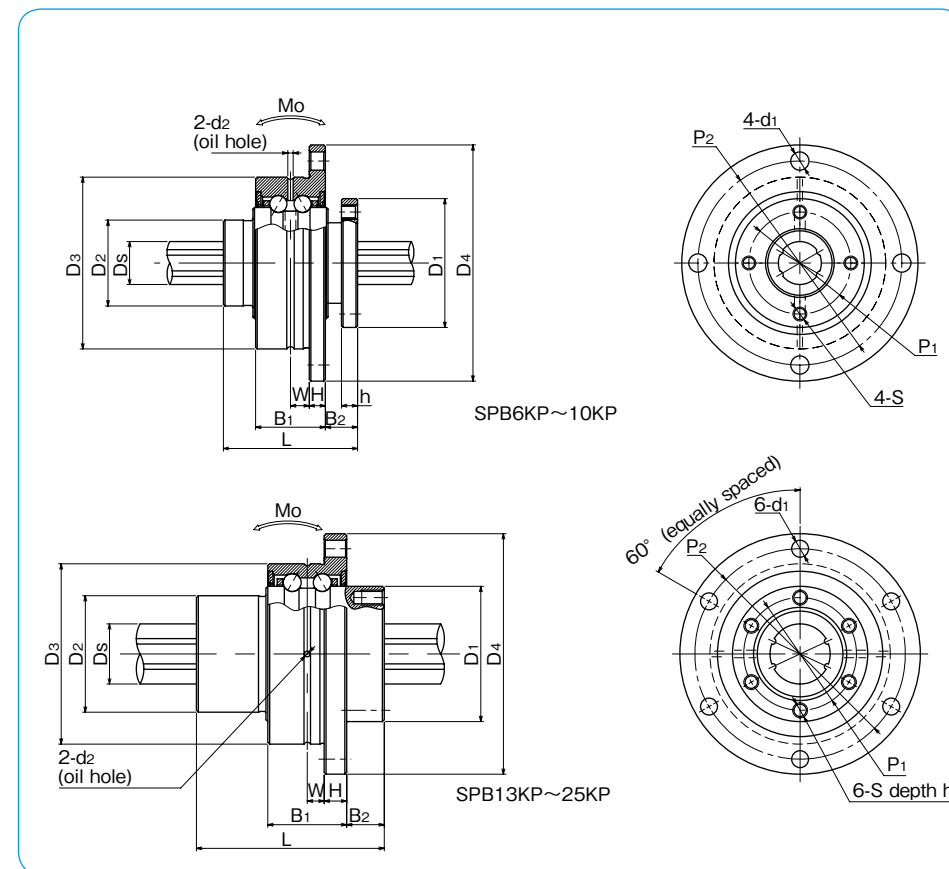

part number	major dimensions							major dimensions of angular contact bearing					
	D ₁ h7	D ₂	L	P ₁	S	h	D ₃ g6	D ₄	H	B ₁	B ₂	P ₂	
	mm	mm	mm	mm	mm	mm	mm	mm	mm	mm	mm	mm	
SPB 6KP	20	14	25	16	M2	3	28	38	3	13	6	33	
SPB 8KP	24	16	25	19	M2.6	3	32	44	3	13	6	38	
SPB10KP	28	21	33	23	M3	4	36	48	3	15	9	42	
SPB13KP	30	24	36	25	M3	5	44	56	4	18	9	50	
SPB16KP	36	31	50	30	M4	6	48	64	6	21	10	56	
SPB20KP	43.5	35	63	36	M5	8	56	72	6	21	12	64	
SPB25KP	52	42	71	44	M5	8	66	86	7	25	13	75	

d ₁	W	d ₂	D _s	rotary ball spline				angular contact bearings		allowable static moment Mo	mass		* maximum revolutions	size
				basic torque rating dynamic C _T	basic torque rating static Co _T	basic load rating dynamic C	basic load rating static Co	dynamic C _R	static Co _R		nut kg	shaft kg/m		
2.4	3.5	1	6	1.5	2.4	1.22	2.28	4.35	2.74	5.1	0.07	0.21	8,100	6
3.4	3.5	1	8	2.1	3.7	1.45	2.87	4.54	3.13	7.4	0.10	0.38	7,000	8
3.4	4.5	1	10	4.4	8.2	2.73	5.07	6.86	4.82	18.0	0.14	0.60	6,200	10
3.4	5	1	13	21	39.2	2.67	4.89	9.45	7.01	13.7	0.23	1.0	5,000	13
4.5	4.5	1.5	16	60	110	6.12	11.2	10.2	8.39	46	0.37	1.5	4,200	16
4.5	4.5	1.5	20	105	194	8.9	16.3	10.9	10.1	110	0.55	2.4	3,600	20
5.5	5.5	1.5	25	189	346	12.8	23.4	13.7	12.9	171	0.84	3.7	3,100	25

*Maximum revolutions for grease lubrication.

SPB TYPE

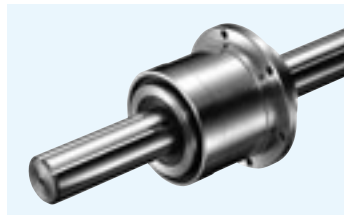

part number structure

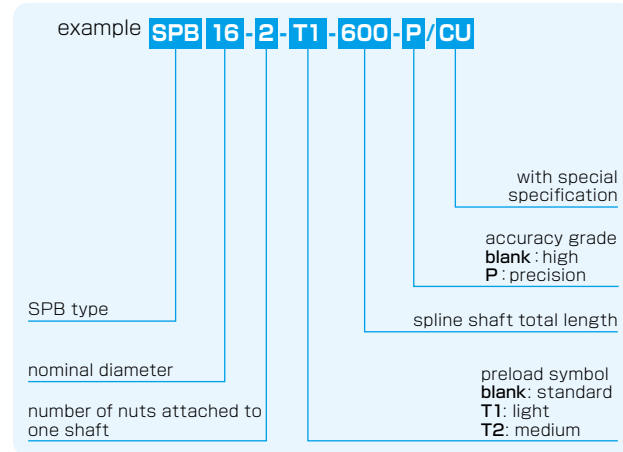

part number	major dimensions						major dimensions of angular contact bearing							
	D _{1h7} tolerance	L	P ₁ P.C.D.	S	f	D ₂ tolerance	D ₃	H	B ₁	B ₂	P ₂ P.C.D.	d		
	mm	μm	mm	mm	mm	mm	μm	mm	mm	mm	mm	mm	mm	
SPB16	39.5	0	50	32	M5	8	52	0	68	5	37	10	60	4.5
SPB20	43.5	-25	63	36	M5	8	56	0	72	6	48	12	64	4.5
SPB25	53	0/-30	71	45	M6	8	62	-7	78	6	55	13	70	4.5

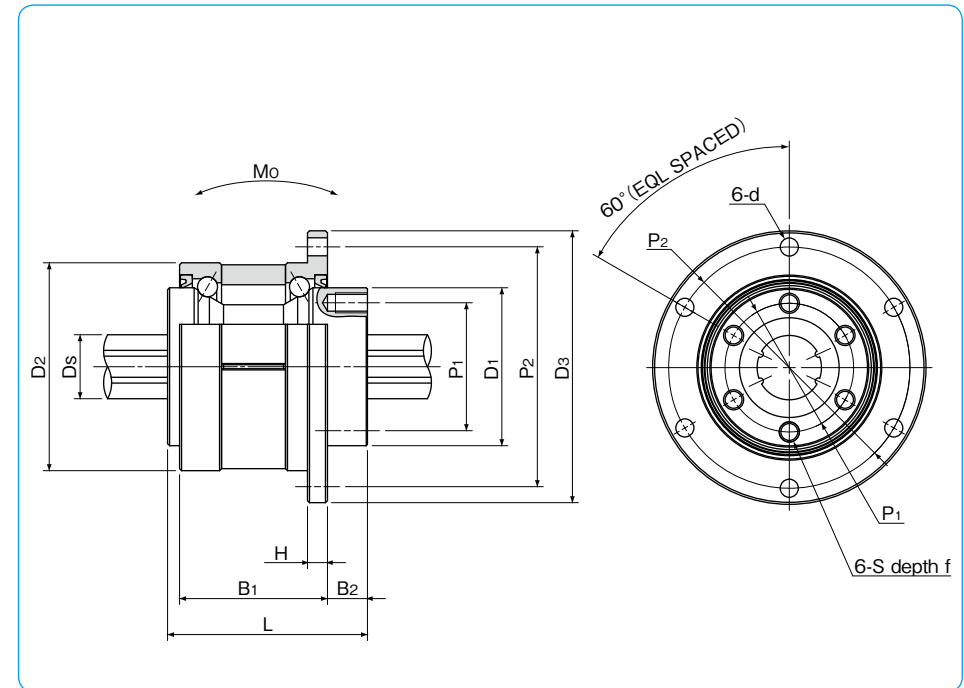

spline shaft D _s tolerance	rotary ball spline				angular contact bearings		allowable static moment M ₀ N·m	mass		* maximum revolutions	size
	basic torque rating C _T N·m	static C _{0T} N·m	basic load rating dynamic C kN	static C ₀ kN	basic load rating dynamic C kN	static C ₀ kN		nut kg	shaft kg/m		
16 0/-18	60	110	6.12	11.2	13.0	12.8	46	0.51	1.5	4,000	16
20 0	105	194	8.9	16.3	17.4	17.2	110	0.70	2.4	3,600	20
25 -21	189	346	12.8	23.4	22.1	22.5	171	0.91	3.7	3,200	25

*Maximum revolutions for grease lubrication. (please contact NB in case of oil lubrication.) 1kN≒102kgf 1N·m≒0.102kgf·m

STROKE BALL SPLINE

The NB stroke ball spine SPLFS type is a highly accurate linear motion bearing with a limited stroke, to which both radial load and torque can be applied at the same time. It operates with extremely low dynamic friction.

STRUCTURE AND ADVANTAGES

The NB stroke ball spline consists of a nut and a shaft both with raceway grooves. The flanged spline nut consists of an outer cylinder, a retainer, side-rings, and ball elements. Since the retainer in the nut is equipped with ball pockets, the ball elements do not contact each other, which allows for a smooth linear motion. The stroke is limited since the retainer is a non-circulating type. For normal operation, it is recommended to consider 80% of the maximum stroke shown in the dimension table as an actual stroke length.

Extremely low Dynamic Friction and Low Noise

The rolling elements are separated by the ball pockets so that they do not contact each other. The stroke length is limited, but extremely low dynamic friction and low noise are realized because the rolling elements do not circulate.

Compact-Size

With the nut about 20% smaller than those of conventional ball splines, it contributes to space saving.

All Stainless Steel Type

Since all the components are made of stainless steel, this stroke ball spline has an excellent corrosion resistance and heat resistance (operating temperature: -20 to 140°C). It is ideal for clean room or vacuum applications.

Lubrication

A lubricant groove and two lubrication holes are provided on the outer surface of the nut, which allows for an easy designing of lubricant replenishment.

Figure B-38 Structure of SPLFS type

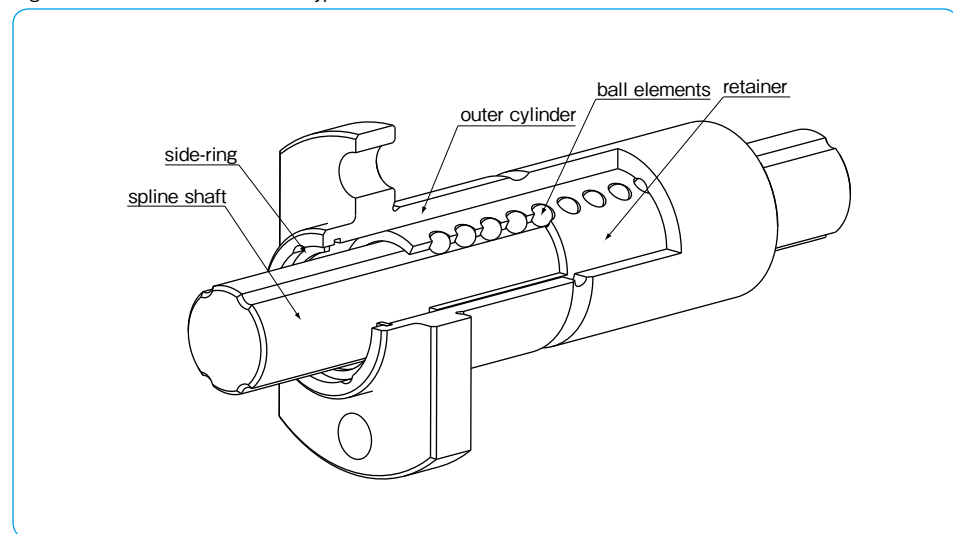

ACCURACY

The accuracy of the NB stroke ball spline is measured at the points shown in Figure B-39.

Figure B-39 Accuracy Measurement Points

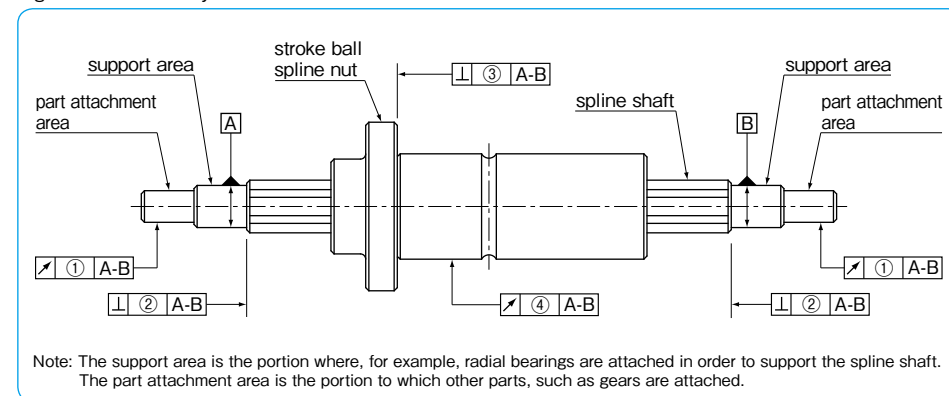

Table B-30 Tolerance of Spline Shaft Groove Torsion (Max.)

The groove torsion is indicated per 100mm, arbitrarily set as the effective length of the spline shaft section.

tolerance
13 μm/100mm

Table B-31 Tolerance Relative to Spline Support Area (Max.) unit: μm

part number	① radial runout of part attachment area	② perpendicularity of the end of the spline shaft section	③ perpendicularity of the flange
SPLFS 6	14	9	11
SPLFS 8	14	9	11
SPLFS10	17	9	13
SPLFS13	19	11	13
SPLFS16	19	11	13

Table B-32 ④ Radial Runout of Outer Surface of Spline Nut Relative to Spline Support Area (Max.) unit: μm

spline shaft total length (mm)		part number		
greater than	or less	SPLFS6, 8	SPLFS10	SPLFS13, 16
—	200	46	36	34
200	315	89	54	45
315	400	126*	68	53
400	500	163*	82	62
500	630	—	102	75
630	800	—	—	92
800	1,000	—	—	115
1,000	1,250	—	—	153
1,250	1,500	—	—	195

* SPLFS6 maximum shaft length: 400 mm

PRELOAD AND CLEARANCE

Preload and clearance are expressed in terms of clearance in the rotational direction. For the SPLFS type, only the standard preload is available as shown in Table B-33. Please contact NB if a special preload is required.

Table B-33 Preload and Clearance in Rotational Direction unit: μm

part number	standard
SPLFS 6	-4~0
SPLFS 8	-4~0
SPLFS10	-4~0
SPLFS13	-4~0
SPLFS16	-4~0

COMPARISON OF DYNAMIC FRICTIONAL RESISTANCE

Figure B-40 Comparison of Dynamic Friction

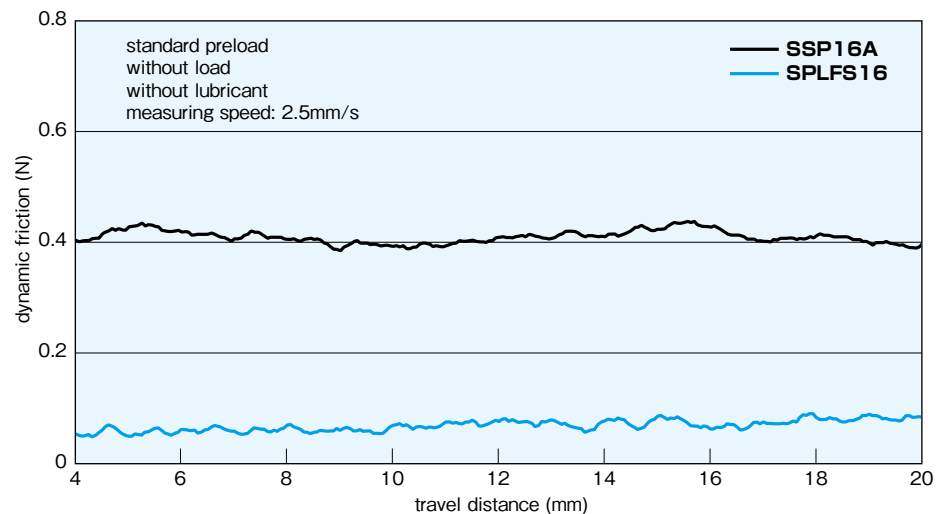

USE AND HANDLING PRECAUTIONS

Dust Prevention

Since the stroke ball spline is designed and manufactured for operation with an extremely low dynamic frictional resistance, seals that increase frictional resistance are not equipped as a standard feature. Please contact NB for a special requirement of seals. For use under harsh conditions, the stroke ball spline should be protected using bellows and protective covers.

Maximum Stroke

The maximum stroke in the dimension table is the stroke limit.

Retainer Slippage

If the stroke ball spline is used at a high speed or with a vertical shaft, or under an asymmetric load or oscillation, a retainer slippage may occur. For general operation, it is recommended to consider 80% of the maximum stroke length shown in the dimension table as the stroke length.

To prevent the retainer slippage, it is recommended to conduct a full-stroke movement of the nut whenever necessary in order for the retainer to be relocated to the center.

SPLFS TYPE

— Two Side Cut Flange Type —

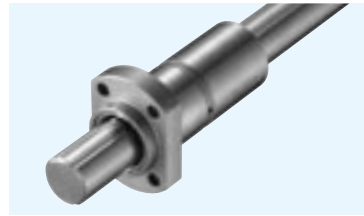

part number structure

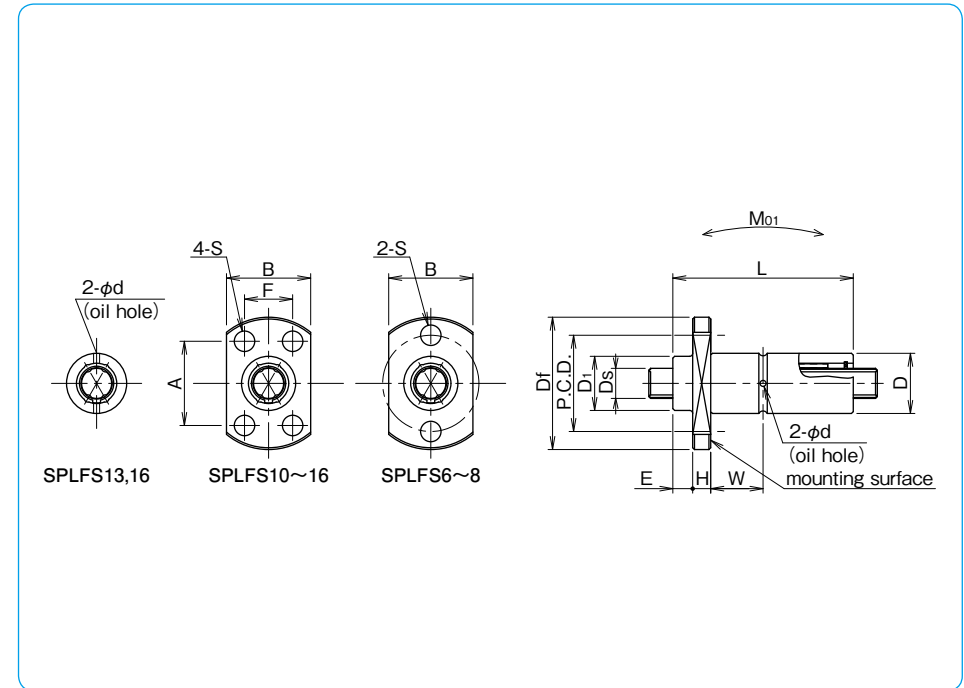
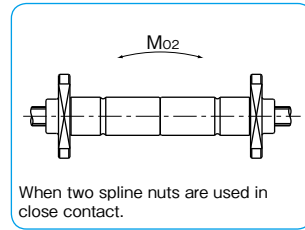
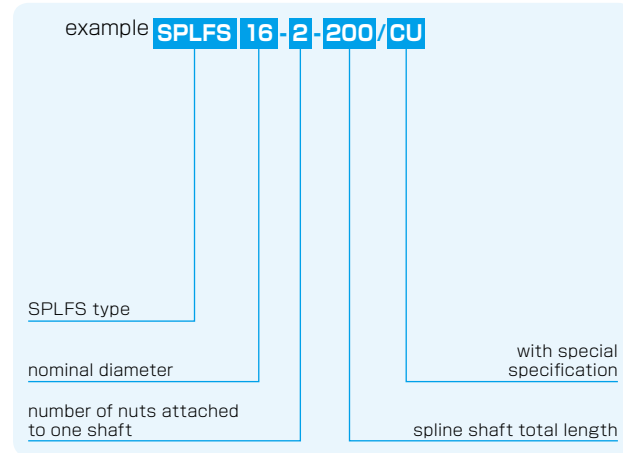

part number	maximum stroke		D tolerance μm	D1 mm	L tolerance mm	major dimensions							
	mm	mm				E mm	Df mm	H mm	B mm	P.C.D. mm	A mm	F mm	
SPLFS 6	22	11	0	10	40	-0.2	3.3	23	4	14	17	—	—
SPLFS 8	20	13		12.5	40		3.3	25.5	4	16	19.5	—	—
SPLFS 10	28	16	-8	15.5	50	-0.2	3.3	28.5	5	20	—	18	13
SPLFS 13	24	20		19.5	50		4.8	36	5	25	—	22	17
SPLFS 16	26	24	-9	23.5	60	-0.2	4.8	40	7	29	—	25	19

S	W	d	Ds	tolerance μm	basic torque rating		basic load rating		allowable static moment		mass		size
					dynamic C _T N·m	static Co _T N·m	dynamic C kN	static Co kN	Mo1 N·m	Mo2 N·m	nut g	shaft kg/m	
3.4	12.7	1.2	6	0/-12	2.3	3.8	1.8	3.0	11.2	45	21.5	0.21	6
3.4	12.7	1.2	8	0	3.3	5.5	2.02	3.37	13.1	52	27.0	0.38	8
3.4	16.7	1.5	10	-15	6.5	10.9	3.21	5.35	25.6	102	47.7	0.6	10
3.4	15.2	1.5	13	0	27.6	50.7	4.15	7.6	38.8	155	75.3	1.0	13
4.5	18.2	2.0	16	-18	62.8	115	7.66	14	88.3	353	123.5	1.5	16

1kN≒102kgf 1N·m≒0.102kgf·m

BALL SCREW SPLINE

STRUCTURE AND ADVANTAGES

The NB Ball Screw Spline consists of a highly accurate and highly rigid Ball Screw nut and Ball Spline nut attached to the ball screw spline shaft which has a screw groove and spline grooves.

SPBR type has a Rotary Ball Screw nut and Rotary Ball Spline nut.

Rotary Ball Screw nut is an integration of ball screw nut and angular contact bearings.

Rotary Ball Spline nut is an integration of ball spline nut and angular contact bearings.

SPBF type has a Rotary Ball Screw nut and a Ball Spline nut.

A single axis of the NB Ball Screw Spline can provide positioning, linear and rotary motion as well as combined spiral motion.

The typical applications are SCARA robot, assembly machine, loader, etc.

Figure B-41 Structure of SPBR type, SPBF type

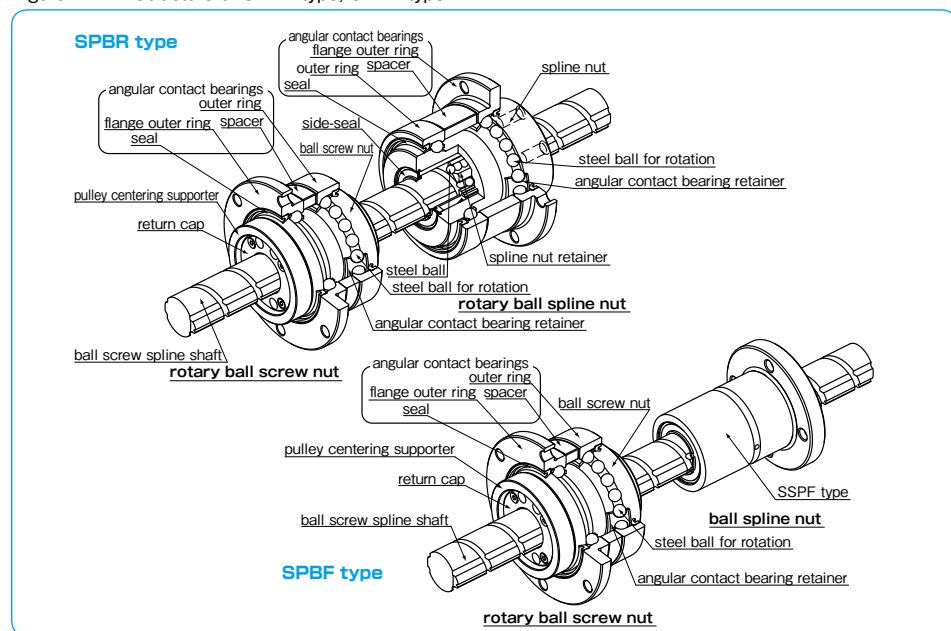

PRELOAD

The preload is properly adjusted for the ball screw nut, spline nut, and angular contact bearings. Please contact NB for preload specification.

USE AND HANDLING PRECAUTIONS

- Please do not adjust the spacer. The spacer is adjusted to provide a proper spacing for the best preload condition.
- Please do not remove the Rotary Ball Screw nut from the shaft. There is no ball-retainer in the Rotary Ball Screw nut.
- Please use the pulley centering supporter when attaching the pulley to the return-cap.

ACCURACY

The NB Ball Screw Spline is measured for accuracy at the points shown in Figure B-42.

Figure B-42 Accuracy Measurement Points

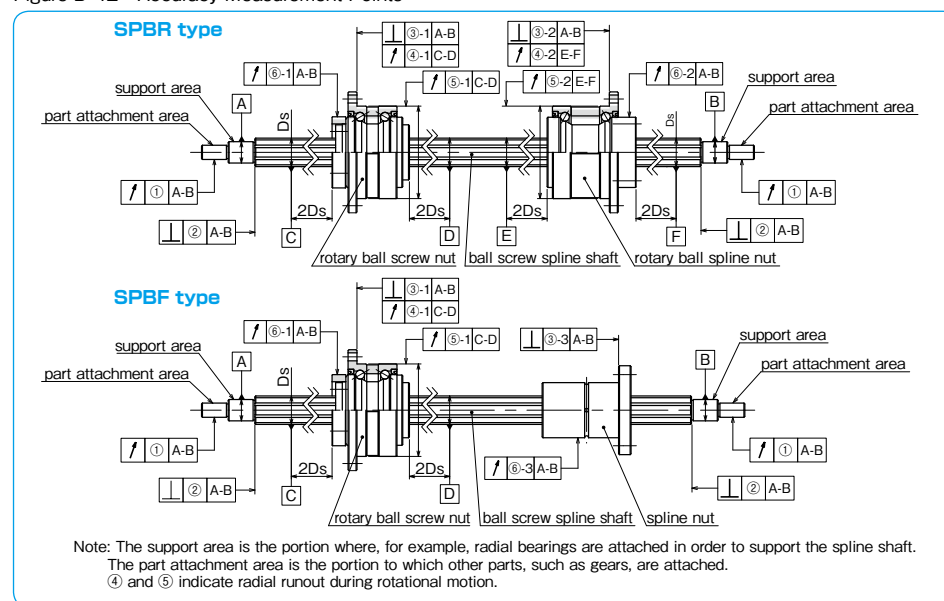

Table B-34 Tolerance of Spline Shaft Groove Torsion (Max.)

tolerance
13μm/100mm

The groove torsion is indicated per 100mm, arbitrarily set within the effective length of the spline shaft section.

Table B-35 Grade of Ball Screw Groove

tolerance
C5

Applied to lead angle accuracy only

Table B-36 Tolerance Relative to Spline Support Area (Max.)

unit: μm

part number	① radial runout of part attachment area	② perpendicularity of the end of the spline shaft section (when grinding is requested on the drawing)	③ perpendicularity of the flange		
			③-1	③-2	③-3
SPBR16,SPBF16	19	11	16	18	13
SPBR20,SPBF20					
SPBR25,SPBF25	22	13	18	21	16

Table B-37 Radial Runout of Outer Surface of Rotary Spline Nut Relative to Spline Shaft Area (Max.) unit: μm

part number	④ lateral runout of flange mounting side		⑤ radial runout of outer ring	
	④-1	④-2	⑤-1	⑤-2
SPBR16	8	8	9	9
SPBR20			10	10
SPBR25				

Table B-38 Radial Runout of Spline Nut Relative to Spline Support Area (Max.) unit: μm

ball screw spline shaft total length (mm)	part number:SPBR,SPBF				
	⑥-1		⑥-2,-3		
greater than	or less	16	20,25	16	20,25
—	200	40	35	18	18
200	315	45	40	25	21
315	400	55	45	31	25
400	500	60	50	38	29
500	630	75	60	46	34
630	800	90	70	58	42
800	1,000	—	85	—	52

SPBR TYPE MOTION PATTERN

One set of SPBR type can handle linear, rotational, and spiral motion.

SPBR type Motion Pattern

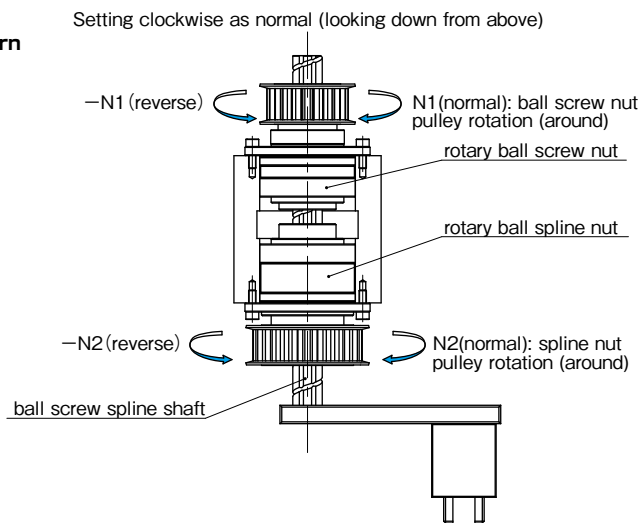

motion	input		motion direction	output		
	ball screw nut	spline nut		travel distance (linear direction)	revolution (rotational direction)	
	N ₁ (normal)	0	①	L=N ₁ ·R (up)	0	
	-N ₁ (reverse)	0	②	L=-N ₁ ·R (down)	0	
	N ₁ =N ₂ (normal) (normal)		①	0	N ₂ (normal)	
	-N ₁ =-N ₂ (reverse) (reverse)		②	0	-N ₂ (reverse)	
	0	N ₂ (normal)	①	L=N ₂ ·R (down)	N ₂ (normal)	
	0	-N ₂ (reverse)	②	L=-N ₂ ·R (up)	-N ₂ (reverse)	
	N ₁ (normal)	N ₂ (normal)	①	L=(N ₂ - (±N ₁))·R	in case of N ₂ - (±N ₁)>0 (down)	N ₂ (normal)
			④		in case of N ₂ - (±N ₁)<0 (up)	
-N ₁ (reverse)	-N ₂ (reverse)	③	L=(-N ₂ - (±N ₁))·R	in case of -N ₂ - (±N ₁)>0 (down)	-N ₂ (reverse)	
		②		in case of -N ₂ - (±N ₁)<0 (up)		

L : travel distance [mm] R : ball screw lead [mm] N₁ : ball screw nut pulley rotation (around) N₂ : ball spline nut pulley rotation (around)

SPBF TYPE MOTION PATTERN

SPBF type can handle linear motion.

SPBF type Motion Pattern

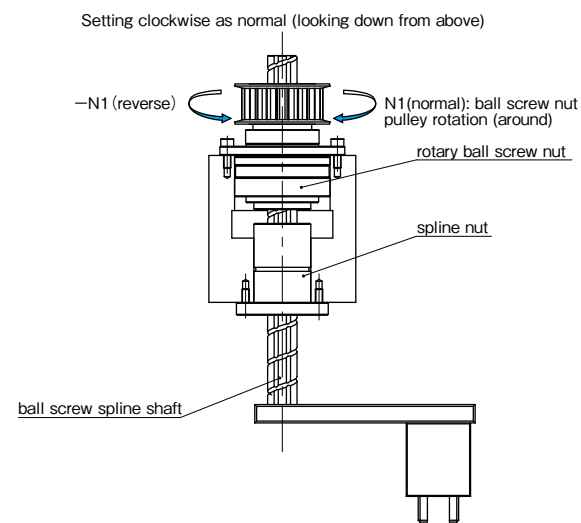

motion	input		output	
	ball screw nut	motion direction	travel distance (linear direction)	revolution (rotational direction)
	N ₁ (normal)	①	L=N ₁ ·R (up)	0
	-N ₁ (reverse)	②	L=-N ₁ ·R (down)	0

L : travel distance [mm] R : ball screw lead [mm] N₁ : ball screw nut pulley rotation (around)

SPBR TYPE

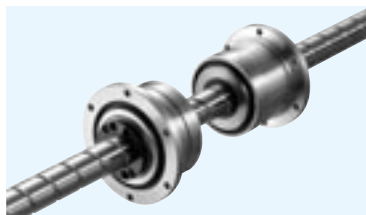

part number structure

example **SPBR 16 - 300 / CU**

SPBR type

with special specification

nominal diameter

ball screw spline shaft total length

Note: retainer material is resin.

ROTARY BALL SCREW NUT

part number	major dimensions										major dimensions of angular contact bearings						
	D ₁	h7	D ₂	H7	L ₁	P ₁	θ	S ₁	f ₁	T _e	D ₃	D ₄	H ₁	B ₁	B ₂	P ₂	d ₁
	mm	μm	mm	tolerance μm	mm	P.C.D. mm	°	mm	mm	mm	mm	mm	mm	mm	mm	P.C.D. mm	mm
SPBR16	40	0	32		43.5	25	40°	M4	12	2	52	68	5	27.5	9	60	4.5
SPBR20	50	-25	39	+25 0	54	31	40°	M5	16	2	62	78	6	34	11	70	4.5
SPBR25	58	0/-30	47		65	38	40°	M6	19	3	72	92	8	43	12.5	81	5.5

ROTARY BALL SPLINE NUT

part number	major dimensions						major dimensions of angular contact bearings						
	D ₅	h7	L ₂	P ₃	S ₂	f ₂	D ₆	D ₇	H ₂	B ₃	B ₄	P ₄	d ₂
	mm	tolerance μm	mm	P.C.D. mm	mm	mm	mm	mm	mm	mm	mm	P.C.D. mm	mm
SPBR16	39.5	0	50	32	M5	8	52	68	5	37	10	60	4.5
SPBR20	43.5	-25	63	36	M5	8	56	72	6	48	12	64	4.5
SPBR25	53	0/-30	71	45	M6	8	62	78	6	55	13	70	4.5

*Please select the smallest maximum revolutions (rpm) in case that more than one portion rotate at the same time.

※Maximum revolutions for grease lubrication.

*Moment of inertia is calculated excluding the angular contact bearings.

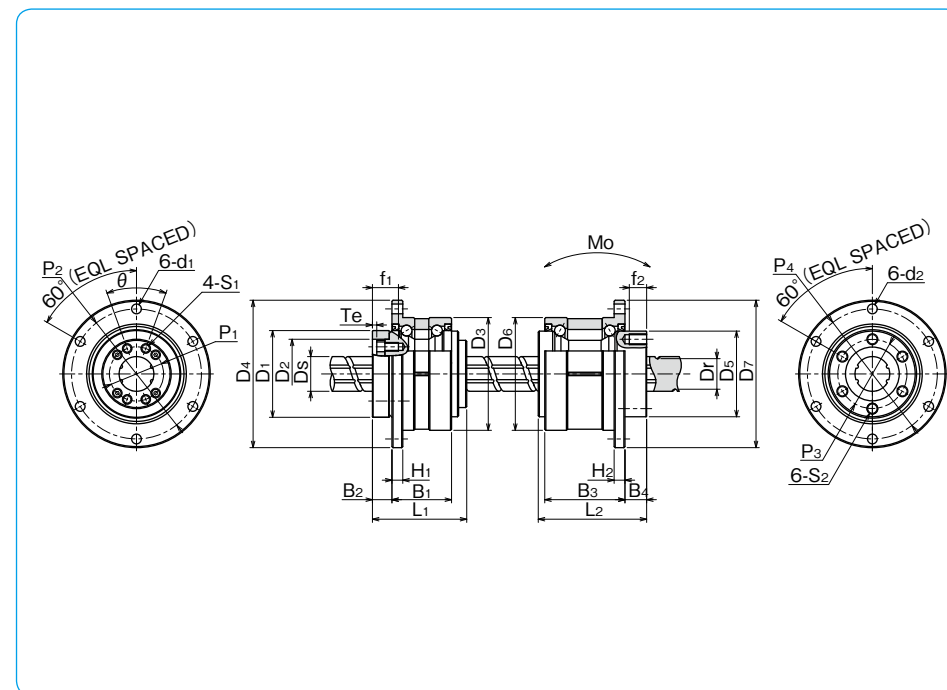

ball screw spline shaft D _s	lead	root diameter D _r	ball screw basic load rating		angular contact bearings basic load rating		moment of inertia for the nut	moment of inertia for the ball screw shaft	mass		ball screw nut maximum revolutions based on D _m ·N	size	
			dynamic Ca	static Coa	dynamic Ca _R	static Coa _R			maximum revolutions	nut			shaft
mm	mm	mm	kN	kN	kN	kN	kg·cm ²	kg·cm ² /mm	kg	kg/m	rpm		
16	16	13.4	4.62	8.59	11.1	22.2	4,000	0.60	4.43×10 ⁻⁴	0.45	1.47	4,179	16
20	20	17.2	5.77	12.2	14.4	30.5	3,200	1.75	1.12×10 ⁻³	0.76	2.33	3,414	20
25	25	21.9	8.62	19.2	18.2	39.8	2,800	3.86	2.74×10 ⁻³	1.26	3.65	2,692	25

ball spline				angular contact bearings			allowable static moment Mo	moment of inertia	mass nut
basic torque rating dynamic C _T	static Co _T	basic load rating dynamic C	static Co	basic load rating dynamic C _R	static Co _R	maximum revolutions			
N·m	N·m	kN	kN	kN	kN	rpm	N·m	kg·cm ²	kg
60	110	6.12	11.2	13.0	12.8	4,000	46	0.63	0.51
105	194	8.9	16.3	17.4	17.2	3,600	110	1.10	0.70
189	346	12.8	23.4	22.1	22.5	3,200	171	2.14	0.91

SPBF TYPE

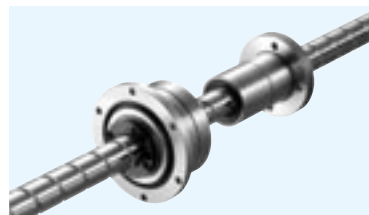

part number structure

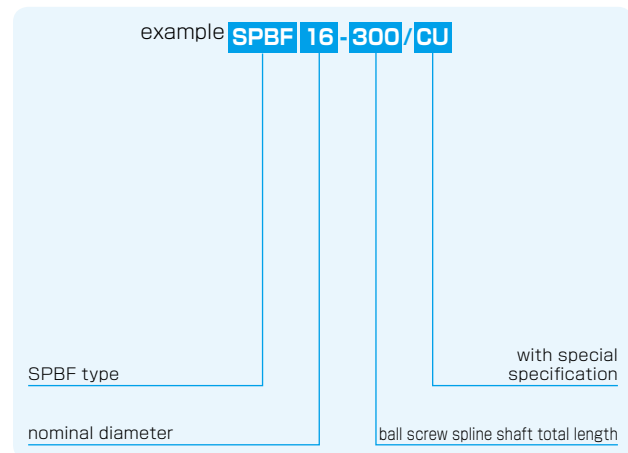

ROTARY BALL SCREW NUT

part number	major dimensions										major dimensions of angular contact bearings						
	D ₁ mm	h7 μm	D ₂ mm	H7 tolerance μm	L ₁ mm	P ₁ P.C.D. mm	θ	S ₁	f ₁ mm	T _e mm	D ₃ mm	D ₄ mm	H ₁ mm	B ₁ mm	B ₂ mm	P ₂ P.C.D. mm	d ₁ mm
SPBF16	40	0	32	+25 0	43.5	25	40°	M4	12	2	52	68	5	27.5	9	60	4.5
SPBF20	50	-25	39	0	54	31	40°	M5	16	2	62	78	6	34	11	70	4.5
SPBF25	58	0/-30	47	0	65	38	40°	M6	19	3	72	92	8	43	12.5	81	5.5

ROTARY BALL SPLINE NUT

part number	major dimensions							
	D ₉ mm	h6 tolerance μm	L ₃ mm	tolerance mm	D ₁₀ mm	H ₃	P ₅ P.C.D. mm	d ₃ ×d ₄ ×h mm
SPBF16	31	0	50	0	50	7	40	4.5×8×4.4
SPBF20	35	-16	63	-0.2	58	9	45	5.5×9.5×5.4
SPBF25	42	-16	71	0/-0.3	65	9	52	5.5×9.5×5.4

•Please select the smallest maximum revolutions (rpm) in case that more than one portion rotate at the same time.

※Maximum revolutions for grease lubrication.

•Moment of inertia is calculated excluding the angular contact bearings.

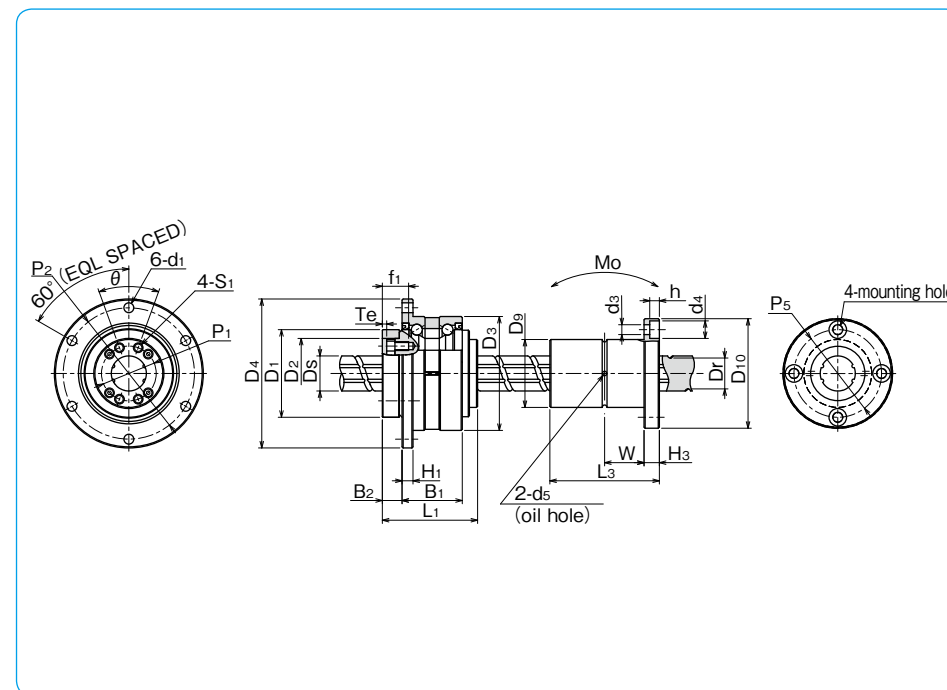

ball screw spline shaft D _s mm	lead mm	root diameter D _r mm	ball screw basic load rating		angular contact bearings basic load rating		bearings * maximum revolutions rpm	moment of inertia for the nut kg·cm ²	moment of inertia for the ball screw shaft kg·cm ² /mm	mass		ball screw nut maximum revolutions based on D _m ·N rpm	size
			dynamic C _a kN	static C _{oa} kN	dynamic C _{aR} kN	static C _{oaR} kN				nut kg	shaft kg/m		
16	16	13.4	4.62	8.59	11.1	22.2	4,000	0.60	4.43×10 ⁻⁴	0.45	1.47	4,179	16
20	20	17.2	5.77	12.2	14.4	30.5	3,200	1.75	1.12×10 ⁻³	0.76	2.33	3,414	20
25	25	21.9	8.62	19.2	18.2	39.8	2,800	3.86	2.74×10 ⁻³	1.26	3.65	2,692	25

W mm	d ₅ mm	basic torque rating		basic load rating		allowable static moment M _o N·m	moment of inertia kg·cm ²	mass nut kg
		dynamic C _T N·m	static C _{oT} N·m	dynamic C kN	static C _o kN			
18	2	60	110	6.12	11.2	46	0.52	0.2
22.5	2	105	194	8.9	16.3	110	1.11	0.33
26.5	3	189	346	12.8	23.4	171	2.01	0.45