

Features

- Developed in alignment with the [SOSA™ Technical Standard](#)
- Incorporates [Xilinx® Zynq® UltraScale+™ RFSoc](#)
- 16 GB of DDR4 [SDRAM](#)
- On-board [GPS](#) receiver
- [10 GigE Interface](#)
- [40 GigE Interface](#)
- Optional [VITA 67.3C optical interface](#) for backplane gigabit serial communication
- Dual 100 GigE [UDP interface](#)
- Compatible with several VITA standards including: VITA 46, VITA 48, VITA 67.3C, and VITA 65 (OpenVPX™ System Specification)
- [Ruggedized and conduction-cooled](#)
- Unique [QuartzXM eXpress Module](#) enables migration to other form factors
- [Navigator® BSP](#) for software development
- [Navigator® FDK](#) for custom IP development
- [Free lifetime applications support](#)



QUARTZ

Applications

- High-bandwidth data streaming
- Waveform signal generator
- Multimode data acquisition system
- Communication receiver and transmitter
- Electronic Warfare transponder
- Analog I/O for digital recording and playback
- Remote monitoring
- Sensor interfaces



General Information

The Quartz® Model 5553 is a high-performance, SOSA aligned 3U OpenVPX board based on the Xilinx Zynq UltraScale+ RFSoc. The RFSoc integrates eight RF class A/D and D/A converters into the Zynq's multiprocessor architecture, creating a multichannel data conversion and processing solution on a single chip. The Model 5553 brings RFSoc performance to 3U VPX with a complete system on a board.



Complementing the RFSoc's on-chip resources are the 5553's sophisticated clocking section for single board and multiboard synchronization, a low-noise front end for RF input and output, 16 GBytes of DDR4, a 10 GigE interface, a 40 GigE interface, a gigabit serial optical interface capable of supporting dual 100 GigE connections and general purpose serial and parallel signal paths to the FPGA.



Board Architecture

The 5553 board design places the RFSoc as the cornerstone of the architecture. All control and data paths are accessible by the RFSoc's programmable logic and processing system. A full suite of [Pentek-developed IP and software functions](#) utilize this architecture to provide data capture, timing, and interface solutions for many of the most common application requirements.

Extendable IP Design

For applications that require specialized functions, users can install their own custom IP for data processing. The Pentek [Navigator FPGA Design Kit \(FDK\)](#) includes the board's entire FPGA design as a block diagram that can be edited in Xilinx's Vivado® IP Integrator. In addition to the IP Integrator block diagrams, all source code and complete IP core documentation is included. Developers can integrate their own IP along with the Pentek factory-installed functions or use the Navigator kit to completely replace the Pentek IP with their own.

The [Navigator Board Support Package \(BSP\)](#), the companion product to the Navigator FDK, provides a complete C-callable library for control of the 5553's hardware and IP. The Navigator FDK and BSP libraries mirror each other where each IP function is controlled by a matching software function, simplifying the job of keeping IP and software development synchronized.

The Navigator BSP includes support for Xilinx's PetaLinux running on the ARM Cortex-A53 processors. When running under PetaLinux, the Navigator BSP libraries enable complete control of the 5553 either from applications running locally or on the ARMs, or using the Navigator API control and command from remote system computers.



5553 Block Diagram

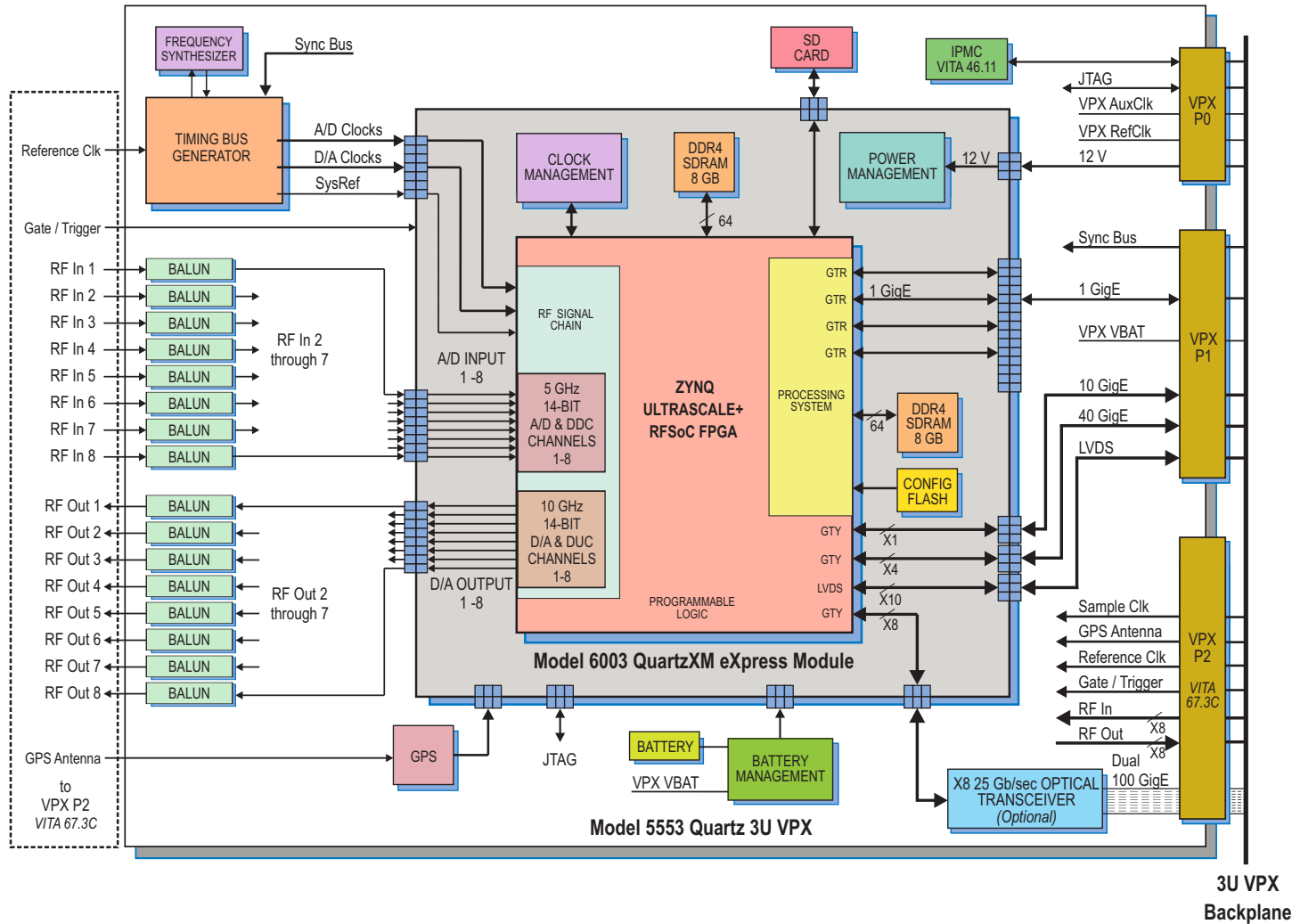

A/D Converter Stage

The analog interface accepts analog IF or RF inputs on eight coax connectors located within a VITA 67.3C connector. These inputs are transformer-coupling into the RF signal chain of the RFSoc. Inside the RFSoc, the analog signals are routed to eight 5 GSPS, 14-bit A/D converters. Each converter has built-in digital downconverters with programmable 1x, 2x, 3x, 4x, 5x, 6x, 8x, 10x, 12x, 16x, 20x, 24x, or 40x decimation and independent tuning.

The A/D digital outputs are delivered into the Zynq's programmable logic and processor system for signal processing, data capture or for routing to other resources. In addition to the A/D's built-in decimation, an additional stage of IP-based decimation provides another 16x stage of data reduction, ideal for applications that need to stream data from all eight A/Ds.

D/A Converter Stage

The RFSoc's eight D/A converters accept baseband real or complex data streams from the FPGA's programmable logic. Each 10 GSPS, 14-bit D/A includes a digital upconverter with independent tuning and interpolations of 1x, 2x, 3x, 4x, 5x, 6x, 8x, 10x, 12x, 16x, 20x, 24x, or 40x. Each D/A output is transformer coupled to a coax connection located within a VITA 67.3C connector.

Clocking and Synchronization

An on-board timing bus generator uses a programmable frequency synthesizer to generate the sample clock and all required timing signals. The on-board sample clock can also be locked to a reference clock received through one of the VITA 67.3C connectors. A multifunction gate/trigger input is also available on one of the VITA 67.3C connectors for external control of data acquisition and playback. For larger systems requiring multiboard synchronization, a multisignal sync bus interface is provided on the VPX P1 connector. These signals include the sample clock and all required complementary timing signals to provide single sample accurate synchronization across multiple boards. The Model 5503 High-Speed Synchronizer and Distribution 3U VPX Board is available as a programmable clocking and sync source for these high channel count Quartz® systems.

Memory Resources

The 5553 architecture supports 8 GBytes of DDR4 SDRAM memory accessible from the Programmable Logic. User-installed IP, which, along with the pentek-supplied DDR4 controller core within the FPGA can take advantage of the memory for custom applications. An additional 8 GByte bank of DDR4 SDRAM is available to the Processing System as program memory and storage.

1, 10 and 40 GigE Interface

The Model 5553 includes 1, 10 and 40 GigE interfaces for control and data transfers. These interfaces are independent of the optical 100 GigE interfaces. The 1 GigE interface provides a direct connection to the Processing System. The 10 and 40 GigE interfaces respond to Ethernet ARP requests and are available for custom implementations in SOSA sensor systems.

GPS

A GPS receiver provides time and position information to the FPGA and ARM processors. This information can be used for precise data tagging. The GPS provides a 1 PPS and a reference clock to the FPGA.

Expandable I/O

The Model 5553 supports eight 25 Gb/sec full duplex optical lanes to the VITA 67.3C connector. With the built-in 100 GigE UDP interface or installation of a user provided serial protocol, this optical interface enables a high-speed gigabit data streaming path between boards.

Intelligent Platform Management Controller

The Model 5553 uses Crossfield Technology LLC's Intelligent Platform Management Controller (IPMC) to provide a fully compliant and flexible management solution for Field Replaceable Units (FRU) that support the VITA 46.11 standard required by HOST and SOSA architectures. The IPMC provides a standardized implementation of FRU management interfaces, control signals, and sensor monitoring. The IPMC provides the Chassis Manager and higher-level System Management Software (SMS) access to FRU information, FRU control signals, and sensor monitoring functions so that they can identify, activate/deactivate, reset, and monitor health of the card and take appropriate system control actions.

The IPMC also provides a low-level path for configuration management and FRU maintenance through both IPMI messages and a Maintenance Port (MP) serial interface. The maintenance port provides a terminal mode command-line interface and supports monitoring, data uploads, and FRU level troubleshooting.

Optimized IP

Xilinx has created an integrated processing solution in the RFSoc that is unprecedented. The key to unlocking the potential of the RFSoc is efficient operation using optimized IP and application software. Pentek helps streamline the process from development to deployed application by providing a full suite of built-in functions. These address the data flow and basic processing needed for some of the most common applications.

Example Application 1 - High Bandwidth Data Streaming

The RFSoc's eight A/Ds are capable of producing an aggregate data rate of 80 GB/sec when all channels are enabled. While capturing and storing this much raw data is not feasible, the A/Ds built-in digital downconverters can reduce this data throughput in many applications to a rate reasonable for the data streaming and storage components downstream in the system.

In some applications capturing the raw, full bandwidth data is crucial. The 5953's dual 100 GigE UDP engine provides a high bandwidth path for moving data off of the board. Along with the built-in data acquisition IP, the 5953 can stream raw data from two A/D channels running at 4 GSPS over optical cable to a downstream storage or processing subsystem.

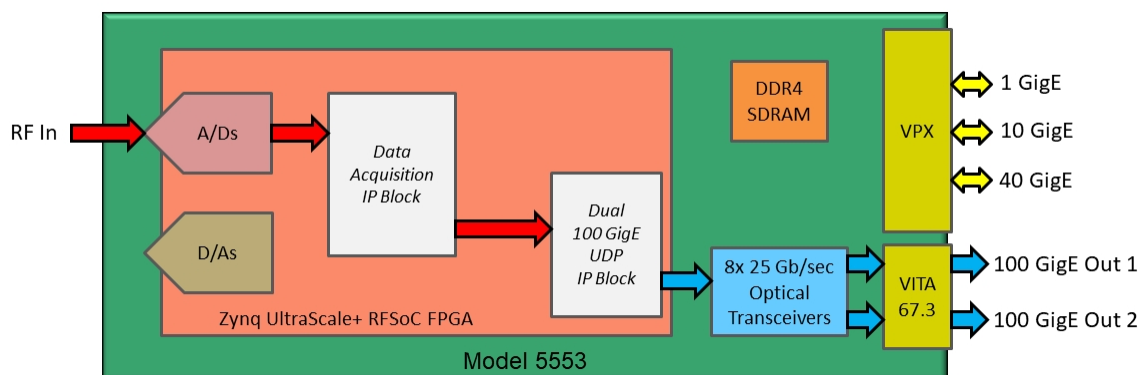

Example Application 2 - Waveform Generator

The 5553's IP supports multiple D/A signal source options. A simple loopback path allows samples received by the A/Ds to be output through the D/As. A CW signal generator produces a sine output with programmable frequency. A chirp generator, ideal for radar applications, outputs sweep signals with programmable frequency, ramp, phase offset, gain offset and length. The generators also include flexible trigger options with both internal and external triggering.

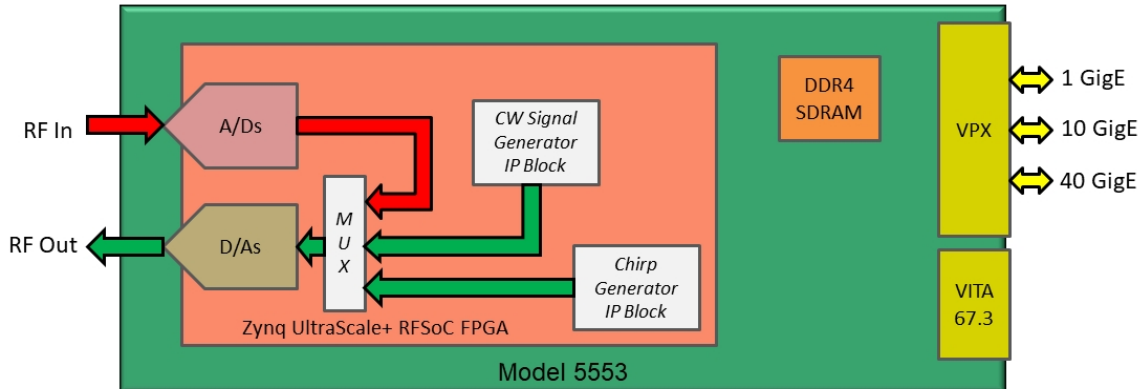

Example Application 3 - Multimode Data Acquisition System

In some applications multiple data acquisition modes may need to be operated at the same time. A required dataflow could be full bandwidth streaming of a single A/D channel over 100 GigE to a data recorder while another channel of A/D data is stored as snapshots in the boards DDR4 SDRAM and read by the ARM processor for analysis or transfer over the 1 GigE interface to an external processor. The 5553 provides these modes with built-in IP supporting complex data streaming scenarios without the need for creating custom IP.

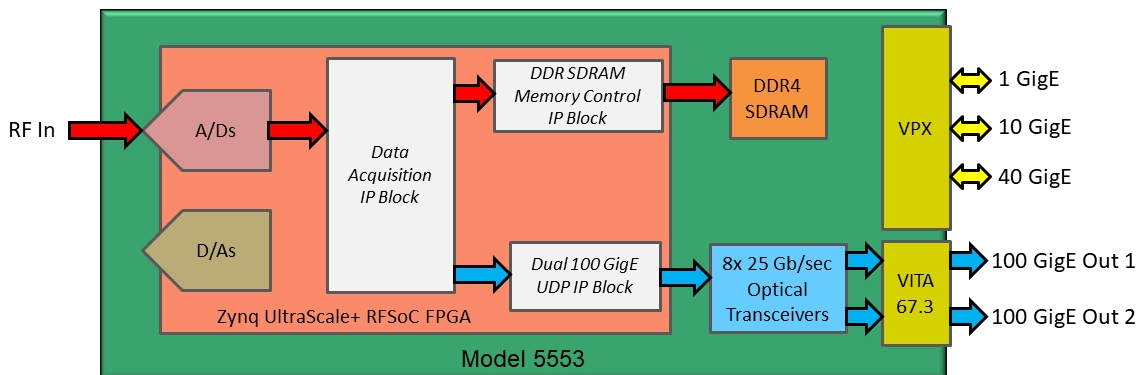

Flexible Modular Design

While the Model 5553 follows the form factor of a standard 3U OpenVPX board, the unique modular design of Pentek's Model 6003 QuartzXM eXpress Module provides the flexibility to deploy this solution in many different situations. The heart of the QuartzXM is a system on module containing all of the key components including the RFSoc FPGA, DDR4 SDRAM, and power and clock management.

In the case of the 5553, the QuartzXM is mounted on a 3U OpenVPX carrier which complements the design with a timing bus generator, analog signal conditioning, a GPS receiver and an 8x 28 Gbps optical transceiver. As a module and carrier board set, the 5553 becomes a complete, ready to deploy 3U OpenVPX solution available for a range of operating environments from commercial to rugged and conduction-cooled.

The Model 6003 QuartzXM can also be mounted on other carriers available from Pentek to support standard form factors; or for applications that require a non-standard footprint, Pentek supports the module with a design kit for users to engineer and build their own custom carrier. As a complete and tested module, the QuartzXM encapsulates best-in-class electrical and mechanical design, eliminating some of the most challenging aspects of embedded circuit design and allowing the user to focus on the application specific carrier design.

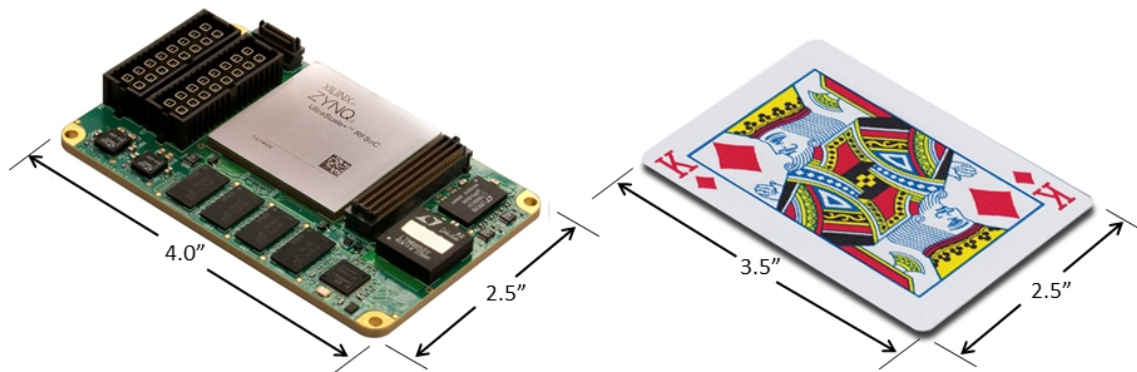

Model 6003 QuartzXM eXpress Module

Navigator Design Suite

For applications that require specialized functions, the Navigator Design Suite allows customers to fully utilize the processing power of the FPGA. It includes an FPGA design kit for integrating custom IP into Pentek's factory-shipped design, and a board support package for creating host applications for control of all hardware and FPGA IP-based functions.



The **Navigator FPGA Design Kit (FDK)** for the Xilinx® Vivado® Design Suite includes the complete Vivado project folder for each Pentek product with all design files for the factory-installed FPGA IP. Vivado's IP Integrator is a graphical design entry tool that visually presents the complete block diagram of all IP blocks so the developer can access every component of the Pentek design. Developers can quickly import, delete, and modify IP blocks and change interconnection paths using simple mouse operations. Navigator FDK includes Pentek's IP core library of more than 100 functions representing a wealth of resources for DSP, data formatting, timing, and streaming operations, all based on the powerful AXI4 standard. Multilevel documentation for each IP core is a mouse click away, and fully consistent with Xilinx IP cores.

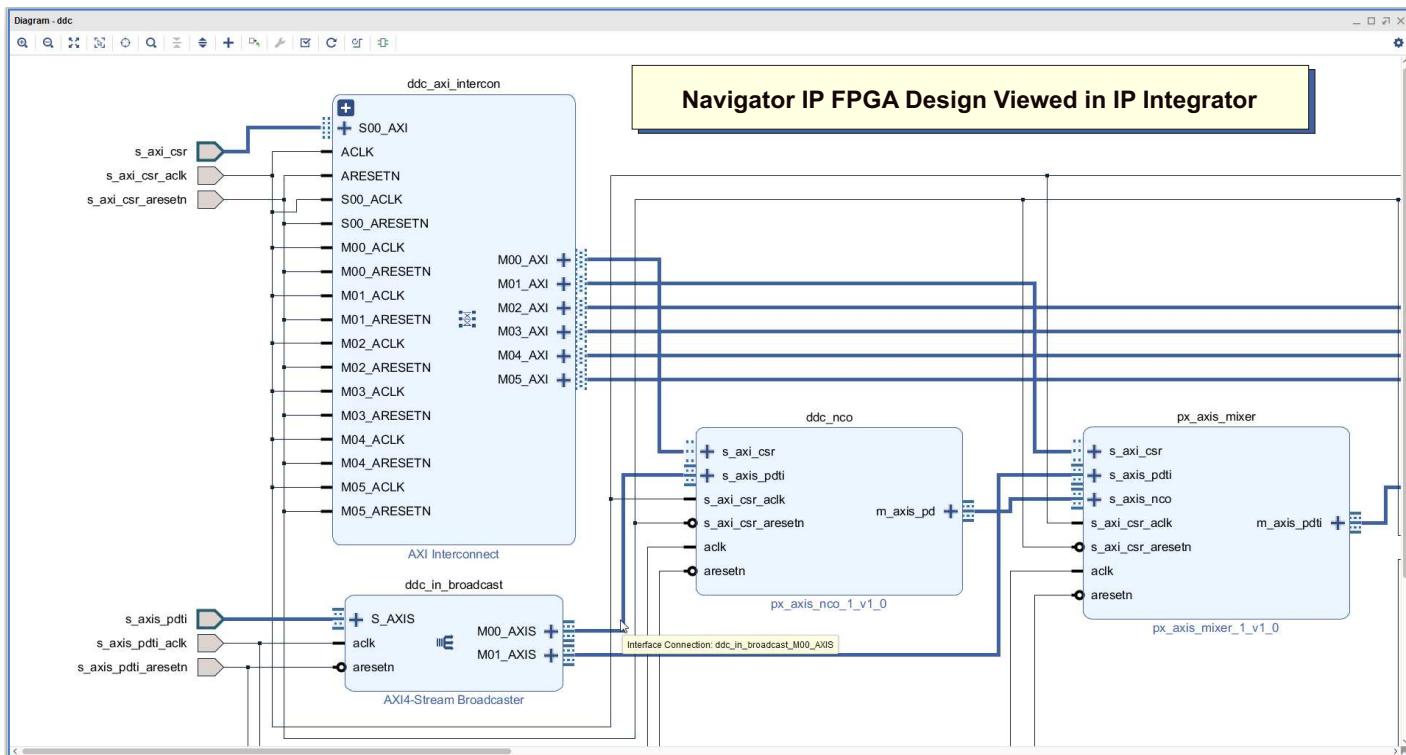

The **Navigator Board Support Package (BSP)** provides software support for Pentek boards. It enables operational control of all hardware functions on the board and IP functions in the FPGA.

The BSP's structure is designed to complement the functions of the FDK by maintaining a one-to-one relationship between FDK and BSP components. For each IP block found in the FDK library, a matching software module can be found in the BSP. This organization simplifies the creation and editing of software to support new IP functions and modifications to existing IP cores.

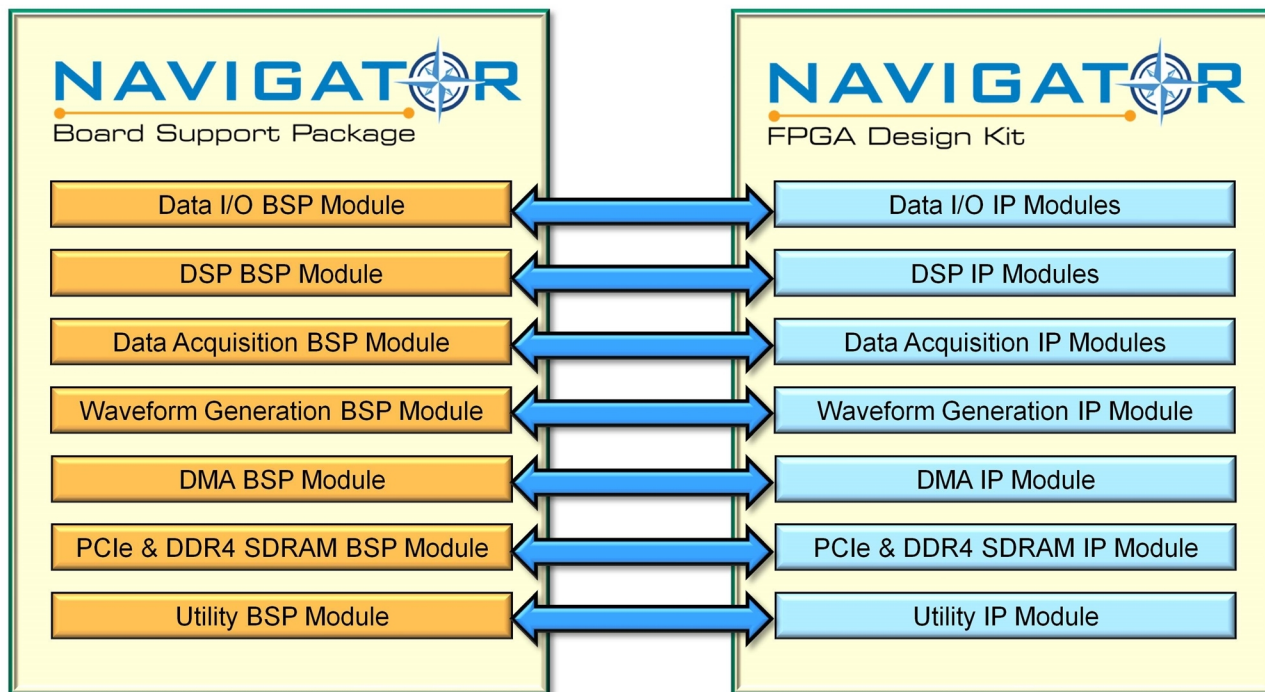

Because all Pentek boards are shipped with a full suite of built-in IP functions and numerous software examples, new applications can be developed by building on the provided software examples or built entirely new with the BSP's extensive libraries. All BSP libraries are provided as C-language source for full access and code transparency.

The Navigator BSP includes the Signal Viewer, a full-featured analysis tool, that displays data in time and frequency domains. Built-in measurement functions display 2nd and 3rd harmonics, THD (total harmonic distortion), and SINAD (signal to noise and distortion). Interactive cursors allow users to mark data points and instantly calculate amplitude and frequency of displayed signals. With the Signal Viewer users can install the Pentek hardware and Navigator BSP and start viewing analog signals immediately.

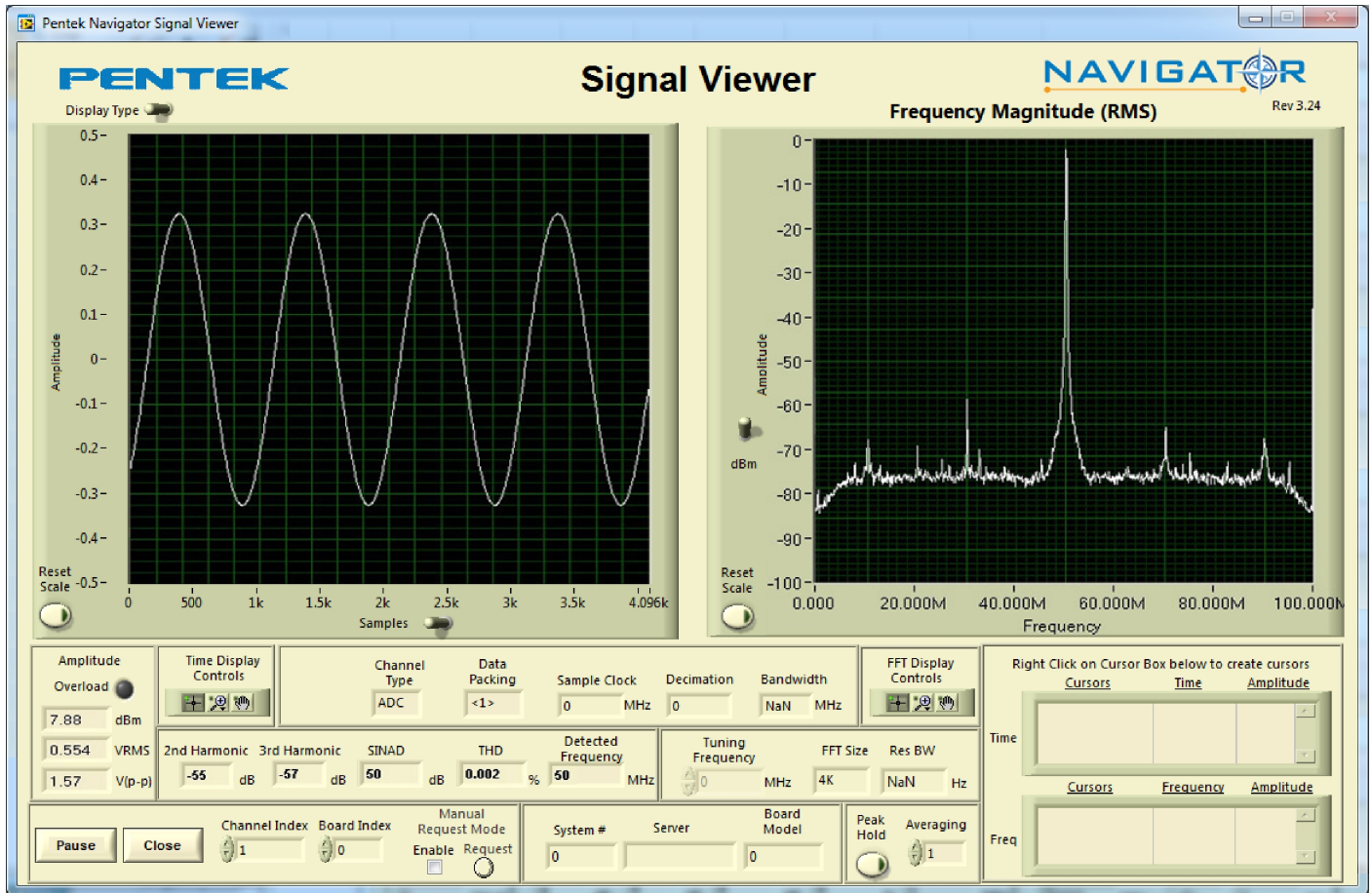

Specifications

Field Programmable Gate Array

Type: (standard) Xilinx Zynq UltraScale+ RFSoc XCZU47DR

Option -048: Xilinx Zynq UltraScale+ RFSoc XCZU48DR

Speed: (standard) -1 speed grade

Option -002: -2 speed grade

RFSoc RF Signal Chain

Analog Inputs

Quantity

Option -113: 4

Option -114: 8

Connector

Option -113: VITA 67.3D

Option -114: VITA 67.3C

Input Type: Transformer-coupled

Transformer Type: Mini-Circuits TCM1-83X+

Full Scale Input: +8 dBm into 50 ohms

A/D Converters

Quantity: 8

Sampling Rate: 5.0 GHz

Resolution: 14 bits

Digital Downconverters

Quantity: 1 per A/D

Decimation Range: 1x, 2x, 3x, 4x, 5x, 6x, 8x, 10x, 12x, 16x, 20x, 24x, and 40x (not all decimations are supported by default IP)

LO Tuning Freq. Resolution: 48 bits, 0 to f_s

Filter: 80% pass band, 89 dB stop-band attenuation

Analog Outputs

Quantity

Option -113: 4

Option -114: 8

Quantity

Option -113: VITA 67.3D

Option -114: VITA 67.3C

Input Type: Transformer-coupled

Transformer Type: Mini-Circuits TCM1-83X+

Full Scale Output: +0 dBm into 50 ohms

D/A Converters

Quantity: 8

Sampling Rate: 10 GHz

Resolution: 14 bits

Digital Upconverters

Quantity: 1 per D/A

Interpolation Range: 1x, 2x, 3x, 4x, 5x, 6x, 8x, 10x, 12x, 16x, 20x, 24x, and 40x (not all interpolations are supported by default IP)

LO Tuning Freq. Resolution: 48 bits

Filter: 80% pass band, 89 dB stop-band attenuation

Sample Clock

Source: On-board programmable clock source or external clock source

Connector Type: VITA 67.3C (for external source)

Level: -10 dBm to +10 dBm

Reference Clock

Source: On-board oscillator, on-board GPS, or external source

Connector Type: VITA 67.3C or VITA 67.3D (for external source)

Level: -10 dBm to +24 dBm

Gate/Trigger:

Source: Programmable through software or external source

Connector Type: VITA 67.3C or VITA 67.3D (for external source)

Level: TTL

Sync Bus

Signals: Sample Clock, Reference Clock, Reference Sync, Gate/Trigger

Location: VPX-P1

RFSoc Processing System

ARM Cortex-A53:

Quantity: 4

Speed: 1.5 GHz

ARM Cortex-R5:

Quantity: 2

Speed: 600 MHz

Processor I/O:

Interface: 1 GigE

Location: VPX-P1

FPGA I/O

Interface: GPIO

Quantity: 10 Pairs

Type: LVDS

Location: VPX-P1

Interface: 10 GigE

Location: VPX-P1

Interface: 40 GigE

Location: VPX-P1

Interface: Optical

Quantity

Option -107: 4 full duplex lanes

Option -108: 8 full duplex lanes

Connector

Option -107: VITA 67.3D

Option -108: VITA 67.3C

Speed: 25 Gb/sec

Laser: 850 nm

Protocol: Factory-installed dual 100 GigE UDP IP cores provides greater than 24 GB/sec data transfers, other protocols supported with user installed IP

GPS**Source:** On-board**Antenna Connector Location:** VITA 67.3C**JTAG****Location:** VPX-P0**Memory****Processing System:****Type:** DDR4 SDRAM**Size:** 8 GB**Speed:** 1200 MHz (2400 MHz DDR)**Programmable Logic:****Type:** DDR4 SDRAM**Size:** 8 GB**Speed:** 1200 MHz (2400 MHz DDR)**FPGA Configuration FLASH:****Type:** QSPI NOR Flash**Size:** 2 x 1 Gbit**Environmental****Option -763: L3 (conduction-cooled)****Operating Temp:** -40° to 70° C**Storage Temp:** -50° to 100° C**Relative Humidity:** 0 to 95%, non-condensing**Physical****Dimensions:** VPX board**Depth:** 170.61 mm (6.717 in)**Height:** 100 mm (3.937 in)**Weight:** Approximately 14 oz (400 grams)**OpenVPX Compatibility**

The Model 5553 is compatible with the following module profile, as defined by the VITA 65 OpenVPX Specification:

SLT3-PAY-1F1U1S1S1U2F1H-14.6.11-n

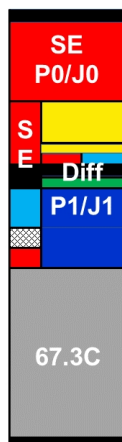
**Ordering Information**

Model	Description
5553	8-Channel A/D & D/A Zynq UltraScale+ RFSoc Gen 3 Processor - SOSA Aligned 3U VPX

Options	Description
-002	-2 FPGA speed grade, -1 standard
-048	XCZU48DR FPGA (XCZU47DR is standard)
-107	VITA 67.3D 4X optical interface
-108	VITA 67.3C 8X optical interface
-113	VITA 67.3D with 4 A/D, 4 D/A, External Reference and Trigger connections installed
-114	VITA 67.3C with 8 A/D, 8 D/A, External Reference, Trigger, GPS Antenna and External Clock connections installed
-763	Conduction cooled, Level L3

Contact Pentek for compatible option combinations and complete specifications of rugged and conduction-cooled versions.

Accessory Products

Model	Description
5503	High-Speed System Synchronization and Distribution Amplifier
8256	SOSA Aligned 3U VPX Development Chassis

Pricing and Availability

To learn more about our products or to discuss your specific application please contact [your local representative](#) or Pentek directly:

Pentek, Inc.
 One Park Way
 Upper Saddle River, NJ 07458 USA
 Tel: +1 (201) 818-5900
 Email: sales@pentek.com

Lifetime Applications Support

Pentek offers the worldwide military embedded computing community shorter development time, reliable, rugged solutions for a variety of environments, reduced costs, and mature software development tools. We offer free lifetime support from our engineering staff, which customers can depend on through phone and email, as well as software updates. Take advantage of Pentek's 30 years of experience in delivering high-performance radar, communications, SIGINT, EW, and data acquisition MIL-Aero solutions worldwide.