

ROBUS IN-LINE HELICAL GEARBOX

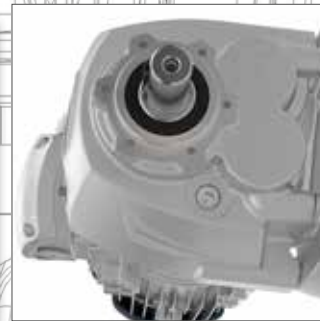

ZERTIFIKAT ◆ CERTIFICATE ◆ CERTIFICADO ◆ CERTIFICAT

CERTIFICATO

Nr. 50 100 1185 Rev.011

SI ATTESTA CHE / THIS IS TO CERTIFY THAT
IL SISTEMA DI GESTIONE PER LA QUALITÀ DI
THE QUALITY MANAGEMENT SYSTEM OF



MOTIVE S.r.l.

SEDE LEGALE E OPERATIVA:
REGISTERED OFFICE AND OPERATIONAL SITE:

VIA LE GHISELLE 20
IT - 25014 CASTENEDOLO (BS)

E CONFORME AI REQUISITI DELLA NORMA
HAS BEEN FOUND TO COMPLY WITH THE REQUIREMENTS OF

UNI EN ISO 9001:2015

QUESTO CERTIFICATO È VALIDO PER IL SEGUENTE CAMPO DI APPLICAZIONE
THIS CERTIFICATE IS VALID FOR THE FOLLOWING SCOPE OF APPLICATION

**Progettazione e fabbricazione di motori elettrici, riduttori meccanici e
inverter (IAF 18, 19)**

**Design and manufacture of electrical motors, mechanical gearboxes
and variable speed drives (IAF 18, 19)**



Per l'Organismo di Certificazione
For the Certification Body
TUV Italia S.r.l.

Validità / Validity

Dal / From: 2022-03-03

Ai / To: 2025-03-02

Data emissione /
Issuing Date

2022-02-28

PRIMA CERTIFICAZIONE / FIRST CERTIFICATION: 2001-07-20

"LA VALIDITÀ DEL PRESENTE CERTIFICATO È SUBORDINATA A SOVRIGLIANZA PERIODICA A 12 MESI E AL RESAME COMPLETO DEL SISTEMA DI
"THE VALIDITY OF THE PRESENT CERTIFICATE IS SUBORDINATED TO PERIODIC TRIENNIAL SURVEILLANCE EVERY 12 MONTHS AND ON THE COMPLETE REVIEW OF THE
QUALITY MANAGEMENT SYSTEM AFTER THREE YEARS"

10V Italia • Gruppo TÜV SÜD • Via Caracciolo, 125, Pal. 23 • 20099 Sesto San Giovanni (MI) • Italia • www.tuvusa.com/it TÜV®

Autorizzazione AEO

1. Titolare dell'Autorizzazione AEO	IT AEOF 21 1809
MOTIVE S.r.l. Codice EDRI: 0723690080114	2. Autorità che rilascia l'Autorizzazione Agenzia delle Dogane e dei Monopoli Direzione Centrale Dogane Ufficio AEO, compliance e grandi imprese
3. Stabile organizzazione	

Il Titolare indicato nel riquadro 1 è un
Operatore economico autorizzato
Semplificazioni doganali / Sicurezza (AEOF)

3. Data di validità dell'Autorizzazione: 15/05/2021

Il Direttore dell'Ufficio
[Signature]



VISIT AND KNOW MOTIVE THANKS
TO THE MOVIE ON WWW.MOTIVE.IT



INDEX

Technical characteristics
ROBUS 25-60 pag. 2-3



Technical characteristics
ROBUS-A pag. 4-5



List of components ROBUS25-60-2
(2 reduction stages) pag. 6-7



List of components ROBUS25-60-3
(3 reduction stages) pag. 8-9



List of components
ROBUSA-2 and ROBUSA-3 pag.10-11



Code system pag. 12

Lubrication pag. 13



Technical data pag. 14-15



Pmax kW pag. 16-17



Pmax kW pag. 18

Configurator pag. 19



Performance table pag. 20-49



Backlash Max (Deg) pag. 50-51



Moment of inertia pag. 52-53



Max axial and radial loads
on output shaft pag. 54-61

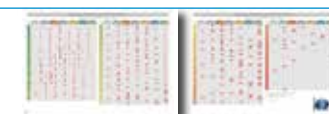

Weights pag. 62

Dimensions pag. 63



Dimensions pag. 64-65



Robus EX series
Also motive itself is ATEX pag. 66

Terms of sale and guarantee pag. 67



ROBUS 25-60 TECHNICAL CHARACTERISTICS



Uniquely contoured, rigid, precise, monobloc, cast iron Body, Base and Flange ensure extreme robustness.



Except version A, all Robus sizes have a screw-on lifting eyebolt



Modular design with detachable output flange and foot base allows easy and quick conversion between foot and flange mounting

ROBUST

A large top cover in light weight aluminium alloy facilitates the inspection



VERSATILE

Various detachable foot bases in solid cast iron make Robus interchangeable with any other gearbox brand

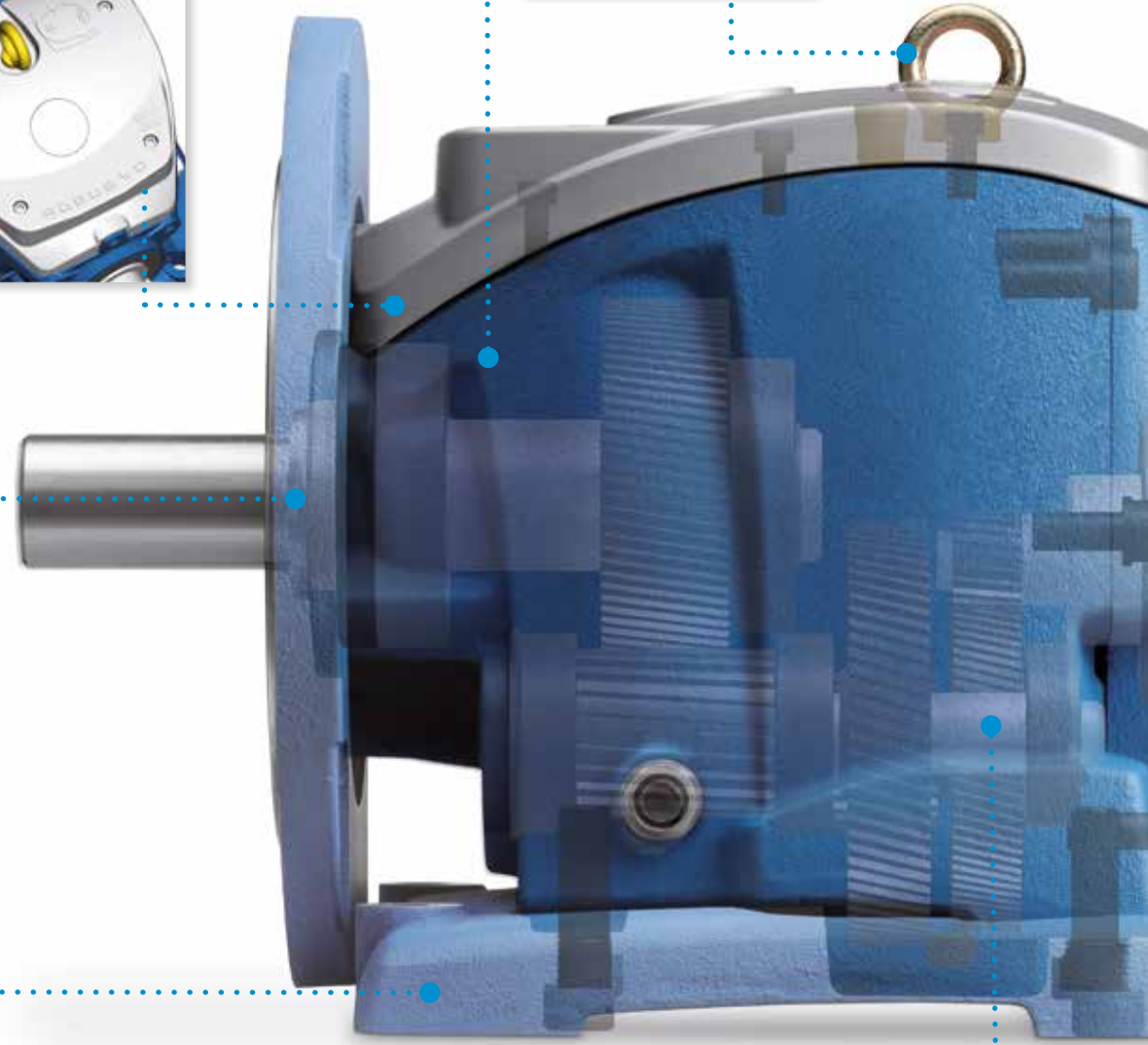
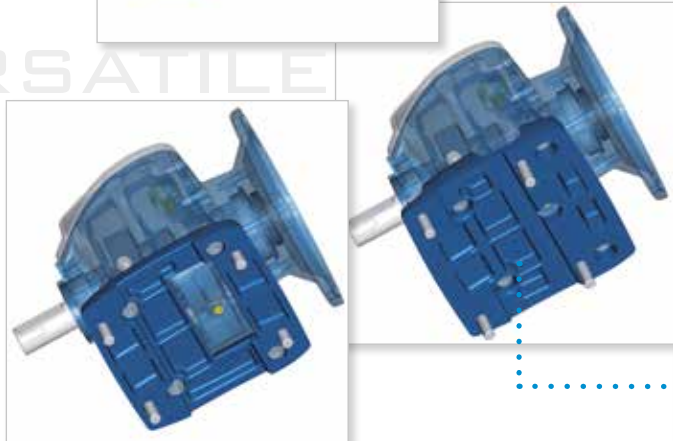



Easy to examine and maintain.
 Minimum maintenance requirement.
 All sizes are supplied with long-life synthetic oil.



IEC flange and hollow shaft.
 Choice of hollow input flanges permits direct mounting of any standard motor



Unique construction of Robus makes it possible to mount any size in any position.
 This flexibility is achieved by:

+ ZZ autolubricating bearings on input and output shaft

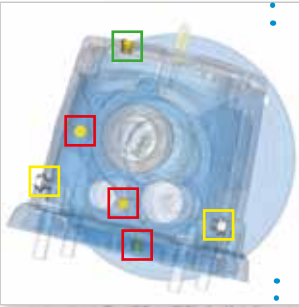

6 interchangeable plugs, including one breather plug and a level plug
 Please note that the vent plug also allows you to reduce the internal pressure on seals, and thus increases the efficiency of the gearbox



+ mechanical parts locked in their positions by snap rings and spacers. This also ensures better absorption of axial thrust and prolongs the life of bearings

FLEXIBLE MOUNTING

ENGINEERED FOR HIGHER RELIABILITY



Use of high strength steels and case hardening to 58 ± 2 HRC reduce the wear rate in wheels.
 All wheels are profile ground to Din 3962 class 6 accuracy for low noise, high efficiency and optimized backlash.

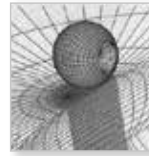

The surface is exposed to a bombardment of micro-spheres that induces compression and increases further the fatigue resistance.



Shafts are made from 42CrMo4 steel and tempered to reach a hardness of 23-35 HRC, thus increasing their capacity to withstand shearing stresses.



If the mechanical robustness and the service factor of an helical gearbox are mainly influenced by the centres distance of the last stage, Robus confirms to be very robust (see "X2" at page 54).



Single stages ratios between 2 and 6, together with proper gears sizes, result mathematically in higher teeth number and size (module) of each wheel and a better fractioned load among the reduction stages. That influences both durability and torque transmission capability.



Dual bearing support on the input shaft assures precise alignment of the first stage gears and reduces vibrations and consequent gear wear.



Intermediate shaft is rigidly supported by 3 bearings, with no overhang wheel, thus imparting greater flexural strength and better meshing. This increases the overloading capacity and takes to lower noise.



Smaller overhang distance of output shaft from supporting bearing in order to withstand higher radial loads.



Abounding bearings size, in order to withstand higher loads.

ROBUS-A TECHNICAL CHARACTERISTICS



Main body of a single piece of aluminum, for an optimal compromise between weight, rigidity and precision

ROBUST



Modular design with detachable output flange and foot base allows easy and quick conversion between foot and flange mounting



VERSATILE



A removable base, with several fixing holes, makes ROBUS-A interchangeable with most of the gearboxes brands

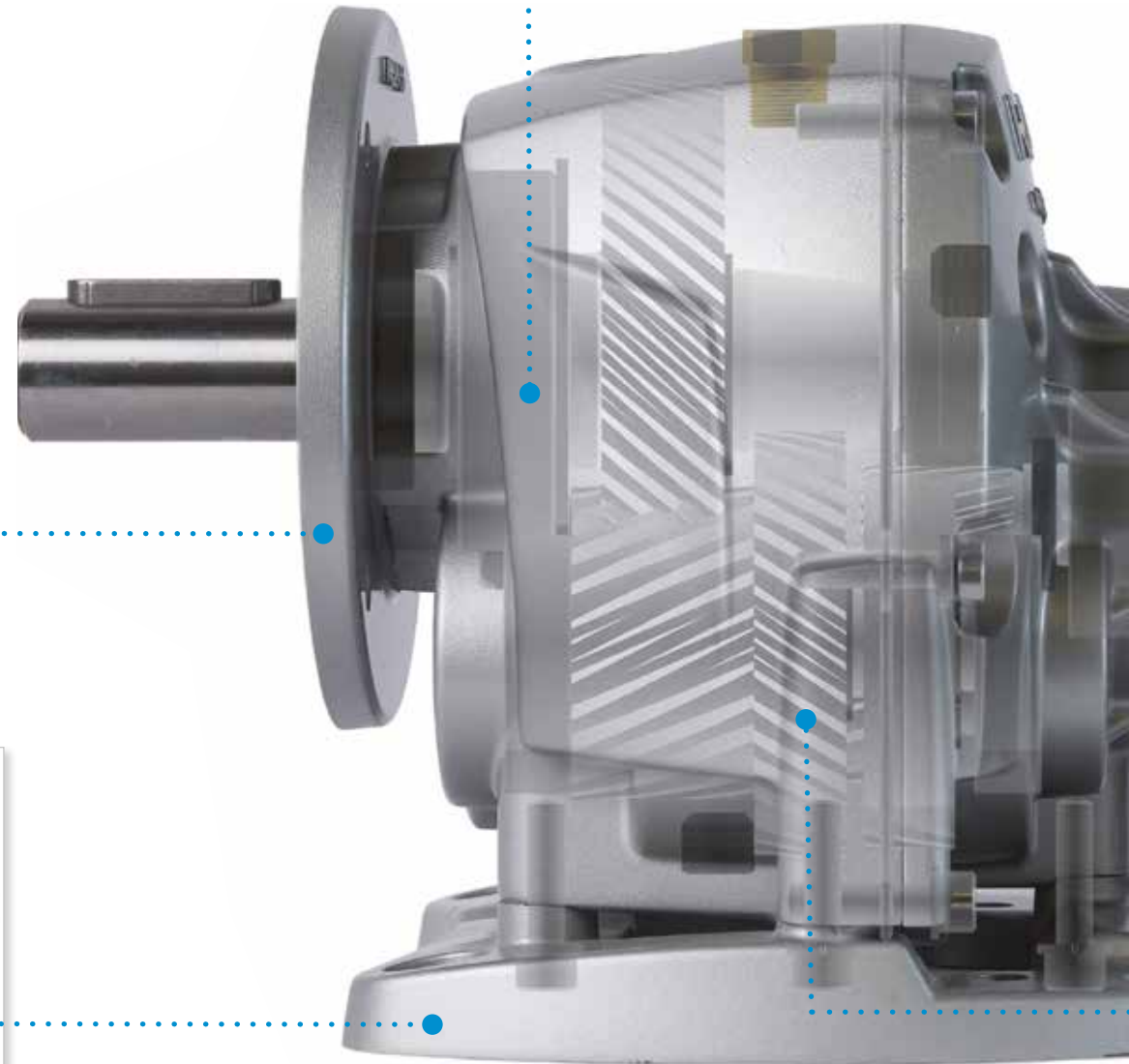



FLEXIBLE MOUNTING



IEC flange and hollow shaft.

Choice of hollow input flanges permits direct mounting of any standard motor



Unique construction of Robus-A makes it possible to mount any size in any position. This flexibility is achieved by:

+ ZZ autolubricating bearings on input and output shaft

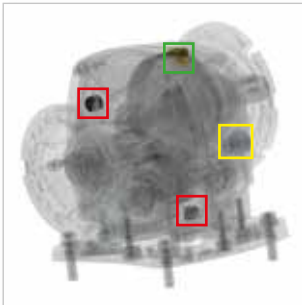

+ 4 interchangeable plugs, including one breather plug and a level plug
Please note that the vent plug also allows you to reduce the internal pressure on seals, and thus increases the efficiency of the gearbox



+ mechanical parts locked in their positions by snap rings and spacers. This also ensures better absorption of axial thrust and prolongs the life of bearings

ENGINEERED FOR HIGHER RELIABILITY



Use of high strength steels and case hardening to 58 ± 2 HRC reduce the wear rate in wheels. All wheels are profile ground to Din 3962 class 6 accuracy for lower noise, higher efficiency and optimized backlash.

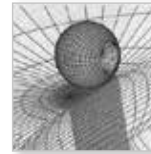

The surface is exposed to a bombardment of micro-spheres that induces compression and increases further the fatigue resistance.



Shafts are made from 42CrMo4 steel and tempered to reach a hardness of 23-35 HRC, thus increasing their capacity to withstand shearing stresses.



If the mechanical robustness and the service factor of an helical gearbox are mainly influenced by the centres distance of the last stage, Robus-A confirms to be very robust (see "X2" at page 54).



Single stages ratios between 2 and 6, together with proper gears sizes, result mathematically in higher teeth number and size (module) of each wheel and a better fractioned load among the reduction stages. That influences both durability and torque transmission capability.



Dual bearing support on the input shaft assures precise alignment of the first stage gears and reduces vibrations and consequent gear wear.



Intermediate shaft is with no overhang wheel, thus imparting greater flexural strength and better meshing. This increases the overloading capacity and takes to lower noise.



Smaller overhang distance of output shaft from supporting bearing in order to withstand higher radial loads.



Abounding bearings size, in order to withstand higher loads.

LIST OF COMPONENTS ROBUS 25-60 2 (2 REDUCTION STAGES)

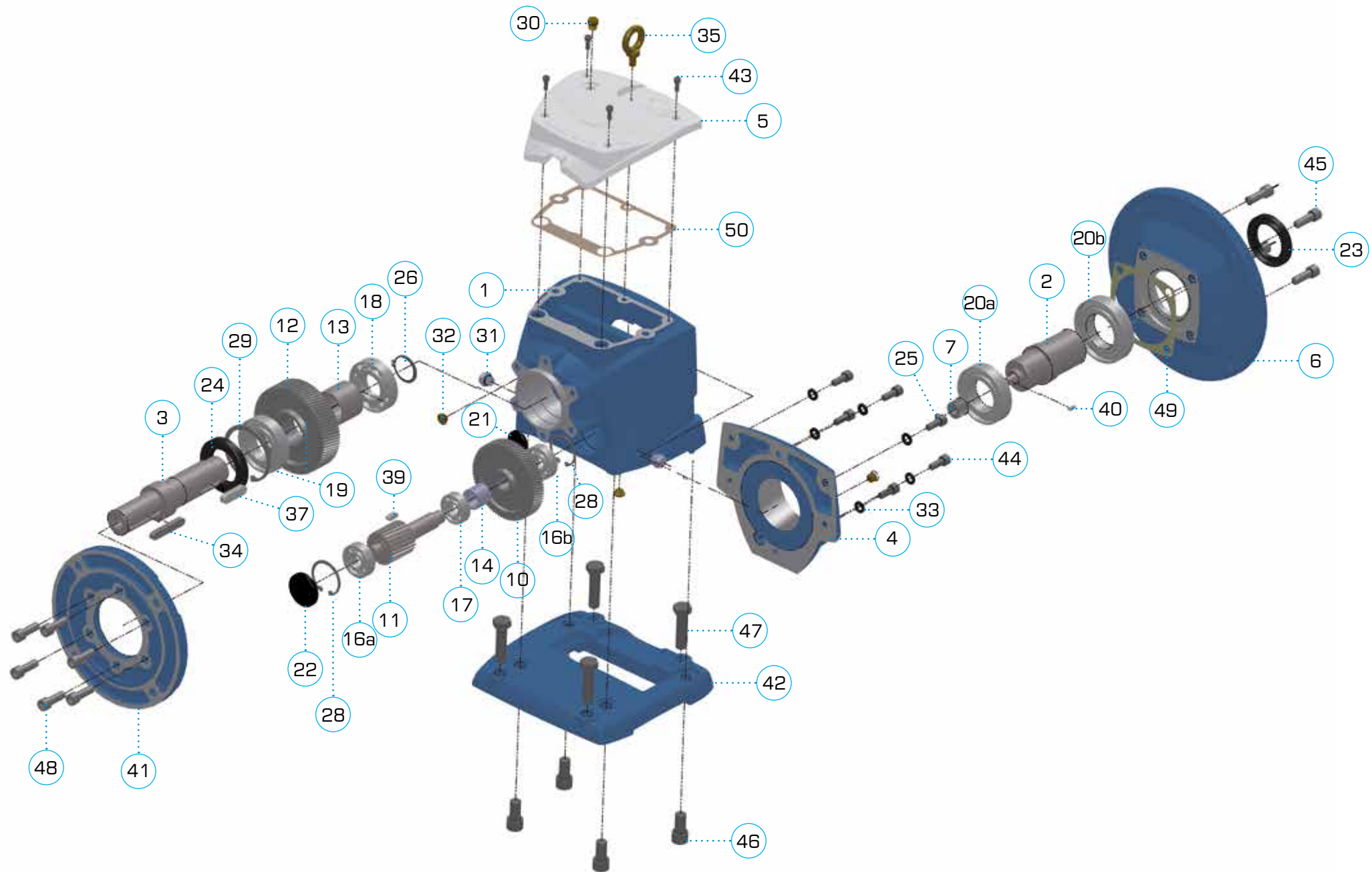

LIST OF COMPONENTS ROBUS 25-60 2 (2 REDUCTION STAGES)

item	code	ROBUS25-2		ROBUS30-2		ROBUS35-2		ROBUS40-2		ROBUS50-2		ROBUS60-2	
		description	q.ty	description	q.ty	description	q.ty	description	q.ty	description	q.ty	description	q.ty
1	HOU	housing	1	housing	1	housing	1	housing	1	housing	1	housing	1
2	ISH	input shaft	1	input shaft	1	input shaft	1	input shaft	1	input shaft	1	input shaft	1
3	OSH	output shaft D25xL50 D30xL60	1	output shaft D30xL60 D35xL70	1	output shaft D35xL70 D40xL80	1	output shaft D40xL80 D50xL100	1	output shaft D50xL100 D60xL120	1	output shaft D60xL120 D70xL140	1
4	ICV	input cover	1	input cover	1	input cover	1	input cover	1	input cover	1	input cover	1
5	TCV	top cover	1	top cover	1	top cover	1	top cover	1	top cover	1	top cover	1
6	IFL	input flange 63B5 71B5 80B5 90B5 100/112	1	input flange 71 80 90 100/112	1	input flange 71 80 90 100/112	1	input flange 80 90 100/112 132	1	input flange 90 100/112 132 160	1	input flange 100/112 132 160 180 200	1
7	P1	pinion 1	1	pinion 1	1	pinion 1	1	pinion 1	1	pinion 1	1	pinion 1	1
10	G2	gear 1	1	gear 1	1	gear 1	1	gear 1	1	gear 1	1	gear 1	1
11	P3	pinion 3	1	pinion 3	1	pinion 3	1	pinion 3	1	pinion 3	1	pinion 3	1
12	G3	gear 3	1	gear 3	1	gear 3	1	gear 3	1	gear 3	1	gear 3	1
13	SP	spacer	1	spacer	1	spacer	1	spacer	1	spacer	1	spacer	1
14	SP	spacer	1	spacer	1	spacer	1	spacer	1	spacer	1	spacer	1
16a	BEA	bearing 7202	1	bearing 7302	1	bearing 7304	1	bearing 7304	1	bearing 7306	1	Bearing 7307	1
16b	BEA	bearing 7202	1	bearing 7203	1	bearing 7204	1	bearing 7204	1	bearing 7306	1	Bearing 7307	1
17	BEA	bearing 6003	1	bearing 6004	1	bearing 6205	1	bearing 6205	1	bearing 6207	1	Bearing 6208	1
18	BEA	bearing 6205	1	bearing 6206	1	bearing 6207	1	bearing 6208	1	bearing 6210	1	Bearing 6212	1
19	BEA	bearing 6206ZZ	1	bearing 6207ZZ	1	bearing 6208ZZ	1	bearing 6209ZZ	1	bearing 6311ZZ	1	Bearing 6313-zz	1
20a)	BEA							bearing 6210ZZ	1	bearing 6212ZZ	1	bearing 6215-zz	1
20b)	BEA							bearing 6211ZZ	1	bearing 6213ZZ	1	bearing 6216-zz	1
20	BEA	bearing 6008ZZ	2	bearing 6009ZZ	2	bearing 6009ZZ	2	bearing 6009ZZ	2	bearing 6009ZZ	2		
21	COV	plug seal D25	1	plug seal D30	1	plug seal D35	1	plug seal D35	1	plug seal D42	1	plug seal D52	1
22	COV	plug seal D35	1	plug seal D42	1	plug seal D52	1	plug seal D52	1	plug seal D72	1	plug seal D80	1
23	OS	oil seal 40x55x8	1	oil seal 45x60x9	1	oil seal 45x60x9	1	oil seal 55x80x10	1	oil seal 65x90x12	1	oil seal 80x105x13	1
24	OS	oil seal 62x35x11	1	oil seal 40x72x10	1	oil seal 50x80x12	1	oil seal 55x85x12	1	oil seal 45x60x9	1	oil seal 72x140x18	1
25	SNR	oil seal 65x120x15	1	oil seal 65x120x15	1	oil seal 65x120x15	1	oil seal 65x120x15	1	oil seal 65x120x15	1	oil seal 65x120x15	1
26	SNR	oil seal 65x120x15	1	oil seal 65x120x15	1	oil seal 65x120x15	1	oil seal 65x120x15	1	oil seal 65x120x15	1	oil seal 65x120x15	1
27	SNR	oil seal 65x120x15	1	oil seal 65x120x15	1	oil seal 65x120x15	1	oil seal 65x120x15	1	oil seal 65x120x15	1	oil seal 65x120x15	1
28	SNR	oil seal 65x120x15	1	oil seal 65x120x15	1	oil seal 65x120x15	1	oil seal 65x120x15	1	oil seal 65x120x15	1	oil seal 65x120x15	1
29	SNR	oil seal 65x120x15	1	oil seal 65x120x15	1	oil seal 65x120x15	1	oil seal 65x120x15	1	oil seal 65x120x15	1	oil seal 65x120x15	1
30	BPL	breather plug	1	breather plug	1	breather plug	1	breather plug	1	breather plug	1	breather plug	1
31	FPL	filler plug	6	filler plug	6	filler plug	6	filler plug	6	filler plug	6	filler plug	6
32	LPL	level plug	1	level plug	1	level plug	1	level plug	1	level plug	1	level plug	1
33	WSH	washer	4	washer	4	washer	4	washer	4	washer	4	washer	4
34	KEY	key	1	key	1	key	1	key	1	key	1	key	1
35	KEY	eye-bolt	1	eye-bolt	1	eye-bolt	1	eye-bolt	1	eye-bolt	1	eye-bolt	1
37	KEY	key	1	key	1	key	1	key	1	key	1	key	1
39	KEY	key	1	key	1	key	1	key	1	key	1	key	1
40	KEY	key	1	key	1	key	1	key	1	key	1	key	1
41	OFL	output flange 200 160	1	output flange 200 160	1	output flange 250 200	1	output flange 300 250	1	output flange 350 300	1	output flange 450 350	1
42	FSW FBF	base SW BF	1	base SW BF	1	base SW BF	1	base SW BF	1	base SW BF	1	base SW BF	1
43	SCR	screw	6	screw	6	screw	6	screw	6	screw	6	screw	6
44	SCR	screw	6	screw	6	screw	6	screw	6	screw	6	screw	6
45	SCR	screw	4	screw	4	screw	4	screw	4	screw	4	screw	4
46	SCR	screw	4	screw	4	screw	4	screw	4	screw	4	screw	4
47	SCR	screw	4	screw	4	screw	4	screw	4	screw	4	screw	4
48	SCR	screw	6	screw	6	screw	6	screw	6	screw	6	screw	6
49	GK49	gasket	1	gasket	1	gasket	1	gasket	1	gasket	1	gasket	1
50	GK50	gasket	1	gasket	1	gasket	1	gasket	1	gasket	1	gasket	1

LIST OF COMPONENTS ROBUS 25-60 3 (3 REDUCTION STAGES)

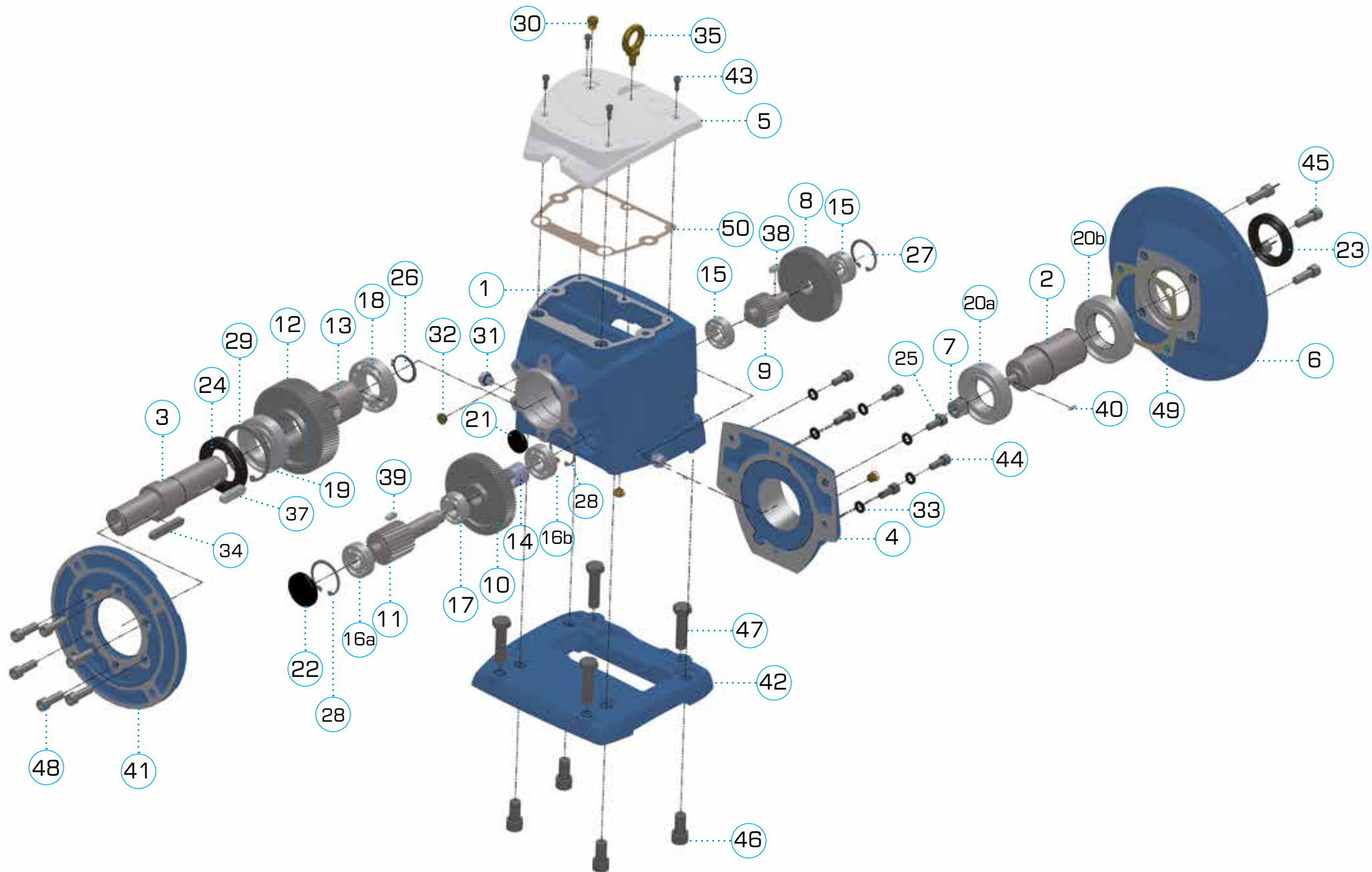

LIST OF COMPONENTS ROBUS 25-60 3 (3 REDUCTION STAGES)

		ROBUS25-3		ROBUS30-3		ROBUS35-3		ROBUS40-3		ROBUS50-3		ROBUS60-3	
item	code	description	q.ty	description	q.ty	description	q.ty	description	q.ty	description	q.ty	description	q.ty
1	HOU	housing	1	housing	1	housing	1	housing	1	housing	1	housing	1
2	ISH	input shaft	1	input shaft	1	input shaft	1	input shaft	1	input shaft	1	input shaft	1
3	OSH	output shaft	1	output shaft	1	output shaft	1	output shaft	1	output shaft	1	output shaft	1
		D25xL50 D30xL60		D30xL60 D35xL70		D35xL70 D40xL80		D40xL80 D50xL100		D50xL100 D60xL120		D60xL120 D70xL140	
4	ICV	input cover	1	input cover	1	input cover	1	input cover	1	input cover	1	input cover	1
5	TCV	top cover	1	top cover	1	top cover	1	top cover	1	top cover	1	top cover	1
6	IFL	input flange	1	input flange	1	input flange	1	input flange	1	input flange	1	input flange	1
		63B5 71B5 80B5 90B5 100/112		71 80 90 100/112		71 80 90 100/112		80 90 100/112 132		90 100/112 132 160		100/112 132 160 180 200	
7	P1	pinion 1	1	pinion 1	1	pinion 1	1	pinion 1	1	pinion 1	1	pinion 1	1
8	G1	gear 1	1	gear 1	1	gear 1	1	gear 1	1	gear 1	1	gear 1	1
9	P2	pinion 2	1	pinion 2	1	pinion 2	1	pinion 2	1	pinion 2	1	pinion 2	1
10	G2	gear 2	1	gear 2	1	gear 2	1	gear 2	1	gear 2	1	gear 2	1
11	P3	pinion 3	1	pinion 3	1	pinion 3	1	pinion 3	1	pinion 3	1	pinion 3	1
12	G3	gear 3	1	gear 3	1	gear 3	1	gear 3	1	gear 3	1	gear 3	1
13	SP	spacer D30.5xL24	1	spacer D35.5xL32.5	1	spacer D40.5xL36.6	1	spacer	1	spacer D55.5xL45	1	spacer D65.5xL50	1
14	SP	spacer D20xL22	1	spacer D20.5xL23.5	1	spacer D21.5xL24.5	1	spacer	1	spacer D35xL32	1	spacer D40.5xL38	1
15inp	BEA	bearing 6002ZZ	1	bearing 6003ZZ	1	bearing 6203ZZ	1	bearing 6204ZZ	1	bearing 6206ZZ	1	bearing 6207ZZ	1
15out	BEA	bearing 6002	2	bearing 6003	2	bearing 6203	2	bearing 6204	2	bearing 6206	2	Bearing 6207	2
16a	BEA	bearing 6202	1	bearing 6302	1	bearing 6304	1	bearing 6304	1	bearing 6306	1	Bearing 6307	1
16b	BEA	bearing 6202ZZ	1	bearing 6203ZZ	1	bearing 6204ZZ	1	bearing 6204ZZ	1	bearing 6306ZZ	1	Bearing 6307ZZ	1
17	BEA	bearing 6003	1	bearing 6004	1	bearing 6205	1	bearing 6205	1	bearing 6207	1	Bearing 6208	1
18	BEA	bearing 6205	1	bearing 6206	1	bearing 6207	1	bearing 6208	1	bearing 6210	1	Bearing 6212	1
19	BEA	bearing 6206	1	bearing 6207ZZ	1	bearing 6208ZZ	1	bearing 6209ZZ	1	bearing 6311ZZ	1	Bearing 6313ZZ	1
20a	BEA							bearing 6210ZZ	1	bearing 6212ZZ	1	bearing 6215ZZ	1
20b	BEA							bearing 6211ZZ	1	bearing 6213ZZ	1	bearing 6216ZZ	1
20	BEA	bearing 6008ZZ	2	bearing 6009ZZ	2	bearing 6009ZZ	2	bearing 6009ZZ	2	bearing 6009ZZ	2		
21	COV	plug seal D25	1	plug seal D30	1	plug seal D35	1	plug seal D35	1	plug seal D42	1	plug seal D52	1
22	COV	plug seal D35	1	plug seal D42	1	plug seal D52	1	plug seal D52	1	plug seal D72	1	plug seal D80	1
23	OS	oil seal 40x55x8	1	oil seal 45x60x9	1	oil seal 45x60x9	1	oil seal 55x80x10	1	oil seal 65x90x12	1	oil seal 80x105x13	1
										oil seal 45x60x9			
24	OS	oil seal 35x62x11	1	oil seal 40x72x10	1	oil seal 50x80x12	1	oil seal 55x85x12	1	oil seal 65x120x15	1	oil seal 72x140x18	1
25	SNR	snap ring	1	snap ring	1	snap ring	1	snap ring	1	snap ring	1	snap ring	1
26	SNR	snap ring	1	snap ring	1	snap ring	1	snap ring	1	snap ring	1	snap ring	1
27	SNR	snap ring	2	snap ring D35	2	snap ring	2	snap ring	2	snap ring	2	snap ring	1
28	SNR	snap ring	2	snap ring	2	snap ring	2	snap ring	2	snap ring	2	snap ring	2
29	SNR	snap ring	1	snap ring	1	snap ring	1	snap ring	1	snap ring	1	snap ring	1
30	BPL	breather plug	1	breather plug	1	breather plug	1	breather plug	1	breather plug	1	breather plug	1
31	FPL	filler plug	6	filler plug	6	filler plug	6	filler plug	6	filler plug	6	filler plug	6
32	LPL	level plug	1	level plug	1	level plug	1	level plug	1	level plug	1	level plug	1
33	WSH												
34	KEY	key	1	key	1	key	1	key	1	key	1	key	1
35	KEY	eye-bolt	1	eye-bolt	1	eye-bolt	1	eye-bolt	1	eye-bolt	1	eye-bolt	1
37	KEY	key	1	key	1	key	1	key	1	key	1	key	1
38	KEY	key	1	key	1	key	1	key	1	key	1	key	1
39	KEY	key	1	key	1	key	1	key	1	key	1	key	1
40	KEY	Key	1	Key	1	Key	1	Key	1	Key	1	Key	1
41	OFL	output flange	1	output flange	1	output flange	1	output flange	1	output flange	1	output flange	1
		200 160		200 160		250 200		300 250		350 300		450 350	
42	FSW FBF	base SW BF	1	base SW BF	1	base SW BF	1	base SW BF	1	base SW BF	1	base SW BF	1
43	SCR	screw	6	screw	6	screw	6	screw	6	screw	6	screw	6
44	SCR	screw	6	screw	6	screw	6	screw	6	screw	6	screw	6
45	SCR	screw	4	screw	4	screw	4	screw	4	screw	4	screw	4
46	SCR	screw	4	screw	4	screw	4	screw	4	screw	4	screw	4
47	SCR	screw	4	screw	4	screw	4	screw	4	screw	4	screw	4
48	SCR	screw	6	screw	6	screw	6	screw	6	screw	6	screw	6
49	GK49	gasket	1	gasket	1	gasket	1	gasket	1	gasket	1	gasket	1
50	GK50	gasket	1	gasket	1	gasket	1	gasket	1	gasket	1	gasket	1

LIST OF COMPONENTS ROBUS A2-2 AND ROBUS A2-3

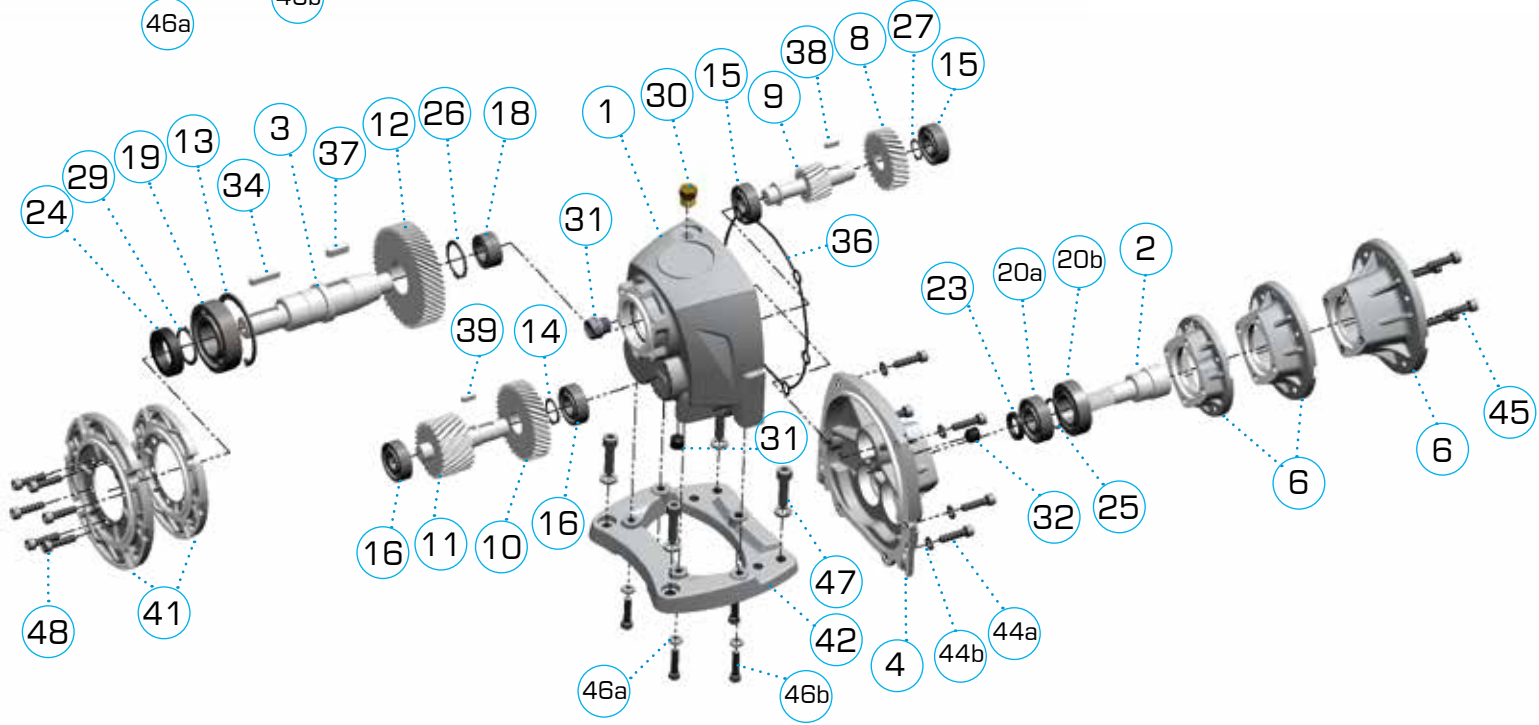
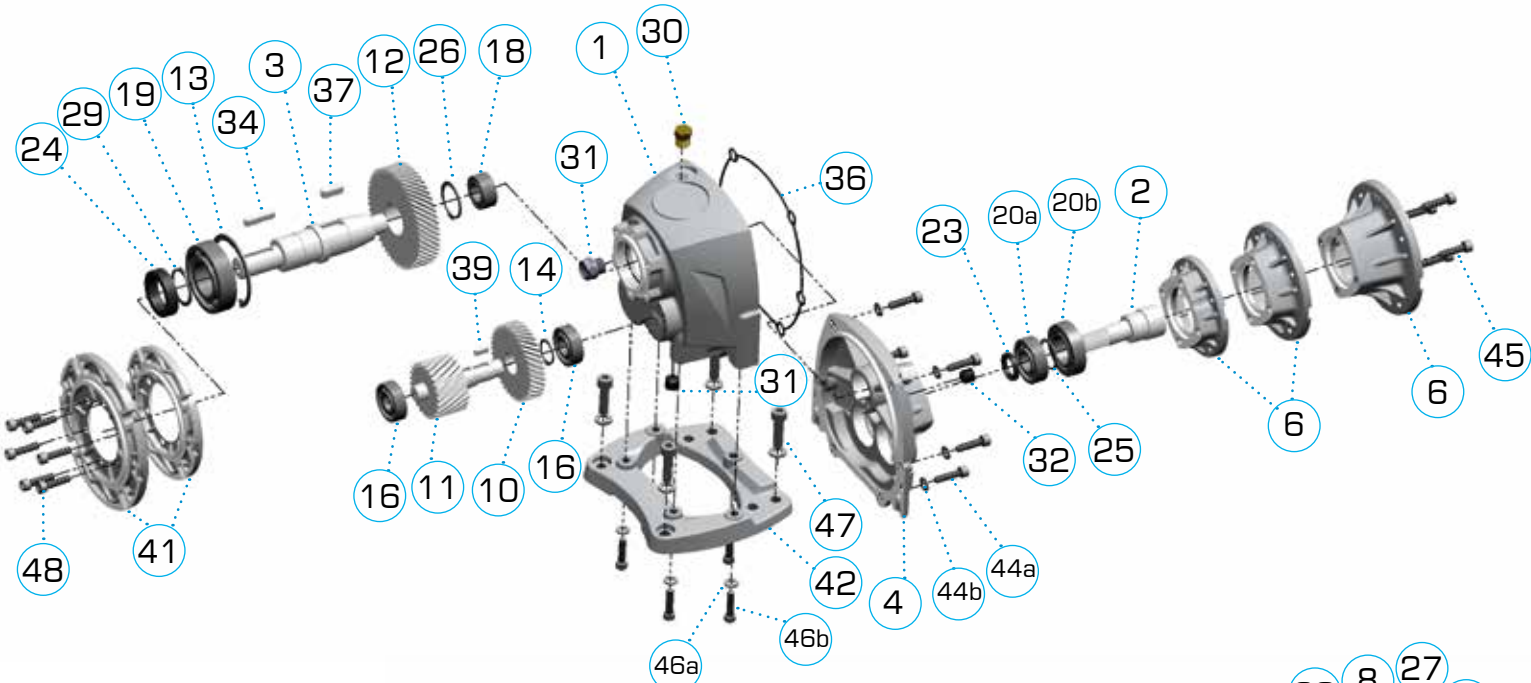

LIST OF COMPONENTS ROBUS A2-2 AND ROBUS A2-3

item	code	description	q.ty
list of components Robus A2-2 (2 reduction stages)			
1	HOU	Housing	1
2	ISH-P1	Input shaft with integrated pinion	1
3	OSH	Output shaft D20x40 D25x50	1
4	ICV	Input cover	1
6	IFL	Input flange 63B14 71B14 80B14	1
10	G1	Gear 1	1
11	P3	Pinion 3	1
12	G3	Gear 3	1
13	SNR	circlip	1
14	SNR	circlip	1
16	BEA	Bearing, 6202ZZ	2
18	BEA	Bearing, NA4903	1
19	BEA	Bearing, 6206ZZ	1
20a	BEA	Bearing, 6203ZZ	1
20b	BEA	Bearing, 6005ZZ	1
23	OS	Oil seal, 17X25X	1
24	OS	Oil seal, 30X42X10	1
25	SNR	circlip	1
26	SNR	circlip	1
29	SNR	circlip	1
30	BPL	Breather plug 1/4"	1
31	FPL	Filler plug 1/4"	2
32	LPL	Level plug 1/4"	1
34	KEY	key	1
36	OR	o-ring	1
37	KEY	key	1
39	KEY	key	1
41	OFL	Output flange 120 140	1
42	FT	Base	1

item	code	description	q.tà
additional components Robus A2-3 (3 reduction stages)			
8	G1	Gear 1	1
9	P2	Pinion 2	1
10	G2	Gear 2	1
15	BEA	Bearing, 6202ZZ	2
27	SNR	External Circlip (G1)	1
38	KEY	Key	1
39	KEY	Key	1



CODE SYSTEM

1 first 4 digits describe the ROBUS size

RB40 =ROBUS 40

RB50 =ROBUS 50

RBA2 =ROBUS A2

etc

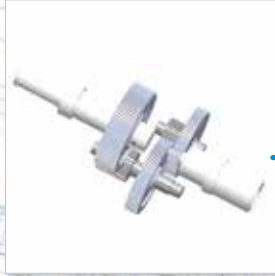

2 then 1 digit tell the nr of stages

2 =2 stages

3 =3 stages

3 then 3 digits are the rated ratio

020 =i:20

120 =i:120

etc

4 then 3 digits for the mounting type

FSW =base type SW

FBF =base type BF

120 =output flange 56B5 KP=120

140 =output flange 63B5 KP=140

160 =output flange 71B5 KP=160

200 =output flange 80/90B5 KP=200

250 =output flange 100/112B5 KP=250

300 =output flange 132B5 KP=300

350 =output flange 160/180 KP=350

450 =output flange 200 KP=450

UNV =without foot or output flange

5 3 digits for the input flange (that determines the input hole diameter too)

714 =71B14

805 =80B5

905 =90B5

125 =100-112B5

135 =132B5

etc ...

6 D2 to indicate whether the output shaft is the biggest option. For example, Robus 25 may have an output shaft with diameter 25 or 30mm. If you ask the 30mm one, write D2 at the end of the code

For instance:

RB603070FSW135

ROBUS 60

3 stages

ratio i:70

SW foot mounting

input PAM flange 132 B5

Plate:

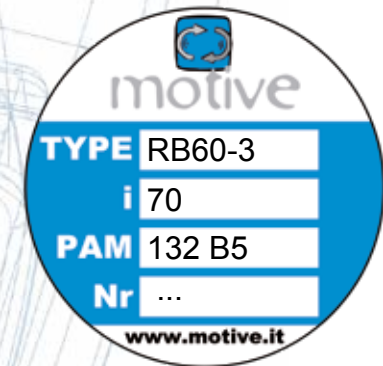

LUBRICATION

Each Robus is supplied with long-life synthetic oil and do not require any maintenance.
The oil quantity is suitable for B3 mounting position

ROBUS	oil (lt)						ISO	temp.	oil type	
	B3	B6	B7	B8	V5	V6				
A2	0,35	0,55	0,65	0,6	0,6	0,55	VG 220	-25 +80°C	Mobil Glygoyle 220	Shell Omala S4 220
25	0,3	0,75	0,95	0,95	1,3	0,85				
30	0,7	1,5	1,5	1,5	2,6	1,6				
35	1,1	2,2	2,2	2	3,9	3,6				
40	1,2	2,5	3,4	3,4	4,75	3,8				
50	2,3	6,3	6,5	6,5	8,80	6,7				
60	4,6	11,3	11,7	11,7	15,30	11,7				

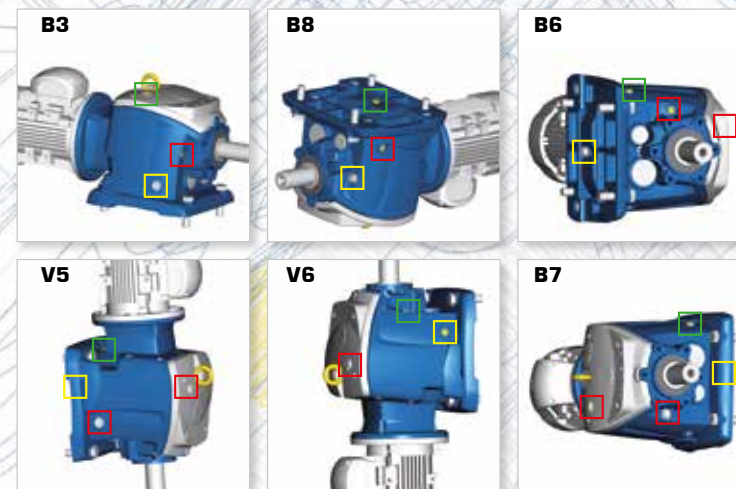

THE MANUAL FIRST OF ALL:



After adapting the oil quantity, each Robus can be mounted in ANY position, thus giving big advantages in the stock management and lead time, thanks to the following 3 characteristics:



1

ZZ autolubricating bearings on input and output shaft

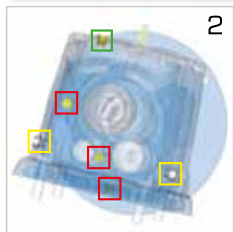

2

6 interchangeable plugs, including one breather plug and a level plug. Level and breather plug must be positioned according to this chart



3

mechanical parts locked in their positions by circlips and spacers. This also ensures better absorption of axial thrust and prolongs the life of bearings

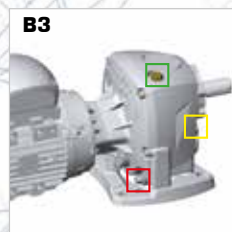

B3



B8

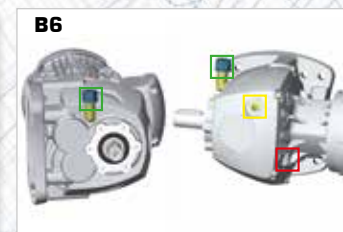

B6

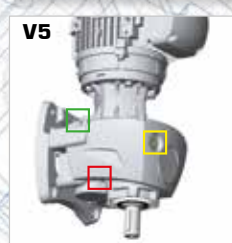

V5

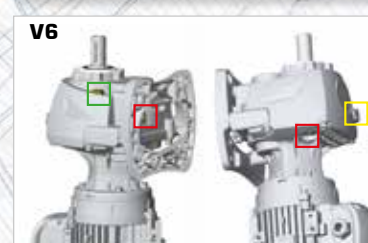

V6



B7



breather plug



level plug



filler plug



Elbow vent plug

Rated output torque M_{n2} [Nm]

Torque output transmissible under uniform loading and referred to the input speed n_1 and the corresponding output speed n_2 .

The output torque can be calculated with the following formula:

$$M_{n2} = \frac{P_{n1} \text{ [kW]} \cdot 9550}{n_2} \cdot \eta$$

Torque demand M_{r2} [Nm]

Torque calculated based on application requirements. It must be $\leq M_{n2}$ of the chosen BOX unit.

Input power P_{n1} [kW]

This is the power value of the motor applied to the input shaft and corresponding to a certain input speed n_1 , a service factor $f_s = 1$ and a duty service S_1 .

It is even possible to calculate the motor-size necessary by using the formula:

$$P_{n1} \text{ [kW]} = \frac{M_{r2} \cdot n_2}{9550 \cdot \eta}$$

Since the value calculated in this way could not really correspond to an input power actually available in the IEC standardised motors, it will be necessary to choose, among the input powers available, the one which is immediately higher, checking this in the Motive catalogue of the motors.

Efficiency η [%]

An inherent factor in the selection worm-gear boxes is the efficiency η , defined as the ratio between the mechanical power coming out from the output shaft, and the power in the input shaft:

$$\eta = \frac{P_{n2}}{P_{n1}}$$

The efficiency in helical gearboxes is mainly determined by the gearing and

bearing friction.

The efficiency of ROBUS varies with the nr of stages: it's 94% when the reduction stages are 3, 96% when the stages are 2.

The starting efficiency is always less than the efficiency at rated speed

Gear ratio i

It is the relationship of the input speed n_1 and the output speed n_2

$$i = \frac{n_1}{n_2}$$

In the combined, the total ratio is the result of the product of the ratio of the two single boxes.

Input speed n_1 [rpm]

It is the speed the BOX unit is driven at.

Output speed n_2 [rpm]

It is the rotation speed of the output shaft.

Service factor f_s

It is a numeric value describing the BOX unit service duty. With unavoidable approximation, it takes into consideration:

- the daily working hours **h/d**
- the load classification (see table 2), and then the moment of inertia of the driven masses.
- The number of starts per hour **s/h**
- The presence of brake motors, for which it is necessary to multiply for 1.12 the service factor value deducted by the graph 2.
- The significance of the application in terms of safety, for example lifting of parts

In the graph 2, the service factor f_{sr} required by a certain application can be attained, after having selected the proper "daily working hours" (h/d) column, by intersecting the number of starts per hour (s/h) and one of the a, b or c curves. The curves a, b and c are linked with the load classification described in the table 2.

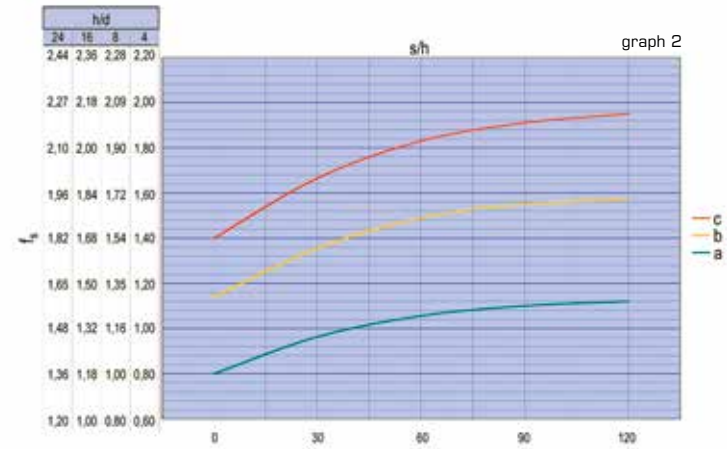

tab. 2

load classification	application
c uneven operation, heavy loads, larger masses to be accelerated	conveyors with violent jerks; compressors ad alternate pumps with 1 or more cylinders; machinery for bricks, tiles and clay; kneaders; milling machines; lifting winches with buckets; rotting furnaces; heavy fans or mining purposes; mixers for heavy materials; machine-tools; planing kinds; alternating saws; shears; tumbling barrels; vibrators; shredders; turntables
b starting with moderate loads, uneven operating conditions, medium size masses to be accelerated	belt conveyors with varied load with transfer of bridge trucks for light duty; levelling machines; shakers and mixed for liquid with variable density and viscosity; machines for the food industry (kneading troughs, mincing machines, slicing machines, etc); sifting machines for sand gravel; textile industry machines; cranes, hoists, goodstifts; fertilizer scrapers; concrete mixers; folding machines; winches; crane mechanisms
a easy starting, smooth operation, small masses be accelerated	belt conveyors for light material; centrifugal pumps; rotary gear pumps; screw feeders for light materials; lifts; bottling machines; auxiliary controls of tool machines; fans; power generators; fillers; small mixers

If, after the selection of the right M_{r2} and n_2 in the following performance tables, you don't find a ROBUS unit whose service factor f_s is \geq of the requested one f_{sr} , you can choose a ROBUS unit in which $M_{n2} > M_{r2}$. In fact, in order to satisfy f_{sr} , you can choose another BOX unit whose output torque is $\geq M_{c2}$ output torque, where:

$$M_{c2} = M_{r2} \cdot f_{sr}$$

Note: This rule is valid only if the new BOX unit that has been selected in this way has a service factor $f_s \geq 1$ in the performance tables.

From another point of view, the value of f_s in the performance tables refers to a case in

which the effective torque requested by the application M_{r2} matches perfectly with the one appearing on the catalogue M_{n2} . Whenever the torque indicated in the performance table is higher than the requested one, the offered service factor of the performance table can be increased according to the formula:

$$f_{s \text{ real}} = \frac{f_s \text{ on the table} \cdot M_{n2} \text{ on the table}}{M_{r2}}$$

The value of f_s calculated in this way must be $\geq f_{sr}$.

Offered service factor

Which features determine the service factor offered by an helical gearbox?

The service factor of a gearbox is its capacity to withstand operating load and overloads, a certain number of starts, the duration of operating time, and mechanical shocks and vibrations. Thus, higher the service factor, greater is the possibility of trouble-free operation and increased life. Without aiming to be completely exhaustive, we list here the main features that influence the service factor:

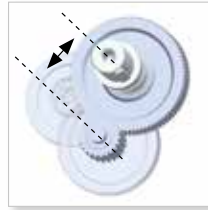

Amongst all parts, the last stage gears are subjected to highest mechanical stresses. Higher centre distance which in turn results in higher module considerably increases the service factor. ROBUS excels in the area (see measures at page 26)

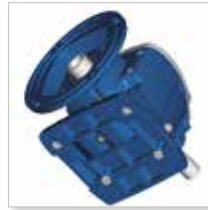

Compared to fractioned or Aluminium body, the monobloc cast-iron body of ROBUS provides higher rigidity and mechanical robustness. At the same time, a one-piece body like that of ROBUS-A is more rigid and reliable than a body composed of several parts



Use of high strength steels and case hardening to 58 ± 2 HRC reduce the wear rate in wheels. All wheels are profile ground to Din 3962 class 6 accuracy for low noise and high efficiency.

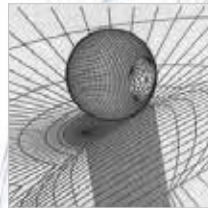

The surface is exposed to a bombardment of micro-spheres that induces compression and increases further the fatigue resistance.



Shafts are made from 42CrMo4 steel and tempered to reach a hardness of 23-35 HRC, thus increasing their capacity to withstand shearing stresses and torsion effect.



Optimal ratios (between 2 and 6) in the several stages, together with appropriate centre distances, result in higher number of teeth and size (module) of each wheel and better torque transmission fractioning through various stages. This improves the overall durability.



Dual bearing support on the input shaft ensures precise alignment of the first stage gears and reduces vibrations and consequent gear wear



If the intermediate shaft is rigidly supported on both ends, with no overhang wheel, imparts greater flexural strength and smoother meshing



Oversized bearings (see ROBUS bearings list), allow the gearbox to withstand higher operating loads



Mechanical parts locked in their position by snap rings and spacers. This ensures better absorption of axial thrust and prolongs the life of bearings

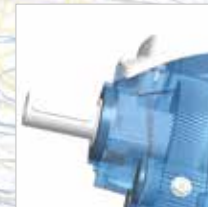

Smaller overhang of output shaft from supporting bearing in order to withstand higher radial loads

P MAX KW

(fs = 1; n₁ = 1400rpm)

i:	ROBUS A2		ROBUS 25		ROBUS 30		ROBUS 35		ROBUS 40		ROBUS 50		ROBUS 60	
	A2-2	A2-3	25-2	25-3	30-2	30-3	35-2	35-3	40-2	40-3	50-2	50-3	60-2	60-3
2							24,82							
2,5					21,98		22,60						108,88	
3					21,98		24,82				66,47			
3,5					17,08		22,60		33,07				108,88	
4			8,35		17,08		18,00		28,07		50,05		73,68	
4,5			6,54		13,12				24,95		55,65		61,03	
5	1,04		6,92		15,34		14,70		25,08		40,31			
5,5			5,42		10,64		15,28		21,07				73,68	
6					8,92						30,99			
6,5							14,47	17,91			40,68			
7			3,51		10,64		11,59		16,80		28,63	42,40	60,02	
8	1,04				7,77		9,36	12,62	15,16	17,15	33,12			
9			3,86		7,77		9,43		14,30			32,09	49,65	
10	1,04		3,03		6,81		7,88			14,74		30,98		60,02
11					5,62	6,34	7,83	9,23	12,37	13,53	24,84			42,35
12						5,88	6,85		11,19				34,85	45,38
13	1,04		2,24		4,21	5,27	6,45	7,33	10,26	11,64	21,32	25,19		40,59
14					3,97			7,09	9,57		18,12			27,51
15	1,04		2,46			4,80		6,60	8,86	9,89				38,45
16			2,25		3,51	4,61	5,71	6,14	8,40	9,55	16,76	19,14		30,15
17			1,94									18,84		
18						3,99		5,53		8,15	14,74			28,25
19			1,77			3,84								
20	1,04		1,42			2,83		5,07		7,38		16,13		29,01
21						2,65	3,47		4,80		7,29			28,77
22				1,68		2,47	3,28					14,63		
23			1,30			2,08		4,54		6,61				23,02
24			1,20					4,25		6,33		11,79		
25	0,83			1,33	1,95	2,91				5,51		12,34		
26				1,41				3,84				12,10		23,25
27						2,73				5,68				21,67
28				1,31				3,69		5,46		11,21		
29														19,39
30		0,58		1,12		2,42		3,49		5,15				
31										4,64				
32						2,34				4,80		9,81		18,98

i:	ROBUS A2		ROBUS 25		ROBUS 30		ROBUS 35		ROBUS 40		ROBUS 50		ROBUS 60	
	A2-2	A2-3	25-2	25-3	30-2	30-3	35-2	35-3	40-2	40-3	50-2	50-3	60-2	60-3
33					1,09								9,71	18,78
34					1,05		2,20		3,07					
35		0,53							3,04		4,44		8,58	
36							2,07		2,90		4,28		8,12	15,65
37					0,86						3,87			
38							1,96		2,58		3,78			
39		0,53			0,90									15,84
40									2,56				7,22	
41					0,84		1,84		2,57		3,45		7,11	14,26
42					0,81		1,62		2,51					14,11
43														
44													3,16	
45					0,76		1,66		2,38				6,56	13,93
46		0,50							1,95		2,81			12,28
47									1,93					
48					0,71		1,44				2,90		6,16	11,33
49									1,93		2,84			
50		0,46			0,72						2,76			11,89
51							1,49		2,11				5,75	12,24
52									1,73				5,69	10,15
53					0,65						2,61			
54					0,62				1,67					10,64
55		0,46					1,40				2,53			
56									1,63				5,34	
57					0,54		1,17				2,44			10,45
58					0,54									
59		0,46							1,78					8,99
60					0,56		1,16						4,46	
61					0,56									9,86
62											2,28		4,82	
63					0,54				1,77					8,43
64		0,42					1,09				2,21			
65					0,53						2,18		4,63	9,27
66														8,31
67									0,93					7,94
68									0,91		1,35			
69					0,45		0,98		1,34					
70		0,38			0,50		0,89		1,31					8,30

The max power of a gearbox is another way to read the service factor, and it is therefore the result of the same features that influence the gearbox reliability

It is the max power of the motor that could be connected to the gearbox, given an hypothetical required service factor of the gearbox = 1 and at a certain motor speed

For the max power in Hp at 60Hz, see the catalogue of the NEMA version

P MAX KW

(fs = 1; n₁ = 1400rpm)

i:	ROBUS A2		ROBUS 25		ROBUS 30		ROBUS 35		ROBUS 40		ROBUS 50		ROBUS 60	
	A2-2	A2-3	25-2	25-3	30-2	30-3	35-2	35-3	40-2	40-3	50-2	50-3	60-2	60-3
71									2,04		4,30		7,51	
72						0,86					4,27			
73				0,45		0,85		1,46					7,29	
74									1,98					
75				0,44		0,84		1,13					7,37	
76		0,31		0,50		0,83							7,10	
77								1,21					7,06	
78						0,81								
79									1,51					
80				0,42		0,79		1,18			3,79			
81		0,29				0,78							6,76	
82						0,78			1,46				6,17	
83											3,81		6,06	
84				0,36		0,76					3,78		6,04	
85		0,30		0,36		0,76		1,13	1,41					
86								0,91					6,42	
87				0,41		0,74			1,32				6,39	
88								0,89			3,15			
89				0,35									6,26	
90						0,72		1,07	1,27					
91				0,34		0,72			1,34					
92		0,27							1,32		2,74		6,07	
93									1,23				6,04	
94						0,70								
95						0,69							5,48	
96									1,28				5,42	
97														
98		0,22		0,32		0,68			1,27				5,34	
99								1,00					5,73	
100								0,88						
101									1,15		2,35		5,18	
102						0,66					2,33		5,61	
103														
104														
105									1,12					
106				0,29		0,63		0,77	1,19					
107											2,44			
108		0,20									2,42		5,34	

i:	ROBUS A2		ROBUS 25		ROBUS 30		ROBUS 35		ROBUS 40		ROBUS 50		ROBUS 60	
	A2-2	A2-3	25-2	25-3	30-2	30-3	35-2	35-3	40-2	40-3	50-2	50-3	60-2	60-3
109														4,90
110					0,23		0,62				1,15			
111														
112														4,79
113					0,23			0,73						
114							0,60							
115					0,22		0,52							5,07
116									1,04					
117											2,08			
118											2,07			
119		0,19			0,22									4,56
120							0,50							
121					0,23						1,00			
122														
123					0,22			0,68						
124														
125														
126														
127														4,33
128														
129									0,47					
130														
131														
132						0,23								
133														
134		0,17												
135														
136														
137														
138														
139														
140														
141														
142														
143									0,20					

Configure what you need by this automatic consultant, and get CAD files and data sheets

Motive configurator allows you to shape Motive products, combine them as you want, and finally to download 2D/3D CAD drawings, and a PDF datasheet.

Search by performance

If you're not sure about the best products combination that you should select for your purpose, you can input your wishes, like final torque, final speed, use, etc, and the configurator will act like a consultant.

It will give you a list of applicable product configurations; you can then download a PDF data sheet featuring performance data and dimensional drawings for each configuration, as well as 2D and 3D drawings.

Search by product

To be used if you already know the product configuration that you want, and you just want to get quicker a PDF data sheet featuring performance data and dimensional drawings for 2D and 3D drawings.



free access without login
<http://www.motive.it/configuratore.php>



PERFORMANCE TABLE



input connection **B5** IEC 72-1

input connection **B5** IEC 72-1

25		ratio i:		input				output																		
stages	rated	real	kW	Hp	motor type	n ₁ [rpm]	fs	n ₂ [rpm]	M ₂ [Nm]	M ₂ [Kgm]	63	71	80	90	100/112	132	160	180	200							
3	123	122,9	0,13	0,18	63A-4	1350	1,63	11	106	10,7																
3			0,18	0,25	63B-4	1390	1,21	11	143	14,4																
3			0,25	0,35	71A-4	1400	0,88	11	197	19,9																
3	121	121,5	0,13	0,18	63A-4	1350	1,67	11	105	10,6																
3			0,18	0,25	63B-4	1390	1,24	11	141	14,3																
3			0,25	0,35	71A-4	1400	0,90	12	195	19,7																
3	119	119,4	0,13	0,18	63A-4	1350	1,60	11	103	10,4																
3			0,18	0,25	63B-4	1390	1,19	12	139	14,0																
3			0,25	0,35	71A-4	1400	0,86	12	192	19,3																
3	115	115,1	0,13	0,18	63A-4	1350	1,64	12	100	10,1																
3			0,18	0,25	63B-4	1390	1,22	12	134	13,5																
3			0,25	0,35	71A-4	1400	0,89	12	185	18,6																
3	113	113,4	0,13	0,18	63A-4	1350	1,68	12	98	9,9																
3			0,18	0,25	63B-4	1390	1,25	12	132	13,3																
3			0,25	0,35	71A-4	1400	0,91	12	182	18,4																
3	110	110,2	0,13	0,18	63A-4	1350	1,72	12	95	9,6																
3			0,18	0,25	63B-4	1390	1,28	13	128	12,9																
3			0,25	0,35	71A-4	1400	0,93	13	177	17,8																
3	106	105,9	0,13	0,18	71B-8	650	1,25	6,1	190	19,2																
3			0,18	0,25	71A-6	910	1,16	8,6	188	19,0																
3			0,13	0,18	63A-4	1350	2,16	13	92	9,3																
3	98	97,8	0,18	0,25	63B-4	1390	1,61	13	123	12,4																
3			0,25	0,35	71A-4	1400	1,17	13	170	17,1																
3			0,13	0,18	71B-8	650	1,39	6,7	176	17,7																
3	91	91,3	0,18	0,25	71A-6	910	1,29	9,3	174	17,5																
3			0,13	0,18	63A-4	1350	2,41	14	85	8,5																
3			0,18	0,25	63B-4	1390	1,79	14	114	11,5																
3	89	88,7	0,25	0,35	71A-4	1400	1,30	14	157	15,8																
3			0,13	0,18	71B-8	650	1,47	7,1	164	16,6																
3			0,18	0,25	71A-6	910	1,36	10,0	162	16,4																
3	87	87,1	0,13	0,18	63A-4	1350	2,54	15	79	8,0																
3			0,18	0,25	63B-4	1390	1,89	15	106	10,7																
3			0,25	0,35	71A-4	1400	1,37	15	146	14,8																
3	87	87,1	0,37	0,5	71B-4	1400	0,93	15	217	21,9																
3			0,13	0,18	71B-8	650	1,50	7,3	159	16,1																
3			0,18	0,25	71A-6	910	1,39	10,3	158	15,9																
3	87	87,1	0,25	0,35	71B-6	910	1,00	10,3	219	22,1																
3			0,13	0,18	63A-4	1350	2,59	15	77	7,7																
3			0,18	0,25	63B-4	1390	1,93	16	103	10,4																
3	87	87,1	0,25	0,35	71A-4	1400	1,40	16	142	14,4																
3			0,37	0,5	71B-4	1400	0,95	16	211	21,3																
3			0,13	0,18	71B-8	650	1,77	7,5	157	15,8																
3	87	87,1	0,18	0,25	71A-6	910	1,64	10,5	155	15,6																
3			0,25	0,35	71B-6	910	1,18	10,5	215	21,7																
3			0,13	0,18	63A-4	1350	3,06	16	75	7,6																
3	87	87,1	0,18	0,25	63B-4	1390	2,28	16	101	10,2																
3			0,25	0,35	71A-4	1400	1,65	16	140	14,1																
3			0,37	0,5	71B-4	1400	1,12	16	207	20,9																

25		ratio i:		input				output																		
stages	rated	real	kW	Hp	motor type	n ₁ [rpm]	fs	n ₂ [rpm]	M ₂ [Nm]	M ₂ [Kgm]	63	71	80	90	100/112	132	160	180	200							
3	85	85,5	0,13	0,18	71B-8	650	1,54	7,6	154	15,5																
3			0,18	0,25	71A-6	910	1,43	10,7	152	15,3																
3			0,25	0,35	71B-6	910	1,03	10,7	211	21,3																
3	85	85,5	0,13	0,18	63A-4	1350	2,67	16	74	7,5																
3			0,18	0,25	63B-4	1390	1,98	16	100	10,0																
3			0,25	0,35	71A-4	1400	1,44	16	137	13,8																
3	85	85,5	0,37	0,5	71B-4	1400	0,97	16	203	20,5																
3			0,13	0,18	71B-8	650	1,56	7,7	151	15,3																
3			0,18	0,25	71A-6	910	1,44	10,8	150	15,1																
3	84	84,2	0,25	0,35	71B-6	910	1,04	10,8	208	21,0																
3			0,13	0,18	63A-4	1350	2,70	16	73	7,4																
3			0,18	0,25	63B-4	1390	2,01	17	98	9,9																
3	84	84,2	0,25	0,35	71A-4	1400	1,45	17	135	13,6																
3			0,37	0,5	71B-4	1400	0,98	17	200	20,2																
3			0,13	0,18	71B-8	650	1,80	8,1	144	14,6																
3	80	80,4	0,18	0,25	71A-6	910	1,67	11,3	143	14,4																
3			0,25	0,35	71B-6	910	1,20	11,3	199	20,0																
3			0,13	0,18	63A-4	1350	3,11	17	70	7,0																
3	80	80,4	0,18	0,25	63B-4	1390	2,31	17	94	9,4																
3			0,25	0,35	71A-4	1400	1,68	17	129	13,0																
3			0,37	0,5	71B-4	1400	1,13	17	191	19,3																
3	76	75,6	0,13	0,18	71B-8	650	2,12	8,6	136	13,7																
3			0,18	0,25	71A-6	910	1,97	12,0	134	13,6																
3			0,25	0,35	71B-6	910	1,42	12,0	187	18,8																
3	76	75,6	0,13	0,18	63A-4	1350	3,67	18	65	6,6																
3			0,18	0,25	63B-4	1390	2,73	18	88	8,9																
3			0,25	0,35	71A-4	1400	1,98	19	121	12,2																
3	76	75,6	0,37	0,5	71B-4	1400	1,34	19	179	18,1																
3			0,13	0,18	71B-8	650	1,89	8,7	135	13,6																
3			0,18	0,25	63A-4	1350	3,28	18	65	6,6																
3	75	75,0	0,18	0,25	63B-4	1390	2,																			

PERFORMANCE TABLE



input connection **B5** IEC 72-1

25	ratio i:		input				output				input connection B5 IEC 72-1												
	stages	rated	real	kW	Hp	motor type	n ₁ [rpm]	fs	n ₂ [rpm]	M ₂ [Nm]	M ₂ [Kgm]	63	71	80	90	100/112	132	160	180	200			
2	24	24,4	0,25	0,35	71A-4	1400	4,81	57	40	4,0													
2			0,37	0,5	71B-4	1400	3,25	57	59	6,0													
2			0,55	0,75	80A-4	1400	2,19	57	88	8,9													
2			0,75	1	80B-4	1400	1,60	57	120	12,1													
2			1,1	1,5	80C-4	1400	1,09	57	176	17,8													
2	23	22,6	0,25	0,35	71A-4	1400	5,19	62	37	3,7													
2			0,37	0,5	71B-4	1400	3,50	62	55	5,5													
2			0,55	0,75	80A-4	1400	2,36	62	81	8,2													
2			0,75	1	80B-4	1400	1,73	62	111	11,2													
2			1,1	1,5	80C-4	1400	1,18	62	163	16,4													
3	22	21,5	0,37	0,5	71B-4	1400	4,53	65	51	5,2													
3			0,55	0,75	80A-4	1400	3,05	65	76	7,7													
3			0,75	1	80B-4	1400	2,24	65	104	10,5													
3			1,1	1,5	80C-4	1400	1,52	65	152	15,3													
3			1,5	2	90L-4	1410	1,13	65	206	20,8													
3	1,9	2,6	90LB-4	1415	0,89	66	260	26,2															
2	20	20,5	0,25	0,35	71A-4	1400	5,69	68	34	3,4													
2			0,37	0,5	71B-4	1400	3,84	68	50	5,0													
2			0,55	0,75	80A-4	1400	2,59	68	74	7,4													
2			0,75	1	80B-4	1400	1,90	68	101	10,1													
2			1,1	1,5	80C-4	1400	1,29	68	147	14,9													
2	19	18,5	0,37	0,5	71B-4	1400	4,78	75	45	4,5													
2			0,55	0,75	80A-4	1400	3,21	75	67	6,7													
2			0,75	1	80B-4	1400	2,36	75	91	9,2													
2			1,1	1,5	80C-4	1400	1,61	75	134	13,5													
2			1,5	2	90L-4	1410	1,13	75	188	18,8													
2	17	16,8	0,37	0,5	71B-4	1400	5,23	83	41	4,1													
2			0,55	0,75	80A-4	1400	3,52	83	61	6,1													
2			0,75	1	80B-4	1400	2,58	83	83	8,3													
2			1,1	1,5	80C-4	1400	1,76	83	121	12,2													
2			1,5	2	90L-4	1410	1,13	83	176	17,6													
2	16	16,1	0,55	0,75	80A-4	1400	4,09	87	58	5,9													
2			0,75	1	80B-4	1400	3,00	87	79	8,0													
2			1,1	1,5	80C-4	1400	2,04	87	116	11,7													
2			1,5	2	90L-4	1410	1,13	87	171	17,1													
2			1,9	2,6	90LB-4	1415	0,89	88	225	22,5													
2	15	14,6	0,55	0,75	80A-4	1400	4,48	96	53	5,3													
2			0,75	1	80B-4	1400	3,29	96	72	7,2													
2			1,1	1,5	80C-4	1400	2,24	96	105	10,6													
2			1,5	2	90S-4	1400	2,24	96	105	10,6													
2			1,9	2,6	90L-4	1410	1,65	97	142	14,4													
2	2,2	3	100LA-4	1420	1,03	97	180	18,1															
2	13	12,7	0,55	0,75	80A-4	1400	4,07	110	46	4,6													
2			0,75	1	80B-4	1400	2,99	110	62	6,3													
2			1,1	1,5	80C-4	1400	2,04	110	91	9,2													
2			1,5	2	90S-4	1400	2,04	110	91	9,2													
2			1,9	2,6	90L-4	1410	1,50	111	124	12,5													
2	2,2	3	100LA-4	1420	1,19	112	156	15,8															
2	10	10,4	0,55	0,75	80A-4	1400	5,51	134	38	3,8													
2			0,75	1	80B-4	1400	4,04	134	51	5,2													
2			1,1	1,5	80C-4	1400	2,76	134	75	7,6													
2			1,5	2	90S-4	1400	2,76	134	75	7,6													
2			1,9	2,6	90L-4	1410	2,04	135	102	10,3													
2	2,2	3	100LA-4	1420	1,40	136	128	12,9															
2	3	4	100LB-4	1420	1,02	136	148	14,9															

input connection **B5** IEC 72-1

25	ratio i:		input				output				input connection B5 IEC 72-1													
	stages	rated	real	kW	Hp	motor type	n ₁ [rpm]	fs	n ₂ [rpm]	M ₂ [Nm]	M ₂ [Kgm]	63	71	80	90	100/112	132	160	180	200				
2	9	9,0	0,75	1	80B-4	1400	5,15	155	44	4,5														
2			1,1	1,5	80C-4	1400	3,51	155	65	6,6														
2			1,1	1,5	90S-4	1400	3,51	155	65	6,6														
2			1,5	2	90L-4	1410	2,59	156	88	8,9														
2			1,9	2,6	90LB-4	1415	2,06	157	111	11,2														
2			2,2	3	100LA-4	1420	1,78	157	128	13,0														
2			3	4	100LB-4	1420	1,31	157	175	17,7														
2			4	5,5	112M-4	1420	0,98	157	234	23,6														
2			0,75	1	80B-4	1400	4,68	205	34	3,4														
2			1,1	1,5	80C-4	1400	3,19	205	49	5,0														
2	1,1	1,5	90S-4	1400	3,19	205	49	5,0																
2	1,5	2	90L-4	1410	2,35	206	67	6,7																
2	1,9	2,6	90LB-4	1415	1,87	207	84	8,5																
2	2,2	3	100LA-4	1420	1,62	208	97	9,8																
2	3	4	100LB-4	1420	1,19	208	133	13,4																
2	4	5,5	112M-4	1420	0,89	208	177	17,8																
2	3	4	100L-2	2880	2,16	421	65	6,6																
2	4	5,5	112M-2	2890	1,63	423	87	8,8																
2	5,5	7,5	112MB-2	2880	1,18	421	120	12,1																
2	7	6,8	1,1	1,5	80C-4	1400	4,93	249	41	4,1														
2			1,1	1,5	90S-4	1400	4,93	249	41	4,1														
2			1,5	2	90L-4	1410	3,64	251	55	5,5														
2			1,9	2,6	90LB-4	1415	2,88	252	69	7,0														
2			2,2	3	100LA-4	1420	2,50	253	80	8,1														
2			3	4	100LB-4	1420	1,83	253	109	11,0														
2			4	5,5	112M-4	1420	1,37	253	145	14,7														
2			5	6,8	112MB-4	1450	1,12	258	178	17,9														
2			3	4	100L-2	2880	3,34	512	54	5,4														
2			4	5,5	112M-2	2890	2,52	514	71	7,2														
2	5,5	7,5	112MB-2	2880	1,82	512	98	9,9																
2	5,5	5,6	1,1	1,5	80C-4	1400	4,93	249	41	4,1														
2			1,1	1,5	90S-4	1400	4,93	2																

PERFORMANCE TABLE



input connection **B5** IEC 72-1

input connection **B5** IEC 72-1

30	ratio i:		input				output																
	stages	rated	real	kW	Hp	motor type	n ₁ [rpm]	fs	n ₂ [rpm]	M ₂ [Nm]	M ₂ [Kgm]	63	71	80	90	100/112	132	160	180	200			
3	87	87,4	0,13	0,18	71B-8	650	3,16	7,4	157	15,8													
3			0,18	0,25	80A-8	690	2,43	7,9	205	20,7													
3			0,25	0,35	80B-8	690	1,75	7,9	285	28,7													
3			0,18	0,25	71A-6	910	2,93	10,4	155	15,7													
3			0,25	0,35	71B-6	910	2,11	10,4	216	21,8													
3			0,37	0,50	80A-6	930	1,46	10,6	313	31,5													
3			0,25	0,35	71A-4	1400	2,95	16	140	14,2													
3			0,37	0,5	71B-4	1400	1,99	16	208	20,9													
3			0,55	0,75	80A-4	1400	1,34	16	309	31,1													
3			0,75	1	80B-4	1400	0,98	16	421	42,5													
3			85	84,8	0,13	0,18	71B-8	650	3,24	7,7	153	15,4											
3					0,18	0,25	80A-8	690	2,48	8,1	199	20,1											
3	0,25	0,35			80B-8	690	1,79	8,1	276	27,9													
3	0,18	0,25			71A-6	910	3,00	10,7	151	15,2													
3	0,25	0,35			71B-6	910	2,16	10,7	209	21,1													
3	0,37	0,50			80A-6	930	1,49	11,0	303	30,6													
3	0,25	0,35			71A-4	1400	3,02	17	136	13,7													
3	0,37	0,5			71B-4	1400	2,04	17	202	20,3													
3	0,55	0,75			80A-4	1400	1,37	17	300	30,2													
3	0,75	1			80B-4	1400	1,01	17	409	41,2													
3	84	84,3			0,13	0,18	71B-8	650	3,26	7,7	152	15,3											
3					0,18	0,25	80A-8	690	2,50	8,2	198	19,9											
3			0,25	0,35	80B-8	690	1,80	8,2	274	27,7													
3			0,25	0,35	71A-4	1400	3,05	17	135	13,6													
3			0,37	0,5	71B-4	1400	2,06	17	200	20,2													
3			0,55	0,75	80A-4	1400	1,38	17	297	30,0													
3	82	81,8	0,13	0,18	71B-8	650	3,34	8,0	147	14,8													
3			0,18	0,25	80A-8	690	2,56	8,4	192	19,3													
3			0,25	0,35	80B-8	690	1,84	8,4	266	26,9													
3			0,25	0,35	71A-4	1400	3,12	17	131	13,2													
3			0,37	0,5	71B-4	1400	2,11	17	194	19,6													
3			0,55	0,75	80A-4	1400	1,42	17	289	29,1													
3	81	81,2	0,13	0,18	71B-8	650	3,36	8,0	146	14,7													
3			0,18	0,25	80A-8	690	2,57	8,5	190	19,2													
3			0,25	0,35	80B-8	690	1,85	8,5	264	26,7													
3			0,25	0,35	71A-4	1400	3,13	17	130	13,2													
3			0,37	0,5	71B-4	1400	2,12	17	193	19,5													
3			0,55	0,75	80A-4	1400	1,42	17	287	28,9													
3	80	80,5	0,13	0,18	71B-8	650	3,37	8,1	145	14,6													
3			0,18	0,25	80A-8	690	2,59	8,6	189	19,0													
3			0,25	0,35	80B-8	690	1,86	8,6	262	26,5													
3			0,25	0,35	71A-4	1400	3,15	17	129	13,0													
3			0,37	0,5	71B-4	1400	2,13	17	191	19,3													
3			0,55	0,75	80A-4	1400	1,43	17	284	28,7													
3	78	77,6	0,13	0,18	71B-8	650	3,48	8,4	139	14,1													
3			0,18	0,25	80A-8	690	2,67	8,9	182	18,3													
3			0,25	0,35	80B-8	690	1,92	8,9	252	25,5													
3			0,25	0,35	71A-4	1400	3,25	18	124	12,6													
3			0,37	0,5	71B-4	1400	2,20	18	184	18,6													
3			0,55	0,75	80A-4	1400	1,48	18	274	27,6													
3	0,75	1	80B-4	1400	1,08	18	373	37,7															

30	ratio i:		input				output																	
	stages	rated	real	kW	Hp	motor type	n ₁ [rpm]	fs	n ₂ [rpm]	M ₂ [Nm]	M ₂ [Kgm]	63	71	80	90	100/112	132	160	180	200				
3	76	75,5	0,13	0,18	71B-8	650	3,54	8,6	136	13,7														
3			0,18	0,25	80A-8	690	2,72	9,1	177	17,9														
3			0,25	0,35	80B-8	690	1,96	9,1	246	24,8														
3			0,25	0,35	71A-4	1400	3,31	19	121	12,2														
3			0,37	0,5	71B-4	1400	2,24	19	179	18,1														
3			0,55	0,75	80A-4	1400	1,50	19	267	26,9														
3			0,75	1	80B-4	1400	1,10	19	364	36,7														
3			75	74,5	0,13	0,18	71B-8	650	3,59	8,7	134	13,5												
3					0,18	0,25	80A-8	690	2,75	9,3	175	17,6												
3					0,25	0,35	80B-8	690	1,98	9,3	243	24,5												
3					0,25	0,35	71A-4	1400	3,35	19	120	12,1												
3					0,37	0,5	71B-4	1400	2,26	19	177	17,9												
3	0,55	0,75			80A-4	1400	1,52	19	263	26,6														
3	73	72,8	0,13	0,18	71B-8	650	3,66	8,9	131	13,2														
3			0,18	0,25	80A-8	690	2,80	9,5	171	17,2														
3			0,25	0,35	80B-8	690	2,02	9,5	237	23,9														
3			0,25	0,35	71A-4	1400	3,41	19	117	11,8														
3			0,37	0,5	71B-4	1400	2,31	19	173	17,5														
3			0,55	0,75	80A-4	1400	1,55	19	257	26,0														
3	72	71,9	0,13	0,18	71B-8	650	3,70	19	351	35,4														
3			0,13	0,18	71B-8	650	3,14	9,1	129	13,0														
3			0,18	0,25	80A-8	690	2,84	9,6	169	17,0														
3			0,25	0,35	80B-8	690	2,04	9,6	234	23,6														
3			0,25	0,35	71A-4	1400	3,45	19	115	11,6														
3			0,37	0,5	71B-4	1400	2,33	19	171	17,2														
3	70	69,8	0,55	0,75	80A-4	1400	1,57	19	254	25,6														
3			0,75	1	80B-4	1400	1,15	19	346	34,9														
3			0,13	0,18	71B-8	650	3,81	9,3	125	12,6														
3			0,18	0,25	80A-8	690	2,92	9,9	164	16,5														
3			0,25	0,35	80B-8	690	2,11	9,9	227	22,9														
3			0,25	0,35	71A-4	1400	3,56	20	112	11,3														
3	69	69,2	0,37	0,5	71B-4	1400	2,41	20	166	16,7														
3			0,55	0,75	80A-4	1400	1,62	20	246	24,9														
3			0,75	1	80B-4	1400	1,19	20	336	33,9														
3			0,13	0,18	71B-8	650	4,21	9,4	124	12,6														
3			0,18	0,25	80A-8	690	3,23	10,0	162	16,4														
3			0,25	0,35	80B-8	690	2,32	10,0	225	22,7														

PERFORMANCE TABLE



input connection **B5** IEC 72-1

input connection **B5** IEC 72-1

30	ratio i:		input				output				input connection B5 IEC 72-1											
	stages	rated	real	kW	Hp	motor type	n ₁ [rpm]	fs	n ₂ [rpm]	M ₂ [Nm]	M ₂ [Kg _m]	63	71	80	90	100/112	132	160	180	200		
3	64	63,9	0,25	0,35	71A-4	1400	4,35	22	103	10,3												
3			0,37	0,5	71B-4	1400	2,94	22	152	15,3												
3			0,55	0,75	80A-4	1400	1,98	22	226	22,8												
3			0,75	1	80B-4	1400	1,45	22	308	31,0												
3			1,1	1,5	80C-4	1400	0,99	22	451	45,5												
3	60	59,5	0,25	0,35	71A-4	1400	4,65	24	96	9,6												
3			0,37	0,5	71B-4	1400	3,14	24	141	14,3												
3			0,55	0,75	80A-4	1400	2,11	24	210	21,2												
3			0,75	1	80B-4	1400	1,55	24	287	28,9												
3			1,1	1,5	80C-4	1400	1,06	24	421	42,4												
3	57	57,4	0,25	0,35	71A-4	1400	4,68	24	92	9,3												
3			0,37	0,5	71B-4	1400	3,16	24	136	13,8												
3			0,55	0,75	80A-4	1400	2,13	24	203	20,4												
3			0,75	1	80B-4	1400	1,56	24	276	27,9												
3			1,1	1,5	80C-4	1400	1,06	24	405	40,9												
3	55	54,8	0,25	0,35	71A-4	1400	5,62	26	88	8,9												
3			0,37	0,5	71B-4	1400	3,80	26	130	13,1												
3			0,55	0,75	80A-4	1400	2,55	26	194	19,5												
3			0,75	1	80B-4	1400	1,87	26	264	26,6												
3			1,1	1,5	80C-4	1400	1,28	26	387	39,1												
3	51	51,1	0,25	0,35	71A-4	1400	5,94	27	82	8,3												
3			0,37	0,5	71B-4	1400	4,02	27	121	12,2												
3			0,55	0,75	80A-4	1400	2,70	27	180	18,2												
3			0,75	1	80B-4	1400	1,98	27	246	24,8												
3			1,1	1,5	80C-4	1400	1,35	27	361	36,4												
3	48	47,5	0,25	0,35	71A-4	1400	5,75	29	76	7,7												
3			0,37	0,5	71B-4	1400	3,88	29	113	11,4												
3			0,55	0,75	80A-4	1400	2,61	29	168	16,9												
3			0,75	1	80B-4	1400	1,92	29	229	23,1												
3			1,1	1,5	80C-4	1400	1,31	29	336	33,9												
3	45	45,5	0,25	0,35	71A-4	1400	4,48	31	108	10,9												
3			0,37	0,5	71B-4	1400	3,01	31	161	16,2												
3			0,55	0,75	80A-4	1400	2,21	31	219	22,1												
3			0,75	1	80B-4	1400	1,51	31	321	32,4												
3			1,1	1,5	80C-4	1400	1,51	31	321	32,4												
3	43	42,5	0,25	0,35	71A-4	1400	4,19	33	101	10,2												
3			0,37	0,5	71B-4	1400	2,82	33	150	15,1												
3			0,55	0,75	80A-4	1400	2,07	33	205	20,7												
3			0,75	1	80B-4	1400	1,41	33	300	30,3												
3			1,1	1,5	80C-4	1400	1,41	33	300	30,3												
3	42	41,8	0,25	0,35	71A-4	1400	4,39	34	99	10,0												
3			0,37	0,5	71B-4	1400	2,95	34	147	14,9												
3			0,55	0,75	80A-4	1400	2,16	34	201	20,3												
3			0,75	1	80B-4	1400	1,48	34	295	29,8												
3			1,1	1,5	80C-4	1400	1,48	34	295	29,8												
3	38	38,1	0,25	0,35	71A-4	1400	4,68	24	92	9,3												
3			0,37	0,5	71B-4	1400	3,16	24	136	13,8												
3			0,55	0,75	80A-4	1400	2,13	24	203	20,4												
3			0,75	1	80B-4	1400	1,56	24	276	27,9												
3			1,1	1,5	80C-4	1400	1,06	24	405	40,9												
3	36	35,8	0,25	0,35	71A-4	1400	5,62	26	88	8,9												
3			0,37	0,5	71B-4	1400	3,80	26	130	13,1												
3			0,55	0,75	80A-4	1400	2,55	26	194	19,5												
3			0,75	1	80B-4	1400	1,87	26	264	26,6												
3			1,1	1,5	80C-4	1400	1,28	26	387	39,1												
3	34	33,7	0,25	0,35	71A-4	1400	5,94	27	82	8,3												
3			0,37	0,5	71B-4	1400	4,02	27	121	12,2												
3			0,55	0,75	80A-4	1400	2,70	27	180	18,2												
3			0,75	1	80B-4	1400	1,98	27	246	24,8												
3			1,1	1,5	80C-4	1400	1,35	27	361	36,4												
3	32	31,8	0,25	0,35	71A-4	1400	5,75	29	76	7,7												
3			0,37	0,5	71B-4	1400	3,88	29	113	11,4												
3			0,55	0,75	80A-4	1400	2,61	29	168	16,9												
3			0,75	1	80B-4	1400	1,92	29	229	23,1												
3			1,1	1,5	80C-4	1400	1,31	29	336	33,9												
3	30	30,4	0,25	0,35	71A-4	1400	4,48	31	108	10,9												
3			0,37	0,5	71B-4	1400	3,01	31	161	16,2												
3			0,55	0,75	80A-4	1400	2,21	31	219	22,1												
3			0,75	1	80B-4	1400	1,51	31	321	32,4												
3			1,1	1,5	80C-4	1400	1,51	31	321	32,4												
3	27	26,7	0,25	0,35	71A-4	1400	4,19	33	101	10,2												
3			0,37	0,5	71B-4	1400	2,82	33	150	15,1												
3			0,55	0,75	80A-4	1400	2,07	33	205	20,7												
3			0,75	1	80B-4	1400	1,41	33	300	30,3												
3			1,1	1,5	80C-4	1400	1,41	33	300	30,3												
3	25	24,7	0,25	0,35	71A-4	1400	4,39	34	99	10,0												
3			0,37	0,5	71B-4	1400	2,95	34	147	14,9												
3			0,55	0,75	80A-4	1400	2,16	34	201	20,3												
3			0,75	1	80B-4	1400	1,48	34	295	29,8												
3			1,1	1,5	80C-4	1400	1,48	34	295	29,8												
3	41	40,8	0,25	0,35	71A-4	1400	4,65	24	96	9,6												
3			0,37	0,5	71B-4	1400	3,14	24	141	14,3												
3			0,55	0,75	80A-4	1400	2,11	24	210	21,2												
3			0,75	1	80B-4	1400	1,55	24	287	28,9												
3			1,1	1,5	80C-4	1400	1,06	24	421	42,4												
3	38	38,1	0,25	0,35	71A-4	1400	4,68	24	92	9,3												
3			0,37	0,5	71B-4	1400	3,16	24	136	13,8												
3			0,55	0,75	80A-4	1400	2,13	24	203	20,4												
3			0,75	1	80B-4	1400	1,56	24	276	27,9												
3			1,1	1,5	80C-4	1400	1,06	24	405	40,9												
3	36	35,8	0,25	0,35	71A																	

PERFORMANCE TABLE



input connection **B5** IEC 72-1

30	ratio i:		input				output				input connection B5 IEC 72-1												
	stages	rated	real	kW	Hp	motor type	n ₁ [rpm]	fs	n ₂ [rpm]	M ₂ [Nm]	M ₂ [Kgm]	63	71	80	90	100/112	132	160	180	200			
3	25	25,0	0,75	1	80B-4	1400	3,88	56	120	12,1													
3			1,1	1,5	80C-4	1400	2,65	56	177	17,8													
3			1,1	1,5	90S-4	1400	2,65	56	177	17,8													
3			1,5	2	90L-4	1410	1,95	56	239	24,1													
3			1,9	2,6	90LB-4	1415	1,55	57	302	30,5													
3			2,2	3	100LA-4	1420	1,34	57	348	35,1													
3			3	4	100LB-4	1420	0,98	57	475	47,9													
2	23	23,0	0,55	0,75	80A-4	1400	3,78	61	83	8,4													
2			0,75	1	80B-4	1400	2,77	61	113	11,4													
2			1,1	1,5	80C-4	1400	1,89	61	166	16,7													
2			1,1	1,5	90S-4	1400	1,89	61	166	16,7													
2			1,5	2	90L-4	1410	1,40	61	225	22,7													
2	1,9	2,6	90LB-4	1415	1,11	61	283	28,6															
2	22	21,8	0,55	0,75	80A-4	1400	4,50	64	79	7,9													
2			0,75	1	80B-4	1400	3,30	64	107	10,8													
2			1,1	1,5	80C-4	1400	2,25	64	157	15,9													
3	22	22,3	0,75	1	80B-4	1400	4,37	63	107	10,8													
3			1,1	1,5	80C-4	1400	2,98	63	157	15,9													
3			1,1	1,5	90S-4	1400	2,98	63	157	15,9													
3			1,5	2	90L-4	1410	2,20	63	213	21,5													
3			1,9	2,6	90LB-4	1415	1,74	63	269	27,2													
3			2,2	3	100LA-4	1420	1,51	64	311	31,3													
3			3	4	100LB-4	1420	1,11	64	423	42,7													
2	21	21,1	0,55	0,75	80A-4	1400	4,81	66	76	7,7													
2			0,75	1	80B-4	1400	3,53	66	103	10,4													
2			1,1	1,5	80C-4	1400	2,41	66	152	15,3													
3	21	21,0	1,1	1,5	80C-4	1400	3,16	67	148	14,9													
3			1,1	1,5	90S-4	1400	3,16	67	148	14,9													
3			1,5	2	90L-4	1410	2,33	67	201	20,2													
3			1,9	2,6	90LB-4	1415	1,85	67	253	25,5													
3			2,2	3	100LA-4	1420	1,60	68	292	29,5													
3			3	4	100LB-4	1420	1,17	68	398	40,2													
2			20	19,6	0,55	0,75	80A-4	1400	5,15	71	71	7,1											
2	0,75	1			80B-4	1400	3,77	71	96	9,7													
2	1,1	1,5			80C-4	1400	2,57	71	141	14,3													
2	1,1	1,5			90S-4	1400	2,57	71	141	14,3													
2	1,5	2			90L-4	1410	1,90	72	191	19,3													
2	1,9	2,6	90LB-4	1415	1,51	72	242	24,4															
3	19	18,7	0,75	1	80B-4	1400	5,11	75	90	9,1													
3			1,1	1,5	80C-4	1400	3,49	75	132	13,3													
3			1,1	1,5	90S-4	1400	3,49	75	132	13,3													
3			1,5	2	90L-4	1410	2,58	76	178	18,0													
3			1,9	2,6	90LB-4	1415	2,04	76	225	22,7													
3			2,2	3	100LA-4	1420	1,77	76	260	26,2													
3			3	4	100LB-4	1420	1,30	76	354	35,8													
3	18	17,9	0,75	1	80B-4	1400	5,33	78	86	8,7													
3			1,1	1,5	80C-4	1400	3,63	78	126	12,7													
3			1,1	1,5	90S-4	1400	3,63	78	126	12,7													
3			1,5	2	90L-4	1410	2,68	79	171	17,3													
3			1,9	2,6	90LB-4	1415	2,12	79	216	21,8													
3			2,2	3	100LA-4	1420	1,84	79	249	25,1													
3			3	4	100LB-4	1420	1,35	79	340	34,3													

input connection **B5** IEC 72-1

30	ratio i:		input				output				input connection B5 IEC 72-1														
	stages	rated	real	kW	Hp	motor type	n ₁ [rpm]	fs	n ₂ [rpm]	M ₂ [Nm]	M ₂ [Kgm]	63	71	80	90	100/112	132	160	180	200					
2	16	15,7	0,75	1	80B-4	1400	4,68	89	77	7,8															
2			1,1	1,5	80C-4	1400	3,19	89	113	11,4															
2			1,1	1,5	90S-4	1400	3,19	89	113	11,4															
2			1,5	2	90L-4	1410	2,36	90	153	15,4															
2			1,9	2,6	90LB-4	1415	1,87	90	193	19,5															
2			2,2	3	100LA-4	1420	1,62	91	223	22,5															
2			3	4	100LB-4	1420	1,19	91	303	30,6															
3	16	15,6	1,1	1,5	80C-4	1400	4,19	90	110	11,1															
3			1,1	1,5	90S-4	1400	4,19	90	110	11,1															
3			1,5	2	90L-4	1410	3,09	91	149	15,0															
3			1,9	2,6	90LB-4	1415	2,45	91	188	19,0															
3			2,2	3	100LA-4	1420	2,12	91	217	21,9															
3			3	4	100LB-4	1420	1,56	91	296	29,8															
3			4	5,5	112M-4	1420	1,17	91	394	39,8															
3	15	14,7	5	6,8	112MB-4	1450	0,95	93	483	48,7															
3			1,1	1,5	80C-4	1400	4,37	95	104	10,5															
3			1,1	1,5	90S-4	1400	4,37	95	104	10,5															
3			1,5	2	90L-4	1410	3,23	96	141	14,2															
3			1,9	2,6	90LB-4	1415	2,56	96	178	17,9															
3			2,2	3	100LA-4	1420	2,21	97	205	20,7															
3			3	4	100LB-4	1420	1,62	97	279	28,2															
3	14	13,8	4	5,5	112M-4	1420	1,22	97	372	37,6															
3			5	6,8	112MB-4	1450	1,00	99	456	46,0															
2			13	12,9	0,75	1	80B-4	1400	5,29	102	68	6,8													
2					1,1	1,5	80C-4	1400	3,61	102	99	10,0													
2					1,1	1,5	90S-4	1400	3,61	102	99	10,0													
2					1,5	2	90L-4	1410	2,67	102	134	13,5													
2					1,9	2,6	90LB-4	1415	2,11	103	169	17,1													
2	2,2	3			100LA-4	1420	1,83	103	196	19,7															
2	3	4			100LB-4	1420	1,34	103	267	26,9															
2	13	13,3	4	5,5	112M-4	1420	1,01	103	355	35,9															
2			0,75	1	80B-4	1400	5,61	108	64	6,4															
2			1,1	1,5	80C-4	1400	3,83	108	93	9,4															
2			1,1	1,5	90S-4	1400	3,83	108	93	9,4															
2			1,5	2	90L-4	1410	2,83	109	126	12,7															
2			1,9	2,6	90LB-4	1415	2,24	109	159	16,1															
2			2,2	3	100LA-4	1420																			

PERFORMANCE TABLE



input connection **B5** IEC 72-1

30	ratio i:		input				output				input connection B5 IEC 72-1												
	stages	rated	real	kW	Hp	motor type	n ₁ [rpm]	fs	n ₂ [rpm]	M ₂ [Nm]	M ₂ [Kgm]	63	71	80	90	100/112	132	160	180	200			
2	11	11,1	1,1	1,5	90S-4	1400	5,11	126	80	8,0													
2			1,5	2	90L-4	1410	3,78	127	108	10,9													
2			1,9	2,6	90LB-4	1415	2,99	128	136	13,8													
2			2,2	3	100LA-4	1420	2,59	128	157	15,9													
2			3	4	100LB-4	1420	1,90	128	214	21,6													
2			4	5,5	112M-4	1420	1,43	128	286	28,9													
2	5	6,8	112MB-4	1450	1,16	131	350	35,3															
3	11	11,1	1,5	2	90L-4	1410	4,26	127	106	10,7													
3			1,9	2,6	90LB-4	1415	3,37	127	134	13,6													
3			2,2	3	100LA-4	1420	2,92	128	155	15,6													
3			3	4	100LB-4	1420	2,14	128	211	21,3													
3			4	5,5	112M-4	1420	1,61	128	282	28,4													
3			5	6,8	112MB-4	1450	1,31	130	345	34,8													
2	10	9,7	1,5	2	90L-4	1410	4,57	145	95	9,6													
2			1,9	2,6	90LB-4	1415	3,62	146	120	12,1													
2			2,2	3	100LA-4	1420	3,14	146	138	13,9													
2			3	4	100LB-4	1420	2,30	146	188	19,0													
2			4	5,5	112M-4	1420	1,73	146	251	25,3													
2			5	6,8	112MB-4	1450	1,41	149	308	31,0													
2	9	9,1	1,5	2	90L-4	1410	5,22	154	89	9,0													
2			1,9	2,6	90LB-4	1415	4,13	155	113	11,4													
2			2,2	3	100LA-4	1420	3,58	155	130	13,1													
2			3	4	100LB-4	1420	2,63	155	177	17,9													
2			4	5,5	112M-4	1420	1,97	155	236	23,8													
2			5	6,8	112MB-4	1450	1,61	159	289	29,2													
2	8	7,6	1,5	2	90L-4	1410	5,22	185	74	7,5													
2			1,9	2,6	90LB-4	1415	4,13	186	94	9,5													
2			2,2	3	100LA-4	1420	3,58	186	108	10,9													
2			3	4	100LB-4	1420	2,63	186	148	14,9													
2			4	5,5	112M-4	1420	1,97	186	197	19,9													
2			5	6,8	112MB-4	1450	1,61	190	241	24,3													
2	7	6,8	2,2	3	100LA-4	1420	4,91	209	96	9,7													
2			3	4	100LB-4	1420	3,60	209	132	13,3													
2			4	5,5	112M-4	1420	2,70	209	175	17,7													
2			5	6,8	112MB-4	1450	2,20	214	215	21,7													
2			6	5,9	2,2	3	100LA-4	1420	4,11	242	83	8,4											
2					3	4	100LB-4	1420	3,01	242	114	11,5											
2	4	5,5			112M-4	1420	2,26	242	151	15,3													
2	5	6,8			112MB-4	1450	1,85	247	185	18,7													
2	5,5	5,7			2,2	3	100LA-4	1420	4,91	251	80	8,1											
2					3	4	100LB-4	1420	3,60	251	110	11,1											
2			4	5,5	112M-4	1420	2,70	251	146	14,8													
2			5	6,8	112MB-4	1450	2,20	256	179	18,1													
2			5	4,9	3	4	100LB-4	1420	5,19	293	94	9,5											
2					4	5,5	112M-4	1420	3,89	293	125	12,7											
2	5	6,8			112MB-4	1450	3,18	299	154	15,5													
2	4,5	4,6			3	4	100LB-4	1420	4,44	311	88	8,9											
2					4	5,5	112M-4	1420	3,33	311	118	11,9											
2					5	6,8	112MB-4	1450	2,72	318	144	14,6											
2			4	5,5	112M-2	2890	6,10	633	58	5,8													
2			5,5	7,5	112MB-2	2880	4,42	631	80	8,1													
2			4	4,0	4	5,5	112M-4	1420	4,33	356	103	10,4											
2	5	6,8			112MB-4	1450	3,54	363	126	12,7													
2	4	5,5			112M-2	2890	7,93	724	51	5,1													
2	5,5	7,5			112MB-2	2880	5,75	721	70	7,1													

input connection **B5** IEC 72-1

30	ratio i:		input				output				input connection B5 IEC 72-1											
	stages	rated	real	kW	Hp	motor type	n ₁ [rpm]	fs	n ₂ [rpm]	M ₂ [Nm]	M ₂ [Kgm]	63	71	80	90	100/112	132	160	180	200		
2	3,5	3,3	4	5,5	112M-4	1420	4,33	426	86	8,7												
2			5	6,8	112MB-4	1450	3,54	435	105	10,6												
2			4	5,5	112M-2	2890	7,93	868	42	4,3												
2			5,5	7,5	112MB-2	2880	5,75	865	58	5,9												
2			3	3,2	4	5,5	112M-4	1420	5,57	440	83	8,4										
2					5	6,8	112MB-4	1450	4,55	449	102	10,3										
2	3	4			100L-2	2880	13,57	893	31	3,1												
2	4	5,5			112M-2	2890	10,21	896	41	4,1												
2	5,5	7,5			112MB-2	2880	7,40	893	57	5,7												
2	2,5	2,7			4	5,5	112M-4	1420	5,57	528	70	7,0										
2			5	6,8	112MB-4	1450	4,55	539	85	8,6												
2			4	5,5	112M-2	2890	10,21	1074	34	3,4												
2			5,5	7,5	112MB-2	2880	7,40	1070	47	4,8												

PERFORMANCE TABLE



input connection **B5** IEC 72-1

input connection **B5** IEC 72-1

35	ratio i:		input				output				input connection B5 IEC 72-1												
	stages	rated	real	kW	Hp	motor type	n ₁ [rpm]	fs	n ₂ [rpm]	M ₂ [Nm]	M ₂ [Kgm]	63	71	80	90	100/112	132	160	180	200			
3	77	77,5	0,18	0,25	80A-8	690	3,98	8,9	182	18,3													
3			0,25	0,35	80B-8	690	2,87	8,9	252	25,4													
3			0,25	0,35	71A-4	1400	4,85	18	124	12,5													
3			0,37	0,5	71B-4	1400	3,27	18	184	18,6													
3			0,55	0,75	80A-4	1400	2,20	18	273	27,6													
3			0,75	1	80B-4	1400	1,62	18	373	37,6													
3	1,1	1,5	80C-4	1400	1,10	18	547	55,2															
3	75	75,2	0,18	0,25	80A-8	690	3,72	9,2	176	17,8													
3			0,25	0,35	80B-8	690	2,68	9,2	245	24,7													
3			0,37	0,5	90S-8	670	1,76	8,9	373	37,7													
3			0,55	0,75	90L-8	700	1,23	9,3	531	53,6													
3			0,25	0,35	71A-4	1400	4,52	19	121	12,2													
3			0,37	0,5	71B-4	1400	3,06	19	179	18,0													
3	0,55	0,75	80A-4	1400	2,06	19	266	26,8															
3	0,75	1	80B-4	1400	1,51	19	362	36,5															
3	1,1	1,5	80C-4	1400	1,03	19	531	53,6															
3	1,1	1,5	90S-4	1400	1,03	19	531	53,6															
3	73	73,4	0,18	0,25	80A-8	690	4,79	9,4	172	17,4													
3			0,25	0,35	80B-8	690	3,45	9,4	239	24,1													
3			0,37	0,5	90S-8	670	2,26	9,1	364	36,8													
3			0,55	0,75	90L-8	700	1,59	9,5	518	52,3													
3			0,25	0,35	71A-4	1400	5,83	19	118	11,9													
3			0,37	0,5	71B-4	1400	3,94	19	174	17,6													
3	0,55	0,75	80A-4	1400	2,65	19	259	26,1															
3	0,75	1	80B-4	1400	1,94	19	353	35,6															
3	1,1	1,5	80C-4	1400	1,33	19	518	52,3															
3	1,1	1,5	90S-4	1400	1,33	19	518	52,3															
3	1,5	2	90L-4	1410	0,98	19	701	70,8															
3	70	70,3	0,18	0,25	80A-8	690	4,31	9,8	165	16,6													
3			0,25	0,35	80B-8	690	3,10	9,8	229	23,1													
3			0,37	0,5	90S-8	670	2,03	9,5	349	35,2													
3			0,55	0,75	90L-8	700	1,43	10,0	497	50,1													
3			0,25	0,35	71A-4	1400	5,24	20	113	11,4													
3			0,37	0,5	71B-4	1400	3,54	20	167	16,9													
3	0,55	0,75	80A-4	1400	2,38	20	248	25,1															
3	0,75	1	80B-4	1400	1,75	20	339	34,2															
3	1,1	1,5	80C-4	1400	1,19	20	497	50,1															
3	1,1	1,5	90S-4	1400	1,19	20	497	50,1															
3	1,5	2	90L-4	1410	0,88	20	673	67,9															
3	69	68,8	0,18	0,25	80A-8	690	4,40	10,0	161	16,3													
3			0,25	0,35	80B-8	690	3,17	10,0	224	22,6													
3			0,37	0,5	90S-8	670	2,08	9,7	341	34,4													
3			0,55	0,75	90L-8	700	1,46	10,2	486	49,0													
3			0,25	0,35	71A-4	1400	5,35	20	110	11,1													
3			0,37	0,5	71B-4	1400	3,62	20	164	16,5													
3	0,55	0,75	80A-4	1400	2,43	20	243	24,5															
3	0,75	1	80B-4	1400	1,78	20	331	33,4															
3	1,1	1,5	80C-4	1400	1,22	20	486	49,0															
3	1,1	1,5	90S-4	1400	1,22	20	486	49,0															
3	1,5	2	90L-4	1410	0,90	20	658	66,4															

35	ratio i:		input				output				input connection B5 IEC 72-1												
	stages	rated	real	kW	Hp	motor type	n ₁ [rpm]	fs	n ₂ [rpm]	M ₂ [Nm]	M ₂ [Kgm]	63	71	80	90	100/112	132	160	180	200			
3	68	68,4	0,18	0,25	80A-8	690	4,42	10,1	161	16,2													
3			0,25	0,35	80B-8	690	3,18	10,1	223	22,5													
3			0,37	0,5	90S-8	670	2,09	9,8	340	34,3													
3			0,55	0,75	90L-8	700	1,47	10,2	483	48,8													
3			0,25	0,35	71A-4	1400	5,38	20	110	11,1													
3			0,37	0,5	71B-4	1400	3,64	20	163	16,4													
3	0,55	0,75	80A-4	1400	2,45	20	242	24,4															
3	0,75	1	80B-4	1400	1,79	20	330	33,3															
3	1,1	1,5	80C-4	1400	1,22	20	483	48,8															
3	1,1	1,5	90S-4	1400	1,22	20	483	48,8															
3	1,5	2	90L-4	1410	0,90	21	654	66,0															
3	63	62,9	0,25	0,35	80B-8	690	4,19	11,0	205	20,7													
3			0,37	0,5	90S-8	670	2,75	10,7	312	31,5													
3			0,55	0,75	90L-8	700	1,93	11,1	444	44,8													
3			0,37	0,5	71B-4	1400	4,78	22	149	15,1													
3			0,55	0,75	80A-4	1400	3,22	22	222	22,4													
3			0,75	1	80B-4	1400	2,36	22	303	30,6													
3	1,1	1,5	80C-4	1400	1,61	22	444	44,8															
3	1,1	1,5	90S-4	1400	1,61	22	444	44,8															
3	1,5	2	90L-4	1410	1,19	22	601	60,7															
3	59	59,3	0,37	0,5	71B-4	1400	4,82	24	141	14,2													
3			0,55	0,75	80A-4	1400	3,24	24	209	21,1													
3			0,75	1	80B-4	1400	2,38	24	286	28,8													
3			1,1	1,5	80C-4	1400	1,62	24	419	42,3													
3			1,1	1,5	90S-4	1400	1,62	24	419	42,3													
3			1,5	2	90L-4	1410	1,20	24	567	57,2													
3	56	55,6	0,37	0,5	71B-4	1400	4,42	25	132	13,3													
3			0,55	0,75	80A-4	1400	2,97	25	196	19,8													
3			0,75	1	80B-4	1400	2,18	25	268	27,0													
3			1,1	1,5	80C-4	1400	1,49	25	393	39,6													
3			1,1	1,5	90S-4	1400	1,49	25	393	39,6													
3			1,5	2	90L-4	1410	1,10	25	532	53,7													
3	54	54,3	0,37	0,5	71B-4	1400	4,51	26	129	13,0													
3			0,55	0,75	80A-4	1400	3,04	26	192	19,4													
3			0,75	1	80B-4	1400	2,23	26	262	26,4													
3			1,1	1,5	80C-4	1400	1,52	26	384	38,7													
3			1,1	1,5	90S-4	1400	1,52	26	384	38,7													
3			1,5	2	90L-4	1410	1,12	26	520</														

PERFORMANCE TABLE



input connection **B5** IEC 72-1

35	ratio i:		input				output				63	71	80	90	100/112	132	160	180	200
	stages	rated	real	kW	Hp	motor type	n ₁ [rpm]	fs	n ₂ [rpm]	M ₂ [Nm]									
3	6,5	6,7	3	4	100LB-4	1420	4,89	213	127	12,8									
3			4	5,5	112M-4	1420	3,67	213	169	17,0									
3			5	6,8	112MB-4	1450	3,00	217	207	20,9									
2	5,5	5,6	3	4	100LB-4	1420	5,17	251	109	11,0									
2			4	5,5	112M-4	1420	3,87	251	146	14,7									
2			5	6,8	112MB-4	1450	3,16	257	179	18,0									
2	5	4,8	3	4	100LB-4	1420	4,97	299	92	9,3									
2			4	5,5	112M-4	1420	3,73	299	123	12,4									
2			5	6,8	112MB-4	1450	3,04	305	150	15,2									
2	4	3,9	4	5,5	112M-4	1420	4,57	369	99	10,0									
2			5	6,8	112MB-4	1450	3,73	377	122	12,3									
2	3,5	3,5	4	5,5	112M-4	1420	5,73	402	91	9,2									
2			5	6,8	112MB-4	1450	4,68	411	112	11,3									
2			4	5,5	112M-2	2890	10,50	819	45	4,5									
2	3	2,9	5,5	7,5	112MB-2	2880	7,61	816	62	6,2									
2			4	5,5	112M-4	1420	6,29	497	74	7,5									
2			5	6,8	112MB-4	1450	5,14	507	90	9,1									
2	2,5	2,5	4	5,5	112M-2	2890	11,53	1011	36	3,7									
2			5,5	7,5	112MB-2	2880	8,35	1007	50	5,1									
2			4	5,5	112M-4	1420	5,73	574	64	6,5									
2	2	2,0	5	6,8	112MB-4	1450	4,68	586	78	7,9									
2			4	5,5	112M-2	2890	10,50	1168	31	3,2									
2			5,5	7,5	112MB-2	2880	7,61	1164	43	4,4									
2	2	2,0	4	5,5	112M-4	1420	6,29	708	52	5,2									
2			5	6,8	112MB-4	1450	5,14	723	63	6,4									
2			4	5,5	112M-2	2890	11,53	1442	25	2,6									
2	2	2,0	5,5	7,5	112MB-2	2880	8,35	1437	35	3,5									

input connection **B5** IEC 72-1

40	ratio i:		input				output				63	71	80	90	100/112	132	160	180	200	
	stages	rated	real	kW	Hp	motor type	n ₁ [rpm]	fs	n ₂ [rpm]	M ₂ [Nm]										M ₂ [Kgm]
3	121	120,9	0,18	0,25	80A-8	690	3,30	5,7	283	28,6										
3			0,25	0,35	80B-8	690	2,38	5,7	394	39,7										
3			0,37	0,50	80A-6	930	1,98	8	432	43,6										
3			0,55	0,75	80B-6	920	1,32	8	650	65,5										
3			0,55	0,75	80A-4	1400	1,83	12	427	43,1										
3			0,75	1	80B-4	1400	1,34	12	582	58,7										
3			0,18	0,25	80A-8	690	3,41	5,9	272	27,5										
3			0,25	0,35	80B-8	690	2,45	5,9	378	38,2										
3			0,37	0,50	80A-6	930	2,05	8	415	41,9										
3	116	116,1	0,55	0,75	80B-6	920	1,36	8	624	63,0										
3			0,55	0,75	80A-4	1400	1,88	12	410	41,4										
3			0,75	1	80B-4	1400	1,38	12	559	56,4										
3			0,18	0,25	80A-8	690	3,78	6,3	259	26,1										
3			0,25	0,35	80B-8	690	2,72	6,3	360	36,3										
3			0,37	0,50	90S-8	670	1,79	6,1	548	55,3										
3			0,55	0,75	90L-8	700	1,25	6,3	780	78,7										
3			0,37	0,50	80A-6	930	2,27	8	395	39,8										
3			0,55	0,75	80B-6	920	1,51	8	593	59,8										
3	110	110,3	0,75	1	90S-6	915	1,10	8,3	813	82,0										
3			0,55	0,75	80A-4	1400	2,09	13	390	39,3										
3			0,75	1	80B-4	1400	1,53	13	531	53,6										
3			1,1	1,5	80C-4	1400	1,05	13	779	78,6										
3			1,1	1,5	90S-4	1400	1,05	13	779	78,6										
3			0,18	0,25	80A-8	690	3,90	6,5	249	25,1										
3			0,25	0,35	80B-8	690	2,81	6,5	345	34,8										
3			0,37	0,50	90S-8	670	1,84	6,3	526	53,1										
3			0,55	0,75	90L-8	700	1,30	6,6	749	75,6										
3	106	106,0	0,37	0,50	80A-6	930	2,34	9	379	38,3										
3			0,55	0,75	80B-6	920	1,56	9	570	57,5										
3			0,75	1	90S-6	915	1,14	8,6	781	78,8										
3			0,55	0,75	80A-4	1400	2,16	13	374	37,8										
3			0,75	1	80B-4	1400	1,58	13	510	51,5										
3			1,1	1,5	80C-4	1400	1,08	13	748	75,5										
3			1,1	1,5	90S-4	1400	1,08	13	748	75,5										
3			0,18	0,25	80A-8	690	3,67	6,6	247	24,9										
3			0,25	0,35	80B-8	690	2,64	6,6	343	34,6										
3	0,37	0,50	90S-8	670	1,73	6,4	523	52,8												
3	105	105,4	0,55	0,75	90L-8	700	1,22	6,6	745	75,1										
3			0,37	0,50	80A-6	930	2,21	9	377	38,0										
3			0,55	0,75	80B-6	920	1,47	9	566	57,1										
3			0,75	1	90S-6	915	1,07	8,7	777	78,4										
3			0,55	0,75	80A-4	1400	2,03	13	372	37,6										
3			0,75	1	80B-4	1400	1,49	13	508	51,2										
3			1,1	1,5	80C-4	1400	1,02	13	745	75,1										
3			1,1	1,5	90S-4	1400	1,02	13	745	75,1										
3			101	101,2	0,18	0,25	80A-8	690	3,79	6,8	237	23,9								
3	0,25	0,35			80B-8	690	2,73	6,8	329	33,2										
3	0,37	0,50			90S-8	670	1,79	6,6	502	50,7										
3	0,55	0,75			90L-8	700	1,26	6,9	715	72,2										
3	0,37	0,50			80A-6	930	2,28	9	362	36,5										
3	0,55	0,75			80B-6	920	1,52	9	544	54,9										
3	0,75	1			90S-6	915	1,11	9,0	746	75,2										
3	0,55	0,75			80A-4	1400	2,10	14	357	36,1										
3	0,75	1			80B-4	1400	1,54	14	487	49,2										
3	101	101,2	1,1	1,5	80C-4	1400	1,05	14	715	72,1										
3			1,1	1,5	90S-4	1400	1,05	14	715	72,1										

PERFORMANCE TABLE



input connection **B5** IEC 72-1

input connection **B5** IEC 72-1

40	ratio i:		input				output				63	71	80	90	100/112	132	160	180	200
	stages	rated	real	kW	Hp	motor type	n ₁ [rpm]	fs	n ₂ [rpm]	M ₂ [Nm]									
3	23	22,7	1,5	2	90L-4	1410	4,44	62	217	21,9									
3			1,9	2,6	90LB-4	1415	3,51	62	274	27,6									
3			2,2	3	100LA-4	1420	3,05	63	316	31,9									
3			3	4	100LB-4	1420	2,23	63	431	43,5									
3			4	5,5	112M-4	1420	1,68	63	575	58,0									
3			5	6,8	112MB-4	1450	1,37	64	703	71,0									
3			5,5	7,5	132S-4	1450	1,24	64	774	78,1									
3			7,5	10	132M-4	1450	1,01	71	954	96,2									
3	21	20,5	1,5	2	90L-4	1410	4,89	69	196	19,8									
3			1,9	2,6	90LB-4	1415	3,88	69	248	25,0									
3			2,2	3	100LA-4	1420	3,36	69	286	28,8									
3			3	4	100LB-4	1420	2,46	69	389	39,3									
3			4	5,5	112M-4	1420	1,85	69	519	52,4									
3			5	6,8	112MB-4	1450	1,51	71	636	64,1									
3			5,5	7,5	132S-4	1450	1,37	71	699	70,5									
3			7,5	10	132M-4	1450	1,01	71	954	96,2									
3	20	20,3	1,5	2	90L-4	1410	4,96	69	194	19,6									
3			1,9	2,6	90LB-4	1415	3,93	70	245	24,7									
3			2,2	3	100LA-4	1420	3,40	70	283	28,6									
3			3	4	100LB-4	1420	2,50	70	386	38,9									
3			4	5,5	112M-4	1420	1,87	70	515	51,9									
3			5	6,8	112MB-4	1450	1,53	71	630	63,6									
3			5,5	7,5	132S-4	1450	1,39	71	693	69,9									
3			7,5	10	132M-4	1450	1,02	71	945	95,3									
3	18	18,3	1,9	2,6	90LB-4	1415	4,34	77	221	22,2									
3			2,2	3	100LA-4	1420	3,76	78	254	25,7									
3			3	4	100LB-4	1420	2,76	78	347	35,0									
3			4	5,5	112M-4	1420	2,07	78	463	46,7									
3			5	6,8	112MB-4	1450	1,69	79	566	57,1									
3			5,5	7,5	132S-4	1450	1,54	79	623	62,9									
3			7,5	10	132M-4	1450	1,13	79	850	85,7									
2			16	16,1	1,9	2,6	90LB-4	1415	4,47	88	198	19,9							
2	2,2	3			100LA-4	1420	3,87	88	228	23,0									
2	3	4			100LB-4	1420	2,84	88	311	31,4									
2	4	5,5			112M-4	1420	2,13	88	415	41,8									
2	5	6,8			112MB-4	1450	1,74	90	508	51,2									
2	5,5	7,5			132S-4	1450	1,58	90	558	56,3									
2	7,5	10			132M-4	1450	1,16	90	762	76,8									
3	16	15,5			2,2	3	100LA-4	1420	4,40	91	216	21,8							
3			3	4	100LB-4	1420	3,23	91	295	29,8									
3			4	5,5	112M-4	1420	2,42	91	393	39,7									
3			5	6,8	112MB-4	1450	1,98	93	482	48,6									
3			5,5	7,5	132S-4	1450	1,80	93	530	53,4									
3			7,5	10	132M-4	1450	1,32	93	722	72,9									
3			9,2	12,5	132MB-4	1450	1,07	93	886	89,4									
2			15	15,4	2,2	3	100LA-4	1420	4,08	92	219	22,1							
2	3	4			100LB-4	1420	2,99	92	299	30,1									
2	4	5,5			112M-4	1420	2,25	92	398	40,2									
2	5	6,8			112MB-4	1450	1,83	94	488	49,2									
2	5,5	7,5			132S-4	1450	1,67	94	536	54,1									
2	7,5	10			132M-4	1450	1,22	94	731	73,8									
2	9,2	12,5			132MB-4	1450	1,00	94	897	90,5									

40	ratio i:		input				output				63	71	80	90	100/112	132	160	180	200
	stages	rated	real	kW	Hp	motor type	n ₁ [rpm]	fs	n ₂ [rpm]	M ₂ [Nm]									
3	15	15,0	2,2	3	100LA-4	1420	4,56	95	208	21,0									
3			3	4	100LB-4	1420	3,35	95	284	28,6									
3			4	5,5	112M-4	1420	2,51	95	379	38,2									
3			5	6,8	112MB-4	1450	2,05	97	463	46,8									
3			5,5	7,5	132S-4	1450	1,86	97	510	51,4									
3			7,5	10	132M-4	1450	1,37	97	695	70,1									
3			9,2	12,5	132MB-4	1450	1,11	97	853	86,0									
2			14	14,2	2,2	3	100LA-4	1420	4,41	100	202	20,4							
2	3	4			100LB-4	1420	3,24	100	275	27,8									
2	4	5,5			112M-4	1420	2,43	100	367	37,0									
2	5	6,8			112MB-4	1450	1,98	102	449	45,3									
2	5,5	7,5			132S-4	1450	1,80	102	494	49,8									
2	7,5	10			132M-4	1450	1,32	102	674	68,0									
2	9,2	12,5			132MB-4	1450	1,08	102	826	83,4									
2	13	13,2			2,2	3	100LA-4	1420	4,73	108	188	18,9							
2			3	4	100LB-4	1420	3,47	108	256	25,8									
2			4	5,5	112M-4	1420	2,60	108	341	34,4									
2			5	6,8	112MB-4	1450	2,13	110	417	42,1									
2			5,5	7,5	132S-4	1450	1,93	110	459	46,3									
2			7,5	10	132M-4	1450	1,42	110	626	63,2									
2			9,2	12,5	132MB-4	1450	1,16	110	768	77,5									
2			11	15	132MC-4	1460	0,97	111	912	92,0									
3	13	12,6	2,2	3	100LA-4	1420	5,36	113	176	17,7									
3			3	4	100LB-4	1420	3,93	113	240	24,2									
3			4	5,5	112M-4	1420	2,95	113	319	32,2									
3			5	6,8	112MB-4	1450	2,41	115	391	39,4									
3			5,5	7,5	132S-4	1450	2,19	115	430	43,4									
3			7,5	10	132M-4	1450	1,61	115	587	59,2									
3			9,2	12,5	132MB-4	1450	1,31	115	719	72,6									
3			11	15	132MC-4	1460	1,10	116	854	86,2									
2	12	11,9	2,2	3	100LA-4	1420	5,16	119	170	17,1									
2			3	4	100LB-4	1420	3,78	119	231	23,3									
2			4	5,5	112M-4	1420	2,84	119	308	31,1									
2			5	6,8	112MB-4	1450	2,32	122	377	38,1									
2			5,5	7,5	132S-4	1450	2,11	122	415	41,9									
2			7,5	10	132M-4	1450	1,55	122	566	57,1									
2			9,2	12,5	132MB-4	1450	1,26	122	694	70,0									
2			11	15	132MC-4	1460	1,06	122	824	83,2									
2	11	10,6	3	4	100LB-4	1420	4,18	134	206	20,8									
2			4	5,5	112M-4	1420	3,14	134	275	27,7									
2			5	6,8	112MB-4	1450	2,56	136	336	33,9									
2			5,5	7,5	132S-4	1450	2,33	136	370	37,3									
2			7,5	10	132M-4	1450	1,71	136	504	50,9									
2			9,2	12,5	132MB-4	1450	1,39	136	619	62,4									
2			11	15	132MC-4	1460	1,17	137	734	74,1									
3			11	10,6	3	4	100LB-4	1420	4,57	134	201	20,3							

PERFORMANCE TABLE



input connection **B5** IEC 72-1

40	ratio i:		input				output				input connection B5 IEC 72-1											
	stages	rated	real	kW	Hp	motor type	n ₁ [rpm]	fs	n ₂ [rpm]	M ₂ [Nm]	M ₂ [Kgm]	63	71	80	90	100/112	132	160	180	200		
3	10	9,6	3	4	100LB-4	1420	4,98	147	183	18,5												
3			4	5,5	112M-4	1420	3,74	147	244	24,6												
3			5	6,8	112MB-4	1450	3,05	150	299	30,2												
3			5,5	7,5	132S-4	1450	2,78	150	329	33,2												
3			7,5	10	132M-4	1450	2,04	150	448	45,2												
3			9,2	12,5	132MB-4	1450	1,66	150	550	55,5												
3			11	15	132MC-4	1460	1,40	151	653	65,9												
2			9	9,0	3	4	100LB-4	1420	4,84	157	175	17,7										
2	4	5,5			112M-4	1420	3,63	157	233	23,6												
2	5	6,8			112MB-4	1450	2,96	160	286	28,8												
2	5,5	7,5			132S-4	1450	2,69	160	314	31,7												
2	7,5	10			132M-4	1450	1,98	160	429	43,3												
2	9,2	12,5			132MB-4	1450	1,61	160	526	53,1												
2	11	15			132MC-4	1460	1,36	162	624	63,0												
2	8	7,6			3	4	100LB-4	1420	5,13	186	148	14,9										
2			4	5,5	112M-4	1420	3,84	186	197	19,9												
2			5	6,8	112MB-4	1450	3,14	190	242	24,4												
2			5,5	7,5	132S-4	1450	2,86	190	266	26,8												
2			7,5	10	132M-4	1450	2,09	190	362	36,6												
2			9,2	12,5	132MB-4	1450	1,71	190	444	44,8												
2			11	15	132MC-4	1460	1,44	191	528	53,2												
3			8	8,1	4	5,5	112M-4	1420	4,35	176	205	20,6										
3	5	6,8			112MB-4	1450	3,55	179	250	25,3												
3	5,5	7,5			132S-4	1450	3,23	179	276	27,8												
3	7,5	10			132M-4	1450	2,37	179	376	37,9												
3	9,2	12,5			132MB-4	1450	1,93	179	461	46,5												
3	11	15			132MC-4	1460	1,63	181	547	55,2												
2	7	6,8	4	5,5	112M-4	1420	4,26	209	176	17,7												
2			5	6,8	112MB-4	1450	3,48	213	215	21,7												
2			5,5	7,5	132S-4	1450	3,16	213	236	23,9												
2			7,5	10	132M-4	1450	2,32	213	322	32,5												
2			9,2	12,5	132MB-4	1450	1,89	213	396	39,9												
2			11	15	132MC-4	1460	1,59	215	470	47,4												
2			9,2	12,5	132MA-2	2900	3,40	427	198	20,0												
2			11	15	132MB-2	2900	2,85	427	236	23,9												
2	6,5	6,6	4	5,5	112M-4	1420	4,54	214	172	17,3												
2			5	6,8	112MB-4	1450	3,71	218	210	21,2												
2			5,5	7,5	132S-4	1450	3,37	218	231	23,3												
2			7,5	10	132M-4	1450	2,47	218	315	31,8												
2			9,2	12,5	132MB-4	1450	2,02	218	387	39,0												
2			11	15	132MC-4	1460	1,70	220	459	46,3												
2			9,2	12,5	132MA-2	2900	3,63	436	193	19,5												
2			11	15	132MB-2	2900	3,04	436	231	23,3												
2	5,5	5,6	5	6,8	112MB-4	1450	4,36	259	177	17,9												
2			5,5	7,5	132S-4	1450	3,97	259	195	19,7												
2			7,5	10	132M-4	1450	2,91	259	266	26,8												
2			9,2	12,5	132MB-4	1450	2,37	259	326	32,9												
2			11	15	132MC-4	1460	2,00	260	388	39,1												
2			9,2	12,5	132MA-2	2900	4,27	517	163	16,5												
2	11	15	132MB-2	2900	3,57	517	195	19,7														
2	5	4,8	5,5	7,5	132S-4	1450	4,72	304	166	16,8												
2			7,5	10	132M-4	1450	3,46	304	227	22,9												
2			9,2	12,5	132MB-4	1450	2,82	304	278	28,0												
2			11	15	132MC-4	1460	2,38	306	330	33,3												
2			9,2	12,5	132MA-2	2900	5,08	607	139	14,0												
2			11	15	132MB-2	2900	4,25	607	166	16,8												

input connection **B5** IEC 72-1

40	ratio i:		input				output				input connection B5 IEC 72-1												
	stages	rated	real	kW	Hp	motor type	n ₁ [rpm]	fs	n ₂ [rpm]	M ₂ [Nm]	M ₂ [Kgm]	63	71	80	90	100/112	132	160	180	200			
2	4,5	4,7	5,5	7,5	132S-4	1450	4,70	308	164	16,5													
2			7,5	10	132M-4	1450	3,45	308	223	22,5													
2			9,2	12,5	132MB-4	1450	2,81	308	274	27,6													
2			11	15	132MC-4	1460	2,37	311	325	32,8													
2			9,2	12,5	132MA-2	2900	5,06	617	137	13,8													
2			11	15	132MB-2	2900	4,23	617	164	16,5													
2			4	4,0	5,5	7,5	132S-4	1450	5,28	360	140	14,1											
2					7,5	10	132M-4	1450	3,88	360	191	19,3											
2	9,2	12,5			132MB-4	1450	3,16	360	235	23,7													
2	11	15			132MC-4	1460	2,66	362	278	28,1													
2	9,2	12,5			132MA-2	2900	5,69	720	117	11,8													
2	11	15			132MB-2	2900	4,76	720	140	14,1													
2	3,5	3,4	5,5	7,5	132S-4	1450	6,23	429	117	11,9													
2			7,5	10	132M-4	1450	4,57	429	160	16,2													
2			9,2	12,5	132MB-4	1450	3,72	429	197	19,8													
2			11	15	132MC-4	1460	3,13	432	233	23,5													
2			9,2	12,5	132MA-2	2900	6,70	859	98	9,9													
2			11	15	132MB-2	2900	5,60	859	117	11,9													

PERFORMANCE TABLE



input connection **B5** IEC 72-1

input connection **B5** IEC 72-1

50	ratio i:		input				output				63	71	80	90	100/112	132	160	180	200	
	stages	rated	real	kW	Hp	motor type	n ₁ [rpm]	fs	n ₂ [rpm]	M ₂ [Nm]										M ₂ [KgM]
3	35	35,4	2,2	3	100LA-4	1420	3,96	40	493	49,8										
3			3	4	100LB-4	1420	2,90	40	673	67,9										
3			4	5,5	112M-4	1420	2,18	40	897	90,5										
3			5	6,8	112MB-4	1450	1,78	41	1098	110,8										
3			5,5	7,5	132S-4	1450	1,62	41	1208	121,9										
3			7,5	10	132M-4	1450	1,19	41	1647	166,2										
3	33	32,5	2,2	3	100LA-4	1420	4,48	44	453	45,7										
3			3	4	100LB-4	1420	3,28	44	618	62,3										
3			4	5,5	112M-4	1420	2,46	44	823	83,1										
3			5	6,8	112MB-4	1450	2,01	45	1008	101,7										
3			5,5	7,5	132S-4	1450	1,83	45	1109	111,9										
3			7,5	10	132M-4	1450	1,34	45	1512	152,5										
3	9,2	12,5	132MB-4	1450	1,09	45	1855	187,1												
3	32	32,2	2,2	3	100LA-4	1420	4,52	44	448	45,2										
3			3	4	100LB-4	1420	3,32	44	611	61,7										
3			4	5,5	112M-4	1420	2,49	44	815	82,2										
3			5	6,8	112MB-4	1450	2,03	45	998	100,7										
3			5,5	7,5	132S-4	1450	1,85	45	1097	110,7										
3			7,5	10	132M-4	1450	1,35	45	1496	151,0										
3	9,2	12,5	132MB-4	1450	1,10	45	1836	185,2												
3	28	28,0	2,2	3	100LA-4	1420	5,17	51	389	39,3										
3			3	4	100LB-4	1420	3,79	51	531	53,6										
3			4	5,5	112M-4	1420	2,84	51	708	71,4										
3			5	6,8	112MB-4	1450	2,32	52	867	87,5										
3			5,5	7,5	132S-4	1450	2,11	52	953	96,2										
3			7,5	10	132M-4	1450	1,55	52	1300	131,2										
3	9,2	12,5	132MB-4	1450	1,26	52	1595	160,9												
3	11	15	132MC-4	1460	1,06	52	1894	191,1												
3	11	15	160M-4	1460	1,06	52	1892	190,9												
3	26	25,9	3	4	100LB-4	1420	4,09	55	493	49,7										
3			4	5,5	112M-4	1420	3,07	55	657	66,3										
3			5	6,8	112MB-4	1450	2,51	56	804	81,1										
3			5,5	7,5	132S-4	1450	2,28	56	885	89,2										
3			7,5	10	132M-4	1450	1,67	56	1206	121,7										
3			9,2	12,5	132MB-4	1450	1,36	56	1480	149,3										
3	11	15	132MC-4	1460	1,15	56	1757	177,3												
3	11	15	160M-4	1460	1,15	56	1755	177,1												
3	25	25,3	3	4	100LB-4	1420	4,17	56	480	48,5										
3			4	5,5	112M-4	1420	3,13	56	640	64,6										
3			5	6,8	112MB-4	1450	2,56	57	784	79,1										
3			5,5	7,5	132S-4	1450	2,32	57	862	87,0										
3			7,5	10	132M-4	1450	1,70	57	1176	118,6										
3			9,2	12,5	132MB-4	1450	1,39	57	1442	145,5										
3	11	15	132MC-4	1460	1,17	58	1713	172,8												
3	11	15	160M-4	1460	1,17	58	1710	172,6												
3	24	24,1	3	4	100LB-4	1420	3,99	59	457	46,1										
3			4	5,5	112M-4	1420	2,99	59	609	61,5										
3			5	6,8	112MB-4	1450	2,44	60	746	75,2										
3			5,5	7,5	132S-4	1450	2,22	60	820	82,8										
3			7,5	10	132M-4	1450	1,63	60	1119	112,8										
3			9,2	12,5	132MB-4	1450	1,33	60	1372	138,4										
3	11	15	132MC-4	1460	1,12	61	1629	164,4												
3	11	15	160M-4	1460	1,12	61	1627	164,2												

50	ratio i:		input				output				63	71	80	90	100/112	132	160	180	200		
	stages	rated	real	kW	Hp	motor type	n ₁ [rpm]	fs	n ₂ [rpm]	M ₂ [Nm]										M ₂ [KgM]	
3	22	22,3	3	4	100LB-4	1420	4,95	64	424	42,7											
3			4	5,5	112M-4	1420	3,71	64	565	57,0											
3			5	6,8	112MB-4	1450	3,03	65	692	69,8											
3			5,5	7,5	132S-4	1450	2,75	65	761	76,7											
3			7,5	10	132M-4	1450	2,02	65	1037	104,7											
3			9,2	12,5	132MB-4	1450	1,65	65	1272	128,4											
3			11	15	132MC-4	1460	1,39	65	1511	152,5											
3			11	15	160M-4	1460	1,39	65	1509	152,3											
3			15	20	160L-4	1460	1,02	65	2058	207,6											
3			20	20,2	4	5,5	112M-4	1420	4,09	70	511	51,5									
3					5	6,8	112MB-4	1450	3,34	72	625	63,1									
3					5,5	7,5	132S-4	1450	3,04	72	688	69,4									
3	7,5	10			132M-4	1450	2,23	72	938	94,6											
3	9,2	12,5			132MB-4	1450	1,82	72	1151	116,1											
3	11	15			132MC-4	1460	1,53	72	1366	137,9											
3	11	15	160M-4	1460	1,53	72	1365	137,7													
3	15	20	160L-4	1460	1,12	72	1861	187,8													
2	18	18,2	4	5,5	112M-4	1420	3,74	78	470	47,4											
2			5	6,8	112MB-4	1450	3,05	80	575	58,0											
2			5,5	7,5	132S-4	1450	2,78	80	632	63,8											
2			7,5	10	132M-4	1450	2,04	80	862	87,0											
2			9,2	12,5	132MB-4	1450	1,66	80	1058	106,7											
2			11	15	132MC-4	1460	1,40	80	1256	126,7											
2	11	15	160M-4	1460	1,40	80	1229	124,0													
2	15	20	160L-4	1460	1,02	80	1676	169,1													
3	17	17,2	4	5,5	112M-4	1420	4,78	83	436	43,9											
3			5	6,8	112MB-4	1450	3,90	84	533	53,8											
3			5,5	7,5	132S-4	1450	3,55	84	586	59,2											
3			7,5	10	132M-4	1450	2,60	84	800	80,7											
3			9,2	12,5	132MB-4	1450	2,12	84	981	99,0											
3			11	15	132MC-4	1460	1,79	85	1165	117,5											
3	11	15	160M-4	1460	1,79	85	1163	117,4													
3	15	20	160L-4	1460	1,31	85	1586	160,1													
3	18,5	25	180M-4	1470	1,07	85	1943	196,1													
2	16	16,3	4	5,5	112M-4	1420	4,25	87	422	42,6											
2			5	6,8	112MB-4	1450	3,47	89	517	52,1											
2			5,5	7,5	132S-4	1450	3,16	89	568	57,4											
2			7,5	10	132M-4	1450	2,31	89	775	78,2											
2			9,2	12,5	132MB-4	1450	1,89	89	951	95,9											
2			11	15	132MC-4	1460	1,59	89	1129	113,9											
2	11	15	160M-4	1460	1,59	89	1105	111,5													
2	15	20	160L-4	1460	1,17	89	1507	152,1													
3	16	16,0	4	5,5	112M-4</																

PERFORMANCE TABLE



input connection **B5** IEC 72-1

50	ratio i:		input				output				63	71	80	90	100/112	132	160	180	200
	stages	rated	real	kW	Hp	motor type	n ₁ [rpm]	fs	n ₂ [rpm]	M ₂ [Nm]									
2	4	4,1	18,5	25	160L-2	2950	5,13	727	233	23,5									
2			22	30	180M-2	2950	4,31	727	277	28,0									
2			7,5	10	132M-4	1450	6,91	357	192	19,4									
2			9,2	12,5	132MB-4	1450	5,63	357	236	23,8									
2			11	15	132MC-4	1460	4,75	360	280	28,3									
2			11	15	160M-4	1460	4,75	360	274	27,7									
2			15	20	160L-4	1460	3,48	360	374	37,7									
2			18,5	25	180M-4	1470	2,84	362	458	46,2									
2			22	30	180L-4	1470	2,39	362	545	55,0									
2			3	2,9	18,5	25	160L-2	2950	6,81	1006	169	17,0							
2	22	30			180M-2	2950	5,73	1006	201	20,2									
2	9,2	12,5			132MB-4	1450	7,48	495	171	17,2									
2	11	15			132MC-4	1460	6,30	498	203	20,4									
2	11	15			160M-4	1460	6,30	498	198	20,0									
2	15	20			160L-4	1460	4,62	498	270	27,3									
2	18,5	25			180M-4	1470	3,77	501	331	33,4									
2	22	30			180L-4	1470	3,17	501	394	39,7									

input connection **B5** IEC 72-1

60	ratio i:		input				output				63	71	80	90	100/112	132	160	180	200	
	stages	rated	real	kW	Hp	motor type	n ₁ [rpm]	fs	n ₂ [rpm]	M ₂ [Nm]										M ₂ [Kgm]
3	127	126,7	1,1	1,5	100LB-8	702	2,37	5,5	1785	180,1										
3			1,5	2	112M-8	710	1,76	5,6	2408	242,9										
3			2,2	3	132S-8	710	1,20	5,6	3531	356,3										
3			1,5	2	100L-6	944	2,14	7,5	1810	182,6										
3			2,2	3	112M-6	950	1,47	7,5	2637	266,0										
3			3	4	132S-6	970	1,10	7,7	3520	355,2										
3			2,2	3	100LA-4	1420	2,00	11	1764	178,0										
3			3	4	100LB-4	1420	1,46	11	2405	242,7										
3			4	5,5	112M-4	1420	1,10	11	3207	323,6										
3			5	6,8	112MB-4	1450	0,90	11	3928	396,4										
3			119	118,8	1,1	1,5	100LB-8	702	2,49	5,9	1673	168,8								
3					1,5	2	112M-8	710	1,85	6,0	2255	227,5								
3					2,2	3	132S-8	710	1,26	6,0	3307	333,6								
3					1,5	2	100L-6	944	2,26	8,0	1696	171,1								
3					2,2	3	112M-6	950	1,55	8,0	2472	249,4								
3	3	4			132S-6	970	1,16	8,2	3305	333,4										
3	2,2	3			100LA-4	1420	2,10	12	1655	167,0										
3	3	4			100LB-4	1420	1,54	12	2256	227,7										
3	4	5,5			112M-4	1420	1,16	12	3009	303,6										
3	5	6,8			112MB-4	1450	0,94	12	3684	371,7										
3	115	115,4			1,1	1,5	100LB-8	702	2,77	6,1	1626	164,1								
3					1,5	2	112M-8	710	2,06	6,2	2192	221,2								
3					2,2	3	132S-8	710	1,40	6,2	3215	324,4								
3					3	4	132M-8	720	1,04	6,2	4321	436,0								
3					1,5	2	100L-6	944	2,51	8,2	1648	166,3								
3			2,2	3	112M-6	950	1,72	8,2	2403	242,4										
3			3	4	132S-6	970	1,29	8,4	3210	323,9										
3			2,2	3	100LA-4	1420	2,34	12	1608	162,2										
3			3	4	100LB-4	1420	1,71	12	2192	221,2										
3			4	5,5	112M-4	1420	1,29	12	2923	294,9										
3			5	6,8	112MB-4	1450	1,05	13	3578	361,0										
3			112	111,7	1,1	1,5	100LB-8	702	2,62	6,3	1574	158,8								
3					1,5	2	112M-8	710	1,94	6,4	2120	213,9								
3					2,2	3	132S-8	710	1,33	6,4	3109	313,7								
3					3	4	132M-8	720	0,99	6,4	4187	422,5								
3	1,5	2			100L-6	944	2,37	8,5	1596	161,0										
3	2,2	3			112M-6	950	1,63	8,5	2326	234,7										
3	3	4			132S-6	970	1,22	8,7	3107	313,4										
3	2,2	3			100LA-4	1420	2,21	13	1556	157,0										
3	3	4			100LB-4	1420	1,62	13	2122	214,1										
3	4	5,5			112M-4	1420	1,21	13	2829	285,4										
3	5	6,8			112MB-4	1450	0,99	13	3462	349,3										
3	109	108,7			1,1	1,5	100LB-8	702	2,68	6,5	1531	154,4								
3					1,5	2	112M-8	710	1,99	6,5	2065	208,3								
3					2,2	3	132S-8	710	1,35	6,5	3028	305,5								
3					3	4	132M-8	720	1,01	6,6	4073	411,0								
3			1,5	2	100L-6	944	2,42	8,7	1553	156,7										
3			2,2	3	112M-6	950	1,66	8,7	2263	228,3										
3			3	4	132S-6	970	1,24	8,9	3023	305,0										
3			2,2	3	100LA-4	1420	2,26	13	1514	152,8										
3			3	4	100LB-4	1420	1,66	13	2065	208,3										
3			4	5,5	112M-4	1420	1,24	13	2753	277,8										
3			5	6,8	112MB-4	1450	1,01	13	3369	339,9										

PERFORMANCE TABLE



input connection **B5** IEC 72-1

input connection **B5** IEC 72-1

60	ratio i:		input				output				input connection B5 IEC 72-1												
	stages	rated	real	kW	Hp	motor type	n ₁ [rpm]	fs	n ₂ [rpm]	M ₂ [Nm]	M ₂ [Kgm]	63	71	80	90	100/112	132	160	180	200			
3	108	108,3	1,1	1,5	100LB-8	702	2,92	6,5	1526	153,9													
3			1,5	2	112M-8	710	2,17	6,6	2055	207,4													
3			2,2	3	132S-8	710	1,48	6,6	3014	304,1													
3			3	4	132M-8	720	1,10	6,7	4055	409,1													
3			1,5	2	100L-6	944	2,64	8,7	1546	156,0													
3			2,2	3	112M-6	950	1,81	8,8	2252	227,2													
3			3	4	132S-6	970	1,36	9,0	3010	303,6													
3			4	5,5	132MA-6	970	1,02	9,0	4013	404,8													
3			2,2	3	100LA-4	1420	2,46	13	1507	152,1													
3			3	4	100LB-4	1420	1,81	13	2055	207,4													
3			4	5,5	112M-4	1420	1,35	13	2740	276,5													
3			5	6,8	112MB-4	1450	1,11	13	3356	338,6													
3	5,5	8	132S-4	1450	1,01	13	3692	372,5															
3	102	101,8	1,1	1,5	100LB-8	702	3,07	6,9	1433	144,6													
3			1,5	2	112M-8	710	2,28	7,0	1932	194,9													
3			2,2	3	132S-8	710	1,55	7,0	2833	285,8													
3			3	4	132M-8	720	1,15	7,1	3814	384,8													
3			1,5	2	100L-6	944	2,77	9,3	1454	146,7													
3			2,2	3	112M-6	950	1,90	9,3	2119	213,8													
3			3	4	132S-6	970	1,43	9,5	2830	285,5													
3			4	5,5	132MA-6	970	1,07	9,5	3773	380,6													
3			2,2	3	100LA-4	1420	2,59	14	1418	143,0													
3			3	4	100LB-4	1420	1,90	14	1933	195,0													
3			4	5,5	112M-4	1420	1,42	14	2577	260,0													
3			5	6,8	112MB-4	1450	1,16	14	3154	318,2													
3	5,5	8	132S-4	1450	1,06	14	3469	350,0															
3	101	101,2	1,1	1,5	100LB-8	702	2,84	6,9	1427	143,9													
3			1,5	2	112M-8	710	2,10	7,0	1923	194,1													
3			2,2	3	132S-8	710	1,43	7,0	2821	284,6													
3			3	4	132M-8	720	1,07	7,1	3793	382,6													
3			1,5	2	100L-6	944	2,56	9,3	1447	146,0													
3			2,2	3	112M-6	950	1,76	9,4	2108	212,7													
3			3	4	132S-6	970	1,32	9,6	2815	284,0													
3			4	5,5	132MA-6	970	0,99	9,6	3753	378,6													
3			2,2	3	100LA-4	1420	2,39	14	1409	142,2													
3			3	4	100LB-4	1420	1,75	14	1922	193,9													
3			4	5,5	112M-4	1420	1,31	14	2563	258,5													
3			5	6,8	112MB-4	1450	1,07	14	3138	316,6													
3	5,5	8	132S-4	1450	0,98	14	3452	348,3															
3	99	99,1	1,1	1,5	100LB-8	702	3,14	7,1	1395	140,7													
3			1,5	2	112M-8	710	2,33	7,2	1880	189,7													
3			2,2	3	132S-8	710	1,59	7,2	2758	278,3													
3			3	4	132M-8	720	1,18	7,3	3709	374,2													
3			1,5	2	100L-6	944	2,84	9,5	1415	142,7													
3			2,2	3	112M-6	950	1,95	9,6	2062	208,0													
3			3	4	132S-6	970	1,46	9,8	2754	277,9													
3			4	5,5	132MA-6	970	1,09	9,8	3672	370,5													
3			2,2	3	100LA-4	1420	2,64	14	1380	139,2													
3			3	4	100LB-4	1420	1,94	14	1882	189,9													
3			4	5,5	112M-4	1420	1,45	14	2509	253,1													
3			5	6,8	112MB-4	1450	1,19	15	3070	309,7													
3	5,5	8	132S-4	1450	1,08	15	3377	340,7															

60	ratio i:		input				output				input connection B5 IEC 72-1												
	stages	rated	real	kW	Hp	motor type	n ₁ [rpm]	fs	n ₂ [rpm]	M ₂ [Nm]	M ₂ [Kgm]	63	71	80	90	100/112	132	160	180	200			
3	98	97,6	1,1	1,5	100LB-8	702	2,92	7,2	1373	138,5													
3			1,5	2	112M-8	710	2,17	7,3	1852	186,9													
3			2,2	3	132S-8	710	1,48	7,3	2716	274,1													
3			3	4	132M-8	720	1,10	7,4	3654	368,6													
3			1,5	2	100L-6	944	2,64	9,7	1393	140,5													
3			2,2	3	112M-6	950	1,81	9,7	2030	204,8													
3			3	4	132S-6	970	1,36	9,9	2713	273,7													
3			4	5,5	132MA-6	970	1,02	9,9	3617	364,9													
3			2,2	3	100LA-4	1420	2,46	15	1359	137,1													
3			3	4	100LB-4	1420	1,81	15	1853	187,0													
3			4	5,5	112M-4	1420	1,35	15	2471	249,3													
3			5	6,8	112MB-4	1450	1,11	15	3024	305,1													
3	5,5	8	132S-4	1450	1,01	15	3327	335,6															
3	96	95,9	1,1	1,5	100LB-8	702	2,96	7,3	1351	136,3													
3			1,5	2	112M-8	710	2,20	7,4	1820	183,6													
3			2,2	3	132S-8	710	1,50	7,4	2669	269,2													
3			3	4	132M-8	720	1,11	7,5	3591	362,3													
3			1,5	2	100L-6	944	2,68	9,9	1369	138,1													
3			2,2	3	112M-6	950	1,84	9,9	1995	201,3													
3			3	4	132S-6	970	1,38	10,1	2665	268,8													
3			4	5,5	132MA-6	970	1,03	10,1	3553	358,4													
3			2,2	3	100LA-4	1420	2,50	15	1335	134,7													
3			3	4	100LB-4	1420	1,83	15	1821	183,7													
3			4	5,5	112M-4	1420	1,37	15	2428	244,9													
3			5	6,8	112MB-4	1450	1,12	15	2927	299,9													
3	5,5	8	132S-4	1450	1,02	15	3270	329,9															
3	95	94,5	1,1	1,5	100LB-8	702	3,00	7,4	1331	134,3													
3			1,5	2	112M-8	710	2,22	7,5	1795	181,1													
3			2,2	3	132S-8	710	1,52	7,5	2633	265,7													
3			3	4	132M-8	720	1,13	7,6	3539	357,0													
3			1,5	2	100L-6	944	2,71	10,0	1351	136,3													
3			2,2	3	112M-6	950	1,86	10,1	1968	198,5													
3			3	4	132S-6	970	1,39	10,3	2628	265,2													
3			4	5,5	132MA-6	970	1,04	10,3	3504	353,6													
3			2,2	3	100LA-4	1420	2,53	15	1317	132,8													
3			3	4	100LB-4	1420	1,85	15	1795	181,1													
3			4	5,5	112M-4	1420	1																

PERFORMANCE TABLE



input connection **B5** IEC 72-1

input connection **B5** IEC 72-1

60	ratio i:		input				output				63	71	80	90	100/112	132	160	180	200	
	stages	rated	real	kW	Hp	motor type	n ₁ [rpm]	fs	n ₂ [rpm]	M ₂ [Nm]										M ₂ [Kgm]
3	54	53,5	2,2	3	100LA-4	1420	4,91	27	745	75,2										
3			3	4	100LB-4	1420	3,60	27	1016	102,5										
3			4	5,5	112M-4	1420	2,70	27	1355	136,7										
3			5	6,8	112MB-4	1450	2,20	27	1659	167,4										
3			5,5	8	132S-4	1450	2,00	27	1825	184,1										
3			7,5	10	132M-4	1450	1,47	27	2488	251,1										
3			9,2	12,5	132MB-4	1450	1,20	27	3053	308,0										
3			11	15	132MC-4	1460	1,01	27	3626	365,8										
3			11	15	160M-4	1460	1,01	27	3626	365,8										
3	52	51,6	2,2	3	100LA-4	1420	4,68	28	719	72,5										
3			3	4	100LB-4	1420	3,43	28	980	98,9										
3			4	5,5	112M-4	1420	2,57	28	1307	131,9										
3			5	6,8	112MB-4	1450	2,10	28	1600	161,4										
3			5,5	8	132S-4	1450	1,91	28	1760	177,6										
3			7,5	10	132M-4	1450	1,40	28	2400	242,1										
3			9,2	12,5	132MB-4	1450	1,14	28	2944	297,0										
3			11	15	132MC-4	1460	0,96	28	3496	352,7										
3			11	15	160M-4	1460	0,96	28	3496	352,7										
3	51	50,5	2,2	3	100LA-4	1420	5,64	28	703	71,0										
3			3	4	100LB-4	1420	4,14	28	959	96,8										
3			4	5,5	112M-4	1420	3,10	28	1279	129,0										
3			5	6,8	112MB-4	1450	2,54	29	1566	158,0										
3			5,5	8	132S-4	1450	2,31	29	1723	173,8										
3			7,5	10	132M-4	1450	1,69	29	2349	237,0										
3			9,2	12,5	132MB-4	1450	1,38	29	2881	290,7										
3			11	15	132MC-4	1460	1,16	29	3421	345,2										
3			11	15	160M-4	1460	1,16	29	3421	345,2										
3	50	50,0	2,2	3	100LA-4	1420	5,48	28	696	70,2										
3			3	4	100LB-4	1420	4,02	28	949	95,8										
3			4	5,5	112M-4	1420	3,02	28	1266	127,7										
3			5	6,8	112MB-4	1450	2,46	29	1549	156,3										
3			5,5	8	132S-4	1450	2,24	29	1704	171,9										
3			7,5	10	132M-4	1450	1,64	29	2324	234,5										
3			9,2	12,5	132MB-4	1450	1,34	29	2851	287,6										
3			11	15	132MC-4	1460	1,13	29	3385	341,5										
3			11	15	160M-4	1460	1,13	29	3385	341,5										
3	48	47,5	2,2	3	100LA-4	1420	5,22	30	662	66,7										
3			3	4	100LB-4	1420	3,83	30	902	91,0										
3			4	5,5	112M-4	1420	2,87	30	1203	121,4										
3			5	6,8	112MB-4	1450	2,35	31	1473	148,6										
3			5,5	8	132S-4	1450	2,13	31	1620	163,4										
3			7,5	10	132M-4	1450	1,56	31	2209	222,9										
3			9,2	12,5	132MB-4	1450	1,28	31	2709	273,4										
3			11	15	132MC-4	1460	1,07	31	3217	324,6										
3			11	15	160M-4	1460	1,07	31	3217	324,6										
3	46	46,1	2,2	3	100LA-4	1420	5,66	31	642	64,7										
3			3	4	100LB-4	1420	4,15	31	875	88,3										
3			4	5,5	112M-4	1420	3,11	31	1167	117,7										
3			5	6,8	112MB-4	1450	2,54	31	1428	144,1										
3			5,5	8	132S-4	1450	2,31	31	1571	158,5										
3			7,5	10	132M-4	1450	1,70	31	2142	216,1										
3			9,2	12,5	132MB-4	1450	1,38	31	2628	265,1										
3			11	15	132MC-4	1460	1,16	32	3120	314,8										
3			11	15	160M-4	1460	1,16	32	3120	314,8										

60	ratio i:		input				output				63	71	80	90	100/112	132	160	180	200	
	stages	rated	real	kW	Hp	motor type	n ₁ [rpm]	fs	n ₂ [rpm]	M ₂ [Nm]										M ₂ [Kgm]
3	45	44,5	2,2	3	100LA-4	1420	6,42	32	620	62,6										
3			3	4	100LB-4	1420	4,71	32	846	85,3										
3			4	5,5	112M-4	1420	3,53	32	1128	113,8										
3			5	6,8	112MB-4	1450	2,89	33	1381	139,3										
3			5,5	8	132S-4	1450	2,62	33	1519	153,2										
3			7,5	10	132M-4	1450	1,92	33	2071	209,0										
3			9,2	12,5	132MB-4	1450	1,57	33	2540	256,3										
3			11	15	132MC-4	1460	1,32	33	3017	304,4										
3			11	15	160M-4	1460	1,32	33	3017	304,4										
3	42	41,8	2,2	3	100LA-4	1420	6,51	34	582	58,7										
3			3	4	100LB-4	1420	4,77	34	793	80,0										
3			4	5,5	112M-4	1420	3,58	34	1057	106,7										
3			5	6,8	112MB-4	1450	2,92	35	1294	130,6										
3			5,5	8	132S-4	1450	2,66	35	1424	143,7										
3			7,5	10	132M-4	1450	1,95	35	1942	195,9										
3			9,2	12,5	132MB-4	1450	1,59	35	2382	240,3										
3			11	15	132MC-4	1460	1,34	35	2828	285,3										
3			11	15	160M-4	1460	1,34	35	2828	285,3										
3	41	41,3	2,2	3	100LA-4	1420	6,58	34	575	58,0										
3			3	4	100LB-4	1420	4,82	34	785	79,2										
3			4	5,5	112M-4	1420	3,62	34	1046	105,5										
3			5	6,8	112MB-4	1450	2,95	35	1280	129,2										
3			5,5	8	132S-4	1450	2,69	35	1408	142,1										
3			7,5	10	132M-4	1450	1,97	35	1921	193,8										
3			9,2	12,5	132MB-4	1450	1,61	35	2356	237,7										
3			11	15	132MC-4	1460	1,35	35	2798	282,3										
3			11	15	160M-4	1460	1,35	35	2798	282,3										
3	39	38,9	2,2	3	100LA-4	1420	7,30	37	542	54,7										
3			3	4	100LB-4	1420	5,36	37	739	74,5										
3			4	5,5	112M-4	1420	4,02	37	985	99,4										
3			5	6,8	112MB-4	1450	3,28	37	1206	121,7										
3			5,5	8	132S-4	1450	2,98	37	1326	133,8										
3			7,5	10	132M-4	1450	2,19	37	1809	182,5										
3			9,2	12,5	132MB-4	1450	1,78	37	2219	223,9										
3			11	15	132MC-4	1460	1,50	38	2634	265,8										
3			11	15	160M-4	1460	1,50	38	2634	265,8										
3	36	35,7	2,2	3	100LA-4	1420	7,22	40	497	50,2										
3			3	4	100LB-4	1420	5,29	40	678	68,4										
3			4	5,5	112M-4	1420	3,97	40	904	91,2										
3			5	6,8	112MB-4	1450	3,24	41	1107	111,7										
3			5,5	8	132S-4	1450	2,95	41	1218	122,9										
3			7,5	10	132M-4	1450	2,16	41	1660	167,5										

PERFORMANCE TABLE



input connection **B5** IEC 72-1

input connection **B5** IEC 72-1

60	ratio i:		input				output				input connection B5 IEC 72-1													
	stages	rated	real	kW	Hp	motor type	n ₁ [rpm]	fs	n ₂ [rpm]	M ₂ [Nm]	M ₂ [KgM]	63	71	80	90	100/112	132	160	180	200				
3	32	32,1	4	5,5	112M-4	1420	4,81	44	814	82,1														
3			5	6,8	112MB-4	1450	3,93	45	996	100,5														
3			5,5	8	132S-4	1450	3,57	45	1096	110,6														
3			7,5	10	132M-4	1450	2,62	45	1494	150,8														
3			9,2	12,5	132MB-4	1450	2,14	45	1833	185,0														
3			11	15	132MC-4	1460	1,80	45	2177	219,6														
3			11	15	160M-4	1460	1,80	45	2177	219,6														
3			15	20	160L-4	1460	1,32	45	2968	299,5														
3			18,5	25	180M-4	1470	1,08	46	3636	366,9														
3	29	28,6	4	5,5	112M-4	1420	4,92	50	723	72,9														
3			5	6,8	112MB-4	1450	4,02	51	885	89,3														
3			5,5	8	132S-4	1450	3,65	51	974	98,2														
3			7,5	10	132M-4	1450	2,68	51	1328	133,9														
3			9,2	12,5	132MB-4	1450	2,18	51	1628	164,3														
3			11	15	132MC-4	1460	1,84	51	1934	195,1														
3			11	15	160M-4	1460	1,84	51	1934	195,1														
3			15	20	160L-4	1460	1,35	51	2637	266,0														
3			18,5	25	180M-4	1470	1,10	51	3230	325,9														
3	27	26,7	4	5,5	112M-4	1420	5,50	53	675	68,1														
3			5	6,8	112MB-4	1450	4,49	54	826	83,4														
3			5,5	8	132S-4	1450	4,08	54	909	91,7														
3			7,5	10	132M-4	1450	2,99	54	1240	125,1														
3			9,2	12,5	132MB-4	1450	2,44	54	1521	153,4														
3			11	15	132MC-4	1460	2,05	55	1806	182,2														
3			11	15	160M-4	1460	2,05	55	1806	182,2														
3			15	20	160L-4	1460	1,51	55	2463	248,5														
3			18,5	25	180M-4	1470	1,23	55	3016	304,3														
3	22	30	180L-4	1470	1,03	55	3587	361,9																
3	26	26,0	5,5	8	132S-4	1450	4,38	56	885	89,3														
3			7,5	10	132M-4	1450	3,21	56	1207	121,8														
3			9,2	12,5	132MB-4	1450	2,62	56	1480	149,4														
3			11	15	132MC-4	1460	2,20	56	1758	177,3														
3			11	15	160M-4	1460	2,20	56	1758	177,3														
3			15	20	160L-4	1460	1,62	56	2397	241,8														
3			18,5	25	180M-4	1470	1,32	57	2936	296,3														
3			22	30	180L-4	1470	1,11	57	3492	352,3														
3			5,5	8	132S-4	1450	4,34	64	771	77,8														
3	23	22,6	7,5	10	132M-4	1450	3,18	64	1052	106,1														
3			9,2	12,5	132MB-4	1450	2,59	64	1290	130,2														
3			11	15	132MC-4	1460	2,18	65	1532	154,6														
3			11	15	160M-4	1460	2,18	65	1532	154,6														
3			15	20	160L-4	1460	1,60	65	2089	210,8														
3			18,5	25	180M-4	1470	1,31	65	2559	258,2														
3			22	30	180L-4	1470	1,10	65	3043	307,0														
3			21	20,8	5,5	8	132S-4	1450	5,42	70	707	71,4												
3					7,5	10	132M-4	1450	3,97	70	965	97,3												
3	9,2	12,5			132MB-4	1450	3,24	70	1183	119,4														
3	11	15			132MC-4	1460	2,73	70	1405	141,8														
3	11	15			160M-4	1460	2,73	70	1405	141,8														
3	15	20			160L-4	1460	2,00	70	1916	193,3														
3	18,5	25			180M-4	1470	1,63	71	2347	236,8														
3	22	30			180L-4	1470	1,37	71	2791	281,6														
3	30	40			200L-4	1480	1,01	71	3781	381,5														

60	ratio i:		input				output				input connection B5 IEC 72-1													
	stages	rated	real	kW	Hp	motor type	n ₁ [rpm]	fs	n ₂ [rpm]	M ₂ [Nm]	M ₂ [KgM]	63	71	80	90	100/112	132	160	180	200				
3	20	19,7	5,5	8	132S-4	1450	5,46	74	671	67,7														
3			7,5	10	132M-4	1450	4,01	74	915	92,3														
3			9,2	12,5	132MB-4	1450	3,27	74	1122	113,2														
3			11	15	132MC-4	1460	2,75	74	1332	134,4														
3			11	15	160M-4	1460	2,75	74	1332	134,4														
3			15	20	160L-4	1460	2,02	74	1817	183,3														
3			18,5	25	180M-4	1470	1,65	75	2225	224,5														
3			22	30	180L-4	1470	1,38	75	2646	267,0														
3			30	40	200L-4	1480	1,02	75	3584	361,6														
3	18	17,6	5,5	8	132S-4	1450	5,32	83	598	60,4														
3			7,5	10	132M-4	1450	3,90	83	816	82,3														
3			9,2	12,5	132MB-4	1450	3,18	83	1001	101,0														
3			11	15	132MC-4	1460	2,68	83	1189	119,9														
3			11	15	160M-4	1460	2,68	83	1189	119,9														
3			15	20	160L-4	1460	1,96	83	1621	163,5														
3			18,5	25	180M-4	1470	1,60	84	1985	200,3														
3			22	30	180L-4	1470	1,35	84	2361	238,2														
3			30	40	200L-4	1480	1,00	84	3198	322,6														
3	16	16,4	7,5	10	132M-4	1450	4,16	88	762	76,9														
3			9,2	12,5	132MB-4	1450	3,39	88	935	94,3														
3			11	15	132MC-4	1460	2,86	89	1110	112,0														
3			11	15	160M-4	1460	2,86	89	1110	112,0														
3			15	20	160L-4	1460	2,10	89	1514	152,7														
3			18,5	25	180M-4	1470	1,71	90	1854	187,1														
3			22	30	180L-4	1470	1,44	90	2205	222,4														
3			30	40	200L-4	1480	1,06	90	2986	301,3														
3			15	15,3	9,2	12,5	132MB-4	1450	4,33	95	873	88,1												
3	11	15			132MC-4	1460	3,65	95	1037	104,6														
3	11	15			160M-4	1460	3,65	95	1037	104,6														
3	15	20			160L-4	1460	2,67	95	1414	142,6														
3	18,5	25			180M-4	1470	2,18	96	1732	174,7														
3	22	30			180L-4	1470	1,83	96	2059	207,8														
3	30	40			200L-4	1480	1,35	97	2789	281,4														
2	14	13,8			5,5																			

PERFORMANCE TABLE

input connection **B5** IEC 72-1

60	ratio i:		input				output				63	71	80	90	100/112	132	160	180	200	
	stages	rated	real	kW	Hp	motor type	n ₁ [rpm]	fs	n ₂ [rpm]	M ₂ [Nm]										M ₂ [Kgm]
3	12	12,4	11	15	160M-4	1460	4,30	118	836	84,4										
3			15	20	160L-4	1460	3,16	118	1141	115,1										
3			18,5	25	180M-4	1470	2,58	119	1397	141,0										
3			22	30	180L-4	1470	2,17	119	1662	167,6										
3			30	40	200L-4	1480	1,60	120	2250	227,1										
3	11	11,3	11	15	160M-4	1460	4,01	129	766	77,2										
3			15	20	160L-4	1460	2,94	129	1044	105,3										
3			18,5	25	180M-4	1470	2,40	130	1279	129,0										
3			22	30	180L-4	1470	2,02	130	1521	153,4										
3			30	40	200L-4	1480	1,49	131	2060	207,8										
3	10	9,6	11	15	160M-4	1460	5,69	152	651	65,7										
3			15	20	160L-4	1460	4,17	152	888	89,6										
3			18,5	25	180M-4	1470	3,41	153	1087	109,7										
3			22	30	180L-4	1470	2,86	153	1293	130,5										
3			30	40	200L-4	1480	2,12	154	1751	176,7										
2	9	9,2	11	15	160M-4	1460	4,71	159	635	64,0										
2			15	20	160L-4	1460	3,45	159	865	87,3										
2			18,5	25	180M-4	1470	2,82	160	1060	107,0										
2			22	30	180L-4	1470	2,37	160	1261	127,2										
2			30	40	200L-4	1480	1,75	161	1708	172,3										
2	7	7,3	15	20	160L-4	1460	4,17	199	692	69,8										
2			18,5	25	180M-4	1470	3,41	200	848	85,5										
2			22	30	180L-4	1470	2,86	200	1008	101,7										
2			30	40	200L-4	1480	2,11	202	1365	137,7										
2			5,5	5,4	15	20	160L-4	1460	4,24	270	510	51,5								
2	18,5	25			180M-4	1470	3,46	271	625	63,1										
2	22	30			180L-4	1470	2,91	271	744	75,0										
2	30	40			200L-4	1480	2,15	273	1007	101,6										
2	4,5	4,5			15	20	160L-4	1460	4,24	324	425	42,9								
2			30	40	200LA-2	2950	3,86	654	421	42,5										
2			37	50	200LB-2	2950	3,13	654	519	52,4										
2			18,5	25	180M-4	1470	3,46	326	521	52,6										
2			22	30	180L-4	1470	2,91	326	619	62,5										
2	4	4,0	30	40	200L-4	1480	2,15	328	839	84,7										
2			15	20	160L-4	1460	5,12	365	377	38,0										
2			30	40	200LA-2	2950	4,66	738	373	37,6										
2			37	50	200LB-2	2950	3,78	738	460	46,4										
2			18,5	25	180M-4	1470	4,18	368	462	46,6										
2	3,5	3,4	22	30	180L-4	1470	3,52	368	549	55,4										
2			30	40	200L-4	1480	2,60	370	744	75,0										
2			30	40	200LA-2	2950	6,88	867	317	32,0										
2			37	50	200LB-2	2950	5,58	867	391	39,5										
2			18,5	25	180M-4	1470	6,18	432	393	39,6										
2	2,5	2,5	22	30	180L-4	1470	5,20	432	467	47,1										
2			30	40	200L-4	1480	3,84	435	632	63,8										
2			30	40	200LA-2	2950	6,88	1175	234	23,6										
2			37	50	200LB-2	2950	5,58	1175	289	29,2										
2			18,5	25	180M-4	1470	6,18	585	290	29,2										
2	2,5	2,5	22	30	180L-4	1470	5,20	585	345	34,8										
2			30	40	200L-4	1480	3,84	589	467	47,1										
2			30	40	200LA-2	2950	6,88	1175	234	23,6										

BACKLASH MAX [DEG]

i:	ROBUS A2		ROBUS 25		ROBUS 30		ROBUS 35		ROBUS 40		ROBUS 50		ROBUS 60	
	A2-2	A2-3	25-2	25-3	30-2	30-3	35-2	35-3	40-2	40-3	50-2	50-3	60-2	60-3
2							1,17							
2,5					2,91		1,17						0,42	
3					2,63		1,09				0,57			
3,5					1,29		1,09		0,78				0,43	
4			1,73		1,27		1,10		0,78		0,57		0,45	
4,5			1,78		2,26				0,80		0,56		0,43	
5	4,59		1,77		1,20		1,10		0,76		0,60			
5,5			1,81		1,23		1,01		0,80				0,45	
6					1,30						0,59			
6,5								0,44	0,79		0,57			
7			1,97		1,22		1,01		0,81		0,60	0,35	0,46	
8	3,50				1,31		1,04	0,36	0,83	0,34	0,58			
9			1,91		1,29		1,03		0,82			0,33	0,47	
10	3,04		1,93		1,31		1,04			0,34		0,34		0,25
11					1,35	0,41	1,10	0,40	0,84	0,32	0,58			0,29
12						0,54	1,05		0,86				0,48	0,23
13	2,71		2,07		1,32	0,37	1,15	0,32	0,87	0,31	0,61	0,34		0,23
14					1,34			0,32	0,91		0,64		0,49	
15	2,60		2,00			0,37		0,32	0,91	0,31				0,24
16			2,02		1,36	0,40	1,21	0,38	0,93	0,32	0,65	0,32		0,19
17			2,01									0,33		
18						0,36		0,31		0,32	0,65			0,19
19			2,03			0,36								
20	2,57		2,14		1,40			0,32		0,31		0,33		0,23
21					1,40	0,40		0,38		0,32				0,24
22				0,41	1,39	0,40						0,34		
23			2,16		1,47			0,30		0,32				0,22
24			2,29					0,31		0,30		0,23		
25	2,64			0,39	1,47	0,35				0,28		0,31		
26				0,41				0,30				0,33		0,24
27						0,36				0,32				0,23
28				0,40				0,31		0,32		0,32		
29														0,23
30		0,51		0,39		0,36		0,30		0,30				
31										0,26				
32						0,46				0,30		0,32		0,23
33				0,38								0,31		0,24

i:	ROBUS A2		ROBUS 25		ROBUS 30		ROBUS 35		ROBUS 40		ROBUS 50		ROBUS 60	
	A2-2	A2-3	25-2	25-3	30-2	30-3	35-2	35-3	40-2	40-3	50-2	50-3	60-2	60-3
34							0,40		0,35		0,31			
35		0,47								0,30		0,30	0,23	
36									0,35		0,31	0,30	0,25	0,22
37							0,35					0,28		
38								0,41		0,26		0,26		
39	0,50						0,38							0,23
40										0,29		0,24		
41									0,35	0,31	0,27	0,25	0,22	
42							0,41	0,34	0,36					0,22
43							0,40	0,34				0,26		
44												0,27		
45								0,35	0,34	0,30		0,24	0,23	
46		0,46							0,27	0,29				0,22
47									0,26					
48							0,38	0,34				0,26	0,23	0,22
49									0,26	0,25				
50		0,52						0,37				0,27		0,22
51									0,39	0,30		0,24	0,23	
52										0,27		0,24	0,20	
53								0,39				0,26		
54									0,39		0,25			0,22
55		0,48							0,34		0,25			
56										0,26		0,23		
57								0,35	0,33			0,26		0,22
58									0,38					
59		0,46								0,29				0,19
60								0,39	0,37			0,22		
61									0,37					0,22
62												0,26	0,23	
63									0,37		0,33			0,20
64		0,45								0,33		0,26		
65									0,40			0,25	0,23	0,22
66														0,22
67										0,29				0,19
68										0,29	0,26			
69									0,37	0,33	0,29			
70		0,43							0,37	0,28	0,25			0,22
71												0,25	0,23	0,19
72										0,29			0,23	

BACKLASH MAX [DEG]

i:	ROBUS A2		ROBUS 25		ROBUS 30		ROBUS 35		ROBUS 40		ROBUS 50		ROBUS 60	
	A2-2	A2-3	25-2	25-3	30-2	30-3	35-2	35-3	40-2	40-3	50-2	50-3	60-2	60-3
73				0,35		0,29		0,32						0,18
74									0,25					
75				0,37		0,28		0,24						0,22
76		0,41		0,37		0,28								0,19
77								0,26						0,18
78						0,29								
79									0,24					
80				0,35		0,28		0,25				0,20		
81		0,41				0,28								0,19
82						0,29			0,24					0,17
83												0,23		0,18
84				0,35		0,31						0,23		0,17
85		0,42		0,33		0,28		0,28	0,24					
86								0,27						0,19
87				0,35		0,30			0,24					0,19
88								0,23				0,20		
89				0,33										0,18
90						0,29		0,25	0,24					
91				0,35		0,28			0,24					
92		0,41							0,24		0,20			0,18
93									0,24					0,18
94						0,28								
95						0,28								0,18
96									0,24					0,17
97														
98		0,37		0,33		0,28			0,24					0,17
99								0,27						0,18
100								0,23						
101									0,24		0,20			0,18
102						0,28					0,20			0,18
103														
104														
105									0,24					
106				0,33		0,30		0,26	0,24					
107											0,20			
108		0,38									0,20			0,18
109														0,17
110				0,31		0,28			0,24					
111														

i:	ROBUS A2		ROBUS 25		ROBUS 30		ROBUS 35		ROBUS 40		ROBUS 50		ROBUS 60	
	A2-2	A2-3	25-2	25-3	30-2	30-3	35-2	35-3	40-2	40-3	50-2	50-3	60-2	60-3
112														0,17
113				0,32				0,23						
114						0,28								
115				0,30		0,27								0,18
116									0,24					
117												0,19		
118												0,19		
119		0,35		0,30										0,17
120						0,29								
121				0,31										
122											0,24			
123				0,31				0,25						
124														
125														
126														
127														0,17
128														
129						0,27								
130														
131														
132				0,31										
133														
134		0,35												
135														
136														
137														
138														
139														
140														
141														
142														
143				0,30										

Backlash, sometimes called lash or play, is a clearance between mating gear teeth. Reasons for the presence of backlash include provide space for a film of lubricating oil between the teeth, deflection under load, thermal expansion, and machining tolerances. It can be seen when the direction of movement is reversed and the slack or lost motion is taken up before the reversal of motion is complete. In certain applications, backlash is an undesirable characteristic and should be known, ratio by ratio, and eventually minimized. With precise gears having a ground profile like in Motive helical gearboxes, the backlash is optimized to be suitable for most of applications while preserving at the same time the lubrication, efficiency, heating, gears life and reliability of the gearbox.

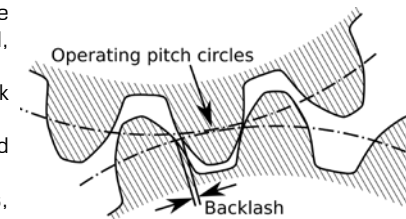

MOMENT OF INERTIA

i:	ROBUS A2		ROBUS 25		ROBUS 30		ROBUS 35		ROBUS 40		ROBUS 50		ROBUS 60	
	A2-2	A2-3	25-2	25-3	30-2	30-3	35-2	35-3	40-2	40-3	50-2	50-3	60-2	60-3
2							0,001325							
2,5					0,000676		0,000968						0,012502	
3					0,000611		0,001022				0,004082			
3,5					0,000523		0,000769		0,001096				0,010008	
4			0,000286		0,000480		0,000850		0,000867		0,002465		0,005905	
4,5			0,000275		0,000517				0,000928		0,003098		0,008291	
5	0,000278		0,000251		0,000402		0,000656		0,000702		0,001794			
5,5			0,000244		0,000318		0,000455		0,000749				0,004922	
6					0,000414						0,002733			
6,5								0,002757	0,000618		0,001951			
7			0,000236		0,000304		0,000349		0,000476		0,001169	0,011960	0,003171	
8	0,000185				0,000260		0,000411	0,005306	0,000425	0,003382	0,001459			
9			0,000193		0,000251		0,000310		0,000451			0,011599	0,002324	
10	0,000140		0,000191		0,000242		0,000324			0,002628		0,006736		0,061924
11					0,000228	0,001116	0,000261	0,001353	0,000392	0,003283	0,000984			0,023494
12						0,002327	0,000291		0,000408				0,001704	0,060950
13	0,000110		0,000189		0,000240	0,001233	0,000243	0,005111	0,000329	0,002558	0,000810	0,004751		0,060737
14					0,000232			0,003306	0,000311		0,000724		0,001339	
15	0,000093		0,000175			0,001638		0,001624	0,000295	0,002066				0,028154
16			0,000173		0,000220	0,000747	0,000220	0,000840	0,000287	0,001555	0,000607	0,004628		0,074822
17			0,000174									0,003076		
18						0,001211		0,001603		0,001344	0,000542			0,074627
19			0,000172			0,000793								
20	0,000070		0,000173		0,000203		0,001083		0,001528		0,002516		0,027770	
21					0,000199	0,000580		0,000693		0,001263				0,018116
22				0,000324	0,000198	0,000556						0,002245		
23			0,000171		0,000201			0,001585		0,001203				0,027606
24			0,000170					0,001070		0,001325		0,006620		
25	0,000057			0,000340	0,000197	0,000782				0,001395		0,002467		
26				0,000278				0,001574				0,001928		0,013779
27						0,000565				0,001115				0,017907
28				0,000321				0,000889		0,001097		0,002205		
29														0,017862
30		0,000119		0,000288		0,000512		0,001060		0,001190				
31										0,002355				
32						0,000459				0,001148		0,001914		0,011063
33				0,000326								0,001898		0,010967

i:	ROBUS A2		ROBUS 25		ROBUS 30		ROBUS 35		ROBUS 40		ROBUS 50		ROBUS 60		
	A2-2	A2-3	25-2	25-3	30-2	30-3	35-2	35-3	40-2	40-3	50-2	50-3	60-2	60-3	
34					0,000276		0,000587		0,000614						
35		0,000115						0,000881		0,001106		0,008030			
36							0,000559		0,000682	0,001089		0,002371		0,013617	
37							0,000342			0,001075					
38								0,000449		0,001009		0,001536			
39		0,000117			0,000279									0,009480	
40									0,000877				0,002749		
41								0,000508	0,000610	0,001182		0,001910		0,010976	
42					0,000205		0,000557		0,000527					0,010882	
43					0,000230		0,000583				0,001367				
44											0,001124				
45							0,000290		0,000460		0,000678		0,002338	0,008670	
46		0,000115									0,000651	0,001083		0,010575	
47											0,001002				
48							0,000207		0,000507			0,001256	0,003540	0,010939	
49											0,000740	0,001363			
50		0,000121			0,000232							0,001043		0,009420	
51									0,000447		0,000607		0,001885	0,008091	
52											0,000599		0,001859	0,009973	
53							0,000208					0,001175			
54							0,000204				0,000998			0,009407	
55		0,000118						0,000416			0,001252				
56									0,000647				0,003521		
57						0,000238		0,000458			0,001118			0,008624	
58						0,000186									
59		0,000116								0,000605				0,011862	
60						0,000190		0,000446				0,001753			
61								0,000209						0,008329	
62													0,002305		
63								0,000206				0,000522		0,008581	
64		0,000115							0,000416			0,001038			
65								0,000185				0,001115	0,002694	0,008056	
66														0,008605	
67									0,000484					0,008234	
68									0,000639		0,000644				
69									0,000191	0,000415		0,000536			
70		0,000112							0,000191	0,000544		0,000733		0,008048	
71													0,001059	0,001860	0,009908
72										0,000603				0,001834	

MOMENT OF INERTIA

i:	ROBUS A2		ROBUS 25		ROBUS 30		ROBUS 35		ROBUS 40		ROBUS 50		ROBUS 60	
	A2-2	A2-3	25-2	25-3	30-2	30-3	35-2	35-3	40-2	40-3	50-2	50-3	60-2	60-3
73				0,000208		0,000537		0,000520						0,011814
74									0,01036					
75				0,000185		0,000611		0,000789						0,008041
76		0,000109		0,000186		0,000543								0,008917
77								0,000594						0,011337
78						0,000422								
79									0,001268					
80				0,000192		0,000424		0,000642			0,002597			
81		0,000109				0,000478								0,008545
82						0,000536			0,001380					0,012025
83										0,001851				0,009055
84				0,000194		0,000456				0,001826				0,010103
85		0,000111		0,000217		0,000542		0,000534	0,001191					
86								0,000557						0,008202
87				0,000186		0,000459			0,001302					0,008537
88								0,000787			0,002704			
89				0,000212										0,009875
90						0,000421		0,000592	0,001423					
91				0,000188		0,000477			0,001266					
92		0,000108							0,001116	0,002058				0,008195
93									0,001220					0,008529
94						0,000424								
95						0,000482								0,008291
96									0,001084					0,009038
97														
98		0,000108		0,000195		0,000421			0,001189					0,010082
99								0,000533						0,008188
100								0,000681						
101									0,001139	0,002134				0,008284
102						0,000423				0,002100				0,008884
103														
104														
105									0,001105					
106				0,000189		0,000458		0,000555	0,001114					
107										0,002050				
108		0,000107								0,002019				0,008515
109														0,008278
110				0,000218		0,000420			0,001082					
111														

i:	ROBUS A2		ROBUS 25		ROBUS 30		ROBUS 35		ROBUS 40		ROBUS 50		ROBUS 60	
	A2-2	A2-3	25-2	25-3	30-2	30-3	35-2	35-3	40-2	40-3	50-2	50-3	60-2	60-3
112														0,009022
113				0,000191				0,000620						
114						0,000423								
115				0,000226		0,000429								0,008176
116										0,001137				
117												0,002126		
118												0,002093		
119		0,000108		0,000221										0,008628
120						0,000465								
121				0,000200									0,001103	
122														
123				0,000193				0,000554						
124														
125														
126														
127														0,008265
128														
129									0,000429					
130														
131														
132				0,000192										
133														
134		0,000107												
135														
136														
137														
138														
139														
140														
141														
142														
143				0,000194										

The **moment of inertia** J_r , expressed in Kgm^2 , represents the measure of the opposition that the gearbox exhibits to its rotation, and is referred to the input shaft. Though a gearbox has, for the mass and geometry of its moved parts, a moment of inertia, adding a gearbox to a motor-driven system reduces the driven load **inertia** a lot, by the inverse square of the gear ratio (i^2).

MAX AXIAL AND RADIAL LOADS ON OUTPUT SHAFT

Max axial load F_A [kg] (with radial load $F_R=0$), with standard output shaft bearings

i:	ROBUS A2		ROBUS 25		ROBUS 30		ROBUS 35		ROBUS 40		ROBUS 50		ROBUS 60	
	A2-2	A2-3	25-2	25-3	30-2	30-3	35-2	35-3	40-2	40-3	50-2	50-3	60-2	60-3
2							223							
2,5					168		238						675	
3					178		252				523			
3,5					176		270		257				743	
4		131			185		284		268		564		762	
4,5		125			195				283		599		809	
5	135	131			200		304		277		531			
5,5		61			201		318		291				833	
6					236						537			
6,5								270	297		639			
7		82			211		347		290		832	394	886	
8	172				207		354	287	295	278	893			
9		139			215		363		225			420	914	
10	184	199			215		380			292		478		199
11					214	209	381	303	157	306	750			212
12					217	389			142				1090	241
13	196	232			265	257	388	320	156	325	666	516		261
14					264			322	187		863			1131
15	202	243			286		325	157	328					266
16		286			308	196	423	314	225	332	560	527		274
17		290										542		
18					300		357		326	730				231
19		296			300									
20	212	308			373			361		363		458		290
21					427	288		351		368				300
22			249		448	276						574		
23		303			412			365		397				284
24		312						367	374		594			
25	249		312	462	288			366		562				
26			312					408		620			313	
27				352					414				294	
28			315					470	384		427			
29														326
30	269		321		343			385		386				
31										431				
32					370					432		646		277
33			321									549		252

i:	ROBUS A2		ROBUS 25		ROBUS 30		ROBUS 35		ROBUS 40		ROBUS 50		ROBUS 60	
	A2-2	A2-3	25-2	25-3	30-2	30-3	35-2	35-3	40-2	40-3	50-2	50-3	60-2	60-3
34					314		294		421					
35		279						421	455		494			
36							377	423	428		661		334	
37						368			470					
38							366	477	470					
39		280			369									481
40								474				785		
41							332	476	519		516		521	
42						373	319	478						692
43						374	426				478			
44											523			
45						380	426	481				1253	699	
46		321						512	511					706
47								512						
48						383	426				526	1384	706	
49								517	620					
50		319				382			689					734
51							425	511			1397		799	
52								552			1399		881	
53						417			694					
54						420			556					941
55		327					493		698					
56								559			1453			
57						427	494		702				1013	
58						427								
59		333						557						1082
60						428	495				1581			
61						429					1570		1283	
62									710					
63						431			563					1374
64		339					497			713				
65						433				715		1583	1491	
66														1943
67								617						1984
68								583		580				
69						479	575		580					
70		344				477	623		582					1954
71										755		1605		1996
72								588				1608		

MAX AXIAL AND RADIAL LOADS ON OUTPUT SHAFT

Max axial load F_A [kg] (with radial load $F_R=0$), with standard output shaft bearings

i:	ROBUS A2		ROBUS 25		ROBUS 30		ROBUS 35		ROBUS 40		ROBUS 50		ROBUS 60	
	A2-2	A2-3	25-2	25-3	30-2	30-3	35-2	35-3	40-2	40-3	50-2	50-3	60-2	60-3
73				484		590		576						2002
74									760					
75				487		631		635						1904
76		350		486		633								2008
77								635						2009
78						595								
79									830					
80				495		640		639			1778			
81		391				599								2230
82						599			835					2309
83											1769			2318
84				502		601					1772			2320
85		393		503		647		646	841					
86								693						2252
87				503		650			846					2254
88								697			1815			
89				507										2262
90						606		699	904					
91				510		607			905					
92		401							908	1936				2275
93									911					2277
94						701								
95						703								2370
96									917					2375
97														
98		435		552		670			920					2382
99								714						2295
100								719						
101									928	1979				2396
102						714				1984				2304
103														
104														
105									936					
106				563		720		729	936					
107										2002				
108		448								2007				2401
109														2484
110				570		683			943					
111														

i:	ROBUS A2		ROBUS 25		ROBUS 30		ROBUS 35		ROBUS 40		ROBUS 50		ROBUS 60	
	A2-2	A2-3	25-2	25-3	30-2	30-3	35-2	35-3	40-2	40-3	50-2	50-3	60-2	60-3
112														2495
113						575			740					
114									731					
115						577			733					2411
116												1015		
117													2046	
118												2050		
119		462				582								2519
120									740					
121						584							1025	
122														
123						586				755				
124														
125														
126														
127														2544
128														
129									750					
130														
131														
132									595					
133														
134		479												
135														
136														
137														
138														
139														
140														
141														
142														
143									635					

The maximum external loads F_R and F_A represent the total load that can be supported by the components of the gearbox minus the internal thrusts given by the gears. F_R and F_A are therefore calculated by difference, in this case considering the combination of each gearbox with a motor having the speed and the power of the PMAX table, the most unfavorable direction of rotation, and an external thrust coming from the most unfavorable tangential direction.



MAX AXIAL AND RADIAL LOADS ON OUTPUT SHAFT

Max radial load F_R [kg] (with axial load $F_A=0$), with standard output shaft bearings

i:	ROBUS A2		ROBUS 25		ROBUS 30		ROBUS 35		ROBUS 40		ROBUS 50		ROBUS 60	
	A2-2	A2-3	25-2	25-3	30-2	30-3	35-2	35-3	40-2	40-3	50-2	50-3	60-2	60-3
2							300							
2.5					220		319						676	
3					278		335				299			
3.5					309		356		365				689	
4			100		293		370		382		313		738	
4.5			81		306				402		345		814	
5	106		112		311		393		397		210			
5.5			120		293		409		402				699	
6					325						269			
6.5								301	326		156			
7			77		281		441		224		224	319	510	
8	128				234		447	325	122	250	252			
9			125		207		457		409			335	1246	
10	137		136		186		480			358		356		350
11					134	283	433	393	396	384	150			369
12						293	463		236				611	392
13	146		241		274	234	384	380	192	412	192	382		420
14					254			352	157		325		404	
15	151		246			173		311	222	418				425
16			336		386	231	482	296	182	425	238	387		432
17			342									393		
18						317		432		423	250			330
19			350			302								
20	159		368		504			382		459	231			468
21					543	221		226		469				477
22				151	545	153						426		
23			360		519			306		465				470
24			375					248		482		434		
25	187			312	564	159				489		428		
26				313				536				444		489
27						394				521				495
28				318				403		504		450		
29														532
30		201		324		343		346		510				
31										554				
32						405				555		484		517
33				327								369		539

i:	ROBUS A2		ROBUS 25		ROBUS 30		ROBUS 35		ROBUS 40		ROBUS 50		ROBUS 60	
	A2-2	A2-3	25-2	25-3	30-2	30-3	35-2	35-3	40-2	40-3	50-2	50-3	60-2	60-3
34						329		294		366				
35		208						358		358		251	348	
36								395		312		165	337	563
37						365						378		
38								366		670		340		
39		209				366								564
40										648			487	
41								332		635		765	517	569
42						372		319		620				530
43						373		519				601		
44												706		
45						380		494		586			517	597
46		240								718		513		554
47										719				
48						385		477				640	498	504
49										728		618		
50		238				385						892		486
51								444		691			405	563
52										762			390	550
53						411						903		
54						415				770				437
55		244						673				911		
56										775			512	
57						422		661				918		446
58						423								
59		248								779				578
60						424		651					926	
61						426								483
62												936	823	
63						429				790				406
64		253						628				914		
65						432						902	775	484
66														902
67								764						1090
68								773		815				
69						465		769		816				
70		257				464		772		821				764
71												988	680	965
72								785					668	

MAX AXIAL AND RADIAL LOADS ON OUTPUT SHAFT

Max radial load F_R [kg] (with axial load $F_A=0$), with standard output shaft bearings

i:	ROBUS A2		ROBUS 25		ROBUS 30		ROBUS 35		ROBUS 40		ROBUS 50		ROBUS 60	
	A2-2	A2-3	25-2	25-3	30-2	30-3	35-2	35-3	40-2	40-3	50-2	50-3	60-2	60-3
73				472		788		769						883
74										998				
75				475		785		871						516
76		262		474		788								795
77								874						774
78						800								
79									1060					
80				483		800		881			1168			
81		292				810								1796
82						811			1070					1836
83											1075			1804
84				491		817					1067			1798
85		294		493		810		894	1081					
86								934						1698
87				493		815			1087					1691
88								939			1131			
89				498										1646
90						831		944		1131				
91				501		833				1133				
92		300								1139	1521			1580
93										1143				1567
94						864								
95						866								1595
96									1151					1568
97														
98		323		532		881				1156				1534
99								968						1440
100								974						
101									1169		1509			1459
102						882					1505			1382
103														
104														
105										1182				
106				544		892		990		1182				
107											1465			
108		330									1460			1239
109														1679
110				552		908				1195				
111														

i:	ROBUS A2		ROBUS 25		ROBUS 30		ROBUS 35		ROBUS 40		ROBUS 50		ROBUS 60	
	A2-2	A2-3	25-2	25-3	30-2	30-3	35-2	35-3	40-2	40-3	50-2	50-3	60-2	60-3
112														1625
113				557				1008						
114						908								
115				560		911								1488
116										1251				
117												1610		
118												1602		
119		339		565										1491
120						922								
121				567							1266			
122														
123				569				1033						
124														
125														
126														
127														1335
128														
129										937				
130														
131														
132				579										
133														
134		348												
135														
136														
137														
138														
139														
140														
141														
142														
143				610										

When transmission parts such as pinions, pulleys, etc. are keyed onto the output shafts of the gearboxes, the resulting radial loads (F_R) must not exceed the maximum values indicated here in order to protect the bearings and other internal parts of the gearbox. It is always advisable to fit pinions or pulleys as close as possible to the shaft stop and, when the radial load exceeds the permitted values, provide an external support.

The maximum external loads F_R and F_A represent the total load that can be supported by the components of the gearbox minus the internal thrusts given by the gears. F_R and F_A are therefore calculated by difference, in this case considering the combination of each gearbox with a motor having the speed and the power of the PMAX table, the most unfavorable direction of rotation, and an external thrust coming from the most unfavorable tangential direction.

F_R = Radial Load in the middle of the shaft
 F_{RX} = Radial Load at a generic point X
 E = Output Shaft Extension

$$F_{RX} = \frac{F_R \cdot E}{2 \cdot X}$$



MAX AXIAL AND RADIAL LOADS ON OUTPUT SHAFT

Max axial load F_A [Kg] (with radial load $F_R=0$), with special output shaft bearings for high loads

i:	ROBUS 25		ROBUS 30		ROBUS 35		ROBUS 40		ROBUS 50		ROBUS 60	
	25-2	25-3	30-2	30-3	35-2	35-3	40-2	40-3	50-2	50-3	60-2	60-3
2					258							
2,5			260		272						1235	
3			271		284				999			
3,5			271		299		266				1339	
4	258		282		310		273		1075		1380	
4,5	272		292				285		1124		1438	
5	284		296		326		280		588			
5,5	299		301		336		293				1489	
6			328						712			
6,5					345	302			1202			
7	310		311		356		293		850	1434	1584	
8			311		361	360	305	306	897			
9	326		320		366		308			1462	1650	
10	336		322		381			321		1526		219
11			323	209	383	375	337	337	763			233
12				217	391		215				1811	266
13	356		361	294	390	395	206	358	679	568		287
14			363			398	368		1079		1872	
15	361			289		402	314	361				293
16	366		400	196	426	394	308	365	572	580		301
17	381									596		
18				300		435		359	745			318
19	383			300								
20	391		456			440		399		504		319
21			498	288		431		405				330
22		351	517	285						631		
23	390		496			446		402				328
24	423					449		412		653		
25		373	533	288				416		618		
26		358				488				681		344
27				352				455				359
28		348				576		422		582		
29												359
30		350		349		519		425				
31								474				
32				370				475		711		406
33		322								604		462

i:	ROBUS 25		ROBUS 30		ROBUS 35		ROBUS 40		ROBUS 50		ROBUS 60	
	25-2	25-3	30-2	30-3	35-2	35-3	40-2	40-3	50-2	50-3	60-2	60-3
34		322		346		505						
35						505		526		1499		
36				377		506		480		725		489
37		466						545				
38				376		558		546				
39		452										529
40						556				952		
41				373		558		613		1031		573
42		445		372		560						762
43		443		426				615				
44								618				
45		449		426		564				1371		769
46						593		603				1035
47						594						
48		440		426				622		1461		1554
49						599		623				
50		421						767				1614
51				425		594				1482		1757
52						632				1485		1744
53		541						773				
54		539				636						1759
55				673				777				
56						639				1527		
57		547		661				780				1962
58		546										
59						639						2143
60		532		651						1929		
61		530										2371
62								788		1931		
63		527				645						2554
64				628				791				
65		523						792		2121		2953
66												3991
67				936								4043
68				922		662						
69		674		881		663						
70		666		934		665						4029
71								832		2361		4085
72				918						2507		

MAX AXIAL AND RADIAL LOADS ON OUTPUT SHAFT

Max axial load F_A [Kg] (with radial load $F_R=0$), with special output shaft bearings for high loads

i:	ROBUS 25		ROBUS 30		ROBUS 35		ROBUS 40		ROBUS 50		ROBUS 60	
	25-2	25-3	30-2	30-3	35-2	35-3	40-2	40-3	50-2	50-3	60-2	60-3
73		676		917		660						4108
74								836				
75		676		930		714						4077
76		667		929								4133
77						715						4138
78				912								
79								905				
80		677		922		719			2658			
81				906								4396
82				905				910				4495
83									2662			4517
84		690		901					2667			4521
85		691		915		727		981				
86						770						4452
87		676		911				986				4456
88						774			2716			
89		690										4480
90				890		776		1047				
91		690		888				1048				
92								1132	2828			4512
93								1230				4519
94				1094								
95				1094								4639
96								1236				4652
97												
98		816		1079				1239				4669
99						791						4574
100						796						
101								1250	2893			4704
102				1094					2899			4597
103												
104								1259				
105												
106		823		1093		806		1258				
107									2932			
108									2939			4751
109												4836
110		836		1075				1268				
111												

i:	ROBUS 25		ROBUS 30		ROBUS 35		ROBUS 40		ROBUS 50		ROBUS 60	
	25-2	25-3	30-2	30-3	35-2	35-3	40-2	40-3	50-2	50-3	60-2	60-3
112												4863
113		838				817						
114				1089								
115		843		1105								4778
116								1355				
117										2997		
118										3004		
119		846										4924
120				1102								
121		844										
122								1366				
123		848				833						
124												
125												
126												
127												4988
128												
129				1095								
130												
131												
132		848										
133												
134												
135												
136												
137												
138												
139												
140												
141												
142												
143		958										

The maximum external loads F_R and F_A represent the total load that can be supported by the components of the gearbox minus the internal thrusts given by the gears. F_R and F_A are therefore calculated by difference, in this case considering the combination of each gearbox with a motor having the speed and the power of the PMAX table, the most unfavorable direction of rotation, and an external thrust coming from the most unfavorable tangential direction.



MAX AXIAL AND RADIAL LOADS ON OUTPUT SHAFT

Max radial load F_R [Kg] (with axial load $F_A=0$), with special output shaft bearings for high loads

i:	ROBUS 25		ROBUS 30		ROBUS 35		ROBUS 40		ROBUS 50		ROBUS 60	
	25-2	25-3	30-2	30-3	35-2	35-3	40-2	40-3	50-2	50-3	60-2	60-3
2					466							
2.5			318		480						903	
3			323		503				404			
3.5			312		513		476				917	
4	146		313		547		444		337		812	
4.5	121		323				456		374		898	
5	142		325		555		407		211			
5.5	237		314		539		417				761	
6			335						280			
6.5						382	337		174			
7	162		301		519		228		239	385	535	
8			275		543	402	151	340	271			
9	248		240		498		450			406	423	
10	267		214		501			394		431		604
11			265	312	455	409	435	423	225			636
12				322	489		259				643	676
13	344		322	257	402	394	224	453	212	462		725
14			296			364	208		345		625	
15	352			286		320	245	459				734
16	382		414	254	507	393	224	468	265	468		745
17	388									475		
18				336		449		465	312			569
19	385			319								
20	386		563			395		505		391		808
21			735	324		227		516				823
22		315	746	276						515		
23	392		568			313		512				811
24	380					250		530		525		
25		367	763	326				538		517		
26		368				558				537		843
27				419				573				854
28		373				443		555		545		
29												918
30		379		361		380		561				
31								609				
32				430				611		585		892
33		381								406		929

i:	ROBUS 25		ROBUS 30		ROBUS 35		ROBUS 40		ROBUS 50		ROBUS 60	
	25-2	25-3	30-2	30-3	35-2	35-3	40-2	40-3	50-2	50-3	60-2	60-3
34		384		305		375						
35						366		562		350		
36				418		317		599		563		970
37		421						603				
38				385		741		606				
39		423										972
40						672				564		
41				346		661		794		569		982
42		428		331		645						914
43		430		555				771				
44								731				
45		436		527		608				597		1031
46						806		526				956
47						802						
48		441		507				661		508		869
49						780		637				
50		441						1069				839
51				470		719				614		971
52						983				580		948
53		469						1045				
54		473				973						754
55				688				1025				
56						966				679		
57		479		695				1002				770
58		480										
59						884						997
60		482		700						1019		
61		483										833
62								945		891		
63		486				858						700
64				673				945				
65		489						936		916		834
66												1557
67				936								1880
68				922		888						
69		525		881		886						
70		524		934		875						1318
71								1079		1073		1664
72				918						1050		

MAX AXIAL AND RADIAL LOADS ON OUTPUT SHAFT

Max radial load F_R [Kg] (with axial load $F_A=0$), with special output shaft bearings for high loads

i:	ROBUS 25		ROBUS 30		ROBUS 35		ROBUS 40		ROBUS 50		ROBUS 60	
	25-2	25-3	30-2	30-3	35-2	35-3	40-2	40-3	50-2	50-3	60-2	60-3
73		531		917		801						1524
74								1050				
75		534		930		1202						1727
76		533		929								1601
77						1165						1840
78				912								
79								1449				
80		543		922		1158				1297		
81				906								1936
82				905				1437				1980
83										1183		1945
84		550		901						1173		1938
85		551		915		1142		1424				
86						1472						1831
87		552		911				1438				2084
88						1474				1251		
89		556										2028
90				890		1452		1765				
91		559		888				1750				
92								1749		1714		2096
93								1764				2079
94				1094								
95				1094								2117
96								1747				2081
97												
98		593		1079				1745				2036
99						1453						2070
100						1480						
101								1759		1698		2097
102				1094						1692		2384
103												
104												
105								1753				
106		604		1093		1480		1735				
107										1641		
108										1635		2137
109												2896
110		612		1075				1727				
111												

i:	ROBUS 25		ROBUS 30		ROBUS 35		ROBUS 40		ROBUS 50		ROBUS 60	
	25-2	25-3	30-2	30-3	35-2	35-3	40-2	40-3	50-2	50-3	60-2	60-3
112												2802
113		616				1477						
114				1089								
115		618		1105								2568
116								2107				
117										1708		
118										1696		
119		624										2572
120				1102								
121		626						2114				
122												
123		628				1469						
124												
125												
126												
127												2304
128												
129				1095								
130												
131												
132		637										
133												
134												
135												
136												
137												
138												
139												
140												
141												
142												
143		670										

When transmission parts such as pinions, pulleys, etc. are keyed onto the output shafts of the gearboxes, the resulting radial loads (F_R) must not exceed the maximum values indicated here in order to protect the bearings and other internal parts of the gearbox. It is always advisable to fit pinions or pulleys as close as possible to the shaft stop and, when the radial load exceeds the permitted values, provide an external support.

The maximum external loads F_R and F_A represent the total load that can be supported by the components of the gearbox minus the internal thrusts given by the gears. F_R and F_A are therefore calculated by difference, in this case considering the combination of each gearbox with a motor having the speed and the power of the PMAX table, the most unfavorable direction of rotation, and an external thrust coming from the most unfavorable tangential direction.

F_R = Radial Load in the middle of the shaft
 F_{RX} = Radial Load at a generic point X
 E = Output Shaft Extension

$$F_{RX} = \frac{F_R \cdot E}{2 \cdot X}$$



WEIGHTS



Weights including oil in Kg

		ROBUSA-2		ROBUS25		ROBUS30		ROBUS35		ROBUS40		ROBUS50		ROBUS60	
input		2	3	2	3	2	3	2	3	2	3	2	3	2	3
63 B14	UNV	5,1	5,9	-	-	-	-	-	-	-	-	-	-	-	-
71 B14		5,2	6,0	-	-	-	-	-	-	-	-	-	-	-	-
80B14		5,4	6,2	-	-	-	-	-	-	-	-	-	-	-	-
63/71 B5		-	-	12,8	13,4	22,2	23,4	32,0	33,5	-	-	-	-	-	-
80/90 B5		-	-	13,7	14,3	23,4	24,2	32,5	34,2	39,4	41,7	74,0	78,6	-	-
100/112 B5		-	-	15,4	16,0	24,7	25,7	34,2	35,7	40,9	43,1	75,1	82,9	135,8	141,2
132 B5		-	-	-	-	-	-	-	-	47,3	49,6	87,5	92,0	136,9	142,3
160 B5		-	-	-	-	-	-	-	-	-	-	89,9	-	139,3	144,3
180 B5		-	-	-	-	-	-	-	-	-	-	-	-	139,0	144,4
63 B14	FSW	5,5	6,3	-	-	-	-	-	-	-	-	-	-	-	-
71 B14		5,6	6,4	-	-	-	-	-	-	-	-	-	-	-	-
80 B14		5,8	6,6	-	-	-	-	-	-	-	-	-	-	-	-
63/71 B5		-	-	14,7	15,3	25,8	27,0	37,2	38,7	-	-	-	-	-	-
80/90 B5		-	-	15,6	16,2	27,0	27,8	37,7	39,4	45,9	48,2	88,0	92,6	-	-
100/112 B5		-	-	17,3	17,9	28,3	29,3	39,4	40,9	47,4	49,6	89,1	96,9	164,8	170,2
132 B5		-	-	-	-	-	-	-	-	53,8	56,1	101,5	106,0	165,9	171,3
160 B5		-	-	-	-	-	-	-	-	-	-	103,9	-	168,3	173,3
180 B5	-	-	-	-	-	-	-	-	-	-	-	-	168,0	173,4	
63 B14	FBF	-	-	-	-	-	-	-	-	-	-	-	-	-	-
71B14		-	-	-	-	-	-	-	-	-	-	-	-	-	-
80 B14		-	-	-	-	-	-	-	-	-	-	-	-	-	-
63/71 B5		-	-	15,6	16,2	26,6	27,8	39,5	41,0	-	-	-	-	-	-
80/90 B5		-	-	16,4	17,1	27,8	28,6	40,0	41,7	49,7	52,0	95,7	100,3	-	-
100/112 B5		-	-	18,1	18,8	29,1	30,1	41,7	43,2	51,2	53,4	96,8	104,6	162,2	167,6
132 B5		-	-	-	-	-	-	-	-	57,6	59,9	109,2	113,7	163,3	168,7
160 B5		-	-	-	-	-	-	-	-	-	-	111,6	-	165,7	170,7
180 B5	-	-	-	-	-	-	-	-	-	-	-	-	165,4	170,8	

120 56B5	=UNV+0,2														
140 63B5	=UNV+0,25														
160 71B5		=UNV+0,9		=UNV+0,9											
200 80/90B5		=UNV+1,7		=UNV+1,7				=UNV+1,8							
250 100/112B5								=UNV+3,8							
300 132B5									=UNV+4,1						
350 160/180B5									=UNV+7,2			=UNV+5,8			
450 200B5												=UNV+9,8		=UNV+8,9	
														=UNV+19,9	

DIMENSIONS

ROBUS	motor type		Nm	Mm	Pm	Sm	Dm	tm	bm	L(PAM)
A2	63	B14	60	75	90	M6	11	12,8	4	204,5
	71	B14	70	85	105	M7	14	16,3	5	211,5
	80	B14	80	100	120		19	21,8	6	231,5
25	63	B5	95	115	140	M8	11	12,8	4	273,0
	71	B5	110	130	160		14	16,3	5	
	80	B5	130	165	200	M10	19	21,8	6	274,0
	90	B5				M10	24	27,3	8	
	100/112	B5	180	215	250	M12	28	31,3	8	280,0
30	71	B5	110	130	160	M8	14	16,3	5	319,0
	80	B5	130	165	200	M10	19	21,8	6	328,0
	90	B5				M10	24	27,3	8	
35	100/112	B5	180	215	250	13	28	31,3	8	329,0
	71	B5	110	130	160	M8	14	16,3	5	357,0
	80	B5	130	165	200	M10	19	21,8	6	366,0
40	90	B5				M10	24	27,3	8	367,0
	100/112	B5	180	215	250	13	28	31,3	8	367,0
	80	B5	130	165	200	M10	19	21,8	6	399,5
	90	B5				M10	24	27,3	8	
	100/112	B5	180	215	250	M12	28	31,3	8	401,5
50	132	B5	230	265	300		38	41,3	10	413,5
	80	B5	130	165	200	M10	24	27,3	8	446,5
	90	B5				M10	24	27,3	8	
	100/112	B5	180	215	250	M12	28	31,3	8	450,0
	132	B5	230	265	300		38	41,3	12	
	160	B5	250	300	350	M16	42	45,3	12	519,5
	180	B5					48	51,8	14	
	90	B5								
	100/112	B5								
	132	B5								
60	160	B5								
	180	B5								
	100/112	B5	180	215	250	M12	28	31,3	8	
	132	B5	230	265	300		38	41,3	12	
	160	B5	250	300	350	M16	42	45,3	12	585,5
	180	B5	250	300	350		48	51,8	14	
	200	B5	300	350	400		55	59,3	16	

PAM

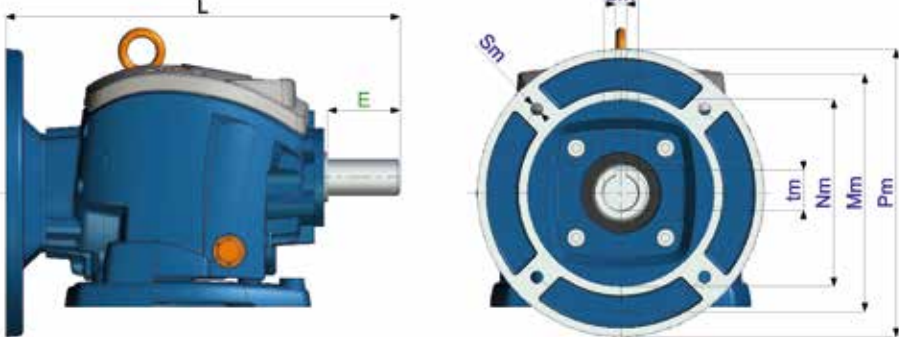

B	D1	f	b1	t1	L (MF)
40	16	M6x16	5	18	249,0
40	19	M6x16	6	21,5	318,5
40	19	M6x16	6	21,5	372,0
50	24	M8x25	8	27	420,0
40	19	M6x16	6	21,5	443,5
50	24	M8x25	8	27	453,5
40	19	M6x16	6	21,5	563,5
60	28	M10x25.5	8	31	583,5
50	24	M8x25	8	27	638,5
60	28	M10x25.5	8	31	648,5

MF



MF kit

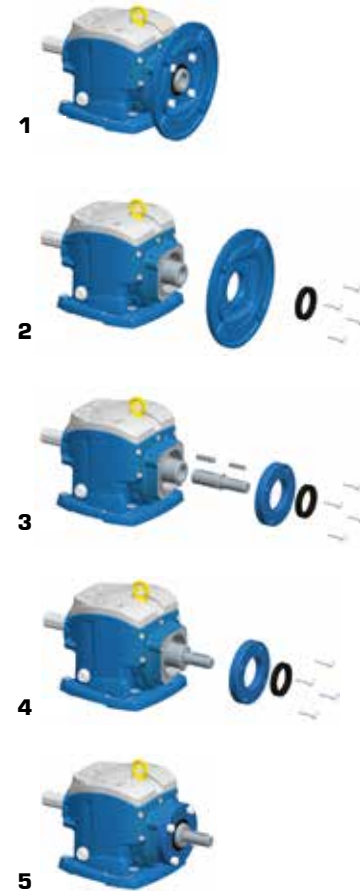

You can download 2D and 3D drawings from www.motive.it

DIMENSIONS

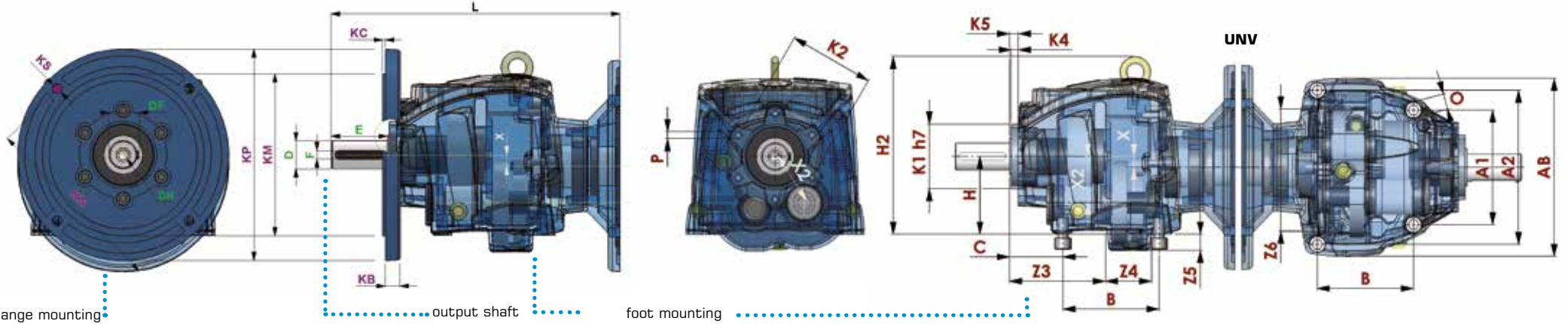

flange mounting

output shaft

foot mounting

ROBUS	IEC	KP	KM	KN	KS	KC	KB	D	E	F	DF	DH	X	X2	type	B	BA	A	AB	O	H	H2	C	P	K1	K2	K4	K5	Z1	Z2	Z3	Z4	Z5	Z6				
25	80/90B5	200	130	165	11	3,5	12	25 (k6)	50	8	28	M10x20L	11	52,5	SW	130	171,5	110	182	9	90	193,6	25	-	-	-	-	-	-	-	-	-	-	-	-			
	71B5	160	110	130	9	3,5	10	30 (k6)	60	8	33	M10x20L			BF	107,5	173,8	130	180,5	9	100	203,5	18	-	-	-	-	-	-	-	-	-	-	-	-	-		
	UNV	90,6	-	-	-	-	-	-	-	-	-	-	-	-	UNV	90,6	-	A1= 108	A2= 145,2	170	M8	73,5	180	54,5	M6	68	80	6,5	9,5	45	44	95	53	16,5	128			
30	80/90B5	200	130	165	11	3,5	12	30 (k6)	60	8	33	M10x20L	13,5	66	SW	165	203	135	230	14	115	238,6	31,6	-	-	-	-	-	-	-	-	-	-	-	-	-	-	
	71B5	160	110	130	9	3,5	10	35 (k6)	70	10	38	M10x20L			BF	130	213,5	160	231,5	14	120	243,5	19,6	-	-	-	-	-	-	-	-	-	-	-	-	-	-	-
	UNV	115,8	-	-	-	-	-	-	-	-	-	-	-	-	UNV	115,8	-	A1= 138	A2= 185,6	215	M12	94	215	64	M8	80	94	6,5	10	56	55	116	54	20	155			
35	100/112B5	250	180	215	14	4	15	35 (k6)	70	10	38	M12x24L	17	72	SW	195	238	150	260	14	130	264	30	-	-	-	-	-	-	-	-	-	-	-	-	-	-	
	80/90B5	200	130	165	11	4	12	40 (k6)	80	12	43	M16x32			BF	149,5	246,8	180	269	14	140	274,5	19,5	-	-	-	-	-	-	-	-	-	-	-	-	-	-	-
	UNV	131	-	-	-	-	-	-	-	-	-	-	-	-	UNV	131	-	A1= 156	A2= 210	243	M12	106	235	74	M10	90	110	7	13	63	57	135	58	20	168			
40	132B5	300	230	265	14	4	21	40 (k6)	80	12	43	M16x32	16	80	SW	205	256	170	292	18	140	287	38	-	-	-	-	-	-	-	-	-	-	-	-	-	-	
	100/112B5	250	180	215	14	4	19	50 (k6)	100	14	53,5	M16x32			BF	156	266	225	290	18	155	302	28	-	-	-	-	-	-	-	-	-	-	-	-	-	-	
	UNV	141	-	-	-	-	-	-	-	-	-	-	-	-	UNV	141	-	A1= 168	A2= 226	262	M16	114	262	81,5	M12	95	125	10,5	16	69	66	143	70	25	190			
50	160/180B5	350	250	300	18	5	21	50 (k6)	100	14	53,5	M16x32	18	103	SW	260	327,7	215	366	18	180	357	39,5	-	-	-	-	-	-	-	-	-	-	-	-	-		
	132B5	300	230	265	14	4	19	60 (m6)	120	18	64	M20x40			BF	180	336	250	372,5	18	195	372	24,5	-	-	-	-	-	-	-	-	-	-	-	-	-	-	
	UNV	181,3	-	-	-	-	-	-	-	-	-	-	-	-	UNV	181,3	-	A1= 216	A2= 290,6	336	M16	148	313	91,5	M14	132	155	11,5	16	91	83,5	170	94	30	250			
60	225B5	450	350	400	18	5	25	60 (m6)	120	18	64	M20x40	20	120	SW	310	393	250	430	22	225	428	40	-	-	-	-	-	-	-	-	-	-	-	-	-		
	160/180B5	350	250	300	18	5	21	70 (m6)	140	20	74,5	M20x40			BF	165	394	300	437,5	22	217	421	25	-	-	-	-	-	-	-	-	-	-	-	-	-		
	UNV	217,6	-	-	-	-	-	-	-	-	-	-	-	-	UNV	217,6	-	A1= 259,2	A2= 348,7	405	M16	176	381	103	M14	154	180	14	18	105	105	185	120	39	295			

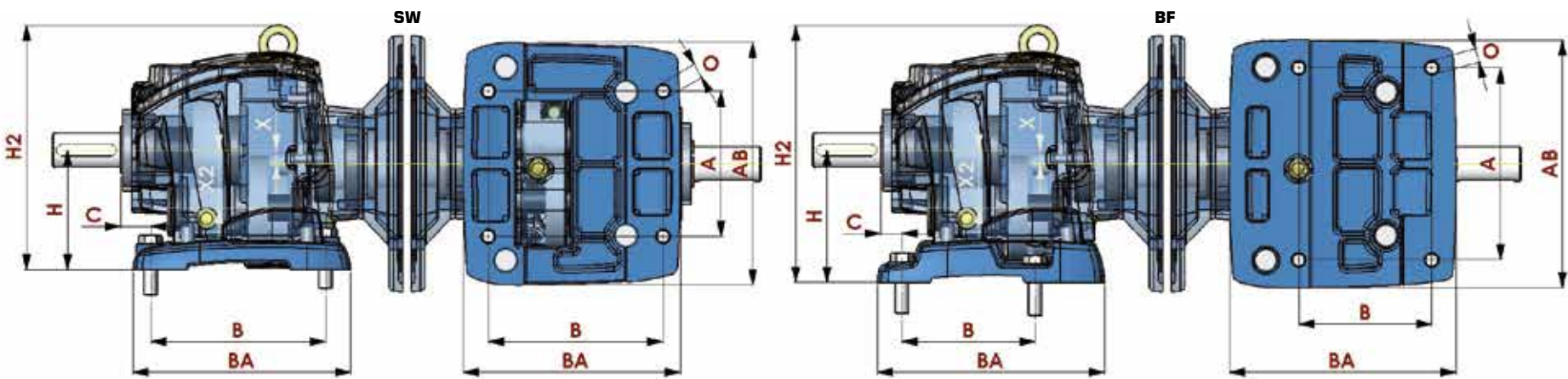

DIMENSIONS

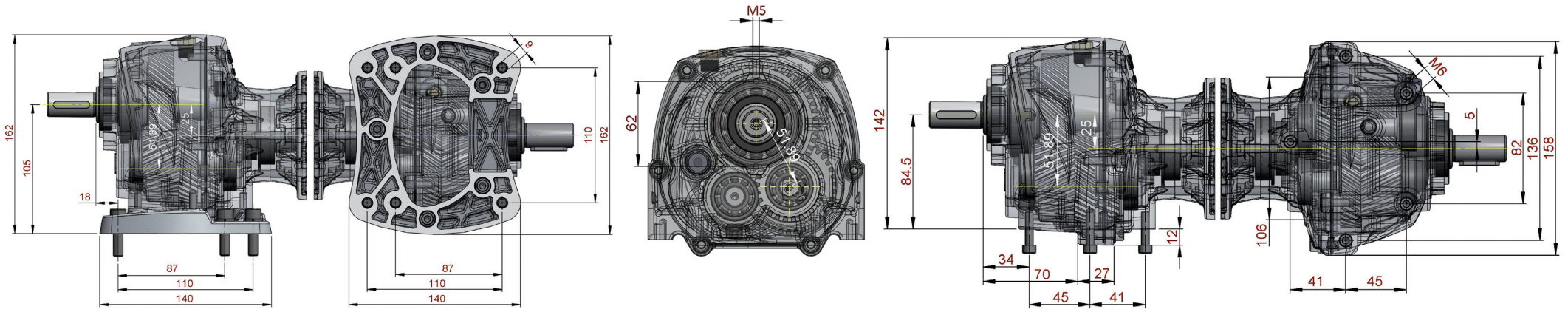

ROBUS	D	E	F	DF	DH
A2	20 (k6)	40	6	23	M5x12,5
	25 (k6)	50	8	28	M10x20L

ROBUS	IEC	KP	KM	KN	KS	KC	KB
A2	56B5	120	80	100	7	3	8
	63B5	140	95	115	10	3	9

ROBUS	motor type	Nm	Mm	Pm	Sm	Dm	tm	bm	L
A2	63 B14	60	75	90	M6	11	12,8	4	212,5
	71 B14	70	85	105	M7	14	16,3	5	212,5
	80 B14	80	100	120		19	21,8	6	227,0

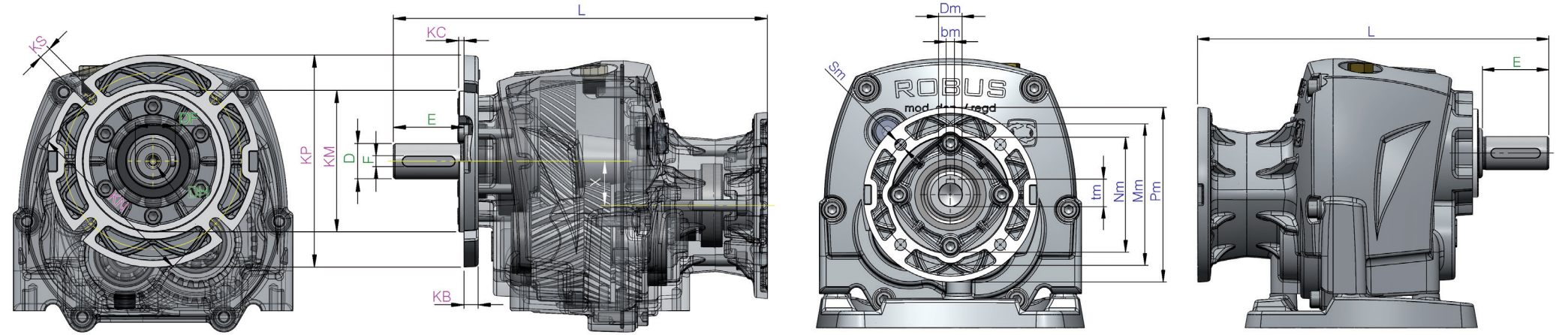

DICHIARAZIONE DECLARATION



- [1] **AVVISO DI RICEVIMENTO**
ACKNOWLEDGEMENT OF RECEIPT
- [2] **Apparecchiature o Sistemi di Protezione destinati ad essere utilizzati in atmosfere potenzialmente esplosive** Direttiva 2014/34/UE
Equipment or Protective System or Component intended for use in potentially explosive atmospheres Directive 2014/34/UE
- [3] Numero dell'avviso di ricevimento: TÜV IT 21 ATEX 026 AR Rev.1
Acknowledgement of receipt number:
- [4] **Apparecchiatura o sistema di protezione:**
Equipment or protective system:



RIDUTTORE A VITE SENZA FINE Serie BOX WORM GEARBOX Series BOX
RIDUTTORE ORTOGONALE Serie ENDURO BEVEL HELICAL GEARBOX Series BOX
RIDUTTORE COASSIALE Serie ROBUS IN-LINE HELICAL GEARBOX Series ENDURO
PRE-COPPIA Serie STADIO PRE-STAGE Series STADIO
RIDUTTORE PENDOLARE Serie STON PARALLEL SHAFT GEARBOX Series STON

- [5] Identificazione del fascicolo tecnico data dal richiedente:
Technical file reference given by applicant:
FASCICOLO TECNICO RIDUTTORI ATEX 2GD FT_RIDEX2GD (Rev.01 - 11/05/2021)
ATEX 2GD GEARBOXES TECHNICAL FILE FT_RIDEX2GD (Rev.01 - 11/05/2021)
- [6] Richiedente / Applicant: **MOTIVE S.r.l.**
Via Le Ghiselle 20
IT - 25014 CASTENEDOLO (BS)
- [7] Costruttore / Manufacturer: **MOTIVE S.r.l.**
Via Le Ghiselle 20
IT - 25014 CASTENEDOLO (BS)

[8] Il TÜV Italia, organismo notificato n° 0948 in conformità Direttiva 2014/34/UE del Consiglio dell'Unione Europea del 26 Febbraio 2014, avvisa il richiedente di aver ricevuto il fascicolo tecnico relativo all'apparecchiatura o sistema di protezione sopra citato in accordo alla procedura definita all'articolo 13 paragrafo 1-b-ii della Direttiva 2014/34/UE. TÜV Italia, notified body n° 0948 in accordance with the Council Directive 2014/34/UE of 26 February 2014, notifies to the applicant to have received the technical file relates to the equipment or protective system above mentioned according to procedure defined to Article 13 paragraph 1-b-ii of the Directive 2014/34/UE.

Data prima emissione / First issue date: 17/03/2021
Data emissione / Issue date: 20/05/2021
Data scadenza / Expiry date: 16/03/2031



TÜV ITALIA Srl
Organismo Notificato No. 0948
Notified Body, No. 0948

Questa dichiarazione può essere riprodotta solo integralmente e senza alcuna variazione.
This declaration may only be reproduced in its entirety and without any change.

ROBUS EX SERIES



II 2G Ex h IIC T4 Gb
II 2D Ex h IIIC T135°C Db
Tamb = -20 +40°C



ATEX is the conventional name of the Directive 14/34/EC for the equipment intended for use in potentially explosive atmospheres.

It imposes the evaluation of the risk for all the equipment operating in such environments. It classifies several levels of "danger" (zones): to every zone it corresponds a different typology of explosive atmosphere, according to its composition and to its probability and time of appearance.

Motive gearboxes series BOX Ex, STADIO Ex, STON Ex, ROBUX Ex and ENDURO Ex are certified according to the norms EN ISO/IEC 80079-36:2016, EN ISO/IEC 80079-37:2016, EN 1127-1:2019 for the zones 1, 21, 2 and 22

DELPHI-Ex three-phase ATEX motors and STON-Ex, ROBUX-Ex, ENDURO-Ex, BOX-Ex, STADIO-Ex ATEX gearboxes also certified in Ukraine, and in the EAC Countries



ALSO MOTIVE ITSELF IS ATEX

Not only its products, but also Motive itself is ATEX

If you design and manufacture ATEX products, the requirements of a normal ISO9001 Quality System are not sufficient for your organization. You must satisfy also another standard that takes its cue from ISO9001 to add much more, the **ISO/IEC 80079-34 "Explosive atmospheres - Part 34: Application of quality systems for Ex product manufacture"**. It is on the basis of this norm that an accredited certification body (such as the TÜV in our case) must verify whether the manufacturer's quality assurance system complies with Annex VII of the ATEX Directive. Receiving an ATEX certified

NOTIFICATION

PRODUCT QUALITY ASSURANCE NOTIFICATION

Equipment or Protective System or Component intended for use in potentially explosive atmospheres
Directive 2014/34/UE

Notification number: **TÜV IT 21 ATEX 021 Q**

Equipment or Component as listed: **Electric Motor, Frequency Converter**

Protection concept: **"n" and "r"**

Manufacturer: **MOTIVE S.r.l.**
Via Le Ghiselle, 20
I-25014 Castenedolo (BS) - ITALIA

Site visited: **identical**

TÜV Italia, notified body no. 0948 in accordance with the Council Directive 2014/34/UE of 26 February 2014, notifies that the manufacturer has a product quality assurance system which complies to Annex VII of the Directive.

This notification is based on audit report no. P.21 EX 015 issued on 02.03.2021

This notification can be withdrawn if the manufacturer no longer satisfies the requirement of Annex VII.

Results of periodical re-assessment of the quality system are a part of this notification.

This notification is valid until 16.03.2031 and can be withdrawn if the Manufacturer does not satisfy the production quality assurance re-assessment.

According to Article 16 paragraph 3 of the Directive 2014/34/UE the CE marking shall be followed by the identification no. 0948 identifying the notified body involved in the production control step.

This notification may only be reproduced in its entirety and without any change.

First Issue Date: 26.03.2021
Issue Date: 26.03.2021

TÜV Italia S.r.l.
Notified Body n° 0948

Industry Service - Real Estate & Infrastructure
Managing Director

1/1

TÜV Italia • Gruppo TÜV SÜD • Via Carcano, 175, Pal. 23 • 20099 Sesto San Giovanni (MI) • Italia • www.tuv.it

product, in fact, does not in itself mean that the manufacturer's organization has done everything to always ensure product and service compliance, even in after-sales. Just to give an example, from a serial number of an Ex motor the manufacturer should be able to trace the batch of each component that is critical for Ex safety (like winding, terminal block, castings of shields, housing, and terminal box, etc.) and, then, the chemical composition of the aluminum or iron castings with which they were made, the mechanical properties of the batch of the terminal block, and so on. Serial number by serial number. Lot by lot. It is a commitment that Motive has managed to standardize on all its products, ATEX and not, through the digitization of all internal processes, and which also adds value to standard products. A guarantee, therefore, that goes well beyond the ISO9001 that Motive already boasted since it was born in 2000, and which demonstrates the excellence of a company set up to give certainty and serenity to the customer.

Cat	DUST	GAS	Zone	description	motive gearboxes
2			1	A place in which an explosive atmosphere consisting of a mixture with air or flammable substances in the form of gas, vapor or mist is likely to occur in normal operation occasionally.	✓
3			2	A place in which an explosive atmosphere consisting of a mixture with air of flammable substances in the form of gas, vapor or mist is not likely to occur in normal operation but, if it does occur, will persist for a short period only.	✓
2			21	A place in which an explosive atmosphere in the form of a cloud of combustible dust in air is likely to occur in normal operation occasionally.	✓
3			22	A place in which an explosive atmosphere in the form of a cloud of combustible dust in air is not likely to occur in normal operation but, if it does occur, will persist for a short period only.	✓



You can download each motor or gearbox final test report from www.motive.it, starting from its serial number

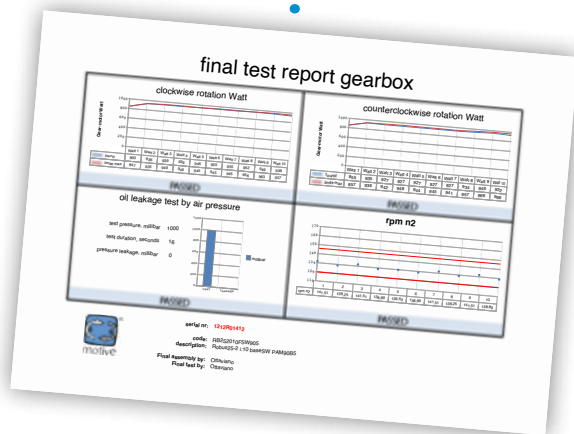

TERMS OF SALE AND GUARANTEE

ARTICLE 1 - **GUARANTEE**

1.1 Barring written agreements, entered into between the parties hereto each time, Motive hereby guarantees compliance with specific agreements.

The guarantee for defects shall be restricted to product defects following design, materials or manufacturing defects leading back to Motive.

The guarantee shall not include:

- * Faults or damages ensuing from transport. Faults or damages ensuing from installation defects; incompetent use of the product, or any other unsuitable use.
- * Tampering or damages ensuing from use by non-authorized staff and/or use of non-original parts and/or spare parts;
- * Defects and/or damages ensuing from chemical agents and/or atmospheric phenomena (e.g. burnt out material, etc.); routine maintenance and required action or checks;
- * Products lacking a plate or having a tempered plate.

1.2 Returns to credit or replace will be accepted only in exceptional cases; however returns of goods already used to credit or replace won't be accepted in any case. The guarantee shall be effective for all Motive products, with a term of validity of 12 months, starting from the date of shipment.

The guarantee shall be subject to specific written request for Motive to take action, according to statements, as described at the paragraphs herein below. By virtue of aforesaid approval, and as regards the claim, Motive shall be bound at its discretion, and within a reasonable time-limit, to alternatively take the following actions:

- a) To supply the Buyer with products of the same type and quality as those having proven defective and not complying with agreements, free ex-works; in aforesaid case, Motive shall have the right to request, at Buyer's charge, early return of defective goods, which shall become Motive's property;
- b) To repair, at its charge, the defective product or to modify the product which does not comply with agreements, by performing aforesaid action at its facilities; in aforesaid cases, all costs regarding product transport shall be sustained by the Buyer.
- c) To send spare parts free of charge: all costs regarding product transport shall be sustained by the Buyer.

1.3. The guarantee herein shall assimilate and replace legal guarantees for defects and discrepancies, and shall exclude any other eventual Motive liability, however caused by supplied products; in particular, the Buyer shall have no right to submit any further claims.

Motive shall not be liable for the enforcement of any further claims, as of the date the guarantee's term of validity expires.

ARTICLE 2 - **CLAIMS**

2.1. Claims, regarding quantity, weight, gross weight and colour, or claims regarding faults and defects in quality or compliance, and which the Buyer may discover on goods delivery, shall be submitted by a max. 7 days of aforesaid discovery, under penalty of nullity.

ARTICLE 3 - **DELIVERY**

3.1. Any liability for damages ensuing from total or partial delayed or failed delivery, shall be excluded.

3.2. Unless differently communicated by written to the Client, the transport terms have to be intended ex-works.

ARTICLE 4 - **PAYMENT**

4.1. Any delayed or irregular payments shall entitle Motive to cancel ongoing agreement, including agreements which do not regard the payments at issue, as well as entitling Motive to claim damages, if any.

4.2. The Buyer shall be bound to complete payment, including cases whereby claims or disputes are underway.



**DOWNLOAD
THE TECHNICAL MANUAL
FROM WWW.MOTIVE.IT**

ALL DATA HAVE BEEN WRITTEN AND CHECKED WITH THE GREATEST CARE. WE DO NOT TAKE ANY RESPONSIBILITY FOR POSSIBLE ERRORS OR OMISSIONS. MOTIVE CAN CHANGE THE CHARACTERISTIC OF THE SOLD ITEMS ON HIS FIRM OPINION AND IN EVERY MOMENT.



ASK OUR FURTHER CATALOGUES:



LOOKS GOOD, PERFORMS BETTER



ROBUS TECHNICAL CATALOGUE ENG GIU 21 REV.09



Motive s.r.l.

Via Le Ghiselle, 20

25014 Castenedolo (BS) - Italy

Tel.: +39.030.2677087 - Fax: +39.030.2677125

web site: www.motive.it

e-mail: motive@motive.it



AREA DISTRIBUTOR