



HOLLAND FIFTH WHEELS

GC 6, FW3214-W, SK-S 36.20 H, FWAL-E, SK-S 36.20,
SK-S 36.20 W, SK-S 36.20 NOLUBE, FW3510, SK-HD 38.36,
SK-HD 38.36 G, FW0100, FW0165, FW3510-TR, FW0E70-T

FIFTH WHEELS AND KINGPINS



Perfectly matched:
SAF-HOLLAND
fifth wheel and
kingpin

SAF-HOLLAND
develops and
manufactures
innovative,
high-quality
connections

The reliable connection between tractor unit and trailer

All fifth wheels and kingpins from SAF-HOLLAND are the result of permanent, systematic product optimisation – precisely matched to all types of tractor units and their area of application. Whether light trucks of up to 7.5 tons, heavy all-terrain transport of 36 tons or abnormal loads of up to 75 tons, our fifth wheels and kingpins are the perfect solution for any transport task – both in rail transport, with terminal tractor units and in harbour applications. When used in combination with the SAF-HOLLAND kingpins, we guarantee complete safety and reliability.



6t

- light distribution traffic
- mid-sized carrier class
- recreational vehicles up to 7.5t



14/15t

- flexible distribution traffic
- volume carrier
- two-axle tractor



20t

- standard long-distance haulage
- silo, tank and volume transport
- two- and three-axle tractors



36t

- HGV traffic
- traffic in difficult terrain

GC 6



Imposed load: 6,000 kg
 D-value: 49 kN
 Overall height: 120 mm

FW3214-W

Page 9



Imposed load: 14,000 kg
 D-value: 104 kN
 Overall heights: 165, 190, 225 mm

FWAL-E



Imposed load: 20,000 kg
 D-value: 150 kN
 Overall heights: 167, 197, 219 mm

SK-HD 38.36



Lock size: 2"/3.5"
 Imposed load: 23,000 kg (2")
 36,000 kg (3.5")
 D-value: 162/260 kN
 Overall heights: 150, 190 mm

SK-S 36.20 H

Page 15



Imposed load: 15,000 kg
 D-value: 110 kN
 Overall height: 167 mm
 Lift heights: 100, 150, 200 mm

SK-S 36.20

Page 11



Imposed load: 20,000 kg
 D-value: 152 kN
 Overall heights: 128, 150, 185,
 225, 250 mm

SL-HD 38.36 G



Fifth wheel for off-road use
 with gimbal mounting
 Lock size: 2"/3.5"
 Imposed load: 23,000 kg (2")
 36,000 kg (3.5")
 D-value: 162/260 kN
 Overall height: 290 mm

SK-S 36.20 W/ SK-S 36.20 NoLube

Page 13



Imposed load: 20,000 kg
 D-value: 152 kN
 Overall heights: 128, 150, 185,
 225, 250 mm

FW3510

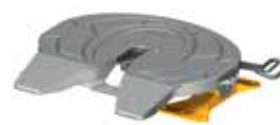

Imposed load: 23,000 kg
 D-value: 175 kN
 Overall heights: 150, 180, 200 mm



45 – 75t

- Extremely heavy goods transports and special transports



TERMINAL

- For transport with terminal tractor units



HARBOUR

- Special model for harbour applications

FW0100

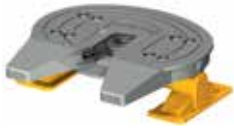

Imposed load: 45,000 kg
D-value: 165/170 kN (2")
240 kN (3.5")
Overall heights: 230, 270 mm

FW3510-TR

Page 17



Imposed load: 36,000 kg
23,000 kg*
D-value: 175 kN
*(when used in highway traffic)

FW0E70-T



Imposed load: 45,000 kg
D-value: 165 kN (2")
250 kN (3.5")

FW0165

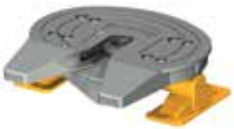

Imposed load: 74,000 kg
D-value: 165/170 kN (2")
240 kN (3.5")
Overall heights: 230, 270 mm

Kingpin

Page 19



D-value 2" 50S15 165 kN
D-value 2" 50S18 165 kN
D-value 3.5" 90S15 165 kN
D-value 3.5" 90S18 350 kN

Specifications

The load data specified only applies to operation on paved roads and to transport conditions usual in Central Europe. Please contact us regarding operating conditions which deviate from these. We reserve the right to modify dimensions or design if required. No responsibility is taken for the correctness of the details provided, these are solely intended for technical information.



Imposed load: 6,000 kg
D-value: 49 kN

Overall height: 120 mm
ECE test no.: E11 55R-01 6737

Lighweight, spheroidal graphite cast iron 6t fifth wheel optimised for midsized distribution vehicles and volume transports

- 2" fifth wheel with exchangeable wear ring
- Safe and comfortable single-handed operation
- Automatic safety lock
- Low-maintenance bearings
- Lubrication channels for effective grease flow
- Wear ring fully compatible with SK-S 36.20
- Connections for optional grease cartridge
- Approved for forced steering

GC 6



Imposed load: 14,000 kg
D-value: 104 kN

Overall heights: 165, 190, 225 mm
ECE test no.: E11 55R-01 7836

The first 14t chassis-integrated fifth wheel

- Weight- and load-optimised for more potential payload
- Tuned exactly to the tractor unit
- Use of load-optimised and wear-optimised slide plates
- Low maintenance and particularly service-friendly
- Safe and comfortable single-handed operation
- Available for Mercedes-Benz Actros and Antos

Page 9

FW3214-W (LOW MAINTENANCE)



Imposed load: 15,000 kg
D-value: 110 kN

Overall heights: 167-267, 167-317, 167-367 mm
ECE test no.: E11 55R-01 1381

The proven height adjustable spheroidal graphite cast iron 15t fifth wheel

- Extremely robust and user friendly
- Weight optimised model
- Connections for central lubrication
- Simple wear adjustment
- Automatic safety lock
- Approved for forced steering
- Can be optionally combined with RECOSS® system (available ex works as standard at Volvo and Daimler)

Page 15

SK-S 36.20 H (HEIGHT ADJUSTABLE)



Imposed load: 20,000 kg
D-value: 150 kN

Overall heights: 167, 197, 219 mm
ECE test no.: E11 55R-01 6168

The innovative 20t forged aluminium fifth wheel

- Up to 55 kg lighter
- Greaseless NoLube technology with low-friction, replaceable wear plates and pocket inserts
- Protection against coupling errors
- Option of additional weight reduction with weightsaver mounting plate (180, 205 and 243 mm)

FWAL-E



Imposed load: 20,000 kg
D-value: 152 kN

Overall heights: 128, 150, 185, 225, 250 mm
ECE test no.: E1 55R-01 0218

The lightweight, spheroidal graphite cast iron 20t fifth wheel

- Up to 33 kg lighter, reliable and robust
- Safe single-handed operation, automatic safety lock
- Simple and safe wear adjustment
- Permanent, maintenance-free bearings
- Optimised lubrication channels for effective grease flow
- Connections for central lubrication
- Optionally available with RECOSS® system (available ex works as standard at Mercedes-Benz, Volvo and Renault)
- Optionally available with direct or angle bracket mounting
- Approved for forced steering

Page 11

SK-S 36.20



Imposed load: 20,000 kg
D-value: 152 kN

Overall heights: 128, 150, 185, 225, 250 mm
ECE test no.: E1 55R-01 0218

The lightweight, low maintenance spheroidal graphite cast iron 20t fifth wheel

- Up to 33 kg lighter, designed for highway application
- Less grease consumption
- Easily replaceable low friction wear plates
- Safe single-handed operation, automatic safety lock
- Simple and safe wear adjustment
- Permanent, maintenance-free bearings
- Optionally available with RECOSS® system
- Optionally available with direct or angle bracket mounting
- Approved for forced steering

SK-S 36.20 W (LOW MAINTENANCE)



Imposed load: 20,000 kg
D-value: 152 kN

Overall heights: 128, 150, 185, 225, 250 mm
ECE test no.: E1 55R-01 0218

The lightweight 20t fifth wheel with grease-free NoLube Technology

- Up to 33 kg lighter, designed for highway application
- Easily replaceable low friction wear plates
- Safe single-handed operation
- Automatic safety lock
- Simple and safe wear adjustment
- Permanent, maintenance-free bearings
- Optionally available with RECOSS® system
- Optionally available with direct or angle bracket mounting
- Approved for forced steering

Page 13

SK-S 36.20 NOLUBE



Imposed load: 23,000 kg
D-value: 175 kN

Overall heights: 150, 180, 200 mm
ECE test no.: E11 55R-01 6172

The 23t robust cast steel fifth wheel for universal use

- Long service life and universal scope of application
- Exemplary reliability
- Low operation costs
- ISO mounting system
- Available with grease-free NoLube technology
- Suitable for steering wedge applications
- Infinite wear adjustment
- Flat, machined top surface
- Approved for forced steering
- Twin lock system with greater kingpin-to-lock surface contact

FW3510



The 36t cast steel fifth wheel for heavy transportation

- Permanent, maintenance-free bearings
- Conversion from 3.5" to 2" and vice versa possible
- Simple adjustment of locking mechanism
- Suitable for steering wedge applications

Imposed load: 23,000 kg (2"), 36,000 kg (3.5") **Overall heights:** 150, 190 mm
D-value: 162 kN (2"), 260 kN (3.5") **ECE test no.:** E11 55R-01 8550 (2"), E11 55R-01 8549 (3.5")

SK-HD 38.36



The 36t cast steel fifth wheel for heavy transportation – off-road use

- Off-road version with cardanic bearings
- Conversion from 3.5" to 2" and vice versa possible
- Simple adjustment of locking mechanism
- Suitable for steering wedge applications

Imposed load: 23,000 kg (2"), 36,000 kg (3.5") **Overall height:** 290 mm
D-value: 162 kN (2"), 260 kN (3.5")

SK-HD 38.36 G



The 45t heavy-duty fifth wheel made from high-strength cast steel for extreme applications

- Forged steel lock, heat-treated and precision machined
- Simple infinitely adjustable locking mechanism
- Recessed lubrication channels for longer grease adhesion
- Simple lubrication
- Available with 2" - or 3.5" locks

Imposed load: 45,000 kg **Overall heights:** 230, 270 mm
D-value: 165 kN (2"), 240 kN (3.5")

FW0100



The 74t heavy-duty fifth wheel made from high-strength cast steel

- Forged steel lock, heat-treated and precision machined
- Simple infinitely adjustable locking mechanism
- Recessed lubrication channels for longer grease adhesion
- Simple lubrication
- Available with 2" - or 3.5" locks

Imposed load: 74,000 kg **Overall heights:** 230, 270 mm
D-value: 165 kN (2"), 240 kN (3.5")

FW0165

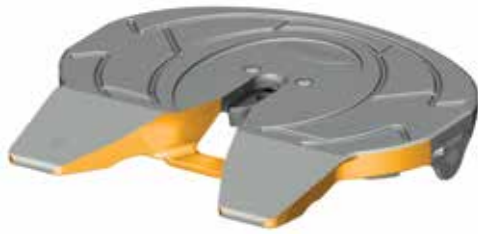

Imposed load: up to 36,000 kg (23,000 kg when used in highway traffic)
D-value: 175 kN **ECE test no.:** : E11 55R-01 6172

The Ideal 36t cast steel air-operated fifth wheel – specially designed for terminal tractor applications

- Designed and adapted for the use in terminal tractors
- Cast from particularly high-grade steel
- Designed for higher imposed loads and long service life
- Optionally available with manual secondary locking mechanism for trailer movements on public roads
- Optionally available with electronic locking sensor technology
- Suitable for steering wedge applications

FW3510-TR TERMINAL TRACTOR



Imposed load: up to 45,000 kg
D-value: 165 kN (2"), 240 kN (3.5")

The 45t heavy-duty cast steel air operated fifth wheel – specially designed for harbour applications

- Available with 2" or 3.5" locks
- Precisely adjusted for heavy duty use in terminal tractors
- Cast from particularly high-grade steel
- Designed for higher imposed loads and long service life

FW0E70-T TERMINAL TRACTOR

FW3214-W

FRAME-INTEGRATED FIFTH WHEEL

SAF-HOLLAND developed the first 14t frame-integrated fifth wheel in close cooperation with Mercedes-Benz Trucks. With coupling plates from Georg Fischer made from spheroidal graphite cast iron, it offers a complete solution for Mercedes-Benz Actros and Antos that is both weight-optimised and load-optimised.

The frame-integrated fifth wheel is found directly in the vehicle frame and is tuned optimally to the tractor unit, meaning it achieves a significantly higher payload potential compared to similar products.

BENEFITS AT A GLANCE:

- **Low-maintenance and particularly easy to use thanks to practical single-handed operation**
- **Added payload potential thanks to direct integration in the vehicle frame**
- **Load-optimised and wear-optimised coupling plates from Georg Fischer in spheroidal graphite cast iron**

VEHICLE SPECIFICATIONS

For Antos and Actros 4x2 tractor units with the following specifications:

- Wheelbase 3,700 mm with coupling point 600 mm
- Wheelbase 3,850 mm with coupling point 550, 600, 650, 700, 750 or 800 mm
- Daimler order code Q4Y (fifth wheel, integrated, SAF SK-S 32.14)



Clear weight-optimised: The integration of the fifth wheel in the vehicle frame significantly reduces the tare weight of the tractor unit.



SYSTEM WEIGHT IN kg

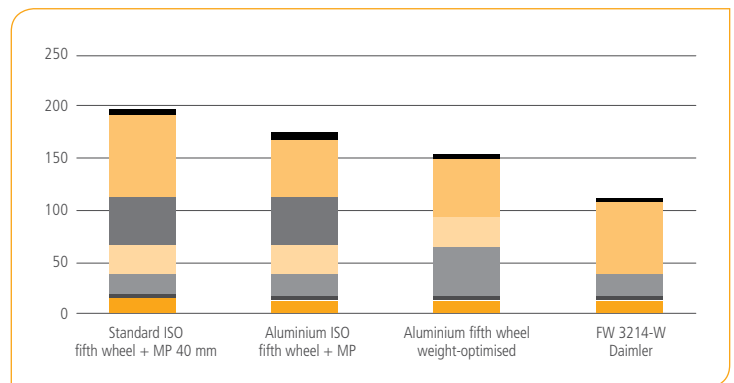

■ Lock | ■ Bearing | ■ Bearing blocks | ■ Auxiliary bracket | ■ Mounting plate 40
■ Coupling plate | ■ Fastening / mounting

SK-S 36.20 SERIES SPHEROIDAL GRAPHITE CAST IRON 20T FIFTH WHEEL



All of the fifth wheels in the SK-S 36.20 range from HOLLAND are particularly light thanks to the spheroidal graphite cast iron, and are equipped with a safety latch that allows coupling or uncoupling with one hand.

The additional benefit of the safety latch is the clear visual indication that indicates to the driver if the locking mechanism is safely engaged – or not: simply by the “up” or “down” position of the latch.

A simple mechanical safety alert that makes all the difference when it comes to safety!



Lever up – closed and locked = OK



Lever down – not locked = DANGER

Top access and pivot design result in shortest repair

LIGHTWEIGHT
116 KG
(150 MM)

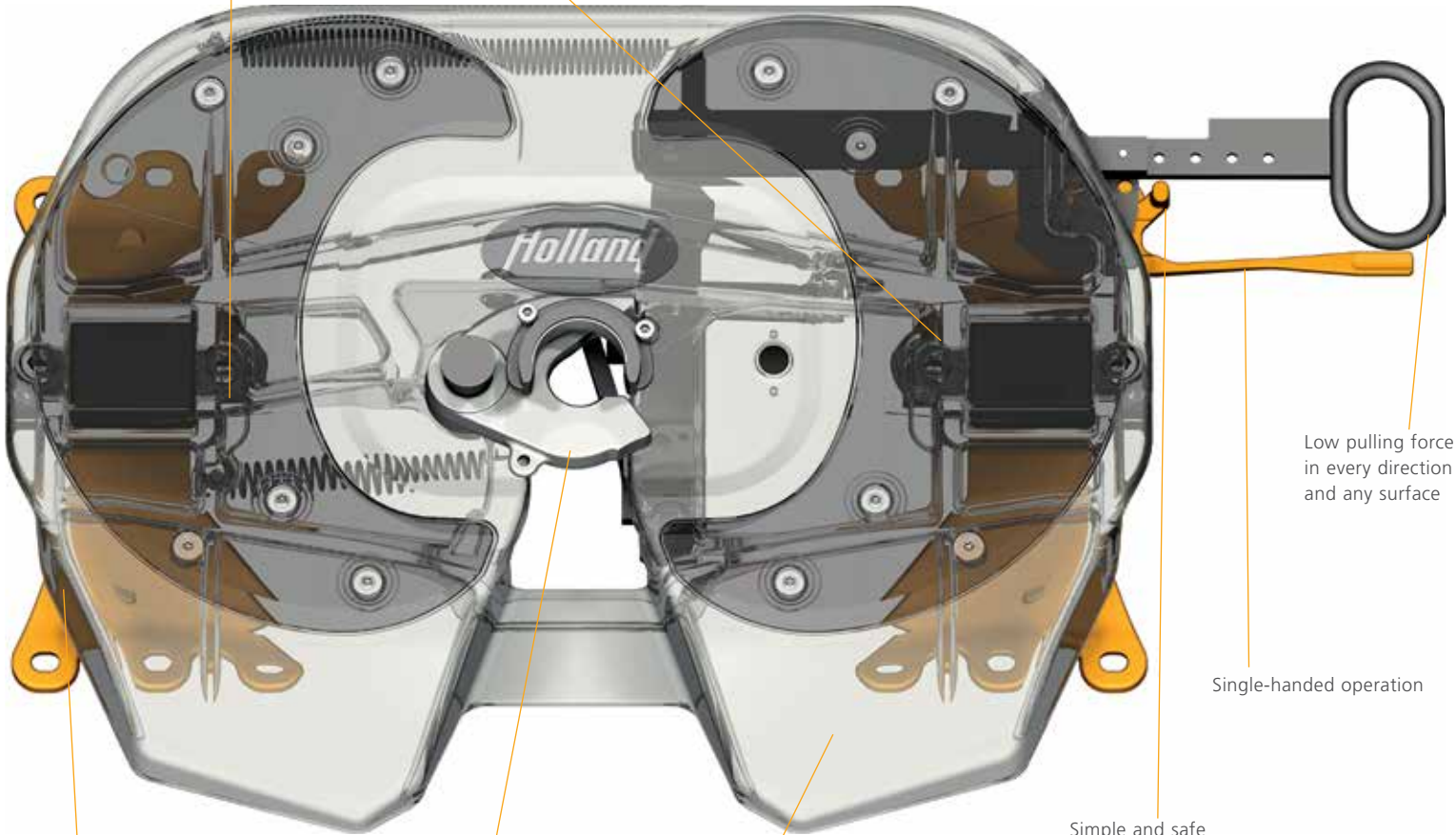

Low pulling force in every direction and any surface

Single-handed operation

Simple and safe wear adjustment

Interchangeable bracket ISO/direct mount

Unique design of spare parts – cost saving

High-quality cast components (cast by Georg Fischer)

SK-S 36.20 NoLube WITH GREASE FREE NoLube TECHNOLOGY



NoLube is short for "no lubrication" and means "no lubricating grease". The specially designed NoLube wear plates really do not require greasing any more.

The same goes for the NoLube locking mechanism components, which in the past had to be greased. The bearing inserts between the fifth wheel plate and the mounting brackets remain absolutely grease-free, too.

There is no question about it: Driving without grease does not only make sense ecologically but, in the long run, is also more favourable economically.

THE GREAT BENEFIT

No need to purchase, stock or the requirement to grease from now on.
No other comparable fifth-wheels, for example those with a central lubricating system underneath the fifth-wheel plate, are able to offer you such benefits in this form.

Overall weight: 116 kg (total height 150 mm)
Imposed load: 20t
D-value: 152 kN
Type approved to: E1 55R-01 0218

GREASE
FREE



SPECIAL LOCKING SYSTEM WITH SPECIFIC BENEFITS

1. Wear ring: designed as a polymer injection moulding produced in a single mould, the 2 component wear ring offers the optimum combination of low friction, wear resistance and strength.

2. Coupler Jaw: manufactured from a heat treated steel forging and treated with a robust low friction coating.

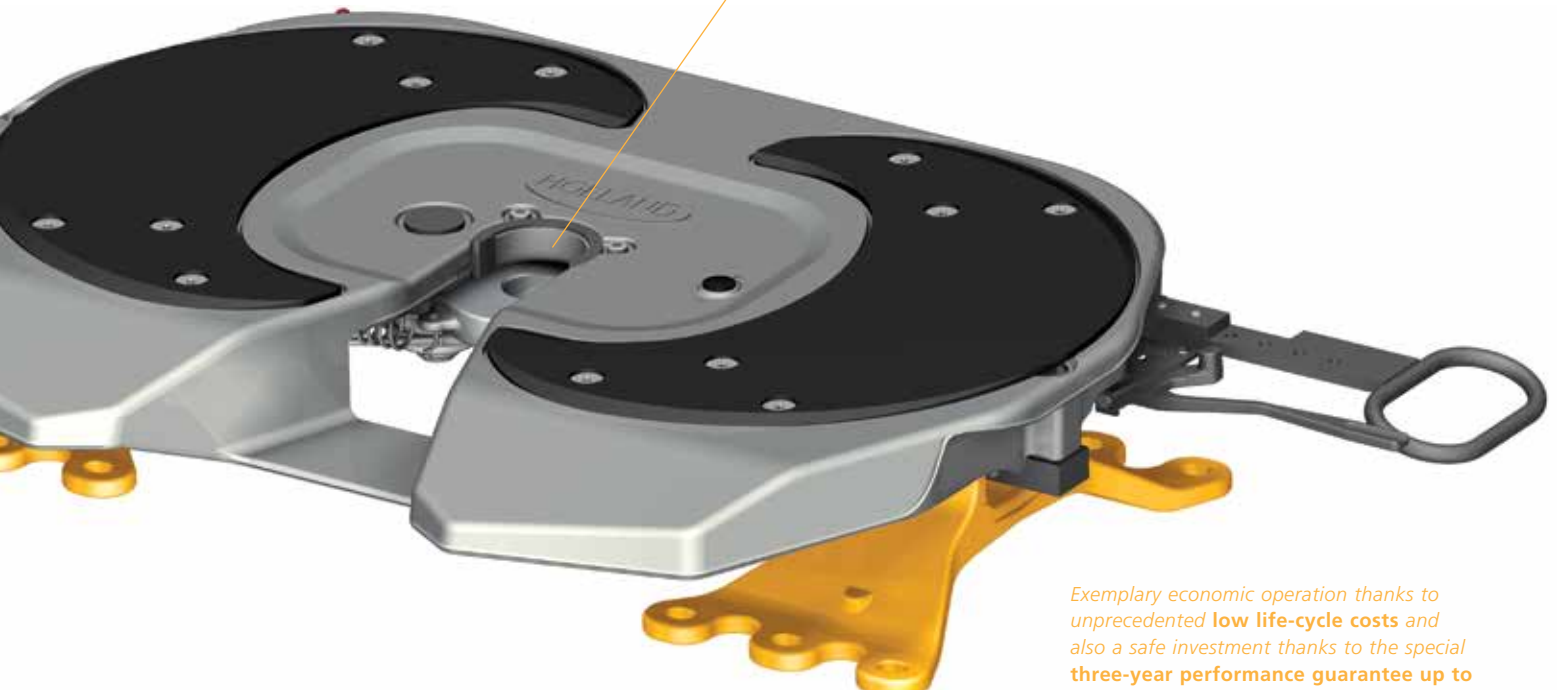

*Exemplary economic operation thanks to unprecedented **low life-cycle costs** and also a safe investment thanks to the special **three-year performance guarantee up to 500,000 km** according to the SAF-HOLLAND guarantee conditions.*

SK-S 36.20 H (HUB) HEIGHT ADJUSTABLE FIFTH WHEEL

The dual-height fifthwheel is designed for volume transportation with 2-axle low liner tractors and MEGA-trailers. The adjustable height of the fifth wheel means the low liner tractor can also be used for standard trailers.

TECHNICAL SPECIFICATIONS:

- Movement around lateral axis at basic height 6°
- Operation: adjustable (to max. 8 bar) in unhitched state by tractor's compressed air system
- Reduction of fifth wheel lead at (lift heights):
11 mm (267)/24 mm (317)/34 mm (367)

Overall height:	167 to 367 mm
Imposed load:	15t
D-value:	110 kN
Weight:	329 to 336 kg
Type Approval No.:	E1 55R-01 0218

OVERALL HEIGHTS:



Lowered position



Overall height 100 mm



Overall height 150 mm



Overall height 200 mm



FW3510-TR SERIE FOR TERMINAL TRACTORS

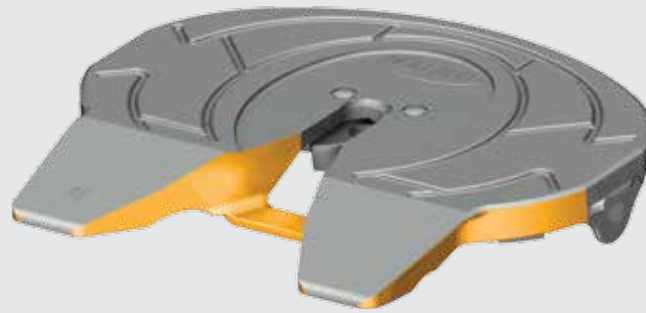

The FW3510-TR with air operation is a special development by HOLLAND and is perfectly tuned for heavy duty applications using terminal tractor units.

This fifth wheel is thus cast from particularly high-quality steel. The components are also designed for increased vertical loads and a very long service life.

The HOLLAND FW3510-TR is also optionally available with an additional manual lock for trailer transport on public roads.

Correct Couple



Incorrect Couple

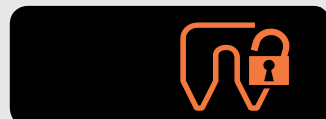

Available with Electronic Lock Indicating Sensors

Drivers can effectively manage the coupling process from inside the cab as a "back up" to visual inspection and pull test locking procedures. In addition, it can reduce the potential for improper locking, component damage and downtime.

AIR OPERATED
LOCK RELEASE
MECHANISM

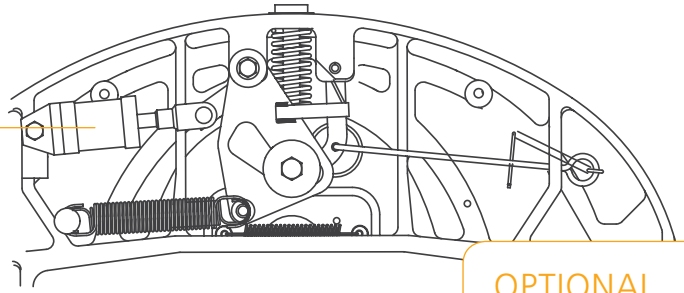

OPTIONAL
MANUAL
SECONDARY
LOCK

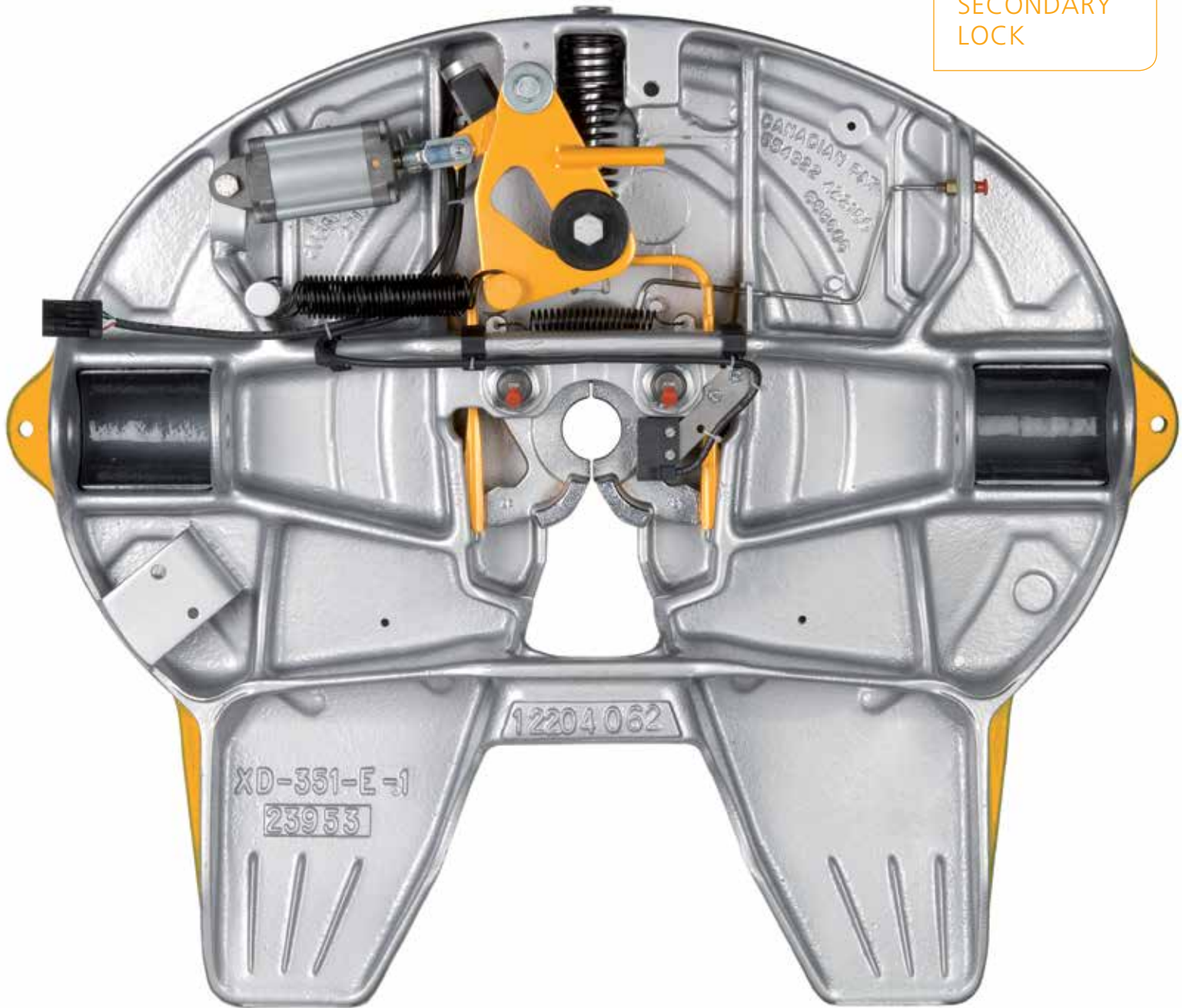

SPECIFICATIONS –
standard version

Part number	Weight	GCW	Vertical load	Max. speed
FW3510-TR	120 kg	100,000 kg	36,000 kg	35 km/h
FW3510-TR-EL	120 kg	100,000 kg	36,000 kg	35 km/h

(EL- Version with electronic lock sensor)

SPECIFICATIONS –
with optional manual secondary lock

Part number	Weight	Vertical load	D-value
FW3510-TR-EG	121 kg	23,000 kg	175 kN
FW3510-TR-EG-EL	121 kg	23,000 kg	175 kN

(EL- Version with electronic lock sensor)

THE KINGPIN – ENSURING A SAFE CONNECTION

Together with the fifth wheel, the kingpin is one of the most important vehicle components.

The safe connection between the fifth wheel and kingpin is decisive for trouble-free operation. It is of crucial importance

being able to rely on tractor/trailer connection remaining safe and in flawless condition during every trip. A very precisely integrated “system-based” approach ensures that the SAF kingpins function flawlessly at all times. Rigorous checks during production guarantee top quality.



2" SAF KINGPIN 50S15

D-value: 165 kN
Semi-trailer skid-plate thickness: 6/8/10/12 mm
Approval mark: E1 55R-01 2289

Semi-trailer skid-plate thickness	SAF kingpin mounted	Individual components		Attachment
T	Kingpin complete	Flange	Pin	Hexagon bolts (8 pcs.)
6 mm	1030 30 000005 0	2031 10 000005 0	2108 30 000002 0	2088 10 000005 0
8 mm	1030 30 000004 0	2031 10 000004 0		
10 mm	1030 30 000003 0	2031 10 000003 0		
12 mm	1030 30 000002 0	2031 10 000002 0		



2" SAF KINGPIN 50S18

D-value: 165 kN
Semi-trailer skid-plate thickness: 16 mm
Approval mark: E1 55R-01 2418

Semi-trailer skid-plate thickness	SAF kingpin mounted	Individual components		Attachment
T	Kingpin complete	Flange	Pin	Hexagon bolts (8 pcs.)
16 mm	1030 30 000012 0	2031 10 000009 0	2108 30 000006 0	2088 10 000006 0

We monitor each individual production stage intensively for all kingpins, from steel-making through to the forging and ultimately the delivery.

All forged components have to meet strict requirements during machining and are thus able to meet the highest standards – always with outstanding precision and complete reliability.



D-value: 165 kN
Semi-trailer skid-plate thickness: 8/10/12 mm
Approval mark: E1 55R-01 2371

3.5" SAF KINGPIN 90S15

Semi-trailer skid-plate thickness	SAF kingpin mounted	Individual components		Attachment
T	Kingpin complete	Flange	Pin	Hexagon bolts (8 pcs.)
8 mm	1030 30 000011 0	2031 10 000004 0	2108 30 000005 0	2088 10 000005 0
10 mm	1030 30 000010 0	2031 10 000003 0		
12 mm	1030 30 000009 0	2031 10 000002 0		



D-value: 320 kN
Semi-trailer skid-plate thickness: 16 mm
Approval mark: E1 55R-01 2426

3.5" SAF KINGPIN 90S18

Semi-trailer skid-plate thickness	SAF kingpin mounted	Individual components		Attachment
T	Kingpin complete	Flange	Pin	Hexagon bolts (8 pcs.)
16 mm	1030 30 000014 0	2031 10 000009 0	2108 30 000007 0	2088 10 000006 0

OPTIIONS

SLIDER

RECOSS

GREASE CARTRIDGE

SLIDERS AND ADDITIONAL OPTIONS

FOR OPTIMAL
UTILISATION OF
PERMISSABLE
AXLE LOADS AND
VEHICLE LENGTH

Slider with 18t imposed load

- Direct mounting on vehicle frame
- High rigidity – lightweight
- Extra low overall height
- 14 selectable coupling points
- Total slider travel of 525 mm
- Available in 2 different widths
- One person/single-handed operation, optional pneumatic version available
- Approved for forced steering
- Mounting hole pattern according to DIN 74081, DIN 74084 and ISO 3842

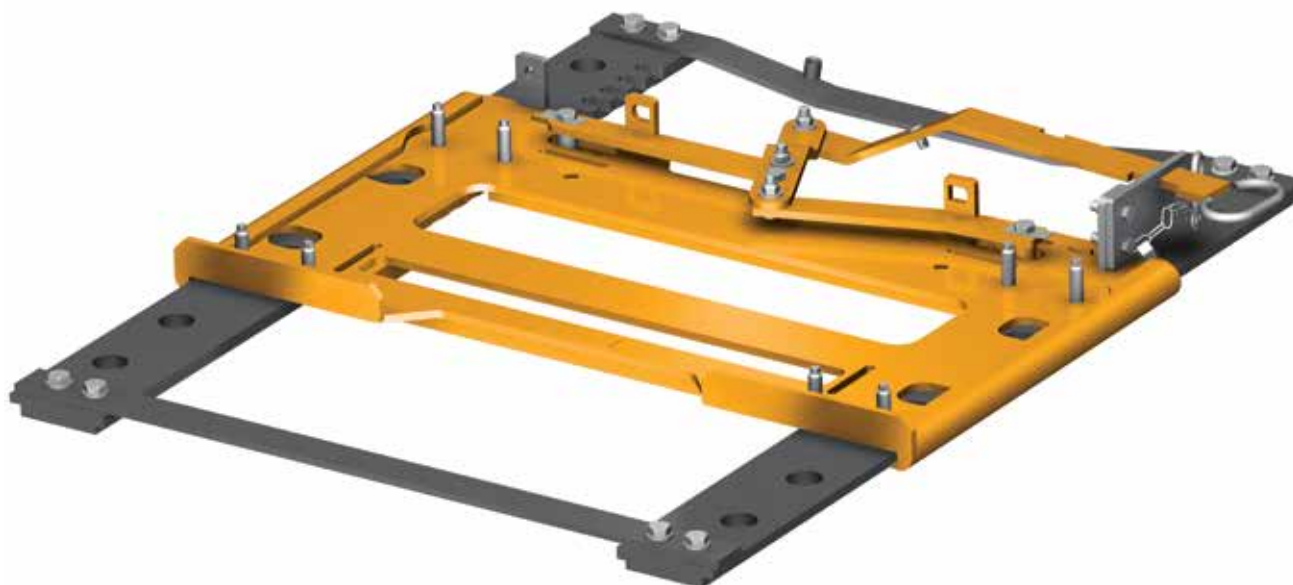

Imposed load: 18,000 kg
D-value: 135 kN

Overall height: 35 mm
ECE test no.: E11 55R-01 5482

SK-V 20 WITH 18T IMPOSED LOAD



Imposed load: 20,000 kg **Overall heights:** 180, 200, 225 mm
D-value: 150 kN **ECE test no.:** E11 55R-01 0056

Slider with 20t imposed load

- Available for all standard Holland fifth wheels FW3510
- Standard slider travel of 610 and 1220 mm
- Other versions with 915 or 1555 mm slider travel are available on request
- Standard air-operation for all types
- Fifth wheel position can be adjusted in steps of 50.8 mm spacing
- Pre-drilled hole patterns for direct mounting on vehicle chassis

ILS WITH 20T IMPOSED LOAD

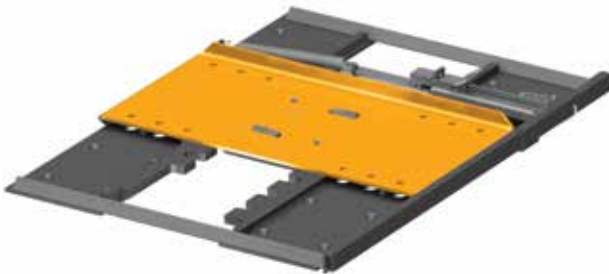

Imposed load: 22,000 kg **Overall height:** 45 mm
D-value: 162.4 kN **ECE test no.:** E11 55R-01 0386

Slider with 22t imposed load

- Easy mounting due to different versions of mounting kits
- One person/single-handed operation
- Pre-selectable coupling point
- Automatic locking, free of play, self adjusting
- 7 selectable coupling points
- Total slider travel 630 mm
- 2 designs for frame width of up to 970 mm
- Approved for forced steering

SK-V 22 WITH 22T IMPOSED LOAD



Imposed load: 36,000 kg **Overall height:** 57 mm
D-value: 260 kN **ECE test no.:** E11 55R-01 7609

Slider with 36t imposed load

- For heavy duty fifth wheels with 150 and 190 mm overall height
- Mounting hole pattern according to DIN 74081, DIN 74084 and ISO 3842
- High rigidity – lightweight
- Low overall height of 57 mm
- Frame width 760-800 mm
- Dimensions 1400-850 mm
- Single-handed operation and 9 selectable coupling points
- Total slider travel 800 mm
- Approved for forced steering

SK-V 36 WITH 36T IMPOSED LOAD

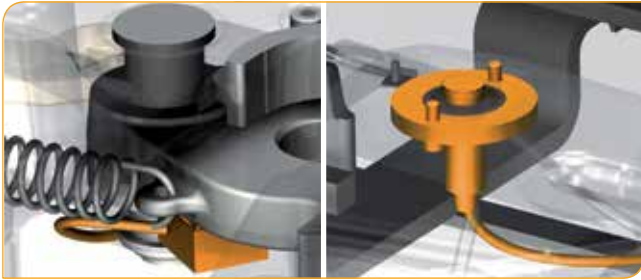

The sensors on the primary lock and the secondary lock permanently monitor the safe, correct state of the coupling. Another sensor monitors the distance between the semi-trailer skid-plate and coupling and guarantees the correct entry height during the coupling procedure.

The Safety Sensor System for the SK-S 36.20 fifth wheel **RE**mote **CO**ntrrolled **S**afety **S**ystem

- Available for all models of fifth wheel type SK-S 36.20*
- More safety due to visual and acoustic indication in cockpit
- More convenience due to monitoring of entire coupling process from the cabin

*Available in OEM versions ex works with vehicles from Mercedes-Benz, Volvo and Renault.

Simple Retrofitting

A special RECOSS retrofit kit is available to enhance the efficiency of all models of the SK-S 36.20 fifth wheel in a simple and cost-effective manner.



RECOSS®



Automatic single point long term dispenser

- No manual lubrication of lock mechanism required
- TÜV approved
- Contents: 125 ml
- Operating system:
 - Hydrogen gas formation cell
- Operating pressure max. 3 bar
- Setting: continuous 1-12 months
- Average period of use approx. 6 months
- Operating temperature: -20°C up to +55°C
- Recommended storage temperature of 20°C ± 5°C

GREASE CARTRIDGE FOR SK-S 36.20 W



TRAILER AXLES AND
SUSPENSION SYSTEMS



COUPLING AND LIFTING
TECHNOLOGY



SUSPENSIONS FOR
TRUCKS AND BUSES

safholland.com

SAF-HOLLAND GmbH

Hauptstraße 26 - 63856 Bessenbach - Germany

Tel +49 6095 301-0 - info@safholland.de