

# Installation Guide

Ultrastar<sup>®</sup> Serv60+8

Regulatory Model: H4060-S

December 2018

Rev. 1.2

1ET1114

Long Live Data<sup>™</sup> | [www.hgst.com](http://www.hgst.com)



a Western Digital brand

**Contents**

Revision History.....	4
Copyright.....	5
<b>Chapter 1 Overview.....</b>	<b>6</b>
1.1 Ultrastar® Serv60+8 Description.....	6
1.2 Ultrastar Serv60+8 Layout.....	7
1.3 Ultrastar Serv60+8 Specification Summary.....	9
1.4 Ultrastar Serv60+8 Rack Requirements.....	10
1.4.1 Compatible Hardware Configuration.....	12
1.5 List of Compatible Drives.....	13
<b>Chapter 2 Disclaimers.....</b>	<b>23</b>
2.1 Restricted Access Location.....	23
2.2 Safety Compliance.....	23
2.3 Electromagnetic Compatibility (EMC) Class A Compliance .....	23
2.4 Country Certifications.....	24
<b>Chapter 3 Safety.....</b>	<b>25</b>
3.1 Electrostatic Discharge.....	25
3.2 Optimizing Location.....	25
3.3 Power Connections.....	25
3.4 Power Cords.....	26
3.5 Rackmountable Systems.....	26
3.6 Safety and Service.....	26
3.7 Safety Warnings and Cautions.....	27
<b>Chapter 4 Packaging.....</b>	<b>28</b>

4.1	Ultrastar Serv60+8 Packaging Overview.....	28
4.2	Ultrastar Serv60+8 Unpacking Procedure.....	29
<b>Chapter 5</b>	<b>Installation.....</b>	<b>33</b>
5.1	Ultrastar Serv60+8 Installation Overview.....	33
5.2	Ultrastar Serv60+8 Installation Procedure.....	33
<b>Chapter 6</b>	<b>Points of Contact.....</b>	<b>52</b>

## Revision History

Date	Revision	Comment
June 2018	Revision 1.0	Initial Release
August 2018	Revision 1.1	Updated the following sections: <ul style="list-style-type: none"><li>• <a href="#">List of Customer Replaceable Units (CRUs)</a></li></ul>
December 2018	Revision 1.2	Updated the following section: <ul style="list-style-type: none"><li>• <a href="#">List of Compatible Drives</a> on page 13</li></ul>

## Copyright

**The following paragraph does not apply to the United Kingdom or any country where such provisions are inconsistent with local law: HGST a Western Digital company PROVIDES THIS PUBLICATION "AS IS" WITHOUT WARRANTY OF ANY KIND, EITHER EXPRESS OR IMPLIED, INCLUDING, BUT NOT LIMITED TO, THE IMPLIED WARRANTIES OF MERCHANTABILITY OR FITNESS FOR A PARTICULAR PURPOSE. Some states do not allow disclaimer or express or implied warranties in certain transactions, therefore, this statement may not apply to you.**

This publication could include technical inaccuracies or typographical errors. Changes are periodically made to the information herein; these changes will be incorporated in new editions of the publication. HGST may make improvements or changes in any products or programs described in this publication at any time.

It is possible that this publication may contain reference to, or information about, HGST products (machines and programs), programming, or services that are not announced in your country. Such references or information must not be construed to mean that HGST intends to announce such HGST products, programming, or services in your country.

Technical information about this product is available by contacting your local HGST representative or on the Internet at: [support.hgst.com](http://support.hgst.com)

HGST may have patents or pending patent applications covering subject matter in this document. The furnishing of this document does not give you any license to these patents.

© 2017-2018 Western Digital Corporation or its affiliates.

Western Digital  
5601 Great Oaks Parkway  
San Jose, CA 95119

Long Live Data™ is a trademark of HGST, Inc. and its affiliates in the United States and/or other countries.

HGST trademarks are authorized for use in countries and jurisdictions in which HGST has the right to use, market and advertise the brands.

Other product names are trademarks or registered trademarks of their respective owners.

One MB is equal to one million bytes, one GB is equal to one billion bytes, one TB equals 1,000GB (one trillion bytes) and one PB equals 1,000TB when referring to storage capacity. Usable capacity will vary from the raw capacity due to object storage methodologies and other factors.

References in this publication to HGST products, programs or services do not imply that HGST intends to make these available in all countries in which HGST operates.

Product information is provided for information purposes only and does not constitute a warranty.

Information is true as of the date of publication and is subject to change. Actual results may vary. This publication is for general guidance only. Photographs may show design models.

## 1 Overview

This section provides a high level overview of the features of the Ultrastar Serv60+8.

### 1.1 Ultrastar® Serv60+8 Description

**Figure 1: Ultrastar Serv60+8**

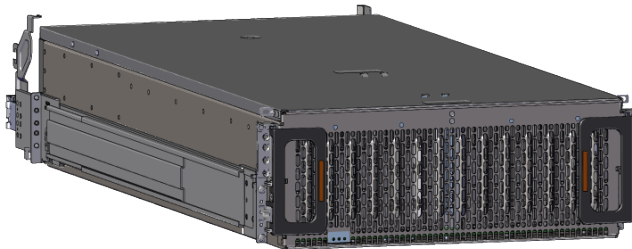

The Ultrastar® Serv60+8 is a 4U form factor, high density, rack-mounted storage enclosure that is capable of hosting up to 60 HDD SAS or SATA drives. The maximum data storage capacity of the Ultrastar Serv60+8 is 720TB using 12TB HGST Ultrastar® He12 HDDs plus an additional 61.44 TB using HGST Ultrastar® SS300 SSDs in the system SSD slots. (For a full list of compatible drives and total storage capacities, see the [List of Compatible Drives](#) on page 13.) The Ultrastar Serv60+8 also integrates an Intel Skylake based server front end. The server is built around an Intel Sawtooth Pass S2600ST motherboard and supports 2 LGA3647-0 (Socket P) processor sockets CPUs, 16 (8 per CPU) slots of DDR4 ECC DIMM memory, and leverages an AST2500 BMC for out-of-band management of the server subsystem. The enclosure runs on an input voltage of 200 - 240 VAC and consumes ~1800W of power under typical conditions. It requires a maximum of ~2000W at full load.

---

**Note:** Max and Typical Power Consumption values represent the output power to the system. Input power will vary depending on the PSU efficiency and load sharing between PSUs

---

The system contains three externally facing Half-Height, Half-Length (HHHL) PCIe x16 slots, and 3 externally facing HHHL PCIe x8 slots.

It is designed to fit within a 4U rack space and requires 1200 mm (47.24in.) of usable rack space, frame to frame. A fully loaded system will add 95.25 kg / 210 lbs. of static load when fully loaded with drives.

- 4U Storage Server
- Supports up to 60 HDD Drives
- Can support 3.5" drives and 2.5" SSD drives (2.5" requires an adapter) in the 60 available drive bays. Supports an additional 8 2.5" drives in the system SSD slots located in the center channel
- Up to 12W per drive slot for the 60 HDD data storage drives (Cannot exceed 85A on the 5V rail) and 25W per slot for the 8 system SSD slots
- House and control six (6) N+1 redundant 80mm fans
- Powered by two (2) redundant 2000W PSUs
- Toolless replacement of all Customer Replaceable Units (CRUs)
- Fits within a standard EIA-310 rack including all necessary cable management
- Supports Highline Input Power

- Dual Skylake LGA3647 Socket Processors
- 16 DDR4 ECC DIMM slots
- ASPEED AST2500 BMC
- Lewisburg PCH C624 Chipset

## 1.2 Ultrastar Serv60+8 Layout

*Figure 2: Front and Rear Product Layout*

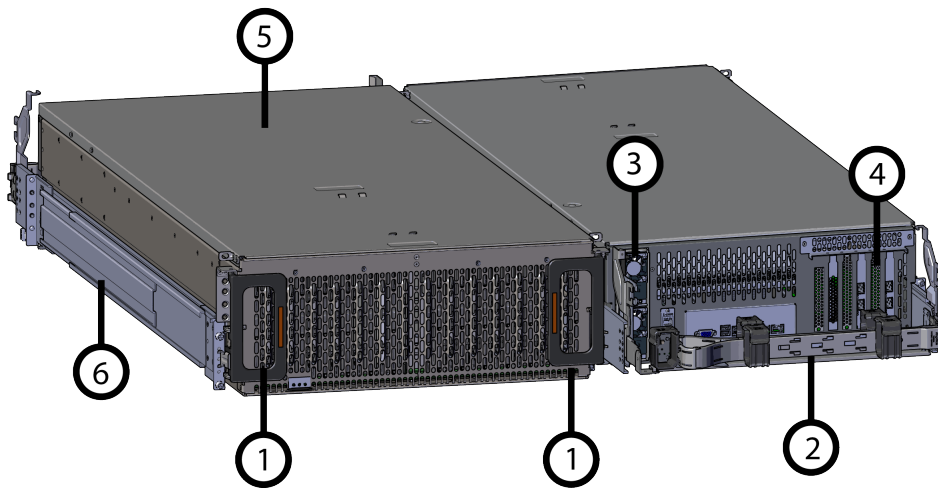
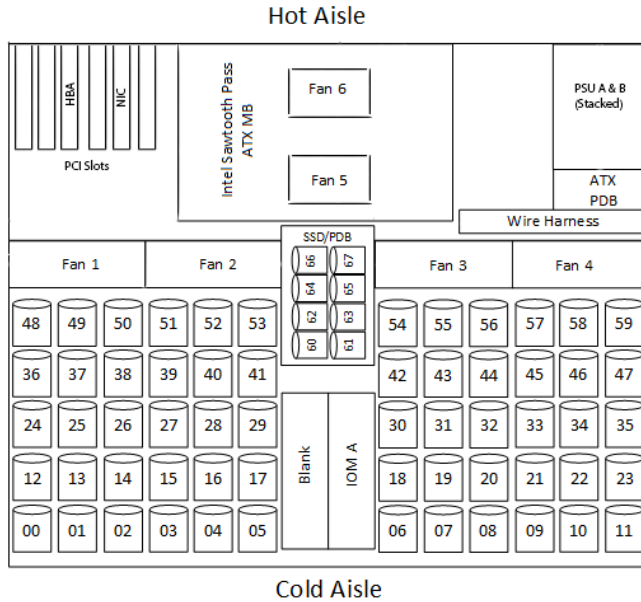

*Table 1: Front and Rear Component Identification*

Number	Component
1	Enclosure Handles
2	CMA
3	PSUs
4	Rear IO Ports
5	Chassis Cover
6	Rails

The following is an image of the layout of the major system components inside the Ultrastar Serv60+8.

**Figure 3: Component Layout**



**Figure 4: Rear IO Ports**

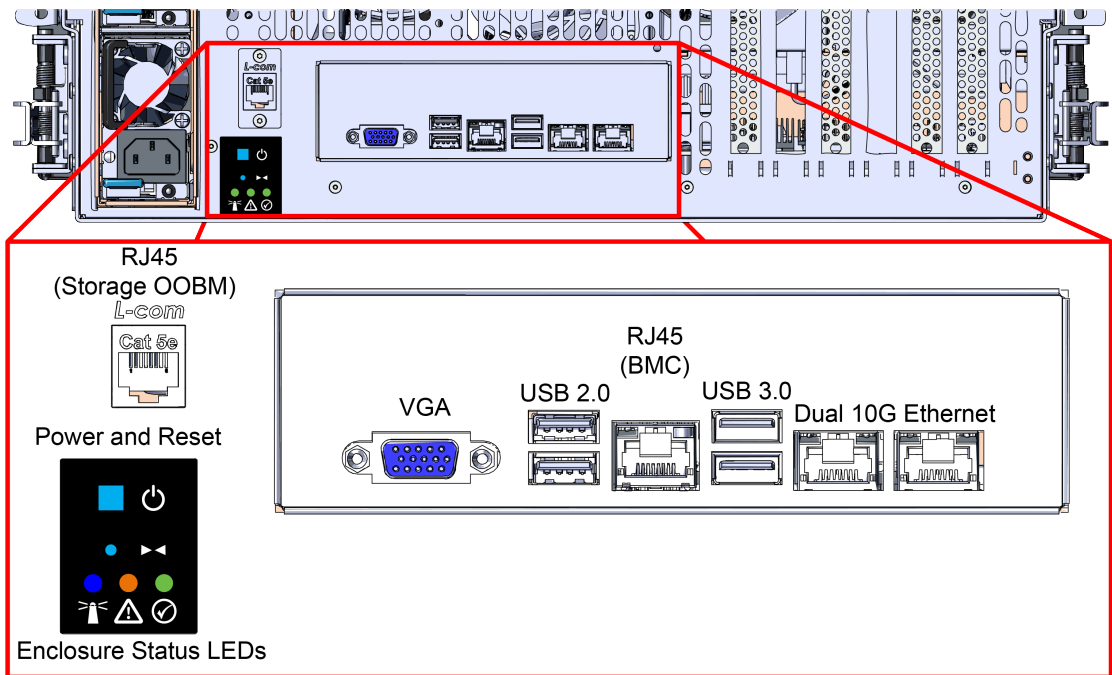



## 1.3 Ultrastar Serv60+8 Specification Summary

**Table 2: Environmental Specification Summary**

Specification	Non-Operational	Operational
Temperature	-40°C to 70°C	5°C to 35°C
Temperature Gradient	30°C per hour maximum	20°C per hour maximum
Temperature De-rating	1°C per 300m above 3000m	1°C per 300m above 900m
Relative Humidity	8-90% Non-Condensing	8-90% Non-Condensing
Relative Humidity Gradient	30% per hour maximum	30% per hour maximum
Altitude	-300m to 12,000m / -984 ft. to 39,370 ft	-300m to 3048m / -984 ft. to 10,000 ft.

**Table 3: Electrical Specifications**

Specification	Value
Max Power Consumption	~2000W
Typical Power Consumption	~1800W
<p><b>Note:</b> Max and Typical Power Consumption values represent the output power to the system. Input power will vary depending on the PSU efficiency and load sharing between PSUs</p>	
Input Voltage	200 - 240 VAC
PSU Connector Type	C14
PSU Efficiency	80 PLUS Platinum
Inrush Current Maximum (per PSU)	AC line inrush current shall not exceed 35A peak measured per IPC-9592B(L) Appendix C-4.1.
Typical Inrush Current (per PSU)	15A

**Caution:** The Ultrastar Serv60+8 can only be plugged into highline. If the unit is plugged into lowline, the PSU will report a "Critical" state when status pages are queried using SES. In this case, the enclosure will power up, but the drives will not.

**Table 4: Mechanical Specifications**

Specification	Non-Operational	Operational
Shock	10G, 0 - peak, 11ms half sine; 3 positive and 3 negative pulses in each axis shock	5G, 0 - peak, 11ms half sine; 3 positive and 3 negative pulses in each axis- minimum 6 seconds between

Specification	Non-Operational	Operational
		shocks to allow for write/read recovery
Vibration	0.75G, 0 - peak swept sine; 5 -500Hz; 1 complete sweep @ 1/2 octave per minute	0.10G, 0 - peak swept sine; 5 -500Hz; 1 complete sweep @ 1/2octave per minute
Weight	95.25 kg / 210 lbs.	
Dimensions with CMA	<b>W:</b> 447mm x <b>L:</b> 1197 mm x <b>H:</b> 175mm / <b>W:</b> 17.6in. x <b>L:</b> 47.13in. x <b>H:</b> 6.89in.	
Length without CMA	1026 mm / 40.39in.	
Required Rack Width	450mm with (17.72in.) with 465mm (18.31in.) ± 1.5mm nominal hole spacing. See EIA-310 Rack Standard	
Required Rack Depth	1200 mm (47.24in.) of usable rack space, frame to frame	
Rack Units (U)	4U	
Vertical Rack Rail Spacing	32 in. - 36 in.	

**Table 5: Performance Specifications**

Specification	Value
Mother Board	Intel Sawtooth Pass S2600ST
Processor Type	Intel Skylake
Socket	LGA3647-0 (Socket P) processor sockets
Number of Processors	2
Chipset	Lewisburg PCH C624 Chipset
Memory Type	DDR4 ECC DIMM
Number of Memory Slots	16 (8 per CPU)
Graphics	Integrated
Sever BMC Chip	AST2500
Number of Drive Slots	60 HDD / 8 SSD
Data Transfer Rates	12Gbps SAS / 6Gbps SATA
Max Raw Data Storage Capacity	720TB using 12TB HGST Ultrastar® He12 HDDs / 61.44 TB using HGST Ultrastar® SS300 SSDs

## 1.4 Ultrastar Serv60+8 Rack Requirements

The Ultrastar Serv60+8 is designed to be installed into a rack that meets the EIA-310 standard at a minimum 1200 mm (47.24in.) of usable rack space, frame to frame. The vertical rack rails must be set between 32 in.

- 36 in. to support the enclosure. It requires 4U of rack space, and it should be installed into the rack at the lowest possible U height to keep the load on the rack balanced.

**Table 6: Required Rack Specifications**

Parameter	Requirement
Rack Depth	1200 mm (47.24in.) of usable rack space, frame to frame
Rack Width	450mm with (17.72in.) with 465mm (18.31in.) ± 1.5mm nominal hole spacing. See EIA-310 Rack Standard
Rack Units (U)	4U
Vertical Rack Rail Spacing	32 in. - 36 in.
Static Load Rating	2250 lbs.
Dynamic Load Rating	1360.77 / 3000 lbs.



**Warning:** When extended out of the rack on the rail system, the Ultrastar Serv60+8 will be ~950 mm / 37.4in. extended outward. This is a tipping hazard. Make sure that any rack supporting the enclosure **MUST BE BOLTED TO THE FLOOR** before servicing or extending out of the rack. Ensure that leveling feet, anti-tilt, and any other safety features recommended by the specific rack manufacturers have also been deployed before servicing.

The following section provides specific information necessary to install, service, and remove the Ultrastar Serv60+8. The installation of the Ultrastar Serv60+8 requires two people and a space of 1371mm / 54in. in front of the installation space. The servicing of the enclosure requires one person and a minimum of 1219.2mm / 48in. of space in front of the installation space. The removal of the enclosure requires two people, 1371mm / 54in. of space in front of the installation space, and 24in. on either side of the enclosure for two people to remove the enclosure.

**Warning:** The handles on the front of the chassis are not intended to be used to support the weight of the Ultrastar Serv60+8. Lifting the unit by the chassis handles or trying to support the unit on the handles can cause them to fail. This can cause serious damage to the unit or serious bodily harm to those

handling the unit. Always team lift the chassis by gripping the underside of the unit, and never try to lift a chassis that is filled with drives.

**Figure 5: Installation, Servicing, and Removal**

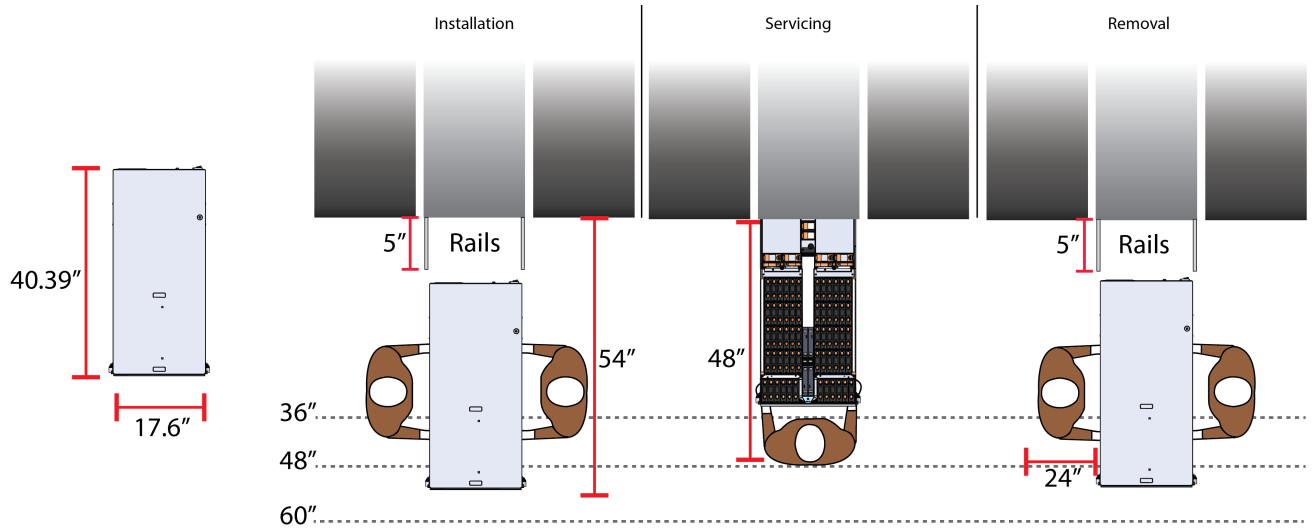

**1.4.1 Compatible Hardware Configuration**

The following table(s) list the approved hardware configurations for the Ultrastar Serv60+8:

**Table 7: Compatible Hardware Configuration 1**

Parameter	Rack	PDU (Vertical)	PDU Mounting Bracket	Additional Mounting Bracket Hardware
<b>Vendor</b>	CRENLO/EMCOR	Server Technology	Server Technology	Various
<b>Part Number</b>	AS-160099-03 (Drawing Number EMCOR 526121 Rev 5)	412-0761-11_STV-4501 412-0761-20_STV-4502 412-0761-23_STV-4503	KIT-MBVPT-1B (one kit per PDU)	4 x M6 x 16 Hex Cap Screws 8 x M6 Fender Washers 4 x M6 Hex Nut with Nylon Lock
<b>Quantity</b>	1	2	2	Varies

**Table 8: Compatible Hardware Configuration 2**

Parameter	Rack	PDU (Vertical)	PDU Mounting Bracket	Additional Mounting Bracket Hardware
<b>Vendor</b>	AFCO/Legrand	Server Technology	Server Technology	Various
<b>Part Number</b>	<b>Options:</b> 42RU – WEDIT605	412-0761-11_STV-4501 412-0761-20_STV-4502	KIT-MB-40	None

Parameter	Rack	PDU (Vertical)	PDU Mounting Bracket	Additional Mounting Bracket Hardware
	45RU – WEDIT604 48RU – WEDIT603 51RU – WEDIT606	412-0761-23_STV-4503		
<b>Quantity</b>	1 rack	2	1	N/A

**Table 9: Compatible Hardware Configuration 3**

Parameter	Rack	PDU (Vertical)	PDU Mounting Bracket	Additional Mounting Bracket Hardware
<b>Vendor</b>	TRIPP LITE	Server Technology	Server Technology	Various
<b>Part Number</b>	<b>Options:</b> SR42UBDP (Rack) SREXTENDER 25U (Rack Extension) SREXTENDER 42U (Rack Extension) SREXTENDER 48U (Rack Extension)	412-0761-11_STV-4501 412-0761-20_STV-4502 412-0761-23_STV-4503	KIT-MBVPT-1B	None
<b>Quantity</b>	1 rack	2	1	N/A

## 1.5 List of Compatible Drives

**Table 10: HDDs**

Drive	Type	Interface	Sector Size	Encryption	Volume	Part Number
HGST Ultrastar® DC HC310 w/ 3.5 in. drive carrier	HDD	SAS 12Gb/s	4Kn	SE	6TB	1EX1183
HGST Ultrastar® DC HC310 w/ 3.5 in. drive carrier	HDD	SAS 12Gb/s	4Kn	TCG	6TB	1EX1182
HGST Ultrastar® DC HC310 w/ 3.5 in. drive carrier	HDD	SAS 12Gb/s	512e	SE	6TB	1EX1185
HGST Ultrastar® DC HC310 w/ 3.5 in. drive carrier	HDD	SAS 12Gb/s	512e	TCG	6TB	1EX1184
HGST Ultrastar® DC HC310 w/ 3.5 in. drive carrier	HDD	SATA 6Gb/s	4Kn	SE	6TB	1EX1187
HGST Ultrastar® DC HC310 w/ 3.5 in. drive carrier	HDD	SATA 6Gb/s	4Kn	TCG	6TB	1EX1186

Drive	Type	Interface	Sector Size	Encryption	Volume	Part Number
HGST Ultrastar® DC HC310 w/ 3.5 in. drive carrier	HDD	SATA 6Gb/s	512e	SE	6TB	1EX1189
HGST Ultrastar® DC HC310 w/ 3.5 in. drive carrier	HDD	SATA 6Gb/s	512e	TCG	6TB	1EX1188
HGST Ultrastar® DC HC320 w/ 3.5 in. drive carrier	HDD	SAS 12Gb/s	4Kn	SE	8TB	1EX1221
HGST Ultrastar® DC HC320 w/ 3.5 in. drive carrier	HDD	SAS 12Gb/s	4Kn	TCG	8TB	1EX1220
HGST Ultrastar® DC HC320 w/ 3.5 in. drive carrier	HDD	SAS 12Gb/s	4Kn	TCG-FIPS	8TB	1EX1342
HGST Ultrastar® DC HC320 w/ 3.5 in. drive carrier	HDD	SAS 12Gb/s	512e	SE	8TB	1EX1223
HGST Ultrastar® DC HC320 w/ 3.5 in. drive carrier	HDD	SAS 12Gb/s	512e	TCG	8TB	1EX1222
HGST Ultrastar® DC HC320 w/ 3.5 in. drive carrier	HDD	SAS 12Gb/s	512e	TCG-FIPS	8TB	1EX1343
HGST Ultrastar® DC HC320 w/ 3.5 in. drive carrier	HDD	SATA 6Gb/s	4Kn	SE	8TB	1EX1225
HGST Ultrastar® DC HC320 w/ 3.5 in. drive carrier	HDD	SATA 6Gb/s	4Kn	TCG	8TB	1EX1224
HGST Ultrastar® DC HC320 w/ 3.5 in. drive carrier	HDD	SATA 6Gb/s	512e	SE	8TB	1EX1227
HGST Ultrastar® DC HC320 w/ 3.5 in. drive carrier	HDD	SATA 6Gb/s	512e	SED	8TB	1EX1226
HGST Ultrastar® He10 w/ 3.5 in. drive carrier	HDD	SAS 12Gb/s	4Kn	ISE	10TB	1EX0482
HGST Ultrastar® He10 w/ 3.5 in. drive carrier	HDD	SAS 12Gb/s	4Kn	SE	10TB	1EX0484
HGST Ultrastar® He10 w/ 3.5 in. drive carrier	HDD	SAS 12Gb/s	4Kn	TCG	10TB	1EX0483
HGST Ultrastar® He10 w/ 3.5 in. drive carrier	HDD	SAS 12Gb/s	4Kn	TCG-FIPS	10TB	1EX1340
HGST Ultrastar® He10 w/ 3.5 in. drive carrier	HDD	SAS 12Gb/s	512e	ISE	10TB	1EX0485

Drive	Type	Interface	Sector Size	Encryption	Volume	Part Number
HGST Ultrastar® He10 w/ 3.5 in. drive carrier	HDD	SAS 12Gb/s	512e	SE	10TB	1EX0487
HGST Ultrastar® He10 w/ 3.5 in. drive carrier	HDD	SAS 12Gb/s	512e	TCG	10TB	1EX0486
HGST Ultrastar® He10 w/ 3.5 in. drive carrier	HDD	SAS 12Gb/s	512e	TCG-FIPS	10TB	1EX1341
HGST Ultrastar® He10 w/ 3.5 in. drive carrier	HDD	SATA 6Gb/s	4Kn	ISE	10TB	1EX0494
HGST Ultrastar® He10 w/ 3.5 in. drive carrier	HDD	SATA 6Gb/s	4Kn	SE	10TB	1EX0496
HGST Ultrastar® He10 w/ 3.5 in. drive carrier	HDD	SATA 6Gb/s	4Kn	SED	10TB	1EX0495
HGST Ultrastar® He10 w/ 3.5 in. drive carrier	HDD	SATA 6Gb/s	512e	ISE	10TB	1EX0497
HGST Ultrastar® He10 w/ 3.5 in. drive carrier	HDD	SATA 6Gb/s	512e	SE	10TB	1EX0499
HGST Ultrastar® He10 w/ 3.5 in. drive carrier	HDD	SATA 6Gb/s	512e	SED	10TB	1EX0498
HGST Ultrastar® He12 w/ 3.5 in. drive carrier	HDD	SAS 12Gb/s	4Kn	ISE	12TB	1EX1004
HGST Ultrastar® He12 w/ 3.5 in. drive carrier	HDD	SAS 12Gb/s	4Kn	SE	12TB	1EX1006
HGST Ultrastar® He12 w/ 3.5 in. drive carrier	HDD	SAS 12Gb/s	4Kn	TCG	12TB	1EX1005
HGST Ultrastar® He12 w/ 3.5 in. drive carrier	HDD	SAS 12Gb/s	4Kn	TCG-FIPS	12TB	1EX1339
HGST Ultrastar® He12 w/ 3.5 in. drive carrier	HDD	SAS 12Gb/s	512e	ISE	12TB	1EX1007
HGST Ultrastar® He12 w/ 3.5 in. drive carrier	HDD	SAS 12Gb/s	512e	SE	12TB	1EX1009
HGST Ultrastar® He12 w/ 3.5 in. drive carrier	HDD	SAS 12Gb/s	512e	TCG	12TB	1EX1008
HGST Ultrastar® He12 w/ 3.5 in. drive carrier	HDD	SAS 12Gb/s	512e	TCG-FIPS	12TB	1EX1338

Drive	Type	Interface	Sector Size	Encryption	Volume	Part Number
HGST Ultrastar® He12 w/ 3.5 in. drive carrier	HDD	SATA 6Gb/s	4Kn	ISE	12TB	1EX1010
HGST Ultrastar® He12 w/ 3.5 in. drive carrier	HDD	SATA 6Gb/s	4Kn	SE	12TB	1EX1012
HGST Ultrastar® He12 w/ 3.5 in. drive carrier	HDD	SATA 6Gb/s	4Kn	SED	12TB	1EX1011
HGST Ultrastar® He12 w/ 3.5 in. drive carrier	HDD	SATA 6Gb/s	512e	ISE	12TB	1EX1013
HGST Ultrastar® He12 w/ 3.5 in. drive carrier	HDD	SATA 6Gb/s	512e	SE	12TB	1EX1015
HGST Ultrastar® He12 w/ 3.5 in. drive carrier	HDD	SATA 6Gb/s	512e	SED	12TB	1EX1014
HGST Ultrastar® HC530 w/ 3.5 in. drive carrier	HDD	SAS 12Gb/s	4Kn	SE	14TB	1EX1788
HGST Ultrastar® HC530 w/ 3.5 in. drive carrier	HDD	SAS 12Gb/s	4Kn	TCG	14TB	1EX1789
HGST Ultrastar® HC530 w/ 3.5 in. drive carrier	HDD	SAS 12Gb/s	512e	SE	14TB	1EX1791
HGST Ultrastar® HC530 w/ 3.5 in. drive carrier	HDD	SAS 12Gb/s	512e	TCG	14TB	1EX1792
HGST Ultrastar® HC530 w/ 3.5 in. drive carrier	HDD	SATA 6Gb/s	4Kn	SE	14TB	1EX1790
HGST Ultrastar® HC530 w/ 3.5 in. drive carrier	HDD	SATA 6Gb/s	512e	SE	14TB	1EX1793

**Table 11: SSDs w/ 2.5 in. drive carrier**

Drive	Type	Interface	Drive Writes	Encryption	Volume	Part Number
HGST Ultrastar® SS200 w/ 2.5 in. drive carrier	SSD	SAS 12Gb/s	RI-3DW/D	ISE	400GB	1EX1276
HGST Ultrastar® SS200 w/ 2.5 in. drive carrier	SSD	SAS 12Gb/s	RI-3DW/D	SE	400GB	1EX1278
HGST Ultrastar® SS200 w/ 2.5 in. drive carrier	SSD	SAS 12Gb/s	RI-3DW/D	TCG	400GB	1EX1353



Drive	Type	Interface	Drive Writes	Encryption	Volume	Part Number
HGST Ultrastar® SS300 w/ 2.5 in. drive carrier	SSD	SAS 12Gb/s	ME-10DW/D	ISE	400GB	1EX1273
HGST Ultrastar® SS300 w/ 2.5 in. drive carrier	SSD	SAS 12Gb/s	ME-10DW/D	SE	400GB	1EX1159
HGST Ultrastar® SS300 w/ 2.5 in. drive carrier	SSD	SAS 12Gb/s	ME-10DW/D	TCG	400GB	1EX1346
HGST Ultrastar® SS300 w/ 2.5 in. drive carrier	SSD	SAS 12Gb/s	ME-10DW/D	TCG-FIPS	400GB	1EX1347
HGST Ultrastar® SS300 w/ 2.5 in. drive carrier	SSD	SAS 12Gb/s	RI-3DW/D	ISE	400GB	1EX1282
HGST Ultrastar® SS300 w/ 2.5 in. drive carrier	SSD	SAS 12Gb/s	RI-3DW/D	SE	400GB	1EX1284
HGST Ultrastar® SS300 w/ 2.5 in. drive carrier	SSD	SAS 12Gb/s	RI-3DW/D	TCG	400GB	1EX1350
HGST Ultrastar® SS300 w/ 2.5 in. drive carrier	SSD	SAS 12Gb/s	RI-3DW/D	TCG-FIPS	400GB	1EX1351
Sandisk® Cloudspeed Ultra Gen. II w/ 2.5 in. drive carrier	SSD	SATA 6Gb/s	RI-1.8DW/D	SE	400GB	1EX1279
HGST Ultrastar® SS200 w/ 2.5 in. drive carrier	SSD	SAS 12Gb/s	RI-3DW/D	ISE	800GB	1EX1275
HGST Ultrastar® SS200 w/ 2.5 in. drive carrier	SSD	SAS 12Gb/s	RI-3DW/D	SE	800GB	1EX1277
HGST Ultrastar® SS200 w/ 2.5 in. drive carrier	SSD	SAS 12Gb/s	RI-3DW/D	TCG	800GB	1EX1352
HGST Ultrastar® SS300 w/ 2.5 in. drive carrier	SSD	SAS 12Gb/s	ME-10DW/D	ISE	800GB	1EX1272
HGST Ultrastar® SS300 w/ 2.5 in. drive carrier	SSD	SAS 12Gb/s	ME-10DW/D	SE	800GB	1EX1274
HGST Ultrastar® SS300 w/ 2.5 in. drive carrier	SSD	SAS 12Gb/s	ME-10DW/D	TCG	800GB	1EX1344
HGST Ultrastar® SS300 w/ 2.5 in. drive carrier	SSD	SAS 12Gb/s	ME-10DW/D	TCG-FIPS	800GB	1EX1345
HGST Ultrastar® SS300 w/ 2.5 in. drive carrier	SSD	SAS 12Gb/s	RI-3DW/D	ISE	800GB	1EX1281

Drive	Type	Interface	Drive Writes	Encryption	Volume	Part Number
HGST Ultrastar® SS300 w/ 2.5 in. drive carrier	SSD	SAS 12Gb/s	RI-3DW/D	SE	800GB	1EX1283
HGST Ultrastar® SS300 w/ 2.5 in. drive carrier	SSD	SAS 12Gb/s	RI-3DW/D	TCG	800GB	1EX1348
HGST Ultrastar® SS300 w/ 2.5 in. drive carrier	SSD	SAS 12Gb/s	RI-3DW/D	TCG-FIPS	800GB	1EX1349
Sandisk® Cloudspeed Ultra Gen. II w/ 2.5 in. drive carrier	SSD	SATA 6Gb/s	RI-1.8DW/D	SE	800GB	1EX1280
HGST Ultrastar® SS200 w/ 2.5 in. drive carrier	SSD	SAS 12Gb/s	RI-3DW/D	TCG-FIPS	1.6TB	1EX1782

**Table 12: SSDs w/ 3.5 in to 2.5 in drive carrier**

Drive	Type	Interface	Drive Writes	Encryption	Volume	Part Number
HGST Ultrastar® SS200 w/ 3.5 in to 2.5 in drive carrier	SSD	SAS 12Gb/s	RI-3DW/D	ISE	400GB	1EX1291
HGST Ultrastar® SS200 w/ 3.5 in to 2.5 in drive carrier	SSD	SAS 12Gb/s	RI-3DW/D	SE	400GB	1EX1293
HGST Ultrastar® SS200 w/ 3.5 in to 2.5 in drive carrier	SSD	SAS 12Gb/s	RI-3DW/D	TCG	400GB	1EX1315
HGST Ultrastar® SS300 w/ 3.5 in to 2.5 in drive carrier	SSD	SAS 12Gb/s	ME-10DW/D	ISE	400GB	1EX1287
HGST Ultrastar® SS300 w/ 3.5 in to 2.5 in drive carrier	SSD	SAS 12Gb/s	ME-10DW/D	SE	400GB	1EX1289
HGST Ultrastar® SS300 w/ 3.5 in to 2.5 in drive carrier	SSD	SAS 12Gb/s	ME-10DW/D	TCG	400GB	1EX1312
HGST Ultrastar® SS300 w/ 3.5 in to 2.5 in drive carrier	SSD	SAS 12Gb/s	ME-10DW/D	TCG-FIPS	400GB	1EX1479
HGST Ultrastar® SS300 w/ 3.5 in to 2.5 in drive carrier	SSD	SAS 12Gb/s	RI-3DW/D	ISE	400GB	1EX1296
HGST Ultrastar® SS300 w/ 3.5 in to 2.5 in drive carrier	SSD	SAS 12Gb/s	RI-3DW/D	SE	400GB	1EX1298
HGST Ultrastar® SS300 w/ 3.5 in to 2.5 in drive carrier	SSD	SAS 12Gb/s	RI-3DW/D	TCG	400GB	1EX1309

Drive	Type	Interface	Drive Writes	Encryption	Volume	Part Number
HGST Ultrastar® SS300 w/ 3.5 in to 2.5 in drive carrier	SSD	SAS 12Gb/s	RI-3DW/D	TCG-FIPS	400GB	1EX1481
Sandisk® Cloudspeed Ultra Gen. II w/ 3.5 in to 2.5 in drive carrier	SSD	SATA 6Gb/s	RI-1.8DW/D	SE	400GB	1EX1294
HGST Ultrastar® SS200 w/ 3.5 in to 2.5 in drive carrier	SSD	SAS 12Gb/s	RI-1DW/D	TCG	480GB	1EX1318
HGST Ultrastar® SS200 w/ 3.5 in to 2.5 in drive carrier	SSD	SAS 12Gb/s	RI-3DW/D	ISE	800GB	1EX1290
HGST Ultrastar® SS200 w/ 3.5 in to 2.5 in drive carrier	SSD	SAS 12Gb/s	RI-3DW/D	SE	800GB	1EX1292
HGST Ultrastar® SS200 w/ 3.5 in to 2.5 in drive carrier	SSD	SAS 12Gb/s	RI-3DW/D	TCG	800GB	1EX1314
HGST Ultrastar® SS300 w/ 3.5 in to 2.5 in drive carrier	SSD	SAS 12Gb/s	RI-3DW/D	ISE	800GB	1EX1295
HGST Ultrastar® SS300 w/ 3.5 in to 2.5 in drive carrier	SSD	SAS 12Gb/s	RI-3DW/D	SE	800GB	1EX1297
HGST Ultrastar® SS300 w/ 3.5 in to 2.5 in drive carrier	SSD	SAS 12Gb/s	RI-3DW/D	TCG	800GB	1EX1308
HGST Ultrastar® SS300 w/ 3.5 in to 2.5 in drive carrier	SSD	SAS 12Gb/s	RI-3DW/D	TCG-FIPS	800GB	1EX1480
HGST Ultrastar® SS300 w/ 3.5 in to 2.5 in drive carrier	SSD	SAS 12Gb/s	ME-10DW/D	ISE	800GB	1EX1286
HGST Ultrastar® SS300 w/ 3.5 in to 2.5 in drive carrier	SSD	SAS 12Gb/s	ME-10DW/D	SE	800GB	1EX1288
HGST Ultrastar® SS300 w/ 3.5 in to 2.5 in drive carrier	SSD	SAS 12Gb/s	ME-10DW/D	TCG	800GB	1EX1311
HGST Ultrastar® SS300 w/ 3.5 in to 2.5 in drive carrier	SSD	SAS 12Gb/s	ME-10DW/D	TCG-FIPS	800GB	1EX1478
Sandisk® Cloudspeed Ultra Gen. II w/ 3.5 in to 2.5 in drive carrier	SSD	SATA 6Gb/s	RI-1.8DW/D	SE	800GB	1EX1305
HGST Ultrastar® SS200 w/ 3.5 in to 2.5 in drive carrier	SSD	SAS 12Gb/s	RI-1DW/D	TCG	960GB	1EX1317
HGST Ultrastar® SS200 w/ 3.5 in to 2.5 in drive carrier	SSD	SAS 12Gb/s	RI-3DW/D	ISE	1.6TB	1EX1303

Drive	Type	Interface	Drive Writes	Encryption	Volume	Part Number
HGST Ultrastar® SS200 w/ 3.5 in to 2.5 in drive carrier	SSD	SAS 12Gb/s	RI-3DW/D	ISE	1.6TB	1EX1783
HGST Ultrastar® SS200 w/ 3.5 in to 2.5 in drive carrier	SSD	SAS 12Gb/s	RI-3DW/D	SE	1.6TB	1EX1304
HGST Ultrastar® SS200 w/ 3.5 in to 2.5 in drive carrier	SSD	SAS 12Gb/s	RI-3DW/D	SE	1.6TB	1EX1784
HGST Ultrastar® SS200 w/ 3.5 in to 2.5 in drive carrier	SSD	SAS 12Gb/s	RI-3DW/D	TCG	1.6TB	1EX1313
HGST Ultrastar® SS200 w/ 3.5 in to 2.5 in drive carrier	SSD	SAS 12Gb/s	RI-3DW/D	TCG	1.6TB	1EX1785
HGST Ultrastar® SS300 w/ 3.5 in to 2.5 in drive carrier	SSD	SAS 12Gb/s	RI-3DW/D	ISE	1.6TB	1EX1299
HGST Ultrastar® SS300 w/ 3.5 in to 2.5 in drive carrier	SSD	SAS 12Gb/s	RI-3DW/D	ISE	1.6TB	1EX1779
HGST Ultrastar® SS300 w/ 3.5 in to 2.5 in drive carrier	SSD	SAS 12Gb/s	ME-10DW/D	ISE	1.6TB	1EX1768
HGST Ultrastar® SS300 w/ 3.5 in to 2.5 in drive carrier	SSD	SAS 12Gb/s	RI-3DW/D	SE	1.6TB	1EX1300
HGST Ultrastar® SS300 w/ 3.5 in to 2.5 in drive carrier	SSD	SAS 12Gb/s	RI-3DW/D	SE	1.6TB	1EX1780
HGST Ultrastar® SS300 w/ 3.5 in to 2.5 in drive carrier	SSD	SAS 12Gb/s	ME-10DW/D	SE	1.6TB	1EX1776
HGST Ultrastar® SS300 w/ 3.5 in to 2.5 in drive carrier	SSD	SAS 12Gb/s	RI-3DW/D	TCG	1.6TB	1EX1307
HGST Ultrastar® SS300 w/ 3.5 in to 2.5 in drive carrier	SSD	SAS 12Gb/s	RI-3DW/D	TCG	1.6TB	1EX1781
HGST Ultrastar® SS300 w/ 3.5 in to 2.5 in drive carrier	SSD	SAS 12Gb/s	ME-10DW/D	TCG	1.6TB	1EX1777
HGST Ultrastar® SS300 w/ 3.5 in to 2.5 in drive carrier	SSD	SAS 12Gb/s	RI-3DW/D	TCG-FIPS	1.6TB	1EX1787
HGST Ultrastar® SS300 w/ 3.5 in to 2.5 in drive carrier	SSD	SAS 12Gb/s	RI-3DW/D	TCG-FIPS	1.6TB	1EX1782
HGST Ultrastar® SS300 w/ 3.5 in to 2.5 in drive carrier	SSD	SAS 12Gb/s	RI-10DW/D	ISE	1.6TB	1EX1301

Drive	Type	Interface	Drive Writes	Encryption	Volume	Part Number
HGST Ultrastar® SS300 w/ 3.5 in to 2.5 in drive carrier	SSD	SAS 12Gb/s	RI-10DW/D	SE	1.6TB	1EX1302
HGST Ultrastar® SS300 w/ 3.5 in to 2.5 in drive carrier	SSD	SAS 12Gb/s	RI-10DW/D	TCG	1.6TB	1EX1310
HGST Ultrastar® SS300 w/ 3.5 in to 2.5 in drive carrier	SSD	SAS 12Gb/s	ME-10DW/D	TCG-FIPS	1.6TB	1EX1786
Sandisk® Cloudspeed Ultra Gen. II w/ 3.5 in to 2.5 in drive carrier	SSD	SATA 6Gb/s	RI-1.8DW/D	SE	1.6TB	1EX1319
HGST Ultrastar® SS200 w/ 3.5 in to 2.5 in drive carrier	SSD	SAS 12Gb/s	RI-1DW/D	TCG	1.92TB	1EX1316
HGST Ultrastar® SS200 w/ 3.5 in to 2.5 in drive carrier	SSD	SAS 12Gb/s	RI-3DW/D	ISE	3.2TB	1EX0578
HGST Ultrastar® SS300 w/ 3.5 in to 2.5 in drive carrier	SSD	SAS 12Gb/s	RI-3DW/D	ISE	3.2TB	1EX1285
HGST Ultrastar® SS300 w/ 3.5 in to 2.5 in drive carrier	SSD	SAS 12Gb/s	RI-3DW/D	SE	3.2TB	1EX1306
HGST Ultrastar® SS200 w/ 3.5 in to 2.5 in drive carrier	SSD	SAS 12Gb/s	RI-1DW/D	ISE	3.84TB	1EX0579
HGST Ultrastar® SS200 w/ 3.5 in to 2.5 in drive carrier	SSD	SAS 12Gb/s	RI-1DW/D	ISE	7.68TB	1EX0580

**Table 13: M.2s**

Drive	Type	Form Factor	Interface	Encryption	Volume	Part Number
HGST Ultrastar® SA210	SSD	M.2 2280	SATA 6Gb/s	SED	120GB	1EX1143
SanDisk® X600	SSD	M.2 2280	SATA 6Gb/s	N/A	128GB	1EX1569
SanDisk® X600	SSD	M.2 2280	SATA 6Gb/s	SED	128GB	1EX1574
HGST Ultrastar® SA210	SSD	M.2 2280	SATA 6Gb/s	SED	240GB	1EX1354
SanDisk® X600	SSD	M.2 2280	SATA 6Gb/s	N/A	256GB	1EX1570
SanDisk® X600	SSD	M.2 2280	SATA 6Gb/s	SED	256GB	1EX1575
HGST Ultrastar® SA210	SSD	M.2 2280	SATA 6Gb/s	SED	480GB	1EX1579
SanDisk® X600	SSD	M.2 2280	SATA 6Gb/s	N/A	512GB	1EX1571
SanDisk® X600	SSD	M.2 2280	SATA 6Gb/s	SED	512GB	1EX1576

Drive	Type	Form Factor	Interface	Encryption	Volume	Part Number
HGST Ultrastar® SA210	SSD	M.2 2280	SATA 6Gb/s	SED	960GB	1EX1580
SanDisk® X600	SSD	M.2 2280	SATA 6Gb/s	N/A	1TB	1EX1572
SanDisk® X600	SSD	M.2 2280	SATA 6Gb/s	SED	1TB	1EX1577
HGST Ultrastar® SA210	SSD	M.2 2280	SATA 6Gb/s	SED	1.92TB	1EX1581
SanDisk® X600	SSD	M.2 2280	SATA 6Gb/s	N/A	2TB	1EX1573
SanDisk® X600	SSD	M.2 2280	SATA 6Gb/s	SED	2TB	1EX1578

## 2 Disclaimers

Learn about the Regulatory, Safety, and Electromagnetic standards for which this product is compliant.

The following chapter describes the Regulatory Statement of Compliance, Safety Compliance, and Electromagnetic Compatibility Agency Requirements for the Ultrastar Serv60+8.

### 2.1 Restricted Access Location

The Ultrastar Serv60+8 is intended for installation in a server room or computer room where at least one of the following conditions apply:

- access can only be gained by **service persons** or by **users** who have been instructed about the restrictions applied to the location and about any precautions that shall be taken and/or
- access is through the use of a **tool** or lock and key, or other means of security, and is controlled by the authority responsible for the location.

### 2.2 Safety Compliance

Product Name: **Ultrastar Serv60+8**

Regulatory Model: **H4060-S**

Electromagnetic Compatibility Emissions: **Class A**

This product has been tested and evaluated as Information Technology Equipment (ITE) at accredited third-party laboratories for all safety, emissions and immunity testing required for the countries and regions where the product is marketed and sold. The product has been verified as compliant with the latest applicable standards, regulations and directives for those regions/countries. The suitability of this product for other product categories other than ITE may require further evaluation.

The product is labeled with a unique regulatory model that is printed on the label and affixed to every unit. The label will provide traceability to the regulatory approvals listed in this document. The document applies to any product that bears the regulatory model and type names including marketing names other than those listed in this document.

### 2.3 Electromagnetic Compatibility (EMC) Class A Compliance

The **H4060-S** complies with and conforms to the latest international standards as applicable:

**Table 14: Emissions and Immunity Compliance Lists**

Emissions	Immunity
FCC CFR 47 Part 15, Subpart B	EN 61000-3-2 Harmonic Current Emissions
ICES-003	EN 61000-3-3 Voltage Fluctuations and Flicker
EN 55032	EN 55024
CISPR 32	KN35
CE – EMC Directive 2014/30/EU	EN 61000-4-2 ESD

Emissions	Immunity
VCCI V-3	EN 61000-4-3 Radiated Immunity
BSMI CNS13438	EN 61000-4-4 EFT
KN32	EN 61000-4-5 Surge
AS/NZS CISPR 32	EN 61000-4-6 RF Common Mode
TR CU 020/2011	EN 61000-4-8 Power Frequency Magnetic Field
	EN 61000-4-11 Voltage Dips and Interruptions

## 2.4 Country Certifications

**Table 15: Country Certifications**

Country/Region	Authority or Mark
North America (Canada, USA)	Nemko
European Union	CE
Japan	VCCI
Korea	MSIP
Taiwan	BSMI
Australia/New Zealand	RCM
Russia, Kazakhstan, Belarus, Armenia	CU EAC
Ukraine	Ukrsepro
Mexico	NOM
Israel	SII
South Africa	SABS
India	BIS



## 3 Safety

The following chapter provides safety and regulatory information for the Ultrastar Serv60+8.

### 3.1 Electrostatic Discharge



Electrostatic discharge can harm delicate components inside HGST products.

Electrostatic discharge (ESD) is a discharge of stored static electricity that can damage equipment and impair electrical circuitry. It occurs when electronic components are improperly handled and can result in complete or intermittent failures.

Wear an ESD wrist strap for installation, service and maintenance to prevent damage to components in the product. Ensure the antistatic wrist strap is attached to a chassis ground (any unpainted metal surface). If possible, keep one hand on the frame when you install or remove an ESD-sensitive part.

Before moving ESD-sensitive parts place them in ESD static-protective bags until you are ready to install the part.

### 3.2 Optimizing Location

Failure to recognize the importance of optimally locating your product and failure to protect against electrostatic discharge (ESD) when handling your product can result in lowered system performance or system failure.

Do not position the unit in an environment that has extreme high temperatures or extreme low temperatures. Be aware of the proximity of the unit to heaters, radiators, and air conditioners.

Position the unit so that there is adequate space around it for proper cooling and ventilation. Consult the product documentation for spacing information.

Keep the unit away from direct strong magnetic fields, excessive dust, and electronic/electrical equipment that generate electrical noise.

### 3.3 Power Connections

Be aware of the ampere limit on any power supply or extension cables being used. The total ampere rating being pulled on a circuit by all devices combined should not exceed 80% of the maximum limit for the circuit.

**CAUTION** The power outlet must be easily accessible close to the unit.



Always use properly grounded, unmodified electrical outlets and cables. Ensure all outlets and cables are rated to supply the proper voltage and current.



This unit has more than one power supply connection; both power cords must be removed from the power supplies to completely remove power from the unit. There is no switch or other disconnect device.

### 3.4 Power Cords



Use only tested and approved power cords to connect to properly grounded power outlets or insulated sockets of the rack's internal power supply.

If an AC power cord was not provided with your product, purchase one that is approved for use in your country or region.

**CAUTION** To avoid electrical shock or fire, check the power cord(s) that will be used with the product as follows:

- The power cord must have an electrical rating that is greater than that of the electrical current rating marked on the product.
- Do not attempt to modify or use the AC power cord(s) if they are not the exact type required to fit into the grounded electrical outlets.
- The power supply cord(s) must be plugged into socket-outlet(s) that is / are provided with a suitable earth ground.
- The power supply cord(s) is / are the main disconnect device to AC power. The socket outlet(s) must be near the equipment and readily accessible for disconnection.

### 3.5 Rackmountable Systems

#### CAUTION

**Always install rack rails and storage enclosure according to Ultrastar Serv60+8 product documentation. Follow all cautions, warnings, labels, and instructions provided within the rackmount instructions.**

Reliable grounding of rack-mounted equipment should be maintained.

If installed in a closed or multi-unit rack assembly, the operating ambient temperature of the rack environment may be greater than room ambient. Therefore, consideration should be given to installing the equipment in an environment compatible with the maximum ambient temperature (T<sub>ma</sub>) specified by the manufacturer.

Observe the maximum rated ambient temperature, which is specified in the product documentation.

**For safe operation of the equipment, installation of the equipment in a rack should be such that the amount of air flow is not impeded so that the safe operation of the equipment is not compromised.**

### 3.6 Safety and Service



All maintenance and service actions appropriate to the end-users are described in the product documentation. All other servicing should be referred to an HGST-authorized service technician.



To avoid shock hazard, turn off power to the unit by unplugging both power cords before servicing the unit. Use extreme caution around the chassis because potentially harmful voltages are present.



When replacing a hot-plug power supply, unplug the power cord to the power supply being replaced before removing it from the Ultrastar Serv60+8.



The power supply in this product contains no user-serviceable parts. Do not open the power supply. Hazardous voltage, current and energy levels are present inside the power supply. Return to manufacturer for servicing.



Use caution when accessing part of the product that are labeled as potential shock hazards, hazardous access to moving parts such as fan blades or caution labels.

### 3.7 Safety Warnings and Cautions

To avoid personal injury or property damage, before you begin installing the product, read, observe, and adhere to all of the following safety instructions and information. The following safety symbols may be used throughout the documentation and may be marked on the product and/or the product packaging.

**CAUTION** Indicates the presence of a hazard that may cause minor personal injury or property damage if the CAUTION is ignored.

**WARNING** Indicates the presence of a hazard that may result in serious personal injury if the WARNING is ignored.



Indicates potential hazard if indicated information is ignored.



Indicates shock hazards that result in serious injury or death if safety instructions are not followed.



Indicates do not touch fan blades, may result in injury.



Indicates disconnect all power sources before servicing.

## 4 Packaging

### 4.1 Ultrastar Serv60+8 Packaging Overview

**Figure 6: Packaging Layout**

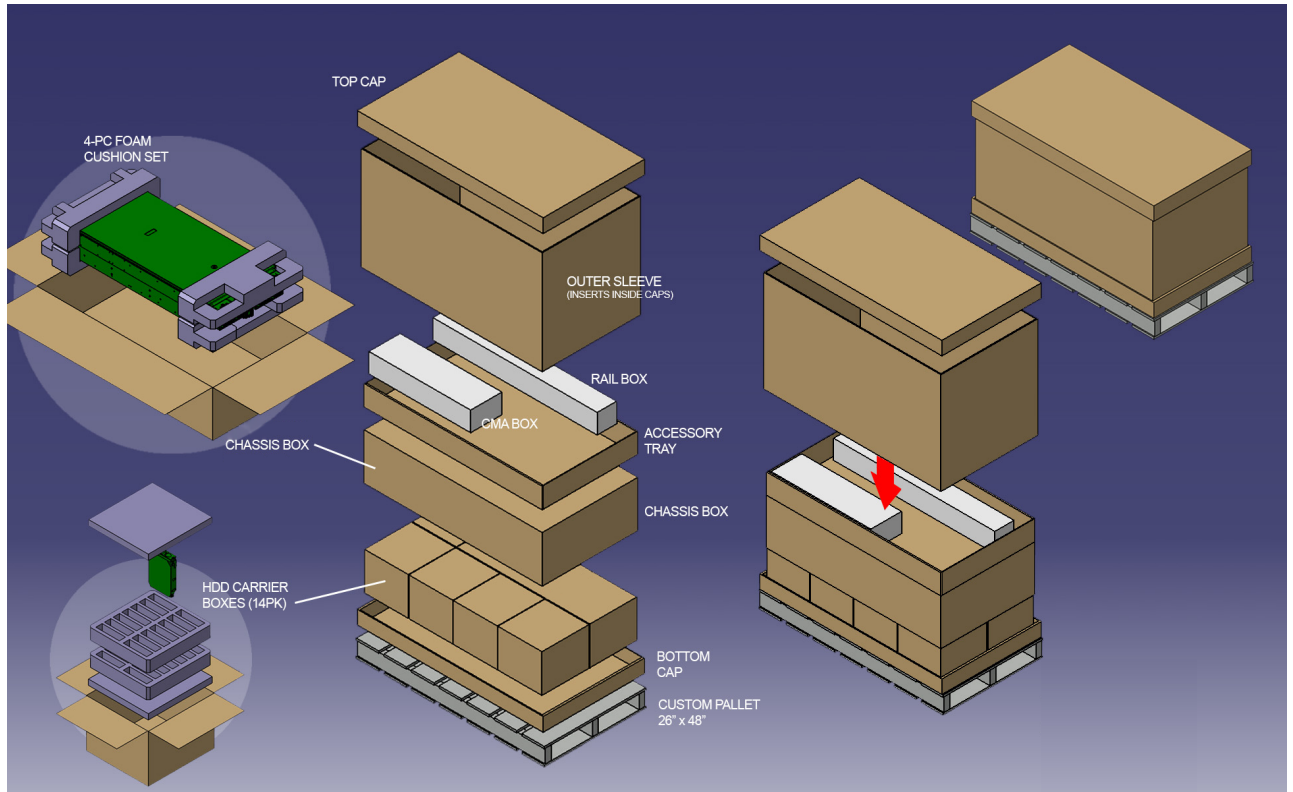

The Ultrastar Serv60+8 packaging consists of three layers of packaging: The accessory tray is on top, the enclosure chassis box is in the middle, and the drive assemblies are on the bottom. The accessory tray contains two cartons, one for the CMA assembly and one for the rails, as well as plastic bags that contain all necessary hardware listed below in the tables and the included cables. The chassis is boxed in the middle and protected by foam padding. It has the rear fans, PSUs, and IOM pre-installed. On the bottom there are four containers that hold fourteen HDD drive assemblies and one container that holds four, and one container that holds the eight SSDs included inside the Ultrastar Serv60+8. These three layers of packaging are contained by cardboard caps on the top and bottom, and an outer sleeve that surrounds the sides. Plastic banding surround the packaging and pallet to keep them contained.

**Table 16: Box Contents**

Container	Contents
CMA Box	CMA arm
Accessory Tray	<ul style="list-style-type: none"> <li>2 Top Cover Guide Brackets</li> </ul>

Container	Contents
	<ul style="list-style-type: none"> <li>• 2 Rack Latch brackets (One Left, One Right)</li> <li>• Screws &amp; Nuts               <ul style="list-style-type: none"> <li>10 M5 Cagenuts</li> <li>30 M5 x 12, T15 Torx screws</li> <li>2 M5 x 12 Philips Panhead screws (for cover retention)</li> <li>16 Custom Round Washers</li> </ul> </li> <li>• Cables               <ul style="list-style-type: none"> <li>2 C13 to C14 Power Cables (3m)</li> </ul> </li> </ul>
Rails Box	2 Rack Rails w/ 1 Inner Rail per Rack Rail
Chassis	Chassis w/ all internal components pre-installed except drives and SSDs.
5 Drive boxes	4 with 14 driver per container, 1 with 4 HDDs and 8 SSD assemblies.

## 4.2 Ultrastar Serv60+8 Unpacking Procedure

1. Make sure that all of the necessary equipment is available, including any equipment necessary to support the enclosure during installation. To verify the list of necessary equipment, see: [Table 16: Box Contents](#) on page 28.
2. Cut the straps that secure the packaging to the pallet with a box cutter.

3. Remove the top cap and the outer sleeve and discard them both.

**Figure 7: Top Cap and Sleeve Removal**

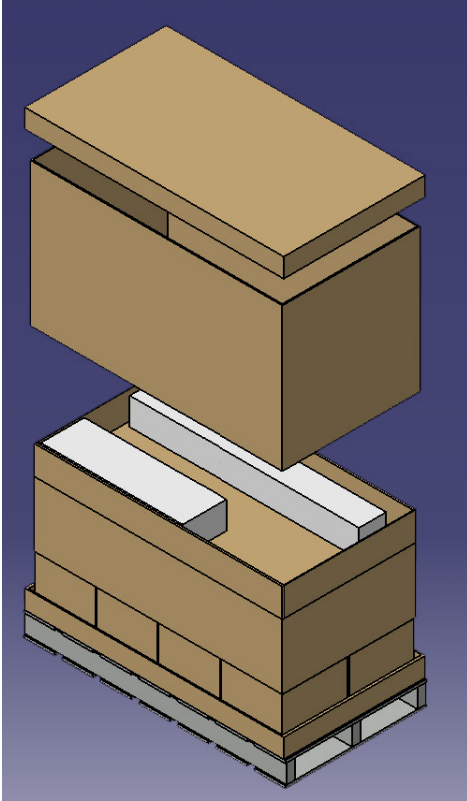

4. Open the rail box and remove the two rail assemblies. Set them aside.

**Figure 8: Accessory Tray**

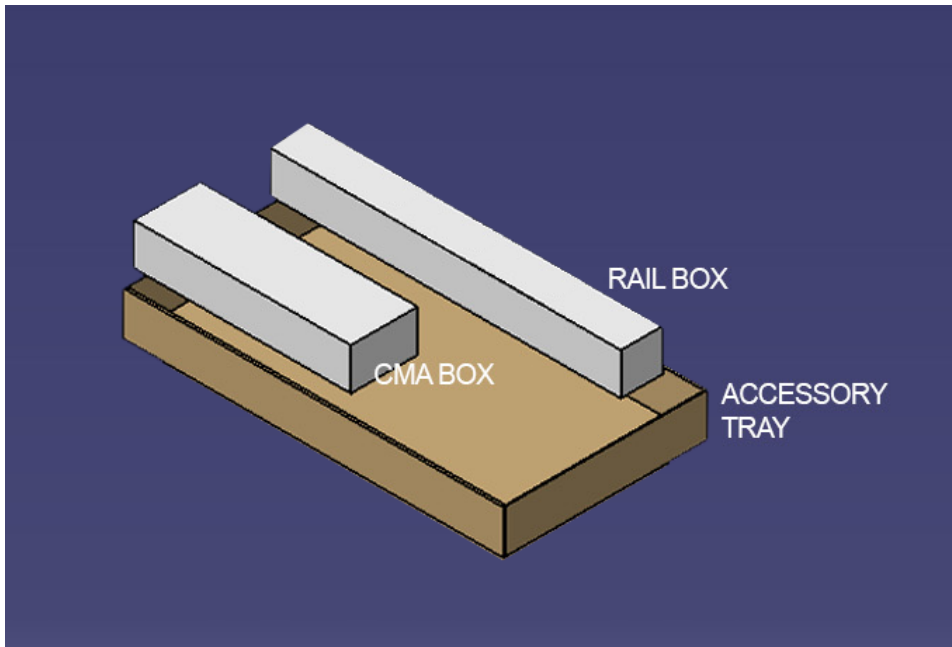

5. Open the CMA box and remove the two CMA arms and the cross-bar. Set them aside.
6. Open the chassis box and remove the top cushions, on the front and rear of the chassis.

**Figure 9: Unpack Chassis**

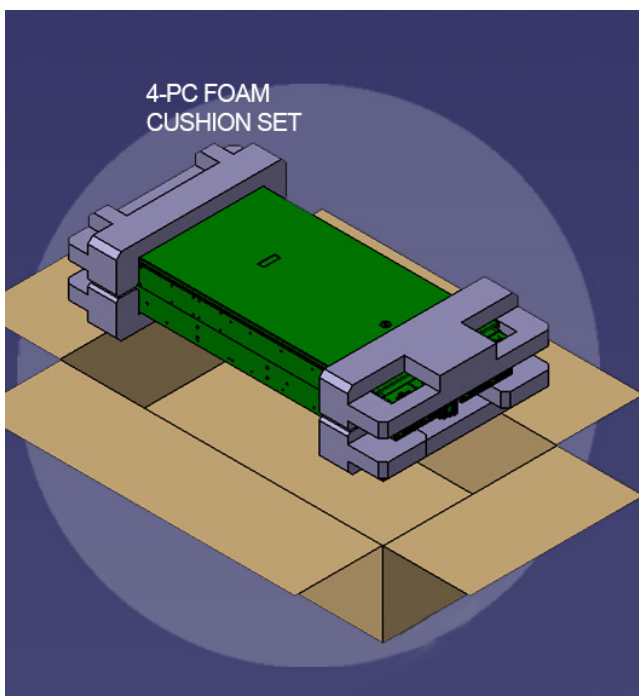

7. Remove the chassis itself from the chassis box. The chassis should be team lifted for safety.
8. Open the HDD boxes and verify their contents. Depending on the version of the Ultrastar Serv60+8 being unpacked, they should contain four containers that hold fourteen HDD drive assemblies and one container that holds four, and one container that holds the eight SSDs included inside the Ultrastar Serv60+8. Once the contents are verified, leave them in the boxes. This will protect them from damage until they are installed in the enclosure.

**Figure 10: Inspect Drives and Drive Blanks**

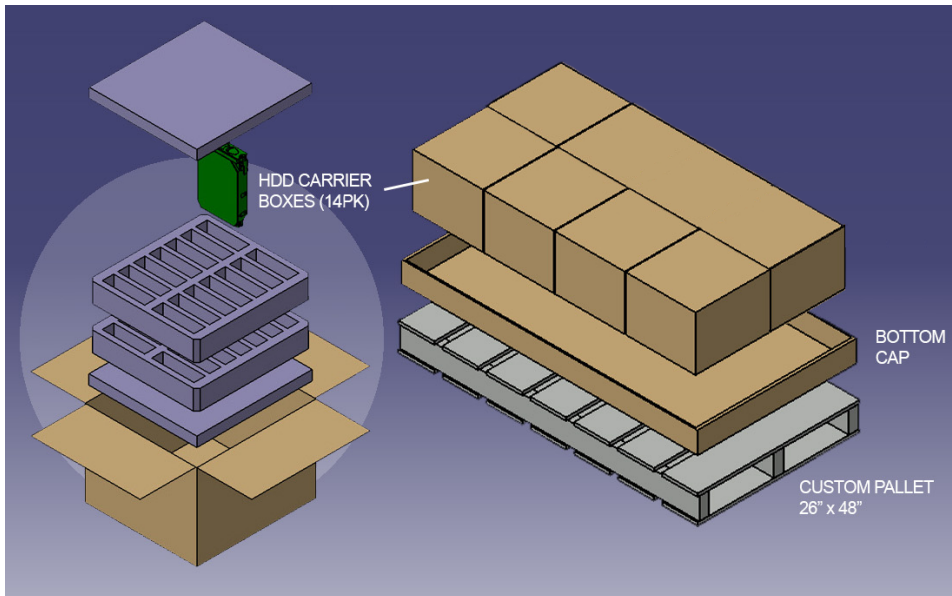



## 5 Installation

### 5.1 Ultrastar Serv60+8 Installation Overview

**Table 17: Procedure Info**

Required Tools	Required Parts	# of People Required	Time Required
<ul style="list-style-type: none"> <li>• Long T15 Torx Screwdriver</li> <li>• # 2 Phillips Screwdriver</li> <li>• Long T10 Torx Screwdriver</li> <li>• Tape Measure</li> <li>• Level</li> </ul>	<ul style="list-style-type: none"> <li>• M5 x 10mm T15 Torx screws</li> <li>• M5 x 12mm Phillips Pan Head screws (to secure top cover)</li> <li>• Included Washers</li> <li>• Low-Profile M4 x 3.2mm Phillips screws (included with rail assembly)</li> <li>• M3 x 8mm T10 Torx screws</li> <li>• 10 M5 cage nuts</li> <li>• Zip Tie (from CMA box)</li> </ul>	3 Total (2 for Team Lifting Purposes and 1 to Guide and Spot)	45 min.

**Table 18: Torque Specifications for Screws**

Screw Type	Torque Value
M5 x 10mm T15 Torx screws	3.38-3.61 Nm / 30-32 in-lbf
M5 x 12mm Phillips Pan Head screws	3.38-3.61 Nm / 30-32 in-lbf
Low-Profile M4 x 3.2mm Phillips screws	.90-1.12 Nm / 8-10 in-lbf
M3 x 8mm T10 Torx screws	.33-.56 Nm / 3-5 in-lbf

### 5.2 Ultrastar Serv60+8 Installation Procedure

1. Remove the inner rail that is nested inside the rack rails.

**Note:** There are Right and Left rails and they must be installed as a set. Each inner rail will read "R" for the right or "L" for the left embossed on the inside. Each outer rail will read "R-Front" for the right or "L-Front" for the left. Right and Left refer to when you are facing the front of the rack.

- a) Start by sliding the inner rail out of the outer/rack rail until the safety latch engages and the inner rail will not extend further. It will only slide one way.

- b) Press on the safety latch release spring located on the side of the rail and slide the inner rail out the rest of the way.

**Figure 11: Rail Safety Latch**

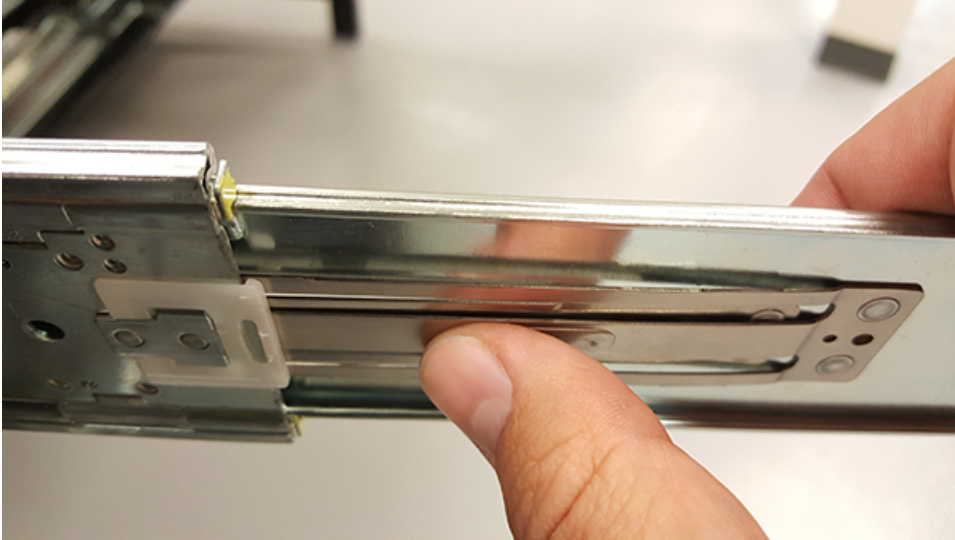

2. Install the inner rail onto the chassis making sure they are installed on the correct side. Each inner rail will read "R" for the right or "L" for the left embossed on the side that faces away from the chassis. Right and Left are with reference to looking at the front of the enclosure.
  - a) Orient the inner rails so that the flat side is facing the enclosure and the side with the grooves is facing away from the enclosure.

- b) Align the keyholes on the inner rail to the mounting pegs on the side of the enclosure and press the inner rail flush against the chassis. If the keyholes don't line up with the pegs, flip the rail length-wise to see if this will align them.

**Figure 12: Inner Rail Attachment**

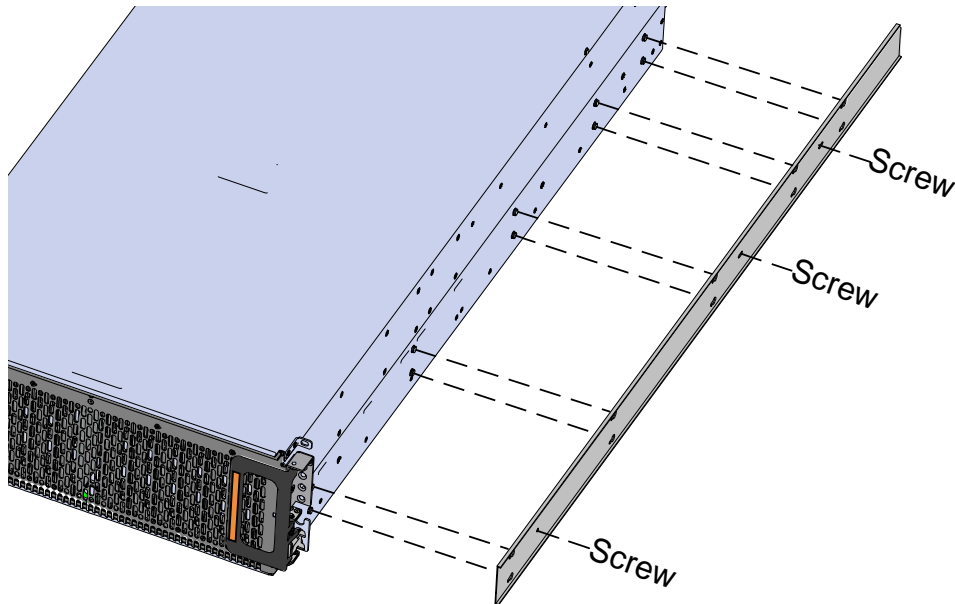

- c) Slide the inner rail toward the rear of the chassis to lock it in place. There will be an audible click and the mounting pegs will cover the front part of the keyhole.

**Figure 13: Slide Inner Rail**

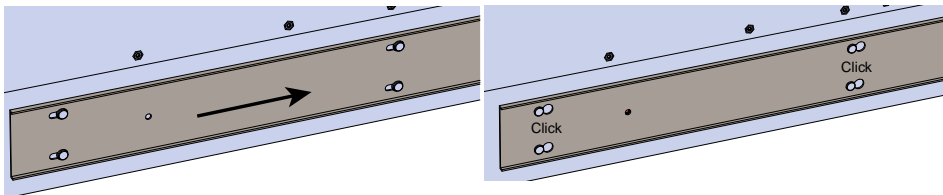

d)

**Caution:**  When installing the inner rail onto the chassis, make sure to only use the special Low-Profile M4 x 3.2mm Philips screws provided in the accessory kit with the CMA. These screws should be tightened to .90-1.12 Nm / 8-10 in-lbf using a # 2 Philips Screwdriver. These screws are specially designed for this purpose. Using unapproved screws could cause damage to the slides inside the rail.

Install the three special low-profile M4 x 3.2mm Philips screws provided to secure the inner rail to the chassis.

- e) Follow these steps for the second inner rail on the opposite side of the enclosure.
3. Set the vertical rack rail depth to between 32" and 36".
- 
- Note:** Ensure that all of the vertical rails are set to the same depth using a tape measure.
- 
4. Install the outer rails into the rack. Pay special attention to which side is being installed. The embossed R is for the right side and L is for the left side. Right and Left refer to when you are facing the front of the rack.
- Move to the rear of the rack.
  - Orient the rail so that the word "REAR" that is embossed into the metal of the rail is at the rear end of the rack, and the release latch is facing the inside of the rack posts as shown in the following image.

**Figure 14: Rear Rail Latch Release Latch**

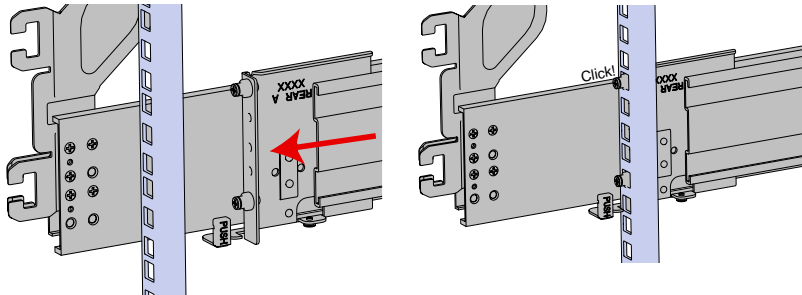

- Align the rail on the rack posts at the U-height desired for installation. The bottom of the rail will be the lower most U of the total 4U height.
- Pull the rail toward the rack post until the toolless latching mechanism engages the rack. The latching mechanism may need to be pulled open to get around the rack post.
- Move to the front of the rack.

- f) Align the front of the rail with the holes on the rack posts that will receive the rails and pull the rail toward the holes until the toolless latching mechanism engages the rack.

**Figure 15: Front Rail Release Clip Operation**

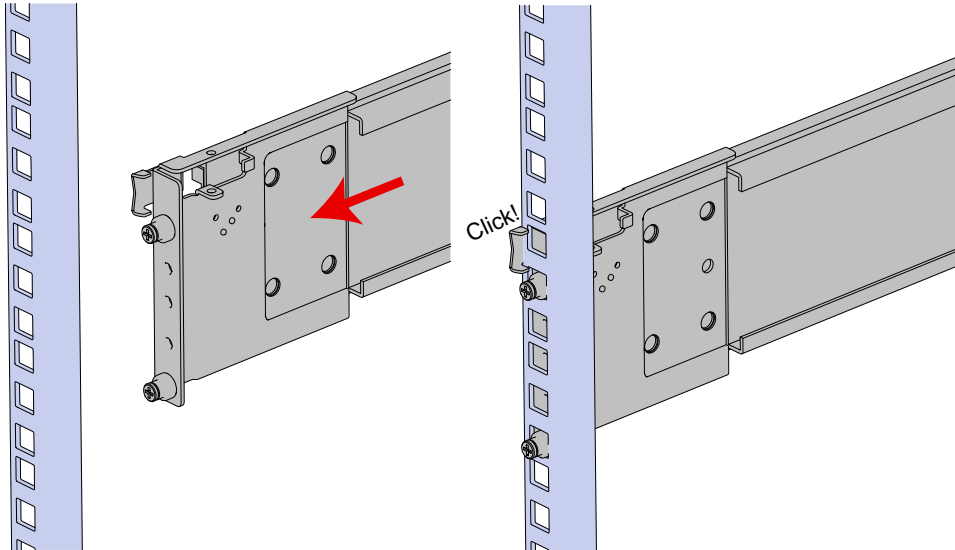

- g) Use a level to make sure that the rails are aligned properly.
  - h) Follow these steps for the other outer rail.
5. Install five M5 cage nuts, per side, starting at the uppermost rack mounting hole of the 4U space on the front of the rack.
    - a) Install one cagenut at the uppermost mounting hole of the 4U space that the enclosure will occupy.

- b) If the Ultrastar Serv60+8 will be installed in a rack for shipping purposes, install four more M5 cage nuts in the holes 3-6 of the 4U space. These will receive the M5 x 10mm T15 Torx screws that secure the enclosure to the rack with the shipping bracket.

**Figure 16: Cage Nut Spacing**

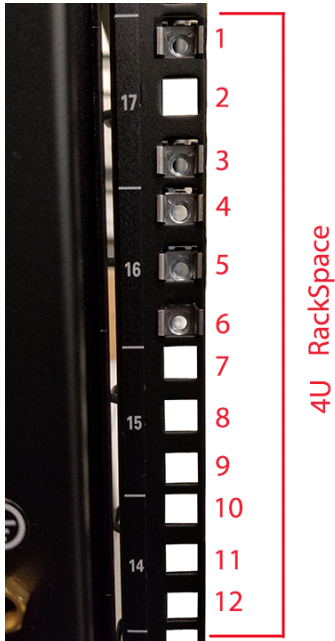

6. Install the rear cover alignment brackets.

- a) From the rear of the rack, orient the alignment brackets so that the groove that will catch the cover is facing the inside of the rack.

**Figure 17: Alignment Bracket Groove (highlighted in red)**

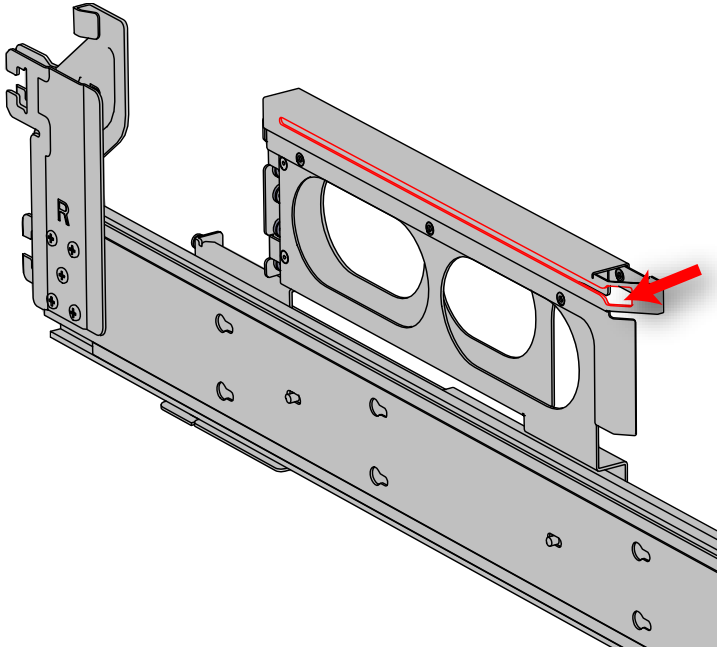

- b) Use five of the M5 x 10mm T15 Torx screws and five of the included washers and attach the rear cover alignment bracket to the vertical rail with the Long T15 Torx Screwdriver. Add three M5 x 10mm T15 Torx screws and three included washers to attach the rear rail (the three lower holes) to the rack posts as shown in the following image. These screws should be tightened to 3.38-3.61 Nm / 30-32 in-lbf using a Long T15 Torx Screwdriver.

**Figure 18: Screw and Washer Order**

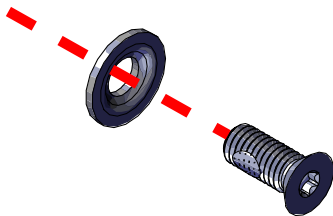

**Caution:**  Be careful to set the screw properly into the cage nuts to prevent crossthreading.

**Figure 19: Screw Installation Location**

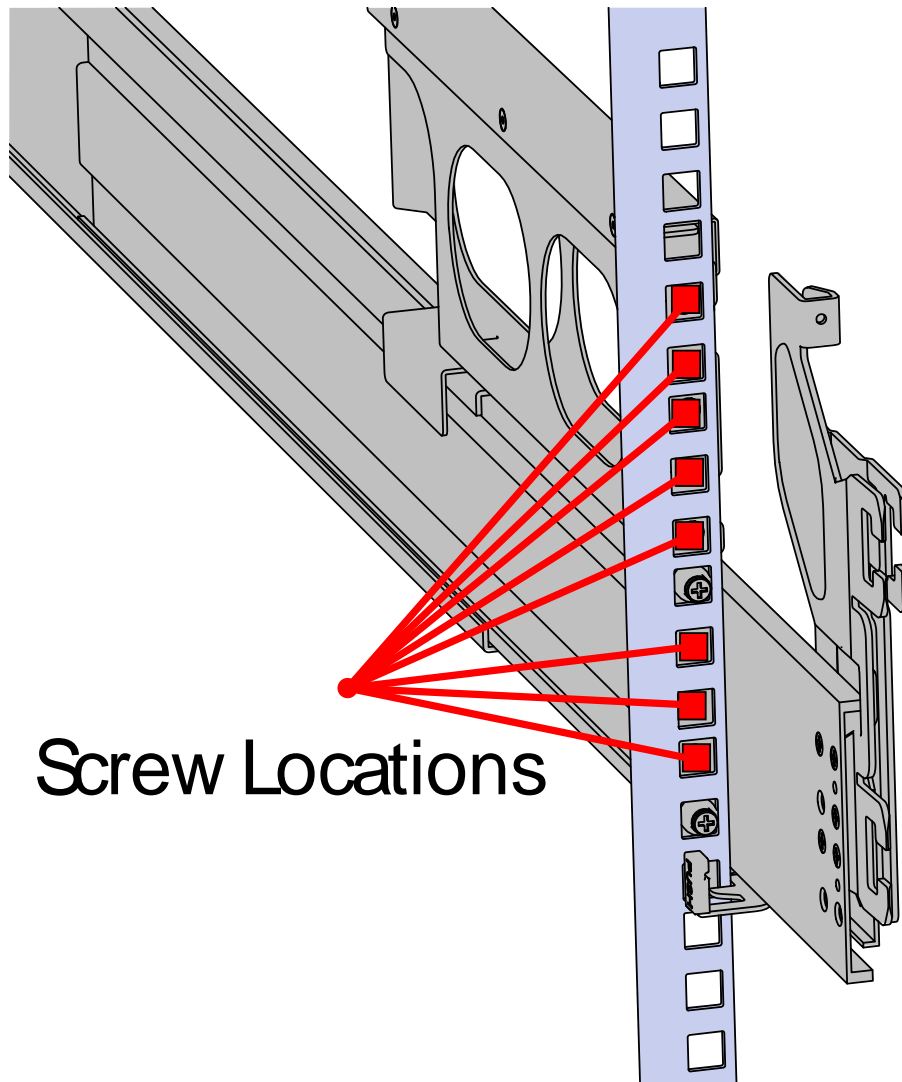

7. Install the two rack latch brackets at the front of the rack.
  - a) Orient the brackets so that the screw holes are between the two pins supporting the outer rails as shown in the following image. There is a left and a right. Use the image below as a guide for how to



orient this bracket and mirror it for the other side. Notice the increased distance between the top two screw holes and the lower screwholes and the flange being oriented on the outside.

**Figure 20: Rack Latch Bracket Installed**



- b) Use 6 of the included M5 x 12mm screws and the T15 Torx screwdriver to install each bracket, 3 screws per bracket.

**Caution:**  Always install the top cover onto the enclosure before installing the chassis into a rack. Not having the top cover installed may damage the alignment brackets.

8. Extend the mid-rails out of the rack so that they are protruding from the front of the rack and the safety latches engage.

**Figure 21: Extend Mid-Rails**

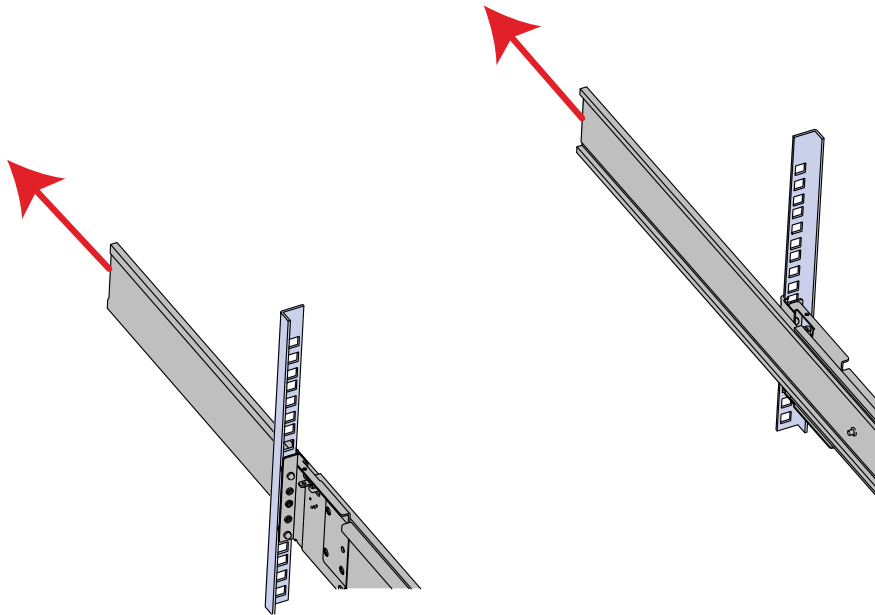

9. Install the chassis into the rails.

a)

**Caution:**  This step in the installation requires a minimum of 3 individuals to install safely, two to lift and one to guide the others whom may have difficulty seeing because the enclosure is in the way. Ensure that the appropriate measures are taken to safely support the enclosure during installation. The enclosure **MUST** have no drives installed and requires a two person team lift to install. **Do not attempt to lift the system if it is fully populated with drives.** The only case in which the system may be installed or removed with the drives populated is if the facility has a lift that is rated to handle the maximum weight of the fully loaded system.

**Warning:**  Do not lift the chassis by the Cable Tray while removing the chassis from the rack OR while installing it into a rack. This can cause serious damage to the unit or serious

bodily harm to those handling the unit. Always team lift the chassis by gripping the underside of the unit, and never try to lift a chassis that is filled with drives.

**Figure 22: Bearing Plate**

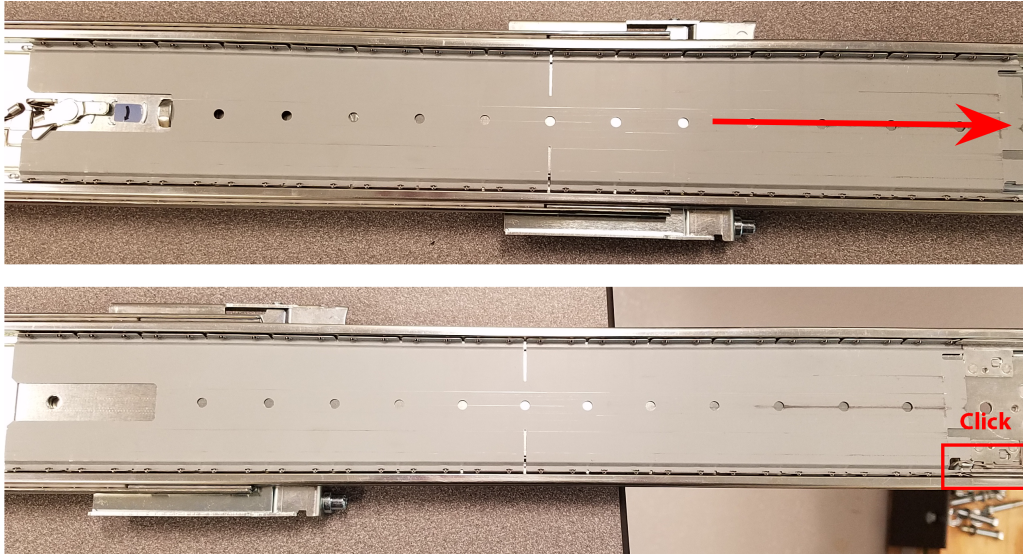

**Figure 23: Installing the Chassis**

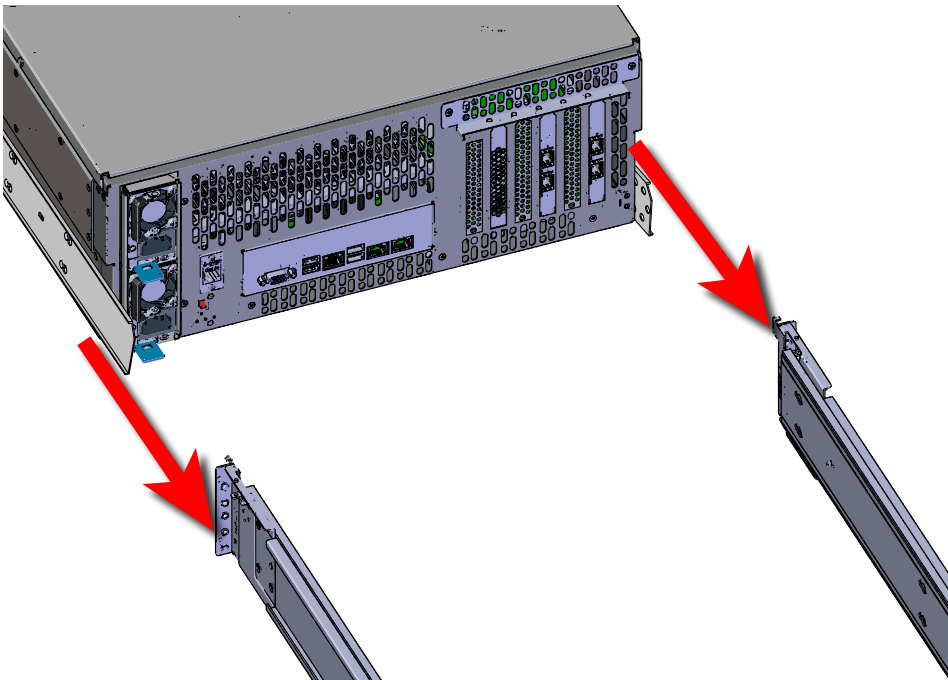

b)

**Caution:**  Make sure that the bearing plate on the inside of the mid-rails are fully forward and that the detent has engaged. This is to prevent potential damage due to improper mating of the rails.

Position one individual on each side of the enclosure to perform a team lift and have the third individual standing at the protruding rack rails to guide the chassis to mate with rack rails.

- c) Team-lift the enclosure until the inner rails that are attached to the chassis align with the extended mid-rails attached to the rack, and guide the inner rails on the chassis to mate with the rack rails.
- d) Once the rails are mated properly, slide the enclosure into the rack until it is stopped by the safety catch on the rails. Push the release lever on the safety latch located on the side of each of the rails and push the enclosure the rest of the way into the rack.

**Figure 24: Safety Latch Release**

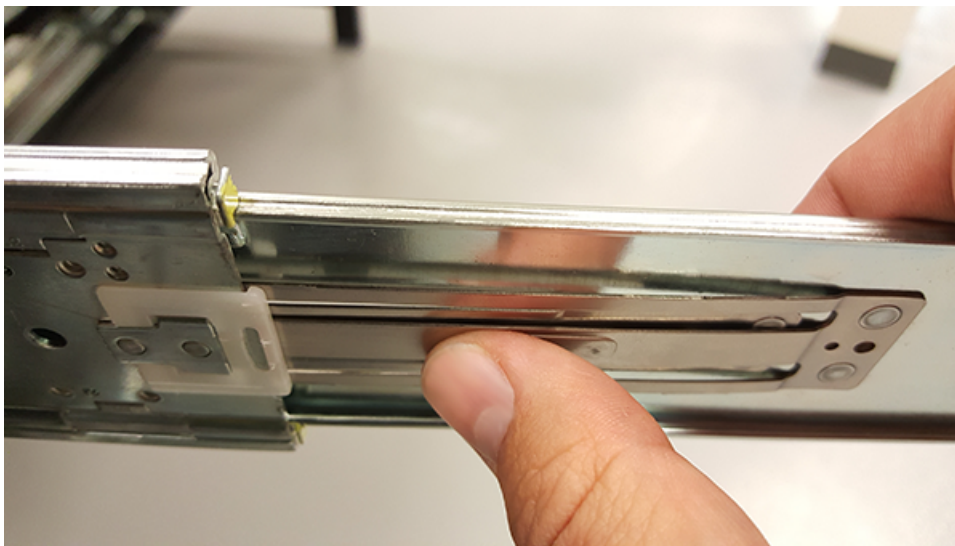

- e) As the chassis is slid into the rack, position one installer at the rear of the rack to ensure that the pegs on the sides of the cover will slide correctly into the rear cover alignment brackets on both sides of the rack. If the chassis does not install smoothly or snags, check that the rear cover alignment brackets are not interfering with the chassis sidewalls, and try again.

## 10. Install the CMA.

- a) Orient the CMA so that the elbow is on the left hand side.

- b) Attach all of the connectors to the brackets on the rails and chassis. There should be one at the elbow side and two at the other end.

**Figure 25: CMA Orientation**

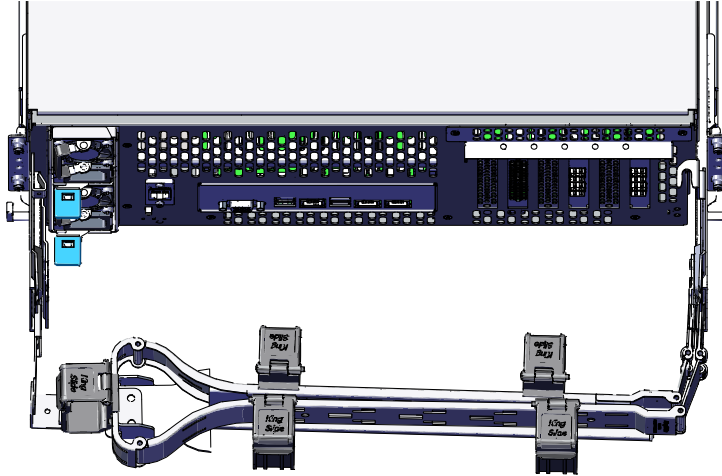

- c) Slowly slide the enclosure forward to ensure the CMA arm is operating properly, then slide it back into the rack.
- 11. Cable the CMA.**
- a) Unlatch the elbow side of the CMA arm and swing it forward by pressing the blue button that says “push” to unlatch it.

- b) Open all of the baskets

**Figure 26: Open Baskets**

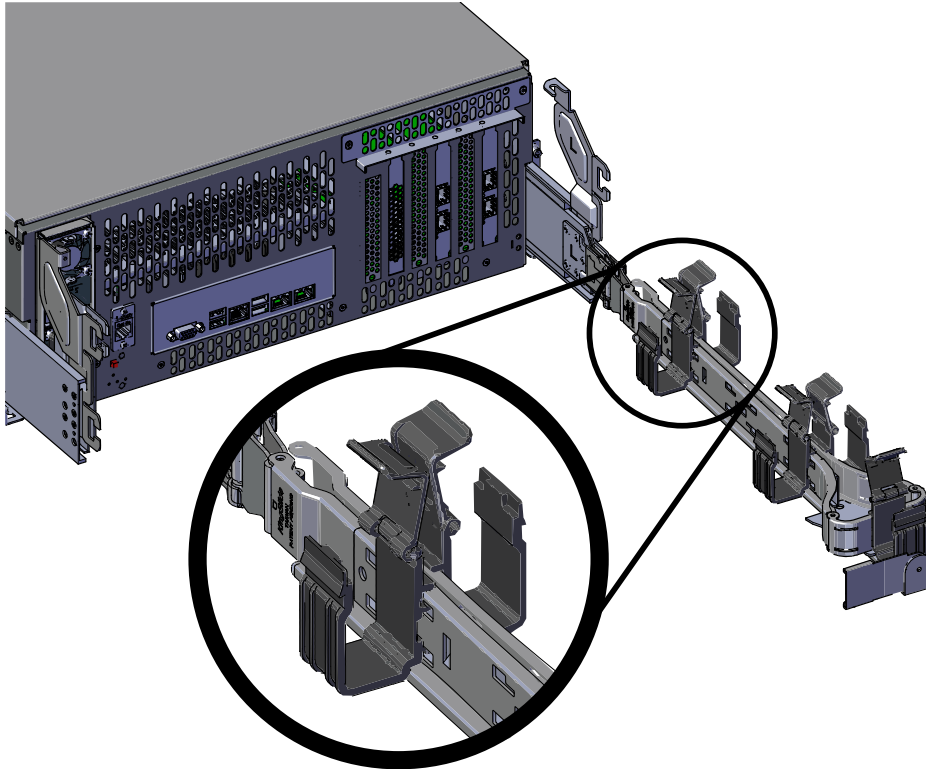

- c) Route all of the cables being connected to the enclosure through the open baskets.
- d) Close all of the baskets.
- e) If the Ultrastar Serv60+8 is being installed in a rack and will subsequently be transported inside that rack, it is important to use the included cable tie to wrap the CMA bundle to ensure it does not get damaged during transport. If the Ultrastar Serv60+8 is instead being installed where it will operated, skip this step. Remember to remove the cable ties after the enclosure has reached its final operational location.
- f) Reconnect the CMA at the elbow to the connectors on the rail.
- 12.** Test for binding in the extension of the CMA by gently pulling the enclosure out of the rack to ensure the cables extend properly and that the system doesn't bind at all. If it does, examine the point at which the binding occurred and adjust the seating of cables in the baskets, check the connections to the rails, and examine the joints of the CMA arm to ensure that they are all functioning properly.
- 13.** Make sure the CMA is in operational position by folding the arm in toward the enclosure and attaching the elbow end of the CMA to the connector that is attached to the rail. Verify that all of the cabling is in functional order and does not bind or catch.

14. Secure the chassis top cover to the rack using the included washers, the M5 x 12mm Phillips Pan Head screws, and a Philips screwdriver as shown in the following image. These screws should be tightened to 3.38-3.61 Nm / 30-32 in-lbf using a # 2 Philips Screwdriver.

**Figure 27: Cover Retention Screws**

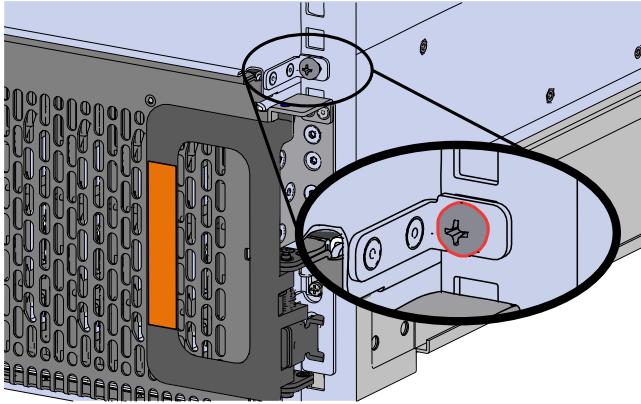

15. Now that the chassis is installed, test the installation by sliding the enclosure in and out of the rack a minimum of three times. If the enclosure binds, catches, or displays any incorrect motion or behavior retry the installation.

**Note:** Adjustments of the vertical rack rails may be required to fix any issues that may occur.

16. Grasp both handles at the front of the enclosure and pull with even pressure to extend the chassis out of the rack until it is stopped by the safety latches. The safety latches will prevent the enclosure from coming out of the rack completely and the cover will remain in the rack attached to the rear alignment brackets.

**Figure 28: Chassis Handle Operation**

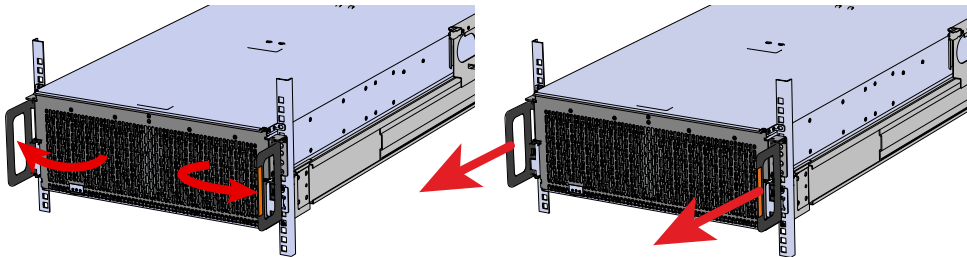

17. Perform this same action two more times without the drives loaded to make sure the rail kits are installed properly.
18. Install the Drive Assembly.
  - a) Ensure that the enclosure has been pulled out of the rack until the rail latches engage.

- b) Find the LED pointer on the top of the drive carrier. This pointer should point toward the front of the unit as shown in the following image.

**Figure 29: LED Pointer Orientation**

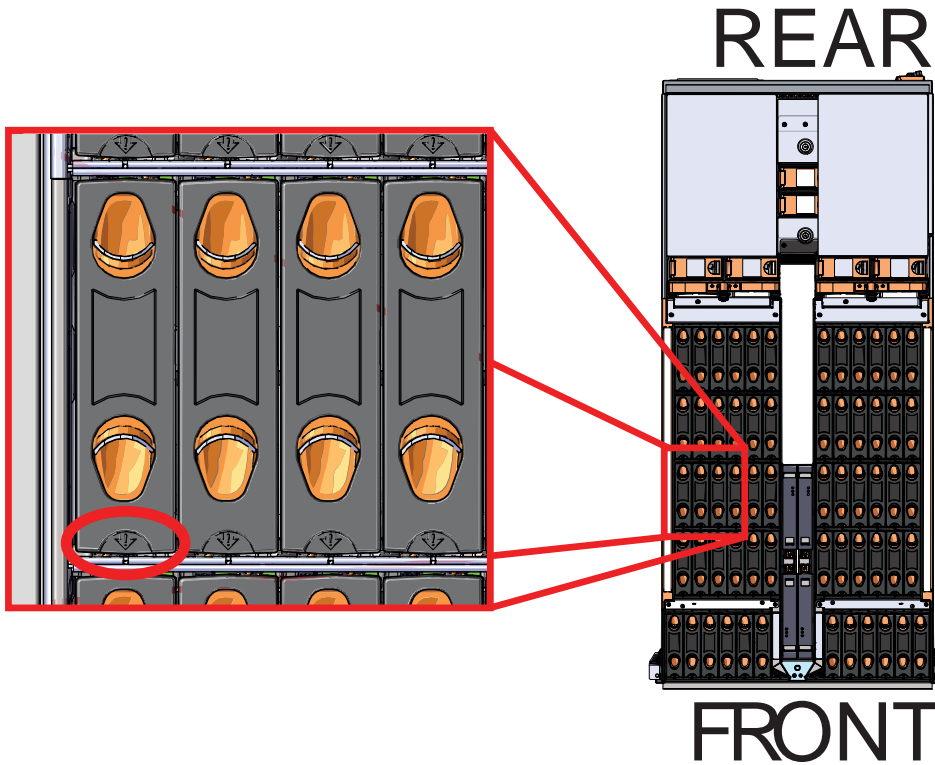



- c) Align the drive with the empty slot that will receive it. Lower it into the slot, making sure it stays level and does not snag.

**Figure 30: Installing a Drive Assembly**

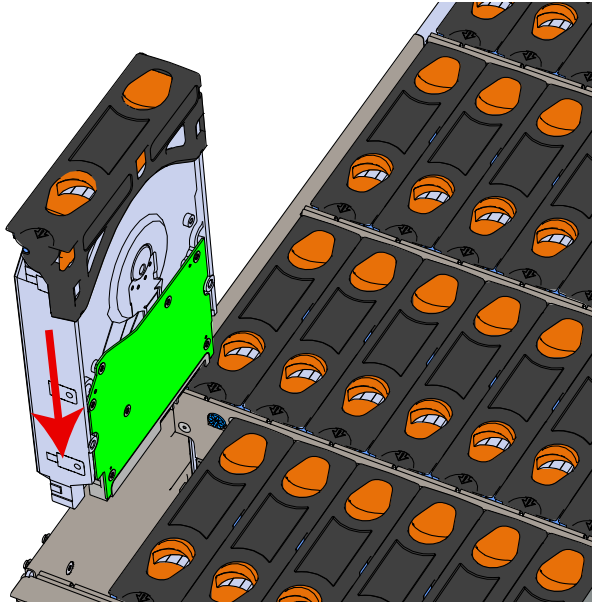

- d) Pinch the latch release and carefully press downward to seat the Drive Assembly the rest of the way.

19. Install each drive in the same way the first was installed. Make sure to follow the drive layout shown in the following image.

**Figure 31: Drive Layout**

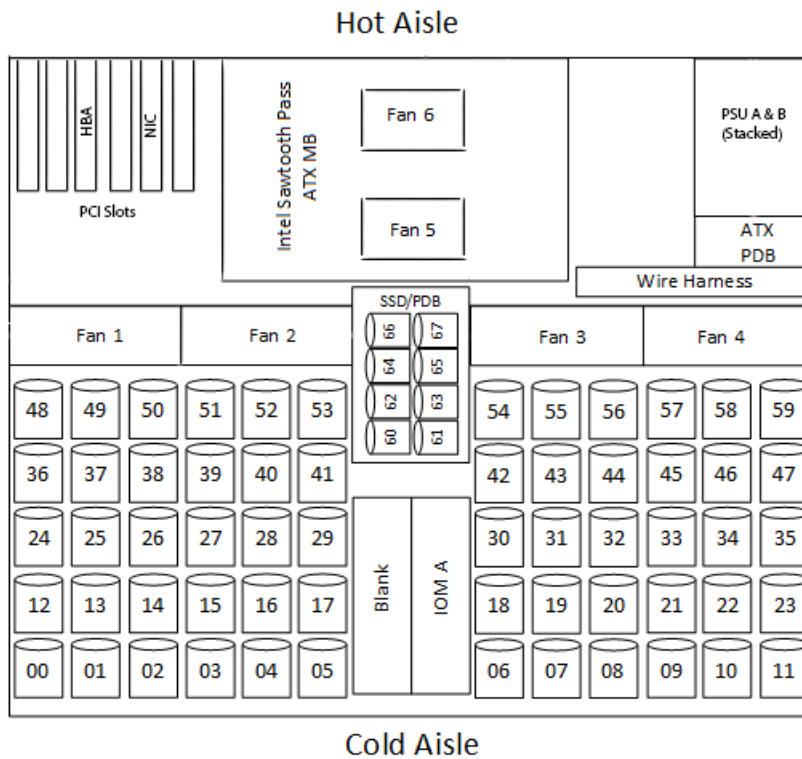

20. Now that the drives are installed into the chassis, test the installation by sliding the enclosure in and out of the rack a minimum of three times. If the enclosure binds, catches, or displays any incorrect motion or behavior retry the installation of the drives and chassis.
21. If the chassis is being installed into a rack that will be shipped fully assembled, you **must** install eight (four per side) of the included M5 x 10mm T15 Torx screws into the two brackets at the front of the chassis in the following locations. These screws should be tightened to 3.38-3.61 Nm / 30-32 in-lbf using a Long

T15 Torx Screwdriver. If this chassis will not be installed into a rack for shipping purposes, skip this step and move on to the next one.

**Figure 32: Shipping Bracket Screw Locations**

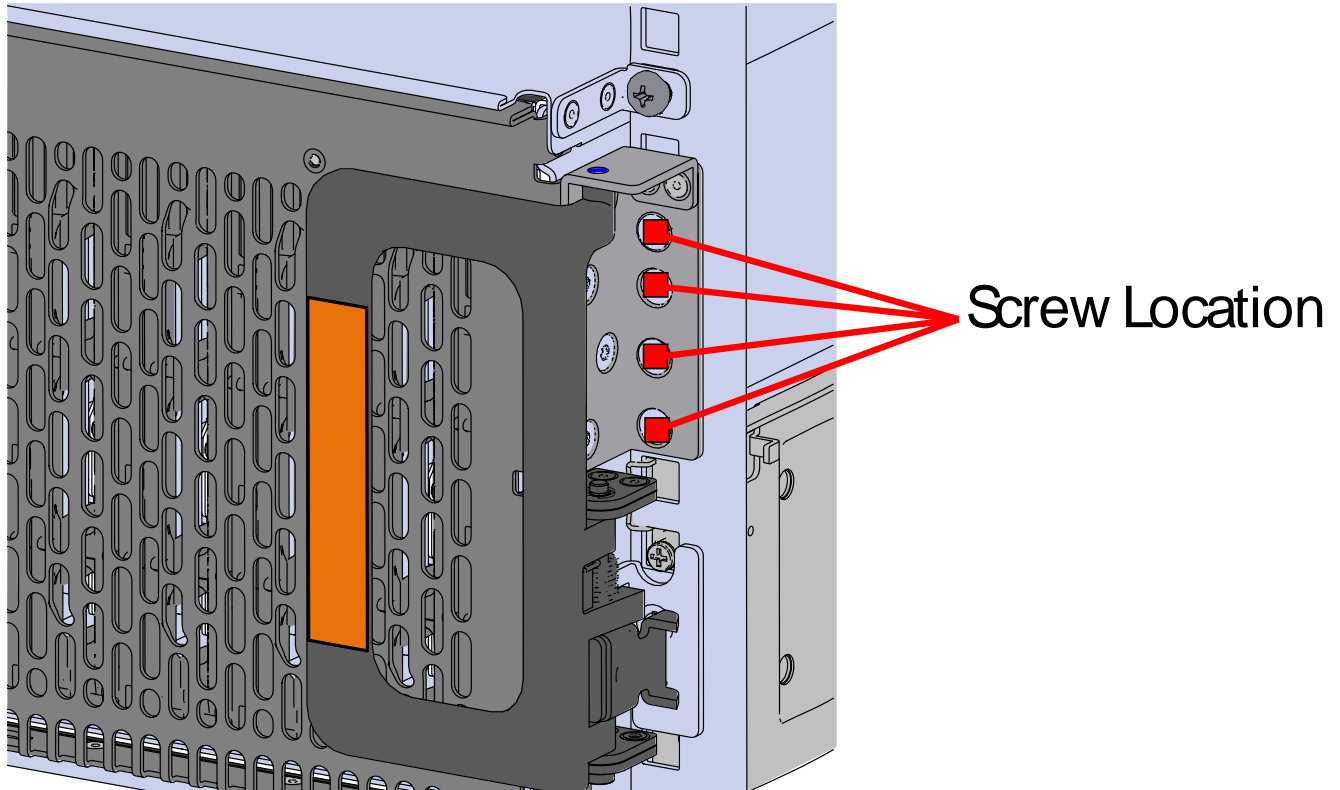

22. Plug the enclosure power cords into a PDU to power the enclosure.
23. Press the power button at the back of the enclosure to power it up.
24. Double check the power indicators and other LEDs to ensure that the system is booting.

## 6 Points of Contact

For further assistance with an HGST product, contact Platform Engineering technical support. Please be prepared to provide the following information: Serial Number (S/N), product name, model number, and a brief description of the issue.

**Email:**

[support@wdc.com](mailto:support@wdc.com)

**Website:**

<http://support.hgst.com>