



Operating Instructions and Parts Manual

18" Band Saw

Model JWBS-18X



WMH TOOL GROUP

2420 Vantage Drive
Elgin, Illinois 60123
Ph.: 800-274-6848
www.wmhtoolgroup.com

Part No. M-710750
Revision A 3/04
Copyright © WMH Tool Group

This manual has been prepared for the owner and operators of a JET JWBS-18X Band Saw. Its purpose, aside from machine operation, is to promote safety using accepted operating and maintenance procedures. To obtain maximum life and efficiency from your band saw and to aid in using it safely, please read this manual thoroughly and follow the instructions carefully.

Warranty and Service

WMH Tool Group warrants every product it sells. If one of our tools needs service or repair, one of our Authorized Repair Stations located throughout the United States can provide quick service or information.

In most cases, a WMH Tool Group Repair Station can assist in authorizing repair work, obtaining parts, or perform routine or major maintenance repair on your JET product.

For the name of an Authorized Repair Station in your area, please call 1-800-274-6848, or visit our web site at www.wmhtoolgroup.com

More Information

Remember, WMH Tool Group is consistently adding new products to the line. For complete, up-to-date product information, check with your local WMH Tool Group distributor, or visit our web site at www.wmhtoolgroup.com

WMH Tool Group Warranty

WMH Tool Group makes every effort to assure that its products meet high quality and durability standards and warrants to the original retail consumer/purchaser of our products that each product be free from defects in materials and workmanship as follows: 1 YEAR LIMITED WARRANTY ON ALL PRODUCTS UNLESS SPECIFIED OTHERWISE. This Warranty does not apply to defects due directly or indirectly to misuse, abuse, negligence or accidents, normal wear-and-tear, repair or alterations outside our facilities, or to a lack of maintenance.

WMH TOOL GROUP LIMITS ALL IMPLIED WARRANTIES TO THE PERIOD SPECIFIED ABOVE, BEGINNING FROM THE DATE THE PRODUCT WAS PURCHASED AT RETAIL. EXCEPT AS STATED HEREIN, ANY IMPLIED WARRANTIES OR MERCHANTABILITY AND FITNESS ARE EXCLUDED. SOME STATES DO NOT ALLOW LIMITATIONS ON HOW LONG THE IMPLIED WARRANTY LASTS, SO THE ABOVE LIMITATION MAY NOT APPLY TO YOU. IN NO EVENT SHALL WMH TOOL GROUP BE LIABLE FOR DEATH, INJURIES TO PERSONS OR PROPERTY, OR FOR INCIDENTAL, CONTINGENT, SPECIAL, OR CONSEQUENTIAL DAMAGES ARISING FROM THE USE OF OUR PRODUCTS. SOME STATES DO NOT ALLOW THE EXCLUSION OR LIMITATION OF INCIDENTAL OR CONSEQUENTIAL DAMAGES, SO THE ABOVE LIMITATION OR EXCLUSION MAY NOT APPLY TO YOU.

To take advantage of this warranty, the product or part must be returned for examination, postage prepaid, to an Authorized Repair Station designated by our office. Proof of purchase date and an explanation of the complaint must accompany the merchandise. If our inspection discloses a defect, we will either repair or replace the product at our discretion, or refund the purchase price if we cannot readily and quickly provide a repair or replacement. We will return the repaired product or replacement at WMH Tool Group's expense, but if it is determined there is no defect, or that the defect resulted from causes not within the scope of WMH Tool Group's warranty, then the user must bear the cost of storing and returning the product. This warranty gives you specific legal rights; you may also have other rights, which vary from state to state.

WMH Tool Group sells through distributors only. Members of the WMH Tool Group reserve the right to effect at any time, without prior notice, alterations to parts, fittings and accessory equipment, which they may deem necessary for any reason whatsoever.

Table of Contents

Warranty and Service	2
Warning.....	4
Introduction.....	6
Specifications	6
Grounding Instructions.....	7
115 Volt Operation	7
230 Volt Operation	8
Unpacking	9
Contents of Shipping Container.....	9
Assembly and Setup.....	10
Upper Bearing Guide Adjustment	10
Lower Bearing Guide Adjustment	11
Mounting the Table.....	11
Adjusting 90 Degree Table Stop	12
Rail Assembly	12
Fence Assembly and Adjustment.....	13
Resaw Guide	14
Miter Gauge	14
Height Scale Adjustment	14
Changing Blades.....	15
Adjusting Blade Tension.....	16
Adjusting Blade Tracking.....	16
Replacing V-Belt	17
Adjusting Belt Tension.....	17
Electrical Connections	18
Operation.....	18
Saw Blade Selection	18
Blade Breakage.....	20
Making Cuts.....	20
Maintenance.....	20
Blade Selection Guide	21
Optional Accessories: Band Saw Blades.....	23
Replacement Parts	23
Parts List: Upper Wheel Assembly.....	24
Upper Wheel Assembly	25
Parts List: Lower Wheel and Motor Assembly	26
Lower Wheel and Motor Assembly	27
Parts List: Blade Guide Assembly.....	28
Blade Guide Assembly	29
Parts List: Table and Fence Assembly.....	30
Table and Fence Assembly	31
Electrical Connections	32



Warnings

1. Read and understand the entire owners manual before attempting assembly or operation.
2. Read and understand the warnings posted on the machine and in this manual. Failure to comply with all of these warnings may cause serious injury.
3. Replace the warning labels if they become obscured or removed.
4. This band saw is designed and intended for use by properly trained and experienced personnel only. If you are not familiar with the proper and safe operation of a band saw, do not use until proper training and knowledge have been obtained.
5. Do not use this band saw for other than its intended use. If used for other purposes, WMH Tool Group disclaims any real or implied warranty and holds itself harmless from any injury that may result from that use.
6. Always wear approved safety glasses/face shields while using this band saw. Everyday eyeglasses only have impact resistant lenses; they are not safety glasses.
7. Before operating this band saw, remove tie, rings, watches and other jewelry, and roll sleeves up past the elbows. Remove all loose clothing and confine long hair. Non-slip footwear or anti-skid floor strips are recommended. Do **not** wear gloves.
8. Wear ear protectors (plugs or muffs) during extended periods of operation.
9. Some dust created by power sanding, sawing, grinding, drilling and other construction activities contain chemicals known to cause cancer, birth defects or other reproductive harm. Some examples of these chemicals are:
 - Lead from lead based paint.
 - Crystalline silica from bricks, cement and other masonry products.
 - Arsenic and chromium from chemically treated lumber.Your risk of exposure varies, depending on how often you do this type of work. To reduce your exposure to these chemicals, work in a well-ventilated area and work with approved safety equipment, such as face or dust masks that are specifically designed to filter out microscopic particles.
10. Do not operate this machine while tired or under the influence of drugs, alcohol or any medication.
11. Make certain the switch is in the **OFF** position before connecting the machine to the power supply.
12. Make certain the machine is properly grounded.
13. Make all machine adjustments or maintenance with the machine unplugged from the power source.
14. Remove adjusting keys and wrenches. Form a habit of checking to see that keys and adjusting wrenches are removed from the machine before turning it on.
15. Keep safety guards in place at all times when the machine is in use. If removed for maintenance purposes, use extreme caution and replace the guards immediately.
16. Check damaged parts. Before further use of the machine, a guard or other part that is damaged should be carefully checked to determine that it will operate properly and perform its intended function. Check for alignment of moving parts, binding of moving parts, breakage of parts, mounting and any other conditions that may affect its operation. A guard or other part that is damaged should be properly repaired or replaced.
17. Provide for adequate space surrounding work area and non-glare, overhead lighting.
18. Keep the floor around the machine clean and free of scrap material, oil and grease.
19. Keep visitors a safe distance from the work area. **Keep children away.**

Warnings

20. Make your workshop child proof with padlocks, master switches or by removing starter keys.
21. Give your work undivided attention. Looking around, carrying on a conversation and “horse-play” are careless acts that can result in serious injury.
22. Maintain a balanced stance at all times so that you do not fall or lean against the blade or other moving parts. Do not overreach or use excessive force to perform any machine operation.
23. Use the right tool at the correct speed and feed rate. Do not force a tool or attachment to do a job for which it was not designed. The right tool will do the job better and safer.
24. Use recommended accessories; improper accessories may be hazardous.
25. Maintain tools with care. Keep blades sharp and clean for the best and safest performance. Follow instructions for lubricating and changing accessories.
26. Make sure the workpiece is held securely on the table and against the fence while moving it through the blade.
27. Turn off the machine before cleaning. Use a brush or compressed air to remove chips or debris — do not use your hands.
28. Do not stand on the machine. Serious injury could occur if the machine tips over.
29. Never leave the machine running unattended. Turn the power off and do not leave the machine until it comes to a complete stop.
30. Remove loose items and unnecessary work pieces from the area before starting the machine.

Familiarize yourself with the following safety notices used in this manual:

CAUTION This means that if precautions are not heeded, it may result in minor injury and/or possible machine damage.

WARNING This means that if precautions are not heeded, it may result in serious injury or possibly even death.

- - SAVE THESE INSTRUCTIONS - -

Introduction

This manual is provided by Jet covering the safe operation and maintenance procedures for a Model JWBS-18X Band Saw. This manual contains instructions on installation, safety precautions, general operating procedures, maintenance instructions and parts breakdown. This machine has been designed and constructed to provide years of trouble free operation if used in accordance with instructions set forth in this manual. If there are any questions or comments, please contact either your local supplier or WMH Tool Group. WMH Tool Group can also be reached at our web site: www.wmhtoolgroup.com.

Specifications

Model Number.....	JWBS-18X
Stock Number.....	710750
Cutting Capacity (height) (in.).....	12
Cutting Capacity (width) (in.).....	18-3/8
Maximum Rip Left of Blade w/Fence (in.).....	16-1/2
Maximum Rip Right of Blade w/Fence (in.).....	7-5/8
Blade Length (in.).....	137
Blade Speed (SFPM).....	3000
Minimum Blade Width (in.).....	1/8
Maximum Blade Width (in.).....	1-1/2
Table Size (in.).....	19" x 19"
Table Tilt (degrees).....	45°R to 10°L
Table Height from Floor (in.).....	37-1/2
Wheel Diameter (in.).....	18-5/8
Dust Chute Diameter (in.).....	4
Overall Dimensions (HxWxD) (in.).....	71 x 39 x 31
Motor.....	1.75 HP, 1Ph, 115/230V (prewired 115V)
Net Weight (approx.) (lbs.).....	346
Shipping Weight (approx.) (lbs.).....	407

The above specifications were current at the time this manual was published, but because of our policy of continuous improvement, WMH Tool Group reserves the right to change specifications at any time and without prior notice, without incurring obligations.

Grounding Instructions

▲WARNING This machine must be grounded while in use to protect the operator from electric shock.

In the event of a malfunction or breakdown, grounding provides a path of least resistance for electric current to reduce the risk of electric shock. This tool is equipped with an electric cord having an equipment-grounding conductor and a grounding plug. The plug must be plugged into a matching outlet that is properly installed and grounded in accordance with all local codes and ordinances.

Do not modify the plug provided. If it will not fit the outlet, have the proper outlet installed by a qualified electrician.

Improper connection of the equipment-grounding conductor can result in a risk of electric shock. The conductor, with insulation having an outer surface that is green with or without yellow stripes, is the equipment-grounding conductor. If repair or replacement of the electric cord or plug is necessary, do not connect the equipment-grounding conductor to a live terminal.

Check with a qualified electrician or service personnel if the grounding instructions are not completely understood, or if in doubt as to whether the tool is properly grounded. Use only three wire extension cords that have three-prong grounding plugs and three-pole receptacles that accept the tool's plug.

Repair or replace a damaged or worn cord immediately.

115 Volt Operation

As received from the factory, your bandsaw is ready to run at 115 volt operation. This bandsaw, when wired for 115 volts, is intended for use on a circuit that has an outlet and a plug that looks the one illustrated in Figure A. A temporary adapter, which looks like the adapter as illustrated in Figure B, may be used to connect this plug to a two-pole receptacle, as shown in Figure B if a properly grounded outlet is not available. The temporary adapter should only be used until a properly grounded outlet can be installed by a qualified electrician. **This adapter is not applicable in Canada.** The green colored rigid ear, lug, or tab, extending from the adapter, must be connected to a permanent ground such as a properly grounded outlet box, as shown in Figure B.

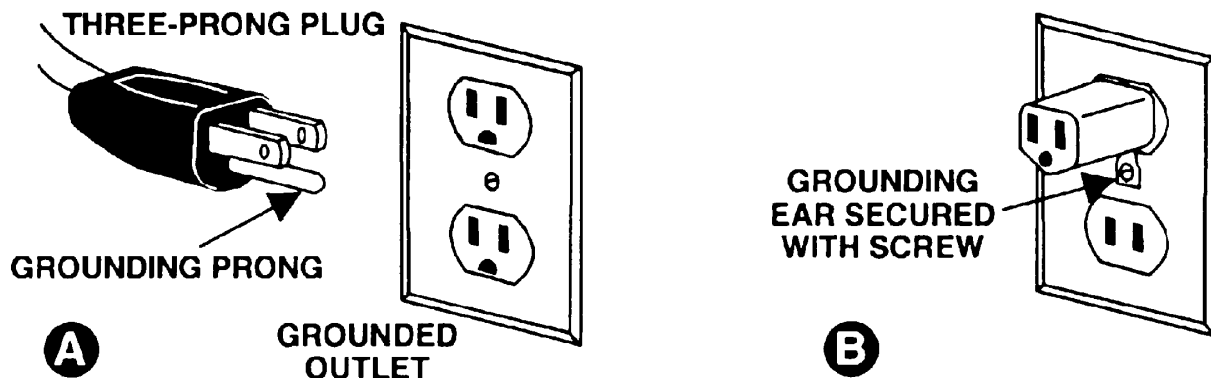

230 Volt Operation

If 230V, single phase operation is desired, the following instructions must be followed:

1. Disconnect the machine from the power source.
2. This bandsaw is supplied with four motor leads that are connected for 115V operation, as shown in Figure A. Reconnect these four motor leads for 230V operation, as shown in Figure B.
3. The 115V attachment plug supplied with the bandsaw must be replaced with a UL/CSA listed plug suitable for 230V operation. Contact your local Authorized JET Service Center or qualified electrician for proper procedures to install the plug. The bandsaw must comply with all local and national codes after the 230V plug is installed.
4. The bandsaw with a 230V plug should only be connected to an outlet having the same configuration. No adapter is available or should be used with the 230V plug.

Important: In all cases (115 or 230 volts), make certain the receptacle in question is properly grounded. If you are not sure, have a registered electrician check the receptacle.

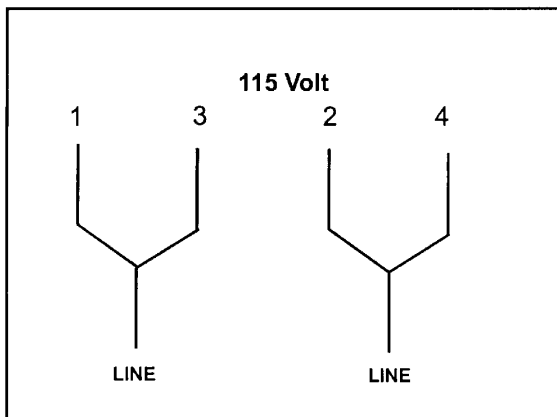

FIGURE A

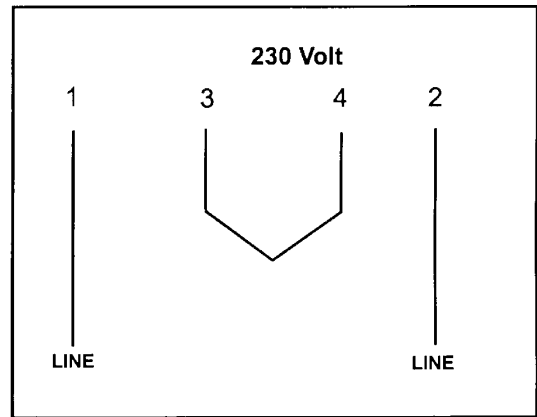
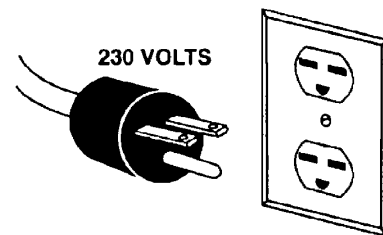
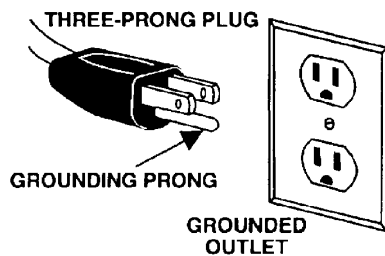

FIGURE B



Unpacking

Contents of Shipping Container

- 1 Bandsaw
- 1 Table
- 1 Fence and Rail Assembly
- 1 Resaw Guide and Knob
- 1 Miter Gauge
- 1 Owner's Manual
- 1 Warranty Card
- 1 Accessory Package Contains:
 - Hardware Bag*
 - 2 Knobs
 - 1 Hex Wrench
 - 1 Handle
 - 1 10/12mm Wrench
 - Fence Hardware Bag*
 - 4 Hex Cap Screws
 - 4 Flat Washers
 - 4 Lock Washers
 - Rail Hardware Bag*
 - 9 Hex Cap Screws
 - 9 Flat Washers
 - 9 Lock Washers



- 1. Remove the crate and packing material from the bandsaw except for the transport skid on the bottom.
- 2. Move the saw to its permanent working location. The site should be dry, well lit, and have enough room to handle long stock and the service and/or adjustment of the machine from any side.
- 3. Move the bandsaw off the skid.
- 4. Clean all rust protected surfaces with a mild solvent or diesel fuel and a soft cloth. Do not use lacquer thinner, paint thinner, or gasoline. These will damage painted surfaces.

Tools Included for Assembly

- 1. 10/12mm Open End Wrench
- 1. Hex Wrench

Tools Required for Assembly & Adjustments

- 2. 14mm Open End Wrench
- 1. Cross Point Screw Driver
- 1. Combination Square

Assembly and Setup

1. Attach the handle (A, Figure 1) to the handwheel (B, Figure 1).
2. Turn blade tension handwheel (C, Figure 1) counterclockwise to tension blade and clockwise to loosen the tension. A gauge on the upper wheel slide bracket (D, Figure 1) indicates the approximate tension according to the width of the blade. The JWBS-18X comes with a 3/4" blade so the tension should be set at 3/4".

Note: It is easier to adjust the bearing guides before mounting the table.

Upper Bearing Guide Adjustment

⚠WARNING Disconnect machine from power source (unplug) before making any adjustments! Blade teeth are sharp - use care when working near the saw blade. Failure to comply may cause serious injury.

1. Blade tension must be properly adjusted prior to bearing guide setup. See "Adjusting Blade Tension" on page 16.
2. Adjust the back-up bearing (E, Figure 2) so that it is 0.003" away from the back of the blade, about the thickness of a piece of paper. To make this adjustment loosen thumb screw (F, Figure 2) and slide the bearing and bearing post into position. Tighten thumb screw.
3. Loosen the socket head cap screw (G, Figure 3) and slide the bearing assembly until the bearing guides rest just behind the gullet of the blade teeth. You may need to readjust the back-up bearing (E, Figure 2).
4. Loosen the wing nut (H, Figure 3) and turn the adjusting screw (I, Figure 3) clockwise or counterclockwise until the bearing is 0.003" away from the side of the blade, about the thickness of a piece of paper. Tighten wing nut (H, Figure 3).
5. Adjust the opposite side bearing.
6. Check to make sure the adjustments have not changed and the bearing guides do not pinch the blade.

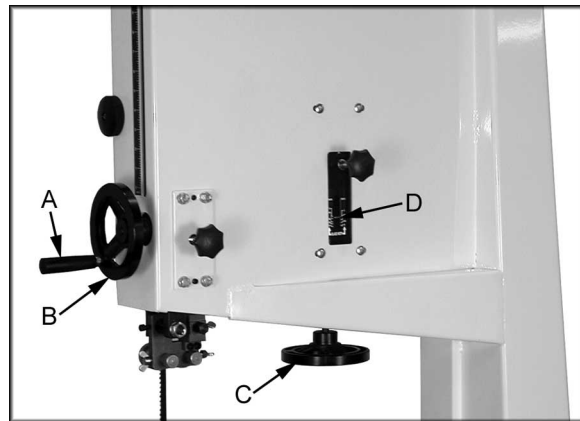

Figure 1

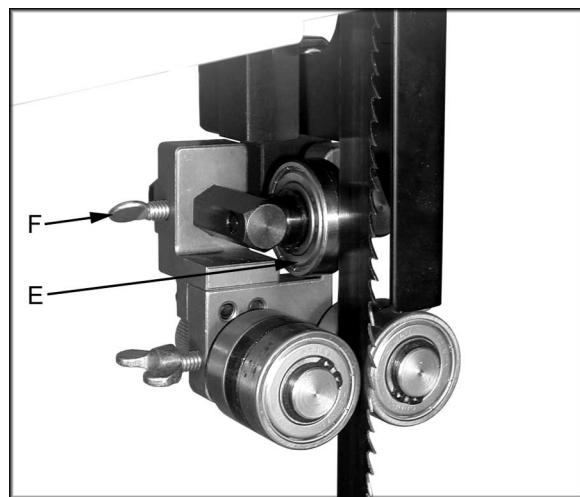

Figure 2

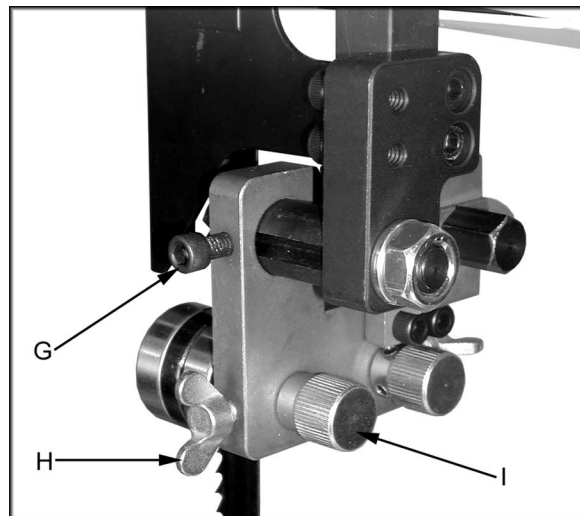

Figure 3

Lower Bearing Guide Adjustment

⚠WARNING Disconnect machine from power source (unplug) before making any adjustments! Blade teeth are sharp - use care when working near the saw blade. Failure to comply may cause serious injury.

1. Blade tension must be properly adjusted prior to bearing guide setup. See "Adjusting Blade Tension" on page 16.
2. Adjust the back-up bearing (A, Figure 4) so that it is 0.003" away from the back of the blade, about the thickness of a piece of paper. To make this adjustment loosen thumb screw (B, Figure 4) and slide the bearing and bearing post into position. Tighten thumb screw (B, Figure 4).
3. Loosen the two socket head cap screws (C, Figure 4) and slide the bearing assembly until the bearing guides rest just behind the gullet of the blade teeth. You may need to readjust the back-up bearing. Tighten socket head cap screws.
4. Loosen the thumb screw (D, Figure 4) and turn adjusting screw (E, Figure 4) clockwise or counter-clockwise until the bearing is 0.003" away from the side of the blade, about the thickness of a piece of paper.
5. Adjust the opposite side bearing.
6. Tighten thumb screw (D, Figure 4). Check to make sure the adjustments have not changed and the bearing guides do not pinch the blade.

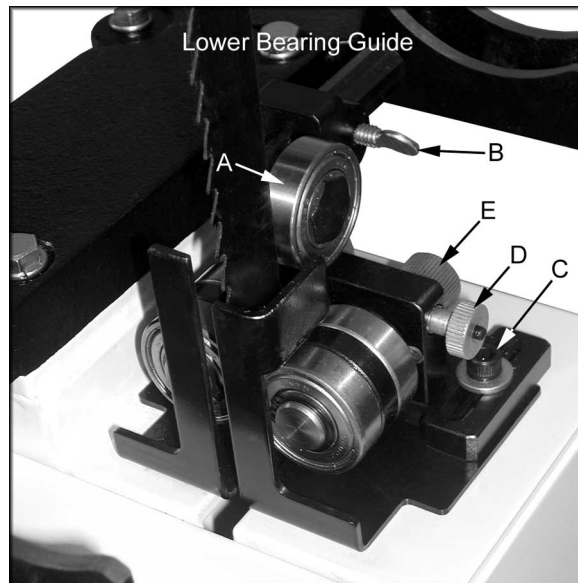

Figure 4

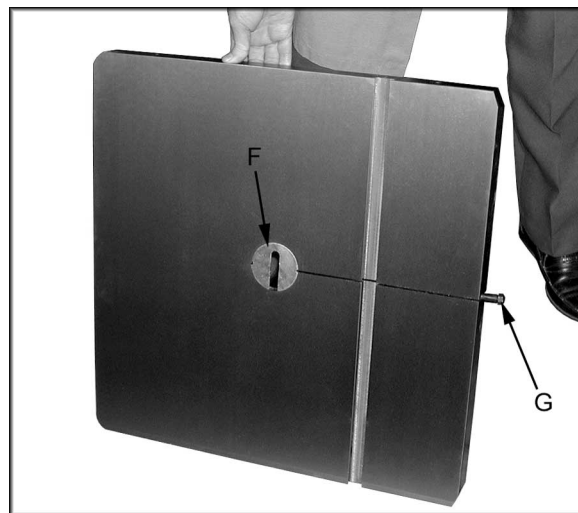

Figure 5

Mounting the Table

1. With help from another person mount the table. Remove the table insert (F, Figure 5) and table pin (G, Figure 5).
2. Slide saw blade through slot in table where the table pin was located. Rotate the table 90 degrees so that the miter slot is parallel to the blade, and to the right of the blade when facing the bandsaw.
3. Line up the trunnions so that the bolts feed through the trunnion support bracket. Secure the table with two lock knobs (H, Figure 6). Reinstall the table insert and table pin.

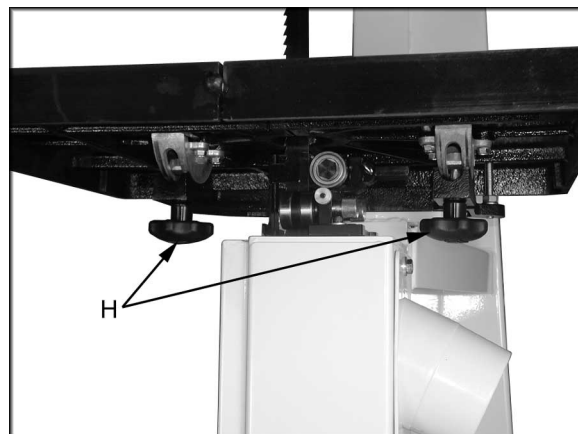

Figure 6

Adjusting 90 Degree Table Stop

1. Blade tension must be properly adjusted prior to adjusting 90 degree stop, see "Adjusting Blade Tension" on page 16.
2. Loosen lock knobs (A, Figure 7) and tilt table until it rests against table stop bolt (B, Figure 7). Tighten knobs.
3. Use a square (E, Figure 8) placed on the table and against the blade to see if the table is 90 degrees to the blade.
4. If an adjustment is necessary, loosen the lock knobs. Tilt the table until it is square to the blade, and tighten the lock knobs.
5. Loosen lock nut (C, Figure 7) and turn table stop bolt (B, Figure 7) until it contacts the table. Tighten the nut (C, Figure 7) to hold table stop in place. When tightening the nut hold the table stop bolt in place with a wrench to prevent movement.
6. If necessary, adjust pointer (D, Figure 7) to zero.

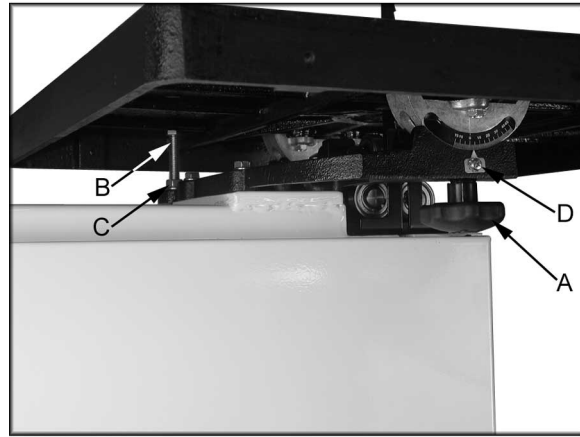

Figure 7

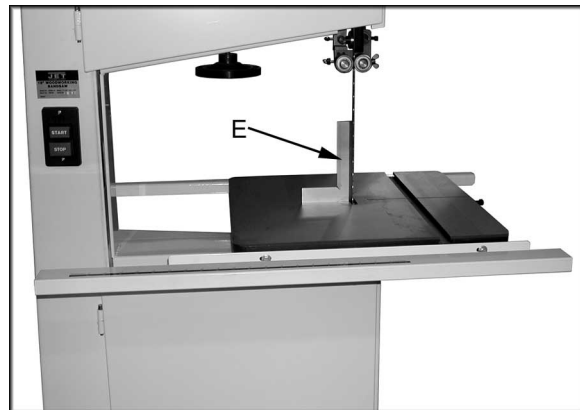

Figure 8

Rail Assembly

1. Attach the front rail (F, Figure 9) to the cast iron table with two 1/4" x 5/8" hex cap screws, two 1/4" lock washers, and two 1/4" flat washers. Screws should be in approximately the center of the slot. Hand tighten only at this time.
2. Attach the rear rail (G, Figure 9) to the table with two 1/4" x 5/8" hex cap screws, two 1/4" lock washers, and two 1/4" flat washers. Screws should be in approximately the center of the slot. Hand tighten only at this time.
3. Push the front, and rear rails up as far as they will go.
4. Tighten the four hex cap screws holding the front, and rear rails to the table. Do not over tighten the screws.
5. Attach the guide tube (H, Figure 9) to the front rail with five 1/4" x 5/8" hex cap screws, five 1/4" lock washers, and five 1/4" flat washers. Screws should be in approximately the center of the slot.

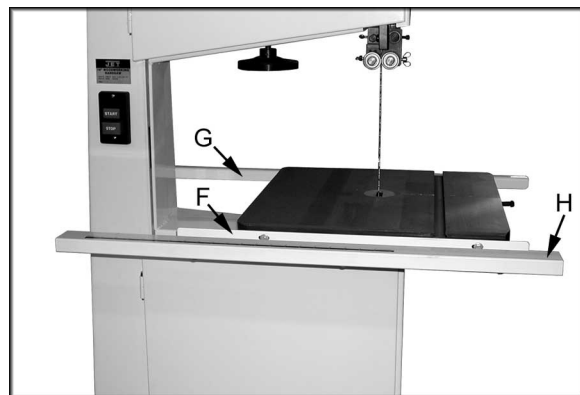

Figure 9

Fence Assembly and Adjustment

1. Attach the fence (A, Figure 10) to the fence body (B, Figure 10) with four 5/16" x 3/4" hex cap screws, four 5/16" lock washers, and four 5/16" flat washers.
2. Thread a hex nut (D, Figure 11) onto the pad's threaded stud (E, Figure 11) and insert through the fence and rear hook (F, Figure 11). Secure in place using a hex nut, lock washer and flat washer (G, Figure 11).
3. Note: The hook should be adjusted so that it overlaps the rear rail by approximately 1/8".
4. Place fence assembly onto the guide tube. The rear hook should engage the rear rail.
5. Check the clearance between the table and the fence. The gap should be the same at the front of the table as it is at the rear. If the gap width is different, adjust the foot at the rear of the fence until the gap width is the same. See Figure 12.

Note: You can also adjust the front rail or rear rail up or down to achieve the proper clearance.

6. With a square, verify the fence face is perpendicular to the table top. If it is not the front rail will need to be adjusted parallel to the table top. This can be accomplished by measuring from the top of the table to the top of the front rail. The measurement should be the same at both ends of the table.
7. Move the fence assembly so that it aligns parallel to the blade, and lock the fence by pushing the lock handle down, Figure 10.
8. Loosen the four hex cap bolts that hold the fence to the fence body, and align the fence to the blade. Tighten the four hex cap screws.
9. Check to see that the pointer (C, Figure 10) is aligned with the zero marking on the guide rail. If adjustment is necessary loosen the screw that holds the pointer in place and line up to the zero mark. Tighten the screw.

Note: If you cannot get the pointer lined up with the zero mark you can slide the guide tube and front rail left or right to achieve the proper setting.

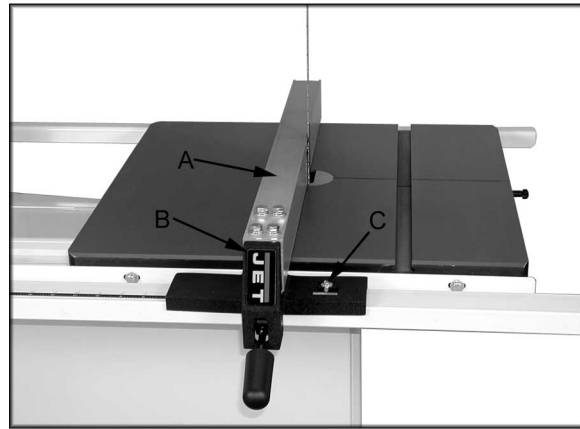

Figure 10

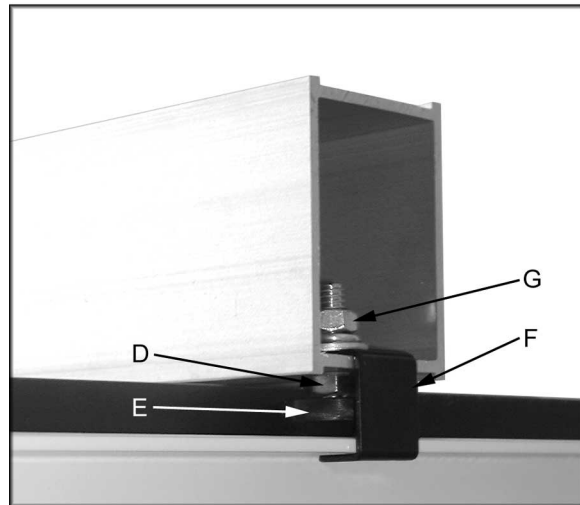

Figure 11

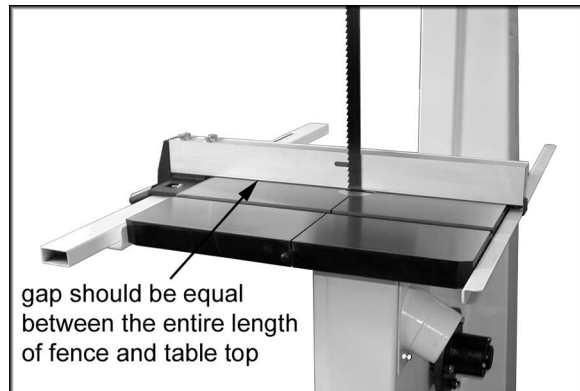

Figure 12

Resaw Guide

For resawing attach the post (A, Figure 13) to fence with the lock knob (B, Figure 13). There is a slotted hole in the fence that will accommodate the resaw kit. Position the post so that it is centered with the front edge of the blade. The resaw guide will give you a taller, single point contact surface during resawing.

Miter Gauge

1. Place the miter gauge in the table slot.
2. With a square verify the miter gauge face is square to the blade.
3. If the miter gauge is not square to the blade loosen the lock knob (C, Figure 13) and adjust to the proper setting. Tighten the lock knob.
4. If the pointer is not at 90 degrees, loosen the screw (D, Figure 13) holding the pointer and move the pointer to 90 degrees.

Tilting the Table

1. Disconnect machine from power source.
2. Loosen the lock knobs (E, Figure 14).
3. Tilt table up to 45 degrees to the right, or up to 10 degrees to the left.
4. Tighten the lock knobs.

Note: Table stop bolt (F, Figure 14) must be removed to tilt table to the left.

Height Scale Adjustment

1. Disconnect machine from power source.
2. The upper bearing guide should be set about 1/8" above the material to be cut.
3. Measure from the table top to the bottom of the bearing guides, Figure 15.
4. Set the indicator to this measurement on the height scale. Grasp the end of the indicator (G, Figure 15) between your finger, and thumb. Move the indicator into position.

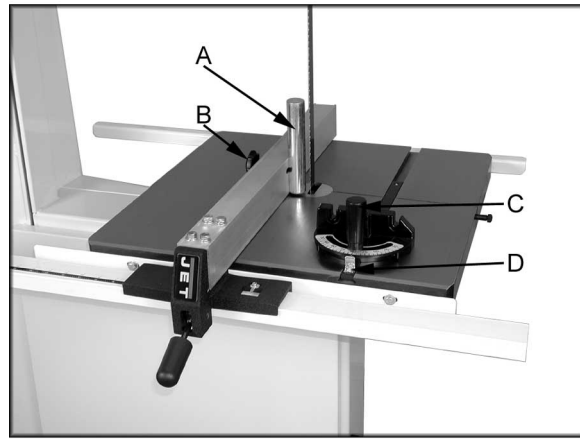

Figure 13

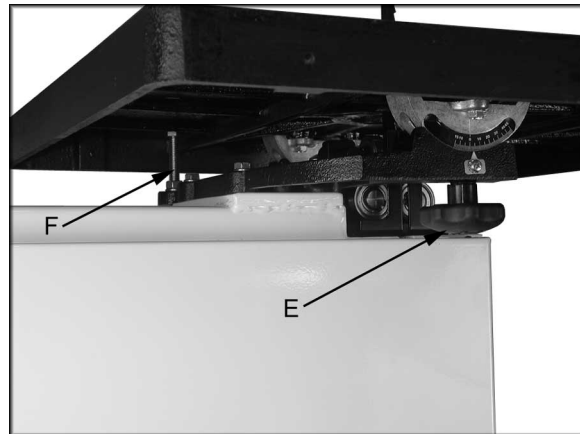

Figure 14

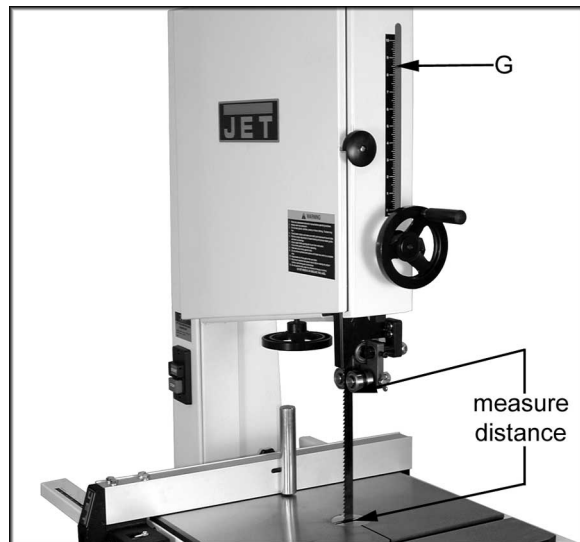

Figure 15

Changing Blades

⚠WARNING Disconnect machine from power source. Blade teeth are sharp, use care when handling the blade. Failure to comply may cause serious injury.

1. Disconnect machine from power source.
2. Remove the table insert (A, Figure 16), and table pin (B, Figure 16).
3. Lower the upper blade guide assembly about half way by loosening the lock knob (F, Figure 17) and turning the hand wheel (G, Figure 17).
4. Loosen socket head cap screw (C, Figure 16) and slide the bearing assembly back as far as it will go.
5. Open both wheel covers (D, Figure 16).
6. Loosen blade tension by turning blade tension handwheel (E, Figure 17) clockwise until it stops.

Note: You may want to wear leather work gloves while removing and handling the blade.

7. Carefully remove blade from upper and lower wheels. Remove the blade from between upper and lower bearing guides. Turn blade and direct through slot in table.
8. Make sure blade teeth point down toward table and guide the new blade through table slot. Place blade in upper and lower bearing guides.
9. Place blade in the middle of the upper and lower wheels.
10. Tension and track blade before operating saw. Find instructions for tensioning and tracking the blade on the next page under "Adjusting Blade Tension" and "Adjusting Blade Tracking".
11. Replace table insert and table pin.

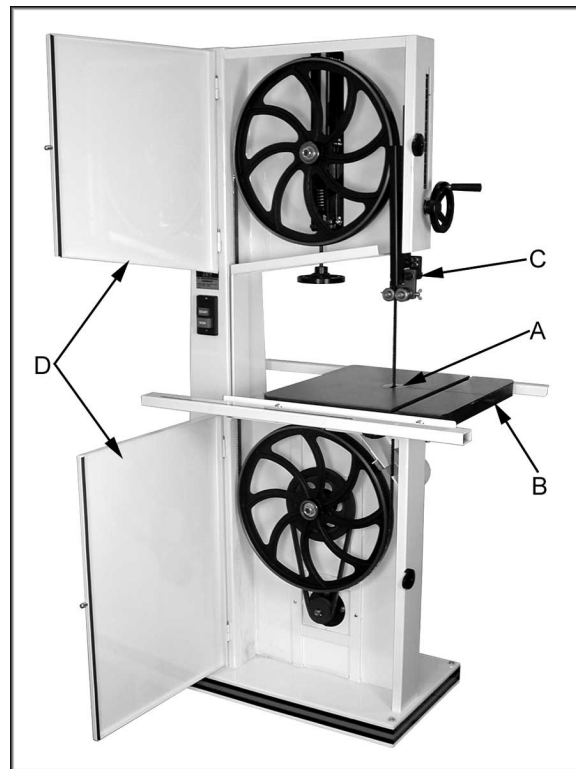

Figure 16

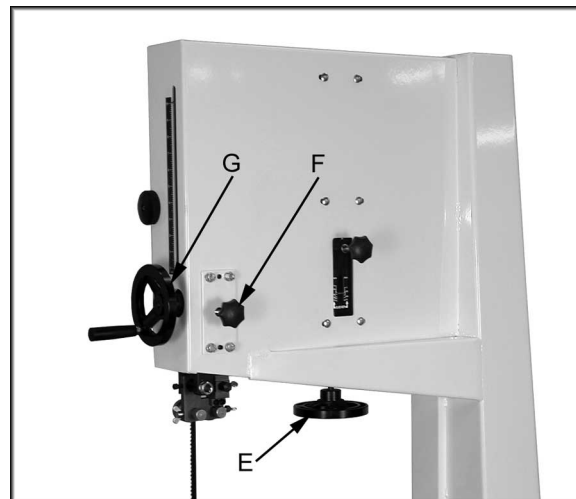

Figure 17

Adjusting Blade Tension

1. Disconnect machine from power source.
2. Turn blade tension handwheel (A, Figure 18) counterclockwise to tension blade, and clockwise to loosen the tension. A gauge on the upper wheel slide bracket (B, Figure 18) indicates the approximate tension according to the width of the blade. The JWBS-18 comes with a 3/4" blade so the tension should be set at 3/4" when using this blade.
3. As you become familiar with the saw, you may find it necessary to change the blade tension from the initial setting. Changes in blade width, and the type of material being cut will have an effect on blade tension.
4. Keep in mind that too little, or too much blade tension can cause blade breakage and/or poor cutting performance.

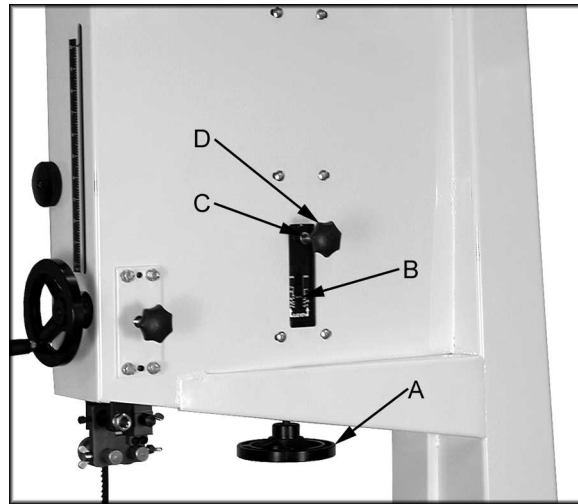

Figure 18

Adjusting Blade Tracking

⚠WARNING Disconnect machine from power source. Never adjust blade tracking with the machine running. Failure to comply may cause serious injury.

Note: Blade tracking has been adjusted at the factory. If, however, it is determined that blade tracking needs adjustment:

1. Blade must be properly tensioned before adjusting blade tracking. Make sure upper and lower bearing guides do not interfere with the blade while adjusting the tracking.
2. Open the upper wheel door. Rotate the wheel forward, and observe the position of the blade on the wheel. The blade should rest in approximately the center of the wheel.
3. If adjustment is necessary, loosen the wing nut (C, Figure 18) at the top rear of the saw.
4. Adjust tracking by turning the knob (D, Figure 18) in 1/4 turn increments. Rotate the wheel forward, and observe the position of the blade on the wheel. Rotating knob (D, Figure 18) counterclockwise should move the blade towards the front of the wheel. Rotating the knob clockwise should move the blade towards the back of the wheel.
5. Continue with adjustments until the blade is tracking properly.
6. Tighten the wing nut (C, Figure 18).

Replacing V-Belt

1. Disconnect machine from power source.
2. Release blade tension by turning blade tension handwheel clockwise.
3. Release belt tension by loosening the two hex cap screws (A, Figure 19, *the pivot bolt is not shown in the photo*). Raise the motor and place a block of wood under the motor to take the tension off the belt.
4. Open the lower wheel door and remove hex nut, and washer (B, Figure 20).
5. Remove the wheel (C, Figure 21). If the lower wheel does not come off easily you may need to use a pulley puller to remove the lower wheel.
6. Remove the old belt (D, Figure 21) and install the new belt.
7. Reinstall the lower wheel and tighten the hex nut.
8. Remove the wood block or support from below the motor and adjust the belt tension. See "Adjusting the Belt Tension."
9. Set the blade tension. See "Adjusting Blade Tension" on the previous page.
10. Check the blade tracking. See "Adjusting Blade Tracking" on the previous page.



Figure 19

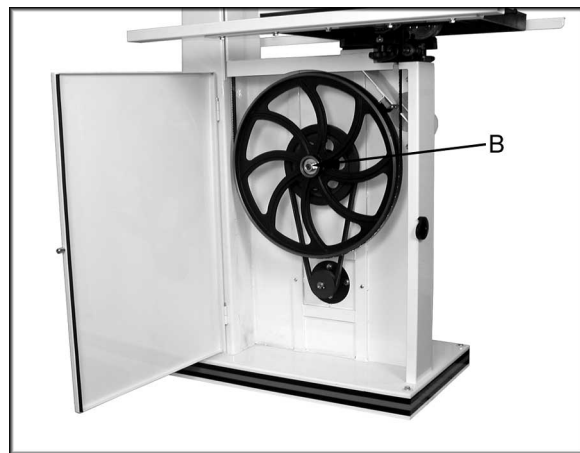

Figure 20

Adjusting Belt Tension

The belt comes adjusted from the factory. If future adjustment is needed:

1. Disconnect machine from power source.
2. Set the belt tension by lightly pressing down on the motor and tightening the hex cap screw (A, Figure 19, *the pivot bolt is not shown in the photo*).

Note: The weight of the motor should put enough tension on the belt. You just want to push down lightly to take up any slack.

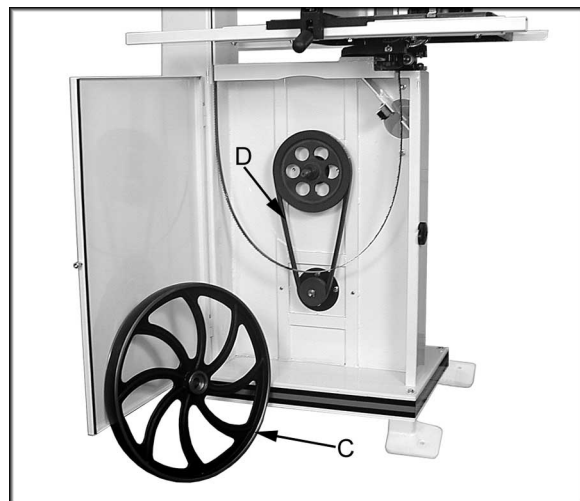

Figure 21

Electrical Connections

⚠WARNING All electrical connections must be done by a qualified electrician. Failure to comply may result in loss of property and/or serious injury.

JWBS-18X is rated at 1.75 HP, 1Ph, 115/230V, prewired 115V.

The bandsaw comes with a 115V plug (A, Fig. 22). If you switch to 230V a plug needs to be purchased for the bandsaw that matches the 230V outlet you intend to use.

Confirm power at the site is the same as the saw before making any electrical connections. Review the wiring diagram on page 28.

Review "Grounding Instructions" on page 7, "115 Volt Operation" also on page 7 and "230 Volt Operation" on page 8.

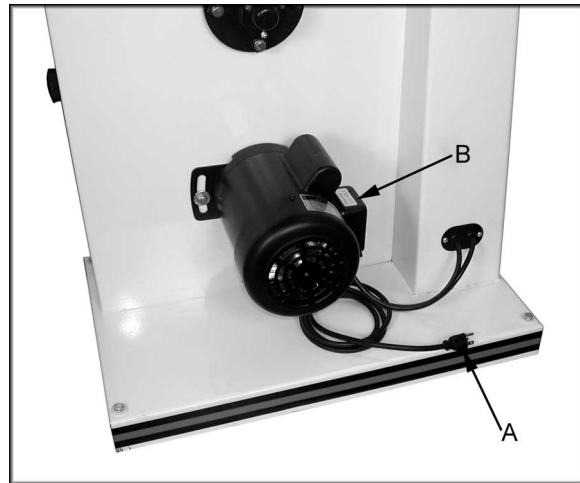

Figure 22

Operation

Saw Blade Selection

Using the proper blade for the job will increase the operating efficiency of your band saw, help reduce necessary saw maintenance, and improve your productivity. Thus, it is important to follow certain guidelines when selecting a saw blade.

Here are factors to consider when selecting a blade:

1. The type of material you will be cutting.
2. The thickness of the workpiece or part.
3. The features of the workpiece or part, such as bends or curves with small radii.

These factors are important because they involve basic concepts of saw blade design. There are five (5) blade features that are normally changed to meet certain kinds of sawing requirements. They are:

1. width
2. pitch (number of teeth per inch),
3. tooth form (or shape),
4. the "set" of the teeth
5. the blade material itself.

Width

Band saw blades come in different standard widths, measured from the back of the blade to the tip of the tooth. Generally, wider blades are used for ripping or making straight cuts; narrower blades are often used when the part being cut has curves with small radii. (When cutting straight lines with a narrow blade, the blade may have a tendency to wander, causing "blade lead".)

Pitch

Pitch is measured in "teeth per inch" (TPI). Figure 23 shows blades with different pitches. A fine pitch (more teeth per inch) will cut slower but smoother. A coarse pitch (fewer teeth per inch) will cut rougher but faster. As a rule of thumb, the thicker the workpiece, the coarser will be the blade pitch. If you have to cut a hard or very brittle material, you will probably want to use a blade with a finer pitch in order to get good clean cuts.

General rule: Use a blade that will have no fewer than 6 and no more than 12 teeth in the workpiece at any given time.

Shape

Figure 24 shows common types of tooth shape. Tooth shape has an effect on cutting rate, and with few exceptions, the Skip and Hook types are used to obtain higher feed rates when cutting thick workpieces. Variable-tooth blades are also available, which combine features of the other styles.

Set

The term "set" refers to the way in which the saw teeth are bent or positioned. Set patterns are usually selected depending on the type of material that needs to be cut. Three common set patterns are shown in Fig. 25.

Generally, the Raker set is used for cutting metal workpieces; the Wave set, when the thickness of the workpiece changes, such as cutting hollow tubing or structurals. The Straight set is most often preferred when cutting wood or plastics.

Material

Band saw blades can be made from different types of materials. Some of the most common include spring steel, carbon steel, carbon steel equipped with a high speed or welded edge (bi-metal), or carbide tips. A special type of saw blade is made from "high speed steel"; these should not be used on band saws with low rates of speed.

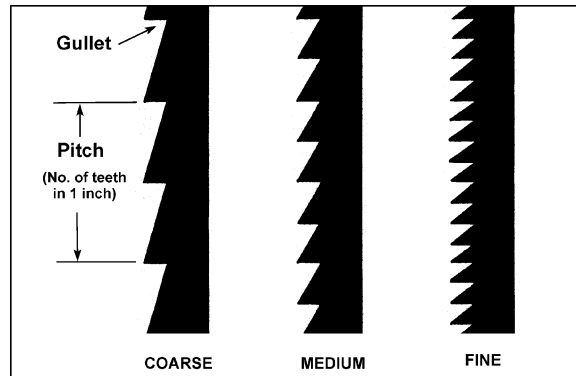

Figure 23

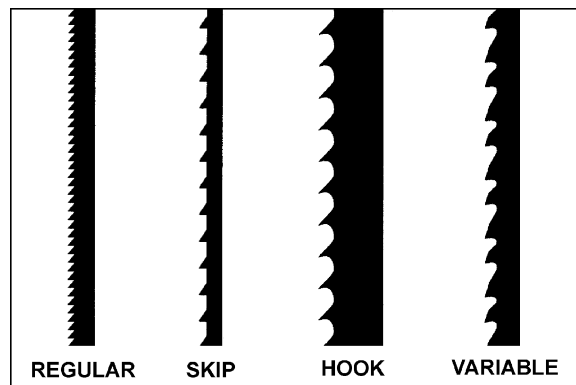

Figure 24

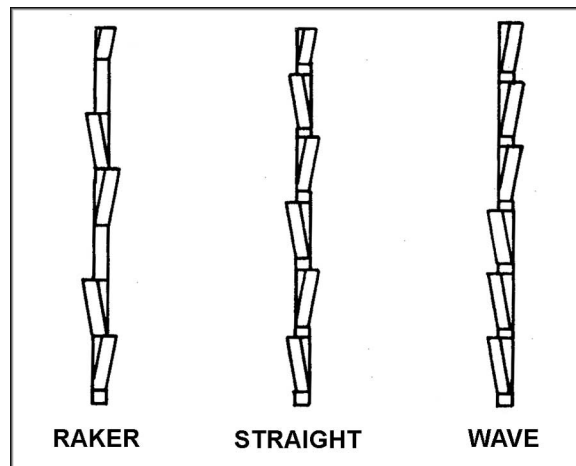

Figure 25

Because of the importance of blade selection, it is recommended that you use the blade selection guide on page 21.

▲WARNING When cutting, do not overfeed the blade; overfeeding will reduce blade life, and may cause the blade to break.

Blade Breakage

Band saw blades are subject to high stresses and breakage may sometimes be unavoidable. However, many factors can be controlled to help prevent most blade breakage. Here are some common causes for breakage:

1. Misalignment of the blade guides
2. Feeding work too fast
3. Using a wide blade to cut a short radius curve
4. Excessive tension
5. Teeth are dull or improperly set
6. Upper guides are set too high off the workpiece
7. Faulty weld on blade

Making Cuts

1. Make sure blade is adjusted correctly for tension and tracking.
2. Adjust blade guard so that it is just above the workpiece (about 3/16"), allowing minimum exposure to the blade.
3. Move the fence into position.
4. Feed the stock slowly, with the straightest edge against the fence. DO NOT FORCE the workpiece into the blade.

▲WARNING Whenever possible, use a push stick, hold-down, power feeder, jig, or similar device while feeding stock to prevent your hands getting too close to the blade.

NOTE: When cutting long stock, the operator should use roller stands, support tables, or an assistant to help stabilize the workpiece.

Maintenance

▲WARNING Before any intervention on the machine, disconnect it from the electrical supply by pulling out the plug. Failure to comply may cause serious injury.

Keep bearing guides clean and free of build-up.

Check that the cleaning brush over the band wheel is working properly, and remove any deposits from the band wheels to avoid vibration and blade breakage.

The table surface should be kept clean and free of rust for best results. Some users prefer a paste wax coating. Another option is talcum powder applied with a blackboard eraser rubbed in vigorously once a week; this will fill casting pores and form a moisture barrier. This method provides a table top that is slick and allows rust rings to be easily wiped from the surface. Important also is the fact that talcum powder will not stain wood or mar finishes as wax pickup does.

Do not let saw dust build up in the upper and lower wheel housings. Vacuum out frequently.

Connect the bandsaw to a JET dust collection system.

Clean and grease the raising/lowering rack for the upper bearing guides if it becomes difficult to raise or lower.

Clean and oil the tensioning mechanism if it becomes difficult to adjust.

Vacuum out the motor fan cover.

Blade Selection Guide

Identify the material and thickness of your workpiece. The chart will show the recommended PITCH, blade TYPE, and FEED RATE.

Key: L – Low H – Hook
 M – Medium S – Skip
 H – High R – Regular

Example: 10/H/M means 10 teeth per inch / Hook Type Blade / Medium Feed

MATERIAL/S		WORKPIECE THICKNESS			
		½"	1"	3"	6+"
WOODS	HARDWOOD	10/R/L	8/R/L	3/H/M	3/H/M
	SOFTWOOD	10/R/L	8/R/L	3/H/M	3/H/M
NON-METALS	CARBON	10/R/L	6/R/L	3/S/M	3/S/M
	MICA	32/R/L	—	—	—
	ASBESTOS	8/R/L	6/R/L	3/S/M	3/S/M
	HARD RUBBER	10/R/L	8/R/L	6/R/M	2/S/H
PLASTICS	FORMICA	14/R/M	10/R/M	4/H/H	4/H/H
	MASONITE	10/R/L	4/S/L	3/S/M	3/H/M
	MICARTA	14/R/M	10/R/M	4/H/H	3/H/H
	PLEXIGLAS	10/R/L	6/R/L	3/S/M	3/S/M
	PAPER	14/R/L	10/R/L	4/S/L	3/S/M

Study the part drawing or prototype, or actually measure the smallest cutting radius required, and locate this radius (in inches) on the chart at the right. Follow the curve to where the approximate blade width is specified. If a radius falls between two of the curves, select the widest blade that will saw this radius.

This procedure should be used for making initial blade selections. These recommendations can, of course, be adjusted to meet specific requirements of a cutting job. Compromises may be necessary if you cannot find all needed specifications in a single blade.

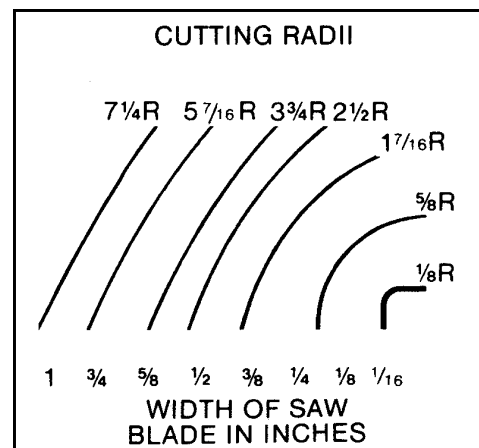

Troubleshooting

Trouble	Probable Cause	Remedy
Saw stops or will not start	Saw unplugged	Check plug connections
	Fuse blown, or circuit breaker tripped	Replace fuse, or reset circuit breaker
	Cord damaged	Replace cord
Does not make accurate 45° or 90° cuts	Stop not adjusted correctly	Check blade with square and adjust stop [page 12]
	Angle pointer not set accurately	Check blade with square and adjust pointer [page 12]
	Miter gauge out of adjustment	Adjust miter gauge [page 14]
Blade wanders during cut	Fence not aligned with blade	Check and adjust fence [page 13]
	Warped wood	Select another piece of wood
	Excessive feed rate	Reduce feed rate
	Incorrect blade for cut	Change blade to correct type
	Blade tension not set properly	Set blade tension according to blade size
	Guide bearings not set properly	Review guide bearing adjustment on pages 10 and 11.
Saw makes unsatisfactory cuts	Dull blade	Replace blade
	Blade mounted wrong	Teeth should point down
	Gum or pitch on blade	Remove blade and clean
	Incorrect blade for cut	Change blade to correct type [pg. 21]
	Gum or pitch on table	Clean table
Blade does not come up to speed	Extension cord too light or too long	Replace with adequate size and length cord
	Low shop voltage	Contact your local electric company
Saw vibrates excessively	Base on uneven floor	Reposition on flat, level surface
	Bad v-belt	Replace v-belt
	Motor mount is loose	Tighten motor mount hardware
	Loose hardware	Tighten hardware

Optional Accessories: Band Saw Blades

Stock No.	Material	Length	Width	Thickness	Type	TPI
710030	Carbon Steel	137"	1/4"	0.025"	Skip	6
710031	Carbon Steel	137"	3/8"	0.025"	Skip	4
710032	Carbon Steel	137"	1/2"	0.025"	Hook	3
710033	Carbon Steel	137"	3/4"	0.032"	Hook	3
710034	Carbon Steel	137"	1"	0.035"	Hook	2
710035	Carbon Steel	137"	1.25"	0.035"	Hook	1.3
710036	Carbon Steel	137"	1/4"	0.025"	Hook	6
710037	Carbon Steel	137"	1/4"	0.025"	Raker	14
710038	Carbon Steel	137"	3/8"	0.025"	Hook	4
710039	Carbon Steel	137"	3/8"	0.025"	Raker	14
710040	Carbon Steel	137"	1/2"	0.025"	Hook	3
710041	Carbon Steel	137"	1/2"	0.025"	Hook	6
710042	Carbon Steel	137"	3/4"	0.032"	Hook	3
710043	Carbon Steel	137"	3/4"	0.032"	Raker	10
710044	Carbon Steel	137"	1"	0.035"	Hook	6
710045	Carbon Steel	137"	1"	0.035"	Hook	10
710046	Carbon Steel	137"	1.25"	0.035"	Hook	1.3
710047	Silicon Steel	137"	3/16"	0.025"	Raker	10
710048	Silicon Steel	137"	3/8"	0.025"	Hook	6
710049	Silicon Steel	137"	3/8"	0.025"	Raker	10
710050	Silicon Steel	137"	3/8"	0.025"	Raker	14
710051	Silicon Steel	137"	1/2"	0.025"	Hook	4
710052	Silicon Steel	137"	1/2"	0.025"	Hook	6
710053	Silicon Steel	137"	3/4"	0.032"	Hook	3
710054	Silicon Steel	137"	3/4"	0.032"	Raker	10

Replacement Parts

Replacement parts are listed on the following pages. To order parts or reach our service department, call 1-800-274-6848 between 7:00 a.m. and 6:00 p.m. (CST), Monday through Friday. Having the Model Number and Serial Number of your machine available when you call will allow us to serve you quickly and accurately.

Parts List: Upper Wheel Assembly

Index No.	Part No.	Description	Size	Qty
1	JWBS18X-101	Saw Body		1
2	TS-0680031	Carriage Bolt	5/16 x 5/8	6
3	JWBS18-103	Upper Wheel Bracket		2
4	TS-0680031	Flat Washer	5/16	6
5	TS-0720081	Lock Washer	5/16	6
6	TS-0561021	Hex Nut	5/16	6
7	JWBS18-107	Switch		1
8	JWBS18-108	Hex Cap Screw	M8 x 65	1
9	TS-1550061	Flat Washer	1/4	4
10	JWBS18-110	Sliding Bracket		1
11	JWBS18-111	Blade Tension Indicator		1
12	JWBS18-112	Adjustment Bracket		1
13	JWBS18-113	Shaft Bracket		1
14	TS-154006	Hex Nut	M8	1
15	JWBS18-115	Spring		1
16	JWBS18-116	Square Nut		1
17	JWBS18-117	Pointer		1
18	JWBS18-118	Screw	M5 x 8	1
19	JWBS18-119	Set Block		1
20	TS-0267021	Socket Set Screw	1/4 x 1/4	1
21	JWBS18-121	Bracket		1
22	TS-0050021	Hex Cap Screw	1/4 x 5/8	4
23	JWBS18-123	Blade Adjusting Screw		1
24	JWBS18-124	E-Ring	E-9	1
25	JWBS18-125	Hand Wheel		1
26	TS-0267041	Socket Set Screw	1/4 x 3/8	2
27	TS-0209021	Socket Head Cap Screw	3/8 x 5/8	1
28	TS-0720091	Lock Washer	3/8	1
29	JWBS18-129	Upper Wheel Shaft		1
30	BB-6203ZZ	Ball Bearing		2
31	JWBS18-131	Retaining Ring	R40	2
32	JWBS18-132	Upper Wheel		1
33	JWBS18-133	Tire		1
34	JWBS18-134	Flat Washer		1
35	JWBS18-135	Hex Nut	5/8-18UNF L.H.	1
36		Blade (local purchase)	137"	1
37	TS-0590061	Wing Nut	5/16	1
38	JWBS18-138	Lock Knob	5/16	1
39	JWBS18-139W	Upper Front Door		1
40	JWBS18-140	JET Plaque		1
41	JWBS18-141	Warning Label		1
42	JWBS18-142	Bolt		1
43	TS-0561011	Hex Nut	1/4	1
44	JWBS18-144	Screw	3/16 x 3/4	2
45	JWBS18-39A	Door Hinge Pin		2

Upper Wheel Assembly

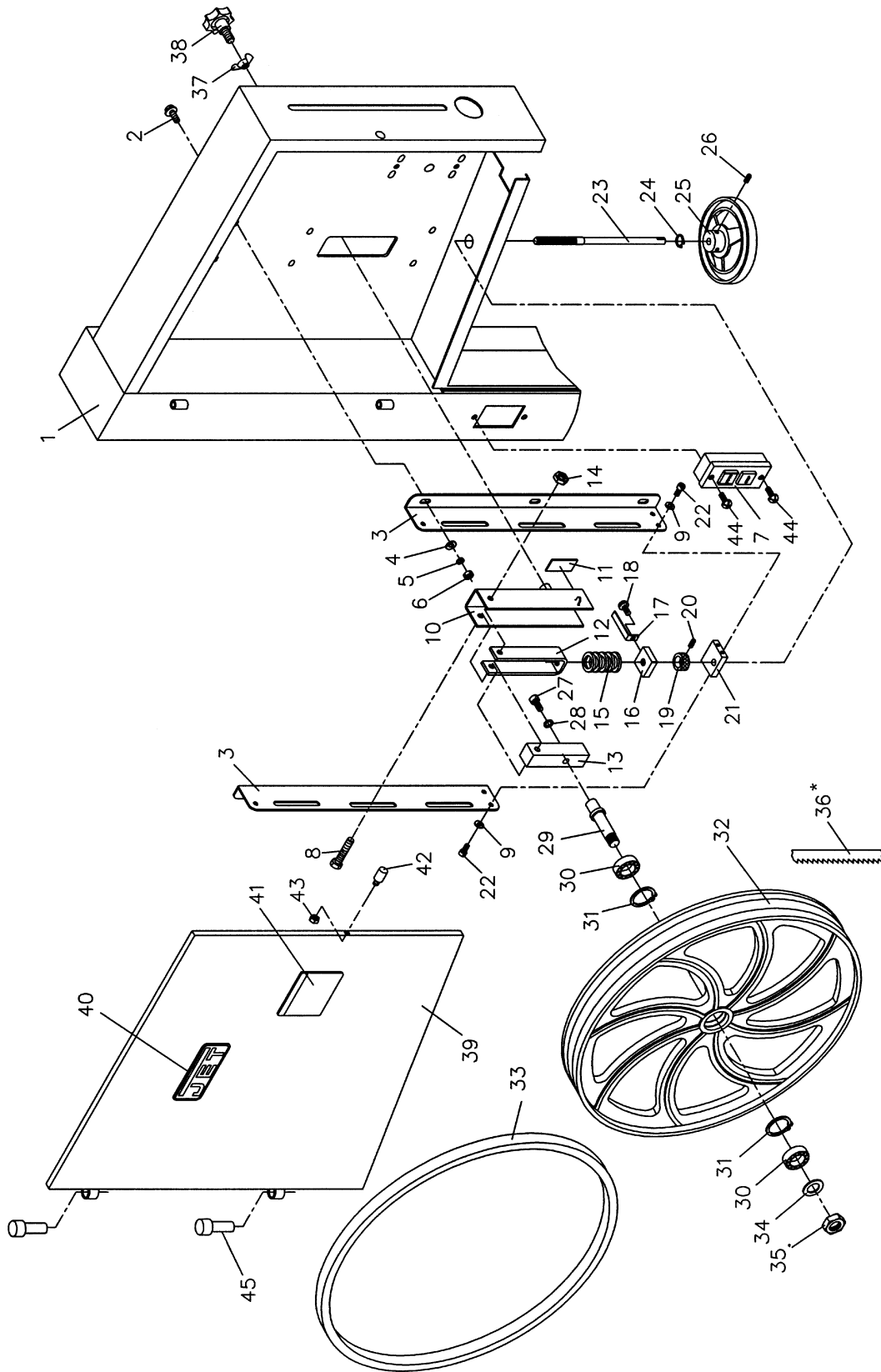

* See page 23 for blade offering

Parts List: Lower Wheel and Motor Assembly

Index No.	Part No.	Description	Size	Qty
1	JWBS18-201	Bearing Base		1
2	JWBS20-62	Adjusting Bolt		4
3	TS-0720091	Lock Washer	3/8	4
4	TS-0060081	Hex Cap Screw	3/8 x 1-3/4	4
5	BB-6204ZZ	Ball Bearing		2
6	JWBS18-206	Spindle		1
7	JWBS18-207	Key	7 x 7 x 40	1
8	JWBS18-208	Spindle Pulley		1
9	VB-B42	V-Belt		1
10	JWBS18-210	Lower Wheel		1
11	JWBS18-133	Tire		1
12	TS-0680081	Flat Washer	5/8	1
13	JWBS18-135	Hex Nut	5/8-18UNF L.H.	1
14	JWBS18-214	Hex Nut	5/8-18UNF R.H.	1
15	JWBS18-215	Bearing Cover		1
16	JWBS18-216	Lock Washer	3/16	3
17	JWBS18-217	Screw	3/16 x 3/8	3
18	JWBS18X-218	Motor 1.75HP, 1Ph, 115/230V (prewired 115)		1
	JWBS18X-MFC	Motor Fan Cover (not shown)		1
19	JWBS18-219	Motor Bracket		1
20	TS-0081031	Hex Cap Screw	5/16 x 3/4	4
21	TS-0680031	Flat Washer	5/16	4
22	TS-0060051	Hex Cap Screw	3/8 x 1	2
23	TS-0720091	Lock Washer	3/8	2
24	TS-0680041	Washer	3/8	2
25	JWBS18-225	Motor Pulley		1
26	TS-0267021	Socket Set Screw	1/4 x 3/8	2
27	JWBS18-227W	Lower Front Door		1
28	JWBS18-142	Bolt		1
29	TS-0561011	Hex Nut	1/4	1
30	JWBS20-2	Lock Knob		1
31	JWBS20-3	Screw	1/4 x 3/4	1
32	JWBS20-8W	Dust Chute		1
33	TS-0680031	Flat Washer	5/16	2
34	TS-0208061	Hex Cap Screw	5/16 x 1	2
35	JWBS18-235	Plate		1
36	JWBS18-236	Screw	3/16 x 1/2	2
37	JWBS18-237	Strain Relief Bushing		2
38	JWBS18-238	Screw	3/16 x 1-1/2	2
39	TS-0680011	Flat Washer	3/16	2
40	JWBS18-240	Brush		1
41	JWBS18-241	Lock Washer	3/16	2
42	JWBS18-242	Hex Nut	3/16	2
43	JWBS18-243	Motor Cord		1
44	JWBS18-244	Power Cord		1
45	JWBS18-245	Bushing		1
46	JWBS18X-246	I.D. Label		1
47	JWBS18X-247	Motor Label		1
48	JWBS18-39A	Door Hinge Pin		2

Lower Wheel and Motor Assembly

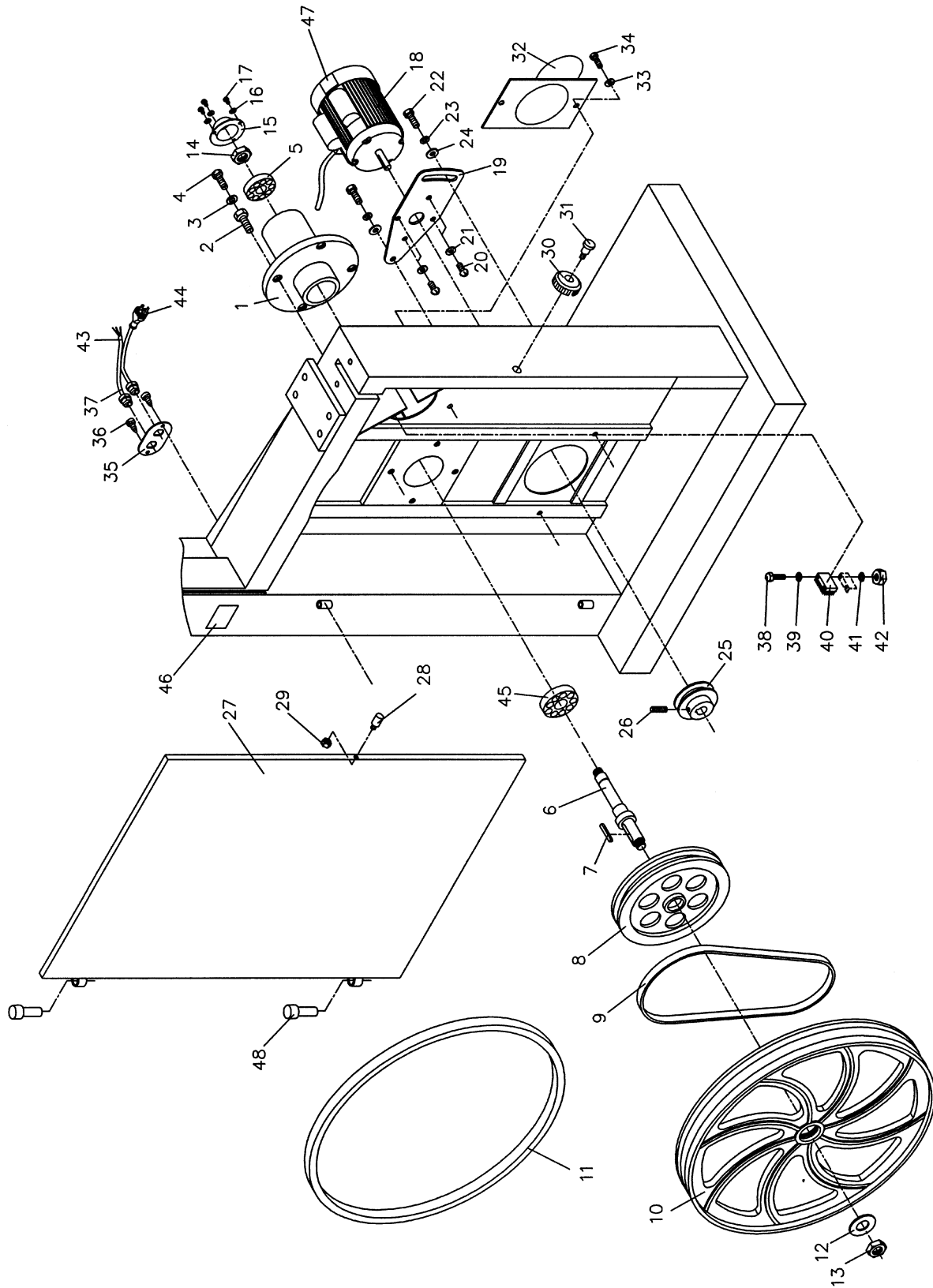

Parts List: Blade Guide Assembly

Index No.	Part No.	Description	Size	Qty
1	TS-0208061	Hex Cap Screw	5/16 x 1	4
2	TS-0720081	Lock Washer	5/16	4
3	TS-0680031	Flat Washer	5/16	8
4	JWBS18-304	Guide Bar Bracket		1
5	JWBS18-305	Worm		1
6	JWBS18-306	E-Ring	E-8	2
7	JWBS18-307	Gear Base		1
8	JWBS18-308	Bushing		1
9	JWBS18-309	C-Ring	S-12	2
10	JWBS18-310	Shaft		1
11	JWBS18-311	Gear		1
12	TS-0208071	Socket Head Cap Screw	5/16 x 1-1/4	2
13	JWBS18-313	Lock Knob	5/16	1
14	JWBS18-314	Plate		1
15	TS-0051011	Hex Cap Screw	5/16 x 1/2	4
16	JWBS18X-316	Guide Bar		1
17	JWBS18-317	Pointer		1
18	TS-0720071	Lock Washer	1/4	3
19	TS-0207021	Hex Cap Screw	1/4 x 1/2	1
20	JWBS18-320N	Guide Bracket		1
21	TS-0207011	Socket Head Cap Screw	1/4 x 1/2	4
22	JWBS18X-322	Blade Guard		1
23	TS-0720111	Lock Washer	1/2	1
24	TS-0561051	Hex Nut	1/2	1
25	JWBS20-110	Locking Shaft		1
26	JWBS20-326	C-Ring		10
27	BB-6202ZZ	Ball Bearing		10
28	JWBS20-328	Spacer		4
29	JWBS20-329	Shaft		2
30	TS-0270031	Socket Set Screw	5/16 x 3/8	2
31	JWBS20-2	Lock Knob		1
32	JWBS20-3	Screw	1/4 x 3/4	1
33	JWBS18-333	Hand Wheel		1
34	TS-0267041	Socket Set Screw	1/4 x 3/8	1
35	TS-1540061	Handle		1
36	JWBS18X-336	Cutting Height Scale		1
37	JWBS20-337	Bracket		1
38	JWBS20-338	Base		1
39	JWBS20-339	Threaded Lock Bushing		1
40	JWBS20-340	Bolt		1
41	JWBS20-341	Lock Knob		1
42	JWBS20-342	Screw		2
43	JWBS18-343	Lower Blade Guard		1
44	TS-0050021	Socket Head Cap Screw	1/4 x 5/8	2
45	TS-0680021	Flat Washer	1/4	2
46	JWBS20-360	Bracket		1
47	JWBS20-324	Wing Screw		2
48	JWBS20-348	Socket Set Screw	M4 x 4	8
49	JWBS20-349	Knob		4
50	TS-0050021	Socket Head Cap Screw	1/4 x 5/8	3
51	TS-0207011	Socket Head Cap Screw	1/4 x 1/2	2
52	JWBS20-352	Bracket		1
53	JWBS20-353	Thumb Screw	1/4 x 1/2	2
54	JWBS20-354	Bearing Support		2
55	JWBS20-355	Lock Bushing		1
56	JWBS20-357	Socket Head Cap Screw	3/16 x 3/8	2
57	JWBS20-358	Bearing Bracket		1

Blade Guide Assembly

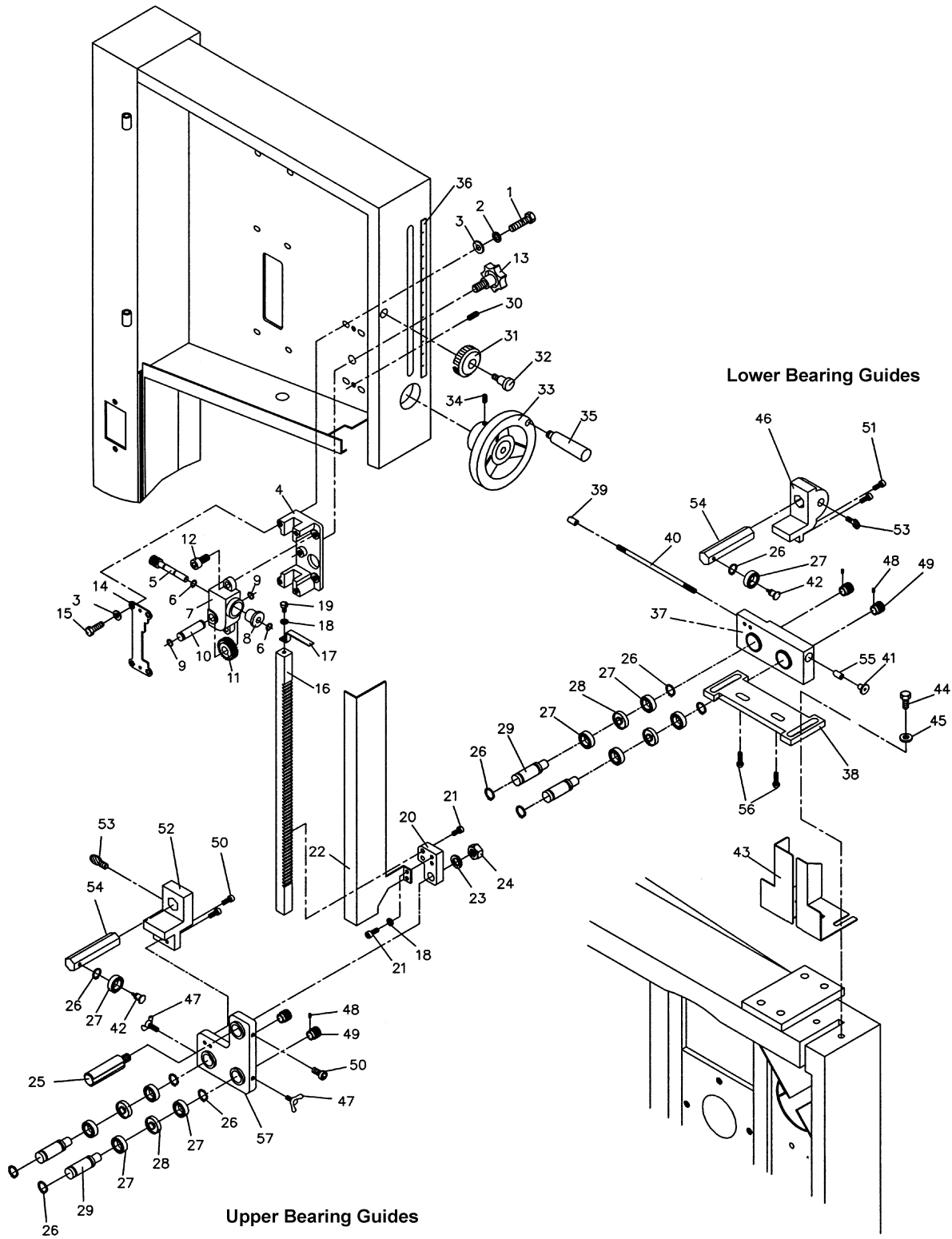

Parts List: Table and Fence Assembly

Index No.	Part No.	Description	Size	Qty
1	JWBS18-401	Lock Knob		1
2	TS-0680021	Flat Washer	1/4	11
3	JWBS18-403	Miter Gauge Body		1
4	JWBS20-156	Guide Disc		1
5	JWBS18-405	Phillips Pan Head Machine Screw	M6 x 8	1
6	JWBS18-406	Pointer		1
7	JWBS18-407	Guide Bar		1
8	JWBS18X-408	Trunnion Support Bracket		1
9	TS-0051071	Hex Cap Screw	5/16 x 1-1/2	4
10	TS-0720081	Lock Washer	5/16	8
11	TS-0270061	Socket Set Screw	5/16 x 5/8	2
12	TS-0060111	Hex Cap Screw	3/8 x 2-1/2	1
13	TS-0561031	Hex Nut	3/8	1
14	TS-0720091	Lock Washer	3/8	1
15	JWBS18-415	Lock Knob		2
16	JWBS18X-416	Trunnion		2
17	JWBS18-417	Trunnion Clamp Shoe		2
18	TS-1491081	Hex Cap Screw	M10 x 50	2
19	TS-0207011	Socket Head Cap Screw	M6 x 12	6
20	JWBS18-420	Scale		1
21	JWBS18-421	Table		1
22	JWBS18-422W	Front Rail		1
23	TS-0050021	Hex Cap Screw	1/4 x 5/8	9
24	TS-0720071	Lock Washer	1/4	10
25	JWBS18-425	Scale		1
26	JWBS18-426W	Guide Rail		1
27	JWBS18-427W	Rear Rail		1
28	JWBS20-144	Table Insert		1
29	JWBS20-145	Roll Pin	3 x 10	1
30	JWBS18-430	Fence Body		1
31	JWBS18-431	Knob		1
32	JWBS18-432	Lock Handle		1
33	JWBS18-433W	Lock Plate		1
34	JWBS18-434	Pad		5
35	JWBS18-435	Pin		1
36	JWBS18-436	Pin		1
37	JWBS18-437	Fence		1
38	TS-0081031	Hex Cap Screw	5/16 x 3/4	4
39	JWBS18-439	Flat Washer	5/16	4
40	JWBS18-440	Screw	3/16 x 1/4	2
41	JWBS18-441	Star Washer	3/16	1
42	JWBS18-442	Pointer		1
43	TS-0561011	Hex Nut	1/4	2
44	JWBS18-444	Sliding Pad		1
45	JWBS18-445	Rear Hook		1
46	JWBS18-446	Pointer		1
47	JWBS18-447	Screw	M5 x 8	1
48	JWBS18-448	Table Pin		1
49	JWBS18-449	Resaw Kit		1
50	JWBS18-450	Lock Knob		1
51	JWBS18-451	JET Plaque		1
	JWBS18-MGCP	Miter Gauge Assembly		1
	JWBS18-FCPW	Fence Assembly		1

Table and Fence Assembly

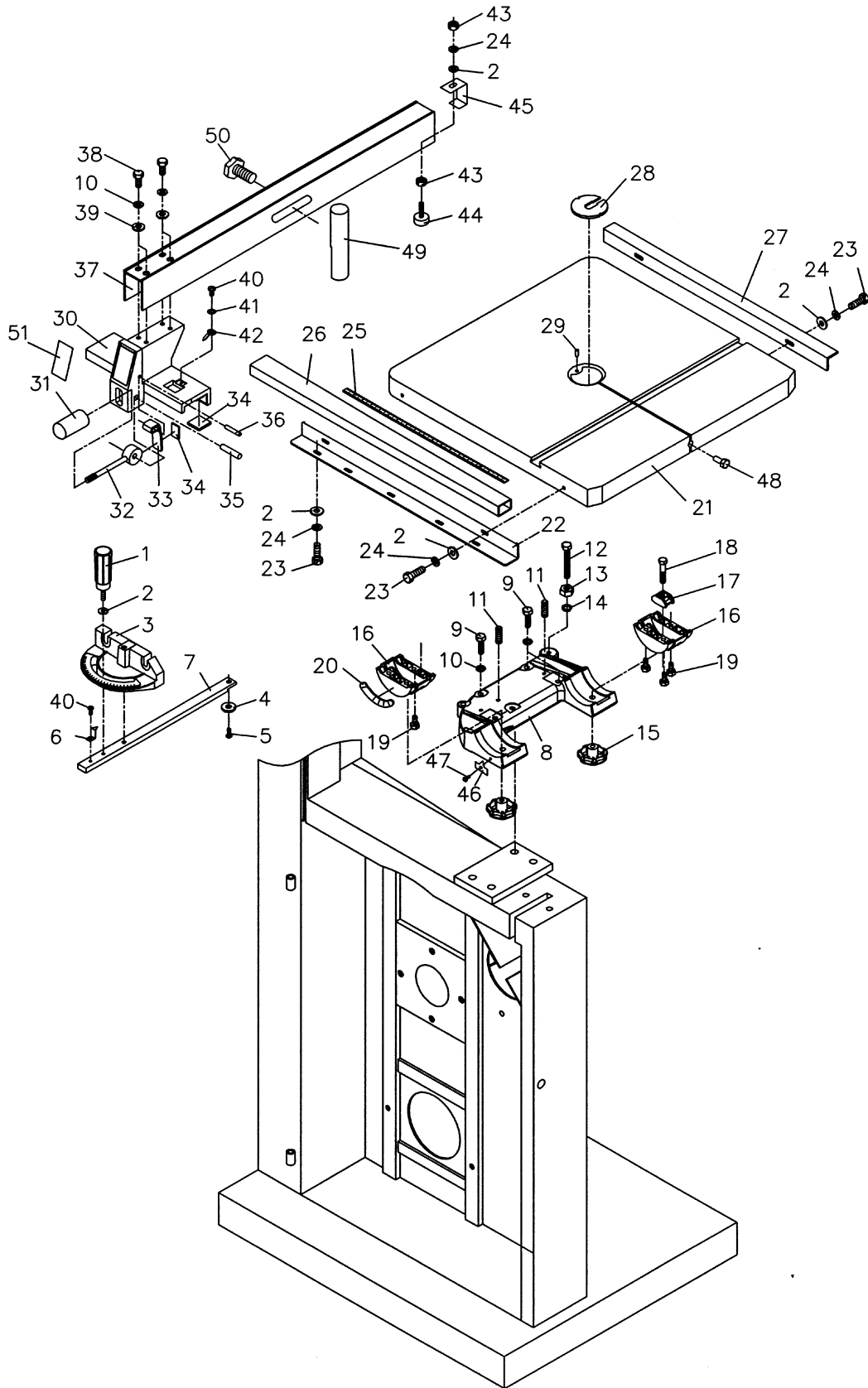

Electrical Connections

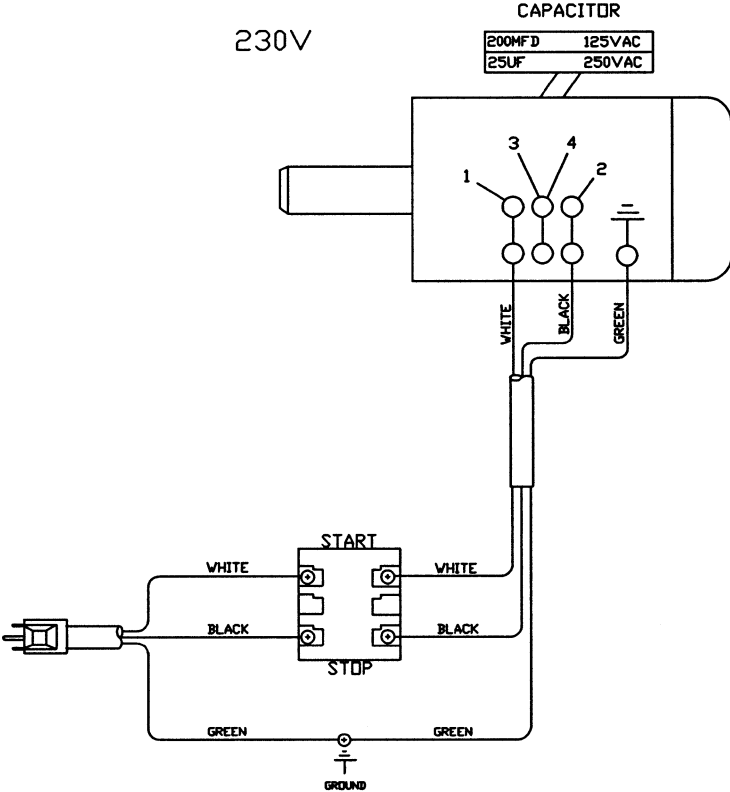
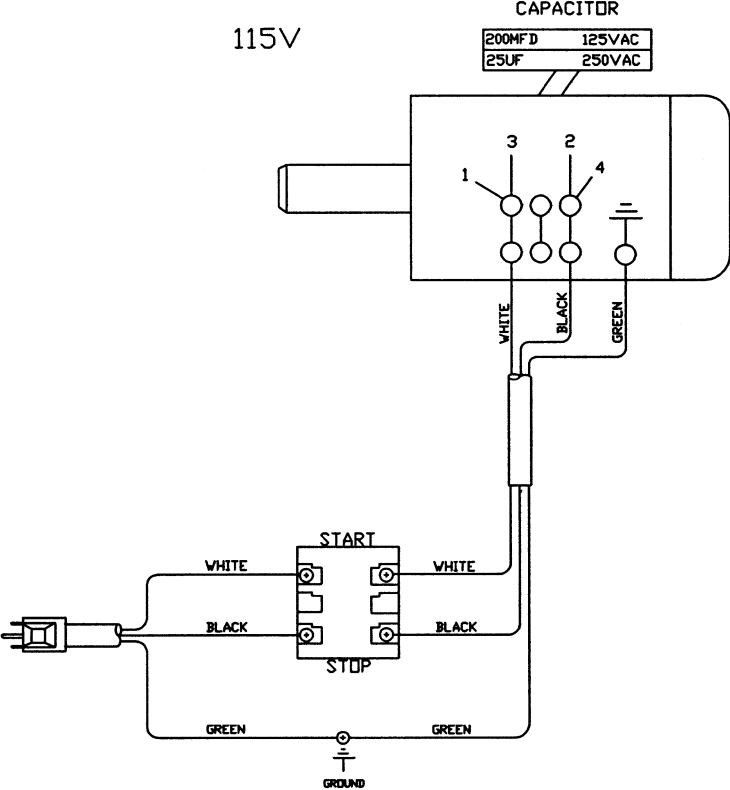

NOTES

NOTES

NOTES



WMH Tool Group
2420 Vantage Drive
Elgin, Illinois 60123
Phone: 800-274-6848
www.wmhtoolgroup.com