

**WEB-ENABLED
REMOTE TERMINAL UNIT
Model: DL8**

USERS MANUAL

Contents

1. INTRODUCTION	9
1.1 BEFORE USE.....	9
1.2 POINTS OF CAUTION.....	10
2. GETTING STARTED	11
2.1 PREPARATION.....	11
2.2 GENERAL SETUP FLOWCHART.....	12
3. SPECIFICATIONS	13
3.1 RELATED PRODUCTS	13
3.2 GENERAL SPECIFICATIONS.....	13
3.3 ETHERNET COMMUNICATION.....	14
3.4 INSTALLATION.....	14
3.5 PERFORMANCE.....	14
3.6 EXTERNAL VIEW.....	15
3.7 I/O.....	15
4. NETWORK CONFIGURATION	16
4.1 GENERAL DESCRIPTIONS	16
4.2 NETWORK CONFIGURATION.....	16
4.2.1 STYLE 1: WAN	16
4.2.2 STYLE 2: LAN	17
4.2.3 STYLE 3: WAN-LAN	17
4.3 IP ADDRESS SETTING	18
5. CONNECTING I/O MODULES	20
5.1 INSTALLATION.....	20
5.1.1 POINTS OF CAUTION.....	20
5.1.2 MOUNTING.....	20
5.2 CONFIGURATION.....	22
6. CONNECTING SLAVE DEVICES	23
6.1 CONNECTING REMOTE I/O	23
6.1.1 GENERAL DESCRIPTIONS.....	23
6.1.2 ASSIGNING REMOTE I/O	24
6.2 CONNECTING SLMP-COMPATIBLE DEVICES.....	26
6.2.1 GENERAL DESCRIPTIONS	26
6.2.2 ASSIGNING SLMP DEVICES	27
6.3 COMMUNICATION SETTING	28
7. SETTING UP I/O CHANNELS	29
7.1 CONNECTING DLCFG.....	29
7.2 ANALOG INPUT (AI).....	30
7.2.1 ASSIGNING I/O SIGNALS	30

7.2.2	BASIC SETTING	36
7.2.3	ALARM ZONE SETTING	37
7.2.4	ALARM OUTPUT (TYPE B, C, D & E)	38
7.2.5	COPYING CH CONFIGURATION	38
7.3	DISCRETE INPUT (DI)	39
7.3.1	ASSIGNING I/O SIGNALS	39
7.3.2	BASIC SETTING	46
7.3.3	ALARM OUTPUT (TYPE B, C, D & E)	47
7.3.4	COPYING CH CONFIGURATION	47
7.4	PULSE INPUT (PI)	48
7.4.1	ASSIGNING I/O SIGNALS	48
7.4.2	BASIC SETTING	55
7.4.3	ALARM ZONE SETTING	56
7.4.4	ALARM OUTPUT (TYPE B, C, D & E)	57
7.4.5	COPYING CH CONFIGURATION	57
7.4.6	RESETTING COUNTER IN A REGULAR INTERVAL	58
7.5	DISCRETE OUTPUT (DO)	59
7.5.1	ASSIGNING I/O SIGNALS	59
7.5.2	BASIC SETTING	67
7.5.3	COPYING CH CONFIGURATION	67
7.5.4	OUTPUT LOGIC	67
7.6	ANALOG OUTPUT (AO)	68
7.6.1	ASSIGNING I/O SIGNALS	68
7.6.2	BASIC SETTING	73
7.6.3	COPYING CH CONFIGURATION	73
7.7	START MODE	74
7.8	UPLOADING SETTING	74
8.	WEB SERVER	75
8.1	GENERAL DESCRIPTIONS	75
8.2	TERMINAL, BROWSER	75
8.3	MENU VIEW	76
8.3.1	DISPLAY	76
8.3.2	SYSTEM	77
8.3.3	USER-DEFINED IMAGE	78
8.4	DATA VIEW	79
8.4.1	DISPLAY	79
8.4.2	AI DATA VIEW	79
8.4.3	DI DATA VIEW	80
8.4.4	PI DATA VIEW	80
8.4.5	DO DATA VIEW	81
8.4.6	AO DATA VIEW	81
8.5	TREND VIEW	82
8.5.1	DISPLAY	82
8.5.2	SCREEN COMPONENTS	83
8.5.3	SETTING	84

8.6	EVENT VIEW.....	86
8.7	REFRESHING SCREEN.....	87
8.7.1	UPDATE INTERVAL SETTING.....	87
8.8	CLOUD MODE.....	90
8.8.1	DESCRIPTIONS.....	90
8.8.2	SETTING.....	91
8.8.3	STATUS VERIFICATION.....	92
8.9	LOGIN ID, PASSWORD, PORT NUMBER.....	94
8.10	PRINT.....	96
8.10.1	DESCRIPTIONS.....	96
8.10.2	PROCEDURE.....	96
8.10.3	PRINT SETTING.....	97
9.	EVENT REPORTING E-MAIL (TYPE B, C, D & E).....	99
9.1	GENERAL DESCRIPTIONS.....	99
9.2	COMMUNICATION SETTING.....	100
9.3	E-MAIL SETTING.....	102
9.3.1	ADDRESS LIST.....	102
9.3.2	EVENT REPORT.....	103
9.3.3	COPYING MESSAGES.....	105
9.3.4	REGULAR REPORT.....	106
9.3.5	DELIVERY FAILURE OUTPUT.....	107
9.4	TEST MAIL.....	108
9.5	MAIL SETTING VIA WEB BROWSER.....	109
9.5.1	DESCRIPTION.....	109
9.5.2	SETTING.....	109
9.5.3	ACCESSING THE URL.....	110
9.5.4	ADDRESS LIST.....	110
9.5.5	REPORT SETTING.....	111
9.6	RETRANSMISSION.....	112
9.7	DISABLING E-MAIL FUNCTION.....	112
9.8	STATUS VERIFICATION.....	112
10.	FTP CLIENT (TYPE B, C, D & E).....	113
10.1	GENERAL DESCRIPTIONS.....	113
10.2	SPECIFICATIONS.....	113
10.3	SETTING.....	115
10.4	TEST TRANSMISSION.....	116
10.5	STATUS VERIFICATION.....	116
11.	LOGGING FUNCTION (TYPE C, D & E).....	117
11.1	GENERAL DESCRIPTIONS.....	117
11.2	UNIT OPERATION AND LED INDICATION.....	118
11.2.1	SD CARD.....	118

11.2.2 LOGGING.....	119
11.3 DATA LOGGING	121
11.3.1 SPECIFICATIONS.....	121
11.3.2 SETTING.....	123
11.4 SYSTEM LOG.....	127
11.4.1 SPECIFICATIONS.....	127
11.4.2 SETTING.....	127
11.5 EVENT LOG	128
11.5.1 SPECIFICATIONS.....	128
11.5.2 SETTING.....	128
11.6 MAILING LOG	129
11.6.1 SPECIFICATIONS.....	129
11.6.2 SETTING.....	129
11.7 CHANNEL EVENT LOG.....	130
11.7.1 SPECIFICATIONS.....	130
11.7.2 SETTING.....	130
11.8 AUTOMATIC FILE DELETION.....	132
11.8.1 DESCRIPTIONS.....	132
11.8.2 SETTING.....	132
11.9 APPROXIMATE LOGGING TIME PERIOD.....	133
12. FTP SERVER (TYPE C, D & E).....	134
12.1 GENERAL DESCRIPTIONS.....	134
12.2 SPECIFICATIONS	134
12.3 SETTING.....	136
12.4 FTP CLIENT SOFTWARE.....	137
12.4.1 TEMPORARY INTERNET FILES SETTING.....	137
12.4.2 SETTING.....	138
12.4.3 CONNECTION.....	139
13. I/O MAPPING (TYPE D & E).....	140
13.1 GENERAL DESCRIPTIONS.....	140
13.2 SETTING.....	140
14. OTHER SETTINGS.....	142
14.1 CLOCK SYNCHRONIZATION	142
14.1.1 SNTP.....	142
14.1.2 TIME ZONE.....	143
14.2 MODBUS/TCP SLAVE	144
14.2.1 SPECIFICATIONS	144
14.2.2 SETTING.....	149
14.3 DLCFG VIA NETWORK.....	150
14.4 LANGUAGE.....	152
15. MAINTENANCE	153

15.1 CONFIGURATION FILE	153
15.1.1 SAVING CONFIGURATION FILE.....	153
15.1.2 READING CONFIGURATION FILE.....	153
15.1.3 CREATING NEW CONFIGURATION.....	153
15.2 MAINTENANCE MENU	154
15.2.1 DESCRIPTIONS.....	154
15.2.2 DATE/TIME	154
15.2.3 USER DEFINED IMAGERY DATA	154
15.2.4 MAC ADDRESS.....	155
15.2.5 DL8 VERSION	155
15.2.6 SYSTEM LOG.....	156
15.2.7 PRESET COUNT.....	157
15.2.8 FTP CLIENT TEST (TYPE B, C, D & E).....	157
15.2.9 TEST MAIL (TYPE B, C, D & E)	157
15.2.10 START/STOP LOGGING (TYPE C, D & E).....	158
15.2.11 DISK USAGE (TYPE C, D & E).....	158
15.2.12 USER DEFINED BROWSER VIEW (TYPE D & E)	158
15.2.13 BIOS UPDATE	159
15.3 DLCFG VERSION.....	159
16. USER DEFINED BROWSER VIEW (TYPE D & E)	160
16.1 GENERAL DESCRIPTION	160
16.1.1 POINTS OF CAUTION	160
16.2 PROCEDURE FOR CREATING AND TRANSFERRING BROWSER VIEW DATA	160
16.2.1 STEP 1: CREATING A FOLDER.....	160
16.2.2 STEP 2: CREATING HTML FILES.....	160
16.2.3 STEP 3: DOWNLOADING TO THE DL8	161
16.2.4 STEP 4: CONFIRMING BROWSER VIEWS.....	162
16.3 USER DEFINED VIEW	163
16.4 DATA FILE SPECIFICATIONS	164
16.4.1 ORIGINAL TAGS	164
16.4.2 JAVASCRIPT FORMAT DATA FILES (.js).....	165
16.4.3 JSON FORMAT DATA FILES (.json).....	168
16.4.4 XML FORMAT DATA FILES (command.xml)	170
16.5 CLOUD MODE	171
17. TROUBLESHOOTING.....	172
17.1 DLCFG	172
17.2 LED INDICATION	172
17.3 R8 I/O MODULE.....	173
17.4 LAN CONNECTION	173
17.5 WI-FI CONNECTION.....	174
17.6 INTERNET	174
17.7 WEB SERVER.....	175
17.8 MODBUS/TCP SLAVE	175
17.9 MODBUS/TCP MASTER.....	175

17.10	SLMP CLIENT	176
17.11	E-MAILING (TYPE B, C, D & E)	176
17.12	FTP CLIENT (TYPE B, C, D & E).....	177
17.13	LOGGING (TYPE C, D & E)	177
17.14	FTP SERVER (TYPE C, D & E)	178
18.	VERSION HISTORY.....	179
18.1	ADDING FUNCTION OR SPECIFICATION CHANGE.....	179
18.1.1	Rev.0	179
18.1.2	Rev.1	179
18.1.3	Rev.2	179
18.1.4	Rev.3	179
18.1.5	Rev.4	180
18.1.6	Rev.5 to Rev.7	180
18.1.7	Rev.8	180
18.1.8	Rev.9 to Rev.14.....	180
18.1.9	Rev.15	180
18.1.10	Rev.16.....	180
18.1.11	Rev.17	180
18.1.12	Rev.18.....	180
18.1.13	Rev.19 to 21.....	180
18.1.14	Rev.22	181
18.1.15	Rev.23	181
18.1.16	Rev.24	181
18.1.17	Rev.25 to 29.....	181
18.1.18	Rev.30	181
18.1.19	Rev.31	181
18.1.20	Rev.32	181
18.1.21	Rev.33	181
18.1.22	Rev.34	182
18.1.23	SUPPORTING SIGNATURE ALGORITHM OF SSL CERTIFICATE FOR MAIL SERVER, SHA-2.....	182
18.1.24	CHANGE IN PROCESSING OF ABNORMAL DETECTION OF NODE	182
18.1.25	RESOLVE THE PROBLEM THAT SOMETIMES WRITING THE SETTING IS FAILED WITH DLCFG (ONLY FOR VERSION 1.8.X)	182
18.1.26	RESOLVE THE PROBLEM THAT SOMETIMES THE FTP CLIENT DOES NOT UPLOAD A FILE	183
18.1.27	IMPROVEMENT OF FTP SERVER PROCESSING	183
18.1.28	RESOLVE THE PROBLEM THAT SOMETIMES ACCUMULATED VALUE IS MISSING AFTER RECOVERY FROM COMMUNICATION ERROR.....	183
18.1.29	RESOLVE THE PROBLEM THAT OUTPUT VALUES (DO and AO) ARE NOT CORRECT AT POWER ON	183
18.1.30	IMPROVEMENT OF FTP SERVER PROCESSING	183
18.1.31	IMPROVEMENT OF SLAVE COMMUNICATION PROCESSING.....	183
18.1.32	IMPROVEMENT OF SLAVE COMMUNICATION PROCESSING.....	183
18.1.33	IMPROVEMENT OF PRESET COUNT PROCESSING.....	184
18.1.34	IMPROVEMENT OF SLMP CLIENT PROCESSING	184
18.1.35	IMPROVEMENT OF FTP SERVER PROCESSING	184
18.1.36	IMPROVEMENT OF WEB SERVER PROCESSING	184

18.1.37 IMPROVEMENT OF CLOUD MODE	184
18.1.38 IMPROVEMENT OF THE PULSE ACCUMULATION AT OCCURRING OVER- FLOW	184
18.2 BIOS UPDATE	184
18.2.1 1.2.0	184
19. LICENSE	185

1. INTRODUCTION

1.1 BEFORE USE....

Thank you for choosing us. Before use, please check contents of the package you received as outlined below.

■ PACKAGE INCLUDES:

Remote terminal unit	(1)
Protective cover	(1)
Ferrite core (ZCAT 3035-1330, TDK)	(1)

■ MODEL NO.

Confirm that the model number described on the product is exactly what you ordered.

■ USERS MANUAL

This manual is applicable to the DL8 firmware version 3.3.x (Refer to 15.2.5 DL8 VERSION.)
Descriptions of this manual are based on the PC Configurator Software DLCFG Version 3.2.x
Refer to 15.3 DLCFG VERSION to check your DLCFG version No.

1.2 POINTS OF CAUTION

■ CONFORMITY WITH EU DIRECTIVES

- The actual installation environments such as panel configurations, connected devices, connected wires, may affect the protection level of this unit when it is integrated in a panel system. The user may have to review the CE requirements in regard to the whole system and employ additional protective measures to ensure the CE conformity.

■ GENERAL PRECAUTIONS

- Before you remove the unit from or connect to other modules, turn off the power supply for safety.

■ ENVIRONMENT

- Indoor use.
- When heavy dust or metal particles are present in the air, install the unit inside proper housing with sufficient ventilation.
- Do not install the unit where it is subjected to continuous vibration. Do not subject the unit to physical impact.
- Environmental temperature must be within -10 to +55°C (14 to 131°F) with relative humidity within 30 to 90% RH in order to ensure adequate life span and operation.

■ WIRING

- Do not install cables close to noise sources (relay drive cable, high frequency line, etc.).
- Do not bind these cables together with those in which noises are present. Do not install them in the same duct.
- Attach a ferrite core close to the unit for communication line. Turn the cable twice around the core (1 round) as shown in the figure below.

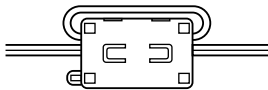

■ SD CARD (Type C, D & E)

- Do NOT turn off the power of DL8 during writing data. Insert or eject SD card according to the specified procedure.
- Confirm the front and back side of the SD card.
- When formatting SD card, use a dedicated software "SD Card Formatter".
"SD Card Formatter" is downloadable at SD Association's web site.
<https://www.sdcard.org>

■ AND....

- The unit is designed to function as soon as power is supplied, however, a warm up for 10 minutes is required for satisfying complete performance described in the data sheet.

2. GETTING STARTED

2.1 PREPARATION



Windows PC
OS: Windows 8,10



Router, Switching HUB
(If necessary)

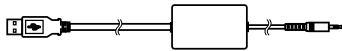

PC Configurator cable, driver software and manual (model: COP-US or MCN-CON)

Driver software and manual are downloadable at our web site.

The COP-US driver software is downloadable at URL shown below.



DL8 PC configurator software (model: DLCFG)

Downloadable at our web site.



R8 PC configurator software and manual (model: R8CFG)

Downloadable at our web site.

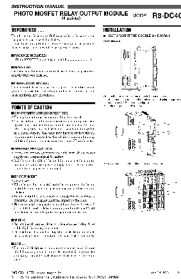

Manuals for your R8 I/O and other Remote I/O modules
Downloadable at our web site.

2.2 GENERAL SETUP FLOWCHART

Set up the DL8 according to the following procedure.

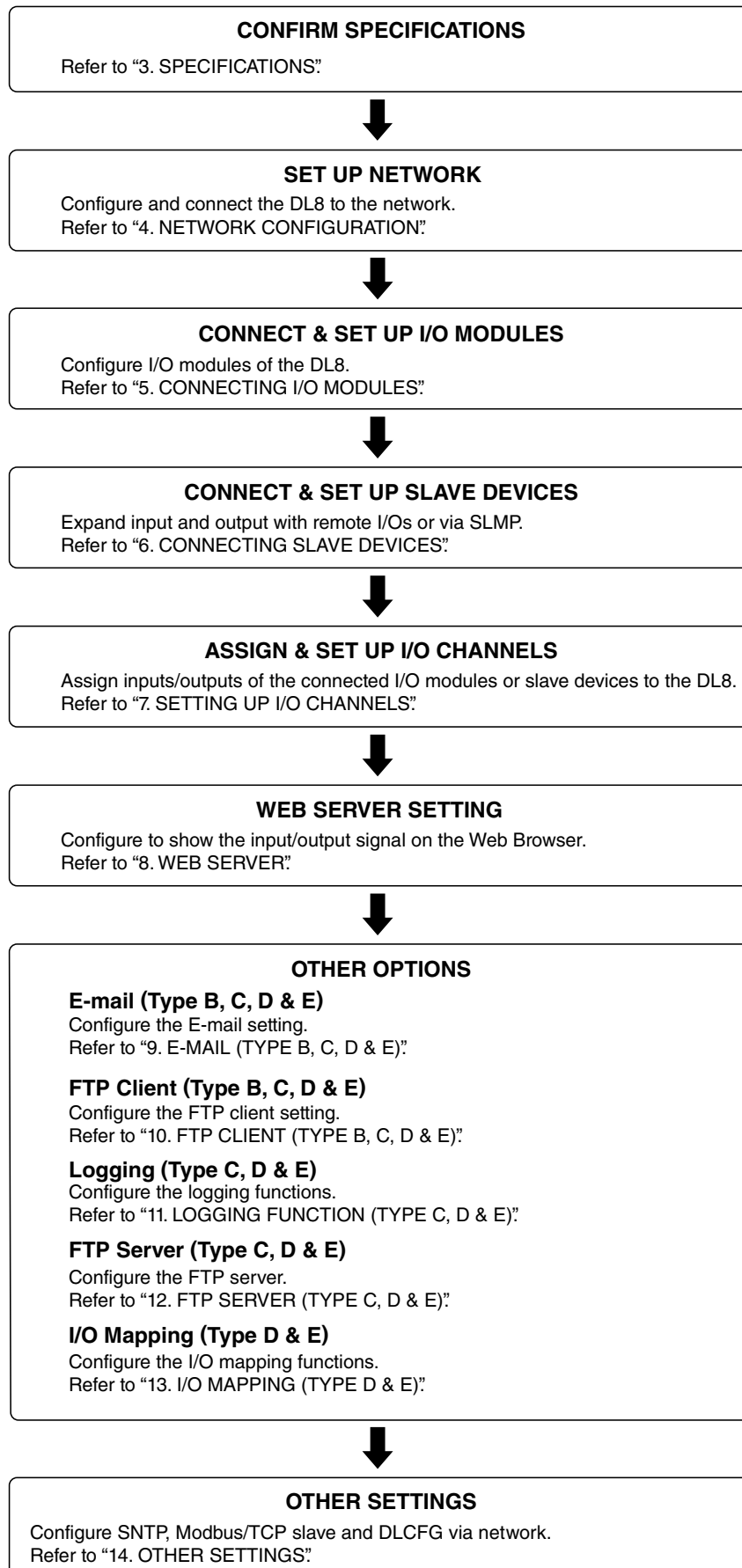

SPECIFICATIONS

3. SPECIFICATIONS

3.1 RELATED PRODUCTS

- Remote I/O R8 Series
(model: R8-SS2, R8-SS4NJ, R8-SS4N, R8-SST8, R8-SV2, R8-SV4N, R8-TS2, R8-RS4N, R8-FS16N, R8-FST4N, R8-YS2, R8-YS2NJ, R8-YST4N, R8-YV4N, R8-CT4E, R8-PA4, R8-PC4A, R8-DA4A, R8-DAM16A, R8-DAT16A2, R8-DAT8A2, R8-DAT8B2, R8-DC4A, R8-DC4A2, R8-DC4C, R8-DCT4D, R8-DCM16A, R8-DCM16ALZ, R8-DC-M16ALK, R8-DCM16ALH, R8-DCM32B2, R8-DCT16A2, R8DCT8A2, R8DCT8B2)
- PC configurator cable (model: MCN-CON or COP-US)
- PC configurator software (model: DLCFG)
- PC configurator software (model: R8CFG)
- Local certification authority creator (model: LCA-DL8) (For Type:E)
The software is downloadable at our web site.
- SD card (Type C, D & E)
An SD card is necessary to store date. Use a memory card of the specified model number.
Hagiwara Solutions NSD6-004GH(B21SEI)
(NSD6-004GH(A00SDI, NSDA-004GL ... discontinued)
Apacer AP-ISD04GIS4B-3T
Also available from us. Consult us for purchase.

3.2 GENERAL SPECIFICATIONS

■ CONNECTION

Power supply (excitation supply), RUN contact output	Tension clamp terminal (T branch plug) Unit side connector MSTB2,5/5-GF-5,08AU Cable side connector TFKC2,5/5-STF-5,08AU (applicable wire size: 0.2 to 2.5 mm ² , 10 mm exposed) Recommended solderless terminal AI0,25-10YE 0.25 mm ² (Phoenix Contact) AI0,34-10TQ 0.34 mm ² (Phoenix Contact) AI0,5-10WH 0.5 mm ² (Phoenix Contact) AI0,75-10GY 0.75 mm ² (Phoenix Contact) AI1-10RD 1.0 mm ² (Phoenix Contact) AI1,5-10BK 1.5 mm ² (Phoenix Contact) AI2,5-10BU 2.5 mm ² (Phoenix Contact)
Ethernet	RJ-45 connector
Internal bus, internal power, excitation	Connector
Max. number of I/O modules	16 (Max. consumption current of I/O modules: 1.6 A)
Isolation	Ethernet to internal bus or internal power or power supply (exc. supply) to RUN contact output to FE (DL8 breaks the isolation between discrete input/output and power supply of the I/O modules.)
Status Indicator LED	POWER, LOGGING, SD CARD, SEND, COM, ERROR
Calendar clock	Year (4 digits), month, date, day, hour, minute, second

■ RUN CONTACT OUTPUT

RUN contact output	Photo MOSFET relay (no polarity); (OFF in error detected)
Peak load voltage	50 V max.
Continuous load current	50 mA max.
Peak load current	300 mA max. (≤ 0.1 sec.)
Operation	Power down OFF Firmware operating ON Error in Ethernet LNK OFF Internal bus error OFF SD card writing error OFF

(Run contact output is applicable for Type C with the DL8 firmware version 1.4.x or later.)

3.3 ETHERNET COMMUNICATION

Communication Standard	IEEE 802.3u
Transmission	10BASE-T, 100BASE-TX
Baud rate	10/100 Mbps (Auto Negotiation function)
Protocol	TCP/IP, Modbus/TCP, SLMP, HTTP, HTTPS, FTP, FTPS, SMTP, SNMP
Transmission media	10BASE-T (STP, Category 5) 100BASE-TX (STP, Category 5e)
Max. segment length	100 meters
Ethernet indicator LED	DPLX, LNK
IP address	192.168.0.1 (factory default)

3.4 INSTALLATION

Power consumption	DC: Approx. 12 W 24 V DC (Internal power max. current 1.6A)
Internal power (Power supply for I/O module)	DC: 5 V DC Operational current: 1.6 A
Excitation supply output (excitation for I/O module)	DC: 24V DC $\pm 10\%$ Operational current: 7 A (From power supply (excitation supply) connector, via connector for internal bus, supplied to each I/O module. Power output current consumption must be under operational current.)
Operating temperature	-10 to +55°C (14 to 131°F)
Operating humidity	30 to 90 %RH (non-condensing)
Atmosphere	No corrosive gas or heavy dust
Mounting	DIN rail
Weight	190 g (0.42 lb)

3.5 PERFORMANCE

Calendar clock accuracy	Monthly deviation 2 minutes at 25°C
Battery backup	Approx. 2 months
Battery	Vanadium-lithium secondary battery (undetachable)
Insulation resistance	$\geq 100\text{ M}\Omega$ with 500 V DC
Dielectric strength	1500 V AC @ 1 minute (Ethernet to internal bus or internal power or power supply (exc. supply) to RUN contact output to FE)

3.6 EXTERNAL VIEW

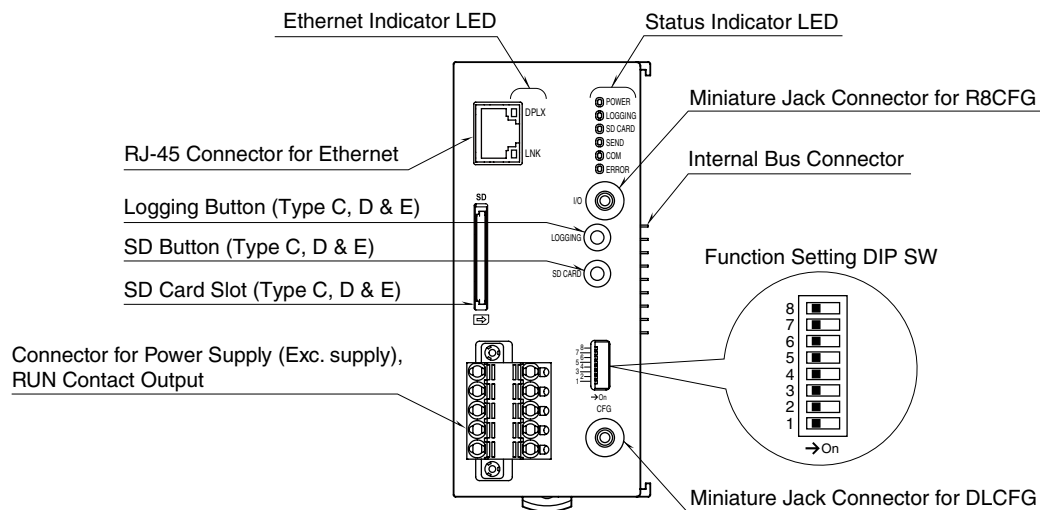

■ STATUS INDICATOR LED

LED	COLOR	FUNCTION
POWER	Green	ON at device operating normally. Blinking before obtaining IP address by DHCP.
LOGGING	Green	ON at logging (Type C, D & E)
SD CARD	Green	ON during SD card mounted. Blinking at reading/writing SD card. (Type C, D & E)
SEND	Green	Blinking at e-mailing
COM	Green	Blinking at communication (except for Modbus/TCP master function and SLMP function)
ERROR	Red	ON at error • R8 I/O module reading error • SD card access error • SD card insufficient capacity

■ ETHERNET INDICATOR LED

LED	COLOR	FUNCTION
DPLX	Amber	ON at full duplex
LNK	Green	ON at link

■ FRONT SWITCH

• DL CFG MINIATURE JACK CONNECTOR FUNCTION (SW1)

SW1	FUNCTION
OFF (*)	Enabling setting with the DL CFG
ON	FTP transfer and obtaining mailing log

(*) Factory setting

• E-MAIL (SW2) *1

SW2	E-MAIL
OFF (*)	Enable
ON	Disable

*1. Not valid for Type A

Note: Be sure to set unused SW3 8 to OFF.

■ LOGGING BUTTON

Hold down the button for 1 second to start or stop logging.

■ SD BUTTON

Hold down the button for 4 seconds to safely eject the SD card after the SD CARD LED is off.

3.7 I/O

Sampling cycle	1 second (fixed)
Analog input	AI1 to 32
Discrete input	DI1 to 64
Pulse input	PI1 to 32
Discrete output	DO1 to 64
Analog output	AO1 to 32

- The input channel that could not obtain data due to communication error occurrence holds the last obtained value.

4. NETWORK CONFIGURATION

4.1 GENERAL DESCRIPTIONS

The DL8 can be used with one of the following three network configurations. Choose a suitable one for your purpose of use.

- When connecting to the DL8 via WAN, it is strongly recommended to use VPN in terms of security.

4.2 NETWORK CONFIGURATION

4.2.1 STYLE 1: WAN

Single DL8 device is connected to Internet via a broadband router to allow remote monitoring.

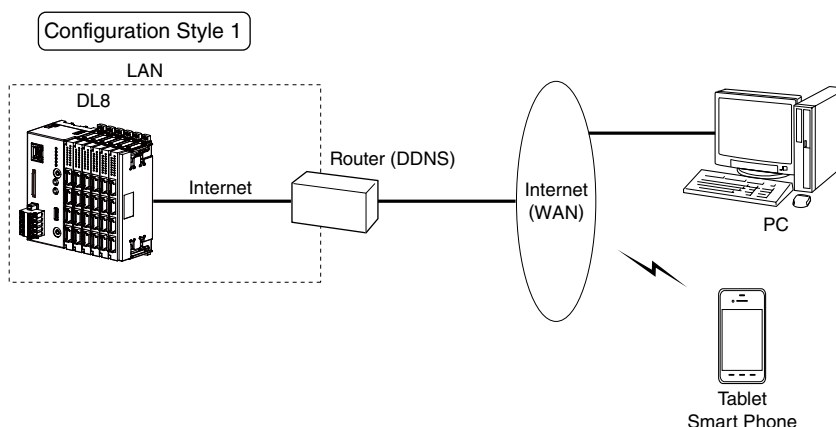

Set up the DL8 as explained below depending on required server functions. Refer also to the router's manual.

SERVER FUNCTION	DL8 SETTING	ROUTER SETTING
Web server	Set IP address manually. (Refer to 4.3 IP ADDRESS SETTING.)	<ul style="list-style-type: none"> • Static IP address or dynamic DNS is necessary. • Allow HTTP packet (TCP port 80) to access the DL8 IP address.
Modbus/TCP slave	Set IP address manually. (Refer to 4.3 IP ADDRESS SETTING.)	<ul style="list-style-type: none"> • Static IP address or dynamic DNS is necessary. • Allow Modbus/TCP packet (TCP port 502) to access the DL8 IP address.
DLCFG via network	Set IP address manually. (Refer to 4.3 IP ADDRESS SETTING.)	<ul style="list-style-type: none"> • Static IP address or dynamic DNS is necessary. • Allow DLCFG packet (TCP port 30301) to access the DL8 IP address.
FTP server (Type C, D & E)	Set IP address manually. (Refer to 4.3 IP ADDRESS SETTING.)	<ul style="list-style-type: none"> • Static IP address or dynamic DNS is necessary. • Allow FTP packet (FTP control port 21 and FTP data port 45967 to 45970) to access the DL8 IP address.
Server function not used	Set IP address with DHCP. Manual setting is also available. (Refer to 4.3 IP ADDRESS SETTING.)	Setting is not necessary.

4.2.2 STYLE 2: LAN

Multiple DL8 devices are connected to LAN, allowing to monitor them on a terminal connected to the same network.

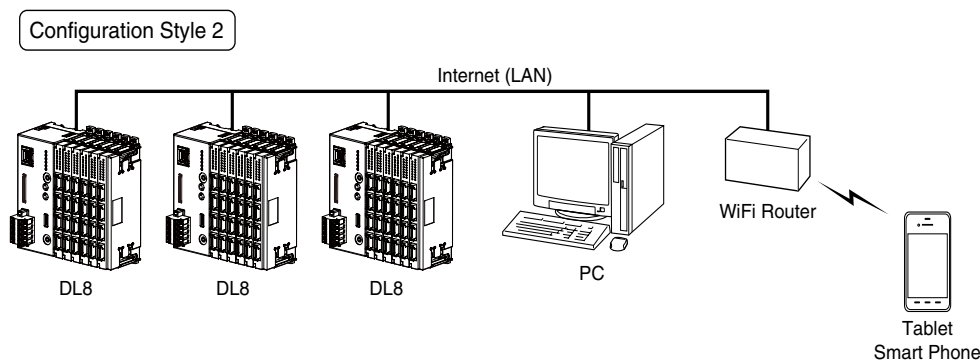

Set up the DL8 as explained below depending on required server functions. Please ask your IT network administrator about detailed setting.

SERVER FUNCTION	DL8 SETTING
Web server	Set IP address manually. (Refer to 4.3 IP ADDRESS SETTING.)
Modbus/TCP slave	
DLCFG via network	
FTP server (Type C, D & E)	
Server function not used	Set IP address with DHCP. Manual setting is also available. (Refer to 4.3 IP ADDRESS SETTING.)

4.2.3 STYLE 3: WAN-LAN

Multiple DL8 devices are connected to a broadband router via a hub/switch, in order to upload data to a generic web server (web server, cloud mode; refer to 8.8 CLOUD MODE).

You can browse via URL of the web server from the PC (B), tablet terminal or smart phone.

In this case, the server function of the DL8 is not used.

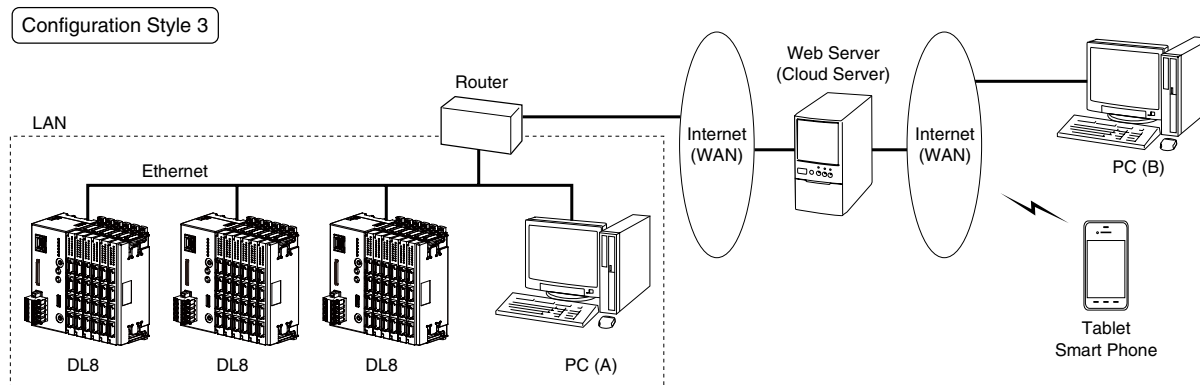

SERVER FUNCTION	DL8 SETTING
Server function not used	Set IP address with DHCP. Manual setting is also available. (Refer to 4.3 IP ADDRESS SETTING.)

NOTE

- Style 2 (LAN) configuration is also available with PC (A) with the same network setting for Style 2.
- Style 1 (WAN) configuration is also available with PC (B) with the same network setting for Style 1.
Only one (1) DL8 device can be accessed.
- User must prepare the cloud server.

4.3 IP ADDRESS SETTING

- (1) Install the DLCFG program to a PC. Connect the COP-US cable between the DLCFG port (CFG) of DL8 and the PC. Install the driver software of COP-US to the PC in advance and take a note of the COM port number which has been added. Turn on the power supply of the DL8 before connecting it to the PC.

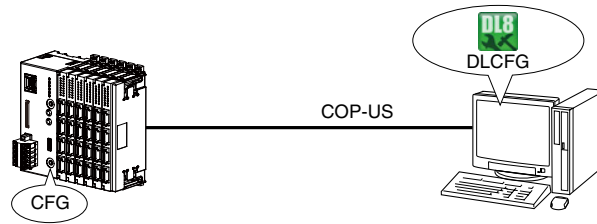

- (2) Start the DLCFG and click [Connect]. Then a dialog as shown below to the right appears. Check the radio button of "Local" and choose the COM port number of the COP-US which has been added. Then click [OK].

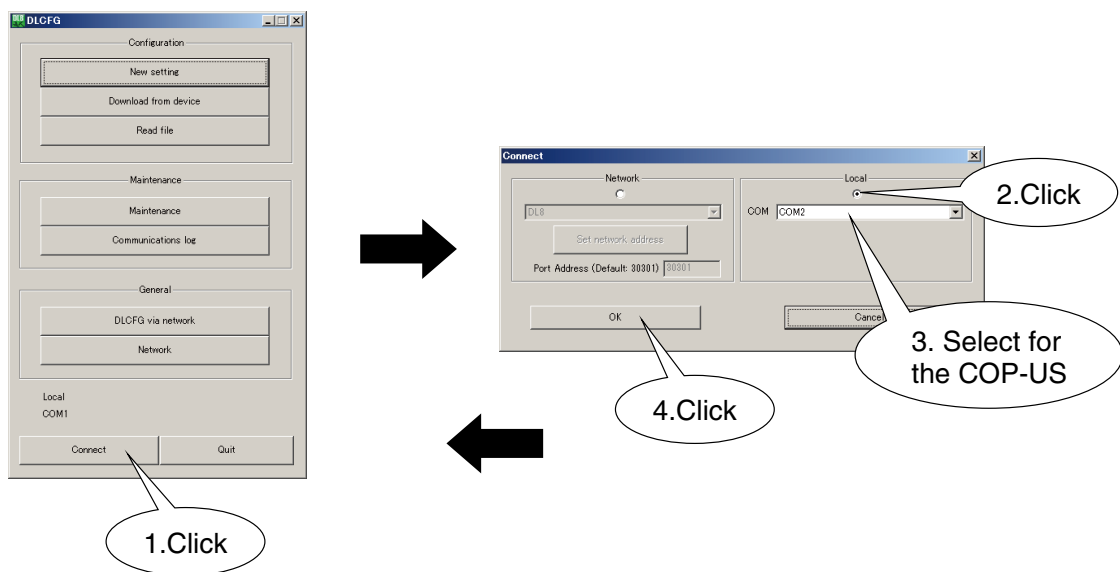

(3) Click [Network] button on the main window to display the [Network] setting window.

- Manual IP setting : Select “Manual setting” for “IP address setting,” and set each IP address.
- Automatic IP setting : Select “Automatic setting (DHCP)” for “IP address setting.”

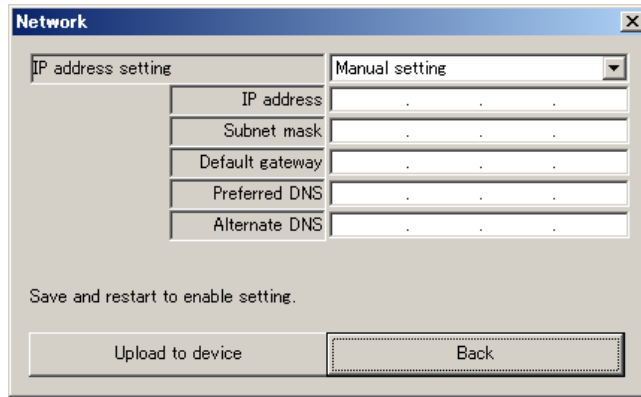

PARAMETER	DESCRIPTION
IP address setting	<ul style="list-style-type: none"> • Manual setting Specify IP address and other parameters manually. • Automatic setting (DHCP) Get IP address and other parameters automatically from the DHCP server. Once DHCP is selected, IP address cannot be changed manually.
IP address	Specify the IP address of the DL8 device.
Subnet mask	Specify the Subnet mask.
Default gateway	Specify the IP address of the default gateway.
Preferred DNS	Specify the IP address of the preferred DNS server.
Alternate DNS	Specify the IP address of the alternate DNS server.

Click [Upload to device] and confirm successful change. Then click [Back] to return to the main window.

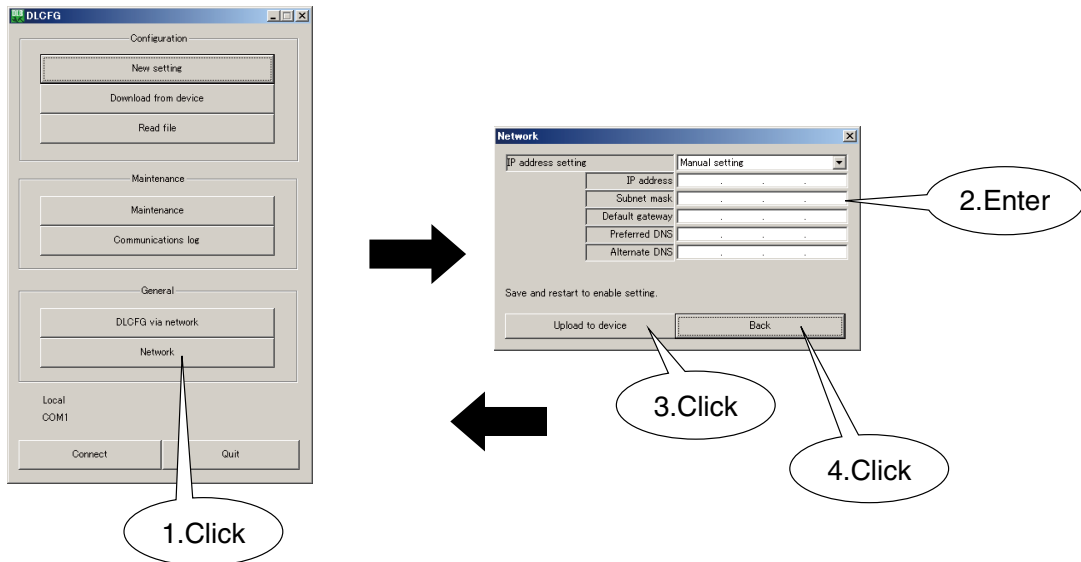

(4) Turn off and on the power supply to the device to enable the new setting. Confirm again the setting (3) is correctly applied on the “Network” setting window.
When DHCP is selected, the IP address assigned by the DHCP server (router) appears.

5. CONNECTING I/O MODULES

5.1 INSTALLATION

The R8 series Remote I/O modules can be used in combination with the DL8. Follow the procedure below to install I/O modules. Refer also to the instruction manuals of respective I/O modules.

5.1.1 POINTS OF CAUTION

- Switches on the side of I/O modules must be set while the power is removed. DO NOT switch them while the power is on.
- The DL8 is usable with the R8 module address from 0 to 31. Other addresses cannot be used.
- Modules' addresses can be chosen regardless of their mounting locations. Be sure not to use duplicated addresses.
- 4-point analog I/O module occupies 2 addresses.
e.g. When R8-SV4 is set to address 5, Input 1 and Input 2 are assigned to address 5, and Input 3 and Input 4 are assigned to address 6. In this case, do not use address 6 for other I/O modules.

5.1.2 MOUNTING

■ HOW TO MOUNT THE MODULE ON DIN RAIL

- I/O Module

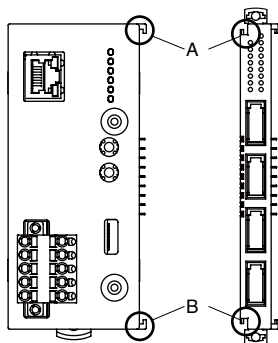

Confirm that the locking clamps of the I/O module are set.
Insert the module in parallel to the next one while aligning the grooves of both modules (A & B in the above figure).
Maintain it perpendicularly to the rail.

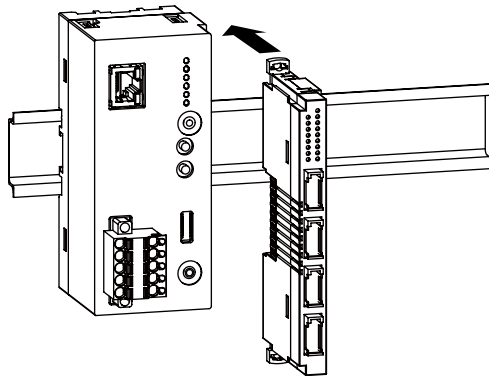

More I/O modules can be added in the same manner.

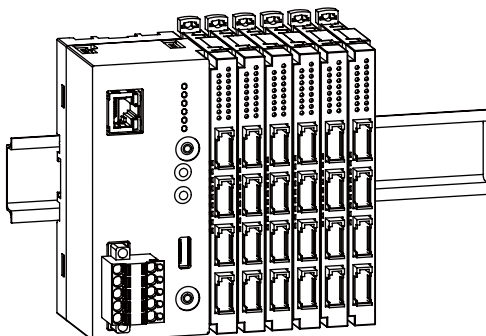

• Protective Cover

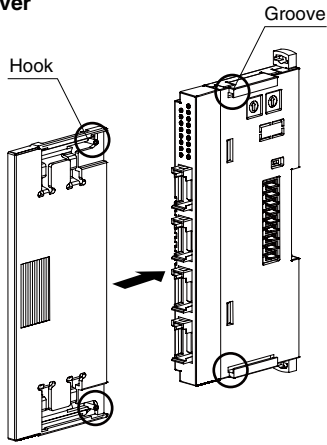

The protective cover is to be attached over the connected I/O module at the right end.
Align the hooks on the cover with the grooves of the module and slide it straight until the hooks are latched.

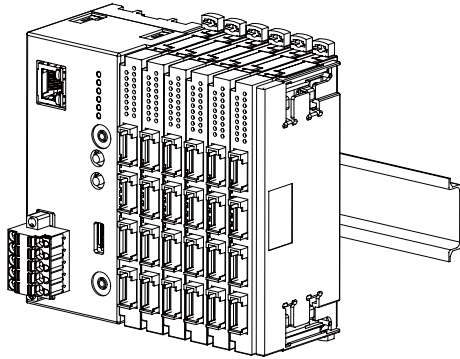

When removing the cover, pull it out while squeezing the hooks inward.

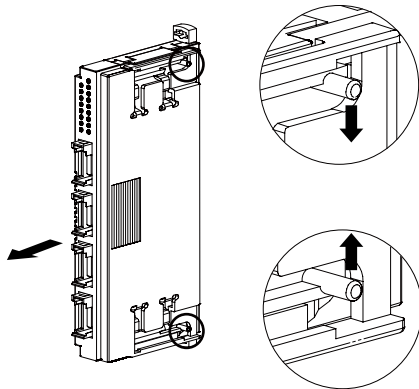

■ HOW TO DISMOUNT THE MODULE FROM DIN RAIL

Release the locking clamps and pull out straight the module.

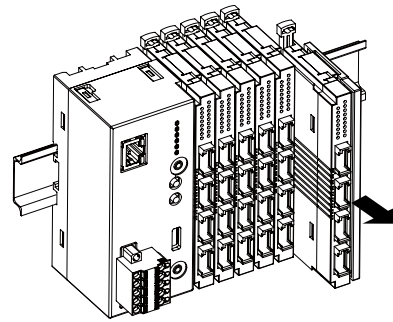
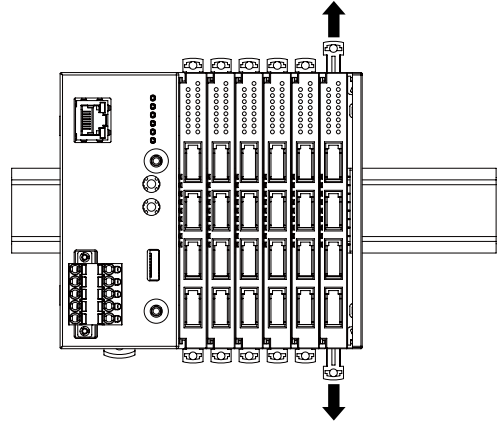

• Removing an intermediate module

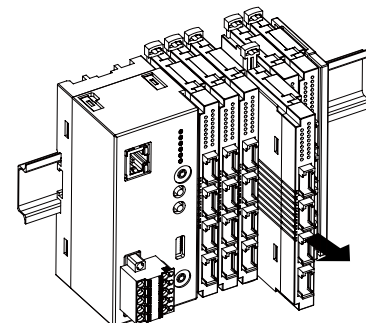
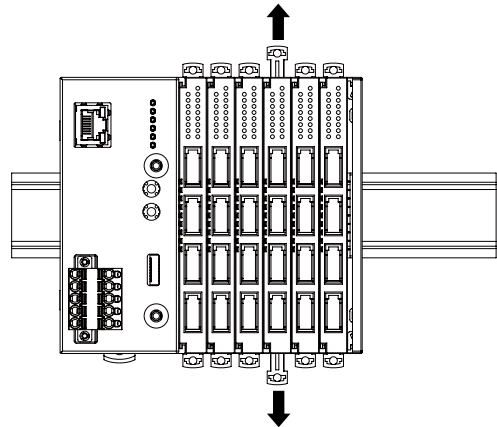

Caution !

- 1) Be careful not to hurt your hand by pointed edges of the internal bus connector.
- 2) I/O modules cannot hold tightly on the DIN rail by themselves without power/network module.
Secure them to the position if necessary by using DIN rail end plates.

5.2 CONFIGURATION

After mounting all I/O modules, configure each module.

- (1) Install the R8CFG program to a PC. Connect the COP-US cable between the R8CFG port (I/O) of DL8 and the PC. Install the driver software of COP-US to the PC in advance and take a note of the COM port number which has been added. Turn on the power supply of the DL8 before connecting it to the PC.

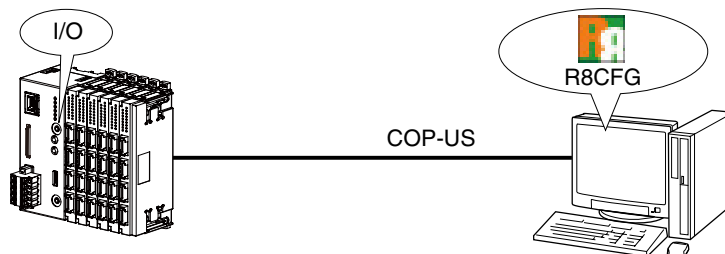

- (2) Configure sensor type, signal range and other parameters of the I/O modules according to their manuals.

NOTE

- I/O module configuration cannot be performed via network.

6. CONNECTING SLAVE DEVICES

6.1 CONNECTING REMOTE I/O

6.1.1 GENERAL DESCRIPTIONS

Inputs and outputs can be expanded using Modbus/TCP master function of the DL8 via remote I/Os that have Modbus/TCP slave function.

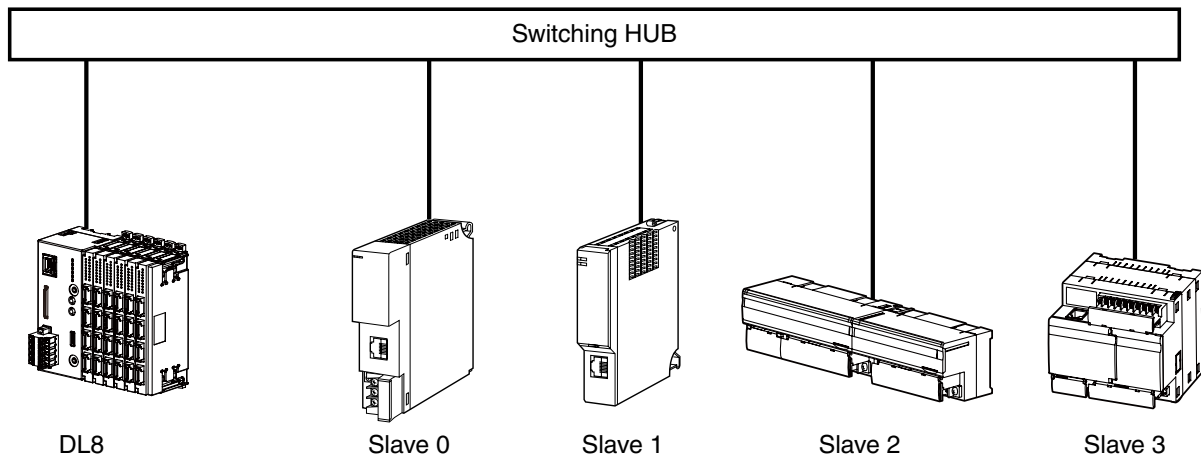

Up to twelve (12) remote I/O modules can be connected to a single DL8 device.

Assign unique IP address to each I/O module (slave 0 to 11) so as not to overlap with the one assigned to the DL8.

■ Usable Remote I/O

- DL8
- R3-NE1
- R5-NE1
- R6-NE1
- R6-NE2
- R7E
- R9EWTU
- 72EM2-M4
- DL30-G
- TR30-G
- GR8-EM
- WL40EW2x
- IT series

NOTE

- Refer to the manual of each I/O device for necessary setup.
- When connecting to the DL8 via WAN, it is strongly recommended to use VPN in terms of security

6.1.2 ASSIGNING REMOTE I/O

Register remote I/O modules to be connected to the DL8 via Modbus/TCP.

- (1) Start the DLCFG to show the main window.
Click [Download from device] button to open "Configuration" window.
Click [Input/Output] button to open "Input/Output" menu.

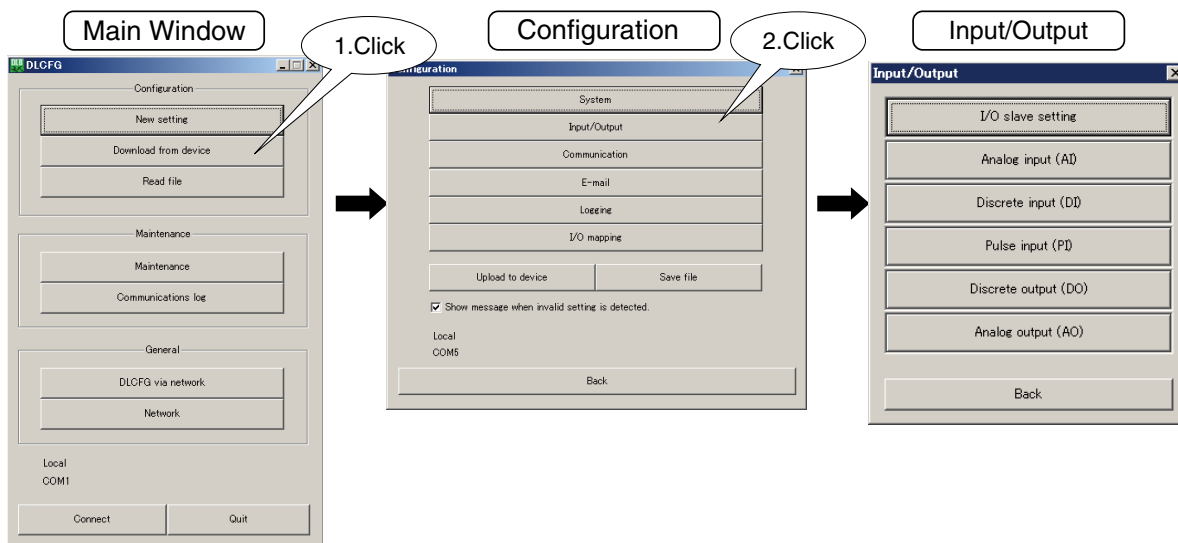

- (2) Click [I/O slave setting] button in "Input/Output" menu to open "I/O slave setting" window.
- (3) Double-click the Slave number to configure to open the Slave setting dialog.

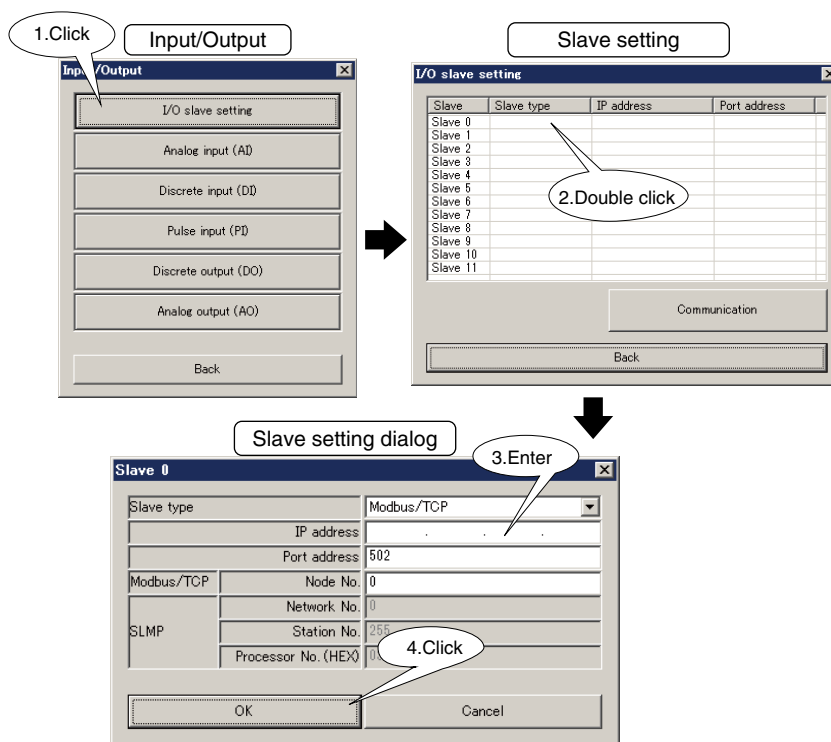

(4) Set the following parameters for each slave.

PARAMETER	DESCRIPTION
Slave type	Select "Modbus/TCP".
IP address	Enter IP address of remote I/O module.
Port address	Enter port address of remote I/O module (0 to 65535).
Node No.	Enter Node No. (Modbus RTU node number) for remote I/O module (0 to 255).

(5) Click [OK] to save setting.

NOTE

- When a Modbus/RTU (RS-485) remote I/O module is connected via a protocol converter (e.g. model GR8-EM), set IP address of the converter to "IP address" and the node address of the Modbus RTU device to "Node No."

6.2 CONNECTING SLMP-COMPATIBLE DEVICES

6.2.1 GENERAL DESCRIPTIONS

Using the SLMP client function of the DL8, I/O can be expanded using SLMP devices having the SLMP server function.

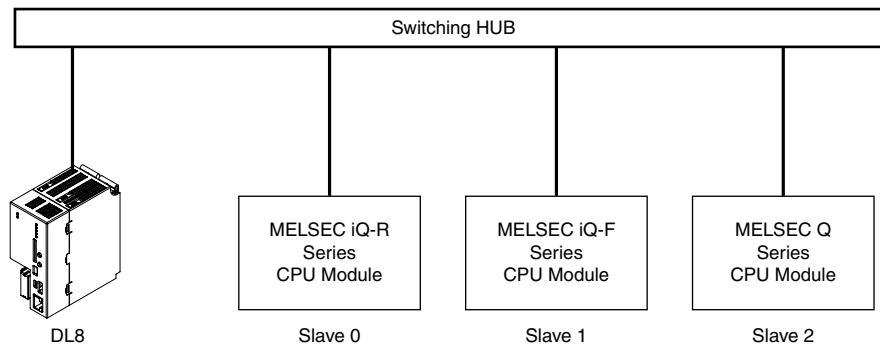

■ SLMP-compatible devices that can be connected to the DL8

- MELSEC iQ-R Series CPU units (Mitsubishi Electric)
- MELSEC iQ-F Series CPU units (Mitsubishi Electric)
- MELSEC Q Series CPU units (Mitsubishi Electric)

(Tested and verified)

- R04CPU
- FX5U-32M
- Q03UDECPU

■ Connecting with SLMP-compatible device

The DL8 is connected to SLMP devices via TCP/IP over Ethernet.

Register the SLMP device on the Ethernet Device setting window and set as follows:

PARAMETER	DESCRIPTION
Communication data code	Binary
Communication method	SLMP
Protocol	TCP
IP address	IP address specified in the I/O slave setting of the DLCFG
Port No.	Port No. specified in the I/O slave setting of the DLCFG

NOTE

- See the User Manual of each product for the SLMP setting.
- When connecting to the DL8 via WAN, It is strongly recommended to use VPN in terms of security.

6.2.2 ASSIGNING SLMP DEVICES

Register SLMP-compatible devices to be connected to the DL8 via SLMP.

- (1) Click [I/O slave setting] button in “Input/Output” menu to open “I/O slave setting” window.
- (2) Double-click the Slave number to configure to open the Slave setting dialog.

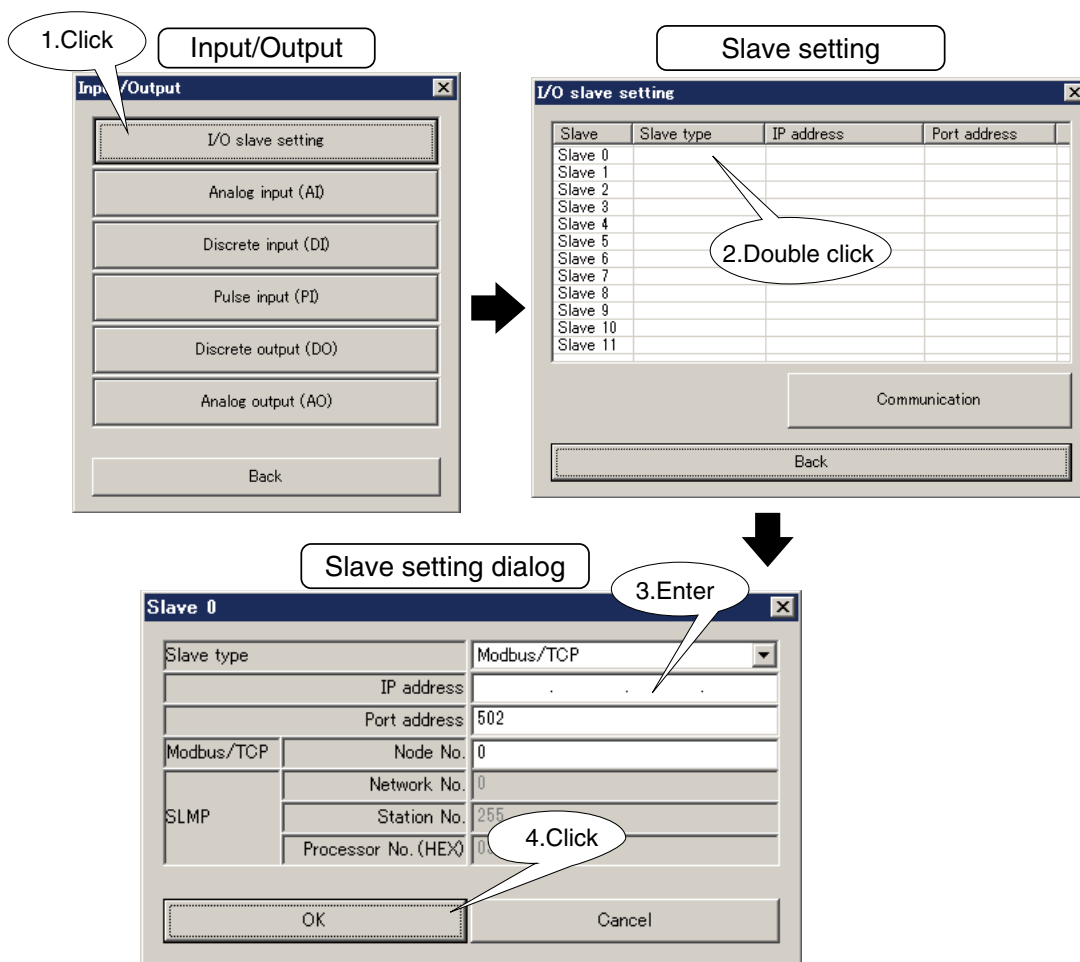

- (3) Set the following parameters.

PARAMETER	DESCRIPTION
Slave type	Select "SLMP_16" or "SLMP_32" depending on the SLMP device to be connected.
IP address	Enter IP address of the SLMP device.
Port address	Enter port address of the SLMP device. (0 to 65535).
Network No.	Enter Network No. of the SLMP device.
Station No.	Enter the station No. of the SLMP device.
Processor No. (HEX)	Enter the processor No. of the SLMP device in hexadecimal.

- (4) Click [OK] to save setting.

6.3 COMMUNICATION SETTING

Configure communication setting for the slave devices to be connected to the DL8.

- (1) Click [I/O slave setting] button in “Input/Output” menu to open “I/O slave setting” window.
- (2) Click [Communication] button to open the Communication setting dialog.

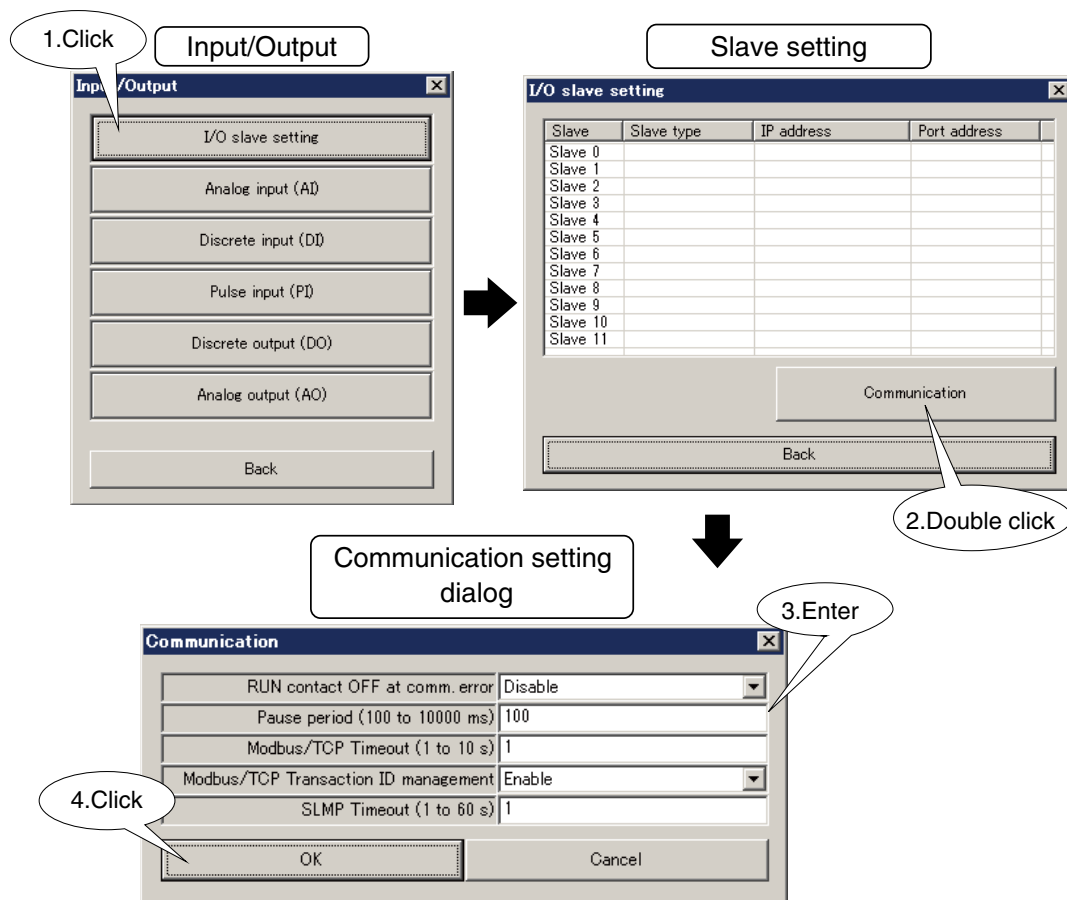

- (3) Set the following parameters.

PARAMETER	DESCRIPTION
RUN contact OFF at comm. error	Enable to turn OFF RUN contact output when communication with slave device has failed. RUN contact turns ON again when communication has been established.
Pause period	Set time interval between transmissions via Modbus/TCP. (100 to 10000 msec.) (Fixed at 100 msec. for Ver. 1.4 or earlier)
Modbus/TCP timeout	Set Modbus/TCP timeout. (1 to 10 sec.)
Modbus/TCP Transaction ID management	Modbus messages are managed by IDs so as to skip unexpected messages. Normally set it to 'Enable'.
SLMP Timeout	Set SLMP timeout. (1 to 60 sec.)

- (4) Click [OK] to save setting.

NOTE

- When the unit is connected to a Modbus gateway such as GR8-EM or WL40EW2 , set 'Timeout' so as to be longer than the timeout of the Modbus gateway.

7. SETTING UP I/O CHANNELS

7.1 CONNECTING DL8

- (1) Connect the DL8 with the COP-US cable to the PC to which the DLCFG is installed.
For connection setting, refer to 4.3 IP ADDRESS SETTING.

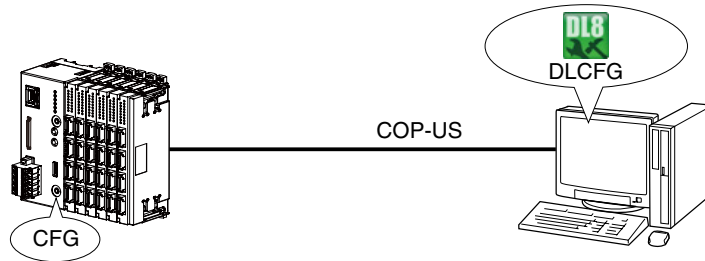

- (2) Start the DLCFG to display the main window.
Click [Download from device] button to read setting from the DL8 and to open “Configuration” window.
Click [Input/Output] button to open “Input/Output” menu.

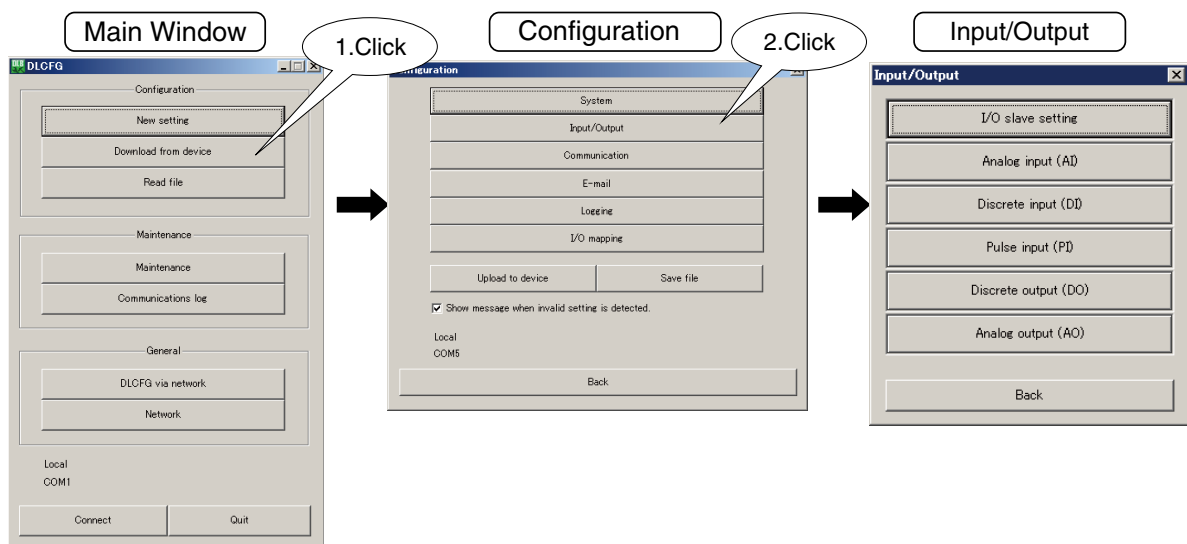

- (3) AI, DI, PI, DO, and AO setting dialogs are accessed from “Input/Output” menu.

NOTE

- An engineering unit value can be specified between -10,000,000,000 and 10,000,000,000.
Default value in setting dialogs shows the maximum usable decimal places.

7.2 ANALOG INPUT (AI)

7.2.1 ASSIGNING I/O SIGNALS

A maximum of 32-point analog inputs (AI1 to AI32) can be monitored.

Assign analog inputs of I/O modules and/or remote I/Os connected to the DL8, following the procedure below. 16 bit integer data can be handled. Allocate 32 bit integer data such as power data to pulse input (PI).

7.2.1.1 ASSIGNING I/O MODULE TO AI

(1) Click [Analog input (AI)] button in "Input/Output" menu to open "Analog input (AI)" list.

Double-click a row of the AI channel to configure to open the AI configuration dialog.

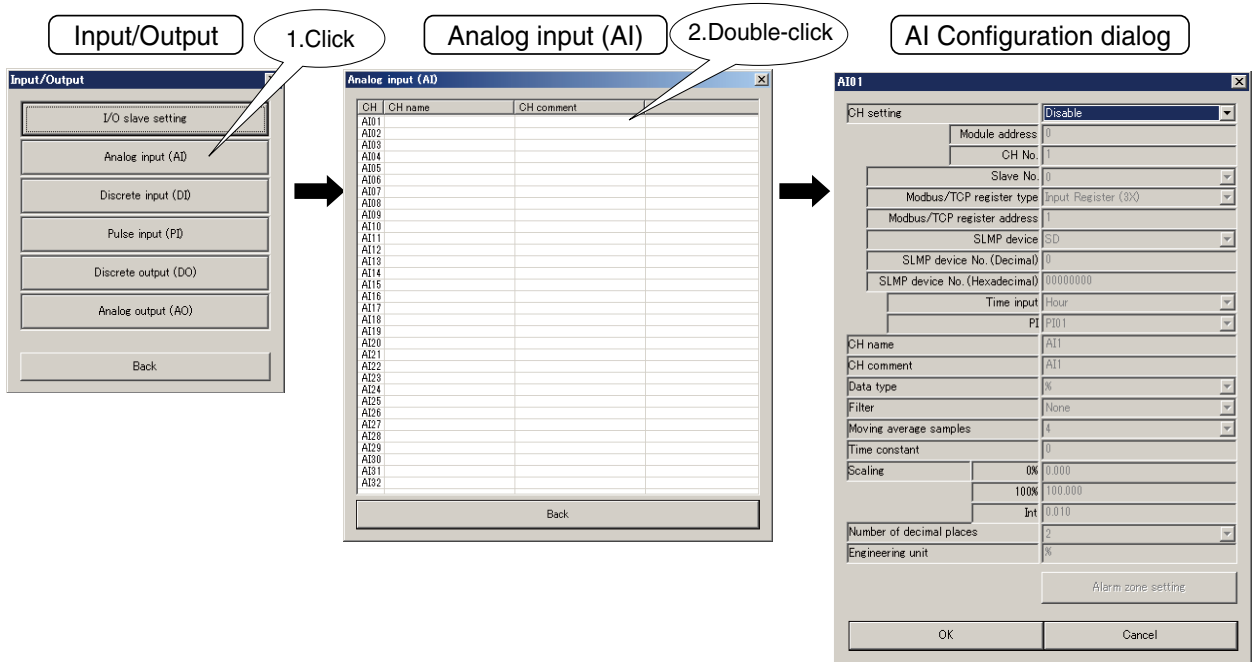

(2) Choose "I/O module" under "CH setting" and assign "Module address" and enter "CH No." (Refer to 5. CONNECTING I/O MODULES.)

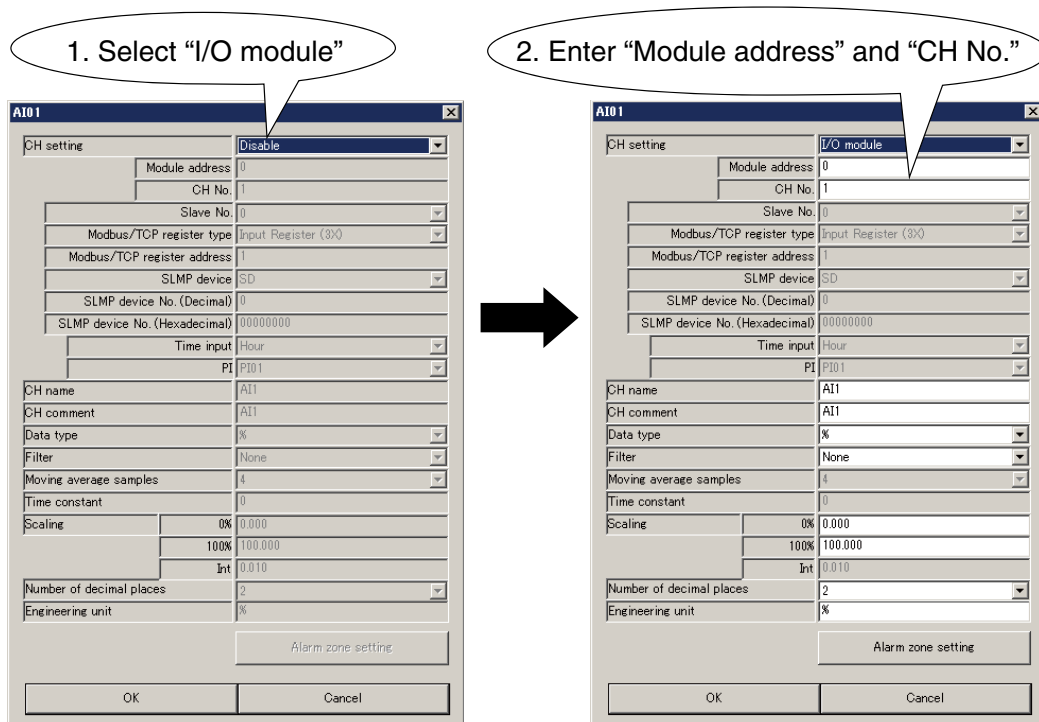

2 channels of analog input are available per module. When a 4-channel module is installed, use 2 module addresses.
(N: module address assigned to the module)

MODULE TYPE	MODEL NUMBER	CH NO.	MODULE ADDRESS OF DL8	CH NO. FOR DL8
2-channel module	R8-SV2 R8-SS2 R8-TS2	CH1	N	1
		CH2	N	2
4-channel module	R8-SS4NJ R8-SS4N R8-SV4N R8-RS4N R8-CT4E R8-FST4N	CH1	N	1
		CH2	N	2
		CH3	N+1	1
		CH4	N+1	2
8-channel module	R8-SST8	CH1	N	1
		CH2	N	2
		CH3	N+1	1
		CH4	N+1	2
		CH5	N+2	1
		CH6	N+2	2
		CH7	N+3	1
		CH8	N+3	2
16-channel module	R8-FS16N	CH1	N	1
		CH2	N	2
		CH3	N+1	1
		CH4	N+1	2
		CH5	N+2	1
		CH6	N+2	2
		CH7	N+3	1
		CH8	N+3	2
		CH9	N+4	1
		CH10	N+4	2
		CH11	N+5	1
		CH12	N+5	2
		CH13	N+6	1
		CH14	N+6	2
		CH15	N+7	1
		CH16	N+7	2

7.2.1.2 ASSIGNING REMOTE I/O TO AI

(1) Refer to 6.1.2 ASSIGNING REMOTE I/O to assign remote I/O slaves.

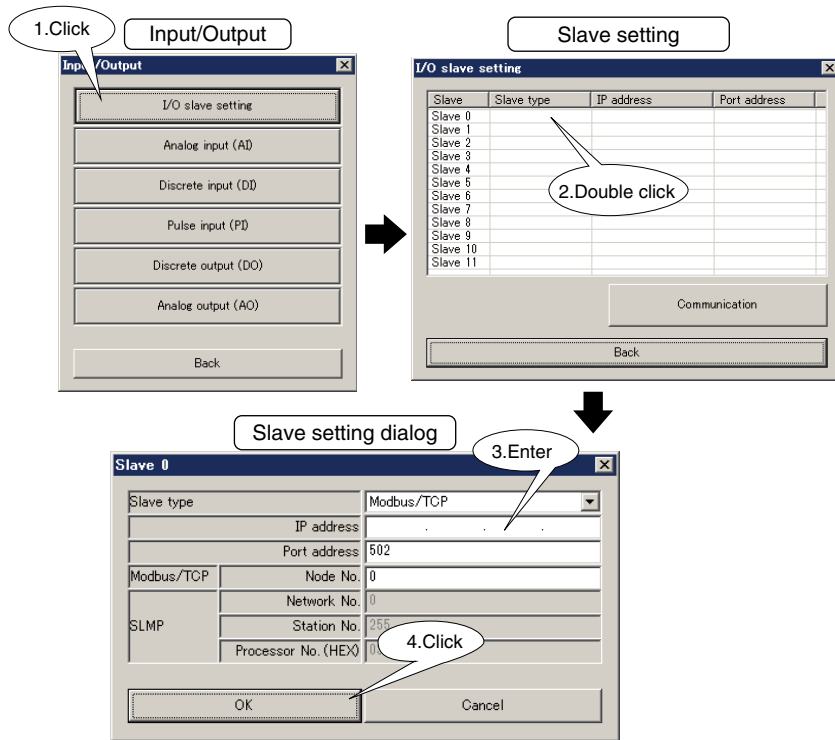

(2) Open "AI" configuration dialog as explained in 7.2.1.1 ASSIGNING I/O MODULE TO AI.

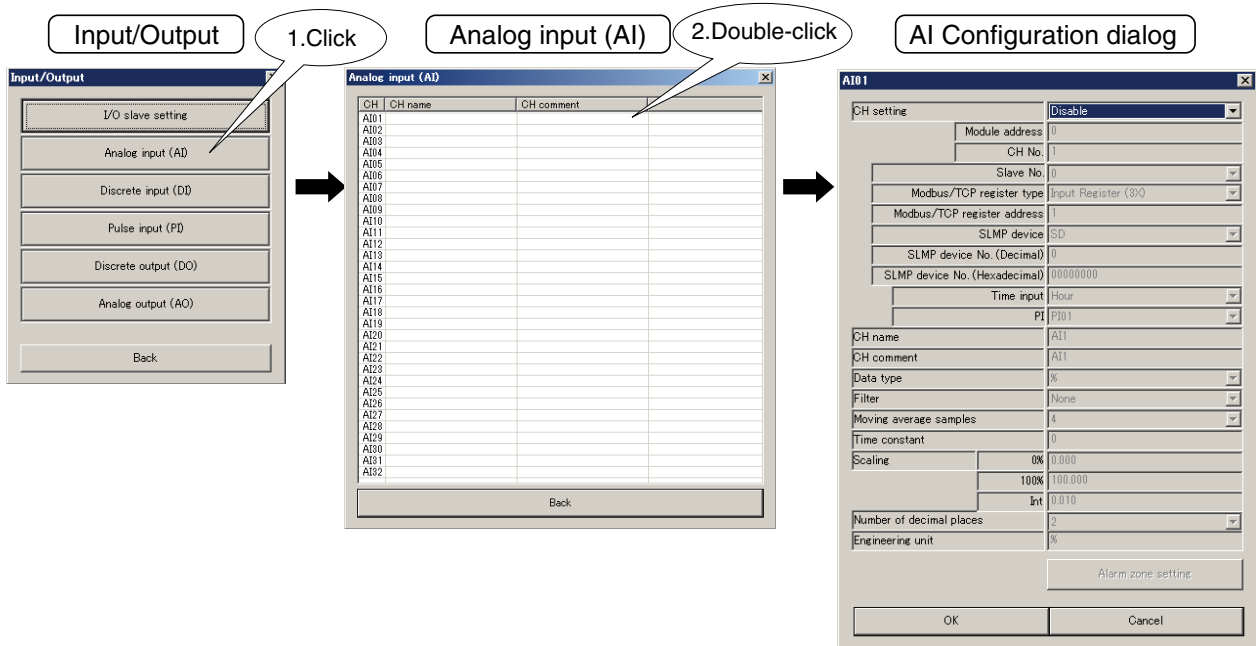

(3) Choose “Modbus/TCP” under “CH setting” and enter “Slave No.,” “Modbus/TCP register type,” and “Modbus/TCP register address.”

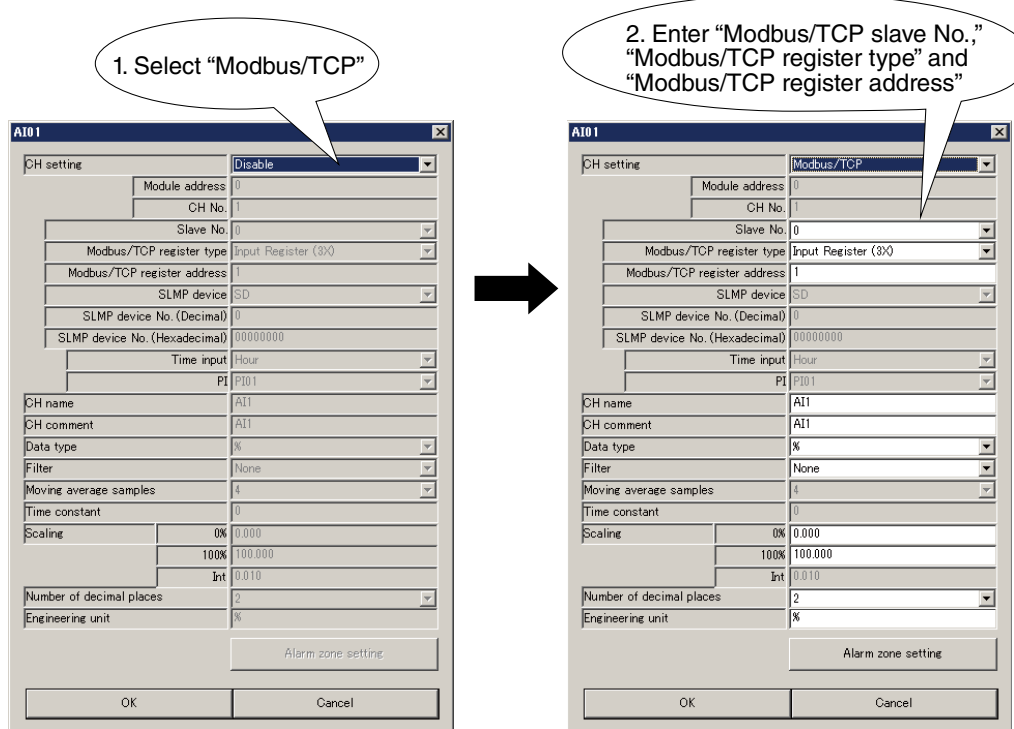

PARAMETER	DESCRIPTION
Slave No.	Enter slave No. (0 to 11) set in (1).
Modbus/TCP register type	Choose [Input Register (3X)] or [Holding Register (4X)].
Modbus/TCP register address	Set register address usable in the register type described above. Range: 1 to 65536

7.2.1.3 ASSIGNING SLMP DEVICES TO AI

(1) Refer to 6.2.2 ASSIGNING SLMP DEVICES TO AI to assign SLMP devices as slaves.

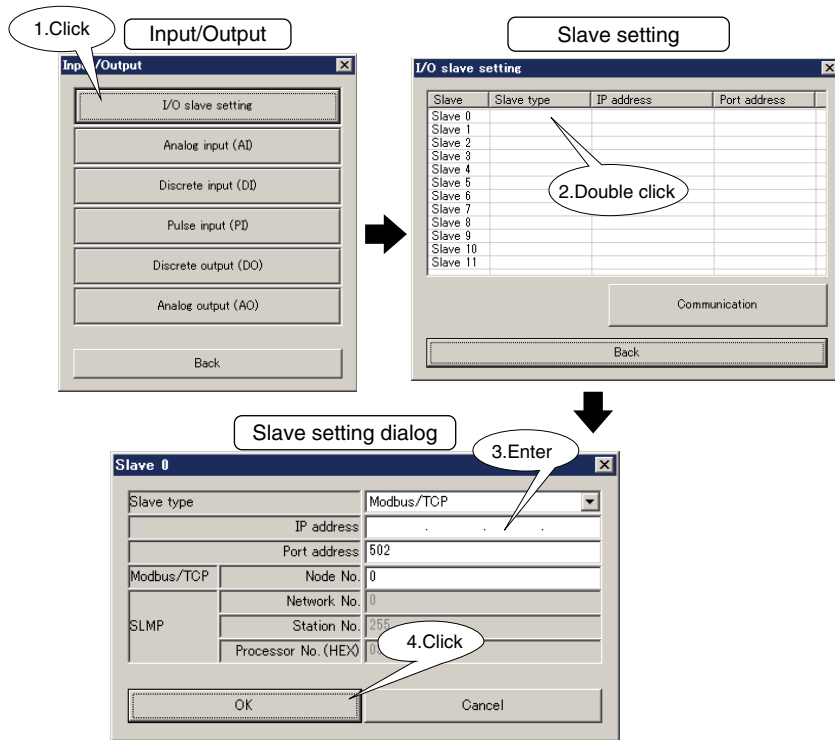

(2) Open "AI" configuration dialog as explained in 7.2.1.2 ASSIGNING REMOTE I/O TO AI.

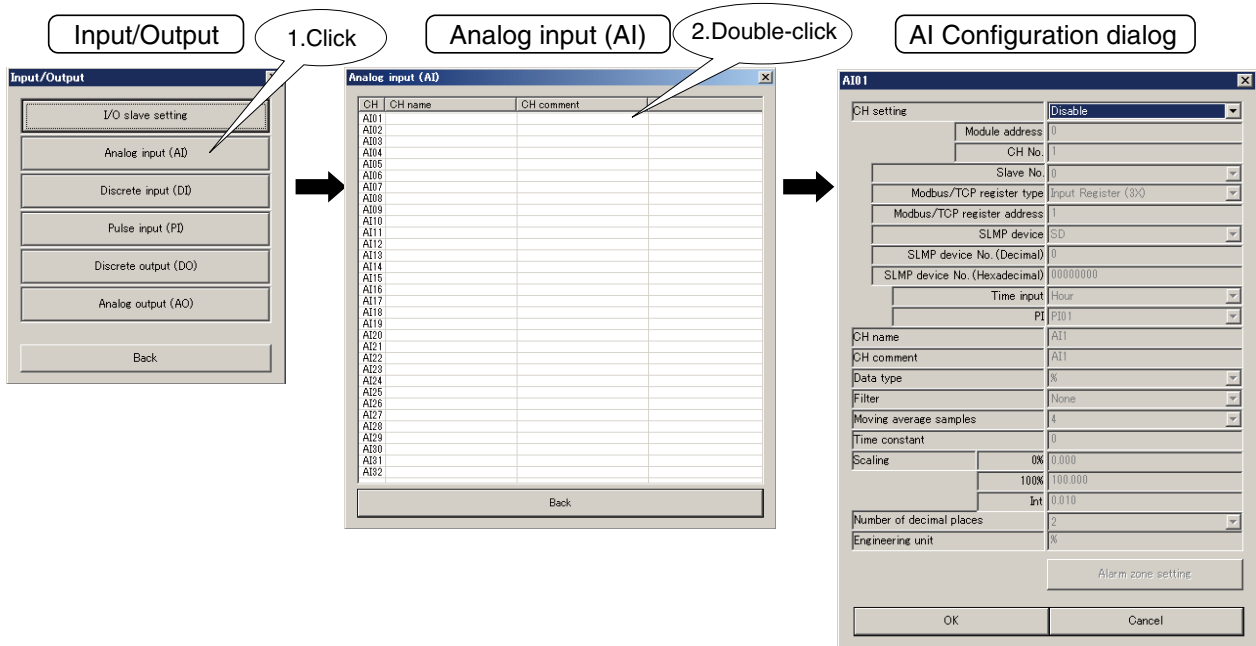

(3) Choose "SLMP" under "CH setting" and enter "Slave No.," "SLMP device," and "SLMP device No."

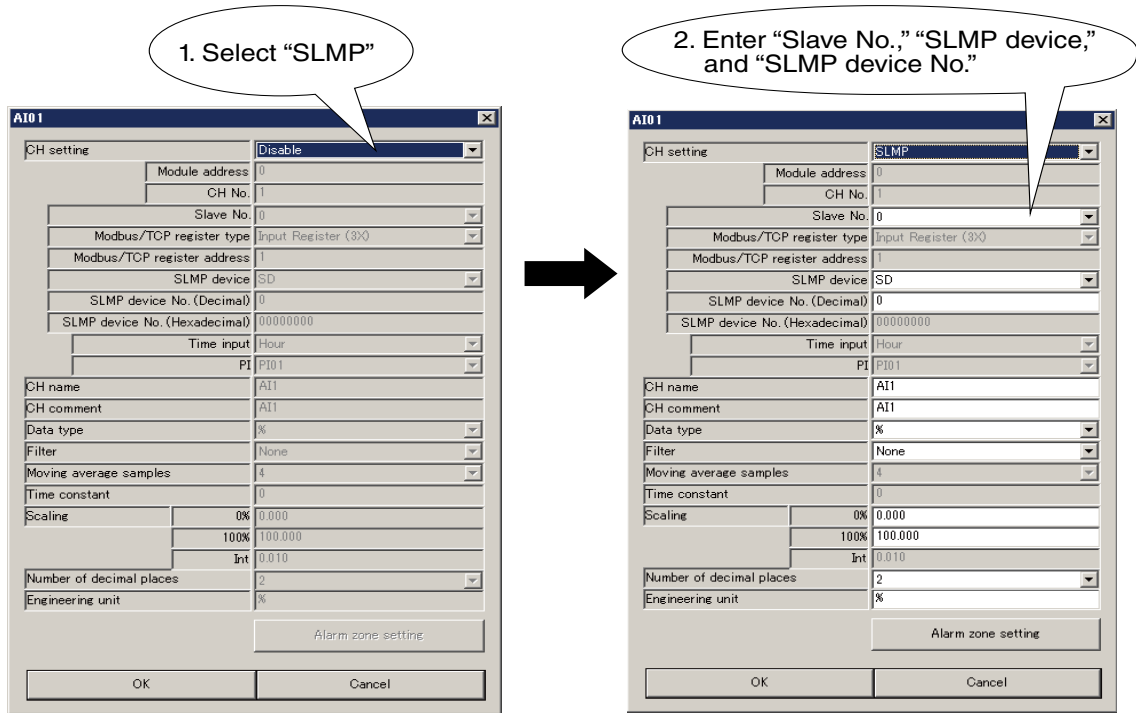

PARAMETER	DESCRIPTION
Slave No.	Enter slave No. (0 to 11) set in (1).
SLMP device	Choose the device from the pull-down list.
SLMP device No.	Set the device number for the SLMP device. The input field of either "SLMP device No. (Decimal)" or "SLMP device No. (Hexadecimal)" will be active depending on the selected SLMP device.

7.2.1.4 TIME INPUT

Present time (hour/minute/second) can be treated as AI.
Time input is used to reset PI counts in a regular time interval.

7.2.1.5 PI

PI input value can be converted into 0 to 10000 range by entering 0% and 100% values in "Scaling" to assign as an AI.
The converted value can be multiplied by the factor "Int" to display as an engineering unit value.

7.2.2 BASIC SETTING

After channel assignment, configure basic settings for each channel.
Click [OK] to temporarily save the settings.

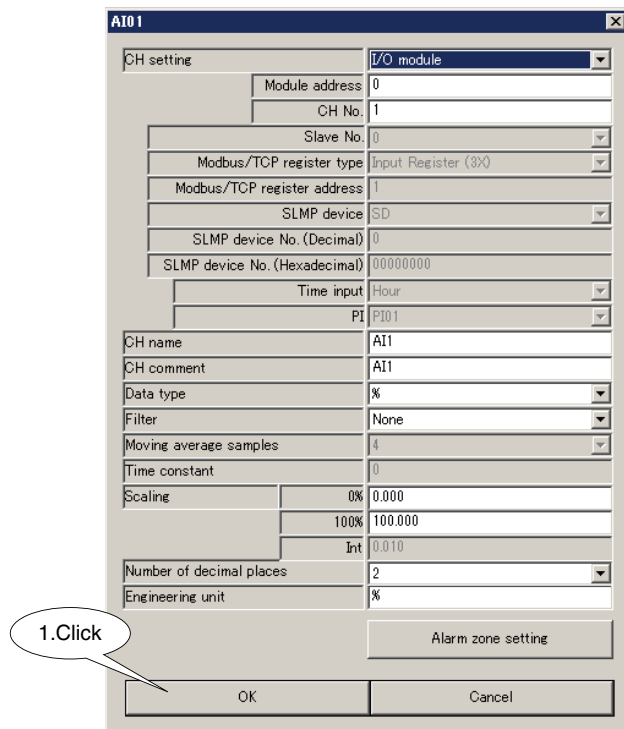

PARAMETER	DESCRIPTION
CH name	Enter the name for channel (max. 32 characters).
CH comment	Enter comment regarding channel and tag name (max. 64 characters).
Data type	Select a data type between 2 types below. <ul style="list-style-type: none"> • %: % x 100 format (-2000 to 12000) (voltage or current data of remote I/O) • Int: Signed 16-bit integer format (-32768 to 32767) (temperature data of remote I/O)
Filter	Set filter function. Select within None / Moving average / Delay buffer. Not usable when CH setting is specified to Time or PI.
Moving average samples	Select number of samples for the moving average filter. Selectable from: 4 / 8 / 16 / 32 / 64. Sampling interval is 1 second.
Time constant	Set time constant for the delay buffer filter. (0 to 100 seconds)
Scaling	<ul style="list-style-type: none"> • Data type: % Set engineering unit values at 0 % and 100 %. (-10,000,000,000 to 10,000,000,000) • Data type: Int Set multiple to convert data to an engineering unit value. e.g. 0.1 in case that the temperature data is represented as engineering unit value x 10. (-10,000,000,000 to -0.0001, 0.0001 to 10,000,000,000)
Number of decimal places	Set the number of decimal places of the value displayed on the web browser. Selectable within 0 to 3. Fixed at 0 when CH setting is specified to Time.
Engineering unit	Set engineering unit of the engineering unit value in "Scaling." Input within 16 characters.

7.2.3 ALARM ZONE SETTING

Input range can be divided into max. 5 zones, and deadband can be set between zones.

(1) Click [Alarm zone setting] button in "AI" configuration dialog to open "Alarm zone setting (AI)" dialog.

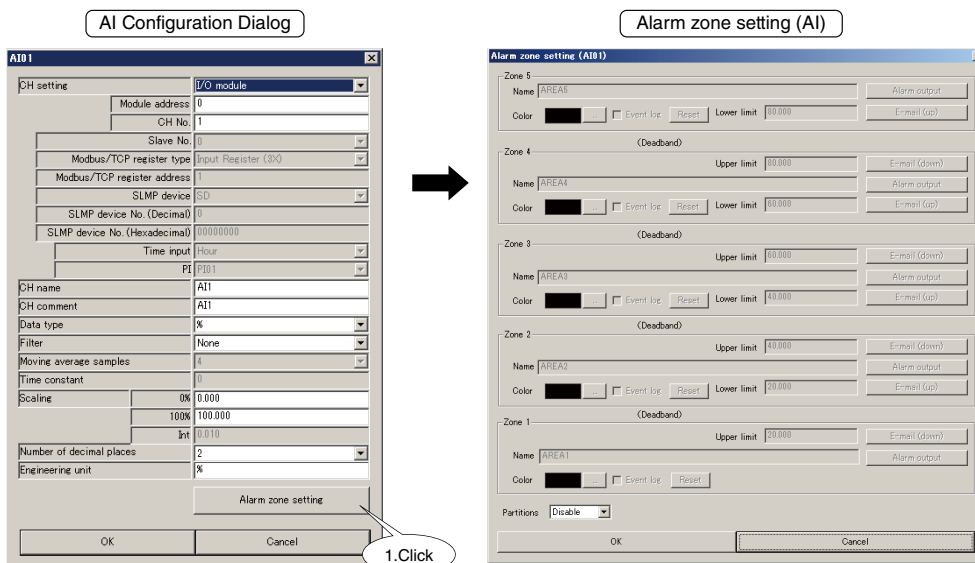

(2) Set parameters according to the table below.

PARAMETER	DESCRIPTION
Partitions	Select the number of zones to use. Selectable from: None / 2 / 3 / 4 / 5.
Name	Enter zone name (max. 64 characters).
Color	Set a color to identify the zone on the web browser.
Upper limit Lower limit	The boundary of each zone is defined by upper limit, lower limit, specified in engineering unit value. Set such that the upper limit > lower limit. <ul style="list-style-type: none"> Setting deadband When deadband is required between zone 1 and zone 2, set apart the upper limit value of zone 1 from the lower limit value of zone 2 so that the gap in between is defined as deadband. For other zones, choose limit values in the same manner. No deadband When deadband is not required between zone 1 and zone 2, set the upper limit value of zone 1 to the same value as the lower limit value of zone 2. For other zones, choose limit values in the same manner.
Event log	The signal entering a zone can be recorded as an event in the event log on the web browser. Check the box to enable the event log.
PI Reset	PI count value can be reset when the AI enters a specific zone. Click PI Reset button to open a dialog box and specify which PI channels are to be reset.

(3) Click [OK] button to temporarily save the setting.



7.2.4 ALARM OUTPUT (TYPE B, C, D & E)

A specific DO can be turned on or off when the input signal enters a signal zone.

- Click [Alarm zone setting] button in "AI" configuration dialog to open "Alarm zone setting (AI)" dialog. Clicking [Alarm output] button for specified zone opens the "Alarm output" list. Double-click over a DO channel to set ON/OFF operation.

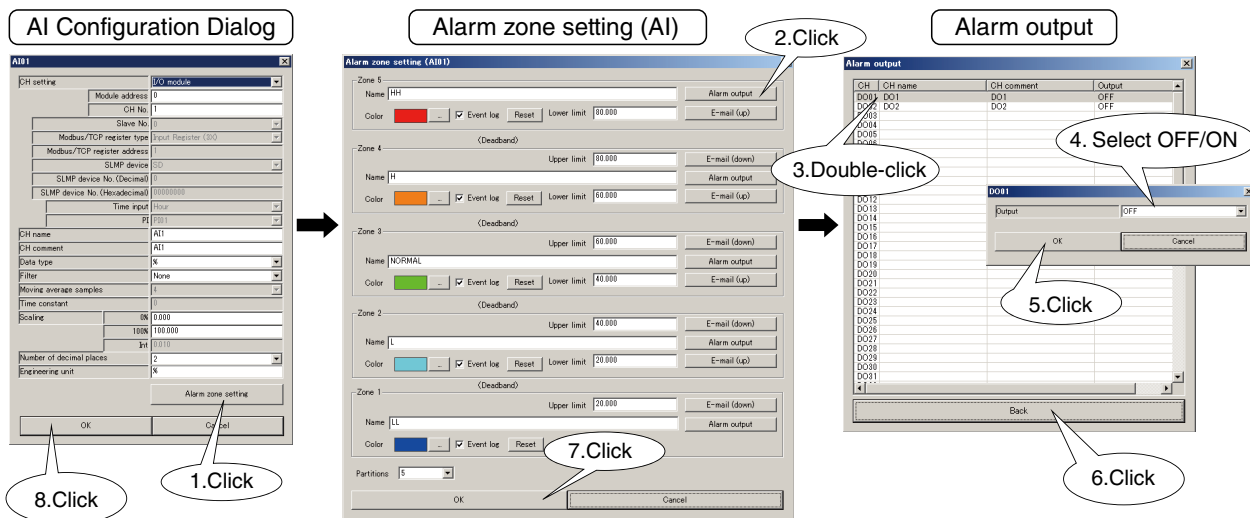

- Click [OK] button to temporarily save the setting.

NOTE

- This function is not available for Type A.
- DO setting must be finished in advance. (Refer to 7.5 DISCRETE OUTPUT (DO).)
- When alarm output turns on a DO, the ON status is maintained while input value is in the zone.
- DO controlled by web server or Modbus/TCP server, is operated in OR logic against the alarm output.
- When alarm output is not used, set it to OFF.

7.2.5 COPYING CH CONFIGURATION

Set each channel according to the above procedure.

One channel setting in the "Analog input (AI)" list can be copied to another channel and modified.

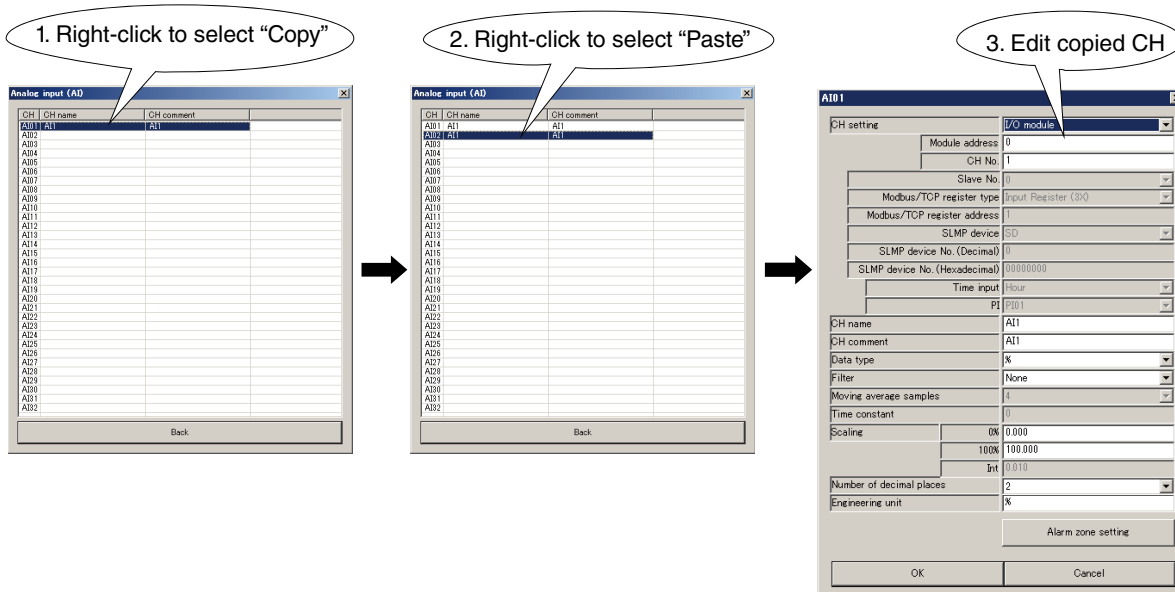

7.3 DISCRETE INPUT (DI)

7.3.1 ASSIGNING I/O SIGNALS

A maximum of 64-point discrete inputs (DI1 to DI64) can be monitored.

Assign discrete inputs of I/O modules and/or remote I/Os connected to the DL8, following the procedure below.

7.3.1.1 ASSIGNING I/O MODULE TO DI

(1) Click [Discrete input (DI)] button in “Input/Output” menu to open “Discrete input (DI)” list.

Double-click a row of the DI channel to configure to open the DI configuration dialog.

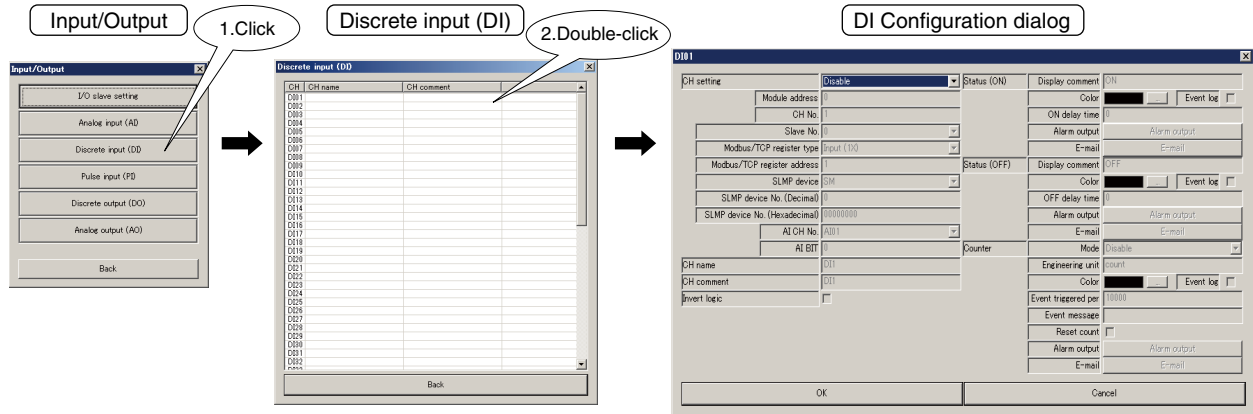

(2) Choose “I/O module” under “CH setting” and assign “Module address” and enter “CH No.” (Refer to 5. CONNECTING I/O MODULES.)

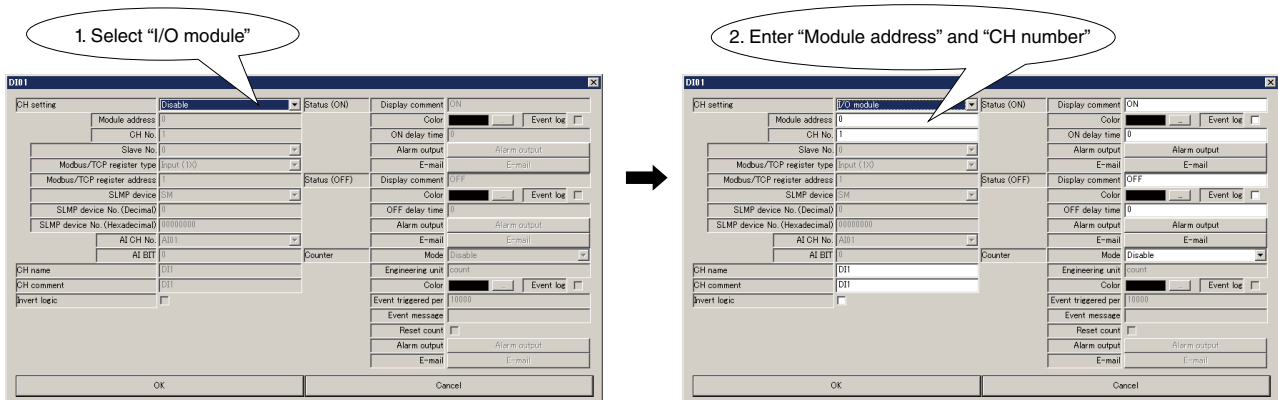

Max. 16 channels per module can be assigned for discrete input. (N: module address assigned to the module)

MODULE TYPE	MODEL NUMBER	CH NO.	MODULE ADDRESS OF DL8	CH NO. OF DL8
4-channel module	R8-DA4A	CH1	N	1
		CH2	N	2
		CH3	N	3
		CH4	N	4
8-channel module	R8-DAT8A2 R8-DAT8B2	CH1	N	1
		CH2	N	2
		CH3	N	3
		CH4	N	4
		CH5	N	5
		CH6	N	6
		CH7	N	7
		CH8	N	8
16-channel module	R8-DAM16A R8-DAT16A2	CH1	N	1
		CH2	N	2
		CH3	N	3
		CH4	N	4
		CH5	N	5
		CH6	N	6
		CH7	N	7
		CH8	N	8
		CH9	N	9
		CH10	N	10
		CH11	N	11
		CH12	N	12
		CH13	N	13
		CH14	N	14
		CH15	N	15
		CH16	N	16

7.3.1.2 ASSIGNING REMOTE I/O TO DI

(1) Refer to 6.1.2 ASSIGNING REMOTE I/O to assign remote I/Os as slave.

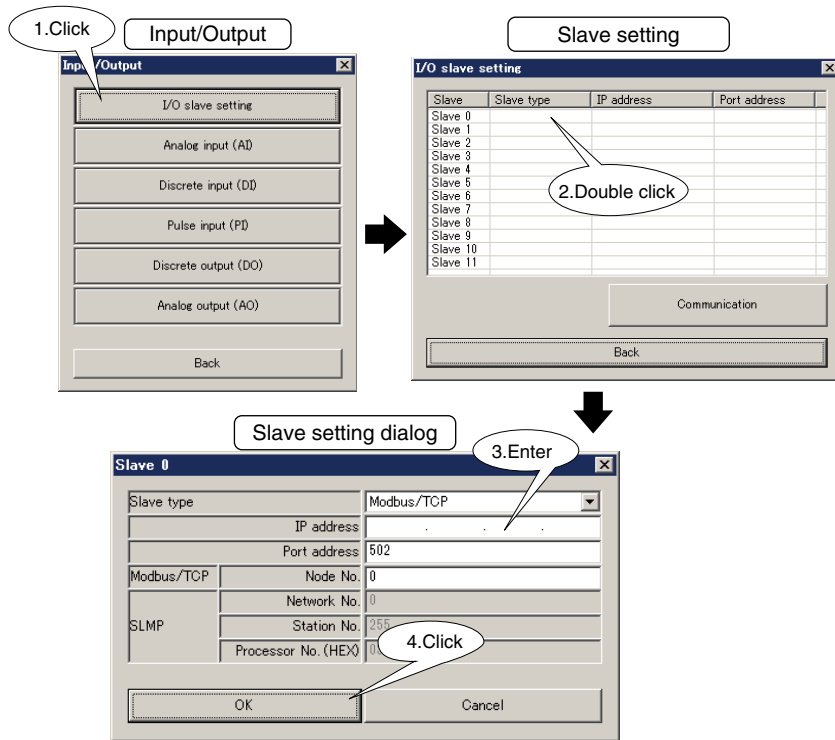

(2) Open "DI" configuration dialog.

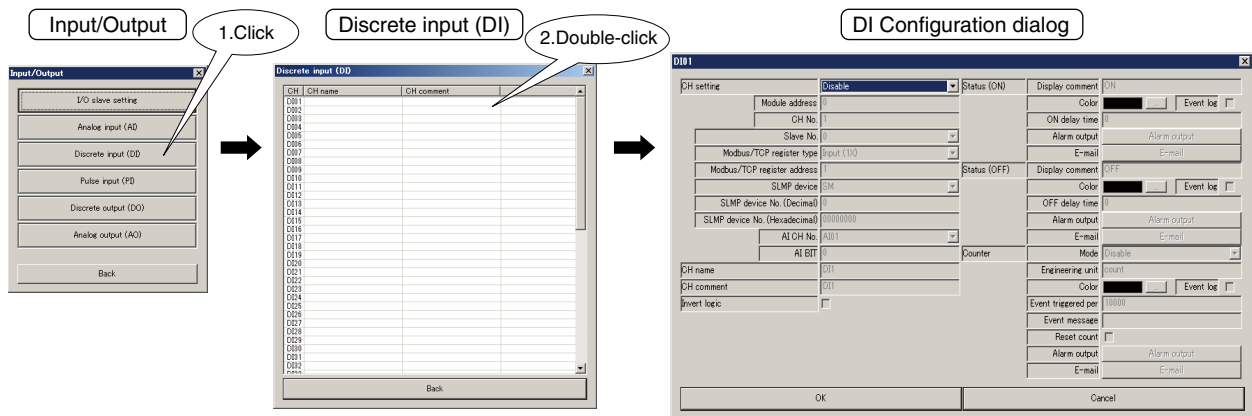

(3) Choose “Modbus/TCP” under “CH setting” and enter “Slave No.,” “Modbus/TCP register type,” and “Modbus/TCP register address.”

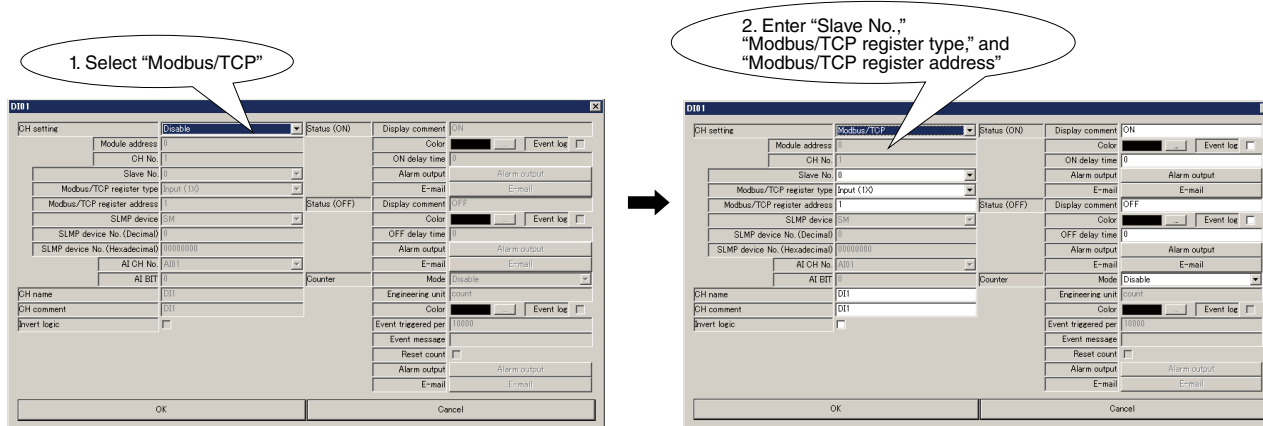

PARAMETER	DESCRIPTION
Slave No.	Enter slave No. (0 to 11) set in (1).
Modbus/TCP register type	Choose [Input (1X)] or [Coil (0X)].
Modbus/TCP register address	Set register address usable in the register type described above. Range: 1 to 65536

7.3.1.3 ASSIGNING SLMP DEVICES TO DI

(1) Refer to 6.2.2 ASSIGNING SLMP DEVICES TO DI to assign SLMP devices as slaves.

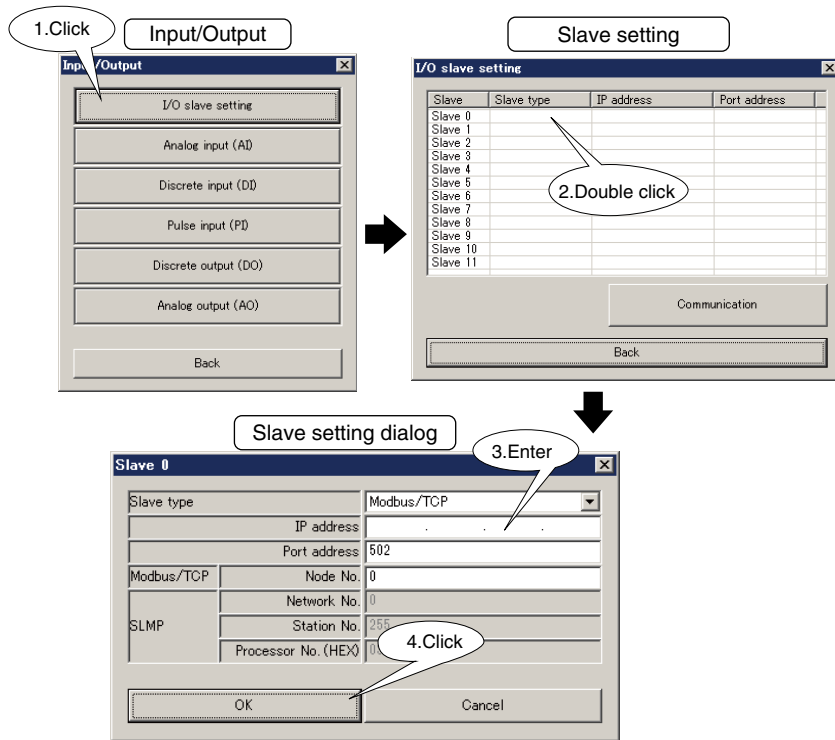

(2) Open “DI” Configuration dialog as explained in 7.3.1.2 ASSIGNING REMOTE I/O TO DI.

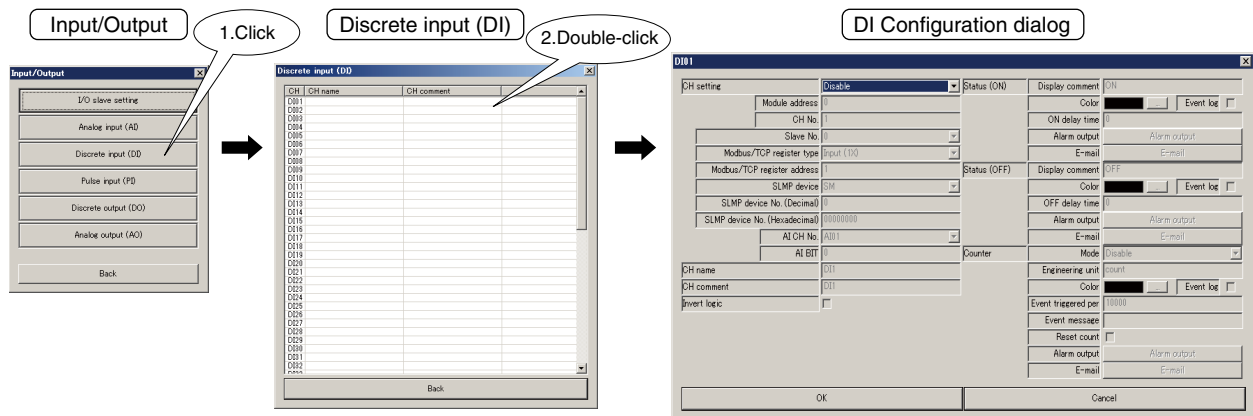

(3) Choose "SLMP" under "CH setting" and enter "Slave No.," "SLMP device," and "SLMP device No."

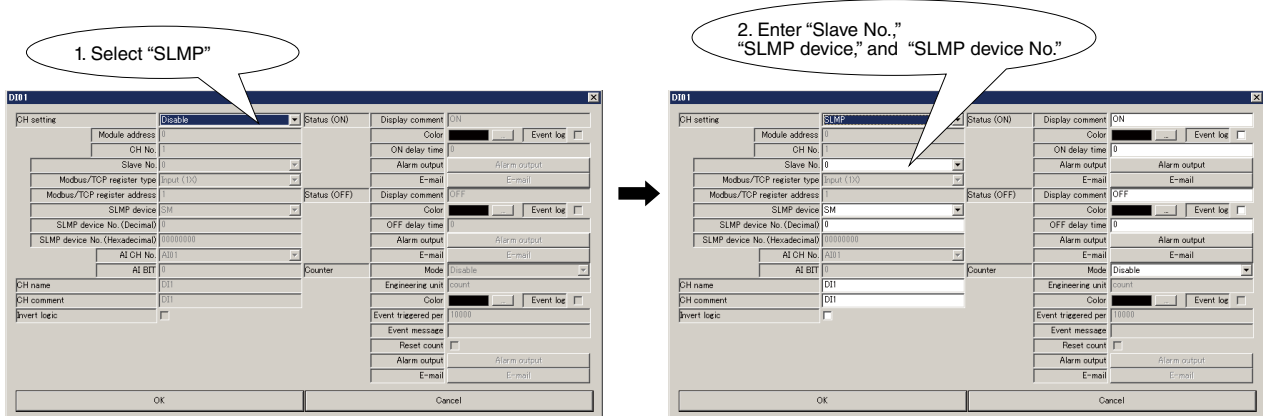

PARAMETER	DESCRIPTION
Slave No.	Enter slave No. (0 to 11) set in (1).
SLMP device	Choose the device from the pull-down list.
SLMP device No.	Set the device number for the SLMP device. The input field of either "SLMP device No. (Decimal)" or "SLMP device No. (Hexadecimal)" will be active depending on the selected SLMP device.

7.3.1.4 ANALOG INPUT (AI) ASSIGNED FOR DI

(1) Open “DI” configuration dialog.

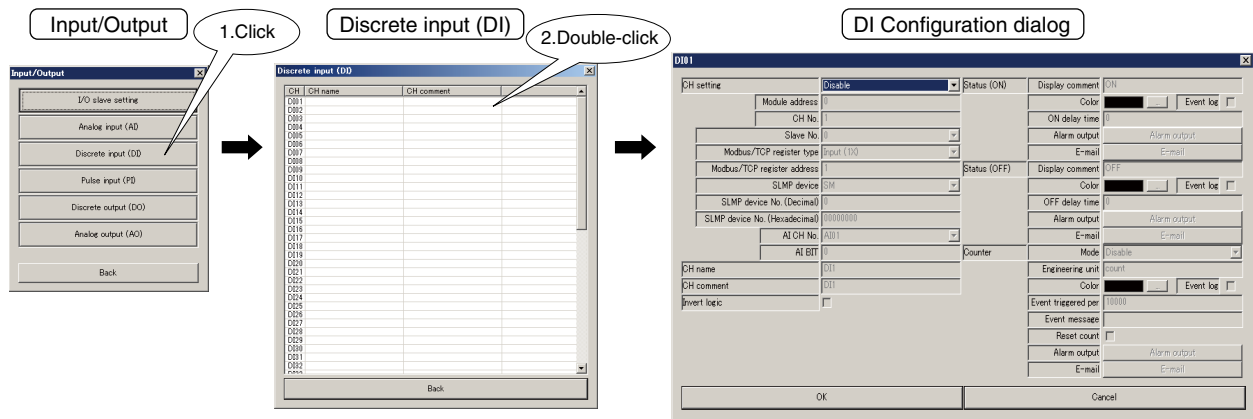

(2) Choose “AI” under “CH setting.” Enter the AI channel No. used for DI in “AI CH No.” and bit assignment (0 to 15) for ON status in “AI BIT” fields. Refer to 7.2 ANALOG INPUT (AI).

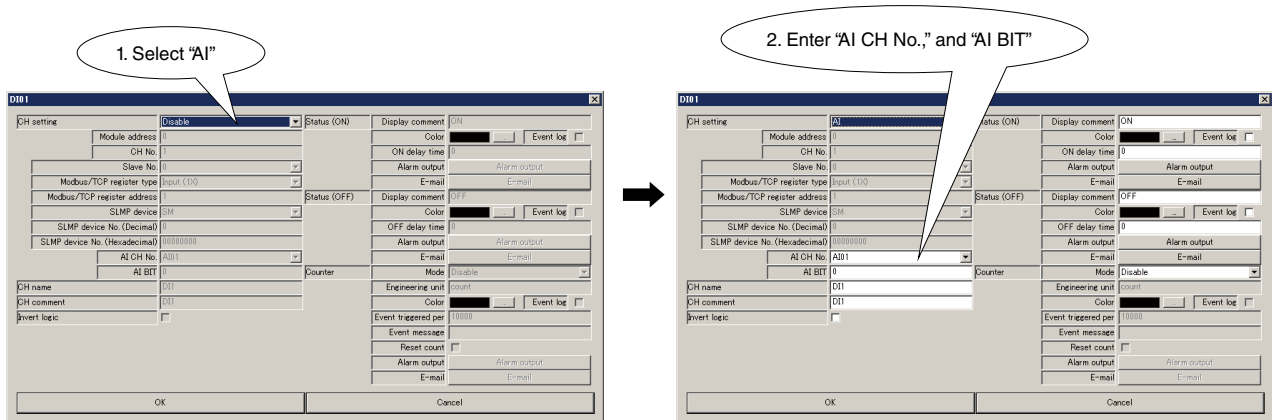

NOTE

• This function is not available when “CH setting” of selected AI channel is set to PI.

7.3.2 BASIC SETTING

After channel assignment, configure basic settings for each channel. Click [OK] to temporarily save the settings.

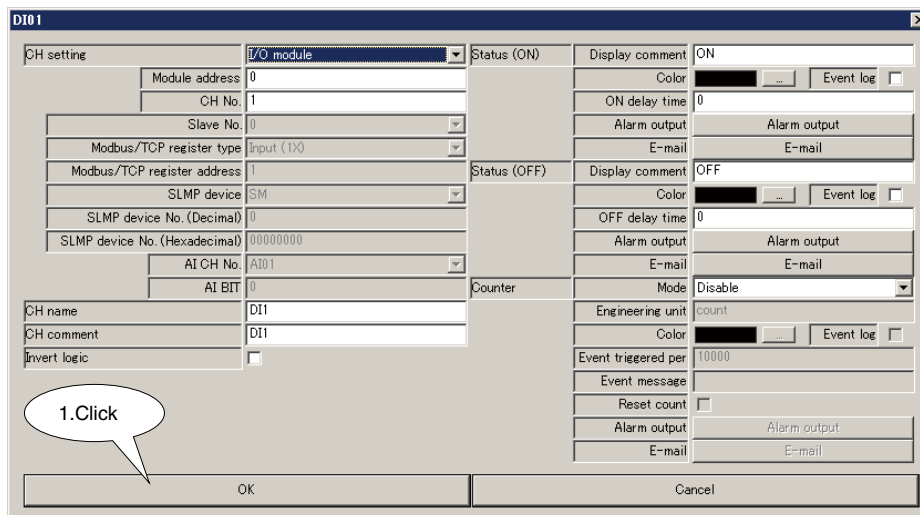

PARAMETER	DESCRIPTION
CH name	Enter the name for channel (max. 32 characters).
CH comment	Enter comment regarding channel and tag name (max. 64 characters).
Invert logic	ON/OFF of input signal and ON/OFF for application signal are reversed, put a check mark into check box.
Status (ON) (OFF)	<ul style="list-style-type: none"> • Display comment Set text strings corresponding to ON/OFF, respectively (max. 16 characters). • Color Set respective colors for ON and OFF to show the status on the web browser. • Event log Set whether or not to record in the event log view of web browser when the input state changes. To record put a check mark in the check box. • ON delay time, OFF delay time (Range: 0 to 999 sec.) Set delay time in second for ON/OFF respectively.
Counter	<ul style="list-style-type: none"> • Mode The DL8 has a function which realizes DI as slow pulse (detection interval: 1 sec.). Choose from below the mode for the function. Disable: DI is not used as counter ON: ON time of DI is accumulated in second OFF: OFF time of DI is accumulated in second UP: Numbers of rising edge of DI are accumulated DOWN: Numbers of falling edge of DI are accumulated • Engineering unit Set an engineering unit. It is available to set within 16 characters. • Color When counter value exceeds the event value, set the color displayed in the web browser. (continued to next page)
	<ul style="list-style-type: none"> • Event log When counter value reaches event value, Set whether or not to record in the event log view of web browser. To record put a check mark in the check box. • Event triggered per (XX counts) Set a count value that initiates an event, in numerical number (0 to 4294967295). • Event message Set a text string displayed in the event log view when the count reaches the event value (max. 64 characters). • Reset count The counter can be reset when the count value reaches the event value. To reset, put a check mark in the check box.

7.3.3 ALARM OUTPUT (TYPE B, C, D & E)

A specific DO can be turned on or off when the input status or counter value is true to the event value.

(1) Clicking [Alarm output] button in the “DI” configuration dialog opens the “Alarm output” list. Double click a DO channel to control ON/OFF operation.

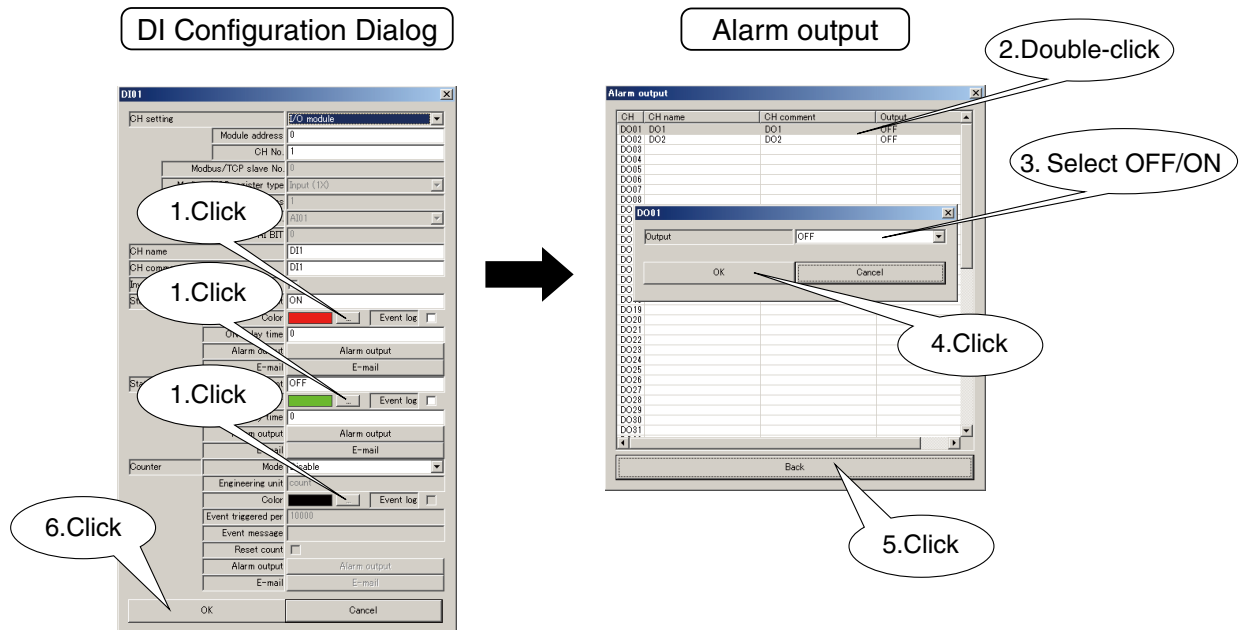

(2) Click [OK] button to temporarily save the setting.

NOTE

- This function is not available for Type A.
- DO setting must be finished in advance. (Refer to 7.5 DISCRETE OUTPUT (DO).)
- When alarm output turns on a DO, the ON status is maintained while input status is true.
- DO controlled by web server or Modbus/TCP server, is operated in OR logic against the alarm output.
- When alarm output is not used, set it to OFF.

7.3.4 COPYING CH CONFIGURATION

CH configuration of one channel can be copied to another. Refer to 7.2.5 COPYING CH CONFIGURATION.

7.4 PULSE INPUT (PI)

7.4.1 ASSIGNING I/O SIGNALS

A maximum of 32-point pulse inputs (PI1 to PI32) can be monitored. 32-bit integer data used for power monitoring signals and analog accumulation value for analog input (AI) are assigned to PI.

Assign 32-bit data inputs of remote I/Os connected to the DL8, following the procedure below.

7.4.1.1 ASSIGNING I/O MODULE TO PI

(1) Click [Pulse input (PI)] button in the “Input/Output” menu to open “Pulse Input (PI)” list.

Double-click a row of the PI channel to configure to open the PI configuration dialog.

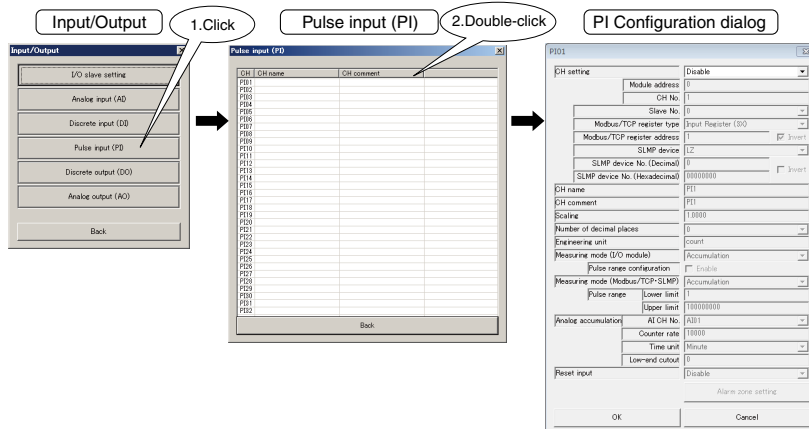

(2) Choose “I/O module” under “CH setting” and assign “Module address” and enter “CH No.” (Refer to 5. CONNECTING I/O MODULES.)

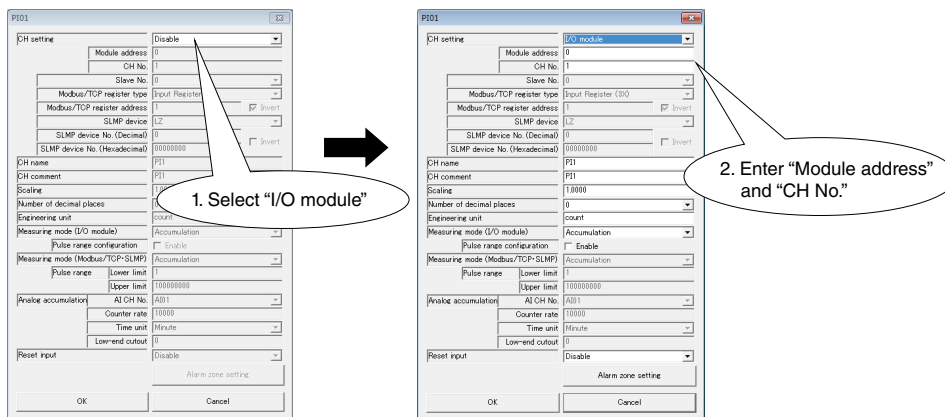

1 channel of pulse input is available per module. When a 4-channel module is installed, use 4 module addresses.

(N: module address assigned to the module)

MODULE TYPE	MODEL NUMBER	CH NO.	MODULE ADDRESS OF DL8	CH NO. OF DL8
4-channel module	R8-PA4	CH1	N	1
		CH2	N+1	1
		CH3	N+2	1
		CH4	N+3	1

NOTE

- For pulse input, only 32 bit data is available. It is not available for the products using 16 bit data (model: R3-PA16, etc.)

(3) Set parameters according to the table below.

PARAMETER	DESCRIPTION
Measuring mode (Module)	Set the type of 32-bit data read from I/O module. Choose from below. <ul style="list-style-type: none"> • Accumulation The difference from the time at start and time at reset is accumulated for every sampling. The mode corresponds to counter data of remote I/O. When pulse input module is used choose the mode. • Engineering unit value Signed 32-bit integer value is identified as sampling data as it is.
Pulse range configuration	If the pulse range configuration of the I/O module is changed, check [Enable], and put the same value set to the I/O module to the pulse range
Pulse range	If the pulse range configuration of the I/O module is changed, enable the "pulse range configuration" and set the same value set to the I/O module. If the different value is set, an error occurs for accumulated value when overflow occurs. Configurable when "measurement mode" is set to accumulation and "pulse range configuration" is enabled.

7.4.1.2 ASSIGNING REMOTE I/O TO PI

(1) Refer to 6.1.2 ASSIGNING REMOTE I/O to assign remote I/O slaves.

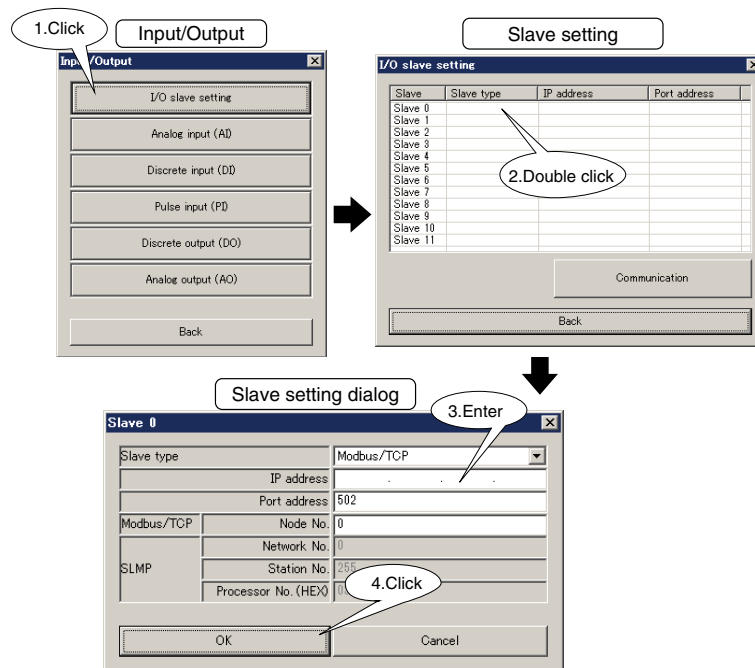

(2) Open "PI" configuration dialog.

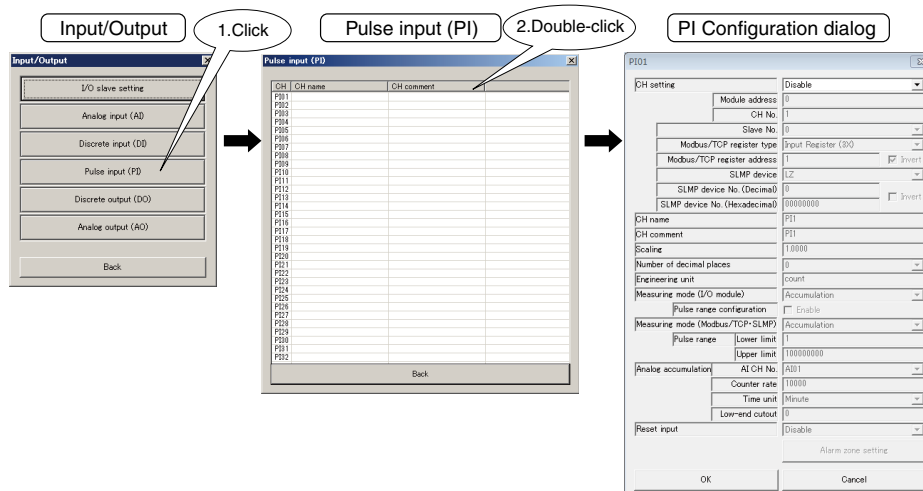

(3) Choose “Modbus/TCP” under “CH setting” and enter “Slave No.,” “Modbus/TCP register type,” and “Modbus/TCP register address.”

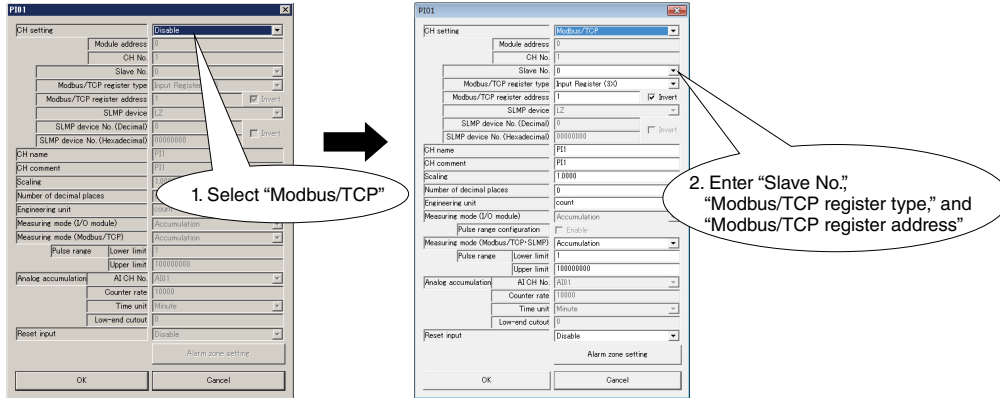

PARAMETER	DESCRIPTION
Slave No.	Enter slave No. (0 to 11) set in (1).
Modbus/TCP register type	Choose [Input Register (3X)] or [Holding Register (4X)].
Modbus/TCP register address	Set register address usable in the register type described above. Range: 1 to 65535 PI data takes 32 bits, handled as 2 consecutive-address data. Set the lower register address. Check or uncheck the [Invert] check box depending on the order of high/low registers. That is, when unchecked, the set register address is handled as upper data and the subsequent address is handled as lower data. Refer to the specification of each remote I/O for the register address allocation.
Invert	When upper and lower registers are not inverted, leave “Invert” check box blank. When our remote I/O is used, enter a check mark.

(4) Set parameters according to the table below.

PARAMETER	DESCRIPTION
Measuring mode (Modbus/TCP)	Set the type of 32-bit data read from remote I/O. Choose from below. <ul style="list-style-type: none"> • Accumulation The difference from the time at start and time at reset is accumulated for every sampling. This corresponds counter data of remote I/O. When pulse input module is used choose this. • Engineering unit value Signed 32-bit integer value of data such as power data of remote I/O is identified and used as sampling data as it is. • Floating point Floating point value (single precision floating type) is identified and used as sampling data as it is. (display range: ±10,000,000,000.000) • Pulse range Set the same pulse range which is set at remote I/O. For detailed information, refer to the manuals for respective remote I/Os.

7.4.1.3 ASSIGNING SLMP DEVICES TO PI

(1) Refer to 6.2.2 ASSIGNING SLMP DEVICES to assign SLMP devices as slaves.

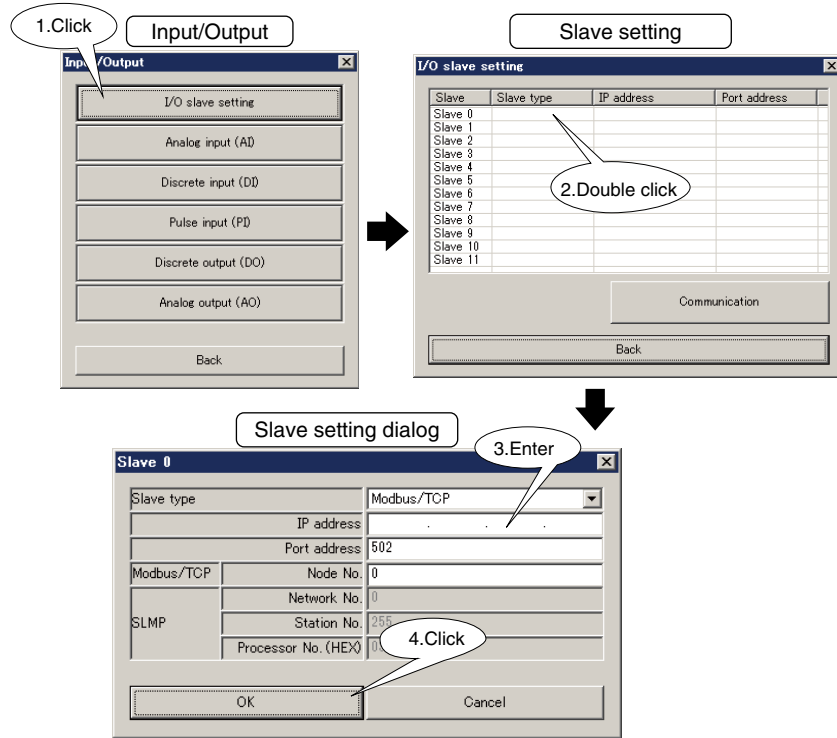

(2) Open “PI” Configuration dialog as explained in 7.4.1.2 ASSIGNING REMOTE I/O TO PI.

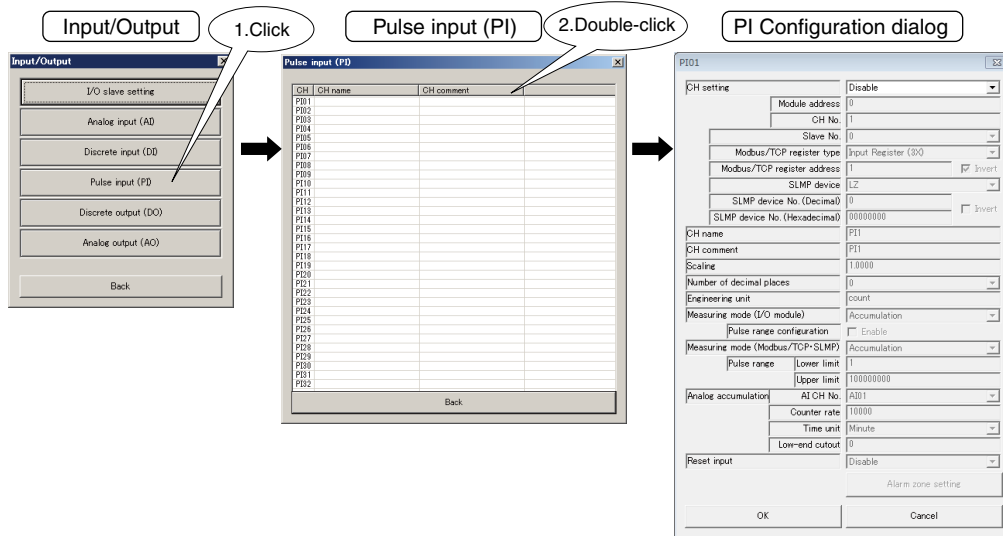

(3) Choose "SLMP" under "CH setting" and enter "Slave No.," "SLMP device," and "SLMP device No."

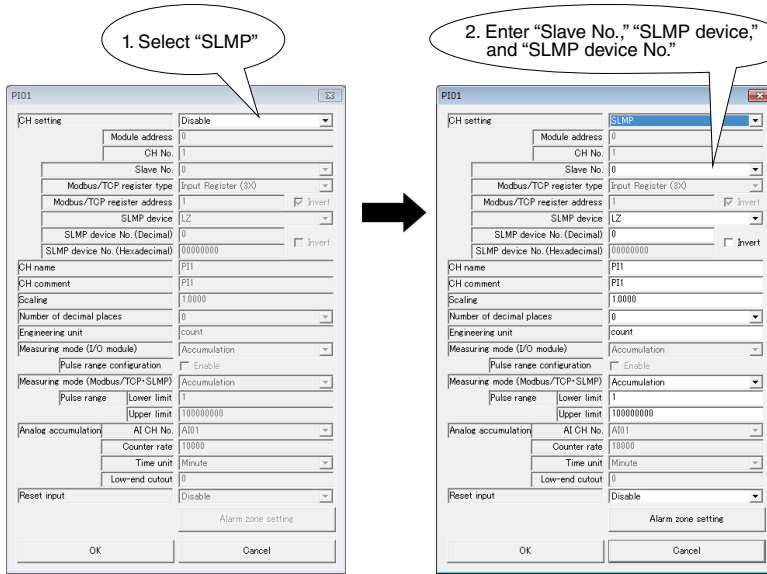

PARAMETER	DESCRIPTION
Slave No.	Enter slave No. (0 to 11) set in (1).
SLMP device	Choose the device from the pull-down list.
SLMP device No.	Set the device number for the SLMP device. The input field of either "SLMP device No. (Decimal)" or "SLMP device No. (Hexadecimal)" will be active depending on the selected SLMP device.
Invert	When upper and lower registers are not inverted, leave "Invert" check box blank.

(4) Set parameters according to the table below.

PARAMETER	DESCRIPTION
Measuring mode (SLMP)	<p>Set the type of 32-bit data read from SLMP devices. Choose from below.</p> <ul style="list-style-type: none"> • Accumulation The difference from the time at start and time at reset is accumulated for every sampling. This corresponds counter data of SLMP devices. When pulse input module is used choose this. • Engineering unit value Signed 32-bit integer value of data such as power data from SLMP devices is identified and used as sampling data as it is. • Floating point Floating point value (single precision floating type) is identified and used as sampling data as it is. (display range: $\pm 10,000,000,000.000$) • Pulse range Set the same pulse range which is set at SLMP device. For detailed information, refer to the manuals for respective SLMP devices.

7.4.1.4 ASSIGNING ANALOG ACCUMULATION TO PI

(1) Open “PI” configuration dialog.

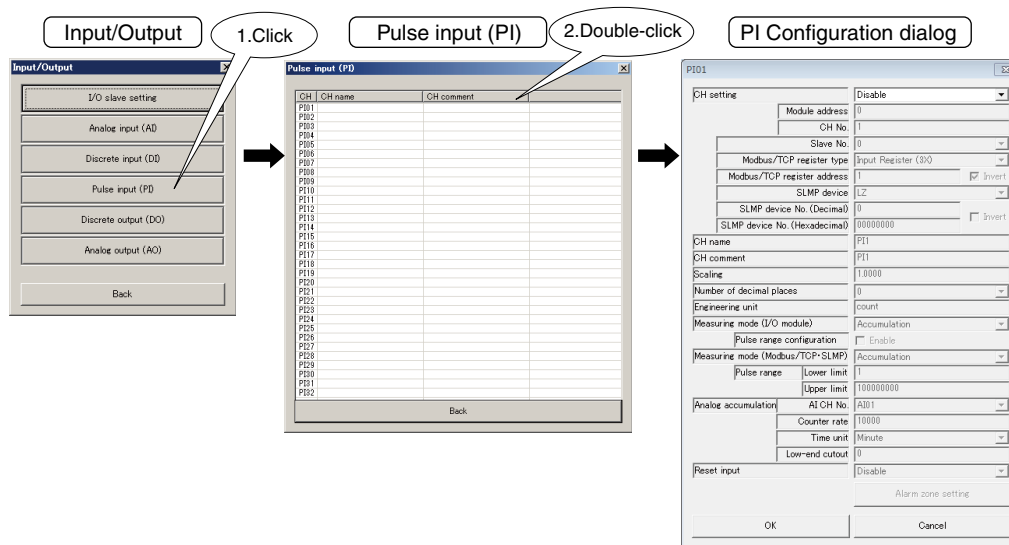

(2) Set “CH setting” to “Analog accumulation.”

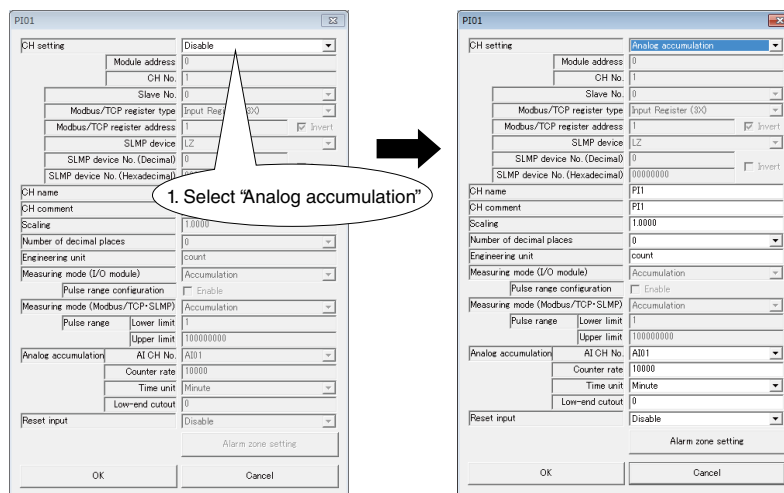

(3) Set parameters according to the table below.

PARAMETER	DESCRIPTION
Analog accumulation	<ul style="list-style-type: none"> • AI CH No. Select AI CH to use for accumulation. Choose among AI1 to AI32. • Counter rate Set the number of counts you need the module counts with continuous 100% status for the time unit. • Time unit Choose among Minute / Hour / Day. • Low-end cutout The lower limit value for AI sampling data (-2000 to 12000)

Analog Accumulation

Analog input is treated as pulse input.

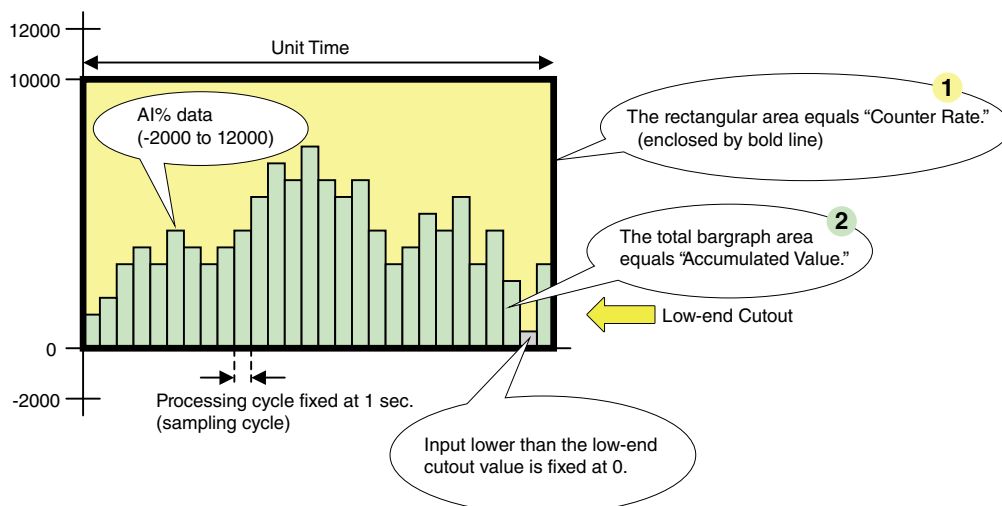

When the AI% data remains at 100% (10000) for the unit time period, it is converted to a preset number of pulses called "Counter Rate." The rectangular area in the above graphs corresponds to the Counter Rate. **1**

Actual AI% value (0 to 10000) is accumulated and converted as "Accumulated Value" into the number of pulses using the Counter Rate. The total graph area in the above graphs corresponds to the Accumulated Value. **2**

The Accumulated Value is treated just like other pulse inputs, multiplied by "Scaling" into an engineering unit value.

[Example]

Flow value is sent as a voltage signal. 1 V corresponds to 0 t/h, while 5 V corresponds to 30 t/h.

In order to use analog accumulation, choose "%" as "Data Type": 1 V at 0%, 5 V at 100%.

Choose "Hour" as "Time Unit" for the engineering unit t/h.

If "Counter Rate" is set to "30" an accumulated value of 30 is given when AI remains at 100% (5 V) for 1 hour.

7.4.2 BASIC SETTING

After channel assignment, configure basic settings for each channel. Click [OK] to temporarily save the settings.

The screenshot shows a dialog box titled "PI01" with the following fields and values:

- I/O module:** (Dropdown menu)
- Module address:** 0
- CH No.:** 1
- Slave No.:** 0
- Modbus/TCP register type:** Input Register (32)
- Modbus/TCP register address:** 1 Invert
- SLMP device:** LZ
- SLMP device No. (Decimal):** 0 Invert
- SLMP device No. (Hexadecimal):** 00000000
- CH name:** PI1
- CH comment:** PI1
- Scaling:** 1.0000
- Number of decimal places:** 0
- Engineering unit:** count
- Measuring mode (I/O module):** Accumulation
- Pulse range configuration:** Enable
- Measuring mode (Modbus/TCP·SLMP):** Accumulation
- Pulse range:** 1
- Lower limit:** 100000000
- Upper limit:** 100000000
- Analog accumulation:** AI CH No. AI01
- Counter rate:** 10000
- Time unit:** Minute
- Low-end cutout:** 0
- Reset input:** Disable
- Alarm zone setting:** (Button)
- OK** (Button)
- Cancel** (Button)

PARAMETER	DESCRIPTION
CH name	Enter the name for channel (max. 32 characters).
CH comment	Enter comment regarding channel and tag name (max. 64 characters).
Scaling	Set weight per one pulse in a numerical number. (-10,000,000,000 to 10,000,000,000)
Number of decimal places	Set the number of decimal places of the value displayed on the web browser. Selectable within 0 to 3.
Engineering unit	Set the engineering unit of the engineering unit value set in Scaling. (max. 16 characters)
Reset input	The counter can be reset at the timing of rising edge of a discrete input (DI). When this function is not used, set it to [Disable]. To enable the function, select a DI from the pull-down list.

7.4.3 ALARM ZONE SETTING

Input range can be divided into max. 5 zones, and deadband can be set between zones.

(1) Click [Alarm zone setting] button in the “PI” configuration dialog to open “Alarm zone setting (PI)” dialog.

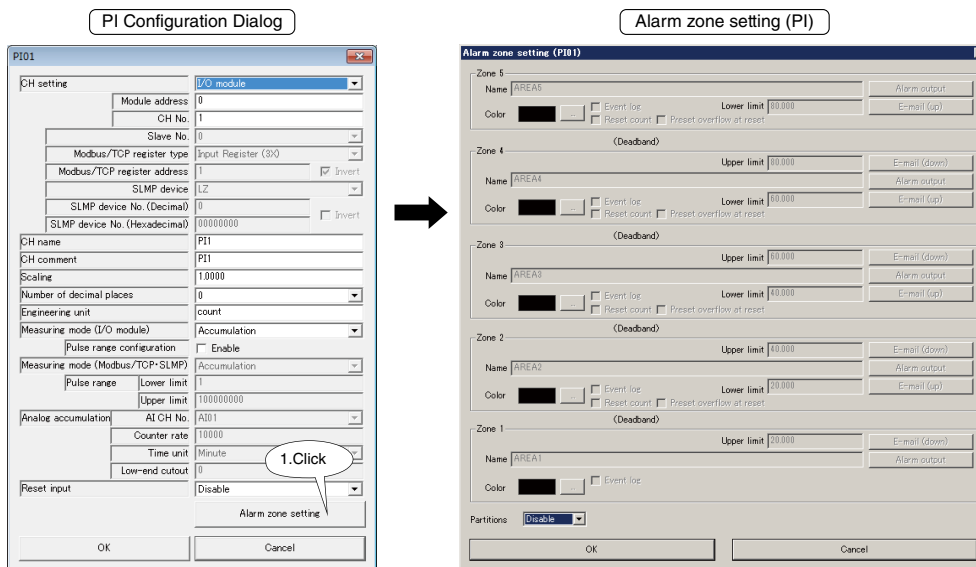

(2) Set parameters according to the table below.

PARAMETER	DESCRIPTION
Partitions	Select the number of zones to use. Selectable from: None / 2 / 3 / 4 / 5.
Name	Input zone name (max. 64 characters).
Color	Set a color to identify the zone on the web browser.
Upper limit Lower limit	<p>The boundary of each zone is defined by upper limit, lower limit, specified in engineering unit value. Set such that the upper limit > lower limit.</p> <ul style="list-style-type: none"> Setting deadband When deadband is required between zone 1 and zone 2, set apart the upper limit value of zone 1 from the lower limit value of zone 2 so that the gap in between is defined as deadband. For other zones, choose limit values in the same manner. No deadbands When deadband is not required between zone 1 and zone 2, set the upper limit value of zone 1 to the same value as the lower limit value of zone 2. For other zones, choose limit values in the same manner.
Event log	The signal entering a zone can be recorded as an event in the event log on the web browser. Check the box to enable the event log.
Reset count	Count value can be reset when it enters a zone. Check the box to enable the resetting.
Preset overflow at reset	<p>Set whether to preset the pulse count as an offset for when the count is reset. Check the box to enable [Preset overflow at reset].</p> <p>Note that this function is invalid when analog accumulation value for analog input (AI) are assigned to PI.</p> <ul style="list-style-type: none"> Positive scaling The difference between the pulse count when the value has entered a zone and the pulse count of the lower limit value of the zone is added as an offset. However, no offset is added when the difference is larger than the pulse count of the lower limit value. Negative scaling The difference between the pulse count when the value has entered a zone and the pulse count of the upper limit value of the zone is added as an offset. However, no offset is added when the difference is larger than the pulse count of the upper limit value. <p>Note that this function is invalid even if it is checked for a zone with the largest upper limit value while [Reset count] remains valid for the zone.</p>

(3) After configuration is completed, click [OK] to temporarily save the settings.

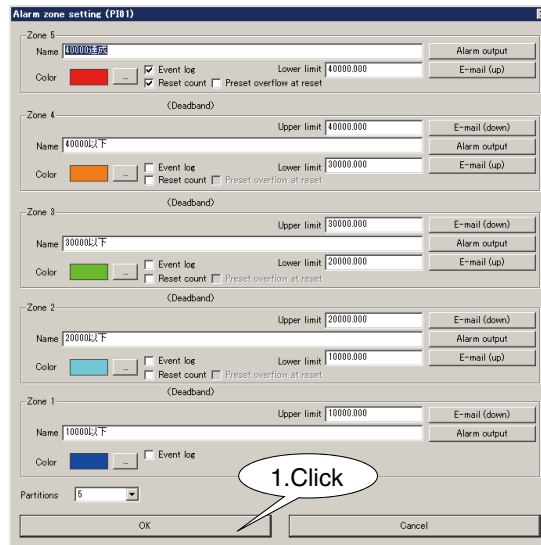

7.4.4 ALARM OUTPUT (TYPE B, C, D & E)

A specific DO can be turned on or off when the input signal enters a signal zone.

- (1) Click [Alarm zone setting] button in “PI” configuration dialog to open “Alarm zone setting (PI)” dialog.
Clicking [Alarm output] button for specified zone opens the “Alarm output” list.
Double click a DO channel to set ON/OFF operation.

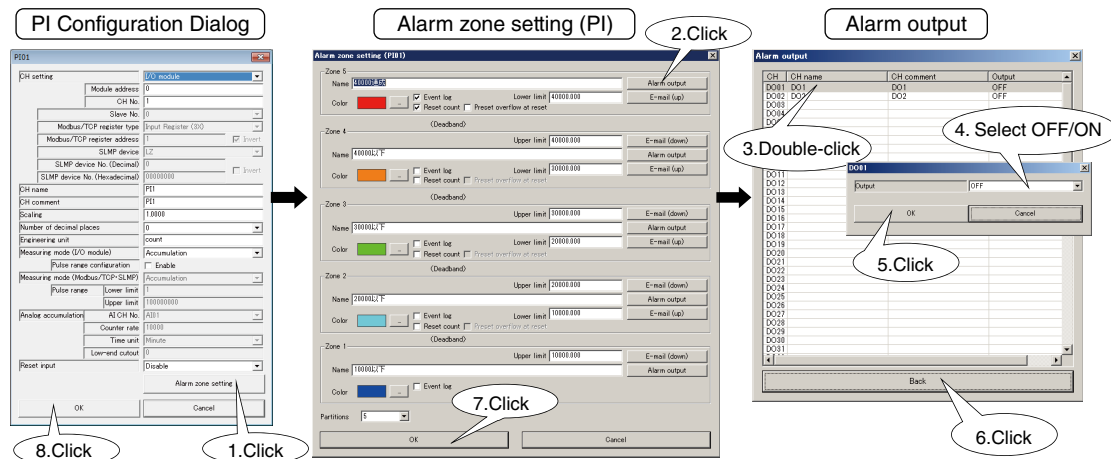

(2) Click [OK] button to temporarily save the setting.

NOTE

- This function is not available for Type A.
- DO setting must be finished in advance. (Refer to 7.5 DISCRETE OUTPUT (DO).)
- When alarm output turns on a DO, the ON status is maintained while input value is in the zone.
- DO controlled by web server or Modbus/TCP server, is operated in OR logic against the alarm output.
- When alarm output is not used, set it to OFF.

7.4.5 COPYING CH CONFIGURATION

CH configuration of one channel can be copied to another. Refer to 7.2.5 COPYING CH CONFIGURATION.

7.4.6 RESETTING COUNTER IN A REGULAR INTERVAL

This function is added to the DL8 Ver. 1.5.x or later.

AI "Time" input is used to reset PI counters in a regular interval so that pulse counts for a fixed period can be logged continuously.

Refer to the following setting examples to reset PI by AI with fixed cycle.

■ Logging pulse counts for every minute, resetting at 0 second

SETTING DIALOG	PARAMETER	DESCRIPTION
AI1	CH setting	Time
	Time input	Second
	Alarm zone setting	Partitions : 2 Zone 1 upper limit = Zone2 = 10 PI Reset : Reset PI1 in Zone 1
PI1	Assign the relevant pulse input channel.	

■ Logging pulse counts for every hour, resetting at 0 minute

SETTING DIALOG	PARAMETER	DESCRIPTION
AI1	CH setting	Time
	Time input	Minute
	Alarm zone setting	Partitions : 2 Zone 1 upper limit = Zone 2 lower limit = 10 PI Reset : Reset PI1 in Zone 1
PI1	Assign the relevant pulse input channel.	

■ Logging pulse counts for every day, resetting at 0 hour

SETTING DIALOG	PARAMETER	DESCRIPTION
AI1	CH setting	Time
	Time input	Hour
	Alarm zone setting	Partitions : 2 Zone 1 upper limit = Zone 2 lower limit = 2 PI Reset : Reset PI1 in Zone 1
PI1	Assign the relevant pulse input channel.	

NOTE

- Refer to 11. LOGGING FUNCTION (TYPE C, D & E) for detailed data logging setting.

7.5 DISCRETE OUTPUT (DO)

7.5.1 ASSIGNING I/O SIGNALS

A maximum of 64-point discrete outputs (DO1 to DO64) can be used.

Assign discrete outputs of I/O modules and/or remote I/Os connected to the DL8, following the procedure below.

7.5.1.1 ASSIGNING I/O MODULE TO DO

(1) Click [Discrete output (DO)] button in “Input/Output” menu to open “Discrete output (DO)” list.

Double-click a row of the DO channel to configure to open the DO configuration dialog.

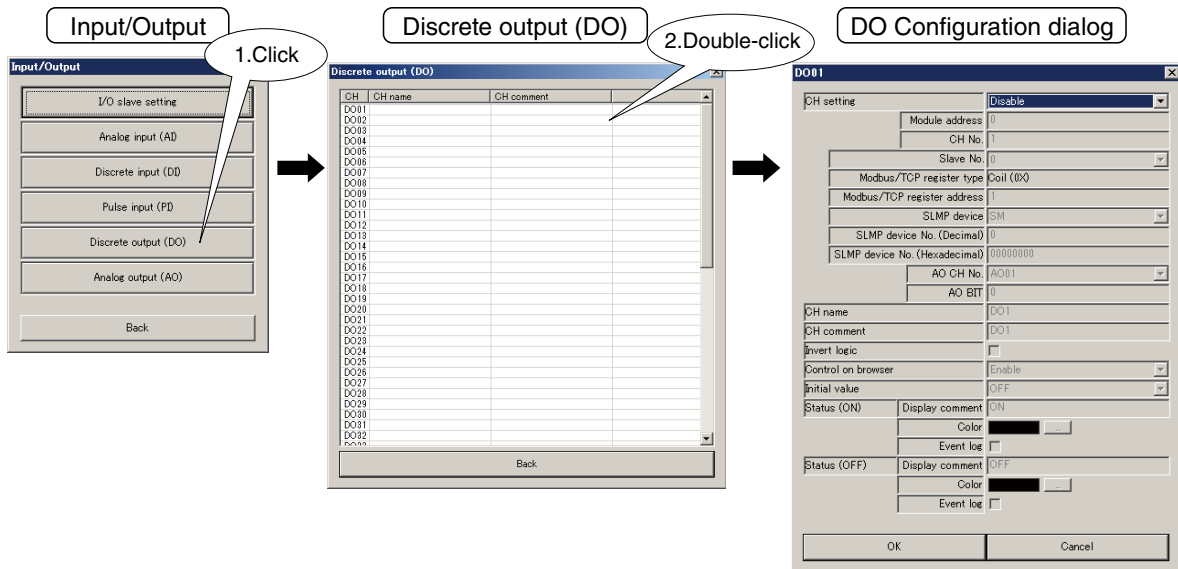

(2) Choose “I/O module” under “CH setting” to assign “Module address” and enter “CH No.” (Refer to 5. CONNECTING I/O MODULES.)

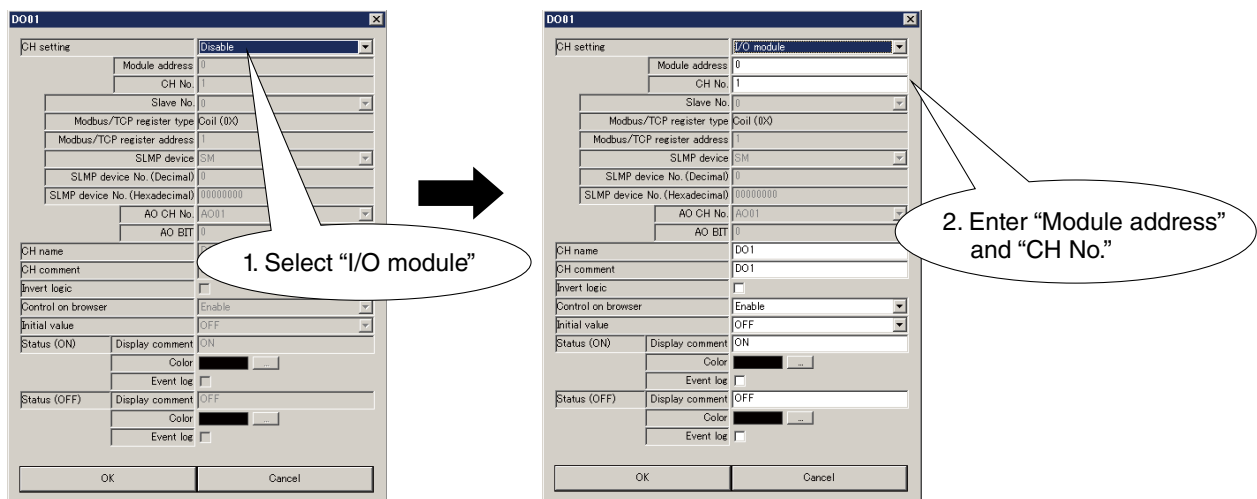

Max. 16 channels per module can be assigned for discrete output. (N: module address assigned to the module)

MODULE TYPE	MODEL NUMBER	CH NO.	MODULE ADDRESS OF DL8	CH NO. IN DL8
4-channel module	R8-DC4A	CH1	N	1
	R8-DC4A2	CH2	N	2
	R8-DC4C	CH3	N	3
	R8-DCT4D	CH4	N	4
8-channel module	R8-DCT8A2 R8-DCT8B2	CH1	N	1
		CH2	N	2
		CH3	N	3
		CH4	N	4
		CH5	N	5
		CH6	N	6
		CH7	N	7
		CH8	N	8
16-channel module	R8-DCM16A R8-DCM16ALZ R8-DCM16ALK R8-DCM16ALH R8-DCT16A2	CH1	N	1
		CH2	N	2
		CH3	N	3
		CH4	N	4
		CH5	N	5
		CH6	N	6
		CH7	N	7
		CH8	N	8
		CH9	N	9
		CH10	N	10
		CH11	N	11
		CH12	N	12
		CH13	N	13
		CH14	N	14
		CH15	N	15
		CH16	N	16

32-channel module	R8-DCM32B2	CH1	N	1
		CH2	N	2
		CH3	N	3
		CH4	N	4
		CH5	N	5
		CH6	N	6
		CH7	N	7
		CH8	N	8
		CH9	N	9
		CH10	N	10
		CH11	N	11
		CH12	N	12
		CH13	N	13
		CH14	N	14
		CH15	N	15
		CH16	N	16
		CH17	N+1	1
		CH18	N+1	2
		CH19	N+1	3
		CH20	N+1	4
		CH21	N+1	5
		CH22	N+1	6
		CH23	N+1	7
		CH24	N+1	8
		CH25	N+1	9
		CH26	N+1	10
		CH27	N+1	11
		CH28	N+1	12
		CH29	N+1	13
		CH30	N+1	14
		CH31	N+1	15
		CH32	N+1	16

7.5.1.2 ASSIGNING REMOTE I/O TO DO

(1) Refer to 6.1.2 ASSIGNING REMOTE I/O to assign remote I/O slaves.

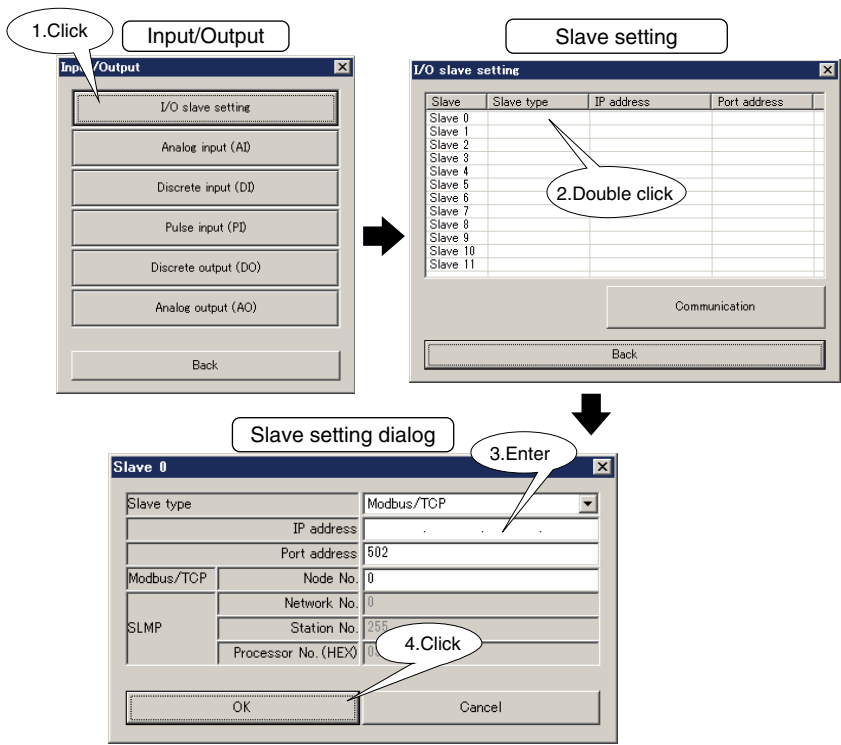

(2) Open "DO" configuration dialog.

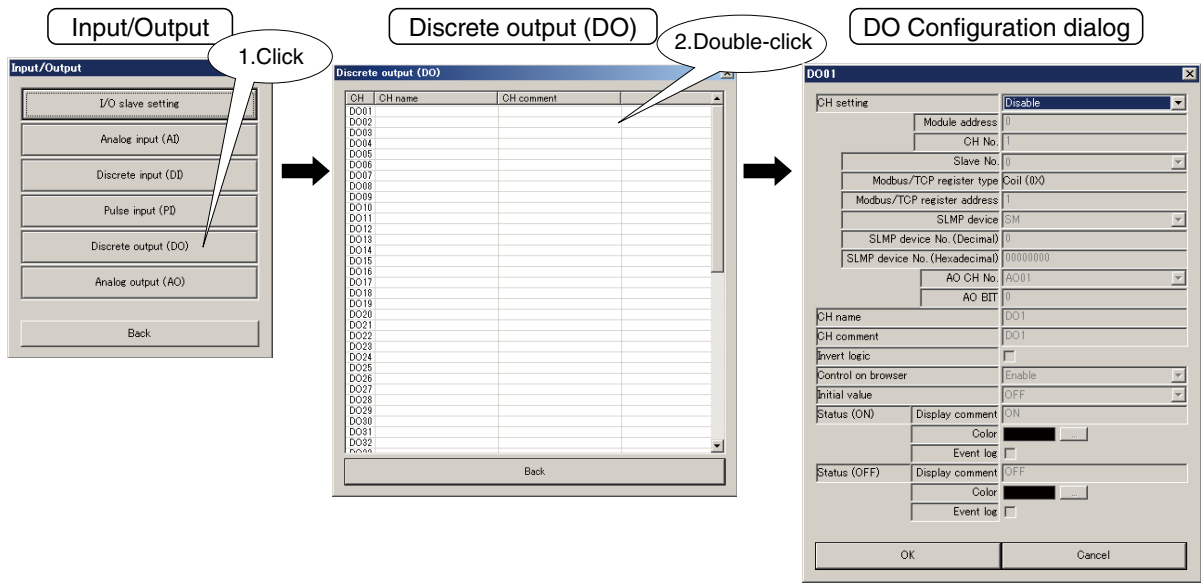

(3) Choose “Modbus/TCP” under “CH setting” and enter “Slave No.,” “Modbus/TCP register type,” and “Modbus/TCP register address.”

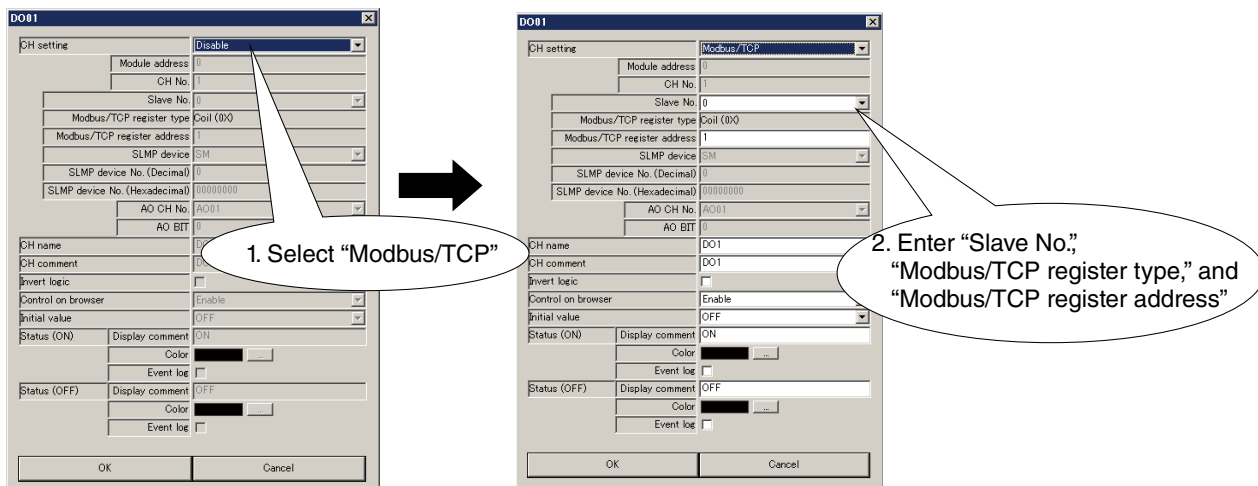

PARAMETER	DESCRIPTION
Slave No.	Enter slave No. (0 to 11) set in (1).
Modbus/TCP register type	Fixed at [Coil (0X)].
Modbus/TCP register address	Set register address usable in the register type described above. Range: 1 to 65536

7.5.1.3 ASSIGNING SLMP DEVICES TO DO

(1) Refer to 6.2.2 ASSIGNING SLMP DEVICES to assign SLMP devices as slaves.

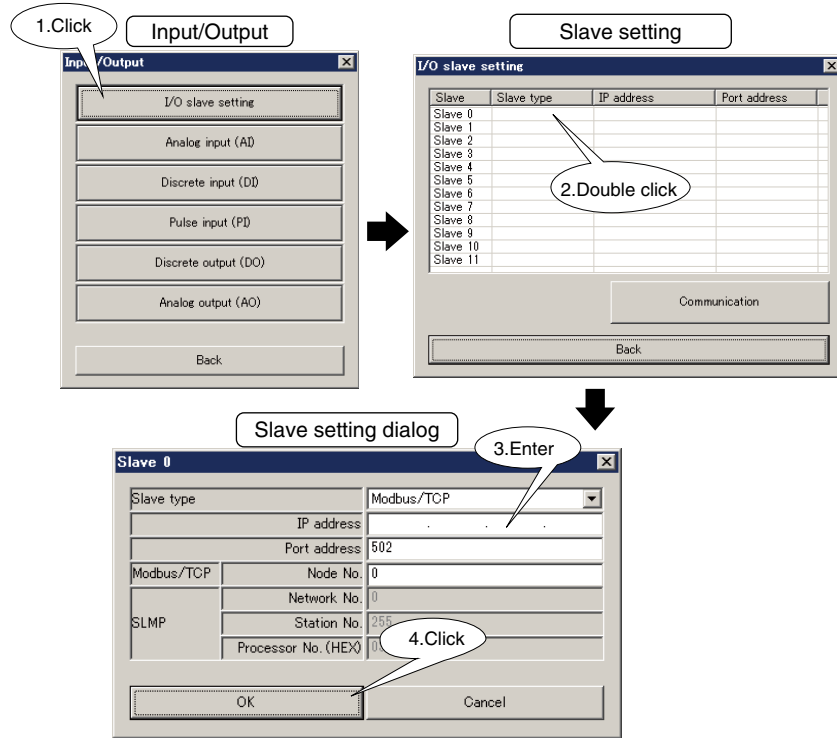

(2) Open "DO" Configuration dialog as explained in 7.5.1.2 ASSIGNING REMOTE I/O TO DO.

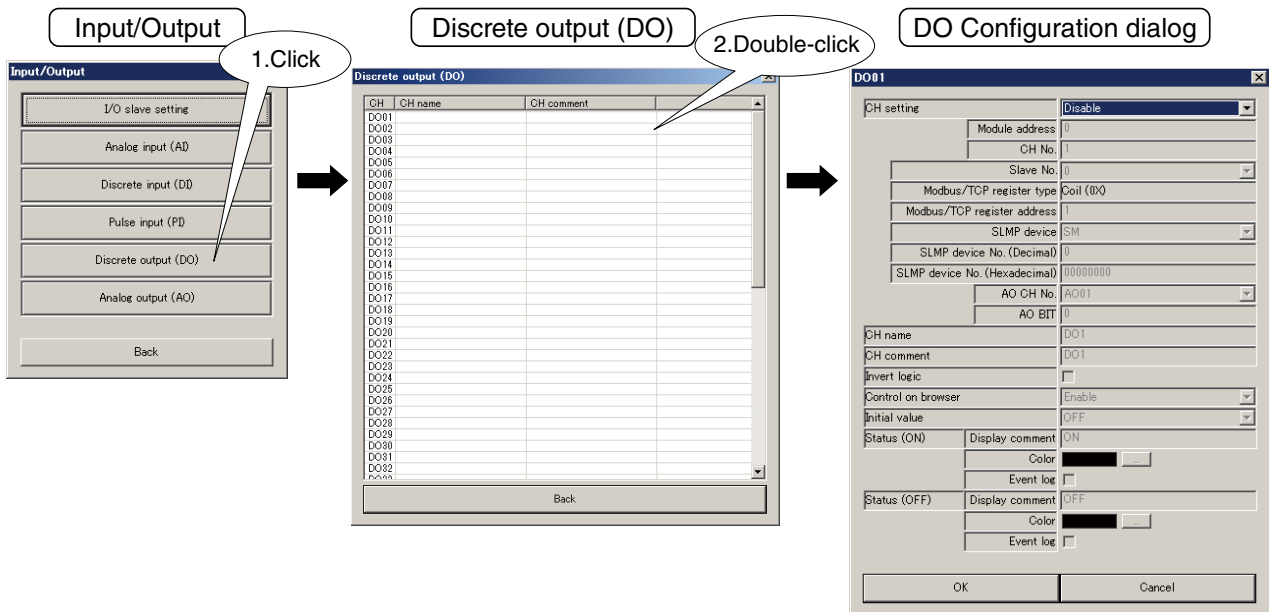

(3) Choose "SLMP" under "CH setting" and enter "Slave No.," "SLMP device," and "SLMP device No."

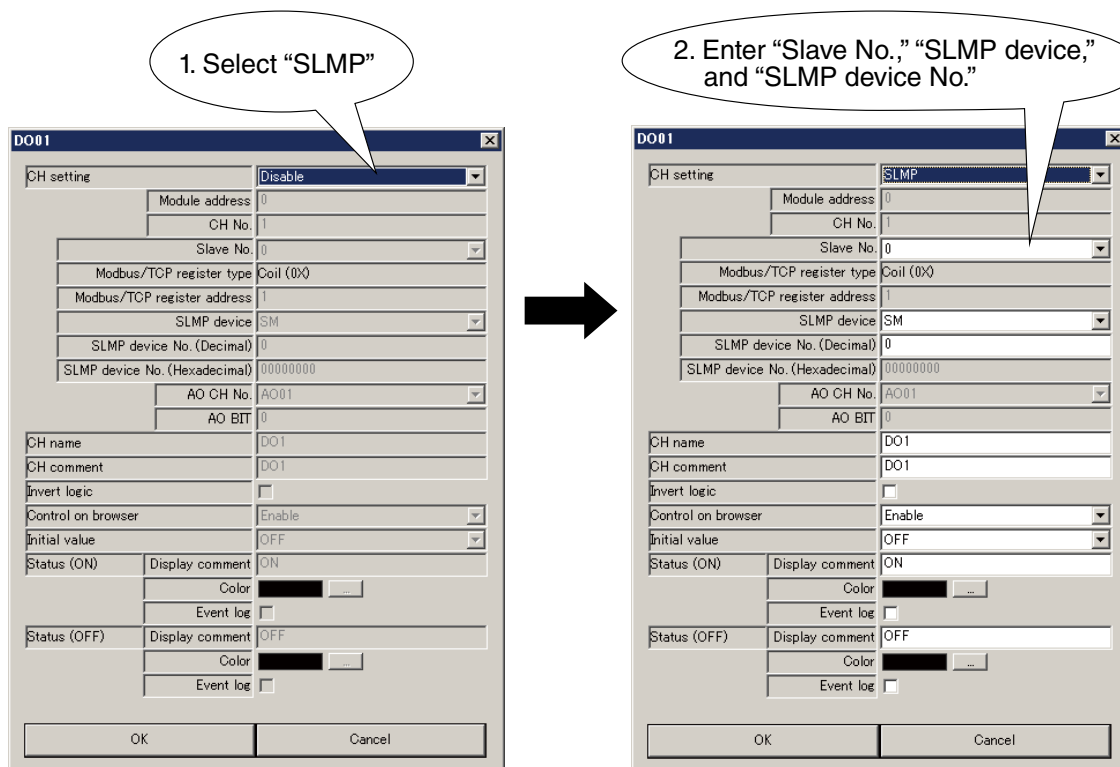

PARAMETER	DESCRIPTION
Slave No.	Enter slave No. (0 to 11) set in (1).
SLMP device	Choose the device from the pull-down list.
SLMP device No.	Set the device number for the SLMP device. The input field of either "SLMP device No. (Decimal)" or "SLMP device No. (Hexadecimal)" will be active depending on the selected SLMP device.

7.5.1.4 ASSIGNING ANALOG OUTPUT TO DO

(1) Open “DO” configuration dialog.

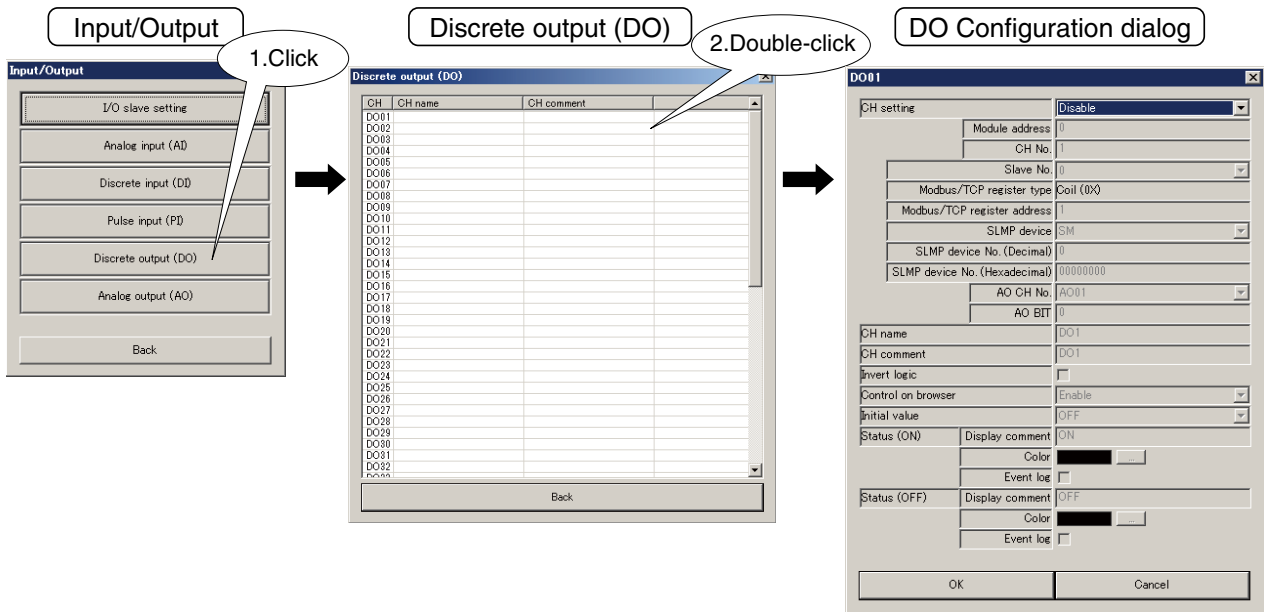

(2) Set “CH setting” to “AO.” Enter AO channel No. to be assigned in “AO CH No.” and AO bit assignment in “AO BIT” (0 to 15) to be identified as ON status. Refer to 7.6 ANALOG OUTPUT (AO).

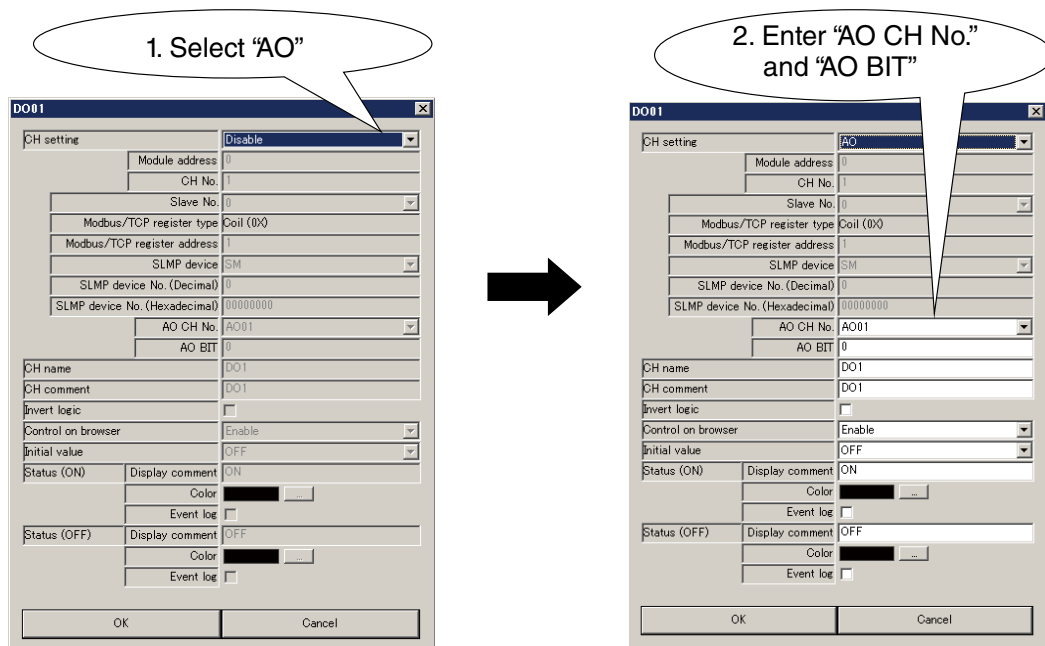

7.5.2 BASIC SETTING

After channel assignment, configure basic settings for each channel. Click [OK] to temporarily save the settings.

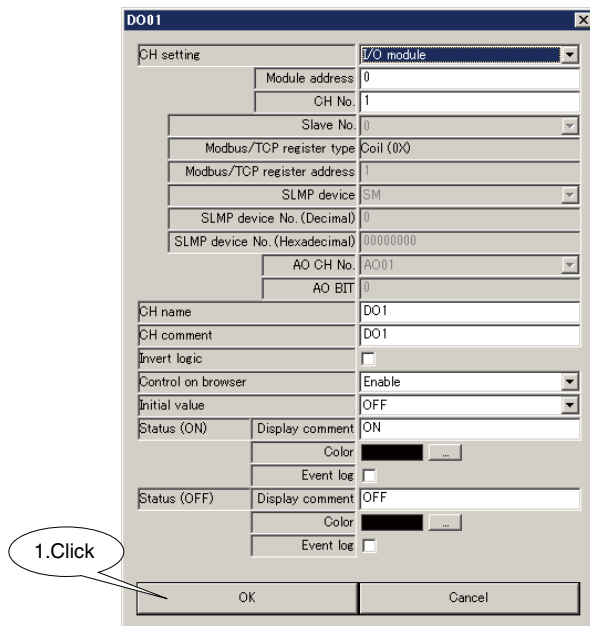

PARAMETER	DESCRIPTION
CH name	Enter the name for channel (max. 32 characters).
CH comment	Enter comment regarding channel and tag name (max. 64 characters).
Invert logic	When ON/OFF of output signal and ON/OFF for application signal are reversed, put a check mark into check box.
Control on browser	Enable or disable controlling of individual DO channel on the browser view.
Initial value	Set the initial output value used when 'cold start' mode is specified. (Refer to 7.7 START MODE.)
Status (ON) (OFF)	<ul style="list-style-type: none"> • Display comment Set text strings corresponding to ON/OFF, respectively (max. 16 characters). • Color Set respective colors for ON and OFF to show the status on the web browser. • Event log Set whether or not to record in the event log view of web browser when the input state changes. To record put a check mark in the check box.

7.5.3 COPYING CH CONFIGURATION

CH configuration of one channel can be copied to another. Refer to 7.2.5 COPYING CH CONFIGURATION.

7.5.4 OUTPUT LOGIC

DO is operated by control output, alarm output or I/O mapping output.

I/O mapping assignment prevails other DO assignment (Type: D & E). A channel that I/O mapping combination is not assigned is operated in OR logic among the control output and the alarm output.

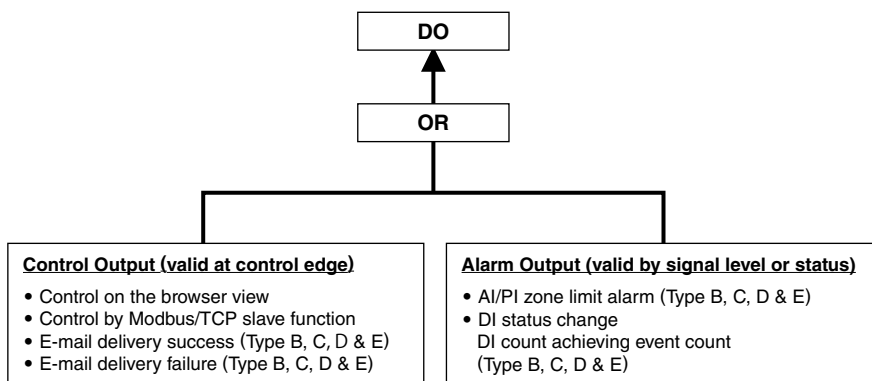

7.6 ANALOG OUTPUT (AO)

7.6.1 ASSIGNING I/O SIGNALS

A maximum of 32-point analog outputs (AO1 to AO32) can be used.

Assign analog outputs of I/O modules and/or remote I/Os connected to the DL8, following the procedure below.

7.6.1.1 ASSIGNING I/O MODULE TO AO

(1) Click [Analog output (AO)] button in “Input/Output” menu to open “Analog output (AO)” list.

Double-click a row of the AO channel to configure to open the AO configuration dialog.

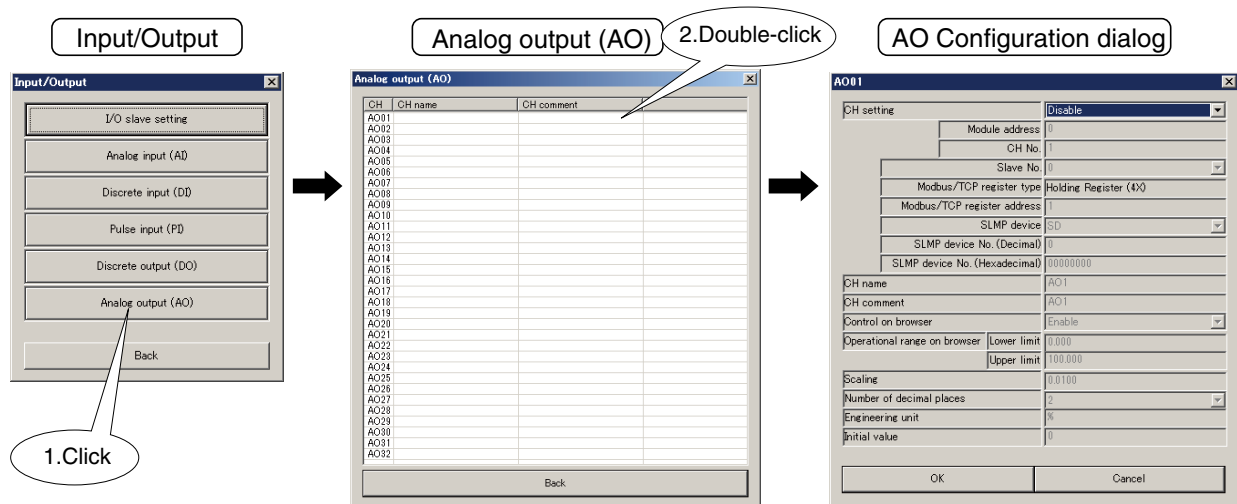

(2) Choose “I/O module” under “CH setting” to assign “Module address” and enter “CH No.” (Refer to 5. CONNECTING I/O MODULES.)

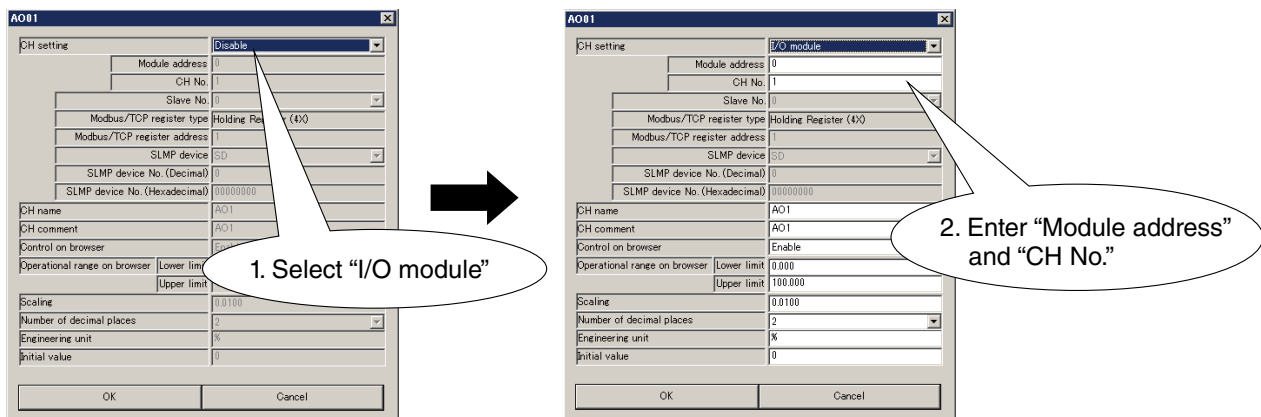

2 channels of analog output are available per module. When a 4-channel module is installed, use 2 module addresses. (N: module address assigned to the module)

MODULE TYPE	MODEL NUMBER	CH NO.	MODULE ADDRESS OF DL8	CH NO. FOR DL8
2-channel module	R8-YS2	CH1	N	1
	R8-YS2NJ	CH2	N	2
4-channel module	R8-YV4N R8-PC4A R8-YST4N	CH1	N	1
		CH2	N	2
		CH3	N+1	1
		CH4	N+1	2

7.6.1.2 ASSIGNING REMOTE I/O TO AO

(1) Refer to 6.1.2 ASSIGNING REMOTE I/O to assign remote I/O slaves.

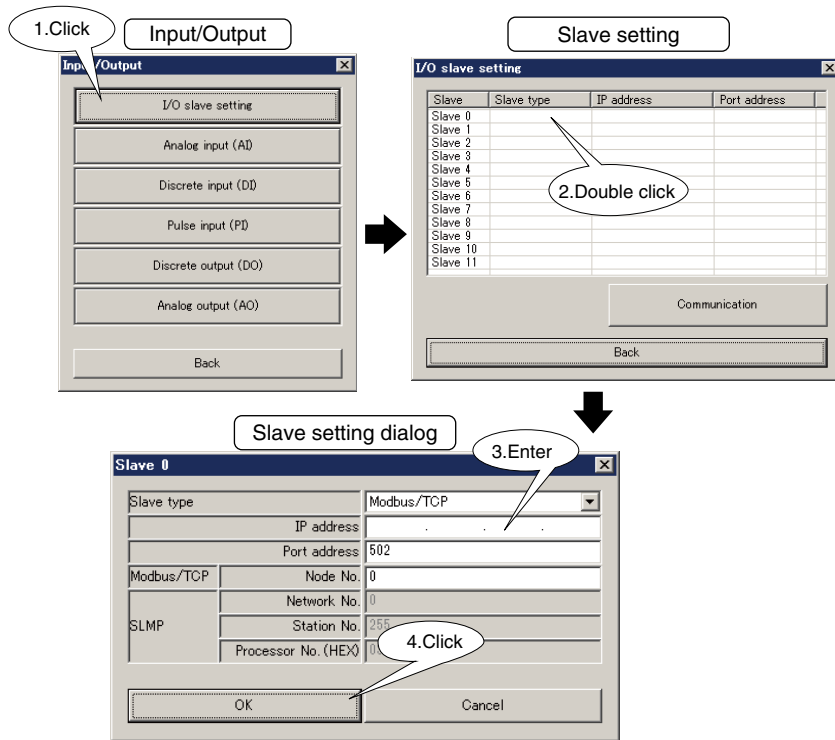

(2) Open "AO" configuration dialog.

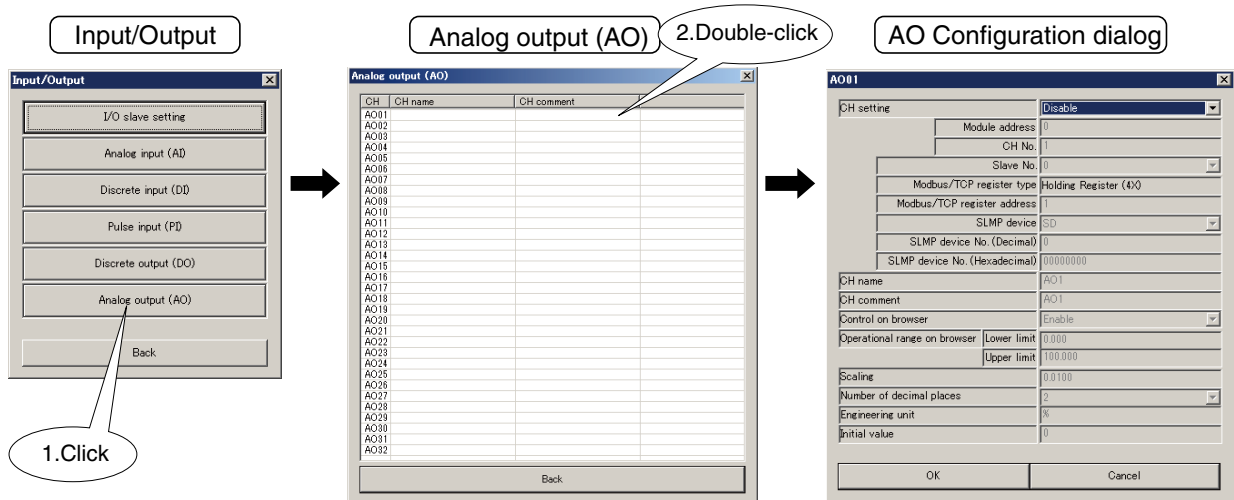

(3) Choose “Modbus/TCP” under “CH setting” and enter “Slave No.,” “Modbus/TCP register type” and “Modbus/TCP register address.”

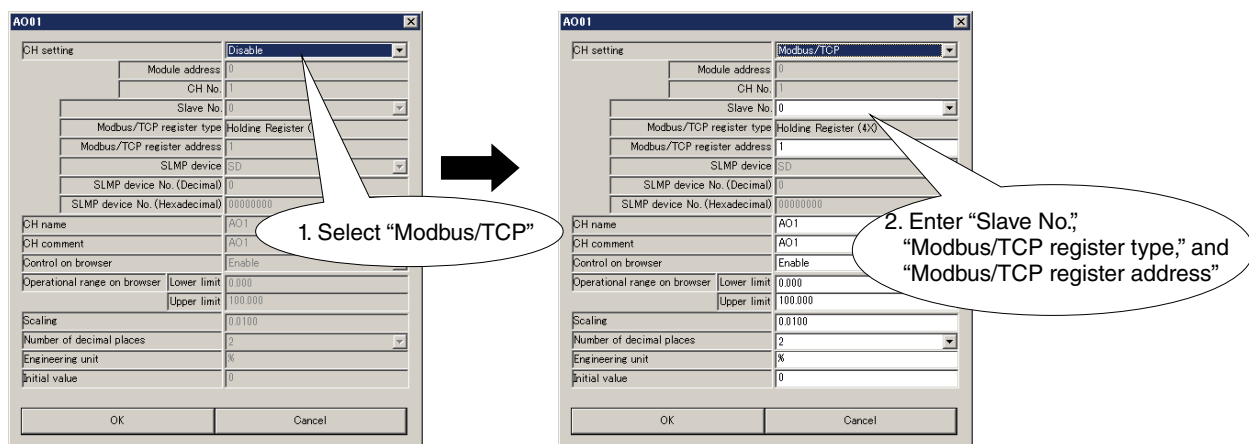

PARAMETER	DESCRIPTION
Slave No.	Enter slave No. (0 to 11) set in (1).
Modbus/TCP register type	Fixed at [Holding Register (4X)].
Modbus/TCP register address	Set register address usable in the register type described above. Range: 1 to 65536

7.6.1.3 ASSIGNING SLMP DEVICES TO AO

(1) Refer to 6.2.2 ASSIGNING SLMP DEVICES TO AO to assign SLMP devices as slaves.

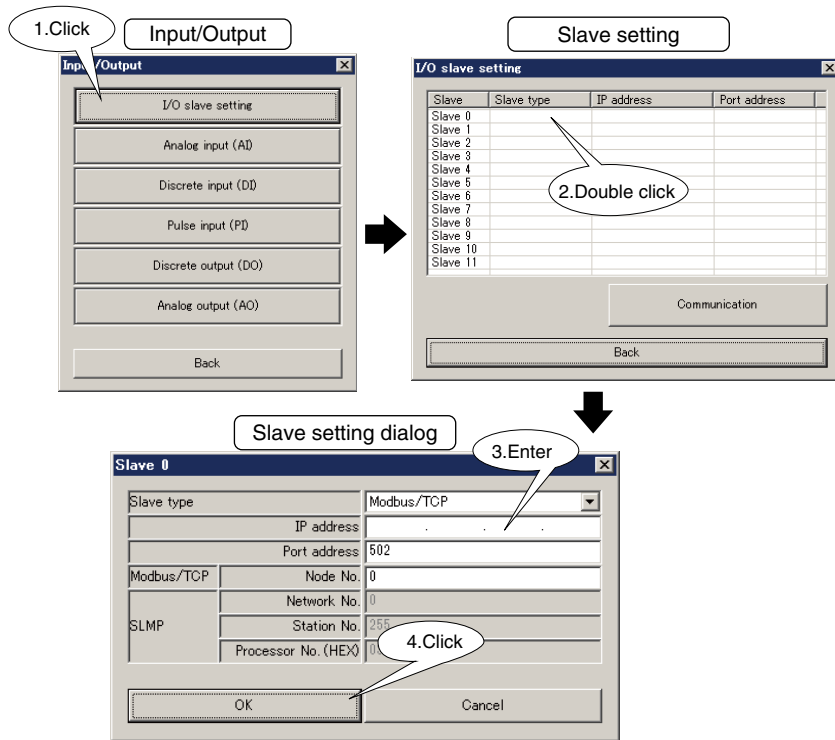

(2) Open "AO" Configuration dialog as explained in 7.6.1.2 ASSIGNING REMOTE I/O TO AO.

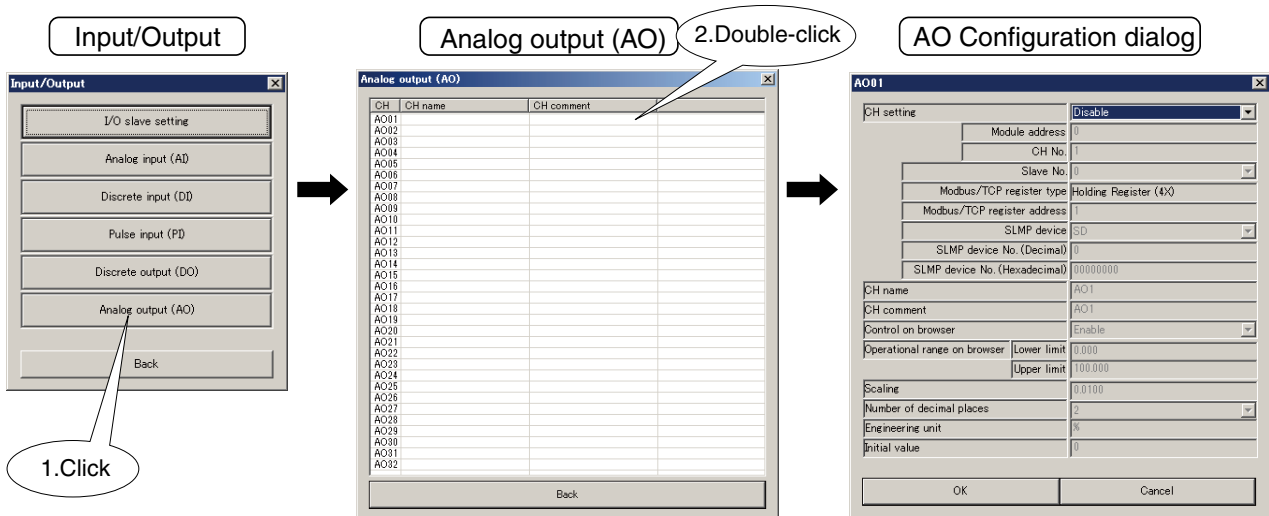

(3) Choose "SLMP" under "CH setting" and enter "Slave No.," "SLMP device," and "SLMP device No."

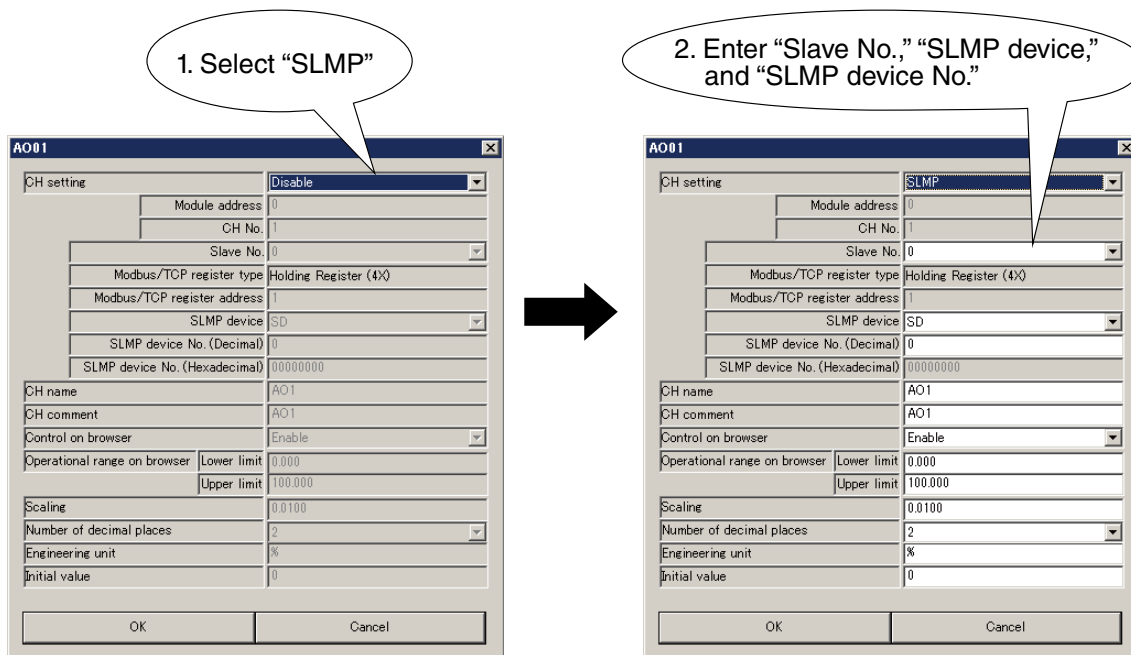

PARAMETER	DESCRIPTION
Slave No.	Enter slave No. (0 to 11) set in (1).
SLMP device	Choose the device from the pull-down list.
SLMP device No.	Set the device number for the SLMP device. The input field of either "SLMP device No. (Decimal)" or "SLMP device No. (Hexadecimal)" will be active depending on the selected SLMP device.

7.6.2 BASIC SETTING

After channel assignment, configure basic settings for each channel. Click [OK] to temporarily save the settings.

The screenshot shows the 'AO1' configuration dialog box. The fields are as follows:

- CH setting: I/O module
- Module address: 0
- CH No.: 1
- Slave No.: 0
- Modbus/TCP register type: Holding Register (4X)
- Modbus/TCP register address: 1
- SLMP device: SD
- SLMP device No. (Decimal): 0
- SLMP device No. (Hexadecimal): 00000000
- CH name: AO1
- CH comment: AO1
- Control on browser: Enable
- Operational range on browser: Lower limit 0.000, Upper limit 100.000
- Scaling: 0.0100
- Number of decimal places: 2
- Engineering unit: %
- Initial value: 0

At the bottom, there are 'OK' and 'Cancel' buttons. A callout bubble labeled '1.Click' points to the 'OK' button.

PARAMETER	DESCRIPTION
CH name	Enter the name for channel (max. 32 characters).
CH comment	Enter comment regarding channel and tag name (max. 64 characters).
Control on browser	Enable or disable controlling of individual AO channel on the browser view. Upper/lower limit divided by Scaling must be within the range from -32768 to 32767. (Fraction is rounded off.)
Operational range on browser	Output can be limited within a specific range when it is controlled on the browser view. Specify upper and lower limits.
Scaling	Set a weight to convert into 16-bit output data (-32768 to 32767). Output data = Engineering unit value ÷ Scaling (Fraction is rounded off.) (-10,000,000,000 to -0.0001, 0.0001 to 10,000,000,000)
Number of decimal places	Set number of decimal places of the value displayed on the web browser. Selectable within 0 to 3.
Engineering unit	Set engineering unit of the engineering unit value. Input within 16 characters.
Initial value	Set the initial output value used when the cold start mode is specified. Specify Output data value (Engineering value ÷ Scaling) (-32768 to 32767). (Refer to 7.7 START MODE.)

7.6.3 COPYING CH CONFIGURATION

CH configuration of one channel can be copied to another. Refer to 7.2.5 COPYING CH CONFIGURATION.

7.7 START MODE

Specific output values (DO and AO) can be set for when the DL8 power supply is reset and restarted.

- (1) Click [Back] button to return to “Configuration” window from “Input/Output” menu.
Click [System] to open “System” dialog box, and choose “Start mode” from the pull-down list.
Click [OK] to temporarily save the new setting.

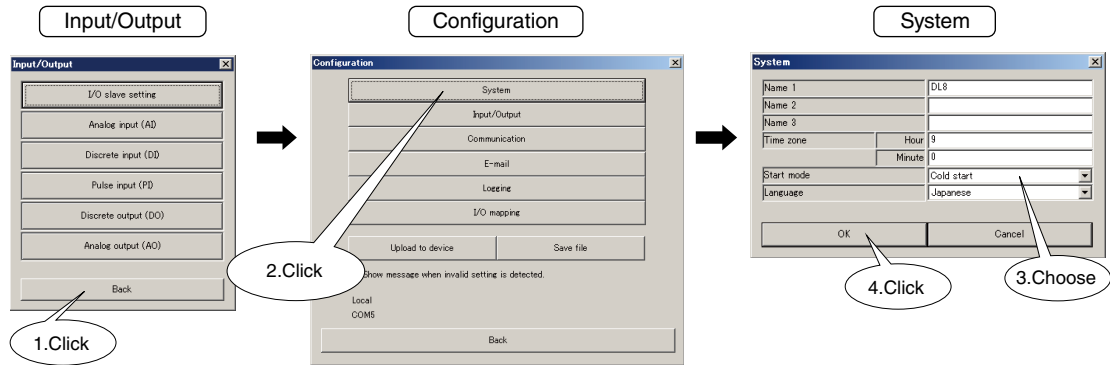

PARAMETER	DESCRIPTION
Start mode	Select the type of output set after power supply is reset. <ul style="list-style-type: none"> • Cold start: Values specified per each output channel are set. • Hot start: Values provided by control on the web browser view or via Modbus/TCP are held.

7.8 UPLOADING SETTING

To upload a temporarily saved new setting, return to “Configuration” window and click [Upload to device] button.

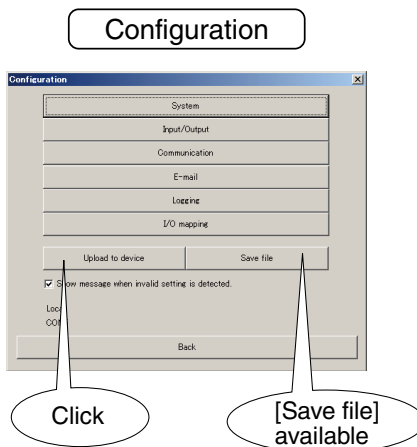

8. WEB SERVER

8.1 GENERAL DESCRIPTIONS

Remote monitoring PC, tablet or smart phone is available by the web server function of the DL8.
Set up the web server following the procedure explained in the below sections.

8.2 TERMINAL, BROWSER

The function check is performed with following environment.

TERMINAL	OS & APPLICATION
PC	<ul style="list-style-type: none"> • OS Windows 8.1, or Windows 10 • Browser Internet Explorer (HTTPS not supported) Microsoft Edge Firefox Chrome
Tablet	<ul style="list-style-type: none"> • OS iPad Android • Browser iOS: Safari Android: Chrome
Smart phone	<ul style="list-style-type: none"> • OS iPhone Android • Browser iOS: Safari Android: Chrome

OS	BROWSER	MOUSE OPERATION	TOUCH OPERATION
iOS	Safari	✓	✓
iPadOS	Safari	✓	✓
Android	Chrome	✓	✓
Windows 8.1	Internet Explorer	✓	✓
	Firefox	✓	✓
	Chrome	✓	✓
Windows 10	Microsoft Edge	✓	✓
	Internet Explorer	✓	✓
	Firefox	✓	✓
	Chrome	✓	✓

NOTE

- Refer to the manual supplied with terminal equipment for network setting.
- HTTPS is available only for Type E.

8.3 MENU VIEW

8.3.1 DISPLAY

Two types of browser views, PC view for operation with a mouse and smart phone view for touch panel operation, are available for convenience of users.

Enter the following URL on the browser and confirm that Menu view appears on the screen.

- **For PC:**
[Domain name or IP address of the router or the DL8]/index.html
- **For Smart Phone:**
[Domain name or IP address of the router or the DL8]/s_index.html

For PC



For Smart Phone



NOTE

- If Menu view does not open, check 4. NETWORK CONFIGURATION.
- The two view types are available for use independently from the type of your terminal.

8.3.2 SYSTEM

Names and comments indicated on the browser menu view can be specified for your system.

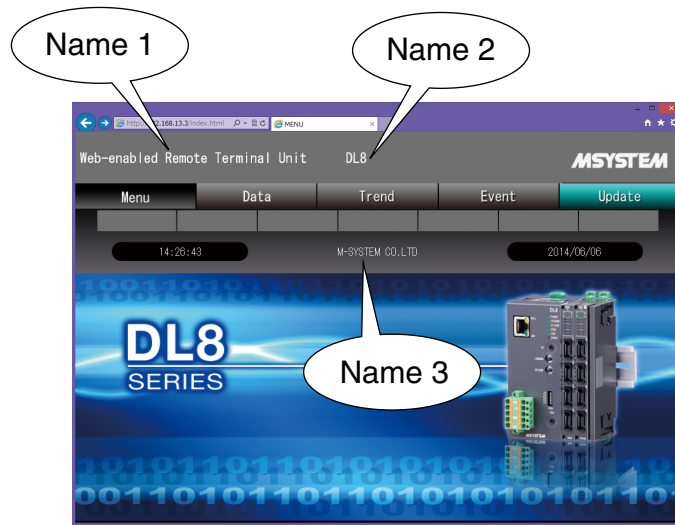

- (1) Click [Download from device] button in the main window to open “Configuration” window.
Click [System] button to open “System” dialog.
Enter texts for identification of your system to be displayed on the web browser menu. (Max. 64 characters)

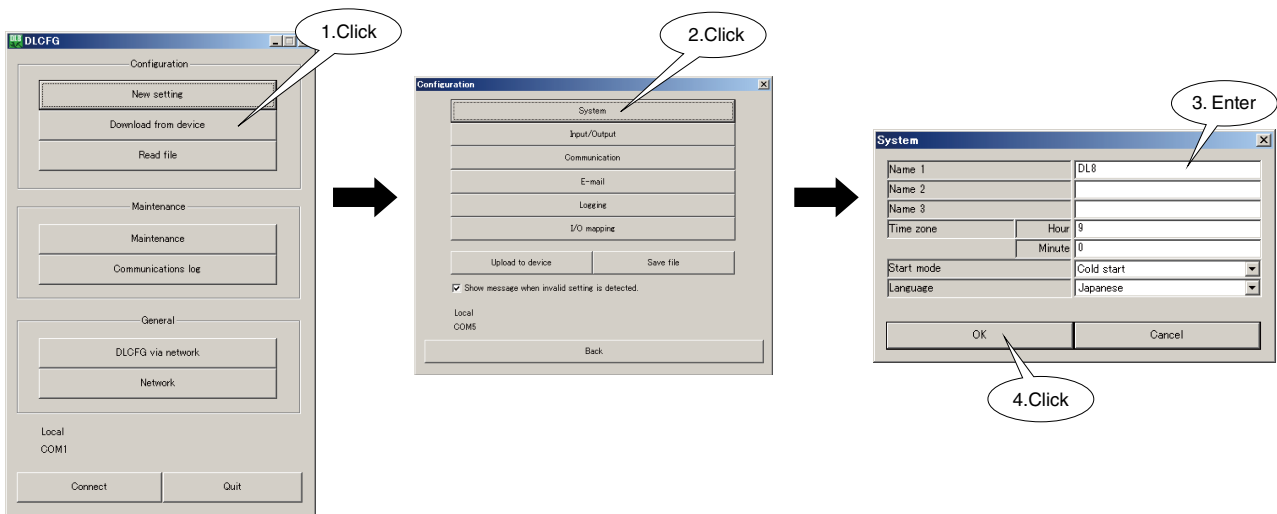

8.3.3 USER-DEFINED IMAGE

Three images of JPEG format in the Menu view can be replaced with those of your own choice. Size of each image is fixed.

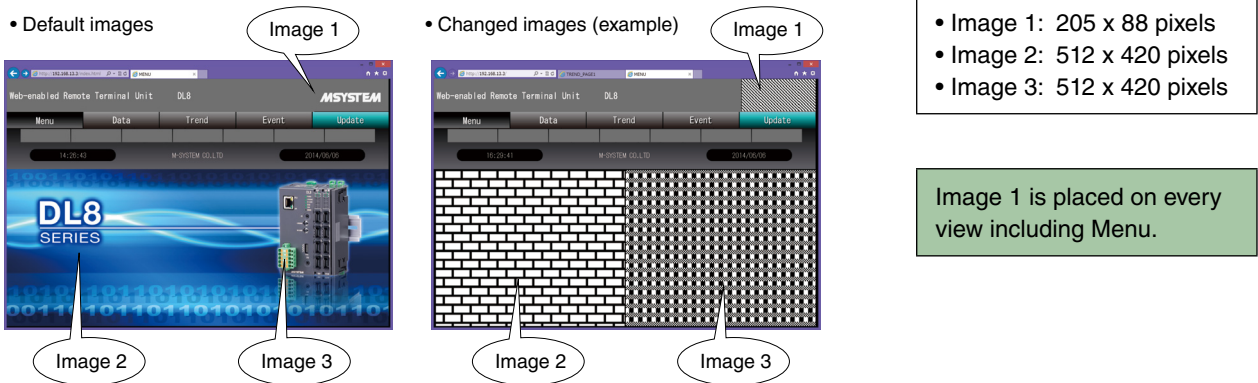

To replace images, follow the procedure below.

- (1) Connect the DL8 with the COP-US cable to the PC to which the DLCFG is installed. For connection setting, refer to 4.3 IP ADDRESS SETTING.

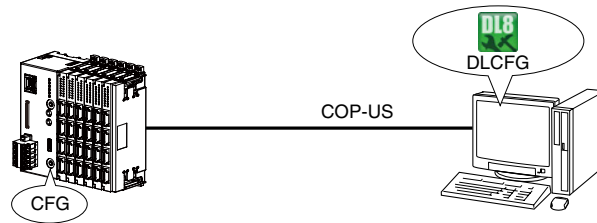

- (2) Choose [Maintenance] – [User-defined imagery data] to open “User-defined imagery data” dialog. Enter path to the folder containing each image.

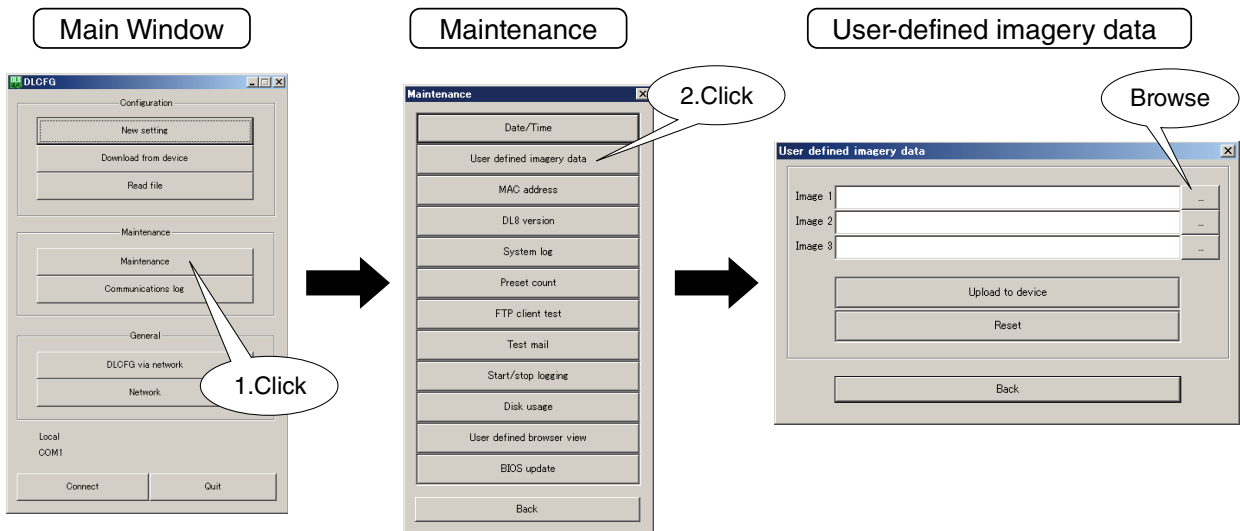

- (3) Click [Upload to device] to apply the image to the device.
- (4) Click [Reset] button to delete user-defined images saved in the device.

NOTE

- Click [Refresh] button on the browser to refresh browser cache after transferring data.
- Browser may not be able to display the images correctly if the image size is not as specified.

8.4 DATA VIEW

8.4.1 DISPLAY

Click [Data] button to show “Data” view, and then choose data type among [AI Data / DI Data / PI Data / DO Data].

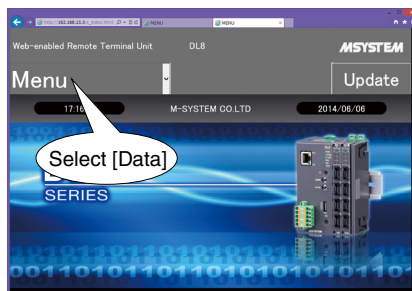

DATA View for PC

DATA View for Smart Phone

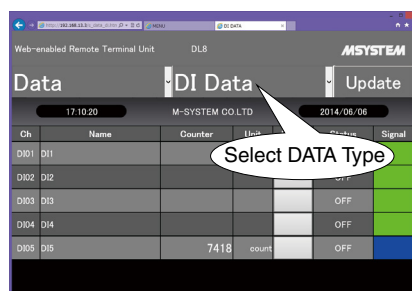
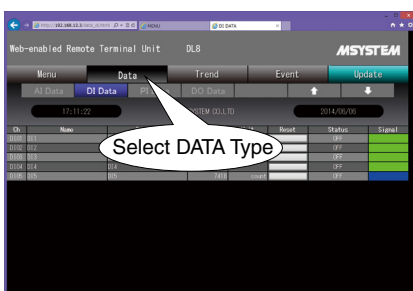

8.4.2 AI DATA VIEW

Select [AI Data] to show “AI Data” view.

AI Data View for PC

Ch	Name	Comment	Data	Unit	%	Status	Signal
A101	A11	A11_Demo (50)	5.00	%	5.00	LL	Blue
A102	A12	A12_Demo (50)	22.35	%	22.35	L	Light Blue
A103	A13	A13_Demo (50)	42.49	%	42.49	NORMAL	Green
A104	A14	A14_Demo (50)	5.00	%	5.00	LL	Blue

AI Data View for Smart Phone

Ch	Name	Data	Unit	Status	Signal
A101	A11	5.00	%	LL	Blue
A102	A12	22.35	%	L	Light Blue
A103	A13	42.49	%	NORMAL	Green
A104	A14	5.00	%	LL	Blue

- Ch
Channel number for AI
- Name
CH name for each channel
- Comment
CH comment for each channel (only for PC)
- Data
Scaled engineering unit value
- Unit
Engineering unit set to each channel
- %
AI in percentage (only for PC)
- Status
Zone name is displayed according to the signal value.
- Signal
Color set for the zone is displayed according to the signal value.

8.4.3 DI DATA VIEW

Select [DI Data] to show “DI Data” view.

DI Data View for PC

Ch	Name	Comment	Counter	Unit	Reset	Status	Signal
DI01	DA4A-1					OFF	Green
DI02	DA4A-2					OFF	Green
DI03	DA4A-3					OFF	Green
DI04	DA4A-4					OFF	Green
DI05	DIS					ON	Red

DI Data View for Smart Phone

Ch	Name	Counter	Unit	Reset	Status	Signal
DI01	DA4A-1				OFF	Green
DI02	DA4A-2				OFF	Green
DI03	DA4A-3				OFF	Green
DI04	DA4A-4				OFF	Green
DI05	DIS				ON	Red

- Ch
Channel number for DI
- Name
CH name for each channel
- Comment
CH comment for each channel (only for PC)
- Counter
Count value (for counter mode)
- Unit
Engineering unit (for counter mode)
- Reset
Used to reset the counter value (for counter mode)
- Status
Comment is displayed according to the signal status.
- Signal
Color set for the status is displayed according to the signal status.

8.4.4 PI DATA VIEW

Select [PI Data] to show “PI Data” view.

PI Data View for PC

Ch	Name	Comment	Data	Unit	Reset	Status	Signal
PI01	PI1		39800	count		AREA5	Orange
PI02	PI2		27800	count		AREA1	Green

PI Data View for Smart Phone

Ch	Name	Data	Unit	Reset	Status	Signal
PI01	PI1	39800	count		AREA5	Orange
PI02	PI2	27800	count		AREA1	Green

- Ch
Channel number for PI
- Name
CH name for each channel
- Comment
CH comment for each channel (only for PC)
- Data
Scaled engineering unit value
- Unit
Engineering unit set to each channel
- Reset
Used to reset the counter value
- Status
Zone name is displayed according to the signal value.
- Signal
Color set for the zone is displayed according to the signal value.

8.4.5 DO DATA VIEW

Select [DO Data] to show “DO Data” view.

DO Data View for PC

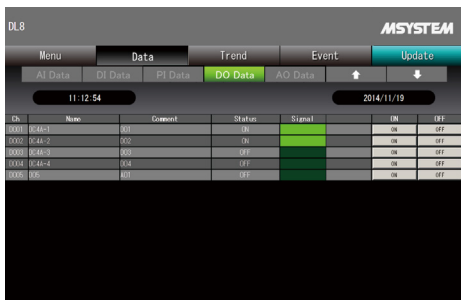

DO Data View for Smart Phone

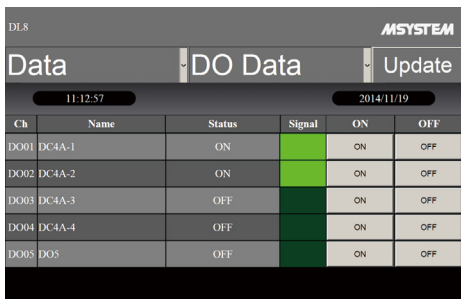

- Ch
Channel number for DO
- Name
CH name for each channel
- Comment
CH comment for each channel (only for PC)
- Status
Comment is displayed according to the signal status.
- Signal
Color setting is displayed according to the signal status.
- ON
Button to turn the DO ON.
- OFF
Button to turn the DO OFF.

8.4.6 AO DATA VIEW

Select [AO Data] to show “AO Data” view.

AO Data View for PC

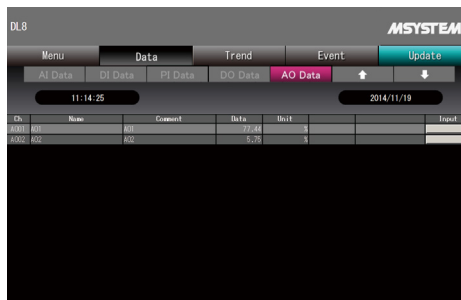

AO Data View for Smart Phone

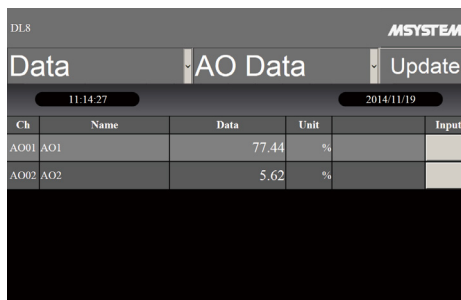

- Ch
Channel number for AO
- Name
CH name for each channel
- Comment
CH comment for each channel (only for PC)
- Data
Scaled engineering unit value
- Unit
Engineering unit set to each channel
- Input
Button to open the data field to set an output value

8.5 TREND VIEW

8.5.1 DISPLAY

Select [Trend] to show "Trend" view.

"Trend" view contains eight (8) pages, from PAGE 1 to PAGE 8.



Trend View for PC

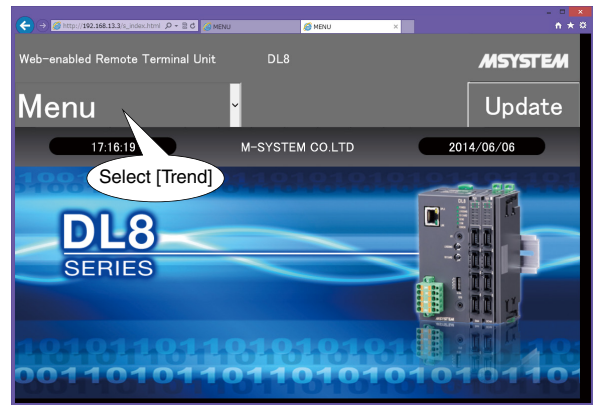

Trend View for Smart Phone

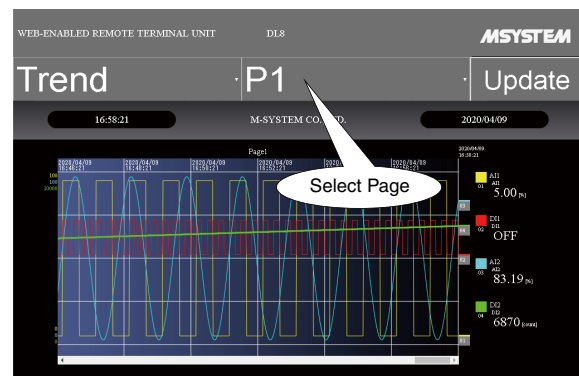
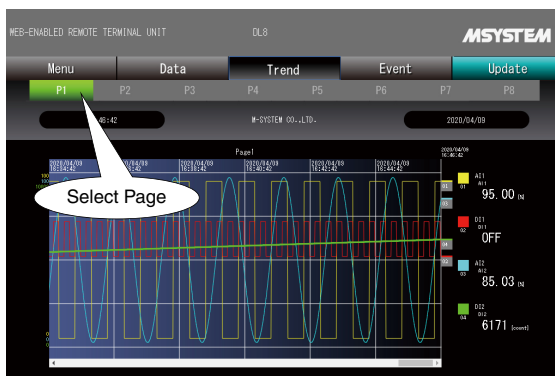

NOTE

- Trend data is initialized when the power supply is reset.
- Trend graphs are plotted by using "canvas" of HTML5.
Graphs are plotted by quasi-canvas with "excanvas.js" if your browser does not support HTML5.
Drawing complex lines or refreshing multiple screens may take a significant time.

8.5.2 SCREEN COMPONENTS

Screen components of a trend page is explained. For configuration, refer to 8.5.3 SETTING.

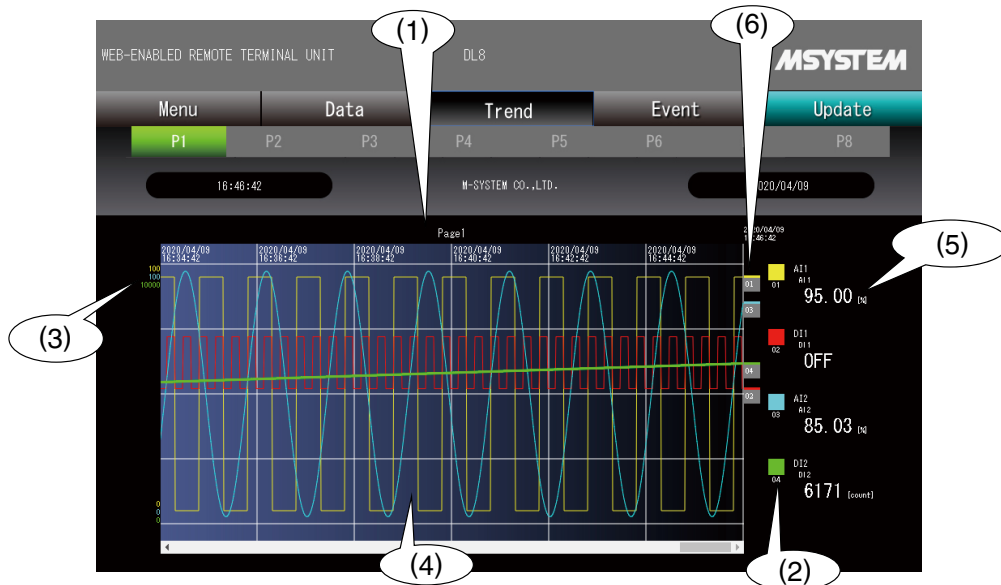

No.	DESCRIPTION
(1)	Page name
(2)	Up to 4 pens per one page are plotted. Pen color set for each pen is shown by a square indicator.
(3)	The upper/lower limit values (0, 100%) are displayed in each pen color when AI, PI, DI (counter) or AO is assigned to the pen.
(4)	<p>Plotting area</p> <ul style="list-style-type: none"> Horizontal lines are drawn at 0, 25, 50, 75 and 100 % positions. Vertical lines are drawn depending upon the trend speed setting.*1 The time stamp is indicated. The screen can be scrolled. Max. 720 samples can be plotted in one screen. Historical trend can be plotted up to 10 screens. Graphs are drawn in specified pen colors. For AI, PI, DI (counter) or AO, Graphs are drawn within 0 to 100% defined by the upper/lower limit values described in (3). For DI and DO, square waves are drawn within each pen's graph area ruled off by horizontal lines.
(5)	<p>Numerical value display area</p> <ul style="list-style-type: none"> CH name and CH comment assigned to each pen is displayed. For AI, PI, DI (counter) or AO, engineering unit value and engineering unit are displayed. For DI and DO, text corresponding to the status is displayed. The display shows value/status at the right end of the chart. When the chart is scrolled, value/status changes accordingly.
(6)	<p>Pen marks display area</p> <ul style="list-style-type: none"> Pen marks are displayed in respectively set colors.

*1. The relationship of the time between vertical line to the trend speed is shown in the table below.

TREND SPEED	TIME BETWEEN VERTICAL LINE
1 second	2 minutes
5 seconds	10 minutes
10 seconds	20 minutes
30 seconds	1 hour
1 minute	2 hours
5 minutes	10 hours
10 minutes	1 day
30 minutes	3 days
1 hour	5 days
1 day	120 days

8.5.3 SETTING

- (1) Connect the DL8 with the COP-US cable to the PC to which the DLCFG is installed.
For connection setting, refer to 4.3 IP ADDRESS SETTING.

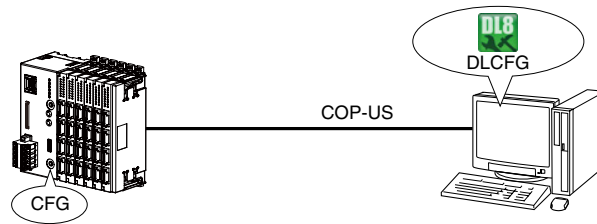

- (2) Start the DLCFG to show the main window. Click [Download from device] button to read setting from the DL8 and to open “Configuration” window. Click [Communication] – [Web server] buttons to open “Web server” dialog.

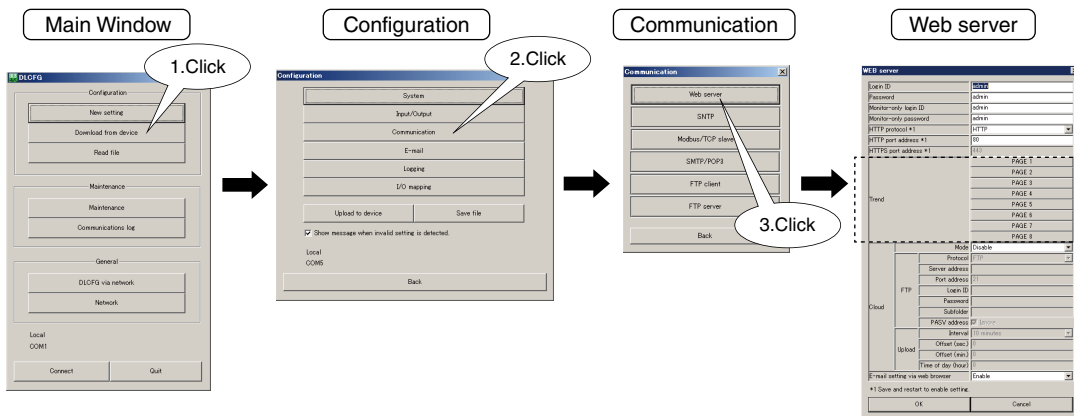

- (3) Click [PAGE 1] button to show “PAGE 1” configuration dialog.

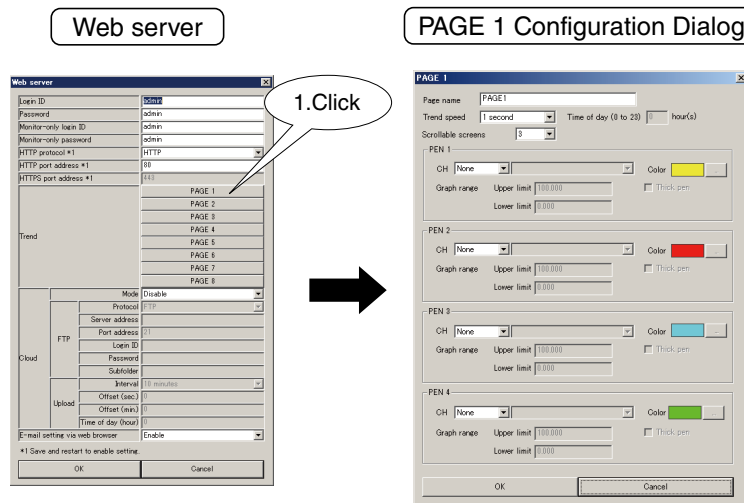

(4) Set parameters according to the table below.

Refer to 8.5.2 SCREEN COMPONENTS for explanations of each parameter.

PARAMETER	DESCRIPTION
Page name	Enter a name for the page (max. 64 characters).
Trend speed	Choose trend speed (sampling interval) from the list. (For 1 day, specify sampling timing between 0 to 23 hours.)
Scrollable screens	Choose the number of screens of historical trend between 1 to 10 screens.
PEN 1 PEN 2 PEN 3 PEN 4	<ul style="list-style-type: none">• CH Specify channel to plot data. Select [None] when the pen is not used.• Color Specify color for the pen.• Graph range (0 to 100%) Specify the upper/lower limit values of the graph in engineering unit value.• Thick pen Put the check mark to draw with bold line.

(5) When all 4 pens are set, click [OK] to temporarily save the setting.

(6) To apply the new setting to the DL8, go back to "Configuration" window and click [Upload to device] button.

8.6 EVENT VIEW

Select [Event] to show “Event” view. Up to 128 latest events can be listed.



Event View for PC

Event View for Smart Phone

Time	Ch	Name	Comment	Event/Status	Signal
2014/06/06 16:55:37	DO01	DO1	AI1	ON	Red
2014/06/06 16:55:37	AI01	AI1	AREA2	ON	Blue
2014/06/06 16:55:35	DO01	DO1	AI1	ON	Red
2014/06/06 16:55:35	AI01	AI1	AREA2	ON	Blue
2014/06/06 16:55:37	DO01	DO1	AI1	ON	Red
2014/06/06 16:55:37	AI01	AI1	AREA2	ON	Blue
2014/06/06 16:55:35	DO01	DO1	AI1	ON	Red
2014/06/06 16:55:35	AI01	AI1	AREA2	ON	Blue
2014/06/06 16:55:37	DO01	DO1	AI1	ON	Red
2014/06/06 16:55:37	AI01	AI1	AREA2	ON	Blue
2014/06/06 16:55:35	DO01	DO1	AI1	ON	Red
2014/06/06 16:55:35	AI01	AI1	AREA2	ON	Blue
2014/06/06 16:55:37	DO01	DO1	AI1	ON	Red
2014/06/06 16:55:37	AI01	AI1	AREA2	ON	Blue
2014/06/06 16:55:35	DO01	DO1	AI1	ON	Red
2014/06/06 16:55:35	AI01	AI1	AREA2	ON	Blue
2014/06/06 16:55:37	DO01	DO1	AI1	ON	Red
2014/06/06 16:55:37	AI01	AI1	AREA2	ON	Blue
2014/06/06 16:55:35	DO01	DO1	AI1	ON	Red
2014/06/06 16:55:35	AI01	AI1	AREA2	ON	Blue
2014/06/06 16:55:37	DO01	DO1	AI1	ON	Red
2014/06/06 16:55:37	AI01	AI1	AREA2	ON	Blue

Time	Ch	Name	Comment	Event/Status	Signal
2014/06/06 16:55:37	DO01	DO1	AI1	ON	Red
2014/06/06 16:55:37	AI01	AI1	AREA2	ON	Blue
2014/06/06 16:55:35	DO01	DO1	AI1	ON	Red
2014/06/06 16:55:35	AI01	AI1	AREA2	ON	Blue
2014/06/06 16:55:37	DO01	DO1	AI1	ON	Red
2014/06/06 16:55:37	AI01	AI1	AREA2	ON	Blue
2014/06/06 16:55:35	DO01	DO1	AI1	ON	Red
2014/06/06 16:55:35	AI01	AI1	AREA2	ON	Blue
2014/06/06 16:55:37	DO01	DO1	AI1	ON	Red
2014/06/06 16:55:37	AI01	AI1	AREA2	ON	Blue
2014/06/06 16:55:35	DO01	DO1	AI1	ON	Red
2014/06/06 16:55:35	AI01	AI1	AREA2	ON	Blue
2014/06/06 16:55:37	DO01	DO1	AI1	ON	Red
2014/06/06 16:55:37	AI01	AI1	AREA2	ON	Blue
2014/06/06 16:55:35	DO01	DO1	AI1	ON	Red
2014/06/06 16:55:35	AI01	AI1	AREA2	ON	Blue
2014/06/06 16:55:37	DO01	DO1	AI1	ON	Red
2014/06/06 16:55:37	AI01	AI1	AREA2	ON	Blue

- Time
Time of event
- Ch
Channel of event
- Name
Ch name of event
- Comment
CH comment of event
- Event / Status
Zone name and status
- Signal
Color for zone and status

NOTE

- Event data is initialized when the power supply to the device is reset.

8.7 REFRESHING SCREEN

Select [Update] to refresh the screen with the latest data.
Automatic updating in a regular interval is possible by setting.

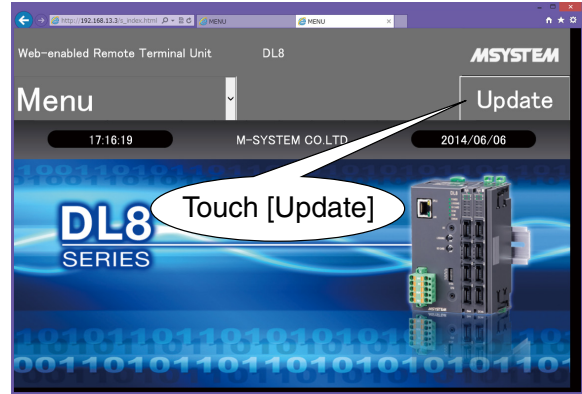

NOTE

When a part of the browser view is not correctly displayed when the DL8 setting has been changed or due to other reasons such as communication failure, click [Refresh] button to refresh the browser view.

8.7.1 UPDATE INTERVAL SETTING

8.7.1.1 DATA VIEW

Automatic update interval can be specified for each data type (AI, DI, etc.).
The same interval is applied for PC and smart phone views.

■ PC

Click on a data type selector (e.g. "AI Data") on the screen to call up a dialog box.
Specify an interval between 0 and 999 (seconds) and click [OK].

■ Smart Phone

Click on "Data" under "Menu" and select "-AutoRef-" to call up a dialog box.
Specify an interval between 0 and 999 (seconds) and click [OK].

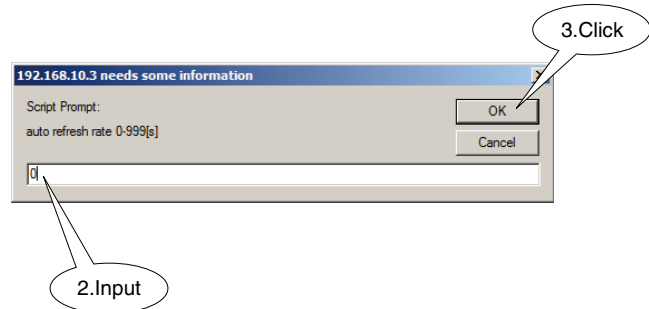
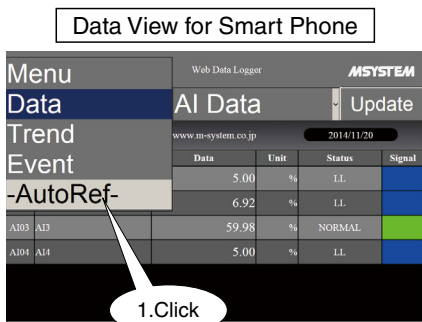
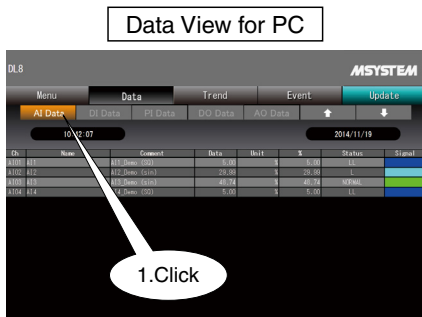

8.7.1.2 TREND VIEW

Automatic update interval can be specified for each page.
The same interval is applied for PC and smart phone views.

■ PC

Click on a page selector (e.g. "P1") on the screen to call up a dialog box.
Specify an interval between 0 and 999 (seconds) and click [OK].

■ Smart Phone

Click on "Trend" under "Menu" and select "-AutoRef-" to call up a dialog box.
Specify an interval between 0 and 999 (seconds) and click [OK].

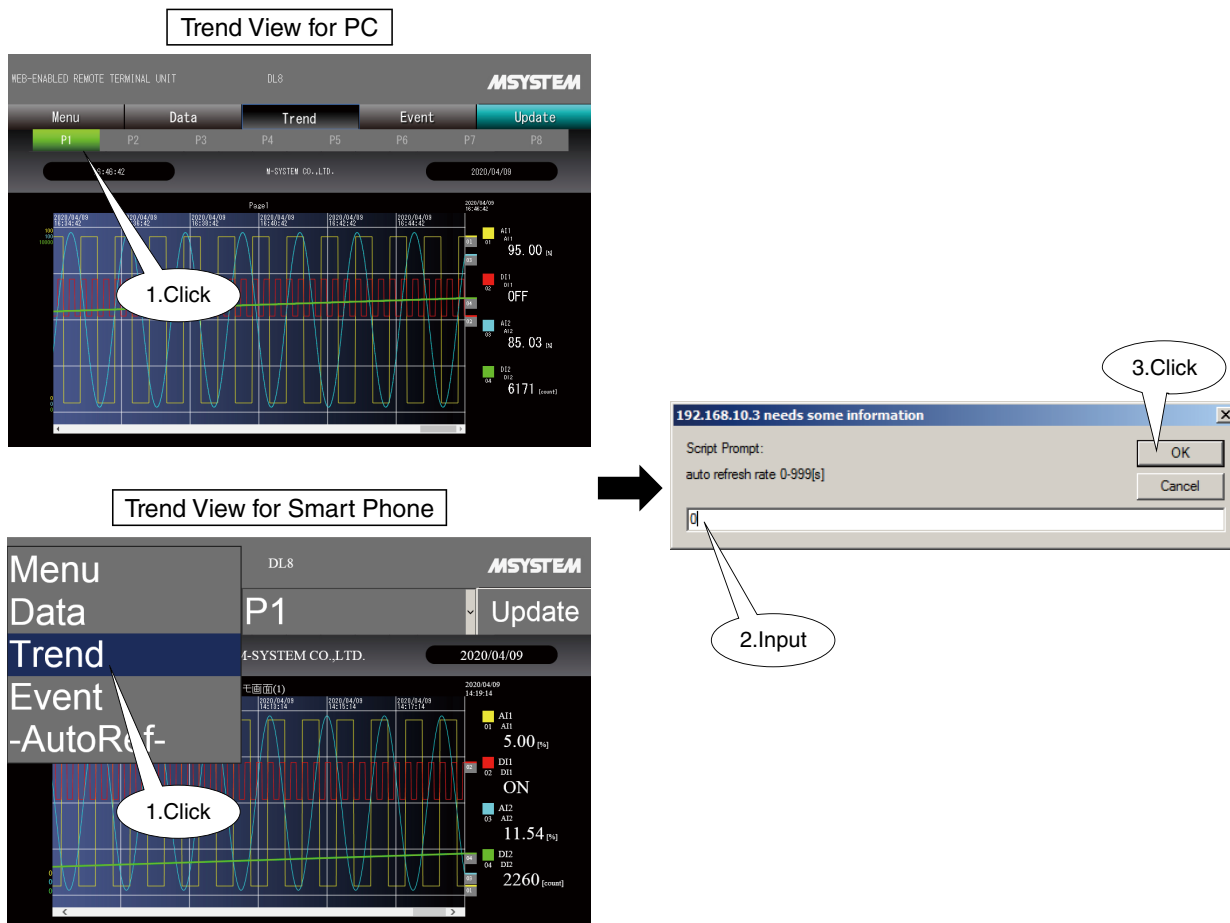

8.7.1.3 EVENT VIEW

The same interval is applied for PC and smart phone views.

■ PC

Click on the yellow tile on the screen to call up a dialog box.
Specify an interval between 0 and 999 (seconds) and click [OK].

■ Smart Phone

Click on “Event” under “Menu” and select “-AutoRef-” to call up a dialog box.
Specify an interval between 0 and 999 (seconds) and click [OK].

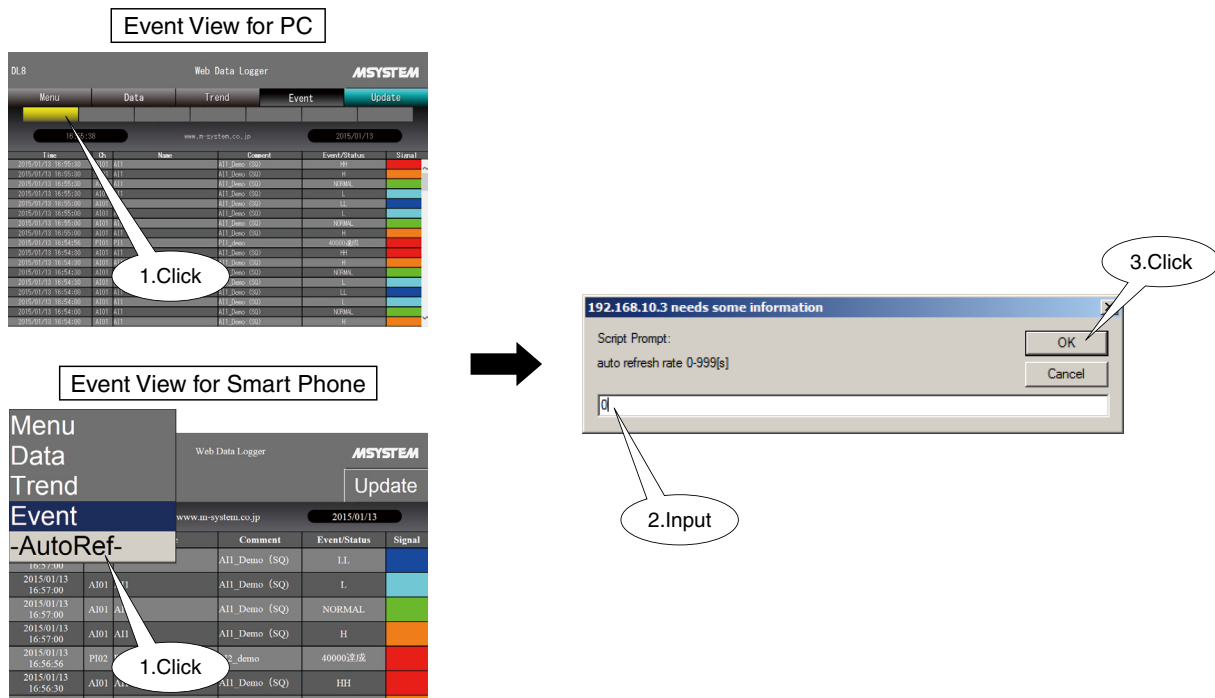

8.8 CLOUD MODE

8.8.1 DESCRIPTIONS

In the network configuration such as 4.2.3 STYLE 3: WAN-LAN, only one DL8 device can be accessed from WAN.

For a monitoring system with more than one DL8 device, the same number of routers are required, and may result in expensive communication cost.

In order to manage such a system at low cost, "Cloud Mode" is available in addition to web server function.

Using the cloud mode, the DL8 uploads files such as HTML files required for web browsing to a web server.

Data can be browsed by specifying the URL of the web server, not the one of the DL8.

Data uploading is achieved by FTP.

The web server must have FTP server function while the DL8 acts as a FTP client.

When uploading, a subfolder for each DL8 device can be specified.

The cloud mode is also useful when many operators browse at once the web screen of single DL8 device.

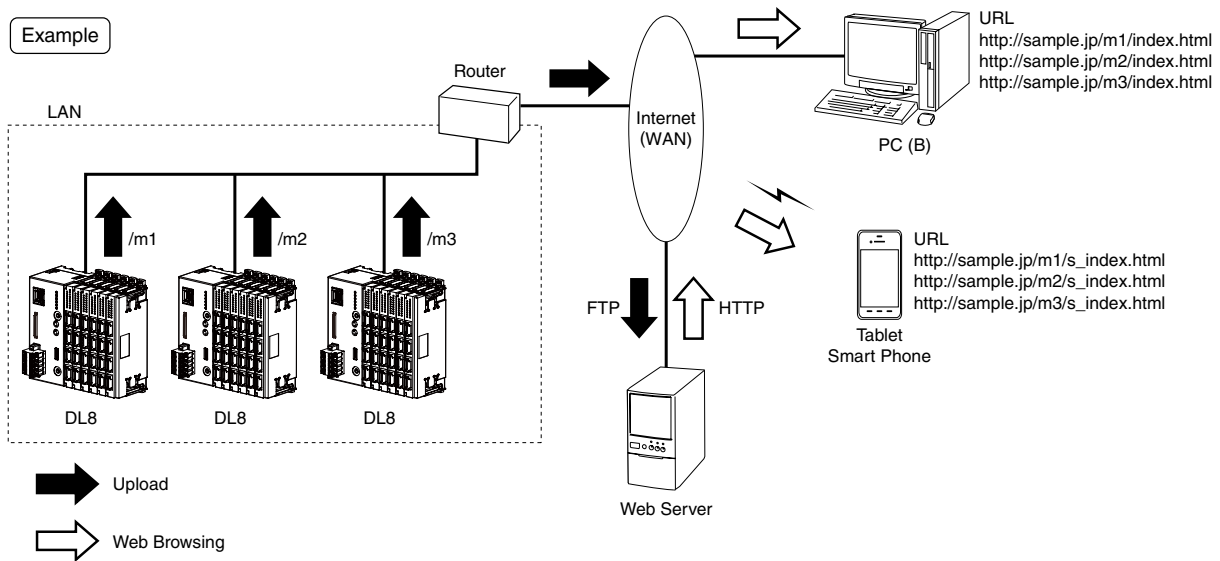

NOTE

- The following operations/functions are NOT available in the cloud mode:
(1) Resetting of DI or PI count; (2) Control of DO or AO; and (3) Automatic screen updating.
- Normal web server function of the DL8 can be used at the same time.
Basically, only one device is connectable from WAN side. Multiple devices can be set by "Port Address" setting.
- All files including JPEG images are uploaded every time when the power is turned on or when the setting is changed.
Once they are successfully uploaded, only data is uploaded from second time.
- FTP transfer is executed in passive mode.
- Web server must be provided by the user.

8.8.2 SETTING

- (1) Connect the DL8 with the COP-US cable to the PC to which the DLCFG is installed.
For connection setting, refer to 4.3 IP ADDRESS SETTING.

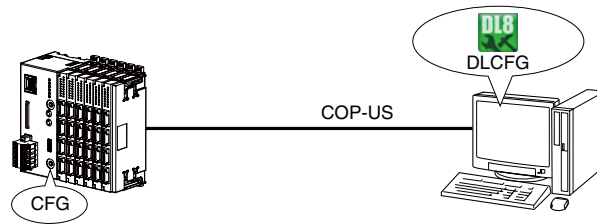

- (2) Start the DLCFG to show the main window.
Click [Download from device] button to read setting from the DL8 and to open “Configuration” window.
Click [Communication] – [Web server] to open “Web server” dialog.

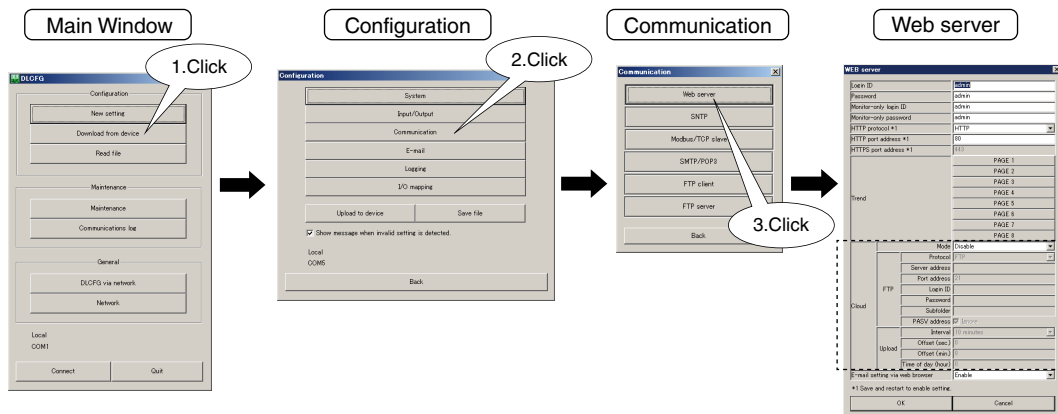

- (3) Configure the cloud mode parameters according to the table below.

PARAMETER	DESCRIPTION
Mode	Enable/Disable the cloud mode.
Protocol	Select the protocol between FTP and FTPS to be used for uploading web page files to the FTP server. Explicit mode when FTPS is selected.
Server address	Specify domain name or IP address as the address of the web server.
Login ID	Specify FTP login name for the web server.
Password	Specify FTP login password for the web server.
Subfolder	Specify sub-folder name such as “m1” of 8.8.1 DESCRIPTIONS. If this is left blank, data is transferred to root directory.
PASV address	Ignore addresses returned with PASV mode. Uncheck when the server address of control connection and data connection are different.
Interval	Specify the interval of uploading data files to FTP server for web. Select from: 1 / 2 / 5 / 10 / 30 min. / 1 hr / 1 day
Offset (min., sec.)	In order to avoid overloading when multiple DL8 units start data transfer at once, specify certain time delays for each device, in minutes and seconds.
Time of day (hour)	When the interval is set to 1 day, specify the timing to transfer between 0 to 23 hours.

- (4) Click [OK] to temporarily save the setting.
To apply the new setting to the DL8, go back to “Configuration” window and click [Upload to device] button.

8.8.3 STATUS VERIFICATION

FTP data uploading status can be confirmed by the following setup.

Shows the communication log that occurs while communication log window is opened.

8.8.3.1 VERIFICATION WITH DLCFG

(1) Connect the DL8 and the PC with the COP-US cable.

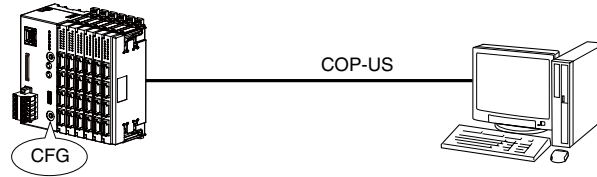

(2) Turn on the DIP SW1 at the front of the DL8.

(3) Start the DLCFG to show the main window.

Click [Communications log] button to display “Communications log” window.

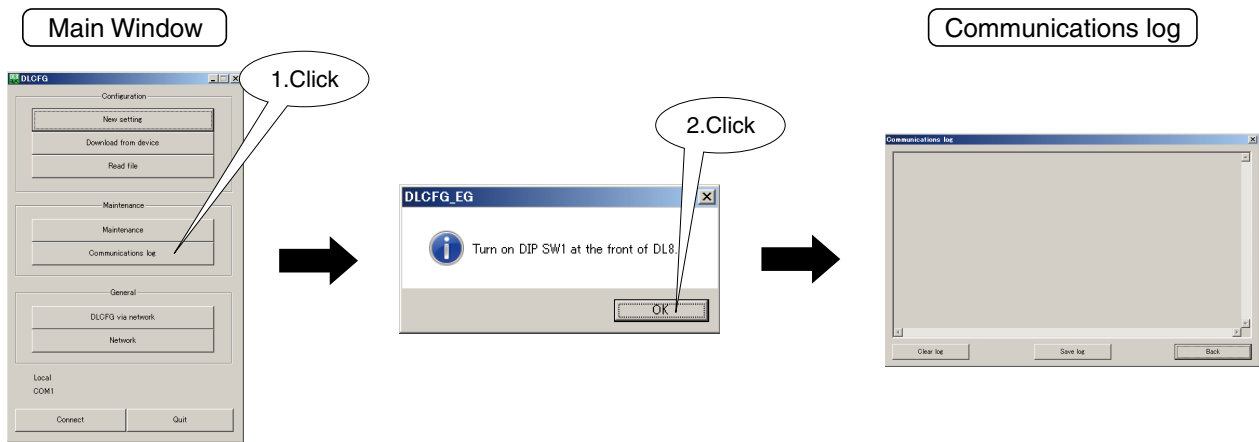

PARAMETER	DESCRIPTION
Clear log	Deletes all logs being displayed on the communications log window.
Save log	Saves logs being displayed on the communications log window in text format.
Back	Exits the communications log window and returns to the main window.

(4) When FTP transfer is started, its communication log can be checked on the “Communications log” window. While watching the log, confirm the settings until transfer is successfully completed.

(5) After status confirmation is completed, click [Back] button to exit the “Communications log” window, and turn off the DIP SW1.

NOTE

- Be sure to turn off DIP SW1 on the front of the device after confirming completion of FTP transfer.
- “Communications log” window can be displayed when “Local” setting has been configured (Refer to 4.3 IP ADDRESS SETTING).

8.8.3.2 VERIFICATION WITH TERMINAL SOFTWARE

(1) Connect the DL8 and the PC with the COP-US cable.

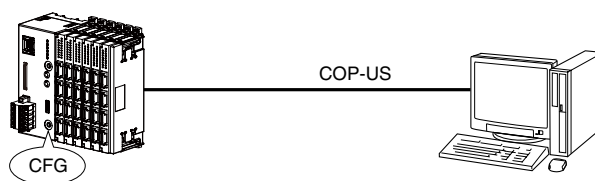

(2) Start PC terminal software program, and set communication parameters as shown below.

Baud rate : 38400 bps

Data : 8 bit

Start bit : 1

Stop bit : 1

Parity : None

(3) Turn on the DIP SW1 at the front of the DL8.

(4) When FTP transfer is started, communication log can be checked by the terminal software.
While watching the log, confirm the settings until transfer is successfully completed.

(5) After status confirmation is completed, turn off the DIP SW1.

NOTE

- When DIP SW1 on the front of the device is ON, communication with the DLCFG is not available.
After confirming completion of FTP transfer, be sure to turn it OFF.
- Hyper Terminal incorporated in Windows or other free software such as Tera Term can be used as terminal software.

8.9 LOGIN ID, PASSWORD, PORT NUMBER

Password is usable to access the DL8 web server. Set as explained below. HTTP port number can be changed.

- (1) Connect the DL8 with the COP-US cable to the PC to which the DLCFG is installed.
For connection setting, refer to 4.3 IP ADDRESS SETTING.

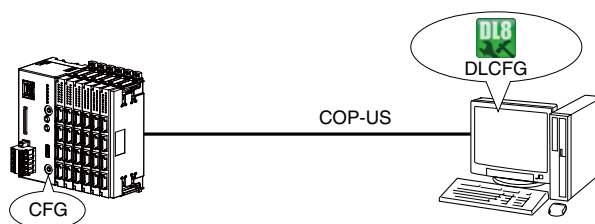

- (2) Start the DLCFG to show the main window.
Click [Download from device] button to read setting from the DL8 and to open “Configuration” window.
Click [Communication] – [Web server] button to open “Web server” dialog.

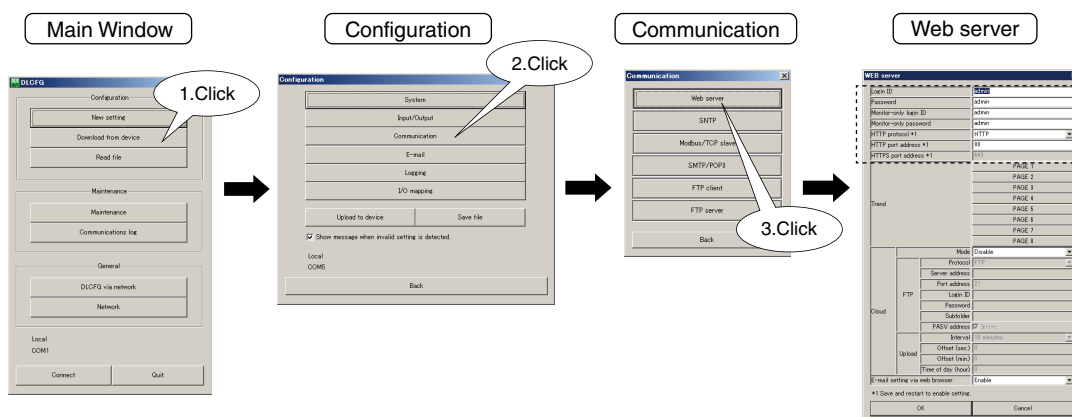

- (3) Configure the parameters according to the table below.

PARAMETER	DESCRIPTION
Login ID	Specify login name for web server of the DL8 (max. 64 characters).
Password	Specify password for web server of the DL8 (max. 64 characters).
Monitor-only login ID	Specify login name for web server of the DL8 (max. 64 characters). The user of this ID can only browse on the views without authorization for control/operation functions.
Monitor-only password	Specify password for Monitor-only login ID (max. 64 characters).
HTTP Protocol	Select the HTTP protocol between HTTP and HTTPS to be used on web server. Turn off and on the power supply to apply the setting.
HTTP port address	<ul style="list-style-type: none"> • When HTTP is selected Specify HTTP port address for web server. Save and restart to apply the setting. Set the port address to 0 to disable the web server function and not to display web pages. • When HTTPS is selected Specify HTTPS port address for downloading Certification Authority certificate. Save and restart to apply the setting. Setting the port address to 0 disables download of the certificate.
HTTPS port address	This field is active only when HTTPS is selected. Specify HTTPS port address for web server. Save and restart to apply the setting. Set the port address to 0 to disable the web server function and not to display web pages.

- (4) Click [OK] to temporarily save the setting.
To apply the new setting to the DL8, go back to “Configuration” window and click [Upload to device] button.

NOTE

- Login ID and password for the DL8 web server are used for basic identification purpose, not for any security.
- After changing login ID or password, click [Refresh] button of the browser to refresh the cache.
- For the cloud mode, refer to how to use your web server.
- Be sure to change the default ID and password.
- It is highly recommended to change the password regularly.
- HTTPS is available only for Type E.

8.10 PRINT

8.10.1 DESCRIPTIONS

Screen images are printed by print function provided by web browsers.
The screen for PC has “print mode” for printing. Print by switching to this mode.

8.10.2 PROCEDURE

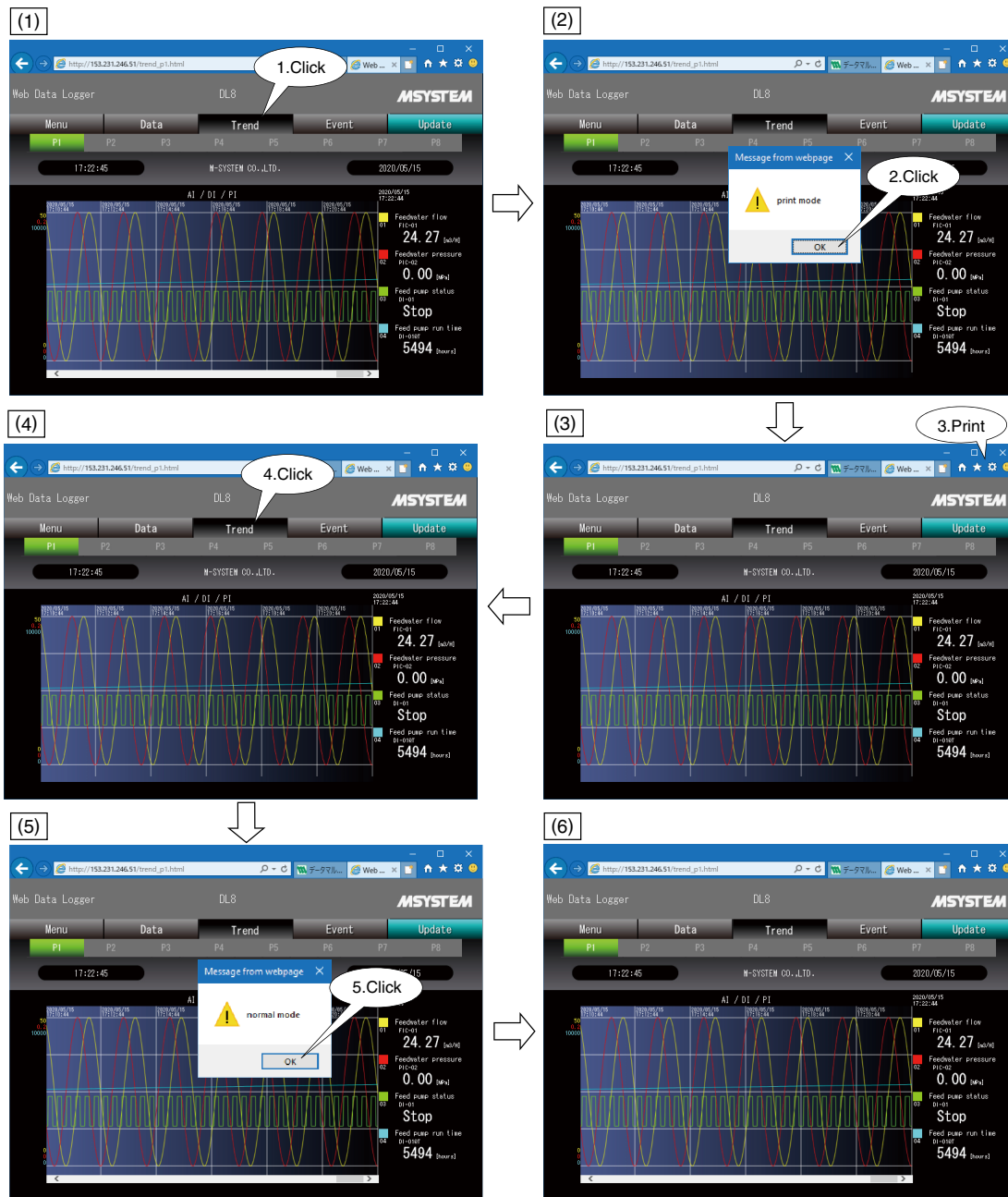

No.	OPERATION
(1)	Click [Data], [Trend], or [Event] button in the same view to switch to “print mode”. In the above example, click [Trend] button as “Trend View” is displayed.
(2)	The view is switched to “print mode” and a message appears. Click [OK].
(3)	The scroll bar disappears and the screen is fixed. Execute the print operation with this status. Regarding print, refer to 8.10.3 PRINT SETTING.
(4)	After printing is completed, click the same view selector button again to return to “normal mode”.
(5)	When the view is switched to “normal mode”, a message appears. Click [OK].
(6)	The view returns to the state as in (1).

8.10.3 PRINT SETTING

Internet Explorer, Firefox or Chrome among the browsers introduced in 8.2 TERMINAL, BROWSER can be used for printing.

8.10.3.1 INTERNET EXPLORER

Choose [File] – [Page Setup...] and set as shown below.

Check [Print Background Colors and Images] and [Enable Shrink-to-Fit].

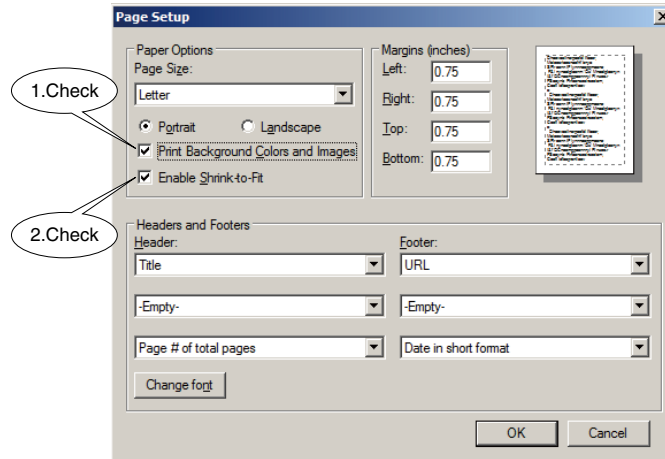

8.10.3.2 FIREFOX

Choose [File] – [Page Setup...] and set as shown below.

Check [Print Background (colors & images)] and [Shrink to fit Page Width].

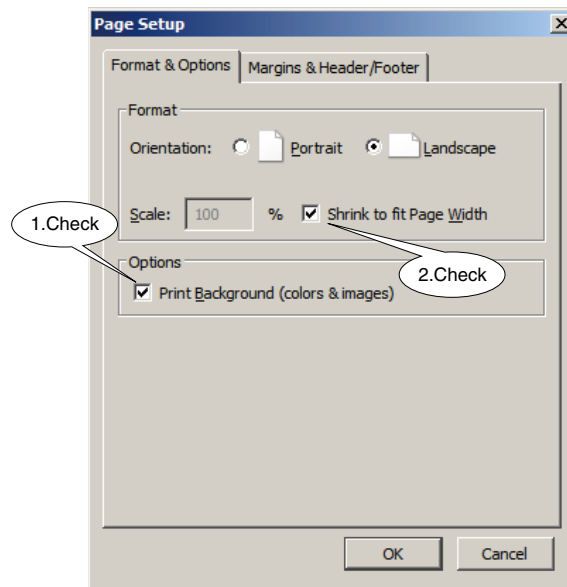

8.10.3.3 Chrome

Screen image can be printed as it is on Chrome. Setup as shown below. Check [Background graphics].

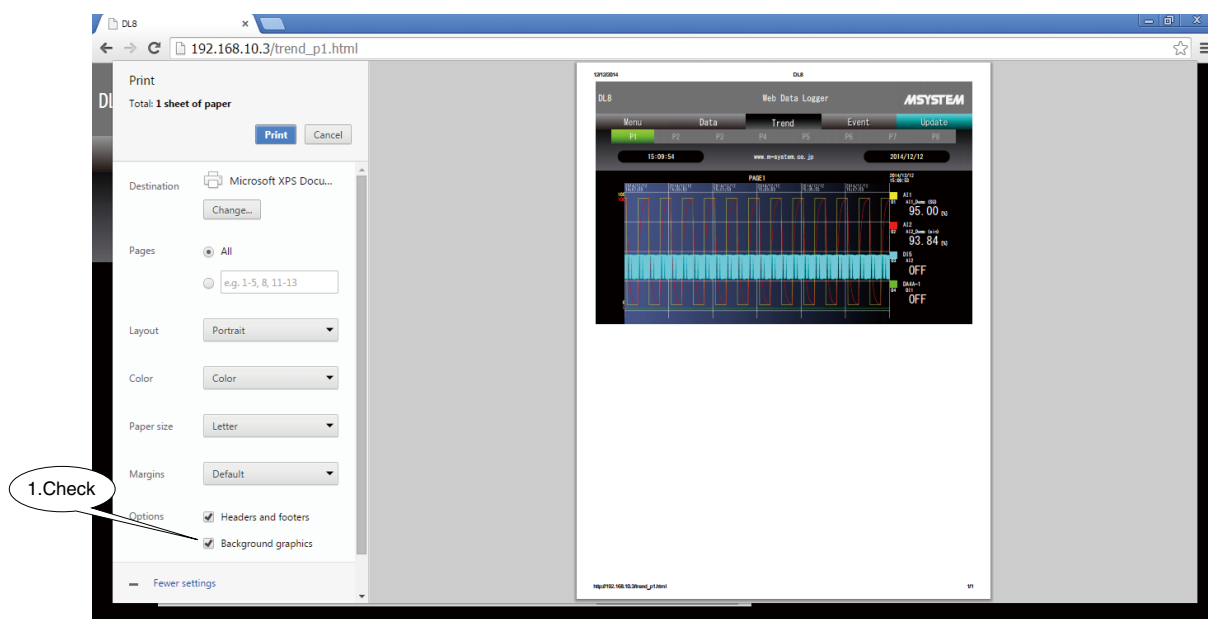

NOTE

- For the screen for smart phone, print mode is not available.
- If setup for background printing is not found, check the software version of your web browser.

9. EVENT REPORTING E-MAIL (TYPE B, C, D & E)

9.1 GENERAL DESCRIPTIONS

E-mails can be sent by event triggers (such as AI or PI going into a specified zone, DI status changing or DI count reaching a target value) or at a specified time.

The DL8 sends an e-mail to a mail server by SMTP (Simple Mail Transfer Protocol).
Each terminal receives the mail from the server.

Configure the communication setting concerning the SMTP and the mail server first.
Then configure the e-mail setting concerning e-mail addresses and messages.

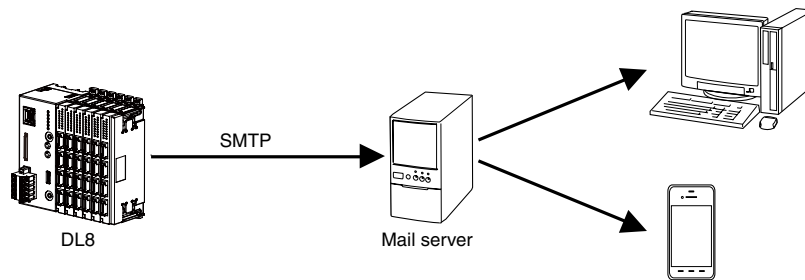

FEATURES

- The DL8 supports 'SMTP over SSL' encryptions.
- Latest input figures can be attached to the end of a mail.
- Specific DO can be manipulated when an e-mailing is complete.

NOTE

- This function is not available with Type A.
- The SMTP over SSL function is intended for encryption only.
The DL8 does not verify a certificate issued by the mail server.

9.2 COMMUNICATION SETTING

- Connect the DL8 with the COP-US cable to the PC to which the DLCFG is installed.
For connection setting, refer to 4.3 IP ADDRESS SETTING.

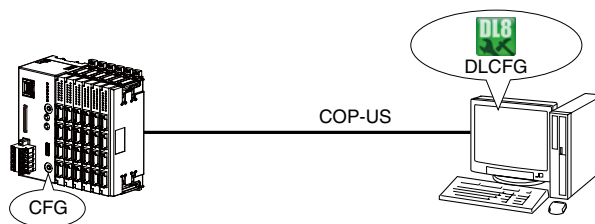

- Start the DLCFG to show the main window.
Click [Download from device] button to read setting from the DL8 and to open "Configuration" window.
Click on [Communication] – [SMTP/POP3] button to open "SMTP/POP3" dialog.

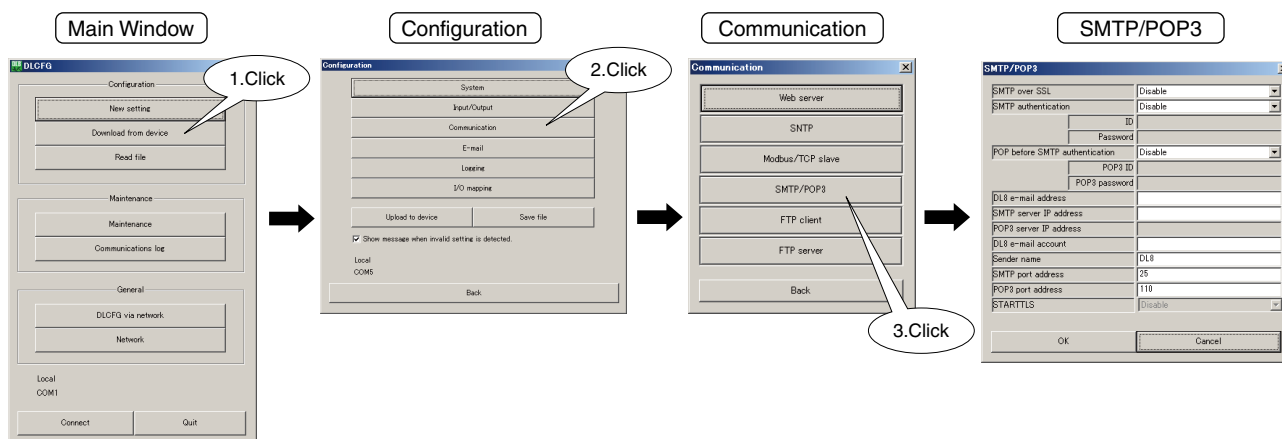

- See the following table and configure each parameter.

PARAMETER		DESCRIPTION
SMTP over SSL		Encrypted communication setting. Set "Enable" to use.
SMTP authentication	Authentication method	SMTP authentication setting Disable: No SMTP authentication Auto: Authentication algorithm is determined automatically CRAM-MD5: CRAM-MD5 authentication LOGIN: LOGIN authentication PLAIN: PLAIN authentication
	ID	Set an ID except when "Disable" is set in SMTP authentication.
	Password	Set a password except when "Disable" is set in SMTP authentication.
POP before SMTP	Authentication	Set "Enable" when POP before SMTP is required.
	POP3 ID	Set a POP3 ID when "Enable" is set in POP before SMTP.
	POP3 password	Set a POP3 password when "Enable" is set in POP before SMTP.
DL8 e-mail address		Set an e-mail address of the DL8.
SMTP server IP address		Set a domain name or IP address of SMTP server.
POP3 server IP address		Set a domain name or IP address of POP3 server. Used for POP before SMTP.
DL8 e-mail account		Set the part of e-mail address preceding "@" as an e-mail account of the DL8.
Sender name		Set a sender name to show on the recipients' screen.
SMTP port address		Set a SMTP port address.
POP3 port address		Set a POP3 port address. Used for POP before SMTP.
STARTTLS		Set "Disable" or "Enable" when "Enable" is selected in SMTP over SSL.

- Click [OK] button to save the setting temporarily.
To enable the new setting, return to "Configuration" window and click [Upload to device] button.

Setting examples for popular free e-mail services are shown in the following table (As of Nov. 2015).

PARAMETER	Yahoo mail (Yahoo Japan)	Gmail (Google)
SMTP over SSL	Disable	Enable
SMTP authentication	Auto	Auto
ID	Part of the e-mail address preceding "@" e.g. dl8	E-mail address e.g. dl8@gmail.com
Password	Registered password e.g. abcde	Registered password e.g. abcde
DL8 e-mail address	E-mail address e.g. dl8@yahoo.co.jp	E-mail address e.g. dl8@gmail.com
SMTP server	smtp.mail.yahoo.co.jp	smtp.gmail.com
DL8 e-mail account	Part of the e-mail address preceding "@" e.g. dl8	Part of the e-mail address preceding "@" e.g. dl8
SMTP port address	587	465
STARTTLS	Disable	Disable

NOTE

- POP3 is incorporated for POP before SMTP. The DL8 is unable to receive e-mails.
- Most mail servers provide means to prevent nuisance e-mails.
Please contact the management company for details.
- It is not guaranteed that this function can connect to all mail server.
- Email service providers place various restrictions on their own. In addition, there may be occasional changes in functions or the authentication method or termination of some functions they provide. To keep up with their respective restrictions and changes, check the mail communication on a regular basis and perform adequate operational administrative.

9.3 E-MAIL SETTING

The DL8 can register 32 mail addresses, 32 event messages, 1 regular message, and 1 delivery failure contact output. Setting procedure is as follows.

9.3.1 ADDRESS LIST

- (1) Connect the DL8 with the COP-US cable to the PC to which the DLCFG is installed.
For connection setting, refer to 4.3 IP ADDRESS SETTING.

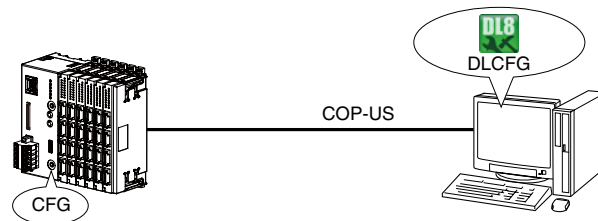

- (2) Start the DLCFG to show the main window.
Click [Download from device] button to read setting from the DL8 and to open "Configuration" window.
Click [E-mail] – [Address list] button to open "Address list."

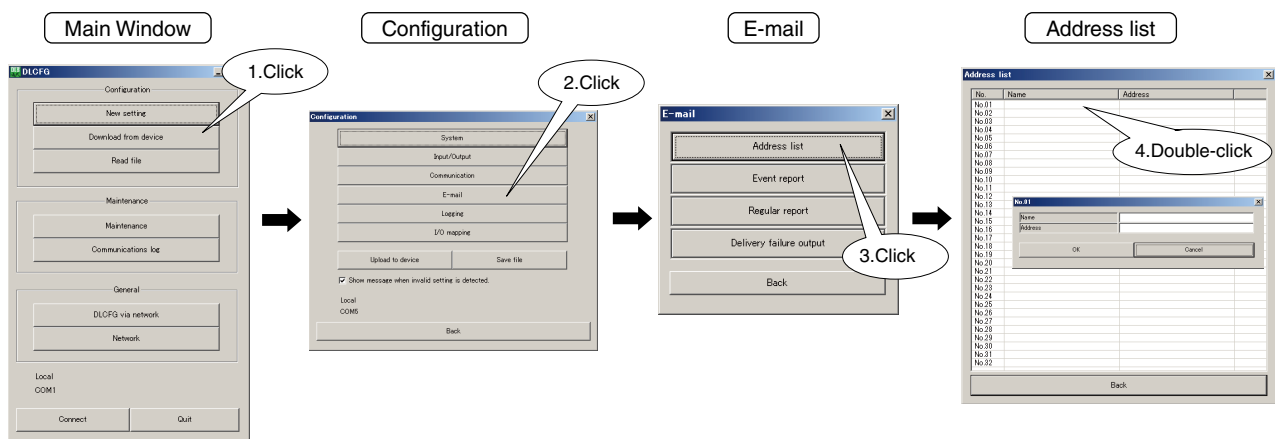

- (3) Double-click a row to display the setup dialog.
Enter a name and an e-mail address.
Repeat the process to register more mail addresses.
- (4) Click [OK] button to save the setting temporarily.
To enable the new setting, return to "Configuration" window and click [Upload to device] button.

9.3.2 EVENT REPORT

- Prepare a message reporting an event. Click [Event report] button in “E-mail” menu to open “Event report” list.
 Double-click a row to open “Event report” setting dialog.
 Set the mode to “Enable”. The DL8 does not send e-mails if the mode is set to “Disable”.

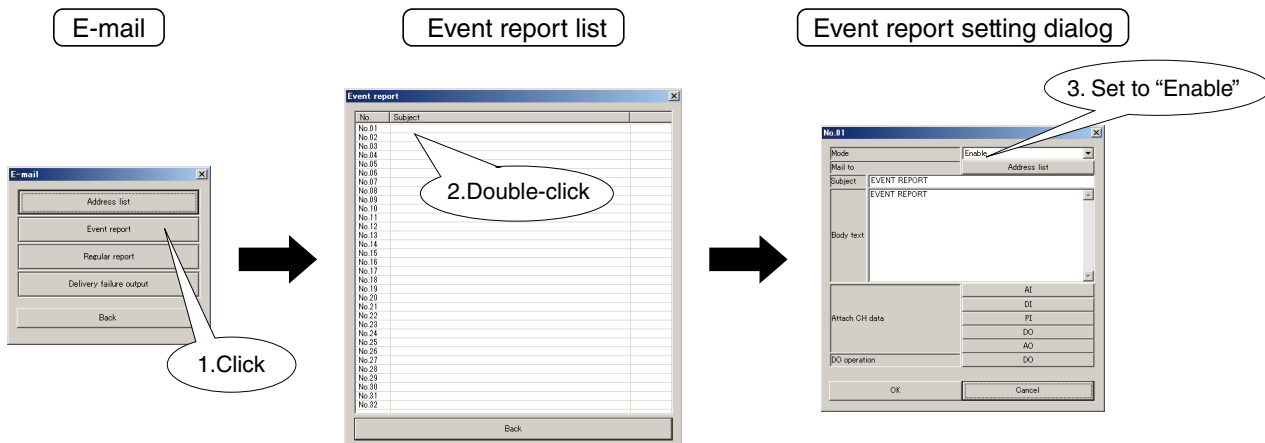

- Click [Address list] button to open “Address list”, listing names and addresses.
 Double-click over e-mail address of a recipient, and select “To” or “Cc”.
 Set “None” for those addresses to which the message is not to be sent.
 Click [OK] button to temporarily save the setting.
 Click [Back] button to return to “Event report” setting dialog upon completion of setting all recipients.

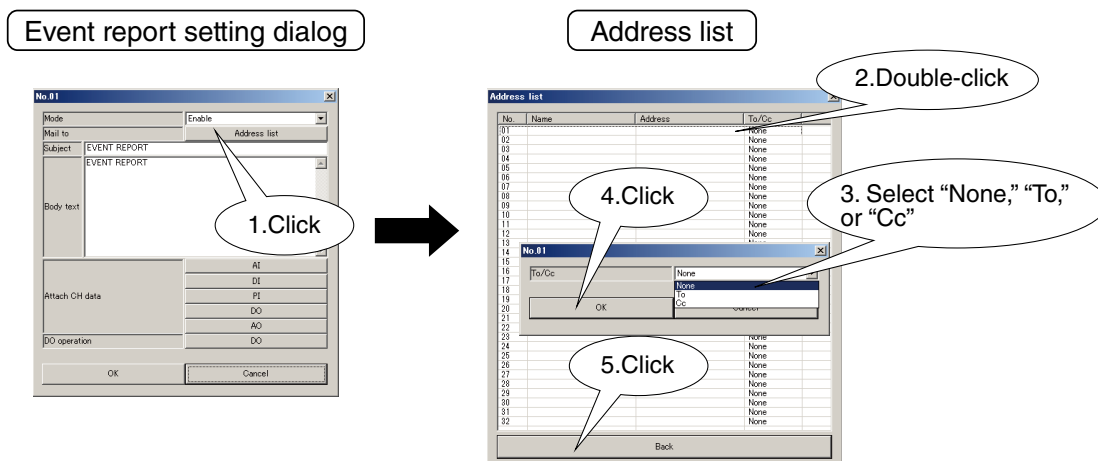

- Fill in “Subject” (max. 64 characters) and “Body text” (max. 512 characters).

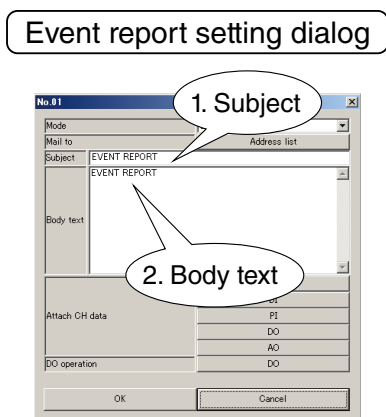

- (4) Then choose which channel data should be attached to the end of the message.
 Channel data set to "Enable" is added to the message. Set for AI, DI, and PI.
 Set also for DO and AO.

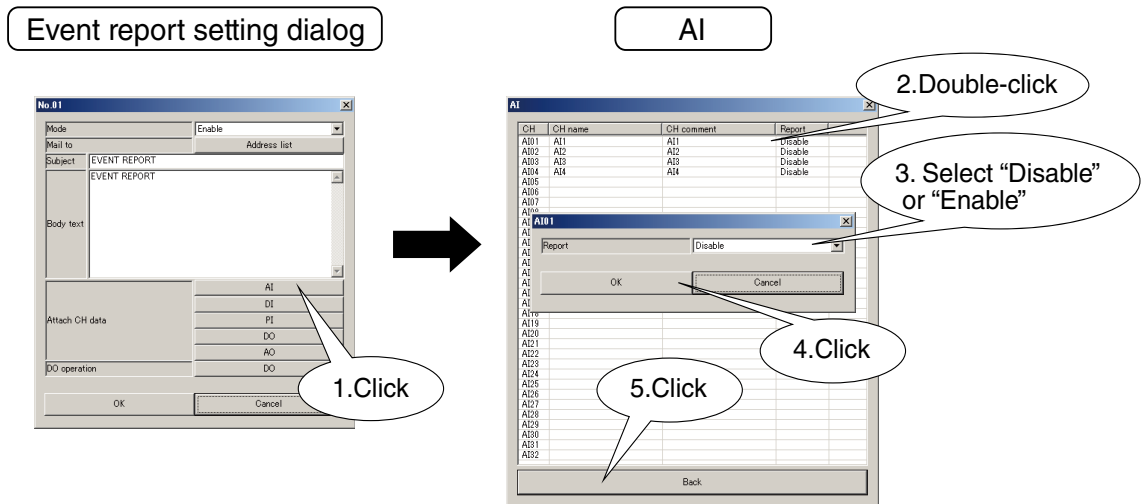

- (5) Set DOs to output upon successful mail delivery.
 DOs set to "ON" or "OFF" are manipulated. Select "None" not to use this function.

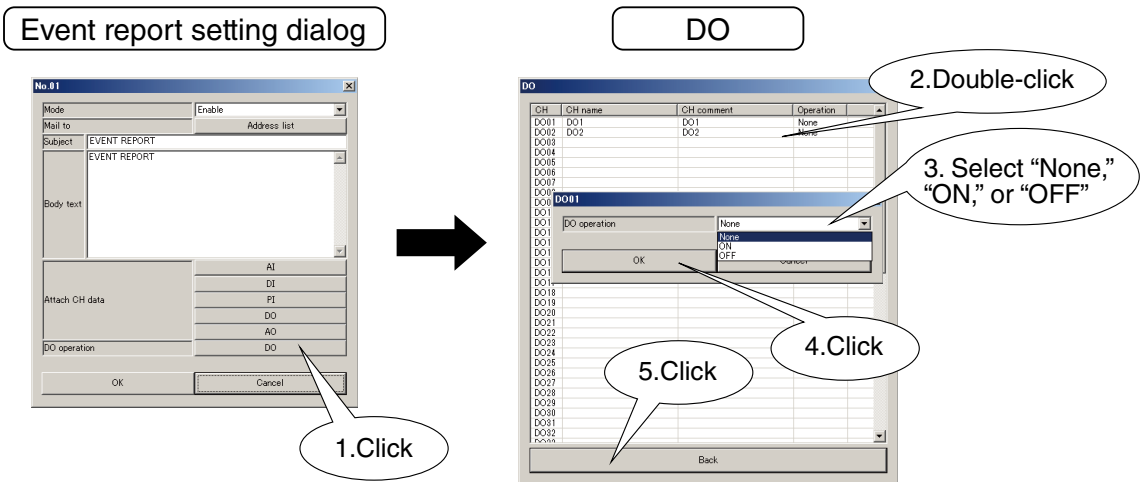

- (6) Click [OK] button to temporarily save the setting.
 To enable the setting, return to "Configuration" window and click [Upload to device] button.

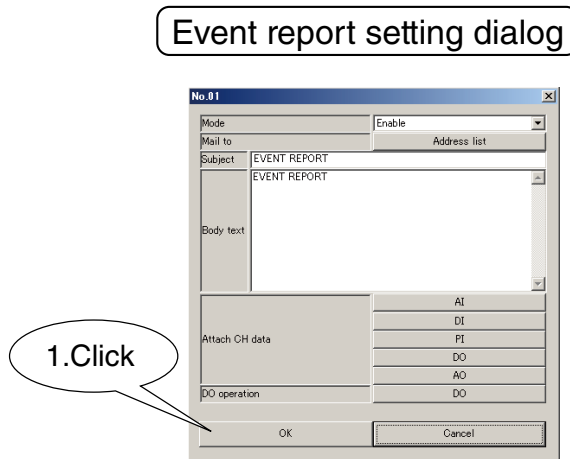

(7) Assign a prepared message to an event.

The below example illustrates how to assign an event when AI goes into a specific zone.

The setting procedure is the same for DI status changes, DI count reaching target value, or PI going into a specific zone. Click [Alarm zone setting] button in "AI" setting dialog to open "Alarm zone setting" dialog.

Click [E-mail] button in the zone to display "Select event" list.

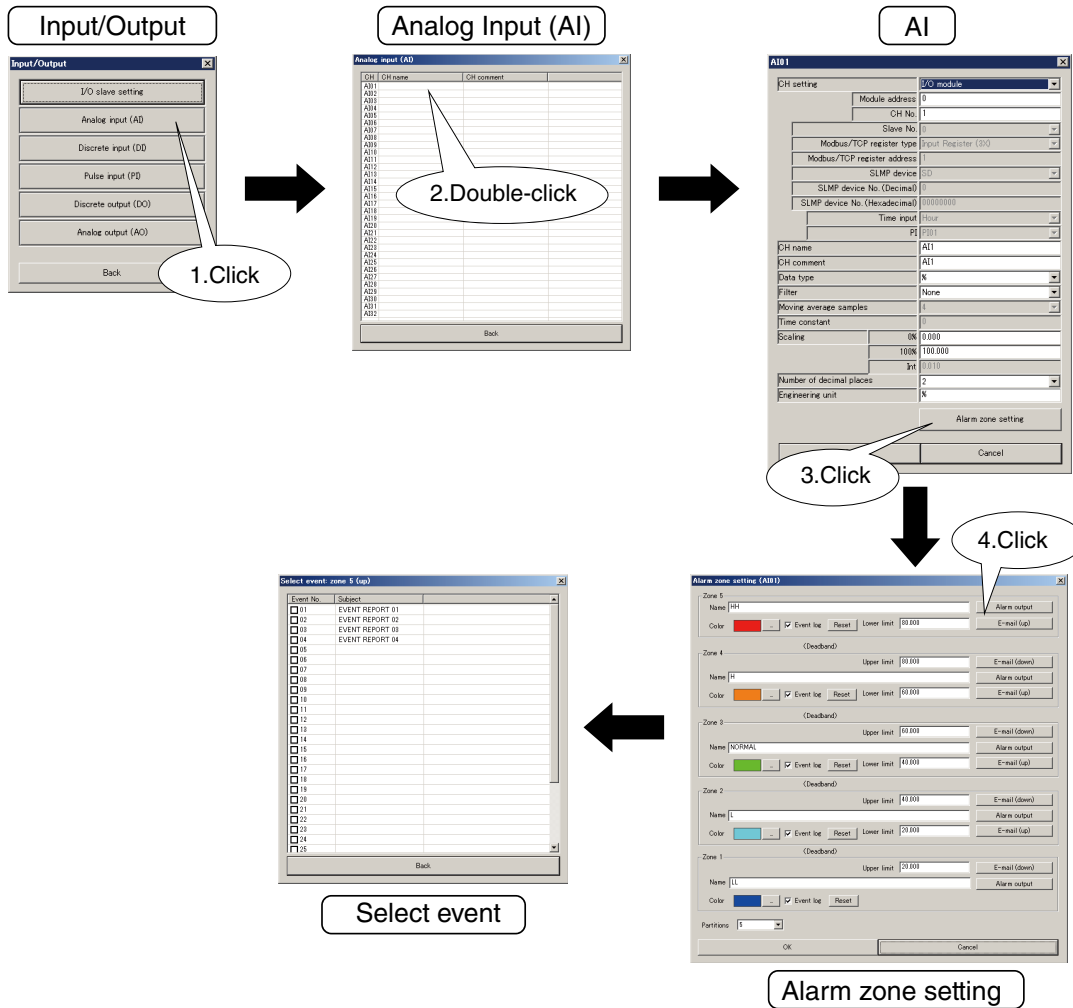

Different messages can be sent depending on the signal's transition direction (up/down) from one zone to another for AI and PI. Prepared messages for event report are listed in "Select event" list. Choose a mail to send. Transfer the setting to the DL8 on completion of setting all zones and channels.

9.3.3 COPYING MESSAGES

Messages can be copied in "Event report" list.

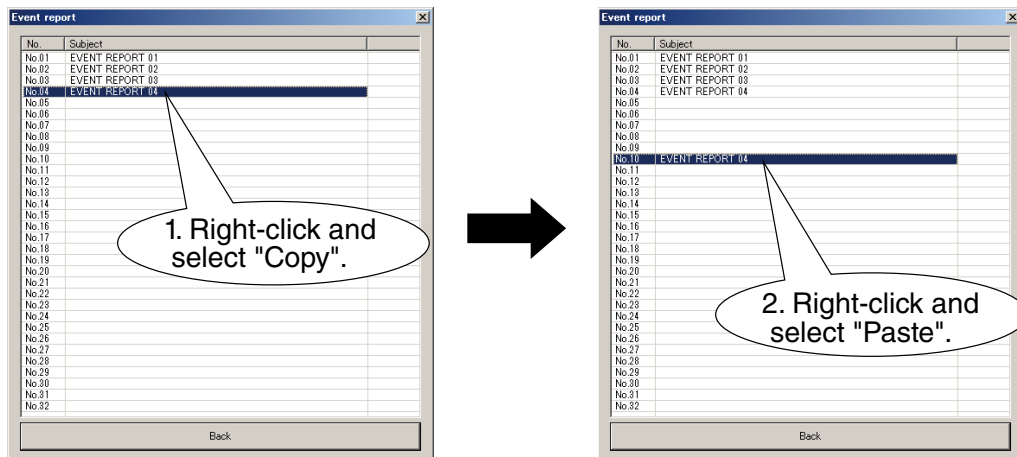

9.3.4 REGULAR REPORT

(1) Click [Regular report] button in “E-mail” menu to open “Regular report” setting dialog. Set “Mode,” “Mail to,” “Subject,” “Body text,” “Attach CH data,” and “Do operation” respectively in the same procedure as for the event report.

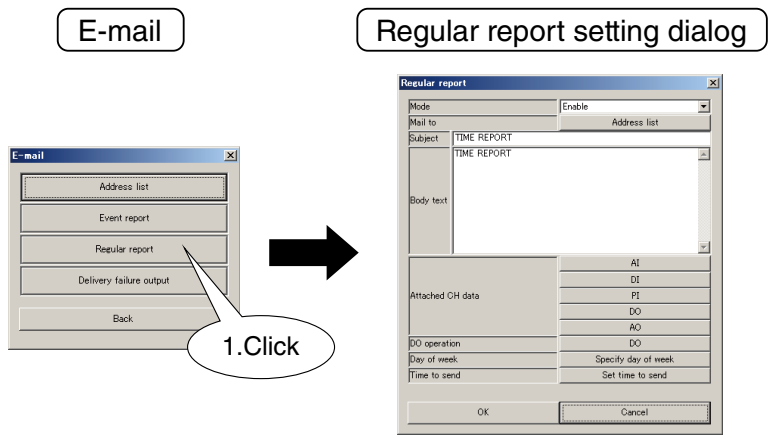

(2) Day of the week to send reports can be specified. Click [Specify day of week] button in “Regular report” setting dialog to open “Specify day of week” dialog. Remove check symbols for the days not to report, and click [OK] button.

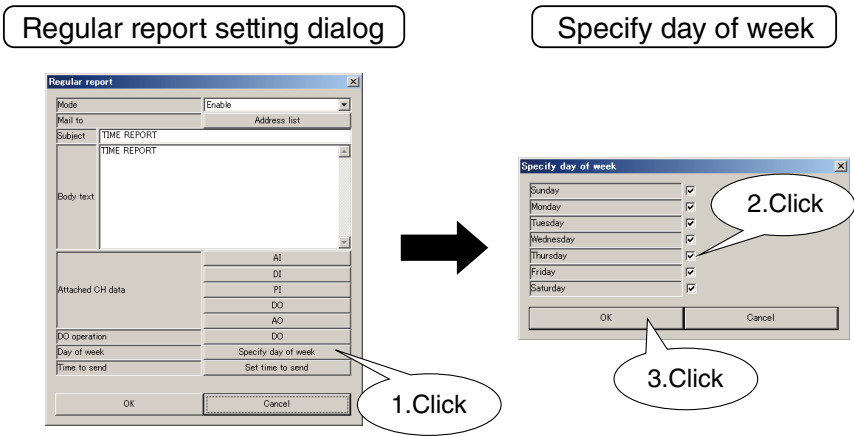

(3) Specify time to send the e-mail. Click [Set time to send] button in “Regular report” setting dialog to open “Set time to send” list. Double-click over a time of day among 0 to 23 hours to show the setup dialog. Set whether or not to report regularly (“Enable” or “Disable”) at the timing. Also set time offset (minute & second) if necessary. Click [Back] button to return to “Regular report” setting dialog upon completion of setting all hours.

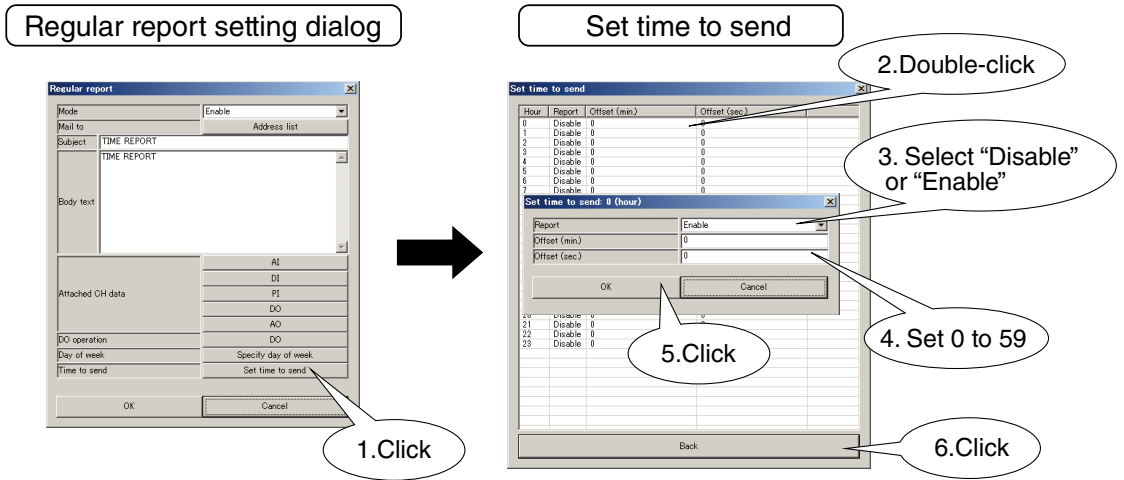

(4) Click [OK] button to temporarily save the setting. To enable the setting, return to “Configuration” window and click [Upload to device] button.

9.3.5 DELIVERY FAILURE OUTPUT

A contact signal output can be set to report an undelivered mail.

The assigned DO channel is turned off upon successful mail delivery and on upon failure.

Set "None" not to use this function.

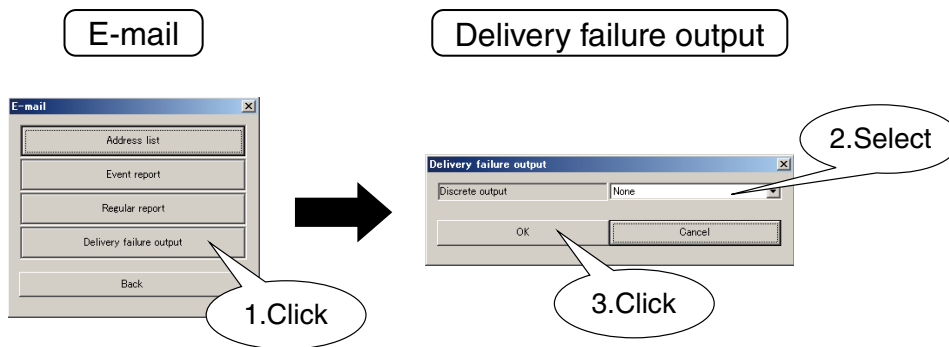

NOTE

- A contact output (control output, alarm output, and I/O mapping DO) is provided by logical OR operation.
- Contact output can be turned off via web server or Modbus/TCP server regardless of delivery failure status.
- We recommend that the delivery failure contact be assigned to a dedicated DO channel, not shared with other alarm contact outputs or control outputs.
- Maximum data volume of one e-mail attached with CH data is limited to approx. 4 kB.
If a large volume of CH data is attached, some of the data may not be sent completely.

9.4 TEST MAIL

Event report and regular report can be tested by sending mails manually from the DL8.

- (1) Connect the DL8 with the COP-US cable to the PC to which the DLCFG is installed.
For connection setting, refer to 4.3 IP ADDRESS SETTING.

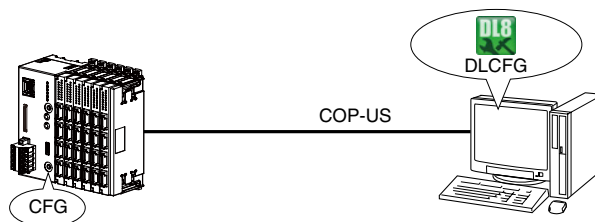

- (2) Start the DLCFG to show the main window. Click [Maintenance] button to open “Maintenance” menu.
Click [Test mail] button to read setting from the DL8 and to open “Test mail” dialog.

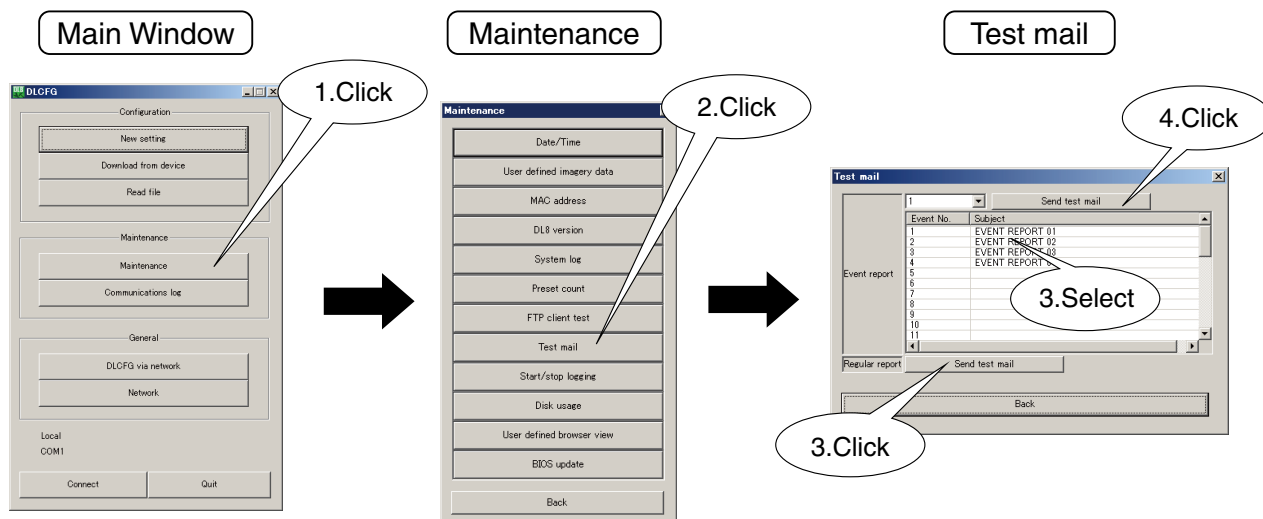

- **To test an event report**

Select one in “Event report” list and click [Send test mail] button at the top of the window.

- **To test a regular report**

Click [Send test mail] button next to “Regular report”.

- (3) Confirm that the terminal receives the e-mail. COM LED blinks while the DL8 is sending a mail.

NOTE

- When the mode of a message in the event or regular report is set to “Disable,” test mailing of the message is not possible.
- The mail server may automatically sort the e-mail as a nuisance mail depending on the message contents.

9.5 MAIL SETTING VIA WEB BROWSER

9.5.1 DESCRIPTION

“Address list,” “Mode,” “Subject,” “Body,” and mail recipients can be changed via web browser. Test mail is also available.

9.5.2 SETTING

- (1) Connect the DL8 with the COP-US cable to the PC to which the DLCFG is installed.
For connection setting, refer to 4.3 IP ADDRESS SETTING.

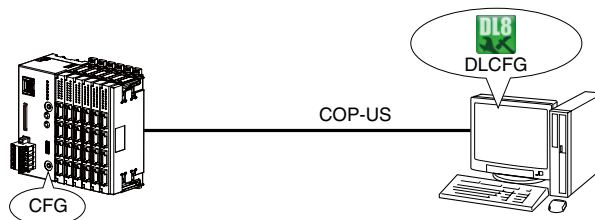

- (2) Start the DLCFG to show the main window.
Click [Download from device] button to read setting from the DL8 and to open “Configuration” window.
Click [Communication] – [Web server] to open “Web server” dialog.

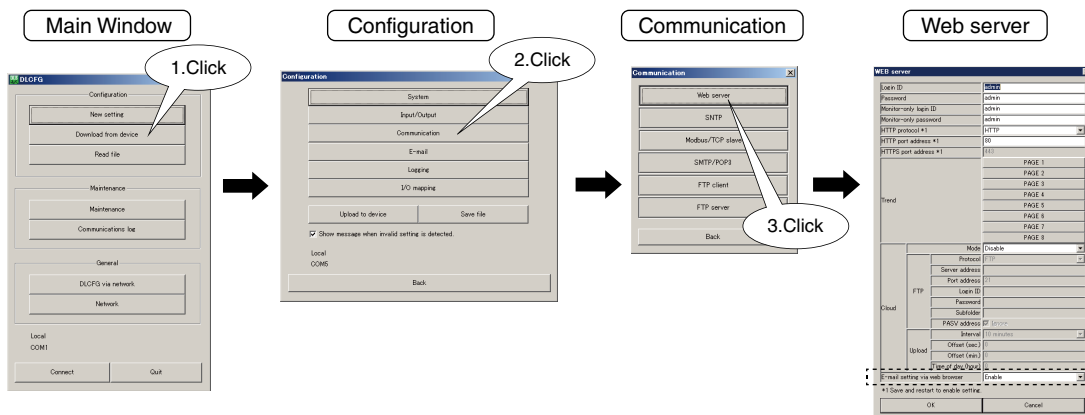

- (3) Set E-mail setting via web browser

PARAMETER	DESCRIPTION
E-mail setting via web browser	By selecting "Enable," "E-mail setting" view can be displayed on the web browser.

9.5.3 ACCESSING THE URL

(1) Specify the URL below on your browser.

• **MAIL SETTING:**
[Domain name or IP address of the router or the DL8]/cfg_e/mail.html

(2) Enter the login ID and your password.

• **LOGIN ID:**
dl8cfg
• **PASSWORD:**
Password set for the DLCFG access via network. Refer to 14.3 DLCFG VIA NETWORK.

(3) Once the ID and your password is authenticated, “E-mail setting” as shown below opens.

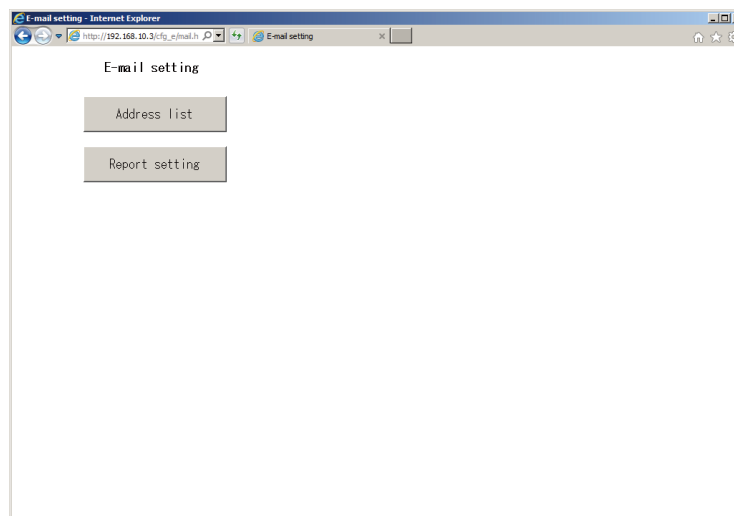

9.5.4 ADDRESS LIST

Click [Address list] in “E-mail setting” view to open “Address list” setting.
Edit names and e-mail addresses in the list, and click [OK].

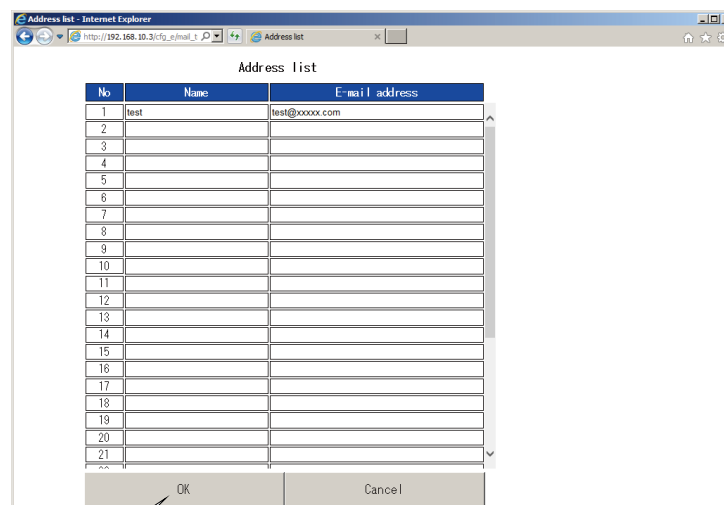

1.Click

9.5.5 REPORT SETTING

(1) Click [Report setting] in “E-mail setting” view to open “Report setting”

A maximum of 32 event message templates and 1 regular mail template can be created and edited.

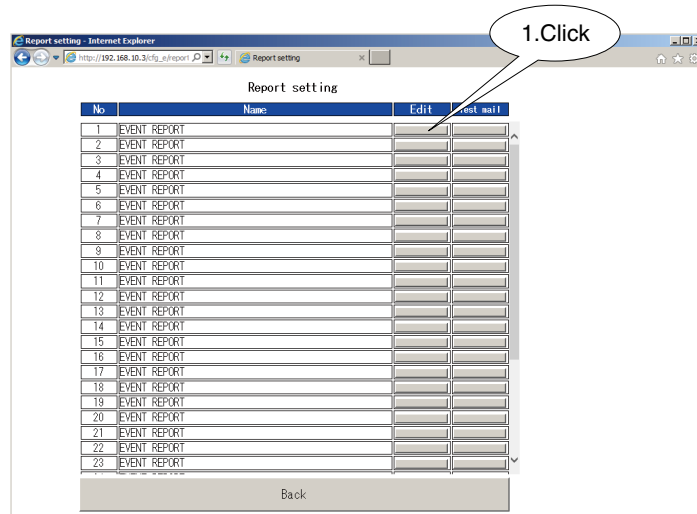

(2) Click [Edit] button to open a template as shown below. Edit its contents and click [OK] to save.

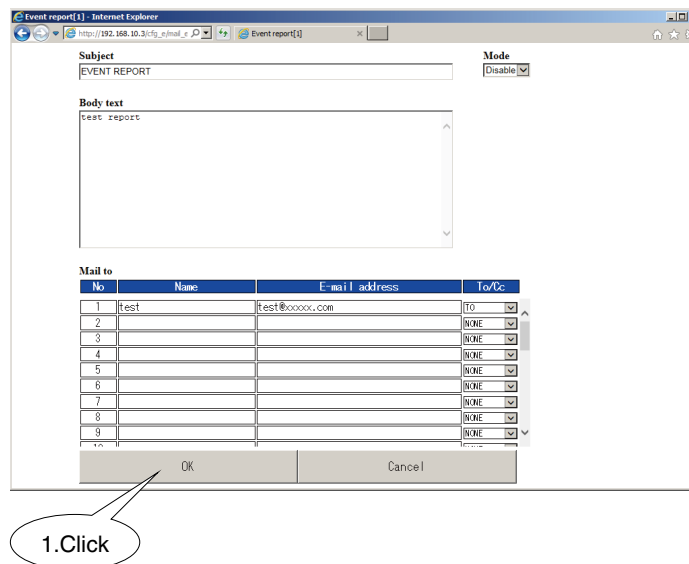

(3) Click [Test mail] button to send a test mail.

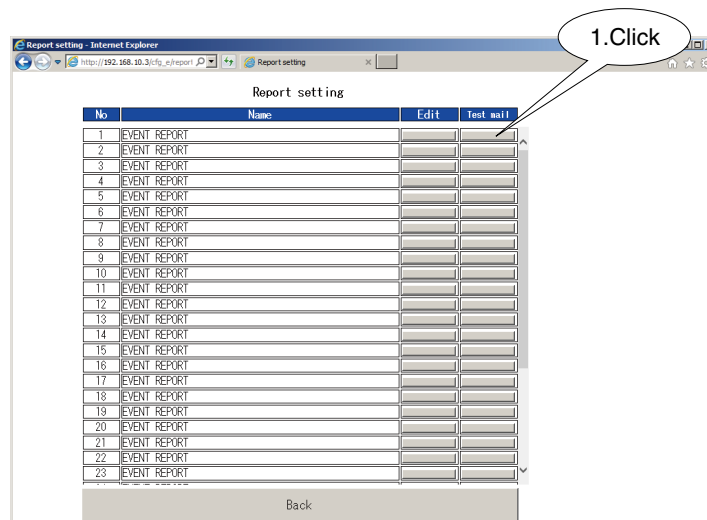

9.6 RETRANSMISSION

The DL8 retries transmission of an undelivered message in 30 seconds after timeout, up to 5 times, and then discards the message if it is still not sent.

9.7 DISABLING E-MAIL FUNCTION

The e-mail function can be disabled by turning on the front DIP SW2. Event, regular, or test mails generated while in the disabled mode are discarded without being sent.

9.8 STATUS VERIFICATION

The e-mailing status can be confirmed via terminal software in the same way as in the cloud access mode of the web server.

Refer to 8.8.3 STATUS VERIFICATION.

NOTE

- The DL8 can hold up to 64 messages in its mail buffer memory. When multiple events occur simultaneously or in case of delivery failure, up to 64 messages are saved temporarily, while those beyond 64 are discarded.
- Mails stored in the mail buffer memory are lost when the power supply is turned off.

10. FTP CLIENT (TYPE B, C, D & E)

10.1 GENERAL DESCRIPTIONS

Data collected at a specified interval can be uploaded to an FTP server in CSV format by using the FTP client function.

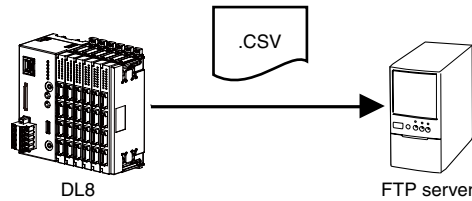

10.2 SPECIFICATIONS

PARAMETER	DESCRIPTION
FTP	Passive mode
FTPS	Explicit mode
Channel	Max. 32 channels (AI, DI, DI (counter), PI, DO, and AO)
Sampling rate (synchronized with internal clock)	1 sec. / 2 sec. / 5 sec. / 10 sec. / 30 sec. / 1 min. / 2 min. / 5 min. / 10 min. / 15 min. / 20 min. / 30 min.
Transfer interval (synchronized with internal clock)	Sampling rate 1 or 2 sec.: Transferred every 1 min., 10 min. or 1 hour (selectable) Sampling rate 5, 10 or 30 sec.: Transferred every 10 min. or 1 hour (selectable) Sampling rate 1, 2, 5, 10, 15, 20 or 30 min.: Transferred every day (fixed) Dateline can be specified.
File name	User defined name using date/time of the leading sample. Up to 64 characters (including the file extension) using: [YEAR]; [MONTH]; [DAY]; [HOUR]; [MIN]; and/or [SEC]. e.g. DB[YEAR][MON][DAY].CSV to be transferred as DB20130304.CSV
Header	User defined header can be added in comma-separated text strings (Up to 3 rows).
Column contents	1st column: Date/time (2013/03/04 15:00:00) 2nd and following columns: Data for 32 channels AI, PI, AO: Engineering unit value DI, DO: Text assigned to status DI (counter): Count value
Data format	AI, PI, AO: Engineering unit value DI (counter): Count value DI, DO: Text assigned to status
FTP file size	Max. 1 MB per file
FTP retry	Resent in 2 minutes after transmission failure. Data is discarded with successful transfer. Retried every 2 minutes until next scheduled transfer timing. Data is discarded when the next timing comes. Not retried with 1-minute transfer cycle. Data is discarded at transmission failure.
Behavior in correcting time	<ul style="list-style-type: none"> When adjusting the clock forward DL8 continues storing data. When adjusting the clock backward for 10 sec. or more DL8 creates a new file to store data again. When adjusting the clock backward within 10 sec. DL8 waits until the clock reaches the time when the latest data was stored and starts storing data.

■ [Data sample]

	A	B	C	D	E	F	G	H	I	J	K	L	M	N
1		CH01	CH02	CH03	CH04	CH05	CH06	CH07	CH08	CH09	CH10	CH11	CH12	CH13
2		AI 20	AI 21	AI 22	AI 23	DI 21	DI 22	DI(Counter)64	PI 01	PI 02	DO 29	DO 30	DO 31	DO 32
3		demo AI1	demo AI2	demo AI3	demo AI4	demo DI1	demo DI2	DI64	demo PI1	demo PI2	DO29	DO30	DO31	DO32
4	2014/6/12/20:00:00	95.24	67.2	4.75	5 OFF	OFF	OFF	0	44111382	44110582	OFF	OFF	OFF	OFF
5	2014/6/12/20:00:01	96.48	56.83	3.51	5 OFF	OFF	OFF	0	44111482	44110682	OFF	OFF	OFF	OFF
6	2014/6/12/20:00:02	97.55	48.19	2.44	5 OFF	OFF	OFF	0	44111582	44110782	OFF	OFF	OFF	OFF
7	2014/6/12/20:00:03	98.42	40.99	1.57	5 OFF	OFF	OFF	0	44111682	44110882	OFF	OFF	OFF	OFF
8	2014/6/12/20:00:04	99.11	34.99	0.88	5 OFF	OFF	OFF	0	44111782	44110982	OFF	OFF	OFF	OFF
9	2014/6/12/20:00:05	99.6	29.99	0.39	5 OFF	OFF	OFF	0	44111882	44111082	OFF	OFF	OFF	OFF
10	2014/6/12/20:00:06	99.9	25.82	0.09	5 OFF	OFF	OFF	0	44111982	44111182	OFF	OFF	OFF	OFF
11	2014/6/12/20:00:07	99.99	22.35	0	5 OFF	OFF	OFF	0	44112082	44111282	OFF	OFF	OFF	OFF
12	2014/6/12/20:00:08	99.9	19.45	0.09	5 OFF	OFF	OFF	0	44112182	44111382	OFF	OFF	OFF	OFF
13	2014/6/12/20:00:09	99.6	17.04	0.39	5 ON	ON	ON	0	44112282	44111482	OFF	OFF	OFF	OFF
14	2014/6/12/20:00:10	99.11	15.09	0.88	5 ON	ON	ON	0	44112382	44111582	OFF	OFF	OFF	OFF
15	2014/6/12/20:00:11	98.42	13.35	1.57	5 ON	ON	ON	0	44112482	44111682	OFF	OFF	OFF	OFF
16	2014/6/12/20:00:12	97.55	11.95	2.44	5 ON	ON	ON	0	44112582	44111782	OFF	OFF	OFF	OFF
17	2014/6/12/20:00:13	96.48	10.79	3.51	5 ON	ON	ON	0	44112682	44111882	OFF	OFF	OFF	OFF
18	2014/6/12/20:00:14	95.24	9.82	4.75	5 ON	ON	ON	0	44112782	44111982	OFF	OFF	OFF	OFF
19	2014/6/12/20:00:15	93.81	9.01	6.18	5 ON	ON	ON	0	44112882	44112082	OFF	OFF	OFF	OFF
20	2014/6/12/20:00:16	92.21	8.34	7.78	5 ON	ON	ON	0	44112982	44112182	OFF	OFF	OFF	OFF
21	2014/6/12/20:00:17	90.45	7.78	9.54	5 OFF	OFF	OFF	0	44113082	44112282	OFF	OFF	OFF	OFF
22	2014/6/12/20:00:18	88.52	7.31	11.47	5 OFF	OFF	OFF	0	44113182	44112382	OFF	OFF	OFF	OFF
23	2014/6/12/20:00:19	86.44	6.92	13.55	5 OFF	OFF	OFF	0	44113282	44112482	OFF	OFF	OFF	OFF
24	2014/6/12/20:00:20	84.22	6.6	15.77	5 OFF	OFF	OFF	0	44113382	44112582	OFF	OFF	OFF	OFF
25	2014/6/12/20:00:21	81.87	6.33	18.12	5 OFF	OFF	OFF	0	44113482	44112682	OFF	OFF	OFF	OFF
26	2014/6/12/20:00:22	79.38	6.1	20.31	5 OFF	OFF	OFF	0	44113582	44112782	OFF	OFF	OFF	OFF
27	2014/6/12/20:00:23	76.79	5.91	23.2	5 OFF	OFF	OFF	0	44113682	44112882	OFF	OFF	OFF	OFF
28	2014/6/12/20:00:24	74.08	5.75	25.91	5 OFF	OFF	OFF	0	44113782	44112982	OFF	OFF	OFF	OFF
29	2014/6/12/20:00:25	71.28	5.62	28.71	5 OFF	OFF	OFF	0	44113882	44113082	OFF	OFF	OFF	OFF
30	2014/6/12/20:00:26	68.4	5.51	31.59	5 OFF	OFF	OFF	0	44113982	44113182	OFF	OFF	OFF	OFF
31	2014/6/12/20:00:27	65.45	5.42	34.51	5 OFF	OFF	OFF	0	44113982	44113182	OFF	OFF	OFF	OFF
32	2014/6/12/20:00:28	62.43	5.35	37.56	5 OFF	OFF	OFF	0	44113982	44113182	OFF	OFF	OFF	OFF
33	2014/6/12/20:00:29	59.36	20.29	40.63	95 ON	ON	ON	0	44114082	44113282	OFF	OFF	OFF	OFF
34	2014/6/12/20:00:30	56.26	32.74	43.73	95 ON	ON	ON	0	44114182	44113382	OFF	OFF	OFF	OFF
35	2014/6/12/20:00:31	53.14	43.11	46.85	95 ON	ON	ON	0	44114282	44113482	OFF	OFF	OFF	OFF
36	2014/6/12/20:00:32	50	51.75	49.99	95 ON	ON	ON	0	44114382	44113582	OFF	OFF	OFF	OFF

NOTE

- This function is not available with Type A.
- Data is discarded at power failure.
- Seconds are not indicated in opening a CSV file using Excel, however you can confirm in a text editor that they are recorded. They can be indicated by setting the cell format to “yyyy/m/d h:mm:ss” in Excel.
- Check the file size if some part of the data is not indicated on a PC application.
- The transfer interval setting is ignored by the DL8 version 1.1 or earlier.
- FTP transfer is executed in passive mode.
- FTP server must be provided by the user.

10.3 SETTING

- (1) Connect the DL8 with the COP-US cable to the PC to which the DLCFG is installed.
For connection setting, refer to 4.3 IP ADDRESS SETTING.

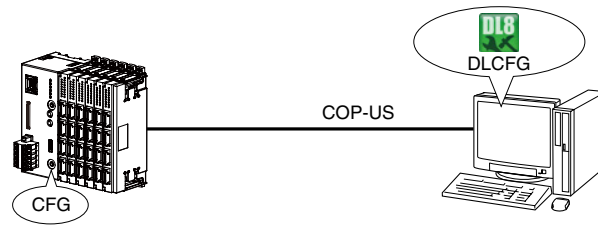

- (2) Start the DLCFG to show the main window.
Click [Download from device] button to read setting from the DL8 and to open “Configuration” window.
Click [Communication] button to open “Communication” menu.
Click [FTP client] button to open “FTP client” dialog.

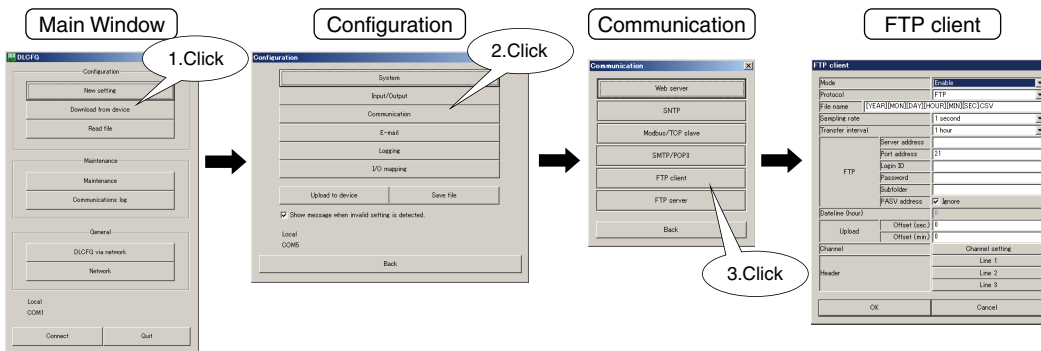

- (3) See the following table and configure each parameter.

PARAMETER	DESCRIPTION	
Mode	Select “Disable” or “Enable” for the FTP client function.	
Protocol	Select the protocol between FTP and FTPS. FTPS is used in explicit mode.	
File name	Enter a file name according to the specifications.	
Sampling rate	Select from the pull-down list.	
Transfer rate	Select from the pull-down list.	
FTP	Server address	Set a domain name or IP address of the FTP server.
	Port address	Set a port address.
	Login ID	Set an ID to log into the FTP server.
	Password	Set a password to log into the FTP server.
	Subfolder	Set a subfolder name. If left blank, CSV files are transferred to the root directory.
	PASV address	Ignore addresses returned with PASV mode. Uncheck when the server address of control connection and data connection are different.
Dateline (hour)	Set the time to transfer among 0 to 23 hours with the storing interval 1 min. or more.	
Upload	Offset (minute)	Set time offset (minute) on the hour to transfer. Valid with the transfer cycle 1 hour or longer.
	Offset (second)	Set time offset (second) on the hour to transfer. Valid with the transfer cycle 10 min. or longer.
Channel	Assign channels to store from CH 01 to 32.	
Header	Set headers in comma-separated text strings. Max. 3 rows (1024 letters or less per row) are available.	

- (4) Click [OK] button to temporarily save the setting.
To enable the setting, return to “Configuration” window and click [Upload to device] button.

10.4 TEST TRANSMISSION

FTP test transmission is available using the DLCFG. Follow the procedure as explained below.

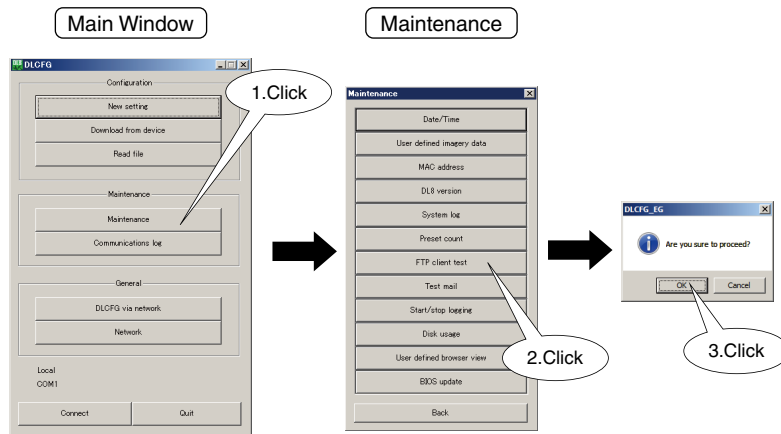

The DL8 sends data stored in the memory and at the moment of the transmission.

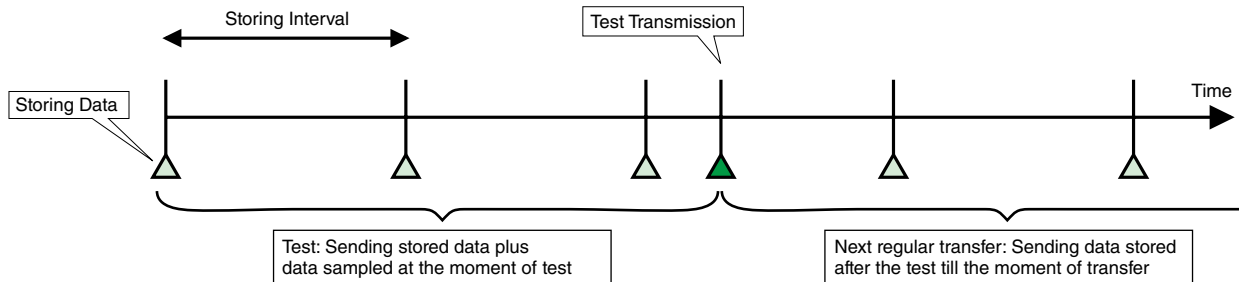

NOTE

- If test transmissions are repeated multiple times, data sent in the following regular transmission is the one from the last test to the scheduled transmission time.
- If the FTP client test file name is the same as that of the regular transmission, the older one is overwritten.

10.5 STATUS VERIFICATION

You can check transmission status via terminal software in the same way as in the cloud access mode of the web server. Refer to 8.8.3 STATUS VERIFICATION.

NOTE

- To verify transmission status while conducting a test transmission, connect the DLCFG via network. Refer to 14.3 DLCFG VIA NETWORK.

11. LOGGING FUNCTION (TYPE C, D & E)

11.1 GENERAL DESCRIPTIONS

The DL8 can store data and various log files in a SD card.

ITEM	DESCRIPTION
Data logging	Sampled data is saved in CSV format.
System log	System information regarding the DL8 is saved in a text format.
Event log	Event information is saved collectively in a file of text format.
Mailing log	Mailing history information is saved per channel in a file of text format.
Channel event log	Event information is saved in a text format.

NOTE

- This function is not available with Type A or B.
- Logging must be stopped before uploading a setting regarding logging to the DL8. (Refer to 11.3.2 SETTING.)
- The DL8 stops storing data in the SD card when it is full.
If "Auto file delete" is disabled, delete data manually as needed.
Refer to 11.3.1 SPECIFICATIONS and 12. FTP SERVER (TYPE C, D & E).

11.2 UNIT OPERATION AND LED INDICATION

11.2.1 SD CARD

11.2.1.1 INSERTING SD CARD

Place an SD card with its terminal surface faced to the left, and gently push it into the slot until it hits the bottom. SD CARD LED turns on when the card is recognized.

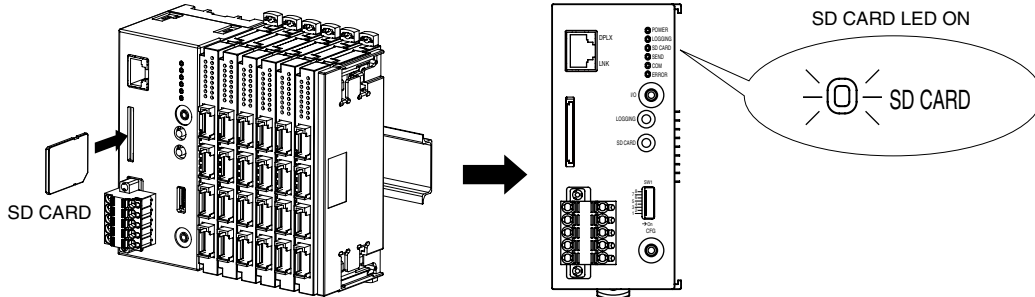

11.2.1.2 EJECTING SD CARD

- (1) Make sure that DL8 is not logging. Logging must be stopped.
- (2) Hold down SD CARD button for 4 sec. or more until SD CARD LED turns off.
- (3) Push in the SD card and release it to unlock. Remove the card gently.

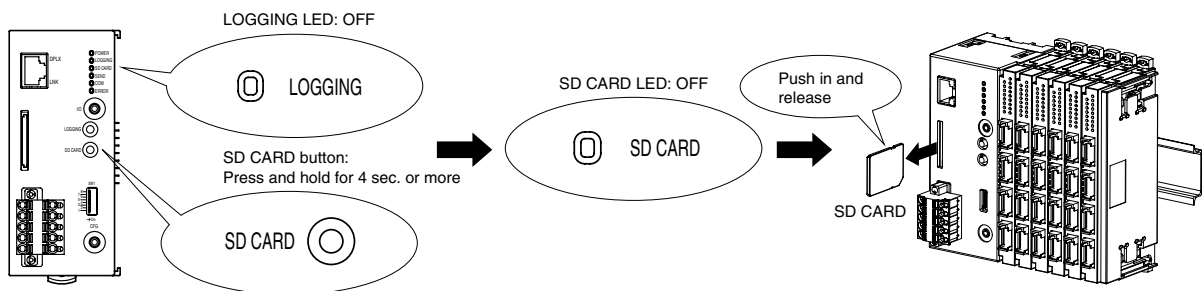

11.2.1.3 SD CARD LED

SD CARD LED turns on in recognizing a card. The LED blinks when the card memory is accessed.

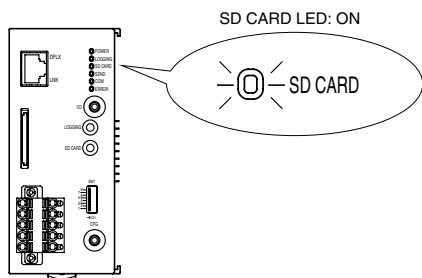

11.2.2 LOGGING

11.2.2.1 STARTING LOGGING

- (1) Make sure that the DL8 recognizes the SD card.
- (2) Press and hold LOGGING button for 1 sec. or more to start logging functions set to "Enable" in advance. Refer to each section for the setting.

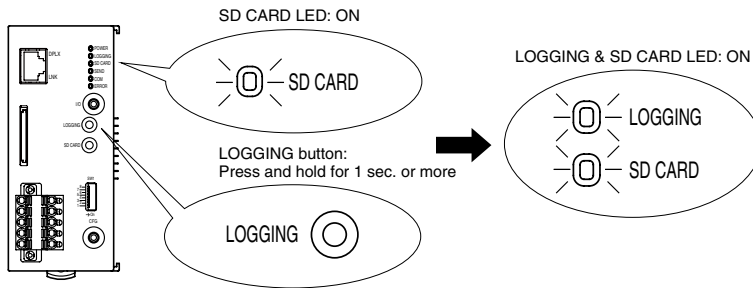

11.2.2.2 STOPPING LOGGING

Press and hold LOGGING button for 1 sec. or more while the logging function is running.

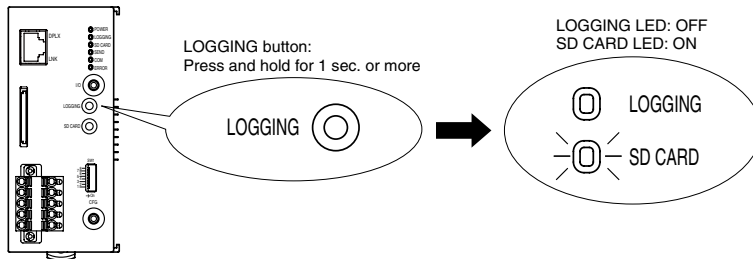

11.2.2.3 LOGGING LED

LOGGING LED turns on while one or more logging function(s) is/are running.

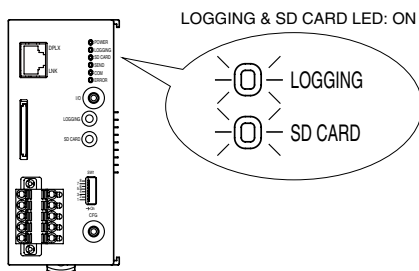

NOTE

- Be sure to stop logging before turning off the power of the DL8.

11.2.2.4 AUTO START

The logging functions set to “Enable” can be started automatically when the power is supplied to the DL8. The setting procedure is as follows.

- (1) Connect the DL8 with the COP-US cable to the PC to which the DLCFG is installed.
For connection setting, refer to 4.3 IP ADDRESS SETTING.

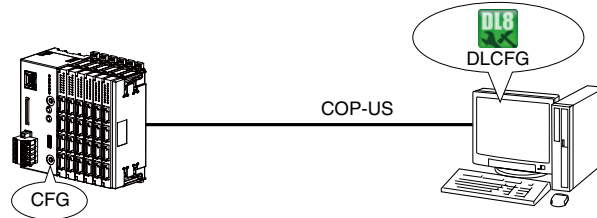

- (2) Start the DLCFG to show the main window.
Click [Download from device] button to read setting from the DL8 and to open “Configuration” window.
Click [Logging] button to open “Logging” menu.
Then click [General] button to show “General” dialog.

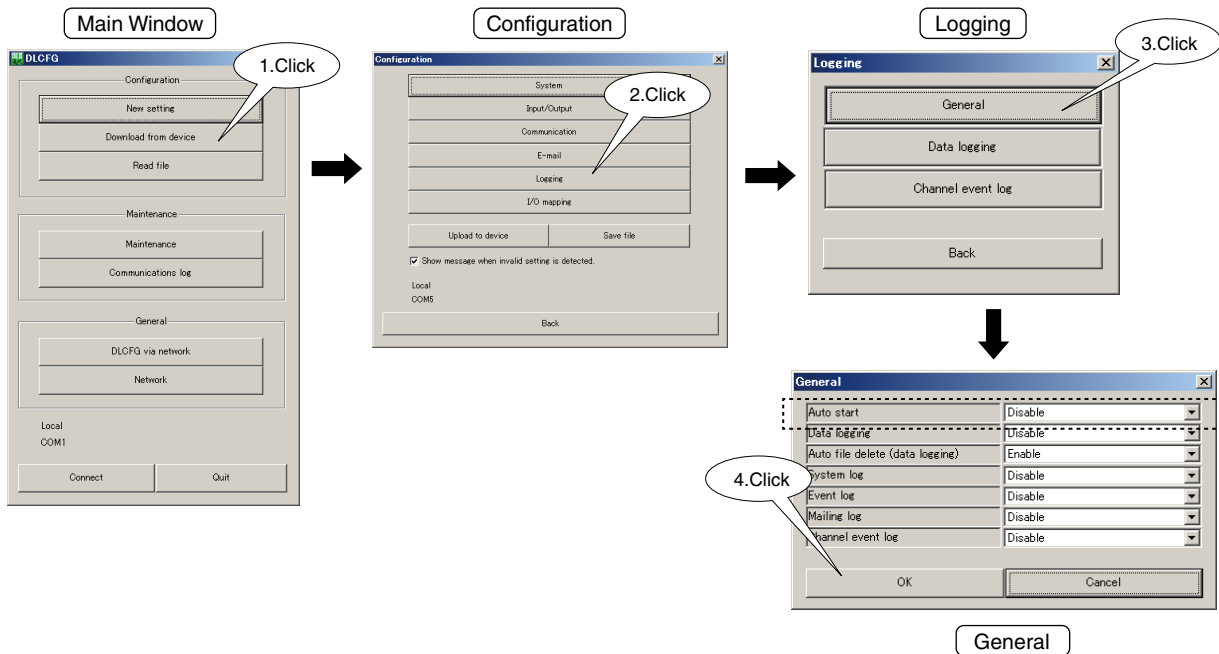

- (3) Set “Auto start” to “Enable” and click [OK] button to return to “Logging” menu.
- (4) To enable the setting, return to “Configuration” window and click [Upload to device] button.
When the DL8 is logging, stop logging before uploading the new setting.

NOTE

- When “Auto start” is enabled, be sure to set an SD card into the slot before turning on the power supply to the DL8. Logging does not start automatically if no SD card is detected at the startup.

11.3 DATA LOGGING

11.3.1 SPECIFICATIONS

ITEM	DESCRIPTION
Recording medium	SD card (FAT16, FAT32)
File	CSV format (engineering unit value stored)
Character code	Shift JIS
File header (*1)	1st row: Blank 2nd row: User defined header 1 3rd row: User defined header 2 4th row: User defined header 3 User defined header: 1024 characters or less per row
Contents per row (6th and following rows)	1st column: Date/time (year/month/date/hour/minute/second) 2nd and the following columns: Engineering unit data (for channel No.)
Logging cycle (synchronized with RTC)	Seconds: 1, 2, 5, 10, 20, or 30 seconds Minutes: 1, 2, 5, 10, 15, 20, or 30 minutes (on the second) Hours: 0 to 23 hours (multiple selection with time delay (minutes, seconds)) Dateline (*3): 0 to 23 hours Day of week: Sunday to Saturday, multiple selection
Channel	Max. 32 channels (AI, DI, DI (counter), PI, DO, and AO)
Sampling method (*2)	Momentary value, average value, peak value (max. or min.) (Basic sampling rate: 1 second)
File storage	<ul style="list-style-type: none"> • Folders Folders to store data files is created under the root directory, each named by year and month. e.g. \2013_05 • Files Logging cycle: seconds Data is saved at one-minute intervals and data for one day is saved in a file named by date. e.g. \2013_05\D26.CSV (a file of May 26, 2013) Logging cycle: minutes Data is saved in the same cycle as the logging cycle and data for one day is saved in a file named by date. e.g. \2013_05\D26.CSV (a file of May 26, 2013) Logging cycle: hours Data is saved in the same cycle as the logging cycle and data for one month is saved in a file named by year and month. e.g. \2013_05\M05.CSV (a file of May, 2013) Data logging can be enabled or disabled by setting.
Error handling	File access error: Logging stopped due to SD card access error Abnormal disk: Abnormal SD card recognition Disk-full: Logging stopped due to the SD card memory capacity shortage Deficient logging: Data deficiency due to the internal buffer overflow Logging error information in the system log (Refer to 15.2.6 SYSTEM LOG.)

*1. The DL8 records file headers at the moment when the file is created and data logging is started.
If an identical file name is detected, the file header is added to the tail end of this file.
Data is handled in the similar way when the name is changed by adjusting the clock backwards.
Headers are ignored if there is no header setting.

*2.

SAMPLING METHOD	DESCRIPTION
Momentary value	Logging the latest value of data sampled at every storing interval
Average value	Logging the average value of data sampled at every storing interval
Peak value (max.)	Logging the max. value of data sampled at every storing interval
Peak value (min.)	Logging the min. value of data sampled at every storing interval

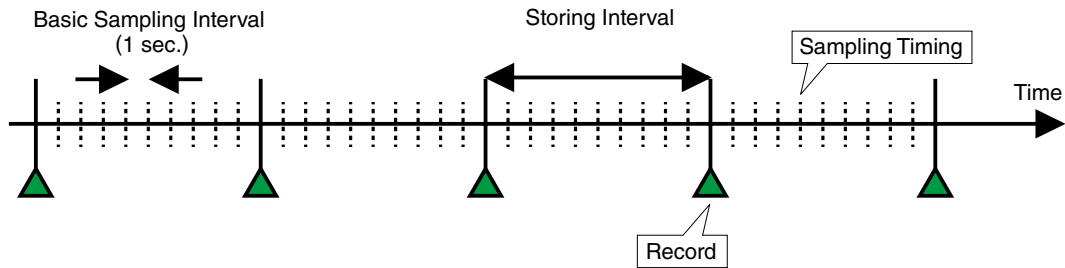

*3. Start timing of a logging file (dateline) can be specified.

The DL8 creates a new file as follows.

- File with a name designating a date : The DL8 creates a new file when the first data is sampled after the dateline.
- File with a name designating a month : The DL8 creates a new file when the first data is sampled after the first dateline of month.

■ [Data sample]

	A	B	C	D	E	F	G	H	I	J
1										
2		AI01	AI01	AI01	AI01	AI02	AI02	AI02	AI02	DI01
3		demo	demo	demo	demo	demo	demo	demo	demo	demo
4		Moment	Average	Peak(Max.)	Peak(Min.)	Moment	Average	Peak(Max.)	Peak(Min.)	DI02 OFF
5	2014/6/17 7:00	34.84	74.35	99.92	34.84	9764	8534.633	9999	5282	DI01 ON
6	2014/6/17 7:00	9.36	8.85	31.8	0	2086	6223.033	9660	2086	DI02 OFF
7	2014/6/17 7:01	90.26	51.07	90.26	11.27	2035	708.167	2035	0	DI01 ON
8	2014/6/17 7:01	65.75	90.47	99.99	65.75	9745	6428.167	9745	2294	DI02 OFF
9	2014/6/17 7:02	0	2.9	62.73	0	5031	8407.867	9999	5031	DI01 ON
10	2014/6/17 7:02	65.15	25.64	65.15	0.07	235	1464.367	4717	0	DI02 OFF
11	2014/6/17 7:03	90.63	91.14	99.99	68.11	7913	3775.967	7913	339	DI01 ON
12	2014/6/17 7:03	9.73	48.92	88.72	9.73	7964	9290.833	9999	7964	DI02 OFF
13	2014/6/17 7:04	34.24	9.51	34.24	0	254	3570.833	7705	254	DI01 ON
14	2014/6/17 7:04	99.99	76.09	99.99	37.26	4968	1591.133	4968	0	DI02 OFF
15	2014/6/17 7:05	34.84	74.35	99.92	34.84	9764	8534.633	9999	5282	DI01 ON
16	2014/6/17 7:06	9.36	8.85	31.88	0	2086	6223.033	9660	2086	DI02 OFF
17	2014/6/17 7:06	90.26	51.07	90.26	11.28	2035	708.167	2035	0	DI01 ON
18	2014/6/17 7:07	65.75	90.47	99.99	65.75	9745	6428.167	9745	2294	DI02 OFF
19	2014/6/17 7:07	0	23.9	62.73	0	5031	8407.867	9999	5031	DI01 ON
20	2014/6/17 7:08	65.15	25.64	65.15	0.07	235	1464.367	4717	0	DI02 OFF
21	2014/6/17 7:08	90.63	91.14	99.99	68.11	7913	3775.967	7913	339	DI01 ON
22	2014/6/17 7:08	9.73	48.92	88.72	9.73	7964	9290.833	9999	7964	DI02 OFF
23	2014/6/17 7:09	34.24	9.51	34.24	0	254	3570.833	7705	254	DI01 ON
24	2014/6/17 7:10	99.99	76.09	99.99	37.26	4968	1591.133	4968	0	DI02 OFF
25	2014/6/17 7:10	34.84	74.35	99.92	34.84	9764	8534.633	9999	5282	DI01 ON
26	2014/6/17 7:11	9.36	8.85	31.88	0	2086	6223.033	9660	2086	DI02 OFF
27	2014/6/17 7:11	90.26	51.07	90.26	11.27	2035	708.167	2035	0	DI01 ON
28	2014/6/17 7:12	65.75	90.47	99.99	65.75	9745	6428.167	9745	2294	DI02 OFF
29	2014/6/17 7:12	0	23.9	62.73	0	5031	8407.867	9999	5031	DI01 ON
30	2014/6/17 7:13	65.15	25.64	65.15	0.07	235	1464.367	4717	0	DI02 OFF
31	2014/6/17 7:13	90.63	91.14	99.99	68.11	7913	3775.967	7913	339	DI01 ON

NOTE

- When the clock is adjusted during data logging, the corrected time is applied immediately.

NOTE

- Seconds are not indicated in opening a CSV file using Excel, however you can confirm in a text editor that they are recorded. They can be indicated by setting the cell format to "yyyy/m/d h:mm:ss" in Excel.

11.3.2 SETTING

- (1) Connect the DL8 with the COP-US cable to the PC to which the DLCFG is installed.
For connection setting, refer to 4.3 IP ADDRESS SETTING.

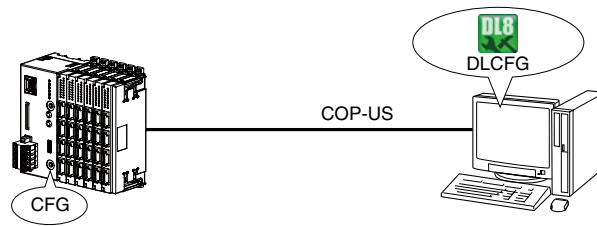

- (2) Start the DLCFG to show the main window.
Click [Download from device] button to read setting from the DL8 and to open “Configuration” window.
Click [Logging] button to open “Logging” menu.
Then click [General] button to open “General” dialog.

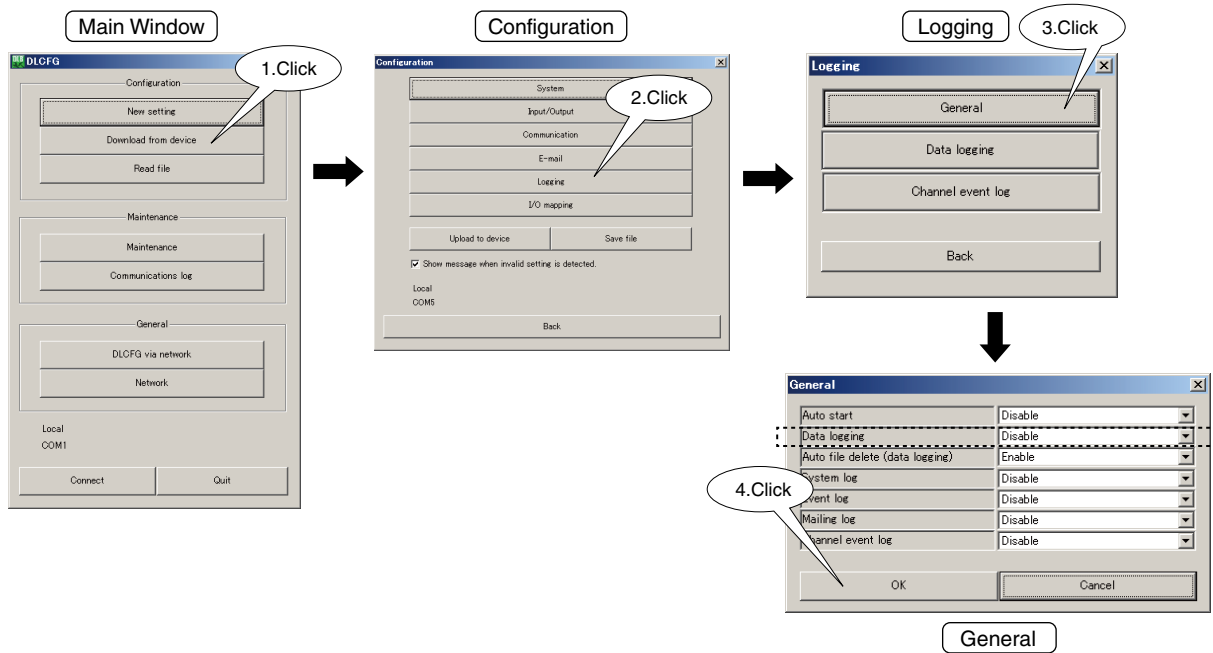

- (3) Set “Data logging” to “Enable” and click [OK] button to return to “Logging” menu.

- (4) Click [Data logging] button in “Logging” window to open “Data logging” dialog.

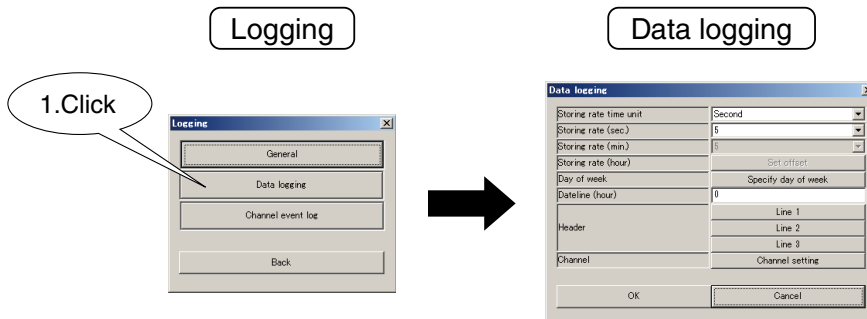

(5) Set a storing interval.

■ Storing rate in seconds

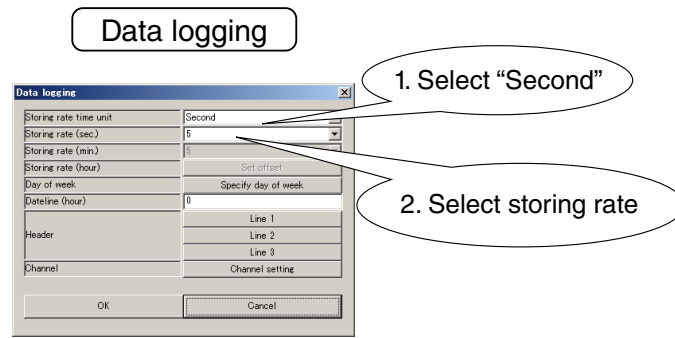

■ Storing rate in minutes

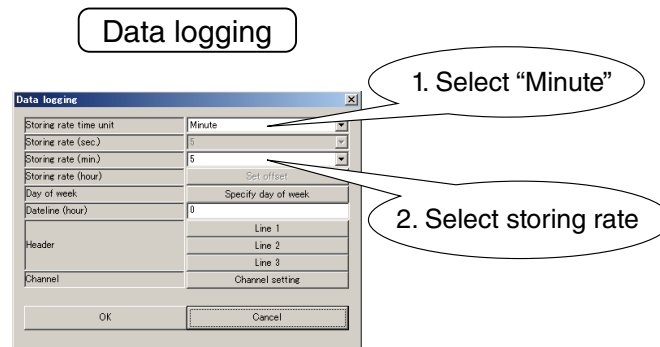

■ Storing rate in hours

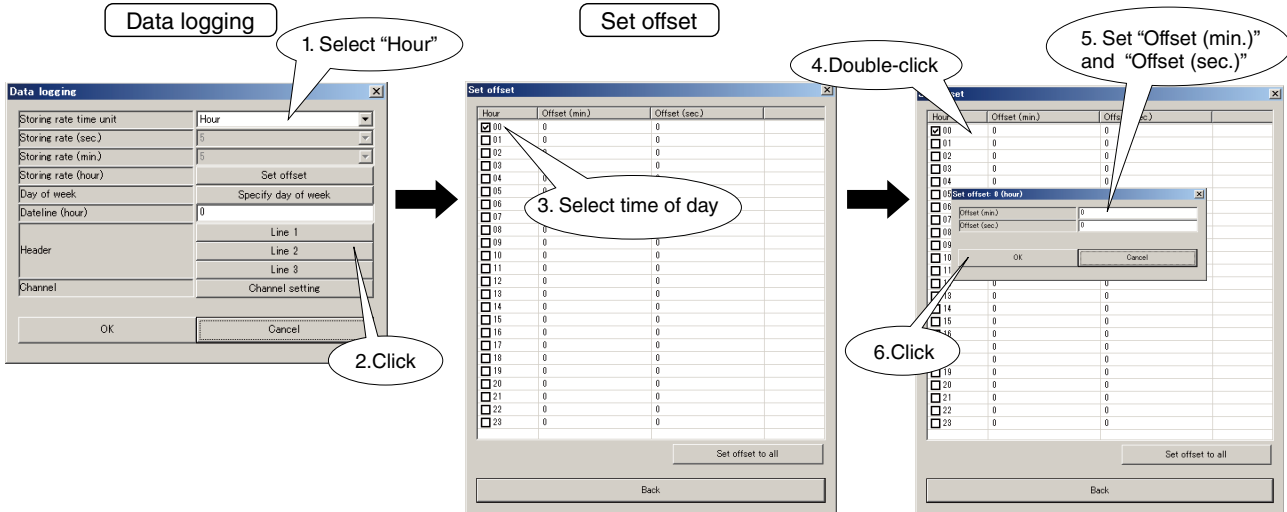

Click [Set offset to all] button in "Set offset" window to open "Set offset to all" dialog, and single offset setting of 0 to 23 hours can be applied to all hours.

(6) Set days of the week to log.

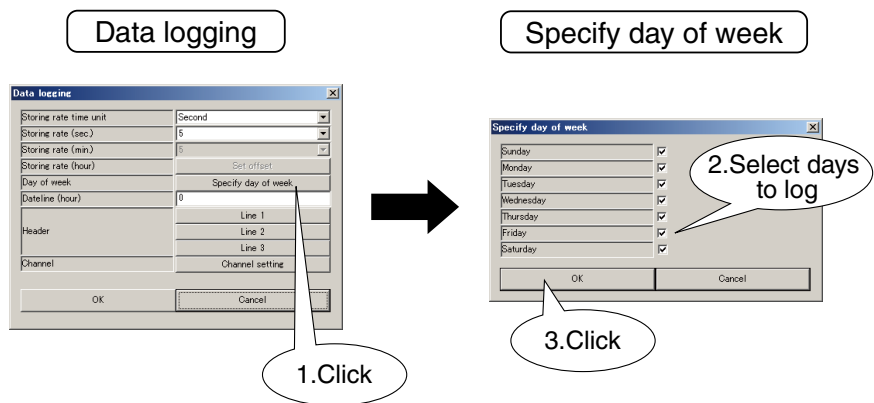

(7) Set a dateline between 0 to 23 hours. Refer to (*3) in 11.3.1 SPECIFICATIONS.

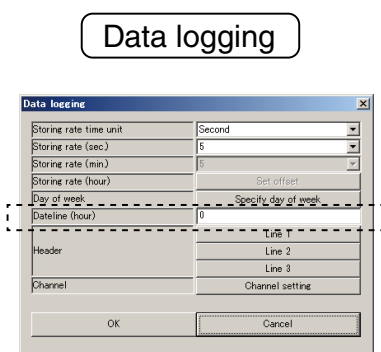

(8) Set headers (1st to 3rd rows) in comma-separated text strings (max. 1024 characters).

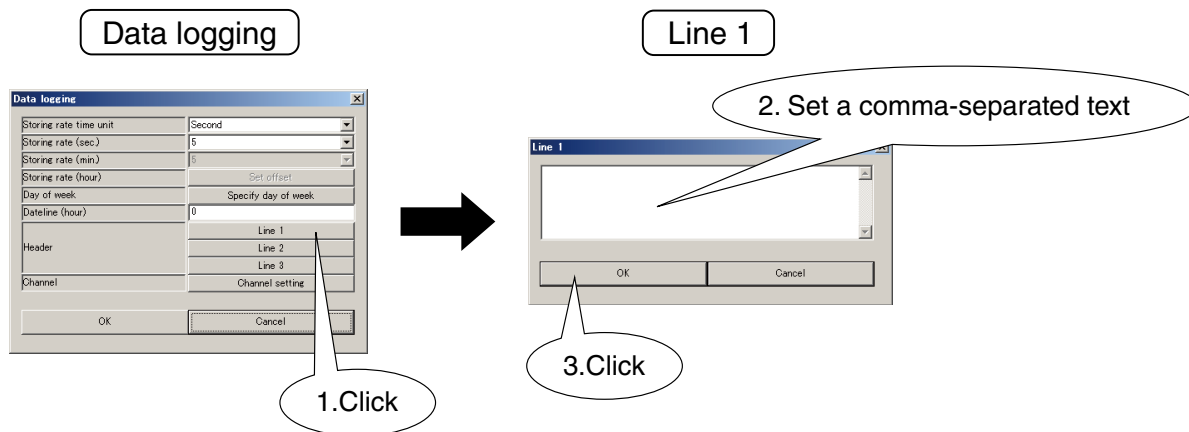

(9) Set channels to log.

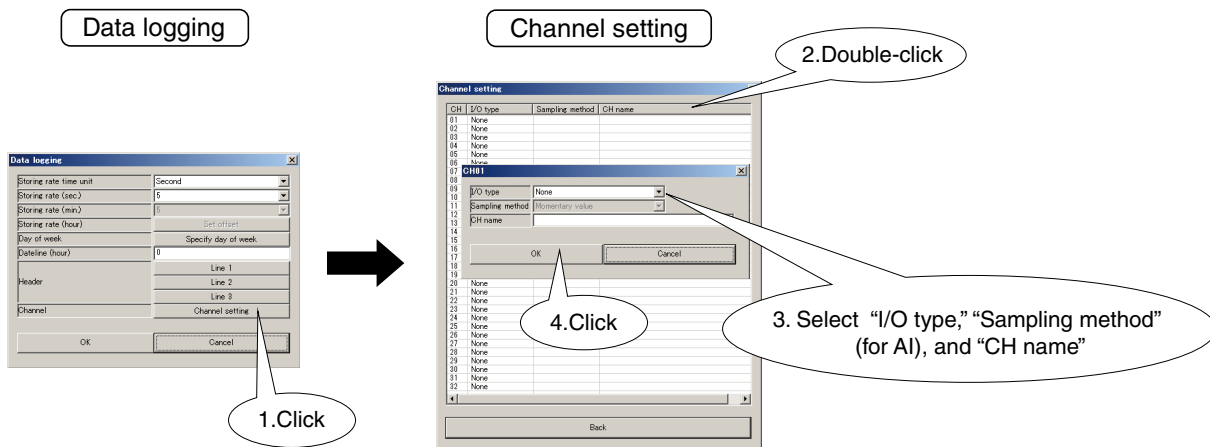

11.4 SYSTEM LOG

11.4.1 SPECIFICATIONS

A log on the internal system operation of the DL8 can be stored in the SD card.
Refer to 15.2.6 SYSTEM LOG for the contents.

ITEM	DESCRIPTION
File path	“SLOG.TXT” file is created in “\LOG” folder created under the root directory of the SD card.
File format (text)	Date/time, system log
Automatic deletion of past data	“SLOG.TXT” file is renamed as “SLOG1.TXT” when its data volume reaches 1 MB. If a “SLOG1.TXT” already exists, the older file is deleted before another file is renamed. Then a new file “SLOG.TXT” is created to continue the log.

11.4.2 SETTING

- Start the DLCFG and click [Download from device] button in the main window to open “Configuration” window.
Click [Logging] button to open “Logging” menu.
Then click [General] button to open “General” dialog.

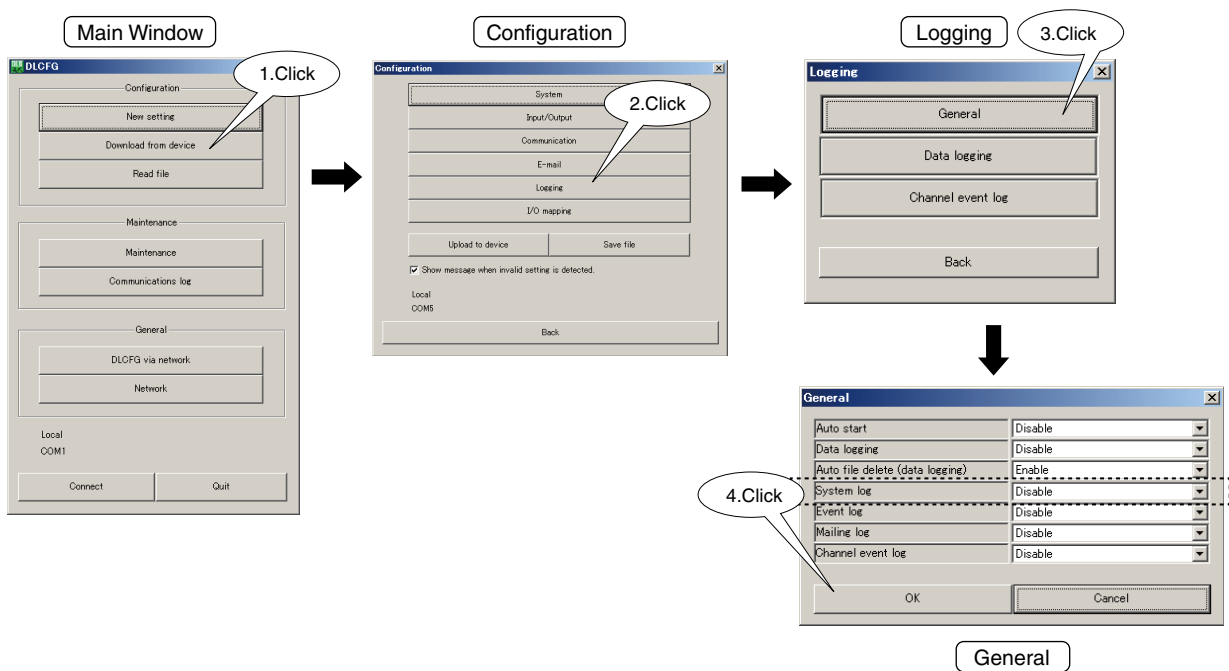

- Set “System log” to “Enable” and click [OK] button to return to “Logging” menu.

- To enable the setting, return to “Configuration” window and click [Upload to device] button.
While the DL8 is logging, stop logging before uploading the new setting.

■ [Data sample]

```
2013/06/03 21:00:55 *power off
2013/06/03 21:01:58 power on Ver1.0.24
2013/06/03 21:01:58 link ok
```

11.5 EVENT LOG

11.5.1 SPECIFICATIONS

A log of events having occurred can be stored in the SD card.

ITEM	DESCRIPTION
File path	“ELOG.TXT” file is created in “\LOG” folder created under the root directory of the SD card.
File format (text)	AI event : Date/time, CH No., name, CH comment, zone name DI event : Date/time, CH No., name, CH comment, text assigned to status/event message PI event : Date/time, CH No., name, CH comment, zone name DO event: Date/time, CH No., name, CH comment, text assigned to status
Automatic deletion of past data	“ELOG.TXT” file is renamed as “ELOG1.TXT” when its data volume reaches 1 MB. If a “ELOG1.TXT” already exists, the older file is deleted before another file is renamed. Then a new file “ELOG.TXT” is created to continue the log.

11.5.2 SETTING

- (1) Start the DLFCFG and click [Download from device] button in the main window to display “Configuration” window.
Click [Logging] button to open “Logging” menu.
Then click [General] button to open “General” dialog.

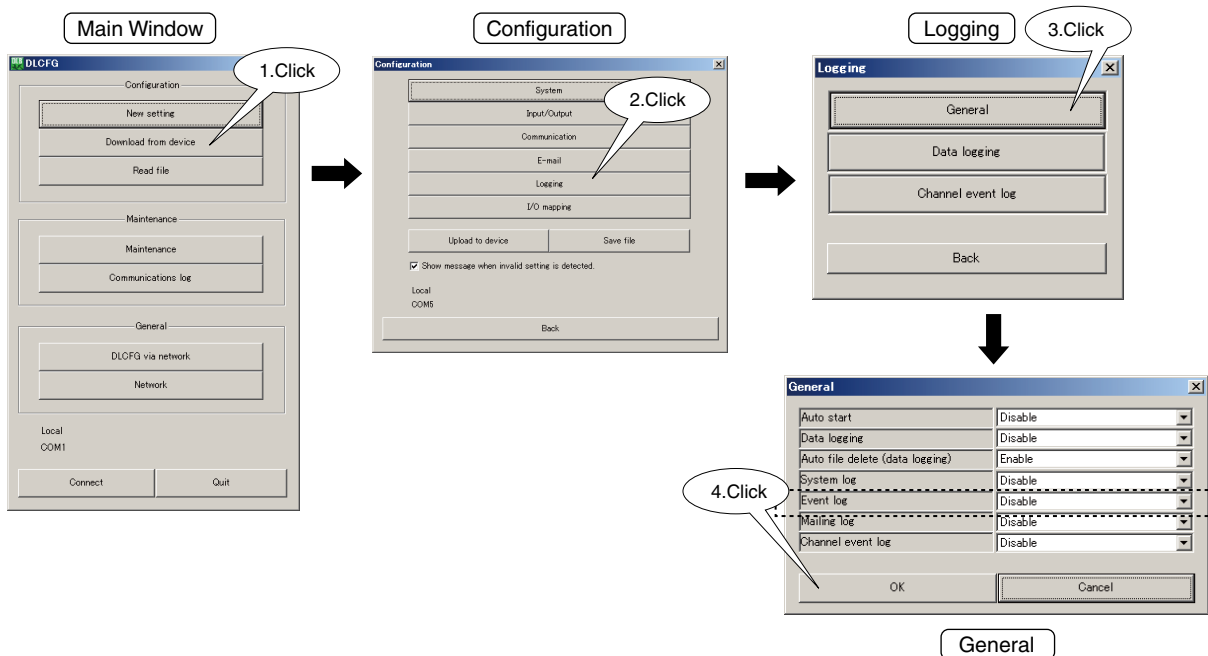

- (2) Set “Event log” to “Enable” and click [OK] button to return to “Logging” menu.

- (3) To enable the settings, return to “Configuration” window and click [Upload to device] button.
When the DL8 is logging, stop logging before uploading the new setting.

■ [Data sample]

```

2013/06/28 20:26:55 DI02 DI2 DA430-1 DI02 Counter event
2013/06/28 20:26:56 AI32 AI32 R8-SV2 AI32 AREA4
2013/06/28 20:27:00 DI01 DI1 DA4 1-1 DI1 DI02 OFF
2013/06/28 20:27:00 DI18 DI18 DA4 1-2 DI18 DI18 OFF
2013/06/28 20:27:00 DI36 DI36 DA4 1-3 DI36 DI36 OFF
2013/06/28 20:27:00 DI64 DI64 DA4 1-4 DI64 DI64 OFF
2013/06/28 20:27:03 AI32 AI32 R8-SV2 AI32 AREA3
2013/06/28 20:27:10 AI32 AI32 R8-SV2 AI32 AREA2
2013/06/28 20:27:10 DI01 DI1 DA4 1-1 DI1 DI01 ON
    
```

11.6 MAILING LOG

11.6.1 SPECIFICATIONS

Communication history on mailing can be stored in the SD card.

ITEM	DESCRIPTION
File path	"MLOG.TXT" file is created in "LOG" folder created under the root directory of the SD card.
File format (text)	Date/time, message type (event / regular), delivery (OK / NG), subject
Automatic deletion of past data	"MLOG.TXT" file is renamed as "MLOG1.TXT" when its data volume reaches 1 MB. If a "MLOG1.TXT" already exists the older file is deleted before another file is renamed. Then a new file "MLOG.TXT" is created to continue the log.

11.6.2 SETTING

(1) Start the DLFCG to show the main window.

Click [Download from device] button to read setting from the DL8 and to open "Configuration" window.

Click [Logging] button to open "Logging" menu.

Then click [General] button to open "General" dialog.

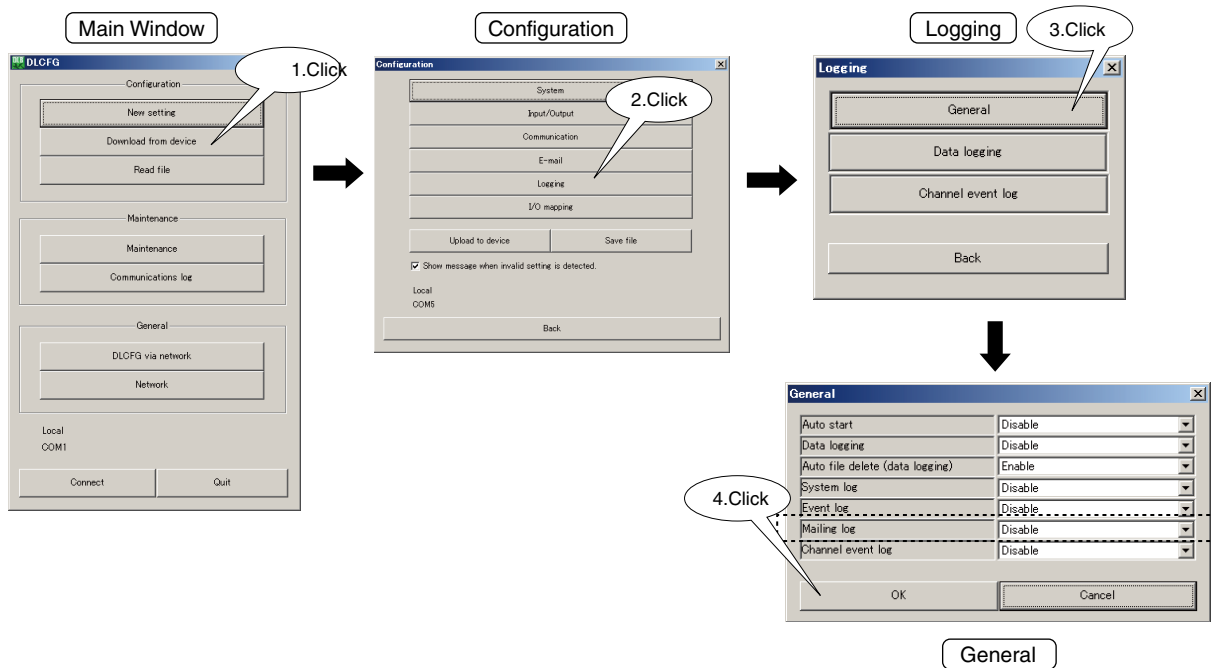

(2) Set "Mailing log" to "Enable" and click [OK] button to return to "Logging" menu.

(3) To enable the setting, return to "Configuration" window and click [Upload to device] button. While the DL8 is logging, stop logging before uploading the new setting.

■ [Data sample]

```
2013/06/28 20:27:03 Event report OK EVENT REPORT1
2013/06/28 20:27:10 Event report NG EVENT REPORT2
2013/06/28 21:00:00 Regular report OK TIME REPORT
```

NOTE

- In order to change the format for Mailing log to English, set "Language" to English in the "System" menu. ("14.4 LANGUAGE" on page 152)

11.7 CHANNEL EVENT LOG

11.7.1 SPECIFICATIONS

Events per channel can be stored in a SD card, regardless of the event log setting.

ITEM	DESCRIPTION										
File path	Subfolders “\AI,” “\DI,” “\PI,” and “\DO” are created in “\LOG” folder created under the root directory of the SD card. Following files are created in the respective subfolders. <table border="1" style="margin: 10px auto;"> <thead> <tr> <th>Channel type</th> <th>File name</th> </tr> </thead> <tbody> <tr> <td>AI channel</td> <td>AIxxLOG.TXT (xx = channel No.)</td> </tr> <tr> <td>DI channel</td> <td>DIxxLOG.TXT (xx = channel No.)</td> </tr> <tr> <td>PI channel</td> <td>PIxxLOG.TXT (xx = channel No.)</td> </tr> <tr> <td>DO channel</td> <td>DOxxLOG.TXT (xx = channel No.)</td> </tr> </tbody> </table>	Channel type	File name	AI channel	AIxxLOG.TXT (xx = channel No.)	DI channel	DIxxLOG.TXT (xx = channel No.)	PI channel	PIxxLOG.TXT (xx = channel No.)	DO channel	DOxxLOG.TXT (xx = channel No.)
Channel type	File name										
AI channel	AIxxLOG.TXT (xx = channel No.)										
DI channel	DIxxLOG.TXT (xx = channel No.)										
PI channel	PIxxLOG.TXT (xx = channel No.)										
DO channel	DOxxLOG.TXT (xx = channel No.)										
File format (text)	AI channel : Date/time, zone name DI channel : Date/time, text assigned to status/event message PI channel : Date/time, zone name DO channel: Date/time, text assigned to status										
Automatic deletion of past data	(Example with AI1) “AI01LOG.TXT” file is renamed as “AI01LOG1.TXT” when its data volume reaches 1 MB. If a “AI01LOG1.TXT” already exists the older file is deleted before another file is renamed. Then a new file “AI01LOG.TXT” is created to continue the log.										

11.7.2 SETTING

(1) Start the DLFCG to show the main window.

Click [Download from device] button to read setting from the DL8 and to open “Configuration” window.

Click [Logging] button to open “Logging” menu.

Then click [General] button to open “General” dialog.

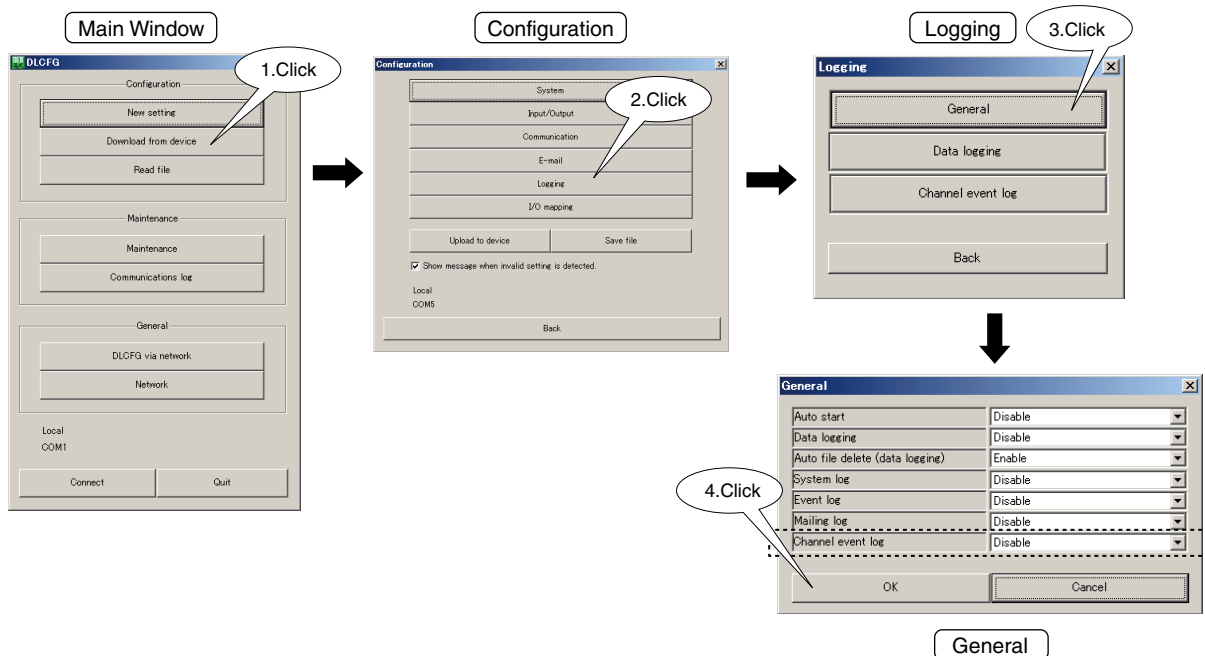

(2) Set “Channel log” to “Enable” and click [OK] button to return to “Logging” menu.

(3) Click [Channel event log] button in “Logging” menu to open “Channel event log” list. Select channels to log.

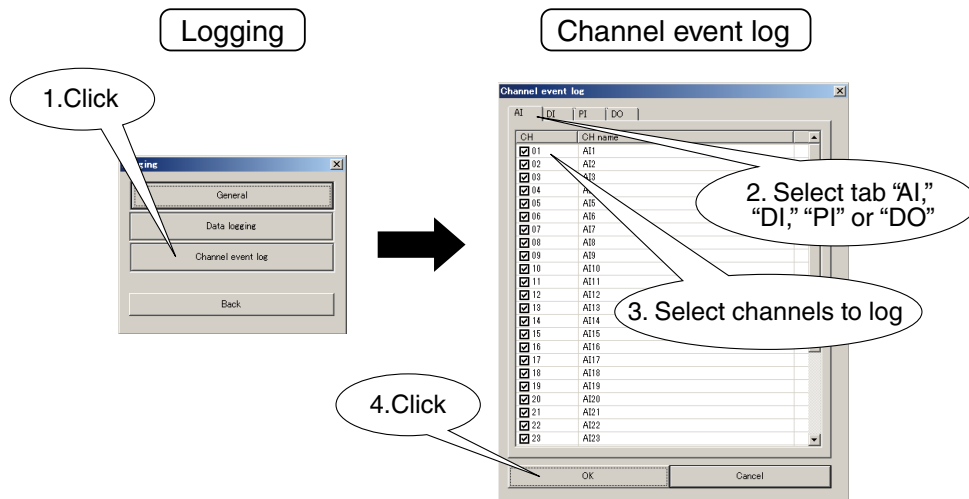

(4) To enable the setting, return to “Configuration” window and click [Upload to device] button. When the DL8 is logging, stop logging before uploading the new setting.

[Data sample]

```
2013/06/28 20:28:32 AI01 AREA1
2013/06/28 20:29:01 AI01 AREA2
2013/06/28 20:29:08 AI01 AREA3
2013/06/28 20:29:15 AI01 AREA4
2013/06/28 20:29:22 AI01 AREA5
```

11.8 AUTOMATIC FILE DELETION

11.8.1 DESCRIPTIONS

Old data can be automatically deleted when remaining free area of the SD card is less than 100 MB.

The data folder of the oldest month is deleted when the DL8 detects less than 100 MB of free area when logging data has been saved in the card. The folder of the present month is not deleted.

11.8.2 SETTING

(1) Start the DLCFG to show the main window.

Click [Download from device] button to read setting from the DL8 and to open “Configuration” window.

Click [Logging] button to open “Logging” menu.

Then click [General] button to open “General” dialog.

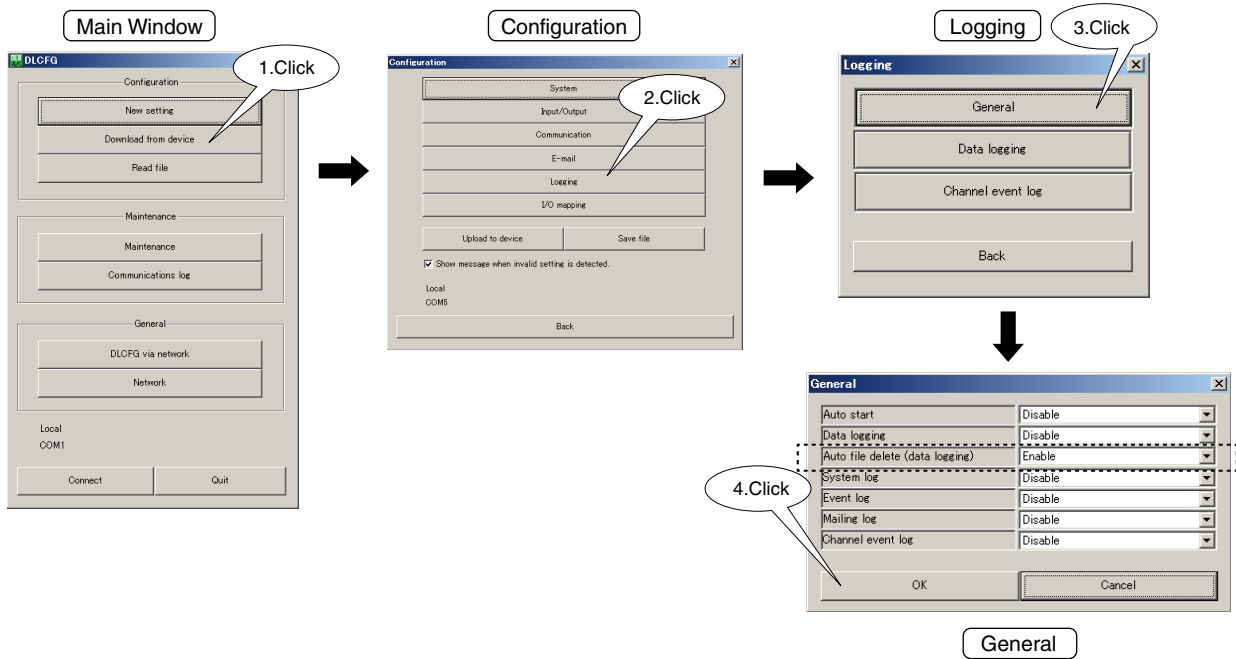

(2) Set “Auto file delete (data logging)” to “Enable” and click [OK] button to return to “Logging” menu.

(3) To enable the setting, return to “Configuration” window and click [Upload to device] button.

When the DL8 is logging, stop logging before uploading the new setting.

11.9 APPROXIMATE LOGGING TIME PERIOD

The following table shows approximate logging time period (disk-full) at each storing interval calculated from the SD card capacity.

[Calculation conditions]

- SD card capacity 4 GB
- 32 channels, 6 digits per channel
- Data logging only

STORING INTERVAL	LOGGING TIME PERIOD (approx.)
1 second	180 days
2 seconds	370 days
5 seconds	940 days
10 seconds	1800 days
20 seconds	3700 days
30 seconds	5600 days
1 minute	30 years
2 minutes	60 years
5 minutes	150 years
10 minutes	300 years
20 minutes	600 years
30 minutes	880 years
1 hour	1800 years

NOTE

- The above-mentioned logging time periods are only for reference and not guaranteed.
- If the automatic file deletion function is not used, files may be deleted using FTP server function.
Establish a regular practice for smooth operations.
- With the automatic file deletion function enabled, be aware of remaining free memory area as files are deleted in a unit of a folder for a month.

12. FTP SERVER (TYPE C, D & E)

12.1 GENERAL DESCRIPTIONS

The FTP server function is used for remote maintenance of files in a SD card.

NOTE

- This function is not available with Type A or B.
- FTPS is available for Type E only.

12.2 SPECIFICATIONS

ITEM	DESCRIPTION																					
FTP	Passive mode (Port 45967 to 45970 is used.)																					
Protocol	FTP / FTPS (Explicit mode)																					
Number of terminals to be connected at once	4																					
Terminal	<ul style="list-style-type: none"> • OS <ul style="list-style-type: none"> · Windows 8.1 (32 bit/64 bit) · Windows 10 (32 bit/64 bit) • FTP client <ul style="list-style-type: none"> · Explorer · FFFTP • FTPS client <ul style="list-style-type: none"> · FFFTP 																					
Operation	<table border="1"> <thead> <tr> <th>Operation</th> <th>Explorer</th> <th>Browser</th> </tr> </thead> <tbody> <tr> <td>Listing subfolders and files</td> <td>✓</td> <td>✓</td> </tr> <tr> <td>Download of a file (transferring 1 file)</td> <td>✓</td> <td>✓</td> </tr> <tr> <td>Download of files (transferring multiple files collectively)</td> <td>✓</td> <td>—</td> </tr> <tr> <td>Deletion of files</td> <td>✓</td> <td>—</td> </tr> <tr> <td>Batch download of subfolders and internal files</td> <td>✓</td> <td>—</td> </tr> <tr> <td>Batch deletion of subfolders and internal files</td> <td>✓</td> <td>—</td> </tr> </tbody> </table>	Operation	Explorer	Browser	Listing subfolders and files	✓	✓	Download of a file (transferring 1 file)	✓	✓	Download of files (transferring multiple files collectively)	✓	—	Deletion of files	✓	—	Batch download of subfolders and internal files	✓	—	Batch deletion of subfolders and internal files	✓	—
Operation	Explorer	Browser																				
Listing subfolders and files	✓	✓																				
Download of a file (transferring 1 file)	✓	✓																				
Download of files (transferring multiple files collectively)	✓	—																				
Deletion of files	✓	—																				
Batch download of subfolders and internal files	✓	—																				
Batch deletion of subfolders and internal files	✓	—																				
Time stamp	Transmitted in local time																					
Restrictions	<ul style="list-style-type: none"> • Deleting files during logging (writing) is prohibited. • Downloading an updated file during logging (writing) is available. • Simultaneous access to a file by multiple clients is prohibited. • File writing related functions are not guaranteed. 																					

NOTE

- To use FTPS protocol to perform encrypted communication, it is required to install a web server certificate on the DL8. (For FTPS communication, it is not necessary to install a certificate for the certification authority on a terminal such as a PC which connects to the DL8.)
- Refer to the users manual of Local certification authority creator (model: LCA-DL8) for how to install a web server certificate.

The software program of Local certification authority creator can be downloaded from our web site.

- When using FTPS protocol with the FTP client function, be sure that the FTP client software allows FTPS connection.
- When using FFFTP for FTPS connection, enable:
 - 'Ignore addresses returned with PASV mode'; and
 - 'Connect with FTPS (Explicit)'in the Host Setting.

12.3 SETTING

- (1) Connect the DL8 with the COP-US cable to the PC to which the DLCFG is installed. For connection setting, refer to 4.3 IP ADDRESS SETTING.

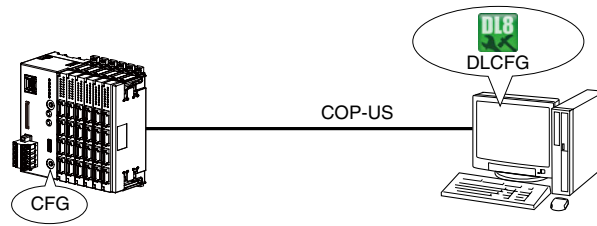

- (2) Start the DLCFG to show the main window.
 Click [Download from device] button to read setting from the DL8 and to open "Configuration" window.
 Click [Communication] button to open "Communication" menu.
 Then click [FTP server] button to open "FTP server" dialog.

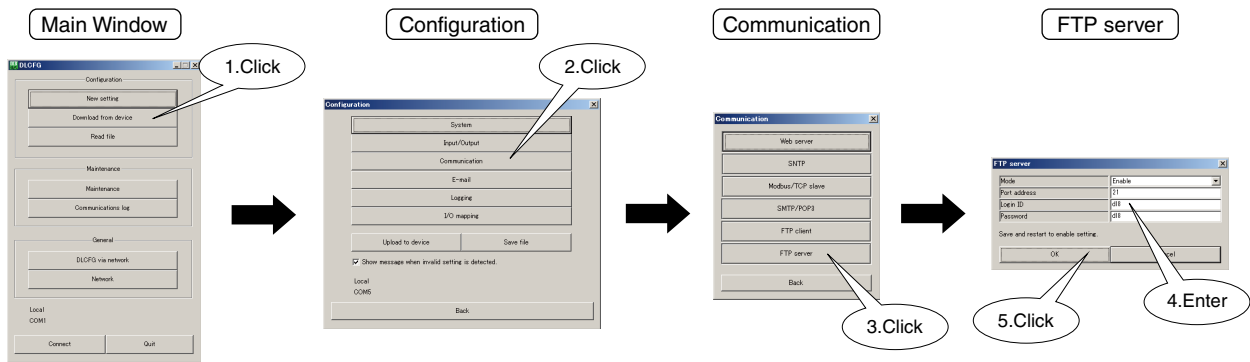

- (3) See the following table and configure parameters.

PARAMETER	DESCRIPTION
Mode	Set "Disable" or "Enable" for the FTP server function.
Port address	Set a port address of the FTP server.
Login ID	Set a login ID of the FTP server. (Max. 64 characters)
Password	Set a password of the FTP server. (Max. 64 characters)

- (4) Click [OK] button to temporarily save the setting.
 To enable the setting, return to "Configuration" window and click [Upload to device] button.

NOTE

- To reflect the settings of mode and port address, save and restart the DL8.
- Be sure to change the default ID and password.
- It is highly recommended to change the password regularly.

12.4 FTP CLIENT SOFTWARE

12.4.1 TEMPORARY INTERNET FILES SETTING

When Internet Explorer is used as FTP client, it is required to change the setting that confirms version of the temporary internet files.

- (1) Open "Internet Properties"
"Start" → "Control Panel" → ("Network and Internet Connections") → "Internet Options"
- (2) Click "General" tab of "Internet Properties"
Click "settings" button to show "Temporary Internet Files and History settings"

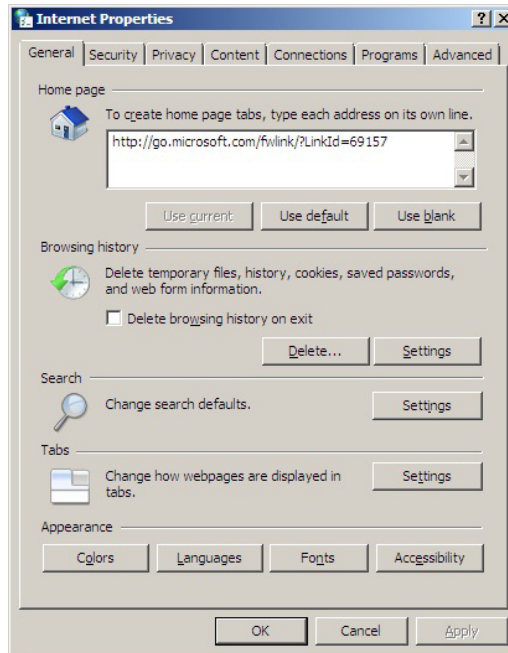

- (3) Under "Check for newer versions of stored pages:," check "Every time I visit the webpage."

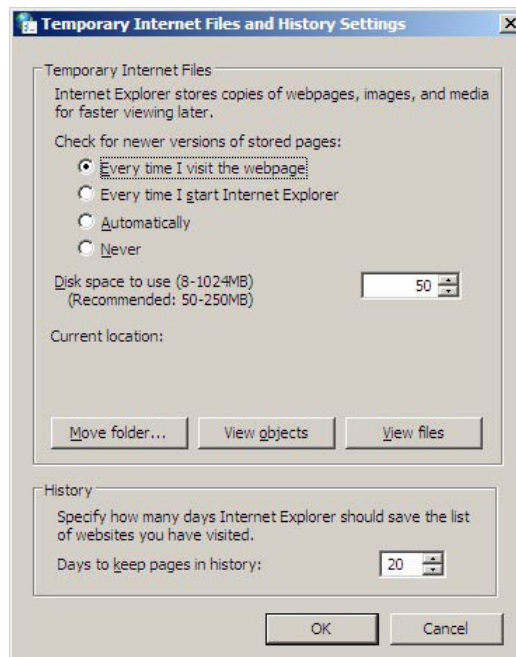

12.4.2 SETTING

Folders and files can be viewed graphically on Internet Explorer as FTP client.

Open "Internet Options" or "Internet Properties" and check "Enable FTP folder view (outside of Internet Explorer)" under "Browsing" in "Advanced" tab.

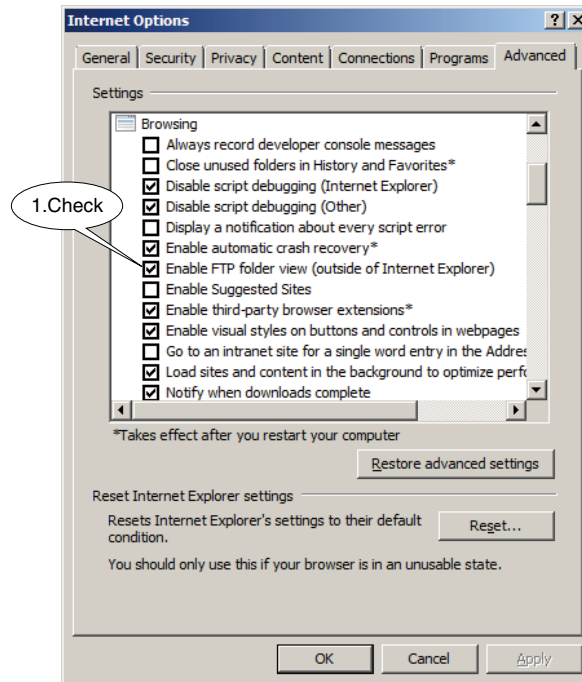

12.4.3 CONNECTION

(1) Start FTP client software (Explorer or a browser) and enter the following in the address input field.

ftp://(Domain name or IP address of the router or DL8)

(2) A login dialog appears.

Enter the login ID and password set in 12.3 SETTING and click [Log on] button.

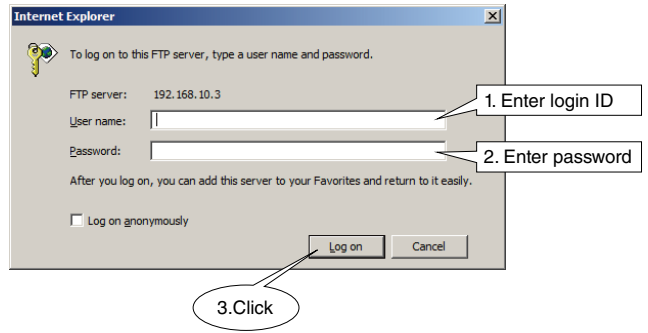

NOTE

- When a file list is displayed instead of a login dialog, cache contents may be displayed. Click [Refresh] button of the browser to update the display.

(3) When logged in successfully, the root directory of the SD card is shown.

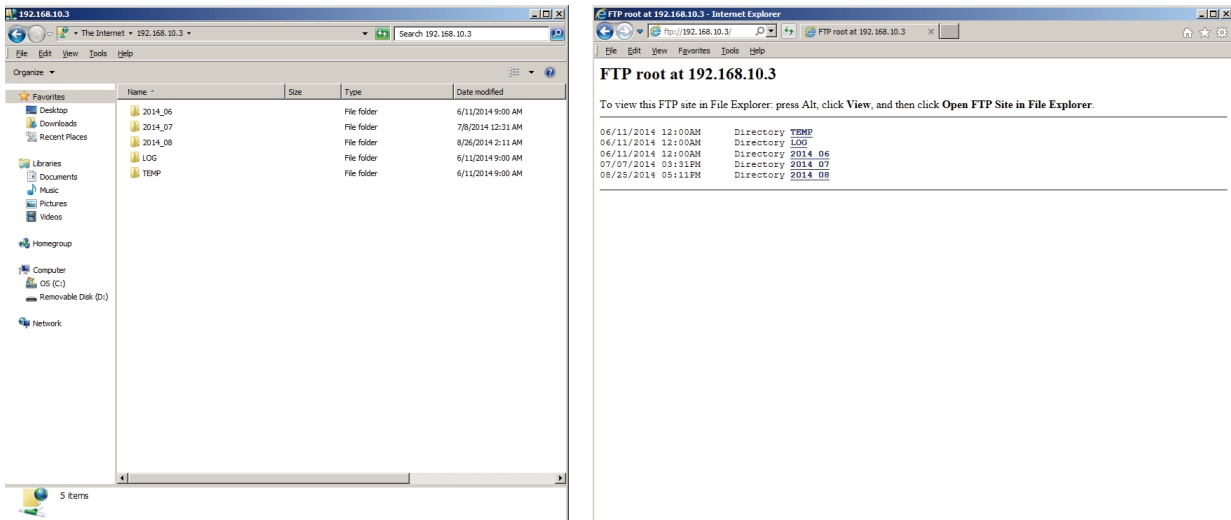

(4) Close the window on completion of the file maintenance, and the FTP connection is disconnected automatically.

NOTE

- Be sure to update the contents of display before downloading files.

13. I/O MAPPING (TYPE D & E)

13.1 GENERAL DESCRIPTIONS

I/O mapping function is used to connect between DI and DO, AI and AO in remote locations. 'DI to DO' and 'AI to AO' combinations are to be set.

NOTE

- This function is not available for Type A, B, or C.
- AO or DO channels mapped by the I/O mapping function cannot be controlled via a web browser or Modbus/TCP network.

13.2 SETTING

- (1) Connect the DL8 with the COP-US cable to the PC to which the DLCFG is installed.
For connection setting, refer to 4.3 IP ADDRESS SETTING.

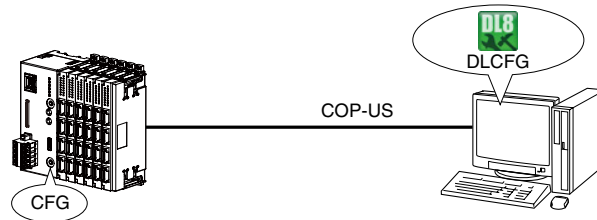

- (2) Start the DLCFG to show the main window.
Click [Download from device] button to read setting from the DL8 and to open "Configuration" window.
Click [I/O mapping] button to open "I/O mapping" menu.

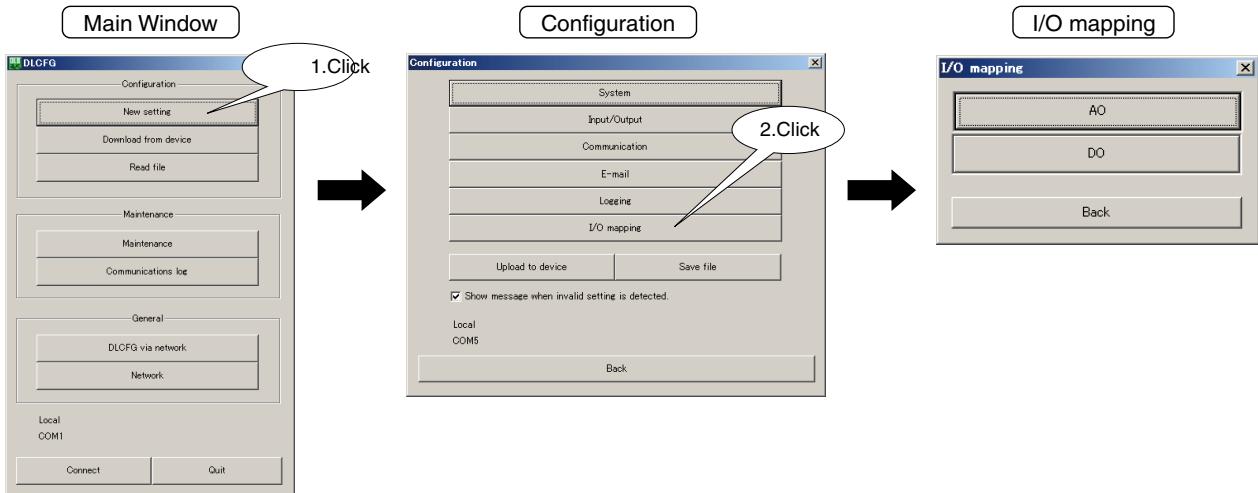

- (3) Click [AO] button to open “AO mapping” list.
 Double-click a row indicating the relevant AO channel and choose an AI channel to be paired.

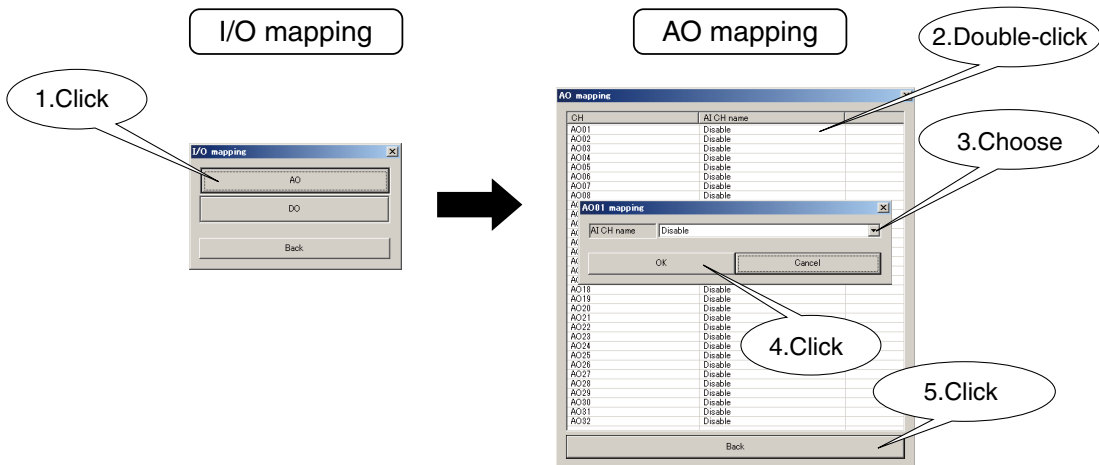

- (4) When all relevant AO channels are paired, click [Back] button to go back to “I/O mapping” menu.

- (5) Click [DO] button to open “DO mapping” list.
 Double-click a row indicating the relevant DO channel and choose a DI channel to be paired.

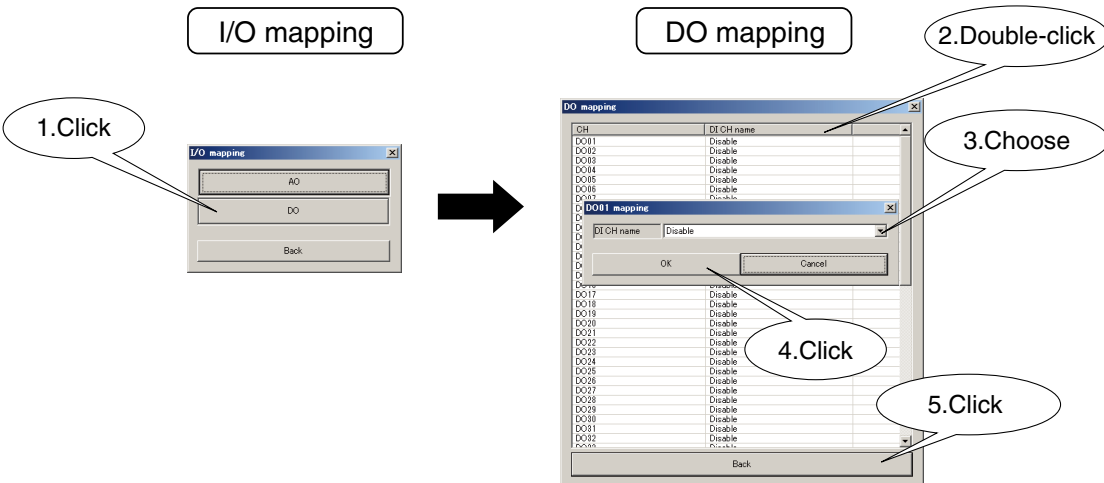

- (6) When all relevant DO channels are paired, click [Back] button to go back to “I/O mapping” menu.

- (7) To enable the setting, click [Back] button and return to “Configuration” window.
 Click [Upload to device] button.

NOTE

- When connecting to the DL8 via WAN, it is strongly recommended to use VPN in terms of security.

14. OTHER SETTINGS

14.1 CLOCK SYNCHRONIZATION

14.1.1 SNTP

The SNTP client function is used for automatic clock time correction. The internal RTC is adjusted when the date changes (at 0 hour) and at power up. Follow the procedure shown below to set the SNTP.

- (1) Connect the DL8 with the COP-US cable to the PC to which the DLCFG is installed. For connection setting, refer to 4.3 IP ADDRESS SETTING.

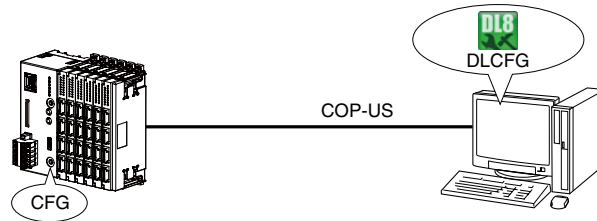

- (2) Start the DLCFG to show the main window. Click [Download from device] button to read setting from the DL8 and to open "Configuration" window. Click [Communication] button to open "Communication" menu. Then click [SNTP] button to open "SNTP" dialog.

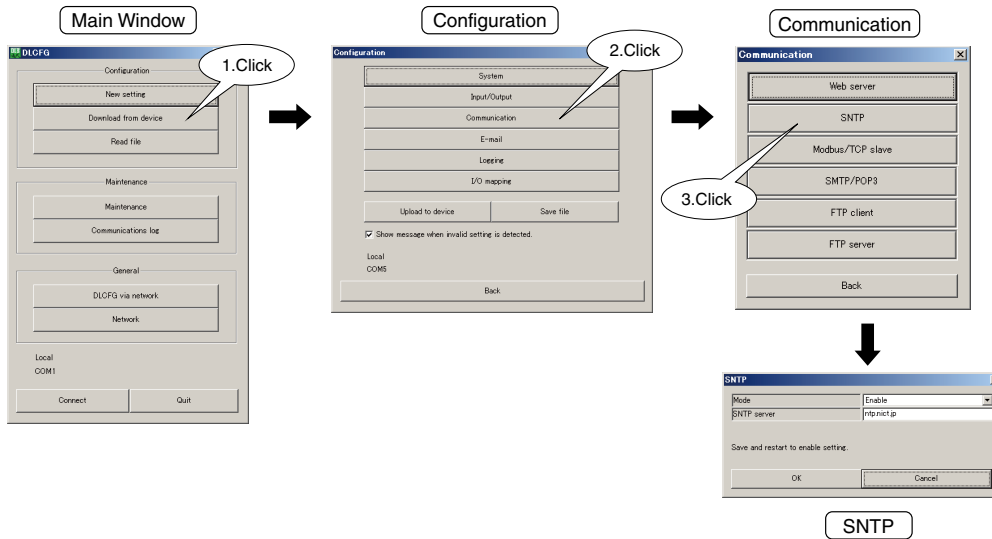

- (3) See the following table and configure each parameter.

PARAMETER	DESCRIPTION
Mode	Set "Disable" or "Enable" for the SNTP client function of DL8.
Server	Set a domain name or IP address of the SNTP server to connect.

- (4) Click [OK] button to temporarily save the setting. To enable the setting, return to "Configuration" window and click [Upload to device] button.

NOTE

- To apply the new setting to the DL8, save and restart the device.
- Be sure to set time zone according to the DL8 location to use the automatic time correction function. Refer to 14.1.2 TIME ZONE
- When Mode of SNTP is set to "Enable" and time of the DL8 is changed over the turn of a day, the clock synchronization works.

14.1.2 TIME ZONE

Set the time zone (-12 to 13) of the DL8 location so that the local time of the DL8 is corrected based on the set time zone when time is obtained from the SNTP server.

Factory setting is +09:00 (Japan time).

- (1) Click [Download from device] button in the main window to show "Configuration" window.
Click [System] button in the "Configuration" window to open "System" dialog.
Enter the time zone of the DL8 location.

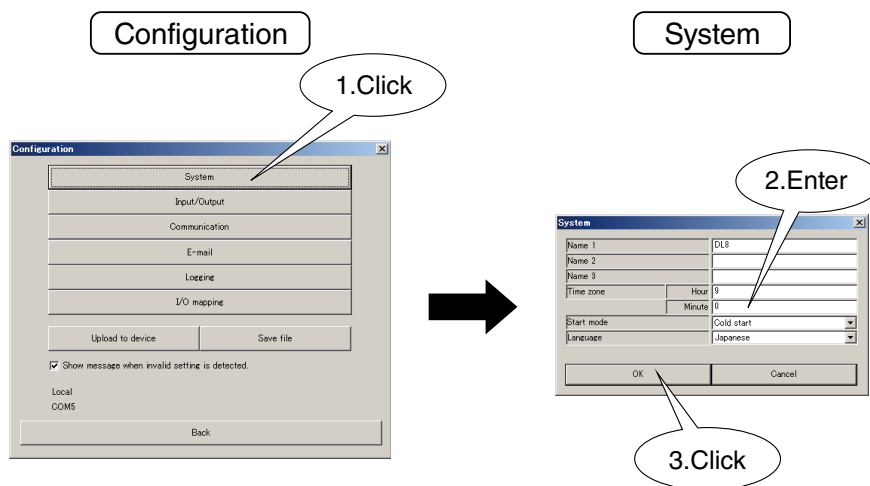

NOTE

- Time zone setting by minutes is not available for the DL8 Ver.1.3 or earlier versions.

14.2 MODBUS/TCP SLAVE

14.2.1 SPECIFICATIONS

The Modbus/TCP slave function is used to read data of the DL8 via network by a PLC or a SCADA system with Modbus/TCP master function.

The register map of the Modbus/TCP is shown in the following table.

CHANNEL	REGISTER TYPE	REGISTER ADDRESS
AI1 to AI32	Input Register (3X)	1 to 32
DI1 to DI64	Input (1X)	1 to 64
PI1 to PI32	Input Register (3X)	101/102 to 163/164 (Lower-digit data in the smaller register)
CI1 to CI64 (DI counter)	Input Register (3X)	201/202 to 327/328 (Lower-digit data in the smaller register)
DO1 to DO64	Coil (0X)	1 to 64
AO1 to AO32	Holding Register (4X)	1 to 32

0X

REGISTER	CHANNEL	REGISTER	CHANNEL
00001	DO1	00033	DO33
00002	DO2	00034	DO34
00003	DO3	00035	DO35
00004	DO4	00036	DO36
00005	DO5	00037	DO37
00006	DO6	00038	DO38
00007	DO7	00039	DO39
00008	DO8	00040	DO40
00009	DO9	00041	DO41
00010	DO10	00042	DO42
00011	DO11	00043	DO43
00012	DO12	00044	DO44
00013	DO13	00045	DO45
00014	DO14	00046	DO46
00015	DO15	00047	DO47
00016	DO16	00048	DO48
00017	DO17	00049	DO49
00018	DO18	00050	DO50
00019	DO19	00051	DO51
00020	DO20	00052	DO52
00021	DO21	00053	DO53
00022	DO22	00054	DO54
00023	DO23	00055	DO55
00024	DO24	00056	DO56
00025	DO25	00057	DO57
00026	DO26	00058	DO58
00027	DO27	00059	DO59
00028	DO28	00060	DO60
00029	DO29	00061	DO61
00030	DO30	00062	DO62
00031	DO31	00063	DO63
00032	DO32	00064	DO64

1X

REGISTER	CHANNEL	REGISTER	CHANNEL
10001	DI1	10033	DI33
10002	DI2	10034	DI34
10003	DI3	10035	DI35
10004	DI4	10036	DI36
10005	DI5	10037	DI37
10006	DI6	10038	DI38
10007	DI7	10039	DI39
10008	DI8	10040	DI40
10009	DI9	10041	DI41
10010	DI10	10042	DI42
10011	DI11	10043	DI43
10012	DI12	10044	DI44
10013	DI13	10045	DI45
10014	DI14	10046	DI46
10015	DI15	10047	DI47
10016	DI16	10048	DI48
10017	DI17	10049	DI49
10018	DI18	10050	DI50
10019	DI19	10051	DI51
10020	DI20	10052	DI52
10021	DI21	10053	DI53
10022	DI22	10054	DI54
10023	DI23	10055	DI55
10024	DI24	10056	DI56
10025	DI25	10057	DI57
10026	DI26	10058	DI58
10027	DI27	10059	DI59
10028	DI28	10060	DI60
10029	DI29	10061	DI61
10030	DI30	10062	DI62
10031	DI31	10063	DI63
10032	DI32	10064	DI64

3X

REGISTER	CHANNEL	REGISTER	CHANNEL	REGISTER	CHANNEL
30001	AI1	30101	PI1 (lower)	30133	PI17 (lower)
30002	AI2	30102	PI1 (upper)	30134	PI17 (upper)
30003	AI3	30103	PI2 (lower)	30135	PI18 (lower)
30004	AI4	30104	PI2 (upper)	30136	PI18 (upper)
30005	AI5	30105	PI3 (lower)	30137	PI19 (lower)
30006	AI6	30106	PI3 (upper)	30138	PI19 (upper)
30007	AI7	30107	PI4 (lower)	30139	PI20 (lower)
30008	AI8	30108	PI4 (upper)	30140	PI20 (upper)
30009	AI9	30109	PI5 (lower)	30141	PI21 (lower)
30010	AI10	30110	PI5 (upper)	30142	PI21 (upper)
30011	AI11	30111	PI6 (lower)	30143	PI22 (lower)
30012	AI12	30112	PI6 (upper)	30144	PI22 (upper)
30013	AI13	30113	PI7 (lower)	30145	PI23 (lower)
30014	AI14	30114	PI7 (upper)	30146	PI23 (upper)
30015	AI15	30115	PI8 (lower)	30147	PI24 (lower)
30016	AI16	30116	PI8 (upper)	30148	PI24 (upper)
30017	AI17	30117	PI9 (lower)	30149	PI25 (lower)
30018	AI18	30118	PI9 (upper)	30150	PI25 (upper)
30019	AI19	30119	PI10 (lower)	30151	PI26 (lower)
30020	AI20	30120	PI10 (upper)	30152	PI26 (upper)
30021	AI21	30121	PI11 (lower)	30153	PI27 (lower)
30022	AI22	30122	PI11 (upper)	30154	PI27 (upper)
30023	AI23	30123	PI12 (lower)	30155	PI28 (lower)
30024	AI24	30124	PI12 (upper)	30156	PI28 (upper)
30025	AI25	30125	PI13 (lower)	30157	PI29 (lower)
30026	AI26	30126	PI13 (upper)	30158	PI29 (upper)
30027	AI27	30127	PI14 (lower)	30159	PI30 (lower)
30028	AI28	30128	PI14 (upper)	30160	PI30 (upper)
30029	AI29	30129	PI15 (lower)	30161	PI31 (lower)
30030	AI30	30130	PI15 (upper)	30162	PI31 (upper)
30031	AI31	30131	PI16 (lower)	30163	PI32 (lower)
30032	AI32	30132	PI16 (upper)	30164	PI32 (upper)

3X

REGISTER	CHANNEL	REGISTER	CHANNEL	REGISTER	CHANNEL	REGISTER	CHANNEL
30201	CI1 (lower)	30233	CI17 (lower)	30265	CI33 (lower)	30297	CI49 (lower)
30202	CI1 (upper)	30234	CI17 (upper)	30266	CI33 (upper)	30298	CI49 (upper)
30203	CI2 (lower)	30235	CI18 (lower)	30267	CI34 (lower)	30299	CI50 (lower)
30204	CI2 (upper)	30236	CI18 (upper)	30268	CI34 (upper)	30300	CI50 (upper)
30205	CI3 (lower)	30237	CI19 (lower)	30269	CI35 (lower)	30301	CI51 (lower)
30206	CI3 (upper)	30238	CI19 (upper)	30270	CI35 (upper)	30302	CI51 (upper)
30207	CI4 (lower)	30239	CI20 (lower)	30271	CI36 (lower)	30303	CI52 (lower)
30208	CI4 (upper)	30240	CI20 (upper)	30272	CI36 (upper)	30304	CI52 (upper)
30209	CI5 (lower)	30241	CI21 (lower)	30273	CI37 (lower)	30305	CI53 (lower)
30210	CI5 (upper)	30242	CI21 (upper)	30274	CI37 (upper)	30306	CI53 (upper)
30211	CI6 (lower)	30243	CI22 (lower)	30275	CI38 (lower)	30307	CI54 (lower)
30212	CI6 (upper)	30244	CI22 (upper)	30276	CI38 (upper)	30308	CI54 (upper)
30213	CI7 (lower)	30245	CI23 (lower)	30277	CI39 (lower)	30309	CI55 (lower)
30214	CI7 (upper)	30246	CI23 (upper)	30278	CI39 (upper)	30310	CI55 (upper)
30215	CI8 (lower)	30247	CI24 (lower)	30279	CI40 (lower)	30311	CI56 (lower)
30216	CI8 (upper)	30248	CI24 (upper)	30280	CI40 (upper)	30312	CI56 (upper)
30217	CI9 (lower)	30249	CI25 (lower)	30281	CI41 (lower)	30313	CI57 (lower)
30218	CI9 (upper)	30250	CI25 (upper)	30282	CI41 (upper)	30314	CI57 (upper)
30219	CI10 (lower)	30251	CI26 (lower)	30283	CI42 (lower)	30315	CI58 (lower)
30220	CI10 (upper)	30252	CI26 (upper)	30284	CI42 (upper)	30316	CI58 (upper)
30221	CI11 (lower)	30253	CI27 (lower)	30285	CI43 (lower)	30317	CI59 (lower)
30222	CI11 (upper)	30254	CI27 (upper)	30286	CI43 (upper)	30318	CI59 (upper)
30223	CI12 (lower)	30255	CI28 (lower)	30287	CI44 (lower)	30319	CI60 (lower)
30224	CI12 (upper)	30256	CI28 (upper)	30288	CI44 (upper)	30320	CI60 (upper)
30225	CI13 (lower)	30257	CI29 (lower)	30289	CI45 (lower)	30321	CI61 (lower)
30226	CI13 (upper)	30258	CI29 (upper)	30290	CI45 (upper)	30322	CI61 (upper)
30227	CI14 (lower)	30259	CI30 (lower)	30291	CI46 (lower)	30323	CI62 (lower)
30228	CI14 (upper)	30260	CI30 (upper)	30292	CI46 (upper)	30324	CI62 (upper)
30229	CI15 (lower)	30261	CI31 (lower)	30293	CI47 (lower)	30325	CI63 (lower)
30230	CI15 (upper)	30262	CI31 (upper)	30294	CI47 (upper)	30326	CI63 (upper)
30231	CI16 (lower)	30263	CI32 (lower)	30295	CI48 (lower)	30327	CI64 (lower)
30232	CI16 (upper)	30264	CI32 (upper)	30296	CI48 (upper)	30328	CI64 (upper)

4X

REGISTER	CHANNEL	REGISTER	CHANNEL	REGISTER	CHANNEL	REGISTER	CHANNEL
40001	AO1	40009	AO9	40017	AO17	40025	AO25
40002	AO2	40010	AO10	40018	AO18	40026	AO26
40003	AO3	40011	AO11	40019	AO19	40027	AO27
40004	AO4	40012	AO12	40020	AO20	40028	AO28
40005	AO5	40013	AO13	40021	AO21	40029	AO29
40006	AO6	40014	AO14	40022	AO22	40030	AO30
40007	AO7	40015	AO15	40023	AO23	40031	AO31
40008	AO8	40016	AO16	40024	AO24	40032	AO32

■ Data and Control Functions

CODE	NAME		
01	Read Coil Status	✓	Digital output from the slave
02	Read Input Status	✓	Status of digital inputs to the slave
03	Read Holding Registers	✓	General purpose register within the slave
04	Read Input Registers	✓	Collected data from the field by the slave
05	Force Single Coil	✓	Digital output from the slave
06	Preset Single Registers	✓	General purpose register within the slave
07	Read Exception Status		
08	Diagnostics		
09	Program 484		
10	Poll 484		
11	Fetch Comm. Event Counter		
12	Fetch Comm. Event Log		
13	Program Controller		
14	Poll Controller		
15	Force Multiple Coils	✓	Digital output from the slave
16	Preset Multiple Registers	✓	General purpose register within the slave
17	Report slave ID		slave type / 'RUN' status
18	Program 884/M84		
19	Reset Comm. Link		
20	Read General Reference		
21	Write General Reference		
22	Mask Write 4X Register		
23	Read/Write 4X Register		
24	Read FIFO Queue		

■ Exception Codes

CODE	NAME		
01	Illegal Function	✓	Function code is not allowable for the slave
02	Illegal Data Address	✓	Address is not available within the slave
03	Illegal Data Value		
04	slave Device Failure		
05	Acknowledge		
06	slave Device Busy		
07	Negative Acknowledge		
08	Memory Parity Error		

■ Diagnostic Subfunctions

CODE	NAME		
00	Return Query Data		
01	Restart Comm. Option		
02	Return Diagnostic Register		
03	Change ASCII Input Delimiter		
04	Force Listen Only Mode		

Modbus/TCP data is composed of the following elements (values divided by bytes converted into a hexadecimal value.)

No.	0	1	2	3	4	5	6	7	8 ...	
Content	(1) Transaction ID		(2) Protocol ID		(3) Length		(4) Node ID	(5) Function code	(6) Data	
setting	0		0		Total of No. 6 and following bytes		1			
Byte data	0	0	0	0	(0)	(4)	1	(1)	(0)	(4)
HEX data	00	00	00	00	(00)	(04)	01	(01)	(00)	(04)

(1) Transaction ID

The DL8 does not check the transaction identifier.
Set "00" "00" in hexadecimal.

(2) Protocol ID

The DL8 does not check the protocol identifier.
Set "00" "00" in hexadecimal.

(3) Length

Set the total data bytes of No. 6 and following bytes.

(4) Node ID

The DL8 does not check the node identifier.
Set "01" in hexadecimal.

(5) Function code

Function codes are defined specific to I/O types by Modbus protocol.

(6) Data

Data section.

The range of data returned from the slave to the Modbus/TCP master and data written by the master is as shown in the table below.

Item	Description
AI	<ul style="list-style-type: none"> When the data type is [%] (0 to 10000; voltage/current data of R8 I/O modules or remote I/O devices): -2000 to 12000 When the data type is [Int] (signed integer): Signed 16 bit integer (-32768 to 32767)
PI	<ul style="list-style-type: none"> When the data type is [Accumulation] in Measurement mode: Unsigned 32 bit integer When the data type is [Actual value] in Measurement mode: Signed 32 bit integer When the data type is [Float] in Measurement mode: 32 bit single precision floating point
CI	Unsigned 32 bit integer
AO	Signed 16 bit integer (-32768 to 32767)

14.2.2 SETTING

Follow the procedure shown below to set the Modbus/TCP slave.

- (1) Connect the DL8 with the COP-US cable to the PC to which the DLCFG is installed.
For connection setting, refer to 4.3 IP ADDRESS SETTING.

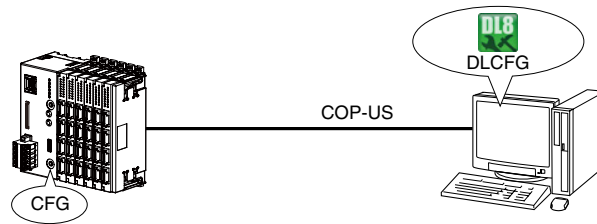

- (2) Start the DLCFG to show the main window.
Click [Download from device] button to read setting from the DL8 and to open “Configuration” window.
Click [Communication] button to open “Communication” menu.
Then click [Modbus/TCP slave] button to open “Modbus/TCP slave” dialog.

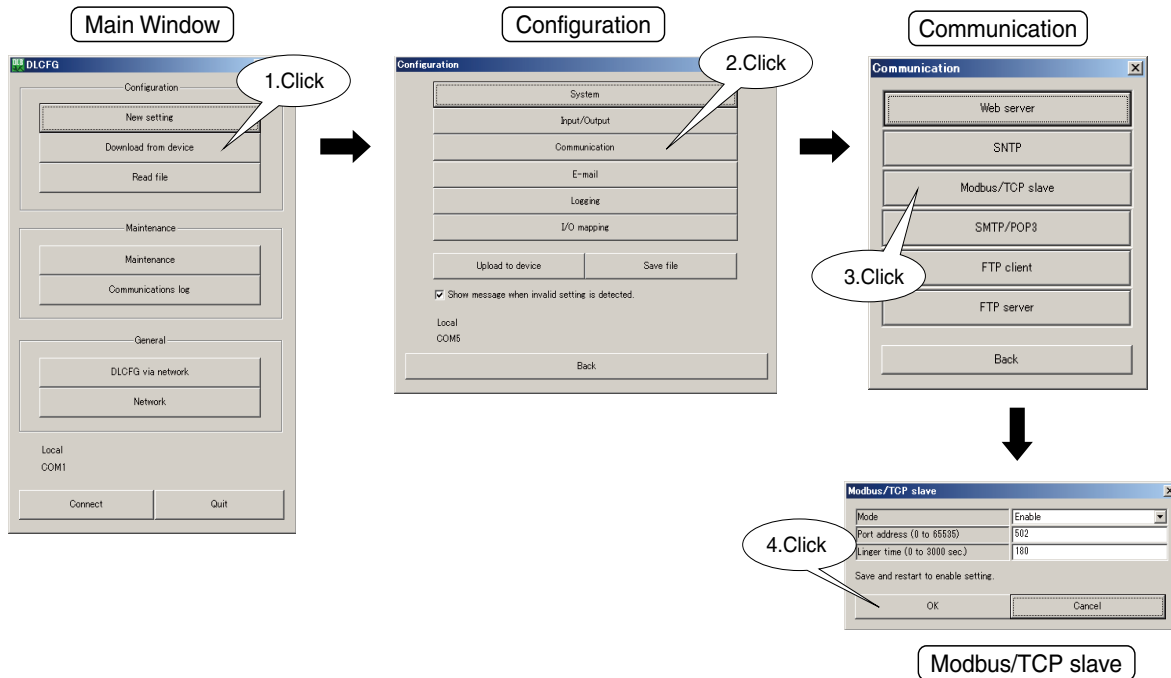

- (3) See the following table and configure each parameter.

PARAMETER	DESCRIPTION
Mode	Set “Disable” or “Enable” for the Modbus/TCP slave function of DL8.
Port address	Any port can be specified but use 502 normally.
Linger time	Set network timeout.

- (4) Click [OK] button to temporarily save the setting.
To enable the setting, return to “Configuration” window and click [Upload to device] button.

NOTE

- To apply the mode and the port address to the DL8, save and restart the device.
- The number of simultaneous connection is four.

14.3 DLCFG VIA NETWORK

The DL8 can be configured remotely by the DLCFG via network access.
Follow the procedure shown below.

- (1) Connect the DL8 with the COP-US cable to the PC to which the DLCFG is installed.
For connection setting, refer to 4.3 IP ADDRESS SETTING.

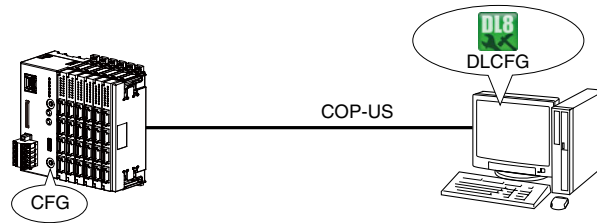

- (2) Start the DLCFG to show the main window.
Click [DLCFG via network] button to read setting from the DL8 and to open “DLCFG network” dialog.
Set as follows.
 Connection via network : Enable
 Password : Max. 64 single-byte alphanumeric characters
- (3) Click [Upload to device] button to transfer the setting to the DL8, and then restart the device.
Click [Back] button to return to the DLCFG main window.
- (4) Click [Connect] button to open “Connect” dialog.
Check the radio button under “Network”.
Click [Set network address] button to open “Set network address” dialog.
Double-click a row to open a dialog for address registration.
- (5) Set a name and a domain name or IP address, and click [OK] button.
Max. 32 addresses can be registered.
- (6) Confirm the registered network address, and click [OK] button.
- (7) Select a target name in the list.
- (8) Click [OK] button to return to the main window, and confirm that the target name is shown in the lower part of the menu.
- (9) You can configure via network in the same way as via local connection.
When connecting to a remote DL8 device, a dialog box appears prompting you for a password.
Enter the password set in (2).

NOTE

- The factory setting for the network connection is as follows.
 Connection via network: Disable
 Password: admin
- Be sure to change the default ID and password.
- It is highly recommended to change the password regularly.

(2) (3)

(4)

Main Window

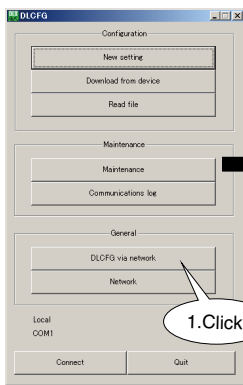

DLCFG via network

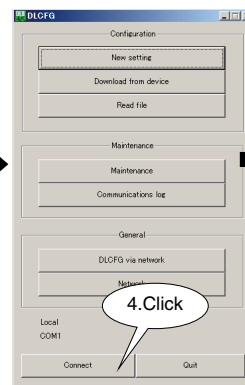
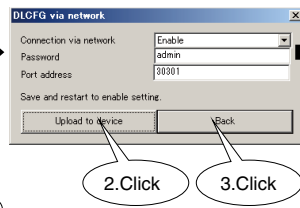

Connect

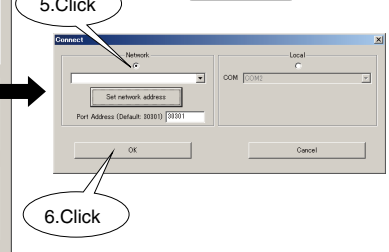

(4)

(5)

(6)

(7)

Set network address

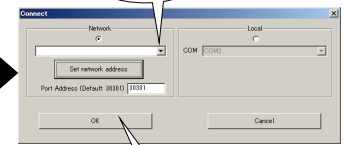
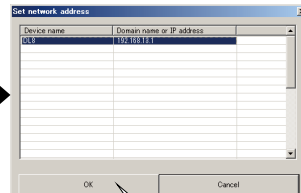
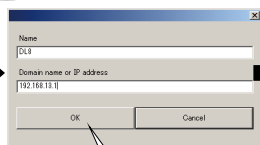
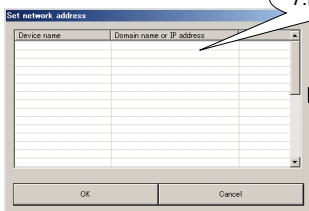

(8)

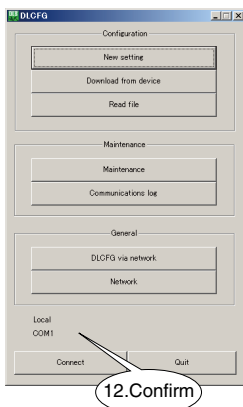

NOTE

- When connecting via network, parameters under “General” in the main window cannot be modified.
- When setting from the in-plant LAN, data packets may be blocked.
Contact your IT network administrator in such cases.
- The port address used for the DLCFG is 30301. Set the same port address for the DL8 and the DLCFG.

14.4 LANGUAGE

Set the Language for the system.

- (1) Click [Download from device] button in the main window to open “Configuration” window.
Click [System] button to open “System” dialog.

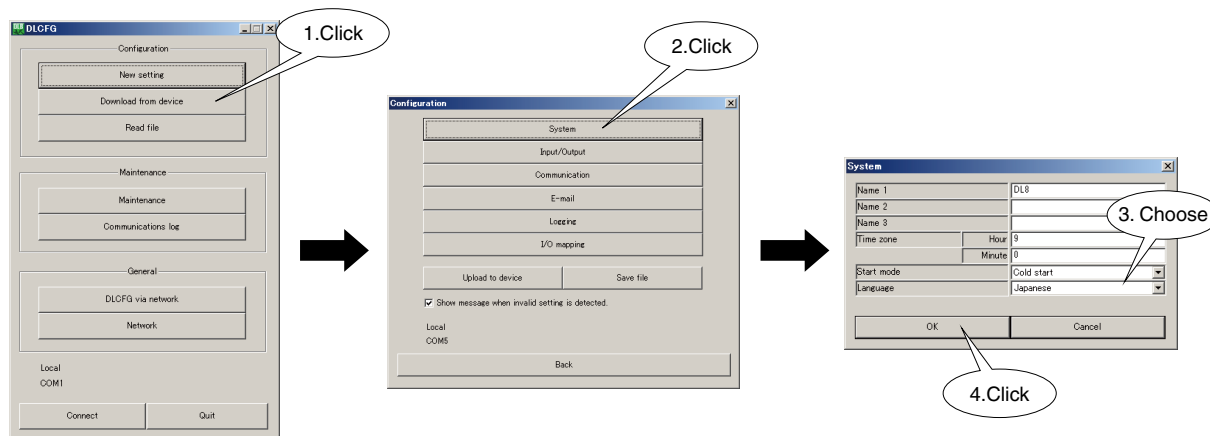

- (2) Choose “Language.”
Click [OK] to return to “Configuration” window.
- (3) To enable the setting, click [Upload to device] on the “Configuration” window.

Item affected by changing language.

ITEM	DESCRIPTION
Mailing log	The format of logging recorded to SD card. (11.6 MAILING LOG)

15. MAINTENANCE

15.1 CONFIGURATION FILE

15.1.1 SAVING CONFIGURATION FILE

To save configuration setting in a file, click [Save file] button in “Configuration” window and specify a file path.

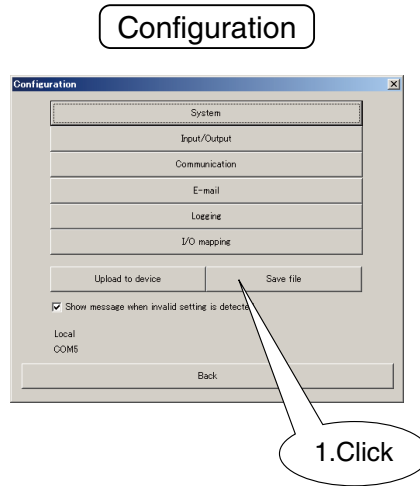

15.1.2 READING CONFIGURATION FILE

To read configuration setting in a file, click [Read file] button in the main window and specify the file to read.

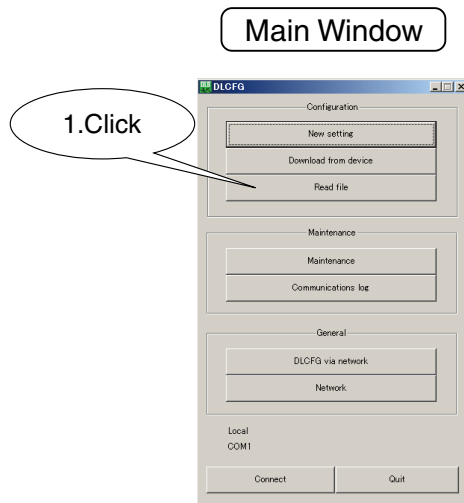

15.1.3 CREATING NEW CONFIGURATION

To create new configuration setting, start by clicking [New setting] button in the main window.

NOTE

- Be sure to use the DLCFG PC Configurator Software when you edit the DL8 setting file. The DL8 is not supported when its setting file is edited by another tool such as a text editor.

15.2 MAINTENANCE MENU

15.2.1 DESCRIPTIONS

Click [Maintenance] button in the main window to open “Maintenance” menu.
Various setting for maintenance is available.

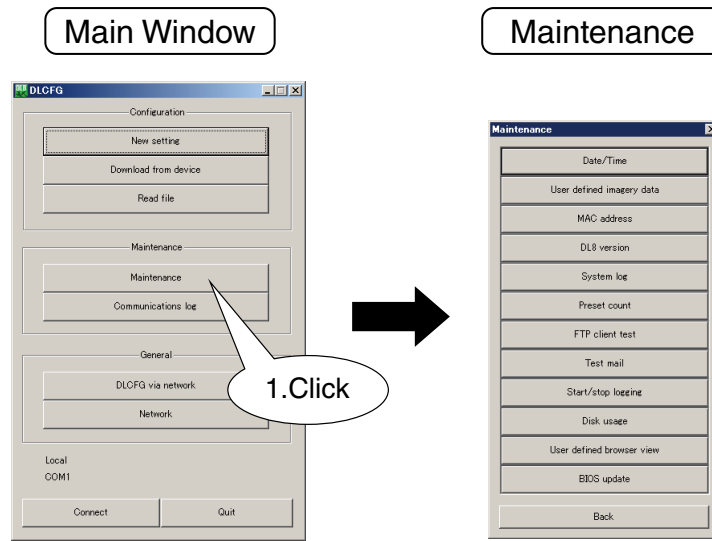

15.2.2 DATE/TIME

The calendar clock of the DL8 can be manually adjusted.
Click [Date/time] button to open “Date/Time” dialog, in which the current time of your PC is indicated.
Enter a new time and click [Apply] button to set it in the internal RTC (real-time clock).

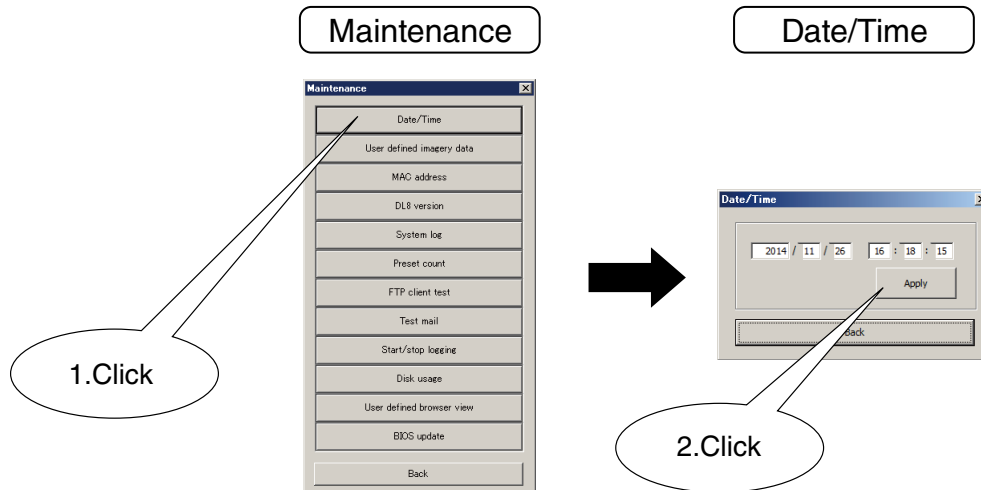

15.2.3 USER DEFINED IMAGERY DATA

Three images of a web server can be arbitrarily changed.
Refer to 8.3.3 USER-DEFINED IMAGE for details.

15.2.4 MAC ADDRESS

Click [MAC address] button to indicate the MAC address of the DL8.

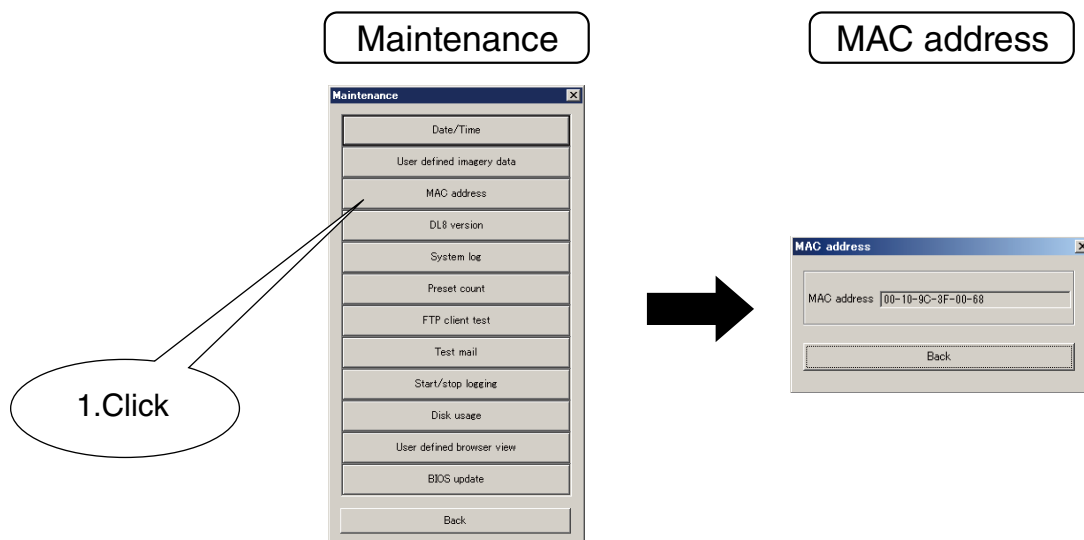

15.2.5 DL8 VERSION

Click [DL8 version] button to indicate the firmware version of the DL8.

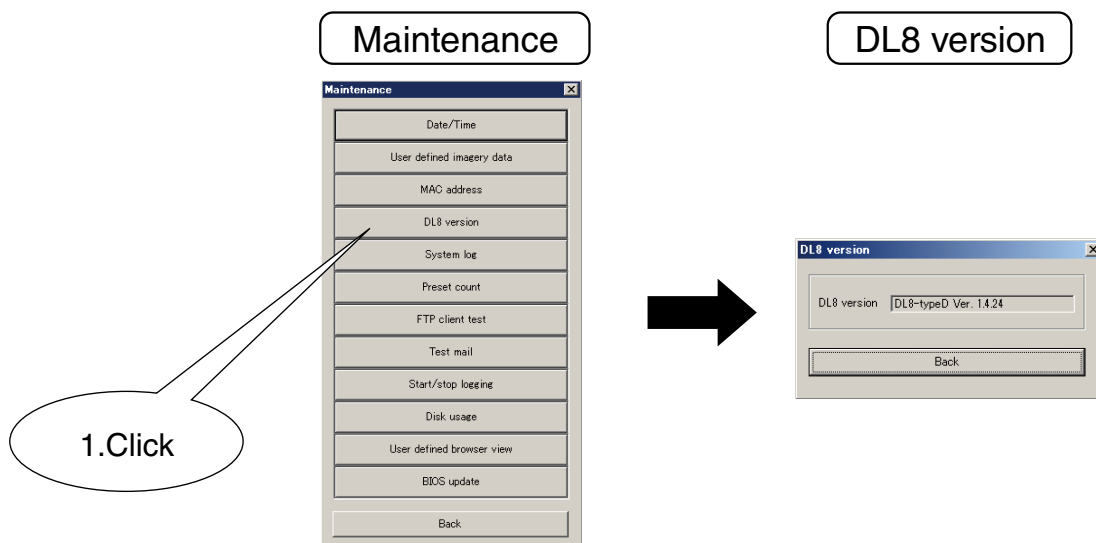

15.2.6 SYSTEM LOG

Click [System log] button to display system logs.
 Latest 64 logs are stored in the nonvolatile memory.
 Click [Reset system log] button to clear the logs.

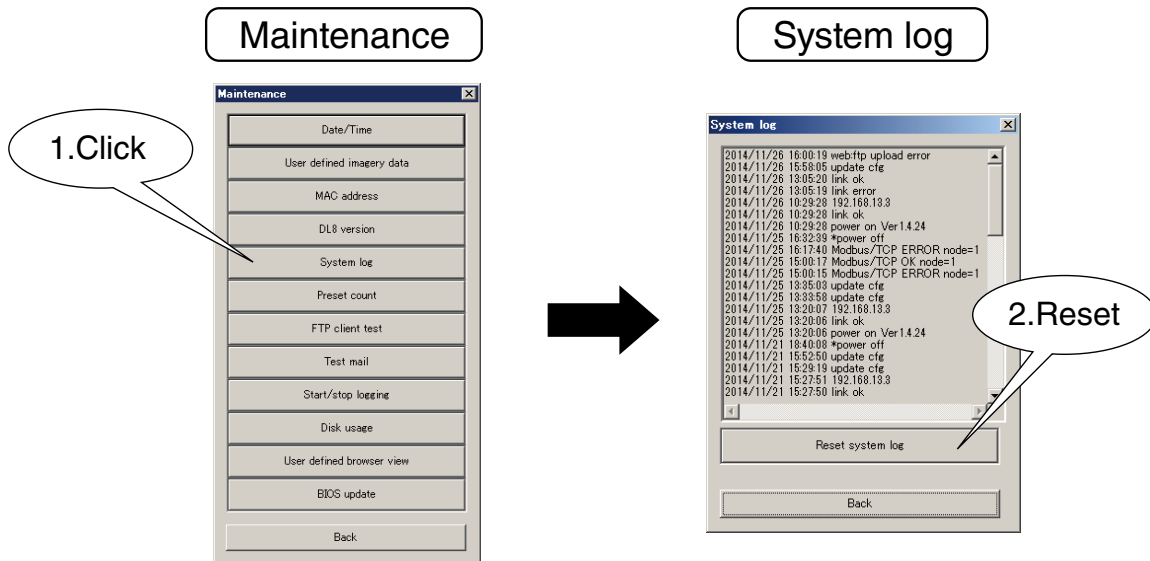

System log message list (excerpt)

MESSAGE	DESCRIPTION
power on Ver X.X.X	Power supply on, firmware version No.
*power off	Power supply off
link ok	Normal Ethernet link
link error	Abnormal Ethernet link
card comm. error	Abnormal communication between modules
DISK error	Abnormal SD card

NOTE

- Please provide the system log contents when you consult us for checking your DL8 operation.
- Messages are subject to change without notice.

15.2.7 PRESET COUNT

Counter values of PI and DI can be changed arbitrarily.

(1) Click [Preset count] button to open “Preset count” dialog.

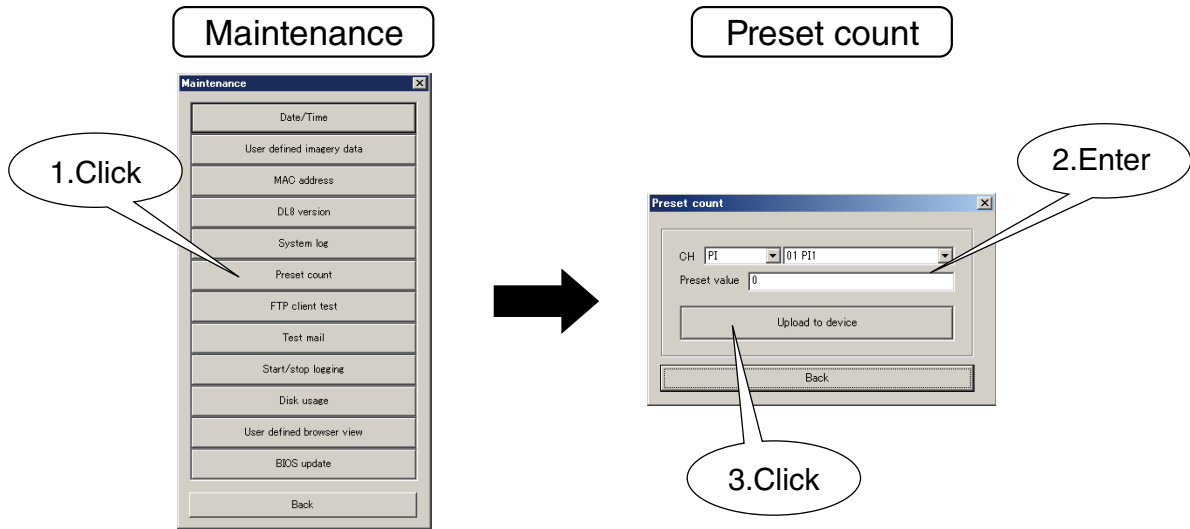

(2) See the following table and configure each parameter.

PARAMETER	DESCRIPTION
CH	Set a channel to preset.
Preset value	Set a preset value in engineering unit value.

(3) Click [Upload to device] button to write the preset value to the DL8.

15.2.8 FTP CLIENT TEST (TYPE B, C, D & E)

Test transmission of the FTP client function is available. Refer to 10.4 TEST TRANSMISSION.

15.2.9 TEST MAIL (TYPE B, C, D & E)

Test mailing is available. Refer to 9.4 TEST MAIL.

15.2.10 START/STOP LOGGING (TYPE C, D & E)

Manual starting or stopping logging is available.

Click [Start/Stop logging] button.

Confirmation dialog box appears. Click [OK] button to start or stop logging.

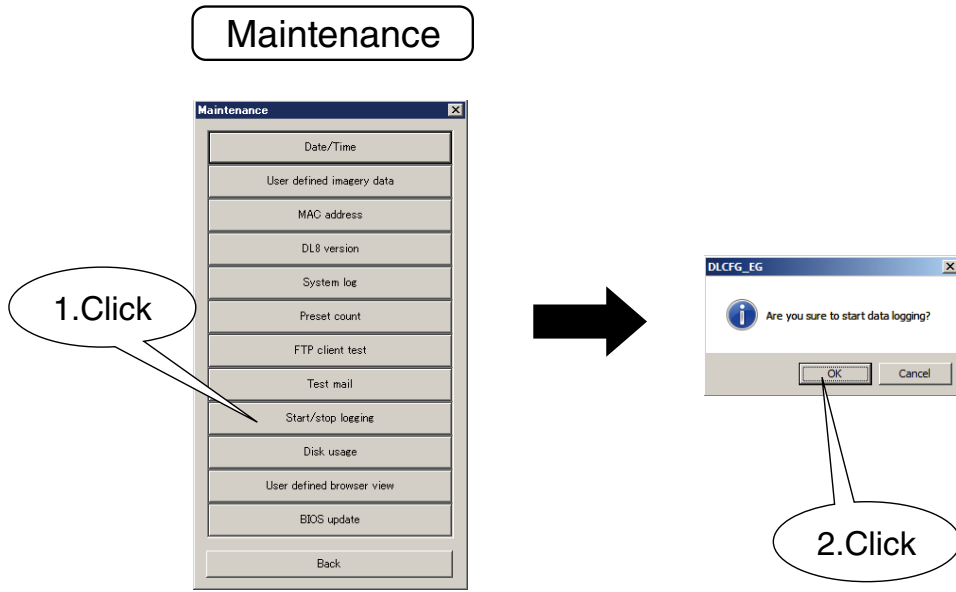

NOTE

- Refer to 11. LOGGING FUNCTION (TYPE C, D & E) for details of the logging function.

15.2.11 DISK USAGE (TYPE C, D & E)

Total capacity, free capacity, and usage of the SD card can be confirmed.

Click [Disk usage] button to open “Disk usage” window. Click [Back] button to quit.

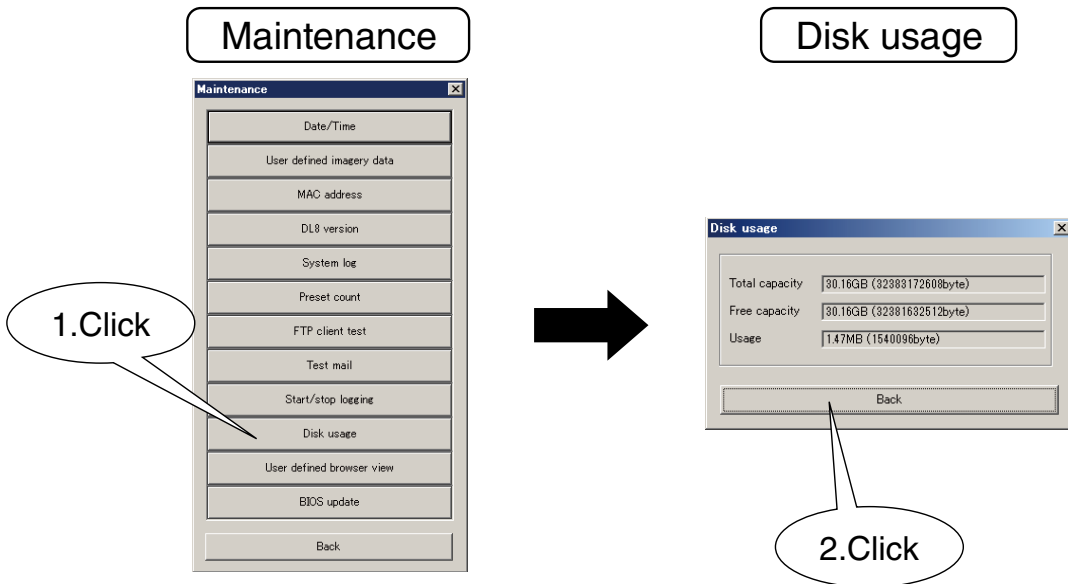

15.2.12 USER DEFINED BROWSER VIEW (TYPE D & E)

Browser views of the user's own programming is imported to the DL8.

Resetting the browser views to the initial state (ex-factory state) is also possible.

Refer to 16.2 PROCEDURE FOR CREATING AND TRANSFERRING BROWSER VIEW DATA for details.

15.2.13 BIOS UPDATE

Update the BIOS in necessary when the fimware of the DL8 is updated.
Click [BIOS update] button to open "BIOS update" window.
Click [OK] button to update BIOS.

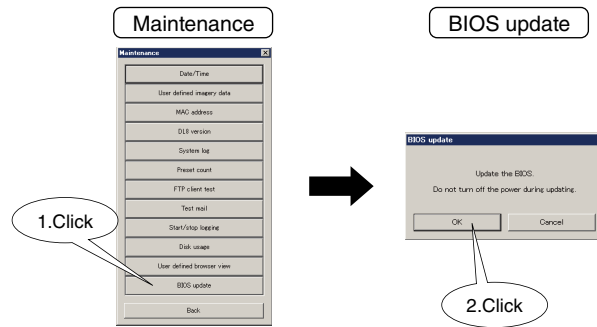

NOTE

- Do not turn off the power during updating. Doing so may result in malfunction of the unit.
- Restart the DL8 after BIOS update.
- After the firmware update, update BIOS in necessary by referring "18.3 BIOS UPDATE"

15.3 DLCFG VERSION

Click (or right-click) on the DLCFG icon at the left top of the DLCFG main window to show a menu.
Choose "About DLCFG_EG..." to show the version No. information.

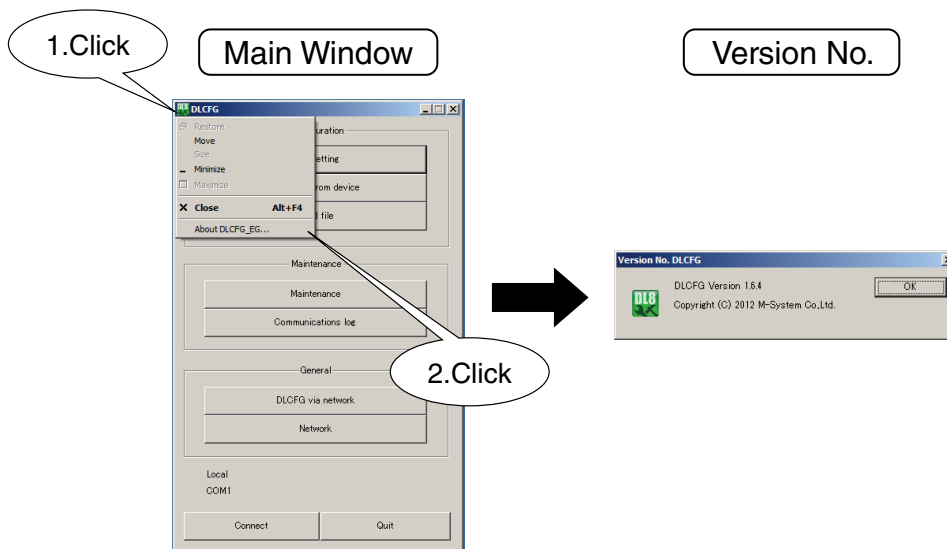

16. USER DEFINED BROWSER VIEW (TYPE D & E)

16.1 GENERAL DESCRIPTION

This section provides supplementary information for creating user defined browser views, focused on relationships between the DL8's I/O data and web data files (.js, .json).

16.1.1 POINTS OF CAUTION

The user defined browser view function is provided for users who have technical knowledge and skill to program web files using HTML, JavaScript, or other programming languages. HTML editor and other tools must be ready by the users, not provided by us. Please be aware that we do not extend customer support to basic questions regarding web site programming.

The DL8 is only capable of basic web server function for file I/O handling, NOT capable of running programs such as CGI or Script, provided from the server side.

A user defined browser view imported to the device cannot be retrieved. Please have a copy of it separately on a PC.

16.2 PROCEDURE FOR CREATING AND TRANSFERRING BROWSER VIEW DATA

16.2.1 STEP 1: CREATING A FOLDER

A user defined browser view is created on a Windows PC. First, create a file folder.

NOTE

- Be sure not to have any subfolder in the created file folder.
- File name length must be within 24 characters including its file name extension.
- Max. 1024 files can be saved in the file folder.
- Max. size per file is limited to 1 MB.
- The total file size in the folder is limited to 4 MB.

16.2.2 STEP 2: CREATING HTML FILES

Describe user's browser views using HTML, JavaScript, CSS and other languages and save in the folder created in STEP 1.

Here is a simple example of HTML file. Write texts as shown below using a text editor tool and save it as "sample.html."

```
<!DOCTYPE HTML PUBLIC "-//W3C//DTD HTML 4.01 Transitional//EN" >
<html>
<head>
<meta http-equiv="Content-Type" content="text/html; charset=utf-8">
<title></title>
</head>
<body bgcolor="#80ffff">
<p>TEST</p>
</body>
</html>
```



16.2.3 STEP 3: DOWNLOADING TO THE DL8

Download the file “sample.html” created in STEP 2 to the DL8, using the DLCFG.

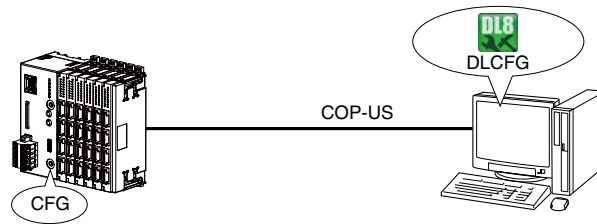
- (1) Connect the DL8 with the COP-US cable to the PC to which the DLCFG is installed.
For connection setting, refer to 4.3 IP ADDRESS SETTING.

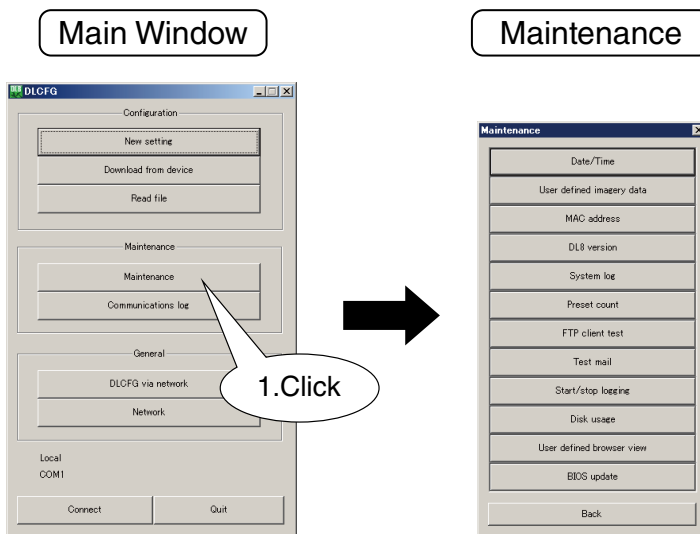

- (2) Start DLCFG to show the main window.
Click [Maintenance] button to open “Maintenance” menu.



- (3) Click [User defined browser view] button to open “User defined browser view” dialog.
Specify the folder you created in STEP 1.

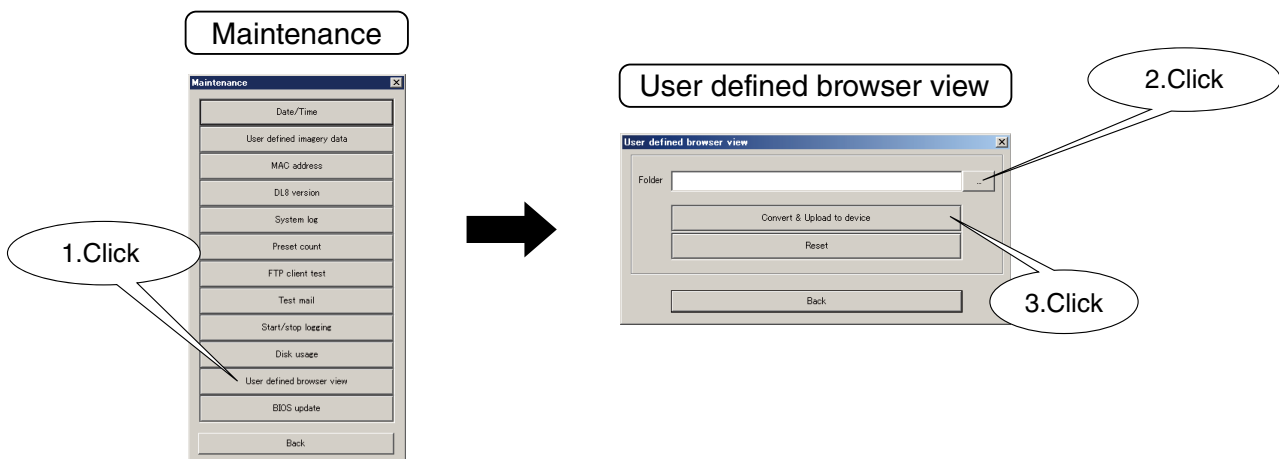

- (4) Click [Convert and upload to device] button to upload the user’s data to the DL8 device.
- (5) To delete the data saved in the DL8, click [Reset] button.

16.2.4 STEP 4: CONFIRMING BROWSER VIEWS

Now open “sample.html” uploaded to the DL8 in STEP 3 on a web browser.
The data is located under “/user” directory.
Specify “user/sample.html” to view the data.

Example	: DL8 IP address 192.168.0.1
Default menu view	: http://192.168.0.1/index.html
User’s view	: http://192.168.0.1/user/sample.html

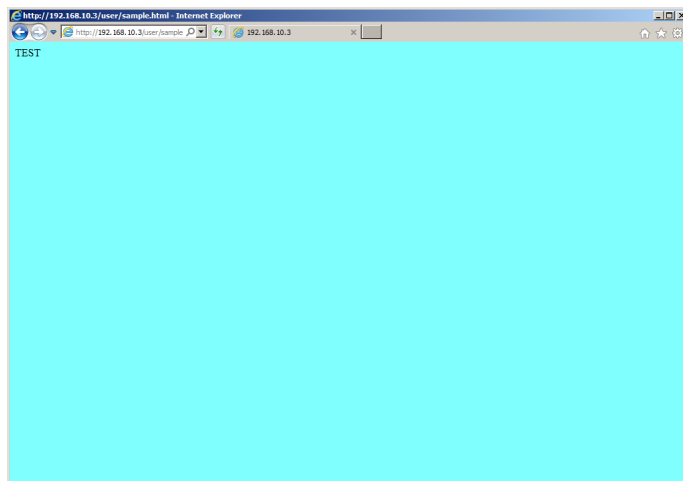

16.3 USER DEFINED VIEW

The simple HTML file created in 16.2 PROCEDURE FOR CREATING AND TRANSFERRING BROWSER VIEW DATA, showing only a fixed character string, is not usable for real applications.

JavaScript is usually used to realize a variable character string such as a process value indicator. In addition, the DL8 is available with its original tags.

Modify as shown below the "sample.html" file created in 16.2 PROCEDURE FOR CREATING AND TRANSFERRING BROWSER VIEW DATA and upload to the DL8. Refresh the browser view.

```
<!DOCTYPE HTML PUBLIC "-//W3C//DTD HTML 4.01 Transitional//EN">
<html>
<head>
<meta http-equiv="Content-Type" content="text/html; charset=utf-8">
<title></title>
</head>
<body bgcolor="#80ffff">
<p>TEST AI1=[AI1_DATA]</p>
</body>
</html>
```

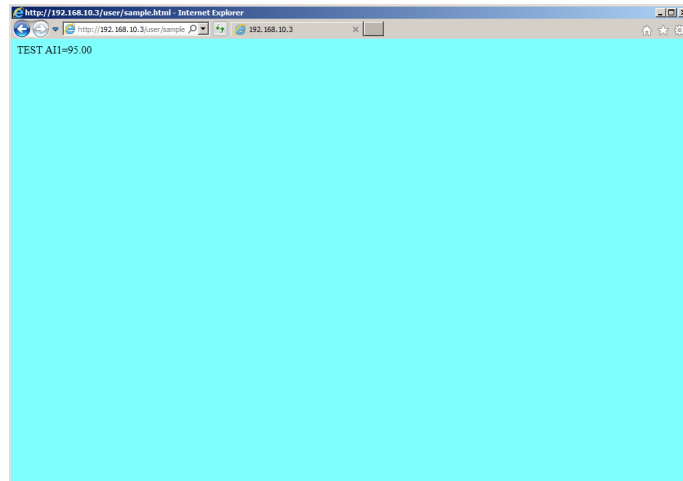

The [AI1_DATA] part is now replaced with AI1 value.
The [AI1_DATA] is one of the original tags provided by the DL8.
A data monitoring view can be built without using JavaScript.

The DL8 original tags are usable only in .html files.
Refer to 16.4 DATA FILE SPECIFICATIONS for details of available tags.

16.4 DATA FILE SPECIFICATIONS

16.4.1 ORIGINAL TAGS

Character set : UTF-8

ORIGINAL TAG	CONTENTS	NOTES
[NAME1]	Name 1	
[NAME2]	Name 2	
[NAME3]	Name 3	
[TIME1]	Present time (1)	2014/11/29 11:00:00
[TIME2]	Not Used	Not Used
[AI■_NAME]	AI■ CH name	■ : 1 to 32
[AI■_COMM]	AI■ CH comment	
[AI■_DATA]	AI■ Engineering unit value	
[AI■_DATA_P]	AI■ % value [% x 100]	
[AI■_UNIT]	AI■ Engineering unit	
[AI■_AREA]	AI■ Zone name	
[DI■_NAME]	DI■ CH name	■ : 1 to 64
[DI■_COMM]	DI■ CH comment	
[DI■_DATA]	DI■ Status (display comment)	
[DI■_COUNT]	DI■ Count	
[DI■_UNIT]	DI■ Engineering unit (counter)	
[PI■_NAME]	PI■ CH name	■ : 1 to 32
[PI■_COMM]	PI■ CH comment	
[PI■_DATA]	PI■ Engineering unit value	
[PI■_UNIT]	PI■ Engineering unit	
[PI■_AREA]	PI■ Zone name	
[DO■_NAME]	DO■ CH name	■ : 1 to 64
[DO■_COMM]	DO■ CH comment	
[DO■_DATA]	DO■ Status (display comment)	
[AO■_NAME]	AO■ CH name	■ : 1 to 32
[AO■_COMM]	AO■ CH comment	
[AO■_DATA]	AO■ Engineering unit value	
[AO■_UNIT]	AO■ Engineering unit	

16.4.2 JAVASCRIPT FORMAT DATA FILES (.js)

Character set : UTF-8

Cloud mode : Available (DL8 data is transferred to the cloud server.)

FILE NAME	DATA	VARIABLE DEFINITION FORMAT
dl_header.js	Present time	var year = 2014; var mon = 7; var day = 3; var hour = 17; var min = 0; var sec = 0; var dl_time1 = "2014/07/03"; var dl_time2 = "17:00:00"
	Name 1	var dl_name1 = "name1";
	Name 2	var dl_name2 = "name2";
	Name 3	var dl_name2 = "name2";
data_ai.js	Number of AI channels (Number of array elements in the following format descriptions equals the number of AI channels.) AI Channel AI CH name AI CH comment AI Engineering unit value AI % value [% x 100] AI Engineering unit AI Zone name AI Zone color AI Channel No.	var ai_chs = 16; var ai_ch = ["AI1", "AI2", ...]; var ai_name = ["AI_NAME1", "AI_NAME2", ...]; var ai_comm = ["Ai-0001", "Ai-0002", ...]; var ai_real = [-50.32, 30.55, ...]; var ai_per = [20.00, 15.00, ...]; var ai_unit = ["km", "kg", ...]; var ai_area = ["HH", "H", ...]; var ai_color = ["#FFFFFF", ...]; var ai_chno = [1, 2, ...];
data_di.js	Number of DI channels Enable/Disable DI control (Number of array elements in the following format descriptions equals the number of DI channels.) DI Channel DI CH name DI CH comment DI Count DI Engineering unit (counter) DI Status (display comment) DI Status color DI Channel No.	var di_chs = 16; var di_enable = 0; (0: Disable, 1: Enable) var di_ch = ["DI1", "DI2", ...]; var di_name = ["DI_NAME1", "DI_NAME2", ...]; var di_comm = ["Di-0001", "Di-0002", ...]; var di_count = ["1000", "335", ...]; var di_unit = ["counts", "cycles", ...]; var di_data = ["OFF", "Shut", ...]; var di_color = ["#FFFFFF", ...]; var di_chno = [1, 2, ...];
data_pi.js	Number of PI channels Enable/Disable PI control (Number of array elements in the following format descriptions equals the number of PI channels.) PI Channel PI CH name PI CH comment PI Engineering unit value PI Engineering unit PI Zone name PI Zone color PI Channel No.	var pi_chs = 16; var pi_enable = 0; (0: Disable, 1: Enable) var pi_ch = ["PI1", "PI2", ...]; var pi_name = ["PI_NAME1", "PI_NAME2", ...]; var pi_comm = ["Pi-0001", "Pi-0002", ...]; var pi_real = [100, 500, ...]; var pi_unit = ["km", "kg", ...]; var pi_area = ["HH", "H", "L", "LL", ...]; var pi_color = ["#FFFFFF", ...]; var pi_chno = [1, 2, ...];

(continued to next page)

(continued from previous page)

FILE NAME	DATA	VARIABLE DEFINITION FORMAT
data_do.js	Number of DO channels (Number of array elements in the following format descriptions equals the number of DO channels.) DO Channel DO CH name DO CH comment DO Data (display comment) DO Status color DO Status ON (display comment) DO Status OFF (display comment) DO Channel No. Enable/Disable DO control	<pre>var do_chs = 16; var do_ch = ["DO1","DO2",...]; var do_name = ["DO_NAME1","DO_NAME2",...]; var do_comm = ["Do-0001","Do-0002",...]; var do_data = ["OFF","Shut",...]; var do_color = ["#FFFFFF",...]; var do_string_on = ["ON","Open",...]; var do_string_off = ["OFF","Shut",...]; var do_chno = [1,2,...]; var do_enable = [1,0,...];</pre>
data_ao.js	Number of AO channels (Number of array elements in the following format descriptions equals the number of AO channels.) AO Channel AO CH name AO CH comment AO Engineering unit value AO Engineering unit AO Channel No. Enable/Disable AO control AO Web control limit (lower) AO Web control limit (upper)	<pre>var ao_chs = 16; var ao_ch = ["AO1","AO2",...]; var ao_name = ["AO_NAME1","AO_NAME2",...]; var ao_comm = ["Ao-0001","Ao-0002",...]; var ao_real = [-20.00,15.00,...]; var ao_unit = ["%","kg",...]; var ao_chno = [1,2,...]; var ao_enable = [1,0,...]; var ao_lower = [0.00,0.00,...,0.00]; var ao_upper = [100.00,100.00,...,100.00];</pre>
auth_level.js	Authorization level	<pre>var auth_level = 0; (0: Unauthorized, 1: Authorized for monitoring, 2: Authorized for control)</pre>
trend_page.js	Trend page name	<pre>var trend_page = ["PAGE1","PAGE2",...,"PAGE8"];</pre>
trend_p■.js ■ : 1 to 8 (=Trend Page No.)	Page name Number of data samples Trend speed (Number of array elements: 4; in the order of Pen No. within the page) CH Type CH name CH comment Pen color Decimal point position Engineering unit or Status ON (display comment) Engineering unit or Status OFF (display comment) Graph offset (%) Pen thickness (Number of array elements: 2; in the order of lower, upper) Graph range (Pen 1) Graph range (Pen 2) Graph range (Pen 3) Graph range (Pen 4) (Number of array elements in the following format descriptions equals the number of data samples.) Year data string Month data string Day data string Hour data string Minute data string Second data string Engineering unit value data string (Pen 1) Engineering unit value data string (Pen 2) Engineering unit value data string (Pen 3) Engineering unit value data string (Pen 4)	<pre>var trend_p■_pagename = "PAGE1"; var trend_p■_samples = 720, var trend_p■_speed = "1S"; var trend_p■_type[4] = ["AI","DI","PI","NONE"]; var trend_p■_name[4] = ["AI1","AI2","AI3","AI4"]; var trend_p■_comm[4] = ["AI1","AI2","AI3","AI4"]; var trend_p■_color[4] = ["#FF0000",...]; var trend_p■_point[4] = [2,2,1,0]; var trend_p■_unit_on[4] = ["%","ON","kPa","J"]; var trend_p■_unit_off[4] = ["%","OFF","kPa","J"]; var trend_p■_offset[4] = [0,20,0,0]; var trend_p■_thick[4] = [1,3,1,1]; var trend_p■_range1[2] = [0.0,100.0]; var trend_p■_range2[2] = [0.0,100.0]; var trend_p■_range3[2] = [0.0,100.0]; var trend_p■_range4[2] = [0.0,100.0]; var trend_p■_year = [2014,...,2014]; var trend_p■_mon = [11,11,...,11]; var trend_p■_day = [8,8,...,8]; var trend_p■_hour = [9,9,...,10]; var trend_p■_min = [10,10,...,23]; var trend_p■_sec = [5,6,...,30]; var trend_p■_ch1 = [90.00,...,100.00]; var trend_p■_ch2 = [90.00,...,100.00]; var trend_p■_ch3 = [90.00,...,100.00]; var trend_p■_ch4 = [90.00,...,100.00];</pre>

(continued to next page)

(continued from previous page)

FILE NAME	DATA	VARIABLE DEFINITION FORMAT
event_log.js	Number of events (Number of array elements in the following format descriptions equals the number of events.) Date/Time (Year/Mon/Day) Date/Time (Hour/Min/Sec) CH CH name CH comment Event message string Color	var event_cnt = 128; var ev_time1 = ["2014/07/03",...]; var ev_time2 = ["11:00:00",...]; var ev_ch = ["AI1","AI2","AI3","AI4",...]; var ev_comment = ["AI1","AI2","AI3","AI4",...]; var ev_message = ["HH","L","NORMAL","H",...]; var ev_color = ["#008040",...];

16.4.3 JSON FORMAT DATA FILES (.json)

Character set : UTF-8

Cloud mode : Not available (DL8 data is not transferred to the cloud server.)

FILE NAME	DATA	VARIABLE DEFINITION FORMAT
data_ai.json	<p>Present time</p> <p><u>(Number of array elements in the following format descriptions equals the number of AI channels.)</u></p> <p>AI Engineering unit value AI % value [% x 100] AI Zone name AI Zone color</p>	<pre>{ year:2014, mon:7, day:3, hour:17, min:0, sec:0, dl_time1:"2014/07/03", dl_time2:"17:00:00", ai_real:[-50.32,30.55,...], ai_per:[20.00,15.00,...], ai_area:["HH","H",...], ai_color:["#FFFFFF",...] }</pre>
data_di.json	<p>Present time</p> <p><u>(Number of array elements in the following format descriptions equals the number of DI channels.)</u></p> <p>DI Count DI Status (display comment) DI Status color</p>	<pre>{ year:2014, mon:7, day:3, hour:17, min:0, sec:0, dl_time1:"2014/07/03", dl_time2:"17:00:00", di_count:["1000","335",...], di_data:["OFF","Shut",...], di_color:["#FFFFFF",...] }</pre>
data_pi.json	<p>Present time</p> <p><u>(Number of array elements in the following format descriptions equals the number of PI channels.)</u></p> <p>PI Engineering unit value PI Zone name PI Zone color</p>	<pre>{ year:2014, mon:7, day:3, hour:17, min:0, sec:0, dl_time1:"2014/07/03", dl_time2:"17:00:00", pi_real:[100,500,...], pi_area:["HH","H","L","LL",...], pi_color:["#FFFFFF",...] }</pre>

(continued to next page)

(continued from previous page)

FILE NAME	DATA	VARIABLE DEFINITION FORMAT
data_do.json	<p>Present time</p> <p>(Number of array elements in the following format descriptions equals the number of DO channels.)</p> <p>DO Data (display comment)</p> <p>DO Status color</p>	<pre>{ year:2014, mon:7, day:3, hour:17, min:0, sec:0, dl_time1:"2014/07/03", dl_time2:"17:00:00", do_data:["OFF","Shut",...], do_color:["#FFFFFF",...] }</pre>
data_ao.json	<p>Present time</p> <p>(Number of array elements in the following format descriptions equals the number of AO channels.)</p> <p>AO Engineering unit value</p>	<pre>{ year:2014, mon:7, day:3, hour:17, min:0, sec:0, dl_time1:"2014/07/03", dl_time2:"17:00:00", ao_real:[-20.00,15.00,...] }</pre>
trend_p■■.json ■ : 1 to 8 (=Trend Page No.)	<p>Present time</p> <p>Number of data samples (Number of array elements in the following format descriptions equals the number of data samples.)</p> <p>Year data string</p> <p>Month data string</p> <p>Day data string</p> <p>Hour data string</p> <p>Minute data string</p> <p>Second data string</p> <p>Engineering unit value data string (Pen 1)</p> <p>Engineering unit value data string (Pen 2)</p> <p>Engineering unit value data string (Pen 3)</p> <p>Engineering unit value data string (Pen 4)</p>	<pre>{ year:2014, mon:7, day:3, hour:17, min:0, sec:0, dl_time1:"2014/07/03", dl_time2:"17:00:00", trend_samples:720, trend_year:[2014,...,2014], trend_mon:[11,11,...,11], trend_day:[8,8,...,8], trend_hour:[9,9,...,10], trend_min:[10,10,...,23], trend_sec:[5,6,...,30], trend_ch1:[90.00,...,100.00], trend_ch2:[90.00,...,100.00], trend_ch3:[90.00,...,100.00], trend_ch4:[90.00,...,100.00] }</pre>

(continued to next page)

(continued from previous page)

FILE NAME	DATA	VARIABLE DEFINITION FORMAT
event_log.json	Present time Number of events (Number of array elements in the following format descriptions equals the number of events.) Date/Time (Year/Mon/Day) Date/Time (Hour/Min/Sec) CH CH name CH comment Event message string Color	<pre>{ year:2014, mon:7, day:3, hour:17, min:0, sec:0, dl_time1:"2014/07/03", dl_time2:"17:00:00", event_cnt:128, ev_time1:["2014/07/03",...], ev_time2:["11:00:00",...], ev_ch:["AI1","AI2","AI3","AI4",...], ev_comment:["AI1","AI2","AI3","AI4",...], ev_message:["HH","L","NORMAL","H",...], ev_color:["#008040",...] }</pre>

16.4.4 XML FORMAT DATA FILES (command.xml)

Cloud mode : Not available (Commands are executed by the DL8 device itself.)

TAG 1	TAG 2	TAG 3 (start)	VALUE	DATA	TAG 3 (end)	NOTES
<DL_CMD>	<DO>					
		<CH■>	ON OFF	Turn DO■ ON Turn DO■ OFF	</CH■>	■ : 1 to 64
	</DO>					
	<PI>					
		<CH■>	RESET	Reset PI■ count	</CH■>	■ : 1 to 32
		<CH■>	(Engineering unit value)	Preset PI■ count	</CH■>	
	</PI>					
	<CI>					
		<CH■>	RESET	Reset DI■ count	</CH■>	■ : 1 to 64
		<CH■>	(Accumulated value)	Preset DI■ count	</CH■>	
	</CI>					
	<AO>					
		<CH■>	(Engineering unit value)	Set AO■ output value	</CH■>	■ : 1 to 32
	</AO>					
</DL_CMD>						

16.5 CLOUD MODE

User defined browser view data files can be transferred to a server specified for use as cloud server.

ITEM	DESCRIPTION
File directory	"/user" folder directly under a folder specified for use as cloud server folder. Files are not transferred when there is no "/user" folder.
Data	First time: All files of user defined browser view data + JavaScript format data files (Refer to 16.4.3 JSON FORMAT DATA FILES (.json).) Second time and later: .html files of user defined browser view data + JavaScript format data files (Refer to 16.4.3 JSON FORMAT DATA FILES (.json).)

17. TROUBLESHOOTING

17.1 DLCFG

PROBLEM	CHECK	TO DO
Unable to connect with DL8 (via COP-US)	Is the COP-US driver installed?	Download and install the driver software from the CD provided with COP-US or our web site.
	Is the COM port No. correct?	Check the COM port No. Match the COM No. (Refer to Section 4.3.)
	Is the miniature jack connected with DLCFG configurator port?	Connect the miniature jack with DLCFG configurator port. Make sure that the connected port is for DLCFG, not for R8CFG.
	Is the front DIP switch SW1 not turned on?	Turn SW1 off. (Refer to Section 3.6.)
Unable to connect with DL8 (via Ethernet)	Is "Connection via network" set to "Enable"?	Connect with COP-US and set "Connection via network" to "Enable". (Refer to Section 14.3.)
	Is the IP address correct?	Connect with COP-US and check the IP address. (Refer to Section 4.3.)
	Is the LAN cable not disconnected or removed from a hub?	Connect the LAN cable firmly. Use 'cross' cable to directly connect the DL8 to a PC.
	Do the IP addresses of DL8 and the PC have the same network address?	Review the IP addresses and transmit a ping command from the PC to make sure that there is a response. e.g. DL8: 192.168.0.1 PC: 192.168.0.2 Subnet mask: 255.255.255.0
	Is the password correct?	Connect with COP-US and check the password set in "DLCFG via network". (Refer to Section 14.3.)
Unable to connect with DL8 (via Internet)	Is the port address 30301 of the router used for DLCFG open?	Set the IP address and the port address 30301 of DL8 manually in the NAT setting of the router. (Refer to the instruction manual of the router.)

17.2 LED INDICATION

PROBLEM	CHECK	TO DO
LEDs turned OFF	Is the power of DL8 turned on?	Check the power supply.
POWER LED blinking	Was the power cycled after setting the IP address to DL8?	Reset the power.
	Is an IP address assigned from a DHCP server such as a router when the address is automatically set to DL8? (Refer to Section 4.3-(4).)	Check the settings of your router. (Refer to the instruction manual of the router.)

17.3 R8 I/O MODULE

PROBLEM	CHECK	TO DO
RUN LED turned OFF	Are the I/O modules installed properly?	Check installation of the I/O modules. (Refer to Section 5.1.)
	Is the terminator DIP switch turned on?	Turn on the terminator DIP switch of the rightmost module, and off the switches of other modules. (Refer to the instruction manual of each R8 series I/O module.)
	Aren't the module addresses overlapped?	Review the module addresses. (Refer to Section 5.1.)
	Is reading data of the I/O modules set with DLCFG?	RUN LED does not turn on unless reading data of the I/O modules is set with DLCFG.
	Does POWER LED turn on?	(Refer to Section 17.2.)
Input value of an analog module is not correct.	Is the range setting correct?	Check the range setting. (Refer to the instruction manual of each R8 series I/O module.)
	Is the voltage or current signal input properly?	Make a loop check, while monitoring with R8CFG. (Refer to the users manual of R8CFG.)

17.4 LAN CONNECTION

PROBLEM	CHECK	TO DO
Web screen is not displayed.	Is the URL correct?	Check the URL. (Refer to Section 8.3.1.)
	Is the IP address correct?	Connect with COP-US and check the IP address. (Refer to Section 4.3.)
	Isn't the LAN cable disconnected or removed from a hub?	Make sure that the PC and the LAN cable are connected with the hub. Use a crossing cable in connecting DL8 directly.
	Is POWER LED of DL8 on?	(Refer to Section 17.2.)
	Aren't the IP addresses overlapped?	Review the IP addresses.
	Do the IP addresses of DL8 and the PC have the same network address?	Review the IP addresses and transmit a ping command from the PC to make sure that there is a response. e.g. DL8: 192.168.0.1 PC: 192.168.0.2 Subnet mask: 255.255.255.0
	Isn't a firewall or a proxy server set on the PC?	Ask your IT network administrator the settings of the firewall and the proxy server.
	Doesn't your terminal or PC have a problem?	Check the version No. of the terminal or the browser software. (Refer to Section 8.2.) Or, try with another terminal or PC.

17.5 WI-FI CONNECTION

PROBLEM	CHECK	TO DO
Unable to connect to the access point with a terminal or a PC.	Is the password for the access point correct?	Check the password for the access point. (Refer to the instruction manual of the access point.)
	Is an IP address allocated?	Make sure that the access point has a DHCP server function. If not, enter an IP address manually. (Refer to the instruction manual of the access point.)

17.6 INTERNET

PROBLEM	CHECK	TO DO
Unable to connect to the Internet (provider).	Are the settings (user name, password) of the router to connect to the provider correct?	Check the settings of the router on the provider. (Refer to the provider information and the instruction manual of the router.)
	Isn't a mobile router used in the place where the radio wave is weak?	Check where the radio wave is strong.
	Are the IP addresses and/or default gateway of DL8 set correctly?	Check the settings of the IP addresses and/or default gateway of DL8. (Refer to Section 4.3.)
Screen is not displayed in Style 1 (WAN) network connection. (Refer to Section 4.2.1.)	Is the URL correct?	Check the fixed IP address or the dynamic DNS of the device in the contracted WAN side. (Refer to the contract with the provider.) (Refer to Section 8.3.1.)
	Is the port open in setting the IP address of DL8 manually?	Set the IP address and the port address (default: 80) of DL8 manually in the NAT setting of the router. (Refer to the instruction manual of the router.)
	Does the router issue an IP address when the address is automatically set to DL8?	Set the router manually to issue the IP address. Also set manually the issued address and the port address (default: 80) of DL8 in the NAT setting. (Refer to the instruction manual of the router.)
Screen is not displayed in the cloud mode.	Are the domain name and the IP address of the FTP server to transfer correct?	Review the contract of the FTP server comparing with the settings of DLCFG. (Refer to Section 8.8.)
	Are the login and the password for the FTP server correct?	Review the login and the password for the FTP server comparing with the settings of DLCFG. (Refer to Section 8.8.)
	Is a subfolder to transfer specified?	Review the subfolder name of the FTP server comparing with the settings of DLCFG. (Refer to Section 8.8.)
	Is the URL correct?	Check the URL. In using a subfolder, specify the name following the domain name or the IP address. e.g. Domain name/subfolder name/index.html (Refer to Section 8.3.1.)

17.7 WEB SERVER

PROBLEM	CHECK	TO DO
Intranet sites are not displayed correctly.	Are the intranet sites displayed in Compatibility View?	Uncheck the "Display intranet sites in Compatibility View" option of your browser.
Unable to control DO or AO on the browser view	Have you not log on with the monitor-only ID & password?	Log on with the general ID & password. (Refer to Section 8.9.)
	Is the control on browser setting for the channel enabled?	Enable "control on browser" setting for the channel. (Refer to Section 7.6.2.)
	Is the channel No. assigned for I/O mapping?	Channel assigned for I/O mapping cannot be manually controlled. Remove the setting. (Refer to Section 13.)

17.8 MODBUS/TCP SLAVE

PROBLEM	CHECK	TO DO
Unable to connect with DL8 from the Modbus master side.	Is the Modbus/TCP slave function enabled?	Enable the Modbus/TCP slave function. (Refer to Section 14.2.)
Unable to read data.	Are the register type and the address of the channel correct?	Check the register type and the address. (Refer to Section 14.2.)
Unable to connect via the router.	Is the port address 502 of the router used for Modbus/TCP open?	Set the IP address and the port address 502 of DL8 manually in the NAT setting of the router. (Refer to the instruction manual of the router.)

17.9 MODBUS/TCP MASTER

PROBLEM	CHECK	TO DO
DL8 is unable to connect to Modbus slave devices.	Isn't the LAN cable disconnected or removed from a hub?	Connect the LAN cable firmly. Check the connection lamp of the hub.
	Is the IP address set to DL8 manually?	Set the IP address manually. (Refer to Section 4.3.)
	Do DL8 and the Modbus slave devices have the same network address?	Check the network address. e.g. DL8: 192.168.0.1 slave: 192.168.0.2 Subnet mask: 255.255.255.0
	Do the IP addresses of the slave devices coincide with those registered with DLCFG?	Check the IP addresses. (Refer to Section 7.2.1.2.)
	Are the IP addresses of the slave side set?	Set the IP addresses of the slave devices. In using our remote I/O modules, cycle the power after setting the IP address. (Refer to the instruction manual of each I/O module to set the IP address.)

17.10 SLMP CLIENT

PROBLEM	CHECK	TO DO
DL8 is unable to connect to SLMP-compatible devices.	Isn't the LAN cable disconnected or removed from a hub?	Connect the LAN cable firmly. Check the connection lamp of the hub.
	Is the IP address set to DL8 manually?	Set the IP address manually. (Refer to Section 4.3.)
	Do DL8 and the SLMP devices have the same network address?	Check the network address. e.g. DL8: 192.168.0.1 slave: 192.168.0.2 Subnet mask: 255.255.255.0
	Do the IP addresses of the SLMP devices coincide with those IP addresses registered as slaves with DLCFG?	Check the IP addresses. (Refer to Section 7.2.1.2.)
	Is the SLMP server function of each SLMP device enabled?	Enable the SLMP server function of each SLMP device.

17.11 E-MAILING (TYPE B, C, D & E)

PROBLEM	CHECK	TO DO
DL8 is unable to send an e-mail.	Is the PC connecting to the Internet?	Make sure that the PC connects to the Internet. (Refer to Section 17.6.)
	Are the IP addresses and/or default gateway of DL8 set correctly?	Check the settings of the IP addresses and/or default gateway of DL8. (Refer to Section 4.3.)
	Is the destination e-mail address correct?	Check the destination e-mail address. Be careful of the difference between “_” and “-” for instance.
	settings on e-mailing · Mail account · IP address or domain name of SMTP server · IP address or domain name of POP3 server · Mail password Are the above settings correct?	Check the settings on e-mailing the provider supplies. Make sure that an e-mail can be sent to the attention address with mail software of the PC.
	Doesn't the mail server of the provider need authentication (SMTP, POP before SMTP, etc.) in sending an e-mail?	Confirm the authentication the provider requires and configure the e-mail settings. (Refer to Section 9.2.)
	With POP before SMTP, is the specified port address of the router open?	Manually set the No. specified in the NAT setting of the router. (Refer to the instruction manual of the router.)
	Doesn't the mail service of the provider have a nuisance e-mail reception prevention function?	Check a response from the mail server with terminal software. (Refer to Section 9.8.)
Unable to open the web browser view for e-mail setting.	URL	Confirm the URL. (Refer to Section 9.5.)
	Login ID and password	Confirm the login ID “dl8cfg” and your password. (Refer to Section 9.5.)

17.12 FTP CLIENT (TYPE B, C, D & E)

PROBLEM	CHECK	TO DO
Unable to connect to the FTP server on the LAN.	Are the FTP server settings correct?	Check the settings in the FTP server side.
	Is login to the FTP server which is set to DL8 as transfer destination possible from FTP client such as a PC ?	Make sure that login to the FTP server is possible using DOS commands for example.
Unable to connect to the FTP server via the Internet.	Is the PC connecting to the Internet?	Make sure that the PC connects to the Internet. (Refer to Section 17.6.)
	Is the port address (default: 21), used for the FTP, of the router in the FTP server side open?	Set the port address (default: 21) manually in the NAT setting of the router. (Refer to the instruction manual of the router.)
	Doesn't security software or a firewall block the connection?	Disable the security software and the firewall, and try again.
DL8 is unable to transfer a CSV file.	Are the address, login ID, password, and the folder name to store the file of the FTP server correct?	Review the login ID and the password of the FTP server comparing with the settings of DLCFG. (Refer to Section 10.3.)
	Is the subfolder to transfer specified?	Review the subfolder name of the FTP server comparing with the settings of DLCFG. (Refer to Section 10.3.)
	Does DL8 regularly transmit to the FTP server?	Check the transmission. (Refer to Section 8.8.3.)
FTPS connection cannot be established.	What is the type of DL8?	Only Type E supports FTPS.
	Can the DL8 connect to the FTP server on the LAN?	See "Unable to connect to the FTP server on the LAN." in this table.
	Can the DL8 connect to the FTP server via the Internet?	See "Unable to connect to the FTP server via the Internet." in this table.
	What is the mode of FTPS?	FTPS is used in "Explicit mode" only.

17.13 LOGGING (TYPE C, D & E)

PROBLEM	CHECK	TO DO
Unable to write data to an SD card.	Is a SD card inserted? (Is SD CARD LED on?)	Insert our recommended SD card. (Refer to Section 11.2.1.1.)
	Are the logs to store set to "Enable"?	Set the logs to store to "Enable" with DLCFG. (Refer to Section 11.3.2-(2).)
	Does LOGGING LED turn on?	Press and hold Logging Button of DL8 for 1 second or more. (Refer to Section 11.2.2.1.) Click [Start/stop logging] button in "Maintenance" window of DLCFG to start logging. (Refer to Section 15.2.10.)
	Are the channels to log data specified correctly?	Check the specified channels with DLCFG. (Refer to Section 11.3.2-(9).)
	Does the SD card have free capacity?	Delete unnecessary data in the SD card.
Logging does not start automatically.	Is the auto start of logging set to "Enable"?	Set "Auto start" to "Enable" with DLCFG. (Refer to Section 11.2.2.4.)
	Are days to log specified?	Specify the days with DLCFG. (Refer to Section 11.3.2-(6).)
It takes long time to start up logging.	Is SD card fragmented?	Check the status of fragmentation with Windows Disk Defragmenter. If required, defragment the card.

17.14 FTP SERVER (TYPE C, D & E)

PROBLEM	CHECK	TO DO
Unable to connect to DL8 with FTP via LAN.	Is the FTP server function of DL8 set to "Enable"?	Set the mode of the FTP server function to "Enable" with DL-CFG. (Refer to Section 12.3.)
	Are the address, login ID, and password of DL8 correct?	Review the address for FTP. (Refer to Section 12.4.3.) Review the login ID and the password set with DLCFG. (Refer to Section 12.3.)
	Is login to DL8 possible from FTP client such as a PC?	Make sure that login to DL8 is possible using DOS commands for example.
Unable to make FTP connection to DL8 via the Internet.	Is DL8 connecting to the Internet?	Make sure that the PC connects to the Internet. (Refer to Section 17.6.)
	Is the URL correct?	Check the fixed IP address or the dynamic DNS of the device in the contracted WAN side. (Refer to the contract with the provider.) (Refer to Section 12.4.3.)
	Is the port address (default: 21) of the router used for the FTP in the DL8 side open?	Set the port address (default: 21) manually in the NAT setting of the router. (Refer to the instruction manual of the router.)
	Doesn't security software or a firewall block the connection?	Disable the security software and the firewall, and try again.
Unable to maintain DL8 files with FTP client.	Is your FTP client software described in the operation manual?	Use the FTP client of which the operation is confirmed. (Refer to Section 12.2.)
FTPS connection cannot be established.	What is the type of DL8?	Only Type E supports FTPS.
	Can an FTP client connect to the DL8 with FTP via LAN?	See "Unable to connect to DL8 with FTP via LAN." in this table.
	Can an FTP client connect to the DL8 with FTP via the Internet?	See "Unable to make FTP connection to DL8 via the Internet." in this table.
	What is the mode of FTPS?	FTPS is used in "Explicit mode" only.
	Is the web server certificate installed?	Create and transfer the certificate to DL8.

18. VERSION HISTORY

18.1 ADDING FUNCTION OR SPECIFICATION CHANGE

18.1.1 Rev.0

DL8 VERSION			
TYPE A	TYPE B	TYPE C	TYPE D
1.2.0 or later	1.2.0 or later	1.2.0 or later	---

- “ON delay time, OFF delay time” is added to DI. (7.3.2 BASIC SETTING)
- setting HTTP port address for web server is supported. (8.9 LOGIN ID, PASSWORD, PORT NUMBER)
- Transfer interval for FTP client can be set to variable partially. (10.2 SPECIFICATIONS)

18.1.2 Rev.1

DL8 VERSION			
TYPE A	TYPE B	TYPE C	TYPE D
1.4.0 or later	1.4.0 or later	1.4.0 or later	1.4.0 or later

- “AO” is added to I/O. (7.6 ANALOG OUTPUT (AO))
- “AO DATA VIEW” is added to Web Server display. (8.4.6 AO DATA VIEW)
- In case of Modbus/TCP master communication error, RUN contact can be OFF, (6.1.2 ASSIGNING REMOTE I/O)
- Address range for Modbus/TCP master is expanded to 65536. (7.2.1.2 ASSIGNING REMOTE I/O TO AI)
- AI bit can be assigned to DI. (7.3.1.4 ANALOG INPUT (AI) ASSIGNED FOR DI)
- AO bit can be assigned to DO. (7.5.1.4 ASSIGNING ANALOG OUTPUT TO DO)
- Floating point data via Modbus/TCP can be assigned to PI. (7.4.1.2 ASSIGNING REMOTE I/O TO PI)
- DO operation from browser can be prohibited. (7.5.2 BASIC SETTING)
- AO operation from browser can be prohibited. (7.6.2 BASIC SETTING)
- “START MODE” is added to set initial value to DO and AO when the DL8 power supply is reset and restarted. (7.7 START MODE)
- “5 sec.” and “5 min.” are added to trend speed in the trend page of web server. (8.5.2 SCREEN COMPONENTS)
- “Automatic updating” is added to the web screen of web server. (8.7 REFRESHING SCREEN)
- “Monitor-only login ID” is added to login ID of web server. (8.9 LOGIN ID, PASSWORD, PORT NUMBER)
- DO and AO are added to the channel data attached to body text for event report of e-mail. (9.3.2 EVENT REPORT)
- AO is added to the channel of FTP client. (10.2 SPECIFICATIONS)
- AO is added to the channel of data logging. (11.3.1 SPECIFICATIONS)
- “Auto file delete (data logging)” is added. (11.8 AUTOMATIC FILE DELETION)
- DI counter data and AO data are added to the register map of the Modbus/TCP. (14.2.1 SPECIFICATIONS)
- The procedure to confirm DLCFG version is changed. (15.3 DLCFG VERSION)

18.1.3 Rev.2

DL8 VERSION			
TYPE A	TYPE B	TYPE C	TYPE D
1.5.0 or later	1.5.0 or later	1.5.0 or later	1.5.0 or later

- Port address of Modbus/TCP master can be configured. (6.1.2 ASSIGNING REMOTE I/O)
- “Pause period” and “Timeout” are added to Modbus/TCP master. (6.1.2 ASSIGNING REMOTE I/O)
- Present time can be treated as AI. (7.2.1.4 TIME INPUT)
- PI input value can be converted into 0 to 10000 range to assign as an AI. (7.2.1.5 PI)
- PI count value can be reset when the AI enters a specific zone. (7.2.3 ALARM ZONE SETTING)
- Port address of the FTP client can be configured. (10.3 SETTING)
- “15 min.” is added to storing rate for data logging. (11.3.1 SPECIFICATIONS)
- 1 MB of upper limit for system log, event log and mailing log is added to the specification. (11.4 SYSTEM LOG, 11.5 EVENT LOG, 11.6 MAILING LOG and 11.7 CHANNEL EVENT LOG)
- Port address of the FTP server can be configured. (12.3 SETTING)

18.1.4 Rev.3

- Unused.

18.1.5 Rev.4

DL8 VERSION			
TYPE A	TYPE B	TYPE C	TYPE D
1.6.0 or later	1.6.0 or later	1.6.0 or later	1.6.0 or later

- “15 min.” and “20 min.” are added to sampling rate of the FTP client. (10.2 SPECIFICATIONS)

18.1.6 Rev.5 to Rev.7

- Unused.

18.1.7 Rev.8

DL8 VERSION			
TYPE A	TYPE B	TYPE C	TYPE D
---	---	1.8.0 or later	1.8.0 or later

- Language setting is added (14.4 LANGUAGE), Mailing log is recorded in English.

18.1.8 Rev.9 to Rev.14

- Unused.

18.1.9 Rev.15

DL8 VERSION			
TYPE A	TYPE B	TYPE C	TYPE D
1.12.0 or later	1.12.0 or later	1.12.0 or later	1.12.0 or later

- Transaction ID management is added to the communication at Modbus/TCP master. When unexpected message is received, it is skipped.

18.1.10 Rev.16

DL8 VERSION			
TYPE A	TYPE B	TYPE C	TYPE D
1.13.0 or later	1.13.0 or later	1.13.0 or later	1.13.0 or later

- Chrome is added as supported FTP client. (12.2 SPECIFICATIONS)

18.1.11 Rev.17

- Unused.

18.1.12 Rev.18

DL8 VERSION			
TYPE A	TYPE B	TYPE C	TYPE D
2.0.0 or later	2.0.0 or later	2.0.0 or later	2.0.0 or later

- Network communication security between DL8 and DLCFG is improved.
- Basic web server function can be disabled by setting the web server port number to 0.
- On a simple web server, it is possible to enable/disable the setting to display E-mail setting view.
- When the settings in which ID and/or password fields are left as default or blank are transferred to the DL8, a warning message is displayed.
- When “RUN contact OFF at comm. error” is enabled on “Modbus/TCP master (I/O slave setting)” window; for DL8 with firmware version 1.x.x, when DL8 detected communication error after succeeding in linking to the slave once, RUN contact turned OFF, on the other hand, for DL8 with firmware version 2.0.0, even if DL8 does not succeed in linking to the slave at all, RUN contact turns OFF.

18.1.13 Rev.19 to 21

- Unused.

18.1.14 Rev.22

DL8 VERSION				
TYPE A	TYPE B	TYPE C	TYPE D	TYPE E
---	---	---	---	2.3.0 or later

- Added Type E which supports SLMP client function, HTTPS, and FTPS protocols.
- Fixed so that an I/O module reading error occurs when a module address where no module is mounted is specified.

18.1.15 Rev.23

- Unused.

18.1.16 Rev.24

DL8 VERSION				
TYPE A	TYPE B	TYPE C	TYPE D	TYPE E
2.4.0 or later	2.4.0 or later	2.4.0 or later	2.4.0 or later	2.4.0 or later

- Fixed so that an I/O module reading error occurs when a module address where no module is mounted is specified.
- Fixed so that, when the FTP client function is used, data connection is established with the IP address having been configured on DLCFG.
- Mouse operation is now supported when connecting with the web server from Safari.
- Chrome has been removed from the list of FTP clients as it no longer supports FTP from version 80.
- [Preset overflow at reset] option has been added to the [Reset count] function for PI.
- Fixed to retry up to two times when time synchronization by SNTP has failed.
- Pen marks display area has been added to trend graphs.

18.1.17 Rev.25 to 29

- Unused.

18.1.18 Rev.30

DL8 VERSION				
TYPE A	TYPE B	TYPE C	TYPE D	TYPE E
3.1.0 or later	3.1.0 or later	3.1.0 or later	3.1.0 or later	3.1.0 or later

- When using FTP client and cloud mode, server to connect by data connection is possible to choose from FTP server set by DLCFG or the address returned with PASV mode.
- Saving location of setting value (i.g. automatic updating and etc.) on web screen has been changed from Cookie to Web Storage.

18.1.19 Rev.31

DL8 VERSION				
TYPE A	TYPE B	TYPE C	TYPE D	TYPE E
3.1.0 or later	3.1.0 or later	3.1.0 or later	3.1.0 or later	3.1.0 or later

- R8-DAT8A2, R8-DAT8B2, R8-DCT8A2, R8-DCT8B2, and R8-FST4N supported.

18.1.20 Rev.32

- unused

18.1.21 Rev.33

DL8 VERSION				
TYPE A	TYPE B	TYPE C	TYPE D	TYPE E
3.3.0 or later	3.3.0 or later	3.3.0 or later	3.3.0 or later	3.3.0 or later

- Added the function to set pulse range when "I/O module" is selected for CH setting in the pulse input (PI) of the I/O setting.

18.1.22 Rev.34

- Deleted "Blinking at Ethernet LINK error." from "3.6 EXTERNAL VIEW" > status indicator LED.
- Added "If the different value is set, an error occurs for accumulated value when overflow occurs." to "7.4.1.1 ASSIGNING I/O MODULE TO PI" > pulse range.
- Deleted the description about data logging from "7.4.6 RESETTING COUNTER IN A REGULAR INTERVAL".
- Added "Shows the communication log that occurs while communication log window is opened." to "8.8.3 STATUS VERIFICATION".
- Deleted setting example of free e-mail services and added note to "9.2 COMMUNICATION SETTING".
- Deleted the description about the LAN cable from "17.2 LED INDICATION".

OTHERS

18.1.23 SUPPORTING SIGNATURE ALGORITHM OF SSL CERTIFICATE FOR MAIL SERVER, SHA-2

DL8 VERSION			
TYPE A	TYPE B	TYPE C	TYPE D
---	1.750 or later	1.770 or later	1.751 or later

- The problem that for e-mail sending, when the signature algorithm of SSL certificate for an e-mail server connected to the DL8 is SHA-2, an e-mail sending error may occur is resolved.

* During recent years, as signature algorithm of SSL certificate migrates from SHA-1 to SHA-2, sending e-mail is not available even with an e-mail server which sends e-mail correctly. For users who are using the firmware version earlier than listed above, consult us.

18.1.24 CHANGE IN PROCESSING OF ABNORMAL DETECTION OF NODE

DL8 VERSION			
TYPE A	TYPE B	TYPE C	TYPE D
1.8.0 or later	1.8.0 or later	1.8.0 or later	1.8.0 or later

- With earlier versions from shown above, when one sub-node out of sub-nodes (remote I/Os) connected to a gateway (72EM2-M4 or IB10W2) with Modbus-RTU generates communication error, it is detected as node error of the gateway and the communication with all sub-node is disconnected. With later versions shown above, it is detected as communication error of each sub-node. By this change, if a communication error from a sub-node is detected, communication with other sub-nodes is maintained. (When a communication error with gateway is detected, as same as previous versions, communication with all sub-node is disconnected.)

18.1.25 RESOLVE THE PROBLEM THAT SOMETIMES WRITING THE SETTING IS FAILED WITH DLCFG (ONLY FOR VERSION 1.8.X)

DL8 VERSION			
TYPE A	TYPE B	TYPE C	TYPE D
1.9.0 or later	1.9.0 or later	1.9.0 or later	1.9.0 or later

- Fixed the following problem. With Modbus/TCP master function of the version 1.8.x, when the setting is written to the web-enabled remote terminal unit with DLCFG during detecting node error*, sometimes "Failed to save" is displayed and it fails to write.

* With system log, the period between recording "Modbus/TCP node error node=n" and recording return message of the node "Modbus/TCP OK node=n".

18.1.26 RESOLVE THE PROBLEM THAT SOMETIMES THE FTP CLIENT DOES NOT UPLOAD A FILE

DL8 VERSION			
TYPE A	TYPE B	TYPE C	TYPE D
1.10.0 or later	1.10.0 or later	1.10.0 or later	1.10.0 or later

- Fixed the following problem. When communication error occurs during the FTP client and the FTP server are communicating, a file is sometimes not uploaded.

18.1.27 IMPROVEMENT OF FTP SERVER PROCESSING

DL8 VERSION			
TYPE A	TYPE B	TYPE C	TYPE D
1.11.0 or later	1.11.0 or later	1.11.0 or later	1.11.0 or later

- Fixed the following problem. The file name requested to FTP server may not be processed, and download may fail.
- 45968 to 45970 were added to passive port of FTP server.

18.1.28 RESOLVE THE PROBLEM THAT SOMETIMES ACCUMULATED VALUE IS MISSING AFTER RECOVERY FROM COMMUNICATION ERROR

DL8 VERSION			
TYPE A	TYPE B	TYPE C	TYPE D
1.14.0 or later	1.14.0 or later	1.14.0 or later	1.14.0 or later

- Fixed the following problem. ON a channel where CH setting is set to “Modbus/TCP”, and measuring mode is set to “Accumulation” in PULSE INPUT (PI), the accumulated value during communication error is missing after recovery from the error.

18.1.29 RESOLVE THE PROBLEM THAT OUTPUT VALUES (DO and AO) ARE NOT CORRECT AT POWER ON

DL8 VERSION			
TYPE A	TYPE B	TYPE C	TYPE D
2.1.0 or later	2.1.0 or later	2.1.0 or later	2.1.0 or later

- Fixed the following problems that:
 In Hot start mode, first, 0 (or OFF) is output before outputting the saved output value at power on; and
 In Cold start mode, first, 0 (or OFF) is output before outputting the initial value set for each channel at power on.

18.1.30 IMPROVEMENT OF FTP SERVER PROCESSING

DL8 VERSION			
TYPE A	TYPE B	TYPE C	TYPE D
---	---	2.2.0 or later	2.2.0 or later

- Fixed the problem that files in an SD card cannot be accessed when using an FTP server.

18.1.31 IMPROVEMENT OF SLAVE COMMUNICATION PROCESSING

DL8 VERSION				
TYPE A	TYPE B	TYPE C	TYPE D	TYPE E
---	---	---	---	2.3.0 or later

- Fixed the problem that when the identical IP address is set for multiple slaves and the leading one of such slaves is not assigned with any I/O channel, the rest of slaves cannot be connected.
- Fixed the problem that even though the communication setting has been changed, the new setting will not be applied and/or the previous connection is maintained.

18.1.32 IMPROVEMENT OF SLAVE COMMUNICATION PROCESSING

DL8 VERSION				
TYPE A	TYPE B	TYPE C	TYPE D	TYPE E
2.4.0 or later	2.4.0 or later	2.4.0 or later	2.4.0 or later	---

- Fixed the problem that when the identical IP address is set for multiple slaves and the leading one of such slaves is not assigned with any I/O channel, the rest of slaves cannot be connected.

- Fixed the problem that even though the communication setting has been changed, the new setting will not be applied and/or the previous connection is maintained.

18.1.33 IMPROVEMENT OF PRESET COUNT PROCESSING

DL8 VERSION				
TYPE A	TYPE B	TYPE C	TYPE D	TYPE E
2.5.0 or later	2.5.0 or later	2.5.0 or later	2.5.0 or later	2.5.0 or later

- The problem that sometimes the PI cumulative count is not correctly reset to the preset value by using the [Preset count] function on DLCFG under the condition that [Scaling] of the PI channel is set to a decimal value and “Preset value” of [Preset count] is set to a decimal value, is solved.

18.1.34 IMPROVEMENT OF SLMP CLIENT PROCESSING

DL8 VERSION				
TYPE A	TYPE B	TYPE C	TYPE D	TYPE E
–	–	–	–	2.6.0 or later

- The problem that the value is not correctly reflected to the DI under the condition that [CH setting] of [Discrete input (DI)] in “Input/Output” is set to “SLMP”, is solved.

18.1.35 IMPROVEMENT OF FTP SERVER PROCESSING

DL8 VERSION				
TYPE A	TYPE B	TYPE C	TYPE D	TYPE E
–	–	–	–	2.7.0 or later

- Fixed the problem that a file operation error of SD card may occur when using an FTP server.

18.1.36 IMPROVEMENT OF WEB SERVER PROCESSING

DL8 VERSION				
TYPE A	TYPE B	TYPE C	TYPE D	TYPE E
3.0.0 or later	3.0.0 or later	3.0.0 or later	3.0.0 or later	3.0.0 or later

- Fixed the problem that sometimes web server accepts POST request with login information of Monitor-only login ID.
- Fixed the problem that web server does not reply when the POST request is illegal data.

18.1.37 IMPROVEMENT OF CLOUD MODE

DL8 VERSION				
TYPE A	TYPE B	TYPE C	TYPE D	TYPE E
–	–	–	–	3.1.0 or later

- Fixed the problem that protocol setting of cloud mode referred the one of FTP client.

18.1.38 IMPROVEMENT OF THE PULSE ACCUMULATION AT OCCURRING OVERFLOW

DL8 VERSION				
TYPE A	TYPE B	TYPE C	TYPE D	TYPE E
3.2.0 or later	3.2.0 or later	3.2.0 or later	3.2.0 or later	3.2.0 or later

- Fixed the problem that when accumulating Modbus/TCP or SLMP of PI, the value is may not accumulated correctly if the difference value when overflow occurs exceeds 2147483647.

18.2 BIOS UPDATE

18.2.1 1.2.0

DL8 VERSION				
TYPE A	TYPE B	TYPE C	TYPE D	TYPE E
3.0.0 or later	3.0.0 or later	3.0.0 or later	3.0.0 or later	3.0.0 or later

- Improved the stability at startup.

19. LICENSE

DL8 and DLCFG incorporate exPat.

Copyright (c) 1998, 1999, 2000 Thai Open Source Software Center Ltd and Clark Cooper
Copyright (c) 2001, 2002, 2003, 2004, 2005, 2006 Expat maintainers.

Permission is hereby granted, free of charge, to any person obtaining a copy of this software and associated documentation files (the "Software"), to deal in the Software without restriction, including without limitation the rights to use, copy, modify, merge, publish, distribute, sublicense, and/or sell copies of the Software, and to permit persons to whom the Software is furnished to do so, subject to the following conditions:

The above copyright notice and this permission notice shall be included in all copies or substantial portions of the Software.

THE SOFTWARE IS PROVIDED "AS IS", WITHOUT WARRANTY OF ANY KIND, EXPRESS OR IMPLIED, INCLUDING BUT NOT LIMITED TO THE WARRANTIES OF MERCHANTABILITY, FITNESS FOR A PARTICULAR PURPOSE AND NONINFRINGEMENT.

IN NO EVENT SHALL THE AUTHORS OR COPYRIGHT HOLDERS BE LIABLE FOR ANY CLAIM, DAMAGES OR OTHER LIABILITY, WHETHER IN AN ACTION OF CONTRACT, TORT OR OTHERWISE, ARISING FROM, OUT OF OR IN CONNECTION WITH THE SOFTWARE OR THE USE OR OTHER DEALINGS IN THE SOFTWARE.

DL8 incorporates excanvas.js.

Copyright 2006 Google Inc.

Licensed under the Apache License, Version 2.0 (the "License");
you may not use this file except in compliance with the License.
You may obtain a copy of the License at

<http://www.apache.org/licenses/LICENSE-2.0>

Unless required by applicable law or agreed to in writing, software distributed under the License is distributed on an "AS IS" BASIS, WITHOUT WARRANTIES OR CONDITIONS OF ANY KIND, either express or implied.
See the License for the specific language governing permissions and limitations under the License.

DL8 incorporates the software subject to the terms and conditions of Camellia license below.

camellia.c ver 1.2.0

Copyright (c) 2006,2007

NTT (Nippon Telegraph and Telephone Corporation) . All rights reserved.

Redistribution and use in source and binary forms, with or without modification, are permitted provided that the following conditions are met:

1. Redistributions of source code must retain the above copyright notice, this list of conditions and the following disclaimer as the first lines of this file unmodified.
2. Redistributions in binary form must reproduce the above copyright notice, this list of conditions and the following disclaimer in the documentation and/or other materials provided with the distribution.

THIS SOFTWARE IS PROVIDED BY NTT "AS IS" AND ANY EXPRESS OR IMPLIED WARRANTIES, INCLUDING, BUT NOT LIMITED TO, THE IMPLIED WARRANTIES OF MERCHANTABILITY AND FITNESS FOR A PARTICULAR PURPOSE ARE DISCLAIMED.

IN NO EVENT SHALL NTT BE LIABLE FOR ANY DIRECT, INDIRECT, INCIDENTAL, SPECIAL, EXEMPLARY, OR CONSEQUENTIAL DAMAGES (INCLUDING, BUT NOT LIMITED TO, PROCUREMENT OF SUBSTITUTE GOODS OR SERVICES; LOSS OF USE, DATA, OR PROFITS; OR BUSINESS INTERRUPTION) HOWEVER CAUSED AND ON ANY THEORY OF LIABILITY, WHETHER IN CONTRACT, STRICT LIABILITY, OR TORT (INCLUDING NEGLIGENCE OR OTHERWISE) ARISING IN ANY WAY OUT OF THE USE OF THIS SOFTWARE, EVEN IF ADVISED OF THE POSSIBILITY OF SUCH DAMAGE.

DL8 incorporates MD5.

Copyright (c) 1991-2, RSA Data Security, Inc. Created 1991. All rights reserved.

License to copy and use this software is granted provided that it is identified as the "RSA Data Security, Inc. MD5 Message-Digest Algorithm" in all material mentioning or referencing this software or this function.

License is also granted to make and use derivative works provided that such works are identified as "derived from the RSA Data Security, Inc.

MD5 Message-Digest Algorithm" in all material mentioning or referencing the derived work.

RSA Data Security, Inc. makes no representations concerning either the merchantability of this software or the suitability of this software for any particular purpose. It is provided "as is" without express or implied warranty of any kind.

These notices must be retained in any copies of any part of this documentation and/or software.

0