

COUPLINGS

PRODUCT	PAGE
INDEX	C-1
COMPARISON CHART	C-2
QUADRA-FLEX®	C-4 – C-24
SLEEVE SELECTION	C-7 – C-8
SELECTION PROCEDURE	C-9
SLEEVES	C-14
FLANGES	C-15 – C-19
KEYSEAT DIMENSIONS	C-18
SPACER FLANGES	C-20 – C-23
INSTALLATION	C-24
CHAIN COUPLING	C-25 – C-27
BORED-TO-SIZE	C-26
QD	C-26
TAPER BUSHED	C-26
COUPLING SELECTION	C-27
PLAIN BORE	C-27
COVERS	C-27
JAW COUPLING	C-28 – C-30
HORSEPOWER RATINGS	C-29
ML AND MS HUBS	C-30
ML AND MS SPIDERS	C-30
IMPERIAL, METRIC AND SPLINE BORE GUIDES	C-31 – C-32
MARTIN-FLEX®	C-33 – C-34
STOCK SIZES	C-33
ENGINEERING	C-34
BLUE-FLEX® GRID COUPLING	C-35 – C-59
COMPONENT GUIDE	C-36 – C-37
SELECTION PROCEDURE	C-38 – C-43
T10 STYLE	C-44
T20 STYLE	C-45
T31 STYLE	C-46 – C-47
T35 STYLE	C-48 – C-49
BORE-TO-SIZE HUBS	C-50
SPACER AND SHAFT HUBS	C-51
COMPONENTS	C-52
ENGINEERING DATA	C-53 – C-59
GO-FLEX® FLEXIBLE COUPLING	C-60 – C-78
NOMENCLATURE	C-61
INSERTS	C-62
COVERS	C-63
SELECTION GUIDE	C-64 – C-75
INSTALLATION INSTRUCTIONS	C-76 – C-78

Coupling Comparison Chart



Selection Criterion	Coupling Type						
	ML - Jaw	Chain	Quadra-Flex	Martin-Flex	Go-Flex	Blue-Flex	
Shaft Size Range	inch	1/8 to 2-5/8	7/16 to 6-1/8	3/8 to 5-1/2	3/8 to 3-1/2	1/2 to 11	1/2 to 13
	mm	4 to 65	12 to 160	9 to 140	9 to 90	12 to 280	12 to 330
Torque Range	in-lbs	3.5 to 6,228	1,921 to 151,622**	60 to 72,480	649 to 9,076	365 to 1,680,000	460 to 1,650,000
	Nm	0.4 to 704	218 to 17,135	6.78 to 8,190	73 to 1025	40 to 189,840	52 to 186,450
Maximum Angular Misalignment Capability		1/2° to 1°	2°	1°	4°	2°	.25°
Temperature Range Standard Element		-40° to 212° F	-30° to 225° F	-30° to 275° F	-40° to 180° F	-60° to 212° F	-40° to 250° F
		-40° to 100° C	-35° to 108° C	-35° to 135° C	-40° to 85° C	-50° to 100° C	-40° to 121° C
Reactionary Loads due to Misalignment		Medium	Low	Low	Medium	Low	High
Torque to OD Capability		Good	Good	Fair	Fair	Fair	Good
Speed Capability		Good	Good	Fair	Fair	Good	Good
Torsional Stiffness		Low	Medium	Low	Low	Medium	Medium
Ease of Installation/ Maintenance		Excellent	Excellent	Excellent	Excellent	Excellent	Fair
Chemical Resistance		Good	Good	Good	Fair	Good	Fair
Adaptable to Several Designs		Excellent	Poor	Excellent	Good	Excellent	Excellent
Damping Capacity		Good	Poor	Excellent	Excellent	Good	Good
Industry Interchangeable		Yes	Yes	Yes	Yes	Yes	Yes

** MAX allowable torque below 50 RPM

*** Half-coupling ONLY

Whatever Your Need For Couplings — Martin Has Them

Martin Jaw Couplings

Two complete lines of jaw couplings. One for greater horsepower and one for interchangeability.

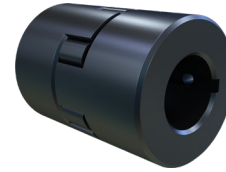

ML — Type

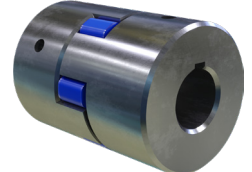

MS — Type

Martin-Flex® flexible couplings

Smoothly transmit power while compensating for shaft misalignment to 4°, parallel misalignment to .125 and end float to .313. The two piece flange design provides quick and easy installation and the elastomeric element absorbs shock and torsional vibration through a wide temperature range.



Martin Chain Couplings

The most complete line of chain couplings available in the industry

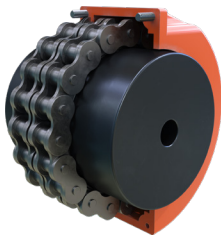

S/B

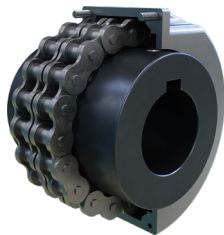

BS

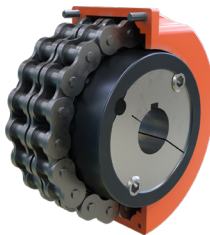

TB

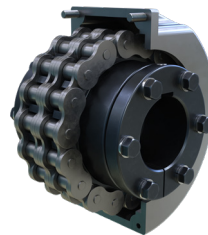

QD

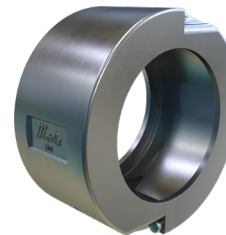

Aluminum



Plastic

Martin Quadra-Flex®

A proven design which offers long life, torsional flexibility, ease of installation, and withstands misalignment, shock, and vibration.

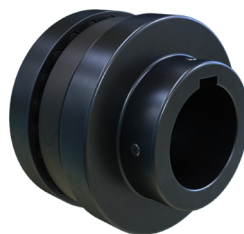

BS

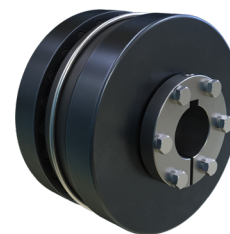

QD



Spacers

Martin Blue-Flex® Grid Couplings

Are the best option where both high torque levels and dampening requirements exist.



Horizontal Cover

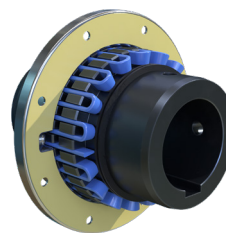

Vertical Cover

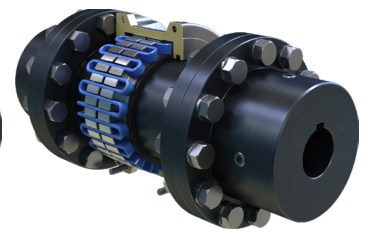

Spacers

Martin Go-Flex® Flexible Couplings

Is one of the easiest to install, maintain, and repair!

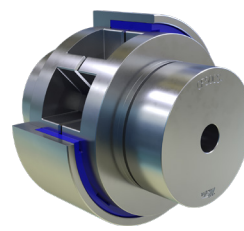

Standard Cover

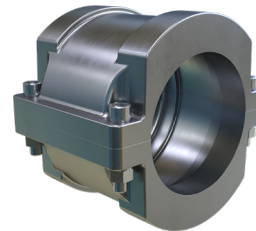

Horizontal Cover

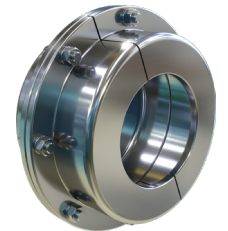

Vertical/Split Cover

Quadra-Flex®
4-Way Flexing

Martin

QUADRA-FLEX® FLEXIBLE COUPLINGS

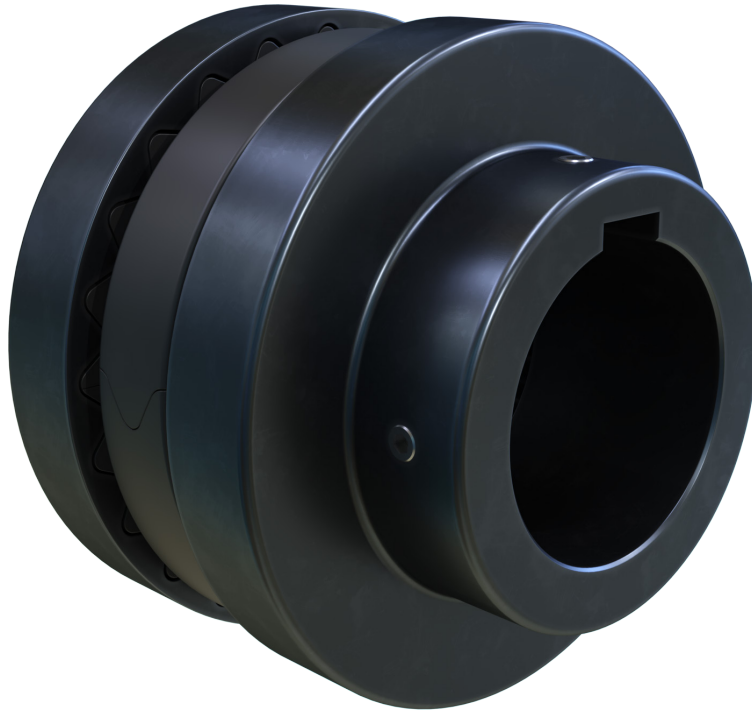

**Stocked nationwide
In sizes 3 through 16**

**Styles J, S, B, and
SC spacers**



**Martin Quadra-Flex® couplings, non lubricated, maintenance free, easy and quick installation
Handles all combinations of shock, vibration, and misalignment**

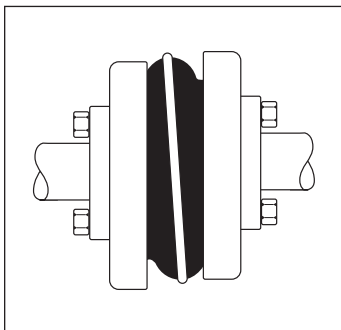

Parallel

Quadra-Flex® couplings absorb parallel misalignment without wear and with minimal loss of energy.

The amount of parallel offset handled varies by size from .015 on the size 5 up to .062 on the size 16. This minimizes the radial loads on bearings when parallel misalignment occurs.

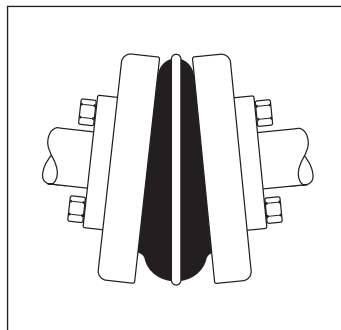

Angular

Due to the flexing characteristics of the sleeve and the locking action of the teeth, Quadra-Flex® couplings easily handle angular misalignment up to 1 degree without any appreciable wear.

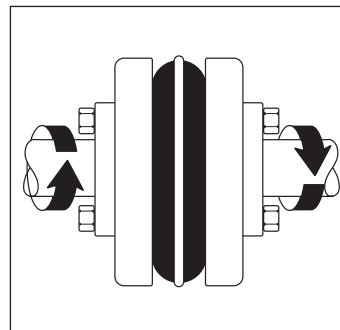

Torsional

Quadra-Flex® sleeves are torsionally resilient and are well suited to absorbing shocks and dampening vibrations that would otherwise be transmitted between the equipment.

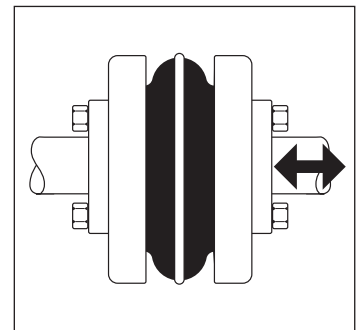

S/B

The axial flexibility of the sleeve allows the Quadra-Flex® coupling to accept a limited amount of end float. This serves to reduce thrust loads transferred to bearings. Quadra-Flex® units will accept axial movement of approximately .125.

Available in Three Styles

Type J and S Flanges

Bored-to-size flanges are manufactured for a slip fit on standard shafting. Available from stock in a wide range of shaft sizes.

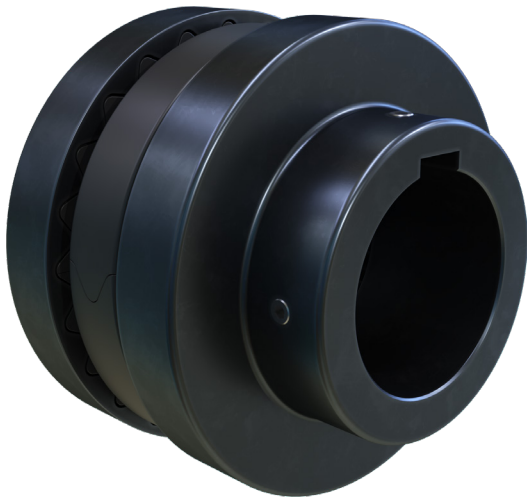

Available in Three Styles

Manufactured from high strength cast iron to fit standard QD bushings in sizes 6 thru 16.

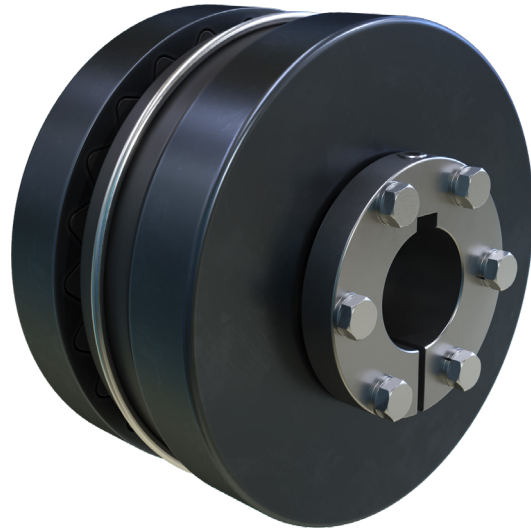

Fast Coupling Disassembly

Martin offers the first true drop-out spacer assembly for the 4JSC spacer coupling. The center portion of the spacer can be taken out, just as in the 5SC thru 14SC, by simply removing four cap screws in each hub. The couplings center section can then be lifted out and the pump gaskets exposed. Flats on the spacer hubs facilitate turning shafts with a wrench.

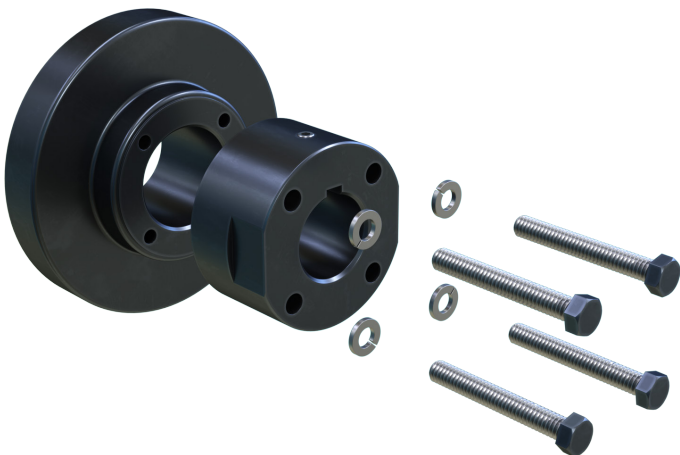

Type SC Spacer Flange

Quadra-Flex® SC spacer couplings feature all standard spacing requirements for the pump industry. Spacer sizes range from sizes 4 thru 14.

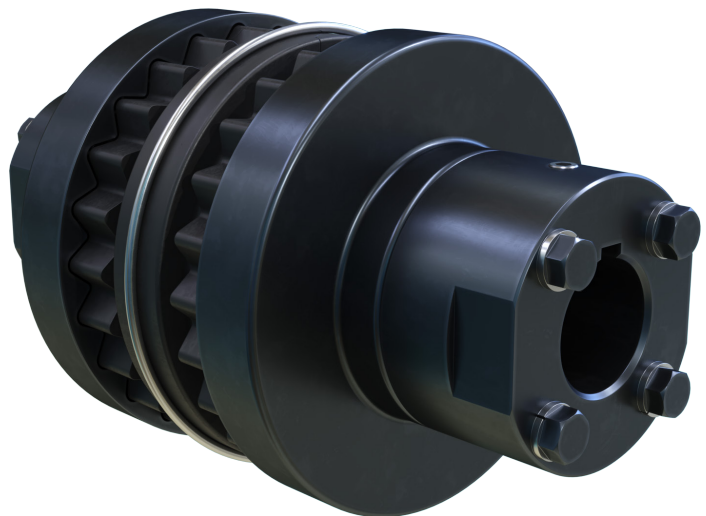

Quadra-Flex® Nomenclature

Type	Description
J ★	SINTERED STEEL, BORED-TO-SIZE
S	CAST IRON, BORED-TO-SIZE
B	CAST IRON, QD BUSHED
SC	SPACER COUPLING FLANGES

★ #6 Currently Supplied in Cast Iron

Hubs — (For SC flanges)

Type	Description
H	REGULAR LENGTH
HS	SHORT LENGTH

Quadra-Flex® couplings come in a variety of styles and designs to meet specific customer needs. These include flanges and sleeves of various types and materials. The total product line includes 13 sizes varying in torque ratings up to 72,000 in-lbs.

When ordering Quadra-Flex® couplings, the following basic procedure should help expedite order processing. For coupling flanges, give the basic coupling size, then the letter for the type flange followed by the bore size required. For coupling sleeves, give the coupling size followed by the letter(s) designating the type and material required. (See above)

The following are various examples for reference:

Example: Type J Flange

	Size	Flange	Bore
5J × .75	5	J	.75
7S × 30mm	7	S	30mm

(Note: Bored-to-size flanges are furnished with standard keyway and 2 setscrews unless specified otherwise.)

Sleeves

Type	Description
JEM	TPR – 1-PIECE SOLID, THERMOPLASTIC
JEMS	TPR – 1-PIECE SPLIT, THERMOPLASTIC
EM	TPR – 2-PIECE W/RETAINING RING
E	EPDM – 2-PIECE W/RETAINING RING
N	NEOPRENE – 2-PIECE W/RETAINING RING
H	HYTREL – 1-PIECE SOLID
HS	HYTREL – 2-PIECE

Example: Type B Flange

	Size	Flange	Bushing
8B — SH	8	B	SH

(Note: The SH bushing with required bore size should be specified separately.)

Example: Sleeves

	Size	Style and Material
8JEM	8	Solid, TPR
13E	13	2 Piece, EPDM

(Note: Unless specified, TPR (3 thru 12) or EPDM (13 thru 16) will be supplied.)

Example: Complete spacer coupling

1	6EM	(6 TPR 2 Piece Sleeve)
2	6sc35	(Flanges for 3.5 dropout)
1	6H × 1	(6 Spacer Hub for 1 Bore)
1	6H × 1.125	(6 Spacer Hub for 1.125 Bore)

Sleeve Selection



Quadra-Flex® coupling sleeves are available in four different types of compounds. These include TPR (Thermoplastic Rubber) in types JEM, JEMS, EM; EPDM Rubber in type E; Neoprene in type N; Hytrel in type H and HS. To determine the sleeve best suited for the application, the material characteristics are given below.

TPR (Sizes 3-12)

Quadra-Flex® couplings are usually supplied with TPR sleeves in sizes 3-12. TPR is a general use sleeve which combines the characteristics of both EPDM and Neoprene into one. These sleeves operate within a temperature range from -50° F to +275° F (-46° C to +135° C). Torsional flexibility is 15°.

EPDM (Sizes 13-16)

Quadra-Flex® couplings are usually supplied with EPDM rubber sleeves in sizes 13-16. EPDM is a general use sleeve and can operate within a temperature range from -30° F to +275° F (-34° C to +135° C). Torsional flexibility is 15°.

NEOPRENE (Sizes 11-16)

Neoprene flexible sleeves are also available in sizes 11-14. These sleeves offer a higher resistance than EPDM and are self-extinguishing. Operating temperature range for this sleeve is 0° F to +200° F (-18° C to +93° C). Torsional flexibility is 15°.

*HYTREL® (Sizes 6-14)

Hytrel sleeves are molded specifically for high torque applications. The type H will transmit approximately four times as much power as an equivalent TPR, EPDM, or Neoprene sleeve. Hytrel has an operating temperature from -65° F to +250° F (-54° C to +121° C). Torsional flexibility is 7°.

Note: Do not use a Hytrel sleeve as a replacement for a TPR, EPDM, or Neoprene sleeve.

Sleeve Chemical Resistance

Resistance To:	TPR	EPDM	Neoprene	Hytrel ★	Resistance To:	TPR	EPDM	Neoprene	Hytrel ★
Acetone	A	A	B	B	Kerosene	B	X	B	T
Ammonia, Anhydrous	B	T	A	N	Lacquer Solvents	T	...	C	B
Ammonium Hydroxide Solutions	T	A	A(158F)	T	Lubricating Oils	B	X	B(158F)	A
ASTM hydrocarbon test fluid	N	C	X	A	Methyl Alcohol	A	T	A(158F)	A
ASTM oil no. 1	B	C	A	A	Mineral Oil	B	X	A	A
ASTM oil no. 3	B	C	B(158F)	A	Naphtha	B	C	C	A
ASTM reference fuel A	B	C	A	A	Nitric Acid, 10%	A	T	B	B
ASTM reference fuel B	B	C	C	A	Nitrobenzene	T	A	C	C
ASTM reference fuel C	B	X	C	B	Phenol	T	T	B	C
Benzene	C	C	C	B	Phosphoric Acid, 20%	A	T	T	N
Butane	B	B	A	A	Phosphate Esters	A	A	C	A
Carbon Tetrachloride	X	C	C	C	Pickling Solution (20% Nitric Acid, 4% HF)	N	X	B-C	X
Chlorobenzene	C	X	X	X	Soap Solutions	A	T	A(158F)	A
Chloroform	X	C	C	C	Sodium Hydroxide, 20%	A	A	A	A
Chromic Acid, 10-50%	T	T	C	N	Stearic Acid	T	T	B(158F)	T
Dowtherm A Solvent	X	N	B	N	Sulfuric Acid, up to 50%	A	T	A(158F)	A
Ethyl Alcohol	A	A	A(158F)	A	Sulfuric Acid, up to 80%	A	T	B-C	C
Ethylene Glycol	A	A	A(158F)	A	Tannic Acid, 10%	T	T	A	T
Fuel Oil	B	X	A	A	Toluene	C	C	C	B
Gasoline	B	B-C	B	A	Trichloroethylene	C	X	C	C
Glycerine	A	T	A(158F)	A	Turpentine	B	C	C	N
Hydraulic Oils	B	N	A	A	Water	A	A(158F)	A(212F)	A(158F)
Hydrochloric Acid, 20%	A	T	A	B	Xylene	C	C	X	B
Hydrogen Peroxide, 881/2%	N	T	B	T					
Isopropyl	A	T	A	A					

A — Fluid has little or no effect
 B — Fluid has minor to moderate effect
 C — Fluid has severe effect

N — No evaluation has been attempted.
 T — No data; likely to be compatible
 X — No data; not likely to be compatible

*Hytrel is a Registered Trademark of Dupont

Selection Procedure

When the driver is an electric motor with standard speed.

Step 1. Determine Service Factor (SF) Symbol based on equipment listed on page C-10.

Step 2. Determine proper Service Factor from chart at top of page C-10.

Step 3. Refer to page C-12 and C-13 for proper selection of coupling. Based on chemical resistance and operating environment found on page C-8, select from chart the type of sleeve material. Find RPM of motor, then, in the column for service factor determined in Step 2, read down to the corresponding horsepower of motor being used as the driver. The number listed is the correct coupling size.

Example: A coupling is needed to connect a 25 HP standard electric motor to a lumber log haul at 1750 RPM.

1. Service Factor Symbol — H
2. Service Factor — 2.0
3. Coupling Size — 9 with TPR sleeve or 6 with Hytrel Sleeve

Step 4. Select flanges from pages C-15 thru C-19, check coupling bore size range for proper shaft fit.

★ **NOTE: Do not oversize coupling hub — will cause premature wear of element.**

When the driver is other than an electric motor or the speeds are different than those shown in the chart on page C-11.

Step 1. Follow steps 1 and 2 in previous procedure.

Step 2. Calculate Horsepower at 100 RPM as follows:

$$\text{HP at 100 RPM} = \frac{\text{HP} \times \text{Service Factor} \times 100}{\text{Coupling RPM}}$$

Step 3. Select coupling size from Tables A or C. Find a HP equal to or greater than the HP/100 RPM

Step 4. Check Maximum bore to be sure that both shaft sizes do not exceed figure listed for size selected in step 4. If maximum is exceeded select the next largest size which will allow for bore size. Do not exceed maximum RPM for new size selected.

Example: A bucket elevator is driven by a motor/reducer and requires a coupling to transmit 14 HP at 1300 RPM.

1. Service Factor Symbol — M
2. Service Factor — 1.5
3. HP at 100 RPM = $\frac{14 \times 1.5 \times 100}{1300} = 1.61 \text{ HP/100 RPM}$
4. Refer to page C-11; under column for 100 RPM the required 1.61 HP falls between the size 7 (1.2) and the size 8 (1.8). Correct selection is size 8 with TPR sleeve. Check bore sizes for flanges on pages C-15 thru C-19.

Maximum RPM and Allowable Misalignment

Size	Maximum RPM	Types JEM, JEMS, EM, E and N		Types H and HS	
		Parallel	Angular	Parallel	Angular
3	9200	0.010	0.035	—	—
4	7600	0.010	0.043	—	—
5	7600	0.015	0.056	—	—
6	6000	0.015	0.070	0.010	0.016
7	5250	0.020	0.081	0.012	0.020
8	4500	0.020	0.094	0.015	0.025
9	3750	0.025	0.109	0.017	0.028
10	3600	0.025	0.128	0.020	0.032
11	3600	0.032	0.151	0.022	0.037
12	2800	0.032	0.175	0.025	0.042
13	2400	0.040	0.195	0.030	0.050
14	2200	0.045	0.242	0.035	0.060
16	1500	0.062	0.330	—	—

Note: Values shown above apply if the actual torque transmitted is more than 1/4 the coupling rating. For lesser torque, reduce the above values by .5.

Service Factors For Quadra-Flex® Couplings

Service Factor Symbol	Electric Motor Standard Torque	Electric Motor High Torque	Turbines	Reciprocating Engines
L (LIGHT)	1.25	1.5	1.0	1.5
M (MEDIUM)	1.5	2.0	1.25	2.0
H (HEAVY)	2.0	2.5	1.5	2.5

Table 1

Application	SF Symbol	Application	SF Symbols	Application	SF Symbols
AGITATORS - Paddle, Propeller, Screw	L	DISC FEEDER	L	MILLS	
BAND RESAW	M	DOUGH MIXER	M	Ball, Pebble, Rod, Tube	H
BARGE HAUL PULLER	H	DRAW BENCH CONVEYOR AND Main Drive	H	Rubber, Tumbling	H
BARKING (Lumber).....	H	DREDGES		Dryer and Cooler.....	M
BAR SCREEN (sewage).....	L	Cable Reel, Pumps.....	M	MIXER	
BATCHES (textile).....	L	Cutter Head Drive, Jig Drive	H	Concrete, Muller	M
BEATER AND PULPER (paper).....	M	Screen Drive	H	Banbury	H
BENDING ROLL (metal).....	M	Maneuvering and Utility Winch.....	M	ORE CRUSHER	H
BLEACHER (paper)	L	Stacker	M	OVEN CONVEYOR	L
BLOWERS		DYNAMOMETER	L	PLANER (metal or wood)	M
Centrifugal, Vane	L	DRYERS (rotary)	M	PRESSES	
Lobe	M	EDGER (lumber)	H	Brick, Briquette Machine.....	H
BOTTLING MACHINERY.....	L	ELEVATORS		Notching, Paper, Punch, Printing	M
BREW KETTLES (distilling).....	L	Bucket	M	PUG MILL	M
BUCKET ELEVATOR OR CONVEYOR	M	Escalator	L	PULP GRINDER (paper)	H
CALENDERS		Freight, Passenger, Service, Man Lift.....	H	PULVERIZERS	
Calender (paper)	M	ESCALATORS	L	Hammermill — light duty, Roller	M
Calender-super (paper, rubber).....	H	EXTRUDER (metal)	H	Hammermill — heavy duty, Hog.....	H
CANE KNIVES (sugar)	M	FANS		PUMPS	
CARD MACHINE (textile)	H	Centrifugal	L	Centrifugal, Axial	L
CAR DUMPERS.....	H	Cooling Tower.....	H	Gear, Lobe, Vane	M
CEMENT KILN	H	Forced Draft, Large Industrial, Mine	M	Reciprocating — sgl. or dbl. acting	*
CENTRIFUGAL BLOWERS		FEEDERS		REEL, REWINDER (paper) CABLE	M
COMPRESSORS, FANS or PUMPS	L	Apron, Belt, Disc.....	L	ROD MILL	H
CHEMICAL FEEDERS (sewage).....	L	Reciprocating.....	H	SAWDUST CONVEYOR	L
CHILLER (oil).....	M	Screw	M	SCREENS	
CHIPPER (paper)	H	FILTER, PRESS-OIL.....	M	Air Washing, Water	L
CIRCULAR RESAW	M	GENERATORS		Rotary for coal or sand	M
CLARIFIER or CLASSIFIER.....	L	Uniform load.....	L	Vibrating	H
CLAY WORKING MACHINERY.....	M	Varying load, Holst	M	SCREW CONVEYOR	L
COLLECTORS (sewage).....	L	Welders	H	SLAB CONVEYOR (lumber)	M
COMPRESSORS		GRIT COLLECTOR (sewage)	L	SLITTERS (metal)	M
Centrifugal	L	GRIZZLY.....	H	SOAPERS (textile)	L
Reciprocating.....	*	HAMMERMILL		SORTING TABLE (lumber).....	M
Screw, Lobe	L	Light Duty, Intermittent.....	M	SPINNER (textile)	M
CONCRETE MIXERS	M	Heavy Duty, Continuous.....	H	STOKER	L
CONVERTING MACHINE (paper)	M	HOISTS		SUCTION ROLL (paper)	M
CONVEYORS		Heavy Duty	H	TENTER FRAMES (textile).....	M
Apron, Assembly Belt, Flight.....	L	Medium Duty	M	TIRE BUILDING MACHINES.....	H
Oven, Screw	L	JORDAN (paper)	H	TIRE AND TUBE PRESS OPENER	L
Bucket.....	M	KILN, ROTARY	H	TUMBLING BARRELS	H
COOKERS- Brewing, Distilling, Food.....	L	LAUNDRY WASHER or TUMBLER	H	WASHER and THICKENER (paper)	M
COOLING TOWER FANS.....	H	LINE SHAFTS	L	WINCHES	M
COUCH (paper)	M	LOG HAUL (lumber).....	H	WINDERS, Paper, Textile, Wire	M
CRANES AND HOISTS	M	LOOM (textile).....	M	WINDLASS	M
Heavy Duty Mine.....	H	MACHINE TOOLS, MAIN DRIVE.....	M	WIRE	
CRUSHERS — Cane (sugar), Stone, Ore	H	MANGLE (textile)	L	Drawing	H
CUTTER — Paper	H	MASH TUBS (distilling).....	L	Winding	M
CYLINDER (paper).....	H	MEAT GRINDER	M	WOODWORKING MACHINERY	L
DEWATERING SCREEN (sewage)	M	METAL FORMING MACHINES.....	M		

Coupling Rating

Table 2A **Thermoplastic Rubber (TPR), EPDM and Neoprene**

Coupling Size	Sleeve Construction	Basic HP Rating Per Given RPM					Rated Torque (in-lb)	Torsional • Stiffness Factor (in-lb/radians)	Maximum RPM
		100	860	1160	1750	3500			
3	TPR	0.12	1.1	1.4	2.2	4.3	78	229	9200
4	TPR	0.25	2.1	2.9	4.3	8.7	156	458	7600
5	TPR	0.50	4.3	5.7	8.7	17	312	916	7600
6	TPR	0.93	8	11	16	32	585	1718	6000
7	TPR	1.5	13	17	26	52	940	2769	5250
8	TPR	2.3	20	27	41	82	1475	4335	4500
9	TPR	3.7	32	43	65	130	2340	6875	3750
10	TPR	5.9	51	69	104	207	3735	10980	3600
11	TPR	9.3	80	108	164	327	5890	17300	3600
12	TPR	15	128	172	260	-	9360	27500	2800
13	EPDM and Neoprene	23	201	271	410	-	14750	43350	2400
14	EPDM and Neoprene	37	319	431	650	-	23400	68755	2200
16	EPDM	75	645	870	-	-	47250	180480	1500

Table 2C

Hytrell

Coupling Size	Sleeve Construction	Basic HP Rating Per Given RPM					Rated Torque (in-lb)	Torsional • Stiffness Factor (in-lb/radians)	Maximum RPM
		100	860	1160	1750	3500			
3★	HYTREL	-	-	-	-	-	-	-	-
4★	HYTREL	-	-	-	-	-	-	-	-
5★	HYTREL	-	-	-	-	-	-	-	-
6	HYTREL	2.90	25	33	50	100	1800	10000	6000
7	HYTREL	4.6	39	53	80	160	2875	20000	5250
8	HYTREL	7.2	62	83	126	252	4530	30000	4500
9	HYTREL	11.4	98	133	200	400	7200	47500	3750
10	HYTREL	18	155	209	315	630	11350	100000	3600
11	HYTREL	29	246	331	500	1000	18000	125000	3600
12	HYTREL	50	430	580	875	-	31500	225000	2800
13	HYTREL	75	645	870	1312	-	47268	368900	2400
14	HYTREL	115	989	1334	2013	-	72480	593250	2200

★ Hytrell sleeves are available on a made-to-order basis, Consult factory.

• Values shown are for an ambient temperature of 75° F (24° C)

Sleeve Selection Chart



Selection Chart for TPR¹, EPDM, and Neoprene Sleeves

HP	860 RPM Motor					1160 RPM Motor					1750 RPM Motor					3500 RPM Motor				
	Service Factor					Service Factor					Service Factor					Service Factor				
	1.0	1.25	1.5	2.0	2.5	1.0	1.25	1.5	2.0	2.5	1.0	1.25	1.5	2.0	2.5	1.0	1.25	1.5	2.0	2.5
.5	3	3	3	4	4	3	3	3	3	4	3	3	3	3	3	—	—	—	—	—
.75	3	4	4	4	5	3	3	4	4	4	3	3	3	3	4	3	3	3	3	3
1	4	4	4	5	5	3	4	4	4	5	3	3	3	4	4	3	3	3	3	3
1.5	4	5	5	5	6	4	4	5	5	5	3	4	4	4	5	3	3	3	3	4
2	5	5	5	6	6	4	5	5	5	6	4	4	4	5	5	3	3	3	4	4
3	5	6	6	6	7	5	5	6	6	6	4	5	5	5	6	3	4	4	4	5
5	6	6	7	7	8	6	6	6	7	7	5	5	6	6	6	4	4	5	5	5
7.5	7	7	8	8	9	6	7	7	8	8	6	6	6	7	7	5	5	5	6	6
10	7	8	8	9	9	7	7	8	8	9	6	6	7	7	8	5	5	6	6	6
15	8	9	9	10	10	8	8	9	9	10	7	7	8	8	9	6	6	6	7	7
20	9	9	10	10	11	8	9	9	10	10	7	8	8	9	9	6	6	7	7	8
25	9	10	10	11	11	9	9	10	10	11	8	8	9	9	10	6	7	7	8	8
30	10	10	11	11	12	9	10	10	11	11	8	9	9	10	10	7	7	8	8	9
40	10	11	11	12	12	10	10	11	11	12	9	9	10	10	11	7	8	8	9	9
50	11	11	12	12	13	10	11	11	12	12	9	10	10	11	11	8	8	9	9	10
60	11	12	12	13	13	11	11	12	12	13	10	10	11	11	12	8	9	9	10	10
75	12	12	13	13	14	11	12	12	13	13	10	11	11	12	12	9	9	10	10	11
100	12	13	13	14	14	12	12	13	13	14	11	11	12	12	13	9	10	10	11	11
125	13	13	14	14	—	12	13	13	14	14	11	12	12	13	13	10	10	11	11	—
150	13	14	14	16	16	13	13	14	14	16	12	12	13	13	14	10	11	11	—	—
200	14	14	16	16	16	13	14	14	16	16	12	13	13	14	14	11	11	—	—	—
250	14	16	16	16	16	14	14	16	16	16	13	13	14	14	—	11	—	—	—	—
300	16	16	16	16	—	14	16	16	16	16	13	14	14	—	—	—	—	—	—	—
350	16	16	16	—	—	16	16	16	16	16	14	14	—	—	—	—	—	—	—	—
400	16	16	16	—	—	16	16	16	16	—	14	14	—	—	—	—	—	—	—	—
450	16	16	—	—	—	16	16	16	—	—	14	—	—	—	—	—	—	—	—	—
500	16	16	—	—	—	16	16	16	—	—	14	—	—	—	—	—	—	—	—	—
600	16	—	—	—	—	16	16	—	—	—	—	—	—	—	—	—	—	—	—	—
700	—	—	—	—	—	16	16	—	—	—	—	—	—	—	—	—	—	—	—	—
800	—	—	—	—	—	16	—	—	—	—	—	—	—	—	—	—	—	—	—	—

¹ Thermoplastic Rubber

Caution: Applications involving reciprocating engines and reciprocating driven devices are subject to critical rotational speeds which may damage the coupling and/or connected equipment. Contact factory with specific requirements.



Hytrell Selection Chart

Selection Chart for Hytrell Sleeves

HP	860 RPM Motor					1160 RPM Motor					1750 RPM Motor					3500 RPM Motor				
	Service Factor					Service Factor					Service Factor					Service Factor				
	1.0	1.25	1.5	2.0	2.5	1.0	1.25	1.5	2.0	2.5	1.0	1.25	1.5	2.0	2.5	1.0	1.25	1.5	2.0	2.5
1	—	—	—	—	—	—	—	—	—	—	—	—	—	—	—	—	—	—	—	—
1.5	—	—	—	—	—	—	—	—	—	—	—	—	—	—	—	—	—	—	—	—
2	—	—	—	—	—	—	—	—	—	—	—	—	—	—	—	—	—	—	—	—
3	—	—	—	—	—	—	—	—	—	—	—	—	—	—	—	—	—	—	—	—
5	—	—	—	—	—	—	—	—	—	—	—	—	—	—	—	—	—	—	—	—
7.5	6H	6H	6H	6H	6H	—	—	—	—	—	—	—	—	—	—	—	—	—	—	—
10	6H	6H	6H	6H	6H	6H	6H	6H	6H	6H	—	—	—	—	—	—	—	—	—	—
15	6H	6H	6H	7H	7H	6H	6H	6H	6H	7H	6H	6H	6H	6H	6H	—	—	—	—	—
20	6H	6H	7H	7H	8H	6H	6H	6H	7H	7H	6H	6H	6H	6H	6H	—	—	—	—	—
25	6H	7H	7H	8H	8H	6H	6H	7H	7H	8H	6H	6H	6H	6H	7H	—	—	—	—	—
30	7H	7H	8H	8H	9H	6H	7H	7H	8H	8H	6H	6H	6H	7H	7H	6H	6H	6H	6H	6H
40	7H	8H	8H	9H	9H	7H	7H	8H	8H	9H	6H	6H	7H	7H	8H	6H	6H	6H	6H	6H
50	8H	8H	9H	9H	10H	7H	8H	8H	9H	9H	6H	7H	7H	8H	8H	6H	6H	6H	6H	7H
60	8H	9H	9H	10H	10H	8H	8H	9H	9H	10H	7H	7H	8H	8H	9H	6H	6H	6H	7H	7H
75	9H	9H	10H	10H	11H	8H	9H	9H	10H	10H	7H	8H	8H	9H	9H	6H	6H	7H	7H	8H
100	9H	10H	10H	11H	11H	9H	9H	10H	10H	11H	8H	8H	9H	9H	10H	6H	7H	7H	8H	8H
125	10H	10H	11H	11H	12H	9H	10H	10H	11H	11H	8H	9H	9H	10H	10H	7H	7H	8H	8H	9H
150	10H	11H	11H	12H	12H	10H	10H	11H	11H	12H	9H	9H	10H	10H	11H	7H	8H	8H	9H	9H
200	11H	11H	12H	12H	13H	10H	11H	11H	12H	12H	9H	10H	10H	11H	11H	8H	8H	9H	9H	10H
250	11H	12H	12H	13H	13H	11H	11H	12H	12H	13H	10H	10H	11H	11H	12H	8H	9H	9H	10H	10H
300	12H	12H	13H	13H	14H	11H	12H	12H	13H	13H	10H	11H	11H	12H	12H	9H	9H	10H	10H	11H
350	12H	12H	13H	14H	14H	12H	12H	12H	13H	14H	11H	11H	12H	12H	12H	9H	10H	10H	11H	11H
400	12H	13H	13H	14H	14H	12H	12H	13H	13H	14H	11H	11H	12H	12H	13H	9H	10H	10H	11H	11H
500	13H	13H	14H	14H	—	12H	13H	13H	14H	14H	11H	12H	12H	13H	13H	10H	10H	11H	11H	—
600	13H	14H	14H	—	—	13H	13H	13H	14H	—	12H	12H	13H	13H	14H	10H	11H	11H	—	—
700	14H	14H	—	—	—	13H	13H	14H	14H	—	12H	12H	13H	14H	14H	11H	11H	—	—	—
800	14H	14H	—	—	—	13H	14H	14H	—	—	12H	13H	13H	14H	14H	11H	11H	—	—	—
900	14H	—	—	—	—	14H	14H	14H	—	—	13H	13H	14H	14H	—	11H	—	—	—	—
1000	—	—	—	—	—	14H	14H	—	—	—	13H	13H	14H	14H	—	11H	—	—	—	—

Quadra-Flex® Sleeves

Martin flexible sleeve elements are offered in four material compounds (Thermoplastic Rubber (TPR), EPDM, Neoprene, and Hytrel) available in three construction styles. Our EM sleeve offers the combination of EPDM's extended temperature range as well as the higher oil resistance which Neoprene provides.

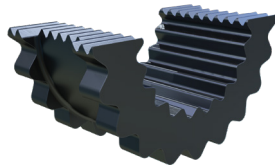
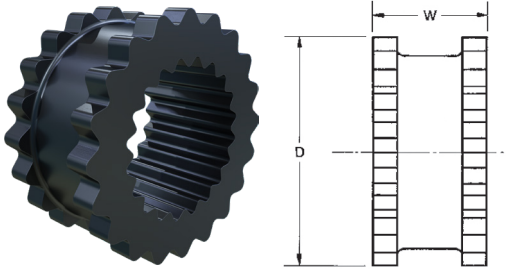

Types JEM — JEMS

Type J sleeves are molded Thermoplastic Rubber (TPR). Available in 1 piece solid (JEM), and 1 piece split, construction (JEMS). TPR material will handle higher temperature ranges as well as be oil resistant.

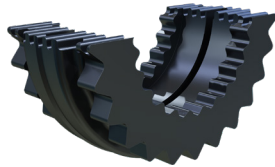
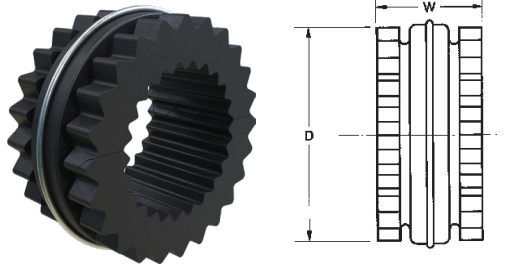

Types EM — E — N

Type EM, E, and N sleeves are of two piece molded construction with retaining ring. They are available in Thermoplastic Rubber (type TPR), EPDM (Type E), or Neoprene (type N). These can be used with any type flanges within a given size range.

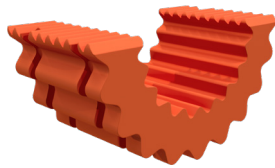
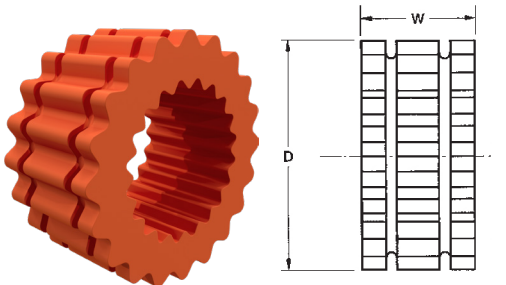

Types H and HS

Martin H and HS sleeves are molded Hytrel for higher torque loading than standard EM sleeves. H and HS sleeves cannot be used with style J and B flanges. Hytrel sleeves are not a direct replacement for TPR, EPDM, or Neoprene sleeves.

Dimensions (Inches)

Coupling Size	JEM — JEMS Sleeves			EM — E — N Sleeves			H and HS Sleeves Hytrel •		
	D	W	Wt. (lb)	D	W	Wt. (lb)	D	W	Wt. (lb)
3	1.875	1.000	0.1	—	—	—	—	—	—
4	2.313	1.250	0.1	2.313	1.250	0.1	—	—	—
5	2.938	1.563	0.2	2.938	1.563	0.3	—	—	—
6	3.750	1.875	0.4	3.750	1.875	1.0	3.750	1.875	0.4
7	4.344	2.188	0.5	4.344	2.188	0.8	4.344	2.188	0.7
8	5.063	2.500	0.9	5.063	2.500	1.4	5.063	2.500	1.4
9	6.000	3.000	2.0	6.000	3.000	2.0	6.000	3.000	1.8
10	7.063	3.438	2.2	7.063	3.438	2.9	7.063	3.438	3.0
11	—	—	—	8.188	4.000	4.7	8.188	4.000	4.7
12	—	—	—	9.563	4.688	8.1	9.563	4.688	8.0
13	—	—	—	11.188	5.500	13.0	11.188	5.500	11.8
14	—	—	—	13.094	6.500	21.1	13.094	6.500	19.3
16	—	—	—	17.906	8.750	53.0	—	—	—

• 13 and 14 Hytrel available with HS sleeves only.

Quadra-Flex® Type J Flanges

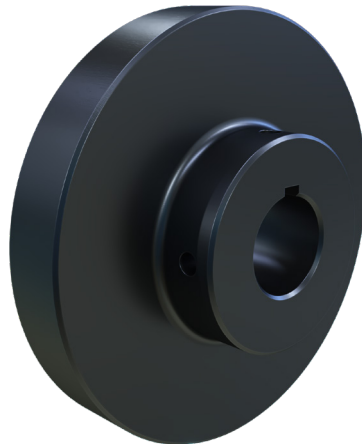
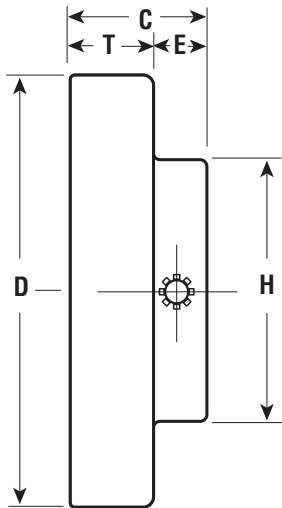

Quadra-Flex® Type J Flanges

Martin Type J Flanges are supplied bored to size with standard keyway and two setscrews to slip fit on standard shafting.

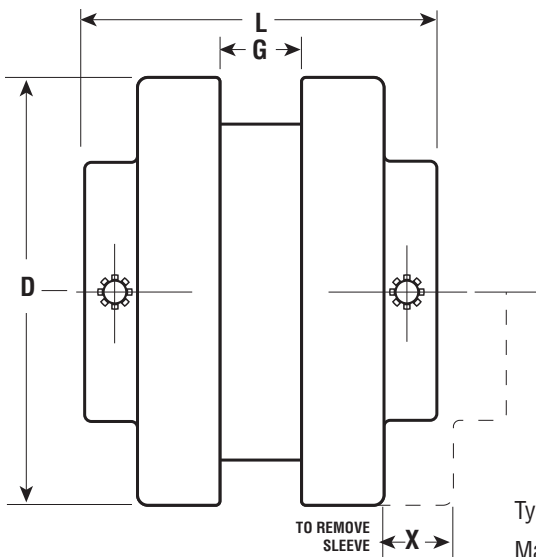

Type J Flanges use the Martin JEM 1 Piece, the Martin JEMS 1 piece split and the Martin EM 2 piece split sleeves.
(Note: Hytrel sleeves are not intended for use with this type of flange.)

Dimensions (Inches)

Coupling Size	Dimensions								Wt. (lb) ★	Finished Bore Sizes •							Max. Bore	Millimeters			
	C	D	E	G	H	L	T	X		(Inches)											
3J	0.813	2.062	0.438	0.375	1.250	2.000	0.375	0.563	0.3	0.375**	0.500	0.625	0.750	0.875	0.938	1.000	1.125	1.375	—	—	—
	0.813	2.062	0.438	0.375	1.500	2.000	0.375	0.563													
4J	0.875	2.460	0.438	0.625	1.625	2.375	0.438	0.750	0.5	0.500	0.625	0.750	0.875	0.938	1.000	1.000	1.125	1.375	15	20	25
5J	0.688	3.250	0.469	0.750	1.875	2.875	0.594	0.969	0.9	0.500	0.625	0.750	0.875	0.938	1.000	1.125	1.375	1.375	—	—	—
6J	0.531	4.000	0.594	0.875	1.938	3.313	0.625	1.094	1.7	0.625	0.750	0.875	0.938	1.000	1.125	1.188	1.250	1.375	—	—	—
	0.531	4.000	0.594	0.875	2.500	3.313	0.625	1.094													

★ Approximate weight for each flange.
 ** .375 Bore has no Keyway
 • J flanges can be rebored if necessary.

Type S Flanges

Quadra-Flex® Type S Couplings (Bored-to-Size)

Type S flexible coupling flanges are bored to size to fit on any standard shaft. They are produced from high strength cast iron. Units are easy to install and remove and are stocked in a wide range of bore sizes as shown on the next page.

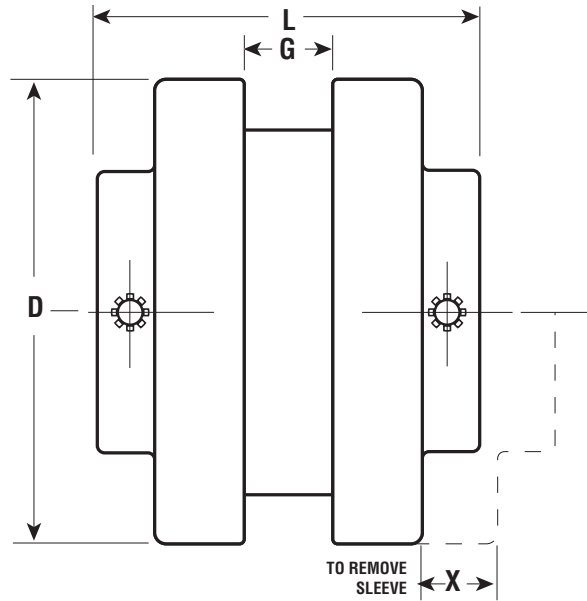
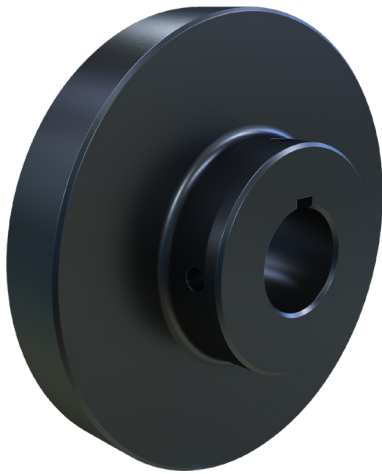

Dimensions

Coupling Size	Flange Diameter (D)	Bore (Inches)			Hub (Inches)			G	L	T	X	Weight (lb) •
		Stock	Rec. Max. ★	Rec. Max. ★★	Hub Diameter (H)	Length Thru (C)	Hub Projected (E)					
5S	3.250	0.500	1.188	1.250	1.875	1.375	0.453	0.750	2.813	0.594	0.969	1.0
6S	4.000	0.625	1.438	1.500	2.500	1.625	0.531	0.875	3.500	0.750	1.094	2.1
	4.000	0.625	—	1.875	2.500	1.563	0.813	0.875	4.000	0.750	1.094	2.1
7S	4.625	0.625	1.625	1.875	2.813	1.844	0.688	1.000	3.938	0.781	1.313	2.7
8S	5.450	0.750	1.938	2.250	3.250	0.719	0.750	1.125	4.438	0.906	1.500	4.5
	5.450	0.750	—	2.375	3.250	1.938	1.031	1.125	5.000	0.906	1.500	4.5
9S	6.350	0.875	2.375	2.500	3.625	2.406	0.781	1.438	5.063	1.031	1.750	6.5
	6.350	0.875	—	2.875	4.125	2.281	1.250	1.438	6.000	1.031	1.750	6.5
10S	7.500	1.125	2.750	3.125	4.375	2.719	0.813	1.625	5.688	1.219	2.000	11.3
	7.500	1.125	—	3.375	4.750	2.688	1.469	1.625	7.000	1.219	2.000	11.3
11S	8.625	1.250	3.375	3.625	5.250	3.438	1.125	1.875	7.125	1.500	2.375	17.6
	8.625	1.250	—	3.875	5.625	3.063	1.563	1.875	8.000	1.500	2.375	17.6
12S	10.000	1.500	3.875	3.938	5.750	4.000	0.594	2.313	8.250	1.688	2.688	27.2
13S	11.750	2.000	4.500	—	6.750	4.375	0.938	2.688	9.250	1.969	3.063	45.6
14S	13.875	2.000	5.000	—	7.500	4.500	0.688	3.250	9.875	2.250	3.500	70.0
16S	18.875	2.000	5.500	6.000	8.000	6.000	2.000	4.750	14.250	2.750	4.250	162.0

- ★ Recommended max. bore with standard keyway.
- ★★ Recommended max. bore with shallow keyway. See chart on page C-18 for recommended keyway size.
- Approximate weight for each flange.

Quadra-Flex® Type S Couplings (Bored-to-Size)

Type S flexible coupling flanges are bored to size to fit on any standard shaft. They are produced from high strength cast iron. Units are easy to install and remove and are stocked in a wide range of bore sizes as shown on the next page.

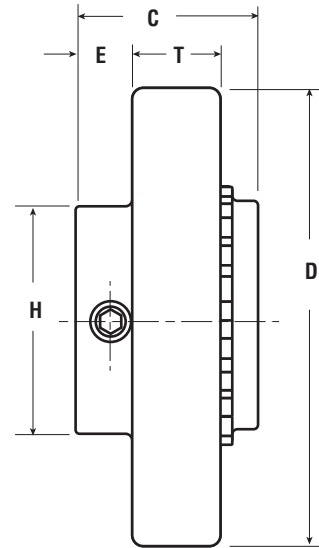

Inches / Millimeters

Coupling Size	Finished Bore Sizes
	Inches /mm
5S	.625, .75, .813, .875, .938, 1, 1.063, 1.125, 1.188, 1.25 15mm, 20mm, 25mm
6S	.75, .875, .938, 1, 1.063, 1.125, 1.188, 1.25, 1.313, 1.375, 1.438, 1.5, 1.625, 1.75, 1.875 20mm, 25mm, 28mm, 30mm, 35mm
7S	.75, .875, .938, 1, 1.063, 1.125, 1.188, 1.25, 1.313, 1.375, 1.438, 1.5, 1.563, 1.625, 1.688, 1.75, 1.875 25mm, 28mm, 30mm, 38mm, 42mm
8S	.875, .938, 1, 1.063, 1.125, 1.188, 1.25, 1.313, 1.375, 1.438, 1.5, 1.563, 1.625, 1.688, 1.75, 1.875, 1.938, 2.063, 2.125, 2.375 28mm, 30mm, 32mm, 38mm, 42mm, 48mm
9S	.938, 1, 1.063, 1.125, 1.25, 1.375, 1.438, 1.5, 1.563, 1.625, 1.688, 1.75, 1.875, 1.938, 2, 2.063, 2.125, 2.188, 2.25, 2.375, 2.5, 2.875 30mm, 32mm, 38mm, 42mm, 48mm
10S	1.125, 1.25, 1.375, 1.438, 1.5, 1.563, 1.625, 1.688, 1.75, 1.875, 1.938, 2, 2.063, 2.125, 2.188, 2.25, 2.375, 2.438, 2.5, 2.75, 2.875, 3.375 55mm, 60mm
11S	1.25, 1.375, 1.438, 1.563, 1.625, 1.75, 1.875, 2.063, 2.125, 2.25, 2.375, 2.625, 2.75, 2.875, 3.375, 3.875
12S	1.875, 2.125, 2.375, 2.625, 2.875, 3.375, 3.875, 3.938 90mm
13S	2.375, 2.875, 3.375
14S	2.875
16S	*

* Plain bore only.

Keyseat Dimensions

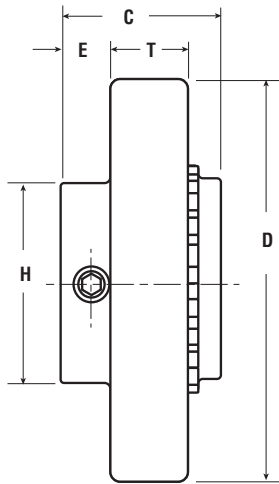

Standard Keyway Dimensions

Shaft Diameter	Width	Depth
0.500 – 0.563	1/8	1/16
0.625 – 0.875	3/16	3/32
0.938 – 1.250	1/4	1/8
0.938 – 1.375	5/16	5/32
1.438 – 1.750	3/8	3/16
1.813 – 2.750	1/2	1/4
2.313 – 2.750	5/8	5/16
2.813 – 3.250	3/4	3/8
3.313 – 3.750	7/8	7/16
3.813 – 4.500	1	1/2
4.563 – 5.500	1 1/4	5/8
5.563 – 6.500	1 1/2	3/4

Bore Tolerances for Types J and S Flanges, SC Hubs

Shaft Diameter	Width
UP to 1.000	+0.000 to +0.0010
1.063 to 2.125	+0.000 to +0.0015
2.188 to 2.625	+0.000 to +0.0020
2.688 to 3.688	+0.000 to +0.0025
3.750 to 4.750	+0.000 to +0.0030
4.813 to 6.000	+0.000 to +0.0035

Shallow Keyseat Dimensions

Coupling Size	Hub Dia. (H)	Length Thru (C)	Shallow Keyseat Dimensions								
			Bore	Keyway	Key	Bore	Keyway	Key	Bore	Keyway	Key
6S	2.500	1.313	1.625	3/8 × 1/8	3/8 × 5/16 × 1 1/4	1.750	3/8 × 1/16	3/8 × 1/4 × 1 1/4	1.875	1/2 × 1/16	1/2 × 5/16 × 11/2
	2.813	1.563									
7S	2.813	1.818	1.875	1/2 × 1/8	1/2 × 3/8 × 1 13/16	-	-	-	-	-	-
8S	3.250	2.188	2.125	1/2 × 3/16	1/2 × 7/16 × 2	2.375	5/8 × 1/8	5/8 × 7/16 × 2	-	-	-
	3.250	1.938	2.125	1/2 × 3/16	1/2 × 7/16 × 2	2.375	5/8 × 1/8	5/8 × 7/16 × 2	-	-	-
9S	3.625	2.406	2.500	5/8 × 3/16	5/8 × 3/8 × 2 3/8	2.875	3/4 × 1/8	3/4 × 1/2 × 2	-	-	-
	4.125	2.281	2.500	5/8 × 3/16	5/8 × 3/8 × 2 3/8	2.875	3/4 × 1/8	3/4 × 1/2 × 2	-	-	-
10S	4.375	2.636	2.875	3/4 × 1/4	3/4 × 5/8 × 2 11/16	3.375	7/8 × 3/16	7/8 × 3/8 × 2 11/16	-	-	-
	4.750	2.688	2.875	3/4 × 1/4	3/4 × 5/8 × 2 11/16	3.375	7/8 × 3/16	7/8 × 3/8 × 2 11/16	-	-	-
11S	3.250	3.438	3.875	1 × 1/4	1 × 3/4 × 3	-	-	-	-	-	-
	4.875	3.438	3.875	1 × 1/4	1 × 3/4 × 3	-	-	-	-	-	-
	5.250	3.438	3.875	1 × 1/4	1 × 3/4 × 3	-	-	-	-	-	-
	5.625	3.063	3.875	1 × 1/4	1 × 3/4 × 3	-	-	-	-	-	-
12S	3.750	4.000	3.938	1 × 1/4	1 × 3/4 × 4	-	-	-	-	-	-
	4.875	4.000	3.938	1 × 1/4	1 × 3/4 × 4	-	-	-	-	-	-
	5.750	4.000	3.938	1 × 1/4	1 × 3/4 × 4	-	-	-	-	-	-

Type B Bushed Quadra-Flex®

Flanges

Type B flanges are made of high quality cast iron, the same high strength cast iron used in the Type S and SC Quadra-Flex® flanges. Type B is designed to accommodate Martin QD bushings for easy installation and removal. Type B flanges are not intended for use with Hytrel sleeves

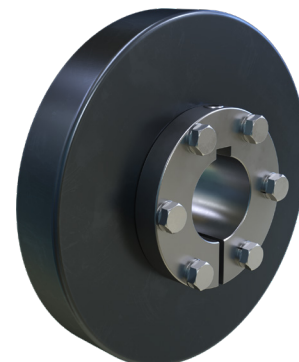
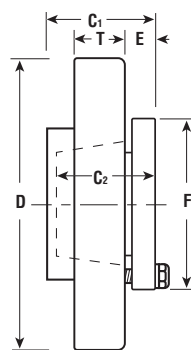

Coupling Size	Bushing Required	Dimensions									Max. Bore ★	Weight (lb) †	
		C ₁	C ₂	D	E	F	G	L	T	X		Flange	Bushing
6B	JA	1.531	1.000	4.000	0.438	2.000	0.875	3.313	0.758	1.094	1.188	1.7	0.9
7B	JA	1.594	1.000	4.625	0.438	2.000	1.000	3.438	0.758	1.313	1.188	2.0	1.0
8B	SH	1.818	1.250	5.450	0.500	2.688	1.438	3.938	2.281	1.500	1.625	3.1	1.0
9B	SD	2.188	1.188	6.350	0.438	3.188	1.438	4.625	1.031	1.750	1.938	4.9	1.5
10B	SK	1.818	1.875	7.500	0.625	3.875	1.625	5.313	1.219	2.000	2.500	7.0	2.0
11B	SF	2.125	2.000	8.625	0.625	4.625	1.875	6.125	1.500	2.375	2.750	11.8	3.0
12B	E	2.688	2.625	10.000	0.875	6.000	2.313	7.438	1.688	2.688	3.438	17.2	10.0
13B	F	3.688	3.625	11.750	1.000	6.625	2.688	8.625	1.939	3.000	3.938	30.5	11.5
14B	F	3.688	3.625	13.875	1.000	6.625	3.250	9.750	2.250	3.500	3.938	51.0	11.5
16B	J	4.750	4.500	18.875	1.188	7.250	4.750	12.625	2.750	4.250	4.500	120.0	18.0

★ Maximum bore with keyseat.
† Approximate weight for each flange.

QD Bushing Keyway Dimensions

Bushing	Bores	Keyset
JA	1/2 - 1	STANDARD
	11/16 - 1 1/8	1/4 × 1/16
	13/16	1/4 × 1/16
	1 1/4	NO K.S.
SH	1/2 - 1 3/8	STANDARD
	1 7/16 - 1 5/8	3/8 × 1/16
	1 11/16	NO K.S.
SD	1/2 - 1 11/16	STANDARD
	1 3/4	3/8 × 1/8
	1 13/16	1/2 × 1/8
	1 7/8 - 1 15/16	1/2 × 1/16
SK	1/2 - 2 1/8	STANDARD
	2 3/16 - 2 1/4	1/2 × 1/8
	2 5/16 - 2 1/2	5/8 × 1/16
	2 9/16 - 2 5/8	NO K.S.
SF	1/2 - 2 1/4	STANDARD
	2 5/16 - 2 1/2	5/8 × 3/16
	2 9/16 - 2 3/4	5/8 × 1/16
	2 13/16 - 2 7/8	3/4 × 1/16
E	2 15/16	3/4 × 1/16
	7/8 - 2 7/8	STANDARD
	2 13/16 - 3 1/4	3/4 × 1/8
	3 5/16 - 3 7/16	7/8 × 1/16
F	3 1/2	7/8 × 1/16
	1 - 3 5/16	STANDARD
	3 3/8 - 3 3/4	7/8 × 3/16
	3 13/16 - 3 15/16	1 × 1/8
J	4	NO K.S.
	1 1/4 - 3 3/4	STANDARD
	3 13/16 - 3 15/16	1 × 1/8
	4 - 4 1/2	1 × 1/8

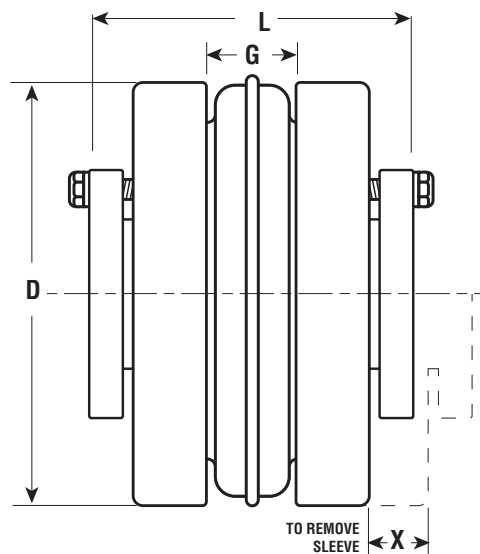

Bushings

Martin QD bushings offer convenient mounting of the flange to the shaft securely without setscrews. They are tapered and are split through both the bushing flange and taper to provide a clamp fit, eliminating wobble, vibration, and fretting corrosion. This is the same bushing used in Martin sprockets and sheaves and is readily available.

Type SC Spacer Couplings

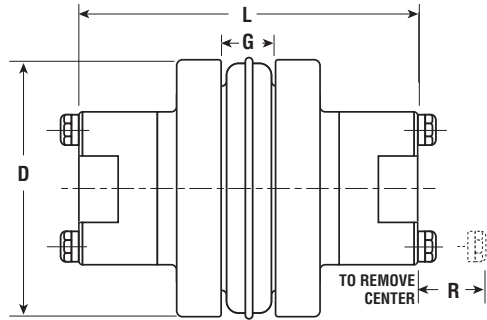

The dimensions for completely assembled Quadra-Flex® Type SC Spacer Couplings are shown below. See next page for dimensions of separate components.

Coupling Size	Required Distance Between Shafts	Use Flange Number	Use Hub Number	Max. Bore Standard Keyway	Dimensions				Weight ² (lb) •
					D	L ²	G	R	
4JSC	3.500	4JSC35 ¹	4H	1 1/8	2.460	5.625	0.625	0.500	4.7
5SC	3.500	5SC35	5H	1 1/8	3.250	5.625	0.750	0.563	4.1
6SC	3.500	6SC35	6H	1 3/8	4.000	5.875	0.875	0.750	7.1
	4.375	6SC44	6H	1 3/8	4.000	6.750	0.875	0.750	7.9
	5.000	6SC50	6H	1 3/8	4.000	7.375	0.875	0.750	8.5
7SC	3.500	7SC35	7H	1 5/8	4.625	6.375	1.000	0.625	9.1
	4.375	7SC44	7H	1 5/8	4.625	7.250	1.000	0.625	10.1
	5.000	7SC50	7H	1 5/8	4.625	7.875	1.000	0.625	10.7
8SC	3.500	8SC35	8H	1 7/8	5.450	6.875	1.125	0.813	14.7
	3.500	8SC35-10	10H★	2 3/8	5.450	8.125	1.125	0.813	22.7
	4.375	8SC44	8H	1 7/8	5.450	7.750	1.125	0.813	16.1
	5.000	8SC50	8H	1 7/8	5.450	8.375	1.125	0.813	15.9
	5.000	8SC50-10	10H★	2 3/8	5.450	9.625	1.125	0.813	26.5
9SC	3.500	9SC35	9H★	2 1/8	6.350	7.500	1.438	0.688	22.0
	4.375	9SC44	9H★	2 1/8	6.350	8.250	1.438	0.688	23.4
	5.000	9SC50	9H★	2 1/8	6.350	8.875	1.438	0.688	24.6
	5.000	9SC50-11	11H★	2 7/8	6.350	10.375	1.438	0.813	40.2
	7.000	9SC70-11	11H★	2 7/8	6.350	12.375	1.438	0.813	48.2
	7.750	9SC78-11	11H★	2 7/8	6.350	13.125	1.438	0.813	50.8
10SC	4.750	10SC48	10H★	2 3/8	7.500	9.375	1.625	0.813	35.4
	5.000	10SC50	10H★	2 3/8	7.500	9.625	1.625	0.813	38.2
	7.000	10SC70-13	13H★	3 3/8	7.500	13.625	1.625	1.875	71.8
	7.750	10SC78-13	13H★	3 3/8	7.500	14.375	1.625	1.875	75.6
	10.000	10SC100-13	13H★	3 3/8	7.500	16.625	1.625	1.875	89.0
11SC	4.750	11SC48	11H★	2 7/8	8.625	10.625	1.875	0.813	54.5
	5.000	11SC50	11H★	2 7/8	8.625	10.375	1.875	0.813	54.8
	7.000	11SC70-14	14H	3 7/8	8.625	14.625	1.875	2.000	85.7
	7.750	11SC78-14	14H	3 7/8	8.625	15.375	1.875	2.000	90.1
	10.000	11SC100-14	14H	3 7/8	8.625	17.625	1.875	2.000	102.5
12SC	7.000	12SC70	12H★	2 7/8	10.000	12.875	2.313	1.500	87.7
	7.000	12SC70-14	14H	3 7/8	10.000	14.625	2.313	2.000	98.9
	7.750	12SC78	12H★	2 7/8	10.000	13.625	2.313	1.500	91.5
	7.750	12SC78-14	14H	3 7/8	10.000	15.375	2.313	2.000	103.3
	10.000	12SC100-14	14H	3 7/8	10.000	17.625	2.313	2.000	115.5
13SC	7.750	13SC78	13H★	3 3/8	11.750	14.375	2.688	1.875	121.8
14SC	7.750	14SC78	14H	3 7/8	13.875	15.375	3.250	2.000	179.4

★ Short (HS) hub also available.
 • Approximate weight for completely assembled spacer coupling.
¹ 4JSC35 × 1.125 has a shallow keyway.
² L dimension and weight will change if one or two short (HS) hubs are used.
 NOTE: Refer to page C-23 to order — specify components separately.

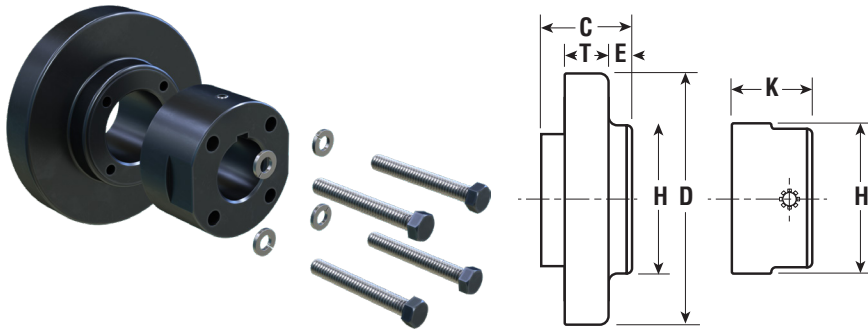

Type SC Flanges and Hubs

Tables below provide dimensional information for Quadra-Flex® Flanges and Hubs used for Spacer Couplings. Assembled dimensions are listed on opposite page. Any of the sleeves shown on page C-14 can be used.

Coupling Size	Flange Number	For Distance Between Shafts ★	For Hubs	Dimensions					Weight (lb) •
				D	E	H	C	T	
4JSC	4JSC35	3.500	4H	2.460	0.438	2.000	0.875	0.438	1.2
5SC	5SC35	3.500	5H	3.250	0.797	2.000	1.688	0.594	1.2
6SC	6SC35	3.500	6H	4.000	0.594	2.500	1.625	0.697	2.0
	6SC44	4.375	6H	4.000	0.344	2.500	2.063	0.697	2.4
	6SC50	5.000	6H	4.000	1.344	2.500	2.375	0.697	2.7
7SC	7SC35	3.500	7H	4.625	0.469	2.813	1.625	0.758	2.3
	7SC44	4.375	7H	4.625	0.879	2.813	2.063	0.758	2.8
	7SC50	5.000	7H	4.625	0.531	2.813	2.375	0.758	3.1
8SC	8SC35	3.500	8H	5.450	0.281	3.250	1.625	0.879	3.5
	8SC35-10	3.500	10H-10HS	5.450	0.281	4.375	1.625	0.879	3.4
	8SC44	4.375	8H	5.450	0.697	3.540	2.063	0.879	4.2
	8SC50	5.000	8H	5.450	0.344	3.250	2.375	0.879	4.6
	8SC50-10	5.000	10H-10HS	5.450	0.344	4.375	2.375	0.879	5.3
9SC	9SC35	3.500	9H-9HS	6.350	0.063	3.625	1.688	0.344	5.1
	9SC44	4.375	9H-9HS	6.350	0.438	3.625	2.063	0.344	5.8
	9SC50	5.000	9H-9HS	6.350	0.750	3.625	2.375	0.344	6.4
	9SC50-11	5.000	11H-11HS	6.350	0.750	5.250	2.375	0.344	6.9
	9SC70-11	7.000	11H-11HS	6.350	1.750	5.250	3.375	0.344	10.9
	9SC78-11	7.750	11H-11HS	6.350	2.125	5.250	3.750	0.344	12.1
10SC	10SC48	4.750	10H-10HS	7.500	0.344	4.375	2.250	0.531	9.8
	10SC50	5.000	10H-10HS	7.500	0.469	4.375	2.375	0.531	10.1
	10SC70-13	7.000	13H-13HS	7.500	1.469	6.125	3.375	0.531	14.5
	10SC78-13	7.750	13H-13HS	7.500	1.818	6.125	3.750	0.531	16.3
	10SC100-13	10.000	13H-13HS	7.500	2.939	6.125	4.875	0.531	22.5
11SC	11SC48	4.750	11H-11HS	8.625	0.031	5.250	1.500	1.500	12.5
	11SC50	5.000	11H11HS	8.625	0.063	5.250	1.563	1.500	12.7
	11SC70-14	7.000	14H	8.625	0.688	6.500	2.563	1.500	16.1
	11SC78-14	7.750	14H	8.625	1.438	6.500	2.938	1.500	18.3
	11SC100-14	10.000	14H	8.625	2.563	6.500	4.063	1.500	24.5
12SC	12SC70	7.000	12H-12HS	10.000	0.636	5.750	2.469	1.688	23.2
	12SC70-14	7.000	14H	10.000	0.636	6.500	2.469	1.688	21.2
	12SC78	7.750	12H-12HS	10.000	0.344	5.750	2.818	1.688	25.1
	12SC78-14	7.750	14H	10.000	0.344	6.500	2.818	1.688	23.4
	12SC100-14	10.000	14H	10.000	0.758	6.500	3.939	1.688	29.5
13SC	13SC78	7.750	13H-13HS	11.750	0.563	6.125	3.250	1.939	38.4
14SC	14SC78	7.750	14H	13.875	0.031	6.500	2.697	2.250	55.0

★ Flanges can be mixed to form different Between-Shaft Dimensions. See chart on page 23.
 • Approximate weight for each flange.

SC Spacer Hub Bores

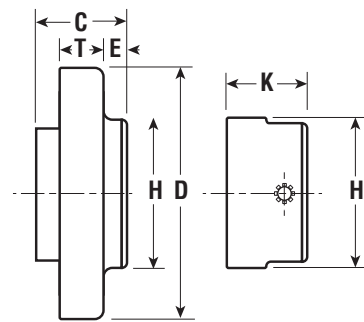
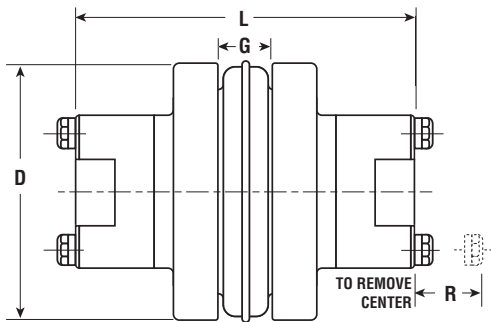
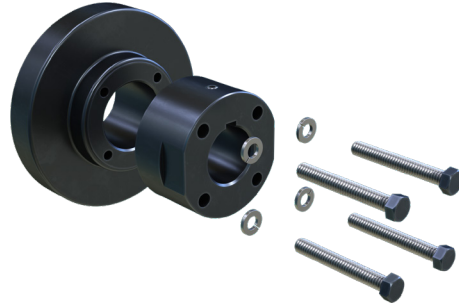

Coupling Size	Hub Number	Max. Bore	Stock Bore							Dimensions			Weight ² (lb) •		
			Plain Bore	Bore with Standard Keyway and Setscrew						K	H	Cap Screws Furnished			
4JSC	4H	1.125	—	0.625	0.875	1.000	1.125★				1.625	2.000	4 — 10 × 2	1.1	
5SC	5H	1.125	0.500	0.625	0.750	0.875	1.000	1.125			0.406	2.000	4 — 10 × 1 1/2	0.7	
6SC	6H	1.375	0.625	0.750	0.875	1.000	1.125	1.250	1.375		0.531	2.500	4 — 1/4 × 1 3/4	1.3	
7SC	7H	1.625	0.625	0.875	1.000	1.125	1.375	1.500	1.625		1.469	2.813	4 — 1/4 × 1 7/8	1.9	
8SC	8H	1.875	0.750	0.875	1.000	1.125	1.375	1.500	1.625	1.750	1.875	1.697	3.250	4 — 5/16 × 2 1/4	3.2
9SC	9H	2.125	0.875	1.000	1.125	1.375	1.500	1.625	1.750	1.875	2.125	1.939	3.625	4 — 3/8 × 2 3/4	4.4
	9HS	1.500	—	1.125								1.531	3.625	4 — 3/8 × 2 1/4	3.7
10SC	10H	2.375	1.125	1.625	1.875	2.125	2.375					2.344	4.375	4 — 7/16 × 3	7.3
	10HS	1.625	—	1.125								1.636	4.375	4 — 7/16 × 2 1/2	5.5
11SC	11H	2.875	1.125	1.875	2.125	2.375	2.875					2.697	5.250	4 — 1/2 × 3 1/2	12.2
	11HS	1.875	—	1.125	1.625							1.879	5.250	4 — 1/2 × 2 3/4	9.3
12SC	12H	2.875	1.875	1.875	2.125	2.375	2.875					2.939	5.750	4 — 5/8 × 4	16.6
	12HS	2.500	—	2.375								2.531	5.750	4 — 5/8 × 3 1/2	14.1
13SC	13H	3.375	—	2.375	2.875	3.375						3.344	6.125	4 — 5/8 × 4 3/4	19.9
	13HS	2.500	—	2.125	2.375							2.469	6.125	4 — 5/8 × 3 1/2	16.0
14SC	14H	3.875	—	2.375	2.875	3.375	3.875					3.818	6.500	4 — 5/8 × 5	24.2

★ 4JSC × 1.125 has a shallow keyseat.
 • Approximate weight for each hub.

Type B Bushed Quadra-Flex®

Spacer couplings are available with the most popular between shaft dimensions. Spacings other than standard can be achieved by mixing flanges.

The standard column provides spacings using identical flanges; the combination column provides spacings with mixed flanges; the column headed semi-spacer uses one flange that is not made for spacer coupling and therefore does not have a detachable hub.

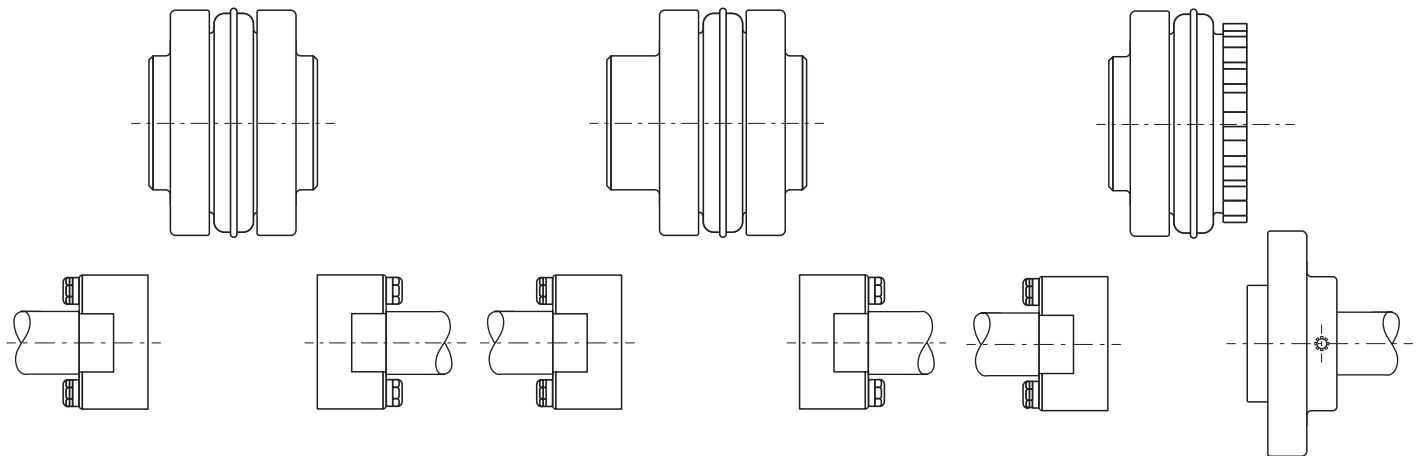

Standard

Combination

Semi-Spacer

Spacing	Use Flanges ★
3.500	2 - () SC35
4.375	2 - () SC44
5.000	2 - () SC50
7.000	2 - () SC70
7.750	2 - () SC78
10.000	2 - () SC100

Spacing	Use Flanges ★
3.938	SC35 and SC44
4.250	SC35 and SC50
4.688	SC44 and SC50
5.250	SC35 and SC70
5.625	SC35 and SC78
5.688	SC44 and SC70
6.000	SC50 and SC70
6.063	SC44 and SC78
6.375	SC50 and SC78
6.750	SC35 and SC100 ★★
7.188	SC44 and SC100 ★★
7.375	SC70 and SC78
7.500	SC50 and SC100
8.500	SC70 and SC100
8.875	SC78 and SC100

Spacing	Use Flanges ★
1.875	S and SC35
2.313	S and SC44
2.625	S and SC50
3.625	S and SC70
4.000	S and SC78
5.125	S and SC100

★ Check individual coupling size for flange
 ★★ Non-Stock
 Note: Other combinations available – consult factory

Installation Instructions



Martin Quadra-Flex® flanges (hubs) and elastomeric elements (sleeves) come in a wide range of sizes and types. First, determine the size and type of coupling components required. Remove all components from their boxes and loosely assemble the coupling. Do not install the wire ring on the two piece sleeves at this time. Check maximum RPM values in table against operating speeds.

Martin EM sleeves are rated the same as other EPDM and Neoprene sleeves, and may be used interchangeably; however, Hytrel sleeves are rated at different values and may not be interchanged with Martin EM sleeves, or the EPDM and Neoprene sleeves. Check horsepower and torque ratings when selecting Hytrel sleeves.



Step 1. Make sure the motor driving the part or components is locked out electrically in such a manner that it cannot be started by anyone, however remote from the area. The same type of lockout procedure applies to any other driving device which may be used. Failure to follow these instructions may result in personal injury or property damage.

Step 2. Prepare shafts for coupling installation. Inspect all coupling components and remove any protective coating or lubricants from bores, mating surfaces, and fasteners.

Step 3. Slide one coupling flange onto each prepared shaft using key stock where required. With the QD Type B flange, it may be necessary to expand the QD bushing bore for ease of installation.

Step 4. Position the flange on the shafts to achieve the approximate Y dimension (distance between flanges) shown in table. It is best to have equal shaft length into each flange. Tighten one flange in position, and slide the other flange sufficient distance back to install sleeve. Do not install wire ring on two piece sleeve in its final position at this time, but allow it to hang loosely in groove next to teeth.

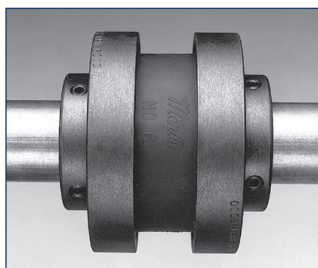
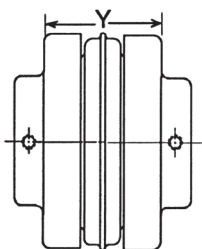

Step 5. Slide loose flange on the shaft until the sleeve has seated completely in teeth of both flanges. Refer to Y dimension although not a critical dimension. Secure the flange to shaft and torque set screws and cap screws to correct torque values.

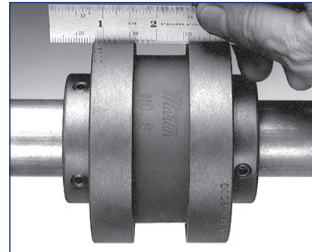

Parallel

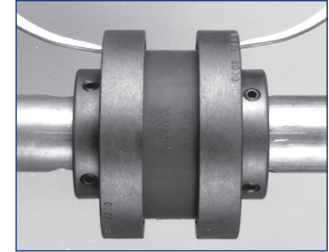

Angular

Step 6. Check parallel alignment by placing a straight edge across the two coupling flanges and measure the maximum offset at several points around the periphery of coupling. Do not rotate coupling when taking these measurements. Refer to table for maximum allowed offset of parallel alignment. Realign the coupling if necessary.

Step 7. Check angular alignment with a micrometer, vernier, or caliper. Take measurement from outside to outside of flanges at several points around the periphery of coupling. Do not rotate coupling when taking these measurements. Determine the difference between maximum and minimum dimensions and check to make sure they do not exceed the angular figure on the table. If a correction is necessary, recheck parallel alignment.

Maximum RPM and Allowable Misalignment (Dimensions in Inches)

Sleeve Size	Max. RPM	Types JEM, EM, E and N			★ Type H and HS		
		Parallel	Angular	Y	Parallel	Angular	Y
3	9200	0.010	0.035	1.188	—	—	—
4	7600	0.010	0.043	1.500	—	—	—
5	7600	0.015	0.056	1.938	—	—	—
6	6000	0.015	0.070	2.438†	0.010	0.016	2.500
7	5250	0.020	0.081	2.563	0.012	0.020	2.625
8	4500	0.020	0.094	2.938	0.015	0.025	3.000
9	3750	0.025	0.109	3.500	0.017	0.028	3.563
10	3600	0.025	0.128	4.053	0.020	0.032	4.125
11	3600	0.032	0.151	4.875	0.022	0.037	4.938
12	2800	0.032	0.175	5.688	0.025	0.042	5.750
13	2400	0.040	0.195	6.688	0.030	0.050	6.688
14	2200	0.045	0.242	7.750	0.035	0.060	7.813
16	1500	0.062	0.330	10.250	—	—	—

NOTE: Values shown above may apply if the actual torque transmitted is more than .25 the coupling rating. For lesser torque, reduce the above values by .5.

★ Type H and HS sleeves should not be used as direct replacements for JEM or EM sleeves.

† Value when using 6J flanges is 2.125.

Step 8. If the coupling employs the two-piece sleeve with wire ring, install ring in center groove of sleeve.

Note: Some force may be required to seat the ring in groove.

Step 9. Install protective guards and/or shields per OSHA and any other additional local or state safety codes as required.

Warning: Coupling sleeves may be forced from coupling when subjected to a severe shock load or abuse.

Stock Flexible Couplings



TBH



TBF

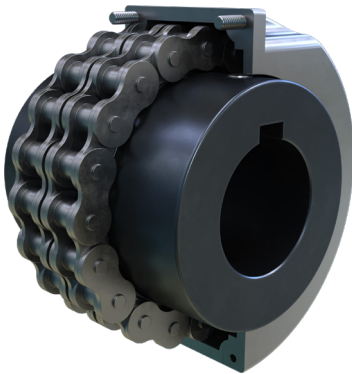

**Bored-To-Size
And Stock Bore**

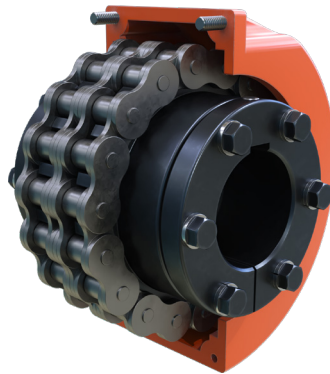

**QD
Bushed**

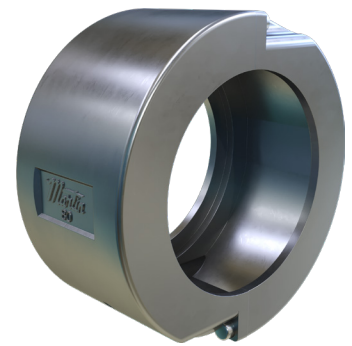

Covers

Stock Flexible Couplings



Bored-to-Size Couplings with Finished Bore, Keyway, and Set Screw

Coupling Number	Stock Finished Bores Include Standard Keyway and Setscrew	A	B	C	L	Coupling O.D.	Weight (lb)
4016	0.625, 0.750, 0.875, 0.938, 1.000, 1.125, 1.188, 1.250, 1.969, 1.125, 0.281, 2.531, 3.031	1.969	1.125	0.281	2.531	3.031	.8
5016	0.750, 0.875, 1.000, 1.125, 1.188, 1.250, 1.375, 1.438, 1.500, 1.625, 2.500, 1.438, 0.375, 3.250, 3.781	2.500	1.438	0.375	3.250	3.781	1.6
5018	0.750, 0.875, 1.000, 1.125, 1.188, 1.250, 1.375, 1.438, 1.500, 1.625, 1.750, 1.875, 1.938, 2.969, 1.688, 0.375, 3.750, 4.188	2.969	1.688	0.375	3.750	4.188	2.4
6018	1.000, 1.125, 1.188, 1.250, 1.375, 1.438, 1.500, 1.625, 1.750, 1.875, 1.938, 2.000, 2.125, 2.188, 2.250, 2.375, 2.438, 3.500, 1.875, 0.438, 4.188, 5.000	3.500	1.875	0.438	4.188	5.000	4.8
6020	1.125, 1.250, 1.500, 1.750, 1.938, 2.125, 2.375, 2.438, 2.625, 3.875, 2.000, 0.438, 4.438, 5.500	3.875	2.000	0.438	4.438	5.500	5.2
6022	1.125, 1.750, 1.875, 1.938, 2.125, 2.375, 2.438, 2.625, 2.750, 2.875, 4.500, 2.125, 0.438, 4.688, 5.953	4.500	2.125	0.438	4.688	5.953	7.8
8018	1.125, 1.750, 1.938, 2.000, 2.125, 2.375, 2.438, 2.625, 2.875, 2.938, 4.563, 2.375, 0.578, 5.328, 6.656	4.563	2.375	0.578	5.328	6.656	9.5
8020	1.500, 2.188, 2.438, 2.688, 2.938, 3.125, 3.375, 3.438, 5.375, 2.625, 0.578, 5.516, 7.297	5.375	2.625	0.578	5.516	7.297	13.4
10018	1.500, 2.438, 2.875, 2.938, 3.438, 5.688, 2.750, 0.719, 6.219, 8.328	5.688	2.750	0.719	6.219	8.328	18.2
10020	2.000, 3.375, 3.688, 3.938, 6.719, 3.125, 0.719, 6.969, 9.125	6.719	3.125	0.719	6.969	9.125	25.0
12018	3.438, 3.938, 4.438, 6.750, 3.500, 0.859, 7.875, 10.000	6.750	3.500	0.859	7.875	10.000	28.0
12022	4.375, 4.438, 4.938, 8.750, 4.000, 0.859, 8.875, 11.891	8.750	4.000	0.859	8.875	11.891	55.0

CAUTION: All rotating power transmission products are potentially dangerous and must be properly guarded for the speeds and applications for which they were intended.

QD Couplings

Coupling Number	Bushing Used	Max. Bore**	A	B	D	C	L	Coupling O. D.	K†	Weight (lb)
4016JA	JA	1.000	2.000	0.875	1.313	0.281	2.906	3.031	1.250	0.9
5018SH	SH	1.375	2.969	1.000	1.500	0.375	3.375	4.188	1.750	1.3
6020SK	SK	2.125	3.875	1.250	1.875	0.438	4.188	5.500	2.250	2.5
8018SF	SF	2.313	4.563	1.750	2.375	0.578	5.328	6.656	2.250	5.3

** Maximum bore shown is the maximum bore with standard keyway. It is recommended that this maximum not be exceeded in both halves of a coupling.

† Minimum clearance required to remove the coupling half by using the screws as jack screws.

Taper Bushed Couplings Type

Type TBH	Type TBF	Bushing Data			A	B	C	J*	K†	L	OD	Weight (lb)
Coupling Number	Coupling Number	Bushing Used	Max. Bore	Min. Bore								
4016TBH	4016TBF	1108	1.125	0.500	1.969	0.875	0.281	0.625	0.750	2.031	3.031	0.9
5018TBH	5018TBF	1610	1.625	0.500	2.969	1.000	0.375	0.813	1.167	2.375	4.188	1.1
6020TBH	6020TBF	2012	2.000	0.500	3.875	1.250	0.438	0.938	1.375	2.938	5.500	2.7
8020TBH	8020TBF	3020	3.000	0.938	5.375	2.000	0.578	1.188	2.167	4.578	7.297	6.1
10020TBH	10020TBF	3535	3.500	1.188	6.719	3.500	0.719	2.000	2.625	7.719	9.125	19.0

** Space needed for (1) tightening bushing with shortened hex key (2) loosening screws for puller to remove hub.

† Minimum clearance required to remove the coupling half by using the screws as jack screws with shortened hex key.

Our High-Speed Standard Covers Fit These Couplings

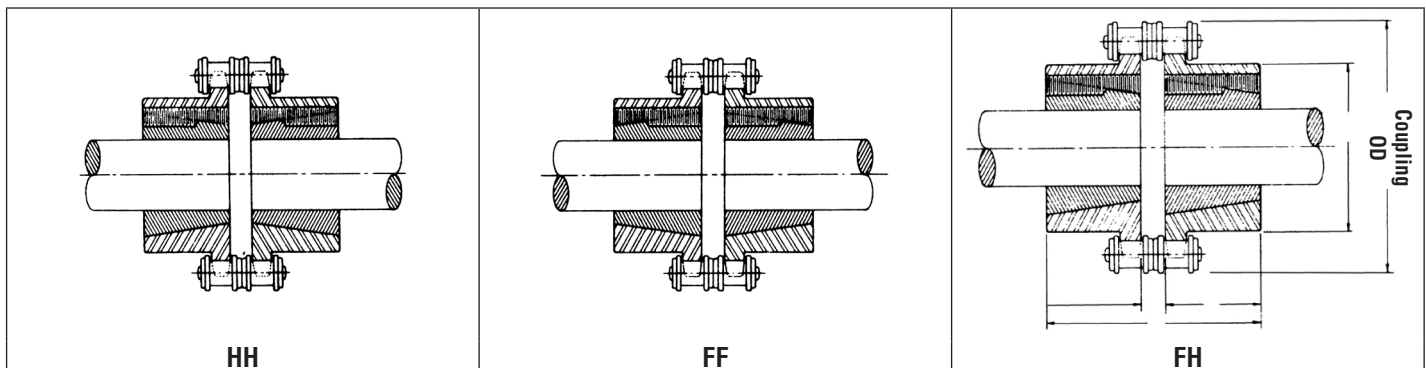

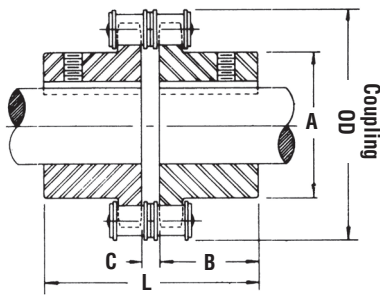

BS Coupling

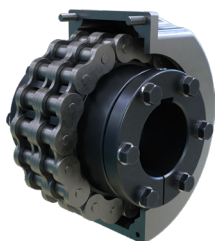
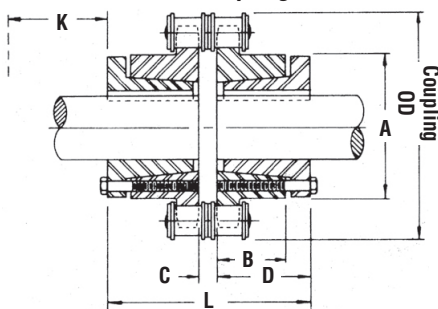

QD Coupling



Type TBF



Type TBH

All Martin chain couplings have hardened teeth

Coupling Selection

Roller chain couplings have a torque capacity in excess of the torque normally transmitted by shafting which falls within the coupling bore range. Select the smallest coupling which will accommodate both shafts. For a reversing operation, shock or pulsating loads, or other severe operating conditions, select the next larger coupling size.

A cover should be used to assure maximum service life, particularly if the coupling operates at high speeds or under moist conditions. For proper lubrication, fill the space between the cover and the coupling with soft to medium consistency coupling grease.

Coupling with Plain Bores for Reboring

Coupling Number	Maximum Bore Inches	Minimum Plain Bore Inches	Weight (lb)	Recommended Maximum RPM	Coupling Chain Number	Weight (lb)
4012	0.875	0.438	0.5	5000	4012 CHN	0.4
4016	1.313	0.625	1.0	5000	4016 CHN	0.5
5016	1.688	0.625	2.2	4000	5016 CHN	1.2
5018	2.000	0.750	3.5	3600	5018 CHN	1.3
6018	2.438	1.000	5.0	3000	6018 CHN	2.2
6020	2.750	1.125	6.5	2500	6020 CHN	2.6
6022	3.000	1.125	9.4	2500	6022 CHN	2.7
8018	3.125	1.125	11.0	2000	8018 CHN	5.3
8020	3.563	1.500	16.3	2000	8020 CHN	5.9
10018	3.875	1.500	20.3	1800	10018 CHN	9.8
10020	4.625	1.500	31.8	1800	10020 CHN	10.9
12018	4.688	2.000	36.8	1500	12018 CHN	17.3
12022	6.125	2.000	70.0	1200	12022 CHN	21.2

Stock Coupling Covers

Covers fit taper bushed, QD and stock, and finished bore couplings. Covers allow excellent lubrication, and their use is recommended to obtain maximum coupling life. Covers are of aluminum or plastic, and are made in halves for easy installation. Synthetic rubber oil seals, which contact the coupling hubs, retain the lubricant and prevent the entry of dirt. Covers are fitted with gaskets between the halves.

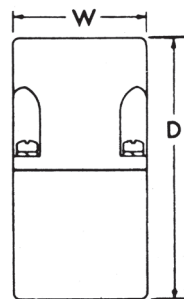
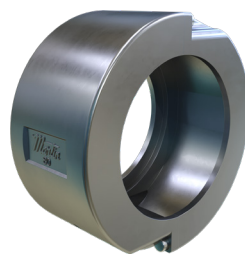

Aluminum and Plastic

Cover Cat. No.	Aluminum		Plastic		Weight (lb)
	D	W	D	W	
4012COV**	4.000	2.000	4.000	2.313	0.8
4016COV**	4.000	2.000	4.000	2.313	0.9
5016COV**	5.125	2.375	5.125	2.625	1.3
5018COV**	5.125	2.375	5.125	2.625	1.3
6018COV**	6.375	2.938	6.375	3.167	2.4
6020COV**	6.375	2.938	6.375	3.167	2.4
6022COV*	8.188	4.000	8.188	4.000	4.9
8018COV	8.188	4.000	8.188	4.000	4.9
8020COV	8.188	4.000	8.188	4.000	4.9
10018COV	9.375	5.938	9.375	5.938	8.8
10020COV	10.125	5.250	10.125	5.250	12.7
12018COV	11.375	7.375	11.375	7.375	16.5
12022COV	13.250	7.938	13.250	7.938	19.5

* Use 8018 cover — Special Seals Available
 ** Furnished in Plastic unless specified with AL Suffix when ordering.

Flexible Jaw Couplings

Martin

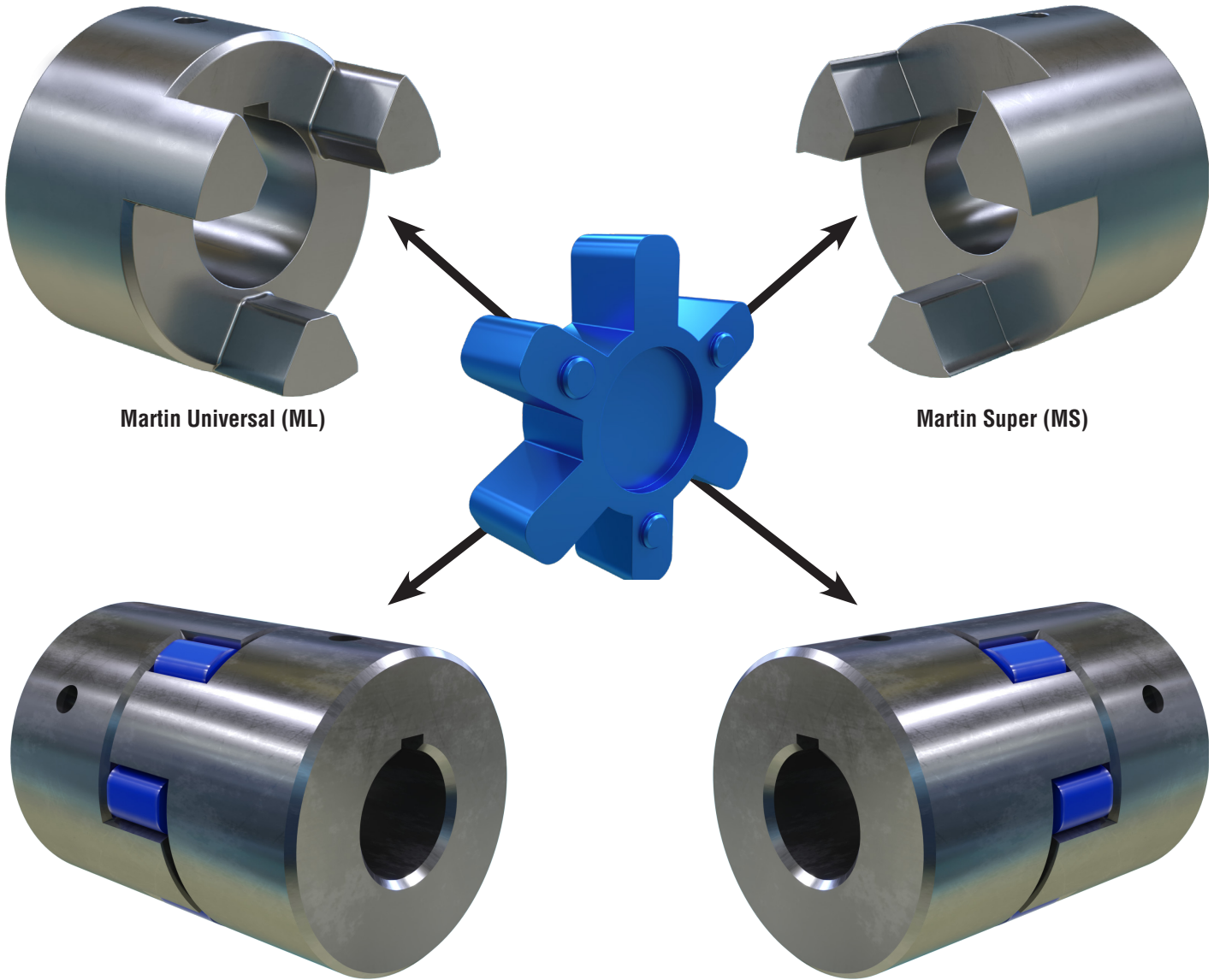

Martin Universal (ML)

Martin Super (MS)

Now Martin Offers Two Styles

The Martin Super — Higher Horsepower

The Martin Universal — Completely Interchangeable

- No lubrication
- Easy installation
- No metal to metal contact
- Resistant to oil, dirt, sand, moisture, grease
- Easy inspection of load carrying spider
- Flexibility of angular or parallel misalignment of shafts by buna-n spider member permits smooth power transmission

Jaw Coupling Selection Procedure

- A. Determine service factor by matching driven unit with prime mover in service factor guide. B. Multiply service factor by driven unit or motor hp to obtain adjusted HP. C. Select flexible coupling with horsepower capacity equal to or greater than adjusted hp.

Service Factor Guide Driven Unit (Machinery)	Prime Mover		
	Electric Motor or Steam Turbine	Gasoline or Diesel Engine, 6 or More Cyl.	Gasoline or Diesel Engine, Less Than 6 Cyl.
Light: Uniform or steady load never exceeding horsepower rating, infrequent starting. Agitators, Blowers, Conveyors, Evaporators, Fans, Generators, Centrifugal Pumps, Stokers	1.0	1.5	2.0
Moderate: Heavy inertia, moderate shock, frequent starting; peak loads do not exceed 125 per cent average horsepower. Uneven load. Beaters, Rotary Pumps and Compressors, Cranes, Elevators, Mine and Propellor Fans, Generators, Pulp Grinders, Hoists, Kilns, Machine Tools, Mixers, Gear Pumps, Woodworking Machines	1.5	2.0	2.5
Heavy: Heavy shock conditions or frequent reversing. Peak loads do not exceed 150 per cent average horsepower. Uneven load. Reciprocating Pumps and Compressors, Crushers, Freight and Passenger Elevators, Mills (Hammer, Ball, Rolling, Turf, Flour), Vibrating Screens, Winches, Wire Drawing Machines, Punches, Shears	2.0	2.5	3.0

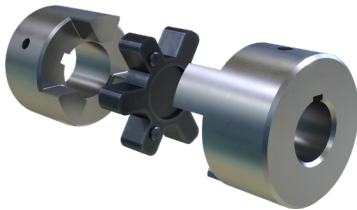

Bore Tolerances:
 0.5 – 1.75 + 0.001 – 0.000
 1.8125 – 2.625 + 0.0015 – 0.0000

Martin ML (Universal Series) — Torque and Horsepower Ratings

Catalog Number	Stainless Steel Catalog Number	Torque Rating lb — in		Buna-N Horsepower Capacity at Various RPM					Max. Bore	(Each) Weight
		Buna-N	Hytrel®	100	300	1200	1800	3600		
ML035	ML035SS	3.5	—	0.006	0.02	0.07	0.10	0.20	0.375	0.10
ML050	ML050SS	31.5	94.5	0.05	0.15	0.60	0.9	1.8	0.625	0.15
ML070	ML070SS	43.2	126	0.07	0.21	0.84	1.2	2.5	0.750	0.31
ML075	ML075SS	90	242	0.13	0.39	1.56	2.3	4.7	0.875	0.45
ML090	ML090SS	144	420	0.22	0.66	2.64	4.0	7.9	1.125	0.75
ML095	ML095SS	194	567	0.30	0.90	3.6	5.4	10.8	1.125	0.89
ML099	ML099SS	318	870	0.46	1.4	5.5	8.3	16.6	1.375	1.02
ML100	ML100SS	417	1,248	0.66	2.0	7.9	11.9	23.8	1.375	1.48
ML110	ML110SS	792	2,268	1.2	3.6	14.4	21.6	43.2	1.625	3.18
ML150	ML150SS	1,240	3,708	1.9	5.7	22.8	34.2	68.4	1.875	4.83
ML190	ML190SS	1,728	4,680	2.4	7.2	28.8	43.2	86.4	2.125	7.65
ML225	ML225SS	2,340	6,804	3.6	10.8	43.2	64.8	129.6	2.625	10.66
ML276	ML276SS	4,716	7,860							

Martin MS (Super Series) — Torque and Horsepower Ratings

Catalog Number	Torque Rating lb — in		Buna-N Horsepower Capacity at Various RPM					Max. Bore	(Each) Weight
	Buna-N	Hytrel®	100	300	1200	1800	3600		
MS050	37.3	112	0.06	0.18	0.71	1.0	2.1	0.625	0.13
MS070	59.4	178	0.09	0.28	1.1	1.7	3.4	0.750	0.25
MS075	157	471	0.25	0.75	3.0	4.5	8.9	0.875	0.53
MS090	241	723	0.38	1.1	4.6	6.9	13.7	1.125	0.58
MS095	241	723	0.38	1.1	4.6	6.9	13.7	1.125	0.70
MS099	512	1536	0.81	2.4	9.7	14.6	29.2	1.325	1.12
MS100	512	1536	0.81	2.4	9.7	14.6	29.2	1.325	1.43
MS110	1014	3042	1.6	4.8	19.3	28.9	57.8	1.325	3.24
MS150	1630	4890	2.6	7.7	31.0	46.5	93.0	1.875	4.76
MS190	2450	7350	3.9	11.6	46.6	69.9	139.7	2.125	7.66
MS225	2920	8760	4.6	13.9	55.5	83.2	166.5	2.625	10.76

NOTE: Above HP capacities are for Buna-N rubber spider and service factor of one. When Hytrel spider is used multiply capacities by three.

Misalignment Capacities: Angular up to 1°, Parallel up to .015 inches.

Hytrel is a registered trademark of E.I. DuPont & Co.

Stock Jaw Couplings



Catalog Number	Hub Dia.	Overall Length	Distance Between Flanges	Length Thru Bore	Bore		Wt. (lb)
	A	B	C	D	Min.	Max.	
ML035 or MS035	0.625	0.813	0.281	0.266	0.125	0.375	0.1
ML050 or MS050	1.167	1.719	0.469	0.625	0.250	0.625	0.1
ML070 or MS070	1.375	2.000	0.500	0.750	0.250	0.750	0.3
ML075 or MS075	1.750	2.125	0.500	0.813	0.250	0.875	0.4
ML090 or MS090	2.125	2.125	0.500	0.813	0.250	1.125	0.7
ML095 or MS095	2.125	2.500	0.500	1.000	0.438	1.125	0.8
ML099 or MS099	2.531	2.875	0.750	1.067	0.500	1.375	1.2
ML100 or MS100	2.531	3.500	0.750	1.375	0.438	1.375	1.5
ML110 or MS110	3.313	4.250	0.875	1.688	0.500	1.625	3.2
ML150 or MS150	3.750	4.500	1.000	1.750	0.625	1.875	4.5
ML190 or MS190	4.500	4.875	1.000	1.938	0.750	2.125	8.3
ML225 or MS225	5.000	5.375	1.000	2.188	0.750	2.625	12.0
ML276	6.180	7.813	1.580	3.120	0.875	2.875	30.5

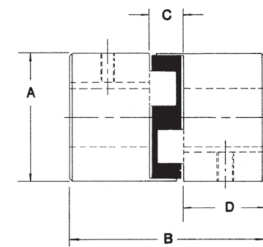
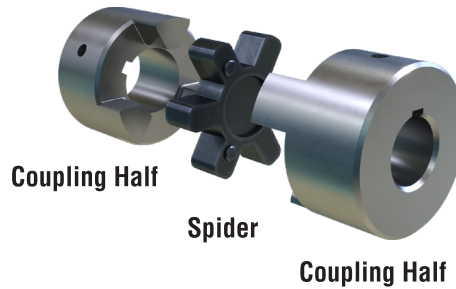

Coupling Half
Spider
Coupling Half

Bore sizes are standard in .0625 increments from minimum to maximum bore range and have keyway and set screw except as shown below:
 .125 through .375 Bore — No KW — No SS
 #050 — .438 through .625 Bore — No KW — 1-SS
 #070, 075, 090, 095 — .438 and .5 Bore — No KW — 1-SS
 #099, 100, 110 — .5 Bore — No KW — No SS
 #150 — .625 Bore — No KW — No SS
 #190, 225 — .75 Bore — No KW — No SS

Note: in each coupling size a min. Plain bore is available that can be used to make special bores such as spline, hex, metric, or other shapes or sizes. For standard keyway sizes see Martin catalog, page E-158 and E-159.

Spiders

Description	Temp Range	Misalignment		Dampening	Color																					
		Angular	Parallel																							
Buna-N – Nitrile butadiene rubber is a flexible elastomer material that is oil resistant, resembles natural rubber in resilience and elasticity. Good resistance to oil. Standard elastomer.	-40° to 212° F -40° to 100° C	1°	0.015	High	Black																					
URETHANE – Urethane has greater torque capability than NBR (1.5 times), provides less dampening effect. Good resistance to oil and chemicals. Not recommended for cyclic or start/stop applications.	-30° to 160° F -34° to 71° C	1°	0.015	Low	Blue																					
HYTREL® – Hytrel is a flexible elastomer designed for high torque and high temperature operations. Hytrel has an excellent resistance to oil and chemicals. Not recommended for cyclic or start/stop applications.	-60° to 250° F -51° to 121° C	1/2°	0.015	Low	Tan																					
BRONZE – Bronze is a rigid, porous oil-impregnated metal insert exclusively for slow speed (maximum 250 RPM) applications requiring high torque capabilities. Bronze operations are not affected by extreme temperatures, water, oil, or dirt.	-40° to 450° F -40° to 232° C	1/2°	0.015	N/A	Bronze																					
Temperature Range	-40° to 212°	-30° to 160°			-60° to 250°	-40° to 450°																				
Size	Max Bore	Buna-N Torque				Urethane Torque				Hytrel Torque				Bronze Torque												
	in mm	Part Number	in-lb	Nm	RPM	Wt. lb	Part Number	in-lb	Nm	RPM	Wt. lb	Part Number	in-lb	Nm	RPM	Wt. lb	Part Number	in-lb	Nm	RPM	Wt. lb					
ML035	0.375	9	SRL35	3.5	0.4	31,000	0.01	—	—	—	—	SHL50	39	4.5	18,000	0.01	SHL50	50	5.6	18,000	0.01	SBL50	50	5.6	250	0.06
ML050	0.625	16	SRL50	31.5	3	18,000	0.01	SUL50	39	4.5	18,000	0.01	SHL50	50	5.6	18,000	0.01	SBL50	50	5.6	250	0.06				
ML070	0.750	19	SRL70	43.2	4.9	14,000	0.02	SHL70	65	7.3	14,000	0.02	SHL70	114	12.9	3,600	0.02	SBL70	114	12.9	250	0.08				
ML075	0.875	22	SRL75	90	10.2	11,000	0.03	SHL75	135	15.3	11,000	0.03	SHL75	227	25.6	3,600	0.03	SBL75	227	25.6	250	0.15				
ML090	1.000	25	SRL90	144	16.3	9,000	0.04	SHL90	216	24.4	9,000	0.04	SHL90	401	45.3	3,600	0.04	SBL90	401	45.3	250	0.17				
ML095	1.125	28	SRL95	194	21.9	9,000	0.04	SHL95	291	32.9	9,000	0.04	SHL95	561	63.4	3,600	0.04	SBL95	561	63.4	250	0.17				
ML099	1.188	30	SRL99	318	35.9	7,000	0.07	SHL99	477	53.9	7,000	0.07	SHL99	792	89.5	3,600	0.07	SBL99	792	89.5	250	0.50				
ML100	1.375	35	SRL100	417	47.1	7,000	0.07	SHL100	626	70.7	7,000	0.07	SHL100	1,134	128	3,600	0.07	SBL100	1,134	128	250	0.50				
ML110	1.625	42	SRL110	792	89.5	5,000	0.14	SHL110	1,188	134	5,000	0.14	SHL110	2,268	256	5,000	0.14	SBL110	2,268	256	250	0.62				
ML150	1.875	48	SRL150	1,240	140	5,000	0.21	SHL150	1,860	210	5,000	0.21	SHL150	3,708	419	5,000	0.21	SBL150	3,706	419	250	1.00				
ML190	2.125	55	SRL190	1,728	195	5,000	0.27	SHL190	2,592	293	5,000	0.27	SHL190	4,680	529	5,000	0.27	SBL190	4,680	529	250	1.30				
ML225	2.625	65	SRL225	2,340	264	4,200	0.41	SHL225	3,510	397	4,200	0.41	SHL225	6,228	704	4,200	0.41	SBL225	6,228	704	250	1.60				
ML276	2.875	73	SRL276	4,716	533	1,800	1.04	SHL276	4,750	397	1,800	1.04	SHL276	7,860	704	1,800	1.04	SBL276	12,500	1,412	250	2.80				

Coupling Selection Chart for 60 Hz Nema Motor Frames Based on Buna-N (Rubber) Spider ★†

Shaft Dia.	Nema Frame	Coupling Size	Max. HP @ RPM					
			1140		1725		3450	
			MS	ML	MS	ML	MS	ML
0.375	42	050	0.5	0.5	1	0.75	2	1.5
0.500	48	050	0.5	0.5	1	0.75	2	1.5
0.625	56,56 H	050	0.5	0.5	1	0.75	2	1.5
0.750	66	070	1	0.75	1.5	1	3	2
0.875	56HZ, 143T, 145T	075	2	1	3	2	7.5	3
	182, 184	090	3	2	5	3	10	7.5
1.375	182T, 184T, 213	095	3	3	5	5	10	10
	215	099	7.5	5	10	7.5	25	15

Shaft Dia.	Nema Frame	Coupling Size	Max. HP @ RPM					
			1140		1725		3450	
			MS	ML	MS	ML	MS	ML
1.875	213T, 215T, 245U, 256U	100	7.5	7.5	10	10	25	20
2.125	254T, 256T, 248U, 286U	110	15	10	25	20	50	40
2.375	284T, 286T, 324U, 326U, 326TS	150	30	20	40	30	75	60
2.125	324T, 326T, 364U, 365U	190	40	25	60	40	125	75
2.375	364T, 365T	225	50	40	75	60	150	100

Coupling Sizes are based on the rated torque, max. bore and a have a service factor of 1.0.
 ★ When using Hytrel or Bronze spider multiply above horsepower ratings by 3.
 † When using Urethane spider multiply above horsepower ratings by 1.5.



Jaw Couplings Imperial Bores

Bore	Keyway	ML035	ML050	ML070	ML075	ML090	ML095	ML099	ML100	ML110	ML150	ML190	ML225	ML276
Reboreable														
Reboreable														
1/8	No KW	ML035 1/8												
3/16	No KW	ML035 3/16												
1/4	No KW	ML035 1/4												
1/4	No KW	ML035 5/16	ML050 1/4	ML070 1/4	ML075 1/4									
5/16	No KW	ML035 5/16	ML050 5/16	ML070 5/16	ML075 5/16									
3/8	No KW	ML035 3/8	ML050 3/8	ML070 3/8	ML075 3/8	ML090 3/8								
3/8	No KW		ML050 3/8 W/KW	ML070 3/8 W/KW	ML075 3/8 W/KW	ML090 3/8 W/KW								
3/8	No KW		ML050 3/8 W/KW	ML070 3/8 W/KW	ML075 3/8 W/KW	ML090 3/8 W/KW								
7/16	No KW		ML050 7/16	ML070 7/16	ML075 7/16	ML090 7/16	ML095 7/16	ML099 7/16 W/KW	ML100 7/16					
7/16	No KW		ML050 7/16	ML070 7/16	ML075 7/16	ML090 7/16	ML095 7/16	ML099 7/16	ML100 7/16					
1 1/2	No KW		ML050 1 1/2	ML070 1 1/2	ML075 1 1/2	ML090 1 1/2	ML095 1 1/2	ML099 1 1/2	ML100 1 1/2	ML110 1/2				
1 1/2	No KW		ML050 1 1/2 W/KW	ML070 1 1/2 W/KW	ML075 1 1/2 W/KW	ML090 1 1/2	ML095 1 1/2 W/KW	ML099 1 1/2 W/KW	ML100 1 1/2					
9/16	No KW		ML050 9/16 W/KW	ML070 9/16	ML075 9/16	ML090 9/16	ML095 9/16	ML099 9/16	ML100 9/16					
9/16	No KW		ML050 9/16	ML070 9/16	ML075 9/16	ML090 9/16	ML095 9/16	ML099 9/16	ML100 9/16					
5/8	No KW		ML050 5/8	ML070 5/8	ML075 5/8	ML090 5/8	ML095 5/8	ML099 5/8	ML100 5/8	ML110 5/8	ML150 5/8 NKW			
5/8	No KW		ML050 5/8	ML070 5/8	ML075 5/8	ML090 5/8	ML095 5/8	ML099 5/8	ML100 5/8	ML110 5/8	ML150 5/8			
5/8	No KW		ML050 5/8	ML070 5/8	ML075 5/8	ML090 5/8	ML095 5/8	ML099 5/8	ML100 5/8	ML110 5/8	ML150 5/8			
1 1/16	No KW			ML070 1 1/16	ML075 1 1/16	ML090 1 1/16	ML095 1 1/16	ML099 1 1/16	ML100 1 1/16	ML110 1 1/16	ML150 1 1/16			
3/4	No KW			ML070 3/4	ML075 3/4	ML090 3/4	ML095 3/4	ML099 3/4	ML100 3/4	ML110 3/4	ML150 3/4	ML190 3/4	ML225 3/4	
3/4	No KW			ML070 3/4 NSKW	ML075 3/4 NSKW	ML090 3/4	ML095 3/4	ML099 3/4	ML100 3/4	ML110 3/4	ML150 3/4	ML190 3/4 W/KW		
13/16	No KW				ML075 13/16	ML090 13/16	ML095 13/16	ML099 13/16	ML100 13/16	ML110 13/16	ML150 13/16	ML190 13/16	ML225 13/16	ML276 7/8
7/8	No KW				ML075 7/8	ML090 7/8	ML095 7/8	ML099 7/8	ML100 7/8	ML110 7/8	ML150 7/8	ML190 7/8	ML225 7/8	
7/8	No KW				ML075 7/8	ML090 7/8	ML095 7/8	ML099 7/8	ML100 7/8	ML110 7/8	ML150 7/8	ML190 7/8	ML225 7/8	
15/16	No KW					ML090 15/16	ML095 15/16	ML099 15/16	ML100 15/16	ML110 15/16	ML150 15/16	ML190 15/16	ML225 15/16	
1	No KW					ML090 1	ML095 1	ML099 1	ML100 1	ML110 1	ML150 1	ML190 1	ML225 1	ML276 1
1	No KW					ML090 1 N/S KW	ML095 1 N/S KW	ML099 1	ML100 1 NSKW	ML110 1	ML150 1 N/S KW	ML190 1	ML225 1 N/S KW	
1 1/16	No KW					ML090 1 1/16	ML095 1 1/16	ML099 1 1/16	ML100 1 1/16	ML110 1 1/16	ML150 1 1/16	ML190 1 1/16	ML225 1 1/16	
1 1/8	No KW					ML090 1 1/8	ML095 1 1/8	ML099 1 1/8	ML100 1 1/8	ML110 1 1/8	ML150 1 1/8	ML190 1 1/8	ML225 1 1/8	ML276 1 1/8
1 3/16	No KW					ML090 1 3/16	ML095 1 3/16	ML099 1 3/16	ML100 1 3/16	ML110 1 3/16	ML150 1 3/16	ML190 1 3/16	ML225 1 3/16	ML276 1 3/16
1 1/4	No KW					ML090 1 1/4	ML095 1 1/4	ML099 1 1/4	ML100 1 1/4	ML110 1 1/4	ML150 1 1/4	ML190 1 1/4	ML225 1 1/4	ML276 1 1/4
1 1/4	No KW					ML090 1 1/4	ML095 1 1/4	ML099 1 1/4	ML100 1 1/4	ML110 1 1/4	ML150 1 1/4	ML190 1 1/4	ML225 1 1/4	ML276 1 1/4
1 5/16	No KW					ML090 1 5/16	ML095 1 5/16	ML099 1 5/16	ML100 1 5/16	ML110 1 5/16	ML150 1 5/16	ML190 1 5/16	ML225 1 5/16	ML276 1 5/16
1 3/8	No KW					ML090 1 3/8	ML095 1 3/8	ML099 1 3/8	ML100 1 3/8	ML110 1 3/8	ML150 1 3/8	ML190 1 3/8	ML225 1 3/8	ML276 1 3/8
1 3/8	No KW					ML090 1 3/8	ML095 1 3/8	ML099 1 3/8	ML100 1 3/8	ML110 1 3/8	ML150 1 3/8	ML190 1 3/8	ML225 1 3/8	ML276 1 3/8
1 7/16	No KW					ML090 1 7/16	ML095 1 7/16	ML099 1 7/16	ML100 1 7/16	ML110 1 7/16	ML150 1 7/16	ML190 1 7/16	ML225 1 7/16	ML276 1 7/16
1 1/2	No KW					ML090 1 1/2	ML095 1 1/2	ML099 1 1/2	ML100 1 1/2	ML110 1 1/2	ML150 1 1/2	ML190 1 1/2	ML225 1 1/2	ML276 1 1/2
1 1/2	No KW					ML090 1 1/2	ML095 1 1/2	ML099 1 1/2	ML100 1 1/2	ML110 1 1/2	ML150 1 1/2	ML190 1 1/2	ML225 1 1/2	ML276 1 1/2
1 9/16	No KW					ML090 1 9/16	ML095 1 9/16	ML099 1 9/16	ML100 1 9/16	ML110 1 9/16	ML150 1 9/16	ML190 1 9/16	ML225 1 9/16	ML276 1 9/16
1 5/8	No KW					ML090 1 5/8	ML095 1 5/8	ML099 1 5/8	ML100 1 5/8	ML110 1 5/8	ML150 1 5/8	ML190 1 5/8	ML225 1 5/8	ML276 1 5/8
1 11/16	No KW					ML090 1 11/16	ML095 1 11/16	ML099 1 11/16	ML100 1 11/16	ML110 1 11/16	ML150 1 11/16	ML190 1 11/16	ML225 1 11/16	ML276 1 11/16
1 3/4	No KW					ML090 1 3/4	ML095 1 3/4	ML099 1 3/4	ML100 1 3/4	ML110 1 3/4	ML150 1 3/4	ML190 1 3/4	ML225 1 3/4	ML276 1 3/4
1 3/4	No KW					ML090 1 3/4	ML095 1 3/4	ML099 1 3/4	ML100 1 3/4	ML110 1 3/4	ML150 1 3/4	ML190 1 3/4	ML225 1 3/4	ML276 1 3/4
1 13/16	No KW					ML090 1 13/16	ML095 1 13/16	ML099 1 13/16	ML100 1 13/16	ML110 1 13/16	ML150 1 13/16	ML190 1 13/16	ML225 1 13/16	ML276 1 13/16
1 7/8	No KW					ML090 1 7/8	ML095 1 7/8	ML099 1 7/8	ML100 1 7/8	ML110 1 7/8	ML150 1 7/8	ML190 1 7/8	ML225 1 7/8	ML276 1 7/8
1 7/8	No KW					ML090 1 7/8	ML095 1 7/8	ML099 1 7/8	ML100 1 7/8	ML110 1 7/8	ML150 1 7/8	ML190 1 7/8	ML225 1 7/8	ML276 1 7/8
1 15/16	No KW					ML090 1 15/16	ML095 1 15/16	ML099 1 15/16	ML100 1 15/16	ML110 1 15/16	ML150 1 15/16	ML190 1 15/16	ML225 1 15/16	ML276 1 15/16
2	No KW					ML090 2	ML095 2	ML099 2	ML100 2	ML110 2	ML150 2	ML190 2	ML225 2	ML276 2
2 1/16	No KW					ML090 2 1/16	ML095 2 1/16	ML099 2 1/16	ML100 2 1/16	ML110 2 1/16	ML150 2 1/16	ML190 2 1/16	ML225 2 1/16	ML276 2 1/16
2 1/8	No KW					ML090 2 1/8	ML095 2 1/8	ML099 2 1/8	ML100 2 1/8	ML110 2 1/8	ML150 2 1/8	ML190 2 1/8	ML225 2 1/8	ML276 2 1/8
2 3/16	No KW					ML090 2 3/16	ML095 2 3/16	ML099 2 3/16	ML100 2 3/16	ML110 2 3/16	ML150 2 3/16	ML190 2 3/16	ML225 2 3/16	ML276 2 3/16
2 1/4	No KW					ML090 2 1/4	ML095 2 1/4	ML099 2 1/4	ML100 2 1/4	ML110 2 1/4	ML150 2 1/4	ML190 2 1/4	ML225 2 1/4	ML276 2 1/4
2 5/16	No KW					ML090 2 5/16	ML095 2 5/16	ML099 2 5/16	ML100 2 5/16	ML110 2 5/16	ML150 2 5/16	ML190 2 5/16	ML225 2 5/16	ML276 2 5/16
2 3/8	No KW					ML090 2 3/8	ML095 2 3/8	ML099 2 3/8	ML100 2 3/8	ML110 2 3/8	ML150 2 3/8	ML190 2 3/8	ML225 2 3/8	ML276 2 3/8
2 7/16	No KW					ML090 2 7/16	ML095 2 7/16	ML099 2 7/16	ML100 2 7/16	ML110 2 7/16	ML150 2 7/16	ML190 2 7/16	ML225 2 7/16	ML276 2 7/16
2 1/2	No KW					ML090 2 1/2	ML095 2 1/2	ML099 2 1/2	ML100 2 1/2	ML110 2 1/2	ML150 2 1/2	ML190 2 1/2	ML225 2 1/2	ML276 2 1/2
2 5/8	No KW					ML090 2 5/8	ML095 2 5/8	ML099 2 5/8	ML100 2 5/8	ML110 2 5/8	ML150 2 5/8	ML190 2 5/8	ML225 2 5/8	ML276 2 5/8
2 3/4	No KW					ML090 2 3/4	ML095 2 3/4	ML099 2 3/4	ML100 2 3/4	ML110 2 3/4	ML150 2 3/4	ML190 2 3/4	ML225 2 3/4	ML276 2 3/4
2 7/8	No KW					ML090 2 7/8	ML095 2 7/8	ML099 2 7/8	ML100 2 7/8	ML110 2 7/8	ML150 2 7/8	ML190 2 7/8	ML225 2 7/8	ML276 2 7/8

Jaw Couplings Metric and Spline Bores



Metric Bore Chart

Bore	Keyway	ML035	ML050	ML070	ML075	ML090	ML095	ML099	ML100	ML110	ML150	ML190	ML225	ML276
4MM	No KW	ML035 4MM												
5MM	No KW	ML035 5MM												
6MM	No KW	ML035 6MM												
7MM	No KW		ML050 7MM	ML070 7MM NKW										
8MM	No KW	ML035 8MM	ML050 8MM NKW	ML070 8MM NKW		ML090 8MM NKW								
9MM	No KW													
10MM	No KW		ML050 9MM	ML070 9MM	ML075 9MM									
11MM	No KW		ML050 10MM NKW	ML070 10MM NKW	ML075 10MM NKW									
12MM	No KW		ML050 10MM	ML070 10MM	ML075 10MM	ML090 10MM								
14MM	No KW		ML050 11MM	ML070 11MM	ML075 11MM	ML090 12MM NKW	ML095 11MM							
14MM	No KW		ML050 12MM	ML070 12MM	ML075 12MM	ML090 14MM NKW	ML095 12MM		ML100 12MM					
14MM	No KW		ML050 14MM NKW	ML070 14MM NKW	ML075 14MM NKW	ML090 14MM	ML095 14MM	ML099 14MM	ML100 14MM					
15MM	No KW		ML050 14MM	ML070 14MM	ML075 14MM	ML090 15MM	ML095 15MM	ML099 15MM	ML100 15MM					
16MM	No KW		ML050 15MM	ML070 15MM	ML075 15MM	ML090 16MM	ML095 16MM	ML099 16MM	ML100 16MM	ML110 16MM				
17MM	No KW					ML090 18MM	ML095 17MM	ML099 18MM	ML100 17MM	ML110 17MM				
18MM	No KW					ML090 19MM NKW	ML095 18MM	ML099 18MM	ML100 18MM	ML110 18MM				
19MM	No KW					ML090 19MM	ML095 19MM	ML099 19MM	ML100 19MM	ML110 19MM		ML190 19MM		
20MM	No KW					ML090 20MM	ML095 20MM	ML099 20MM	ML100 20MM	ML110 20MM		ML190 20MM		
22MM	No KW					ML090 22MM	ML095 22MM	ML099 22MM	ML100 22MM	ML110 22MM		ML190 22MM		
24MM	No KW					ML090 24MM	ML095 24MM	ML099 24MM	ML100 24MM	ML110 24MM		ML190 24MM		
25MM	No KW					ML090 25MM	ML095 25MM	ML099 25MM	ML100 25MM	ML110 25MM		ML190 25MM		
28MM	No KW						ML095 28MM	ML099 28MM	ML100 28MM	ML110 28MM		ML190 28MM		
30MM	No KW							ML099 30MM	ML100 30MM	ML110 30MM		ML190 30MM	ML225 30MM	ML276 32MM NKW
32MM	No KW								ML100 32MM	ML110 32MM		ML190 32MM	ML225 32MM	ML276 32MM
34MM	No KW								ML100 34MM					
35MM	No KW										ML150 35MM NKW	ML190 35MM NKW	ML225 35MM NKW	
35MM	No KW								ML100 35MM	ML110 35MM		ML190 35MM	ML225 35MM	
38MM	No KW											ML190 38MM	ML225 38MM	ML276 38MM
40MM	No KW											ML190 42MM	ML225 42MM	ML276 42MM
45MM	No KW											ML190 45MM	ML225 45MM	ML276 45MM
48MM	No KW											ML190 48MM	ML225 48MM	ML276 48MM
48MM	No KW											ML190 50MM NKW	ML225 50MM NKW	ML276 50MM NKW
50MM	No KW											ML190 50MM	ML225 50MM	ML276 50MM
50MM	No KW											ML190 55MM NKW	ML225 55MM NKW	ML276 55MM NKW
55MM	No KW											ML190 55MM	ML225 55MM	ML276 55MM
60MM	No KW											ML190 55MM	ML225 55MM	ML276 60MM NKW
60MM	No KW											ML190 60MM	ML225 60MM	ML276 60MM
65MM	No KW											ML190 65MM	ML225 65MM	ML276 65MM NKW
65MM	No KW											ML190 65MM	ML225 65MM	ML276 65MM
70MM	No KW											ML190 70MM	ML225 70MM	ML276 70MM

Spline Bore Chart

Major Dia.	Teeth	Pitch	ML090	ML095	ML099	ML100	ML110	ML150	ML190	ML225	ML276
5/8	9	16/32	ML090SPL 5/8	ML095SPL 5/8	ML099SPL 5/8	ML100SPL 5/8					
3/4	11	16/32	ML090SPL 3/4	ML095SPL 3/4	ML099SPL 3/4	ML100SPL 3/4	ML110SPL 3/4	ML150SPL 3/4	ML190SPL 3/4		
7/8	13	16/32	ML090SPL 7/8	ML095SPL 7/8	ML099SPL 7/8	ML100SPL 7/8	ML110SPL 7/8	ML150SPL 7/8	ML190SPL 7/8		
1	15	16/32			ML099SPL 1	ML100SPL 1	ML110SPL 1	ML150SPL 1	ML190SPL 1	ML225SPL 1	
1 1/4	14	12/24					ML110SPL 1 1/4	ML150SPL 1 1/4	ML190SPL 1 1/4	ML225SPL 1 1/4	ML276SPL 1 1/4
1 3/8	21	16/32					ML110SPL 1 3/8	ML150SPL 1 3/8	ML190SPL 1 3/8	ML225SPL 1 3/8	
1 1/2	23	16/32								ML225SPL 1 1/2	
1 3/4	27	16/32					ML110SPL 1 3/4	ML150SPL 1 3/4	ML190SPL 1 3/4	ML225SPL 1 3/4	

Parts List and Engineering Data

Coupling Size	QD Bushing (2 Required Per Coupling)*	Steel Flange Assembly (2 Required Per Coupling)		Rubber Element (1 Required Per Coupling)		Max RPM	Horsepower @ 100 RPM (1.0 Factor)	Torque (1.0 Service Factor)		Average Static Torsional Stiffness Coefficient (K)		Approx. WR** (LB - Ft²)
		Flange No.	Weight Each	Element No.	Weight			LB - In	LB - Ft	LB - In/DEG	LB - In/RAD	
5	JA	F5JA	3.0	E5	.6	4500	1.03	649	54.1	244	12,850	.08
6	JA	F6JA	4.0	E6	.9	4000	1.80	1134	94.5	414	23,700	.22
7	SH	F7SH	7.0	E7	1.3	3600	3.12	1966	163.8	544	31,200	.40
8	SDS	F8SDS	8.0	E8	1.7	3100	4.68	2950	245.8	876	50,200	.70
9	SK	F9SK	13.0	E9	2.0	2800	6.90	4349	362.4	1088	62,400	1.33
10	SF	F10SF	17.0	E10	2.0	2600	8.33	5250	437.5	1530	87,700	2.10
11	SF	F11SF	18.0	E11	3.0	2300	9.92	6252	521.0	2420	138,700	2.90
12	E	F12E	31.0	E12	3.8	2100	14.40	9076	756.3	4014	217,000	5.80

* See page B5 for QD bushing bore sizes and dimensions.

Rubber tire element also available in Neoprene.

** Coupling plus QD bushing.

Weight in pounds.

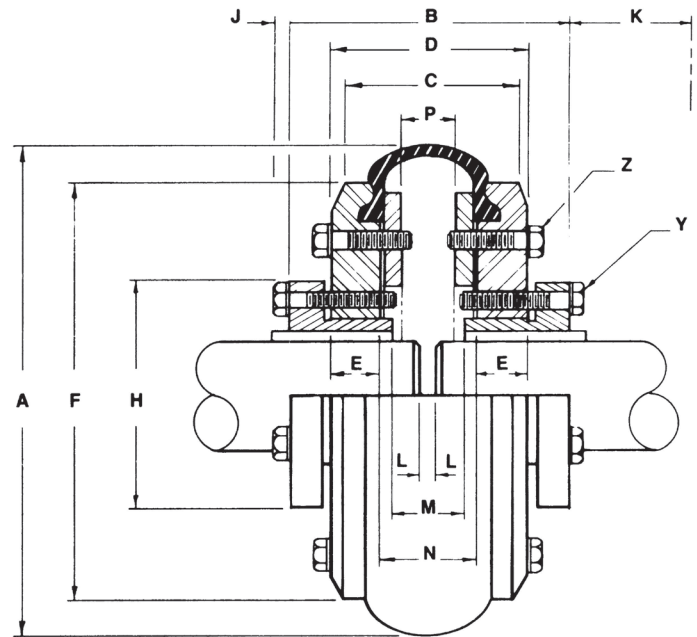

Dimensions

Coupling Size	A	B	C	D	E	F	H	J	K*	M	N	P	Y		Z Clamp Ring Bolts		Torque In lb
													B.C. Dia.	B.C. Dia.	No. and Size***	Cap screws	
5	5.250	3.438	2.167	2.563	0.625	4.000	2.000	0.156	1.250	1.438	1.313	0.375	1.660	2.438	(5) 1/4 - 20 × 1 1/8	125	
6	6.500	3.563	2.188	2.688	0.625	4.938	2.000	0.156	1.250	1.563	1.438	0.500	1.660	3.313	(5) 5/16 - 18 × 1 1/8	200	
7	7.375	4.313	2.688	3.188	0.813	5.625	2.688	0.219	1.625	1.688	1.563	0.750	2.250	3.875	(5) 5/16 - 18 × 1 1/4	300	
8	8.375	4.438	2.813	3.313	0.813	6.500	3.188	0.219	1.625	1.813	1.688	0.875	2.688	4.625	(6) 5/16 - 18 × 1 1/2	300	
9	9.250	5.188	3.438	3.938	1.167	7.375	3.875	0.281	2.250	1.438	1.813	0.875	3.313	5.250	(6) 3/8 - 16 × 1 3/4	400	
10	10.000	5.813	3.563	4.167	1.167	8.313	4.625	0.313	2.750	1.563	1.563	1.000	3.875	6.000	(6) 3/8 - 16 × 1 3/4	400	
11	11.000	5.625	3.125	3.875	1.167	9.000	4.625	0.313	2.750	1.375	1.375	0.938	3.875	6.500	(6) 3/8 - 16 × 1 3/4	400	
12	12.375	7.250	4.000	4.750	1.375	10.167	6.000	0.438	3.250	1.250	1.250	0.750	5.000	7.250	(6) 1/2 - 13 × 2 1/4	900	

Shaft ends are normally M or N apart; they may project beyond the bushings. In this case allow space for end float and misalignment.

* Clearance required to remove bushing using pull-up capscrews as jackscrews.

** Grade 8.

Dimensions in inches.

Other Sizes Available as Made-to-Order

Martin-Flex® Couplings



Martin Flex® flexible couplings smoothly transmit power while compensating for shaft misalignment to 4°, parallel misalignment to .125 and end float to .313. The two piece flange design provides quick and easy installation and the elastomeric element absorbs shock and torsional vibration through a wide temperature range.

Selection Procedure

1. Select the proper service factor from Chart 1.
2. Determine **Design Horsepower** by multiplying the **Service Factor** and the **Drive Horsepower**.
3. Locate the intercept of **Shaft Speed** and **Design Horsepower** from Chart 2.
4. Order per coupling: (2) bushings, (2) flange assemblies, (1) flexible tire element.

Chart 1 Service Factors

Application	Factor	Application	Factor	Application	Factor	Application	Factor
AGITATORS		Cutter Head Drive, Jog Drive	2.5	METAL FORMING MACHINES		PROPELLER (MARINE)	1.5
Paddle or Propeller (Vert. or Horiz.), Screw	1.0	Pump, Screen Drive, Stacker, Utility Winch	1.5	Draw Bench Carriage, Main Drive, Extruder, Wire Drawing, Flattening Machine	2.0	PULVERIZERS	
BREWING AND DISTILLING		DYNAMOMETER	1.0			Hammermill — Light Duty	1.5
Bottling Machinery, Brew Kettle, Cooker (Cont Duty), Mash Tub	1.0	ELEVATORS		MILLS (ROTARY TYPE)		Hammermill — Heavy Duty	2.0
Scale Hopper — Frequent Starting Peaks	1.5	Bucket, Freight	2.0	Ball or Pebble Direct or on LS Shaft Gear Reducer	2.5	Hog	2.0
CAN FILLING MACHINE	1.0	EXCITER	1.0	on HS Shaft Gear Reducer	2.0	Roller	1.5
CAR DUMPER	1.5	FANS		Dryer and Cooler	1.5	PUMPS	
CAR PULLER	1.5	Centrifugal	1.0	Rod or Tube Direct or on LS Shaft Gear Reducer	2.5	Centrifugal	1.0
CLARIFIER	1.0	Cooling Tower	2.0	on HS Shaft Gear Reducer	2.0	Descaling, Gear Type	1.5
CLASSIFIER	1.0	Large (Mine, etc.)	1.5	on LS Shaft Gear Reducer	2.5	Oil Well Pumping (not over 150% peak torque)	2.0
CLAY-WORKING MACHINES		Light	1.0	on HS Shaft Gear Reducer	2.0	Rotary — other than gear	1.5
Brick Press, Briquette Machine, Clay Working Machine, Pug Mill	1.5	Propeller (indoor)	1.5	Tumbling Barrel	1.5	Reciprocating —	
COMPRESSORS		FOOD INDUSTRY		MIXERS		1 cyl. — single acting	2.5
Lobe, Rotary	2.0	Beet Slicer	1.5	Concrete (Continuous or Intermittent), Muller- Simpson type	1.5	1 cyl. — double acting	2.0
Reciprocating** —		Cereal Cooker	1.0	OIL INDUSTRY		2 cyl. — single acting	2.0
1 cyl. — single acting	3.5	Dough Mixer, Meat Grinder	1.5	Chiller	1.0	2 cyl. — double acting	1.5
1 cyl. — double acting	3.0	GENERATORS		Oil Well Pumping (not over 150% peak torque)	2.0	3 cyl. — or more	1.5
2 cyl. — single acting	3.0	Even Load	1.0	Paraffin Filter Press	1.5	RUBBER INDUSTRY	
2 cyl. — double acting	2.5	Hoist or Railway Service	1.5	PAPER MILLS		BANBURY MIXER	2.5
3 cyl. or more — single acting	2.5	Welder Load	2.0	Agitator	1.0	Calender	2.0
3 cyl. or more — double acting	2.0	GRIZZLY	2.0	Barking Drum	2.5	Cracker, Mixing Mill, Plasticator	2.5
CONVEYORS		KILN	2.0	Beater and Pulper	1.5	Refiner, Sheeter, Tire Building Machine	2.0
Apron, Assembly, Belt, Chain, Flight, Oven	1.0	LAUNDRY MACHINES		Bleacher	1.0	Tire and Tube Press Opener (Based on Peak Torque)	1.0
Reciprocating	2.5	Tumbler, Washer	2.0	Calender	2.0	Tuber and Strainer	1.5
Screw	1.0	LINE SHAFTS		Chipper	3.0	Warming Mill	2.0
CRANES AND HOISTS		Driving Processing Machinery	1.0	Couch, Cylinder, Dryer	1.5	Washer	2.5
Main Hoist — Medium Duty	1.5	Light	1.0	Felt Stretcher	1.0	SCREENS	
Main Hoist — Heavy Duty	2.0	LUMBER INDUSTRY		Fourdrinier	1.5		
Skip Hoist, Travel Motion, Trolley Motion, Slope	1.5	Band Resaw, Circular Resaw	1.5	Jordan	2.0		
CRUSHERS		Edger, Head Rig, Hog, Log Haul	2.0	Press	2.0		
Cane	2.0	Planer	1.5	Pulp Grinder	2.0		
Gyratory	2.5	Rolls Non-Reversing	1.5	Stock Chest	1.5		
DREDGES		Rolls Reversing	2.0	Stock Pump Reciprocating	2.0		
Cable Reel, Conveyor	1.5	Sawdust Conveyor	1.0	Rotary	1.5		
		Slab Conveyor, Sorting Table	1.5	Suction Roll	2.0		
		MACHINE TOOLS		Winder	1.5		
		Auxiliary	1.0	PARAFFIN FILTER PRESS	1.5		
		Main Drive, Notching Press, Planer (Reversing), Plate	1.5	PRINTING PRESS	1.5		
		Planer, Punch Press	1.5				
		Traverse	1.0				

The service factors listed are intended only as a general guide for smooth power sources such as electric motors and steam turbines. Add 0.5 to factor for somewhat rougher power sources such as internal combustion engines of four or more cylinders, steam engines and water turbines. Where substantial shock occurs or starting or stopping is frequent as on some inching drives and on some reversing drives or where the power source is an internal combustion engine with less than four cylinders — consult factory. Where torsional vibrations occur as in, for example, internal combustion engines or reciprocating compressors or pump applications, check the coupling for possible development of damaging large amplitude vibrations.

** Add 0.5 to factor if without flywheel.

Chart 2 Size Selection

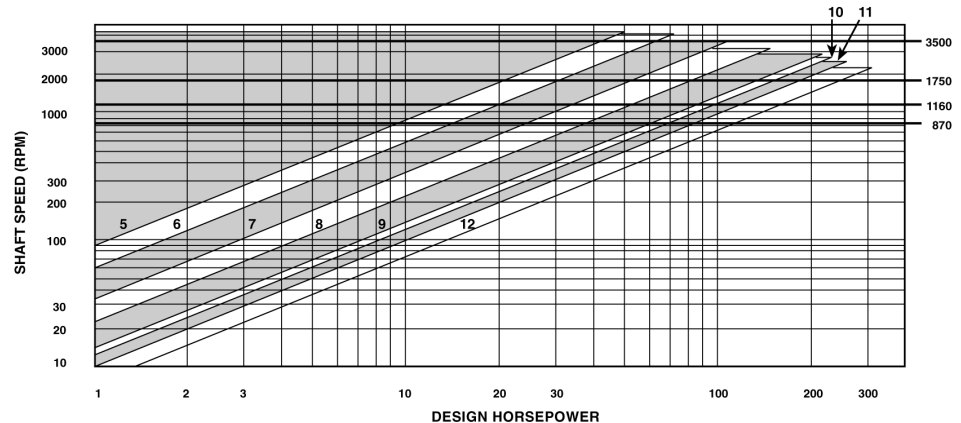

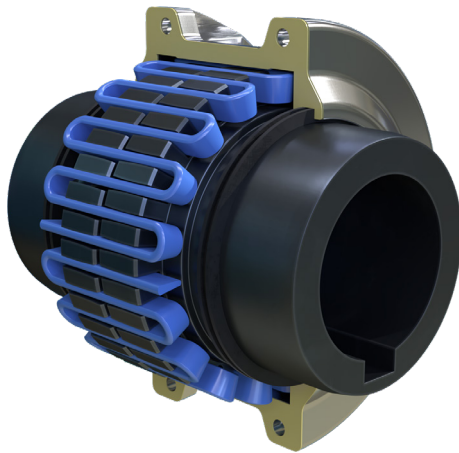

Martin Blue-Flex® grid couplings are the best option where both high torque levels and dampening requirements exist. Unlike other metallic couplings, Martin Blue-Flex® grid

Couplings have the ability to reduce vibration and cushion shock loads to driven and driving power transmitting equipment components.

Progressive contact between the curved profile of the hub teeth and the flexible grid makes it possible to absorb impact energy by spreading it out, reducing the magnitude of the peak loads.

Martin Blue-Flex® grid couplings follow the same Martin product/service standards that make Martin the one industries rely on for quality, availability, service and response time that is second to none.

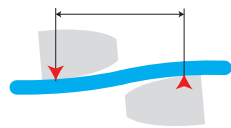
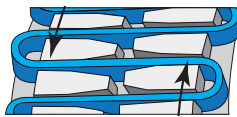

Light Load

The grid bears the stress near the outer edge of the hub teeth. The long span between the point of contact remains free to flex under load variations.

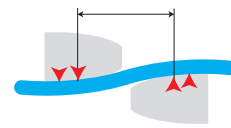
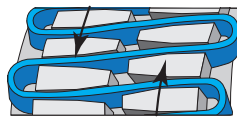

Normal Load

As the load increases, the distance between contact points on the hub teeth is shortened, but a free span still remains to cushion shock loads.

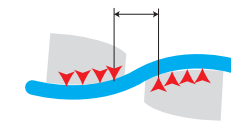
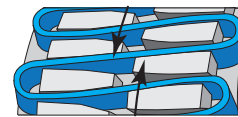

Shock Load

The coupling is flexible within its rated capacity. Under extreme overloads, the grid bears the stress fully on the hub teeth and transmits full load directly.

Available in 2 Close-Coupled Styles

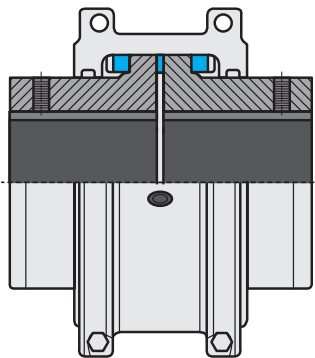

T10

A flexing, close-coupled design for use in four-bearing systems. Includes a horizontally split cover which allows for grid replacement without disturbance of the connected equipment.

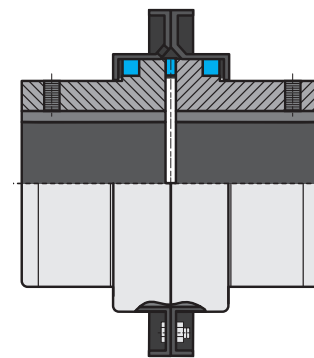

T20

A flexing design featuring a vertically-split steel cover. Ideal for higher running speeds and higher torque capacity.

Cover Design Component Guide

Martin

Type T10 Horizontal Cover Design

A flexing, close-coupled design for use in four-bearing systems. Includes a horizontally split cover which allows for grid replacement without disturbance of the connected equipment.

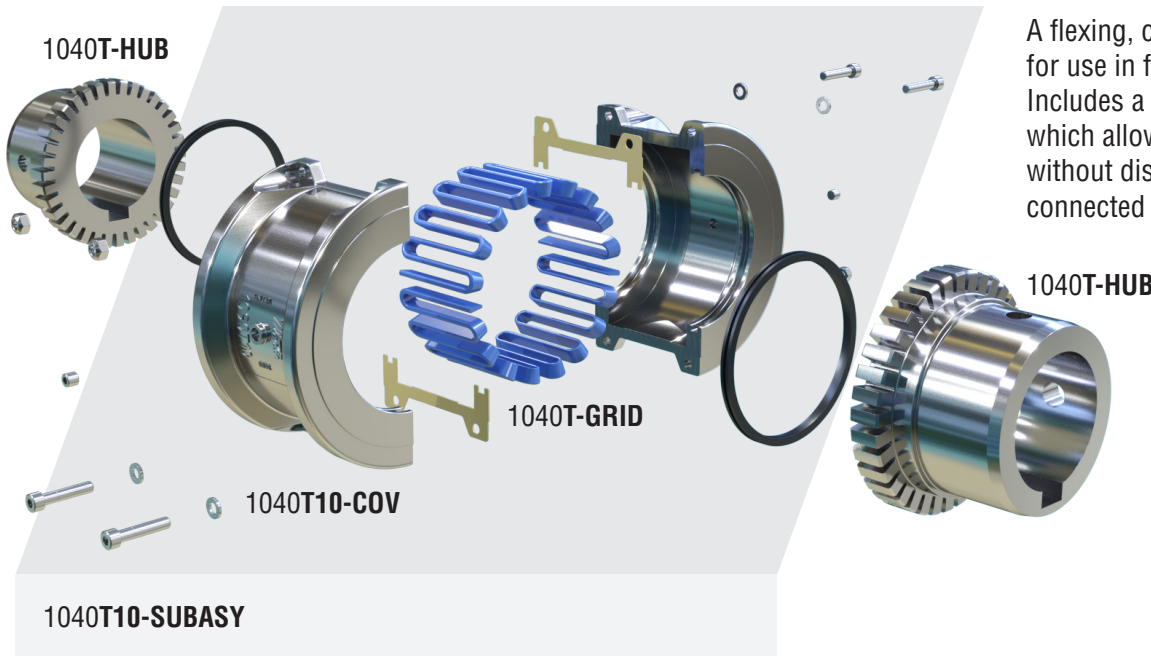

Type T20 Vertical Cover Design

A flexing design featuring a vertically-split steel cover. Ideal for higher running speeds and higher torque capacity.

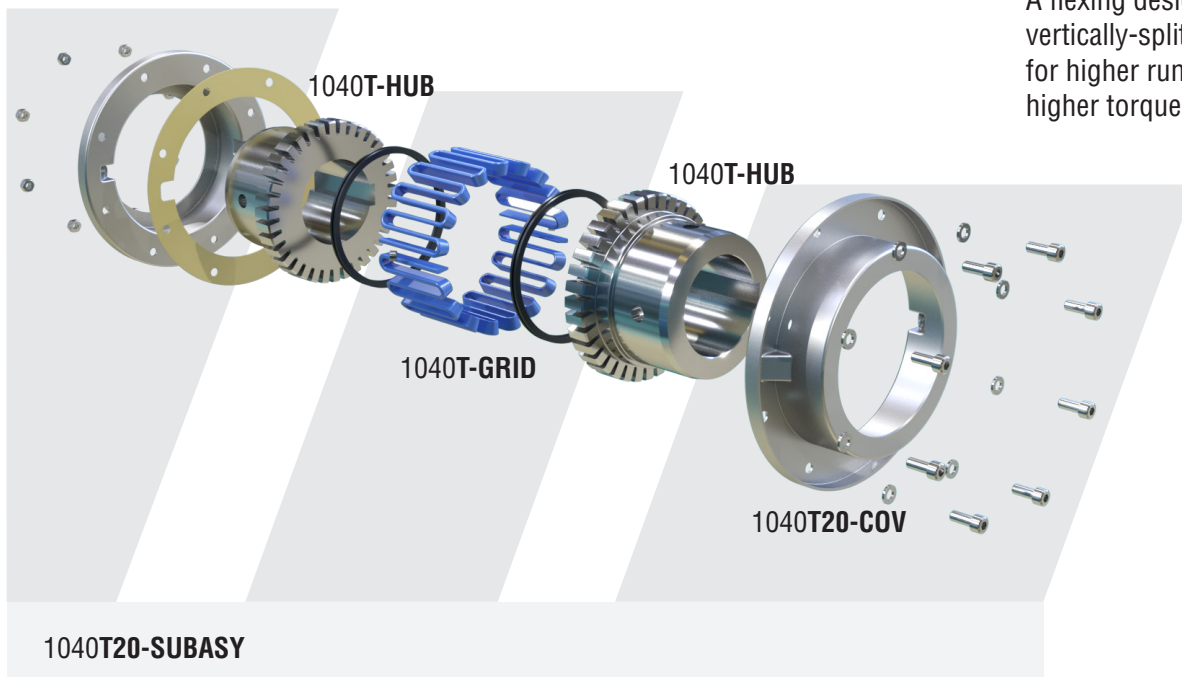

Type T31 Spacer Design

A complete Full Spacer drop out center section allowing easy maintenance of connected equipment, seals and bearings.

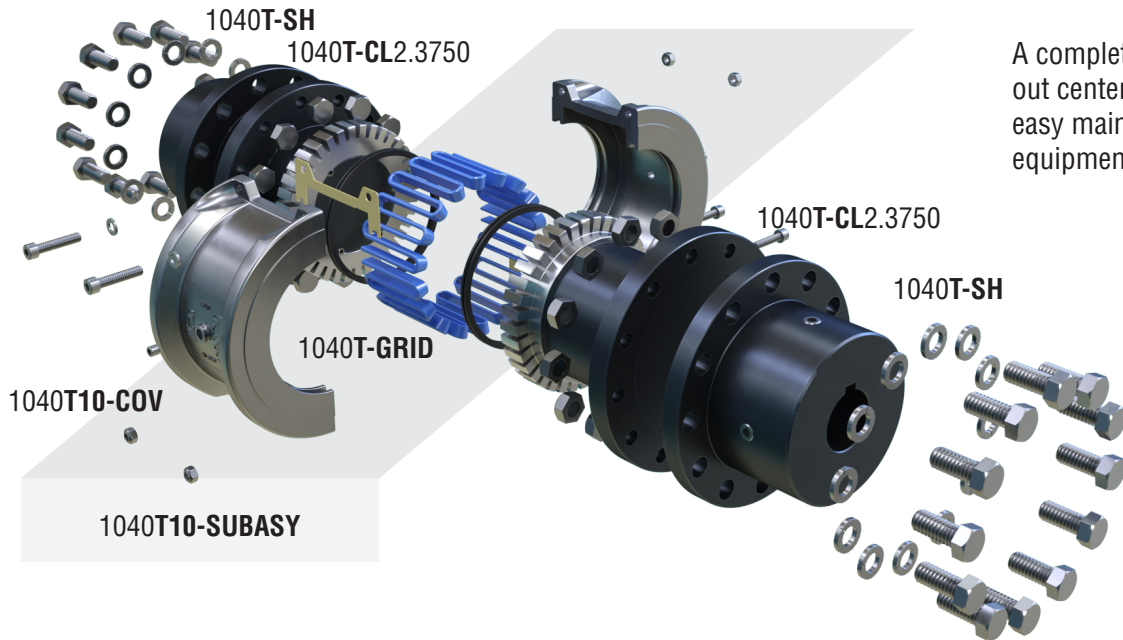

Type T35 Half Spacer Design

An economical solution, offering Half Spacer drop out section allowing easy maintenance of connected equipment, seals and bearings.

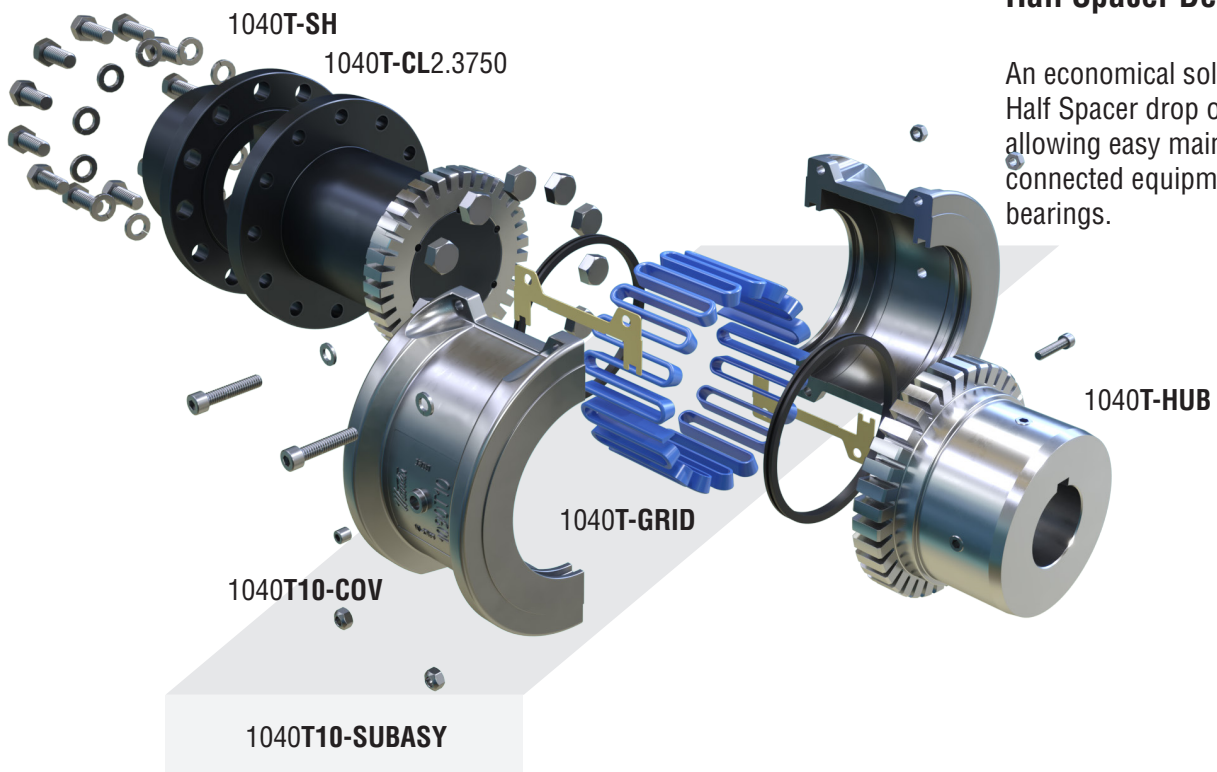

Standard Selection Method

The standard selection method can be used for most motor, turbine or engine-driven applications. The following information is required to select a flexible coupling:

- Horsepower or torque
- Running RPM
- Application or type of equipment to be connected
- Shaft diameters
- Shaft gaps
- Physical space limitations
- Special bore or finish, and type of fit

Step 1. Rating: Determine system torque. If torque is not given, calculate as shown below:

$$\text{Torque (lb-in)} = \frac{\text{HP} \times 63,000}{\text{RPM}}$$

Where horsepower is the actual or transmitted power required by the application (if unknown, use the motor or turbine nameplate rating) and rpm is the actual speed the coupling is rotating. Applications that require rapid changes in direction or torque reversals should be referred to Martin Engineering.

Step 2. Service Factor: Determine appropriate service factor from C-40.

Step 3. Required Minimum Coupling Rating: Determine the required minimum coupling rating as shown below:

$$\text{Min. Coupling Rating} = \text{S.F. (Service Factor)} \times \text{Torque (lb-in)}$$

Step 4. Type: Refer to pages C-34 and C-35 and select the appropriate coupling type.

Step 5. Size: Turn to appropriate pages for the coupling type chosen and trace down the torque column to a value that is equal or greater than that determined in Step 3 above. The coupling size is shown in the first column.

Step 6. Check: Speed (RPM), bore, gap and dimensions.

Example: A Field Engineer wants to use a Grid Coupling to connect a 60 horsepower electric motor running at 1750 RPM to a rotary lobe compressor. The shaft diameter of both the motor and compressor is 1 3/4. Motor shaft extension is 3 and compressor shaft extension is 2 1/2. Gap between shaft ends is 1/8.

1. Determine Required Rating:

$$\text{Torque (lb-in)} = \frac{60 \times 63,000}{1750 \text{ RPM}} = 2160 \text{ lb-in}$$

2. Service Factor: From C-38 = 1.25

3. Required Min. Coupling Rating:

$$1.25 \times 2160 \text{ lb-in} = 2700 \text{ lb-in}$$

4. Size: From page C-42 a size 1050T10 is the proper selection based on a torque rating of 3850 lb-in exceeding the required min. coupling rating of 2700 lb-in.

5. Check: Allowable speed capacity of 4500 (T10) exceeds the required speed of 1750 rpm. Maximum bore capacity of 1 7/8 exceeds the actual shaft diameters.

Formula Selection Method

The Standard Selection Method will work when selecting most couplings. The Formula Selection Method should be used for:

- High Peak Loads
- High Braking Torques

Providing system peak torque and frequency, duty cycle and brake torque rating will allow for a more refined selection using the Formula Selection Method.

1. High Peak Loads: Use one of the following formulas for applications using motors with torque characteristics that are higher than normal; applications with intermittent operations, shock loading, inertia effects due to starting and stopping and/or system-induced repetitive high peak torques. System Peak Torque is the maximum torque that can exist in the system. Select a coupling with a torque rating equal to or greater than selection torque calculated below.

a. Non-Reversing High Peak Torque

Selection Torque (lb-in) = System Peak Torque
or

$$\text{System Torque (lb-in)} = \frac{\text{System Peak HP} \times 63,000}{\text{RPM}}$$

b. Reversing High Peak Torque

Selection Torque (lb-in) = 2 x System Peak Torque
or

$$\text{System Torque (lb-in)} = \frac{2 \times \text{Peak HP} \times 63,000}{\text{RPM}}$$

c. Occasional Peak Torques (Non-reversing) If a system peak torque occurs less than 1000 times during the expected coupling life, use the following formula:

Selection Torque (lb-in) = 0.5 x System Peak Torque
or

$$\text{System Torque (lb-in)} = \frac{0.5 \times \text{Peak HP} \times 63,000}{\text{RPM}}$$

2. High Braking Torques: If the torque rating of the braking exceeds the motor torque, use the braking rating as follows:

Selection Torque (lb-in) = Braking Torque Rating x S.F.

Example: A Maintenance Engineer needs a Grid Coupling to connect an electric motor to a reversing runout mill table roll. The system peak torque is estimated to be 118,000 lb-in with the motor running at 80 RPM. The motor shaft diameter is 7 and the driven shaft diameter is 8. The motor and driven shaft extensions are both 8 1/2. Distance between shaft ends is 8.00.

1. Type: Refer to pages C-34 and C-35 and select the appropriate.

2. Required Minimum Coupling Rating:

Use the Reversing High Peak Torque formula.
2 x 118,000 = 236,000 = Selection Torque

3. Size: From page C-44 a size 1140T10 with a torque rating of 253,000 exceeds the selection torque of 236,000 lb-in.

4. Check: The 1140T35 has a maximum BE dimension of 8.06; maximum bore of 8 with one rectangular key (Table 3, page C-39); and the allowable speed of 1650 rpm and the dimensions on page C-46, meet the requirements.

Table 3 – Coupling Ratings and Allowable Speeds

Coupling Size	HP per 100 RPM	Torque Rating (lb-in)	Allowable Speeds – RPM		
			T10	T20	T31, T35, T10/82
1020T	0.73	460	4,500	6,000	3,600
1030T	2.09	1,320	4,500	6,000	3,600
1040T	3.49	2,200	4,500	6,000	3,600
1050T	6.11	3,850	4,500	6,000	3,600
1060T	9.60	6,050	4,350	6,000	3,600
1070T	14.0	8,800	4,125	5,500	3,600
1080T	28.8	18,150	3,600	4,750	3,600
1090T	52.4	33,000	3,600	4,000	3,600
1100T	88.1	55,550	2,440	3,250	2,440
1110T	131	82,500	2,250	3,000	2,250
1120T	192	121,000	2,025	2,700	2,025
1130T	279	176,000	1,800	2,400	1,800
1140T	401	253,000	1,650	2,200	1,650
1150T	559	352,000	1,500	2,000	1,500
1160T	785	495,000	1,350	1,750	1,350
1170T	1047	660,000	1,225	1,600	1,225
1180T	1452	915,200	1,100	1,400	1,100
1190T	1920	1,210,000	1,050	1,300	1,050
1200T	2618	1,650,000	900	1,200	900

Consult Martin for higher speeds.

Blue-Flex® Selection Procedure



Quick Selection Method

Step 1. Select Coupling Type. Refer to pages C-34 and C-35 and select the type of coupling to suit your application. If an application requires a special purpose coupling, refer application details to your local Martin representative.

Step 2. Determine Service Factor. Refer to Table 6 and Table 7.

A. Refer to the formula selection method if your application has high braking torques or high peak loads.

Step 3. Determine Equivalent Horsepower. Refer to Table 4 – Under the actual HP required and tracing horizontally from the service factor determined in Step 2, read the equivalent HP.

Step 4. Determine Coupling Size.

- Refer to Table 5 – Trace horizontally from the required speed to a HP value equal to or larger than the hp determined in Step 3. Read the coupling size at top of column.
- Check shaft diameters on coupling maximum bores shown on pages for the type of coupling selected. If a larger bore is required, select a larger coupling.
- Check the required speed against the allowable speed shown in Table 3 page C-39 for the type of coupling selected. If a higher speed is required, refer to Martin Engineering.
- Check application dimension requirements against catalog page for the type of coupling selected.

Example: A 400 horsepower electric motor rated for 1200 RPM needs a grid coupling to drive a tire shredder. The shaft gap is 0.1 to 0.2. The motor shaft diameter is 3 and the driven shaft diameter is 3 1/4. The motor and driven shaft extensions are both 5.

- Select Coupling Type:** To connect close-coupled shafts (0.1 to 0.2 gap), a Type T10 or T20 coupling is the proper selection. Type T10 is selected.
- Determine Service Factor:** From Table 6, the service factor is 1.5.
- Determine Equivalent HP:** From Table 4, the equivalent HP is 600.
- Select Coupling Size:** (A) From Table 5, the coupling size is 1090T10. (B) From Table 8, the maximum bore with square key is 3.500. (C) From Table 3, the allowable speed of a 1090T10 is 3600 RPM. (D) Dimensions for the 1090T10 coupling shown on page C-44 satisfies the application requirements.

Table 4 – Equivalent Horsepower = (Actual HP x Service Factor)

Service Factor •	Actual HP																									
	3/4	1	1-1/2	2	3	5	7-1/2	10	15	20	25	30	40	50	60	75	100	125	150	200	250	300	350	400	450	500
1.00	0.75	1.0	1.5	2.0	3.0	5.0	7.5	10	15	20	25	30	40	50	60	75	100	125	150	200	250	300	350	400	450	500
1.25	0.94	1.25	1.9	2.5	3.8	6.3	9.4	12.5	19	25	31	38	50	63	75	94	125	156	188	250	312	375	438	500	563	625
1.50	1.1	1.5	2.3	3.0	4.5	7.5	11.3	15	23	30	38	45	60	75	90	113	150	188	225	300	375	450	525	600	675	750
1.75	1.3	1.8	2.6	3.5	5.3	8.8	13.1	18	26	35	44	53	70	88	105	131	175	219	262	350	438	525	613	700	787	875
2.00	1.5	2.0	3.0	4.0	6.0	10.0	15.0	20	30	40	50	60	80	100	120	150	200	250	300	400	500	600	700	800	900	1000
2.50	1.9	2.5	3.8	5.0	7.5	12.5	18.8	25	38	50	63	75	100	125	150	187	250	312	375	500	625	750	875	1000	1125	1250
3.00	2.3	3.0	4.5	6.0	9.0	15.0	22.5	30	45	60	75	90	120	150	180	225	300	375	450	600	750	900	1050	1200	1350	1500
3.50	2.6	3.5	5.3	7.0	10.5	17.5	26.2	35	52	70	87	105	140	175	210	262	350	437	525	700	875	1050	1225	1400	1575	1750

• For service factor not listed, Equivalent HP = Actual HP x Service Factor.



Blue-Flex® Selection Procedure

Table 5 – Coupling Selection Based on Equivalent HP Ratings

Coupling Size	1020T	1030T	1040T	1050T	1060T	1070T	1080T	1090T	1100T	1110T	1120T	1130T	1140T	1150T	1160T	1170T	1180T	1190T	1200T
Max Bore (in)	1.125	1.375	1.625	1.875	2.125	2.500	3.000	3.500	4.000	4.500	5.000	6.000	7.250	8.000	9.000	10.000	11.000	12.000	13.000
Max Speed T10 RPM	4500	4500	4500	4500	4350	4125	3600	3600	2440	2250	2025	1800	1650	1500	1350	1225	1100	1050	900
Max Speed T20 RPM	6000	6000	6000	6000	6000	5500	4750	4000	3250	3000	2700	2400	2200	2000	1750	1600	1400	1300	1100
Torque (lb-in)	460	1320	2200	3850	6050	8800	18,150	33,000	55,550	82,500	121,000	176,000	253,000	352,000	495,000	660,000	915,200	1,210,000	1,650,000
HP/100 RPM	0.73	2.09	3.49	6.11	9.60	14.0	28.8	52.4	88.1	131	192	279	401	559	785	1047	1452	1920	2618
HP Ratings																			
RPM	4500	32.8	94.2	157	275	432	628	1296	1885	2644	3927	5864	8430	10053	13745	15184	14521	19199	22777
	3600	26.3	75.4	126	220	346	503	1037	1885	2644	3927	5864	8430	10053	13745	15184	14521	19199	22777
	3000	21.9	62.8	105	183	288	419	864	1571	2203	3273	4749	6633	8430	10053	13745	14521	19199	22777
	2500	18.2	52.4	87	153	240	349	720	1309	1920	2846	4049	5633	7226	8919	10472	11135	14799	17017
	2100	15.3	44.0	73.3	128	202	293	605	1100	1611	2356	3360	4697	6339	8098	9432	10472	13823	18850
	1800	13.1	37.7	62.8	110	173	251	518	942	1360	1992	2846	3967	5355	6633	7854	8633	11135	15184
	1750	12.8	36.7	61.1	107	168	244	504	916	1339	1920	2793	3926	5226	6533	7745	8430	10996	14799
	1450	10.6	30.4	50.6	89	139	202	418	759	1114	1611	2356	3360	4697	6339	7854	8633	11135	15184
	1170	8.5	24.5	40.8	71.5	112	163	337	613	916	1339	1920	2793	3926	5226	6533	7226	9432	12777
	1000	7.3	20.9	34.9	61.1	96	140	288	524	811	1199	1700	2430	3360	4455	5555	6339	8430	11135
	870	6.3	18.2	30.4	53.1	84	121	251	456	767	1139	1670	2430	3360	4455	5555	6339	8430	11135
	720	5.3	15.1	25.1	44.0	69	101	207	377	635	942	1382	2011	2890	4021	5655	7540	10455	14799
	650	4.7	13.6	22.7	39.7	62.4	91	187	340	573	851	1248	1815	2609	3630	5105	6807	9432	12777
	580	4.2	12.1	20.2	35.4	55.7	81	167	304	511	759	1114	1620	2328	3239	4555	6074	8422	11135
	520	3.8	10.9	18.2	31.8	49.9	73	150	272	458	681	998	1452	2087	2904	4084	5445	7551	9983
	420	3.1	8.8	14.7	25.7	40.3	59	121	220	370	550	806	1173	1686	2346	3299	4398	6063	81996
	350	2.6	7.3	12.2	21.4	33.6	49	101	183	308	458	672	977	1405	1955	2749	3665	5082	6720
	280	2.0	5.9	9.8	17.1	26.9	39.1	81	147	247	367	538	782	1124	1564	2199	2932	4066	5376
	230	1.7	4.8	8.0	14.0	22.1	32.1	66	120	203	301	442	642	923	1285	1806	2409	3340	4416
	190	1.4	4.0	6.6	11.6	18.2	26.5	55	99	167	249	365	531	763	1061	1492	1990	2759	3648
	155	1.1	3.2	5.4	9.5	14.9	21.6	44.6	81	137	203	298	433	622	866	1217	1623	2251	2976
	125	0.9	2.6	4.4	7.6	12.0	17.5	36.0	65	110	164	240	349	502	698	982	1309	1815	2400
	100	0.73	2.1	3.5	6.1	9.6	14.0	28.8	52	88	131	192	279	401	559	785	1047	1452	1920
	84	0.61	1.8	2.9	5.1	8.1	11.7	24.2	44.0	74	110	161	235	337	469	660	880	1220	1613
	68	0.50	1.4	2.4	4.2	6.5	9.5	19.6	35.6	60	89	131	190	273	380	534	712	987	1306
	56	0.41	1.17	2.0	3.4	5.4	7.8	16.1	29.3	49	73	108	156	225	313	440	586	813	1075
	45	0.33	0.94	1.6	2.7	4.3	6.3	13.0	23.6	39.7	59	86	126	181	251	353	471	653	864
	37	0.27	0.77	1.3	2.3	3.6	5.2	10.7	19.4	32.6	48.4	71	103	149	207	291	387	537	710
	30	0.22	0.63	1.0	1.8	2.9	4.2	8.6	15.7	26.4	39.3	58	84	120	168	236	314	436	576
	25	0.18	0.52	0.9	1.5	2.4	3.5	7.2	13.1	22.0	32.7	48.0	70	100	140	196	262	363	480
	20	0.15	0.42	0.70	1.2	1.9	2.8	5.8	10.5	17.6	26.2	38.4	56	80	112	157	209	290	384
	16.5	0.12	0.35	0.58	1.0	1.6	2.3	4.8	8.6	14.5	21.6	31.7	46.1	66	92	130	173	240	317
	13	0.095	0.27	0.45	0.79	1.2	1.8	3.7	6.8	11.5	17.0	25.0	36.3	54	75	106	141	196	259
	11	0.080	0.23	0.38	0.67	1.1	1.5	3.2	5.8	9.7	14.4	21.1	30.7	44.2	61	86	115	160	211
	9	0.066	0.19	0.31	0.55	0.86	1.3	2.6	4.7	7.9	11.8	17.3	25.1	36.1	50	71	94	131	173
	7.5	0.055	0.16	0.26	0.46	0.72	1.0	2.2	3.9	6.6	9.8	14.4	20.9	30.1	42	59	79	109	144
	5	0.036	0.10	0.17	0.31	0.48	0.7	1.4	2.6	4.4	6.5	9.6	14.0	20.1	27.9	39	52	73	96

◇ Ratings apply to Type T20 only.

Blue-Flex® Selection Procedure



Table 6 – Flexible Coupling Service Factors • Service factors listed are typical values based on normal operation of the drive systems.

Application	Service Factor	Application	Service Factor	Application	Service Factor	Application	Service Factor
AERATOR	2.0	Live Roll, Shaker and Reciprocating	3.0	Welder Load	2.0	Centrifugal — Constant Speed	1.0
AGITATORS		CRANES AND HOIST		HAMMERMILL	1.75	Frequent Speed Changes under Load	1.25
Vertical and Horizontal Screw, Propeller, Paddle	1.0	Main Hoist	1.7	LAUNDRY WASHER OR TUMBLER	2.0	Descaling, with accumulators	1.25
BARGE HAUL PULLER	1.5	Skip Hoist	1.75	LINE SHAFTS		Gear, Rotary, or Vane	1.25
BLOWERS		Slope	1.5	Any Processing Machinery	1.5	Reciprocating, Plunger Piston	
Centrifugal	1.0	Bridge, Travel or Trolley	1.75	MACHINE TOOLS		1 cyl., single or double act	3.0
Lobe or Vane	1.25	DYNAMOMETER	1.0	Auxiliary and Traverse Drive	1.0	2 cyl., single acting	2.0
CAR DUMPERS	2.5	ELEVATORS		Bending Roll, Notching Press, Punch Press, Planer, Plate Reversing	1.75	2 cyl., double acting	1.75
CAR PULLERS	1.5	Bucket, Centrifugal Discharge	1.25	Main Drive	1.5	3 or more cylinders	1.5
CLARIFIER OR CLASSIFIER	1.0	Freight or Passenger	∅	Gravity Discharge	∅	Screw Pump, Progressing Cavity	1.25
COMPRESSORS		ESCALATORS	∅	MAN LIFTS		Vacuum Pump	1.25
Centrifugal	1.0	EXCITER, GENERATOR	1.0	METAL FORMING MACHINES		SCREENS	
Rotary, Lobe or Vane	1.25	EXTRUDER, PLASTIC	1.5	Continuous Caster	1.75	Air Washing	1.0
Rotary, Screw	1.0	FANS		Draw Bench Carriage and Main Drive	2.0	Grizzly	2.0
Reciprocating Direct Connected	•	Centrifugal	1.0	Extruder	2.0	Rotary Coal or Sand	1.5
Without Flywheel	•	Cooling Tower	2.0	Farming Machine and Forming Mills	2.0	Vibrating	2.5
With Flywheel and Gear between Compressor and Prime Mover		Forced Draft — Across the Line start	1.5	Slitters	1.0	Water	1.0
1 cylinder, single acting	3.0	Forced Draft Motor driven thru fluid or electric slip clutch	1.0	Wire Drawing or Flattening	1.75	SKI TOWS AND LIFTS	∅
2 cylinders, single acting	3.0	Gas Recirculating	1.5	Wire Winder	1.5	STEERING GEAR	1.0
3 cylinders, single acting	3.0	Induced Draft with damper control or blade cleaner	1.25	Coilers and Uncoilers	1.5	STOKER	1.0
3 cylinders, double acting	2.0	Induced Draft without controls	2.0	MIXERS (see Agitators)		TIRE SHREDDER	1.50
4 or more cyl., single act	1.75	FEEDERS		Concrete	1.75	TUMBLING BARREL	1.75
4 or more cyl., double act	1.75	Apron, Belt, Disc, Screw	1.0	Muller	1.5	WINCH, MANEUVERING	
CONVEYORS		Reciprocating	2.5	PRESS, PRINTING	1.5	Dredge, Marine	1.5
Apron, Assembly, Belt, Chain, Flight, Screw	1.0	GENERATORS		PUG MILL	1.75	WINDLASS	1.5
Bucket	1.25	Even Load	1.0	PULVERIZERS		WOODWORKING MACHINERY	1.0
		Hoist or Railway Service	1.5	Hammermill and Hog	1.75	WORK LIFT PLATFORMS	∅
				Roller	1.5		
				PUMPS			
				Boiler Feed	1.5		

Industry	Service Factor	Industry	Service Factor	Industry	Service Factor	Industry	Service Factor
AGGREGATE, CEMENT, MINING		Rolls, Non-Reversing	1.25	Shear, Croppers	•	Constant Speed	1.0
KILNS; TUBE, ROD AND BALL MILLS		Rolls, Reversing	2.0	Sideguards	3.0	Frequent Speed Changes Under Load	1.25
Direct or on L.S. shaft of Reducer, with final drive Machined Spur Gears	2.0	Sawdust Conveyor	1.25	Skelp Mills	•	Suction Roll	1.75
Single Helical or Herringbone Gears	1.75	Slab Conveyor	1.75	Slitters, Steel Mill only	1.75	Vacuum Pumps	1.25
Conveyors, Feeders, Screens, Elevators		Sorting Table	1.5	Soaking Pit Cover Drives —		RU BBER INDUSTRY	
Crushers, Ore or Stone	2.5	Trimmer	1.75	Lift	1.0	Calender	2.0
Dryer, Rotary	1.75	METAL ROLLING MILLS		Travel	2.0	Cracker, Plasticator	2.5
Grizzly	2.0	Coilers (Up or Down) Cold Mills only	1.5	Straighteners	2.0	Extruder	1.75
Hammermill or Hog	1.75	Coilers (Up or Down) Hot Mills only	2.0	Unscramblers (Billet Bundle Busters)	2.0	Intensive or Banbury Mixer	2.5
Tumbling Mill or Barrel	1.75	Coke Plants		Wire Drawing Machinery	1.75	Mixing Mill, Refiner or Sheeter	
BREWING AND DISTILLING		Pusher Ram Drive	2.5	OIL INDUSTRY		One or two in line	2.0
Bottle and Can Filling Machines	1.0	Door Opener	2.0	Chiller	1.25	Three or four in line	2.5
Brew Kettle	1.0	Pusher or Larry Car Traction Drive	3.0	Oilwell Pumping	2.0	Five or more in line	1.75
Cookers, Continuous Duty	1.25	Continuous Caster	1.75	(not over 150% peak torque)		Tire Building Machine	2.5
Lauter Tub	1.5	Cold Mills — Strip Mills	•	Paraffin Filter Press	1.5	Tire and Tube Press Opener (Peak Torque)	1.0
Mash Tub	1.25	Temper Mills	•	Rotary Kiln	2.0	Tuber, Strainer, Pelletizer	1.75
Scale Hopper, Frequent Peaks	1.75	Cooling Beds	1.5	PAPER MILLS		Warming Mill	
CLAY WORKING INDUSTRY		Drawbench	2.0	Barker Auxiliary, Hydraulic	2.0	One or two Mills in line	2.0
Brick Press, Briquette Machine, Clay Working		Feed Rolls - Blooming Mills	3.0	Barker, Mechanical	2.0	Three or more Mills in line	1.75
Machine, Pug Mill	1.75	Furnace Pushers	2.0	Barking Drum		Washer	2.5
DREDGES		Hot and Cold Saws	2.0	L.S. shaft of reducer with final drive - Helical		SEWAGE DISPOSAL EQUIPMENT	
Cable Reel	1.75	Hot Mills —		or Herringbone Gear	2.0	Bar Screen, Chemical Feeders, Collectors, Dewatering Screen, Grit Collector	1.0
Conveyors	1.25	Strip or Sheet Mills	•	Machined Spur Gear	2.5	SUGAR INDUSTRY	
Cutter head, Jig Drive	2.0	Reversing Blooming	•	Cast Tooth Spur Gear	3.0	Cane Carrier and Leveler	1.75
Maneuvering Winch	1.5	Slabbing Mills	•	Beater and Pulper	1.75	Cane Knife and Crusher	2.0
Pumps (uniform load)	1.5	Edger Drives	•	Bleachers, Coaters	1.0	Mill Stands, Turbine Driver with all Helical or Herringbone gears	1.5
Screen Drive, Stacker	1.75	Ingot Cars	2.0	Calender and Super Calender	1.75	Electric Drive or Steam Engine Drive with Helical, Herringbone, or Spur Gears with any Prime Mover	1.75
Utility Winch	1.5	Manipulators	3.0	Chipper	2.5	TEXTILE INDUSTRY	
FOOD INDUSTRY		Merchant Mills	•	Converting Machine	1.25	Batcher	1.25
Beet Slicer	1.75	Mill Tables		Couch	1.75	Calender, Card Machine	1.5
Bottling, Can Filling Machine	1.0	Roughing Breakdown Mills	3.0	Cutter, Felt Whipper	2.0	Cloth Finishing Machine	1.5
Cereal Cooker	1.25	Hot Bed or Transfer, non-reversing	1.5	Cylinder	1.75	Dry Can, Loom	1.5
Dough Mixer, Meat Grinder	1.75	Runout, reversing	3.0	Dryer	1.75	Dyeing Machinery	1.25
LUMBER		Runout, non-reversing, non-plugging	2.0	Felt Stretcher	1.25	Knitting Machine	•
Band Resaw	1.5	Reel Drives	1.75	Fourdrinier	1.75	Mangle, Napper, Soaper	1.25
Circular Resaw, Cut-off	1.75	Rod Mills	•	Jordan	2.0	Spinner, Tenter Frame, Winder	1.5
Edger, Head Rig, Hog	2.0	Screwdown	2.0	Log Haul	2.0		
Gang Saw (Reciprocating)	•	Seamless Tube Mills		Line Shaft	1.5		
Log Haul	2.0	Piercer	3.0	Press	1.75		
Planer	1.75	Thrust Block	2.0	Pulp Grinder	1.75		
		Tube Conveyor Rolls	2.0	Reel, Rewinder, Winder	1.5		
		Reeler	2.0	Stock Chest, Washer, Thickener	1.5		
		Kick Out	2.0	Stock Pumps, Centrifugal	1.5		

Table 7 – Engine Drive Service Factors

Service Factors (S. F.) for engine drives are those required for applications where good flywheel regulation prevents torque fluctuations greater than ±20%. For drives where torque fluctuations are greater or where the operation is near a serious critical or torsional vibration, a mass elastic study is necessary.

No. of Cylinders	4 or 5					6 or more				
	Table 6 S.F.	1.0	1.25	1.5	1.75	2.0	1.0	1.25	1.5	1.75
Engine S.F.	2.0	2.25	2.5	2.75	3.0	1.5	1.75	2.0	2.25	2.5

To use Table 7, first determine application service factor from Table 6. Use that factor to determine Engine Service Factor from Table 7. When service factor from Table 6 is greater than 2.0, or where 1, 2 or 3 cylinder engines are involved, refer complete application details to Martin Engineering.

• Refer to Factory

∅ Not Approved

See Application Listing

• For engine drives, refer to Table 7. Electric motors, generators, engines, compressors and other machines fitted with sleeves or straight roller bearings usually require limited end float couplings. If in doubt, provide axial clearances and centering forces to the Factory for a recommendation.

How to Order

To ensure your exact specifications are met the following information is required for a quote or order.

Step 1. Application: Driver and Driven

Step 2. Power: Normal hp, Maximum hp or Torque (lb-in)

Step 3. Speed (RPM)

Step 4. Quantity

Step 5 Coupling Size and Type

Step 6. Shaft Gap or distance between shaft ends (BE Dimension)

Step 7. Bore Sizes: Must specify clearance or interference fit, or fit will be furnished per Table 14, page C-56. Bore sizes will be furnished as per Table 16 on page C-57 or Table 17 on pages C-58 and C-59 unless specified differently

Step 8. Shaft Dimensions as follows:







For Straight Shafts:

Driving Shaft		Driven Shaft	
Diameter	_____	Diameter	_____
Tolerance	_____	Tolerance	_____
Length	_____	Length	_____
Keyway	_____	Keyway	_____

NOTE: Provide shaft tolerances if different than those shown in Table 15 through Table 17, pages C-56 to C-58. Unless otherwise specified, keyway sizes in inch shafts will be furnished based on key sizes listed in Table 14, page C-56, to Martin tolerances; metric keyways will be furnished for keys listed in Table 14, page C-56 per ISO/R773-1969 (ANSI/AGMA 9112) and JS9 width tolerances. For other shaft/bore requirements, consult Martin.

Service Factors

Are a guide, based on experience, of the ratio between coupling catalog rating and system characteristics. The system characteristics are best measured with a torque meter.

Torque Demands Driven Machine	Typical applications for electric motor or turbine driven equipment	Typical Service Factor
	Constant torque such as Centrifugal Pumps, Blowers and Compressors.	1.0
	Continuous duty with some torque variations including Plastic Extruders, Forced Draft Fans.	1.5
	Light shock loads from Metal Extruders, Cooling Towers, Cane Knife, Log Haul.	2.0
	Moderate shock loading as expected from a Car Dumper, Stone Crusher, Vibrating Screen.	2.5
	Heavy shock load with some negative torques from Roughing Mills, Reciprocating Pumps, Compressors, Reversing Runout Tables.	3.0
	Applications like Reciprocating Compressors with frequent torque reversals, which do not necessarily cause reverse rotations.	Refer to Factory

Stock T10 Cover Design

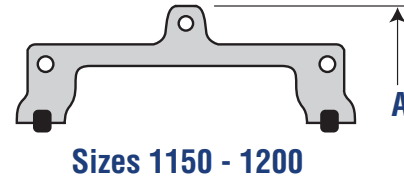
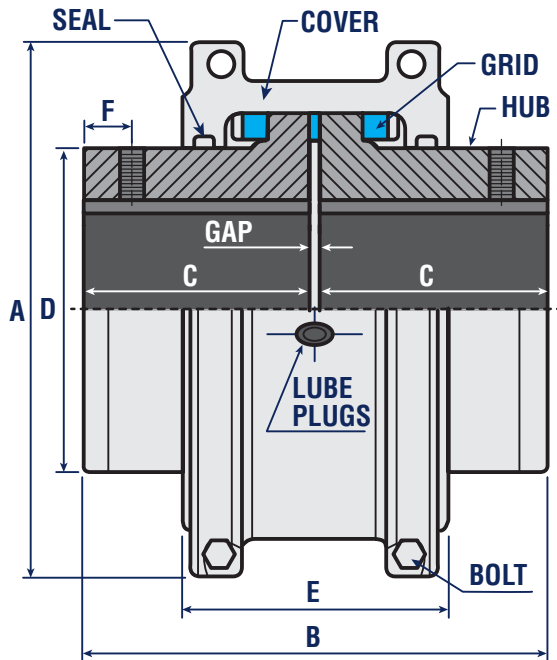

Martin Blue-Flex® Grid Coupling – T10 Style

Coupling Size	HP per 100 RPM	Max Speed (RPM)	Basic Torque (lb-in)	Bore Dia.		Dimensions (in)						Gap (in) Normal	Complete Weight (lb)	Lub. Wt. (lb)
				Max.	Min.	A	B	C	D	E	F			
1020T10	0.68	4,500	460	1.12	0.50	4.00	3.86	1.87	1.56	2.62	0.31	0.12	4.2	0.1
1030T10	1.93	4,500	1,320	1.37	0.50	4.37	3.86	1.87	1.94	2.69	0.31	0.12	5.7	0.1
1040T10	3.22	4,500	2,200	1.62	0.50	4.63	4.12	2.00	2.25	2.76	0.31	0.12	7.5	0.1
1050T10	5.63	4,500	3,850	1.87	0.50	5.43	4.87	2.37	2.63	3.13	0.31	0.12	11.9	0.1
1060T10	8.85	4,350	6,050	2.12	0.75	5.93	5.12	2.50	3.00	3.62	0.31	0.12	16.1	0.2
1070T10	13	4,125	8,800	2.50	0.75	6.37	6.12	3.00	3.44	3.74	0.50	0.12	22.0	0.2
1080T10	27	3,600	18,150	3.00	1.06	7.64	7.12	3.50	4.13	4.57	0.50	0.12	39.7	0.4
1090T10	48	3,600	33,000	3.50	1.06	8.39	7.87	3.87	4.87	4.80	0.63	0.12	55.1	0.6
1100T10	81	2,400	55,550	4.00	1.63	9.84	9.67	4.75	5.59	6.12	0.63	0.18	92.6	0.9
1110T10	121	2,250	82,500	4.50	1.63	10.63	10.18	5.00	6.31	6.36	0.75	0.18	119.0	1.1
1120T10	177	2,025	121,000	5.00	2.37	12.13	11.98	5.87	7.06	7.54	0.75	0.25	178.6	1.6
1130T10	257	1,800	176,000	6.00	2.63	13.62	12.98	6.37	8.56	7.68	1.19	0.25	266.8	2.0
1140T10	370	1,650	253,000	7.25	2.63	15.12	14.63	7.20	10.00	7.91	1.19	0.25	392.4	2.5
1150T10	515	1,500	352,000	8.00	4.25	17.84	14.64	7.20	10.60	10.68	1.19	0.25	515.9	4.3
1160T10	724	1,350	495,000	9.00	4.75	19.74	15.83	7.80	12.00	10.98	1.19	0.25	698.9	6.2
1170T10	965	1,225	660,000	10.00	5.25	22.30	17.24	8.50	14.00	11.98	1.19	0.25	987.7	7.7
1180T10	1338	1,100	915,000	11.00	6.00	24.80	19.05	9.40	15.50	12.64	1.50	0.25	1364.7	8.3
1190T10	1770	1,050	1,210,000	12.00	6.00	26.60	20.64	10.20	17.20	12.80	1.50	0.25	1710.8	9.7
1200T10	2413	900	1,650,000	13.00	7.00	29.80	22.24	11.00	19.60	14.00	1.50	0.25	2330.3	12.4

Consult Martin for higher speeds.

Max. bores listed fit standard recommended keys per ANSI B17.1

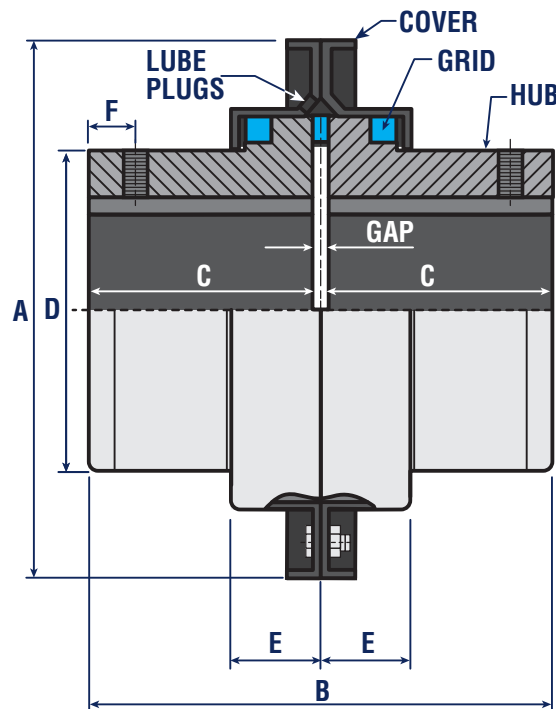

Martin Blue-Flex® Grid Coupling – T20 Style

Coupling Size	HP per 100 RPM	Max Speed (RPM)	Basic Torque (lb-in)	Bore Dia.		Dimensions (in)						Gap (in) Normal	Complete Weight (lb)	Lub. Wt. (lb)
				Max.	Min.	A	B	C	D	E	F			
1020T20	0.68	6000	460	1.12	0.50	4.37	3.86	1.87	1.56	0.95	0.31	0.12	4.4	0.1
1030T20	1.93	6000	1,320	1.37	0.50	4.75	3.86	1.87	1.94	0.98	0.31	0.12	5.7	0.1
1040T20	3.22	6000	2,200	1.62	0.50	5.06	4.12	2.00	2.25	1.01	0.31	0.12	7.5	0.1
1050T20	5.63	6000	3,850	1.87	0.50	5.81	4.87	2.37	2.63	1.23	0.31	0.12	11.9	0.1
1060T20	8.85	6000	6,050	2.12	0.75	6.40	5.12	2.50	3.00	1.27	0.31	0.12	16.1	0.2
1070T20	13	5500	8,800	2.50	0.75	6.81	6.12	3.00	3.44	1.33	0.50	0.12	22.9	0.2
1080T20	27	4750	18,150	3.00	1.06	7.87	7.12	3.50	4.13	1.74	0.50	0.12	39.0	0.4
1090T20	48	4000	33,000	3.50	1.06	8.42	7.87	3.87	4.87	1.88	0.63	0.12	56.0	0.6
1100T20	81	3250	55,550	4.00	1.63	10.50	9.67	4.75	5.59	2.36	0.63	0.18	93.0	0.9
1110T20	121	3000	82,500	4.50	1.63	11.25	10.18	5.00	6.31	2.53	0.75	0.18	119.9	1.1
1120T20	177	2700	121,000	5.00	2.37	12.56	11.98	5.87	7.06	2.89	0.75	0.25	179.9	1.6
1130T20	257	2400	176,000	6.00	2.63	14.87	12.98	6.37	8.56	2.96	1.19	0.25	270.1	2.0
1140T20	370	2200	253,000	7.25	2.63	16.38	14.63	7.20	10.00	3.08	1.19	0.25	397.1	2.5
1150T20	515	2000	352,000	8.00	4.25	18.75	14.64	7.20	10.60	4.21	1.19	0.25	507.1	4.3
1160T20	724	1750	495,000	9.00	4.75	21.00	15.83	7.80	12.00	4.50	1.19	0.25	707.9	6.2
1170T20	965	1600	660,000	10.00	5.25	23.00	17.24	8.50	14.00	4.70	1.19	0.25	988.1	7.7
1180T20	1,338	1400	915,000	11.00	6.00	24.80	19.04	9.40	15.50	5.12	1.50	0.25	1302.9	8.3
1190T20	1,770	1300	1,210,000	12.00	6.00	26.97	20.64	10.20	17.20	5.31	1.50	0.25	1677.7	9.7
1200T20	2,413	1100	1,650,000	13.00	7.00	29.02	22.24	11.00	19.60	5.71	1.50	0.25	2250.9	12.4

Consult Martin for higher speeds.

Max. bores listed fit standard recommended keys per ANSI B17.1

Stock T31 Spacer Design

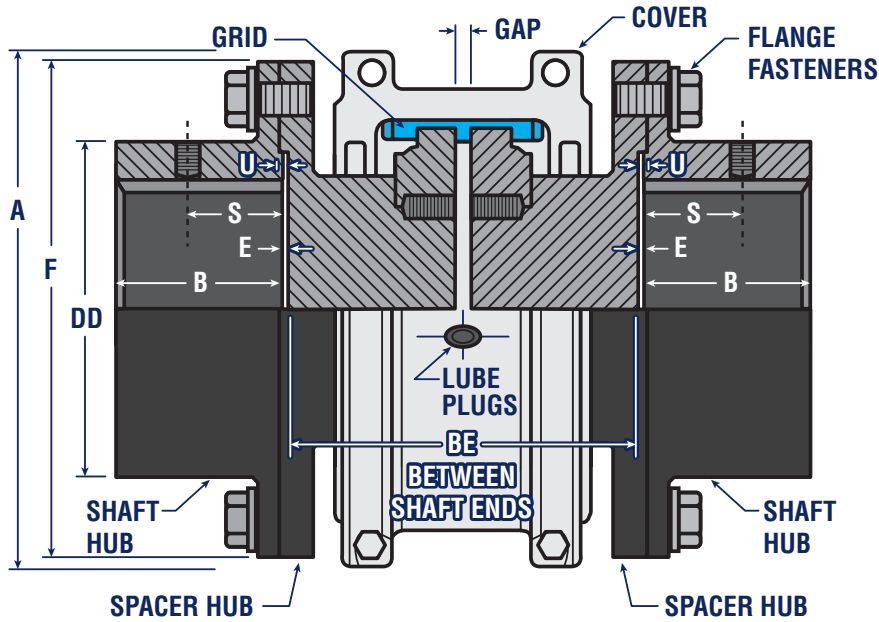

Martin Blue-Flex® Grid Coupling – T31 Style

Coupling Size	Torque Rating (in-lb)*	Allow Speed RPM**	Bore		A	B	BE		E	F	S	U	GAP	Flange Fasteners		Wt Without Bore and Min BE (lb)	Wt Added per inch of BE over Min (lb)	Lube Wt (lb)
			Max	Min ***			Min	Max						No. per Flange and Grade	Dia (in)			
1020T	460	3,600	1.38	0.5	3.82	1.38	3.5	8	0.03	3.38	1.08	0.08	0.19	4, GR 8	0.25	8.5	0.57	0.06
1030T	1,320	3,600	1.63	0.5	4.16	1.62	3.5	8.5	0.03	3.69	1.24	0.08	0.19	8, GR 8	0.25	11.5	0.87	0.09
1040T	2,200	3,600	2.13	0.5	4.5	2.12	3.5	8.5	0.03	4.44	1.08	0.08	0.19	8, GR 8	0.25	18.6	1.17	0.12
1050T	3,850	3,600	2.38	0.5	5.32	2.38	4.37	8.5	0.03	4.94	1.6	0.08	0.19	8, GR 8	0.31	28.2	1.58	0.15
1060T	6,050	3,600	2.88	0.75	5.82	2.88	4.81	13	0.06	5.69	1.7	0.11	0.19	8, GR 8	0.38	45.1	2.06	0.19
1070T	8,800	3,600	3.13	0.75	6.25	3.12	5	13	0.06	6	1.84	0.11	0.19	12, Gr 8	0.38	54.6	2.69	0.25
1080T	18,150	3,600	3.50	1.06	7.5	3.5	6.12	16	0.06	7	1.96	0.11	0.19	12, Gr 8	0.5	88.1	3.86	0.38
1090T	33,000	3,600	4	1.06	8.31	4	6.44	16	0.06	8.25	2.24	0.11	0.19	12, Gr 8	0.63	132	5.37	0.56
1100T	55,550	2,440	4.75	1.5	9.88	3.56	8	16	0.06	9.88	-	0.12	0.25	12, Gr 8	0.75	199	6.95	0.94
1110T	82,500	2,250	5.50	2	10.62	4.1	8.25	16	0.06	10.88	-	0.12	0.25	12, Gr 8	0.75	261	8.98	1.12
1120T	121,000	2,025	6.25	2.5	12.12	4.7	9.69	16	0.06	12.56	-	0.16	0.38	12, Gr 8	0.88	392	11.2	1.62
1130T	176,000	1,800	7	3	13.62	5.3	10.12	16	0.06	13.62	-	0.16	0.38	12, Gr 8	1	522	16.5	2
1140T	253,000	1,650	8	3.5	15.12	6	10.5	16	0.06	15.19	-	0.16	0.38	12, Gr 8	1.13	720	22.4	2.5

* Peak torque capacity is two times the published rating. Torque ratings for hubs with bushings differ from those shown, refer to Table 9, page C48.

** Consult Martin for higher speeds..

*** Minimum bore is the smallest bore to which a Rough Stock Bore (RSB) hub can be bored. Depending upon coupling size, RSB hubs may have only a blind centering hole or a through hole that will permit remachining of the hubs to the minimum bores specified.

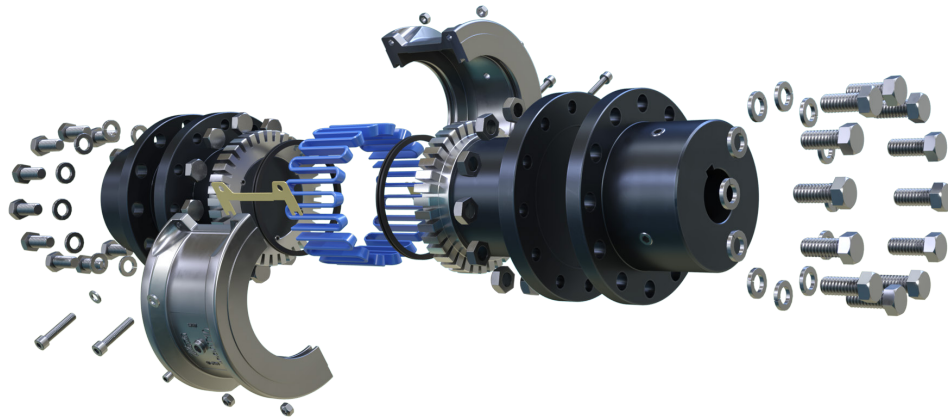

Full Spacer Type T31 Application Shaft Separation – DBSE (Distance Between Shaft Ends)

DBSE	Spacer Hubs	1020T	1030T	1040T	1050T	1060T	1070T	1080T	1090T	1100T	1110T
3.500	Hub 1	1.625	1.625	1.625							
	Hub 2	1.625	1.625	1.625							
3.938	Hub 1	1.625	1.625	1.625							
	Hub 2	2.062	2.062	2.062							
4.250	Hub 1	1.625	1.625	1.625							
	Hub 2	2.375	2.375	2.375							
4.375	Hub 1	2.062	2.062	2.062	2.062						
	Hub 2	2.062	2.062	2.062	2.062						
4.688	Hub 1	2.062	2.062	2.062	2.062						
	Hub 2	2.375	2.375	2.375	2.375						
5.000	Hub 1	2.375	2.375	2.375	2.375	2.344	2.344				
	Hub 2	2.375	2.375	2.375	2.375	2.344	2.344				
5.219	Hub 1			1.625							
	Hub 2			3.344							
5.375	Hub 1		1.625	1.625							
	Hub 2		3.500	3.500							
5.510	Hub 1	2.631	2.631	2.631	2.631	2.600	2.600				
	Hub 2	2.631	2.631	2.631	2.631	2.600	2.600				
5.656	Hub 1		2.062	2.062	2.062						
	Hub 2		3.344	3.344	3.344						
5.813	Hub 1		2.062	2.062	2.062						
	Hub 2		3.500	3.500	3.500						
5.969	Hub 1		2.375	2.375	2.375						
	Hub 2		3.344	3.344	3.344						
6.125	Hub 1		2.375	2.375	2.375	2.344	2.344				
	Hub 2		3.500	3.500	3.500	3.469	3.469				
6.938	Hub 1	3.344	3.344	3.344	3.344	3.312					
	Hub 2	3.344	3.344	3.344	3.344	3.312					
7.000	Hub 1						3.344	3.344			
	Hub 2						3.344	3.344			
7.094	Hub 1			3.344	3.344		3.387	3.387	3.387		
	Hub 2			3.500	3.500		3.387	3.387	3.387		
7.250	Hub 1		3.500	3.500	3.500	3.469	3.469	3.469	3.469		
	Hub 2		3.500	3.500	3.500	3.469	3.469	3.469	3.469		
8.000	Hub 1									3.812	
	Hub 2									3.812	
8.593	Hub 1							3.469			
	Hub 2							4.812			
8.625	Hub 1					2.344	2.344				
	Hub 2					5.696	5.696				
8.875	Hub 1									3.812	
	Hub 2									4.688	
9.750	Hub 1					3.469	3.469	3.469	3.469	4.688	4.688
	Hub 2					5.969	5.969	5.969	5.969	4.688	4.688
9.938	Hub 1							4.812		4.733	4.733
	Hub 2							4.812		4.733	4.733
11.093	Hub 1							4.812			
	Hub 2							5.969			
12.250	Hub 1					5.969	5.969	5.969	5.969	5.938	
	Hub 2					5.969	5.969	5.969	5.969	5.938	
14.049	Hub 1										6.837
	Hub 2										6.837

Stock T35 Spacer Design

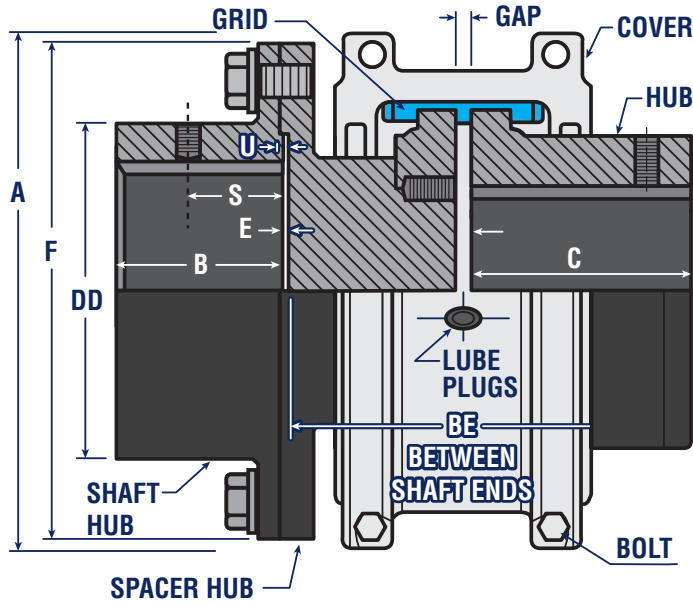

Martin Blue-Flex® Grid Coupling – T35 Style

Coupling Size	Torque Rating (in-lb)*	Allow Speed RPM**	Max Bore		Min Bore ***	A	B	BE		E	F	S	U	GAP	Flange Fasteners		Wt Without Bore and Min BE (lb)	Wt Added per inch of BE over Min (lb)	Lube Wt (lb)
			Shaft Hub	Hub				Min	Max						No. per Flange and Grade	Dia (in)			
1020T	460	3,600	1.38	1.13	0.5	3.82	1.38	1.78	4.03	0.03	3.38	1.08	0.08	0.19	4, GR 8	0.25	8.5	0.57	0.06
1030T	1,320	3,600	1.63	1.38	0.5	4.16	1.62	1.78	4.28	0.03	3.69	1.24	0.08	0.19	8, GR 8	0.25	11.5	0.87	0.09
1040T	2,200	3,600	2.13	1.63	0.5	4.5	2.12	1.78	4.28	0.03	4.44	1.08	0.08	0.19	8, GR 8	0.25	18.6	1.17	0.12
1050T	3,850	3,600	2.38	1.88	0.5	5.32	2.38	2.22	4.28	0.03	4.94	1.6	0.08	0.19	8, GR 8	0.31	28.2	1.58	0.15
1060T	6,050	3,600	2.88	2.13	0.75	5.82	2.88	2.44	6.53	0.06	5.69	1.7	0.11	0.19	8, GR 8	0.38	45.1	2.06	0.19
1070T	8,800	3,600	3.13	2.5	0.75	6.25	3.12	2.53	6.53	0.06	6	1.84	0.11	0.19	12, Gr 8	0.38	54.6	2.69	0.25
1080T	18,150	3,600	3.5	3	1.06	7.5	3.5	3.09	8.03	0.06	7	1.96	0.11	0.19	12, Gr 8	0.5	88.1	3.86	0.38
1090T	33,000	3,600	4	3.5	1.06	8.31	4	3.25	8.03	0.06	8.25	2.24	0.11	0.19	12, Gr 8	0.63	132	5.37	0.56
1100T	55,550	2,440	4.75	4	1.63	9.88	3.56	4.06	8.06	0.06	9.88	-	0.12	0.25	12, Gr 8	0.75	199	6.95	0.94
1110T	82,500	2,250	5.5	4.5	1.63	10.62	4.1	4.19	8.06	0.06	10.88	-	0.12	0.25	12, Gr 8	0.75	261	8.98	1.12
1120T	121,000	2,025	6.25	5	2.38	12.12	4.7	4.91	8.06	0.06	12.56	-	0.16	0.38	12, Gr 8	0.88	392	11.2	1.62
1130T	176,000	1,800	7	6	2.63	13.62	5.3	5.12	8.06	0.06	13.62	-	0.16	0.38	12, Gr 8	1	522	16.5	2
1140T	253,000	1,650	8	7.25	2.63	15.12	6	5.31	8.06	0.06	15.19	-	0.16	0.38	12, Gr 8	1.13	720	22.4	2.5

* Peak torque capacity is two times the published rating. Torque ratings for hubs with bushings differ from those shown, refer to Table 9, page C48.

** Consult Martin for higher speeds..

*** Minimum bore is the smallest bore to which a Rough Stock Bore (RSB) hub can be bored. Depending upon coupling size, RSB hubs may have only a blind centering hole or a through hole that will permit remachining of the hubs to the minimum bores specified.

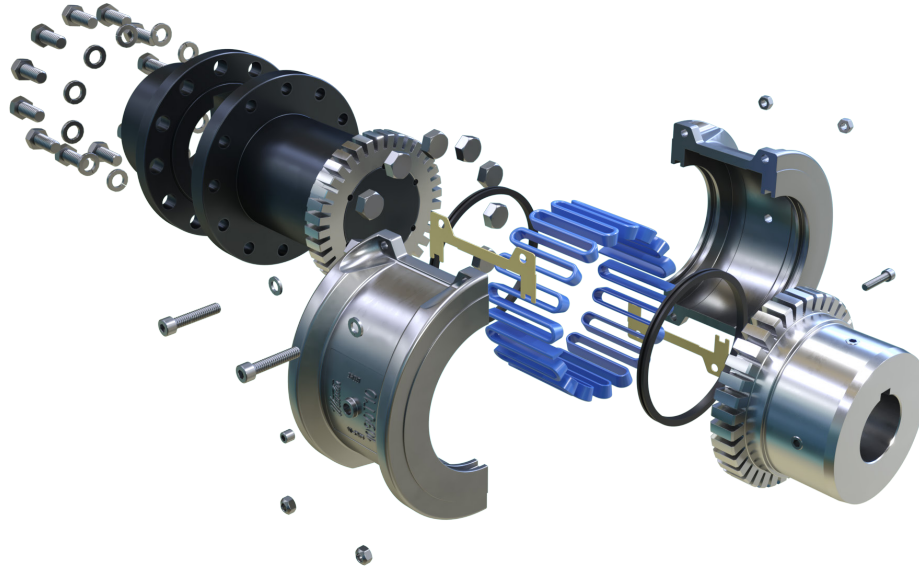

Half Spacer Type T35 Application Shaft Separation – DBSE (Distance Between Shaft Ends)

DBSE	Spacer Hub 1 side only	Half Spacer type T35 Application Shaft Separation DBSE (Distance Between Shaft Ends)									
		1020T	1030T	1040T	1050T	1060T	1070T	1080T	1090T	1100T	1110T
1.781	Hub 1	1.625	1.625	1.625							
	Hub 2	STD	STD	STD							
2.219	Hub 1	2.062	2.062	2.062	2.062						
	Hub 2	STD	STD	STD	STD						
2.531	Hub 1	2.375	2.375	2.375	2.375	2.344	2.344				
	Hub 2	STD	STD	STD	STD	STD	STD				
3.500	Hub 1	3.344	3.344	3.344	3.344	3.312					
	Hub 2	STD	STD	STD	STD	STD					
3.531	Hub 1						3.344	3.344			
	Hub 2						STD	STD			
3.656	Hub 1			3.500	3.500	3.469	3.469	3.469	3.469		
	Hub 2			STD	STD	STD	STD	STD	STD		
4.062	Hub 1									3.812	
	Hub 2									STD	
4.938	Hub 1									4.688	4.688
	Hub 2									STD	STD
5.000	Hub 1							4.812		4.733	4.733
	Hub 2							STD		STD	STD
6.156	Hub 1					5.969	5.969	5.969	5.969		
	Hub 2					STD	STD	STD	STD		
6.188	Hub 1									5.938	
	Hub 2									STD	
7.090	Hub 1										6.837
	Hub 2										STD

Bore-To-Size Hubs



Blue-Flex® Bored-To-Size Hubs with Finished Bore, Keyway, and 2 Set Screw

Bore Size	Keyway (Inches)	Part Number by Coupling Size							
		1020T	1030T	1040T	1050T	1060T	1070T	1080T	1090T
Plain Bore		1020T-HUB	1030T-HUB	1040T-HUB	1050T-HUB	1060T-HUB	1070T-HUB	1080T-HUB	1090T-HUB
Inches									
1/2	1/8 x 1/16	1020T-HUB1/2	—	—	—	—	—	—	—
5/8	3/16 x 3/32	1020T-HUB5/8	1030T-HUB5/8	1040T-HUB5/8	—	—	—	—	—
3/4	3/16 x 3/32	1020T-HUB3/4	1030T-HUB3/4	1040T-HUB3/4	1050T-HUB3/4	1060T-HUB3/4	—	—	—
7/8	3/16 x 3/32	1020T-HUB7/8	1030T-HUB7/8	1040T-HUB7/8	1050T-HUB7/8	1060T-HUB7/8	—	—	—
15/16	1/4 x 1/8	1020T-HUB15/16	1030T-HUB15/16	1040T-HUB15/16	1050T-HUB15/16	1060T-HUB15/16	—	—	—
1	1/4 x 1/8	1020T-HUB1	1030T-HUB1	1040T-HUB1	1050T-HUB1	1060T-HUB1	1070T-HUB1	—	—
1 1/8	1/4 x 1/8	1020T-HUB1 1/8	1030T-HUB1 1/8	1040T-HUB1 1/8	1050T-HUB1 1/8	1060T-HUB1 1/8	1070T-HUB1 1/8	1080T-HUB1 1/8	—
1 3/16	1/4 x 1/8	—	1030T-HUB1 3/16	1040T-HUB1 3/16	1050T-HUB1 3/16	1060T-HUB1 3/16	1070T-HUB1 3/16	—	—
1 1/4	1/4 x 1/8	—	1030T-HUB1 1/4	1040T-HUB1 1/4	1050T-HUB1 1/4	1060T-HUB1 1/4	1070T-HUB1 1/4	1080T-HUB1 1/4	—
1 3/8	5/16 x 5/32	—	1030T-HUB1 3/8	1040T-HUB1 3/8	1050T-HUB1 3/8	1060T-HUB1 3/8	1070T-HUB1 3/8	1080T-HUB1 3/8	1090T-HUB1 3/8
1 7/16	3/8 x 3/16	—	—	1040T-HUB1 7/16	1050T-HUB1 7/16	1060T-HUB1 7/16	1070T-HUB1 7/16	1080T-HUB1 7/16	1090T-HUB1 7/16
1 1/2	3/8 x 3/16	—	—	1040T-HUB1 1/2	1050T-HUB1 1/2	1060T-HUB1 1/2	1070T-HUB1 1/2	1080T-HUB1 1/2	1090T-HUB1 1/2
1 9/16	3/8 x 3/16	—	—	1040T-HUB1 9/16	1050T-HUB1 9/16	1060T-HUB1 9/16	1070T-HUB1 9/16	1080T-HUB1 9/16	—
1 5/8	3/8 x 3/16	—	—	1040T-HUB1 5/8	1050T-HUB1 5/8	1060T-HUB1 5/8	1070T-HUB1 5/8	1080T-HUB1 5/8	1090T-HUB1 5/8
1 11/16	3/8 x 3/16	—	—	—	1050T-HUB1 11/16	1060T-HUB1 11/16	1070T-HUB1 11/16	1080T-HUB1 11/16	1090T-HUB1 11/16
1 3/4	3/8 x 3/16	—	—	—	1050T-HUB1 3/4	1060T-HUB1 3/4	1070T-HUB1 3/4	1080T-HUB1 3/4	1090T-HUB1 3/4
1 13/16	1/2 x 1/4	—	—	—	1050T-HUB1 13/16	1060T-HUB1 13/16	1070T-HUB1 13/16	1080T-HUB1 13/16	1090T-HUB1 13/16
1 7/8	1/2 x 1/4	—	—	—	1050T-HUB1 7/8	1060T-HUB1 7/8	1070T-HUB1 7/8	1080T-HUB1 7/8	1090T-HUB1 7/8
1 15/16	1/2 x 1/4	—	—	—	—	1060T-HUB1 15/16	1070T-HUB1 15/16	1080T-HUB1 15/16	1090T-HUB1 15/16
2	1/2 x 1/4	—	—	—	—	1060T-HUB2	1070T-HUB2	1080T-HUB2	1090T-HUB2
2 1/8	1/2 x 1/4	—	—	—	—	1060T-HUB2 1/8	1070T-HUB2 1/8	1080T-HUB2 1/8	1090T-HUB2 1/8
2 3/16	1/2 x 1/4	—	—	—	—	—	1070T-HUB2 3/16	1080T-HUB2 3/16	1090T-HUB2 3/16
2 1/4	1/2 x 1/4	—	—	—	—	—	1070T-HUB2 1/4	1080T-HUB2 1/4	1090T-HUB2 1/4
2 3/8	5/8 x 5/16	—	—	—	—	—	1070T-HUB2 3/8	1080T-HUB2 3/8	1090T-HUB2 3/8
2 7/16	5/8 x 5/16	—	—	—	—	—	1070T-HUB2 7/16	1080T-HUB2 7/16	1090T-HUB2 7/16
2 1/2	5/8 x 5/16	—	—	—	—	—	1070T-HUB2 1/2	1080T-HUB2 1/2	1090T-HUB2 1/2
2 5/8	5/8 x 5/16	—	—	—	—	—	—	1080T-HUB2 5/8	1090T-HUB2 5/8
2 11/16	5/8 x 5/16	—	—	—	—	—	—	1080T-HUB2 11/16	1090T-HUB2 11/16
2 3/4	5/8 x 5/16	—	—	—	—	—	—	1080T-HUB2 3/4	1090T-HUB2 3/4
2 7/8	3/4 x 3/8	—	—	—	—	—	—	1080T-HUB2 7/8	1090T-HUB2 7/8
2 15/16	3/4 x 3/8	—	—	—	—	—	—	1080T-HUB2 15/16	1090T-HUB2 15/16
3	3/4 x 3/8	—	—	—	—	—	—	1080T-HUB3	1090T-HUB3
3 1/8	3/4 x 3/8	—	—	—	—	—	—	—	1090T-HUB3 1/8
3 1/4	3/4 x 3/8	—	—	—	—	—	—	—	1090T-HUB3 1/4
3 3/8	7/8 x 7/16	—	—	—	—	—	—	—	1090T-HUB3 3/8
3 7/16	7/8 x 7/16	—	—	—	—	—	—	—	1090T-HUB3 7/16
3 1/2	7/8 x 7/16	—	—	—	—	—	—	—	1090T-HUB3 1/2
Taper Bushed		—	1030T-HUB1108	1040T-HUB1108	1050T-HUB1215	1060T-HUB1615	1070T-HUB2012	1080T-HUB2525	1090T-HUB3030
Metric									
14	5 x 2.3	1020T-HUB14MM	—	—	—	—	—	—	—
15	5 x 2.3	1020T-HUB15MM	—	—	—	—	—	—	—
16	5 x 2.3	1020T-HUB16MM	—	—	—	—	—	—	—
19	6 x 2.8	1020T-HUB19MM	1030T-HUB19MM	—	—	—	—	—	—
20	6 x 2.8	1020T-HUB20MM	1030T-HUB20MM	—	—	—	—	—	—
22	6 x 2.8	1020T-HUB22MM	1030T-HUB22MM	—	—	—	—	—	—
24	8 x 3.3	1020T-HUB24MM	1030T-HUB24MM	1040T-HUB24MM	—	—	—	—	—
25	8 x 3.3	1020T-HUB25MM	1030T-HUB25MM	1040T-HUB25MM	—	—	—	—	—
28	8 x 3.3	—	1030T-HUB28MM	1040T-HUB28MM	1050T-HUB28MM	—	—	—	—
30	8 x 3.3	—	1030T-HUB30MM	1040T-HUB30MM	1050T-HUB30MM	—	—	—	—
32	10 x 3.3	—	1030T-HUB32MM	1040T-HUB32MM	1050T-HUB32MM	1060T-HUB32MM	—	—	—
35	10 x 3.3	—	1030T-HUB35MM	1040T-HUB35MM	1050T-HUB35MM	1060T-HUB35MM	1070T-HUB35MM	—	—
38	10 x 3.3	—	—	1040T-HUB38MM	1050T-HUB38MM	1060T-HUB38MM	1070T-HUB38MM	1080T-HUB38MM	—
40	12 x 3.3	—	—	—	—	1060T-HUB40MM	1070T-HUB40MM	—	—
42	12 x 3.3	—	—	1040T-HUB42MM	1050T-HUB42MM	1060T-HUB42MM	1070T-HUB42MM	1080T-HUB42MM	1090T-HUB42MM
45	14 x 3.8	—	—	—	—	1060T-HUB45MM	1070T-HUB45MM	—	—
48	14 x 3.8	—	—	—	1050T-HUB48MM	1060T-HUB48MM	1070T-HUB48MM	1080T-HUB48MM	1090T-HUB48MM
50	14 x 3.8	—	—	—	—	1060T-HUB50MM	—	—	—
55	16 x 4.3	—	—	—	—	1060T-HUB55MM	1070T-HUB55MM	1080T-HUB55MM	1090T-HUB55MM
60	18 x 4.4	—	—	—	—	—	—	1080T-HUB60MM	—
65	18 x 4.4	—	—	—	—	—	—	—	1090T-HUB65MM
70	20 x 4.9	—	—	—	—	—	—	1080T-HUB70MM	1090T-HUB70MM
80	22 x 5.4	—	—	—	—	—	—	1080T-HUB80MM	1090T-HUB80MM
85	22 x 5.4	—	—	—	—	—	—	—	1090T-HUB85MM



Spacer and Shaft Hubs



Spacer Hubs

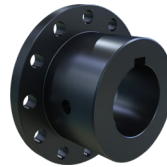

Shaft Hubs
Plain Bore and Finished Bore with Keyway,
and 2 Set Screws Taper Bushed Available

Spacer Length	Part Number by Coupling Size									
	1020T	1030T	1040T	1050T	1060T	1070T	1080T	1090T	1100T	1110T
1.625	1020T-CL1.6250	1030T-CL1.6250	1040T-CL1.6250							
2.0620	1020T-CL2.0620	1030T-CL2.0620	1040T-CL2.0620	1050T-CL2.0620						
2.3440										
2.3750	1020T-CL2.3750	1030T-CL2.3750	1040T-CL2.3750	1050T-CL2.3750						
2.6000										
2.6310	1020T-CL2.6310	1030T-CL2.6310	1040T-CL2.6310	1050T-CL2.6310						
3.3120										
3.3440	1020T-CL3.3440	1030T-CL3.3440	1040T-CL3.3440	1050T-CL3.3440						
3.3870										
3.4690										
3.5000		1030T-CL3.5000	1040T-CL3.5000	1050T-CL3.5000						
3.8120										
4.6880										1100T-CL3.8120
4.7330										1100T-CL4.6880
4.8120										1100T-CL4.7330
4.8120								1080T-CL4.8120		
5.2620										1100T-CL5.2620
5.3250								1080T-CL5.3250	1090T-CL5.3250	
5.9375										1100T-CL5.9375
5.9690								1080T-CL5.9690	1090T-CL5.9690	
6.8370										1110T-CL6.8370
6.9000									1090T-CL6.9000	

Blue-Flex® Shaft Hubs with Plain Bore and Finished Bore (with Keyway, and 2 Set Screws)

Bore Size	Keyway (Inches)	Part Number by Coupling Size									
		1020T	1030T	1040T	1050T	1060T	1070T	1080T	1090T	1100T	1110T
Plain Bore		1020T-SH	1030T-SH	1040T-SH	1050T-SH	1060T-SH	1070T-SH	1080T-SH	1090T-SH	1100T-SH	1110T-SH
1/2	1/8 x 1/16	1020T-SH1/2									
5/8	3/16 x 3/32	1020T-SH5/8	1030T-SH5/8								
3/4	3/16 x 3/32	1020T-SH3/4	1030T-SH3/4	1040T-SH3/4							
7/8	3/16 x 3/32	1020T-SH7/8	1030T-SH7/8	1040T-SH7/8							
1	1/4 x 1/8	1020T-SH1	1030T-SH1	1040T-SH1	1050T-SH1						
1 1/8	1/4 x 1/8	1020T-SH1 1/8	1030T-SH1 1/8	1040T-SH1 1/8	1050T-SH1 1/8	1060T-SH1 1/8					
1 1/4	1/4 x 1/8	1020T-SH1 1/4	1030T-SH1 1/4	1040T-SH1 1/4	1050T-SH1 1/4	1060T-SH1 1/4					
1 3/8	5/16 x 5/32	1020T-SH1 3/8	1030T-SH1 3/8	1040T-SH1 3/8	1050T-SH1 3/8	1060T-SH1 3/8	1070T-SH1 3/8				
1 1/2	3/8 x 3/16		1030T-SH1 1/2	1040T-SH1 1/2	1050T-SH1 1/2	1060T-SH1 1/2	1070T-SH1 1/2				
1 5/8	3/8 x 3/16		1030T-SH1 5/8	1040T-SH1 5/8	1050T-SH1 5/8	1060T-SH1 5/8	1070T-SH1 5/8	1080T-SH1 5/8		1100T-SH1 5/8	
1 3/4	3/8 x 3/16			1040T-SH1 3/4	1050T-SH1 3/4	1060T-SH1 3/4	1070T-SH1 3/4	1080T-SH1 3/4			
1 7/8	1/2 x 1/4			1040T-SH1 7/8	1050T-SH1 7/8	1060T-SH1 7/8	1070T-SH1 7/8	1080T-SH1 7/8	1090T-SH1 7/8		
2	1/2 x 1/4			1040T-SH2	1050T-SH2	1060T-SH2	1070T-SH2	1080T-SH2	1090T-SH2		
2 1/8	1/2 x 1/4			1040T-SH2 1/8	1050T-SH2 1/8	1060T-SH2 1/8	1070T-SH2 1/8	1080T-SH2 1/8	1090T-SH2 1/8		
2 1/4	1/2 x 1/4				1050T-SH2 1/4	1060T-SH2 1/4	1070T-SH2 1/4	1080T-SH2 1/4	1090T-SH2 1/4		
2 3/8	5/8 x 5/16				1050T-SH2 3/8	1060T-SH2 3/8	1070T-SH2 3/8	1080T-SH2 3/8	1090T-SH2 3/8		
2 1/2	5/8 x 5/16					1060T-SH2 1/2	1070T-SH2 1/2	1080T-SH2 1/2	1090T-SH2 1/2		
2 5/8	5/8 x 5/16					1060T-SH2 5/8	1070T-SH2 5/8	1080T-SH2 5/8	1090T-SH2 5/8		
2 7/8	3/4 x 3/8					1060T-SH2 7/8	1070T-SH2 7/8	1080T-SH2 7/8	1090T-SH2 7/8		
3	3/4 x 3/8						1070T-SH3	1080T-SH3	1090T-SH3	1100T-SH3	1110T-SH3
3 1/8	3/4 x 3/8							1080T-SH3 1/8	1090T-SH3 1/8		
3 1/4	3/4 x 3/8							1080T-SH3 1/4	1090T-SH3 1/4		
3 3/8	7/8 x 7/16							1080T-SH3 3/8	1090T-SH3 3/8	1100T-SH3 3/8	
3 1/2	7/8 x 7/16								1090T-SH3 1/2		
3 5/8	7/8 x 7/16								1090T-SH3 5/8		
3 7/8	1 x 1/2								1090T-SH3 7/8		
4	1 x 1/2								1090T-SH4	1100T-SH4	

Components



Plain Bore Hubs
1-Day Rebore Available



Bored-To-Size Hubs
Finished Bore, Keyway,
and 2 Set Screws
Taper Bushed Available

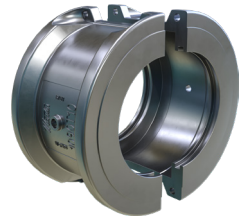

T10 Cover



T20 Cover



Fastener Sets

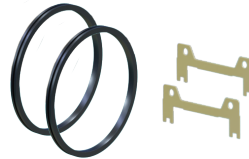

Seal and Gasket Kits



Blue-Flex® Grid

Coupling Size	Part Number
1020T	1020T-GRID
1030T	1030T-GRID
1040T	1040T-GRID
1050T	1050T-GRID
1060T	1060T-GRID
1070T	1070T-GRID
1080T	1080T-GRID
1090T	1090T-GRID
1100T	1100T-GRID
1110T	1110T-GRID
1120T	1120T-GRID
1130T	1130T-GRID
1140T	1140T-GRID
1150T	1150T-GRID
1160T	1160T-GRID
1170T	1170T-GRID
1180T	1180T-GRID
1190T	1190T-GRID
1200T	1200T-GRID

Blue-Flex® Parts and Kits

Coupling Size	T10 Cover Horizontal Split				T20 Cover Vertical Split for Higher RPM			
	Cover (Cover, Seals, Gaskets and Fasteners)	Cover Fastener Set	Seal Kit (Seal and Gasket)	Cover Grid Assemblies (Cover, Grid, Seals, Gaskets and Fasteners) *Includes Grease	Cover (Cover, Seals, Gaskets and Fasteners)	Cover Fastener Set	Seal Kit (Seal and Gasket)	Cover Grid Assemblies (Cover, Grid, Seals, Gaskets and Fasteners) *Includes Grease
1020T	1020T10-COV	1020T10-FAS	1020T10-SEAL	1020T10-SUBASY*	1020T20-COV	1020T20-FAS	1020T20-SEAL	1020T20-SUBASY*
1030T	1030T10-COV	1030T10-FAS	1030T10-SEAL	1030T10-SUBASY*	1030T20-COV	1030T20-FAS	1030T20-SEAL	1030T20-SUBASY*
1040T	1040T10-COV	1040T10-FAS	1040T10-SEAL	1040T10-SUBASY*	1040T20-COV	1040T20-FAS	1040T20-SEAL	1040T20-SUBASY*
1050T	1050T10-COV	1050T10-FAS	1050T10-SEAL	1050T10-SUBASY*	1050T20-COV	1050T20-FAS	1050T20-SEAL	1050T20-SUBASY*
1060T	1060T10-COV	1060T10-FAS	1060T10-SEAL	1060T10-SUBASY*	1060T20-COV	1060T20-FAS	1060T20-SEAL	1060T20-SUBASY*
1070T	1070T10-COV	1070T10-FAS	1070T10-SEAL	1070T10-SUBASY*	1070T20-COV	1070T20-FAS	1070T20-SEAL	1070T20-SUBASY*
1080T	1080T10-COV	1080T10-FAS	1080T10-SEAL	1080T10-SUBASY*	1080T20-COV	1080T20-FAS	1080T20-SEAL	1080T20-SUBASY*
1090T	1090T10-COV	1090T10-FAS	1090T10-SEAL	1090T10-SUBASY*	1090T20-COV	1090T20-FAS	1090T20-SEAL	1090T20-SUBASY*
1100T	1100T10-COV	1100T10-FAS	1100T10-SEAL	1100T10-SUBASY	1100T20-COV	1100T20-FAS	1100T20-SEAL	1100T20-SUBASY
1110T	1110T10-COV	1110T10-FAS	1110T10-SEAL	1110T10-SUBASY	1110T20-COV	1120T20-FAS	1110T20-SEAL	1110T20-SUBASY
1120T	1120T10-COV	1120T10-FAS	1120T10-SEAL	1120T10-SUBASY	1120T20-COV	1120T20-FAS	1120T20-SEAL	1120T20-SUBASY
1130T	1130T10-COV	1130T10-FAS	1130T10-SEAL	1130T10-SUBASY	1130T20-COV	1130T20-FAS	1130T20-SEAL	1130T20-SUBASY
1140T	1140T10-COV	1140T10-FAS	1140T10-SEAL	1140T10-SUBASY	1140T20-COV	1140T20-FAS	1140T20-SEAL	1140T20-SUBASY
1150T	1150T10-COV	1150T10-FAS	1150T10-SEAL	1150T10-SUBASY	1150T20-COV	1150T20-FAS	1150T20-SEAL	1150T20-SUBASY
1160T	1160T10-COV	1160T10-FAS	1160T10-SEAL	1160T10-SUBASY	1160T20-COV	1160T20-FAS	1160T20-SEAL	1160T20-SUBASY
1170T	1170T10-COV	1170T10-FAS	1170T10-SEAL	1170T10-SUBASY	1170T20-COV	1170T20-FAS	1170T20-SEAL	1170T20-SUBASY
1180T	1180T10-COV	1180T10-FAS	1180T10-SEAL	1180T10-SUBASY	1180T20-COV	1180T20-FAS	1180T20-SEAL	1180T20-SUBASY
1190T	1190T10-COV	1190T10-FAS	1190T10-SEAL	1190T10-SUBASY	1190T20-COV	1190T20-FAS	1190T20-SEAL	1190T20-SUBASY
1200T	1200T10-COV	1200T10-FAS	1200T10-SEAL	1200T10-SUBASY	1200T20-COV	1200T20-FAS	1200T20-SEAL	1200T20-SUBASY

Note: All Covers include Seal Kits

Table 8 – Type T Hub Bore Ranges with Square and Rectangular Keys

Size	Inches																Millimeters			
	Min Bore	For One Square Key				For One Rectangular Key						For Two Square Keys			For Two Rectangular Keys			Min Bore	Max Bore	
		Max Bore	Y=X		Max Bore	Y=X		Max Bore	Y=W/2		Max Bore	Y=X		Max Bore	Y=X		Std Bore Fits per Table 16		Int Fit per Table 16 w/Setscrew Over Keyway	
			W	X		W	X		W	X		W	X		W	X				
1020T	0.500	1.125	0.250	0.125	1.187	0.250	0.093	1.250	0.250	0.062	-	-	-	-	-	-	13	28	24	
1030T	0.500	1.375	0.312	0.156	1.437	0.375	0.125	1.562	0.375	0.062	-	-	-	-	-	-	13	35	30	
1040T	0.500	1.625	0.375	0.187	1.750	0.375	0.125	1.750	0.375	0.062	-	-	-	-	-	-	13	43	38	
1050T	0.500	1.875	0.500	0.250	2.000	0.500	0.187	2.125	0.500	0.125	-	-	-	-	-	-	13	50	45	
1060T	0.750	2.125	0.500	0.250	2.250	0.500	0.187	2.375	0.625	0.125	-	-	-	-	-	-	20	56	50	
1070T	0.750	2.500	0.625	0.312	2.687	0.625	0.218	2.875	0.750	0.125	-	-	-	-	-	-	20	67	60	
1080T	1.062	3.000	0.750	0.375	3.250	0.750	0.250	3.375	0.875	0.187	-	-	-	-	-	-	27	80	75	
1090T	1.062	3.500	0.875	0.437	3.750	0.875	0.312	3.875	1.000	0.250	-	-	-	-	-	-	27	95	90	
1100T	1.625	4.000	1.000	0.500	4.250	1.000	0.375	4.500	1.000	0.250	-	-	-	-	-	-	42	110	100	
1110T	1.625	4.500	1.000	0.500	4.625	1.250	0.437	5.000	1.250	0.250	-	-	-	-	-	-	42	120	110	
1120T	2.375	5.000	1.250	0.625	5.375	1.250	0.437	5.750	1.500	0.250	-	-	-	-	-	-	61	140	120	
1130T	2.625	6.000	1.500	0.750	6.500	1.500	0.500	6.500	1.500	0.250	-	-	-	-	-	-	67	170	150	
1140T	2.625	7.000	1.750	0.875	7.250	1.750	0.750	7.750	2.000	0.500	-	-	-	-	-	-	67	200	180	
1150T	4.250	7.500	1.750	0.875	8.000	2.000	0.750	-	-	-	-	-	-	-	-	-	108	215	190	
1160T	4.750	8.500	2.000	1.000	9.000	2.000	0.750	-	-	-	-	-	-	-	-	-	121	240	215	
1170T	5.250	9.750	2.500	1.250	10.000	2.500	0.875	-	-	-	10.750	1.750	0.875	11.000	1.750	0.750	134	280	240	
1180T	6.000	10.750	2.500	1.250	11.000	2.500	0.875	-	-	-	12.000	1.750	0.875	12.250	2.000	0.750	153	300	260	
1190T	6.000	11.750	3.000	1.500	12.000	3.000	1.000	-	-	-	13.000	2.000	1.000	13.250	2.000	0.750	153	336	290	
1200T	7.000	12.750	3.000	1.500	13.000	3.000	1.000	-	-	-	14.000	2.500	1.250	14.250	2.500	0.875	178	360	320	

Y = Shaft keyway depth; X = Hub keyway depth; W = Keyway width
 • Maximum bores using standard recommended keys on Table 13.
 ◇ Consult Martin.

Table 9 – Taper Bushings for Type T Hubs

Coupling Size	M Hub			
	Taper Bushing			L (in)
	Catalog Part No.	Bore Range (in)	Torque (lb-in)	
1020T	-	-	-	-
1030T	1108	0.500 to 1.125	1,300	1.62
1040T	1108	0.500 to 1.125	1,300	1.62
1050T	1215	0.500 to 1.250	3,550	1.88
1060T	1615	0.500 to 1.625	4,300	2.12
1070T	2012	0.500 to 2.000	7,150	2.12
1080T	2525	0.750 to 2.500	11,300	2.62
1090T	3030	0.938 to 3.000	24,000	3.12
1100T	3030	0.938 to 3.000	24,000	3.50
1110T	3535	1.188 to 3.500	44,800	3.62
1120T	4040	1.438 to 4.000	77,300	4.38
1130T	4545	1.938 to 4.500	110,000	4.62
1140T	5050	2.438 to 5.000	126,000	5.12
1150T	5050	2.438 to 5.000	126,000	7.20
1160T	5050	2.438 to 5.000	126,000	7.80
1170T	7060	3.938 to 7.000	416,000	8.50
1180T	8065	4.438 to 8.000	456,000	9.40
1190T	8065	4.438 to 8.000	456,000	10.20
1200T	10085	7.000 to 10.000	869,000	11.00

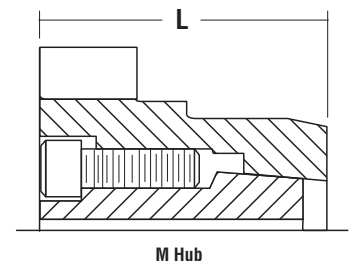

Bushings require shaft keyways as calculated in Table 13.
 Taper bores not recommended for shock load, reverse load, or 1.75+ coupling service factor applications.

Table 10 – WR² Values (lb-in²)

WR² values are based on hubs with no bore; seals, lube plugs and gaskets are not considered.

Coupling Size	Coupling Type					
	T10	T20	T31		T35	
			WR ² (Min DBSE)	WR ² Added per inch of DBSE	WR ² (Min DBSE)	WR ² Added per inch of DBSE
1020T	4.83	5.32	9.8	0.18	7.3	0.18
1030T	7.61	7.99	15.3	0.42	11.5	0.42
1040T	11.19	11.99	31.8	0.76	21.5	0.76
1050T	24.85	25.76	62	1.4	43.4	1.4
1060T	40.66	41.16	132	2.38	86.4	2.38
1070T	63.18	61.68	175	4.06	119	4.06
1080T	154	148	396	8.37	275	8.37
1090T	269	272	805	16.2	537	16.2
1100T	609	608	1756	27.2	1183	27.2
1110T	923	930	2726	45.4	1825	45.4
1120T	1755	1611	5341	70.9	3548	70.9
1130T	3378	3568	8563	153	5970	153
1140T	6306	6431	14871	283	10588	283
1150T	11922	11243	–	–	–	–
1160T	19876	20597	–	–	–	–
1170T	35621	35625	–	–	–	–
1180T	62553	63343	–	–	–	–
1190T	89359	90487	–	–	–	–
1200T	148676	150553	–	–	–	–

Table 11 – Type T Coupling Puller Bolt Holes (in)

Coupling Size	Coupling Type	
	B.C.	Tap Size (UNC)
1020T	1.531	#6-32 x 0.38
1030T	1.875	#6-32 x 0.38
1040T	2.125	#10-24 x 0.38
1050T	2.500	#10-24 x 0.38
1060T	2.875	0.250-20 x 0.38
1070T	3.312	0.250-20 x 0.38
1080T	3.937	0.250-20 x 0.38
1090T	4.562	0.3125-18 x 0.44
1100T	5.250	0.375-16 x 0.50
1110T	5.875	0.4375-14 x 0.62
1120T	6.625	0.4375-14 x 0.62
1130T	7.750	0.625-11 x 0.82
1140T	9.125	0.625-11 x 0.82
1150T	10.375	0.750-10 x 0.94
1160T	11.750	0.875-9 x 1.06
1170T	13.250	1.125-7 x 1.25
1180T	14.875	1.250-7 x 1.50
1190T	16.250	1.500-6 x 1.75
1200T	17.937	1.500-6 x 1.75

Table 12 – Reduced Max Bores Interference Fit and Setscrew Over Keyway — All Type M Couplings

Size	Bore
1020T	1.000
1030T	1.250
1040T	1.375
1050T	1.750
1060T	1.875
1070T	2.250
1080T	2.750
1090T	3.250
1100T	3.500
1110T	4.000

Size	Bore
1120T	4.500
1130T	5.500
1140T	6.500
1150T	7.000
1160T	8.000
1170T	9.000
1180T	9.750
1190T	10.750
1200T	11.750

Table 13 – Misalignment Capability (in)

Maximum life and minimum maintenance for the coupling and connected machinery will result if couplings are accurately aligned. Coupling life expectancy between initial alignment and maximum operating limits is a function of load, speed and lubrication. For applications requiring greater misalignment, refer application details to Martin.

Angular misalignment is expressed in degrees and as the difference between the value of X minus Y, as illustrated.

Parallel misalignment is the distance P between shaft center lines as shown.

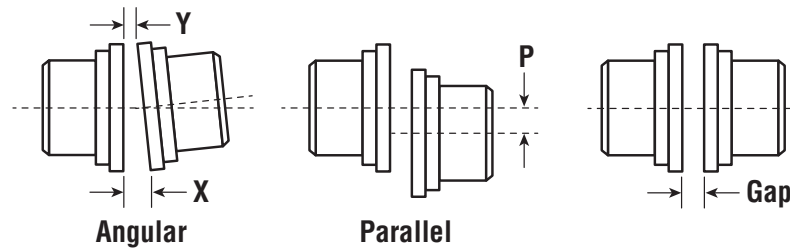

Coupling Size	Recommended Installation Maximum		Maximum Operating		Normal GAP +/- 10%	
	Parallel Offset -P	Angular (1/16°) X Minus Y	Parallel Offset -P	Angular (1/16°) X Minus Y	T10, T20, T35	T31
	T10, T20, T31, T35		T10, T20, T31, T35			
1020T	0.006	0.002	0.012	0.009	0.125	0.188
1030T	0.006	0.003	0.012	0.010	0.125	0.188
1040T	0.006	0.003	0.012	0.013	0.125	0.188
1050T	0.008	0.004	0.016	0.016	0.125	0.188
1060T	0.008	0.004	0.016	0.018	0.125	0.188
1070T	0.008	0.005	0.016	0.020	0.125	0.188
1080T	0.008	0.006	0.016	0.024	0.125	0.188
1090T	0.008	0.007	0.016	0.028	0.125	0.188
1100T	0.010	0.008	0.020	0.032	0.188	0.250
1110T	0.010	0.009	0.020	0.035	0.188	0.250
1120T	0.011	0.010	0.022	0.040	0.250	0.375
1130T	0.011	0.012	0.022	0.047	0.250	0.375
1140T	0.011	0.013	0.022	0.053	0.250	0.375
1150T	0.012	0.015	0.024	0.061	0.250	0.375
1160T	0.012	0.017	0.024	0.070	0.250	0.375
1170T	0.012	0.020	0.024	0.079	0.250	0.375
1180T	0.015	0.022	0.030	0.089	0.250	0.375
1190T	0.015	0.024	0.030	0.096	0.250	0.375
1200T	0.015	0.027	0.030	0.107	0.250	0.375

Table 14 – Recommended Commercial Keys for Bores with One Key (in/mm)

Inches (Per ANSI B17.1 Standard)											
Shaft Dia.		Key	Shaft Dia.		Key	Shaft Dia.		Key	Shaft Dia.		Key
Over	Through		Over	Through		Over	Through		Over	Through	
0.438	0.562	0.125 x 0.125	1.750	2.250	0.500 x 0.500	4.500	5.500	1.250 x 1.250	11.000	13.000	3.000 x 2.000
0.562	0.875	0.188 x 0.188	2.250	2.750	0.625 x 0.625	5.500	6.500	1.500 x 1.500	13.000	15.000	3.500 x 2.500
0.875	1.250	0.250 x 0.250	2.750	3.250	0.750 x 0.750	6.500	7.500	1.750 x 1.500	15.000	18.000	4.000 x 3.000
1.250	1.375	0.312 x 0.312	3.250	3.750	0.875 x 0.875	7.500	9.000	2.000 x 1.500	18.000	20.000	5.000 x 3.500
1.375	1.750	0.375 x 0.375	3.750	4.500	1.000 x 1.000	9.000	11.000	2.500 x 1.750	–	–	–
Millimeters (Per ISO R773 Standard)											
6	8	2 x 2	38	44	12 x 8	95	110	28 x 16	260	290	63 x 32
8	10	3 x 3	44	50	14 x 9	110	130	32 x 18	290	330	70 x 36
10	12	4 x 4	50	58	16 x 10	130	150	36 x 20	330	380	80 x 40
12	17	5 x 5	58	65	18 x 11	150	170	40 x 22	380	440	90 x 45
17	22	6 x 6	65	75	20 x 12	170	200	45 x 25	440	500	100 x 50
22	30	8 x 7	75	85	22 x 14	200	230	50 x 28	–	–	–
30	38	10 x 8	85	95	25 x 14	230	260	56 x 32	–	–	–

Table 15 – Standard Bore Fits — Unless Otherwise Specified

Model	Coupling Size	Coupling Type	Bore Fit
Blue-Flex® Grid Couplings	1020 - 1090	T10, T20	Clearance
	1100 and Larger	T10, T20	Interference

Table 16 – Recommended Bores for Steel Hubs (in)

Shaft Dia.	Clearance Fit		Interference Fit		Shaft Dia.	Clearance Fit		Interference Fit		Shaft Dia.	Interference Fit	
	Hub Bore	Clearance	Hub Bore	Interference		Hub Bore	Clearance	Hub Bore	Interference		Hub Bore	Interference
+.0000 -.0005	+.0010 -.0000	.0000 .0015	+.0005 -.0000	.0000 .0010	+.0000 -.0010	+.0015 -.0000	.0000 .0025	+.0010 -.0000	.0005 .0025	0000 -.0010	+.0015 -.0000	.0015 .0040
0.5000	0.5000	↓	0.4990	↓	3.0625	3.0625	↓	3.0600	↓	6.7500	6.7460	↓
0.5625	0.5625		0.5615		3.1250	3.1250		3.1225		7.0000	6.9960	
0.6250	0.6250		0.6240		3.1875	3.1875		3.1850		+.0000	+.0020	.0020
0.6875	0.6875		0.6865		3.2500	3.2500		3.2475		-.0010	-.0000	.0050
0.7500	0.7500		0.7490		3.3125	3.3125		3.3100		7.250	7.2450	↓
0.8125	0.8125		0.8115		3.3750	3.3750		3.3725		7.500	7.4950	
0.8750	0.8750		0.8740		3.4375	3.4375		3.4350		7.750	7.7450	↓
0.9375	0.9375		0.9365		3.5000	3.5000		3.4975		8.000	7.9950	
1.0000	1.0000		0.9990		3.5625	3.5625		3.5600		8.250	8.2445	.0025
1.0625	1.0625		1.0615		3.6250	3.6250		3.6225		8.500	8.4945	.0055
1.1250	1.1250		1.1240		3.6875	3.6875		3.6850		8.750	8.7445	↓
1.1875	1.1875		1.1865		3.7500	3.7500		3.7475		9.000	8.9945	
1.2500	1.2500		1.2490		3.8125	3.8125		3.8100		9.250	9.2440	.0030
1.3125	1.3125		1.3115		3.8750	3.8750		3.8725		9.500	9.4940	.0060
1.3750	1.3750		1.3740		3.9375	3.9375		3.9350		9.750	9.7440	↓
1.4375	1.4375	1.4365	4.0000	4.0000	3.9975	10.000	9.9940					
1.5000	1.5000	1.4990	+.0000	+.0015	.0000	+.0015	.0010	.0035				
+.0000 -.0010	+.0010 -.0000	.0000 .0020	+.0005 -.0000	.0000 .0015	-.0010 -.0000	.0025 .0035	+.0015 -.0000	.0035 .0035	10.250	10.2435	.0035	↓
1.5625	1.5625	1.5610	4.0625	4.0625	4.0590	10.500	10.4935	.0065				
1.6250	1.6250	1.6235	4.1250	4.1250	4.1215	10.750	10.7435	↓				
1.6875	1.6875	1.6860	4.1875	4.1875	4.1840	11.000	10.9935					
1.7500	1.7500	1.7485	4.2500	4.2500	4.2465	11.250	11.2430	.0040				
1.8125	1.8125	1.8110	4.3125	4.3125	4.3090	11.500	11.4930	.0070				
1.8750	1.8750	1.8735	4.3750	4.3750	4.3715	11.750	11.7430	↓				
1.9375	1.9375	1.9360	4.4375	4.4375	4.4340	12.000	11.9930					
2.0000	2.0000	1.9985	4.5000	4.5000	4.4965	12.500	12.4925	.0045				
+.0000 -.0010	+.0015 -.0000	.0000 .0025	+.0005 -.0000	.0000 .0015	4.5625	4.5625	4.5590	4.5590	13.000	12.9925	.0075	↓
2.0625	2.0625	2.0610	4.6250	4.6250	4.6215	4.6250	4.6215	13.500	13.4920	.0050		
2.1250	2.1250	2.1235	4.6875	4.6875	4.6840	4.7500	4.7465	14.000	13.9920	.0080	↓	
2.1875	2.1875	2.1860	4.7500	4.7500	4.7465	4.8125	4.8090	14.500	14.4915	.0055		
+.0000 -.0010	+.0015 -.0000	.0000 .0025	+.0010 -.0000	.0000 .0020	4.8750	4.8750	4.8715	4.8715	15.000	14.9915	.0085	↓
2.2500	2.2500	2.2480	4.9375	4.9375	4.9340	4.9375	4.9340	+.000	+.0025	.0055		
3.3125	3.3125	3.3105	5.0000	5.0000	4.9965	5.0000	4.9965	-.001	-.0000	.0090	↓	
2.3750	2.3750	2.3730	5.0625	5.0625	5.0585	5.0625	5.0585	15.500	15.4910	↓		
2.4375	2.4375	2.4355	5.1250	5.1250	5.1210	5.1250	5.1210	16.000	15.9910		.0060	
2.5000	2.5000	2.4980	5.1875	5.1875	5.1835	5.1875	5.1835	16.500	16.4905	.0095	↓	
2.5625	2.5625	2.5605	5.2500	5.2500	5.2460	5.2500	5.2460	17.000	16.9905			
2.6250	2.6250	2.6230	5.3125	5.3125	5.3085	5.3125	5.3085	17.500	17.4895	.0070		
2.6875	2.6875	2.6855	5.3750	5.3750	5.3710	5.3750	5.3710	18.000	17.9895	.0105		
2.7500	2.7500	2.7480	5.4375	5.4375	5.4335	5.4375	5.4335	18.500	18.4890	.0075		
2.8125	2.8125	2.8105	5.5000	5.5000	5.4960	5.5000	5.4960	19.000	18.9890	.0110		
2.8750	2.8750	2.8730	5.5625	5.5625	5.5585	5.5625	5.5585	19.500	19.4880	.0085		
2.9375	2.9375	2.9355	5.6250	5.6250	5.6210	5.6250	5.6210	20.000	19.9880	.0120		
3.0000	3.0000	2.9980	5.6875	5.6875	5.6835	5.6875	5.6835					
			5.7500	5.7500	5.7460	5.7500	5.7460					
			5.8125	5.8125	5.8085	5.8125	5.8085					
			5.8750	5.8750	5.8710	5.8750	5.8710					
			5.9375	5.9375	5.9335	5.9375	5.9335					
			6.0000	6.0000	5.9960	6.0000	5.9960					
			6.2500	6.2500	6.2460	6.2500	6.2460					
			6.5000	6.5000	6.4960	6.5000	6.4960					

For shaft diameters larger than 20.000, use an average interference fit of 0.0005 per inch of shaft diameter within the following bore tolerances:

- +.003, -.000 for over 20 to 30 dia. incl.
- +.004, -.000 for over 30 to 40 dia. incl.

Tolerances and fits comply with, or are within, AGMA 9002 standard (Class 1 clearance fit).

Table 17 – Recommended Bores for Metric Shafts per ISO/R775–1969 (ANSI/AGMA 9112)

	Shaft Diameter	Clearance Fit		Transitional Fit		Interference Fit	
		Hub Bore	Fit*	Hub Bore	Fit*	Hub Bore	Fit*
MM	j6 +.008 / -.003	F7 +.016 / +.034	+.008 +.037	H7 +.000 / +.018	-.008 +.021	M6 -.015 / -.004	-.023 -.001
12	0.4727 / 0.4724	0.4731 / 0.4737	+0.0003	0.4725 / 0.4731	-0.0003	0.4718 / 0.4723	-0.0009
14	0.5515 / 0.5511	0.5518 / 0.5525	+0.0015	0.5512 / 0.5519	+0.0008	0.5506 / 0.5511	+0.0000
16	0.6302 / 0.6298	0.6306 / 0.6312	↓	0.6300 / 0.6306	↓	0.6293 / 0.6298	↓
18	0.7089 / 0.7086	0.7093 / 0.7100	↓	0.7087 / 0.7093	↓	0.7080 / 0.7085	↓
MM	j6 +.009 / -.004	F7 +.020 / +.041	+.011 +.045	H7 +.000 / +.021	-.009 +.025	M6 -.017 / -.004	-.026 -.000
19	0.7483 / 0.7479	0.7488 / 0.7496	+0.0004	0.7481 / 0.7488	-0.0004	0.7473 / 0.7479	-0.0010
20	0.7877 / 0.7873	0.7882 / 0.7890	+0.0018	0.7874 / 0.7882	+0.0010	0.7867 / 0.7873	+0.0000
22	0.8665 / 0.8660	0.8670 / 0.8677	↓	0.8662 / 0.8669	↓	0.8654 / 0.8660	↓
24	0.9452 / 0.9448	0.9457 / 0.9465	↓	0.9449 / 0.9457	↓	0.9442 / 0.9448	↓
25	0.9846 / 0.9841	0.9851 / 0.9858	↓	0.9843 / 0.9850	↓	0.9835 / 0.9841	↓
28	1.1027 / 1.1022	1.1032 / 1.1039	↓	1.1024 / 1.1032	↓	1.1017 / 1.1022	↓
30	1.1814 / 1.1810	1.1819 / 1.1827	↓	1.1811 / 1.1819	↓	1.1804 / 1.1810	↓
>30	k6 +.018 / +.002	F7 +.025 / +.050	+.007 +.048	H7 +.000 / +.025	-.018 +.023	K6 -.013 / +.003	-.031 +.001
32	1.2605 / 1.2600	1.2609 / 1.2618	+0.0003	1.2599 / 1.2608	-0.0007	1.2593 / 1.2600	-0.0012
35	1.3786 / 1.3781	1.3790 / 1.3799	+0.0019	1.3780 / 1.3789	+0.0009	1.3774 / 1.3781	+0.0000
38	1.4967 / 1.4962	1.4971 / 1.4980	↓	1.4961 / 1.4970	↓	1.4955 / 1.4962	↓
40	1.5755 / 1.5750	1.5758 / 1.5767	↓	1.5748 / 1.5758	↓	1.5743 / 1.5750	↓
42	1.6542 / 1.6537	1.6546 / 1.6555	↓	1.6536 / 1.6545	↓	1.6530 / 1.6537	↓
45	1.7723 / 1.7718	1.7727 / 1.7736	↓	1.7717 / 1.7726	↓	1.7711 / 1.7718	↓
48	1.8904 / 1.8899	1.8908 / 1.8917	↓	1.8898 / 1.8907	↓	1.8892 / 1.8899	↓
50	1.9692 / 1.9686	1.9695 / 1.9704	↓	1.9685 / 1.9695	↓	1.9680 / 1.9687	↓
>50	m6 +.030 / +.011	F7 +.030 / +.060	+.000 +.049	H7 +.000 / +.030	-.030 +.019	K6 -.021 / +.009	-.051 +.002
55	2.1665 / 2.1658	2.1666 / 2.1677	+0.0000	2.1654 / 2.1665	-0.0012	2.1645 / 2.1657	-0.0020
56	2.2059 / 2.2052	2.2059 / 2.2071	+0.0019	2.2047 / 2.2059	+0.0007	2.2039 / 2.2051	-0.0001
60	2.3634 / 2.3627	2.3634 / 2.3645	↓	2.3622 / 2.3634	↓	2.3614 / 2.3626	↓
63	2.4815 / 2.4808	2.4815 / 2.4827	↓	2.4803 / 2.4815	↓	2.4795 / 2.4807	↓
65	2.5602 / 2.5595	2.5603 / 2.5614	↓	2.5591 / 2.5602	↓	2.5582 / 2.5594	↓
70	2.7571 / 2.7564	2.7571 / 2.7582	↓	2.7559 / 2.7571	↓	2.7551 / 2.7563	↓
71	2.7964 / 2.7957	2.7965 / 2.7976	↓	2.7953 / 2.7964	↓	2.7944 / 2.7957	↓
75	2.9539 / 2.9532	2.9540 / 2.9551	↓	2.9528 / 2.9539	↓	2.9519 / 2.9531	↓
80	3.1508 / 3.1501	3.1508 / 3.1519	↓	3.1496 / 3.1508	↓	3.1488 / 3.1500	↓
>80	m6 +.035 / +.013	F7 +.036 / +.071	+.001 +.058	H7 +.000 / +.035	-.035 +.022	M7 -.035 / +.000	-.070 -.013
85	3.3478 / 3.3470	3.3479 / 3.3492	+0.0000	3.3465 / 3.3478	-0.0014	3.3451 / 3.3465	-0.0028
90	3.5447 / 3.5438	3.5447 / 3.5461	+0.0023	3.5433 / 3.5447	+0.0009	3.5419 / 3.5433	-0.0005
95	3.7415 / 3.7407	3.7416 / 3.7429	↓	3.7402 / 3.7415	↓	3.7388 / 3.7402	↓
100	3.9384 / 3.9375	3.9384 / 3.9398	↓	3.9370 / 3.9384	↓	3.9356 / 3.9370	↓
>100	m6 +.035 / +.013	F7 +.036 / +.071	+.003 +.068	H7 +.000 / +.035	-.040 +.025	P7 -.059 / -.024	-.094 -.037
110	4.3321 / 4.3312	4.3321 / 4.3335	↓	4.3307 / 4.3321	↓	4.3284 / 4.3298	-0.0037
120	4.7258 / 4.7249	4.7258 / 4.7272	↓	4.7244 / 4.7258	↓	4.7221 / 4.7235	-0.0015
>120	m6 +.040 / +.015	F7 +.043 / +.083	+.003 +.068	H7 +.000 / +.040	-.040 +.025	P7 -.068 / -.028	-.108 -.043
125	4.9228 / 4.9219	4.9230 / 4.9245	+0.0001	4.9213 / 4.9228	-0.0016	4.9186 / 4.9202	-0.0043
130	5.1197 / 5.1187	5.1198 / 5.1214	+0.0027	5.1181 / 5.1197	+0.0010	5.1154 / 5.1170	-0.0017
140	5.5134 / 5.5124	5.5135 / 5.5151	↓	5.5118 / 5.5134	↓	5.5091 / 5.5107	↓
150	5.9071 / 5.9061	5.9072 / 5.9088	↓	5.9055 / 5.9071	↓	5.9028 / 5.9044	↓
160	6.3008 / 6.2998	6.3009 / 6.3025	↓	6.2992 / 6.3008	↓	6.2965 / 6.2981	↓
170	6.6945 / 6.6935	6.6946 / 6.6962	↓	6.6929 / 6.6945	↓	6.6902 / 6.6918	↓
180	7.0882 / 7.0872	7.0883 / 7.0899	↓	7.0866 / 7.0882	↓	7.0839 / 7.0855	↓
>180	m6 +.046 / +.017	F7 +.050 / +.096	+.004 +.079	H7 +.000 / +.046	-.046 +.029	P7 -.079 / -.033	-.125 -.050
190	7.4821 / 7.4810	7.4823 / 7.4841	+0.0002	7.4803 / 7.4821	-0.0018	7.4772 / 7.4790	-0.0049
200	7.8758 / 7.8747	7.8760 / 7.8778	+0.0031	7.8740 / 7.8758	+0.0011	7.8709 / 7.8727	-0.0020

Dimensions in **BOLD** are in millimeters, rest is in inches.

* Positive values are clearance, negative values are interference. For reference only.

Continued on Continued on Page C-59

Table 17 – Recommended Bores for Metric Shafts per ISO/R775–1969 (ANSI/AGMA 9112)

	Shaft Diameter	Clearance Fit		Transitional Fit		Interference Fit	
		Hub Bore	Fit*	Hub Bore	Fit*	Hub Bore	Fit*
>200	m6	F7	↓	H7	↓	R7	-.155
MM	+.046 / +.017	+.050 / +.096		+.000 / +.046		-109 / -.063	-.080
210	8.2695 / 8.2684	8.2697 / 8.2715		8.2677 / 8.2695		8.2634 / 8.2652	-0.061
220	8.6632 / 8.6621	8.6634 / 8.6652		8.6614 / 8.6632		8.6571 / 8.6589	-0.031
225	8.8601 / 8.8589	8.8602 / 8.8620		8.8583 / 8.8601		8.8540 / 8.8558	↓
>225	m6	F7		H7		R7	-.159
MM	+.046 / +.017	+.050 / +.096		+.000 / +.046		-.113 / -.067	-.084
230	9.0569 / 9.0558	9.0571 / 9.0589		9.0551 / 9.0569		9.0507 / 9.0525	-0.063
240	9.4506 / 9.4495	9.4508 / 9.4526		9.4488 / 9.4506		9.4444 / 9.4462	-0.033
250	9.8443 / 9.8432	9.8445 / 9.8463		9.8425 / 9.8443		9.8381 / 9.8399	↓
>250	m6	F7	H7	R7	-.178		
MM	+.052 / +.020	+.056 / +.108	+.000 / +.052	-.126 / -.074	-.094		
260	10.2383 / 10.2370	10.2384 / 10.2405	10.2362 / 10.2383	10.2313 / 10.2333	-0.070		
270	10.6320 / 10.6307	10.6321 / 10.6342	10.6299 / 10.6320	10.6250 / 10.6270	-0.037		
280	11.0257 / 11.0244	11.0258 / 11.0279	11.0236 / 11.0257	11.0187 / 11.0207	↓		
>280	m6	F7	H7	R7	-.182		
MM	+.052 / +.020	+.056 / +.108	+.000 / +.052	-.130 / -.078	-.098		
290	11.4194 / 11.4181	11.4195 / 11.4216	11.4173 / 11.4194	11.4122 / 11.4143	-0.072		
300	11.8131 / 11.8118	11.8132 / 11.8153	11.8110 / 11.8131	11.8059 / 11.8080	-0.039		
310	12.2068 / 12.2055	12.2069 / 12.2090	12.2047 / 12.2068	12.1996 / 12.2017	↓		
315	12.4036 / 12.4024	12.4038 / 12.4058	12.4016 / 12.4036	12.3965 / 12.3985	↓		
>315	m6	F7	H7	R7	-.201		
MM	+.057 / +.021	+.062 / +.119	+.000 / +.057	-.144 / -.087	-.108		
320	12.6007 / 12.5993	12.6009 / 12.6031	12.5984 / 12.6007	12.5928 / 12.5950	-0.079		
330	12.9944 / 12.9930	12.9946 / 12.9968	12.9921 / 12.9944	12.9865 / 12.9887	-0.043		
340	13.3881 / 13.3867	13.3883 / 13.3905	13.3858 / 13.3881	13.3802 / 13.3824	↓		
350	13.7818 / 13.7804	13.7820 / 13.7842	13.7795 / 13.7818	13.7739 / 13.7761	↓		
355	13.9786 / 13.9772	13.9788 / 13.9811	13.9764 / 13.9786	13.9707 / 13.9730	↓		
>355	m6	F7	H7	R8	-.260		
MM	+.057 / +.021	+.062 / +.119	+.000 / +.057	-.203 / -.114	-.135		
360	14.1755 / 14.1741	14.1757 / 14.1779	14.1732 / 14.1755	14.1652 / 14.1687	-0.102		
370	14.5692 / 14.5678	14.5694 / 14.5716	14.5669 / 14.5692	14.5589 / 14.5624	-0.053		
380	14.9629 / 14.9615	14.9631 / 14.9653	14.9606 / 14.9629	14.9526 / 14.9561	↓		
390	15.3566 / 15.3552	15.3568 / 15.3590	15.3543 / 15.3566	15.3463 / 15.3498	↓		
400	15.7503 / 15.7489	15.7505 / 15.7527	15.7480 / 15.7503	15.7400 / 15.7435	↓		
>400	m6	F7	H7	R8	-.286		
MM	+.063 / +.023	+.068 / +.131	+.000 / +.063	-.223 / -.126	-.149		
410	16.1442 / 16.1426	16.1444 / 16.1469	16.1417 / 16.1442	16.1330 / 16.1368	-0.113		
420	16.5379 / 16.5363	16.5381 / 16.5406	16.5354 / 16.5379	16.5267 / 16.5305	-0.059		
430	16.9316 / 16.9300	16.9318 / 16.9343	16.9291 / 16.9316	16.9204 / 16.9242	↓		
440	17.3253 / 17.3237	17.3255 / 17.3280	17.3228 / 17.3253	17.3141 / 17.3179	↓		
450	17.7190 / 17.7174	17.7192 / 17.7217	17.7165 / 17.7190	17.7078 / 17.7116	↓		
>450	m6	F7	H7	R8	-.292		
MM	+.063 / +.023	+.068 / +.131	+.000 / +.063	-.229 / -.132	-.155		
460	18.1127 / 18.1111	18.1129 / 18.1154	18.1102 / 18.1127	18.1012 / 18.1050	-0.115		
470	18.5064 / 18.5048	18.5066 / 18.5091	18.5039 / 18.5064	18.4949 / 18.4987	-0.061		
480	18.9001 / 18.8985	18.9003 / 18.9028	18.8976 / 18.9001	18.8886 / 18.8924	↓		
490	19.2938 / 19.2922	19.2940 / 19.2965	19.2913 / 19.2938	19.2823 / 19.2861	↓		
500	19.6875 / 19.6859	19.6877 / 19.6902	19.6850 / 19.6875	19.6760 / 19.6798	↓		

Dimensions in **BOLD** are in millimeters, rest is in inches.

* Positive values are clearance, negative values are interference. For reference only.

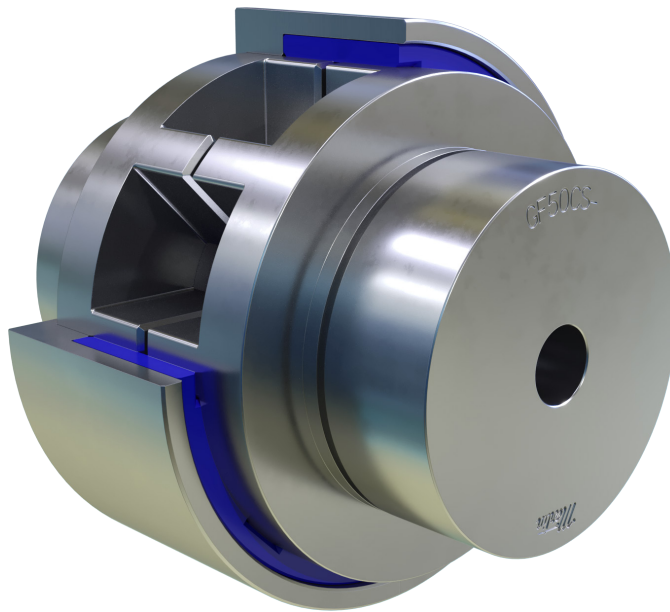

Martin Go-Flex® couplings are one of the easiest to install, maintain, and replace!

A complete coupling consists of 2 hubs, available in carbon or stainless steel, a urethane split insert (choose from 5 types), and a cover – either a slide over cover retained by a snap ring, a vertically split for high-speed applications, or a horizontally split cover for extreme torque applications.

Advantages

- Fast and easy insert replacement
- Low maintenance
- Minimal downtime
- No lubrication
- Urethane inserts available from standard to extreme duty, high temperature, and metal detectable

Once you have correctly selected and properly installed a Martin Go-Flex® coupling, the split insert is all you should have to replace. Replacement of the insert is easy and your equipment can be back up and running in minutes! Once the hubs are installed, they never need to be moved again.

Remove only the cover, replace the insert, re-install the cover, and you are ready to go!

- Can be installed vertically or horizontally
- The teeth on the hubs do not touch or overlap thus if the insert fails, you do not have metal to metal contact that could potentially destroy the hubs
- Reversing applications
- No realignment required after insert replacement

Hubs (2 required)

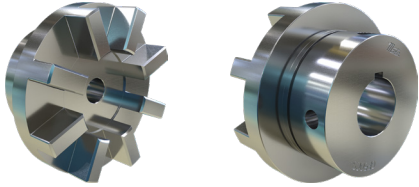

Go-Flex®

GF 20 CS 010 H

Coupling Size

10, 20, 30, 40, 50, 60 70
80, 90, 100, 110 and 120

Material

CS Carbon Steel
SS Stainless Steel

Bore Size*

PB Plain Bore	114	1-7/8
008	115	1-15/16
010	200	2
012	202	2-1/8
014	203	2-3/16
100	204	2-1/4
102	206	2-3/8
103	207	2-7/16
104	208	2-1/2
106	210	2-5/8
107	212	2-3/4
108	214	2-7/8
110	215	2-15/16
112	300	3

*Metric, Shrink Fit, Spline Bores available on request

Description

H Hub

Inserts

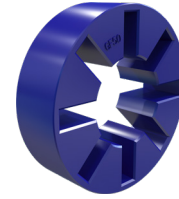

Go-Flex®

GF 20 SD - INS

Coupling Size

10, 20, 30, 40, 50, 60 70
80, 90, 100, 110 and 120

Insert Type

SD Standard Duty (Red)
MD Medium Duty (Dark Blue)
XD Extreme Duty (Black)
HT Hi-Temp (White)
FG Food Grade Metal Detectable (Light Blue)

Description

INS Insert

Covers

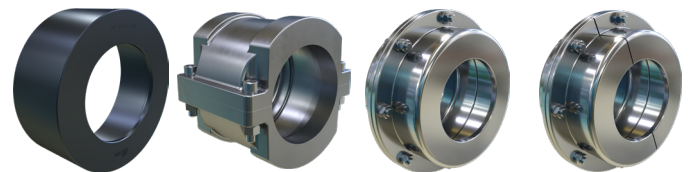

Go-Flex®

GF 20 SD - CVR

Coupling Size

10, 20, 30, 40, 50, 60 70
80, 90, 100, 110 and 120

Cover Type

SD Standard Duty (Carbon Steel)
SS Standard Duty (Stainless Steel)
XP Horizontal Split (Aluminum)
VS Vertical Split
HS Horizontal/Vertical Split

Description

CVR Cover

Go-Flex® Inserts

Martin Go-Flex® Insert Dimensions (in)

Coupling Series	R	D	W	Wt. (lb)
GF10	1.23	2.23	0.63	0.05
GF20	1.66	2.86	0.85	0.1
GF30	2.16	3.80	1.23	0.3
GF40	2.41	5.05	1.64	0.8
GF50	3.05	6.44	2.02	1.45
GF60	3.90	7.37	2.35	2.0
GF70	4.13	8.20	2.32	3.0
GF80	4.34	9.98	2.63	5.0
GF90	6.19	11.30	2.96	6.0
GF100	7.60	13.61	3.24	9.0
GF110	9.15	15.93	3.67	13.0
GF120	11.25	19.04	5.43	31.0

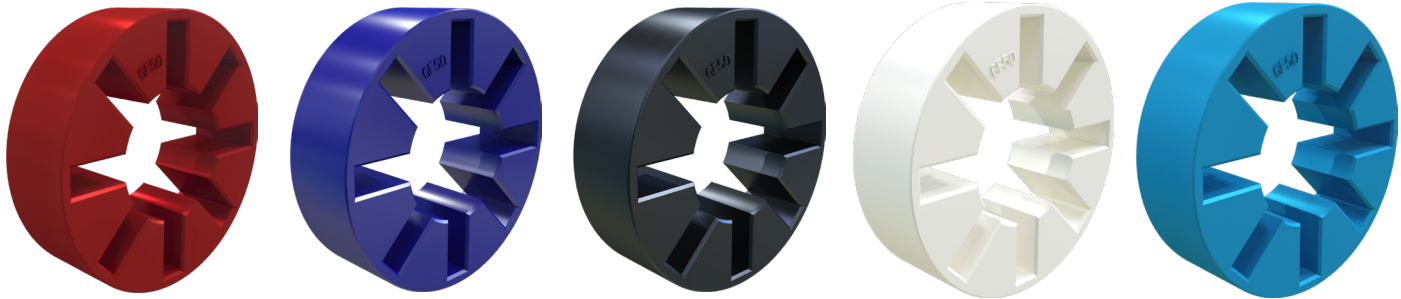
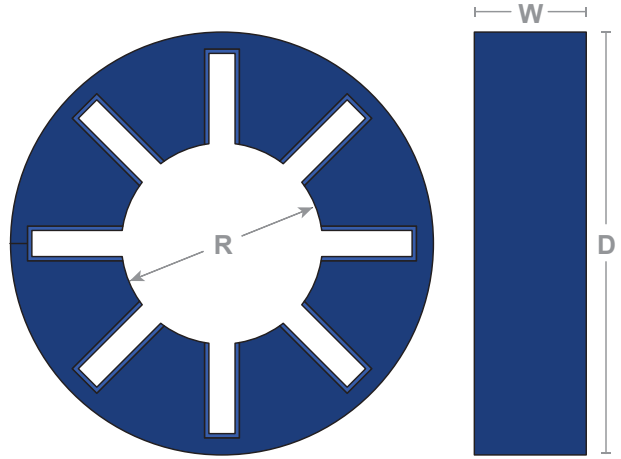

Standard	Medium Torque	Extreme High Torque	Hi-Temp	Metal Detectable
Operational temperature range of -60°F to 212°F (-50°C to 100°C)	Operational temperature range of -60°F to 212°F (-50°C to 100°C)	Operational temperature range of -60°F to 212°F (-50°C to 100°C)	Operational temperature range up to 300°F (148°C)	Operational temperature range of -60°F to 212°F (-50°C to 100°C)
Moderately soft urethane compound	Higher durometer urethane resulting in a more rigid insert designed for higher torque applications than the regular insert	Insert provides our highest torque ratings	Urethane compound made for Hi-temp applications	Metal Detectable Inserts are made with a FDA compliant additive that provides metal detectability
Applications Vibration dampening, cushioning of shock loads, reversing, or quick starting and stopping of high inertial loads	Applications Moderate to high torque	Applications High torque	Applications Moderate to high torque	Applications Food and chemical Industries where plastic contamination compromises production

Martin Go-Flex® – Standard Cover

Designed for applications where low torque and/or high speed is present.

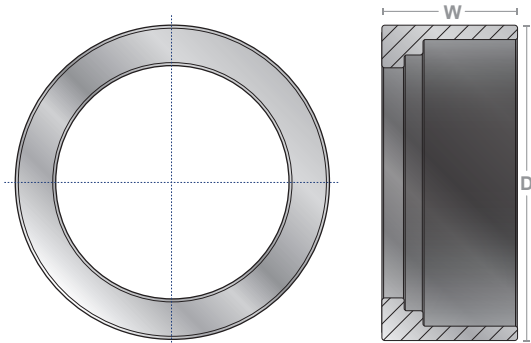

Part Number		Max. RPM \diamond	W	D	Bolt Size
Carbon Steel	Stainless Steel				
GF10SD-CVR	GF10SS-CVR	12,000	0.95	2.49	Retaining Ring
GF20SD-CVR	GF20SS-CVR	9,000	1.35	3.16	Retaining Ring
GF30SD-CVR	GF30SS-CVR	7,000	1.95	4.21	Retaining Ring
GF40SD-CVR	GF40SS-CVR	6,000	2.38	5.48	Retaining Ring
GF50SD-CVR	GF50SS-CVR	4,800	2.96	7.00	Retaining Ring
GF60SD-CVR	GF60SS-CVR	4,200	3.27	8.00	Retaining Ring
GF70SD-CVR	GF70SS-CVR	3,800	3.50	8.88	(8) M10-1.5 x 35MM
GF80SD-CVR	GF80SS-CVR	3,400	4.05	10.77	(8) M10-1.5 x 35MM
GF90SD-CVR	GF90SS-CVR	3,000	4.88	12.13	(8) M10-1.5 x 35MM
GF100SD-CVR	GF100SS-CVR	2,400	5.00	14.38	(8) M12-1.75 x 45MM
GF110SD-CVR	GF110SS-CVR	2,000	5.50	16.75	(8) M20-2.5 x 45MM
GF120SD-CVR	GF120SS-CVR	1,800	7.94	20.10	(8) M20-2.5 x 45MM

G10 to GF 60 Cover are held into position with a retaining ring. GF70 covers are held into position with (8) bolts.

Martin Go-Flex® – Horizontal Split Cover

Designed for all applications including high and/or low torque and high or low speeds while reducing axial loading.

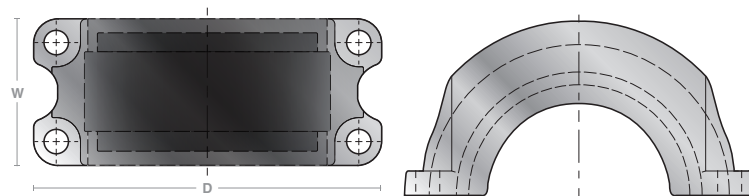

Part Number	Max. RPM \diamond *	W	D	Bolt Size
GF20XP-CVR	9,000	1.93	3.99	(4) M6-1.00 x 25MM
GF30XP-CVR	7,000	2.61	5.34	(4) M10-1.5 x 35MM
GF40XP-CVR	6,000	3.02	7.28	(4) M12-1.75 x 45MM
GF50XP-CVR	4,800	5.96	7.76	(4) M12-1.75 x 60MM
GF60XP-CVR	4,200	6.17	8.52	(4) M16-2.0 x 65MM
GF70XP-CVR	3,800	6.54	10.29	(4) M20-2.5 x 60MM
GF80XP-CVR	3,400	7.93	12.05	(4) M20-2.5 x 60MM

* With Extreme-Duty Insert.

Stainless Steel hardware provided with all High Performance Covers.

Martin Go-Flex® – Vertical Split and Horizontal/Vertical Split Covers

Designed for high-Speed applications.

Part Number		Max. RPM \diamond	W	D	Flange Bolt Size	Hub Bolt Size
Vertical Split	Horizontal/Vertical Split					
GF20VS-CVR	GF20HS-CVR	9,000	4.7	1.78	(8) M6-1.00 x 20MM	Retaining Ring
GF30VS-CVR	GF30HS-CVR	7,000	5.62	2.5	(8) M6-1.00 x 20MM	Retaining Ring
GF40VS-CVR	GF40HS-CVR	6,000	7.62	3.46	(8) M10-1.5 x 20MM	Retaining Ring
GF50VS-CVR	GF50HS-CVR	4,800	8.95	4.35	(8) M10-1.5 x 35MM	Retaining Ring
GF60VS-CVR	GF60HS-CVR	4,200	9.85	4.5	(8) M10-1.5 x 35MM	Retaining Ring
GF70VS-CVR	GF70HS-CVR	3,800	10.5	4.68	(8) M10-1.5 x 35MM	(8) M10-1.5 x 35MM
GF80VS-CVR	GF80HS-CVR	3,400	13.5	5.88	(12) M12-1.75 x 45MM	(8) M10-1.5 x 35MM
GF90VS-CVR	GF90HS-CVR	3,000	15.25	6.21	(16) M12-1.75 x 45MM	(8) M10-1.5 x 35MM
GF100VS-CVR	GF100HS-CVR	2,800	17.75	7.32	(16) M12-1.75 x 50MM	(8) M12-1.75 x 45MM
GF110VS-CVR	GF110HS-CVR	2,000	19.59	7.42	(20) M12-1.75 x 45MM	(8) M20-2.5 x 45MM
GF120VS-CVR	GF120HS-CVR	1,200	24.38	10.85	(20) M12-1.75 x 45MM	(8) M20-2.5 x 45MM

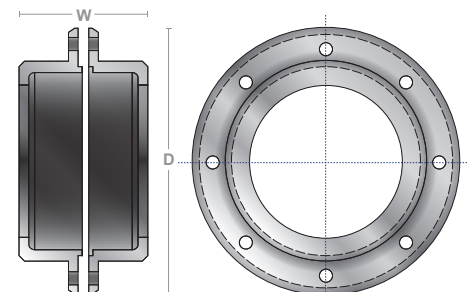

Vertical Split Cover

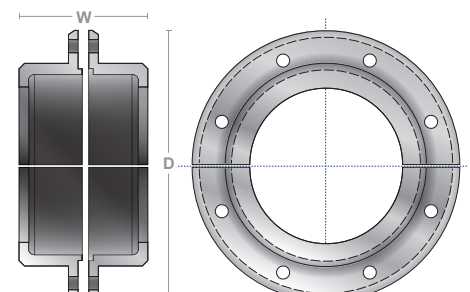

Horizontal/Vertical Split Cover

\diamond For applications above listed RPM, consult Martin.

Go-Flex® Quick Selection Guide



Insert Features

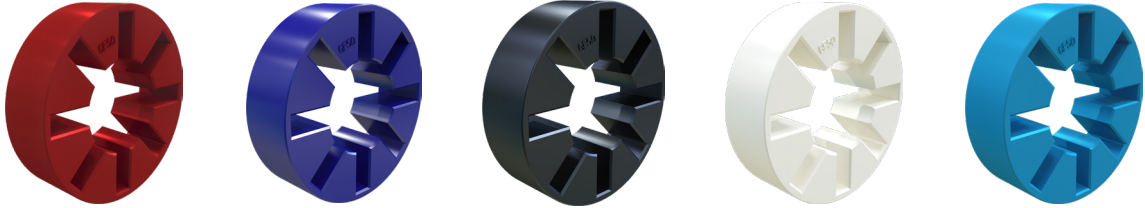

Standard-Duty (Red)	Medium-Duty (Dark Blue)	Extreme-Duty (Black)	High Temp (White)	Metal Detectable (Light Blue)
Max Temp: 212°F	Max Temp: 212°F	Max Temp: 212°F	Max Temp: 300°F	Max Temp: 212°F
Greatest Dampening	Lower Dampening	Lowest Dampening	Lower Dampening	Greatest Dampening
Lowest Torque	Higher Torque	Highest Torque	Higher Torque	Lowest Torque

High-Speed Standard Cover

Max Bore	Coupling Series	Max Torque Rating (in. lb.)				
1-1/4	GF10	377	792	792	792	365

Horizontal Split, Vertical Split and Horizontal/Vertical Split Covers

Max Bore	Coupling Series	Max Torque Rating (in. lb.)				
1-5/8	GF20	1,254	2,457	3,789	2,457	1,254
2-1/4	GF30	4,099	7,730	11,914	7,730	4,099
2-3/8	GF40	8,630	17,099	25,870	17,099	8,630
3	GF50	17,315	34,336	52,408	34,336	17,315
3-7/8	GF60	30,353	58,137	87,110	58,137	30,353
4-1/8	GF70	38,048	75,538	116,432	75,538	38,048
4-1/2	GF80	75,000	145,000	220,000	145,000	75,000
5-1/2	GF90	105,000	204,000	310,000	204,000	105,000
7	GF100	175,000	345,000	550,000	345,000	175,000
8	GF110	300,000	565,000	870,000	565,000	300,000
11	GF120	599,700	1,120,000	1,680,000	1,120,000	599,700

Formula Selection Method

Information required before a coupling can be selected:

- HP and RPM or torque of driver
- Shaft sizes of driver and driven equipment
- Corresponding keyways
- Application description to determine service factor
- Environmental conditions

Step 1. Determine the Nominal Torque (T) of your application

$$\text{in/lb} = T = \frac{(63025 \times \text{HP})}{\text{RPM}}$$

Step 2. Refer to pages C-68 and 71 to determine Application Service Factor

Step 3. Calculate the Design Torque of your application.

Design Torque = Nominal Torque (T) x Application Service Factor

Example:

Driver: 5HP, 1800RPM electric motor

Driven: belt conveyor (refer to pages C-68 and 71)

$$\text{in/lbs} = T = \frac{(63025 \times 5\text{HP})}{1800}$$

Nominal Torque (T) = 175 in/lbs

Design Torque = 175 (Nominal Torque) x 1.75 (Application Service Factor from pages C-68 and 71)

Design Torque = 306.25 in/lbs Torque

Step 4. Refer to page C-64 to select correct coupling size - ie. GF10

Step 5. Confirm that the shaft size of the driver and driven shafts are equal to or less than the maximum bore size (refer to coupling dimensional pages)

Step 6. Confirm environmental conditions to determine correct cover, hubs, and insert material (stainless steel or carbon steel hubs and cover, food grade, high temp or standard insert)

For reversing applications with high inertia loads, please consult Martin.

Go-Flex[®] with Standard Cover Dimensions/Ratings



Go-Flex[®] Couplings up to GF60 have machined Snap Ring Grooves to hold the Covers in Place

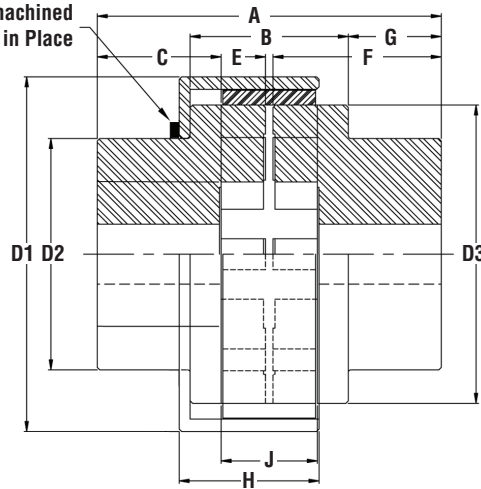

Martin Go-Flex[®] Coupling with Standard Cover Dimensions/Ratings (Carbon Steel and Stainless Steel)

Coupling Series	Pilot Bore Diameter	Maximum Bore Size \circ Square Key	Max RPM*	Maximum Torque (in-lbs)■	A	B	D1	D2	D3	C	E MIN	E MAX	F	G	H	J	Wt. \diamond (lb)
GF10	1/2	1-1/4	12,000	792	2.8	1.03	2.49	2	2.07	1.08	0.062	0.092	1.37	0.88	0.95	0.66	4
GF20	1/2	1-5/8	9,000	2,457	3.54	1.28	3.16	2.31	2.55	1.34	0.089	0.104	1.75	1.14	1.35	0.88	5
GF30	3/4	2-1/4	7,000	7,730	4.86	2	4.21	3.19	3.37	1.81	0.1	0.13	2.39	1.42	1.95	1.25	11
GF40	7/8	2-3/8	6,000	17,099	5.96	2.42	5.48	3.52	4.49	2.16	0.105	0.181	2.96	1.78	2.38	1.66	15
GF50	1	3	4,800	34,336	7.07	3.48	7	4.25	5.92	2.46	0.18	0.211	3.4	1.76	2.96	2.19	37
GF60	1	3-7/8	4,200	58,137	7.69	3.67	8	5.5	6.75	2.67	0.253	0.293	3.75	2	3.27	2.45	57
GF70	1-1/2	4-1/8	3,800	75,538	8.51	3.96	8.88	5.79	7.48	3.1	0.17	0.209	4.21	2.33	3.5	2.49	71
GF80	1-7/8	4-1/2	3,400	145,000	10.13	4.67	10.77	7	9.25	3.75	0.196	0.25	5	2.75	4.05	2.75	126
GF90	1-7/8	5-1/2	3,000	204,000	12.29	5.09	12.13	7.81	10.5	4.6	0.237	0.349	6	3.6	4.88	3.04	216
GF100	2-1/8	7	2,400	345,000	14.28	5.92	14.38	9.5	12.8	5.74	0.25	0.347	7.26	4.45	5	3.35	400
GF110	2-1/8	8	2,000	565,000	16.2	6.2	16.75	11	15.09	6.18	0.167	0.309	7.98	5	5.5	3.99	532
GF120	2-1/8	11	1,800	1,120,000	20.08	9.18	20.1	15	17.75	7.22	0.236	0.424	9.88	5.45	7.94	5.68	1116

* For applications above listed RPM, consult Martin.

\diamond All weights shown are approximate for a complete standard coupling assembly.

■ Maximum torque values (in-lbs) are based on use with black insert. Refer to page C-64 for complete torque ratings.

\circ Maximum bore size has reduced keyway on sizes GF20, GF30, and GF40.

Reduced keyways in max bore hubs measure as follows:

GF20SD1-5/8 - 3/8 x 3/32 keyway; GF30SD2-1/8 - 1/2 x 1/8

keyway; GF40SD2-3/8 - 5/8 x 5/32 keyway.

Martin Go-Flex[®] Insert Maximum Torque Ratings (in-lb)

Coupling Series	Standard-Duty Red	Medium-Duty Dark Blue	Extreme-Duty Black	High Temp White	Metal Detectable Light Blue
GF10	377	792	-	792	377
GF20	1,254	2,457	-	2,457	1,254
GF30	4,099	7,730	-	7,730	4,099
GF40	8,630	17,099	-	17,099	8,630
GF50	17,315	34,336	-	34,336	17,315
GF60	30,353	58,137	-	58,137	30,353
GF70	38,048	75,538	-	75,538	38,048
GF80	75,000	145,000	-	145,000	75,000
GF90	105,000	204,000	-	204,000	105,000
GF100	175,000	345,000	-	345,000	175,000
GF110	300,000	565,000	-	565,000	300,000
GF120	599,700	1,120,000	-	1,120,000	599,700

Note:
It is not recommended to use the Black insert with the Standard Cover. In high torque applications we recommend the use of the Horizontal Split Cover.



Go-Flex[®] with Horizontal Split Cover Dimensions/Ratings

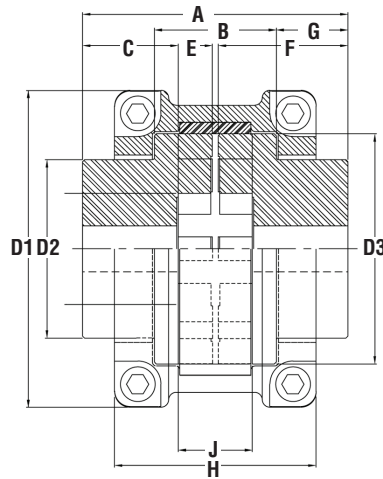

Martin Go-Flex[®] Coupling with Horizontal Split Cover Dimensions/Ratings (Carbon Steel Only)

Coupling Series	Pilot Bore Diameter	Maximum Bore Size \circ Square Key	Max RPM*	Maximum Torque (in-lbs)■	A	B	D1	D2	D3	C	E MIN	E MAX	F	G	H	J	Wt. \diamond (lb)
GF20	1/2	1-5/8	9,000	2,457	3.54	1.28	3.99	2.31	2.55	1.34	0.089	0.104	1.75	1.14	1.93	0.88	5
GF30	3/4	2-1/4	7,000	7,730	4.86	2	5.34	3.19	3.37	1.81	0.1	0.13	2.39	1.42	2.61	1.25	12
GF40	7/8	2-3/8	6,000	17,099	5.96	2.42	7.28	3.52	4.49	2.16	0.105	0.14	2.96	1.78	3.02	1.66	17
GF50	1	3	4,800	34,336	7.07	3.48	7.76	4.25	5.92	2.46	0.221	0.32	3.4	1.76	5.96	2.19	40
GF60	1	3-7/8	4,200	58,137	7.69	3.67	8.52	5.5	6.75	2.67	0.253	0.314	3.75	2	6.17	2.45	59
GF70	1-1/2	4-1/8	3,800	75,538	8.51	3.96	10.29	5.79	7.48	3.1	0.17	0.209	4.21	2.33	6.54	2.49	81
GF80	1-7/8	4-1/2	3,400	145,000	10.13	4.67	12.02	7	9.25	3.75	0.196	0.335	5	2.75	7.92	2.75	138

* For applications above listed RPM, consult Martin.

\diamond All weights shown are approximate for a complete standard coupling assembly.

■ Maximum torque values (in-lbs) are based on use with black insert. Refer to page C-64 for complete torque ratings.

\circ Maximum bore size has reduced keyway on sizes GF20, GF30, and GF40.

Reduced keyways in max bore hubs measure as follows: GF20XP1-5/8 - 3/8 x 3/32 keyway; GF30XP2-1/8 - 1/2 x 1/8 keyway; GF40XP2-3/8 - 5/8 x 5/32 keyway.

Martin Go-Flex[®] Insert Maximum Torque Ratings (in-lb)

Coupling Series	Standard-Duty Red	Medium-Duty Dark Blue	Extreme-Duty Black	High Temp White	Metal Detectable Light Blue
GF20	1,254	2,457	3,789	2,457	1,254
GF30	4,099	7,730	11,914	7,730	4,099
GF40	8,630	17,099	25,870	17,099	8,630
GF50	17,315	34,336	52,408	34,336	17,315
GF60	30,353	58,137	87,110	58,137	30,353
GF70	38,048	75,538	116,432	75,538	38,048
GF80	75,000	145,000	220,000	145,000	75,000

Go-Flex[®] with Vertical Split Dimensions/Ratings

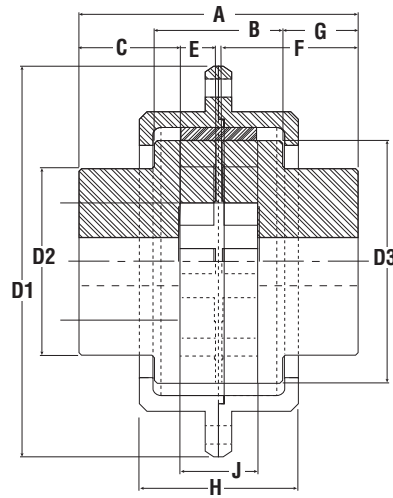

Martin Go-Flex[®] Coupling with Vertical Split Cover Dimensions/Ratings

Coupling Series	Pilot Bore Diameter	Maximum Bore Size \circ Square Key	Max RPM*	Maximum Torque (in-lbs)■	A	B	D1	D2	D3	C	E MIN	E MAX	F	G	H	J	Wt. \diamond (lb)
GF20	1/2	1-5/8	9,000	2,457	3.54	1.28	4.7	2.31	2.55	1.34	0.089	0.104	1.75	1.14	1.78	0.88	7
GF30	3/4	2-1/4	7,000	7,730	4.86	2	5.62	3.19	3.37	1.81	0.1	0.13	2.39	1.42	2.5	1.25	13
GF40	7/8	2-3/8	6,000	17,099	5.96	2.42	7.62	3.52	4.49	2.16	0.105	0.181	2.96	1.78	3.08	1.66	20
GF50	1	3	4,800	34,336	7.07	3.48	8.95	4.25	5.92	2.46	0.221	0.32	3.4	1.76	4.36	2.19	47
GF60	1	3-7/8	4,200	58,137	7.69	3.67	9.85	5.5	6.75	2.67	0.253	0.314	3.75	2	4.5	2.45	65
GF70	1-1/2	4-1/8	3,800	75,538	8.51	3.96	10.5	5.79	7.48	3.1	0.17	0.209	4.21	2.33	4.67	2.49	80
GF80	1-7/8	4-1/2	3,400	145,000	10.13	4.67	13.5	7	9.25	3.75	0.196	0.335	5	2.75	5.88	2.75	136
GF90	1-7/8	5-1/2	3,000	204,000	12.29	5.09	15.25	7.81	10.5	4.6	0.237	0.349	6	3.6	6.21	3.04	226
GF100	2-1/8	7	2,400	345,000	14.28	5.92	17.75	9.5	12.8	5.74	0.288	0.397	7.26	4.45	7.32	3.35	410
GF110	2-1/8	8	2,000	565,000	16.2	6.2	19.56	11	15.09	6.18	0.167	0.309	7.98	5	7.42	3.99	542
GF120	2-1/8	11	1,800	1,120,000	20.08	9.18	24.38	15	17.75	7.22	0.236	0.424	9.88	5.45	10.85	5.68	1136

* For applications above listed RPM, consult Martin.

\diamond All weights shown are approximate for a complete standard coupling assembly.

■ Maximum torque values (in-lbs) are based on use with black insert. Refer to page C-64 for complete torque ratings.

\circ Maximum bore size has reduced keyway on sizes GF20, GF30, and GF40.

Reduced keyways in max bore hubs measure as follows:

GF20VS1-5/8 - 3/8 x 3/32 keyway; GF30VS2-1/8 - 1/2 x 1/8 keyway;

GF40VS2-3/8 - 5/8 x 5/32 keyway.

Martin Go-Flex[®] Insert Maximum Torque Ratings (in-lb)

Coupling Series	Standard-Duty Red	Medium-Duty Dark Blue	Extreme-Duty Black	High Temp White	Metal Detectable Light Blue
GF20	1,254	2,457	3,789	2,457	1,254
GF30	4,099	7,730	11,914	7,730	4,099
GF40	8,630	17,099	25,870	17,099	8,630
GF50	17,315	34,336	52,408	34,336	17,315
GF60	30,353	58,137	87,110	58,137	30,353
GF70	38,048	75,538	116,432	75,538	38,048
GF80	75,000	145,000	220,000	145,000	75,000
GF90	105,000	204,000	310,000	204,000	105,000
GF100	175,000	345,000	550,000	345,000	175,000
GF110	300,000	565,000	870,000	565,000	300,000
GF120	599,700	1,120,000	1,680,000	1,120,000	599,700



Go-Flex® Keyway Sizes and Tolerances

Martin Go-Flex® Standard Bore Sizes

Coupling Size	PB	1/2	5/8	3/4	7/8	1	1-1/8	1-3/16	1-1/4	1-3/8	1-7/16	1-1/2	1-5/8	1-3/4	1-7/8	1-15/16
GF10	X	X	X	X	X	X	X	X	X							
GF20	X		X	X	X	X	X	X	X	X	X	X	X			
GF30	X				X	X	X	X	X	X	X	X	X	X	X	X
GF40	X				X	X	X		X	X	X	X	X	X	X	X
GF50	X											X	X	X	X	X
GF60	X															
GF70	X															
GF80	X															

Martin Go-Flex® Standard Bore Sizes (cont'd)

Coupling Size	2	2-1/8	2-3/16	2-1/4	2-3/8	2-7/16	2-1/2	2-5/8	2-3/4	2-7/8	2-15/16	3
GF10												
GF20												
GF30	X	X										
GF40	X	X	X	X	X							
GF50	X	X		X	X	X	X	X	X	X	X	X
GF60												
GF70												
GF80												

Martin Go-Flex® Bore Tolerances and Keyway Sizes

Shaft Diameter (Nom)	Keyway Size (Nom)		Bore Tolerances				Set Screw Size
	Width	Depth	Clearance Fit**		Interference fit**		
1/2 - 9/16	1/8	1/16	+0.0015	-0.0000	-0.0005	-0.0010	5/16
5/8 - 7/8	3/16	3/32	+0.0015	-0.0000	-0.0005	-0.0010	5/16
15/16 - 1-1/4	1/4	1/8	+0.0015	-0.0000	-0.0005	-0.0010	5/16
1-15/16 - 1-3/8	5/16	5/32	+0.0015	-0.0000	-0.0005	-0.0010	5/16
1-7/16 - 1-3/4	3/8	3/16	+0.0015	-0.0000	-0.0005	-0.0015	5/16
1-13/16 - 2-1/4	1/2	1/4	+0.0025	-0.0000	-0.0005	-0.0015	3/8
2-5/16 - 2-3/4	5/8	5/16	+0.0025	-0.0000	-0.0010	-0.0020	1/2
2-13/16 - 3-1/4	3/4	3/8	+0.0025	-0.0000	-0.0010	-0.0020	5/8
3-5/16 - 3-3/4	7/8	7/16	+0.0025	-0.0000	-0.0015	-0.0025	5/8
3-13/16 - 4-1/2	1	1/2	+0.0025	-0.0000	-0.0025	-0.0035	5/8

** For Class 1 Fit

Reduced keyways in max bore hubs measure as follows: GF20X1-5/8 - 3/8 x 3/32 keyway; GF30X2-1/8 - 1/2 x 1/8 keyway; GF40X2-3/8 - 5/8 x 5/32 keyway.

Torque Ratings



Torque Ratings for Martin Go-Flex® Carbon Steel Couplings with Standard Cover

Coupling Series	Insert Part Number	Insert Color	Continuous Torque (in-lb)	HP Ratings @ Various RPM (Service Factor = 1)							
				100	300	600	900	1200	1800	2400	3600
GF10	GF10SD-INS	Red	365	1	2	3	5	7	10	14	21
	GF10MD-INS	Blue	792	1	4	8	11	15	23	30	45
	GF10HT-INS	White	792	1	4	8	11	15	23	30	45
	GF10FG-INS	Light Blue	365	1	2	3	5	7	10	14	21
GF20	GF20SD-INS	Red	1,254	2	6	12	18	24	36	48	72
	GF20MD-INS	Blue	2,457	4	12	23	35	47	70	94	140
	GF20HT-INS	White	2,457	4	12	23	35	47	70	94	140
	GF20FG-INS	Light Blue	1,254	2	6	12	18	24	36	48	72
GF30	GF30SD-INS	Red	4,099	7	20	39	59	78	117	156	234
	GF30MD-INS	Blue	7,730	12	37	74	110	147	221	294	442
	GF30HT-INS	White	7,730	12	37	74	110	147	221	294	442
	GF30FG-INS	Light Blue	4,099	7	20	39	59	78	117	156	234
GF40	GF40SD-INS	Red	8,630	14	41	82	123	164	246	329	493
	GF40MD-INS	Blue	17,099	27	81	163	244	326	488	651	977
	GF40HT-INS	White	17,099	27	81	163	244	326	488	651	977
	GF40FG-INS	Light Blue	8,630	14	41	82	123	164	246	329	493
GF50	GF50SD-INS	Red	17,315	27	82	165	247	330	495	659	989
	GF50MD-INS	Blue	34,336	54	163	327	490	654	981	1,308	1,961
	GF50HT-INS	White	34,336	54	163	327	490	654	981	1,308	1,961
	GF50FG-INS	Light Blue	17,315	27	82	165	247	330	495	659	989
GF60	GF60SD-INS	Red	30,353	48	144	289	433	578	867	1,156	1,734
	GF60MD-INS	Blue	58,137	92	277	553	830	1,107	1,660	2,214	3,321
	GF60HT-INS	White	58,137	92	277	553	830	1,107	1,660	2,214	3,321
	GF60FG-INS	Light Blue	30,353	48	144	289	433	578	867	1,156	1,734
GF70	GF70SD-INS	Red	38,048	60	181	362	543	724	1,087	1,449	2,173
	GF70MD-INS	Blue	75,538	120	360	719	1,079	1,438	2,157	2,877	4,315
	GF70HT-INS	White	75,538	120	360	719	1,079	1,438	2,157	2,877	4,315
	GF70FG-INS	Light Blue	38,048	60	181	362	543	724	1,087	1,449	2,173
GF80	GF80SD-INS	Red	75,000	119	357	714	1,071	1,428	2,142	2,856	-
	GF80MD-INS	Blue	145,000	230	690	1,380	2,071	2,761	4,141	5,522	-
	GF80HT-INS	White	145,000	230	690	1,380	2,071	2,761	4,141	5,522	-
	GF80FG-INS	Light Blue	75,000	119	357	714	1,071	1,428	2,142	2,856	-
GF90	GF90SD-INS	Red	105,000	167	500	1,000	1,499	1,999	2,999	3,998	-
	GF90MD-INS	Blue	204,000	324	971	1,942	2,913	3,884	5,826	7,768	-
	GF90HT-INS	White	204,000	324	971	1,942	2,913	3,884	5,826	7,768	-
	GF90FG-INS	Light Blue	105,000	167	500	1,000	1,499	1,999	2,999	3,998	-
GF100	GF100SD-INS	Red	175,000	278	833	1,666	2,499	3,332	4,998	6,664	-
	GF100MD-INS	Blue	345,000	547	1,642	3,284	4,927	6,569	9,853	13,138	-
	GF100HT-INS	White	345,000	547	1,642	3,284	4,927	6,569	9,853	13,138	-
	GF100FG-INS	Light Blue	175,000	278	833	1,666	2,499	3,332	4,998	6,664	-
GF110	GF110SD-INS	Red	300,000	476	1,428	2,856	4,284	5,712	8,568	-	-
	GF110MD-INS	Blue	565,000	896	2,689	5,379	8,068	10,758	16,136	-	-
	GF110HT-INS	White	565,000	896	2,689	5,379	8,068	10,758	16,136	-	-
	GF110FG-INS	Light Blue	300,000	476	1,428	2,856	4,284	5,712	8,568	-	-
GF120	GF120SD-INS	Red	599,700	952	2,855	5,709	8,564	11,418	17,127	-	-
	GF120MD-INS	Blue	1,120,000	1,777	5,331	10,662	15,994	21,325	31,987	-	-
	GF120HT-INS	White	1,120,000	1,777	5,331	10,662	15,994	21,325	31,987	-	-
	GF120FG-INS	Light Blue	599,700	952	2,855	5,709	8,564	11,418	17,127	-	-

Martin Go-Flex® flexible couplings can sustain momentary peak torque loads in excess of 200% of its maximum torque rating.



Torque Ratings

Torque Ratings for Martin Go-Flex® Carbon Steel Couplings with Horizontal Split, Vertical Split and Horizontal/ Vertical Split Cover

Coupling Series	Insert Part Number	Insert Color	Continuous Torque (in-lb)	HP Ratings @ Various RPM (Service Factor = 1)							
				100	300	600	900	1200	1800	2400	3600
GF20	GF20SD-INS	Red	1,254	2	6	12	18	24	36	48	72
	GF20MD-INS	Blue	2,457	4	12	23	35	47	70	94	140
	GF20XD-INS	Black	3,789	6	18	36	54	72	108	144	216
	GF20HT-INS	White	2,457	4	12	23	35	47	70	94	140
	GF20FG-INS	Light Blue	1,254	2	6	12	18	24	36	48	72
GF30	GF30SD-INS	Red	4,099	7	20	39	59	78	117	156	234
	GF30MD-INS	Blue	7,730	12	37	74	110	147	221	294	442
	GF30XD-INS	Black	11,914	19	57	113	170	227	340	454	681
	GF30HT-INS	White	7,730	12	37	74	110	147	221	294	442
	GF30FG-INS	Light Blue	4,099	7	20	39	59	78	117	156	234
GF40	GF40SD-INS	Red	8,630	14	41	82	123	164	246	329	493
	GF40MD-INS	Blue	17,099	27	81	163	244	326	488	651	977
	GF40XD-INS	Black	25,870	41	123	246	369	493	739	985	1,478
	GF40HT-INS	White	17,099	27	81	163	244	326	488	651	977
	GF40FG-INS	Light Blue	8,630	14	41	82	123	164	246	329	493
GF50	GF50SD-INS	Red	17,315	27	82	165	247	330	495	659	989
	GF50MD-INS	Blue	34,336	54	163	327	490	654	981	1,308	1,961
	GF50XD-INS	Black	52,408	83	249	499	748	998	1,497	1,996	2,994
	GF50HT-INS	White	34,336	54	163	327	490	654	981	1,308	1,961
	GF50FG-INS	Light Blue	17,315	27	82	165	247	330	495	659	989
GF60	GF60SD-INS	Red	30,353	48	144	289	433	578	867	1,156	1,734
	GF60MD-INS	Blue	58,137	92	277	553	830	1,107	1,660	2,214	3,321
	GF60XD-INS	Black	87,110	138	415	829	1,244	1,659	2,488	3,317	4,976
	GF60HT-INS	White	58,137	92	277	553	830	1,107	1,660	2,214	3,321
	GF60FG-INS	Light Blue	30,353	48	144	289	433	578	867	1,156	1,734
GF70	GF70SD-INS	Red	38,048	60	181	362	543	724	1,087	1,449	2,173
	GF70MD-INS	Blue	75,538	120	360	719	1,079	1,438	2,157	2,877	4,315
	GF70XD-INS	Black	116,432	185	554	1,108	1,663	2,217	3,325	4,434	6,651
	GF70HT-INS	White	75,538	120	360	719	1,079	1,438	2,157	2,877	4,315
	GF70FG-INS	Light Blue	38,048	60	181	362	543	724	1,087	1,449	2,173
GF80	GF80SD-INS	Red	75,000	119	357	714	1,071	1,428	2,142	2,856	-
	GF80MD-INS	Blue	145,000	230	690	1,380	2,071	2,761	4,141	5,522	-
	GF80XD-INS	Black	220,000	349	1,047	2,094	3,142	4,189	6,283	8,378	-
	GF80HT-INS	White	145,000	230	690	1,380	2,071	2,761	4,141	5,522	-
	GF80FG-INS	Light Blue	75,000	119	357	714	1,071	1,428	2,142	2,856	-
GF90	GF90SD-INS	Red	105,000	167	500	1,000	1,499	1,999	2,999	3,998	-
	GF90MD-INS	Blue	204,000	324	971	1,942	2,913	3,884	5,826	7,768	-
	GF90XD-INS	Black	310,000	492	1,476	2,951	4,427	5,902	8,854	11,805	-
	GF90HT-INS	White	204,000	324	971	1,942	2,913	3,884	5,826	7,768	-
	GF90FG-INS	Light Blue	105,000	167	500	1,000	1,499	1,999	2,999	3,998	-
GF100	GF100SD-INS	Red	175,000	278	833	1,666	2,499	3,332	4,998	6,664	-
	GF100MD-INS	Blue	345,000	547	1,642	3,284	4,927	6,569	9,853	13,138	-
	GF100XD-INS	Black	550,000	873	2,618	5,236	7,854	10,472	15,708	20,944	-
	GF100HT-INS	White	345,000	547	1,642	3,284	4,927	6,569	9,853	13,138	-
	GF100FG-INS	Light Blue	175,000	278	833	1,666	2,499	3,332	4,998	6,664	-
GF110	GF110SD-INS	Red	300,000	476	1,428	2,856	4,284	5,712	8,568	-	-
	GF110MD-INS	Blue	565,000	896	2,689	5,379	8,068	10,758	16,136	-	-
	GF110XD-INS	Black	870,000	1,380	4,141	8,282	12,424	16,565	24,847	-	-
	GF110HT-INS	White	565,000	896	2,689	5,379	8,068	10,758	16,136	-	-
	GF110FG-INS	Light Blue	300,000	476	1,428	2,856	4,284	5,712	8,568	-	-
GF120	GF120SD-INS	Red	599,700	952	2,855	5,709	8,564	11,418	-	-	-
	GF120MD-INS	Blue	1,120,000	1,777	5,331	10,662	15,994	21,325	-	-	-
	GF120XD-INS	Black	1,680,000	2,666	7,997	15,994	23,990	31,987	-	-	-
	GF120HT-INS	White	1,120,000	1,777	5,331	10,662	15,994	21,325	-	-	-
	GF120FG-INS	Light Blue	599,700	952	2,855	5,709	8,564	11,418	-	-	-

Martin Go-Flex® flexible couplings can sustain momentary peak torque loads in excess of 200% of its maximum torque rating.

Misalignment Tolerances



Martin Go-Flex® Couplings Misalignment Tolerances

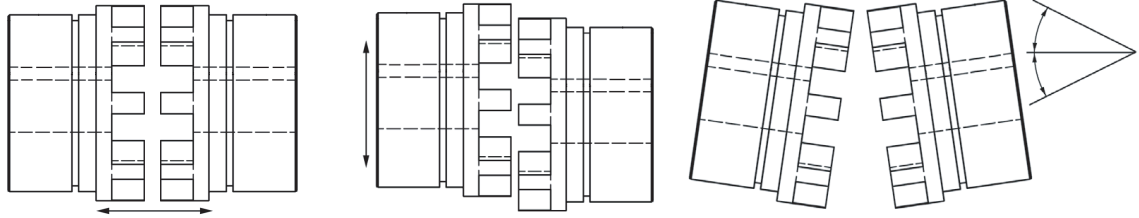

Coupling Series	Axial Misalignment Tolerance (in)	Radial Misalignment Tolerance (in)	Angular Misalignment Tolerance
GF10	0.078	0.020	2°
GF20	0.116	0.039	2°
GF30	0.116	0.039	2°
GF40	0.116	0.039	2°
GF50	0.156	0.058	2°
GF60	0.175	0.058	1.3°
GF70	0.234	0.058	1.3°
GF80	0.234	0.058	1°
GF90	0.234	0.058	1°
GF100	0.312	0.058	1°
GF110	0.312	0.078	1°
GF120	0.312	0.078	1°

Application	Factor
AERATORS	2.5
AGGREGATE PROCESSING, CEMENT, MINING KILNS	
Direct or on Line Shaft of Reducer	
With Final Drive Machined Spur Gears	2.25
With Single Helical or Herringbone Gears	2.0
Crushers, Ore or Stone	2.75
Dryer, Rotary	2.0
Grizzly	2.25
Hammermill or Hog	2.0
Tumbling Mill or Barrel	2.0
AGITATORS	
Vertical, Horizontal, Screw, Propeller, Paddle	1.25
BARGE HAUL PULLER	1.75
BLOWERS	
Centrifugal	1.5
Lobe or Vane	1.5
BREWING AND DISTILLING	
Bottle and Can Filling Machines	1.5
Brew Kettle	1.25
Cookers, Continuous Duty	1.5
Lauter Tub	1.75
Mash Tub	1.5
Scale Hopper, Frequent Peaks	2.0
CLARIFIER OR CLASSIFIER	1.25
CLAY WORKING INDUSTRY	
Brick Press, Briquette Machine, Clay Working Machine, Pug Mill	2.0
COMPRESSORS	
Centrifugal	1.25
Rotary, Lobe or Vane	1.5
Rotary, Screw	1.5
Reciprocating	
Direct Connected	Refer to Factory
Without Flywheels	Refer to Factory
With Flywheel and Gear between Compressor and Prime Monitor	
1 Cylinder, Single Acting	3.0
1 Cylinder, Double Acting	3.0
2 Cylinders, Single Acting	3.0
2 Cylinders Double Acting	3.0
3 Cylinders Single Acting	3.0
3 Cylinders, Double Acting	2.0
4 Or More Cyl Single Acting	2.5
4 Or More Cyl Double Acting	2.5

Application	Factor
CONVEYORS	
Apron, Assembly, Belt, Chain, Flight, Screw	1.75
Bucket	1.75
Live Roll, Shaker and Reciprocating	3.0
Bridge, Travel or Trolley	2.50
DREDGERS	
Cable Reel	2.0
Conveyors	1.50
Cutter Head, Jig Drive	2.5
Maneuvering Winch	1.75
Pumps (Uniform Load)	1.75
Screen Drive, Stacker	2.0
Utility Winch	2.0
DYNAMOMETER	1.5
ELEVATORS - BUCKET, CENTRIFUGAL DISCHARGE	1.75
EXCITER, GENERATOR	1.5
EXTRUDER, PLASTIC	1.5
FANS	
Centrifugal	1.25
Cooling Tower	2.0
Forced Draft-Across the Line Start	1.75
FOOD INDUSTRY	
Beet Slicer	2.0
Bottling, Can, Filling Machine	1.5
Cereal Cooker	1.5
Dough Mixer, Meat Grinder	2.0
Forced Draft Motor driven thru fluid or Electric Slip Clutch	1.25
Gas Recirculating	1.50
Induced Draft with damper control or blade cleaner	1.50
Induced Draft without controls	2.0
FEEDERS	
Apron, Belt, Disc, Screw	1.25
Reciprocating	2.5
GENERATORS	
Even Load	1.25
Hoist or Railway Service	1.75
Welder Load	2.0
HAMMERMILL	1.75
LAUNDRY WASHER OR TUMBLER	2.0
LINE SHAFTS ANY PROCESSING MACHINERY	1.5
LUMBER	
Band Resaw	2.0
Circular Resaw, Cutoff	2.0
Edger, Head Rig, Hog	2.5
Gang Saw (Reciprocating)	3.0

Application	Factor
Log Haul	2.5
Planer	2.0
Rolls, Non-Reversing	1.5
Rolls, Reversing	2.5
Sawdust Conveyor	1.5
Slab Conveyor	2.0
Sorting Table	1.75
Trimmer	2.0
MACHINE TOOLS	
Auxiliary and Traverse Drive	1.0
Bending Roll, Notching Press, Punch, Press, Planer, Plate Reversing	1.75
Main Drive	1.5
METAL ROLLING MILLS	
Coilers (Up or Down) Cold Mill Only	1.75
Coilers (Up or Down) Hot Mill Only	2.25
Coke Plants	
Pusher Ram Drive	2.75
Door Opener	2.25
Pusher or Larry Car Traction Drive	3.25
Continuous Caster	2.0
Cold Mills	
Strip Mills	Refer to Factory
Temper Mills	Refer to Factory
Cooling Beds	1.75
Drawbench	2.25
Feed Rolls - Blooming Mills	3.25
Furnace Pushers	2.25
Hot and Cold Saws	2.25
Hot Mills	
Strip or Sheet Mills	Refer to Factory
Reversing Blooming	Refer to Factory
Slabbing Mills	
Edger Drives	
Ingot Cars	2.25
Manipulators	3.25
Merchant Mills	Refer to Factory
Mill Tables	
Roughing Breakdown Mills	3.25
Hot Bed or Transfer (non-reversing)	1.75
Runout (reversing)	3.25
Runout (non-reversing, non-plugging)	2.25
Reel Drives	2.0
Rod Mills	Refer to Factory
Screwdown	2.25
Seamless Tube Mills	
Piercer	3.25

* For reversing applications with high inertia loads, please consult Martin.

Go-Flex® Service Factors (Cont'd)



Application	Factor
Thrust Block	2.25
Tube Conveyor Rolls	2.25
Reeler	2.25
Kick Out	2.25
Shear, Croppers	Refer to Factory
Sideguards	3.25
Skelp Mills	Refer to Factory
Slitters (Steel Mill only)	2.0
Soaking Pit Cover Drives	
Lift	1.25
Travel	2.25
Straighteners	2.25
Unscramblers (Billet Bundle Busters)	2.25
Wire Drawing Machinery	2.0
MIXERS (ALSO SEE AGITATORS)	
Concrete	1.75
Muller	1.5
OIL INDUSTRY	
Chiller	1.50
Oilwell Pumping (not over 150% peak torque)	2.5
Paraffin Filter Press	1.75
Rotary Kiln	2.5
PAPER MILLS	
Barker, Auxiliary, Hydraulic	2.5
Barker, Mechanical	2.5
Barker, Drum L.S. shaft of reducer with final drive-	
Helical or Herringbone Gear	2.5
Machined Spur Gear	3.0
Cast Tooth Spur Gear	3.0
Beater and Pulper	2.0
Bleachers, Coaters	1.5
Calendar and Super Calendar	2.0
Chipper	3.0
Converting Machine	1.5
Couch	2.0
Cutter, Felt Whipper	2.25
Cylinder, Dryer	2.0
Felt Stretcher	1.75
Fourdrinier	2.0
Jordan	2.5
Log Haul	2.5
Line Shaft	1.75
Press	2.0
Pulp Grinder	2.0
Reel, Rewinder, Winder	2.0
Stock Chest, Washer, Thickener	1.75

Application	Factor
Stock Pumps, Centrifugal	
Constant Speed	1.25
Frequent Speed Changes Under Load	1.5
Suction Roll	2.0
PRESS, PRINTING	1.5
PUG MILL	1.75
PULVERIZERS	
Hammermill and Hog	1.75
Roller	1.5
PUMPS CENTRIFUGAL	
Constant Speed	1.0
Frequent Speed Changes Under Load	1.75
Descaling, with Accumulators	1.75
Gear, Rotary, or Vane	1.75
PUMPS RECIPROCATING	
1 Cyl., single or double acting	3.0
2 Cyl., single acting	2.5
2 Cyl., double acting	2.0
3 or more cylinders	2.0
RUBBER INDUSTRY	
Calendar	2.25
Cracker, Plasticolour	2.5
Extruder	2.0
Tire and Tube Press Opener (peak torque)	1.5
Warming Mill	
One or two mills in line	2.0
Three or more mills in line	2.5
Washer	2.75
SCREENS	
Air Washing	1.5
Grizzly	2.5
Rotary Coal or Sand	2.0
Vibrating	2.5
Water	1.5
SEWAGE DISPOSAL EQUIPMENT	
Bar Screen, Chemical Feeders, Collectors,	
Dewatering Screen, Grit Collector	1.5
Mill Stands, Turbine Driven with all Helical or Herringbone Gears	1.75
Electric Drive or Steam Engine Drive with Helical or Herringbone	2.0
STOKER	1.0
SUGAR INDUSTRY	
Cone Carrier and Leveler	2.25
Cane Knife and Crusher	2.5
Mill Stands, Turbine Driver with all helical or Herringbone Gears	1.75

Application	Factor
Electric Drive or Steam Engine Drive with helical, Herringbone, or Spur Gears with any Prime Mover	2.0
TEXTILE INDUSTRY	
Batcher	1.5
Calendar, Card Machine	1.75
Cloth Finishing Machine	1.75
Dry Can, Loom	1.75
Dyeing Machinery	1.5
Knitting Machine	Refer to Factory
Mangle, Napper, Soaper	1.5
Spinner, Tenter Frame, Winder	1.75
TUMBLING BARREL	2.0
WINCH, MANEUVERING - DREDGE, MARINE	1.5
WINDLASS	1.5

Engine Service Factors

Service Factors for engine drives are those required for applications where good flywheel regulation prevents torque fluctuation greater than 20%. For drives where torque fluctuations are greater or where the operation is near a serious critical or torsional vibration, a mass elastic study is necessary.

To determine an engine drive service factor, first determine the application service factor for motors. Then, use that to find the correct engine service factor in the table below. When the application service factor for motors is greater than 2.0 or where 1, 2, or 3 cylinder engines are involved, please contact customer service with complete application details for engineering review.

Application Service Factor	Engine Factor	
	4 to 5 Cylinders	6+ Cylinders
1.0	2.0	1.5
1.25	2.25	1.75
1.5	2.5	2.0
1.75	2.75	2.25
2.0	3.0	2.5

* For reversing applications with high inertia loads, please consult Martin.

A = Little to No Effect

Acetaldehyde	C
Acetamide	N
Acetic Acid	C
Acetic Anhydride	C
Acetone	C
Acetyl Bromide	C
Acetyl Chloride	C
Acetylene	C
Adipic Acid	A
Aero Shell Grease	B
Aero Lubriplate	A
Aero Safe 2300	N
Aerocene 50	N
Aluminum Acetate	N
Aluminum Bromide	N
Aluminum Chloride	B
Aluminum Sulfate	B
Ammonia	B
Ammonium Carbonate	B
Ammonium Chloride	N
Ammonium Hydroxide	B
Ammonium Nitrate	B
Ammonium Persulfate	B
Ammonium Sulfate	B
Ammonium Sulfide	B
Ammonium Thiocyanate	B
Ammonium Acetate	C
Amyl Acetate	C
Amyl Alcohol	C
Aniline	C
Aniline Hydrochloride	C
Animal Fats and Oils	B
Antimony Salts	B
Aqua Regia	C
Arsenic Salts	B
ASTM Oil #1	A
ASTM Oil #2	B
ASTM Oil #3	B
ASTM Reference Fuel	A
ASTM Reference Fuel	B
Atlantic Oil	A
Barium Carbonate	B
Barium Hydroxide	A
Beer	A
Benzaldehyde	B
Benzene	C
Benzoic Acid	B
Black Sulphate Liquors	N
Bleach Solutions	N
Boric Acid	A

B = Minor to Moderate Effect

Brake Fluid	N
Bromine	B
Bunker Oil	A
Butane	A
Butyl Acetate	C
Butyl Alcohol	B
Calcium Carbonate	B
Calcium Chloride	A
Calcium Hydroxide	A
Calcium Nitrate	B
Calcium Sulfate	B
Carbon Dioxide	A
Carbon Disulfide	B
Carbon Monoxide	A
Carbon Tetrachloride	C
Chlorine	N
Chloroacetic Acid	C
Chloroform	C
Chromic Acid	C
Chromium Potassium Sulfate	B
Citric Acid	B
Corn Oil	A
Cottonseed Oil	A
Cresol	C
Crude Oil	B
Cupric Chloride	A
Cupric Nitrate	B
Cupric Sulfate	B
Cutting Oil	B
Cyclohexane	B
Cyclohexanone	C
Dibutyl Phthalate	C
Dichlorobenzene	C
Diesel Fuel	B
Diester Oil	B
Dimethyl Acetamide	C
Dimethyl Formamide	C
Dodecyl Mercaptan	B
DTE Oil	B
Dibutyl Ether	B
EP Lubes	A
Esso #90 Lube Oil	A
Ether	B
Ethyl Acetate	C
Ethyl Alcohol (Ethanol)	C
Formic Acid	C
Freon, 12 or 113	A
Fuel Oil	B
Gasoline	B
Glucose	A

C = Severe Effect to Destruction

Glue	N
Glycerin	A
Heptane	A
Hexane	A
Hydrazine	C
Hydrobromic Acid	B
Hydrocarbon Oil	A
Hydrochloric Acid	B
Hydrofluoric Acid	B
Hydrogen	A
Hydrogen Peroxide	B
Hydrogen Sulfide	C
Hydrologic Acid	B
Iodine	A
Isobutyl Alcohol	N
Isopropyl Chloride	N
Isopropyl Ether	B
Isopropyl Alcohol (Propanol)	B
JP4 Oil	B
JP5 and 6 Oil	C
Kerosene	B
Lactic Acid	B
Lead Acetate	B
Linseed Oil	B
Liquefied Petroleum Gas	A
Lubrication Oil	B
Lye	N
Magnesium Chloride	N
Magnesium Hydroxide	A
Magnesium Salts	B
Malaic Acid	C
Mercury	B
Methyl Alcohol (methanol)	A
Methyl Ethyl Ketone	C
Methylene Chloride	C
MIL-D-5606 Oil	C
MIL-L-7808 Oil	B
Mineral Oil	A
Mineral Spirits	N
Naphthalene	B
Natural Gas	B
Nickel Salts	C
Oxygen	A
Ozone	A
Palmitic Acid	A
Paint Thinner	B
Peanut Oil	A
Perchloric Acid	C
Perchloroethylene	C
Petroleum	B

N = No Data; Test Prior to Use

Phenol (carbolic acid)	C
Phosphoric Acid	C
Potassium Cyanide	A
Potassium Salts	B
Propane	B
Propyl Alcohol	B
Propylene Glycol	B
Pydraul Oil	C
SAE #10 Oil	A
Seawater	A
Silicic Acid	B
Silver Nitrate	B
Skydrol Oil	C
Soap	B
Sodium Acetate	A
Sodium Bicarbonate	B
Sodium Borate	B
Sodium Carbonate	B
Sodium Chloride	B
Sodium Cyanide	B
Sodium Hydrosulfite	B
Sodium Hydroxide	B
Sodium Hypochlorite	C
Sodium Nitrate	B
Sodium Silicate	A
Sodium Sulfate	B
Sodium Sulfide	B
Steam	C
Styrene	B
Sulfur Dioxide	B
Sulfuric Acid	C
Tannic Acid	A
Tartaric Acid	A
Toluene	C
Transformer Oil	B
Turpentine	C
Urea	B
Varnish	B
Water	B

Go-Flex® Coupling Installation Instructions



Please follow the step by step installation instructions to properly install Martin Go-Flex® Couplings:

Required components:

2 Hubs

1 Insert

1 Cover with hardware: Identify what style cover you are using as this will determine the proper installation procedure.

There are three types of covers (Figure 1):

- 1. Standard Cover (SD):** for coupling sizes GF10 through GF70 a standard snap ring secures cover in place.
- 2. Horizontal Split Cover (XP):** It is a free floating cover that encapsulates the insert and the shoulder of both hubs. Each cover assembly comes with four socket head cap screws to secure the two halves together.
- 3. Vertical Split Cover (VS):** GF20 through GF70 use eight bolts around the rim to secure the two halves together, GF80 through GF100 use 16 bolts with lock washers to secure the covers to one of the hubs.
- 4. Horizontal/Vertical Split Cover (HS):** GF20 through GF70 use eight bolts around the rim to secure the 4 parts. Together, GF80 through GF100 use 16 bolts with lock washers to secure the covers to one of the hubs.

Figure 1. Martin Go-Flex® covers and types

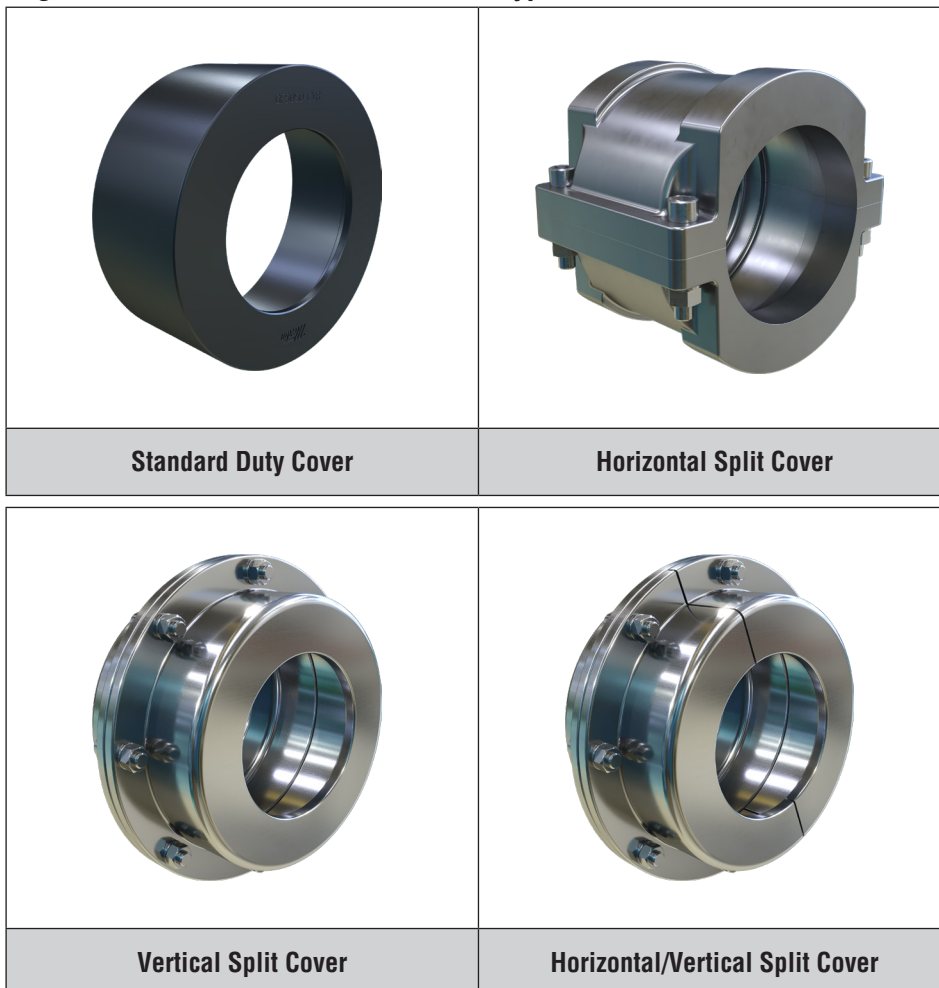

Installation Instructions:

1. Confirm bore sizes of each coupling half and the corresponding shaft diameter to ensure that you have the proper bore size.
2. Ensure that the shafts are clean and free from burrs.
3. Verify cover style:
 - When using a **Standard Duty Cover (SD)**, it should be located on the driven shaft. If space is limited, then it can be mounted on the drive shaft. Slide snap ring first, then **Standard Duty Cover (SD)** with larger opening facing the shaft separation.
 - When using an **Horizontal Split Cover (XP)**, proceed to step 4.
 - When using a **Vertical Split Cover (VS)**, Install one cover half on each shaft with flange side facing the shaft separation prior to installing the hubs.
 - If using a **Vertical Split Cover (VS)**, **GF70 or larger**, use bolts and washers to secure in place. Slide one bolt into place until installation is complete.
4. Installing the first hub: It should be mounted so that the end of the shaft is flush with surface A as shown in Figure 2. It is acceptable for the shaft to extend past A as long as it is not past the teeth shown as B.

Please note: Standard hubs are supplied with a clearance fit and should slide onto the shaft without excessive force. If the hubs have been ordered with interference fit (shrink fit), then heat the coupling halves to approximately 572°F (300°C) before installing on shafts.
5. With the insert in place, install the second hub. This will help establish set the hubs at the minimum hub gap (E min) dimension to ensure proper clearance. Please see Table 1 on the next page for specific E min and E max dimensions.
6. Now ensure both hubs are securely tightened to the shafts.
7. Check coupling for misalignment and align as necessary. Please refer to page C-72 Martin Big Catalog for misalignment tolerances.
8. Installation of cover:
 - **Standard Duty Cover (SD)**: slide the cover over hub and insert until the step in the cover contacts the shoulder of the hub. Use snap ring pliers to slide snap ring over hub and into snap ring groove in hub to hold the cover in place for GF10 through GF60. GF70 and above use the bolts and washer to secure the cover to the hub. Reference Table 2 for recommended tightening torque..
 - **Horizontal Split Cover (HP)**: place each half over the insert and shoulder on hubs. Secure the two housing halves together by using the included hardware set supplied. Reference Table 2 for recommended tightening torque.
 - **Vertical Split Cover (VS)**: slide the two cover halves over the hub and insert until faces meet. Install the radial outer bolts used to secure the two halves together. If cover uses a snap ring, use snap ring pliers to slide snap ring over hub and into snap ring groove in hub to hold the cover in place. For GF70 or larger, use bolts and washers to secure the cover to one hub. Reference Table 2 for recommended tightening torque.
 - **Horizontal/Vertical Split Cover (HS)**: place each part around the hub and Install the radial outer bolts used to secure the parts together. If cover uses a snap ring, use snap ring pliers to slide snap ring over hub and into snap ring groove in hub to hold the cover in place. For GF70 or larger, use bolts and washers to secure the cover to one hub. Reference Table 2 for recommended tightening torque.

Maximum RPM and Balance:

The Martin Go-Flex® Coupling inherently has good dynamic balance due to our manufacturing process. In high speed applications, it is important that the key used to attach hubs to shaft is the same length as the hub. The set screws should also be changed to full length to fill the hole. Please refer to Table 1 on the next page for maximum RPM ratings.

Go-Flex® Coupling Installation Instructions



Figure 2. Martin Go-Flex® shaft-to-hub alignment.
See page C-72 for Misalignment Tolerances.

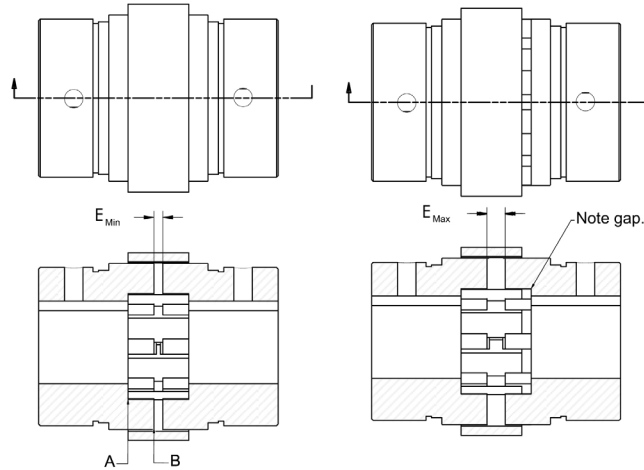

Table 1. EMIN and EMAX Dimensions

Coupling Series	Maximum RPM*	Standard Split Cover		Horizontal Split Cover		Vertical and Horizontal/Vertical Split Covers	
		EMIN	EMAX	EMIN	EMAX	EMIN	EMAX
GF10	4000	0.062	0.092	—	—	—	—
GF20	4000	0.036	0.110	0.036	0.220	0.036	0.126
GF30	4000	0.080	0.205	0.080	0.160	0.080	0.140
GF40	4000	0.035	0.208	0.035	0.160	0.035	0.220
GF50	4000	0.140	0.290	0.140	0.370	0.140	0.380
GF60	4000	0.188	0.208	0.188	0.368	0.188	0.348
GF70	3800	0.100	0.230	0.100	0.318	0.100	0.258
GF80	3400	0.125	0.250	0.204	0.375	0.204	0.375
GF90	3000	0.194	0.388	—	—	0.189	0.410
GF100	2400	0.241	0.278	—	—	0.242	0.454
GF110	2000	0.121	0.305	—	—	0.121	0.380
GF120	1800	0.158	0.505	—	—	0.147	0.492

For applications over 4000 RPM, consult Martin.

Table 2. Tightening Torque Chart

Coupling Size	Standard Split Cover	Horizontal Split Cover	Vertical and Horizontal/Vertical Split Covers	
	Cover Bolt Torque (in-lbs)	Cover Bolt Torque (in-lbs)	Cover Bolt Torque (in-lbs)	Cover Side Bolt Torque (in-lbs)
GF10	Snap Ring	-	-	-
GF20	Snap Ring	300	150	Snap Ring
GF30	Snap Ring	600	150	Snap Ring
GF40	Snap Ring	1000	775	Snap Ring
GF50	Snap Ring	1000	775	Snap Ring
GF60	Snap Ring	2500	775	Snap Ring
GF70	775	2500	775	775
GF80	775	2500	1300	775
GF90	775	-	1300	775
GF100	1300	-	1300	1300
GF110	1300	-	1300	1300
GF120	1300	-	1300	1300

Notes

Martin