

1101

--*-- --*-- --*-- --*-- --*-- --*-- --*-- --*-- --*-- --*-- --*--

A PROPOSED COURSE OF STUDY
IN
HOME MECHANICS FOR GIRLS
With special reference to
A GIRLS' JUNIOR TECHNICAL HIGH SCHOOL

By
Ruth Hurlbut, A. B.

0378.37
H93p
c.2

A Thesis submitted to the Faculty of the Graduate School,
Marquette University, in Partial Fulfillment of the
Requirements for the Degree of Master of Arts.

MILWAUKEE, WISCONSIN

May, 1934

--*-- --*-- --*-- --*-- --*-- --*-- --*-- --*-- --*-- --*-- --*--

TABLE OF CONTENTS

	<u>Pages</u>
Chapter I. Introduction.....	1 - 8
Need for the Course.....	2
Terminology.....	3
Mechanical Ability of Girls and Boys Com- pared.....	6
Chapter II. Criteria for the Selection of Subject Mat- ter.....	8 - 14
Method of Procedure.....	9
Technic for Survey Materials.....	10
Analysis as the Basis of Processes.....	11
Time Allowance.....	12
Chapter III. Historical Evolution of Home Mechanics.....	14 - 24
Early Objectives.....	15
Movements of the Seventeenth Century.....	16
Outstanding Leaders 1632-1827.....	17
Leaders of the Nineteenth and Twentieth Centuries.....	18
First Industrial Education Association.....	21
Smith-Hughes Act.....	21
Beginnings of Home Mechanics.....	22
Chapter IV. Home Mechanics a Part of General Education Suitable to the Junior High School Period...	24 - 28
Junior High School Objectives.....	25
Some Adolescent Characteristics.....	26
Chapter V. Objectives.....	28 - 36
Dept. of Education 7-B Industrial Arts Ob- jectives.....	29
Aims of Cleveland Home Mechanics for Boys...	31
Bobbitt - Practical Activities for Girls....	32
Edgerton's Idea.....	34
Snedden's Idea.....	34
Aims of this Course.....	34
Chapter VI. Materials to Assist in Effective Teaching...	36 - 47
Visual Materials.....	37
Exhibits and Panels.....	37
Wall Charts and Pictures.....	37
Browsing Corner.....	37
Excursions.....	37
Talks.....	37
Individual Instruction Sheets as an Aid to Teaching.....	37

	<u>Pages</u>
Chapter VII. Method of Administering the Course.....	47 - 53
Fundamental Jobs Defined.....	48
Core Jobs Defined.....	49
Supplementary Jobs Defined.....	50
Chapter VIII. Records and Tests.....	53 - 67
Class List and Job Sheet Record.....	56
Individual Progress Card.....	57
Class Progress Card.....	58
Individual Cost Record.....	59
Testing - Purposes.....	61
Plan for this Course.....	62
Essentials of a Good Test.....	62
Various Types of Tests.....	63
Suggestive Tests for use in Home Mechanics Classes.....	65
What a Home Mechanics Test Should Do.....	66
Chapter IX. The General Shop.....	67 - 72
Definitions.....	68
White House Conference Standards.....	69
Equipment for Teaching this Course.....	69
Chapter X. A Proposed Course of Study.....	72 - 119
Fundamental Jobs.....	73
Supplementary Jobs.....	97
Suggested Core Jobs.....	99
Suggested Cooperative Civic Projects.....	99
Illustrative Job Sheets.....	100
What Pupils Should Know and Be Able to Do.....	114
Appendix A.....	120 - 133
Table I. Results of Questionnaire Showing Number of Cases and Ranking of Each of 128 Jobs.....	121
Table II. Fifty Jobs of Greatest Frequency Ar- ranged According to Rank and Fre- quency.....	125
Table III. Analysis of Woodworking Jobs.....	127
Table IV. Analysis of Painting and Finishing Jobs.....	128
Table V. Analysis of Electrical Jobs.....	129
Table VI. Analysis of Plumbing and Miscellaneous Jobs.....	130
Table VII. List of Essential Operations.....	131

	<u>Pages</u>
Appendix B. Some Typical Test Forms.....	133 - 141
Wells Woodworking Test.....	134
Newkirk Home Mechanics Test.....	135
Stenquist Mechanical Aptitudes Test.....	136
Detroit Mechanical Aptitudes Test for Girls.....	137
Hunter Shop Tests, W1.....	138
Hunter Shop Tests, W6.....	139
Hunter Shop Tests, W7.....	140
Appendix C. Suggested Books for the Shop Library.....	141 - 147
Appendix D. List of Free Films, Pamphlets, and Bulletins....	147 - 151
Bibliography.....	151 - 173
I. Books.....	152
II. Periodicals.....	171

PREFACE

This thesis is an attempt to give to the teacher of industrial arts a course of study in home mechanics for girls, based upon the principle of social utility.

The groundwork of the course is an analysis of the home repair activities actually participated in by girls and women. A definite technic for finding the essential learning units of each job is given. Sample operation sheets based upon this technic are shown. An effort has been made to provide a remedy for the defect most commonly found in job sheets by constructing them in such a manner that the pupil is obliged to do her own organizing.

Each job in the course is provided with ample references. Lists of books for the school bookshelves, references for teachers, and sources of visual materials and pamphlets are also given.

Grateful acknowledgment is made to Mr. Chas. Perry and Mr. Roy Radtke of the Milwaukee Public Schools, for their assistance in compiling the material for the questionnaire.

Thanks is also due Lewis Newkirk, R. W. Selvidge, and others who so kindly supplied material and courses of study.

Ruth Hurlbut

--*-- --*-- --*-- --*-- --*-- --*-- --*-- --*-- --*-- --*--

--*--

CHAPTER I

INTRODUCTION

--*--

--*-- --*-- --*-- --*-- --*-- --*-- --*-- --*-- --*-- --*--

We of today live in a world of devices, mechanical, electrical, chemical and physical. The average home employs, as a matter of course, many wonderful appliances and others are almost daily being invented.

So extensive is the array of mechanisms and the list of necessary tools employed in living that increasingly we need, as a part of general education, an organized and orderly process of training in their use and appreciation. Such training is given by work in Home Mechanics.

The term "home mechanics" is one chosen from a great variety of titles seeking to designate the particular type of activities of the home. Bobbitt defines them as "unspecialized practical arts". Charters calls them "home repair projects". Bedell names them "household mechanics", while Boynton classifies them as "manual arts projects" and justifies his choice by this quotation from the Bureau of Education:

"It (manual arts) is the historic term and defines and limits more clearly the work with which we are concerned; it is more definite than Practical Arts, which includes Household Arts and Agriculture: it is less restricted than Mechanic Arts: it avoids the possible confusion of Industrial Arts and Industrial Education. The term Manual Training has in recent years fallen into such disuse that it is doubtful if it will in the future be recognized in educational work." 1

1. Bureau of Education Bulletin, #11, 1924, p. 2.

The Board of Education of Cleveland calls these tasks "Simple Mechanics" while many others term activities of a similar type, "Farm Mechanics".

The basis of all courses, however, is practically the same - the

need of the ordinary individual for certain knowledges and skills by means of which he or she may renovate and repair home appliances.

In most cities these courses are open only to boys and are variously defined according to their various objectives.

Earl Bedell, in his course for the City of Detroit, defines it thus:

"Household Mechanics is a shop course which aims to provide general education; it does not give training for a definite vocation. From the practical point of view, its purpose is to teach every boy what he should know about the use of tools and materials, especially in relation to the care of the home. It should make the pupil understand better the principles of construction, the use of tools, and the selection of materials - not as a specialized craftsman but as an intelligent, practical citizen." 2

-
2. Bedell, Earl, "Course of Study in Household Mechanics", City of Detroit, Board of Education, p. 10.
-

The Cleveland Course states:

"It would seem that a course of Study in manual arts should deal with the broad general aspects of industrial activities rather than with a specific subject and that the objectives of such a course should anticipate general rather than specific accomplishment..... This means focusing the attention upon the development of elements of character rather than upon material results of the work." 3

-
3. "Course of Study in 7B Grade Simple Mechanics", Cleveland Public Schools, p. 3.
-

The last phrase is particularly striking, not only because of its truth and value, but also for the unusualness of its inclusion in a course of study in what is too often considered a purely manual subject.

In a discussion of Household Mechanics as a Continuation School activity, W. W. Dunbar defines it thus:

"Household Mechanics presents a type of training which includes almost anything that can be used about the home in everyday life.This type of work gives greater latitude or choice of work to the teacher and more general and useful knowledge to the pupil with less cost to the taxpayer." 4

-
4. Dunbar, W. W., Household Mechanics as Continuation School Activity, Industrial Education, p. 422.
-

The fundamental idea, then, regardless of phraseology, seems to be that Home Mechanics should embody all those unspecialized activities of renovation, repair and replacement necessary about the home, and which, if given the elementary skills, knowledges and attitudes, the individual may care for himself.

That these skills, attitudes and knowledges should be included in the general education of girls as well as of boys is amply justified by their social needs. They are a help to living and

"the clear trend of the curriculum is toward living - not memorizing!" 5

-
5. Bobbitt, F. R., Second Yearbook, Department of Superintendence, 1924, p. 250.
-

In a study made for the Board of Education of Chicago on curricular material for the junior high school, E. T. Filbey said:

"I hold that all of the boys and girls going through our public schools need to be familiar with modern homemaking, agricultural, commercial, and industrial problems; modern problems as they are being met in everyday life. It is a very practical matter. They need to be informed, not from the specialized point of view but from the non-special-

ized point of view of being able to use repair, tear down and put together, adjust and manipulate in a very simple non-specialized fashion and not in a specialized way." 6

6. Filbey, E. T., The Junior High School, Chicago Board of Education, p. 60.

In his Los Angeles Study Bobbitt itemized some forty unspecialized practical activities of the home. This list, the result of a questionnaire sent to hundreds of housewives, he explains thus:

"In the following list we have set down a composite series of unspecialized activities which have been mentioned at least with moderate frequency by several hundred women. It is probable that a majority of these things are valid for at least a majority of women." 7

7. Bobbitt, F. R., How to Make a Curriculum, p. 213.

Continuing with the thought of women's unspecialized home activities, he gives the following as some of the unsolved problems of the curriculum-maker.

- "4. In what measure should they care for the household equipment and contrivances, such as electrical system and appliances, the plumbing system, vacuum cleaner, electric washing machine, the home heating system, etc.; and to what extent should these be left to the men of the household and to the tradesmen?
6. To what extent should she perform simple matters of painting, papering, kalsomining, glazing, hanging of curtains, putting up household pictures which require the use of simple tools; and to what extent should these be left to specialists?" 8

8. Ibid., p. 212.

Girls are capable of doing, and in many cases do, the same type of mechanical jobs as boys. This is proved by surveys for boys' courses in home mechanics as well as the report of Department of Psychology of the University of Minnesota.

Newkirk lists 76 home mechanics jobs with the highest ranking for boys. The frequency of the jobs appearing on his and this questionnaire is very similar. In addition, all except 17 of the 76 activities which he lists are also checked as being done by women and girls.

(Cf., Newkirk, L., Validating and Testing Home Mechanics Content, pp. 8 - 9.)

Walter A. Scott of Iowa made a survey of farm mechanical activities on 50 farms listing them under those done by the father, mother, daughter, son, and others.

His survey paralleled the present one in several items. The majority of the activities of the mother and daughter there, as here, centered around painting and finishing, care of the stove and sewing machine, and sharpening knives and scissors and other "within-the-house" activities.

(Cf., Scott, W. A., Course of Study in Farm Mechanics, Industrial and Vocational Education, 21:319.)

The University of Minnesota sponsored a study of mechanical ability. Some of their findings with respect to the mechanical ability of girls are:

"Seventh grade girls actually excel seventh grade boys in the Minnesota Spatial Relations, Card Sorting, and Packing Block tests. In the face of unequal social pressure exerted upon the sexes in things mechanical, this superiority of the girls is most striking. The only test in which boys and men clearly excel is the Minnesota Assembly test, such superiority undoubtedly being based upon greater opportunities for practice in manipulating mechanical contrivances. In the absence of such specific practice effects, as in

all the other tests, the differences between the sexes tend to disappear. In short, boys and men are not definitely superior to girls and women in mechanical ability." 9

-
9. University of Minnesota, Mechanical Ability Tests, Report of Research Committee, p. 263.
-

This idea of the equality of mechanical ability is being experimented with in a course in the Iowa University High School.

In his "General Shop", Newkirk reports the course in these words:

"The needs of boys and girls in shopwork are different chiefly with respect to quantity and the emphasis placed on specific instructional aims. The girl needs the shop experience which will enable her to become a more efficient member of the modern home. Industrial-arts appreciation and 'handy-man' activities seem to be of special value as guiding aims in organization of shop content for girls.

The projects which follow have been used with success in the instruction of eighth grade girls in the University of Iowa High School. It seems advisable to teach the boys and girls as separate groups; girls do not have the same type of background as boys, and adjustments are easier when the sexes are separated." 10

-
10. Newkirk, L., General Shop, p. 40.
-

--*-- --*-- --*-- --*-- --*-- --*-- --*-- --*-- --*-- --*-- --*--

--*--

CHAPTER II

CRITERIA FOR THE SELECTION OF SUBJECT MATTER

--*--

--*-- --*-- --*-- --*-- --*-- --*-- --*-- --*-- --*-- --*-- --*--

In order to determine which mechanical jobs around the home were of a practical nature for girls, and women, it was necessary to make an analysis of practical activities in and about the home and then a survey to check these jobs.

But two schools in the middle west were found teaching home mechanics for girls, - University of Iowa High School, and the Milwaukee Vocational School. The jobs given in the courses of these two cities were listed, as were also jobs from boys' courses of other cities: (Detroit, Ithica, New York, Cleveland, Harrisburg, Pennsylvania, and the Kosciusko-Junior Technical High School, Milwaukee); lists from texts, magazine articles, and topics from tests such as the Newkirk-Stoddard, House Mechanics, and the Hunter Shop Tests were also used.

This resulted in a group of 348 jobs which were checked by the Industrial Arts Director of the Milwaukee Public Schools, as to their adaptability and practicability for shop instruction.

The 127 most frequently mentioned jobs were then listed under the seven headings of: 1. repairs which have to do with woodworking; 2. repairs which have to do with the electric system; 3. repairs to the plumbing and water supply; 4. painting, varnishing, glueing, and staining; 5. jobs that have to do with glass; 6. adjustments to auto or radio; and 7. miscellaneous repairs.

As a means of determining which of these jobs were commonly practiced by girls and women of the community, and if there were additional jobs, this material was put into a questionnaire (See Appendix A) which was given to 218 girls and housekeepers of Milwaukee.

These people were asked to underline the jobs they had done and also to indicate those they had had need for but were unable to do.

Space was also allowed for jobs not listed in the questionnaire.

Table II, Appendix A, shows the fifty activities ranking highest in this survey.

However, a list of activities taking place in the homes cannot constitute a course of study.

The Denver Survey of Home Mechanics Activities submits the following technic for transition from the survey to the course of study material:

1. Make a list of desirable activities to be used in the course. These are determined by the frequency rank from the survey.
2. Make a list of desirable processes to be used in the course. These are determined by the frequency rank from the survey.
3. Make sure that the activities chosen contain the desirable processes.
4. Discard the activities that are too complex on the basis of: (a) Number of processes involved; (b) Difficulty of the job; (c) Lack of job facilities.
5. Include additional activities based upon the judgment of the committee on revision.
6. Arrange activities according to simplicity and convenience.
7. Develop topics of subject-matter by the analysis of activities set forth in the course.

(Cf., Department of Superintendence, Fifth Year-book, 1927, p. 413.)

On the basis of the application of the principles stated, two or more activities were combined in one job wherever more convenient for teaching purposes. This gave a group of thirty-two jobs for the major part of the course and ten supplementary jobs to be given to the more

able pupils.

These thirty-two fundamental jobs were then analyzed on the basis of operations involved, to discover which processes were common to a majority of the jobs of a certain class (Appendix A, Tables III, IV, V, VI). By means of this analysis we were able to determine:

1. Minimum essentials of skill.
2. Suitable core jobs.
3. Material for job and operation sheets.

Charters justifies this practice in these words:

"It is apparent if home repair and construction be made the basis for a course in manual arts it is not necessary to use the project method. For once the processes have been derived it is a matter of choice whether they be taught systematically and in isolation from practical jobs as projects at home or as problems in the shop. The important point to bear in mind is that it is entirely practicable to draw off the processes from home projects and determine which of them to teach and emphasize." 1

1. Charters, W. W., Curriculum Construction, p. 307.

Selvidge also advocates analysis for he says:

"When the list of jobs has been prepared, they should be arranged with some respect to the order of difficulty, placing the least difficult ones first. Every job should then be placed on the Analysis-Chart, and analyzed on the basis of the things we wish to teach. This will enable us to determine what instructions will be required and what experiences will be obtained in doing each job." 2

2. Selvidge and Fryklund, Principles of Trade and Industrial Teaching, p. 92.

Thus it was found that there were 15 essential woodworking operations to be taught with a lesser number in each of the other divisions.

A list of these operations will be given in the chapter devoted to "Methods".

This course is planned for one semester. In conformity with the general practice in Industrial Arts in the junior high school, home mechanics in the eighth grade should be given three clock hours per week. This is supported by a study of Industrial Arts in 14 metropolitan junior high schools made by the University of Chicago. This concludes that:

"Meanwhile, industrial arts, in some general type as household mechanics or general shop, should be made a required subject in the seventh and eighth years and continued as at least an elective in the ninth year. The average time allotment in each of the seventh, eighth, and ninth years approximates three clock-hours a week." 3

3. Glass, J. M., Curriculum Practices in the Junior High School and Grades 5 and 6, p. 44.

In a junior technical high school it is recommended that this be a required course but in the academic junior high it might be either required or elective, providing that there are other industrial arts courses open to girls of this grade.

In this same study Glass found that:

"Industrial arts continues as a required subject, in the eighth year in all 6-3-3 and 6-6 school systems except St. Louis, which offers it as an elective. Five centers complete a progressively organized junior high school course in industrial arts by continuing the required work in the ninth year." 4

4. Idib., p. 43.

This plan presupposes home mechanics as an integral part of a continuous course of industrial arts throughout the junior high school. It

might be preceded by a course in line-drawing and lettering or practical arts and succeeded in the ninth grade by a course in home beautifying.

* * * * *

* * *

CHAPTER III

HISTORICAL EVOLUTION OF HOME MECHANICS

* * *

* * * * *

Before determining the objectives in a course of this type, it may be well to survey the various objectives of general industrial education as they have been transmitted to us through the ages. Thus we will better understand the broad general principles and practices for teaching such a course and how this special branch is a logical outgrowth of these principles. Industrial education was born of the need of man to improve his living conditions.

In primitive life the sole objective for any industrial training was self-preservation. The parents and elders were the teachers and failure was penalized by death.

Plato - advocated performance of the crafts for the dual purposes of appreciation and vocational efficiency.

Aristotle - also advocated training of the hand along with the training of the mind.

The Jewish Talmud - the book of traditional law, gives one of the most ancient records of the teaching of manual arts. Here we find the religion as the fundamental motive, but that second to instruction in The Law, was instruction in some trade for here we find these statements:

"He who does not have his son taught a trade prepares him to be a robber."

"He who applies himself to study alone is like him who has no God."

"Beautiful is the intellectual occupation if combined with some practical work."

John Amos Comenius (1592-1670) - believed in teaching the mechanic arts, in fact, he was one of the earliest advocates of try-out courses and vocational guidance. In his great Didactic he said that -

"Boys would discover their special aptitudes if in addition to academic subjects they were given instruction in the mechanical arts." 1

Among the nine principles of method which he developed were these:

- "1. If anything is to be learned, its general principles must first be explained. Its details may then be considered and not till then.
2. Whatever is taught should be taught as being of practical application in everyday life and of some definite use.
3. Stress should be laid on the differences which exist between things in order that what knowledge of them is acquired may be clear and distinct." 2

2. Monroe, Paul, A Textbook on the History of Education, pp. 483-489.

Jesuit Missionaries - in America founded manual training schools for their recruits, the object being skill of hand and a trade useful in a new community.

Moravian Brothers - founded at Bethlehem and Lititz in the new world what now appears to have been manual labor schools.

(Cf., "Records of the Moravians in North Carolina," College of North Carolina Hist. Soc., 1923, p. 282.)

Sir Wm. Petty - drew up a plan in 1647 for an industrial school whose object was the expression of ideas by means of manual work.

(Cf., American Journal of Education, Vol. XI, p. 202.)

Industrial Trade School at Winston Salem, N. C. - as early as 1764 is shown by records found in the church of that city. Many tales are told, of the hardships endured by both boys and girls in crossing the primitive wilderness in order to enter this school.

(Cf., Coats, Charles, "Pioneer Manual Labor Schools", Industrial Arts Magazine, September, 1924, p. 323.)

John Locke (1632-1704) - had the formal discipline theory of learning. He drew up a plan for a school for poor children which should "accustom them to work so that they might relieve their mothers of their care and the parish of the cost of supporting them." His idea was that the aim of education should be to fit them for practical life.

(Cf., Locke, John, Some Thoughts Concerning Education.)

Leibnitz (1646-1716) - was the first recorded to suggest trade schools for "those boys not fitted by nature for intellectual pursuits" and to recognize the value of hand-workers to society.

(Cf., Payne, A. F., Methods of Teaching Industrial Subjects, 1926, p. 7.)

Rousseau (1712-1778) - recommended that children be allowed to develop "according to nature" and in his book Emile has the boy Emile, learn a trade and his sister Sophie, taught to embroider, sew and make lace, with the idea of preparing them for the life they were to live. His theory was that it was natural for children to wish to handle tools and make things.

(Cf., Monroe, Paul, op. cit., p. 557.)

Jean de LaHowe (17---1796) - through his will established a manual labor school for both girls and boys at New Berdeau, S. C. with the purpose of "raising useful citizens to the state, many whorooof would, without such an institution, become a nuisance." This school still survives under the name "De La Howe State School".

(Cf., Coates, Chas. "Pioneer Manual Labor schools", Industrial Arts Magazine, September, 1924, p. 323.)

Pestalozzi (1746-1827) - was probably the first man to consciously apply psychology to education. He believed in combining knowledge and

skill. Some of his principles were:

1. All knowledge comes through the senses.
2. Begin with the simplest elements and proceed by orderly stages to the complex.
3. Begin with the concrete and lead to the abstract.
4. Power must be linked to knowledge and skill to learning.
5. The end of education is the harmonious development of all the natural powers.

He organized the first industrial school for the poor where more than half the time was given to manual activities.

(Cf., Monroe, Paul, op. cit., pp. 620 - 621.)

Freobel (1783-1852) - believed that "we learn to do by doing."

He is perhaps known best through his development of the kindergarten. He believed that self-activity was a form of self-expression and self-development. He was a student of Pestalozzi but differed from him in his idea of creative self-expression. One of his greatest disciples in present day teaching is John Dewey.

The Fellenberg Manual Labor Schools (1825-1835) - of which a great many sprang up in this country, were the outgrowth of a school founded in Germany. The objectives of this school were:

- "1. To educate the youth of the peasant class in a agricultural and technical pursuits and in connection with the pursuits to give them the elements of an intellectual education.
2. To bring the upper classes into closer sympathy and understanding with the peasant class by educating them together." 3

3. Payne, A. G., Methods of Teaching Industrial Subjects, p. 11.

The methods used were so poor that the schools failed but the idea

of industrial education persisted and appeared in a series of industrial schools for orphans and delinquents where the programs called for a great deal of manual education.

Herbert Spencer (1820-1903) - in his efforts to find "What Knowledge is of most Worth?" divides all knowledge into five parts.

1. Knowledge which leads directly to self-preservation;
2. Knowledge which leads indirectly to self-preservation by securing food, shelter and clothing (vocational education);
3. Knowledge which has to do with the rearing of children;
4. Knowledge of social and political life;
5. Knowledge of literature and cultural subjects.

His decision seems to have been that the most worthwhile knowledge is that which is useful and utilitarian. Although he accomplished little as far as methods go, he did have a definite influence on the objectives and methods of those who were to follow him.

Theodore Weld - called "one of the fathers of the Manual Labor School Movement" made and published the first recorded educational survey in 1831.

(Cf., "Report of Society for Promoting Manual Labor in Literary Institutions", New York, 1831.)

During this time apprenticeship had come to be a well grounded institution but its doom was sounded by the Industrial Revolution with its invention of machinery and quantity production. Ever since then the schools have been attempting unsuccessfully to furnish a satisfactory substitute.

Dr. Calvin Woodward about 1879 started a Manual Training High School in connection with Washington University. He set up a metal working shop, and a woodworking shop.

His idea was that occupational activities should begin in the kindergarten and continue through all the grades and even into the high school. This was the beginning of a strong manual training movement throughout the United States.

The Centennial Exposition was held at Philadelphia about this time (1876).

This gave a great impetus to manual work because of two exhibits - one from the Technical School at Moscow and the other samples of arts and crafts from England.

The Russian System taught tool processes in an entirely abstract manner. This method did not long survive as work with tools which produced no object of use or beauty did not appeal to the average American boy.

However, the idea survived, as it was from this exhibit that Dr. John Runkle of Massachusetts Institute of Technology derived his idea for founding a department of mechanic arts in that school.

Swedish Sloyd was brought to this country about 1880. Its objectives as stated by the Eighth Annual Report of the Commissioner of Labor were:

"Pleasure in bodily attention and respect for it; habits of independence, order, accuracy, attention, and industry; increase of physical strength, development of the power of observation in the eye, and of execution in the hand. Educational Sloyd has also in view the development of mental power or, in other words, is disciplinary in its aim." 4

4. Commissioner of Labor, "Eighth Annual Report", Industrial Education, 1893, p. 21.

This seems to have been too heavy a load for one branch of educa-

tion to carry, for Sloyd gradually died out of the curriculum.

As is common to many educational movements, manual training begun outside the schools, was first adopted by high schools and colleges, and then sifted down into elementary schools.

As early as 1882 Boston experimented with handwork in the elementary schools, - an outgrowth of private "whittling schools" of that city.

No discussion of the development of handwork would be complete without the mention of such leaders as Colonel Parker, head of the Cook County and Chicago Normal Schools, Horace Mann, and John Dewey - all of whom exerted a great influence in favor of Frobelian Principles, the idea that "we learn to do by doing".

The first Industrial Education Association was founded in New York as an outgrowth of the Kitchen Garden Association. Its stated objects were:

- "1. To secure the introduction of manual training as an important factor, in general education.
2. To devise methods and systems of industrial training and to put them into operation in the schools and institutions of all grades.
3. To provide and train teachers for this work.

This last item was the immediate cause for the establishment of a teachers' college for the specific purpose of training industrial teachers. The college was organized by Nicholas Murray Butler, President of Columbia University, and has since developed into Teachers' College of Columbia University." 5

5. Payne, Methods of Teaching Industrial Subjects, p. 18.

In 1917 the Smith-Hughes Act for Vocational Education was passed.

This law organized a board under Federal Supervision and radically ^{plan} changed the old standards and methods but gave a great impetus to purely Vocational Education.

From this time on manual education developed along many lines in conjunction with the rapid changes in education and the development of more scientific methods.

Thus we find at the present time such terms as Trade Training, Part-Time Vocational Training, Vocational Rehabilitation, Industrial Arts, Pre-Vocational Training, Home Mechanics, and many others all out-growths of the old "manual training".

Home Mechanics as a school course in Industrial Arts first developed at Stout Institute in Menomonie, Wisconsin, in 1908.

"It was offered at that time to fifth and sixth grade pupils of the public schools in Menomonie.

It was incorporated at the time as a regular part of the teacher-training course of Stout Institute. I have a feeling that some of the early graduates of Stout, who went to the City of Detroit, possibly carried the germ of Home Mechanics Idea." 6

6. "Letter from R. H. Rodgers to C. A. Bennett", Industrial Education Magazine, March, 1927, p. 324.

Detroit seems to be the first large city to have adopted the Home Mechanics Idea as part of the industrial arts work of the elementary schools.

Thus -

"We find a remarkably interesting picture of the thorough change in objectives and point of view which has had a far-reaching influence not only on teaching industrial subjects but in much wider fields." 7

7. Payne, op. cit., p. 19/

"The purpose of household mechanics is similar in many respects to that of other industrial arts courses used in the past. The principal departure lies in the enrichment of the subject matter to include a more varied field of activities involving the use of a greater variety of tools and materials." 8

8. Bedell, Earl, Detroit Course of Study, p. 3.

--*-- --*-- --*-- --*-- --*-- --*-- --*-- --*-- --*-- --*-- --*--

--*--

CHAPTER IV

HOME MECHANICS A PART OF GENERAL EDUCATION
SUITABLE TO THE JUNIOR HIGH SCHOOL PERIOD

--*--

--*-- --*-- --*-- --*-- --*-- --*-- --*-- --*-- --*-- --*-- --*--

Home Mechanics for girls is a part of general education adapted to the Junior High School period.

Dr. Woodward, the founder of the original Manual Training School, recognized this fact, for he says:

"Now a manual training school is neither a technical school nor an industrial school. It is far too elementary to deserve the name technical or polytechnic. It forms a fine foundation which to build up a technical training. In a manual training school the aim is not the narrow one of 'learning a trade'. Neither is dexterity sought in special operations which may be only small parts of even a trade. Neither is there any thought of manufacture with a view of selling something which will yield an income. The object of every feature is education in a broad and high sense." 1

1. Woodward, C. M., Manual Training in Education, p. 60.

The function of the school is to provide experiences which will develop the individual to her highest potentialities, potentialities of skill and judgment as well as of knowledge. This must be considered in constructing this course.

Dr. Judd sums up the situation when he states:

"There is a new spirit in elementary education: it is the spirit of attention to practical needs..... If one says that the schools must become more intelligent in preparing their pupils for life, again there will be no one to deny the truth of the assertion..... It certainly would be more expeditious and more economical of human energy if we could devise some way of reconstructing the school program on the basis of a national consideration of the demands of modern life." 2

2. Judd, Curriculum Practices, University of Chicago Education Monograph #25, p. 84.

The following acknowledged objectives of the junior high school make courses in manual or industrial arts imperative at this period of

the child's education, as such courses contribute largely toward the accomplishment of these objectives:

- "1. The retention of pupils in school.
2. The recognition of individual differences.
3. Providing for differentiated curricula.
4. Providing opportunities for educational and vocational guidance.
5. Providing means for prevocational and vocational training (negative as well as positive).
6. Providing for better teaching and scholarship through departmentalized organization and specialized teaching.
7. Preparing pupils better to perform the academic work of senior high school.
8. Providing training in ideals of citizenship." 3

-
3. Leavitt, Frank, Fifth Yearbook, Dept. of Superintendence, "Statement of Objectives of Industrial Arts in the Junior High School", p. 403.
-

The author would teach this course in the 8th-B grade of the junior high school because this is the period of adolescence - the period of transition from childhood to youth. It is characterized by awakening interests, by unrest, by changing ideals and changing purposes. Now, too, comes a great increase in both physical and mental development. The pupil exhibits a great amount of physical energy and a desire to be doing something all the time. Her interest seems to be in experiences rather than in ideas, and these interests center largely in her home and social life. She has a desire to emulate adults, an interest in home and a wish to improve her own home.

The social instincts are developing. This makes cooperative work imperative.

Then, too, many girls at this period are over-age for their grade, and are physically over-developed. Manual activities is one means of helping them to find themselves.

Discussing this same problem with respect to the over-age boy we learn that:

"There is a clearly recognized obligation on the part of junior high school workers to meet the needs of the overage boy who has failed to master the requirements of the elementary school or who is failing to keep up with the demands of the junior high school. The problem is recognized as incidental to the junior high school, but an obligation nevertheless." 4

4. Fifth Yearbook, Dept. of Superintendence, 1927, p. 403.

G. Stanley Hall summarizes the characteristics of this period when he says:

"It is the age of sentiment and religion, of rapid fluctuation of mood and the world seems strange and new. Interest in adult life and vocations develops. Youth awakens to a new world and understands neither it nor himself." 5

5. Hall, G. Stanley, Adolescence, Vol. 1, p.

Response to these needs is found in the activities of the home mechanics shop.

--*-- --*-- --*-- --*-- --*-- --*-- --*-- --*-- --*-- --*--

--*--

CHAPTER V

OBJECTIVES

--*--

--*-- --*-- --*-- --*-- --*-- --*-- --*-- --*-- --*-- --*--

A bare statement of aims for a course as new and untried as that of home mechanics for girls, seems hardly sufficient.

Before formulating our objectives it would be well to survey the objectives as worked out for courses of a similar nature.

A study of the aims of Home Mechanics courses shows a wide range of purposes. These vary from the all-inclusive ones of "character development" and "vocational efficiency" to an exact statement of just what the pupils should know and be able to do by the end of the course. Many city courses fail to list any objectives but plunge at once into the activities to be taught.

I have chosen objectives on Industrial Art from several authentic sources as being typical of the kind of aims suitable for a course in home mechanics in a girls' junior high school.

In the Bulletin of the Department of the Interior on Manual Arts in the Junior High School ten objectives of simple mechanics in the 7-B grade are listed:

- "1. To give practical working knowledge of the fundamentals of a number of industrial occupations.
2. To train the pupil to plan and execute necessary repairs and necessary or desirable simple constructions.
3. To develop self-reliance, confidence, and initiative in emergency.
4. To develop habits of observation and appreciation and a just pride in personal accomplishment.
5. To teach habits of thrift and a wholesome respect for the furnishings and appliances of the home, the school and the community.
6. To give opportunity to try out simple processes in a variety of simple industrial activities.
7. To give a practical knowledge of simple mechanical devices and of materials of common use.

8. To teach the typical uses of common tools.
9. To train the pupil to work from verbal and written directions and from drawings.
10. To give an insight into a variety of industrial occupations which may discover interests, aptitudes and skills which will be suggestive in guidance.

The most important work of the teacher in the administration of this course of study will be the just evaluation of these objectives, expressed in terms of a wise choice of subject matter and in skillful teaching. This means focusing the attention upon elements of character rather than upon material results of the work." 1

1. Department of the Interior Bulletin, #11, p. 38.

A detailed statement of aims for manual arts in the junior high school is given by the committee of the Department of Superintendence:

- "1. To develop handiness.
2. To promote the immediate carrying over of ideas into action.
3. To help through exploratory courses in the discovery of special interests and attitudes important for proper educational and vocational guidance.
4. To provide a means for developing technical skill.
5. To provide a means for imparting technical knowledge.
6. To enable the pupil to apply the test of practice to some of his thinking.
7. To develop the mind by providing constructive problems, in materials, which demand a vigorous mental reaction.
8. To interest in school work, through the concrete application of theory to practice, those pupils to whom the academic studies do not appeal strongly.

9. To create interest in the arts and industries without any reference to their vocational significance.
10. To enable the pupil, through the making of minor repairs and the undertaking of minor construction in the home, to contribute to its economical and material upkeep.
11. To enable the pupil, through participation in cooperative problems, to perform better his duties as a member of his home, his school, and his country.
12. To serve as an introduction to vocational and prevocational training." 2

2. Department of Superintendence, Fifth Yearbook, p. 406.

The Cleveland Course lists these admirable aims:

- "1. To give a practical working knowledge of the fundamentals of a number of industrial occupations
2. To train the pupil to plan and execute necessary repairs and necessary or desirable simple constructions
3. To develop self reliance, confidence and initiative in emergency
4. To develop habits of observation and appreciation and a just pride in personal accomplishment
5. To teach habits of thrift and a wholesome respect for the furnishings and appliances of the home, the school and the community
6. To give opportunities to try out simple processes in a variety of simple industrial activities
7. To give a practical knowledge of simple mechanical devices and of materials of common use
8. To teach the typical uses of common tools
9. To train the pupil to work from verbal and written directions and from drawings

10. To give an insight into a variety of industrial occupations which may discover interests, aptitudes and skills which may be suggestive in guidance." 3

3. Cleveland Board of Education, Course in Manual Arts, p. 6.

One of the few curriculum makers who analyzes their objectives is Franklin Bobbit of Chicago. He was one of the earliest advocates of teaching women and girls in school how to care for the unspecialized practical activities of the home. He organized his objectives as abilities to do certain acts and then subdivided these certain acts into the activities which would be likely to accomplish them.

From a list of over a hundred abilities and activities I have selected those which seem particularly applicable to a course in Home Mechanics for girls.

- "801. Ability to sharpen, adjust, clean, lubricate, replace worn or broken parts and otherwise keep household and garden tools and appliances in good order and good working condition.
802. Ability to make repairs, adjustments, and additions to the house and its equipment.
- (1) Putting up shelving or extra hooks, etc., in the clothes closet.
 - (2) Window screens: making, mending, cleaning, painting, placing, storing, etc.
 - (3) Adjusting window stops to prevent
 - (4) rattling.
 - (5) Repairing window shades; and fixtures for curtains.
 - (13) Simple painting, varnishing, white-washing; preparing surfaces for the work; care of materials.
 - (16) Renewing worn-out fuller balls in the water faucets.
 - (17) Putting on door-bells and chains, special locks, etc.
803. Ability to repair, adjust, and sometimes to construct household furniture or other equipment.

- (1) The mending of furniture.
 - (3) The making of simple pieces of furniture.
 - (4) Readjusting of dresser or table drawers, etc., making them properly fit.
 - (6) Framing pictures.
- (804). Ability to participate intelligently in the original planning of one's home.
- (2) Reading architectural plans.
 - (3) Planning a house in its general arrangements.
805. Ability to operate household equipment.
- (4) Adjusting the gas and air mixture in the gas range.
 - (5) Operation and care of the plumbing fixtures in the house.
806. Ability to keep the house, premises, and equipment, house utensils and appliances clean and sanitary.
- (3) Polishing and other special care of floors and furniture.
 - (8) Keeping the silver and other metal ware properly cleaned and polished.
 - (10) Removing stains from floors, furniture, etc.
 - (11) Keeping all the mechanical appliances of the home clean and in good working condition.
 - (14) Using a vacuum cleaner.
 - (15) Sanitary care of sinks, toilets, and lavatories.
808. Ability to keep the house in good order.
- (1) Operation and care of the electrical lighting system of the house.
 - (3) Renewing burnt-out fuse plugs in the electric wiring system.
 - (5) Joining wires and otherwise repairing broken electric circuits.
 - (6) Operation, adjustment, lubrication, simple repair, etc., of household electric appliances: electric iron, washing machine, fan, toaster, heater, vacuum cleaner, sewing machine, telephone, etc." 4

Edgerton gives his idea of two of the aims of industrial arts courses in these words:

"In the main, their educational philosophy assumes that the future wage-earner is a consumer and a citizen, as well as a producer; that a program which neglects to help all individuals to consume intelligently and utilize the hours of leisure wisely is decidedly undemocratic." 5

-
5. Edgerton, "Vocational Guidance and Education for the Industries", N. S. S. E., Twenty-Third Yearbook, Part II, p. 203.
-

Snedden makes a plea for the liberizing of vocational material.

"Girls who are studying dressmaking become interested in the possibilities of color combinations. Economic history becomes especially significant to the person who has had some contact with the commerce of the present time. These and many more possible examples suggest that the beginnings in vocational study may inspire interests and motives which carry the student far over into the field of liberal education, with a degree of vital appreciation which could be procured in no other way..... It is clear, however, that the aim of liberal education can be to some extent realized through the measures adopted for a generous vocational education. This result may be achieved in several ways. In practical life, this is the active interest which is developed in the study of physics by one who has become vocationally interested in mechanics, electricity, or steam." 6

-
6. Snedden, The Problem of Vocational Education, p. 75.
-

From this survey I have selected Worthy Home Membership as the major aim for this course.

The minor aims are:

1. To help them learn to think.
2. To develop a certain amount of skill with, and knowledge of the common tools and mechanics of the home.

3. To develop judgment and appreciation as consumers.
4. To assist the pupil in a proper interpretation of contemporary life.
5. To provide enjoyable and profitable leisure activity.
6. Through home projects, stimulate greater interest in home and its orderly upkeep.
7. To help pupils to whom academic work does not appeal to find themselves by means of the application of concrete experiences to theoretical problems.
8. To develop cooperation and a sense of responsibility.

--*-- --*-- --*-- --*-- --*-- --*-- --*-- --*-- --*-- --*--

--*--

CHAPTER VI

MATERIALS TO ASSIST IN EFFECTIVE TEACHING

--*--

--*-- --*-- --*-- --*-- --*-- --*-- --*-- --*-- --*-- --*--

To help make the teaching in home mechanics as interesting and efficient as possible, many devices and materials are necessary. These are not new in the field of teaching but their application to this work is relatively new.

As discussed in this chapter they are:

1. Pictures and posters,
2. Moving pictures and slides,
3. Exhibits and panels,
4. Wall charts,
5. Bulletin board,
6. Browsing corner for reference and reading,
7. Excursions,
8. Talks or demonstrations by workers or tradesmen,
9. Individual instruction sheets.

Pictures and posters, made, if possible, by these same pupils in art class, - moving pictures, slides and projected pictures, all help clarify ideas. Visual instruction is becoming daily more important as a teaching aid.

Movies have many uses - they supplement the teaching demonstration, show new or different methods and give related information.

Still another use for films and slides is found in this description of the activities in the General Shop:

"At the beginning of the semester why not show the entire class a pictorial demonstration of all the projects? This would be possible in one or two periods and in the end would enable the instructor to cut much more than two hours off the class instruction time. The advantage would be in increased visualization of the teaching content." 1

1. Newkirk and Stoddard, General Shop, p. 47.

Many firms furnish films which demonstrate their materials, or methods. For most of these there is little or no charge. A list of such firms and other sources of visual aids will be found in the appendix.

Exhibits and panels may be made to serve at least three important purposes. These are given by Earl Bedell in the Detroit Courses as follows:

1. The displaying of interesting and well made articles stimulate in a student the desire to make something similar and just as good.
2. Articles can be dissembled; samples of the raw materials which are used in the construction can be secured; these materials and tools can be arranged on an exhibit panel to show a student how to proceed with his own work.
3. Scales can be made to show degrees of proficiency in the use of tools and materials." 2

2. Course of Study, City of Detroit, p. 46.

This auxiliary type of teaching material is again advocated by Newkirk. He says:

"Wall charts and pictures will continue to be helpful. This is a type of visual instruction which requires none of the instructor's teaching time. Numerous charts are available from tool companies specializing in school equipment..... Or the instructor may make his own charts. This is the best way to provide charts closely related to the work, but it often fails to function because of lack of time on the part of the instructor." 3

3. Newkirk and Stoddard, op. cit., p. 47.

The teacher who fails to make full use of the bulletin board is neglecting one of the most interesting teaching devices. Pictures,

charts, graphs, and newspaper clippings form the material for posting. This should be changed frequently to give way for new information to maintain interest.

A browsing corner containing books, periodicals, and pamphlets may be provided. This may not only contain books to which reference is made in the job sheets, but also volumes showing constructive activities and materials, and books relating to various manufactures and industries. Magazines, of which there is as great a variety as of books, may also be found there. Back numbers, not more than three years old, are quite as useful as the current issues. Many stories and much interesting reading material related to the various types of work should be included with the hope that habits of reading will be formed which may carry over as an interesting leisure activity. A suggested list is given in connection with this course of study.

(Appendix C)

Two or three excursions a semester to observe materials or methods will be found helpful. To obtain the greatest benefit from them, these trips should be carefully prepared for by discussions of what to look for and summarized by the pupils in their notebooks upon their return.

Talks or demonstrations by workers or tradesmen may be arranged several times throughout the term. Most people come willingly if they are asked far enough in advance so as to plan their talk or demonstration.

Be sure to get people who will stick to their point and not use language too technical for junior high school pupils.

Individual instruction sheets are an aid to teaching - not a substitute for it. They are based on the idea that any subject may be analyzed into definite essential units which may be the basis for in-

struction. They are especially economical in a school where the classes are large, the attendance irregular, or the subject matter diversified, as in home mechanics.

Rodger says that as a means of individual instruction -

"The unit instruction sheet is specially for the purpose of supplementing the efforts of the teacher, thus freeing him to render greater assistance to the individual members of his class.....

The classification of pupils into groups on the basis of individual needs will enable the teacher to rotate sheets successfully." 4

4. Rodgers, "Industrial Instruction in the Vocational School", N. S. S. E., Twenty-Third Yearbook, p. 27.

Selvidge's definition of an instruction sheet is:

"Instruction sheet is a general term applied to written or printed instructions, quite generally issued in loose-leaf form. Job sheets, operation sheets, information sheets, and lesson sheets are special forms of the instruction sheet. These special forms differ somewhat in method of organizing the material and in special purpose, but the general aim of bringing to the student definite instructions in a permanent form is the same in all of them." 5

5. Selvidge, Individual Instruction Sheets, p. 12.

They are not the perfect teaching device but they are a great help from the standpoint of individual interest, and individual progress. They put pupils under conditions similar to those they will meet in their working lives by making them follow directions in written form and they permit each pupil to advance at her own rate.

The greatest defect of the usual instruction sheets appears to

be a lack of provision for analysis and planning on the part of the pupil.

Several workers in the field of Industrial Arts are attempting to do away with this defect.

One of these is Newkirk. His plan in home mechanics calls for job sheets, job plan sheets, job record sheets, a set of procedure cards to accompany every job sheet, and an individual pupil's two day summary sheet.

(Cf., Newkirk and Stoddard, op. cit., pp. 52-77.)

Although the job plan sheets, job record sheets, and summary sheets are form blanks, it is still necessary for the teacher to formulate job sheets, job procedure cards, and to check the job plan and job record sheets at the beginning and completion of every job for every pupil. Even though this plan does provide for a certain amount of pupil analysis and planning one is impressed by the excessive amount of preparation and clerical work involved; more, probably, than the average industrial arts teacher would successfully undertake.

R. W. Selvidge, who is perhaps the best authority on the compilation and use of individual instruction sheets, recognizes these shortcomings in the job sheet when he says:

"It should be recognized, however, that while the job sheet does what it pretends to do, that is, tells exactly how to do a particular job, it has some fundamental faults from the standpoint of training. It takes away from the student two very important things: the opportunity to analyze the job to find out what is to be done; and an opportunity to plan the doing of the job. These are perhaps the most important phases of the student's training. However, if this defect is recognized and care is taken in the preparation and use of these sheets, this difficulty may be overcome to some degree." 6

What we are attempting to discover is a plan for administering a course of study in home mechanics by which pupils, working under directions and individually, will be forced to analyze and plan their work in the measure to which eighth grade girls are capable.

Some light is thrown on this problem by a suggestion from Dean Schweichardt who says:

"In the attempt to provide for individual interests and individual development, two extremes of practice have grown up. On the one hand, detailed job sheets have been employed as a means of instructing the pupil in all the necessary details of information and manipulation involved in his chosen job. Strict adherence to such a plan limits the scope of selection to the jobs for which job sheets can be secured and a large collection of these sheets reveals much duplication of instruction and directions. The other extreme is noted in the methods of the teacher who turns the boys loose to discover what they may concerning facts, principles, and processes, without the aid of definite instruction....."

The more desirable plan is some sort of combination or mean between the two extremes, by which the instructor will analyze the field he wishes to cover in each course, and select the facts, principles, and processes involved. In teaching these things he may use, as an instructional device, instruction sheets which he has purchased, prepared, or improvised....."

Each project should represent a problem to be solved, for which the boy can work out his own solution by mapping out a plan of performance based upon his own knowledge and ability and supplemented by the necessary instruction sheets." 7

7. Schweickhardt, D., Industrial Arts in Education, pp. 248 - 250.

This course in home mechanics is an effort to attain that "combination" or "mean" of instruction. As aids to teaching we will use job sheets and operation sheets. Samples of both types of sheets will be found in this course. (See pages 100 - 114.)

Job sheets are defined as "those instruction sheets that tell how to do a complete work job."

(Cf., Selvidge, op. cit., p. 12.)

Selvidge submits the following items as characteristic of job sheets:

1. Job sheets are prepared for specific work jobs and the instructions are given for these jobs and for no others.
2. They give a list of all tools and materials required for the job.
3. They give the plan for doing the job, listing the steps in order.
4. They give instruction for performing certain operations involved in the job.
5. They give illustrations to clarify written instructions.
6. They present the information as a part of the job.
7. They give questions concerning the job.
8. References to available sources of information are given." 8

8. Selvidge, op. cit., p. 15.

Besides these specifications of content, there are certain other requirements of form which help to make the job sheet more effective:

"The page should have an attractive appearance. The sentences should be relatively short and to the point. Paragraphs should be short, and the different divisions of the sheet should be indented and separated so that they stand out clearly.....if the job sheet is to be really objective and take advantage of all its opportunities, it must have objective questions which bring out the main points of the sheet in a relatively short time.....the procedure-question and the completion-question are two types which seem admirably adapted to measuring individual

instruction sheet content in a relatively short time and in a manner which is easily used for diagnosis and teaching." 9

9. Newkirk and Stoddard, op. cit., pp. 51 - 52.

Another advantage of this type of statement questions is that it not only lends variety but also accustoms pupils to a form of question met in many tests. Examples of this type of question will be found on the job sheets on "How to Stain an Article of New Wood", (page 109), and "How to Make a Bread Board", (page 100).

The job sheets to be constructed for use in this course are a co-operative project embodying the knowledge and organization of the teacher combined with the effort at analysis and planning of the pupil. The plan, beginning with the supplementary jobs of few operations and gradually leading the pupil to the job which requires the organization of many operations into their proper working sequence.

The divisions of the sheet are:

1. Title clearly stated.
2. General directions.
This embodies a direction to examine, if possible, an exhibit of similar work to see how it was done.
3. Specifications,
Drawings,
Tools,
Materials.
4. Information - if any is needed.
5. Directions.
6. Checking.
For the best results it is often desirable to check at several points. These should be indicated on the Job Sheet.
7. Questions - or some test of related information.
8. References.
9. Space for recording necessary data.

The essential point of difference between this and the usual home mechanics job sheet is found in the technique of organizing the division known as "Directions". The first directions are: "In the blanks at the right, list the steps in these directions in the order in which you would do them." "Have your list checked by your forewoman or teacher."

The list of processes which follows is not in sequence. It is the task of the pupil to arrange them in proper working order. (See page 73)

Processes which are confined to any one job are given in detail on that job sheet. It was thought wise to organize processes, which, from an analysis of the job, (Appendix A, III), and experience have been found to be essential elements of great many jobs, into separate operation sheets.

These instructions might of course be all written out on the job sheet but they would have to be written again many times for the many jobs in which they are involved. These are the learning units and the operations in which the girl must receive specific instructions. It is a matter of economy, therefore, to write out the instructions for these operations separately and thus have them available for use on any job where they are needed.

The job sheets on "How to Stain a Piece of New Wood", (page 109), "How to Make a Bread Board", (page 100), and "How to Make an Extension Cord", (page 102), are examples of the type of sheet in which the directions for one or more operations must be found by the use of operation sheets. The processes for the sheet "How to Repair Roller Shades", (page 105), are all shown on the job sheet, as they are peculiar to that one job.

The essential steps in the making of an operation sheet are:

- "1. State the title in very specific terms.
2. List all the steps involved in performing the operation and arrange them in order.
3. Write the instructions for performing each step as simple directions for doing.
4. Use illustrations liberally.
5. Ask questions, if necessary, to bring out the reasons for doing things in a certain way.
6. Give one or two good available references, if needed." 10

10. Selvidge, op. cit., p. 41.

Pupils, through the forewoman, will get operation sheets from the files in the order in which they are needed.

When the job is finished, the girl is free to go to the Browsing Corner to look up references or interesting related material.

The completed and checked job sheet is kept as part of the pupil's record of attainment in both theory and practice.

Short, comprehensive, individual tests should be given to each pupil when she finishes one unit of work and before she retates to the next. These tests properly organized, will give us a perspective of the extent to which we have developed the powers of analysis and planning in our pupils. Further details on kinds of tests will be found in the chapter on "Records and Tests".

"The primary purpose of the unit instruction method is to provide through carefully organized and planned assignments of educational work, in terms of individual needs, interests, and aptitudes for the fullest possible progress of each boy and girl without undue loss of time and effort." 11

11. Rodgers, R. H., "Industrial Instruction in the Vocational School", N. S. S. E., Twenty-Third Yearbook, Part Two, p. 262.

*- *- *- *- *- *- *- *- *- *-

-

CHAPTER VII

METHOD OF ADMINISTERING THE COURSE

-

*- *- *- *- *- *- *- *- *- *-

The method suggested as the most satisfactory for the teaching of home mechanics is a combination of demonstration and lecture with laboratory practice.

The success of the application of this type of instruction to work in the shop is discussed in the Yearbook:

"All forms of shopwork or laboratory instruction in home-making, industrial and commercial subjects.....may be most effectively organized and taught through the medium of units of instruction used with the individual pupil or small groups of pupils." 1

1. Rodgers, Twenty-third Yearbook, Part 2, N. S. S. E., p. 263.

Kitson continues this discussion by saying:

".....the learner makes no blind procedure but has available one which has been laid down by some one who has already mastered the skill." 2

2. Kitson, H., "Trade Job Analysis as an Aid in Vocational Curriculum Building", Twenty-third Yearbook, p. 237.

Bedell gives the time proportions as 80% for jobs with tools and 20% to be spent in demonstration, study of reference material and class discussion.

(Cf., Bedell, "Industrial and Vocational Education",
Industrial and Vocational Education Magazine,
21:209.)

The instruction as outlined by this course will comprise both individual and group work effected through the use of three types of jobs:

1. Fundamental jobs,
2. Core jobs,
3. Supplementary jobs.

The fundamental jobs are those which, from the analysis of the questionnaire, have been found fundamental in the lives of girls and women. These jobs also fulfill the requirements as set up by Selvidge and Fryklund for what they designate as "standard jobs":

- "1. The job should be simple enough to be within the capacity of the boy, yet difficult enough to call forth his ingenuity in planning.
2. The job should be such that it can be handled readily under the conditions of the schoolroom.
3. The jobs should be well designed.
4. The job should be such that it can be completed in a relatively short period of time.
5. In the estimate of the boys, the project should have a real use.
6. The job must contain some of the elements we wish to teach." 3

3. Selvidge and Fryklund, Principles of Industrial Teaching, p. 89.

The core job is considered the best means of teaching the unit-operations in a natural setting and thus doing away with the old mechanical exercises. Bedell discusses their value as follows:

"The core job is one selected by the teacher for demonstration and as a basis for giving the pupil practice in developing skill. Such jobs, if interesting, have been found better than exercises.

The core job is demonstrated by the teacher to the class.....The demonstration of tools, tool processes and operations and the use of materials requires utmost skill. In the same way that a vaudeville player sets the stage for his act, so should the teacher have the demonstration material carefully arranged and have ready a carefully prepared explanation to cover each operation demonstrated.

The demonstration should provide the pupil with a plan of work. The plan of work may be written by the pupil or it may be provided by the teacher in the form of a job sheet.

The core jobs are the simple jobs selected by the teacher for instructional purposes.

Additional jobs are available to the pupil as soon as he has demonstrated his ability by doing a core job successfully." 4

4. Bedell, "Industrial and Vocational Education", Industrial and Vocational Education Magazine, 21:206,

During the demonstration of the core-jobs pupils may make notes or write questions which they wish to ask during the discussion period. At the close of the demonstration every pupil should have an opportunity to practice the particular job demonstrated.

In a discussion of jobs for production purposes Selvidge also advocates the use of core-jobs:

"The use of practical jobs does not preclude the use of a fixed series of jobs which form the core of the course of instruction around which the production jobs are grouped. The specially selected series of jobs should involve the operations which the student must learn if he has no opportunity to learn them in production jobs. Practice is necessary in order to develop skill, and it is folly to suppose that, for any considerable length of time, it can supply production jobs in sufficient quantity and variety and with suitable distribution of the elements in which the student must be trained to meet all the requirements of instruction." 5

5. Selvidge, op. cit., p. 83.

The charts, (Appendix A), demonstrate the graphic method used to extract the essential processes in the various units of work. These processes, then, form the basis for the selection of core jobs and the construction of the necessary operation sheets.

The job chosen as a core job may be one of the fundamental jobs or it may be chosen simply on its merits as a worthwhile medium for

teaching certain essential operations. Any unit of work will require several core jobs before all the necessary processes and tools have been taught. No set outline for the method of demonstrating these core jobs can be given as this must depend entirely upon the teacher presenting it, the class to whom it is to be presented, and the job selected.

This course of study contains a suggested list of core jobs which have been found good in connection with each type of subject matter.

(Cf., Selvidge, op. cit., p. 83.)

The supplementary jobs are jobs of a little greater difficulty but of high frequency. These include many of the operations learned in the core jobs besides some new ones. They are extra-credit jobs and are intended for the pupils who master the essential operations and finish the fundamental jobs before the rest of the class.

In addition to the individual projects, at least one group project will be carried out each term. This plan is essential to a cooperative spirit.

Payne gives as his opinion that:

"Young pupils are generally speaking, strong individualists, but if they are to take their proper places as efficient members of society, this individualistic tendency must be at least tempered by the desire and ability to cooperateeach pupil contributing thought and effort and subordinating himself to the accomplishment of the task. In our complex social order this is a very necessary attribute of good citizenship." 6

6. Payne, Methods of Teaching Industrial Subjects, p. 204.

It is not expected that every girl will do every job of each unit in this course, but she must have enough practice in each type of work to demonstrate that she has acquired the required information and skills.

It is hoped that projects will be brought in from the homes. These will provide extra practice in the various processes. Home credit will be given for home jobs certified to by the parents.

The list of jobs given in this course comprises the activities commonly engaged in by the home-maker in the maintenance of the home premises. Jobs related to the radio and automobile have not been included because of the low frequency of the great majority of these jobs and other practical reasons.

It is anticipated that this instruction will lead the pupil to apply her skill and knowledge to other situations and be the means of an economic and worthwhile activity.

..*.. ..*.. ..*.. ..*.. ..*.. ..*.. ..*.. ..*.. ..*.. ..*.. ..*..

..*..

CHAPTER VIII

RECORDS AND TESTS

..*..

..*.. ..*.. ..*.. ..*.. ..*.. ..*.. ..*.. ..*.. ..*.. ..*..

Record keeping in a general shop should be reduced to a minimum. The records themselves should be simple in form and easy to mark and analyze. The various kinds of records recommended for this course are:

- Class List,
- Job Sheet Records,
- Individual Progress Cards,
- Class Progress Record,
- Individual Cost Records.

All of these except the Class Progress Record should be on standard 8- $\frac{1}{2}$ x 11 size paper to facilitate filing.

The Class List or Record (Fig. 1) is in many school systems a standard book or sheet used for all classes. This should show the names of pupils, grades, home rooms, and a space for markings of absence or tardiness. Some schools also combine with the attendance record, one for the grades of the pupils.

Job Sheet Records are the completed job sheets. These should show the pupil's plan for the job, answers to questions, checks by forewoman and teacher, and her grades in both theory and the finished job. These marks are used as the basis for the final grades on her Individual Progress Record. It serves the double purpose of giving instructions for the job and a record of the completed job.

The Individual Progress Card (Fig. 2 - 3) is a sheet arranged for the completed scholarship record of the pupil. It contains space for the following facts: pupil's name, semester, grade, home-room, job, mark in theory (related information), mark in practice (finished product), citizenship.

The theory mark is obtained from the manner in which the pupil

answers the questions of the job sheet, the part taken in class discussions, and the quality of questions asked by the pupil.

The grade in practice is derived not only from the workmanship but also from the method of attacking the job.

If one of our objectives is the proper development of ideals and attitude, we should make the pupil conscious that she is being judged on these qualities and use some concrete form to show improvement in them.

The Class Progress Record, (Fig. 4), lists the names of pupils horizontally and the jobs taught vertically. The marks and total cost of materials for every job done, are put in the squares opposite the pupil's names. If the median for the class is then found the teacher has one picture of the effectiveness of his teaching.

CLASS LIST

Class _____ Hour _____ Shop _____ Semester No. _____ 193

Teacher _____ Grade _____

Names	M:T:W:T:F	M:T:W:T:F	M:T:W:T:F	M:T:W:T:F	Tot

Fig. 1. Class List Sheet

GRADUATE SCHOOL
LIBRARY
MARQUETTE UNIVERSITY

INDIVIDUAL PROGRESS CARD

Name _____ Hour _____ Semester _____ 193
 Grade _____ Shop _____ Home Room _____

JOB	TH·RY	PRAC.	CIT.	JOB	TH·RY	PRAC.	CIT.

Fig. 2, Individual Progress Card (Face)

TESTS	1	2	3	4	FINAL	REMARKS
SCORES	Form: Ave	Form: Ave	Form: Ave	Form: Ave	Form: Ave	

Fig. 3, Individual Progress Card (Reverse)

CLASS PROGRESS CARD

CLASS _____ HOUR _____ SEMESTER _____ 193

TEACHER _____

UNITS		PAINTING	WOOD	ELEC.	METAL
		/	/	/	/
No.	Name	/	/	/	/
		/	/	/	/
		/	/	/	/
		/	/	/	/
		/	/	/	/
		/	/	/	/
		/	/	/	/
		/	/	/	/

Fig. 4. Class Progress Sheet.

INDIVIDUAL COST RECORD

NAME _____ DEPOSIT _____
 ADDRESS _____ DEBT _____
 GRADE _____ HOUR _____ SEMESTER _____ BALANCE _____

Quantity	Item	Job	Unit Cost	Total Cost

Fig. 5. Individual Cost Record.

The Individual Cost Record, (Fig. 5), is for the purpose of keeping track of the cost of materials used by each pupil, although this will be probably less in home mechanics than in most laboratory courses. A good plan is to require a deposit from each pupil at the beginning of the term and return what has not been spent when the course is finished. This plan also tends to greater economy in the use of school materials, as all of us like to get money back.

Although the teacher's observation of pupils' work in the shop is one means of measuring the results of instruction, it is not the only, nor the most effective, one. The failure of shop tests in home mechanics as well as in other industrial subjects is largely due to a lack of organization of instructional material.

Limiting the discussion to the needs of this course, this chapter touches on the following points:

- (1) the object of testing,
- (2) the four standards of judging a test,
- (3) the kinds of tests,
- (4) some examples of tests of different kinds.

The purposes of testing are:

- (1) To set up standards for the pupil,
- (2) To measure pupil progress,
- (3) To measure teaching efficiency,
- (4) To diagnose pupil difficulty,
- (5) To use for promotional data,
- (6) To provide guidance data.

(Cf., Ruch and Stoddard, Tests and Measurements in High School Instruction, Chap. II & III.)

Before any testing program is undertaken the teacher should list those items of both skill and information which it is reasonable to expect every pupil in the class to know and be able to do by the end of the course, that is, minimum essentials. In this way only, does the planning of instructional material become orderly and organized. Copies of these lists should be given pupils at the beginning of the term to help them see more clearly the road ahead and give them standards of work. Such lists will be found in the last chapter of this thesis.

A plan of testing suggested for this course in home mechanics for girls is:

1. A pre-test at the beginning of the semester.
2. Individual tests given as each pupil completes a unit of work.
3. A final test covering the minimum essentials at the end of the course.

For the pre-test the Detroit Mechanical Aptitude Test for girls, or a modification of either the Stenquist Mechanical Aptitude Test or the Newkirk Test in Home Mechanics for Boys might be given.

Thus at the outset of the term the teacher would have a picture of the abilities of her class for assignment purposes and for remedial help.

The system of giving individual tests at the completion of a unit of work is adopted from the same plan which has been found effective in academic subjects, notably at Winnetka.

It will be necessary to make several forms of these tests for each unit of work to increase the validity of the results.

The final test should cover the most essential points in all of the four major units of work.

There are six principles which have been laid down as essentials

to a good test. These essentials must be taken into consideration when making tests and also in judging the worth of standard tests.

These principles are:

1. Validity - does the test measure what it pretends to measure?
2. Reliability - will the test always give approximately the same results?
3. Objectivity - does it exclude the personal bias of the scorer?
4. Flexibility of Form - different types of questions suitable to different teaching situations.
5. Ease of Scoring - can it be accurately and easily scored?
6. Economy - Of such form that a person with little test training could score it quickly and accurately?

Each of these principles could be discussed at some length, but for a paper of this type, these limited notations must suffice. A complete explanation and discussion will be found by those interested in W. A. McCall's How to Measure in Education, published by the Macmillan Company.

There are several types of examinations which may be constructed so that they will fulfill these requirements. Some of the most useful for our purposes are: The true-false test. This kind of test has its advantages and its disadvantages. There should be about half true and half false statements. The statements should be short. There should be plenty of them so that they give a wide sampling of the material to be tested. The questions should be independent of each other to avoid danger of association. If the entire test is true-false there should be about 100 questions. In scoring, the number of wrong answers are subtracted from the number right, and untried questions are not counted.

An example of this type is:

Directions: Write the letter T after each statement that is true, and F after each one that is untrue. Do not guess. If you are not sure of an answer, skip it and go on to the next.

1. Varnish is made with white paint. _____
2. Lacquer dries more rapidly than paint. _____
3. Putty is made from whiting and linseed oil. _____
4. Wood filler should be used on close-grained wood. _____

The multiple answer test (multiple choice). This test is spoken of as the 2-response, 3-response, etc., test depending upon the number of choices given with each answer. The correct answer may be underscored but an easier method for scoring is to have the pupil put the number of the correct answer in the parenthesis.

Example of Multiple choice:

Directions: Place (in the parentheses), the number of the one word which will make each statement correct.

- () The best finish for outside steps is:
- | | |
|-------------|-------------|
| 1. Varnish. | 2. Lacquer. |
| 3. Paint. | 4. Stain. |

- () Varnish is thinned with:
- | | |
|----------------|----------------|
| 1. Water. | 2. Turpentine. |
| 3. Banana-oil. | 4. Alcohol. |

The use of this type of question in home mechanics job sheets is illustrated by the sheet entitled "How to Make an Extension Cord", page 102.

The sentence completion test is a form of recall and is more difficult than either of the former tests. One important word is to be supplied by the pupil.

An example is:

1. A fire caused by oily rags is said to be caused through _____.
2. The edge where two faces of a board meet is called the _____.

The matching test is a test well suited to home mechanics because:

1. It is highly objective,
2. It is easily scored,
3. It can cover a large amount of material in a relatively short time.

It consists of two columns of related words or statements. The first column is disarranged. The correct number of the word in the first column must be placed in front of its related word in the second. Example:

- | | |
|--------------|--------------------|
| 1. T square. | () Marking lines. |
| 2. Compass. | () Smoothing. |
| 3. Gauge. | () Measuring. |
| 4. Plane. | () Making curves. |

Similarities Test is a recognition test, objective and easy to score. Four or more words are placed together. The first is usually in heavier type. This word is related rather closely to one of the others. The one to which it is related is to be underlined. Thus:

1. Oil, lead, turpentine, water.
2. Brush, can, plane, paddle.

The Cross-out test is another type that is seldom used. Here one word in a series is out of association with the others. It is to be crossed out. This test has been much used in intelligence tests. An example is:

1. Wire, socket, fuse, hammer.
2. Brace, saw, wrench, square.

Of course, there are oral tests of all kinds, the essay type of written test, and performance tests.

These latter provide a good occasional shop test as by means of them knowledge as well as skill may be tested. A good printed performance test which may be suggested to the home mechanics teacher is

the Nash-Van Duzee Test in Woodwork - Scale B.

A good home-made recognition test for the shop is made by posting a large sheet on which pictures cut from trade catalogs have been pasted. Each tool or implement is numbered. The pupils are told to write on paper the name of the tool after its number. This is a modification of the tool tests, such as the Hunter Tool Test (Appendix B), the Zorger Woodwork Recognition Test.

There are, to my knowledge, only two standardized tests in home mechanics available. These are the tests given in the Detroit Public Schools and the Newkirk-Stoddard Home Mechanics Test Forms A and B.

The plan used in the Newkirk-Stoddard Test is the very excellent one of disarranged order of procedure. As I was unable to obtain any copies of the Detroit Home Mechanics Test it cannot be discussed in this paper.

The Detroit Mechanical Aptitude Test for Girls, which is used as a prognostic test, consists of eight parts. These include household tools and appliances, a maze, a form test, multiple response test on fastenings, and a test on lines and angles. Samples of these tests will be found in Appendix B.

There are, however, many excellent trade and shop tests. The shop teacher will find helpful suggestions both as to form and content in any of these. Samples of such forms as could be obtained are included with this course.

A few of the published shop tests are:

1. Shop tests by Wm. Hunter - There are 17 individual tests covering a number of phases of shop work.

2. Nash-Van Duzee Industrial Arts Tests - Test I woodwork contains 60 true-false statements regarding tools and materials and 43-3 response items on related materials.

3. Test II Wood Constructions - showing various kinds of joints.

4. Test III Reading a drawing and Part IV Tools and processes - consisting of procedure questions.

G. K. Wells has recently issued through the Manual Arts Press, a group of knowledge tests in the field of mechanical drawing, woodwork, printing, and machine shop. These tests give their entire attention to the related information side of industrial arts. They each contain 100 true-false statements. Woodworking and printing include a second part consisting of 25 statements to be completed.

Patrick's "Industrial Arts Test" measures diversified activities in grades 7 to 9. It contains 100-4 response questions covering miscellaneous knowledge. So far, this test has not been standardized.

There are many other unstandardized tests dealing with subjects closely related to the units of work given in home mechanics. Many of these are available from school systems.

A well constructed test in home mechanics should:

1. Test the pupil,
2. Test the teacher,
3. Test the value of the job.

* * * * *

* * *

CHAPTER IX

THE GENERAL SHOP

* * *

* * * * *

The general shop is a shop where several activities are carried on at the same time, usually under one teacher.

Bedoll defines it as:

"A general shop may be defined as a shop in which a variety of stations or places to work are provided. Each station represents a work bench, a machine, or other suitable equipment for doing a specialized job." 1

-
1. Bedoll, Earl C., "General Shop Idea", Industrial and Vocational Education Magazine, July, 1932.
-

However, Wm. Roberts, in his report for the Bureau of Education, says:

"It would seem that a better organization could be developed by dividing the work between two rooms and two teachers. In this way pupils would have the advantage of more complete equipment utilizing with very small additions the regular equipment of the standard shops. Teachers would have fewer activities to direct and supervise and both rooms would be available for regular class work in the subjects for which they were equipped." 2

-
2. Roberts, Wm., "Manual Arts in Junior High School", Bureau of Education Bulletin, # 11, p. 39.
-

Whether of one or two rooms, the shop should conform to the standard laid down by the White House Conference for all schools. These are:

- "1. Adequate protection against fire and other life and health hazards.
2. Healthful air conditions secured by effective heating and ventilation.
3. Both natural and artificial lighting to prevent eye strain or development of defective vision.
4. Equipment - particular chairs and tables con-

structed and adjusted to meet the individual health needs of children.

5. Playfields and gym. of adequate size, the latter properly equipped with showers, locker rooms, and dressing rooms.
6. Sanitary provisions for drinking water, toilet and hand washing facilities.
7. Janitorial service judged primarily for quality of constructive contribution to the health of pupils and teachers, practical service and personal influence." 3

3. "Report of the White House Conference", 1930, p. 169.

In order to administer this course satisfactorily the shop should accommodate four groups of six girls, each. One girl of each group acts as forewoman. Each group works at a separate activity. This will necessitate twenty-four table-arm seats for demonstration and lecture work, along electrical bench with six outlets, a plumbing unit with faucets, sink, drain, flush tank and vises. There should be a sheet metal bench with gas burners, for heating soldering coppers. The wood-working benches will take up about half the space as they lend themselves to a variety of jobs, such as work with locks, doorknobs, and hinges as well as woodwork.

There should be tables and comfortable chairs for reading and reference work. Tools, lumber, and all supplies must be adequately but conveniently stored so that they are accessible, not only to the instructor, but also to the forewoman whose duty it is to distribute and collect them.

Files or cupboards for job and operation-sheets are also essential. These too should be in such places that the forewomen have easy access to them. Lockers for girls' aprons and ample storage space for projects

under construction must be planned.

Time can be saved and discipline reduced if the shop is carefully organized. The basis for this organization must always be the material of the course of study - the shop's reason for being.

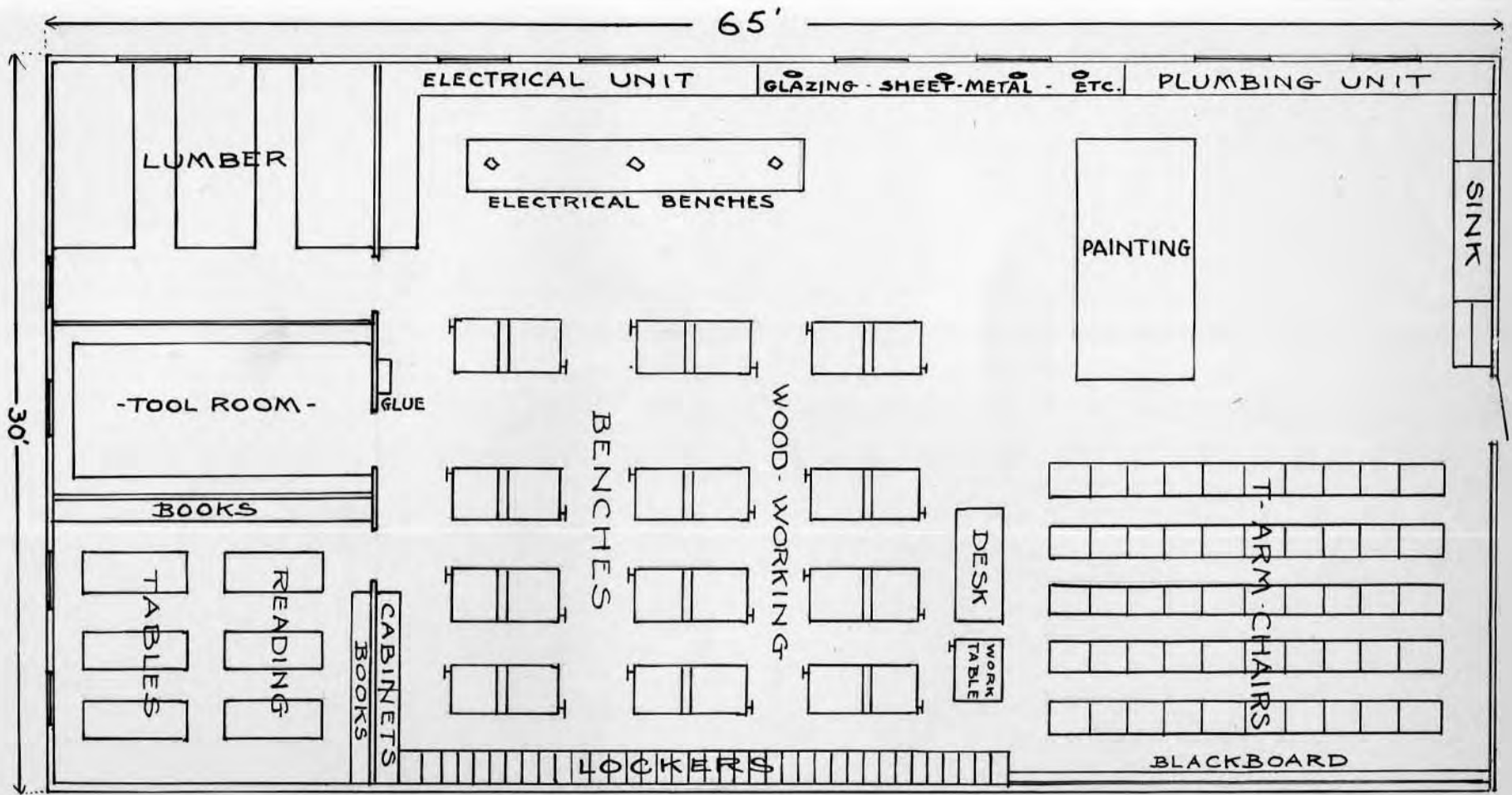

A SUGGESTED PLAN FOR A GENERAL SHOP

—*—

CHAPTER X

A PROPOSED COURSE OF STUDY

—*—

FUNDAMENTAL JOBS

I. PAINTING UNIT

1. To polish furniture

Operations

- 1) Remove spots,
- 2) Apply polish,
- 3) Rub with grain.

Related Information

- 1) How to remove white spots from varnished surface,
- 2) Method of cleaning and polishing waxed surface.

References

- McGee and Brown, Instruction Units in Wood Finishing, p. 62.
- Wakeling, Home Workshop Manual, p. 285.
- Wakeling, Fix It Yourself, p. 227.
- Collins, Home Handy Book, pp. 104 - 105.

2. To remove varnish from old piece of furniture

Operations

- 1) Apply remover,
- 2) Use scraper,
- 3) Sand surface,
- 4) Reglue loose parts.

Related Information

- 1) When and how varnish should be removed,
- 2) Cautions to be observed with varnish removers,
- 3) Strong soap and lye as varnish removers.

References

- Kidder, Architects and Builders Pocket Book, pp. 1482-1487.
- Wood and Smith, Prevocational and Industrial Arts, pp. 54-55.

Jeffrey, Wood Finishing, pp. 110 - 119.

Bedell, Household Mechanics Job Sheets, p. 19.

5. To repaint or enamel old article of furniture

Operations

- 1) Use of putty or wood filler,
- 2) Preparation of surface,
- 3) Removing old paint,
- 4) How to use sandpaper,
- 5) Use of undercoats,
- 6) Preparation of paint for use,
- 7) How to apply paint,
- 8) Care of brushes.

Related Information

- 1) Composition of paint,
- 2) Kinds of paint for various purposes, outside, inside, etc.,
- 3) Use of undercoats,
- 4) How to choose good brushes for various painting purposes,
- 5) When and how old finish should be removed,
- 6) How to prevent drips and brush marks,

References

Brown and Tustison, Practical Woodworking Job Sheets, Sheet #18,

Wood and Smith, Prevocational and Industrial Arts, pp. 53,56.

Griffith, Essentials of Wood Working, p. 18.

Churchill-Wickenden, House Owner's Book, Chapter 5,

Jeffrey, Wood Finishing, pp. 118 - 119, Enameling, Chap. 8.

4. To paint or enamel surface of new wood

Operations

- 1) Plane surface,

- 2) Use woodfile on rough ends,
- 3) Sand,
- 4) Apply shellac to any knots in wood,
- 5) Apply priming coat,
- 6) Prepare paint,
- 7) Apply paint.

Related Information

- 1) Some common painting troubles and their causes,
- 2) Peeling, blisters, crawling, slow drying.

References

Tustison, Home Mechanics Job Sheets, Sheet #

Brown and Tustison, Instruction Units in Hand Woodwork, pp. 91,95.

Wood and Smith, Prevocational and Industrial Arts, p. 52,

Wakeling, Fix It Yourself, pp. 121 - 128.

5. To lacquer or enamel a box or other small article of new wood

Operations

- 1) Prepare surface,
- 2) Apply lacquer,
- 3) Polish surface.

Related Information

- 1) Why lacquer is often applied with air brush,
- 2) Advantages of lacquer over enamel,
- 3) Solvents for lacquer.

References

Wood and Smith, Prevocational and Industrial Arts,

McGee and Brown, Instructional Units in Wood Finishing, p. 58.

6. To clean and store brushes of various kinds of paint, varnish, stains, lacquer

Operations

- 1) Cleaning brushes of various kinds of finish,
- 2) Boring hole in brush, or attaching screw hook by which it hangs in can,
- 3) Prepare cans to hold brushes - one for each color.

Related Information

- 1) Solvents for various finishes - wood alcohol, turpentine, kerosene, banana oil, etc.,
- 2) Kinds and sizes of brushes best adapted to various uses,
- 3) Proper cleaning of brushes,
- 4) Some types of brush-cans or containers.

References

Wood and Smith, Prevocational and Industrial Arts, p. 56.

Wakeling, Fix It Yourself, pp. 120-121.

Wakeling, Home Workshop Manual, pp. 399, 402.

7. To wax and polish new surface of jewel box

Operations

- 1) Prepare surface,
- 2) File surface if necessary,
- 3) Apply wax,
- 4) Polish surface.

Related Information

- 1) Kinds of wood which best take wax finish,
- 2) Kinds of wood which need filing,
- 3) Composition of wax.

References

Jeffrey, Wood-Finishing, Chapter 5,

Wood and Smith, Prevocational and Industrial Arts, p. 57.

8. To varnish surface

Operations

- 1) Preparation of surface,
- 2) Apply shellac,
- 3) Apply varnish,

Related Information

- 1) Purpose and uses of shellac,
- 2) Kinds of varnish,
- 3) Composition of Varnish,
- 4) Temperature for varnishing,
- 5) Care of brushes.

References

Sabin, House Painting,

Churchill-Wickenden, House Owner's Book, p. 178.

Jeffrey, Wood Finishing, Chapter 2 and pp. 16 - 75.

9. To stain articles of wood.

Operations

- 1) Prepare surface,
- 2) Apply stain,
- 3) Apply filler if needed,
- 4) Apply varnish or wax.

Related Information

- 1) Kinds of stains,
- 2) What filler is,
- 3) Kinds of wood with which filler should be used,
- 4) Care of brushes,

References

Tustison, Home Mechanics Job Sheets, Sheet # 23.

Jeffrey, Wood Finishing, pp. 16 - 75.

Churchill-Wickenden, House Owner's Book, p. 173.

Bedell, Household Mechanics Job Sheets, Sheet A-17.

Brown and Smith - Prevocational and Industrial Arts, pp. 55-56.

II. WOOD UNIT

1. To repair dresser drawer

Operations

- 1) Use of plane,
- 2) Use of glue,
- 3) Use of drill,
- 4) Screwing,
- 5) Nailing,
- 6) Use of sand paper,

Related Information

- 1) Three kinds of glue,
- 2) Proper uses for each kind,
- 3) Best kind of nails for use in light wood.

References

Brown and Tustison, Instruction Units in Wood Finishing, pp. 70, 74, 135, 140.

Wood and Smith, Prevocational and Industrial Arts, pp. 21, 47.

2. To put partition in drawer or box

Operations

- 1) Measuring,
- 2) Squaring,
- 3) Sawing,
- 4) Use of chisel,
- 5) Making a half-lap joint,
- 6) Nailing in place.

Related Information

- 1) Measure to 1/16 in kinds of nails for use in ply-wood,
- 2) Uses of half-lap joint.

References

Allen, Manual Training for the Common Schools, p. 199.

Vits, Problems in Elementary Woodwork, pp. 41 - 42.

3. To fill wood

Operations

- 1) Preparation of surface,
- 2) Thin paste wood filler,
- 3) Brush filler well into wood,
- 4) Allow filler to set,
- 5) Rub with rough cloth across the grain of wood,
- 6) Allow to dry at least a day.

Related Information

- 1) Kinds of filler,
- 2) Why filler is used,
- 3) How filler can be made,
- 4) Types of wood requiring filler,
- 5) Solvent to thin filler.

References

Wood and Smith, Prevocational and Industrial Arts, p. 56.

4. To repair chair with glue and corner brace

Operations

- 1) Clean all parts needing glueing,
- 2) Reglue all loose parts,
- 3) Drill holes to fit screws,
- 4) Attach corner plates or braces where needed.

Related Information

- 1) How to measure size of screw to be used,
- 2) Purposes of different plates and braces.

References

Tustison, Job Sheets in Home Mechanics, Sheet 5.

Wood and Smith, Provocational and Industrial Arts, p. 57.

Brown and Tustison, Instruction Units in Hand Woodwork, pp. 135, 140, 173, 175.

5. To make a wooden toy

Operations

- 1) Trace pattern,
- 2) Measure gauging,
- 3) Use of coping saw,
- 4) Use of back saw,
- 5) Use of block plane,
- 6) Sanding,
- 7) Screwing,
- 8) Painting or finishing,
- 9) Chamfering.

Related Information

- 1) How to prevent plane splitting in the end,
- 2) Kinds of saws best for various purposes,
- 3) Parts of the plane,
- 4) Special uses for block plane, smoothing plane,
- 5) Chamfering-Meaning and use.

References

Vitz, Problems in Elementary Woodwork, p. 15.

Noyes, Handwork in Wood, pp. 78 and 184.

Brown and Tustison, Practical Woodworking Job Sheets, Sheet #5.

6. To sharpen and assemble household tools, knives, and scissors

Operations

- 1) Clean oilstone,

- 2) Apply oil to stone,
- 3) Whet tool on coarse stone,
- 4) Whet tool on fine stone,
- 5) Test edge for sharpness,
- 6) Clean tool,
- 7) Clean stone and replace cover.

Related Information

- 1) How to sharpen both beveled and straight edged tools,
- 2) Proper shape for screwdriver,
- 3) Kinds of edges necessary for different kinds of work,
- 4) Temper in tools,
- 5) Burning the tool edge,
- 6) Angle for bevel,
- 7) Leather for sharpening tools.

References

Brown and Tustison, Instruction Units in Hand Woodwork, pp. 56 - 65.

Brown and Tustison, Practical Woodworking Job Sheets, Sheets #4 and #19.

Bedell, Household Mechanics Job Sheets, Sheets #A-12 and #A-3.

Allen, Mechanical Devices in the Home, pp. 41 and 57.

Wood and Smith, Prevocational and Industrial Arts, pp. 30-34 and 44 and 216.

Griffith, Essentials of Woodworking, pp. 91 - 92.

7. To make and frame a picture.

Operations

- 1) Measure for size of frame,
- 2) Saw to length by using mitre box,
- 3) Nail mitre-joint,
- 4) Use corrugated fasteners,

- 5) Cut glass to size,
- 6) Insert glass,
- 7) Make back of cardboard,
- 8) Attach screw eyes and wire.

Related Information

- 1) Kind of joint best for picture frame,
- 2) Where and how to use corrugated fasteners,
- 3) Steps in cutting glass.

References

Wood and Smith, Prevocational and Industrial Arts, pp. 51, 60-61.

Tustison, Job Sheets in Home Mechanics, Sheets 12 and 13.

Brown and Tustison, Instruction Units in Hand Woodwork, pp. 150, and 165-171.

8. To rewire or make a window screen

Operations

- 1) Measure,
- 2) Gauge,
- 3) Saw with rip saw - with cross cut saw,
- 4) Use try square,
- 5) Nailing,
- 6) Apply corner plates,
- 7) Put on wire,
- 8) Apply moulding,
- 9) Apply paint or stain.

Related Information

- 1) How size in screening is indicated,
- 2) How size in nails is indicated,
- 3) Kinds of screening - comparative costs and wearing qualities of different screenings,

- 4) Uses of plates and braces.

References

Wakeling, Fix It Yourself, pp. 201-206.

Tustison, Job Sheets in Home Mechanics, Sheet #7.

Brown and Tustison, Instruction Units in Hand Woodwork, pp. 73, 175.

Wood and Smith, Prevocational and Industrial Arts, pp. 25 - 26, and 51.

Griffith, Essentials of Woodworking, p. 116.

Churchill-Wickenden, House Owner's Book, p. 72.

Bedell, Household Mechanics Job Sheets, Sheet #A-2.

9. To recognize various kinds of woods

Operations

- 1) Practice in identifying samples of common woods - both finished and unfinished,
- 2) Excursions to identify local woods from the trees,
- 3) Trips to the lumber yards.

Related Information

- 1) Kinds of lumber best adapted to different uses - interiors, furniture,
- 2) Lumber grown in Middle West.

References

Wood and Smith, Prevocational and Industrial Arts, pp. 35 - 41.

Griffith, Essentials of Woodworking, pp. 116 - 150.

Richey, Woodwork, pp. 16 - 37.

Hough, Handbook of Trees,

U. S. Dept. of Agriculture, Bulletin #552.

III. ELECTRICAL UNIT

1. To clean and lubricate electrical appliances

Operations

- 1) Put grease in grease cups as indicated in instruction book,
- 2) Clean off surplus oil and grease,
- 3) Remove and clean brushes of vacuum cleaner.

Related Information

- 1) Why oiling is necessary,
- 2) Why kerosene helps clean oily parts.

References

Wakeling, Fix It Yourself, pp. 157 - 160.

Instruction books accompanying vacuum cleaners, washing machines, etc.

2. To test and replace fuses

Operations

- 1) Find right circuit,
- 2) Locate burned out fuse,
- 3) If it is a refillable fuse attach new piece of fuse wire to posts,
- 4) If not refillable, use new fuse.

Related Information

- 1) Why fuse is called a safety valve,
- 2) Reasons why fuses blow - cause and effect of short circuit,
- 3) Kinds of fuses,
- 4) Meaning of amperes,
- 5) Dangers of using penny instead of new fuse,
- 6) Composition of fuse wire.

References

Tustison, Job Sheets in Home Mechanics, Sheet #33.

Keene, Mechanics of Household, p. 334.

Churchill-Wickenden, House Owner's Book, pp. 210 and 366.

3. To read electric, gas, and water meters

Operations

- 1) Practice with cardboard dials, with movable pointers - one set representing electric meter, one water, and the other gas. Read from right to left.

Related Information

- 1) How to figure costs per unit of consumption,
- 2) Sources of electric current,
- 3) Meaning of kWh and cubic feet.

References

Keene, Mechanics of Household, pp. 350-353.

Churchill-Wickenden, House Owner's Book, pp. 218-220.

Tustison, Job Sheets in Home Mechanics, Sheet 46.

4. To replace cord to electric appliance

Operations

- 1) Remove old cord,
- 2) Measure length of cord needed,
- 3) Attach a separable plug,
- 4) Put on attachment piece,
- 5) Test attachment cord.

Related Information

- 1) How wind wire on posts,
- 2) Separable and screw plugs,
- 3) To identify socket, binding posts element, insulation,
- 4) Know common types of conductors and non-conductors.
- 5) Reason for use of stranded wire in cord,
- 6) Economical care of electrical appliances.

References

- Tustison, Job Sheets in Home Mechanics, Sheet #35,
 Bedell, Household Mechanics Job Sheets, Sheet #a-32.
 Keene, Mechanics of the Household, p. 327.
 Willoughby, Practical Electricity for Beginners, pp. 64-76,
 and 54-62.
 Allen, Mechanical Devices in the Home, p. 19.

5. To splice and tape wire

Operations

- 1) Removing insulation,
- 2) Cleaning wire,
- 3) Making joint,
- 4) Soldering both joints,
- 5) Taping joint.

Related Information

- 1) Why splices should be soldered,
- 2) Kinds of covering on wire,
- 3) Law of resistance - nicking wire,
- 4) Need for use of two kinds of tape.

References

- Tustison, Job Sheets in Home Mechanics, Sheet #29.
 Wood and Smith, Prevocational and Industrial Arts, p. 266.
 Schuhler, Electrical Wiring, pp. 2 - 59.
 Bedell, Household Mechanics Job Sheets, Sheet #A-26.

6. To give first aid for electric shock

Operations

- 1) How to remove person from high tension wire,
- 2) Practice motions in artificial respiration.

Related Information

- 1) Water as a conductor,

- 2) Conductors and non-conductors,
- 3) How to avoid dangers of electricity,
- 4) Proper location of fixtures and outlets in bathroom and kitchen.

References

Collins, Book of Electricity, pp. 160 - 164.

Willoughby, Practical Electricity for Beginners, pp. 96-100.

IV. PLUMBING AND METAL UNIT

1. To clean sink trap

Operations

- 1) Try lye and hot water poured down sink as grease solvent,
- 2) If unsuccessful, put pan under grease trap,
- 3) With wrench or pliers remove cap at base or side of trap,
- 4) Clean out grease with stick,
- 5) Work stiff hooked wire back and forth in both legs of trap,
- 6) Pour hot water down sink,
- 7) Close trap.

Related Information

- 1) Composition of lye and precautions necessary,
- 2) Some commercial grease solvents,
- 3) Common types of traps.

References

Wakeling, Fix It Yourself, pp. 141 - 142.

Home Handy Book, p. 78.

Keene, Mechanics of the Home, pp. 109 - 115.

Allen, Mechanical Devices in the Home, p. 129.

Kidder-Nolan, Architects and Builders Pocket Book, p. 1326.

2. To clean stopped up pipes

Operations

- 1) Use hand force pump to force out obstruction,
- 2) Use of force and lift suction pump,
- 3) Use of coil spring pipe clean by rotating,
- 4) Pour hot water and caustic potash or lye.

Related Information

- 1) Damage and expense of pouring greasy or undrained water down the sink,

- 2) Some grease solvents,
- 3) Caustic acid as a solvent of organic matter.

References

Wakeling, Fix It yourself, pp. 141 - 142.

Home Handy Book, p. 78.

Keene, Mechanics of the Home, p. 109.

3. To repair a leaking faucet

Operations

- 1) Decide on type of faucet,
- 2) Locate leak,
- 3) Shut off water,
- 4) Remove valve stem with wrench,
- 5) Replace with new washer,
- 6) Assemble faucet,
- 7) Test.

Related Information

- 1) Difference between compression and fuller faucet,
- 2) How to protect faucet when using wrench,
- 3) How and where to shut off water supply.

References

Tustison, Job Sheets in Home Mechanics, Sheet #24.

Allen, Mechanical Devices in the Home, pp. 120 - 122.

Keene, Mechanics of the Household, pp. 88 - 93.

Wakeling, Fix It Yourself, pp. 136 - 138.

Bedell, Household Mechanics Job Sheets, Sheet #A-21.

4. To repair cooking utensil by use of solder or by rivets

Operations

- 1) Clean around hole to be soldered with knife or sandpaper,

- 2) Apply soldering paste,
- 3) Tin soldering copper,
- 4) Melt solder into hole with copper,
- 5) Apply patch over hole in same way.

Related Information

- 1) Effect of dirt or grease on soldering,
- 2) What flux it,
- 3) What is meant by tinning a soldering copper,
- 4) Why rosine is used,
- 5) Effect of letting tinned copper get hot.

References

- Wood and Smith, Prevocational and Industrial Arts, pp. 218-219.
- Home Handy Book, pp. 24 - 25.
- Churchill-Wickenden, House Owner's Book, pp. 266 - 267.
- Bedell, Household Mechanics Job Sheets, Sheet #A-9.
- Tustison, Job Sheets in Home Mechanics, Sheets 16 and 17.
- Thatcher, Tin Can Toys.

V. MISCELLANEOUS UNIT

1. To put up curtain rods and fixtures

Operations

- 1) Measure height and width for placing fixture,
- 2) Try fixture,
- 3) Make a pilot hole with awl,
- 4) Insert awl or nail in screw-hole to hold fixture in place while other screws are put in,
- 5) Repeat with other fixture,
- 6) Slip rod in place.

Related Information

- 1) How to measure exact distances,
- 2) How to use hammer and screwdriver.

References

Wakeling, Fix It Yourself, pp. 218 - 219.

Brown and Rustison, Instruction Units in Hand Woodwork, pp. 156 - 160.

2. To clean and regulate gas-stove

Operations

- 1) Clean burners,
- 2) Clean tray,
- 3) Clean pipes,
- 4) Adjust air in burner,
- 5) Adjust pilot light,
- 6) Locate cut off valve for gas stove.

Related Information

- 1) Safety precautions in use of gas,
- 2) First aid for person overcome with gas,
- 3) Parts of gas stove,
- 4) Why blue flame gives most heat,

- 5) Why every stove should have a cut off valve,
- 6) Why the pilot light sometimes makes a roaring sound.

References

- Collins, Home Handy Book, p. 88.
- Allen, Mechanical Devices in the Home, p. 9.
- Wakeling, Fix It Yourself, pp. 145 - 147.

3. To repair roller shades

Operations

- 1) Remove shade from brackets,
- 2) Roll up by hand,
- 3) Test in brackets,
- 4) Held spring at end and test by hand,
- 5) If worn remove from roller, and reverse shade, tacking on,
- 6) Re-hem new end,
- 7) To clean shade wipe off with heavy mixture of soap suds,
- 8) Wipe again, with dry cloth.

Related Information

- 1) How shade roller may be rewound if spring is weak,
- 2) How to relieve tension,
- 3) How to turn shades end for end,
- 4) How to clean roller shades.

References

- Allen, Mechanical Devices in the Home, p. 43.
- Wakeling, Fix It Yourself, p. 219.
- Home Handy Book, pp. 26 - 27.

4. To oil and care for sewing machine

Operations

- 1) Remove thread and bobbin case,

- 2) Clean all threads and knots,
- 3) Clean gummed oil with cloth dipped in kerosene,
- 4) Turn back head of machine and clean underneath,
- 5) Wipe off all excess oil,
- 6) Test machine.

Related Information

- 1) Economic reasons for proper care of machine,
- 2) Name of parts of sewing machine,
- 3) Effects of too much oil,
- 4) How and where to clean machine,
- 5) Kerosene - a grease solvent.

References

- Allen, Mechanical Devices in the Home, p. 53.
- Singer Sewing Machine Company, Instruction Books,
- Cook, Sewing Machine, pp. 72 - 77, and 125 - 129.
- Home Handy Book, pp. 33 - 36.

5. To repair belts

Operations

- 1) Remove belt,
- 2) Remove old staple,
- 3) Shorten belt,
- 4) Puncture new holes,
- 5) Make staple from brad or wire,
- 6) Use of pliers.

Related Information

- 1) Reason for break at joint,
- 2) Correct position for connector,
- 3) Kinds of wire most suitable for connector,
- 4) Elastic properties of leather - wet and dry.

References

Allen, Mechanical Devices in the Home, p. 55.

Tustison, Job Sheets in Home Mechanics, Sheet #11.

6. To replace a pane of glass

Operations

- 1) Remove sash or door,
- 2) Remove old putty and broken glass,
- 3) Measure,
- 4) Cut glass to size,
- 5) Prepare putty,
- 6) Back putty rabbet,
- 7) Fasten with glazer points.

Related Information

- 1) Why it is necessary to oil or paint wood before using putty,
- 2) Composition of putty,
- 3) Uses of putty in glazing - in painting,
- 4) What the bowed side of glass is,
- 5) Zinc point will not rust.

References

Wood and Smith, Prevocational and Industrial Arts, pp. 60-61.

Tustison, Job Sheets in Home Mechanics, Sheet #12.

Bedell, Household Mechanics Job Sheets, Sheet A-15.

Home Handy Manual, pp. 90 - 96.

7. To repair a hole or crack in a plastered wall

Operations

- 1) Cutting away loose material,
- 2) Wetting old plaster,

- 3) Mixing plaster,
- 4) Applying plaster,
- 5) Finishing surface.

Related Information

- 1) Properties of Plaster of Paris,
- 2) Plaster sets in twenty-four hours,
- 3) How to give rough and smooth finish to plaster,
- 4) Composition of plaster,
- 5) Composition of Plaster of Paris.

References

Tustison, Job Sheets in Home Mechanics, Sheet #44.

Directions on cartons of commercial patching plasters.

8. To read simple working drawing

Operations

- 1) Interpret simple house floor-plan,
- 2) Make simple working drawing of bread-board.

Related Information

- 1) Reasons for blue-printing,
- 2) Method of making blue-prints,
- 3) Essentials of working drawing.

References

Diamond Thomas, A Primer of Blue-Print Reading,

Getty, How to Read a Blue-print,

Wyatt, Blue-print Reading,

Brown and Tustison, Instruction Units in Hand Woodwork, pp. 4-9.

Sturtevant, W. W., Mechanical Pictorial Drawing.

SUPPLEMENTARY JOBS

1. How to Make an Extension Cord

References:

- Willoughby, Practical Electricity, pp. 59 - 65.
- Tustison, Job Sheets in Home Mechanics, Job #35.
- Wood and Smith, Prevocational and Industrial Arts, p. 266.
- Bedell, Household Mechanics, Job Sheet #A-31.
- Wakeling, Home Workshop Manual, pp. 298 - 301.
- Wakeling, Fix It Yourself, p. 263.

2. How to Put on or Adjust Hinges

References:

- Wakeling, Fix It Yourself, pp. 47 and 54.
- Brown and Tustison, Practical Woodworking Job Sheets, Job #16.
- Griffith, Woodworking for Secondary Schools, pp. 295-296.
- Noyes, Handwork in Wood, pp. 131-152 and pp. 295-296.
- Brown and Tustison, Instruction Units in Hand Woodwork, pp. 212 - 213.

3. How to Repair Spring in Mortised Lock

References:

- Wakeling, Fix It Yourself, pp. 72 - 73.
- Brown and Tustison, Instruction Units in Hand Woodwork, p. 217.
- Wood and Smith, Prevocational and Industrial Arts, p. 50.
- Tustison, Job Sheets in Home Mechanics, Job #20.
- Collins, Home Handy Book, p. 39.

4. How to Repair Loosened Door Knob

References:

- Collins, Home Handy Book, p. 38.

5. How to Repair Toilet Flush Tank

References:

- Wakeling, Fix It Yourself, pp. 138 - 140.
 Keene, Mechanics of the Household, pp. 108 - 115
 Allen, Mechanical Devices in the Home, pp. 129 - 130.
 Bedell, Home Mechanics Job Sheets, Job #55.

6. How to Make a Cocky Cutter of Sheet Tin

References:

- Tustison, Job Sheets in Home Mechanics, Job #49.
 Thatcher, Tin Can Toys.

7. How to Make a Sugar Scoop of an Old Tin Can

References:

- Thatcher, Tin Can Toys.
 Tustison, Job Sheets in Home Mechanics, Job #19.

8. How to Make a Bird House

Reference:

- Wood and Smith, Prevocational and Industrial Arts,
 pp. 102 - 103.

9. How to Make a Plant Trellis

Reference:

- Brown and Tustison, Practical Woodworking Job Sheets,
 Job #17.

10. How to Make a Flower Box

References:

- Brown and Tustison, Instruction Units in Hand Wood-
 work, pp. 151 - 153.
 Brown and Tustison, Practical Woodworking Job Sheets,
 Job #9.

SOME SUGGESTED CORE JOBS

Wood:

1. Bread board,
2. Salt box,
3. Window screen,
4. Repairing chair.

Electrical:

1. Install two way switch on appliance cord,
2. Make an extension cord for a lamp,
3. Soldering and taping wire.

Finishing:

1. Lacquering,
2. Use of outside paint,
3. Removing finish and painting old piece of furniture.

SUGGESTED COOPERATIVE CIVIC PROJECTS

1. Dool house for the kindergarten,
2. Bird houses for parks,
3. Toys for Children's Hospital,
4. Flower boxes for the school

JOB SHEETWOODWORKING UNITCORE JOBHow To Make a Bread-Board

Examine the bread board in the exhibit. Notice particularly how the corners are finished. Peel the surface of the board. Read this sheet through.

INFORMATION - This job teaches you how to do a number of operations, which you will need to know in working with wood in and about your home. At the end of the demonstration you will be given all the operation sheets to go with this job sheet so that you can do the job yourself.

TOOLS - Cross-cut saw, smoothing-plane, pencil, gauge, try-square, hand drill, 5/32 bit, ruler.

MATERIALS - Board about 8 x 12". It is better a little larger rather than smaller.

DIRECTIONS - After you have watched the demonstration, see if you can fill in the blanks in the order in which these operations should be done:

- | | | |
|--|-----|-------|
| Drill hole. | (1) | _____ |
| Sawing off corners. | (2) | _____ |
| Layout the block.
(try-square, ruler) | (3) | _____ |
| Measure exact size.
(Use try-square) | (4) | _____ |
| Gauging. | (5) | _____ |
| Plane long edge. | (6) | _____ |
| Plane across grain. | (7) | _____ |
| Sand. | (8) | _____ |

HAVE YOUR LIST CHECKED BY YOUR FOREWOMAN BEFORE STARTING ANY WORK.



Fig. 1.
Testing the Edge.

GRADUATE SCHOOL
LIBRARY
MARQUETTE UNIVERSITY

JOB SHEET (Reverse side)

LAYING OUT THE BLOCK - This is almost the first operation in every job with wood. Each lay-out is different. This one is done in the following order:

1. Test the edge with the try-square.
2. Test the end with the try-square.
3. Draw a line across the width (use try-square) that will divide the length into two parts.
4. Draw a line across the length that will divide the width into two parts. (See Illustration, Fig. 2)
5. Make two dots on each long edge $4\frac{1}{2}$ " from the center line.
6. Mark two dots on each end $2\frac{1}{2}$ " from the center line.
7. Draw lines across the corners connecting these dots that were just marked.
8. Mark a point $1\frac{1}{2}$ " from the end of the board on the center line for the drill hole.

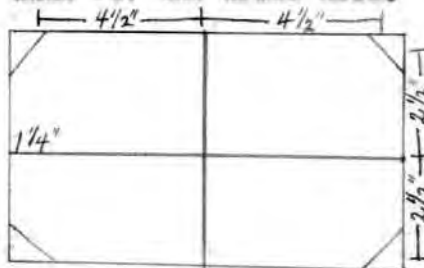

Fig. 2, Layout

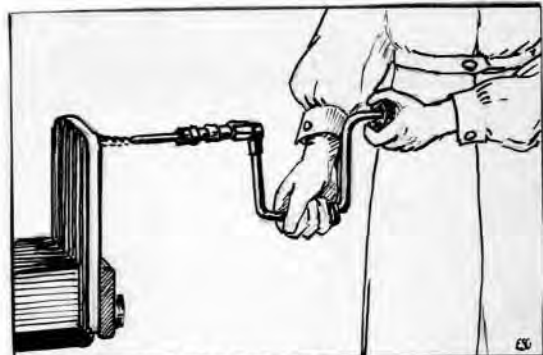

FIG. 3 BORING A HOLE

HAVE YOUR WORK CHECKED HERE.

Now take the operation sheets and go on with the job in proper order. Do NOT hurry.

When you have finished the job, have your work checked.

QUESTIONS:

1. What is a "true edge"?
2. What is the face of the board?
3. How do you plane across the grain?
4. How do you use a try-square?
5. Where is the pressure put in planing - at the beginning of the stroke? At the end of the stroke?

REFERENCES:

- Brown and Tustison, Instructional Units in Hand Woodwork, pp. 33 - 38, and pp. 71 - 74.
- Brown and Tustison, Practical Woodworking Job Sheets, Job #5,
- Vitz, Problems in Elementary Woodwork,
- Noyes, Handwork in Wood, p. 78.
- Griffith, Essentials of Woodworking, pp. 9 - 36.

JOB SHEETELECTRICAL UNITSUPP. JOB #6How to Make an Extension Cord

Examine the sample extension cord in the exhibit. See if you can name some of the parts and tell their relation to other parts. Read the job through and think out the order in which you will do the different steps of the job.

TOOLS - Screwdriver, pliers.

MATERIALS - Lamp cord, separable plug, key socket.

DIRECTIONS - In the blanks on the right, list the steps of these directions for attaching the socket, in the order in which you would do them. Then do the same with the directions for attaching the plug. Measure and cut off the amount of cord needed.

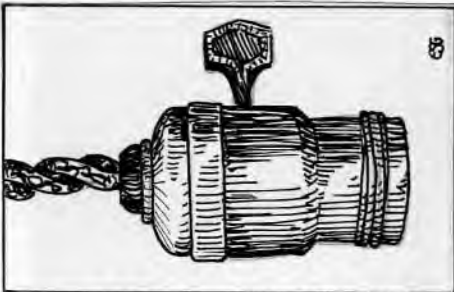

FIG. 1. SOCKET.

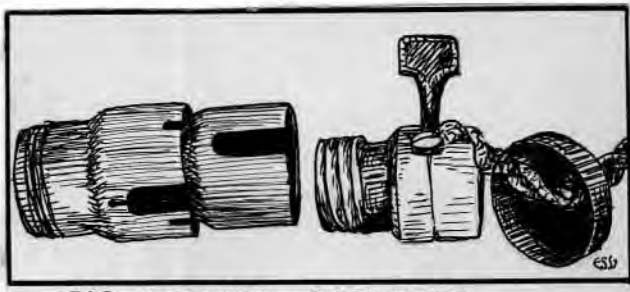

FIG. 2-SOCKET SEPARATED

TO ATTACH SOCKET.

- Remove the cap. (1) _____
- Loosen the brushing. (2) _____
- Loosen small screw at top
of socket. (3) _____
- Tie an underwriter's
knot. (4) _____
- Insert two cords in plug
cap. (5) _____
- Remove porcelain from
brass case. (6) _____
- Remove insulation. (7) _____
- Replace cap. (8) _____

JOB SHEET (Reverse side)

Attach wires to binding posts. (9) _____

Slip brass case over. (10) _____

At this point have your list checked by your forewoman.

TO REMOVE THE CAP - Loosen the small screw at the top of the cap of the socket and screw in the small rubber brushing unless the brushing is already in the socket and again tighten the screw just enough to prevent the brushing from turning. Press against the side of the socket marked "Press" with the thumb and pull off the cap with other hand.

Do the operations in order, then have your work checked.

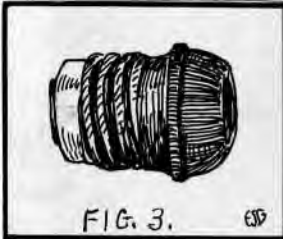

FIG. 3. ESP
SWIVEL PLUG
TO ATTACH PLUG

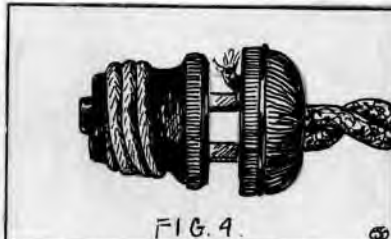

FIG. 4. S
SEPARABLE PLUG



FIG. 5. ESP
PLUG - SHOWING PARTS

Attach wires to binding posts. (1) _____

Tie an underwriter's knot. (2) _____

Pull plug apart. (3) _____

Remove insulation. (4) _____

Lay base of plug aside. (5) _____

Insert two cords through hole at
base of plug. (6) _____

Replace base. (7) _____

Have your list checked here.

If there are any of the other operations which you are not sure you can do, ask your forewoman for the operation sheets for them.

Do all these operations in order, then have your work checked.

Now test your work by screwing the plug in a lamp socket and placing the lamp in the socket of the cord.

JOB SHEETHow to Make an Extension Cord (Cont'd.)

QUESTIONS:

Put the number of the correct answer in the parenthesis.

- () If you cut the small wires in the cord, you
1. Reduce the power,
 2. Cause a short circuit,
 3. Cut off the current.
- () We use the underwriter's knot
1. To increase the current,
 2. To keep the fixture from slipping,
 3. To alternate the current.
- () The wires are wound around the binding posts
1. From right to left,
 2. From left to right,
 3. In either direction.

REFERENCES:

- Tustison, Job Sheets in Home Mechanics, Job #34.
- Bedell, Home Mechanics Job Sheets, Job #A-32,
- Keene, Mechanics of the Household, p. 327.
- Willoughby, Practical Electricity for Beginners, pp. 64 - 76, and pp. 84 - 82.
- Allen, Mechanical Devices in the Home, p. 19.

JOB SHEETMISCELLANEOUS UNITJOB #3How To Repair Roller Shades

Examine the shade roller in the exhibit. See if you can find the "dogs" at the end of the roller. Where is the spring that rolls the shade up? When the shade will not roll up the spring is unwound.

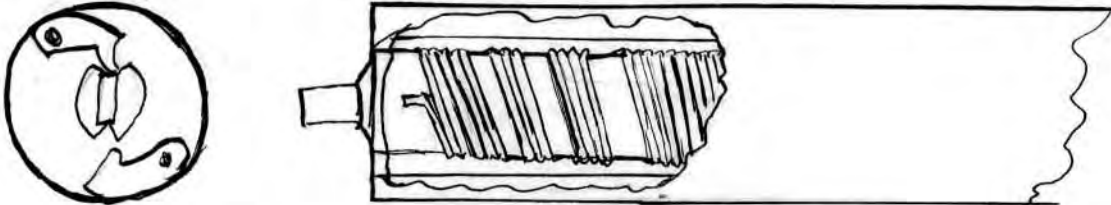

Sectional side view showing spring and end-view of roller.

TOOLS - hammer, small tacks 1/8", needle, thread, ruler, pencil, and scissors.

MATERIALS - Shade roller, soap flakes, warm water, cloth or sponge.

DIRECTIONS - In the blanks at the right, list the steps of adjusting the shade roller spring in the order in which you would do them:

- Roll up shade by hand. (1) _____
- Remove from brackets. (2) _____
- Test to see if spring is too loose or too tight. (3) _____
- See if the dogs catch in ratchets. (4) _____
- Return to brackets. (5) _____
- Test to see if spring is adjusted. (6) _____
- Repeat until spring is tight enough. (7) _____

At this point have your list checked by your forewoman to be sure you have the right order.

JOB SHEET (Reverse side)How to Repair Roller Shades

1. Testing the spring - Try raising and lowering the shade. If it comes down but will not roll up easily, the spring is unwound. If it flies up and will not stay down, the spring is too strong and needs unwinding.
2. Remove the shade from its brackets.
3. Roll up by hand holding roller so that shade rolls from you (See illus.).
4. See if dogs catch in the ratchets. If these little catches at the end of the roller do fall into the ratchets easily, look for threads or dust. If they are still stiff apply two drops of oil.
5. Return to brackets.
6. Test by pulling (not snapping) up and down.
7. Repeat until spring is tight. If spring refuses to tighten it is probably broken and it is cheaper to get a new roller than to try to repair it.



Rolling the Shade.

Have your work checked here.

II. To Fasten Shade on the RollerDIRECTIONS -

1. Remove shade from brackets.
2. Unwind shade and remove tacks which fasten shade to roller.
3. Mark with your yardstick and pencil to get straight cut. Trim top of shade where worn.
4. Line up top of shade with mark on roller.
5. Place a tack, part way in, at each end of shade and one in center.
6. Roll up shade by hand to see if it rolls true. If not, take out tacks and adjust it till it does.
7. Finish tacking shade on roller, placing tacks about 4 in. apart.

Have your work checked here.

8. Replace in brackets.

JOB SHEETHow To Repair Roller Shades (Page 2.)III. To Put New Hem in Window Shade and Clean

1. Unroll the shade on table or flat surface to prevent cracking.
2. Unscrew shade pull and remove stick.
3. Cut off frayed hem and any worn parts on a ruled line.
4. Measure $2\frac{1}{2}$ in. from edge. Mark lightly on wrong side.
5. Fold up hem on right side.
6. Turn in $\frac{1}{2}$ " for finish and crease with rule.
7. Lay off dots $\frac{1}{4}$ " apart and $1/8$ " from top of hem.

Have your work checked here.

8. Use thread the same color as the shade. Sew from left to right as shown in the illustration. When the right edge is reached, sew back to the left side, crossing the stitches. Fasten thread by tying.
9. Place wooden strip in hem with thick part at bottom.
10. Measure for center and screw in curtain pull.

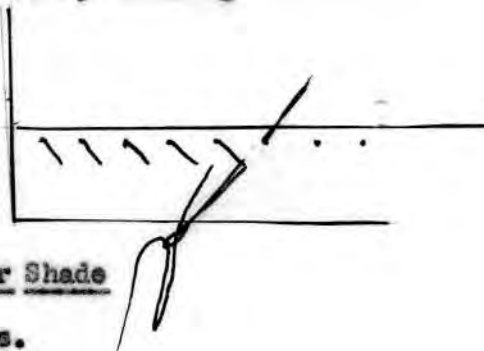
IV. To Clean Roller Shade

1. Make heavy suds of soap or flakes.
2. Wring cloth or sponge almost dry.
3. Dip cloth in suds, keeping out of water.
4. Rub over shade.
5. Wipe off with clean cloth.
6. Be careful not to let suds soak into the fabric.

Have your work checked here.

JOB SHEETHow To Repair Roller Shades (Page 2 - Reverse)

QUESTIONS:

1. What would happen if $3/4$ in. tacks were used to fasten the shade to the roller? _____
2. Which is the spring end of the roller when it is in the brackets? _____
3. Why use heavy suds instead of soap and water to clean a shade? _____
4. How will you regulate a shade which will not stay down? _____

REFERENCES:

Allen, Mechanical Devices in the Home, p. 135.

Wakeling, Fix It Yourself, p. 219.

Collins, Home Handy Book, pp. 26 - 27.

RECORD:

NAME _____ GR. _____ CLASS _____

DATE BEGUN _____ DATE FINISHED _____

FOREWOMAN'S GRADE _____ TEACHER'S GRADE _____

JOB SHEETPAINTING UNITJOB #9How to Stain an Article of New Wood

Examine the exhibit for a wooden article which has been stained. See if you can make the finish on your article look as well as this.

TOOLS - Varnish brush, putty knife, and clean container.

MATERIALS - sandpaper and block, stain, paste-filler, varnish, turpentine, and rags.

DIRECTIONS: In the blanks on the right, list the steps in these directions in the order in which you would do them.



Applying Stain.

- | | | |
|---------------------------|-----|-------|
| Apply filler. | (1) | _____ |
| Apply stain. | (2) | _____ |
| Prepare surface. | (3) | _____ |
| Apply varnish - 2nd coat. | (4) | _____ |
| Apply varnish - 1st coat. | (5) | _____ |

At this point have your list checked by your forewoman.

If you are not sure how to do any of the other operations given in the directions, ask your forewoman for the operation sheet or sheets which will tell you how.

HOW TO APPLY STAIN - After the new wood has been sanded smooth, we are ready to apply the stain.

1. Select the color of stain you wish to use,
2. Mix stain well,
3. Pour small amount into saucer or dish,

JOB SHEET (Reverse Side)

4. Apply with brush working with grain and drawing brush slowly that stain will have time to sink in.
5. Work with strokes that overlap.
6. When partly dry, wipe off surplus stain.
7. Clean brush and put away.

Have your work checked here. Continue with the other operations in their proper order. When you are finished, have your work checked by your forewoman and look up the references. Then fill in the answers to these questions.

QUESTIONS:

Fill in the blanks with the right word.

1. Filler is used on _____ grained wood.
2. Two kinds of filler are _____ and _____.
3. _____ wood takes the stain more readily than _____ wood.
4. Stain evaporates _____.
5. Stain should be brushed _____ the grain of the wood.

REFERENCES:

- Brown and Smith, Prevocational and Industrial Arts, pp. 55-56.
 Churchill-Wickenden, House Owner's Book, p. 178.
 Jeffrey, Wood Finishing, pp. 16 - 75.
 Tustison, Job Sheets in Home Mechanics, Job Sheet #23.

RECORD:

NAME _____ GR. _____ CLASS _____
 DATE BEGUN _____ DATE FINISHED _____
 FOREWOMAN'S GRADE _____ TEACHER'S GRADE _____

WOOD OPERATION SHEET #6

To Prepare a Surface by Sanding

INFORMATION - All planing and scraping should be completed before sanding is begun. After sanding the surface should be smooth all over and ready for the proper finish. Sheets of sandpaper are about 9 x 11 in. The sizes ranging from fine to coarse are 2/0, 0-1/2, 1, 1 1/2, and 2. Some things to observe when sandpapering are:

- 1. Never use sandpaper when you should use an edged tool.
- 2. Always sand with the grain, if possible.
- 3. Do not expect sandpaper to remedy the effects of careless work with edged tools.
- 4. Never sand surfaces that are to be joined.

DIRECTIONS -

- 1. Select the proper grade of sandpaper - rougher surfaces require coarser grades - continue by using finer grades in order. Numbers 2/0 and 1/2 are good for average work. Number 1/0 usually gives a good final surface.
- 2. Limber sandpaper by drawing back and forth over edge of bench.
- 3. Tear paper into either four or six pieces. To tear, fold with sanded side down and tear over sharp edge or along blade of hand-saw. Use a quick movement.
- 4. Make or select a block to fit size of paper. Use of a block gives a truer surface.
- 5. Sand the surface. Hold paper firmly with thumb and finger. Sand with the grain to prevent scratches that would show on finished article. Keep the block flat on surface. Rub back and forth until the surface is uniformly smooth. Be careful not to sand off the arris, or edge where two surfaces meet. After sanding with the coarser grades, finish with the finer.
- 6. To break an edge, hold sandpaper in hand. Use a block on curved edges if possible. Sometimes the paper is wrapped around a rod or dowel to get at concave surfaces.



SAND BLOCK IN USE

RETURN THIS SHEET AS SOON AS YOU HAVE FINISHED WITH IT.

PAINT OPERATION SHEET #3To Use Paste Filler

INFORMATION - Filler is used on open grained wood such as ash, butternut, chestnut, and oak. It is of two kinds, paste and liquid. Paste filler is recommended for all shop work. If the work is to be stained, stain should be applied before filler is put on.

TOOLS - Stiff, stubby brush, clean container.

MATERIALS - Paste, filler, rags.

DIRECTIONS -

1. Choose filler corresponding to the color of the wood.
2. Put some filler in dish.
3. Thin the paste with turpentine or benzine.
4. Apply with a stiff brush across the grain and well into pores of wood.
5. Allow to dry until it has a dull appearance.
6. Rub across the grain with a rough cloth or piece of gumysack.
7. Wipe off excess filler with a clean cotton rag.
8. Give second coat if necessary.



APPLYING FILLER.

CAUTION - Never put oily rags, waste, or any other similar material in a place like a cupboard after it has been used. There is always danger of spontaneous combustion, which may cause serious fires. Rags should be placed in a galvanized waste can or garbage can, if possible, one which has feet to keep the bottom away from the floor. Then should the contents catch fire there will be an air space beneath, which will prevent the wood from catching fire. The contents of these cans should be burned every day.

RETURN THIS SHEET AS SOON AS YOU HAVE FINISHED WITH IT.

PAINT OPERATION SHEET #6How to Prepare and Apply Varnish

INFORMATION - Varnish is made from vegetable gums cooked in linseed oil and turpentine and then thoroughly filtered and allowed to stand for many months. Varnishes are sticky and dry slowly so articles to be varnished should be kept in a room free from dust. Varnish flows best in a room moderately warm - about 70 . The purpose of varnishing is to give a hard glossy surface and keep out moisture. Spar varnish is water proof. Varnished articles are sometimes waxed to give them a polish.

TOOLS - Varnish brush of good grade, clean container.

MATERIALS - Article to be varnished, turpentine, rags, varnish, shellac.

DIRECTIONS -

1. If shellac is used for the first coat, pour a small quantity into the dish. Use a clean brush and work with the grain of the wood.
2. If varnish is to be the first coat thin some varnish with turpentine, using about $\frac{1}{2}$ the amount of turpentine to varnish.
3. Spread varnish evenly. Take long even strokes. Let each stroke overlap a little the one before. Work with the grain. Let varnish flow on rather than spreading it, as we do with paint.
4. Be careful not to get too much varnish in one spot. Avoid runs. These show that your brush is too full. Wipe brush on the edge of the container, to remove excess varnish.
5. Let first coat dry 36 hours.
6. If shellac is used it will dry a little more quickly. Shellac is thinned and removed with alcohol.
7. To apply second coat - sand surface lightly with fine sandpaper. Do not thin varnish, but use it as it comes from the can. Follow same directions as for first coat.
8. Allow 48 hours for drying.
9. If a large surface like a floor or woodwork is varnished wipe it off with clear cold water the second day or as soon as it has lost the sticky feeling. This helps to harden it.
10. If a waxed finish is desired, see operation sheet on waxing.



RETURN THIS SHEET AS SOON AS YOU HAVE FINISHED WITH IT.

By the end of the course the girls could be expected to know and to do definite things. A list of these, arranged according to types of work, follows:

What Girls Should Know and Be Able To Do

At The End of This Course

(Adapted from Committee Report A. V. A., 1929.)

I. ABILITIES IN WOODWORK

1. Sharpen plane, iron and scissors, knives, screwdriver by using oilstone or grindstone.
2. Set up and operate smooth plane and block plane.
3. Set and use marking gauge.
4. Square a board of soft wood to three dimensions.
5. Insert blade in coping saw and use properly. Use sandpaper correctly with and without block.
6. Use hammer correctly for driving and drawing nails.
7. Bore for screws and drive with common screwdriver.
8. Set and use bevel.
9. Test with try square for straightness and squares.
10. Use cross-cut saw, general use, and in meter box.
11. Use rip saw.
12. Use back-saw.
13. Use augur-bit properly.
14. Use knife for marking.
15. Construct butt joint.
16. Use rule for accurate measuring.

UNITS OF RELATED KNOWLEDGE

1. Identify the following kinds of lumber: the pines, oak, walnut, maple, mahogany, gum.
2. Know the principal characteristics, working qualities, uses, and the sources of supply of each.

3. Know in general the methods of cutting and milling lumber.
4. How lumber is dried.
5. The effect of moisture on wood.
6. Know how lumber is measured and sold.
7. The kinds and sizes of nails.
8. Uses of the different kinds of nails.
9. How nails are sold.
10. The kinds of screws.
11. Uses of different kinds of screws.
12. How sizes of screw are indicated.
13. How screws are sold.
14. Kinds of sandpaper.
15. Grades of sandpaper.
16. Principal uses.
17. Location of important wood products manufacturing concerns in the city.

II. ABILITIES PERTAINING TO PAINTS AND FINISHES

1. Mix paint.
2. Mix enamel.
3. Mix stain.
4. Mix varnish.
5. Mix lacquer.
6. Apply wood filler.
7. Thin various finishes.
8. Remove varnish.
9. Remove paint.
10. Remove lacquer.
11. How to use shellac.
12. Mix and use putty.

13. Clean and care for brushes.

14. Priming coats.

UNITS OF RELATED KNOWLEDGE

1. The object of finishes.
2. The kinds of finishes such as: stain, oil, shellac, varnish, lacquer, enamel, paint.
3. The durability of various finishes.
4. The conditions or places in which various kinds of finish may be used to advantage.
5. Materials from which finishes are made.
6. Kinds of glue.
7. Preparation of glue.
8. The conditions and requirements in the use of glue.
9. Various methods of storing and caring for brushes.

III. ABILITIES IN ELECTRICAL WORK

1. Find, test, and replace fuses.
2. Read electric meter.
3. Connect socket or plug.
4. Make common wire splices.
5. Construct an extension cord.
6. Solder and tape splices.

UNITS OF RELATED KNOWLEDGE

1. How to judge electric household appliances.
2. Sources of electric current.
3. What are conductors and non-conductors of current.
4. Why splices should be soldered.
5. Cause and effect of short circuits.
6. Use of socket and plug.
7. Use of extension cords.

8. Use of fuses.
9. Dangers of electricity. - First aid.
10. How to avoid dangers of electricity.
11. Economical uses of commercial electrical household appliances.
12. How to figure costs per unit of consumption of electricity for household purposes.

IV. ABILITIES PERTAINING TO PLUMBING AND MISCELLANEOUS JOBS

1. Clean a sink trap.
2. Clean stopped up pipes.
3. Use pliers.
4. Use wrench without damage to fixture.
5. Use screwdriver.
6. Tin a soldering copper.
7. Use solder for simple repair.
8. Read gas and water meter.
9. Repair sewing machine belt.
10. Oil sewing machine and vacuum cleaner.
11. Put up curtain fixtures.
12. Cut window glass.
13. Clean and regulate gas stove.
14. Read a simple working drawing.
15. Make simple repairs to roller shades.

UNITS OF RELATED KNOWLEDGE

1. Kinds of mechanical devices to assist in keeping plumbing system in order, plumber's plunger, hand force pump, etc.
2. Effects of acid of various kinds as solvents.
3. Dangers of certain types of solvents.
4. Know two common kinds of faucets.

5. How and where to shut off home water supply.
6. Need and uses of flux in soldering.
7. Safety precautions in use of gas.
8. Proportion of air mixture necessary for best gas consumption.
9. Economical home use of gas.
10. Reading gas meter - its relation to the gas bill.

(Cf., "Analysis of High School Subjects", Committee A. V. A., 1929, Industrial Education Magazine, XXXI, Jan. 1930, p. 265.)

* * * * *

APPENDICES

* * * * *

Student:

On this sheet you will find a list of things which have been or be done by girls or women in their homes.

Please draw a line under each type of work which you have done y time. Draw a double line under the kinds of jobs which you have one but would like to be able to do.

Take the sheet home and ask your mother and sisters to do the

I Repairs which have to do with woodworking:

1. Repaired window screen.
2. Repaired door screen.
3. Made window screen.
4. Repaired furniture.
5. Adjusted hinge.
6. Put hinge on door, screen, or box.
7. Put up shelf.
8. Made stop to keep window from rattling
9. Made door stop.
10. Put partition in drawer or box.
11. Repaired dresser drawer which stuck.
12. Filled in holes or cracks in floor or woodwork.
13. Made wooden tray.
14. Made wooden frame.
15. Cut wood according to pattern.
16. Hung a door in a door frame.
17. Put in new window cord or adjusted window weights.
18. Made wooden toy.
19. Repaired wooden toy.
20. Names of other articles I have made from wood are:
21. Names of other articles of wood which I have repaired are:

II Repairs which have to do with the electric system:

1. Repaired electric bell.
2. Repaired electric button (light or bell)
3. Replaced wornout batteries (dry cells)
4. Repaired light switch.
5. Repaired cord of electric lamp, toaster, curling iron or perculator.
6. Repaired cord of electric wash machine.
7. Oiled electric wash machine.
8. Repaired cord of electric vacuum cleaner.
9. Oiled vacuum cleaner.
10. Repaired or replaced cord to electric iron.
11. Repaired cord to electric ironing machine.
12. Oiled electric ironing machine.
13. Repaired cord to electric plate.
14. Spliced or replaced electric wire.
15. Attached extension cord.
16. Replaced wornout fuse.
17. Repaired flashlight.
18. Am able to read the electric meter.

19. Know the various circuits of the wiring in my home.
20. Know what a short-circuit is.
21. Have used tape to insulate wires.
22. Know how and where to cut off the electric current.
23. ~~of my~~ home through the use of the proper switch.
23. Have attached an attachment plug.
24. Have added water to a wet battery.
25. Have connected a socket.
26. Have tested a wet cell with hydrometer.
27. Have connected dry cells in series.
28. Have connected dry cells parallel.
29. Other kinds of electrical repairs which I have made are: _____

II Repairs to the plumbing system and water supply:

1. ~~Rep~~ Repaired faucet.
2. Repaired toilet.
3. Cleaned sink trap.
4. Cleaned stopped-up pipes.
5. Thawed out frozen pipes!
6. Drained pipes in preparation for vacating or closing the house.
7. Know the proper method of shutting off the home water supply.
8. Know how to read a water meter.
9. Other plumbing repairs which I have made are: _____

IV Painting, varnishing, glueing, etc:

1. Removed old paint.
2. Painted furniture. ,
3. Painted walls or woodwork.
4. Painted floor.
5. Varnished floor.
6. Gilded radiator, pipes, or picture frame.
7. Polished furniture.
8. Cleaned floors, or wooden furniture.
9. Mixed paint.
10. Stained floor, door, or wooden article.
11. Repaired broken furniture.
12. Waxed and polished floor.
13. Waxed and polished other article of wood!
14. E nameled woodwork.
15. Enameled wooden toy.
16. Removed spots from polished furniture.
17. Have cleaned a stained brush.
18. Have cleaned an enamel brush.
19. Have cleaned a varnish brush.
20. Have cleaned a paint brush.
21. Have cleaned a lacquer brush.
22. Have reclaimed hardened brushes.
23. Have thinned shellac.
24. Have thinned paint.
25. Have thinned varnish.
26. Other uses I have made of paint, varnish, stain, or glue are: _____

Jobs that have to do with glass:

1. Cut glass.
2. Put new pane of glass in window or door.

3. Made frosted glass.
 4. Have used and mixed putty.
 5. Have inserted glazer.points.
 6. Have used a putty knife.
 7. Other work I have done with glass is:
-

VI Adjustments to the Auto or Radio:

1. Put new tubes in radio.
2. Repaired radio wiring.
3. Repaired aerial of radio.
4. Oiled auto.
5. Cleaned spark plug.
6. Installed new spark plug.
7. Changed tire.
8. Tested spark plug.
9. Cleaned and polished auto.
10. Adjusted cotter pins.
11. Filled grease cups.
12. Adjusted carburetor.
13. Patched tire tube.
- 14 Other repairs or adjustments I have made to auto or radio are: _____

VII Miscellaneous repairs:

1. Repaired door lock.
2. Sharpened knives.
3. Sharpened scissors.
4. Sharpened hatchet or ax.
5. Replaced handle in tool.
6. Repaired door-knob.
7. Repaired hole in plaster.
8. Put nail or hook in plastered wall without breaking plaster.
9. Read blueprint.
10. Adjusted lawnmower blades.
11. Sharpened lawnmower.
12. Cared for furnace or stove.
13. Adjusted air in gas burner.
14. Cleaned sewing machine.
15. Repaired sewing machine
16. Repaired sewing machine belt.
17. Repaired carpet-sweeper.
18. Put up curtain rods and fixtures.
19. Mended books or magazines.
20. Cleaned wall paper.
21. Repaired kitchen utensil or other metal with the use of solder.
22. Repaired roller window shades.
23. Used tanners-shears.
24. Have drawn a floor plan of a home.
25. Oiled a sewing machine.
26. Used a wood file.
27. Used a metal file.
28. Tinned a soldering copper.
29. Other miscellaneous repairs I have made are: _____

* * * * *

APPENDIX A

* * * * *

TABLE I

RESULTS OF QUESTIONNAIRE SHOWING NUMBER OF CASES AND
RANKING OF EACH OF 127 JOBS (218 INDIVIDUALS)

Number of Cases	Rank	
I. Repairs which have to do with woodworking:		
62	21	1. Repaired window screen.
39	51	2. Repaired door screen.
15	49	3. Made window screen.
62	12	4. Repaired furniture.
12	52	5. Adjusted hinge.
16	48	6. Put hinge on door, screen, or box.
23	41	7. Put up shelf.
39	31	8. Made stop to keep window from rattling.
19	45	9. Made door stop.
76	15	10. Put partition in drawer or box.
89	11	11. Repaired dresser drawer which stuck.
65	19	12. Filled in holes or cracks in floor or woodwork.
9	56	13. Made wooden tray.
26	39	14. Made wooden frame.
39	31	15. Cut wood according to pattern.
2	62	16. Hung a door in a door frame.
2	62	17. Put in new window cord or adjusted window weights.
62	21	18. Made wooden toy.
32	34	19. Repaired wooden toy.
		20. Names of other articles I have made from wood are _____
		21. Names of other articles of wood which I have re- paired are: _____
II. Repairs which have to do with the electric system:		
2	62	1. Repaired electric bell.
1	63	2. Repaired electric button (light or bell).
3	61	3. Replaced wornout batteries (dry cells).
0	-	4. Repaired light switch.
45	26	5. Repaired cord of electric lamp, toaster, curling iron or perculator.
0	-	6. Repaired cord of electric wash machine.
30	14	7. Oiled electric wash machine.
		8. Repaired cord of electric vacuum cleaner.
58	22	9. Oiled vacuum cleaner.
30	35	10. Repaired or replaced cord to electric iron.
0	-	11. Repaired cord to electric ironing machine.
2	62	12. Oiled electric ironing machine.
0	-	13. Repaired cord to electric plate.
12	50	14. Spliced or replaced electric wire.
25	40	15. Attached extension cord.
75	16	16. Replaced wornout fuse.
7	57	17. Repaired flashlight.
46	25	18. Am able to read the electric meter.

TABLE I (Cont'd.)

Number of Cases	Rank	
8	56	19. Know the various circuits of the wiring in my home.
22	42	20. Know what a short-circuit is.
63	20	21. Have used tape to insulate wires.
16	48	22. Know how and where to cut off the electric current, of my home through the use of the proper switch.
7	57	23. Have attached an attachment plug.
2	62	24. Have added water to a wet battery.
21	43	25. Have connected a socket.
4	60	26. Have tested a wet cell with hydrometer.
0	-	27. Have connected dry cells in series.
0	-	28. Have connected dry cells parallel.
		29. Other kinds of electrical repairs which I have made are: _____

III. Repairs to the plumbing system and water supply:

20	44	1. Repaired faucet.
18	46	2. Repaired toilet.
81	13	3. Cleaned sink trap.
62	21	4. Cleaned stopped-up pipes.
28	37	5. Thawed out frozen pipes.
11	53	6. Drained pipes in preparation for vacating or closing the house.
38	32	7. Know the proper method of shutting off the home water supply.
29	36	8. Know how to read a water meter.
		9. Other plumbing repairs which I have made are: _____

IV. Painting, varnishing, gluing, etc.:

113	9	1. Removed old paint.
160	6	2. Painted furniture.
141	7	3. Painted walls or woodwork.
44	27	4. Painted floor.
72	17	5. Varnished floor.
38	32	6. Gilded radiator, pipes, or picture frame.
176	1	7. Polished furniture.
127	8	8. Cleaned floors, or wooden furniture.
113	9	9. Mixed paint.
30	35	10. Stained floor, door, or wooden article.
62	12	11. Repaired broken furniture.
13	51	12. Waxed and polished floor.
14	50	13. Waxed and polished other articles of wood.
41	29	14. Enameled woodwork.
27	38	15. Enameled wooden toy.
17	47	16. Removed spots from polished furniture.
25	40	17. Have cleaned a stained brush.

TABLE I (Cont'd.)

Number of Cases	Rank	
63	20	18. Have cleaned an enamel brush.
57	23	19. Have cleaned a varnish brush.
163	5	20. Have cleaned a paint brush.
16	48	21. Have cleaned a lacquer brush.
72	17	22. Have reclaimed hardened brushes.
22	40	23. Have thinned shellac.
102	10	24. Have thinned paint.
40	30	25. Have thinned varnish.
		26. Other uses I have made of paint, varnish, stain, or glue are: _____

V. Jobs that have to do with glass:

40	30	1. Cut glass.
42	28	2. Put new pane of glass in window or door.
72	17	3. Have used and mixed putty.
32	34	4. Have inserted glazer points.
38	32	5. Have used a putty knife.
		6. Other work I have done with glass is: _____

VI. Adjustments to the Auto or Radio:

7	57	1. Put new tubes in radio.
0	-	2. Repaired radio wiring.
0	-	3. Repaired aerial of radio.
4	60	4. Oiled auto.
6	58	5. Cleaned spark plug.
6	58	6. Installed new spark plug.
10	54	7. Changed tire. (helped)
6	58	8. Tested spark plug.
15	49	9. Cleaned and polished auto.
4	60	10. Adjusted cotter pins.
3	61	11. Filled grease cups.
2	62	12. Adjusted carburetor.
1	63	13. Patched tire tube.
		14. Other repairs or adjustments I have made to auto or radio are: _____

VII. Miscellaneous repairs:

15	49	1. Repaired door lock.
168	2	2. Sharpened knives.
35	33	3. Sharpened scissors.
7	57	4. Sharpened hatchet or ax.
3	61	5. Replaced handle in tool.
8	56	6. Repaired door-knob.
30	35	7. Repaired hole in plaster.
32	34	8. Put nail or hook in plastered wall without breaking plaster.

TABLE I (Cont'd.)

Number of Cases	Rank	
35	32	9. Read blueprint.
2	62	10. Adjusted lawnmower blades.
0	-	11. Sharpened lawnmower.
35	33	12. Cared for furnace or stove.
53	24	13. Adjusted air in gas burner.
89	11	14. Cleaned sewing machine.
41	29	15. Repaired sewing machine.
67	18	16. Repaired sewing machine belt.
9	57	17. Repaired carpet-sweeper.
168	3	18. Put up curtain rods and fixtures.
39	31	19. Mended books or magazines.
21	41	20. Cleaned wall paper.
65	19	21. Repaired kitchen utensil or other metal with the use of solder.
58	22	22. Repaired roller window shades.
30	34	23. Used tinners-shears.
29	36	24. Have drawn a floor plan of a home.
164	4	25. Oiled a sewing machine.
18	46	26. Used a wood file.
9	55	27. Used a metal file.
35	33	28. Tinned a soldering copper.
		29. Other miscellaneous repairs I have made are: _____

TABLE II

LIST OF FIFTY JOBS OF GREATEST FREQUENCY ARRANGED
ACCORDING TO RANK AND FREQUENCY (218 INDIVIDUALS)

Job No.		Frequency	Rank
1.	IV-7 Polished furniture.	176	1
2.	VII-2 Sharpened knives.	168	2
3.	VII-18 Put up curtain rods or fixtures.	166	3
4.	VII-25 Oiled sewing machine.	164	4
5.	IV-20 Cleaned paint brush.	163	5
6.	IV-2 Painted furniture.	160	6
7.	IV-3 Painted walls or woodwork.	141	7
8.	IV-8 Cleaned floor in preparation for refinish.	127	8
9.	IV-1 Removed old paint.	113	9
10.	IV-9 Mixed paint.	115	9
11.	IV-24 Thinned paint.	102	10
12.	I-11 Repaired dresser drawer.	89	11
13.	I-4 Repaired furniture.	82	12
14.	III-5 Cleaned sink trap.	81	13
15.	II-7 Oiled electric washing machine.	80	14
16.	II-22 Put partition in drawer or box.	76	15
17.	II-16 Replaced worn-out fuse.	75	16
18.	IV-5 Varnished floor.	72	17
19.	V-4 Used and mixed putty.	72	17
20.	IV-22 Reclaimed hardened brushes.	72	17
21.	VII-16 Repaired sewing machine belt.	67	18
22.	VII-21 Repaired utensil or metal by use of solder.	65	19
23.	I-12 Filled holes or cracks in wood.	65	19

TABLE II (Cont'd.)

Job No.		Frequency	Rank	
24.	II-21	Used tape to insulate wires.	63	20
25.	IV-18	Cleaned enamel brush.	63	20
26.	I-2	Repaired window screen.	62	21
27.	I-18	Made wooden toy.	62	21
28.	III-4	Clean stopped up pipe.	62	21
29.	VII-22	Repaired roller shades.	59	22
30.	II-9	Oiled vacuum cleaner.	58	22
31.	IV-19	Cleaned varnish brush.	57	23
32.	VII-13	Adjusted air in gas burner.	56	24
33.	II-18	Read electric meter.	46	25
34.	II-5	Repaired or replaced cord of electric lamp, toaster, iron, etc.	45	26
35.	IV-4	Painted floor.	44	27
36.	V-2	Put in new glass in door or window.	42	28
37.	VII-15R	Repaired sewing machine.	41	29
38.	IV-14	Enamelled wooden article.	41	29
39.	IV-25	Thinned varnish.	40	30
40.	V-1	Cut glass.	40	30
41.	I-15	Cut wood to pattern.	39	31
42.	I-8	Made window stop.	39	31
43.	IV-6	Gilded.	38	32
44.	VII-23	Used tinners' shears.	32	34
45.	IV-10	Stained floor or wooden article	30	35
46.	VII-7	Repaired hole in plaster.	30	35
47.	VII-9	Read blue print.	35	33
48.	VII-29	Tinned soldering copper.	35	33
49.	I-14	Made wooden frame.	26	39
50.	II-15	Attached extension cord.	25	40

TABLE III
ANALYSIS OF WOODWORKING JOBS

	Rep. Furn.	Drawer	Filling	Frame	Screen	Toy	Partition	Rep. Chair	Rep. Toy	Bread Board	Totals
Boring	X			X		X		X		X	5
Bracing	X			X	X			X			4
Clamping	X	X						X			3
Gauging	X			X	X	X	X			X	6
Glueing	X	X		X		X	X	X	X		7
Grinding		X		X	X	X	X	X	X	X	8
Nitre-box		X		X	X		X				4
Nailing	X	X		X	X	X	X	X	X		8
Planing	X	X		X	X	X	X			X	7
Measuring	X	X		X	X	X	X			X	7
Sanding	X	X	X	X	X	X	X	X	X	X	9
Sawing	X	X		X	X		X			X	6
Screwing	X	X			X	X		X			5
Square				X	X	X	X			X	5
Wheting	X	X		X	X	X					6

TABLE IV
ANALYSIS OF PAINTING & FINISHING JOBS

	Pol. Wax	Rem. Varnish	Repaint	Re-enamel	Lacquer	Brushes	Stain	Varnish	Mint - New	Totals
Applying finishes			X	X	X		X	X	X	6
Brushes		X	X	X	X	X	X	X	X	9
Filling	X				X		X	X	X	5
Mixing			X	X	X			X	X	5
Putty			X	X					X	3
Stain removal	X	X								2
Thinning			X	X	X		X	X	X	6
Undercoats			X	X				X	X	4
Varnishing	X						X	X		3
Removal-old finish		X	X	X						3

TABLE V
ANALYSIS OF ELECTRICAL JOBS

	Lubricate	Fuses	Meters	Repair Cord	Replace Cord	Splicing	Taping	Make Cord	Totals
Binding posts				X	X	X		X	4
Pliers		X		X	X	X		X	5
Insulation-removal				X	X	X	X	X	5
Screwdriver		X		X	X	X		X	5
Splicing wires				X		X	X		2
Soldering				X		X			2
Taping				X		X	X		3
Underwriter's knot				X	X	X			3

TABLE VI

ANALYSIS OF PLUMBING AND MISCELLANEOUS JOBS

	Shades	Cooky cutter	Sink trap	Pipes	Fuller fau.	Compr. fau.	Cook Uten.	Rods-Fixt.	Gas Stove	Sewing mach.	Belts	Glass	Plaster	Totals
Glass-cutting												X		1
Lubricating					X	X				X				3
Pliers					X	X			X	X				4
Plumber's Plunger			X	X										2
Putty												X		1
Plaster													X	1
Screwdriver	X		X		X	X		X	X	X	X			8
Solvents			X	X										2
Staples		X					X				X			3
Solder		X					X							2
Tinning-solder-cop.		X					X							2
Wrenches			X	X	X	X			X	X				6

TABLE VIIEssential Operationsas Derived by Analysis and for WhichOPERATION SHEETS ARE RECOMMENDED

1. COMMON TO WOODWORK

Boring
 Bracing
 Clamping
 Gauging with marking gauge
 Glueing
 Grinding
 Mitre-box use
 Nailing
 Planing
 Measuring
 Sanding
 Sawing hand, cross-cut, rip, copping, and back
 Screwing-use of screwdriver
 Square-testing and measuring
 Whetting

2. COMMON TO PAINTING AND FINISHING

Applying finishes of different kinds
 Brushes - choice and care
 Filling
 Mixing
 Putty-use as filler
 Stain removal
 Thinning
 Undercoats - kinds and uses
 Varnishing
 Removal of old finishes - paint, varnish, lacquer, etc.

3. COMMON TO ELECTRICAL JOBS

Binding posts - making loops and winding
 Pliers - use for holding, cutting, bending
 Insulation-removal
 Screwdriver-use
 Splicing wires
 Soldering
 Taping
 Underwriter's knot

4. COMMON TO PLUMBING AND MISCELLANEOUS JOBS

Glass cutting
 Lubricating
 Pliers
 Plumber's plunger

Putty
Plaster
Screwdriver
Solvents
Staples
Solder
Tinning of soldering copper
Wrenches - open end, monkey, pipe.

* * * * *

APPENDIX B

SOME TYPICAL TEST FORMS

* * * * *

FORM A. WOODWORK TEST

By

GEORGE K. WELLS, M. A.

*State Supervisor of Trade and Industrial Education
State Department of Education, Indianapolis, Indiana*

(To be filled in by the Student)

NOTE:—Do not open this paper, or turn it over, until told to do so. Fill the blanks in this section. **WRITE PLAINLY.**

.....
 First name Initial Last name
 Date of birth..... Class in High School
 Address.....
 Name of teacher
 Reason for this examination

NOTE:—Counting a semester as 18 weeks, fill in the following spaces to show how much work in the School Woodworking Shop you will have had by the close of the present semester.

Number of semesters.....Number of hours per week (60 min. each).....

SCORE

(To be filled in by the instructor)

Part I	
Total number	100
Subtract number not attempted
Balance
Subtract twice the number wrong
Score of Part I
Part II	
Add total number right
Total score

DIRECTIONS

This is a test of knowledge of *Elementary Woodwork*. The directions for each division and the tasks are given on the following pages. When you turn the page, you will find directions for PART I. Read the directions, and begin immediately with the test. When you have finished as much of PART I as you are able to do, go on immediately to PART II. In a similar manner read the directions for PART II, and do as much as you are able to do of both PART I and PART II. You will be allowed **25 minutes** to complete the test.

DIRECTIONS. The letters T and F precede each statement below. Encircle the letter T if the statement is true. Encircle the letter F if the statement is false. DO NOT GUESS. If you are unable to decide whether a statement is true or false, mark it alone. You will be penalized for each statement incorrectly marked by a deduction of one point or credit from the total of correctly marked statements. Notice the sample statement.

F (Sample) : Mahogany is a costly wood.

BEGIN HERE.

- T F 1. It is easier to plane with the grain of the wood than against it.
- T F 2. The jack-plane should never be filed.
- T F 3. The block-plane is the smallest plane.
- T F 4. The old-fashioned wooden plane bed is as efficient as the steel bed plane.
- T F 5. The Y adjustment on the plane is used to line up the bit.
- T F 6. The blade of a plane should not have a wire edge.
- T F 7. The shape of the tooth of the rip-saw is identical to the shape of the tooth of the cross-cut saw.
- T F 8. The back-saw secures its name from its reinforcement back.
- T F 9. The hack-saw is used to cut nails, screws, or iron.
- T F 10. The keyhole saw is used to cut boards to length.
- T F 11. The rip-saw is used to saw across the grain.
- T F 12. The coping saw is used to cut thick pieces of wood.
- T F 13. The miter saw is used in a miter-box to cut angles.
- T F 14. The back-saw is used either as a rip-saw or as a cross-cut saw on small work.
- T F 15. A drill-bit does not have a spur.
- T F 16. Auger-bits are numbered in 32nds of an inch.
- T F 17. In boring a hole the cutting is done by the brace.
- T F 18. The larger the sweep of the brace the greater the leverage obtained.
- T F 19. The diameter of the hole cut by a bit is determined by the spur of the bit.
- T F 20. The expansion-bit can be used to bore several diameters of holes.
- T F 21. The ratchet device is used to adjust the brace when you cannot get a full turn on the brace.

Do not stop, go right on with the next page.

- T F 81. Wood with 20 per cent of moisture is too wet to work into furniture.
- T F 82. Burl and butt walnut are the same.
- T F 83. Doors should be fitted tightly into their cases.
- T F 84. Oak is a close grained wood.
- T F 85. Gum is the base wood of most cheap furniture.
- T F 86. Birdseye maple is used as a decorative wood.
- T F 87. Oak lumber is used extensively in cabinet work.
- T F 88. Yellow pine is a more expensive wood than walnut.
- T F 89. Yellow poplar is a hard wood.
- T F 90. Walnut takes a beautiful dark natural finish.
- T F 91. All drawings should be inked in for shop use.
- T F 92. All cabinet work should be done from a drawing.
- T F 93. The T-square is the drawing square.
- T F 94. Drawings need not be accurate to produce the best results.
- T F 95. Artistic designing is not important if the work is well done.
- T F 96. There are two board feet in a piece of lumber 1 inch by 6 inches by 24 inches.
- T F 97. Lumber, when sold in large quantities, is sold by the thousand board feet.
- T F 98. Kiln drying is a common way of seasoning lumber.
- T F 99. A pupil must make friends with his tools to become a skilled mechanic.
- T F 100. Cabinet-making and carpentry are the same.

Do not stop, go right on with PART II.

PART II

The following statements are incomplete, one word having been omitted where each blank is. You are to fill the blank with the proper word that will make the sentence a true statement.

Example: Common nails are made of wire.

BEGIN HERE.

1. The is that part of the plane on which the plane-bit rests.
2. A rip-saw and a saw resemble each other in appearance in all save the teeth.
3. The stock to be worked on is usually fastened in a to hold it.

4. A should be used when pounding
5.hammers are used to draw nails out of if the nail protrudes far enough to get a hold on it.
6. The cutting edge of a is turned over.
7. The is used to gage wide thickness.
8. are used to hold glued parts of a together until the glue dries.
9. Miter should be cut in a miter-box.
10. The size of a chisel is told by the of the
11. are used to sharpen wood scrapers.
12. Sanding should always be done the grain
13. After planing a board, any roughness is removed sanding, with a
14. The working should be with the working surface.
15. In testing whether stock is square or not the..... is used on smaller pieces, and the..... is used on larger pieces.
16. is full of beautiful flakes when quartered.
17. Black is commonly used in construction.
18. The initials mean that two sides of the are to be surfaced.
19. The unit of lumber measure is the
20. Nails are described as 4, 6, 8, or 10
21. stain will raise the grain of the wood, oil and spirit stain will not.
22. or may be used to fill wood filler.
23. Oil and paint should never be left in because of the danger of spontaneous combustion.
24. A piece of lumber $\frac{1}{2}$ " x 12" x 12" would be figured as board foot.
25. Lumber in piles should be so arranged that circulate freely thruout the pile.

22. The ball-pein hammer is the one most commonly used in woodwork.
23. A straight edge may be cut with a draw-knife.
24. A marking-gage is always used when marking a line to cut to.
25. The tongue is the shortest arm of the framing-square.
26. The try-square may be used for testing the thickness of a board.
27. Before marking with a marking-gage, the distance from the spur to the head should be tested with a ruler.
28. The try-square is larger than the framing-square.
29. Linseed oil should be used on the oilstone.
30. Grinding wheels should always turn toward the cutting edge of the tool being sharpened.
31. Brads are larger than casing nails.
32. A corrugated nail may be used as a corner fastener.
33. The finishing nail has a small head.
34. Joints should always be sanded.
35. The tenon is the opening into which the mortise fits in a mortise-and-tenon-joint.
36. The dove-tail joint is identical with the butt joint.
37. Joints between long boards are usually made on a machine.
38. All parts of a project should be properly fitted before assembling.
39. A butt joint is the most simple of all joints.
40. The housed joint is the same as a half-lap joint.
41. A nailed joint is as permanent as a screwed joint.
42. The mortise-and-tenon joint is used to fasten rails into legs.
43. There is only one kind of mortise-and-tenon joint.
44. A tongue-and-groove joint is often used in putting long boards together.
45. The rabbet joint is used in drawer construction.
46. Animal glue may be used when cold.
47. We glue-size wood to raise the grain.
48. Glued-butt joints hold best if planed perfectly straight.
49. Glue on the surface of the wood prevents stain from penetrating.
50. The project should always be sanded after glue-sizing.

Do not stop, go right on with the next page.

- T F 51. Sandpaper should not be used until all edge tool work is completed.
 - T F 52. Rough sandpaper is grade No. 0.
 - T F 53. The nailset should be used to countersink the heads of screws.
 - T F 54. When driving a screw close to an inside corner the ratchet screwdriver can be used to the best advantage.
 - T F 55. The holes for screws should always be countersunk.
 - T F 56. A brad-awl may be used to make pilot holes for screws.
 - T F 57. In ordering screws it is necessary to state the number and the length.
 - T F 58. Bright steel screws may be used in cabinet construction when the head of the screw will be exposed.
 - T F 59. A screwdriver may be used as a chisel.
 - T F 60. All screws are made of steel.
 - T F 61. Dividers are used to mark circles.
 - T F 62. Oak is usually filled with a paste filler.
 - T F 63. Usually the first coat applied to a close-grained wood is a liquid stain.
 - T F 64. Shellac is thinned with linseed oil.
 - T F 65. Gum cannot be finished in walnut.
 - T F 66. A rub finish may be made with shellac or varnish.
 - T F 67. A wax finish is waterproof.
 - T F 68. Finishing with lacquer is common practice today.
 - T F 69. A final coat of varnish is rubbed if you desire a fine finish.
 - T F 70. All stains are mixed with water.
 - T F 71. Varnish should never be applied to wood without other finishing material.
 - T F 72. A shellacked surface should never be sanded.
 - T F 73. The metal faces of the vise should never come in contact with the wood you are working.
 - T F 74. Putty is made of whiting and linseed oil.
 - T F 75. A jig is a device used in making several pieces alike.
 - T F 76. Wood filler is never rubbed after applying.
 - T F 77. Varnish dries more quickly than shellac.
 - T F 78. Red cedar is the most common wood used in linen chest construction.
 - T F 79. A veneered walnut table top is made of solid walnut.
 - T F 80. Three-ply paneling is less liable to warp than a single board of the same thickness.
- Do not stop, go right on with the next page.

NEWKIRK-STODDARD HOME MECHANICS TEST

By

LOUIS V. NEWKIRK & GEORGE D. STODDARD

Date

School

Grade in School

Jobs

Points

SCORE: PART 1

years and months to nearest birthday: years, months.

PART 2

of teacher

TOTAL

DIRECTIONS TO PUPIL

Do not write anything until told to do so. At the beginning of each part will be found directions. Follow carefully, but do not ask questions.

PART 1

Directions: On this and the following pages are given a number of common jobs in home mechanics. The steps for carrying out each job are given here, but these steps are not placed in the correct order. Examine each job in turn, and decide which step should come first. Place the number of this step in the first parentheses, that is, the parentheses at the left. In the same way insert the numbers of the remaining steps in proper order or sequence, so that when you have finished, one can read the numbers in the parentheses from right and find out just how to carry out the steps in the whole job.

Job: To set casters

Rearrange the numbers to show correct procedure:

- (1) Drive in caster sheafs.
- (2) Select a bit and drill the hole.
- (3) Select a suitable caster.
- (4) Insert the caster and test.
- (5) Mark the point for the location of the caster.

(3) (5) (2) () ()

The first thing to do is to "select a suitable caster." Since this is marked "3" in the above paragraph, a "3" should be placed in the parentheses as shown. Marking the point for the caster is the next thing to do, so a "5" is next in the answer. Then you should select a bit and drill the hole. Since this was marked "2" in the paragraph a "2" comes next in the answer row. What step should come next? Find it in the paragraph and place its number in the next place in the answer row. In this job what is the last thing to be done? It is given in the paragraph. Find it, and copy its number in the last place in the answer row. You now have a row of numbers in parentheses which shows just how the numbered steps in the paragraph should be taken in order to carry out this job in the right way.

You are now ready to go on, but do not turn over the page or do any writing until the teacher gives the signal. Don't waste time on a job you know nothing about; skip it, and go on to the next one. You are allowed ten minutes to complete the test.

Wait for signal.

Copyright, 1928, by the State University of Iowa

Published and Distributed by
Bureau of Educational Research and Service
University of Iowa, Iowa City

No. 1 To Make a Picture Frame.

- Procedure:
- (1) Fasten the remaining corners.
 - (2) Cut the molding into the proper lengths.
 - (3) Determine the size of frame.
 - (4) Stain, fill and varnish.
 - (5) Clamp one corner in the vise and fasten with glue and brads.
 - (6) Select the molding.

() () () () () ()

No. 2 To Make an End Splice in No. 14 National Code Wire.

- Procedure:
- (1) Apply the soldering flux and solder.
 - (2) Wrap the joint with friction tape.
 - (3) Scrape the wire clean.
 - (4) Twist the wires together.
 - (5) Peel off the insulation.
 - (6) Wrap the joint with rubber tape.

() () () () () ()

No. 3 To Fasten a Joint with Corrugated Fasteners.

- Procedure:
- (1) Drive corrugated fasteners in place.
 - (2) Clamp the joint in place.
 - (3) Test the strength of the joint.
 - (4) Cut and fit the joint.
 - (5) Fasten the joint with a nail.

() () () () () ()

No. 4 To Whet a Plane Iron.

- Procedure:
- (1) Test the edge for sharpness.
 - (2) Clean the stones.
 - (3) Whet on coarse stone.
 - (4) Apply oil to the stones.
 - (5) Whet on fine stone.

() () () () () ()

No. 5 To Cut a Piece of Pipe.

- Procedure:
- (1) Set the cutter on the mark.
 - (2) Ream the end.
 - (3) Determine the length of pipe.
 - (4) Cut the pipe.
 - (5) Measure and mark.
 - (6) Adjust the pipe cutter.

() () () () () ()

No. 6 To Fasten Two Pieces of Stock Together with Flat Head Screws.

- Procedure:
- (1) Drive the screws in place.
 - (2) Drill holes and countersink in piece through which screws pass.
 - (3) Select the screws and a correctly pointed screw driver.
 - (4) Drill pilot holes for anchoring screws.
 - (5) Locate position of holes on a center line.

() () () () () ()

Turn to Page 3 and go right on working

Rearrange the numbers
to show correct procedure:

To Assemble an Extension Cord for an Electric Lamp.

- re: (1) Check to see if all strands of wire are under the binding posts.
(2) Attach the plug and socket.
(3) Tie underwriter's knot.
(4) Prepare the terminals for the binding posts.
(5) Determine the length of cord.
(6) Screw in light and test.

() () () () () () ()

To Set a Pair of Butt Hinges.

- re: (1) Chisel out the gains.
(2) Mark the hinge length.
(3) Gage the width and depth of the cut.
(4) Mark the position of the hinges.
(5) Test the hinges.
(6) Screw the hinges in place.

() () () () () () ()

To Grind a Chisel.

- re: (1) Remove the wire edge and sharpen on oil stone.
(2) Hold chisel at proper angle and grind the bevel.
(3) Remove nicks and square the cutting edge.
(4) Test edge for sharpness.
(5) Determine the bevel.

() () () () () () ()

To Replace a Defective Spring in a Mortise Lock.

- re: (1) Remove the face plate.
(2) Replace broken spring.
(3) Assemble and test.
(4) Oil moving parts.
(5) Remove the lock from door.
(6) Remove the door knobs.

() () () () () () ()

To Make a Joint with Round Head Screws.

- re: (1) Drill the pilot holes.
(2) Select the screws and a correctly pointed screw driver.
(3) Locate the position of the holes on a center line.
(4) Drive the screws in place.
(5) Redrill holes to diameter of screw in the piece of stock through which screws pass.

() () () () () () ()

To Cast an Article in Concrete Using a Form.

- re: (1) Allow the concrete to set.
(2) Mix the dry ingredients together.
(3) Put the concrete into the form.
(4) Get the form ready, and decide on the proportion of sand, gravel and cement.
(5) Determine the amount of concrete that will fill the form.
(6) Add clean water and mix.

() () () () () () ()

Turn to Page 4 and go right on working.

No. 13 To Repair a Small Hole in a Plastered Wall.

- Procedure:
- (1) Determine the amount and mixture.
 - (2) Remove all loose plaster.
 - (3) Finish to match the wall.
 - (4) Fill the hole with plaster.
 - (5) Mix the plaster.
 - (6) Dampen the plaster around the hole.

() () () () ()

No. 14 To Cut a Right Hand Thread on a Rod.

- Procedure:
- (1) Slip the die on the rod.
 - (2) Remove the die and test the thread.
 - (3) Push die toward rod and turn in clockwise direction threading the rod.
 - (4) Oil portion to be threaded.
 - (5) Select a die of correct size.

() () () ()

No. 15 To Remove Old Varnish and Revarnish.

- Procedure:
- (1) Sand paper the cleaned wood.
 - (2) Apply varnish of average consistency.
 - (3) Stain to desired color.
 - (4) Wash the surface with benzine and allow to dry.
 - (5) Apply varnish remover and scrape off old finish.
 - (6) Apply thin varnish.

() () () () ()

No. 16 To Drill a Hole in Masonry Using a Star Drill.

- Procedure:
- (1) Select the proper size star drill.
 - (2) Place the drill in position directly on the mark and perpendicular to the surface.
 - (3) Inspect the drill and sharpen if necessary.
 - (4) Determine size, location, and depth of hole needed.
 - (5) Remove the drill and test the hole for depth.
 - (6) Drill the hole by striking the drill head with the hammer, giving a quarter turn after each stroke.

() () () () ()

No. 17 To Re-Seat the Ball Cock of a Closet Tank.

- Procedure:
- (1) Put in a new seat.
 - (2) Assemble and test.
 - (3) Take out ball and lever mechanism.
 - (4) Remove the tank cover and test for leaks.
 - (5) Shut off the water.
 - (6) Remove the seat with a wrench.

() () () () ()

No. 18 To Wind an Electro-Magnet.

- Procedure:
- (1) Wind core with No. 20 d.c.c. wire.
 - (2) Attach wire to poles of battery.
 - (3) Select a soft iron core.
 - (4) Using a compass determine north and south poles of magnet.
 - (5) Test core for magnetism.

() () () ()

Turn to Page 5 and go right on working

*Rearrange the numbers
to show correct procedure:*

To Put a New Handle in a Hammer.

- e: (1) Shape and fit the handle into the head through the "adze eye."
(2) Put the fitted handle into the head.
(3) Drive out the broken handle and select a suitable new handle.
(4) Drive a wedge into the saw kerf.
(5) Saw a wedge kerf in the end of the handle.

(1) (2) (3) (4) (5)
() () () () () () ()

To File a Key for a Common Door Lock.

- e: (1) Assemble lock and test.
(2) File the end wards.
(3) Select the key blank.
(4) Remove the lock and face plate.
(5) File the bit to correct length.
(6) File the tumbler wards.

(1) (2) (3) (4) (5) (6)
() () () () () () ()

To Clean a Clogged Drain Trap.

- e: (1) Assemble and test.
(2) Unscrew clean-out plug.
(3) Pour lye water into the clogged drain.
(4) Locate clean-out plug.
(5) Place a pan to catch water from trap.
(6) Clean trap with a wire.

(1) (2) (3) (4) (5) (6)
() () () () () () ()

To Attach a Swivel Coupling to a Garden Hose.

- e: (1) Test finished work for leaks.
(2) Put in hose washer.
(3) Slip on the clamp.
(4) Cut off the leaking portion.
(5) Tighten the clamp.
(6) Insert the swivel end of the coupling.

(1) (2) (3) (4) (5) (6)
() () () () () () ()

To Prepare a Pot of Glue.

- e: (1) Add enough clean cold water to cover the glue.
(2) Melt the glue down with a slow even heat not over 155° F.
(3) Break the hard glue into small pieces.
(4) Thin the glue with clean warm water (150° F.)
(5) Put the pieces of glue into a clean container.
(6) Soak the glue until it becomes a jelly like mass.

(1) (2) (3) (4) (5) (6)
() () () () () () ()

Turn to Page 6 and go right on working

Rearrange the numbers to show correct procedure

No. 24 To Sharpen a Rip Saw.

- Procedure:
- (1) Shape the teeth.
 - (2) Give the teeth a "shiner" or bright top.
 - (3) Clamp the saw in a vise.
 - (4) File the teeth.
 - (5) Set the teeth.
 - (6) Joint the teeth.

() () () () () ()

No. 25 To Glaze a Sash.

- Procedure:
- (1) Work and apply the putty.
 - (2) Place pane in rebate with bowed side up.
 - (3) Remove the broken glass and putty.
 - (4) Cut the pane to size.
 - (5) Set the pane with glazier points.
 - (6) Back putty the rebate.

() () () () () ()

No. 26 To Tin Soldering Copper.

- Procedure:
- (1) Rub heated copper with sal ammoniac and solder until tinned.
 - (2) Clean and file copper to shape.
 - (3) Heat the copper.
 - (4) Wipe copper until bright on a rough cloth.

() () () () () ()

No. 27 To Read the Electric Meter.

- Procedure:
- (1) Read the remaining dials and record.
 - (2) Note the direction of rotation of the next dial to the left, read and multiply by number directly above.
 - (3) Read dial to extreme right.
 - (4) Add the readings and get the total kilowatt hours.
 - (5) Multiply by number directly above and record.
 - (6) Note the direction of rotation of dial to extreme right.

() () () () () ()

No. 28 To Clean and Care for a Varnish or Paint Brush.

- Procedure:
- (1) Pour enough clean turpentine into the container to cover one-third the bristles.
 - (2) Wash out the brush with clean turpentine.
 - (3) Keep the brushes and container in a dry cool place until needed.
 - (4) Suspend the brush by the handle in a clean dust proof container so that the bristles just touch the bottom.

() () () () () ()

Turn to Page 7 and go right on working

*Rearrange the numbers
to show correct procedure:*

To Repair Leather Heel That Has the Back Worn Down.

- re: (1) Trim and burnish the sides, rasp nail heads and smooth the bottom.
(2) Nail on the top lift.
(3) Cut off nails with a pair of nippers.
(4) Remove the top lift.
(5) Nail on leather skivings to restore the shape.

() () () () ()

To Repair Defective Window Weights in a Double Hung Window Frame.

- re: (1) Open weight pocket.
(2) Take out lower sash.
(3) Remove one inside stop.
(4) Remove the upper sash.
(5) Repair weights, assemble and test.
(6) Remove parting stop.

() () () () () ()

To Apply Paste Filler to Open Grained Wood.

- re: (1) Apply the filler with a stiff brush.
(2) Remove the surplus filler by rubbing across the grain with a coarse rag.
(3) Allow to dry twenty-four hours.
(4) Thin filler with turpentine and color to match the stain.
(5) Sand lightly with the grain.
(6) Allow filler to dry until it has a dull appearance.

() () () () () ()

To Read the Gas Meter.

- re: (1) Note the direction of rotation of the next dial to the left,
read and multiply by number directly above.
(2) Note the direction of rotation of dial to extreme right.
(3) Multiply by number directly above and record.
(4) Read the remaining dials and record.
(5) Add the readings and get the total cubic feet.
(6) Read dial to extreme right.

() () () () () ()

Go on to Part 2 on the next page.

Score on Part 1

Job-score.....

Point-score.....

Turn to Page 8 and go right on working

PART 2

Directions: For the four jobs which follow the connections called for are to be indicated right or wrong by drawing in lines with pencil or pen. Read the directions for each job very carefully. When figured out how the wires should go, mark them in *neatly and clearly*. If you don't know all the correct mark those you think are right.

Job 1. To wire two bells in series using one push button.

Directions: Show the correct circuit by drawing lines between the black dots.



PUSH BUTTON



Job 2. To connect three dry cells in parallel.

Directions: Show the correct circuit by drawing lines between the black dots.



DRY CELLS

Job 3. To wire two bells in parallel using one push button.

Directions: Show the correct circuit by drawing lines between the black dots.



PUSH BUTTON



Job 4. To show the proper connections for hooking up "A" and "B" batteries, aerial and ground on a five tube radio set.

Directions: Show the proper connections by drawing lines between the black dots.



Score on Part 2

No. jobs completely right.....

Total no. right connections.....

End of the Test

.....
 Birthday (Tell in figures).....years. Birthday.....
School.....
State.....
Date.....192.....

Exercise	Score
1	
2	
3	
4	
5	
6	
Total	
T-Score	

STENQUIST MECHANICAL APTITUDE TESTS

By J. L. STENQUIST
 Director of Research, Baltimore, Maryland

TEST I

DIRECTIONS

Study the pictures below. Each thing in Part 1 belongs with, is used with, or is a part of one particular thing in Part 2. Thus, No. 1 in Part 1 belongs with Letter H in Part 2; so H is written beside 1 in the list of answers. No. 2 belongs with Letter D; so D is written beside 2 in the list of answers. No. 3 belongs with Letter A; so A is written beside 3 in the list of answers. No. 4 belongs with Letter C; so C is written beside 4 in the list of answers. No. 5 belongs with Letter P; so P is written beside 5 in the list of answers. Do the same for all the exercises in this booklet. If you are not sure, guess. Try all. Write *some* letter beside each number.

SAMPLE EXERCISE

PART 1

PART 2

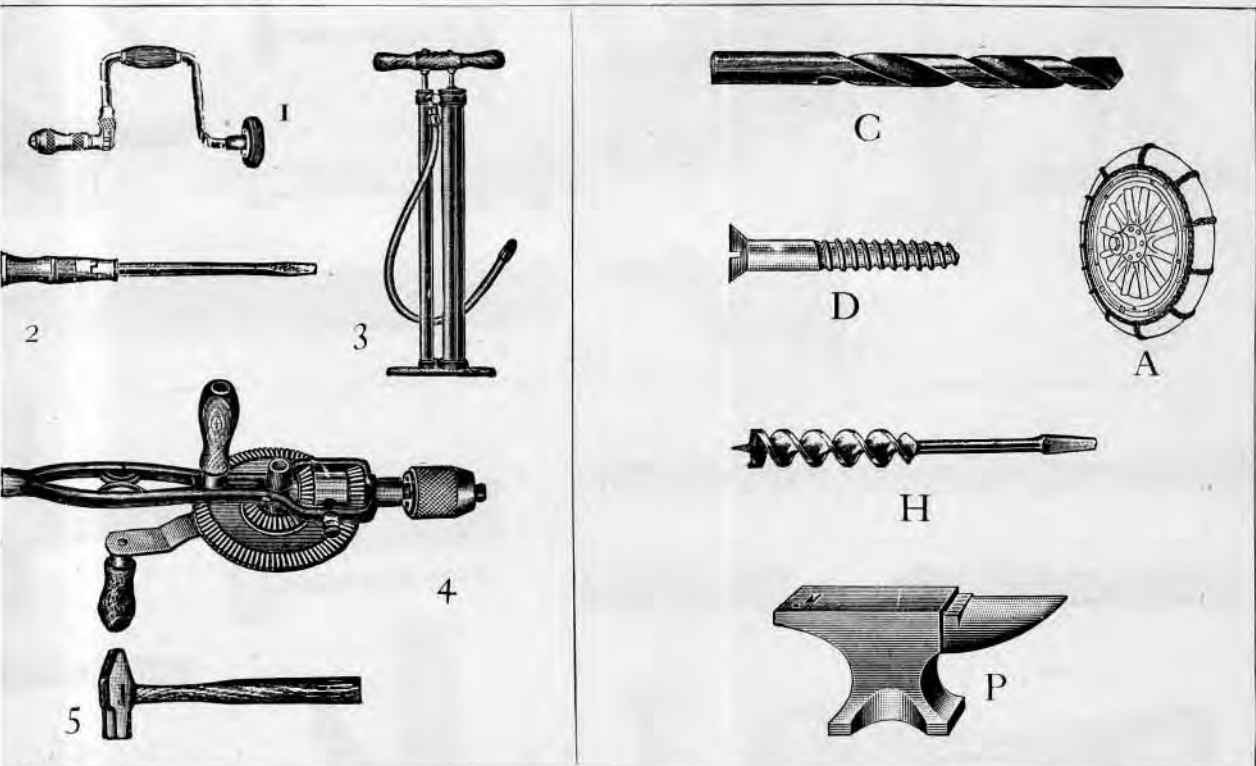

EXERCISE 6

PART 1

PART 2

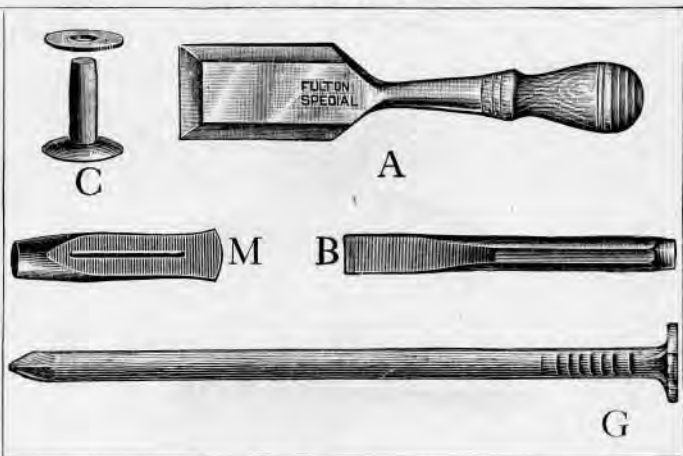

I	<input type="checkbox"/>
2	<input type="checkbox"/>
3	<input type="checkbox"/>
4	<input type="checkbox"/>
5	<input type="checkbox"/>

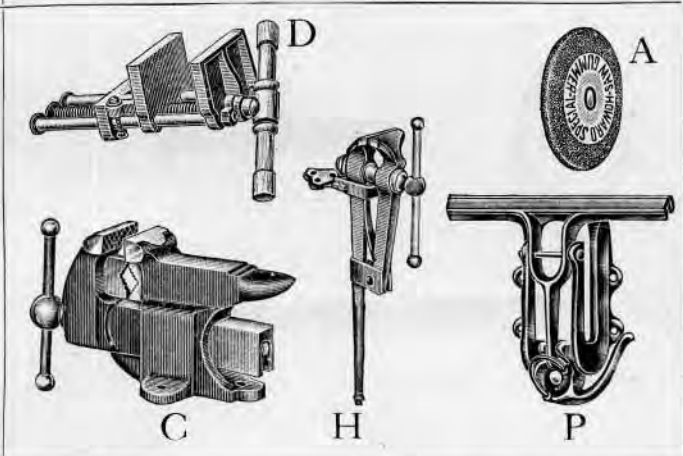
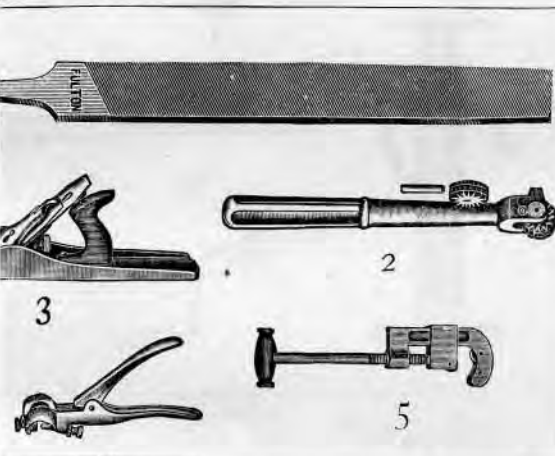

I	<input type="checkbox"/>
2	<input type="checkbox"/>
3	<input type="checkbox"/>
4	<input type="checkbox"/>
5	<input type="checkbox"/>

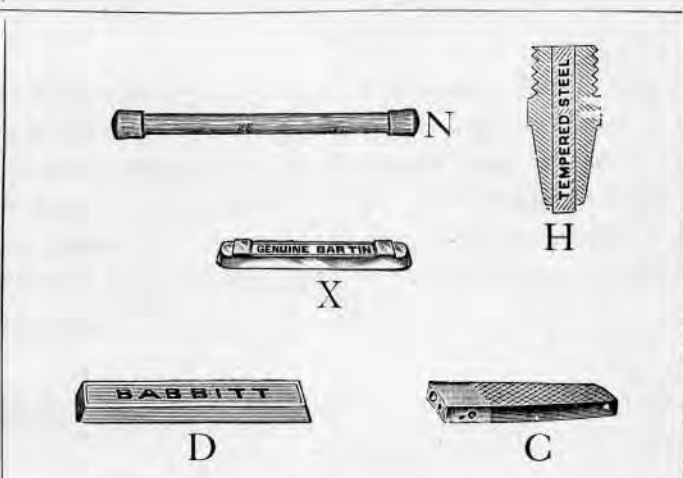
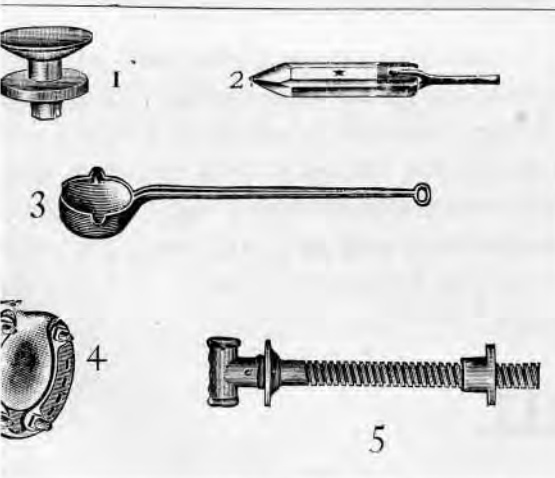

I	<input type="checkbox"/>
2	<input type="checkbox"/>
3	<input type="checkbox"/>
4	<input type="checkbox"/>
5	<input type="checkbox"/>

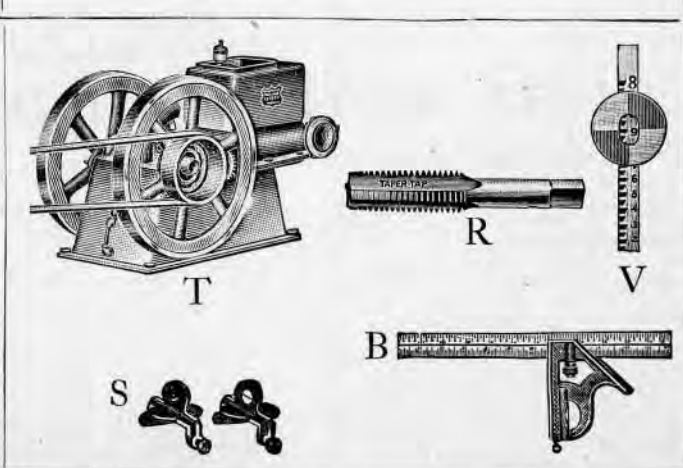
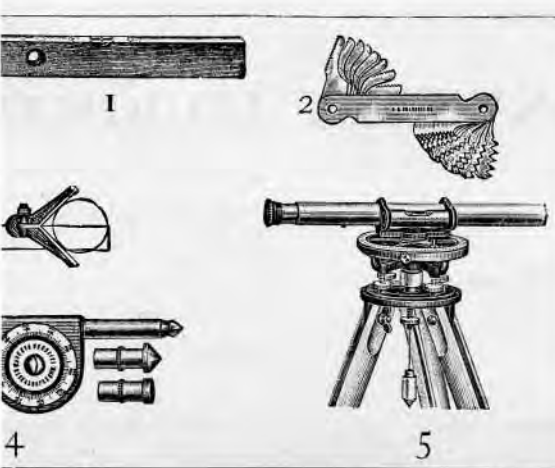

I	<input type="checkbox"/>
2	<input type="checkbox"/>
3	<input type="checkbox"/>
4	<input type="checkbox"/>
5	<input type="checkbox"/>

EXERCISE 1

PART 1

PART 2

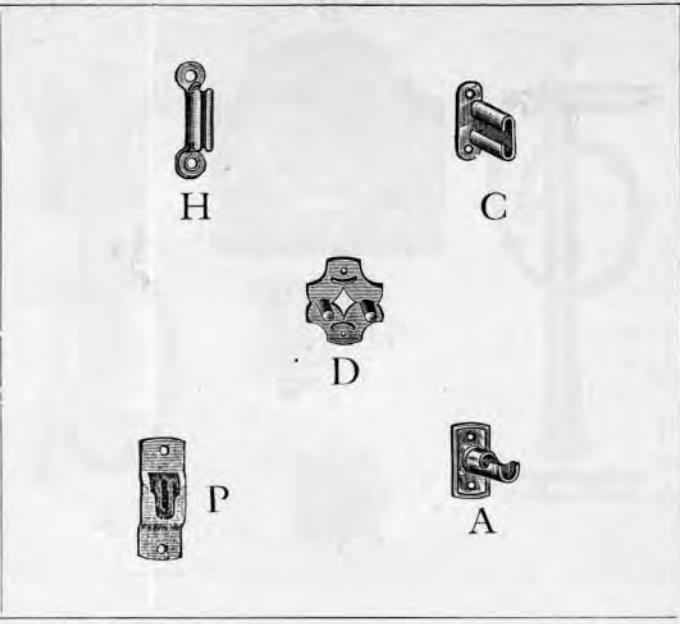
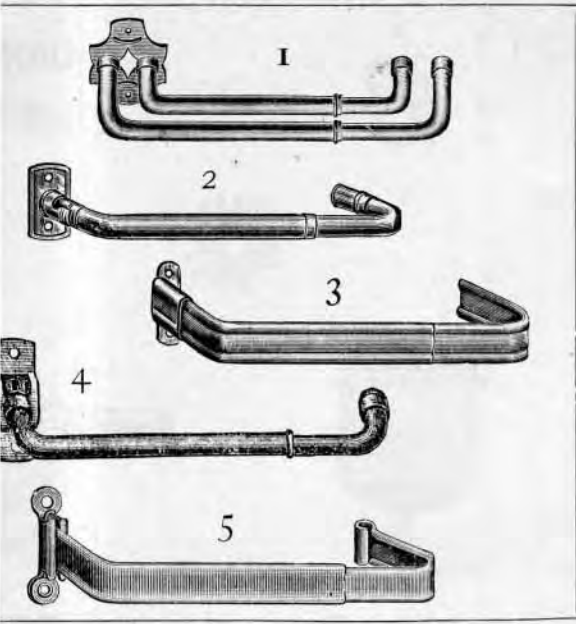

1	<input type="checkbox"/>
2	<input type="checkbox"/>
3	<input type="checkbox"/>
4	<input type="checkbox"/>
5	<input type="checkbox"/>

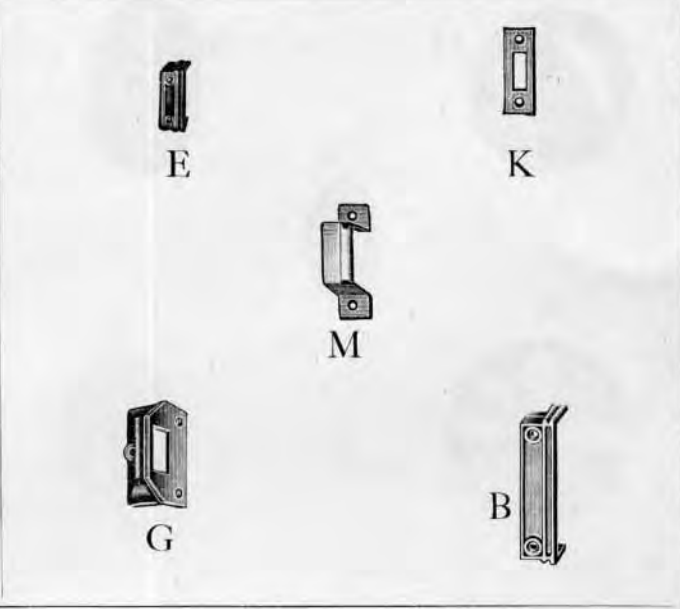
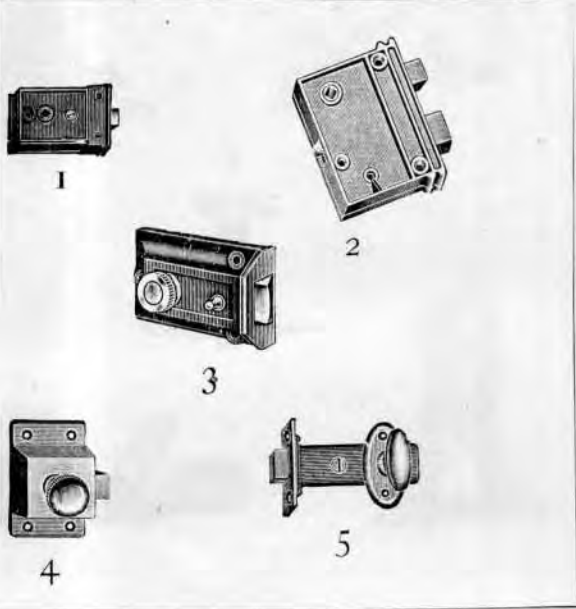

1	<input type="checkbox"/>
2	<input type="checkbox"/>
3	<input type="checkbox"/>
4	<input type="checkbox"/>
5	<input type="checkbox"/>

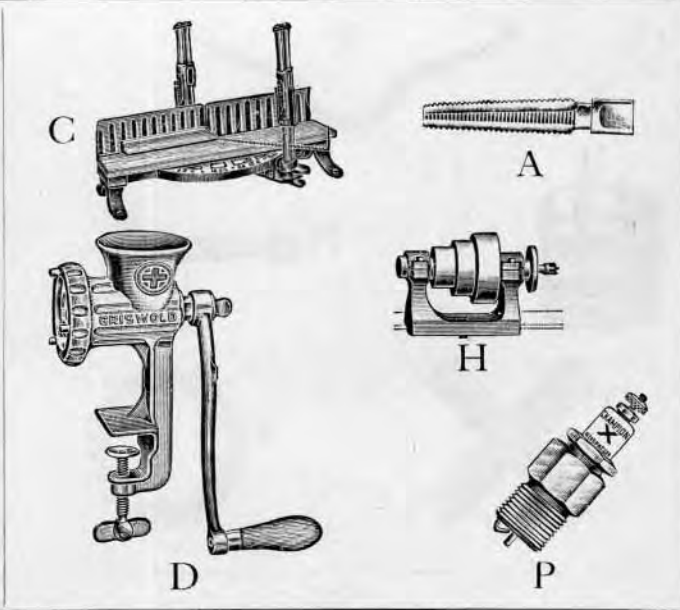
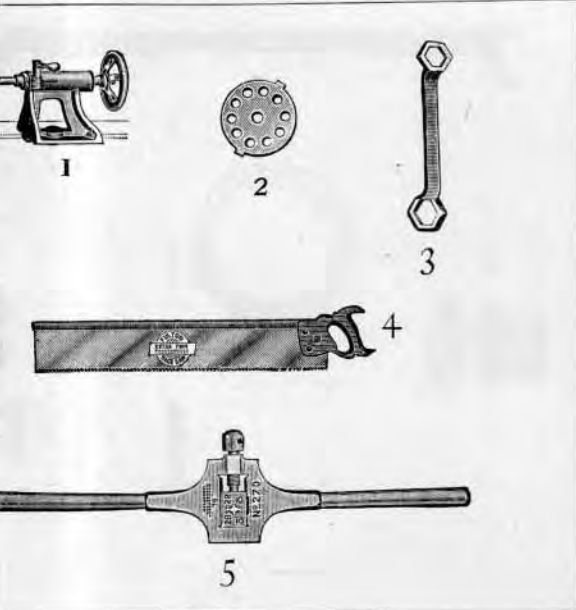

1	<input type="checkbox"/>
2	<input type="checkbox"/>
3	<input type="checkbox"/>
4	<input type="checkbox"/>
5	<input type="checkbox"/>

EXERCISE 5

PART 1

PART 2

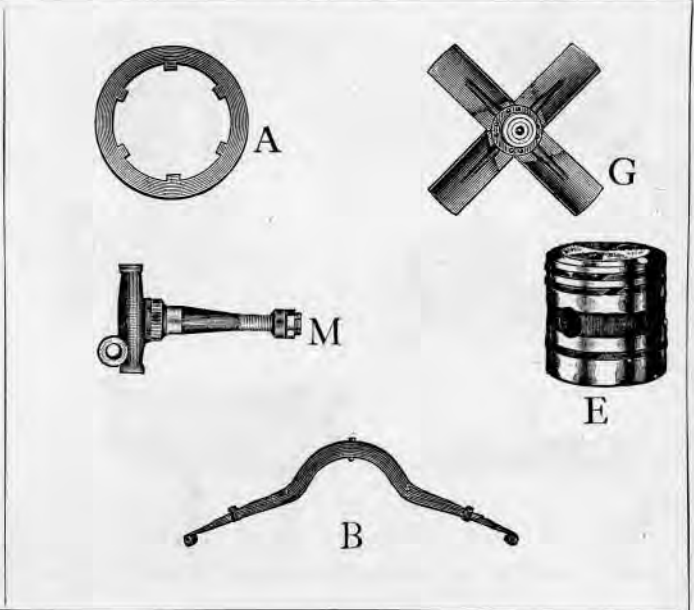
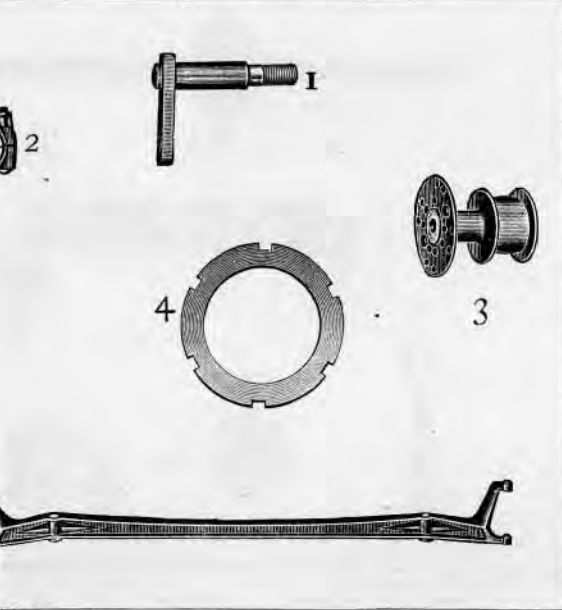

- 1
- 2
- 3
- 4
- 5

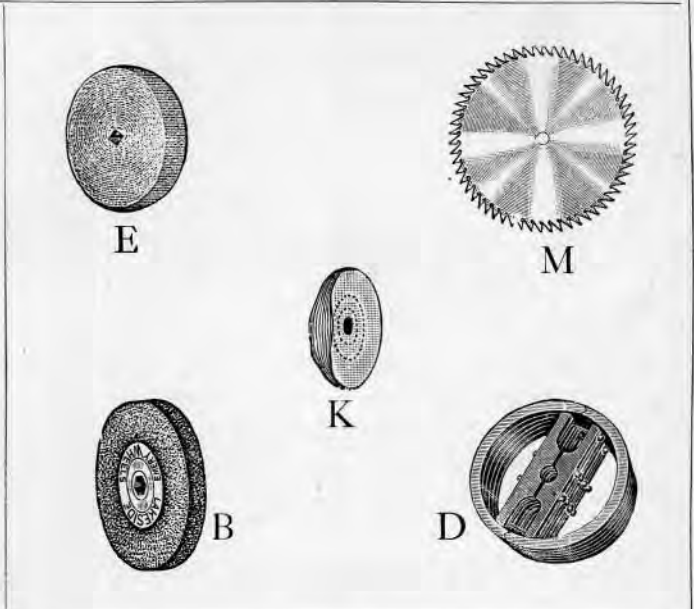
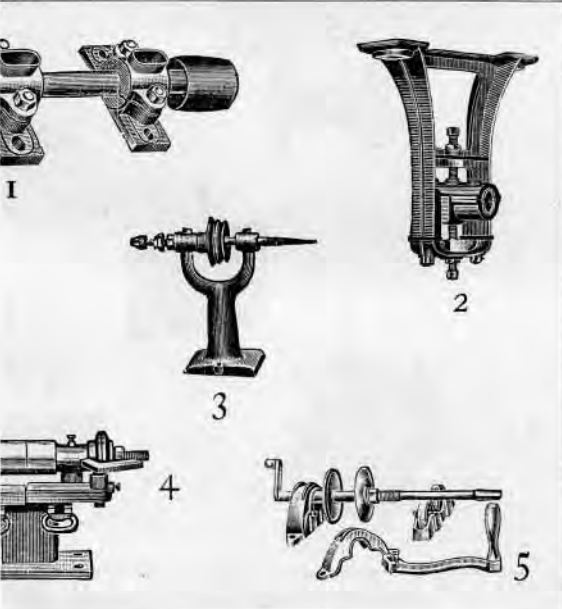

- 1
- 2
- 3
- 4
- 5

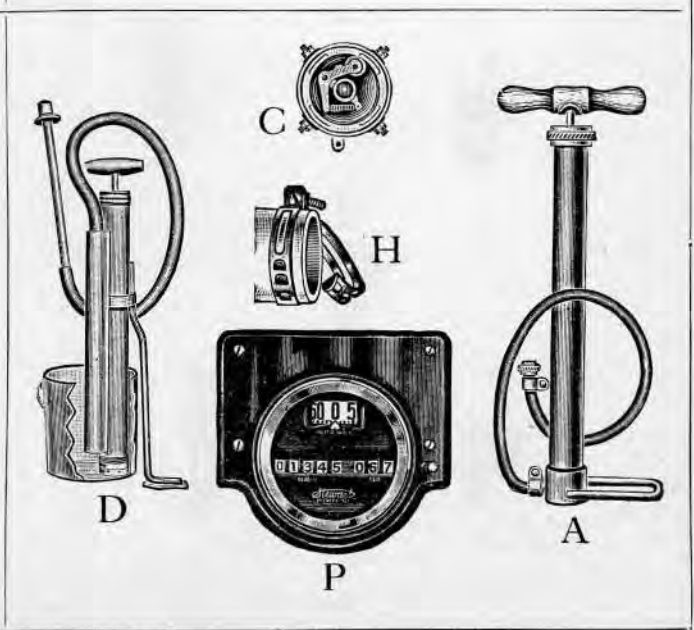
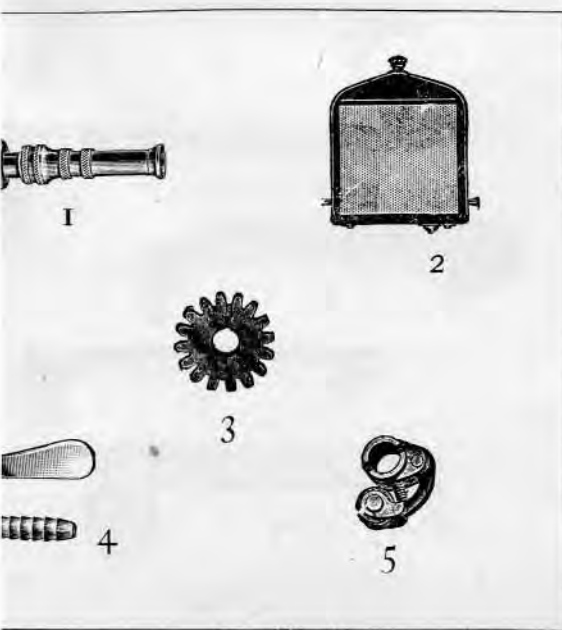

- 1
- 2
- 3
- 4
- 5

EXERCISE 2

PART 1

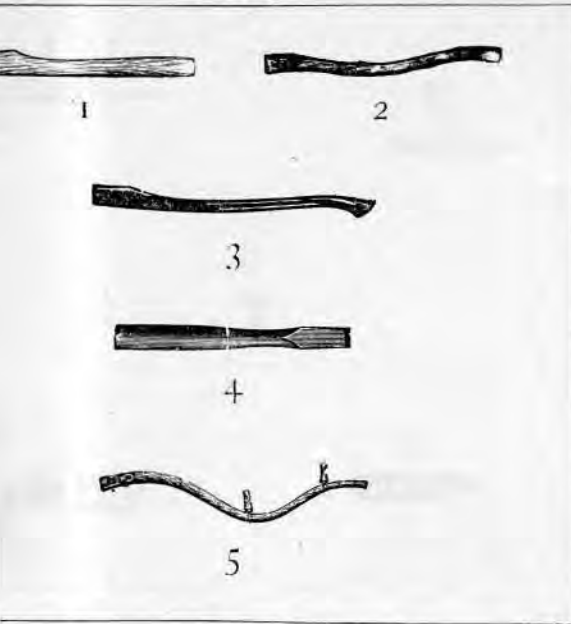

PART 2

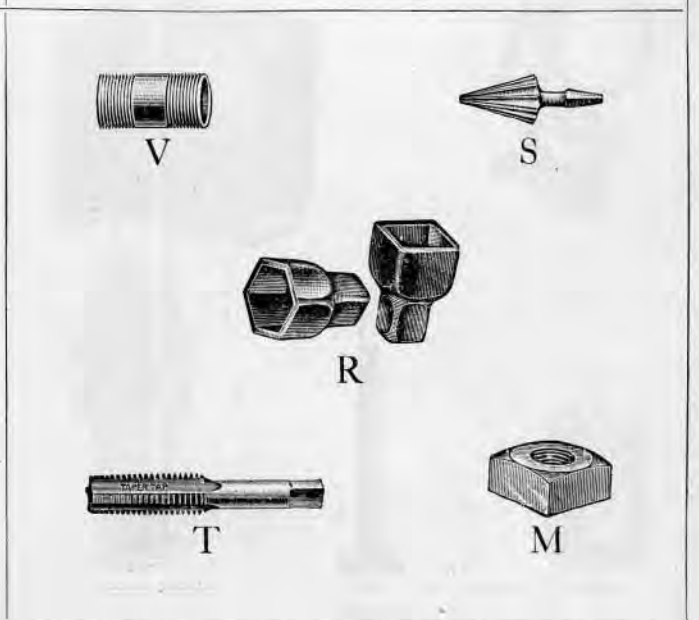
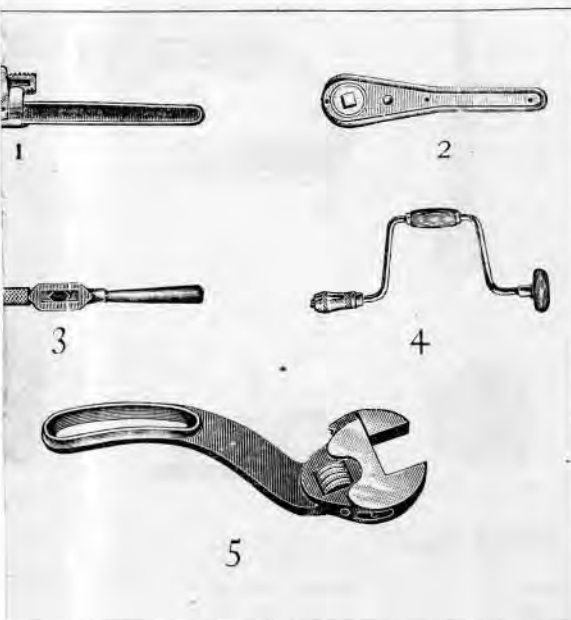
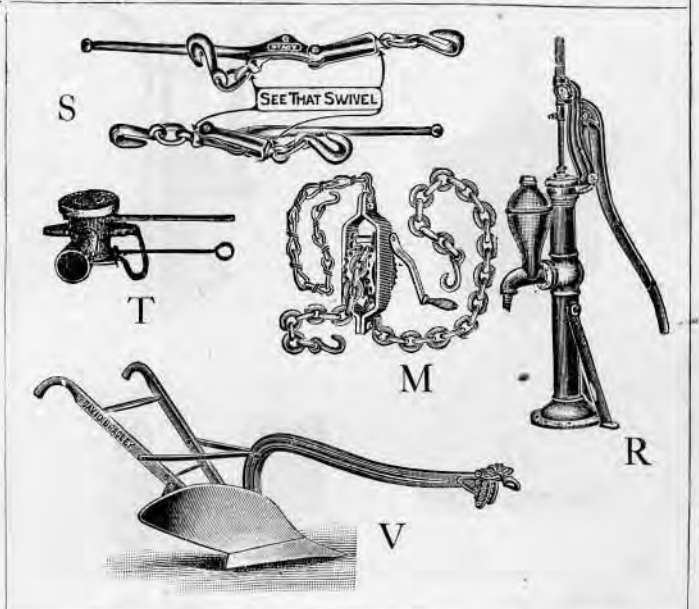
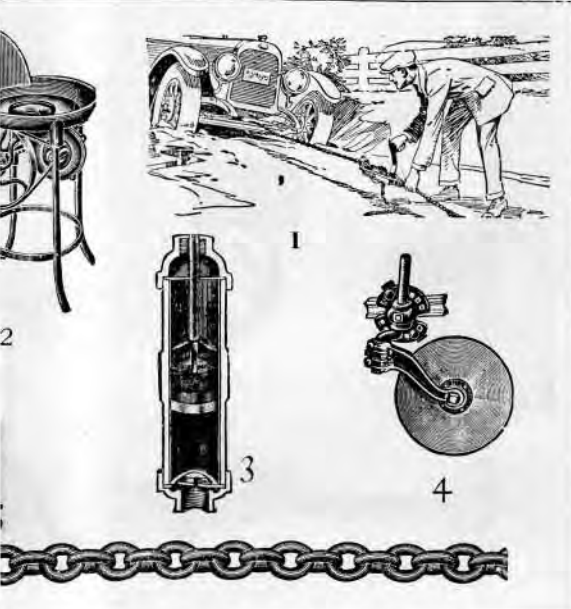
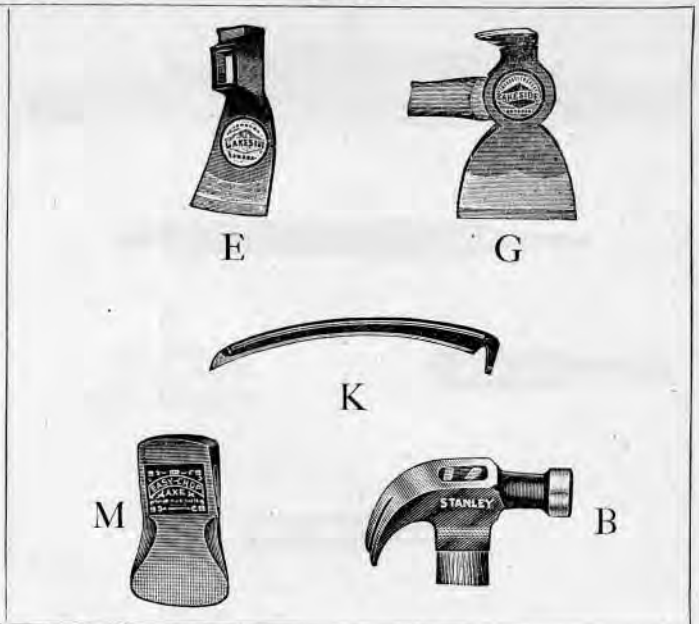

- 1
- 2
- 3
- 4
- 5

- 1
- 2
- 3
- 4
- 5

- 1
- 2
- 3
- 4
- 5

EXERCISE 4

PART 1

PART 2

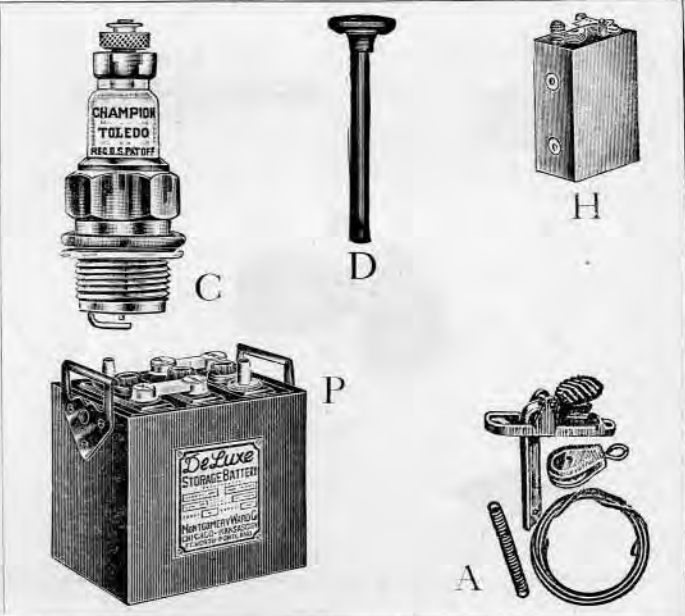

I	<input type="checkbox"/>
2	<input type="checkbox"/>
3	<input type="checkbox"/>
4	<input type="checkbox"/>
5	<input type="checkbox"/>

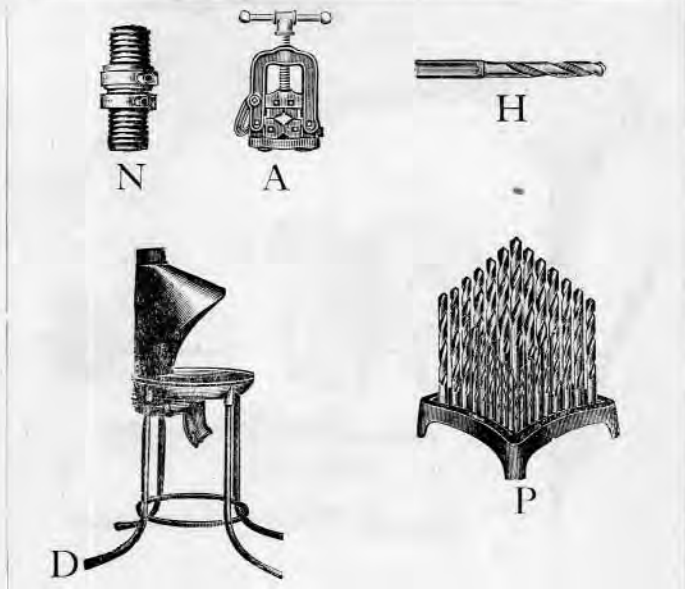
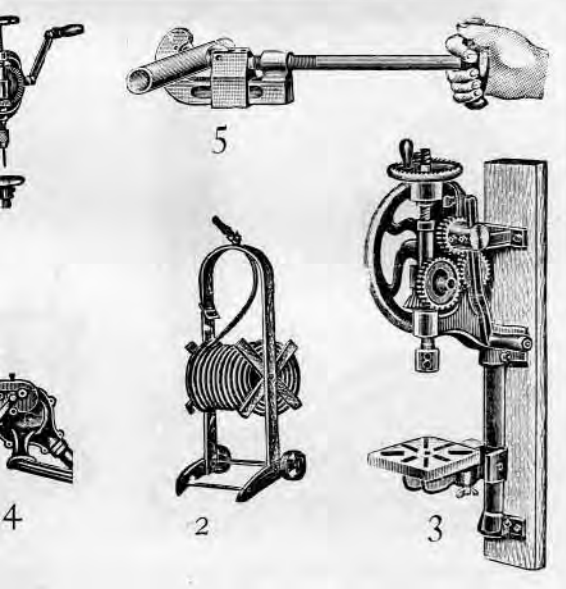

I	<input type="checkbox"/>
2	<input type="checkbox"/>
3	<input type="checkbox"/>
4	<input type="checkbox"/>
5	<input type="checkbox"/>

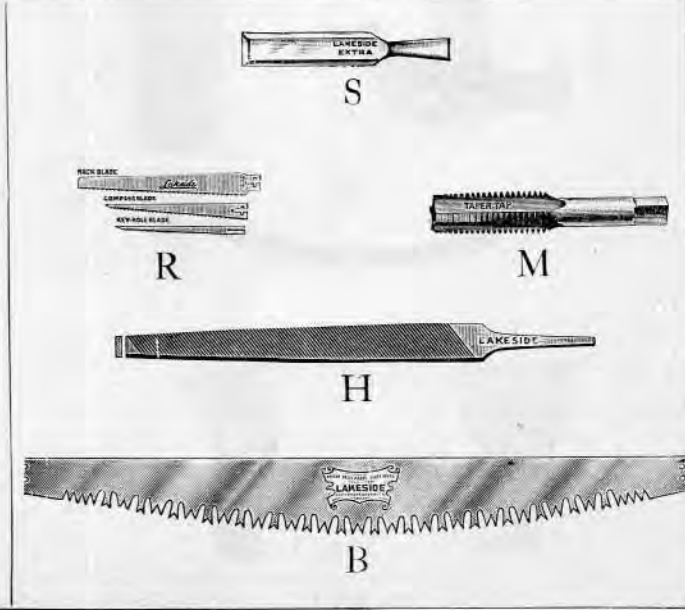
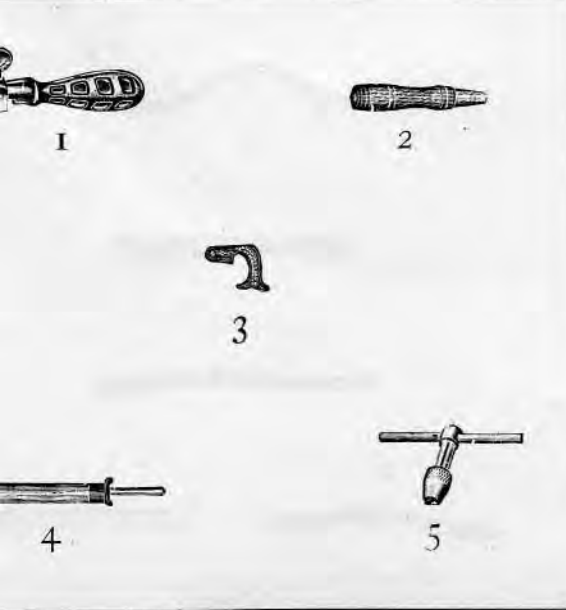

I	<input type="checkbox"/>
2	<input type="checkbox"/>
3	<input type="checkbox"/>
4	<input type="checkbox"/>
5	<input type="checkbox"/>

EXERCISE 3

PART 1

PART 2

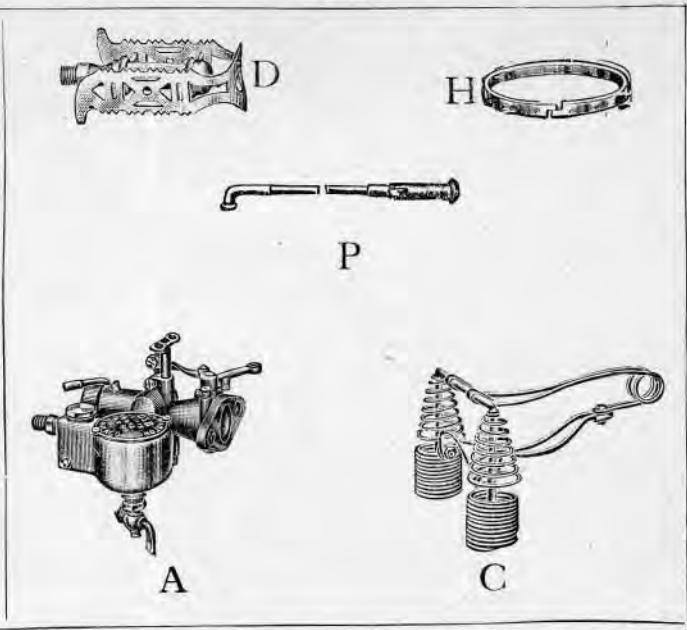
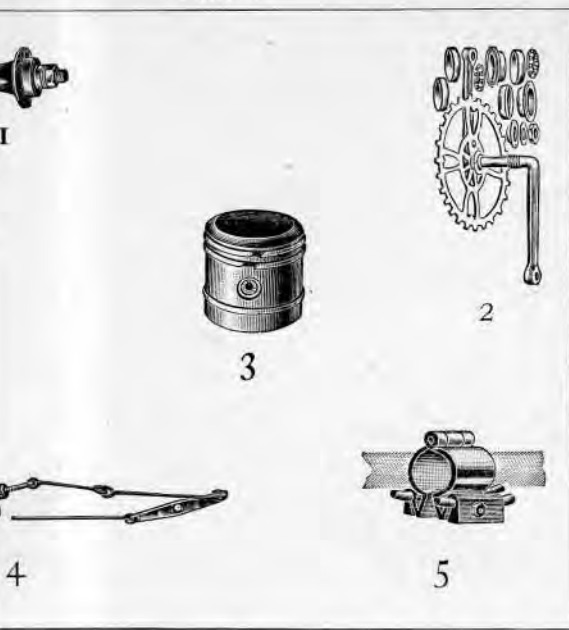

- I
- 2
- 3
- 4
- 5

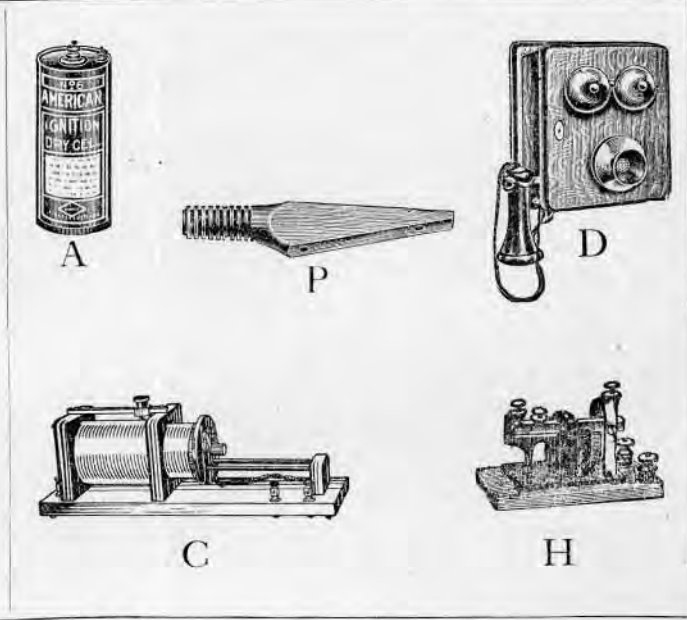
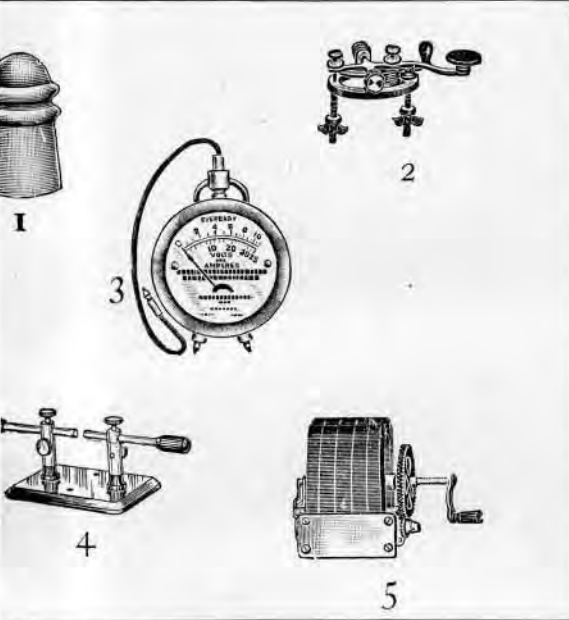

- I
- 2
- 3
- 4
- 5

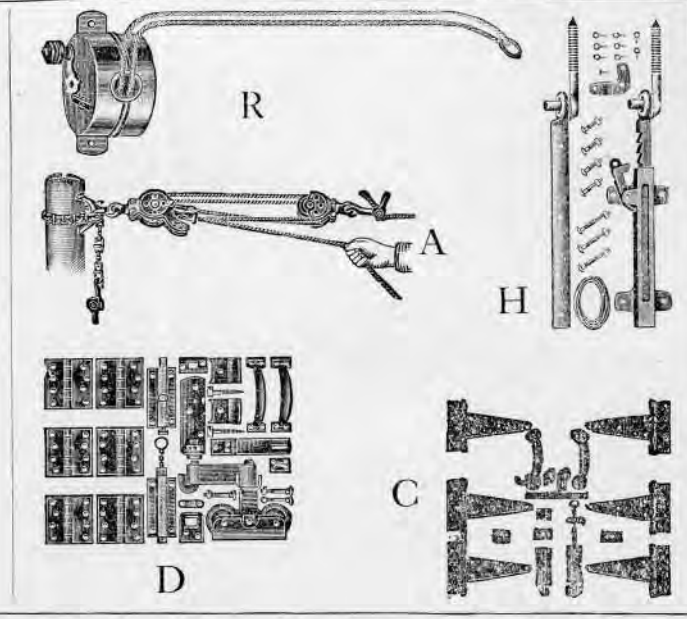
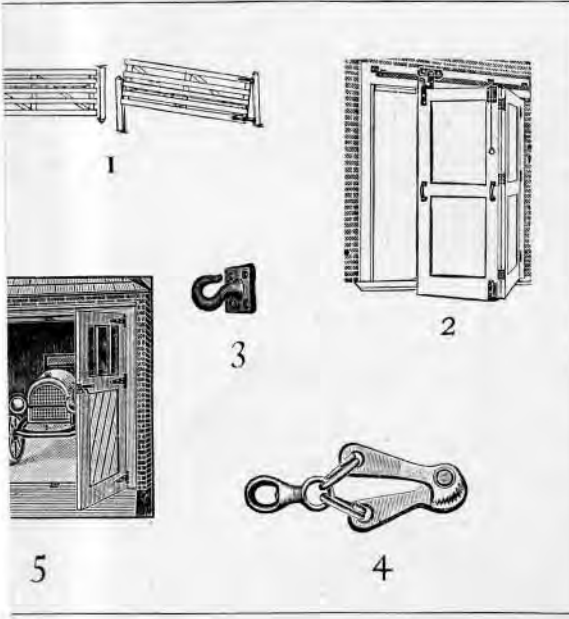

- I
- 2
- 3
- 4
- 5

DETROIT MECHANICAL APTITUDES EXAMINATION FOR GIRLS

..... Years..... Months.....
First Last

..... School..... Date.....

of Occupation (1).....(2).....

er of Tools in Home.....

Copyright, 1928, by Harry J. Baker and A. C. Crockett. Printed in U.S.A.
The right to modify or print this material for use in the Detroit public schools has been assigned to the Detroit Board of Education.

No.	Score
1	
2	
3	
4	
5	
6	
7	
8	
Total	

	5TH
	4TH
	3RD
	2ND
	1ST

ORDER

5

	5TH
	4TH
	3RD
	2ND
	1ST

ORDER
DIRECTION

4

	4TH
	3RD
	2ND
	1ST

ORDER

3

	3RD
	2ND
	1ST

ORDER
DIRECTION

2

	3RD
	2ND
	1ST

ORDER

1

	3RD
	2ND
A	1ST

ORDER
DIRECTION





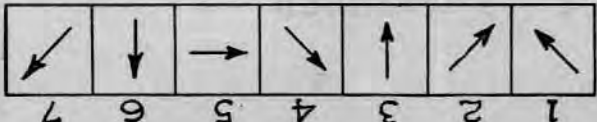









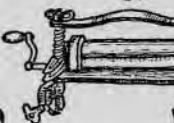





















A

Score, page 8:
No. right, "Order"
No. right, "Direction"
Score (add).....



DIRECTION
OF NEEDLE

1

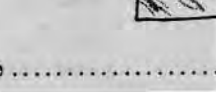
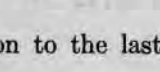
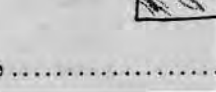
A		()	ATOMIZER	20	
B		()	BUTCHER'S CLEAVER	21	
1		()	BUTTER KNIFE	22	
2		()	BUTTON HOLE SCISSORS	23	
3		()	CAN OPENER	24	
4		()	CLIPPERS	25	
5		()	COFFEE PERCOLATOR	26	
6		()	CROCHET HOOK	27	
7		()	EGG BEATER	28	
8		()	ELECTRIC BELL	29	
9		()	ELECTRIC BULB	30	
10		()	ELECTRIC PLUG	31	
11		()	EMERY WHEEL	32	
12		()	FAUCET	33	
13		()	FILE	34	
14		()	GRAVY LADLE	35	
15		()	HAMMER	36	
16		()	ICE CREAM FREEZER	37	
17		()	MONKEY WRENCH	38	
18		()	NEEDLE	39	
19		()	OIL CAN	40	
		()	PAIN BRUSH		
		()	PAINT SPRAYER		
		()	PENCIL SHARPENER		
		()	PICKLE FORK		
		()	PLIERS		
		()	POTATO RICER		
		()	SALAD FORK		
		()	SCREW DRIVER		
		()	SHEARS		
		()	SRAW CUTTER		
		()	SPATULA		
		()	SPOON		
		()	STEAM VALVE		
		()	STOCKING DARNER		
		()	THERMOSTAT		
		()	THIMBLE		
		()	TROWEL		
		()	WAFFLE IRON		
		()	WRINGER		

RT → A

STOP

PART → B

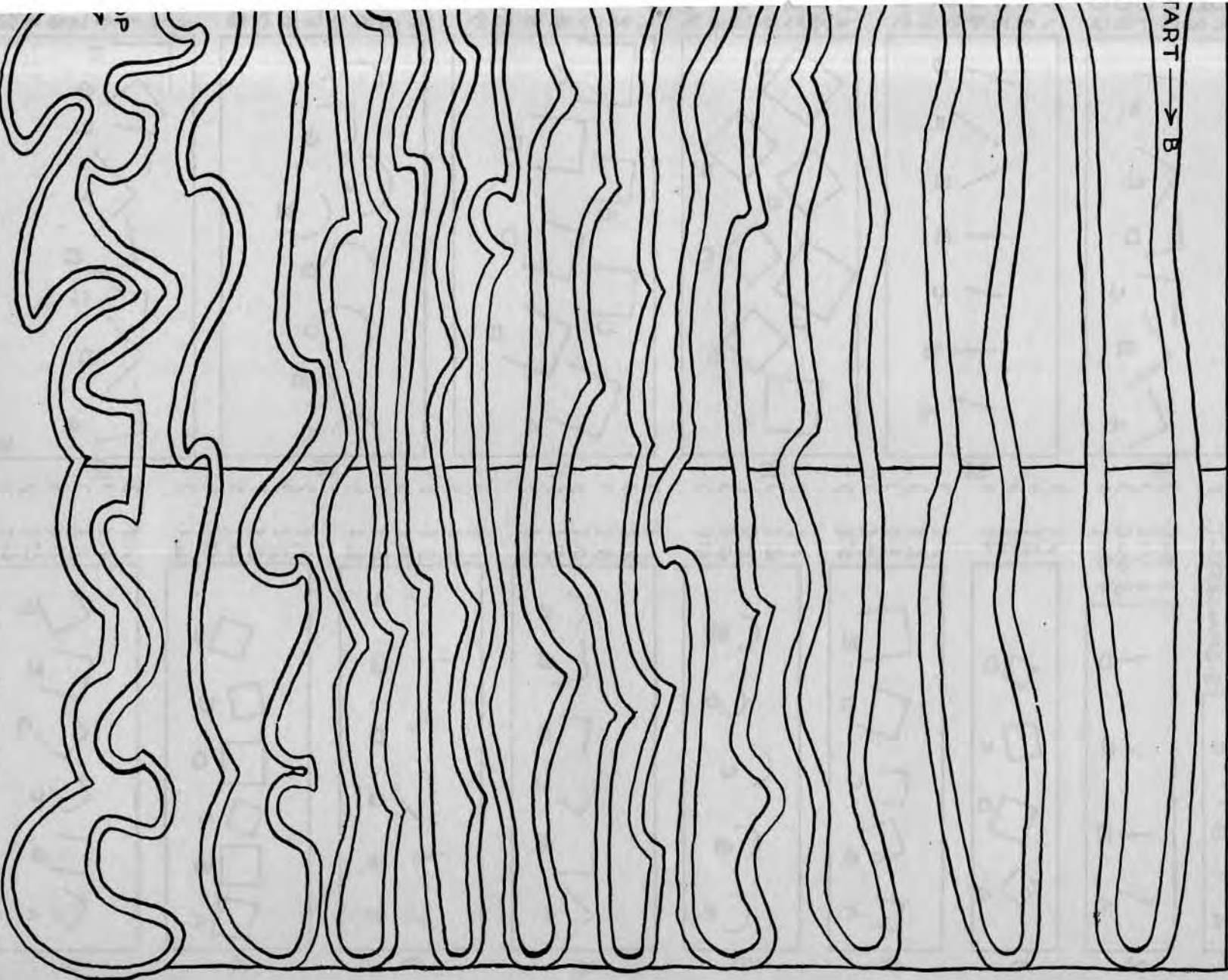

Score.....

SAMPLE

1-BIGGEST---()
 2-NEXT-----()
 3-SMALLEST--()

1

1-BIGGEST---()
 2-NEXT-----()
 3-SMALLEST--()

2

1 B-()
 2 N-()
 3 N-()
 4 S-()

3

1 ()
 2 ()
 3 ()
 4 ()

4

1 ()
 2 ()
 3 ()
 4 ()
 5 ()

5

1 ()
 2 ()
 3 ()
 4 ()
 5 ()

6

1 ()
 2 ()
 3 ()
 4 ()
 5 ()
 6 ()

7

1 ()
 2 ()
 3 ()
 4 ()
 5 ()
 6 ()

8

1 ()
 2 ()
 3 ()
 4 ()
 5 ()
 6 ()

9

1 ()
 2 ()
 3 ()
 4 ()
 5 ()
 6 ()

10

1
 2
 3
 4
 5
 6

11

1
 2
 3
 4
 5
 6

12

1
 2
 3
 4
 5
 6
 7

13

1
 2
 3
 4
 5
 6
 7

14

1
 2
 3
 4
 5
 6
 7

15

1
 2
 3
 4
 5
 6
 7
 8









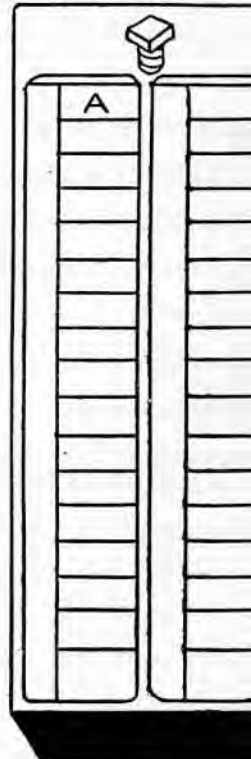
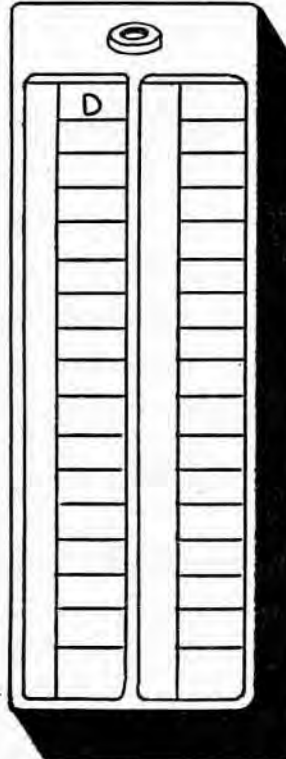
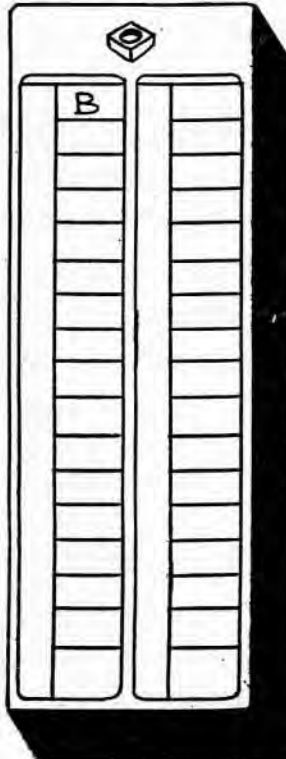
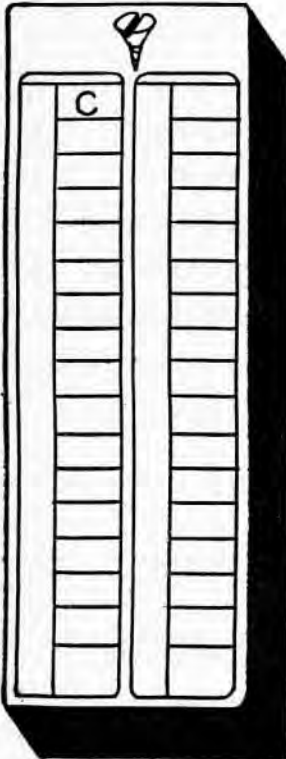
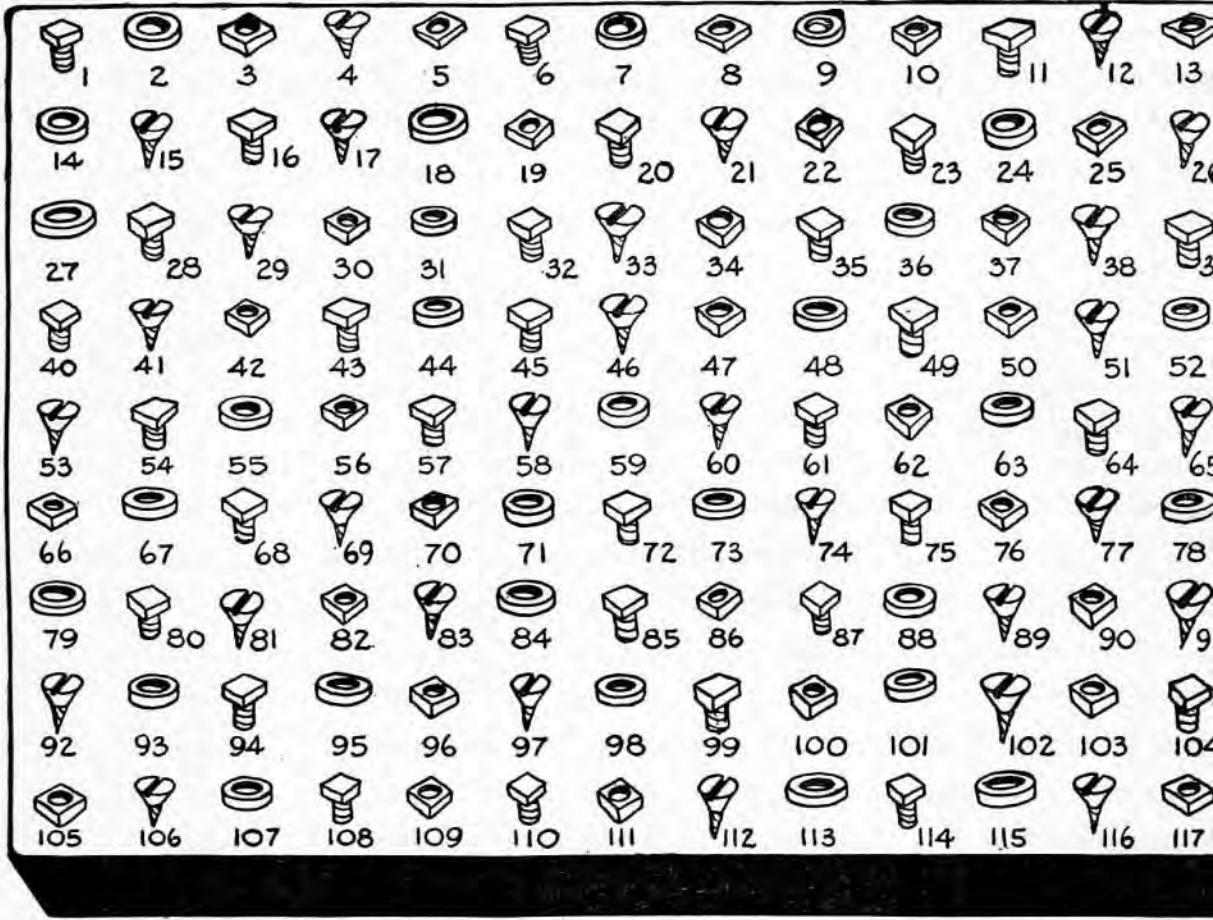

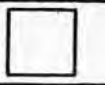





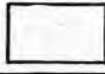

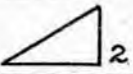











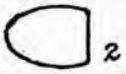



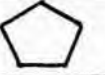
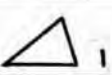
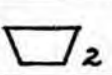



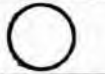





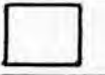

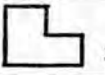
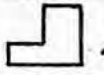

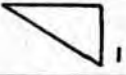
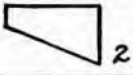

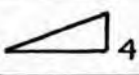
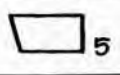



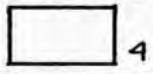

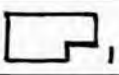

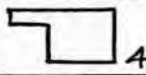









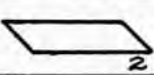
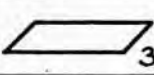







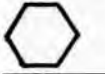

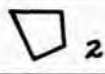
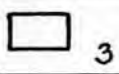
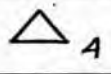
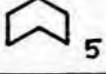

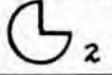
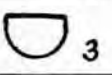









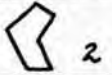
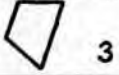
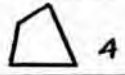

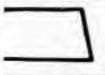
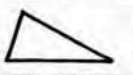
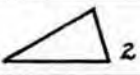

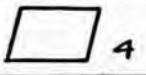
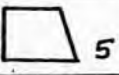

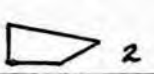

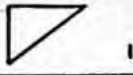
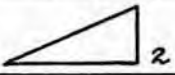
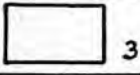

16

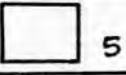
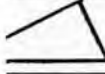
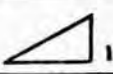
1
 2
 3
 4
 5
 6
 7
 8

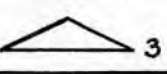
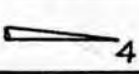
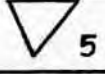
jack-knife will cut	1 gold	2 iron	3 steel	4 wood	()
bacon is a kind of	1 beef	2 mutton	3 pork	4 veal	()
bread consists chiefly of	1 baking powder	2 flour	3 soda	4 yeast	()
toast is a kind of	1 drink	2 meat	3 soup	4 vegetable	()
the warmest cloth is	1 calico	2 cotton	3 silk	4 wool	()
sausages are made from	1 mutton	2 pork	3 rabbit	4 venison	()
gingham is used for	1 dresses	2 gloves	3 sheets	4 table cloths	()
bread should be cut on a surface of	1 aluminum	2 glass	3 porcelain	4 wood	()
natural linen is	1 blue	2 cream	3 red	4 green	()
the chief ingredient of omelette is	1 bacon	2 eggs	3 flour	4 ham	()
the faintest light usually comes from a	1 candle	2 electric bulb	3 gas light	4 oil lamp	()
buffer is used to	1 grind	2 polish	3 roughen	4 smooth	()
to thin paint we use	1 alcohol	2 gasoline	3 kerosene	4 turpentine	()
seam is made with a	1 back stitch	2 gathering stitch	3 hem stitch	4 running stitch	()
glue will stick best to	1 glass	2 lead	3 leather	4 wood	()
the bobbin sets in the	1 lock	2 needle	3 shuttle	4 slide	()
to clean a drain pipe we use	1 oil	2 lye	3 sand	4 soap	()
to change a tire we must have an	1 air pump	2 hammer	3 jack	4 screw driver	()
the strongest thread is	1 basting	2 cotton	3 linen	4 silk	()
the window is best cleaned with a	1 brush	2 chamois	3 cloth	4 sponge	()
glass is usually cut with a	1 chisel	2 file	3 scissors	4 wheel	()
blue is most effective with	1 brick	2 leather	3 metal	4 wood	()
fuse is used for	1 economy	2 efficiency	3 safety	4 speed	()
spark plug is in the	1 commutator	2 cylinder head	3 manifold	4 piston	()
dark blue dress may be dyed	1 black	2 green	3 orange	4 red	()
for fine hemstitching we use a	1 No. 5 needle	2 No. 8 needle	3 No. 3 needle	4 No. 7 needle	()
to paint enamel we must use a	1 hard brush	2 soft brush	3 stiff brush	4 wire brush	()
carburetor	1 explodes gas	2 measures gas	3 mixes air and gas	4 times spark	()
bread is best cut with a	1 round edge	2 scalloped edge	3 saw edge	4 straight edge	()
to weld means to	1 fuse together	2 glue	3 harden	4 melt	()
the number of wires in an ordinary light socket is	1 five	2 one	3 three	4 two	()
to put out a burning motor we use	1 chemical	2 gas	3 oil	4 water	()
nails are a kind of	1 nail	2 rivet	3 screw	4 wire	()
rivet is used for	1 appearance	2 smoothness	3 elasticity	4 strength	()
linen is a kind of	1 dress	2 embroidery	3 hose	4 lace	()
an electric doorbell requires	1 current	2 fuse	3 plug	4 switch	()

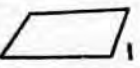
Score



	 ₁	 ₂	 ₃	 ₄	 ₅	
	 ₁	 ₂	 ₃	 ₄	 ₅	
	 ₁	 ₂	 ₃	 ₄	 ₅	
	 ₁	 ₂	 ₃	 ₄	 ₅	
	 ₁	 ₂	 ₃	 ₄	 ₅	
	 ₁	 ₂	 ₃	 ₄	 ₅	
	 ₁	 ₂	 ₃	 ₄	 ₅	
	 ₁	 ₂	 ₃	 ₄	 ₅	
	 ₁	 ₂	 ₃	 ₄	 ₅	
	 ₁	 ₂	 ₃	 ₄	 ₅	
	 ₁	 ₂	 ₃	 ₄	 ₅	
	 ₁	 ₂	 ₃	 ₄	 ₅	
	 ₁	 ₂	 ₃	 ₄	 ₅	
	 ₁	 ₂	 ₃	 ₄	 ₅	
	 ₁	 ₂	 ₃	 ₄	 ₅	
	 ₁	 ₂	 ₃	 ₄	 ₅	
	 ₁	 ₂	 ₃	 ₄	 ₅	
	 ₁	 ₂	 ₃	 ₄	 ₅	
	 ₁	 ₂	 ₃	 ₄	 ₅	
	 ₁	 ₂	 ₃	 ₄	 ₅	
	 ₁	 ₂	 ₃	 ₄	 ₅	
	 ₁	 ₂	 ₃	 ₄	 ₅	

Score..... × 2 =

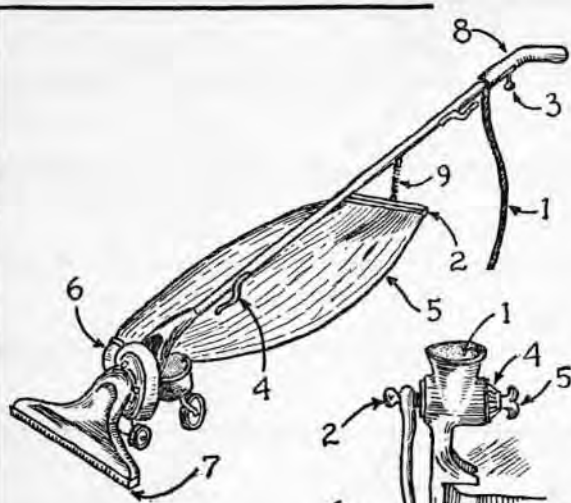

- 1 HOLDS DIRT-----
- 2 HAND GRIP-----
- 3 HOLDS CORD-----
- 4 SUSPENDS BAG-----
- 5 ELECTRIC SWITCH-----
- 6 SUCKS DIRT-----
- 7 EXHAUSTS DIRT-----
- 8 CONDUCTS ELECTRICITY--
- 9 HOLDS BAG SHUT-----

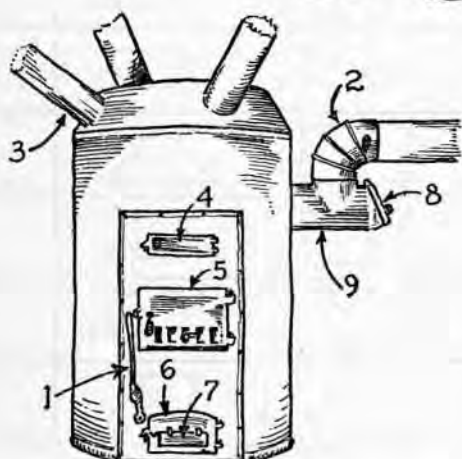

- 10 RECEIVES FOOD-----
- 11 FASTENS GRINDER-----
- 12 HAND GRIP-----
- 13 GRINDS FOOD-----
- 14 FASTENS HANDLE-----
- 15 FASTENS BLADES-----

- 16 FEED DOOR-----
- 17 MOVES GRATES-----
- 18 ASH-PIT DOOR-----
- 19 PROVIDES DRAFT-----
- 20 CONDUCTS HEAT-----
- 21 CHECKS DRAFT-----
- 22 ELBOW-----
- 23 OPENS TO AIR CHAMBER--
- 24 SMOKE VENT-----

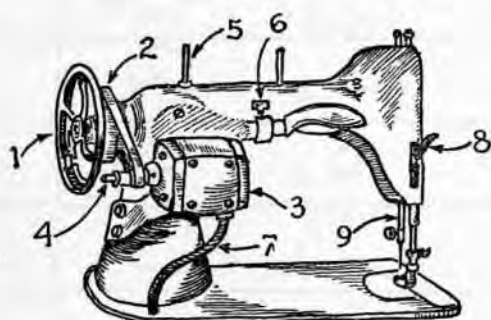

- 25 HOLDS SPOOL-----
- 26 ELECTRIC MOTOR-----
- 27 LIGHT SWITCH-----
- 28 TRANSMITS POWER-----
- 29 HAND CONTROL-----
- 30 CONDUCTS ELECTRICITY---
- 31 FOOT LIFT-----
- 32 MOTOR SHAFT-----
- 33 NEEDLE BAR-----

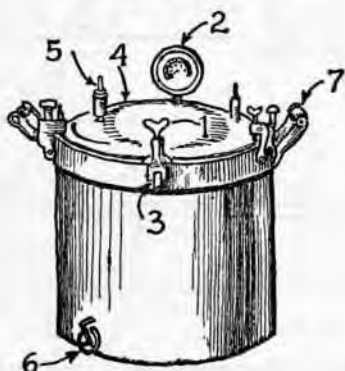

- 34 PRESSURE GAUGE-----
- 35 HAND GRIP-----
- 36 SAFETY VALVE-----
- 37 COVER CLAMP-----
- 38 CLAMP PIVOT-----
- 39 HOLDS COOKER DOWN---
- 40 COVER-----

W-1. TOOLS TEST FOR WOODWORK

PUBLISHED BY

THE MANUAL ARTS PRESS

PEORIA, ILLINOIS

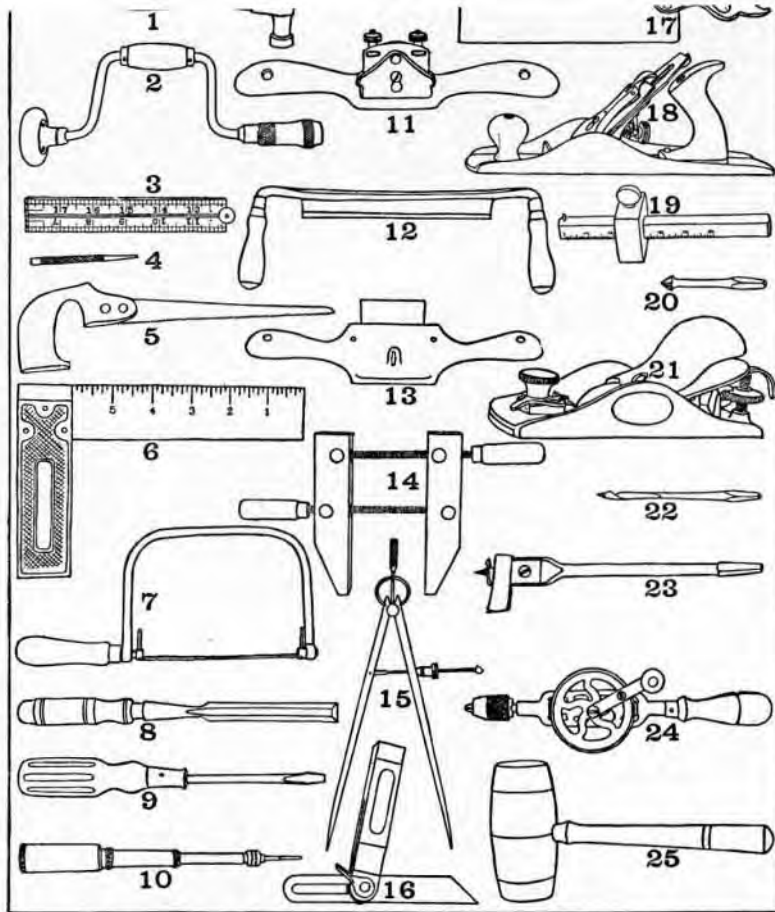

Copyright 1927, William L. Hunter

Directions: Give the names of the tools shown in the illustration. Be as definite as you can. If there is a picture of a saw or plane tell what kind of saw or plane it is. Time—5 minutes.

1	13
2	14
3	15
4	16
5	17
6	18
7	19
8	20
9	21
10	22
11	23
12	24
25

Your Name Age.....

Grade or Classification

School

Number Right

W-6. TRUE-FALSE TEST FOR WOODWORK

PUBLISHED BY

THE MANUAL ARTS PRESS
PEORIA, ILLINOIS

Directions: Underline the parenthesis that you believe makes each of the sentences read correctly. Time—5 minutes.

1. A No. 7 wood-screw is (**larger**) (**smaller**) in diameter than a No. 6 wood-screw.
2. Maple is an example of (**open**) (**close**) grained wood.
3. Summer wood is (**less**) (**more**) porous than spring wood.
4. Quarter-sawed lumber shrinks (**more**) (**less**) in thickness than plain-sawed lumber.
5. Kiln dried lumber ordinarily costs (**more**) (**less**) than air dried lumber.
6. Sap wood is ordinarily (**softer**) (**harder**) than heart wood.
7. Quarter-sawed lumber warps (**more**) (**less**) than plain-sawed lumber.
8. A square is used to test angles of (**45**) (**90**) degrees.
9. Whenever possible wood should be sandpapered (**parallel to**) (**across**) the grain.
10. No. 00 sandpaper is (**coarser**) (**finer**) than No. 2.
11. Hammer handles are ordinarily made of (**hickory**) (**spruce**).
12. To do fine work with a plane the throat opening should be (**narrow**) (**wide**).
13. A wood chisel should be ground at approximately (**20**) (**45**) degrees.

(teeth) (points) per inch.

15. A jack-plane is (**shorter**) (**longer**) than a fore-plane.
16. The height of an ordinary library table is (**30**) (**36**) inches.
17. A suitable wood for mallet heads is (**lignum vitae**) (**yellow pine**).
18. A blade in a coping saw should have the teeth point (**toward**) (**away from**) the handle.
19. To do smooth work with a plane on knotty lumber the shaving breaker should be set (**farther from**) (**closer to**) the cutting edge.
20. When filing a (**rip**) (**crosscut**) saw the file is held perpendicular to the blade of the saw.
21. A countersink is used for (**round**) (**flat**) headed screws.
22. Plain-sawed lumber is ordinarily (**more expensive**) (**cheaper**) than quarter-sawed lumber.
23. Wood ordinarily splits more easily along the (**annual rings**) (**medullary rays**).
24. Picture frames are ordinarily made with (**miter**) (**cross-lap**) joints.
25. A tenon should be gaged from (**one surface and one edge**) (**two surfaces and two edges**).

Your Name..... Age.....

Grade or Classification.....

School

Number Right.....

W-7. COMPLETION TEST FOR WOODWORK

PUBLISHED BY

THE MANUAL ARTS PRESS
PEORIA, ILLINOIS

Directions: Fill in the blanks with necessary words to complete each of the following sentences. Time—5 minutes.

1. The tool used for making conical depressions for the heads of flat-head wood-screws is called a
2. The tool used with a hammer to assist in driving finishing nails below the surface of wood is a
3. Round pieces of wood used to assist in joining boards which are glued edge to edge are
4. A joint is made when two pieces of wood cross at right angles, one-half of each piece being removed.
5. A tool used to turn screws into wood is a
6. A tool used for making lines parallel to a surface or edge is a
7. A joint is made when two pieces are cut at 45 degrees as for a picture frame.
8. A device which holds a saw in position for cutting a board at various angles is a
9. Boards sawed with their larger surfaces in a plane with the center of the tree are boards.
10. The part of a plane moved back and forth to afford different widths of throat opening is called the
11. A saw is used to cut wood across the grain.
12. A piece of wood one inch or less in thickness must have square inches of face-surface area in order to contain one board foot.

13. A tool used for cutting various sizes of round holes from $\frac{1}{8}$ to 3 inches in diameter is called an
14. A tool having a crank and used to hold auger bits when boring holes is called a
15. Dimensions for lumber are given in the following order:,,
16. The first side of a board planed is called the
17. Put on screws to make them go into wood more easily.
18. A is used for laying off angles other than 90 degrees.
19. For accurate work a rule should be held on
20. A recess cut in wood as for a panel to fit in rail of a door is called a
21. A two-handled tool used for curved surfaces and working on the same principle as a plane is called a
22. A small hand tool used for testing to see that edges are at right angles to surfaces is called a
23. A device about 20 inches high for holding lumber while it is sawed by hand is a
24. The size of an auger bit in of an inch may be found on the tang or round.
25. A recess cut in wood as for a pane to fit in a window sash is called a

Your Name Age

Grade or Classification

School

Number Right

--*-- --*-- --*-- --*-- --*-- --*-- --*-- --*-- --*-- --*-- --*--

APPENDIX C

SUGGESTED LIST OF BOOKS FOR THE SHOP LIBRARY

--*-- --*-- --*-- --*-- --*-- --*-- --*-- --*-- --*-- --*-- --*--

GENERAL REFERENCES

- Allen, E., Mechanical Devices in the Home, The Manual Arts Press, Peoria, Ill., 1922,
- Burton: Shop Projects Based Upon Community Problems, Ginn and Company, New York, 1918.
- Bedell: Household Mechanics Job Sheets, The Manual Arts Press, Peoria, Ill., 1923.
- Churchill-Wickenden: The House Owner's Book, Funk and Wagnallis, New York, 1922.
- Collins: The Amateur Mechanic, Appleton and Company, New York, 1922.
- Collins: Home Handy Book, Appleton and Company, New York.
- Fredericks, Mrs. J., The New Housekeeping, Macmillan Company, 1923.
- Keene, Mechanics of the Household, McGraw-Hill Book Company, New York, 1918.
- Koues, H., "How to be Your Own Decorator", Good Housekeeping, New York, 1926.
- Tustison, Job Sheets in Home Mechanics, The Bruce Publishing Company, Milwaukee, Wisconsin, 1923 - 1926,
- Wakeling, A., Fix It Yourself, Popular Science Publishers, New York, 1930.
- Wakeling, A., Home Workshop Manual, Popular Science Publishers, New York, 1929.
- Wood and Smith: The Prevocational and Industrial Arts, Atkinson, Mentzer and Co., Chicago, 1919.

ELECTRICAL

- Burling and Karweik: Elementary Electric Wiring, The Bruce Publishing Company, Milwaukee, Wisconsin, 1922.
- Collins: The Book of Electricity, D. Appleton and Company, New York, 1916.
- Mills: Letters of a Radio Engineer to His Son, Harcourt, Brace and Co., New York, 1922.
- Perry and Buck: Practical Problems in Electrical Construction, The Bruce Publishing Co., Milwaukee, Wis., 1923.

Timbie: Essentials of Electricity, John Wiley and Son, New York, 1925.

Willoughby: Practical Electricity for Beginners, The Manual Arts Press, Peoria, Ill., 1921.

Willoughby: Lesson Sheets Elementary Electricity, The Manual Arts Press, Peoria, Ill., 1923.

METAL

Disston and Sons Co., Henry: Tool and File Book, Philadelphia, Pa.

Simonds Saw and Steel Co.: How To File and Set a Saw, Fitchburg, Mass.

Trew and Bird: Sheet Metal Work, The Manual Arts Press, Peoria, Ill., 1923.

Welch: Elements of Sheet Metal, The Bruce Publishing Company, Milwaukee, Wis., 1923.

DRAWING

Bennett: Grammar School Problems in Mechanical Drawing, The Manual Arts Press, Peoria, Ill., 1920.

Diamond, Thos.: A Primer of Blueprint Reading, The Bruce Publishing Company, Milwaukee, Wis., 1928.

Getty: How to Read a Blueprint, Lippincott Publishing Company, Philadelphia, 1912.

Sturtevant: Mechanical Pictorial Drawing, The Bruce Publishing Company, Milwaukee, Wis.

Wyatt: Blue Print Reading, The Bruce Publishing Company, Milwaukee, Wis., 1920.

WOODWORKING

Allen: Manual Training for the Common Schools, Chas. Scribner's Sons, New York, 1910.

Brown and Tustison: Practical Woodworking Job Sheets, Bruce Publishing Company, Milwaukee, Wis., 1925.

Fairham: Carpentry for Beginners, J. B. Lippincott Company, Philadelphia, Pa., 1922.

Griffith: Essentials of Woodworking, The Manual Arts Press, Peoria, Ill., 1916.

Griffith: Woodworking for Secondary Schools, The Manual Arts Press, Peoria, Ill., 1916.

Noyes: Handwork in Wood, The Manual Arts Press, Peoria, Ill., 1910.

Seldon: Woodworking for the Grades, Maudsley Publishing Company, Cranesville, Pa., 1917.

Dept. of Commerce, You Can Make It, National Common Wood Utilization, U. S. Government, Dept. of Commerce.

FINISHING

Jeffrey: Wood-Finishing, The Manual Arts Press, Peoria, Ill., 1924.

McGeo and Brown: Instruction Units in Wood Finishing, Bruce Publishing Company, Milwaukee, Wis., 1927.

PLUMBING

Dibble: Elements of Plumbing, McGraw-Hill Book Company, New York, 1918.

MAGAZINES

Industrial Arts Magazine, Bruce Publishing Company, Milwaukee, Wisconsin.

Industrial Education Magazine, Manual Arts Press, Peoria, Ill.

Popular Mechanics Magazine, 200 E. Ontario Street, Chicago, Ill.

FICTION

Apple Tree, Bianco, Mrs. M.,

Emerald Story Book, The, Skinner, A. & E.,

Forge in the Forest, Colum, P.,

In Search of Gold, Fordyce, W. D.,

Johnny Appleseed, Atkinson, E.,

Little Fir Tree, Anderson, H.,

Little Match Girl, Anderson, H.,

Little Wooden Doll, Bianco, Mrs. M.,

Mary Frances Housekeeper, The, Fryer, J. E.,

Paul Bunyan and His Great Blue Ox, Wadsworth, W.,

Tin Soldier, The, Anderson H., (In Anderson's Fairy Tales),

Two Kettles, The, Eggleston, E.,

INFORMATIONAL - (Scientific and Semi-Scientific)

A Year in the Wonderland of Trees, Hawksworth, H.,

American Girls Handy Book, The, Beard L.,
(Simple Carpentry, Wood Carving, Stenciling, and Enameling)

Products of the Soil, Richeleau, F.,
(Lumber)

Rainy Day Book for Boys and Girls, Lutkenhaus, A., and Knox, M.,

Something To Do, Foxter, E.,

Something To Make, Wood E.,
(Electricity)

Stories in Trees, Curtis, M. J.,

Thinkers and Doers, Darrow, F. L.,

Three Hundred Things a Bright Girl Can Do., Kelly, L. E.,

"Tribute to the Tin Can" in Great Moments in Science, pp. 42-45.

What a Girl Can Make, Beard, P.,

Wonderland of Plant Life, Fabre, J. H.,

Wood and What We Make of It, Hall, C.,

Woodlands of the Old World, Jordan, D. S., and Gather, K. D.,

Working in Metals, Steffel, C. C.,

BOOKS SUGGESTED FOR THE TEACHER

Bobbitt, How to Make a Curriculum, Houghton-Mifflin Company,
New York, 1924.

Griffith, Teaching Manual of Industrial Arts, Manual Arts
Press, Peoria, Ill.

Payne, Methods of Teaching Industrial Subjects, McGraw-Hill
Publishing Co., New York.

Selvidge, How to Teach a Trade.

Selvidge and Fryklund, Principles of Trade and Industrial Teaching,
Manual Arts Press, Peoria, Ill.

Selvidge, Individual Instruction Sheets, Manual Arts Press,
Peoria, Ill.

Vaughn and Mays, Content and Method of the Industrial Arts,
The Century Co., New York, 1924.

* * * * *

APPENDIX D

A LIST OF FULL FILMS, PAMPHLETS AND BULLETINS

* * * * *

INDUSTRIAL FILMS WHICH MAY BE SECURED FREE OF CHARGE

BY PAYING TRANSPORTATION

Bureau of Mines (Director), 4800 Forbes Street, Pittsburgh, Pa.,

"Mining and Metallurgy", - Steel,
 "Rails, Rods, and Plates",
 "Wire Products".

American Steel and Wire, 208 S. LaSalle Street, Chicago, Illinois.

Bell Telephone Company, - Local Office,

"Learning by Doing",
 "Wires and Wings".

Carborundum Company, Niagara Falls, New York.

Catalogs from Educational Screen, Chicago, Illinois.

Cleveland Twist Drill Company, Cleveland, Ohio.

De Frenes and Company, 60 N. State Street, Wilkes-Barre, Pa.

"The University of the Night",
 "A Trip Through Finland",
 "Cotton - The Making of a Turkish Towel",
 "American Glove Craft",
 "The Reading Full-Fashioned Knitting Machine",
 "Manufacture of Steel Sheets and Tin Plate".

Henry Desstou and Sons Inc., Philadelphia, Pa.

Eastman Kodak Company, Rochester, New York.

"The Farm",
 "Cattle",
 "Anthracite Coal",
 "Bituminous Coal",
 "Coffee",
 "Mining and Smelting of Copper",
 "Corn",
 "Cotton Goods",
 "Cotton Growing",
 "Wisconsin Dairies",
 "From Flax to Linen",
 "Furniture Making",
 "Irrigation",
 "Lead",
 "Leather",
 "Ocean Liners",
 "Lumbering",
 "Market Gardening",
 "Meat Packing",
 "New England Fisheries", I and II,

GRADUATE SCHOOL
 LIBRARY
 MARQUETTE UNIVERSITY

"Producing Crude Oil",
 "The Panama Canal",
 "Peanuts",
 "Pig Iron to Steel",
 "Railroad Safety",
 "Rubber",
 "Safety at Sea",
 "Pacific Coast Salmon",
 "Beet and Cane Sugar",
 "Maple Syrup and Sugar",
 "Tableware",
 "Tin",
 "From Tree to Newspaper",
 "Wheat",
 "Woolen Goods",
 "Bacteria",) Shows something of work of Laboratory Technician,
 "Blood",) Bacteriologist, and Haematologist.
 "Sewage Disposal", Related to work of Sanitary Engineer.
 "Tuberculosis", Work of Physician.

Extension of State Universities,

General Electric Company, Schenectady, New York.

Synchronized with Sound,
 "The Romance of Power",
 "The Conquest of the Cascades",
 "Mountains of Copper",

Silent Films

"The King of the Rails",
 "The Benefactor",
 "The Potter's Wheel",
 "The Island of Sugar",
 "Queen of the Waves",
 "The Land of Cotton",
 "A Woolen Yarn",
 "The Sugar Trail",
 "Conquest of the Forest",
 "Thomas A. Edison",
 "The Molder",

International Harvester Company, 606 S. Michigan Ave., Chicago, Ill.

Northwestern Electric Company, Rochester, New York,

Reading Iron Co., 401 N. Broad Street, Philadelphia, Pa.,

Lincoln Electric Company, 12318 Coit Road, Cleveland, Ohio.

U. S. Steel Corporation, 71 Broadway, New York,

Visugraphic Pictures, 347 Park Ave., New York,

"The Mechanics of the Nation's Market Place",
 "The Broadway Limited",

"The Nation's Market Place",
 "The Earth's Four Corners",
 "Man Made Miracles", - Radio.

Westinghouse Electric Company, E. Pittsburgh, Pa.

PAMPHLETS, MAGAZINES AND BULLETINS

American Sheet and Tin Plate Co., Pittsburgh, Pa.,

"Bright Tin Plates", - Booklet,
 "Evolution of a Tin Can", - Booklet,

American Trees Association, Washington, D. C.,

"Forestry Primer",

Art Color Publishing Company, Dunellen, New Jersey,

"Home Craftsmen", - A Bi-monthly, 10¢ per copy.

Cement Products Co.,

"Cement Products",

Creo Department Company, N. Tonawanda, New York.

"Shingles treated with Creosote", - Pamphlet.

Disston Company,

"Why the Saw Cuts",

Electrical Supply, Catalogues,

Gross Hardware Company,

Hardware Catalogues,

Metal Crafts Supply Company, Providence, Rhode Island,

"The Metal Crafts", - A quarterly magazine, 50¢ per copy.

National Lumberman's Association, New York,

"Wood",

Plumbers' Catalogues,

Sears, Roebuck Company,

"How to Paint", - Advertising Booklet,

U. S. Department of Agriculture,

Bulletins #609, 630, 1456, 744, 927, 1180, 1219, 1227.

* * * * *

* *

BIBLIOGRAPHY

* *

* * * * *

I. Books

Allen, C. R., Instructor the Man and the Job, Philadelphia, Pa., J. B. Lippincott Co., 1919, 373 pp.

A handbook for instructors of industrial and vocational subjects. It stresses the importance of teacher attitudes and personal relationships.

Allen, E. G., Manual Training for the Common Schools, New York, C. Scribners' Sons, 1910, 217 pp.

An organized course in woodworking applied to the eight elementary grades.

Allen, E. R., Mechanical Devices in the Home, Peoria, Ill., Manual Arts Press, 1922, 251 pp.

Tells of the proper use and care of some of the household equipment of twelve years ago. Included are such things as wood and coal stoves, kerosene lamps, fireless cookers, lamp mantels, electric flat irons, threading and oiling the sewing machine, faucets, etc.

On the whole, the directions are not detailed enough and in many cases, knowledges and skills are assumed unwarrantedly.

Bedell, Earl, Job Sheets in Household Mechanics, Peoria, Ill., Manual Arts Press, 1929.

A set of fifty sheets each of which gives detailed instructions for the performance of such home jobs as repairing a faucet, making a window box, or putting a two-way switch on an electric appliance. Very use-ful to the general or home mechanics shop.

Bennett, Charles A., History of Manual and Industrial Education, up to 1870, Peoria, Ill., Manual Arts Press, 1926, 461 pp.

Gives the background of industrial arts, avoiding criticism or comment. Much source material is supplied, or translations of such material. Photos, plates, and diagrams are used freely to supplement the text.

One of the most complete and valuable books on the history of industrial education.

Bennett, Charles A., The Manual Arts, Peoria, Ill., Manual Arts Press, 1917, 116 pp.

Tells how to select and organize teaching material in manual arts, and discusses three methods of teaching - imitative, discovery, and inventive. Locates manual arts in the general scheme of education.

Bobbitt, Franklin R., How to Make a Curriculum, New York, Houghton Mifflin Co., 1924.

Bobbitt is one of the pioneers in scientific curriculum construction. He believes that major and minor objectives should be laid down and then analyzed as to the activities which will be most helpful in accomplishing these objectives.

This book should be read by every teacher and curriculum builder.

Bobbitt, Franklin R., "Report on Organization of the Industrial Arts Curriculum", in Second Yearbook, Dept. of Superintendence, Washington, D. C., National Education Association, 1924, 277 pp.

Advises a survey of jobs done in the community as a basis for industrial arts projects for the junior high school.

Bonser, F. G., Sykes, F. H., and Brandon, H. C., Industrial Education, New York, Teachers' College, Columbia University, 1911, 61 pp.

Outlines the differences between industrial arts and industrial education training. Modified within a public school program to meet industrial needs. Gives cost of industrial education in the United States. Study of 50 typical cities.

Bonser, Fred G., and Mossman, Louis C., Industrial Arts for Elementary Schools, New York, Macmillan Co., 1923, 491 pp.

A very fine and helpful volume written to the teacher. Organization of material, questions, reference readings, are treated.

Bowman, Claude A., Graphic Aids in Occupational Analysis, Milwaukee, Wis., Bruce Publishing Co., 1924, 103 pp.

An analysis of common industrial occupations for purposes of guidance and teaching. Contains graphic charts and diagrams. Gives routes of advancement in schools and occupations.

Bowman, Claude A., The Lesson Plan, Job Sheet, and Graphic Aids, Milwaukee, Wis., Bruce Publishing Co., 1923, 26 pp.

Describes the making of job sheets in conformity with the five-fold Harvey Lesson Plan. Tells the type of illustration or drawing to be used. This is one of the pioneer brochures on job-sheet construction, but which is now rather out-moded.

Briggs, Thos H., The Junior High School, New York, Houghton Mifflin Co., 1920, 327 pp.

Chapter 6 of this work gives the curricula for 7th, 8th, and 9th grades of 75 junior high schools, and includes the kinds of industrial work offered for boys in 173 junior high schools. This report includes the length of period and average size of class. A classic with respect to junior high school standards.

Broome, Edwin C., and Others, The Junior High School Curriculum, Department of Superintendence, Fifth Yearbook, Washington, D. C., National Education Association, 1927, 562 pp.

The results of the work of committees working in 300 school systems on a revision of the junior high school curriculum. Suggestive maximum and minimum courses are given in many subjects. Advantages and disadvantages of severing it from college entrance requirements, are discussed.

Brown, Arthur and Tustison, F. E., Practical Woodworking Sheets, Milwaukee, Bruce Publishing Co., 1925.

A set of 50 loose sheets each of which contains full directions for one fairly simple job. These directions are grouped under the headings: job specification, materials, tools, procedure questions, references and pupil's record. Many of these sheets may be used in a girls' course of home mechanics.

Brown, Arthur and Tustison, F. E., Instructional Units in Hand Woodwork, Milwaukee, Bruce Publishing Co., 1930, 222pp.

This is a set "of operation sheets on hand-woodwork in bound form." It is a most complete and helpful work for the teacher of home-mechanics as the directions are short and well worded, and each sheet is illustrated with several photographs showing various steps in the operation.

Butler, Nicholas M., Mearing of Education: Training for Vocation and for Avocation, New York, Charles Scribners' Sons, 1915.

Presents principles for a philosophy of education and then shows how this philosophy may be applied to situations in the life of the individual. Gives five characteristics of an educated man.

Burnham, W. H., The Wholesome Personality, New York, D. Appleton Co., 1932, 387 pp.

A wholesome personality is an integrated personality, one which works in harmony of all its parts. Fatigue, disease, haste and fear are all disintegrating influences. The problem of healthful mental attitudes is bound with the social group. An interesting job is one of the best means for maintaining mental health.

Challman, Samuel A., Rooms and Equipment for Industrial Arts Milwaukee, Bruce Publishing Co., 1922, 48 pp.

Shows floor plans and gives short descriptions of 23 industrial arts shops in various parts of the United States. Interesting in that it depicts the beginnings of the general shop.

Chapman, J. Crosby, Trade Tests, New York, Henry Holt & Co., 1921, 435 pp.

An outgrowth and summary of the methods and some of the materials used by the committee on classification of personnel during the World War. Suggestive to the maker of tests in home mechanics because it contains many sample tests, oral, performance, picture and written.

Charters, W. W., Curriculum Construction, New York, Macmillan Co., 1923, 306 pp.

Method of making a curriculum on the basis of selected objectives and research as to the social need for material to be included. Reviews several investigations made for the bases of curricula. Of particular interest is the investigation of "Home Jobs" .

Charters, W. W., Methods of Teaching, Row Peterson Company,
Chicago, 1912.

Based on the theory that subject matter has been created to "satisfy needs and solve problems". Some time these needs and conditions must be aroused. Methods for doing this are discussed.

Churchill, A. L., Wickenden, L., The House-Owner's Book, New York, Funk & Wagnalls, 1923, 388 pp.

"Written for the house-owner who, from necessity or choice, prefers to run his own house, to tinker about, to make minor repairs; in short to be a real house-owner."

Written more for the man of the house than for the woman.

Cleveland Public Schools, Course of Study in 7B Grade Simple Mechanics, Cleveland, Ohio, Board of School Directors, 1924,
16 pp.

Contains Organization of work, Suggested Shop outlines and one sample lesson plan with instruction sheet for each type of work.

Suggestive but lacks completeness and exactness.

Collin, A. F., Book of Electricity, New York, Thomas J. Crowell Co., 1924, 373 pp.

For amateur electrician. Gives directions in simple form for the man, boy or girl who wants to make or do things.

Collins, Frederick A., The Home Handy Book, New York, D. Appleton Co., 1920, 164 pp.

A very interesting and readable text written primarily from the point of view of the economical householder. The language is simple and the drawings explanatory so that it can be used equally well by pupil, teacher or home-maker.

Commissioner of Labor of United States, Industrial Education,
Eighth Annual Report, Washington, D. C., Gov't. Printing Office,
1893, 71 pp.

Discusses Sloyd and other educational activities of that day.

Cook, A., The Sewing Machine, New York, Singer Sewing Machine Co., 1920, 37 pp.

A handbook for the use of the machine. It gives diagrammed directions for its use, care and repair.

Davenport, E., Education for Efficiency, Boston, D. C. Heath & Co., 1909, 27 pp.

A speech given at the University of Tennessee. It discusses the problem of education for all, academic ideals and academic methods.

Detroit, City of, Course of Study in Household Mechanics, Detroit, Board of Education.

A scientifically worked out course of study for 7B boys. Gives projects, necessary shop equipment and essential processes. One of the best of its kind.

Diamond, Thos., A Primer of Blueprint Reading, Milwaukee, Bruce Publishing Co., 1927, 70 pp.

Contains many diagrams which simplify the translating of blueprints to the novice. Suggestions for teaching mechanical drawing.

Dopp, Katherine A., Place of Industries in Elementary Education, Chicago, University of Chicago Press, 1905, 208 pp. Ph.D. Thesis.

One of the pioneer volumes on industrial education. Miss Dopp weaves together a history of various types of industrial work with plans for its application in the school as it applies at the various stages of the child's development.

Douglas, Paul H., American Apprenticeship and Industrial Education, New York, Columbia University, 1921, 348 pp.

Treats the subjects of apprenticeship work of juveniles; suggestions for an education program. Chapter six, "Vocational Education for Women", contains some particularly good suggestions for teachers of girls.

Edgerton, A. H., Industrial Arts and Prevocational Education in Intermediate and Junior High Schools, Milwaukee, Bruce Publishing Co., 1922, 104 pp.

A study of the many types of industrial arts being given throughout the United States. Three hundred seventy-nine schools contributed. These studies are given to show the need for "scientifically determining how to modify our present methods in order to have 7th, 8th, and 9th year boys learn most effectively and economically."

Edgerton, A. H., Vocational Guidance and Education for the Industries (in 23 Yearbook, National Society for Study of Education, Part Two), p. 203. Bloomington, Ill., Public School Publishing Co., 1924, 435 pp.

Treats industrial arts as both a means to a livelihood and a training for leisure activities.

Eliot, C. W., Tendency to the Concrete and Practical in Modern Education, Boston, Houghton Mifflin Co., 1913, 57 pp.

A plea for the new curriculum which will fit pupils better for their various vocations by combining practical work with constructive imagination.

Filby, E. T., The Junior High School, Chicago, Board of Education Offices, 1923, 65 pp.

Written at a time when the Junior High School was entering the educational field, this book gives some very excellent suggestions many of which have since been incorporated in the junior high school program.

The sections on Vocational Guidance and Industrial Arts training are particularly valuable.

Friese, John F., Exploring the Manual Arts, New York, Century Co., 1926, 411 pp.

This work takes up industrial arts at the junior high school level as a subject of cultural general education. It stresses non-manipulative and partially manipulative aims. It contains a large section of sample lessons of material correlated with industrial arts.

Getty, Vincent C., How to Read a Blueprint, Philadelphia, Lippincott Co., 1912, 64 pp.

Gives explicit directions with illustrations of the method of interpreting blue prints and other working drawings clear and concise.

Glass, J. M., Curriculum Practices in the Junior High School and Grades 5 and 6, Monograph #25, Chicago, Ill., University of Chicago Press, 1924, pp. 181.

One of the most frequently quoted of recent monographs. It details the curriculum practices in fourteen city high schools, covering thirteen subject fields. These are analyzed into teaching units and tables of comparison given. Recommendations are made as to scientific methods of revision.

Griffith, Ira S., Essentials of Wood Working, Peoria, Ill., Manual Arts Press, 1922, 219 pp.

Written as a text for the teacher of manual arts, and based on the principle of "social usefulness". Illustrated.

Griffith, Ira S., Teaching Manual and Industrial Arts, Peoria, Ill., Manual Arts Press, 1924, pp. 259.

A text written primarily for use in normal schools and colleges. It states "what we teach is determined by social and economic conditions". The major part of the text is devoted to chapters applying educational psychology to industrial arts teaching. Topics for class discussion are at the end of every chapter.

Hall, G. Stanley, Adolescence, New York, D. Appleton Co., 1904, 2 vols., Vol. 1, 321 pp.

Its psychology and relationship to physiology and sociology. Its attitudes toward sex, crime and religion. For many years the authority on all problems of adolescent behavior and development.

Ham, C. H., Manual Training, New York, Harper Brothers, 1886, 464 pp.

Manual training is given as the solution of social and industrial problems.

Hanus, P. H., Beginnings of Industrial Education, New York, Houghton Mifflin Co., 1908, 199 pp.

What type of industrial education is most needed? Discusses industrial education in Massachusetts and compares it to that of Germany and Austria.

Hough, R. B., Handbook of Trees, Lowville, New York, 1907, 470 pp.

Description and photographs of the common trees of the northern states and Canada, east of the Rockies. Very complete and detailed.

Ithica Public Schools, Course of Study in Manual Arts, Ithica, New York, Ithican Public Schools, 1926, 42 pp.

Based on the seven aims of education which are to be realized through activities carried on in the shops and unspecialized activities carried on in the homes. Suggested field trips and lists of "What pupil should know and be able to do".

Jeffrey, Harry R., Wood Finishing, Peoria, Ill., Manual Arts Press, 1924, 177 pp.

An excellent treatise on the most suitable finishes for the different varieties of woods and the proper methods of finishing suitably for various purposes. Has an excellent section on refinishing old woods.

Keene, Edward S., Mechanics of the Home, New York, McGraw-Hill Book Co., 1918, 391 pp.

A book devoted to domestic machinery and household mechanical devices with directions for their most economical use and care. Contains many illustrations and helpful diagrams.

Kent, E. B., Constructive Interests of Children, New York, Bureau of Publications, Teachers' College, 1903, 78 pp.

"This is probably the first attempt to obtain a really scientific basis for selecting constructive work for the elementary school. The purpose of the study was to find the natural constructive interests of children by finding what kinds of constructive projects they made voluntarily, outside of school."

Kidder, F. E., and Nolan, Thos., Architects and Builders Pocket-Book, New York, Wiley Co., 1921, 1907 pp.

A complete indexed reference book giving designs, blueprints, definitions, and illustrations of terms used in the various phases of the building trade.

Kitson, H., Trade Job Analysis as an Aid in Vocational Curriculum Building, in National Society for the Study of Education, 23rd Yearbook, Part II, p. 237. Bloomington, Ill, Public School Publishing Co., 1924, 362 pp.

Shows the advantages of analyzing each trade into its jobs and each job into its particular skills.

Lasson, Gustaf, Elementary Sloyd and Whittling, New York, Silver, Burdett Co., 1906, 94 pp.

One of the many volumes which emerged with the rise of Sloyd teaching. Gives pictures and descriptions of all necessary equipment and directions, with drawings for 26 articles of wood. Has a very good chapter on wood and timber.

Leavitt, Frank M., Examples of Industrial Education, New York, Ginn & Co., 1912, 330 pp.

Gives the status of Industrial and Vocational Training before the World War. Gives examples of training taking place in schools and classes in various parts of the country in an effort "to convince the public that educators are dominated by a desire to advance, in every way possible, the social and moral welfare of every child committed to their care." Most interesting is the chapter on "Prevocational Work" with illustrations of how such work is administered in some of the large cities.

Leavitt, F. M., Brown, E., Prevocational Education in the Public Schools, New York, Houghton Mifflin, 1915, 245 pp.

An effort to throw some light on a form of education for those out of step with the aims and methods of so-called "general education". It is written with work and education of boys principally in mind.

Locke, John, Some Thoughts Concerning Education in the Educational Writings of John Locke, London, E. Arnold, 1912, 272 pp.

The substance of a letter sent to Edward Clarke in which he discusses his ideas on health, punishment, work, recreation and all the phases of a child's life. He was one of the first to advocate that a child's training should begin with infancy.

MacArthur, A., Education in Its Relation to Manual Industry, D. Appleton Co., New York, 1884, 393 pp.

Interesting only as one of the first efforts to combine liberal and manual education. The sphere of woman's education and work is discussed with the attitude that "we ought to be sufficiently liberal and enlightened to see that girls have a liberal education as well as general industrial training."

Mays, A. B., Determining Factors in the Evolution of Industrial Arts in America, Milwaukee, Bruce Publishing Co., 1922, 32 pp.

A brochure giving an overview of the various types of industrial education and their rise and fall in America beginning about 1840.

Mays, A. B., The Problem of Industrial Education, New York, Century Co., 1927, 416 pp.

Industrial education is treated from two suggested angles, that of technical education, and apprenticeship.

McGee, R. A., and Brown, Arthur G., Instructional Units in Wood Finishing, Milwaukee, Bruce Publishing Co., 1927, 128 pp.

Unit lessons in bound form on the various methods of preparing and finishing woods of different kinds for particular uses.

McMurry, O. L., Eggers, G. W., and McMurry, C. A., Teaching of Industrial Arts, New York, Macmillan Co., 1923, 357 pp.

A course of elementary schools in which design and construction are correlated. The psychology of these two phases is discussed quite

fully. The latter half of the volume is occupied with definite courses in woodwork and bookmaking. Plates showing how designs are developed are helpful.

Milwaukee Public Schools, Industrial Arts Dept., Course of Study in Metalworking, Grades 7A and 8B, Milwaukee, Board of Education, 1932, 25 pp.

A set of twenty-five unit instruction sheets in simple metalwork such as cookie cutters, candle-holders, etc.

Minnesota Mechanical Ability Tests, Dept. of Psychology, University of Minnesota, Minneapolis, Minn., 1930, 586 pp.

An extremely technical report of "a research investigation subsidized by the committee on Human Migration of the National Research Council". It is an effort to analyze the trait known as mechanical ability into its constituent processes. This study is chiefly interesting as related to a curriculum in home mechanics for girls because of the chapter on "Distribution of Mechanical Ability". In this chapter the so-called native mechanical ability of boys and men is compared with that of girls and women.

Monroe, Paul A., Textbook on History of Education, New York, Macmillan Co., 1905, 772 pp.

One of the most complete and authentic histories of the educational movement in existence. It is written as a textbook and as such contains detailed supplementary references and topical questions at the end of each chapter.

National Society for the Study of Education, Eleventh Yearbook, Part I, "Industrial Education", Bloomington, Ill., Public School Publishing Co., 1912, 124 pp.

Gives some experiments along the lines of industrial training in several large cities of the United States, comparing methods and curriculum content.

National Society for the Study of Education, Twenty-sixty Yearbook, Part II, "Foundations of Curriculum Making, Bloomington, Ill.,

Public School Publishing Co., 1926, 238 pp.

Lays down principles for making a curriculum according to the plans of the leaders in that field. Familiarity with its contents is essential to anyone attempting to build a curriculum in any subject.

Newkirk, L. V., Validating and Testing Home Mechanics Content, Studies in Education, #4, Iowa City, Iowa, University of Iowa, 1931, 39 pp.

Report of a survey as foundation for a test. Selection of material on basis of (1) use in 75 school systems, and (2) social utility. Analysis of the instructional efficiency through test results - conclusions.

Newkirk, Louis, and Stoddard, G. D., The General Shop, Peoria, Ill., Manual Arts Press, 1929, 190 pp.

The general shop is a place for try-out work along industrial lines. This book gives a complete picture of such a shop, its course of study, type of teacher, methods for teaching, records, and sample lessons. A most helpful text.

Norsworthy, H., Strayer, G., How to Teach, New York, Macmillan Co., 1917, 297 pp.

Treats of such subjects as the formation of habit, stimulating thinking, development of moral conduct, use of child's imagination, and many other phases of development.

An effort has been made to show the interdependence of the various aspects of mental development and teaching method.

North Carolina, College of, Historical Society Records of the Moravians in North Carolina, Raleigh, N. C., 1923, 65 pp.

Of especial interest to the student of industrial arts is this book because of its interesting description of the manner in which these pioneers introduced industrial arts as part of their educational scheme.

Noyes, Wm., Handwork in Wood, Peoria, Ill., Manual Arts Press, 1913, 159 pp.

A manual for design and construction in wood. It contains many diagrams and has a

bibliography on wood design. Useful to Junior of Senior High School students.

Payne, A. F., Administration of Vocational Education, New York, McGraw-Hill Book Co., 1924, 354 pp.

Similar to all of Payne's writings, this book is carefully organized. It explains all branches of vocational education, especially those which come under the Smith-Hughes Law. One chapter is devoted to Vocational Guidance.

Payne, A. F., Methods of Teaching Industrial Subjects, New York, McGraw-Hill Book Co., 1926, 293 pp.

This book is designed mainly for the mature tradesman who is entering the teaching profession but will be found equally helpful to the experienced teacher. It deals with the history, philosophy and psychology of teaching, industrial arts.

The copious footnotes and lists of references for the various topics are especially helpful.

Rasche, Wm. F., Shop Objectives and Physical Equipment for Home Mechanics Classes, Milwaukee, Bruce Publishing Co., 1927, 39 pp.

Gives the plan and equipment for a course in home mechanics to be taught to boys in a vocational school. Lists twenty jobs to be taught. It contains many good illustrations and a very excellent outline of home mechanics in its early stages.

Reed, Amy Y., Junior Wage Earners, New York, Macmillan Co., 1920, 171 pp.

Prepared especially for public school teachers and counselors of juniors. It gives and discusses some very interesting statistics on school leaving, types of junior occupations, and age-grade norms.

Richey, H. G., Woodwork, New York, Wiley Co., 1906, 226 pp.

This book is a ready reference for carpenters and woodworkers. Many tables are given.

Roberts, Wm. E., Manual Arts in the Junior High School,

Dept. of Interior, Bureau of Education Bulletin #11, Washington,

D. C., Government Printing Office, 1924, 89 pp.

A most practical and helpful discussion of manual arts for junior high school pupils. It deals with the aims, methods, subject matter and organization. Gives outlines of typical cities, sample lesson plans and suggests methods of correlating with other subjects.

Rodgers, R. H., Industrial Instruction in the Vocational School,

in National Society for the Study of Education, Twenty-third

Yearbook, Part Two, p. 27. Bloomington, Ill., Public School Publishing Co., 1924, 362 pp.

Gives outlines of courses, methods of administering and uses and purposes of instruction sheets.

Row, R. K., Educational Meaning of Manual Arts and Industries,

Row, Peterson Co., Chicago, 1909, 248 pp.

Deals with manual and industrial arts from the rather unusual point of view of its aesthetic value, physical and physiological benefits, and intellectual rewards. Contains some courses of study from the first through the eighth grade.

Ruch, G. M., and Stoddard, Geo. E., Tests and Measurements in

High School Instruction, Yonkers-on-Hudson, World Book Co.,

1923, 365 pp.

Tests of various types and their values. Chapters II and III give one of the best of modern discussions on the purposes of testing.

Sabin, Alvah H., House Painting, New York, Wiley Co., 1908, 143 pp.

Contains instructions for the householder on painting, glazing, paper hanging, and white-washing.

Salomon, Otto, The Theory of Educational Sloyd, New York, Silver,

Burdett Co., 1900, 150 pp.

Interesting only as a retrospect to one of the important steps in the growth and development of industrial arts.

Salomon, Otto, Handbook of Sloyd, London, George Philip Sons, 1891, 216 pp.

Written originally for Swedish people, this book was translated into English when the wave of interest in this type of work arose. The statement that "Sloyd and gymnasia should go hand in hand" reveals the faith in the physical benefits of this type of work. A list of educational values (real and imagined) is appended to each lesson.

Schuhler, A. A., Electric Wiring, New York, McGraw-Hill Book Co., 1924, 361 pp.

A book written for vocational and trade schools. Replete with explanatory diagrams and illustrations. A good guide for the student.

Schweichard, Dean M., Industrial Arts in Education, Peoria, Ill., Manual Arts Press, 1929, 367 pp.

Discusses the place of industrial arts in the scheme of general education. Contains an interesting discussion of five kinds of manipulative ability vs. a single ability. The appendix contains a detailed outline of a course in Industrial Arts from the first grade through the seventh.

Selvidge, R. W., and Fryklund, Verne C., Principles of Trade and Industrial Teaching, Peoria, Ill., Manual Arts Press, 1930, 419 pp.

Here we find a "sound method of selection and organization of subject matter and practical methods for individual instruction." The teaching methods are based on fundamental psychological principles. The two chapters on "Analyzing our Task" and "Arranging our Material" are particularly interesting and helpful to one attempting to construct a curriculum in industrial arts.

Selvidge, R. W., How to Teach a Trade, Peoria, Ill., Manual Arts Press, 1933, 111 pp.

A small book which puts the technic of trade analysis in plain language. It analyzes the trade to secure a list of the things one must know and the things one must be able to do. These are the units of instruction.

Selvidge, R. W., Individual Instruction Sheets, Peoria, Ill.,
Manual Arts Press, 1926, 267 pp.

Here Selvidge defines and describes each of the four types of instruction sheets in very clear language. He differentiates between job analysis for production purposes, and that for instructional purposes.

Sample instruction sheets occupy about half the volume. These are given as illustration of the good and the poor in the classes of job, operation information and assignment sheets.

Snedden, David, The Problem of Vocational Education, New York,
Houghton Mifflin Co., 1910, 85 pp.

In this small volume Snedden seeks to show that while "our schools have always been dominantly cultural in their aims, the new vocational training must be practical. It must be variable, and specialized." And for this newer education we need a broad, social point of view. He gives suggestive plans for clarification of the old and induction of the new.

Society for Promoting Manual Labor in Literary Institutions,
New York, State Legislature, Committee Report, 1931, 31 pp.

One of the pioneer reports published. This was a survey of the educational facilities of New York State.

Strayer, Geo. D., and Englehardt, H. L., The Classroom Teacher,
New York, American Book Co., 1920, 400 pp.

Deals with methods and techniques of teaching, class discipline, relations to the administration, etc. A valuable handbook for every teacher.

Strong, E. K., and Uhrbrook, R. S., Job Analysis and the Curriculum, Williams and Wilkins, Baltimore, 1923.

Applies the principle of job analysis to the selection of suitable materials to be included in the courses of study of public schools.

Sturtevant, W. W., Mechanical Pictorial Drawing, Milwaukee,
Bruce Publishing Co., 1928, 128 pp.

A group of problems in mechanical drawing selected from practical shop projects.

GRADUATE SCHOOL
LIBRARY
MARQUETTE UNIVERSITY

Thatcher, Edward, Tin Can Toys, Philadelphia, Lippincott Co.,
1919, 214 pp.

How to construct toys and useful articles from the discarded tin containers of the home. Drawings and photographs illustrate these articles. Interesting to adults as well as industrial arts students.

Vankleeck, Mary, Working Girls in Evening Schools, New York, Survey Associates, 1914, 252 pp.

"It is not an intensive investigation of girls in any one occupation, but an extensive view of the workers in many fields of employment represented among the women who attend evening school. As a study of wage earning women who are seeking to supplement an inadequate education, the facts secured relate especially to the problems of industrial training."

Vaughn, S.J., and Mays, A.B., Content and Methods of Industrial Arts, New York, Century Co., 1924, 397 pp.

An excellent work dealing with all phases of industrial arts teaching. Invaluable to the teacher of this subject.

Vitz, Hugo J., Problems in Elementary Woodwork, Dallas, Texas, Southern Publishing Co., 1920, 126 pp.

Graded for instruction in group. Useful to teacher of woodworking. Well illustrated.

Wakeling, Arthur, Home Workshop Manual, New York, Popular Science Publishing Co. Inc., 1930, 502 pp.

A fine guide to the use of leisure by the handy-man. It contains instructions for the construction of articles of furniture, radio-sets, airplane models, sporting equipment, use and care of tools, art metal work, and decoration. Has some useful material for reference for the home mechanics students but the projects in general are too advanced.

Wakeling, Arthur, Fix It Yourself, New York, Popular Science Publishing Co. Inc., 1929, 256 pp.

A very practical work written with the idea of making home repairs easy for the average man. It

contains well indexed and illustrated articles on such subjects as woodworking, painting, plumbing, electrical appliances, concrete and metal work.

White House Conference, Report of 1930, New York, Century Co., 1930, 365 pp.

Committee reports by leaders in the various fields of child-care and welfare. Topics reported upon are: Medical service and its branches, education and training, vocational guidance, the handicapped, public health service, and administration. Recommendations are made for bettering each type of work.

Willoughby, George A., Practical Electricity for Beginners, Peoria, Ill., Manual Arts Press, 1932, 104 pp.

Written by a teacher, the language is within the scope of the average junior high school student. It deals with the various branches of electricity, and its application and control, contains experiments and directions for construction of appliances. There is also a chapter on the "Dangers of Electricity - How to Avoid Them."

Winslow, Leon Loyal, Elementary Industrial Arts, New York, Macmillan Co., 1922, 355 pp.

Course for lower grades. A text for the teacher. Suggested readings at end of each chapter.

Wood, Harry E., and Smith, James H., Prevocational and Industrial Arts, Chicago, Ill., Metzger, Bush & Co., 1919, 266 pp.

Although not one of the latest, this is one of the most helpful texts on industrial arts which I have seen. The material is concise and well organized, and each description is accompanied by a detailed illustration. An excellent reference book for both pupils and instructors, being particularly fine in the material on sources and ingredients.

Woodward, Calvin M., Manual Training in Education, New York, Chas. Scribners' Sons, 1890, 310 pp.

Even at that early day writers were finding fault with the school curriculum and the opening of this volume discusses these faults. This is followed by some suggestions of remedies, the principal one being hand-training in wood and metals combined

with academic instruction as carried on by Mr. Woodward at that time in the Manual Training School of St. Louis.

Wyatt, E. M., Blueprint Reading, Milwaukee, Bruce Publishing Co., 1920, 86 pp.

Gives the fundamental facts of the blueprint and some means of interpreting drawings. Deals with both machine and architectural drawings. Questions at the end of each chapter.

II. Periodicals

Bedell, Earl, "General Shop Idea", Industrial Arts and Vocational Education Magazine, July, 1932,

Describes what is meant by a general shop and gives floor plans of two different types of shop. Contains suggested lists of projects for the general shop curriculum.

Coats, Chas., "Pioneer Manual Labor Schools", Industrial Arts Magazine, September, 1924.

Gives the early history of industrial arts and describes some of the earliest types which were practiced in these schools in the middle of the seventeenth century.

Dunbar, W. W., "Household Mechanics as a Continuation School Activity", Industrial Education Magazine, Vol. 31, pp. 422-23, May, 1930.

A discussion of appropriate industrial arts material for use in continuation school curriculum. Shows how household mechanics fulfills all requirements and at less cost than any other type.

Letter - R. H. Rodgers to C. A. Bennett, Industrial Education Magazine, March, 1927.

Contains a short outline of the history of home mechanics.

Newkirk, L. V., and Stoddard, G. D., "Teaching Content and Objective Testing in Home Mechanics," Industrial Arts Magazine, Vol. 17, February, 1928, pp. 47 - 50.

Report of study made at University of Iowa of material contained in courses of 75 cities and the

use of this material as the basis for a home mechanics test.

Payne, A. F., "Problem of the Try-Out Courses", Industrial Arts Magazine, Volume 14, pp. 166 - 170, May, 1925.

How many activities should be given in one school - is the general shop or the special shop best, and many problems of a similar nature are discussed.

Reese, Madge J., "Farm Home Conveniences", U. S. Dept. of Agriculture, Farm Bulletin #927, Washington, D.C., Government Printing Office, 1918, 32 pp.

Gives pictures and drawings of many articles for use about the farm home, both within and without. Dimensions are given, but it is presumed that the construction is within the skill of the ordinary farmer.

Scott, W. A., "Course of Study in Farm Mechanics", Industrial Arts and Vocational Education Magazine, Volume 21.

Report of a thesis based on a survey of work of a mechanical nature which is done by the various members of the farm family. Jobs tabulated as to those done by mother, father, son, and daughter. The findings are interesting.

Spencer, H. L., "Some Present Tendencies in Industrial Try-out Courses in Junior High School", Industrial Education Magazine, Volume 30, pp. 50-51, August, 1928.

Principally the tendency to a more scientific method.

"Standards of Attainment in Industrial Arts", Report of American Vocational Association, 1929, Industrial Education Magazine, Vol. 31, p. 263, January, 1930.

Report of questionnaire sent to 40 cities as to the type of jobs taught. These are arranged in six tables. Each table has a test of related knowledges. Also gives a frequency report on each job.

U. S. Dept. of Agriculture, "Farm Carpenter", Bulletin #52,
Washington, D. C., Government Printing Office, 1905, 23 pp.

Gives some projects to be made in wood by
the handy-man on the farm.