



BY **LOKAR** INC.

## LS Valve Covers

- Machined from billet aluminum
- Features a removable panel that can be painted and customized to your specific design
- Includes “carbon fiber look” inserts
- Uses OEM O-ring gaskets
- Threaded oil cap included
- Available in raw and polished finish
- Breather configuration is user supplied



FINISH	PART NUMBER
Machined	LSV-01
Polished	LSV-01-P

## LS Coil Relocation Kit

- Relocation brackets allow you to remotely mount your coil packs virtually anywhere
- Machined from billet aluminum
- Black anodized
- Designed to work with LS-2,3,7, and 9
- Kit includes 4 brackets and all mounting hardware, including spacers (required when using Delphi coils)
- Will not work with truck or LS-1 coils



FINISH	PART NUMBER
Black Anodized	CRK-LS

## LS Coil Covers

- Elegantly hides LS coil packs
- Machined aluminum
- Black powder coated or mill finish with machined highlights
- Fits GM LS engines utilizing existing coil bracket mounting points
- Designed to fit LS crate motors and will not clear factory high mount alternators (such as those found on Corvettes) unless a cutout is fabricated or aftermarket alternator and brackets are used
- Best suited for aftermarket serpentine pulley systems
- Can also be used with relocated coil packs for lower profile appearance
- Dimensions: 19.5" X 5"



FINISH	OIL FILL CUTOUT	PART NUMBER
Black	Passenger Side	LSC-01-B
Black	None	LSC-02-B
Mill Finish	Passenger Side	LSC-01-M
Mill Finish	None	LSC-02-M
Polished	Passenger Side	LSC-01-P
Polished	None	LSC-02-P



## Gated Automatic Transmission Shifter

The Clayton Machine Works Gated Automatic Transmission Shifter is available only in a floor mount configuration. It features gated style and the side shift detent pattern allows for unlimited lever and knob options. The innovative lever design allows for easy removal and 360 degree rotation.

The shifter is available with standard street rod or muscle car knob and in your choice of a chrome or black finish. Lever lengths of 6", 8", 10", 12", 16", 23" and 32" are available as well as 16", 23" and 32" double bend. Options available for mounting Tremec style levers. This shifter also features durable coated bracketry. The neutral safety switch is included and it's available for most GM, Ford & Chrysler transmissions.



Gated Automatic Transmission Shifter  
Shown With Chrome Single Bend Lever  
& Black Solid Round Knob

*To configure your gated shifter go  
to Page 28*



! { Knob & Lever  
Sold Separately

Gated Automatic Transmission Shifter  
Shown With Tremec Style Lever Adapter

*Part Numbers found on Page 31*

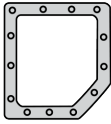
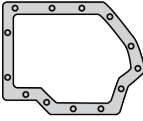
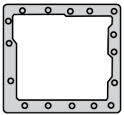
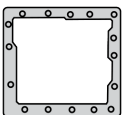
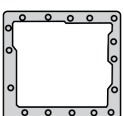
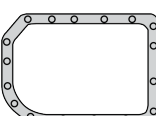
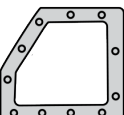
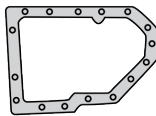
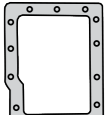

PAN GASKET	TRANSMISSION TYPE	CODE
	13 Bolts TH350	<b>350</b>
	13 Bolts TH400	<b>400</b>
	16 Bolts 700-R4	<b>700</b>
	16 Bolts 4L60	<b>4L60</b>
	16 Bolts 4L60E	<b>4L60E</b>
	17 Bolts 4L80E	<b>4L80</b>
	11 Bolts TH200	<b>200</b>
	16 Bolts 200-4R	<b>200R</b>
	14 Bolts Aluminum Case PG	<b>PG</b>

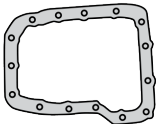
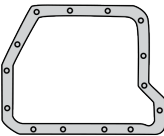
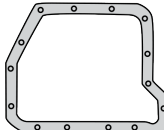
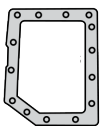
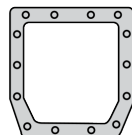
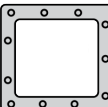
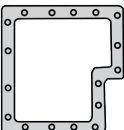
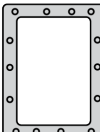
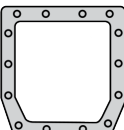
PAN GASKET	TRANSMISSION TYPE	CODE
	15 Bolts 45RFE	<b>45RFE</b>
	14 Bolts 518	<b>518</b>
	14 Bolts 727	<b>727</b>
	14 Bolts 904	<b>904</b>
	14 Bolts AOD	<b>AOD</b>
	11 Bolts C4	<b>C4</b>
	17 Bolts C6	<b>C6</b>
	14 Bolts FMX	<b>FMX</b>
	14 Bolts 4R70W AODE	<b>4R70W</b>

CHROME					BLACK				
CODE <b>E</b>	<b>D</b>	<b>C</b>	<b>B</b>	<b>A</b>	<b>EX</b>	<b>DX</b>	<b>CX</b>	<b>BX</b>	<b>AX</b>
8" Single Bend	10" Single Bend	12" Single Bend	16" Single Bend	23" Single Bend	8" Single Bend	10" Single Bend	12" Single Bend	16" Single Bend	23" Single Bend

CHROME			BLACK		
CODE <b>CN</b>	<b>BN</b>	<b>AN</b>	<b>CNX</b>	<b>BNX</b>	<b>ANX</b>
12" Double Bend	16" Double Bend	23" Double Bend	12" Double Bend	16" Double Bend	23" Double Bend

CODE <b>R2</b> <b>R1</b> <b>R2X</b> <b>R1X</b>			
32" Radical Double Bend	32" Radical Single Bend	32" Radical Double Bend	32" Radical Single Bend
CHROME		BLACK	

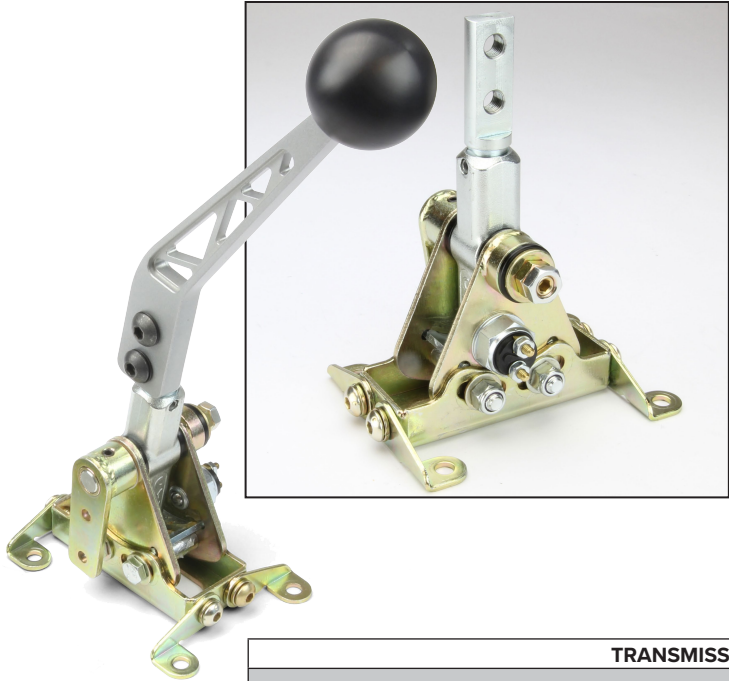
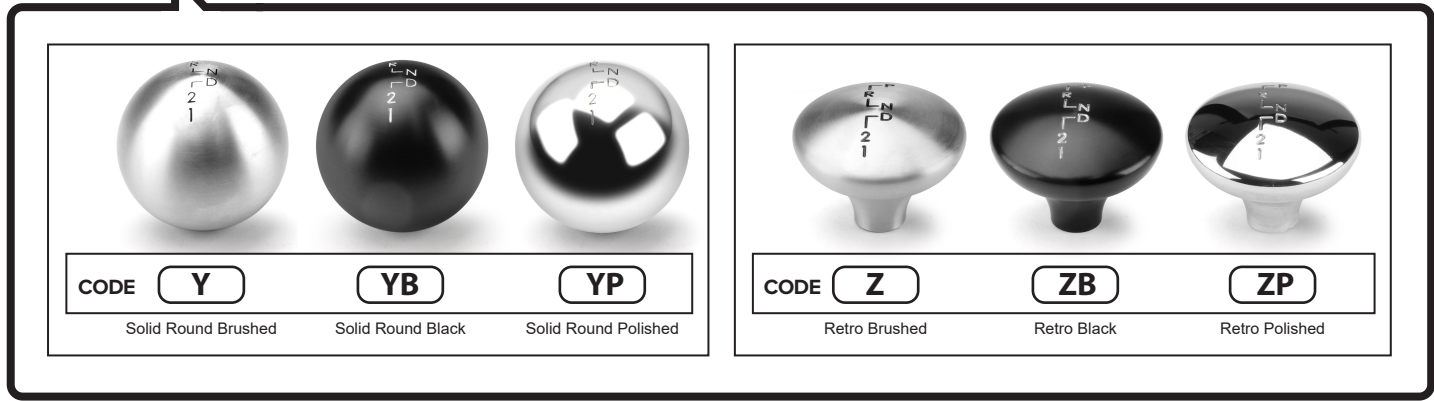

CHROME		BLACK	
CODE <b>J</b>	<b>G</b>	<b>JX</b>	<b>GX</b>
12" Bench Bend	16" Bench Bend	12" Bench Bend	16" Bench Bend

CHROME		BLACK	
CODE <b>H</b>	<b>F</b>	<b>HX</b>	<b>FX</b>
4" Straight	6" Straight	4" Straight	6" Straight



### Gated Automatic Transmission Shifter With Tremec Style Lever Adapter

We also offer our gated shifter equipped with a standard 2-bolt Tremec style shifter lever adapter.

-  If you choose this option, your shifter will not include a lever or knob. These can be purchased separately.
-  See our Clayton Machine Works Tremec style lever options on page 34. See our Lokar Tremec style lever options on pages 50 & 51.
-  Lokar and Clayton Machine Works Tremec Style levers are designed to work with any Shifter Knob that uses a 3/8"-16 thread size. See page 48 for knob options.

TRANSMISSION	PART NUMBER
GM Turbo-Hydramatic 350	GS350T
GM Turbo-Hydramatic 400	GS400T
GM 700-R4	GS700T
GM 4L60	GS4L60T
GM 4L60E	GS4L60ET
GM 4L80E	GS4L80T
GM Turbo-Hydramatic 200	GS200T
GM 200-4R	GS200RT
Aluminum Case Powerglide	GSPGT
Ford 45RFE	GS45RET
Chrysler 518	GS518T
Chrysler 727	GS727T
Chrysler 904	GS904T
Ford AOD	GSAODT
Ford C4	GSC4T
Ford C6	GSC6T
Ford FMX	GSFMXT
Ford 4R70W, AODE	GS4R70WT

# Muscle Car Pedal Assemblies

- Manufactured from lightweight aluminum
- Available for manual and automatic transmissions
- Includes all hardware needed for complete installation

(steering column support bracket not included)

APPLICATION	KIT TYPE	PART NUMBER
67-69 Camaro, 64-66 Chevelle, 68-74 Nova	Automatic	MCP-A1-A
	Manual	MCP-A1-M
1967 Chevelle	Automatic	MCP-A2-A
	Manual	MCP-A2-M
68-72 Chevelle	Automatic	MCP-A3-A
	Manual	MCP-A3-M

APPLICATION	BRAKE & CLUTCH PEDALS ONLY	
67-69 Camaro, 64-66 Chevelle, 68-74 Nova	Automatic	MCP-A1
	Manual	MCP-M1
67-72 Chevelle	Automatic	MCP-A2
	Manual	MCP-M2

APPLICATION	THROTTLE ASSEMBLY ONLY
67-69 Camaro, 64-67 Chevelle, 68-74 Nova	MCP-P1
2nd Gen Camaro, Universal	MCP-P2
68-72 Chevelle	MCP-P3
Tri-Five	MCP-P7
Full Size Chevy	MCP-P8
62-67 Nova	MCP-P9

BRAKE / CLUTCH & THROTTLE PADS	
Throttle Pad	MCP-P4
Brake / Clutch Pad	MCP-P5
Automatic Brake Pad	MCP-P6
E-Brake Cover	EB-P1-G



E-Brake Cover

## Billet Throttle Assemblies With Matching Pedal Covers

- Black anodized finish with machined highlights and perforated aluminum inserts
- Fully adjustable and features molded rubber inserts with a spring-loaded throttle pedal
- Pedal Covers require no drilling for installation



Drive-By-Wire  
Pedal Pad

APPLICATION	KIT TYPE	PART NUMBER
67-69 Camaro, 64-67 Chevelle, 68-74 Nova	Throttle Assembly Only	TA-206-B1
	Automatic Transmission Kit w/ Brake Cover	TA-206-BKA1
	Manual Transmission Kit w/ Brake & Clutch Cover	TA-206-BKM1
Second Generation Camaro Universal Firewall Mount	Throttle Assembly Only	TA-206-B2
	Automatic Transmission Kit w/ Brake Cover	TA-206-BKA2
	Manual Transmission Kit w/ Brake & Clutch Cover	TA-206-BKM2
68-72 GM Chevelle	Throttle Assembly Only	TA-206-B3
	Automatic Transmission Kit w/ Brake Cover	TA-206-BKA3
	Manual Transmission Kit w/ Brake & Clutch Cover	TA-206-BKM3
Tri-Five	Throttle Assembly Only	TA-206-B7
Full Size Chevy	Throttle Assembly Only	TA-206-B8
62-67 Chevy II / Nova	Throttle Assembly Only	TA-206-B9
Drive-By-Wire	Throttle Pad Only	TA-206-DBW



## Billet Pedal Covers

- Black anodized finish with machined highlights
- Uniquely designed rubber inserts
- No drilling is required for installation
- Available for manual and automatic applications
- Sold individually

FITMENT	PART NUMBER
Automatic Brake Pad	BPA-206-B
Manual Clutch / Brake Pad	BPM-206-B
E-Brake Cover	EB-P1-B



E-Brake Cover



## Drive-By-Wire Throttle Assembly

- Pre-programmed for specific OEM and aftermarket DBW applications
- Billet aluminum construction
- Complements other Clayton Machine Works products
- Available in black or gray finishes with machined details



APPLICATION	OEM PEDAL NUMBERS (OR EQUIVALENT)	GRAY FINISH	BLACK FINISH
Late '07-'12 Silverado (except Classic), Suburban, Tahoe, Avalanche, Sierra, Yukon, Escalade & Hummer	# 25832864 # 15847349	CDBW-GM01G	CDBW-GM01B
'06-'12 Corvette	# 25835421 # 15864594	CDBW-GM02G	CDBW-GM02B
'04-'09 TrailBlazer, Ranier, Bravada, SSR, and Envoy	# 15145758 # 15187573	CDBW-GM03G	CDBW-GM03B
'06-'07 Monte Carlo and '04-'08 Grand Prix	# 25830024 # 10345632 # 15831256 # 15884315	CDBW-GM04G	CDBW-GM04B
'06-'07 Silverado Classic, Escalade, Avalanche, Suburban, Tahoe, Sierra, and Yukon	# 15107594 # 15233970	CDBW-GM05G	CDBW-GM05B
All GM Crate Engines, '08-'12 Cadillac CTS / CTSV, and '10-'12 Camaro	# 10379038 # 10367117 # 22741799 # 22741800 # 92199239	CDBW-GM06G	CDBW-GM06B
'05-'06 Pontiac GTO	# 92188385	CDBW-GM07G	CDBW-GM07B
'07-'11 Express and Savana Van	# 15821777 # 20827131	CDBW-GM08G	CDBW-GM08B
All Coyote 5.0 Crate Engines and '11-'12 Ford Mustang	N/A	CDBW-FORD01G	CDBW-FORD01B
'05-'12 Charger, Magnum, 300, Ram Truck, Grand Cherokee, Durango, and '08-'12 Challenger	All OEM Pedals	CDBW-MOPAR01G	CDBW-MOPAR01B
Dominator EFI	# 10379038	CDBW-HOLLEY01G	CDBW-HOLLEY01B
All Mast M90 Applications	# 25835421	CDBW-MAST01G	CDBW-MAST01B

U.S. Patent No. D751,002  
U.S. Patent No. 9,275,541



## Truss-Style Shifter Arms

- Machined from billet aluminum
- Gray powder coated or black anodized finish
- Available in 8" and 10" lengths with 30 degree kickback
- Fits Hurst, Tremec TKO-500 , TKO-600 and T-56 with the standard 2 bolt flange
- 3/8"-16 Threaded stud for shift knob *(knob not included)*

LEVER LENGTH	FINISH	PART NUMBER
8"	Black Anodized	SH-205-8
10"	Black Anodized	SH-205-10
8"	Gray Powder Coat	SH-202-8
10"	Gray Powder Coat	SH-202-10

## Truss-Style Adjustable Shifter Arm

- Adjustable to 3 settings in 10 degree increments
- Machined from billet aluminum
- Gray powder coated or black anodized finish
- Fits Hurst, Tremec TKO-500, TKO-600 and T-56 with the standard 2 bolt flange
- 3/8"-16 Threaded stud for shift knob *(knob not included)*

LEVER LENGTH	FINISH	PART NUMBER
10"	Gray Powder Coat	SH-204-10
10"	Black Anodized	SH-206-10



## Billet Shifter Arms

- Machined from billet aluminum
- Black anodized finish with machined edges and perforated aluminum inserts
- Available in 8" and 10" lengths with 30 degree kickback
- Fits Hurst, Tremec TKO-500, TKO-600 and T-56 with the standard 2 bolt flange
- 3/8"-16 Threaded stud for shift knob *(knob not included)*

LEVER LENGTH	FINISH	PART NUMBER
8"	Black Anodized	SH-203-8
10"	Black Anodized	SH-203-10





## Billet Door Handles & Window Cranks Truss-Style

- Gray powder coated or black anodized with machined highlights
- Fits GM and Ford (1949 and newer)

APPLICATION	FINISH	TYPE	PART NUMBER
1949 & Up GM / Ford	Gray Powder Coat	Door Handles (Pair)	PT-202
		Window Cranks (Pair)	PT-203
		Vent Window Cranks (Pair)	PT-204
1949 & Up GM / Ford	Black Anodized	Door Handles (Pair)	PT-402
		Window Cranks (Pair)	PT-403
		Vent Window Cranks (Pair)	PT-404

## Billet Door Handles & Window Cranks Mesh-Style

- Black anodized with machined highlights and perforated aluminum insert
- Fits GM and Ford (1949 and newer)

APPLICATION	FINISH	TYPE	PART NUMBER
1949 & Up GM / Ford	Black Anodized	Door Handles (Pair)	PT-302
		Window Cranks (Pair)	PT-303
		Vent Window Cranks (Pair)	PT-304



Groove

Dished

Modern

## Billet Aluminum LS Oil Caps

- Contemporary designs and finishes
- Billet aluminum construction
- Complements other Clayton Machine Works products
- Available in black anodized, brushed, or polished finishes

STYLE	BRUSHED FINISH	BLACK FINISH	POLISHED FINISH
Groove	LSO-01	LSO-01-B	LSO-01-P
Dished	LSO-02	LSO-02-B	LSO-02-P
Modern	LSO-03	LSO-03-B	LSO-03-P

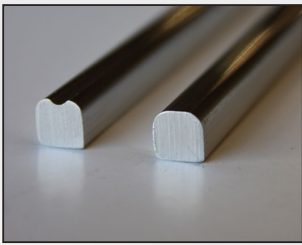

## Interior Trim

- Available in 4 and 6 foot lengths
- Smooth or grooved style
- Easily shaped to virtually any contour
- Mill finish extruded aluminum
- Easily polished to a mirror finish
- Dimensions: .25" X .25"



STYLE	TYPE	PART NUMBER
Smooth	4 Foot	AES-4
	6 Foot	AES-6
	Kit of 24 Pieces - 4 Foot	AES-4KT
	Kit of 24 Pieces - 6 Foot	AES-6KT
Grooved	4 Foot	AEG-4
	6 Foot	AEG-6
	Kit of 24 Pieces - 4 Foot	AEG-4KT
	Kit of 24 Pieces - 6 Foot	AEG-6KT
12 Each Smooth 12 Each Grooved	Kit of 24 Pieces - 4 Foot	AEB-4KT
	Kit of 24 Pieces - 6 Foot	AEB-6KT

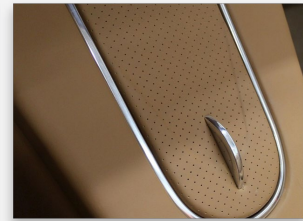

## Exterior Trim

- Mill finish extruded aluminum, easily polished to a mirror finish
- Smooth or ribbed style
- No drilling required (Can be drilled and tapped if necessary)
- Easily shaped to any contour
- Easy installation with high-strength adhesive backing  
(Adhesive only included with kit)
- Kit includes – (2) 8 ft, (2) 6 ft, (2) 4 ft pieces and 3M high-strength adhesive backing

STYLE	TYPE	PART NUMBER
Smooth	4 Foot	EXT-4
	6 Foot	EXT-6
	8 Foot	EXT-8
	Smooth Trim Kit	ETK-1
Ribbed	4 Foot	TRIM-01-4
	6 Foot	TRIM-01-6
	8 Foot	TRIM-01-8
	Ribbed Trim Kit	TRIM-01-KIT

