

CPDLC END2END DESCRIPTION

January 23, 2020 Version 1.6

DCIT Approved

*Data Comm
Implementation Team*

An overview of the FAA Segment 1 Phase 1 (S1P1) and Segment 1 Phase 2 (S1P2) Implementation of CPDLC processing from an end-to-end perspective.

REVISION RECORDS

REVISION	DATE	DESCRIPTION
1.0	November 15, 2017	Initial Release.
1.1	December 20, 2017	Minor updates throughout the document: updated the term definition for <i>partial load</i> , and the figure captions to identify that the flight deck display mockups are examples of the <i>B737 MCDU Test Bench – FAA Tech Center</i> .
1.2	November 08, 2018	Various updates throughout the document: Changed “DCL” references to “CPDLC DCL”, “DataComm” references to “CPDLC”, and “connection” references to “session”; Moved various sections around the document for improved flow (swapped sections 3.1.4 and 3.1.5, moved section 4.5 to section 4.2, moved section 4.11.1 to section 5.2, moved section 5.14 to 5.12), created new section 5.15.2 regarding stand-alone Confirm Assigned Altitude; updated Appendix E Table 12 (ICAO FPL Field 10a and Field 18 DAT/Codes); various updates regarding system enhancements through ERAM EAE130 release; Removed Monitor TOC sections/references.
1.3	March 19, 2019	Various updates throughout the document surrounding ground system enhancements implemented through the TDLS 12.6 release.
1.4	May 15, 2019	Various updates throughout the document surrounding ground system enhancements implemented through the EAE200 release.
1.5	September 10, 2019	Various updates throughout the document surrounding ground system enhancements implemented through the EAE210 and EAE300 releases; changed “session” references to “connection”.
1.6	January 23, 2020	Updated section 5.4 and Appendix B for a ground system enhancement implemented through the EAE310 release.

TABLE OF CONTENTS

<u>PARAGRAPH</u>	<u>TITLE</u>	<u>PAGE</u>
1	OVERVIEW	1
1.1	Summary of Departure Clearance Service – Ground Operations	1
1.2	Summary of Connection and Frequency Management. – Airborne Operations ...	1
1.3	Summary of ATC Routes Services - Airborne Operations	2
1.4	Equipment Assumptions	2
1.5	Messages Addressed in this End to End Document.....	2
2	TERMS	3
3	GROUND OPERATIONS – DEPARTURE CLEARANCE SERVICE VIA CPDLC	6
3.1	Flight Plan Filing – Prior to Flight	6
3.1.1	CPDLC Service Eligibility	6
3.1.2	User Preference in Flight Plan	6
3.1.3	Flight Plan Fallback Hierarchy.....	6
3.1.4	Subscriber Data Base	7
3.1.5	Ground System Processing of Routes	7
3.2	Initial CPDLC Departure Clearance Service.....	10
3.3	Clearance Type Determination.....	10
3.3.1	User Preferences.....	10
3.3.2	Cleared as Filed (CAF)	10
3.3.3	Initial UM79.....	11
3.3.4	Initial UM80.....	12
3.3.5	Exceptions	12
3.4	Initial Processing of CPDLC DCL Departure Clearances	12
3.4.1	Departure Procedure Information.....	12
3.4.2	Controller/System Approval	13
3.5	Gate Request Message	13
3.6	Log on and Connection Establishment While on the Ground	13
3.6.1	Log On.....	13
3.6.2	Connection Establishment	14
3.7	CONTACT ME Function.....	15
3.8	CPDLC Re-log on and Call Sign Changes	16
3.8.1	Continuation Flight Nominal Desired Scenarios	16
3.8.2	Continuation Flight Non-Nominal Undesired Scenarios.....	17
3.8.3	Hull Swap Nominal Desired Scenarios.....	17
3.8.4	Hull Swap Non-Nominal Undesired Scenarios	18
3.9	Tower Re-Logon	18
3.9.1	Identical Re-logon During CPDLC Connection Establishment.....	18
3.9.2	Identical Re-logon When the Aircraft has a CPDLC Connection	19
3.9.3	Re-logon with Different Logon Data	19
3.10	CPDLC DCL Delivery and Uplink Response	19
3.10.1	Departure Clearance Delivery	19
3.10.2	Initial CPDLC Clearance Uplink Contents	19
3.10.3	CPDLC-Departure Clearance Formats and Guidelines	20
3.11	Revised CPDLC Uplinks	22
3.12	Revised Clearance Content/Constraints	23
3.12.1	Content.....	23

3.12.2	UM79	23
3.12.3	UM80	23
3.13	Flight Crew Response to Revised Clearances (UM79, UM80)	24
3.13.1	FMS Load and Review	24
3.13.2	Downlink Response	24
3.13.3	Additional DM25 Clearance Requests	24
3.14	ATC Handling of Revised Clearances	25
3.15	AOC/FOC Dispatch Message Generation and Response	25
3.15.1	Dispatch Message Delivery – User Preference	25
3.15.2	Dispatch Message Delivery to the Aircraft	25
3.15.3	Dispatch Message Response	25
3.15.4	Revised Clearances, Dispatch Messages	26
3.16	CPDLC Service Termination	26
3.16.1	Controller Termination and Uplink Cancellation	26
3.16.2	En Route Flight Crew Termination	27
3.16.3	Ground System Termination	27
3.16.4	Enable/Disable CPDLC Tower Service	27
4	TAKEOFF AND TRANSITION TO CPDLC EN ROUTE AIRSPACE FOR CONNECTION AND FREQUENCY MANAGEMENT	29
4.1	Flight Plan	29
4.2	VDL Capability for NAS CPDLC Services	29
4.2.1	Tower	29
4.2.2	En Route	29
4.3	Log On	30
4.4	Logon/Flight Plan Correlation	30
4.5	Connection Establishment	31
4.5.1	Logon / Connection Establishment	31
4.5.2	Tower	32
4.5.3	En Route	33
4.5.4	En Route Connection CDA Confirmation	34
4.6	Blocked List	35
4.7	Eligibility Assignment	35
4.7.1	Tower	35
4.7.2	En Route	35
4.8	En Route Re-logon with a Connection	36
4.9	Transfer of Communications	36
4.10	Nominal Case	36
4.11	Off-Nominal Cases	37
4.11.1	Abnormal Transfers	37
4.12	TOC CONTACT Message Flow	38
4.13	CPDLC Status	38
4.14	Connection Termination	39
4.14.1	Connection Termination Uplinks	39
4.14.2	Automatic Connection Termination	39
4.14.3	Manual Connection Termination	40
5	EN ROUTE CLEARANCES VIA CPDLC	42
5.1	Operational assumptions	42
5.2	Use of Pilot Free Text	42
5.3	Abnormal Uplink Conditions	42

5.4	En Route Route Clearance Services.....	43
5.4.1	Operational Context for Flight Crew Initiated Request for Direct To	43
5.4.2	Operational Context for Controller Initiated Direct To	45
5.4.3	Operational Context for Ground System Initiated Reroute.....	46
5.5	Considerations for Loadable Content	47
5.6	General Guidance for All Uplinks	47
5.7	Guidance for constructing a [routeclearance]	48
5.8	General [routeclearance] Instructions.....	48
5.9	Airways in a [routeclearance]	49
5.10	Message Specific Instructions.....	50
5.10.1	UM74	50
5.10.2	UM79	50
5.10.3	UM80	51
5.10.4	UM83 (Future Use - Currently Switched Off)	52
5.10.5	UM169	52
5.11	Guidance for Multi-Element Messages.....	52
5.12	Guidance for Intercepting Arrival and Transition Procedures Midway.....	52
5.13	Controller Initiated Route Clearances.....	53
5.13.1	Controller Initiated Direct-To-Fix	53
5.13.2	Controller Initiated Route Clearance	54
5.13.3	Traffic Flow Management Airborne Reroute Execution (ABRR)	57
5.14	Pilot-Initiated Downlink Request.....	58
5.14.1	Flight Crew Initiated Direct-to-Fix	59
5.14.2	Flight Crew Initiated Altitude Requests.....	60
5.14.3	UNABLE Responses to Flight Crew Requests	60
5.14.4	Request Voice Contact	61
5.14.5	Emergency Downlink Messages	61
5.14.6	Processing of Open Requests.....	63
5.14.7	Subsequent Request Received with Open Request of Same Type	64
5.14.8	Downlink Latency Checks	65
5.15	Altimeter Settings.....	65
5.15.1	Manual Uplink of Altimeter	66
5.16	Altitudes and Crossing Restrictions.....	66
5.16.1	Climb/Descend/Maintain Altitude Instructions	67
5.16.2	Confirm Assigned Altitude	68
5.16.3	Altitude Crossing Restrictions Instructions	68
6	NEXT DATA AUTHORITY AND BOUNDARY CONDITIONS.....	69
6.1	Aircraft Outbound from U.S.	70
6.2	Aircraft Inbound to US.....	71
7	EN ROUTE DATA LINK DISPATCH SERVICE.....	73

APPENDICES

<u>APPENDIX</u>	<u>TITLE</u>	<u>PAGE</u>
APPENDIX A	CPDLC DCL PRODUCTION SYSTEM MESSAGE TABLES	75
APPENDIX B	CPDLC ERROR PROCESSING	83

APPENDIX C CPDLC MESSAGE ELEMENTS USED WITHIN THE NAS	94
APPENDIX D EXPLANATION OF ROUTE AND ROUTE SEGMENT CLEARANCES (UM79, UM80, AND UM83).....	127
APPENDIX E ICAO FPL CPDLC FILING CODES	132
APPENDIX F ACRONYMS	134

FIGURES

<u>FIGURE</u>	<u>TITLE</u>	<u>PAGE</u>
FIGURE 1 – CPDLC DEPARTURE CLEARANCE WITH ROUTE FREE TEXT		22
FIGURE 2 – LOGON / CONNECTION ESTABLISHMENT DIAGRAM (SOURCE: DO-258A, APRIL 7, 2005)		31
FIGURE 3 – CPDLC NOT IN USE MESSAGE WITH AN ACTIVE CONNECTION (B737 MCDU TEST BENCH – FAA TECH CENTER)		36
FIGURE 4 – FLIGHT CREW INITIATED REQUEST FOR DIRECT TO OR REQUEST FOR REROUTE		44
FIGURE 5 – CONTROLLER INITIATED DIRECT TO OR CONTROLLER INITIATED REROUTE		45
FIGURE 6 – UM79 ROUTE CLEARANCE AND SUPPLEMENTARY ROUTE FREE TEXT (B737 MCDU TEST BENCH – FAA TECH CENTER)		55
FIGURE 7 – UM80 FULL ROUTE CLEARANCE AND SUPPLEMENTARY ROUTE FREE TEXT (B737 MCDU TEST BENCH – FAA TECH CENTER)		56
FIGURE 8 – UM80 FULL ROUTE CLEARANCE WITH FREE TEXT ARRIVAL PROCEDURE AND FREE TEXT MODIFIED ROUTE (B737 MCDU TEST BENCH – FAA TECH CENTER)		57
FIGURE 9 – TFM REROUTE EXAMPLE WITH AWE965.....		58
FIGURE 10 – DCNS-TO-AOC ARCHITECTURE OVERVIEW		73
FIGURE 11 – DLD SERVICE OVERVIEW.....		74
FIGURE 12 – INITIAL CLEARANCE – ‘THEN AS FILED’.....		76
FIGURE 13 – INITIAL CLEARANCE – ‘THEN AS FILED’, WITH CLIMB VIA SID.....		77
FIGURE 14 – FULL ROUTE CLEARANCE.....		78
FIGURE 15 – CLEARED TO POSITION VIA RTE CLR.....		79
FIGURE 16 – LOADING OF UM80 WHEN AIRCRAFT IS AIRBORNE		128
FIGURE 17 – LOADING OF UM80 WHEN AIRCRAFT IS ON THE GROUND.....		129
FIGURE 18 – LOADING OF UM79		130
FIGURE 19 – LOADING OF UM83		131

TABLES

<u>TABLE</u>	<u>TITLE</u>	<u>PAGE</u>
TABLE 1 – OPERATIONAL STEPS FOR FLIGHT CREW INITIATED REQUEST FOR DIRECT TO ROUTING		44
TABLE 2 – OPERATIONAL STEPS FOR CONTROLLER INITIATED DIRECT TO ROUTING		45

TABLE 3 – OPERATIONAL STEPS FOR GROUND INITIATED REROUTE.....	46
TABLE 4 – NDA OUTBOUND TIMER VALUES.....	70
TABLE 5 – CONDITIONAL DEPARTURE INFORMATION MESSAGE EXAMPLES....	80
TABLE 6 – TOWER CPDLC DCL GROUND ERROR PROCESSING.....	83
TABLE 7 – EN ROUTE CPDLC GROUND ERROR PROCESSING.....	86
TABLE 8 – UPLINK MESSAGE	94
TABLE 9 – DOWNLINK MESSAGES.....	95
TABLE 10 – AFN AND CPDLC CONNECTION ESTABLISHMENT AND TRANSFER MESSAGES.....	96
TABLE 11 – S1P2 EN ROUTE MESSAGE STRUCTURE AND CONTENT – A SUBSET OF ISO ASN.1.....	97
TABLE 12 – TOC “CONTACT” OPERATING METHOD – FAA DOMESTIC	126
TABLE 13 – ICAO FPL FIELD 10A AND FIELD 18 DAT/CODES.....	133
TABLE 14 – TABLE OF ACRONYMS	134

DCIT End-to-End Procedures for CPDLC Operations in the US NAS

1 OVERVIEW

This document describes the Future Air Navigation System (FANS) 1/A(+) Controller Pilot Data Link Communication (CPDLC) air traffic control (ATC) service descriptions for the “ground system” that is being deployed by the Federal Aviation Administration (FAA), from an end-to-end (E2E) view. It also contains the agreed E2E system behavior that was used to derive FAA ATC system requirements, and includes Data Comm Implementation Team (DCIT) inputs into the system that highlights procedures and concepts for CPDLC capability. This E2E is designed to be a work in progress document, leveraging the DCIT, industry, and user community inputs, and will be updated as additional information becomes available.

Most of the ground system documents use the term “CPDLC DCL” when referring to the FANS CPDLC departure clearance. Within this E2E DCIT document, the term CPDLC will be used, which may be considered synonymous for both ground and airborne CPDLC operations.

The following high-level ATC services will be described in this document.

1.1 Summary of Departure Clearance Service – Ground Operations

CPDLC Departure Clearance Services (CPDLC DCL) is available at local Tower Data Link Services (TDLS) equipped facilities to provide the delivery of departure clearances and revised departure clearances. This will be done through advanced automation and CPDLC as part of the FAA NextGen introduction of advanced communications services in the National Airspace System (NAS). This section of the E2E will contain flight plan filing, CPDLC log on, and CPDLC DCL uplink and downlink message information.

1.2 Summary of Connection and Frequency Management. – Airborne Operations

With the introduction of NextGen CPDLC services in the NAS, the DCIT was tasked to put together a working E2E section describing both connection establishment and transfer of communication (TOC) between controllers, ground systems and flight crews. This document describes how a CPDLC connection is established while airborne, transferred both within the NAS and outside the NAS, and terminated using FAA ground equipment and properly equipped FANS aircraft. It also details the operating methods of TOC from one radio frequency to another as an aircraft proceeds from sector to sector, and facility to facility.

1.3 Summary of ATC Routes Services - Airborne Operations

This document provides an overview of CPDLC En Route services from the DCIT's perspective. Additionally, this document includes rules for the ground automation to have the greatest chance of building route uplinks that are loadable and operationally acceptable. These rules will serve as the basis for the requirements for the ground systems.

1.4 Equipage Assumptions

The DCIT's strategy for the E2E is to write rules for uplinks to accommodate the lowest common denominator in terms of aircraft type specific limitations. The ground system is not expected to build messages specific to aircraft type. Operators and Original Equipment Manufacturers (OEMs) should review the FAA/Harris minimum/recommended avionics list for CPDLC participation (www.harris.com/datacomm).

1.5 Messages Addressed in this End to End Document

Appendix C contains the full list of uplink and downlink messages that are supported for CPDLC Tower and En Route services, as well as message structure and content (ISO ASN.1 extracts) information for the supported messages.

2 TERMS

Active Flight Plan

An active flight plan (FP, FPL) is one that is being processed by ERAM¹ in the NAS for an airborne aircraft. The flight may have departed an airport in the NAS or may be entering the U.S from an adjacent FIR² (e.g., ATOP³, Canada).

Correlation

The term correlation is used to describe the process of associating the logon data with flight plan data. Data items used for correlation are: aircraft registration, flight identification, and departure airport (the departure airport is correlated with the latitude/longitude of the logon).

CPDLC Eligibility

The term “CPDLC eligibility” is used to describe the authority of a sector or tower to exchange CPDLC messages using that CPDLC connection. Only the facility or sector with eligibility may exchange CPDLC messages with a given aircraft at any time.

CPDLC National Application (National)

The CPDLC National Application resides at both National sites (ZLC, ZTL) and performs multiple CPDLC functions:

- Processes CPDLC logons;
- Performs logon/FP correlation supporting connection establishment;
- Facilitates assignment/transfer of CPDLC eligibility for a CDA connection for aircraft within and between ATC facilities; and
- Facilitates automatic termination of CPDLC connections.

CPDLC Connection

The term “CPDLC connection” is used to describe the virtual session established between the ground system and an aircraft for CPDLC message exchange. When “connection” is used within this document, it is synonymous with “session” and should be considered equal when describing an ATC Connection. The goal is to automatically establish and maintain a CPDLC connection for any properly equipped aircraft from departure airport to destination. To maintain a CPDLC connection from departure to destination across multiple ATC authorities, the FAA ground system supports current data authority (CDA) connections and next data authority (NDA) connections when applicable. Only the CDA/active center is allowed to exchange messages with the aircraft. The NDA connection is established after the CDA notifies the avionics of its NDA and terminates

¹ ERAM – En Route Automation Modernization.

² FIR – Flight Information Region.

³ ATOP – Advanced Technologies and Oceanic Procedures.

the current CDA connection, then the NDA ground system subsequently establishes a CPDLC connection with the avionics.

Discontinuity

A discontinuity in the Flight Management Computer (FMC) route can occur after loading a [routeclearance]. Discontinuities indicate that there is a gap in the route, i.e., no defined path between two waypoints. Flight crews should reject any clearance that results in a discontinuity that they are unable to resolve and revert to voice communications with ATC.

FMC Loadable

A loadable message can be automatically entered into the FMC when the flight crew selects the LOAD prompt. For example, when route clearances are loaded into the FMC, the new route is automatically populated rather than manually entered by the flight crew.

Logical Data Authority

Logical data authority (LDA) represents the facility that is the current data authority allowed to communicate via CPDLC with an aircraft.

Non-loadable

A non-loadable message cannot be auto-loaded into the Flight Management System (FMS) and the LOAD prompt is not displayed or “UNABLE TO LOAD CLEARANCE” scratchpad message is displayed after selecting “LOAD.” Some messages are non-loadable by design. For example, free text is not loadable. Whether a specific message is loadable or non-loadable depends on the aircraft type.

Partial load

After the flight crew selects the LOAD prompt, the FMC may display a message, “Partial Clearance Loaded” to indicate that one or more elements in the uplink did not load. For example, the loaded route may be missing an airway or procedure.

Proposed Flight Plan

A proposed flight plan is a flight plan which has been entered into the system, by either a NAS user, or more frequently filed by a flight planning service or Airline Operations Center (AOC) and which has not yet departed. Regardless of when a proposed flight plan is filed, the En Route automation system, which performs the flight planning function for the NAS, does not send the flight plan to the appropriate departure airport tower until a defined amount of time prior to the departure time. This time is nominally thirty (30) minutes, but may be different at some airports. A proposed flight plan becomes an active flight plan when the aircraft departs.

Transfer of Communication (TOC)

The TOC function allows the controller to uplink a CPDLC message instructing the flight crew to CONTACT (voice check-in) the next controller's voice frequency. The system provides CPDLC indications to the sending and receiving controllers for each flight during the TOC process. The TOC process is triggered when track control for an aircraft is transferred.

3 GROUND OPERATIONS – DEPARTURE CLEARANCE SERVICE VIA CPDLC

3.1 Flight Plan Filing – Prior to Flight

3.1.1 CPDLC Service Eligibility

In order to receive CPDLC or Pre-Departure Clearance (PDC) service, users should file an ICAO⁴ flight plan, not later than forty-five (45) minutes prior to P-Time (P-Time is defined within this document as the proposed departure time in the flight plan), via normal flight plan filing mechanisms.

The flight plan must have the Flight Identification (FLID) in Field 7 (e.g., FDX123), the departure airport, and registration number in field 18, per standard requirements for FANS operations (see GOLD⁵ 2.2.3 for additional information).

3.1.2 User Preference in Flight Plan

For flights that will participate in the CPDLC service or the legacy PDC service, users may designate the flight as CPDLC or PDC in either the ICAO flight plan and/or the FAA Web-Access SDB⁶ (see section 3.1.4).

If using the ICAO FPL, the user includes the relevant equipage codes, including “Z” in the Equipage Field 10a, and the appropriate CPDLC/PDC delivery preference code in the DAT⁷/ sub-field of Field 18 (see Appendix E for the specific preference codes).

In the ground system, the ICAO FPL always takes precedence; if the clearance delivery preference codes are in the flight plan, they will override anything in the SDB.

3.1.3 Flight Plan Fallback Hierarchy

In addition to designating the preferred clearance delivery mechanism, users may optionally designate a “CPDLC DCL primary/PDC secondary” hierarchy in the ICAO FPL.

- If the user designates it as such, a flight may revert to PDC if the CPDLC service becomes unavailable. If no PDC secondary code is provided, then the ground system will revert to voice for CPDLC flights.
- Hierarchy codes in the flight plan supersede any hierarchy preferences in the SDB.
- If the user did not file a CPDLC or PDC preference code in the original flight plan, a subsequent flight plan amendment may be entered to provide it within a site adaptable time prior to P-Time, i.e., forty-five (45) to sixty (60) minutes.

⁴ ICAO – International Civil Aviation Organization.

⁵ GOLD – ICAO Global Operational Data Link Document (Second Edition 26 April 2013).

⁶ SDB – Subscriber Database.

⁷ DAT – Other Data Application.

Users may also update the flight plan codes in the flight plan up to the existing site adaptable parameter that allows users to amend flight plans. After that time, any issues/requests would require voice discussion with ATC.

Note: The adaptable time is currently configured per site based on flight strip printing times, e.g., thirty (30) minutes expected at most sites, and other values up to a maximum of sixty (60) minutes at other sites.

3.1.4 Subscriber Data Base

Prior to specific flight plan filing, the user has an option to designate flights that will participate in the CPDLC Departure Clearance service, using a new FAA Web-Access Subscriber Data Base. Details for using the SDB are provided in the User's Guide for TDLS Subscriber Database Web-based Application, which can be found at <http://dcis.harris.com>. Using standard browser capabilities, users may designate CPDLC and PDC clearance delivery settings independently from flight plan filing.

The SDB values for CPDLC or PDC service are superseded by the service preferences provided in the flight plan.

The SDB allows the user to provide a fleet default value, or an airport/fleet value. For example, all airline flights at airport X get PDC, or a flight-specific value, e.g., XYZ123 gets CPDLC. For those users currently receiving PDC service, the default settings for the SDB will be the current PDC options.

3.1.4.1 SDB Fallback Hierarchy

If desired, users may designate a CPDLC primary/ PDC secondary hierarchy for CPDLC flights. If the CPDLC service is not available, flights that are explicitly designated as "PDC secondary" will revert to PDC if they have not yet been processed as a CPDLC flight. This user preference can be implemented in the SDB, the filed flight plan, both, or none.

Note: The fallback to PDC capability applies when the entire CPDLC service is unavailable at an airport, not when an individual flight ends up not being eligible for a CPDLC clearance.

3.1.4.2 SDB Updates

Users may update the SDB up to sixty (60) minutes prior to the filed departure time (P-time). If a user wants to change delivery preferences after that time, they should either cancel and refile or amend the flight plan accordingly (up to approximately forty-five [45] minutes).

3.1.5 Ground System Processing of Routes

This section contains route loadability rules for FANS equipped aircraft. If the user files a flight plan that does not adhere to these rules, the ground system will not create a PDC

or CPDLC clearance for the flight. Clearances will then be handled via voice. The following definitions apply:

- Fix – as used below, the term ‘fix’ means published intersections, waypoints, or Navigational Aids (NAVAIDs). A fix may also be a Fix-Radial-Distance (FRD), or a latitude/longitude (L/L). For CPDLC DCL services, an airport is not considered a ‘fix’.
- Route Element – airways and fixes define a route of flight. Departure/Arrival airports are NOT considered route elements.

1. General Rules

- a. Use of an airway as a route element requires a published entry and exit point for the airway (e.g., ..SJM.J108.GINGR..).
- b. An implied airway/airway junction (i.e., no fix between airways) is NOT loadable (e.g., .J4..J65.).
- c. If a named fix is published at the implied junction, it may be added to make the route loadable (e.g., .J4.ABI.J65.).

Note: This is the preferred option.

- d. A NAVAID radial is NOT a loadable route element in a DataComm clearance (e.g., .AIR111. or .ABQ092R.).
- e. An FRD may be used in place of a NAVAID radial, or unnamed airway junction (e.g., ..TCH..TCH094074..MTU..).

Note: Use a named fix, if available. Some FRDs are also an issue for some aircraft and may not be loadable.

- f. Unpublished, named (Ghost) fixes are not contained in the FAA NAV database and are not loadable (e.g., KMSY..TIKDP..).
- g. *ClearanceSupportAlphas* (formerly Host G-Keys) are non-standard route elements applied by ground automation (e.g., MAXIE-STAR or RV LAIRD or RV HDG030). They may be forwarded to the AOC for PDCs, but not for CPDLC Dispatch messages. They will not be included in CPDLC uplinks to the flight crew. Use of *ClearanceSupportAlphas* should be avoided, if possible.

2. Departure Phase (ADR/PDR⁸, ADAR/PDAR⁹, CDR¹⁰, IFR¹¹ Preferential Route, Playbook Routes, etc.)

- a. The first route element after departure must NOT be an airway (e.g., KPHX.J65..).

⁸ ADR/PDR – Adapted Departure Route / Preferential Departure Route.

⁹ ADAR / PDAR – Adapted Departure-Arrive Route / Preferential Departure-Arrival Route.

¹⁰ CDR – Coded Departure Routes.

¹¹ IFR – Instrument Flight Rules.

- b. The first route element may be a fix, or a SID/DP¹² followed by the last fix on the common route, or a published transition fix. Other exit fixes are NOT loadable.
- 3. **Arrival Phase** (AAR/PAR, ADAR/PDAR, APR, CDR, IFR Preferential Route, Playbook Routes, etc.)
 - a. The last route element prior to destination must NOT be an airway (e.g., ..J78.KAMA).
 - b. The last route element must be a fix, or a STAR¹³ proceeded by a published transition fix, or the first fix on the common route (e.g., ...J78.AMA..KAMA). Other entry fixes are NOT loadable.
 - c. Arrival procedures, i.e., STARS, should be filed with a published arrival transition.
- 4. **Dynamic Routes.** When included in the filed flight plan, NAT¹⁴ tracks or other dynamic routes will be handled as any other initial or revised departure clearance. The following is a summary.
 - a. If the filed route has not changed and the flight is eligible, a Cleared As Filed (CAF) uplink will be sent as the initial CPDLC departure clearance. The portion of the route containing NAT tracks, as either latitude/longitude or name (e.g., NATW) will be considered part of the “AS FILED” clearance.
 - b. If the filed route does not match the En Route automation processed route then the initial CPDLC departure clearance will be a UM79, clearing the flight to where it rejoins the route, as long as the join point is within the ground system navigational database.
 - c. If a UM79 is not possible, the ground system will attempt to generate a UM80. Some dynamic routes may be eligible for a UM80 if the En Route NAV database contains all relevant route elements. However, it is expected that the majority of flights flying international routes with NAT Tracks will not be eligible for a UM80.
- 5. For both initial and revised clearances, if a UM79 or UM80 is not possible, then the controller will revert to a voice clearance.
 - a. **Other.** Additional filing guidelines are designed to minimize discontinuities and auto-loading issues. These include the following undesirable filings:
 - i. Three (3) Letter Identifiers being utilized as origin and destination airports.
 - ii. “XXX” indicating an incomplete route. This will prevent a CPDLC or PDC departure clearance from being generated.

¹² SID – Standard Instrument Departure; DP – Departure Procedure.

¹³ STAR – Standard Terminal Arrival Route.

¹⁴ NAT – North Atlantic Tracks.

- iii. Any custom non-published points inserted into the route.

Note: Some undesirable route elements are also being applied by ground automation today based on local facility adaptation, e.g., coded routes or Traffic Flow Playbook routes. The FAA is working to remove or significantly reduce any automation-applied adapted route elements that cause loadability issues.

3.2 Initial CPDLC Departure Clearance Service

Approximately thirty (30) minutes prior to the proposed departure time (specifically at a parameter time configured to the site's current strip printing time), the ERAM ground system triggers strip printing in the tower with the planned route. The ground system will evaluate the route for CPDLC after ground system route processing.

3.3 Clearance Type Determination

The following summarizes the ground system determination of the type of CPDLC departure clearance that a flight will receive as an initial clearance. Within this section, the ground system's processed route, after route conversion of either an original filed route or a subsequent amended route, will be referred to as the Data Comm route. The ERAM ground system may add, delete, or modify SIDs and transitions based on adaptation rules for the application of ADR/PDRs.

3.3.1 User Preferences

The ground system first determines which type of clearance the flight will receive: CPDLC, PDC or voice, based on previous user designation.

Note: The tower controller does not have the capability to modify the flight plan hierarchy codes. At any time, the controller can revert to voice.

3.3.2 Cleared as Filed (CAF)

If the route of flight contained in the original filed flight plan is not altered by the ground system route processing automation from what it received, the ground system will create a CAF CPDLC clearance for the initial departure clearance.

For example:

- Original Filed Route: KSLC.LEETZ3.HOLTR..TCH..CYS..LBF..KBWI
- Controller Route: KSLC.LEETZ3.HOLTR..TCH..CYS..LBF..KBWI
- CAF Clearance: CLEARED TO KBWI LEETZ3.HOLTR THEN AS FILED, CLIMB VIA SID.

If the filed flight plan included a SID/transition, the CAF will include the SID/transition name and the phrase "THEN AS FILED"; if there is no SID, and no climb-out instructions then the phrase will be "AS FILED".

The CAF clearance will not include a loadable [routeclearance] variable, but will include any applicable SID and transition in a UM169. It will also include Climb Via instructions in a UM169 in lieu of a UM19 initial altitude, when applicable. If the automation or controller adds, modifies, or removes a SID and/or departure transition, then the flight is not eligible for a CAF initial clearance, and an initial UM79 will be sent instead.

3.3.3 Initial UM79

If the cleared route, starting from the transition fix (if applicable), is changed in any way from the original filed route, the flight is not eligible for a CAF initial clearance. The ground system will attempt to create an initial UM79 specifying the route from departure transition to the route element where the original filed route is rejoined. For example:

- Original filed route: KSLC.LEETZ3.HOLTR..TCH..CYS..EMI
- Data Comm route: KSLC.PECOP3.BAM..OTT..EMI
- UM79 clearance: CLEARED TO EMI VIA BAM OTT, PECOP3.BAM, AFTER EMI CLEARED TO KBWI ARPT AS FILED, CLIMB VIA SID {3 lines condensed for space}

When the filed route can be rejoined within the FAA ATC controlled airspace, the ground system will uplink an INITIAL UM79 message with “AFTER [position] CLEARED TO [airport] ARPT AS FILED”, plus other elements as required (e.g., expected altitude, departure frequency, etc.).

When a filed SID is removed from the cleared route, the flight is no longer eligible for a CAF initial clearance. The ground system will then create an initial UM79, which includes text in the UM169 “NO DPP”¹⁵ or “NO SID” to explicitly indicate that the SID (and transition if applicable) has been removed. The “NO SID” tag is used if other elements of a local departure procedure still apply, e.g., climb-out such as FLY HDG xxx.

Note: The NO DPP or NO SID text is also included if a subsequent revision removes the SID.

If the cleared route, starting from the first element after the transition fix, is unchanged, and En Route automation adds a SID and transition, then the flight is not eligible for a CAF initial clearance and the system will generate an initial UM79. For example:

- Original filed route: KSLC..TCH
- Cleared route: KSLC.LEETZ3.HOLTR..TCH
- UM79 clearance: CLEARED TO TCH VIA HOLTR, LEETZ3.HOLTR, AFTER TCH CLEARED TO KBWI ARPT AS FILED, CLIMB VIA SID

¹⁵ DPP – Departure Procedure Parameter.

3.3.4 Initial UM80

If a CAF or a UM79 is not possible for the initial CPDLC DCL, and the En Route ground system has NAV database information and can process the entire route to destination, then the ground system will uplink a UM80 CPDLC DCL clearance.

3.3.5 Exceptions

If the flight is eligible for a CAF clearance, yet the flight plan remarks includes “FRC”¹⁶, the ground system will build an initial UM80 when possible. If the ground system cannot convert the route to its destination, then an initial UM79 will be built instead.

If the flight is eligible for a CAF clearance, and CAF eligibility has been disabled/deselected by the controller for the flight, i.e., the controller wants to send the entire route, the ground system will build an initial UM80 when possible. If the ground system cannot build a UM80, for flights beyond the NAS FIR boundary, then a new connection cannot be established, and the controller and flight crew will coordinate clearance delivery via voice.

Note: This is one of the conditions when the system will not try to build a UM79. If either the flight crew or the controller wants a full route clearance and it cannot be generated, then the controller will handle the clearance via voice procedures.

If the filed route is not identical to the ground system processed route and the ground system could not create a CPDLC clearance with an initial UM79 or a UM80, then the controller will be notified, a CPDLC connection will not be established with the aircraft, and the clearance will be provided via voice procedures to the flight crew.

Incomplete Route (XXX). If the user files XXX, an incomplete route, or the ground automation cannot process the route to the destination, the ground system will not create a PDC or CPDLC clearance for the flight, and the clearance will be handled via voice.

3.4 Initial Processing of CPDLC DCL Departure Clearances

3.4.1 Departure Procedure Information

The CPDLC clearance will include departure procedure/SID text (when applicable) and altitude instructions in the form of an initial MAINTAIN altitude or a Climb Via instruction. Whether a Climb Via instruction or a MAINTAIN altitude instruction is included will be based on facility operations. The ground system will provide automation support for the appropriate options, i.e., adapted defaults for controller/system selection in generating the CPDLC DCL and rules to ensure appropriate combinations.

If applicable, the ground system will provide additional departure procedure/SID transition information by inserting the required data elements, i.e., the first filed route fix for a SID/Transition combination.

¹⁶ FRC – Full Route Clearance.

If there is no published departure procedure (SID or SID plus transition) in the original filed route and it is identical to the ground system processed route, and the controller adds a SID or SID plus transition, the ground system will generate a CAF clearance.

3.4.2 Controller/System Approval

The controller reviews the clearance before sending to the aircraft when the ground system is in manual mode. At TDLS facilities running CPDLC in auto mode, no controller approval is required to send a CPDLC DCL or PDC clearance unless FRC is in the flight plan or there are revisions to the flight plan or clearance data.

The ground system automation formats the clearance into a FANS-1/A clearance using UM79, UM80, UM169, and UM19 message elements as appropriate, and once a successful aircraft log on and connection establishment has been completed with TDLS, the CPDLC DCL will automatically be sent to the aircraft. Otherwise, TDLS will place the approved CPDLC DCL in the appropriate queue. See Appendix A for sample CPDLC DCL messages.

Note: The ground system initiates the flight plan correlation and connection establishment as described in section 3.6.

3.5 Gate Request Message

If gate request messages are required operationally at the departure tower, the user can “opt in” in order to receive the Gate Request (GREQ) message from TDLS by providing user preferences in the Subscriber Database.

For CPDLC DCL, the ground system will send a GREQ message to the user/airline host system, as described in the TDLS-CSP IRD, upon clearance approval by the controller, or by the ground system in auto mode.

The user/airline host system responds to the GREQ message with two messages: a system acknowledgement (ACK) on receipt of the GREQ, and a GREQ response message within an operationally appropriate time period (currently two [2] minutes for a PDC). The GREQ response message from the user/airline host system contents are specified by the TDLS-CSP IRD and include the departure parking gate, if known, or “G” if the gate is unknown.

3.6 Log on and Connection Establishment While on the Ground

3.6.1 Log On

3.6.1.1 Flight Crew Log On

At the appropriate time, and while still at the departure gate, the flight crew logs on to CPDLC using KUSA as the single logon identifier for all participating TDLS CPDLC DCL facilities. This can be done any time after the airline has filed the flight plan with the FAA.

3.6.1.2 Ground System Logon Processing

The ground system will accept a valid logon, provided that the logon contains the registration number, correct facility ID (KUSA), flight ID, and a matching flight plan on file. The position in the log-on request must be within an adapted distance of the departure airport. Specifically:

- When a log on request message (FN_CON) has valid and required data, and a proposed flight plan exists with matching registration, flight identification, and airport location, the ground system will accept the logon and send a positive log on response (FN_AK with a reason code zero [0]). In all other cases, with the exception of KUSA not being used as the facility ID, the ground system will send a negative response for a failed logon request (FN_AK with a reason code one [1]). An indication is provided to the flight crew for both of these cases (ACCEPTED or REJECTED).
- When KUSA is not used as the facility ID, the ground system will not send any log on response.
- If the log on is attempted and no response is received, or a negative response is received, the flight crew may attempt another log on or may choose to revert to voice for their departure clearance.

Note: Actual flight plan correlation and CPDLC connection occurs only after the tower controller approves the CPDLC clearance at some point after P-Time thirty (30) minutes. If the flight crew logs on prior to controller approval, the ground system will wait until the controller approval and FP correlation has been completed to initiate a CPDLC connection. If the controller approves the clearance prior to the log on request from the flight crew, the ground system will initiate the connection establishment once TDLS is in receipt of the FP correlation and detection of a successful log on. The CPDLC DCL will be automatically sent to the aircraft once an ATC CPDLC connection is established. The flight crew does not need to downlink a request DM25 to obtain an ATC clearance.

3.6.2 Connection Establishment

3.6.2.1 Correlation

Upon approval of the CPDLC clearance by the controller (or by the ground system if the facility is operating in auto mode), and when there is an accepted log on, the ground system will attempt to correlate the flight plan data with the logon data. If correlation fails, an error message is provided to the controller, and the controller and flight crew coordinate via voice.

Note: Flight data items used for correlation from the aircraft are the aircraft registration/tail number, the Flight ID (ABC123) and the latitude/longitude position reported in the logon. The ICAO facility ID is used, i.e., logging on to KUSA, but correlation uses the latitude/longitude to determine if the aircraft's location matches the departure airport in the flight plan.

When an update (change) to flight data items used for correlation, are received for a FP that is correlated with a log on, the CPDLC connection that is associated with that flight plan will first be terminated, and the flight crew will then need to re-establish the log on with a new CPDLC log on request.

Blocked List. If the aircraft has been identified as ineligible for CPDLC service due to log on problems, e.g., duplicate registrations that caused the flight to be on the “blocked list”, the ground automation will provide failure information to the controller when the flight plan correlation is attempted. The impacted aircraft registration will not be eligible for CPDLC until the duplicate flight plan registration condition is resolved (e.g. flight plan removed or amended, flight lands and strip removed, etc.), and FAA personnel manually remove the registration from the blocked list (typically as soon as a tail number is added to the blocked list, unless the blocked list reason is for excessive logons). See section 4.6 for additional information.

3.6.2.2 Connection

When a log on correlation is successful, the ground system will attempt to establish a CPDLC connection with the aircraft by sending a CR1 (to which the aircraft [normally] responds with a CC1). Upon receipt of an error indication in response to the CR1, e.g., a DR1, or no response is received, the ground system will retry sending the CR1 to the aircraft one more time, after an adaptable parameter of time has passed.

Upon successful CPDLC connection establishment, the ATC ground automation and avionics may notify the controller or flight crew of the availability of CPDLC service for the flight. The ground system provides a display indication to the controller, while some avionics will provide an aural notification to the flight crew.

For ground operations, if the controller/system approves the departure clearance and there is no accepted log on available, the ground system will “wait” until there is an accepted log on, and perform flight plan correlation, then attempt to establish the CPDLC connection.

3.7 CONTACT ME Function

The CONTACT ME function is used by the tower controller to send a free text message to the flight crew to discuss potential route amendments. This function can be utilized prior to an initial departure clearance uplink to establish a connection in cases where the clearance cannot be generated by the ground system. In these cases, after the connection has been established, a UM169 free text message instructing the flight crew to contact ATC will be uplinked in lieu of an initial departure clearance. Alternatively this can be uplinked after an initial departure clearance has been uplinked to discuss potential amendments to the clearance. The free text will contain up to 80 characters and is adaptable per site (i.e. may not contain “CONTACT ME”). The flight crew will acknowledge the message with a ROGER downlink and contact ATC via voice, but the connection will remain in a CONTACT ME state. While a CONTACT ME free text message is open (i.e., the flight crew has not downlinked a ROGER response in return),

DM25 clearance requests from the flight crew will not be displayed to the controller and will receive an automatic response by the ground system with a free text message to contact the controller by voice. The controller will have an indicator designating the connection is in the CONTACT ME state. The connection will remain in the CONTACT ME state until a departure clearance is uplinked or the flight departs.

3.8 CPDLC Re-log on and Call Sign Changes

The following section describes expected behavior when a departing flight on the ground is the continuation of a delayed inbound arrival, or when two flights on the ground perform a hull swap.

3.8.1 Continuation Flight Nominal Desired Scenarios

The departing flight will modify its call sign (flight identification), e.g., DAL416 becomes DAL416P. Timing and sequence determine the ground system processing.

1. Prior to P-30.
 - a. Flight crew has already logged on with the old FLID (DAL416) before the controller processes DAL416, which means there is no active connection.
 - b. The AOC amends the call sign (FLID) from DAL416 to DAL416P. The amendment by the AOC has to occur prior to any strip printing (P-30), otherwise the ground system rejects the AOC amendment. Alternately, the AOC can cancel the DAL416 and refile as DAL416P.
 - c. Flight crew performs a new log on with DAL416P. The ground system accepts the log on and replaces the FLID with the new FLID DAL416P.
 - d. Once the tower controller approves the desired flight plan, DAL416P after P-30, the ground system will initiate connection establishment with the aircraft.
2. After P-30, with a connection already established for DAL416 (old).
 - a. The flight crew coordinates with tower controller via voice.
 - b. The controller removes (RS) DAL416 and may manually terminate the connection.
 - c. The ground system closes the logon for DAL416 and immediately terminates the CPDLC connection.
 - d. Dispatch enters a new flight plan for DAL416P. When received, the controller/system processes the new flight plan.
 - e. Meanwhile, the flight crew re-logs on with the new FLID DAL416P.
Note: Some avionics will terminate the connection if it is still established upon re-log on.
 - f. Flight plan correlation is successful, a new connection is established, and the CPDLC DCL, once approved, is automatically sent to the aircraft.

3.8.2 Continuation Flight Non-Nominal Undesired Scenarios

The departing flight does not modify its call sign (FLID), and uses DAL416 from the original flight plan, and a second DAL416 inbound aircraft is airborne with a CPDLC connection within the same ERAM facility. Timing and sequence determine the ground system processing. A new flight plan has been filed as DAL416P.

1. Prior to P-30.
 - a. The flight crew on the ground does not send a new logon with DAL416P (the ground system still has a logon for the inbound DAL416 aircraft).
 - b. When the controller/system processes the flight at P-30, the flight plan correlation will fail (FLID logon call sign mismatch); the controller is not notified. Since this is a recoverable correlation failure, the system will standby for a subsequent correct logon from the flight crew on the ground, DAL416P, to then establish a connection.
2. After P-30, with a connection already established for the inbound DAL416 aircraft.
 - a. A flight plan correlation failure will occur and CPDLC will not be available to the flight crew on the ground if: the flight crew logs on again, the controller removes the old flight plan, or the flight crew logs on prior to the flight plan being corrected to DAL416P.
 - b. If dispatch does not refile the flight plan, the flight will be handled via voice.

3.8.3 Hull Swap Nominal Desired Scenarios

1. Prior to P-30.
 - a. The flight crew logs on from the aircraft with the tail number N123GQ, before the tower controller processes the associated flight plan. Thus, the flight crew does not have an active connection.
 - b. A hull swap occurs, and the AOC amends the flight plan tail number (REG[1]) from N123GQ to N456GQ. The amendment by the AOC needs to occur prior to any strip printing (P-30) or the ground system rejects the AOC amendment. Alternatively, the AOC can cancel the flight plan with the tail number N123GQ and refile as N456GQ.
 - c. The flight crew moves to a new aircraft and sends a new log on with the tail number N456GQ. The ground system accepts the logon, and creates a new log on entry for tail number N456GQ.
 - d. At P-30, the tower controller receives and approves the desired flight plan, with the N456GQ tail number, and the ground system will initiate a connection establishment with the aircraft.
2. After P-30, with a connection already established for N123GQ (old).
 - a. The flight crew coordinates with the tower controller via voice.

- b. The controller removes (RS) the old flight plan and may manually terminate the connection.
- c. The ground system closes the log on for N123GQ. If the controller did not manually terminate the connection, the ground system will terminate the CPDLC connection.
- d. Dispatch enters a new flight plan for N456GQ. When received, the tower controller/system processes the new flight plan.
- e. The flight crew logs on from the new aircraft with tail number N456GQ, and the ground system accepts the logon.

Note: Any logon attempt prior to dispatch entering the new flight plan will be rejected since there is no matching flight plan.

- f. The new flight plan is successfully correlated with the new logon from N456GQ, a connection is established, the CPDLC DCL is approved, and the clearance is automatically sent to the aircraft.

3.8.4 Hull Swap Non-Nominal Undesired Scenarios

1. Prior to P-30.
 - a. The flight crew does not send a new log on with N456GQ (the ground system still has a log on for N123GQ).
 - b. When the controller/system processes the flight at P-30, the flight plan correlation will fail (logon registration mismatch). The controller is not notified, since this is a recoverable correlation failure, and the system will standby for a subsequent correct logon to then establish a connection.
2. After P-30, with a connection already established for N123GQ (old).
 - a. An amendment to the tail number on the flight plan, either by the controller or the AOC in coordination with the center, will result in a flight plan correlation failure and a connection termination error. No further CPDLC will be available.
 - b. If dispatch does not refile the flight plan, the flight will be handled via voice.

3.9 Tower Re-Logon

3.9.1 Identical Re-logon During CPDLC Connection Establishment

If the re-logon contains all the same correlation data as the original logon (aircraft registration and call sign), the ground system will restart the connection establishment process. A notification of connection establishment failure will occur if the connection establishment after the relogon fails.

3.9.2 Identical Re-logout When the Aircraft has a CPDLC Connection

If the re-logout contains all the same correlation data as the original logout (aircraft registration and call sign), the ground system will send a connection request to the aircraft to establish a new connection. If the ground system had any open uplinks (i.e., a CPDLC DCL was uplinked, no flight crew response was received), and the flight crew attempts another log on, the ground system will keep the uplinked CPDLC DCL message open for flight crew response. If the flight crew does downlink a response, the ground system will close out the message on receipt of response. In addition, the ground system will provide the ability for the Clearance Delivery controller to resend the identical uplink to the flight crew after voice coordination.

3.9.3 Re-logout with Different Logout Data

If the re-logout contains different flight plan information, the new logout will have to go through the correlation process again, as described in section 3.6.2.1.

3.10 CPDLC DCL Delivery and Uplink Response

3.10.1 Departure Clearance Delivery

Once the CPDLC DCL has been approved by the controller and a successful ATC connection has been established, the CPDLC DCL will be automatically sent to the aircraft for flight crew review and approval.

If appropriate, and after the first accepted uplinked clearance, the flight crew may request a subsequent CPDLC DCL using only the DM25 [REQUEST CLEARANCE] feature in the avionics.

- The flight crew should not append free text to the DM25. If free text is concatenated with the DM25, the ground system will respond with an error, UM159 “Unexpected Data” concatenated with a UM169 “ATSU CANNOT PROCESS DATA APPENDED TO CLEARANCE REQUEST”.
- If the flight crew uses free text (DM67 or DM68) to request the Departure Clearance, the ground system will respond with an error, UM159, and a UM169 free text “MESSAGE NOT SUPPORTED BY THIS ATS UNIT”.
- If the flight crew has not accepted the uplinked clearance and downlinks a DM25 [REQUEST CLEARANCE], the ground system will respond with a UM169 “CLEARANCE SENT, RESPONSE REQUIRED. IF NO CLEARANCE MESSAGE EXISTS, CONTACT ATC AND REQUEST A RESEND OF DEPARTURE CLEARANCE”.

3.10.2 Initial CPDLC Clearance Uplink Contents

The ground system will automatically send a CPDLC DCL as follows:

- Upon ATC connection establishment with the aircraft, the ground system delivers the pre-approved, stored departure clearance to the aircraft using FANS-1/A

message elements UM19, UM79, UM80, and UM169, as appropriate. A subset of the elements may be sent in a message (see Appendix A for message samples).

- The clearance will contain either a CAF, or a full or partial route, and all other relevant data elements from the flight plan or locally applied procedures. The clearance will contain an expected cruise altitude, a departure frequency, and either a Climb Via text or a MAINTAIN altitude. It may also contain climb-out instructions, a beacon code, a SID/transition from the departure airport, and/or STAR/transition at the arrival airport.

The clearance type will be based on the following (see section 3.3 – Clearance Type Determination above for details):

- When a filed route matches the En Route automation processed route, the ground system will uplink a CAF CPDLC DCL message.
 - If there is a departure procedure/SID, the terminology will be “THEN AS FILED”.
- An initial UM79 when a CAF clearance cannot be generated and the flight is eligible for a UM79.
- An initial UM80 when the ground system cannot create a CAF or initial UM79 clearance.
- When the ground system cannot create a CAF, an initial UM79 or a UM80 clearance, the controller will revert to voice, using current voice procedures.

3.10.3 CPDLC-Departure Clearance Formats and Guidelines

The following information describes CPDLC functionality that operators can expect when participating in TDLs CPDLC DCL services.

CPDLC DCL will not include loadable DP/Transition information in departure clearances. DP/TRN information will be provided in free text when appropriate.

Note: The SID is included in the non-loadable portion because FAA systems cannot include the departure runway in the uplink and this is required for correct loading of the SID.

If the [routeclearance] variable in an uplink contains an arrival procedure/transition, then the last waypoint in the [routeinformation] variable must be the same as the first fix in the arrival transition, if specified, or the arrival procedure, if a transition is not used. If the uplink contains an arrival transition, the arrival transition name must be included in the [proceduretransition] field of the [procedurename] variable.

The ground system will include the optional latitude/longitude field for Published identifiers (waypoint names) in the route information variable of Departure Clearance uplinks.

UM169 [free text] elements will include no more than 256 characters.

When an airway is included in the filed flight plan with published named waypoints for the entry and exit points, the entry and exit point will be designated by the published named waypoints in the [routeclearance] variable.

When an airway intersects with another consecutive airway with no intersecting waypoint in the flight plan, and the proposed uplink would contain a route, i.e., not a CAF, the ground system will prevent an uplink from being constructed and a connection cannot be established with the aircraft. The controller and flight crew will then need to resolve the issue via voice.

ERAM route conversion processing will allow step climbs to be recognized when two traversals of an adapted route have the same entry/exit points, which will retain the original route. This will allow for more Cleared as Filed clearances from TDLS.

A UM79 will be used when the clearance includes a route change ending at a specified position (the “TO” point), which must be a point after the SID or the SID transition (if these are present) up to and including the last En Route point prior to the first point in the first Arrival, Approach, or associated Transition in the aircraft’s cleared route.

When a UM79 is used for the initial departure clearance, the uplink will include a UM169 free text stating that the rest of the route is unchanged following the “TO” point in the uplink (i.e., an initial UM79 with a “TO” point of MCB will be followed by a UM169 with “AFTER MCB CLEARED TO KBWI ARPT AS FILED” and then the initial altitude information [Climb Via SID or MAINT altitude]).

Note: The position variable in a UM169 does not allow for the same level of resolution as a latitude/longitude in the position variable of a UM79. Because each avionics displays the UM79 position differently, the UM169 [position] may not match the expanded latitude/longitude definition of the UM79 TO [position]. A UM169 latitude/longitude position will be rounded to the minute and be sent as Direction, Hours, Minutes. Example: UM79 position displayed as N21 20 22.1 W157 55 44.8, UM169 sent as N2120W15755.

For a UM79, when the “TO” point is an airway exit waypoint, the ground system will include the “TO” point as the last element in the [routeinformation] field. When the “TO” point is not an airway exit waypoint, the ground system will omit the “TO” point as the last element in the [routeinformation] field.

If the arrival procedure and/or arrival transition is changed from what was filed, the initial CPDLC DCL clearance will be a UM80 (this ensures loadability of the arrival), unless the flight is not eligible for a UM80, in which case it will revert to a voice clearance.

The ground system will not include the departure or arrival airport in the UM79 [routeclearance] variable.

When a UM80 contains an arrival procedure without a published arrival transition fix, the ground system will prevent an uplink from being generated and sent. The clearance will then be coordinated via voice.

If the departure clearance contains the [routeclearance] variable (UM79 and UM80), it will include a supplementary textual representation of the route modification in free text (UM169) beginning from the departure airport; only the portion of the route that has been modified will be represented in this free text. For UM79 clearances, a truncated route indication (“./.”) between the TO point and the destination airport will be included.

In the event the FAA produced route string for a UM80 clearance exceeds 256 characters, then the free text route will be truncated with a “./.” with the last modified route element as the last piece of information e.g., J94 FOD ./ LVZ.

In the event the FAA produced route string for a UM79 clearance exceeds 256 characters, the ground system will include the separator text, followed by the route from departure airport to the TO point (inclusive) in the free text route string so long as it does not exceed 256 characters. If the separator text and route from the departure airport to the TO point exceeds 256 characters then the following free text will be uplinked: “---- ROUTE TOO LONG TO DISPLAY IN TEXT - LOAD ROUTE TO REVIEW”.

Note: It is unlikely that the 256-character limit will be exceeded with most clearances.



Figure 1 – CPDLC Departure Clearance with Route Free Text

3.11 Revised CPDLC Uplinks

For aircraft participating in CPDLC departure clearances, one or more revised departure clearances may be sent by ATC prior to the aircraft’s departure (see Appendix A for sample messages). For aircraft receiving PDC clearances, revisions will be handled via voice.

3.12 Revised Clearance Content/Constraints

Revised clearances will contain some or all of the same information as the initial CPDLC DCL. In general, formatting rules and notes listed for the initial CPDLC DCL clearance also apply to CPDLC DCL revisions.

3.12.1 Content

A revised clearance uplink will never contain a departure runway or SID in the loadable portion of the clearance (UM79, UM80), though it may contain a SID and transition, climb-out instructions, initial altitude, Climb Via instruction, etc., as appropriate in a non-loadable UM169 free text element(s).

According to the information being revised, revisions may be sent as a UM79 or UM80. No altitude or speed constraints will be included in the loadable part of the message, other than those automatically loaded from the aircraft's NAV database with an uplinked STAR contained in the [routeclearance] variable.

Revisions will include a free text header indicating which portions of the departure clearance have been revised, e.g., "DPP" or "ALT". Revised clearances may also include truncated text strings, when required, to meet overall message length constraints, e.g., 256 characters.

A revised CPDLC clearance may contain information that is unchanged, but is repeated, to reduce ambiguity, such as the initial altitude, Climb Via text, climb-out, SID, and transition fields. Whenever part of the departure procedure or related route portion is changed, the ground system will resend the entire departure procedure. For a revised CPDLC departure clearance with a UM79 or UM80, the ground system will include non-blank fields for the SID, transition, climb-out, climb via or MAINT ALT in the revised uplink whether or not there was a change.

3.12.2 UM79

The UM79 route message will be used when the clearance includes a route change ending at the specified position (the "TO" point), which is a point after the SID or the SID transition, if present, up to and including the last En Route point, prior to the first point in the first arrival, approach, or associated transition in the aircraft's active route.

When constructing a UM79, the ground system will not include the departure airport or the destination airport in the route clearance element.

3.12.3 UM80

A UM80 will be used when the revision includes a route change, and a UM79 is not appropriate according to the rules above.

If a UM80 cannot be generated, the controller will revert to voice clearances.

When a UM80 contains an arrival procedure without a published arrival transition fix, the ground system will prevent an uplink from being generated and sent.

After receiving an UNABLE, if a revised flight plan is received by the ground system, the ground system will construct a UM80 reflecting the full revised route. For international flights a UM80 may not be able to be sent, so the system will attempt to generate a UM79 or advise the controller to revert to voice.

3.13 Flight Crew Response to Revised Clearances (UM79, UM80)

3.13.1 FMS Load and Review

Upon receiving a CPDLC DCL clearance, the flight crew loads the revised CPDLC clearance into the FMS and reviews it. If the CPDLC DCL clearance is acceptable, the flight crew activates the route in the FMS, addressing any potential discontinuities or loading issues.

3.13.2 Downlink Response

Upon loading and acceptance of a clearance into the FMS, the flight crew selects the appropriate downlink message.

- If acceptable, a positive response is generated, i.e., DM0 [WILCO] or DM3 [ROGER].
- If unacceptable, or if a “Partial Load” or “Load Failure” indication occurs, the flight crew downlinks a DM1 [UNABLE].
- If a DISCON is present when the clearance is loaded, the flight crew may downlink a DM2 [STANDBY] response while trying to resolve the discontinuity. If the flight crew cannot resolve the DISCON, the flight crew downlinks a DM1 [UNABLE] and reverts to voice.

Note: If the flight crew appends a “DUE TO” clarification via a DM65 [DUE TO WEATHER], DM66 [DUE TO AIRCRAFT PERFORMANCE], or comprised of free text (DM67) to a DM1 [UNABLE], the controller will receive the UNABLE portion without the free text/DUE TO rationale - revert to ATC voice procedures with Clearance Delivery after sending the “REJECT/UNABLE” response if clarification is required.

3.13.3 Additional DM25 Clearance Requests

If the flight crew requests a clearance again after sending the WILCO to the initial CPDLC clearance, the ground system will provide an indication to the controller and propose a CPDLC departure clearance using a UM80 reflecting the full route as held in the current ground system data.

The controller will manually approve the CPDLC departure clearance, and the ground system will transmit it to the aircraft. For some flights, such as international flights, a UM80 may not be able to be sent, in which case the system will attempt to generate a UM79 or advise the controller to revert to voice.

Note: If the original DM25 request is still open, then the ground system will send an open transaction error back to the aircraft (see Table 6 for error message details).

3.14 ATC Handling of Revised Clearances

All CPDLC clearance revisions will be reviewed and approved by tower ATC before being transmitted to the flight crew. These include revisions generated by changes to the flight plan and revisions initiated by the controller for locally applied clearance information, e.g., frequency.

3.15 AOC/FOC Dispatch Message Generation and Response

3.15.1 Dispatch Message Delivery – User Preference

Operators may opt out of receiving the dispatch message by using the SDB capability.

3.15.2 Dispatch Message Delivery to the Aircraft

When a CPDLC clearance is uplinked to the aircraft, the ground system will provide a dispatch message which includes the required parts of the clearance, except the beacon code, to the user host system via the user-supplied seven (7) character IATA¹⁷ address, as defined in the Appendix E and in the TDLS-CSP Interface Requirements Document (IRD).

In addition to clearance contents, for CAF clearances or initial UM79 clearances, the dispatch message will include the full route from the ground automation processed flight plan.

The dispatch message will also include a header of “CPDLC DCL DISPATCH MSG – NOT TO BE USED AS A CLEARANCE”, and any contents sourced from the uplinked CPDLC clearance will be included as text.

When the ground system receives a flight crew response of WILCO, ROGER or UNABLE to the CPDLC uplink message, it will provide the flight crew response to the AOC/FOC¹⁸ in a dispatch message update, as a flight crew response dispatch message, as defined in the TDLS-CSP IRD.

3.15.3 Dispatch Message Response

Note: In this context, some Communication Service Providers (CSPs) may provide user host functions to their clients.

- Operators shall be capable of distinguishing an initial or updated Dispatch Message from a PDC clearance.

¹⁷ IATA – International Air Transport Association.

¹⁸ FOC - Flight Operations Center.

- Upon receipt of an initial or updated dispatch message, the user host system shall send a system acknowledgement back to the ground system.
- The user shall ensure that the dispatch message is not forwarded to the flight crew/aircraft.

3.15.4 Revised Clearances, Dispatch Messages

When a revised CPDLC clearance is sent to the aircraft, the ground system will provide a revised dispatch message which includes required parts of the clearance, with the exception of a beacon code, to the user host system via the user-supplied seven (7) character IATA address.

The Revised Dispatch Message will include a header “CPDLC DCL DISPATCH MSG – NOT TO BE USED AS A CLEARANCE” and any contents sourced from the uplinked CPDLC clearance, in text format. It will also include the type of revision in the header information, e.g., RTE.

When a revised clearance contains a route revision, the ground system will include the full route from the ground automation processed flight plan in the revised dispatch message regardless of whether or not a full route was sent to the flight crew in the revised uplink.

User systems should be capable of distinguishing the revised dispatch message from a PDC clearance. Upon receipt of the revised dispatch message the user/airline host system will send an acknowledgement back to the ground system. The user shall ensure that the revised dispatch message is not forwarded to the flight crew/aircraft.

3.16 CPDLC Service Termination

CPDLC service termination for an individual flight can occur as a result of the connection termination being initiated by the controller, the ground system, or flight crew. In addition, the entire CPDLC service may also be terminated by a facility.

3.16.1 Controller Termination and Uplink Cancellation

If the controller needs to cancel or modify a CPDLC message, the controller shall contact the aircraft using voice with the accepted phraseology, e.g., “*(flight ID) DISREGARD CPDLC DCL (type) CLEARANCE (description of clearance) AND DOWNLINK AN UNABLE RESPONSE (clearance)*” – this will be followed by the correct clearance information via voice as appropriate.

- Example: “American fifty-two, disregard CPDLC DCL altitude expect clearance to flight-level three five zero and downlink an unable response. EXPECT flight-level three one zero.”

If the controller terminates a CPDLC connection, the ground system will uplink a UM161 end service message.

3.16.2 En Route Flight Crew Termination

If the flight crew needs to terminate the CPDLC connection, the aircraft sends a disconnect request to the ground system, which terminates the connection.

3.16.3 Ground System Termination

If the ground system terminates a CPDLC connection, either due to the nominal case when a flight departs, or due to system error conditions (Appendix B), the ground automation will uplink a UM161 end service message.

After notification that the flight has taken off and the flight plan has become an active flight plan, for aircraft only participating in CPDLC DCL operations, the ground system will disconnect CPDLC with the aircraft at a parameter amount of time after departure. The disconnect time will be an adaptable parameter for each facility (currently set to five (5) minutes for aircraft that are not eligible to participate in En Route CPDLC operations). For aircraft participating in both DCL and En Route operations, the CPDLC connection will be retained by the ground system until a CPDLC connection is assigned to the appropriate En Route controller.

Note: Flight crews transiting to another FANS-supporting airspace (e.g., Oakland Oceanic, New York Oceanic) will need to log-on to the next FANS facility. No automatic transfer of the CPDLC connection will occur until En Route CPDLC services are established at the bordering ARTCC.

If ATC or the user deletes the flight plan, or if the flight plan times out of the En Route system, the ground system will prevent any further CPDLC message exchange and will disconnect CPDLC with the aircraft after a set time parameter (same time parameter as for when a flight becomes active). If the deletion involves multiple flight plans in the system, the CPDLC disconnect will occur on controller action.

3.16.4 Enable/Disable CPDLC Tower Service

If FAA personnel need to disable Tower CPDLC DCL Services, tower personnel:

- Will follow current procedures and notification mechanisms to notify users, e.g., NOTAM or D-ATIS¹⁹.
- Issue PDC clearances for CPDLC DCL flights that are eligible to “fallback” to PDCs. If the user has filed the appropriate codes in the ICAO flight plan and/or designated the appropriate preferences in the SDB, and the clearance has not yet been processed, the ground system will generate a PDC for any initial clearance that is otherwise eligible for a PDC. If the aircraft is not eligible for a PDC, the ground system will provide the controller with an indication, and the controller will revert to a voice clearance.

¹⁹ D - ATIS - Digital Automatic Terminal Information Service.

- Issue clearances by voice for those flights which specified FANS CPDLC and did not specify 'PDC' as the fallback choice in the SDB or ICAO flight plan, or for which PDCs cannot be generated.

4 TAKEOFF AND TRANSITION TO CPDLC EN ROUTE AIRSPACE FOR CONNECTION AND FREQUENCY MANAGEMENT

Note: Some information may be repeated from section 3 – Ground Operations – Departure Clearance Service via CPDLC. This section also includes aircraft which enter En Route airspace from non-participating CPDLC DCL airports, adjacent ANSP²⁰ airspace, or when it is required to create/re-establish a new CPDLC connection.

4.1 Flight Plan

For flights that will participate in U.S. CPDLC operations, FOCs must file an ICAO FP and include the appropriate CPDLC equipage code (field 10 FANS and VDL²¹ Mode equipage, e.g., J4), aircraft registration number (REG in field 18), and relevant CPDLC codes for CPDLC DCL and en route service (DAT in field 18). Other remarks should be included as necessary in the field 18 for the airlines operational area.

4.2 VDL Capability for NAS CPDLC Services

4.2.1 Tower

For CPDLC DCL service, both VDL-Mode 0 (plain-old Aircraft Communications Addressing and Reporting System [ACARS]) and VDL-Mode 2 capabilities will be supported. However, the FAA has only contracted for VDL-Mode 2 service with the Network Service Provider and Mode 0 service availability is not guaranteed.

4.2.2 En Route

Currently, VDL-Mode 2 capability is required in the En Route environment. Alternate subnetworks may be authorized by the FAA, as described in Section 4.6 of the AC90-117.

The FAA will implement a mechanism to enable/disable support of non-VDL-Mode 2 in the En Route environment. If support of non-VDL-Mode 2 is disabled in the En Route environment, and the aircraft ICAO flight plan does not indicate that the aircraft is VDL-Mode 2 capable, after departure, CPDLC eligibility will be transferred from the tower automation system back to the En Route automation system and held at the National facility. After an adapted amount of time (five (5) minutes), the connection will be automatically terminated.

If non-VDL-Mode 2 support in En Route is disabled, airborne log on attempts will be rejected by the En Route automation system for aircraft that do not have VDL-Mode 2 capability indicated in the flight plan.

²⁰ ANSP – Air Navigation Service Provider.

²¹ VDL – VHF Data Link. VHF – Very High Frequency.

4.3 Log On

For the purpose of CPDLC connections, the domestic U.S airspace (twenty [20] En Route ARTCCs and all CPDLC equipped towers) will be considered a single ATC authority, and therefore a single data authority using a single identifier (KUSA). Accordingly, regardless of the aircraft's location within the domestic U.S. airspace, or approaching domestic U.S. airspace, the flight crew will log on using the single identifier. The advantage of the single data authority design, is that it requires flight crews to logon only once for each flight.

For the U.S. CPDLC implementation, FP correlation is separate from logon acceptance. Acceptance of a logon is based on there being at least one (1) FP, active or proposed, with a call sign and registration that matches that contained in the logon. Successful FP correlation is dependent on additional conditions (see section 4.4).

A flight crew may log on while on the ground (at either a CPDLC-equipped tower, or at a non-CPDLC equipped tower when there is coincidental network coverage allowing the logon to be received by the service provider and sent to the FAA ground system), or while airborne (either while flying within U.S. domestic airspace, or prior to entering U.S. domestic airspace).

If the logon is being performed at a non-CPDLC equipped tower or while airborne, the ground system will immediately check if the aircraft is approved for CPDLC en route services, and if the aircraft has VDLM2 capabilities. If the aircraft's flight plan does not contain "FANSE" or "FANSER" in the field 18 DAT/ indicator, or J4 in field 10, FANS and VDL Mode 2 equipage, the logon will be rejected.

If the logon was performed at a CPDLC equipped tower, and the aircraft is CPDLC DCL approved ("1FANS" is filed in field 18 DAT/ indicator, or, is indicated in the SDB), the aircraft will be capable of establishing a CPDLC connection with the tower that (nominally) will be maintained through departure.

Once the flight departs from the CPDLC equipped airport, the ground system will check if the aircraft is approved for en route CPDLC services and if the aircraft has VDLM2 capabilities. If the aircraft's flight plan does not contain "FANSE" or "FANSER" in the field 18 DAT/ indicator, or J4 in field 10, FANS and VDL Mode 2 equipage, the CPDLC connection previously established by tower will be terminated.

If the flight crew logs on to the U.S. ground system but does not have a connection, and then for any reason, re-logs on to KUSA, the ground system will close the previous logon and use the latest logon data.

4.4 Logon/Flight Plan Correlation

The logon/FP correlation process ensures that the correct aircraft is associated with a given FP. The logon/FP correlation application resides at both CPDLC National sites (ZLC and ZTL), with one always in the primary role and the other operating as a backup.

1. The flight crew sends a CPDLC log on to the ground system. (This can occur any time within four [4] hours of the proposed departure time or entry into U.S. airspace. An accepted logon that is not correlated with a flight plan is generally only kept for four [4] hours before it times out. The flight crew should attempt to log on at least five [5] minutes prior to the proposed departure time.)
2. The ground system sends an acknowledgement back to the aircraft as either accept or reject.
3. The ground system will attempt to correlate any accepted logon with a flight plan.
4. If correlation is successful, and other conditions are met, the ground system will send a connection request (CR1) to the aircraft
5. The aircraft will respond to the CR1 with a connection confirm (CC1).
6. Upon a successful CPDLC connection, the ATC ground system notifies the controller via a CDA or NDA symbol in the controller display associated with the aircraft, and the avionics notifies the flight crew of the availability of CPDLC service for the flight. Some avionics will provide an aural notification to the flight crew.
7. Unsuccessful connection initiation:
 - a. Automatic – If the automation system attempts to initiate a connection with an aircraft but is unsuccessful, there is no indication provided to the controller. If the flight crew thinks that they should have a CPDLC connection in the En Route environment, but does not, the flight crew may contact the AOC or ask the controller about the situation. The En Route controller will have the ability to query the system to help solve the issue.
 - b. Manual – If the flight crew queries the controller and the controller manually attempts to start a CPDLC connection, the system will reject the entry if the flight plan is not correlated with the logon. If the manual connection establishment entry is accepted but the CR1 does not result in a CC1, the controller will not receive an explicit failed indication, but the expected connection symbol would not be displayed, and this would indicate to the controller that manual connection establishment was unsuccessful.

4.5.2 Tower

The following events describe a departure from a tower facility with a CPDLC connection established.

- The tower releases the CPDLC connection and assigns the LDA to National after the departure message has been generated.
- National will perform a check to determine if the flight is approved for en route CPDLC services and to determine if the aircraft is appropriately equipped for VDL-Mode 2 operations (if support of non-VDL-Mode 2 is disabled).

- If the two checks pass, National will verify the connection still exists in the aircraft by uplinking a CR1 and receiving a CC1 in return.
- National will assign the LDA to the controlling En Route facility.
- The controlling En Route sector within the assigned ARTCC facility is identified via automation, and the receiving controller will have an indication of CPDLC eligibility.
- Subsequently, the flight crew will use normal voice check-in and altitude confirmation procedures once entering En Route airspace and the controller will mark that aircraft On-Frequency.
- Once CPDLC eligibility is established, and the aircraft is marked On-Frequency, CPDLC messages can be sent to the aircraft.

4.5.3 En Route

The following events will trigger an En Route connection initiation when an aircraft departs an airport without a CPDLC connection already established.

1. Automatic connection initiation:
 - a. In general, when departing a U.S. airport without a connection and entering En Route airspace, the earliest a CPDLC connection initiation should normally occur is when the TRACON initiates the track handoff (transfer initiate message) to En Route provided the flight crew has already logged on.
 - b. If the flight crew has not already logged on, then connection initiation would immediately follow logon acceptance/correlation, provided ERAM is the controlling facility for this aircraft or has received a transfer initiate message.
 - c. Normally, the En Route automation system will automatically initiate a connection with an airborne IFR aircraft that does not already have a connection using the following triggers and conditions:
 - i. Triggers for automatic connection initiation:
 - Receipt of correlated logon data;
 - Establishment or re-establishment of a paired track²², unless flight is originating from external FIR;
 - Establishment or re-establishment of surveillance track data, unless flight is originating from external FIR;
 - Change of an aircraft trajectory predicted altitude from below a locally adapted connection establishment altitude to above;
 - Receipt of a transfer initiate message.

²² 'Paired Track' refers to the ground system automation's correlation of aircraft track surveillance data and an aircraft flight plan.

- ii. Conditions (all of which must be met) for automatic connection initiation:
 - The aircraft has a correlated logon, and
 - The aircraft is paired (unless originating from an external FIR), and
 - The aircraft has surveillance track data (unless originating from an external FIR), and
 - The aircraft trajectory predicted altitude is above a locally adapted connection establishment altitude, and
 - ERAM is the controlling facility for this aircraft or has received a transfer initiate message.

Note: The ground system will provide the capability to adapt altitudes below which automatic CPDLC connection initiation is prohibited for active flight plans. This addresses flight deck concerns, expressed by the flight crew community, regarding aural CPDLC alerts at low altitudes.

2. Manual connection establishment

- a. The controller with track control can manually initiate a connection with an IFR aircraft. When the controller makes an entry to manually initiate a connection, the only condition that does not apply is the minimum altitude for connection establishment.

Note: Training and procedures will need to address the concern of aural alerts from connection establishment at low altitudes.

4.5.4 En Route Connection CDA Confirmation

After successful initiation of a CPDLC connection by the En Route system (rather than established by TDLS), the En Route system will uplink a CDA confirmation message to confirm that the connection is recognized by the aircraft as a CDA connection. A UM169 free text message containing adapted text (e.g., CONFIRM CPDLC CONTACT WITH KUSA. ROGER/ACCEPT THIS MESSAGE) is used for this uplink.

The flight crew's ROGER or STANDBY downlink response will confirm that the ground system is indeed the CDA.

After the first free text uplink is sent, if no response is received (i.e., timeout), the uplink is retried two (2) more times. CDA confirmation messages will not be uplinked to aircraft that depart from a CONUS airport with a connection. For these aircraft, the system simply coordinates transfer of the CPDLC eligibility from the TDLS facility to the ARTCC/sector with track control for that aircraft.

The controller is unaware of the CDA confirmation message uplinks because these are uplinked by the National application. Until the connection is confirmed to be a CDA connection, CPDLC eligibility will not be assigned to an ARTCC controller.

If the aircraft responds with DM63 NOT CURRENT DATA AUTHORITY, the connection is designated an NDA connection. In this case the ground will retry the CDA confirmation uplink after a preset amount of time (e.g., two [2] minutes). The process is repeated as long as the aircraft continues to respond with NOT CURRENT DATA AUTHORITY, or the connection is terminated, or the preset maximum number of retries is reached. Once the flight crew responds to the uplink with a ROGER, the ground system will designate the connection a CDA connection.

4.6 Blocked List

The following events will result in an aircraft registration being added to the blocked list:

- National receives fifty (50) logons within fifty (50) seconds from the same aircraft registration.
- Aircraft registration manually added to the blocked list by ARTCC personnel when duplicate aircraft registrations are detected.

Aircraft registrations will manually be removed from the blocked list by an ARTCC personnel routinely or by operator request to the program office.

4.7 Eligibility Assignment

The system will manage which tower, or En Route facility and sector, has CPDLC eligibility for an aircraft.

4.7.1 Tower

When a tower marks an aircraft as looking for a connection as a result of a CPDLC DCL approval, and the FP correlates with a logon, the tower is granted eligibility to initiate a CPDLC connection. After that flight plan is set to active, i.e., the flight departs, CPDLC eligibility will be released by the tower facility, held at National, and then assigned by the system to the first En Route CPDLC-capable sector with track control of that aircraft, and subsequently passed from sector to sector in domestic En Route airspace.

4.7.2 En Route

When the CPDLC connection is established by an En Route facility, eligibility will be assigned to the sector with track control. As the aircraft moves from ARTCC to ARTCC, eligibility will be managed by the system, and typically, is transferred in conjunction with a TOC associated with the transfer of track control, which is covered later in this document. The sector with eligibility will show a CPDLC eligibility symbol. All other sectors will display a CPDLC connection symbol.

Note: There will be times when no sector has CPDLC eligibility for an aircraft (i.e., during the time the aircraft is transitioning through TRACON airspace or when a facility does not have CPDLC enabled). During these times, the system will hold eligibility at National and automatically respond to a flight crew request with an UNABLE and a UM169 containing CPDLC NOT IN USE UNTIL FURTHER NOTIFICATION. See Figure 3 below.



Figure 3 – CPDLC Not In Use Message with an Active Connection (B737 MCDU Test Bench – FAA Tech Center)

4.8 En Route Re-logout with a Connection

If the flight crew has a connection with KUSA and re-logs on to KUSA, the existing connection will be terminated with an END SERVICE uplink, any open uplinks will be closed in the ground system, and those uplinks will be displayed in the failed status to the controller. This is done to ensure that the ground system and the avionics are in sync in regard to connection status. The flight crew will be able to re-establish a connection with KUSA by sending a subsequent logon request. Any CPDLC messages that were failed as a result of the termination would have to be coordinated between the controller and flight crew via voice.

4.9 Transfer of Communications

TOC messages into another facility (e.g., ARTCC/TRACON), as well as TOC messages into another sector within the same facility (e.g., sector/sector), will always use the CONTACT message.

CONTACT TOCs require the flight crew to check in with the receiving controller via voice, and to confirm the assigned altitude.

4.10 Nominal Case

In order to send any CPDLC message, including a TOC, to an aircraft, a controller must have eligibility for that aircraft, and the aircraft must be marked on-frequency at that sector. CPDLC eligibility and on-frequency information is indicated near the aircraft call sign on the controller's display.

Upon each ATC transfer of track control, a Held TOC will be built and available for uplink at the sector with CPDLC eligibility. When the controller is ready to uplink a TOC message, that controller will select one of the available Held TOCs, and may modify the frequency pre-selected for that Held TOC before uplink.

4.11 Off-Nominal Cases

The ground system will prohibit the uplink of a TOC under certain conditions, i.e., when an open controller initiated uplink exists, or when an IC mismatch, abnormally closed uplink, or emergency downlink has not yet been acknowledged by the controller. In these cases, the controller may either first resolve the condition and then proceed to uplink the TOC, or direct the frequency transfer via voice.

4.11.1 Abnormal Transfers

When an ARTCC into which an aircraft is being transferred does not have CPDLC On, a CONTACT message will be sent, and the CPDLC eligibility token will be released to and held at National, until the aircraft enters a facility with CPDLC On, or meets other conditions for terminating the connection (i.e., flight plan deletion in the ground system).

4.11.1.1 When an aircraft is handed off to a TRACON, and no TOC is uplinked

Within a given ARTCC, if that TRACON is the landing TRACON, or if the aircraft will be passing through that TRACON into the landing TRACON in that ARTCC, and no TOC is uplinked, connection termination will occur as follows:

- If the aircraft is above an adapted altitude, the connection for that aircraft will be terminated when the controller releases CPDLC eligibility. Releasing of eligibility can be triggered by a number of events including controller marking an aircraft off frequency after the track handoff to TRACON is complete.
- If the aircraft is not above an adapted altitude (designed to avoid nuisance alerts on the flight deck during critical phases of flight), the connection will not be terminated until after ground system flight plan removal for that flight (e.g., after landing).

Within a given ARTCC, if that TRACON is not the landing TRACON, yet the aircraft is not re-entering that ARTCC's airspace, and a TOC is not uplinked, connection termination will occur as follows:

- If the aircraft is above an adapted altitude, and within an adapted distance of its destination, the connection for that aircraft will be terminated when the controller releases CPDLC eligibility.
- If the aircraft is either not above an adapted altitude or not close enough to its destination, the connection will not be terminated until after ground system flight plan removal for that flight (e.g., after landing).

Lastly, if an aircraft will be re-entering the ARTCC's airspace from the TRACON to which it was handed off, and a TOC is not uplinked, the connection will remain. CPDLC eligibility will be re-assigned to an ARTCC sector upon re-entry into the ARTCC.

Operational Rationale: Scenario – If the controller hands off an aircraft but does not uplink a TOC, and transfers the aircraft on voice, then having completed the transfer, the controller often simply drops display of the data block. CPDLC eligibility would be released and the system would automatically attempt to assign eligibility to an En Route sector if one had track control. In the case of a handoff to Approach, the National CPDLC service would hold eligibility until other system conditions trigger an automatic connection termination.

4.12 TOC CONTACT Message Flow

The controller will uplink:

- UM117 CONTACT [icao unit name] [frequency]
- Example: CONTACT INDY CENTER 126.750 MHZ
- Example: CONTACT MONTREAL CENTER 124.65 MHZ
- Example: CONTACT NY ARINC RADIO CENTER 11352 KHZ, RADAR SERVICES TERMINATED

Note: When the UM117 CONTACT message is uplinked to an aircraft entering non-radar airspace, the UM154 RADAR SERVICES TERMINATED message may be concatenated to the UM117 message element.

When the aircraft receives a CPDLC TOC message, it will alert the flight crew via an aural (some aircraft) and/or visual means to indicate the aircraft has received a CPDLC message that is to be acted upon.

The flight crew will select the message, review the CONTACT message independently, confer between them the message content, input the new ATC frequency into the radio tuning panel and ensure it is active, respond to the CPDLC message appropriately, and then call the receiving controller via voice with their call sign and altitude confirmation (GOLD Section 5 flight crew procedures for reviewing uplinked CPDLC messages).

Upon receipt of the WILCO Response to the CONTACT message, CPDLC eligibility is transferred to the receiving sector and the on-frequency indication is automatically removed from the transferring sector. When the flight crew checks in via voice, the receiving controller will confirm the assigned altitude and mark the aircraft as on-frequency. For inter-facility transfers, the receiving controller will also verify the Mode C of the aircraft.

4.13 CPDLC Status

When flying in U.S. Domestic En Route airspace, flight crews will automatically be notified when the CPDLC "in use" status changes to OFF. Normally, upon exiting a CPDLC ON ARTCC, CPDLC eligibility is momentarily passed through National and "immediately"

directed to the next CPDLC ON ARTCC and to the sector with track control in the facility. When CPDLC is not ON in the next facility, National will wait momentarily (currently set to 1 minute) to allow an ARTCC to request eligibility. When no facility requests eligibility, the system will uplink notification to the flight crew in an adapted UM169 free text message containing CPDLC NOT IN USE UNTIL FURTHER NOTIFICATION.

Through experience and training, flight crews will already be aware that TRACONs will not have CPDLC. Therefore, there is no need to uplink a possibly distracting message notifying them when transitioning from either tower or En Route into the TRACON environment. Additionally, the U.S. Domestic CPDLC En Route system will not monitor the CPDLC status of non-domestic facilities; therefore, the ground system will be unable to advise the flight crew of the adjacent ATSU²³ CPDLC capability/status.

Flight crews will not be explicitly notified when transitioning from CPDLC not in use back into a CPDLC in use state. The first uplink from the controller will signify that CPDLC is in use.

During the time that CPDLC is not in use and CPDLC eligibility is not assigned to a sector, any non-emergency flight crew request will be responded to with an adapted UM169 free text message containing CPDLC NOT IN USE UNTIL FURTHER NOTIFICATION.

4.14 Connection Termination

4.14.1 Connection Termination Uplinks

Both the Tower and En Route ground systems will use the UM161 END SERVICE message for terminating connections.

4.14.2 Automatic Connection Termination

The system will automatically terminate a CPDLC connection upon any of the following:

- Receipt of a WILCO to a TOC generated due to track control transfer to an approach control facility when that flight will not re-enter En Route airspace. Determination of whether the flight will re-enter En Route airspace is done once, at the time of the TOC uplink. If a TOC is not sent in conjunction with the handoff to the TRACON, the connection will be terminated according to the conditions outlined for “abnormal transfers” (Section 4.11.1), or when the flight plan is removed from the ground system (typically after landing or a parameter amount of time after the aircraft departs U.S. airspace).
 - TOC + End Service
 - This handles multiple cases – handoff to landing TRACON and handoff to TRACON when not re-entering En Route.

²³ ATSU – Air Traffic Services Unit.

- Receipt of a WILCO to a voice radio frequency uplink independent of track control transfer, when the controller specified termination of the CPDLC connection.
 - Frequency + End Service
 - This handles the case where a TOC cannot be generated, i.e., when an automated handoff capability to an adjacent FIR does not exist. Uplink of HF²⁴ frequencies will support transfer to Oceanic FIRs.
- When the sector with CPDLC eligibility enters Visual Flight Rules (VFR) altitude in the Flight Data Block (FDB) altitude field (requires logic override).
- When an aircraft's flight plan is deleted from the En Route automation system.
- When a controller enters a flight plan amendment to change the ACID (Aircraft ID Code, i.e., call sign) of a flight with a CPDLC connection (requires logic override).
- When support for non-VDL Mode 2 equipped aircraft is adapted as OFF, and such an aircraft departs with a connection, CPDLC eligibility will not be assigned to an En Route sector, and the aircraft's connection will be terminated after a parameter amount of time after eligibility has been released by TDLS.
- When the flight crew does not accept the CDA confirmation message after three (3) uplink attempts.
- When an aircraft's registration is added to the blocked list.
- When penetrating Terminal Radar Approach Controls (TRACONS) as described in the Off-Nominal Cases, Abnormal Transfers section (section 4.11.1).
- When a controller amends an aircraft's flight plan to indicate non-VDL2 equipped and support for non-VDL-2 equipped aircraft is Off.
- When a flight plan amendment with a change to the DAT/ code is received indicating that the flight is no longer approved for en route CPDLC services.
- When an aircraft enters a CPDLC OFF facility and will either be landing in that facility or exiting to an external FIR (termination will occur after an adapted amount of time, nominally 5.5 minutes).

Note: Except for the Abnormal Transfer cases into or through TRACONS, for these automatic termination conditions, there is no ground system enforced minimum altitude for connection termination. Not distracting the flight crew with an audible alarm on the flight deck as a result of connection termination during the critical phases of flight will be addressed via controller training.

4.14.3 Manual Connection Termination

Connection termination may also occur as the result of a controller or flight crew initiated termination. Some of these termination events determine whether auto connection initiations will be performed with an aircraft.

The system will allow the controller to manually terminate a CPDLC connection with an aircraft. Situations where a controller might manually terminate the CPDLC connection with an aircraft are:

²⁴ HF – High Frequency.

- Upon transferring that aircraft to a non-domestic ATC authority.
- Inbound to an un-controlled airport.
- Following voice handoff to non-radar approach controls and VFR Towers.
- When a particular aircraft consistently fails to respond to CPDLC messages.

When a controller or supervisor manually terminates a CPDLC connection for an aircraft, the system will:

- Uplink the End Service message (UM161),
- Close or fail any open CPDLC messages for that aircraft, and
- Provide a FAIL indication to the controller if the CPDLC message failed, and
- Remove the logon from the ground system.

When the ground system receives an unsolicited DR1, the system will:

- Fail any open CPDLC messages for that aircraft,
- Provide an indication to the controller, and
- Remove the logon from the ground system.

Subject to conditions and checks described in section 4.5 – Connection Establishment, the aircraft may be able to re-establish the CPDLC connection by manually logging on.

5 EN ROUTE CLEARANCES VIA CPDLC

5.1 Operational Assumptions

All properly equipped FANS aircraft are eligible to participate, and flight crew will be properly trained.

For the ground automation to build route messages that load in the FMCs, the ground automation assumes both the aircraft and current ground automation routes match before a route amendment is applied and uplinked.

FAA personnel have the ability to turn CPDLC OFF at each En Route facility. All En Route communication and clearances must be performed via voice while CPDLC is OFF.

5.2 Use of Pilot Free Text

Flight crews may add a “DUE TO” clarification (DM65 DUE TO WEATHER or DM66 DUE TO AIRCRAFT PERFORMANCE only) to the REJECT/UNABLE of a CPDLC clearance, however, they should not add a “DUE TO” clarification comprised of free text (DM67) - revert to ATC voice procedures with the controller after sending the “REJECT/UNABLE” response if clarification is required. If the flight crew appends a clarification comprised of free text to a DM1 UNABLE, the controller will receive the UNABLE portion without the free text rationale, and the ground system will uplink a free text UM169 message: “UNABLE RECEIVED. FREE TEXT/DUE TO REASON NOT SHOWN TO ATC”.

Similarly, if the flight crew appends free text to a DM38 ASSIGNED ALTITUDE [altitude], the ground system will accept and process the DM38 without the free text rationale and will uplink a free text UM169 message: “ALTITUDE REPORT RECEIVED. FREE TEXT NOT SHOWN TO ATC”.

Flight crew free text use (outside of the emergency menu), whether sent alone or concatenated to a supported CPDLC message (excluding a DM1 and DM38), will result in an automatic UM0 UNABLE sent by the ground system with appended error free text “MESSAGE NOT DELIVERED. FREE TEXT/DUE TO REASON NOT SUPPORTED. CONTACT ATC OR RESEND REQUEST”. The controller will be unaware that the free text message transaction took place.

5.3 Abnormal Uplink Conditions

In the event an uplink message cannot be delivered to the aircraft, the CSP will generate a Message Assurance message to notify the ground system and controller of the failure. The ground system will remove the uplink in progress indication, cancel the pilot response timer, and display the NOT SENT (NS) abnormal uplink indicator to the controller. The controller can acknowledge the abnormal uplink indicator and subsequently re-issue the clearance using CPDLC or over voice. A NOT SENT condition will also be produced if a route clearance exceeds the 1245 character limit and fails the character length check.

If the flight crew responds to an uplink with an UNABLE, or the uplink is closed due to an ERROR condition, the uplink is now closed and the controller's uplink in progress indicator is replaced with an abnormal indicator (UNA or ERR). This condition must then be subsequently acknowledged by the controller. The controller may then contact the flight crew via voice and subsequently re-issue the clearance using CPDLC or over voice.

In the event that an open uplink exists when the CPDLC connection is terminated, the ground system will remove the uplink in progress indication, cancel the pilot response timer, and display the FAIL abnormal uplink indicator to the controller. The controller must then acknowledge the abnormal indicator and contact the flight crew via voice.

If a CONFIRM ASSIGNED ALTITUDE message closes abnormally, a special Abnormally Closed CAA Uplink Indication is displayed to the controller.

In the case of a route clearance uplink, when the new routing was rejected, or closed with an error, there would now be a discrepancy between the currently cleared route in the ground system, and the route currently loaded in the aircraft. Flight crew and controller procedures will drive flight crew and controller actions to resolve this discrepancy.

5.4 En Route Route Clearance Services

The routes service will support the flight crew initiated request for direct-to-fix, controller initiated direct-to-fix, and some scenarios of ground initiated routes (TFM²⁵ provided and controller initiated).

Each facility can disable the Initial Services Routes functionality; Altitudes are coupled with Routes and both would be disabled together. While the services are disabled, controllers will be unable to uplink any route or altitude clearances to aircraft, and any downlinked flight crew route and altitude requests received after the service is disabled will not be shown to the controller and a rejection message will be provided to the pilot. Controllers will have the ability to only respond with UNABLE to a flight crew route and altitude requests that had not been closed prior to the service being disabled. The ground system will still accept flight crew responses to route and altitude uplinks sent prior to the service being disabled.

5.4.1 Operational Context for Flight Crew Initiated Request for Direct To

The messages used to request a direct-to-fix are shown in Figure 4. The steps of this scenario are summarized in Table 1.

²⁵ TFM – Traffic Flow Management.

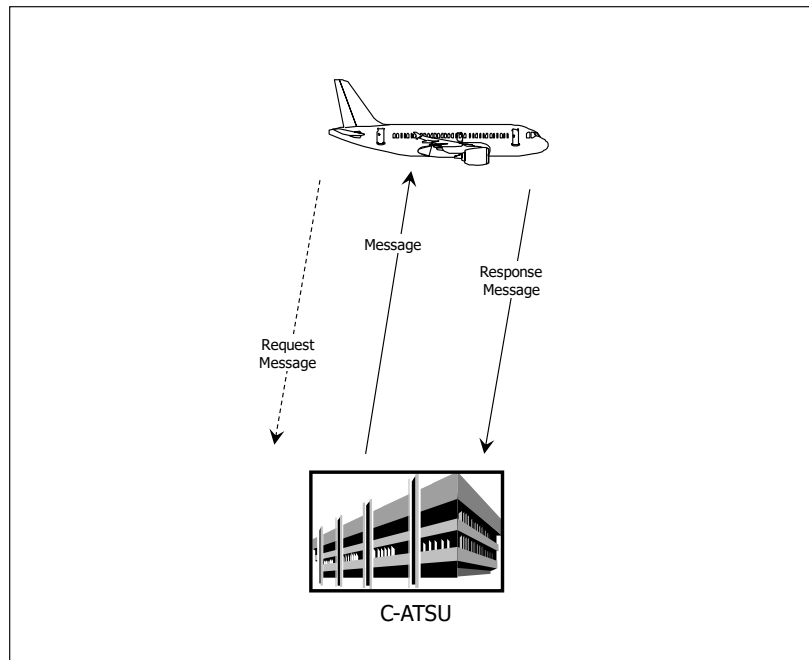

Figure 4 – Flight Crew Initiated Request for Direct To or Request For Reroute

Table 1 – Operational Steps for Flight Crew Initiated Request for Direct to Routing

Step	Operating Method
1	The flight crew sends a CPDLC downlink message, e.g., DM22 REQUEST DIRECT TO [position].
2	Upon ATSU system receipt of DM22, the controller is notified.
3	The controller may respond with a UM1 STANDBY.
4	Upon aircraft system receipt of the STANDBY, the flight crew is notified.
5	If the controller can accommodate the flight crew's request, the controller responds to the downlink with UM74 PROCEED DIRECT TO [position]. The ground system will concatenate UM169 REST OF ROUTE UNCHANGED to any route uplink, except when the clearance includes the destination. If the controller cannot accommodate the flight crew's request, the controller responds to the downlink with UM0 UNABLE.
6	Upon aircraft system receipt of the response message, the flight crew is notified. If the controller sent a UM74, the flight crew views the message and loads it into the FMC (if applicable).
7W	If the flight crew can comply with the direct to, the flight crew responds with DM0 WILCO.
7U	If the flight crew cannot comply with the direct to, the flight crew responds with DM1 UNABLE.

5.4.2 Operational Context for Controller Initiated Direct To

The controller can initiate a direct to clearance through a keyboard command. The steps of this scenario are described, and they are summarized in Table 2. Figure 5 shows the uplinks and downlinks between the aircraft and ground.

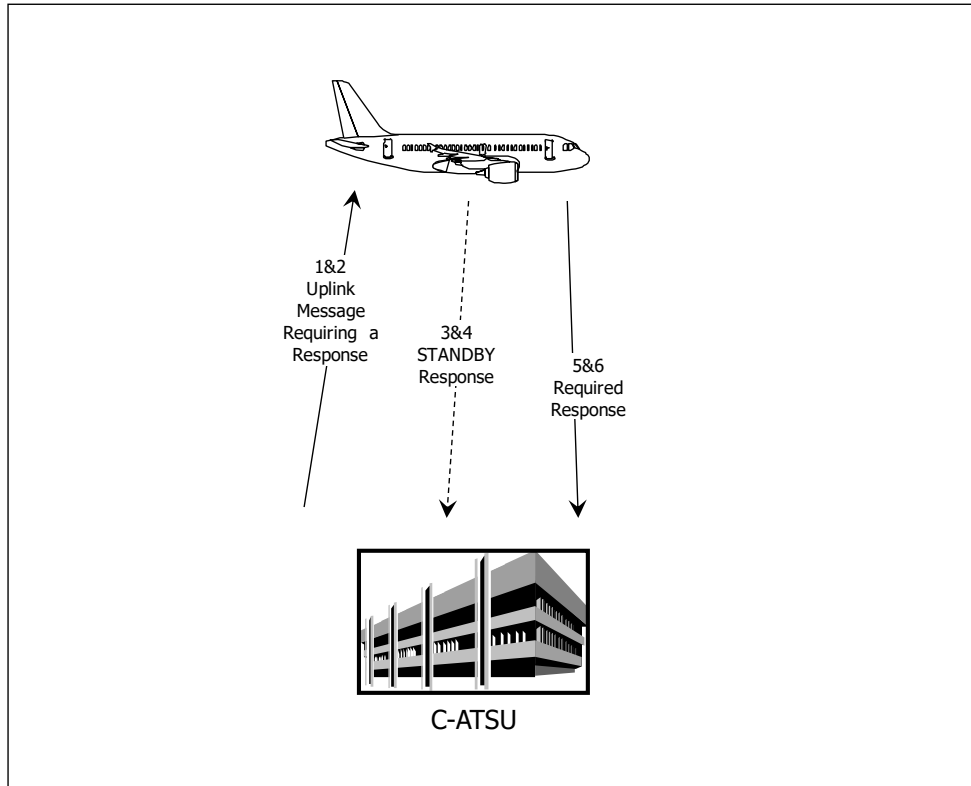

Figure 5 – Controller Initiated Direct To or Controller Initiated Reroute

Table 2 – Operational Steps for Controller Initiated Direct to Routing

Step	Operating Method
1	The controller sends a CPDLC message for direct routing to a fix that is on the aircraft's currently cleared route, UM74 PROCEED DIRECT TO [position] is concatenated with UM169 REST OF ROUTE UNCHANGED, unless the [position] is the destination airport. When the CPDLC message is sent, the controller is provided an indication that the message is open (in progress).
2	Upon the aircraft's system receipt of a CPDLC message requiring a response, the flight crew is notified. The flight crew reviews the uplink, and if the message is loadable, the flight crew loads the clearance in the FMC.
3	The flight crew may respond with a DM2, STANDBY.

Step	Operating Method
4	Upon ATSU system receipt of the DM2 STANDBY, the controller is not notified, but the STANDBY response can be viewed.
5W	After the flight crew has determined that they can comply with the direct to, the flight crew responds with a DM0 WILCO.
5U	If the flight crew cannot comply with the direct to, the flight crew responds with a DM1 UNABLE. The flight crew may append DM65 DUE TO WEATHER or DM66 DUE TO AIRCRAFT PERFORMANCE (see table note).
6	Upon ATSU system receipt of the flight crew response: <ul style="list-style-type: none"> • When the response is WILCO, the uplink in progress indication is removed, or • When the response is an UNABLE or NEGATIVE, the uplink in progress indication is replaced with an abnormal indication.
	<i>Note: DM65 and DM66 are the only UNABLE/Reject reasons supported by the ground system.</i>

5.4.3 Operational Context for Ground System Initiated Reroute

A ground system initiated reroute could occur for several reasons, including a TFM generated reroute or a controller initiated reroute. The following operational method in Table 3 is intentionally written to be generic and capture both types of ground system initiated reroutes. In this example, there are several options for the type of route uplink that could be sent including UM74, UM79, and UM80.

Table 3 shows the messaging for a ground system initiated reroute.

Table 3 – Operational Steps for Ground Initiated Reroute

Step	Operating Method
1	The controller sends a CPDLC message for reroute, UM79 CLEARED TO [position] VIA [routeclearance] + UM169 REST OF ROUTE UNCHANGED. (Alternatively, the ground could build a reroute message with UM80 CLEARED [routeclearance], or even a UM74 PROCEED DIRECT TO [position].) Note that for TFM provided reroutes, UM169 [TRAFFIC FLOW MANAGEMENT REROUTE] will also be prepended to the uplink.
2	Upon aircraft system receipt of the uplink, the flight crew is notified. The flight crew reviews the uplink and loads the clearance in the FMC.
3	The flight crew may respond with DM2, STANDBY.

Step	Operating Method
4	Upon ATSU system receipt of DM2 STANDBY, the controller is not notified but the STANDBY response can be viewed.
5W	After the flight crew has determined that they can comply with the new route, the flight crew responds with a DM0 WILCO.
5U	If the uplink is unacceptable (a partial load occurs or an irresolvable discontinuity results), the flight crew responds with a DM1 UNABLE. The flight crew may append DM65 DUE TO WEATHER or DM66 DUE TO AIRCRAFT PERFORMANCE if those reasons apply (see table note).
6	Upon ATSU system receipt of the flight crew response: <ul style="list-style-type: none"> • When the response is WILCO the uplink in progress indication is removed, or • When the response is an UNABLE or NEGATIVE, the uplink in progress indication is replaced with an abnormal indication.
	<i>Note: DM65 and DM66 are the only UNABLE/Reject reasons supported by the ground system.</i>

5.5 Considerations for Loadable Content

In general, the ground should uplink as much loadable content as possible. The intention is to leverage the capability of auto-loading routes which will reduce workload and input errors for flight crews. The ground system should also construct messages so the least amount of repeat material is uplinked to the cockpit (except as noted below). Reducing the amount of clearance material that the flight crew and controller must review will improve response times and reduce errors. The best example of this is to, when possible, uplink a UM79 which rejoins a position on the current route, rather than uplinking a UM80 which replaces the entire route.

For messages with loadable content, if no load prompt is displayed on the FMC, this may indicate a partial clearance load, or that a load failure exists, and the flight crew is expected to reject (DM1 – UNABLE) the uplink message and revert to voice. In the event the first route element is past or too close to the current aircraft location by the time the route is loaded, the flight crew would be expected to go to voice for further guidance before accepting or rejecting the clearance.

5.6 General Guidance for All Uplinks

The ground system should follow all ASN.1 data definition rules for route construction from DO-258A. As a result, radials cannot be uplinked as they are not defined in the ASN.1.

When using the [position] parameter, the ground should only use published elements and follow data definition rules from DO-258A for fixnames, NAVAIDs, airports, latitudes/longitudes, and Place Bearing Distances (PBDs) This rule will resolve issues

such as non-published intersections, Very High Frequency Omni-Directional Ranges (VORs) coded as airports, XXX (incomplete route indicator), and some problems with duplicate waypoints.

- For example, when sending uplinks with [position], the ground should code the position appropriately as a fixname, NAVAID, airport, latitude/longitude, or PBD.

When using the [procedure] parameter, the ground should follow data definition rules from DO-258A.

When using the [position] parameter with fixnames, NAVAIDs, and airports, the ground should only uplink fixnames, NAVAIDs, and airports that are published in the current ground navigation database. This rule will resolve ghost intersections.

When using the [procedure] parameter, the ground should only uplink [procedurenames] that are published in the current navigation database.

5.7 Guidance for constructing a [routeclearance]

As a reminder, the ground should choose the message that uplinks the least amount of repeat material to the cockpit. The ground should also choose the uplink that will minimize/eliminate the number of partial loads or load failures for various fleet types, and many of the rules in this document are written to achieve that goal.

5.8 General [routeclearance] Instructions

The ground will include the optional latitude/longitude field for published identifiers (waypoint names) in the route information variable of [routeclearance] uplinks.

If the [routeclearance] in an uplink contains an arrival procedure and transition, then the last waypoint in the [routeinformation] must be the same as the first fix in the transition (if specified) or the procedure (if a transition is not specified). If the uplink contains a transition, the transition name must be included in the [proceduretransition] field of the [procedurename] variable. A route clearance uplink may also contain a procedure without including a transition if the arrival common point is the last fix in the [routeinformation]. If the [routeclearance] in an uplink contains a departure procedure/transition, then the first waypoint in the [routeinformation] must be the same as the last fix in the transition (if specified) or the procedure (if a transition is not specified).

- For example, the following uplink abides by this rule, as SXC is the first point of the LEENA6 arrival procedure, so it must be listed last in [routeinformation]:
- UM80: Cleared [routeclr]
dest airport(): KLAX
arr procname(): ARR,LEENA6
route info(): 4
 (pub): MANEY
 (pub): DUETS
 (pub): DINTY

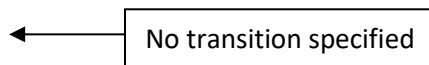

(pub): SXC

- For example, the following uplink abides by this rule, as FICKY is the first point of the FICKY transition, so it must be listed last in [routeinformation]. Additionally, the FICKY transition is included in the [proceduretransition] field:

UM80: Cleared [routeclr]

dest airport(): KLAX

arr procname(): ARR,LEENA6,FICKY

route info(): 4

(pub): MANEY

(pub): DUETS

(pub): DINTY

(pub): FICKY

FICKY transition specified



When an uplink includes the [proceduretransition] variable in a [routeclearance], the ground must use published, named transitions and arrival procedures. For example, the ground cannot uplink PIECH.TUDOR2, where PIECH is coded as the procedure transition, because PIECH is not a published arrival transition. Instead, the ground must use the published transition names for the TUDOR2: LMT, LKV, or RBL in the [proceduretransition] variable.

For messages using the [routeclearance] parameter, a common waypoint must exist between the flight segments listed here to avoid discontinuities in the uplink:

- A departure procedure/transition and the En Route segment.
- The En Route segment and the arrival/transition.
- The arrival and the approach/transition.
- The En Route segment and the approach/transition.
- A departure procedure/transition and the arrival/transition, or approach/transition (if there is no En Route segment).

5.9 Airways in a [routeclearance]

For the clearance to load properly, the ground system must use published named waypoints to designate airway entry, termination, and intersection points. Note, that this rule is an update to the previous guidance given for [airwayidentifier] in DO-258A, Table 4.6-33 [routeclearance] Variables.

As a consequence of this rule, the first element in the route cannot be an airway. Instead, a published identifier specifying the airway entry point must precede any airway in the [routeclearance] element.

For example, the following uplink is properly constructed for a route with multiple airways:

UM80: Cleared [routeclr]

orig airport(): KEWR

dest airport(): KSFO

arr procname(): ARR,MOD4,OAL

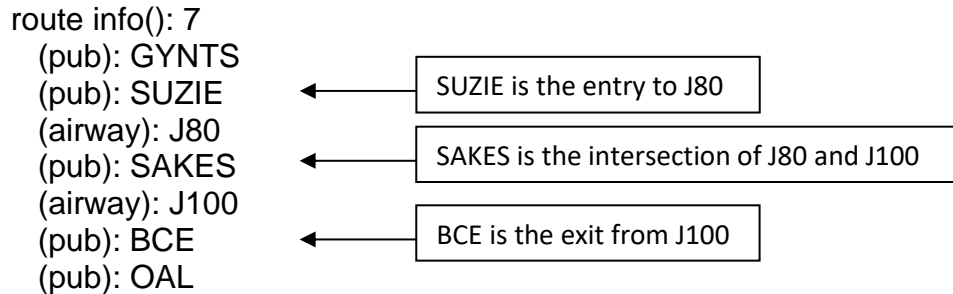

If a published waypoint at an airway intersection does not exist, the ground will not uplink that route clearance.

If no published identifier exists between the aircraft's current position and the intersecting airway, the ground cannot send this type of clearance.

5.10 Message Specific Instructions

For all route uplinks, the first element needs to be a point that is some distance ahead of current aircraft position (X minutes or X miles). The intent is to not send a route point that has already been overflown. This is even more important when that first route point is the first divergent (turn) point from the previous route.

While there is currently no intention to implement automation support (logic) for guarding against this possibility, controller procedures and training will include awareness of this potential issue.

5.10.1 UM74

UM74 PROCEED DIRECT TO [position] will insert a direct leg from the aircraft's present position to the specified fix.

- The specified position will be on the aircraft's current route. Allowed waypoint types are: NAVAID, fixname, airport, latitude/longitude, and PBD.
- Uplinking "PROCEED DIRECT TO [position]" where the position is the destination airport will result in clearing all route points and arrival/approach procedures in the aircraft's route.

5.10.2 UM79

UM79 CLEARED TO [position] VIA [routeclearance] will replace everything in the route before the "TO" position with the [routeclearance] contents.

- The specified "TO" position in a UM79 must be a point in the aircraft's current flight plan.
- The ground will concatenate a UM79 with the free text message, "Rest of route unchanged."

- The specified “TO” position must be a point after the SID or the SID transition (if these are present), up to but excluding the first point in the arrival, approach, or associated transition in the aircraft’s active route.
 - If the Arrival routing into which the UM79 rejoins the route is in the current route, the specified “TO” position may also be any point on that current route (including points downstream of the published Transition and common points).
- For a UM79, when the “TO” point is not an airway termination, the ground system will not include the “TO” point as the last element in the [routeinformation] field. For a UM79, when the “TO” point is an airway termination point, the ground system will include the “TO” point as the last element in the [routeinformation] field after the airway.
- This example message illustrates this rule:
 UM79: Cleared To [pos] Via [routeclr]
 pos(nav): BOS
 route info(): 4
 (pub): BREZY
 (pub): PACER
 (airway): J42
 (pub): BOS ← BOS is repeated in routeinfo
- The ground system will not include the arrival airport as the [position] in a UM79.
- Guidance about when to use a UM79:
 - When the ground wants to replace the route from the aircraft’s present position leading up to a point. UM79s only replace a segment of the route.

5.10.3 UM80

UM80 CLEARED [routeclearance] will replace everything in the route with the [routeclearance] contents.

- UM80s should always be defined from the next fix from the aircraft’s current position to the destination. Therefore, the ground should never concatenate the free text message, REST OF ROUTE UNCHANGED with a UM80.
- Reference GOLD 6.1.3.8, ATC should only use a UM80 CLEARED [routeclearance] to issue CPDLC reroute clearances if the route is specified from the aircraft’s present position to its destination. All forecast weather data is lost from the FMS when the new route is activated.
- For military aircraft, the clearance limit may mean destination airport.
- A UM80 should be used when the ground needs to send arrival procedures.
- Guidance about when to use a UM80:

- This message is ideal for non-airborne reroutes or pre-departure clearances when the ground needs to change the aircraft's route in its entirety.
- In general, the ground should avoid using a UM80 if only a segment is to be changed. However, there are cases (e.g. changing the Arrival procedure) where the use of a UM80 is required.

5.10.4 UM83 (Future Use - Currently Switched Off)

UM83 AT [position] CLEARED [route clearance] will replace everything in the route after the specified AT position with the [route clearance] contents. A UM83 will always include routing to the destination.

While the UM83 is preferred to the UM80 as it only replaces a portion of the route, UM83s are not operationally implemented at this time due to latent avionics loading issues.

5.10.5 UM169

UM169 [free text] elements will include no more than 256 characters.

5.11 Guidance for Multi-Element Messages

While the current ground system design has no instances of multi-element uplinks where more than one message element is loadable, the following guidance is provided.

When an ATC clearance containing one or more loadable message elements is loaded into the route, all loadable elements will load sequentially. Non-loadable elements in the same uplink will be displayed, but will not be loaded and will not affect processing of the loadable elements in any way. Since loadable elements load sequentially, the order of the elements is important. For example, an element like UM61 (CROSS [position] AT AND MAINTAIN [altitude] AT [speed]) depends on the existence of the specified [position] in the route. If the same uplink also contains a UM80, which replaces the entire route and deletes any previous changes, then the UM80 should appear first, and UM61 should follow.

- A clearance that replaces the entire route (UM80) needs to be the first loadable element in an uplink.
- As general guidance, use of [route clearance] elements helps to reduce the potential for unintended loads that can result from concatenating multiple loadable message elements. The ground should use messages with the [route clearance] variable rather than piecing together multiple elements.

5.12 Guidance for Intercepting Arrival and Transition Procedures Midway

Aircraft operators and controllers have a need to intercept procedures mid-way through. For situations where an arrival or transition procedure is to be intercepted part way down, the ground will use the following guidance when the STAR is already loaded into the FMC:

- When an arrival is part of the current route, before a route modification, the ground will use a UM74 when the controller routes an aircraft direct to any fix on that arrival.
- When an arrival is part of the current route, before a route modification, the ground will use a UM79 when the controller uplinks a new route that joins a point on that arrival.

5.13 Controller Initiated Route Clearances

Route clearance uplinks, including airborne reroutes, will allow controllers to initiate and send control instructions and/or replace the entire route of the flight, or rejoin the filed flight plan route further downstream, with a loadable CPDLC clearance.

Airborne reroutes are one key component of the Data Comm Program, and will provide an expected stream of benefits to participating Operators and to the controllers initiating CPDLC clearances. Fuel savings, miles flown and time En Route, in addition to the safety and ease of FMC-loadable clearances, will enhance aircraft performance in the air.

The reduction of voice workload, repeating clearances, spelling out waypoints, and reduction of “hear back read back” events, will enhance and improve controller issuing of airborne reroutes.

5.13.1 Controller Initiated Direct-To-Fix

The controller may initiate a UM74 PROCEED DIRECT TO [position] uplink from the keyboard or the Route Menu area. The following messages may optionally be appended to a UM74:

- UM166 DUE TO TRAFFIC,
- UM167 DUE TO AIRSPACE RESTRICTION, or
- UM169 [free text] DUE TO WEATHER.

The [position] in a Direct-To-Fix uplink must be on the currently cleared route. When the [position] is any fix on the currently cleared route other than the destination the system will automatically append a UM169 REST OF ROUTE UNCHANGED.

The [position] has to be a published fix, not an airport in the middle of the route, nor an unacknowledged arrival route and can only occur once ahead of present position. The Direct-To-Fix clearance is subject to the General Pilot Response Timeout parameter

Examples of route elements not uplinkable to an aircraft:

- VFR/IFR in the route;
- Delay in route;
- Airport in the middle of the route;
- PBD with a distance greater than the allowable tolerance (700nm²⁶);
- Latitude/longitude with Cardinal directions;

²⁶ NM – nautical mile.

- Non-ICAO destination airport;
- Non-ICAO departure airport is caught while the flight is proposed;
- Departure airport followed by an airway or destination airport preceded by an airway;
- Locally adapted PBD with a national fix, whose PBD location is not within a tolerance (one [1] mile/0.5 degree) of the actual location.

Message example: UM74 PROCEED DIRECT TO [position] + UM169 [free text]

- PROCEED DIRECT TO RBV. REST OF ROUTE UNCHANGED.

Flight crew procedural guidance is suggested in other documents. The following is an example.

When the flight crew views the Direct-To-Fix message, they may select DM2 STANDBY and send the response to the ground system. The flight crew may then review, load, and execute the new instructions, and then press ACCEPT/WILCO which will downlink the DM0 WILCO response to the ground system, thus removing the uplink in progress indicator and cancelling the General Pilot Response Timer.

5.13.2 Controller Initiated Route Clearance

The controller may initiate route amendments and route uplinks through keyboard and Route Menu inputs. The controller does not, however, select which route clearance uplink message element to use for the uplink. The ground system automation will compare the route modification to the currently cleared route to determine which of the following messages to use for the uplink:

- UM79 CLEARED TO [position] VIA [routeclearance]
- UM80 CLEARED [routeclearance]

A UM80 will always include the routing to the destination airport, while a UM79 and UM74 will rejoin a point on the currently cleared route.

The controller may append DUE TO reasons to any route uplink except ABRR routes.

All uplinks containing the [routeclearance] variable (UM79 and UM80) will include a supplementary textual representation of the route modification and clearance text (e.g. CLEARED, CLEARED TO ... VIA, AT CLEARED) in the free text (UM169). In the event the FAA produced route string exceeds 256 characters, then the free text route will be truncated with a “./.” with the last modified route element as the last piece of information e.g., J94 FOD ./ LVZ. These uplinks are subject to the Route Pilot Response Timeout parameter.

Flight crew procedural guidance is suggested in other documents. The following is an example.

When the flight crew views a route clearance message they may select DM2 STANDBY and send the response to the ground system. The flight crew may then review, load and

execute the new instructions and then press ACCEPT/WILCO which will downlink the DM0 WILCO response to the ground system, thus removing the uplink in progress indicator and cancelling the Route Pilot Response Timer.

Aircraft without route loading issues will receive a full UM80 (see example below) loadable route when applicable. To support these aircraft an operator will file a specific DAT code in the flight plan to indicate that the airframe is fully capable of loading a route clearance containing a STAR (see Appendix E for additional information on filing codes).

Figure 6 and Figure 7 are examples of a UM79 and UM80 route clearance, including the supplementary textual representation of the route modification in the free text (UM169).

Message example: UM79 CLEARED TO [position] VIA [routeclearance] + UM169 [free text] + UM169 [free text]

- CLEARED TO SAWED VIA ROUTE CLEARANCE
- REST OF ROUTE UNCHANGED
- ----- CLEARED TO SAWED VIA VCN SBY SAWED.

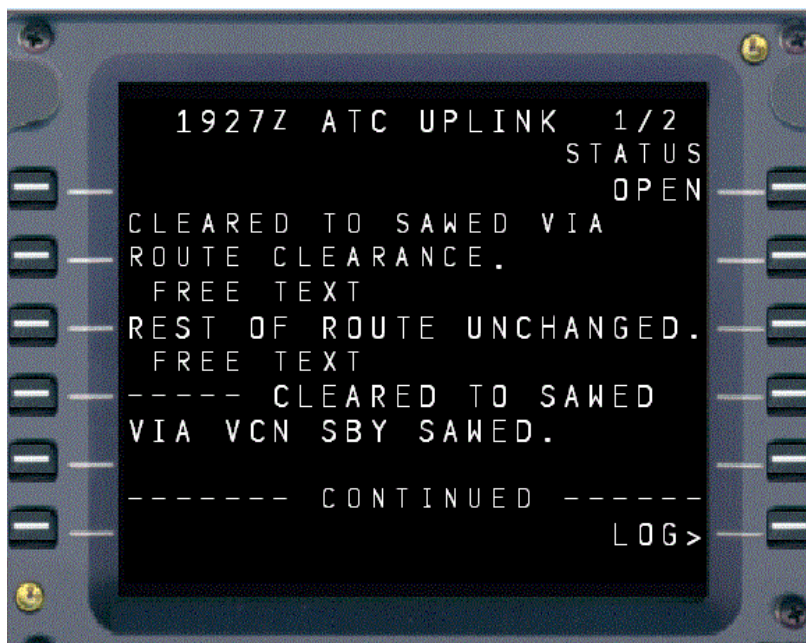

Figure 6 – UM79 Route Clearance and Supplementary Route Free Text (B737 MCDU Test Bench – FAA Tech Center)

Message example: UM80 CLEARED [routeclearance] + UM169 [free text]

- CLEARED ROUTE CLEARANCE
- ----- CLEARED YAZUU EMJAY J174 ORF ISO J121 CHS J79 OMN.HILEY6 KMIA.



Figure 7 – UM80 Full Route Clearance and Supplementary Route Free Text (B737 MCDU Test Bench – FAA Tech Center)

For En Route CPDLC, an option is being implemented in the ground automation to mitigate (prevent) certain known loading issues for some aircraft. The loading issues generally involve loading of route clearances containing STARs. To support participation in the En Route domain, these aircraft will file a specific DAT code in their flight plan (see Appendix E for additional information on filing codes). The ground automation will use this DAT code to enforce an alternate method of encoding uplinks containing STARs to these aircraft.

For these cases, the [routeclearance] string will end at the transition fix to the STAR, and a UM169 continuing flight crew instructions to manually load the STAR and transition will be appended to the uplink (see Figure 8 below, as an example of this). Flight crews of these aircraft will have a two-step process to select the load prompt to load the ATC clearance information into the FMS, and then manually insert the Arrival and Transition.

Message example: UM80 CLEARED [routeclearance] + UM169 [free text] + UM169 [free text]

- CLEARED ROUTE CLEARANCE
- MANUALLY LOAD ARRIVAL OMN.HILEY6.
- ----- CLEARED YAZUU EMJAY J174 ORF ISO J121 CHS J79 OMN.HILEY6 KMIA.



Figure 8 – UM80 Full Route Clearance with Free Text Arrival Procedure and Free Text Modified Route (B737 MCDU Test Bench – FAA Tech Center)

5.13.3 Traffic Flow Management Airborne Reroute Execution (ABRR)

The uplinking of ABRRs are a key component of the Data Comm Program. Typically, these revisions are passed down to the sector controller from ARTCC Traffic Management Units (TMUs), or from the FAA Command Center, to be displayed to the sector controller as a pending clearance that should be given to the aircraft.

The controller will be notified of a pending ABRR in their Aircraft List. When the controller selects the ABRR indicator, a TFM Reroute Menu is opened to allow the controller to evaluate, modify if needed, apply the route amendment, and uplink it to the aircraft.

Again, the ground automation will determine which of the following messages is appropriate for uplinking the route modification:

- UM74 PROCEED DIRECT TO [position]
- UM79 CLEARED TO [position] VIA [routeclearance]
- UM80 CLEARED [routeclearance]

The ground system will prepend an ABRR clearance with a UM169 [free text] TRAFFIC FLOW MANAGEMENT REROUTE. For this reason, the controller is not offered the option to append any DUE TO reasons to these clearances.

When the [position] used in the UM74 or UM79 is any fix other than the destination, the system will automatically append a UM169 REST OF ROUTE UNCHANGED.

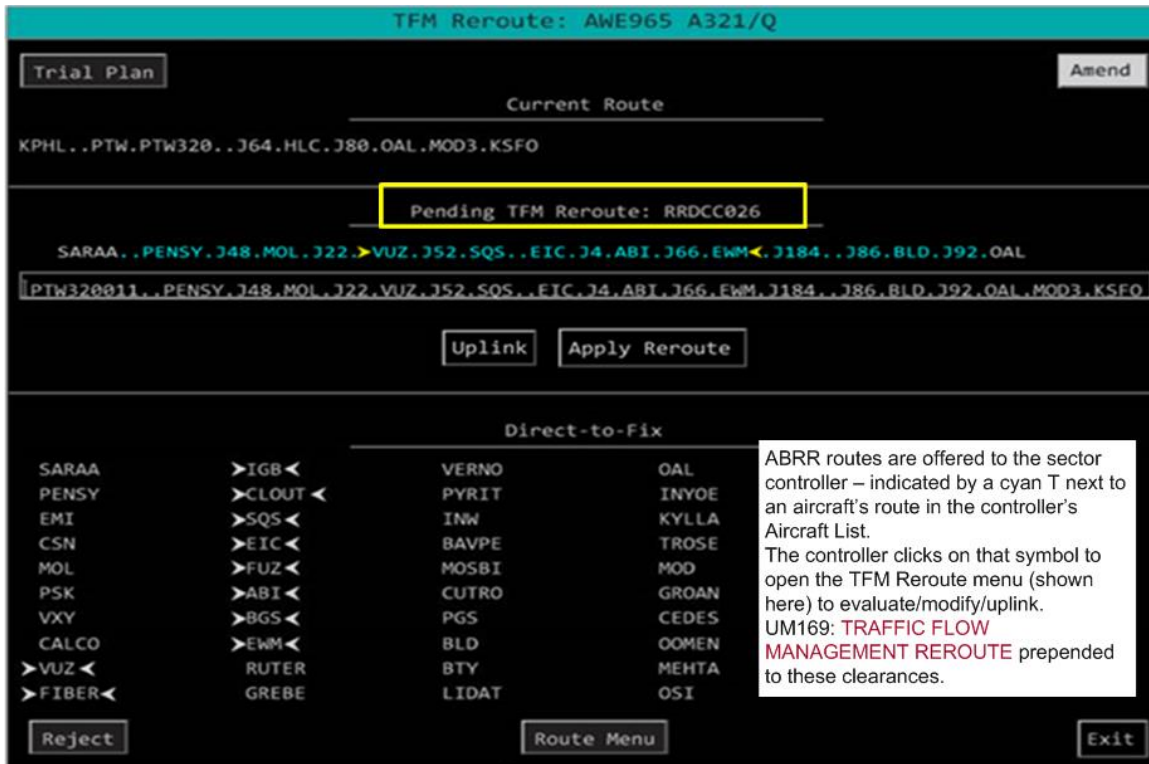

Figure 9 – TFM Reroute Example with AWE965

Flight crew procedural guidance is suggested in other documents. The following is an example.

When the flight crew views a route clearance message, they may select DM2 STANDBY and send the response to the ground system. The flight crew may then review, load, and execute the new instructions, and then select ACCEPT/WILCO which will downlink the DM0 WILCO response to the ground system, thus removing the uplink in progress indicator and cancelling the General or Route Pilot Response Timer.

5.14 Pilot-Initiated Downlink Request

The CPDLC system will allow flight crews to initiate downlink (DM) requests. Flight crews will have the capability to downlink requests for direct to fix clearances on the currently cleared route, altitude changes, and for voice contact. The flight crew is also enabled with the capability of downlinking emergency downlink messages when appropriate.

Flight crews should not make multiple requests that are sent as a single downlink, e.g., [DM10] REQUEST DESCENT TO FL310 [DM22] REQUEST DIRECT TO ROD. The FAA ground system will error back the request to the flight crew with the following response: [UM0] UNABLE [UM169] DOWNLINK MESSAGE NOT SUPPORTED. Reason: the controller may not be able to approve one of the requests when received which would result in an UNABLE to the downlinked message because the request was concatenated as a single message from the flight crew.

Note: All pilot requests should be in the form of a single request e.g., [DM10] REQUEST DESCENT TO FL310.

5.14.1 Flight Crew Initiated Direct-to-Fix

Flight crews may downlink a DM22 REQUEST DIRECT TO [position] where the position is on the currently cleared route of flight. They may optionally indicate a DUE TO reason as follows:

- DM65 DUE TO WEATHER
- DM66 DUE TO AIRCRAFT PERFORMANCE

When the controller receives a request for a direct-to-fix, the ground system displays an indication of a message waiting to be displayed in the FDB and in the Aircraft List (ACL) entry for that aircraft with CPDLC eligibility. The controller is provided with the ability to respond to a direct-to-fix request with a UM74 uplink, STANDBY message (UM), or UNABLE. If the fix in the request is part of, or beyond an unacknowledged auto-route or an unapplied airborne reroute execution (ABRR), the system will prohibit the controller from responding to the request with a UM74 uplink or STANDBY. If the fix in the request is not on the currently cleared route, the ground system will display only the UNABLE response option to the controller. The controller can then only respond with an uplink of UNABLE, but could also optionally then issue an UNABLE response to the received request after voice exchange with the flight crew. It is important to note that the controller has the option to amend the flight plan accordingly, and then uplink a new route clearance separate from any response to the request. In cases where the response to a request is unable to reach the aircraft, the request will remain open on the flight deck, the controller will be notified and may contact the flight crew via voice to either issue the clearance via voice, or generate a new route clearance via CPDLC.

When the controller at the sector with eligibility responds to a valid direct-to-fix request with a UM74 uplink, the system will remove the downlink indication in the FDB and ACL, and send the amendment to the En Route system for flight plan processing. If processing is successful, the system will uplink the UM74 PROCEED DIRECT TO [position] message to the aircraft. If the requested fix is not the destination, the UM169 free text message containing REST OF ROUTE UNCHANGED will be concatenated to the UM74 message. When the UM74 response is uplinked through interaction with the downlink menu, the system will show a route uplink in progress indication in the FDB, ACL, and Message Out view.

The flight crew will accept the message by sending a WILCO downlink response to the ground system. If the uplink causes a discontinuity of a partial load or failed load, the flight crew should adhere to their operating procedures (which will likely lead them to reject/UNABLE the uplink and contact the controller by voice).

5.14.2 Flight Crew Initiated Altitude Requests

Flight crews may downlink the following altitude requests:

- DM6 REQUEST [altitude]
- DM9 REQUEST CLIMB TO [altitude]
- DM10 REQUEST DESCENT TO [altitude]

Flight crews may optionally concatenate and indicate a reason code as follows:

- DM65 DUE TO WEATHER
- DM66 DUE TO AIRCRAFT PERFORMANCE

When the controller receives a downlink requesting an altitude change, the ground system displays an indication of a message waiting to be displayed in the FDB and ACL entry for that aircraft with CPDLC eligibility. The controller is provided with the ability to respond to an altitude request with an altitude uplink, STANDBY, or UNABLE.

When the controller responds to an altitude request, the ground system will process the altitude amendment and uplink one of the following messages as appropriate. If the uplinked altitude is below FL180, the ground system will also concatenate an appropriate altimeter setting using guidance from Section 5.14 to the uplink message as required.

- UM19 MAINTAIN [altitude]
- UM20 CLIMB TO AND MAINTAIN [altitude]
- UM23 DESCEND AND MAINTAIN [altitude]

At the time of the altitude uplink, if the flight does not have a surveillance reported altitude or a controller entered Reported Altitude, the system will use a UM19.

When an altitude request is uplinked through interaction with the appropriate menu, the system will remove the indication in the FDB and ACL, and show an altitude uplink in progress indication in the FDB, ACL, and Message Out view.

The flight crew will be able to accept/WILCO, STANDBY, or reject/UNABLE the message. When the flight crew accepts the altitude clearance, a WILCO downlink is sent and the new altitude is entered on the flight deck, and the altimeter is entered at the appropriate time.

5.14.3 UNABLE Responses to Flight Crew Requests

In response to a flight crew request, the controller may respond with UNABLE with the following concatenated messages:

- UM166 DUE TO TRAFFIC
- UM167 DUE TO AIRSPACE

The flight deck will receive the uplink message, open and review the UNABLE message. If there is a free text UM169 appended to the message (e.g., DUE TO WEATHER reason) the flight crew must ACCEPT the message by sending a ROGER response, thus closing the transaction. When the ground system receives the ROGER response, it is not shown to the controller.

5.14.4 Request Voice Contact

Flight crews are able to request voice contact with the controller who is working their aircraft through a CPDLC downlink message. As long as a TOC is not already in progress, the flight crew may select REQUEST VOICE CONTACT from the FMC and press SEND. A DM20 message is sent to the controller's station and is displayed with a downlink indication. The controller may select either ROGER or UNABLE.

Selecting ROGER, the controller may then contact the flight crew via voice, or decide to specify a frequency for the flight crew to contact the controller that is independent of the track control of the aircraft. Either way will remove the PID downlink indication, and if a new frequency is being uplinked, a generic uplink in progress indication will be displayed. If a frequency for contact was specified by the controller, the CONTACT (UM117) message will be uplinked to the flight deck and displayed and reviewed by the flight crew. The flight crew will dial in the requested frequency and ACCEPT the message sending a WILCO response to the ground system and the controller's display removing the uplink in progress indicator and cancelling the General Pilot Response Timer.

If the controller were to select UNABLE to the request for voice contact, the ground system will remove the downlink indication and send the UNABLE (UM0) to the flight deck. The uplinked UNABLE message is then displayed and reviewed by the flight crew.

5.14.5 Emergency Downlink Messages

Flight crews are able to select and downlink emergency messages when appropriate from the following list:

- DM55 PAN PAN PAN, concatenated with DM48 [position report]
- DM56 MAYDAY MAYDAY MAYDAY, concatenated with DM48 [position report]
- DM57 [remaining fuel] OF FUEL REMAINING AND [remaining souls] SOULS ON BOARD
- DM58 CANCEL EMERGENCY
- DM59 DIVERTING TO [position] VIA [route/clearance]
- DM60 OFFSETTING [distance offset] [direction] OF ROUTE
- DM61 DESCENDING TO [altitude]
- DM68 [free text]
- DM80 DEVIATING [distance offset] [direction] OF ROUTE

5.14.5.1 Emergency Downlink Received while Eligibility at Local Sector

When the flight crew selects one or more emergency messages, they must press SEND to send the message to the ground system and controller.

The ground system will display an unacknowledged Emergency message indication to the controller who will select the indicator and view the message, contact the flight crew by voice, and follow standard operating procedures (SOP) for handling of emergency situations.

The controller can also initiate separate uplink messages to the flight crew if desired, however these are separate from, not paired to, the Emergency messages and do not cancel the emergency condition. Controller training and procedures will include recommended actions.

If a non-emergency message is open when the Emergency message is received, the normal downlink indication will be replaced with the unacknowledged (flashing) Emergency indication.

If a supported non-emergency message is received while there is an acknowledged Emergency message, the Emergency message indicator will flash to alert the controller.

Emergency messages are retained and available for recall/review by the controller until either the controller CANCELS the emergency, or the aircraft is transferred outside of that ARTCC.

If the condition is met where CPDLC eligibility is being held by the National facility, i.e., if CPDLC is OFF in the ARTCC where the aircraft is located, the emergency message will be displayed at adapted AT Specialist workstations at the National Facilities. The emergency message will also be displayed at workstations in the ARTCC that is recognized as the primary source of the National flight plan data for that flight.

Emergency conditions can only be cancelled if the controller takes manual action to cancel the condition, or if CPDLC eligibility is released to another ARTCC. The emergency message will be automatically forwarded upon transfer of eligibility to another sector within an ARTCC (intra-facility transfer). Emergency messages are not forwarded to the next facility/ARTCC.

5.14.5.2 Emergency Downlink Received while Eligibility at National

If an emergency downlink is received while CPDLC eligibility is not assigned to a tower or an En Route sector, i.e., eligibility is held at National, the contents of the message will be displayed at adapted AT Specialist workstations at the active National Data Comm site. These positions may not be monitored by controllers, so the message information will need to be relayed to the controller working the flight via voice. There may not be immediate voice response to the emergency downlink while the information is being relayed.

An alert and the contents of the emergency message will also be provided at an adapted AT Specialist workstation in the ARTCC that is currently recognized by the ground system as the primary source of flight data for that emergency aircraft.

5.14.6 Processing of Open Requests

Requests from flight crews have several “open” conditions. These conditions may affect the normal routine transfer of communications between sectors and facilities and are listed below.

- An open request exists when a TOC begins.
- A new request is received while a TOC is in progress.

5.14.6.1 Processing of Open Requests during Sector Transfers

When a non-emergency message remains “open” at the time the controller transfers that aircraft to the next sector or facility, the ground system will address that message as described below.

Within the same ARTCC, the ground system will transfer an open message only once to the next sector once eligibility is transferred to that sector. When transferring to an adjacent facility outside the ARTCC, the ground system will first automatically close the message by uplinking the following concatenated message, and then uplinking the TOC:

- UM0 UNABLE + UM169 REQUEST AGAIN WITH NEXT ATC UNIT.

The UNABLE, REQUEST AGAIN WITH NEXT ATC UNIT message is displayed on the flight crew’s display, which is reviewed and must be responded to with a response. When the ground system receives the response, it is not shown to the controller.

5.14.6.2 Processing of New Flight Crew Requests When TOC is Already in Progress

When a request is received while a TOC is in progress, the request is handled as follows:

1. Intra-facility:
 - a. A transfer of track control handoff is completed and a TOC is uplinked to the flight crew (TOC in progress indication is displayed).
 - b. The flight crew selects the request message to downlink, presses SEND, and the message is delivered to the ground system and displayed to the controller.
 - c. The ground system will subsequently display to the controller the downlink indication in addition to the already displayed TOC in progress indication.
 - d. Upon completion of the TOC, the TOC in progress indication and the downlink indication will be removed from the transferring sector/facility, the ground system will then assign CPDLC eligibility to the receiving sector, and forward the open message to the receiving sector by displaying the downlink indicator in the receiving controller’s display.

- e. The receiving controller will then process the open message as a new request from the Flight crew.
2. Inter-facility:
 - a. A transfer of track control handoff is completed and a TOC is uplinked to the flight crew (TOC in progress indication is displayed).
 - b. The flight crew selects the request message to downlink, presses SEND, and the message is delivered to the ground system and displayed to the controller.
 - c. The ground system concatenates the following UM169 free text message to the UM0 UNABLE message and sends to the flight crew:
 - i. UNABLE REQUEST AGAIN WITH NEXT ATC UNIT
 - d. The UNABLE REQUEST AGAIN WITH NEXT ATC UNIT message is displayed on the flight crew's display which is reviewed by the flight crew and must be responded to with a ROGER response. When the ground system receives the ROGER response, it is not shown to the controller.
 - e. When the TOC is completed with the adjacent facility the Interfacility TOC process is completed.

5.14.7 Subsequent Request Received with Open Request of Same Type

Flight crews may send multiple requests of different types to the controller, and these different types can remain open at the same time on the controller's display. The downlink indicator will continue to be displayed to the controller when a second unique request is sent from the flight crew. When multiple requests of different types are open at the same time, the controller can respond to the open requests in any order.

The ground system will not allow multiple requests of the same type to be open at the same time. For example, if an altitude request is received from the aircraft when an altitude request is already currently open with that aircraft, the ground system will reject the second altitude request and not display it to the controller.

The following concatenated messages are used when automatically rejecting these subsequent requests:

- UM0 UNABLE + UM169 DOWNLINK REJECTED – OPEN REQUEST OF SAME TYPE EXISTS.

This message above is displayed on the flight crew's display, which is reviewed and must be responded to with a ROGER response. When the ground system receives the ROGER response it is not shown to the controller.

Note: If a duplicate response downlink (WILCO, UNABLE, etc.) is received containing the same MIN as the previous response, the duplicate response will be discarded without controller or flight crew notification.

5.14.8 Downlink Latency Checks

Although there is no latency time value (LTV) downlink, the En Route ground system will employ a latency check for downlinks using an initial default value of 120 seconds (range 60-300 seconds).

If a non-emergency message is received with a timestamp that is between two (2) and ten (10) minutes old (default values), the ground system will respond with an UNABLE message with concatenated UM169 free text DOWNLINK DELAYED – USE VOICE, which closes the request on the flight deck side. The delayed downlink will not be shown to the controller. If a downlink, other than an emergency message, is received with a timestamp that is greater than ten (10) minutes old (default value), the ground system will discard the message and will not send any response to the flight crew.

The downlink latency check will not be applied to flight crew responses to uplinks. If the uplink message is still open on the controller display, a response will be accepted and processed, even if its network delay exceeded the adapted delay value. If the controller did not receive a response in any operationally acceptable period of time, they will communicate with the flight crew via voice and may delete the open uplink.

5.15 Altimeter Settings

FAA Joint Order 7110.65 requires the controller to issue the altimeter setting to an aircraft below the lowest useable flight level at least one time while the aircraft is operating in his/her area of jurisdiction. The order requires the controller to identify the source of the altimeter, to issue the setting for the nearest reporting station along the aircraft's route of flight, and to advise the flight crew of the altimeter setting of the weather reporting station nearest the point the aircraft will descend below FL180 when issuing clearance to descend below FL180. Finally, the order requires the controller to advise the flight crew when the report is more than one hour old, and when the barometric pressure is greater than thirty-one (31.00) inches of Hg, to issue the altimeter of thirty-one (31.00) and advise the flight crew to remain on altimeter thirty-one (31.00) until reaching the final approach segment.

Altimeter settings will be uplinked to the aircraft under the following three (2) conditions:

- Automatically appended to any altitude clearance uplink containing an altitude below FL180.
- When manually uplinked by the controller.

For automatically uplinked altimeters, determination of which altimeter to send is based on the altitude and location of the aircraft. If the aircraft is below FL180, the ground will select the altimeter reporting station adapted for that location. If the aircraft is above but cleared below FL180, the ground will predict the aircraft location when it penetrates FL180 and use the altimeter reporting station adapted for that location.

5.15.1 Manual Uplink of Altimeter

An altimeter setting uplink may be manually uplinked by the controller when the controller desires. The controller may either specify or allow the automation to select the adapted altimeter reporting station.

The controller will enter the altimeter uplink command at the Radar or Radar Associate position, and then (optionally) enter the reporting station designator, and at a minimum, entering the flight ID.

- Example: UA TPA AAL1234
 - Where, UA means “uplink altimeter”, TPA is altimeter reporting station identifier, and AAL1234 is a FLID. Specifying the altimeter reporting station is optional.
- Example: UA AAL1234
 - Where the system selects altimeter based on current aircraft trajectory position.

Note: An altimeter uplink in progress (open) will not prevent another altimeter (auto or manual) from being uplinked.

The ground system will determine the altimeter setting from the specified reporting stations (or will determine the correct reporting station to use based upon aircraft position) and will uplink the altimeter reporting station and the altimeter setting value.

- Example: UM169 [free text] + UM153 ALTIMETER [altimeter]
- TPA LOCAL ALTIMETER. ALTIMETER 29.92IN.

If the altimeter setting is more than one hour old, additional free text (UM169 + UM153) will be sent indicating “LOCAL ALTIMETER MORE THAN ONE HOUR OLD”.

As appropriate, the flight crews accept/ROGER the message, which will respond with a ROGER attribute to the ground system.

5.16 Altitudes and Crossing Restrictions

In the deployment of En Route messages, altitudes and crossing restrictions will be sent to aircraft when certain pre-conditions are met.

Altitude crossing restrictions may be uplinked to an aircraft by the controller when the following conditions are met:

- The En Route controller’s facility has track control of the aircraft.
- The aircraft is marked on frequency.
- An inter-facility handoff was not just completed.

- The following conditions are not present for the aircraft data block display:
 - No IC mismatch alert present.
 - No abnormal uplinks present.
 - No unacknowledged emergency message is present.
 - No TOC or altitude uplink is in progress.

5.16.1 Climb/Descend/Maintain Altitude Instructions

The controller will select the altitude and altitude type; altitudes can be entered as an Assigned, Interim, or Wavier altitude. These altitude terms are internal to the controller ground system; however, all uplinked altitudes are Assigned altitudes to the flight crew.

The controller may optionally specify an urgency clearance if desired. Urgency options include:

- IMMEDIATELY (UM38, UM39),
- EXPEDITE (UM36, UM37), or
- AT PILOTS DISCRETION (UM177).
 - UM177 will not be concatenated with UM36, UM37, UM38, or UM39.

The controller may also indicate a DUE TO reason if desired. DUE TO reasons include:

- UM166 DUE TO TRAFFIC,
- UM167 DUE TO AIRSPACE RESTRICTION, or
- UM169 DUE TO WEATHER.

If the aircraft is unpaired, contains a controller-entered reported altitude, or has no surveillance reported altitude, the altitude uplink will be inhibited. The controller will have the option to perform a logic check override and continue with the uplink.

The ground system will select the correct altitude type uplink from the following list, based on the controller input, and uplink in either feet or flight level, as appropriate:

- UM19 MAINTAIN [altitude]
- UM20 CLIMB TO AND MAINTAIN [altitude]
- UM23 DESCEND TO AND MAINTAIN [altitude]
- UM36 EXPEDITE CLIMB TO [altitude]
- UM37 EXPEDITE DESCENT TO [altitude]
- UM38 IMMEDIATELY CLIMB TO [altitude]
- UM39 IMMEDIATELY DESCEND TO [altitude]

If the aircraft is below FL180, or is assigned an altitude to descend below FL180, the ground system will determine, similar to what is described in section 5.15, if and which altimeter setting to concatenate to the altitude uplink.

Flight crews will accept/WILCO, reject/UNABLE, or STANDBY the altitude clearance received.

5.16.2 Confirm Assigned Altitude

When a controller requires a verification of assigned altitude, the controller may uplink a UM135 CONFIRM ASSIGNED ALTITUDE message to the flight crew. The flight crew will respond with a DM38 ASSIGNED ALTITUDE [altitude] report indicating their assigned altitude. Upon receipt of the assigned altitude downlink, ground automation will compare that altitude against the ATC assigned altitude and provide an alert to the controller if a mismatch is detected.

5.16.3 Altitude Crossing Restrictions Instructions

The controller will select the altitude and altitude type; altitudes can be entered as an Assigned or Interim altitude.

The altitude crossing restriction position is also selected by the controller and must be on the currently cleared route and has to be a published fix (if an FRD, the base fix has to be published), and cannot be an airport, an unacknowledged arrival route, nor ambiguous fix. The position can only occur once on the current route ahead of the aircraft's present position. Optionally, the controller may also select a speed value for uplink in the crossing restriction.

If the aircraft is unpaired, contains a controller-entered reported altitude, or has no surveillance reported altitude, the crossing restriction uplink will be inhibited. The controller will have the option to perform a logic check override and continue with the uplink.

The Crossing Restriction messages available will be uplinked in either feet or flight level, and in Mach or indicated airspeed, if applicable, and include:

- UM49 CROSS [position] AT AND MAINTAIN [altitude]
- UM61 CROSS [position] AT AND MAINTAIN [altitude] AT [speed]

If the aircraft is below FL180, or is assigned an altitude to descend below FL180, the ground system will determine (similar to what is described in section 5.15), if and which altimeter setting to concatenate to the altitude uplink.

Flight crews will accept/WILCO, reject/UNABLE, or STANDBY the crossing restriction clearance received.

Crossing altitudes are considered flight crew's discretion altitude climbs and descent clearances.

6 NEXT DATA AUTHORITY AND BOUNDARY CONDITIONS

There are multiple boundary conditions in the FAA NAS where aircraft are entering and exiting U.S. airspace into foreign ANSPs such as NAVCANADA, Mexico, Cuba, Dominican Republic, and Port Au Prince. Aircraft also enter and exit domestic airspace into FAA Oceanic airspace. These aircraft will cut corners in and out of sectors in a multitude of ways due to weather, traffic, or normal flows. The rules of establishing and terminating authority for transfer of data are well established through FAA documents and GOLD standards by the use of CDA and NDA, and are briefly described here.

An active CPDLC connection allows the ATC ground system and the aircraft to exchange CPDLC messages. Within U.S. domestic airspace, KUSA is the active CPDLC connection and is referred to as the CDA. An inactive CPDLC connection can be established upon completion of address forwarding procedure if an active CPDLC connection exists with the aircraft. The inactive CPDLC connection is referred to as the NDA. Under normal circumstances the FAA ground system will initiate a CPDLC transfer to an adjacent CPDLC enabled external facility (e.g., CZEG – Edmonton Center, Canada) automatically and without flight crew action. The following ground system initiated steps describe a CPDLC transfer to the next CPDLC-enabled facility:

1. The FAA ground system sends an NDA (CZEG) message to notify the aircraft of the identity of the next ATSU permitted to establish a CPDLC connection; and
2. Sends a CPDLC termination request message with a communications contact message when the aircraft is in the vicinity of the boundary with the next ATSU or in this case CZEG.

Note: The aircraft system will only accept a CPDLC connection request from the ATSU specified in the NDA message e.g., CZEG.

An active CPDLC connection is terminated either by a controller initiated manual termination, or with a CPDLC TOC CONTACT message, with a corresponding end service message to start the successful CPDLC transfer. Upon termination of the active connection, the CPDLC communication transfer is dependent upon the receiving CPDLC enabled facility to complete a successful establishment of a CPDLC connection. Once the new connection is established, then the new active CPDLC connection will become the CDA, and CPDLC messaging can be continued per SOP. In the event the aircraft enters the adjacent facility airspace and the CDA does not change to the new facility, the flight crew should attempt terminating the existing connection and manually logging on to the next facility.

If the aircraft enters adjacent Non-U.S. airspace (e.g., Mexico) where data link services are not provided, or if the aircraft enters ATOP airspace but did not file as Satellite Communication (SATCOM) equipped in the flight plan, then flight crews can expect a termination of CPDLC services upon handoff via voice or via a CONTACT CPDLC message. Any future CPDLC connections must be initiated by the flight crew if desired.

6.1 Aircraft Outbound from U.S.

When the En Route ground system has a connection with a FANS aircraft and the aircraft is predicted to enter an adjacent FIR for which it has an adapted CPDLC address, after coordinating the flight plan information with the adjacent FIR, the ground system will then notify the aircraft of its NDA. If a positive Message Assurance is not received for the NDA uplink within a parameter amount of time, the ground system will resend the NDA uplink one (1) more time.

Table 4 – NDA Outbound Timer Values

Outbound NDA Timer Summary		
From ARTCC	To	NDA Time (min)
All	ZWY	35
All	ZAK	35
ZSE	CZVR	35
ZSE, ZLC	CZEG	30
ZLC, ZMP	CZWG	30
ZMP, ZOB	CZYZ	30
ZBW	CZYZ	45
ZOB	CZUL	30
ZBW	CZUL	45
ZBW	CZQM	20

After receiving the positive Message Assurance for a second NDA uplink attempt, or after the parameter of time and a positive Message Assurance has not been received to the second NDA uplink attempt, the ground system will make no further attempt to transfer CPDLC to the next ATSU.

After receiving the positive Message Assurance for the NDA uplink, the ground system will direct the avionics to automatically log on to the NDA using the AFN CONTACT ADVISORY (FN_CAD) message. The AFN Contact Advisory (FN_CAD) message contains the network address of the Air Traffic Services (ATS) provider system to which the requesting ATS provider system desires the aircraft logon. The aircraft automatically responds with a downlink AFN Response (FN_RESP) message indicating intent to perform the AFN logon. If a negative FN_RESP is received, or a positive FN_RESP is not received for the FN_CAD uplink within a parameter amount of time, the ground system will resend the FN_CAD one (1) time.

The aircraft automatically goes through the same process as an initial AFN log on. The aircraft sends a downlink AFN COMPLETE (FN_COMP) message to the requesting ATS provider system with the result of the AFN log on to the next ATS provider system. The En Route ground system will record and then discard the FN_COMP, because it has no control over whether or not a log on is successful with the adjacent FIR.

The receiving ATS provider system then connects to the aircraft in the same manner as described above for the initial connection. However, this CPDLC NDA connection does not allow flight crew – controller dialog until the CPDLC CDA connection with the transferring facility is terminated.

Note: Aircraft departing from TJSJ into ATOP will have connections automatically terminated prior to crossing the border into ATOP.

The CDA facility terminates the active CPDLC connection by sending one of the following:

- UM117 CONTACT [icaounitname] [frequency] message element with an UM161 END SERVICE message element; or
- UM117 CONTACT [icaounitname] [frequency] UM154 RADAR SERVICES TERMINATED message element with an UM161 END SERVICE message element; or
- UM161 END SERVICE message element.

Note: An HF (High Frequency) or a VHF (Very High Frequency) frequency may be uplinked when entering adjacent airspace. When the UM117 CONTACT message is uplinked to an aircraft entering non-radar airspace, the UM154 RADAR SERVICES TERMINATED message may be concatenated to the UM117 message element.

The CPDLC NDA connection with the next ATS provider system becomes the active CPDLC connection when the aircraft sends the Disconnect Request (DR1) in response to the UM161 END SERVICE message element.

If the NDA is unable to establish a connection prior to the aircraft receiving an UM161 END SERVICE message element and responding with a DR1, the existing CPDLC CDA connection will be terminated and the aircraft will have no CPDLC connection with any ATS service provider. The flight crew is to use standard GOLD CPDLC re-logon procedures with the new ATS system provider in order to establish a new connection.

For aircraft transitioning from outside the U.S. into a U.S. En Route ground system, the same process would be employed in reverse, with the En Route ground system as the receiving facility instead of the transferring facility.

6.2 Aircraft Inbound to US

The FAA will coordinate with the adjacent FIRs and ensure that as soon as En Route CPDLC is in use at any ARTCC, NDA processing will occur in the adjacent FIR so the aircraft will automatically log on to KUSA.

The logon will be accepted by the U.S. and a logon accept or reject will be sent back to the aircraft as appropriate, i.e., the logon will be accepted unless there is something wrong with the logon such as the aircraft is on the Blocked List, or the CPDLC version is not supported.

Once the aircraft approaches a CPDLC enabled En Route ARTCC, a connection initiation trigger will cause the ground system to initiate a connection with the aircraft as described in the connection initiation section.

During rollout, in some cases the CDA connection with the adjacent FIR will be terminated prior to the NDA connection being setup with the aircraft, because the first CPDLC enabled ARTCC is not a boundary ARTCC. In this case, the flight crew will receive an indication that the CPDLC connection is terminated, rather than a change in CDA. The previous logon to KUSA will be removed from the avionics in some aircraft. When this occurs, the flight crew will need to manually log on to KUSA. This logon will be accepted as described above, and as soon as the aircraft approaches a CPDLC enabled ARTCC, connection initiation will occur. The aircraft may never receive a connection if they do not fly into a CPDLC enabled ARTCC.

7 EN ROUTE DATA LINK DISPATCH SERVICE

The Data Communications Network Service (DCNS) is the networking component of the FAA Data Communications service. DCNS delivers the ATC CPDLC messages received from FAA automation systems (uplink messages - UMs) to aircraft, and from the aircraft to FAA automation systems (downlink messages - DMs). CPDLC between ground-based ATC and airborne flight crews flow through the FANS Gateway sub-component of the DCNS.

The Data Link Dispatch (DLD) Service receives recorded copies of all the messages that flow through the FANS Gateway in DCNS, converts them to XML²⁷ format, and publishes them to NEMS²⁸ using the Java Message Service (JMS) protocol.

Messages published by the DLD Service provide the following benefits in support of the airline's Dispatch Office functions:

- Improved ability to maintain operational control of flight;
- Improved situational awareness for dispatch function;
- Real-time receipt of messages;
- Allows for direct access into dispatcher flight tracker software;
- Enables analytics that support operational improvements.

Figure 10 shows the connections between DCNS, NEMS, and the AOC(s).

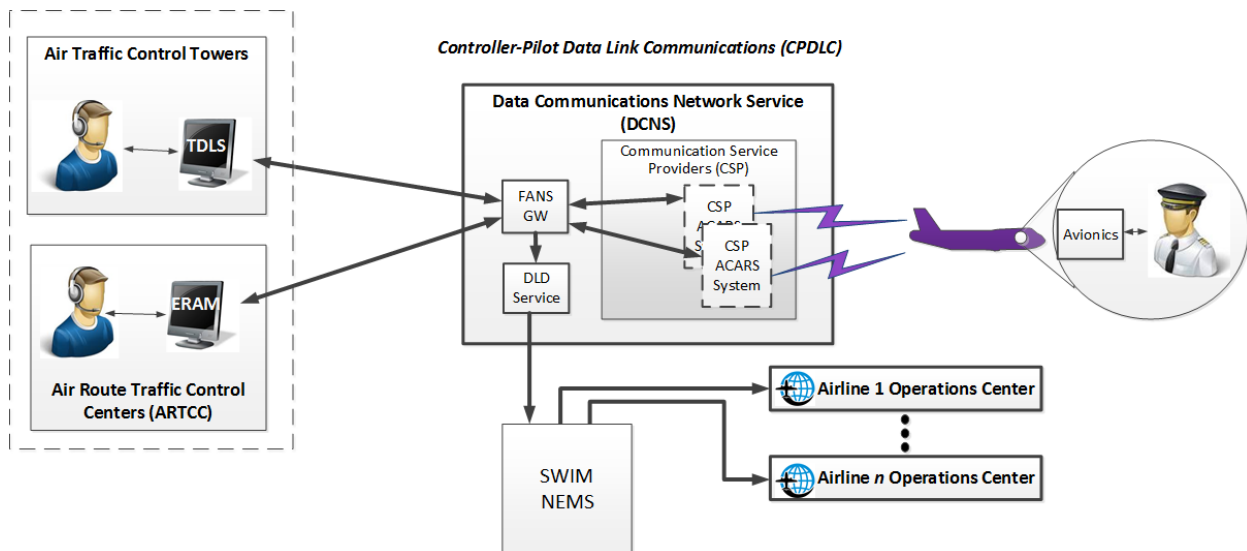

Figure 10 – DCNS-to-AOC Architecture Overview

Messages published by the DLD Service will contain sufficient detail in the message header to allow NEMS to unambiguously route messages to the proper destination

²⁷ XML – extensible markup language.

²⁸ NEMS – NAS Enterprise Messaging Service.

queue(s), to limit distribution of messages to only authorized consumers, and to filter messages based on consumer preference. Figure 11 provides an overview of the service.

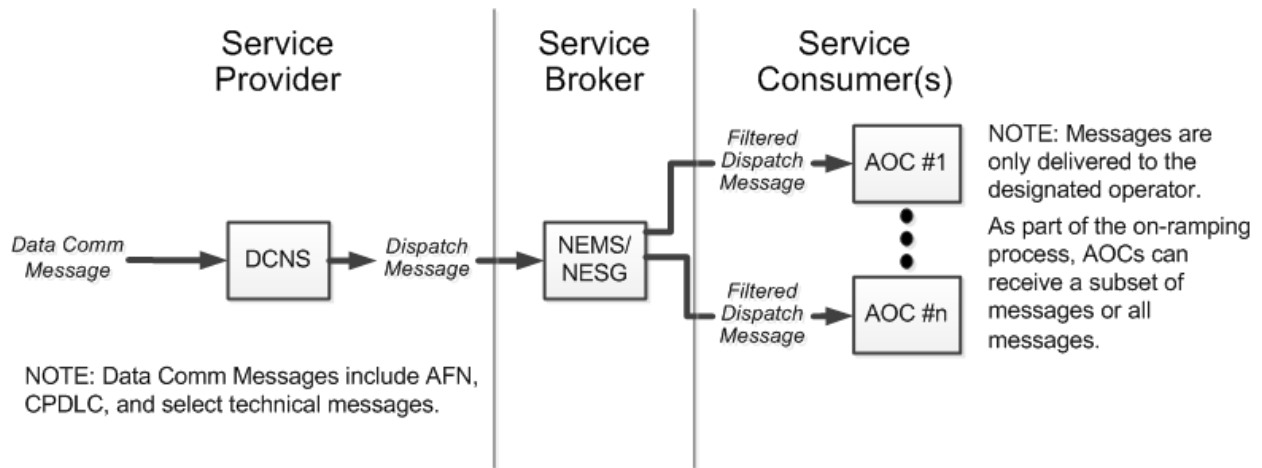

Figure 11 – DLD Service Overview

APPENDIX A CPDLC DCL PRODUCTION SYSTEM MESSAGE TABLES

General Information for Initial and Revised Clearances

Text enclosed in "" is explanatory text representing clearance variables.

Named Departure Procedures and Procedure Transitions (i.e., DPP's) are optional and may either be generated by En Route automation (ERAM) as a result of the filed flight plan, or added by the controller or local adaptation. ERAM-provided values take precedence.

General Information Concerning FMS Loadable Routes (UM79/80) within the CPDLC DCL

All Loadable routes will be identified as either a Full Route Clearance (Cleared Route Clearance) or an amended clearance to a position on your filed ATC route (Cleared To Position via Route Clearance). When a CPDLC DCL is sent to an aircraft with FMS Loadable information a free text flight crew awareness indicator to load the revised route into the FMS is provided e.g., +LOAD NEW RTE TO POS+ or +LOAD NEW ROUTE TO XXXX+ where XXXX is the airport identifier. Flight crews are reminded that all FMS loadable route will require them to reinsert the DPP from the CPDLC DCL and the Transition if applicable. No revised header tags will be provided with FMS Loadable route clearances. See below for Revised Clearance information.

General Information for Free Text Information

UM169 free text is limited to 256 characters by the ground system to facilitate CPDLC DCL format structure.

Note: In any UM169, keyword should be separated by "." or " " separators and the message should not end with a separator.

Revised Clearances

Header Tags. After the initial CPDLC DCL has been accepted/WILCO'd by the flight crew and one or more fields other than the route is amended, the ground system will construct a Revised CPDLC DCL containing a header that identifies all of the fields that have changed, using UM169 as follows:

- UM169 containing "REVISED" concatenated with:
 - "DPP" {if applicable, when any of the SID or climb-out parameters are changed} ",",
 - "CLIMB-OUT" {if applicable},
 - "ALT" {if applicable, when either Maintain altitude of Climb Via text is changed} ",",
 - "EXP ALT" {if applicable} ",",

- “DPFREQ” {if applicable} “,”
- “EDCT” {if applicable} “,”
- “SQUAWK” {if applicable} “,”
- “CONTACT” {if applicable} “,”
- “LCLINFO” {if applicable}.

The remainder of the revised CPDLC DCL contains the actual revised data, using UM169 as applicable, as follows:

- UM169 containing
 - [proceduredeparture] {if applicable} " " [proceduretransition] {if applicable}, [climb-out-procedure] {if applicable}
- UM169 containing
 - ““MAINTAIN” [altitude]” or Climb Via Text, as applicable
 - “EXP” [requestedaltitude] [minutes-miles, free text] {“MIN” or “NM” as determined by the adapted value of [minutes-miles], or free text field, 13} {if applicable} " " AFT DP {if applicable},
 - “DPFRQ” [frequency] {if applicable}, or “SEE SID” {if applicable}
 - “EDCT”[edctime] {if applicable},
- UM169 containing {if applicable}
 - “SQUAWK” [beaconcode] {if applicable},
 - [contactinfo], {if applicable},
 - [localinfo] {if applicable}.

Note: UM169 messages are fixed format. Keywords should be separated by “,” or “ “ when applicable, and the message should not end with a “,” or “ “.

Element	Msg #	Parameters								Note						
1	169	“CLEARED TO”	dest	“ARPT”	sid	“.”	transition	“.”	climb out	“ THEN AS FILED”	If no trans, no “.” If no climbout, no extra “ If dest is not an airport, no “ARPT”					
		11	4/16	6	6	1	5	1	32	14						
2	19	altitude								Use if climbvia = NONE and MAINT ALT <> NONE						
or																
2	169	climb via text								Use if climbvia <> NONE and MAINT ALT = NONE						
3	169	“EXPECT”	altitude	“.”	minutes/miles	“NM”	or “MIN”	“AFT DP”	“,”	“DPFRQ”	“nnn.nnn”	or “SEE SID”	“,”	EDCT	edct	EDCT optional
		7	7	1	2	3/4	7	1	7	7	7	4	7	4		
4	169	“SQUAWK”	beacon	“,”	contact info	“,”	local info									Contact and Local info are optional
		7	4	2	32	2	34									

Figure 12 – Initial Clearance – ‘Then As Filed’

Message Description

The ground system will encode the CAF Initial CPDLC DCL with the message elements and parameters in the following order:

- UM169 containing “CLEARED TO” concatenated with:
 - [airportdestination] “ ARPT,”
 - [proceduredeparture], {if applicable}

- “.” [proceduretransition] {if applicable},
- “ “ [Climb-out procedure] {if applicable},
- “ THEN AS FILED²⁹”.
- UM19 - [altitude] or [climb via text]
- UM169 - “EXP ” [requestedaltitude] “ “ [minutes-miles, or free text “fix”] {“ MIN ” or “ NM ” as determined by the adapted value of [minutes-miles], or free text field “fix”, 13} “AFTER DEP. DEP FREQ ” [frequency] “ EDCT ” [edcttime] {if applicable}
- UM169 “SQUAWK” [beaconcode] {if applicable} “or”, [contactinfo] {if applicable}, [localinfo] {if applicable}

Element	Msg #	Parameters	Note
1	169	“CLEARED TO ” dest “ ARPT” “ AS FILED” 11 4/16 5 10	If dest is not an Airport, no “ARPT”
2	19	altitude	
3	169	“EXPECT ” altitude “ “ minutes/miles “ NM” or “ MIN” “ AFT DP” “,” “ DPFREQ “ “nnn.nnn” or “SEE SID” “,” EDCT “ edct 7 7 1 2 3/4 7 1 7 7 7 7 4	EDCT optional
4	169	“SQUAWK ” beacon “,” contact info “,” local info 7 4 2 32 2 34	Contact and Local info are optional

Figure 13 – Initial Clearance – ‘Then As Filed’, with Climb via SID

Message Description

The ground system will encode the CAF Initial CPDLC DCL with the message elements and parameters in the following order:

- UM169 containing “CLEARED TO” concatenated with:
 - - [airportdestination] “ AIRPORT,”
 - - [proceduredeparture], {if applicable}
 - - “.” [proceduretransition] {if applicable},
 - - “ “ [Climb-out procedure] {if applicable},
 - - “ AS FILED”.
- UM19 - [altitude]
- UM169 - “EXP ” [requestedaltitude] “ “ [minutes-miles, or free text “fix”] {“ MIN ” or “ NM ” as determined by the adapted value of [minutes-miles], or free text field “fix”, 13} “AFTER DEP. DEP FREQ ” [frequency] “ EDCT ” [edcttime] {if applicable}
- UM169 “SQUAWK” [beaconcode] {if applicable} “or”, [contactinfo] {if applicable}, [localinfo] {if applicable}

NOTE: After a previously accepted CPDLC DCL has been received by TDLS, when a Controller makes an amendment to cleared route which results in a revised Full Route clearance being generated only information that has changed will be sent to the aircraft via CPDLC DCL e.g., SQUAWK will not be repeated in a revised CPDLC DCL if it has not

²⁹ If there is no SID [proceduredeparture], the text will be “AS FILED”

changed from the first accepted CPDLC DCL. Accepted CPDLC DCL clearance information remains in force unless revised by the controller.

Element	Msg #	Parameters					Note				
1	80	Dept airport	Dest airport	Arrival Transition	Arrival Procedure	Route					
2	169	"+LOAD NEW RTE TO " dest "+"									
3	169	sid	transition	climb out	"MAINTAIN "	altitude	If no transition, no ". If no climbout, no ".				
or		6	1	5	2	32	2	9	7		
3	169	sid	transition	climb out	Climbvia text					Use if climbvia = NONE and MAINT ALT <> NONE	
		6	1	5	2	32	2	29			
4	169	"EXPECT " altitude " " minutes/miles " NM" or " MIN" " AFT DP" " " DPFRQ " "nnn.nnn" or "SEE SID" " , EDCT " edct					All fields optional (this element continues with next row below)				
		7	7	1	2	3/4	7	1	7	7	4
		", SQUAWK " beacon		" " or " , " contact info		" , " local info				Contact and Local info are optional	
		9	4	1/2	32	2	34				
5	169	Full route freetext									

Figure 14 – Full Route Clearance

Message Description

The ground system will encode the entire Initial CPDLC DCL (UM80-based) with the message elements and parameters in the following order:

- UM80 – [airportdeparture] [airportdestination] [procedurearrival] [routeinformation]
- UM169 – (+LOAD NEW RTE TO XXXX+) XXXX= Destination airport
- UM169 containing the concatenation of:
 - - [proceduredeparture], {if applicable}
 - ". "[proceduretransition] {if applicable},
 - " " [Climb-out procedure] {if applicable},
 - ["MAINTAIN"altitude or [climb via text], as applicable
- UM169 – "EXPECT " [requestedaltitude] " " [minutes-miles, or free text "fix"] {" MIN " or " NM " as determined by the adapted value of [minutes-miles], free text field "fix", 13} " AFT DP. DPFREQ " {[frequency] or "SEE SID"}, " EDCT " [edcttime] {if applicable}, "SQUAWK" [beaconcode] {if applicable}, [contactinfo] {if applicable}, [localinfo] {if applicable}
- UM169 - full route free text

sent with the revised DP. If a climb via was sent with the original DP, it is resent with the revised DP, even if not changed.

Rule 2 is the exception to Rule 1: if only the MAINTAIN altitude is changed (SID, TRANS, CLIMB-OUT unchanged), then MAINTAIN altitude can be sent alone.

Note: MAINTAIN altitude is the altitude selected by the controller in the MAINT ALT selection.

Note: When the controller selects a climb via text other than NONE, the MAINT ALT must be none. And vice versa.

Table 5 – Conditional Departure Information Message Examples

Condition	SID, climb-out, climb via	MAINT [alt]*	UPLINK
any part of DPP changed	SID<>NONE Climbviatxt <> NONE	none	UM169 [procdep] "." [trans] " " [climb-out] " "[climbviatext] <i>Note: (trans) and (climb-out) only if not NONE, but are included even if not changed.</i> <i>Note: 1st UM169 should include REVISED DPP (and ALT if [climbviatext] is changed).</i>
any part of DPP changed	Climbviatext = NONE	yes	UM169 [procdep] "." [trans] " " [climb-out] " " MAINTAIN [alt] <i>Note: (trans) and (climb-out) only if not NONE, but are included even if not changed.</i> <i>Note: 1st UM169 should include REVISED DPP (and ALT if [climbviatext] is changed).</i>
SID changed to NONE	Climb-out <> NONE Climbvia = NONE	yes	UM169 "SID NONE, " [climb-out] UM19 [alt] <i>Note: Include (climb-out) if <> NONE, even if same.</i> <i>Note: 1st UM169 should include REVISED DPP (and ALT if [alt] is changed).</i>
SID changed to NONE	CLIMB-OUT=NONE CLIMB VIA = NONE	yes	UM169 "DPP NONE" UM19 [alt] <i>Note: 1st UM169 should include REVISED DPP (and ALT if [alt] is changed).</i>

Condition	SID, climb-out, climb via	MAINT [alt]*	UPLINK
CLIMB-OUT changed to NONE	SID<>NONE Climbviatext <> NONE	none	UM169 [procdep] "." (trans) ", " [climbviatext] <i>Note: (trans) included only if not NONE, but included even if not changed.</i> <i>Note: 1st UM169 should include REVISED DPP.</i>
CLIMB-OUT changed to NONE	Climbviatext = NONE	yes	UM169 [procdep] "." [trans] UM19 [alt] <i>Note: (trans) included only if not NONE, but included even if not changed.</i> <i>ProcDep included if applicable.</i> <i>Note: 1st UM169 should include REVISED DPP.</i>
CLIMB-OUT changed	SID stays NONE	yes	UM169 [climb-out] UM19 [alt] <i>Note: 1st UM169 should include REVISED DPP.</i>
CLIMBVIA changed	SID<>NONE	none	UM169 [procdep] "." [trans] " " [climb-out] ", " [climbviatext] <i>Note: (trans) and (climb-out) only if not NONE, but are included even if not changed.</i> <i>Note: 1st UM169 should include REVISED DPP.</i>
CLIMBVIA changed to NONE		yes	UM169 [procdep] "." [trans] " " [climb-out] UM19 [alt] <i>Note: (trans) and (climb-out) only if not NONE, but are included even if not changed. ProcDep as applicable.</i> <i>Note: 1st UM169 should include REVISED ALT.</i>
MAINT alt changed to NONE and CLIMBVIA selected		none	UM169 [procdep] "." [trans] " " [climb-out] as appl, ", " [climbviatext] <i>Note: 1st UM169 should include REVISED ALT.</i>
Climb-out changed (and climb-out <> NONE)	SID<> NONE and SID unchanged	yes	UM169 [procdep] "." [trans] " " [climb-out] UM19 [altitude] <i>Note: 1st UM169 should include REVISED DPP (and ALT if [alt] changed).</i>

Condition	SID, climb-out, climb via	MAINT [alt]*	UPLINK
MAINT alt changed	SID, CLIMB-OUT, CLIMBVIA unchanged	yes	UM19 [alt] <i>Note: 1st UM169 should include REVISED ALT.</i>
MAINT alt not changed but part of DPP changed	SID or CLIMB-OUT<>NONE	yes	UM169 [procdep] "." (trans) " " [climb-out] UM19 [altitude] <i>Note: 1st UM169 should include REVISED DPP.</i>

APPENDIX B CPDLC ERROR PROCESSING

The examples below include CPDLC error processing that include Cause, Result, and resultant error messages. The tables below include both ground and aircraft error processing. The tables are representative of known capabilities and system behavior that will be updated as new information becomes available.

Table 6 – Tower CPDLC DCL Ground Error Processing

Cause	Result	ERROR Message
Received CPDLC downlink response message is not expected.	Connection with aircraft is aborted. This is viewed as a Protocol error	UM161 CPDLC End Service – No UM159 is sent.
Received downlink CPDLC message with an operationally unsupported message element/parameter.	Disregard the received message and send a CPDLC message containing message element UM169 "MESSAGE NOT SUPPORTED BY THIS ATS UNIT".	UM169 "MESSAGE NOT SUPPORTED BY THIS ATS UNIT".
Received downlink CPDLC message DM67 or DM68 as a single message element	Disregard the received message and send a CPDLC message containing message element UM159 unexpectedData and UM169 "FREETEXT NOT SUPPORTED".	UM159 unexpectedData and UM169 "FREETEXT NOT SUPPORTED".
DM25 received with appended data	Disregard the received message and send a CPDLC message containing message element UM159 unexpectedData and a UM169 "ATSU CANNOT PROCESS DATA APPENDED TO CLEARANCE REQUEST".	UM159 unexpectedData and a UM169 "ATSU CANNOT PROCESS DATA APPENDED TO CLEARANCE REQUEST".
DM62 received with appended data that is not a DM67 Free text	Connection with aircraft is aborted.	UM161 CPDLC End Service – No UM159 is sent.

Cause	Result	ERROR Message
DM1 UNABLE received with appended data other than DM65, DM66 or DM67	Disregard the received message and send a CPDLC message containing message element UM159 unexpectedData	UM159 unexpectedData
DM1 UNABLE received with DM65, DM66 or DM67	Process the DM1 UNABLE but disregard the concatenated free text	Nothing will be sent back to the flight deck
DM25 received with a DM25 pending	Disregard the received message and send a CPDLC message containing message element UM169 "CLEARANCE REQUEST PENDING".	UM169 "CLEARANCE REQUEST PENDING".
DM25 received with a clearance awaiting a flight crew response	Disregard the received message and send a CPDLC message containing message element UM169 "CLEARANCE SENT, RESPONSE REQUIRED. IF NO CLEARANCE MESSAGE EXISTS, CONTACT ATC AND REQUEST A RESEND OF DEPARTURE CLEARANCE".	UM169 "CLEARANCE SENT, RESPONSE REQUIRED. IF NO CLEARANCE MESSAGE EXISTS, CONTACT ATC AND REQUEST A RESEND OF DEPARTURE CLEARANCE".
DM25 received with an open CONTACT ME message	Disregard the received message and send a CPDLC message containing message element UM169 "CONTACT ME: CONTACT TOWER BY VOICE WITH REQUEST".	UM169 "CONTACT ME: CONTACT TOWER BY VOICE WITH REQUEST".
Received a response message with a MRN that has no match	Disregard the received message and send a CPDLC message containing message element UM159 unrecognizedMsgReference Number	UM159 unrecognizedMsgReference Number
DM0, DM2, DM3, or DM63 received with appended data	Disregard the received message and send a CPDLC message containing message element UM159 unexpectedData	UM159 unexpectedData

En Route CPDLC Ground Error Processing

The following ATC uplinks may be received for review by the flight crew.

Table 7 – En Route CPDLC Ground Error Processing

Item #	Information Message	Condition	Flight Crew Action
1	MESSAGE NOT DELIVERED. FREE TEXT/DUE TO REASON NOT SUPPORTED. CONTACT ATC OR RESEND REQUEST	<p>Air Description: The Flight Crew selected a preformatted free text message or manually added free text to a request with no unsupported message elements by the FAA.</p> <p>Ground Description: Automatically appends error free text to a UM0 UNABLE in response to a supported message containing DM67 free text.</p>	The FAA only accepts “Due To Weather or Performance” as additional reasons/information, Flight crews should avoid all other additional reject reasons or additional information such as free text.
2	UNABLE RECEIVED. FREE TEXT/DUE TO REASON NOT SHOWN TO ATC	<p>Air Description: The Flight Crew selected a preformatted free text message or manually added free text to an UNABLE response.</p> <p>Ground Description: Automatically uplinked upon the receipt of (DM1) UNABLE containing DM67 Free text.</p>	The FAA only accepts “Due To Weather or Performance” as additional reasons/information, Flight crews should avoid all other additional reject reasons or additional information such as free text.

Item #	Information Message	Condition	Flight Crew Action
3	DOWNLINK DELAYED – USE VOICE	<p>Air Description: If a message received by the ground system has a timestamp between 2 and 10 minutes older than the current ground system time, the message is Rejected/UNABLEd automatically.</p> <p>Ground Description: Appended to (UM0) UNABLE and automatically uplinked when a Normal (non-emergency) message is received within the adapted latency value range (120 to 600 seconds).</p> <p>Note: If a message older than 10 minutes is received by the ground system, it is discarded and no message is uplinked in response.</p>	If desired, flight crew should contact ATC via voice for their ATC request.
4	REQUEST AGAIN WITH NEXT ATC UNIT	<p>Air Description: CPDLC message will be appended with an UNABLE (UM0) and automatically uplinked for open messages.</p> <p>Ground Description: Appended to (UM0) UNABLE and automatically uplinked for open messages before uplinking a TOC, when:</p> <ul style="list-style-type: none"> • An inter-facility TOC is uplinked, or • An intra-facility TOC is uplinked and the message has already been forwarded once. 	Make request with the next ATC controller.

Item #	Information Message	Condition	Flight Crew Action
5	YOUR LAST CPDLC RESPONSE NOT EXPECTED. CONTACT ATC BY VOICE	<p>Air Description: The controller has cancelled an uplinked CPDLC message.</p> <p>Ground Description: Sent when (DM0) WILCO received to controller 'Cancelled' (locally closed) uplink.</p> <p>Since it is expected that a controller cancelling an uplink includes voice instructions to the flight crew to reject the uplink, the expected flight crew response is UNABLE. When the UNABLE is received in this scenario, it is simply processed and discarded.</p>	The controller and flight crew should coordinate any related ATC messages closed by the ground system via voice.
6	YOUR LAST CPDLC RESPONSE NOT EXPECTED. CONTACT ATC BY VOICE	<p>Air Description: The ground system has received a CPDLC message, but does not match any corresponding CPDLC message.</p> <p>Ground Description: Automatically uplinked when a response downlink message contains a MRN that does not match the MIN of an open uplink.</p> <p>This does not apply to the case where the ground receives a response message to an uplink that the controller or the system have cancelled.</p>	Contact ATC via voice.

Item #	Information Message	Condition	Flight Crew Action
7	INVALID DATA – DOWNLINK REJECTED. RESEND OR CONTACT BY VOICE	Air Description: none Ground Description: Appended to (UM0) UNABLE and automatically uplinked when the MIN of a received flight crew request matches the MIN of an open flight crew request. However, if the entire contents of the message are determined to be duplicate of an open message, the duplicate message is SAR recorded and discarded (not displayed), and no message is uplinked in response.	Resend message with correct information or contact ATC via voice.
8	DOWNLINK REJECTED - OPEN REQUEST OF SAME TYPE EXISTS	Air Description: A flight crew request is open, and the flight crew downlinks another request of the same type. Ground Description: Appended to (UM0) UNABLE and automatically uplinked upon the receipt of a non- emergency message when an open message of the same message type exists.	Flight crew should contact ATC via voice to coordinate related ATC request.

Item #	Information Message	Condition	Flight Crew Action
9	INVALID MESSAGE FORMAT	<p>Air Description: Message has been rejected and is appended with an Unable response.</p> <p>Ground Description: Appended to (UM0) UNABLE and automatically uplinked when invalid data or data in an invalid format exists in a non-emergency message.</p> <p>Examples: A Direct To [position] request containing a Fix Radial Distance (FRD) with a distance value greater than 700NM. An Altitude request containing other than QNH Feet or Flight Level. An Altitude request containing a FT altitude type but containing an altitude above 18,000 feet. An Altitude request containing a Flight Level altitude field type but containing an altitude below FL180.</p>	Flight crews should review PID and determine if the format is correct for the CPDLC request, otherwise contact ATC if desired.

Item #	Information Message	Condition	Flight Crew Action
10	CONTACT ATC - RESPONSE RECEIVED FOR AN UNKNOWN MESSAGE	<p>Air Description: The ground system has received a CPDLC message, but the downlink message reference number is not included.</p> <p>Ground Description: Automatically uplinked when the ground system receives a downlink message containing valid response element (DM0-DM3, DM63), but without an MRN.</p>	Flight crew should contact ATC via voice.
11	DOWNLINK MESSAGE NOT SUPPORTED	<p>Air Description: Message has been rejected and is appended with an UNABLE response. Either the message is not supported or an acceptable message type may contain unsupported information such as free text.</p> <p>Ground Description: Appended to (UM0) UNABLE and automatically uplinked in response to an unsupported message.</p>	If desired, flight crew should contact ATC via voice for their ATC request.

Item #	Information Message	Condition	Flight Crew Action
12	CPDLC NOT IN USE UNTIL FURTHER NOTIFICATION	<p>Air Description: Controller / flight crew CPDLC communications is currently not available. The message has been rejected and is appended with an UNABLE response</p> <p>Ground Description: Appended to (UM0) UNABLE and automatically uplinked from National.</p> <p>To reject a non-emergency message received when National is the LDA.</p> <p>To close an open message when that ARTCC disables CPDLC.</p>	If desired, flight crew should contact ATC via voice for their ATC request.
13	RESPONSE TO MESSAGE NOT SHOWN TO ATC – CONTACT ATC BY VOICE	<p>Air Description: The Flight Crew selected a response that is not expected/supported by the FAA.</p> <p>Ground Description: Free text uplink sent when the response downlink received for an uplinked message is not expected/not supported.</p>	The FAA only accepts “Due To Weather or Performance” as additional reasons/information, Flight crews should avoid all other additional reject reasons or additional information such as free text.

Item #	Information Message	Condition	Flight Crew Action
14	ROUTE AND ALTITUDE REQUESTS NOT AVAILABLE UNTIL FURTHER ADVISED. CONTACT ATC BY VOICE	<p>Air Description: If a route or altitude request is received by the ground system, and Routes and Altitudes have been disabled on the ground, the request is auto UNABLEd.</p> <p>Ground Description: Appended to (UM0) UNABLE and automatically uplinked when Routes and Altitudes are disabled on the ground</p>	The flight crew should contact ATC for route requests
15	ALTITUDE REPORT RECEIVED. FREE TEXT NOT SHOWN TO ATC	<p>Air Description: The Flight Crew selected a preformatted free text message or manually added free text to an assigned altitude report.</p> <p>Ground Description: Automatically uplinked upon the receipt of (DM38) ASSIGNED ALTITUDE containing DM67 free text.</p>	The FAA does not accept any additional reasons/information with reports, Flight crews should avoid all additional information such as free text when downlinking reports.
16	ALTITUDE REPORT NOT SHOWN TO ATC. CONTACT ATC BY VOICE	<p>Air Description: The Flight Crew downlinked an assigned altitude report while CPDLC is not being used.</p> <p>Ground Description: Automatically uplinked upon the receipt of (DM38) ASSIGNED ALTITUDE while the LDA resides at National.</p>	Contact ATC via voice.

APPENDIX C CPDLC MESSAGE ELEMENTS USED WITHIN THE NAS

The following message tables are a subset of the DO-258A message set implemented in CPDLC Tower and En Route services.

Table 8 shows all the uplink messages supported for Tower and En Route services.

Table 8 – Uplink Message

FANS MSG ID	FANS Message Element
UM0	UNABLE
UM1	STANDBY
UM3	ROGER
UM19	MAINTAIN [altitude]
UM20	CLIMB TO AND MAINTAIN [altitude]
UM23	DESCEND TO AND MAINTAIN [altitude]
UM36	EXPEDITE CLIMB TO [altitude]
UM37	EXPEDITE DESCENT TO [altitude]
UM38	IMMEDIATELY CLIMB TO [altitude]
UM39	IMMEDIATELY DESCEND TO [altitude]
UM49	CROSS [position] AT AND MAINTAIN [altitude]
UM61	CROSS [position] AT AND MAINTAIN [altitude] AT [speed]
UM74	PROCEED DIRECT TO [position]
UM79	CLEARED TO [position] VIA [routeclearance]
UM80	CLEARED [routeclearance]
UM83	AT [position] CLEARED [routeclearance]
UM117	CONTACT [icao unit name][frequency]
UM120	MONITOR [icao unit name][frequency]
UM135	CONFIRM ASSIGNED ALTITUDE
UM153	ALTIMETER [altimeter]
UM154	RADAR SERVICES TERMINATED
UM159	ERROR [error information]
UM160	NEXT DATA AUTHORITY [icao facility designation]
UM161	END SERVICE

FANS MSG ID	FANS Message Element
UM162	SERVICE UNAVAILABLE
UM163	[icao facility designation] [tp4 table]
UM166	DUE TO TRAFFIC
UM167	DUE TO AIRSPACE RESTRICTION
UM169	[free text]
UM177	AT PILOTS DISCRETION

Table 9 shows all of the downlink messages supported for En Route services.

Table 9 – Downlink Messages

FANS MSG ID	FANS Message Element
DM0	WILCO
DM1	UNABLE
DM2	STANDBY
DM3	ROGER
DM6	REQUEST [altitude]
DM9	REQUEST CLIMB TO [altitude]
DM10	REQUEST DESCENT TO [altitude]
DM20	REQUEST VOICE CONTACT
DM22	REQUEST DIRECT TO [position]
DM25 (CPDLC DCL only)	REQUEST CLEARANCE
DM38	ASSIGNED ALTITUDE [altitude]
DM55	PAN PAN PAN
DM56	MAYDAY MAYDAY MAYDAY
DM57	[remaining fuel] OF FUEL REMAINING AND [remaining souls] SOULS ON BOARD
DM58	CANCEL EMERGENCY
DM59	DIVERTING TO [position] VIA [routeclearance]
DM60	OFFSETTING [distance offset] [direction] OF ROUTE
DM61	DESCENDING TO [altitude]
DM62	ERROR [error information]

FANS MSG ID	FANS Message Element
DM63	NOT CURRENT DATA AUTHORITY
DM64	[icao facility designation]
DM65	DUE TO WEATHER
DM66	DUE TO AIRCRAFT PERFORMANCE
DM68	[free text]
DM73	[version number]
DM80	DEVIATING [distance offset] [direction] OF ROUTE

Table 10 shows all CPDLC messages supporting CPDLC logon and connection management.

Table 10 – AFN and CPDLC Connection Establishment and Transfer Messages

FANS MSG ID	FANS Message Element
FN_CON	AFN Contact
FN_AK	AFN Acknowledgement
CR1	Connection Request
CC1	Connection Confirm
DR1	Disconnect Request 'downlink
FN_CAD	AFN Contact Advisory
FN_RESP	AFN Response
FN_COMP	AFN Complete

Table 11 includes excerpts from ISO ASN.1 detailed in DO-258A defining message content and structures observed by the ground system for En Route services.

Table 11 – S1P2 En Route Message Structure and Content – a Subset of ISO ASN.1

Field	Field Type	Supported Message Elements (UMs and DMs)	Remarks
[airport]	Airport ::= IA5String (SIZE (4))	UM74, UM79, UM80, UM83, DM22, DM59	Routes: If used, should be in ICAO format (i.e., four [4] letter airport identifier code); reject the downlink if the field is not four (4) alphabetic characters
[airportdeparture]	Airportdeparture ::= [airport]	DM59	The field is displayed with the "ApDep:" label in the route clearance string.
[airportdestination]	Airportdestination ::= [airport]	UM79, UM80, UM83, DM59	When part of the Emergency PID element DM59, the field is displayed with the "ApDst:" label in the route clearance string.
[airwayidentifier]	Airwayidentifier ::= IA5String (SIZE (1..5))	UM79, UM80, UM83, dm59	
[airwayintercept]	Airwayintercept ::= IA5String (SIZE (1..5))	DM59	The field is displayed with the "AwlIntercept:" label in the route clearance string.
[altimeter]	Altimeter ::= CHOICE { [altimeterenglish], [altimetermetric] }	UM153	Display format defined for individual supported CHOICES. Only Altimeterenglish is supported in Data Comm.

Field	Field Type	Supported Message Elements (UMs and DMs)	Remarks
[altimeterenglish]	Altimeterenglish ::= INTEGER (2500..3100)	UM153	<p>Units = 0.01 Inches of Mercury in message element, representing a range of 25 to 31 inches of Mercury.</p> <p>Units = 0.1 Inches of Mercury in display format.</p> <p>DO-258A specifies a range of INTEGER (2200..3200), but Data Comm restricts the range to be consistent with what is allowed in ERAM.</p>
[altitude]	Altitude ::= CHOICE { [altitudeqnh], [altitudeqnhmeters], [altitudeqfe], [altitudeqfemeters], [altitudegnssfeet], [altitudegnssmeters], [altitudeflightlevel] , [altitudeflightlevelmetric] }	UM19, UM20, UM23, UM36, UM37, UM38, UM39, UM49, UM61, DM6, DM9, DM10, DM38, DM59, DM61	Display format defined for individual CHOICES. [altitudeqnh] and [altitudeflightlevel] are the only altitude choices supported in Data Comm for uplinks and Normal PIDs. Other choices need to be supported for Emergency PIDs.

Field	Field Type	Supported Message Elements (UMs and DMs)	Remarks
[altitudeflightlevel]	Altitudeflightlevel ::= INTEGER (30..600)	UM19, UM20, UM23, UM36, UM37, UM38, UM39, UM49, UM61, DM6, DM9, DM10, DM38, DM59, DM61	Units = 1 level (100 feet). <i>Notes:</i> <i>For an altitude uplink at or above FL180, the altitude unit is specified in Flight Level in the uplink.</i> <i>The altitude is stored and displayed as ddd in all uplinks and downlinks other than the Emergency PID element DM59. When altitude is part of [routeclearance] string in the Emergency PID element DM59, it is displayed as F ddd.</i> Display leading zeros.
[altitudeflightlevelmetric]	Altitudeflightlevelmetric ::= INTEGER (100..2000)	DM59, DM61	Units = 1 level (10 meters). Display leading zeros.
[altitudegnssfeet]	Altitudegnssfeet := INTEGER (0..150000)	DM59, DM61	Units = 1 Foot
[altitudegnssmeters]	Altitudegnssmeters := INTEGER (0..50000)	DM59, DM61	Units = 1 Meter
[altitudeqfe]	Altitudeqfe := INTEGER (0..2100)	DM59, DM61	Units = 10 Feet in message element, representing a range of 0 to 21,000 feet.
[altitudeqfemeters]	Altitudeqfemeters := INTEGER (0..7000)	DM59, DM61	Units = 1 Meter

Field	Field Type	Supported Message Elements (UMs and DMs)	Remarks
[altitudeqnh]	Altitudeqnh ::= INTEGER (0..2500)	UM19, UM20, UM23, UM36, UM37, UM38, UM39, UM49, UM61, DM6, DM9, DM10, DM38, DM59, DM61	<p>Units = 10 Feet in message element, representing a range of 0 to 25,000 feet.</p> <p>Units = 100 Feet in display format ddd.</p> <p><i>Notes:</i></p> <p><i>For an altitude uplink below FL180, the altitude unit is specified in Feet in the uplink.</i></p> <p><i>The altitude is stored and displayed as ddd in all uplinks and downlinks other than the Emergency PID element DM59. When altitude is part of [route clearance] string in the Emergency PID element DM59, it is displayed as QNH dddd0 FT.</i></p> <p>Display leading zeros.</p>
[altitudeqnhmeters]	Altitudeqnhmeters ::= INTEGER (0..16000)	DM59, DM61	Units = 1 Meter
[aTWalongtrackway point]	ATWalongtrackwaypoint ::= SEQUENCE { [position], [aTWdistance], [speed], [aTWaltitudesequence] }	DM59	

Field	Field Type	Supported Message Elements (UMs and DMs)	Remarks
[aTWalongtrackway pointsequence]	ATWalongtrackway pointsequence ::= SEQUENCE SIZE (1..8) OF [ATWalongtrackway point]	DM59	
[aTWaltitude]	ATWaltitude ::= SEQUENCE { [aTWaltitude tolerance], [altitude] }	DM59	
[aTWaltitudesequence]	ATWaltitudesequence ::= SEQUENCE SIZE (1..2) OF [aTWaltitude]	DM59	<i>Note: This field is displayed with a “ to “ separating the two values of [aTWaltitude] in the sequence. i.e., [aTWaltitude] to [aTWaltitude]</i>
[aTWaltitude tolerance]	ATWaltitude tolerance ::= ENUMERATED { at(0), atorabove(1), atorbelow(2) }	DM59	
[aTWdistance]	ATWdistance ::= SEQUENCE { [aTWdistance tolerance], [distance] }	DM59	

Field	Field Type	Supported Message Elements (UMs and DMs)	Remarks
[aTWDistancetolerance]	ATWDistancetolerance ::= ENUMERATED { plus(0), minus(1) }	DM59	
[degrees]	Degrees ::= CHOICE { [degreesmagnetic] [degreestrue] }	UM49, UM61, UM74, UM79, UM80, UM83, DM22, DM59	Display format defined for individual CHOICES. [degreesmagnetic] is the only degrees supported in Data Comm for uplinks and Normal PIDs. [degreestrue] needs to be supported within Emergency PIDs.
[degreeincrement]	Degreeincrement ::= INTEGER (1..20)	DM59	Units = 1 degree, representing a range of 1 degree to 20 degrees. <i>Note: The "a" at the end of the display format is the letter "d". Thus, for example, values of 1 and 20 are displayed as 1d and 20d respectively.</i>
[degreesmagnetic]	Degreesmagnetic ::= INTEGER (1..360)	UM49, UM61, UM74, UM79, UM80, UM83, DM22, DM59	Units = 1 degree, representing a range of 1 degree to 360 degrees. Display leading zeros.
[degreestrue]	Degreestrue ::= INTEGER (1..360)	DM59	Units = 1 degree, representing a range of 1 degree to 360 degrees. Display leading zeros for degrees.

Field	Field Type	Supported Message Elements (UMs and DMs)	Remarks
[direction]	Direction := ENUMERATED { Left (0), Right (1), EitherSide (2), North (3), South (4), East (5), West (6), NorthEast (7), NorthWest (8), SouthEast (9), SouthWest (10) }	DM59, DM60, DM80	
[distance]	Distance ::= CHOICE { [distancenm] [distancekm] }	UM49, UM61, UM74, UM79, UM80, UM83, DM22, DM59	Display format defined for individual CHOICES. Distance of NM is the only distance supported in Data Comm for uplinks. For Normal PIDs, kilometers will be rejected. Distancekm needs to be supported for Emergency PIDs, as part of [placebearingdistance] within [position] field.

Field	Field Type	Supported Message Elements (UMs and DMs)	Remarks
[distancekm]	Distancekm ::= INTEGER (1..1024)	DM59	<p>Units = 1 Kilometer (KM), representing a range of 1 KM to 1024 KM.</p> <p>Display leading zeros.</p> <p>Supported in Emergency PIDs, as part of [placebearingdistance] within [position] field.</p> <p><i>Note: This field/format is invalid for uplinks and Normal PIDs.</i></p>
[distancenm]	Distancenm ::= INTEGER (0..9999)	UM49, UM61, UM74, UM79, UM80, UM83, DM59	<p>Units = 0.1 Nautical Mile (NM) in message element, representing a range of 0 NM to 999.9 NM.</p> <p>For both Uplink and PIDs, display distance in whole miles rounded to the nearest NM as ddd (thus, units = 1NM in display format) when distance is part of placebearingdistance. Otherwise display with a single decimal, as ddd.d.</p> <p>Display leading zeros.</p> <p>DO-258A: [distance] >700NM is not loadable.</p>
[distanceoffset]	Distanceoffset ::= CHOICE { [distanceoffsetnm] } [distanceoffsetkm] }	DM60, DM80	<p>Display format defined for individual CHOICES.</p> <p>Distance offset in both nautical miles and kilometers are supported, since they are used in Emergency PIDs.</p>

Field	Field Type	Supported Message Elements (UMs and DMs)	Remarks
[distanceoffsetkm]	Distanceoffsetkm := INTEGER(1..256)	DM60, DM80	Units = 1 Kilometer(KM), representing a range of 1 KM to 256 KM.
[distanceoffsetnm]	Distanceoffsetnm ::= INTEGER (1..128)	DM60, DM80	Units = 1 Nautical Mile (NM), representing a range of 1 NM to 128 NM.
[eFCtime]	EFCtime ::= [time]	DM59	

Field	Field Type	Supported Message Elements (UMs and DMs)	Remarks
[errorinformation]	Errorinformation ::= ENUMERATED { Applicationerror(0), DuplicateMsgIdentification(1), UnrecognizedMsgReferenceNumber(2), EndServiceWithPendingMsgs(3), EndServiceWithNoValidResponse(4), InsufficientMsgStorageCapacity(5), NoAvailableMsgIdentificationNumber(6), CommandedTermination(7), InsufficientData(8), UnexpectedData(9), InvalidData(10), ReservedErrorMsg(16) }	DM62	<p>When received as part of DR1, any error is stored as ERROR in the Full/Abbreviated text for display.</p> <p>EDSM will display ERR in the Status of the corresponding uplink message whenever an error is received as a response in DM62, based on the status field in the CPDLC Message Data Store for the corresponding uplink.</p> <p>Note that the enumeration values (i.e., 0-10 and 16) are according to DO-258A definition. If 11 to 15 are received (against the standard), a text of ERROR can be stored, to be consistent with other enumeration values.</p>
[fixname]	Fixname ::= IA5String (SIZE (1..5))	UM49, UM61, UM74, UM79, UM80, UM83, DM22, DM59	

Field	Field Type	Supported Message Elements (UMs and DMs)	Remarks
[freetext]	Freetext ::= IA5String (SIZE (1..256))	UM169, DM68	<p>UM169 (other than UM169 Route Freetext) has a set of adapted free text values. UM169-ROUTEFT is derived from [routeclearance] and, if included, [position] in UM79, UM80 and UM83 uplinks.</p> <p>For DM68 that can be included in Emergency PIDs, there is no defined set of free text.</p>
[frequency]	Frequency ::= CHOICE { [frequencyhf], [frequencyvhf], [frequencyuhf], [frequencychannel] }	UM117, um120	Only VHF and HF frequencies are supported in En Route Data Comm.
[frequencyvhf]	Frequencyvhf ::= INTEGER (118000..136975)	UM117, um120	<p>Units = 0.001 Megahertz (MHz), Precision = 0.025 MHz, representing a range of 118.000 MHz to 136.975 MHz.</p> <p><i>Note: DO-258A defines VHF Frequency range as 117.000 to 138.000 MHz. The range specified is from NAS-MD-311, which is more restrictive.</i></p>
[frequencyhf]	Frequencyhf ::= INTEGER (2850..28000)	UM117, um120	Units = 1 Kilohertz (KHz), Precision = 1 KHz

Field	Field Type	Supported Message Elements (UMs and DMs)	Remarks
[holdatwaypoint]	Holdatwaypoint ::= SEQUENCE { [position], [holdatwaypoint speedlow], [aTWaltitude], [holdatwaypoint speedhigh], [direction], [degrees], [eFCtime], [legtype] }	DM59	
[holdatwaypointsequence]	Holdatwaypointsequence ::= SEQUENCE SIZE (1..8) OF [holdatwaypoint]	DM59	
[holdatwaypoint speedhigh]	Holdatwaypoint speedhigh ::= [speed]	DM59	
[holdatwaypoint speedlow]	Holdatwaypoint speedlow ::= [speed]	DM59	
[icaofacilitydesignation]	Icaofacilitydesignation ::= IA5String (SIZE (4))	UM163, DM64, UM160	

Field	Field Type	Supported Message Elements (UMs and DMs)	Remarks
[icaofacilityfunction]	Icaofacilityfunction ::= ENUMERATED { center(0), approach(1), tower(2), final(3), groundControl(4), clearanceDelivery(5), departure(6), control (7) }	UM117	Only the 1st 2 enumerations, with values CENTER and APPROACH, are used for Data Comm
[icaofacilityidentification]	Icaofacilityidentification ::= CHOICE { [icaofacilitydesignation], [icaofacilityname] }	UM117	Format defined for individual choices. Only icaofacilityname choice is used in Data Comm.
[icaofacilityname]	Icaofacilityname ::= IA5String (SIZE (3..18))	UM117	
[icaounitname]	Icaounitname ::= SEQUENCE { [icaofacilityidentification] , [icaofacilityfunction] }	UM117	Display format defined for individual sequence sub-elements.

Field	Field Type	Supported Message Elements (UMs and DMs)	Remarks
[interceptcourseform]	Interceptcourseform ::= SEQUENCE { [interceptcourseformselection], [degrees] }	DM59	
[interceptcourseformselection]	Interceptcourseformselection ::= CHOICE { [publishedidentifier], [latitudelongitude] , [placebearingplacebearing], [placebearingdistance] }	DM59	
[interceptcourseformsequence]	Interceptcourseformsequence ::= SEQUENCE SIZE (1..4) of Interceptcourseform	DM59	
[latitude]	Latitude ::= SEQUENCE { [latitudedegrees] ([minuteslatlon]) [latitudedirection] }	UM49, UM61, UM74, UM79, UM80, UM83, DM22, DM59	Display format defined for individual sequence sub-elements. For display, there are no spaces between the [latitude] sub-elements. Minuteslatlon is optional but is always included in uplinks.

Field	Field Type	Supported Message Elements (UMs and DMs)	Remarks
[latitudedegrees]	LatitudeDegrees ::= INTEGER (0..90)	UM49, UM61, UM74, UM79, UM80, UM83, DM22, DM59	Units = 1 Degree, representing a range of 0 degrees to 90 degrees. Display leading zero.
[latitudedirection]	LatitudeDirection ::= ENUMERATED { north(0) south(1) }	UM49, UM61, UM74, UM79, UM80, UM83, DM22, DM59	
[latitudeLongitude]	LatitudeLongitude ::= SEQUENCE { [latitude], [longitude] }	UM49, UM61, UM74, UM79, UM80, UM83, DM22, DM59	Display format defined for individual sequence sub-elements. For display, a "/" is used to separate the [latitude] and [longitude]. For Crossing Restriction Uplinks, the [latitudeLongitude] is not displayed as part of the [placebearing distance].
[latitudeLongitude-seqOf]	LatitudeLongitude-seqOf ::= SEQUENCE SIZE (1..128) OF [latitudeLongitude]	DM59	
[latlonreportingpoints]	Latlonreportingpoints ::= CHOICE { [latitudereportingpoints], [longitudereportingpoints] }	DM59	

Field	Field Type	Supported Message Elements (UMs and DMs)	Remarks
[latitudereportingpoints]	Latitudereporting points ::= SEQUENCE { [latitudedirection], [latitudedegrees] }	DM59	
[legdistance]	Legdistance ::= CHOICE { [legdistanceenglish], [legdistancemetric] }	DM59	
[legdistanceenglish]	Legdistanceenglish ::= INTEGER (1..999)	DM59	Units = .1 Nautical Mile, representing range of .1 Nautical Mile to 99.9 Nautical Miles.
[legdistancemetric]	Legdistancemetric ::= INTEGER (1..128)	DM59	Units = 1 Kilometer, representing range of 1 kilometers to 128 kilometers.
[legtime]	Legtime ::= INTEGER (1..99)	DM59	Units = .1 Minute, representing range of .1 minutes to 9.9 minutes.
[legtype]	Legtype ::= CHOICE { [legdistance], [legtime] }	DM59	

Field	Field Type	Supported Message Elements (UMs and DMs)	Remarks
[longitude]	Longitude ::= SEQUENCE { [longitudedegrees] ([minuteslatlon]) [longitudedirection] }	UM49, UM61, UM74, UM79, UM80, UM83, DM22, DM59	Display format defined for individual sequence sub-elements. For display, there are no spaces between the [longitude] sub-elements. Minuteslatlon is optional but is always included in uplinks.
[longitudedegrees]	Longitudedegrees ::= INTEGER (0..180)	UM49, UM61, UM74, UM79, UM80, UM83, DM22, DM59	Units = 1 Degree, representing a range of 0 degrees to 180 degrees. Display leading zeros.
[longitudedirection]	Longitudedirection ::= ENUMERATED { east(0) west(1) }	UM49, UM61, UM74, UM79, UM80, UM83, DM22, DM59	
[longitudereportingpoints]	Longitudereportingpoints ::= SEQUENCE { [longitudedirection], [longitudedegrees] }	DM59	

Field	Field Type	Supported Message Elements (UMs and DMs)	Remarks
[minuteslatlon]	Minuteslatlon ::= INTEGER (0..599)	UM49, UM61, UM74, UM79, UM80, UM83, DM22, DM59	Units = 0.1 Minute, representing a range of 0 minute to 59.9 minutes. Display leading zeros. For uplinks, the [minuteslatlon] value is rounded to the nearest tenths of a minute. For display, the value is rounded to the nearest minute, to be consistent with ERAM.
[navaid]	Navaid ::= IA5String (SIZE (1..4))	UM49, UM61, UM74, UM79, UM80, UM83, DM22, DM59	
[placebearing]	Placebearing ::= SEQUENCE { [fixname], [latitudeLongitude], [degrees] }	DM59	
[placebearingplace bearing]	Placebearing ::= SEQUENCE SIZE (2) OF [placebearing]	DM59	The field is displayed with the "pbbp()" label in the routeclearance string.

Field	Field Type	Supported Message Elements (UMs and DMs)	Remarks
[placebearingdistance]	Placebearingdistance ::= SEQUENCE { [fixname] ([latitudeLongitude]) [degrees] [distance] }	UM49, UM61, UM74, UM79, UM80, UM83, DM22, DM59	<p>Display format defined for individual sequence sub-elements.</p> <p>latitudeLongitude is optional in DO-258A, but it will always be uplinked.</p> <p>For display, there are no spaces between the [placebearingdistance] sub-elements.</p> <p>[LatitudeLongitude] in the [placebearingdistance] for the uplink messages is the lat/long of the base fix and is suppressed in the Full/Abbreviated Display Format.</p> <p>DM22 and DM59 are listed because [placebearingdistance] is part of [position].</p> <p>Display of [latitudeLongitude] is suppressed for both uplinks and downlinks, although it may be present in the message itself.</p> <p>When part of the Emergency PID element DM59, the field is displayed with the "pbd()" label in the routeclearance string.</p>

Field	Field Type	Supported Message Elements (UMs and DMs)	Remarks
[position]	Position ::= CHOICE { [fixname], [navaid], [airport], [latitudeLongitude], [placebearingdistance] }	UM49, UM61, UM74, UM79, UM80, UM83, DM22, DM59	<p>Display format defined for individual supported CHOICES.</p> <p>For Crossing Restriction Uplinks, the [position] display format follows the display format of the individual CHOICE that the [position] format was set to during the Crossing Restriction Uplink Message Construction. Airport is not applicable for Crossing Restriction Uplinks.</p> <p>For Route Uplinks, there are special rules for constructing [position] in long text per the Message Data Store Formatting for Route Uplink Messages section of this algorithm document.</p>
[procedure]	Procedure ::= IA5String (SIZE (1..6))	UM79, UM80, UM83, DM59	
[procedureapproach]	Procedureapproach ::= [procedurename]	DM59	The field is displayed with the "ProcAppr()" label in the routeclearance string.

Field	Field Type	Supported Message Elements (UMs and DMs)	Remarks
[procedurearrival]	Procedurearrival ::= [procedurename]	UM79, UM80, UM83, DM59	Specifies procedure as arrival procedure. When part of the Emergency PID element DM59, the field is displayed with the "ProcArr()" label in the routeclearance string.
[proceduredeparture]	Proceduredeparture ::= [procedurename]	UM79, UM80, UM83, DM59	Specifies procedure as departure procedure. When part of the Emergency PID element DM59, the field is displayed with the "ProcDep()" label in the routeclearance string.
[procedurename]	procedurename ::= SEQUENCE { [proceduretype] [procedure] ([proceduretransition]) }	UM79, UM80, UM83, DM59	proceduretransition is optional in DO-258A, but it will always be uplinked. Display format defined for individual sequence of sub-elements.
[proceduretransition]	Proceduretransition ::= IA5String (SIZE (1..5))	UM79, UM80, UM83, DM59	
[proceduretype]	Proceduretype ::= ENUMERATED { arrival(0), approach(1), departure(2) }	UM79, UM80, UM83, DM59	Only the 1st two (2) enumerations, with values ARRIVAL and APPROACH, are used for Data Comm En Route services.

Field	Field Type	Supported Message Elements (UMs and DMs)	Remarks
[publishedidentifier]	Publishedidentifier ::= SEQUENCE { [fixname] ([latitudeLongitude]) }	UM79, UM80, UM83, DM59	latitudeLongitude is optional in DO-258A, but it will always be uplinked. Display of [latitudeLongitude] associated with the identifier is suppressed for both uplinks and downlinks, although it may be present in the message itself. Display format defined for individual sequence sub-elements.
[reportingpoints]	Reportingpoints ::= SEQUENCE { [latlonreportingpoints], [degreeincrement] }	DM59	

Field	Field Type	Supported Message Elements (UMs and DMs)	Remarks
[routeclearance]	<pre>Routeclearance ::= SEQUENCE { [airportdeparture] [airportdestination] [runwaydeparture] [proceduredeparture] [runwayarrival] [procedureapproach] [procedurearrival] [airwayintercept] [routeinformation-seqOf] [routeinformation-additional] }</pre>	UM79, UM80, UM83, DM59	<p>[airportdestination], [procedurearrival], and [routeinformation-seqOf] are used for Data Comm for route uplinks. Other fields need to be supported with Emergency PID DM59, although none except [routeinformation-SeqOf] is expected.</p> <p>Display format of the field for the route uplink elements (UM79, UM80 and UM80) differs from that of DM59, the Emergency PID element. The formats for subfields when part of DM59 are specified in the respective field in this table.</p> <p>There are special rules for constructing [routeclearance] in long text for the uplink elements, per Section 4.2.1.6.7 Message Data Store Formatting for Route Uplink Messages.</p>

Field	Field Type	Supported Message Elements (UMs and DMs)	Remarks
[routeinformation]	Routeinformation ::= CHOICE { [publishedidentifier] [latitudeLongitude] [placebearingplacebearing] [placebearingdistance] [airwayidentifier] [trackdetail] }	UM79, UM80, UM83, DM59	Display format defined for individual CHOICES. [publishedidentifier], [latitudeLongitude], [placebearingdistance], and [airwayidentifier] are used for Data Comm. Other fields need to be supported with Emergency PID DM59.
[routeinformationadditional]	Routeinformationadditional ::= SEQUENCE { [aTWalongtrackwaypointsequence] [reportingpoints] [interceptcoursefromsequence] [holdatwaypointsequence] [waypointspeedaltitudesequence] [rTArequiredtimearrivalsequence] }	DM59	The information in [routeinformationadditional] will not be sent in an uplink message but could be received in an Emergency PID. The field is displayed with the "Addnl()" label in the routeclearance string.

Field	Field Type	Supported Message Elements (UMs and DMs)	Remarks
[routeinformation-seqOf]	Routeinformation-seqOf ::= SEQUENCE SIZE (1..128) OF [routeinformation]	UM79, UM80, UM83, DM59	Display format defined for individual sequence sub-elements. When part of the Emergency PID element DM59, the field is displayed with the "Rt()" label in the routeclearance string.
[remainingfuel]	Remainingfuel := SEQUENCE { [timehours], [timeminutes] }	DM57	Field Type format defined for individual sequence sub-elements. For display, a ":" is used to separate the [timehours] and [timeminutes].
[remainingsouls]	Remainingsouls := INTEGER(1..1024)	DM57	
[rTArequiredtimearrival]	RTArequiredtimearrival ::= SEQUENCE { [position], [rTAtime], [rTAtolerance] }	DM59	Note: This field is displayed with a semicolon, followed by space, "; ", after [rTAtime]. i.e., [position] [rTAtime]; [rTAtolerance]
[rTArequiredtimearrivalsequence]	RTArequiredtimearrivalsequence ::= SEQUENCE SIZE (1..32) OF [rTArequiredtimearrival]	DM59	

Field	Field Type	Supported Message Elements (UMs and DMs)	Remarks
[rTAtime]	RTAtime ::= SEQUENCE { [time], [timetolerance] }	DM59	Note: This field is displayed with a comma, followed by space, “ , “, between the two subfields. i.e., [time], [tolerance]
[rTAtolerance]	RTAtolerance ::= INTEGER (1..150)	DM59	Units = .1 Minute, representing a range of .1 minute to 15.0 minutes.
[runway]	Runway ::= SEQUENCE { [runwaydirection], [runwayconfiguration] }	DM59	
[runwayarrival]	Runwayarrival ::= [runway]	DM59	The field is displayed with the “RwArr:” label in the routeclearance string.
[runwayconfiguration]	Runwayconfiguration ::= ENUMERATED { left(0), right(1), center(2), none(3) }	DM59	For the enumeration of 3 (none), nothing will be displayed.
[runwaydeparture]	Runwaydeparture ::= [runway]	DM59	The field is displayed with the “RwDep:” label in the routeclearance string.

Field	Field Type	Supported Message Elements (UMs and DMs)	Remarks
[runwaydirection]	Runwaydirection ::= INTEGER (1..36)	DM59	Display leading zero.
[speed]	Speed ::= CHOICE { [speedindicated], [speedindicatedmetric], [speedtrue], [speedtruemetric], [speedground], [speedgroundmetric], [speedmach], [speedmachlarge] }	UM61, DM59	Display format defined for individual supported CHOICES. Speedindicated, speedmach, and speedmachlarge are the only speed choices supported in Data Comm.
[speedground]	Speedground ::= INTEGER (7..70)	DM59	Units = 10 Knots, representing range of 70 knots to 700 knots. The speed entered must be in increments of 10.
[speedgroundmetric]	Speedgroundmetric ::= INTEGER (10..265)	DM59	Units = 10 Kilometers/Hour, representing range of 100 Kilometers to 2650 Kilometers.
[speedindicated]	Speedindicated ::= INTEGER (7..38)	UM61, DM59	Units = 10 Knots, representing range of 70 knots to 380 knots. The speed entered must be in increments of 10.
[speedindicatedmetric]	Speedindicatedmetric ::= INTEGER (10..137)	DM59	Units = 10 Kilometers/Hour, representing range of 100 Kilometers/Hour to 1370 Kilometers/Hour.

Field	Field Type	Supported Message Elements (UMs and DMs)	Remarks
[speedmach]	Speedmach ::= INTEGER (61..92)	UM61, DM59	Units = 0.01 Mach, representing a range of 0.61 Mach to 0.92 Mach. For Full Text, a leading digit of zero is displayed. For Abbreviated Text, a leading digit of zero is NOT displayed.
[speedmachlarge]	Speedmachlarge ::= INTEGER (93..604)	UM61, DM59	Units = 0.01 Mach, representing a range of 0.93 Mach to 6.04 Mach. For Uplinks, the speed range supported is 0.93 Mach to 0.99 Mach which is the intersection of the current ERAM syntax and DO-258A range. For Full Text, a leading digit of zero is displayed. For Abbreviated Text, a leading digit of zero is NOT displayed.
[speedtrue]	Speedtrue ::= INTEGER (7..70)	DM59	Units = 10 Knots, representing a range of 70 knots to 700 knots.
[speedtruemetric]	Speedtruemetric ::= INTEGER (10..137)	DM59	Units = 10 Kilometers/Hour, representing a range of 100 Kilometers/Hour to 1370 Kilometers/Hour.
<station ID>	Station ID ::= IA5String (SIZE (2..5))	UM169	

Field	Field Type	Supported Message Elements (UMs and DMs)	Remarks
[time]	Time ::= SEQUENCE { [timehours], [timeminutes] }	DM59	Field Type format defined for individual sequence sub-elements. For display, a “:” is used to separate the [timehours] and [timeminutes].
[timehours]	Timehours ::= INTEGER (0..23)	DM57, DM59	Display leading zeros.
[timeminutes]	Timeminutes ::= INTEGER (0..59)	DM57, DM59	Display leading zeros.
[timetolerance]	Timetolerance ::= ENUMERATED { at(0), at(1), at(2) }	DM59	
[tp4table]	Tp4table ::= ENUMERATED { LabelA(0), LabelB(1) }	UM163	Stored as 0 or 1, and not displayed, since UM163 is not displayed
[trackdetail]	Trackdetail ::= SEQUENCE { [trackname], [latitudeLongitude-seqOf] }	DM59	The field is displayed with the “td()” label in the routeclearance string.
[trackname]	Trackname ::= IA5String (SIZE (3..6))	DM59	
[versionnumber]	Versionnumber ::= INTEGER(0..15)	DM73	

Field	Field Type	Supported Message Elements (UMs and DMs)	Remarks
[waypointspeedaltitude]	Waypointspeedaltitude ::= SEQUENCE { [position], [speed], [aTWaltitudesequence] }	DM59	
[waypointspeedaltitudesequence]	Waypointspeedaltitudesequence ::= SEQUENCE SIZE (1..32) OF [waypointspeedaltitude]	DM59	The field is displayed with the "WpSpAlt ()" label in the routeclearance string. In addition, each [waypointspeedaltitude] within the sequence is enclosed in "("" with a space separating the items. i.e., WpSpAlt(([waypointspeedaltitude]) ...)

Table 12 – TOC “Contact” Operating Method – FAA Domestic

Step	TOC “Contact” Operating Method – FAA Domestic
1	The ATSU sends a TOC CPDLC CONTACT message requiring a response. When the ATSU system sends a TOC CPDLC message, the controller will be provided an indication that uplink is “open.”
2	Upon aircraft system receipt of a TOC CPDLC CONTACT message requiring a response, the flight crew is notified.
3	The flight crew may respond with DM2 STANDBY.
4	Upon ATSU system receipt of a DM2 STANDBY, the standby is available for controller display.

Step	TOC “Contact” Operating Method – FAA Domestic
5W	After the flight crew has determined that they can comply with a received TOC message requiring a W/U response the flight crew responds with a DM0 WILCO.
6	The flight crew tunes into the flight deck radio tuning panel the assigned ATC Frequency from the CONTACT message, then makes voice contact with the receiving controller using standard contact procedures.

APPENDIX D EXPLANATION OF ROUTE AND ROUTE SEGMENT CLEARANCES (UM79, UM80, AND UM83)

This section is an excerpt from Gordon Sandell’s Loading of ATC Clearances into the FMS. UM83 references are included in this section, however, the UM83 is not operationally implemented due to latent avionics loading issues.

There are three (3) clearance elements that replace all or large segments of the existing route that may be loaded directly into the FMS on the various Boeing airplanes. They are as follows:

UM79	CLEARED TO position VIA route clearance
UM80	CLEARED route clearance
UM83	AT position CLEARED route clearance

All three (3) of these message elements are implemented on all Boeing FANS-1 airplane models (737, 747-400, 747-8, 757/ 767, 777, 787, and MD-11).

The way in which each of these clearances modifies the route in the FMC is a little different. Message element UM80 will replace the route in its entirety, as shown in Figure 16 and Figure 17 below.

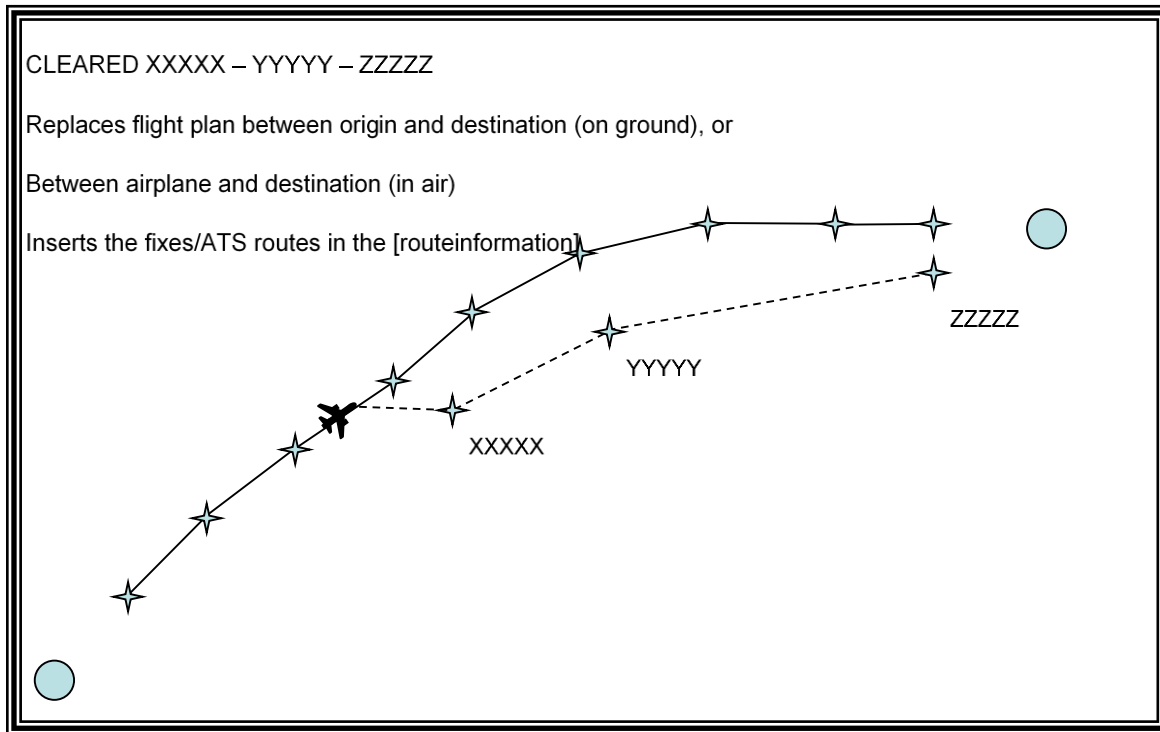

Figure 16 – Loading of UM80 When Aircraft is Airborne

Loading of UM80 when the airplane is on the ground is shown in Figure 17 below.

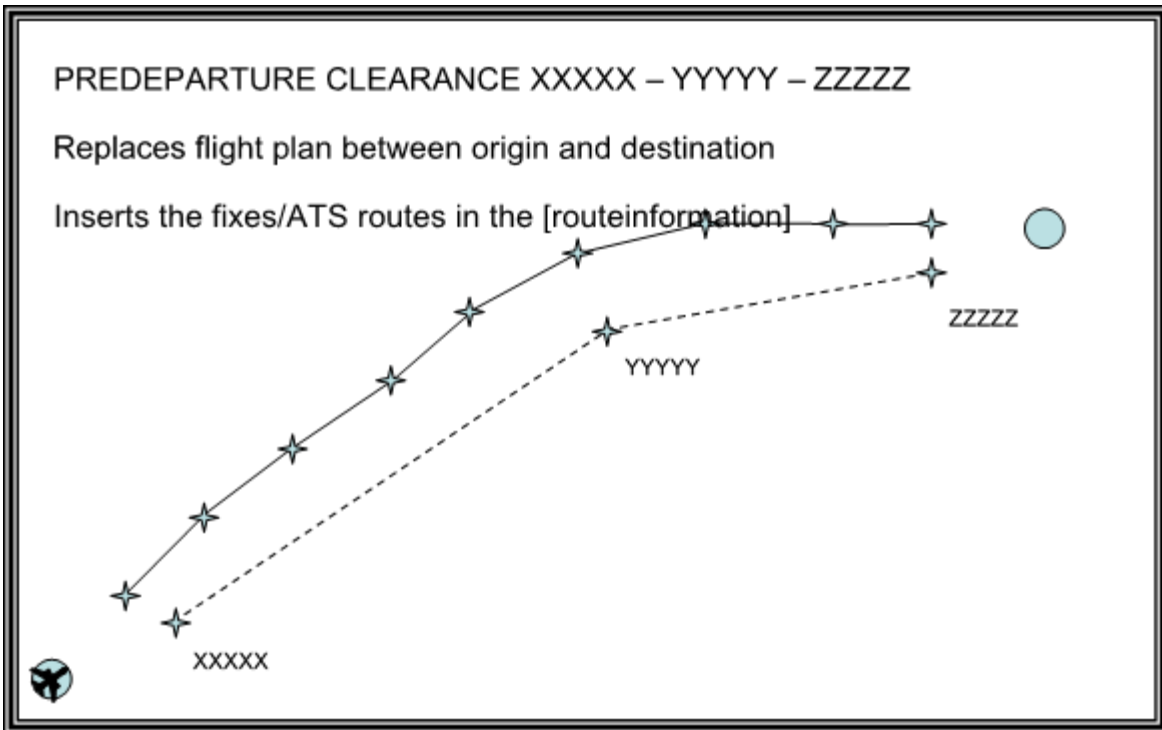

Figure 17 – Loading of UM80 When Aircraft is on the Ground

The other route clearance uplinks (UM79 and UM83) will each only replace a segment of the route. Message element UM79 (CLEARED TO [position] VIA [routeclearance]) will replace the flight plan between where the airplane is and the specified waypoint, as shown in Figure 18 below.

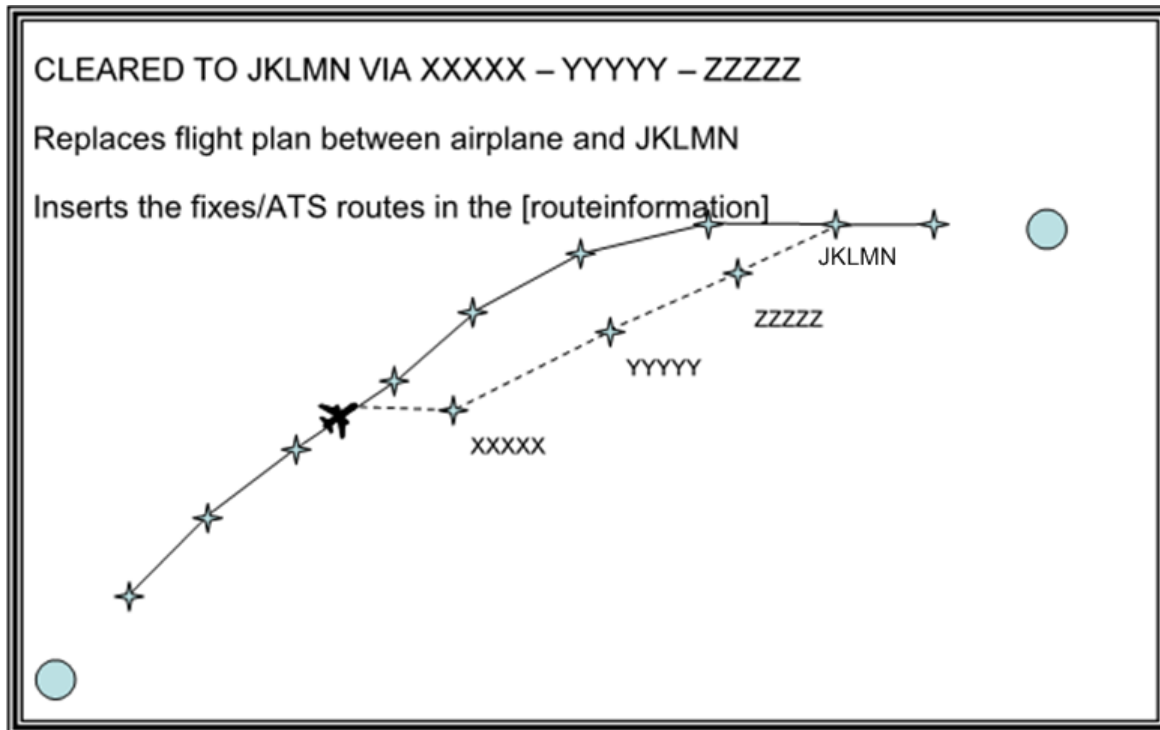

Figure 18 – Loading of UM79

Note that Figure 18 shows what happens when the specified [position] is a fix in the existing active route. If it is not a fix in the existing active route, then the position and the contents of the [routeinformation] parameter will be inserted, followed by a flight plan discontinuity and the remainder of the existing En Route segment of the route. For the example shown, if the waypoint JKLMN did NOT exist in the active route, then the result of this uplink would be:

```

XXXXX
YYYYY
ZZZZZ
JKLMN
-- DISCONTINUITY --
PQRST
UVWXY
ZABCD
EFGHI
OPQRS

```

Message element UM83 (AT [position] CLEARED [routeclearance]) will replace the flight plan, beginning at the specified position, and continuing right up to the destination, as shown in Figure 19 below.

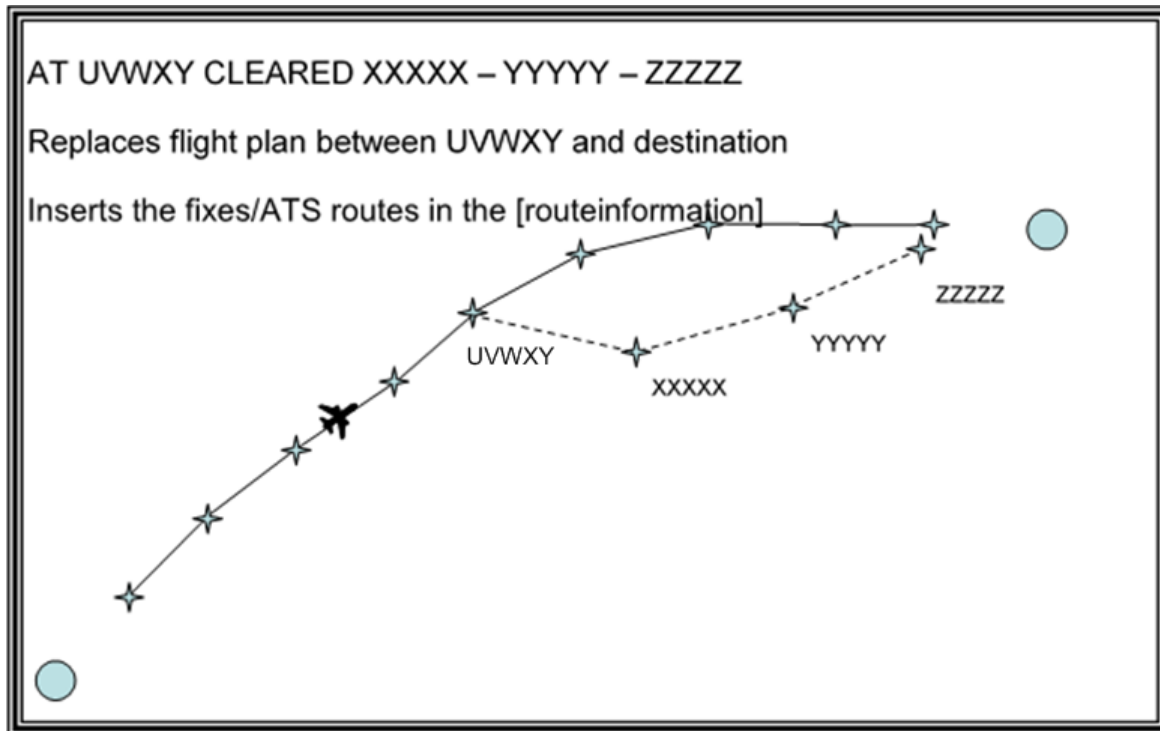

Figure 19 – Loading of UM83

Again, Figure 19 shows what happens when the specified [position] is a fix in the existing active route. If it is not a fix in the existing active route, then the position and the contents of the [routeinformation] parameter will be inserted after the remainder of the existing En Route segment of the route, separated from it by a flight plan discontinuity. For the example shown, if the waypoint UWXYZ did NOT exist in the active route, then the result of this uplink would be:

```

PQRST
ZABCD
EFGHI
JKLMN
OPQRS
-- DISCONTINUITY --
UWXYZ
XXXXX
YYYYY
ZZZZZ

```

APPENDIX E ICAO FPL CPDLC FILING CODES

The ICAO 2012 flight plan is now operational in the NAS and is required for CPDLC service.

The proposed FPL filing “codes” in Field 18/DAT are an optional mechanism for the user to notify FAA automation to generate a CPDLC or PDC clearance for CPDLC-enabled airports, and to determine En Route CPDLC eligibility. The codes were created to differentiate FANS 1/A and FANS 1/A+ support. At this time, there are no differences in the ground system support for either mode.

- ICAO FP codes take precedence over any other user preference mechanism, e.g., SDB
- For En Route CPDLC, ICAO FP codes are the only source of information for CPDLC eligibility
- Field 10a allows any order and is world-wide; “Z” is required in order to get to DAT/field
- No spaces should be included in the actual DAT/ field; they are shown in Table 13 below for clarity only.

Proposed codes include an optional “Fallback” Hierarchy if CPDLC service is not available at a CPDLC-enabled airport.

The FAA ground system uses ICAO 2012 FPL.

- Field 10a (Equipage) used to identify aircraft capabilities
- Field 18 (Other Information) DAT/Codes used to identify flights getting CPDLC or PDC
- Need to fill in Field 10a in order to get to Field 18 DAT/
- Field 18 DAT/ Codes will include a primary/secondary hierarchy
- “1”xxx designates preferred departure clearance delivery mechanism
- “2”xxx designates “back up” delivery mechanism

ICAO FPL preferences take priority over any other sources.

Table 13 – ICAO FPL Field 10a and Field 18 DAT/Codes

User Preference	Data Comm Capability Description	ICAO 2012 Field 10a	Data Comm Field 18 DAT/ Code	Comments •Fld 10a order is any order and world-wide •Z is required to get to DAT/ •No spaces in actual DAT/ field
PDC and CPDLC DCL				
PDC only*	Not ACARS equipped but gets PDC via manual means.	Z	1PDC	Some aircraft are non-ACARS equipped, and 10a is physical equipage. Still get PDC via other means (e.g., gate printer). Optional if currently getting PDC.
PDC only*	Equipped only for ACARS/PDC.	E3 Z	1PDC	Optional if currently getting PDC.
PDC only*	Equipped for ACARS/PDC and FANS but wants PDC only.	E3J4Jx Z	1PDC	Equipped for ACARS/PDC and FANS 1/A or 1/A+, and possibly other capabilities (Jx).
FANS 1/A & FANS 1/A+ CPDLC DCL only	Equipped for ACARS/PDC and FANS but wants FANS 1/A or FANS 1/A+ only for CPDLC DCL.	J4Jx Z	1FANS	Identifies US domestic preference for FANS 1/A or FANS 1/A+ DCL.
FANS 1/A & FANS 1/A+ CPDLC DCL/PDC	Equipped for ACARS/PDC and FANS, with primary/secondary preferences.	E3J4Jx Z	1FANS2PDC	Code number shows priority preference, (e.g., DCL is primary preference; PDC is secondary that will be used if primary is unavailable and feasible.)
PDC Only and En Route Data Link Clearances				
FANS 1/A & FANS 1/A+ No En Route UM80 Load Issues	For flights authorized for en route data link with no UM80 load issues and for PDC service only.	E3J4Jx Z	1PDCFANSE	This code is to be used to obtain PDC and CPDLC en route clearances with aircraft that have no en route UM80 load issues. (No Tower CPDLC DCL)
FANS 1/A & FANS 1/A+ With En Route UM80 Load Issues	For flights authorized for en route data link with UM80 load issues and for PDC service only.	E3J4Jx Z	1PDCFANSER	This code is to be used to obtain a PDC and CPDLC en route clearances with aircraft that have en route UM80 load issues. (No Tower CPDLC DCL)
PDC, DCL, and En Route Data Link Clearances				
FANS 1/A & FANS 1/A+ No En Route UM80 Load Issues	For flights authorized for en route data link with no UM80 load issues, as well as for ACARS/PDC and CPDLC DCL with primary/secondary preferences.	E3J4Jx Z	1FANSE2PDC	This code is to be used to obtain CPDLC DCL and en route clearances with aircraft that have no UM80 load issues; PDC is secondary that will be used if primary is unavailable and if feasible.
FANS 1/A & FANS 1/A+ With En Route UM80 Load Issues	For flights authorized for en route Data Comm with UM80 load issues, as well as for ACARS/PDC and CPDLC DCL with primary/secondary preferences.	E3J4Jx Z	1FANSER2PDC	This code is to be used to obtain CPDLC DCL and en route clearances with aircraft that have UM80 load issues; PDC is secondary that will be used if primary is unavailable and if feasible.
CPDLC DCL Only and En Route Data Link Clearances				
FANS 1/A & FANS 1/A+ No En Route UM80 Load Issues	For flights authorized for en route data link with no UM80 load issues, as well as for CPDLC DCL service.	J4Jx Z	1FANSE	This code is to be used to obtain CPDLC DCL and en route clearances with aircraft that have no UM80 load issues. (No Tower PDC)
FANS 1/A & FANS 1/A+ With En Route UM80 Load Issues	For flights authorized for en route Data Comm with UM80 load issues, as well as for CPDLC DCL service.	J4Jx Z	1FANSER	This code is to be used to obtain CPDLC DCL and en route clearances with aircraft that have UM80 load issues. (No Tower PDC)
En Route Data Link Clearances ONLY				
FANS 1/A & FANS 1/A+ No En Route UM80 Load Issues	For flights authorized for En Route Data Comm with no UM 80 load issues.	J4Jx Z	FANSE	This code is to be used to obtain CPDLC en route clearances with aircraft that have no UM80 load issues. (No Tower CPDLC DCL or PDC)
FANS 1/A & FANS 1/A+ With En Route UM80 Load Issues	For flights authorized for en route data link with UM80 load issues.	J4Jx Z	FANSER	This code is to be used to obtain CPDLC en route clearances with aircraft that have UM80 load issues. (No Tower CPDLC DCL or PDC)

* No ICAO flight plan change required if user currently gets PDC and does not want CPDLC DCL. Current PDC designation will be the default.

APPENDIX F**ACRONYMS****Table 14 – Table of Acronyms**

Acronym	Definition
ABRR	Airborne Reroute Execution
ACARS	Aircraft Communications Addressing and Reporting System
ACID	Aircraft Identification (Code)
ACK	Acknowledge
ACL	Aircraft List
ADAR/PDAR	Adapted Departure-Arrival Route/Preferential Departure-Arrival Route
ADR/PDR	Adapted Departure Route/ Preferential Departure Route
AGL	Above Ground Level
ANSP	Air Navigation Service Provider
AOC	Airline Operations Center
ARTCC	Air Route Traffic Control Center
ATC	Air Traffic Control
ATOP	Advanced Technologies and Oceanic Procedures
ATS	Air Traffic Services
ATSU	Air Traffic Services Unit
CAA	Confirm Assigned Altitude
CAF	Cleared As Filed
CC1	Connect Confirm Message
CDA	Current Data Authority
CDR	Coded Departure Routes
CHI	Computer Human Interface
CPDLC	Controller-Pilot Data Link Communication
CR1	Connect Request Message
CRC	Cyclic Redundancy Check
CSP	Communication Service Provider
D-ATIS	Digital Automatic Terminal Information Service
DAT	Data Application information

Acronym	Definition
DCIT	Data Comm Implementation Team
DCL	Departure Clearance
DCNS	Data Communications Network Service
DLD	Data Link Dispatch
DM	Departure Message
DP	Departure Procedure
DPP	Departure Procedure Parameter (SID/Climb via and Climb out)
DR1	Disconnect Request Message
E2E	End-to-End
ERAM	En Route Automation Modernization
ERR	Error Indicator
FAA	Federal Aviation Administration
FANS	Future Air Navigation System
FDB	Flight Data Block
FIR	Flight Information Region
FLID	Flight Identification
FMC	Flight Management Computer
FMS	Flight Management System
FOC	Flight Operations Center
FPL/FP	Flight Plan
FRC	Full Route Clearance
FRD	Fix-Radial-Distance
GOLD	ICAO Global Operational Data Link Document (Second Edition 26 April 2013)
GREQ	Gate Request
HF	High Frequency
IATA	International Air Transport Association
IC	Initial Contact
ICAO	International Civil Aviation Organization
ID	Identification
IFR	Instrument Flight Rules

Acronym	Definition
IRD	Interface Requirements Document
JMS	Java Message Service
L/L	Latitude/Longitude
LDA	Logical Data Authority
LTV	Latency Time Value
NAS	National Airspace System
NAT	North Atlantic Tracks
NAVAID	Navigational Aid
NDA	Next Data Authority
NEMS	NAS Enterprise Management Service
NM	Nautical Mile
NOTAM	Notice To Airmen
OEM	Original Equipment Manufacturer
PBD	Place Bearing Distance
PDC	Pre-Departure Clearance
REG	Registration
SATCOM	Satellite Communication
SDB	Subscriber Database
SID	Standard Instrument Departure
STAR	Standard Terminal Arrival Route
STBY	Standby indicator
TDLS	Tower Data Link Services
TFM	Traffic Flow Management
TMU	Traffic Management Unit
TOC	Transfer of Communication
TRACON	Terminal Radar Approach Control
UM	Uplink Message
VDL	VHF Data Link
VFR	Visual Flight Rules
VHF	Very High Frequency

Acronym	Definition
VOR	Very High Frequency Omni-Directional Range
XML	Extensible Markup Language