

**KENT
USA**

Since 1979

JHC-18S
Centerless Grinder
Operation Manual



www.kentusa.com | 1.800.KENT.USA

Operator's Manual

MACHINE NAME :

CENTERLESS GRINDING MACHINE

MODEL :

JHC-12BN JHC-12S

JHC-18 JHC-18A JHC-18B

JHC-18S JHC-18AS JHC-18BS

JHC-20 JHC-20S

File NO : JHC-CLGM-E001

Date : 2015.12.25

Version : R00

Original Instructions

Contents

1. SAFETY TIPS	1-1
1.1 Warning tips	1-1
1.2 General safety tips	1-2
1.3 Machine safety tips	1-3
1.4 Tips for electrical equipments	1-4
1.5 The SAMPLE AND POSITION FOR THE WARNING SIGN	1-5
2. MACHINE SPECIFICATION	2-1
2.1 JHC-12 series specification	2-1
2.2 JHC-18 series specification	2-3
2.3 JHC-20 series specification	2-5
2.4 Machanism and part list	2-7
2.5 Parts function	2-10
2.6 Standard accessories	2-12
2.7 Optional accessories	2-13
3. MACHINE LAYOUT	3-1
3.1 Floor space	3-1
4. TRANSPORTATION & INSTALLATION	4-1
4.1 Lifting	4-1
4.2 Transportation	4-2
4.2.1 <i>Center-of-gravity position of forklift and machine</i>	<i>4-2</i>
4.2.2 <i>Position offorklift transportation</i>	<i>4-3</i>
4.3 Foundation	4-4

4.4	Leveling.....	4-5
4.5	Clean	4-6
5.	MECHANISM AND ADJUSTMENT	5-1
5.1	Balance of grinding wheel.....	5-1
5.2	Assemble and disassemble of grinding wheel	5-2
5.2.1	Procedure.....	5-2
5.2.2	Tips:	5-8
5.3	Spindle correction.....	5-9
5.4	Grinding wheel dressing.....	5-10
5.5	Assemble and disassemble of dresser.....	5-11
5.5.1	Procedure	5-11
5.6	Intoduction of regulating wheel.....	5-15
5.7	Workrestand blade support.....	5-28
5.7.1	Workrest.....	5-28
5.7.2	Blade	5-29
5.7.3	Ejection and adjustment workrest andblade.....	5-30
5.8	Adjustment of thrufeed guide plate	5-31
6.	OPERATION	6-1
6.1	Operation key description.....	6-1
6.2	Machine switch off procedure	6-10
6.2.1	Operaton panel	6-10
6.2.2	Auto griding operation panel.....	6-11
6.2.3	Switch of proximal regulating wheel motor.....	6-12
6.3	Machine switch off procedure	6-12
6.4	Cable connection and trial run.....	6-13
6.5	Working lamp replacement	6-14

6.6	Regulating wheel servo motor parameter list	6-15
7.	MAINTENANCE & REPAIR.....	7-1
7.1	Notes of maintenance & repair	7-1
7.2	Period	7-2
7.3	Monthly check list.....	7-3
7.4	Oil-based maintenance	7-5
7.5	Lubrication system	7-6
7.5.1	Lubricator	7-6
7.5.2	Lubrication parts (12S.18S.20Sseries)	7-9
7.5.3	Lubrication parts (12BN.18.18A.18B.20 series)	7-10
7.6	Hydraulic system	7-12
7.6.1	Hydraulic circuit.....	7-12
7.6.2	Hydraulic pressure adjustment.....	7-13
7.6.3	Flow adjustment.....	7-14
7.7	Coolant selection	7-15
8.	TROUBLE SHOOTING	8-1
8.1	Common cause & remedy	8-1
9.	GRINDING APPLICATION	9-1
9.1	Centerlessgrinding principle	9-1
9.2	Centerless grinding method	9-3
9.2.1	Thrufeed method	9-3
9.2.2	Infeed method.....	9-4
9.2.3	Endfeed method.....	9-4
9.2.4	Tangential feed method.....	9-4
9.3	Grinding method for different workpiece	9-5
9.3.1	Short circle workpiece	9-5

9.3.2	<i>Disc-plateworkpiece</i>	9-5
9.3.3	<i>Long bar workpiece</i>	9-5
9.3.4	<i>Attache-head workpiece</i>	9-6
9.3.5	<i>Cross-shape workpiece</i>	9-6
9.3.6	<i>Multi-size workpiece</i>	9-6
9.3.7	<i>Cone workpiece</i>	9-7
9.4	Introduction of grinding wheel	9-8
9.5	Grinding wheel circumferential speed	9-13
9.6	Grinding difficulty and solution	9-16
9.7	Spare parts	9-19
9.8	Size List of Grinding Wheel and Regulating Wheel	9-23

1. SAFETY TIPS

This operation manual is to describe how to install, operate the machine and a basic maintenance and inspection. This manual will teach you how to operate the machine safely and correctly to make this machine work appropriately. Please read this instruction manual carefully before installation and operation. This safety tips and warning sign of manual are very important. Please fully understand before operating machine.

1.1 Warning tips

To avoid serious injury, the owner and all operator should provide necessary protection equipments for the regular operation and special operation. The owner should select qualified person with proper grinding training to operate and maintain the machine. Also, please follow below safety rules and local laborer safety laws.

1. This machine will be only operated by qualified operator who knows the machine's specification and safety rules very well.
2. When machine is running, don't get close to any movable parts of machine. If need, please turn off the machine power.
3. Please wear protective hair cap or hold hat to prevent long hair from falling down during operation.
4. Do not wear relaxed clothing and gloves during operation. Long sleeves and neckties must be buckled.
5. Please wear goggles and protection mask to avoid damage by accident or mis-operation. Wear safety shoes while operating this machine.
6. Do not operation this machine without any guidance and supervision.

7. Please stop the spindles when change / adjust the workpiece or equip / dismantle the accessories.
8. Do not use inflammable or poisonous coolant.
9. Please stop the machine immediately when find out any safe problem and ask for help from local agent.
10. Do not remove any warning sign from the machine.

1.2 General safety tips

To eliminate accident and keep the machine working well, the safety considerations are very important. Pay attention on the safety rules will much increase the productivity.

1. Wear the goggles and mask.
2. Wear the safety shoes.
3. Wear the safety helmet and overall and tight the cuff.
4. Do not wear gloves while operating machine.
5. Keep the area where around machine clean, dry and bright anytime.
6. Make sure machine foundation is rigid and steady, also keep floor tightened around the operation area.

1.3 Machine safety tips

Before operating this machine, the operator must fully understand this manual.

1. The operator and service person must pay attention to the warning sign.
Do not remove or damage.
2. All guard and doors should be secured all the time except maintenance to prevent dirt entering controller.
3. Do not move limit switch to change the slide travel.
4. Use proper tools to adjust, maintain and repair machine.
5. Any problem occurred, please stop the machine immediately.
6. Before operation daily, please be aware of the following tips.
 - 1) When machine is running, do not close to any movement or rotation parts, such as grinding wheel and regulating wheel.
 - 2) Do not use hand to clean the chips which are on the wheel and worktable.
Please clean after machine is stopped.
 - 3) Stop the machine while adjusting the direction of coolant spray.
 - 4) Do not try to touch or change the workpiece when worktable moving or workpiece is near grinding wheel.
 - 5) Place workpiece between centers and make sure it's tightened.
 - 6) Do not use objects to force machine stop.
 - 7) Stop the machine immediately when unusual situation happened during the machine is running. Restart the machine after problems are solved.
 - 8) Make sure the work space is enough for the running stroke of machine worktable. Keep irrelevant staff away from the machine.
7. Standard operation process for daily machine turn off.
 - 9) Turn off the power.

10) Clean worktable.

11) Apply lubricator on sliders and cover to prevent dust.

1.4 Tips for electrical equipments

Please notice below tips before maintainance and inspection.

1. Do not hit controller and pressure control board.
2. Please use appointed wires specification which listed on manual. Wires length shouldn't be to long. If wires drag on floor, it must be covered up.
3. Do not change pressure control board or any other buttons without authority.
4. Do not over load the socket and connector.
5. Turn off main power before changing the fuse or any electrical parts.
6. Turn off NC controller, pressure control board and mainpower and lock at off position while checking electrical equipment to avoid people turn on.
7. Do not use any wet tools to touch electrical equipment.
8. Please use proper and indicated fuse and never use high volume fuse or cooper.
9. Open cabinet shortly to prevent sun light damage.
10. Check electrical circuit screws periodically especially higher current like NFB, MS, Motors...etc., see if any loosen there to avoid mal-function or shorted.

1.5 The SAMPLE AND POSITION FOR THE WARNING SIGN

<p>1</p>	 <p>⚠ 危險 高電壓 保養時請關閉電源 ⚠ DANGER HIGH VOLTAGE Turn power off when maintenance.</p>	<p>2</p>	 <p>⚠ 警告 捲入注意 運轉中請勿鬆開或取下護罩。 ⚠ WARNING ROLLING KEEP CLEAR The operation is prohibited under a cover released or removes.</p>
<p>3</p>	 <p>⚠ 注意 捲入、切傷注意 砂輪運轉時，勿將身體靠近砂輪旋轉範圍。 ⚠ CAUTION ENTANGLING/CUTTING Do not close the wheel. When the wheel is turning.</p>	<p>4</p>	 <p>⚠ 警告 飛散物注意 可能造成人身傷害。請正確安裝砂輪與防護罩，並戴上護目鏡。 ⚠ WARNING FLYING OBJECTS Please install the wheel and guard correctly and wear blinkers.</p>
<p>5</p>	 <p>⚠ 警告 撞擊注意 運轉中，請勿將身體任一部份接觸到機器的可動元件。 ⚠ WARNING CRASHING Do not close to any of running parts, while the machine is operated.</p>	<p>6</p>	

Warning Sign Location

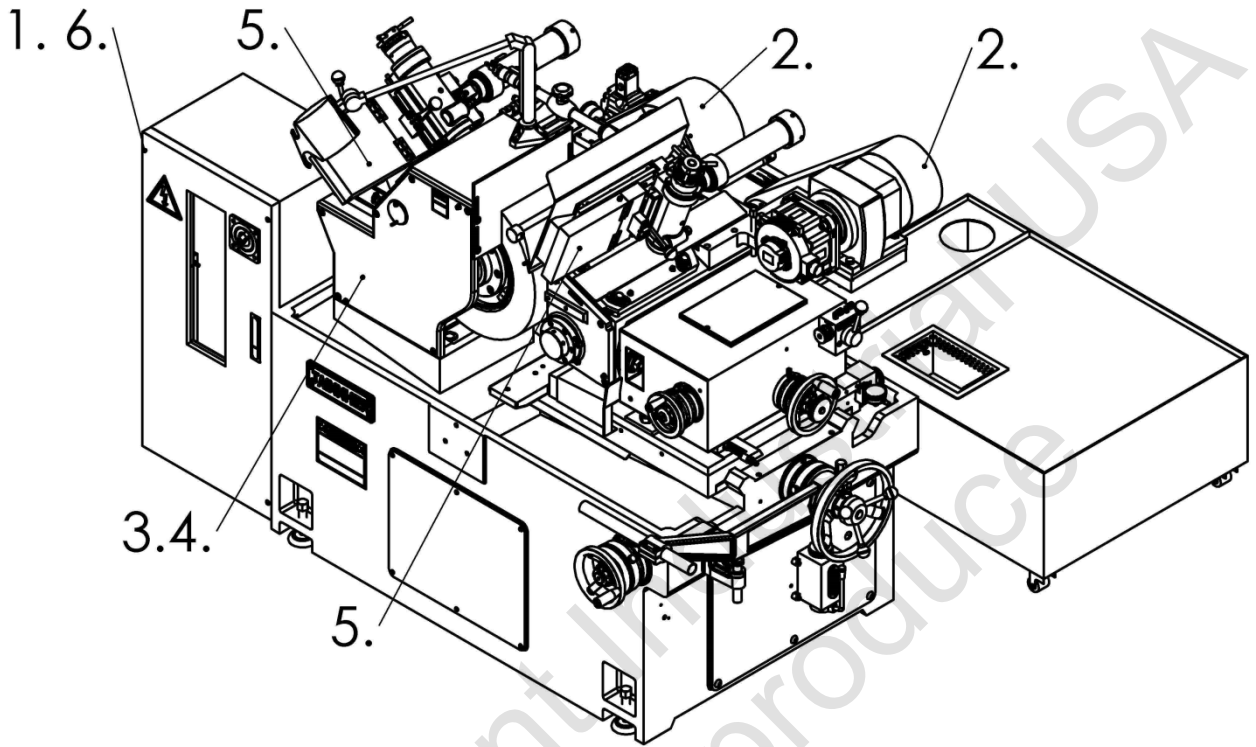

2. MACHINE SPECIFICATION

2.1 JHC-12 series specification

ITEMS	MODELS	
	JHC-12BN	JHC-12S
Std work rest(dia)	ϕ 1~ ϕ 25mm	
Special work rest(dia)	ϕ 25~ ϕ 40mm	
Grinding wheel size(dia×width×hole)	ϕ 305×150× ϕ 120	
Regulating wheel size (dia×width×hole)	ϕ 205×150× ϕ 90	
Grinding wheel speed	1900 R.P.M	
Regulating wheel speed	20-337 R.P.M (7 step)	10-300 R.P.M Stepless
Grinding wheel motor	7.5HP	
Regulating wheel motor	1HP*6P	1.8KW servo motor
Hydraulic pump motor	1HP	
Coolant pump motor	1/8HP	
Regulating wheel feed on handwheel	4mm(Rev) 0.02mm(Gra)	

MODELS ITEMS	JHC-12BN	JHC-12S
Table feed on handwheel	7mm(Rev) 0.05mm(Gra)	
Table micro feed on handwheel	0.2mm(Rev) 0.001mm(Gra)	
Dressing handwheel	1.25mm(Rev) 0.01mm(Gra)	
Regulating wheel tilt angle	+5°~ -3°	
Regulating wheel swivel angle	±5°	
Machine size (L×W×H)(approx)	1800×1400×1400mm	
Net weight (approx)	1600kgs	
Shipping gross weight (approx)	1750kgs	
Packing size(L×W×H) (approx)	2300×1100×1800mm	

2.2 JHC-18 series specification

ITEMS	MODELS					
	JHC-18	JHC-18S	JHC-18A	JHC-18AS	JHC-18B	JHC-18BS
Std work rest(dia)	ϕ 1~ ϕ 50mm					
Special work rest(dia)	ϕ 40~ ϕ 100mm					
Grinding wheel size(dia×width×hole)	ϕ 455×205× ϕ 228.6		ϕ 455×255× ϕ 228.6		ϕ 455×305× ϕ 228.6	
Regulating wheel size (dia×width×hole)	ϕ 255×205× ϕ 111.2		ϕ 255×255× ϕ 111.2		ϕ 255×305×111.2	
Grinding wheel speed	1500 R.P.M					
Regulating wheel speed	13-316 R.P.M (10 step)	10-250 R.P.M stepless	13-316 R.P.M (10 step)	10-250 R.P.Mstepless	13-316 R.P.M (10 step)	10-250 R.P.Mstepless
Grinding wheel motor	15HP				20HP	
Regulating wheel motor	2HP*6P	2.9KW servo motor	2HP*6P	2.9KW servo motor	3HP*6P	4.4KW servo motor
Hydraulic pump motor	1HP					
Coolant pump motor	1/4HP		1/2HP			
Regulating wheel feed on handwheel	3.5mm(Rev) 0.05mm(Gra)					
Regulating micro feed on handwheel	0.1mm(Rev) 0.001mm(Gra)					

ITEMS	MODELS					
	JHC-18	JHC-18S	JHC-18A	JHC-18AS	JHC-18B	JHC-18BS
Table feed on handwheel	9mm(Rev) 0.05mm(Gra)					
Table micro feed on handwheel	0.2mm(Rev) 0.001mm(Gra)					
Dressing handwheel	2mm(Rev) 0.01mm(Gra)					
Regulating wheel tilt angle	+5°~ -3°					
Regulating wheel swivel angle	±5°					
Machine size (L×W×H)approx)	2300×2000×1530mm					
Net weight (approx)	2800kgs		2900kgs		3000kgs	
Shipping gross weight (approx)	3100kgs		3200kgs		3300kgs	
Packing size(L×W×H) (approx)	3200×1400×1900mm					

2.3 JHC-20 series specification

ITEMS	MODELS	
	JHC-20	JHC-20S
Std work rest(dia)	ϕ 1~ ϕ 50mm	
Special work rest(dia)	ϕ 40~ ϕ 100mm	
Grinding wheel size(dia \times width \times hole)	ϕ 510 \times 205 \times ϕ 254	
Regulating wheel size (dia \times width \times hole)	ϕ 305 \times 205 \times ϕ 127	
Grinding wheel speed	1350 R.P.M	
Regulating wheel speed	13-316 R.P.M (10 step)	10-250 R.P.M stepless
Grinding wheel motor	20HP	
Regulating wheel motor	3HP*6P	2.9KW servo motor
Hydraulic pump motor	1HP	
Coolant pump motor	1/2HP	
Regulating wheel feed on handwheel	3.5mm(Rev) 0.05mm(Gra)	
Regulating micro feed on handwheel	0.1mm(Rev) 0.001mm(Gra)	
Table feed on handwheel	9mm(Rev) 0.05mm(Gra)	

ITEMS \ MODELS	JHC-20	JHC-20S
Table micro feed on handwheel	0.2mm(Rev) 0.001mm(Gra)	
Dressing handwheel	2mm(Rev) 0.01mm(Gra)	
Regulating wheel tilt angle	+ 5° ~ - 3°	
Regulating wheel swivel angle	±5°	
Machine size(L×W×H)(approx)	2300×2000×1530mm	
Net weight (approx)	3200kgs	
Shipping gross weight (approx)	3500kgs	
Packingsize(L×W×H) (approx)	3200×1400×1900mm	

2.4 Mechanism and part list

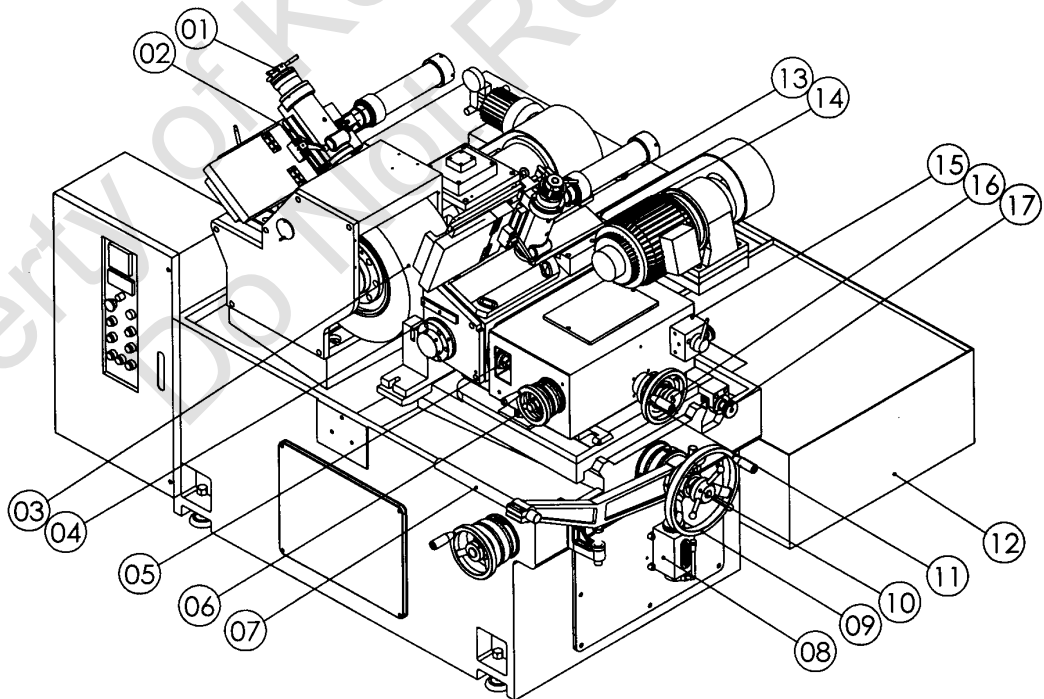
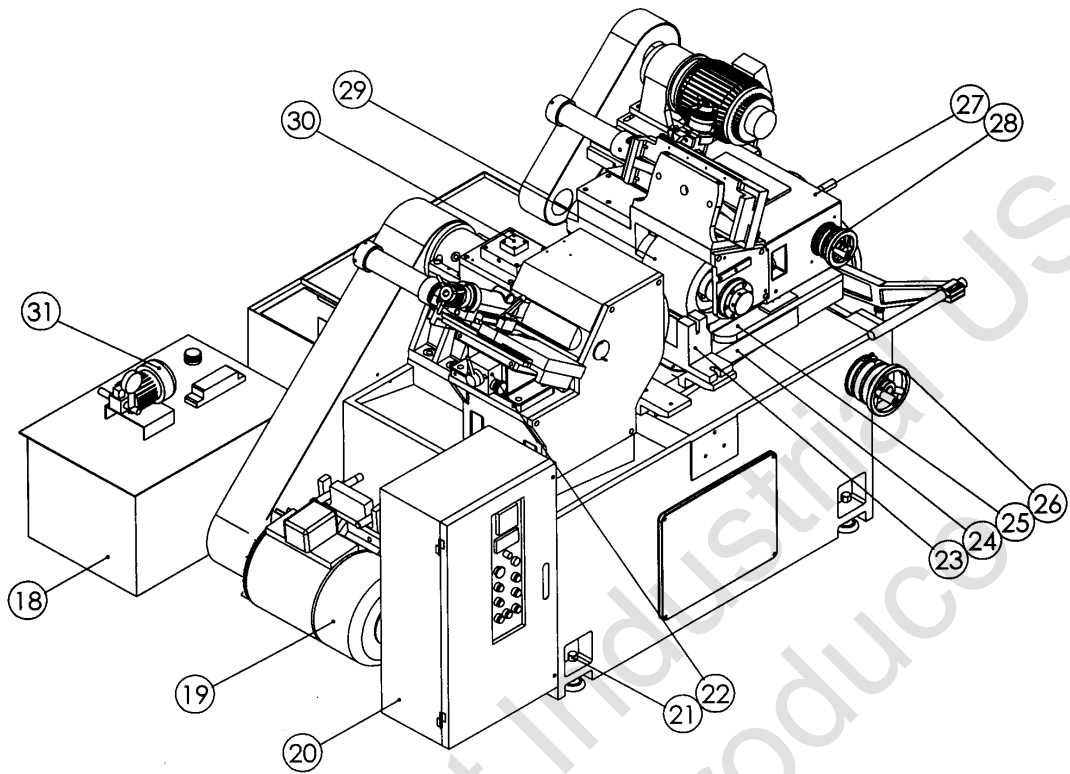

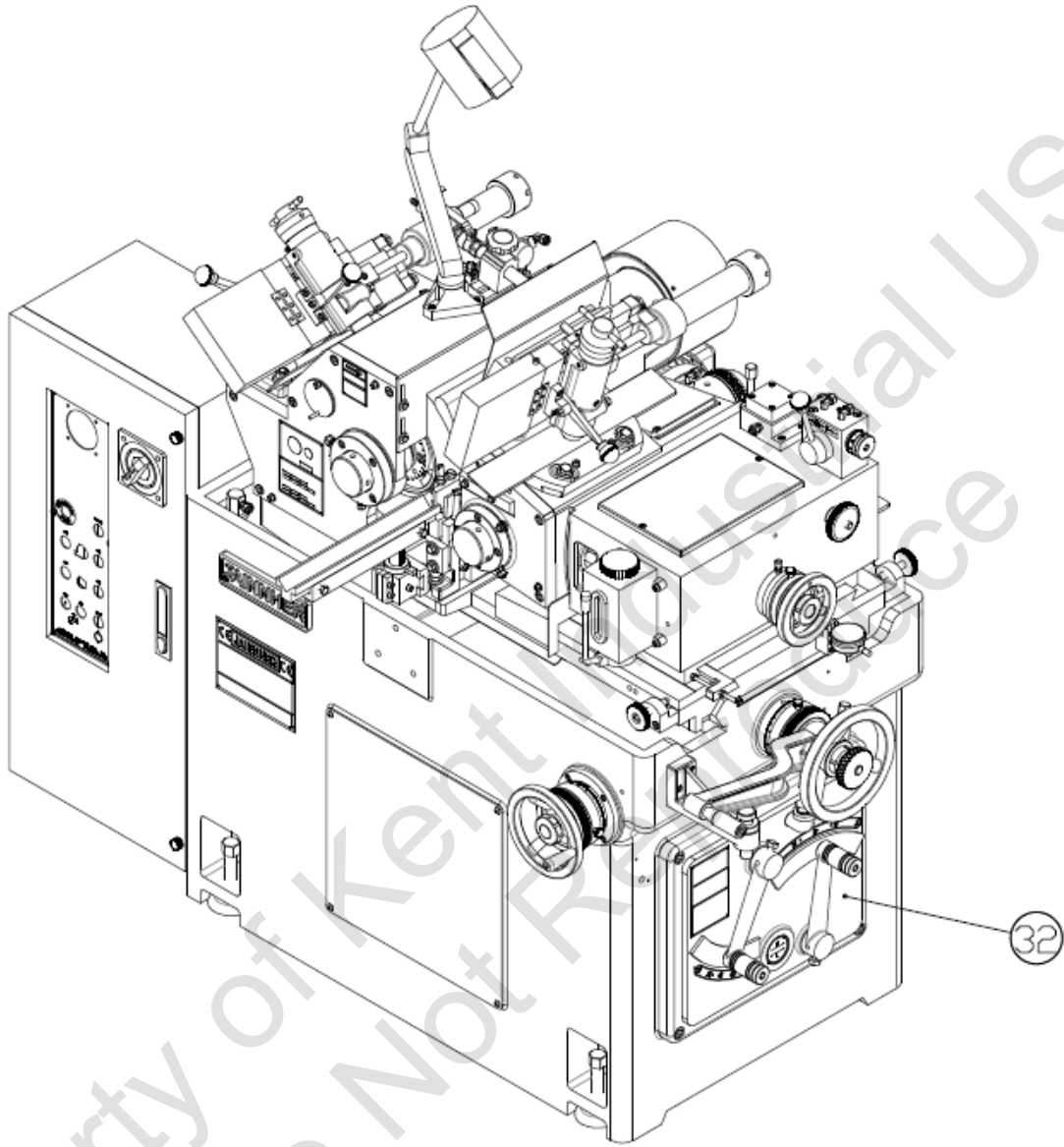

01.	Grinding wheel dresser	20.	Electric box
02.	Grinding wheel dressing emergency return handle	21.	Leveling screw
03.	Grinding wheel	22.	Dressing control for grinding wheel
04.	Blade	23.	Workrest
05.	Regulating wheel fixed screw	24.	Lower slider (worktable)
06.	Nut for regulating wheel swivel angle	25.	Up slider
07.	Handle for grinding wheel feeding	26.	Micro feeding handwheel for worktable
08.	Oiler	27.	Regulating wheel box
09.	Feeding handwheel for worktable	28.	Micro feeding handwheel for regulating wheel
10.	Micro feeding handwheel for worktable	29.	Regulating wheel
11.	Feeding handwheel for regulating wheel	30.	Grinding wheel oil lens
12.	Coolant tank	31.	Hydraulic pump driving motor
13.	Regulating wheel dresser	32.	Regulating gear box
14.	Regulating wheel dressing emergency return handle		
15.	Regulating wheel dressing switch		
16.	Micro feeding handwheel for regulating wheel		
17.	Nut for regulating wheel swivel angle		
18.	Oil tank		
19.	Grinding wheel driving motor		

2.5 Parts function

- 1) Grinding wheel dresser: dress grinding wheel.
- 2) Grinding wheel dressing emergency return handle: avoid damage to grinding wheel by carelessness or human errors.
- 3) Grinding wheel: grinding workpiece.
- 4) Blade: Support to workpiece.
- 5) Regulating wheel fixed screw: one on left and the other on right side to fix regulating wheel.
- 6) Nut for regulating wheel swivel angle: adjust the swivel angle of regulating wheel.
- 7) Handle for grinding wheel feeding: for infeed grinding.
- 8) Oiler: forcing lubricator into slides, slide ways, alloy bearing of various handwheels and screws
- 9) Feeding handwheel for worktable: adjust the distance between the blade and grinding wheel.
- 10) Micro feeding handwheel for worktable: after positioning worktable, the handwheel is functioned.
- 11) Feeding handwheel for regulating wheel: adjust the distance between blade and regulating wheel.
- 12) Coolant tank: where to store coolant.
- 13) Regulating wheel dresser: dress regulating wheel. °
- 14) Regulating wheel dressing emergency return handle: avoid damage to regulating wheel by carelessness or human errors.
- 15) Regulating wheel dressing switch: control cylinder direction and speed.
- 16) Micro feeding handwheel for regulating wheel: after positioning, the

- handwheel is functioned.
- 17) Nut for regulating wheel swivel angle: adjust the horizontal swivel angle of regulating wheel.
 - 18) Oil tank: where to store oil.
 - 19) Grinding wheel driving motor: grinding wheel rotating power source.
 - 20) Electric box: controlling electricity and electric circuit
 - 21) Leveling screw: adjust machine leveling
 - 22) Dressing control for grinding wheel: control the speed and direction.
 - 23) Workrest: fix blade.
 - 24) Lower slider (worktable): place for workrest
 - 25) Up slider: adjust the level angle of regulating wheel and upper feed moving surface.
 - 26) Micro feeding handwheel for worktable: adjust the distance between workrest and grinding wheel slightly.
 - 27) Regulating wheel box: fix regulating wheel housing.
 - 28) Micro feeding handwheel for regulating wheel: adjust the distance between the regulating wheel and blade slightly
 - 29) Regulating wheel: control feeding amount and rpm.
 - 30) Grinding wheel oil lens: check the lubrication system of grinding wheel spindle is normal or not.
 - 31) Hydraulic pump driving motor: supply oil to spindles and dressing units.
 - 32) Regulating gear box: adjust regulating wheel speed(12BN.18.18A.18B.20 series)

2.6 Standard accessories

MODE	STANDARD ACCESSORIES
JHC	1. Grinding wheel and flange
	2. Regulating wheel and flange
	3. Thrufeedworkrest and blade
	4. Infeedworkrest and blade
	5. Tool box and tool
	6. Working lamp
	7. Diamond dresser *2
	8. Thrufeed safety device
	9. Flange exatractor
	10. Leveling screw and plate
	11. Thrufeed process gauge
	12. Oil tank with pump
	13. Water tank with pump (If order paper filter or hydrocyclone coolant filtering unit, water tank is not attached.)

2.7 Optional accessories

MODE	OPTIONAL ACCESSORIES
JHC	1. Magnetic separator
	2. Paper filter
	3. Hydrocyclone cooling filtering unit
	4. Work ejector device
	5. Forming dressing device
	6. Long V-shaped support
	7. Manual parts feeder for infeed grinding
	8. Automatic receiver for thrufeed grinding
	9. Automatic thrufeed device
	10. Vibratory parts feeder
	11. Auto thrufeed taper grinding device
	12. Auto infeed forming grinding device
	13. Wheel balancing arbor
	14. Wheel balancing base
	15. Off-line gauging, non-contact O.D. measuring system
	16. Grinding wheel automatic balancing system
	17. Oil cooler
	18. Rotary type grinding wheel dressing attachment
	19. Jib crane and hook for grinding wheel
	20. Grinding balancer for wheels
	21. Oil mist receiver

3. MACHINE LAYOUT

3.1 Floor space

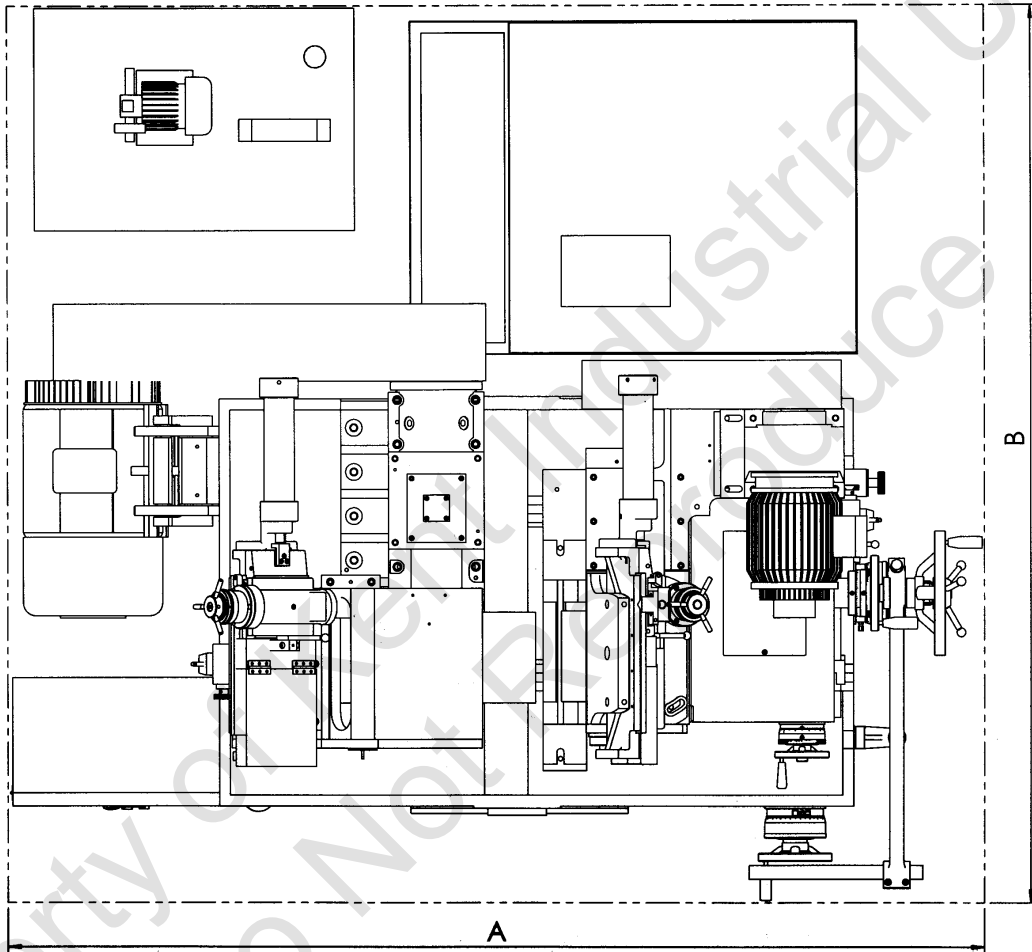

(Unit:mm)

SIZE \ MODEL	JHC-12	JHC-18	JHC-20
A	1800	2300	2300
B	1400	2000	2000

4. TRANSPORTATION & INSTALLATION

4.1 Lifting

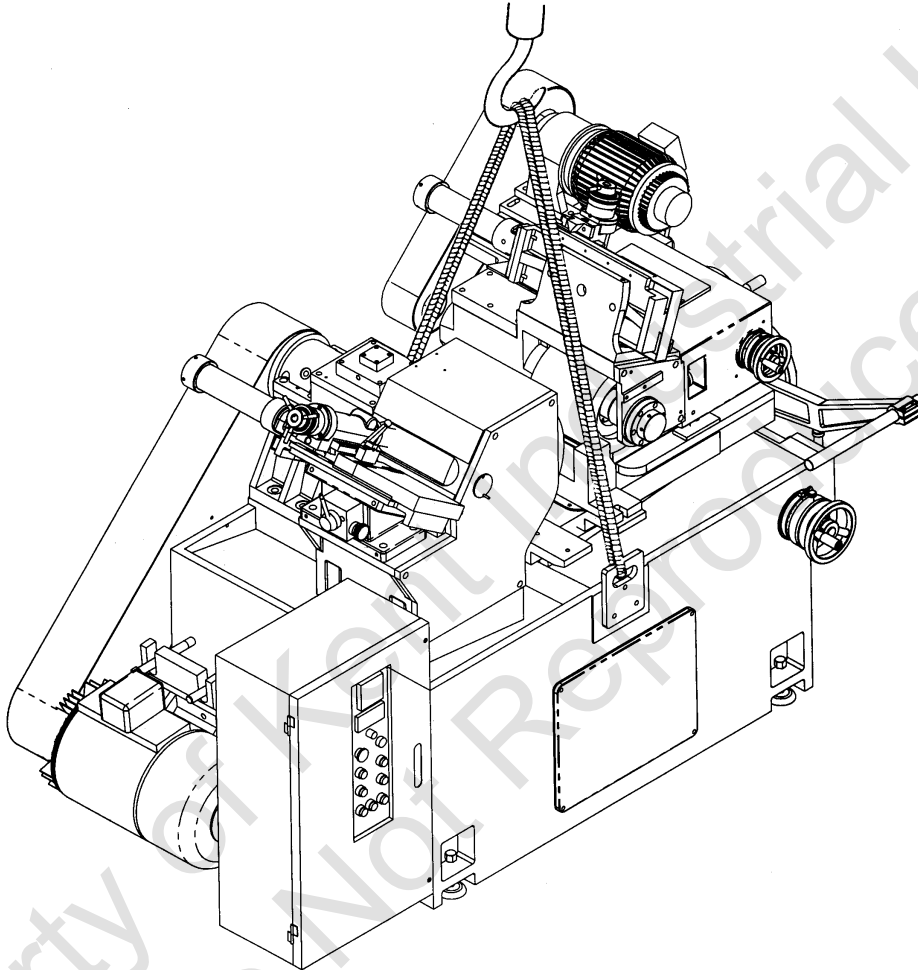

4.2 Transportation

4.2.1 Center-of-gravity position of forklift and machine

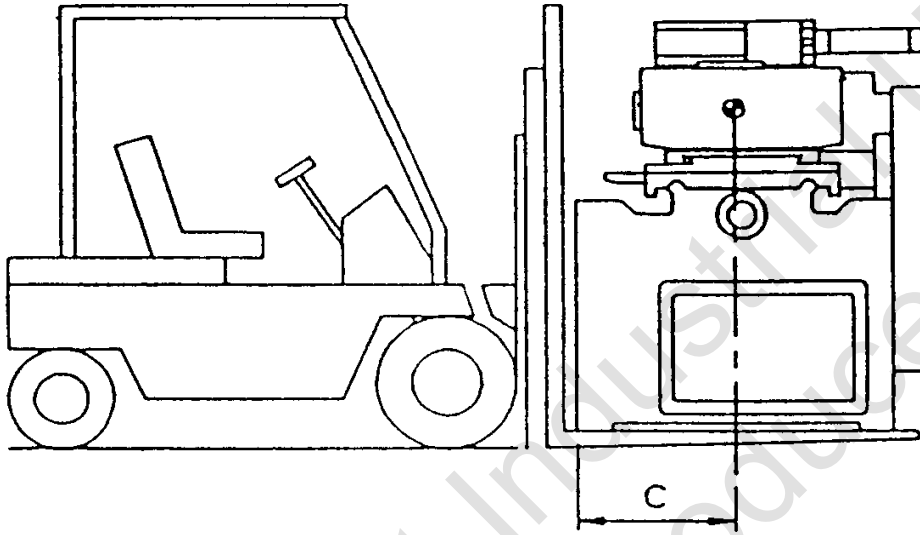

Models	JHC-12	JHC-18	JHC-20
C(mm)	325	460	

4.2.2 Position offorklift transportation

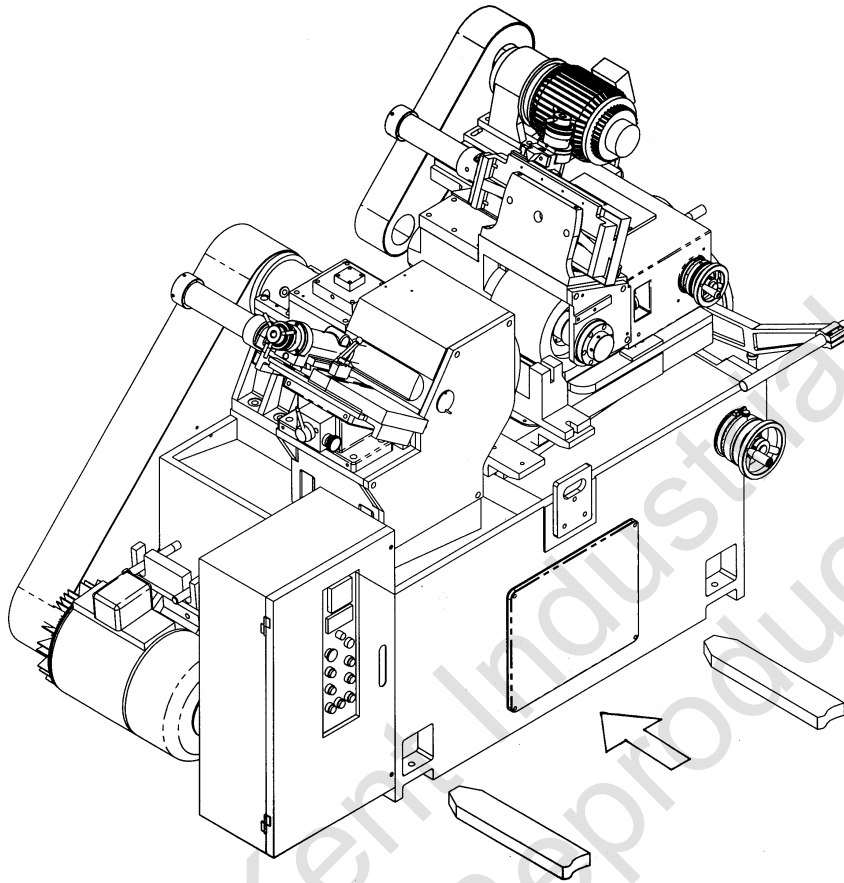

4.3 Foundation

The machine should be installed on rigid and plant floor. It's recommended to use concrete of at least 150mm thickness at the place installing the machine and to keep from source of vibration, such as punching or planer. It would be better to use vibration-isolated equipment at the foundation. This is especially important for high precision grinding machine.

Property of Kent Industrial USA
Do Not Reproduce

4.4 Leveling

The level of machine will be regulated after machine installed for 24 hours. The level precision of machine is subject to change by temperature and other factors. Hence, it should be re-leveling once a year to ensure its precision. Each graduation of level should be 0.02mm/m. Please do not apply wooden level owing to its low precision. In regulating, spirit level (see below) should be laid on worktable of lower slide so as to adjust machine's level and the surface of worktable. Must make sure worktable surface and the spirit level bottom is clear without dust before adjustment.

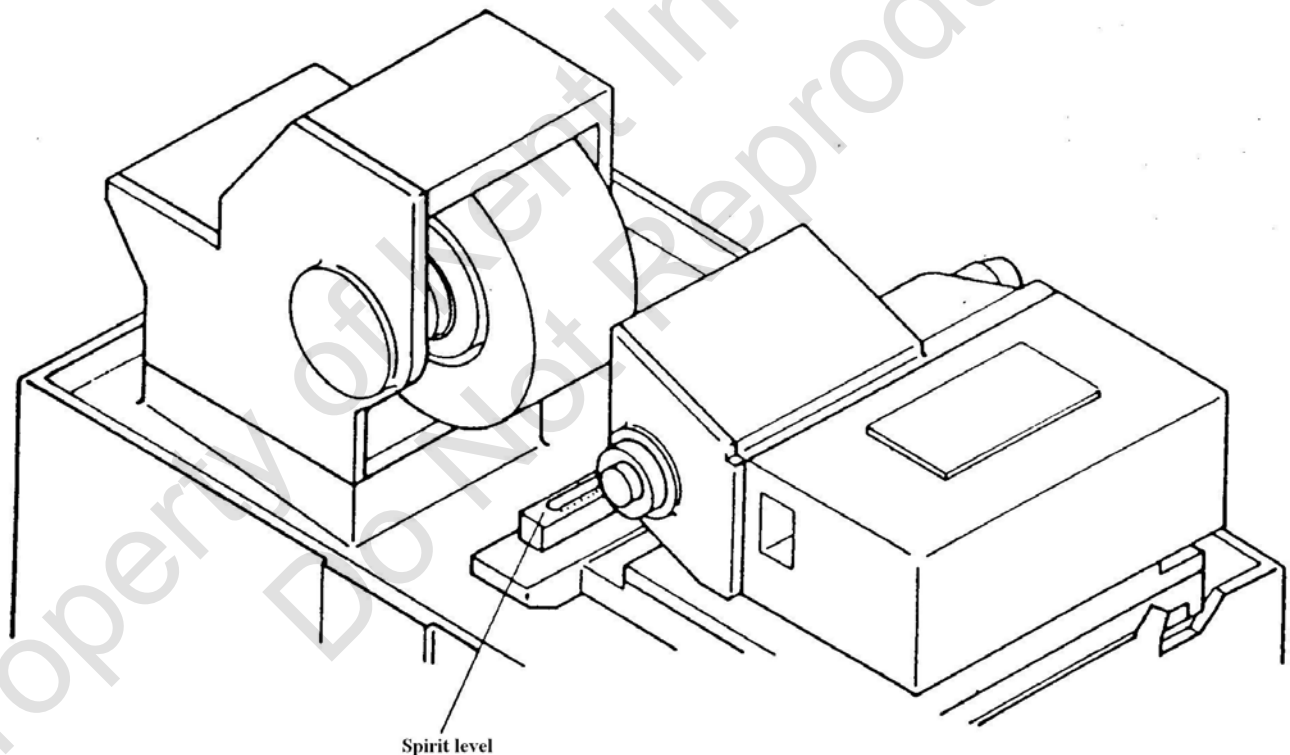

4.5 Clean

For shipment by ocean to user's factory, it has to use anti-rust oil spreading overall machine for protection. When take the plastic cover off machine. Please use soft cloth with kerosene to clean machine body and then put either oil or grease on parts which need to be lubricated before running the machine. Do not clean by gasoline and Vaseline water.

Property of Kent Industrial USA
Do Not Reproduce

5. MECHANISM AND ADJUSTMENT

5.1 Balance of grinding wheel

Balance of grinding wheel is to obtain good smoothness and accuracy of workpiece after grinding and to keep machine in equilibrium condition. The mark caused by tremble appearing on the surface of workpiece is owing to vibration. This kind of deformation can be seen by eyes. Vibration often occurs when grinding wheel is not balanced which is caused by deviation flange mounting on grinding wheel or obliquity between flange and spindle.

Grinding wheel balancing steps: (show as figure)

1. Mount the blancing arbor (1) into grinding wheel with flange (2) and lock it tightly with nuts (3) and place it on the balance base.
2. Rotate the grinding wheel by hand. When it stops, the bottom point is where with the most heavy weight. And then adjust weight blocks (4). Loosen fixing screw (5) while adjusting, move weight blocks (4) and fasten fixing screw (5).
3. By several times of adjustment, make the grinding wheel non-stop at the certain point means get balanced. To mount a new grinding wheel, first measure its balance in general and then balance is made after the surface of grinding wheel is completely corrected and dressed. It's no need to correct balance of regulating wheel because it rotates slowly.

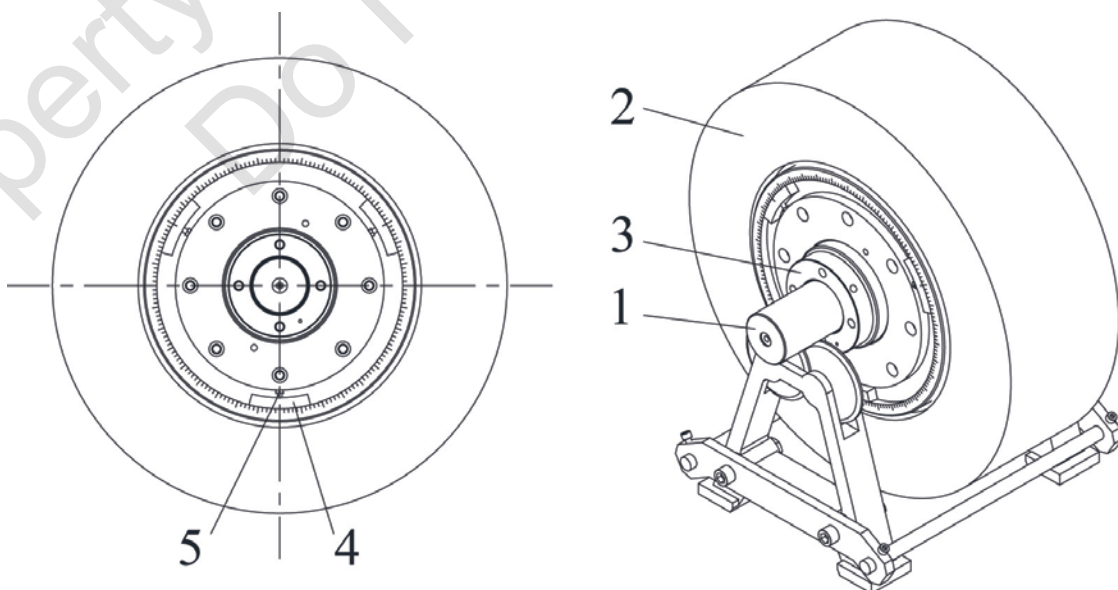

5.2 Assemble and disassemble of grinding wheel

5.2.1 Procedure

Show as figures: (base different models)

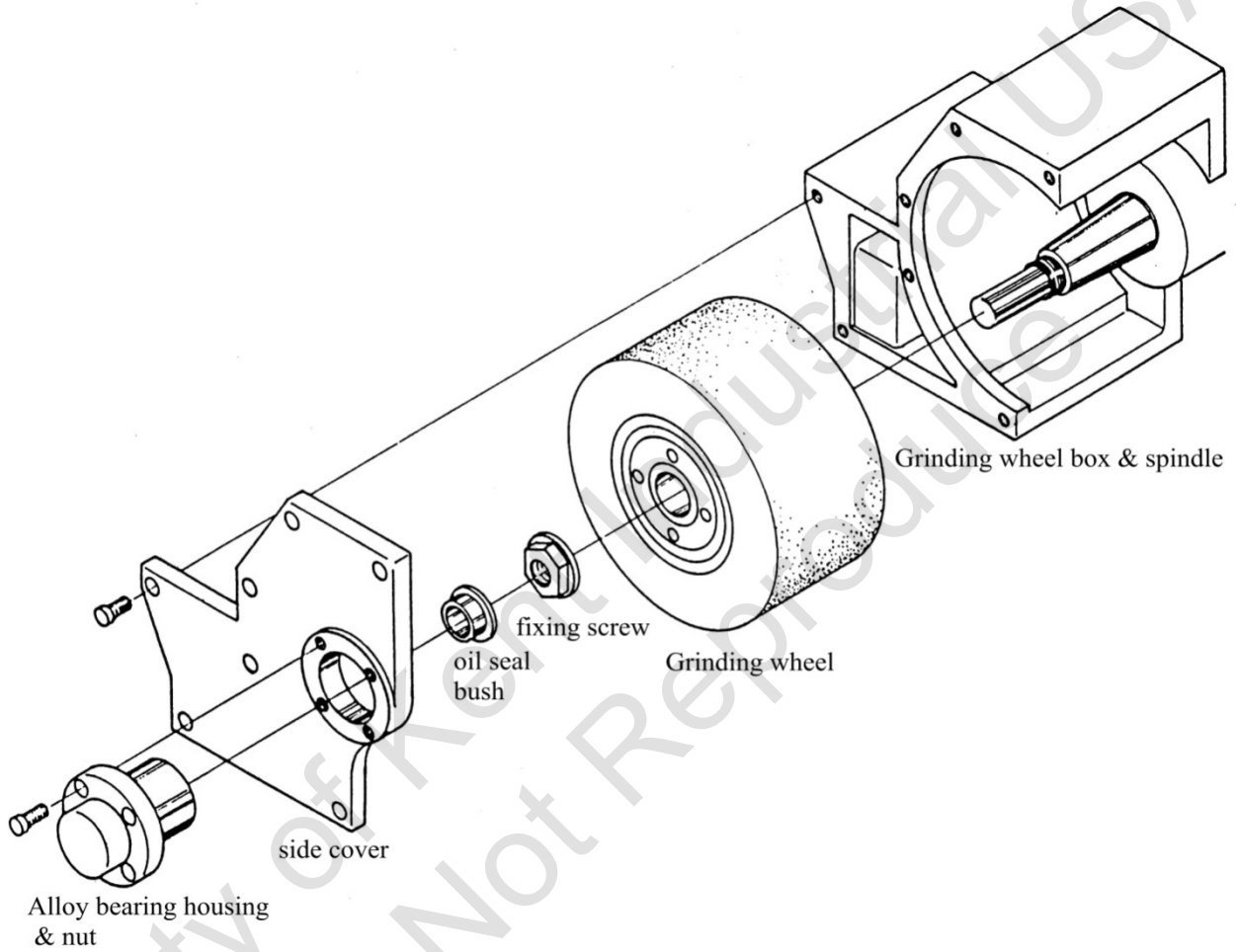

JHC-12S grinding wheel combination

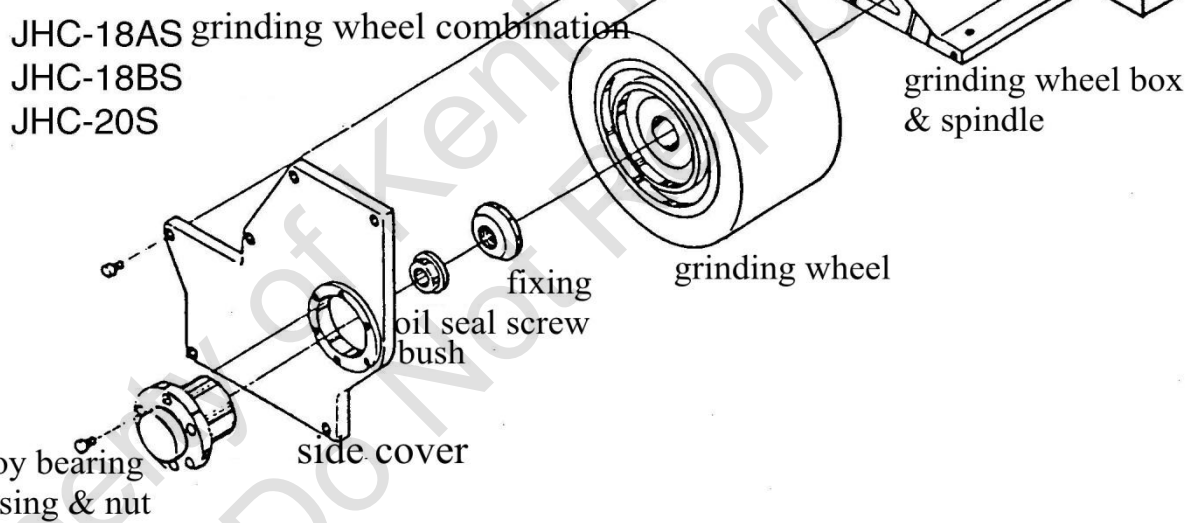
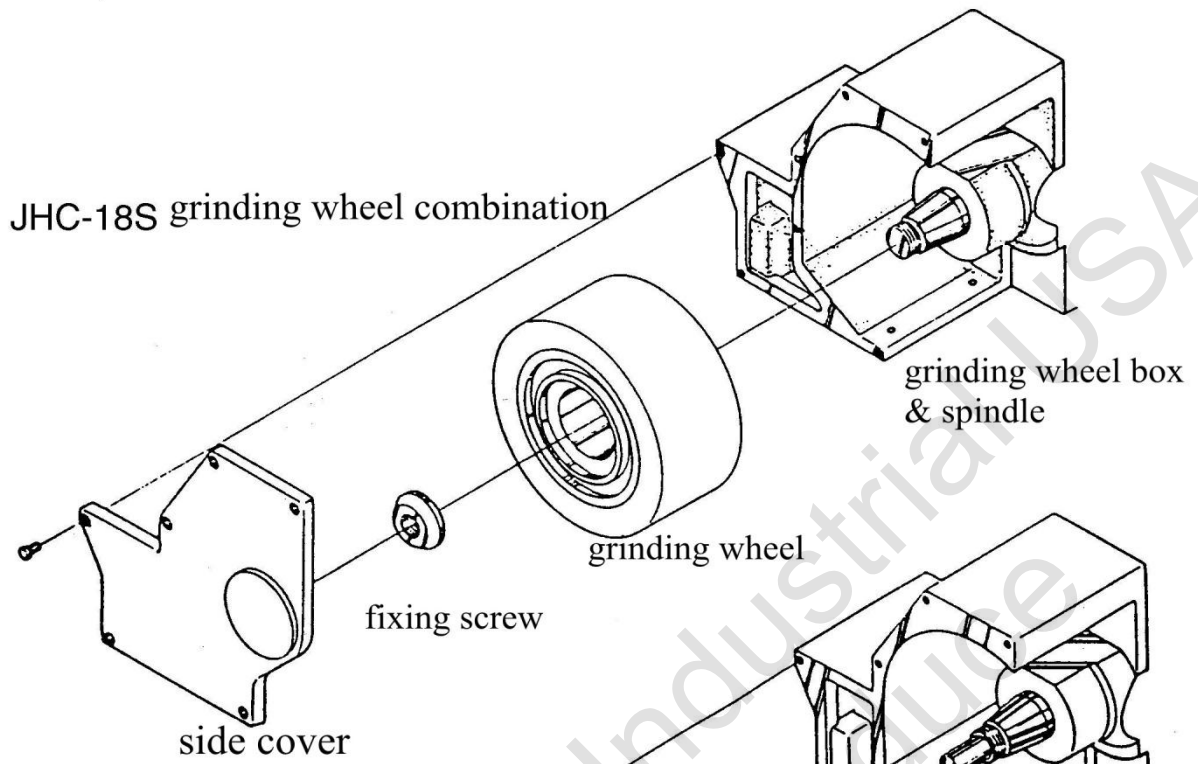

➤ JHC-12 disassemble procedure

Step 1 (Fig. 1)

1. Separate 2 oil pipes connect to alloy bearing housing.
2. Dismantle cover screw and pin.

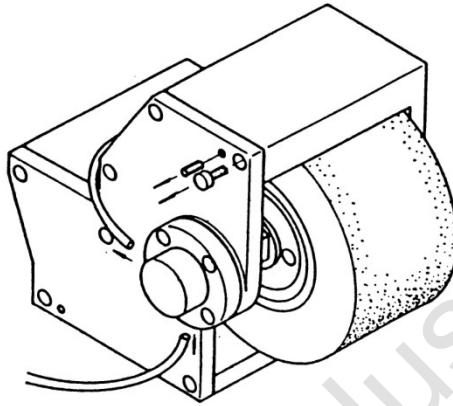

Fig. 1

Step 2 (Fig. 2)

1. Take out oil seal bush.
2. Loosen grinding wheel locked nut along with clockwise direction for 2-3 cycles by spanner (do not draw out completely)
3. Take out spanner and mount flange extractor, then keep grinding wheel away from main shaft.
4. Take out flange extractor and draw out grinding wheel locked nut.
5. Dismantle grinding wheel slightly.

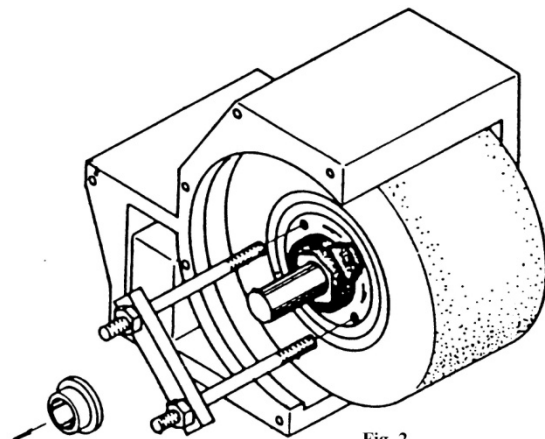

Fig. 2

Step 3(Fig. 3)

1. Draw out screw on flange cover and separate grinding wheel and flange.
2. Follow the above actions in reverse sequence to install back.

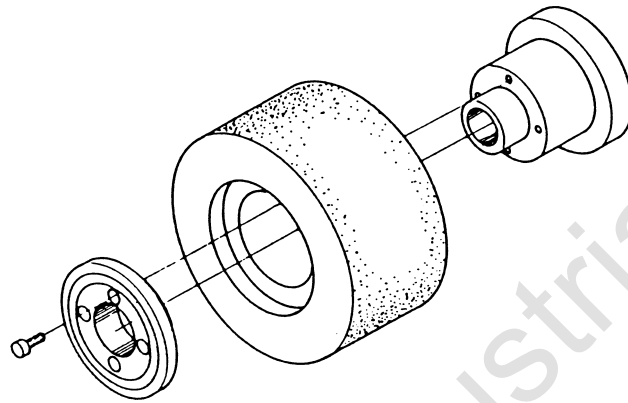

Fig. 3

➤ JHC-18disassemble procedure

Step 1(Fig. 1)

1. Seperate 2 oil pipes connect to alloy bearing housing.
2. Dismantle cover screw and pin.

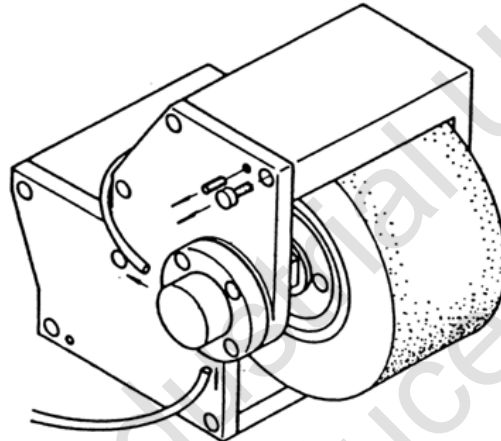

Fig. 1

Step 2(Fig. 2)

1. Take out oilseal bush.
2. Loose grinding wheel locked nut along with clockwise direction for 2-3 cycles by spanner (do not draw out completely)
3. Take out spanner and mount flange extractor, then keep rinding wheel away from main shft.
4. Take out flange extractor and draw out grinding wheel locked nut.

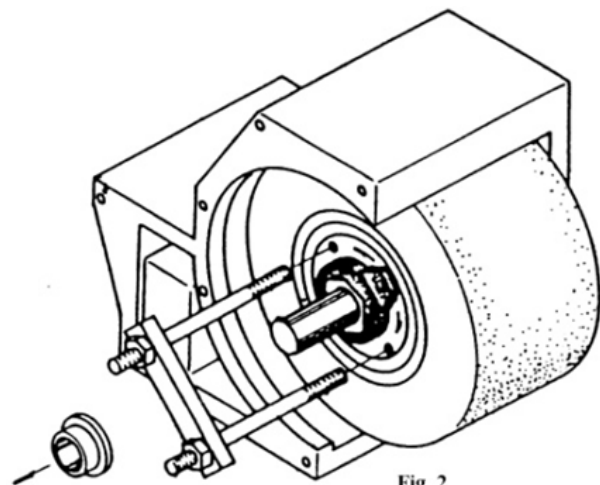

Fig. 2

Step 3 (Fig. 3)

1. Mount grinding wheel loading and unloading tube.
2. Dismantle the grinding wheel slightly.

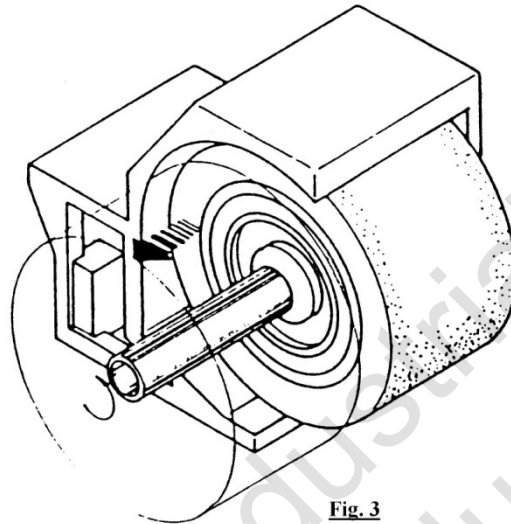

Fig. 3

Step 4 (Fig. 4)

1. Draw out screw on flange cover and separate grinding wheel and flange.
2. Follow the above actions in reverse sequence to install back.

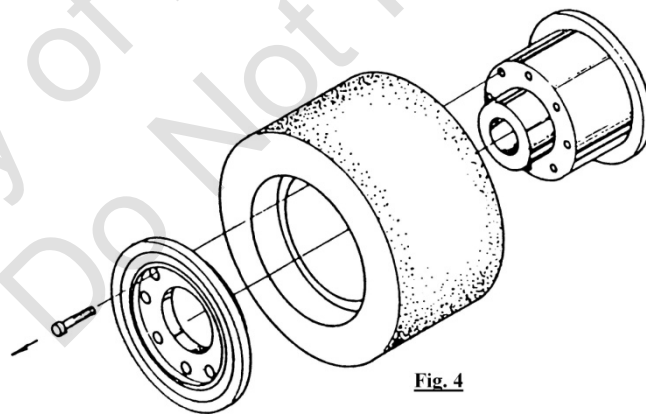

Fig. 4

5.2.2 Tips:

- 1) All dismantled parts should be cleaned and lubricated.
- 2) All assembled contact surfaces should be coated with grease.
- 3) Parts between grinding wheel and flange should be coated with anti-rust grease or paved with a coat of tinfoil for the convenience of disassembling next time.
- 4) When install back alloy bearing housing, all bolts should be fixed by diagonal way.
- 5) Do not release bearing fixing nut.

5.3 Spindle correction

Upon replacing grinding wheel or regulating wheel, the deflection of spindle must be corrected to ensure grinding precision. As below Fig. shown, place 1/1000mm gauge (1) on worktable with gauge needle being leant against circumference of spindle with proper pressure where all contact surface must be cleaned. Then, start grinding wheel or regulating wheel and read out variation from gauge. The maximum variation should not over 0.002mm. If it's over this value, slightly knock flange locked nut along with the variation by reverse direction. The action must be repeated for several times until variation is eliminated.

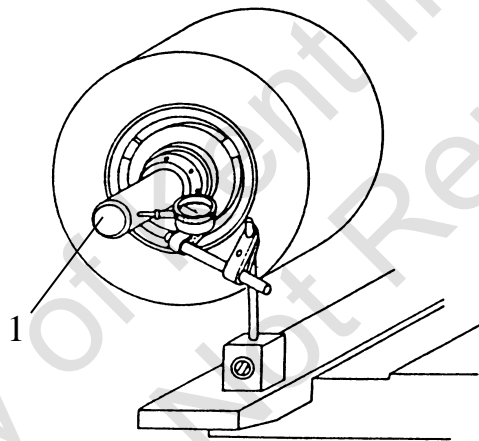

5.4 Grinding wheel dressing

The dressing of grinding wheel almost utilizes single diamond tool method. The size of diamond is subject to dress grinding wheel's diameter and binding degree, but commonly 500-600mm grinding wheel employs 1-2 carat of diamond tool. To avoid vibration when erecting, diaond tool should be completely fixed on feed shaft and the distance from its fixed part to the nose of it must be reduce as much as possible.

Hydraulic driving way is applied in dresing feed, with 0 to 300mm/min of range of continuing regulating structure. Rough grinding is in 200-250mm/min and finishing in 30-50mm/min feed speed where dressing is made. If there is large amount of heart generated owing to diamond tool when dresing, coolant must be added which will not only control temperature rising but also washes out impurities in sands. To dress feed amount, rought grinding is in 0.02mm and finishing is in 0.005-0.01mm where the last dressing is made but not feeding. To meet grinding condition and consider production efficiency, sometimes rotary dresser dress or bounded tool is adopted.

5.5 Assemble and disassemble of dresser

5.5.1 Procudure

As figures (Base different models)

➤ JHC-12 series dresser combination

1. Feeder
2. Feed spindle
3. Hexgon socket fixed screw
4. Diamond tool
5. Hexgon socket fixed screw
6. Feed spindle housing
7. Hexagon socket bolt
8. Locked bolt
9. Locked sleeve
10. Locked nut

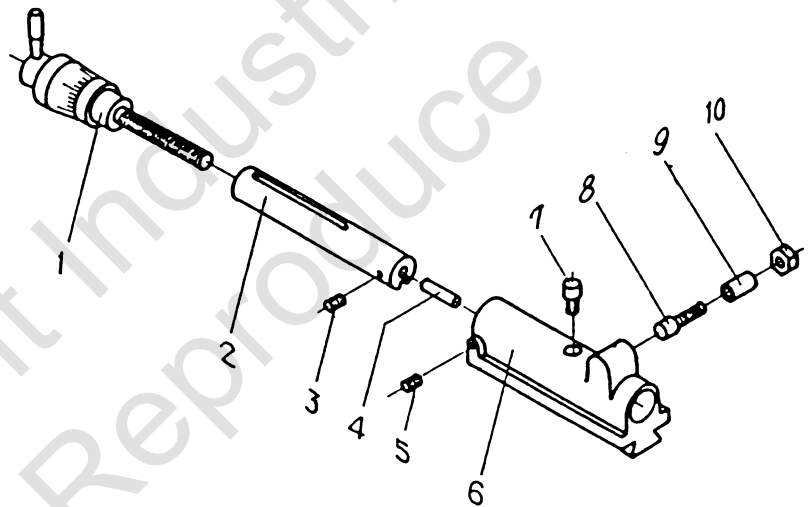

Assemble and disassemble procedure:

- 1) Loose locked nut (10) and slightly knock several times inward to make locked bolt (8) loss feed spindle (2).
- 2) Draw out Hexagon socket bolt (7).
- 3) Release Hexagon socket fixed screw (5) and draw out feed spindle (2) through feeder (1).
- 4) Draw out Hexagon socket fixed screw and dismantle worn diamond tool (4) and replace a new one. Then, lock hexagon socket fixed screw tightly.
- 5) Assemble back base on above mentioned action in reverse sequence, replacement is finished.

➤ JHC-18 series dresser combination

1. Hexagon socket fixed bolt
2. Feeder
3. Feed spindle
4. Hexagon socket fixed screw
5. Diamond tool
6. Feed spindle housing
7. Hexagon socket bolt
8. Locked bolt
9. Locked sleeve
10. Locked nut

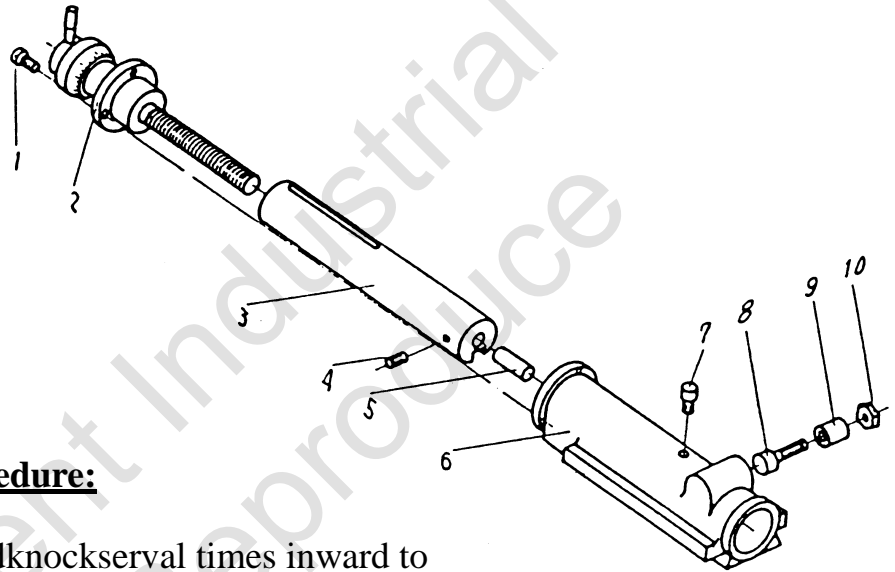
**Assemble and disassemble procedure:**

- 1) Loose locked nut (10) and knock several times inward to make locked bolt (8) to loose feed spindle (3).
- 2) Draw out hexagon socket bolt (7).
- 3) Loose 3 piece hexagon socket fixed bolt (1) and draw out feed spindle through feeder.
- 4) Release hexagon socket fixed screw (4) and disassemble worn diamond tool (5) and replace new one. Then, lock hexagon socket fixed screw (4) tightly.
- 5) Assemble back based on above mentioned action in reverse sequence, replacement is finished.

5.5.2 Tips

- 1) Dismantled parts should be cleaned and lubricated.
- 2) Diamond dresser protruding length is about 15 ~ 20 mm.
- 3) When install back hexgon socket fixed bolt (1), need to align the keyway of feeding axis.

Property of Kent Industrial USA
Do Not Reproduce

5.6 Intoduction of regulating wheel

5.6.1 Regulating wheel feed mechanism

When grinding wheel is fixed, the grinding of workpiece depends on the movement of regulating wheel slide. That is, the travel of regulating wheel slide and lower slide would regulate distances between regulating wheel, grinding wheel and blade. Lower slide and regulating wheel slide are respectively equipped with rough feed handwheel and micro feed handwheel (no micro feed device for regulating wheel slide of JHC-12S.) Micro feed is to lock worm shaft inside feed handwhee by outside nut. Generally, moving regulating wheel slide is to compensate worn size of regulating wheel. Regulating wheel spindle make $\pm 5^\circ$ level swivel to grinding wheel spindle. The advantage is that cone occurred on workpiece can be regulated form level degree not by dressing grinding wheel.

Property of Kent Industrial USA
Do Not Reproduce

5.6.2 Spindle position adjustment of regulating wheel

In thrufeed grinding, the vertical angle of regulating wheel can be inclined $+5^\circ$ to -3° which is adjusted base on feeding speed. While failing to line up grinding wheel owing to adjustment of vertical angle, you must line them up as below figure.

First, loose end cover (A). Then, revolve locked screw (B) forward by clockwise direction and backward by conterclockwise direction (from standing at positiong screw). It might be jammed if not turning by hand. You may start regulate wheel driving motor to rotate regulating spindle. Then, press downpositiong screw to make spindle axial movement. Please do not rotate positioning screw by hand to prevent cutting.

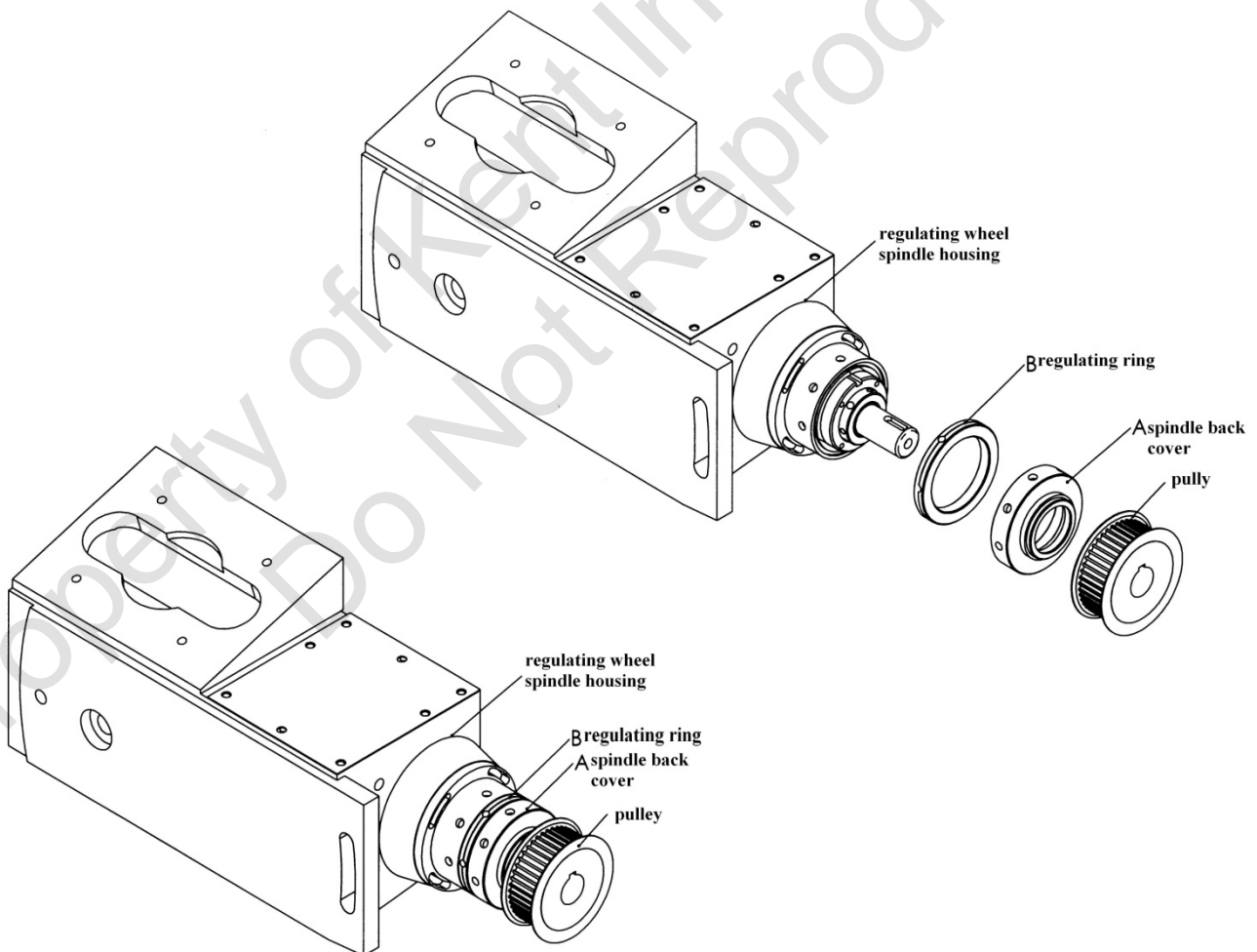

5.6.3 Assemble and disassemble of regulating wheel

1. Procedure (as below fig. shown):

➤ JHC-12 series regulating combination

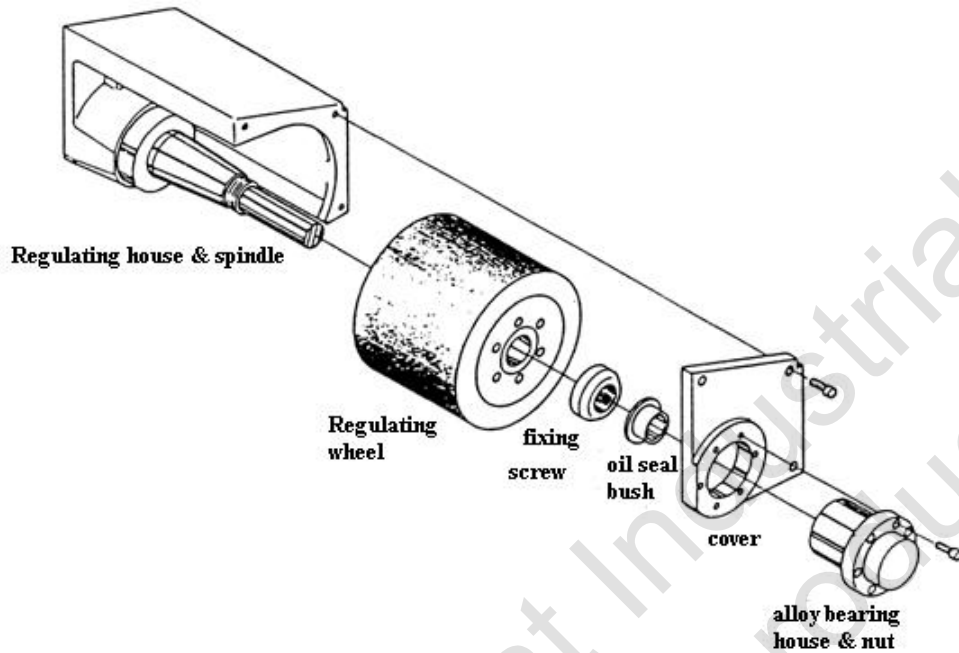

➤ JHC-18 series regulating wheel combination

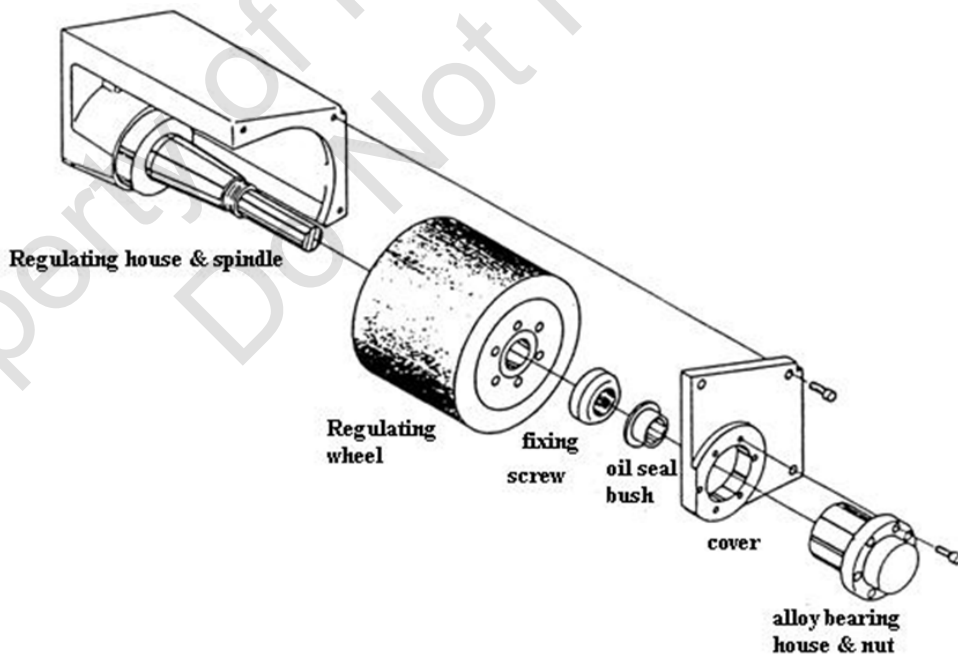

2. Note:

- 1) All disassemble parts should be cleaned and lubricated.
- 2) All assembled contact surfaces should be coated with grease.
- 3) Parts between regulating wheel and flange should be coated with anti-rusting grease or paved with a coat of tinfoil for the convenience of disassembling next time.
- 4) Do not loose alloy bearing fixing nut.
- 5) To install back alloy beawring house, all bolts should be screwed by diagonal way.

➤ JHC-12 series assemble and disassemble procedure

Step 1(Fig. 1)

1. Separate 2 oil pipes connected to alloy bearing seat.
2. Dismantle end cover plate screw and positioning pin.

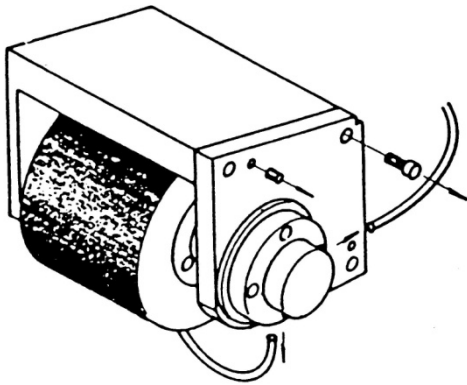

Fig. 1

Step 2(Fig. 2)

1. Take out oil seal bush.
2. Loose 2-3 cycles of regulating wheel locked nut with clockwise direction by spanner. (Do not draw out completely)
3. Take out spanner and mount flange extractor. Then, keep regulating wheel away from spindle.
4. Take out flange extractor and draw out regulating wheel locked nut.
5. Dismantle regulating wheel slightly.

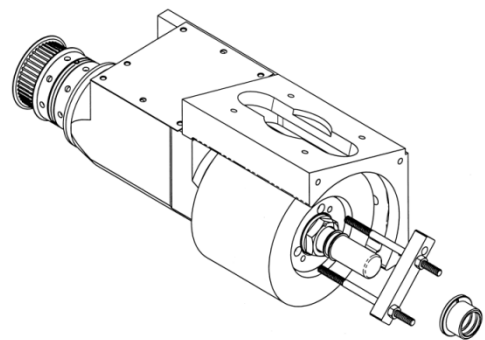

Fig. 2

Step 3 (Fig. 3)

1. Draw out screw on flange cover from and separate flange and regulating wheel.
2. To install back base on above mentioned action in reverse order.

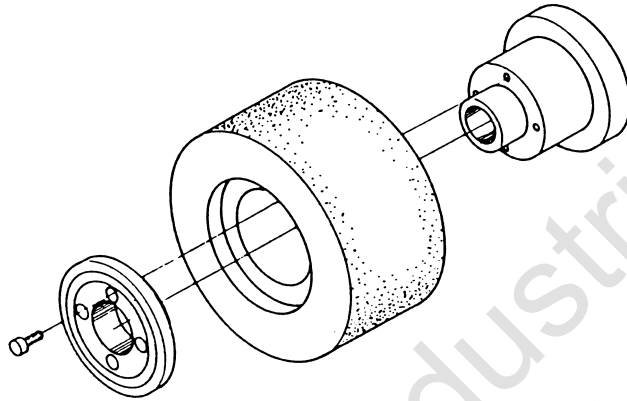

Fig. 3

➤ JHC-18 series assemble and disassemble procedure

Step 1 (Fig. 1)

1. Separate 2 oil pipes (1) from alloy bearing seat (2).
2. Dismantle positioning pin (4) and fixing bolt (5), then, take out cover (6).

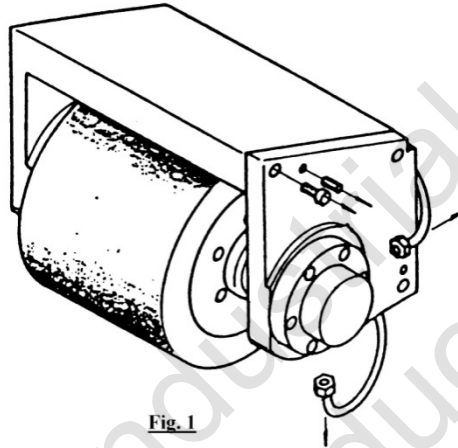

Fig. 1

Step 2 (Fig. 2)

1. Take out oil seal bush.
2. Loose 2-3 cycles of regulaing wheel locked nut with clockwise direction by spanner. (Do not draw out completely)
3. Take out spanner and mout flange extractor, Then, keep grinding wheel away from spindle.
4. Take out flange extractor and draw out regulating wheel locked nut.
5. Dismantle regulating wheel slightly.

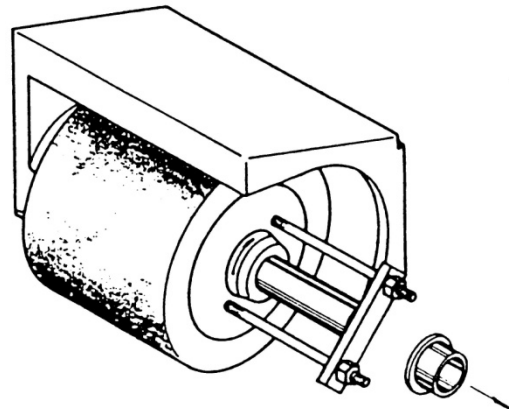

Fig. 2

Step 3 (Fig. 3)

1. Draw out screw on flange cover and separate flange and regulating wheel.
2. To install back base on to above mentioned action in reverse order.

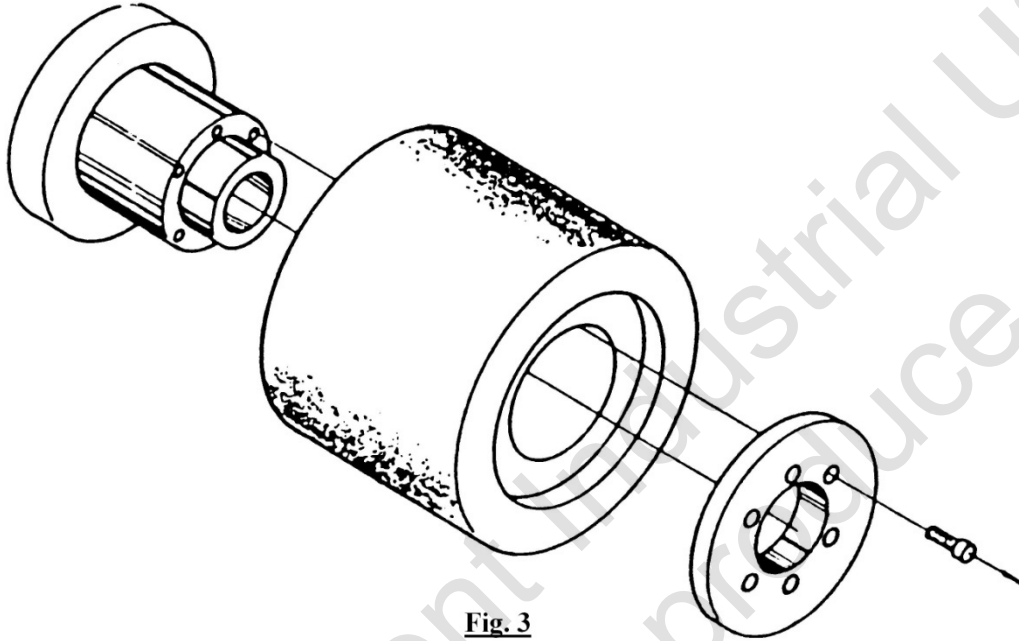

Fig. 3

5.6.4 Speed of regulating wheel

The rotating speed of regulating wheel range is from 10 to 300rpm, and dressing range is 300rpm. Grinding speed is subject to change by (1) the axial feed speed and the circumferential speed (2) of workpiece. Generally, grinding rotating speed of grinding range is from 20 to 40rpm. The axial feed speed can be shown by the following formula.

$$V = \pi D \sin \theta N$$

Where V = axial feed speed of workpiece, m/min

D = diameter of regulating wheel, mm

N = rotating speed of regulating wheel, rpm

θ = slant angle of regulating wheel

Make above formula to project curve can render the following formula which represents relationship between the circumferential speed V of workpiece and the rotating speed of regulating wheel.

$$N = \frac{V}{\pi D}$$

V = circumferential speed, mm/min
 D = diameter of regulating wheel, mm

Usually, the slant angle for grinding is $2 \sim 3^\circ$, and the circumferential speed range of workpiece is from $25 \sim 35$ m/min. Before machining, slant angle of workpiece is in a slight bending state should be expanded and feed speed must be accelerated. When turns out with good real circle, increasing rotating speed to obtain high precision. The axial feed speed workpiece is in direct proportion to regulating wheel. Hence, regulating wheel will lead to reduce feed speed, i.e. diameter of regulating wheel is reduce from 300mm to 250mm and the initial feed speed of 1.2m/min will be down to 1m/min. Generally, reduction on circumferential speed can be corrected gby

higher rotating speed. Although alter regulating wheel's slant angle may adjust workpiece axial feed speed. It's no recommended because correcton must be made up changing slant angle. Besides, be noticed that correction both on workpiece's circumferential aspeed and correcting grinding conditon.

Property of Kent Industrial USA
Do Not Reproduce

5.6.5 Dress on regulating wheel

While dressing regulating wheel, the condition of diamond tool and coolant is similar to dress grinding wheel. However, the dressing rotating speed of regulating wheel is approximately 325rpm so in rough grinding, the dressing speed is 40 to 50 mm/min. As to the speed of finish grinding is similar to that of grinding wheel. Be careful the surface on regulating wheel after dressing will affect grinding surface of workpiece. The difference between regulating wheel and grinding wheel after dressing is that the later's shape is cylindrical and the former shape is like single piece and double curvature planes which is formed by slant angle of regulating wheel and swivel angle of dressing device. Generally speaking, in rough grinding, slant angle of regulating wheel is larger than that of dressing device by $1.5^{\circ} \sim 2.5^{\circ}$. In finishing grinding, it's around 0.5° .

Property of Kent Industrial USA
Do Not Reproduce

5.6.6 Slant angle adjustment of regulating wheel

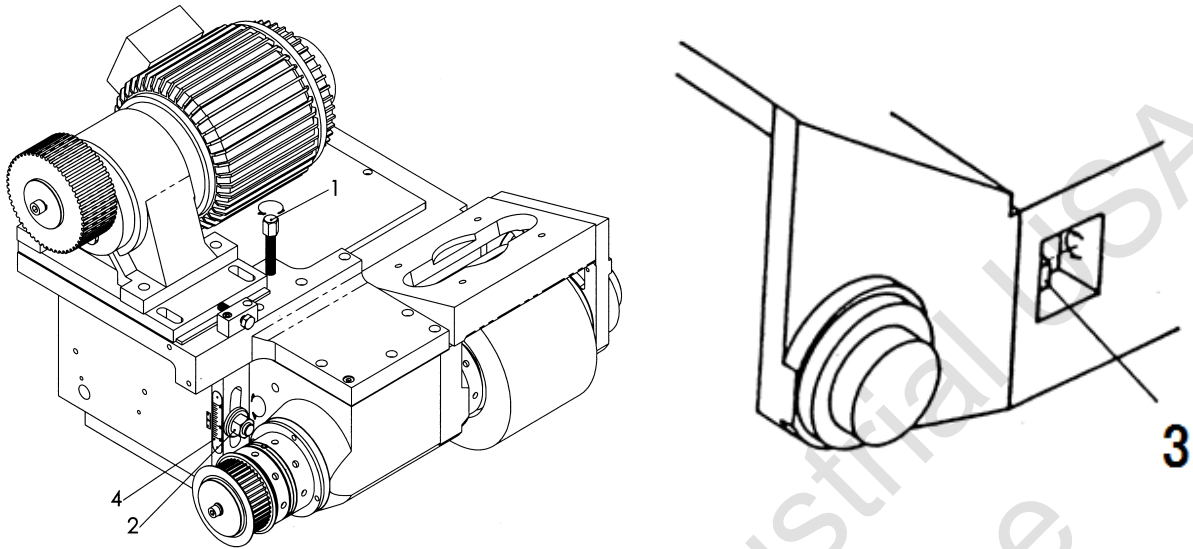

1. Loose lock nuts (2) (3).
2. Rotate regulating bolt (1) to make regulating wheel slant transversely where slant scale can be shown from angle indicator (4).
3. Upon regulating to required angle, lock (2) and (3).

5.6.7 Swivel angle of regulating wheel

1. Loose lock nuts (2) (both sides).
2. Rotate regulating handscrew (1) properly to swive regulating wheel horizontally. ◦

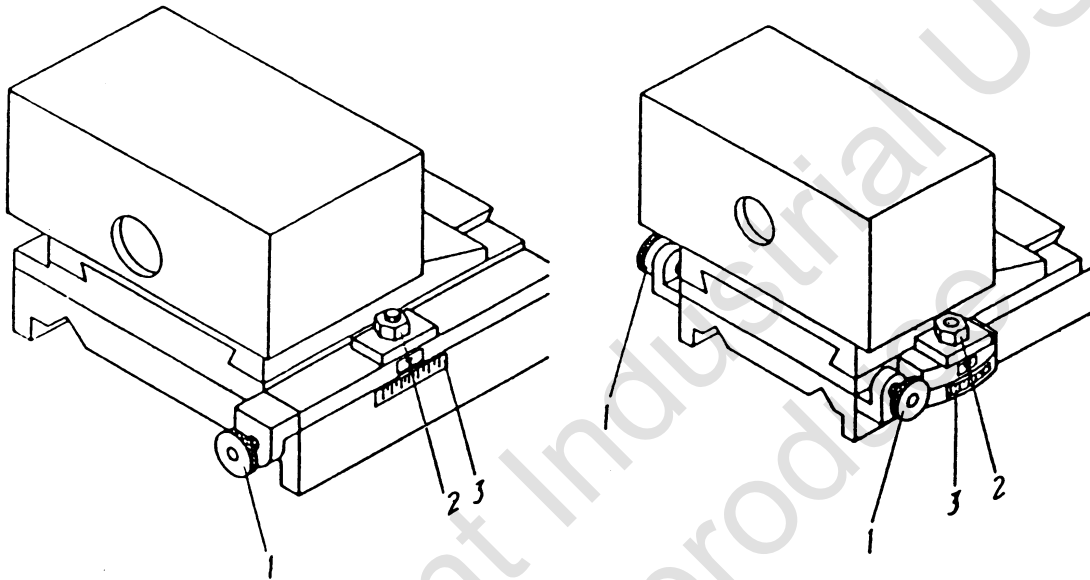

Note: JHC-12 series have handscrews each one for both sides. When adjusting, rotate right on one side and left turn is made on the other side. Upon positioning, you must rotate right for draw tight the left rotate. ◦

3. Horizontal swivel angle can be shown by indicator (3).
4. After positioning, lock (2).

5.7 Workrestand blade support

5.7.1 Workrest

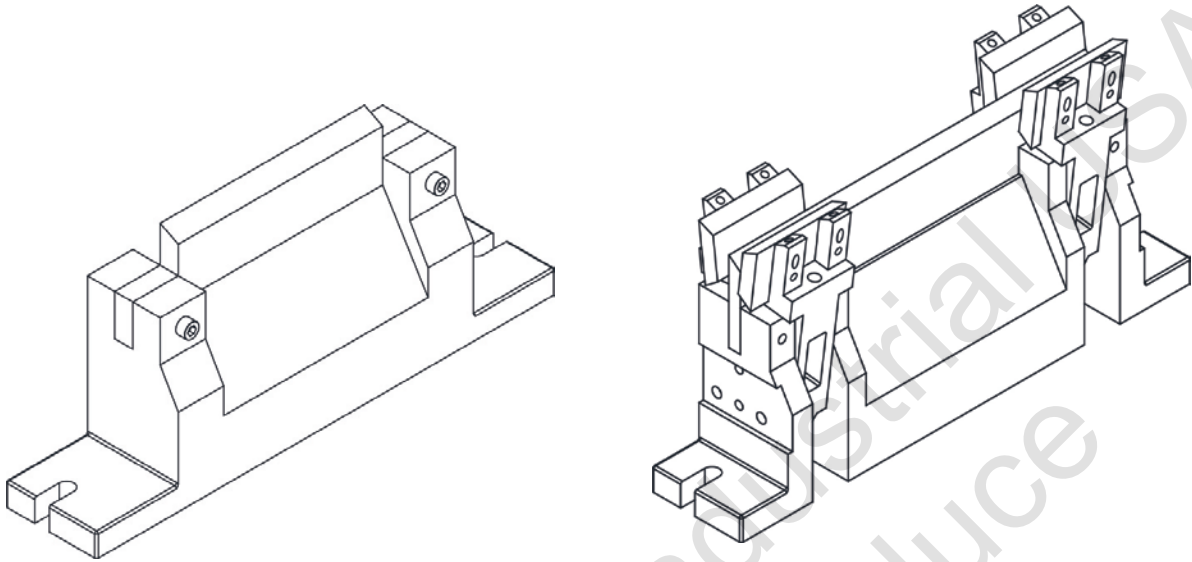

Infeed grinding workrest& blade

Thrufeed grinding workrest& blade

5.7.2 Blade

The support blade in common is 60° . There is more wear in the part of frequent contact on workpiece due to the load of grinding resistance.

Generally, blade is welded with super-hard wolfram shell; sometimes high speed steel is used. The thickness of blade should be smaller than external diameter of workpiece. $1/2$ to $1/6$ of diameter of workpiece plus center height of grinding wheel or regulating wheel is the center height of grinding piece. If the height of support blade is insufficient, packing plate should be used to achieve the required height. The thickness of support blade is shown on chart below.

Thickness of support blade (mm)	Diameter of workpiece (mm)
0.8	1 ~ 2
1	1.5 ~ 3
2	3 ~ 5
3	4 ~ 6
4	5 ~ 8
5	7 ~ 9
6	8 ~ 10
8	10 ~ 12
10	12 ~ 20
13	15 ~ 30
15	17 ~ 40

5.7.3 Ejection and adjustment workrest and blade

Put blade (1) into workrest (2) to a proper position. Lock fixed bolts (3) on two sides to fix blade (1). Place workrest on worktable (5), measure the required position and turn feed handwheel in worktable (5) to move blade near grinding wheel (6). Adjust workrest (2) to make the cutting edge (1) of blade being in parallel with the surface of grinding wheel (6), lock workrest lock bolts (4) to fix workrest on worktable (5).

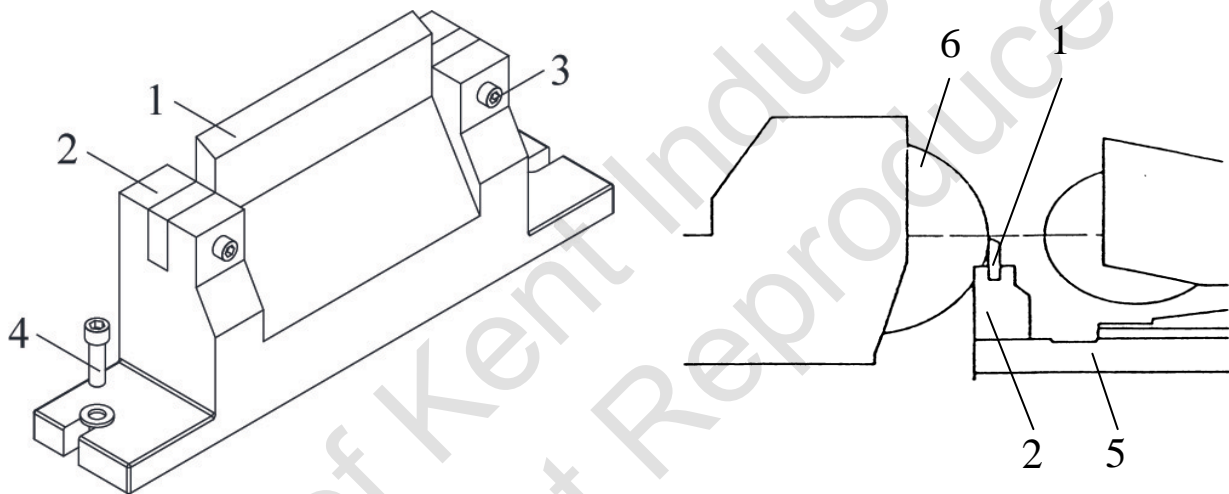

5.8 Adjustment of thrufeed guide plate

The regulation of thrufeed guide plate is shown in (fig. 1). Turn regulating screw (2) by screwdriver (1) to make guide plate (3) close or open to match workpiece size where regulating scale is shown on (fig. 1). The guide plate should be parallel to both grinding wheel and regulating wheel and the entry of regulating wheel's edge is $1/2$ tolerance of workpiece. The exit edge has the gap of 0.01 to 0.03mm and both entry and exit of grinding wheel's edge takes gap of 0.2 to 0.4mm (fig.2). The test method is to put a finish-grounded workpiece to move from entry to exit back and forth to ensure that it is passed smoothly and moves in one direction. If guide plate and regulating wheel are not on the same line, workpiece will become concave or convex as in fig. 3.

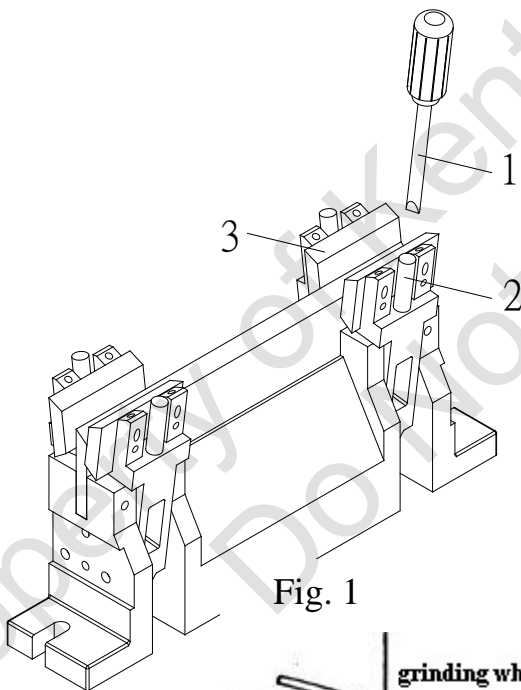

Fig. 1

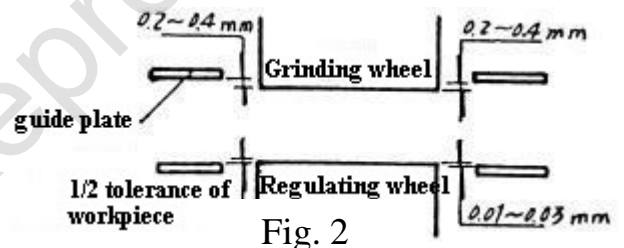

Fig. 2

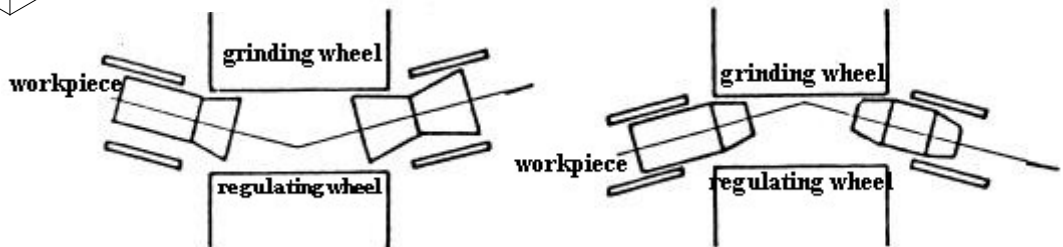

Fig. 3

6. OPERATION

6.1 Operation key description

A. Panel description:

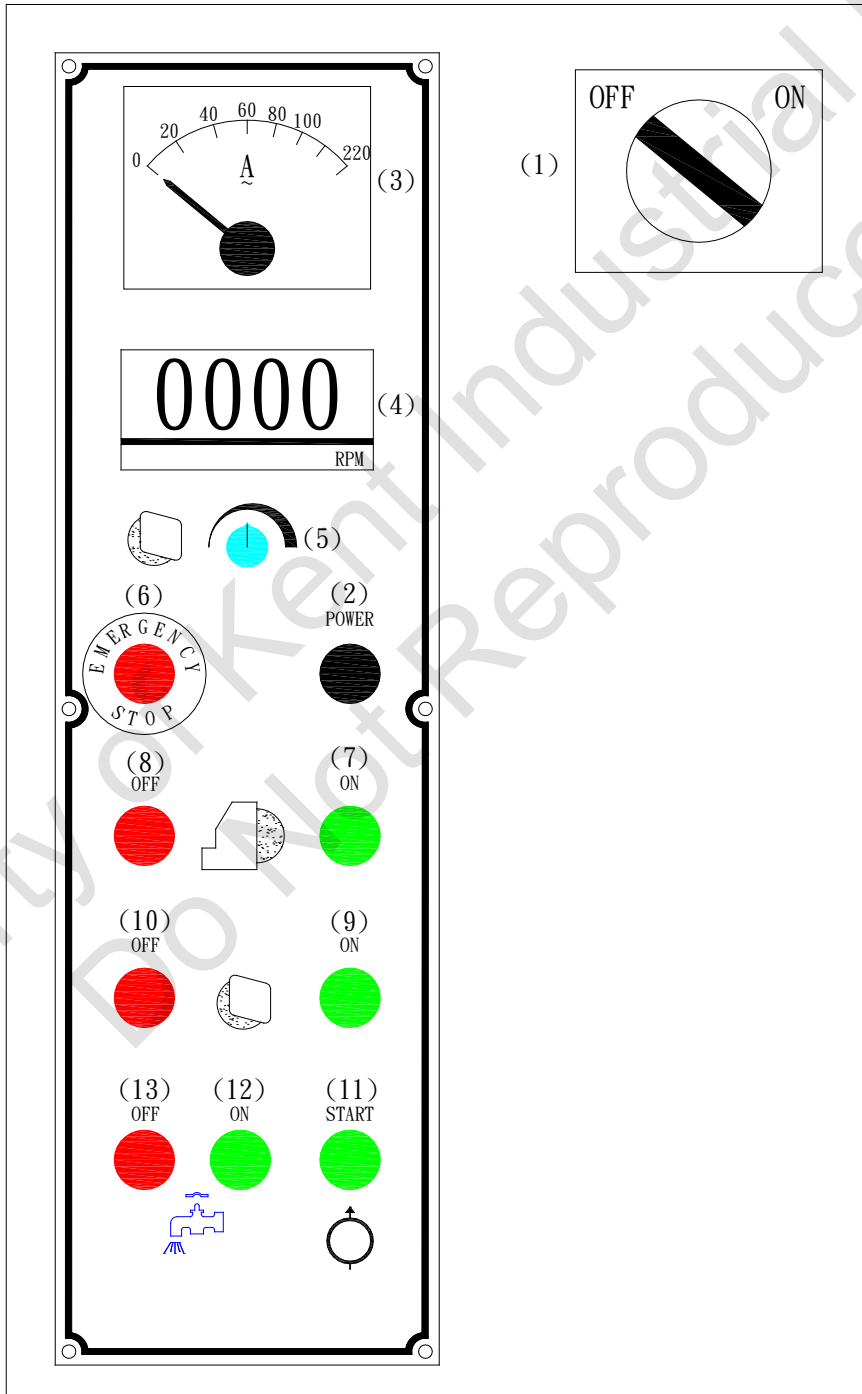
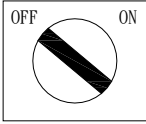

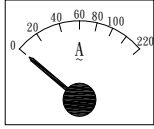
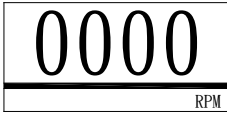







Chart1 Operation key description

NO.	KEY	DESCRIPTION
1		<p>Power switch: ON: turn on power OFF: turn off power</p>
2	<p>POWER</p> 	Power on indicator
3		<p>Load current indicator: When grinding wheel spindle starts and grinds, it display the current of motor.</p>
4		Regulating wheel spindle rotation number indicator
5		<p>Regulating wheel rotation number control knob: Turn the knob to choose required rotation number of regulating wheel spindle</p>
6		<p>Emergency stop button: Press the button to stop all machine operation while abnormal situations happen. Turn the key clockwise to recover operation.</p>
7	<p>ON</p> 	Turn on switch of grinding wheel motor
8	<p>OFF</p> 	Turn off switch of grinding wheel motor
9	<p>ON</p> 	Turn on switch of regulating wheel motor





NO.	KEY	DESCRIPTION
10	OFF 	Turn off switch of regulating wheel motor
11	START 	Hydraulic start switch
12	ON 	Coolant start switch
13	OFF 	Coolant stop switch

Chart 2 JHC-12BN: regulating wheel tachometer



regulating wheel tachometer			
Handle	R.P.M	Handle	R.P.M
N-N	0	B-1	65
A-1	20	B-2	96
A-2	32	B-3	146
A-3	47	S-N	337

Chart 3 JHC-18.18A.18B.JHC-20: regulating wheel tachometer

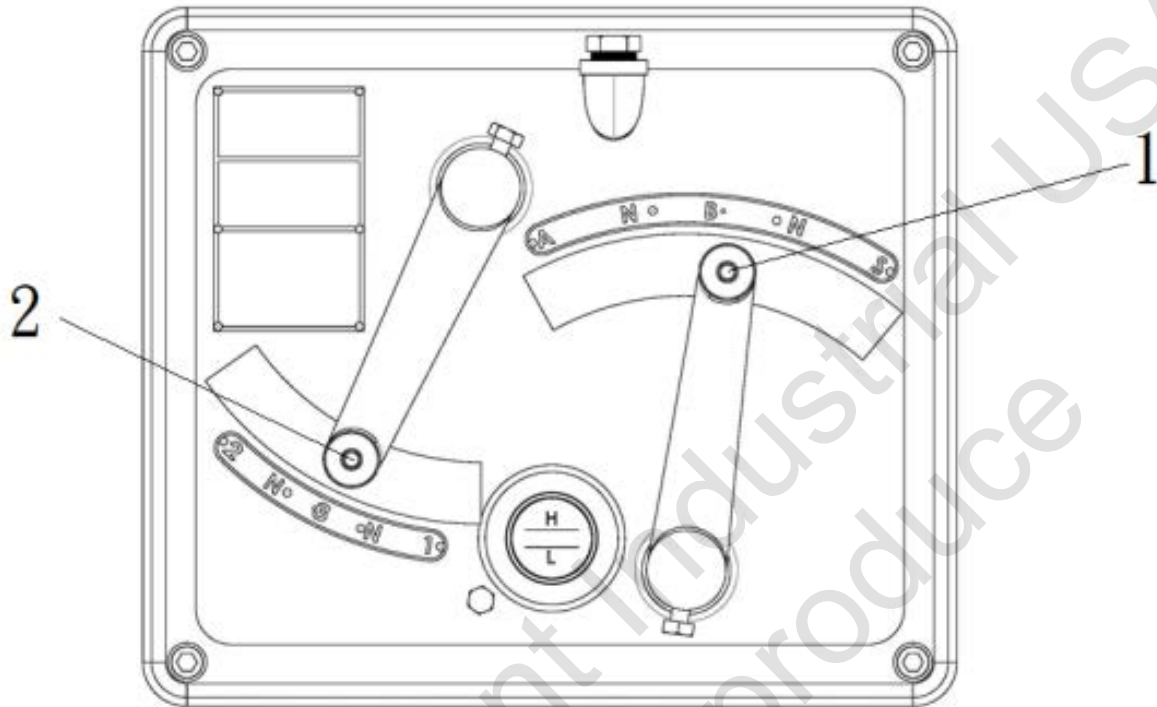
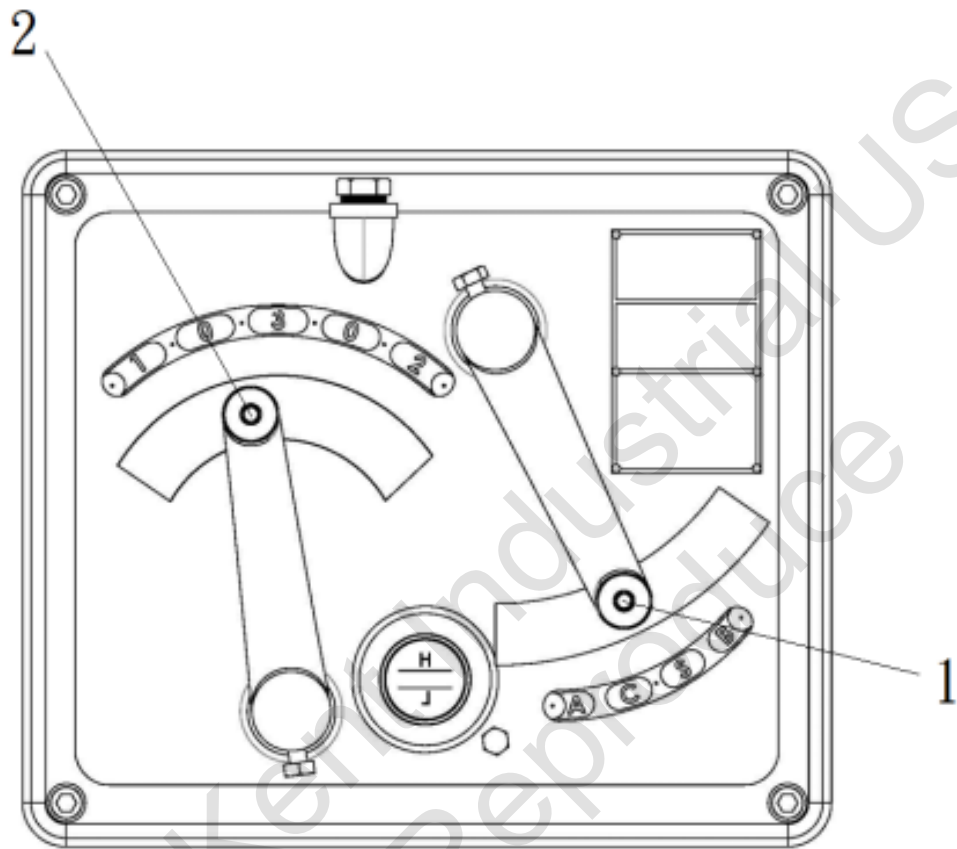

regulating wheel tachometer			
Handle	R.P.M	Handle	R.P.M
1-A	13	2-B	73
2-A	21	2-C	97
3-A	36	3-B	125
1-B	45	3-C	168
1-C	60	0-S	316

Regulating wheel variable operation steps

For example: tachometer A-1

1. Pull up handle (1) and move to A, then, insert and fix.
2. Pull up handle (2) and move to 1, then, insert and fix.
3. Other revolutions base on tachometer to coordinate rpm.

Property of Kent Industrial USA
Do Not Reproduce

Auto-grinding operation panel description: (optional)

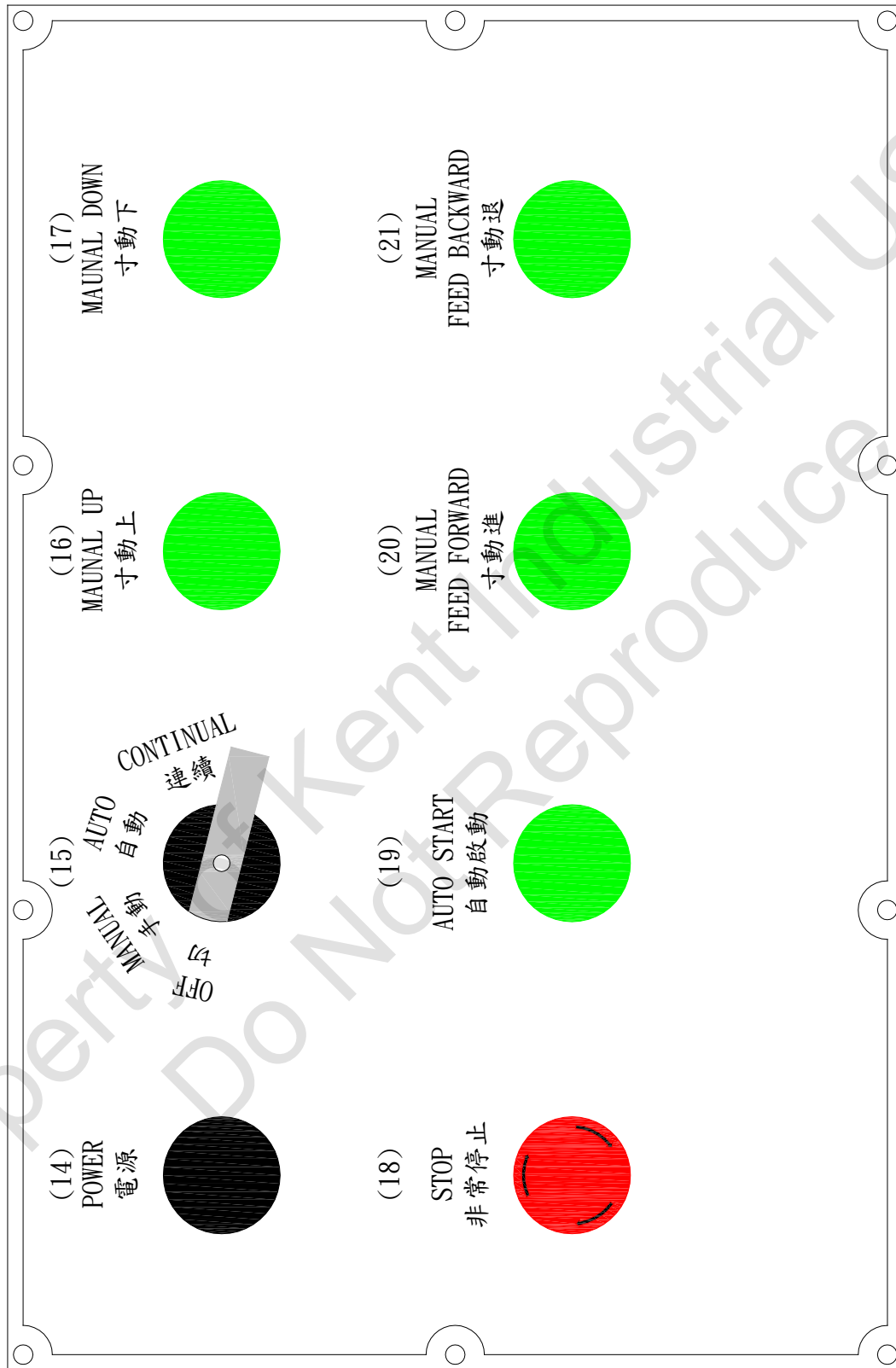







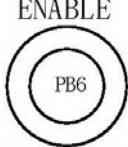

Chart 4 Auto-grinding operation panel key descriptions

NO.	KEY	DESCRIPTION	
14	POWER 電源 	Power on indicator	
15		OFF	Off mode selectoin
		MANUAL	Operate robot arm to elevate and lower slide feeding manually.
		AUTO	Press AUTO START to do once atuo-grinding cycle.
		CONTINUAL	Press AUTO START to do continual auto-grinding cycle.
16	MAUNAL UP 寸動上 	MODE-MANUAL: control robot arm to rise manually	
17	MAUNAL DOWN 寸動下 	MODE-MANUAL: control robot arm to drop manually	
18	STOP 非常停止 	Emergency stop button: Press the button to stop all machine operation while abnormal situations happen. Turn the key clockwise to recover operation.	
19	AUTO START 自動啟動 	Auto start: to do once or continual auto-grinding cycle.	
20	MANUAL FEED FORWARD 寸動進 	MODE-MANUAL: move lower slide forward manually	
21	MANUAL FEED BACKWARD 寸動退 	MODE-MANUAL: move lower slide backward manually	

22		ENABLE(optional) Please press “ENABLE” to do the security scanning process under the safe-mode, after confirming the correct then control loop will start accordingly.
----	---	---

Property of Kent Industrial USA
Do Not Reproduce

6.2 Machine switch off procedure

6.2.1 Operaton panel

1. Turn the switch (1) of electric box door ON.
2. Emergency stop switch (6) is pushed.
3. Release emergency stop switch (6) and POWER indicator (2) lights on.
4. Push STARTswitch (11) to start hydraulic pump motor and hydraulic actuation system begins.
5. Push grinding wheel motor start switch ON (7) and grinding wheel starts to run.
6. When grinding wheel is running, the motor load current indicator (3) displays loading current (A).
7. Push grinding wheel spindle stop switch to stop running.
8. Push regulating wheel spindle motor start switch ON(9) and regulating wheel spindle begins.
9. Turn regulating wheel rotation number control knob(5) to choose required rotating speed of regulating spindle. Regulating wheel spindle rotation number indicator displays the rotation number.
10. Press turn off switch of regulating wheel spindle OFF (10) to stop.
11. Press the coolant start switchON (12) to spray.
12. Press the coolant start switchOFF (13) to stop.

Note:

The procedure for stop regulating wheel rotation of JHC-12BN.18.18A.18B.20 is as below.

1. Base on the steps of regulating wheel gear box tachometer to choose rotation number.
2. Press regulating wheel motor start switch ON (9) to start regulating wheel spindle.

6.2.2 Auto grinding operation panel

1. Release emergency stop switch (6) and release stop switch (18), POWER indicator (18) lights up.
2. Turn model choice knob (15) to choose AUTO and press AUTO START switch (19) to precede once auto grinding cycle. Choose CONTINUAL to precede continual auto grinding cycle.
3. Turn model chose knob (15) to choose MANUAL, and press MANUAL UP button (16) to raise robot arm. Press MANUAL DOWN button (17) to drop robot arm. Press MANUAL FEED FORWARD button (20) to move lower slide forward. Press MANUAL FEED BACKWARD button (21) to move lower slide backward.
4. Turn model chose knob (15) to be OFF, robot arm and auto feeding axis return to reference point.

6.2.3 Switch of proximal regulating wheel motor

1. Set the grinding terminal by regulating wheel motor switch (22) which locates under auto feeding knob. Press green button is to start regulating spindle. Press red button is to stop regulating wheel.

6.3 Machine switch off procedure

1. Turn mode selection knob to be OFF and use operation key to stop coolant and regulating wheel.
2. Dry run the grinding wheel about 5 minutes to dry water fully.
3. Switch off grinding wheel.
4. Press EMERGENCY STOP button.
5. Turn off power switch in the electric box and finish shutdown procedure.

6.4 Cable connection and trial run

Connect auto lubrication motor, coolant motor and power. The green cable of four core cable is grounding wire. Machine, coolant storage tank and oil tank should be grounded to prevent operators get electric shock when electric leakage happens. Buttons in electric box have interlock function. Press auto lubrication switch at first, the rest buttons are effective. Start coolant after grinding wheel is turn on. Press full stop switch (red bulk button) to stop all device. Follow the arrow direction to make the button come out and other keys are effective to restart. After power supply is connected well, test the steering of auto lubrication motor and grinding wheel at first. If no pressure as 6 of hydraulic circuit after turning on auto lubrication motor, need to turn on stop valve(5) in advance. If grinding wheel rotates CCW, need to change any 2 power lines of auto lubrication motor. (Do not change grinding wheel motor wiring because grinding wheel, regulating wheel and motor have been connected to the same rotating direction during assembly.) After that, test direction of coolant pump. The method is turn on coolant and turn off immediately and check the direction same as the indicator or not. There is a timer switch in electric box to control auto lubrication pump off delay after pressing full stop switch to keep lubricating until grinding wheel stop completely.

Turn off coolant 2 to 3 minutes before pressing full stop switch to throw out coolant on grinding wheel surface and prevent absorbing by grinding wheel to damage the balance.

6.5 Working lamp replacement

Unscrew the cover in advance and take out, then, release screw of reflector and take out to replace lamp. The working lamp specification is 12V、55W.

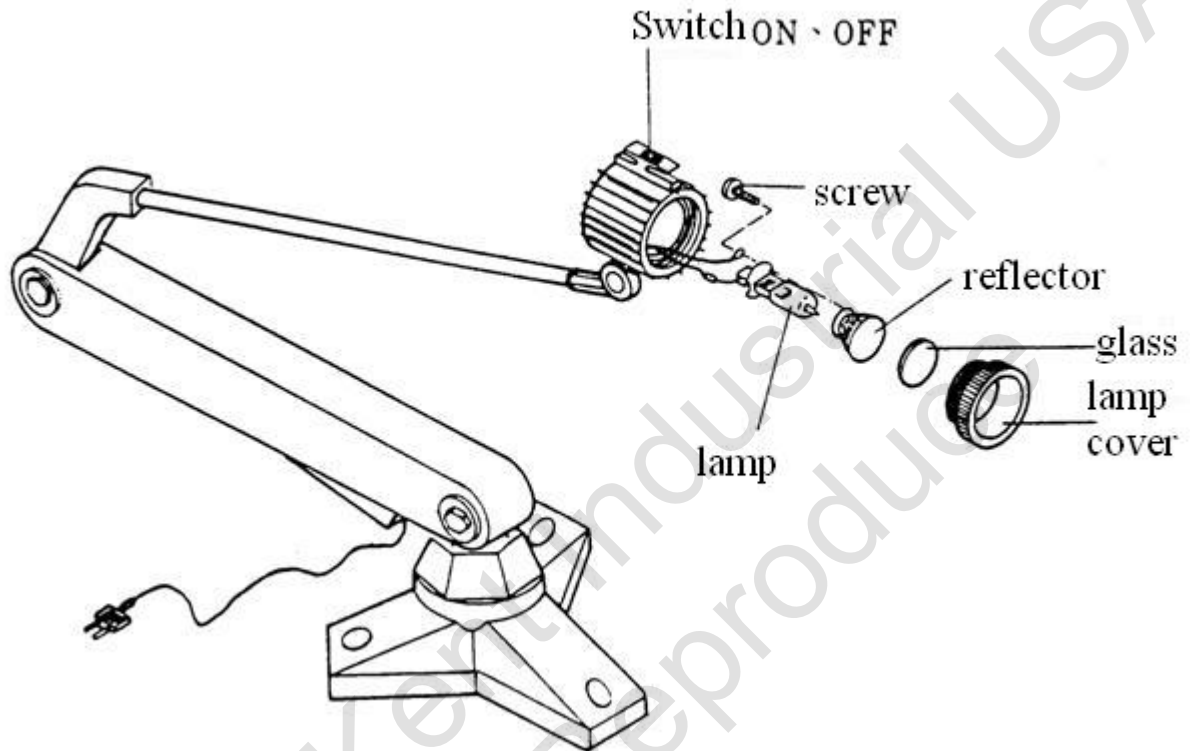

6.6 Regulating wheel servo motor parameter list

PARAMETER NO.	DEFINITION		UNIT	SETTING	REMARK
Pn000.0	Basic function selection switch	Servo motor rotation		0	
Pn000.1		Direction		0	
Pn000.2		Spindle position		0	
Pn000.3		Spare		0	
Pn001.0	Basic function selection switch	WehnSERVO OFF, motor stop mode selection		2	Stop freely
Pn001.1		Overtravel stop mode		0	
Pn001.2		AC/DC power input selection		0	
Pn001.3		Warning code output selection		0	
Pn201	PG dividing ratio		Plus/rev	5000	
Pn300	Speed command input gain		0.01V/ Rated speed	787	JHC-12series
				950	JHC-18/20/24series
Pn305	Soft start acceleration time		Ms	3000	
Pn306	Soft start deceleration time		ms	3000	
Pn50A.0	Input signal selection1	Input signal configuration mode		0	SI0
Pn50A.1		/S-ON signal formed		7	Effective signal
Pn50A.2		/P-CON signal formed		1	SI1
Pn50A.3		P-OT signal formed		8	Signal invalid

Pn50B.0	Input signal selection1	N-OT signal formed		C	SI3
Pn50B.1		/ALM-RST signal formed		4	SI4
Pn50B.2		/P-CL signal formed		5	SI5
Pn50B.3		/N-CL signal formed		6	SI6
Pn600	The power of the external regenerative resistor	10W	30	JHC-12 series	
Pn600	The power of the external regenerative resistor	10W	30	JHC-18/20 series	
Pn600	The power of the external regenerative resistor	10W	40	JHC-18BS/24series	

7. MAINTENANCE & REPAIR

7.1 Notes of maintenance & repair

- 1) Prevent using non-appointed, unknown quality and source oil.
- 2) Clean and maintain machine and turn off machine power (power switch on electric box door) after duty off.
- 3) Maintain machine after machine stops completely or power is shutdown to prevent danger happens.

7.2 Period

ITEM	CYCLE	CONTENT
Oil volume and pressure of grinding wheel oil tank	Each day	Oil volume should be within scale table and pressure should be 8~10kg/cm ² .
Oil volume of manual oiltank	Each day	Oil volume should be within scale table.
Coolant volume	Each day	Maintain coolant volume above half.
Grinding wheel spindle belt tension	Each week	Check if within the tension.
Regulating wheel spindle belt tension.	Each week	Check if within the tension.
Formed diamond dresser belt tension	Each week	Check if within the tension.
Water tank	Each week	Renew base on coolant quality and accuracy requirement.
Filter cleanness	Each week	Include oil cooler and air conditioning filters of electric box
Wheel head filter can	Each season	Check and clean
External hydraulic box and filter	Each season	Check and clean
Wheel head oil tank	Half year	1 st oil renew for new machin is 3 months, after that every half year.

7.3 Monthly check list

Descript	Item
Appearance	1. Rust or damage on two spindles
	2. Safety on protector cover or not
	3. Rust or damage on the joint face
	4. Damage on oil scraper or not
	5. Damage or not on pipe and connector
	6. Damage on the Sprayer or not
	7. Machine works well or not
	8. Clear on the gauge and indication sign
Electricity device	1. Damage or not on switch cover
	2. Coolant mist or dust in to the box
	3. Damage or not on the switch connect point
	4. The fuses are regular
	5. Ground wire has connected
	6. Isolation or not on the wires
	7. Wire connected loosen or not
	8. Damage on wire protector fuse or not
	9. Switch function work well or not
	10. Each indication light work well or not
	11. The galvanometer work well or not
	12. The dynamo work well or not
	13. The magnetic contactor work well or not
	14. The lamp work well or not
Lubrication, hydraulic oil and device	1. Amount of oil
	2. Deteriorate or not on the lubrication oil
	3. Properly on lubrication area or not
	4. Oil cup work well or not
	5. Amount of oil inside the tank

Descript	Item
Lubrication, hydraulic oil and device	6. Change oil regularly
	7. The pressure is normal
	8. Vibration or not on the pressure gauge
	9. Leaking or not on cylinder
	10. Leaking from pipe connector, switch or not
	11. Filter work well or not
Cooler device	12. Vibration, abnormal heat on the magnetic contactor
	1. Pump work well or not
	2. Separator plate, filter work well or not
Grinding wheel spindle	3. Leaking from connector or switch pipe or not
	1. Vibration, abnormal noise or not
	2. Abnormal heat from spindle bearing
Regulating wheel spindle	3. Properly on belt suspending or not
	1. Vibration, abnormal noise or not
	2. Properly on belt suspending or not

7.4 Oil-based maintenance

- 1) Poor quality of hydraulic oil affects machine a lot, please renew oil immediately.
- 2) All filter of pump suction side must keep clean and smooth and maintain periodically.
- 3) Main reason for leaking is poor gasket, please replace new one at any time.
- 4) Open cavities of hydraulic circuit to exclude air to prevent noise and vibration.

7.5 Lubrication system

7.5.1 Lubricator

Whether the use of lubricator is correct or the cycle of lubricator increment (or change oil) is same as the chart influence machine life and accuracy. Hence, please purchase lubricator from reliable oil supplier in accordance with the chart shown below. Depending on convenience and safety transportation, empty lubricator of both grinding wheel spindle and regulating wheel spindle before shipping. In this way, oil tank must be filled with oil before working; otherwise both bearing and spindle will be damaged. The other sliding parts must be lubricated as indicated. But oil in transmission box hasn't been removed. Please do not add oil over H line. Otherwise there will be too much oil as show below. Oil of the same grade from other brand is also available. Lubrication (change oil) cycle is based on the period of 8 hours for each work day.

Property of Kent Industrial USA
Do Not Reproduce

Chart 7-1 machine lubricator

CYCLE	LUBRICATION PARTS	OIL CAPACITY	SPECIFICATION	REMARK
New machine 1 st : 3 months 2 nd : 6 months 3 rd : 12 months	Oil tank(grinding wheel spindle, regulating wheel spindle, auto-lubrication and dressing oil	JHC-12S approx 15 gallon, JHC-18S.20S about 25 gallon	Gulf brand special spindle oil R-12 or ESSO SPINESSO.10.	Check once every half month. If lower than 80mm from surface of barrel, oil must be added to required position
1 st : 100H afterwards, every 500H.	Regulating wheel servo motor reducer (12S.18.S.20S)	Increase to center line of oil level meter	Gulf brand HD-220 Esso EP-220	Lower than oil level meter, need to refill.
1 st : 100H afterwards, every 500H.	Regulating wheel gear box (12BN.18.18A.18B.20)	Increase to center line of oil level meter	C.P.C Advance d gear oil #90.140. Gear oil ST (Esso)	Lower than oil level meter, need to refill.
Each month	Dressing device feed screw (fig. 2)	Appropriate amount	Gulf brand special cycle engine oil R-68.	
Each day	Auto oil filter (fig. 1)	Appropriate amount	Gulf brand special cycle engine oil R-68.	Pull oil filter knob several times
Each day	Level angle adjustment seat bearing	Several drops	Gulf brand special cycle engine oil R-68.	
Each day	Dresser (fig. 2)	Appropriate amount	Gulf brand special cycle engine oil R-68.	

Remark:

1. Oil of the same grade from other brand is available also.
2. Increase (change) oil cycle is based on the period of 8 hours per day.

Property of Kent Industrial USA
Do Not Reproduce

7.5.2 Lubrication parts (12S.18S.20Sseries)

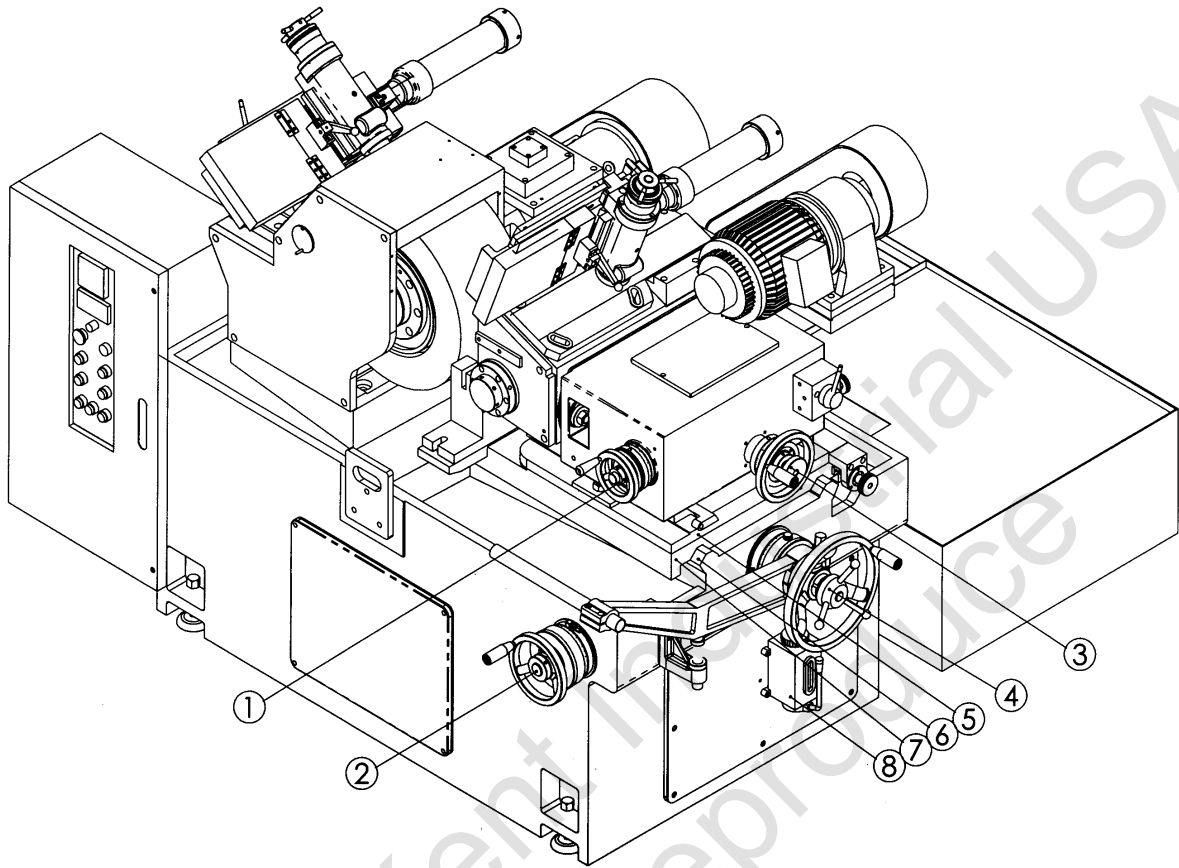

Fig. 1

1. Regulating wheel micro feed bearing
2. Worktable micro feed bearing
3. Regulating wheel feed bearing and screw
4. Worktable feed bearing and screw
5. Rail of slide
6. Plane of revolution on lower slide
7. Rail of lower slide
8. Inlet of oiler

7.5.3 Lubrication parts (12BN.18.18A.18B.20 series)

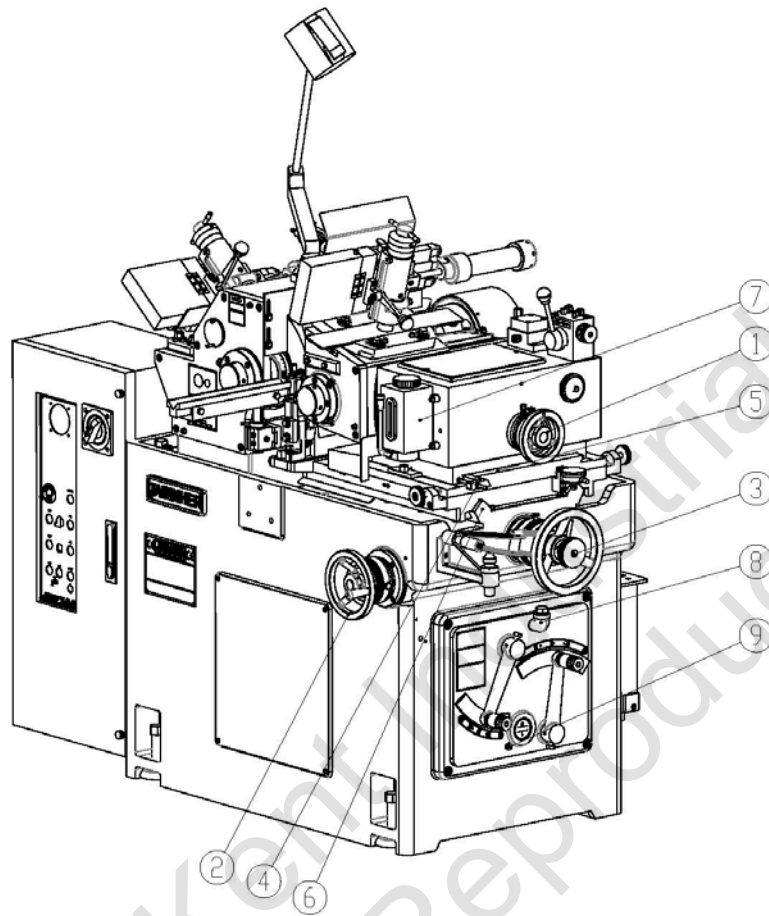

Fig. 2

1. Regulating wheel micro feed bearing and screw
2. Worktable micro feed bearing
3. Worktable feed bearing and screw
4. Rail of slide
5. Plane of revolution on lower slide
6. Rail of lower slide
7. Inlet of oiler
8. Oil port of regulating wheel gear box
9. Drain port of regulating wheel gear box

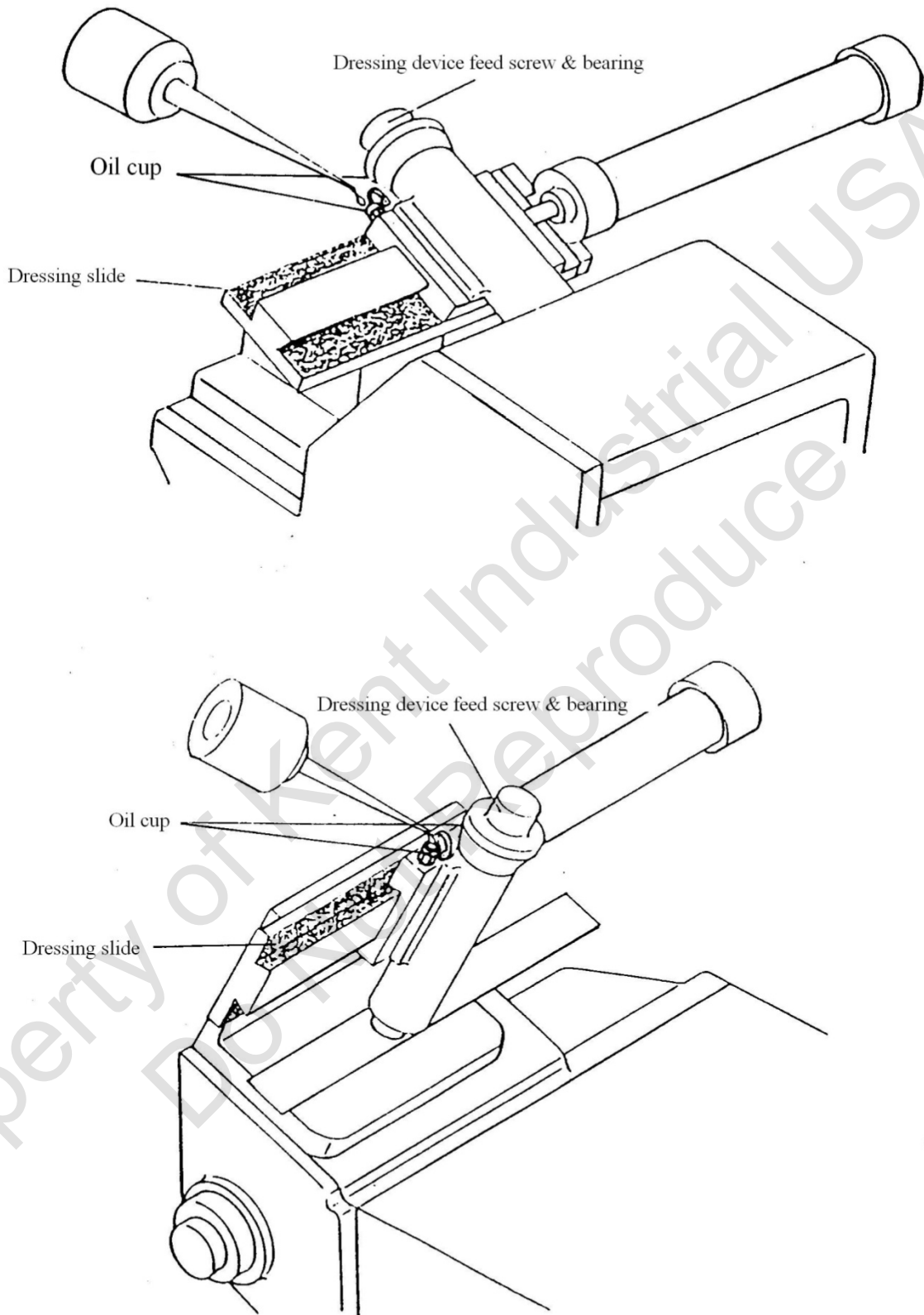
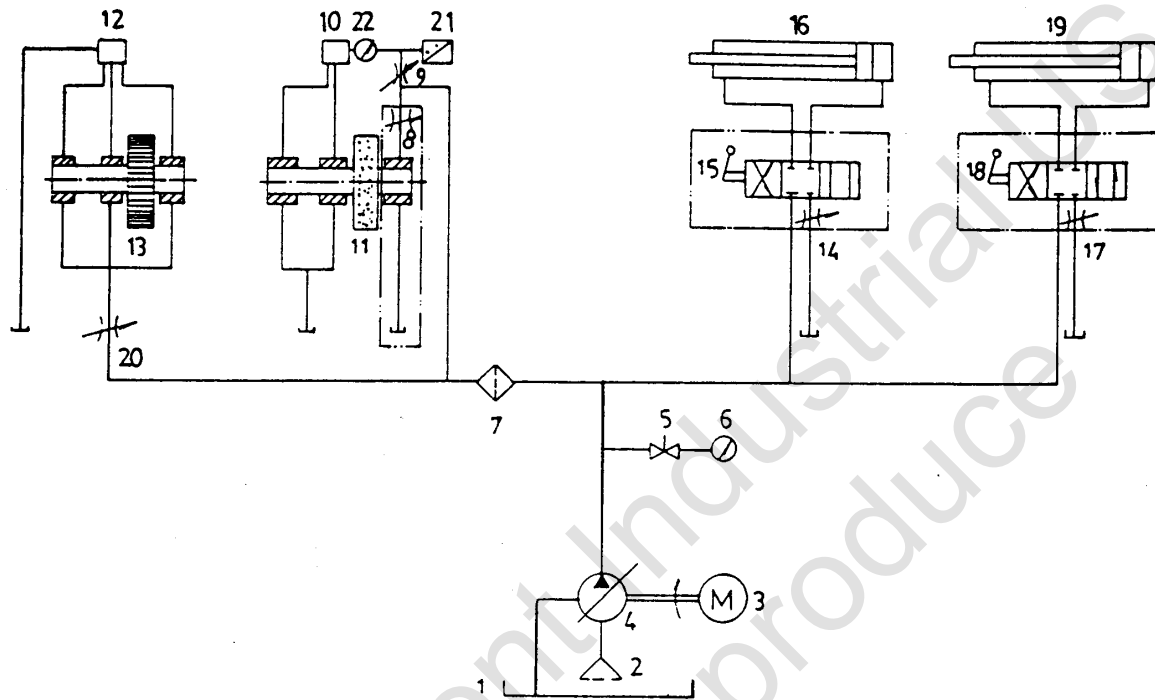

Fig. 3

7.6 Hydraulic system

7.6.1 Hydraulic circuit



(I) Parts list

NO	ITEM	NO	ITEM	NO	ITEM
1	Oil tank	9	Flow control valve	17	Flow control valve
2	Filter (3/4")	10	Grinding oil lens	18	Direction change lever
3	Motor	11	Grinding wheel	19	Dressing oil cylinder
4	Hydraulic pump	12	Regulating wheel oil lens	20	Flow control valve
5	Stop valve	13	Regulating wheel	21	Pressure switch
6	Pressure gage	14	Flow control valve	22	Pressure gage
7	Filter (1/2")	15	Direction change lever		
8	Flow control valve (JHC-18 series has no the device)	16	Dressing oil cylinder		

7.6.2 Hydraulic pressure adjustment

Auto lubrication and hydraulic dressing devices for grinding wheel spindle and regulating wheel spindle are used with same pump. Generally, oil pressure should be kept at 8-10kg / cm². If pressure is higher than capacity of oil seal, oil will leak. If pressure is too low, oil cylinder shaft of dresser will vibrate while moving. When filter is clogged by impurities, oil pressure will decrease. In this condition, take out filter and clean it. If oil pressure is still low, open cap of oil pressure regulator and adjust screws. The pressure increase by clockwise direction and decrease by counterclockwise direction.

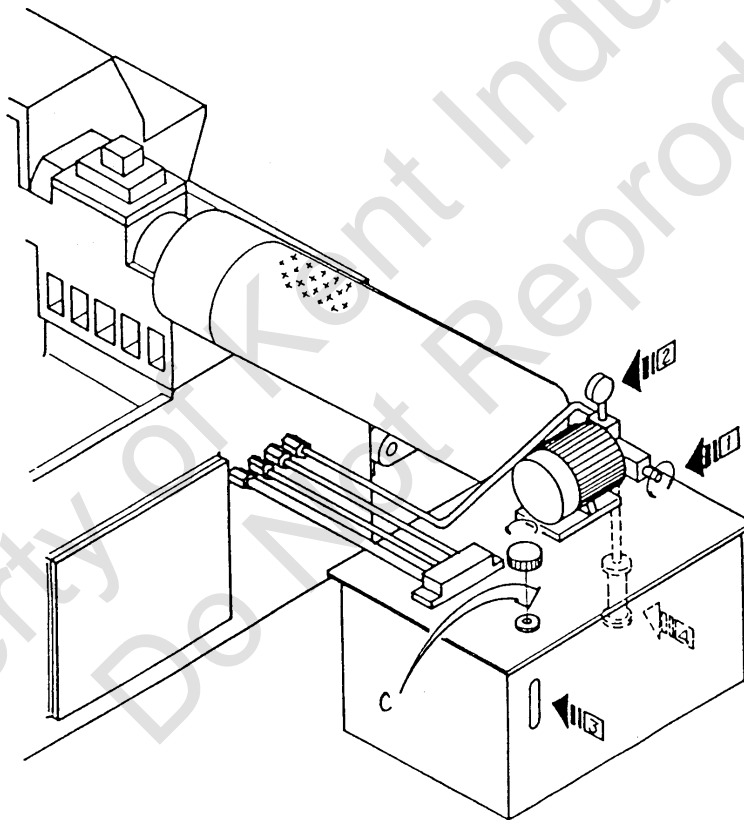

NO	ITME	NO	ITEM	NO	ITEM
C	Oii port	2	Pressure gauge	4	Filter
1	Pressure regulating scre w	3	Oil gauge		

7.6.3 Flow adjustment

Flow control valve is to regulate oil capacity into grinding wheel spindle and regulating wheel spindle and to keep normal oil pressure and capacity so that lubrication and cooling system may obtain high efficiency. The adjusting way is to follow mark direction on hand screw, turn right is to reduce flow and turn left is to increase flow. The amount of flow control valve can be seen from oil lens.

Flow control valve position, pressure switch function and setting:

Pressure switch is to cut off power connection automatically and stop the grinding wheel to protect the alloy beawring among gridning wheel in case of the pressure lower than indication set on the gauge.

Setting:

1. Start the machine and turn on the grindng wheel spindle
2. Rotate adjusting screws above pressure switch to make the pressure over $1\text{kg} / \text{cm}^2$.
3. Clockwise direction adjusting the flow valve when the value on indciator from $3\text{kg} / \text{cm}^2$ goes down to $1\text{kg} / \text{cm}^2$,the grinding wheel motor will stop. If not stop at $1\text{kg} / \text{cm}^2$, need to adjust again to make sure the motor will stop when pressure at $1\text{kg} / \text{cm}^2$.
4. Set the pressure of flow valve to be $3\text{kg} / \text{cm}^2$.

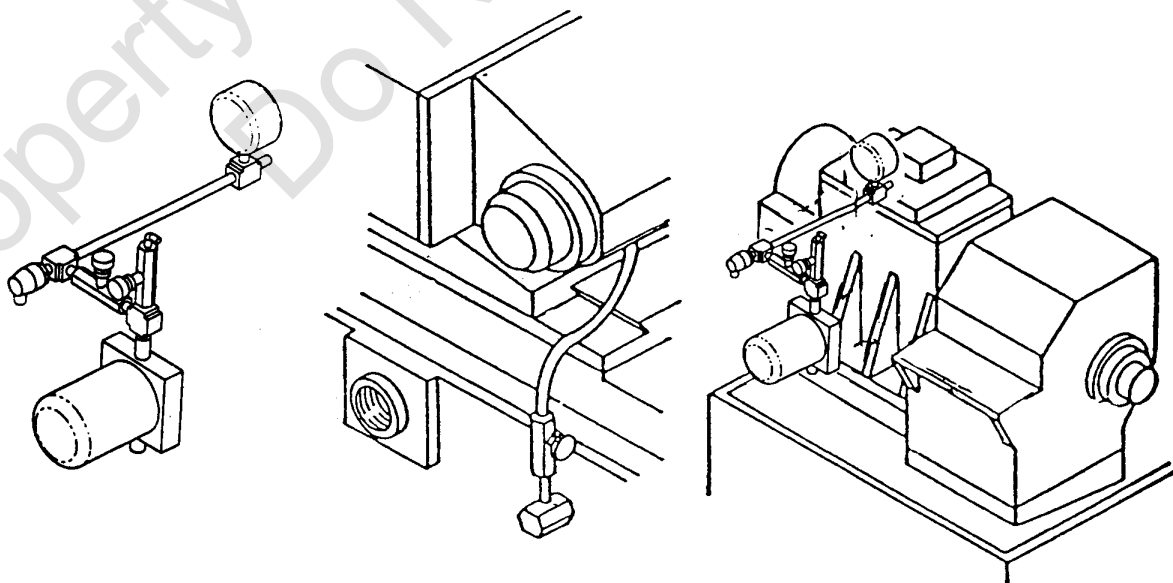

7.7 Coolant selection

Coolant is to get flush grits of binding agent and chips from both grinding wheel and regulating wheel quickly. It can cool workpiece, reduce friction between workpiece and grinding wheel and enhance surface glazing on workpiece.

Coolant flows from tank through pump to machine, then back to coolant tank and flow through some deposit tanks to get rid of sands, bonding agent and chips to recycle. Hence, a great amount of mud-like things is deposited in reservoir. In this case, it's better to change coolant frequently. Otherwise, grinding glazing and accuracy will be affected and pump is easily damaged. Magnetic coolant separator or filter device can get rid of great amount of grinding chips that extends coolant change period.

There are various types of coolant, please choose the proper type.

1. Water-solubility coolant

- 1) Emulsifying series coolant

With mineral oil as the element liquid, fatty acid soap, petroleum resin soap, tea acid soap, petroleum, sulfur soap (5~20%) of negative iron active agent as the emulsifier, mix further with alcohol, fatty acid grease as binding agent. Generally, it's diluted by water 20 to 50 times before use. It appears like milk. The advantage of this series is good lubrication but its cooling and permeability are less good.

- 2) Transparent and emulsifying coolant

With little oil but more emulsifier, when coolant is diluted to 70-100 times, oil is dispersed to the corpuscles nearly as transparent body, whose cooling

and permeability are less good.

3) Transparent water-solubility coolant

Mainly with chemical treatment chrome acid sodium such as inorganic ammonium, dissolves into water and appears transparent which develops anti-solubility and resst prevention with good grinding effect. It's suitable for cast iron and cast steel.

2. Non water-solubility grinding liquid

Mainly with light mineral oil, mixes with sulfur fatty oil or chlorine sulfurfatty oil which has good lubrication including active and inactive. If added with sulfur, chlorine such as extreme pressure additives, it can effectively reduce grits worn and torn and prevent grinding wheel's holes from being clogged, which may reduce heating. Hence, this is suitable for precisin grinding and better for aluminum workpiece. Be ware of its inflammability and hygiene.

3. Water

Water is good for cooling but lessgood for lubrication. It may cause rest for metalworkpieces. Underspecial conditions, it's used for grinding in porcelain and glass fiber but do not apply the used-water. The used grinding liquid should be treated according to general standard industrial wastewater treatment, such as chemical treatment (by acid-base treating method) or burned ash in order to avoid water pollution.

8. TROUBLE SHOOTING

8.1 Common cause & remedy

ABNORMAL	CAUSE	REMEDY
Turn on power, power indicator no light.	1. Lack of power supply.	Check power
	2. No fuse switch (NFB) off.	Turn NFB to ON
	3. Power lamp isn't bright.	Repair power lamp.
	4. NFB is poor quality.	Replace NFB
	5. Transformer burned	Renew transformer
Complete turn on process, hydraulic pump isn't working.	1. Button switches poor contact.	Repair or renew.
	2. Wire failing or poor contact.	Tight fixing screw.
	3. Overload relay and cut off.	Press RESET button.
	4. Electromagnetic switch is poor contact.	Replace new parts.
	5. Motor is burned.	Repair or replace new parts.
Grinding wheel can't be started.	Hydraulic pressure is too low.	Adjust hydraulic pressure to required range.
Grinding wheel spindle motor isn't moving.	1. Overload relay and cut off.	Press RESET button.
	2. The pressure is too low to work. Filter is stuck and micro motion switch is invalid.	Adjust pressure, clean filter and renew.
	3. Hydraulic pump lose function.	Repair or renew.
	4. Oil pump rotates but lubricator isn't lubricated.	Repair or replace new oil pump.
	5. Turn ON pressure switch but motor can't start.	Repair or renew.
	6. Motor is burned.	Repair or renew.
Coolant isn't flown.	1. Overload relay and cut off.	Press Rest button
	2. Electromagnetic switch is poor contact.	Replace a new one.
	3. Coolant switch is off.	Turn on coolant switch.

	4.Pump impeller is worn out.	Replace new parts.
	5. Motor is bun.	Replace new parts.
Hydraulic pump oil is not output.	1. Oil level is too low.	Add appointed or same specification oil.
	2.Pump inlet pipe is stuck.	Check filter and pipe is stuck by obstructions or not.
	3.Oil viscosity is too high.	Check used oil matches oil regulation or not.
	4. Oil pump unit is broken.	Replace unit by engineer base on regulation.
Oil pump noise	1.Inlet pipe is air in.	Sink inlet pipe into oil tank indeed.
	2. Too much air inside system.	Exclude air out of the system indeed.
	3. Too much impurities stuck filter.	Maintain base on period.
	4. Oil pipe is stuck.	Remove impurities inside oil pipe.
	5. Oil pump unit is broken.	Replace by engineer base on regulaton.
	6.Oil viscosity is too high.	Follow oil usage regulation.
	7.Pump shaft and the motor shaft misalignment	Re-install.
Belt noise	1. Belt is loosening.	Adjust motor seat to moderate tightening the belt.
	2. Belt is deformed.	Replace belt.

9. GRINDING APPLICATION

9.1 Centerless grinding principle

Centerless grinding means no need to clamp workpiece for grinding. The grinding method is as figure shown. It's consisting of grinding wheel, regulating wheel and work rest. Grinding wheel is used for grinding, regulating wheel for controlling rotation workpieces and enable its rotation to be the same as feed speed. The workrest is used to support workpiece in grinding. There are other similar ways for the collaboration of these parts. Other methods are the same in principle, except tangential feed grinding.

In the same way as cylindrical grinding, grinding is made by shortening the gap between center of workpiece and surface of grinding wheel. Thus, workrest and regulating wheel are to support, center and rotate workpiece. The turning direction of grinding wheel is reverse to the regulating wheel. The workpiece is pressed against workrest and regulating wheel in the grinding wheel process. The turning speed of workpiece is made to be the same as that of regulating wheel. The drive is carried out by friction between regulating wheel and workpiece. Real circle is formed by the above three elements' arrangement. First assuming that the workpiece's center height is the same as that of the grinding and regulating wheels thus the out of round part on circumference of workpiece pressing directly opposite place on geometry of two grinding wheels will form a concave.

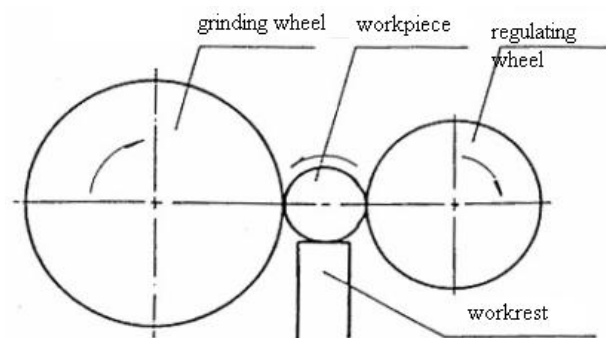

A circle with equal diameters after repeating the action mentioned above is formed

but it is not a real circle, its a triangle-like or quadrangle like-circle. If workpiece is put on the higher place than connecting line between centers of two grinding wheels, when bevel point on workpiece contacts regulating wheel, the point pressing against grinding wheel doesn't symmetrize it. Furthermore, skew point contacts work rest. The other parts on workpiece don't touch the two grinding wheels. In this way, diameter of finished workpiece is longer than diameter got from above mentioned assumptive state; only skew point is ground and coming out a nearly real circle through grinding. In fact real circle is enhanced by support blade which is formed an angle on top of workrest as point and line in fig. shown when lower part on surface of workpiece contacts regulating wheel or blade center of circle on workpiece will descend. Its ground diameter is shorter when center of circle ascends its ground diameter is longer which resulting in a real circle because the uneven parts on workpiece offset each other. Besides workpiece is easily upward severed because of higher angular velocity or too high of center on workpiece.

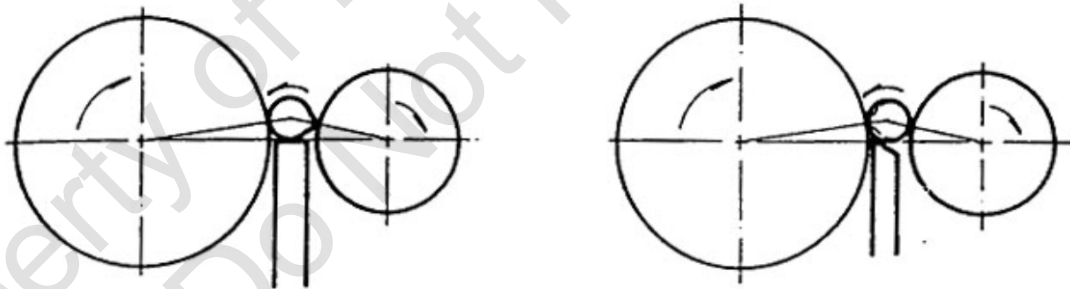

9.2 Centerless grinding method

9.2.1 Thrufeed method

Grinding is made by passing workpiece through two grinding wheels meanwhile. Regulating wheel is made to an inclination for applying its component of velocity in circumferential speed. To guide workpiece to the correct grinding position, four guide plates are placed in front of and rear of blade. Pay attention on correction of regulating wheel and thanworkpiece in line contact with regulating wheel owing to inclination of regulating wheel. Only incline regulating wheel, workpiece touches regulating wheel on one point. Hence, regulating must be corrected to diam-line and its corrected device is placed according to the inclination. This method is only suitable for cylindrical workpiece and few different diameters of workpiece, such as rod, bar, piston pin, needle, bearing retainer and pipe etc. To go on rough grinding and finishing at the same time, several sets of grinding machines are made to a grinding engineering line. Bar feeder, part feeder, ring feeder and hopper elevator are available to heighten work efficiency.

9.2.2 Infeed method

The grinding method is firstly, workpiece is sent from two sides or top of two grinding wheels into the required position, then, move regulating wheel forward to grind which is a kind of radial feed method, suitable for complicated conical workpiece machining. To ensure operators' safety in inserting workpiece, commonly workpiece is placed on the grinding position by machine, and operators only put workpiece to the convey device. Besides, the work process of now commonly operated, such as insert, take out, metering grinding wheel and correction of regulating wheel, compensation to worn grinding wheel, the auto machines and tools are employed including conical roller, roller, engine valve, spindle, crank shaft and rear accelerating box etc.

9.2.3 Endfeed method

Make 2 grinding to be cone shape. Ensure grinding wheels and workrest are fixed and insert workpiece from grinding wheel side until it touches stopper. This grinding method is only fit cone surface machining.

9.2.4 Tangential feed method

Maintain the backlash of grinding wheel and regulating wheel and push the workpiece forward according to grinding wheel cutting line.

9.3 Grinding method for different workpiece

There is a wide selection of shapes on workpieces for centerless grinding. Here are some samples and popular grinding methods.

9.3.1 Short circle workpiece

If no other cause, generally by thrufeed grinding, especially for auto feeder with economical efficiency (short and small workpiece the best) Continuous feeding workpiece in thrufeed grinding is important as size variation can occur with intermittent feeding.

9.3.2 Disc-plate workpiece

The ratio between dia. Of cylinder and its length (R/L) is above 1 that is dia of workpiece larger than its length. Workpiece must be kept in a fixed pose. Some workpieces must be for fixed grinding by using special fitting. Movement occurs in grinding, just place upper disc between two wheels.

9.3.3 Long bar workpiece

In long bar grinding, V-shaped way for feeding can be equipped in front of the machine and V-shaped way for discharge mounted at the rear of the machine. In this method, it's very difficult to centralize by moving the regulating wheel which has to be done due to the grinding wheel. Furthermore, since fixed worn wheels must be respectively dressed and compensated.

Therefore, if the workpiece is not too long, it is better to mount the V-shaped way on workrest, then, centralize in the normal method.

9.3.4 Attache-head workpiece

Infeed grinding method is employed when the external diameter of grinding part is smaller than head part. When its center of gravity is on the grinding part, workpiece is sent into nearly-contact position between bid head end face and two wheel's end face for feeding and grinding. When discharge, it can be taken out by hands. If sent out by electro-magnetism or oil pressure, quicker speed can be made. If center of gravity feel is on the head part, a device for supporting grinding piece should be used. The head can't be supported owing to irregular shape, a upper disc should be mounted on the top of grinding aprt from where to regulate its balance for grinding. Please refer to below figure.

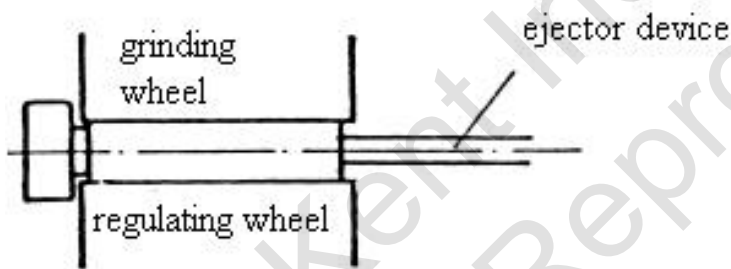

9.3.5 Cross-shape workpiece

For cross-shape workpieces, such as cross connection grinding, two sides of two grinding wheels are ground in the same time but in pre-machining notice its concentricity and right angle on grinding part.

9.3.6 Multi-size workpiece

There are more than two different diameters on grinding aprt. The concentricity of workpiece before machining should be considered at this point. Grinding wheel must be teh same shape as the workpiece but for regulating wheel not necessarily the same. Blade may obtain better effect by less contact to rinding part on workpiee owing to grinding resistance. If there are more than

three different diameters on grinding part, better limit with two grinding parts.

For curve part and void slot not ground, it is difficult for grinding wheel to dress double grinding wheels with spare betwen.

9.3.7 Cone workpiece

The workpiece only with cone not emphasized its concentricity, grinding is made in accordance with the folloing ways.

1. When conical angle is small, regulate level scale of regulating wheel as below left figure.
2. When cnical angle is large, dress grinding wheel and regulating wheel. Then, send workpiece to the fix position for grinding as below right figure.
3. Another type is tapering bar, such as antennas, fishing rod, which is to be ground by automatic tapering grinding device.

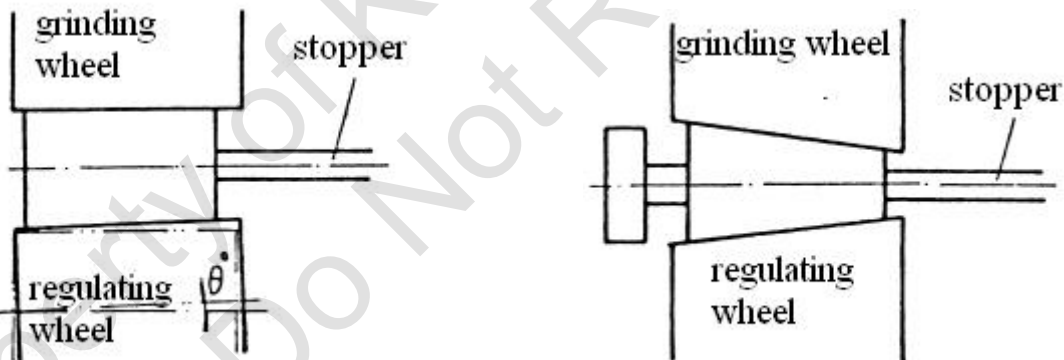

9.4 Introduction of grinding wheel

Selection of grinding wheel:

For desirable grinding process, grinding wheel is selected based on workpiece's requirement and machine's grinding feature. The consideration must also include selecting proper roughness degree, binding degree, texture and binding agent.

A. Grit

Grits of centerless grinding machine include "A" grit, "WA" grit, single-crystallized grit of aluminum oxide series, as well as "C" grit and "GC" grit of silicon carbide. Herein, workpieces of various grits are explained as following:

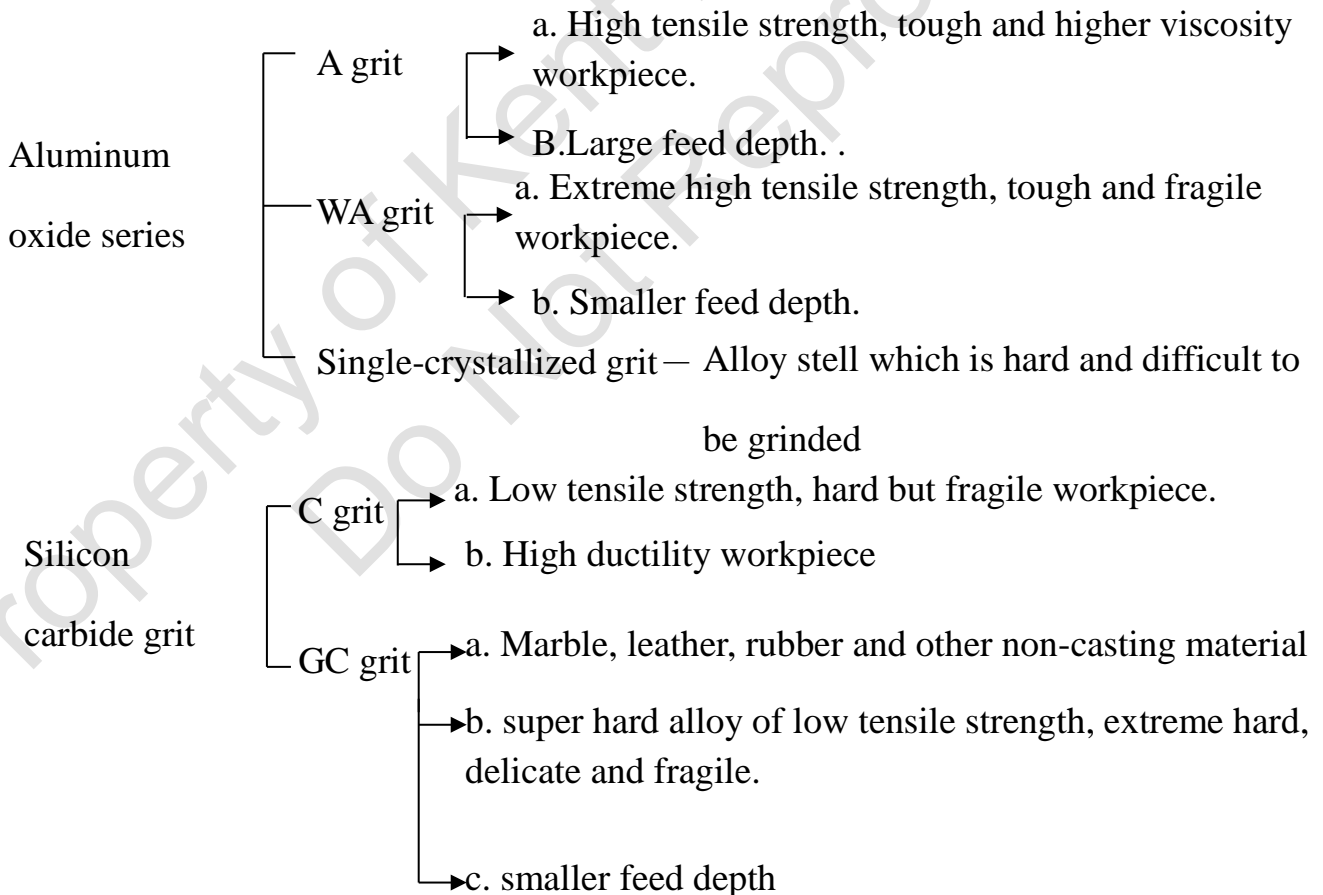

As far as steel is concerned, the most tough "A" grit is better for soft steel

workpiece. Hard material, such as hardened steel and special steel, hard and tough “WA” grit is adapted instead of “A” grit. For general cast iron, brass, copper, tin and tungsten materials, “C” grit is applied. “A’ grit, however, with high hardness and high self-generating function, may prevent lip of grit from being buried. “GC” grit which is harder than “C’ grit is applied in high compression state of special cast iron and super hard alloy with heating treatment. As for stainless steel, it is poor of grinding. The hardest single-crystallized grit in aluminum series and its toughness lying between “A’ grit and “WA” grit is used to attain good rock efficiency.

B. Roughness degree

Roughness degree is classified as shown as below. .

No of roughness	10,12,14,16, 20,24	30,36,46,54,60	70,80,90,100,120,150,180,220	240,280,320,400,500,600,700,800
	Coarse	Medium	Fine	Very fine

The sizes of various grits are given below

Type	Coarse	Medium	Fine	Very fine
Dia. (mm)	1-3	0.4-1	0.1-0.4	0.024-0.08

The roughness degrees which are by centerless grinding process can be summarized as:

Process	Rough	Rough& polishing	Polishing	Lap grinding
Roughness no.	46	60	80	120, 180

Gernally speaking, for better efficiency, high ductility workpiece is applied by tough grinding wheel to improve its grinding surface. Fine grinding wheel is usually adopted for hard machining and delicate materials.

C. Binding agent

Binding agent includes Vitrified(V), Silicate(S), Rubber(R), Resinous(B), Shellac(E) and metal (M). Vitrified is the hardest and strong binding agent, only very few amount would obtain would obtain high hole rate to required binding degree with very few clogs on grinding wheel. The bound wheel is very sharp and has high strength. Hence, it takes the most part in grinding work. Vitrified grinding wheel is used in most centerless grinding machine. When finishing or accuracy is required, shellac or rubber binding grinding wheel are applied. Regulating wheels almost are rubber binding grinding.

D. Binding degree

Binding degree represents strength of binding agent. The following is its classification:

Binding degree	E、F、G	H、I、J、K	L、M、N、O	P、Q、R、S	T、U、V、W、X、Y、Z
Strength	Very soft	Soft	Medium	Hard	Very hard

Grinding wheel has the degrees of K, L, M while regulating wheel has degrees of Q. In all times, hard binding degree is applied to soft workpiece, however, and soft binding is applied to hard workpieces. Besides, brass and copper based soft workpiece adopt hard binding degree to prevent hole from being clogged.

E. Texture

The density of grinding wheel in unit volume is called texture. There are three stages in JIS: rough, medium and dense. The function of texture is to discharge chips. Its effect has close relation with binding degree. The following items are the rules for selecting texture:

1. The hardness and toughness of workpiece.

Tough texture applies to soft workpiece and dense texture applies to hard and brittle workpiece.

2. Finishing degree and grinding volume

Large grinding volume with rough grinding degree is applied by rough texture. Precision grinding is employed by dense texture.

The above mentioned items are the general rules for selecting grinding wheel.

Before grinding, the condition of workpiece and the status of grinding machine must be fully considered in order to attain desirable results.

9.5 Grinding wheel circumferential speed

The higher circumferential speed of grinding wheel is reached, the better grinding efficiency and finishing surface is obtained. But grinding wheel circumferential speed is limited by the strength of binding agent. Generally speaking, centerless grinding machine circumferential speed is around 1800m / min. When the speed of vitrified binding grinding wheel is 1800m / min, 16kg / cm² of centrifugal tension is then generated. Grinding wheel of roughness degree of no. 46 and binding degree of K whose circumferential speed would decelerate because diameter reduced due to abrasion. Once a new grinding wheel circumferential speed is determined, it's not necessary to make any correction until its speed declined by abrasion. When select grinding wheels, please refer to the table shown in next page for correct type.

Selection of grinding wheel

		Grinding material	Hardness of material	Recommended types	
Steel	Common carbon	General structure rolled steel (SS) Mechanical structure carbon steel (SC) (S-CK)	<HRC25	A 60M 38A 60L	
		Structure carbon steel iron pipe (STK) Carbon steel wrought work (SF) Carbon steel cast work (SC)	>HRC25	WA 60L	
		Nickel chromium alloy steel (SNC) Nickel chromium molybdenum alloy steel (SNCM) Chromium alloy steel (SCM) Aluminum chromium molybdenum alloy steel (SACM)	<HRC55	WA 60L	
	Alloy steel	High carbon chromium bearing steel (SUT) Structure alloy steel cast work (SCA) Carbon tool steel (SK)	>HRC55	WA 60K(L)	
		Tool steel	High speed tool steel (SKH)	<HRC60	WA 60K(L) GC60L 32A 60L
	Alloy tool steel (SKS, SKD) (SKT)		>HRC60	WA 60K GC60L 32A 60L	
	Stainless steel	Stainless steel 1~4 (SUS1~4) Heat resisting steel 1~3 (SEH1~3)		WA 60K(L) GC60L 32A 60L	
		Stainless steel 5~16 (SUS5~16) Heat resisting steel 4~5 (SEH4~5)		WA 54L GC60L 32A 60L	
	Cast iron		Common cast iron (black heart cast iron FC)		C 60L
			Special cast iron		GC 60K
Black heart weldable iron (FCMB)				A 60M	
White heart weldable iron (FCMW)					
		Brass (BS)		C 46K	

Non iron	Bronze (BC)	A 60M
	Material for permanent magnet cast magnet	WA 60K C 60L CGC 60L

Property of Kent Industrial USA
Do Not Reproduce

9.6 Grinding difficulty and solution

There are various phenomena and difficulties occurred in centerless grinding work, the following table show their reasons and solution. In fact, a problem results from many reasons and come with several solutions in which each one has relative. Hence, the following measure is not the only way to settle problem.

Phenomenon/fault	Cause	Solution
Scar on finishing surface	<ol style="list-style-type: none"> 1. excessive gabbess of blade 2. chips or small blocks adhered on blade 	<ol style="list-style-type: none"> 1. replace with a soft blade 2. add soluble cutting coolant in cooling water
Come with equal space of screwlike trace	<ol style="list-style-type: none"> 1. hit the edge of grinding wheel 2. undesirable regulation of guide plate 3. high dressing speed 4. diamond tool worn & torn 5. diamond tool holder loose 	<ol style="list-style-type: none"> 1. form the edge as cone shape of grinding wheel 2. make guide plate parallel 3. reduce dressing speed and feeding volume 4. change contact surface of diamond tool
Equal or unequal space of thin line	<ol style="list-style-type: none"> 1. poor dressing 2. external vibration 	<ol style="list-style-type: none"> 1. dressing from edge of grinding wheel, keep fixed dressing speed 2. isolation of vibration
Deep and irregular trace	<ol style="list-style-type: none"> 1. grinding wheel loose 	<ol style="list-style-type: none"> 1. insert packing piece between flange and grinding wheel and lock the m well.

<p>Self-excited vibration</p>	<ol style="list-style-type: none"> 1. Center is too high. 2. The angle of blade is too large. 3. The blade is too thin. 4. The blade isn't equipped well. 5. The blade is bending. 6. Large volume. 7. Undesirable selection of grinding wheel. 8. Undesirable real circle of grinding wheel. 9. Grinding wheel support is loose. 10. Mandrel is loose. 11. Diamond tool holder is loose. 12. External vibration. 	<ol style="list-style-type: none"> 1. Reduce center height. 2. Reduce angle. 3. Increase thickness. 4. Relock screw. 5. Correct blade. 6. Reduce grinding volume and gain grinding times. 7. Consult with grinding wheel manufacturer. 8. Dressing before get balanced, screws locked equally. 9. Relock screws. 10. Regulate the mandrel of regulating wheel. 11. Relock holder and change diamond tool. 12. Isolate external vibration.
<p>Fail to get real circle</p>	<ol style="list-style-type: none"> 1. Center is too low. 2. Blade angle is too small. 3. Excessive hardness of grinding wheel. 4. Large pressure of grinding. 5. Large volume of rough grinding. 6. Regulating wheel is loose. 7. Coolant is not enough. (in grinding hollow piece) 8. Undesirable dressing. 	<ol style="list-style-type: none"> 1. Increase center height. 2. Increase angle. 3. Increase thrust speed. 4. Use sharp diamond tool to increase correcting speed. 5. Reduce feeding volume and do the first grinding by high thrust speed. 6. Relock screw and regulating wheel mandrel. 7. Add coolant on desirable place of contact point. 8. Dressing again.
<p>High central part</p>	<ol style="list-style-type: none"> 1. Undesirable regulation of guide plate. 	<ol style="list-style-type: none"> 1. Make guide plate parallel. 2. Reduce tilt angle of regulating wheel. 3. Increase swivel angle of regulating wheel on dressing device.

<p>Low central part</p>	<p>1. Undesirable regulation of guideplate.</p>	<p>1. Make guide plate parallel. 2. Increase tilt angle of grindingwheel. 3. Reduce swivel angle of regulating wheel on dressing device .</p>
<p>Fail to get real straightness</p>	<p>1. More deformation before grinding. 2. Excessive grinding volume in the first grinding. 3. Insufficient grinding volume.</p>	

Property of Kent Industrial USA
 Do Not Reproduce

9.7 Spare parts

➤ JHC-12S series

LOCATION		NAME	SPECIFICATI ON	Q'TY	REMARK
Grinding wheel	End cover alloy bearing seat	Oil seal	TC45、62、9	1	
		O ring	G35	1	
		O ring	G55	1	
	Spindle front cover	Oil seal	TC75、95、	1	
		O ring	G65	2	
	Spindle rear coveredr	Oil seal	TC60、75、9	1	
		O ring	G50	2	
	Center rest	Thrust bearing	51111	2	
Oil lens	O ring	G45	1		
Regulating wheel	End cover alloy bearing seat	Oil seal	TC45、62、9	1	
		O ring	G35	2	
		O ring	G55	1	
	Front bearing external nut	Oil seal	TC70、88、	1	
		O ring	G60	2	
		O ring	G95	1	
	Rear bearing external nut	O ring	G85	1	
		O ring	G95	1	
	Thrust bearing seat	Thrust bearing	51107	2	
	Rear cover	Oil seal	TC40、50、8	1	
		O ring	G85	1	
	Oil lens	O ring	G45	1	

Regulating wheel feed mechanism	Feed bearing seat	Thrust bearing	51106	2	
Worktable feed mechanism	Feed bearing seat	Thrust bearing	51107	2	
	Micro adjust feed bearing seat	Ball screw bearing	6006Z	1	
		Automatic alignment bearings	1206	1	
Dressing cylinder	Cylinder cover	O ring	P45	2	
		O ring	P14	2	
	Piston	O ring	P32	2	
Oil supply system	Filter	O ring	4033	1	
		O ring	P105	1	
		Filter net	1/2"	1	
	Oil tank	Filter net	3/4"	1	
	Hydraulic pressureswitch valve	O ring	P21	1	
		O ring	P10A	1	

➤ JHC-18S、18AS、18BS、20S series

LOCATION		NAME	SPECIFICATION	Q'TY	REMARK
Grinding wheel	End cover alloy bearing seat	Oil seal	TC65、95、14	1	
		O ring	G55	2	
		O ring	G80	1	
	Spindle front cover	Oil seal	TC105、135、14	1	
		O ring	G95	2	
	Spindle rear cover	Oil seal	TC80、105、13	1	
		O ring	G70	2	
	Center rest	Thrust bearing	51117	2	
	Oil lens	O ring	G45	1	
Regulating wheel	End cover alloy bearing seat	Oil seal	TC50、72、12	1	
		O ring	G40	2	
		O ring	G65	1	
	Front bearing external nut	Oil seal	TC85、110、13	1	
		O ring	G120	1	
		O ring	G75	2	
	Spindle rear cover	Oil seal	TC50、62、7	1	
		O ring	G115	1	
	Rear bearing external nut	O ring	G115	2	
	Thrust bearing seat	Thrust bearing	51109	2	
	Oil lens	O ring	G80	1	
		O ring		1	

Regulating wheel spindle mechanism	Feed bearing seat	Thrust bearing	51106	2	
	Micro feed bearing seat	Thrust bearing	51106	2	
Worktable feeding mechanism	Feed bearing seat	Thrust bearing	51109	2	
	Micro feed bearing seat	Thrust bearing	51107	2	
Dressing cylinder	Feed bearing seat	O ring	P65A	2	
		O ring	P20	2	
	Piston	O ring	P48A	2	
Oil supply system	Filter can	O ring	4033	1	
		O ring	P105	1	
		Filter	1/2"	1	
	Oil tank	Filter	3/4"	1	
	Hydraulic switch valve	O ring	P21	1	
		O ring	P10A	1	

9.8 Size List of Grinding Wheel and Regulating Wheel

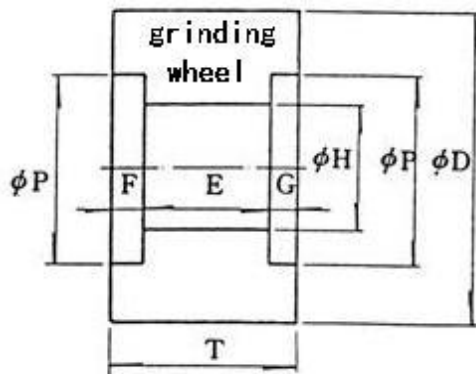

unit : MM

	ϕD	T	ϕH	F	G	P	E
JHC-12 series	305	150	120	25	25	175	100
JHC-18 series	455	205	228.6	25	25	295	155
JHC-18A series	455	255	228.6	50	50	295	155
JHC-18B series	455	305	228.6	50	50	295	205
JHC-20 series	510	205	254	25	25	320	155

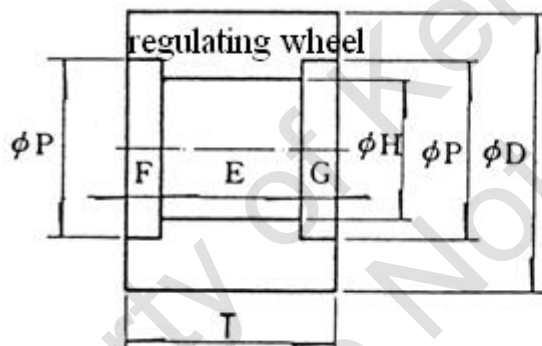

unit : MM

	ϕD	T	ϕH	F	G	P	E
JHC-12 series	205	150	90	25	25	130	100
JHC-18 series	255	205	111.2	75	20	170	110
JHC-18A series	255	255	111.2	100	45	170	110
JHC-18B series	255	305	111.2	100	65	170	140
JHC-20 series	305	205	127	75	20	190	110