

# QFX5120 Switch Hardware Guide

Published  
2024-04-12

Juniper Networks, Inc.  
1133 Innovation Way  
Sunnyvale, California 94089  
USA  
408-745-2000  
www.juniper.net

Juniper Networks, the Juniper Networks logo, Juniper, and Junos are registered trademarks of Juniper Networks, Inc. in the United States and other countries. All other trademarks, service marks, registered marks, or registered service marks are the property of their respective owners.

Juniper Networks assumes no responsibility for any inaccuracies in this document. Juniper Networks reserves the right to change, modify, transfer, or otherwise revise this publication without notice.

*QFX5120 Switch Hardware Guide*

Copyright © 2024 Juniper Networks, Inc. All rights reserved.

The information in this document is current as of the date on the title page.

## YEAR 2000 NOTICE

Juniper Networks hardware and software products are Year 2000 compliant. Junos OS has no known time-related limitations through the year 2038. However, the NTP application is known to have some difficulty in the year 2036.

## END USER LICENSE AGREEMENT

The Juniper Networks product that is the subject of this technical documentation consists of (or is intended for use with) Juniper Networks software. Use of such software is subject to the terms and conditions of the End User License Agreement ("EULA") posted at <https://support.juniper.net/support/eula/>. By downloading, installing or using such software, you agree to the terms and conditions of that EULA.

# Table of Contents

[About This Guide | ix](#)

1

## Overview

[QFX5120 System Overview | 2](#)

[QFX5120 Switches Hardware Overview | 2](#)

[QFX5120 Switch Models and Variants | 17](#)

[QFX5120 Switch Hardware and CLI Terminology Mapping | 21](#)

[QFX5120 Chassis | 27](#)

[Chassis Physical Specifications for QFX5120 Switches | 27](#)

[Field-Replaceable Units in QFX5120 Switches | 28](#)

[Chassis Status LEDs in QFX5120 Switches | 29](#)

[LEDs on the Management Port on QFX5120 Switches | 33](#)

[Network Port LEDs on QFX5120 Switches | 36](#)

[QFX5120 Cooling System | 44](#)

[QFX5120 Power System | 58](#)

[AC Power Supply in QFX5120 Switches | 58](#)

[Power Supply Specifications for AC Power Supplies for QFX5120 Switches | 63](#)

[Specifications of the Power Cord for AC Power Supplies for QFX5120 Switches | 66](#)

[LEDs on the AC Power Supplies Used in QFX5120 Switches | 68](#)

[DC Power Supply in QFX5120 Switches | 71](#)

[Power Supply Specifications for DC Power Supplies for QFX5120 Switches | 78](#)

[LEDs on the DC Power Supplies Used in QFX5120 Switches | 80](#)

[High-Voltage Power Supply for QFX5120-48T Switches | 83](#)

2

## Site Planning, Preparation, and Specifications

[Site Preparation Checklist for QFX5120 Switches | 95](#)

## QFX5120 Site Guidelines and Requirements | 97

- Environmental Requirements and Specifications for QFX5120 Switches | 97
- General Site Guidelines | 98
- Site Electrical Wiring Guidelines | 99
- Rack Requirements for QFX5120 Switches | 100
- Cabinet Requirements for QFX5120 Switches | 101
- Clearance Requirements for Airflow and Hardware Maintenance for QFX5120 Switches | 103

## QFX5120 Network Cable and Transceiver Planning | 106

- Pluggable Transceivers and Direct Attach Cables Supported on QFX5120 Switches | 106
- Cable Specifications for QSFP+ and QSFP28 Transceivers on QFX5120 Switches | 107
- How to Calculate the Fiber-Optic Cable Power Budget for QFX Series Switches | 109
- How to Calculate the Fiber-Optic Cable Power Margin for QFX Series Switches | 110

## QFX5120 Management Cable Specifications and Pinouts | 112

- Console Port Connector Pinout Information | 112
- RJ-45 Management Port Connector Pinout Information | 113
- RJ-45 to DB-9 Serial Port Adapter Pinout Information | 114
- RJ-45 Port, SFP Port, SFP+ Port, QSFP+ Port, and QSFP28 Port Connector Pinout Information | 115

# 3

## Initial Installation and Configuration

### Unpack and Mount the QFX5120 Switch | 123

- Unpack the QFX5120 Switch | 123
- Parts Inventory (Packing List) for a QFX5120 Switch | 124
- Register Products—Mandatory to Validate SLAs | 127
- Mount a QFX5120-32C Switch on a Four-Post Rack | 127
  - Mount a QFX5120-32C Switch on a Two-Post Rack | 130
- Mount a QFX5120-48T, QFX5120-48Y, or QFX5120-48YM Switch in a Rack or Cabinet by Using the JNP-4PST-RMK-1U-E Rack Mount Kit | 133
  - Mount the Device by Using the JNP-4PST-RMK-1U-E Rack Mount Kit On a Square Hole Rack | 134

Mount the Device by Using the JNP-4PST-RMK-1U-E Rack Mount Kit On a Threaded Hole Rack | **138**

Mount a QFX5120-48T, QFX5120-48Y, or QFX5120-48YM Switch Flush with the Front Posts of a Rack or Cabinet | **144**

Mount a QFX5120-48T, QFX5120-48Y, or QFX5120-48YM Switch in a Recessed Position from the Front Posts of a Rack or Cabinet | **149**

Mount a QFX5120-48Y Switch on a Two-Post Rack | **156**

Mount a QFX5120-T Switch on a Two-Post Rack | **158**

Mount a QFX5120-48YM Switch on a Two-Post Rack | **160**

### **Connect the QFX5120 to Power | 163**

Connect the QFX5120 Switch to Earth Ground | **163**

Connect Power to an AC-Powered QFX5120 Switch | **168**

Connect Power to a DC-Powered QFX5120 Switch | **171**

Connect Power to a QFX5120-48T Switch Powered by a High-Voltage Power Supply | **177**

### **Connect the QFX5120 to the Network | 179**

Install a Transceiver | **179**

Install a QSFP28 Transceiver | **182**

Connect a Fiber-Optic Cable | **184**

### **Connect the QFX5120 to External Devices | 185**

Connect a Device to a Network for Out-of-Band Management | **186**

Connect a Device to a Management Console Using an RJ-45 Connector | **186**

Connecting 1-PPS and 10-MHz Measurement Devices to the QFX5120 Switch | **188**

### **Configure Junos OS on the QFX5120 | 189**

QFX5120 Default Configuration | **189**

Connect and Configure a QFX5120 Switch | **190**

## **Maintaining Components**

### **Maintain the QFX5120 Cooling System | 197**

Remove a Fan Module from a QFX5120 Switch | **197**

Install a Fan Module in a QFX5120 Switch | 199

## Maintain the QFX5120 Power System | 201

Remove a Power Supply from a QFX5120 Switch | 202

Install a Power Supply in a QFX5120 Switch | 205

## Maintain Transceivers | 208

Remove a Transceiver | 209

Remove a QSFP28 Transceiver | 211

Install a Transceiver | 213

Install a QSFP28 Transceiver | 216

## Maintain Fiber-Optic Cables | 218

Connect a Fiber-Optic Cable | 219

Disconnect a Fiber-Optic Cable | 220

How to Handle Fiber-Optic Cables | 220

## 5

## Troubleshooting Hardware

### Troubleshoot the QFX5120 Device | 223

Alarm Types and Severity Levels | 223

Chassis Alarm Messages | 225

Creating an Emergency Boot Device for QFX Series Switches | 229

Recovering the Installation Using an Emergency Boot Device on QFX Series Switches | 231

## 6

## Contacting Customer Support and Returning the Chassis or Components

### Return a QFX5120 Chassis or Components | 235

How to Return a QFX5120 Switch or Component for Repair or Replacement | 235

Locate the Serial Number on a QFX5120 Switch or Component | 236

List the Switch and Components Details with the CLI | 236

Locate the Chassis Serial Number ID Label on a QFX5120 Switch | 237

Locate the Serial Number ID Labels on FRUs in a QFX5120 Switch | 238

Contact Customer Support to Obtain a Return Material Authorization | 246

Pack a QFX5120 Switch or Component for Shipping | 247

Pack a QFX5120 Switch for Shipping | 247

Pack QFX5120 Switch Components for Shipping | 248

## **Safety and Compliance Information**

**General Safety Guidelines and Warnings | 252**

**Definitions of Safety Warning Levels | 253**

**Qualified Personnel Warning | 255**

**Warning Statement for Norway and Sweden | 255**

**Fire Safety Requirements | 256**

**Installation Instructions Warning | 257**

**Chassis and Component Lifting Guidelines | 258**

**Restricted Access Warning | 258**

**Ramp Warning | 260**

**Rack-Mounting and Cabinet-Mounting Warnings | 260**

**Grounded Equipment Warning | 264**

**Radiation from Open Port Apertures Warning | 265**

**Laser and LED Safety Guidelines and Warnings | 266**

**Maintenance and Operational Safety Guidelines and Warnings | 269**

**General Electrical Safety Guidelines and Warnings | 275**

**Action to Take After an Electrical Accident | 276**

**Prevention of Electrostatic Discharge Damage | 277**

**AC Power Electrical Safety Guidelines | 278**

**AC Power Disconnection Warning | 279**

**DC Power Electrical Safety Guidelines | 280**

**DC Power Disconnection Warning | 281**

**DC Power Grounding Requirements and Warning | 283**

DC Power Wiring Sequence Warning | 283

DC Power Wiring Terminations Warning | 285

Multiple Power Supplies Disconnection Warning | 286

TN Power Warning | 287

Agency Approvals for QFX5120 Switches | 288

Compliance Statements for EMC Requirements for the QFX Series | 290

Restriction of Hazardous Substances (RoHS) Directive Compliance | 294



# About This Guide

Use this guide to install hardware and perform initial software configuration, routine maintenance, and troubleshooting for the QFX5120 switch. After completing the installation and basic configuration procedures covered in this guide, refer to the Junos OS documentation for information about further software configuration.

# 1

CHAPTER

## Overview

---

[QFX5120 System Overview | 2](#)

[QFX5120 Chassis | 27](#)

[QFX5120 Cooling System | 44](#)

[QFX5120 Power System | 58](#)

---

# QFX5120 System Overview

## IN THIS SECTION

- [QFX5120 Switches Hardware Overview | 2](#)
- [QFX5120 Switch Models and Variants | 17](#)
- [QFX5120 Switch Hardware and CLI Terminology Mapping | 21](#)

## QFX5120 Switches Hardware Overview

### IN THIS SECTION

- [Benefits of the QFX5120 Switch | 3](#)
- [System Software and Hardware and Software Features | 3](#)
- [Channelization in QFX5120 Switches | 4](#)
- [Components on the Front and Rear Panels | 6](#)
- [Virtual Chassis | 16](#)
- [QFX5120 Cooling System | 16](#)
- [QFX5120 Power System | 17](#)

The QFX5120 line of switches delivers low latency, flexible deployment options, and rich automation features. QFX5120 Switches build a strong underlay foundation for flexible, high-performance, standards-based fabrics and routing that improve network reliability and agility.

The QFX5120 switch is available in four models—QFX5120-32C, QFX5120-48T, QFX5120-48Y, and QFX5120-48YM. Each model is available in two variants featuring AC power supplies with front-to-back or back-to-front airflow and two models featuring DC power supplies with front-to-back or back-to-front airflow.

For a brief overview of the QFX5120-48T switch, see:



Video: [QFX5120-48T Switch Hardware Overview](#)

For a brief overview of the QFX5120-48Y switch, see:



Video: [QFX5120-48Y Switch Hardware Overview](#)

For a brief overview of the QFX5120-48YM switch, see:



Video: [QFX5120-48YM Switch Hardware Overview](#)

## Benefits of the QFX5120 Switch

EVPN-VXLAN architecture - QFX5120 Switches support IP fabrics with EVPN-VXLAN overlays, enabling Layer 2/3 network virtualization.

Hop-by-hop encryption - QFX5120-48YM supports IEEE 802.1AE MACsec AES-256 on all ports to help secure data center and Ethernet-based DCI/WAN deployments.

Synchronization services – Support for PTP enables QFX5120 to meet the requirements of the financial services industry (FSI) and the broadcasting media industry.

Industry-leading wire speeds—QFX5120 switches offer 25-Gbps and 100-Gbps wire speeds.

Support for channelization—You can channelize the QSFP28 ports and increase the number of interfaces.

Support for Virtual Chassis—All QFX5120 switch models support Virtual Chassis technology. You can interconnect up to two QFX5120-32C, QFX5120-48T, or QFX5120-48Y, or up to four QFX5120-48YM switches in a Virtual Chassis configuration.

## System Software and Hardware and Software Features

Juniper Networks QFX Series Switches run Junos operating system (Junos OS), which provides Layer 2 and Layer 3 switching, routing, and security services. The first Junos OS release and hardware and software features supported on the models are listed in [Table 1 on page 4](#).

**Table 1: First Junos OS Release and Hardware and Software Features Supported on QFX5120 Switch Models**

Switch Model	First Junos OS Release Supported	Hardware Features	Aggregate Throughput (Bidirectional)	Software Features
QFX5120 - 32C	Junos OS Release 19.1R1	<ul style="list-style-type: none"> <li>• 2.2-GHz quad-core Intel CPU</li> <li>• 16-GB memory</li> <li>• 64-GB SSD storage</li> </ul>	6.4 Tbps	<ul style="list-style-type: none"> <li>• Feature-rich automation capabilities with support for Python, Ansible, YANG, Chef, and zero-touch provisioning (ZTP)</li> </ul>
QFX5120 - 48T	Junos OS Release 20.2R1	<ul style="list-style-type: none"> <li>• 2.2-GHz quad-core Intel CPU</li> <li>• 16-GB memory</li> <li>• 100-GB SSD storage</li> </ul>	2.16 Tbps	<ul style="list-style-type: none"> <li>• Support for VXLAN as a Layer 2 or Layer 3 gateway and Open vSwitch Database (OVSDB) protocol as a Layer 2 gateway</li> </ul>
QFX5120 - 48Y	Junos OS Release 18.3R1	<ul style="list-style-type: none"> <li>• 2.2-GHz quad-core Intel CPU</li> <li>• 16-GB memory</li> <li>• 50-GB SSD storage</li> </ul>	4 Tbps	<ul style="list-style-type: none"> <li>• Advanced Junos OS features such as EVPN, BGP, MPLS, Layer 3 VPN, IPv6 Provider Edge (6PE), telemetry, segment routing, and MC-LAG</li> </ul>
QFX5120 - 48YM	Junos OS Release 20.4R1	<ul style="list-style-type: none"> <li>• 2.9-GHz quad-core Intel CPU</li> <li>• 16-GB memory</li> <li>• 100-GB SSD storage</li> </ul>	4 Tbps	

## Channelization in QFX5120 Switches

QFX5120 switches support channelization. You can channelize the 100GbE/40GbE quad small form-factor pluggable (QSFP28) ports into interfaces by connecting breakout cables and by using CLI configuration. [Table 2 on page 5](#) lists the channelization supported on the models.

Table 2: Channelization in QFX5120 Switches

Switch Model	Ports	Port Speed	Supported Channelization	For More Information
QFX5120-32C	0 through 30	40 Gbps	Four 10GbE interfaces	<i>Channelizing Interfaces on QFX5120-32C Switches</i>
	0 through 30	100 Gbps	Four 25GbE interfaces	
	0 through 31 <b>NOTE:</b> The last 100GbE port (31) does not support 4x10GbE or 4x25GbE channelization options since the lanes are shared with the 10GbE SFP port. This port supports only 100GbE/40GbE and 2x50GbE channelization options.	100 Gbps	Two 50GbE interfaces	
QFX5120-48T	50 and 51	40 Gbps	Four 10GbE interfaces	<i>Channelizing Interfaces on QFX5120-48T Switches</i>
	50 and 51	100 Gbps	Four 25GbE interfaces	
	48 through 53	100 Gbps	Two 50GbE interfaces	
QFX5120-48Y	48 through 55	40 Gbps	Four 10GbE interfaces	<i>Channelizing Interfaces on QFX5120-48Y Switches</i>
	48 through 55	100 Gbps	Four 25GbE interfaces	

**Table 2: Channelization in QFX5120 Switches (Continued)**

Switch Model	Ports	Port Speed	Supported Channelization	For More Information
QFX5120-48YM	50 and 52	40 Gbps	Four 10GbE interfaces	<i>Channelizing Interfaces on QFX5120-48YM Switches</i>
	50 and 52	100 Gbps	Four 25GbE interfaces	
	50 and 52	100 Gbps	Two 50GbE interfaces	

## Components on the Front and Rear Panels

### QFX5120-32C Switches

Figure 1 on page 6 shows the front view of the QFX5120-32C switch.

**Figure 1: QFX5120-32C—Front View**



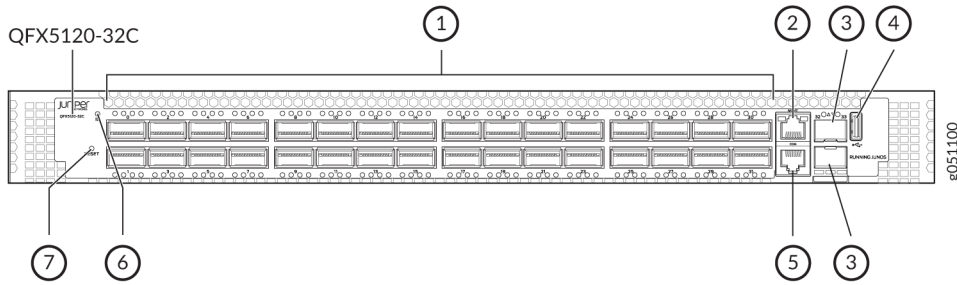
Figure 2 on page 6 shows the rear view of the QFX5120-32C switch.

**Figure 2: QFX5120-32C—Rear View**



Figure 3 on page 7 shows the components on the front panel of a QFX5120-32C switch.

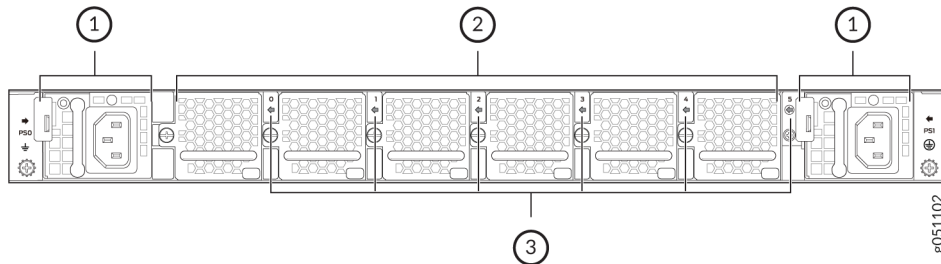
**Figure 3: Components on the Front Panel of a QFX5120-32C Switch**



1– QSFP28 ports	5– RJ-45 console port (labeled <b>CON</b> )
2– RJ-45 management port (labeled <b>MGMT</b> )	6– Chassis ID LED (labeled <b>ID</b> )
3– SFP+ ports	7– Reset button
4– USB port	

Figure 4 on page 7 shows the components on the rear panel of a QFX5120-32C switch with AC power supplies.

**Figure 4: Components on the Rear Panel of a QFX5120-32C Switch with AC Power Supplies**

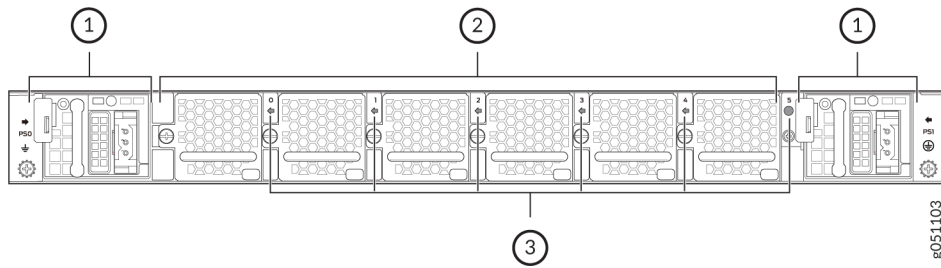


1– AC power supply	3– Fan module LEDs
2– Fan modules	

Figure 5 on page 8 shows the components on the rear panel of a QFX5120-32C switch with DC power supplies.



**Figure 5: Components on the Rear Panel of a QFX5120-32C Switch with DC Power Supplies**



1– DC power supply

3– Fan module LEDs

2– Fan modules

### QFX5120-48T Switches

[Figure 6 on page 8](#) shows the front view of the QFX5120-48T switch.

**Figure 6: QFX5120-48T—Front View**



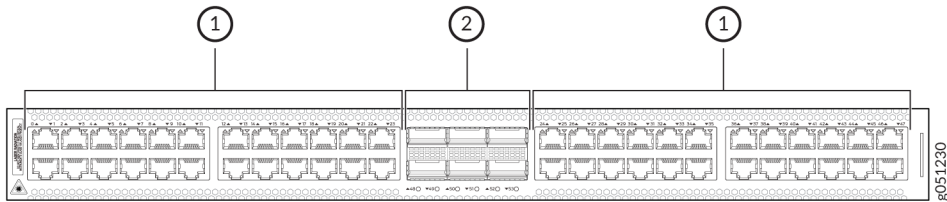
[Figure 7 on page 8](#) shows the rear view of the QFX5120-48T switch.

**Figure 7: QFX5120-48T—Rear View**



[Figure 8 on page 9](#) shows the components on the front panel of a QFX5120-48T switch.

Figure 8: Components on the Front Panel of a QFX5120-48T Switch

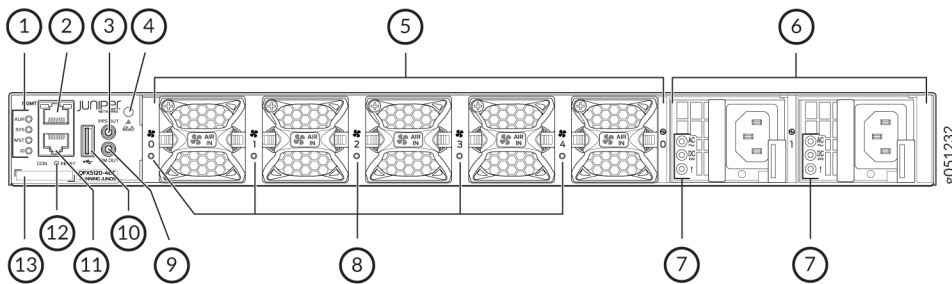


1– 10-Gbps BASE-T ports

2– 100GbE/40GbE QSFP28 ports

Figure 9 on page 9 shows the components on the rear panel of a QFX5120-48T switch with AC power supplies.

Figure 9: Components on the Rear Panel of a QFX5120-48T Switch with AC Power Supplies



1– Chassis status LEDs (labeled **ALM**, **SYS**, **MST**, and **ID**)

8– Fan module LEDs

2– RJ-45 management port (labeled **MGMT**)

9– **10M OUT** port

3– **PPS OUT** port

10– USB port

4– ESD point

11– RJ-45 console port (labeled **CON**)

5– Fan modules

12– Reset button

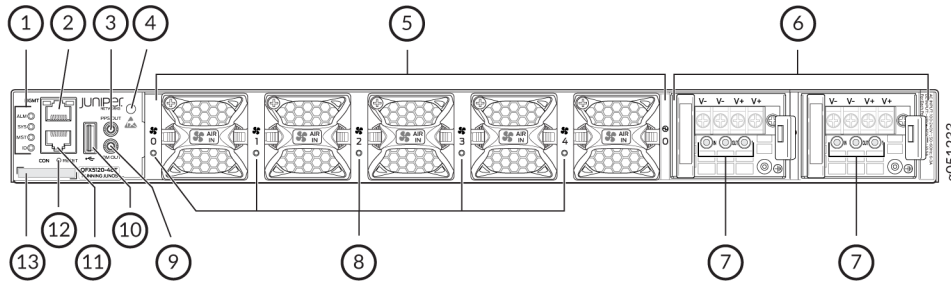
6– AC power supplies

13– CLEI code label

7– AC power supply LEDs

Figure 10 on page 10 shows the components on the rear panel of a QFX5120-48T switch with DC power supplies.

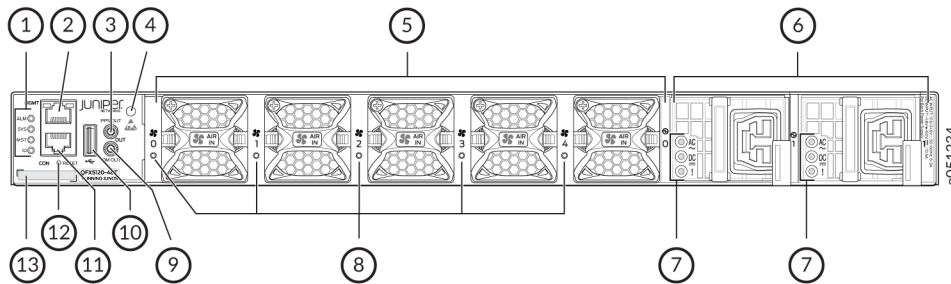
Figure 10: Components on the Rear Panel of a QFX5120-48T Switch with DC Power Supplies



1– Chassis status LEDs (labeled <b>ALM</b> , <b>SYS</b> , <b>MST</b> , and <b>ID</b> )	8– Fan module LEDs
2– RJ-45 management port	9– <b>10M OUT</b> port
3– <b>PPS OUT</b> port	10– USB port
4– ESD point	11– RJ-45 console port
5– Fan modules	12– Reset button
6– DC power supplies	13– CLEI code label
7– DC power supply LEDs	

Figure 11 on page 10 shows the components on the rear panel of a QFX5120-48T switch with high-voltage power supplies.

Figure 11: Components on the Rear Panel of a QFX5120-48T Switch with High-Voltage Power Supplies



1– Chassis status LEDs (labeled <b>ALM</b> , <b>SYS</b> , <b>MST</b> , and <b>ID</b> )	8– Fan module LEDs
2– RJ-45 management port	9– <b>10M OUT</b> port
3– <b>PPS OUT</b> port	10– USB port
4– ESD point	11– RJ-45 console port
5– Fan modules	12– Reset button

6– High-voltage power supplies	13– CLEI code label
7– High-voltage power supply LEDs	

**QFX5120-48Y Switches**

Figure 12 on page 11 shows the front view of the QFX5120-48Y switch.

**Figure 12: QFX5120-48Y—Front View**



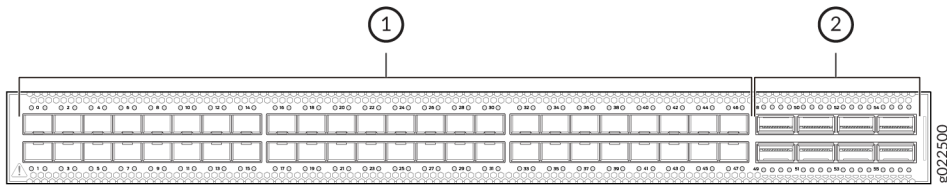
Figure 13 on page 11 shows the rear view of the QFX5120-48Y switch.

**Figure 13: QFX5120-48Y—Rear View**



Figure 14 on page 11 shows the components on the front panel of a QFX5120-48Y switch.

**Figure 14: Components on the Front Panel of a QFX5120-48Y Switch**



1– SFP28 ports	2– QSFP28 ports
----------------	-----------------

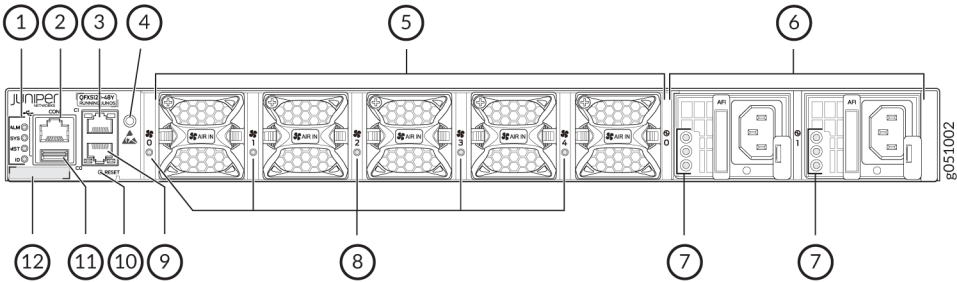
**NOTE:**

- The SFP28 ports are grouped in quads (groups of four) and you can configure the speed of the ports only in quads; you cannot configure the speed for a single SFP28 port.
- The SFP28 ports can operate at 25-Gbps, 10-Gbps, or 1-Gbps speed, based on the configuration set at the quad level. The ports are configured to operate at 10-Gbps speed by default. If you need the ports to support the other speeds, you must configure those speeds.

**CAUTION:** When you use the latest OEM part number FCLF8521P2BTL (printed on the transceiver label), you can install 1GbE transceivers (such as QFX-SFP-1GE-T) in any port with no restrictions. The same applies for devices that support 10GbE copper transceivers. However, if you are using the older OEM part number SP7041-M1-JN (not shipped in last 3+ years) instead, do not install 1GbE copper transceivers (such as QFX-SFP-1GE-T) directly above or below another 1GbE copper transceiver. Use only the top row or bottom row to avoid damage to the device caused when the transceivers are installed above or below each other.

Figure 15 on page 12 shows the components on the rear panel of a QFX5120-48Y switch with AC power supplies.

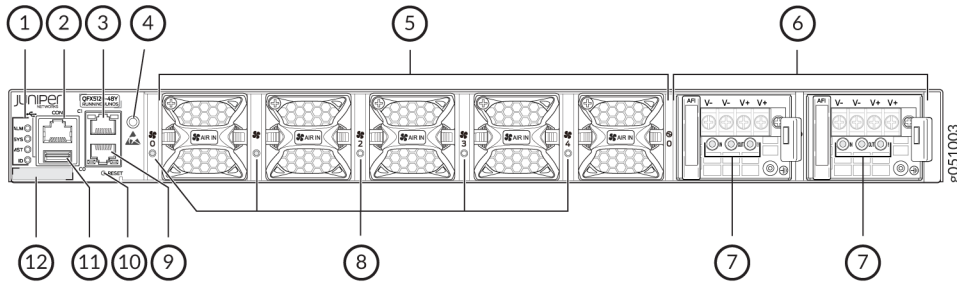
Figure 15: Components on the Rear Panel of a QFX5120-48Y Switch with AC Power Supplies



1– Chassis status LEDs	7– Power supply LEDs
2– RJ-45 console port	8– Fan module LEDs
3– RJ-45 management port (labeled <b>C1</b> )	9– RJ-45 management port (labeled <b>C0</b> )
4– ESD point	10– Reset button
5– Fan modules	11– USB port
6– Power supplies	12– CLEI code label

Figure 16 on page 13 shows the components on the rear panel of a QFX5120-48Y switch with DC power supplies.

Figure 16: Components on the Rear Panel of a QFX5120-48Y Switch with DC Power Supplies



1– Chassis status LEDs	7– Power supply LEDs
2– RJ-45 console port	8– Fan module LEDs
3– RJ-45 management port (labeled <b>C1</b> )	9– RJ-45 management port (labeled <b>C0</b> )
4– ESD point	10– Reset button
5– Fan modules	11– USB port
6– Power supplies	12– CLEI code label

### QFX5120-48YM Switches

Figure 17 on page 13 shows the front view of the QFX5120-48YM switch.

Figure 17: QFX5120-48YM—Front View



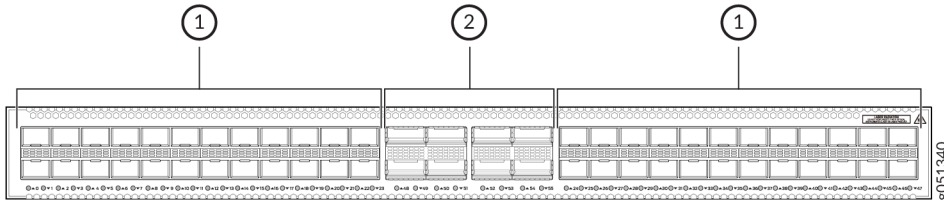
Figure 18 on page 13 shows the rear view of the QFX5120-48YM switch.

Figure 18: QFX5120-48YM—Rear View



Figure 19 on page 14 shows the components on the front panel of a QFX5120-48YM switch.

Figure 19: Components on the Front Panel of a QFX5120-48YM Switch



1– SFP28 ports

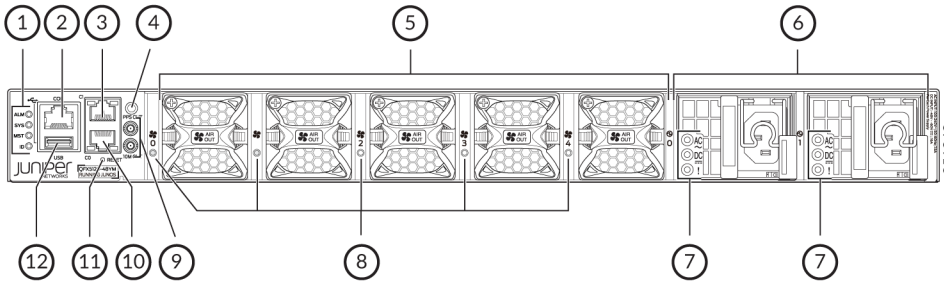
2– QSFP28 ports

**NOTE:**

- The SFP28 ports are grouped in quads (groups of four) and you can configure the speed of the ports only in quads; you cannot configure the speed for a single SFP28 port.
- The SFP28 ports can operate at 25-Gbps, 10-Gbps, or 1-Gbps speed, based on the configuration set at the quad level. The ports are configured to operate at 10-Gbps speed by default. If you need the ports to support the other speeds, you must configure those speeds.

Figure 20 on page 14 shows the components on the rear panel of a QFX5120-48YM switch with AC power supplies.

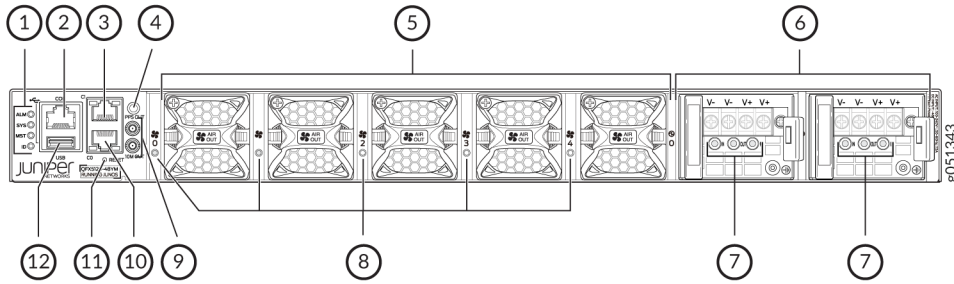
Figure 20: Components on the Rear Panel of a QFX5120-48YM Switch with AC Power Supplies



1– Chassis status LEDs (labeled <b>ALM</b> , <b>SYS</b> , <b>MST</b> , and <b>ID</b> )	7– Power supply LEDs
2– RJ-45 console port	8– Fan module LEDs
3– RJ-45 management port (labeled <b>C1</b> )	9– <b>10M OUT</b> and <b>PPS OUT</b> ports
4– ESD point	10– RJ-45 management port (labeled <b>C0</b> )
5– Fan modules	11– Reset button
6– Power supplies	12– USB port

Figure 21 on page 15 shows the components on the rear panel of a QFX5120-48YM switch with DC power supplies.

Figure 21: Components on the Rear Panel of a QFX5120-48YM Switch with DC Power Supplies

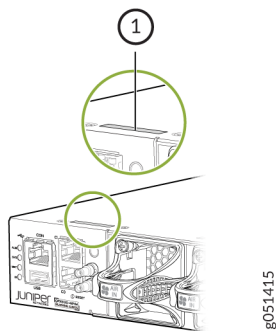


1– Chassis status LEDs (labeled <b>ALM</b> , <b>SYS</b> , <b>MST</b> , and <b>ID</b> )	7– Power supply LEDs
2– RJ-45 console port	8– Fan module LEDs
3– RJ-45 management port (labeled <b>C1</b> )	9– <b>10M OUT</b> and <b>PPS OUT</b> ports
4– ESD point	10– RJ-45 management port (labeled <b>C0</b> )
5– Fan modules	11– Reset button
6– Power supplies	12– USB port

The CLEI code label is on the top panel of QFX5120-48YM switches, above the management ports.

Figure 22 on page 15 shows the location of the CLEI code label.

Figure 22: Location of the CLEI Code Label on QFX5120-48YM Switches



1– CLEI code label



## Virtual Chassis

All QFX5120 switch models support Virtual Chassis technology. You can connect a QX5120 switch only with another QFX5120 switch of the same model in a Virtual Chassis configuration. QFX5120 switches do not have dedicated or default Virtual Chassis ports (VCPs). However, you can configure any of the QSFP28 ports as VCPs when those ports are not channelized. [Table 3 on page 16](#) lists the Junos OS release in which Virtual Chassis support is introduced and the QSFP28 ports that you can configure as VCPs.

**Table 3: Virtual Chassis Support in QFX5120 Switches**

Model	Support Introduced in Release	Maximum Number of Switches in the Virtual Chassis	Virtual Chassis Ports
QFX5120-32C	Junos OS Release 20.3R1	2	32 QSFP28 ports ( <b>0</b> through <b>31</b> )
QFX5120-48T	Junos OS Release 20.2R1	2	6 QSFP28 ports ( <b>48</b> through <b>53</b> )
QFX5120-48Y	Junos OS Release 19.3R1	2	8 QSFP28 ports ( <b>48</b> through <b>55</b> )
QFX5120-48Y M	Junos OS Release 23.1R1	4	8 QSFP28 ports ( <b>48</b> through <b>55</b> )

You configure, monitor, and maintain the QFX5120 Virtual Chassis the same way as you configure, monitor, and maintain a Virtual Chassis involving other QFX Series switches. See the following topics for more details on how to configure and change the members in a QFX5120 Virtual Chassis:

- *Understanding Virtual Chassis Components*
- *Removing or Replacing a Member Switch of a Virtual Chassis Configuration*
- *Adding a New Switch to an Existing EX4650 or QFX Series Virtual Chassis*
- *Virtual Chassis Fabric Overview*

## QFX5120 Cooling System

The cooling system in QFX5120 switches consists of fan modules and built-in fans in the power supplies. The airflow direction depends on the fan modules and power supplies installed in the switch. You can order a QFX5120 switch that supports front-to-back airflow (air enters through the front of the switch) or back-to-front airflow (air enters through the back of the switch).

The fan modules are hot-removable and hot-insertable field-replaceable units (FRUs) installed in the rear panel of the switch: You can remove and replace them without powering off the switch or disrupting switch functions.

## QFX5120 Power System

QFX5120-32C, QFX5120-48T, and QFX5120-48Y switches support two 650-W AC or DC power supplies with front-to-back or back-to-front airflow. Additionally, QFX5120-48T switches support two 850-W high-voltage power supplies with AC or DC input and front-to-back or back-to-front airflow. QFX5120-48YM switches support two 850-W AC or DC power supplies with front-to-back or back-to-front airflow. Power supplies for the QFX5120 switch are fully redundant, load-sharing, and hot-removable and hot-insertable FRUs when the second power supply is installed and running. You can remove and replace them without powering off the switch or disrupting switch functions. Each power supply is cooled by its own internal cooling system. We ship QFX5120 switches with two AC or DC power supplies preinstalled in the rear panel of the chassis.



**CAUTION:** Do not mix:

- AC and DC power supplies in the same chassis.
- 650-W and 850-W power supplies in the same QFX5120-48T chassis.
- Power supplies with different airflow directions in the same chassis.
- Fan modules with different airflow directions in the same chassis.
- Power supplies and fan modules with different airflow directions in the same chassis.

If you install power supplies or fan modules with different airflow directions, Junos OS raises an alarm.

## QFX5120 Switch Models and Variants

The QFX5120 has four models: QFX5120-32C, QFX5120-48T, QFX5120-48Y, and QFX5120-48YM. Each of these models has variants depending on power supply (AC or DC) and airflow (front-to-back or back-to-front). All variants of the QFX5120-32C switch ship with two power supplies and six fans installed by default. All variants of the QFX5120-48T, QFX5120-48Y, and QFX5120-48YM switches ship with two power supplies and five fans installed by default. [Table 4 on page 18](#) lists the components shipped with QFX5120 switch models and their variants.

Table 4: QFX5120 Switch Models and Their Configurations

Model Number	Number of Ports and Their Types	Power Supplies Shipped by Default	Fan Modules Shipped by Default
QFX5120-32C-AFO	<ul style="list-style-type: none"> <li>• 2 10GbE SFP+</li> <li>• 32 100GbE/40GbE QSFP28</li> </ul>	Two 650-W AC power supplies with front-to-back airflow, indicated by a red ejector lever.	Six fan modules with front-to-back airflow, indicated by the label <b>F2B</b> and a red handle.
QFX5120-32C-AFI	<ul style="list-style-type: none"> <li>• 2 10GbE SFP+</li> <li>• 32 100GbE/40GbE QSFP28</li> </ul>	Two 650-W AC power supplies with back-to-front airflow, indicated by a blue ejector lever.	Six fan modules with back-to-front airflow, indicated by the label <b>B2F</b> and a blue handle.
QFX5120-32C-DC-AFO	<ul style="list-style-type: none"> <li>• 2 10GbE SFP+</li> <li>• 32 100GbE/40GbE QSFP28</li> </ul>	Two 650-W DC power supplies with front-to-back airflow, indicated by a red ejector lever.	Six fan modules with front-to-back airflow, indicated by the label <b>F2B</b> and a red handle.
QFX5120-32C-DC-AFI	<ul style="list-style-type: none"> <li>• 2 10GbE SFP+</li> <li>• 32 100GbE/40GbE QSFP28</li> </ul>	Two 650-W DC power supplies with back-to-front airflow, indicated by a blue ejector lever.	Six fan modules with back-to-front airflow, indicated by the label <b>B2F</b> and a blue handle.
QFX5120-48T-AFO	<ul style="list-style-type: none"> <li>• 6 100GbE/40GbE QSFP28</li> <li>• 48 10GbE BASE-T</li> </ul>	Two 650-W AC power supplies with front-to-back airflow, indicated by a Juniper Gold ejector lever.	Five fan modules with front-to-back airflow, indicated by the label <b>AIR OUT</b> and a Juniper Gold handle.
QFX5120-48T-AFI	<ul style="list-style-type: none"> <li>• 6 100GbE/40GbE QSFP28</li> <li>• 48 10GbE BASE-T</li> </ul>	Two 650-W AC power supplies with back-to-front airflow, indicated by a Juniper Azure Blue ejector lever.	Five fan modules with back-to-front airflow, indicated by the label <b>AIR IN</b> and a Juniper Azure Blue handle.
QFX5120-48T-DC-AFO	<ul style="list-style-type: none"> <li>• 6 100GbE/40GbE QSFP28</li> <li>• 48 10GbE BASE-T</li> </ul>	Two 650-W DC power supplies with front-to-back airflow, indicated by a Juniper Gold ejector lever.	Five fan modules with front-to-back airflow, indicated by the label <b>AIR OUT</b> and a Juniper Gold handle.

Table 4: QFX5120 Switch Models and Their Configurations (Continued)

Model Number	Number of Ports and Their Types	Power Supplies Shipped by Default	Fan Modules Shipped by Default
QFX5120-48T-DC-AFI	<ul style="list-style-type: none"> <li>• 6 100GbE/40GbE QSFP28</li> <li>• 48 10GbE BASE-T</li> </ul>	Two 650-W DC power supplies with back-to-front airflow, indicated by a Juniper Azure Blue ejector lever.	Five fan modules with back-to-front airflow, indicated by the label <b>AIR IN</b> and a Juniper Azure Blue handle.
QFX5120-48Y-AFO2	<ul style="list-style-type: none"> <li>• 8 100GbE/40GbE QSFP28</li> <li>• 48 25GbE/10GbE/1GbE SFP28</li> </ul>	Two 650-W AC power supplies with front-to-back airflow, indicated by a Juniper Gold ejector lever.	Five fan modules with front-to-back airflow, indicated by the label <b>AIR OUT</b> and a Juniper Gold handle.
QFX5120-48Y-AFI2	<ul style="list-style-type: none"> <li>• 8 100GbE/40GbE QSFP28</li> <li>• 48 25GbE/10GbE/1GbE SFP28</li> </ul>	Two 650-W AC power supplies with back-to-front airflow, indicated by a Juniper Azure Blue ejector lever.	Five fan modules with back-to-front airflow, indicated by the label <b>AIR IN</b> and a Juniper Azure Blue handle.
QFX5120-48Y-DC-AFO2	<ul style="list-style-type: none"> <li>• 8 100GbE/40GbE QSFP28</li> <li>• 48 25GbE/10GbE/1GbE SFP28</li> </ul>	Two 650-W DC power supplies with front-to-back airflow, indicated by a Juniper Gold ejector lever.	Five fan modules with front-to-back airflow, indicated by the label <b>AIR OUT</b> and a Juniper Gold handle.
QFX5120-48Y-DC-AFI2	<ul style="list-style-type: none"> <li>• 8 100GbE/40GbE QSFP28</li> <li>• 48 25GbE/10GbE/1GbE SFP28</li> </ul>	Two 650-W DC power supplies with back-to-front airflow, indicated by a Juniper Azure Blue ejector lever.	Five fan modules with back-to-front airflow, indicated by the label <b>AIR IN</b> and a Juniper Azure Blue handle.

Table 4: QFX5120 Switch Models and Their Configurations (Continued)

Model Number	Number of Ports and Their Types	Power Supplies Shipped by Default	Fan Modules Shipped by Default
QFX5120-48YM-AFO	<ul style="list-style-type: none"> <li>• 8 100GbE/40GbE QSFP28 that support Media Access Control Security (MACsec)</li> <li>• 48 25GbE/10GbE/1GbE SFP28 that support MACsec</li> </ul>	Two 850-W AC power supplies with front-to-back airflow, indicated by a Juniper Gold ejector lever.	Five fan modules with front-to-back airflow, indicated by the label <b>AIR OUT</b> and a Juniper Gold handle.
QFX5120-48YM-AFI	<ul style="list-style-type: none"> <li>• 8 100GbE/40GbE QSFP28 that support MACsec</li> <li>• 48 25GbE/10GbE/1GbE SFP28 that support MACsec</li> </ul>	Two 850-W AC power supplies with back-to-front airflow, indicated by a Juniper Azure Blue ejector lever.	Five fan modules with back-to-front airflow, indicated by the label <b>AIR IN</b> and a Juniper Azure Blue handle.
QFX5120-48YM-DC-AO	<ul style="list-style-type: none"> <li>• 8 100GbE/40GbE QSFP28 that support MACsec</li> <li>• 48 25GbE/10GbE/1GbE SFP28 that support MACsec</li> </ul>	Two 850-W DC power supplies with front-to-back airflow, indicated by a Juniper Gold ejector lever.	Five fan modules with front-to-back airflow, indicated by the label <b>AIR OUT</b> and a Juniper Gold handle.
QFX5120-48YM-DC-AI	<ul style="list-style-type: none"> <li>• 8 100GbE/40GbE QSFP28 that support MACsec</li> <li>• 48 25GbE/10GbE/1GbE SFP28 that support MACsec</li> </ul>	Two 850-W DC power supplies with back-to-front airflow, indicated by a Juniper Azure Blue ejector lever.	Five fan modules with back-to-front airflow, indicated by the label <b>AIR IN</b> and a Juniper Azure Blue handle.



**CAUTION:** Do not mix:

- AC and DC power supplies in the same chassis.
- 650-W and 850-W power supplies in the same QFX5120-48T chassis.
- Power supplies with different airflow directions in the same chassis.
- Fan modules with different airflow directions in the same chassis.
- Power supplies and fan modules with different airflow directions in the same chassis.

## QFX5120 Switch Hardware and CLI Terminology Mapping

This topic describes the hardware terms used in QFX5120 switch documentation and the corresponding terms used in the Junos OS CLI (see [Table 5 on page 21](#)).

**Table 5: CLI Equivalents of Terms Used in the Documentation for QFX5120 Switches**

Hardware Item (CLI)	Description (CLI)	Value	Item in Documentation	Additional Information
Chassis	One of the following: <ul style="list-style-type: none"> <li>• QFX5120-32C</li> <li>• QFX5120-48T-CHAS</li> <li>• JNP48Y8C-CHAS</li> <li>• QFX5120-48YM-8C</li> </ul>	-	Switch chassis	<a href="#">"QFX5120 Switch Models and Variants" on page 17</a>

Table 5: CLI Equivalents of Terms Used in the Documentation for QFX5120 Switches (*Continued*)

Hardware Item (CLI)	Description (CLI)	Value	Item in Documentation	Additional Information
Routing Engine ( <i>n</i> )	<p>One of the following:</p> <ul style="list-style-type: none"> <li>RE-QFX5120-32C</li> <li>RE-QFX5120-48T-6C</li> <li>RE-QFX5120-48Y-8C</li> <li>RE-QFX5120-48YM-8C</li> </ul>	<ul style="list-style-type: none"> <li><i>n</i> is a value in the range 0 through 1 for a switch that is part of a Virtual Chassis.</li> <li>On a standalone switch, the default value is 0.</li> </ul>	Routing Engine	-
FPC ( <i>n</i> )	<p>Abbreviated name of the Flexible PIC Concentrator (FPC)</p> <p>One of the following:</p> <ul style="list-style-type: none"> <li>QFX5120-32C</li> <li>QFX5120-48T-CHAS</li> <li>JNP48Y8C-CHAS</li> <li>QFX5120-48YM-8C</li> </ul>	<ul style="list-style-type: none"> <li><i>n</i> is a value in the range 0 through 1 for a switch that is part of a Virtual Chassis.</li> <li>On a standalone switch, the default value is 0.</li> </ul>	In QFX5120, FPC refers to the switch itself.	<i>Understanding Interface Naming Conventions</i>
Xcvr ( <i>n</i> )	Abbreviated name of the transceiver	<i>n</i> is a value equivalent to the number of the port in which the transceiver is installed.	Optical transceivers	<a href="#">"QFX5120 Network Cable and Transceiver Planning" on page 106</a>

Table 5: CLI Equivalents of Terms Used in the Documentation for QFX5120 Switches (*Continued*)

Hardware Item (CLI)	Description (CLI)	Value	Item in Documentation	Additional Information
Fan tray (n)	QFX5120-32C		Fan module	<a href="#">"QFX5120 Cooling System" on page 44</a>
	One of the following:	<i>n</i> has a value 0 through 5, corresponding to the fan module slot number.		
	<ul style="list-style-type: none"> <li>QFX5120-32C Fan Tray <i>n</i>, Front to Back Airflow - AFO</li> <li>QFX5120-32C Fan Tray <i>n</i>, Back to Front Airflow - AFI</li> </ul>			
	QFX5120-48T			
	One of the following:	<i>n</i> has a value 0 through 4, corresponding to the fan module slot number.		
	<ul style="list-style-type: none"> <li>Fan-board Fan Tray <i>n</i>, Front to Back Airflow - AFO</li> <li>Fan-board Fan Tray <i>n</i>, Back to Front Airflow - AFI</li> </ul>			
QFX5120-48Y				
One of the following:	<i>n</i> has a value 0 through 4, corresponding to the fan module slot number.			
<ul style="list-style-type: none"> <li>fan-ctrl-<i>n</i>, Front to Back Airflow - AFO</li> <li>fan-ctrl-<i>n</i>, Back to Front Airflow - AFI</li> </ul>				
QFX5120-48YM				



Table 5: CLI Equivalents of Terms Used in the Documentation for QFX5120 Switches (*Continued*)

Hardware Item (CLI)	Description (CLI)	Value	Item in Documentation	Additional Information
	One of the following: <ul style="list-style-type: none"> <li>• Fan-board Fan Tray <i>n</i>, Front to Back Airflow - AFO</li> <li>• Fan-board Fan Tray <i>n</i>, Back to Front Airflow - AFI</li> </ul>	<i>n</i> has a value 0 through 4, corresponding to the fan module slot number.		
Power Supply (n)	QFX5120-32C One of the following: <ul style="list-style-type: none"> <li>• QFX520048Y -650W-AC -AFI</li> <li>• QFX520048Y -650W-AC -AFO</li> </ul>	<i>n</i> has a value 0 through 1, corresponding to the power supply slot number.	Power supply	<a href="#">"QFX5120 Power System" on page 58</a>

Table 5: CLI Equivalents of Terms Used in the Documentation for QFX5120 Switches (*Continued*)

Hardware Item (CLI)	Description (CLI)	Value	Item in Documentation	Additional Information
	<p>QFX5120-48T</p> <p>One of the following:</p> <ul style="list-style-type: none"> <li>• JPSU -650W-AC -AO</li> <li>• JPSU -650W-AC -AI</li> <li>• JPSU -850W-HV -AFO</li> <li>• JPSU -850W-HV -AFI</li> <li>• JPSU -650W-DC -AFO</li> <li>• JPSU -650W-DC -AFI</li> </ul>			

Table 5: CLI Equivalents of Terms Used in the Documentation for QFX5120 Switches (*Continued*)

Hardware Item (CLI)	Description (CLI)	Value	Item in Documentation	Additional Information
	QFX5120-48Y  One of the following: <ul style="list-style-type: none"> <li>• JPSU -650W-AC -AO</li> <li>• JPSU -650W-AC -AI</li> <li>• JPSU -650W-DC -AFO</li> <li>• JPSU -650W-DC -AFI</li> </ul>			
	QFX5120-48YM  One of the following: <ul style="list-style-type: none"> <li>• JPSU -850W-AC -AFO</li> <li>• JPSU -850W-AC -AFI</li> <li>• JPSU -850W-DC -AFO</li> <li>• JPSU -850W-DC -AFI</li> </ul>			



**CAUTION:** Do not mix:

- AC and DC power supplies in the same chassis.
- 650-W and 850-W power supplies in the same QFX5120-48T chassis.
- Power supplies with different airflow directions in the same chassis.
- Fan modules with different airflow directions in the same chassis.
- Fan modules and power supplies with different airflow directions in the same chassis.

## QFX5120 Chassis

### IN THIS SECTION

- [Chassis Physical Specifications for QFX5120 Switches | 27](#)
- [Field-Replaceable Units in QFX5120 Switches | 28](#)
- [Chassis Status LEDs in QFX5120 Switches | 29](#)
- [LEDs on the Management Port on QFX5120 Switches | 33](#)
- [Network Port LEDs on QFX5120 Switches | 36](#)

### Chassis Physical Specifications for QFX5120 Switches

The QFX5120 switch chassis is a rigid sheet-metal structure that houses all components of the switch. [Table 6 on page 28](#) shows the physical specifications of the QFX5120 switch models.

**Table 6: Physical Specifications of the QFX5120 Switch Models**

Model	Height	Width	Depth	Weight
QFX5120-32C	1.7 in. (4.33 cm)	17.26 in. (43.84 cm)	20.27 in. (51.5 cm) excluding fan and power supply handles	21.12 lb (9.58 kg) with two power supplies and fans installed
QFX5120-48T	1.72 in. (4.37 cm)	<ul style="list-style-type: none"> <li>17.36 in. (44.09 cm)</li> <li>The outer edges of the front-mounting brackets extend the width to 19 in. (48.2 cm)</li> </ul>	20.48 in. (52.02 cm) excluding fan and power supply handles	24.25 lb (11 kg) with two power supplies and fans installed
QFX5120-48Y	1.72 in. (4.37 cm)	<ul style="list-style-type: none"> <li>17.36 in. (44.09 cm)</li> <li>The outer edges of the front-mounting brackets extend the width to 19 in. (48.2 cm)</li> </ul>	20.48 in. (52.02 cm) excluding fan and power supply handles	23.7 lb (10.75 kg) with two power supplies and fans installed
QFX5120-48YM	1.72 in. (4.37 cm)	<ul style="list-style-type: none"> <li>17.36 in. (44.09 cm)</li> <li>The outer edges of the front-mounting brackets extend the width to 19 in. (48.2 cm)</li> </ul>	20.48 in. (52.02 cm) excluding fan and power supply handles	24.8 lb (11.25 kg) with two power supplies and fans installed

## Field-Replaceable Units in QFX5120 Switches

Field-replaceable units (FRUs) are components that you can replace at your site. The FRUs in QFX5120 switches are hot-removable and hot-insertable: You can remove and replace them without powering off the switch or disrupting switch functions. The QFX5120 switches have the following FRUs:

- Power supplies
- Fan modules

- Transceivers

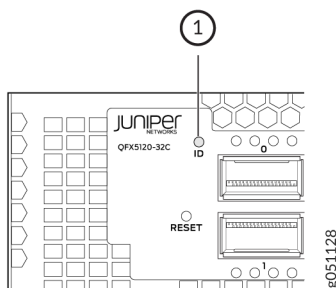
**NOTE:** Transceivers are not part of the shipping configuration. If you want to purchase any of these components, you must order them separately.

**NOTE:** If you have a Juniper J-Care service contract, register any addition, change, or upgrade of hardware components at <https://www.juniper.net/customers/support/tools/updateinstallbase/>. Failure to do so can result in significant delays if you need replacement parts. This note does not apply if you replace existing components with the same type of component.

## Chassis Status LEDs in QFX5120 Switches

The rear panel of QFX5120-32C switches has a chassis ID LED labeled **ID** (see [Figure 23 on page 29](#)).

**Figure 23: Chassis ID LED on a QFX5120-32C Switch**



1– Chassis ID LED (labeled **ID**)

[Table 7 on page 29](#) describes the chassis ID LED on QFX5120-32C switches, its color and states, and the status they indicate.

**Table 7: Chassis ID LED on QFX5120-32C Switches**

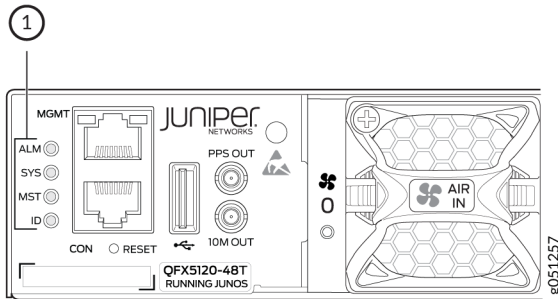
LED Label	Color	State and Description
<b>ID</b>	Amber	Blinking—The beacon feature is enabled on the switch.

**Table 7: Chassis ID LED on QFX5120-32C Switches (Continued)**

LED Label	Color	State and Description
	Unlit	The beacon feature is not enabled on the switch. You can enable the beacon feature by using the <code>request chassis beacon</code> command.

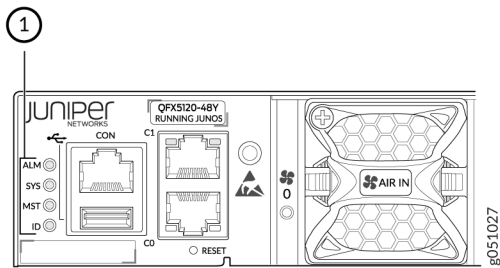
The rear panel of QFX5120-48T, QFX5120-48Y, and QFX5120-48YM switches has four chassis status LEDs labeled **ALM**, **SYS**, **MST**, and **ID** (see [Figure 24 on page 30](#), [Figure 25 on page 30](#), and [Figure 26 on page 31](#)).

**Figure 24: Chassis Status LEDs on QFX5120-48T Switches**



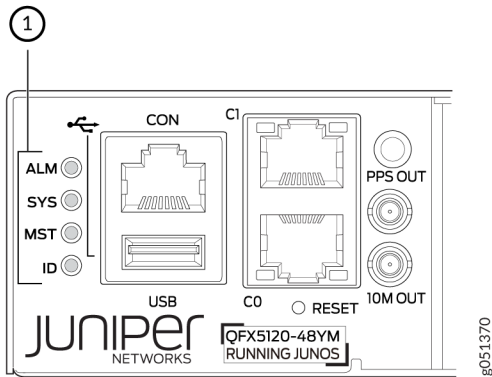
1– Chassis status LEDs (labeled **ALM**, **SYS**, **MST**, and **ID**)

**Figure 25: Chassis Status LEDs on QFX5120-48Y Switches**



1– Chassis status LEDs (labeled **ALM**, **SYS**, **MST**, and **ID**)

Figure 26: Chassis Status LEDs on QFX5120-48YM Switches



1– Chassis status LEDs (labeled **ALM**, **SYS**, **MST**, and **ID**)

Table 8 on page 31 describes the chassis status LEDs on QFX5120-48T, QFX5120-48Y, and QFX5120-48YM switches, their colors and states, and the status they indicate.

Table 8: Chassis Status LEDs on QFX5120-48T, QFX5120-48Y, and QFX5120-48YM Switches

LED Label	Color	State and Description
<b>ALM</b>	Red	There is a major hardware fault, such as a temperature alarm or a power failure alarm, and the switch is halted.  A major alarm indicates a critical error condition that requires immediate action. See Chassis Component Alarm Conditions on QFX5120 Switches.
	Amber	There is a minor alarm such as a software or a hardware error. Power off the switch and then power it on. Monitor the switch to see if it is working properly.  A minor alarm indicates a noncritical condition that requires monitoring or maintenance. A minor alarm that is left unchecked might cause interruption in service or performance degradation.
	Unlit	There is no alarm or the switch is halted.



**Table 8: Chassis Status LEDs on QFX5120-48T, QFX5120-48Y, and QFX5120-48YM Switches**  
*(Continued)*

LED Label	Color	State and Description
SYS	Green	On steadily—Junos OS for QFX Series switches is loaded on the switch.
		Blinking—The switch is a member in a QFX Series Virtual Chassis configuration.
	Unlit	The switch is powered off or is halted.
MST	Green	In a standalone QFX5120 switch: On steadily—The switch is functioning normally as the primary switch.
		In a Virtual Chassis configuration: <ul style="list-style-type: none"> <li>• On steadily—The switch is functioning normally and is the primary switch.</li> <li>• Blinking—The switch is functioning normally and is the backup.</li> </ul>
	Unlit	<ul style="list-style-type: none"> <li>• In a standalone QFX5120 switch: The switch is powered off or halted.</li> <li>• In a Virtual Chassis configuration: The switch is a linecard member.</li> </ul>
ID	Blue	Blinking—The beacon feature is enabled on the switch.
	Unlit	The beacon feature is not enabled on the switch. You can enable the beacon feature by using the <code>request chassis beacon</code> command.

## LEDs on the Management Port on QFX5120 Switches

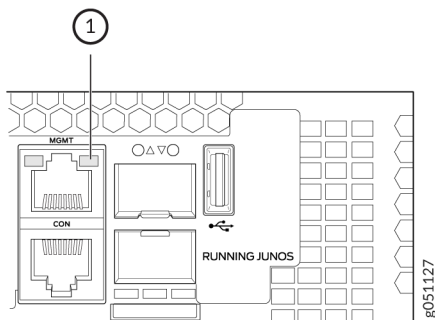
QFX5120-32C switches have one management port on the front panel. [Figure 27 on page 33](#) shows the location of the management port on the QFX5120-32C and the LED on the port. The LED indicates link activity of the port. [Table 9 on page 33](#) describes the LED on the management port on QFX5120-32C switches.

QFX5120-48T switches have one management port on the rear panel. [Figure 28 on page 34](#) shows the location of the management port on the QFX5120-48T and the LEDs on the port. The LEDs indicate link activity and status of the port. [Table 10 on page 35](#) describes the LEDs on the management port on QFX5120-48T switches.

QFX5120-48Y switches have two management ports on the rear panel. [Figure 29 on page 34](#) shows the location of the management ports on the QFX5120-48Y and the LEDs on the ports. The LEDs indicate link activity and status of the port. [Table 10 on page 35](#) describes the LEDs on the management ports on QFX5120-48Y switches.

QFX5120-48YM switches have two management ports on the rear panel. [Figure 30 on page 35](#) shows the location of the management ports on the QFX5120-48YM and the LEDs on the ports. The LEDs indicate link activity and status of the port. [Table 10 on page 35](#) describes the LEDs on the management ports on QFX5120-48YM switches.

**Figure 27: Location of the Management Port on QFX5120-32C Switches and the LED on the Port**



1– Link activity LED

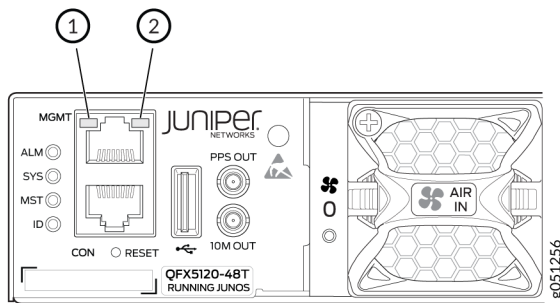
**Table 9: LED on the Management Port on QFX5120-32C Switches**

LED	Color	State and Description
Link activity	Green	On steadily—The port and the link are active, but there is no link activity.

**Table 9: LED on the Management Port on QFX5120-32C Switches (Continued)**

LED	Color	State and Description
		Blinking—The port and the link are active and there is link activity.
	Unlit	The port is administratively disabled, there is no power, the link is down, or there is a fault.

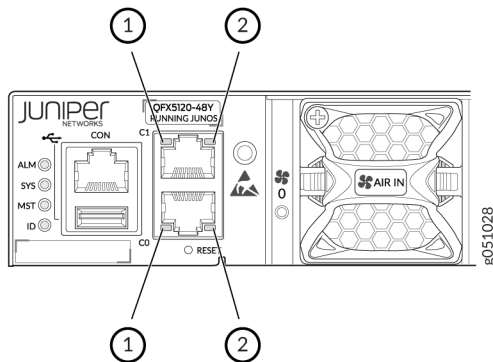
**Figure 28: Location of the Management Port on QFX5120-48T Switches and the LEDs on the Port**



1– Status LED

2– Link activity LED

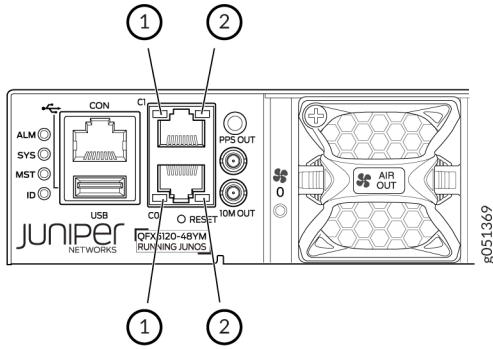
**Figure 29: Location of the Management Ports on QFX5120-48Y Switches and the LEDs on the Port**



1– Status LED

2– Link activity LED

Figure 30: Location of the Management Ports on QFX5120-48YM Switches and the LEDs on the Port



1– Status LED

2– Link activity LED

Table 10: LEDs on the Management Ports on QFX5120-48T, QFX5120-48Y, and QFX5120-48YM Switches

LED	Color	State and Description
Link activity	Green	On steadily—The port and the link are active, but there is no link activity.
		Blinking—The port and the link are active and there is link activity.
	Unlit	The port is administratively disabled, there is no power, the link is down, or there is a fault.
Status	Green	On steadily—The link speed is 1000 Mbps.
	Yellow	On steadily—The link speed is 100 Mbps.
	Unlit	Either the port speed is 10 Mbps or the link is down.

## Network Port LEDs on QFX5120 Switches

### IN THIS SECTION

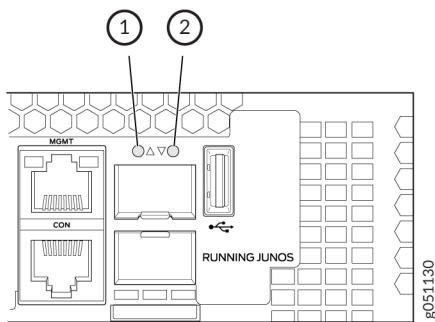
- Network Port LEDs on QFX5120-32C Switches | 36
- Network Port LEDs on QFX5120-48T Switches | 38
- Network Port LEDs on QFX5120-48Y Switches | 40
- Network Port LEDs on QFX5120-48YM Switches | 43

### Network Port LEDs on QFX5120-32C Switches

Each SFP+ port on QFX5120-32C switches has one LED that shows the link activity of the port (see [Figure 31 on page 36](#)). See [Table 11 on page 36](#) to learn more about that LED.

Each QSFP28 port on QFX5120-32C switches has four LEDs that show the link activity of the port (see [Figure 32 on page 37](#)). The first LED operates when the port is not channelized; the other three LEDs operate when the port is channelized. See [Table 12 on page 37](#) to learn more about those LEDs.

**Figure 31: LED on the SFP+ Ports on QFX5120-32C Switches**



1– LED for the SFP+ port 32

2– LED for the SFP+ port 33

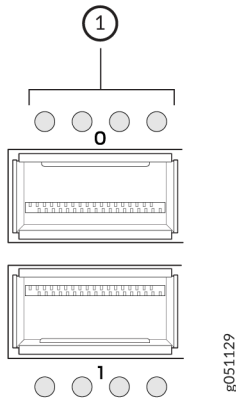
**Table 11: LED on the SFP+ Ports on QFX5120-32C Switches**

Color	State and Description
Green	On steadily—The port and the link are active, but there is no link activity.

**Table 11: LED on the SFP+ Ports on QFX5120-32C Switches (Continued)**

Color	State and Description
	Blinking—The port and the link are active and there is link activity.
Unlit	The port is not active.

**Figure 32: LEDs on the QSFP28 Ports on QFX5120-32C Switches**



1– LEDs on the QSFP28 ports

**Table 12: LEDs on the QSFP28 Ports on QFX5120-32C Switches**

Position	Color	State	Description
1	Green	On steadily	The port is not channelized, a 100 -Gbps or 40 -Gbps link is established, but there is no link activity. When this LED is on, the LEDs in positions 2 through 4 are off.
		Blinking	The port is not channelized, a 100 -Gbps or 40 -Gbps link is established, and there is link activity.
1-4	Green	On steadily	The port is channelized, a 25-Gbps or 10-Gbps link is established, but there is no link activity.

**Table 12: LEDs on the QSFP28 Ports on QFX5120-32C Switches (Continued)**

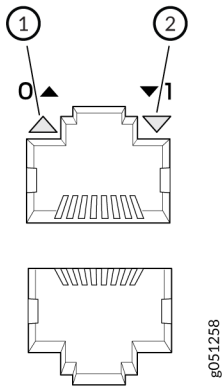
Position	Color	State	Description
		Blinking	The port is channelized, a 25-Gbps or 10-Gbps link is established, and there is link activity.
1-4	Unlit	Unlit	The port is administratively disabled, there is no power, the link is down, or there is a fault.

**Network Port LEDs on QFX5120-48T Switches**

Each BASE-T port on QFX5120-48T switches has one LED that indicates the status of the port (see [Figure 33 on page 38](#)). See [Table 13 on page 38](#) to learn more about that LED.

Each QSFP28 port on QFX5120-48T switches has one LED that indicates the status of the port (see [Figure 34 on page 39](#)). See [Table 14 on page 40](#) to learn more about that LED.

**Figure 33: LEDs on the 10-GbE BASE-T Ports on QFX5120-48T Switches**



1– LED for the BASE-T ports in the top row

2– LED for the BASE-T ports in the bottom row

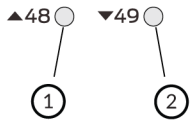
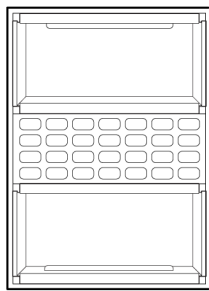
**Table 13: LEDs on the BASE-T Ports on QFX5120-48T Switches**

Color	State and Description
Green	On steadily—The port is operating at 10-Gbps speed, but there is no link activity.

**Table 13: LEDs on the BASE-T Ports on QFX5120-48T Switches (Continued)**

Color	State and Description
	Blinking—The port is operating at 10-Gbps speed and there is link activity.
Amber	On steadily—The port is operating at 1-Gbps speed, but there is no link activity.
	Blinking—The port is operating at 1-Gbps speed and there is link activity.
	Blipping—The beacon function is enabled on the port.
Unlit	The port is administratively disabled, there is no power, the link is down, or there is a fault.

**Figure 34: LED on the QSFP28 Ports on QFX5120-48T Switches**



g051259

1– LED for the QSFP28 ports in the top row

2– LED for the QSFP28 ports in the bottom row



**Table 14: LED on the QSFP28 Ports on QFX5120-48T Switches**

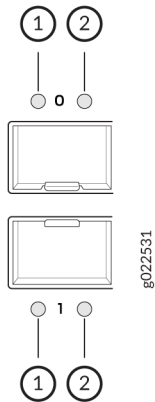
Color	State and Description
Green	<p>When the port is not channelized and is configured to operate as one 100GbE or 40GbE interface:</p> <ul style="list-style-type: none"> <li>• On steadily—The port is operational, but there is no link activity.</li> <li>• Blinking—The port is operational and there is link activity.</li> </ul>
	<p>When the port is channelized and is configured to operate as two 50GbE interfaces:</p> <ul style="list-style-type: none"> <li>• On steadily—The port is operational, both the interfaces are operational, but there is no link activity.</li> <li>• Blinking—The port is operational and there is link activity on at least one of the interfaces.</li> </ul>
	<p>When the ports <b>50</b> and <b>51</b> are channelized and are configured to operate as four 25GbE or 10GbE interfaces:</p> <ul style="list-style-type: none"> <li>• On steadily—All four breakout links are established, but there is no link activity on any of the channelized interfaces.</li> <li>• Blinking—All four breakout links are established and there is link activity on at least one of the channelized interfaces.</li> </ul>
Amber	<p>When the port is channelized and is configured to operate as two 50GbE interfaces:</p> <ul style="list-style-type: none"> <li>• Blipping—The beacon function is enabled on the port.</li> </ul>
Unlit	The port is administratively disabled, there is no power, the link is down, or there is a fault.

### Network Port LEDs on QFX5120-48Y Switches

Each SFP28 port on QFX5120-48Y switches has two LEDs that show the link activity and status of the port (see [Figure 35 on page 41](#)). See [Table 15 on page 41](#) to learn more about those LEDs.

Each QSFP28 port on QFX5120-48Y switches has four LEDs that show the link activity of the port (see [Figure 36 on page 42](#)). The first LED operates when the port is not channelized; the other three LEDs operate when the port is channelized. See [Table 16 on page 42](#) to learn more about those LEDs.

Figure 35: LEDs on the SFP28 Ports on QFX5120-48Y Switches



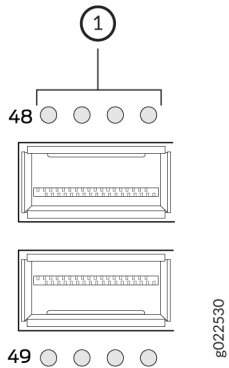
1– Link activity LED for the SFP28 ports

2– Status LED for the SFP28 ports

Table 15: LEDs on the SFP28 Ports on QFX5120-48Y Switches

LED	Color	State and Description
Link activity	Green	On steadily—The port and the link are active, but there is no link activity.
		Blinking—The port and the link are active and there is link activity.
	Unlit	The port is not active.
Status	Green	On steadily—The port is operating at 25-Gbps speed.
		Blinking—The port is operating at 1-Gbps or 10-Gbps speed.

Figure 36: LEDs on the QSFP28 Ports on QFX5120-48Y Switches



1– LEDs on the QSFP28 ports in the top row

Table 16: LEDs on the QSFP28 Ports on QFX5120-48Y Switches

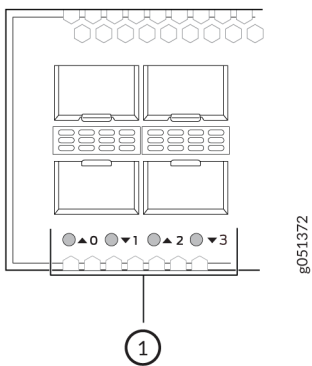
Position	Color	State	Description
1	Green	On steadily	The port is not channelized, a 100 Gbps or 40 Gbps link is established, but there is no link activity. When this LED is on, the LEDs in positions 2 through 4 are off.
		Blinking	The port is not channelized, a 100 Gbps or 40 Gbps link is established, and there is link activity.
1-4	Green	On steadily	The port is channelized, a 25-Gbps or 10-Gbps link is established, but there is no link activity.
		Blinking	The port is channelized, a 25-Gbps or 10-Gbps link is established, and there is link activity.
All	Amber	Blinking	The beacon function is enabled on the port.
1-4	Unlit	Unlit	The port is administratively disabled, there is no power, the link is down, or there is a fault.

## Network Port LEDs on QFX5120-48YM Switches

Each SFP28 port on QFX5120-48YM switches has one LED that shows the link activity and status of the port (see [Figure 37 on page 43](#)). See [Table 17 on page 43](#) to learn more about that LED.

Each QSFP28 port on QFX5120-48YM switches has one LED that shows the link activity and status of the port (see [Figure 38 on page 44](#)). See [Table 18 on page 44](#) to learn more about those LEDs.

**Figure 37: LED on the SFP28 Ports on QFX5120-48YM Switches**

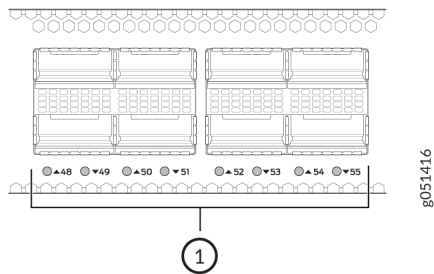


1– LED on the SFP28 ports on QFX5120-48YM switches

**Table 17: LED on the SFP28 Ports on QFX5120-48YM Switches**

Color	State and Description
Green	On steadily—A link is established, but there is no link activity.
	Blinking—A link is established and there is link activity.
Yellow	Blinking—The beacon function is enabled on the port.
Unlit	The port is administratively disabled, there is no power, the link is down, or there is a fault.

Figure 38: LED on the QSFP28 Ports on QFX5120-48YM Switches



1– LED on the QSFP28 ports on QFX5120-48YM switches

Table 18: LED on the QSFP28 Ports on QFX5120-48YM Switches

Color	State	Description
Green	On steadily	A link is established, but there is no link activity.
	Blinking	A link is established and there is link activity.
Yellow	Blinking	The beacon function is enabled on the port.
Unlit	Unlit	The port is administratively disabled, there is no power, the link is down, or there is a fault.

## QFX5120 Cooling System

### IN THIS SECTION

- [Fan Modules for QFX5120 Switches | 45](#)
- [QFX5120 Models and Airflow Direction | 47](#)
- [QFX5120 Models with Front-to-Back Airflow | 51](#)
- [QFX5120 Models with Back-to-Front Airflow | 53](#)

- [How to Position the Switch | 56](#)
- [QFX5120 Fan Module Status | 57](#)

The cooling system in QFX5120 switches consists of fan modules and built-in fans in the power supplies. The airflow direction depends on the fan modules and power supplies installed in the switch. You can order a QFX5120 switch that supports front-to-back airflow (air enters through the front of the switch) or back-to-front airflow (air enters through the back of the switch).

The fan modules are hot-removable and hot-insertable field-replaceable units (FRUs) installed in the rear panel of the switch: You can remove and replace them without powering off the switch or disrupting switch functions.

## Fan Modules for QFX5120 Switches

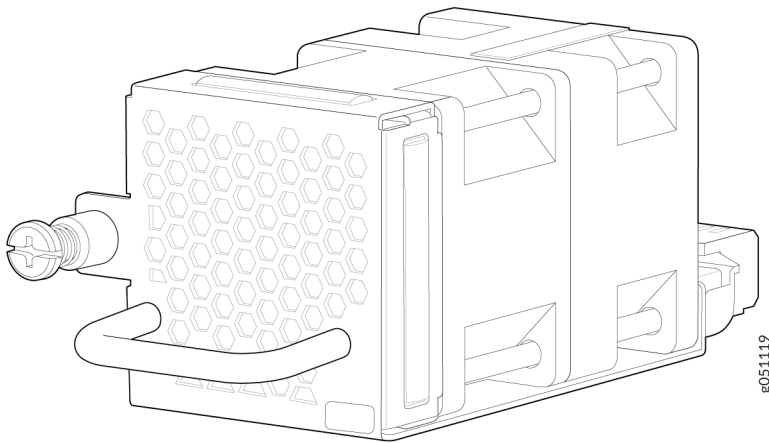
We ship QFX5120-32C switches with six fan modules (5+1 redundancy) preinstalled in the rear panel. We ship QFX5120-48T, QFX5120-48Y, and QFX5120-48YM switches with five fan modules (4+1 redundancy) preinstalled in the rear panel.

The fan modules are available in two models that have different airflow directions:

- Front-to-back (cold air enters through the front of the switch and hot air exhausts through the back of the switch), indicated by the label **F2B** and red handle in QFX5120-32C switches and by the label **AIR OUT** and Juniper Gold handle in QFX5120-48T, QFX5120-48Y, and QFX5120-48YM switches.
- Back-to-front (cold air enters through the back of the switch and hot air exhausts through the front), indicated by the label **B2F** and blue handle in QFX5120-32C switches and by the label **AIR IN** and Juniper Azure Blue handle in QFX5120-48T, QFX5120-48Y, and QFX5120-48YM switches.

[Figure 39 on page 46](#) shows the fan module for QFX5120-32C switches.

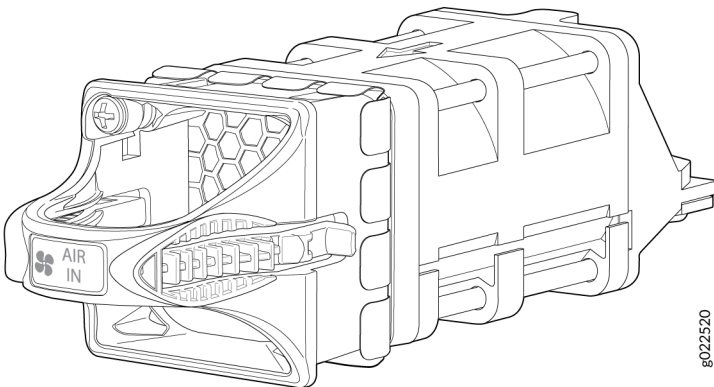
**Figure 39: Fan Module for QFX5120-32C Switches**



The fan module slots on the switch chassis are numbered **0** through **5** from left to right and have an arrow-shaped LED each next to them.

[Figure 40 on page 46](#) shows the fan module for QFX5120-48T, QFX5120-48Y, and QFX5120-48YM switches.

**Figure 40: Fan Module for QFX5120-48T, QFX5120-48Y, and QFX5120-48YM Switches**



The fan module slots on the switch chassis are numbered **0** through **4** from left to right and have a fan icon and a round LED each next to them.

**NOTE:** You must install all the fan modules for optimal functioning of the switch.

If the switch is operational while you are replacing fan modules, you must remove only one fan module at a time. The switch continues to operate for 30 seconds without thermal shutdown while you are replacing a fan module.

## QFX5120 Models and Airflow Direction

Table 19 on page 47 shows the airflow direction in QFX5120 switch models.

**Table 19: Airflow Direction in QFX5120 Switch Models**

Model Number	Fan Model Number	Fan Modules and Power Supplies	Direction of Airflow in the Fan Modules and Power Supplies
QFX5120-32C-AFO	QFX520048Y-FAN-AO	We ship the switch with six fan modules (with front-to-back airflow, indicated by the label <b>F2B</b> and a red handle) and two AC power supplies (with a red ejector lever).	Front-to-back—Cold air intake to cool the chassis is through the vents on the front panel of the chassis, and hot air exhausts through the vents on the rear panel of the chassis.
QFX5120-32C-AFI	QFX520048Y-FAN-AI	We ship the switch with six fan modules (with front-to-back airflow, indicated by the label <b>B2F</b> and a blue handle) and two AC power supplies (with a blue ejector lever).	Back-to-front—Cold air intake to cool the chassis is through the vents on the rear panel of the chassis, and hot air exhausts through the vents on the front panel of the chassis.
QFX5120-32C-DC-AFO	QFX520048Y-FAN-AO	We ship the switch with six fan modules (with front-to-back airflow, indicated by the label <b>F2B</b> and a red handle) and two DC power supplies (with a red ejector lever).	Front-to-back—Cold air intake to cool the chassis is through the vents on the front panel of the chassis, and hot air exhausts through the vents on the rear panel of the chassis.
QFX5120-32C-DC-AFI	QFX520048Y-FAN-AI	We ship the switch with six fan modules (with front-to-back airflow, indicated by the label <b>B2F</b> and a blue handle) and two DC power supplies (with a blue ejector lever).	Back-to-front—Cold air intake to cool the chassis is through the vents on the rear panel of the chassis, and hot air exhausts through the vents on the front panel of the chassis.



Table 19: Airflow Direction in QFX5120 Switch Models (*Continued*)

Model Number	Fan Model Number	Fan Modules and Power Supplies	Direction of Airflow in the Fan Modules and Power Supplies
QFX5120-48T-AFO	QFX5110-FANAFO	We ship the switch with five fan modules (with the label <b>AIR OUT</b> ) and two AC power supplies (with a Juniper Gold handle).	Front-to-back—Cold air intake to cool the chassis is through the vents on the front panel of the chassis, and hot air exhausts through the vents on the rear panel of the chassis.
QFX5120-48T-AFI	QFX5110-FANAFI	We ship the switch with five fan modules (with the label <b>AIR IN</b> ) and two AC power supplies (with a Juniper Azure Blue handle).	Back-to-front—Cold air intake to cool the chassis is through the vents on the rear panel of the chassis, and hot air exhausts through the vents on the front panel of the chassis.
QFX5120-48T-DC-AFO	QFX5110-FANAFO	We ship the switch with five fan modules (with the label <b>AIR OUT</b> ) and two DC power supplies (with a Juniper Gold handle).	Front-to-back—Cold air intake to cool the chassis is through the vents on the front panel of the chassis, and hot air exhausts through the vents on the rear panel of the chassis.
QFX5120-48T-DC-AFI	QFX5110-FANAFI	We ship the switch with five fan modules (with the label <b>AIR IN</b> ) and two DC power supplies (with a Juniper Azure Blue handle).	Back-to-front—Cold air intake to cool the chassis is through the vents on the rear panel of the chassis, and hot air exhausts through the vents on the front panel of the chassis.
QFX5120-48Y-AFO2	QFX5110-FANAFO	We ship the switch with five fan modules (with the label <b>AIR OUT</b> ) and two AC power supplies (with a Juniper Gold handle).	Front-to-back—Cold air intake to cool the chassis is through the vents on the front panel of the chassis, and hot air exhausts through the vents on the rear panel of the chassis.

Table 19: Airflow Direction in QFX5120 Switch Models (*Continued*)

Model Number	Fan Model Number	Fan Modules and Power Supplies	Direction of Airflow in the Fan Modules and Power Supplies
QFX5120-48Y-AFI2	QFX5110-FANAFI	We ship the switch with five fan modules (with the label <b>AIR IN</b> ) and two AC power supplies (with a Juniper Azure Blue handle).	Back-to-front—Cold air intake to cool the chassis is through the vents on the rear panel of the chassis, and hot air exhausts through the vents on the front panel of the chassis.
QFX5120-48Y-DC-AFO2	QFX5110-FANAFO	We ship the switch with five fan modules (with the label <b>AIR OUT</b> ) and two DC power supplies (with a Juniper Gold handle).	Front-to-back—Cold air intake to cool the chassis is through the vents on the front panel of the chassis, and hot air exhausts through the vents on the rear panel of the chassis.
QFX5120-48Y-DC-AFI2	QFX5110-FANAFI	We ship the switch with five fan modules (with the label <b>AIR IN</b> ) and two DC power supplies (with a Juniper Azure Blue handle).	Back-to-front—Cold air intake to cool the chassis is through the vents on the rear panel of the chassis, and hot air exhausts through the vents on the front panel of the chassis.
QFX5120-48YM-AFO	QFX5110-FANAFO	We ship the switch with five fan modules (with the label <b>AIR OUT</b> ) and two AC power supplies (with a Juniper Gold handle).	Front-to-back—Cold air intake to cool the chassis is through the vents on the front panel of the chassis, and hot air exhausts through the vents on the rear panel of the chassis.
QFX5120-48YM-AFI	QFX5110-FANAFI	We ship the switch with five fan modules (with the label <b>AIR IN</b> ) and two AC power supplies (with a Juniper Azure Blue handle).	Back-to-front—Cold air intake to cool the chassis is through the vents on the rear panel of the chassis, and hot air exhausts through the vents on the front panel of the chassis.

Table 19: Airflow Direction in QFX5120 Switch Models (*Continued*)

Model Number	Fan Model Number	Fan Modules and Power Supplies	Direction of Airflow in the Fan Modules and Power Supplies
QFX5120-48YM-DC-AO	QFX5110-FANAFO	We ship the switch with five fan modules (with the label <b>AIR OUT</b> ) and two DC power supplies (with a Juniper Gold handle).	Front-to-back—Cold air intake to cool the chassis is through the vents on the front panel of the chassis, and hot air exhausts through the vents on the rear panel of the chassis.
QFX5120-48YM-DC-AI	QFX5110-FANAFI	We ship the switch with five fan modules (with the label <b>AIR IN</b> ) and two DC power supplies (with a Juniper Azure Blue handle).	Back-to-front—Cold air intake to cool the chassis is through the vents on the rear panel of the chassis, and hot air exhausts through the vents on the front panel of the chassis.

**CAUTION:** Do not mix:

- Power supplies with different airflow directions in the same chassis.
- Fan modules with different airflow directions in the same chassis.
- Power supplies and fan modules with different airflow directions in the same chassis.

Mixing components with different airflow directions in the same chassis hampers the performance of the cooling system of the switch and leads to overheating of the chassis.

If you install power supplies or fan modules with different airflow directions, Junos OS raises an alarm.

Under normal operating conditions, the fan modules operate at a moderate speed. Temperature sensors in the chassis monitor the temperature within the chassis.

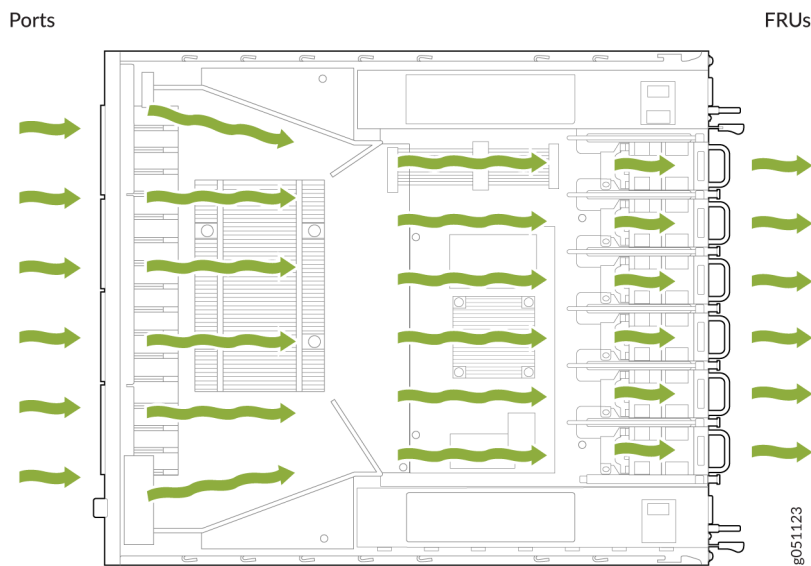
If a fan module fails or if the ambient temperature inside the chassis rises above the acceptable range, Junos OS raises an alarm. If the temperature inside the chassis rises above the threshold temperature, the system shuts down automatically.

## QFX5120 Models with Front-to-Back Airflow

In the QFX5120 switch models that have front-to-back airflow, the cold air intake to cool the chassis is through the vents on the front panel of the switch and hot air exhausts through the vents on the rear panel.

[Figure 41 on page 51](#) shows the front-to-back airflow through the QFX5120-32C switch chassis.

**Figure 41: Front-to-Back Airflow Through the QFX5120-32C Switch Chassis**



[Figure 42 on page 52](#) shows the front-to-back airflow through the QFX5120-48T switch chassis.

Figure 42: Front-to-Back Airflow Through the QFX5120-48T Switch Chassis

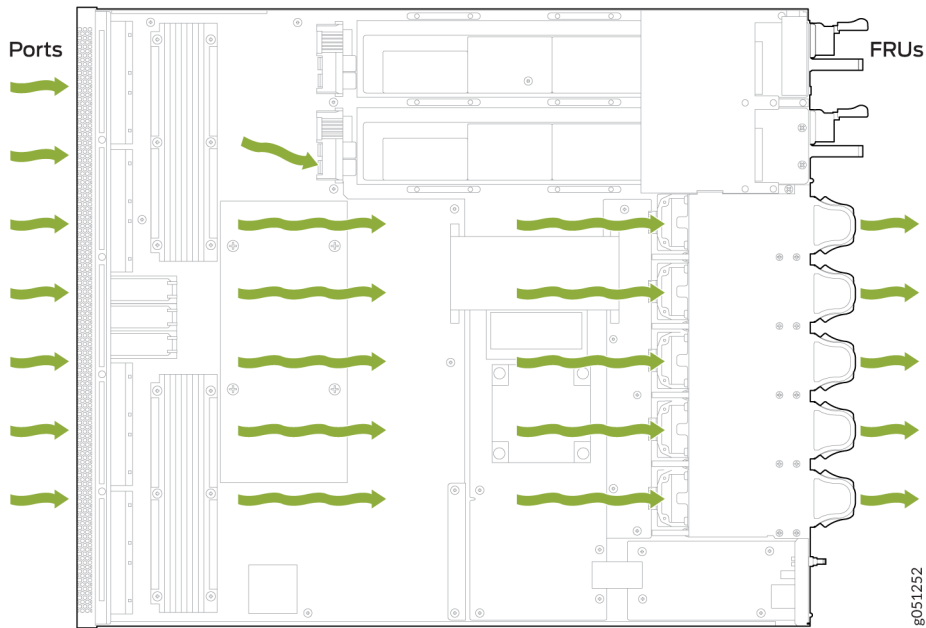


Figure 43 on page 52 shows the front-to-back airflow through the QFX5120-48Y switch chassis.

Figure 43: Front-to-Back Airflow Through the QFX5120-48Y Switch Chassis

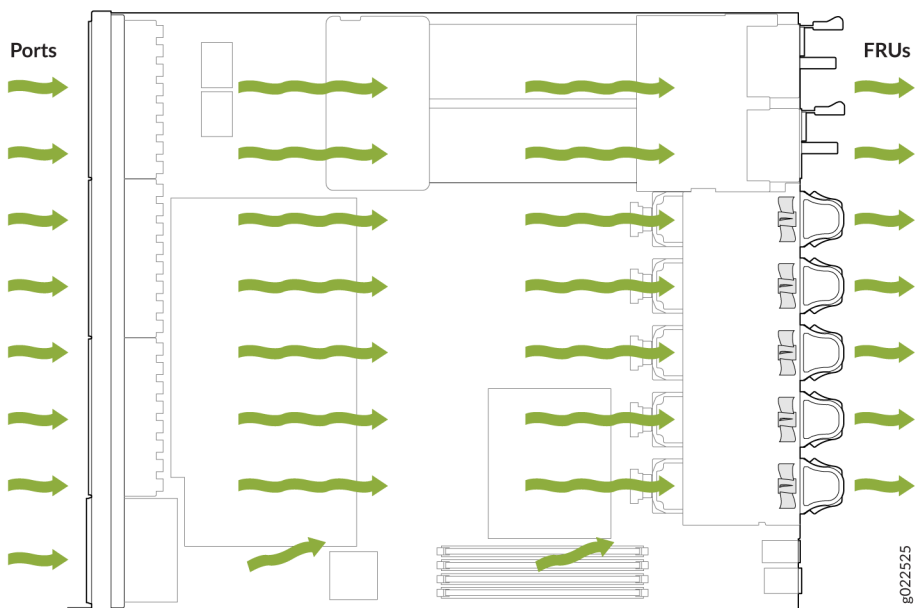
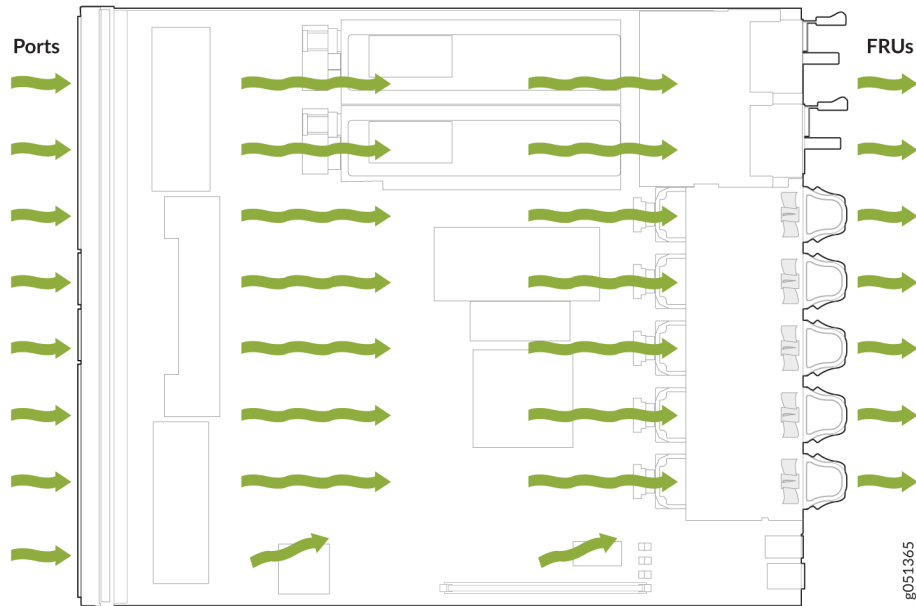


Figure 44 on page 53 shows the front-to-back airflow through the QFX5120-48YM switch chassis.

Figure 44: Front-to-Back Airflow Through the QFX5120-48YM Switch Chassis



## QFX5120 Models with Back-to-Front Airflow

In the QFX5120 switch models that have back-to-front airflow, the cold air intake to cool the chassis is through the vents on the rear panel and hot air exhausts through the vents on the front panel of the switch.

[Figure 45 on page 54](#) shows the back-to-front airflow through the QFX5120-32C switch chassis.

Figure 45: Back-to-Front Airflow Through the QFX5120-32C Switch Chassis

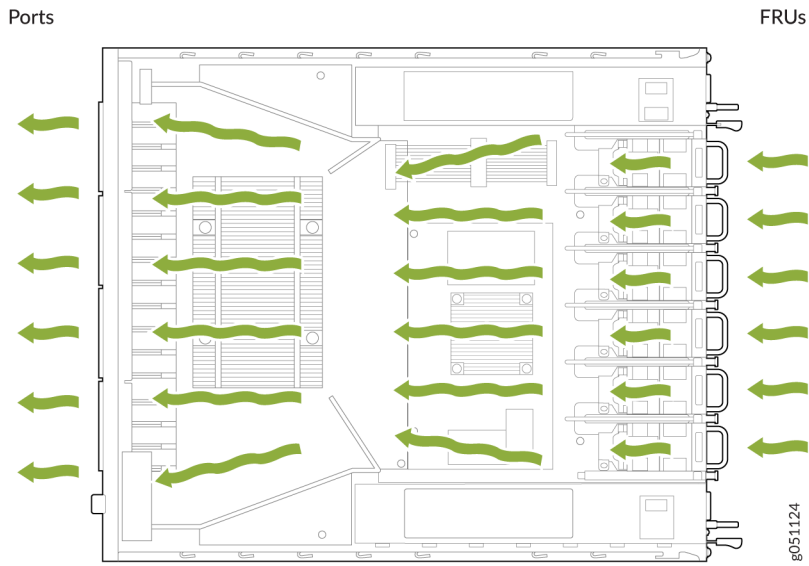


Figure 46 on page 54 shows the back-to-front airflow through the QFX5120-48T switch chassis.

Figure 46: Back-to-Front Airflow Through the QFX5120-48T Switch Chassis

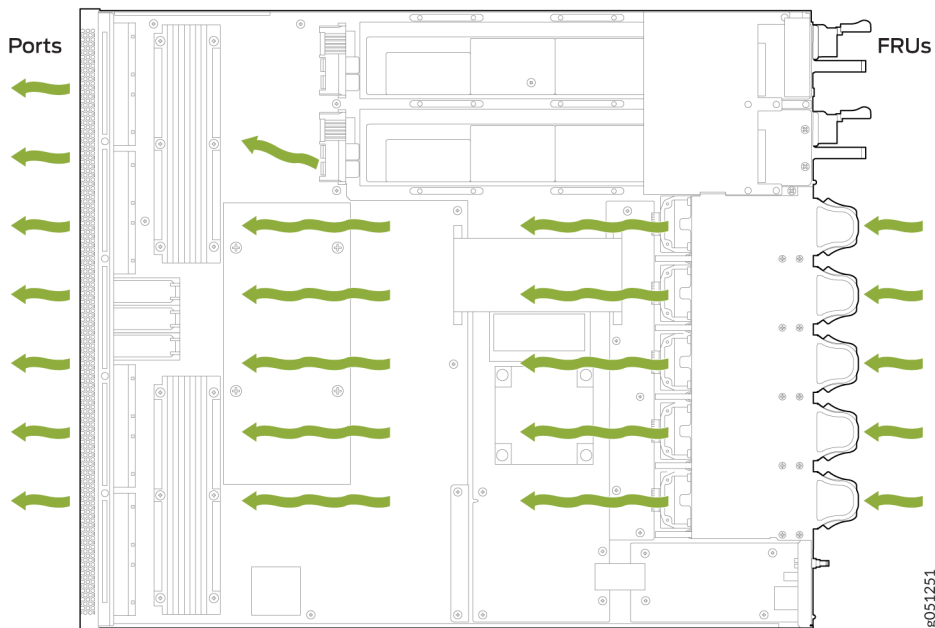


Figure 47 on page 55 shows the back-to-front airflow through the QFX5120-48Y switch chassis.

Figure 47: Back-to-Front Airflow Through the QFX5120-48Y Switch Chassis

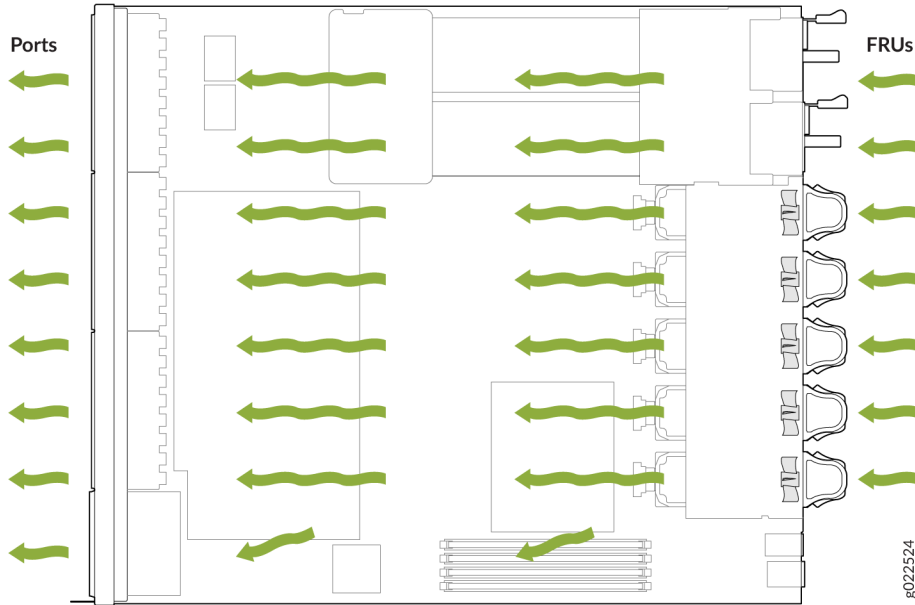


Figure 48 on page 55 shows the back-to-front airflow through the QFX5120-48YM switch chassis.

Figure 48: Back-to-Front Airflow Through the QFX5120-48YM Switch Chassis





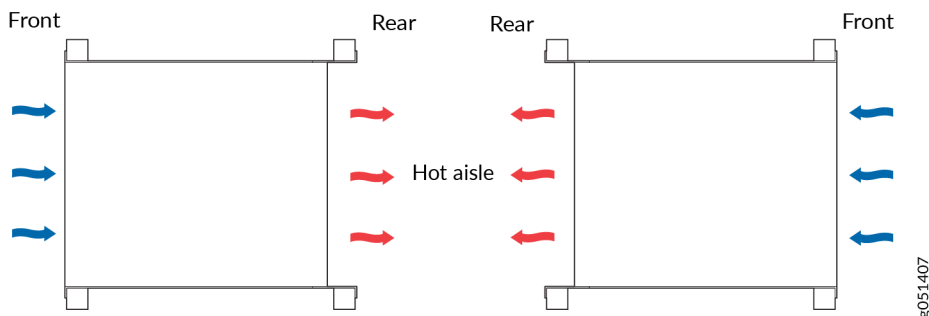
## How to Position the Switch

In front-to-back airflow, hot air exhausts through the vents on the rear panel of the switch. In back-to-front airflow, hot air exhausts through the vents on the front panel of the switch.

In data center deployments, position the switch in such a manner that:

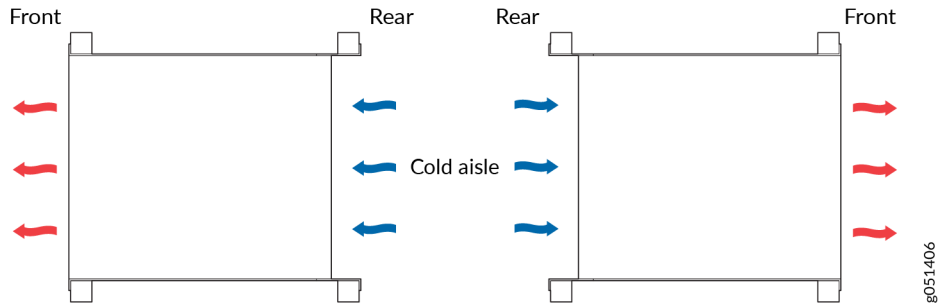
- The **F2B** labels on the fan modules for QFX5120-32C switches and the **AIR OUT** labels on the fan modules for QFX5120-48T, QFX5120-48Y, and QFX5120-48YM switches are facing the hot aisle (see [Figure 49 on page 56](#)).

**Figure 49: Deployment of Switches with Front-to-Back Airflow Through the QFX5120 Switch Chassis**



- The **B2F** labels on the fan modules for QFX5120-32C switches and the **AIR IN** labels on the fan modules for QFX5120-48T, QFX5120-48Y, and QFX5120-48YM switches are facing the cold aisle (see [Figure 50 on page 57](#)).

**Figure 50: Deployment of Switches with Back-to-Front Airflow Through the QFX5120 Switch Chassis**



## QFX5120 Fan Module Status

There is a status LED for each fan module on QFX5120 switches, next to the fan module slot on the rear panel of the chassis, indicating the status of the fan module. [Table 20 on page 57](#) describes the fan module LED.

**Table 20: Fan Module Status LED**

LED	Color	State	Description
Status	Green	On steadily	The switch has verified that the fan module is engaged, that the airflow is in the correct direction, and that the fan module is functioning normally.
	<ul style="list-style-type: none"> <li>QFX5120-32C—Red</li> <li>QFX5120-48T, QFX5120-48Y, and QFX5120-48YM—Amber</li> </ul>	Blinking	The switch has detected an error in the fan module. Either the fan has failed or it is seated incorrectly. Replace the fan module as soon as possible. To maintain proper airflow through the chassis, leave the fan module installed in the chassis until you are ready to replace it.

# QFX5120 Power System

## IN THIS SECTION

- [AC Power Supply in QFX5120 Switches | 58](#)
- [Power Supply Specifications for AC Power Supplies for QFX5120 Switches | 63](#)
- [Specifications of the Power Cord for AC Power Supplies for QFX5120 Switches | 66](#)
- [LEDs on the AC Power Supplies Used in QFX5120 Switches | 68](#)
- [DC Power Supply in QFX5120 Switches | 71](#)
- [Power Supply Specifications for DC Power Supplies for QFX5120 Switches | 78](#)
- [LEDs on the DC Power Supplies Used in QFX5120 Switches | 80](#)
- [High-Voltage Power Supply for QFX5120-48T Switches | 83](#)

## AC Power Supply in QFX5120 Switches

### IN THIS SECTION

- [Characteristics of the AC Power Supply for QFX5120 Switches | 59](#)
- [AC Power Supply Airflow | 62](#)

QFX5120-32C, QFX5120-48T, and QFX5120-48Y switches support two 650-W AC or DC power supplies. Additionally, QFX5120-48T switches support two 850-W high-voltage power supplies with AC or DC input. QFX5120-48YM switches support two 850-W AC or DC power supplies. The power supplies support front-to-back or back-to-front airflow. The power supplies are fully redundant, load-sharing, and hot-removable and hot-insertable FRUs when the second power supply is installed and running. You can remove and replace them without powering off the switch or disrupting switch functions. We ship QFX5120 switch models with two AC or DC power supplies preinstalled in the rear panel of the chassis. This topic describes the AC power supplies supported on QFX5120 switches.



**CAUTION:** Do not mix:

- AC and DC power supplies in the same chassis.
- 650-W and 850-W power supplies in the same QFX5120-48T chassis.
- Power supplies with different airflow directions in the same chassis.
- Power supplies and fan modules with different airflow directions in the same chassis.

## Characteristics of the AC Power Supply for QFX5120 Switches

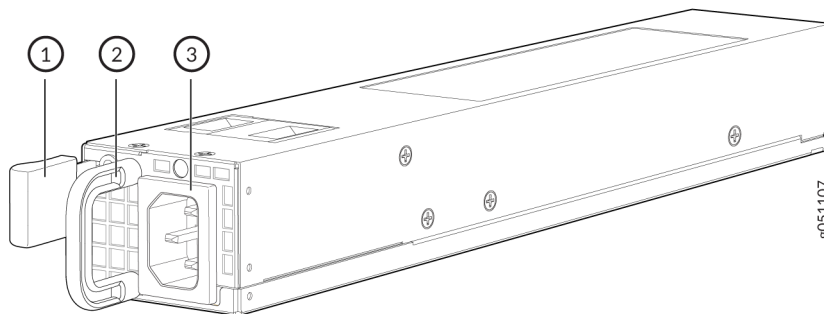
You can install up to two power supplies in the power supply slots in the rear panel of the QFX5120 switch chassis. On QFX5120-32C switches, the slots are labeled **PS0** and **PS1**. On QFX5120-48T, QFX5120-48Y, and QFX5120-48YM switches, the slots are labeled **0** and **1** and have a power icon next to them.

**NOTE:** You must install both the power supplies for optimal functioning of the switch.

If the switch is operational while you are replacing power supplies, you must remove only one power supply at a time.

Figure 51 on page 59 shows the AC power supply for a QFX5120-32C switch.

**Figure 51: AC Power Supply for QFX5120-32C Switches**



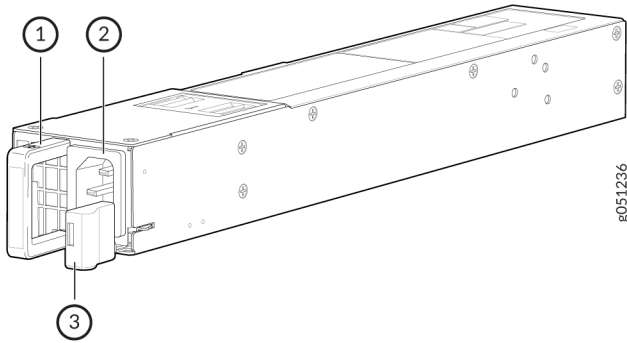
1– Ejector lever

2– Power supply handle

3– AC power cord inlet

Figure 52 on page 60 shows the AC power supply for QFX5120-48T and QFX5120-48Y switches.

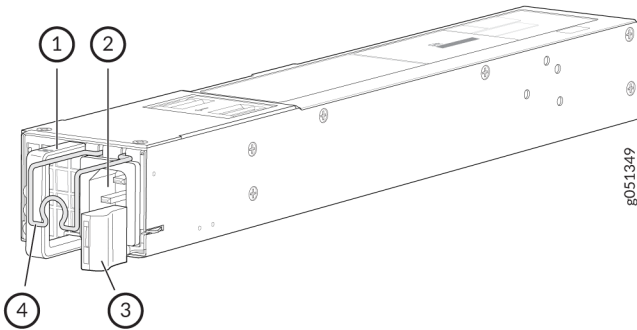
**Figure 52: AC Power Supply for QFX5120-48T and QFX5120-48Y Switches**



1- Power supply handle	3- Ejector lever
2- AC power cord inlet	

Figure 53 on page 60 shows the AC power supply for QFX5120-48YM switches.

**Figure 53: AC Power Supply for QFX5120-48YM Switches**



1- Power supply handle	3- Ejector lever
2- AC power cord inlet	4- Power cord retainer

Table 21 on page 61 lists the specifications of the AC power supplies used in QFX5120 switches.

Table 21: Specifications of the AC Power Supplies Used in QFX5120 Switches

Item	Specifications
Model number	<ul style="list-style-type: none"> <li>• QFX5120-32C: QFX520048Y-APSU-AO or QFX520048Y-APSU-AI</li> <li>• QFX5120-48T and QFX5120-48Y: JPSU-650W-AC-AO or JPSU-650W-AC-AI</li> <li>• QFX5120-48YM: JPSU-850W-AC-AFO or JPSU-850W-AC-AFI</li> </ul>
Field-replaceable unit (FRU) type	Hot-insertable and hot-removable
Weight	<ul style="list-style-type: none"> <li>• QFX5120-32C: 2.1 lb (0.93 kg)</li> <li>• QFX5120-48T and QFX5120-48Y: 2.2 lb (0.98 kg)</li> <li>• QFX5120-48YM: 2.3 lb (1.04 kg)</li> </ul>
Minimum installed in chassis	1
Maximum installed in chassis	2
Power supply slots	<ul style="list-style-type: none"> <li>• QFX5120-32C switches—Install power supply in slots labeled <b>PS0</b> and <b>PS1</b> in the rear panel of the chassis.</li> <li>• QFX5120-48T, QFX5120-48Y, and QFX5120-48YM switches—Install power supply in slots labeled <b>0</b> and <b>1</b> with a power icon next to them in the rear panel of the chassis.</li> </ul>
Airflow	<ul style="list-style-type: none"> <li>• Front-to-back, indicated by the label <b>F2B</b> and a red handle in QFX5120-32C switches and by the label <b>AIR OUT</b> and a Juniper Gold handle in QFX5120-48T, QFX5120-48Y, and QFX5120-48YM switches.</li> <li>• Back-to-front, indicated by label <b>B2F</b> and a blue handle in QFX5120-32C switches and by the label <b>AIR IN</b> and a Juniper Azure Blue handle in QFX5120-48T, QFX5120-48Y, and QFX5120-48YM switches.</li> </ul>

**Table 21: Specifications of the AC Power Supplies Used in QFX5120 Switches (Continued)**

Item	Specifications
Status LEDs	<ul style="list-style-type: none"> <li>• QFX5120-32C switch—Bicolored LED</li> <li>• QFX5120-48T, QFX5120-48Y, and QFX5120-48YM switch—AC, DC, and ! (fault)</li> </ul>

To prevent electrical injury while installing or removing AC power supplies, carefully follow instructions in ["Connect Power to an AC-Powered QFX5120 Switch" on page 168](#) and ["Maintain the QFX5120 Power System" on page 201](#).

## AC Power Supply Airflow

Each power supply is cooled by its own internal cooling system.



**CAUTION:** Verify that the airflow direction in the power supplies matches the airflow direction in the fan modules. Ensure that each power supply that you install in the chassis has the same airflow direction. If you install power supplies with two different airflow directions, Junos OS raises an alarm. If you need to convert the airflow direction in a chassis, you must replace all the fan modules and power supplies with the other airflow direction and update the installation base (see *Register Products—Mandatory to Validate SLAs*).

[Table 22 on page 62](#) lists the AC power supplies used in QFX5120 switches and the direction of airflow in them. The power supplies have color-coded handles and labels that indicate the direction of the airflow.

**Table 22: Airflow Direction in AC Power Supplies for QFX5120 Switches**

Power Supply	Color of the Power Supply Handle	Label	Direction of Airflow
QFX5120-32C— QFX520048Y- APSU-AO	Red	<b>F2B</b>	Front-to-back—Cold air intake to cool the chassis is through the vents on the front panel of the chassis and hot air exhausts through the vents on the rear panel of the chassis.

**Table 22: Airflow Direction in AC Power Supplies for QFX5120 Switches (Continued)**

Power Supply	Color of the Power Supply Handle	Label	Direction of Airflow
QFX5120-48T and QFX5120-48Y—JPSU-650W-AC-AO	Juniper Gold	<b>AIR OUT</b>	Back-to-front—Cold air intake to cool the chassis is through the vents on the rear panel of the chassis and hot air exhausts through the vents on the front panel of the chassis.
QFX5120-48YM—JPSU-850W-AC-AFO	Juniper Gold	<b>AIR OUT</b>	
QFX5120-32C—QFX520048Y-APSU-AI	Blue	<b>B2F</b>	
QFX5120-48T and QFX5120-48Y—JPSU-650W-AC-AI	Juniper Azure Blue	<b>AIR IN</b>	
QFX5120-48YM—JPSU-850W-AC-AFI	Juniper Azure Blue	<b>AIR IN</b>	

## Power Supply Specifications for AC Power Supplies for QFX5120 Switches

QFX5120-32C, QFX5120-48T, and QFX5120-48Y switches support 650-W AC or DC power supplies. Additionally, QFX5120-48T switches support two 850-W high-voltage power supplies with AC or DC input. QFX5120-48YM switches support two 850-W AC or DC power supplies.

[Table 23 on page 64](#) shows the power supply specifications for AC power supplies for QFX5120-32C switches.



**Table 23: Power Supply Specifications for AC Power Supplies for QFX5120-32C Switches**

Item	Specification
AC input voltage	Operating range: 100 VAC through 240 VAC
AC input line frequency	50–60 Hz
AC input current rating	<ul style="list-style-type: none"> <li>• 6 A at 100 VAC</li> <li>• 3.8 A at 240 VAC</li> </ul>
Typical power consumption	193 W
Maximum power consumption	473 W

**NOTE:** The maximum power consumption values specified here assumes 3.5W power per 100G optical module used.

Table 24 on page 64 shows the power supply specifications for AC power supplies for QFX5120-48T switches.

**Table 24: Power Supply Specifications for AC Power Supplies for QFX5120-48T Switches**

Item	Specification
AC input voltage	Operating range: 100 VAC through 240 VAC
AC input line frequency	50–60 Hz
AC input current rating	5 A at 100–240 VAC
Typical power consumption	213 W

**Table 24: Power Supply Specifications for AC Power Supplies for QFX5120-48T Switches (Continued)**

Item	Specification
Maximum power consumption	218 W

[Table 25 on page 65](#) shows the power supply specifications for AC power supply for QFX5120-48Y switches.

**Table 25: Power Supply Specifications for AC Power Supplies for QFX5120-48Y Switches**

Item	Specification
AC input voltage	Operating range: 100 VAC through 240 VAC
AC input line frequency	50–60 Hz
AC input current rating	6 A at 100–240 VAC
Typical power consumption	247 W
Maximum power consumption	272 W

[Table 26 on page 65](#) shows the power supply specifications for AC power supply for QFX5120-48YM switches.

**Table 26: Power Supply Specifications for AC Power Supplies for QFX5120-48YM Switches**

Item	Specification
AC input voltage	Operating range: 100 VAC through 240 VAC
AC input line frequency	50–60 Hz
AC input current rating	<ul style="list-style-type: none"> <li>• 7.5 A at 100 VAC</li> <li>• 3 A at 240 VAC</li> </ul>

**Table 26: Power Supply Specifications for AC Power Supplies for QFX5120-48YM Switches**  
(Continued)

Item	Specification
Typical power consumption	329 W
Maximum power consumption	351 W

## Specifications of the Power Cord for AC Power Supplies for QFX5120 Switches

A detachable AC power cord is supplied with the AC power supplies. The coupler for AC power supplies is type C13 as described by International Electrotechnical Commission (IEC) standard 60320. The plug end of the power cord fits into the power source outlet that is standard for your geographical location.



**CAUTION:** The AC power cord provided with each power supply is intended for use with that power supply only and not for any other use.

**NOTE:** In North America, AC power cords must not exceed 4.5 meters in length, to comply with National Electrical Code (NEC) Sections 400-8 (NFPA 75, 5-2.2) and 210-52 and Canadian Electrical Code (CEC) Section 4-010(3). The cords supplied with the switch are in compliance.

[Table 27 on page 66](#) lists the specifications of the AC power cord for the AC power supplies provided for the countries and regions listed in the table.

**Table 27: Specifications of the AC Power Cord for the AC Power Supplies**

Country/Region	Electrical Specifications	Plug Standards	Juniper Model Number
Argentina	250 VAC, 10 A, 50 Hz	IRAM 2073 Type RA/3	CBL-EX-PWR-C13-AR

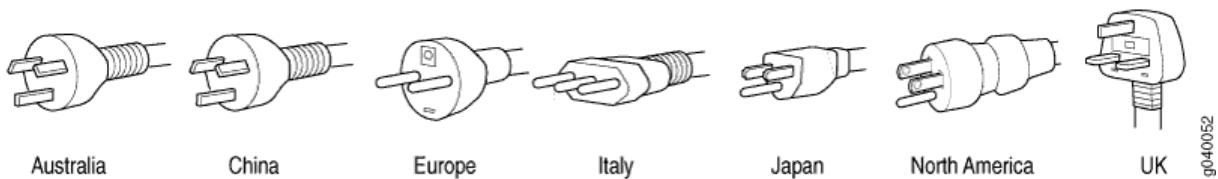
**Table 27: Specifications of the AC Power Cord for the AC Power Supplies (Continued)**

Country/Region	Electrical Specifications	Plug Standards	Juniper Model Number
Australia	250 VAC, 10 A, 50 Hz	AS/NZS 3112 Type SAA/3	CBL-EX-PWR-C13-AU
Brazil	250 VAC, 10 A, 50 Hz	NBR 14136 Type BR/3	CBL-EX-PWR-C13-BR
China	250 VAC, 10 A, 50 Hz	GB 1002-1996 Type PRC/3	CBL-EX-PWR-C13-CH
Europe (except Italy, Switzerland, and United Kingdom)	250 VAC, 10 A, 50 Hz	CEE (7) VII Type VIIG	CBL-EX-PWR-C13-EU
India	250 VAC, 10 A, 50 Hz	IS 1293 Type IND/3	CBL-EX-PWR-C13-IN
Israel	250 VAC, 10 A, 50 Hz	SI 32/1971 Type IL/3G	CBL-EX-PWR-C13-IL
Italy	250 VAC, 10 A, 50 Hz	CEI 23-16 Type I/3G	CBL-EX-PWR-C13-IT
Japan	125 VAC, 12 A, 50 Hz or 60 Hz	SS-00259 Type VCTF	CBL-EX-PWR-C13-JP
Korea	250 VAC, 10 A, 50 Hz or 60 Hz	CEE (7) VII Type VIIGK	CBL-EX-PWR-C13-KR
North America	125 VAC, 13 A, 60 Hz	NEMA 5-15 Type N5-15	CBL-EX-PWR-C13-US
South Africa	250 VAC, 10 A, 50 Hz	SABS 164/1:1992 Type ZA/13	CBL-EX-PWR-C13-SA

**Table 27: Specifications of the AC Power Cord for the AC Power Supplies (Continued)**

Country/Region	Electrical Specifications	Plug Standards	Juniper Model Number
Switzerland	250 VAC, 10 A, 50 Hz	SEV 6534-2 Type 12G	CBL-EX-PWR-C13-SZ
Taiwan	125 VAC, 11 A and 15 A, 50 Hz	NEMA 5-15P Type N5-15P	CBL-EX-PWR-C13-TW
United Kingdom	250 VAC, 10 A, 50 Hz	BS 1363/A Type BS89/13	CBL-EX-PWR-C13-UK

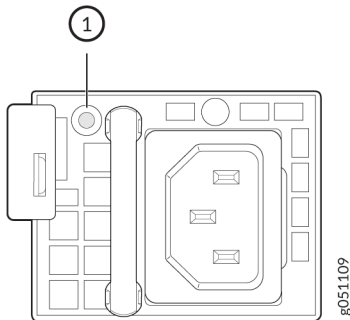
Figure 54 on page 68 illustrates the plug on the power cord for the AC power supplies for a few of the countries or regions listed in Table 27 on page 66.

**Figure 54: AC Plug Types for AC Power Supplies**

## LEDs on the AC Power Supplies Used in QFX5120 Switches

Figure 55 on page 69 shows the LED on the AC power supply for QFX5120-32C switches.

**Figure 55: LED on the AC Power Supply for QFX5120-32C Switches**



1- LED

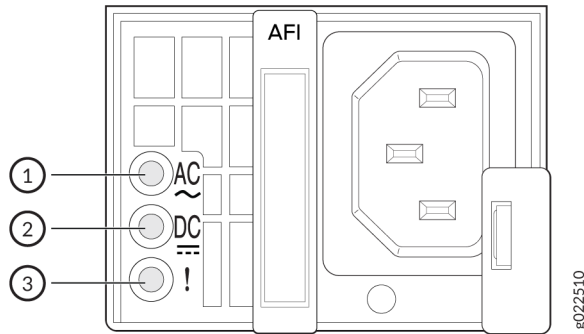
Table 28 on page 69 describes the LED on the AC power supply for QFX5120-32C switches.

**Table 28: LED on the AC Power Supply for QFX5120-32C Switches**

Color	State	Description
Green	On steadily	The power supply is sending out power correctly.
	Blinking	The power supply is in standby mode.
Red	On steadily	An error is detected in the power supply. Replace the power supply as soon as possible. To maintain proper airflow through the chassis, leave the power supply installed in the chassis until you are ready to replace it.
	Blinking	The internal fan in the power supply has failed. Replace the power supply as soon as possible. To maintain proper airflow through the chassis, leave the power supply installed in the chassis until you are ready to replace it.
Unlit	Unlit	The power supply is disconnected from power, or the power supply is not receiving power.

Figure 56 on page 70 shows the LEDs on the AC power supply for QFX5120-48T and QFX5120-48Y switches. Figure 57 on page 70 shows the LEDs on the AC power supply for QFX5120-48YM switches.

Figure 56: LEDs on the AC Power Supply for QFX5120-48T and QFX5120-48Y Switches

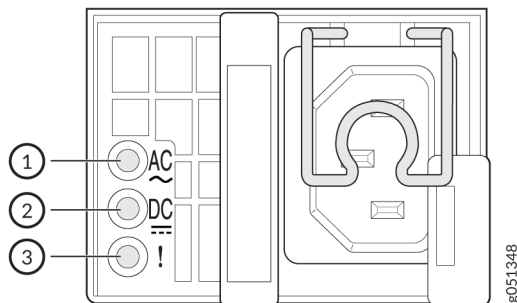


1– AC LED (labeled **AC**)

3– Fault LED (labeled **!**)

2– DC LED (labeled **DC**)

Figure 57: LEDs on the AC Power Supply for QFX5120-48YM Switches



1– AC LED (labeled **AC**)

3– Fault LED (labeled **!**)

2– DC LED (labeled **DC**)

Table 29 on page 70 describes the LEDs on the AC power supply for QFX5120-48T, QFX5120-48Y, and QFX5120-48YM switches.

Table 29: LEDs on the AC Power Supply for QFX5120-48T, QFX5120-48Y, and QFX5120-48YM Switches

LED Label	Color	State	Description
<b>AC</b>	Green	On steadily	The power supply is receiving power.

**Table 29: LEDs on the AC Power Supply for QFX5120-48T, QFX5120-48Y, and QFX5120-48YM Switches (Continued)**

LED Label	Color	State	Description
	Unlit	Unlit	<ul style="list-style-type: none"> <li>The power supply is disconnected from power, or the power supply is not receiving power.</li> <li>The AC power cord might not be installed properly, or the power input voltage might not be within normal operating range.</li> </ul>
DC	Green	On steadily	The power supply is sending out power correctly.
	Unlit	Unlit	<ul style="list-style-type: none"> <li>The power supply is disconnected from power, or the power supply is not receiving power.</li> <li>The AC power cord might not be installed properly, or the power input voltage might not be within normal operating range.</li> <li>The power supply might have an internal failure.</li> </ul>
! (Fault)	Amber	On steadily	An error is detected in the power supply. Replace the power supply as soon as possible. To maintain proper airflow through the chassis, leave the power supply installed in the chassis until you are ready to replace it.

## DC Power Supply in QFX5120 Switches

### IN THIS SECTION

- [Characteristics of the DC Power Supply | 72](#)
- [DC Power Supply Airflow | 77](#)



QFX5120-32C, QFX5120-48T, and QFX5120-48Y switches support two 650-W AC or DC power supplies. Additionally, QFX5120-48T switches support 850-W high-voltage power supplies with AC or DC input. QFX5120-48YM switches support two 850-W AC or DC power supplies. The power supplies support front-to-back or back-to-front airflow. The power supplies are fully redundant, load-sharing, and hot-removable and hot-insertable FRUs when the second power supply is installed and running. You can remove and replace it without powering off the switch or disrupting switch functions. We ship QFX5120 switch models with two AC or DC power supplies preinstalled in the rear panel of the chassis. This topic describes the DC power supplies supported on QFX5120 switches.



**CAUTION:** Do not mix:

- AC and DC power supplies in the same chassis.
- 650-W and 850-W power supplies in the same QFX5120-48T chassis.
- Power supplies with different airflow directions in the same chassis.
- Power supplies and fan modules with different airflow directions in the same chassis.

## Characteristics of the DC Power Supply

You can install up to two power supplies in the power supply slots in the rear panel of the QFX5120 switch chassis. On QFX5120-32C switches, the slots are labeled **PS0** and **PS1**. On QFX5120-48T, QFX5120-48Y, and QFX5120-48YM switches, the slots are labeled **0** and **1** and have a power icon next to them.

**NOTE:** You must install both the power supplies for optimal functioning of the switch.

If the switch is operational while you are replacing power supplies, you must remove only one power supply at a time.

[Figure 58 on page 73](#) shows the DC power supply for a QFX5120-32C switch.

**Figure 58: DC Power Supply for QFX5120-32C Switches**

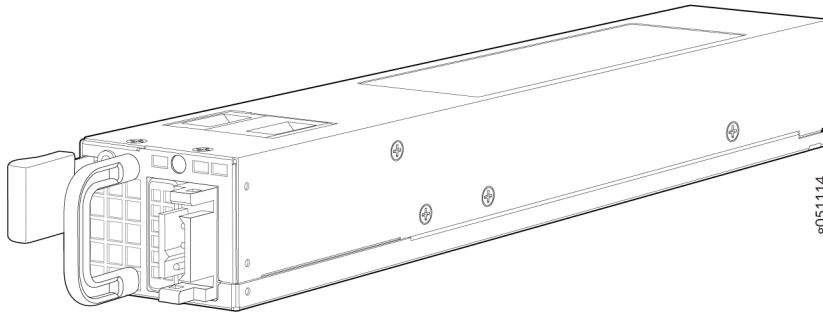
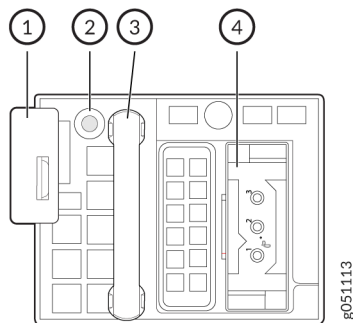


Figure 59 on page 73 shows the faceplate of a DC power supply for QFX5120-32C switches.

**Figure 59: Faceplate of a DC Power Supply for QFX5120-32C Switches**



1– Ejector lever

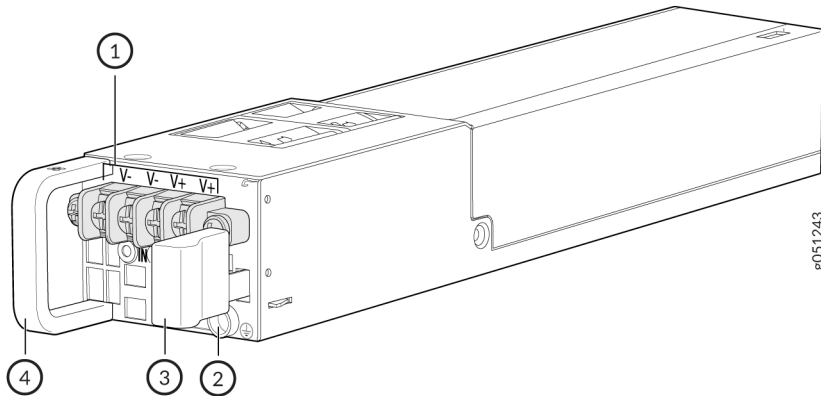
2– LED

3– Power supply handle

4– Input terminals

Figure 60 on page 74 shows the DC power supply for QFX5120-48T and QFX5120-48Y switches.

**Figure 60: DC Power Supply for QFX5120-48T and QFX5120-48Y Switches**



1– Input terminals

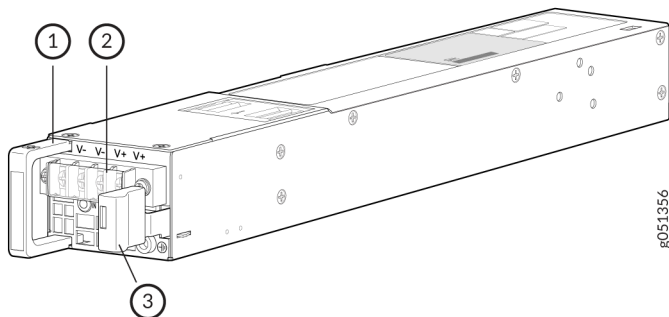
3– Ejector lever

2– Protective earthing terminal

4– Power supply handle

Figure 61 on page 74 shows the DC power supply for QFX5120-48YM switches.

**Figure 61: DC Power Supply for QFX5120-48YM Switches**



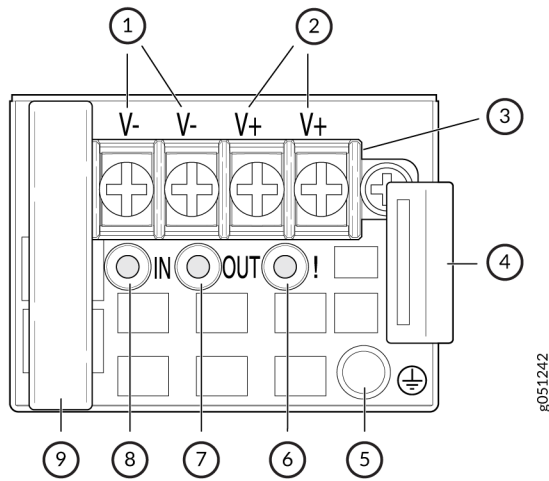
1– Power supply handle

3– Ejector lever

2– Input terminals

Figure 62 on page 75 shows the faceplate of a DC power supply for QFX5120-48T, QFX5120-48Y, and QFX5120-48YM switches.

Figure 62: Faceplate of a DC Power Supply for QFX5120-48T, QFX5120-48Y, and QFX5120-48YM Switches



1– Negative Input terminals	6– Fault LED (labeled !)
2– Positive Input terminals	7– Out LED (labeled <b>OUT</b> )
3– Terminal cover	8– In LED (labeled <b>IN</b> )
4– Ejector lever	9– Power supply handle
5– Protective earthing terminal	

Table 30 on page 75 lists the specifications of the DC power supplies used in QFX5120 switches.

Table 30: Specifications of the DC Power Supplies Used in QFX5120 Switches

Item	Specifications
Model number	<ul style="list-style-type: none"> <li>QFX5120-32C: QFX520048Y-DPSU-AO and QFX520048Y-DPSU-AI</li> <li>QFX5120-48T and QFX5120-48Y: JPSU-650W-DC-AFO and JPSU-650W-DC-AFI</li> <li>QFX5120-48YM: JPSU-850W-DC-AFO and JPSU-850W-DC-AFI</li> </ul>
Field-replaceable unit (FRU) type	Hot-insertable and hot-removable

Table 30: Specifications of the DC Power Supplies Used in QFX5120 Switches (Continued)

Item	Specifications
Weight	<ul style="list-style-type: none"> <li>• QFX5120-32C: 2.2 lb (0.98 kg)</li> <li>• QFX5120-48T and QFX5120-48Y: 2.2 lb (0.98 kg)</li> <li>• QFX5120-48YM: 2.2 lb (1 kg)</li> </ul>
Minimum installed in chassis	1
Maximum installed in chassis	2
Power supply slots	<ul style="list-style-type: none"> <li>• QFX5120-32C switches—Install power supply in slots labeled <b>PS0</b> and <b>PS1</b> in the rear panel of the chassis.</li> <li>• QFX5120-48T, QFX5120-48Y, and QFX5120-48YM switches—Install power supply in slots labeled <b>0</b> and <b>1</b> with a power icon next to them in the rear panel of the chassis.</li> </ul>
Fans	Internal
Airflow	<ul style="list-style-type: none"> <li>• Front-to-back, indicated by the label <b>F2B</b> and a red handle in QFX5120-32C switches and by the label <b>AIR OUT</b> and a Juniper Gold handle in QFX5120-48T, QFX5120-48Y, and QFX5120-48YM switches.</li> <li>• Back-to-front, indicated by label <b>B2F</b> and a blue handle in QFX5120-32C switches and by the label <b>AIR IN</b> and a Juniper Azure Blue handle in QFX5120-48T, QFX5120-48Y, and QFX5120-48YM switches.</li> </ul>
Power supply status LEDs	<ul style="list-style-type: none"> <li>• QFX5120-32C switch—Bi-colored LED</li> <li>• QFX5120-48T switch—<b>AC</b>, <b>DC</b>, and <b>!</b> (fault)</li> <li>• QFX5120-48Y switch—<b>AC</b>, <b>DC</b>, and <b>!</b> (fault)</li> <li>• QFX5120-48YM switch—<b>AC</b>, <b>DC</b>, and <b>!</b> (fault)</li> </ul>

To prevent electrical injury while installing or removing DC power supplies, carefully follow instructions in ["Connect Power to a DC-Powered QFX5120 Switch"](#) on page 171 and ["Maintain the QFX5120 Power System"](#) on page 201.

## DC Power Supply Airflow

Each power supply has its own fan and is cooled by its own internal cooling system.



**CAUTION:** Verify that the airflow direction in the power supplies matches the airflow direction in the fan modules. Ensure that each power supply that you install in the chassis has the same airflow direction. If you install power supplies with two different airflow directions, Junos OS raises an alarm. If you need to change the airflow direction in a chassis, you must replace all the fan modules and power supplies with the other airflow direction and update the installation base (see *Register Products—Mandatory to Validate SLAs*).

[Table 31 on page 77](#) lists the DC power supply models and the direction of airflow in them. The power supplies have color-coded handles and labels that indicate the direction of the airflow.

**Table 31: Airflow Direction in DC Power Supplies for QFX5120 Switches**

Model	Color of the Power Supply Handle	Label	Direction of Airflow
QFX5120-32C— QFX520048Y- DC-AFO	Red	<b>F2B</b>	Front-to-back—Cold air intake to cool the chassis is through the vents on the front panel of the chassis and hot air exhausts through the vents on the rear panel of the chassis.
QFX5120-48T and QFX5120-48Y— JPSU-650W-DC-AFO	Juniper Gold	<b>AIR OUT</b>	
QFX5120-48YM— JPSU-850W-DC-AFO	Juniper Gold	<b>AIR OUT</b>	
QFX5120-32C— QFX520048Y- DC-AFI	Blue	<b>B2F</b>	Back-to-front—Cold air intake to cool the chassis is through the vents on the rear panel of the chassis and hot air exhausts through the vents on the front panel of the chassis.

**Table 31: Airflow Direction in DC Power Supplies for QFX5120 Switches (Continued)**

Model	Color of the Power Supply Handle	Label	Direction of Airflow
QFX5120-48T and QFX5120-48Y– JPSU-650W-DC-AFI	Juniper Azure Blue	<b>AIR IN</b>	
QFX5120-48YM– JPSU-850W-DC-AFI	Juniper Azure Blue	<b>AIR IN</b>	

## Power Supply Specifications for DC Power Supplies for QFX5120 Switches

QFX5120-32C, QFX5120-48T, and QFX5120-48Y switches support 650-W AC or DC power supplies. Additionally, QFX5120-48T switches support two 850-W high-voltage power supplies with AC or DC input. QFX5120-48YM switches support two 850-W AC or DC power supplies.

[Table 32 on page 78](#) shows the power supply specifications for DC power supplies for QFX5120-32C switches.

**Table 32: Power Supply Specifications for DC Power Supplies for QFX5120-32C Switches**

Item	Specifications
DC input voltage	<ul style="list-style-type: none"> <li>Rated operating voltage: –48 VDC through 60 VDC</li> <li>Operating voltage range: –40.8 VDC through 72 VDC</li> </ul>
DC input current rating	16 A maximum
Typical power consumption	231 W
Maximum power consumption	493 W

**NOTE:** The maximum power consumption values specified here assumes 3.5W power per 100G optical module used.

Table 33 on page 79 shows the power supply specifications for DC power supplies for QFX5120-48T switches.

**Table 33: Power Supply Specifications for DC Power Supplies for QFX5120-48T Switches**

Item	Specifications
DC input voltage	<ul style="list-style-type: none"> <li>Rated operating voltage: -48 VDC through 60 VDC</li> <li>Operating voltage range: -44 VDC through 72 VDC</li> </ul>
DC input current rating	10 A maximum
Typical power consumption	222 W
Maximum power consumption	227 W

Table 34 on page 79 shows the power supply specifications for DC power supplies for QFX5120-48Y switches.

**Table 34: Power Supply Specifications for DC Power Supplies for QFX5120-48Y Switches**

Item	Specifications
DC input voltage	<ul style="list-style-type: none"> <li>Rated operating voltage: -48 VDC through 60 VDC</li> <li>Operating voltage range: -40.8 VDC through 72 VDC</li> </ul>
DC input current rating	10.5 A maximum
Typical power consumption	319 W
Maximum power consumption	342 W



Table 35 on page 80 shows the power supply specifications for DC power supplies for QFX5120-48YM switches.

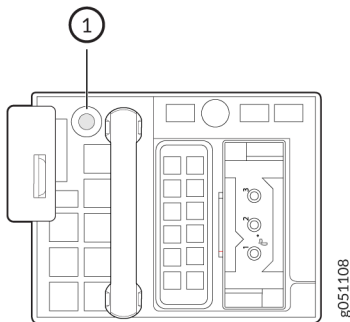
**Table 35: Power Supply Specifications for DC Power Supplies for QFX5120-48YM Switches**

Item	Specifications
DC input voltage	<ul style="list-style-type: none"> <li>Rated operating voltage: -48 VDC through 60 VDC</li> <li>Operating voltage range: -43.2 VDC through 69 VDC</li> </ul>
DC input current rating	16 A maximum
Typical power consumption	333 W
Maximum power consumption	356 W

## LEDs on the DC Power Supplies Used in QFX5120 Switches

Figure 63 on page 80 shows the LED on the DC power supply for QFX5120-32C switches. Figure 64 on page 82 shows the LEDs on the DC power supply for QFX5120-48T, QFX5120-48Y, and QFX5120-48YM switches.

**Figure 63: LED on the DC Power Supply for QFX5120-32C Switches**



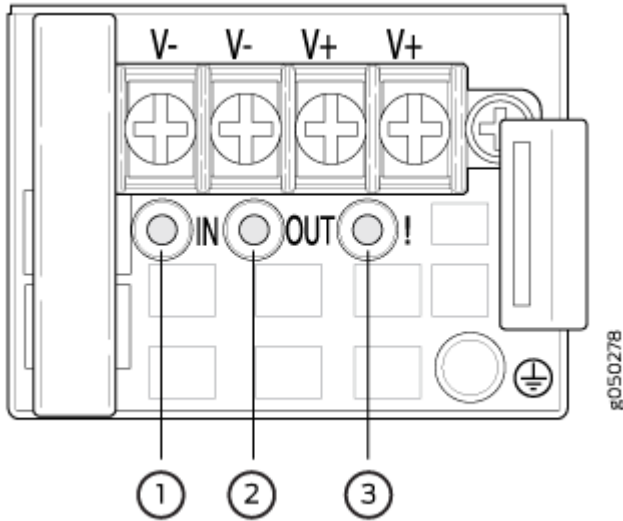
1- LED

Table 36 on page 81 describes the LED on the DC power supply for QFX5120-32C switches.

**Table 36: LED on the DC Power Supply for QFX5120-32C Switches**

Color	State	Description
Green	On steadily	The power supply is sending out power correctly.
	Blinking	The power supply is in standby mode and is receiving power at +5 V.
Alternating red/green	Blinking	Power supply warning. Check the logs for related messages.
Red	On steadily	An error is detected in the power supply. Replace the power supply as soon as possible. To maintain proper airflow through the chassis, leave the power supply installed in the chassis until you are ready to replace it.
	Blinking	The internal fan in the power supply has failed. Replace the power supply as soon as possible. To maintain proper airflow through the chassis, leave the power supply installed in the chassis until you are ready to replace it.
Unlit	Unlit	The power supply is disconnected from power, or the power supply is not receiving power.

Figure 64: LEDs on the DC Power Supply for QFX5120-48T, QFX5120-48Y, and QFX5120-48YM Switches



1– In LED (labeled **IN**)

3– Fault LED (labeled **!**)

2– Out LED (labeled **OUT**)



**CAUTION:** The V+ terminals are shunted internally together, as are the V- terminals. You can wire the same polarity terminal together from the same source to provide an additional current path in a higher power chassis. Do not connect the terminals to different sources.

Table 37 on page 82 describes the LEDs on the DC power supplies for QFX5120-48T, QFX5120-48Y, and QFX5120-48YM switches.

Table 37: LEDs on the DC Power Supplies for QFX5120-48T, QFX5120-48Y, and QFX5120-48YM Switches

LED Label	Color	State	Description
<b>IN</b>	Green	On steadily	The power supply is receiving power.
	Unlit	Unlit	The power supply is disconnected from power, or the power supply is not receiving power.
<b>OUT</b>	Green	On steadily	The power supply is sending out power correctly.

**Table 37: LEDs on the DC Power Supplies for QFX5120-48T, QFX5120-48Y, and QFX5120-48YM Switches (Continued)**

LED Label	Color	State	Description
	Unlit	Unlit	The power supply is disconnected from power, or the power supply is not sending out power correctly.
! (Fault)	Amber	On steadily	An error is detected in the power supply. Replace the power supply as soon as possible. To maintain proper airflow through the chassis, leave the power supply installed in the chassis until you are ready to replace it.

## High-Voltage Power Supply for QFX5120-48T Switches

### IN THIS SECTION

- [Characteristics of the High-Voltage Power Supply for QFX5120-48T Switches | 84](#)
- [High-Voltage Power Supply Airflow | 85](#)
- [Power Supply Specifications for High-Voltage Power Supplies for QFX5120-48T switches | 86](#)
- [Specifications of the Power Cord for High-Voltage Power Supply for QFX5120-48T Switches | 87](#)
- [LEDs on the High-Voltage Power Supply Used in QFX5120-48T Switches | 91](#)

QFX5120 switches support two 650-W AC or DC power supplies with front-to-back or back-to-front airflow directions. Additionally, QFX5120-48T switches support two 850-W high-voltage power supplies with AC or DC input and front-to-back or back-to-front airflow. You must order a high-voltage power supply separately. Power supplies for the QFX5120 switch are fully redundant, load-sharing, and hot-removable and hot-insertable FRUs when the second power supply is installed and running. You can remove and replace them without powering off the switch or disrupting switch functions. We ship QFX5120 switch models with two AC or DC power supplies preinstalled in the rear panel of the chassis. This topic describes the high-voltage power supplies supported on QFX5120-48T switches.



**CAUTION:** Do not mix:

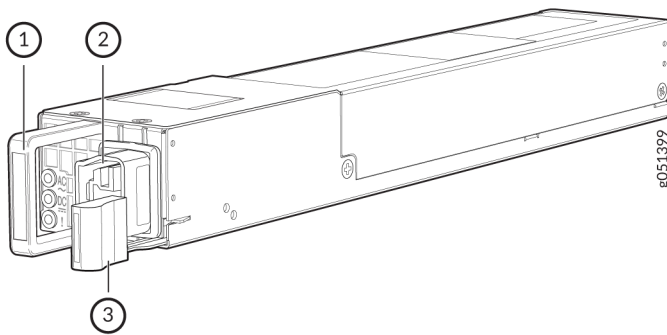
- AC and DC power supplies in the same chassis.
- 650-W and 850-W power supplies in the same QFX5120-48T chassis.
- Power supplies with different airflow directions in the same chassis.
- Power supplies and fan modules with different airflow directions in the same chassis.

## Characteristics of the High-Voltage Power Supply for QFX5120-48T Switches

QFX5120-48T switches support two high-voltage power supplies with AC or DC input and front-to-back or back-to-front airflow.

Figure 65 on page 84 shows the high-voltage power supply for QFX5120-48T switches.

**Figure 65: High-Voltage Power Supply for QFX5120-48T Switches**



1– Power supply handle

3– Ejector lever

2– Power cord inlet

You can install up to two power supplies in the power supply slots in the rear panel of the QFX5120 switch chassis. On QFX5120-48T switches, the slots are labeled **0** and **1** and have a power icon next to them.

Table 38 on page 85 lists the specifications of the high-voltage power supplies used in QFX5120-48T switches.

**Table 38: Specifications of the High-Voltage Power Supplies Used in QFX5120-48T Switches**

Item	Specifications
Model number	QFX5120-48T: JPSU-850W-HV-AFO or JPSU-850W-HV-AFI
Field-replaceable unit (FRU) type	Hot-insertable and hot-removable
Weight	2.2 lb (1 kg)
Minimum installed in chassis	1
Maximum installed in chassis	2
Power supply slots	Slots labeled <b>0</b> and <b>1</b> with a power icon next to them in the rear panel of the chassis.
Fans	Internal
Power supply status LEDs	<b>AC</b> , <b>DC</b> , and <b>!</b> (fault)

To prevent electrical injury while installing or removing power supplies, carefully follow instructions in ["Connect Power to a QFX5120-48T Switch Powered by a High-Voltage Power Supply" on page 177](#) and ["Maintain the QFX5120 Power System" on page 201](#).

## High-Voltage Power Supply Airflow

Each power supply is cooled by its own internal cooling system.

The power supplies have color-coded handles that indicate the direction of the airflow. The Juniper Gold handles and **AIR OUT** label on the power supplies for QFX5120-48T switches indicate front-to-back airflow. The Juniper Azure Blue handles and **AIR IN** label on the power supplies for QFX5120-48T switches indicate back-to-front airflow.



**CAUTION:** Verify that the airflow direction in the power supplies matches the airflow direction in the fan modules. Ensure that each power supply that you install in the chassis has the same airflow direction. If you install power supplies with two different

airflow directions, Junos OS raises an alarm. If you need to change the airflow direction in a chassis, you must replace all the fan modules and power supplies with the other airflow direction and update the installation base (see *Register Products—Mandatory to Validate SLAs*).

Table 39 on page 86 lists the high-voltage power supplies used in QFX5120-48T switches and the direction of airflow in them.

**Table 39: Airflow Direction in High-Voltage Power Supplies for QFX5120-48T Switches**

Power Supply	Direction of Airflow	Color of the Power Supply Handle
JPSU-850W-HV-AFO	Front-to-back—cold air intake to cool the chassis is through the vents on the front panel of the chassis and hot air exhausts through the vents on the rear panel of the chassis.	Juniper Gold
JPSU-850W-HV-AFI	Back-to-front—cold air intake to cool the chassis is through the vents on the rear panel of the chassis and hot air exhausts through the vents on the front panel of the chassis.	Juniper Azure Blue

## Power Supply Specifications for High-Voltage Power Supplies for QFX5120-48T switches

Table 40 on page 86 shows the power supply specifications for the high-voltage power supplies for QFX5120-48T switches operating with AC input.

**Table 40: Power Supply Specifications for the High-Voltage Power Supplies for QFX5120-48T Switches Operating with AC Input**

Item	Specification
AC input voltage	Operating range: 100 VAC through 277 VAC
AC input line frequency	50–60 Hz

**Table 40: Power Supply Specifications for the High-Voltage Power Supplies for QFX5120-48T Switches Operating with AC Input (Continued)**

Item	Specification
AC input current rating	<ul style="list-style-type: none"> <li>• 6 A at 100 VAC</li> <li>• 3 A at 277 VAC</li> </ul>
Typical power consumption	290 W
Maximum power	440 W

[Table 41 on page 87](#) shows the power supply specifications for the high-voltage power supplies for QFX5120-48T switches operating with DC input.

**Table 41: Power Supply Specifications for the High-Voltage Power Supplies for QFX5120-48T Switches Operating with DC Input**

Item	Specification
DC input voltage	Operating range: 240 VDC through 380 VDC
DC input current rating	4 A
Typical power consumption	290 W
Maximum power	440 W

### Specifications of the Power Cord for High-Voltage Power Supply for QFX5120-48T Switches

You can order a detachable power cord separately for your high-voltage power supplies. The plug or connector of the power cord fits into the power source outlet that is standard for your geographical location.



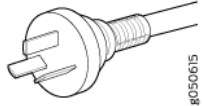
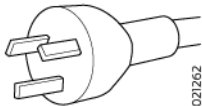
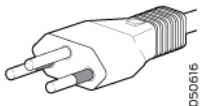
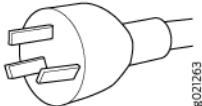
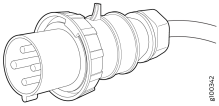


**CAUTION:** The power cord provided with each power supply is intended for use with that power supply only and not for any other use.



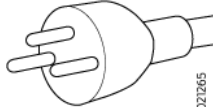

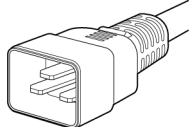

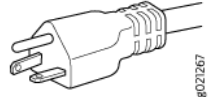
**NOTE:** In North America, AC power cords must not exceed 4.5 meters in length, to comply with National Electrical Code (NEC) Sections 400-8 (NFPA 75, 5-2.2) and 210-52 and Canadian Electrical Code (CEC) Section 4-010(3). The cords supplied with the switch are in compliance.

Table 42 on page 88 lists the specifications of the power cord for the high-voltage power supplies provided for the countries and regions listed in the table.

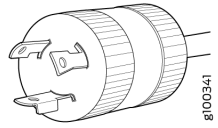
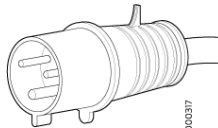


**Table 42: Specifications of the Power Cords for the High-Voltage Power Supplies**

Locale	Cord Set Rating	Plug Standards	Spare Juniper Model Number	Graphic
Argentina	16 A, 250 VAC	IRAM 2073 Type RA/3	CBL-JNP-SG4-AR	
Australia and New Zealand	15 A, 250 VAC	AS/NZS 4417	CBL-JNP-SG4-AU	
Brazil	16 A, 250 VAC	NBR 14136 Type BR/3	CBL-JNP-SG4-BR	
China	16 A, 250 VAC	GB2099	CBL-JNP-SG4-CH	
Europe (except Italy, Switzerland, and United Kingdom)	20 A, 250 VAC	CEE 7/7 STRAIGHT	CBL-JNP-SG4-EU	

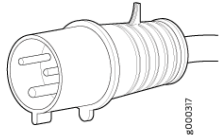
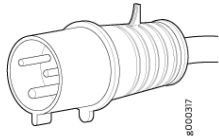
**Table 42: Specifications of the Power Cords for the High-Voltage Power Supplies (Continued)**

Locale	Cord Set Rating	Plug Standards	Spare Juniper Model Number	Graphic
Great Britain	13 A, 250 VAC,	BS1363	CBL-JNP-SG4-UK	 8021271
India	16 A, 250 VAC	SANS 164-1	CBL-JNP-SG4-SA	 8021270
Israel	16 A, RA, 250 VAC	SI 32/1971 Type IL/3G	CBL-JNP-SG4-IL	 8021265
Italy	16 A, 250 VAC	CEI 23-16	CBL-JNP-SG4-IT	 8021266
North America	20 A, 250 VAC	C20 to Anderson 3-5958p4	CBL-JNP-SG4-C20	 8050751
North America	16 A, 250 VAC	Locking NEMA L6-20P	CBL-JNP-SG4-US-L	 8021268
North America	16 A, 250 VAC	NEMA 6-20P	CBL-JNP-SG4-US	 8021267

**Table 42: Specifications of the Power Cords for the High-Voltage Power Supplies (Continued)**

Locale	Cord Set Rating	Plug Standards	Spare Juniper Model Number	Graphic
North America	15 A, 277 V	NEMA I7-20P	CBL-JNP-SG4-HVAC	 #100341
North America	20 A, 250 V	IEC 320P6W	CG_CBL-APP-400-02	 #00037
South Africa	16 A, 250 VAC	SANS 164-1	CBL-JNP-SG4-SA	 #021270
Switzerland	16 A, 250 VAC	CEI 23-50	CBL-JNP-SG4-SZ	 #021266
All countries	16 A, 400 VAC	You can attach a plug as permitted by the local code.	CBL-PWR2-BARE	This bare cable is used for connecting to DC power input and is shipped without any lug attached. You can attach DC connector lugs as permitted by the local code.

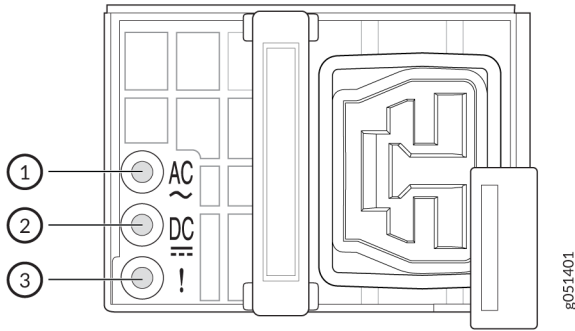
**Table 42: Specifications of the Power Cords for the High-Voltage Power Supplies (Continued)**

Locale	Cord Set Rating	Plug Standards	Spare Juniper Model Number	Graphic
All countries	16 A, 400 VAC	You can attach a plug as permitted by the local code.	CBL-PWR2-BARE-RA	This bare cable is used for connecting to DC power input and is shipped without any lug attached. You can attach DC connector lugs as permitted by the local code.
North America	30 A, 400 VAC	Both the ends of this cable have the same SAF-D-Grid connector.	CBL-PWR-SG4	Both the ends of this cable have the same SAF-D-Grid connector.
Europe	16 A, 250 VAC	IEC 316P6	CBL-JNP-SG4-316P6	 A technical drawing of a SAF-D-Grid connector, showing a cylindrical body with a grid of pins on the front and a small tab on the side. The part number #000317 is visible at the bottom right.
North America and Canada	20 A, 250 VAC	IEC 320P6	CBL-JNP-SG4-320P6	 A technical drawing of a SAF-D-Grid connector, showing a cylindrical body with a grid of pins on the front and a small tab on the side. The part number #000317 is visible at the bottom right.

### LEDs on the High-Voltage Power Supply Used in QFX5120-48T Switches

Figure 66 on page 92 shows the location of the LEDs on the high-voltage power supply used in QFX5120-48T switches.

Figure 66: LEDs on the High-Voltage Power Supply Used in QFX5120-48T Switches



1– AC LED (labeled AC)

3– Fault LED (labeled !)

2– DC LED (labeled DC)

Table 43 on page 92 describes the LEDs on the high-voltage power supply used in QFX5120-48T switches.

Table 43: LEDs on the High-Voltage Power Supply Used in QFX5120-48T Switches

LED Label	Color	State	Description
AC	Green	On steadily	The power supply is receiving power.
	Unlit	Unlit	<ul style="list-style-type: none"> <li>The power supply is disconnected from power, or the power supply is not receiving power.</li> <li>The AC power cord or DC input cables might not be installed properly, or the power input voltage might not be within normal operating range.</li> </ul>
DC	Green	On steadily	The power supply is sending out power correctly.
	Unlit	Unlit	<ul style="list-style-type: none"> <li>The power supply is disconnected from power, or the power supply is not receiving power.</li> <li>The AC power cord or DC input cables might not be installed properly, or the power input voltage might not be within normal operating range.</li> <li>The power supply might have an internal failure.</li> </ul>

**Table 43: LEDs on the High-Voltage Power Supply Used in QFX5120-48T Switches (Continued)**

LED Label	Color	State	Description
!(Fault)	Amber	On steadily	An error is detected in the power supply. Replace the power supply as soon as possible. To maintain proper airflow through the chassis, leave the power supply installed in the chassis until you are ready to replace it.

# 2

CHAPTER

## Site Planning, Preparation, and Specifications

---

Site Preparation Checklist for QFX5120 Switches | 95

QFX5120 Site Guidelines and Requirements | 97

QFX5120 Network Cable and Transceiver Planning | 106

QFX5120 Management Cable Specifications and Pinouts | 112

---

# Site Preparation Checklist for QFX5120 Switches

The checklist in [Table 44 on page 95](#) summarizes the tasks you need to perform to prepare a site for installing a QFX5120 switch.

**Table 44: Site Preparation Checklist**

Item or Task	For More Information	Performed by	Date
<b>Environment</b>			
Verify that environmental factors such as temperature and humidity do not exceed switch tolerances.	<a href="#">"Environmental Requirements and Specifications for QFX5120 Switches" on page 97</a>		
<b>Power</b>			
Measure the distance between external power sources and the switch installation site.	<a href="#">"Clearance Requirements for Airflow and Hardware Maintenance for QFX5120 Switches" on page 103</a>		
Locate sites to connect system grounding.			
Calculate the power consumption and requirements.	<ul style="list-style-type: none"> <li>• <a href="#">"Power Supply Specifications for AC Power Supplies for QFX5120 Switches" on page 63</a></li> <li>• <a href="#">"Power Supply Specifications for DC Power Supplies for QFX5120 Switches" on page 78</a></li> <li>• <a href="#">"High-Voltage Power Supply for QFX5120-48T Switches" on page 83</a></li> </ul>		
<b>Hardware Configuration</b>			



Table 44: Site Preparation Checklist (Continued)

Item or Task	For More Information	Performed by	Date
Choose the number and types of switches you want to install.	<a href="#">"QFX5120 Switches Hardware Overview" on page 2</a>		
<b>Rack or Cabinet</b>			
Verify that the rack or cabinet meets the minimum requirements for installing the switch.	<ul style="list-style-type: none"> <li>• <a href="#">"Rack Requirements for QFX5120 Switches" on page 100</a></li> <li>• <a href="#">"Cabinet Requirements for QFX5120 Switches" on page 101</a></li> </ul>		
Plan rack or cabinet location, including required space clearances.			
Secure the rack or cabinet to the floor and building structure.			
<b>Cables</b>			
<p>Acquire cables and connectors:</p> <ul style="list-style-type: none"> <li>• Determine the number of cables needed based on your planned configuration.</li> <li>• Review the maximum distance allowed for each cable. Choose the length of the cable based on the distance between the hardware components being connected.</li> </ul>			
Plan the cable routing and management.			

# QFX5120 Site Guidelines and Requirements

## IN THIS SECTION

- Environmental Requirements and Specifications for QFX5120 Switches | 97
- General Site Guidelines | 98
- Site Electrical Wiring Guidelines | 99
- Rack Requirements for QFX5120 Switches | 100
- Cabinet Requirements for QFX5120 Switches | 101
- Clearance Requirements for Airflow and Hardware Maintenance for QFX5120 Switches | 103

## Environmental Requirements and Specifications for QFX5120 Switches

You must install the switch in a rack or cabinet. It must be housed in a dry, clean, well-ventilated, and temperature-controlled environment.

Follow these environmental guidelines:

- The site must be as dust-free as possible, because dust can clog air intake vents and filters, reducing the efficiency of the switch cooling system.
- Maintain ambient airflow for normal switch operation. If the airflow is blocked or restricted, or if the intake air is too warm, the switch might overheat, leading to the switch temperature monitor shutting down the device to protect the hardware components.

[Table 45 on page 97](#) provides the required environmental conditions for normal switch operation for QFX5120.

**Table 45: QFX5120 Environmental Tolerances**

Switch	Altitude	Relative Humidity	Temperature	Seismic
QFX5120-32C	No performance degradation up to 16,404 feet (5000 meters)	Normal operation ensured in relative humidity range of 5%	<ul style="list-style-type: none"> <li>● Normal operation ensured in</li> </ul>	

Table 45: QFX5120 Environmental Tolerances (Continued)

Switch	Altitude	Relative Humidity	Temperature	Seismic
QFX5120-48T	No performance degradation up to 6000 feet (1829 meters)	through 90%, noncondensing	temperature range of 32° F through 104° F (0° C through 40° C) <ul style="list-style-type: none"> <li>• Nonoperating storage temperature in shipping container: -40° F through 158° F (-40° C through 70° C)</li> </ul>	
QFX5120-48Y	No performance degradation up to 6000 feet (1829 meters)			
QFX5120-48Y M	No performance degradation up to 6000 feet (1829 meters)			

**NOTE:** Install the QFX5120 only in restricted-access areas, such as dedicated equipment rooms and equipment closets, in accordance with Articles 110-16, 110-17, and 110-18 of the National Electrical Code, ANSI/NFPA 70.

## General Site Guidelines


Efficient device operation requires proper site planning and maintenance. It also requires proper layout of the equipment, rack or cabinet, and wiring closet.

To plan and create an acceptable operating environment for your device and prevent environmentally caused equipment failures:

- Keep the area around the chassis free from dust and conductive material, such as metal flakes.
- Follow the prescribed airflow guidelines to ensure that the cooling system functions properly. Ensure that exhaust from other equipment does not blow into the intake vents of the device.
- Follow the prescribed electrostatic discharge (ESD) prevention procedures to prevent damaging the equipment. Static discharge can cause components to fail completely or intermittently over time.
- Install the device in a secure area, so that only authorized personnel can access the device.

## Site Electrical Wiring Guidelines

Table 46 on page 99 describes the factors you must consider while planning the electrical wiring at your site.

 **WARNING:** You must provide a properly grounded and shielded environment and use electrical surge-suppression devices.

**Avertissement** Vous devez établir un environnement protégé et convenablement mis à la terre et utiliser des dispositifs de parasurtension.

**Table 46: Site Electrical Wiring Guidelines**

Site Wiring Factor	Guidelines
Signaling limitations	<p>If your site experiences any of the following problems, consult experts in electrical surge suppression and shielding:</p> <ul style="list-style-type: none"> <li>• Improperly installed wires cause radio frequency interference (RFI).</li> <li>• Damage from lightning strikes occurs when wires exceed recommended distances or pass between buildings.</li> <li>• Electromagnetic pulses (EMPs) caused by lightning damage unshielded conductors and electronic devices.</li> </ul>
Radio frequency interference	<p>To reduce or eliminate RFI from your site wiring, do the following:</p> <ul style="list-style-type: none"> <li>• Use a twisted-pair cable with a good distribution of grounding conductors.</li> <li>• If you must exceed the recommended distances, use a high-quality twisted-pair cable with one ground conductor for each data signal, when applicable.</li> </ul>
Electromagnetic compatibility	<p>If your site is susceptible to problems with electromagnetic compatibility (EMC), particularly from lightning or radio transmitters, seek expert advice.</p> <p>Strong sources of electromagnetic interference (EMI) can cause:</p> <ul style="list-style-type: none"> <li>• Destruction of the signal drivers and receivers in the device</li> <li>• Electrical hazards as a result of power surges conducted over the lines into the equipment.</li> </ul>

## Rack Requirements for QFX5120 Switches

You can mount QFX5120 switches on a four-post 19-in. rack or a two-post 19-in. rack as defined in *Cabinets, Racks, Panels, and Associated Equipment* (document number EIA-310-D) published by the Electronics Industry Association.

[Table 47 on page 100](#) provides the rack requirements and specifications for QFX5120 switches.

**Table 47: Rack Requirements and Specifications for QFX5120 Switches**

Rack Requirements	Specifications
Type and strength	<p>Use a four-post rack that provides bracket holes or hole patterns spaced at 1-U (1.75 in. or 4.45 cm) increments and that meets the size and strength requirements to support the weight.</p> <p>Use a two-post rack that provides bracket holes or hole patterns spaced at 1-U (1.75 in. or 4.45 cm) increments and that meets the size and strength requirements to support the weight.</p> <p>A U is the standard rack unit defined in <i>Cabinets, Racks, Panels, and Associated Equipment</i> (document number EIA-310-D) published by the Electronics Industry Association.</p>
Size, airflow, and clearance requirements	<ul style="list-style-type: none"> <li>• If you are mounting a QFX5120-32C switch, ensure that the rack has a depth of 23.6 in. (60 cm).</li> <li>• If you are mounting a QFX5120-48T, QFX5120-48Y, or QFX5120-48YM switch flush with the front posts of a rack, ensure that the distance between the front posts and the rear posts is between 27.5 in. (69.9 cm) and 30.5 in. (77.5 cm).</li> <li>• If you are mounting a QFX5120-48T, QFX5120-48Y, or QFX5120-48YM switch in a recessed position from the front posts of a rack, ensure that the distance between the front posts and the rear posts is between 29.5 in. (75 cm) and 32.5 in. (82.6 cm).</li> <li>• Ensure that the rack rails are spaced widely enough to accommodate the external dimensions of the switch chassis. The outer edges of the front-mounting brackets extend the width to 19 in. (48.26 cm).</li> <li>• Route and dress all cables to minimize the blockage of airflow to and from the chassis.</li> <li>• Ensure that the spacing of rails and adjacent racks allows for proper clearance around the switch and rack.</li> </ul>

**Table 47: Rack Requirements and Specifications for QFX5120 Switches (Continued)**

Rack Requirements	Specifications
Connection to building structure	<ul style="list-style-type: none"> <li>• Secure the rack to the building structure.</li> <li>• If your geographical area is earthquake-prone, secure the rack to the floor.</li> <li>• Secure the rack to the ceiling brackets as well as wall or floor brackets for maximum stability.</li> </ul>

## Cabinet Requirements for QFX5120 Switches

You can mount QFX5120 switches in a cabinet that contains a four-post 19-in. rack as defined in *Cabinets, Racks, Panels, and Associated Equipment* (document number EIA-310-D) published by the Electronics Industry Association.

[Table 48 on page 101](#) provides the cabinet requirements and specifications for QFX5120 switches.

**Table 48: Cabinet Requirements and Specifications for QFX5120 Switches**

Cabinet Requirements	Specifications
Type and strength	<p>Use a cabinet that is at least 36 in. (91.4 cm) deep. Large cabinets improve airflow and reduce the chance of overheating. The cabinet must contain a four-post rack that provides bracket holes or hole patterns spaced at 1-U (1.75 in. or 4.45 cm) increments and that meets the size and strength requirements to support the weight.</p> <p>A U is the standard rack unit defined in <i>Cabinets, Racks, Panels, and Associated Equipment</i> (document number EIA-310-D) published by the Electronics Industry Association.</p>

**Table 48: Cabinet Requirements and Specifications for QFX5120 Switches (Continued)**

Cabinet Requirements	Specifications
Size, airflow, and clearance requirements	<ul style="list-style-type: none"> <li>• If you are mounting a QFX5120-32C switch, ensure that the rack inside the cabinet has a depth of 23.6 in. (60 cm).</li> </ul> <p>If you are mounting a QFX5120-48T, QFX5120-48Y, or QFX5120-48YM switch flush with the front posts of a rack inside the cabinet, ensure that the distance between the front posts and the rear posts is between 27.50 in. (69.9 cm) and 30.5 in. (77.5 cm).</p> <ul style="list-style-type: none"> <li>• If you are mounting a QFX5120-48T, QFX5120-48Y, or QFX5120-48YM switch in a recessed position from the front posts of a rack inside the cabinet, ensure that the distance between the front posts and the rear posts is between 29.50 in. (75 cm) and 32.5 in. (82.6 cm).</li> <li>• When you mount the switch in a cabinet, ensure that ventilation through the cabinet is sufficient to prevent overheating.</li> <li>• Ensure that the cold air supply you provide through the cabinet adequately dissipates the thermal output of the switch (or switches).</li> <li>• Ensure that the cabinet allows the hot exhaust air from the switch to exit the cabinet without recirculating into the chassis. An open cabinet (without a top or doors) that employs hot air exhaust extraction from the top allows the best airflow through the chassis. If the cabinet contains a top or doors, perforations in these elements assist with removing the hot air exhaust.</li> <li>• The QFX5120 fans exhaust hot air either through the vents on the front panel or through the fan modules and power supplies. Install the switch in the cabinet in a way that maximizes the open space in front of or behind the chassis depending on the airflow direction inside the chassis. This maximizes the clearance for critical airflow.</li> <li>• Route and dress all cables to minimize the blockage of airflow to and from the chassis.</li> <li>• Ensure that the spacing of rails and adjacent cabinets allows for the proper clearance around the switch and cabinet.</li> </ul>
Connection to building structure	<ul style="list-style-type: none"> <li>• Secure the cabinet to the building structure.</li> <li>• If your geographical area is earthquake-prone, secure the cabinet to the floor.</li> <li>• Secure the cabinet to the ceiling brackets as well as wall or floor brackets for maximum stability.</li> </ul>

## Clearance Requirements for Airflow and Hardware Maintenance for QFX5120 Switches

When planning the site for installing a QFX5120 switch, you must ensure sufficient clearance around the switch.

- See [Figure 67 on page 104](#) for clearance requirements for QFX5120-32C switches.
- See [Figure 68 on page 104](#) for clearance requirements for QFX5120-48T switches.
- See [Figure 69 on page 105](#) for clearance requirements for QFX5120-48Y switches.
- See [Figure 70 on page 105](#) for clearance requirements for QFX5120-48YM switches.

Follow these clearance requirements:

- For the cooling system to function properly, ensure that the airflow around the chassis is unrestricted.
- If you are mounting the switch on a rack or cabinet along with other equipment, ensure that the hot air exhaust from other equipment does not blow into the cold air intake vents of the chassis.
- Leave at least 6 in. (15.2 cm) clearance in front of and behind the chassis for airflow.
- Leave at least 6 in. (15.2 cm) clearance on the left of the chassis for installing the grounding lug.
- NEBS GR-63 recommends that you allow at least 30 in. (76.2 cm) in front of the rack or cabinet and 24 in. (61 cm) behind the rack or cabinet.
- Leave at least 24 in. (61 cm) clearance in front of and behind the switch for service personnel to remove and install hardware components.



Figure 67: Clearance Requirements for Airflow and Hardware Maintenance for QFX5120-32C Switches

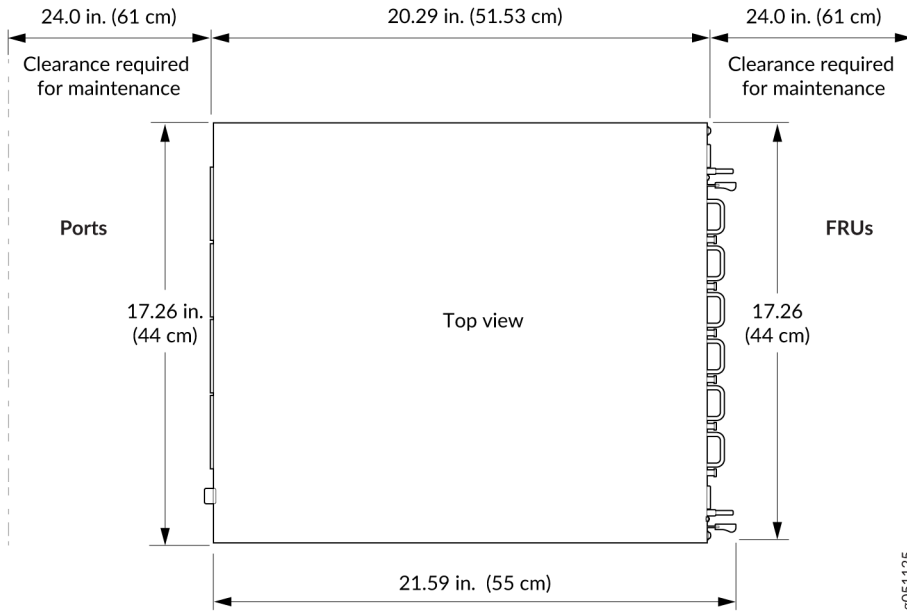
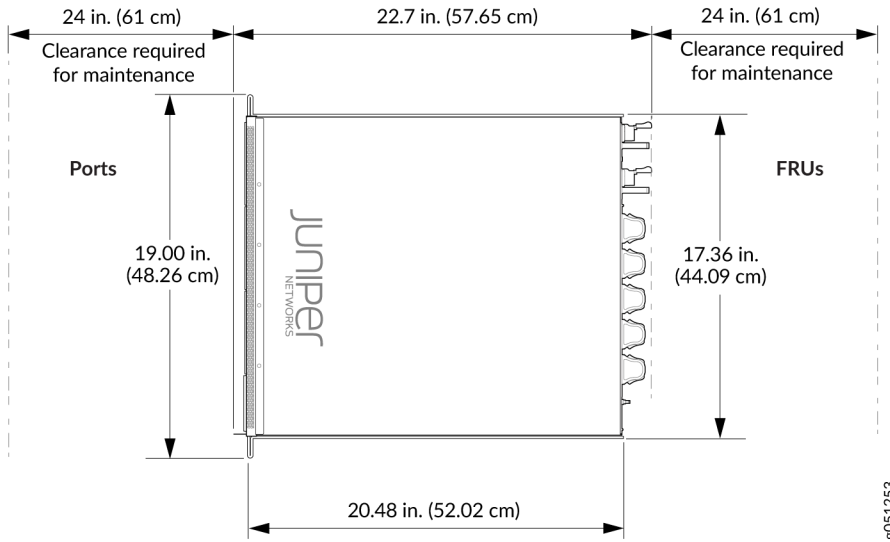
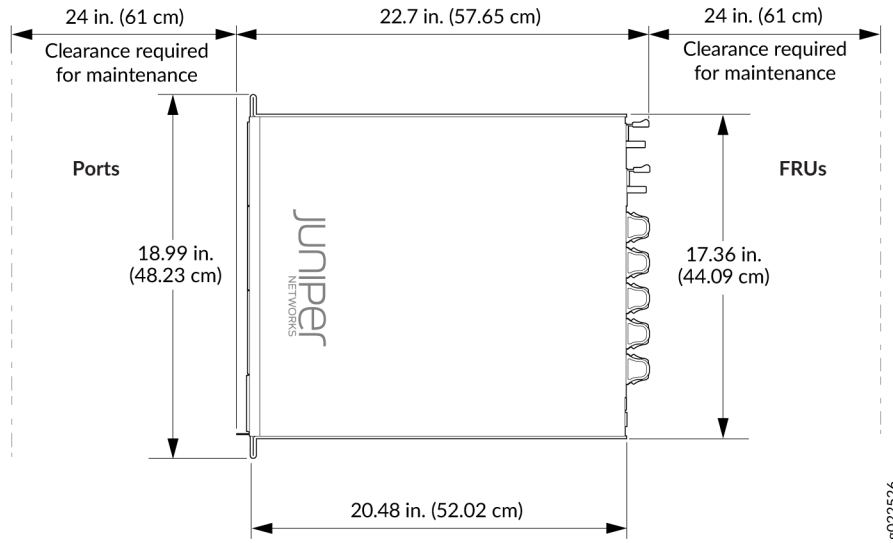


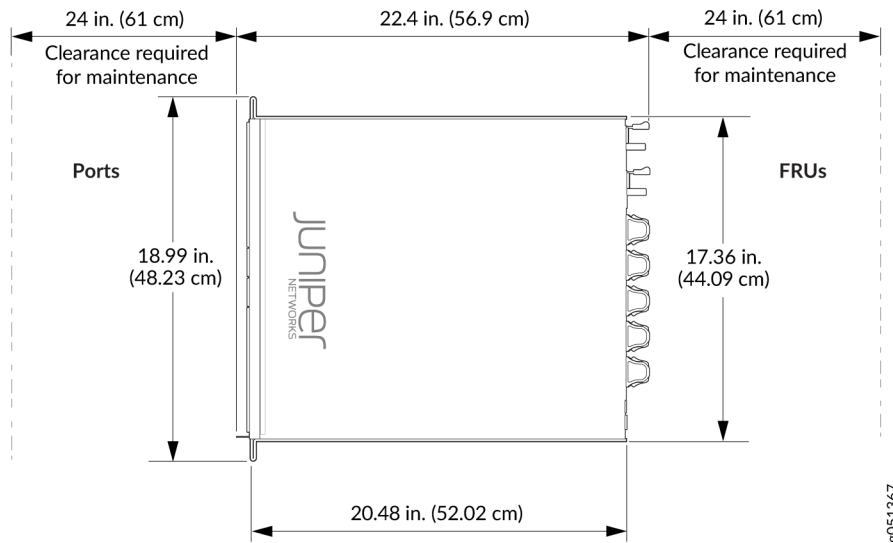
Figure 68: Clearance Requirements for Airflow and Hardware Maintenance for QFX5120-48T Switches



**Figure 69: Clearance Requirements for Airflow and Hardware Maintenance for QFX5120-48Y Switches**



**Figure 70: Clearance Requirements for Airflow and Hardware Maintenance for QFX5120-48YM Switches**



# QFX5120 Network Cable and Transceiver Planning

## IN THIS SECTION

- [Pluggable Transceivers and Direct Attach Cables Supported on QFX5120 Switches | 106](#)
- [Cable Specifications for QSFP+ and QSFP28 Transceivers on QFX5120 Switches | 107](#)
- [How to Calculate the Fiber-Optic Cable Power Budget for QFX Series Switches | 109](#)
- [How to Calculate the Fiber-Optic Cable Power Margin for QFX Series Switches | 110](#)

## Pluggable Transceivers and Direct Attach Cables Supported on QFX5120 Switches

QFX5120 switches support SFP, SFP+, SFP28, QSFP+, and QSFP28 transceivers. They also support direct attach cables. You can find the list of transceivers supported on QFX5120 switches and information about those transceivers at the following pages:

- QFX5120-32C—[Hardware Compatibility Tool page for QFX5120-32C](#)
- QFX5120-48T—[Hardware Compatibility Tool page for QFX5120-48T](#)
- QFX5120-48Y—[Hardware Compatibility Tool page for QFX5120-48Y](#)
- QFX5120-48YM—[Hardware Compatibility Tool page for QFX5120-48YM](#)

**NOTE:** We recommend that you use only optical transceivers and optical connectors purchased from Juniper Networks with your Juniper Networks device.



**CAUTION:** The Juniper Networks Technical Assistance Center (JTAC) provides complete support for Juniper-supplied optical modules and cables. However, JTAC does not provide support for third-party optical modules and cables that are not qualified or supplied by Juniper Networks. If you face a problem running a Juniper device that uses third-party optical modules or cables, JTAC may help you diagnose host-related issues if the observed issue is not, in the opinion of JTAC, related to the use of the third-party

optical modules or cables. Your JTAC engineer will likely request that you check the third-party optical module or cable and, if required, replace it with an equivalent Juniper-qualified component.

Use of third-party optical modules with high-power consumption (for example, coherent ZR or ZR+) can potentially cause thermal damage to or reduce the lifespan of the host equipment. Any damage to the host equipment due to the use of third-party optical modules or cables is the users' responsibility. Juniper Networks will accept no liability for any damage caused due to such use.

The Gigabit Ethernet transceivers installed in QFX5120 switches support digital optical monitoring (DOM): You can view the diagnostic details for these transceivers by issuing the operational mode CLI command `show interfaces diagnostics`.

## Cable Specifications for QSFP+ and QSFP28 Transceivers on QFX5120 Switches

The 40GbE QSFP+ and 100GbE QSFP28 transceivers used in QFX5120 switches use 12-ribbon multimode fiber crossover cables with MPO/UP, MPO/UPC, or MPO/APC socket connectors. The fiber can be either OM3 or OM4. We do not sell these cables.



**CAUTION:** To maintain agency approvals, use only a properly constructed, shielded cable.

**TIP:** Ensure that you order cables with the correct polarity. Vendors refer to these crossover cables as *key up to key up*, *latch up to latch up*, *Type B*, or *Method B*. If you are using patch panels between two QSFP+ ports, ensure that the proper polarity is maintained through the cable plant.

[Table 49 on page 108](#) describes the signals on each fiber. [Table 50 on page 108](#) shows the pin-to-pin connections for proper polarity.

**Table 49: QSFP+ and QSFP28 MPO Cable Signals**

Fiber	Signal
1	Tx0 (Transmit)
2	Tx1 (Transmit)
3	Tx2 (Transmit)
4	Tx3 (Transmit)
5	Unused
6	Unused
7	Unused
8	Unused
9	Rx3 (Receive)
10	Rx2 (Receive)
11	Rx1 (Receive)
12	Rx0 (Receive)

**Table 50: QSFP+ and QSFP28 MPO Fiber-Optic Crossover Cable Pinouts**

Pin	Pin
1	12
2	11

Table 50: QSFP+ and QSFP28 MPO Fiber-Optic Crossover Cable Pinouts (*Continued*)

Pin	Pin
3	10
4	9
5	8
6	7
7	6
8	5
9	4
10	3
11	2
12	1

## How to Calculate the Fiber-Optic Cable Power Budget for QFX Series Switches

Calculate the fiber-optic data link's power budget when planning fiber-optic cable layout and distances to ensure that fiber-optic connections have sufficient power for correct operation. The power budget is the maximum amount of power the link can transmit. When you calculate the power budget, you use a worst-case analysis to provide a margin of error, even though all the parts of an actual system do not operate at the worst-case levels.

To calculate the worst-case estimate for the fiber-optic cable power budget ( $P^B$ ) for the link:

1. Determine values for the link's minimum transmitter power ( $P_T$ ) and minimum receiver sensitivity ( $P_R$ ). For example, here, ( $P_T$ ) and ( $P_R$ ) are measured in decibels, and decibels are referenced to 1 milliwatt (dBm):

$$P_T = -15 \text{ dBm}$$

$$P_R = -28 \text{ dBm}$$

**NOTE:** See the specifications for your transmitter and receiver to find the minimum transmitter power and minimum receiver sensitivity.

2. Calculate the power budget ( $P^B$ ) by subtracting ( $P_R$ ) from ( $P_T$ ):
 
$$-15 \text{ dBm} - (-28 \text{ dBm}) = 13 \text{ dBm}$$

## How to Calculate the Fiber-Optic Cable Power Margin for QFX Series Switches

Before you calculate the power margin, calculate the power budget. See ["How to Calculate the Fiber-Optic Cable Power Budget for QFX Series Switches" on page 109](#).

Calculate the fiber-optic data link's power margin when planning fiber-optic cable layout and distances to ensure that fiber-optic connections have sufficient signal power to overcome system losses and still satisfy the minimum input requirements of the receiver for the required performance level. The power margin ( $P_M$ ) is the amount of power available after attenuation or link loss (LL) is subtracted from the power budget ( $P_B$ ).

When you calculate the power margin, you use a worst-case analysis to provide a margin of error, even though all the parts of an actual system do not operate at worst-case levels. A power margin ( $P_M$ ) greater than zero indicates that the power budget is sufficient to operate the receiver and that it does not exceed the maximum receiver input power. This means the link will work. A power margin ( $P_M$ ) that is zero or negative indicates insufficient power to operate the receiver. See the specification for your receiver to find the maximum receiver input power.

To calculate the worst-case estimate for the power margin ( $P_M$ ) for the link:

1. Determine the maximum value for link loss (LL) by adding estimated values for applicable link-loss factors; for example, use the sample values for various factors as provided in [Table 51 on page 111](#) (here, the link is 2 km long and multimode, and the power margin ( $P_M$ ) is 13 dBm).

Table 51: Estimated Values for Factors Causing Link Loss

Link-Loss Factor	Estimated Link Loss Value	Sample Link Loss Calculation Values
Higher-order mode losses	Multimode—0.5 dBm	0.5 dBm
	Single-mode—None	0 dBm
Modal and chromatic dispersion	Multimode—None, if the sum of bandwidth and distance is less than 500 MHz/km	0 dBm
	Single-mode—None	0 dBm
Connector	0.5 dBm	This example assumes five connectors. Loss for five connectors: 5 (0.5 dBm) = 2.5 dBm.
Splice	0.5 dBm	This example assumes two splices. Loss for two splices: 2 (0.5 dBm) = 1 dBm.
Fiber attenuation	Multimode—1 dBm/km	This example assumes the link is 2 km long. Fiber attenuation for 2 km: 2 km (1 dBm/km) = 2 dBm.
	Single-mode—0.5 dBm/km	This example assumes the link is 2 km long. Fiber attenuation for 2 km: 2 km (0.5 dBm/km) = 1 dBm.
Clock Recovery Module (CRM)	1 dBm	1 dBm

**NOTE:** For information about the actual amount of signal loss caused by equipment and other factors, see your vendor documentation for that equipment.

- Calculate the ( $P_M$ ) by subtracting (LL) from ( $P_B$ ):

$$P_B - LL = P_M$$

$$13 \text{ dBm} - 0.5 \text{ dBm [HOL]} - 5 \times (0.5 \text{ dBm}) - 2 (0.5 \text{ dBm}) - 2 \text{ km} (1.0 \text{ dBm/km}) - 1 \text{ dB [CRM]} = P_M$$



$$13 \text{ dBm} - 0.5 \text{ dBm} - 2.5 \text{ dBm} - 1 \text{ dBm} - 2 \text{ dBm} - 1 \text{ dBm} = P_M$$

$$P_M = 6 \text{ dBm}$$

The calculated power margin is greater than zero, indicating that the link has sufficient power for transmission. Also, the power margin value does not exceed the maximum receiver input power.

Refer to the specifications for your receiver to find the maximum receiver input power.

## QFX5120 Management Cable Specifications and Pinouts

### IN THIS SECTION

- [Console Port Connector Pinout Information | 112](#)
- [RJ-45 Management Port Connector Pinout Information | 113](#)
- [RJ-45 to DB-9 Serial Port Adapter Pinout Information | 114](#)
- [RJ-45 Port, SFP Port, SFP+ Port, QSFP+ Port, and QSFP28 Port Connector Pinout Information | 115](#)

### Console Port Connector Pinout Information

The console port on a Juniper Networks device is an RS-232 serial interface that uses an RJ-45 connector to connect to a console management device. The default baud rate for the console port is 9600 baud.

[Table 52 on page 113](#) provides the pinout information for the RJ-45 console connector.

**NOTE:** If your laptop or desktop PC does not have a DB-9 plug connector pin and you want to connect your laptop or desktop PC directly to a device, use a combination of the RJ-45-to-DB-9 socket adapter and a USB-to-DB-9 plug adapter. You must provide the USB-to-DB-9 plug adapter.

**NOTE:** We no longer include a DB-9 to RJ-45 cable or a DB-9 to RJ-45 adapter with a CAT5E copper cable as part of the device package. If you require a console cable, you can order it separately with the part number JNP-CBL-RJ45-DB9 (DB-9 to RJ-45 adapter with a CAT5E copper cable).

**Table 52: Console Port Connector Pinout Information**

Pin	Signal	Description
1	NC	No connect
2	NC	No connect
3	TxD Output	Transmit data
4	GND	Signal ground
5	GND	Signal ground
6	RxD Input	Receive data
7	DCD Input	Data carrier detect
8	NC	No connect

## RJ-45 Management Port Connector Pinout Information

[Table 53 on page 114](#) provides the pinout information for the RJ-45 connector for the management port on Juniper Networks devices.

**Table 53: RJ-45 Management Port Connector Pinout Information**

Pin	Signal	Description
1	TRP1+	Transmit/receive data pair 1
2	TRP1-	Transmit/receive data pair 1
3	TRP2+	Transmit/receive data pair 2
4	TRP3+	Transmit/receive data pair 3
5	TRP3-	Transmit/receive data pair 3
6	TRP2-	Transmit/receive data pair 2
7	TRP4+	Transmit/receive data pair 4
8	TRP4-	Transmit/receive data pair 4

## RJ-45 to DB-9 Serial Port Adapter Pinout Information

The console port on a Juniper Networks device is an RS-232 serial interface that uses an RJ-45 connector to connect to a management device such as a laptop or a desktop PC. If your laptop or desktop PC does not have a DB-9 plug connector pin and you want to connect your laptop or desktop PC to the device, use a combination of the RJ-45 to DB-9 socket adapter along with a USB to DB-9 plug adapter.

[Table 54 on page 114](#) provides the pinout information for the RJ-45 to DB-9 serial port adapter.

**Table 54: RJ-45 to DB-9 Serial Port Adapter Pinout Information**

RJ-45 pin	Signal	DB-9 pin	Signal
1	NC	8	CTS

Table 54: RJ-45 to DB-9 Serial Port Adapter Pinout Information (*Continued*)

RJ-45 pin	Signal	DB-9 pin	Signal
2	NC	6	DSR
3	TxD	2	RxD
4	GND	5	GND
6	RxD	3	TxD
7	DCD	4	DTR
8	NC	7	RTS

## RJ-45 Port, SFP Port, SFP+ Port, QSFP+ Port, and QSFP28 Port Connector Pinout Information

The tables in this topic describe the connector pinout information for the RJ-45, QSFP+, QSFP28, SFP+, and SFP ports.

- [Table 55 on page 115](#)—10/100/1000BASE-T Ethernet network port connector pinout information
- [Table 56 on page 116](#)—SFP network port connector pinout information
- [Table 57 on page 118](#)—SFP+ network port connector pinout information
- [Table 58 on page 119](#)—QSFP+ and QSFP28 network module ports connector pinout information

Table 55: 10/100/1000BASE-T Ethernet Network Port Connector Pinout Information

Pin	Signal	Description
1	TRP1+	Transmit/receive data pair 1 Negative Vport (in PoE models)

**Table 55: 10/100/1000BASE-T Ethernet Network Port Connector Pinout Information (Continued)**

Pin	Signal	Description
2	TRP1-	Transmit/receive data pair 1 Negative Vport (in PoE models)
3	TRP2+	Transmit/receive data pair 2 Positive Vport (in PoE models)
4	TRP3+	Transmit/receive data pair 3
5	TRP3-	Transmit/receive data pair 3
6	TRP2-	Transmit/receive data pair 2 Positive Vport (in PoE models)
7	TRP4+	Transmit/receive data pair 4
8	TRP4-	Transmit/receive data pair 4

**Table 56: SFP Network Port Connector Pinout Information**

Pin	Signal	Description
1	VeeT	Module transmitter ground
2	TX_Fault	Module transmitter fault
3	TX_Disable	Transmitter disabled
4	SDA	2-wire serial interface data line
5	SCL-	2-wire serial interface clock

Table 56: SFP Network Port Connector Pinout Information (Continued)

Pin	Signal	Description
6	MOD_ABS	Module absent
7	RS	Rate select
8	RX_LOS	Receiver loss of signal indication
9	VeeR	Module receiver ground
10	VeeR	Module receiver ground
11	VeeR	Module receiver ground
12	RD-	Receiver inverted data output
13	RD+	Receiver noninverted data output
14	VeeR	Module receiver ground
15	VccR	Module receiver 3.3 V supply
16	VccT	Module transmitter 3.3 V supply
17	VeeT	Module transmitter ground
18	TD+	Transmitter noninverted data input
19	TD-	Transmitter inverted data input
20	VeeT	Module transmitter ground

**Table 57: SFP+ Network Port Connector Pinout Information**

Pin	Signal	Description
1	VeeT	Module transmitter ground
2	TX_Fault	Module transmitter fault
3	TX_Disable	Transmitter disabled
4	SDA	2-wire serial interface data line
5	SCL-	2-wire serial interface clock
6	MOD_ABS	Module absent
7	RS0	Rate select 0, optionally controls SFP+ module receiver
8	RX_LOS	Receiver loss of signal indication
9	RS1	Rate select 1, optionally controls SFP+ transmitter
10	VeeR	Module receiver ground
11	VeeR	Module receiver ground
12	RD-	Receiver inverted data output
13	RD+	Receiver noninverted data output
14	VeeR	Module receiver ground
15	VccR	Module receiver 3.3-V supply

**Table 57: SFP+ Network Port Connector Pinout Information (Continued)**

Pin	Signal	Description
16	VccT	Module transmitter 3.3-V supply
17	VeeT	Module transmitter ground
18	TD+	Transmitter noninverted data input
19	TD-	Transmitter inverted data input
20	VeeT	Module transmitter ground

**Table 58: QSFP+ and QSFP28 Network Port Connector Pinout Information**

Pin	Signal
1	GND
2	TX2n
3	TX2p
4	GND
5	TX4n
6	TX4p
7	GND
8	ModSelL
9	LPMode_Reset



Table 58: QSFP+ and QSFP28 Network Port Connector Pinout Information *(Continued)*

Pin	Signal
10	VccRx
11	SCL
12	SDA
13	GND
14	RX3p
15	RX3n
16	GND
17	RX1p
18	RX1n
19	GND
20	GND
21	RX2n
22	RX2p
23	GND
24	RX4n

Table 58: QSFP+ and QSFP28 Network Port Connector Pinout Information *(Continued)*

Pin	Signal
25	RX4p
26	GND
27	ModPrsL
28	IntL
29	VccTx
30	Vcc1
31	Reserved
32	GND
33	TX3p
34	TX3n
35	GND
36	TX1p
37	TX1n
38	GND

# 3

CHAPTER

## Initial Installation and Configuration

---

[Unpack and Mount the QFX5120 Switch | 123](#)

[Connect the QFX5120 to Power | 163](#)

[Connect the QFX5120 to the Network | 179](#)

[Connect the QFX5120 to External Devices | 185](#)

[Configure Junos OS on the QFX5120 | 189](#)

---

# Unpack and Mount the QFX5120 Switch

## IN THIS SECTION

- [Unpack the QFX5120 Switch | 123](#)
- [Parts Inventory \(Packing List\) for a QFX5120 Switch | 124](#)
- [Register Products—Mandatory to Validate SLAs | 127](#)
- [Mount a QFX5120-32C Switch on a Four-Post Rack | 127](#)
- [Mount a QFX5120-48T, QFX5120-48Y, or QFX5120-48YM Switch in a Rack or Cabinet by Using the JNP-4PST-RMK-1U-E Rack Mount Kit | 133](#)
- [Mount a QFX5120-48T, QFX5120-48Y, or QFX5120-48YM Switch Flush with the Front Posts of a Rack or Cabinet | 144](#)
- [Mount a QFX5120-48T, QFX5120-48Y, or QFX5120-48YM Switch in a Recessed Position from the Front Posts of a Rack or Cabinet | 149](#)
- [Mount a QFX5120-48Y Switch on a Two-Post Rack | 156](#)

## Unpack the QFX5120 Switch

We ship QFX5120 switches in a cardboard carton, secured with foam packing material.



**CAUTION:** QFX5120 switches are maximally protected inside the shipping carton. Do not unpack the switches until you are ready to mount the switch.

To unpack the switch:

1. Move the shipping carton to a staging area as close to the installation site as possible, but where you have enough room to remove the system components.
2. Position the carton so that the arrows marked on the carton are pointing up.
3. Open the top flaps on the shipping carton.
4. Pull out the packing material holding the switch in place.
5. Verify the parts received against the inventory on the label attached to the carton.
6. Save the shipping carton and packing materials in case you need to move or ship the switch later.

## Parts Inventory (Packing List) for a QFX5120 Switch

The switch shipment includes a packing list. Check the parts you receive with the switch against the items in the packing list. The packing list specifies the part number and provides a description of each part in your order. The parts shipped depend on the switch model you order.

If any part in the packing list is missing, contact your customer service representative or contact Juniper customer care from within the U.S. or Canada by telephone at 1-888-314-5822. For international-dial or direct-dial options in countries without toll-free numbers, see <https://www.juniper.net/support/requesting-support.html>.

Table 59 on page 124 lists the parts and their quantities as in the standard packing list for a QFX5120 switch.

**Table 59: Inventory of Components Provided with a QFX5120 Switch**

Component		Quantity
Switch		1
Fan modules	QFX5120-32C	6 preinstalled
	QFX5120-48T, QFX5120-48Y, and QFX5120-48Y M	5 preinstalled
Power supplies		2 (AC or DC) preinstalled
AC power cords appropriate for your geographical location for AC-powered models		2

Table 59: Inventory of Components Provided with a QFX5120 Switch (Continued)

Component		Quantity
Two-post rack mount kit	QFX5120-32C  (QFX5120-32C-RMK, QFX5K-2PST-RMK)	<ul style="list-style-type: none"> <li>• Front mounting brackets—2</li> <li>• Side mounting rails—2</li> <li>• Flat head M4X8 screws to attach the front mounting brackets and side mounting rails to the switch chassis—20</li> <li>• Rear mounting (L-shaped) brackets—2</li> <li>• Pan head M4X8 screws to attach the rear mounting brackets to the side mounting rails—2</li> </ul>
Four-post rack mount kit	QFX5120-48T, QFX5120-48Y, and QFX5120-48Y M  <ul style="list-style-type: none"> <li>• JNP-4PST-RMK-1U-E (shipped with the switch)</li> <li>• EX-4PST-RMK (seperately orderable)</li> </ul>	<p>JNP-4PST-RMK-1U-E</p> <ul style="list-style-type: none"> <li>• A pair of front and rear mounting rails</li> <li>• A pair of mounting brackets</li> <li>• 16 flat head M4 x 6mm Phillips screws</li> </ul> <p>EX-4PST-RMK</p> <ul style="list-style-type: none"> <li>• Front mounting bracket assembly for mounting the switch flush with the front posts of a rack—2</li> </ul> <p>(The front mounting bracket assembly is made up of a side rail to which an L-shaped bracket is attached.)</p> <ul style="list-style-type: none"> <li>• Recessed mounting brackets for mounting the switch in a recessed position from the front posts of a rack—2</li> <li>• Flat head 4x6-mm Phillips screws for attaching the front mounting brackets to the chassis—12</li> <li>• Flat head 4-40 Phillips screws for attaching recessed mounting brackets to the side rails—6</li> <li>• Rear mounting brackets—2</li> </ul>
Documentation Roadmap		1

**Table 59: Inventory of Components Provided with a QFX5120 Switch (Continued)**

Component	Quantity
End User License Agreement	1

**NOTE:** We no longer include a DB-9 to RJ-45 cable or a DB-9 to RJ-45 adapter with a CAT5E copper cable as part of the device package. If you require a console cable, you can order it separately with the part number JNP-CBL-RJ45-DB9 (DB-9 to RJ-45 adapter with a CAT5E copper cable).

**NOTE:** You must provide the appropriate mounting screws for mounting the switch on a rack or a cabinet.

All the rack mount kits are separately orderable.

**Table 60: Rack Mount Kits for QFX5120-32C, QFX5120-48T, QFX5120-48Y, QFX5120-48YM**

Model	Rack Mount Kit
QFX5120-32C	QFX5120-32C-RMK, QFX5K-2PST-RMK
QFX5120-48YM	<ul style="list-style-type: none"> <li>• JNP-4PST-RMK-1U-E (shipped with the switch)</li> <li>• EX-4PST-RMK (seperately orderable)</li> </ul>
QFX5120-48T	<ul style="list-style-type: none"> <li>• JNP-4PST-RMK-1U-E (shipped with the switch)</li> <li>• EX-4PST-RMK (seperately orderable)</li> </ul>
QFX5120-48Y	<ul style="list-style-type: none"> <li>• JNP-4PST-RMK-1U-E (shipped with the switch)</li> <li>• EX-4PST-RMK (seperately orderable)</li> </ul>

## Register Products—Mandatory to Validate SLAs

Register all new Juniper Networks hardware products and changes to an existing installed product using the Juniper Networks website to activate your hardware replacement service-level agreements (SLAs).



**CAUTION:** Register product serial numbers on the Juniper Networks website. Update the installation base data if any addition or change to the installation base occurs or if the installation base is moved. Juniper Networks is not responsible for not meeting the hardware replacement service-level agreement for products that do not have registered serial numbers or accurate installation base data.

Register your product(s) at <https://tools.juniper.net/svcreg/SRegSerialNum.jsp>.

Update your installation base at <https://www.juniper.net/customers/csc/management/updateinstallbase.jsp>.

## Mount a QFX5120-32C Switch on a Four-Post Rack

### IN THIS SECTION

- [Mount a QFX5120-32C Switch on a Two-Post Rack | 130](#)

Before mounting a QFX5120-32C switch:

- Verify that the site meets the requirements described in "[Site Preparation Checklist for QFX5120 Switches](#)" on page 95.
- Place the rack in its permanent location, allowing adequate clearance for airflow and maintenance, and secure the rack to the building structure.
- Read *General Safety Guidelines and Warnings*, with particular attention to *Chassis and Component Lifting Guidelines*.
- Ensure that you have taken the necessary precautions to prevent electrostatic discharge (ESD) damage (see *Prevention of Electrostatic Discharge Damage*).
- Remove the switch from the shipping carton (see "[Unpack the QFX5120 Switch](#)" on page 123).

Ensure that you have the following parts and tools available:



- Number 2 Phillips (+) screwdriver—not provided
- Eight screws to secure the mounting brackets to the rack—not provided
- Electrostatic discharge (ESD) grounding strap—not provided
- Front mounting brackets—2 (provided with the rack mount kit)
- Side mounting rails—2 (provided with the rack mount kit)
- Flat head M4X8 screws to attach the front mounting brackets and side mounting rails to the switch chassis—20 (provided with the rack mount kit)
- Rear mounting (L-shaped) brackets—2 (provided with the rack mount kit)
- Pan head M4X8 screws to attach the rear mounting brackets to the side mounting rails—2 (provided with the rack mount kit)

You can mount a QFX5120-32C switch on four posts of a 19-in. rack or in a cabinet that contains a four-post 19-in. rack by using a rack mount kit. (The remainder of this topic uses rack to mean rack or cabinet.)

**NOTE:** One person must be available to lift the switch while another person secures the switch to the rack.

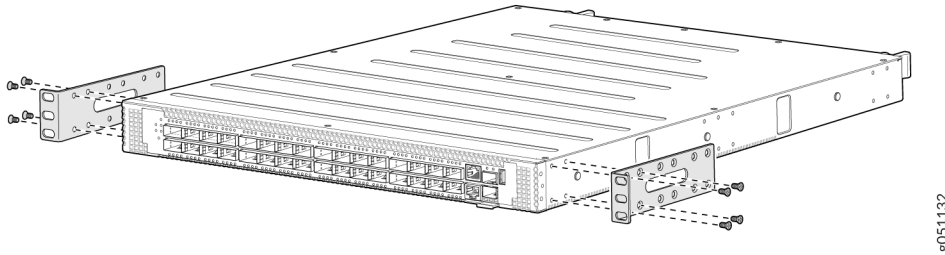


**CAUTION:** If you are mounting multiple units on a rack, mount the heaviest unit at the bottom of the rack, and then mount the other units from the bottom of the rack to the top in decreasing order of the weight of the units.

To mount a QFX5120-32C switch:

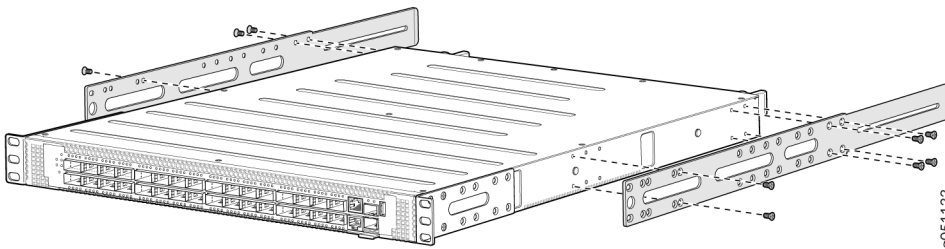
1. Place the switch on a flat, stable surface.
2. Wrap and fasten one end of the ESD wrist strap around your bare wrist, and connect the other end of the strap to a site ESD point.
3. Align the front mounting brackets along the side panel of the switch such that the front of the bracket is flush with the front panel of the switch chassis. Insert the flat head M4X8 screws for attaching the front mounting brackets into the aligned holes on the chassis and tighten the screws (see [Figure 71 on page 129](#)).

Figure 71: Attach the Front Mounting Brackets to a QFX5120-32C Switch Chassis



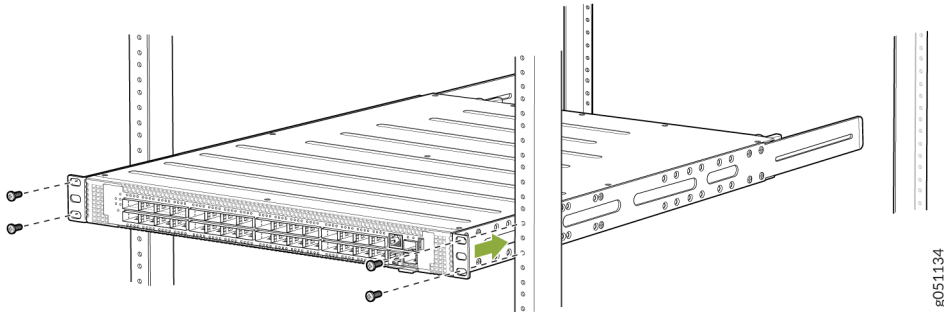
4. Align the side mounting rails along the side panel of the switch. Insert the flat head M4X8 screws for attaching the side mounting rails into the aligned holes on the chassis and tighten the screws (see [Figure 72 on page 129](#)).

Figure 72: Attach the Side Mounting Rails to a QFX5120-32C Switch Chassis



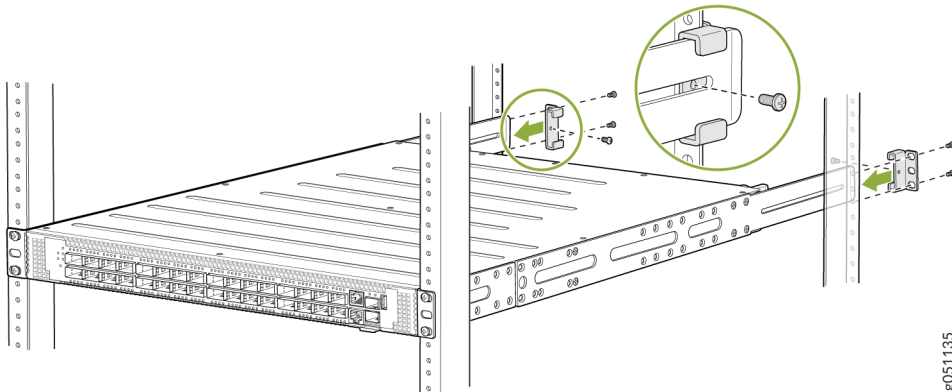
5. Decide which end of the switch you want to place at the front of the rack. Position the switch so that the **F2B** labels on the fan modules are facing the cold aisle, or the **B2F** labels on the fan modules are facing the hot aisle.
6. Have one person grasp both sides of the switch, lift the switch, and position it in the rack, aligning the holes of the mounting brackets with the threaded holes in the front post of the rack. Align the bottom hole in both the mounting brackets with a hole in each rack rail, making sure that the chassis is level.
7. Have a second person secure the front of the switch to the rack by using the screws appropriate for your rack. Tighten the screws (see [Figure 73 on page 130](#)).

**Figure 73: Secure the QFX5120-32C Switch to the Front Posts of a Rack**



8. Slide the rear mounting (L-shaped) brackets on to the side mounting rails (see [Figure 74 on page 130](#)).
9. Ensure that the chassis is level. Align the holes of the rear mounting brackets with the threaded holes in the rear post of the rack. Align the bottom hole in both the mounting brackets with a hole in each rack rail. Align the bottom hole in both the rear mounting brackets with the bottom hole in the front mounting brackets.
10. Secure the rear mounting brackets to the rear post of the rack by using screws appropriate for your rack (see [Figure 74 on page 130](#)). Tighten the screws.

**Figure 74: Secure the QFX5120-32C Switch to the Rear Post of the Rack by Using the Rear Mounting Brackets**



11. Secure the rear mounting (L-shaped) brackets to the side mounting rails by using the pan head M4X8 screws provided (see [Figure 74 on page 130](#)). Tighten the screws.
12. Your switch is now installed on a four-post rack.

## Mount a QFX5120-32C Switch on a Two-Post Rack

Before you mount a QFX5120-32C switch on a two-post rack:

- Verify that the site meets the requirements described in "[Site Preparation Checklist for QFX5120 Switches](#)" on page 95.
- Place the rack in its permanent location, allowing adequate clearance for airflow and maintenance, and secure the rack to the building structure.
- Read *General Safety Guidelines and Warnings*, with particular attention to *Chassis and Component Lifting Guidelines*.
- Ensure that you have taken the necessary precautions to prevent electrostatic discharge (ESD) damage (see *Prevention of Electrostatic Discharge Damage*).
- Remove the switch from the shipping carton (see "[Unpack the QFX5120 Switch](#)" on page 123).

Ensure that you have the following parts and tools available:

- Number 2 Phillips (+) screwdriver—not provided
- Eight screws to secure the mounting brackets to the rack—not provided
- Electrostatic discharge (ESD) grounding strap—not provided
- Two-post rack mounting bracket for mounting the switch on a two-post rack—2 (provided with the two-post rack mount kit)
- Flat head 4x6-mm Phillips screws for attaching the two-post rack mounting brackets to the chassis—8 (provided with the two-post rack mount kit)

You can mount a QFX5120 switch on four posts of a four-post 19-in. rack or in a cabinet that contains a four-post 19-in. rack, flush with the front posts, by using a four-post rack mount kit. (The remainder of this topic uses rack to mean rack or cabinet.) You can mount QFX5120-48T, QFX5120-48Y, and QFX5120-48YM switches in a recessed position inside a four-post rack by using the recessed mounting brackets. You can also mount QFX5120-48YM switches on a two-post rack by using a separately orderable two-post rack mount kit.

**NOTE:** One person must be available to lift the switch while another person secures the switch to the rack.

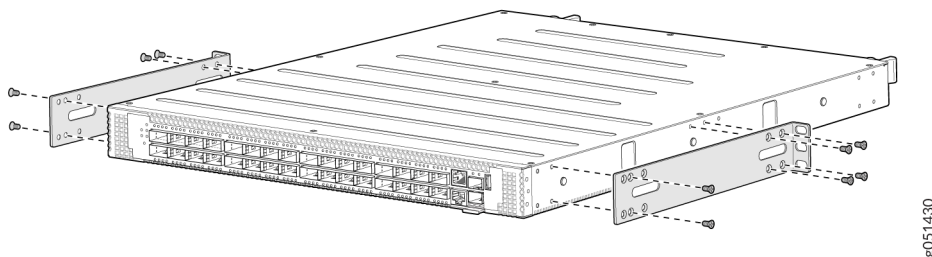


**CAUTION:** If you are mounting multiple units on a rack, mount the heaviest unit at the bottom of the rack, and then mount the other units from the bottom of the rack to the top in decreasing order of the weight of the units.

To mount a QFX5120-32C switch on a two-post rack:

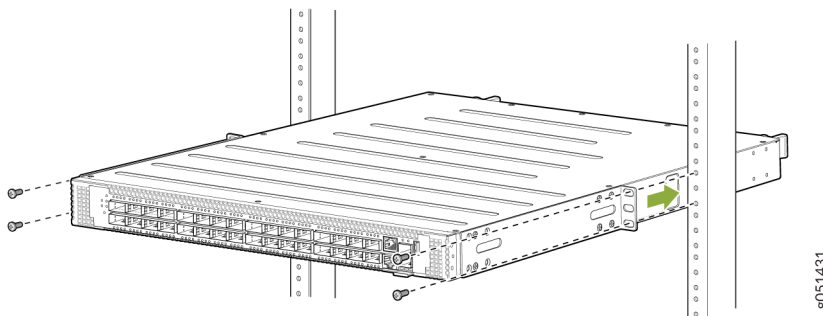
1. Place the switch on a flat, stable surface.
2. Wrap and fasten one end of the ESD wrist strap around your bare wrist, and connect the other end of the strap to a site ESD point.
3. Align the two-post rack mounting bracket (provided with the two-post rack mount kit) along the side panel of the switch.
4. Insert the flat head 4x6-mm Phillips screws for attaching the two-post rack mounting brackets (provided with the two-post rack mount kit) into the aligned holes on the chassis. Tighten the screws (see Figure 5).

**Figure 75: Attach the Two-Post Mounting Brackets to a QFX5120-32C Switch**



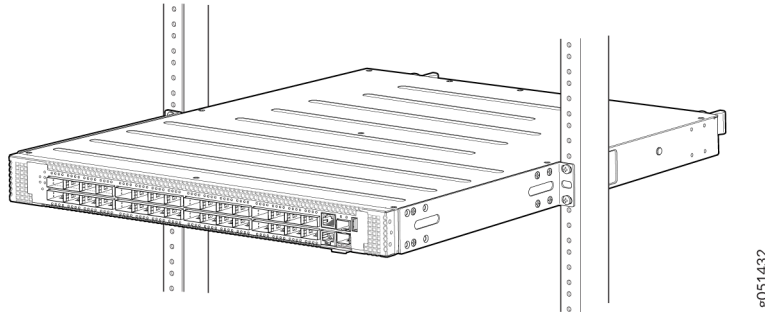
5. Decide which end of the switch you want to place at the front of the rack. Position the switch so that the **AIR IN** labels on the fan modules are facing the cold aisle, or the **AIR OUT** labels on the fan modules are facing the hot aisle.
6. Have one person grasp both sides of the switch, lift the switch, and position it in the rack, aligning the holes of the mounting brackets with the threaded holes in the posts of the rack. Align the bottom hole in both the mounting brackets with a hole in each rack rail, making sure that the chassis is level.
7. Have a second person secure the switch to the rack by using the screws appropriate for your rack. Tighten the screws (see Figure 6).

**Figure 76: Secure the QFX5120-32C Switch to the Two-Post Rack**



8. Your switch is now installed on a two-post rack (see Install the QFX5120-32C Switch to the Two-Post Rack.)

**Figure 77: Mount the QFX5120-32C Switch to the Two-Post Rack**



## Mount a QFX5120-48T, QFX5120-48Y, or QFX5120-48YM Switch in a Rack or Cabinet by Using the JNP-4PST-RMK-1U-E Rack Mount Kit

### IN THIS SECTION

- [Mount the Device by Using the JNP-4PST-RMK-1U-E Rack Mount Kit On a Square Hole Rack | 134](#)
- [Mount the Device by Using the JNP-4PST-RMK-1U-E Rack Mount Kit On a Threaded Hole Rack | 138](#)

You can mount QFX5120-48T, QFX5120-48Y, or QFX5120-48YM switches on a square hole or threaded hole four-post 19-in. racks using the partial tool less JNP-4PST-RMK-1U-E rack mount kit which is available as a spare.

JNP-4PST-RMK-1U-E rack mount kit consists of the following parts:

- A pair of front and rear mounting rails
- A pair of mounting brackets
- 16 flat head M4 x 6mm Phillips screws

A four-post installation evenly supports the device by all four corners.

## Mount the Device by Using the JNP-4PST-RMK-1U-E Rack Mount Kit On a Square Hole Rack

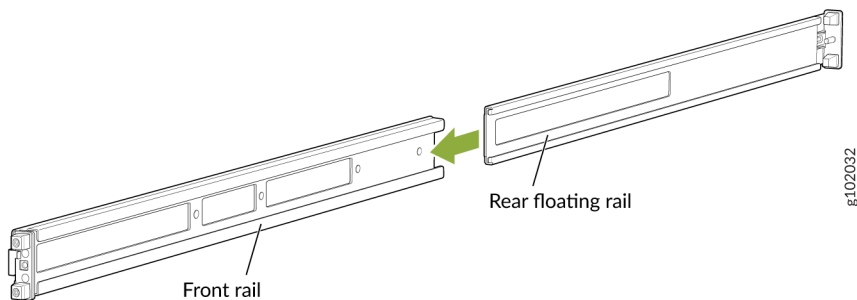
Ensure that you have the following tools and parts available:

- An ESD grounding strap—not provided.
- Number 2 Phillips (+) screwdriver—not provided
- A pair of front and rear mounting rails that attach to the rack posts—provided with the rack mount kit
- A pair of mounting brackets and 16 flat head M4 x 6mm Phillips screws. These brackets attach to the device if not pre-installed—provided with the rack mount kit

To mount the device on four posts in a rack by using the JNP-4PST-RMK-1U-E rack mount kit:

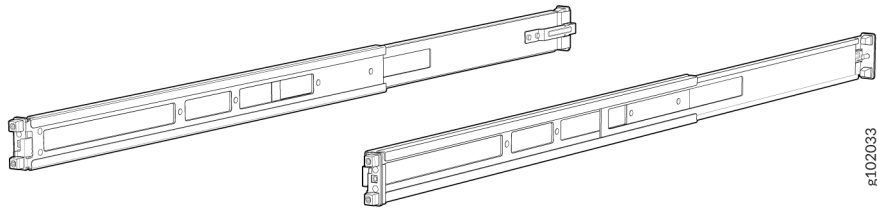
1. Wrap and fasten the ESD grounding strap to your bare wrist and an connect the other end of the strap to the ESD point on the device.
2. Assemble the mounting rails.
  - a. Slide the rear floating bracket into the front bracket. See [Figure 78 on page 134](#).

**Figure 78: Assemble the Mounting Rails**



- b. Mounting rails assembled. See [Figure 79 on page 135](#).

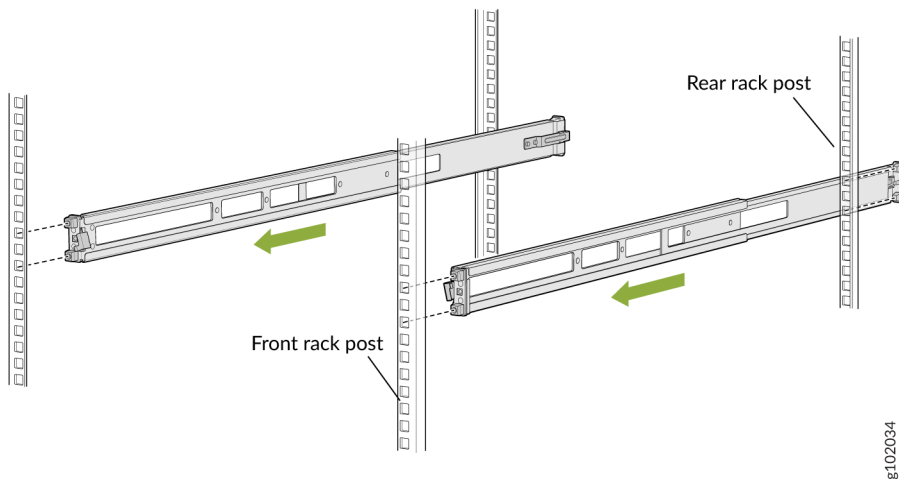
**Figure 79: Front and Rear Rails Assembled**



**3. Attach the mounting rails to the rack.**

- a. Align the guide blocks of the rear mounting rails with the rear-post holes. Pull the rear mounting rails toward the front of the rack to lock the rails in place. You will hear a click sound when the latch locks into the corresponding rack holes. See [Figure 80 on page 135](#).

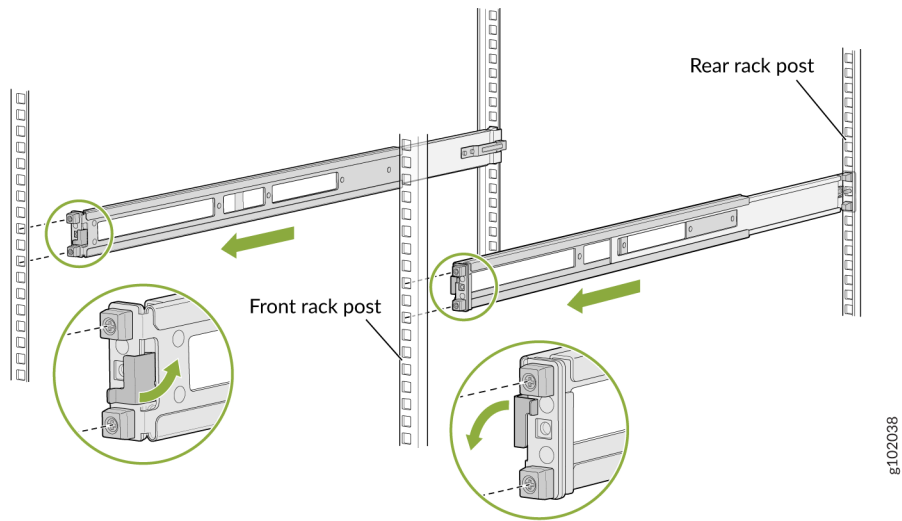
**Figure 80: Install the Rear Floating Rails**



- b. Move the latch lock on the front mounting rails to open position, slide the front mounting rails, and insert the guide blocks into the front rack posts. See [Figure 81 on page 136](#).

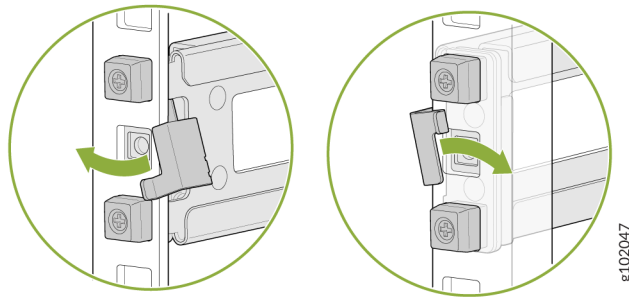


**Figure 81: Install the Front Mounting Rails**



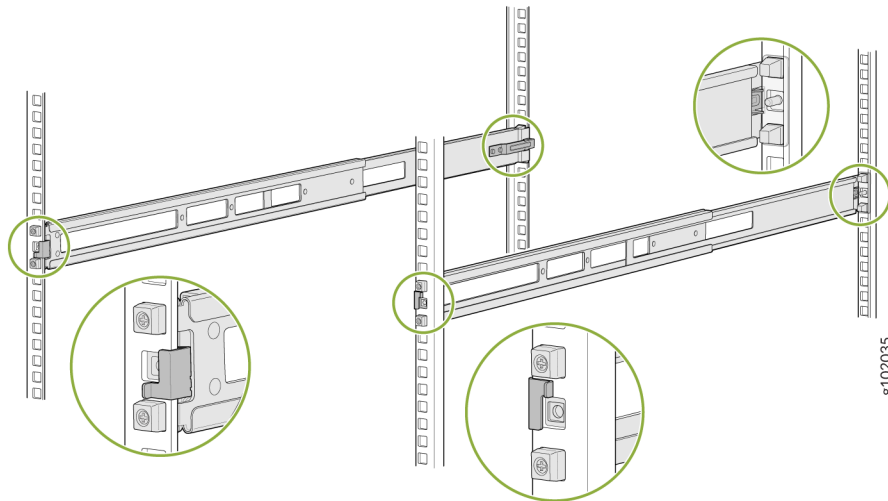
- c. Push the lock latch to the locked position. See [Figure 82 on page 136](#).

**Figure 82: Front Mounting Rails Lock Latch**



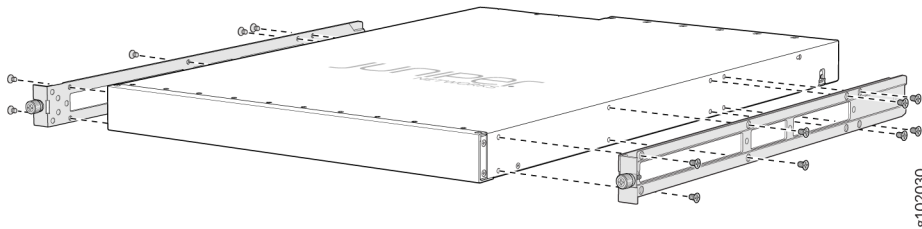
- d. Visually ensure that the front and rear latches are locked into place on the mounting rails. See [Figure 83 on page 137](#).

**Figure 83: Mounting Rails Installed and Locked**



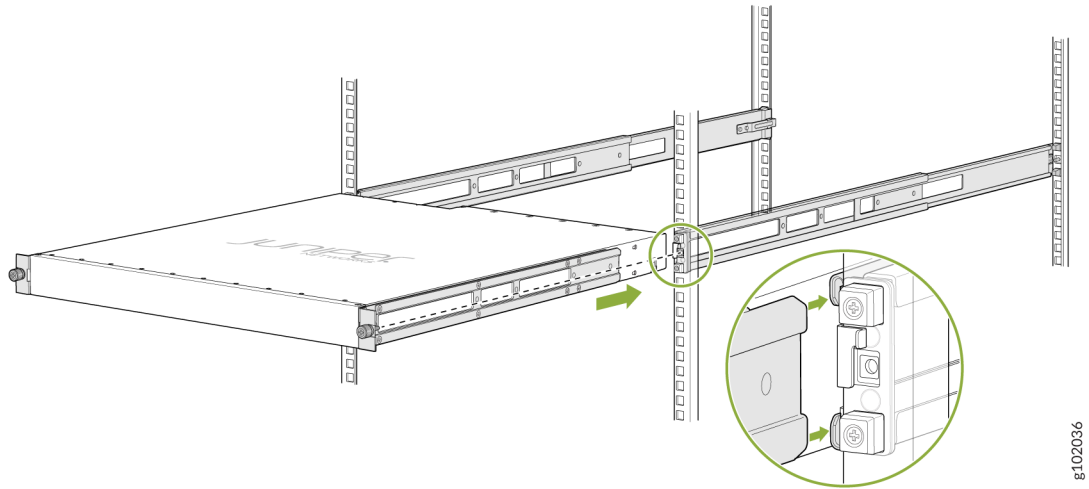
4. Attach mounting brackets to the device if not pre-installed. If your device already has the mounting brackets pre-installed then skip this step and move to the next step.
  - a. Align the holes on the mounting bracket with the screw holes on the side panel of the chassis.
  - b. Insert the flat head M4 x 6mm Phillips screws to attach the mounting bracket into the aligned holes on the chassis (see [Figure 84 on page 137](#)). Tighten the screws.

**Figure 84: Attach the Mounting Brackets to the Device**



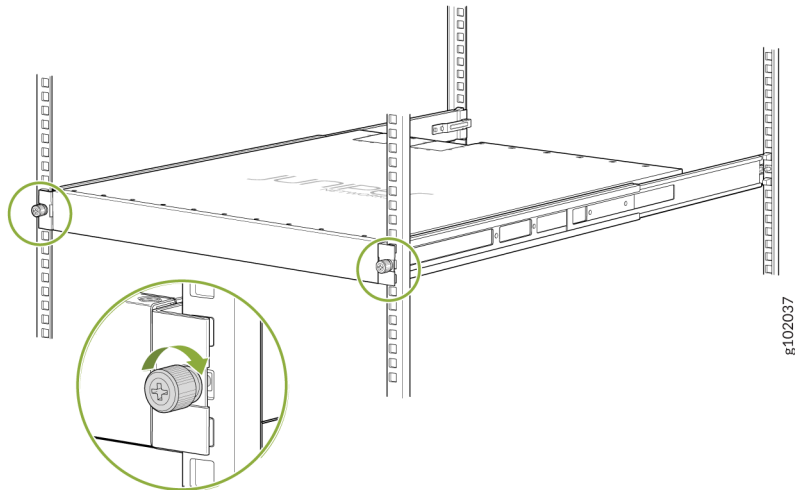
5. Position the device in such a manner that the **AIR OUT** labels on components are next to the hot aisle.
6. Grasp both sides of the device, lift it, and position the device such that the mounting rails slide into the channels of the mounting brackets. See [Figure 85 on page 138](#).

**Figure 85: Slide the Device into the Rack**



7. Tighten the two thumbscrews to secure the device. See [Figure 86 on page 138](#).

**Figure 86: Tighten the Thumb Screws**



### Mount the Device by Using the JNP-4PST-RMK-1U-E Rack Mount Kit On a Threaded Hole Rack

Ensure that you have the following tools and parts available:

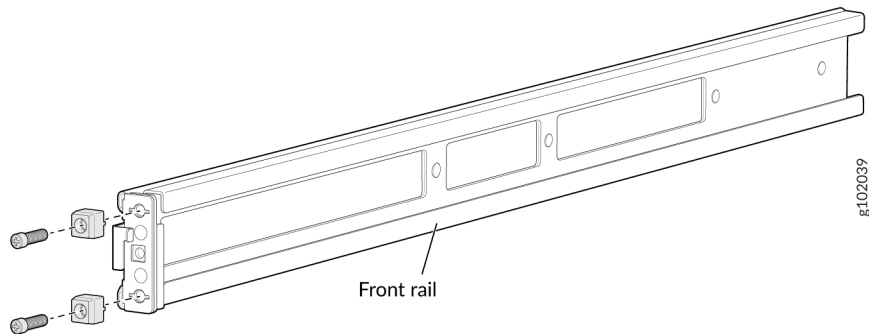
- An ESD grounding strap—not provided
- Number 2 Phillips (+) screwdriver—not provided

- A pair of front and rear mounting rails that attach to the rack posts—provided with the rack mount kit
- A pair of side mounting brackets and 16 flat head M4 x 6mm Phillips screws. These brackets attach to the device if not pre-installed—provided with the rack mount kit

To mount the device on four posts in a threaded hole rack by using the JNP-4PST-RMK-1U-E rack mount kit:

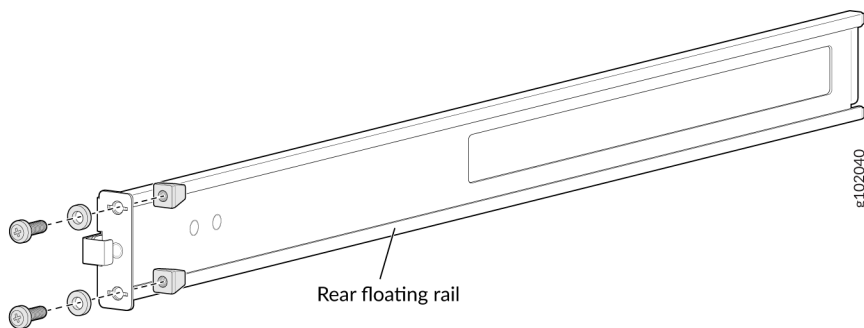
1. Wrap and fasten the ESD grounding strap to your bare wrist and connect the other end of the strap to the ESD point on the device.
2. Assemble the mounting rails.
  - a. Remove the guide blocks from the front mounting rails by loosening the screws and preserve them for later use. See [Figure 87 on page 139](#).

**Figure 87: Remove Guide Blocks from Front Mounting Rail**



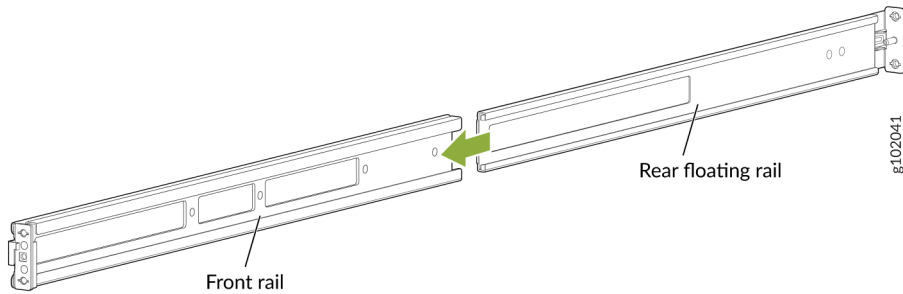
- b. Remove the guide blocks from the rear floating rails by loosening the screws and washers. Preserve the guide blocks, screws, and washers for later use. See [Figure 88 on page 139](#)

**Figure 88: Remove Guide Blocks from Rear Floating Rail**



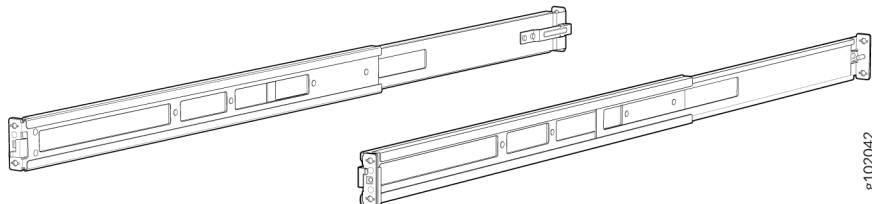
- c. Slide the rear floating rails into the front mounting rails. See [Figure 89 on page 140](#).

**Figure 89: Slide Rear Floating Rail into Front Mounting Rail**



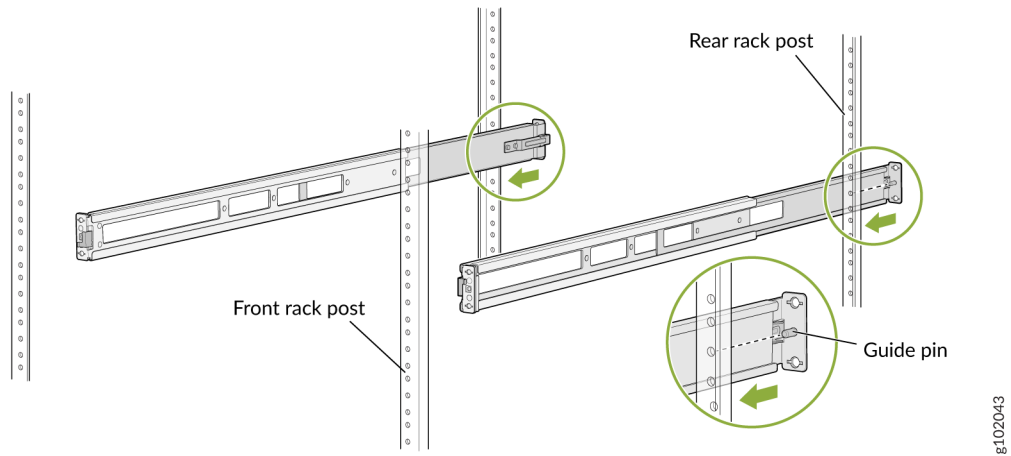
- d. Mounting rails assembled. See [Figure 90 on page 140](#).

**Figure 90: Front and Rear Rails Assembled**



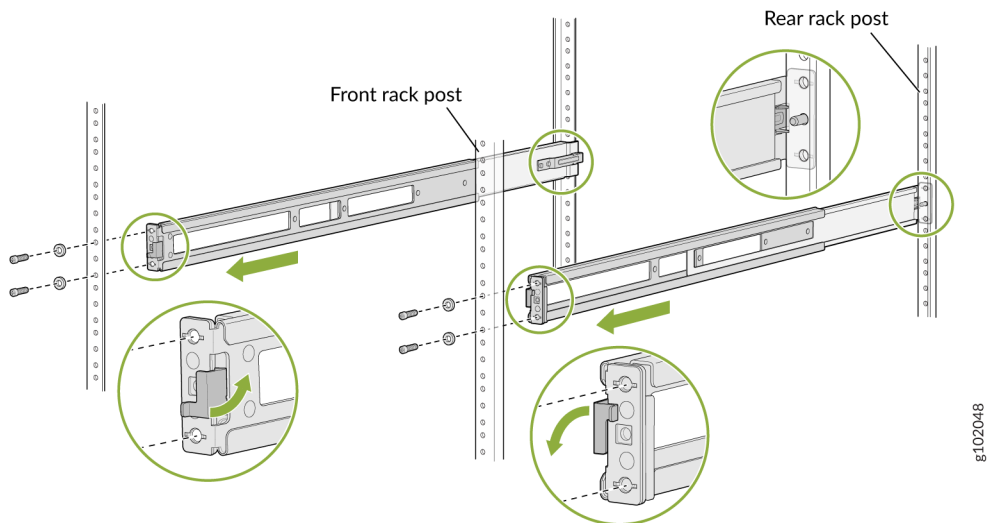
- 3. Attach the mounting rails to the threaded hole rack.**
- a. Align the guide blocks of the rear mounting rails with the rear-post holes. Pull the rear mounting rails toward the front of the rack to lock the rails in place. You will hear a click sound when the latch locks into the corresponding rack holes. See [Figure 91 on page 141](#).

**Figure 91: Install the Rear Floating Rails**



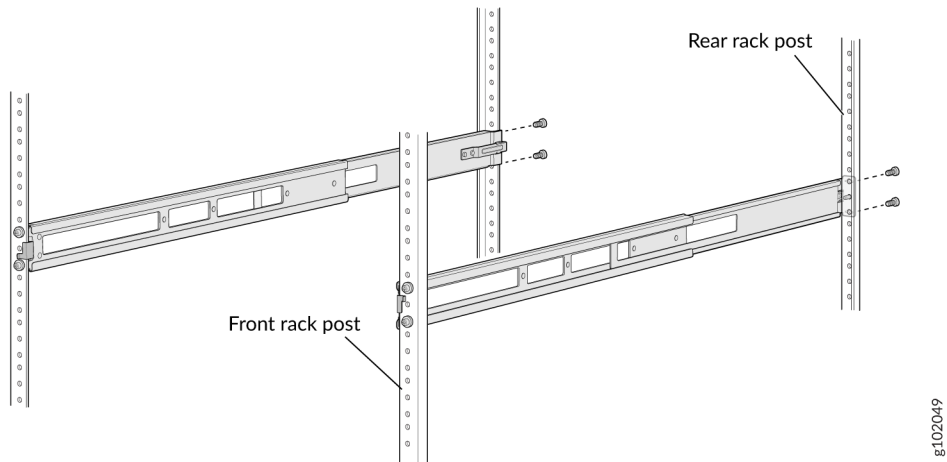
- b. Move the latch locks on the front mounting rails to open position, slide the front mounting rails and align them to the front rack post. Push the lock latch to locked position and using the screws removed in step 2.a and the washers removed in step 2.b, secure the front mounting rails to the front rack post. See [Figure 92 on page 141](#).

**Figure 92: Install the Front Mounting Rails**



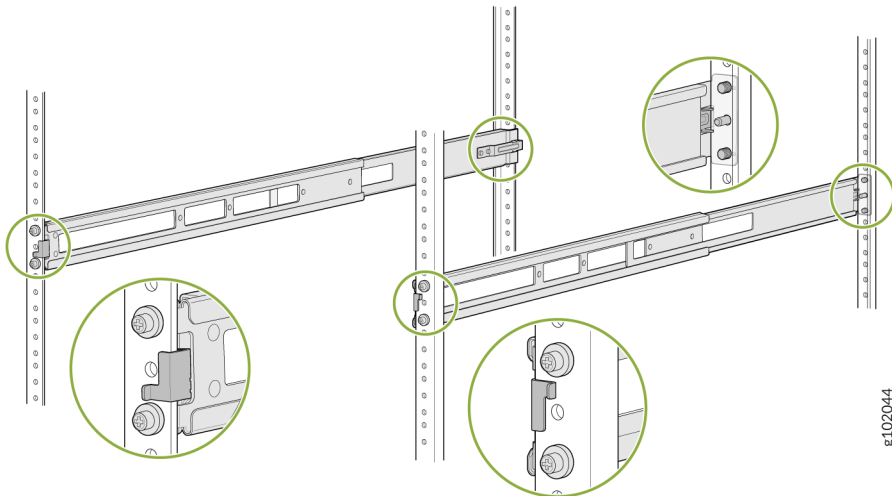
- c. Secure the rear floating rails to the rear rack post by using screws (not provided) appropriate for your rack threaded size. See [Figure 93 on page 142](#).

**Figure 93: Secure the Rear Floating Rails**



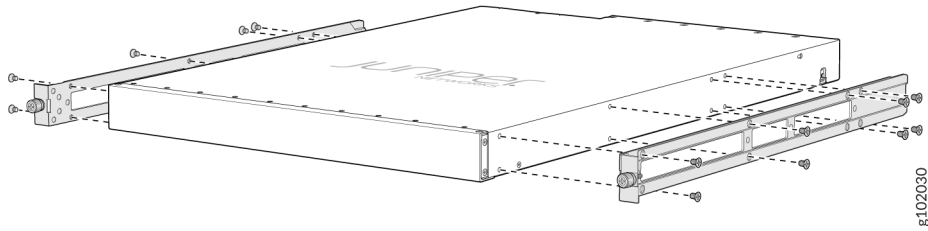
- d. Visually ensure that the front and rear latches are locked into place on the mounting rails. See [Figure 94 on page 142](#).

**Figure 94: Mounting Rails Installed and Secured**



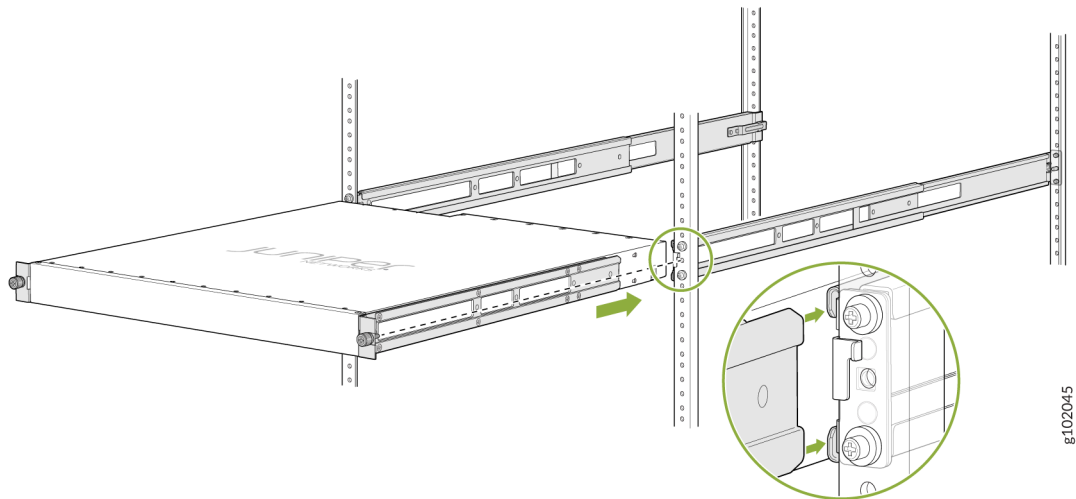
4. Attach mounting brackets to the device if not pre-installed. If your device already has the mounting brackets pre-installed than skip this step and move to the next step.
- a. Align the holes on the mounting bracket with the screw holes on the side panel of the chassis.
  - b. Insert the flat head M4 x 6mm Phillips screws to attach the mounting bracket into the aligned holes on the chassis (see [Figure 95 on page 143](#)). Tighten the screws.

Figure 95: Attach the Mounting Brackets to the Device



5. Position the device in such a manner that the **AIR OUT** labels on components are next to the hot aisle.
6. Grasp both sides of the device, lift it, and position the device such that the mounting rails slide into the channels of the mounting brackets. See [Figure 96 on page 143](#).

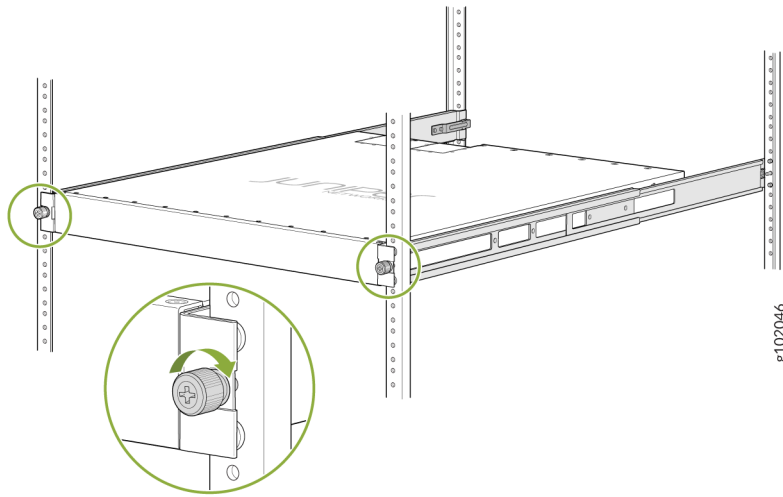
Figure 96: Slide the Device into the Rack



7. Tighten the two thumbscrews to secure the device. See [Figure 97 on page 144](#).



Figure 97: Tighten Thumb Screws



## Mount a QFX5120-48T, QFX5120-48Y, or QFX5120-48YM Switch Flush with the Front Posts of a Rack or Cabinet

**NOTE:** The protective earthing terminal on QFX5120-48T, QFX5120-48Y, and QFX5120-48YM switches mounted flush with the front posts of a rack is accessible through the slot on the left rear bracket only if the distance between the front posts and the rear posts is 23 in. (58.5 cm) through 30.25 in. (76.8 cm).

Before you mount a QFX5120-48T, QFX5120-48Y, or QFX5120-48YM switch:

- Verify that the site meets the requirements described in "[Site Preparation Checklist for QFX5120 Switches](#)" on page 95.
- Place the rack in its permanent location, allowing adequate clearance for airflow and maintenance, and secure the rack to the building structure.
- Read *General Safety Guidelines and Warnings*, with particular attention to *Chassis and Component Lifting Guidelines*.
- Ensure that you have taken the necessary precautions to prevent electrostatic discharge (ESD) damage (see *Prevention of Electrostatic Discharge Damage*).
- Remove the switch from the shipping carton (see "[Unpack the QFX5120 Switch](#)" on page 123).

Ensure that you have the following parts and tools available:

- Number 2 Phillips (+) screwdriver—not provided
- Eight screws to secure the mounting brackets to the rack—not provided
- Electrostatic discharge (ESD) grounding strap—not provided
- Front mounting bracket assembly for mounting the switch flush with the front posts of a rack—2 (provided with the four-post rack mount kit)

(The front mounting bracket assembly is made up of a side rail to which an L-shaped bracket is attached.)

- Flat head 4x6-mm Phillips screws for attaching the front mounting brackets to the chassis—12 (provided with the four-post rack mount kit)
- Rear mounting brackets—2 (provided with the four-post rack mount kit)

You can mount a QFX5120 switch on four posts of a four-post 19-in. rack or in a cabinet that contains a four-post 19-in. rack, flush with the front posts, by using a four-post rack mount kit. (The remainder of this topic uses rack to mean rack or cabinet.) You can mount QFX5120-48T, QFX5120-48Y, and QFX5120-48YM switches in a recessed position inside a four-post rack by using the recessed mounting brackets. You can also mount QFX5120-48YM switches on a two-post rack by using a separately orderable two-post rack mount kit.

This topic describes the procedure to mount QFX5120-48T, QFX5120-48Y, and QFX5120-48YM switches flush with the front posts of a four-post rack. If you want to mount the switch in a recessed position from the front posts of a four-post rack, see ["Mount a QFX5120-48T, QFX5120-48Y, or QFX5120-48YM Switch in a Recessed Position from the Front Posts of a Rack or Cabinet"](#) on page 149. If you want to mount a QFX5120-48YM switch on a two-post rack, see ["Mount a QFX5120-48YM Switch on a Two-Post Rack"](#) on page 160.

**NOTE:** One person must be available to lift the switch while another person secures the switch to the rack.



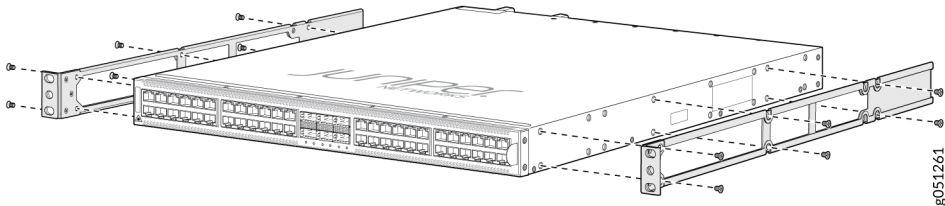
**CAUTION:** If you are mounting multiple units on a rack, mount the heaviest unit at the bottom of the rack, and then mount the other units from the bottom of the rack to the top in decreasing order of the weight of the units.

To mount a QFX5120-48T, QFX5120-48Y, or QFX5120-48YM switch flush with the front posts of a four-post rack:

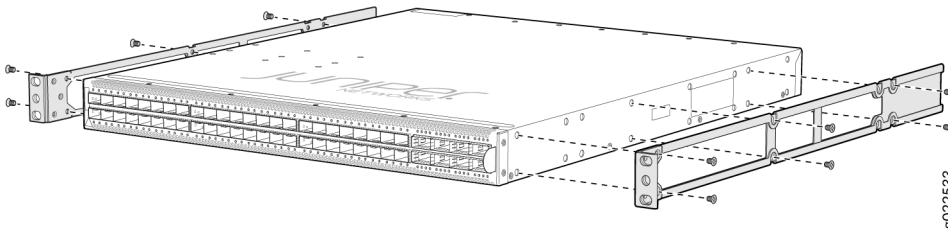
1. Place the switch on a flat, stable surface.

2. Wrap and fasten one end of the ESD wrist strap around your bare wrist, and connect the other end of the strap to a site ESD point.
3. Align the front mounting bracket assembly (provided with the four-post rack mount kit) along the side panel of the switch such that the front of the bracket is flush with the front panel of the switch chassis.
4. Insert the flat head 4x6-mm Phillips screws for attaching the front mounting brackets (provided with the four-post rack mount kit) into the aligned holes on the chassis (see [Figure 98 on page 146](#), [Figure 99 on page 146](#), and [Figure 100 on page 146](#)). Tighten the screws.

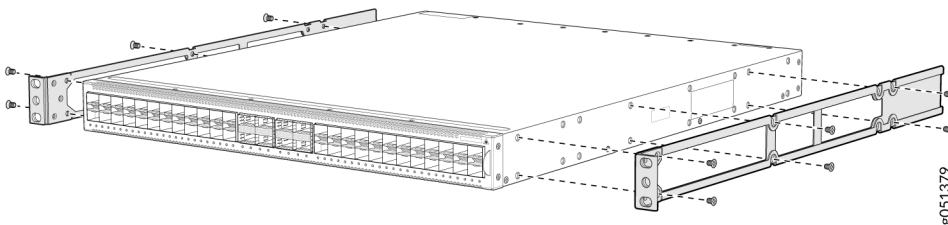
**Figure 98: Attach the Flush Mounting Brackets to a QFX5120-48T Switch Chassis**



**Figure 99: Attach the Flush Mounting Brackets to a QFX5120-48Y Switch Chassis**

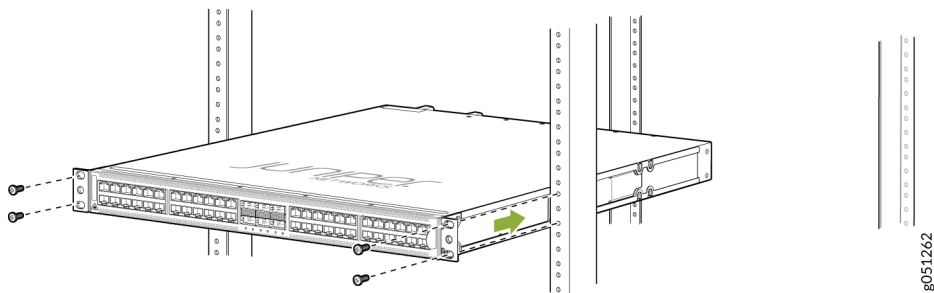


**Figure 100: Attach the Flush Mounting Brackets to a QFX5120-48YM Switch Chassis**

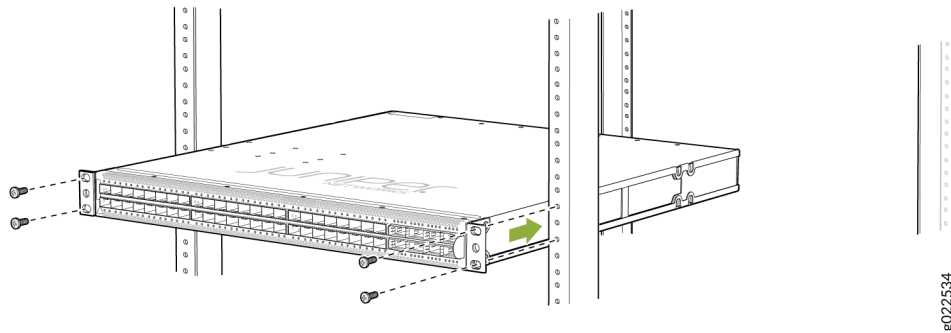


5. Decide which end of the switch you want to place at the front of the rack. Position the switch so that the **AIR IN** labels on the fan modules are facing the cold aisle, or the **AIR OUT** labels on the fan modules are facing the hot aisle.
6. Have one person grasp both sides of the switch, lift the switch, and position it in the rack, aligning the holes of the mounting brackets with the threaded holes in the front post of the rack. Align the bottom hole in both the mounting brackets with a hole in each rack rail, making sure that the chassis is level.
7. Have a second person secure the front of the switch to the rack by using the screws appropriate for your rack. Tighten the screws (see [Figure 101 on page 147](#), [Figure 102 on page 147](#), and [Figure 103 on page 148](#)).

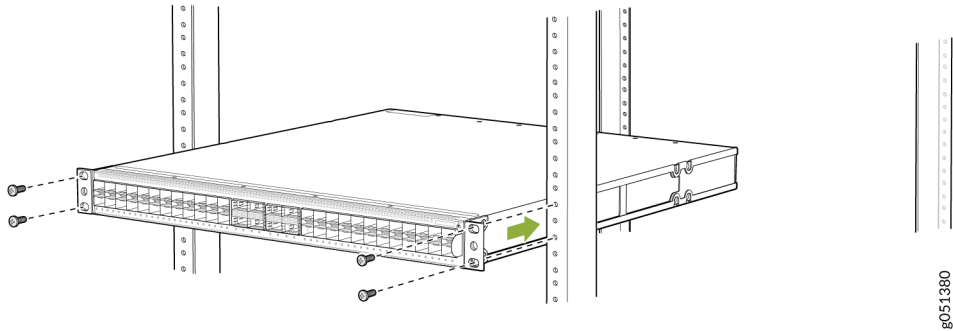
**Figure 101: Secure the QFX5120-48T Switch to the Front Posts of a Rack**



**Figure 102: Secure the QFX5120-48Y Switch to the Front Posts of a Rack**

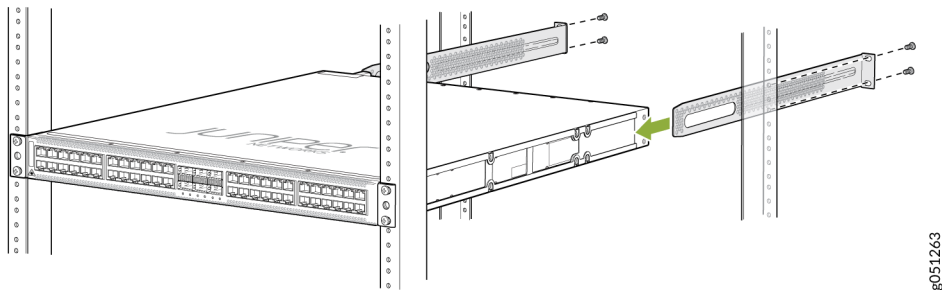


**Figure 103: Secure the QFX5120-48YM Switch to the Front Posts of a Rack**

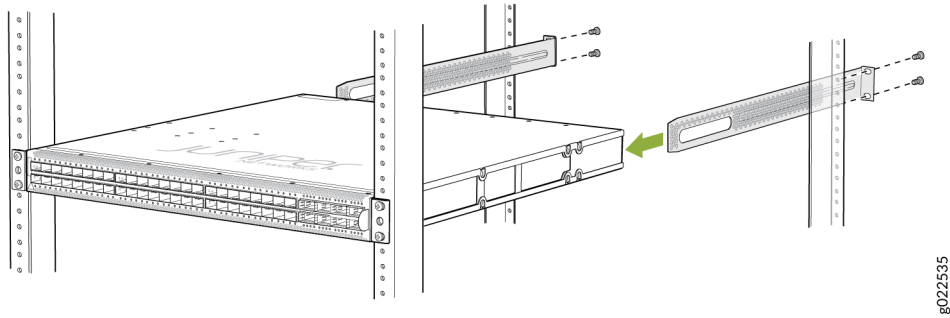


8. Slide the rear mounting bracket blades into the side rails of the front mounting brackets attached to the switch chassis (see [Figure 104 on page 148](#), [Figure 105 on page 149](#), and [Figure 106 on page 149](#)).
9. Ensure that the chassis is level. Align the holes of the rear mounting brackets with the threaded holes in the rear post of the rack. Align the bottom hole in both the mounting brackets with a hole in each rack rail. Align the bottom hole in both the rear mounting brackets with the bottom hole in the front mounting brackets.
10. Secure the rear mounting brackets to the rear post of the rack by using screws appropriate for your rack (see [Figure 104 on page 148](#), [Figure 105 on page 149](#), and [Figure 106 on page 149](#)).

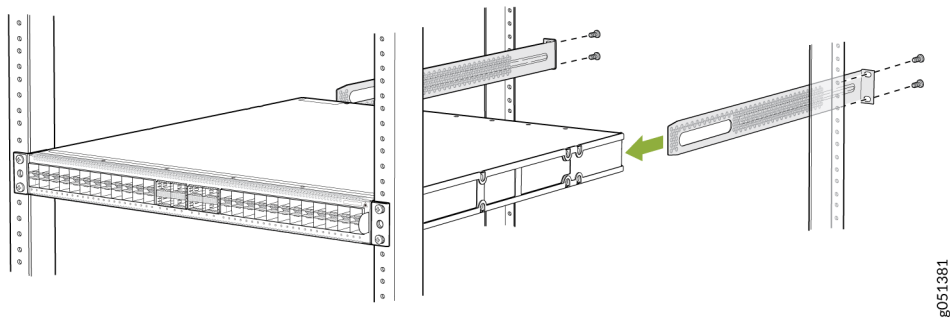
**Figure 104: Secure the QFX5120-48T Switch to the Rear Post of the Rack by Using the Rear Mounting Brackets**



**Figure 105: Secure the QFX5120-48Y Switch to the Rear Post of the Rack by Using the Rear Mounting Brackets**



**Figure 106: Secure the QFX5120-48YM Switch to the Rear Post of the Rack by Using the Rear Mounting Brackets**



Your switch is now installed on a four-post rack.

## Mount a QFX5120-48T, QFX5120-48Y, or QFX5120-48YM Switch in a Recessed Position from the Front Posts of a Rack or Cabinet

**NOTE:** The protective earthing terminal on QFX5120-48T, QFX5120-48Y, and QFX5120-48YM switches mounted in a recessed position from the front posts of a rack is accessible through the slot on the left rear bracket only if the distance between the front posts and the rear posts is 25 in. (63.5 cm) through 32.25 in. (81.9 cm).

Before you mount a QFX5120-48T, QFX5120-48Y, or QFX5120-48YM switch:

- Verify that the site meets the requirements described in "[Site Preparation Checklist for QFX5120 Switches](#)" on page 95.
- Place the rack in its permanent location, allowing adequate clearance for airflow and maintenance, and secure the rack to the building structure.
- Read *General Safety Guidelines and Warnings*, with particular attention to *Chassis and Component Lifting Guidelines*.
- Ensure that you have taken the necessary precautions to prevent electrostatic discharge (ESD) damage (see *Prevention of Electrostatic Discharge Damage*).
- Remove the switch from the shipping carton (see "[Unpack the QFX5120 Switch](#)" on page 123).

Ensure that you have the following parts and tools available:

- Number 2 Phillips (+) screwdriver—not provided
- Eight screws to secure the mounting brackets to the rack—not provided
- Electrostatic discharge (ESD) grounding strap—not provided
- Front mounting bracket assembly for mounting the switch flush with the front posts of a rack—2 (provided with the four-post rack mount kit)  
  
(The front mounting bracket assembly is made up of a side rail to which an L-shaped bracket is attached.)
- Flat head 4x6-mm Phillips screws for attaching the front mounting brackets to the chassis—12 (provided with the four-post rack mount kit)
- Rear mounting brackets—2 (provided with the four-post rack mount kit)
- Recessed mounting brackets for mounting the switch in a recessed position from the front posts of a rack—2 (provided with the four-post rack mount kit)
- Flat head 4-40 Phillips screws for attaching the recessed mounting brackets to the side rails—6 (provided with the four-post rack mount kit)

You can mount a QFX5120 switch on four posts of a four-post 19-in. rack or in a cabinet that contains a four-post 19-in. rack, flush with the front posts, by using a four-post rack mount kit. (The remainder of this topic uses rack to mean rack or cabinet.) You can mount QFX5120-48T, QFX5120-48Y, and QFX5120-48YM switches in a recessed position inside a four-post rack by using the recessed mounting brackets. You can also mount QFX5120-48YM switches on a two-post rack by using a separately orderable two-post rack mount kit.

This topic describes the procedure to mount QFX5120-48T, QFX5120-48Y, and QFX5120-48YM switches in a recessed position from the front posts of a four-post rack. If you want to mount the switch

flush with the front posts of a four-post rack, see ["Mount a QFX5120-48T, QFX5120-48Y, or QFX5120-48YM Switch Flush with the Front Posts of a Rack or Cabinet"](#) on page 144. If you want to mount a QFX5120-48YM switch on a two-post rack, see ["Mount a QFX5120-48YM Switch on a Two-Post Rack"](#) on page 160.

**NOTE:** One person must be available to lift the switch while another person secures the switch to the rack.

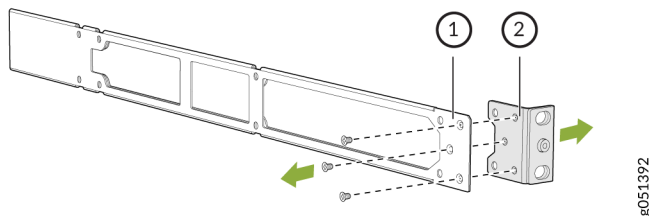


**CAUTION:** If you are mounting multiple units on a rack, mount the heaviest unit at the bottom of the rack, and then mount the other units from the bottom of the rack to the top in decreasing order of the weight of the units.

To mount a QFX5120-48T, QFX5120-48Y, or QFX5120-48YM switch in a recessed position from the front posts of a four-post rack:

1. Place the switch on a flat, stable surface.
2. Wrap and fasten one end of the ESD wrist strap around your bare wrist, and connect the other end of the strap to a site ESD point.
3. Unscrew and detach the L-shaped bracket from the side rail in the front mounting bracket assembly provided with the four-post rack mount kit (see [Figure 107 on page 151](#)).

**Figure 107: Unscrew and Detach the L-Shaped Bracket from the Side Rail**



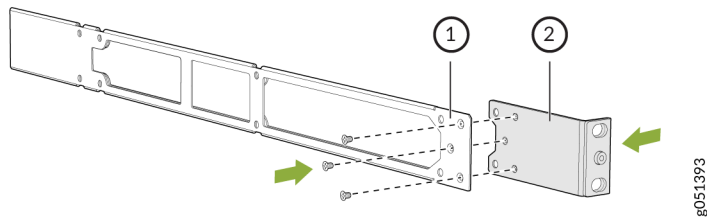
1– Side rail

2– L-shaped bracket

4. Attach the recessed mounting brackets provided with the four-post rack mount kit to the side rails by using the flat head 4-40 Phillips screws provided with the four-post rack mount kit (see [Figure 108 on page 152](#)).



**Figure 108: Attach the Recessed Mounting Bracket to the Side Rail**

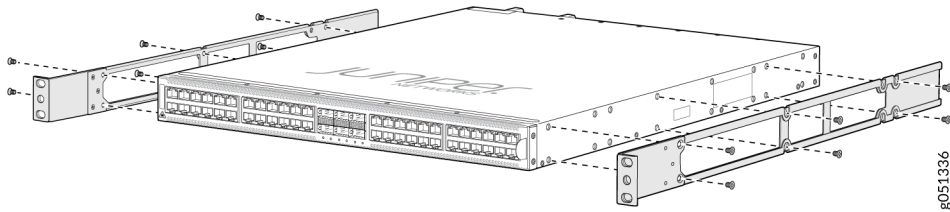


1– Side rail

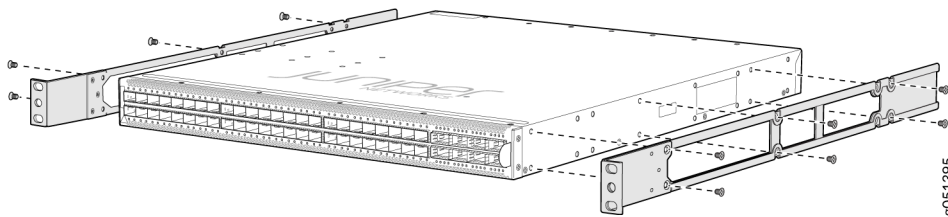
2– Recessed mounting bracket

5. Align the recessed mounting bracket assembly along the side panel of the switch.
6. Insert the flat head 4x6-mm Phillips screws for attaching the recess mounting bracket assembly (provided with the four-post rack mount kit) into the aligned holes on the chassis (see [Figure 109 on page 152](#), [Figure 110 on page 152](#), and [Figure 111 on page 153](#)). Tighten the screws.

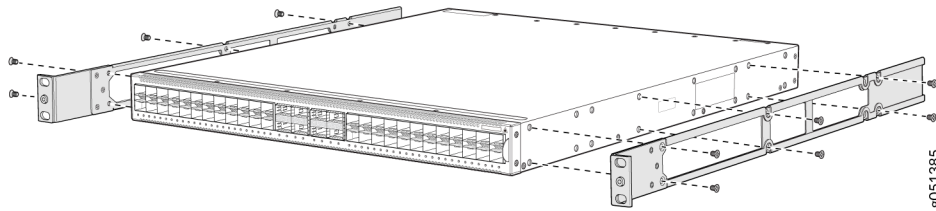
**Figure 109: Attach the Recessed Mounting Bracket Assembly to the QFX5120-48T Switch Chassis**



**Figure 110: Attach the Recessed Mounting Bracket Assembly to the QFX5120-48Y Switch Chassis**

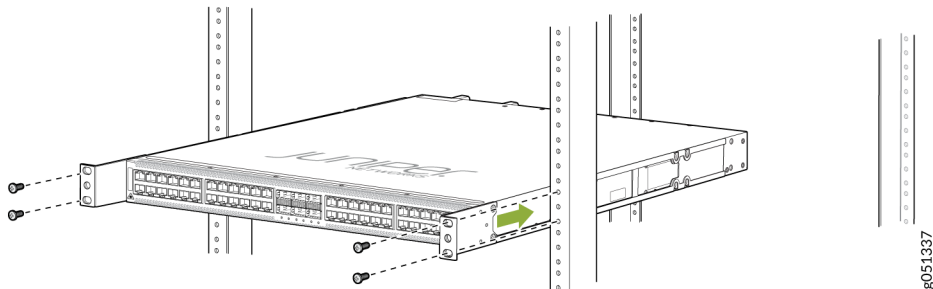


**Figure 111: Attach the Recessed Mounting Bracket Assembly to the QFX5120-48YM Switch Chassis**

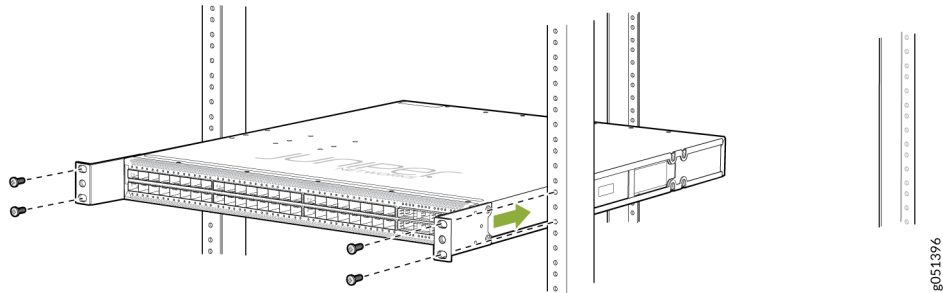


7. Decide which end of the switch you want to place at the front of the rack. Position the switch so that the **AIR IN** labels on the fan modules are facing the cold aisle, or the **AIR OUT** labels on the fan modules are facing the hot aisle.
8. Have one person grasp both sides of the switch, lift the switch, and position it in the rack, aligning the holes of the mounting brackets with the threaded holes in the front post of the rack. Align the bottom hole in both the mounting brackets with a hole in each rack rail, making sure that the chassis is level.
9. Have a second person secure the front of the switch to the rack by using the screws appropriate for your rack. Tighten the screws (see [Figure 112 on page 153](#), [Figure 113 on page 154](#), and [Figure 114 on page 154](#)).

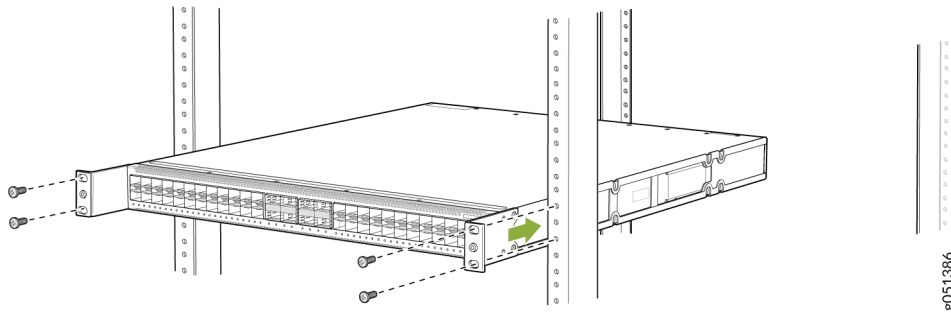
**Figure 112: Secure the QFX5120-48T Switch to the Front Posts of a Rack**



**Figure 113: Secure the QFX5120-48Y Switch to the Front Posts of a Rack**

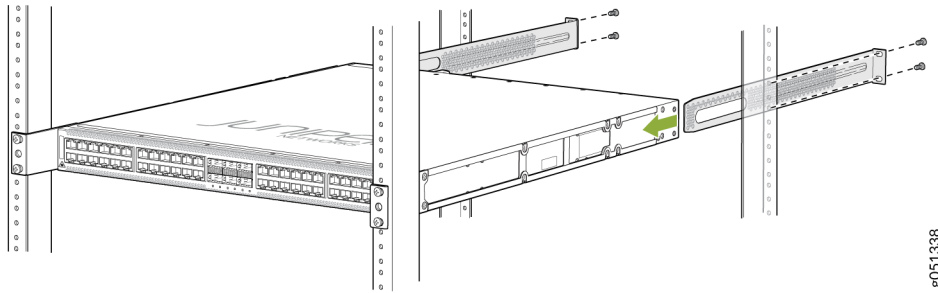


**Figure 114: Secure the QFX5120-48YM Switch to the Front Posts of a Rack**

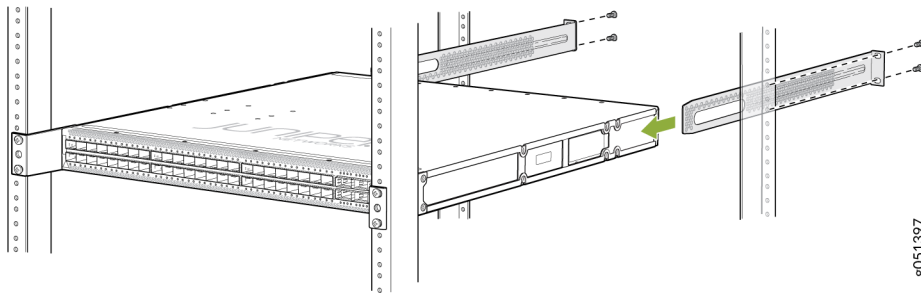


10. Slide the rear mounting bracket blades into the side rails of the recess mounting bracket assembly attached to the switch chassis (see [Figure 115 on page 155](#), [Figure 116 on page 155](#), and [Figure 117 on page 155](#)).
11. Ensure that the chassis is level. Align the holes of the rear mounting brackets with the threaded holes in the rear post of the rack. Align the bottom hole in both the mounting brackets with a hole in each rack rail. Align the bottom hole in both the rear mounting brackets with the bottom hole in the front mounting brackets.
12. Secure the rear mounting brackets to the rear post of the rack by using screws appropriate for your rack (see [Figure 115 on page 155](#), [Figure 116 on page 155](#), and [Figure 117 on page 155](#)).

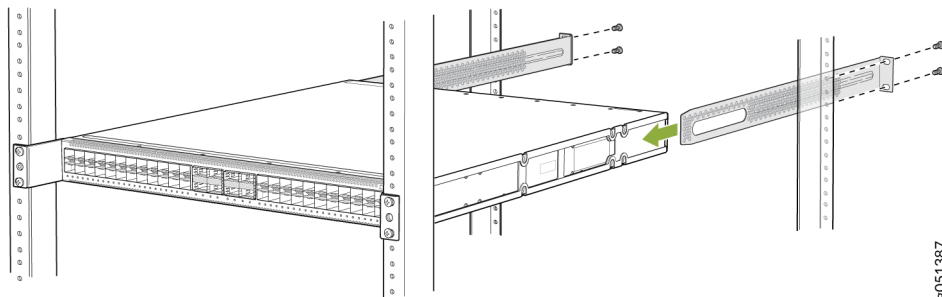
**Figure 115: Secure the QFX5120-48T Switch to the Rear Post of the Rack by Using the Rear Mounting Brackets**



**Figure 116: Secure the QFX5120-48Y Switch to the Rear Post of the Rack by Using the Rear Mounting Brackets**



**Figure 117: Secure the QFX5120-48YM Switch to the Rear Post of the Rack by Using the Rear Mounting Brackets**



Your switch is now installed on a four-post rack.

## Mount a QFX5120-48Y Switch on a Two-Post Rack

### IN THIS SECTION

- [Mount a QFX5120-T Switch on a Two-Post Rack | 158](#)
- [Mount a QFX5120-48YM Switch on a Two-Post Rack | 160](#)

Before you mount a QFX5120-48Y switch on a two-post rack:

- Verify that the site meets the requirements described in "[Site Preparation Checklist for QFX5120 Switches](#)" on page 95.
- Place the rack in its permanent location, allowing adequate clearance for airflow and maintenance, and secure the rack to the building structure.
- Read *General Safety Guidelines and Warnings*, with particular attention to *Chassis and Component Lifting Guidelines*.
- Ensure that you have taken the necessary precautions to prevent electrostatic discharge (ESD) damage (see *Prevention of Electrostatic Discharge Damage*).
- Remove the switch from the shipping carton (see "[Unpack the QFX5120 Switch](#)" on page 123).

Ensure that you have the following parts and tools available:

- Number 2 Phillips (+) screwdriver—not provided
- Eight screws to secure the mounting brackets to the rack—not provided
- Electrostatic discharge (ESD) grounding strap—not provided
- Two-post rack mounting bracket for mounting the switch on a two-post rack—2 (provided with the two-post rack mount kit)
- Flat head 4x6-mm Phillips screws for attaching the two-post rack mounting brackets to the chassis—8 (provided with the two-post rack mount kit)

You can mount a QFX5120 switch on four posts of a four-post 19-in. rack or in a cabinet that contains a four-post 19-in. rack, flush with the front posts, by using a four-post rack mount kit. (The remainder of this topic uses rack to mean rack or cabinet.) You can mount QFX5120-48Y switches in a recessed position inside a four-post rack by using the recessed mounting brackets. You can also mount QFX5120-48Y switches on a two-post rack by using a separately orderable two-post rack mount kit.

This topic describes the procedure to mount a QFX5120-48Y switch on a two-post rack. If you want to mount the switch flush with the front posts of a four-post rack, see ["Mount a QFX5120-48T, QFX5120-48Y, or QFX5120-48YM Switch Flush with the Front Posts of a Rack or Cabinet" on page 144](#). If you want to mount the switch in a recessed position from the front posts of a four-post rack, see ["Mount a QFX5120-48T, QFX5120-48Y, or QFX5120-48YM Switch in a Recessed Position from the Front Posts of a Rack or Cabinet" on page 149](#).

**NOTE:** One person must be available to lift the switch while another person secures the switch to the rack.

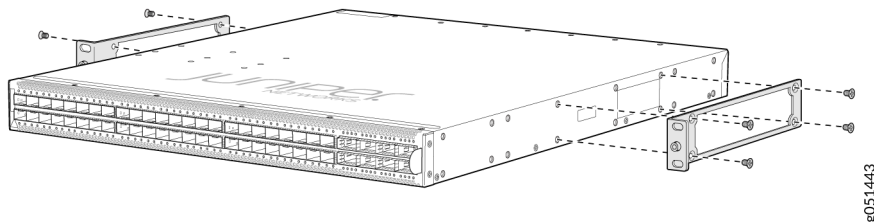


**CAUTION:** If you are mounting multiple units on a rack, mount the heaviest unit at the bottom of the rack, and then mount the other units from the bottom of the rack to the top in decreasing order of the weight of the units.

To mount a QFX5120-48Y switch on a two-post rack:

1. Place the switch on a flat, stable surface.
2. Wrap and fasten one end of the ESD wrist strap around your bare wrist, and connect the other end of the strap to a site ESD point.
3. Align the two-post rack mounting bracket (provided with the two-post rack mount kit) along the side panel of the switch.
4. Insert the flat head 4x6-mm Phillips screws for attaching the two-post rack mounting brackets (provided with the two-post rack mount kit) into the aligned holes on the chassis. Tighten the screws.

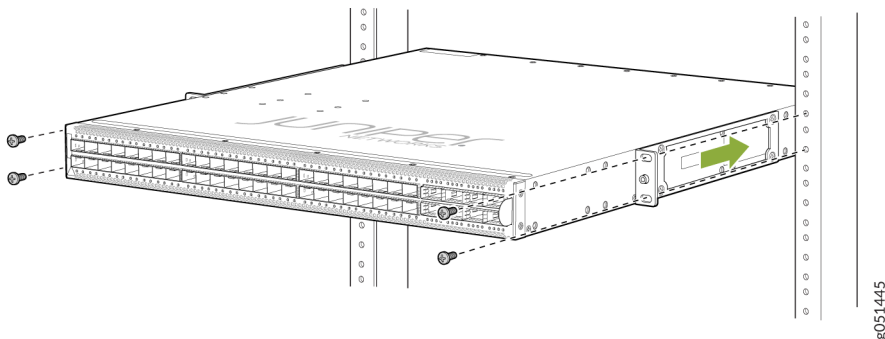
**Figure 118: Attach the Two-Post Rack Mounting Brackets to a QFX5120-48Y Switch Chassis**



5. Decide which end of the switch you want to place at the front of the rack. Position the switch so that the **AIR IN** labels on the fan modules are facing the cold aisle, or the **AIR OUT** labels on the fan modules are facing the hot aisle.

6. Have one person grasp both sides of the switch, lift the switch, and position it in the rack, aligning the holes of the mounting brackets with the threaded holes in the posts of the rack. Align the bottom hole in both the mounting brackets with a hole in each rack rail, making sure that the chassis is level.
7. Have a second person secure the switch to the rack by using the screws appropriate for your rack. Tighten the screws.

**Figure 119: Secure the QFX5120-48Y Switch to the Two-Post Rack**



Your switch is now installed on a two-post rack.

## Mount a QF5120-T Switch on a Two-Post Rack

Before you mount a QFX5120-48T switch on a two-post rack:

- Verify that the site meets the requirements described in "[Site Preparation Checklist for QFX5120 Switches](#)" on page 95.
- Place the rack in its permanent location, allowing adequate clearance for airflow and maintenance, and secure the rack to the building structure.
- Read *General Safety Guidelines and Warnings*, with particular attention to *Chassis and Component Lifting Guidelines*.
- Ensure that you have taken the necessary precautions to prevent electrostatic discharge (ESD) damage (see *Prevention of Electrostatic Discharge Damage*).
- Remove the switch from the shipping carton (see "[Unpack the QFX5120 Switch](#)" on page 123).

Ensure that you have the following parts and tools available:

- Number 2 Phillips (+) screwdriver—not provided
- Eight screws to secure the mounting brackets to the rack—not provided

- Electrostatic discharge (ESD) grounding strap—not provided
- Two-post rack mounting bracket for mounting the switch on a two-post rack—2 (provided with the two-post rack mount kit)
- Flat head 4x6-mm Phillips screws for attaching the two-post rack mounting brackets to the chassis—8 (provided with the two-post rack mount kit)

You can mount a QFX5120 switch on four posts of a four-post 19-in. rack or in a cabinet that contains a four-post 19-in. rack, flush with the front posts, by using a four-post rack mount kit. (The remainder of this topic uses rack to mean rack or cabinet.) You can mount QFX5120-48T switches in a recessed position inside a four-post rack by using the recessed mounting brackets. You can also mount QFX5120-48T switches on a two-post rack by using a separately orderable two-post rack mount kit.

This topic describes the procedure to mount a QFX5120-48T switch on a two-post rack. If you want to mount the switch flush with the front posts of a four-post rack, see ["Mount a QFX5120-48T, QFX5120-48Y, or QFX5120-48YM Switch Flush with the Front Posts of a Rack or Cabinet"](#) on page 144. If you want to mount the switch in a recessed position from the front posts of a four-post rack, see ["Mount a QFX5120-48T, QFX5120-48Y, or QFX5120-48YM Switch in a Recessed Position from the Front Posts of a Rack or Cabinet"](#) on page 149.

**NOTE:** One person must be available to lift the switch while another person secures the switch to the rack.



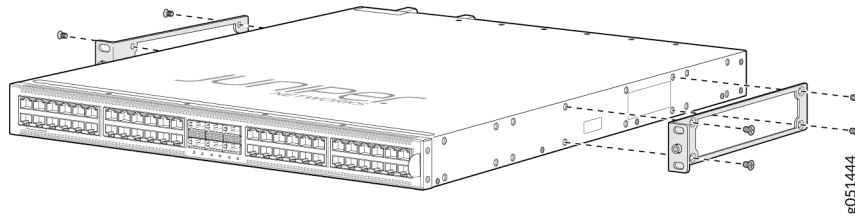
**CAUTION:** If you are mounting multiple units on a rack, mount the heaviest unit at the bottom of the rack, and then mount the other units from the bottom of the rack to the top in decreasing order of the weight of the units.

To mount a QFX5120-48T switch on a two-post rack:

1. Place the switch on a flat, stable surface.
2. Wrap and fasten one end of the ESD wrist strap around your bare wrist, and connect the other end of the strap to a site ESD point.
3. Align the two-post rack mounting bracket (provided with the two-post rack mount kit) along the side panel of the switch).
4. Insert the flat head 4x6-mm Phillips screws for attaching the two-post rack mounting brackets (provided with the two-post rack mount kit) into the aligned holes on the chassis. Tighten the screws.

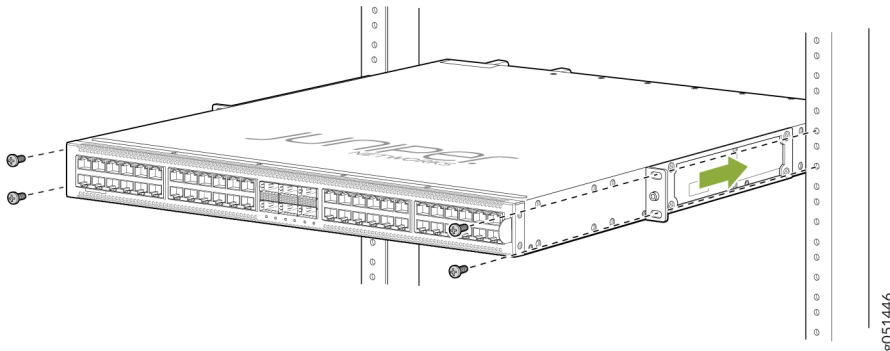


Figure 120: Attach the Two-Post Rack Mounting Brackets to a QFX5120-48T Switch Chassis



5. Decide which end of the switch you want to place at the front of the rack. Position the switch so that the **AIR IN** labels on the fan modules are facing the cold aisle, or the **AIR OUT** labels on the fan modules are facing the hot aisle.
6. Have one person grasp both sides of the switch, lift the switch, and position it in the rack, aligning the holes of the mounting brackets with the threaded holes in the posts of the rack. Align the bottom hole in both the mounting brackets with a hole in each rack rail, making sure that the chassis is level.
7. Have a second person secure the switch to the rack by using the screws appropriate for your rack. Tighten the screws).

Figure 121: Secure the QFX5120-48T Switch to the Two-Post Rack



Your switch is now installed on a two-post rack.

## Mount a QFX5120-48YM Switch on a Two-Post Rack

Before you mount a QFX5120-48YM switch on a two-post rack:

- Verify that the site meets the requirements described in "[Site Preparation Checklist for QFX5120 Switches](#)" on page 95.
- Place the rack in its permanent location, allowing adequate clearance for airflow and maintenance, and secure the rack to the building structure.

- Read *General Safety Guidelines and Warnings*, with particular attention to *Chassis and Component Lifting Guidelines*.
- Ensure that you have taken the necessary precautions to prevent electrostatic discharge (ESD) damage (see *Prevention of Electrostatic Discharge Damage*).
- Remove the switch from the shipping carton (see ["Unpack the QFX5120 Switch" on page 123](#)).

Ensure that you have the following parts and tools available:

- Number 2 Phillips (+) screwdriver—not provided
- Eight screws to secure the mounting brackets to the rack—not provided
- Electrostatic discharge (ESD) grounding strap—not provided
- Two-post rack mounting bracket for mounting the switch on a two-post rack—2 (provided with the two-post rack mount kit)
- Flat head 4x6-mm Phillips screws for attaching the two-post rack mounting brackets to the chassis—8 (provided with the two-post rack mount kit)

You can mount a QFX5120 switch on four posts of a four-post 19-in. rack or in a cabinet that contains a four-post 19-in. rack, flush with the front posts, by using a four-post rack mount kit. (The remainder of this topic uses rack to mean rack or cabinet.) You can mount QFX5120-48YM switches in a recessed position inside a four-post rack by using the recessed mounting brackets. You can also mount QFX5120-48YM switches on a two-post rack by using a separately orderable two-post rack mount kit.

This topic describes the procedure to mount a QFX5120-48YM switch on a two-post rack. If you want to mount the switch flush with the front posts of a four-post rack, see ["Mount a QFX5120-48T, QFX5120-48Y, or QFX5120-48YM Switch Flush with the Front Posts of a Rack or Cabinet" on page 144](#). If you want to mount the switch in a recessed position from the front posts of a four-post rack, see ["Mount a QFX5120-48T, QFX5120-48Y, or QFX5120-48YM Switch in a Recessed Position from the Front Posts of a Rack or Cabinet" on page 149](#).

**NOTE:** One person must be available to lift the switch while another person secures the switch to the rack.

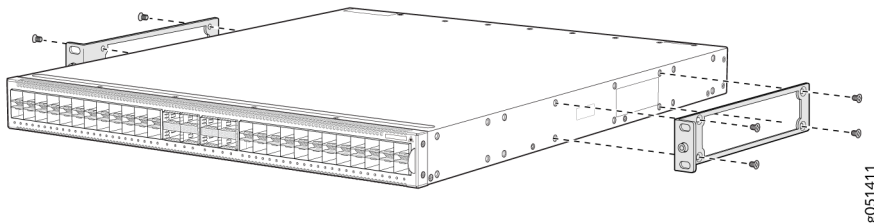


**CAUTION:** If you are mounting multiple units on a rack, mount the heaviest unit at the bottom of the rack, and then mount the other units from the bottom of the rack to the top in decreasing order of the weight of the units.

To mount a QFX5120-48YM switch on a two-post rack:

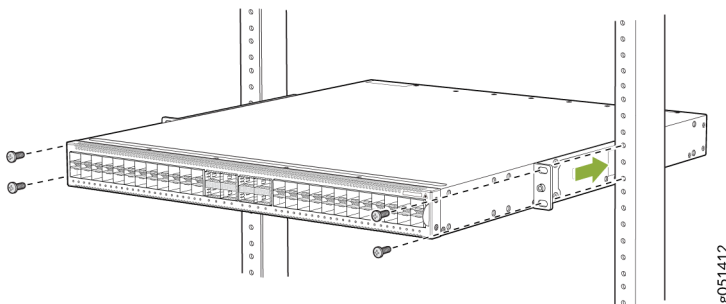
1. Place the switch on a flat, stable surface.
2. Wrap and fasten one end of the ESD wrist strap around your bare wrist, and connect the other end of the strap to a site ESD point.
3. Align the two-post rack mounting bracket (provided with the two-post rack mount kit) along the side panel of the switch.
4. Insert the flat head 4x6-mm Phillips screws for attaching the two-post rack mounting brackets (provided with the two-post rack mount kit) into the aligned holes on the chassis). Tighten the screws.

**Figure 122: Attach the Two-Post Rack Mounting Brackets to a QFX5120-48YM Switch Chassis**



5. Decide which end of the switch you want to place at the front of the rack. Position the switch so that the **AIR IN** labels on the fan modules are facing the cold aisle, or the **AIR OUT** labels on the fan modules are facing the hot aisle.
6. Have one person grasp both sides of the switch, lift the switch, and position it in the rack, aligning the holes of the mounting brackets with the threaded holes in the posts of the rack. Align the bottom hole in both the mounting brackets with a hole in each rack rail, making sure that the chassis is level.
7. Have a second person secure the switch to the rack by using the screws appropriate for your rack. Tighten the screws.

**Figure 123: Secure the QFX5120-48YM Switch to the Two-Post Rack**



Your switch is now installed on a two-post rack.

# Connect the QFX5120 to Power

## IN THIS SECTION

- [Connect the QFX5120 Switch to Earth Ground | 163](#)
- [Connect Power to an AC-Powered QFX5120 Switch | 168](#)
- [Connect Power to a DC-Powered QFX5120 Switch | 171](#)
- [Connect Power to a QFX5120-48T Switch Powered by a High-Voltage Power Supply | 177](#)

## Connect the QFX5120 Switch to Earth Ground

Before you connect earth ground to a QFX5120 switch, ensure that you have the following parts and tools available:

- Grounding cable:
  - QFX5120-32C: 12 AWG (2.5 mm<sup>2</sup>), minimum 90° C wire, or as permitted by the local code—not provided
  - QFX5120-48T, QFX5120-48Y, and QFX5120-48YM: 14 AWG (1.5 mm<sup>2</sup>), minimum 90° C wire, or as permitted by the local code—not provided
- Grounding lug:
  - QFX5120-32C: 4.3-mm circular lug—not provided
  - QFX5120-48T, QFX5120-48Y, and QFX5120-48YM: Panduit LCD10-10A-L or equivalent—not provided
- Screws to secure the grounding lug:
  - QFX5120-32C: 8-mm screw—not provided
  - QFX5120-48T, QFX5120-48Y, and QFX5120-48YM: Two 10-32 x .25-in. screws with #10 split-lock washers—not provided
- Number 2 Phillips (+) screwdriver—not provided
- ESD grounding strap—not provided

To ensure proper operation and to meet safety and electromagnetic interference (EMI) requirements, you must connect the switch to earth ground before you connect power to the switch. You must install the switch in a restricted-access location and ensure that the chassis is properly grounded at all times.

QFX5120-32C switches have two 1-hole protective earthing terminals on the rear panel. The required method to ground the QFX5120-32C chassis is to use one of the protective earthing terminals on the switch chassis. Under all circumstances, use this grounding connection to ground the chassis. For AC-powered systems, you must also use the grounding wire in the AC power cord along with the two-hole grounding lug connection. This tested system meets or exceeds all applicable EMC regulatory requirements with the two-hole protective grounding terminal.

QFX5120-48T and QFX5120-48Y switches have one 2-hole protective earthing terminal on the left panel. The required method to ground the QFX5120-48T and QFX5120-48Y chassis is to use the protective earthing terminal on the switch chassis. Under all circumstances, use this grounding connection to ground the chassis. For AC-powered systems, you must also use the grounding wire in the AC power cord along with the two-hole grounding lug connection. This tested system meets or exceeds all applicable EMC regulatory requirements with the two-hole protective grounding terminal.

QFX5120-48YM switches have two 2-hole protective earthing terminals on the left panel. Under all circumstances, use this grounding connection to ground the chassis. For AC-powered systems, you must also use the grounding wire in the AC power cord along with the two-hole grounding lug connection. This tested system meets or exceeds all applicable EMC regulatory requirements with the two-hole protective grounding terminal.



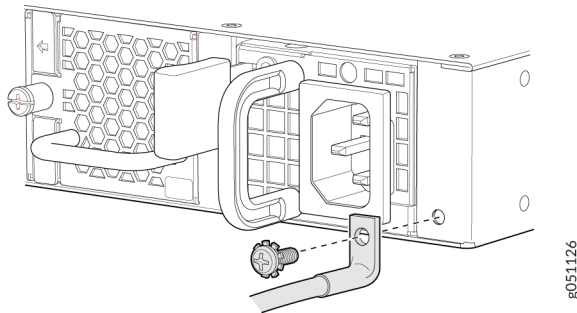
**CAUTION:** Ensure that a licensed electrician has attached the appropriate grounding lug to the grounding cable that you supply. Using a grounding cable with an incorrectly attached lug can damage the switch.

**NOTE:** The protective earthing terminal on QFX5120-48T, QFX5120-48Y, and QFX5120-48YM switches mounted flush with the front posts of a rack is accessible through the slot on the left rear bracket only if the distance between the front posts and the rear posts is 23 in. (58.5 cm) through 30.25 in. (76.8 cm). The protective earthing terminal on QFX5120-48T, QFX5120-48Y, and QFX5120-48YM switches mounted in a recessed position from the front posts of a rack is accessible through the slot on the left rear bracket only if the distance between the front posts and the rear posts is 25 in. (63.5 cm) through 32.25 in. (81.9 cm). AC-powered switches gain additional grounding when you plug the power supply in the switch into a grounded AC power outlet by using the AC power cord appropriate for your geographical location. For DC-powered QFX5120-48T, QFX5120-48Y, or QFX5120-48YM switches, if you are unable to access the protective earthing terminal, you can connect the grounding cable to the earth ground terminal on the DC power supply.

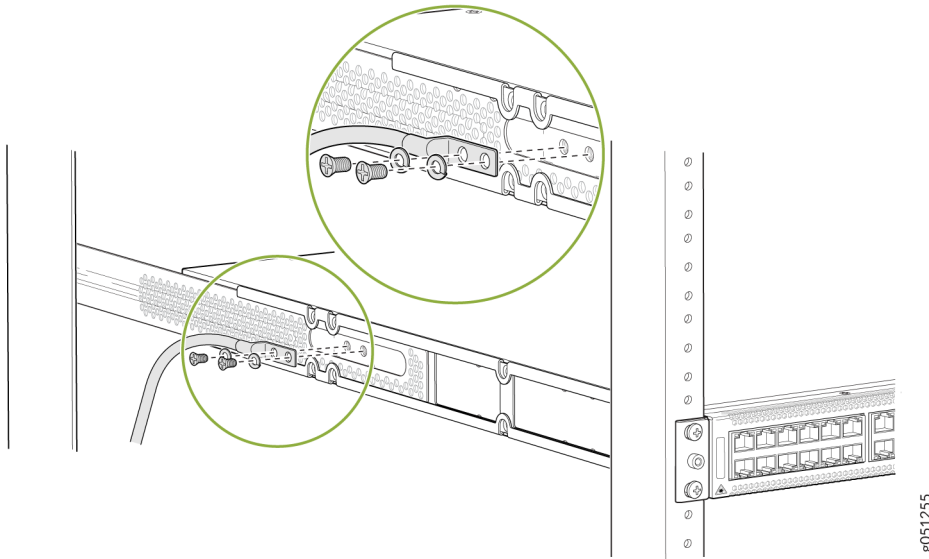
To ground the QFX5120:

1. Connect one end of the grounding cable to a proper earth ground, such as the rack in which the switch is mounted.
2. Place the grounding lug attached to the grounding cable over the protective earthing terminal:
  - On the rear panel of a QFX5120-32C switch (see [Figure 124 on page 165](#)).
  - On the left panel on QFX5120-48T and QFX5120-48Y switches (see [Figure 125 on page 165](#)).
  - On the left panel on a QFX5120-48YM switch (see [Figure 126 on page 166](#), [Figure 127 on page 166](#), [Figure 128 on page 167](#), or [Figure 129 on page 167](#)).

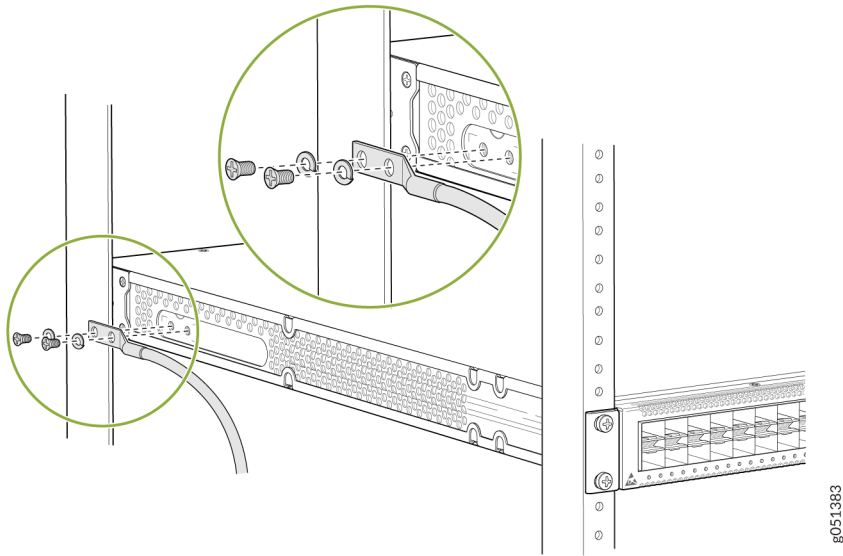
**Figure 124: Connect a Grounding Cable to the QFX5120-32C**



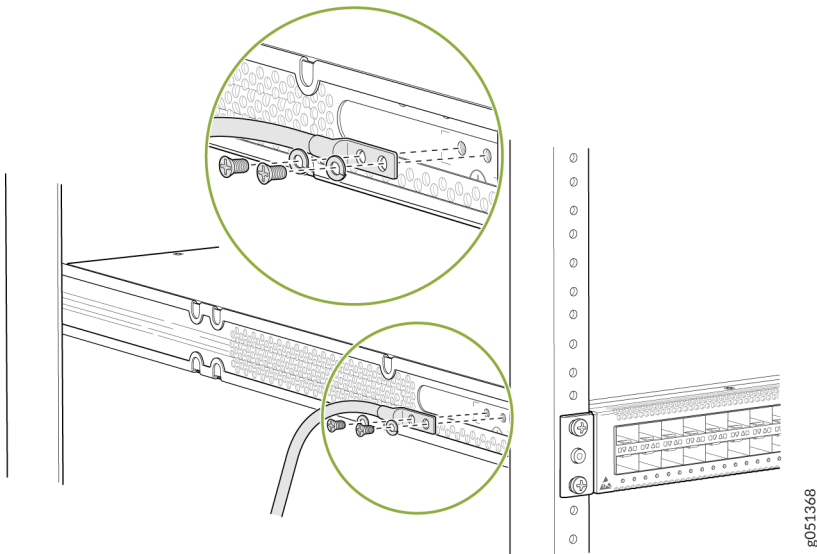
**Figure 125: Connect a Grounding Cable to the QFX5120-48T or QFX5120-48Y**



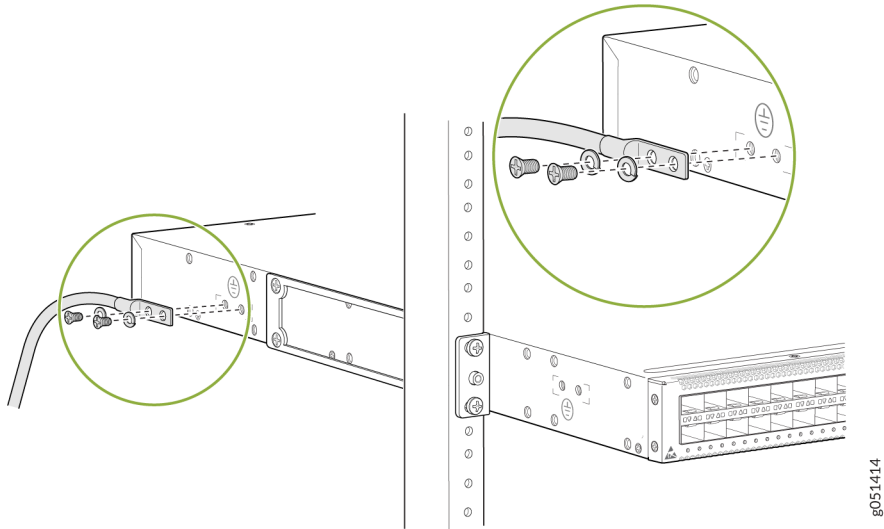
**Figure 126: Connect a Grounding Cable to the Protective Earthing Terminal in the Rear of the Left Panel on the QFX5120-48YM Mounted on Four Posts**



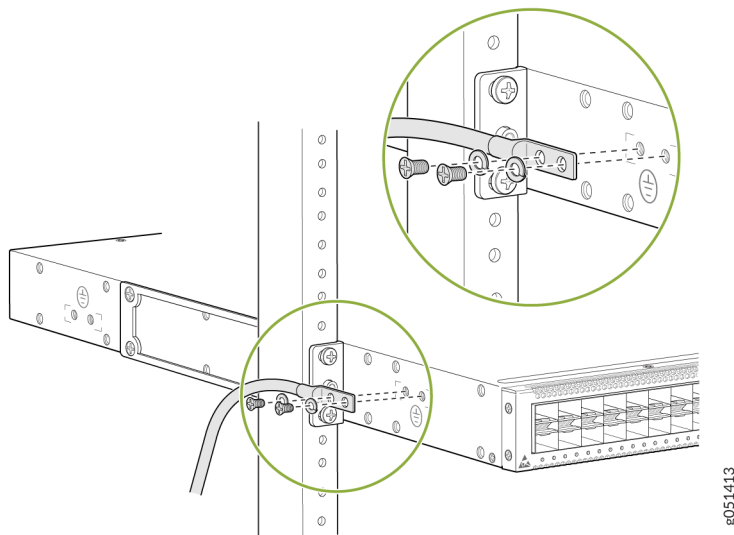
**Figure 127: Connect a Grounding Cable to the Protective Earthing Terminal in the Front of the Left Panel on the QFX5120-48YM Mounted on Four Posts**



**Figure 128: Connect a Grounding Cable to the Protective Earthing Terminal in the Rear of the Left Panel on the QFX5120-48YM Mounted on Two Posts**



**Figure 129: Connect a Grounding Cable to the Protective Earthing Terminal in the Front of the Left Panel on the QFX5120-48YM Mounted on Two Posts**



3. Secure the grounding lug to the protective earthing terminal with the screws.
4. Dress the grounding cable and ensure that it does not touch or block access to other switch components.





**WARNING:** Ensure that the cable does not drape where people could trip over it.

## Connect Power to an AC-Powered QFX5120 Switch

Before you connect AC power to the switch:

- Ensure that you have a power cord appropriate for your geographical location available.
- Ensure that you have the power cord retainer shipped with the switch.
- Ensure that you have taken the necessary precautions to prevent electrostatic discharge (ESD) damage (see *Prevention of Electrostatic Discharge Damage*).
- Ensure that you have connected the switch chassis to earth ground.



**CAUTION:** Before you connect power to the switch, a licensed electrician must attach a cable lug to the grounding and power cables that you supply. A cable with an incorrectly attached lug can damage the switch (for example, by causing a short circuit).

To meet safety and electromagnetic interference (EMI) requirements and to ensure proper operation, you must connect the chassis to earth ground before you connect it to power (see "[Connect the QFX5120 Switch to Earth Ground](#)" on page 163). For installations that require a separate grounding conductor to the chassis, use the protective earthing terminal on the switch chassis to connect to earth ground. The switch gains additional grounding when you plug the power supply in the switch into a grounded AC power outlet by using the AC power cord appropriate for your geographical location.

We ship the QFX5120 switches with two power supplies preinstalled. Each power supply is a hot-removable and hot-insertable field-replaceable unit (FRU) when the second power supply is installed and running: You can remove and replace them without powering off the switch or disrupting switch functions.

To connect power to an AC-powered QFX5120 switch:

1. Wrap and fasten one end of the ESD wrist strap around your bare wrist, and connect the other end of the strap to a site ESD point.
2. Ensure that the power supplies are fully inserted in the chassis.

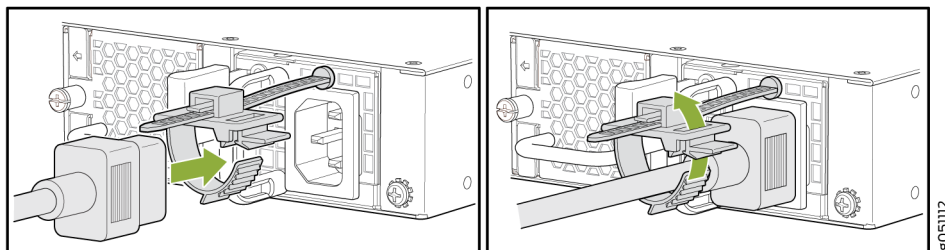
3. Locate the power cord or cords shipped with the switch; the cords have plugs appropriate for your geographical location.



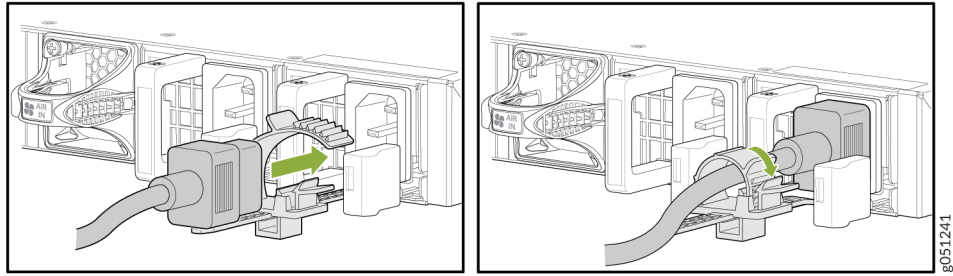
**WARNING:** Ensure that the power cord does not block access to device components or drape where people can trip on it.

4. Connect the power cord.
  - For QFX5120-32C, QFX5120-48T, and QFX5120-48Y switches:
    - a. Push the end of the retainer strip into the hole next to the inlet on the power supply faceplate until it snaps into place. Ensure that the loop in the retainer strip faces the power cord.
    - b. Press the small tab on the retainer strip to loosen the loop. Slide the loop until you have enough space to insert the power cord coupler into the inlet.
    - c. Insert the power cord coupler firmly into the inlet.
    - d. Slide the loop toward the power supply until it is snug against the base of the coupler.
    - e. Press the tab on the loop and draw out the loop into a tight circle (see [Figure 130 on page 169](#) and [Figure 131 on page 170](#)).

**Figure 130: Connect Power Cord to an AC-Powered QFX5120-32C Switch**

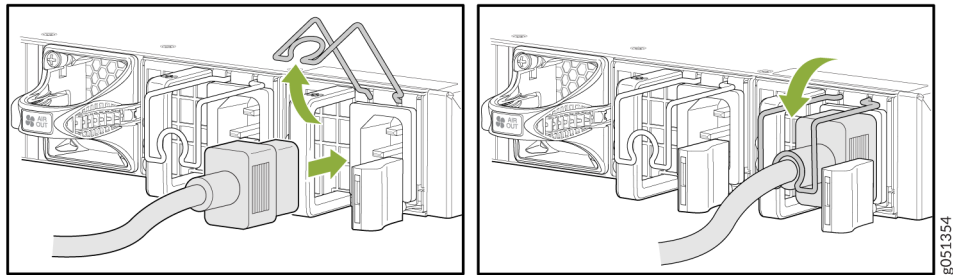


**Figure 131: Connect Power Cord to an AC-Powered QFX5120-48T or QFX5120-48Y Switch**



- For QFX5120-48YM switches:
  - a. Gently lift the retainer clip up.
  - b. Insert the power cord coupler firmly into the inlet.
  - c. Push the retainer clip down until it is snug against the base of the coupler (see [Figure 132 on page 170](#)).

**Figure 132: Connect Power to an AC-Powered QFX5120-48YM Switch**



5. If the AC power source outlet has a power switch, set it to the off position.

**NOTE:** The QFX5120 switch powers on as soon as power is provided to the power supply. There is no power switch on the QFX5120.

6. Insert the power cord plug into an AC power source outlet.
7. If the AC power source outlet has a power switch, set it to the on position.
8.
  - If you are connecting the power supply in a QFX5120-32C switch, verify that the LED on the power supply is lit green. If the LED is lit or blinking red, disconnect the power supply from the power source, and replace the power supply (see ["Maintain the QFX5120 Power System" on page 201](#)).

- If you are connecting the power supply in a QFX5120-48T, QFX5120-48Y, or QFX5120-48YM switch, verify that the **AC** and **DC** LEDs on the power supply are lit green. If the fault LED (!) is lit, disconnect the power supply from the power source, and replace the power supply (see "[Maintain the QFX5120 Power System](#)" on page 201).



**CAUTION:** Do not remove the power supply until you have a replacement power supply ready: you must install the replacement power supply within one minute after removing the failed power supply to ensure proper airflow and prevent chassis overheating.

## Connect Power to a DC-Powered QFX5120 Switch

Before you connect DC power to the switch:

- Ensure that you have taken the necessary precautions to prevent electrostatic discharge (ESD) damage (see *Prevention of Electrostatic Discharge Damage*).
- Ensure that you have connected the switch chassis to earth ground (see "[Connect the QFX5120 Switch to Earth Ground](#)" on page 163).



**CAUTION:** Before you connect power to the switch, a licensed electrician must attach a cable lug to the grounding and power cables that you supply. A cable with an incorrectly attached lug can damage the switch (for example, by causing a short circuit).

To meet safety and electromagnetic interference (EMI) requirements and to ensure proper operation, you must connect the chassis to earth ground before you connect it to power. For installations that require a separate grounding conductor to the chassis, use the protective earthing terminal on the switch chassis to connect to the earth ground.

Ensure that you have the following parts and tools available:

- For the DC-powered models QFX5120-32C-DC-AFO and QFX5120-32C-DC-AFI: DC power cable with a plug—provided
- For the DC-powered models QFX5120-48T-DC-AFO, QFX5120-48T-DC-AFI, QFX5120-48Y-DC-AFO2, and QFX5120-48Y-DC-AFI2: DC power source cables (14–16 AWG) with ring lug (Molex 190700069 or equivalent)—not provided

- For the DC-powered models QFX5120-48YM-DC-AO and QFX5120-48YM-DC-AI: DC power source cables (14–12 AWG) with ring lug (Molex 190700069 or equivalent)—not provided
- Number 2 Phillips (+) screwdriver—not provided
- Multimeter—not provided

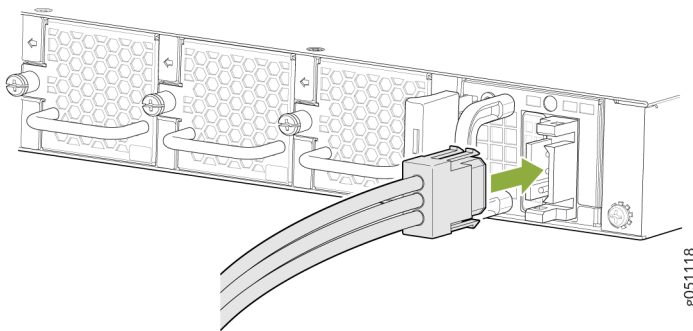
We ship the QFX5120 switches with two power supplies preinstalled. Each power supply is a hot-removable and hot-insertable field-replaceable unit (FRU) when the second power supply is installed and running: You can install power supplies in the slots next to the fan modules without powering off the switch or disrupting switch functions.

**NOTE:** The battery returns of the DC power supply must be connected as an isolated DC return (DC-I).

To connect power to a DC-powered QFX5120-32C switch:

1. Wrap and fasten one end of the ESD wrist strap around your bare wrist, and connect the other end of the strap to a site ESD point.
2. Ensure that the input circuit breaker is open so that the voltage across the DC power source cable leads is 0 V and that the cable leads do not become active while you are connecting DC power.
3. Ensure that the power supplies are fully inserted in the chassis.
4. Connect each power supply to the power source by inserting the DC connector of the power cable provided into the power supply (see [Figure 133 on page 172](#)).

**Figure 133: Connect Power to a DC-Powered QFX5120-32C Switch**



5. Connect each power cable to the power sources. Secure power source cables to the power supplies by screwing the ring lugs attached to the cables to the appropriate terminals.
  - Connect the ring lug of the green-yellow cable to earth ground.
  - Connect the ring lug of the black cable to the negative (-) DC power source.

- Connect the ring lug of the red cable to the positive (+) DC power source.

We've designed the QFX5120-32C switch to operate with a DC power supply that has a single, nonredundant feed input. For source redundancy, you must install two DC power supplies in the QFX5120-32C; connect source (A) to one power supply and connect source (B) to the second power supply. This configuration provides the commonly deployed A/B feed redundancy for the system.



**CAUTION:** The connection between each power source and power supply must include a circuit breaker. Do not connect two sources to a single power supply because doing so can potentially cause circulating current in feed wires whenever there is any difference in the voltage of the two sources.

6. Close the input circuit breaker.

**NOTE:** The QFX5120 switch powers on as soon as power is provided to the power supply. There is no power switch on the QFX5120.

7. Verify that the LED on the power supply is lit green. If the LED is lit or blinking red, disconnect the power supply from the power source, and replace the power supply (see ["Remove a Power Supply from a QFX5120 Switch" on page 202](#)).



**CAUTION:** Do not remove the power supply until you have a replacement power supply ready: you must install the replacement power supply within one minute after removing the failed power supply to ensure proper airflow and prevent chassis overheating.

To connect power to a DC-powered QFX5120-48T, QFX5120-48Y, or QFX5120-48YM switch:

1. Wrap and fasten one end of the ESD wrist strap around your bare wrist, and connect the other end of the strap to a site ESD point.
2. Verify that the DC power cables are correctly labeled before making connections to the power supply. In a typical power distribution scheme where the return is connected to chassis ground at the battery plant, you can use a multimeter to verify the resistance of the -48V and RTN DC cables to chassis ground:
  - The cable with very low resistance (indicating a closed circuit) to chassis ground is positive (+) and will be installed on the V+ (return) DC power input terminal.
  - The cable with very high resistance (indicating an open circuit) to chassis ground is negative (-) and will be installed on the V- (input) DC power input terminal.



**CAUTION:** You must ensure that power connections maintain the proper polarity. The power source cables might be labeled (+) and (-) to indicate their polarity. There is no standard coding for DC power cables. The coding used by the external DC power source at your site determines the coding for the leads on the power cables that attach to the DC power input terminals on each power supply.

3. Install heat-shrink tubing insulation around the power cables.

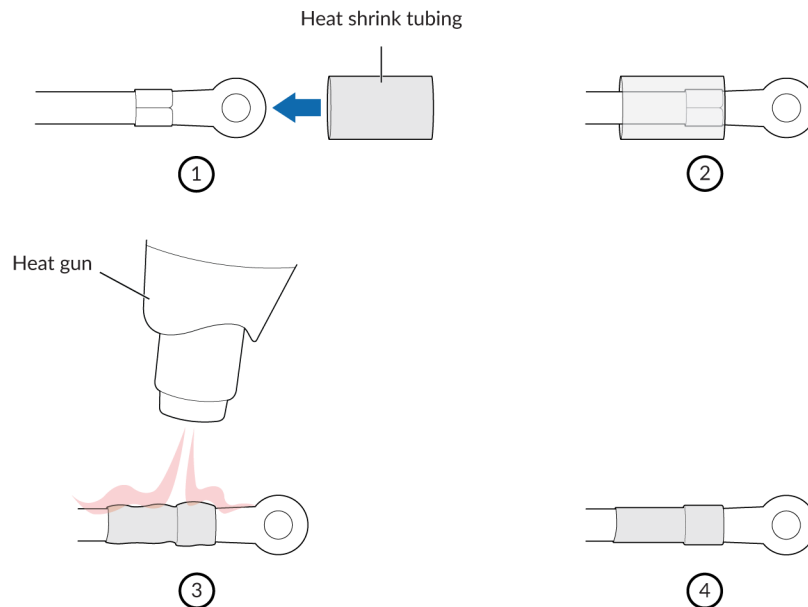
To install heat-shrink tubing:

- a. Slide the tubing over the portion of the cable where it is attached to the lug barrel. Ensure that tubing covers the end of the wire and the barrel of the lug attached to it.
- b. Shrink the tubing with a heat gun. Ensure that you heat all sides of the tubing evenly so that it shrinks around the cable tightly.

Figure 134 on page 174 shows the steps to install heat-shrink tubing.

**NOTE:** Do not overheat the tubing.

**Figure 134: How to Install Heat-Shrink Tubing**



4. Ensure that the input circuit breaker is open so that the voltage across the DC power source cable leads is 0 V and that the cable leads do not become active while you are connecting DC power.

**NOTE:** The V+ terminals are referred to as +RTN, and the V- terminals are referred to as -48 V in *DC Power Wiring Sequence Warning* and *DC Power Electrical Safety Guidelines*.

5. Ensure that the power supplies are fully inserted in the chassis.
6. Remove the terminal block cover. The terminal block cover is a piece of clear plastic that snaps into place over the terminal block.
7. Remove the screws on the terminals using the screwdriver. Save the screws.



**WARNING:** Ensure that the power cables do not block access to device components or drape where people can trip on them.

8. Connect each power supply to the power sources. Secure power source cables to the power supplies by screwing the ring lugs attached to the cables to the appropriate terminals by using the screw from the terminals (see [Figure 135 on page 176](#)).

We've designed the QFX5120-48T, QFX5120-48Y, and QFX5120-48YM switches to operate with a DC power supply that has a single, nonredundant, feed input. For source redundancy, you must install two DC power supplies in the QFX5120-48T, QFX5120-48Y, and QFX5120-48YM switches; and then connect source (A) to one power supply and connect source (B) to the second power supply. This configuration provides the commonly deployed A/B feed redundancy for the system.

The terminal block of the power supply has four terminals labeled V+, V+, V-, and V- for connecting DC power source cables labeled positive (+) and negative (-). The V+ terminals are shunted internally together, as are the V- terminals.



**CAUTION:** The connection between each power source and power supply must include a circuit breaker.

Do not connect two sources to a single power supply because doing so can potentially cause circulating current in feed wires whenever there is any difference in the voltage of the two sources.

- a. Secure the ring lug of the positive (+) DC power source cable to the V+ terminal on the DC power supply.

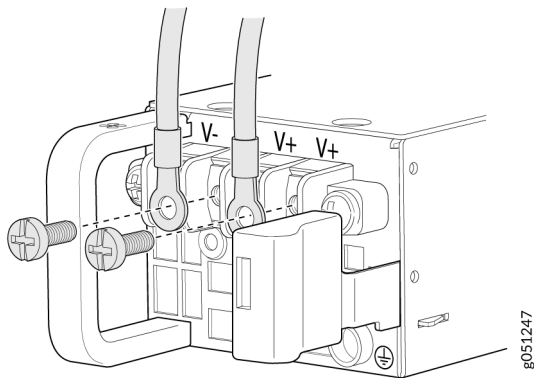


- b. Secure the ring lug of the negative (-) DC power source cable to the V- terminal on the DC power supply.
- c. Tighten the screws on the power supply terminals until snug using the screwdriver. Do not overtighten; apply between 5 lb-in. (0.56 Nm) and 6 lb-in. (0.68 Nm) of torque on the screws.



**CAUTION:** The V+ terminals are shunted internally together, as are the V- terminals. The same polarity terminal can be wired together from the same source to provide an additional current path in a higher power chassis. Do not connect the terminals to different sources.

**Figure 135: Secure Ring Lugs to the Terminals on the QFX5120-48T, QFX5120-48Y, or QFX5120-48YM DC Power Supply**



9. Replace the terminal block cover.
10. Close the input circuit breaker.

**NOTE:** The QFX5120 switch powers on as soon as power is provided to the power supply. There is no power switch on the QFX5120.

11. Verify that the **IN** and **OUT** LEDs on the power supply are lit green. If the fault LED (!) is lit, disconnect the power supply from the power source, and replace the power supply (see ["Remove a Power Supply from a QFX5120 Switch"](#) on page 202).



**CAUTION:** Do not remove the power supply until you have a replacement power supply ready: you must install the replacement power supply within one minute after removing the failed power supply to ensure proper airflow and prevent chassis overheating.

## Connect Power to a QFX5120-48T Switch Powered by a High-Voltage Power Supply

Before you connect power to a QFX5120-48T switch powered by a high-voltage power supply:

- Ensure that you have a power cord appropriate for your geographical location and power input available. You must order the power cord separately.
- Ensure that you have taken the necessary precautions to prevent electrostatic discharge (ESD) damage (see *Prevention of Electrostatic Discharge Damage*).
- Ensure that you have connected the switch chassis to earth ground.



**CAUTION:** Before you connect power to the switch, a licensed electrician must attach a cable lug to the grounding and power cables that you supply. A cable with an incorrectly attached lug can damage the switch (for example, by causing a short circuit).

To meet safety and electromagnetic interference (EMI) requirements and to ensure proper operation, you must connect the chassis to earth ground before you connect it to power (see "[Connect the QFX5120 Switch to Earth Ground](#)" on page 163). For installations that require a separate grounding conductor to the chassis, use the protective earthing terminal on the switch chassis to connect to earth ground. The switch gains additional grounding when you plug the power supply in the switch into a grounded AC power outlet by using the AC power cord appropriate for your geographical location.

We ship the QFX5120 switches with two 650-W AC or DC power supplies preinstalled. You must order a high-voltage power supply separately. Each power supply is a hot-removable and hot-insertable field-replaceable unit (FRU) when the second power supply is installed and running: You can remove and replace them without powering off the switch or disrupting switch functions.

To connect power to a QFX5120-48T switch powered by a high-voltage power supply:

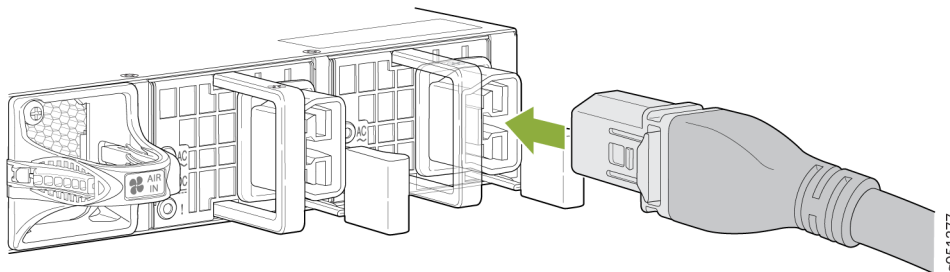
1. Wrap and fasten one end of the ESD wrist strap around your bare wrist, and connect the other end of the strap to a site ESD point.
2. Ensure that the power supplies are fully inserted in the chassis.
3. Locate the power cord appropriate for your geographical location and power input.



**WARNING:** Ensure that the power cord does not block access to device components or drape where people can trip on it.

4. Insert the coupler end of the power cord into the power cord inlet on the power supply faceplate (see [Figure 136 on page 178](#)).

**Figure 136: Connect Power to a QFX5120-48T Switch Powered by a High-Voltage Power Supply**



**NOTE:** The QFX5120 switch powers on as soon as power is provided to the power supply. There is no power switch on the QFX5120.

5. Connect power to the switch:
  - AC power input:
    - a. If the AC power source outlet has a power switch, set it to the off position.
    - b. Insert the power cord plug into an AC power source outlet.
    - c. If the AC power source outlet has a power switch, set it to the on position.
  - DC power input:
    - a. Switch the circuit breaker on the panel board that services the DC circuit to the off position.
    - b. Connect the power cables to the terminals on the power source.
    - c. Close the input circuit breaker.

6. Verify that the **AC** and **DC** LEDs on the power supply are lit green. If the fault LED (!) is lit, disconnect the power supply from the power source, and replace the power supply (see ["Remove a Power Supply from a QFX5120 Switch" on page 202](#)).

## Connect the QFX5120 to the Network

### IN THIS SECTION

- [Install a Transceiver | 179](#)
- [Install a QSFP28 Transceiver | 182](#)
- [Connect a Fiber-Optic Cable | 184](#)

### Install a Transceiver

Before you install a transceiver in a device, ensure that you have taken the necessary precautions for safe handling of lasers (see [Laser and LED Safety Guidelines and Warnings](#)).

Ensure that you have a rubber safety cap available to cover the transceiver.

The transceivers for Juniper Networks devices are hot-removable and hot-insertable field-replaceable units (FRUs). You can remove and replace the transceivers without powering off the device or disrupting the device functions.

**NOTE:** After you insert a transceiver or after you change the media-type configuration, wait for 6 seconds for the interface to display operational commands.

**NOTE:** We recommend that you use only optical transceivers and optical connectors purchased from Juniper Networks with your Juniper Networks device.



**CAUTION:** The Juniper Networks Technical Assistance Center (JTAC) provides complete support for Juniper-supplied optical modules and cables. However, JTAC does not provide support for third-party optical modules and cables that are not qualified or supplied by Juniper Networks. If you face a problem running a Juniper device that uses third-party optical modules or cables, JTAC may help you diagnose host-related issues if the observed issue is not, in the opinion of JTAC, related to the use of the third-party optical modules or cables. Your JTAC engineer will likely request that you check the third-party optical module or cable and, if required, replace it with an equivalent Juniper-qualified component.

Use of third-party optical modules with high-power consumption (for example, coherent ZR or ZR+) can potentially cause thermal damage to or reduce the lifespan of the host equipment. Any damage to the host equipment due to the use of third-party optical modules or cables is the users' responsibility. Juniper Networks will accept no liability for any damage caused due to such use.

Figure 137 on page 182 shows how to install a QSFP+ transceiver. The procedure is the same for all types of transceivers except the QSFP28 and CFP transceivers.

To install a transceiver:



**CAUTION:** To prevent electrostatic discharge (ESD) damage to the transceiver, do not touch the connector pins at the end of the transceiver.

1. Wrap and fasten one end of the ESD wrist strap around your bare wrist, and connect the other end of the strap to the ESD point on the switch.
2. Remove the transceiver from its bag.
3. Check to see whether the transceiver is covered with a rubber safety cap. If it is not, cover the transceiver with a rubber safety cap.



**LASER WARNING:** Do not leave a fiber-optic transceiver uncovered except when inserting or removing a cable. The rubber safety cap keeps the port clean and protects your eyes from accidental exposure to laser light.

4. If the port in which you want to install the transceiver is covered with a dust cover, remove the dust cover and save it in case you need to cover the port later. If you are hot-swapping a transceiver, wait for at least 10 seconds after removing the transceiver from the port before installing a new transceiver.
5. Using both hands, carefully place the transceiver in the empty port. The connectors must face the chassis.



**CAUTION:** Before you slide the transceiver into the port, ensure that the transceiver is aligned correctly. Misalignment might cause the pins to bend, making the transceiver unusable.

6. Slide the transceiver in gently until it is fully seated. If you are installing a CFP transceiver, use your fingers to tighten the captive screws on the transceiver.
7. Remove the rubber safety cap from the transceiver and the end of the cable, and insert the cable into the transceiver.



**LASER WARNING:** Do not look directly into a fiber-optic transceiver or into the ends of fiber-optic cables. Fiber-optic transceivers and fiber-optic cable connected to a transceiver emit laser light that can damage your eyes.



**CAUTION:** Do not leave a fiber-optic transceiver uncovered except when inserting or removing cable. The safety cap keeps the port clean and protects your eyes from accidental exposure to laser light.

8. If there is a cable management system, arrange the cable in the cable management system to prevent the cable from dislodging or developing stress points. Secure the cable so that it does not support its own weight as it hangs toward the floor. Place excess cable out of the way in a neatly coiled loop in the cable management system. Placing fasteners on the loop helps to maintain its shape.



**CAUTION:** Do not let fiber-optic cable hang free from the connector. Do not allow fastened loops of cable to dangle, which stresses the cable at the fastening point.

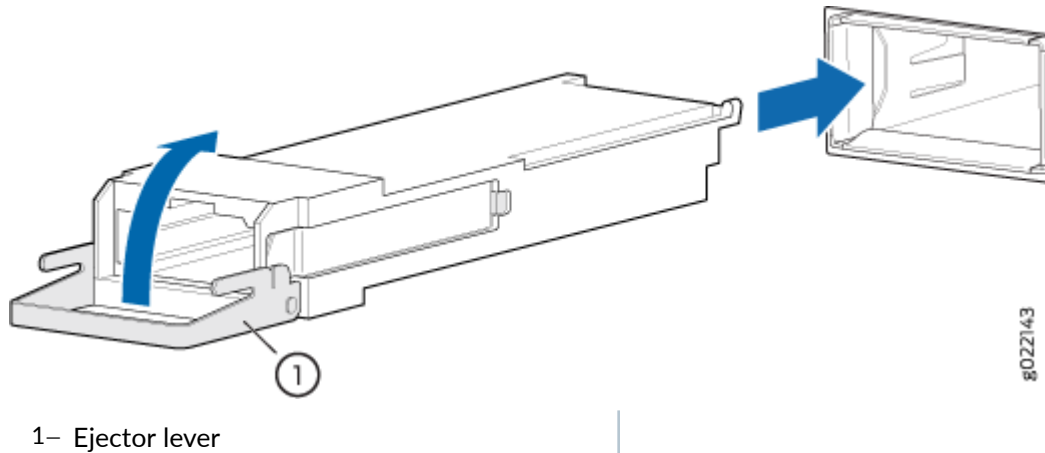


**CAUTION:** Avoid bending fiber-optic cable beyond its minimum bend radius. An arc smaller than a few inches in diameter can damage the cable and cause problems that are difficult to diagnose.

**NOTE:** When you install SFP-DD transceivers, push it hard until you hear a small click.

**NOTE:** Make sure to use a dust cap to cover ports that are unused.

Figure 137: Install a Transceiver



## Install a QSFP28 Transceiver

Before you install a transceiver in a device, ensure that you have taken the necessary precautions for safe handling of lasers (see *Laser and LED Safety Guidelines and Warnings*).

Ensure that you have a rubber safety cap available to cover the transceiver.

The transceivers for Juniper Networks devices are hot-removable and hot-insertable field-replaceable units (FRUs). You can remove and replace the transceivers without powering off the device or disrupting the device functions.

**NOTE:** After you insert a transceiver or after you change the media-type configuration, wait for 6 seconds for the interface to display operational commands.

**NOTE:** We recommend that you use only optical transceivers and optical connectors purchased from Juniper Networks with your Juniper Networks device.



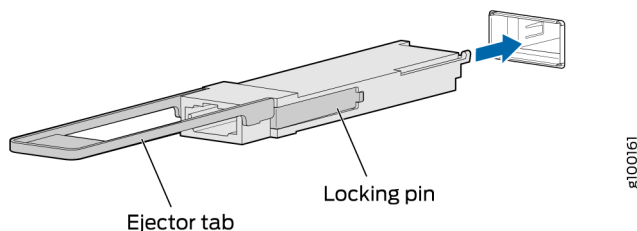
**CAUTION:** The Juniper Networks Technical Assistance Center (JTAC) provides complete support for Juniper-supplied optical modules and cables. However, JTAC does not provide support for third-party optical modules and cables that are not qualified or supplied by Juniper Networks. If you face a problem running a Juniper device that uses third-party optical modules or cables, JTAC may help you diagnose host-related issues if the observed issue is not, in the opinion of JTAC, related to the use of the third-party optical modules or cables. Your JTAC engineer will likely request that you check the third-party optical module or cable and, if required, replace it with an equivalent Juniper-qualified component.

Use of third-party optical modules with high-power consumption (for example, coherent ZR or ZR+) can potentially cause thermal damage to or reduce the lifespan of the host equipment. Any damage to the host equipment due to the use of third-party optical modules or cables is the users' responsibility. Juniper Networks will accept no liability for any damage caused due to such use.

To install a QSFP28 transceiver (see [Figure 138 on page 183](#)):

1. Wrap and fasten one end of an ESD wrist strap around your bare wrist, and connect the other end of the strap to the ESD point on the switch.
2. Verify that a rubber safety cap covers the QSFP28 transceiver.
3. Position the transceiver in front of the port on the device so that the QSFP28 connector faces the port.

**Figure 138: Install a QSFP28 Transceiver**



4. Slide the transceiver into the port until the locking pins lock in place. If there is resistance, remove the transceiver and flip it so that the connector faces the other direction.
5. Remove the rubber safety cap from the transceiver and the end of the cable, and insert the cable into the transceiver.





**LASER WARNING:** Do not look directly into a fiber-optic transceiver or into the ends of fiber-optic cables. Fiber-optic transceivers and fiber-optic cable connected to a transceiver emit laser light that can damage your eyes.



**CAUTION:** Do not leave a fiber-optic transceiver uncovered except when inserting or removing cable. The safety cap keeps the port clean and protects your eyes from accidental exposure to laser light.

6. If there is a cable management system, arrange the cable in the cable management system to prevent the cable from dislodging or developing stress points. Secure the cable so that it does not support its own weight as it hangs to the floor. Place excess cable out of the way in a neatly coiled loop in the cable management system. Placing fasteners on the loop helps to maintain its shape.



**CAUTION:** Do not let fiber-optic cable hang free from the connector. Do not allow fastened loops of cable to dangle, which stresses the cable at the fastening point.



**CAUTION:** Avoid bending fiber-optic cable beyond its minimum bend radius. An arc smaller than a few inches in diameter can damage the cable and cause problems that are difficult to diagnose.

## Connect a Fiber-Optic Cable

Before you connect a fiber-optic cable to an optical transceiver installed in a device, ensure that you have taken the necessary precautions for safe handling of lasers (see *Laser and LED Safety Guidelines and Warnings*).

To connect a fiber-optic cable to an optical transceiver installed in a device:

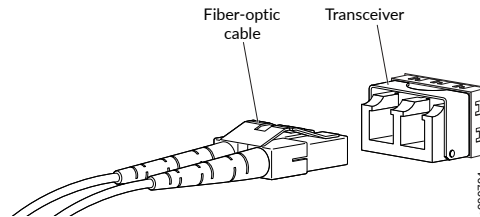


**LASER WARNING:** Do not look directly into a fiber-optic transceiver or into the ends of fiber-optic cables. Fiber-optic transceivers and fiber-optic cables connected to transceivers emit laser light that can damage your eyes.

1. If the fiber-optic cable connector is covered with a rubber safety cap, remove the cap. Save the cap.

2. Remove the rubber safety cap from the optical transceiver. Save the cap.
3. Insert the cable connector into the optical transceiver (see [Figure 139 on page 185](#)).

**Figure 139: Connect a Fiber-Optic Cable to an Optical Transceiver Installed in a Device**



4. Secure the cables so that they do not support their own weight. Place excess cable out of the way in a neatly coiled loop. Placing fasteners on a loop helps cables maintain their shape.



**CAUTION:** Do not bend fiber-optic cables beyond their minimum bend radius. An arc smaller than a few inches in diameter can damage the cables and cause problems that are difficult to diagnose.

Do not let fiber-optic cables hang free from the connector. Do not allow fastened loops of cables to dangle, which stresses the cables at the fastening point.

## Connect the QFX5120 to External Devices

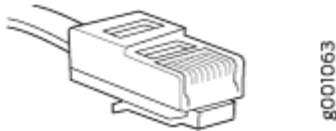
### IN THIS SECTION

- [Connect a Device to a Network for Out-of-Band Management | 186](#)
- [Connect a Device to a Management Console Using an RJ-45 Connector | 186](#)
- [Connecting 1-PPS and 10-MHz Measurement Devices to the QFX5120 Switch | 188](#)

## Connect a Device to a Network for Out-of-Band Management

Ensure that you have an Ethernet cable that has an RJ-45 connector at either end. [Figure 140 on page 186](#) shows the RJ-45 connector of the Ethernet cable.

**Figure 140: RJ-45 Connector on an Ethernet Cable**

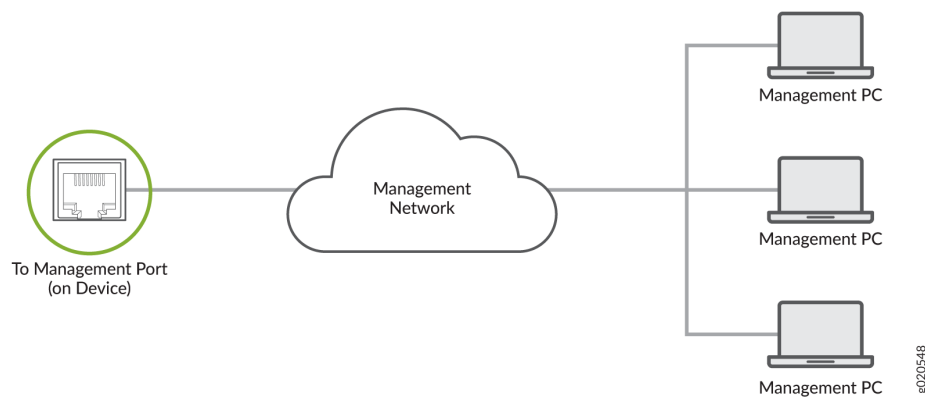


You can monitor and manage these devices by using a dedicated management channel. Each device has a management port to which you can connect an Ethernet cable with an RJ-45 connector. Use the management port to connect the device to the management device.

To connect a device to a network for out-of-band management (see [Figure 141 on page 186](#)):

1. Connect one end of the Ethernet cable to the management port on the device.
2. Connect the other end of the Ethernet cable to the management device.

**Figure 141: Connect a Device to a Network for Out-of-Band Management**

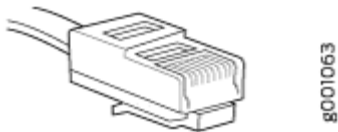


## Connect a Device to a Management Console Using an RJ-45 Connector

Ensure that you have an Ethernet cable that has an RJ-45 connector at either end and an RJ-45-to-DB-9 serial port adapter.

Figure 142 on page 187 shows the RJ-45 connector on the Ethernet cable.

Figure 142: RJ-45 Connector on an Ethernet Cable



**NOTE:** If your laptop or desktop PC does not have a DB-9 plug connector pin and you want to connect your laptop or desktop PC directly to the device, use a combination of the RJ-45-to-DB-9 socket adapter and a USB-to-DB-9 plug adapter. You must provide the USB-to-DB-9 plug adapter.

**NOTE:** We no longer include a DB-9-to-RJ-45 cable or a DB-9-to-RJ-45 adapter with a CAT5E copper cable as part of the device package. If you require a console cable, you can order it separately with the part number JNP-CBL-RJ45-DB9 (DB-9-to-RJ-45 adapter with a CAT5E copper cable).

You can configure and manage your network devices using a dedicated management channel. Each device has a console port that you can connect to using an Ethernet cable with an RJ-45 connector. Use the console port to connect the device to the console server or management console. The console port accepts a cable that has an RJ-45 connector.

To connect the device to a management console (see [Figure 143 on page 188](#) and [Figure 144 on page 188](#)):

1. Connect one end of the Ethernet cable to the console port (labeled **CON**, **CONSOLE**, or **CON1**) on the device.
2. Connect the other end of the Ethernet cable to the console server (see [Figure 143 on page 188](#)) or management console (see [Figure 144 on page 188](#)).

Figure 143: Connect a Device to a Management Console Through a Console Server

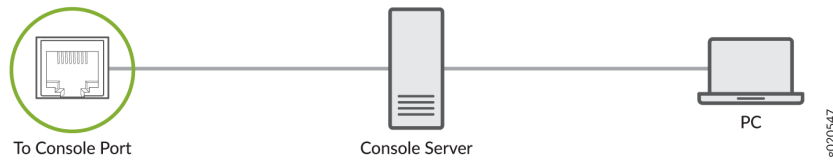
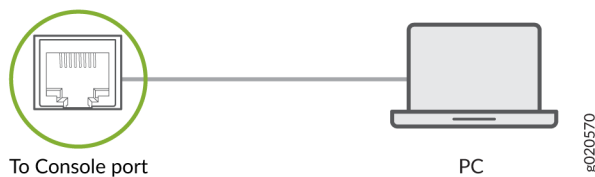


Figure 144: Connect a Device Directly to a Management Console



## Connecting 1-PPS and 10-MHz Measurement Devices to the QFX5120 Switch

Before you connect a QFX5120-48T or QFX5120-48YM switch to measurement devices:

- Ensure that the measurement equipment is compatible with transistor-transistor logic (TTL) (5.0 V).
- Ensure that you have a cable with length up to 3 m.

QFX5120-48T and QFX5120-48YM switches have one 2x1 DIN 1.0/2.3 connector that supports 1-PPS-OUT and 10-MHz-OUT measurement ports, labeled **PPS OUT** and **10M OUT**, on the rear panel of the switch.

To connect the DIN cable to the external measurement device:

1. Connect one end of the DIN cable connectors to the 1-PPS-OUT and the 10-MHz-OUT ports, labeled **PPS OUT** and **10M OUT**, on the rear panel of the switch.
2. Connect the other end of the DIN cable connectors to the measurement equipment.

# Configure Junos OS on the QFX5120

## IN THIS SECTION

- [QFX5120 Default Configuration | 189](#)
- [Connect and Configure a QFX5120 Switch | 190](#)

## QFX5120 Default Configuration

We ship each QFX5120 switch programmed with a factory-default configuration that contains the values set for each configuration parameter. The default configuration file sets values for system parameters such as the system log and file messages.

When you commit changes to the configuration, a new configuration file is created that becomes the active configuration. You can always revert to the factory-default configuration.

This topic shows the factory-default configuration file of a QFX5120 switch:

```
system {
  syslog {
    user * {
      any emergency;
    }
    file messages {
      any notice;
      authorization info;
    }
    file interactive-commands {
      interactive-commands any;
    }
  }
  commit {
    factory-settings;
  }
}
```

## Connect and Configure a QFX5120 Switch

Before you connect and configure a QFX5120, set the following parameter values on the console server or desktop PC:

- Baud Rate—9600
- Data—8
- Flow Control—None
- Parity—None
- Stop Bits—1
- DCD State—Disregard

Ensure that you have the following parts and tools available:

- An Ethernet cable with an RJ-45 connector attached—not provided
- An RJ-45 to DB-9 serial port adapter—not provided
- A management host such as a laptop or desktop PC, with a serial port—not provided

Have the following information available before you configure custom settings for the switch:

- Root password
- IP address of the default gateway
- IP address of the management port
- IP address of a DNS server
- (Optional) Hostname
- (Optional) IP address of a backup router
- (Optional) SNMP read community, location, and contact to configure SNMP parameters
- (Optional) Static routes to remote subnets with access to the management port
- (Optional) Static routes to remote prefixes with access to the management port

We ship the QFX5120 switch with Junos OS preinstalled and ready to be configured when you power on the switch. You must perform the initial configuration of the QFX5120 through the console port (labeled **CON**) on the switch by using the command-line interface (CLI).

This procedure describes how to perform the initial configuration on the switch and to connect it to the network. For the complete information about enabling the switch to forward traffic, including examples, see the Junos OS configuration guides.

To perform the initial configuration on the switch and to connect it to the network:

1. Power the switch on.
2. Connect the console port (labeled **CON**) on the switch to a management host such as a laptop or desktop PC by using an RJ-45 to DB-9 serial port adapter.
3. At the Junos OS login prompt, type **root** to log in. You don't need to enter a password. If the software boots before you connect to the console port, you might need to press the Enter key on the keyboard for the prompt to appear.

```
login: root
```

4. Start the CLI.

```
root@RE:0% cli  
root>
```

5. Enter the configuration mode.

```
root> configure  
[edit]  
root#
```

6. Add a password to the root administration user account. Enter a plain-text password, an encrypted password, or an SSH public key string.

Plain-text password:

```
[edit]  
root# set system root-authentication plain-text-password  
New password: password  
Retype new password: password
```



Encrypted password:

```
[edit]
root# set system root-authentication encrypted-password encrypted-password
```

```
[edit]
root# set system root-authentication ssh-ecdsa public-key
```

SSH-ECDSA password:

```
[edit]
root# set system root-authentication ssh-ed25519 public-key
```

SSH-RSA password:

```
[edit]
root# set system root-authentication ssh-rsa public-key
```

7. (Optional) Configure the hostname of the switch. If the name includes spaces, enclose the name in double quotation marks (" ").

```
[edit]
root# set system host-name host-name
```

8. (Optional) Create a user account.

```
[edit]
root# set system login user user-name authentication plain-text-password
New password: password
Retype new password: password
```

9. (Optional) Set the user account class to super-user.

```
[edit]
root# set system login user user-name class super-user
```

10. (Optional) Configure the domain name of the switch.

```
[edit]
root# set system domain-name domain-name
```

11. Configure the default gateway.

```
[edit]
root# set routing-options static route 0/0 next-hop address
```

12. Configure the IP address and prefix length for the management interface on the switch.

```
[edit]
root# set interfaces em0 unit 0 family inet address address/prefix-length
```

**NOTE:** The management port `em0` (labeled **MGMT**) is located on the front panel of the QFX5120-32C switch. The management port `em0` (labeled **MGMT**) is located on the rear panel of the QFX5120-48T switch. The management ports `em0` (labeled **C0**) and `em1` (labeled **C1**) are located on the rear panel of the QFX5120-48Y and QFX5120-48YM switches.

13. (Optional) Configure the IP address of a backup router, which is used only while the routing protocol is not running.

```
[edit]
root# set system backup-router address
```

14. Configure the IP address of a DNS server.

```
[edit]
root# set system name-server address
```

15. (Optional) Configure the static routes to remote subnets with access to the management port. Access to the management port is limited to the local subnet.

```
[edit]
root# set routing-options static route remote-subnet next-hop destination-IP retain no-
readvertise
```

16. (Optional) Configure the static routes to remote prefixes with access to the management port.

```
[edit]
root# set routing-options static route remote-prefix next-hop destination-IP retain no-
readvertise
```

17. Configure the SSH service.

```
[edit]
root# set system services ssh root-login allow
```

18. Configure in-band management or out-of-band management:

- With in-band management, you can configure a network port interface as the management interface and connect it to the management device. In this scenario, you can do either of the following:
  - Use the automatically created VLAN named *default* for management of all data interfaces as members of the default VLAN. Specify the management IP address and the default gateway.
  - Create a new management VLAN. Specify the VLAN name, VLAN ID, management IP address, and default gateway. Select the ports that must be part of this VLAN.
- With out-of-band management, you use a dedicated management channel (**MGMT**, **C0**, or **C1** port) to connect to the management device. Specify the IP address and gateway of the management interface. Use this IP address to connect to the switch.

19. (Optional) Specify the SNMP read community, location, and contact to configure SNMP parameters.
20. (Optional) Specify the system date and time. Select the time zone from the list. The configured parameters are displayed.
21. Enter **yes** to commit the configuration. The configuration is committed as the active configuration for the switch.
22. (Optional) Display the configuration to verify that it is correct.

```
[edit]
root# show
system {
    host-name host-name;
    domain-name domain-name;
    root-authentication {
        authentication-method (password | public-key);
    }
    name-server {
```

```
        address;  
    }  
}  
interfaces {  
    em0 {  
        unit 0 {  
            family inet {  
                address address/prefix-length;  
            }  
        }  
    }  
}
```

23. (Optional) Configure additional properties by adding the necessary configuration statements.
24. Commit the configuration to activate it on the switch.

```
[edit]  
root# commit
```

25. When you have finished configuring the switch, exit the configuration mode.

```
[edit]  
root@switch# exit  
root@switch>
```

You can now log in by using the CLI and continue configuring the switch.

# 4

CHAPTER

## Maintaining Components

---

Maintain the QFX5120 Cooling System | 197

Maintain the QFX5120 Power System | 201

Maintain Transceivers | 208

Maintain Fiber-Optic Cables | 218

---

# Maintain the QFX5120 Cooling System

## IN THIS SECTION

- [Remove a Fan Module from a QFX5120 Switch | 197](#)
- [Install a Fan Module in a QFX5120 Switch | 199](#)

## Remove a Fan Module from a QFX5120 Switch

Before you remove a fan module in from the switch, ensure that you have the following parts and tools available:

- Number 2 Phillips (+) screwdriver—not provided
- An antistatic bag or an antistatic mat—not provided
- A replacement fan module

We ship QFX5120-32C switches with 5+1 redundant fans preinstalled in the rear panel. We ship QFX5120-48T, QFX5120-48Y, and QFX5120-48YM switches with 4+1 redundant fans preinstalled in the rear panel. The fan modules are hot-removable and hot-insertable field-replaceable units (FRUs) installed in the rear panel of the switch: You can remove and replace them without powering off the switch or disrupting switch functions.

1. Place the antistatic bag or the antistatic mat on a flat, stable surface.
2. Loosen the captive screws on the front faceplate of the fan module by using the screwdriver.



**WARNING:** To prevent injury, do not touch the fan with your hands or any tools as you slide the fan module out of the chassis—the fan might still be running.

3. Grasp the handle on the fan module and pull it firmly to slide the fan module out of the chassis. [Figure 145 on page 198](#) shows how to remove a fan module from a QFX5120-32C switch. [Figure 147 on page 198](#) shows how to remove a fan module from a QFX5120-48T or QFX5120-48Y switch. [Figure 146 on page 198](#) shows how to remove a fan module from a QFX5120-48YM switch.

Figure 145: Remove a Fan Module from a QFX5120-32C Switch

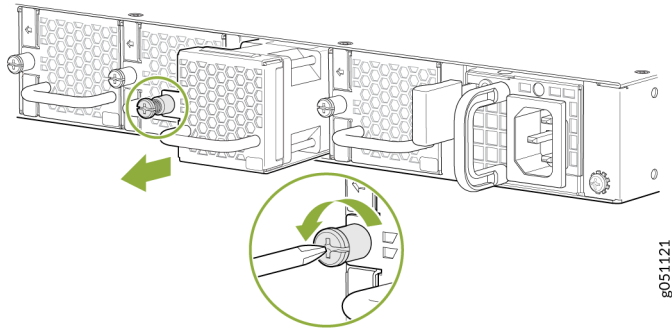


Figure 146: Remove a Fan Module from a QFX5120-48T or QFX5120-48Y Switch

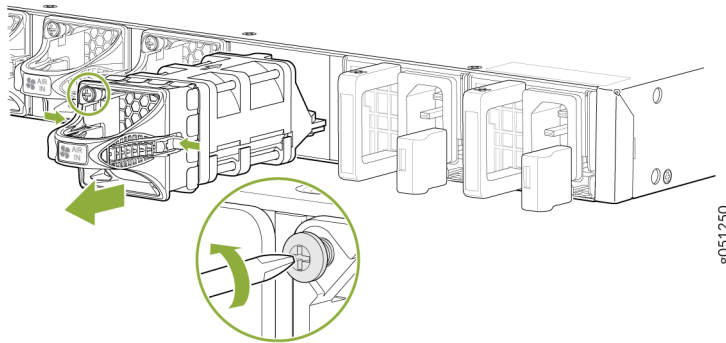
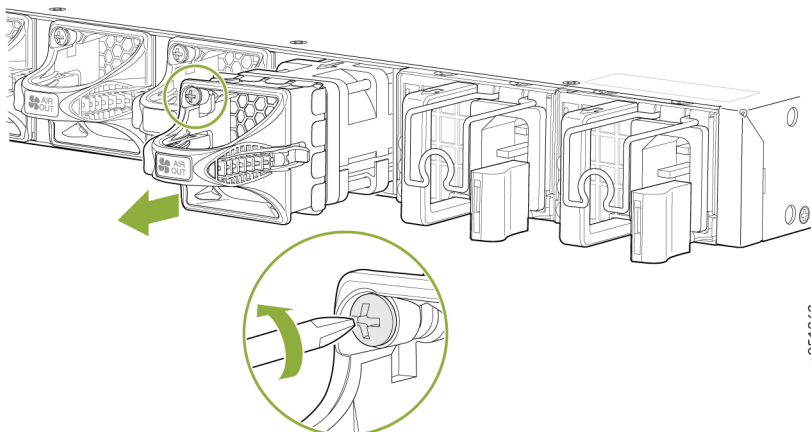


Figure 147: Remove a Fan Module from a QFX5120-48YM Switch



4. Place the fan module in the antistatic bag or on the antistatic mat placed on a flat, stable surface.

**NOTE:** You must install all the fan modules and they must be operational for optimal functioning of the switch.



**CAUTION:** Do not mix:

- Fan modules with different airflow directions in the same chassis.
- Fan modules and power supplies with different airflow directions in the same chassis.

5. Install the replacement fan.

## Install a Fan Module in a QFX5120 Switch

Before you install a fan module in the switch:

- Ensure that you understand how to prevent electrostatic discharge (ESD) damage (see *Prevention of Electrostatic Discharge Damage*).
- Ensure that you have the following parts and tools available:
  - ESD grounding strap—not provided
  - Number 2 Phillips (+) screwdriver—not provided

We ship QFX5120-32C switches with 5+1 redundant fans preinstalled in the rear panel. We ship QFX5120-48T, QFX5120-48Y, and QFX5120-48YM switches with 4+1 redundant fans preinstalled in the rear panel. The fan modules are hot-removable and hot-insertable field-replaceable units (FRUs) installed in the rear panel of the switch: You can remove and replace them without powering off the switch or disrupting switch functions.



**CAUTION:** Do not mix:

- Fan modules with different airflow directions in the same chassis.
- Power supplies with different airflow directions in the same chassis.
- Fan modules and power supplies with different airflow directions in the same chassis.



**NOTE:** If you have a Juniper J-Care service contract, register any addition, change, or upgrade of hardware components at <https://www.juniper.net/customers/support/tools/updateinstallbase/>. Failure to do so can result in significant delays if you need replacement parts. This note does not apply if you replace existing components with the same type of component.

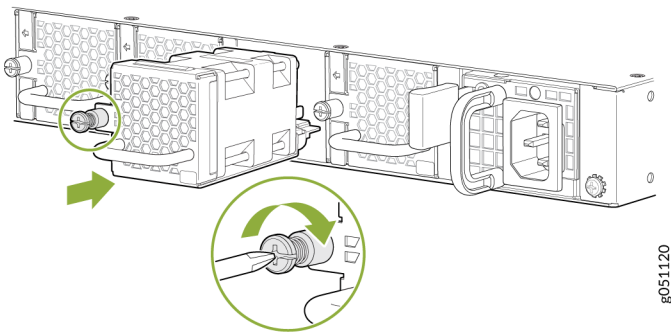
1. Ensure that you have the correct fan module.

If you are installing a fan module with the label **F2B** in a QFX5120-32C switch, verify that the color of the handle of the power supply installed is red. If you are installing a fan module with the label **B2F** in a QFX5120-32C switch, verify that the color of the handle of the power supply installed is blue.

If you are installing a fan module with the label **AIR OUT** in a QFX5120-48T, QFX5120-48Y, or QFX5120-48YM switch, verify that the color of the handle of the power supply installed is Juniper Gold. If you are installing a fan module with the label **AIR IN** in a QFX5120-48T, QFX5120-48Y, or QFX5120-48YM switch, verify that the color of the handle of the power supply installed is Juniper Azure Blue.

2. Wrap and fasten one end of the ESD wrist strap around your bare wrist, and connect the other end of the strap to the ESD point on the switch.
3. Remove the fan module from its bag.
4. Hold the handle of the fan module with one hand and support the weight of the module with the other hand. Place the fan module in the fan module slot on the rear panel of the switch and slide it in until it is fully seated.
5. Tighten the captive screws on the faceplate of the fan module by using the screwdriver. The recommended torque value is 4.34 lb-in. (0.49 Nm). See [Figure 148 on page 200](#), [Figure 149 on page 201](#), and [Figure 150 on page 201](#).

**Figure 148: Install a Fan Module in a QFX5120-32C Switch**



g051120

Figure 149: Install a Fan Module in a QFX5120-48T or QFX5120-48Y Switch

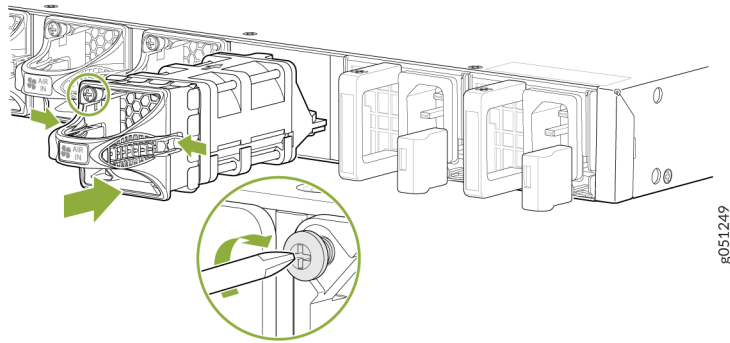
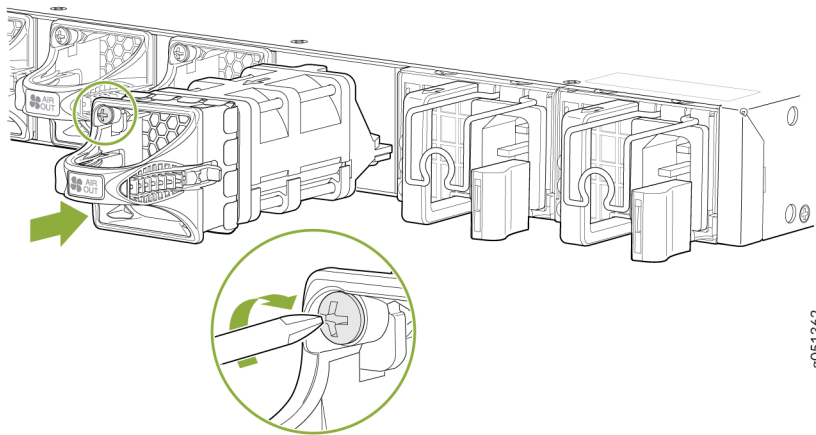


Figure 150: Install a Fan Module in a QFX5120-48YM Switch



## Maintain the QFX5120 Power System

### IN THIS SECTION

- Remove a Power Supply from a QFX5120 Switch | 202
- Install a Power Supply in a QFX5120 Switch | 205

## Remove a Power Supply from a QFX5120 Switch

Before you remove a power supply from a QFX5120 switch:

- Ensure that you have taken the necessary precautions to prevent electrostatic discharge (ESD) damage (see *Prevention of Electrostatic Discharge Damage*).
- Ensure that you have the following parts and tools available:
  - ESD grounding strap—not provided
  - Antistatic bag or an antistatic mat—not provided
  - Number 2 Phillips (+) screwdriver—not provided

We ship QFX5120 switches with two AC or DC power supplies preinstalled in the rear panel. Each power supply is a hot-removable and hot-insertable field-replaceable unit (FRU) when the second power supply is installed and running. You can remove and replace it without powering off the switch or disrupting switch functions.



**CAUTION:** Replace the power supply with a new power supply within one minute of removal to prevent chassis overheating.

To remove a power supply from a QFX5120 switch:

1. Place the antistatic bag or the antistatic mat on a flat, stable surface.
2. Wrap and fasten one end of the ESD wrist strap around your bare wrist, and connect the other end of the strap to the ESD point on the switch.

**NOTE:** If only one power supply is installed in your QFX5120, you need to power off the switch before removing the power supply.

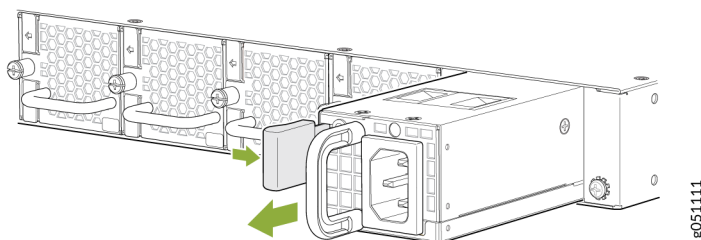
3. Disconnect power to the switch:
  - AC power supply—If the AC power source outlet has a power switch, set it to the off position. If the AC power source outlet does not have a power switch, gently pull out the plug end of the power cord connected to the power source outlet.
  - DC power supply—Switch the circuit breaker on the panel board that services the DC circuit to the off position.
4. Remove the power source cable from the power supply faceplate:

- AC power supply—Remove the power cord from the power supply faceplate by detaching the power cord retainer and gently pulling out the socket end of the power cord connected to the power supply faceplate.
  - DC power supply—Remove the screws securing the ring lugs attached to the power source cables to the power supply using the screwdriver, and remove the power source cables from the power supply. Replace the screws on the terminals and tighten them.
  - High-voltage power supply—Press the latch on the power cord and remove the power source cables from the power supply.
5.
    - On the QFX5120-32C switch, push the ejector lever inward.
    - On the QFX5120-48T, QFX5120-48Y, or QFX5120-48YM switch, push the ejector lever toward the handle until it stops.
  6. Grasp the power supply handle and pull firmly to slide the power supply halfway out of the chassis.
  7. Place one hand under the power supply to support it and slide it completely out of the chassis. Take care not to touch power supply components, pins, leads, or solder connections.

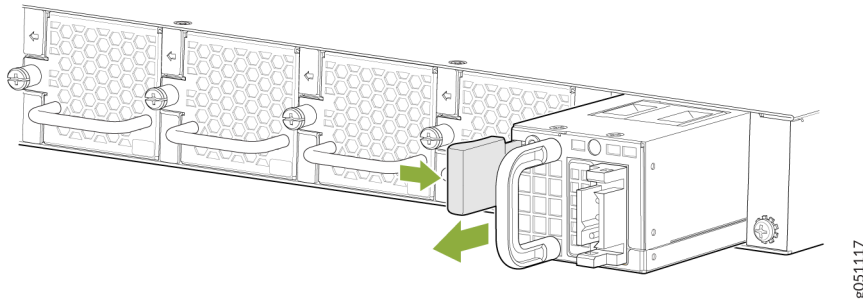
Figure 151 on page 203 shows how to remove an AC power supply from a QFX5120-32C switch and Figure 152 on page 204 shows how to remove a DC power supply from a QFX5120-32C switch.

Figure 153 on page 204 shows how to remove an AC power supply from a QFX5120-48T or QFX5120-48Y switch. The procedure to remove a high-voltage power supply is the same as the procedure to remove a power supply from a QFX5120-48T switch. Figure 154 on page 204 shows how to remove an AC power supply from a QFX5120-48YM switch. Figure 155 on page 205 shows how to remove a DC power supply from a QFX5120-48T, QFX5120-48Y, or QFX5120-48YM switch.

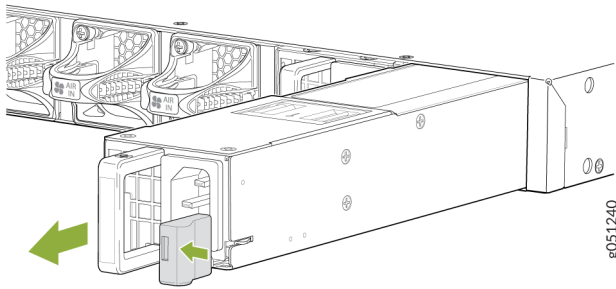
**Figure 151: Remove an AC Power Supply from a QFX5120-32C Switch**



**Figure 152: Remove a DC Power Supply from a QFX5120-32C Switch**



**Figure 153: Remove an AC Power Supply from a QFX5120-48T or QFX5120-48Y Switch**



**Figure 154: Remove an AC Power Supply from a QFX5120-48YM Switch**

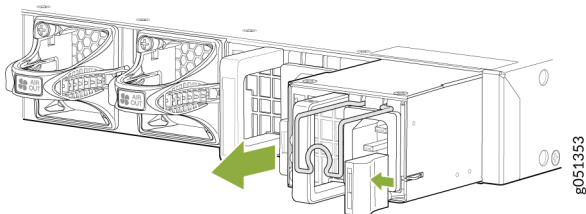
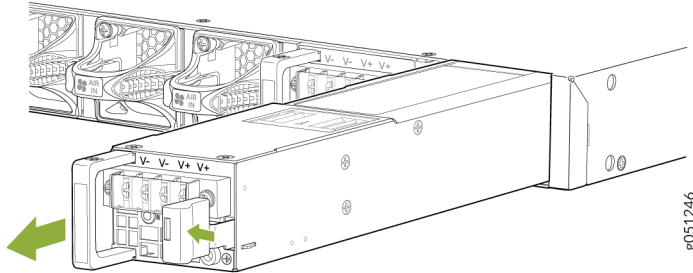


Figure 155: Remove a DC Power Supply from a QFX5120-48T, QFX5120-48Y, or QFX5120-48YM Switch



8. Place the power supply in the antistatic bag or on the antistatic mat placed on a flat, stable surface.

**NOTE:** You must install both the power supplies and they must be operational for optimal functioning of the switch.

9. Install the replacement power supply.

## Install a Power Supply in a QFX5120 Switch

Before you install a power supply:

- Ensure that you understand how to prevent electrostatic discharge (ESD) damage (see *Prevention of Electrostatic Discharge Damage*).
- Ensure that you have the following parts and tools available:
  - ESD grounding strap—not provided
  - Number 2 Phillips (+) screwdriver—not provided

Each power supply is a hot-removable and hot-insertable field-replaceable unit (FRU) when the second power supply is installed and running. You can remove and replace it without powering off the switch or disrupting switch functions.



**CAUTION:** Do not mix:

- AC and DC power supplies in the same chassis.

- 650-W and 850-W power supplies in the same QFX5120-48T chassis.
- Power supplies with different airflow directions in the same chassis.
- Power supplies and fan modules with different airflow directions in the same chassis.

**NOTE:** You must connect each power supply to a dedicated power source outlet.

To install a power supply in the switch:

1. Ensure that you have the correct power supply.

If you are installing a power supply with a red handle in a QFX5120-32C switch, verify that the label on the fan module installed is **F2B**. If you are installing a power supply with a blue handle in a QFX5120-32C switch, verify that the label on the fan module installed is **B2F**.

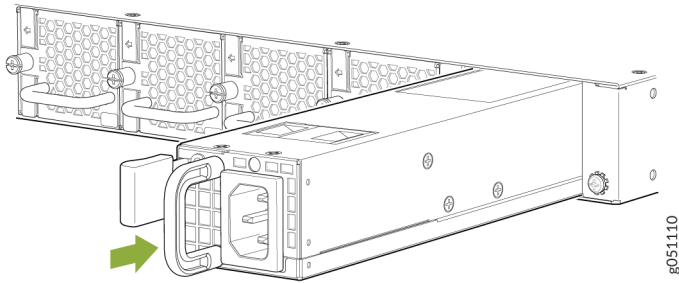
If you are installing a power supply with a Juniper Gold handle in a QFX5120-48T, QFX5120-48Y, or QFX5120-48YM switch, verify that the label on the fan module installed is **AIR OUT**. If you are installing a power supply with a Juniper Azure Blue handle in a QFX5120-48T, QFX5120-48Y, or QFX5120-48YM switch, verify that the label on the fan module installed is **AIR IN**.

2. Wrap and fasten one end of the ESD wrist strap around your bare wrist, and connect the other end of the strap to the ESD point on the switch.
3. Taking care not to touch power supply pins, leads, or solder connections, remove the power supply from the bag.
4. Using both hands, place the power supply in the power supply slot on the rear panel of the switch and slide it in until it is fully seated and the ejector lever fits into place.

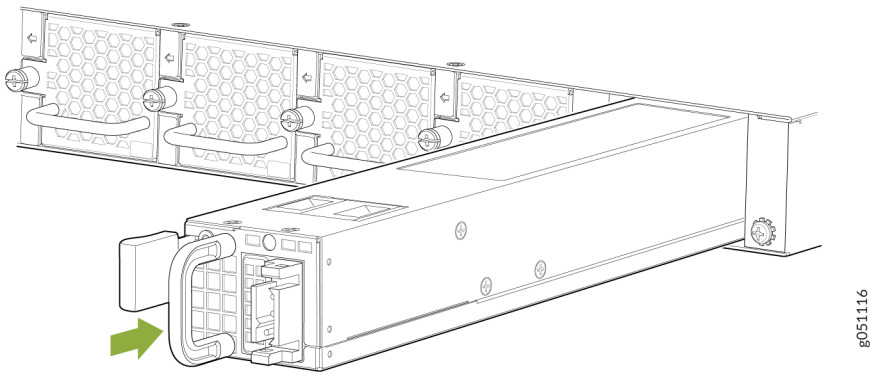
[Figure 156 on page 207](#) shows how to install an AC power supply in a QFX5120-32C switch and [Figure 157 on page 207](#) shows how to install a DC power supply in a QFX5120-32C switch.

[Figure 158 on page 207](#) shows how to install an AC power supply in a QFX5120-48T or QFX5120-48Y switch. The procedure to install a high-voltage power supply is the same as the procedure to install an AC power supply in a QFX5120-48T switch. [Figure 159 on page 208](#) shows how to install an AC power supply in a QFX5120-48YM switch. [Figure 160 on page 208](#) shows how to install a DC power supply in a QFX5120-48T, QFX5120-48Y, or QFX5120-48YM switch.

**Figure 156: Install an AC Power Supply in a QFX5120-32C Switch**



**Figure 157: Install a DC Power Supply in a QFX5120-32C Switch**



**Figure 158: Install an AC Power Supply in a QFX5120-48T or QFX5120-48Y Switch**

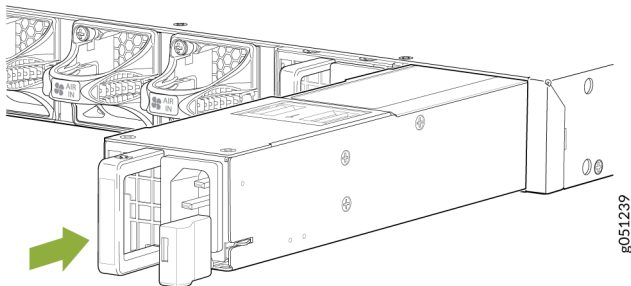




Figure 159: Install an AC Power Supply in a QFX5120-48YM Switch

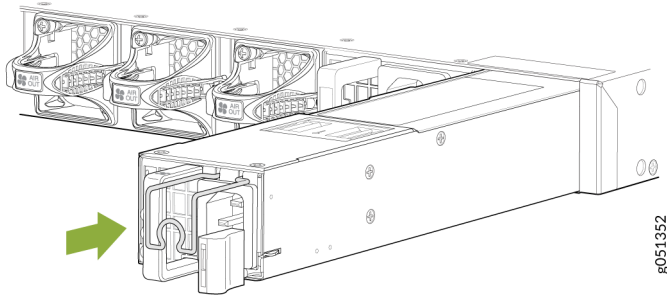
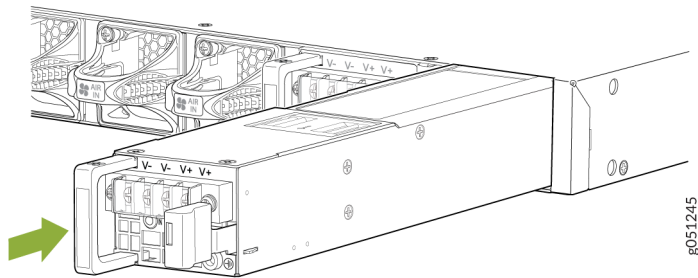


Figure 160: Install a DC Power Supply in a QFX5120-48T, QFX5120-48Y, or QFX5120-48YM Switch



## Maintain Transceivers

### IN THIS SECTION

- [Remove a Transceiver | 209](#)
- [Remove a QSFP28 Transceiver | 211](#)
- [Install a Transceiver | 213](#)
- [Install a QSFP28 Transceiver | 216](#)

## Remove a Transceiver

Before you remove a transceiver from a device, ensure that you have taken the necessary precautions for the safe handling of lasers (see *Laser and LED Safety Guidelines and Warnings*).

Ensure that you have the following parts and tools available:

- An antistatic bag or an antistatic mat
- Rubber safety caps to cover the transceiver and fiber-optic cable connector
- A dust cover to cover the port or a replacement transceiver

The transceivers for Juniper Networks devices are hot-removable and hot-insertable field-replaceable units (FRUs). You can remove and replace the transceivers without powering off the device or disrupting device functions.

**NOTE:** After you remove a transceiver, or when you change the media-type configuration, wait for 6 seconds for the interface to display the operational commands.

[Figure 161 on page 211](#) shows how to remove a QSFP+ transceiver. The procedure is the same for all types of transceivers except the QSFP28 and CFP transceivers.

To remove a transceiver from a device:

1. Place the antistatic bag or antistatic mat on a flat, stable surface.
2. Wrap and fasten one end of the ESD wrist strap around your bare wrist, and connect the other end of the strap to the ESD point on the switch.
3. Label the cable connected to the transceiver so that you can reconnect it correctly.



**LASER WARNING:** Do not look directly into a fiber-optic transceiver or into the ends of fiber-optic cables. Fiber-optic transceivers and fiber-optic cables connected to transceivers emit laser light that can damage your eyes.



**LASER WARNING:** Do not leave a fiber-optic transceiver uncovered except when inserting or removing a cable. The rubber safety cap keeps the port clean and protects your eyes from accidental exposure to laser light.



**CAUTION:** Do not bend fiber-optic cables beyond their minimum bend radius. An arc smaller than a few inches in diameter can damage the cables and cause problems that are difficult to diagnose.

4. Remove the cable connected to the transceiver (see *Disconnect a Fiber-Optic Cable*). Cover the transceiver and the end of each fiber-optic cable connector with a rubber safety cap immediately after disconnecting the fiber-optic cables.
5. If there is a cable management system, arrange the cable in the cable management system to prevent it from dislodging or developing stress points. Secure the cable so that it does not support its own weight as it hangs to the floor. Place excess cable out of the way in a neatly coiled loop in the cable management system. Placing fasteners on the loop helps to maintain its shape.



**CAUTION:** Do not bend the fiber-optic cable beyond its minimum bend radius. An arc smaller than a few inches in diameter can damage the cable and cause problems that are difficult to diagnose.

6. To remove an SFP56-DD, SFP, SFP+, XFP, a QSFP+, or QSFP56-DD transceiver:
  - a. Using your fingers, pull open the ejector lever on the transceiver to unlock the transceiver.  
Note that QSFP-DD and SFP-DD transceivers don't have ejector levers, they have a pull tab instead which can be used to unlock and remove the transceiver.



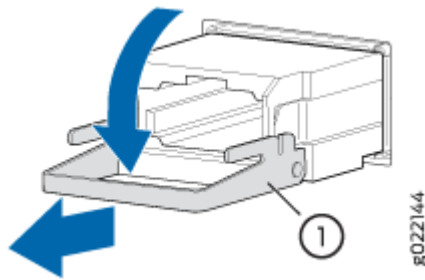
**CAUTION:** Before removing the transceiver, make sure that you open the ejector lever completely until you hear it click. This precaution prevents damage to the transceiver.

- b. Grasp the transceiver ejector lever and gently slide the transceiver approximately 0.5 in. (1.3 cm) straight out of the port.



**CAUTION:** To prevent ESD damage to the transceiver, do not touch the connector pins at the end of the transceiver.

Figure 161: Remove a QSFP+ Transceiver



1- Ejector lever

To remove a CFP transceiver:

- a. Using your fingers, loosen the screws on the transceiver.
- b. Grasp the screws on the transceiver and gently slide the transceiver approximately 0.5 in. (1.3 cm) straight out of the port.



**CAUTION:** To prevent ESD damage to the transceiver, do not touch the connector pins at the end of the transceiver.

7. Using your fingers, grasp the body of the transceiver and pull it straight out of the port.
8. Place the transceiver in the antistatic bag or on the antistatic mat placed on a flat, stable surface.
9. Place the dust cover over the empty port, or install the replacement transceiver.

## Remove a QSFP28 Transceiver

Before you remove a transceiver from a device, ensure that you have taken the necessary precautions for safe handling of lasers (see *Laser and LED Safety Guidelines and Warnings*).

Ensure that you have the following parts and tools available:

- An antistatic bag or an antistatic mat
- Rubber safety caps to cover the transceiver and fiber-optic cable connector
- A dust cover to cover the port or a replacement transceiver

The transceivers for Juniper Networks devices are hot-removable and hot-insertable field-replaceable units (FRUs). You can remove and replace the transceivers without powering off the device or disrupting the device functions.

**NOTE:** After you insert a transceiver, or after you change the media-type configuration, wait for 6 seconds for the interface to display operational commands.

**NOTE:** We recommend that you use only optical transceivers and optical connectors purchased from Juniper Networks with your Juniper Networks device.

To remove a QSFP28 transceiver (see [Figure 162 on page 213](#)):

1. Place an antistatic bag or antistatic mat on a flat, stable surface to receive the QSFP28 transceiver. Have a rubber safety cap ready for the QSFP28 transceiver and the cable.
2. Wrap and fasten one end of an ESD wrist strap around your bare wrist, and connect the other end of the strap to the ESD point on the switch.
3. Label the cable connected to the QSFP28 transceiver so that you can later reconnect it to the correct QSFP28 transceiver.
4. Disconnect the cable from the transceiver. Immediately cover the transceiver and the end of the cable with a rubber safety cap.



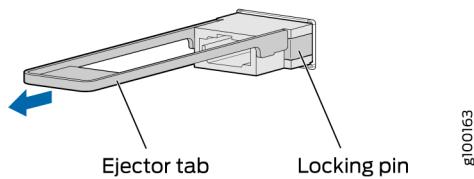
**CAUTION:** Do not leave a fiber-optic transceiver uncovered, except when inserting or removing a cable. The safety cap keeps the port clean and protects your eyes from accidental exposure to laser light.

5. If there is a cable management system, arrange the cable in the cable management system to prevent it from dislodging or developing stress points. Secure the cable so that it does not support its own weight as it hangs to the floor. Place excess cable out of the way in a neatly coiled loop in the cable management system. Placing fasteners on the loop helps to maintain its shape.



**CAUTION:** Do not bend the fiber-optic cable beyond its minimum bend radius. An arc smaller than a few inches in diameter can damage the cable and cause problems that are difficult to diagnose.

Figure 162: Remove a QSFP28 Transceiver



6. Pull the ejector tab straight back. The locking pins on the transceiver automatically release the transceiver.
7. Place the transceiver on the antistatic mat or in the antistatic bag.
8. Place the dust cover over the empty port, or install the replacement transceiver.

## Install a Transceiver

Before you install a transceiver in a device, ensure that you have taken the necessary precautions for safe handling of lasers (see [Laser and LED Safety Guidelines and Warnings](#)).

Ensure that you have a rubber safety cap available to cover the transceiver.

The transceivers for Juniper Networks devices are hot-removable and hot-insertable field-replaceable units (FRUs). You can remove and replace the transceivers without powering off the device or disrupting the device functions.

**NOTE:** After you insert a transceiver or after you change the media-type configuration, wait for 6 seconds for the interface to display operational commands.

**NOTE:** We recommend that you use only optical transceivers and optical connectors purchased from Juniper Networks with your Juniper Networks device.



**CAUTION:** The Juniper Networks Technical Assistance Center (JTAC) provides complete support for Juniper-supplied optical modules and cables. However, JTAC does not provide support for third-party optical modules and cables that are not qualified or supplied by Juniper Networks. If you face a problem running a Juniper device that uses third-party optical modules or cables, JTAC may help you diagnose host-related issues if

the observed issue is not, in the opinion of JTAC, related to the use of the third-party optical modules or cables. Your JTAC engineer will likely request that you check the third-party optical module or cable and, if required, replace it with an equivalent Juniper-qualified component.

Use of third-party optical modules with high-power consumption (for example, coherent ZR or ZR+) can potentially cause thermal damage to or reduce the lifespan of the host equipment. Any damage to the host equipment due to the use of third-party optical modules or cables is the users' responsibility. Juniper Networks will accept no liability for any damage caused due to such use.

Figure 163 on page 216 shows how to install a QSFP+ transceiver. The procedure is the same for all types of transceivers except the QSFP28 and CFP transceivers.

To install a transceiver:



**CAUTION:** To prevent electrostatic discharge (ESD) damage to the transceiver, do not touch the connector pins at the end of the transceiver.

1. Wrap and fasten one end of the ESD wrist strap around your bare wrist, and connect the other end of the strap to the ESD point on the switch.
2. Remove the transceiver from its bag.
3. Check to see whether the transceiver is covered with a rubber safety cap. If it is not, cover the transceiver with a rubber safety cap.



**LASER WARNING:** Do not leave a fiber-optic transceiver uncovered except when inserting or removing a cable. The rubber safety cap keeps the port clean and protects your eyes from accidental exposure to laser light.

4. If the port in which you want to install the transceiver is covered with a dust cover, remove the dust cover and save it in case you need to cover the port later. If you are hot-swapping a transceiver, wait for at least 10 seconds after removing the transceiver from the port before installing a new transceiver.
5. Using both hands, carefully place the transceiver in the empty port. The connectors must face the chassis.



**CAUTION:** Before you slide the transceiver into the port, ensure that the transceiver is aligned correctly. Misalignment might cause the pins to bend, making the transceiver unusable.

6. Slide the transceiver in gently until it is fully seated. If you are installing a CFP transceiver, use your fingers to tighten the captive screws on the transceiver.
7. Remove the rubber safety cap from the transceiver and the end of the cable, and insert the cable into the transceiver.



**LASER WARNING:** Do not look directly into a fiber-optic transceiver or into the ends of fiber-optic cables. Fiber-optic transceivers and fiber-optic cable connected to a transceiver emit laser light that can damage your eyes.



**CAUTION:** Do not leave a fiber-optic transceiver uncovered except when inserting or removing cable. The safety cap keeps the port clean and protects your eyes from accidental exposure to laser light.

8. If there is a cable management system, arrange the cable in the cable management system to prevent the cable from dislodging or developing stress points. Secure the cable so that it does not support its own weight as it hangs toward the floor. Place excess cable out of the way in a neatly coiled loop in the cable management system. Placing fasteners on the loop helps to maintain its shape.



**CAUTION:** Do not let fiber-optic cable hang free from the connector. Do not allow fastened loops of cable to dangle, which stresses the cable at the fastening point.



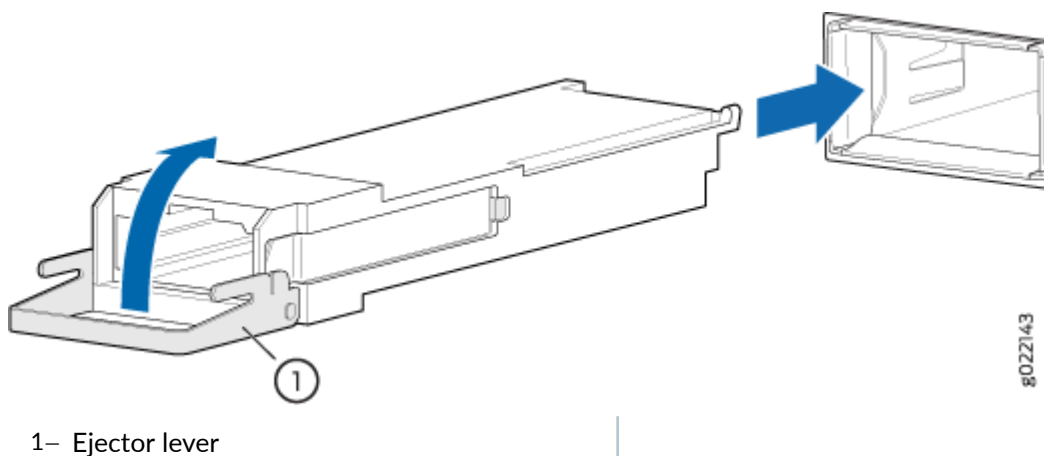
**CAUTION:** Avoid bending fiber-optic cable beyond its minimum bend radius. An arc smaller than a few inches in diameter can damage the cable and cause problems that are difficult to diagnose.

**NOTE:** When you install SFP-DD transceivers, push it hard until you hear a small click.

**NOTE:** Make sure to use a dust cap to cover ports that are unused.



Figure 163: Install a Transceiver



## Install a QSFP28 Transceiver

Before you install a transceiver in a device, ensure that you have taken the necessary precautions for safe handling of lasers (see *Laser and LED Safety Guidelines and Warnings*).

Ensure that you have a rubber safety cap available to cover the transceiver.

The transceivers for Juniper Networks devices are hot-removable and hot-insertable field-replaceable units (FRUs). You can remove and replace the transceivers without powering off the device or disrupting the device functions.

**NOTE:** After you insert a transceiver or after you change the media-type configuration, wait for 6 seconds for the interface to display operational commands.

**NOTE:** We recommend that you use only optical transceivers and optical connectors purchased from Juniper Networks with your Juniper Networks device.



**CAUTION:** The Juniper Networks Technical Assistance Center (JTAC) provides complete support for Juniper-supplied optical modules and cables. However, JTAC does not provide support for third-party optical modules and cables that are not qualified or supplied by Juniper Networks. If you face a problem running a Juniper device that uses third-party optical modules or cables, JTAC may help you diagnose host-related issues if

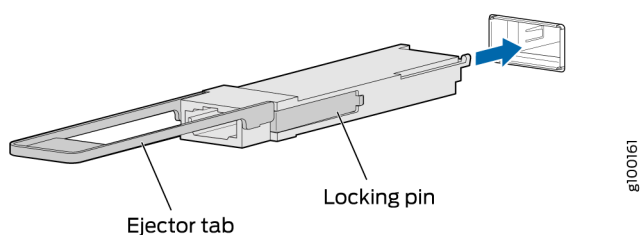
the observed issue is not, in the opinion of JTAC, related to the use of the third-party optical modules or cables. Your JTAC engineer will likely request that you check the third-party optical module or cable and, if required, replace it with an equivalent Juniper-qualified component.

Use of third-party optical modules with high-power consumption (for example, coherent ZR or ZR+) can potentially cause thermal damage to or reduce the lifespan of the host equipment. Any damage to the host equipment due to the use of third-party optical modules or cables is the users' responsibility. Juniper Networks will accept no liability for any damage caused due to such use.

To install a QSFP28 transceiver (see [Figure 164 on page 217](#)):

1. Wrap and fasten one end of an ESD wrist strap around your bare wrist, and connect the other end of the strap to the ESD point on the switch.
2. Verify that a rubber safety cap covers the QSFP28 transceiver.
3. Position the transceiver in front of the port on the device so that the QSFP28 connector faces the port.

**Figure 164: Install a QSFP28 Transceiver**



4. Slide the transceiver into the port until the locking pins lock in place. If there is resistance, remove the transceiver and flip it so that the connector faces the other direction.
5. Remove the rubber safety cap from the transceiver and the end of the cable, and insert the cable into the transceiver.



**LASER WARNING:** Do not look directly into a fiber-optic transceiver or into the ends of fiber-optic cables. Fiber-optic transceivers and fiber-optic cable connected to a transceiver emit laser light that can damage your eyes.



**CAUTION:** Do not leave a fiber-optic transceiver uncovered except when inserting or removing cable. The safety cap keeps the port clean and protects your eyes from accidental exposure to laser light.

6. If there is a cable management system, arrange the cable in the cable management system to prevent the cable from dislodging or developing stress points. Secure the cable so that it does not support its own weight as it hangs to the floor. Place excess cable out of the way in a neatly coiled loop in the cable management system. Placing fasteners on the loop helps to maintain its shape.



**CAUTION:** Do not let fiber-optic cable hang free from the connector. Do not allow fastened loops of cable to dangle, which stresses the cable at the fastening point.



**CAUTION:** Avoid bending fiber-optic cable beyond its minimum bend radius. An arc smaller than a few inches in diameter can damage the cable and cause problems that are difficult to diagnose.

## Maintain Fiber-Optic Cables

### IN THIS SECTION

- [Connect a Fiber-Optic Cable | 219](#)
- [Disconnect a Fiber-Optic Cable | 220](#)
- [How to Handle Fiber-Optic Cables | 220](#)

## Connect a Fiber-Optic Cable

Before you connect a fiber-optic cable to an optical transceiver installed in a device, ensure that you have taken the necessary precautions for safe handling of lasers (see *Laser and LED Safety Guidelines and Warnings*).

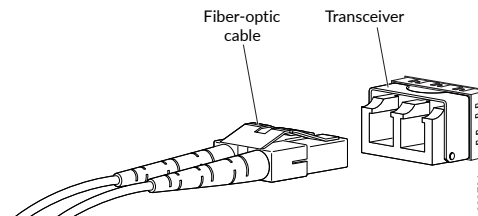
To connect a fiber-optic cable to an optical transceiver installed in a device:



**LASER WARNING:** Do not look directly into a fiber-optic transceiver or into the ends of fiber-optic cables. Fiber-optic transceivers and fiber-optic cables connected to transceivers emit laser light that can damage your eyes.

1. If the fiber-optic cable connector is covered with a rubber safety cap, remove the cap. Save the cap.
2. Remove the rubber safety cap from the optical transceiver. Save the cap.
3. Insert the cable connector into the optical transceiver (see [Figure 165 on page 219](#)).

**Figure 165: Connect a Fiber-Optic Cable to an Optical Transceiver Installed in a Device**



4. Secure the cables so that they do not support their own weight. Place excess cable out of the way in a neatly coiled loop. Placing fasteners on a loop helps cables maintain their shape.



**CAUTION:** Do not bend fiber-optic cables beyond their minimum bend radius. An arc smaller than a few inches in diameter can damage the cables and cause problems that are difficult to diagnose.

Do not let fiber-optic cables hang free from the connector. Do not allow fastened loops of cables to dangle, which stresses the cables at the fastening point.

## Disconnect a Fiber-Optic Cable

Before you disconnect a fiber-optic cable from an optical transceiver, ensure that you have taken the necessary precautions for safe handling of lasers. See *Laser and LED Safety Guidelines and Warnings*.

Ensure that you have the following parts and tools available:

- A rubber safety cap to cover the transceiver
- A rubber safety cap to cover the fiber-optic cable connector

Juniper Networks devices have optical transceivers to which you can connect fiber-optic cables.

To disconnect a fiber-optic cable from an optical transceiver installed in the device:

1. Disable the port in which the transceiver is installed by issuing the following command:

```
[edit interfaces]
user@device# set interface-name disable
```



**LASER WARNING:** Do not look directly into a fiber-optic transceiver or into the ends of fiber-optic cables. Fiber-optic transceivers and fiber-optic cables connected to transceivers emit laser light that can damage your eyes.

2. Carefully unplug the fiber-optic cable connector from the transceiver.
3. Cover the transceiver with a rubber safety cap.



**LASER WARNING:** Do not leave a fiber-optic transceiver uncovered except when inserting or removing a cable. The rubber safety cap keeps the port clean and protects your eyes from accidental exposure to laser light.

4. Cover the fiber-optic cable connector with the rubber safety cap.

## How to Handle Fiber-Optic Cables

Fiber-optic cables connect to optical transceivers that are installed in Juniper Networks devices.

Follow these guidelines when handling fiber-optic cables:

- When you unplug a fiber-optic cable from a transceiver, place rubber safety caps over the transceiver and on the end of the cable.
- Anchor fiber-optic cables to prevent stress on the connectors. When attaching a fiber-optic cable to a transceiver, be sure to secure the fiber-optic cable so that it does not support its own weight as it hangs to the floor. Never let a fiber-optic cable hang free from the connector.
- Avoid bending fiber-optic cables beyond their minimum bend radius. Bending fiber-optic cables into arcs smaller than a few inches in diameter can damage the cables and cause problems that are difficult to diagnose.
- Frequent plugging and unplugging of fiber-optic cables in and out of optical instruments can damage the instruments, which are expensive to repair. To prevent damage from overuse, attach a short fiber extension to the optical equipment. The short fiber extension absorbs wear and tear due to frequent plugging and unplugging, which is easier and less expensive to replace than the instruments.
- Keep fiber-optic cable connections clean. Microdeposits of oil and dust in the canal of the transceiver or cable connector can cause loss of light, reduction in signal power, and possibly intermittent problems with the optical connection.
  - To clean the transceiver canal, use an appropriate fiber-cleaning device such as RIFOCS Fiber Optic Adaptor Cleaning Wands (part number 946). Follow the instructions in the cleaning kit you use.
  - After cleaning the transceiver, make sure that the connector tip of the fiber-optic cable is clean. Use only an approved alcohol-free fiber-optic cable cleaning kit such as the Opptex Cletop-S® Fiber Cleaner. Follow the instructions in the cleaning kit you use.

# 5

CHAPTER

## Troubleshooting Hardware

---

[Troubleshoot the QFX5120 Device](#) | 223

---

# Troubleshoot the QFX5120 Device

## IN THIS SECTION

- [Alarm Types and Severity Levels | 223](#)
- [Chassis Alarm Messages | 225](#)
- [Creating an Emergency Boot Device for QFX Series Switches | 229](#)
- [Recovering the Installation Using an Emergency Boot Device on QFX Series Switches | 231](#)

## Alarm Types and Severity Levels

The QFX Series switches support different alarm types and severity levels. [Table 61 on page 223](#) provides a list of alarm terms and definitions that may help you in monitoring the device.

**Table 61: Alarm Terms and Definitions**

Term	Definition
Alarm	Signal that alerts you to conditions that might prevent normal operation. On the device, alarm indicators might include an LCD panel and LEDs on the device. The LCD panel (if present on the device) displays the chassis alarm message count. Blinking amber or yellow LEDs indicate yellow alarm conditions for chassis components.
Alarm condition	Failure event that triggers an alarm.



Table 61: Alarm Terms and Definitions (*Continued*)

Term	Definition
Alarm severity levels	<p>Seriousness of the alarm. The level of severity can be either major (red) or minor (yellow).</p> <ul style="list-style-type: none"> <li>• Major (red)—Indicates a critical situation on the device that has resulted from one of the following conditions. A red alarm condition requires immediate action. <ul style="list-style-type: none"> <li>• One or more hardware components have failed.</li> <li>• One or more hardware components have exceeded temperature thresholds.</li> <li>• An alarm condition configured on an interface has triggered a critical warning.</li> </ul> </li> <li>• Minor (yellow or amber)—Indicates a noncritical condition on the device that, if left unchecked, might cause an interruption in service or a degradation in performance. A yellow alarm condition requires monitoring or maintenance. For example, a missing rescue configuration generates a yellow system alarm.</li> </ul>
Alarm types	<p>Alarms include the following types:</p> <ul style="list-style-type: none"> <li>• Chassis alarm—Predefined alarm triggered by a physical condition on the device such as a power supply failure or excessive component temperature.</li> <li>• Interface alarm—Alarm that you configure to alert you when an interface link is down. Applies to ethernet, fibre-channel, and management-ethernet interfaces. You can configure a red (major) or yellow (minor) alarm for the link-down condition, or have the condition ignored.</li> <li>• System alarm—Predefined alarm that might be triggered by a missing rescue configuration, failure to install a license for a licensed software feature, or high disk usage.</li> </ul>

## Chassis Alarm Messages

Chassis alarms indicate a failure on the device or one of its components. Chassis alarms are preset and cannot be modified.

Chassis alarms on QFX5100, QFX5110, QFX5210, and QFX5120 devices have two severity levels:

- Major (red)—Indicates a critical situation on the device that has resulted from one of the conditions described in [Table 62 on page 225](#). A red alarm condition requires immediate action.
- Minor (yellow)—Indicates a noncritical condition on the device that, if left unchecked, might cause an interruption in service or degradation in performance. A yellow alarm condition requires monitoring or maintenance.

[Table 62 on page 225](#) describes the chassis alarm messages on QFX5100, QFX5110, QFX5200, QFX5210, and QFX5120 devices.

**Table 62: Chassis Alarm Messages**

Component	Alarm Type	CLI Message	Recommended Action
Fans	Major (red)	Fan Failure	Replace the fan module and report the failure to customer support.
		Fan I2C Failure	Check the system log for one of the following error messages and report the message to customer support: <ul style="list-style-type: none"> <li>• CM ENV Monitor: Get fan speed failed.</li> <li>• <i>fan-number</i> is NOT spinning @ correct speed, where <i>fan-number</i> can be 1, 2, 3, 4, or 5.</li> </ul>
		Fan <i>fan-number</i> Not Spinning	Remove and check the fan module for obstructions, and then reinsert the fan module. If the problem persists, replace the fan module.

Table 62: Chassis Alarm Messages (Continued)

Component	Alarm Type	CLI Message	Recommended Action
	Minor (yellow)	Fan/Blower Absent	<p>Check the system log for the error message <i>fan-number</i> Absent, where <i>fan-number</i> can be 1, 2, 3, 4, or 5.</p> <p>Install fan modules in the slots where they are absent.</p>
Power supplies	Major (red)	PEM <i>pem-number</i> Airflow not matching Chassis Airflow	Replace the power supply with a power supply that supports the same airflow direction as supported by the chassis.
		PEM <i>pem-number</i> I2C Failure	<p>Check the system log for one of the following error messages and report the message to customer support:</p> <ul style="list-style-type: none"> <li>• I2C Read failed for device <i>number</i>, where <i>number</i> where <i>number</i> ranges from 123 through 125.</li> <li>• PS <i>number</i>: Transitioning from online to offline, where power supply <i>number</i> is 1 or 2.</li> </ul>
		PEM <i>pem-number</i> is not powered	Check the power cord connection and reconnect, if necessary.
		PEM <i>pem-number</i> is not supported	Replace the power supply with a supported power supply.
		PEM <i>pem-number</i> Not OK	Indicates a problem with the incoming AC power or outgoing DC power. Report the error to customer support.

Table 62: Chassis Alarm Messages (Continued)

Component	Alarm Type	CLI Message	Recommended Action
	Minor (yellow)	PEM <i>pem-number</i> Absent	Reboot the switch after removing one of the power supply. The switch can continue to operate with a single power supply.  OR Replace the removed power supply and reboot the switch.
		PEM <i>pem-number</i> Power Supply Type Mismatch	Check whether there is a mix of AC and DC power supplies in the same chassis. Reboot the switch with only AC or only DC power supplies.
		PEM <i>pem-number</i> Removed	Replace the removed power supply or reboot the switch. The switch can continue to operate with a single power supply.
Temperature sensors	Major (red)	<i>sensor-location</i> Temp Sensor Fail	Check the system log for the following error message and report the message to customer support:  Temp sensor <i>sensor-number</i> failed, where <i>sensor-number</i> ranges from 1 through 10.
		<i>sensor-location</i> Temp Sensor Too Hot	Check environmental conditions and alarms on other devices. Ensure that environmental factors (such as hot air blowing around the equipment) do not affect the temperature sensor. If the condition persists, the device might shut down.

Table 62: Chassis Alarm Messages (Continued)

Component	Alarm Type	CLI Message	Recommended Action
	Minor (yellow)	<i>sensor-location</i> Temp Sensor Too Warm	Check environmental conditions and alarms on other devices. Ensure that environmental factors (such as hot air blowing around the equipment) do not affect the temperature sensor.
Routing Engine	Minor (yellow)	RE <i>RE number</i> /var partition usage is high	Clean up the system file storage space on the switch. For more information, see <i>Cleaning Up the System File Storage Space</i> .
	Major (red)	RE <i>RE number</i> /var partition is full	Clean up the system file storage space on the switch. For more information, see <i>Cleaning Up the System File Storage Space</i> .
	Minor (yellow)	Rescue configuration is not set	Use the <b>request system configuration rescue save</b> command to set the rescue configuration. For more information, see <i>Setting or Deleting the Rescue Configuration</i> .
		<i>Feature</i> usage requires a license or License for <i>feature</i> expired	Install the required license for the feature specified in the alarm. For more information, see <i>Software Features That Require Licenses on the QFX Series</i> .

Table 62: Chassis Alarm Messages (Continued)

Component	Alarm Type	CLI Message	Recommended Action
Management Ethernet interface	Major (red)	Management Ethernet 1 Link Down	<p>Check whether a cable is connected to the management Ethernet interface, or whether the cable is defective. Replace the cable, if required.</p> <p>On models that have both em0 and em1 management interfaces available, you must connect both interfaces. If both interfaces are not connected, the alarm is raised. However, the alarm has no service impact.</p> <p>If you are unable to resolve the problem, open a support case by using the Case Manager link at <a href="https://www.juniper.net/support/">https://www.juniper.net/support/</a> or call 1-888-314-5822 (tollfree, US or 1-408-745-9500 (from outside the United States)).</p>

## Creating an Emergency Boot Device for QFX Series Switches

Before you begin, you need to download the installation media image for your device and Junos OS release from <https://www.juniper.net/customers/support/>.

If Junos OS on the device is damaged in some way that prevents the software from loading properly, you can use an emergency boot device to repartition the primary disk and load a fresh installation of Junos OS. Use the following procedure to create an emergency boot device.

**NOTE:** You can create the emergency boot device on another Juniper Networks device, or any laptop or desktop PC that supports Linux. The steps you take to create the emergency boot device vary, depending on the device.

To create an emergency boot device:

1. Use FTP to copy the installation media image into the `/var/tmp` directory on the device.
2. Insert a USB storage device into the USB port.
3. From the CLI, start the shell:

```
user@device> start shell
%
```

4. Use the `gunzip` command to unzip the image file.
5. Switch to the root account using the `su` command:

```
% su
Password: password
```

**NOTE:** The password is the root password for the device. If you logged in to the device as the root user, you do not need to perform this step.

6. Enter the following command on the device:

```
root@device% dd if=var/tmp/filename of=/dev/da0 bs=1m
```

The device writes the installation media image to the USB storage device:

```
root@device% dd if=install-media-qfx-5e-15.1X53-D30.5-domestic.img of=/dev/da0 bs=1m
1399+0 records in
1399+0 records out
1466957824 bytes transferred in 394.081902 secs (3722469 bytes/sec)
```

7. Log out of the shell:

```
root@device% exit
% exit
user@device>
```

## Recovering the Installation Using an Emergency Boot Device on QFX Series Switches

If Junos OS on your device is damaged in some way that prevents the software from loading correctly, you may need to perform a recovery installation using an emergency boot device (for example, a USB flash drive) to restore the default factory installation. Once you have recovered the software, you need to restore the device configuration. You can either create a new configuration as you did when the device was shipped from the factory, or if you saved the previous configuration, you can simply restore that file to the device.

If at all possible, you should try to perform the following steps before you perform the recovery installation:

1. Ensure that you have an emergency boot device to use during the installation. See *Creating an Emergency Boot Device for QFX Series Switches* for information on how to create an emergency boot device.
2. Copy the existing configuration in the file `/config/juniper.conf.gz` from the device to a remote system, such as a server, or to an emergency boot device. For extra safety, you can also copy the backup configurations (the files named `/config/juniper.conf.n`, where *n* is a number from 0 through 9) to a remote system or to an emergency boot device.

You can use the system snapshot feature to complete this step. The system snapshot feature takes a “snapshot” of the files currently used to run the QFX Series switch—the complete contents of the `/config` and `/var` directories, which include the running Junos OS, the active configuration, and the rescue configuration—and copies all of these files into a memory source. See *Creating a Snapshot and Using It to Boot a QFX Series Switch*.

**NOTE:** System snapshot is not supported on QFX10000 and QFX5200 switches.



**CAUTION:** The recovery installation process completely overwrites the entire contents of the internal flash storage.

3. Copy any other stored files to a remote system as desired.

To reinstall Junos OS:

1. Connect to the device's console port (either directly or through a console server).
2. Insert the emergency boot device into the QFX Series switch.





The Juniper Linux Installer or GNU GRUB menu opens. The menu and options may differ slightly depending on the platform and release.

7. If you have Junos OS software from the factory installed on the emergency boot device, the software prompts you with the following options:

```
Juniper Linux Installer - (c) Juniper Networks 2014
    Reboot
    Install Juniper Linux Platform
    Boot to host shell [debug]
```

Select **Install Juniper Linux Platform** to install the Junos OS software from the emergency boot device.

**NOTE:** Depending on the platform and release, you may see different entries such as **Install Juniper Linux**, **Install Juniper Linux Platform**, or **Install Juniper Linux with secure boot support**.

8. The device copies the software from the emergency boot device, occasionally displaying status messages. Copying the software can take up to 12 minutes.
9. After the software is copied to the device, the device reboots from the internal flash storage on which the software was just installed.

**NOTE:** If the Boot Manager menu includes both SSD drive and EFI HDD Device entries, manually select the **EFI HDD Device** option.

When the reboot is complete, the device displays the Junos OS login prompt:

```
root@switch#
```

10. Create a new configuration as you did when the device was shipped from the factory, or restore the previously saved configuration file to the device.
11. Remove the emergency boot device.

# 6

CHAPTER

## Contacting Customer Support and Returning the Chassis or Components

---

[Return a QFX5120 Chassis or Components](#) | 235

---

# Return a QFX5120 Chassis or Components

## IN THIS SECTION

- How to Return a QFX5120 Switch or Component for Repair or Replacement | 235
- Locate the Serial Number on a QFX5120 Switch or Component | 236
- Contact Customer Support to Obtain a Return Material Authorization | 246
- Pack a QFX5120 Switch or Component for Shipping | 247

## How to Return a QFX5120 Switch or Component for Repair or Replacement

If you need to return a switch or hardware component to Juniper Networks for repair or replacement, follow this procedure:

1. Determine the serial number of the chassis if you need to return the switch. If you need to return one or more components, determine the serial number for each component. For instructions, see "[Locate the Serial Number on a QFX5120 Switch or Component](#)" on page 236.
2. Obtain a Return Material Authorization (RMA) number from Juniper Networks Technical Assistance Center (JTAC) as described in *Contact Customer Support to Obtain Return Material Authorization*.

**NOTE:** Do not return any component to Juniper Networks unless you have first obtained an RMA number. Juniper Networks reserves the right to refuse shipments that do not have an RMA. Refused shipments are returned to the customer through collect freight.

3. Pack the switch or component for shipping.

For more information about return and repair policies, see the customer support page at <https://www.juniper.net/support/guidelines.html>.

## Locate the Serial Number on a QFX5120 Switch or Component

### IN THIS SECTION

- [List the Switch and Components Details with the CLI | 236](#)
- [Locate the Chassis Serial Number ID Label on a QFX5120 Switch | 237](#)
- [Locate the Serial Number ID Labels on FRUs in a QFX5120 Switch | 238](#)

If you are returning a switch or hardware component to Juniper Networks for repair or replacement, you must locate the serial number of the switch or component. You must provide the serial number to the Juniper Networks Technical Assistance Center (JTAC) when you contact them to obtain Return Material Authorization (RMA).

If the switch is operational and you can access the CLI, you can list serial numbers for the switch and for some components with a CLI command. If you do not have access to the CLI or if the serial number for the component does not appear in the command output, you can locate the serial number ID label on the physical switch or component.

**NOTE:** If you want to find the serial number on the physical switch component, you will need to remove the component from the switch chassis, for which you must have the required parts and tools available.

### List the Switch and Components Details with the CLI

To list the switch and switch components and their serial numbers, enter the following CLI command:

```
show chassis hardware
```

The following output lists the switch components and serial numbers for a QFX5120-48Y switch; the output is similar for other QFX5120 switches:

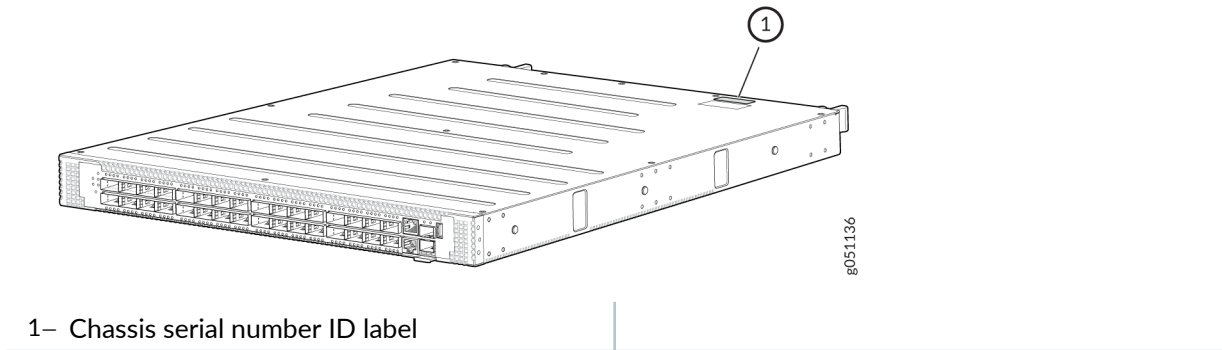
```
user@switch> show chassis hardware
Hardware inventory:
Item           Version  Part number  Serial number  Description
Chassis                               PD3113060008  QFX5120 48Y
Routing Engine 0 REV D  650-044930  PD3113060008  QFX5120-48Y
FPC 0          REV D  650-044930  PD3113060008  QFX5120-48PY PIC 2          REV A0
```

611-044925	MY3112490109	4x 1G/10G SFP/SFP+		
Xcvr 0	REV 01	740-030658	AD0946A02ZT	SFP+-10G-USR
Xcvr 1	REV 01	740-030658	AA1212ALZ5E	SFP+-10G-USR
Power Supply 0	REV 01	740-046871	1EDA2490663	JPSU-1100-AC-AFO-A
Power Supply 1	REV 01	740-046873	1EDE2430149	JPSU-350-AC-AFO-A
Fan Tray 0				Fan Module, Airflow Out (AFO)
Fan Tray 1				Fan Module, Airflow Out (AFO)

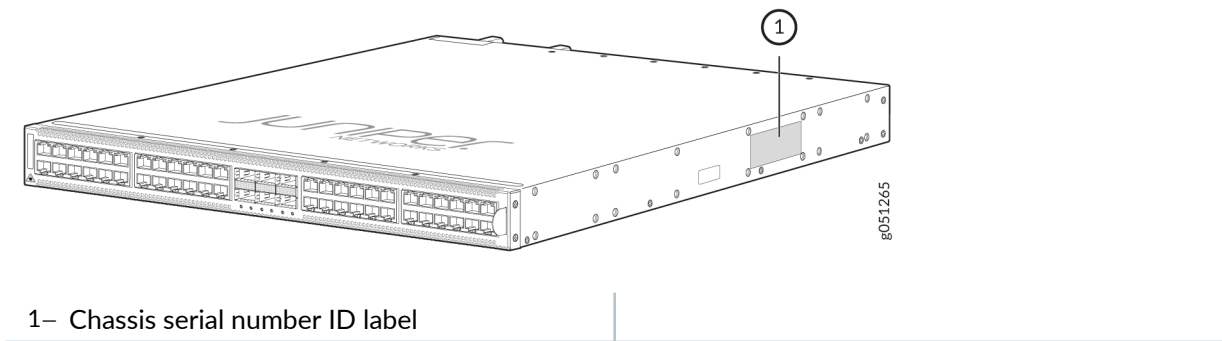
### Locate the Chassis Serial Number ID Label on a QFX5120 Switch

The serial number ID label is located on the top panel of the chassis on QFX5120-32C switches and on the right panel on QFX5120-48T, QFX5120-48Y, and QFX5120-48YM switches. [Figure 166 on page 237](#) shows the location of the serial number ID label on QFX5120-32C switches. [Figure 167 on page 237](#) shows the location of the serial number ID label on QFX5120-48T switches. [Figure 168 on page 238](#) shows the location of the serial number ID label on QFX5120-48Y switches. [Figure 169 on page 238](#) shows the location of the serial number ID label on QFX5120-48YM switches.

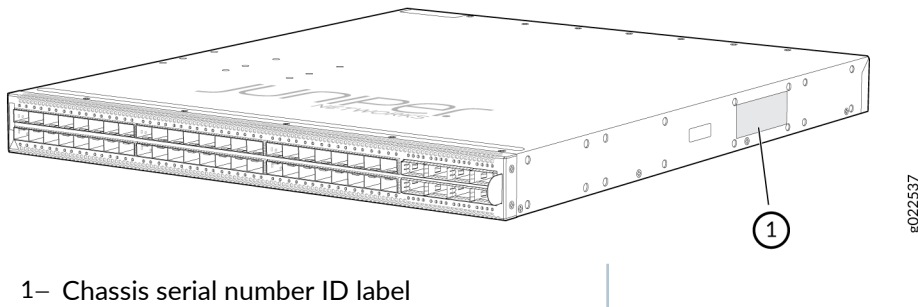
**Figure 166: Location of the Chassis Serial Number ID Label on QFX5120-32C Switches**



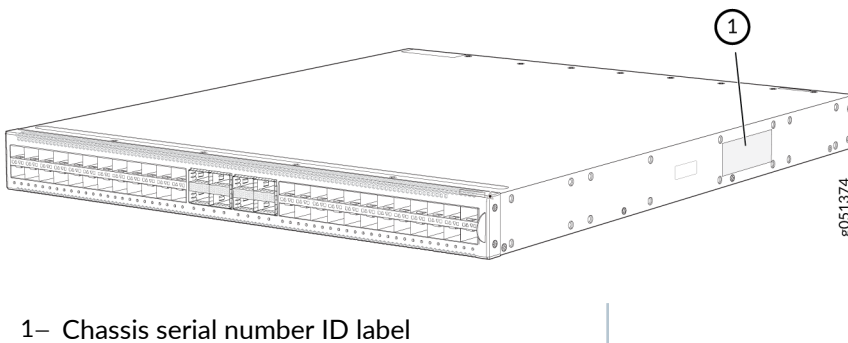
**Figure 167: Location of the Chassis Serial Number ID Label on QFX5120-48T Switches**



**Figure 168: Location of the Chassis Serial Number ID Label on QFX5120-48Y Switches**



**Figure 169: Location of the Chassis Serial Number ID Label on QFX5120-48YM Switches**



### Locate the Serial Number ID Labels on FRUs in a QFX5120 Switch

The power supplies and fan module installed in QFX5120 switches are field-replaceable units (FRUs). You must remove these FRUs from the switch chassis to see the serial number ID label.

*Power Supply*—The serial number ID label is on the top of the power supply.

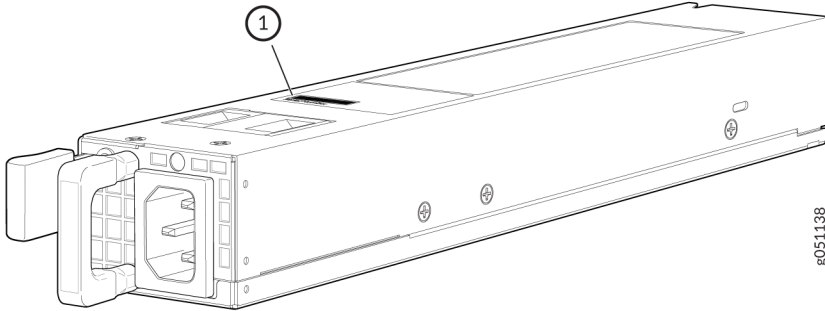
[Figure 170 on page 239](#) shows the location of the serial number ID label on the AC power supply for QFX5120-32C switches. [Figure 171 on page 239](#) shows the location of the serial number ID label on the DC power supply for QFX5120-32C switches.

[Figure 172 on page 240](#) shows the location of the serial number ID label on the AC power supply for QFX5120-48T switches. [Figure 173 on page 240](#) shows the location of the serial number ID label on the DC power supply for QFX5120-48T switches. [Figure 174 on page 241](#) shows the location of the serial number ID label on the high-voltage power supply for QFX5120-48T switches.

[Figure 175 on page 241](#) shows the location of the serial number ID label on the AC power supply for QFX5120-48Y switches. [Figure 176 on page 242](#) shows the location of the serial number ID label on the DC power supply for QFX5120-48Y switches.

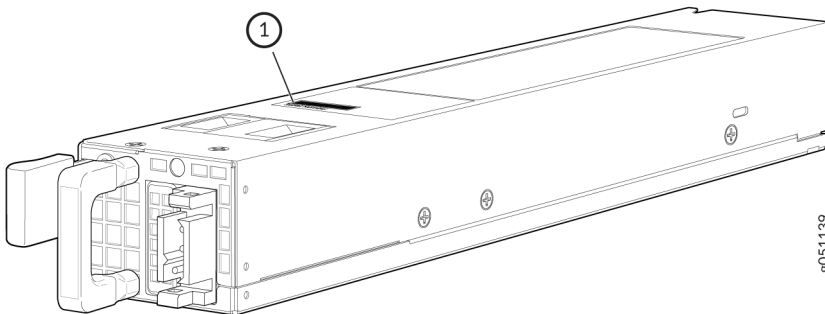
Figure 177 on page 242 shows the location of the serial number ID label on the AC power supply for QFX5120-48YM switches. Figure 178 on page 243 shows the location of the serial number ID label on the DC power supply for QFX5120-48YM switches.

**Figure 170: Location of the Serial Number ID Label on the AC Power Supply for QFX5120-32C Switches**



1– Serial number ID label on the AC power supply for QFX5120-32C switches

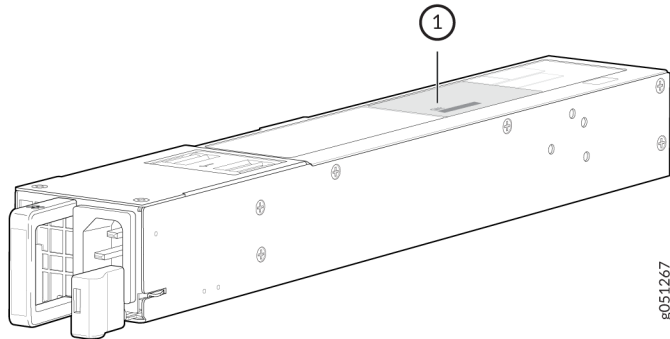
**Figure 171: Location of the Serial Number ID Label on the DC Power Supply for QFX5120-32C Switches**



1– Serial number ID label on the DC power supply for QFX5120-32C switches



**Figure 172: Location of the Serial Number ID Label on the AC Power Supply for QFX5120-48T Switches**

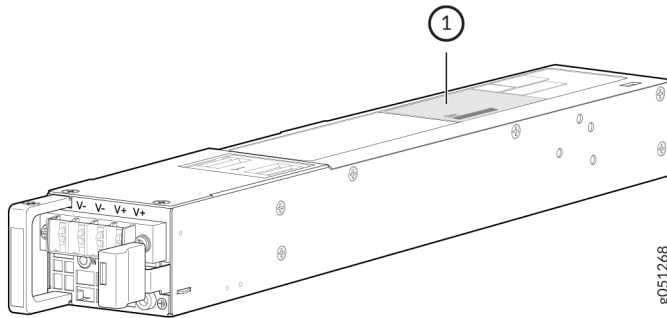


g051267

1– Serial number ID label on the AC power supply for QFX5120-48T switches

---

**Figure 173: Location of the Serial Number ID Label on the DC Power Supply for QFX5120-48T Switches**

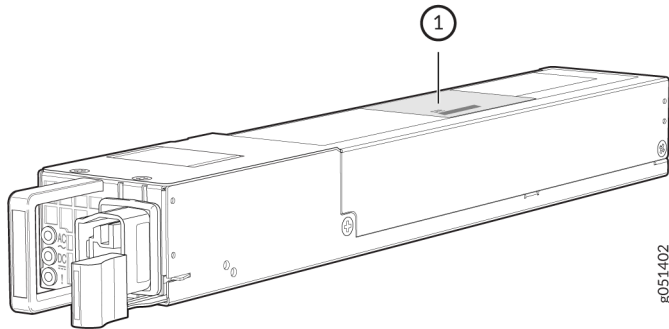


g051268

1– Serial number ID label on the DC power supply for QFX5120-48T switches

---

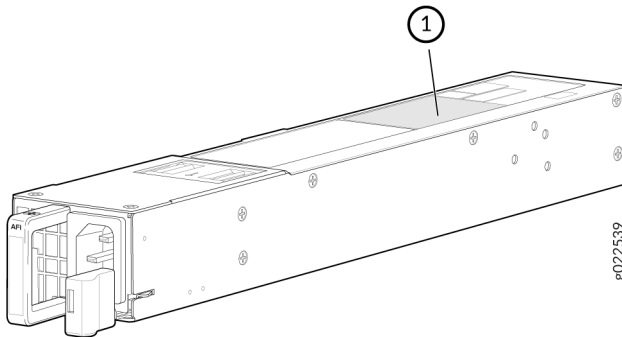
**Figure 174: Location of the Serial Number ID Label on the High-Voltage Power Supply for QFX5120-48T Switches**



1– Serial number ID label on the high-voltage power supply for QFX5120-48T switches

---

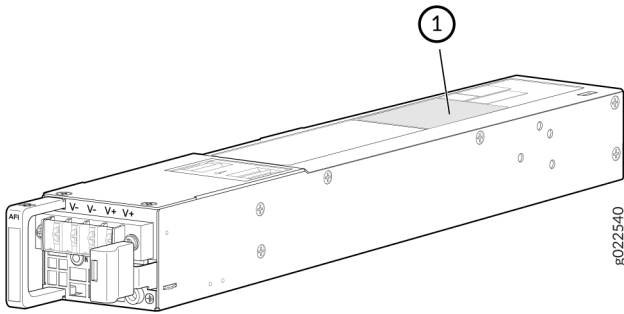
**Figure 175: Location of the Serial Number ID Label on the AC Power Supply for QFX5120-48Y Switches**



1– Serial number ID label on the AC power supply for QFX5120-48Y switches

---

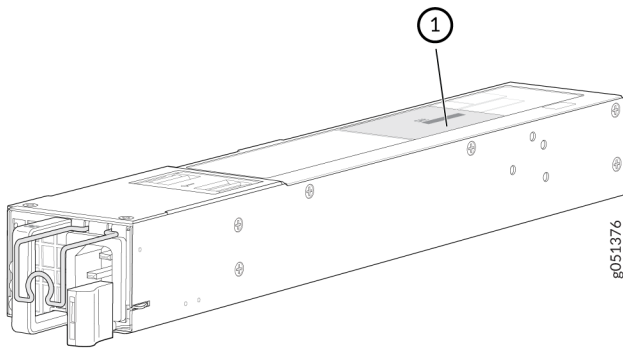
**Figure 176: Location of the Serial Number ID Label on the DC Power Supply for QFX5120-48Y Switches**



1– Serial number ID label on the DC power supply for QFX5120-48Y switches

---

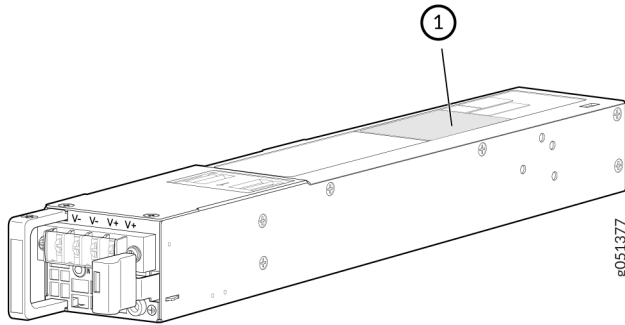
**Figure 177: Location of the Serial Number ID Label on the AC Power Supply for QFX5120-48YM Switches**



1– Serial number ID label on the AC power supply for QFX5120-48YM switches

---

**Figure 178: Location of the Serial Number ID Label on the DC Power Supply for QFX5120-48YM Switches**



1– Serial number ID label on the DC power supply for QFX5120-48YM switches

*Fan Module*—The serial number ID label is at the top panel of the fan module for QFX5120-32C switches. The serial number ID label is at the bottom panel of the fan module for QFX5120-48T, QFX5120-48Y, and QFX5120-48YM switches.

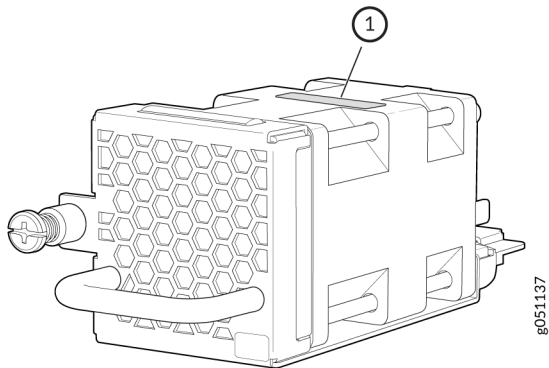
[Figure 179 on page 244](#) shows the location of the serial number ID label on the fan module for QFX5120-32C switches.

[Figure 180 on page 244](#) shows the location of the serial number ID label on the fan module for QFX5120-48T switches.

[Figure 181 on page 245](#) shows the location of the serial number ID label on the fan module for QFX5120-48Y switches.

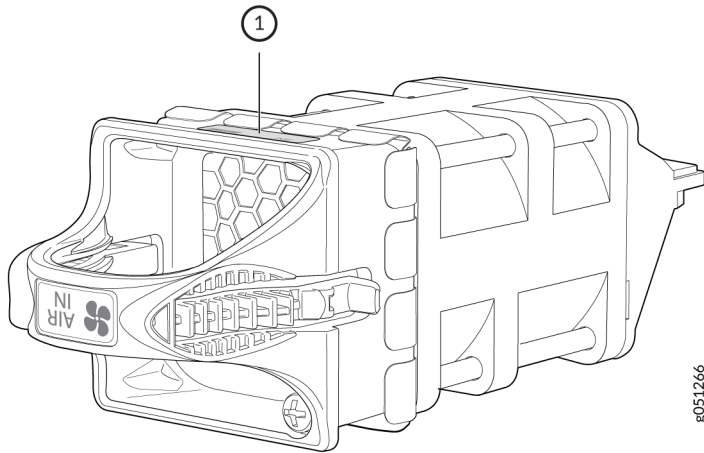
[Figure 182 on page 245](#) shows the location of the serial number ID label on the fan module for QFX5120-48YM switches.

**Figure 179: Location of the Serial Number ID Label on the Fan Module for QFX5120-32C Switches**



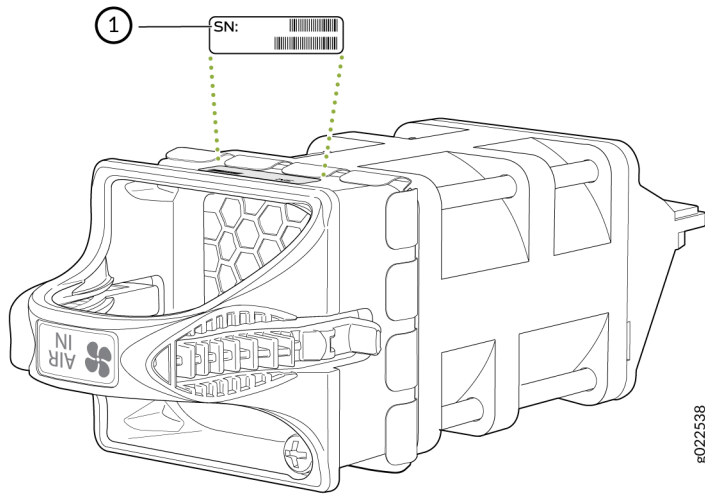
1– Serial number ID label on the fan module for QFX5120-32C switches

**Figure 180: Location of the Serial Number ID Label on the Fan Module for QFX5120-48T Switches**



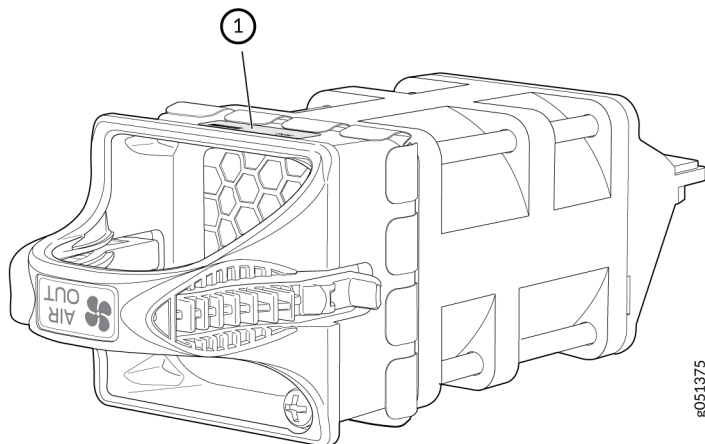
1– Serial number ID label on the fan module for QFX5120-48T switches

Figure 181: Location of the Serial Number ID Label on the Fan Module for QFX5120-48Y Switches



1- Serial number ID label on the fan module for QFX5120-48Y switches

Figure 182: Location of the Serial Number ID Label on the Fan Module for QFX5120-48YM Switches



1- Serial number ID label on the fan module for QFX5120-48YM switches

## Contact Customer Support to Obtain a Return Material Authorization

If you need to return a device or hardware component to Juniper Networks for repair or replacement, obtain a Return Material Authorization (RMA) number from Juniper Networks Technical Assistance Center (JTAC). You must obtain an RMA number before you attempt to return the component.

After locating the serial number of the device or hardware component you want to return, open a service request with the Juniper Networks Technical Assistance Center (JTAC) on the Web or by telephone.

Before you request an RMA number from JTAC, be prepared to provide the following information:

- Your existing service request number, if you have one
- Serial number of the component
- Your name, organization name, telephone number, fax number, and shipping address
- Details of the failure or problem
- Type of activity being performed on the device when the problem occurred
- Configuration data displayed by one or more `show` commands

You can contact JTAC 24 hours a day, seven days a week on the Web or by telephone:

- Service Request Manager: <https://support.juniper.net/support>
- Telephone: +1-888-314-JTAC (+1-888-314-5822), toll free in U.S., Canada, and Mexico

**NOTE:** For international or direct-dial options in countries without toll free numbers, see <https://support.juniper.net/support>.

If you are contacting JTAC by telephone, enter your 12-digit service request number followed by the pound (#) key for an existing case, or press the star (\*) key to be routed to the next available support engineer.

The support representative validates your request and issues an RMA number for return of the component.

## Pack a QFX5120 Switch or Component for Shipping

### IN THIS SECTION

- [Pack a QFX5120 Switch for Shipping | 247](#)
- [Pack QFX5120 Switch Components for Shipping | 248](#)

If you are returning a QFX5120 switch or component to Juniper Networks for repair or replacement, pack the item as described in this topic.

Before pack the switch or component, ensure that you have:

- Followed all the steps listed in *Contact Customer Support to Obtain Return Material Authorization*.
- Retrieved the original shipping carton and packing materials. Contact your JTAC representative if you do not have these materials, to learn about approved packing materials (see *Contact Customer Support to Obtain Return Material Authorization*).
- Ensure that you understand how to prevent electrostatic discharge (ESD) damage (see *Prevention of Electrostatic Discharge Damage*).

### Pack a QFX5120 Switch for Shipping

Before you pack the switch:

1. On the console or other management device connected to the switch, enter the CLI operational mode and issue the following command to shut down the switch software:

```
user@switch> request system halt
```

Wait until a message appears on the console confirming that the operating system has halted.

2. Disconnect power from the switch.
3. Remove the cables that connect the switch to external devices.
4. Remove all optical transceivers installed in the switch (see *Remove a Transceiver*).

If you need to transport the switch to another location or return the switch to Juniper Networks, you need to pack the switch securely in its original packaging to prevent damage during transportation.

Ensure that you have the following parts and tools:



- Number 2 Phillips (+) screwdriver—not provided
- The original switch packing material (cardboard box, accessory box and its contents, and foam padding)
- ESD grounding strap—not provided
- Antistatic bag—not provided



**CAUTION:** Do not pack the switch in anything except its original container, or the switch might be damaged in transit.

To pack the switch:

1. If the switch is installed in a rack or cabinet, have one person support the weight of the switch while another person unscrews and removes the mounting screws.
2. Remove the switch from the rack or cabinet and place the switch on a flat, stable surface.
3. Use the screwdriver to remove the rack mounting brackets from the switch chassis.
4. Place the switch in an antistatic bag.
5. Place the bottom portion of the packaging foam in the shipping carton.
6. Place the switch inside the cavity in the bottom packaging foam.
7. Place the top portion of the packaging foam on top of the switch.
8. If you are returning accessories or field-replaceable units (FRUs) with the switch, pack them as instructed in ["Pack QFX5120 Switch Components for Shipping" on page 248](#).
9. Place the accessory box by the rear end of the chassis in the shipping carton.
10. Close the top of the cardboard shipping box and seal it with packing tape.
11. Write the RMA number on the exterior of the box to ensure proper tracking.

## Pack QFX5120 Switch Components for Shipping

Ensure that you have the following parts and tools available:

- Antistatic bag, one for each component—not provided
- ESD grounding strap—not provided

To pack the switch components, follow the instructions here.



**CAUTION:** Do not stack switch components. Return individual components in separate boxes if they do not fit together on one level in the shipping box.

To pack the switch components:

- Place individual components in antistatic bags.
- Use the original packing materials if they are available. If the original packing materials are not available, ensure the component is adequately packed to prevent damage during transit. The packing material you use must be able to support the weight of the component.
- Ensure that the components are adequately protected by wrapping them well with packing materials. Pack the component in an oversized box (if the original box is not available) with extra packing material around the unit so that the component is prevented from moving around inside the box.
- Securely tape the box closed.
- Write the RMA number on the exterior of the box to ensure proper tracking.

# 7

CHAPTER

## Safety and Compliance Information

---

General Safety Guidelines and Warnings | 252

Definitions of Safety Warning Levels | 253

Qualified Personnel Warning | 255

Warning Statement for Norway and Sweden | 255

Fire Safety Requirements | 256

Installation Instructions Warning | 257

Chassis and Component Lifting Guidelines | 258

Restricted Access Warning | 258

Ramp Warning | 260

Rack-Mounting and Cabinet-Mounting Warnings | 260

Grounded Equipment Warning | 264

Radiation from Open Port Apertures Warning | 265

Laser and LED Safety Guidelines and Warnings | 266

Maintenance and Operational Safety Guidelines and Warnings | 269

General Electrical Safety Guidelines and Warnings | 275

Action to Take After an Electrical Accident | 276

Prevention of Electrostatic Discharge Damage | 277

AC Power Electrical Safety Guidelines | 278

AC Power Disconnection Warning | 279

DC Power Electrical Safety Guidelines | 280

DC Power Disconnection Warning | 281

DC Power Grounding Requirements and Warning | 283

DC Power Wiring Sequence Warning | 283

DC Power Wiring Terminations Warning | 285

Multiple Power Supplies Disconnection Warning | 286

TN Power Warning | 287

Agency Approvals for QFX5120 Switches | 288

Compliance Statements for EMC Requirements for the QFX Series | 290

Restriction of Hazardous Substances (RoHS) Directive Compliance | 294

---

# General Safety Guidelines and Warnings

The following guidelines help ensure your safety and protect the device from damage. The list of guidelines might not address all potentially hazardous situations in your working environment, so be alert and exercise good judgment at all times.

- Perform only the procedures explicitly described in the hardware documentation for this device. Make sure that only authorized service personnel perform other system services.
- Keep the area around the device clear and free from dust before, during, and after installation.
- Keep tools away from areas where people could trip over them while walking.
- Do not wear loose clothing or jewelry, such as rings, bracelets, or chains, which could become caught in the device.
- Wear safety glasses if you are working under any conditions that could be hazardous to your eyes.
- Do not perform any actions that create a potential hazard to people or make the equipment unsafe.
- Never attempt to lift an object that is too heavy for one person to handle.
- Never install or manipulate wiring during electrical storms.
- Never install electrical jacks in wet locations unless the jacks are specifically designed for wet environments.
- Operate the device only when it is properly grounded.
- Follow the instructions in this guide to properly ground the device to earth.
- Replace fuses only with fuses of the same type and rating.
- Do not open or remove chassis covers or sheet-metal parts unless instructions are provided in the hardware documentation for this device. Such an action could cause severe electrical shock.
- Do not push or force any objects through any opening in the chassis frame. Such an action could result in electrical shock or fire.
- Avoid spilling liquid onto the chassis or onto any device component. Such an action could cause electrical shock or damage the device.
- Avoid touching uninsulated electrical wires or terminals that have not been disconnected from their power source. Such an action could cause electrical shock.

- Some parts of the chassis, including AC and DC power supply surfaces, power supply unit handles, SFB card handles, and fan tray handles might become hot. The following label provides the warning for hot surfaces on the chassis:



- Always ensure that all modules, power supplies, and cover panels are fully inserted and that the installation screws are fully tightened.

## Definitions of Safety Warning Levels

The documentation uses the following levels of safety warnings (there are two *Warning* formats):

**NOTE:** You might find this information helpful in a particular situation, or you might overlook this important information if it was not highlighted in a Note.



**CAUTION:** You need to observe the specified guidelines to prevent minor injury or discomfort to you or severe damage to the device.

**Attention** Veillez à respecter les consignes indiquées pour éviter toute incommodité ou blessure légère, voire des dégâts graves pour l'appareil.



**LASER WARNING:** This symbol alerts you to the risk of personal injury from a laser.

**Avertissement** Ce symbole signale un risque de blessure provoquée par rayon laser.



**WARNING:** This symbol means danger. You are in a situation that could cause bodily injury. Before you work on any equipment, be aware of the hazards involved with electrical circuitry, and familiarize yourself with standard practices for preventing accidents.

**Waarschuwing** Dit waarschuwingssymbool betekent gevaar. U verkeert in een situatie die lichamelijk letsel kan veroorzaken. Voordat u aan enige apparatuur gaat werken, dient u zich bewust te zijn van de bij elektrische schakelingen betrokken risico's en dient u op de hoogte te zijn van standaard maatregelen om ongelukken te voorkomen.

**Varoitus** Tämä varoitusmerkki merkitsee vaaraa. Olet tilanteessa, joka voi johtaa ruumiinvammaan. Ennen kuin työskentelet minkään laitteiston parissa, ota selvää sähkökytkentöihin liittyvistä vaaroista ja tavanomaisista onnettomuuksien ehkäisykeinoista.

**Avertissement** Ce symbole d'avertissement indique un danger. Vous vous trouvez dans une situation pouvant causer des blessures ou des dommages corporels. Avant de travailler sur un équipement, soyez conscient des dangers posés par les circuits électriques et familiarisez-vous avec les procédures couramment utilisées pour éviter les accidents.

**Warnung** Dieses Warnsymbol bedeutet Gefahr. Sie befinden sich in einer Situation, die zu einer Körperverletzung führen könnte. Bevor Sie mit der Arbeit an irgendeinem Gerät beginnen, seien Sie sich der mit elektrischen Stromkreisen verbundenen Gefahren und der Standardpraktiken zur Vermeidung von Unfällen bewußt.

**Avvertenza** Questo simbolo di avvertenza indica un pericolo. La situazione potrebbe causare infortuni alle persone. Prima di lavorare su qualsiasi apparecchiatura, occorre conoscere i pericoli relativi ai circuiti elettrici ed essere al corrente delle pratiche standard per la prevenzione di incidenti.

**Advarsel** Dette varselsymbolet betyr fare. Du befinner deg i en situasjon som kan føre til personskade. Før du utfører arbeid på utstyr, må du være oppmerksom på de faremomentene som elektriske kretser innebærer, samt gjøre deg kjent med vanlig praksis når det gjelder å unngå ulykker.

**Aviso** Este símbolo de aviso indica perigo. Encontra-se numa situação que lhe poderá causar danos físicos. Antes de começar a trabalhar com qualquer equipamento, familiarize-se com os perigos relacionados com circuitos eléctricos, e com quaisquer práticas comuns que possam prevenir possíveis acidentes.

**¡Atención!** Este símbolo de aviso significa peligro. Existe riesgo para su integridad física. Antes de manipular cualquier equipo, considerar los riesgos que entraña la corriente eléctrica y familiarizarse con los procedimientos estándar de prevención de accidentes.

**Varning!** Denna varningssymbol signalerar fara. Du befinner dig i en situation som kan leda till personskada. Innan du utför arbete på någon utrustning måste du vara medveten om farorna med elkretsar och känna till vanligt förfarande för att förebygga skador.

## Qualified Personnel Warning



**WARNING:** Only trained and qualified personnel should install or replace the device.

**Waarschuwing** Installatie en reparaties mogen uitsluitend door getraind en bevoegd personeel uitgevoerd worden.

**Varoitus** Ainoastaan koulutettu ja pätevä henkilökunta saa asentaa tai vaihtaa tämän laitteen.

**Avertissement** Tout installation ou remplacement de l'appareil doit être réalisé par du personnel qualifié et compétent.

**Warnung** Gerät nur von geschultem, qualifiziertem Personal installieren oder auswechseln lassen.

**Avvertenza** Solo personale addestrato e qualificato deve essere autorizzato ad installare o sostituire questo apparecchio.

**Advarsel** Kun kvalifisert personell med riktig opplæring bør montere eller bytte ut dette utstyret.

**Aviso** Este equipamento deverá ser instalado ou substituído apenas por pessoal devidamente treinado e qualificado.

**¡Atención!** Estos equipos deben ser instalados y reemplazados exclusivamente por personal técnico adecuadamente preparado y capacitado.

**Varning!** Denna utrustning ska endast installeras och bytas ut av utbildad och kvalificerad personal.

## Warning Statement for Norway and Sweden



**WARNING:** The equipment must be connected to an earthed mains socket-outlet.

**Advarsel** Apparatet skal kobles til en jordet stikkontakt.

**Varning!** Apparaten skall anslutas till jordat nätuttag.



# Fire Safety Requirements

## IN THIS SECTION

- [Fire Suppression | 256](#)
- [Fire Suppression Equipment | 256](#)

In the event of a fire emergency, the safety of people is the primary concern. You should establish procedures for protecting people in the event of a fire emergency, provide safety training, and properly provision fire-control equipment and fire extinguishers.

In addition, you should establish procedures to protect your equipment in the event of a fire emergency. Juniper Networks products should be installed in an environment suitable for electronic equipment. We recommend that fire suppression equipment be available in the event of a fire in the vicinity of the equipment and that all local fire, safety, and electrical codes and ordinances be observed when you install and operate your equipment.

## Fire Suppression

In the event of an electrical hazard or an electrical fire, you should first turn power off to the equipment at the source. Then use a Type C fire extinguisher, which uses noncorrosive fire retardants, to extinguish the fire.

## Fire Suppression Equipment

Type C fire extinguishers, which use noncorrosive fire retardants such as carbon dioxide and Halotron™, are most effective for suppressing electrical fires. Type C fire extinguishers displace oxygen from the point of combustion to eliminate the fire. For extinguishing fire on or around equipment that draws air from the environment for cooling, you should use this type of inert oxygen displacement extinguisher instead of an extinguisher that leaves residues on equipment.

Do not use multipurpose Type ABC chemical fire extinguishers (dry chemical fire extinguishers). The primary ingredient in these fire extinguishers is monoammonium phosphate, which is very sticky and

difficult to clean. In addition, in the presence of minute amounts of moisture, monoammonium phosphate can become highly corrosive and corrodes most metals.

Any equipment in a room in which a chemical fire extinguisher has been discharged is subject to premature failure and unreliable operation. The equipment is considered to be irreparably damaged.

**NOTE:** To keep warranties effective, do not use a dry chemical fire extinguisher to control a fire at or near a Juniper Networks device. If a dry chemical fire extinguisher is used, the unit is no longer eligible for coverage under a service agreement.

We recommend that you dispose of any irreparably damaged equipment in an environmentally responsible manner.

## Installation Instructions Warning



**WARNING:** Read the installation instructions before you connect the device to a power source.

**Waarschuwing** Raadpleeg de installatie-aanwijzingen voordat u het systeem met de voeding verbindt.

**Varoitus** Lue asennusohjeet ennen järjestelmän yhdistämistä virtälähteeseen.

**Avertissement** Avant de brancher le système sur la source d'alimentation, consulter les directives d'installation.

**Warnung** Lesen Sie die Installationsanweisungen, bevor Sie das System an die Stromquelle anschließen.

**Avvertenza** Consultare le istruzioni di installazione prima di collegare il sistema all'alimentatore.

**Advarsel** Les installasjonsinstruksjonene før systemet kobles til strømkilden.

**Aviso** Leia as instruções de instalação antes de ligar o sistema à sua fonte de energia.

**¡Atención!** Ver las instrucciones de instalación antes de conectar el sistema a la red de alimentación.

**Varning!** Läs installationsanvisningarna innan du kopplar systemet till dess strömförsörjningsenhet.

## Chassis and Component Lifting Guidelines

- Before moving the device to a site, ensure that the site meets the power, environmental, and clearance requirements.
- Before lifting or moving the device, disconnect all external cables and wires.
- As when lifting any heavy object, ensure that your legs bear most of the weight rather than your back. Keep your knees bent and your back relatively straight. Do not twist your body as you lift. Balance the load evenly and be sure that your footing is firm.
- Use the following lifting guidelines to lift devices and components:
  - Up to 39.7 lb (18 kg): One person.
  - From 39.7 lb (18 kg) to 70.5 lb (32 kg): Two or more people.
  - From 70.5 lb (32 kg) to 121.2 lb (55 kg): Three or more people.
  - Above 121.2 lb (55 kg): Use material handling systems (such as levers, slings, lifts, and so on). When this is not practical, engage specially trained persons or systems (such as riggers or movers).

## Restricted Access Warning



**WARNING:** This unit is intended for installation in restricted access areas. A restricted access area is an area to which access can be gained only by service personnel through the use of a special tool, lock and key, or other means of security, and which is controlled by the authority responsible for the location.

**Waarschuwing** Dit toestel is bedoeld voor installatie op plaatsen met beperkte toegang. Een plaats met beperkte toegang is een plaats waar toegang slechts door servicepersoneel verkregen kan worden door middel van een speciaal instrument, een slot en sleutel, of een ander veiligheidsmiddel, en welke beheerd wordt door de overheidsinstantie die verantwoordelijk is voor de locatie.

**Varoitus** Tämä laite on tarkoitettu asennettavaksi paikkaan, johon pääsy on rajoitettua. Paikka, johon pääsy on rajoitettua, tarkoittaa paikkaa, johon vain huoltohenkilöstö pääsee jonkin erikoistyökalun, lukkoon sopivan avaimen tai jonkin muun turvalaitteen avulla ja joka on paikasta vastuussa olevien toimivaltaisten henkilöiden valvoma.

**Avertissement** Cet appareil est à installer dans des zones d'accès réservé. Ces dernières sont des zones auxquelles seul le personnel de service peut accéder en utilisant un outil spécial, un mécanisme de verrouillage et une clé, ou tout autre moyen de sécurité. L'accès aux zones de sécurité est sous le contrôle de l'autorité responsable de l'emplacement.

**Warnung** Diese Einheit ist zur Installation in Bereichen mit beschränktem Zutritt vorgesehen. Ein Bereich mit beschränktem Zutritt ist ein Bereich, zu dem nur Wartungspersonal mit einem Spezialwerkzeugs, Schloß und Schlüssel oder anderer Sicherheitsvorkehrungen Zugang hat, und der von dem für die Anlage zuständigen Gremium kontrolliert wird.

**Avvertenza** Questa unità deve essere installata in un'area ad accesso limitato. Un'area ad accesso limitato è un'area accessibile solo a personale di assistenza tramite un'attrezzo speciale, lucchetto, o altri dispositivi di sicurezza, ed è controllata dall'autorità responsabile della zona.

**Advarsel** Denne enheten er laget for installasjon i områder med begrenset adgang. Et område med begrenset adgang gir kun adgang til servicepersonale som bruker et spesielt verktøy, lås og nøkkel, eller en annen sikkerhetsanordning, og det kontrolleres av den autoriteten som er ansvarlig for området.

**Aviso** Esta unidade foi concebida para instalação em áreas de acesso restrito. Uma área de acesso restrito é uma área à qual apenas tem acesso o pessoal de serviço autorizado, que possua uma ferramenta, chave e fechadura especial, ou qualquer outra forma de segurança. Esta área é controlada pela autoridade responsável pelo local.

**¡Atención!** Esta unidad ha sido diseñada para instalarse en áreas de acceso restringido. Área de acceso restringido significa un área a la que solamente tiene acceso el personal de servicio mediante la utilización de una herramienta especial, cerradura con llave, o algún otro medio de seguridad, y que está bajo el control de la autoridad responsable del local.

**Warning!** Denna enhet är avsedd för installation i områden med begränsat tillträde. Ett område med begränsat tillträde får endast tillträdas av servicepersonal med ett speciellt verktyg, lås och nyckel, eller annan säkerhetsanordning, och kontrolleras av den auktoritet som ansvarar för området.

## Ramp Warning



**WARNING:** When installing the device, do not use a ramp inclined at more than 10 degrees.

**Waarschuwing** Gebruik een oprijplaat niet onder een hoek van meer dan 10 graden.

**Varoitus** Älä käytä sellaista kaltevaa pintaa, jonka kaltevuus ylittää 10 astetta.

**Avertissement** Ne pas utiliser une rampe dont l'inclinaison est supérieure à 10 degrés.

**Warnung** Keine Rampen mit einer Neigung von mehr als 10 Grad verwenden.

**Avvertenza** Non usare una rampa con pendenza superiore a 10 gradi.

**Advarsel** Bruk aldri en rampe som heller mer enn 10 grader.

**Aviso** Não utilize uma rampa com uma inclinação superior a 10 graus.

**¡Atención!** No usar una rampa inclinada más de 10 grados.

**Varning!** Använd inte ramp med en lutning på mer än 10 grader.

## Rack-Mounting and Cabinet-Mounting Warnings

Ensure that the rack or cabinet in which the device is installed is evenly and securely supported. Uneven mechanical loading could lead to a hazardous condition.



**WARNING:** To prevent bodily injury when mounting or servicing the device in a rack, take the following precautions to ensure that the system remains stable. The following directives help maintain your safety:

- Install the device in a rack that is secured to the building structure.
- Mount the device at the bottom of the rack if it is the only unit in the rack.
- When mounting the device on a partially filled rack, load the rack from the bottom to the top, with the heaviest component at the bottom of the rack.

- If the rack is provided with stabilizing equipment, install the stabilizers before mounting or servicing the device in the rack.

**Waarschuwing** Om lichamelijk letsel te voorkomen wanneer u dit toestel in een rek monteert of het daar een servicebeurt geeft, moet u speciale voorzorgsmaatregelen nemen om ervoor te zorgen dat het toestel stabiel blijft. De onderstaande richtlijnen worden verstrekt om uw veiligheid te verzekeren:

- De Juniper Networks switch moet in een stelling worden geïnstalleerd die aan een bouwsel is verankerd.
- Dit toestel dient onderaan in het rek gemonteerd te worden als het toestel het enige in het rek is.
- Wanneer u dit toestel in een gedeeltelijk gevuld rek monteert, dient u het rek van onderen naar boven te laden met het zwaarste onderdeel onderaan in het rek.
- Als het rek voorzien is van stabiliseringshulpmiddelen, dient u de stabilisatoren te monteren voordat u het toestel in het rek monteert of het daar een servicebeurt geeft.

**Varoitus** Kun laite asetetaan telineeseen tai huolletaan sen ollessa telineessä, on noudatettava erityisiä varotoimia järjestelmän vakavuuden säilyttämiseksi, jotta vältetään loukkaantumiselta. Noudata seuraavia turvallisuusohjeita:

- Juniper Networks switch on asennettava telineeseen, joka on kiinnitetty rakennukseen.
- Jos telineessä ei ole muita laitteita, aseta laite telineen alaosaan.
- Jos laite asetetaan osaksi täytettyyn telineeseen, aloita kuormittaminen sen alaosasta kaikkein raskaimmalla esineellä ja siirry sitten sen yläosaan.
- Jos telinettä varten on vakaimet, asenna ne ennen laitteen asettamista telineeseen tai sen huoltamista siinä.

**Avertissement** Pour éviter toute blessure corporelle pendant les opérations de montage ou de réparation de cette unité en casier, il convient de prendre des précautions spéciales afin de maintenir la stabilité du système. Les directives ci-dessous sont destinées à assurer la protection du personnel:

- Le rack sur lequel est monté le Juniper Networks switch doit être fixé à la structure du bâtiment.

- Si cette unité constitue la seule unité montée en casier, elle doit être placée dans le bas.
- Si cette unité est montée dans un casier partiellement rempli, charger le casier de bas en haut en plaçant l'élément le plus lourd dans le bas.
- Si le casier est équipé de dispositifs stabilisateurs, installer les stabilisateurs avant de monter ou de réparer l'unité en casier.

**Warnung** Zur Vermeidung von Körperverletzung beim Anbringen oder Warten dieser Einheit in einem Gestell müssen Sie besondere Vorkehrungen treffen, um sicherzustellen, daß das System stabil bleibt. Die folgenden Richtlinien sollen zur Gewährleistung Ihrer Sicherheit dienen:

- Der Juniper Networks switch muß in einem Gestell installiert werden, das in der Gebäudestruktur verankert ist.
- Wenn diese Einheit die einzige im Gestell ist, sollte sie unten im Gestell angebracht werden.
- Bei Anbringung dieser Einheit in einem zum Teil gefüllten Gestell ist das Gestell von unten nach oben zu laden, wobei das schwerste Bauteil unten im Gestell anzubringen ist.
- Wird das Gestell mit Stabilisierungszubehör geliefert, sind zuerst die Stabilisatoren zu installieren, bevor Sie die Einheit im Gestell anbringen oder sie warten.

**Avvertenza** Per evitare infortuni fisici durante il montaggio o la manutenzione di questa unità in un supporto, occorre osservare speciali precauzioni per garantire che il sistema rimanga stabile. Le seguenti direttive vengono fornite per garantire la sicurezza personale:

- Il Juniper Networks switch deve essere installato in un telaio, il quale deve essere fissato alla struttura dell'edificio.
- Questa unità deve venire montata sul fondo del supporto, se si tratta dell'unica unità da montare nel supporto.
- Quando questa unità viene montata in un supporto parzialmente pieno, caricare il supporto dal basso all'alto, con il componente più pesante sistemato sul fondo del supporto.
- Se il supporto è dotato di dispositivi stabilizzanti, installare tali dispositivi prima di montare o di procedere alla manutenzione dell'unità nel supporto.

**Advarsel** Unngå fysiske skader under montering eller reparasjonsarbeid på denne enheten når den befinner seg i et kabinett. Vær nøye med at systemet er stabilt. Følgende retningslinjer er gitt for å verne om sikkerheten:

- Juniper Networks switch må installeres i et stativ som er forankret til bygningsstrukturen.
- Denne enheten bør monteres nederst i kabinettet hvis dette er den eneste enheten i kabinettet.
- Ved montering av denne enheten i et kabinett som er delvis fylt, skal kabinettet lastes fra bunnen og opp med den tyngste komponenten nederst i kabinettet.
- Hvis kabinettet er utstyrt med stabiliseringsutstyr, skal stabilisatorene installeres før montering eller utføring av reparasjonsarbeid på enheten i kabinettet.

**Aviso** Para se prevenir contra danos corporais ao montar ou reparar esta unidade numa estante, deverá tomar precauções especiais para se certificar de que o sistema possui um suporte estável. As seguintes directrizes ajudá-lo-ão a efectuar o seu trabalho com segurança:

- O Juniper Networks switch deverá ser instalado numa prateleira fixa à estrutura do edifício.
- Esta unidade deverá ser montada na parte inferior da estante, caso seja esta a única unidade a ser montada.
- Ao montar esta unidade numa estante parcialmente ocupada, coloque os itens mais pesados na parte inferior da estante, arrumando-os de baixo para cima.
- Se a estante possuir um dispositivo de estabilização, instale-o antes de montar ou reparar a unidade.

**¡Atención!** Para evitar lesiones durante el montaje de este equipo sobre un bastidor, oerriormente durante su mantenimiento, se debe poner mucho cuidado en que el sistema quede bien estable. Para garantizar su seguridad, proceda según las siguientes instrucciones:

- El Juniper Networks switch debe instalarse en un bastidor fijado a la estructura del edificio.
- Colocar el equipo en la parte inferior del bastidor, cuando sea la única unidad en el mismo.



- Cuando este equipo se vaya a instalar en un bastidor parcialmente ocupado, comenzar la instalación desde la parte inferior hacia la superior colocando el equipo más pesado en la parte inferior.
- Si el bastidor dispone de dispositivos estabilizadores, instalar éstos antes de montar o proceder al mantenimiento del equipo instalado en el bastidor.

**Warning!** För att undvika kroppsskada när du installerar eller utför underhållsarbete på denna enhet på en ställning måste du vidta särskilda försiktighetsåtgärder för att försäkra dig om att systemet står stadigt. Följande riktlinjer ges för att trygga din säkerhet:

- Juniper Networks switch måste installeras i en ställning som är förankrad i byggnadens struktur.
- Om denna enhet är den enda enheten på ställningen skall den installeras längst ned på ställningen.
- Om denna enhet installeras på en delvis fylld ställning skall ställningen fyllas nedifrån och upp, med de tyngsta enheterna längst ned på ställningen.
- Om ställningen är försedd med stabiliseringsdon skall dessa monteras fast innan enheten installeras eller underhålls på ställningen.

## Grounded Equipment Warning



**WARNING:** This device must be properly grounded at all times. Follow the instructions in this guide to properly ground the device to earth.

**Waarschuwing** Dit apparaat moet altijd goed geaard zijn. Volg de instructies in deze gids om het apparaat goed te aarden.

**Varoitus** Laitteen on oltava pysyvästi maadoitettu. Maadoita laite asianmukaisesti noudattamalla tämän oppaan ohjeita.

**Avertissement** L'appareil doit être correctement mis à la terre à tout moment. Suivez les instructions de ce guide pour correctement mettre l'appareil à la terre.

**Warnung** Das Gerät muss immer ordnungsgemäß geerdet sein. Befolgen Sie die Anweisungen in dieser Anleitung, um das Gerät ordnungsgemäß zu erden.

**Avvertenza** Questo dispositivo deve sempre disporre di una connessione a massa. Seguire le istruzioni indicate in questa guida per connettere correttamente il dispositivo a massa.

**Advarsel** Denne enheten på jordes skikkelig hele tiden. Følg instruksjonene i denne veiledningen for å jorde enheten.

**Aviso** Este equipamento deverá estar ligado à terra. Siga las instrucciones en esta guía para conectar correctamente este dispositivo a tierra.

**¡Atención!** Este dispositivo debe estar correctamente conectado a tierra en todo momento. Siga las instrucciones en esta guía para conectar correctamente este dispositivo a tierra.

**Varning!** Den här enheten måste vara ordentligt jordad. Följ instruktionerna i den här guiden för att jorda enheten ordentligt.

## Radiation from Open Port Apertures Warning



**LASER WARNING:** Because invisible radiation might be emitted from the aperture of the port when no fiber cable is connected, avoid exposure to radiation and do not stare into open apertures.

**Waarschuwing** Aangezien onzichtbare straling vanuit de opening van de poort kan komen als er geen fiberkabel aangesloten is, dient blootstelling aan straling en het kijken in open openingen vermeden te worden.

**Varoitus** Koska portin aukosta voi emittoitua näkymätöntä säteilyä, kun kuitukaapelia ei ole kytkettyä, vältä säteilylle altistumista äläkä katso avoimiin aukkoihin.

**Avertissement** Des radiations invisibles à l'il nu pouvant traverser l'ouverture du port lorsqu'aucun câble en fibre optique n'y est connecté, il est recommandé de ne pas regarder fixement l'intérieur de ces ouvertures.

**Warnung** Aus der Port-Öffnung können unsichtbare Strahlen emittieren, wenn kein Glasfaserkabel angeschlossen ist. Vermeiden Sie es, sich den Strahlungen auszusetzen, und starren Sie nicht in die Öffnungen!

**Avvertenza** Quando i cavi in fibra non sono inseriti, radiazioni invisibili possono essere emesse attraverso l'apertura della porta. Evitate di esporvi alle radiazioni e non guardate direttamente nelle aperture.

**Advarsel** Unngå utsettelse for stråling, og stirr ikke inn i åpninger som er åpne, fordi usynlig stråling kan emitteres fra portens åpning når det ikke er tilkoblet en fiberkabel.

**Aviso** Dada a possibilidade de emissão de radiação invisível através do orifício da via de acesso, quando esta não tiver nenhum cabo de fibra conectado, deverá evitar a EXposição à radiação e não deverá olhar fixamente para orifícios que se encontrarem a descoberto.

**¡Atención!** Debido a que la apertura del puerto puede emitir radiación invisible cuando no existe un cable de fibra conectado, evite mirar directamente a las aperturas para no exponerse a la radiación.

**Varning!** Osynlig strålning kan avges från en portöppning utan ansluten fiberkabel och du bör därför undvika att bli utsatt för strålning genom att inte stirra in i oskyddade öppningar.

## Laser and LED Safety Guidelines and Warnings

### IN THIS SECTION

- [General Laser Safety Guidelines | 267](#)
- [Class 1 Laser Product Warning | 267](#)
- [Class 1 LED Product Warning | 268](#)
- [Laser Beam Warning | 268](#)

Juniper Networks devices are equipped with laser transmitters, which are considered a Class 1 Laser Product by the U.S. Food and Drug Administration and are evaluated as a Class 1 Laser Product per IEC/EN 60825-1 requirements.

Observe the following guidelines and warnings:

## General Laser Safety Guidelines

When working around ports that support optical transceivers, observe the following safety guidelines to prevent eye injury:

- Do not look into unterminated ports or at fibers that connect to unknown sources.
- Do not examine unterminated optical ports with optical instruments.
- Avoid direct exposure to the beam.



**LASER WARNING:** Unterminated optical connectors can emit invisible laser radiation. The lens in the human eye focuses all the laser power on the retina, so focusing the eye directly on a laser source—even a low-power laser—could permanently damage the eye.

**Avertissement** Les connecteurs à fibre optique sans terminaison peuvent émettre un rayonnement laser invisible. Le cristallin de l'œil humain faisant converger toute la puissance du laser sur la rétine, toute focalisation directe de l'œil sur une source laser, —même de faible puissance—, peut entraîner des lésions oculaires irréversibles.

## Class 1 Laser Product Warning



**LASER WARNING:** Class 1 laser product.

**Waarschuwing** Klasse-1 laser produkt.

**Varoitus** Luokan 1 lasertuote.

**Avertissement** Produit laser de classe I.

**Warnung** Laserprodukt der Klasse 1.

**Avvertenza** Prodotto laser di Classe 1.

**Advarsel** Laserprodukt av klasse 1.

**Aviso** Produto laser de classe 1.

**¡Atención!** Producto láser Clase I.

**Varning!** Laserprodukt av klass 1.

## Class 1 LED Product Warning



**LASER WARNING:** Class 1 LED product.

**Waarschuwing** Klasse 1 LED-product.

**Varoitus** Luokan 1 valodiodituote.

**Avertissement** Alarme de produit LED Class I.

**Warnung** Class 1 LED-Produktwarnung.

**Avvertenza** Avvertenza prodotto LED di Classe 1.

**Advarel** LED-produkt i klasse 1.

**Aviso** Produto de classe 1 com LED.

**¡Atención!** Aviso sobre producto LED de Clase 1.

**Varning!** Lysdiodprodukt av klass 1.

## Laser Beam Warning



**LASER WARNING:** Do not stare into the laser beam or view it directly with optical instruments.

**Waarschuwing** Niet in de straal staren of hem rechtstreeks bekijken met optische instrumenten.

**Varoitus** Älä katso säteeseen äläkä tarkastele sitä suoraan optisen laitteen avulla.

**Avertissement** Ne pas fixer le faisceau des yeux, ni l'observer directement à l'aide d'instruments optiques.

**Warnung** Nicht direkt in den Strahl blicken und ihn nicht direkt mit optischen Geräten prüfen.

**Avvertenza** Non fissare il raggio con gli occhi né usare strumenti ottici per osservarlo direttamente.

**Advarel** Stirr eller se ikke direkte p strlen med optiske instrumenter.

**Aviso** Não olhe fixamente para o raio, nem olhe para ele directamente com instrumentos ópticos.

**¡Atención!** No mirar fijamente el haz ni observarlo directamente con instrumentos ópticos.

**Warning!** Rikta inte blicken in mot strålen och titta inte direkt på den genom optiska instrument.

## Maintenance and Operational Safety Guidelines and Warnings

### IN THIS SECTION

- [Battery Handling Warning | 269](#)
- [Jewelry Removal Warning | 270](#)
- [Lightning Activity Warning | 272](#)
- [Operating Temperature Warning | 273](#)
- [Product Disposal Warning | 274](#)

While performing the maintenance activities for devices, observe the following guidelines and warnings:

### Battery Handling Warning



**WARNING:** Replacing a battery incorrectly might result in an explosion. Replace a battery only with the same or equivalent type recommended by the manufacturer. Dispose of used batteries according to the manufacturer's instructions.

**Waarschuwing** Er is ontploffingsgevaar als de batterij verkeerd vervangen wordt. Vervang de batterij slechts met hetzelfde of een equivalent type dat door de fabrikant

aanbevolen is. Gebruikte batterijen dienen overeenkomstig fabrieksvoorschriften weggeworpen te worden.

**Varoitus** Räjähdyksen vaara, jos akku on vaihdettu väärään akkuun. Käytä vaihtamiseen ainoastaan saman- tai vastaavantyyppistä akkua, joka on valmistajan suosittama. Hävitä käytetyt akut valmistajan ohjeiden mukaan.

**Avertissement** Danger d'explosion si la pile n'est pas remplacée correctement. Ne la remplacer que par une pile de type semblable ou équivalent, recommandée par le fabricant. Jeter les piles usagées conformément aux instructions du fabricant.

**Warnung** Bei Einsetzen einer falschen Batterie besteht Explosionsgefahr. Ersetzen Sie die Batterie nur durch den gleichen oder vom Hersteller empfohlenen Batterietyp. Entsorgen Sie die benutzten Batterien nach den Anweisungen des Herstellers.

**Advarsel** Det kan være fare for eksplosjon hvis batteriet skiftes på feil måte. Skift kun med samme eller tilsvarende type som er anbefalt av produsenten. Kasser brukte batterier i henhold til produsentens instruksjoner.

**Avvertenza** Pericolo di esplosione se la batteria non è installata correttamente. Sostituire solo con una di tipo uguale o equivalente, consigliata dal produttore. Eliminare le batterie usate secondo le istruzioni del produttore.

**Aviso** Existe perigo de explosão se a bateria for substituída incorrectamente. Substitua a bateria por uma bateria igual ou de um tipo equivalente recomendado pelo fabricante. Destrua as baterias usadas conforme as instruções do fabricante.

**¡Atención!** Existe peligro de explosión si la batería se reemplaza de manera incorrecta. Reemplazar la batería EXclusivamente con el mismo tipo o el equivalente recomendado por el fabricante. Desechar las baterías gastadas según las instrucciones del fabricante.

**Varning!** Explosionsfara vid felaktigt batteribyte. Ersätt endast batteriet med samma batterityp som rekommenderas av tillverkaren eller motsvarande. Följ tillverkarens anvisningar vid kassering av använda batterier.

## Jewelry Removal Warning



**WARNING:** Before working on equipment that is connected to power lines, remove jewelry, including rings, necklaces, and watches. Metal objects heat up when connected to power and ground and can cause serious burns or can be welded to the terminals.

**Waarschuwing** Alvorens aan apparatuur te werken die met elektrische leidingen is verbonden, sieraden (inclusief ringen, kettingen en horloges) verwijderen. Metalen voorwerpen worden warm wanneer ze met stroom en aarde zijn verbonden, en kunnen ernstige brandwonden veroorzaken of het metalen voorwerp aan de aansluitklemmen lassen.

**Varoitus** Ennen kuin työskentelet voimavirtajohtoihin kytkettyjen laitteiden parissa, ota pois kaikki korut (sormukset, kaulakorut ja kellot mukaan lukien). Metalliesineet kuumenevat, kun ne ovat yhteydessä sähkövirran ja maan kanssa, ja ne voivat aiheuttaa vakavia palovammoja tai hitsata metalliesineet kiinni liitännänapoihin.

**Avertissement** Avant d'accéder à cet équipement connecté aux lignes électriques, ôter tout bijou (anneaux, colliers et montres compris). Lorsqu'ils sont branchés à l'alimentation et reliés à la terre, les objets métalliques chauffent, ce qui peut provoquer des blessures graves ou souder l'objet métallique aux bornes.

**Warnung** Vor der Arbeit an Geräten, die an das Netz angeschlossen sind, jeglichen Schmuck (einschließlich Ringe, Ketten und Uhren) abnehmen. Metallgegenstände erhitzen sich, wenn sie an das Netz und die Erde angeschlossen werden, und können schwere Verbrennungen verursachen oder an die Anschlußklemmen angeschweißt werden.

**Avvertenza** Prima di intervenire su apparecchiature collegate alle linee di alimentazione, togliersi qualsiasi monile (inclusi anelli, collane, braccialetti ed orologi). Gli oggetti metallici si riscaldano quando sono collegati tra punti di alimentazione e massa: possono causare ustioni gravi oppure il metallo può saldarsi ai terminali.

**Advarsel** Fjern alle smykker (inkludert ringer, halskjeder og klokker) før du skal arbeide på utstyr som er koblet til kraftledninger. Metallgjenstander som er koblet til kraftledninger og jord blir svært varme og kan forårsake alvorlige brannskader eller smelte fast til polene.

**Aviso** Antes de trabalhar em equipamento que esteja ligado a linhas de corrente, retire todas as jóias que estiver a usar (incluindo anéis, fios e relógios). Os objectos metálicos aquecerão em contacto com a corrente e em contacto com a ligação à terra, podendo causar queimaduras graves ou ficarem soldados aos terminais.

**¡Atención!** Antes de operar sobre equipos conectados a líneas de alimentación, quitarse las joyas (incluidos anillos, collares y relojes). Los objetos de metal se calientan cuando se conectan a la alimentación y a tierra, lo que puede ocasionar quemaduras graves o que los objetos metálicos queden soldados a los bornes.



**Warning!** Tag av alla smycken (inklusive ringar, halsband och armbandsur) innan du arbetar på utrustning som är kopplad till kraftledning. Metallobjekt hettas upp när de kopplas ihop med ström och jord och kan förorsaka allvarliga brännskador; metallobjekt kan också sammansvetsas med kontakterna.

## Lightning Activity Warning



**WARNING:** Do not work on the system or connect or disconnect cables during periods of lightning activity.

**Waarschuwing** Tijdens onweer dat gepaard gaat met bliksem, dient u niet aan het systeem te werken of kabels aan te sluiten of te ontkoppelen.

**Varoitus** Älä työskentele järjestelmän parissa äläkä yhdistä tai irrota kaapeleita ukkosilmalla.

**Avertissement** Ne pas travailler sur le système ni brancher ou débrancher les câbles pendant un orage.

**Warnung** Arbeiten Sie nicht am System und schließen Sie keine Kabel an bzw. trennen Sie keine ab, wenn es gewittert.

**Avvertenza** Non lavorare sul sistema o collegare oppure scollegare i cavi durante un temporale con fulmini.

**Advarsel** Utfør aldri arbeid på systemet, eller koble kabler til eller fra systemet når det tordner eller lyner.

**Aviso** Não trabalhe no sistema ou ligue e desligue cabos durante períodos de mau tempo (trovoada).

**¡Atención!** No operar el sistema ni conectar o desconectar cables durante el transcurso de descargas eléctricas en la atmósfera.

**Warning!** Vid åska skall du aldrig utföra arbete på systemet eller ansluta eller koppla loss kablar.

## Operating Temperature Warning



**WARNING:** To prevent the device from overheating, do not operate it in an area that exceeds the maximum recommended ambient temperature. To prevent airflow restriction, allow at least 6 in. (15.2 cm) of clearance around the ventilation openings.

**Waarschuwing** Om te voorkomen dat welke switch van de Juniper Networks router dan ook oververhit raakt, dient u deze niet te bedienen op een plaats waar de maximale aanbevolen omgevingstemperatuur van 40° C wordt overschreden. Om te voorkomen dat de luchtstroom wordt beperkt, dient er minstens 15,2 cm speling rond de ventilatie-openingen te zijn.

**Varoitus** Ettei Juniper Networks switch-sarjan reititin ylikuumentuisi, sitä ei saa käyttää tilassa, jonka lämpötila ylittää korkeimman suositellun ympäristölämpötilan 40° C. Ettei ilmanvaihto estyisi, tuuletusaukkojen ympärille on jätettävä ainakin 15,2 cm tilaa.

**Avertissement** Pour éviter toute surchauffe des routeurs de la gamme Juniper Networks switch, ne l'utilisez pas dans une zone où la température ambiante est supérieure à 40° C. Pour permettre un flot d'air constant, dégagez un espace d'au moins 15,2 cm autour des ouvertures de ventilations.

**Warnung** Um einen Router der switch vor Überhitzung zu schützen, darf dieser nicht in einer Gegend betrieben werden, in der die Umgebungstemperatur das empfohlene Maximum von 40° C überschreitet. Um Lüftungsverschluß zu verhindern, achten Sie darauf, daß mindestens 15,2 cm lichter Raum um die Lüftungsöffnungen herum frei bleibt.

**Avvertenza** Per evitare il surriscaldamento dei switch, non adoperateli in un locale che ecceda la temperatura ambientale massima di 40° C. Per evitare che la circolazione dell'aria sia impedita, lasciate uno spazio di almeno 15.2 cm di fronte alle aperture delle ventole.

**Advarsel** Unngå overoppheting av eventuelle rutere i Juniper Networks switch Disse skal ikke brukes på steder der den anbefalte maksimale omgivelsestemperaturen overstiger 40° C (104° F). Sørg for at klaringen rundt lufteåpningene er minst 15,2 cm (6 tommer) for å forhindre nedsatt luftsirkulasjon.

**Aviso** Para evitar o sobreaquecimento do encaminhador Juniper Networks switch, não utilize este equipamento numa área que exceda a temperatura máxima recomendada de 40° C. Para evitar a restrição à circulação de ar, deixe pelo menos um espaço de 15,2 cm à volta das aberturas de ventilação.

**¡Atención!** Para impedir que un encaminador de la serie Juniper Networks switch se recaliente, no lo haga funcionar en un área en la que se supere la temperatura ambiente máxima recomendada de 40° C. Para impedir la restricción de la entrada de aire, deje un espacio mínimo de 15,2 cm alrededor de las aperturas para ventilación.

**Warning!** Förhindra att en Juniper Networks switch överhettas genom att inte använda den i ett område där den maximalt rekommenderade omgivningstemperaturen på 40° C överskrids. Förhindra att luftcirkulationen inskränks genom att se till att det finns fritt utrymme på minst 15,2 cm omkring ventilationsöppningarna.

## Product Disposal Warning



**WARNING:** Disposal of this device must be handled according to all national laws and regulations.

**Waarschuwing** Dit produkt dient volgens alle landelijke wetten en voorschriften te worden afgedankt.

**Varoitus** Tämän tuotteen lopullisesta hävittämisestä tulee huolehtia kaikkia valtakunnallisia lakeja ja säännöksiä noudattaen.

**Avertissement** La mise au rebut définitive de ce produit doit être effectuée conformément à toutes les lois et réglementations en vigueur.

**Warnung** Dieses Produkt muß den geltenden Gesetzen und Vorschriften entsprechend entsorgt werden.

**Avvertenza** L'eliminazione finale di questo prodotto deve essere eseguita osservando le normative italiane vigenti in materia

**Advarsel** Endelig disponering av dette produktet må skje i henhold til nasjonale lover og forskrifter.

**Aviso** A descartagem final deste produto deverá ser efectuada de acordo com os regulamentos e a legislação nacional.

**¡Atención!** El desecho final de este producto debe realizarse según todas las leyes y regulaciones nacionales

**Warning!** Slutlig kassering av denna produkt bör skötas i enlighet med landets alla lagar och föreskrifter.

## General Electrical Safety Guidelines and Warnings



**WARNING:** Certain ports on the device are designed for use as intrabuilding (within-the-building) interfaces only (Type 2 or Type 4 ports as described in *GR-1089-CORE*) and require isolation from the exposed outside plant (OSP) cabling. To comply with NEBS (Network Equipment-Building System) requirements and protect against lightning surges and commercial power disturbances, the intrabuilding ports *must not* be metallicly connected to interfaces that connect to the OSP or its wiring. The intrabuilding ports on the device are suitable for connection to intrabuilding or unexposed wiring or cabling only. The addition of primary protectors is not sufficient protection for connecting these interfaces metallicly to OSP wiring.

**Avertissement** Certains ports de l'appareil sont destinés à un usage en intérieur uniquement (ports Type 2 ou Type 4 tels que décrits dans le document *GR-1089-CORE*) et doivent être isolés du câblage de l'installation extérieure exposée. Pour respecter les exigences NEBS et assurer une protection contre la foudre et les perturbations de tension secteur, les ports pour intérieur *ne doivent pas* être raccordés physiquement aux interfaces prévues pour la connexion à l'installation extérieure ou à son câblage. Les ports pour intérieur de l'appareil sont réservés au raccordement de câbles pour intérieur ou non exposés uniquement. L'ajout de protections ne constitue pas une précaution suffisante pour raccorder physiquement ces interfaces au câblage de l'installation extérieure.



**CAUTION:** Before removing or installing components of a device, connect an electrostatic discharge (ESD) grounding strap to an ESD point and wrap and fasten the other end of the strap around your bare wrist. Failure to use an ESD grounding strap could result in damage to the device.

**Attention** Avant de retirer ou d'installer des composants d'un appareil, raccordez un bracelet antistatique à un point de décharge électrostatique et fixez le bracelet à votre poignet nu. L'absence de port d'un bracelet antistatique pourrait provoquer des dégâts sur l'appareil.

- Install the device in compliance with the following local, national, and international electrical codes:
  - United States—National Fire Protection Association (NFPA 70), United States National Electrical Code.
  - Other countries—International Electromechanical Commission (IEC) 60364, Part 1 through Part 7.
  - Evaluated to the TN power system.

- Canada—Canadian Electrical Code, Part 1, CSA C22.1.
- Suitable for installation in Information Technology Rooms in accordance with Article 645 of the National Electrical Code and NFPA 75.

Peut être installé dans des salles de matériel de traitement de l'information conformément à l'article 645 du National Electrical Code et à la NFPA 75.

- Locate the emergency power-off switch for the room in which you are working so that if an electrical accident occurs, you can quickly turn off the power.
- Make sure that you clean grounding surface and give them a bright finish before making grounding connections.
- Do not work alone if potentially hazardous conditions exist anywhere in your workspace.
- Never assume that power is disconnected from a circuit. Always check the circuit before starting to work.
- Carefully look for possible hazards in your work area, such as moist floors, ungrounded power extension cords, and missing safety grounds.
- Operate the device within marked electrical ratings and product usage instructions.
- To ensure that the device and peripheral equipment function safely and correctly, use the cables and connectors specified for the attached peripheral equipment, and make certain they are in good condition.

You can remove and replace many device components without powering off or disconnecting power to the device, as detailed elsewhere in the hardware documentation for this device. Never install equipment that appears to be damaged.

## Action to Take After an Electrical Accident

If an electrical accident results in an injury, take the following actions in this order:

1. Use caution. Be aware of potentially hazardous conditions that could cause further injury.
2. Disconnect power from the device.
3. If possible, send another person to get medical aid. Otherwise, assess the condition of the victim, and then call for help.

# Prevention of Electrostatic Discharge Damage

Device components that are shipped in antistatic bags are sensitive to damage from static electricity. Some components can be impaired by voltages as low as 30 V. You can easily generate potentially damaging static voltages whenever you handle plastic or foam packing material or if you move components across plastic or carpets. Observe the following guidelines to minimize the potential for electrostatic discharge (ESD) damage, which can cause intermittent or complete component failures:

- Always use an ESD wrist strap when you are handling components that are subject to ESD damage, and make sure that it is in direct contact with your skin.

If a grounding strap is not available, hold the component in its antistatic bag (see [Figure 183 on page 278](#)) in one hand and touch the exposed, bare metal of the device with the other hand immediately before inserting the component into the device.



**WARNING:** For safety, periodically check the resistance value of the ESD grounding strap. The measurement must be in the range 1 through 10 Mohms.

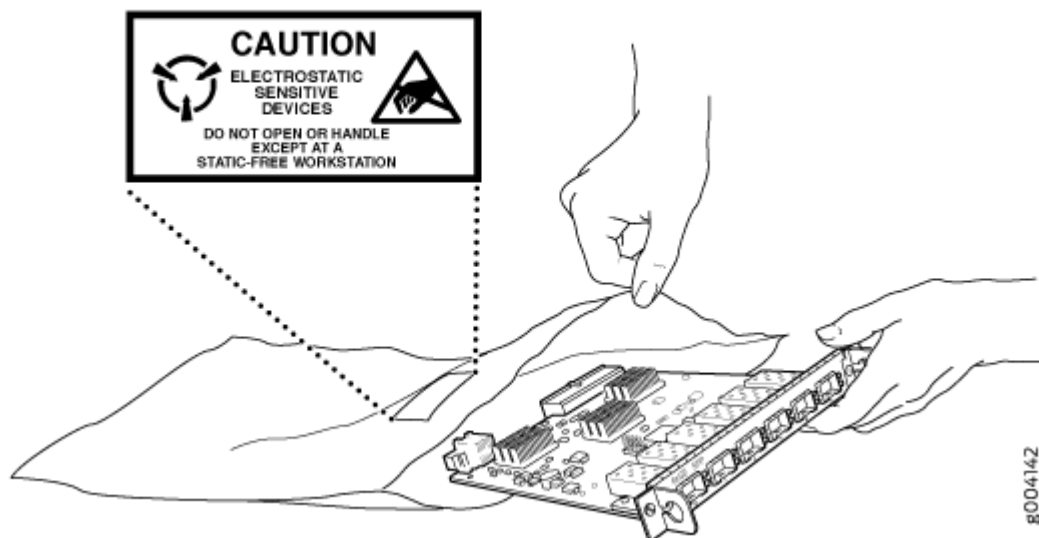
**Avertissement** Par mesure de sécurité, vérifiez régulièrement la résistance du bracelet antistatique. Cette valeur doit être comprise entre 1 et 10 mégohms (Mohms).

- When handling any component that is subject to ESD damage and that is removed from the device, make sure the equipment end of your ESD wrist strap is attached to the ESD point on the chassis.

If no grounding strap is available, touch the exposed, bare metal of the device to ground yourself before handling the component.

- Avoid contact between the component that is subject to ESD damage and your clothing. ESD voltages emitted from clothing can damage components.
- When removing or installing a component that is subject to ESD damage, always place it component-side up on an antistatic surface, in an antistatic card rack, or in an antistatic bag (see [Figure 183 on page 278](#)). If you are returning a component, place it in an antistatic bag before packing it.

Figure 183: Placing a Component into an Antistatic Bag



**CAUTION:** ANSI/TIA/EIA-568 cables such as Category 5e and Category 6 can get electrostatically charged. To dissipate this charge, always ground the cables to a suitable and safe earth ground before connecting them to the system.

**Attention** Les câbles ANSI/TIA/EIA-568, par exemple Cat 5e et Cat 6, peuvent emmagasiner des charges électrostatiques. Pour évacuer ces charges, reliez toujours les câbles à une prise de terre adaptée avant de les raccorder au système.

## AC Power Electrical Safety Guidelines

The following electrical safety guidelines apply to AC-powered devices:

- Note the following warnings printed on the device:

**“CAUTION:** THIS UNIT HAS MORE THAN ONE POWER SUPPLY CORD. DISCONNECT ALL POWER SUPPLY CORDS BEFORE SERVICING TO AVOID ELECTRIC SHOCK.”

**“ATTENTION:** CET APPAREIL COMPORTE PLUS D'UN CORDON D'ALIMENTATION. AFIN DE PRÉVENIR LES CHOCS ÉLECTRIQUES, DÉBRANCHER TOUT CORDON D'ALIMENTATION AVANT DE FAIRE LE DÉPANNAGE.”

- AC-powered devices are shipped with a three-wire electrical cord with a grounding-type plug that fits only a grounding-type power outlet. Do not circumvent this safety feature. Equipment grounding must comply with local and national electrical codes.
- You must provide an external certified circuit breaker (2-pole circuit breaker or 4-pole circuit breaker based on your device) rated minimum 20 A in the building installation.
- The power cord serves as the main disconnecting device for the AC-powered device. The socket outlet must be near the AC-powered device and be easily accessible.
- For devices that have more than one power supply connection, you must ensure that all power connections are fully disconnected so that power to the device is completely removed to prevent electric shock. To disconnect power, unplug all power cords (one for each power supply).

#### Power Cable Warning (Japanese)

**WARNING:** The attached power cable is only for this product. Do not use the cable for another product.

**注意**

附属の電源コードセットはこの製品専用です。  
他の電気機器には使用しないでください。

0017283

## AC Power Disconnection Warning



**WARNING:** Before working on the device or near power supplies, unplug all the power cords from an AC-powered device.

**Waarschuwing** Voordat u aan een frame of in de nabijheid van voedingen werkt, dient u bij wisselstroom toestellen de stekker van het netsnoer uit het stopcontact te halen.

**Varoitus** Kytke irti vaihtovirtalaitteiden virtajohto, ennen kuin teet mitään asennuspohjalle tai työskentelet virtalähteiden läheisyydessä.

**Avertissement** Avant de travailler sur un châssis ou à proximité d'une alimentation électrique, débrancher le cordon d'alimentation des unités en courant alternatif.



**Warnung** Bevor Sie an einem Chassis oder in der Nähe von Netzgeräten arbeiten, ziehen Sie bei Wechselstromeinheiten das Netzkabel ab bzw.

**Avvertenza** Prima di lavorare su un telaio o intorno ad alimentatori, scollegare il cavo di alimentazione sulle unità CA.

**Advarsel** Før det utføres arbeid på kabinettet eller det arbeides i nærheten av strømforsyningsenheter, skal strømledningen trekkes ut på vekselstrømsenheter.

**Aviso** Antes de trabalhar num chassis, ou antes de trabalhar perto de unidades de fornecimento de energia, desligue o cabo de alimentação nas unidades de corrente alternada.

**¡Atención!** Antes de manipular el chasis de un equipo o trabajar cerca de una fuente de alimentación, desenchufar el cable de alimentación en los equipos de corriente alterna (CA).

**Varning!** Innan du arbetar med ett chassi eller nära strömförsörjningsenheter skall du för växelströmsenheter dra ur nätsladden.

## DC Power Electrical Safety Guidelines

- A DC-powered device is equipped with a DC terminal block that is rated for the power requirements of a maximally configured device.
- For permanently connected equipment, a readily accessible disconnect device shall be incorporated external to the equipment.
- For pluggable equipment, the socket-outlet shall be installed near the equipment and shall be easily accessible.
- Be sure to connect the ground wire or conduit to a solid central office earth ground.
- A closed loop ring is recommended for terminating the ground conductor at the ground stud.
- Run two wires from the circuit breaker box to a source of 48 VDC.
- A DC-powered device that is equipped with a DC terminal block is intended only for installation in a restricted-access location. In the United States, a restricted-access area is one in accordance with Articles 110-16, 110-17, and 110-18 of the National Electrical Code ANSI/NFPA 70.

**NOTE:** Primary overcurrent protection is provided by the building circuit breaker. This breaker must protect against excess currents, short circuits, and earth grounding faults in accordance with NEC ANSI/NFPA 70.

- Ensure that the polarity of the DC input wiring is correct. Under certain conditions, connections with reversed polarity might trip the primary circuit breaker or damage the equipment.
- The marked input voltage of -48 VDC for a DC-powered device is the nominal voltage associated with the battery circuit, and any higher voltages are only to be associated with float voltages for the charging function.
- Because the device is a positive ground system, you must connect the positive lead to the terminal labeled **RTN**, the negative lead to the terminal labeled -48 VDC, and the earth ground to the device grounding points.

## DC Power Disconnection Warning



**WARNING:** Before performing any of the DC power procedures, ensure that power is removed from the DC circuit. To ensure that all power is off, locate the circuit breaker on the panel board that services the DC circuit, switch the circuit breaker to the OFF position, and tape the device handle of the circuit breaker in the OFF position.

**Waarschuwing** Voordat u een van de onderstaande procedures uitvoert, dient u te controleren of de stroom naar het gelijkstroom circuit uitgeschakeld is. Om u ervan te verzekeren dat alle stroom UIT is geschakeld, kiest u op het schakelbord de stroomverbreker die het gelijkstroom circuit bedient, draait de stroomverbreker naar de UIT positie en plakt de schakelaarhendel van de stroomverbreker met plakband in de UIT positie vast.

**Varoitus** Varmista, että tasavirtapiirissä ei ole virtaa ennen seuraavien toimenpiteiden suorittamista. Varmistaaksesi, että virta on KATKAISTU täysin, paikanna tasavirrasta huolehtivassa kojetaulussa sijaitseva suojakytkin, käännä suojakytkin KATKAISTU-asentoon ja teippaa suojakytkimen varsi niin, että se pysyy KATKAISTU-asennossa.

**Avertissement** Avant de pratiquer l'une quelconque des procédures ci-dessous, vérifier que le circuit en courant continu n'est plus sous tension. Pour en être sûr, localiser le disjoncteur situé sur le panneau de service du circuit en courant continu, placer le

disjoncteur en position fermée (OFF) et, à l'aide d'un ruban adhésif, bloquer la poignée du disjoncteur en position OFF.

**Warnung** Vor Ausführung der folgenden Vorgänge ist sicherzustellen, daß die Gleichstromschaltung keinen Strom erhält. Um sicherzustellen, daß sämtlicher Strom abgestellt ist, machen Sie auf der Schalttafel den Unterbrecher für die Gleichstromschaltung ausfindig, stellen Sie den Unterbrecher auf AUS, und kleben Sie den Schaltergriff des Unterbrechers mit Klebeband in der AUS-Stellung fest.

**Avvertenza** Prima di svolgere una qualsiasi delle procedure seguenti, verificare che il circuito CC non sia alimentato. Per verificare che tutta l'alimentazione sia scollegata (OFF), individuare l'interruttore automatico sul quadro strumenti che alimenta il circuito CC, mettere l'interruttore in posizione OFF e fissarlo con nastro adesivo in tale posizione.

**Advarsel** Før noen av disse prosedyrene utføres, kontroller at strømmen er frakoblet likestrømkretsen. Sørg for at all strøm er slått AV. Dette gjøres ved å lokalisere strømbryteren på brytertavlen som betjener likestrømkretsen, slå strømbryteren AV og teipe bryterhåndtaket på strømbryteren i AV-stilling.

**Aviso** Antes de executar um dos seguintes procedimentos, certifique-se que desligou a fonte de alimentação de energia do circuito de corrente contínua. Para se assegurar que toda a corrente foi DESLIGADA, localize o disjuntor no painel que serve o circuito de corrente contínua e coloque-o na posição OFF (Desligado), segurando nessa posição a manivela do interruptor do disjuntor com fita isoladora.

**¡Atención!** Antes de proceder con los siguientes pasos, comprobar que la alimentación del circuito de corriente continua (CC) esté cortada (OFF). Para asegurarse de que toda la alimentación esté cortada (OFF), localizar el interruptor automático en el panel que alimenta al circuito de corriente continua, cambiar el interruptor automático a la posición de Apagado (OFF), y sujetar con cinta la palanca del interruptor automático en posición de Apagado (OFF).

**Varning!** Innan du utför någon av följande procedurer måste du kontrollera att strömförsörjningen till likströmskretsen är bruten. Kontrollera att all strömförsörjning är BRUTEN genom att slå AV det överspänningsskydd som skyddar likströmskretsen och tejpa fast överspänningsskyddets omkopplare i FRÅN-läget.

## DC Power Grounding Requirements and Warning

An insulated grounding conductor that is identical in size to the grounded and ungrounded branch circuit supply conductors but is identifiable by green and yellow stripes is installed as part of the branch circuit that supplies the device. The grounding conductor is a separately derived system at the supply transformer or motor generator set.



**WARNING:** When you install the device, the ground connection must always be made first and disconnected last.

**Waarschuwing** Bij de installatie van het toestel moet de aardverbinding altijd het eerste worden gemaakt en het laatste worden losgemaakt.

**Varoitus** Laitetta asennettaessa on maahan yhdistäminen aina tehtävä ensiksi ja maadoituksen irti kytkeminen viimeiseksi.

**Avertissement** Lors de l'installation de l'appareil, la mise à la terre doit toujours être connectée en premier et déconnectée en dernier.

**Warnung** Der Erdanschluß muß bei der Installation der Einheit immer zuerst hergestellt und zuletzt abgetrennt werden.

**Avvertenza** In fase di installazione dell'unità, eseguire sempre per primo il collegamento a massa e disconnetterlo per ultimo.

**Advarsel** Når enheten installeres, må jordledningen alltid tilkobles først og frakobles sist.

**Aviso** Ao instalar a unidade, a ligação à terra deverá ser sempre a primeira a ser ligada, e a última a ser desligada.

**¡Atención!** Al instalar el equipo, conectar la tierra la primera y desconectarla la última.

**Warning!** Vid installation av enheten måste jordledningen alltid anslutas först och kopplas bort sist.

## DC Power Wiring Sequence Warning



**WARNING:** Wire the DC power supply using the appropriate lugs. When connecting power, the proper wiring sequence is ground to ground, +RTN to +RTN, then -48 V to -

48 V. When disconnecting power, the proper wiring sequence is -48 V to -48 V, +RTN to +RTN, then ground to ground. Note that the ground wire must always be connected first and disconnected last.

**Waarschuwing** De juiste bedradingsvolgorde verbonden is aarde naar aarde, +RTN naar +RTN, en -48 V naar -48 V. De juiste bedradingsvolgorde losgemaakt is en -48 naar -48 V, +RTN naar +RTN, aarde naar aarde.

**Varoitus** Oikea yhdistettävä kytkentäjäjestys on maajohto maajohtoon, +RTN varten +RTN, -48 V varten -48 V. Oikea irrotettava kytkentäjäjestys on -48 V varten -48 V, +RTN varten +RTN, maajohto maajohtoon.

**Avertissement** Câblez l'alimentation d'alimentation CC En utilisant les crochets appropriés à l'extrémité de câblage. En reliant la puissance, l'ordre approprié de câblage est rectifié pour rectifier, +RTN à +RTN, puis -48 V à -48 V. En débranchant la puissance, l'ordre approprié de câblage est -48 V à -48 V, +RTN à +RTN, a alors rectifié pour rectifier. Notez que le fil de masse devrait toujours être relié d'abord et débranché pour la dernière fois. Notez que le fil de masse devrait toujours être relié d'abord et débranché pour la dernière fois.

**Warnung** Die Stromzufuhr ist nur mit geeigneten Ringösen an das DC Netzteil anzuschliessen. Die richtige Anschlusssequenz ist: Erdanschluss zu Erdanschluss, +RTN zu +RTN und dann -48V zu -48V. Die richtige Sequenz zum Abtrennen der Stromversorgung ist -48V zu -48V, +RTN zu +RTN und dann Erdanschluss zu Erdanschluss. Es ist zu beachten dass der Erdanschluss immer zuerst angeschlossen und als letztes abgetrennt wird.

**Avvertenza** Mostra la morsettiera dell'alimentatore CC. Cablare l'alimentatore CC usando i connettori adatti all'estremità del cablaggio, come illustrato. La corretta sequenza di cablaggio è da massa a massa, da positivo a positivo (da linea ad L) e da negativo a negativo (da neutro a N). Tenere presente che il filo di massa deve sempre venire collegato per primo e scollegato per ultimo.

**Advarsel** Riktig tilkoples tilkoplingssekvens er jord til jord, +RTN til +RTN, -48 V til -48 V. Riktig frakoples tilkoplingssekvens er -48 V til -48 V, +RTN til +RTN, jord til jord.

**Aviso** Ate con alambre la fuente de potencia cc Usando los terminales apropiados en el extremo del cableado. Al conectar potencia, la secuencia apropiada del cableado se muele para moler, +RTN a +RTN, entonces -48 V a -48 V. Al desconectar potencia, la secuencia apropiada del cableado es -48 V a -48 V, +RTN a +RTN, entonces molió para moler. Observe que el alambre de tierra se debe conectar siempre primero y desconectar por último. Observe que el alambre de tierra se debe conectar siempre primero y desconectar por último.

**¡Atención!** Wire a fonte de alimentação de DC Usando os talões apropriados na Extremidade da fiação. Ao conectar a potência, a seqüência apropriada da fiação é moída para moer, +RTN a +RTN, então -48 V a -48 V. Ao desconectar a potência, a seqüência apropriada da fiação é -48 V a -48 V, +RTN a +RTN, moeu então para moer. Anote que o fio à terra deve sempre ser conectado primeiramente e desconectado por último. Anote que o fio à terra deve sempre ser conectado primeiramente e desconectado por último.

**Warning!** Korrekt kopplingssekvens ar jord till jord, +RTN till +RTN, -48 V till -48 V. Korrekt kopplas kopplingssekvens ar -48 V till -48 V, +RTN till +RTN, jord till jord.

## DC Power Wiring Terminations Warning



**WARNING:** When stranded wiring is required, use approved wiring terminations, such as closed-loop or spade-type with upturned lugs. These terminations must be the appropriate size for the wires and must clamp both the insulation and conductor.

**Waarschuwing** Wanneer geslagen bedrading vereist is, dient u bedrading te gebruiken die voorzien is van goedgekeurde aansluitingspunten, zoals het gesloten-lus type of het grijperschop type waarbij de aansluitpunten omhoog wijzen. Deze aansluitpunten dienen de juiste maat voor de draden te hebben en dienen zowel de isolatie als de geleider vast te klemmen.

**Varoitus** Jos säikeellinen johdin on tarpeen, käytä hyväksyttyä johdinliitintää, esimerkiksi suljettua silmukkaa tai kourumaista liitintää, jossa on ylöspäin käännetyt kiinnityskorvat. Tällaisten liitintöjen tulee olla kooltaan johtimiin sopivia ja niiden tulee puristaa yhteen sekä eristeen että johdinosan.

**Avertissement** Quand des fils torsadés sont nécessaires, utiliser des douilles terminales homologuées telles que celles à circuit fermé ou du type à plage ouverte avec cosses rebroussées. Ces douilles terminales doivent être de la taille qui convient aux fils et doivent être refermées sur la gaine isolante et sur le conducteur.

**Warnung** Wenn Litzenverdrahtung erforderlich ist, sind zugelassene Verdrahtungsabschlüsse, z.B. für einen geschlossenen Regelkreis oder gabelförmig, mit nach oben gerichteten Kabelschuhen zu verwenden. Diese Abschlüsse sollten die angemessene Größe für die Drähte haben und sowohl die Isolierung als auch den Leiter festklemmen.

**Avvertenza** Quando occorre usare trecce, usare connettori omologati, come quelli a occhio o a forcella con linguette rivolte verso l'alto. I connettori devono avere la misura adatta per il cablaggio e devono serrare sia l'isolante che il conduttore.

**Advarsel** Hvis det er nødvendig med flertrådede ledninger, brukes godkjente ledningsavslutninger, som for eksempel lukket sløyfe eller spadetype med oppoverbøyde kabelsko. Disse avslutningene skal ha riktig størrelse i forhold til ledningene, og skal klemme sammen både isolasjonen og ledaren.

**Aviso** Quando forem requeridas montagens de instalação eléctrica de cabo torcido, use terminações de cabo aprovadas, tais como, terminações de cabo em circuito fechado e planas com terminais de orelha voltados para cima. Estas terminações de cabo deverão ser do tamanho apropriado para os respectivos cabos, e deverão prender simultaneamente o isolamento e o fio condutor.

**¡Atención!** Cuando se necesite hilo trenzado, utilizar terminales para cables homologados, tales como las de tipo "bucle cerrado" o "espada", con las lengüetas de conexión vueltas hacia arriba. Estos terminales deberán ser del tamaño apropiado para los cables que se utilicen, y tendrán que sujetar tanto el aislante como el conductor.

**Varning!** När flertrådiga ledningar krävs måste godkända ledningskontakter användas, t.ex. kabelsko av slutet eller öppen typ med uppåtvänd tapp. Storleken på dessa kontakter måste vara avpassad till ledningarna och måste kunna hålla både isoleringen och ledaren fastklämda.

## Multiple Power Supplies Disconnection Warning



**WARNING:** The network device has more than one power supply connection. All connections must be removed completely to remove power from the unit completely.

**Waarschuwing** Deze eenheid heeft meer dan één stroomtoevoerverbinding; alle verbindingen moeten volledig worden verwijderd om de stroom van deze eenheid volledig te verwijderen.

**Varoitus** Tässä laitteessa on useampia virtalähdekytkentöjä. Kaikki kytkennät on irrotettava kokonaan, jotta virta poistettaisiin täysin laitteesta.

**Avertissement** Cette unité est équipée de plusieurs raccordements d'alimentation. Pour supprimer tout courant électrique de l'unité, tous les cordons d'alimentation doivent être débranchés.

**Warnung** Diese Einheit verfügt über mehr als einen Stromanschluß; um Strom gänzlich von der Einheit fernzuhalten, müssen alle Stromzufuhren abgetrennt sein.

**Avvertenza** Questa unità ha più di una connessione per alimentatore elettrico; tutte le connessioni devono essere completamente rimosse per togliere l'elettricità dall'unità.

**Advarsel** Denne enheten har mer enn én strømtilkobling. Alle tilkoblinger må kobles helt fra for å eliminere strøm fra enheten.

**Aviso** Este dispositivo possui mais do que uma conexão de fonte de alimentação de energia; para poder remover a fonte de alimentação de energia, deverão ser desconectadas todas as conexões existentes.

**¡Atención!** Esta unidad tiene más de una conexión de suministros de alimentación; para eliminar la alimentación por completo, deben desconectarse completamente todas las conexiones.

**Warning!** Denna enhet har mer än en strömförsörjningsanslutning; alla anslutningar måste vara helt avlägsnade innan strömtillförseln till enheten är fullständigt bruten.

## TN Power Warning



**WARNING:** The device is designed to work with a TN power system.

**Waarschuwing** Het apparaat is ontworpen om te functioneren met TN energiesystemen.

**Varoitus** Koje on suunniteltu toimimaan TN-sähkövoimajärjestelmien yhteydessä.

**Avertissement** Ce dispositif a été conçu pour fonctionner avec des systèmes d'alimentation TN.

**Warnung** Das Gerät ist für die Verwendung mit TN-Stromsystemen ausgelegt.

**Avvertenza** Il dispositivo è stato progettato per l'uso con sistemi di alimentazione TN.

**Advarsel** Utstyret er utfomet til bruk med TN-strømsystemer.



**Aviso** O dispositivo foi criado para operar com sistemas de corrente TN.

**¡Atención!** El equipo está diseñado para trabajar con sistemas de alimentación tipo TN.

**Varning!** Enheten är konstruerad för användning tillsammans med elkraftssystem av TN-typ.

## Agency Approvals for QFX5120 Switches

### IN THIS SECTION

- [Compliance Statement for Argentina | 290](#)

QFX5120 switches comply with the following standards:

- Safety
  - CAN/CSA-C22.2 No. 60950-1, Safety of Information Technology Equipment
  - UL 60950-1 (2nd Ed.) Information Technology Equipment - Safety
  - EN 60950-1:2006/A2:2013 Information Technology Equipment - Safety
  - IEC 60950-1:2005/A2:2013 Information Technology Equipment - Safety (All country deviations): CB Scheme
  - EN 60825-1 Safety of Laser Products - Part 1: Equipment Classification, Requirements and User's Guide
  - CAN/CSA C22.2 No. 62368-1-14, Audio/Video, Information and Communication Technology Equipment
  - UL 62368-1, Audio/Video, Information and Communication Technology Equipment – Safety
  - IEC 62368-1: 2014 Audio/Video, Information and Communication Technology Equipment – Safety (All country deviations): CB Scheme report
- EMC

- EN 300 386 V1.6.1 (2012-09) Electromagnetic compatibility and Radio spectrum Matters (ERM); Telecommunication network equipment; Electro Magnetic Compatibility (EMC) requirements
- EN 55032:2012 + EN55032:2012/AC:2013 Electromagnetic compatibility of multimedia equipment - Emission requirements
- EN 300 386 V2.1.1 (2016-07) Telecommunication network equipment; Electro Magnetic Compatibility (EMC) requirements; Harmonized Standard covering the essential requirements of the Directive 2014/30/EU
- CISPR 22 edition 6.0 : 2008-09
- EN 55032:2015 (CISPR 32:2015) Electromagnetic compatibility of multimedia equipment - Emission requirements
- EN 55024:2010 (CISPR 24:2010) Information technology equipment - Immunity characteristics - Limits and methods of measurement
- CISPR 24 edition 2b :2010 COREC 2011 IT Equipment Immunity Characteristics
- EN 55035:2017 (CISPR 35:2016) Electromagnetic compatibility of multimedia equipment - Immunity requirements
- IEC/EN 61000 Immunity Test
- AS/NZS CISPR 32:2015 Australia/New Zealand Radiated and Conducted Emissions
- FCC 47 CFR Part 15 USA Radiated and Conducted Emissions
- IC ICES-003 Canada Radiated and Conducted Emissions
- VCCI-CISPR 32:2016 Japanese Radiated and Conducted Emissions
- EN 55022:2010/AC:2011 European Radiated Emissions
- CISPR 32:2016
- BSMI CNS 13438 Taiwan Radiated and Conducted Emissions (at 10 Meter)
- KN 32 and KN 35 Korea Radiated Emission and Immunity Characteristics (at 10 Meter)
- KN 61000 Korea Immunity Test
- IEC/EN 61000 Immunity Test
- TEC/SD/DD/EMC-221/05/OCT-16 (Supersedes No. TEC/EMI/TEL-001/01/FEB-09) India EMC standard
- Juniper Inductive GND (JIG)

- Reduction of Hazardous Substances (ROHS) 6/6
- Telco—Common Language Equipment Identifier (CLEI) code

## Compliance Statement for Argentina

EQUIPO DE USO IDÓNEO.

# Compliance Statements for EMC Requirements for the QFX Series

### IN THIS SECTION

- [Canada | 290](#)
- [European Community | 291](#)
- [Israel | 292](#)
- [Japan | 292](#)
- [Korea | 292](#)
- [Taiwan | 293](#)
- [United States | 293](#)
- [Nonregulatory Environmental Standards | 293](#)

This topic describes the EMC requirements for the QFX Series.

## Canada

This Class A digital apparatus complies with Canadian ICES-003.

Cet appareil numérique de la classe A est conforme à la norme NMB-003 du Canada.

The Industry Canada label identifies certified equipment. This certification means that the equipment meets certain telecommunications network protective, operational, and safety requirements. Industry Canada does not guarantee the equipment will operate to the users' satisfaction.

Before installing this equipment, users should ensure that it is permissible to connect the equipment to the facilities of the local telecommunications company. The equipment must also be installed using an acceptable method of connection. In some cases, the inside wiring associated with a single line individual service may be extended by means of a certified connector assembly. The customer should be aware that compliance with the above conditions may not prevent degradation of service in some situations.

Repairs to certified equipment should be made by an authorized Canadian maintenance facility designated by the supplier. Any repairs or alterations made by the user to this equipment, or equipment malfunctions, may give the telecommunications company cause to request the user to disconnect the equipment.



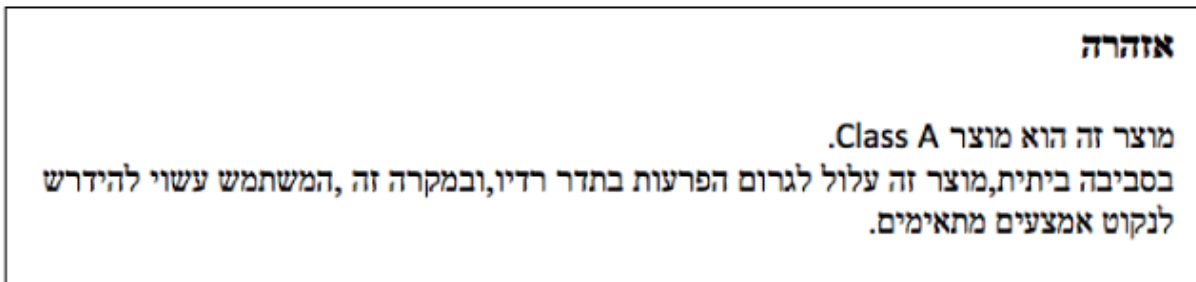
**CAUTION:** Users should not attempt to make electrical ground connections by themselves, but should contact the appropriate inspection authority or an electrician, as appropriate.

Users should ensure for their own protection that the electrical ground connections of the power utility, telephone lines, and internal metallic water pipe system, if present, are connected together. This precaution may be particularly important in rural areas.

## European Community

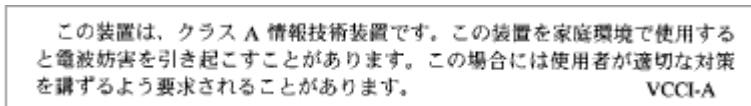
This is a Class A product. In a domestic environment this product may cause radio interference in which case the user may be required to take adequate measures.

## Israel



Translation from Hebrew–Warning: This product is Class A. In residential environments, the product may cause radio interference, and in such a situation, the user may be required to take adequate measures.

## Japan



The preceding translates as follows:

This is a Class A product. In a domestic environment this product may cause radio interference in which case the user may be required to take adequate measures.

VCCI-A

## Korea

이 기기는 업무용(A급) 전자파적합기기로서 판매자 또는 사용자는 이 점을 주의하시기 바라며, 가정외의 지역에서 사용하는 것을 목적으로 합니다.

Korean Class A Warning

g040913

The preceding translates as follows:

This equipment is Industrial (Class A) electromagnetic wave suitability equipment and seller or user should take notice of it, and this equipment is to be used in the places except for home.

## Taiwan

警告使用者：  
這是甲類的資訊產品，在居住的環境中使用時，可能會造成射頻干擾，在這種情況下，使用者會被要求採取某些適當的對策。

Chinese Class A warning

0600018

The preceding translates as follows:

This is Class A product. In a domestic environment this product may cause radio interference in which case the user may be required to take adequate measures.

## United States

The QFX Series device has been tested and found to comply with the limits for a Class A digital device, pursuant to Part 15 of the FCC Rules. These limits are designed to provide reasonable protection against harmful interference when the equipment is operated in a commercial environment. This equipment generates, uses, and can radiate radio frequency energy and, if not installed and used in accordance with the instruction manual, may cause harmful interference to radio communications. Operation of this equipment in a residential area is likely to cause harmful interference in which case the user will be required to correct the interference at his own expense.

## Nonregulatory Environmental Standards

These QFX Series product SKUs are Network Equipment Building System (NEBS) compliant:

- QFX3008-I
- QFX3600-I
- QFX3600

- QFX3500
- QFX5100
- QFX5110
- QFX5200-32C
- QFX10002-36Q and QFX10002-72Q
- QFX10008
- QFX10016

Those device product SKUs meet the following NEBS compliance standards:

- SR-3580 NEBS Criteria Levels (Level 3 Compliance)
- GR-1089-CORE, Issue 6: EMC and Electrical Safety—Generic Criteria for Network Telecommunications Equipment
  - The equipment is suitable for installation in locations where the National Electrical Code (NEC) applies.
  - The battery return connection is to be treated as an Isolated DC return (DC-I), as defined in GR-1089-CORE.
- GR-63-CORE: NEBS, Physical Protection
  - The equipment is suitable for installation as part of the Common Bonding Network (CBN).
  - The equipment is suitable for installation in a central office (CO).

#### RELATED DOCUMENTATION

| *Agency Approvals for the QFX Series*

## Restriction of Hazardous Substances (RoHS) Directive Compliance

Juniper Networks is committed to environmentally responsible behavior. As part of this commitment, we continually work to comply with environmental standards such as the Restriction of Hazardous Substances (RoHS) Directive.

部件名称 (Part)	有毒有害物质或元素 (Hazardous Substance)					
	铅 (Pb)	汞 (Hg)	镉 (Cd)	六价铬 (Cr VI)	多溴联苯 (PBB)	多溴二苯醚 (PBDE)
金属部件 (Metal Parts)	X	O	O	O	O	O
电路模块 (PCB Modules)	X	O	O	O	O	O
电缆及电缆组件 (Cables)	X	O	O	O	O	O
塑料和聚合物部件 (Plastic Parts)	O	O	O	O	O	O

- O: 表示该有毒有害物质在该部件所有均质材料中的含量均在SJ/T11363-2006 标准规定的限量要求以下。  
X: 表示该有毒有害物质至少在该部件的某一均质材料中的含量超出SJ/T11363-2006 标准规定的限量要求。  
注意: 在所售产品中可能会也可能不会含有所有所列的部件。