

John Wood[®] Power Vent water heaters are engineered for increased efficiency and deliver dependable, trouble-free operation. The John Wood[®] Power Vent water heater design includes an advanced gas control with self-diagnostic capabilities for quick and easy servicing.

Features

Energy Savings

- Meets and exceeds NRCAN energy efficiency standards

Designed for Performance

- Compact design – ideal as a replacement water heater and for closet installations
- Exclusive TankSaver[®] design to prolong tank life
- Convenient 3/4" side water connections for combination applications on 62,000 BTU units

Safety Features

- Flammable vapour sensor detects the presence of flammable vapours and automatically disables the unit, preventing ignition
- Robust air intake snorkel inhibits flammable vapours from entering the sealed combustion chamber

Serviceability

- State-of-the-art gas control features advanced self-diagnostic capability that makes troubleshooting easy
- Conveniently located T&P and drain valve for ease of serviceability

The Ultimate in Venting Flexibility

- Can be vented with ULC s636 PVC, CPVC or polypropylene pipe



WARRANTY

8 Year Limited Tank Warranty

6 Year Limited Parts Warranty

Consult installation manual for terms and conditions or visit www.johnwoodwaterheaters.com for more information.

PERFORMANCE

Model	Capacity	Maximum Certified Altitude	Input	Recovery Rate at 100°F/55°C Temp. Rise	First Hour Rating	Energy Factor
	USG (L)	ft (m)	BTU/hr	USG/hr (L/hr)	USG (L)	
NATURAL GAS						
JW840NVH-ES-02	40 (151)	2,000 (610)	33,000	30 (114)	72 (273)	0.64
JW840NVH-ES-04	40 (151)	4,500 (1,372)	30,000	28 (106)	69 (261)	0.62
JW850NVH-ES-02	50 (189)	2,000 (610)	38,000	35 (131)	88 (333)	0.62
JW850NVH-ES-04	50 (189)	4,500 (1,372)	34,000	31 (117)	87 (329)	0.62
JW85065SNV-ES-02*	50 (189)	2,000 (610)	65,000	60 (226)	110 (416)	0.62
JW85065SNV-ES-04*	50 (189)	4,500 (1,372)	58,500	54 (204)	104 (394)	0.62
JW85065LNV-ES-02*	50 (189)	2,000 (610)	62,000	57 (216)	104 (394)	0.62
JW860NVH-ES-02	60 (227)	2,000 (610)	42,000	39 (148)	106 (401)	0.62
JW860NVH-ES-04	60 (227)	4,500 (1,372)	38,000	35 (131)	101 (382)	0.62
PROPANE						
6G40PVH-ES-06	40 (151)	4,500 (1,372)	30,000	27 (103)	69 (261)	0.64
6G50PVH-ES-06	50 (189)	4,500 (1,372)	34,000	31 (117)	87 (329)	0.62
6G5065SPV-ES-06*	50 (189)	4,500 (1,372)	58,500	54 (204)	104 (394)	0.62
6G60PVH-ES-06	60 (227)	4,500 (1,372)	38,000	35 (131)	101 (382)	0.62

* Model has side water connections

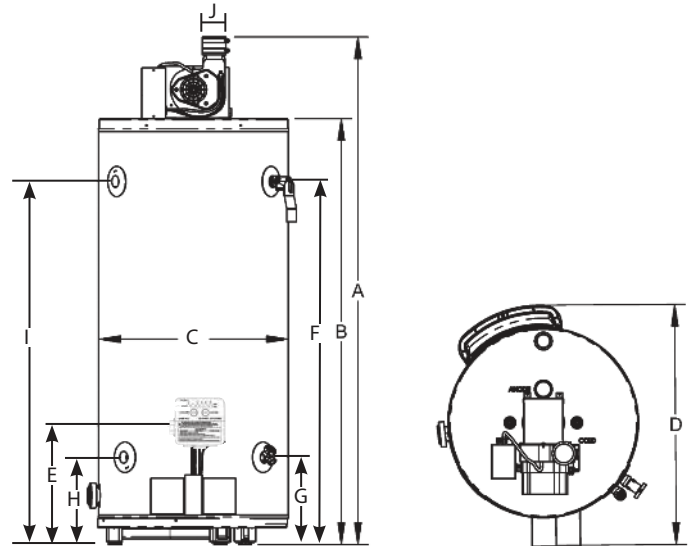
DIMENSIONS & SHIPPING WEIGHT

Model	Installation Height	Height to Top of Tank	Tank Diameter	Overall Depth	Height to Gas Inlet	Height to T&P	Height to Drain Valve	Height to Side Connections		Vent Diameter	Approx. Shipping Weight
	A in (cm)	B in (cm)	C in (cm)	D in (cm)	E in (cm)	F in (cm)	G in (cm)	H in (cm)	I in (cm)	J in (cm)	lb (kg)
NATURAL GAS											
JW840NVH-ES	58 (147)	48 ½ (123)	21 ¼ (54)	27 (68)	13 ¼ (34)	41 ½ (105)	9 ½ (24)	N/A	N/A	2-3	155 (70)
JW850NVH-ES	60 ¾ (154)	51 ¼ (130)	22 ¾ (58)	28 ½ (72)	14 ¾ (37)	44 (112)	10 ½ (27)	N/A	N/A	2-3	187 (85)
JW85065SNV-ES	61 ¼ (156)	51 ½ (131)	22 ¾ (58)	28 ½ (72)	14 ¾ (37)	44 ¼ (113)	10 ½ (27)	10 ½ (27)	44 ¼ (113)	3	200 (90)
JW85065LNV-ES	61 ¼ (156)	51 ½ (131)	22 ¾ (58)	28 ½ (72)	14 ¾ (37)	44 ¼ (113)	10 ½ (27)	10 ½ (27)	44 ¼ (113)	3	200 (90)
JW860NVH-ES	68 (173)	58 ½ (149)	22 ¾ (58)	28 ½ (72)	14 ¾ (37)	51 (130)	10 ½ (27)	N/A	N/A	2-3	202 (91)
PROPANE											
6G40PVH-ES	58 (147)	48 ½ (123)	21 ¼ (54)	27 (68)	13 ¼ (34)	41 ½ (105)	9 ½ (24)	N/A	N/A	2-3	190 (86)
6G50PVH-ES	60 ¾ (154)	51 ¼ (130)	22 ¾ (58)	28 ½ (72)	14 ¾ (37)	44 (112)	10 ½ (27)	N/A	N/A	2-3	200 (90)
6G5065SPV-ES	61 ¼ (156)	51 ½ (131)	22 ¾ (58)	28 ½ (72)	14 ¾ (37)	44 ¼ (113)	10 ½ (27)	10 ½ (27)	44 ¼ (113)	3	200 (90)
6G60PVH-ES	68 (173)	58 ½ (149)	22 ¾ (58)	28 ½ (72)	14 ¾ (37)	51 (130)	10 ½ (27)	N/A	N/A	2-3	202 (91)

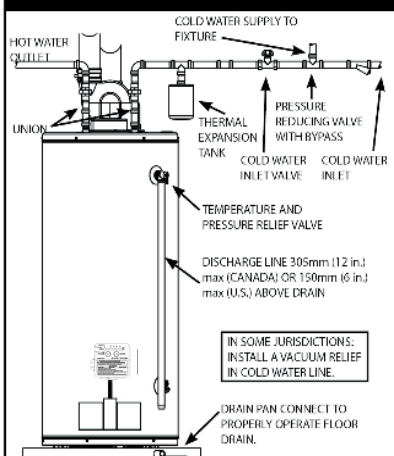
PREFERRED INSTALLATION

VENT PIPE LENGTHS

Model	Vent Pipe Diameter in	Minimum Number of Elbows Required*	Maximum Vent Length with 1 Elbow ft (m)	Minimum Vent Length with 1 Elbow ft (m)
JW840NVH-ES 6G40PVH-ES JW850NVH-ES	2	1	50 (15.2)	10.5 (3.2)
6G50PVH-ES JW860NVH-ES 6G60PVH-ES	3	--	80 (24.3)	50 (15.2)
JW85065SNV-ES 6G5065SPV-ES	3	1	50 (15.2)	11 (3.4)
JW85065LNV-ES	3	--	65 (19.8)	20 (6.1)

* Refer to installation manual for further details.

For Technical Information/Warranty:
Call 1-888-479-8324 or email techsupport@hotwater.com
www.johnwoodwaterheaters.com