

INSTALLATION MANUAL

R-410A ZF SERIES

3 - 6.3 Ton

50 Hertz

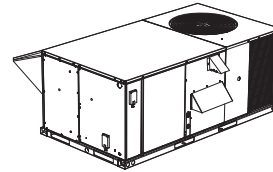

TABLE OF CONTENTS

General	3	Electric Heating Sequence Of Operations	39
Installation	7	Safety Controls	39
Installation Safety Information	7	Heat Anticipator Setpoints	40
Limitations	7	Gas Heating Sequence Of Operation	40
Location	7	Gas Heat Operation Errors	40
Rigging And Handling	8	Flash Codes Or Error Messages	41
Condensate Drain	9	Heat Anticipator Setpoints	41
Compressors	9	Start-up (Cooling)	42
Filters	9	Prestart Check List	42
Service Access	9	Operating Instructions	42
Typical Cool/Heat Control Wiring (Smart Equipment™ ZF036-076)	11	Post Start Check List	42
Thermostat	11	Shut Down	42
Power And Control Wiring	11	Start-up (Gas Heat)	42
Optional Electric Heat	12	Pre-start Check List	42
Optional Gas Heat	13	Operating Instructions	42
Gas Piping	13	Post-start Check List (Gas)	42
Gas Connection	14	Manifold Gas Pressure Adjustment	43
L.p. Units, Tanks And Piping	14	Pilot Checkout	43
Vent And Combustion Air Hoods	15	Burner Instructions	43
RRS Economizer Interface Overview	16	Burner Air Shutter Adjustment	43
Smart Equipment™ Economizer Sequences	16	Checking Gas Input	43
Dry Bulb Changeover	17	Adjustment Of Temperature Rise	44
Single Enthalpy Changeover	17	Troubleshooting	45
Dual Enthalpy Changeover	17	Cooling Troubleshooting Guide	45
Auto	17	Gas Heat Troubleshooting Guide	46
Free Cooling Operation	17	Flash Code Troubleshooting	47
Power Exhaust	17	Symptomatic Troubleshooting	49
Operation	18	Unit Flash Codes	50
Jade Economizer Interface Overview	22	Fan On And Off Delays	50
ZF036-076 Unit Weights	25	Smart Equipment™ Control Board Navigation Components	51
Phasing	35	Smart Equipment™ Firmware Version 3.1 Basic Unit Control Board Navigation Examples:	52
Supply Air Blowers	36	Typical Wiring Diagrams	60
Checking Supply Airflow Rate	36	Simplicity® Lite Control Board	60
Operation	37	Smart Equipment™	64
Cooling Sequence Of Operation	37	Start-Up Sheet	68

LIST OF TABLES

1 Control Wire Sizes	12	17 Supply Air Blower Performance (5 Ton Belt Drive) - Side Duct Application	33
2 Electric Heater Supply Air Limitations	13	18 Supply Air Blower Performance (6.3 Ton Belt Drive) - Side Duct Application	34
3 GAS HEAT APPLICATION DATA	13	19 Belt Drive Motor And Drive Data	35
4 GAS PIPE SIZING	13	20 Static Resistances	35
5 Smart Equipment™ Economizer Board Details	19	21 Limit Control Setting	40
6 Single Enthalpy and Dual Enthalpy High Limit Curves	24	22 Electric Heat Anticipator Setpoints	40
7 ZF036-076 Imperial	25	23 Limit Control Setting	41
8 ZF036-076 Metric	25	24 Gas Heat Anticipator Setpoints	41
9 ZF036-076 Unit Accessory Weights	25	25 Gas Rate - Cubic Feet Per Hour	44
10 ZF036-076 Physical Data	26	26 Simplicity Lite Unit Control Board Flash Codes	51
11 Electrical Data ZF036-076	28	27 Ignition Control Board Flash Codes	51
12 Electric Heat Correction Factors	28	28 Smart Equipment™ UCB Details	54
13 Voltage Limitations	28	29 Cable for FC Buses and SA Buses in Order of Preference	59
14 Utilities Entry	31		
15 Minimum Clearances	31		
16 Supply Air Blower Performance (3 & 4 Ton Direct Drive) - Side Duct Application	32		

LIST OF FIGURES

1	Recommended Drain Piping	9	21	Pressure Drop Across Coil	37
2	Compressor Restraining Bracket	9	22	Gas Valve Piping	40
3	Typical Field Power & Simplicity Lite ZF036-076 Control Wiring	10	23	Proper Flame Adjustment	43
4	Typical Smart Equipment™ Control Wiring	11	24	Typical Gas Valves	43
5	External Supply Connection External Shut-off	14	25	Typical Flame Appearance	43
6	Bottom Supply Connection External Shut-off	15	26	Simplicity Lite Unit Control Board	51
7	Vent And Combustion Air Hood	15	27	Smart Equipment™ Unit Control Board	54
8	RRS Economizer LCD and Keypad Layout	16	28	Typical ZF036, 048 With Simplicity Lite Control, With/without Electric Heat Wiring Diagram	60
9	SE-ECO1001-0 Economizer Controller	19	29	Typical ZF036, 048 With Simplicity Lite Control, With Gas Heat Wiring Diagram	61
10	Economizer LCD and Keypad Layout	22	30	Typical ZF060, 076 with Simplicity Lite Control, With/Without Electric Heat Wiring Diagram	62
11	Single Enthalpy Curve And Boundaries	23	31	Typical ZF060, 076 With Simplicity Lite Control, With Gas Heat Wiring Diagram	63
12	Unit 4 Point Load Weight	25	32	Typical ZF036, 048 With Smart Equipment™ Control, With/without Electric Heat Wiring Diagram	64
13	Unit 6 Point Load Weight	25	33	Typical ZF036, 048 With Smart Equipment™ Control, With Gas Heat Wiring Diagram	65
14	Unit Dimensions (3 - 6.3 Ton Cooling Only/electric Heat) Front View	29	34	Typical ZF060, 076 With Smart Equipment™ Control, With/without Electric Heat Wiring Diagram	66
15	Unit Dimensions (3 - 6.3 Ton Cooling/gas Heat) Front View	29	35	Typical ZF060, 076 With Smart Equipment™ Control, With Gas Heat Wiring Diagram	67
16	Unit With Economizer Rain Hood	30			
17	Unit With Fixed Outdoor Air/motorized Damper Rain Hood	30			
18	Unit Dimensions (Rear View)	31			
19	Disconnect/blower Access Location	31			
20	Belt Adjustment	36			

General

YORK Model ZF units are either single package air conditioners equipped with optional factory installed electric heaters, or single package gas-fired central heating furnaces with cooling unit. Both are designed for outdoor installation on a rooftop or slab.

The units are completely assembled on rigid, permanently attached base rails. All piping, refrigerant charge, and electrical wiring is factory installed and tested. The units require electric power, gas connection, duct connections, installation of combustion air inlet hood, flue gas outlet hoods and fixed outdoor air intake damper (units without economizer or motorized damper option only) at the point of installation.

The supplemental electric heaters have nickel-chrome elements and utilize single point power connection.

These gas-fired heaters have aluminized-steel (or optional stainless steel) tubular heat exchangers. The units have spark ignition with proven pilot. All gas heaters are shipped from the factory equipped for natural gas use, but can be field converted to L.P./ Propane with Kit Model # 1NP0440. See Gas Heat Application Data Table on page 13.

Safety Considerations

 This is a safety alert symbol. When you see this symbol on labels or in manuals, be alert to the potential for personal injury.

Understand and pay particular attention the signal words **DANGER**, **WARNING** or **CAUTION**.

DANGER indicates an **imminently** hazardous situation, which, if not avoided, **will result in death or serious injury**.

WARNING indicates a **potentially** hazardous situation, which, if not avoided, **could result in death or serious injury**.

CAUTION indicates a potentially hazardous situation, which, if not avoided **may result in minor or moderate injury**. It is also used to alert against unsafe practices and hazards involving only property damage.

Due to system pressure, moving parts and electrical components, installation and servicing of air conditioning equipment can be hazardous. Only qualified, trained, service personnel should install, repair, maintain or service this equipment.

Observe all precautions in the literature, on labels and tags accompanying the equipment whenever working on air conditioning equipment. Be sure to follow all other safety precautions that apply.

Wear safety glasses and work gloves, and follow all safety codes. Use a quenching cloth and have a fire extinguisher available for all brazing operations.

WARNING

FIRE OR EXPLOSION HAZARD

Failure to follow safety warnings exactly could result in serious injury, death, or property damage.

- Do not store or use gasoline or other flammable vapors and liquids in the vicinity of this or any other appliance.
- WHAT TO DO IF YOU SMELL GAS:
 - Do not try to light any appliance.
 - Do not touch any electrical switch; do not use any phone in your building.
 - Leave the building immediately.
 - Immediately call your gas supplier from a neighbor's phone. Follow the gas supplier's instructions.
 - If you cannot reach the gas supplier, call the fire department.
- Installation and service must be performed by a qualified installer, service agency or the gas supplier.

Inspection

As soon as a unit is received, it should be inspected for possible damage during transit. If damage is evident, the extent of the damage should be noted on the carrier's freight bill. A separate request for inspection by the carrier's agent should be made in writing.

WARNING

Improper installation may create a condition where the operation of the product could cause personal injury or property damage. Improper installation, adjustment, alteration, service or maintenance can cause injury or property damage. Refer to this manual for assistance or for additional information, consult a qualified contractor, installer or service agency.

CAUTION

This product must be installed in strict compliance with the installation instructions and any applicable local, state and national codes including, but not limited to building, electrical, and mechanical codes.

▲ WARNING

Before performing service or maintenance operations on unit, turn off main power switch to unit. Electrical shock could cause personal injury. Improper installation, adjustment, alteration, service or maintenance can cause injury or property damage. Refer to this manual. For assistance or additional information consult a qualified installer, service agency or the gas supplier.

▲ CAUTION

This system uses R-410A Refrigerant which operates at higher pressures than R-22. No other refrigerant may be used in this system. Gage sets, hoses, refrigerant containers and recovery systems must be designed to handle R-410A. If you are unsure, consult the equipment manufacturer. Failure to use R-410A compatible servicing equipment may result in property damage or injury.

▲ WARNING

If the information in this manual is not followed exactly, a fire or explosion may result causing property damage, personal injury or loss of life.

Do not store or use gasoline or other flammable vapors and liquids in the vicinity of this or any other appliance.

WHAT TO DO IF YOU SMELL GAS:

- a. Do not try to light any appliance.
- b. Do not touch any electrical switch; do not use any phone in your building.
- c. Immediately call your gas supplier from a neighbor's phone. Follow the gas supplier's instructions.
- d. If you cannot reach your gas supplier, call the fire department.

Installation and service must be performed by a qualified installer, service agency or the gas supplier.

Due to system pressure, moving parts, and electrical components, installation and servicing of air conditioning equipment can be hazardous. Only qualified, trained service personnel should install, repair, or service this equipment. Untrained personnel can perform basic maintenance functions of cleaning coils and filters and replacing filters.

Observe all precautions in the literature, labels, and tags accompanying the equipment whenever working on air conditioning equipment. Be sure to follow all other applicable safety precautions and codes including ANSI Z223.1 or CSA-B149.1- latest edition.

Wear safety glasses and work gloves. Use quenching cloth and have a fire extinguisher available during brazing operations.

▲ CAUTION

This product must be installed in strict compliance with the enclosed installation instructions and any applicable local, state and national codes including, but not limited to, building, electrical, and mechanical codes.

The furnace and its individual shut-off valve must be disconnected from the gas supply piping system during any pressure testing at pressures in excess of 1/2 PSIG.

Pressures greater than 1/2 PSIG will cause gas valve damage resulting in a hazardous condition. If it is subjected to a pressure greater than 1/2 PSIG, the gas valve must be replaced.

The furnace must be isolated from the gas supply piping system by closing its individual manual shut-off valve during any pressure testing of the gas supply piping system at test pressures equal to or less than 1/2 PSIG.

Reference

Additional information on the design, installation, operation and service of this equipment is available in the following reference forms:

- 5188250-General Installation
- 723389 -Technical Guide

Renewal Parts

Contact your local York® parts distribution center for authorized replacement parts.

Approvals

Design for use as follows:

1. For use as a cooling only unit, cooling unit with supplemental electric heat or a forced air furnace.
2. For outdoor installation only.
3. For installation on combustible material.
4. For use with natural gas (convertible to LP with kit).

⚠ CAUTION

This product must be installed in strict compliance with the enclosed installation instructions and any applicable local, state, and national codes including, but not limited to, building, electrical, and mechanical codes.

⚠ WARNING

Improper installation may create a condition where the operation of the product could cause personal injury or property damage.

⚠ CAUTION

This system uses R-410A Refrigerant which operates at higher pressures than R-22. No other refrigerant may be used in this system.

Product Nomenclature

3-6.3 Ton York® 50 Hz. Model Number Nomenclature

Z F 036 C 00 A 7 A 1 A A A 1 A 1

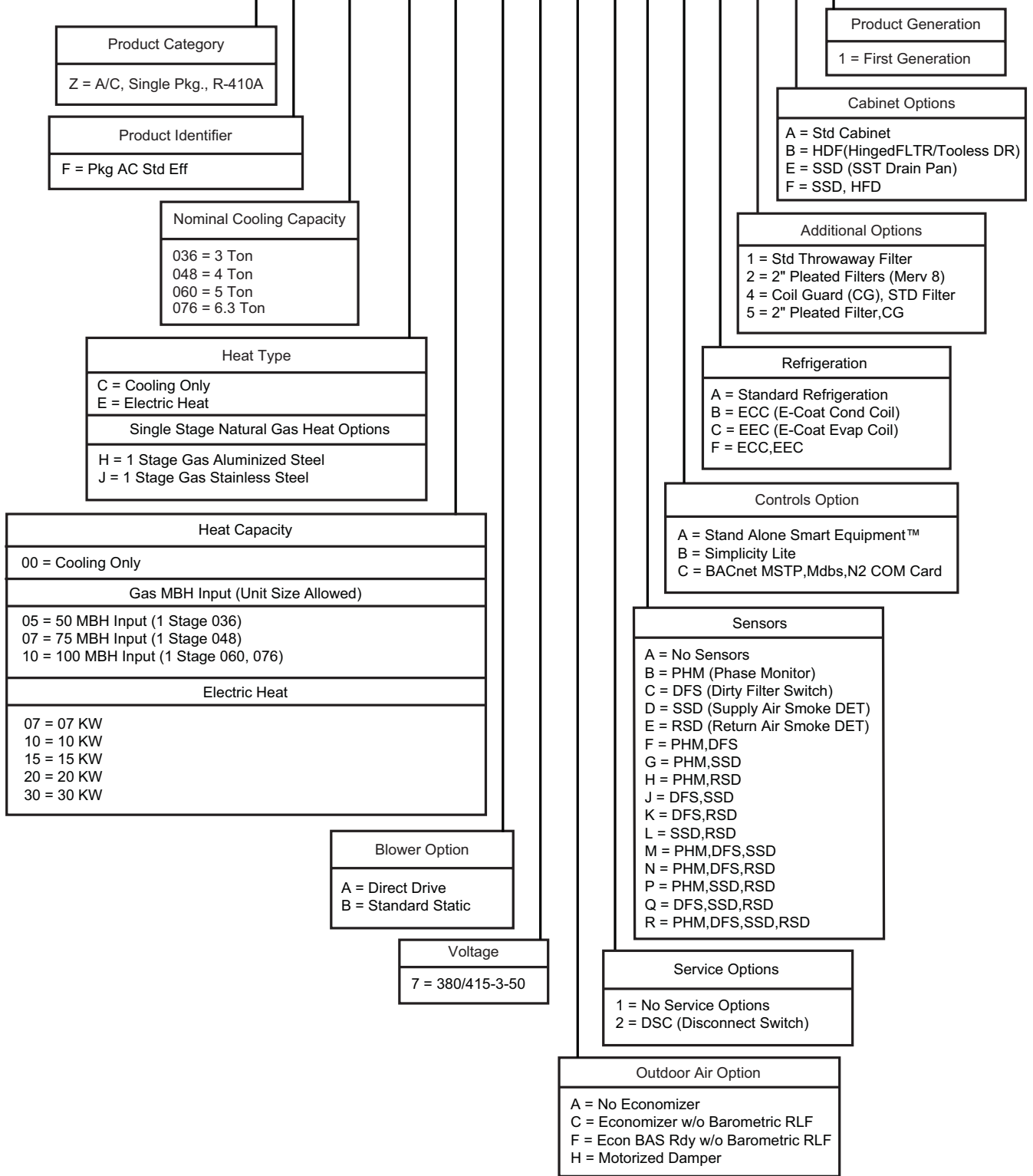

Installation

Installation Safety Information

Read these instructions before continuing this appliance installation. This is an outdoor combination heating and cooling unit. The installer must assure that these instructions are made available to the consumer and with instructions to retain them for future reference.

1. Refer to the unit rating plate for the approved type of gas for this product.
2. Install this unit only in a location and position as specified on Page 7 of these instructions.
3. Never test for gas leaks with an open flame. Use commercially available soap solution made specifically for the detection of leaks when checking all connections, as specified on Pages 7, 14, 15 and 42 of these instructions.
4. Always install furnace to operate within the furnace's intended temperature-rise range with the duct system and within the allowable external static pressure range, as specified on the unit name/rating plate, specified on page 42 of these instructions.
5. This equipment is not to be used for temporary heating of buildings or structures under construction.

WARNING

FIRE OR EXPLOSION HAZARD

Failure to follow the safety warning exactly could result in serious injury, death or property damage.

Never test for gas leaks with an open flame. Use a commercially available soap solution made specifically for the detection of leaks to check all connections. A fire or explosion may result causing property damage, personal injury or loss of life.

6. If a factory option convenience outlet is installed, the weatherproof outlet cover must be field installed. The cover shall be located behind the blower access panel. To install the cover, remove the shipping label covering the convenience outlet and attach the cover to the unit using the (4) screws provided.

CAUTION

380/415-3-50 units with factory installed Powered Convenience Outlet Option are wired for 415v power supply respectively. Change tap on transformer for 380-3-50 operation. See unit wiring diagram.

Limitations

These units must be installed in accordance with the following:

In U.S.A.:

1. National Electrical Code, ANSI/NFPA No. 70 - Latest Edition
2. National Fuel Gas Code, ANSI Z223.1 - Latest Edition
3. Gas-Fired Central Furnace Standard, ANSI Z21.47a. - Latest Edition
4. Local building codes, and
5. Local gas utility requirements

In Canada:

1. Canadian Electrical Code, CSA C22.1
2. Installation Codes, CSA - B149.1.
3. Local plumbing and waste water codes, and
4. Other applicable local codes.

Refer to unit application data found in this document.

After installation, gas fired units must be adjusted to obtain a temperature rise within the range specified on the unit rating plate.

If components are to be added to a unit to meet local codes, they are to be installed at the dealer's and/or customer's expense.

Size of unit for proposed installation should be based on heat loss/heat gain calculation made according to the methods of Air Conditioning Contractors of America (ACCA).

This furnace is not to be used for temporary heating of buildings or structures under construction.

CAUTION

The Simplicity[®] and Smart Equipment[™] control boards used in this product will effectively operate the cooling system down to 0°F when this product is applied in a comfort cooling application for people. An economizer is typically included in this type of application. When applying this product for process cooling applications (computer rooms, switch gear, etc.), please reference applications bulletin AE-011-07 or call the applications department for Unitary Products @ 1-877-UPG-SERV for guidance. Additional accessories may be needed for stable operation at temperatures below 30° F.

Location

Use the following guidelines to select a suitable location for these units:

1. Unit is designed for *outdoor installation only*.

2. Condenser coils must have an unlimited supply of air. Where a choice of location is possible, position the unit on either north or east side of building.
3. Suitable for mounting on roof curb.
4. For ground level installation, use a level concrete slab with a minimum thickness of 101mm (4"). The length and width should be at least 152mm (6") greater than the unit base rails. Do not tie slab to the building foundation.
5. Roof structures must be able to support the weight of the unit and its options/accessories. Unit must be installed on a solid, level roof curb or appropriate angle iron frame.
6. Maintain level tolerance to 13 mm (1/2") maximum across the entire length or width of the unit.

▲ WARNING

Excessive exposure of this furnace to contaminated combustion air may result in equipment damage or personal injury. Typical contaminants include: permanent wave solution, chlorinated waxes and cleaners, chlorine based swimming pool chemicals, water softening chemicals, carbon tetrachloride, Halogen type refrigerants, cleaning solvents (e.g. perchloroethylene), printing inks, paint removers, varnishes, hydrochloric acid, cements and glues, antistatic fabric softeners for clothes dryers, masonry acid washing materials.

If a unit is to be installed on a roof curb or special frame other than a YORK roof curb, gasketing must be applied to all surfaces that come in contact with the unit underside.

Rigging And Handling

Exercise care when moving the unit. Do not remove any packaging until the unit is near the place of installation. Rig the unit by attaching chain or cable slings to the lifting holes provided in the base rails. Spreader bars, whose length exceeds the largest dimension across the unit, **MUST** be used across the top of the unit.

Units may be moved or lifted with a forklift. Slotted openings in the base rails are provided for this purpose.

Remove the nesting brackets from the four corners on the top of the unit. All screws that are removed when removing the brackets must be replaced on the unit.

Refer to Tables 7 and 8 for unit weights and to the Figure 9 for approximate center of gravity.

▲ CAUTION

Before lifting a unit, make sure that all panels are in place and that its weight is distributed equally on all cables so it will lift evenly.

▲ CAUTION

An adhesive backed label is provided over the outside of the combustion air inlet opening to prevent moisture from entering the unit, which could cause damage to electrical components. Allow this closure label to remain in place until the combustion air hood is to be installed (refer to Vent and Combustion Hood Figure 6).

▲ CAUTION

If a unit is to be installed on a roof curb other than a York® roof curb, gasketing must be applied to all surfaces that come in contact with the unit underside.

▲ CAUTION

Before lifting, make sure the unit weight is distributed equally on the rigging cables so it will lift evenly.

Clearances

All units require particular clearances for proper operation and service. Installer must make provisions for adequate combustion and ventilation air in accordance with section 5.3 of Air for Combustion and Ventilation of the National Fuel Gas Code, ANSI Z223.1 – Latest Edition (in U.S.A.), or Sections 7.2, 7.3, or 7.4 of Gas Installation Codes, CSA-B149.1 (in Canada) – Latest Edition, and/or applicable provisions of the local building codes. Refer to Table 15 for clearances required for combustible construction, servicing, and proper unit operation.

▲ WARNING

Do not permit overhanging structures or shrubs to obstruct condenser air discharge outlet, combustion air inlet or vent outlets.

LENGTH OF FORKS MUST BE A MINIMUM OF 1067MM (42").

▲ CAUTION

All panels must be secured in place when the unit is lifted.
The condenser coils should be protected from rigging cable damage with plywood or other suitable material.

Condensate Drain

Plumbing must conform to local codes. Use a sealing compound on male pipe threads. Install a condensate drain line from the 3/4" NPT female connection on the unit to an open drain.

NOTE: The condensate drain operates in a negative pressure in the cabinet. The condensate drain line **MUST** be trapped to provide proper drainage. See Figure 1.

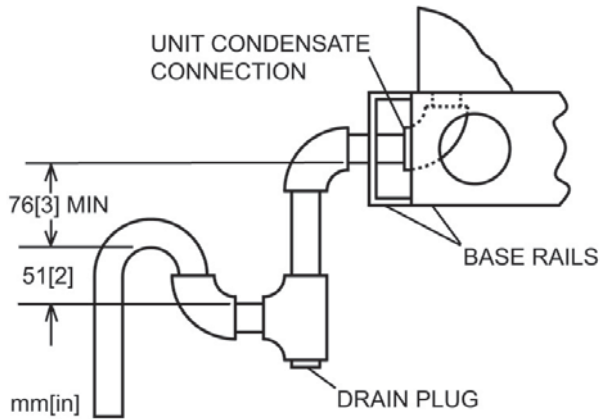

Figure 1: Recommended Drain Piping

Compressors

Units are shipped with compressor mountings factory-adjusted and ready for operation.

Units with scroll compressors have a shipping bracket which must be removed after the unit is set in place. See Figure 2.

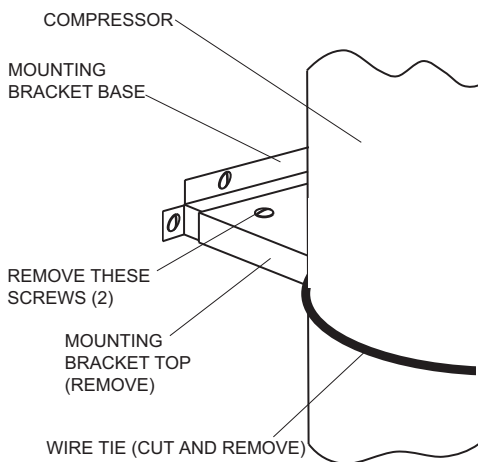

Figure 2: Compressor Restraining Bracket

CAUTION

Do not loosen compressor mounting bolts.

Filters

25 mm (1") or 51 mm (2") filters can be supplied with each unit. Filters must always be installed ahead of the evaporator coil and must be kept clean or replaced with same size and type. Dirty filters will reduce the capacity of the unit and will result in frosted coils or safety shutdown. Minimum filter area and required sizes are shown in Physical Data Table 10.

Service Access

The following removable panels provide access to all serviceable components:

- Compressor compartment
- Electric Heat compartment
- Gas Heat compartment
- Blower compartment
- Main control box
- Filter compartment

Refer to the Dimensions and Clearances shown in Figures 11, 12, 13 and 14 for location of these access panels.

CAUTION

Make sure that all screws and panel latches are replaced and properly positioned on the unit to maintain an airtight seal.

TYPICAL POWER WIRING

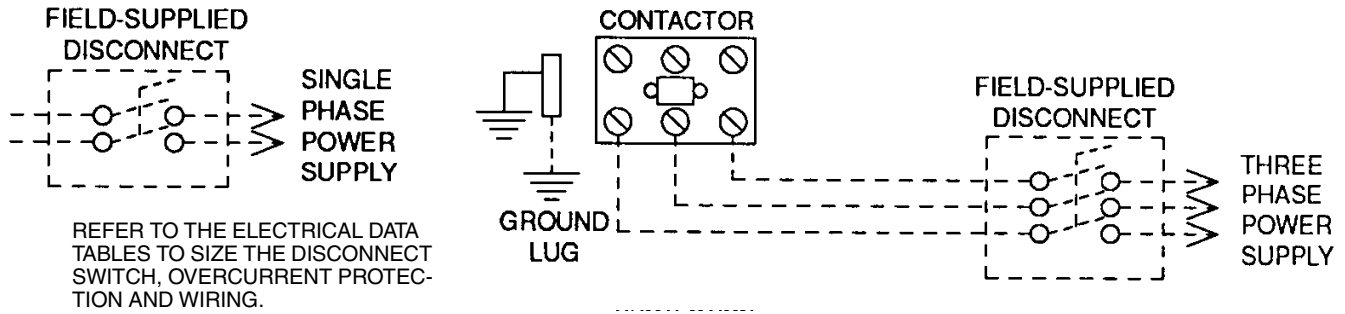

TYPICAL CONTROL WIRING

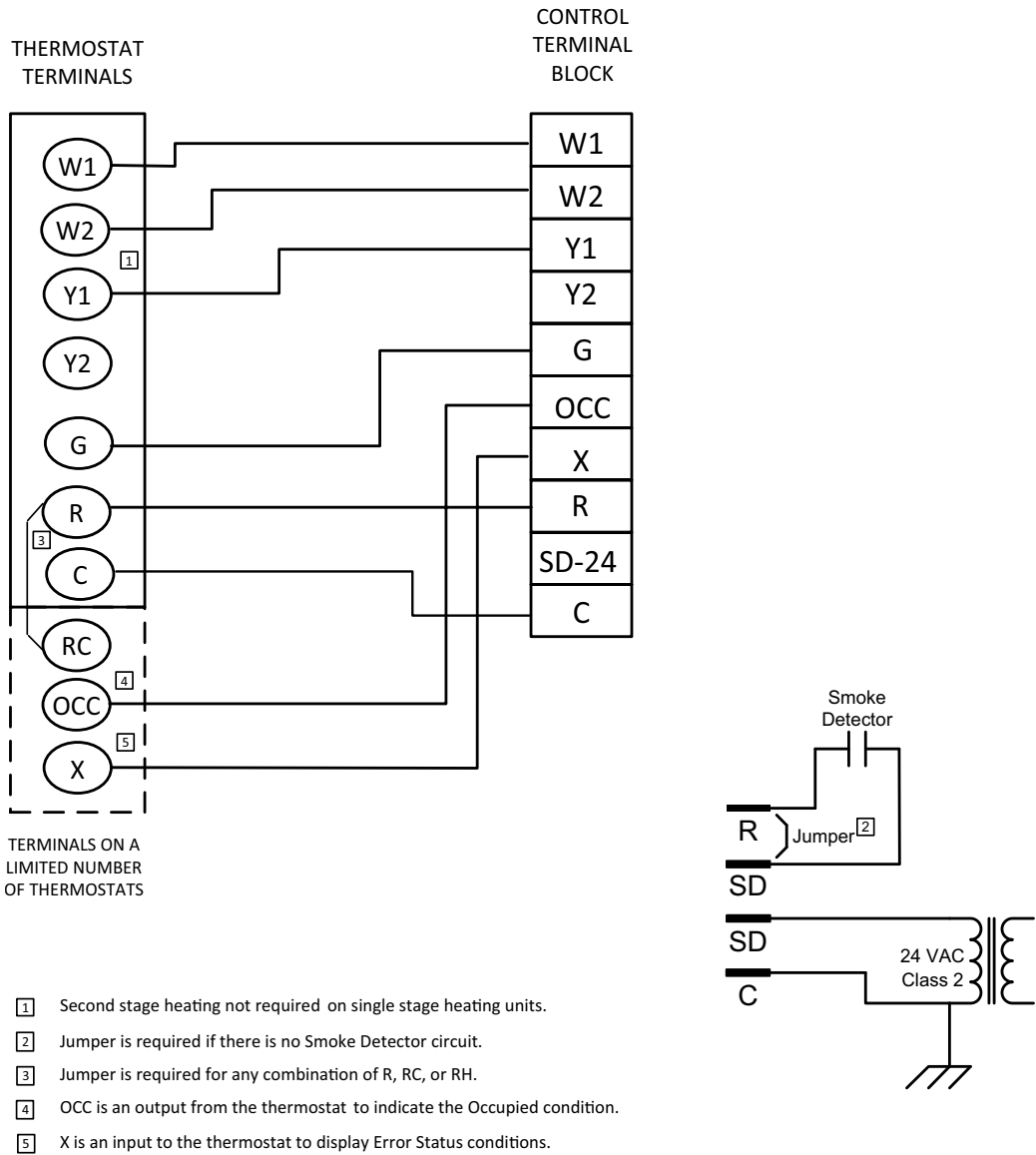
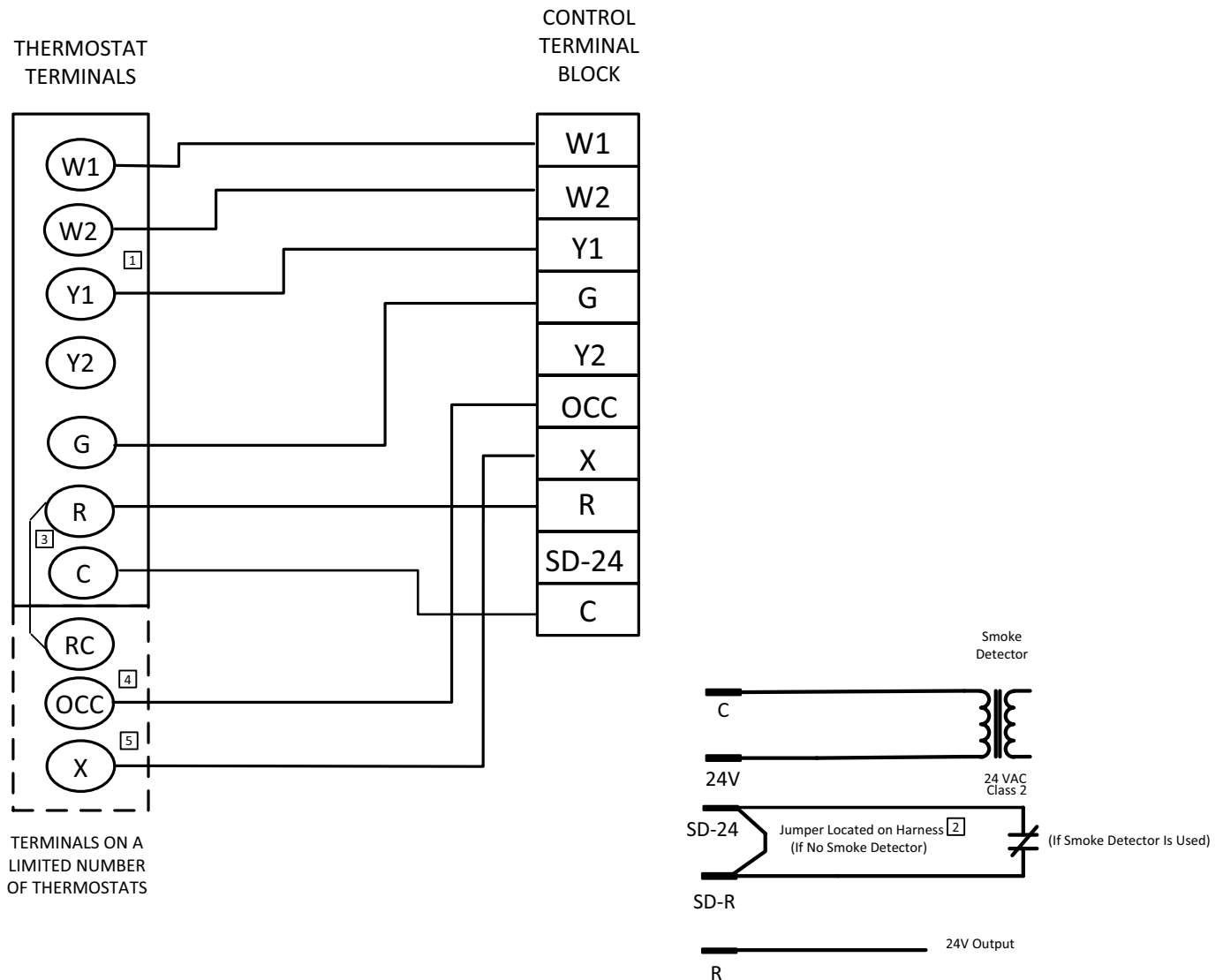

Figure 3: Typical Field Power & Simplicity Lite ZF036-076 Control Wiring

Typical Cool/Heat Control Wiring (Smart Equipment™ ZF036-076)



- 1 Second stage heating not required on single stage heating units.
- 2 Jumper is required if there is no Smoke Detector circuit.
- 3 Jumper is required for any combination of R, RC, or RH.
- 4 OCC is an output from the thermostat to indicate the Occupied condition.
- 5 X is an input to the thermostat to display Error Status conditions.

Figure 4: Typical Smart Equipment™ Control Wiring

Thermostat

The room thermostat should be located on an inside wall approximately 1422 mm (56") above the floor where it will not be subject to drafts, sun exposure or heat from electrical fixtures or appliances. Follow manufacturer's instructions enclosed with thermostat for general installation procedure. A minimum of seven color-coded insulated wires (#18 AWG) should be used to connect thermostat to unit.

Power And Control Wiring

Field wiring to the unit must conform to provisions of the National Electrical Code, ANSI / NFPA No. 70 (in U.S.A.), current Canadian Electrical Code C22.1 (in Canada) and/or local ordinances. The unit must be electrically grounded in accordance with NEC and CEC (as specified above) and/or local codes. Voltage tolerances, which must be maintained at the compressor terminals, during starting and running

conditions, are indicated on the unit Rating Plate and the Unit Application Data table.

CAUTION

380/415-3-50 units control transformers are factory wired for 415v power supply respectively. Change tap on transformer for 380-3-50 operation. See unit wiring diagram.

A fused disconnect switch should be field provided for the unit. The switch must be separate from all other circuits. Wire entry at knockout openings require conduit fittings to comply with NEC (in U.S.A.), CEC (in Canada) and/or local codes. Refer to Figures 11, 12, 13 and 14 for installation location. If any of the wire supplied with the unit must be replaced, replacement wire must be of the type shown on the wiring diagram and the same minimum gauge as the replaced wire.

Electrical line must be sized properly to carry the load. Use copper conductors only. Each unit must be wired with a separate branch circuit fed directly from the meter panel and properly fused.

CAUTION

When connecting electrical power and control wiring to the unit, waterproof type connectors **MUST BE USED** so that water or moisture cannot be drawn into the unit during normal operation. The above waterproofing conditions will also apply when installing a field-supplied disconnect switch.

Refer to the Typical Field Wiring Figures 3 and 4 and to the appropriate unit wiring diagram for control circuit and power wiring information.

Table 1: Control Wire Sizes

Wire Size	Maximum Length ¹
18 AWG	46 m (150 ft)

1. From the unit to the thermostat and back to the unit.

Optional Electric Heat

The factory-installed heaters are wired for single point power supply. Power supply need only be brought into the single point terminal block and thermostat wiring to the low voltage terminal strip located in the upper portion of the unit control box.

These heaters are located within the central compartment of the unit with the heater elements extending into the supply air chamber. Refer to Figure 10 for access panel location.

Fuses are supplied, where required, by the factory. Some KW sizes require fuses and others do not. Refer to Table 2 for minimum Volumetric Flow Rate limitations and to Table 11 for electrical data.

Table 2: Electric Heater Supply Air Limitations

UNIT MODEL SIZE NOMINAL TONS	VOLTAGE	MINIMUM SUP- PLY AIR	HEATER SIZE NOMINAL KW				
			7	10	15	20	30
3	380/415-3-50	M ³ /S	0.47	0.57	0.57	0.61	-
		CFM	1100	1200	1200	1300	-
4	380/415-3-50	M ³ /S	0.61	0.61	0.61	0.61	-
		CFM	1300	1300	1300	1300	-
5	380/415-3-50	M ³ /S	0.75	0.75	0.75	0.75	0.75
		CFM	1600	1600	1600	1600	1600
6.3	380/415-3-50	M ³ /S	0.85	0.85	0.85	0.85	0.85
		CFM	1800	1800	1800	1800	1800

Optional Gas Heat

These gas-fired heaters have aluminized-steel or optional stainless steel, tubular heat exchangers with spark ignition with proven pilot.

All gas heaters are shipped from the factory equipped for natural gas use. See Gas Heat Application Data Table.

For natural gas heating installations in locations requiring low NOx emissions, Accessory model 1LN0406 must be used.

Table 3: Gas Heat Application Data

GAS HEAT OPTION	INPUT CAPACITY kW[MBH]	OUTPUT CAPACITY kW[MBH]	AVAILABLE ON MODELS	GAS RATE ¹ M ³ / S[Ft ³ /Hr]	TEMPERATURE RISE °C[°F] AT FULL INPUT ²	
					MIN.	MAX.
H05	15[50]	12[40]	3 TON	0.02[47]	8[15]	25[45]
H07	22[75]	18[60]	4 TON	0.03[70]	14[25]	31[55]
H10	29[100]	23[79]	5/6 TON	0.04[93]	14[25]	31[55]

1. Based on 1075 Btu/Ft³.

2. The air flow must be adjusted to obtain a temperature rise within the range shown.

NOTE: Gas Heaters are shipped available for natural gas, but can be converted to L.P. with Kit Model No. 1NP0434.

All furnaces meet the latest California seasonal efficiency requirements.

Gas Piping

Proper sizing of gas piping depends on the cubic feet per hour of gas flow required, specific gravity of the gas and the length of run. "National Fuel Gas Code" Z223.1 (in U.S.A.) or the current Gas Installation Codes CSA-B149.1 (in Canada) should be followed in all cases unless superseded by local codes or gas utility requirements. Refer to the Pipe Sizing Table 4.

The heating value of the gas may differ with locality. The value should be checked with the local gas utility.

NOTE: There may be a local gas utility requirement specifying a minimum diameter for gas piping. All units require a 1/2" pipe connection at the entrance fitting.

Table 4: GAS PIPE SIZING

LENGTH IN M[FT]	NOMINAL IRON PIPE SIZE			
	12.7mm [1/2 in.]	19.0mm [3/4 in.]	25.0mm [1 in.]	32.0mm [1-1/4 in.]
3[10]	3.74[132]	7.87[278]	14.72[520]	29.72[1050]
6[20]	2.60[92]	5.38[190]	9.91[350]	20.66[730]
9[30]	2.07[73]	4.3[152]	8.07[285]	16.70[590]
12[40]	1.78[63]	3.68[130]	6.93[245]	14.15[500]
15[50]	1.58[56]	3.25[115]	6.08[215]	12.45[440]
18[60]	1.42[50]	2.97[105]	5.52[195]	11.32[400]
21[70]	1.30[46]	2.72[96]	5.09[180]	10.47[370]
24[80]	1.22[43]	2.55[90]	4.81[170]	9.91[350]
27[90]	1.13[40]	2.38[84]	4.53[160]	9.06[320]
30[100]	1.08[38]	2.23[79]	4.25[150]	8.63[305]

Maximum capacity of pipe in cubic meter/cubic feet of gas per hour. (Based upon a pressure drop of 7.62mm/0.3 inch water column and 0.6 specific gravity gas).

Gas Connection

The gas supply line can be routed through the knockouts located on the front of the unit or through the opening provided in the unit's base. Refer to Figures 13 and 15 to locate these access openings. Typical supply piping arrangements are shown in Figures 5 and 6. All shaded items are field-supplied.

If gas supply line is routed through the unit's base ensure that the burner assembly can be removed for maintenance without disturbing the supply line. The supply piping and fittings must lie below the bottom gas manifold to avoid interference with the burner assembly.

Two grommets are shipped in the blower compartment (in parts bag taped to the blower housing) of every unit with gas heat and should be used in the knockouts when the gas piping penetrates the front of the unit.

After the gas supply piping has been installed, the bottom opening in the unit should be sealed to prevent water from leaking into the building.

Gas piping recommendations:

1. A drip leg and a ground joint union must be installed in the gas piping.
2. When required by local codes, a manual shut-off valve may have to be installed outside of the unit.
3. Use wrought iron or steel pipe for all gas lines. Pipe compound should be applied sparingly to male threads only.

WARNING

Natural gas may contain some propane. Propane, being an excellent solvent, will quickly dissolve white lead or most standard commercial compounds. Therefore, a special pipe compound must be applied when wrought iron or steel pipe is used. Shellac base compounds such as Gas-kolac or Stalastic, and compounds such as Rectorseal #5, Clyde's or John Crane may be used.

4. All piping should be cleaned of dirt and scale by hammering on the outside of the pipe and blowing out the loose dirt and scale. Before initial start-up, be sure that all of the gas lines external to the unit have been purged of air.
5. The gas supply should be a separate line and installed in accordance with all safety codes as prescribed under "Limitations". After the gas connections have been completed, open the main shut-off valve admitting normal gas pressure to the mains. Check all joints for leaks with soap solution or other material suitable for the purpose.
NEVER USE A FLAME.

WARNING

FIRE OR EXPLOSION HAZARD

Failure to follow the safety warning exactly could result in serious injury, death or property damage.

Never test for gas leaks with an open flame. Use a commercially available soap solution made specifically for the detection of leaks to check all connections. A fire or explosion may result causing property damage, personal injury or loss of life.

6. The furnace and its individual manual shut-off valve must be disconnected from the gas supply piping system during any pressure testing of that system at test pressures in excess of 1/2 psig (3.48kPa).
7. The furnace must be isolated from the gas supply piping system by closing its individual manual shut-off valve during any pressure testing of the gas supply piping system at test pressures equal to or less than 1/2 psig (3.48kPa).
8. A 1/8 inch NPT plugged tap, accessible for test gage connection, must be installed immediately upstream of the gas supply connection to the furnace.

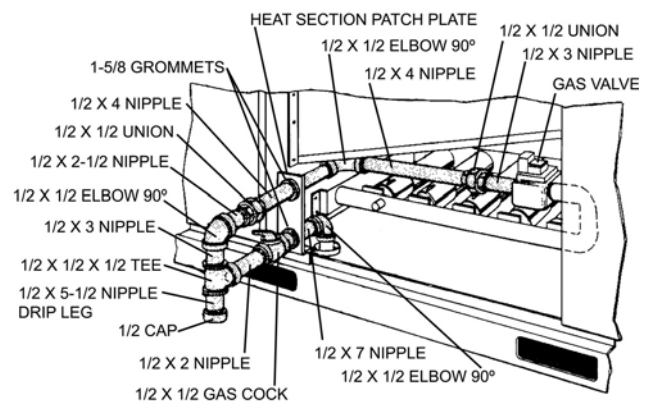

Figure 5: External Supply Connection External Shut-Off

L.P. Units, Tanks And Piping

All gas heat units are shipped from the factory equipped for natural gas use only. The unit may be converted in the field for use with L.P./propane gas with accessory kit model number 1NP0440.

All L.P./propane gas equipment must conform to the safety standards of the National Fire Protection Association.

For satisfactory operation, adequate L.P./propane gas pressure must be provided at the unit manifold under full load. Maintaining proper gas pressure depends on three main factors:

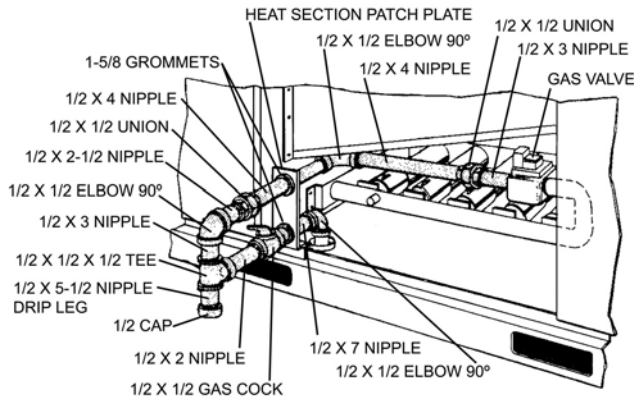

Figure 6: Bottom Supply Connection External Shut-Off

1. The vaporization rate depends on (a) the temperature of the liquid and (b) the “wetted surface” area of the container or containers.
2. The proper pressure regulation. (Two-stage regulation is recommended from the standpoint of both cost and efficiency.)
3. The pressure drop in the lines between regulators and between the second stage regulator and the appliance. Pipe size required will depend on the length of the pipe run and the total load of all appliances.

Complete information regarding tank sizing for vaporization, recommended regulator settings, and pipe sizing is available from most regulator manufacturers and L.P./propane gas suppliers.

L.P./propane gas is an excellent solvent and special pipe compound must be used when assembling piping for this gas as it will quickly dissolve white lead or most standard commercial compounds. Shellac base compounds such as Rectorseal #5 are satisfactory for this type of gas.

Check all connections for leaks when piping is completed, using a soap solution. **NEVER USE A FLAME.**

▲WARNING

FIRE OR EXPLOSION HAZARD

Failure to follow the safety warning exactly could result in serious injury, death or property damage.

Never test for gas leaks with an open flame. Use a commercially available soap solution made specifically for the detection of leaks to check all connections. A fire or explosion may result causing property damage, personal injury or loss of life.

Vent And Combustion Air Hoods

The vent hood and combustion air hood (with screens) are shipped attached to the blower housing in the blower compartment. These hoods must be installed to assure proper unit function. All hoods must be fastened to the outside of the gas heat access panel with the screws provided in the bag also attached to the blower housing.

The screen for the combustion air intake hood is secured to the inside of the access panel opening with three fasteners and the screws used for mounting the hood to the panel. The top flange of this hood slips in under the top of the access panel opening when installing. Refer to Vent and Combustion Air Hood Figure 7.

The vent hood is installed by inserting the top flange of the hood into the slotted opening in the access panel and securing in place.

The products of combustion are discharged horizontally through this screened, hooded vent openings on the gas heat access panel.

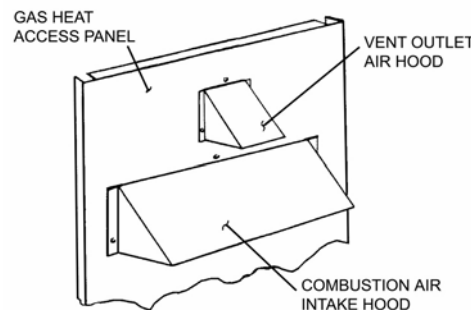

Figure 7: Vent And Combustion Air Hood

Optional Economizer/Motorized Damper Rain Hood

The instruction for the optional economizer/motorized damper rain hood can be found in form 5004998. Use these instructions when field assembling an economizer rain hood onto a unit. The outdoor and return air dampers, the damper actuator, the damper linkage, the outdoor and return air divider baffles, and all the control sensors are factory mounted as part of the “Factory installed” economizer option.

Optional Power Exhaust/Barometric Relief Damper And Rain Hood

The instructions for the power exhaust/barometric relief damper and rain hood can be found in form 1200060. The exhaust fan, all supporting brackets, angles, and the wiring are factory installed as part of the power exhaust option.

All of the components, including the dampers, hardware, and mounting instructions are shipped in a single package external from the unit. The hood must be field assembled and installed.

Power exhaust is only available as a field installed accessory.

RRS Economizer Interface Overview

Units with Simplicity Lite Controls will have a field installed (RRS) Economizer Kit Offered.

This section describes how to use the Economizer's user interface for:

- Keypad and menu navigation
- Settings and parameter changes
- Menu structure and selection

User Interface

The user interface consists of an LCD display and a 4-button keypad on the front of the economizer module.



Figure 8: RRS Economizer LCD and Keypad Layout.

Keypad

The 4 navigation buttons illustrated in Figure 18 are used to scroll through the menus and menu items, select menu items, and to change parameter and configuration settings.

Using the Keypad with Menus

To use the keypad when working with menus:

- Press the ↵ (enter) button navigates to the next level.
- Each press of the ^ (scroll up) and v (scroll down) buttons move the > cursor.
- Each press of the esc (cancel) button navigates to the previous level.

Level 0 of the parameter menu, where either a blank screen is shown or active Alarm(s) are shown in 20-second intervals, is displayed following:

- The boot-up sequence
- 45 minutes of menu navigation inactivity
- Multiple presses of the esc (cancel) button

From Level 0 of the parameter menu, navigation to Level 1 of the menu is done with a press of the ^ (scroll up), v (scroll down) or ↵ (enter) button.

The LEDs at the center-left of the RRS Economizer Controller indicate:

- POWER (green)
- Lit whenever 24 volts AC power is present to the RRS Economizer Controller C and R pins
- FAULT (red)
- Lit, then flashes during the boot-up sequence of the RRS Economizer Controller
- Not lit when there are no Alarms active
- Double-flash/pause continuously when Alarms are active
- SA BUS (green)
- Will not be lit

Menu Structure

The top level menus are:

- STATUS
- ALARMS
- SUMMARY → ECONOMIZER, POWER EXHAUST, COMPRESSOR
- COMMISSION
- CONTROLLER SETTINGS
- UPDATE
- DETAILS
- SELF TEST
- VIEW RESULTS

NOTE: Your menu parameters will be different depending on your configuration. See the RRS Economizer Control Quick Start Guide P/N 5292230-USG-A-1016, found on [UPG.net \Controls](http://UPG.net).

RRS Economizer Controller Parameter Menu Functions

There are several "conditional" parameters within the menu. Parameters for temperature, humidity and CO₂ inputs are only shown in the menu once sensor presence has been detected. Parameters associated with a function are only shown in the menu when that function is enabled.

Smart Equipment™ Economizer Sequences

Units with the Smart Equipment™ Control will have a factory option or field kit with Johnson Controls Economizer.

Several functions can drive the economizer, including: minimum position, free cooling, economizer loading, and minimum outdoor air supply.

Economizer Minimum Position

The economizer minimum position is set during occupied mode when outside air is not suitable for free cooling. The position of the damper is set proportionally between the "Economizer Minimum Position" and the Economizer Minimum Position Low

Speed Fan" set points, in relationship to the VFD output percentage. On a constant volume single speed supply fan system both set-points should be set to the same value.

Free Cooling

Four types of free cooling options are available: dry bulb changeover, single enthalpy, dual enthalpy changeover, and Auto.

Dry Bulb Changeover

For dry bulb economizer operation, the outside air is suitable for free cooling if the outside air temperature is 1°F below the Economizer OAT Enable Setpoint **and** 1°F below the Return Air Temperature.

Free cooling is no longer available if the outside air temperature rises above **either** the Economizer OAT Enable setpoint **or** the return air temperature.

Single Enthalpy Changeover

For single enthalpy economizer operation, the outside air is suitable for free cooling if the outside air enthalpy is at least 1 BTU/lb below the Economizer Outside Air Enthalpy Setpoint **and** the outside air temperature is no greater than the RAT plus 9°F.

If the outside air temperature rises above the RAT plus 10°F, free cooling is no longer available. The outside air temperature must drop to no greater than RAT plus 9°F to enter free cooling again.

Free cooling is no longer available if the outside air enthalpy rises above the Economizer Outside Air Enthalpy Setpoint.

Dual Enthalpy Changeover

For dual enthalpy economizer operation, the outside air enthalpy must be lower than the return air enthalpy by 1 btu/lb **AND** the outside air temperature is no greater than the RAT plus 9°F.

Auto

The control determines the type of free cooling changeover based on which sensors are present and reliable. Conditions include:

- Return and outside air dry bulb = dry bulb changeover
- Return and outside air dry bulb and outside air humidity = single enthalpy
- Return and outside air dry bulb and return and outside air humidity = dual enthalpy
- If either the return or outside air dry bulb sensors are unreliable, free cooling is not available

Free Cooling Operation

When the control determines that the outside air is suitable, the first stage of cooling will always be free cooling.

Thermostat

In free cooling, with a thermostat input to Y1, the dampers modulate to control the supply air temperature to the Economizer Setpoint +/- 1°F (default 55°F).

If the thermostat provides an input to Y2 **and** the parameter Compressors Off in Free Cooling is turned OFF a compressor output energizes. The economizer dampers continue to modulate to control the supply air temperature to the Economizer Setpoint.

If the supply air temperature cannot be maintained within 50F of the economizer setpoint, the first stage compressor (C1) will be turned on. Second stage compressor (C2) will be added as needed to keep the supply air temperature within the 50F of the economizer setpoint.

Sensor

In free cooling, with a demand from the zone/return sensor for the first stage of cooling, the dampers modulate to control the supply air temperature to the Economizer Setpoint +/- 1°F.

If the economizer output is at 100% **and** the SAT is greater than the Economizer setpoint + 1°F, the control starts a 12-minute timer to energize a compressor output.

If at any time the economizer output drops below 100% the timer stops and resets when the economizer output returns to 100%.

Once a compressor output is turned ON, the economizer dampers continue to modulate to control the supply air temperature to the Economizer Setpoint.

At no time will a compressor output be turned ON if the economizer output is less than 100%, even if the differential between zone (or return) temperature and the current cooling setpoint is great enough to demand more than one stage of cooling.

If the economizer output goes to minimum position **and** the SAT is less than Economizer Setpoint -1°F, the control starts a 12-minute timer to de-energize a compressor output.

If at any time the economizer output goes above the minimum position the timer stops and resets when the economizer output returns to minimum position.

If the demand for cooling from the space/return is satisfied, the economizer output will modulate to minimum position and the compressor outputs will be de-energized as long as their minimum run timers have expired.

Power Exhaust

Setpoints

- | | |
|-----------------------------|-----|
| a. Economizer Enable | ON |
| b. Power Exhaust Enable | ON |
| c. Modulating Power Exhaust | OFF |

- d. Exhaust VFD Installed OFF
- e. Building Pressure Sensor Enabled OFF
- f. Econo Damper Position For Exh Fan ON Percent
- g. Econo Damper Position For Exh Fan OFF Percent

Inputs

No inputs are present for non-modulating power exhaust.

Outputs

- a. 2-10 VDC from ECON on Economizer Expansion module

- b. 24 vac from EX-FAN to energize exhaust fan on Economizer Expansion module

Operation

Operation details include:

- a. Compares economizer output to the Economizer Damper Position For Exhaust Fan On and OFF.
- b. Energizes exhaust fan when economizer output is above Economizer Damper Position For Exhaust Fan On.

De-energizes exhaust fan when economizer output is below the Economizer Damper Position for Exhaust Fan OFF



Figure 9: SE-ECO1001-0 Economizer Controller

Table 5: Smart Equipment™ Economizer Board Details

Board Label	Cover Label	Description	Function & Comments
Directional orientation: viewed with the center text of the cover label upright			
ANALOG INPUTS Terminal at left on upper edge of economizer board			
C	COM	24 VAC common/0-10 VDC negative for economizer actuator position feedback	Connects through circuit trace to 24V~ IN pin COM
IN2	ECOFB	0-10 VDC positive input from Economizer actuator position Feedback	EconDampPos parameter reports input status (0-100%). Used to meet Cali. Title 24 requirements for economizer actuator position feedback
R	24V~	24 VAC hot supplied for economizer actuator position feedback	Connects through circuit trace to 24V~ IN pin HOT
C	COM	Mixed Air Temperature sensor input from 10KΩ	MAT parameter reports input status (°F/°C), 3.65 VDC reading
IN1	MAT	@ 77°F, Type III negative temperature coefficient thermistor	MAT (+) to COM (-) with open circuit. Read-only use in current control revision.
LEDs at left on upper edge of economizer board			
POWER	POWER	Green UCB power indicator	Lit indicates 24 VAC is present at 24V~ IN COM and HOT pins
FAULT	FAULT	Red networking error and firmware error indicator	1/10th second on/off flashing indicates a networking error (polarity, addressing, etc.) or a firmware error (likely correctable with re-loading from USB flash drive)
SA BUS	SA BUS	Green UCB SA bus communication transmission indicator	Lit/flickering indicates UCB-to-economizer board SA bus communication is currently active, off indicates the economizer board is awaiting SA bus communication
SA BUS¹ Pin connections at left on upper edge of economizer board			
C	COM	Common for SA BUS power and communication circuits	EconCtrlr parameter reports UCB-to-economizer board SA bus communication status. Negative of the SA BUS communication circuit to the UCB. Through the unit wiring harness, may continue on to the 4-stage board and/or fault detection & diagnostics board

Table 5: Smart Equipment™ Economizer Board Details (Continued)

Board Label	Cover Label	Description	Function & Comments
-	-	Communication for SA BUS devices	EconCtrlr parameter reports UCB-to-economizer board SA BUS communication status. Positive of the VDC (typically, a fluctuating 1.5 to 3.5 volts reading to C; at least 0.25 volts lower than +) SA BUS communication circuit to the UCB. Through the unit wiring harness, may continue on to the 4-stage board and/or fault detection & diagnostics board
+	+	Communication for SA BUS devices	EconCtrlr parameter reports UCB-to-economizer board SA BUS communication status. Positive of the VDC (typically, a fluctuating 1.5 to 3.5 volts reading to C; at least 0.25 volts higher than -) SA BUS communication circuit to the UCB. Through the unit wiring harness, may continue on to the 4-stage board and/or fault detection & diagnostics board
ANALOG OUTPUTS Pin at center on upper edge of economizer board			
J4	EX VFD	2-10 VDC positive output for the modulating power Exhaust fan Variable Frequency Drive/ discharge damper modulating power exhaust actuator	ExFanVFD parameter reports output status (0-100%) when ExFType selection is Variable Frequency Fan; EAD-O parameter reports output status (0-100%) when ExFType selection is Modulating Damper. Used to ramp the power exhaust fan VFD/ position the discharge damper actuator.
	COM	24 VAC common/0-10 VDC negative for the power exhaust variable frequency drive/ discharge damper modulating power exhaust actuator	Connects through circuit trace to 24V~ IN pin COM
	24V~	24 VAC hot supplied for the discharge damper modulating power exhaust actuator and economizer actuator	Connects through circuit trace to 24V~ IN pin HOT
	ECON	2-10 VDC output for the Economizer actuator	Econ parameter reports output status (0-100%). Used to position the economizer actuator for minimum position, free cooling, demand ventilation, cooling economizer loading and purge functions
	COM	24 VAC common/0-10 VDC negative for economizer actuator	Connects through circuit trace to 24V~ IN pin COM
BINARY OUTPUTS Pin at right on upper edge of economizer board			
J3	24V~	24 VAC hot supplied for an incremental (floating control) economizer actuator	Connects through circuit trace to 24V~ IN pin HOT
	ACT-A	24 VAC hot outputs to position an incremental (floating control) economizer actuator	Unused in current control revision
	ACT-B	24 VAC return	Unused in current control revision
	COM	24 VAC common for an incremental (floating control) economizer actuator	Connects through circuit trace to 24V~ IN pin COM
	EX-FAN	24 VAC hot output to energize power exhaust fan contactor coil/VFD enable relay coil	ExFan parameter reports output status (Off-On) when ExFType selection is Non-Modulating, Modulating Damper or Variable Frequency Fan. Used to turn on/enable the power exhaust fan motor.
	COM	24 VAC common/0-10 VDC negative for economizer actuator	Connects through circuit trace to 24V~ IN pin COM
24V~ IN Pin connections at right on upper edge of economizer board			
C	COM	24 VAC transformer Common referenced to cabinet ground	24 VAC common connection to power the economizer board. Connects through circuit traces to C/COM terminals and pins distributed on the economizer board.

Table 5: Smart Equipment™ Economizer Board Details (Continued)

Board Label	Cover Label	Description	Function & Comments
R	HOT	24 VAC transformer HOT	24 VAC hot connection to power the economizer board. Connects through circuit traces to R/24V~ terminals and pins distributed on the economizer board.
ANALOG INPUTS Terminal on lower edge of economizer board			
R	24V~	24 VAC hot supplied for the outdoor air humidity sensor	Connects through circuit trace to 24V~ IN pin HOT
IN3	OAH	0-10 VDC positive input from the Outdoor Air Humidity sensor	OAH parameter reports input status (0-100%H). Used in outdoor air enthalpy calculation for dual enthalpy economizer free cooling changeover.
C	COM	24 VAC common/0-10 VDC negative for the outdoor air humidity sensor	Connects through circuit trace to 24V~ IN pin COM
R	24V~	24 VAC hot supplied for the supply air humidity sensor	Connects through circuit trace to 24V~ IN pin HOT
IN4	SAH	0-10 VDC positive input from the Supply Air Humidity sensor	SAH parameter reports input status (0-100%H). Unused in current control revision.
C	COM	24 VAC common/0-10 VDC negative for the supply air humidity sensor	Connects through circuit trace to 24V~ IN pin COM
R	24V~	24 VAC hot supplied for the indoor air quality sensor	Connects through circuit trace to 24V~ IN pin HOT
IN5	IAQ	0-10 VDC positive input from the Indoor Air Quality sensor	IAQRange parameter sets the CO2 parts per million measured by the indoor air quality sensor when it outputs 10 VDC; IAQ parameter reports input status (0-5000ppm). Used for demand ventilation functions if the NetIAQ parameter indicates ?Unrel.
C	COM	24 VAC common/0-10 VDC negative for the indoor air quality sensor	Connects through circuit trace to 24V~ IN pin COM
R	24V~	24 VAC hot supplied for the outdoor air quality sensor	Connects through circuit trace to 24V~ IN pin HOT
IN6	OAQ	0-10 VDC positive input from the Outdoor Air Quality sensor	OAQRange parameter sets the CO2 parts per million measured by the outdoor air quality sensor when it outputs 10 VDC; OAQ parameter reports input status (0-5000ppm). Used for demand ventilation function when DVent-Mode selection is Diff between IAQ and OAQ and the NetOAQ parameter indicates ?Unrel.
C	COM	24 VAC common/0-10 VDC negative for the outdoor air quality sensor	Connects through circuit trace to 24V~ IN pin COM
R	24V~	24 VAC hot supplied for the air monitoring station sensor	Connects through circuit trace to 24V~ IN pin HOT
IN7	FR AIR	0-10 VDC positive input from the air monitoring station sensor	MOA-Range parameter sets the cubic feet per minute/liters per second measured by the air monitoring station sensor when it outputs 10 VDC; Fr Air parameter reports input status (0-50000CFM/23595lps). Used for economizer minimum position reset in speed-controlled indoor blower applications.
C	COM	24 VAC common/0-10 VDC negative for the air monitoring station sensor	Connects through circuit trace to 24V~ IN pin COM
R	24V~	24 VAC hot supplied for the building pressure sensor	Connects through circuit trace to 24V~ IN pin HOT
IN8	BLDG PRES	0-5 VDC positive input from the Building Pressure sensor	BldgPres parameter reports input status (-.250-.250"/w/-.062-.062kPa). Used for modulating power exhaust functions when ExFType selection is Modulating Damper or Variable Frequency Fan.

Table 5: Smart Equipment™ Economizer Board Details (Continued)

Board Label	Cover Label	Description	Function & Comments
C	COM	24 VAC common/0-5 VDC negative for the building pressure sensor	Connects through circuit trace to 24V~ IN pin COM
BINARY INPUTS at right on lower edge of economizer board			
IN9	PURGE	24 VAC hot input from the PURGE dry contact	Purge parameter reports input status (False with 0 VAC input-True with 24 VAC input). When Purge status is True, heating and cooling operation is prevented, the indoor blower and power exhaust fan operate, the economizer actuator is positioned to 100%.
	24V~	24 VAC hot supplied for the purge dry contact	Connects through circuit trace to 24V~ IN pin HOT
IN10	EX VFD FLT	24 VAC hot input from the power Exhaust Variable Frequency Drive Fault contact	ExFanVFDFIt parameter reports input status (Normal with 0 VAC input-Alarm with 24 VAC input) when ExFType selection is Variable Frequency Fan. When ExFanVFDFIt status is Alarm, EX-FAN fan output is prevented.
	24V~	24 VAC hot supplied for the power exhaust variable frequency drive fault contact	Connects through circuit trace to 24V~ IN pin HOT

1. When wiring unit and other devices using the SA Bus and FC Bus, see Table 29.

Indoor Air Quality

Indoor Air quality (indoor sensor input): Terminal AQ accepts a +2 to +10 Vdc signal with respect to the (AQ1) terminal. When the signal is below its setpoint, the actuator is allowed to modulate normally in accordance with the enthalpy and mixed air sensor inputs. When the AQ signal exceeds its setpoint setting and there is no call for free cooling, the actuator is proportionately modulated from the 2 to 10 Vdc signal, with 2 Vdc corresponding to full closed and 10 Vdc corresponding to full open. When there is no call for free cooling, the damper position is limited by the IAQ Max damper position setting. When the signal exceeds its setpoint (Demand Control Ventilation Setpoint) setting and there is a call for free cooling, the actuator modulates from the minimum position to the full open position based on the highest call from either the mixed air sensor input or the AQ voltage input.

- Optional CO₂ Space Sensor Kit Part # 2AQ04700324
- Optional CO₂ Unit Sensor Kit Part # 2AQ04700424

Replace the economizer access panel.

Jade Economizer Interface Overview

Units with Simplicity Lite Controls will have a field installed (Jade) Economizer Kit Offered.

This section describes how to use the Economizer's user interface for:

- Keypad and menu navigation
- Settings and parameter changes
- Menu structure and selection

User Interface

The user interface consists of an LCD display and a 4-button keypad on the front of the Economizer module. The LCD is a 16 character by 2 line dot matrix display.

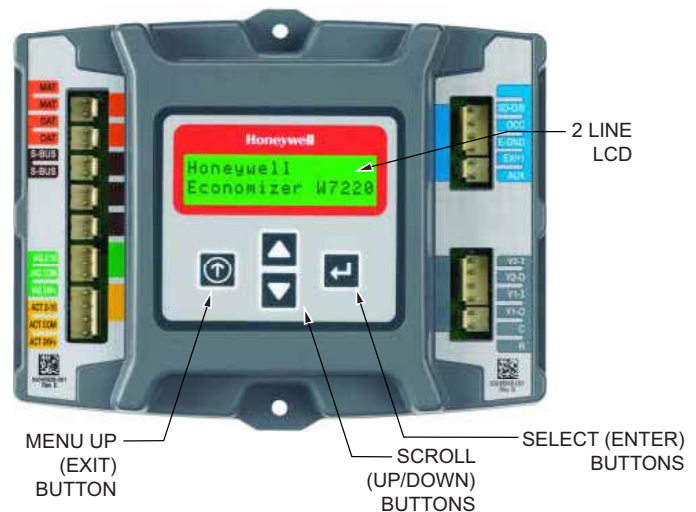

Figure 10: Economizer LCD and Keypad Layout.

Keypad

The four navigation buttons illustrated in Fig. 8 are used to scroll through the menus and menu items, select menu items, and to change parameter and configuration settings.

Using the Keypad with Menus

To use the keypad when working with menus:

- Press the ▲ button to move to the previous menu.
- Press the ▼ button to move to the next menu.
- Press the ↵ button (Enter) to display the first item in the currently displayed menu.
- Press the ↑ button (Menu up) to exit a menu's item and return to the list of menus.

Using the Keypad with Settings and Parameters

To use the keypad when working with Setpoints, System and

Advanced Settings, Checkout tests, and Alarms:

- Navigate to the desired menu.
- Press the \leftarrow button (Enter) to display the first item in the currently displayed menu.
- Use the \blacktriangle and \blacktriangledown buttons to scroll to the desired parameter.
- Press the \leftarrow button (Enter) to display the value of the
- Press the \blacktriangle button to increase (change) the displayed parameter value.¹
- Press the \blacktriangledown button to decrease (change) the displayed parameter value.
- Press the \leftarrow button to accept the displayed value and store it in non-volatile RAM.
- CHANGE STORED displays.
- Press the \uparrow button (MenuUp/Exit) to return to the previous menu.

Menu Structure

The Menus in display order are:

- STATUS
- SETPOINTS

1. When values are displayed, pressing and holding the \blacktriangle and \blacktriangledown button causes the display to automatically increment.

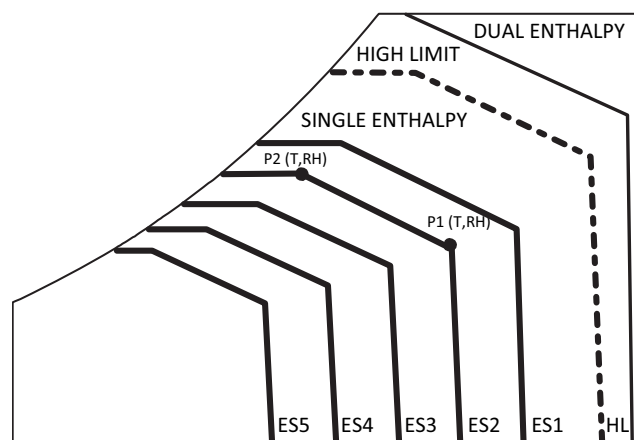
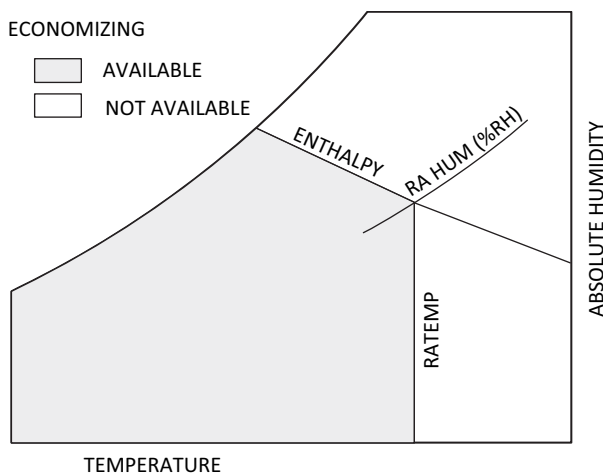

Figure 11: Single Enthalpy Curve And Boundaries

- SYSTEM SETUP
- ADVANCED SETUP
- CHECKOUT
- ALARMS

NOTE: Your menu parameters will be different depending on your configuration. See the JADE™ Economizer Module accessory instruction P/N 1150208-UAI-A-0514 included in this instruction packet for additional menu information.

Economizer Setup And Configuration

Before being placed into service, the JADE™ Economizer module must be setup and configured for the installed system.

NOTE: During setup, the Economizer module is live at all times.

The setup process uses a hierarchical menu structure that is easy to use. You press the \blacktriangle and \blacktriangledown arrow buttons to move forward and backward through the menus and press the \leftarrow button to select and confirm setup item changes.

Time-out and Screensaver

When no buttons have been pressed for 10 minutes, the LCD displays a screen saver, which cycles through the Status items. Each Status items displays in turn and cycles to the next item after 5 seconds.

Table 6: Single Enthalpy and Dual Enthalpy High Limit Curves.

Enthalpy Curve	Temp. Dry-Bulb (°F)	Temp. Dewpoint (°F)	Enthalpy (btu/lb/da)	Point P1		Point P2	
				Temp. °F	Humidity %RH	Temp. °F	Humidity %RH
ES1	80.0	60.0	28.0	80.0	36.8	66.3	80.1
ES2	75.0	57.0	26.0	75.0	39.6	63.3	80.0
ES3	70.0	54.0	24.0	70.0	42.3	59.7	81.4
ES4	65.0	51.0	22.0	65.0	44.8	55.7	84.2
ES5	60.0	48.0	20.0	60.0	46.9	51.3	88.5
HL	86.0	66.0	32.4	86.0	38.9	72.4	80.3

Enthalpy Settings

When the OA temperature, enthalpy and dew point are below the respective setpoints, the Outdoor Air can be used for economizing. Fig. 9 shows the new single enthalpy boundaries in the W7220. There are 5 boundaries (setpoints ES1 through ES5), which are defined by dry bulb temperature, enthalpy and dew point.

Refer to Table 5 for the ENTH CURVE setpoint values.

To use enthalpy the W7220 must have a C7400S Sylkbus sensor for OA. The W7220 calculates the enthalpy and dew point using the OA temperature and humidity input from the OA

sensor. When the OA temperature, OA humidity and OA dew point are all below the selected boundary, the economizer sets the economizing mode to YES, economizing is available.

When conditions are above the selected boundary, the conditions are not good to economize and the mode is set to NO.

Fig. 9 shows the 5 current boundaries. There is also a high limit boundary for differential enthalpy. The high limit boundary is ES1 when there are no stages of mechanical cooling energized and HL when a compressor stage is energized.

Table 5 provides the values for each boundary limit.

ZF036-076 Unit Weights

Figure 12: Unit 4 Point Load Weight

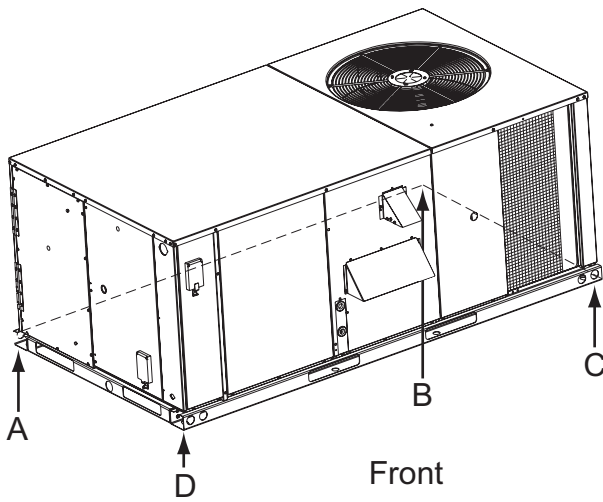

Figure 13: Unit 6 Point Load Weight

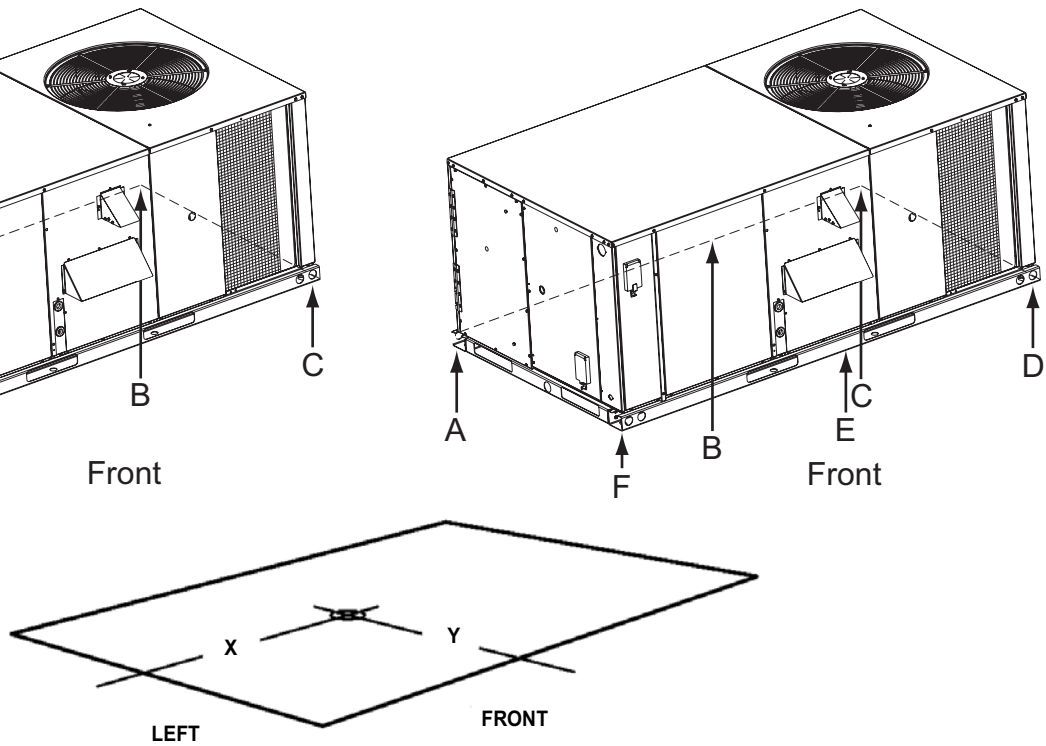

Table 7: ZF036-076 Imperial

Size (Tons)	Model	Weight (lbs.)		Center of Gravity		4 Point Load Location (lbs.)				6 Point Load Location (lbs.)					
		Shipping	Operating	X	Y	A	B	C	D	A	B	C	D	E	F
036 (3.0)	ZF036	502	497	39.6	19.4	111	103	136	146	75	72	68	89	94	99
048 (4.0)	ZF048	525	520	39.2	18.9	115	104	143	158	78	73	69	94	100	107
060 (5.0)	ZF060	554	549	39.2	18.9	121	110	151	166	82	77	72	99	106	113
076 (6.3)	ZF076	584	579	37.7	18.4	128	109	156	185	88	79	71	101	113	127

Table 8: ZF036-076 Metric

Size (Tons)	Model	Weight (kg.)		Center of Gravity (mm)		4 point Load Location (kg.)				6 point Load Location (kg.)					
		Shipping	Operating	X	Y	A	B	C	D	A	B	C	D	E	F
036 (3.0)	ZF036	228	225	1005.8	492.8	50.3	46.7	61.7	61.7	34.0	32.7	30.8	40.4	42.6	44.9
048 (4.0)	ZF048	238	236	995.7	480.1	52.2	47.2	64.9	71.7	35.4	33.1	31.3	42.6	45.5	48.5
060 (5.0)	ZF060	251	249	995.7	480.1	54.9	49.9	68.5	75.3	37.2	34.9	32.7	44.9	48.1	51.3
076 (6.3)	ZF076	265	263	957.6	467.4	58.1	49.4	70.8	83.9	39.9	35.8	32.2	45.8	51.3	57.6

Table 9: ZF036-076 Unit Accessory Weights

Unit Accessory	Weight (lbs.)	
	Shipping	Operating
Economizer	55	50
Power Exhaust	55	50
Electric Heat ¹	28	28
Gas Heat ²	70	70

1. Weight given is for the maximum heater size available (30KW).
2. Weight given is for the maximum number of tube heat exchangers available (5 tube).

Table 10: ZF036-076 Physical Data

Component	Models			
	ZF036	ZF048	ZF060	ZF076
Nominal Tonnage	3.0	4.0	5.0	6.3
ARI COOLING PERFORMANCE				
Gross Capacity @ ARI A point (Btu)	36400	51300	60400	72600
ARI net capacity (Btu)	35200	47000	57800	69100
EER (Net)	11.5	11.5	11.5	10.9
SEER	13.0	13.0	13.0	-
Nominal CFM	1200	1600	2000	2500
System power (KW)	4.2	4.2	4.9	6.3
Refrigerant type	R-410A	R-410A	R-410A	R-410A
Refrigerant charge (lb-oz)				
System 1	4-12	5-4	5-4	6-8
ARI HEATING PERFORMANCE				
Heating model	H05	H07	H10	H10
Heat input (K Btu)	50	75	100	100
Heat output (K Btu)	40	60	80	80
AFUE %	80.9	80.9	80.5	80.5
Steady state efficiency (%)	-	-	-	-
No. burners	2	3	4	4
No. stages	1	1	1	1
Temperature Rise Range (°F)	15-45	25-70	25-55	25-55
Gas Limit Setting (°F) - Direct Drive	240	210	-	-
Gas Limit Setting (°F) - Belt Drive	-	-	210	210
Gas piping connecting (in.)	1/2	1/2	1/2	1/2
DIMENSIONS (inches)				
Length	82 1/4	82 1/4	82 1/4	82 1/4
Width	44 7/8	44 7/8	44 7/8	44 7/8
Height	32 5/8	32 5/8	32 5/8	32 5/8
OPERATING WT. (lbs.)	468	541	569	640
COMPRESSORS				
Type	Recip	Recip	Scroll	Scroll
Quantity	1	1	1	1
Unit Capacity Steps (%)	100	100	100	100
CONDENSER COIL DATA				
Face area (Sq. Ft.)	16.3	16.3	16.3	16.3
Rows	1	1	1	1
Fins per inch	23	23	23	23
Tube diameter (in./mm)	0.71 / 18	0.71 / 18	0.71 / 18	1.0 / 25.4
Circuitry Type	2-pass Microchannel	2-pass Microchannel	2-pass Microchannel	2-pass Microchannel
EVAPORATOR COIL DATA				
Face area (Sq. Ft.)	5.06	5.06	5.06	5.06
Rows	3	4	4	4
Fins per inch	13	13	13	13
Tube diameter	0.375	0.375	0.375	0.375
Circuitry Type	Intertwined	Intertwined	Intertwined	Intertwined
Refrigerant control	Fixed Orifice	Fixed Orifice	Fixed Orifice	Fixed Orifice

Table 10: ZF036-076 Physical Data (Continued)

Component	Models			
	ZF036	ZF048	ZF060	ZF076
Nominal Tonnage	3.0	4.0	5.0	6.3
CONDENSER FAN DATA				
Quantity	1	1	1	1
Fan diameter (Inch)	24	24	24	24
Type	Prop	Prop	Prop	Prop
Drive type	Direct	Direct	Direct	Direct
Quantity of motors	1	1	1	1
Motor HP each	1/2	1/2	1/2	3/4
No. speeds	1	1	1	1/2
RPM	910	910	910	910
Nominal total CFM	-	-	-	-
BELT DRIVE EVAP FAN DATA				
Quantity	-	-	1	1
Fan Size (Inch)	-	-	12 x 10	12 x 11
Type	-	-	Centrifugal	Centrifugal
Motor Sheave	-	-	1VL44	IVM50
Blower Sheave	-	-	AK54	AK56
Belt	-	-	A35	A36
Motor HP each	-	-	1-1/2	1-1/2
RPM	-	-	1450	1450
Frame size	-	-	56	56
DIRECT DRIVE EVAP FAN DATA				
Quantity	1	1	-	-
Fan Size (Inch)	12 x 10	12 x 10	-	-
Type	Centrifugal	Centrifugal	-	-
Motor HP each	1/2	1	-	-
RPM	1050	1050	-	-
FILTERS				
15" x 20" x 1" or 2"	2	2	2	2
14" x 25" x 1" or 2"	1	1	1	1

Table 11: Electrical Data ZF036-076

Model	Power Supply	Compressors (each)			OD Fan Motors (each)	Supply Blower Motor	Electric Heat Option				MCA ¹ (Amps)	Max Fuse / BRKR ² Size (Amps)
		RLA	LRA	MCC	FLA	FLA	Model ^{3,4}	KW	Stages	Amps		
ZF036	380-3-50	4.8	35	7.5	1.3	2.5	NONE	-	-	-	9.8	15
							2EH04510746	4.3	1	6.5	11.3	15
							2EH04511046	6.3	1	9.6	15.1	20
							2EH04511546	8.5	2	12.9	19.3	20
							2EH04512046	12.2	2	18.5	26.3	30
	415-3-50	4.8	35	7.5	1.3	2.5	NONE	-	-	-	9.8	15
							2EH04510746	5.1	1	7.1	12	15
							2EH04511046	7.5	1	10.4	16.2	20
							2EH04511546	10.2	2	14.2	20.9	25
							2EH04512046	14.6	2	20.3	28.5	30
ZF048	380-3-50	7.1	54	11.1	1.3	4.24	NONE	-	-	-	14.4	20
							2EH04510746	4.3	1	6.5	14.4	20
							2EH04511046	6.3	1	9.6	17.3	20
							2EH04511546	8.5	2	12.9	21.4	25
							2EH04512046	12.2	2	18.5	28.5	30
	415-3-50	7.1	54	11.1	1.3	4.24	NONE	-	-	-	14.4	20
							2EH04510746	5.1	1	7.1	14.4	20
							2EH04511046	7.5	1	10.4	18.3	20
							2EH04511546	10.2	2	14.2	23	25
							2EH04512046	14.6	2	20.3	30.7	35
ZF060	380-3-50	8	67.1	12.5	1.3	2.7	NONE	-	-	-	14	20
							2EH04510746	4.3	1	6.5	14	20
							2EH04511046	6.3	1	9.6	15.3	20
							2EH04511546	8.5	2	12.9	19.5	20
							2EH04512046	12.2	2	18.5	26.5	30
	415-3-50	8	67.1	12.5	1.3	2.7	2EH04513046	18.1	2	27.5	37.8	40
							NONE	-	-	-	14	20
							2EH04510746	5.1	1	7.1	14	20
							2EH04511046	7.5	1	10.4	16.4	20
							2EH04511546	10.2	2	14.2	21.1	25
ZF076	380-3-50	11.2	75	17.5	2.03	2.7	2EH04512046	14.6	2	20.3	28.8	30
							2EH04513046	18.1	2	27.5	37.8	40
							NONE	-	-	-	18.7	25
							2EH04510746	4.3	1	6.5	18.7	25
							2EH04511046	6.3	1	9.6	18.7	25
	415-3-50	11.2	75	17.5	2.03	2.7	2EH04511546	8.5	2	12.9	19.5	25
							2EH04512046	12.2	2	18.5	26.5	30
							2EH04513046	18.1	2	27.5	37.8	40
							NONE	-	-	-	18.7	25
							2EH04510746	5.1	1	7.1	18.7	25

1. Minimum Circuit Ampacity.
2. HACR Type per NEC.
3. These electric heaters DO NOT include a fuse box. If required to meet local code, the fuse block accessory 2FB04700546 is available for field installation.
4. Heaters are suitable for operation on 380/415-3-50 power supply

Table 12: Electric Heat Correction Factors

NOMINAL VOLT-AGE	VOLTAGE	KW CAP. MULTI-PLIER
380	380	0.627
415	415	0.75

Table 13: Voltage Limitations

POWER SUPPLY	VOLTAGE	
	MIN.	MAX.
380/415-3-50	342	456

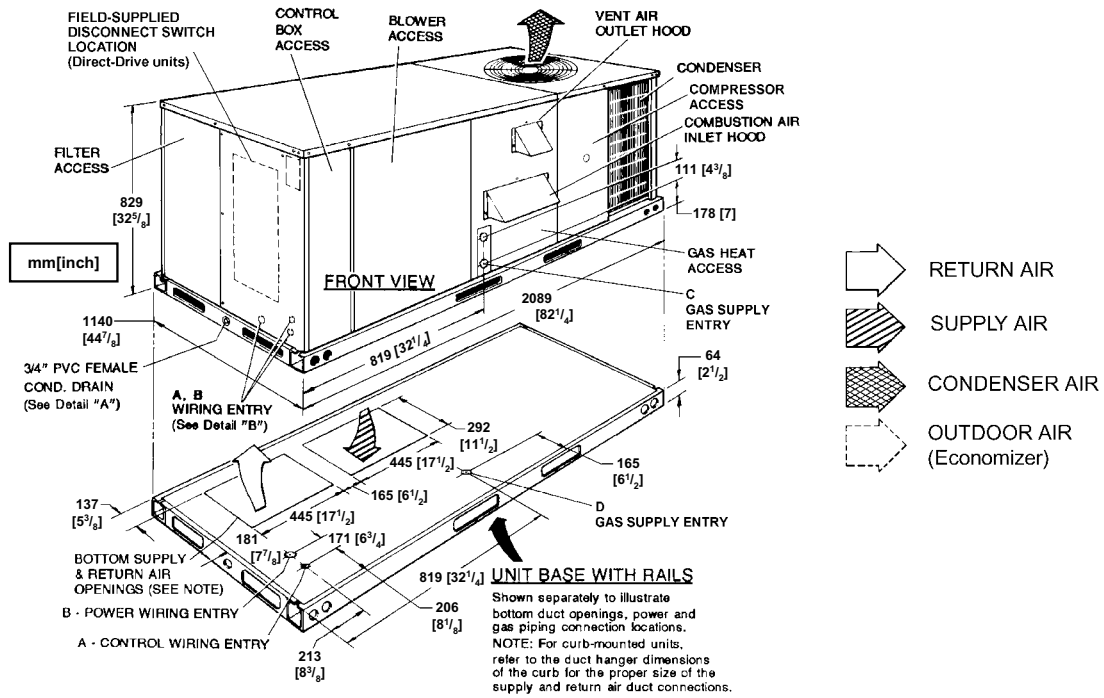

Figure 14: Unit Dimensions (3 - 6.3 Ton Cooling Only/Electric Heat) Front View

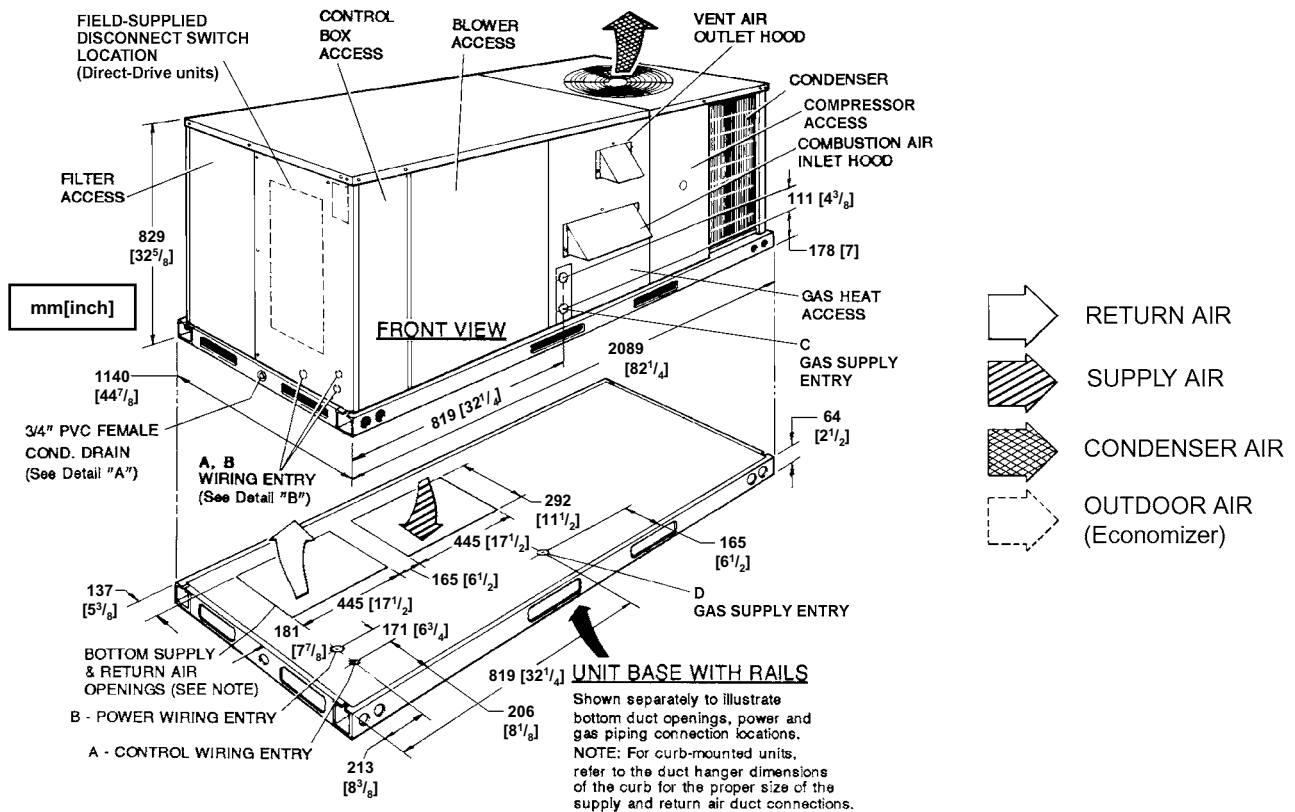

Figure 15: Unit Dimensions (3 - 6.3 Ton Cooling/Gas Heat) Front View

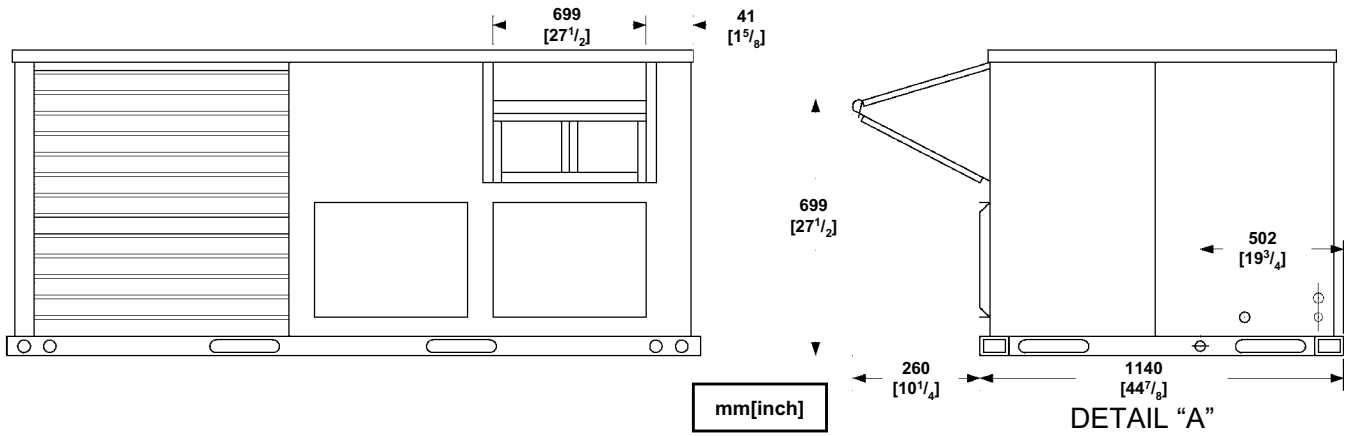

Figure 16: Unit With Economizer Rain hood

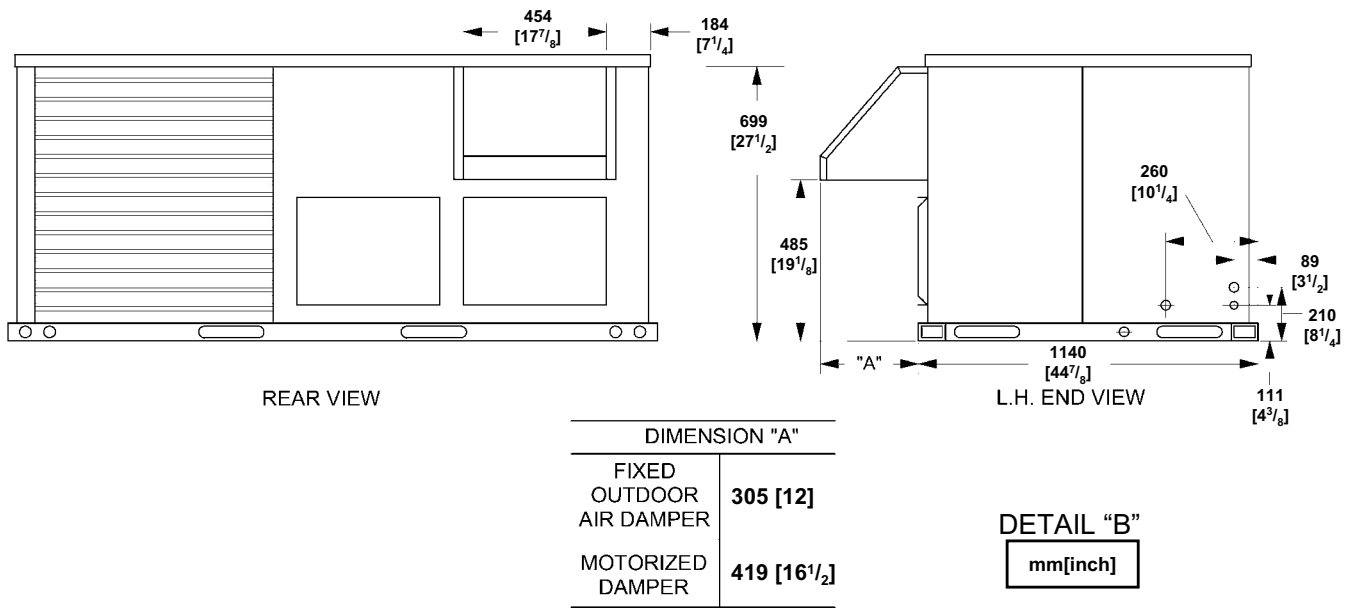
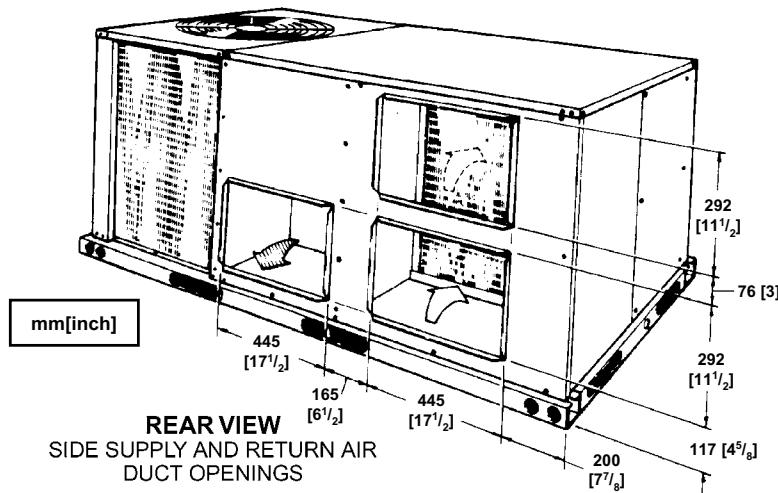

Figure 17: Unit With Fixed Outdoor Air/Motorized Damper Rain hood



DUCT COVERS - Units are shipped with all air duct openings covered.

For **side** duct applications;

1. Remove and discard the supply and return air duct covers.
2. Connect ductwork to duct flanges on the rear of the unit.

For **bottom** duct applications;

1. Remove the side supply air duct cover to gain access to the bottom supply air knockout panel.
2. Remove and discard the bottom knockout panel.
3. Replace the side duct cover.
4. With filter section access panel removed from the unit, remove and discard the bottom return air knockout panel.
5. Replace the filter access panel.

Figure 18: Unit Dimensions (Rear View)

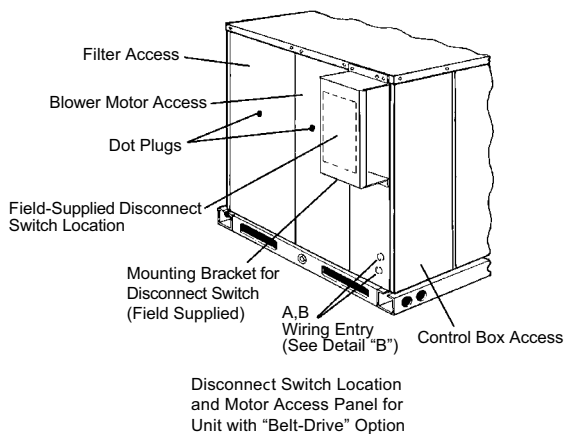

Figure 19: Disconnect/Blower Access Location

Table 15: Minimum Clearances

LOCATION	CLEARANCE (mm / In.)
Front	610 / 24.0 (Cooling/Electric Heat)
	813 / 32.0 (Gas Heat)
Back	305 / 12.0 (Less Economizer)
	914 / 36.0 (With Economizer or Fixed Air/Motorized Damper)
Left Side (Filter Access)	610 / 24.0 (Less Economizer)
Right Side (Cond. Coil)	914 / 36.0 (With Economizer)
Below Unit ¹	0
Above Unit ²	1829 / 72.0 (For Condenser Air Discharge)

1. Units may be installed on combustible floors made from wood or class A, B, or C roof covering material.
2. Units must be installed outdoors. Overhanging structures or shrubs should not obstruct condenser air discharge outlet.

Table 14: UTILITIES ENTRY

HOLE	OPENING SIZE (DIA.) (mm/in)	USED FOR
A	22 / 0.88 KO ¹	Control Wiring ²
		Side
B	51 / 2.0 KO ¹	Power Wiring
		Side
C	41 / 1.63 KO	Gas Piping (Front)
D	38 / 1.5 KO	Gas Piping (Bottom)

1. Opening in the bottom to the unit can be located by the side in the insulation.
2. Do not remove the 2" knockout ring.

Table 16: Supply Air Blower Performance (3 & 4 Ton Direct Drive) - Side Duct Application

M³/S											
UNIT TONNAGE	MOTOR SPEED	AVAILABLE EXTERNAL STATIC PRESSURE-Pa*									
		50		74		99		124		149	
		M ³ /S	WATTS	M ³ /S	WATTS	M ³ /S	WATTS	M ³ /S	WATTS	M ³ /S	WATTS
3 ¹	HI	-	-	-	-	0.80	825	0.78	785	0.74	755
	MED	0.79	800	0.77	780	0.75	750	0.72	720	0.67	690
	LOW	0.70	710	0.69	690	0.67	670	0.64	650	0.62	620
4 ¹	HI	0.94	960	0.91	936	0.88	910	0.85	880	0.81	845
	MED	0.85	838	0.83	810	0.80	785	0.78	765	0.75	735
	LOW	0.79	760	0.77	738	0.76	715	0.73	695	0.70	670
UNIT TONNAGE	MOTOR SPEED	AVAILABLE EXTERNAL STATIC PRESSURE-Pa*									
		174		198		223		248			
		M ³ /S	WATTS	M ³ /S	WATTS	M ³ /S	WATTS	M ³ /S	WATTS	M ³ /S	WATTS
3 ¹	HI	0.67	725	0.64	700	0.60	680	0.56	655		
	MED	0.62	650	0.59	630	0.59	610	0.52	590		
	LOW	0.59	605	0.56	590	0.55	570	0.48	545		
4 ¹	HI	0.77	820	0.73	790	0.67	765	0.61	740		
	MED	0.71	705	0.66	675	0.61	645	0.56	625		
	LOW	0.67	645	0.63	620	0.58	595	0.53	575		
CFM											
UNIT TONNAGE	MOTOR SPEED	AVAILABLE EXTERNAL STATIC PRESSURE-IWG*									
		0.20		0.30		0.40		0.50		0.60	
		CFM	WATTS	CFM	WATTS	CFM	WATTS	CFM	WATTS	CFM	WATTS
3 ¹	HI	-	-	-	-	1699	825	1650	785	1570	755
	MED	1684	800	1631	780	1582	750	1524	720	1410	690
	LOW	1487	710	1464	690	1421	670	1367	650	1315	620
4 ¹	HI	1996	960	1933	936	1868	910	1795	880	1722	845
	MED	1804	838	1765	810	1714	785	1650	765	1589	735
	LOW	1681	760	1640	738	1604	715	1541	695	1490	670
UNIT TONNAGE	MOTOR SPEED	AVAILABLE EXTERNAL STATIC PRESSURE-IWG*									
		0.70		0.80		0.90		1.00			
		CFM	WATTS	CFM	WATTS	CFM	WATTS	CFM	WATTS	CFM	WATTS
3 ¹	HI	1430	725	1360	700	1280	680	1180	655		
	MED	1324	650	1260	630	1185	610	1100	590		
	LOW	1246	605	1185	590	1110	570	1020	545		
4 ¹	HI	1635	820	1544	790	1419	765	1300	740		
	MED	1508	705	1407	675	1306	645	1195	625		
	LOW	1416	645	1337	620	1230	595	1120	575		

1. Side Duct application (380/415 Volts)

*Includes allowances for a wet evaporator coil, 25mm [1 in] filters, and the heat exchangers. Refer to STATIC RESISTANCES Table for resistance values on applications other than gas/electric units with side duct airflows.

Table 17: Supply Air Blower Performance (5 Ton Belt Drive) - Side Duct Application

		M³/S														
UNIT TONNAGE	AIR FLOW M ³ /S	AVAILABLE EXTERNAL STATIC PRESSURE-Pa*														
		50		74		99		124		149		174		198		
		RPM	WATTS	RPM	WATTS	RPM	WATTS	RPM	WATTS	RPM	WATTS	RPM	WATTS	RPM	WATTS	
5 ¹	1.18	1059	1560	1077	1590	1095	1630	1114	1650	1134	1660	1158	1685	-	-	
	1.13	1032	1405	1054	1470	1074	1525	1094	1560	1116	1595	1140	1620	1167	1640	
	1.08	1005	1260	1024	1275	1049	1370	1069	1440	1090	1475	1116	1505	1142	1535	
	1.04	980	1160	1002	1170	1022	1190	1044	1250	1066	1350	1090	1410	1117	1440	
	0.99	930	1060	957	1070	983	1080	1010	1100	1039	1160	1064	1260	1092	1340	
	0.94	877	950	908	975	941	1000	976	1020	1009	1050	1040	1100	1070	1225	
	0.90	-	-	-	-	894	885	940	940	980	980	1014	1020	1047	1095	
	0.85	-	-	-	-	855	815	903	860	950	905	988	940	1022	970	
	0.80	-	-	-	-	-	-	884	815	925	850	964	880	1001	910	
	0.75	-	-	-	-	-	-	864	770	908	805	948	835	987	870	
0.71	-	-	-	-	-	-	-	-	882	740	926	780	965	830		
UNIT TONNAGE	AIR FLOW M ³ /S	AVAILABLE EXTERNAL STATIC PRESSURE-Pa*														
		223		248		273		298		322		347		372		
		RPM	WATTS	RPM	WATTS	RPM	WATTS	RPM	WATTS	RPM	WATTS	RPM	WATTS	RPM	WATTS	
5 ¹	1.18	-	-	-	-	-	-	-	-	-	-	-	-	-	-	
	1.13	-	-	-	-	-	-	-	-	-	-	-	-	-	-	
	1.08	1170	1580	-	-	-	-	-	-	-	-	-	-	-	-	
	1.04	1148	1480	1180	1530	-	-	-	-	-	-	-	-	-	-	
	0.99	1121	1385	1155	1425	-	-	-	-	-	-	-	-	-	-	
	0.94	1100	1285	1133	1340	1169	1385	-	-	-	-	-	-	-	-	
	0.90	1079	1180	1110	1240	1143	1280	1178	1330	-	-	-	-	-	-	
	0.85	1058	1060	1090	1135	1122	1190	1158	1240	-	-	-	-	-	-	
	0.80	1035	960	1071	1030	1103	1100	1134	1140	1164	1175	-	-	-	-	
	0.75	1020	900	1056	965	1088	1035	1118	1065	1145	1105	1170	1130	-	-	
0.71	1004	860	1038	880	1070	925	1101	980	1130	1045	1158	1075	-	-		
		CFM														
UNIT TONNAGE	AIR FLOW CFM	AVAILABLE EXTERNAL STATIC PRESSURE- IWG *														
		0.20		0.30		0.40		0.50		0.60		0.70		0.80		
		RPM	WATTS	RPM	WATTS	RPM	WATTS	RPM	WATTS	RPM	WATTS	RPM	WATTS	RPM	WATTS	
5 ¹	2500	1059	1560	1077	1590	1095	1630	1114	1650	1134	1660	1158	1685	-	-	
	2400	1032	1405	1054	1470	1074	1525	1094	1560	1116	1595	1140	1620	1167	1640	
	2300	1005	1260	1024	1275	1049	1370	1069	1440	1090	1475	1116	1505	1142	1535	
	2200	980	1160	1002	1170	1022	1190	1044	1250	1066	1350	1090	1410	1117	1440	
	2100	930	1060	957	1070	983	1080	1010	1100	1039	1160	1064	1260	1092	1340	
	2000	877	950	908	975	941	1000	976	1020	1009	1050	1040	1100	1070	1225	
	1900	-	-	-	-	894	885	940	940	980	980	1014	1020	1047	1095	
	1800	-	-	-	-	855	815	903	860	950	905	988	940	1022	970	
	1700	-	-	-	-	-	-	884	815	925	850	964	880	1001	910	
	1600	-	-	-	-	-	-	864	770	908	805	948	835	987	870	
	1500	-	-	-	-	-	-	-	-	882	740	926	780	965	830	
	UNIT TONNAGE	AIR FLOW CFM	AVAILABLE EXTERNAL STATIC PRESSURE- IWG *													
			0.90		1.00		1.10		1.20		1.30		1.40		1.50	
RPM			WATTS	RPM	WATTS	RPM	WATTS	RPM	WATTS	RPM	WATTS	RPM	WATTS	RPM	WATTS	
5 ¹	2500	-	-	-	-	-	-	-	-	-	-	-	-	-	-	
	2400	-	-	-	-	-	-	-	-	-	-	-	-	-	-	
	2300	1170	1580	-	-	-	-	-	-	-	-	-	-	-	-	
	2200	1148	1480	1180	1530	-	-	-	-	-	-	-	-	-	-	
	2100	1121	1385	1155	1425	-	-	-	-	-	-	-	-	-	-	
	2000	1100	1285	1133	1340	1169	1385	-	-	-	-	-	-	-	-	
	1900	1079	1180	1110	1240	1143	1280	1178	1330	-	-	-	-	-	-	
	1800	1058	1060	1090	1135	1122	1190	1158	1240	-	-	-	-	-	-	
	1700	1035	960	1071	1030	1103	1100	1134	1140	1164	1175	-	-	-	-	
	1600	1020	900	1056	965	1088	1035	1118	1065	1145	1105	1170	1130	-	-	
1500	1004	860	1038	880	1070	925	1101	980	1130	1045	1158	1075	-	-		

1. Side Duct application (380/415 Volts)

*Includes allowances for a wet evaporator coil, 25mm [1 in] filters, and the heat exchangers. Refer to STATIC RESISTANCES Table for resistance values on applications other than gas/electric units with side duct airflows.

Table 18: Supply Air Blower Performance (6.3 Ton Belt Drive) - Side Duct Application

		M³/S													
UNIT TONNAGE	AIR FLOW M ³ /S	AVAILABLE EXTERNAL STATIC PRESSURE-Pa*													
		50		74		99		124		149		174		198	
		RPM	WATTS	RPM	WATTS	RPM	WATTS	RPM	WATTS	RPM	WATTS	RPM	WATTS	RPM	WATTS
6.3 ¹	1.50	1150	2325	1182	2425	-	-	-	-	-	-	-	-	-	-
	1.42	1100	2010	1129	2090	1157	2150	1185	2225	-	-	-	-	-	-
	1.32	1045	1700	1074	1780	1102	1850	1131	1940	1160	2025	1190	2075	-	-
	1.23	985	1425	1015	1475	1045	1540	1075	1630	1103	1715	1135	1760	1163	1825
	1.13	930	1240	958	1300	990	1350	1020	1400	1051	1430	1081	1490	1111	1600
	1.04	-	-	905	1070	933	1160	965	1210	997	1250	1028	1285	1060	1325
	0.94	-	-	-	-	-	-	919	1025	950	1100	982	1130	1014	1160
	0.85	-	-	-	-	-	-	-	-	909	925	939	1005	968	1030
UNIT TONNAGE	AIR FLOW M ³ /S	AVAILABLE EXTERNAL STATIC PRESSURE-Pa*													
		223		248		273		298		322		347		372	
		RPM	WATTS	RPM	WATTS	RPM	WATTS	RPM	WATTS	RPM	WATTS	RPM	WATTS	RPM	WATTS
6.3 ¹	1.50	-	-	-	-	-	-	-	-	-	-	-	-	-	-
	1.42	-	-	-	-	-	-	-	-	-	-	-	-	-	-
	1.32	-	-	-	-	-	-	-	-	-	-	-	-	-	-
	1.23	1193	1920	-	-	-	-	-	-	-	-	-	-	-	-
	1.13	1142	1675	1173	1730	-	-	-	-	-	-	-	-	-	-
	1.04	1090	1380	1124	1450	1155	1550	1186	1640	-	-	-	-	-	-
	0.94	1045	1175	1077	1200	1109	1275	1140	1360	1170	1460	-	-	-	-
	0.85	998	1050	1028	1060	1058	1060	1087	1075	1118	1150	1148	1250	1176	1360
		CFM													
UNIT TONNAGE	AIR FLOW CFM	AVAILABLE EXTERNAL STATIC PRESSURE-IWG*													
		0.20		0.30		0.40		0.50		0.60		0.70		0.80	
		RPM	WATTS	RPM	WATTS	RPM	WATTS	RPM	WATTS	RPM	WATTS	RPM	WATTS	RPM	WATTS
16.3 ¹	3200	1150	2325	1182	2425	-	-	-	-	-	-	-	-	-	-
	3000	1100	2010	1129	2090	1157	2150	1185	2225	-	-	-	-	-	-
	2800	1045	1700	1074	1780	1102	1850	1131	1940	1160	2025	1190	2075	-	-
	2600	985	1425	1015	1475	1045	1540	1075	1630	1103	1715	1135	1760	1163	1825
	2400	930	1240	958	1300	990	1350	1020	1400	1051	1430	1081	1490	1111	1600
	2200	-	-	905	1070	933	1160	965	1210	997	1250	1028	1285	1060	1325
	2000	-	-	-	-	-	-	919	1025	950	1100	982	1130	1014	1160
	1800	-	-	-	-	-	-	-	-	909	925	939	1005	968	1030
UNIT TONNAGE	AIR FLOW CFM	AVAILABLE EXTERNAL STATIC PRESSURE-IWG*													
		0.90		1.00		1.10		1.20		1.30		1.40		1.50	
		RPM	WATTS	RPM	WATTS	RPM	WATTS	RPM	WATTS	RPM	WATTS	RPM	WATTS	RPM	WATTS
6.3 ¹	3200	-	-	-	-	-	-	-	-	-	-	-	-	-	-
	3000	-	-	-	-	-	-	-	-	-	-	-	-	-	-
	2800	-	-	-	-	-	-	-	-	-	-	-	-	-	-
	2600	1193	1920	-	-	-	-	-	-	-	-	-	-	-	-
	2400	1142	1675	1173	1730	-	-	-	-	-	-	-	-	-	-
	2200	1090	1380	1124	1450	1155	1550	1186	1640	-	-	-	-	-	-
	2000	1045	1175	1077	1200	1109	1275	1140	1360	1170	1460	-	-	-	-
	1800	998	1050	1028	1060	1058	1060	1087	1075	1118	1150	1148	1250	1176	1360

1. Side Duct application (380/415 Volts)

*Includes allowances for a wet evaporator coil, 25mm [1 in] filters, and the heat exchangers. Refer to STATIC RESISTANCES Table for resistance values on applications other than gas/electric units with side duct airflows.

Table 19: Belt Drive Motor And Drive Data

MODEL	BLOWER RANGE (RPM)	MOTOR ¹				ADJUSTABLE MOTOR PULLY				FIXED BLOWER PULLY				BELT			
		HP	RPM	FRAME SIZE	SERVICE FACTOR	DESIG-NATION	PITCH DIA.		BORE		PITCH DIA.		BORE		PITCH LENGTH		DESIG-NATION
							mm	inch	mm	inch	mm	inch	mm	inch	mm	inch	
5 TON	812-1102	1.5	1450	56	1.0	IVL44	69-97	2.8-3.8	22	7/8	127	5.0	25	1	922	36.3	A35
6 TON	948-1227	1.5	1450	56	1.0	IVM50	86-112	3.4-4.4	22	7/8	132	5.2	25	1	947	37.3	A36

1. All motors have solid bases and are inherently protected. These motors can be selected to operate into their service factor because they are located in the moving air, upstream of any heating device.

Table 20: Static Resistances

DESCRIPTION		RESISTANCE, Pa										
		M ³ /S										
		0.47	0.57	0.66	0.75	0.85	0.94	1.03	1.13	1.23	1.32	1.42
ECONOMIZER ^{1,2}		17.4	19.8	22.3	27.3	32.2	37.2	42.2	49.6	57.0	64.5	74.4
ELECTRIC HEATERS ¹	7-15KW	10.0	12.4	14.9	17.4	19.8	24.8	29.8	34.7	39.7	47.1	54.6
	20-30KW	14.9	17.4	19.8	22.3	27.3	32.2	37.2	42.2	49.6	57.0	64.5
BOTTOM DUCT CONNECTIONS ¹		14.9	17.4	19.8	22.3	24.8	27.3	29.8	34.7	39.7	47.1	54.6
COOLING ONLY ³		19.8	25.0	29.8	34.7	39.7	44.6	49.6	57.0	64.5	71.9	79.4
DESCRIPTION		RESISTANCE, IWG										
		CFM										
		1000	1200	1400	1600	1800	2000	2200	2400	2600	2800	3000
ECONOMIZER ^{1,2}		0.07	0.08	0.09	0.11	0.13	0.15	0.17	0.20	0.23	0.26	0.30
ELECTRIC HEATERS ¹	7-15KW	0.04	0.05	0.06	0.07	0.08	0.10	0.12	0.14	0.16	0.19	0.22
	20-30KW	0.06	0.07	0.08	0.09	0.11	0.13	0.15	0.17	0.20	0.23	0.26
BOTTOM DUCT CONNECTIONS ¹		0.06	0.07	0.08	0.09	0.10	0.11	0.12	0.14	0.16	0.19	0.22
COOLING ONLY ³		0.08	0.10	0.12	0.14	0.16	0.18	0.20	0.23	0.26	0.29	0.32

1. Deduct these resistance values from the available external static pressure shown in SUPPLY AIR BLOWER PERFORMANCE Tables.
2. The pressure through the economizer is greater for 100% outdoor air than for 100% return air. If the resistance of the return air duct system is less than 62.0 Pa [0.25 IWG], the unit will deliver less M3/S or CFM during full economizer operation.
3. Add these resistance values to the available static resistance values on SUPPLY AIR BLOWER PERFORMANCE Tables.

Phasing

YORK MODEL ZF units are properly phased at the factory. Check for proper compressor rotation. If the blower or compressors rotate in the wrong direction at start-up, the electrical connection to the unit is misphased. Change the incoming line connection phasing to obtain proper rotation. (Scroll compressors operate in only one direction. If the scroll is drawing low amperage, has similar suction and discharge pressures, or producing a high noise level, the scroll is misphased).

CAUTION

Scroll compressors require proper rotation to operate correctly. Units are properly phased at the factory. Do not change the internal wiring to make the blower, condenser fans, or compressor rotate correctly.

Supply Air Blowers

These blowers have either 3-speed direct drive motors, or single speed motors equipped with a belt drive. Belt drive units have a variable pitch pulley that allows the blower speed to be adjusted.

Checking Supply Airflow Rate

The RPM of the supply air blower will depend on the required Volumetric Flow Rate, the unit accessories or options and the static resistances of both the supply and the return air duct systems. With this information, the motor speed tap (direct drive) or the motor pulley number of turns open (belt drive) can be determined from the Blower Performance Data Tables.

CAUTION

Belt drive blower systems **MUST** be adjusted to the specific static and CFM requirements for the application. The belt drive blowers are **NOT** set at the factory for any specific static or CFM. Adjustments of the blower speed and belt tension are **REQUIRED**. Tighten blower pulley and motor sheave set screws after these adjustments. Re-checking set screws after 10-12 hrs. run time is recommended.

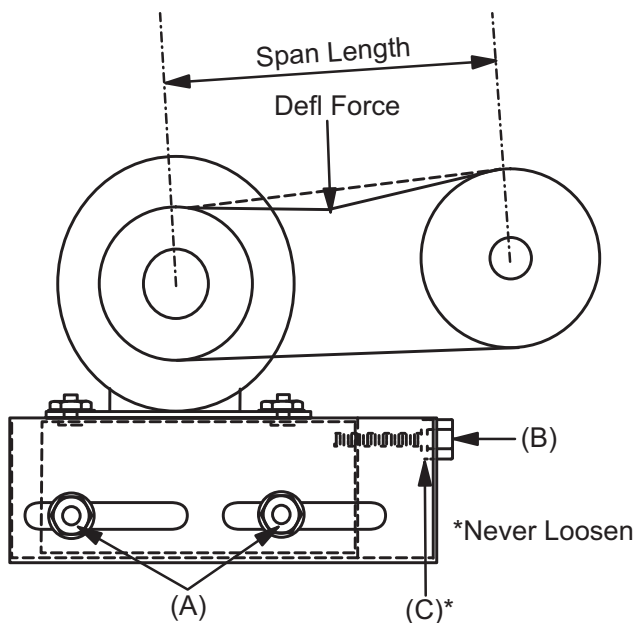

Figure 20: Belt Adjustment

CAUTION

Procedure for adjusting belt tension:

1. Loosen six nuts (top and bottom) A.
2. Adjust by turning (B).
3. Never loosen nuts (C).
4. Use belt tension checker to apply a perpendicular force to one belt at the midpoint of the span as shown. Deflection distance of 4mm (5/32") is obtained. To determine the deflection distance from normal position, use a straight edge from sheave to sheave as reference line. The recommended deflection force is as follows: Tension new belts at the max. deflection force recommended for the belt section. Check the belt tension at least two times during the first 24 hours of operation. Any retensioning should fall between the min. and max. deflection force values.
5. After adjusting re-tighten nuts (A).

Note the following:

1. Pulleys can be adjusted in half turn increments.
2. The tension on the belt should be adjusted as shown in the Belt Adjustment Figure 20.
3. Tighten blower pulley and motor sheave set screws after any adjustments. Re-check set screws after 10-12 hrs. run time is recommended.

Start the supply air blower motor. Adjust the resistances in both the supply and the return air duct systems to balance the air distribution throughout the conditioned space. The job specifications may require that this balancing be done by someone other than the equipment installer.

To check the supply air volumetric flow rate after the initial balancing has been completed:

1. Remove the two 8 mm (5/16") dot plugs from the blower motor and the filter access panels shown in Figure 19.
2. Insert at least 200 mm (8") of 6 mm (1/4") tubing into each of these holes for sufficient penetration into the air flow on both sides of the indoor coil.

NOTE: The tubes must be inserted and held in a position perpendicular to the air flow so that velocity pressure will not affect the static pressure readings.

3. Using an inclined manometer, determine the pressure drop across a dry evaporator coil. Since the moisture on an evaporator coil may vary greatly, measuring the pressure drop across a wet coil under field conditions would be inaccurate. To assure a dry coil, the compressors should be deactivated while the test is being run.
4. Knowing the pressure drop across a dry coil, the actual volumetric flow rate through the unit can be determined from the curve in Pressure Drop vs. Supply Air flow rate (Figure 21).

▲WARNING

Failure to properly adjust the total system air quantity can result in extensive blower damage.

After readings have been obtained, remove the tubes and reinstall the two 8 mm (5/16") dot plugs that were removed in Step 1.

NOTE: De-energize the compressors before taking any test measurements to assure a dry indoor coil.

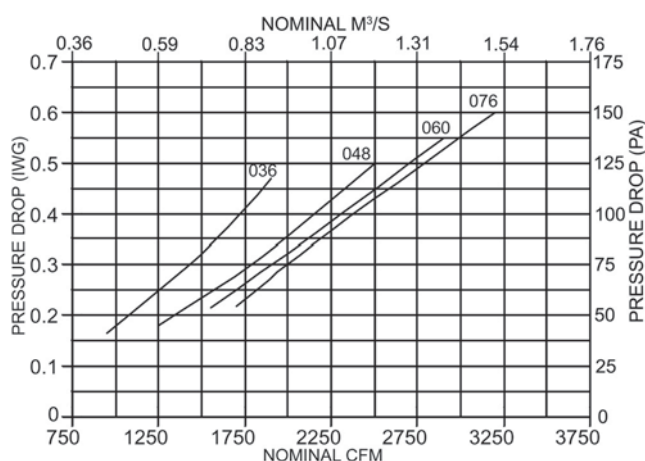

Figure 21: Pressure Drop Across Coil Operation

Cooling Sequence Of Operation

ZF units have either a Simplicity Lite or a Smart Equipment™ Control Board. Both control boards work in a similar fashion, as outlined below.

For the ZF series of units, the thermostat makes a circuit between "R" and "Y1" for the first stage of cooling.

The call is passed to the **Unit Control Board (UCB)**, which then determines whether the requested operation is available and, if so, which components to energize.

For gas heating, the UCB monitors the "W1" call but does not handle the operation of the gas furnace. An ignition control board controls the gas heater operation. For electric heat units, the UCB passes the call to the electric heater. In both cases, when the "W1" call is sensed, the indoor air blower is energized following a specified heating delay.

If at any time a call for both heating and cooling are present, the heating operation will be performed. If operating, the cooling system is halted as with a completion of a call for cooling. Heating always takes priority.

Continuous Blower

By setting the room thermostat fan switch to "ON," the supply air blower will operate continuously.

Intermittent Blower

With the room thermostat fan switch set to "AUTO" and the system switch set to either the "AUTO" or "HEAT" settings, the blower is energized whenever a cooling or heating operation is requested. The blower is energized after any specified delay associated with the operation.

When energized, the indoor blower has a minimum run time of 30 seconds. Additionally, the indoor blower has a delay of 10 seconds between operations.

No Outdoor Air Options

When the thermostat calls for cooling, the low-voltage control circuit from "R" to "Y1" and "G" is completed. The compressor and condenser fan motor are energized. After completing the specified fan on delay for cooling, the UCB will energize the blower motor.

Once the thermostat has been satisfied, it will de-energize Y1. If the compressor has satisfied its minimum run time, the compressor and condenser fan de-energize. Otherwise, the unit operates the cooling system until the minimum run time for the compressor has been completed. After the compressor de-energizes, the blower is stopped following the elapse of the fan off delay for cooling.

To be available, a compressor must not be locked-out due to a high or low-pressure switch or freezestat trip Simplicity Lite Control or Evaporator Low Limit sensor detecting a temperature below 26° F Smart Equipment™ Control and the anti-short cycle delay (ASCD) must have elapsed.

Economizer With Single Enthalpy Sensor (Simplicity Lite) or Economizer With Dry Bulb Sensor (Smart Equipment™)

When the room thermostat calls for cooling, the low voltage control circuit from "R" to "G" and "Y1" is completed. The UCB energizes the blower motor (if the fan switch on the room thermostat is set in the "AUTO" position) and drives the economizer dampers from fully closed to their minimum position. If the enthalpy (Simplicity Lite) or Dry bulb temperature (Smart Equipment™) of the outdoor air is below the setpoint of the enthalpy or dry bulb controller (previously determined), "Y1" energizes the economizer. The dampers will modulate to maintain a constant supply air temperature as monitored by the discharge air sensor. If the outdoor air enthalpy (Simplicity Lite) or dry bulb temperature (Smart Equipment™) is above the setpoint, "Y1" energizes the compressor and condenser fan motor only.

Once the thermostat has been satisfied, it will de-energize "Y1". If the compressor has satisfied its minimum run time, the compressor and condenser fan are de-energized. Otherwise, the unit operates the cooling system until the minimum run times for the compressor has been completed. After the compressor de-energizes, the blower is stopped following the elapse of the fan off delay for cooling, and the economizer damper goes to the closed position. If the unit is in continues fan operation the economizer damper goes to the min. position.

Economizer With Dual Enthalpy Sensors

The operation with the dual enthalpy sensors is identical to the single sensor except that a second enthalpy sensor is mounted in the return air. This return air sensor allows the economizer to choose between outdoor air and return air, whichever has the lowest enthalpy value, to provide maximum operating efficiency.

Economizer With Power Exhaust

A unit equipped with an economizer (dry bulb single or dual enthalpy) and a power exhaust operates as specified above with one addition. The power exhaust motor is energized 45 seconds after the actuator position exceeds the exhaust fan set point on the economizer control. When the power exhaust is operating, the second stage of mechanical cooling will not operate. As always, the "R" to "G" connection provides minimum position but does not provide power exhaust operation.

Motorized Outdoor Air Dampers

This system operation is the same as the units with no outdoor air options with one exception. When the "R" to "G" circuit is complete, the motorized damper drives open to a position set by the thumbwheel on the damper motor. When the "R" to "G" circuit is opened, the damper spring returns fully closed.

Cooling Operation Errors

Each cooling system is monitored for operation outside of the intended parameters. Errors are handled as described below. All system errors override minimum run times for compressors.

High-Pressure Limit Switch

During cooling operation, if a high-pressure limit switch opens, the UCB will de-energize the compressor, initiate the ASCD (Anti-short cycle delay), and stop the condenser fan. If the call for cooling is still present at the conclusion of the ASCD, the UCB will re-energize the compressor.

Should a high-pressure switch open three times within two hours of operation, the UCB will lock-out the associated compressor and flash a code on the Simplicity Lite Control (see Table 26) or sent error message to the LCD Smart Equipment™ Control.

Low-Pressure Limit Switch

The low-pressure limit switch is not monitored during the initial 30 seconds of a cooling system's operation. For the following 30 seconds, the UCB will monitor the low-pressure switch to ensure it closes. If the low-pressure switch fails to close after the 30-second monitoring phase, the UCB will de-energize the compressor, initiate the ASCD, and stop the condenser fan.

Once the low-pressure switch has been proven (closed during the 30-second monitor period described above), the UCB will monitor the low-pressure limit switch for any openings. If the low-pressure switch opens for greater than 5 seconds, the UCB will de-energize the compressor, initiate the ASCD, and stop the condenser fan.

If the call for cooling is still present at the conclusion of the ASCD, the UCB will re-energize the compressor.

Should a low-pressure switch open three times within one hour of operation, the UCB will lock-out the compressor and flash a code on the Simplicity Lite Control (Table 26) or sent error message to the LCD Smart Equipment™ Control.

Freezestat (Simplicity Lite Control)

During cooling operation, if a freezestat opens, the UCB will de-energize the compressor, initiate the ASCD, and stop the condenser fan. If the call for cooling is still present at the conclusion of the ASCD, the UCB will re-energize the halted compressor.

Should a freezestat open three times within two hours of operation, the UCB will lock-out the associated compressor and flash a code on the Simplicity Lite Control (Table 26).

Evaporator Low Limit (Smart Equipment™ Control)

During cooling operation, if the evaporator sensor detects a temperature below 26 Deg. F (default), the UCB will de-energize the compressor, initiate the ASCD, and stop the condenser fan. If the call for cooling is still present at the conclusion of the ASCD, the UCB will re-energize the halted compressor.

Should the evaporator sensor detect a temperature below 26°F three times within two hours of operation, the UCB will lock-out the associated compressor and flash an error message.

Low Ambient Cooling (Simplicity Lite Control)

To determine when to operate in low ambient mode, the UCB has a pair of terminals connected to a temperature-activated switch set at 45°F. When the low ambient switch is closed and the thermostat is calling for cooling, the UCB will operate in the low ambient mode.

Low ambient mode operates the compressors in this manner: 10 minutes on, 5 minutes off. The indoor blower is operated throughout the cycle. The 5-minute off period is necessary to defrost the indoor coil.

Low ambient mode always begins with compressor operation. Compressor minimum run time may extend the minutes of compressor operation. The defrost cycle will begin immediately following the elapse of the minimum run time.

When operating in low ambient mode, the UCB will not lockout the compressors due to a freezestat trip. However, a freezestat trip will de-energize the associated compressor. If the call for cooling is still present at the end of the ASCD and the freezestat has closed, the unit will resume operation.

Low Ambient Cooling (Smart Equipment™ Control)

To determine when to operate in low ambient mode, the UCB has an **Outdoor Air Temperature Sensor (OAT)** with a low ambient setpoint at 45°F (default). When the **OAT Sensor** senses a temperature below the low ambient setpoint and the

thermostat is calling for cooling, the UCB will operate in the low ambient mode.

Low ambient mode operates the compressors in this manner:

10 minutes on, 5 minutes off. The indoor blower is operated throughout the cycle. The 5-minute off period is necessary to defrost the indoor coil.

Low ambient mode always begins with compressor operation. Compressor minimum run time may extend the minutes of compressor operation. The off cycle will begin immediately following the elapse of the minimum run time.

When operating in low ambient mode, an evaporator temperature below 26°F will de-energize the compressor. If the call for cooling is still present at the end of the ASCD and the evaporator temperature is above 26°F, the unit will resume operation.

Safety Controls

The unit control board monitors the following inputs for each cooling system:

1. A suction line freezestat to protect against low evaporator temperatures due to a low airflow or a low return air temperature, (opens at 26 ± 5 °F and resets at 38 ± 5 °F) or an evaporator low limit sensor to protect against low evaporator temperatures due to a low airflow or a low return air temperature, set at 26°F.
2. A high-pressure switch to protect against excessive discharge pressures due to a blocked condenser coil or a condenser motor failure, (opens at 625 ± 25 psig).
3. A low-pressure switch to protect against loss of refrigerant charge, (opens at 50 ± 5 psig).

The above pressure switches are hard-soldered to the unit. The refrigeration systems are independently monitored and controlled. On any fault, only the associated system will be affected by any safety/preventive action.

The unit control board monitors the temperature limit switch of electric heat units and the temperature limit switch and the gas valve of gas furnace units.

Compressor Protection

In addition to the external pressure switches, the compressor also has inherent (internal) protection. If there is an abnormal temperature rise in a compressor, the protector will open to shut down the compressor. The UCB incorporates features to minimize compressor wear and damage. An **Anti-Short Cycle Delay (ASCD)** is utilized to prevent operation of a compressor too soon after its previous run. Additionally, a minimum run time is imposed any time a compressor is energized.

The ASCD is initiated on unit start-up and on any compressor reset or lock-out.

Flash Codes or Error Messages

The UCB will initiate flash a code on the Simplicity Lite Control (see Table 26) or sent error message to the LCD Smart Equipment™ Control associated with errors within the system.

Reset

Remove the call for cooling, by raising thermostat setting higher than the conditioned space temperature. This resets any pressure or freezestat lockouts.

Electric Heating Sequence Of Operations

The following sequence describes the operation of the electric heat section.

Single-stage heating (7, 10, & 15 kW 460V heaters. All other heaters MUST use a two-stage thermostat):

- a. Upon a call for heat by the thermostat, the heater sequencer (1S) will be energized. After completing the specified fan on delay for heating, the UCB will energize the blower motor.
- b. The thermostat will cycle the electric heat to satisfy the heating requirements of the conditioned space.

Two-stage heating (applies only to 20 and 30 kW heater 460V heaters.):

- a. Upon a call for first-stage heat by the thermostat, the heater sequencer (1S) and contactor (2M) (20, 30 kW 460 volt) will be energized. After completing the specified fan on delay for heating, the UCB will energize the blower motor.

If the second stage of heat is required, heater sequencer (2S) or contactor (3M) (20, 30 kW 460 volt) will be energized. After completing the specified fan on delay for heating, the UCB will energize the blower motor.

- b. The thermostat will cycle the electric heat to satisfy the heating requirements of the conditioned space.

Safety Controls

The control circuit includes the following safety controls:

1. Temperature Limit Switch (TLS) - This control is located inside the heater compartment and is set to open at the temperature indicated in the Limit Control Setting Table 21. It resets automatically. The limit switch operates when a high temperature condition, caused by inadequate supply air flow occurs, thus shutting down the heater and energizing the blower.

Table 21: Limit Control Setting

VOLTAGE	kW	TEMPERATURE LIMIT SWITCH	Open Temp °C[°F]
380/415-3-50	7	2, 4, 6	58[140]
	10	2, 4, 6	58[140]
	15	2, 4, 6	58[140]
	20	3	71[160]
	30	3	65[150]

Flash Codes or Error Messages

The UCB will initiate a flash code associated with errors within the system. Refer to flash code on the Simplicity Lite Control (See Table 26) or sent error message to the LCD Smart Equipment™ Control.

Reset

Remove the call for heating by lowering the thermostat setting lower than the conditioned space temperature. This resets any flash codes.

Heat Anticipator Setpoints

It is important that the anticipator setpoint be correct. Too high of a setting will result in longer heat cycles and a greater temperature swing in the conditioned space. Reducing the value below the correct setpoint will give shorter "ON" cycles and may result in the lowering of the temperature within the conditioned space. Refer to Table 22 for the required heat anticipator setting.

Table 22: Electric Heat Anticipator Setpoints

HEATER KW	VOLTAGE	SETTING, AMPS	
		TH1	TH2
7	380/415-3-50	0.35	-
10		0.35	-
15		0.35	-
20		0.37	0.29
30		0.37	0.29

Gas Heating Sequence Of Operation

When there is a W1 call for heat, the heat relay (RW1) is energized by the unit control board (UCB). The RW1-1 contacts immediately close energizing the ignition control board (ICB). The ICB checks the state of the flame sense circuit, the roll out switch, the centrifugal switch and the primary / auxiliary temperature limit switch circuit. If they are in the expected state, then the ICB energizes the draft motor and verifies that the centrifugal switch located on the end of the draft motor closes. After the centrifugal switch closes, a 15 second heat exchanger purging period is completed. After this purging period, the ICB will simultaneously energize the pilot gas valve and the ignition

coil. Once the flame sensor senses a pilot flame is present, the ignition coil is de-energized. The ICB checks for pilot flame stability and once the ICB is satisfied that the pilot flame is stable, the main gas valve is energized by the ICB. The UCB will energize the indoor blower after a 45 second delay from the call for heat. The ICB and UCB both monitor the furnace safety devices during the furnace operation. When the call for heat is satisfied, the ICB closes the pilot and main gas valves and performs a 30 second purging of the heat exchanger by continuing the operation of the draft motor. The UCB continues the operation of the indoor blower for a configurable amount of time after the call for heat is satisfied.

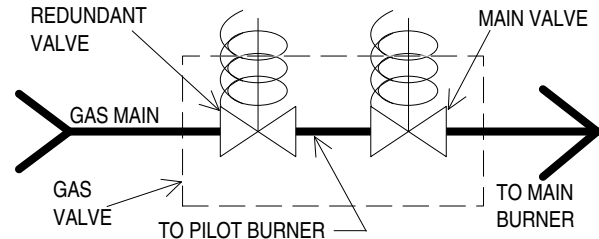
**Figure 22: Gas Valve Piping**

Two Stage Furnace Only

If a W1 only call for heat from a two stage thermostat is present, then a two stage furnace will start on high fire for 1 minute and then reduce to low fire until the call for heat is satisfied or a W2 call for heat is received. If a W2 call for heat is received while in low fire operation, then the ICB will immediately move to high fire operation. If a W1 and W2 call for heat is present, then the furnace will remain on high fire operation until the W2 call for heat is satisfied.

Automatic staging of a two stage furnace using a single stage thermostat is possible. To achieve automatic staging of a two stage furnace using a single stage thermostat, a jumper is installed between R and W2 on the UCB with the single stage thermostat heat control connected to W1. Wired in this manner, the ICB will interpret the continuous power on W2 as automatic two stage operation of the two stage furnace. The unit will operate the same as a W1 only call for heat for 10 minutes. If the call for heat is not satisfied in the 10 minutes, then the ICB will move to high fire operation until the W1 call for heat has been satisfied.

Gas Heat Operation Errors

During furnace operation, the ICB monitors the flame sense circuit, the centrifugal switch, the primary limit switch and the roll out switch. If a signal from any of the inputs moves to a fault state, then the ICB immediately closes the pilot and main gas valves. The ICB will determine the device that is signaling a fault and flash a code for that device. A primary limit trip, centrifugal switch trip or flame sense fault triggers a temporary lock out. An auxiliary limit or a roll out switch trip requires intervention to reset the ICB. The UCB also monitors the primary limit and gas valve.

Temperature Limits

The primary limit is located such that the temperature sensitive switch can sense the temperature of the heat exchanger tubes. On single stage models the limit is mounted to the condenser partition panel. On two stage models the limit is mounted just above the inlet of the heat exchanger tubes on the right side. If a primary limit (LS) fault occurs (the primary limit opens due to excessive heat exchanger temperature), then the ICB will flash the appropriate code (Table 27) and monitor the primary limit. The UCB will energize the indoor blower and the ICB will energize the draft motor while the primary limit is open. When the primary limit closes and the call for heat still exists, the ICB will start the ignition sequence over and the UCB will de-energize the blower for 45 seconds. However, the auxiliary limit is in series with the primary limit and it takes first control. If the excessive heat has been high enough to cause the auxiliary limit (AUX) to open, then the ICB will flash the primary limit code but the furnace will not retry ignition during the same call for heat. The auxiliary limit is of the manual reset type and is mounted in the upper right hand corner of the panel between the burner manifold and the flue gas collector box just behind the draft motor. If the auxiliary switch has opened, then special attention should be paid to the primary limit as it may be faulty as well. However, the auxiliary switch is sized such that multiple trips of the primary limit due to complete blower failure will cause enough heat to build up and trip the auxiliary.

If the primary limit opens three times within one hour, then the UCB will lock on the indoor blower and flash a code on the Simplicity Lite Control (Table 26) or sends error message to the LCD Smart Equipment™ Control.

Gas Valve

The UCB monitors the gas valve (GV). Any time the UCB senses voltage at the GV without a call for heat for a continuous five-minute period, the UCB will lock on the indoor blower and a flash code on the UCB is initiated (Table 26). When the UCB no longer senses voltage at the GV the UCB will de-energize the indoor blower after the expiration of the indoor blower heating off delay.

If the voltage has been sensed at the GV for at least 15 seconds during the fan on delay for heating and the UCB no longer senses voltage at the GV (W1 call for heat removed or an ICB fault exists), then the UCB forces the indoor blower on for the indoor blower heating off delay.

The gas valve is of the redundant type. If for any reason the main gas valve fails in the open position, then the redundant valve ahead of the main gas valve will shut off the flow of gas to both the pilot and main gas valves.

Centrifugal Switch

The centrifugal switch is mounted on the end of the draft motor and it is an integral part of the motor assembly. On a call for heat, the ICB checks the centrifugal switch (CS) for open state before it energizes the draft motor. If it is closed, then the ICB will lock out the furnace and flash a code (Table 27). If open,

then the ICB will energize the draft motor and verify that the switch closes before initiating the purging and ignition sequence. If at any time during furnace operation the centrifugal switch opens, then the ICB will de-energize the pilot and main gas valves and monitor the centrifugal switch. If the centrifugal switch closes and the call for heat still exists, then the ICB will retry the purging and ignition sequence.

Rollout Switch

This temperature sensitive switch is located in the burner vestibule just above the right hand side of the burner assembly. In the event of the flame spilling out into the burner manifold area the rollout switch will open, the ICB will close both the main and pilot gas valves and flash a code (Table 27). The ICB will not retry the ignition sequence during the same call for heat.

Flame Sense Circuit

The flame sensor is mounted on the left hand side of the burner assembly and is positioned such that the pilot flame surrounds the tip of the sensor. On a call for heat the ICB checks for the flame sense circuit to be open. If open, then the ICB initiates the purging and ignition sequence. Once the pilot flame is present, the ICB monitors the flame sense circuit for pilot flame stability. If the pilot flame is unstable or lost completely, then the ICB will immediately close both the pilot and main gas valves. The ICB will retry the purging and ignition sequence. If the flame is unstable or lost more than 16 times during the same call for heat, then the ICB will lock out furnace operation for 5 minutes.

Table 23: Limit Control Setting

Unit (Tons)	Capacity, MBH		Limit Control Opens, °F	
	Input	Output	Direct Drive	Belt Drive
3	15 (50)	12 (40)	115 (240)	-
4	22 (75)	18 (60)	99 (210)	-
5, 6.3	29 (100)	29 (80)	-	99 (210)

Flash Codes or Error Messages

The UCB will initiate a flash code associated with errors within the system. Refer to flash a code on the Simplicity Lite Control (See Table 26) or sent error message to the LCD Smart Equipment™ Control.

Heat Anticipator Setpoints

It is important that the anticipator setpoint be correct. Too high of a setting will result in longer heat cycles and a greater temperature swing in the conditioned space. Reducing the value below the correct setpoint will give shorter "ON" cycles and may result in the lowering of the temperature within the conditioned space.

Table 24: Gas Heat Anticipator Setpoints

Gas Valve	Anticipator Setpoint
Honeywell VR8204M	0.60 amp
White-Rodgers 36E36	0.54 amp

Start-Up (Cooling)

Prestart Check List

After installation has been completed:

1. Check the electrical supply voltage being supplied. Be sure that it is the same as listed on the unit nameplate.
2. Set the room thermostat to the off position.
3. Turn unit electrical power on.
4. Set the room thermostat fan switch to on.
5. Check indoor blower rotation.
 - If blower rotation is in the wrong direction. Refer to Phasing Section in general information section.
 - Check blower drive belt tension.
6. Check the unit supply air flow rate. See "CHECKING SUPPLY AIR FLOW RATE" on page page 36.
7. Measure evaporator fan motor's amp draw.
8. Set the room thermostat fan switch to off.
9. Turn unit electrical power off.

Operating Instructions

1. Turn unit electrical power on.
2. Set the room thermostat setting to lower than the room temperature.
3. Compressor will energize after the built-in time delay (five minutes).

Post Start Check list

1. Verify proper system pressures.
2. Measure the temperature drop across the evaporator coil.
3. Measure the system Amperage draw across all legs of 3 phase power wires.
4. Measure the condenser fan amp draw.

Shut Down

1. Set the thermostat to highest temperature setting.
2. Turn off the electrical power to the unit.

Start-Up (Gas Heat)

Pre-Start Check List

Complete the following checks before starting the unit.

1. Check the type of gas being supplied. Be sure that it is the same as listed on the unit nameplate.
2. Make sure that the vent and combustion air hoods have been properly installed.

Operating Instructions

CAUTION

This furnace is equipped with an intermittent pilot and automatic re-ignition system. DO NOT attempt to manually light the pilot.

TO LIGHT PILOT AND MAIN BURNERS:

1. Turn "off" electric power to unit.
2. Turn room thermostat to lowest setting.
3. Turn gas valve knob to "on" position.
4. Turn "on" electric power to unit.
5. Set room thermostat to desired temperature. (If thermostat "set" temperature is above room temperature, pilot burner ignition will occur and, after an interval to prove pilot flame, main burners will ignite).

To Shut Down:

1. Turn "off" electric power to unit.
2. Depress knob of gas valve while turning to "off" position.

Post-Start Check List (Gas)

After the entire control circuit has been energized and the heating section is operating, make the following checks:

1. Check for gas leaks in the unit piping as well as the supply piping.

WARNING

FIRE OR EXPLOSION HAZARD

Failure to follow the safety warning exactly could result in serious injury, death or property damage.

Never test for gas leaks with an open flame. use a commercially available soap solution made specifically for the detection of leaks to check all connections. A fire or explosion may result causing property damage, personal injury or loss of life.

2. Check for correct manifold gas pressures. See "Checking Gas Input" on page page 43.
3. Check the supply gas pressure. It must be within the limits shown on rating nameplate. Supply pressure should be checked with all gas appliances in the building at full fire. At no time should the standby gas line pressure exceed 3.24 kPa (13.0"), nor the operating pressure drop below 1.25 kPa (5.0") for natural gas units. If gas pressure is outside these limits, contact the local gas utility for corrective action.

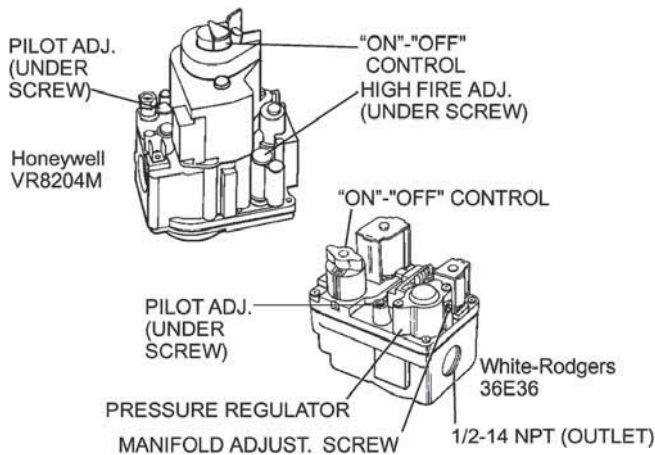

Figure 23: Typical Gas Valves

Manifold Gas Pressure Adjustment

Small adjustments to the high-fire gas flow may be made by turning the pressure regulator adjusting screw on the automatic gas valve.

Adjust as follows:

1. Remove the cap on the regulator. It's located next to the push-on electrical terminals.
2. To decrease the gas pressure, turn the adjusting screw counterclockwise.
3. To increase the gas pressure, turn the adjusting screw clockwise.

NOTE: The correct manifold pressure for these furnaces is 872 \pm 74 Pa gauge (3.50 IWG \pm 0.3).

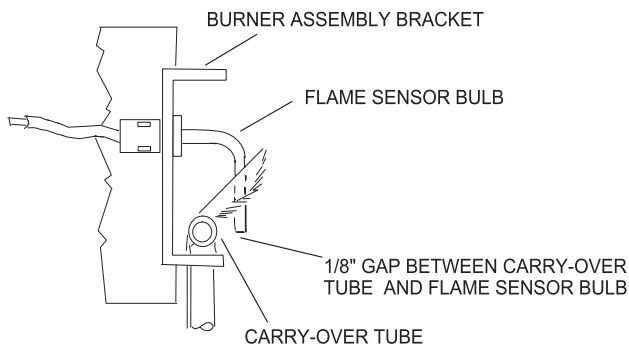

Figure 24: Proper Flame Adjustment

Pilot Checkout

The pilot flame should envelope the end of the flame sensor. To adjust pilot flame, (1) remove pilot adjustment cover screw, (2)

increase or decrease the clearance for air to the desired level, (3) be sure to replace cover screw after adjustment to prevent possible gas leakage.

Put the system into operation and observe through complete cycle to be sure all controls function properly.

Burner Instructions

To check or change burners, pilot or orifices, CLOSE MAIN MANUAL SHUT-OFF VALVE AND SHUT OFF ALL ELECTRIC POWER TO THE UNIT.

1. Remove the screws holding either end of the manifold to the burner supports.
2. Open the union fitting in the gas supply line just upstream of the unit gas valve and downstream from the main manual shut-off valve.
3. Remove the gas piping closure panel.
4. Disconnect wiring to the gas valves and spark ignitors. Remove the manifold-burner gas valve assembly by lifting up and pulling back.

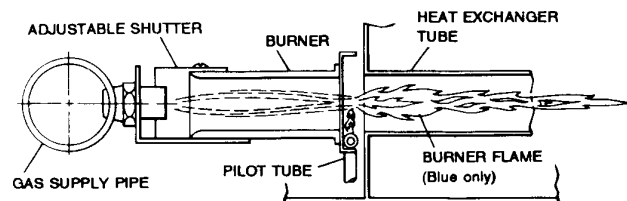

Figure 25: Typical Flame Appearance

Burners are now accessible for service.

Reverse the above procedure to replace the assemblies. Make sure that burners are level and seat at the rear of the heat exchanger.

Burner Air Shutter Adjustment

Adjust burner shutters so no yellow flame is observed in the heat exchanger tubes.

Checking Gas Input

Natural Gas

1. Turn off all other gas appliances connected to the gas meter.
2. With the furnace turned on, measure the time needed for one revolution of the hand on the smallest dial on the meter. A typical gas meter usually has a 1/2 or a 1 cubic foot test dial.
3. Using the number of seconds for each revolution and the size of the test dial increment, find the cubic feet of gas

consumed per hour from the Gas Rate - Cubic Feet Per Hour (Table 25).

If the actual input is not within 5% of the furnace rating (with allowance being made for the permissible range of the regulator setting), replace the orifice spuds with spuds of the proper size.

NOTE: To find the Btu input, multiply the number of cubic feet of gas consumed per hour by the Btu content of the gas in your particular locality (contact your gas company for this information - it varies widely from city to city.)

Table 25: Gas Rate - Cubic Feet Per Hour¹

Seconds for one rev.	Size of Test Dial	
	1/2 cu. ft.	1 cu. ft.
10	180	360
12	150	300
14	129	257
16	113	225
18	100	200
20	90	180
22	82	164
24	75	150
26	69	138
28	64	129
30	60	120
32	56	113
34	53	106
36	50	100
38	47	95
40	45	90
42	43	86
44	41	82
46	39	78
48	37	75
50	36	72
52	35	69

Table 25: Gas Rate - Cubic Feet Per Hour¹

Seconds for one rev.	Size of Test Dial	
	1/2 cu. ft.	1 cu. ft.
54	34	67
56	32	64
58	31	62
60	30	60

1. By actual measurement, it takes 38 seconds for the hand on the 1-cubic foot dial to make a revolution with a 100,000 Btuh furnace running. Using this information, located 38 seconds in the first column in the table above. Read across to the column headed "1 Cubic Foot", where you will see that 95 cubic feet of gas per hour are consumed by the furnace at that rate. Multiply 95 X 1050 (the Btu rating of the gas obtained from the local gas company). The result is 99,750 Btuh, which is close to the 100,000 Btuh rating of the furnace.

Adjustment Of Temperature Rise

The temperature rise (or temperature difference between the return air and the heated air from the furnace) must lie within the range shown on the rating plate and the data in the Gas Heat Application Table 3.

$$CFM = \frac{Btuh\ Input \times 0.8}{108 \times \text{°F Temp. Rise}}$$

After the temperature rise has been determined, the Volumetric Flow Rate can be calculated as follows:

After about 20 minutes of operation, determine the furnace temperature rise. Take readings of both the return air and the heated air in the ducts (about six feet from the furnace) where they will not be affected by radiant heat. Increase the blower Volumetric Flow Rate to decrease the temperature rise; decrease the blower Volumetric Flow Rate to increase the rise. Refer to the Blower Motor and Drive Data Table 19.

Troubleshooting

Cooling Troubleshooting Guide

⚠ WARNING

Troubleshooting of components may require opening the electrical control box with the power connected to the unit. **Use extreme care when working with live circuits!** Check the unit nameplate for the correct line voltage and set the voltmeter to the correct range before making any connections with line terminals.

When not necessary, shut off all electric power to the unit prior to any of the following maintenance procedures so as to prevent personal injury.

⚠ CAUTION

Label all wires prior to disconnection when servicing controls. Wiring errors can cause improper and dangerous operation, which could cause injury to person and/or damage unit components. Verify proper operation after servicing.

On calls for cooling, if the compressors are operating but the supply air blower motor does not energize after a short delay (the room thermostat fan switch is in the "AUTO" position).

1. Turn the thermostat fan switch to the ON position. If the supply air blower motor does not energize, go to Step 3.
 2. If the blower motor runs with the fan switch in the ON position but will not run after the compressor has energized when the fan switch is in the AUTO position, check the room thermostat for contact between R and G in the AUTO position during calls for cooling.
 3. If the supply air blower motor does not energize when the fan switch is set to ON, check that line voltage is being supplied to the contacts of the M2, contactor, and that the contactor is pulled in. Check for loose wiring between the contactor and the supply air blower motor.
 4. If M2 is pulled in and voltage is supplied to M2, lightly touch the supply air blower motor housing. If it is hot, the motor may be off on internal protection. Cancel any thermostat calls and set the fan switch to AUTO. Wait for the internal overload to reset. Test again when cool.
 5. If M2 is not pulled in, check for 24 volts at the M2 coil. If 24 volts are present at M2 but M2 is not pulled in, replace the contactor.
 6. Failing the above, if there is line voltage supplied at M2, M2 is pulled in, and the supply air blower motor still does not operate, replace the motor.
7. If 24 volts is not present at M2, check that 24 volts is present at the UCB supply air blower motor terminal, "FAN". If 24 volts is present at the FAN, check for loose wiring between the UCB and M2.
 8. If 24 volts is not present at the "FAN" terminal, check for 24 volts from the room thermostat. If 24 volts are not present from the room thermostat, check for the following:
 - a. Proper operation of the room thermostat (contact between R and G with the fan switch in the ON position and in the AUTO position during operation calls).
 - b. Proper wiring between the room thermostat and the UCB.
 - c. Loose wiring from the room thermostat to the UCB.
 9. If 24 volts is present at the room thermostat but not at the UCB, check for proper wiring between the thermostat and the UCB, i.e. that the thermostat G terminal is connected to the G terminal of the UCB, and for loose wiring.
 10. If the thermostat and UCB are properly wired, replace the UCB.
- On a call for cooling, the supply air blower motor is operating but the compressor is not (the room thermostat fan switch is in the "AUTO" position).
1. If installed, check the position of the economizer blades. If the blades are open, the economizer is providing free cooling and the compressors will not immediately operate. If both stages of cooling are requested simultaneously and the economizer provides free cooling, following a short delay the compressor will be energized unless it is locked out.
 2. If no economizer is installed or the economizer is not opening to provide free cooling and the compressor does not energize on a call for cooling, check for line voltage at the compressor contactor, M1, and that the contactor is pulled in. Check for loose wiring between the contactor and the compressor.
 3. If M1 is pulled in and voltage is supplied at M1, lightly touch the compressor housing. If it is hot, the compressor may be off on inherent protection. Cancel any calls for cooling and wait for the internal overload to reset. Test again when cool.
 4. If M1 is not pulled in, check for 24 volts at the M1 coil. If 24 volts are present and M1 is not pulled in, replace the contactor.
 5. Failing the above, if voltage is supplied at M1, M1 is pulled in, and the compressor still does not operate, replace the compressor.
 6. If 24 volts is not present at M1, check for 24 volts at the UCB terminal, C1. If 24 volts is present, check for loose wiring between C1 and the compressor contactor.
 7. If 24 volts is not present at the C1 terminal, check for 24 volts from the room thermostat at the UCB Y1 terminal. If 24 volts is not present from the room thermostat, check for the following:

- a. 24 volts at the thermostat Y1 terminal
 - b. Proper wiring between the room thermostat and the UCB, i.e. Y1 to Y1, Y2 to Y2
 - c. Loose wiring from the room thermostat to the UCB.
8. If 24 volts is present at the UCB Y1 terminal, the compressor may be out due to an open high-pressure switch, low-pressure switch, or freezestat. Check for 24 volts at the HPS1, LPS1, and FS1 terminals of the UCB. If a switch has opened, there should be a voltage potential between the UCB terminals, e.g. if LPS1 has opened, there will be a 24-volt potential between the LPS1 terminals.
 9. If 24 volts is present at the UCB Y1 terminal and none of the protection switches have opened, the UCB may have locked out the compressor for repeat trips. The UCB should be flashing an alarm code. If not, press and release the ALARMS button on the UCB. The UCB will flash the last five alarms on the LED. If the compressor is locked out, cancel any call for cooling. This will reset any compressor lock outs.

NOTE: While the above step will reset any lockouts, the compressor may be held off for the ASCD. See the next step.

10. If 24 volts is present at the UCB Y1 terminal and none of the switches are open and the compressor is not locked out, the UCB may have the compressor in an ASCD. Check the LED for an indication of an ASCD cycle. The ASCD should time out within 5 minutes. Press and release the TEST button to reset all ASCDs.
11. If 24 volts is present at the UCB Y1 terminal and the compressor is not out due to a protective switch trip, repeat trip lock out, or ASCD, the economizer terminals of the UCB may be improperly wired. Check for 24 volts at the Y1 "OUT" terminal of the UCB. If 24 volts is present, trace the wiring from Y1 "OUT" for incorrect wiring. If 24 volts is not present at the Y1 "OUT" terminal, the UCB must be replaced.
12. *For units without economizers:* If 24 volts is present at the Y1 OUT terminal, check for 24 volts at the Y1 "ECON" terminal. If 24 volts is not present, check for loose wiring from the Y1 "OUT" terminal to the Mate-N-Lock plug, the jumper in the Mate-N-Lock plug, and in the wiring from the Mate-N-Lock plug to the Y1 "ECON" terminal.
13. *For units with economizers:* If 24 volts is present at the Y1 "OUT" terminal, check for 24 volts at the Y1 "ECON" terminal. If 24 volts is not present, check for loose wiring from the Y1 "OUT" terminal to the Mate-N-Lock plug, a poor connection between the UCB and economizer Mate-N-Lock plugs, loose wiring from the Mate-N-Lock plug to the economizer, back to the Mate-N-Lock plug, and from the Mate-N-Lock plug to the Y1 "ECON" terminal. If nothing is found, the economizer DME may have faulted and is

failing to return the 24-volt "call" to the Y1 "ECON" terminal even though the economizer is not providing free cooling. To test, disconnect the Mate-N-Locks and jumper between the WHITE and YELLOW wires of the UCB's Mate-N-Lock plug. If the compressor energizes, there is a fault in the economizer wiring or DME.

14. The UCB can be programmed to lock out compressor operation during free cooling and in low ambient conditions. These options are not enabled by default. Local distributors can test the UCB for this programming.

For units with factory installed economizers, the UCB is programmed to lock out compressor operation when the LAS set point is reached.

For units without factory installed or with field installed economizers, the UCB allows compressor operation all the time. This programming can be checked or changed by the local distributor.

15. If none of the above corrected the error, test the integrity of the UCB. Disconnect the C1 terminal wire and jumper it to the Y1 terminal. DO NOT jump the Y1 to C1 terminals. If the compressor engages, the UCB has faulted.
16. If none of the above correct the error, replace the UCB.

GAS HEAT TROUBLESHOOTING GUIDE

WARNING

Troubleshooting of components may require opening the electrical control box with the power connected to the unit. **Use extreme care when working with live circuits!** Check the unit nameplate for the correct line voltage and set the voltmeter to the correct range before making any connections with line terminals.

When not necessary, shut off all electric power to the unit prior to any of the following maintenance procedures so as to prevent personal injury.

CAUTION

Label all wires prior to disconnection when servicing controls. Wiring errors can cause improper and dangerous operation, which could cause injury to person and/or damage unit components. Verify proper operation after servicing.

▲WARNING

The furnace may shut down on a high temperature condition during the procedure. If this occurs, the UCB energize the supply air blower motor until the high temperature limit has reset. Caution should be used at all times as the supply air blower may energize regardless of the room thermostat fan switch position.

Before beginning symptomatic troubleshooting activities read the flash code LEDs on the unit control board (UCB) and the ignition control board (ICB). Fault codes have a quick sequence of flashes indicating the flash code number followed by a pause with the LED off. The ICB flash codes are repeated until the fault is cleared. The ICB monitors itself, the centrifugal switch, lockout due to > 16 pilot flame losses, primary limit, rollout and a flame present when the ICB expects no flame.

With power applied to the unit, if the LED on the ICB is flashing the heartbeat and the furnace will not operate, then proceed to the symptomatic troubleshooting section. If the ICB LED is not flashing, then perform the ICB troubleshooting procedures. If the ICB has a flash code other than the heartbeat, then determine the flash code and locate its troubleshooting procedures in the flash code troubleshooting section. Refer to Table 27 for flash code identification and component causing fault.

Flash Code Troubleshooting

Power to the unit should be interrupted during the troubleshooting of individual components unless otherwise indicated. All troubleshooting procedures assume the unit is wired per the wiring diagram. If there is any indication the unit has been previously repaired, then the first priority is to verify that the furnace is wired per the wiring diagram. Miss-wired units will give false flash codes.

Ignition Control Board

The ICB controls the ignition of the pilot, the opening and closing of the gas valves and the operation of the draft (inducer) motor. It also monitors all the furnace safety components.

If the ICB LED is on steady, then verify the wiring of the unit to the wiring diagram and if ok, then replace the ICB. If the unit has power and the ICB LED is not flashing, then remove the 3 pin connector (single stage gas heat) or 4 pin connector (2 stage gas heat) from the ICB. Measure the control voltage between terminals 1 and 2 of the wiring harness connector. The control voltage must be between 18 and 30 volts. If control voltage is not present, then check the 3.2A circuit breaker to verify that the circuit breaker has control voltage on both input and output terminals. If control voltage is present on the input and not the output of the circuit breaker, then reset or replace the circuit breaker as necessary. If control voltage is present on both sides of the circuit breaker, then check the power and

common wires between the unit control box and the ICB and repair as necessary. If the control voltage is present, then verify the cleanliness of the harness and the ICB connector, clean if necessary and reconnect the wiring harness to the ICB and observe ICB LED. If it now flashes the heartbeat, then the fault was a bad connection between the harness connector and the ICB connector or a broken wire exists in the harness. With the harness connected to the ICB, gently move the wires in the harness while observing the ICB LED. If heartbeat is steady, then verify proper operation of the furnace. If the ICB does not flash the heartbeat, then gently move the wires in the harness connector while observing the ICB LED. If you get any flashes of the ICB LED, then there is still a bad connection or a broken wire. If no flashes are seen while gently moving the wires with the harness connected to the ICB, then replace the ICB and verify proper operation of the furnace.

Centrifugal Switch

The centrifugal switch is an integral part of the draft motor. The centrifugal switch closes when the motor speed increases to ~2500 rpm and opens when the motor speed descends to ~2000 rpm.

If a flash code indicates the centrifugal switch is causing a fault, then

1. If the flash code indicates the switch is open with the draft (inducer) motor on (flash code 2), then
 - Disconnect power to the unit. Using a screw driver, spin the draft motor blower wheel. If bound or dragging, then visually inspect the draft motor blower wheel area for debris. If debris is present, then clear debris and verify proper furnace operation. If clear, then replace the draft motor and verify proper furnace operation.
 - Restore power to unit and induce a call for heat. Measure the voltage across the two draft motor power leads. If it is less than 342 volts, then check and repair the power circuit to the draft motor. If the voltage is greater than 342 volts and the draft motor is not turning, then disconnect power and draft motor power leads. Measure the resistance of the draft motor windings. If an open circuit exists in the motor, then replace the draft motor. If the voltage is greater than 342 volts and the motor is turning, then check the centrifugal switch wiring between the ICB and the draft motor. If ok, then disconnect power to the unit and place the gas valve in the off position. Prepare to temporarily jumper the wires connected to terminals 3 and 8 of the ICB 9 pin harness connector by disconnecting the draft motor leads from the 9 pin harness. Restore the power to the unit and induce a call for heat. Jumper wires 3 and 8. If the ignition sequence is started after 15 seconds (audible sparking of the igniter), then replace the draft motor reconnecting the centrifugal switch wiring per the wiring diagram. If not, then replace the ICB, remove the jumper and reconnect the centrifugal switch wiring

per the wiring diagram. Place the gas valve in the on position and verify proper furnace operation.

2. If the flash code indicates the switch is closed with the draft (inducer) motor off (flash code 3), then disconnect the 9 pin connector from the ICB and measure the continuity of the centrifugal switch with a battery powered test light or an ohm meter between terminals 3 and 8 of the harness connector. If a closed circuit is indicated, then check the wiring between the ICB and the draft motor. If the wiring is not shorted together, then replace the draft motor. If an open circuit is indicated, then reconnect the 9 pin wiring harness to the ICB and remove power to the unit for at least 20 seconds. Restore power to the unit. If the ICB continues to flash a code 3, then replace the ICB.

Pilot flame Lockout

The ICB counts the number of flame losses during the same call for heat. If more than 16 flame losses occur within the same call for heat, then the control temporarily locks out furnace operation for 5 minutes (flash code 5). If the call for heat remains after the 5 minutes, then the ICB will retry the ignition sequence. The flame losses can be due to low inlet pressure, debris around flame sensor, plugged pilot burner, soot on the surface of the flame sensor or misadjusted pilot pressure. Remove the power to the unit for 20 seconds and then restore power to the unit. Induce a call for heat and observe the pilot flame in the flame sensor area to determine the best course of action.

1. If the flame is strong and stable in the flame sensor area, then verify the position of the flame sensor per the start up procedures. If ok, then remove the flame sensor and check the cleanliness of the electrode. If clean, then replace the flame sensor and adjust pilot per the start up procedures. If not clean, then clean, reinstall and adjust pilot per the start up procedures.
2. If the flame is weak or unstable in the flame sensor area, then verify the gas inlet pressure. If gas inlet pressure is above the minimum inlet pressure stated on unit data label, then adjust the pilot pressure per the start up procedures. If the pilot cannot be adjusted to obtain a strong and stable flame in the flame sensor area, then remove the burner assembly and verify the pilot burner assembly is open internally and the holes in the burner are clean. Check the pilot orifice size to the unit data plate and the cleanliness of the pilot orifice. Verify that the flame sensor electrode is clean and is adjusted properly. After cleaning or replacement of the pilot assembly components, reinstall the burner assembly and adjust pilot per the start up procedure.

Primary Or Aux Temperature Limit

The temperature limits limit the temperature in the furnace to a safe level. If a temperature higher than the preset limit is achieved due to low or no air flow through the furnace, then the temperature limits opens and the ICB closes the gas valve and flashes code 6. The primary limit is automatic reset type while the auxiliary limit is manual reset type. If either one opens, then the ICB removes power to the gas valve and the UCB

energizes the indoor blower until the primary limit automatically resets or the auxiliary limit is manually reset. Verify adequate air flow through the furnace. If air flow is nonexistent or weak, then troubleshoot and repair the conditioned space air circulation system as necessary. Reset the auxiliary limit and verify proper operation of the furnace. If airflow is normal, then verify the gas input rate to the furnace following the start up procedures (auxiliary limit must be reset before the furnace will operate). If after verifying the circulating air system, the input rate to the furnace and that the air temperature rise through the furnace is within the rise range on the unit data plate the flash code still exists, then set the gas valve to the off position and temporarily apply control voltage (~24 volts) to pin 9 of the 9 pin ICB connector. With power applied to the unit, if the ICB LED continues to flash a code 6, then replace the ICB and return unit to operation (you must remove the temporary voltage to pin 9 before the gas valve is turned on). If the ICB LED flashes a heartbeat, then replace the limit that is opening, remove the temporary voltage applied to pin 9, turn on the gas valve, restart the furnace and verify proper operation of the furnace.

Rollout Switch

The rollout switch is installed to protect the furnace from damage due to excessive heat in the burner area. There are 4 main reasons the rollout switch will open (flash code 7) due to excessive heat in the burner area. You must remove power to the unit for 20 seconds to reset the ICB.

1. A blocked flue outlet is the most common cause for the rollout switch to open. Check the flue outlet for debris and clear if necessary.
2. Loose blower wheel on draft motor. Verify that the blower wheel is securely fastened to the draft motor shaft.
3. Unit operating outside the air temperature rise range stated on the unit data plate. Either the air flow through the furnace is not sufficient or the gas input rate to the furnace exceeds the recommended rate. Verify both conditions are within the published ranges.
4. Cracked heat exchanger tube(s). If a heat exchanger tube or tubes is cracked, then the flow through the heat exchanger is restricted and the flame will either roll out of the tube inlet or heat will build to an abnormal level in the burner area. This can usually be determined by observing burner flame with and without indoor blower operation. If the flame changes when the blower is running compared to when it is not, then visually inspect the heat exchanger tubes.

If all of the above are found to be in good condition or within the operating ranges, then set the gas valve to the off position and temporarily apply control voltage (~24 volts) to pin 6 of the 9 pin ICB connector. With power applied to the unit, if the ICB LED continues to flash a code 7, then replace the ICB and return unit to operation (you must remove the temporary voltage to pin 6 before the gas valve is turned on). If the ICB LED flashes a heartbeat, then replace the rollout switch, remove the temporary voltage applied to pin 6, turn on the gas valve, restart the furnace and verify proper operation of the furnace.

Unexpected Flame Presence

If a flame is present without a call for heat (flash code 8), then the ICB will continue operation of the draft motor and the UCB will call for indoor operation when either of the temperature limit opens. If the unit is correctly wired and there is not a call for heat, then check for control voltage to the gas valve. If control voltage exists at the gas valve, then replace the ICB. If voltage is not present at the gas valve, then replace the gas valve.

Gas Valve Stuck Off Or On

If the pilot and/or the main valves are sensed to be off more than 1 second when commanded to be on, the control will shut off all outputs and enter a hard lockout (flash code 9). Likewise, if the pilot and/or the main valves are sensed to be on more than 1 second when commanded to be off, the control will shut off all outputs and enter a hard lockout (flash code 9). The control will not respond to thermostat demands during a hard lockout. The only way to recover from a hard lockout is to remove and reapply 24VAC power to the control.

Flame Sense Circuit Failure

If the control detects an internal hardware failure in the flame sense circuit, it shuts off all outputs and enters a hard lockout (flash code 10). The control will not respond to thermostat demands during a hard lockout. The only way to recover from a hard lockout is to remove and reapply 24VAC power to the control. If problem persists after removal and reapplication of 24VAC power, the board may need to be replaced.

Symptomatic Troubleshooting

On calls for heating, the draft motor operates and the furnace lights but the supply air blower motor does not energize after a short delay (the room thermostat fan switch is in "AUTO" position).

1. Place the thermostat fan switch in the "ON" position. If the supply air blower motor energizes, go to Step 10.
2. If the supply air blower motor does not energize when the fan switch is set to "ON," check that line voltage is being supplied to the contacts of the M2 contactor, and that the contactor is pulled in. Check for loose wiring between the contactor and the supply air blower motor.
3. If M2 is pulled in and voltage is supplied at M2, lightly touch the supply air blower motor housing. If it is hot, the motor may be off on inherent protection. Cancel any thermostat calls and set the fan switch to "AUTO", wait for the internal overload to reset. Test again when cool.
4. If M2 is not pulled in, check for 24 volts at the M2 coil. If 24 volts is present at M2 but M2 is not pulled in, replace the contactor.
5. Failing the above, if there is line voltage supplied at M2, M2 is pulled in, and the supply air blower motor still does not operate, replace the motor.
6. If 24 volts is not present at M2, check that 24 volts is present at the supply air blower motor terminal on the UCB.

If 24 volts is present at the UCB terminal, check for loose wiring between the UCB and M2.

7. If 24 volts is not present at the UCB supply air blower motor terminal, check for 24 volts from the room thermostat. If 24 volts is not present from the room thermostat, check for the following:
 - Proper operation of the room thermostat (contact between R and G with the fan switch in the "ON" position and in the "AUTO" position during operation calls).
 - Proper wiring between the room thermostat and the UCB.
 - Loose wiring from the room thermostat to the UCB.
8. If 24 volts is present at the room thermostat but not at the UCB, check for proper wiring between the thermostat and the UCB, i.e. that the thermostat G terminal is connected to the G terminal of the UCB, and for loose wiring.
9. If the thermostat and UCB are properly wired, replace the UCB.
10. If the blower motor runs with the fan switch in the "ON" position but does not run shortly after the furnace has ignited when the fan switch is in the "AUTO" position, check the room thermostat for contact between R and G during "W1" calls.

On calls for heating, the supply air blower operates but the draft motor does not (the room thermostat fan switch is in the "AUTO" position).

1. The draft motor has inherent protection. If the motor shell is hot to the touch, wait for the internal overload to reset.
2. If the motor shell is cold with the room thermostat calling for heat, check if 24 volts is present at the room thermostat but not at the UCB, check for proper wiring between the thermostat and the UCB, i.e. that the thermostat "W1" terminal is connected to the "W1" terminal of the UCB, and for loose wiring.
3. The draft motor is a 230 volt draft motor on all models regardless of unit supply voltage. If the ICB is flashing a code other than the heartbeat, then troubleshoot the device indicated by the fault code. If not, then remove power to the unit for more than 20 seconds. If upon restoring the power to the unit the draft motor does not start with a call for heat, then verify that terminal "L1" of the ICB has a minimum of 120 volts to ground on 230 and 460 volt models or a minimum of 18 volts to ground on 575 volt models. If terminal "L1" does not have the minimum voltage, then check the wiring between the unit control box and the ICB on all models and on 460 volt models, the transformer in the gas heat compartment and its wiring. If terminal "L1" does have the minimum voltage, then check for the minimum voltage on terminal "IND" of the ICB on single stage models and terminal "IND HIGH" of the ICB on two stage models. If voltage is not present at the terminal, then verify wiring between the control box and the ICB. If all wiring is intact, then ICB is at fault. If voltage is present at the terminal on 230 and 460 volt models, then the draft

motor is at fault. On 575 volt models, if voltage is present at the terminal, then check the draft motor relay (DMR on single stage gas heat and DMR-2 on two stage gas heat) mounted above the ICB. First verify that the relay is pulled in by visual inspection. If not, then verify the minimum voltage is present between terminals "A" and "B" of the relay. If the minimum voltage is not present, then check the wiring. If it is present, then verify that a minimum of 150 volts is present at terminals "5" and "7" of the draft motor relay. If not present at terminal "7" of the draft motor relay, then troubleshoot the transformer in blower section and its wiring. If present at terminal "7" and not at terminal "5" of the draft motor relay, then the relay is at fault. If the minimum voltage is present at terminal 5 of the draft motor relay, then the draft motor is at fault.

The ignitor sparks at the pilot burner but the pilot does not ignite and a gas odor is detected at the draft motor outlet.

1. Adjust the pilot adjust screw on the gas valve as described in "PILOT CHECKOUT" on page 43.
2. Check the supply pressure as described in "POST START CHECK LIST" on page 42. Make adjustments as necessary.
3. Check the pilot orifice and pilot burner for obstruction as described in paragraph above. Clean as needed but the problem should not be the gas valve.

The pilot burner ignites but the ignitor continues to spark and the main burners do not ignite.

1. Make the same checks and adjustment as described in "PILOT CHECKOUT" on page 43.
2. Check the supply pressure as described in "POST START CHECK LIST" on page page 42. Make adjustments as necessary.
3. Make sure that the pilot burner is not bent or damaged.
4. Make sure that the ground connections at the pilot burner, gas valve and ignition control are intact. Check the ignitor wire for good electrical connection. If all are intact, replace the ignition control.

The pilot burner lights and the spark stops but the main burners do not light.

1. Check electrical connections between the ignition control and the gas valve. If intact, check for 24 volts across terminals "MV" and "GROUND" terminals. If no voltage detected, replace ignition control. If voltage is present, replace gas valve.

Main burners light but exhibit erratic flame characteristics.

1. Adjust air shutters as described in "BURNER AIR SHUTTER ADJUSTMENT" on page 43.
2. Check the main burner orifices for obstruction and alignment. Removal procedure is described in BURNER INSTRUCTIONS on page 43. Clean or replace burner orifices and burners as needed.

Unit Flash Codes

Various flash codes are utilized by the unit control board (UCB) and the ignition control board (ICB) to aid in troubleshooting. Flash codes are distinguished by the short on and off cycle used (approximately 200ms on and 200ms off). To show normal operation, the control boards flashes a 1 second on, 1 second off "heartbeat" during normal operation. This is to verify that the UCB and the ICB are functioning correctly. Do not confuse this with an error flash code. To prevent confusion, a 1-flash, flash code is not used.

Current alarms or active restrictions are flashed on the UCB LED.

- **LAST ERROR** - When this button is pressed and released one time within five seconds, it flashes the last five flash codes on the board's LED. The most recent alarm is shown first and the oldest alarm is shown last.

When pressed and released twice within a five second span, the fault history is cleared.

- **TEST RESET** - When this button is pressed and released one time within five seconds, any anti-short cycle delays (ASCD) is by-passed for one cycle.

When this button is pressed twice within five seconds, any active lockouts are reset.

- **COMM SET UP** - If the board is to be networked with other units, this button is used to set the network address.

The first time the button is pressed within five seconds, it scans the bus, then assigns itself the first available address {starts at 2}. It then flashes that address one time.

Pressing the button two times within five seconds causes the control to flash its address.

Pressing the button three times within five seconds forces the control to reset its address to 1, which is the factory default.

Current alarms or active restrictions are flashed on the ICB LED. No history is stored on the ICB.

Fan On And Off Delays

The fan ON and OFF delays can be field adjusted by pressing a combination of buttons on the UCB.

- **Gas Heat Option #1** - Press the **LAST ERROR** and **TEST RESET** buttons simultaneously and then release. The control flashes three times as it writes a 30 second delay ON and a 90 second delay OFF to the program.
- **Gas Heat Option #2** - Press the **COMM SETUP** and **TEST RESET** buttons simultaneously and then release. The control flashes four times as it writes a 30 second delay ON and a 180 second delay OFF to the program.
- **Electric Heat** - Press and release the **COMM SETUP** and **LAST ERROR** buttons at the same time. The control flashes twice on the LED as the control writes a 0 second ON and a 30 second OFF fan delay to the control's program memory.

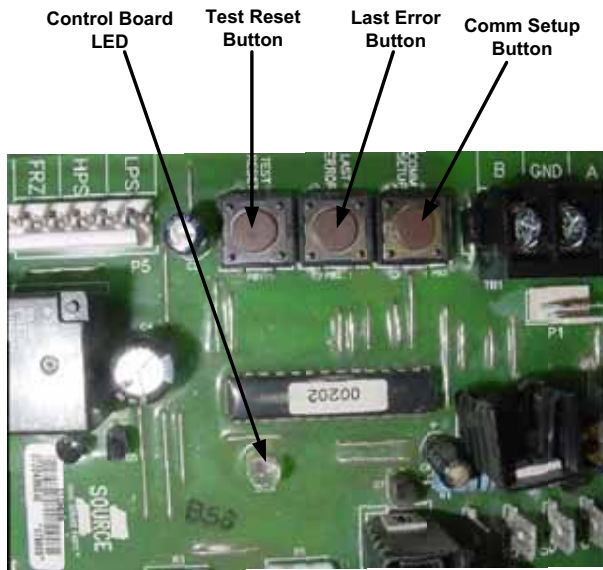

Figure 26: Simplicity Lite Unit Control Board

Table 26: Simplicity Lite Unit Control Board Flash Codes

Flash Code	Description
On Steady	Control Failure - Replace Control
Heart Beat	Normal Operation
1 Flash	Not Applicable
2 Flashes	Control waiting ASCD ¹
3 Flashes	HPS1 - Compressor Lock out
5 Flashes	LPS1 - Compressor Lock out
7 Flashes	FS1 - Compressor Lock out
9 Flashes	Ignition Control Locked Out/ Ignition Control Failure / Limit Switch Trip / No Jumper Plug in Heat Section
10 Flashes	Compressors Locked Out On Low Outdoor Air Temperature ¹
11 Flashes	Compressors Locked Out Because The Economizer Is Using Free Cooling ¹
13 Flashes	Compressor Held Off Due To Low Voltage ¹

Table 26: Simplicity Lite Unit Control Board Flash Codes

Flash Code	Description
14 Flashes	EEPROM Storage Failure (Control Failure)
OFF	No Power or Control Failure

1. These flash codes do not represent alarms.

Table 27: Ignition Control Board Flash Codes

Flash Code	Description
Heart Beat	Normal Operation
1 Flash	Not Applicable
2 Flashes	Pressure / Centrifugal Switch Open with Inducer On
3 Flashes	Pressure / Centrifugal Switch Closed with Inducer Off
4 Flashes	Not Applicable
5 Flashes	Lock Out From Too Many Flame Losses
6 Flashes	High Temperature Switch Open (Primary or Aux.)
7 Flashes	Rollout Switch Open
8 Flashes	Flame Present With Gas Off
9 Flashes	Gas Valve Stuck Off or On
10 Flashes	Flame Sense Circuit Failure

Smart Equipment™ Control Board Navigation Components

The following components are needed to access the control points in the Smart Equipment™ control. Installation and operation guides are located on www.upgnet.com under Product Center \ Equipment Catalog \ Commercial Products \ Zoning Systems and Controls.

1. Local LCD on Unit Control Board.
2. Mobile Access Portal (MAP) Gateway (Portable).
 - Source 1 P/N S1-JC-MAP1810-OP
 - MAP Gateway Quick Start Guide P/N 24-10737-16
 - MAP Gateway Instruction P/N 24-10737-8

NOTE: For more in-depth sequence of operation of the Smart Equipment™ control please refer to LIT-12011950 on www.upgnet.com under Product Center \ Equipment

SMART EQUIPMENT™ FIRMWARE VERSION 3.1 BASIC UNIT CONTROL BOARD NAVIGATION EXAMPLES:

The following document details the navigation and viewing of the LCD display screen equipped as a standard item on the Smart Equipment™ control installed within various commercial UPG packaged and split system equipment. The following information provides a step-by-step demonstration on how to

navigate the basic status menu and how to change basic configuration settings. The basic navigation steps outlined in this short demonstration applies to most menus within the Smart Equipment™ control.



Understanding the Local LCD

After you apply power to your Rooftop Unit (RTU), a start-up countdown begins on the Unit Control Board (UCB) LCD. When the controller is ready, the screen is blank because no faults are present. Use the joystick and the two push buttons below the LCD, to navigate through the menus.

Step 1 - After the start-up countdown is complete the first screen displayed is the "Status & Alarms" screen. When the cursor is on the top "Status" line hit the "ENTER" button. This action steps the LCD display into the status mode. Hit "ENTER" to view the status menu.



Step 2 - Scroll down to "DVent-Mode". This is the demand ventilation mode.

Step 3 - When the cursor is on the "DVent-Mode" hit "ENTER" to view the status of this mode. In this case a CO2 sensor is not installed, thus Demand Ventilation or DVent is disabled.

Step 4 - To exit out of the "DVent-Mode status screen push "Cancel". The screen returns to that shown below.

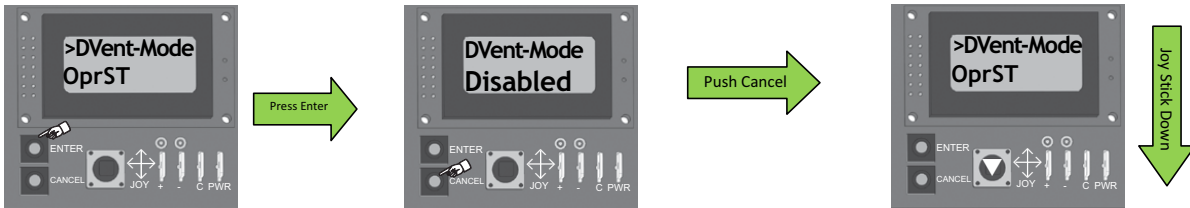

Step 5 - By pushing the joystick down, the cursor toggles to OprST (Operating Space Temp).

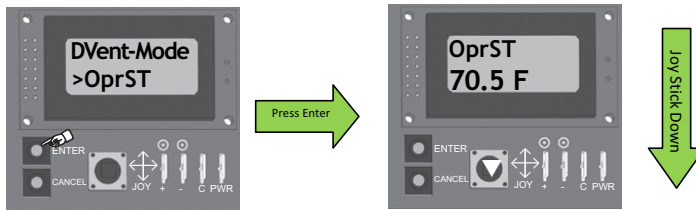

Step 6 - By pushing "ENTER" the actual OprST (Operating Space Temp) appears. Pushing the joystick down scrolls through SAT, RAT, OAT and other available sensor readings.

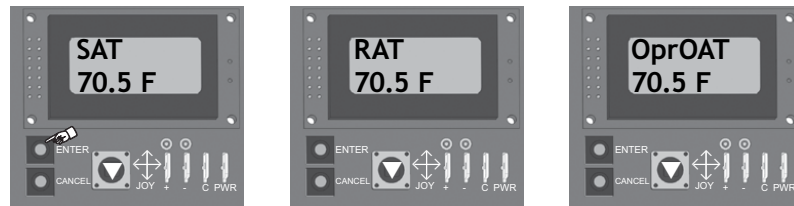

Press the "Cancel" button to exit each menu level. Repeatedly pressing "Cancel" returns the menu to the first "Status, Alarms" screen.

When the "Cancel" button is pressed multiple times to exit each menu level and the screen returns to the first "Status, Alarms" display the next demonstration can begin. In this demonstration the information below steps through the "Commissioning" menu.

Step 1- Beginning at the status/alarm screen toggle the joystick down three times. This accesses the "Commissioning " screen. In this menu section various settings can be changed. Please see the Unit Control Board menu for a list of parameters that can be modified.

Step 2- Once commission appears next to the cursor, press "ENTER" to begin viewing parameters.

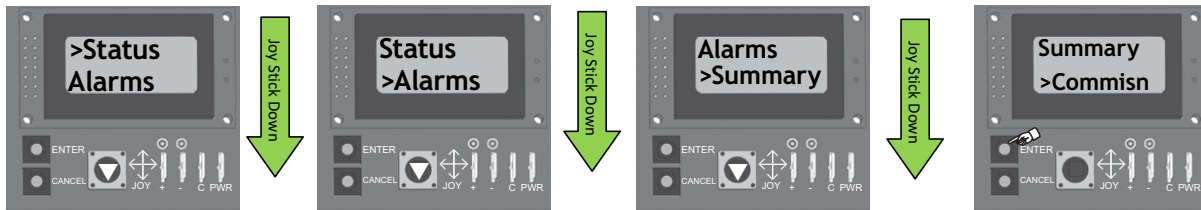

Step 3- After "ENTER" is pressed the various parameter sections appear, such as: HVAC zone, Indoor Fan, Clg, Htg, Econ and others.

Step 4- After toggling the joystick down two times "Clg" appears. This allows items, such as lead-lag and OCC/UNOCC cooling set points, to be changed.

Step 5- At the "Clg" screen once "ENTER" is pushed the status indicates if cooling is engaged/disengaged and lead-lag is engaged/disengaged.



Step 6- By toggling down twice the screen reaches the "ClgOcc-SP" screen or "Cooling Occupied Set Point".

Step 7- After pressing "ENTER" at the "ClgOCC-SP" screen the space temperature set point appears. NOTE: Only applies to units controlled by a space sensor.

Step 8- In order to change set points push the toggle switch left or right. Note: The screen flashes. Left decreases the value, right increases. In this demonstration the ClgOCC setpoint is changed from 72F to 95F.



Step 9- The joystick was toggled right to increase the set point temperature. The screen flashes when in the change mode. Once the desired set point/value is reached press the "ENTER" button to save the value.

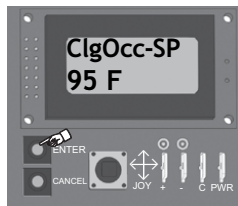

These few pages provide a simple demonstration how to navigate the menu's of the Smart Equipment™ control containing Version 3 firmware. Please utilize this document along with the additional information in the Users Guide and detailed navigation menu to adjust the control to customer preferences or job specifications.

NOTE: IF OPERATING THE EQUIPMENT WITH A THERMOSTAT, THE UCB SETPOINTS AND PARAMETERS SHOULD NOT REQUIRE ALTERATION; HOWEVER, THERE MAY BE THE CASE WHERE MINIMUM OUTSIDE AIR, LEAD-LAG OR OTHER CUSTOM SETTINGS ARE REQUIRED. PLEASE READ THIS DOCUMENT IN DETAIL TO UNDERSTAND THE IMPLICATIONS OF MAKING CHANGES BEFORE PROCEEDING. IT IS STRONGLY RECOMMENDED THAT A BACKUP OF PARAMETER SETTINGS BE SAVED ON A USB DRIVE BEFORE MAKING ANY MAJOR CHANGES TO THE CONTROL!



Figure 27: Smart Equipment™ Unit Control Board

Table 28: Smart Equipment™ UCB Details

Description		Function & Comments
Terminal Directional orientation: viewed with silkscreen labels upright		
Limit, 24 VAC power and shutdown connections from unit wiring harness at left on upper edge of UCB		
LIMIT	Monitored 24 VAC input through heat section limit switch(es)	If voltage is absent, indicating the heat section is over-temperature, the UCB will bring on the indoor blower
C	24 VAC, 75 VA transformer Common referenced to cabinet ground	Connects through circuit traces to thermostat connection strip C and indoor blower VFD pin C
24V	24 VAC, 75 VA transformer hot	Powers the UCB microprocessor, connects through circuit trace to the SD 24 terminal
SD 24	24 VAC hot out for factory accessory smoke detector, condensate overflow and/or user shutdown relay switching in series	Connects through circuit trace to thermostat connection strip SD-24. A wiring harness jumper plug connecting SD 24 to SD R is in place if factory accessories for unit shutdown are not used - this jumper plug must be removed if the switching of field-added external accessories for unit shutdown are wired between thermostat connection strip SD-24 and R
SD R	24 VAC hot return from factory accessory smoke detector, condensate overflow and user shutdown relay switching in series	Connects through circuit trace to the R terminal on the upper left of the board
R	24 VAC hot for switched inputs to the UCB	Connects through circuit trace to the thermostat connection strip R terminal, right FAN OVR pin, right HPS1 pin, right HPS2 pin, lower DFS pin and lower APS pin

Table 28: Smart Equipment™ UCB Details (Continued)

Description		Function & Comments
Terminal Thermostat connection strip on left edge of UCB		
W1	1st stage heating request, 24 VAC input switched from R	Not effective for cooling-only units
W2	2nd stage heating request, 24 VAC input switched from R	Not effective for cooling-only units or units with single-stage heat sections
Y1	1st stage cooling request, 24 VAC input switched from R	
Y2	2nd stage cooling request, 24 VAC input switched from R	Visible in the display menu when the #ClgStgs parameter is set for 2 or more, also effective for economizer free cooling supply air temperature reset when the #ClgStgs parameter is set for 1 or more
G	Continuous indoor blower request, 24 VAC input switched from R	
OCC	Occupancy request, 24 VAC input switched from R	Must have the OccMode parameter set for External to be effective
X	Hard lockout indicator, 24 volt output to a light thermostat LED	
R	24 VAC hot for thermostat switching and power	If field-added external accessories for unit shutdown are used, 24 VAC hot return from smoke detector, condensate overflow and/or user shutdown relay switching in series
SD-24	If field-added external accessories for unit shutdown are used, 24 VAC hot out for smoke detector, condensate over- flow and/or user shutdown relay switching in series	Unit wiring harness jumper plug for factory shutdown accessories must be removed if the switching of field-added external accessories for unit shutdown are wired between thermo- stat connection strip SD-24 and R
C	24 VAC common for thermostat power	
LEDs on left edge of UCB		
POWER	Green UCB power indicator	Lit indicates 24 VAC is present at C and 24V terminals
FAULT	Red hard lockout, networking error and firmware error indicator	1/2 second on/off flashing indicates one or more alarm is currently active, 1/10th second on/off flashing indicates a networking error (polarity, addressing, etc.) or a firmware error (likely correctable with re-loading from USB flash drive)
SA BUS	Green UCB SA bus communication transmission indicator	Lit/flickering indicates UCB SA bus communication is currently active, off indicates the UCB is awaiting SA bus communication
Terminal Space temperature sensor connections at center on upper edge of UCB		
ST	Space Temperature sensor input from 10KΩ @ 77°F, Type III negative temperature coefficient thermistor	Positive of VDC circuit (3.625 VDC reading to COM with open circuit), effective if "Thermo- stat-only Control" parameter is set OFF, space sensor override momentarily shorts ST to COM to initiate/terminate temporary occupancy
COM	Common for ST and SSO inputs	Negative of VDC circuit for ST and SSO inputs
SSO	Space Sensor Offset input from 0 to 20KΩ potentiometer	Positive of VDC circuit (3.625 VDC reading to COM with open circuit), 10KΩ/2.5 VDC is 0°F offset, 0Ω/0 VDC is maximum above offset and 20KΩ/3.4 VDC is maximum below offset from active space temperature setpoint
Pin Temperature sensor connections at right on upper edge of UCB		
SAT+	Supply Air Temperature sensor input from 10KΩ @ 77°F, Type III negative temperature coefficient thermistor	Input required for operation; 3.625 VDC reading SAT+ to SAT- with open circuit. Used in heat/cool staging cutouts, free cooling operation, demand ventilation operation, comfort ventilation operation, economizer loading operation, VAV cooling operation, hydronic heat operation.

Table 28: Smart Equipment™ UCB Details (Continued)

Description		Function & Comments
RAT+	Return Air Temperature sensor input from 10KΩ @ 77°F, Type III negative temperature coefficient thermistor	Input required for operation; 3.625 VDC reading RAT+ to RAT- with open circuit. Used in return air enthalpy calculation. Substitutes for space temperature if no other space temperature input is present.
OAT+	Outside Air Temperature sensor input from 10KΩ @ 77°F, Type III negative temperature coefficient thermistor	Input required for operation but may be a communicated value; 3.625 VDC reading OAT+ to OAT- with open circuit. Used in heat/cool cutouts, low ambient cooling determination, dry bulb free cooling changeover, outside air enthalpy calculation, economizer loading operation, heat pump demand defrost calculation.
CC1+	#1 refrigerant circuit Condenser Coil temperature sensor input from 10KΩ @ 77°F, Type III negative temperature coefficient thermistor	Input required for heat pump units, not required for A/C units; 3.625 VDC reading CC1+ to CC1- with open circuit. Used in heat pump demand defrost calculation.
EC1+	#1 refrigerant circuit Evaporator Coil temperature sensor input from 10KΩ @ 77°F, Type III negative temperature coefficient thermistor	Input required for operation; 3.625 VDC reading EC1+ to EC1- with open circuit. Used in suction line temperature safety.
CC2+	#2 refrigerant circuit Condenser Coil temperature sensor input from 10KΩ @ 77°F, Type III negative temperature coefficient thermistor	Input required for 2-compressor heat pump units, not required for 2-compressor A/C units, not active for 1-compressor units; 3.625 VDC reading CC2+ to CC2- with open circuit. Used in heat pump demand defrost calculation.
EC2+	#2 refrigerant circuit Evaporator Coil temperature sensor input from 10KΩ @ 77°F, Type III negative temperature coefficient thermistor	Input required for operation of 2-compressor units, not active for 1-compressor units; 3.625 VDC reading EC2+ to EC2- with open circuit. Used in suction line temperature safety.
Pinned connections on right edge of UCB		
RAH+	Return Air Humidity input from 0-10 VDC @ 0-100% RH sensor	Input required for reheat units, optional in all other units, may be a communicated value. Used in return air enthalpy calculation, temperature/humidity setpoint reset, reheat operation.
DCT PRS+	Supply Duct Pressure input from 0-5 VDC @ 0-5" w.c. sensor	Input required for variable air volume units. Used in VAV indoor blower operation.
DFS (upper pin)	24 VAC hot return from Dirty Filter Switch	Optional input; switch closure for greater than 15 seconds during indoor blower operation initiates a notification alarm
DFS (lower pin)	24 VAC hot out for Dirty Filter Switch	Connects through circuit trace to the R terminal
APS (upper pin)	24 VAC hot return from Air Proving Switch	When this optional input is enabled: the air proving switch must close within 30 seconds of initiation of indoor blower operation and not open for greater than 10 seconds during indoor blower operation to allow heat/cool operation and prevent an "APS open" alarm; the air proving switch must open within 30 seconds of termination of indoor blower operation to prevent an "APS stuck closed" notification alarm
APS (lower pin)	24 VAC hot out for Air Proving Switch	Connects through circuit trace to the R terminal
C	Common for the VFD output	Negative of the VDC circuit for the VFD output
VFD	2-10 VDC (0-100%) output for the indoor blower Variable Frequency Drive	Output is active with indoor blower operation. For CV units: this output provides stepped IntelliSpeed control of the indoor blower VFD based on fan-only, cooling stage and heating stage outputs. For VAV units: this output provides control of the indoor blower VFD based on supply duct static pressure input and setpoint.
VFDFLT	24 VAC hot input from the normally open VFD alarm contact	The VFD alarm contact switches from R within the unit wiring harness. 24 VAC input results in unit shutdown and a "VFD fault" alarm

Table 28: Smart Equipment™ UCB Details (Continued)

Description		Function & Comments
Terminal at lower right corner of UCB		
24V FOR OUTPUTS	24 VAC hot for H1, H2, CN-FAN, AUX HGR, FAN C1 and C2 output relay contact switching	Output relay circuitry is isolated from other UCB components and the 24 VAC hot source may be from a second transformer in the unit
Pin Heat section connections at right on lower edge of UCB		
H1	24 VAC hot output for heat section stage 1	Not effective for cooling-only units. Output if demand is present and permissions allow one stage or two stages of heat section operation
H2	24 VAC hot output for heat section stage 2	Not effective for cooling-only units or units with single-stage heat sections. Output if demand is present and permissions allow two stages of heat section operation
MV	24 VAC hot input confirming heat section operation	Sourced from gas valve in gas heat units or first stage heat contactor in electric heat units. Input within 5 minutes from initiation of H1 output initiates the "Heat On Fan Delay" timer, loss of input following the termination of H1 output initiates the "Heat On Fan Delay" timer, no input within 5 minutes from initiation of H1 output initiates an "Ignition Failure" alarm, input for longer than 5 minutes without H1 output initiates a "Gas Valve Mis-wire" alarm
Pin Cooling and fan output connections at right on lower edge of UCB		
CN-FAN	24 VAC hot output for the condenser fan contactor coil	Output with either C1 or C2 output; interrupted during defrost cycle for heat pump units
AUX HGR	24 VAC hot output for hot gas reheat components	Effective only for reheat units, output with reheat operation
FAN	24 VAC hot output for indoor blower contactor coil/ indoor blower VFD enable relay coil	Output with heat/cool operation, G input or schedule demand
C1	24 VAC hot output for compressor 1	If demand is present and permissions allow compressor 1 operation; output with compressor cooling, comfort ventilation cooling, reheat or heat pump heating demands
C2	24 VAC hot output for compressor 2	Not effective for one stage compressor UCBs. If demand is present and permissions allow compressor 2 operation; output with compressor cooling, comfort ventilation cooling or heat pump heating demands
Pin Refrigerant circuit safety switch and indoor blower overload connections at center on lower edge of UCB		
HPS1 (right pin)	24 VAC hot out for refrigerant circuit 1 High Pressure Switch	Connects through circuit trace to the R terminal
HPS1 (left pin)	24 VAC hot return from refrigerant circuit 1 High Pressure Switch	Input is only considered if C1 output is needed; input must be present to allow C1 output. Three HPS1 trips in a two hour period cause a "High Pressure Switch 1 Lockout" and C1 output is then prevented until alarm reset. Connects through circuit trace to the right LPS1 pin.
LPS1 (right pin)	24 VAC hot out for refrigerant circuit 1 Low Pressure Switch	Connects through circuit trace to the left HSP1 pin
LPS1 (left pin)	24 VAC hot return from refrigerant circuit 1 Low Pressure Switch	Input is only considered after 30 seconds of C1 output; afterwards, input must be present to allow C1 output. Three LPS1 trips in a one hour period cause a "Low Pressure Switch 1 Lockout" and C1 output is then prevented until alarm reset.
HPS2 (right pin)	24 VAC hot out for refrigerant circuit 2 High Pressure Switch	Not effective for one stage compressor UCBs. Connects through circuit trace to the R terminal

Table 28: Smart Equipment™ UCB Details (Continued)

Description		Function & Comments
HPS2 (left pin)	24 VAC hot return from refrigerant circuit 2 High Pressure Switch	Not effective for one stage compressor UCBs. Input is only considered if C2 output is needed; input must be present to allow C1 output. Three HPS2 trips in a two hour period cause a "High Pressure Switch 1 Lockout" and C2 output is then prevented until alarm reset. Connects through circuit trace to the right LPS2 pin.
LPS2 (right pin)	24 VAC hot out for refrigerant circuit 2 Low Pressure Switch	Not effective for one stage compressor UCBs. Connects through circuit trace to the left HSP2 pin
LPS2 (left pin)	24 VAC hot return from refrigerant circuit 2 Low Pressure Switch	Not effective for one stage compressor UCBs. Input is only considered after 30 seconds of C2 output; afterwards, input must be present to allow C2 output. Three LPS2 trips in a one hour period cause a "Low Pressure Switch 2 Lockout" and C2 output is then prevented until alarm reset.
FAN OVR (right pin)	24 VAC hot out for indoor blower FAN Overload relay contact/motor protector switch	Connects through circuit trace to the R terminal
FAN OVR (left pin)	24 VAC hot return from indoor blower FAN Overload relay contact/motor protector switch	Input is only considered if FAN output is needed; input must be present to allow FAN output and unit operation. One FAN OVR trip lasting longer than 5 minutes or three FAN OVR trips in a two hour period cause a "Fan Overload Lockout" and unit operation is then prevented until alarm reset.
Terminal SA BUS¹ connections on at left on lower edge and center of UCB		
PWR	Power for SA ("Sensor-Actuator") BUS devices	Also incorporated in the J8 6-pin phone jack connector at the left-center of the board. Positive of the 15 VDC (reading to C) circuit for powering an optional netstat and/or Multi Touch gateway
C	Common for SA BUS power and communication circuits	Also incorporated in the J8 6-pin phone jack connector at the left-center of the board. Negative of the SA BUS circuits
-	Communication for SA BUS devices	Also incorporated in the J8 6-pin phone jack connector at the left-center of the board. Positive of the VDC (typically, a fluctuating 1.5 to 3.5 volts reading to C; at least 0.25 volts lower than +) SA BUS communication circuit to optional economizer board, 4-stage board, fault detection & diagnostics board, netstat and/or Multi Touch gateway
+	Communication for SA BUS devices	Also incorporated in the J8 6-pin phone jack connector at the left-center of the board. Positive of the VDC (typically, a fluctuating 1.5 to 3.5 volts reading to C; at least 0.25 volts higher than -) SA BUS communication circuit to optional economizer board, 4-stage board, fault detection & diagnostics board, netstat and/or Multi Touch gateway
J8	6-pin phone jack connector	Incorporates the SA BUS terminals for convenience/alternate connection of SA BUS devices, primarily used for temporary service connection of the Multi Touch gateway
Item Integrated user interface at lower left corner of UCB		
Display	On-board, 2-line x 8-character back-lit display	On-board display, buttons and joystick allow access to UCB, economizer, 4-stage and FDD board parameters
ENTER	Button for display menu acknowledgment and navigation	
CANCEL	Button for display menu navigation and zeroing of active compressor ASCD timer	
JOY	4-way Joystick for display menu navigation	
Item USB connector at right of UCB		
J10	Type A female Universal Serial Bus connector	Used for backup, restoration, & copying of board parameters as well as board software updating through a flash drive

Table 28: Smart Equipment™ UCB Details (Continued)

Description		Function & Comments
J15	Factory wired SA Bus connector	
Optional communication sub-board at center of UCB		
Terminal FC BUS¹ connections on left edge of the communication board		
FC+	FC ("Field Connected") BUS BACnet MSTP communication	Positive of the VDC (typically, a fluctuating 1.5 to 3.5 volts reading to COM; at least 0.25 volts higher than -) FC bus BACnet MSTP communication circuit
FC-	FC ("Field Connected") BUS BACnet MSTP communication	Positive of the VDC (typically, a fluctuating 1.5 to 3.5 volts reading to COM; at least 0.25 volts lower than +) FC bus BACnet MSTP communication circuit
COM	Common for the FC ("Field Connected") BUS BACnet MSTP communication circuit	Negative of the VDC FC bus BACnet MSTP communication circuit
SHLD	Shield for the FC ("Field Connected") BUS BACnet MSTP communication circuit	Earth ground reference of the cable to prevent interference on the FC bus BACnet MSTP communication circuit
Item Selector in red housing at left on top edge of the communication board		
EOL switch	End Of Line selector switch for the FC BUS BACnet MSTP communication circuit	ON selected only for the UCB that is the terminus of the FC bus BACnet MSTP communication cable to prevent signal "bounce-back"
LEDs on the communication board		
EOL	Green End Of Line indicator	Lit indicates the EOL switch is selected ON
FC BUS	Green FC bus communication transmission indicator	Lit/flickering indicates outgoing UCB FC bus communication is currently active, off indicates the UCB is awaiting incoming FC bus communication
ISO PWR	Green communication board Isolated Power indicator	Lit indicates the UCB is supplying power to the communication sub-board

1. When wiring unit and other devices using the SA Bus and FC Bus, see Table 29.

Table 29: Cable for FC Buses and SA Buses in Order of Preference

Bus and Cable Type	Non-Plenum Applications		Plenum Applications	
	Part Number	O.D.	Part Number	O.D.
FC Bus: 22 AWG Stranded, 3-Wire Twisted Shielded Cable ¹	Anixter: CBL-22/3-FC-PVC Belden®: B5501FE	0.138 in.	Anixter: CBL-22/3-FC-PLN Belden: B6501FE	0.140 in.
SA Bus (Terminal Block): 22 AWG Stranded, 4-Wire, 2 Twisted-Pair Shielded Cable	Anixter: CBL-22/2P-SA-PVC Belden: B5541FE	0.209 in.	Anixter: CBL-22/2P-SA-PLN Belden: B6541FE	0.206 in.
SA Bus (Modular Jack): 26 AWG Solid 6-Wire, 3 Twisted-Pair Cable ²	—	—	Anixter preassembled: CBL-NETWORK25 CBL-NETWORK50 CBL-NETWORK75 CBL-NETWORK100	0.15 in.
FC Bus: 22 AWG Stranded, 3-Wire Twisted Non-Shielded Cable	Belden: B5501UE	0.135 in.	Belden: B6501UE	0.131 in.
SA Bus (Terminal Block): 22 AWG Stranded, 4-Wire, 2 Twisted-Pair Non-Shielded Cable	Belden: B5541UE	0.206 in.	Belden: B6541UE	0.199 in.

1. We strongly recommend 3-wire (for FC bus) and 4-wire, 2 twisted-pair (for SA bus), 22 AWG stranded, shielded cable. A 22 gauge cable offers the best performance for various baud rates, cable distances, and number of trunk devices primarily due to lower conductor-to-conductor capacitance. Shielded cable offers better overall electrical noise immunity than non-shielded cable. Observe the shield grounding requirements.
2. We recommend 26 AWG solid, 6-wire (3 twisted pairs) cable as the best fit for fabricating modular cables with the modular jack housing assembly. Be sure the cable you use fits the modular jack housing. The preassembled cables that are available from Anixter (Part No. CBL-NETWORKxxx) use 24 gauge wire.

Typical Wiring Diagrams

Simplicity® Lite Control Board

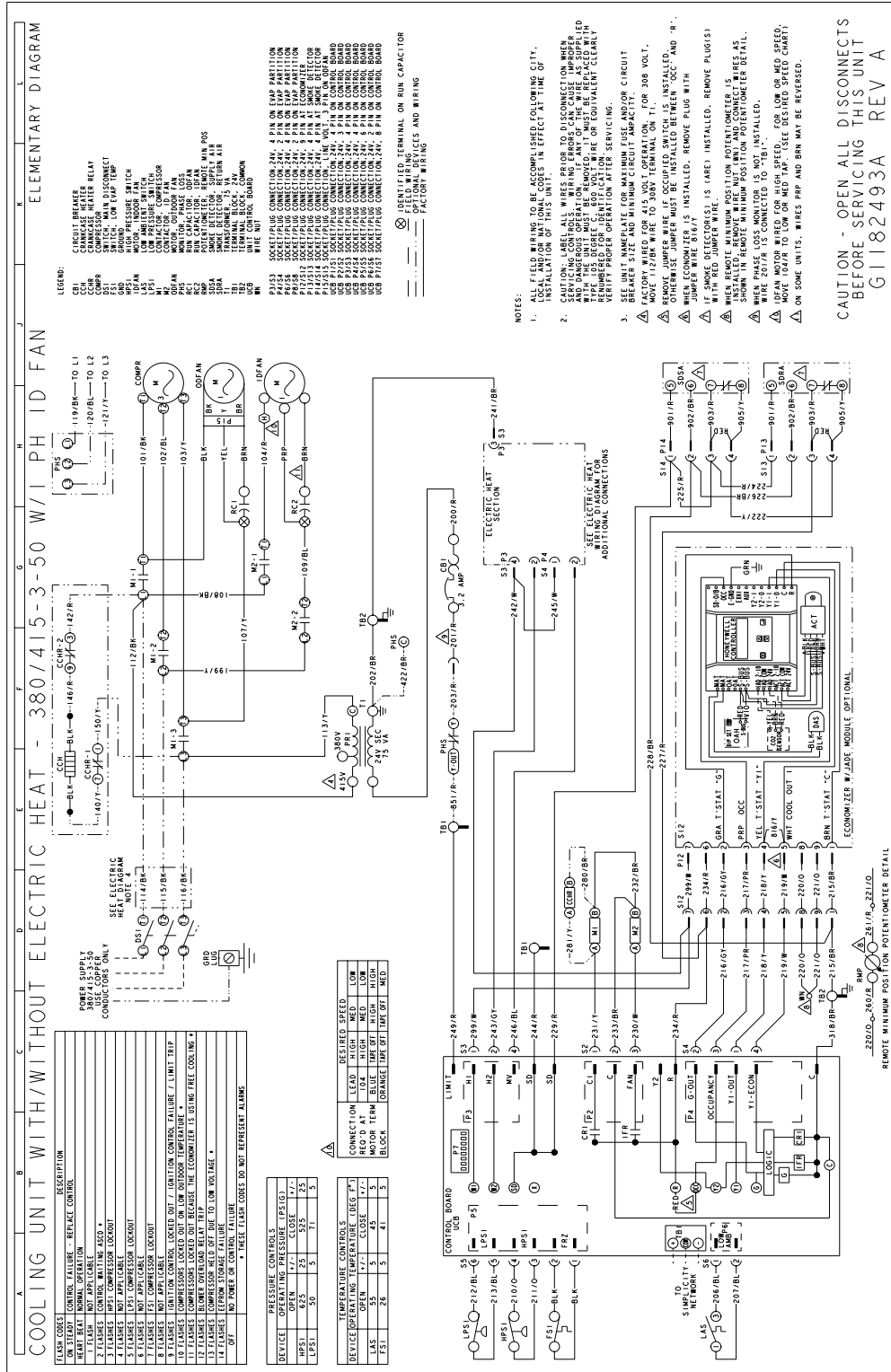

Figure 28: Typical ZF036, 048 With Simplicity Lite Control, With/without Electric Heat Wiring Diagram

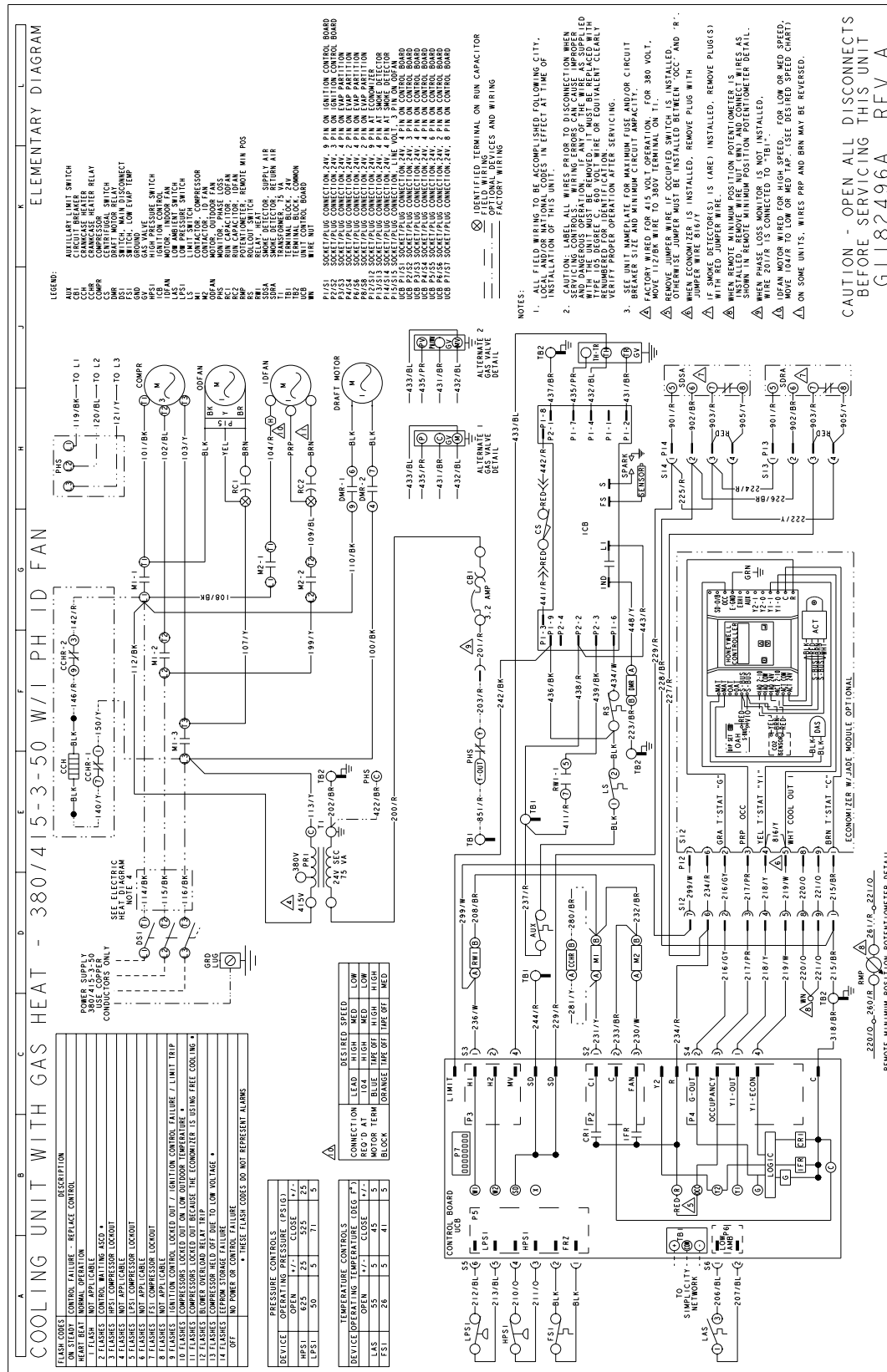

Figure 29: Typical ZF036, 048 With Simplicity Lite Control, With Gas Heat Wiring Diagram

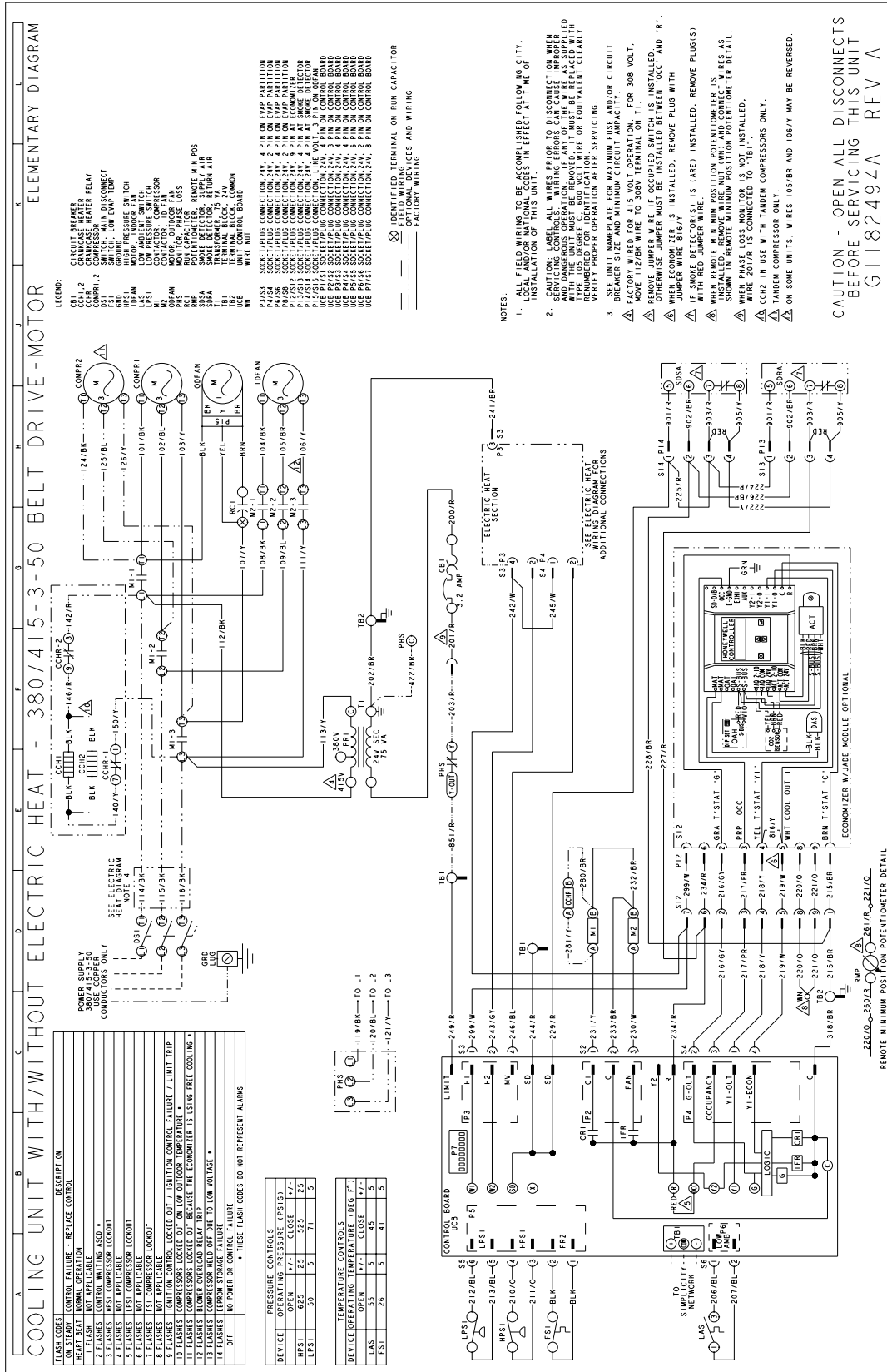

Figure 30: Typical ZF060, 076 with Simplicity Lite Control, With/Without Electric Heat Wiring Diagram

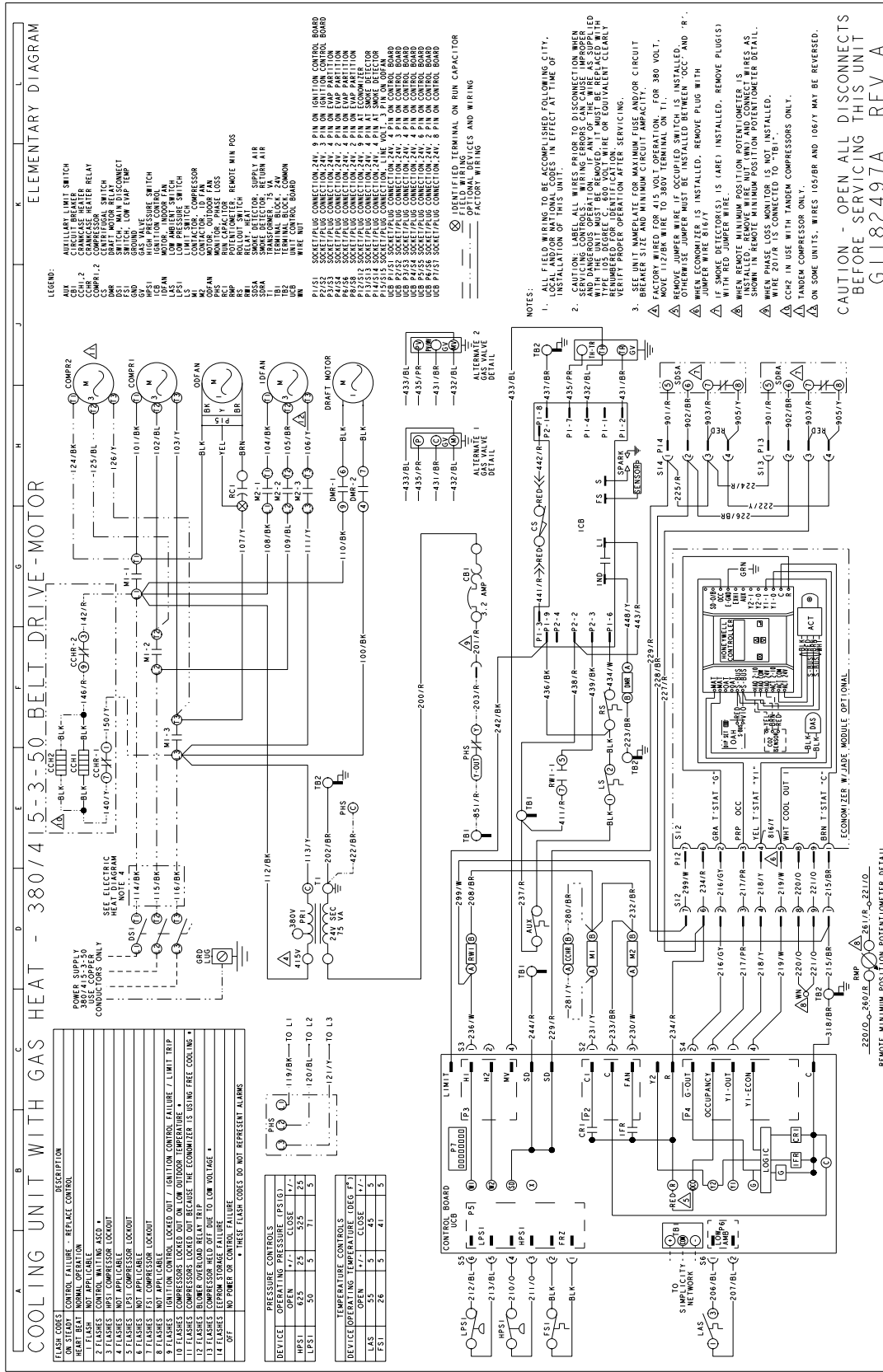

Figure 31: Typical ZF060, 076 With Simplicity Lite Control, With Gas Heat Wiring Diagram

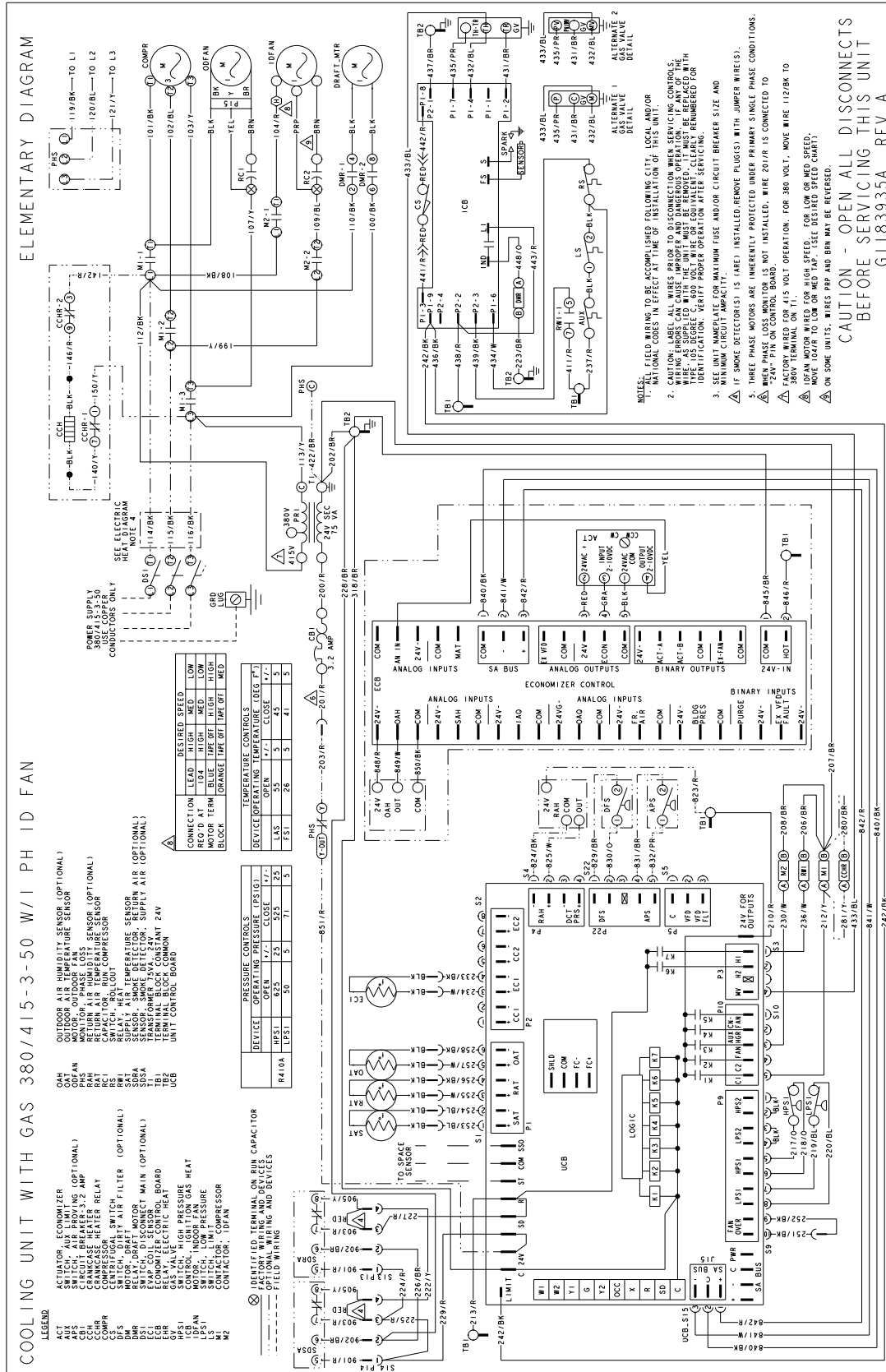

Figure 33: Typical ZF036, 048 With Smart Equipment™ Control, With Gas Heat Wiring Diagram

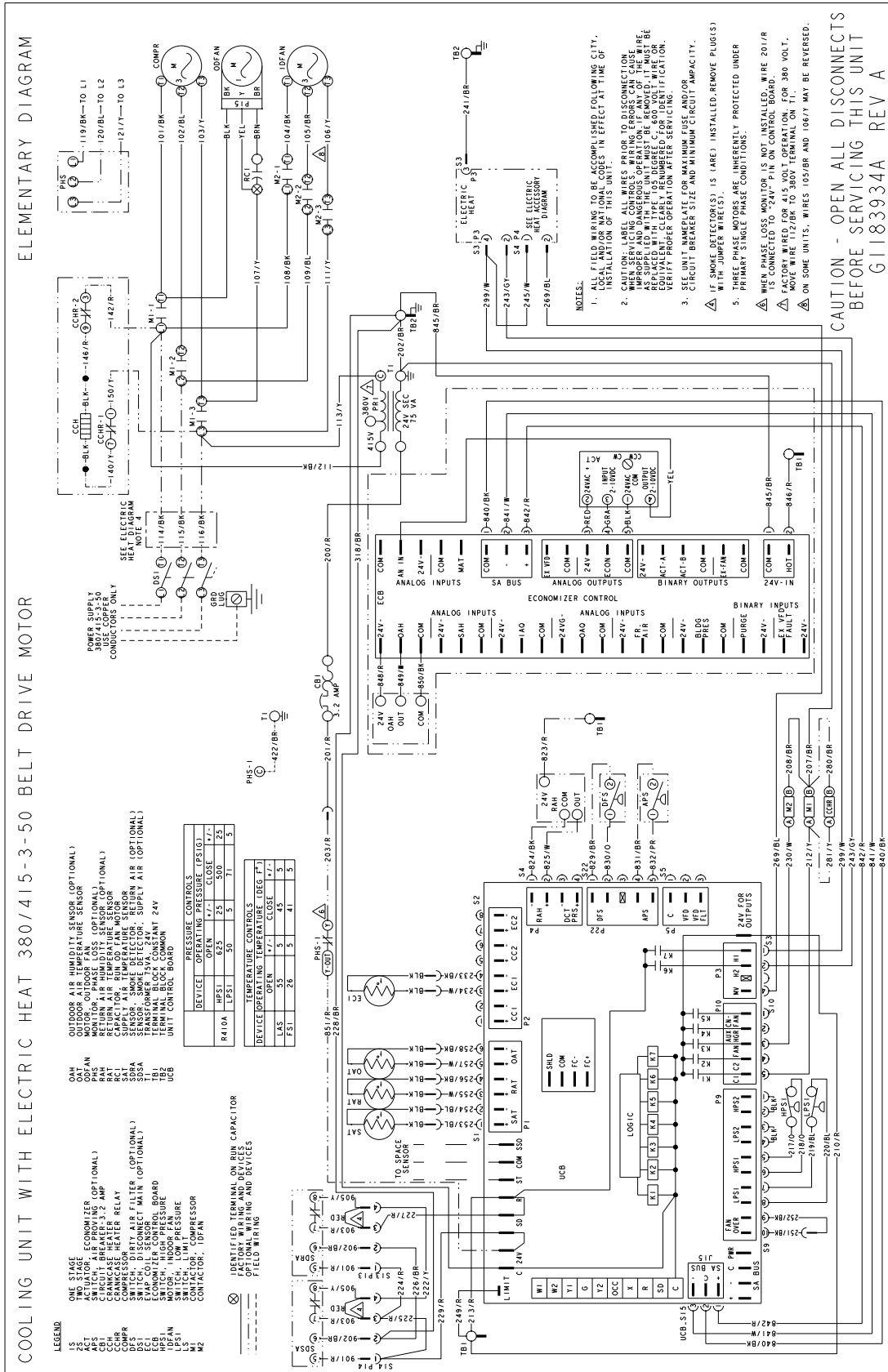

Figure 34: Typical ZF060, 076 With Smart Equipment™ Control, With/without Electric Heat Wiring Diagram

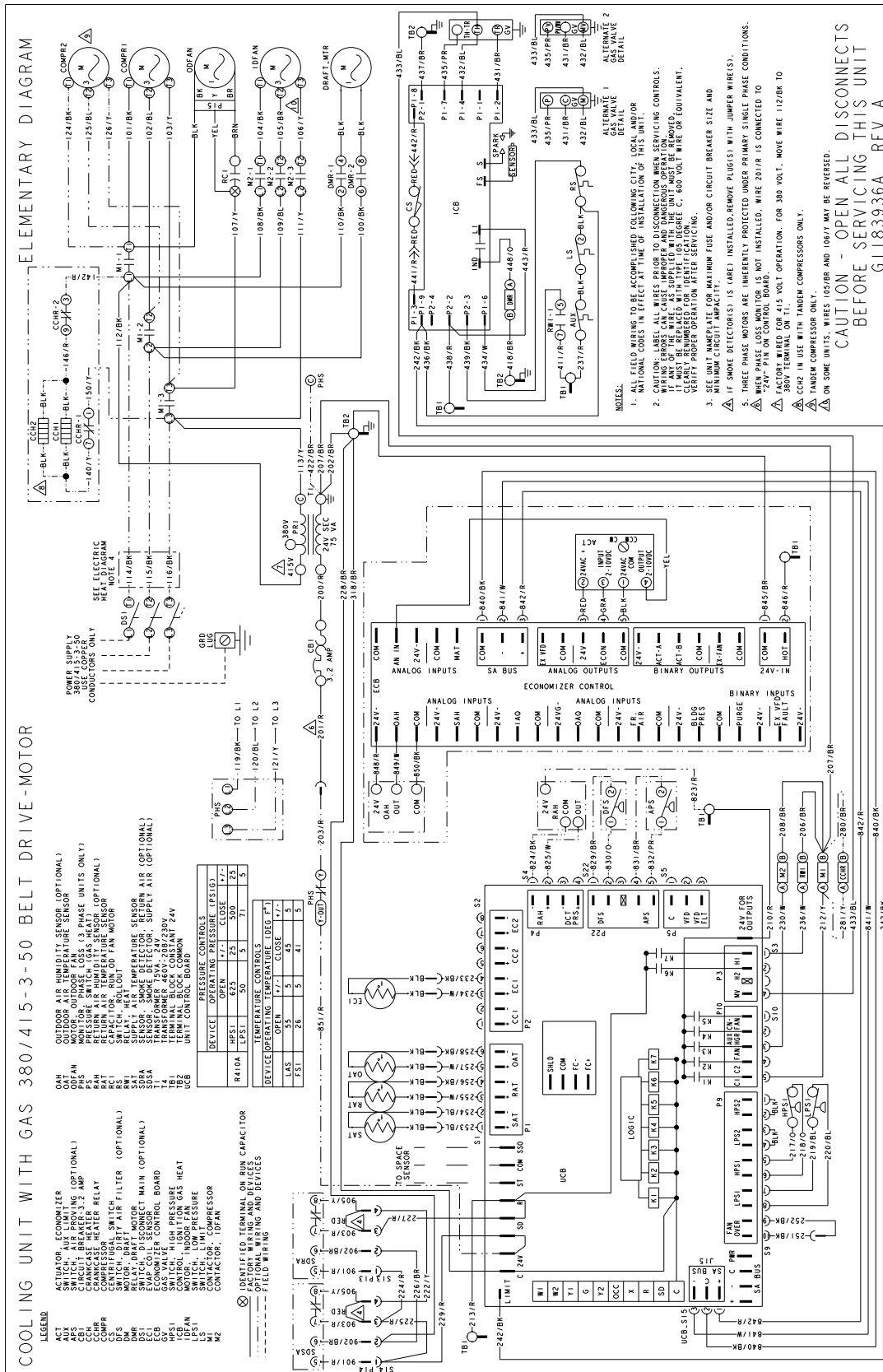

Figure 35: Typical ZF060, 076 With Smart Equipment™ Control, With Gas Heat Wiring Diagram

Start-Up Sheet

START-UP & SERVICE DATA INSTRUCTION

COMMERCIAL PACKAGE UNITS

3.0 To 40.0 TONS

START-UP CHECKLIST

Date: _____

Job Name: _____

Customer Name: _____

Address: _____

City: _____ State: _____ Zip: _____

Model Number: _____ Serial Number: _____

Qualified Start-up Technician: _____ Signature: _____

HVAC Contractor: _____ Phone: _____

Address: _____

Contractor's E-mail Address: _____

Electrical Contractor: _____ Phone: _____

Distributor Name: _____ Phone: _____

WARRANTY STATEMENT

Johnson Controls/UPG is confident that this equipment will operate to the owner's satisfaction if the proper procedures are followed and checks are made at initial start-up. This confidence is supported by the 30 day dealer protection coverage portion of our standard warranty policy which states that Johnson Controls/UPG will cover parts and labor on new equipment start-up failures that are caused by a defect in factory workmanship or material, for a period of 30 days from installation. Refer to current standard warranty policy and warranty manual found on UPGnet for details.

In the event that communication with Johnson Controls/UPG is required regarding technical and/or warranty concerns, all parties to the discussion should have a copy of the equipment start-up sheet for reference. A copy of the original start-up sheet should be filed with the Technical Services Department.

The packaged unit is available in constant or variable air volume versions with a large variety of custom options and accessories available. Therefore, some variation in the startup procedure will exist depending upon the products capacity, control system, options and accessories installed.

This start-up sheet covers all startup check points common to all package equipment. In addition it covers essential startup check points for a number of common installation options. Depending upon the particular unit being started not all sections of this startup sheet will apply. Complete those sections applicable and use the notes section to record any additional information pertinent to your particular installation.

Warranty claims are to be made through the distributor from whom the equipment was purchased.

EQUIPMENT STARTUP

Use the local LCD or Mobile Access Portal (MAP) Gateway to complete the start-up.

A copy of the completed start-up sheet should be kept on file by the distributor providing the equipment and a copy sent to:

Johnson Controls/UPG
 Technical Services Department
 5005 York Drive
 Norman, OK 73069

SAFETY WARNINGS

The inspections and recording of data outlined in this procedure are required for start-up of Johnson Controls/UPG's packaged products. Industry recognized safety standards and practices must be observed at all times. General industry knowledge and experience are required to assure technician safety. It is the responsibility of the technician to assess all potential dangers and take all steps warranted to perform the work in a safe manner. By addressing those potential dangers, prior to beginning any work, the technician can perform the work in a safe manner with minimal risk of injury.

 WARNING
Lethal voltages are present during some start-up checks. Extreme caution must be used at all times.

 WARNING
Moving parts may be exposed during some startup checks. Extreme caution must be used at all times.

NOTE: Read and review this entire document before beginning any of the startup procedures.

DESIGN APPLICATION INFORMATION

This information will be available from the specifying engineer who selected the equipment. If the system is a VAV system the CFM will be the airflow when the remote VAV boxes are in the

full open position and the frequency drive is operating at 60 HZ. **Do not proceed with the equipment start-up without the design CFM information.**

Design Supply Air CFM: _____ Design Return Air CFM: _____

Design Outdoor Air CFM At Minimum Position: _____

Total External Static Pressure: _____

Supply Static Pressure: _____

Return Static Pressure: _____

Design Building Static Pressure: _____

Outside Air Dilution: Economizer Position Percentage: _____ CFM: _____

Supply Gas Pressure After Regulator W/o Heat Active _____ Inches _____

ADDITIONAL APPLICATION NOTES FROM SPECIFYING ENGINEER:

1034349-UCL-D-0516

REFERENCE

General Inspection	Completed	See Notes
Unit inspected for shipping, storage, or rigging damage	<input type="checkbox"/>	<input type="checkbox"/>
Unit installed with proper clearances	<input type="checkbox"/>	<input type="checkbox"/>
Unit installed within slope limitations	<input type="checkbox"/>	<input type="checkbox"/>
Refrigeration system checked for gross leaks (presence of oil)	<input type="checkbox"/>	<input type="checkbox"/>
Terminal screws and wiring connections checked for tightness	<input type="checkbox"/>	<input type="checkbox"/>
Filters installed correctly and clean	<input type="checkbox"/>	<input type="checkbox"/>
Economizer hoods installed in operating position	<input type="checkbox"/>	<input type="checkbox"/>
Condensate drain trapped properly, refer to Installation Manual	<input type="checkbox"/>	<input type="checkbox"/>
Economizer damper linkage tight	<input type="checkbox"/>	<input type="checkbox"/>
Gas Heat vent hood installed	<input type="checkbox"/>	<input type="checkbox"/>
All field wiring (power and control) complete	<input type="checkbox"/>	<input type="checkbox"/>

Air Moving Inspection	Completed	See Notes
Alignment of drive components	<input type="checkbox"/>	<input type="checkbox"/>
Belt tension adjusted properly	<input type="checkbox"/>	<input type="checkbox"/>
Blower pulleys tight on shaft, bearing set screws tight, wheel tight to shaft	<input type="checkbox"/>	<input type="checkbox"/>
Pressure switch or transducer tubing installed properly	<input type="checkbox"/>	<input type="checkbox"/>

Exhaust Inspection Powered <input type="checkbox"/> Barometric Relief <input type="checkbox"/>	Completed	See Notes
Check hub for tightness	<input type="checkbox"/>	<input type="checkbox"/>
Check fan blade for clearance	<input type="checkbox"/>	<input type="checkbox"/>
Check for proper rotation	<input type="checkbox"/>	<input type="checkbox"/>
Check for proper mounting (screen faces towards unit)	<input type="checkbox"/>	<input type="checkbox"/>
Prove operation by increasing minimum setting on economizer	<input type="checkbox"/>	<input type="checkbox"/>

Economizer Inspection Standard <input type="checkbox"/> BAS <input type="checkbox"/>	Completed	See Notes
CO ₂ sensor installed Yes <input type="checkbox"/> No <input type="checkbox"/>	<input type="checkbox"/>	<input type="checkbox"/>
Check economizer setting (Reference Smart Equipment™ Control Board LCD menu location)	<input type="checkbox"/>	<input type="checkbox"/>
Prove economizer open/close through Smart Equipment™ Board Setting	<input type="checkbox"/>	<input type="checkbox"/>

Reheat Mode Normal <input type="checkbox"/> or Alternate <input type="checkbox"/> Not Applicable <input type="checkbox"/>
Humidity Sensor (2SH0401) _____

1034349-UCL-D-0516

Operating Measurements - Air Flow

Fan operates with proper rotation	ID Fans <input type="checkbox"/>	Exh. Fans <input type="checkbox"/>	Cond. Fans <input type="checkbox"/>
Pressure drop across dry evaporator coil (At maximum design CFM) ¹			IWC
External Static Pressure			IWC
Return Static Pressure			IWC
Supply Static Pressure			IWC
Supply Air CFM Using Dry Coil Chart			CFM
Final Adjusted Supply Air CFM ²			CFM

1. Consult the proper airflow to pressure drop table to obtain the actual airflow at the measured pressure differential.
2. Was a motor pulley adjustment or change required to obtain the correct airflow?
 Was it necessary to increase or decrease the airflow to meet the design conditions?
 If the motor pulley size was changed, measure the outside diameters of the motor and blower pulleys and record those diameters here;

Blower Motor HP _____ FLA _____ RPM _____

Pulley Pitch Diameter _____ Turns Out _____ Final Turns Out _____

Blower Pulley Pitch Diameter _____ Fixed Sheave _____

ELECTRICAL DATA

T1 - T2 _____ Volts T2 - T3 _____ Volts

Control Voltage _____ Volts T1 - T3 _____ Volts

Device	Nameplate	Measured List All Three Amperages
Supply Fan Motor ^{1, 2}	AMPS	AMPS
Exhaust Motor (Dampers 100%)	AMPS	AMPS
Condenser Fan #1	AMPS	AMPS
Condenser Fan #2 (if equipped)	AMPS	AMPS
Condenser Fan #3 (if equipped)	AMPS	AMPS
Condenser Fan #4 (if equipped)	AMPS	AMPS
Compressor #1	AMPS	AMPS
Compressor #2 (if equipped)	AMPS	AMPS
Compressor #3 (if equipped)	AMPS	AMPS
Compressor #4 (if equipped)	AMPS	AMPS

1. VAV units with heat section - simulate heat call to drive VAV boxes and VFD/IGV to maximum design airflow position.
2. VAV units without heat section - VAV boxes must be set to maximum design airflow position.

1034349-UCL-D-0516

OPERATING MEASUREMENTS - COOLING

Stage	Discharge Pressure	Discharge Temp.	Liquid Line Temp. ¹	Subcooling ²	Suction Pressure	Suction Temp.	Superheat
First	#	°	°	°	#	°	°
Second (if equipped)	#	°	°	°	#	°	°
Third (if equipped)	#	°	°	°	#	°	°
Fourth (if equipped)	#	°	°	°	#	°	°
Reheat 1st Stage	#	°	°	°	#	°	°

- Liquid temperature should be taken before filter/drier.
- Subtract 10 psi from discharge pressure for estimated liquid line pressure

Outside air temperature _____ °F db _____ °F wb _____ %RH
 Return Air Temperature _____ °F db _____ °F wb _____ %RH
 Mixed Air Temperature _____ °F db _____ °F wb _____ %RH
 Supply Air Temperature _____ °F db _____ °F wb _____ %RH

REFRIGERANT SAFETIES

Action	Completed	See Notes
Prove Compressor Rotation (3 phase only) by gauge pressure	<input type="checkbox"/>	<input type="checkbox"/>
Prove High Pressure Safety, All Systems	<input type="checkbox"/>	<input type="checkbox"/>
Prove Low Pressure Safety, All Systems	<input type="checkbox"/>	<input type="checkbox"/>

OPERATING MEASUREMENTS - GAS HEATING

Fuel Type: Natural Gas LP Gas

Action	Completed	See Notes
Check for gas leaks	<input type="checkbox"/>	<input type="checkbox"/>
Prove Ventor Motor Operation	<input type="checkbox"/>	<input type="checkbox"/>
Prove Primary Safety Operation	<input type="checkbox"/>	<input type="checkbox"/>
Prove Auxiliary Safety Operation	<input type="checkbox"/>	<input type="checkbox"/>
Prove Rollout Switch Operation	<input type="checkbox"/>	<input type="checkbox"/>
Prove Smoke Detector Operation	<input type="checkbox"/>	<input type="checkbox"/>
Manifold Pressure	Stage 1	IWC <input type="checkbox"/>
	Stage 2 (If Equipped)	IWC <input type="checkbox"/>
	Stage 3 (If Equipped)	IWC <input type="checkbox"/>
Supply gas pressure at full fire		IWC <input type="checkbox"/>
Check temperature rise ¹	<input type="checkbox"/> measured at full fire	°F <input type="checkbox"/>

1. Input X Eff. (BTU output)
 1.08 X Temp. Rise

OPERATIONAL MEASUREMENTS - STAGING CONTROLS

Verify Proper Operation of Heating/Cooling Staging Controls	
Create a cooling demand at the Thermostat, BAS System or Smart Equipment™ Verify that cooling/economizer stages are energized.	<input type="checkbox"/>
Create a heating demand at the Thermostat, BAS System or Smart Equipment™ Verify that heating stages are energized.	<input type="checkbox"/>
Verify Proper Operation of the Variable Frequency Drive (If Required)	
Verify that motor speed modulates with duct pressure change.	<input type="checkbox"/>

FINAL - INSPECTION

Verify that all operational control set points have been set to desired value Scroll through all setpoints and change as may be necessary to suit the occupant requirements.	<input type="checkbox"/>
Verify that all option parameters are correct Scroll through all option parameters and ensure that all installed options are enabled in the software and all others are disabled in the software. (Factory software settings should match the installed options)	<input type="checkbox"/>
Verify that all access panels have been closed and secured	<input type="checkbox"/>

OBSERVED PRODUCT DEFICIENCIES & CONCERNS:
