

Intel® NUC 8 Business, a Mini PC with Windows® 10 – NUC8i7HNKQC

Intel® NUC 8 Enthusiast, a Mini PC with Windows® 10 – NUC8i7HVKVA

---

## User Guide

## Before You Begin



### CAUTIONS

*The procedures in this user guide assume familiarity with the general terminology associated with personal computers and with the safety practices and regulatory compliance required for using and modifying electronic equipment.*

*Disconnect the computer from its power source and from any telecommunications link or network before performing any of the procedures described in this guide. Failure to disconnect power, telecommunications links, or networks before you open the computer or perform any procedures can result in personal injury or equipment damage. Some circuitry on the board can continue to operate even though the front panel power button is off.*

Follow these guidelines before you begin:

- Always follow the steps in each procedure in the correct order.
- Set up a log to record information about your computer, such as model, serial numbers, installed options, and configuration information.
- Electrostatic discharge (ESD) can damage components. Perform the procedures described in this chapter only at an ESD workstation using an antistatic wrist strap and a conductive foam pad. If such a station is not available, you can provide some ESD protection by wearing an antistatic wrist strap and attaching it to a metal part of the computer chassis.

## Installation Precautions

When you install and test the Intel NUC, observe all warnings and cautions in the installation instructions.

To avoid injury, be careful of:

- Sharp pins on connectors
- Sharp pins on circuit boards
- Rough edges and sharp corners on the chassis
- Hot components (such as SSDs, processors, voltage regulators, and heat sinks)
- Damage to wires that could cause a short circuit

Observe all warnings and cautions that instruct you to refer computer servicing to qualified technical personnel.

## Observe Safety and Regulatory Requirements

If you do not follow these instructions, you increase your safety risk and the possibility of noncompliance with regional laws and regulations.

## This guide tells you how to:

- [Open and Close the Chassis](#)
- [Install and Remove Memory](#)
- [Install an M.2 SSD](#)
- [Install a VESA Mount Bracket](#)
- [Connect Power](#)
- [Install an Operating System](#)
- [Install the latest device drivers and software](#)
- [Operating System Recovery](#)

## Open the Intel NUC Chassis

To open the Intel NUC chassis, follow these steps:

1. Using the included hex wrench, unscrew the six screws on the top cover of the chassis and lift the cover.

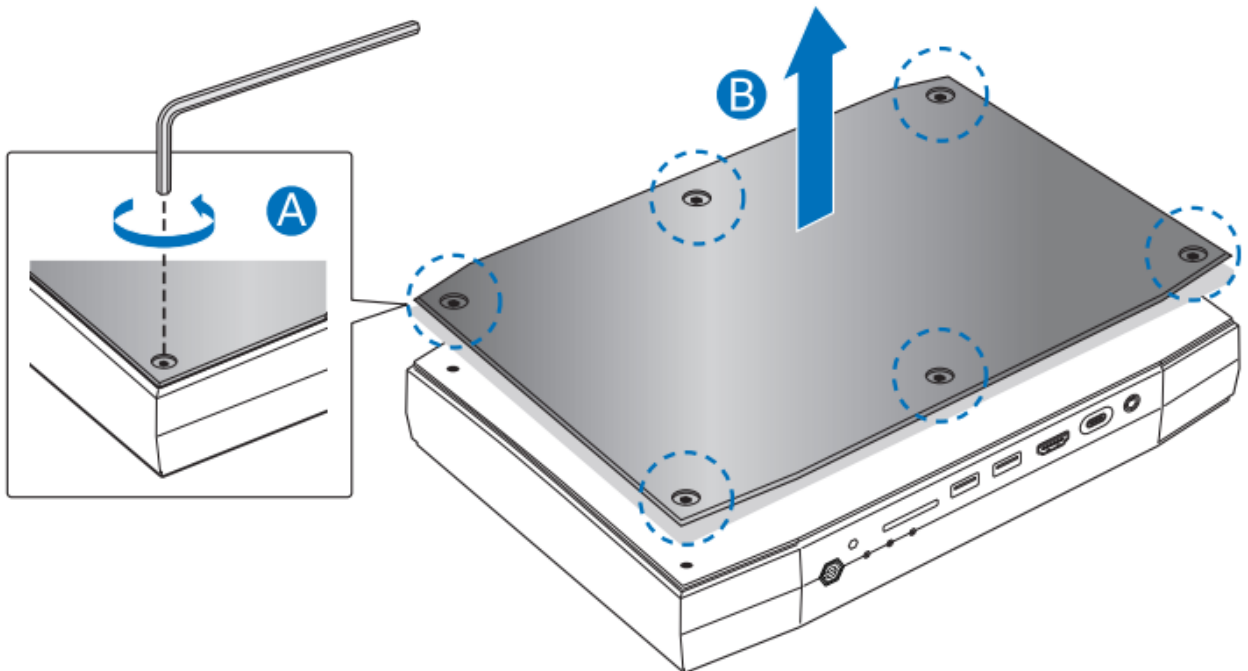

2. Detach the cable from the top of the NUC.

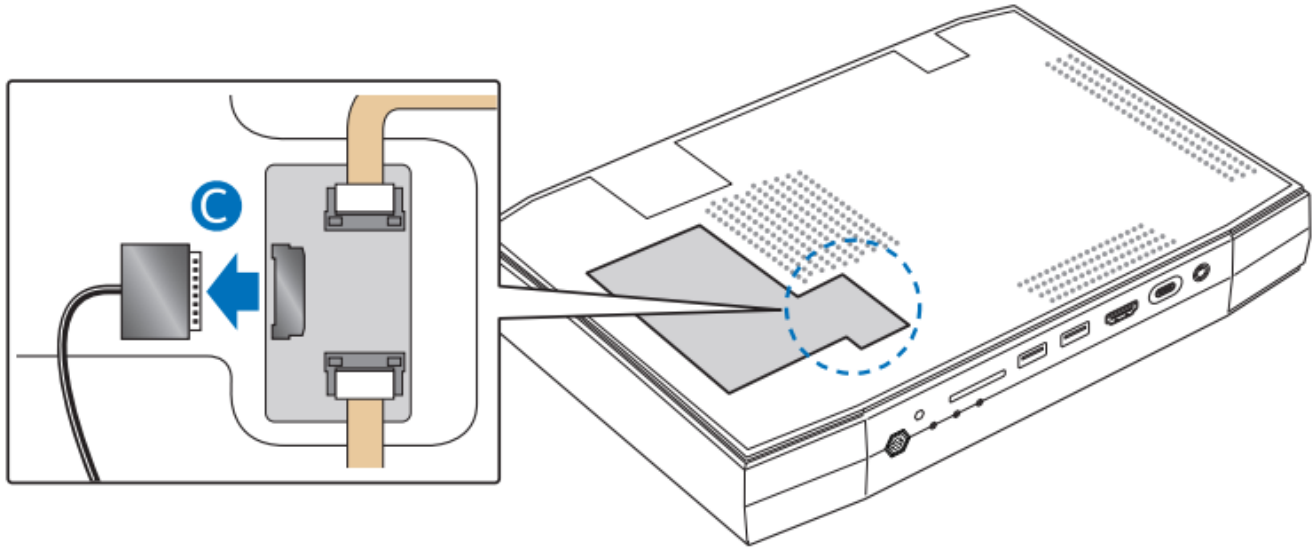

3. Unscrew the single screw to release the top plate.

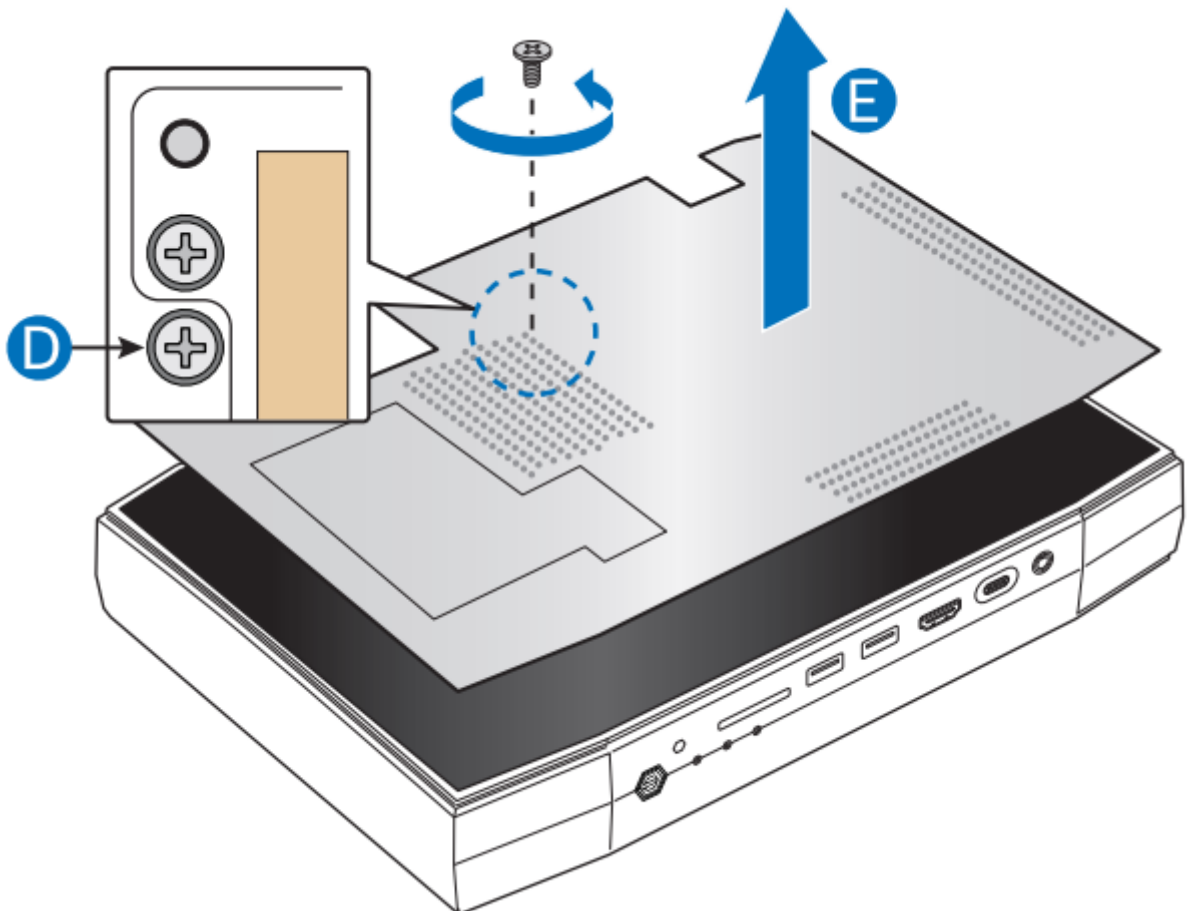

## Installing and Removing Memory

The Intel NUC 8 Business - NUC8i7HNKQC and Intel NUC 8 Enthusiast - NUC8i7HVKVA have two 260-pin DDR4 SO-DIMM sockets. Although these NUCs come with both memory slots filled, follow these steps if memory is removed or installed.

### Pre-installed memory

|   |                                      |
|---|--------------------------------------|
| Intel® NUC 8 Business, a Mini PC with Windows® 10 – NUC8i7HNKQC   | Two 8GB memory modules<br>16GB total |
| Intel® NUC 8 Enthusiast, a Mini PC with Windows® 10 – NUC8i7HVKVA | Two 8GB memory modules<br>16GB total |

Memory requirements:

- 1.2V low voltage memory
- 2400 MHz SO-DIMMs
- Non-ECC

Find tested memory at the Intel® Product Compatibility Tool:

- [NUC8i7HNKQC](#)
- [NUC8i7HVKVA](#)

|             |  |
|-------------|--|
| <b>NOTE</b> | If only installing one SO-DIMM, install it in the lower memory socket. |
|-------------|--|

**To install memory, follow these steps:**

1. Observe the precautions in "Before You Begin" on page 2.
2. Turn off all peripheral devices connected to the computer. Turn off the computer and disconnect the AC power cord.

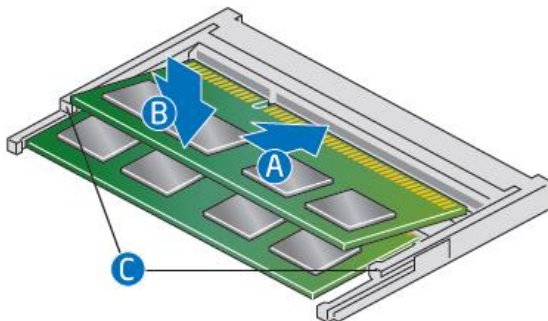

3. Align the small notch at the bottom edge of the SO-DIMM with the key in the socket.
4. Insert the bottom edge of the SO-DIMM into the socket.
5. When the SO-DIMM is inserted, push down on the outer edge of the SO-DIMM until the retaining clips snap into place. Make sure the clips are firmly in place.

**To remove memory, follow these steps:**

1. Observe the precautions in "Before You Begin" on page 2.
2. Turn off all peripheral devices connected to the computer. Turn off the computer.
3. Remove the AC power cord from the computer.
4. Remove the computer's cover.
5. Gently spread the retaining clips at each end of the SO-DIMM socket. The SO-DIMM pops out of the socket.
6. Hold the SO-DIMM by the edges, lift it away from the socket, and store it in an anti-static package.
7. Reinstall and reconnect any parts you removed or disconnected to reach the SO-DIMM sockets.
8. Replace the computer's cover and reconnect the AC power cord.

## Installing an M.2 SSD

The Intel NUC 8 Business - NUC8i7HNKQC and Intel NUC 8 Enthusiast - NUC8i7HVKVA support both 80mm and 42mm SSDs.

Find compatible M.2 SSDs at the Intel® Product Compatibility Tool:

- [NUC8i7HNKQC](#)
- [NUC8i7HVKVA](#)

**To install an 80mm M.2 SSD:**

1. Remove the small silver screw from the 80mm metal standoff on the motherboard (A).
2. Align the small notch at the bottom edge of the M.2 card with the key in the connector (B).
3. Insert the bottom edge of the M.2 card into the connector (B).
4. Secure the card to the standoff with the small silver screw (C).

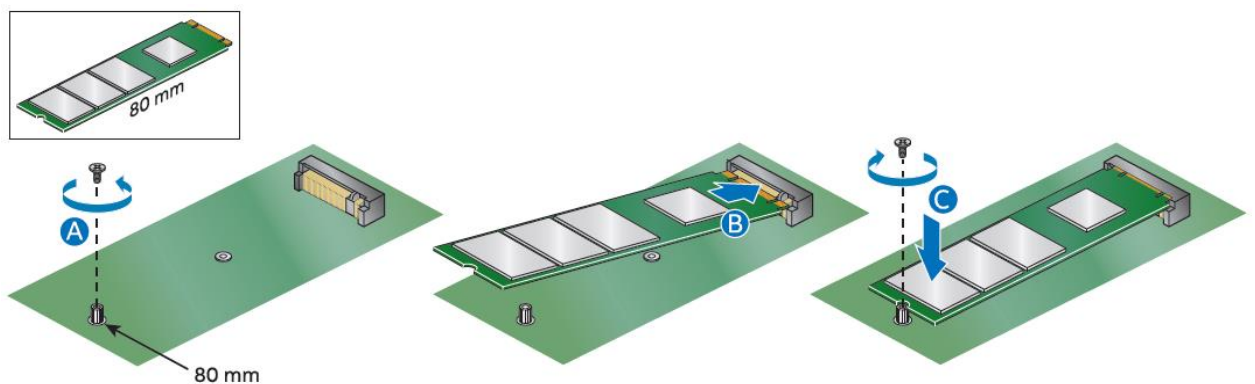

**To install a 42mm M.2 SSD:**

1. Remove the small silver screw from the metal standoff on the motherboard (A).
2. Move the standoff (B) from the 80mm position to the 42mm position (C).
3. Align the small notch at the bottom edge of the M.2 card with the key in the connector.
4. Insert the bottom edge of the M.2 card into the connector (D).
5. Secure the card to the standoff with the small silver screw (E).

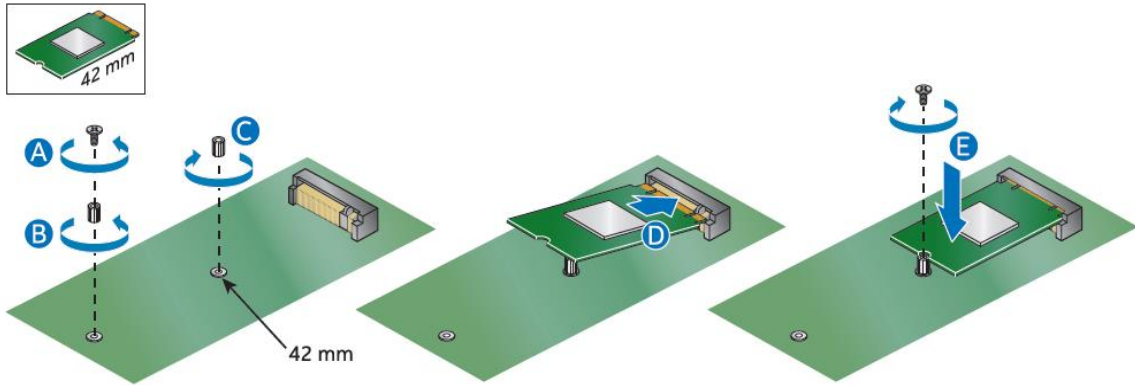

## Closing the Chassis

After all the components have been installed, close the Intel NUC chassis. Intel recommends this be done by hand with a screwdriver to avoid over-tightening and possibly damaging the screws.

1. Place the top plate on the NUC chassis.

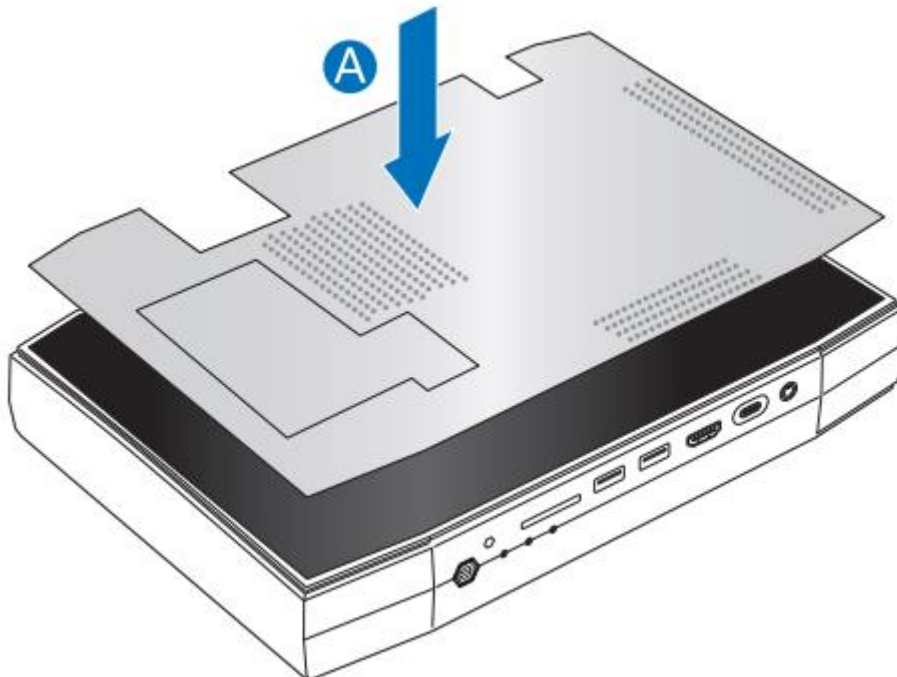

2. Reattach the cable and secure the top plate with a screwdriver.

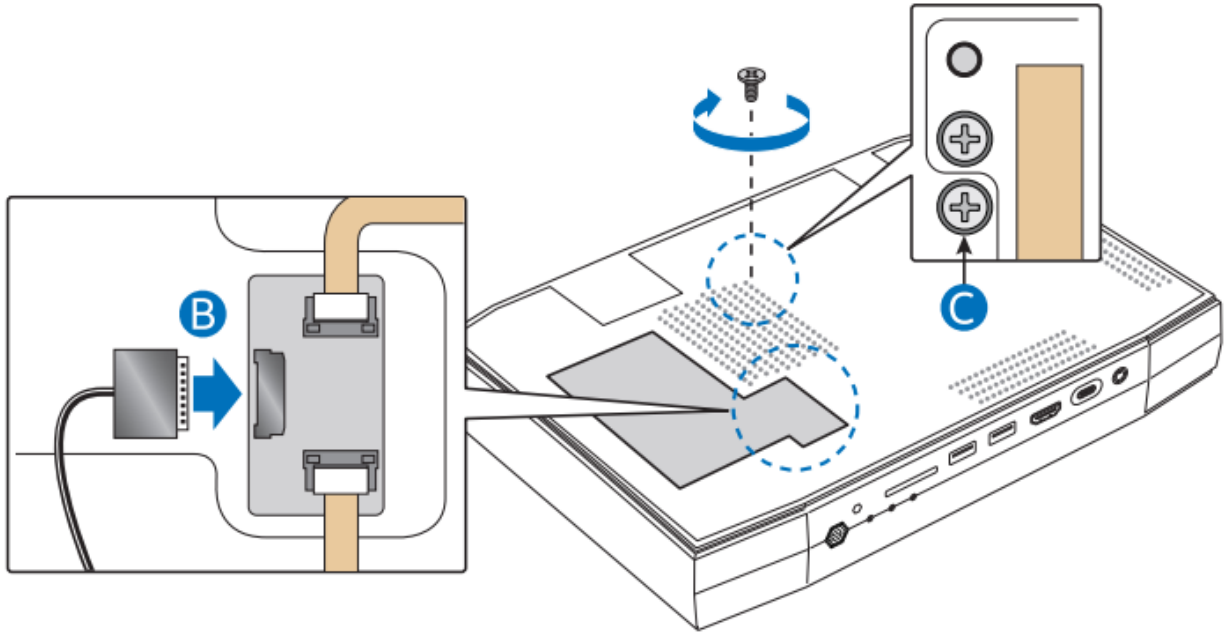

3. Place the top lid on the NUC and use the hex tool to tighten all the screws.

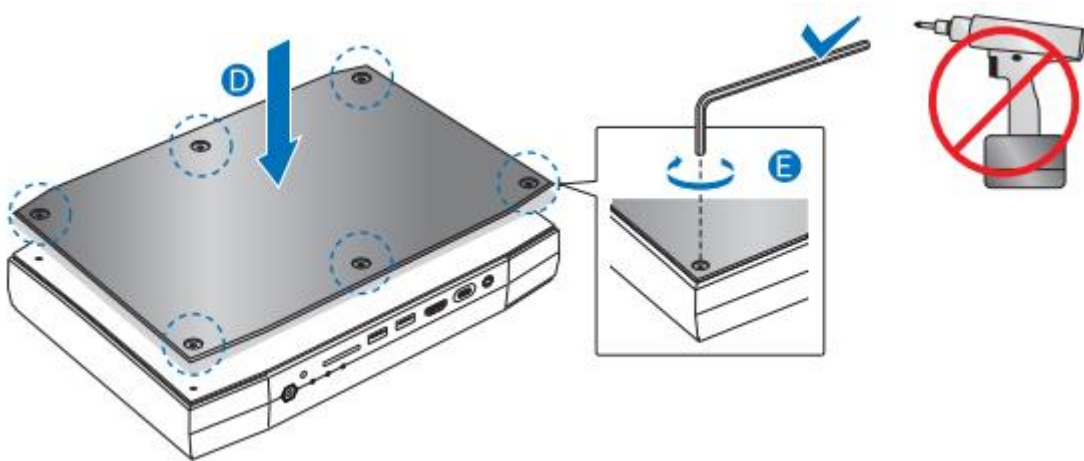



## Attaching and Using the VESA Bracket (Optional)

Follow these instructions to attach and use the VESA mount bracket:

1. Using the four small black screws that were included in the box, attach the VESA bracket to the back of the monitor or TV.

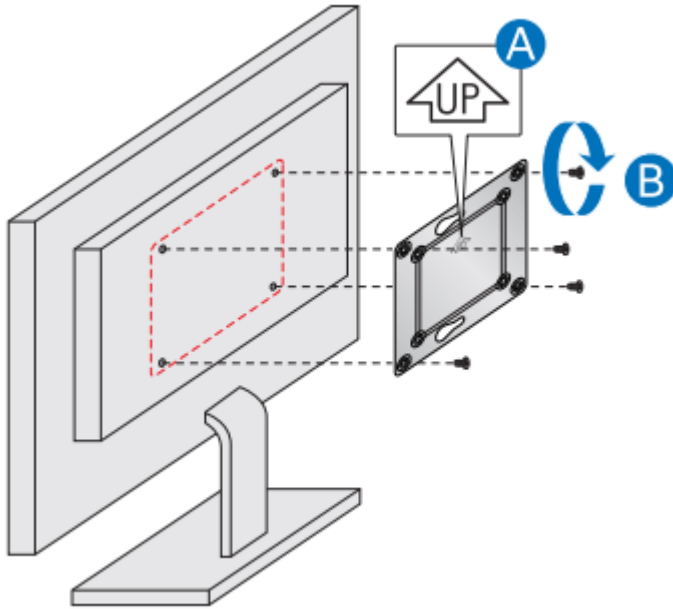

2. Attach the two slightly larger black screws to the bottom chassis cover of the Intel NUC.

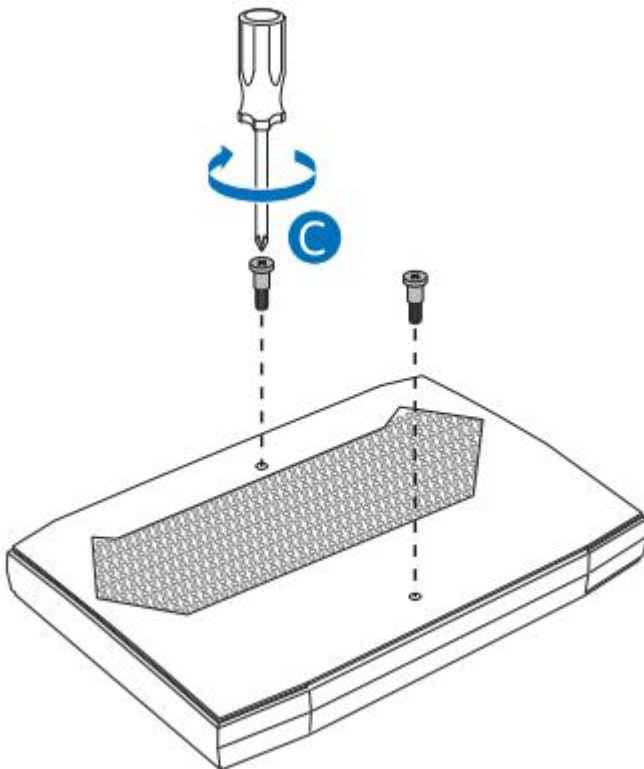



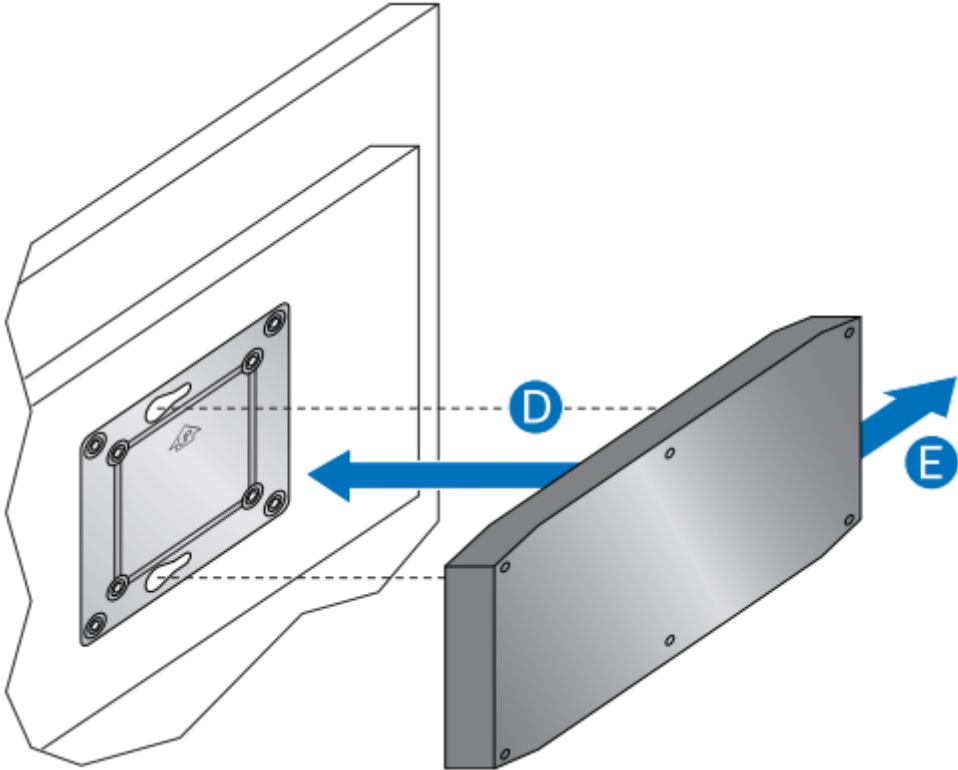

3. Slide the Intel NUC onto the VESA mount bracket.

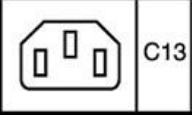
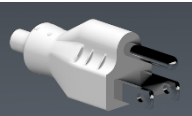

## Power

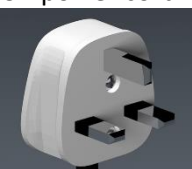
Each Intel NUC box includes a region-specific AC power cord, or no AC power cord (only the power adapter).

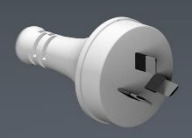
| Product codes                      | Power cord type   |
|------------------------------------|---|
| BOXNUC8i7HMKQC<br>BOXNUC8i7HVKVA   | No power cord included. An AC power cord needs to be purchased separately. The connector on the power adapter is a C13 type connector.<br> |
| BOXNUC8i7HMKQC1<br>BOXNUC8i7HVKVA1 | US power cord included.<br>  |
| BOXNUC8i7HMKQC2<br>BOXNUC8i7HVKVA2 | EU power cord included.<br>  |
| BOXNUC8i7HMKQC3<br>BOXNUC8i7HVKVA3 | UK power cord included.<br>   |
| BOXNUC8i7HMKQC4<br>BOXNUC8i7HVKVA4 | Australia/New Zealand power cord included.<br>   |
| BOXNUC8i7HVKVA6                    | China power cord included.<br>   |

Connect the power cord to the adapter (A). Plug the power adapter into the wall (B). Lastly, plug the power into the NUC (C).

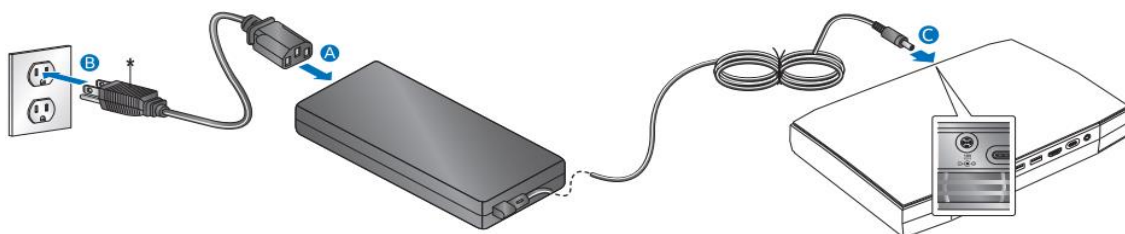

## Set Up Microsoft® Windows® 10

Microsoft Windows 10 is already installed on the Intel NUC. The first time you start the computer, you are guided through the Windows 10 setup steps, including:

- Selecting your region and language.
- Accepting the Microsoft Windows license terms.
- Personalizing Windows and assign a PC Name.
- "Get Online" dialog to pick a wireless network (this step is optional).
- Choosing Express Settings or Customize.
- Assigning a User Name and Password.

### Reinstalling the Operating System

If you upgrade or replace the computer's drive, you may need to install a new version of the operating system. See these resources:

- [Supported Operating Systems](#)
- [Windows Setup Guide](#)

## Install the Latest Device Drivers and Software

Here are the options for keeping device drivers current:

- Allow the [Intel® Driver & Support Assistant \(Intel® DSA\)](#) to detect out-of-date drivers.
- Manually download drivers, BIOS, and software from Download Center:
  - [NUC8i7HMKQC](#)
  - [NUC8i7HVKVA](#)

The following device drivers and software are available.

- Intel® Chipset Device Software
- Intel® HD Graphics
- Radeon™ RX Vega M Graphics
- Intel® Wireless
- Intel® Bluetooth
- Intel® Gigabit Ethernet
- Intel® Management Engine
- Intel® Rapid Storage Technology
- Intel® Serial IO
- Thunderbolt™ Bus
- USB Type C Power Delivery
- Realtek\* High Definition Audio
- Bay Hub\* SD Card Reader
- ITE Tech\* Consumer Infrared
- Intel® Software Guard Extensions
- Intel® Rapid Storage Technology
- Intel® LED Manager

|             |   |
|-------------|---|
| <b>NOTE</b> | This NUC requires both the Intel® HD Graphics driver and the Radeon™ RX Vega M Graphics driver to be installed. |
|-------------|---|

## Operating System Recovery

There's a Windows recovery partition on the Intel NUC. You can use this partition to Refresh, Reset, or Restore Windows. Here is what each of these actions do:

|                |  |
|----------------|--|
| <b>Refresh</b> | <p>If your PC isn't performing as well as it once did, and you don't know why, you can refresh your PC. This action doesn't delete any of your personal files or change your settings. Refresh does the following:</p> <ul style="list-style-type: none"> <li>• Files and personalization settings won't change.</li> <li>• PC settings are changed back to their defaults.</li> <li>• Apps from the Windows Store are kept.</li> <li>• Apps installed from disks or websites are removed.</li> <li>• List of removed apps is saved on the desktop.</li> </ul> |
| <b>Reset</b>   | <p>If you want to recycle your PC, give it away, or start over with it, you can reset it completely. This process removes everything. Reset does the following:</p> <ul style="list-style-type: none"> <li>• All personal files and apps are removed.</li> <li>• PC settings are changed back to their defaults.</li> <li>• Windows is reinstalled.</li> </ul>   |
| <b>Restore</b> | <p>If a recently installed app or driver is causing problems with your PC, you can restore Windows back to an earlier point in time, called a restore point. System Restore doesn't change your personal files, but it can remove recently installed apps and drivers.</p>   |

### Caution - Before performing a Refresh or Reset:

- Make sure to back up all personal data to external storage.
- Remove SD card from the card slot, if one is inserted.

To access the recovery media:

|                                 |   |
|---------------------------------|---|
| <b>If Windows starts</b>        | <p>From Windows Start, type <b>Recovery</b> and select <b>Recovery Options</b>.</p> <p>See <a href="#">Recovery options in Windows 10</a> for complete details on how to use the recovery options.</p>  |
| <b>If Windows doesn't start</b> | <p>The recovery process should automatically start. If Recovery doesn't automatically start, you can try to initiate it as follows:</p> <ol style="list-style-type: none"> <li>1. Press <b>F8</b> during boot, when you see the prompt "F8 to Activate Windows 8.1/10 Recovery Mode".</li> <li>2. Follow the recovery steps.</li> </ol> |