

# Qeedji

User manual

**SLATE106**

**1.11.11 002A**



Room 207

08:00 am - 06:00 pm

Technical review  
UI design

Next Meeting : 06:00 pm - 08:00 pm

## Legal notice

### SLATE106 1.11.11 (002A\_en)

© 2020 Qeedji

#### Rights and Responsibilities

All rights reserved. No part of this manual may be reproduced in any form or by any means whatsoever, or by any means whatsoever without the written permission of the publisher. The products and services mentioned herein may be trademarks and/or service marks of the publisher, or trademarks of their respective owners. The publisher and the author do not claim any rights to these Marks.

Although every precaution has been taken in the preparation of this document, the publisher and the author assume no liability for errors or omissions, or for damages resulting from the use of the information contained in this document or the use of programs and source code that can go with it. Under no circumstances can the publisher and the author be held responsible for any loss of profits or any other commercial prejudice caused or alleged to have been caused directly or indirectly by this document.

#### Product information

Product design and specifications are subject to change at any time and `Qeedji` reserves the right to modify them without notice. This includes the hardware, the embedded software and this manual, which should be considered as a general guide to the product. The accessories supplied with the product may differ slightly from those described in this manual, depending on the developments of the various suppliers.

#### Precautions for use

Please read and heed the following warnings before turning on the power: - installation and maintenance must be carried out by professionals. - do not use the device near water. - do not place anything on top of the device, including liquids (beverages) or flammable materials (fabrics, paper). - do not expose the device to direct sunlight, near a heat source, or in a place susceptible to dust, vibration or shock.

#### Warranty clauses

The `Qeedji` device is guaranteed against material and manufacturing defects for a certain duration. Check the device warranty duration value at the end of the document. These warranty conditions do not apply if the failure is the result of improper use of the device, inappropriate maintenance, unauthorized modification, operation in an unspecified environment (see operating precautions at the beginning of the manual) or if the device has been damaged by shock or fall, incorrect operation, improper connection, lightning, insufficient protection against heat, humidity or frost.

#### WEEE Directive



This symbol means that your appliance at the end of its service life must not be disposed of with household waste, but must be taken to a collection point for waste electrical and electronic equipment or returned to your dealer. Your action will protect the environment. In this context, a collection and recycling system has been set up by the European Union

# Table of contents

## Part I : Description and installation

Introduction	1.1
Getting started with the device	1.2
Dimensions	1.3
Labelling	1.4
Device installation	1.5
Batteries	1.6
Built-in RFID reader	1.7
Pictureframe application	1.8
Features summary	1.8.1
Storage file system	1.8.2
LEDs behaviour	1.8.3
General diagram	1.8.4
RTC, Date & time	1.8.5
Software release	1.8.6
Recovery mode	1.8.7
Hardware reset	1.8.8
Batteries level	1.8.9
Connection quality	1.8.10

## Part II : Configuration

APPLI.HTA	2.1
Heartbeat wake-up	2.2
SPE Desktop	2.3
Temporarily secondary content display with key press or NFC badging	2.4
Working with a SMH300 hub or a SAP10e device	2.5
Configuration for mobile devices	2.6
Appendix: actions matrix (advanced user)	2.7

## Part III : Mobile applications

Mobile applications	3.1
Slate Message Overlay	3.1.1
Slate Maintainer	3.1.2

## Part IV : Technical information

Technical specifications	4.1
Conformities	4.2

## Part V : Contacts

Contacts	5.1
----------	-----

# Part I

## Description and installation

## 1.1 Introduction

This manual explains how to install and configure your device SLATE106.

### Recommendations and warnings

This device is designed for use inside a building.

This device is a Class A device. In a residential environment, this device may cause radio interference. In this case, the user is required to take appropriate measures.

This device is designed to operate with 4 CR2430 batteries.

▮ The batteries life time is estimated to be 3 years by considering 5 daily screen updates using Bluetooth Low Energy synchronization with the SMH300 device, with the wake up conditions: every 15 minutes, 5 days a week, from 8:00 am to 7:00 pm. The battery life time will be shortened as soon as the vibration sensor or the touch sensing key or the badge reader is activated.

When replacing the batteries, replace the four batteries at the same time. The batteries must be changed by a qualified person knowing the replacement procedure. For further information, refer to the chapter § [Battery replacement](#). The warranty does not cover batteries. The batteries must be recycled according to the regulations of your country.

The Bluetooth system operates in the 2.4 GHz ISM<sup>1</sup> frequency bands, the operation of which does not require a licence due to the low transmission power and the low risk of interference. This frequency band is between 2402 and 2480 MHz.

To ensure correct rendering of the screen content, the device should be not installed under direct sunlight.

### Package Contents

Articles	Description	Quantity
Device	SLATE106 device with <code>Pictureframe</code> firmware embedded	1
Power pack	four batteries CR2430 with plastic holder	1
Mounting bracket	Bracket for wall mounting	1
Screws	M2.5x25	2
Adhesive	3M double sided tape (W x H x D): 65 mm x 19 mm x 0.5 mm	1

### Compatibility

The SLATE106 device is compatible with `SMH300` hub or `SAP10e` device. In this case, the communication is done over `WPAN1` BLE channel. For further information about these devices, contact [sales@qeedji.tech](mailto:sales@qeedji.tech).

### Mobile application with Bluetooth

The SLATE106 device is also compatible with `Slate Message Overlay` and `Slate Maintainer` applications running on mobile devices supporting Bluetooth. In this case, the communication is done over `WPAN2` BLE channel.

## 1.2 Getting started with the device

### Front face

The SLATE106 device has:

- 1 touch sensing key,
- 3 red LEDs,
- 1 RFID/NFC sensor,
- 1 vibration sensor.

Please find below the location of each peripheral:

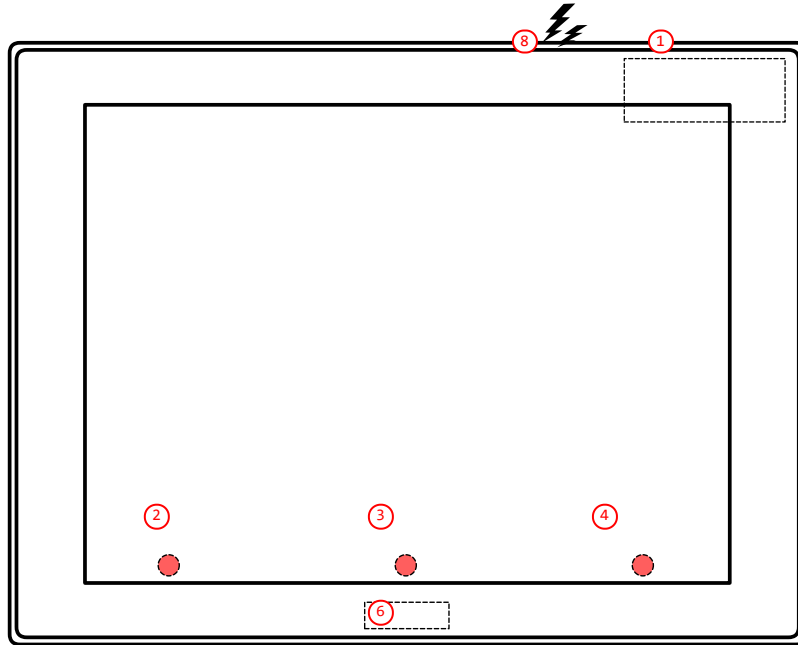

- ① RFID/NFC antenna
- ② Left LED
- ③ Middle LED
- ④ Right LED
- ⑤ Touch sensing key
- ⑥ Internal vibration sensor

☞ So that the Touch sensing key is successfully detected, leading to red LED blinking, press lightly on the middle button with your finger index and keep it pressed for 0,5 second like it was for a fingerprint detection. To activate and use the touch sensing key detection, refer to the chapter § [Features summary](#).

☞ So that your badge is successfully detected, touch the SLATE with your badge and keep it stuck on the SLATE for 0,5 second. To activate and use the NFC detection, refer to the chapter § [Features summary](#).

**Side face**

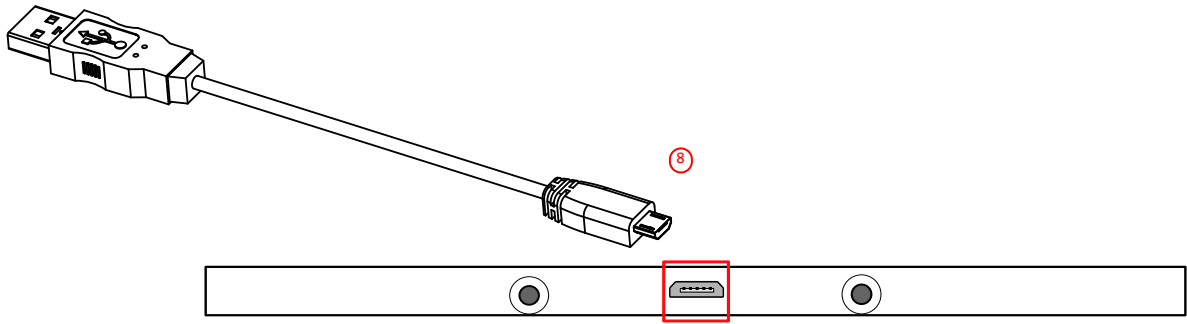

⑧ USB client cable (Male micro-USB type B)

**Rear face**

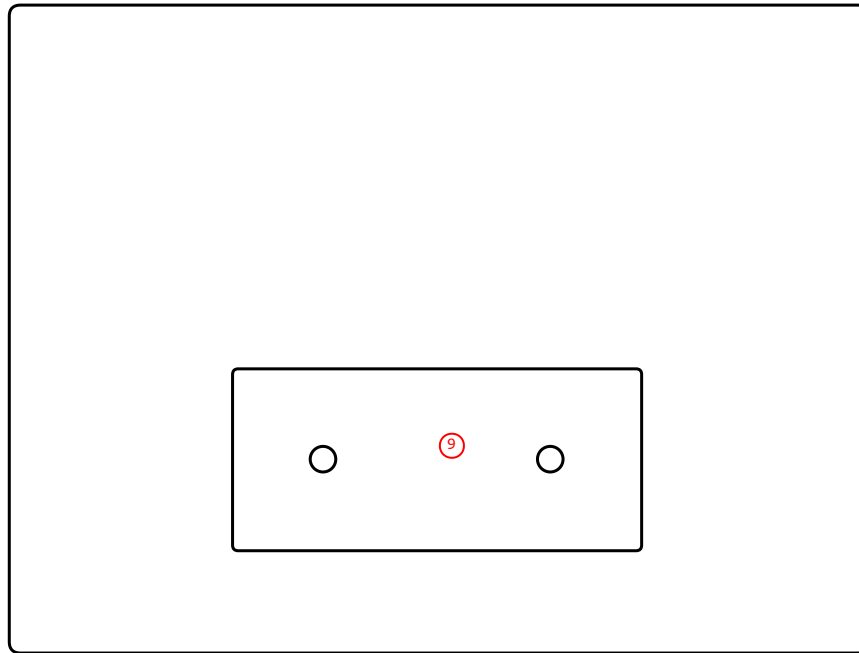

⑨ Mounting bracket

## Device dimensions

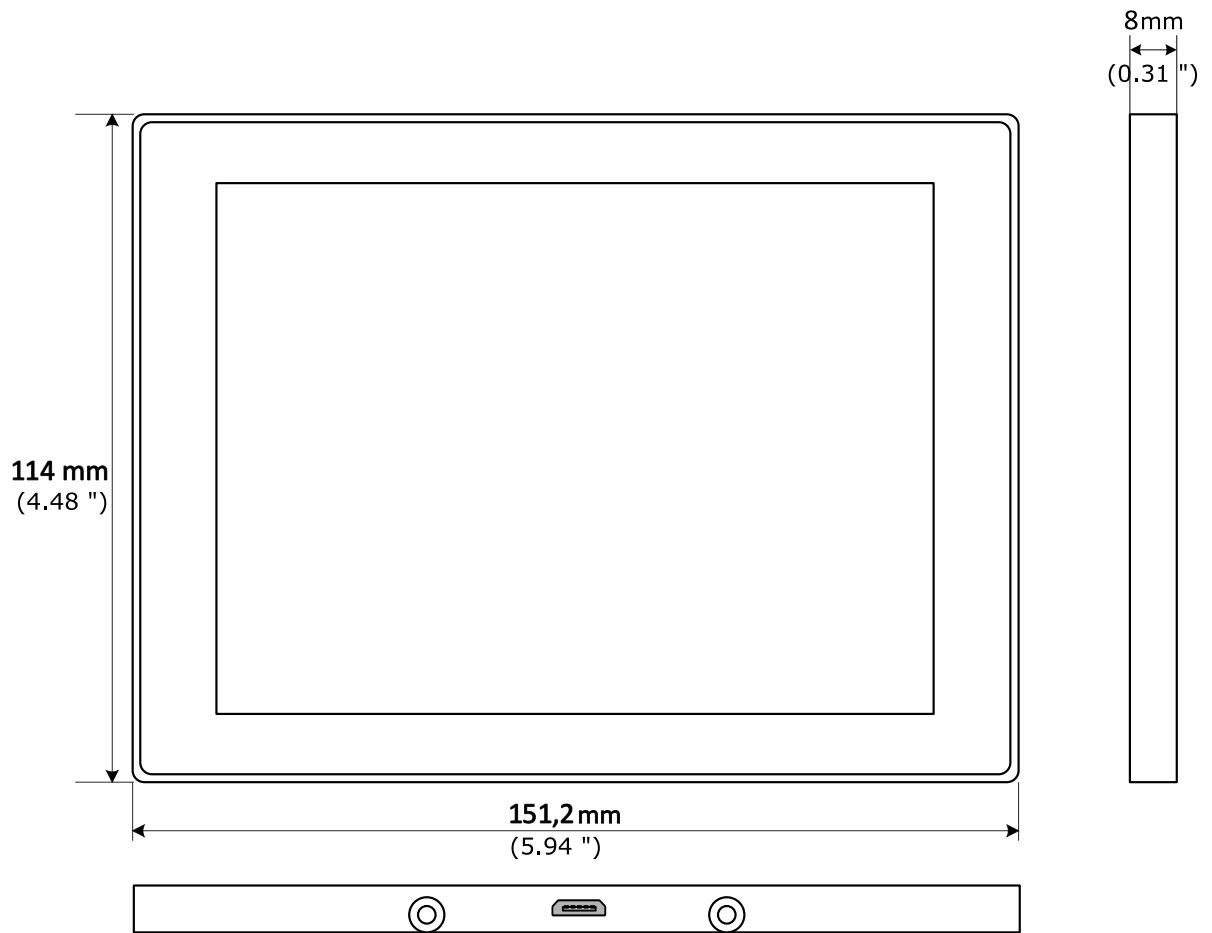



### 1.3 Dimensions

#### Dimensions in millimeters

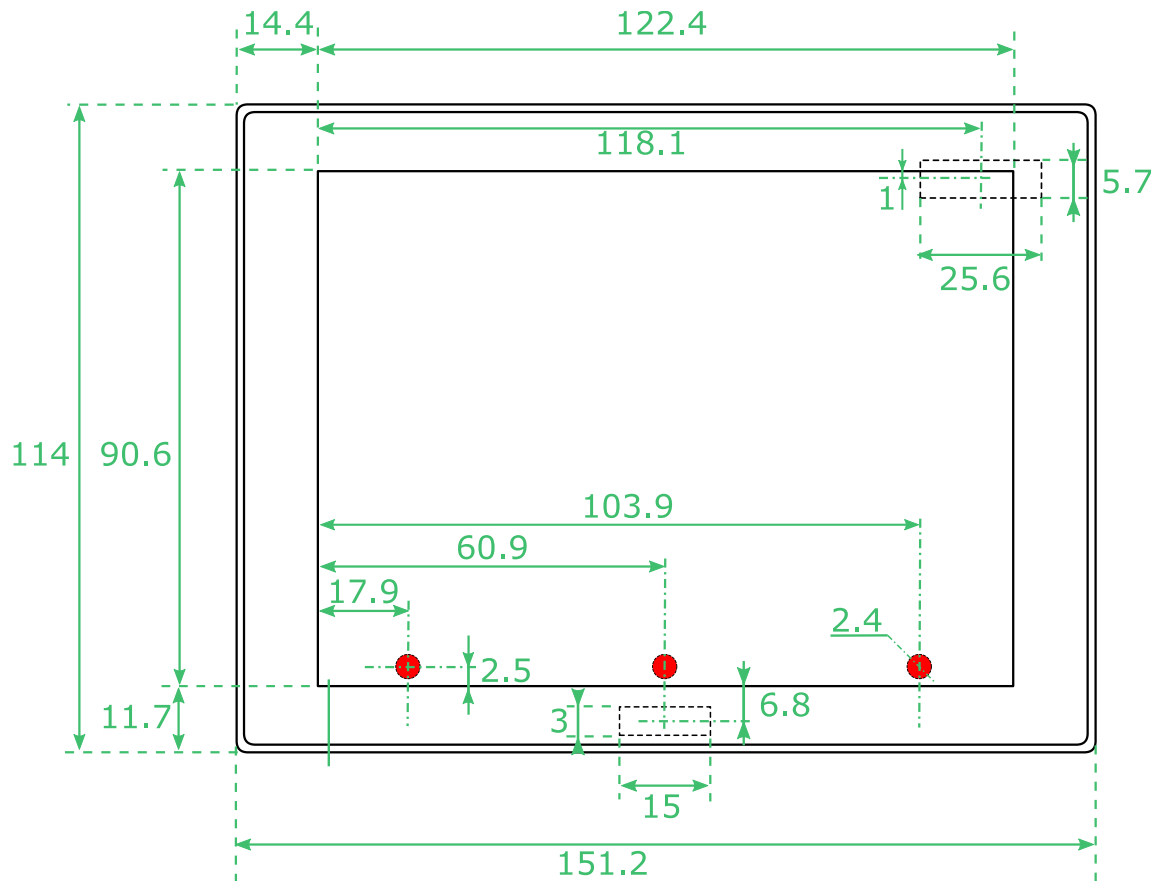

#### Coordinates [X,Y] in pixels

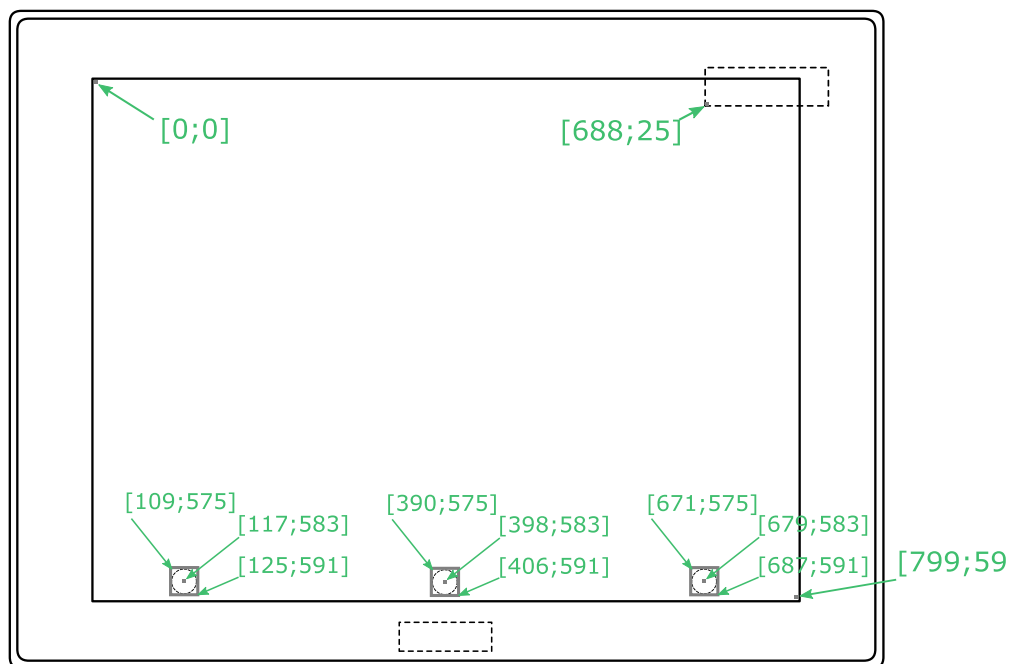

## 1.4 Labelling

### PSN label

The model of the device, the power supply characteristics, the serial number (PSN) and the MAC address are written on labels stuck on the case.

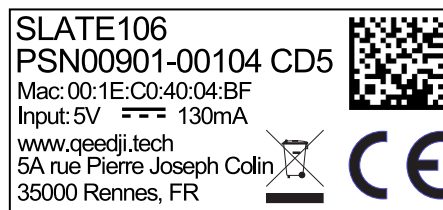

### EAN label

This is the label stuck also on the cardbox. They are showing information on:

- the device model,
- the serial number (PSN).



Some additional labels may be present in case of built-in options.

- ▮ *The serial number of the device can be requested in case of technical support.*

## 1.5 Device installation

### Batteries

Place the SLATE106 device, with the back face in front of you.

Keep the battery in its plastic holder like shown below.

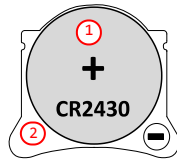

- ① CR2430 battery,
- ② Battery holder.

⚠ Warning: check that the battery is inserted in its holder with the right polarity (positive side facing up). In case the battery is not delivered with its holder, contact [support@qeedji.tech](mailto:support@qeedji.tech).

Slide the 1st battery ③ with its holder into its place. Use your finger or a screwdriver to push the plastic of the holder part until you feel a clip, meaning that the battery is properly installed.

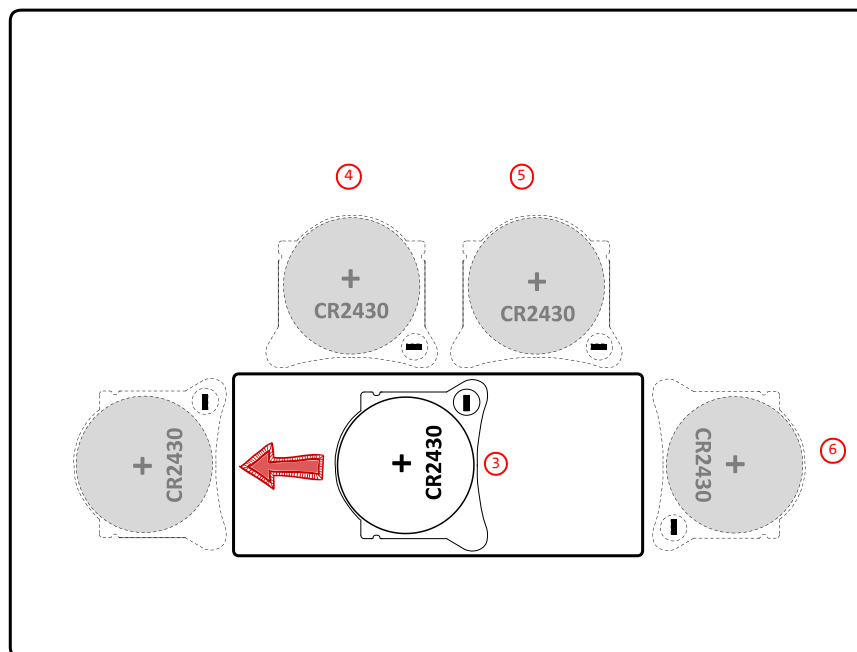

Slide the other batteries with their holder in the right orientation like explained on the content above:

- 2nd battery ④,
- 3rd battery ⑤,
- 4th battery ⑥.

Once the batteries are installed, they are all hidden.

## Fixture

The device must be used indoor and has to be installed using the provided mounting bracket. To ensure correct rendering of the screen content, the device should not be installed under direct sunlight.

This support can be fixed using screws (recommended). The screws and dowels for tighten the mounting bracket to the wall are not delivered with the product because they are depending on your wall material. If it is not possible to fix the device with screws, for example when needing to be fixed on a glass wall, you can use the provided double-sided tape.

⚠ Clean carefully the surface before sticking the tape.

The SLATE106 device is generally fixed by keeping its bottom at 140 cm far from the floor.

### SLATE106 DRILL PATTERN

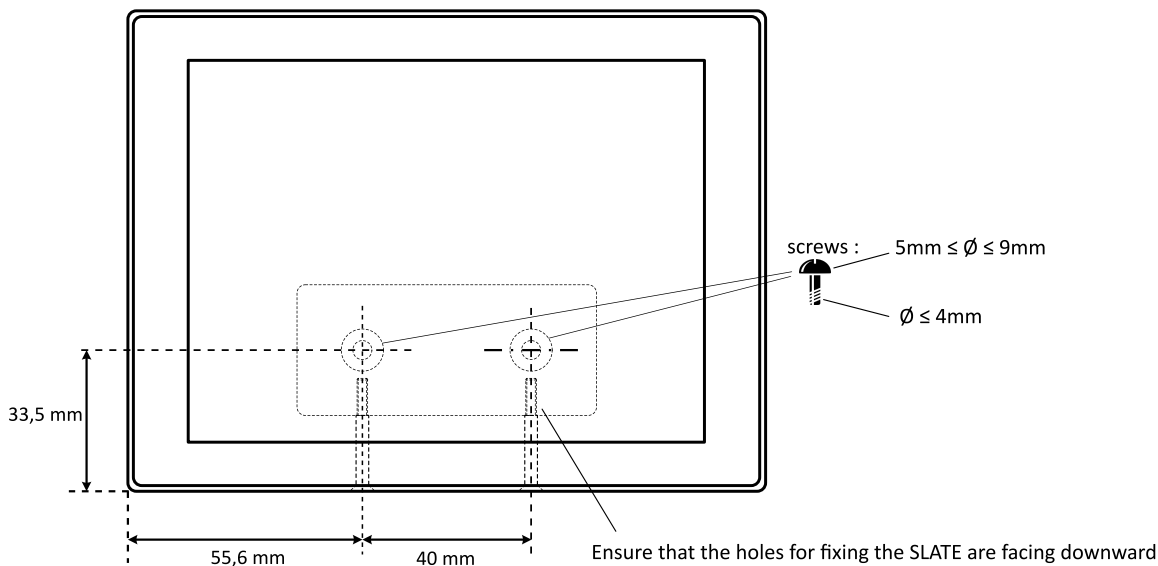

Fix the mounting bracket with the right orientation.

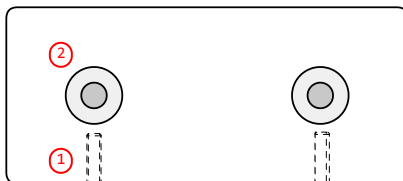

- ① Counterbores are facing to you (to integrate the screw head),
- ② Holes for fixing the SLATE106 device are facing downward.

Once the mounting bracket is fixed (with some screws or an adhesive tape), place the SLATE106 device face to the mounting bracket. Fix it definitively with the 2 M2.5x25 screws provided using a little slotted screwdriver ③.

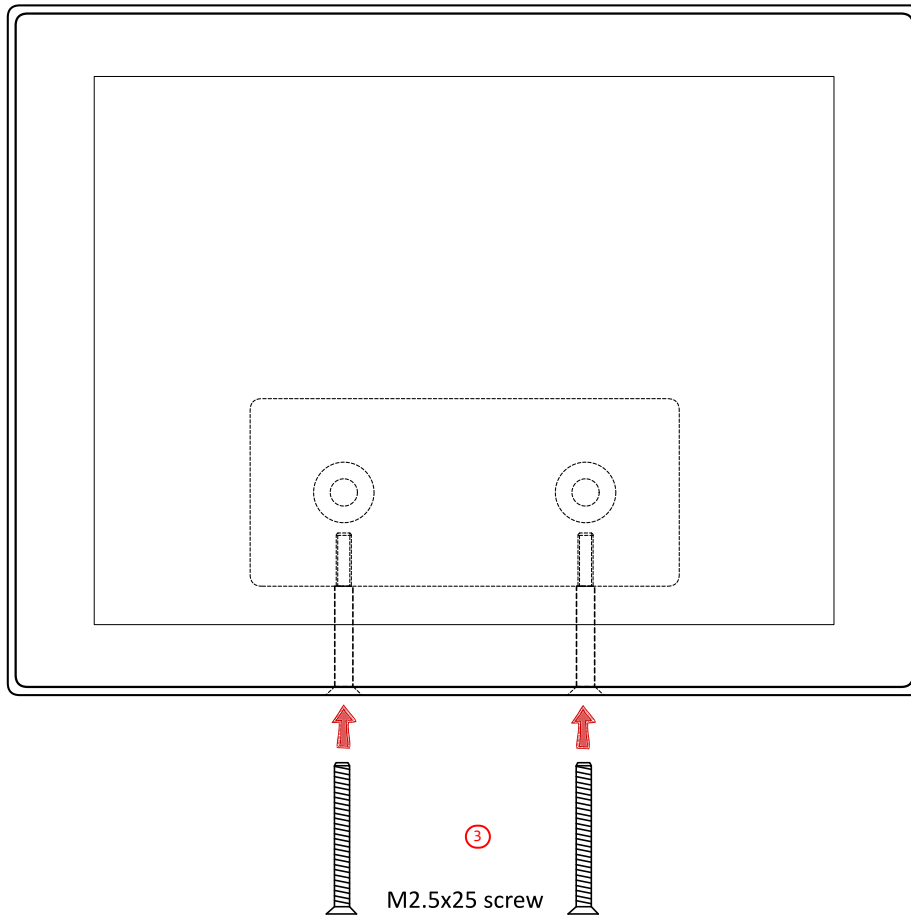

Tighten the screw until the screw head reaches the edge<sup>1</sup> of the case.

<sup>1</sup> *Tighten too much the screws may prevent the vibration sensor of the SLATE106 device to work properly.*

Follow the customer installation plan to install all the other SLATE106 devices.

## 1.6 Batteries

### Batteries specifications

The SLATE106 device is designed to work with 4 CR2430 Lithium coin batteries. The battery model has been chosen to obtain the best performances for SLATE106 device using. The batteries features are described below. Use the same reference to obtain the best battery lifetime. However, an equivalent reference may be used.

Type	CR2430
Nominal voltage	3 V
Typical capacity	290 mAh
Chemical system	Lithium Manganese Dioxide
Reference	2430/CR2430 VP-1 ENERGIZER LITHIUM [Energizer]

### Replacement procedure

⚠ In case of batteries replacement, change the four batteries at the same time with the new ones. The batteries must be changed by a qualified people, who is knowing perfectly the replacement procedure. The batteries must be recycled according to your country's regulations.

Remove each battery with its holder, using a little slotted screwdriver. Grab and then pull the edge of the plastic holder, remove the old battery from the holder

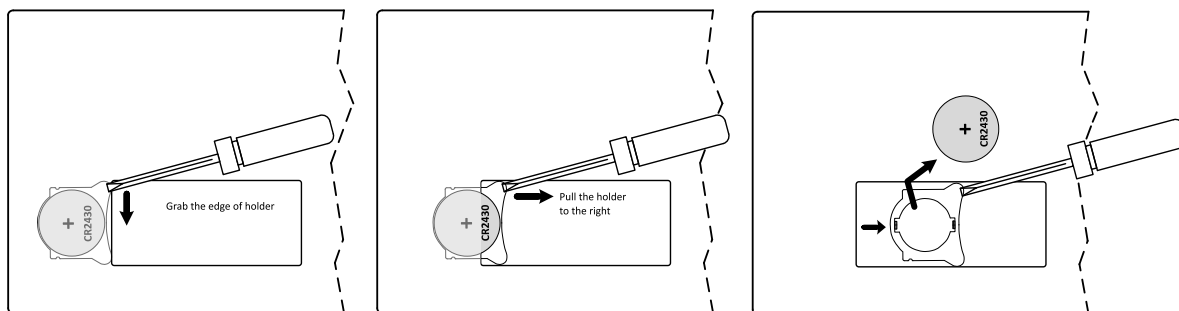

Insert the new battery **with the positive side facing up**. Glide the battery with holder into its place using your finger or screwdriver pushing into the plastic of holder part: you must feel a clip when the battery is installed

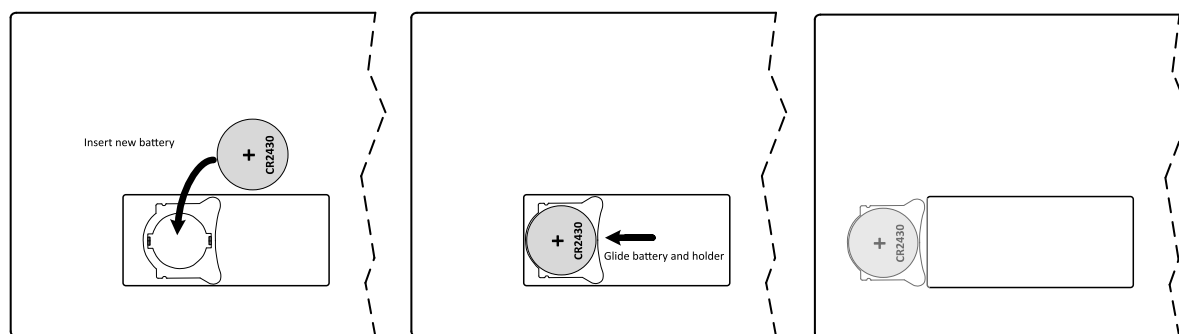

Repeat the same operation for the four batteries.

### Battery energy status (%)

The battery energy status in percent (%) is reported:

- in the device Web user interface of the SMH300 hub. For further information, refer to the appropriate SMH300 user manual on the [Qeedji Web site](#) Web site,
- through the [Slate Maintainer](#) mobile application. Refer to the chapter § [Slate Maintainer application](#).

## 1.7 Built-in RFID reader

The device SLATE106 has a RFID tag reader allowing to recognize the badges supporting the NFC technology.

Type	Modulation frequency	Brand (Manufacturer)	Applicable standard	Data rate (kbps)	Supported	Tested configuration
NFC type A	13.56 MHz	Mifare Classic 1K/4K EV1 & mini <sup>1</sup> (NXP)	ISO 14443 typeA	106	Yes	1K, 106 kbps
NFC type A	13.56 MHz	Mifare Plus 2K/4K S/X <sup>1</sup> (NXP)	ISO 14443 typeA	106	Yes	
NFC type A	13.56 MHz	Mifare UltraLight / UltraLight C (NXP)	ISO 14443 typeA	106	Yes	106 kbps
NFC type A	13.56 MHz	Mifare DESFire D40, EV1 2K/4K/8K (NXP)	ISO 14443 typeA	106	Yes	4K, 106 kbps
NFC type A	13.56 MHz	Mifare NTAG203	ISO 14443 typeA	106	Yes	NTAG203, 106 kbps
NFC type A	13.56 MHz	Jewel (Innovision)	ISO 14443 typeA	106	Yes	106 kbps
NFC type A	13.56 MHz	Topaz 512 (BCM512)	ISO 14443 typeA	106	Yes	BCM 512, 106 kbps
NFC type A	13.56 MHz	Kovio (Kovio)	ISO 14443 typeA	106	NC	
NFC type A	13.56 MHz	SLE66 (Infineon), SmartMx (NXP)	ISO 14443 typeA	106	NC	
NFC type B	13.56 MHz	Cartes de transport (Innovatron), Calypso	ISO 14443 typeB	106	Yes	
NFC type B	13.56 MHz	Micropass, Vault (Inside), 16RF (ST), SLE66 (Infineon)	ISO 14443 typeB	106	NC	
NFC type F	13.56 MHz	Felica (Sony) JIS 6319,	ISO 18092	212, 424	Yes	
NFC type V	13.56 MHz	Icode (NXP), iclass (Hid), Tag-it (TI), LR (ST)	ISO 15693		No	
RFID LF	125 KHz	Hitag (NXP), 125KHz Prox (HID)	ISO 18000-2, ISO11784/11785/14223		No	

<sup>1</sup> not fully compliant with the ISO14443A relevant standard

## 1.8 Pictureframe application

The SLATE106 device embeds the `Pictureframe` application which is able to display on the SLATE106 device screen, and in 4 grey levels, a full screen content, which is defined by a `.ppk` file (proprietary format) with a specific naming pattern.

The content can be updated:

- through the `USB mass storage`,
- by a key press,
- by NFC badging,
- by a `SMH300` hub or `SAP10e` device, through the `WPAN1` BLE channel.

Thanks to a mobile application, a additional message can be transmitted through the `WPAN2` BLE channel, then displayed in overlay above the existing content.

These are the BLE channel types used in the device:

BLE channel	Device type	BLE type
WPAN1	<code>SMH300</code> hub or <code>SAP10e</code> device	BLE (Bluetooth Low Energy)
WPAN2	Mobile device	BLE over GATT profile

The SLATE106 device is designed to spend a part of the time in sleep mode to save power and increase the battery lifetime.

It can be woken-up by 3 event types:

- when an USB cable is connected or disconnected,
- when the internal timer has elapsed,
- when a `vibration` is detected.

▮ *The `vibration` detection is inactivated by default. It can be activated or inactivated according to your needs.*

### Content update strategy

The content can be updated only when it is strictly different from the previous one.

It is done with the heartbeat, by default every quarter of a hour, plus its index x 10 sec. For example, when your slate is paired with the index 7, its content is updated at  $xxh\ n \times 15\ min + 7 \times 10\ sec$ , for example:

- 15 h 16 min 10 sec,
- 15 h 31 min 10 sec,
- 15 h 46 min 10 sec,
- 15 h 01 min 10 sec...

When the touch key is activated, after the key is pressed, the appropriate LED is blinking until the content is updated.

When the NFC badging is activated, after a NFC badging is done, the middle LED is blinking until the content is updated.

▮ *In case the content is not updated, please check the battery level. For further information, refer to the chapter § [Slate Maintainer application](#).*

▮ *In case several content updates are done very closely inside a very short period by using for example the touch sensing key or NFC badging, the content update may be delayed.*



## 1.8.1 Features summary

### Content update with Spe Desktop tool with a MS-Windows computer

The full screen content can be updated through the USB mass storage thanks to the `SPE_Desktop` tool (`spe.exe`) available on the file system, able to edit a text, format it and save it as new content. For further information, refer to the chapter § [Spe\\_desktop tool](#).

### Content update dropped through USB with a MS-Windows computer

The full screen content can be updated through the USB mass storage with a simple \*.ppk file dropping from your MS-Windows computer to your SLATE106 device.

Use the `img2ppk.exe` tool to create some content from any `.PNG` or a `BMP` image in the 800x600 resolution. For further information, refer to the [img2ppk user manual](#) Web site.

The expected filename for the default content is `spe.ppk`. This default filename can be modified in the `Picture filename` field when executing the `APPLI.HTA` HTML application. This filename must contain ASCII character. The filename size is limited to 8 characters maximum, the file extension size is limited to 3 characters maximum).

### Temporarily secondary content update by key press

A temporarily full screen content can be displayed for a specific duration by pressing a key on the SLATE106 device. For further information, refer to the chapter § [Temporarily secondary content display with key press or NFC badging](#).

### Temporarily secondary content update by NFC badging

A temporarily full screen content can be displayed for a specific duration by badging with a NFC tag. For further information, refer to the chapter § [Temporarily secondary content display with key press or NFC badging](#).

### Message Overlay: partial update with a message sent from a mobile device

The `Slate Message Overlay` mobile application is able to send a message to the SLATE106 through `WPAN2`, which is then displayed in overlay over the full screen content in a predefined area and for a programmable duration. For further information, refer to the chapter § [Slate Message Overlay application](#).

### Content update from a SMH300 hub

When paired to `SMH300` hub, the full screen content, the configuration file and the software release are downloaded automatically from the `SMH300` hub through the `WPAN1` BLE channel. For further information, refer to the chapter § [Working with a SMH300 hub](#).

### Content update from a SLATE106 device

When paired to `SAP10e` device, the full screen content are downloaded automatically from the `SAP10e` device through the `WPAN1` BLE channel. For further information, refer to the chapter § [Working with a SAP10e](#).

### System configuration

Some of the feature described above may be not activated by default. To check whether some features are fully activated, edit the SLATE106 configuration by executing the `APPLI.HTA` HTML application. For further information, refer to the chapter § [APPLI.HTA](#).

▮ If the SLATE is paired to a `SMH300` hub or to a `SAP10e` device, you have to check the SLATE configuration in the `Administration console user interface`.

### Battery status, reset WPAN2 private PIN code, set device time

Even if the SLATE is not paired to a BLE access point, the `Slate Maintainer` mobile application allows to monitor the device battery level and make some light operation like reset the WPAN2 private PIN code and set the device time. For further information, refer to the chapter § [Slate Maintainer application](#).

## 1.8.2 Storage file system

The storage file system of the SLATE106 device is FAT .

The filename size is:

- 8 characters max. for filename,
- 3 characters max. for extension.

The file system of the SLATE106 device can store about 976 KB of data file (.CFG, .PPK, .PAIRED) and applications files (.HTA, .EXE).

Firmware rev	used space	available free space
1.11.10	15 MB	976 KB

Description of the main files which can be found in the file system:

Description	File name	Average size
Configuration file	APPLI.CFG	2 KB
HTML application	APPLI.HTA	30 KB
SPE Desktop tool	SPE.EXE	109 KB
.ppk content generated by SPE Desktop application	spe.ppk	118 KB
.ppk content generated by the SMH300 hub or SAP10e device	hub.ppk	118 KB
.ppk content generated by the img2slate tool	<filename>.ppk	118 KB
Software release	pictureframe-slate106-setup-1.XX.YY.rpk	< 220 KB
File created each time a pairing PIN code has been set	PINCODE	< 1 KB
Mounting information (hidden directory)	/System Volume Information	8 KB
<i>The file system is not case sensitive (no difference between lower case and upper case).</i>		

It is possible to modify the APPLI.CFG configuration file by executing the APPLI.HTA HTML application or add/remove some .ppk file.

⚠ After having added, modified or removed some file through the USB mass storage of the SLATE106 device, DO ALWAYS EJECT IT PROPERLY with your MS-Windows before unplugging the USB cable to avoid file corruption. In case a corrupted APPLI.CFG is detected, the file is deleted and the SLATE returns to factory settings. Consequently the Test card is displayed.

⚠ In case the USB mass storage used space does not match at all the sum of the size of the file available on the file system and prevent to add some .ppk files, you can make an USB mass storage format:

- save all the file present on your SLATE106 device USB mass storage,
- format the SLATE106 device USB mass storage with your MS-Windows
  - file system type: FAT ,
  - allocation unit size: 4096 Bytes,
  - speed: fast .
- when the format has completed, copy back the file saved on your computer.

### Restore factory settings

To return to SPE Desktop configuration, after having already paired your SLATE106 device,

- unpair the SLATE106 device from the SMH300 hub. For further information, refer to the SMH300 User manual on the [Qeedji Web site](#),
- plug the SLATE106 device to a computer with an USB cable (micro USB type B to USB) and wait for the USB mass storage is mounted properly,
- execute the APPLI.HTA HTML application and click on the Restore factory preferences button.
- **eject properly the SLATE106 device USB mass storage,**
- then wait for a while so that the USB mass storage is mounted back again,
- unplug the USB cable.

### 1.8.3 LEDs behaviour

#### • Step 1: Device start-up initialisation

LEDs	Information
The Left LED is flashing 3 times	Start-up: the device is booting
The Left LED is blinking 5 times	Phase 1 to enter in recovery mode <sup>1</sup>
The Right LED is blinking 5 times	Phase 1 to enter in recovery mode <sup>1</sup>
The Left LED is blinking	The software release upgrading in progress. The duration of this process is depending on the size of the software release file which is around 3 minutes
The 3 LEDs are blinking once slowly	There is no valid software on the device. So the device goes into sleep mode, then in recovery mode when an USB cable is connected
The 3 LEDs are blinking continuously and slowly	Error <sup>2</sup>
The 3 LEDs are Off	Nominal mode: no important user information to return

#### • Step 2: Recovery mode

LEDs	Information
The SLATE106 device is flashing twice	Recovery mode activated
The middle LED is blinking	File copying on SLATE106 device through USB
The 3 LEDs are blinking continuously and slowly	Error <sup>2</sup>

#### • Step 3: Application mode

LEDs	Information
The left LED and the right LED are blinking once	Entering in nominal mode
The 3 LEDs are blinking continuously and slowly	Error <sup>2</sup>

<sup>1</sup> The phases to enter in recovery mode exist only when an USB cable is connected.

<sup>2</sup> Error condition has 2 behaviors:

- 1) If an USB cable is connected, the 3 LEDs are blinking slowly. When the cable is removed, the SLATE106 device is rebooting.
- 2) If no USB cable is connected, the SLATE106 device is rebooting. If the problem persists, contact [support@qeedji.tech](mailto:support@qeedji.tech).

## 1.8.4 General diagram

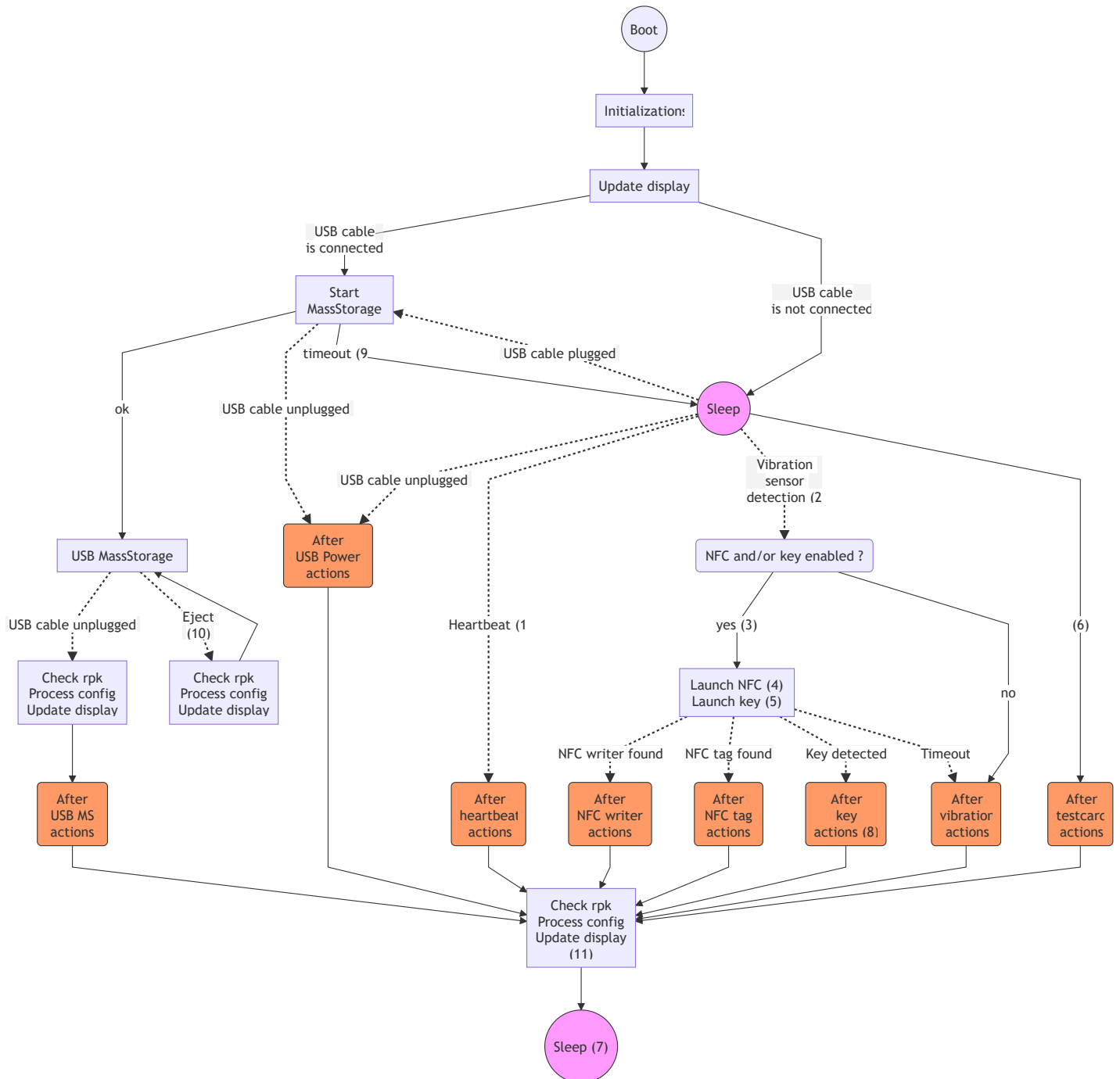

(1): Only if done inside the active interval and when `pictureframe.wakeup.heartbeat.mode` is not `none`.

▣ If the RTC has never been updated, the active interval is 7/7 days 24/24 hours. If the action `Folder synchronization with WPANI (image, config, firmware)` is programmed `After heartbeat` wake-up source, and `WPANI` communication has an error, 2 others automatic retries are done.

(2): Only if done inside the active interval and `pictureframe.vibration_sensor.enabled` is `true`. ▣ If the RTC has never been updated, the active interval is 7/7 days 24/24 hours.

(3): Yes means `pictureframe.key.enabled = true` or `pictureframe.nfc.enabled = true`.

(4): Launch NFC detection for NFC writer and NFC tag for a fixed duration.

(6): If `pictureframe.testcard.enabled` is `true` and if an USB power bank is connected, the SLATE106 is exiting sleep mode automatically until the powerbank is unplugged.

(7): For diagram readability, this `Sleep` state is the same as the one shown at the top of the diagram.

(8): During `key` actions, the LED corresponding to the key pressed is blinking.

(9): This case correspond to USB power bank detection

(10): `Eject` is the case when the SLATE106 USB storage device has been unmounted properly by the computer user without disconnecting the USB cable

(11): in this step, `Pictureframe` is deciding to launch these actions only if required.

## 1.8.5 RTC, Date & time

The SLATE106 device embeds a real-time clock (RTC) used to maintain the `Date & Time` up-to-date.

### Behaviour when the RTC has not been updated

After a SLATE106 device startup or after a batteries change, the RTC stays to a default value, so the `Date & time` information is not consistent. The wake up policy using `Date & Time` information can not working properly.

To ensure that the SLATE106 device configuration can be taken into account, when the `Time & Date` is not consistent,

- the active interval by default is:
  - 7/7 days,
  - 24/24 hours.
- the wake-up period mode is set to `Period` with the `period` value : 15 minutes.

### RTC update

These are the 2 ways to update the RTC on each WPAN connection:

- through the SLATE access point when paired to it,
- through the `Slate Maintainer` mobile application.

## 1.8.6 Software release

When paired to a `SMH300` hub or `SAP10e` device, the device is able to install a new software release provided by it.

A minimum available free space of 220 KB is required on the USB storage to warranty the SLATE106 device software upgrade.

If not paired to a `SMH300`, it is possible to trig a software release upgrade:

- plug the SLATE106 device to a computer with an USB cable (\*micro USB type B to USB) and wait for the USB mass storage is mounted properly,
- copy the software file **pictureframe-SLATE106-setup-1.11.11.rpk**<sup>1</sup> on the USB mass storage,
- eject properly the USB mass storage,
- wait for about 3 minutes the time for the SLATE106 device to reboot and install the new software release (the left red LED is blinking during the installation),
- wait for a while so that the USB mass storage is mounted back again. The software release upgrading has completed.

<sup>1</sup> If you have not, download the latest *Pictureframe* version on the [Qeedji Web site](#).

## 1.8.7 Recovery mode

The recovery mode allows to:

- reinstall a new SLATE106 device software,
- erase the whole file system.

### Material

- 1 Micro USB type B to USB cable (like standard charging smartphone cable),
- 1 Paperclip,
- 1 MS-Windows computer.

### Procedure

1. Remove the SLATE106 device from its mounting bracket.
2. Place the SLATE106 device, with the back face in front of you. Connect the USB cable between the computer and the SLATE106 device.
3. Perform a hardware reset (for further information, refer to the corresponding chapter §)
4. Turn around the SLATE106 device, the 3 LEDs are then blinking very shortly.  
*▮ You could not have time enough to see the LED blinking.*
5. Few seconds after, the left LED blinks 5 times; **PRESS IMMEDIATELY THE LEFT KEY** just after this LED blinking sequence.  
*▮ You have 2 seconds to perform this operation, otherwise the software is starting. Then you should have to return to step Perform a hardware reset again to reach recovery mode.*
6. After the left key is pressed, the right LED blinks 5 times; **PRESS IMMEDIATELY THE RIGHT KEY** just after this LED blinking sequence.  
*▮ You have 2 seconds to perform this operation, otherwise the software is starting. Then you should have to return to step Perform a hardware reset again to reach recovery mode.*
7. The left LED and the right LED are turned on, you are now in **recovery mode**. The file system is automatically erased.
8. The USB mass storage should be detected on your computer which is now asking for starting an USB mass storage Format . Select the **FAT** file system type and click on the **START** button:

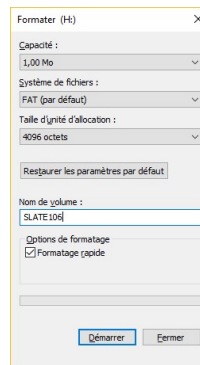

After few seconds, the USB mass storage **Format** is completed; Your volume should be mounted back again like one USB mass storage.

9. Copy a new software on the SLATE106 device.
10. Eject properly your USB mass storage and unplug the USB cable.

This is the state diagram of the Recovery mode activation after a SLATE106 device hardware reset:

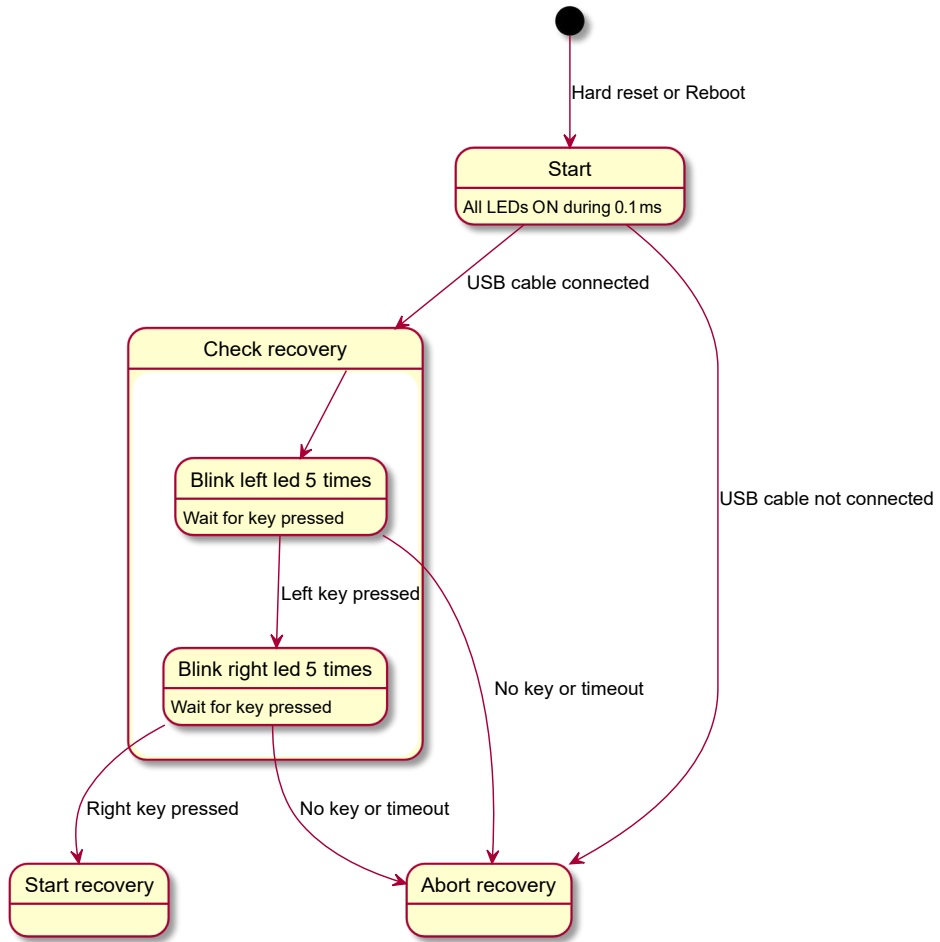



## 1.8.8 Hardware reset

It is possible to perform a Hardware reset , leading to a hardware reboot.

### Procedure

- remove the SLATE106 device from the wall,
- place the SLATE106 device with the back face in front of you,
- use a paperclip ③ to make a short circuit between the pin 1 and the pin 2.

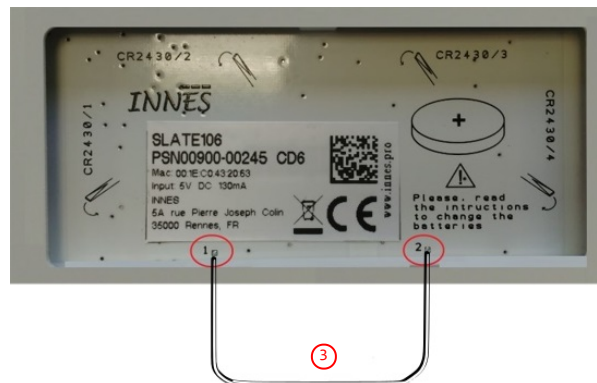

- ③ Short circuit with a paperclip.

Once done, turn around the SLATE106 device **as fast as possible**. You should see that the device is entering in nominal mode with the left LED and the right LED blinking once, meaning that the SLATE106 device has reset successfully.

## 1.8.9 Batteries level

The batteries level is the estimation of the current power of the four batteries in percent.

If a wake-up by vibration or a wake-up by key press is done inside this timeout windows, the timeout is reset. So, in this case, 13 more minutes are required again to update the batteries level value.

When the four batteries have been changed by new one, the battery level value is 100%. If the batteries level is less than 100% after the replacement, contact [support@qeedji.tech](mailto:support@qeedji.tech).

The battery level value can be viewed:

- with the device Web user interface of the `SMH300` device,
- with the `Slate Maintainer` mobile application.

### 1.8.10 Connection quality

The averaged connection quality, computed on the `SMH300` hub, is based on the last 10 connections with each SLATE106, with one connection every 15 minutes.

The averaged connection quality, computed on the `SAP10e` device, is based on the last 5 connections with each SLATE106, with one connection every 15 minutes.

For further information, refer to the appropriate user manual on the [Qeedji Web site](#).

▮ For installation purpose, a SLATE106 device can work in a test mode to wake-up every 10 seconds instead of every 15 minutes to speed-up the quality connection computation. In this mode the averaged quality connection can be displayed in 2 minutes. When the SLATE106 device are paired, activate the *Test Card* mode for this SLATE106 device, plug one USB Power bank for 2 minutes. The averaged quality connection level should be updated and displayed in the device Web user interface of the `SMH300` hub or the `SAP10e` device.

# Part II

## Configuration

## 2.1 APPLI.HTA

The `Pictureframe` application embeds a `APPLI.HTA` HTML application, file which is available as soon as the SLATE is plugged on a computer. The `APPLI.HTA` HTML application allows to modify the `APPLI.CFG` configuration file which is created as soon as a pictureframe user preference is modified.

When it is not paired to a SMH300 hub, you can modify the values according to your needs:

- execute the `APPLI.HTA` HTML application,
- modify some value,
- click on the `Save` button,
- close the `APPLI.HTA` HTML application,
- eject properly the USB mass storage of the SLATE106 device with your MS-Windows system,
- wait for a while so that the USB mass storage is mounted back again,
- unplug the USB cable.

Each parameter in the `APPLI.HTA` HTML application interface is linked to an associated configuration key in the `APPLI.CFG` configuration file, called *conf key*.

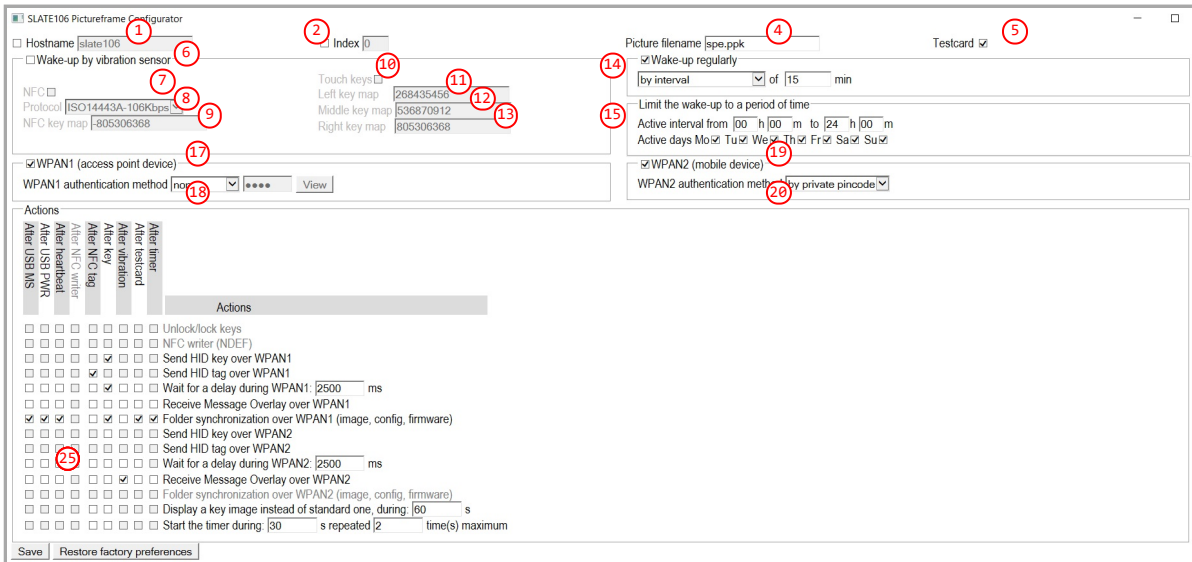

Number	Description	Supported value in APPLI HTA HTML application interface	Configuration key
①	Set the SLATE106 device hostname.	0..9, a..z, A..Z, . , -	pictureframe.hostname
②	Set the index of SLATE106 device when used with a SMH300 hub or SAP10e device.	1..10	pictureframe.index
④	Full screen main content filename (default values: <i>spe.ppk</i> ) <sup>1</sup> .	ASCII 7-bit, 8 digits max for filename, 3 digits for extension.	pictureframe.picture.filename
⑤	Activate/inactivate the test card display (instead of the main full screen content).	true , false	pictureframe.testcard.enabled
⑥	Activate/inactivate the vibration sensor.	true , false	pictureframe.vibration_sensor.enabled .
⑦	Activate/inactivate the NFC detection.	true , false	pictureframe.nfc.enabled
⑧	Set the NFC protocol.	0 for ISO14443-A-106kbps 1 for JEWEL-106kbps 3 for FELICA-212kbps 23 for ISO14443-B-106kbps 39 for FELICA-424 kbps 8 for DEP-106 kbps 24 for DEP-212 kbps 40 for DEP-424 kbps	pictureframe.nfc.tag.protocol
⑨	Set the keymap for NFC.	default value: signed integer value for 0xD0000000	pictureframe.nfc.map
⑩	Activate/inactivate the touch keys detection.	true , false	pictureframe.key.enabled
⑪	Set the keymap for left touch key.	default value: signed integer value for 0x10000000	pictureframe.key.left.map
⑫	Set the keymap for middle touch key.	default value: signed integer value for 0x20000000	pictureframe.key.middle.map
⑬	Set the keymap for right touch key.	default value: signed integer value for 0x30000000	pictureframe.key.right.map
⑭	Activate/inactivate the heartbeat timer wake-up + Set the heartbeat mode + Set the heartbeat period value in minutes.	true , false quarter , period 15 to 1440 minutes	pictureframe.wakeup.heartbeat.enabled pictureframe.wakeup.heartbeat.mode pictureframe..wakeup.heartbeat.period
⑮	Set the time range for the active interval + Set the week days for the active interval.	Format: T0000/T2359 1 :Mo + 2 :Tu + 3 :We + 4 :Th + 5 :Fr + 6 :Sa + 7 :Su	pictureframe.wakeup.day.interval pictureframe.wakeup.weekdays.mask
⑰	Activate/inactivate the WPAN1 channel required to access to SMH300 hub or SAP10e device.	true , false	pictureframe.wpan.enabled
⑱	Set whether a WPAN1 PIN code if required + Set the WPAN1 pincode value.	0000..9999	pictureframe.wpan1.authentication.method pictureframe.wpan1.authentication.pincode
⑲	Activate/inactivate the WPAN2 channel required to access to mobile device.	true , false	pictureframe.wpan2.enabled
⑳	Set whether a WPAN2 PIN private code if required.	by private pincode , none	pictureframe.wpan2.authentication.method
㉑	Wake-up sources versus actions matrix allowing to customize the pictureframe application.	for further information about the possible values, contact support@qeedji.tech	pictureframe.after_usb_ms_actions.mask pictureframe.after_usb_power_actions.mask pictureframe.after_heartbeat_actions.mask pictureframe.after_nfc_writer_actions.mask pictureframe.after_nfc_tag_actions.mask pictureframe.after_key_actions.mask pictureframe.after_vibration_actions.mask pictureframe.after_testcard_actions.mask pictureframe.after_timer_actions.mask
㉒	Allows to increase the WPAN1 connection duration, for example, when the SMH300 hub is facing slowness to access to the calendar system (in ms).	1 to 5000 ms	pictureframe.action.delay1

Number	Description	Supported value in APPLI HTA HTML application interface	Configuration key
23	Allows to increase the WPAN2 connection duration when facing BLE connection with SLATE Maintainer or SLATE message overlay (in ms).	1 to 5000 ms	pictureframe.action.delay2
24	Generally after NFC badging or after key event, allows to activate and define the duration for the temporary alternate content ( Display a key image instead of standard one, during ) on key press or NFC badging (in seconds).	0..65535 (default value: 60)	pictureframe.key.picture.duration
25	For specific custom application, allows to set the SLATE106 device in an enhanced interactivity mode allowing the device to wake up several times with a specific duration Start the timer during <m> sec repeated <n> time(s) maximum .	<m> : 30..60 <n> :0..9	pictureframe.wakeup.timer.period pictureframe.wakeup.timer.max_repeat
26	The Save button allows to save any change in the APPLI.CFG file.	NA	NA
27	The Restore factory preferences button allows return to default factory preferences.	NA	NA

<sup>1</sup> When modified, the content with the appropriate .ppk filename has to be copied on the file system.

## Default values when not paired

If not paired neither to a SMH300 hub, nor to a SAP10e device, the default SLATE106 configuration is:

- picture filename: *spe.ppk*,
- wake up regularly: *every 15 minutes*,
- active interval from: *0.00 AM to 12.00 PM*,
- active days: *7/7*,
- vibration: *inactivated*,
  - touch key: *inactivated*,
    - temporarily secondary content update by key press: *inactivated*,
  - NFC badging: *inactivated*,
    - temporarily secondary content update by NFC: *inactivated*,
  - message overlay: *activated*.
    - private PIN code required: *yes*.

## Default values when paired to a SMH300 hub

If paired to a SMH300 hub, the SLATE106 configuration is the one coming from the SMH300 hub. The APPLI.CFG can be edited from the SLATE USB mass storage by executing the APPLI.HTA HTML application but just to read the pictureframe preferences. In case wishing to modify the pictureframe preferences, connect to the device Web user interface of the appropriate SMH300 hub.

In the default factory configuration file coming from the SMH300 hub, the wake up policy is:

- wake up regularly: *every 15 minutes*,
- active interval from: *8.00 AM - 7.00 PM*,
- active days: *5/7*.

For further information, refer to the SMH300 user manual on the [Qeedji Web site](#) Web site.

## Default values when paired to a SLATE106 device

If paired to a SAP10e device, some pictureframe user preference are coming from the SAP10e device, some others are restored to their default factory preferences:

- default user preference values transmitted by the SAP10e , in the default factory configuration:
  - picture filename: *hub.ppk*,
  - testcard: *inactivated*,
  - pairing PIN code required: *no*,
  - pairing PIN code value: *0*,
  - vibration: *inactivated*.
  - active interval from: *8.00 AM to 19.00 PM*:
  - active days: *5/7*,
- all the pictureframe user preferences, not defined by the SAP10e , are reinitialized to their factory settings values by the SLATE:
  - wake up regularly: *every 15 minutes*,
  - touch key: *inactivated*:
    - temporarily secondary content update by key press: *inactivated*,
  - NFC badging: *inactivated*:
    - temporarily secondary content update by NFC: *inactivated*,
  - message overlay: *activated*:
    - private PIN code required: *yes*.

## Restore factory preferences

To restore the factory preferences:

- unpair the SLATE106 device from the SMH300 hub or SAP10e device by connecting to its device Web user interface. For further information, refer to the appropriate SMH300 hub or SAP10e device user manual on the [Qeedji Web site](#),
- plug the SLATE106 device to a computer with an USB cable (*micro USB type B to USB*) and wait for the USB mass storage is mounted properly,
- execute the APPLI.HTA HTML application and click on the Restore factory preferences button. If they exist, you can delete these files:
  - APPLI.CFG ,
  - HUB.PPK ,
  - PAIRED ,
  - PINCODE .
- eject properly the USB mass storage of the SLATE106 device with your MS-Windows system,
- wait for a while so that the USB mass storage is mounted back again,
- unplug the USB cable.

⚠ After having added, modified or removed some file through the USB mass storage, DO ALWAYS EJECT PROPERLY the SLATE106 device with your MS-Windows before unplugging the USB cable to avoid the corruption of the APPLI.CFG file.



## 2.2 Heartbeat wake-up

The heartbeat wake-up consists in defining the active interval and the active day when the SLATE106 devices is able to wake-up and then treat some actions like

- update .ppk file,
- install a new software release,
- load a new configuration.

Both wake-up by vibration and wake-up by heartbeat mode ( Period OR Quarter of an hour ) are concerned by:

- the active interval (for example: from 8:00 to 19:01),
- the active day (for example: Mon, Tue, Wed, Thu, Fri).

⚠ If neither of wake-up by vibration and wake-up by heartbeat mode are activated, the active interval and the active day are not taken into account. In this case the SLATE106 devices can not wake up anymore. The only way to wake it up is to connect to it a MS-Windows computer with an USB cable, and activate again, either wake-up by vibration and/or wake-up by heartbeat mode .

▣ The SMH300 hub supports only one WPAN1 connection at the time. If the SMH300 hubs heartbeat mode is Quarter of a hour, all the SLATE106 devices will wake-up at the same time. To avoid that, the SLATE106 device uses its index to add a specific delay between to its theory wake-up time. For further information, refer to the paragraph § [APPLI.HTA](#).

### In case WPAN failure

When using WPAN1 features, after a heartbeat wake-up, the SLATE106 device tries to connect to the SMH300 hub or to the SAP10e device. In case the WPAN1 connection fails, it retries 2 times more, with a delay of 30 seconds. The same After heartbeat actions are done after each attempt.

## 2.3 SPE Desktop

When it is executed directly from the SLATE106 device, `spe desktop (spe.exe)` tool offers a graphical interface allowing to enter a rich text and to save it as a proprietary format content into the SLATE, with `spe.ppk` default name.

### Configuration

If the SLATE has already been paired to a `SMH300` hub, the SLATE must be unpaired properly from the `SMH300` hub else the SLATE content could take an unexpected configuration and take an unexpected content. To unpair the SLATE from the `SMH300` hub, refer to the `SMH300` hub user manual. In this case, it is recommended to proceed to a SLATE factory settings restoring. For further information, refer to the chapter § [APPLI.HTA](#).

To display an `.ppk` content with SPE Desktop:

- the Picture filename **1** must be `spe.ppk`,
- the Test card **2** must be inactivated.

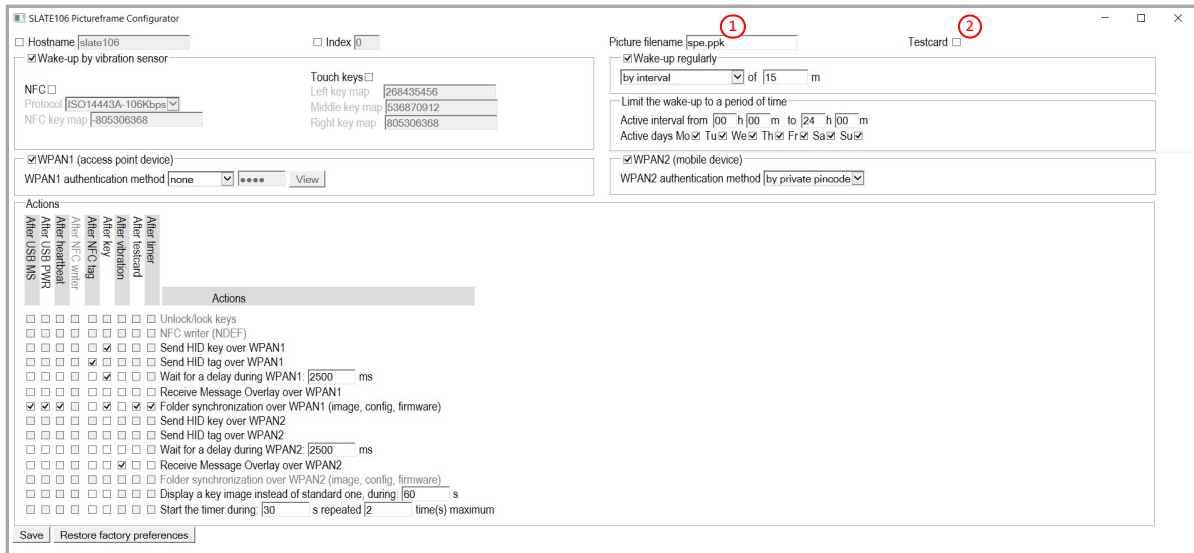

For further information, refer to the chapter § [APPLI.HTA configuration application](#).

At least, `spe.exe` must be available on the file system:

- connect the SLATE device to your computer with an USB cable (*micro USB type B to USB*) and wait for the USB mass storage is mounted properly,
- check that the `spe.exe` tool is present<sup>1</sup>,
- eject properly the SLATE106 device USB mass storage.

<sup>1</sup> The `spe.exe` tool is stored by default at factory on the USB mass storage. If it is not present, download [SPE Desktop](#), connect the SLATE106 device to your computer with an USB cable, and copy the `spe.exe` tool into the SLATE106 device USB mass storage.

### Content update with SPE Desktop tool

To build a new content (`spe.ppk`) with `SPE Desktop` tool:

- connect the SLATE106 device to your computer with an USB cable (*micro USB type B to USB*) and wait for the USB mass storage is mounted properly,
- execute `spe.exe` directly from the SLATE106 device USB mass storage:
  - if an `spe.pk` content is already present, is displayed in the SPE Desktop window. Click in the window so that SPE desktop detects the text format,
  - type your text like any other text editor<sup>2</sup>,
  - select some text part and format it:
    - change the font size,
    - align the text,
    - insert bullet if any,
    - change the font type **3**
    - change font color in grey levels (black, dark grey, light grey) **4**.
  - when finished, in the menu `File`, select `Save to Slate`. Your content is saved automatically as `spe.ppk` in the SLATE106 device USB mass storage and the content is updated,
- eject properly the SLATE106 device USB mass storage,
  - the SLATE106 device USB mass storage is mounted back again automatically until the USB cable is really unplugged,
- unplug the USB cable.

<sup>2</sup> Copy-pasting of a formatted text from other text editor is supported.

For example:

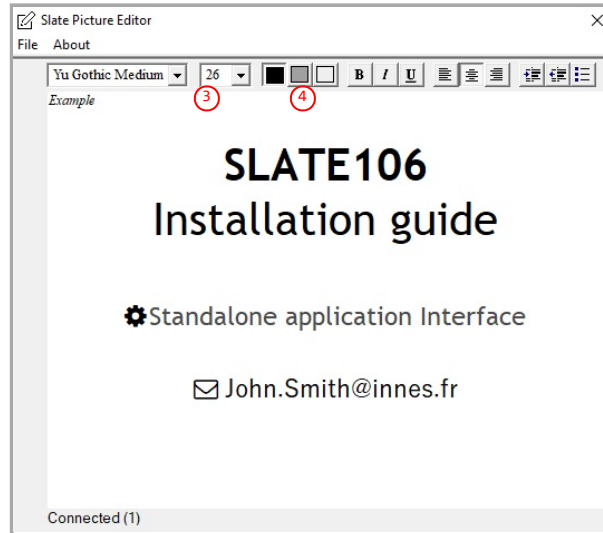

▮ To edit the current content with the `spe.exe` tool, in the menu `File`, select `Open from Slate`. The function `Open from Slate` does not work with PPK generated with the tool `Img2ppk.exe`.

### System files

These are the files available on the file system after a content update with `SPE desktop`:

- `APPLI.HTA`,
- `APPLI.CFG`,
- `spe.exe`,
- `spe.ppk`.

▮ If they are present, the `HUB.PPK` and the `.PAIRED` files can be removed because they are not useful.

### Case sensivity

The `pictureframe` application is not case sensitive. So it makes no difference between lower case characters (for example: `azerty.com`) and upper case characters (for example: `AZERTY.COM`).

## 2.4 Temporarily secondary content display with key press or NFC badging

The temporarily secondary content allows to display an alternate content stored on the SLATE106 device:

- either on key press,
- or on NFC badging.

Each time a key is pressed or a NFC badging is done, a new appropriate temporarily secondary content is displayed following the keycode list defined in the keymap.

- ▮ The maximal duration for the temporarily secondary content is 65535 seconds = 18 hours.
- ▮ In case the SLATE106 device is paired to a `SMH300` hub, remember that the content could be unexpectedly overwritten.

### Temporarily secondary content display with a key press

The temporarily secondary content display with keypress is not active by default. To activate it, plug the SLATE on your computer, and execute the `APPLI.HTA HTML` application:

- activate the support for `Wake-up by vibration sensor` <sup>1</sup>,
- activate the action `Display a key image instead of standard one, during: <duration> seconds for After key wake-up event` <sup>2</sup>:
  - Adjust the `<duration>` if required (0..65535, default..60 seconds) <sup>9</sup>.
- activate the support for `Touch keys` <sup>3</sup>,
  - let the `middle key map` <sup>1</sup> <sup>4</sup> input with the default value allows to display the `F2.ppk` content,
- depending on the keymap, drop the appropriate `.ppk` file in the SLATE file system (for example: `F2.ppk`),
- the `Test card` <sup>10</sup> must be inactivated.

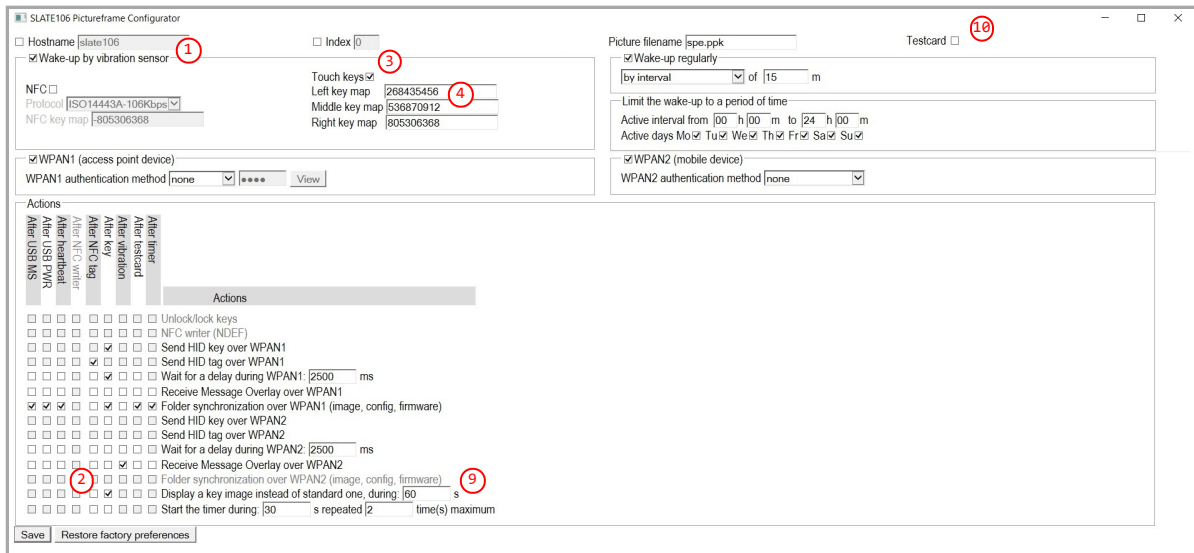

<sup>1</sup> For example, for the default `Middle key map` value (536870912 = 2000000 hexa), the value 2 at the first position means that a `F2.ppk` content is required on the file system to be able to display a temporarily secondary content after having pressed on the middle key.

## Temporarily secondary content display with NFC badging

The temporarily secondary content display with NFC badging is not active by default. To activate it, plug the SLATE on your computer, and execute the APPLI.HTA` HTML application:

- activate the support for wake-up by vibration sensor **1**,
- activate the action Display a key image instead of standard one, during: <duration> seconds for After NFC tag wake-up event **8**:
  - Adjust the <duration> if required (0..65535, default..60 seconds) **9**.
- activate the support for NFC **2**:
  - choose the appropriate NFC protocol suitable for your badge **3**,
  - let the NFC key map **1** **5** input with the default value allows to display the F13.ppk content.
- depending on the keymap, drop the appropriate .ppk file in the SLATE file system (for example: F13.ppk),
- the Test card **10** must be inactivated.

## Configuration example

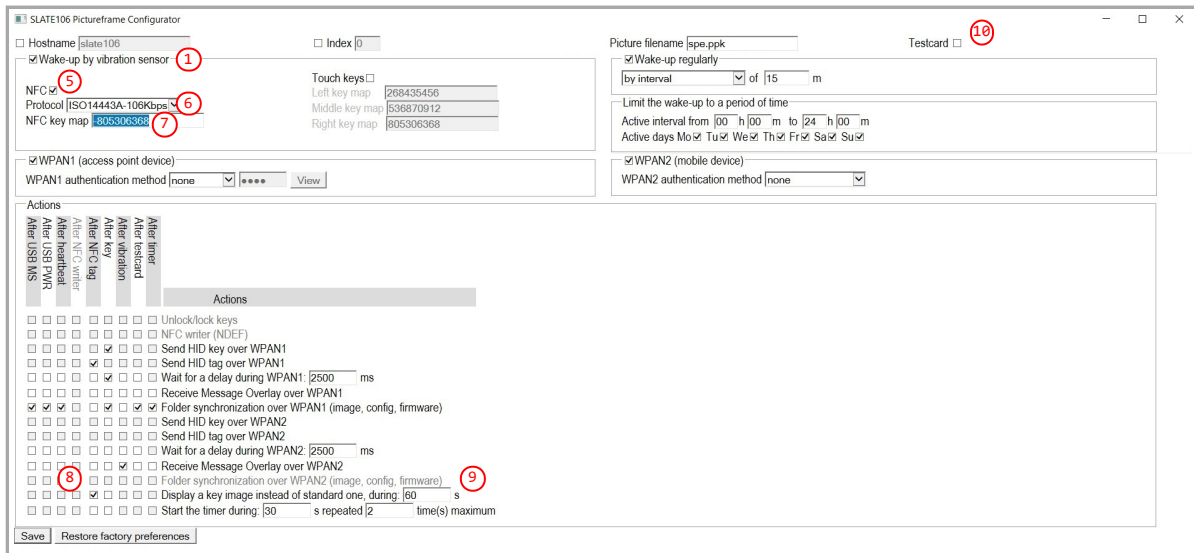

For further information, refer to the chapter § APPLI.HTA.

## Appendix for keymap configuration

The keymap is the concatenation of keycode values.

The keycode values go from 1 to 15 (1 to F in hexa). That defines the expected filename:

Keycode value (hexa)	1	2	3	4	5	6	7	8
Expected filename	F1.PPK	F2.PPK	F3.PPK	F4.PPK	F5.PPK	F6.PPK	F7.PPK	F8.PPK
Keycode value (hexa)	9	A	B	C	D	E	F	
Expected filename	F9.PPK	F10.PPK	F11.PPK	F12.PPK	F13.PPK	F14.PPK	F15.PPK	

\* F1.ppk to F15.ppk filenames are supported with NFC badging. Only F1.ppk to F12.ppk filenames are supported when a key is pressed.

The keymap is a list of maximum 8 following keycodes, corresponding to 8 different contents which can be displayed after several *Middle key press* or *NFC badging*. There is one independant keymap for *Middle key press* and another one for *NFC badging*.

Default keymaps:

- Having a 20000000 (hexa) value for the *Middle key* keymap, means that the F2.ppk content is displayed when the Middle key is pressed. So this file needs to be available on the file system.
- Having a D0000000 (hexa) value for the *NFC* keymap, means that the F13.ppk content is displayed when the NFC badging is done. So this file needs to be available on the file system.

▮ If there is not the appropriate .ppk file on the file system, the temporary content can not be displayed.

▮ If there is the keymap is 0 for a touch key, this key is inactivated.

For each of the keymap, it is possible to change the keymap to modify the content possibilities each time a touch key is pressed or NFC badging is done.

⚠ \*The remaining place on the file system is defining the max. number of .PPK files (118 KB) that you can store.

▮ \*When executing the APPLI.HTA` HTML application, the keymap is entered as integer value (signed value). \*

Default keymap:

Touch key or NFC badge	Keymap (signed integer) = keymap (hexa)	1	2	3	4	5	6	7	8
Middle	536870912 = 20000000 (hexa)	2	0	0	0	0	0	0	0
NFC	-805306368 = D0000000 (hexa)	D	0	0	0	0	0	0	0

▮ The 0 value in a column means the end of the keycode list.

Example of another keymap:

Touch key or NFC badge	Keymap signed integer = keymap hex	1	2	3	4	5	6	7	8
Middle	536870912 = 24560000 (hexa)	2	4	5	6	0	0	0	0
NFC	-554696704 = DEF00000 (hexa)	D	E	F	0	0	0	0	0

Example:

- for the middle key:
  - the 2 keycode means that at the first key press on the middle key, the F2.PPK content is played,
  - the 4 keycode means that at the next key press on the middle key, the F4.PPK content is played,
  - the 5 keycode means that at the next key press on the middle key, the F5.PPK content is played,
  - the 6 keycode means that at the next key press on the middle key, the F6.PPK content is played.
- for NFC badging:
  - the D keycode means that at the first NFC badging, the F13.PPK content is played,
  - the E keycode means that at the next NFC badging, the F14.PPK content is played,
  - the F keycode means that at the next NFC badging, the F15.PPK content is played.

When this sequence is done [middle key, NFC badging, middle key, NFC badging], the content display order will be [ F2.PPK , F13.PPK , F4.PPK , F14.PPK ].

After the timeout has expired, the SLATE106 device is displaying back the default full screen content.

▮ The values upper than 2147483647 for signed integer are not supported. In this case, transform it into negative value by removing 4294967296.

⚠ Fully fill the available space with image F<keycode>.ppk images may prevent SLATE106 device to upgrade its software.

## Reserve 220 KB for software upgrade

If you want to still support software upgrade, a minimum available free space of 220 KB is required on the file system.

## Optimize free space on the file system

The spe.exe application (109 KB) is present by default on the file system. It is used to generate a default full screen content (default name: spe.ppk ). When your spe.ppk is generated and you don't need to changed it afterwards, you can remove this spe.exe file to free up about 109 KB. To restore the spe.exe , you can download it from the [SPE Desktop](#).

## Supported feature versus PSN

The supported Touch keys and NFC badging capability are depending on the SLATE106 device PSN value.

SLATE106 device PSN value	Middle Touch keys	NFC badging
00900-xxxxx	no	no
00901-xxxxx	no	yes
00902-xxxxx	no	no
00903-xxxxx (and above)	yes	yes

It is considered that the left and right keys are not supported.

## 2.5 Working with a SMH300 hub or a SAP10e device

The SLATE106 device can work with a SMH300 hub or with a SAP10e device. In this case the SLATE106 device is communicating over the WPAN1 channel, BLE 4.1 protocol (Bluetooth Low Energy).

When working with a SMH300 hub or with a SAP10e device, the SLATEs are designed to work with content whose the filename is hub.ppk .

▮ The SMH300 hub and SAP10e devices have a build-in HTTP/WebDAV server allowing to store the current hub.ppk content for each SLATE106 device. Thanks to an IP network, the content of these HTTP/WebDAV directories can be updated by dedicated applications running on the SMH300 hub or by any third party WebDAV clients or appliance able to push content on the HTTP/WebDAV directories.

Once the hub.ppk content has been updated in their HTTP/WebDAV directories, the SLATE106 device should display the new hub.ppk content, transmitted through the WPAN1 channel, within 15 minutes afterwards (in the default heartbeat value configuration).

### Pairing configuration

⚠ If the SLATE was previously paired to an SMH300 with an unexpected wake up policy prevent the SLATE to wake up during the pairing procedure, it could be required to proceed to a SLATE106 device factory preferences restoring to ensure that the default heartbeat is the default one. For further information about the *Restore factory settings* button, refer to the chapter § APPLI.HTA. This warning does not concern new SLATE106 devices coming straight from factory.

To pair the SLATE106 device to a SMH300 hub, refer to the appropriate user manual on the [Qeedji Web site](#).

▮ When working with a SMH300 hub or SAP10e device, each SLATE106 device get an index value, between 1 and 10 set during the configuration.

The SLATE106 device must wake up to be detected during the pairing procedure. A pairing PIN code could be required to proceed to the pairing.

If the pairing is done with SMH300 hub, the SLATE takes the new configuration from the SMH300 hub like:

- pairing PIN code for each SLATE: required or not:
  - if the PIN code is required, the PIN code value can be different for each SLATE
- Test card for each SLATE: activated or not,
- hostname: slate106 (default value for all the SLATE)
- wake up policy, vibration, touch key, NFC, and so on...

If the pairing is done with SAP10e hub, the SLATE takes also the new configuration from the SAP10e device like:

- pairing PIN code : required or not for all the SLATE:
  - if a pairing PIN code is required, that worth for all the SLATE at a time and the same pairing PIN code value is set for all the SLATE,
- Test card : activated or not:
  - the same state is set for all the SLATEs,
- hostname: by default automatically generated with the pattern slate-<index> : slate-01, slate-02, ... , slate-10:
  - each hostname can be modified individually by the SAP10e.

▮ By default, the SLATE106 device is configured to wake-up every 15 minutes. It may be required to wait 15 minutes to detect all the devices.

▮ In the default configuration, once configured, the Test card should be displayed on the SLATE106 devices.

▮ It is possible to not wait 15 minutes by forcing a SLATE106 device wake-up by plugging for 3 seconds one USB power bank (or to a laptop having an USB 2.0 connector).

⚠ In case you have modified the configuration matrix, take care to not activate *Receive Message Overlay over WPAN1* else the SLATE106 device could not be paired.

▮ In the default configuration, the SLATE106 device can wake-up and able to update its content when it is connected by USB to a computer or to an USB power bank.

▮ The SLATE106 device can wake-up also with a single tap instead of with the heartbeat. That is not activated in the default to save battery lifetime. For further information, refer to the appropriate SMH300 user manual on the [Qeedji Web site](#) Web site.

### Content, configuration, software release update through WPAN1

Each SLATE106 device makes periodically, by default every 15 minutes, some connections with the SMH300 hub or with the SAP10e device. This communication allows to check whether a new content, a new configuration or a new software release is available.

#### Content update:

In case the new hub.ppk content to display is different from the one already displayed, it downloads immediately the new hub.ppk content from the SMH300 hub or from the SAP10e device then displays it.

▮ To be able to display a new hub.ppk content, the Test card needs to be inactivated. For further information, refer to the SMH300 user manual on the [Qeedji Web site](#).

▮ In case content update issue, check first that the SLATE106 device is properly paired with the right Index to the appropriate SMH300 hub.

▮ Even in case the WPAN communication between the SLATE106 device and the SMH300 hub (or the SAP10e device) is very difficult, the file downloading time can be longer but cannot be over 10 seconds.

#### Configuration update:

In case the new APPLI.CFG configuration file is different from the previous one, it downloads immediately the new APPLI.CFG configuration file from the SMH300 hub and takes it into account.

- It is possible to change the heartbeat wake-up configuration. For further information, refer to the appropriate `SMH300` hub user manual` on the [Qeedji Web site](#).
- The SLATE106 device has to wake up to be able to take into account a new configuration (add, modify or remove the pairing `PIN code`, add or remove the `Test card`, change the hostname).



## Software release update:

In case the new `pictureframe-slate106-setup-xx.yy.zz.rpk` software release version is different from the one installed on the SLATE106 device, it downloads immediately the new `pictureframe-slate106-setup-xx.yy.zz.rpk` software release from the `SMH300` hub or from the `SAP10e` device and install it.

▮ The version of the software release and the version of the firmware release installed on each paired SLATE device is displayed in the `Administration console` user interface of the `SMH300` hub and of the `SAP10e` device. For further information, refer to the appropriate `SMH300` or `SAP10e` user manual on the [Qeedji Web site](#).

▮ The WPAN1 communication is exclusive and implies that the `SMH300` hub and `SAP10e` device can communicate with only one SLATE106 device at a time, starting with device paired with the `Index` value: `1`, and ending with device paired with `Index` value: `10`.

## System files

When the pairing is successful and the content updated, these files are available on the SLATE106 device USB mass storage:

- `.PAIRED` : present if the device is paired (or has been already paired) to a `SMH300` hub,
- `HUB.PPK` : content to display (proprietary format) when `TestCard` is not inactivated,
- `APPLI.CFG` : SLATE106 device configuration file set by the `SMH300` hub or the `SAP10e` device,
- `APPLI.HTA` : HTML application allowing to edit and save parameters in `APPLI.CFG` file.

▮ The SLATE106 device file system is not case sensitive, meaning that it makes not difference between lower cases and upper case.

▮ When the SLATE106 device is paired to a `SMH300` hub, it inherits of the `APPLI.CFG` configuration entered in the `SMH300` hub. Do not modify this file directly by executing the `APPLI.HTA` HTML application from the USB mass storage of the SLATE106 device because it would be overwritten anyway by the configuration transmitted by the `SMH300` hub. For further information, refer to the `SMH300` hub user manual on the [Qeedji Web site](#).

▮ When the SLATE106 device is paired to a `SAP10e` device, it inherits of the `APPLI.CFG` configuration entered in the `SAP10e` device. It is possible to modify this file directly by executing the `APPLI.HTA` HTML application from the USB mass storage of the SLATE106. Warning, some parameters transmitted by the SLATE106 device may be overwritten anyway. For further information, refer to the `SAP10e` user manual on the [Qeedji Web site](#).

## Device replacement

In case you must replace a SLATE106 device which needs to be paired again to the same `SMH300` hub or a `SAP10e` device:

- get the PSN of your old SLATE106 device (written on the label), note the `Index` associated to this SLATE106, and unpair it from the `SMH300` hub or from the `SAP10e` device,
- get the PSN of your new SLATE106 device, (written on the label at the back of the product) and pair it to the `SMH300` hub or to the `SAP10e` device by assigning the same `Index`.

▮ For further information, refer to the appropriate `SMH300` hub or `SAP10e` user manual on the [Qeedji Web site](#).

## Touch key

When working with `SMH300` hub, the SLATE106 device can support *Touch keys*. This feature is not activated in the default configuration. For further information, refer to the `SMH300` user manual on the [Qeedji Web site](#).

▮ When a key is pressed, the associated red LED just below the button is blinking showing that the key has been taken into account.

## NFC badging

When working with `SMH300` hub, the SLATE106 device can support *NFC badging*. This feature is not activated in the default configuration. For further information, refer to the `SMH300` user manual on the [Qeedji Web site](#).

▮ To be taken into account, tap the SLATE106 device with your NFC badge upon the appropriate sensor location to wake up the SLATE. Then the Middle red LED is blinking showing that the NFC tag has taken into account.

## State diagram

This is the state diagram of `PictureFrame` when configured with a `SMH300` hub:

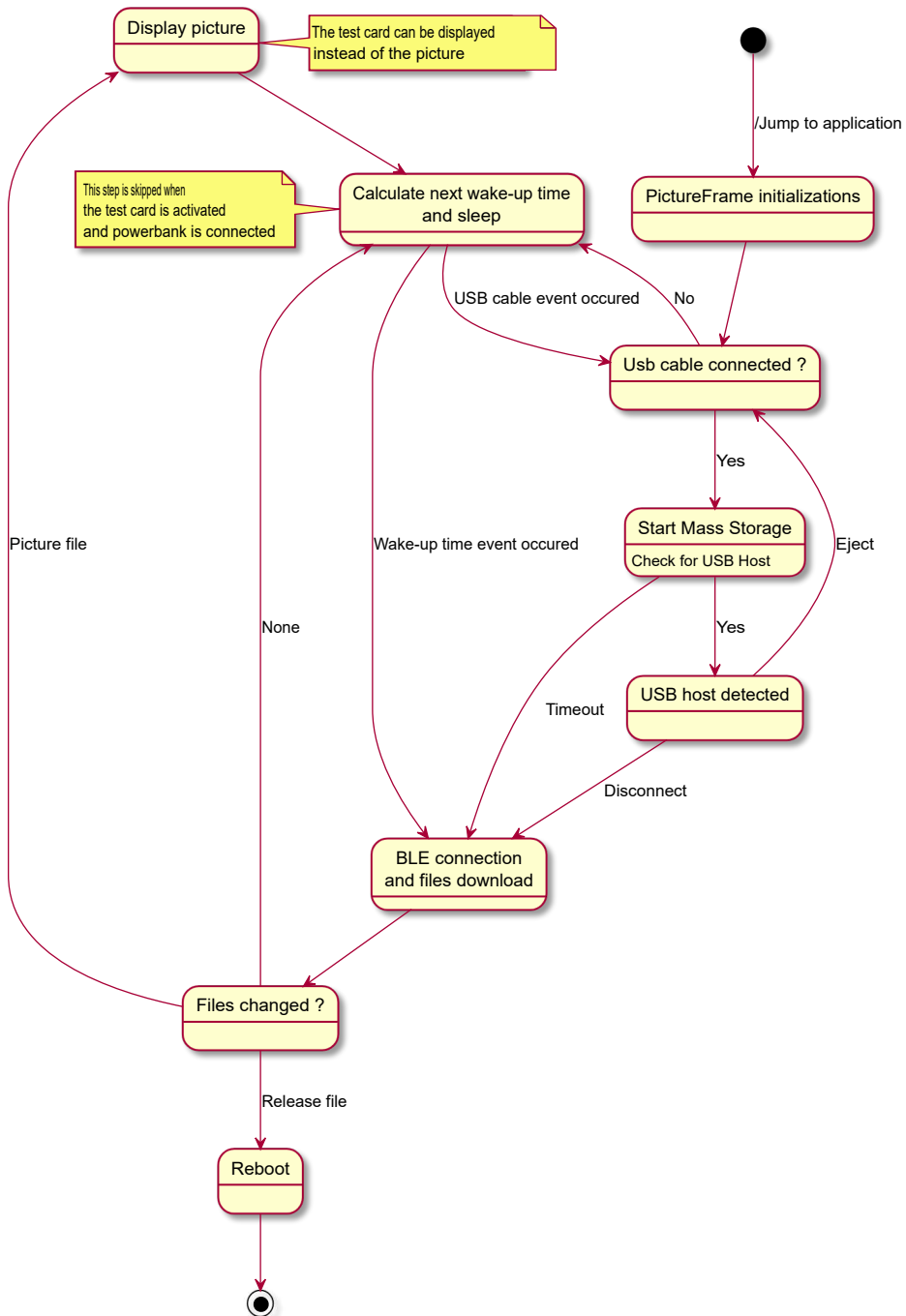

## 2.6 Configuration for mobile devices

To support mobile applications, the SLATE must be configured to support WPAN2 and vibration.

The Wake-up by vibration sensor is not activated in the default factory configuration.

Connect the SLATE106 device to your computer with an USB cable (*micro USB type B to USB*) and wait for the USB mass storage is mounted properly. Then execute the `APPLI.HTA HTML` application:

- deactivate Test card <sup>1</sup>
- activate Wake-up by vibration sensor <sup>2</sup>,
- activate WPAN2 (mobile device) <sup>3</sup> and for WPAN2 authentication method, keep the default value by private PIN code<sup>1</sup> <sup>4</sup>,
- keep activated Receive Message Overlay over WPAN2 after a Vibration event <sup>5</sup>.

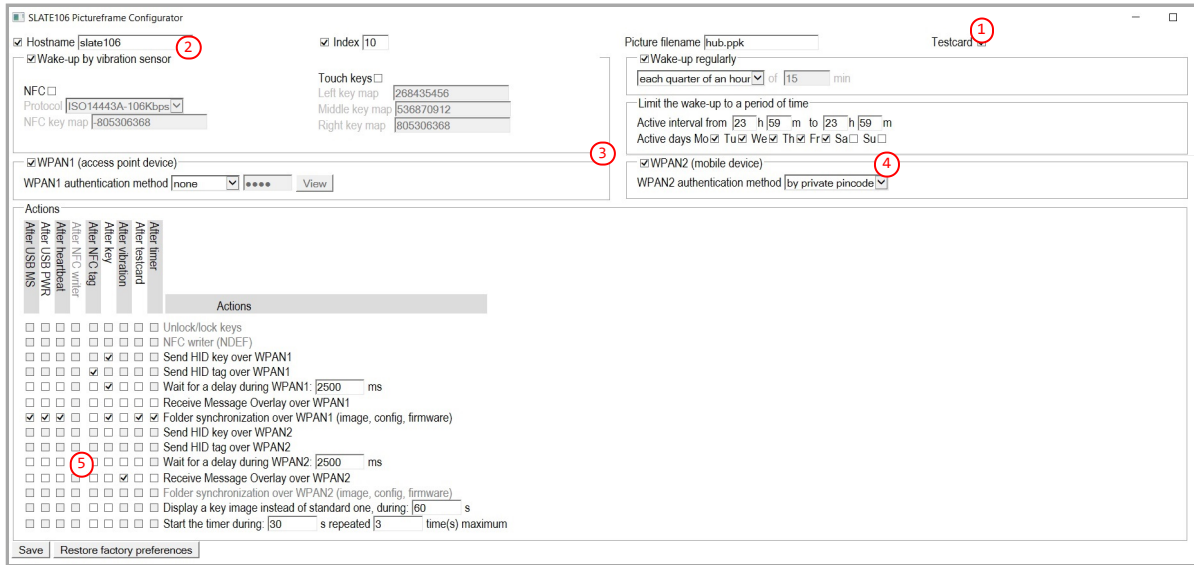

<sup>1</sup> A private PIN code is required by default when connecting with a mobile. To inactivate the private PIN code, in the WPAN2 authentication method field, set *none* instead of *by private PIN code*.

- When the expected private value is set, it is stored in the SLATE and a `.PINCODE` file, whose content is empty, is created on the file system.
- Is not not required to enter again the PINCODE value to send another message as long as the SLATE device is still paired in the *SLate Message Overlay* application.

### SLATE Compatibility

The SLATE device whose PSN are 00902-xxxxx are not compatible with the mobile application (vibration not supported).

### Link to mobile applications

Chapter § [Slate Message Overlay application](#) Chapter § [Slate Maintainer application](#)

## 2.7 Appendix: actions matrix (advanced user)

The action matrix allows to

- activate the temporarily secondary content display on key press feature,
- customize or optimize the pictureframe application behaviour (advanced user only).

The matrix summarizes the activated actions with its order which are done depending on the wake-up sources.

### Wake-up sources

When the SLATE106 device is in sleep mode, it can be woken up by these different wake-up sources:

- After USB MS : occurs when USB Mass Storage has been mounted first, then after the USB cable is disconnected,
- After USB Power : occurs when an USB power bank is connected, and after the USB cable is disconnected,
- After heartbeat : occurs each time the heartbeat timer has elapsed (during the active interval),
- After NFC Writer (RFU): occurs each time a NFC writer is detected,
- After NFC tag : occurs each time a NFC tag is detected,
- After key : occurs each time a key press is detected,
- After vibration : occurs each time a vibration is detected,
- After testcard : occurs each time the testcard is displayed.
- After timer : occurs each time the timer has elapsed.

### Actions name

- key\_lock (RFU): NC
- nfc\_writer (RFU): NC
- tx\_hid\_key1 : this action allows to send the detected key pressed value through WPAN1 ,
- tx\_hid\_tag1 : this action allows to send the detected NFC tag value through WPAN1 ,
- delay1 : during the WPAN1 connection, insert a delay (in ms) after the txhidxxx actions, and before doing the next action(s),
- rx\_mo1 : supports for receiving a Message Overlay through WPAN1 ,
- folder\_sync1 : this action launches the folder synchronization through WPAN1 from the WPAN host to the SLATE106 device. The files to be updated can be: the configuration file APPLI.CFG , the content HUB.PPK content or the software release files .rpk ,
- tx\_hid\_key2 : this action allows to send the detected key pressed value through WPAN2 ,
- tx\_hid\_tag2 (RFU): this action allows to send the detected NFC tag value through WPAN2 ,
- delay2 : during the WPAN2 connection, insert a delay (in ms) after the txhidxxx actions, and before doing the next action(s),
- rx\_mo2 : support for receiving a Message Overlay through WPAN2 ,
- folder\_sync2 (RFU): this action launches the folder synchronization through WPAN2 from the WPAN host to the SLATE106 device. The files to be updated can be: the configuration file APPLI.CFG , the content HUB.PPK content or the software release files .rpk ,
- secondary\_picture : support for the display of temporarily secondary content on key press above the nominal one for a programmable duration. The names of the temporarily secondary content are depending on the key detected and the Touch key mapping (ex: F1.ppk , F2.ppk , F3.ppk ).

### Actions scheduling order

The matrix shows also the actions scheduling order after an event occurred.

### Mask

This column is showing the equivalent integer values of the default matrix configuration stored in the APPLI.CFG configuration file.

# Part III

## Mobile applications

## 3.1 Mobile applications

Two applications are available:

- Slate Message Overlay ,
- Slate Maintainer .

There are compatible either with *Android* or *iOS* systems mobile devices.

A private pairing PIN code (between 0000 to 9999) is required by default to pair the device to your mobile device. Then the SLATE106 device is paired with this private pairing PIN code. Another user cannot pair this same device with its mobile device except if the right private pairing PIN code is entered.

In case a wrong pairing PIN code is entered 3 times, the `Slate Maintainer` application can not work anymore for the SLATE106 device. To reset a private pairing PIN code:

- either connect the SLATE106 device to you computer and remove the `PINCODE` file,
- or pair the SLATE106 device with `SLATE Maintainer` mobile application and press on the `Reset WPAN2 PIN code` button,
- or use the device Web user interface of the `SMH300` hub.

### 3.1.1 Slate Message Overlay

This `Slate Message Overlay` mobile application allows to send a text message to a SLATE106 device, which is displayed over the existing content in a predefined area for a specific duration.

The text message is sent through the WPAN2 channel by the `Slate Message Overlay` mobile application.

#### Prerequisite

OS name	OS version	Peripheral
Android	4.4.2 (or above)	Bluetooth V4.1 (Bluetooth Low energy)
iOS	11.2.1 (or above)	Bluetooth V4.1 (Bluetooth Low energy)

#### Configuration

To work with a mobile application, double check that the SLATE is properly configured. For further information, refer to chapter § [Configuration for mobile device \(WPAN2\)](#).

#### Overlay area parameters

This is the overlay area dimensions:

Information	Abbr.	Value in pixel
Begin from the left	X	42
Begin from the top	Y	330
Width	W	656
Height	H	215

#### Message

The `text message` is 144 characters maximum.

The supported unicode characters are:

Integer value	Hexadecimal value	Description
32 to 126	U+0020 to U+007E	Printable basic latin characters
161 to 255	U+00A1 to U+00FF	Printable latin-1 supplement characters
338 and 339	U+0152 and U+0153	Latin supplement A, characters "OE" and "oe"
8364	U+20AC	currency symbols, character "euro".

▣ If the character is not supported, a blank square is displayed.

#### Duration

The message overlay duration value is set automatically by the `Slate Message Overlay` application when the user is entering the end date & time for the `Message Overlay` display. The default end time set by the `Slate Message Overlay` mobile application is 23:59 for the current day.

▣ The maximal display duration is more than one century. Do consider there is no date limit.

▣ The time difference in seconds between the current time and the end time is transmitted to the SLATE. That means that the `Message Overlay` disappears automatically as expected even if the internal device RTC is not been set yet.

⚠ The `Message Overlay` disappears automatically each time a full screen content is updated:

- by a `SMH300` hub or `SAP10e` device:
  - `hub.ppk` .
- through the USB mass storage:
  - `spe.ppk` with SPE Desktop,
  - `<custom>.ppk` with a .ppk drag'n drop,
  - `F1.ppk` .. `F12.ppk` temporary contents when a key is pressed
  - `F1.ppk` .. `F15.ppk` temporary contents after NFC badging.

## Slate message overlay usage

If not yet done, install once the `Slate Message Overlay` application on your mobile device. For further information about this application, contact [support@qeedji.tech](mailto:support@qeedji.tech).

Launch the application `Slate Message Overlay` on your mobile device.

- ▮ The application requires that the `BlueTooth` is activated.
- ▮ The mobile OS may need to know your position else the `BlueTooth` scanning may not work properly.

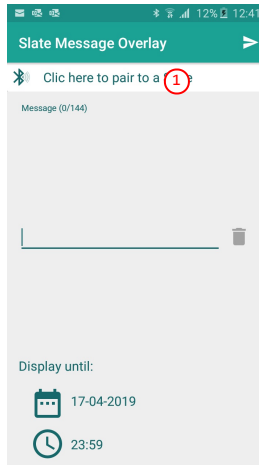

Enter your text in the message input (4) (max. 144 characters).

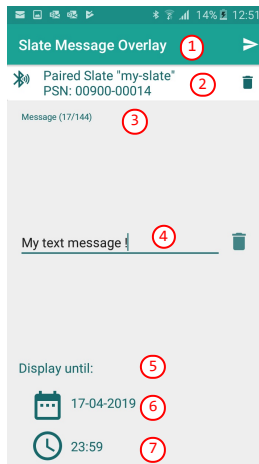

The `Slate Message Overlay` interface supports:

- A `Send the message` (1) button to send the message value to the paired `SLATE106` device,
- A `Delete` (2) button to unpair the `SLATE106` device,
- A `length label` (3) showing dynamically the character length of the message,
- An `text input` (4) to enter the message value,
- A `Display until` (5) parameter allowing to configure `Message Overlay` ending in terms of `Date` (6) and `Time` (7).

- ▮ The default `Date` and `Time` value are initialized to clear the message at the end of the current day.



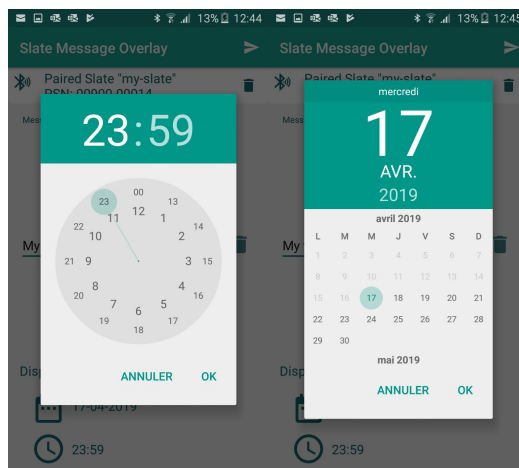

Click on the button **Send the message** ①.

If you wish to pair your device before sending the message, click on the **Clic here to pair a SLATE** ① button. The BLE scanning is in progress. The nearby BLE devices should appear soon...

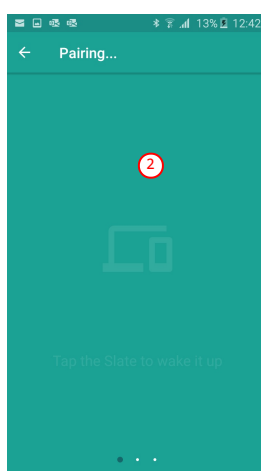

Wait for a while, the time for the SLATE106 devices close to your mobile device to be detected by the application. They should then appear the one after the other in the list ②. You can also tap again the SLATE106 device to wake it up and complete the SLATE pairing.

▮ If your SLATE106 device is not detected in the list after few seconds, if you are in proximity with this SLATE106 device, wake it up by tapping the SLATE106 device with your mobile phone. Your SLATE106 device should appear immediately.

If asked on the **Slate Message Overlay** interface, click on the appropriate SLATE106 device ③.

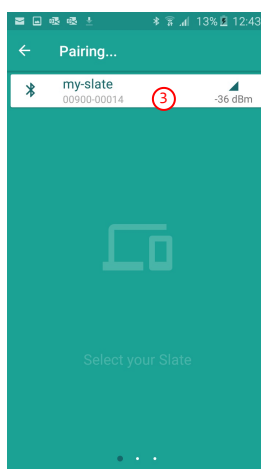

Once selected, if a private PIN code is required, enter a pincode (between 0000 and 9999) and store it precisely.

▮ The same private PIN code value will be required each time you are pairing again this SLATE.

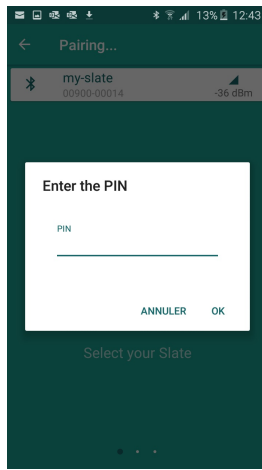

The message *Sending ...* appears for a while on the mobile device.

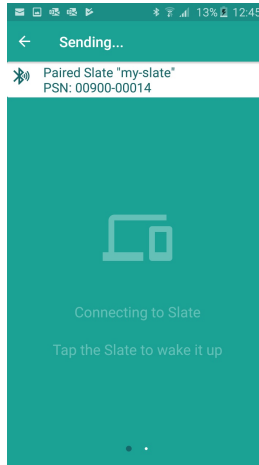

To activate a private PIN code for the application *Slate Message Overlay*, execute the *APPLI.HTA* from the SLATE106 device, and set the value by private PIN code for the parameter *WPAN2 authentication method*.

⚠ In case a private PIN code is required, and a wrong private PIN code is entered 3 times, the *Slate Message Overlay* application can not work anymore for the SLATE106 device. To work around, connect the SLATE106 device to you computer and remove the *PINCODE* file to reset the private PIN code.

⚠ At the end of the pairing, in case the message *Connection to SLATE failed* appears at the bottom of the mobile screen, despite of a right private PIN code entered, contact [support@qeedji.tech](mailto:support@qeedji.tech).

When the message sending has completed, the information message *Message successfully sent* is displayed at the bottom of the screen ⑦.

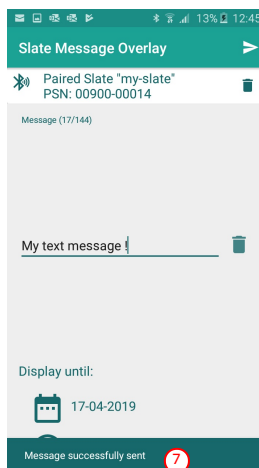

### 3.1.2 Slate Maintainer

The `Slate Maintainer` mobile application allows to:

- display some SLATE106 device information like the power level per battery (in %),
- set the SLATE106 device `Date & Time`,
- reset the `WPAN2` authentication PIN code used for mobile applications.

#### Prerequisite

OS name	OS version	Peripheral
Android	4.4.2 (or above)	Bluetooth V4.1 (Bluetooth Low energy)

#### Configuration

To work with a mobile application, double check that the SLATE is properly configured. For further information, refer to chapter § [Configuration for mobile device \(WPAN2\)](#).

#### Slate Maintainer usage

If not yet done, install once the `Slate Maintainer` application on your mobile device available on the [Qeedji Web site](#). For further information, contact [support@qeedji.tech](mailto:support@qeedji.tech).

Launch the `Slate Maintainer` application on your mobile device and press on `Click here to pair a SLATE` ①.



The BLE scanning is in progress. The nearby BLE devices should appear soon ②.

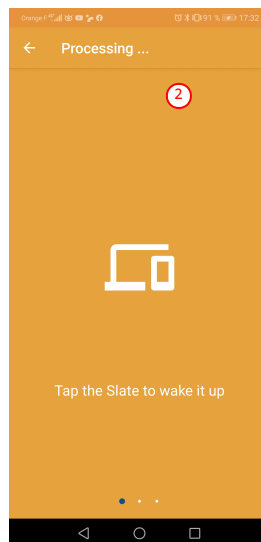

Wake up the SLATE106 by tapping it with your mobile phone. Your SLATE106 device should appear immediately in the list **(3)**. In the `Slate maintainer` mobile application, press on one of the detected SLATE106 devices.

▮ If you are not tapping the SLATE106 device, the device should appear in the list between few seconds and 15 minutes.

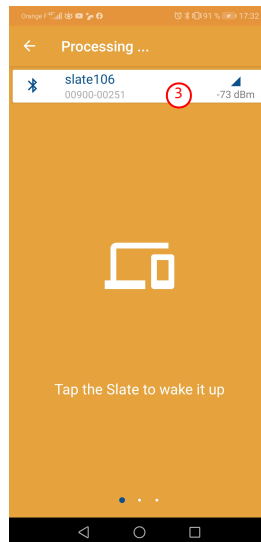

If a pairing PIN code is required, a PIN code popup is prompted. Enter a private pincode, between 0000 and 9999, and store it precisely.

▮ *The same PIN code value will be required each time you are pairing again this SLATE.*



The `Slate Maintainer` interface gives some system information on the SLATE device. For example:

- `Manufacturer` : Qeedji
- `PSN` : 00904-0002
- `Firmware rev.` : 1.11.10
- `Software rev.` : 1.11.11
- `Model` : SLATE106
- `Hardware rev.` : Rev. D
- `Battery` : 88%
  - `CR2430/1` : 88%
  - `CR2430/2` : 89%
  - `CR2430/3` : 88%
  - `CR2430/4` : 87%

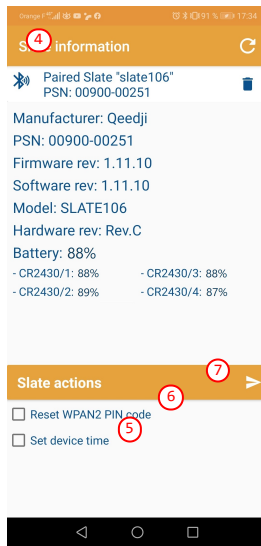

Three more functions are also supported:

- **redo** (4) button: allows to get again information on the device by connecting again to the same SLATE,
- **Set device time** (5) check box: when selected, pressing on the *Slate actions* (7) buttons allows to set the device RTC with the date and time of your mobile phone,
- **Reset WPAN2 PIN code** (6) check box: when selected, pressing on the *Slate actions* (7) buttons allows to reset the private PIN code required for *Slate Message Overlay* and *Slate Maintainer* application.

⚠ At the end of the pairing, in case the message *Connection to Slate failed* appears at the bottom of the mobile screen, despite of a right private PIN code entered, contact [support@qeedji.tech](mailto:support@qeedji.tech).

## SLATE Compatibility

The SLATE devices whose PSN number are 00902-xxxx do not support the *Slate Maintainer* mobile application.

# Part IV

## Technical information

## 4.1 Technical specifications

<b>Model</b>	<b>Manufacturer</b>	
SLATE106	Qeedji	
<b>Processor</b>		
CPU	STM32	
<b>Peripherals</b>	<b>Information</b>	
1x micro USB 2.0 (device)	min.:4.5 V, max.: 5.5 V	
1x touch sensing key	<i>For devices whose the PSN is PSN00903-XXXXX (or above) and hardware rev RevD (or later)</i>	
3x red LEDs		
1x vibration sensor		
<b>Storage</b>		
Internal Flash Memory for file system	1 MBytes	
<b>Display</b>		
Electronic paper 6" with 4 grey levels		
800x600 pixels		
<b>WPAN</b>		
Bluetooth Low Energy 4.1		
Frequency band: 2.402 to 2.480 GHz		
Tx Power: +7.5 dBm		
<b>RFID/NFC Interface</b>		
Modulation 13.56 MHz <sup>1</sup>		

<sup>1</sup> For further information, refer to the chapter § [Built-in RFID reader](#).



<b>Operating temperature</b>	<b>Storage temperature</b>
+0 °C to +40 °C	-20 °C to +60 °C
<b>Operating humidity</b>	<b>Storage humidity</b>
< 80 %	< 85 %
<b>Weight (mounting bracket + batteries included)</b>	<b>Dimensions (W x H x D)</b>
203 g	151,2 x 114 x 8 mm
0,44 lb	5,94" x 4,48" x 0,31"
<b>Enclosure flame rating</b>	
V0	
<b>Warranty</b>	
1 year	

## 4.2 Conformities

In conformity with the following European directives:

- LVD 2014/35/EU ,
- EMC 2014/30/EU ,
- RED 2014/53/EU .

# Part V | **Contacts**

## 5.1 Contacts

For further information, please contact us:

- **Technical support:** [support@qeedji.tech](mailto:support@qeedji.tech),
- **Sales department:** [sales@qeedji.tech](mailto:sales@qeedji.tech).

Refer to the [Qeedji](https://www.qeedji.tech/) Web site for FAQ, application notes, and software downloads: <https://www.qeedji.tech/>

Qeedji FRANCE  
INNES SA  
5A rue Pierre Joseph Colin  
35700 RENNES

Tel: +33 (0)2 23 20 01 62  
Fax: +33 (0)2 23 20 22 59

Qeedji GERMANY  
INNES SA  
Verbindungsbüro Deutschland  
Lebacher Str. 4  
66113 Saarbrücken

Tel: 09386-979 39-14  
Fax: 09386-979 39-15  
Mob: 0175 853 67 81