

## NIPPON THOMPSON CO., LTD. (JAPAN)

Head office : 19-13 Takanawa 2-chome Minato-ku  
Tokyo 108-8586, Japan  
Phone : +81 (0)3-3448-5850  
Fax : +81 (0)3-3447-7637  
E-mail : ntt@ikonet.co.jp  
URL : <http://www.ikont.co.jp/eg/>  
Plant : Gifu, Kamakura

## IKO-THOMPSON (SHANGHAI) LTD. (CHINA)

### Shanghai Headquarters

1608-10 MetroPlaza No.555 LouShanGuan Road  
ChangNing District Shanghai  
People's Republic of China 200051  
Phone : +86 (0)21-3250-5525  
Fax : +86 (0)21-3250-5526  
E-mail : ntc@ikonet.co.jp

### Beijing Branch

Room 609 Scitech Tower  
No.22 Jianguomenwai Avenue, Chaoyang District, Beijing  
People's Republic of China 100004  
Phone : +86 (0)10-6515-7681  
Fax : +86 (0)10-6515-7681\*106  
E-mail : ntc@ikonet.co.jp

### Guangzhou Branch

Room 834, Garden Tower, Garden Hotel  
368 Huanshi East Road, Yuexiu District, Guangzhou, Guangdong  
People's Republic of China 510064  
Phone : +86 (0)20-8384-0797  
Fax : +86 (0)20-8381-2863  
E-mail : ntc@ikonet.co.jp

### Wuhan Branch

Room 2300, Truroll Plaza No.72 Wusheng Road,  
Qiao kou District, Wuhan, Hubei  
People's Republic of China 430033  
Phone : +86 (0)27-8556-1610  
Fax : +86 (0)27-8556-1630  
E-mail : ntc@ikonet.co.jp

### Xi'an Office

Room 605, Zhongcai Finance Building,  
No.22 Heping Road, Beilin District, Xi'an City, Shanxi Province,  
People's Republic of China 710001  
Phone : +86 (0)29-8882-3225  
Fax : +86 (0)29-8882-3215  
E-mail : ntc@ikonet.co.jp

### Shenzhen Office

Room 532, Oriental Plaza,  
1072 Jianshe Road, Luohu District, Shenzhen, Guangdong  
People's Republic of China 518001  
Phone : +86 (0)755-2265-0553  
Fax : +86 (0)755-2298-0665  
E-mail : ntc@ikonet.co.jp

### Chengdu Office

Room 604 of Tower5, Weima Plaza,  
No.2 Gaopan Rd, Wuhou District, Chengdu, Sichuan,  
People's Republic of China 610041  
Phone : +86 (0)28-6250-5159  
Fax : +86 (0)28-6250-5159  
E-mail : ntc@ikonet.co.jp

### Ningbo Office

Room 3406, Zhongnongxin Building, No.181  
Zhongshan East Road, Haishu Ward, Ningbo, Zhejiang  
People's Republic of China 315000  
Phone : +86 (0)574-8718-9535  
Fax : +86 (0)574-8718-9533  
E-mail : ntc@ikonet.co.jp

### Qingdao Office

2107 Block A, World Trade Center Building, No.230  
Changjiang Middle Road, Development Zone Qingdao  
People's Republic of China 266555  
Phone : +86 (0)532-8670-2246  
FAX : +86 (0)532-8670-2242  
E-mail : ntc@ikonet.co.jp

### Shenyang Office

2-1203 Tower I, City Plaza Shenyang, No.206  
Nanjing North Street Heping District, Shenyang  
People's Republic of China 110001  
Phone : +86 (0)24-2334-2662  
FAX : +86 (0)24-2334-2442  
E-mail : ntc@ikonet.co.jp

## IKO THOMPSON ASIA CO., LTD. (THAILAND)

1-7 Zuellig House, 3rd Floor  
Silom Road, Silom, Bangkok  
Bangkok 10500, Thailand  
Phone : +66 (0)2-637-5115  
FAX : +66 (0)2-637-5116  
E-mail : ita@ikonet.co.jp

## IKO INTERNATIONAL, INC. (U.S.A.)

### East Coast Operation (USA Headquarters)

91 Walsh Drive  
Parsippany, NJ 07054  
U.S.A.  
Phone : +1 973-402-0254  
Toll Free : 1-800-922-0337  
Fax : +1 973-402-0441  
E-mail : eco@ikonet.co.jp

### Midwest Operations

500 East Thorndale Avenue, Suite K  
Wood Dale, IL 60191  
U.S.A.  
Phone : +1 630-766-6464  
Toll Free : 1-800-323-6694  
Fax : +1 630-766-6869  
E-mail : mwo@ikonet.co.jp

### West Coast Operations

9830 Norwalk Boulevard, Suite 198  
Santa Fe Springs, CA 90670  
U.S.A.  
Phone : +1 562-941-1019  
Toll Free : 1-800-252-3665  
Fax : +1 562-941-4027  
E-mail : wco@ikonet.co.jp

### Silicon Valley Sales Office

1500 Wyatt Drive, Suite 10  
Santa Clara, CA 95054  
U.S.A.  
Phone : +1 408-492-0240  
Toll Free : 1-800-252-3665  
Fax : +1 408-492-0245  
E-mail : wco@ikonet.co.jp

### Southeast Operations

2150 Boggs Road, Suite 100  
Duluth, GA 30096  
U.S.A.  
Phone : +1 770-418-1904  
Toll Free : 1-800-874-6445  
Fax : +1 770-418-9403  
E-mail : seo@ikonet.co.jp

### Southwest Operations

8105 N. Beltline Road, Suite 130  
Irving, TX 75063  
U.S.A.  
Phone : +1 972-929-1515  
Toll Free : 1-800-295-7886  
Fax : +1 972-915-0060  
E-mail : swo@ikonet.co.jp

See you again at

**IKO Website**

<http://www.ikont.co.jp/eg/>

## NIPPON THOMPSON EUROPE B.V. (EUROPE)

### The Netherlands (Europe Headquarters)

Sheffieldstraat 35-39  
3047 AN Rotterdam  
The Netherlands  
Phone : +31 (0)10-462 68 68  
Fax : +31 (0)10-462 60 99  
E-mail : nte@ikonet.co.jp

### Germany Branch

Mündelheimer Weg 56  
40472 Düsseldorf  
Germany  
Phone : +49 (0)211-41 40 61  
Fax : +49 (0)211-42 76 93  
E-mail : ntd@ikonet.co.jp

### Regensburg Sales Office

Im Gewerbepark D 30  
93059 Regensburg  
Germany  
Phone : +49 (0)941-20 60 70  
Fax : +49 (0)941-20 60 719  
E-mail : ntdr@iko-nt.de

### Neunkirchen Sales Office

Gruben Str.95c  
66540 Neunkirchen  
Germany  
Phone : +49 (0)6821-99 98 60  
Fax : +49 (0)6821-99 98 626  
E-mail : ntdn@iko-nt.de

### U.K. Branch

2 Vincent Avenue, Crownhill  
Milton Keynes, Bucks, MK8 0AB  
United Kingdom  
Phone : +44 (0)1908-566144  
Fax : +44 (0)1908-565458  
E-mail : sales@iko.co.uk

### Spain Branch

Autovia Madrid-Barcelona, Km. 43,700  
Polig. Ind. AIDA - Nove A-8, Ofic. 2-1<sup>a</sup>  
19200 Azuqueca de Henares  
(Guadalajara) Spain  
Phone : +34 949-26 33 90  
Fax : +34 949-26 31 13  
E-mail : nts@ikonet.co.jp

### France Branch

Roissypole Le Dôme  
2 rue de La Haye  
BP 15950 Tremblay en France  
95733 Roissy C. D. G. Cedex  
France  
Phone : +33 (0)1-48 16 57 39  
Fax : +33 (0)1-48 16 57 46  
E-mail : contact@iko-france.com

Recognizing that conservation of the global environment is the top-priority challenge for the world's population, Nippon Thompson will conduct its activities with consideration of the environment as a corporate social responsibility, reduce its negative impact on the environment, and help foster a rich global environment.

**ISO 9001 & 14001 Quality system  
registration certificate**



- The specifications and dimensions of products in this catalog are subject to change without prior notice.
- When these products are exported, the exporter should confirm a forwarding country and a use, and, in case of falling under the customer's requirements, take necessary procedures such as export permission application.
- Although all data in this catalog has been carefully compiled to make the information as complete as possible, NIPPON THOMPSON CO., LTD. shall not be liable for any damages whatsoever, direct or indirect, based upon any information in this catalog. NIPPON THOMPSON CO., LTD. makes no warranty, either express or implied, including the implied warranty of merchantability or fitness for a particular purpose.
- Reproduction and conversion without permission are prohibited.

# IKO Linear Motion Rolling Guide Series General Catalog

## BLUE

IKO Linear Motion Rolling Guide Series General Catalog BLUE

# Eco-friendly and Excellent Quality

**IKO** Linear Motion Rolling Guides are used with satisfactory results for various applications requiring precision positioning such as semi-conductor manufacturing equipment, large sized machine tools, industrial robots, and precision equipment. In contrast to conventional rolling bearings used in rotating parts, Linear Motion Rolling Guides are the products applicable to plane sliding surfaces, and meet the increasing needs for linear motion and precision positioning in machines and equipment. Linear Way and Linear Roller Way of rail guide type, Linear Ball Spline of shaft guide type, and other products, recognized for their high quality and excellent features, are available.

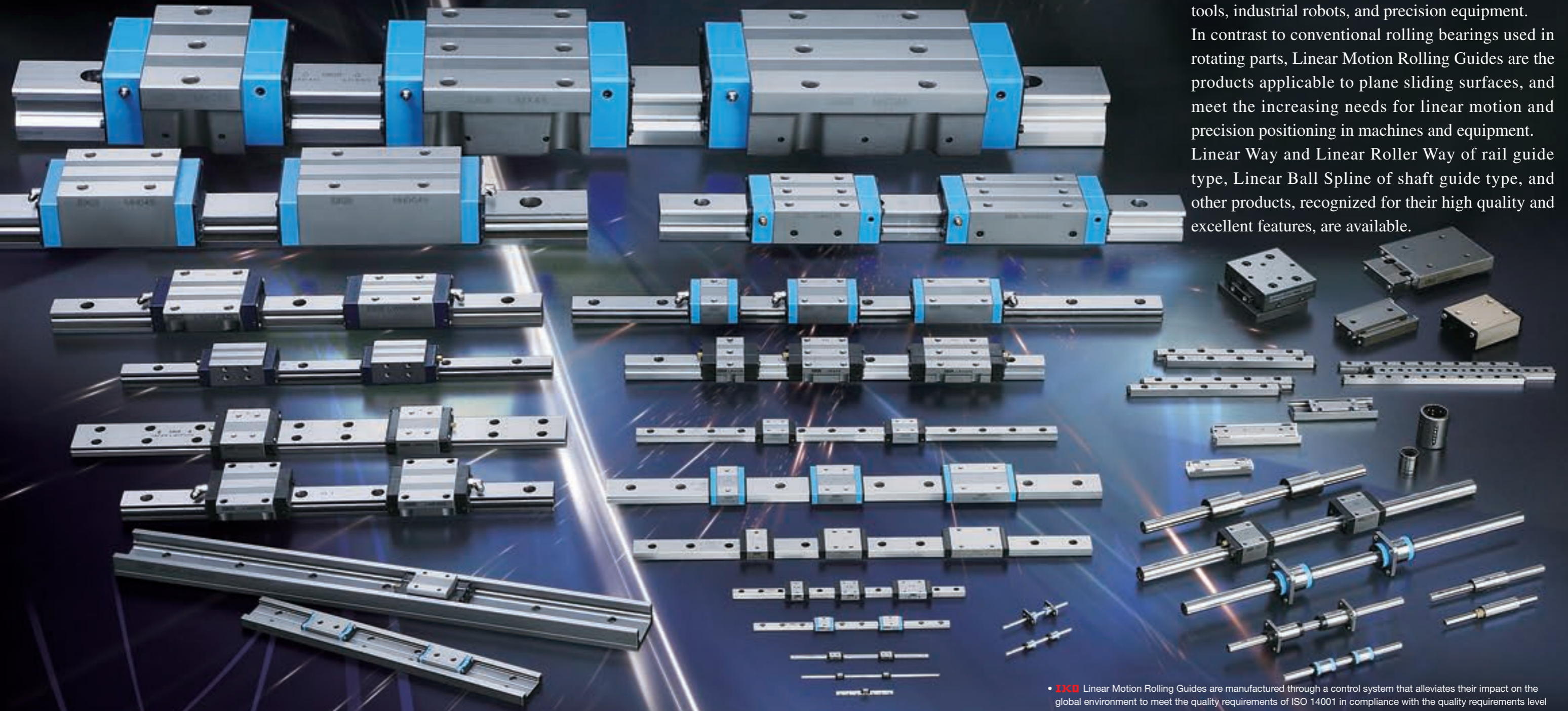

- **IKO** Linear Motion Rolling Guides are manufactured through a control system that alleviates their impact on the global environment to meet the quality requirements of ISO 14001 in compliance with the quality requirements level of ISO 9001 for quality improvement.
- The standard products listed in this catalog comply with the specifications of the six hazardous materials mentioned cited in the European RoHS Directive.



Recorded in CAT-1560E





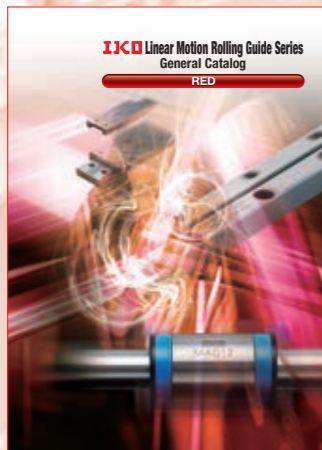

## Linear Way Linear Roller Way

	C-Lube Maintenance Free Series		
 <b>Ball Type Miniature Series</b> Super small-size linear motion rolling guide produced by original small sizing technology	<b>C-Lube Linear Way ML</b> ML : Standard type MLF : Wide type	<b>Linear Way L</b> LWL : Standard type LWLF : Wide type	
 <b>Ball Type Miniature Value Series</b> Economical linear motion rolling guides without changing the superior performance of Ball Type Miniature Series	<b>C-Lube Linear Way MLV</b> MLV		
 <b>Ball Type Low Profile/Light Weight Series</b> Super low profile and super light weight linear motion rolling guides with high load capacity	<b>C-Lube Linear Way MV</b> MV		
 <b>Ball Type Compact Series</b> Versatile linear motion rolling guides pursuing compactness in every aspect	<b>C-Lube Linear Way ME</b> ME : Flange type mounting from bottom MET : Flange type mounting from top MES : Block type mounting from top	<b>Linear Way E</b> LWE : Flange type mounting from bottom LWET : Flange type mounting from top LWES : Block type mounting from top	<b>Low Decibel Linear Way E</b> LWE...Q : Flange type mounting from bottom LWET...Q : Flange type mounting from top LWES...Q : Block type mounting from top
 <b>Ball Type High Rigidity Series</b> High rigidity linear motion rolling guides designed to evenly support high load capacity by incorporating large-diameter balls	<b>C-Lube Linear Way MH</b> MH : Flange type mounting from bottom MHT : Flange type mounting from top MHD : Block type mounting from top MHS : Compact block type mounting from top	<b>Linear Way H</b> LWH : Flange type mounting from bottom LWHT : Flange type mounting from top LWHD : Block type mounting from top LWHS : Compact block type mounting from top LWHY : Side mounting type	
 <b>Ball Type Wide Rail Type Series</b> Linear motion rolling guide suitable to single-row use due to having resistance to across-the-width moment load by using a wide track rail		<b>Linear Way F</b> LWFH : Flange type mounting from top / bottom LWFF : Flange type mounting from top / bottom LWFS : Block type mounting from top	
 <b>Ball Type U-Shaped Track Rail Series</b> Linear motion rolling guide of high track rail rigidity with U-shaped track rail	<b>C-Lube Linear Way MUL</b> MUL : Small type	<b>Linear Way U</b> LWUL...B : Small type LWU...B : Standard ball-retained type LWU : Standard ball non-retained type	
 <b>Roller Type</b> Linear motion rolling guide that has achieved the highest level of performance in all characteristics utilizing the roller's superior characteristic	<b>C-Lube Linear Roller Way Super MX</b> MX : Flange type mounting from top / bottom MXD : Block type mounting from top MXS : Compact block type mounting from top MXN : Low profile flange type mounting from top / bottom MXNS : Low profile block type mounting from top	<b>Linear Roller Way Super X</b> LRX : Flange type mounting from top / bottom LRXD : Block type mounting from top LRXS : Compact block type mounting from top	
 <b>Roller Type</b> Roller type linear motion rolling guide with cylindrical rollers in four-rows		<b>Linear Roller Way X</b> LRWX : Block type mounting from top LRWXH : Flange type mounting from bottom	
 <b>Module Type</b> Minimum compact linear motion rolling guide with both a track rail and slide member provided		<b>Linear Way Module</b> LWLM : Ball type small type LWM : Ball type standard type LRWM : Roller type	



Recorded in CAT-1561E

## Crossed Roller Way Linear Slide Unit Linear Ball Spline Linear Bushing Stroke Rotary Bushing Roller Way & Flat Roller Cage











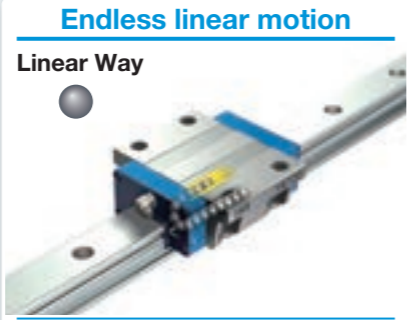

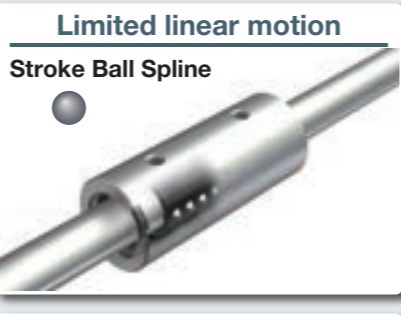

 <b>Crossed Roller Way</b> Linear motion rolling guide incorporating a roller cage between two ways whose two V-shaped surfaces are used as track groove		<b>Anti-Creep Cage Crossed Roller Way</b> CRWG	<b>Anti-Creep Cage Crossed Roller Way H</b> CRWG...H	<b>Crossed Roller Way</b> CRW : Standard type CRWM : Module type
 <b>Linear Slide Unit</b> Light weight, small, and compact linear motion rolling guide that has achieved light and smooth motion		<b>Anti-Creep Cage Crossed Roller Way Unit</b> CRWUG	<b>Crossed Roller Way Unit</b> CRWU / CRWU...R / CRWU...RS	
 <b>High Rigidity Precision Linear Slide Unit</b> BWU			<b>Precision Linear Slide Unit</b> BSP : Limited linear motion type BSPG : Built-in rack & pinion type BSR : Endless linear motion type	<b>Linear Slide Unit</b> BSU...A
 <b>Linear Ball Spline</b> Linear motion rolling guide performing linear motion while performing torque transmission along the spline shaft by external cylinder or slide unit	<b>C-Lube Linear Ball Spline MAG</b> MAG : Standard type MAGF : Flange type	<b>Linear Ball Spline G</b> LSAG : Standard type LSAGF : Flange type	<b>Block Type Linear Ball Spline</b> LSB	<b>Stroke Ball Spline</b> LS
 <b>Linear Bushing</b> A wide variety of linear motion rolling guides facilitating the rolling motion in bush guide portion		<b>Linear Bushing G</b> LMG	<b>Linear Bushing</b> LM / LME / LMB	<b>Miniature Linear Bushing</b> LMS
 <b>Stroke Rotary Bushing</b> Linear motion rolling guide enabling the rolling motion and rotary and linear motion in axial direction		<b>Stroke Rotary Bushing</b> ST : Ordinary type ST...B : For heavy load	<b>Miniature Stroke Rotary Bushing</b> STSI : Assembled set with a shaft STS : Assembled set without a shaft	<b>Stroke Rotary Cage</b> BG
 <b>Roller Way &amp; Flat Roller Cage</b> High accuracy linear motion rolling guide providing high rigidity in load direction		<b>Roller Way</b> RW / SR / GSN	<b>Flat Roller Cage</b> FT : Single row type FTW...A : Double row angle type	



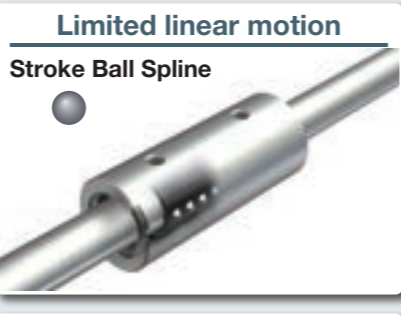







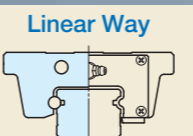
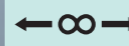

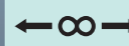

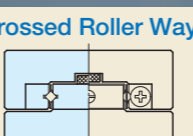

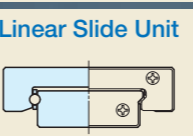



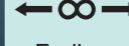
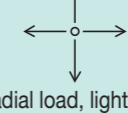

# IKO Types and Specifications of

# Linear Motion Rolling Guide Series

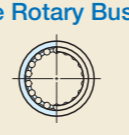
## Types of Linear Motion Rolling Guides

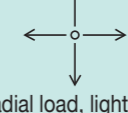
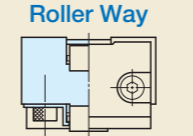
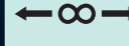
## Specifications of Linear Motion Rolling Guides

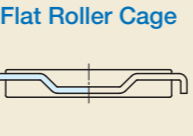
Types of Linear Motion Rolling Guides	Endless linear motion	Limited linear motion
<b>Rail Guide Type</b> The rail guide type achieves linear motion along a rail. This product can receive a complex load and features high performance, excellent total balance and easy handling.	<b>Linear Way</b> 	<b>Crossed Roller Way</b> 
	<b>Linear Roller Way</b> 	<b>Linear Slide Unit</b> 
	<b>Linear Ball Spline</b> 	<b>Stroke Ball Spline</b> 
	<b>Linear Bushing</b> 	<b>Limited linear motion + rotation Stroke Rotary Bushing</b> 
<b>Shaft Guide Type</b> The shaft guide type achieves linear motion along a shaft. This product is easy to handle and suitable for relatively low load conditions. Some shaft guide products can achieve both rotation and reciprocating linear motion.	<b>Linear Ball Spline</b> 	<b>Stroke Ball Spline</b> 
	<b>Linear Bushing</b> 	<b>Limited linear motion + rotation Stroke Rotary Bushing</b> 
<b>Flat Guide Type</b> The flat guide type achieves linear motion on a surface. This product can receive only a unidirectional load but feature high rigidity in the load direction.	<b>Roller Way</b> 	<b>Flat Roller Cage</b> 
	<b>Roller Way</b> 	<b>Flat Roller Cage</b> 

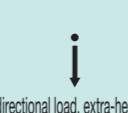
	Type of rolling element	Type of motion	Load direction and load carrying capacity	Rigidity	Frictional characteristic	Ease of mounting	General applications	Item-listed catalog
<b>Rail Guide Type</b>	<b>Linear Way</b>  Ball Endless linear motion Complex load, medium to heavy load	Endless linear motion 		○	○	○	<ul style="list-style-type: none"> <li>NC machine tool</li> <li>Precision working machine</li> <li>Robot</li> <li>Transfer machine</li> </ul>	BLUE
	<b>Linear Roller Way</b>  Roller Endless linear motion Complex load, heavy to extra-heavy load	Endless linear motion 		○	○	○	<ul style="list-style-type: none"> <li>Heavy duty machine tool</li> <li>Large working machine</li> <li>High-rigidity robot</li> </ul>	BLUE
	<b>Crossed Roller Way</b>  Roller Limited linear motion Complex load, medium load	Limited linear motion 		○	○	○	<ul style="list-style-type: none"> <li>Precision working machine</li> <li>Electronic parts assembling machine</li> <li>Precision measuring instrument</li> </ul>	RED
	<b>Linear Slide Unit</b>  Ball Limited linear motion Complex load, light to medium load	Limited linear motion 		△	○	○	<ul style="list-style-type: none"> <li>Electronic parts assembling machine</li> </ul>	RED
<b>Shaft Guide Type</b>	<b>Linear Ball Spline</b>  Ball Endless linear motion Complex load, medium to heavy load	Endless linear motion 		○	○	○	<ul style="list-style-type: none"> <li>Robot</li> <li>Testing and inspection equipment</li> <li>Transfer machine</li> </ul>	RED
	<b>Linear Bushing</b>  Ball Endless linear motion Radial load, light load	Endless linear motion 		△	○	○	<ul style="list-style-type: none"> <li>Packaging machine</li> <li>Measuring instrument</li> <li>Medical instrument</li> </ul>	RED
	<b>Stroke Ball Spline</b>  Ball Limited linear motion Complex load, medium to heavy load	Limited linear motion 		○	○	○	<ul style="list-style-type: none"> <li>Robot</li> <li>Testing and inspection equipment</li> </ul>	RED
	<b>Stroke Rotary Bushing</b>  Ball Limited linear motion + rotation Radial load, light load	Limited linear motion + rotation 		△	○	○	<ul style="list-style-type: none"> <li>Printing press</li> <li>Press die set</li> <li>Precision measuring instrument</li> </ul>	RED
<b>Flat Guide Type</b>	<b>Roller Way</b>  Roller Endless linear motion Unidirectional load, extra-heavy load	Endless linear motion 		○	○	△	<ul style="list-style-type: none"> <li>NC machine tool</li> <li>Precision working machine</li> </ul>	RED
	<b>Flat Roller Cage</b>  Roller Limited linear motion Unidirectional load, extra-heavy load	Limited linear motion 		○	○	○	<ul style="list-style-type: none"> <li>Precision working machine</li> <li>Optical measuring instrument</li> </ul>	RED

Code description ○Excellent ○Good △Fair



## Ball Type Miniature Series

### C-Lube Linear Way ML

#### Linear Way L / Micro Linear Way L

Super small-size linear motion rolling guide produced by original small sizing technology

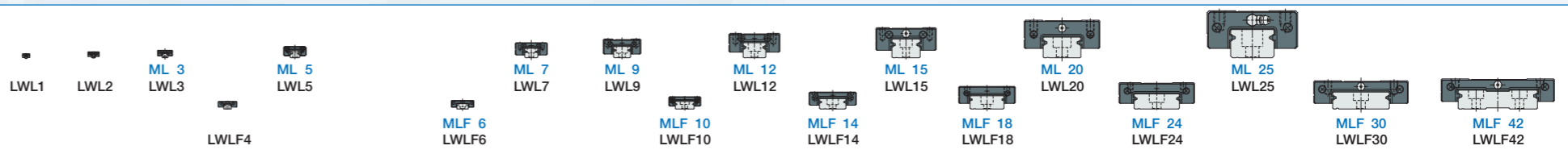

## Ball Type Miniature Value Series

### C-Lube Linear Way MLV

Economical linear motion rolling guides without changing the superior performance of Ball Type Miniature Series



## Ball Type Low Profile/Light Weight Series

### C-Lube Linear Way MV

Super low profile and super light weight linear motion rolling guides with high load capacity

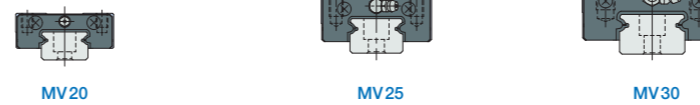

## Ball Type Compact Series

### C-Lube Linear Way ME

#### Linear Way E / Low Decibel Linear Way E

Versatile linear motion rolling guides pursuing compactness in every aspect

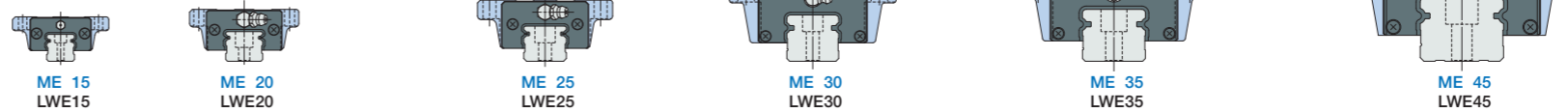

## Ball Type High Rigidity Series

### C-Lube Linear Way MH

#### Linear Way H

High rigidity linear motion rolling guides designed to evenly support high load capacity by incorporating large-diameter balls

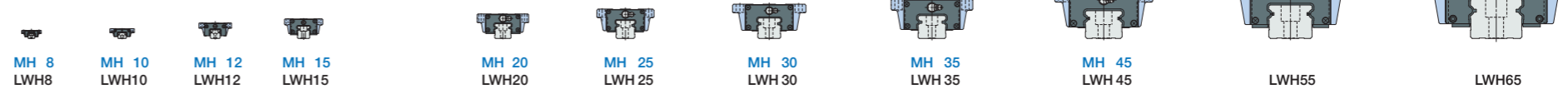

## Ball Type Wide Type Series

### Linear Way F

Linear motion rolling guide suitable to single-row use due to having resistance to across-the-width moment load by using a wide track rail



## Ball Type U-Shaped Track Rail Series

### C-Lube Linear Way MUL

#### Linear Way U

Linear motion rolling guide of high track rail rigidity with U-shaped track rail



## Roller Type

### C-Lube Linear Roller Way Super MX

#### Linear Roller Way Super X

Linear motion rolling guide that has achieved the highest level of performance in all characteristics utilizing the roller's superior characteristic

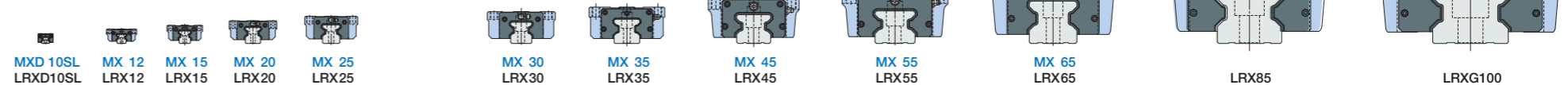

## Roller Type

### Linear Roller Way X

Roller type linear motion rolling guide with cylindrical rollers in four-rows



## Module Type

### Linear Way Module

Minimum compact linear motion rolling guide with both a track rail and slide member provided

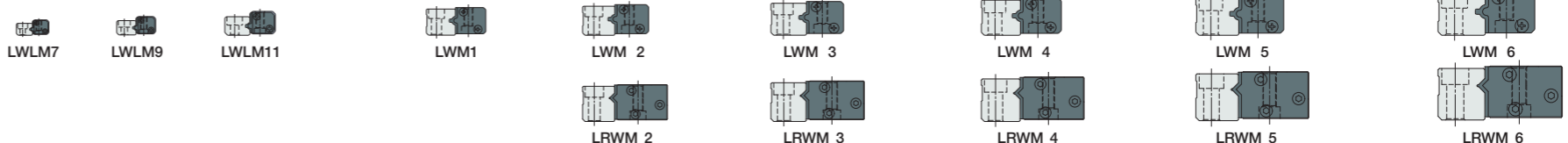

ML · LWL

MLV

MV

ME · LWE

MH · LWH

LWF

MUL · LWU

MX · LRX

LRWX

LW(L)M · LRWM

# Environment

## **IKO Gentle to The Earth**

Nippon Thompson Co., Ltd. is working to develop global environment-friendly products.

It is committed to developing products that make its customer's machinery and equipment more reliable, thereby contributing to preserving the global environment.

This development stance manifests well in the keyword "Oil Minimum".



## **Our pursuit of Oil Minimum has led to the creation of IKO's proprietary family of lubricating parts as "C-Lube".**

"C-Lube" minimizes usage of lubrication oil and supplies the optimal amount of lubrication oil for long period of time. So it realizes long term maintenance free and contributes to the global environment preservation.



## **The "Interchangeable" is a result of our consideration to the environment and radical pursuit of elimination of material and inventory waste.**

Interchangeable is a collective name of "systems of products selection from users' perspective" which allows free interchange and replacement totally retaining the accuracy and preload of slide units and track rails.

## **The integration of maintenance free and advanced interchangeable system with C-Lube is the "Free & Interchangeable".**



## Eco-friendly specification

## Reducing usage of lubrication oil



U.S. PATENTED

<b>C-Lube Linear Way ML</b>	<b>Linear Way L</b>
No. 7677804 7252435 6729761 6712511	No. 7258486 6517244 6176617 6082899 5967667
<b>C-Lube Linear Way MLV</b>	<b>Linear Way E</b>
No. 8465206	No. 7677804 6176617 5967667
<b>C-Lube Linear Way MV</b>	<b>Linear Way H</b>
No. 6712511 6729761	No. 7677804 6082899 6176617 5967667 6461045 5622433 6250805 6176617
<b>C-Lube Linear Way ME</b>	<b>Linear Way F</b>
No. 7748905 7677804 6729761 6712511	No. 6176617 5967667
<b>C-Lube Linear Way MH</b>	<b>Linear Way U</b>
No. 7832929 6712511 7762723 7748905 7677804 6729761	No. 6880975 6176617 6851857 6082899 6517244 5967667 6461045 6309107
<b>C-Lube Linear Way MUL</b>	
No. 5435649	
<b>C-Lube Linear Roller Way Super MX</b>	
No. 8403563 7950852 8403562 7927016 8123408 7862234 8113714 7832930 8033730 7997800	No. 8585288 7458721 8506166 7458720 8206036 5800064 8113714 7780356 7534042
<b>Linear Roller Way Super X</b>	
No. 7832930 6766897 7458721 6461045 7458720 6176617	No. 7341378 5622433 5967667 5464288 5800064

### Eco-friendly

Consumption of precious oil resource is minimized! And elimination of oil feeder and its piping reduces the initial cost!

**Contributes to reduction of total cost and environmental loads!!**

Oil usage reduction effect

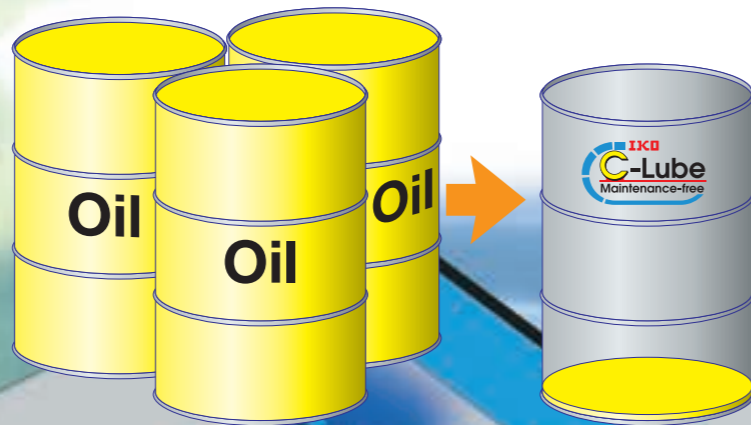

### Maintenance free

Endures running over 20,000 km without oil feeding!

**Troublesome lubrication maintenance process is reduced!!**

Distance equivalent to halfway around the globe

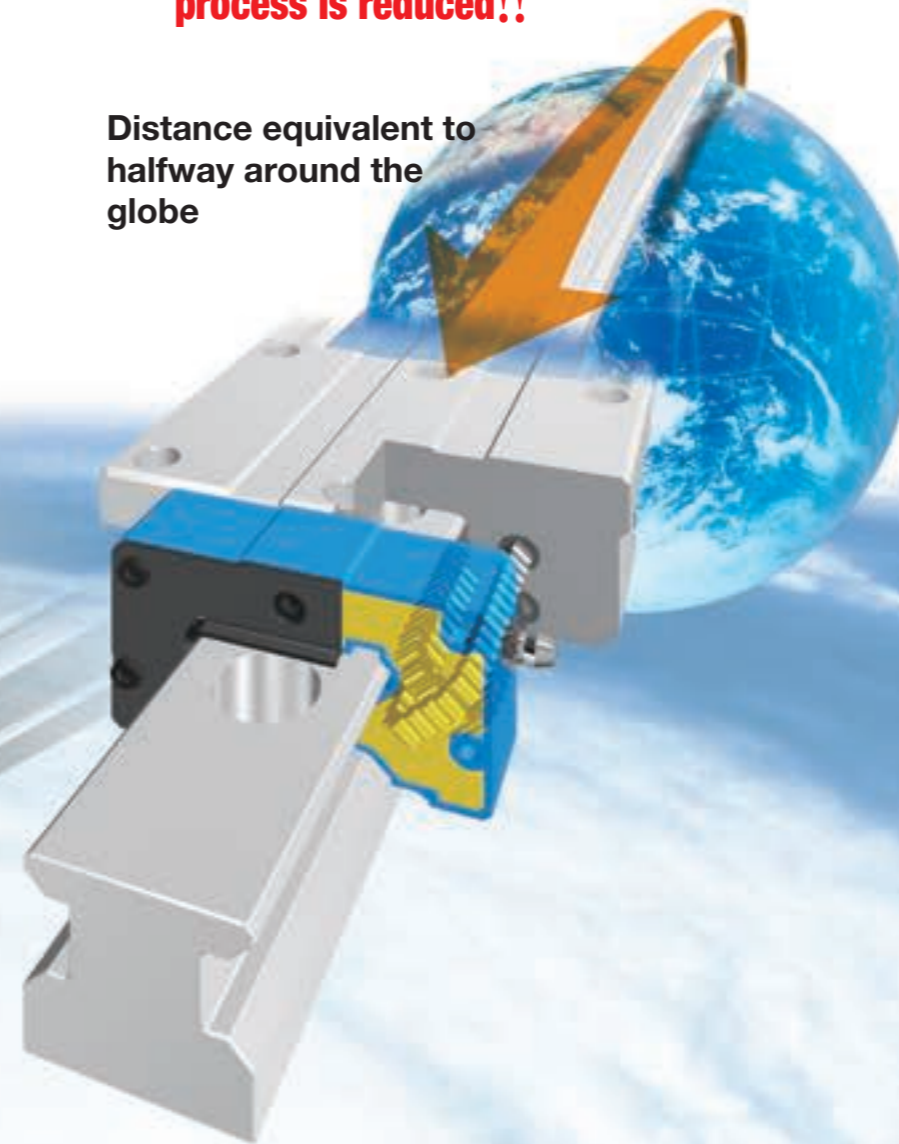

### Compactness

The space consuming oil feeder is eliminated to save the space!

**Freedom of machine designing is expanded for user!!**

Efficient use of space

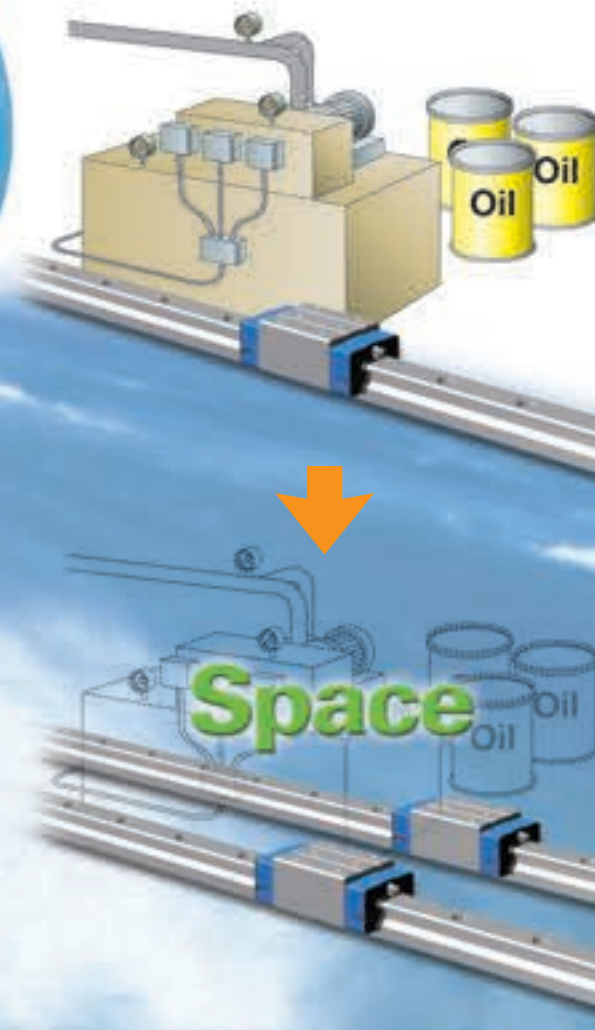



Features of C-Lube Linear Way and C-Lube Linear Roller Way

Original and world's first structure with [C-Lube]

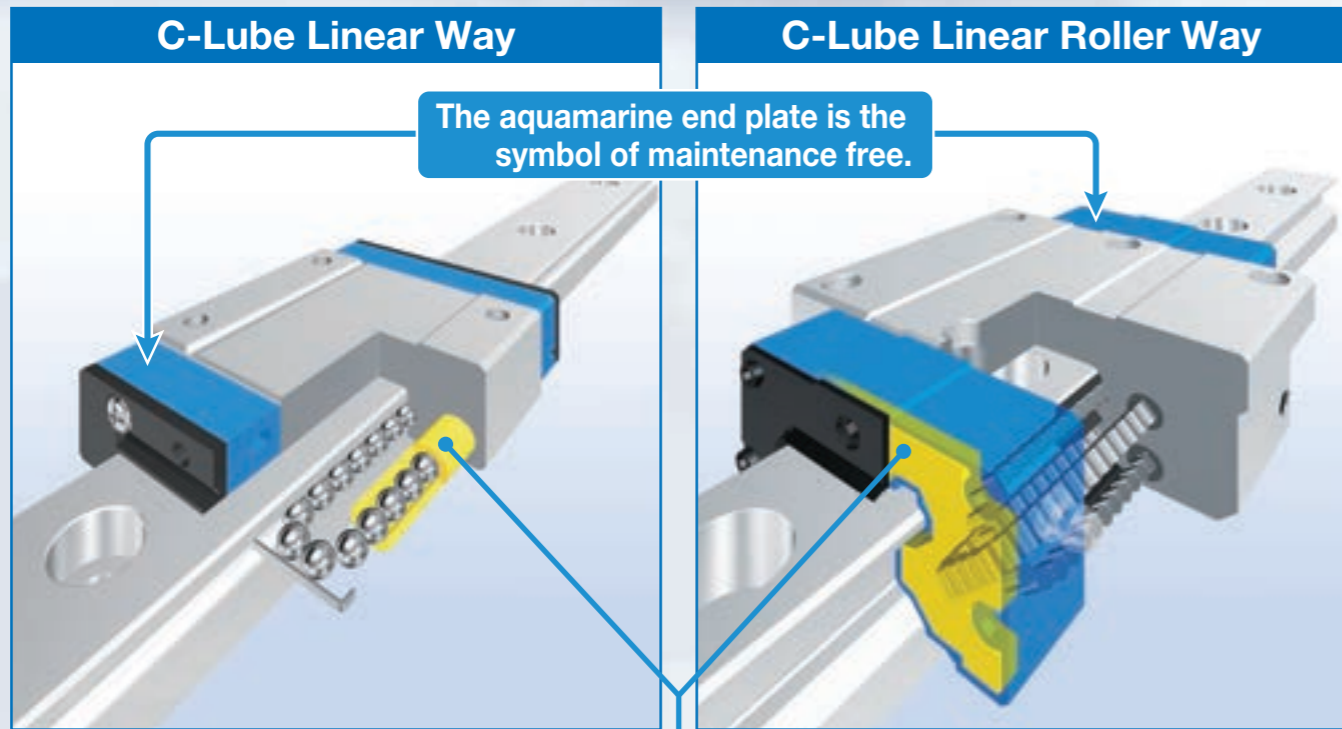

C-Lube integrated

Lubrication oil is carried through circulation of rolling elements

The lubrication oil is supplied directly to the rolling elements, not to the track rail. When rolling elements make contact with the capillary lubricating element integrated with the circulation path of slide unit rolling elements, the lubrication oil is supplied to surfaces of rolling elements and carried to the loading area through circulation of rolling elements. This results in adequate lubrication oil being properly maintained in the loading area and lubrication performance will last for a long time.

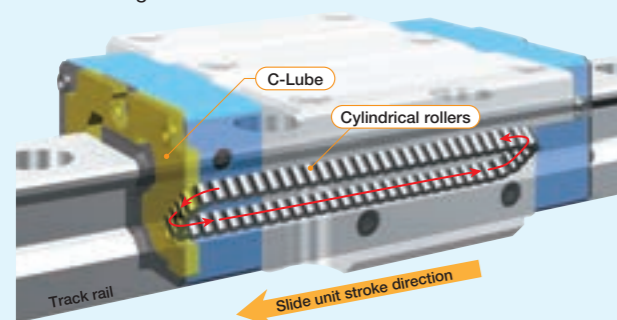

Lubrication oil is directly supplied to surfaces of the rolling elements

The surface of capillary lubricating element is always covered with the lubrication oil. Lubrication oil is continuously supplied to the surface of rolling elements by surface tension in the contact of capillary lubricating element surface and rolling elements. On the surface of capillary lubricating element with which the rolling elements make contact, new lubrication oil is always supplied from the other sections.

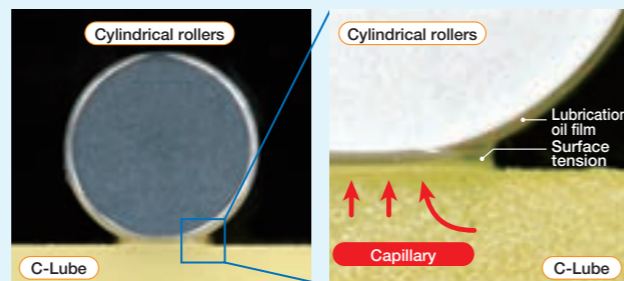

long term maintenance free is realized with oil impregnated with C-Lube only !!



Maintenance free

This endures running over 20,000 km without oil feeding with lubrication oil in the C-Lube only. Furthermore, grease is pre-packed in the slide unit so long term maintenance free can be realized.

**Maintenance free is achieved until the end of device life!**

\*1. Typical device life is assumed. Re-greasing may be necessary depending on use conditions.

Durability test result

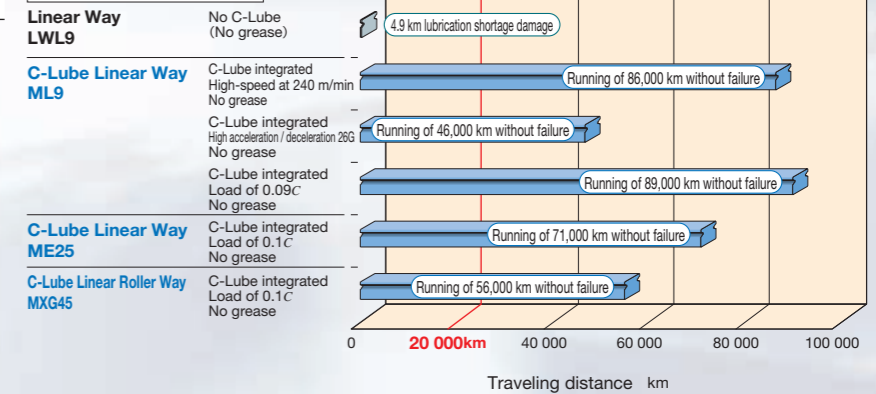

Eco-friendly

As lubrication oil in C-Lube is supplied by the amount necessary to maintain lubrication performance of the rolling guide, the consumption of lubrication oil is reduced and lubrication performance is maintained even when it run for a long period.

**Eco-friendly specification reducing usage of lubrication oil!**

Oil supply test result

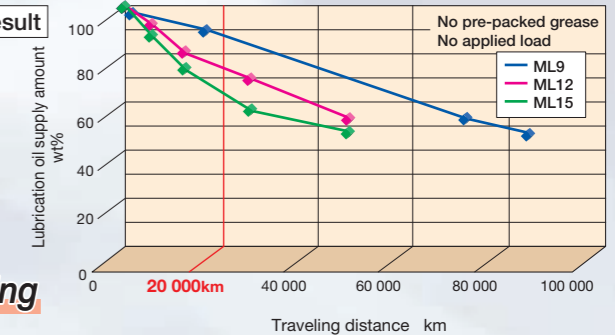

Compact

As C-Lube Linear Way and C-Lube Linear Roller Way are integrated with lubrication part C-Lube, their slide units are not long unlike types with external lubrication parts. Replacement of conventional parts is easy free from constraints of mounting space and stroke length.

**Compact design taking into account compactness!**

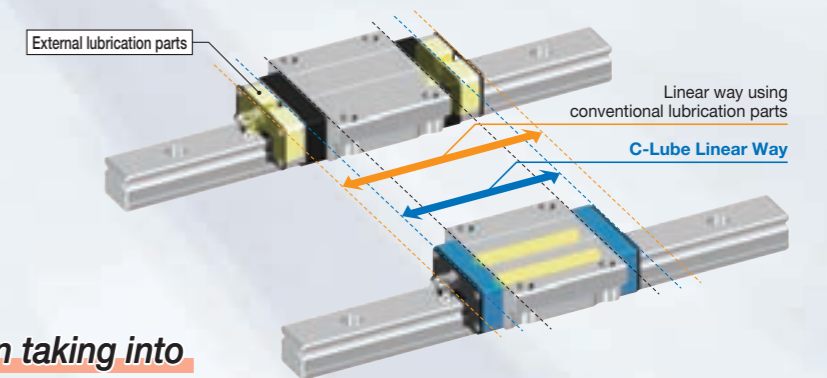

Smooth

C-Lube Linear Way and C-Lube Linear Roller Way do not generate slide resistance unlike lubrication parts external to the slide unit that make contact with the track rail. Driving force follow-up property is superior and energy is saved by improvement of accuracy and reduction of friction loss.

**Light and smooth motion is achieved!**

Frictional resistance test result

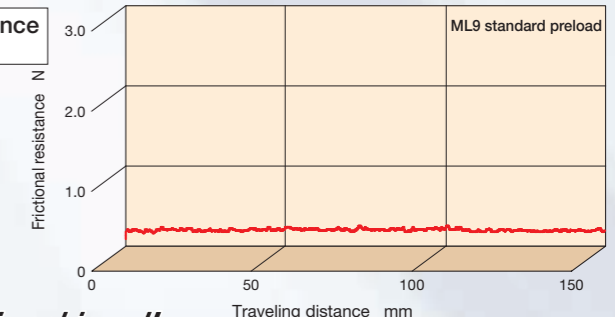



# Ultimate **Interchangeable** pursuit of elimination

# system by radical of any waste

## Accuracy interchangeability

Three accuracy classes are available!  
Height variation can be controlled with multiple assembled sets!

**High accuracy of the device can be maintained in the multiple-use environment!!**

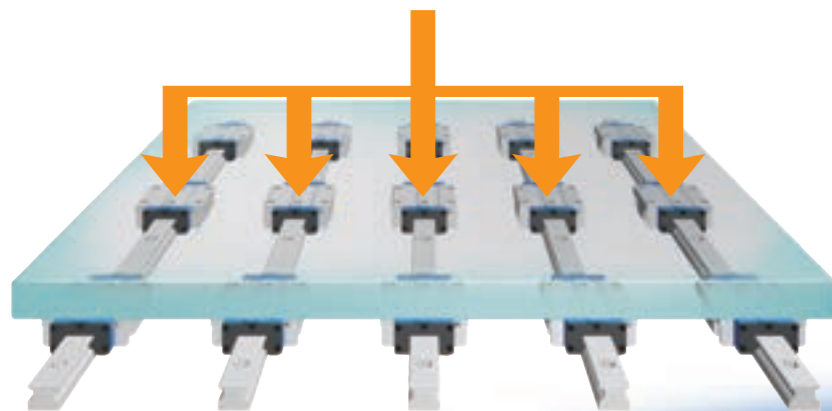

## Unit interchangeability

Many type of slide units are available!  
Every slide unit is interchangeable with the same track rail!

**It is easily added or replaced!!**

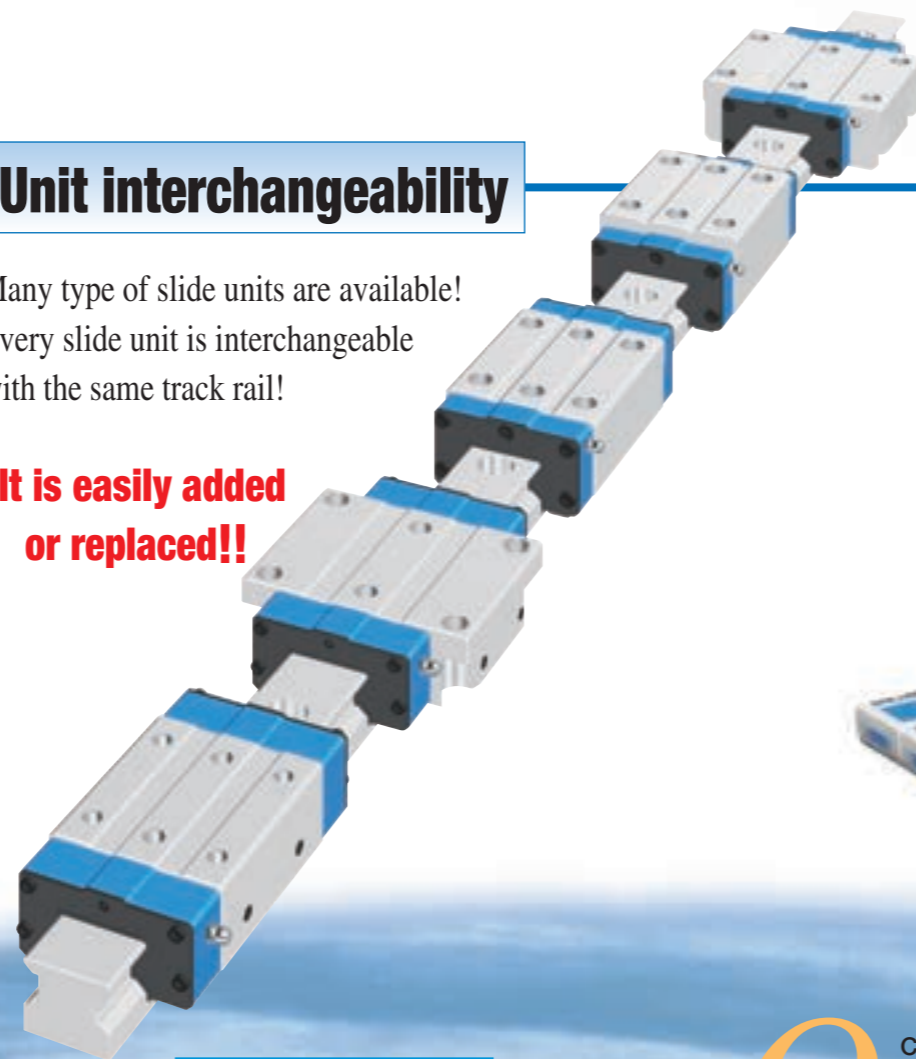

## Short delivery products

Separate delivery of slide unit and track rail!

**You may order what you need by any quantity at any time!!**



**Q** I dropped the linear way unit by mistake, and the unit is damaged. Can I replace it?



**A** **Unit interchangeability**  
If you use Linear way of Interchangeable specification, you may need to replace only slide unit.



**Q** I need to increase the rigidity of the unit because of sudden specification change.

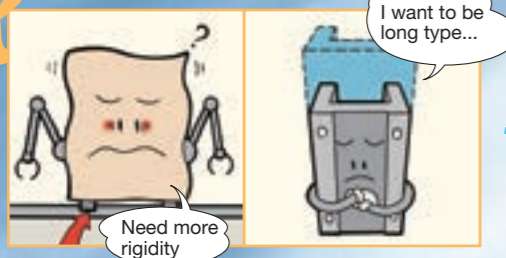

**A** **Unit interchangeability**  
The rigidity can be improved easily by increasing the unit length.

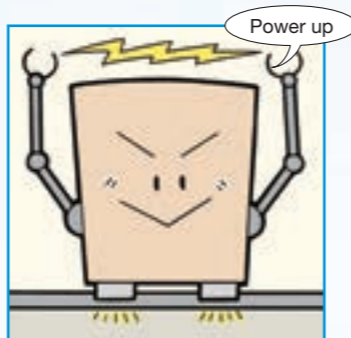

**Q** Calculated accuracy cannot be achieved after assembly of the device?

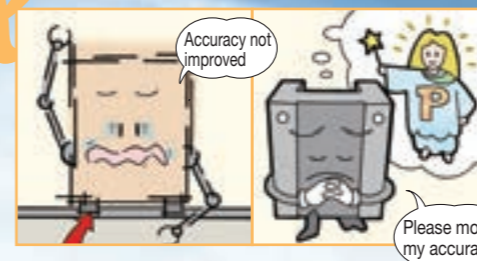

**A** **Accuracy interchangeability, preload interchangeability**  
How do you like to use accuracy higher by one class or higher preload type?  
As accuracy of the interchangeable products is controlled strictly by parts, setting can be modified.

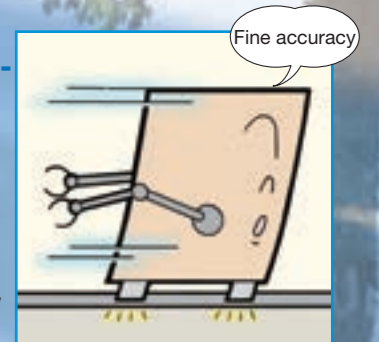

**Q** I carelessly forgot to arrange some parts, but I need them urgently. Can it be delivered soon?



**A** **Short delivery available**  
Interchangeable parts are available for short delivery, they can be delivered quickly with our perfect inventory system.  
Slide unit and track rail can be ordered individually.



**Free combination is enabled for model, accuracy, preload!!**

**Ultimate interchangeable system**

# Interchangeable specification

### Requirements of ;

- Wish to improve the rigidity and life of machines
- Wish to improve the accuracy of machines
- Wish to replace the slide unit immediately
- The number of slide units is in short
- Wish to replace the track rail immediately
- The length of track rail is not sufficient
- Wish to store only the slide units in stock for emergency

### Interchangeable specification realizes ;

- Wish to prepare for a sudden design change
- Wish to select freely the combination of high accuracy and preload
- Slide unit and track rail are separately handled
- Free combination of slide unit and track rail can be selected
- Compactness-independent storing of slide units and track rails

Select the products as many as you wish.

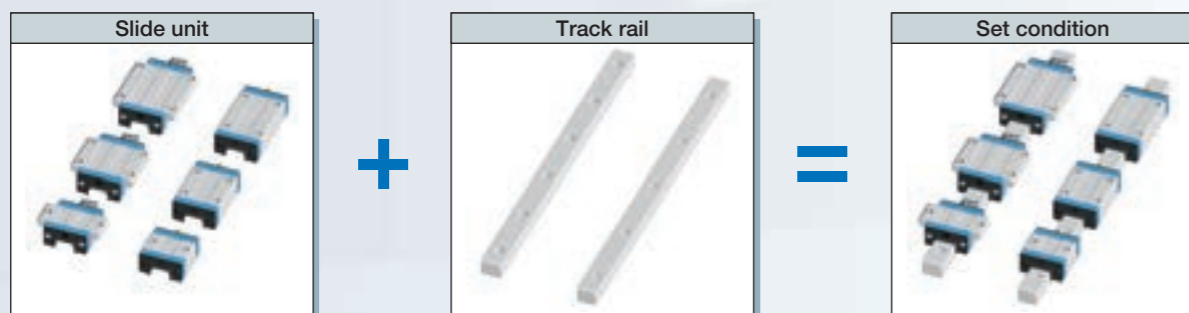

## Unit interchangeability

A wide variety of slide unit models with different sectional shape and length are provided, for free replacement on the same track rail.

### Interchangeability of slide unit

#### Slide unit shape

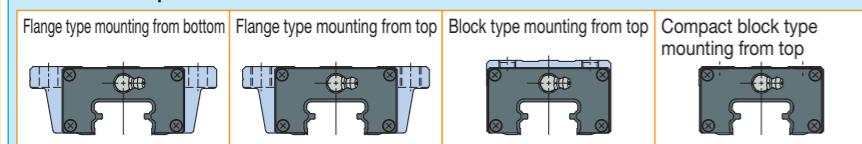

#### Length of slide unit

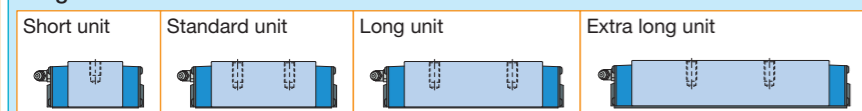

### Interchangeability of track rail

Track rail		
High carbon steel-made track rail	Stainless steel-made track rail	Butt-jointing track rails

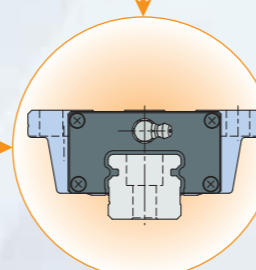

**Free selection is possible for slide units and track rails!**

Interchangeable specification has realized the incomparable high interchangeability by severely managing the dimensions of slide unit and track rail with the background of unique high processing technology. This feature allows independent handling of slide unit and track rail, thus allowing you to select free combination and to order any products for any volume at any necessary time.

## Accuracy interchangeability

Three accuracy classes of Ordinary, High and Precision class are provided, to support even high traveling accuracy purposes. In addition, as height variation of multiple assembled sets is managed with high accuracy, you may use parallel track rails at ease.

### Standard setting up to precision

- Tolerances of dimensions  $H$  and  $N$
- Variation of dimensions  $H$  and  $N$  in 1 set
- Parallelism in operation of the C surface to A surface
- Parallelism in operation of the D surface to B surface

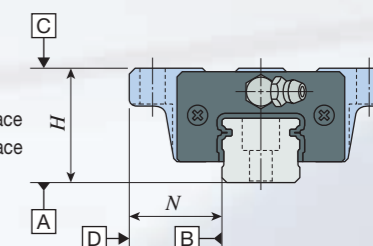

**It allows the accuracy improvement of units without design changes!**

Corresponding to parallel arrangement of multiple assembled sets as standard

- Variation of dimensions  $H$  of multiple assembled sets is specified

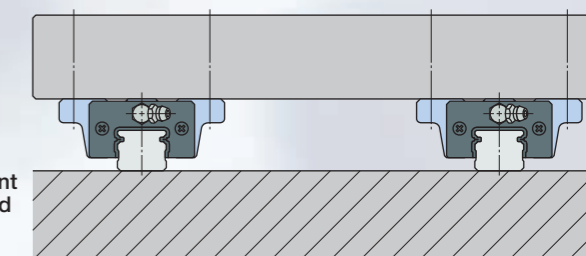

## Preload interchangeability

The high accuracy dimensions management utilizing the simple structure achieved the interchangeability of preloaded slide units. It supports the applications requiring the rigidity of one higher rank.

High preload setting is possible thanks to high accuracy dimensions control

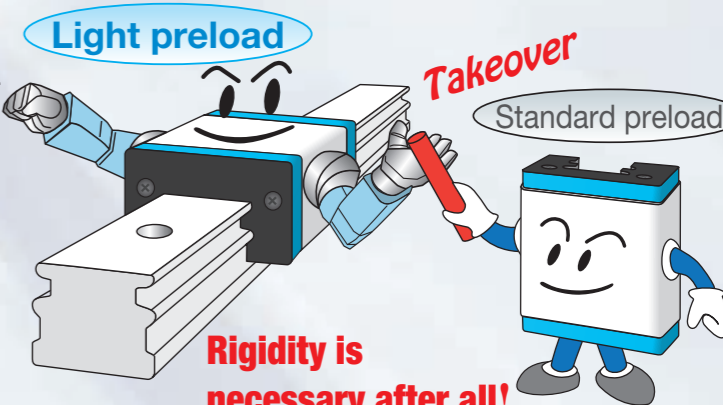
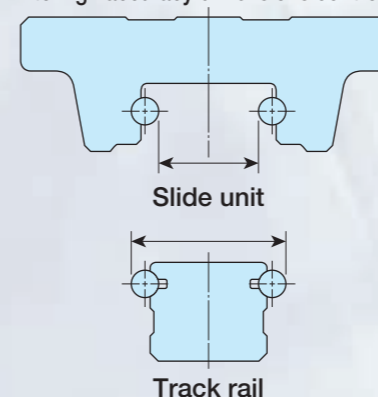

**Rigidity is necessary after all!**

**It allows the rigidity improvement of units without design changes!**

## Maintenance free is achieved only by replacing the slide unit!

By replacing the interchangeable linear way or linear roller way slide unit with C-Lube Linear Way or C-Lube Linear Roller Way slide unit, maintenance free is achieved while using the same track rail.



# IKO's excellent features realized by contact in two-row raceways

# a simple structure by **four-points**

## Two-row four-point contact type simple structure

IKO adopts two-row four-point contact type for every Linear Way series. Thanks to our design know how and production technologies having been fostered for long time, high accuracy and smooth motion is realized in the micro series.

In addition, load in every direction can be received evenly and therefore stable high accuracy and rigidity can be achieved even in applications where load has variable direction and size or complex load is applied.

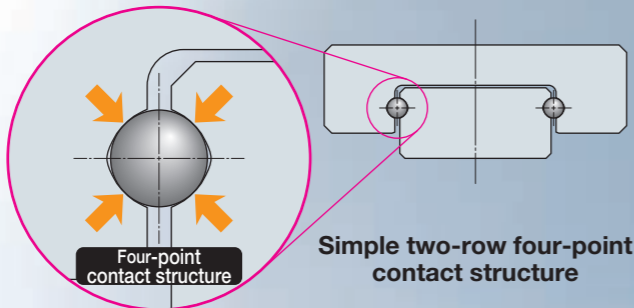

**Essential for micro sizing!**

## Micro Linear Way L realized by simple structure

Micro linear way L for further needs of miniaturization produced by original small sizing technology. Wide variety of track rail width from 1 mm to 6 mm is available and high accuracy of micro positioning mechanism is realized.



## World's smallest size!

- High accuracy even with the smallest size of 1 mm\*!  
\*Track rail width of 1 mm
- Even the smallest size of 1 mm can be securely mounted and fixed\*\*!  
\*\*Tapped rail specification
- Even the smallest size of 1 mm can ensure stable operation!

IKO Micro Linear Way L

# LWL1

LWL1 can be used for further super miniaturization of machines and devices with free-minded thinking.

## Interchangeable

The simple structure of four-contact in two-row raceway yields small manufacturing errors or accuracy measurement errors, allowing the maintenance of each raceway in the high dimensions accuracy.

**This technology realizes interchangeable specification and high interchangeable system in every series!**

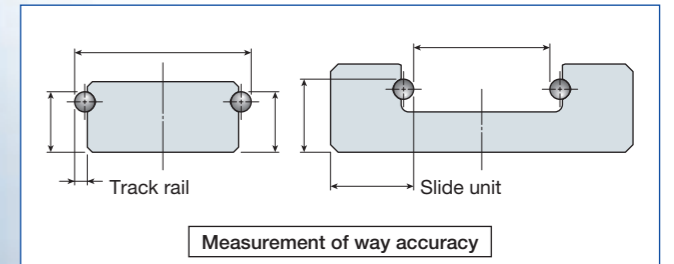

As the ball is stabilized during track groove measurement, measurement of high accuracy and precise preload management are possible.

## Variety of models and size variations

A wide variety of models and sizes, such as super miniature size of only 1 mm track rail width, is provided for your selection to meet each requirement.

Series	Model	Size	Track rail width	
			Min	Max
C-Lube Linear Way ML	<b>ML</b>	13 models	15 sizes	3 ~ 42 mm
	<b>LWL</b>	20 models	18 sizes	1 ~ 42 mm
C-Lube Linear Way MLV	<b>MLV</b>	1 model	3 sizes	7 ~ 12 mm
C-Lube Linear Way MV	<b>MV</b>	1 model	3 sizes	20 ~ 30 mm
C-Lube Linear Way ME	<b>ME</b>	18 models	6 sizes	15 ~ 45 mm
	<b>LWE</b>	21 models	6 sizes	15 ~ 45 mm
C-Lube Linear Way MH	<b>MH</b>	19 models	9 sizes	8 ~ 45 mm
	<b>LWH</b>	25 models	11 sizes	8 ~ 65 mm
Linear Way F	<b>LWF</b>	4 models	7 sizes	33 ~ 90 mm
C-Lube Linear Way MUL	<b>MUL</b>	1 model	2 sizes	25 ~ 30 mm
	<b>LWU</b>	3 models	8 sizes	25 ~ 130 mm



# Ultimate high performance produced by world's

# first roller guide structure of IKO

## Super high load capacity

The Linear Roller Way Super X has a large contact area with the way and a number of cylindrical roller with excellent load capacity, which allows to achieve larger load rating.

Comparison of basic dynamic load rating

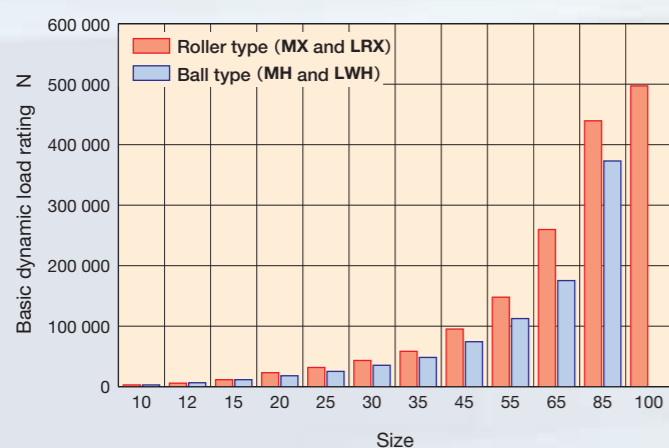

Comparison of basic static load rating

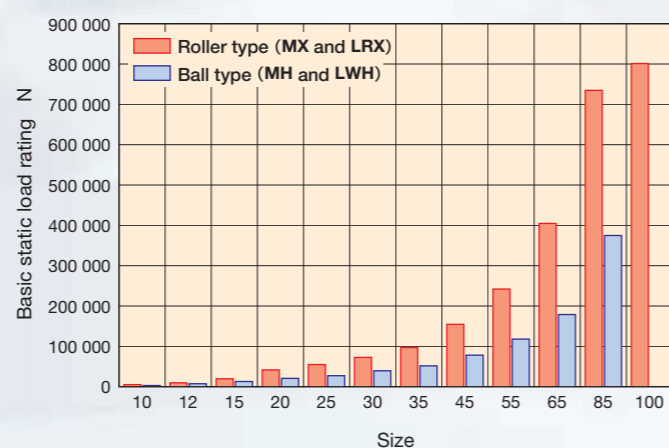

**Size smaller by one size than the ball type can be used!**

## Long life

《Roller Type》MXG45

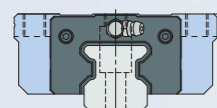

$C = 124\ 000\ \text{N}$   
 $C_0 = 223\ 000\ \text{N}$

《Ball Type》MHG45

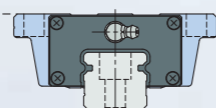

$C = 95\ 200\ \text{N}$   
 $C_0 = 114\ 000\ \text{N}$

Same size

$C$  : Basic dynamic load rating N  
 $C_0$  : Basic static load rating N  
 $L$  : Life km  
 $P$  : Applied load N

**Roller type has large basic dynamic load rating  $C$  and long life due to the different "index"!**

[Life calculation example]

Roller Type

$$L = 50 \left( \frac{C}{P} \right)^{10/3}$$

Applied load  
In case of 10000 N

$$L \approx 220\ 000\ \text{km}$$

Ball type

$$L = 50 \left( \frac{C}{P} \right)^3$$

$$L \approx 43\ 000\ \text{km}$$

**Significant increase!**

## Super high rigidity

The rigidity of linear motion rolling guide significantly affects properties of machines and devices to be incorporated.

The Linear Roller Way Super X achieves high rigidity as a number of small cylindrical rollers with smaller elastic deformation relative to load than that of balls are incorporated in the slide unit.

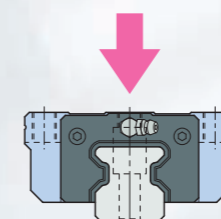
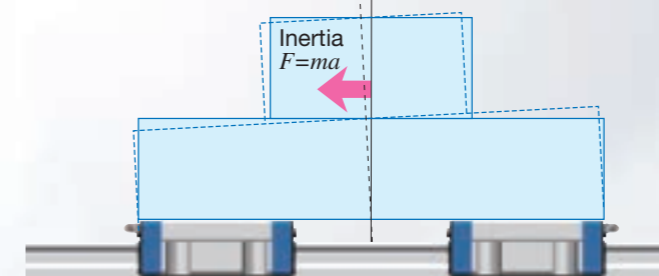

Comparison of elastic deformation

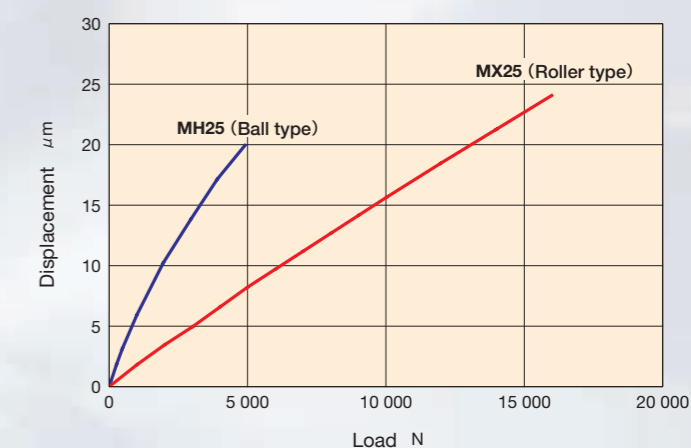

**Well-balanced high rigidity is realized in every direction!**

### Vibration characteristics

The Linear Roller Way Super X has high rigidity relative to ball types of the same size, so deformation amount is low relative to repeated fluctuating load, natural frequency is high and vibration damping time is short.

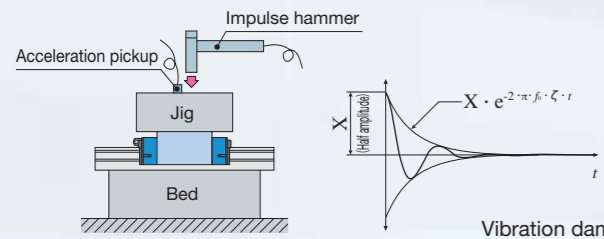

Vibration damping curve in downward vibration (Half amplitude)

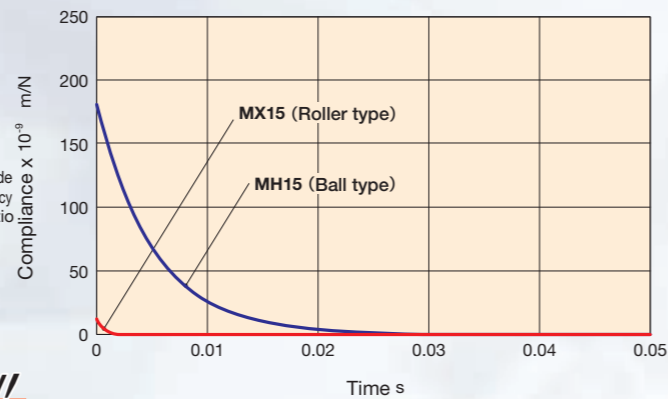

**Positioning time can be shortened!**

### Allows accurate positioning with excellent frictional characteristic

The Linear Roller Way Super X prevents skew of cylindrical roller and achieves smooth motion by adopting unique retaining method to accurately guide cylindrical roller ends with retaining plate.

The Linear Roller Way Super X has good response characteristics to micro-feeding and allows for accurate positioning, thanks to small frictional resistance against preload and load and excellent frictional characteristics relative to plain guides and ball type linear motion rolling guide.

MXDL25 and MXDG45 T<sub>3</sub> preload frictional resistance

Test portion	Extra long unit <b>MXDL25</b> Long unit <b>MXDG45</b>
Preload	T <sub>3</sub> preload
Velocity	0.6 m/min
Lubrication	C-Lube integrated, with grease

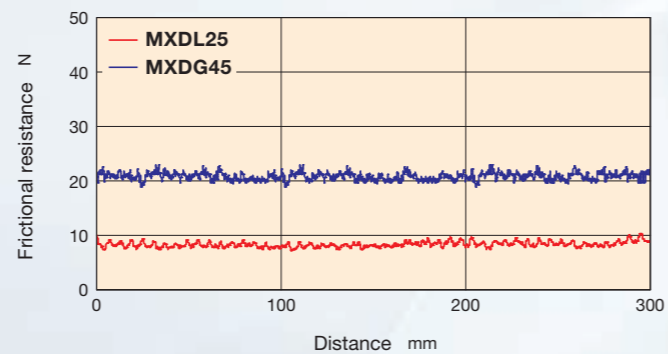

**High follow-up property is ensured even for micro-feeding!**

### High running accuracy

Optimal design based on analysis of re-circulation behavior of cylindrical roller circulation realizes smooth and quiet motion. In addition, load is applied to many cylindrical rollers and therefore the micro deflection during running is minimized. Extra long unit is optimal for applications requiring higher running accuracy. (For details, see page I -29)

Deflection amount during running

unit:  $\mu m$

MXDG30 T <sub>3</sub> preload	0.12
-------------------------------	------

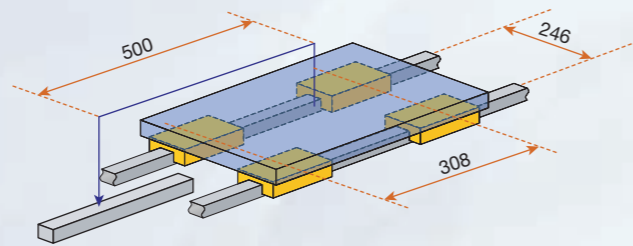

**Stable running accuracy is achieved!**

### Corresponding to compactification

Roller type with significantly higher load capacity than the ball type. The Linear Roller Way Super X allows for downsizing from many size variations for compactification of devices.

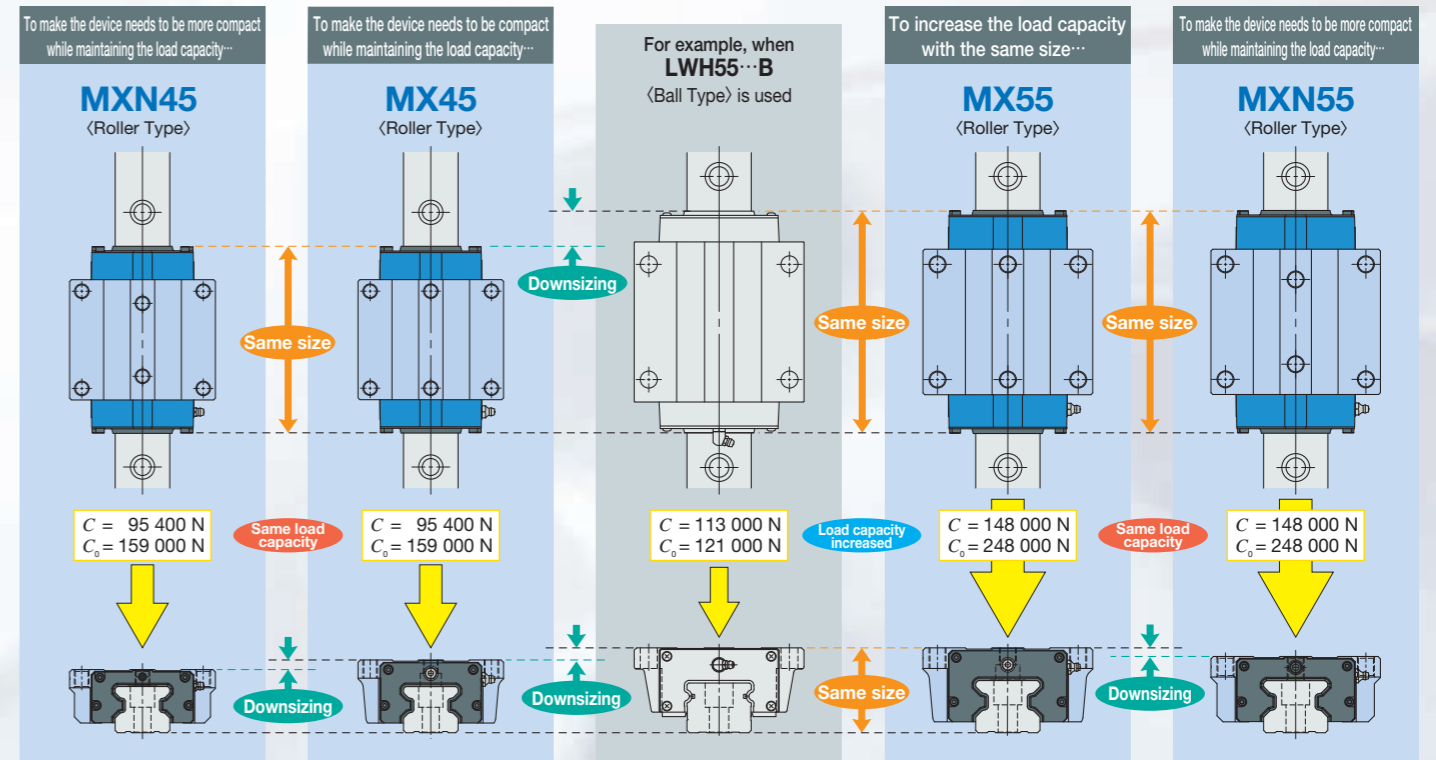

**Downsizing and increased load capacity!**

**Roller type with large increase of load capacity!**

### Compatible ball type and mounting dimensions

The Linear Roller Way Super X has mounting dimensions compatible with the ball type Linear Way H. Replacement with roller type is possible without significant design change to machine or device.

«Roller Type» C-Lube Linear Roller Way Super MX	«Ball type» C-Lube Linear Way MH
---	--

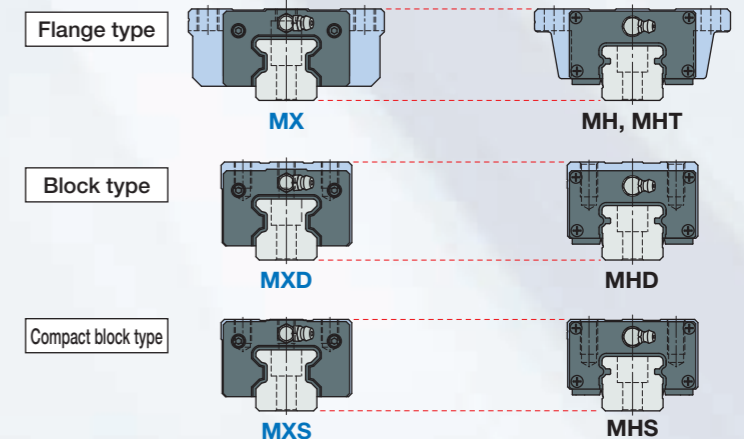

**Downsizing and increased load capacity are possible!**

# A variety of models and size variations



## Ball Type Miniature Series

### C-Lube Linear Way ML C-Lube Linear Way MLV Linear Way L

Thanks to the structure with two rows of balls to contact with the way at four points, stable accuracy and rigidity can be achieved even in applications where load has variable direction and size or complex load is applied, despite its very small body.



## Micro Linear Way L

As the lineup of track rail width from 1 mm to 6 mm is available, you can select an optimal product for the specifications of your machine and device. For LWL1, world's smallest size is realized: track rail width of 1 mm, slide unit width of 4 mm and assembly height of 2.5 mm.

Standard type  
**ML**  
**LWL**

Wide type  
**MLF**  
**LWLF**

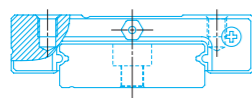
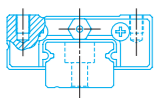

	Length of slide unit
C	Short
No symbol	Standard
G	Long
L	Extra long

	Size
Standard type	1, 2, 3, 5, 7, 9, 12, 15, 20, 25
Wide type	4, 6, 10, 14, 18, 24, 30, 42

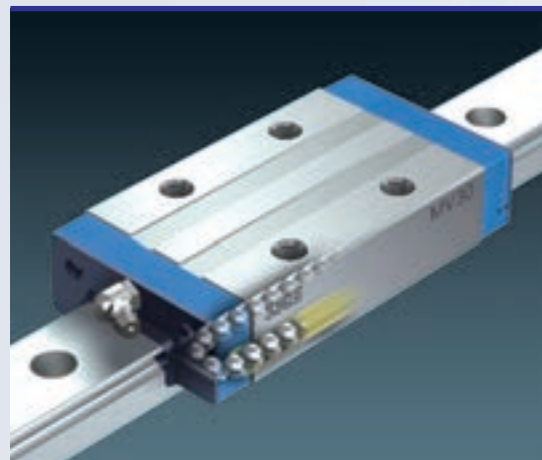

## Ball Type Low Profile/Light Weight Series

### C-Lube Linear Way MV

Despite its extra low profile and extra light weight, this linear motion rolling guide has the maximum load rating among the ball types while achieving high load capacity.

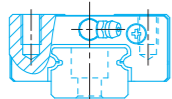

	Length of slide unit
Standard	

	Size
	20, 25, 30

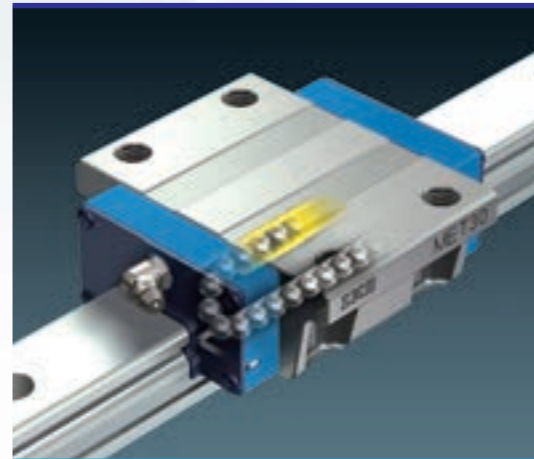

## Ball Type Compact Series

### C-Lube Linear Way ME Linear Way E Low Decibel Linear Way E

Versatile linear motion rolling guide that has achieved utility pursuing compactness in every aspect. Low decibel types with resin separator to prevent direct contact between balls are also available.

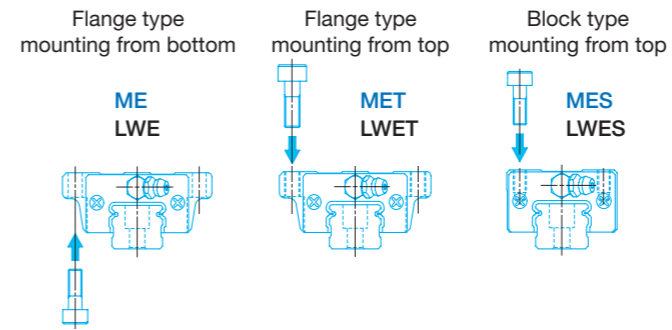

	Length of slide unit	Size
C	Short	15, 20, 25, 30, 35, 45
No symbol	Standard	
G	Long	

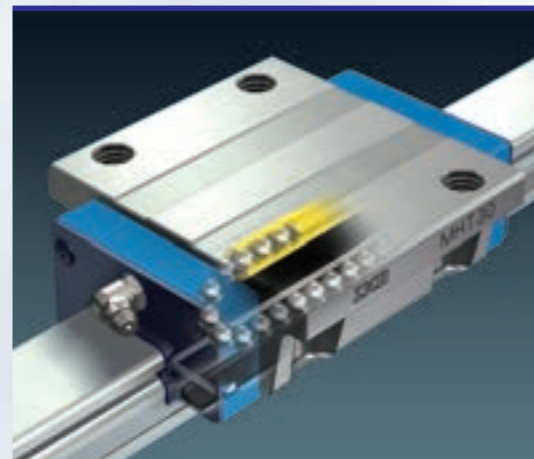

## Ball Type High Rigidity Series

### C-Lube Linear Way MH Linear Way H

High rigidity linear motion rolling guides designed to evenly support high load capacity by incorporating large-diameter balls. Stable accuracy and rigidity can be achieved even in applications where load with variable direction and size and complex load are applied.

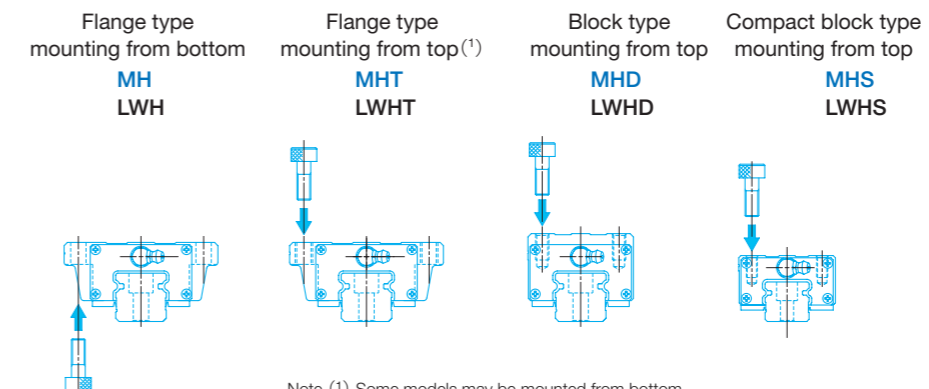

Note (1) Some models may be mounted from bottom.

	Length of slide unit
C	Short
No symbol	Standard
G	Long
L	Extra long

	Size
	8, 10, 12, 15, 20, 25, 30, 35, 45, 55, 65

A variety of models and size variations

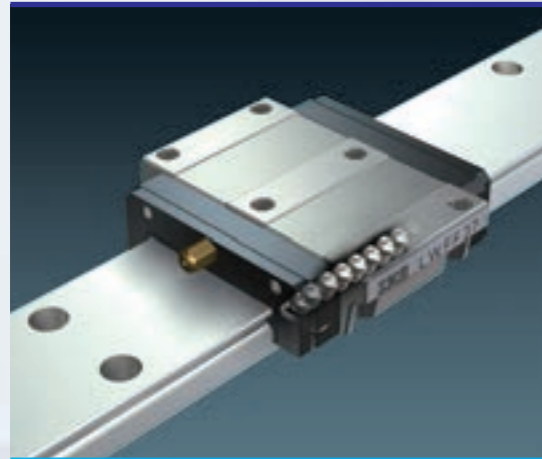

**Ball Type Wide Type Series**

**Linear Way F**

As wide track rail is used and the distance between the load points is long, this is a linear motion rolling guide suitable to single-row use due to the structure resistant to across-the-width moment load. It is also resistant to complex load.

Flange type mounting from top / bottom  
**LWFH**

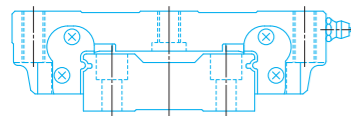

Flange type mounting from top / bottom  
**LWFF**

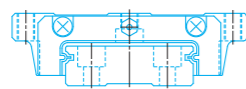

Block type mounting from top  
**LWFS**

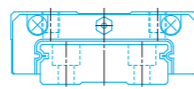

Length of slide unit	
No symbol	Standard
Size	
LWFH	40,60,90
LWFF	33,37,42,69
LWFS	33,37,42



**Roller Type**

**C-Lube Linear Roller Way Super MX  
Linear Roller Way Super X**

Linear motion rolling guide that has achieved the highest level of performance in all characteristics utilizing the roller's superior characteristic, such as rigidity, load capacity, running accuracy and vibration damping property. With extra long unit with the maximum slide unit length, load capacity and rigidity are improved and running performance with super high accuracy is realized.

Flange type mounting from top / bottom  
**MX<sup>(1)</sup>**  
**LRX<sup>(1)</sup>**

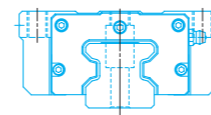

Block type mounting from top  
**MXD**  
**LRXD**

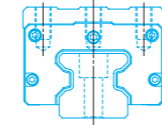

Compact block type mounting from top  
**MXS**  
**LRXS**

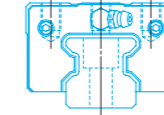

Low profile flange type mounting from top  
**MXN**

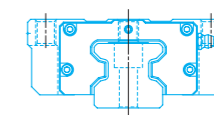

Low profile block type mounting from top  
**MXNS**

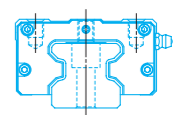

Note (1) Size 20 series allows only for mounting from top and model mounting from bottom is MXH and LRXH.

Length of slide unit				Size
C	No symbol	G	L	10, 12, 15, 20, 25, 30, 35, 45, 55, 65, 85, 100
Short	Standard	Long	Extra long	

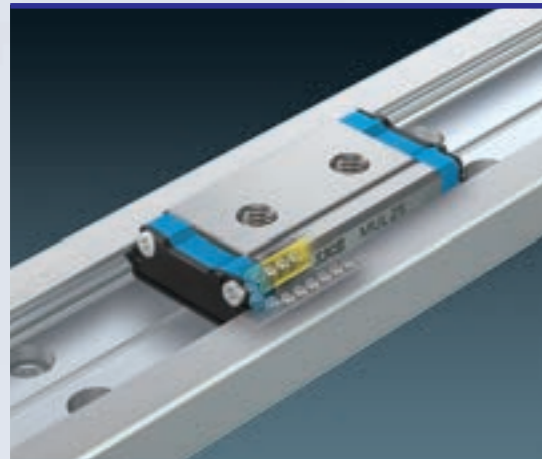

**Ball Type U-Shaped Track Rail Series**

**C-Lube Linear Way MUL  
Linear Way U**

Linear motion rolling guide of the structure with way inside the track rail of U-shaped section and slide unit therein. With the U-shaped track rail, rigidity against the track rail moment load and torsion is significantly improved.

Small type  
**MUL**  
**LWUL**

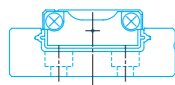

Standard type  
**LWU**

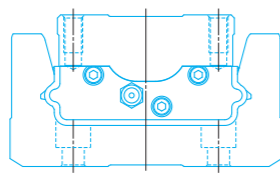

Length of slide unit	
No symbol	Standard
Size	
MUL	25, 30
LWUL	25, 30
LWU	40, 50, 60, 86, 100, 130



**Four-row roller guide of world's smallest size  
Track rail width of 10 mm**

- Super high rigidity**
- Super high load capacity**
- High running performance**
- Excellent frictional characteristics**

Stainless steel made

**LRXD10...SL**

# Features of extra long unit

## C-Lube Linear Roller Way Super MX

Length of slide unit is **1.4 to 1.5 times longer** than that of standard unit

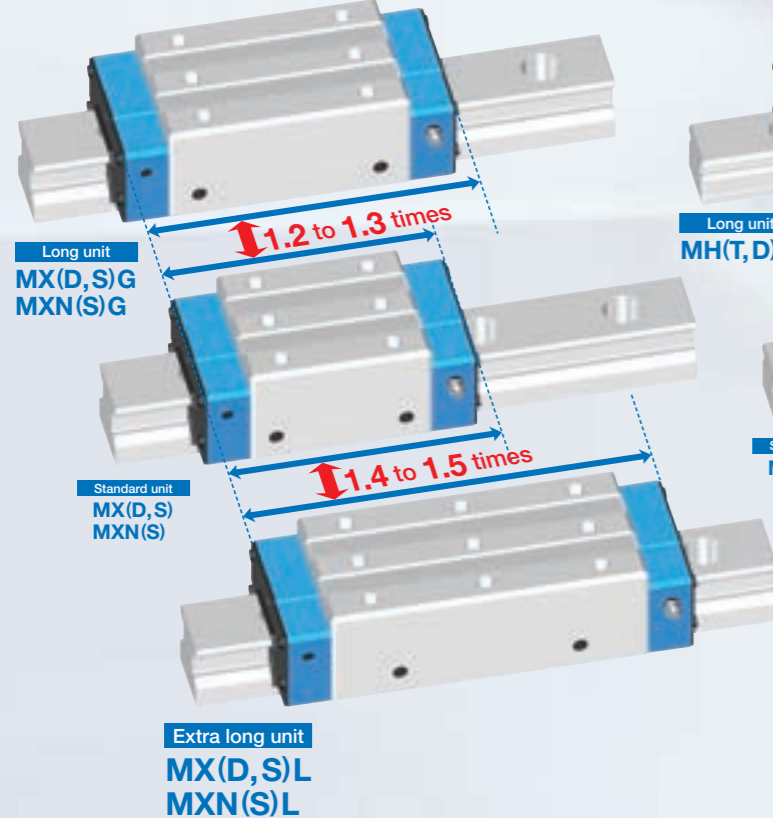

## C-Lube Linear Way MH

Length of slide unit is **1.6 times longer** than that of standard unit

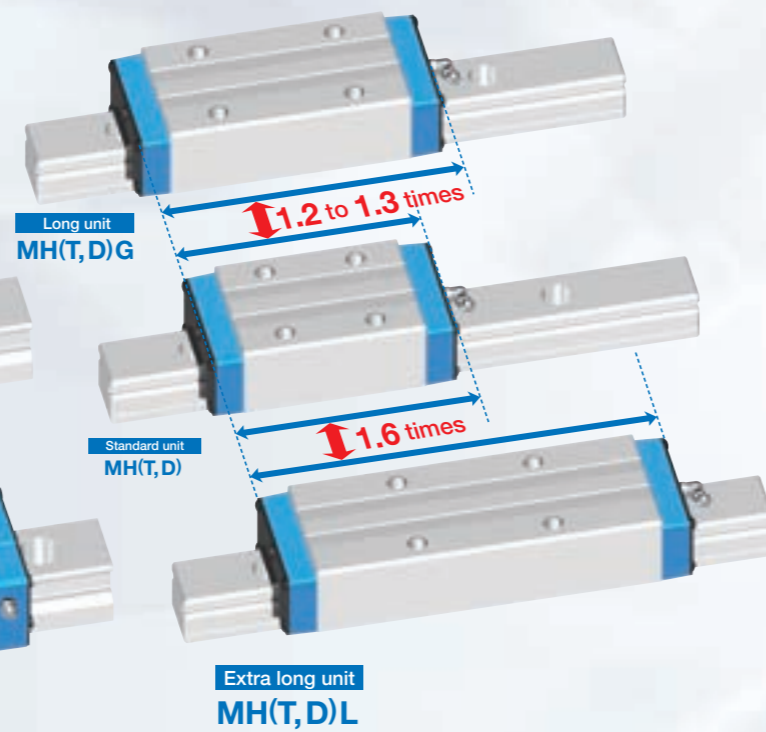

## Super accurate feeding mechanism is realized

As running accuracy is as low as a half of that of long unit, feeding mechanism with super high accuracy can be realized.

### Test conditions

Test portion	Extra long unit
Preload	T <sub>3</sub> preload

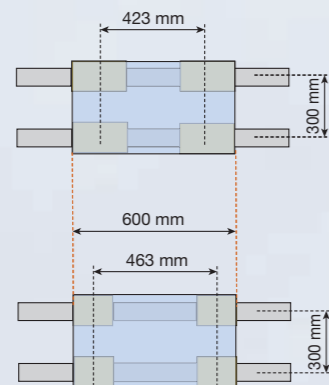

### Test conditions

Test portion	Long unit
Preload	T <sub>3</sub> preload

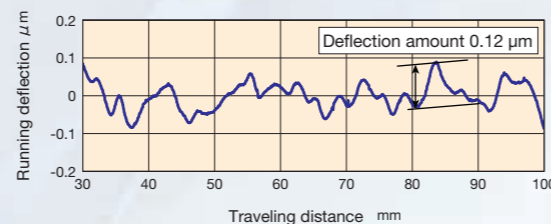
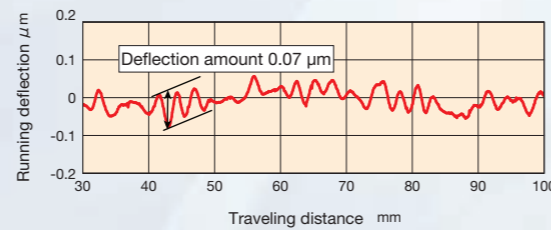
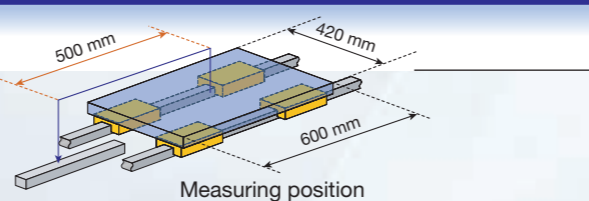

**High accuracy running performance is realized without major change of machine or device design<sup>(1)</sup>!**

Note (1) Position of the slide unit mounting hole is changed.

## Further improvement of running accuracy

## Load capacity and rigidity are significantly improved!!

### Load capacity of machine or device is improved

As its basic dynamic load rating and basic static load rating are larger than those of Long type by 122% and 129%, respectively, life and margin safety of machine or device are improved.

#### Comparison of basic dynamic load rating

Increased to **158%** relative to standard unit!  
Increased to **122%** relative to long unit!

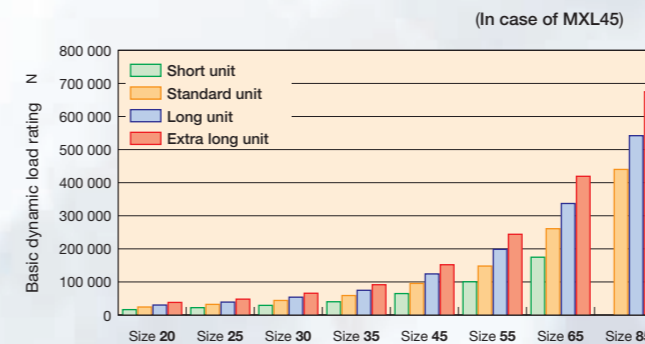

#### Comparison of basic static load rating

Increased to **181%** relative to standard unit!  
Increased to **129%** relative to long unit!

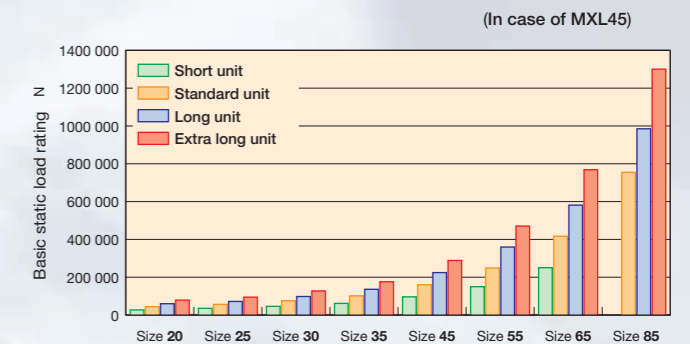

## Contributing to improvement of machine or device rigidity

Elastic deformation relative to load is small in comparison with long unit, device rigidity is improved, accuracy is improved, and resonance can be avoided.

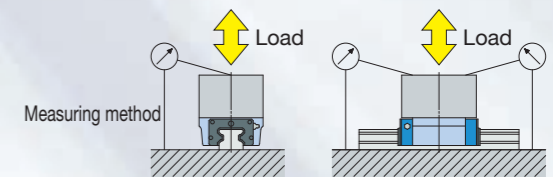

#### Comparison of elastic deformation under downward load

Rigidity increased to **155%** relative to standard unit!  
Rigidity increased to **117%** relative to long unit!

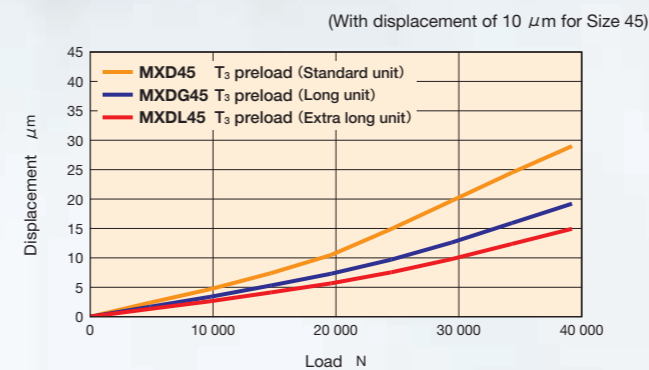

#### Comparison of elastic deformation under upward load

Rigidity increased to **152%** relative to standard unit!  
Rigidity increased to **113%** relative to long unit!

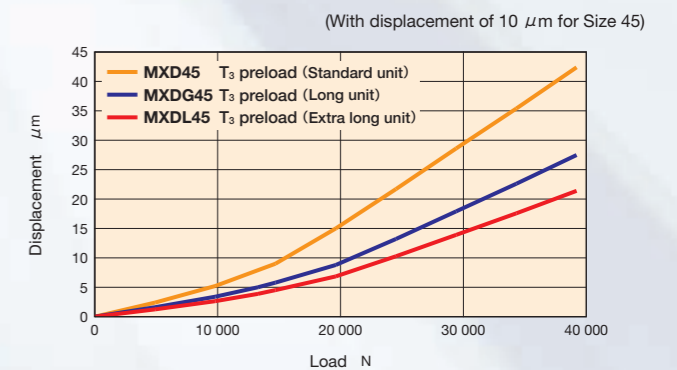

1N=0.102kgf=0.2248lbs.  
1mm=0.03937inch



# IKO's unique ideas and experiences are utilized to explore new world for special environment applications.

IKO Linear Way and Linear Roller Way are available for various special environment by using different materials and grease, surface treatment and dust protection measures, etc. Typical application fields and major countermeasures are described below.

## Clean Environment

When the Linear Way or Linear Roller Way is used in clean environment such as a clean room, it is required that the environment is not polluted by dust-generation by the Linear Way or Linear Roller Way and it must have excellent rust prevention property as rust prevention oil cannot be used.

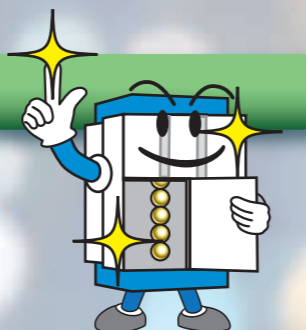

## Vacuum Environment

When the Linear Way or Linear Roller Way is used in vacuum environment, it is required that the gas discharged from the Linear Way or Linear Roller Way does not pollute the environment or reduce the degree of vacuum, and it must have excellent rust prevention property as rust prevention oil cannot be used.



## Heat Resistance Measures

When the Linear Way is used in an environment where temperature is higher than usual, heat resistance of synthetic resin components and metal parts will be an issue.



## Dust Protection

If dust such as metal or wooden chips get into the way of the Linear Way or Linear Roller Way, reduction of life and accuracy may be caused. Therefore, measures to prevent foreign substances from entering into the way are necessary.

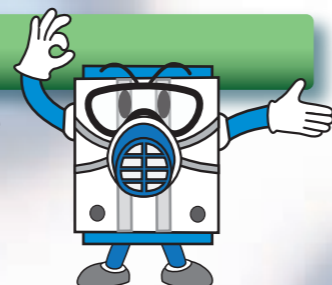

## Spatter Protection

Spatter of welding, etc. is so hot that it adheres to components. Foreign substances adhering to the track rail firmly cannot be fully removed by normal dust protection measures, so measures to avoid adherence and enhanced foreign substances removal measures are necessary.

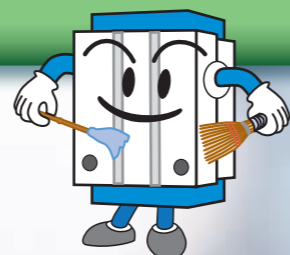

are utilized to explore new world for

### Clean

- Hybrid Lubrication Linear Way L
- Stainless Linear Way and Linear Roller Way
- Black chrome surface treatment
- Specified grease (CG2 or CGL grease)
- ◇ Fluorine grease

### Corrosion resistance

- Non-Magnetic Hard Alloy Linear Way L
- Stainless Linear Way and Linear Roller Way
- Black chrome surface treatment

### Vacuum

- Vacuum Environment Linear Roller Way Super X
- Hybrid Lubrication Linear Way L
- No end seal
- Stainless steel end plate
- ◇ Fluorine grease

### Heat resistance

- Stainless steel end plate
- Special environment seal
- Specified grease (CG2 grease)
- ◇ High temperature grease

### Foreign substances (wood chips and metal powder, etc.)

- Linear Way H Ultra seal specification
- Track rail mounting from bottom
- Double end seals
- Scrapers
- C-Wiper
- Caps for rail mounting holes
- Rail cover plate for track rail
- Rail cover sheet
- Female threads for bellows
- Specific bellows

### Spatter

- Scrapers
- Caps for rail mounting holes (aluminum alloy)
- Rail cover sheet
- Fluorine black chrome surface treatment
- Stainless steel end plate

- Linear motion rolling guide series for special environment :  
Collective name of linear motion rolling guide series models corresponding to special environment.
- Special specification for special environment :  
Special specification corresponding to special environment by combination of linear motion rolling guide series.
- ◇ Lubricant :  
Lubricant suitable for each special environment can be selected.

# Vacuum Environment Linear Roller Way Super X

When a linear motion rolling guide is used in vacuum environment, generation of outgas from resin parts such as end plates will be an issue if standard products are still used. In addition, the specification must be applicable to high temperature environment during baking. As roller type linear motion rolling guide has a precise roller circulation structure, it has not been compatible with stainless steel end plate widely used in ball type linear motion rolling guides for special environment applications.

The newly developed Vacuum Environment Linear Roller Way Super X is a roller type linear motion rolling guide realizing excellent outgas reduction property by combining corrosion-resistant stainless steel casing and resin parts such as super engineering plastic (PEEK resin) end plate to resolve these issues. Excellent properties of roller type such as high load capacity, high rigidity and smooth sliding characteristic with low frictional resistance can be ensured even under vacuum environment.

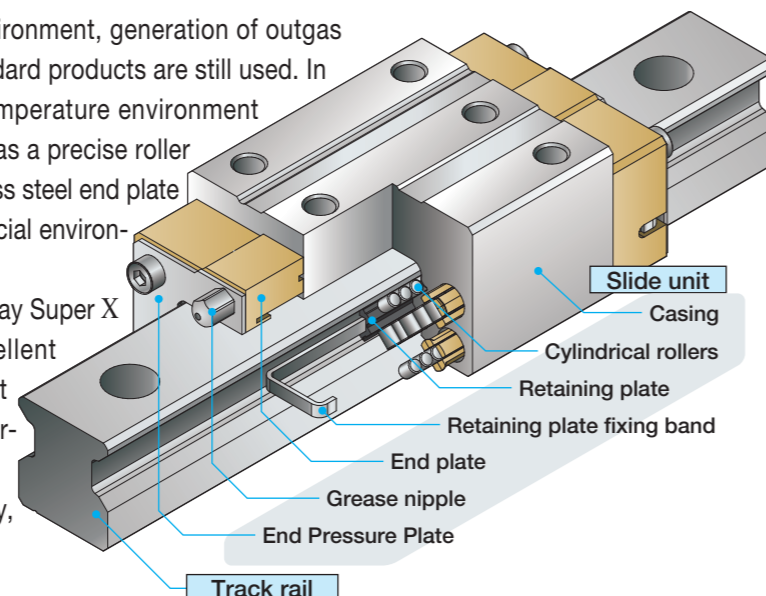

## Features

**Newly developed!**  
**Roller type linear motion guide available under vacuum environment!**

**1** Corresponding to low to high vacuum area (degree of vacuum  $10^{-3}$  [Pa])!

**2** Excellent outgas reduction property!

**3** Baking temperature can be up to 200°C!

- Temperature in still condition.
- If baking temperature exceeds 150°C, multiply the basic load rating by the temperature factor.

**4** Excellent corrosion resistance!

- Corrosion-resistant stainless steel is used in all steel made parts.

## Selection of lubricant

Though fluorine grease is recommended for lubricant, carefully select grease since vapor pressure and temperature of base oil are correlated as vapor pressure goes up along with increase of the temperature. For details, see chosen grease manufacturer's catalog.

Relationship example between fluorine grease vapor pressure and temperature

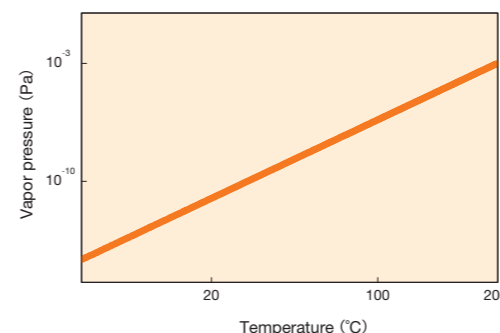

### Representative brands of fluorine grease

Brand	Manufacturer
KRYTOX® LVP	DU PONT
DEMNUM™ GREASE L-200	DAIKIN INDUSTRIES, LTD.
BARRIERA SUPER IS/V	NOK KLUEBER
FOMBLIN® Y-VAC3	SOLVAY SOLEXIS
FULLTRIBO VAC	KYODO YUSHI CO., LTD.

Remarks 1. KRYTOX® is a registered trademark of DU PONT.  
2. FOMBLIN® is a registered trademark of SOLVAY SOLEXIS.

## Specifications

We can offer optimal specification for your use conditions. If needed, please contact IKO.

### Applicable products

Series	Linear Roller Way Super X
Applicable model	LRXD20...SL

### Main component materials

Casing	Martensitic stainless steel
Track rail	Martensitic stainless steel
Cylindrical rollers	Martensitic stainless steel
End plate	Super engineering plastic (PEEK resin)

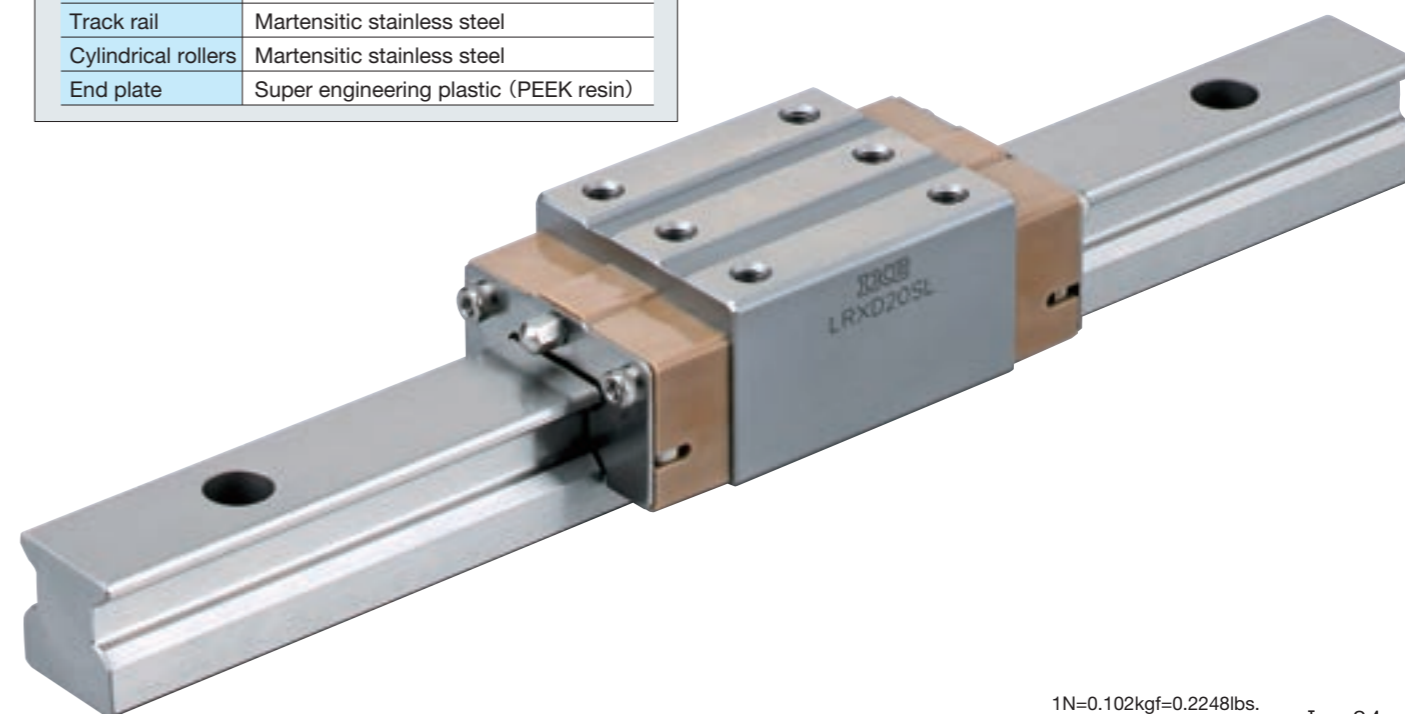

# Hybrid Lubrication Linear Way L

In clean environment, vacuum or high temperature environment of semiconductor producer and LCD producer, etc, pollution by outgas and particles is extremely not welcome. Therefore, solid lubrication film has been used as lubricant.

IKO developed "Hybrid Lubrication Linear Way" with dust-generation life and load resistance substantially higher than conventional solid lubrication film.

Optimal for applications where general grease or oil cannot be used, such as vacuum environment.

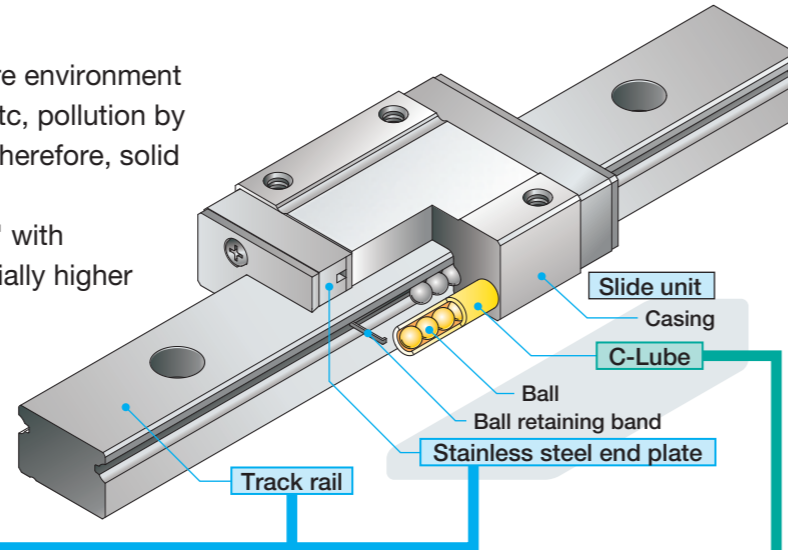

## What is hybrid lubrication

IKO Hybrid system of IKO's landmark lubrication system "C-Lube" and newly developed "Low dust-generation coating" achieves low dust generating performance, outgas reduction property, long life and excellent load resistance of Linear Way.

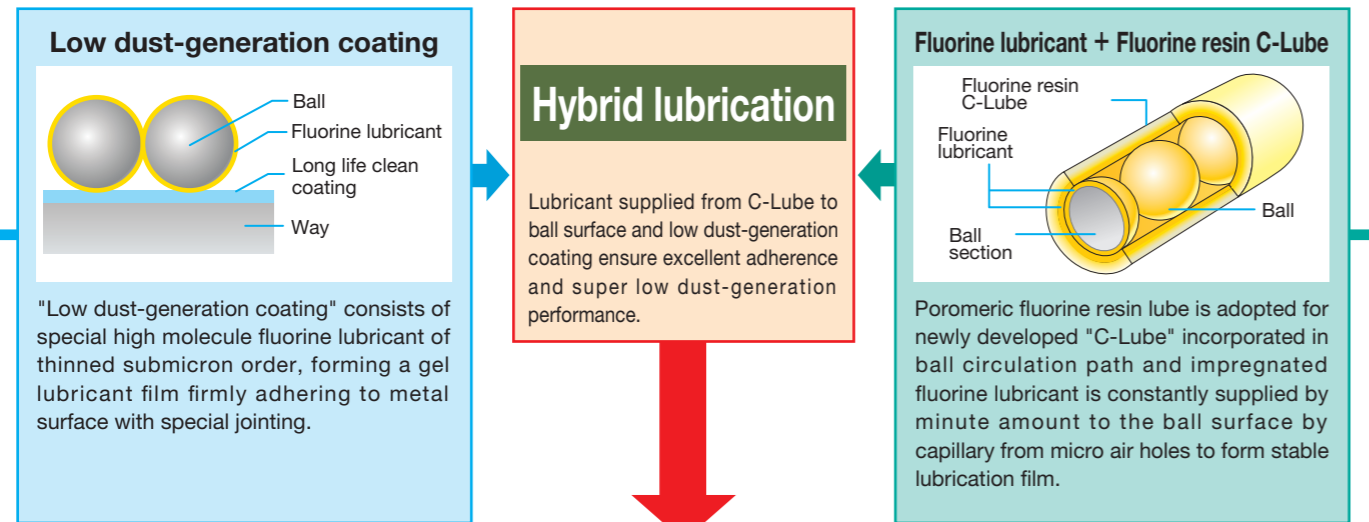

## Features

**Clean**  
(Low dust-generation)

JIS cleanliness class 4 compliant  
(Up to 352 particles of diameter 0.5 μm/m<sup>3</sup>)

**Vacuum**

Corresponding to low to high vacuum environment

**High temperature property**

~200°C\* (fluorine lubricant and fluorine resin C-Lube are adopted) compliant

**Load resistance**

Load resistance more than double of general clean coating

\* For continuous operation, up to 150°C.

## Performance

### Class 4 low dust generating performance

#### Dust-generation property

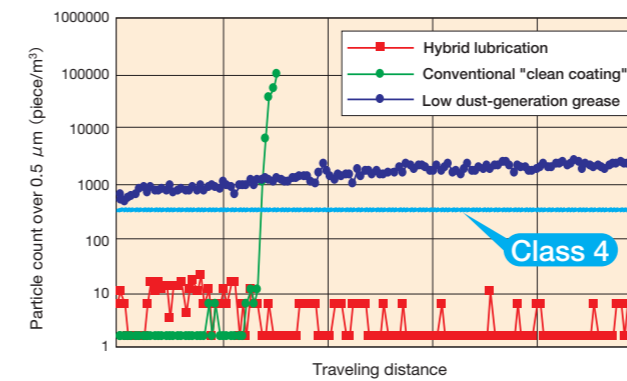

Test conditions Model : ML9 equivalent load: 80N stroke: 500 mm

### Life 10 times longer than general clean coating is achieved

#### Dust-generation life comparison

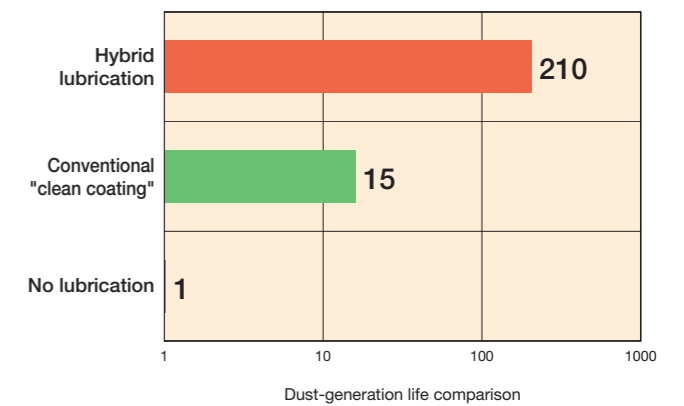

### Excellent outgas reduction property

#### Outgas reduction property

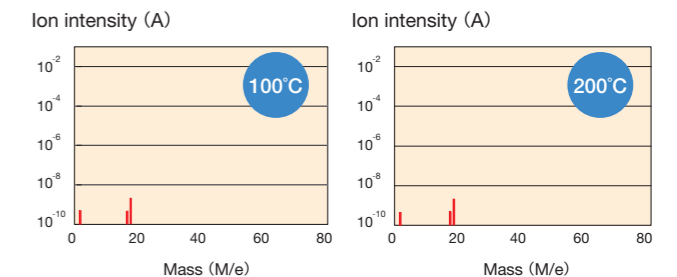

#### Outgassing property of Hybrid Lubrication Linear Way

Measuring condition Model : ML9 Degree of vacuum: 10<sup>-5</sup> Pa Temperature: 100°C, 200°C

Life **10 times** longer than general clean coating is achieved

#### ● Applicable products

Series	C-Lube Linear Way ML
Main model code	ML7, 9, 12, 15

#### ■ Standard specification

Casing	Martensitic stainless steel	This is made-to-order. If needed, please contact <b>IKO</b> . In addition, we also offer non-magnetic stainless steel specification. Please ask us for your request.
Track rail	Martensitic stainless steel	
Ball	Martensitic stainless steel	
End plate	Stainless steel	
C-Lube	Poromeric fluorinated resin	

#### ● Precaution for Use

- Although heat resistant fluorinated lubricant and parts are used, operating temperature shall be 200°C at the maximum or up to 150°C for continuous operation.
- The unit must be stored in a dry and clean place and unpacked in the same environment right before use. In addition, do not touch the product directly by bare hand.
- Hybrid Lubrication Linear Way is packed in clean condition and therefore cleaning is not necessary. In addition, do not wipe off the coating film on the raceway as it may affect lubrication and dust-generation properties.

# Hybrid C-Lube Linear Way ML

ML.../HB

While maintenance free performance of C-Lube Linear Way ML is maintained, the silicon nitride ceramics ball improves high-speed performance and reduces noise level. Ceramics has more resistance to deformation and more rigidity than bearing steel and stainless steel.

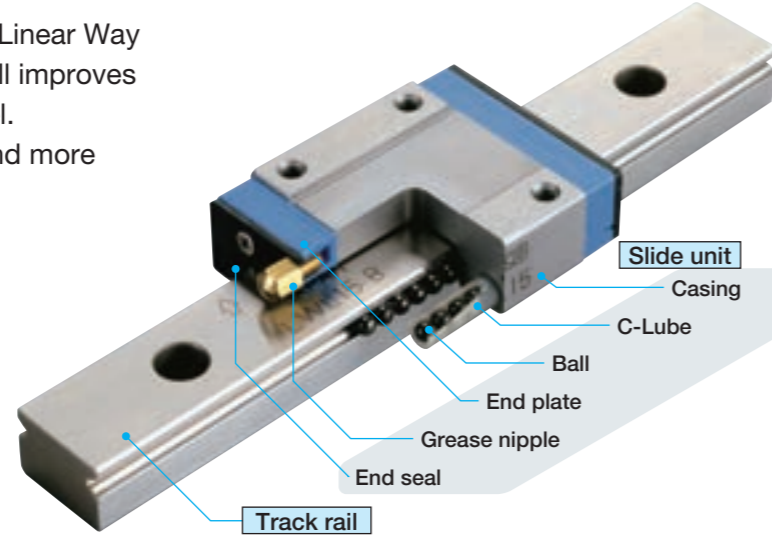

Standard specification	
Casing	Martensitic stainless steel
Track rail	Martensitic stainless steel
Ball	Silicon nitride ceramics
C-Lube	Capillary lubricating element (Porous resin)

## Features

- 1 Superior high-speed performance** ... More than three times durability
- 2 Noise reduction** ... Noise reduction by about 4.5 dB
- 3 High rigidity** ... Displacement volume reduced by about 10%
- 4 Superior abrasion resistance** ... Preload reduction volume is about one fourth

※ All of the above based on comparison with our C-Lube Linear Way ML



**Maintenance free**  
Achieved long term maintenance free

**Eco-friendly**  
Minimized lubrication oil consumption

**Compact**  
Integral lubrication parts

**Smooth**  
Excellent sliding characteristic

## Performance

### More than three times durability

#### High-speed performance

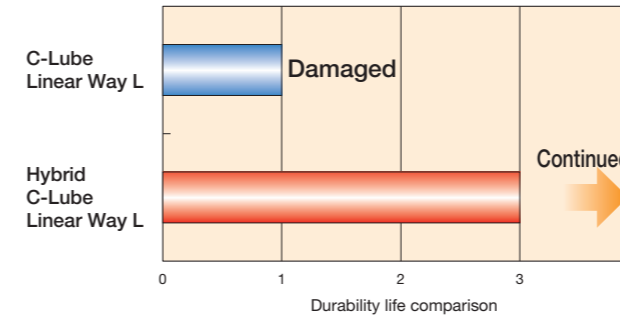

Test conditions Model : ML12 Velocity: 300 m/min Acceleration: 40 G

### Noise reduction by about 4.5 dB

#### Low decibel

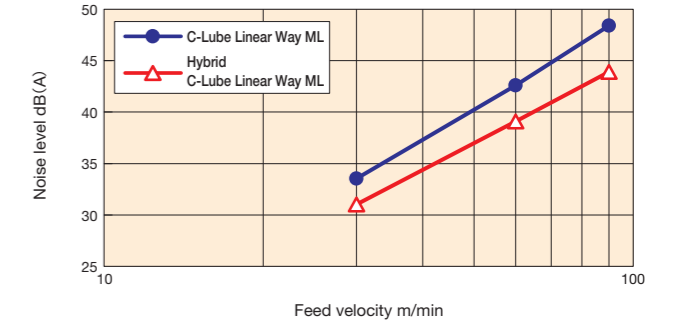

Test conditions Model : ML12 Measurement velocity: 30, 60, 90 m/min

### Small deformation of rolling elements and excellent rigidity

#### High rigidity

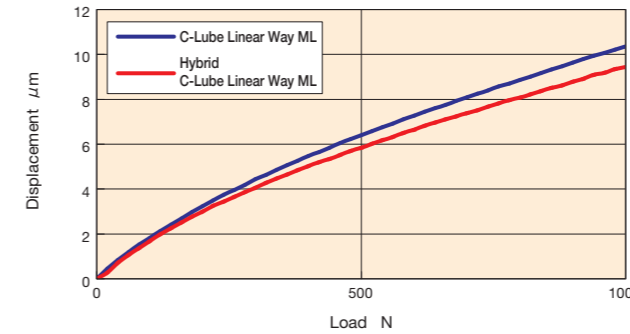

Test conditions Model : ML12 Preload: Standard Preload Load direction: Downward

### Low preload reduction volume and accuracy maintained after operation

#### Abrasion resistance

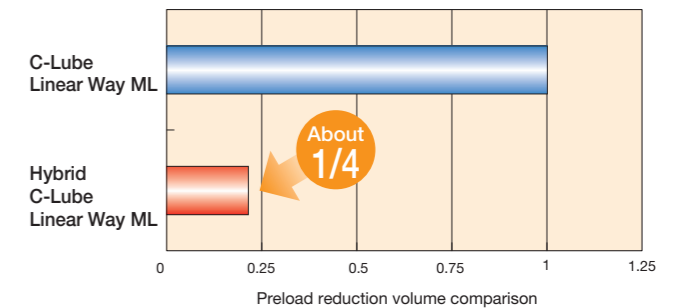

Test conditions Model : ML12 Velocity: 300 m/min Acceleration: 40 G Traveling distance: 13,000 km

## Basic performance of C-Lube Linear Way

### Achieved long term maintenance free

#### Maintenance free

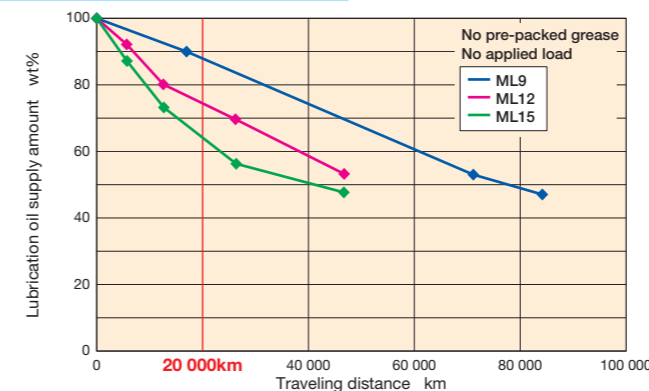

### Achieved light and smooth sliding

#### Sliding characteristic

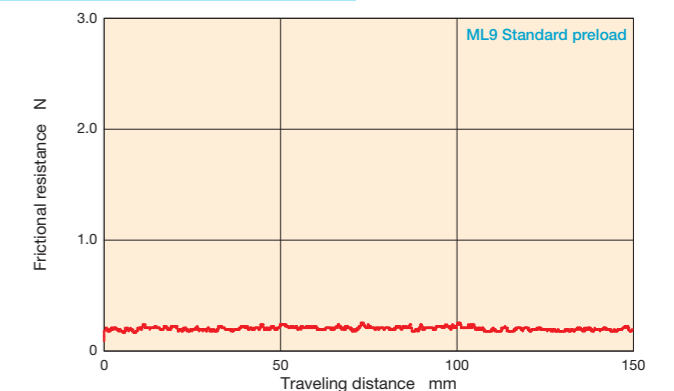

1N=0.102kgf=0.2248lbs.  
1mm=0.03937inch

# Non-Magnetic Hard Alloy Linear Way L

Non-magnetic hard alloy Linear Way L is a linear motion rolling guide that realizes relative magnetic permeability lower than 1.001 and relative magnetic permeability lower than one tenth of that of conventional non-magnetic stainless steel products. Further, durability more than three times as higher as that of non-magnetic stainless steel products is realized.

Non-magnetic hard alloy Linear Way L is a non-magnetic linear motion rolling guide optimal to avoid effects of magnetic force in magnetic field environment.

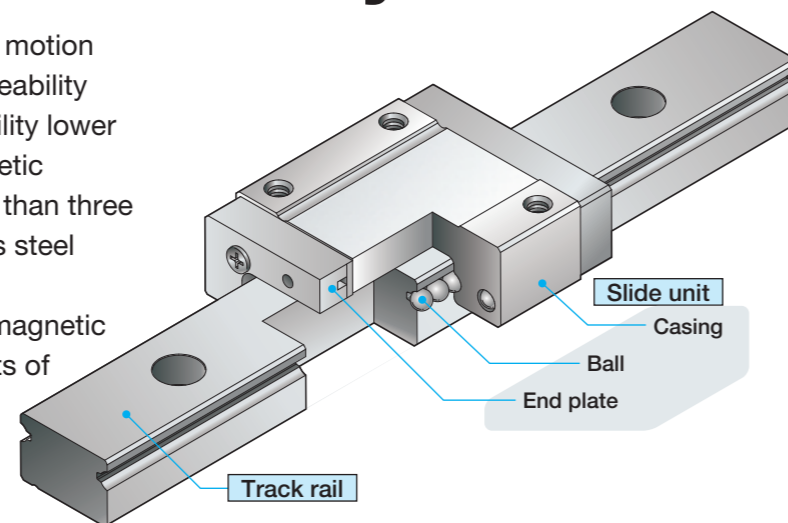

Relative magnetic permeability  
**Below 1.001**



## Features

### Relative magnetic permeability lower than 1.001

Relative magnetic permeability lower than one tenth of that of non-magnetic stainless steel products

### More than three times durability

More than three times durability with hardness 1.5 times as much as that of non-magnetic stainless steel products

### High corrosion resistance

Optimal for use in clean environment thanks to corrosion-resistant alloy

### Easy handling

Casing and track rail have excellent ductility and coefficient of linear expansion similar to general metals as they are made of metal

## Non-magnetic hard alloy characteristics

Material name	Non-magnetic hard alloy	Silicon nitride ceramics	Non-magnetic stainless steel
Characteristics			
Relative magnetic <sup>(1)</sup> permeability	1.001 or less	1 (0.999991)	1.01 or less (1.005)
Electric conductivity	○	×	○
Hardness (HV)	610 ~ 700	1400 ~ 1600	380 ~ 450
Linear expansion coefficient (×10 <sup>-6</sup> /°C)	11.5 (30 ~ 200°C)	3.2 (20 ~ 400°C)	19.0 (20 ~ 400°C)
Specific gravity (g/cm)	7.7	3.2	7.9
Main component	Ni, Cr	Si <sub>3</sub> N <sub>4</sub>	Fe, Mn, Cr
Cost	○	△	○
Remark	Good corrosion resistance	Good corrosion resistance	—

Note (1) ( ) is only an example of the measurement value.

## Selection of lubricant

By selecting appropriate lubricant such as vacuum grease and low dust-generating grease, this may be corresponding to any operating environment.

### ● Applicable products

Series	Linear Way L
Main model	LWL5...B ~ LWL15...B

Remark: No ball retaining band is included.

### ■ Main component materials

Casing	Non-magnetic hard alloy
Track rail	Non-magnetic hard alloy
Ball	Silicon nitride ceramics
End plate	Non-magnetic alloy steel

# Stainless Linear Way and Linear Roller Way

## A variety of stainless steel series

**IKO** Linear Way and Linear Roller Way lineup includes products with stainless steel made parts instead of steel parts. As stainless steel is resistant to rust relative to high carbon steel made products, they are optimal for use in applications where oil **IKO** content and rust prevention oil are not preferred. It is also suitable for use in cleanroom environment room, so use clean grease that inhibits dust-generation amount together.

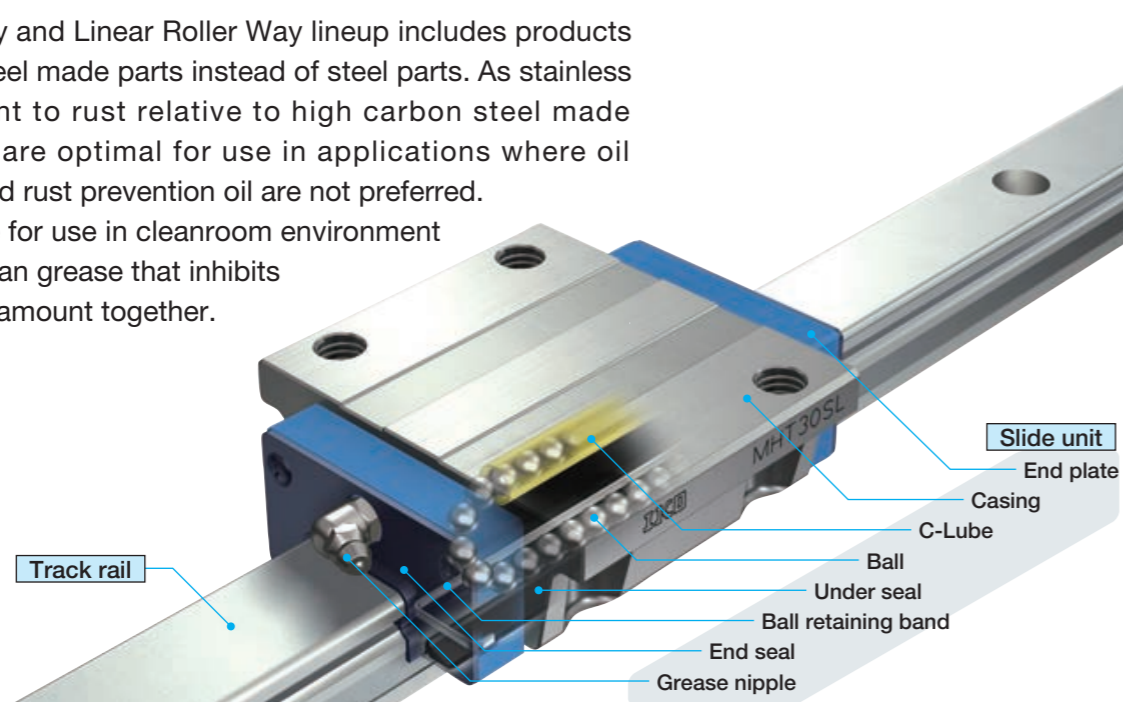

Main component materials	
Casing	Martensitic stainless steel
Track rail	Martensitic stainless steel
Ball	Martensitic stainless steel
Ball retaining band	Stainless steel
End plate	Engineering plastic
End seal	Stainless steel + Synthetic rubber
Grease nipple	Brass

### Series name

#### Linear Way

##### Ball Type Miniature Series

- C-Lube Linear Way ML
- C-Lube Linear Way MLV
- Linear Way L
- Micro Linear Way L

##### Ball Type Compact Series

- C-Lube Linear Way ME
- Linear Way E

##### Ball Type High Rigidity Series

- C-Lube Linear Way MH
- Linear Way H

##### Ball Type Wide Type Series

- Linear Way F

##### Ball Type U-Shaped Track Rail Series

- C-Lube Linear Way MUL
- Linear Way U

#### Linear Roller Way

##### Roller Type

- C-Lube Linear Roller Way Super MX
- Linear Roller Way Super X

## Combination with special specification corresponds to use in special environment!

### Rust prevention

#### Black chrome surface treatment /L

Black chrome surface treatment on the track rail and slide unit improves rust prevention capacity.

#### Fluorine black chrome surface treatment /LF

Coating of fluorinated resin is applied over the black chrome surface treatment to prevent foreign substances from sticking and improve the rust prevention capacity.



### Black chrome surface treatment

#### Features

- Thin film
- Uniform film
- Strong adhesion
- Excellent rust prevention capacity
- Low temperature processing to prevent distortion
- No peeling and no effects on life and cleanroom environment

Corrosion resistance comparison based on humidity cabinet test

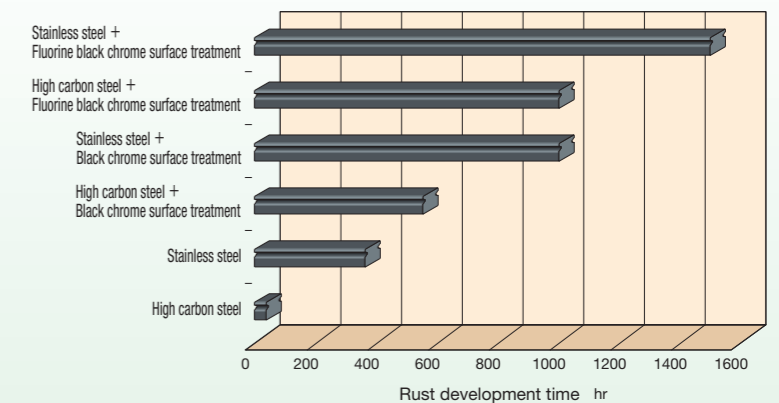

Test conditions Temperature 50°C, Relative humidity 95%RH

# Special specification for special environment

IKO Linear Way and Linear Roller Way lineup includes following special specifications to correspond to various special environments.

## Dust protection

### C-Wiper /RC

Mounted to the outside of end seal, it may be used for long time even under environment where metal chips are spattering. End seal, inner seal (/UR) and scraper (/Z) may be equipped as standard when you specify special specification /RC with C-Wiper.

If you need inner seal only, specify /UR.

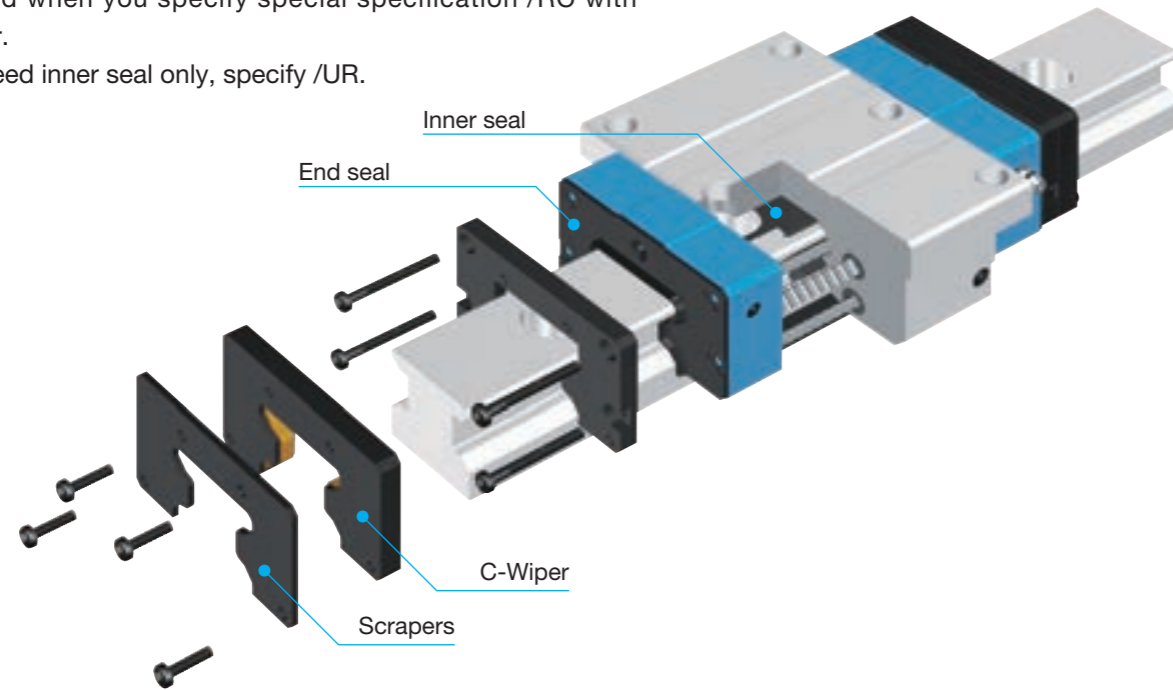

Applicable C-Wiper size

Model	Length of slide unit	Model code	Size								
			12	15	20	25	30	35	45	55	65
Flange type mounting from top / bottom	Short	<b>MXC</b>	—	—	○ <sup>(1)</sup>	○	○	○	○	○	○
	Standard	<b>MX</b>	—	—	○ <sup>(1)</sup>	○	○	○	○	○	○
	Long	<b>MXG</b>	—	—	○ <sup>(1)</sup>	○	○	○	○	○	○
	Extra long	<b>MXL</b>	—	—	○ <sup>(1)</sup>	○	○	○	○	○	○
Block type mounting from top	Short	<b>MXDC</b>	—	—	○	○	○	○	○	○	○
	Standard	<b>MXD</b>	—	—	○	○	○	○	○	○	○
	Long	<b>MXDG</b>	—	—	○	○	○	○	○	○	○
	Extra long	<b>MXDL</b>	—	—	○	○	○	○	○	○	○
Compact block type mounting from top	Short	<b>MXSC</b>	—	—	○	○	○	—	—	—	—
	Standard	<b>MXS</b>	—	—	○	○	○	○	○	○	—
	Long	<b>MXSG</b>	—	—	○	○	○	○	○	○	—
	Extra long	<b>MXSL</b>	—	—	○	○	○	—	—	—	—
Low profile flange type mounting from top	Standard	<b>MXN</b>	—	—	—	—	○	○	○	○	—
	Long	<b>MXNG</b>	—	—	—	—	○	○	○	○	—
	Extra long	<b>MXNL</b>	—	—	—	—	○	○	○	○	—
	Standard	<b>MXNS</b>	—	—	—	—	○	○	○	○	—
Low profile block type mounting from top	Long	<b>MXNSG</b>	—	—	—	—	○	○	○	○	—
	Extra long	<b>MXNSL</b>	—	—	—	—	○	○	○	○	—

Note <sup>(1)</sup> Also applicable to models mounting from bottom (MXHC20, MXH20, MXHG20, MXHL20).

## Dust protection

### Durability test result backing excellent dust protection effect of [C-Wiper]!

#### Durability test in environment with foreign substances

##### Test conditions

Test portion	MX35 T <sub>3</sub> preload / caps for rail mounting holes and C-Wiper included
Maximum velocity	18 m/min
Stroke length	500 mm
Foreign substances	Fine metal chips Particle diameter lower than 125 μm Hardness HRC40 ~ 50 Application dose 1 g/hr (total dose: 1 kg)

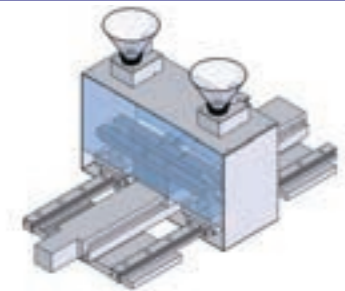

After operation of 1,000 km

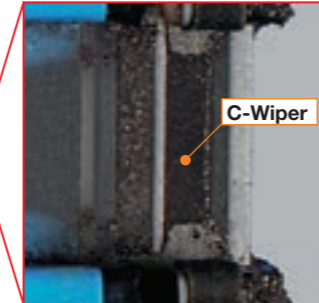

After operation of 1,000 km

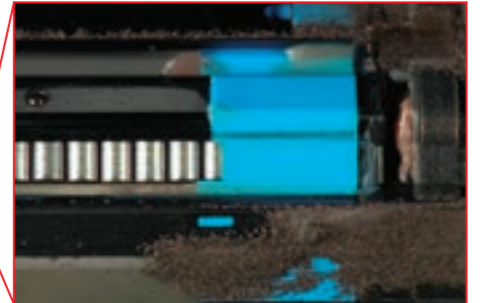

Only few foreign substances may get into the slide unit.

Only few foreign substances get into the way!

#### Durability test in coolant mist environment

##### Test conditions

Test portion	MX35 T <sub>3</sub> preload / caps for rail mounting holes and C-Wiper included
Maximum velocity	115.2 m/min
Stroke length	300 mm
Coolant	Soluble type Dilute strength 20 times Spray amount 5 cc/hr

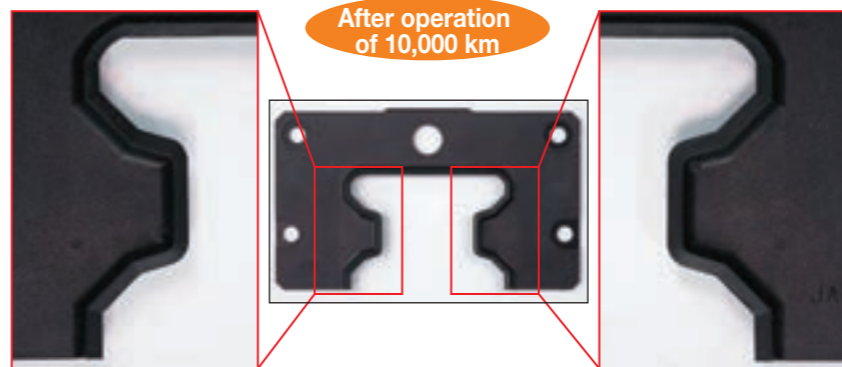
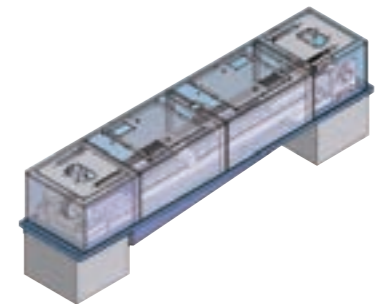

End seal is not damaged.

Wear condition of end seal lip tip

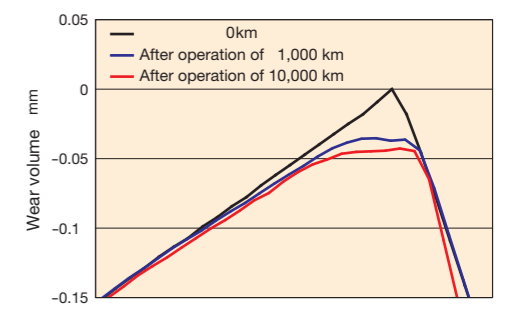

Wear on the end seal is negligible!

**Special specification for special environment**

**Dust protection**

**Rail cover sheet**

Rail cover sheet that consists of steel plate and adhesive tape and fastened to the dedicated track rail with groove on the track rail prevents foreign substances from entering into the slide unit.

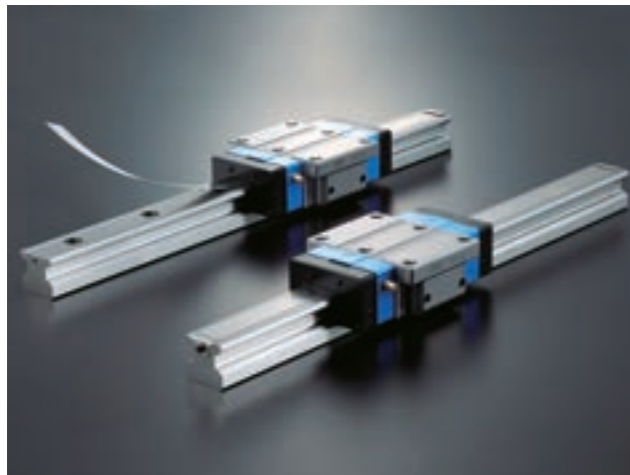

**Caps for rail mounting holes /F**

Caps for rail mounting holes close the track rail mounting holes to prevent foreign substances from entering into the slide unit.  
Contact **IKO** for aluminum alloy caps for rail mounting holes.

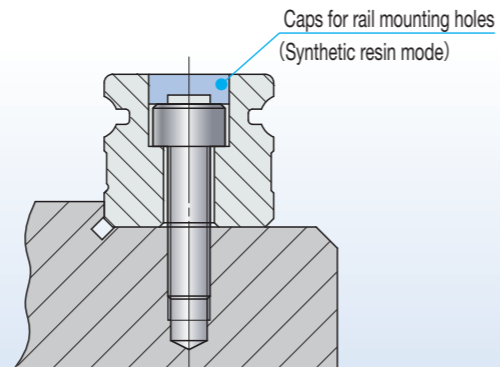

**Dust protection**

**Double end seals /V**

Double end seals improve the dust protection property further.

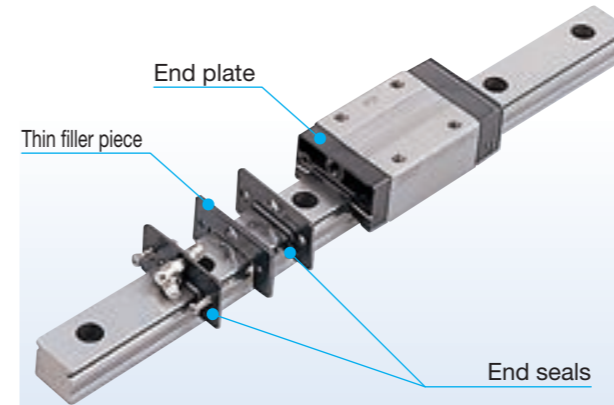

**Scraper /Z**

Mounted to the outside of end seal, it may remove large foreign substances adhering to the track rail.

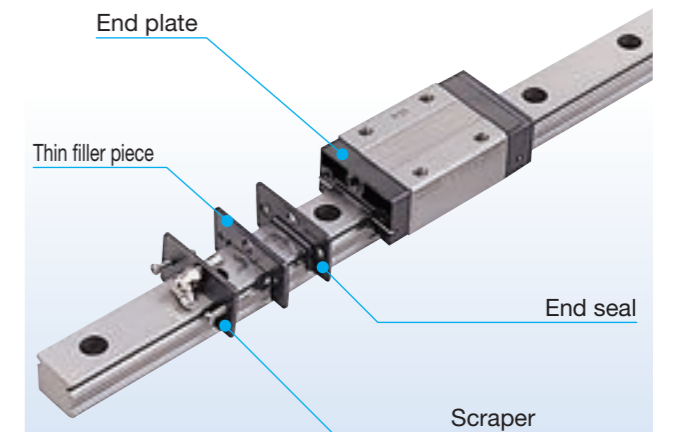

**Rail cover plate /PS**

Rail cover plate totally covers the upper surface of the track rail to prevent foreign substances from entering into the track rail.



**Track rail mounting from bottom**

This is the specification that track rail is fixed from the mounting surface side. As there are no mounting holes on the track rail upper surface, adherence with the seal is superior and better dust protection effect is achieved.

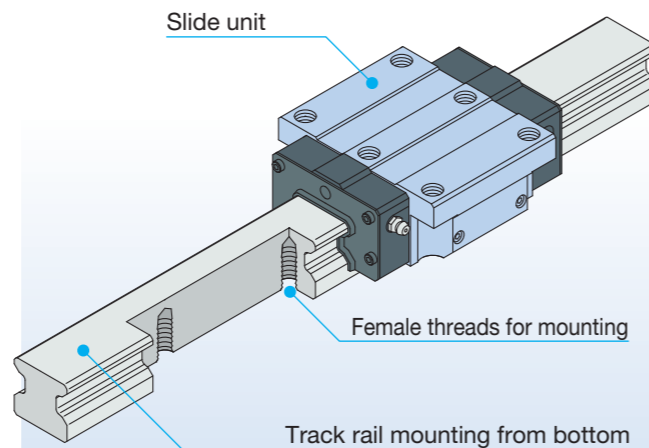

**Female threads for bellows /J**

Female threads for bellows are prepared on the slide unit and track rail ends.

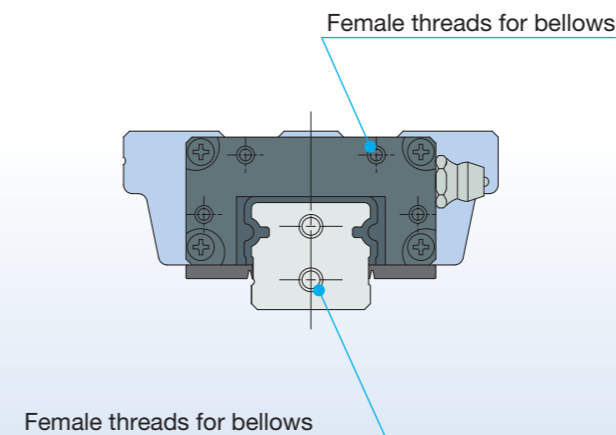

**Specific bellows**

Dust protection cover over the exposed part of the track rail.

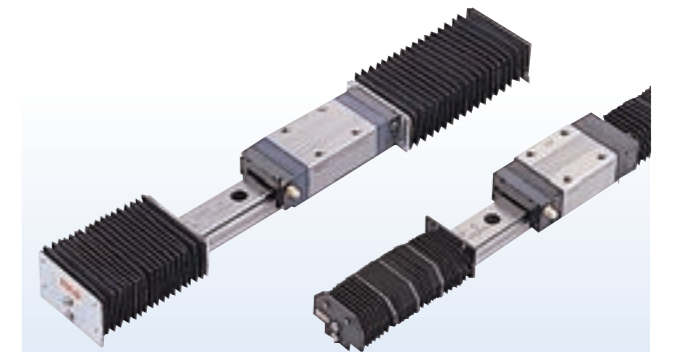



**Special specification for special environment**

**Lubrication**

**With C-Lube plate /Q**

Lubrication parts to substantially reduce the need for lubrication management, i.e. grease job.



**Low Dust-Generation Grease for Clean Environment CGL /YCL**

For this grease, mixed soap is used as thickener and synthetic oil and low pour point mineral oil are mixed with base oil, so it has excellent low dust generating performance, rolling resistance, lubrication, and rust prevention property.

Bellows cartridge (80 g)  
JG80 /CGL

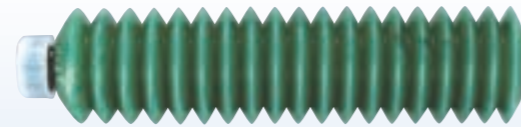

With miniature greaser (2.5 ml)  
MG2.5 /CGL

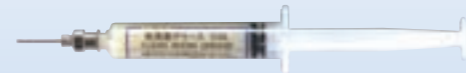

**Low Dust-Generation Grease for Clean Environment CG2 /YCG**

For this grease, urea is used as thickener and synthetic oil is used as base oil, so it has excellent low dust generating performance, operating temperature range, lubrication property, rust prevention property and oxidation stability.

Bellows cartridge (80 g)  
JG80 /CG2

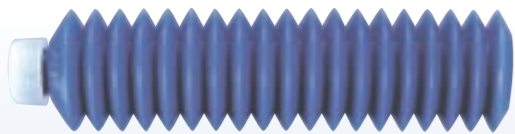

With miniature greaser (2.5 ml)  
MG2.5 /CG2



MG10 /CG2 with 10 ml are also available.

**Anti-Fretting Corrosion Grease AF2 /YAF**

Grease with excellent fretting-proof corrosion property.

Bellows cartridge (80 g)  
JG80 /AF2

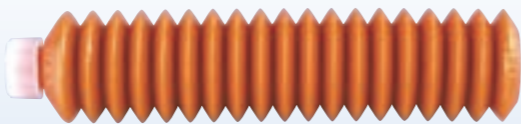

With miniature greaser (2.5 ml)  
MG2.5 /AF2



**Other special grease**

If you need any special grease for vacuum or high temperature, ask for **IKO** your request.

**Others**

**Stainless steel end plate /BS**

End plate is changed to stainless steel.

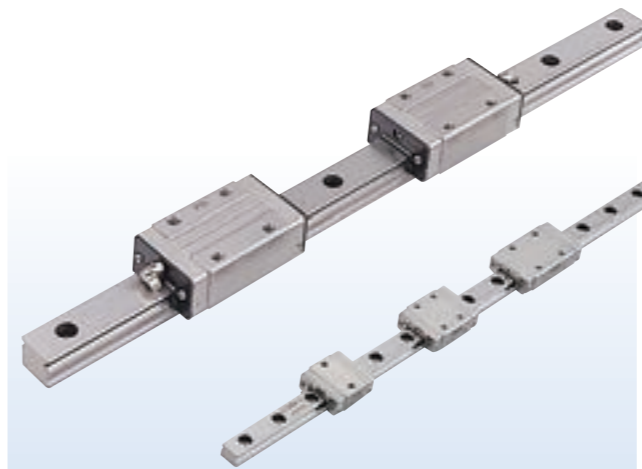

**Special environment seal /RE**

The end and under seals are replaced with end seals for special environment that can be used at high temperatures. When it is used in high temperature environment, stainless steel end plate (/BS) and high temperature grease should be combined.

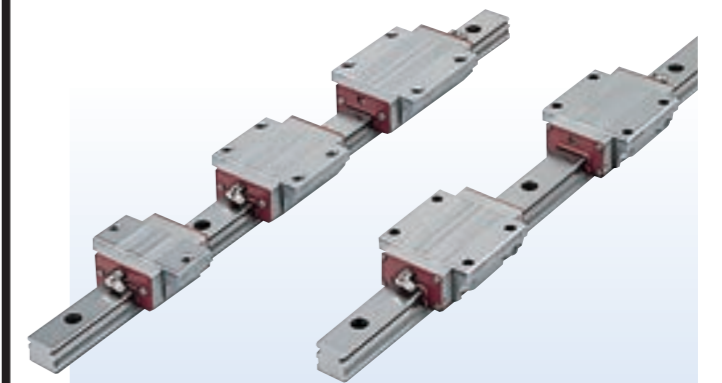

The photo shows a combination of special environment seal (/RE) and stainless steel end plate (/BS).

**IKO can offer products for special environment!**

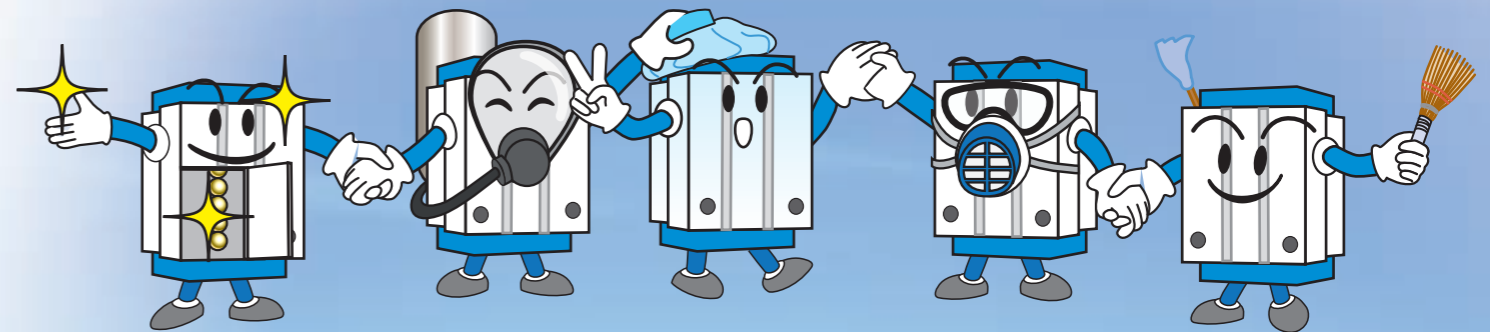

If needed, ask **IKO** for your request.

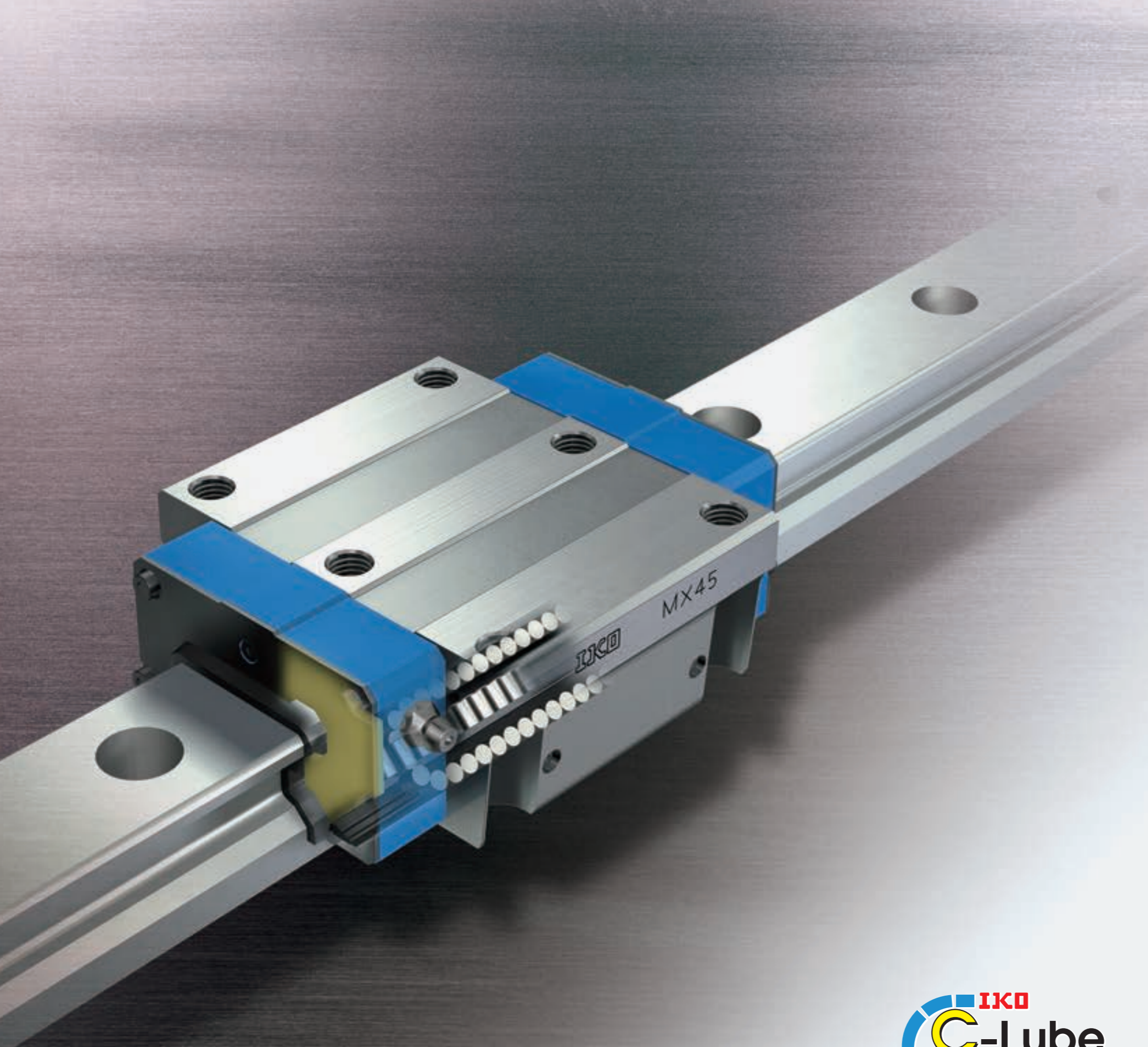

Explanation and Dimension Table for Respective Product Series

**Rail Guide Type**

- C-Lube Linear Way ML  
Linear Way L  
Explanation ..... II-5  
Dimension Table ..... II-23
- C-Lube Linear Way MLV  
Explanation ..... II-41  
Dimension Table ..... II-47
- C-Lube Linear Way MV  
Explanation ..... II-51  
Dimension Table ..... II-59
- C-Lube Linear Way ME  
Linear Way E  
Explanation ..... II-63  
Dimension Table ..... II-75
- C-Lube Linear Way MH  
Linear Way H  
Explanation ..... II-89  
Dimension Table ..... II-107
- Linear Way F  
Explanation ..... II-135  
Dimension Table ..... II-149
- C-Lube Linear Way MUL  
Linear Way U  
Explanation ..... II-157  
Dimension Table ..... II-167
- C-Lube Linear Roller Way Super MX  
Linear Roller Way Super X  
Explanation ..... II-171  
Dimension Table ..... II-191
- Linear Roller Way X  
Explanation ..... II-219  
Dimension Table ..... II-227
- Linear Way Module  
Explanation ..... II-233  
Dimension Table ..... II-241

**General Explanation**

- General Explanation ..... III-2

**Introduction of Application Examples**

- Introduction of Application Examples ..... IV-2



# C-Lube Linear Way ML Linear Way L

# C-Lube Linear Way ML

# ML



long term maintenance free supported!

The aquamarine end plate is the symbol of maintenance free.



## Points

### ● Extremely small size realized by simple structure

For details ▶ P.I-19

Super small-size linear motion rolling guide produced by two-row four-point contact simple structure and original small sizing technology. The track rail width of LWL1, the smallest size, is only 1mm.

### ● Wide range of variations for your needs

For details ▶ P.I-25

The slide unit shape can be selected from two types, the standard type and the wide type suited for single-row track rail uses, and there are four types with different lengths of slide unit with same section. Furthermore, the track rail has the variation of standard type and tapped rail type with the screw thread implanted, allowing you to select an optimal product for the specifications of your machine and device.

### ● Ball retained type for easy operation

The slide unit of ball retained type incorporates the ball retaining band, which prevents the ball from dropping down when the slide unit is removed from the track rail.

This safety structure brings you an easy operation to the machines / equipment.

### ● Stainless steel selections for excellent corrosion resistance

For details ▶ P.I-41

Stainless steel highly corrosion-resistant is used as the basic specification, so that the products are suitable for applications where rust prevention oil is not preferred, such as in cleanroom environment. High carbon steel products suited to general purposes are also provided.

### ● Widely supports special environment uses

For details ▶ P.I-31

C-Lube Linear Way L for special environment uses are provided as a series. Increasingly varied special environment uses are supported, such as by high-speed / low-noise specifications by combining silicon nitride ceramics and low dust-generation specifications.

## Identification Number and Specification

### Example of an identification number

The specifications of ML(F) and LWL(F) series are indicated by the identification number. Indicate the identification number, consisting of a model code, dimensions, a part code, a material code, a preload symbol, a classification symbol, an interchangeable code, and any supplemental codes for each specification to apply.

Non-interchangeable specification	1	2	4	5	6	3	7	8	9	10	11
Assembled set	ML	C	12	C1	R200			T <sub>1</sub>	P		/U
Interchangeable specification											
Single slide unit	ML	C	12	C1				T <sub>1</sub>	P	S1	/U
Single track rail (1)	LWL		12		R200	B			P	S1	
Assembled set	ML	C	12	C1	R200			T <sub>1</sub>	P	S1	/U

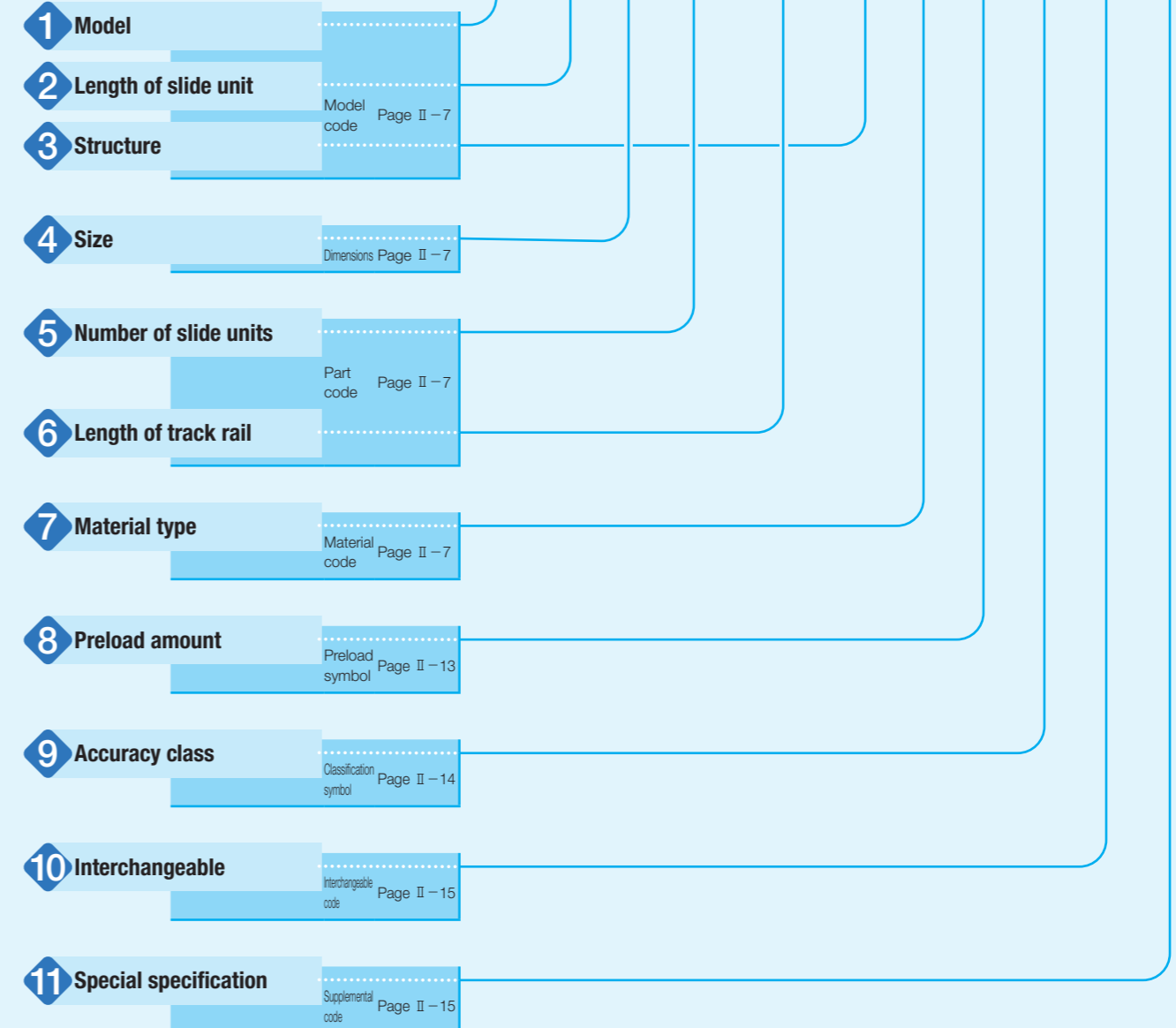

Note (1) Indicate "LWL...B" or "LWLF...B" for the model code of the single track rail regardless of the series and the combination of slide unit models.  
 1N=0.102kgf=0.2248lbs.  
 1mm=0.03937inch

# Identification Number and Specification — Model · Length of Slide Unit ·

<b>1 Model</b>	C-Lube Linear Way ML (ML(F) series)	Standard type : ML Wide type : MLF	For applicable models and sizes, see Table 2.1 and Table 2.2. Indicate "LWL...B" or "LWLF...B" for the model code of the single track rail regardless of the series and the combination of slide unit models. Note (1) This model has no built-in C-Lube.
	Linear way L (1) (LWL (F) series)	Standard type : LWL Wide type : LWLF	

<b>2 Length of slide unit</b>	Short	: C	For applicable models and sizes, see Table 2.1 and Table 2.2.
	Standard	: No symbol	
	Long	: G	
	Extra long	: L	

<b>3 Structure</b>	<b>Table 1.1 Structure of ML and LWL</b>			
	Model	Types and sizes of track rails	Structure	
ML	Standard rail specification	Size: 5~25	Ball retained type : No symbol	
	Tapped rail specification	Size: 3 Size: 5, 7, 9	Ball non-retained type : No symbol Ball retained type : N	
LWL	Standard rail specification		Ball retained type : B	
	Tapped rail specification	Mounting from bottom	Size: 2, 3 Size: 5, 7, 9	Ball non-retained type : No symbol Ball retained type : N
		Mounting from lateral	Size: 1	Ball non-retained type : Y
	Solid rail specification	Size: 1	Ball non-retained type : No symbol	

<b>3 Structure</b>	<b>Table 1.2 Structure of MLF and LWLF</b>		
	Model	Types of track rails	Structure
MLF	Standard rail specification	Size: 6 Size: 10~42	Ball non-retained type : No symbol Ball retained type : N
	Tapped rail specification	Size: 6 Size: 10~18	Ball non-retained type : N Ball retained type : N
LWLF	Standard rail specification	Size: 4, 6 Size: 10~42	Ball non-retained type : No symbol Ball retained type : B
	Tapped rail specification	Size: 6 Size: 10~18	Ball non-retained type : N Ball retained type : N

For applicable models and sizes, see Table 2.1 and Table 2.2.

<b>4 Size</b>	Standard type 1, 2, 3, 5, 7, 9, 12, 15, 20, 25	For applicable models and sizes, see Table 2.1 and Table 2.2.
	Wide type 4, 6, 10, 14, 18, 24, 30, 42	











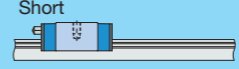

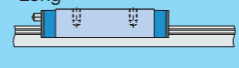

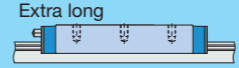
<b>5 Number of slide units</b>	: C○	For an assembled set, indicates the number of slide units assembled on a track rail. For a single slide unit, only "C1" is specified.
--------------------------------	------	---

<b>6 Length of track rail</b>	: R○	Indicate the length of track rail in mm. For standard and maximum lengths, see Table 3.1, Table 3.2, and Table 3.3.
-------------------------------	------	---

<b>7 Material type</b>	Stainless steel made	: No symbol	For applicable models and sizes, see Table 2.1 and Table 2.2.
	High carbon steel made	: CS	

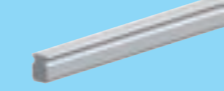
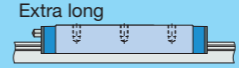

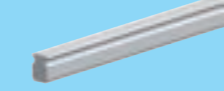



# Structure · Size · Number of Slide Unit · Length of Track Rail · Material Type —

Table 2.1 Models and sizes of standard type ML(F) and LWL(F) series

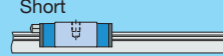
Types of track rails	Material type	Length of slide unit	Structure	Model	Size											
					1	2	3	5	7	9	12	15	20	25		
Standard rail specification 	Stainless steel made	Short 	Ball retained type	MLC	○	○	○	○	○	○	○	○	○	○	○	○
		LWLC...B		○	○	○	○	○	○	○	○	○	○	○		
		ML		○	○	○	○	○	○	○	○	○	○	○		
		LWL...B		○	○	○	○	○	○	○	○	○	○	○		
Tapped rail specification Mounting from bottom 	Stainless steel made	Long 	Ball retained type	MLG	○	○	○	○	○	○	○	○	○	○	○	
		LWLG...B		○	○	○	○	○	○	○	○	○	○			
Tapped rail specification Mounting from lateral 	Stainless steel made	Extra long 	Ball retained type	MLL	○	○	○	○	○	○	○	○	○	○	○	
		LWL...BCS		○	○	○	○	○	○	○	○	○	○			
Standard rail specification 	High carbon steel made	Standard 	Ball non-retained type	MLC	○	○	○	○	○	○	○	○	○	○	○	
		LWLC		○	○	○	○	○	○	○	○	○	○			
		MLC...N		○	○	○	○	○	○	○	○	○	○			
		LWLC...N		○	○	○	○	○	○	○	○	○	○			
Tapped rail specification Mounting from bottom 	Stainless steel made	Standard 	Ball non-retained type	ML	○	○	○	○	○	○	○	○	○	○	○	
		LWL		○	○	○	○	○	○	○	○	○	○			
Tapped rail specification Mounting from lateral 	Stainless steel made	Long 	Ball retained type	ML...N	○	○	○	○	○	○	○	○	○	○	○	
		LWL...N		○	○	○	○	○	○	○	○	○	○			
Solid rail specification 	Stainless steel made	Extra long 	Ball retained type	MLG...N	○	○	○	○	○	○	○	○	○	○	○	
		LWLG...N		○	○	○	○	○	○	○	○	○	○			
Tapped rail specification Mounting from lateral 	Stainless steel made	Standard 	Ball non-retained type	MLL...N	○	○	○	○	○	○	○	○	○	○	○	
		LWL...Y		○	○	○	○	○	○	○	○	○	○			
Solid rail specification 	Stainless steel made	Standard 	Ball non-retained type	LWL	○	○	○	○	○	○	○	○	○	○	○	

Remark: For the models indicated in  , the interchangeable specification is available.

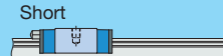
Table 2.2 Models and sizes of wide type ML(F) and LWL(F) series

Types of track rails	Material type	Length of slide unit	Structure	Model	Size							
					4	6	10	14	18	24	30	42
Standard rail specification 	Stainless steel made	Short 	Ball retained type	MLFC	-	-	○	○	○	○	○	○
				LWLF...B	-	-	○	○	○	○	○	○
		Ball non-retained type	MLFC	-	○	-	-	-	-	-	-	-
			LWLF	-	○	-	-	-	-	-	-	-
		Standard 	Ball retained type	MLF	-	-	○	○	○	○	○	○
				LWLF...B	-	-	○	○	○	○	○	○
	Ball non-retained type	MLF	-	○	-	-	-	-	-	-	-	
		LWLF	○	○	-	-	-	-	-	-	-	
	Long 	Ball retained type	MLFG	-	-	-	○	○	○	○	○	
			LWLF...B	-	-	-	○	○	○	○	○	
High carbon steel made	Standard 	Ball retained type	LWLF...BCS	-	-	-	-	○	○	○	○	
Tapped rail specification Mounting from bottom 	Stainless steel made	Short 	Ball retained type	MLFC...N	-	-	○	○	○	-	-	-
				LWLF...N	-	-	○	○	○	-	-	-
		Ball non-retained type	MLFC...N	-	○	-	-	-	-	-	-	-
			LWLF...N	-	○	-	-	-	-	-	-	-
		Standard 	Ball retained type	MLF...N	-	-	○	○	○	-	-	-
				LWLF...N	-	-	○	○	○	-	-	-
	Ball non-retained type	MLF...N	-	○	-	-	-	-	-	-	-	
		LWLF...N	-	○	-	-	-	-	-	-	-	
	Long 	Ball retained type	MLFG...N	-	-	-	○	○	-	-	-	
			LWLF...N	-	-	-	○	○	-	-	-	

Remark: For the models indicated in  , the interchangeable specification is available.

Table 3.1 Standard and maximum length of stainless steel track rail (Standard type)

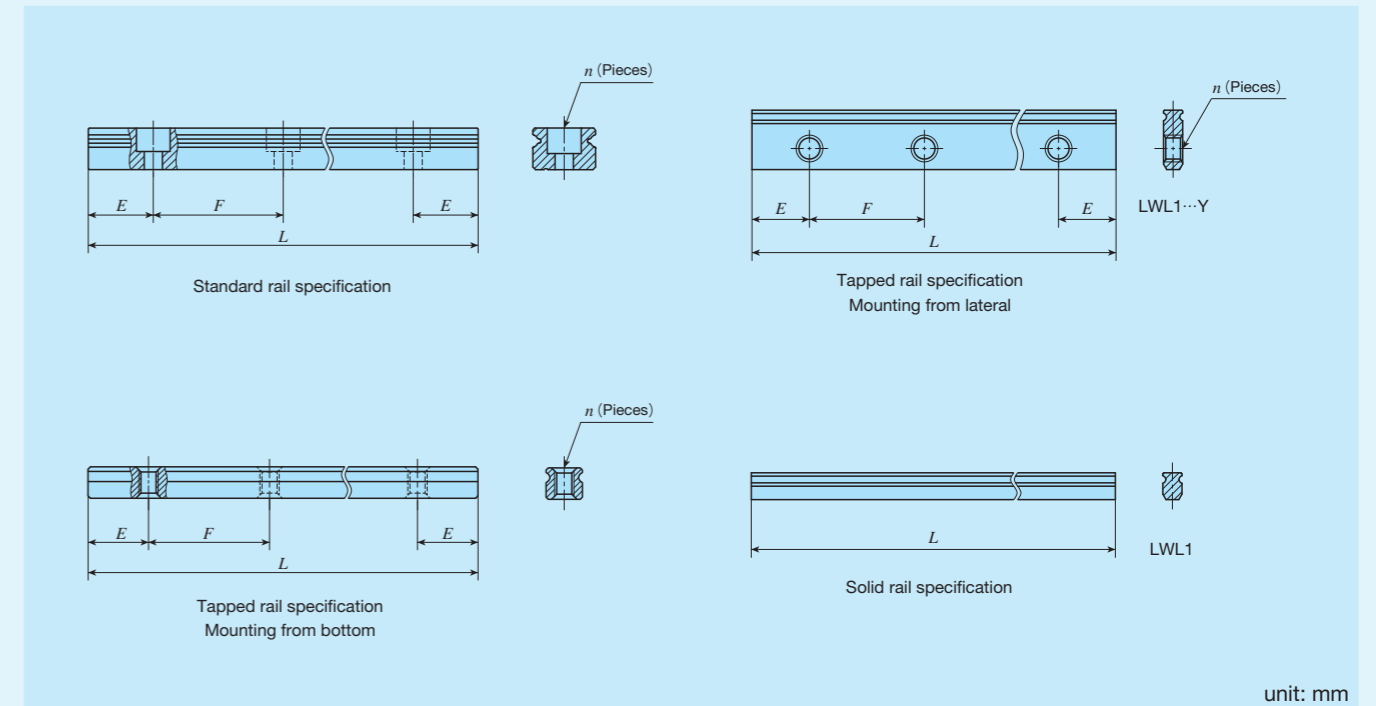

Item	Identification number						
	LWL1...Y	LWL1	LWL2	ML 3 LWL3	ML 5 LWL5...B	ML 7 LWL7...B	
Standard length $L$ ( $n$ )	18 ( 3)	18 ( -)	32 ( 4)	30 ( 3)	60 ( 4)	60 ( 4)	
	30 ( 5)	30 ( -)	40 ( 5)	40 ( 4)	90 ( 6)	90 ( 6)	
	42 ( 7)	42 ( -)	56 ( 7)	60 ( 6)	105 ( 7)	120 ( 8)	
			80 ( 10)	80 ( 8)	120 ( 8)	150 ( 10)	180 ( 12)
Pitch of mounting holes $F$	6	-	8	10	15	15	
$E$	3	-	4	5	7.5	7.5	
Standard $E$ or higher dimensions <sup>(1)</sup> below	2.5	-	2.5	3	4	4.5	
	5.5	-	6.5	8	11.5	12	
Maximum length <sup>(2)</sup>	102	102	104 (200)	150 (300)	210 (510)	300 (990)	
Maximum number of butt-jointing track rail <sup>(3)</sup>	-	-	-	-	5	7	
Maximum length of butt-jointing track rail <sup>(3)</sup>	-	-	-	-	915	1 905	
Item	Identification number						
	ML 9 LWL9...B	ML 12 LWL12...B	ML 15 LWL15...B	ML 20 LWL20...B	ML 25 LWL25...B		
Standard length $L$ ( $n$ )	60 ( 3)	100 ( 4)	160 ( 4)	180 ( 3)	240 ( 4)		
	80 ( 4)	150 ( 6)	240 ( 6)	240 ( 4)	300 ( 5)		
	120 ( 6)	200 ( 8)	320 ( 8)	320 ( 6)	360 ( 6)		
	160 ( 8)	275 ( 11)	440 ( 11)	480 ( 8)	480 ( 8)		
	220 ( 11)	350 ( 14)	560 ( 14)	660 ( 11)	660 ( 11)		
	280 ( 14)	475 ( 19)	680 ( 17)	840 ( 14)	900 ( 15)		
Pitch of mounting holes $F$	20	25	40	60	60		
$E$	10	12.5	20	30	30		
Standard $E$ or higher dimensions <sup>(1)</sup> below	4.5	5	5.5	8	9		
	14.5	17.5	25.5	38	39		
Maximum length <sup>(2)</sup>	860 (1 200)	1 000 (1 450)	1 000 (1 480)	960 (1 800)	960 (1 800)		
Maximum number of butt-jointing track rail <sup>(3)</sup>	2	2	2	2	2		
Maximum length of butt-jointing track rail <sup>(3)</sup>	1 660	1 925	1 880	1 740	1 740		

Notes <sup>(1)</sup> Not applicable to track rail with stopper pins (supplemental code "S").

<sup>(2)</sup> Length up to the value in ( ) can be produced. If needed, please contact **IKO**. Not applicable to tapped rail specification.

<sup>(3)</sup> Not applicable to interchangeable specifications or tapped rail specifications.

Remarks 1. A typical identification number is indicated, but is applied to all models of the same size.

2. Indicate "LWL...B" for the model code of the single track rail regardless of the series and the combination of slide unit models.

3. If not directed,  $E$  dimensions for both ends will be the same within the range of standard  $E$  dimensions. To change the dimensions, indicate the specified rail mounting hole positions "/ $E$ " of special specification. For more information, see page III-30.

Table 3.2 Standard and maximum length of stainless steel track rail (Wide type)

Item	Identification number	LWLF4	MLF 6 LWLF6	MLF 10 LWLF10...B	MLF 14 LWLF14...B
Standard length $L$ (n)		40 ( 4) 60 ( 6) 70 ( 7) 80 ( 8) 100 (10)	60 ( 4) 90 ( 6) 105 ( 7) 120 ( 8) 150 (10)	60 ( 3) 80 ( 4) 120 ( 6) 160 ( 8) 220 (11) 280 (14)	90 ( 3) 120 ( 4) 150 ( 5) 180 ( 6) 240 ( 8) 300 (10)
Pitch of mounting holes $F$		10	15	20	30
$E$		5	7.5	10	15
Standard $E$ or higher dimensions (1) below		3.5	4.5	4.5	5.5
Maximum length (2)		180 (300)	240 (300)	300 (500)	300 (990)
Maximum number of butt-jointing track rail (3)		—	—	7	8
Maximum length of butt-jointing track rail (3)		—	—	1 840	1 950
Item	Identification number	MLF 18 LWLF18...B	MLF 24 LWLF24...B	MLF 30 LWLF30...B	MLF 42 LWLF42...B
Standard length $L$ (n)		90 ( 3) 120 ( 4) 150 ( 5) 180 ( 6) 240 ( 8) 300 (10)	120 ( 3) 160 ( 4) 240 ( 6) 320 ( 8) 400 (10) 480 (12)	160 ( 4) 240 ( 6) 320 ( 8) 440 (11) 560 (14) 680 (17)	160 ( 4) 240 ( 6) 320 ( 8) 440 (11) 560 (14) 680 (17)
Pitch of mounting holes $F$		30	40	40	40
$E$		15	20	20	20
Standard $E$ or higher dimensions (1) below		5.5	6.5	6.5	6.5
Maximum length (2)		690 (1 860)	680 (1 960)	680 (2 000)	680 (2 000)
Maximum number of butt-jointing track rail (3)		3	3	3	3
Maximum length of butt-jointing track rail (3)		1 920	1 840	1 840	1 840

Notes (1) Not applicable to track rail with stopper pins (supplemental code "/S").

(2) Length up to the value in ( ) can be produced. If needed, please contact **IKO**. Not applicable to tapped rail specifications.

(3) Not applicable to interchangeable specifications or tapped rail specifications.

Remarks 1. A typical identification number is indicated, but is applied to all models of the same size.

2. Indicate "LWLF...B" for the model code of the single track rail regardless of the series and the combination of slide unit models.

3. If not directed,  $E$  dimensions for both ends will be the same within the range of standard  $E$  dimensions. To change the dimensions, indicate the specified rail mounting hole positions "/E" of special specification. For more information, see page III-30.

Table 3.3 Standard and maximum length of high carbon steel track rail (Standard type, Wide type)

Item	Identification number	LWL 9...BCS	LWL12...BCS	LWL15...BCS	LWL20...BCS
Standard length $L$ (n)		80 ( 4) 160 ( 8) 220 (11) 280 (14) 380 (19) 500 (25) 600 (30)	100 ( 4) 200 ( 8) 275 (11) 350 (14) 475 (19) 600 (24) 700 (28)	160 ( 4) 320 ( 8) 440 (11) 560 (14) 680 (17) 800 (20) 920 (23)	180 ( 3) 240 ( 4) 360 ( 6) 480 ( 8) 660 (11) 900 (15) 1 020 (17)
Pitch of mounting holes $F$		20	25	40	60
$E$		10	12.5	20	30
Standard $E$ or higher dimensions (1) below		4.5	5	5.5	8
Maximum length		1 000	1 500	1 520	1 560
Item	Identification number	LWLF18...BCS	LWLF24...BCS	LWLF30...BCS	LWLF42...BCS
Standard length $L$ (n)		90 ( 3) 180 ( 6) 240 ( 8) 300 (10) 420 (14) 510 (17) 600 (20)	120 ( 3) 240 ( 6) 320 ( 8) 400 (10) 600 (15) 720 (18) 800 (20)	160 ( 4) 320 ( 8) 440 (11) 560 (14) 680 (17) 800 (20) 920 (23)	160 ( 4) 320 ( 8) 440 (11) 560 (14) 680 (17) 800 (20) 920 (23)
Pitch of mounting holes $F$		30	40	40	40
$E$		15	20	20	20
Standard $E$ or higher dimensions (1) below		5.5	6.5	6.5	6.5
Maximum length		1 500	1 520	1 600	1 600

Note (1) Not applicable to track rail with stopper pins (supplemental code "/S").

Remarks 1. A typical identification number is indicated, but is applied to all models of the same size.

2. If not directed,  $E$  dimensions for both ends will be the same within the range of standard  $E$  dimensions. To change the dimensions, indicate the specified rail mounting hole positions "/E" of special specification. For more information, see page III-30.

— Preload Amount —

<b>8 Preload amount</b>	Clearance	: T <sub>0</sub>	Specify this item for an assembled set or a single slide unit. For details of the preload amount, see Table 4. For applicable preload types, see Table 5.1 and Table 5.2.
	Standard	: No symbol	
	Light preload	: T <sub>1</sub>	

Table 4 Preload amount

Preload type	Item	Preload symbol	Preload amount N	Operational conditions
Clearance		T <sub>0</sub>	0 <sup>(1)</sup>	• Very light motion
Standard		(No symbol)	0 <sup>(2)</sup>	• Light and precise motion
Light preload		T <sub>1</sub>	0.02 C <sub>0</sub>	• Almost no vibrations • Load is evenly balanced • Light and precise motion

Notes <sup>(1)</sup> There is zero or subtle clearance.

<sup>(2)</sup> Indicates zero or minimal amount of preload.

Remark: C<sub>0</sub> indicates the basic static load rating.

Table 5.1 Application of preload (Standard type)

Size	Preload type (preload symbol)		
	Clearance (T <sub>0</sub> )	Standard (No symbol)	Light preload (T <sub>1</sub> )
1	○	—	—
2	○	—	—
3	○	—	—
5	○	○	—
7	○ <sup>(1)</sup>	○	○ <sup>(1)</sup>
9	○ <sup>(1)</sup>	○	○ <sup>(1)</sup>
12	○ <sup>(1)</sup>	○	○ <sup>(1)</sup>
15	○ <sup>(1)</sup>	○	○ <sup>(1)</sup>
20	○	○	○
25	○	○	○

Note <sup>(1)</sup> Not applicable when /HB is specified.

Remark: The mark  indicates that interchangeable specification products are available.

Table 5.2 Application of preload (Wide type)

Size	Preload type (preload symbol)		
	Clearance (T <sub>0</sub> )	Standard (No symbol)	Light preload (T <sub>1</sub> )
4	○	—	—
6	○	—	—
10	○	○	—
14	○	○	○
18	○	○	○
24	○	○	○
30	○	○	○
42	○	○	○

Remark: The mark  indicates that interchangeable specification products are available.

— Accuracy class —

<b>9 Accuracy class</b>	High	: H	For interchangeable specification products, assemble a slide unit and a track rail of the same accuracy class. Size 1 series have "No symbols." For the details of accuracy class, see Table 6.1 and 6.2.
	Precision	: P	

Table 6.1 Tolerance and allowable values (Series of size 1)

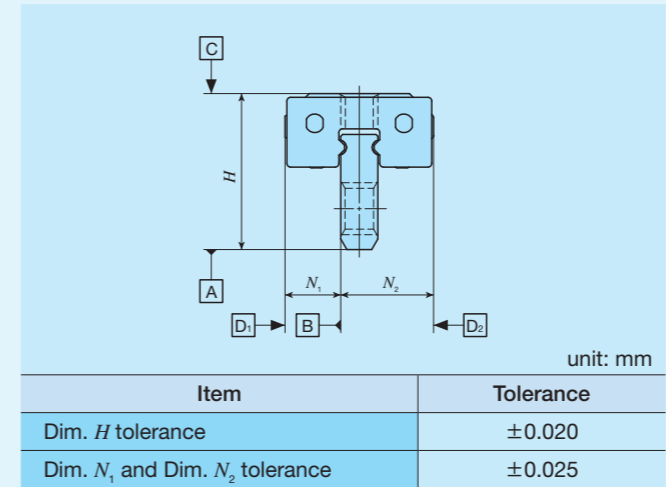
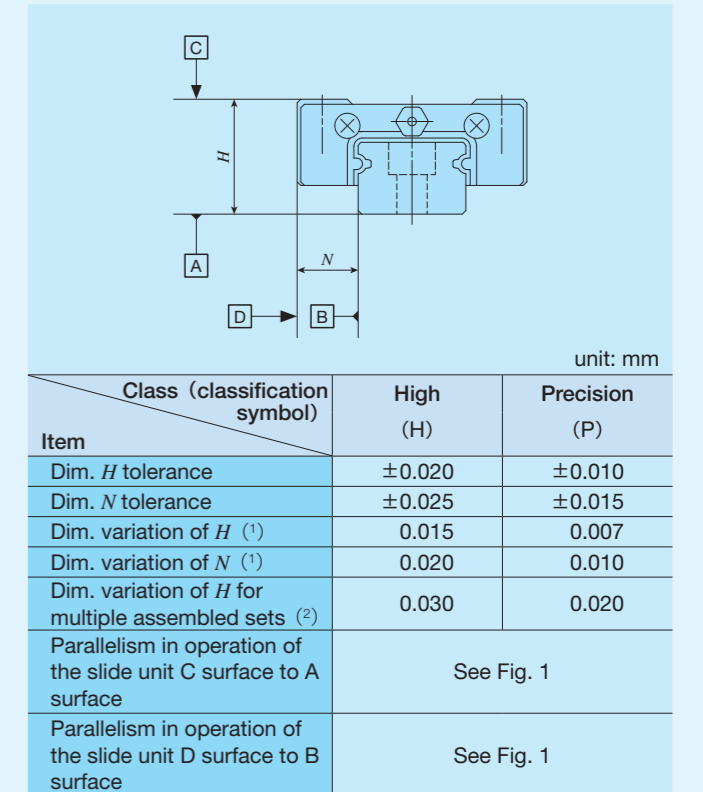
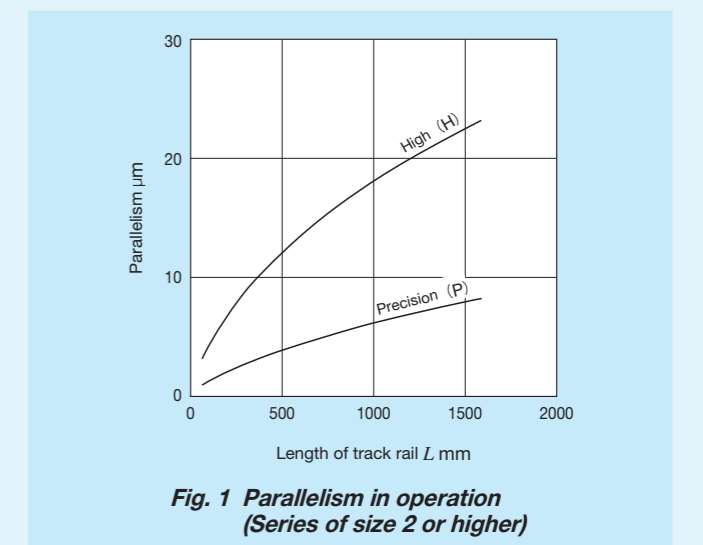

Table 6.2 Tolerance and allowance (Series of size 2 or higher)



Notes <sup>(1)</sup> It means the size variation between slide units mounted on the same track rail.

<sup>(2)</sup> Applicable to the interchangeable specification.





10 Interchangeable	S1 specification	: S1	This is specified for the interchangeable specifications. Assemble a track rail and a slide unit with the same interchangeable code. Performance and accuracy of "S1" and "S2" are the same. For applicable models and sizes, see Table 2.1 and Table 2.2. "No symbol" is indicated for non-interchangeable specification.
	S2 specification	: S2	
	Non-interchangeable specification	: No symbol	

11 Special specification	/A, /BS, /D, /E, /HB, /I, /LR, /MN, /N, /Q, /RE, /S, /U, /W○, /Y○	For applicable special specifications, see Tables 7.1, 7.2, 7.3, and 7.4. For combination of multiple special specifications, see Table 8. For details of special specification, see page III-29.
--------------------------	---	---

Table 7.1 Application of special specifications (Interchangeable specification, single slide unit)

Special specification	Supplemental code	Size									
		1	2	3	5	7	9	12	15	20	25
No end seal	/N	-	-	-	○	○	○	○	○	○	○
With C-Lube plate <sup>(1)</sup>	/Q	-	-	-	○	○	○	○	○	○	○
Under seal	/U	-	-	-	×	×	○	○	○	○	○

Note <sup>(1)</sup> Applicable to LWW(F) series.

Table 7.2 Application of special specifications (Interchangeable specification, single track rail)

Special specification	Supplemental code	Size									
		1	2	3	5	7	9	12	15	20	25
Specified rail mounting hole positions	/E	-	-	-	○	○	○	○	○	○	○
Without track rail mounting bolt	/MN	-	-	-	○	○	○	○	○	○	○

Table 7.3 Application of special specifications (Interchangeable specification, assembled set)

Special specification	Supplemental code	Size									
		1	2	3	5	7	9	12	15	20	25
Opposite reference surfaces arrangement	/D	-	-	-	○	○	○	○	○	○	○
Specified rail mounting hole positions	/E	-	-	-	○	○	○	○	○	○	○
Without track rail mounting bolt <sup>(1)</sup>	/MN	-	-	-	○	○	○	○	○	○	○
No end seal	/N	-	-	-	○	○	○	○	○	○	○
With C-Lube plate <sup>(2)</sup>	/Q	-	-	-	○	○	○	○	○	○	○
Under seal	/U	-	-	-	×	×	○	○	○	○	○

Notes <sup>(1)</sup> Not applicable to tapped rail specification.

<sup>(2)</sup> Applicable to LWL(F) series.

Table 7.4 Application of special specifications (Non-interchangeable specification)

Special specification	Supplemental code	Size									
		1	2	3	5	7	9	12	15	20	25
Butt-jointing track rails <sup>(1)</sup> <sup>(2)</sup>	/A	×	×	×	○	○	○	○	○	○	○
Stainless steel end plate <sup>(3)</sup>	/BS	×	○ <sup>(5)</sup>	○ <sup>(5)</sup>	○	○	○	○	○	○	×
Opposite reference surfaces arrangement	/D	×	○	○	○	○	○	○	○	○	○
Specified rail mounting hole positions	/E	×	○	○	○	○	○	○	○	○	○
Hybrid C-Lube Linear Way	/HB	×	×	×	×	○ <sup>(6)</sup>	○ <sup>(6)</sup>	○ <sup>(6)</sup>	○ <sup>(6)</sup>	×	×
Inspection sheet	/I	×	○	○	○	○	○	○	○	○	○
Black chrome surface treatment (track rail)	/LR	×	×	×	×	○	○	○	○	○	○
Without track rail mounting bolt <sup>(2)</sup>	/MN	×	○ <sup>(7)</sup>	○ <sup>(7)</sup>	○	○	○	○	○	○	○
No end seal	/N	×	×	×	○	○	○	○	○	○	○
With C-Lube plate <sup>(3)</sup>	/Q	×	×	×	○	○	○	○	○	○	○
Special environment seal <sup>(3)</sup>	/RE	×	×	×	○	○	○	○	○	○	×
Track rail with stopper pins	/S	×	×	×	○	○	○	○	○	○	○
Under seal	/U	×	×	×	×	×	○	○	○	○	○
A group of multiple assembled sets	/W○	×	○	○	○	○	○	○	○	○	○
Specified grease <sup>(4)</sup>	/Y○	×	○ <sup>(8)</sup>	○	○	○	○	○	○	○	○

Notes <sup>(1)</sup> Not applicable to high carbon steel made products.

<sup>(2)</sup> Not applicable to tapped rail specification.

<sup>(3)</sup> Applicable to LWL(F) series. / YCG is applicable to ML(F) series.

<sup>(4)</sup> ML(F) series is applicable only to /YCG.

<sup>(5)</sup> Not applicable to size 4 and 6 series.

<sup>(6)</sup> Applicable to size 7, 9, 12, and 15 of ML series.

<sup>(7)</sup> Not applicable to size 2 and 3 series.

<sup>(8)</sup> Applicable only to /YNG.

Table 8 Combination of supplemental codes

BS	○														
D	○	○													
E	-	○	-												
HB	○	-	○	○											
I	○	○	○	○	○										
LR	-	○	○	○	○	○									
MN	○	○	○	○	○	○	○								
N	○	○	○	○	○	○	○	○							
Q	○	○	○	○	-	○	○	○	○						
RE	○	○	○	○	-	○	○	○	○	-	○				
S	○	○	○	○	○	○	○	○	○	○	○				
U	○	○	○	○	○	○	○	○	○	-	○	-	○		
W	○	○	○	-	○	○	○	○	○	○	○	○	○	○	
Y	○	○	○	○	-	○	○	○	○	-	○	○	○	○	○
A	BS	D	E	HB	I	LR	MN	N	Q	RE	S	U	W		

Remarks 1. The combination of " - " shown in the table is not available.

2. When using multiple types for combination, please indicate by arranging the symbols in alphabetical order.

**Table 9 Dimension of slide unit with C-Lube plate (Supplemental code /Q)**

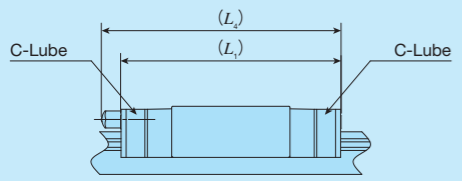

unit: mm

Identification number	$L_1$	$L_4$	Identification number	$L_1$	$L_4$
LWLC 5...B	22	—	LWLFC 10...B	26.5	—
LWL 5...B	25	—	LWLFC 10...B	30.5	—
LWLC 7...B	27	—	LWLFC 14...B	30.5	—
LWL 7...B	31.5	—	LWLFC 14...B	39.5	—
LWLG 7...B	39	—	LWLFC 14...B	50	—
LWLC 9...B	30	—	LWLFC 18...B	34.5	—
LWL 9...B	39	—	LWLFC 18...B	46.5	—
LWLG 9...B	49	—	LWLFC 18...B	58.5	—
LWLC 12...B	33	—	LWLFC 24...B	38.5	—
LWL 12...B	42	—	LWLFC 24...B	52	—
LWLG 12...B	52	—	LWLFC 24...B	67	—
LWLC 15...B	42	47	LWLFC 30...B	45.5	50
LWL 15...B	52	57	LWLFC 30...B	59.5	64
LWLG 15...B	67	72	LWLFC 30...B	78.5	83
LWLC 20...B	48	53	LWLFC 42...B	51.5	56
LWL 20...B	60	65	LWLFC 42...B	65	70
LWLG 20...B	78	83	LWLFC 42...B	84.5	89
LWLC 25...B	63.5	74			
LWL 25...B	87.5	98			
LWLG 25...B	107.5	117			

Remarks 1. The dimensions of the slide unit with C-Lube at both ends are indicated.  
 2. A typical identification number is indicated, but is applied to all LWL(F) series models of the same size.

**Table 10 Load rating / static moment rating of Hybrid C-Lube Linear Way (Supplemental code /HB)**

Identification number	C N	$C_0$ N	$T_0$ N·m	$T_x^{(1)}$ N·m	$T_y^{(1)}$ N·m
MLC 7.../HB	937	965	3.5	1.6 12.6	1.3 10.6
ML 7.../HB	1 330	1 610	5.9	4.0 23.9	3.3 20.1
MLG 7.../HB	1 690	2 250	8.2	7.5 43.1	6.3 36.2
MLC 9.../HB	1 180	1 260	5.9	2.4 18.2	2.1 15.3
ML 9.../HB	1 810	2 340	10.9	7.7 43.4	6.5 36.4
MLG 9.../HB	2 370	3 420	15.9	15.9 83.6	13.4 70.1
MLL 9.../HB	2 870	4 500	20.9	27.1 134	22.7 112
MLC 12.../HB	2 210	2 030	12.6	4.5 35.5	3.8 29.8
ML 12.../HB	3 330	3 650	22.6	13.1 79.2	11.0 66.4
MLG 12.../HB	4 310	5 270	32.7	26.0 143	21.9 120
MLL 12.../HB	5 820	8 110	50.3	59.3 288	49.8 242
MLC 15.../HB	3 490	3 310	25.5	9.9 71.8	8.3 60.3
ML 15.../HB	4 980	5 520	42.5	25.3 146	21.2 122
MLG 15.../HB	6 620	8 280	63.7	54.3 288	45.5 241
MLL 15.../HB	8 370	11 600	89.2	104 497	86.9 417

Note (1) The upper values of  $T_x$  and  $T_y$  are for one slide unit and the lower values are for two slide units in close contact.

**Table 11 Dimension of track rail with stopper pins (Supplemental code /S)**

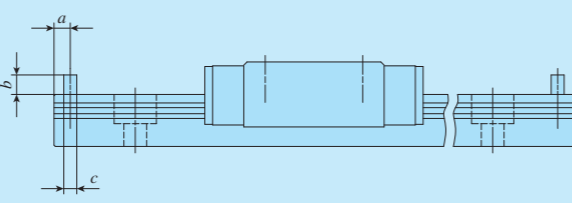

unit: mm

Size	$a$	$b$	$c$
5	—	2	1.6
7	—	2.5	2
9	—	3	2
—	10	2	1.6
12	—	3	2
—	14	3	2
15	—	4	2
—	18	3	2
20	—	5	2
—	24	3	2
25	—	5	2
—	30	4	2
—	42	5	2

**Table 12  $H_1$  dimension with under seal (Supplemental code /U)**

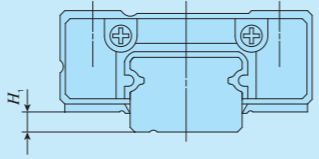

unit: mm

Size	$H_1$
9	—
12	—
15	—
—	18
20	—
—	24
25	—
—	30
—	42

Note (1) The dimensions are the same as those before mounting of under seal.

## Lubrication

Lithium-soap base grease (MULTEMP PS No.2 [KYODO YUSHI CO., LTD.]) is pre-packed in ML(F) and LWL(F) series. Additionally, ML(F) series has C-Lube placed in the recirculation part of balls, so that the interval for reapplying lubricant can be extended and maintenance works such as grease job can be reduced significantly.

ML(F) series and LWL(F) series have grease nipple or oil hole as indicated in Table 14. Since the Size 1, 2, 3, 4 and 6 series do not have an oil hole, apply grease directly to the raceway part of the track rail for re-greasing. Supply nozzles fit to each shapes of grease nipple and dedicated supplying equipment (miniature greasers) fit to oil holes are also available. For order of these parts for lubrication, see Table 13 and Table 14.1 on Page III-23, and Table 15 on page III-24.

**Table 13 Oil hole specifications**

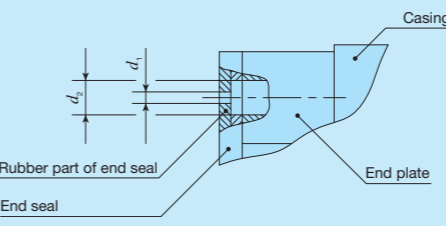

unit: mm

Size	$d_1$	$d_2$
5	10	1.1
7	14	1.2
9	18	1.5
12	24	2

**Table 14 Parts for lubrication**

Size	Grease nipple type (1)	Applicable supply nozzle type	Bolt size of female threads for piping
5, 7, 9, 12	10, 14, 18, 24	Oil hole	Miniature greaser
15, 20	30, 42	A-M3	A-5120V A-5240V B-5120V B-5240V
25	—	B-M4	A-8120V B-8120V

Note (1) For grease nipple specification, see Table 14.1 on page III-23.

Remark: Stainless steel grease nipple is also available. If needed, please contact **IKO**.

## Dust Protection

The slide units of ML(F) series and LWL(F) series are equipped with end seals as standard for dust protection. However, if large amount of contaminant or dust are floating, or if large particles of foreign substances such as chips or sand may adhere to the track rail, it is recommended to attach a protective cover to the linear motion mechanism.



No end seal is provided for size 1, 2, 3, 4 or 6 series. For applications in the environment not clean enough, cover the entire unit with a protective case, etc. to prevent harmful foreign substances such as dust and particles from outside to enter.

# Precaution for Use

## ① Mounting surface, reference mounting surface and general mounting structure

When mounting the ML(F) series and LWL(F) series, properly align the reference mounting surfaces B and D (D1 or D2) of the track rail and slide unit with the reference mounting surface of the table and bed and fix them. (See Fig. 2)

Reference mounting surfaces B and D (D1 or D2) and mounting surfaces A and C are precisely ground. By machining the mounting surface of the mating member, such as machine or device, to high accuracy and mounting them properly, stable linear motion with high accuracy is obtained.

Reference mounting surface of the slide unit of size 2 or higher is the opposite side of the  mark. The track rail reference mounting surface is identified by locating the  mark on the top surface of the track rail. It is the side surface above the mark (in the direction of the arrow). (See Fig. 5.2)

Reference mounting surface of the slide unit of size 1 is located at both right and left sides (D1 and D2). (See Fig. 5.1)

The track rail of LWL1...Y has the mounting structure of lateral direction. Two types of mounting structure as shown in Fig. 3.1 and Fig. 3.2 are available.

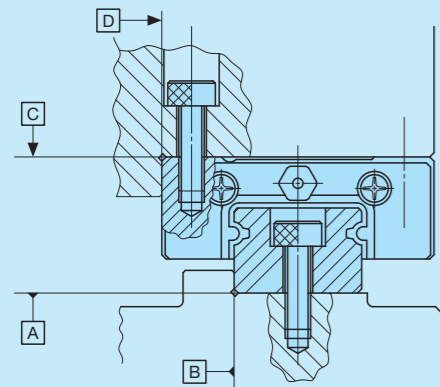

Fig. 2 Reference mounting surface and typical mounting structure

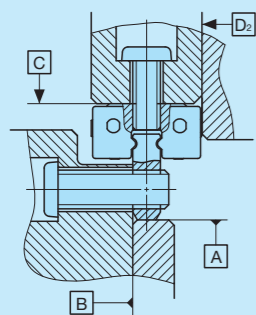

Fig. 3.1 Reference mounting surface of LWL1...Y and typical mounting structure ①

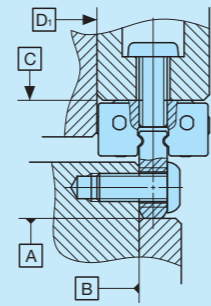

Fig. 3.2 Reference mounting surface of LWL1...Y and typical mounting structure ②

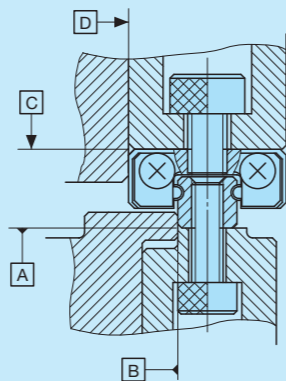

Fig. 4 Reference mounting surface of size 2, 3, 4 and 6 series and typical mounting structure

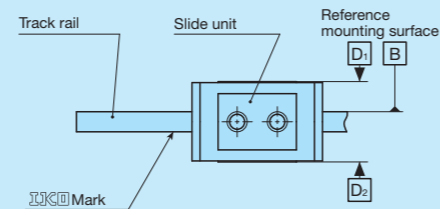

Fig. 5.1 Reference mounting surface of series size 1 or higher

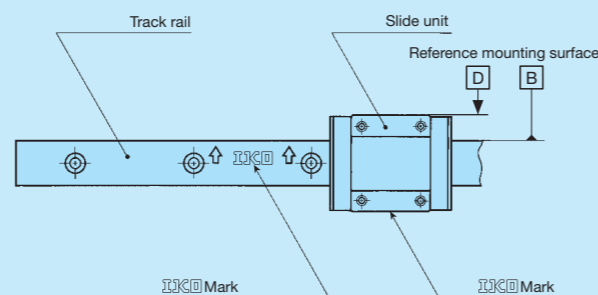

Fig. 5.2 Reference mounting surface of series size 2 or higher

## ② Mounting screws for slide unit

To mount a slide unit, tightly fasten the bolt against female thread of slide unit.

The female thread is created through holes of the slide unit for size 1 series, and also through holes for the slide unit and track rail for size 2, 3, 4 and 6 series. When the fixing thread depth of the mounting screw goes too deep, it can interfere with the track rail and impact the running accuracy or product life so that the fixing thread depth should be within the screwing depth specified in the dimension table.

Also prepare the small screws dedicated to precision devices (head diameter 1.8 mm or smaller) for the mounting bolt of slide unit of size 1.

## ③ Mounting screws for track rail

In the size 2 and 3 series and tapped rail specifications, track rail mounting bolts are not appended. Prepare mounting bolts whose fixing thread depth is less than  $H_4$  in dimension table.

## ④ Shoulder height and corner radius of the reference mounting surface

For the opposite corner of the mating reference mounting, it is recommended to have relieved fillet as indicated in Fig. 6. Recommended value for the shoulder height on the mating side is indicated in Table 16.

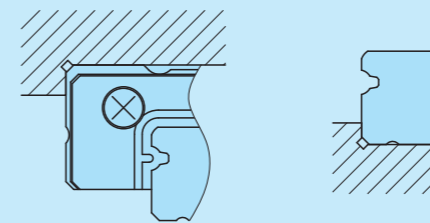

Fig. 6 Corner of the mating reference mounting

## ⑤ Tightening torque for fixing screw

Typical tightening torque for mounting ML(F) series and LWL(F) series to the steel mating member material is indicated in Table 15. When vibration and shock of the machine or device are large, fluctuating load is large, or moment load is applied, fix it by using the torque 1.2 to 1.5 times larger than the value indicated in the table as necessary. If the mating member material is cast iron or aluminum alloy, reduce the tightening torque depending on the strength characteristics of the mating member material.

Table 15 Tightening torque for fixing screw

Bolt size	Tightening torque N · m	
	Stainless steel-made screw	High carbon steel-made screw
M1 ×0.25	0.04	—
M1.4×0.3	0.10	—
M1.6×0.35	0.15	—
M2 ×0.4	0.31	—
M2.5×0.45	0.62	—
M3 ×0.5	1.1	1.3
M4 ×0.7	2.5	2.9
M5 ×0.8	5.0	5.7
M6 ×1	8.5	—

Remarks 1. The tightening torque is calculated based on strength division 8.8 and property division A2-70.

2. It is recommended that the tightening torque of slide unit mounting holes for series size 1 is to be 70 to 80 % of the values in the table.

Table 16 Shoulder height and corner radius of the reference mounting surface

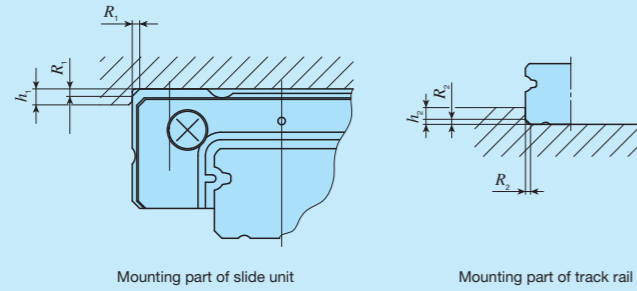

unit: mm

Identification number		Mounting part of slide unit		Mounting part of track rail	
		Shoulder height $h_1$	Corner radius $R_1$ (Maximum)	Shoulder height $h_2$ <sup>(1)</sup>	Corner radius $R_2$ (Maximum)
—	LWL 1··Y	1.3	—	2	—
—	LWL 1			—	
—	LWL 2	1	0.1	0.5	0.05
ML 3	LWL 3	1.2	0.15	0.8	0.1
ML 5	LWL 5··B	2	0.3	0.8	0.2
ML 7	LWL 7··B	2.5	0.2	1.2	0.2
ML 9	LWL 9··B	3	0.2	1.5	0.2
—	LWL 9··BCS		0.4		
ML 12	LWL 12··B	4	0.2	2.5	0.2
—	LWL 12··BCS		0.4		
ML 15	LWL 15··B	4.5	0.2	3	0.2
—	LWL 15··BCS		0.4		
ML 20	LWL 20··B	5	0.2	4	0.2
—	LWL 20··BCS		0.4		
ML 25	LWL 25··B	6.5	0.7	4	0.7
—	LWLF 4	1.5	0.1	0.8	0.1
MLF 6	LWLF 6	2	0.1	0.8	0.1
MLF 10	LWLF 10··B	2	0.3	1.2	0.2
MLF 14	LWLF 14··B	2.5	0.2	1.2	0.2
MLF 18	LWLF 18··B	3	0.2	2.5	0.2
—	LWLF 18··BCS		0.4		
MLF 24	LWLF 24··B	4	0.2	2.5	0.2
—	LWLF 24··BCS		0.4		
MLF 30	LWLF 30··B	4.5	0.2	2.5	0.2
—	LWLF 30··BCS		0.4		
MLF 42	LWLF 42··B	5	0.2	3	0.2
—	LWLF 42··BCS		0.4		

Note <sup>(1)</sup> For models with under seals (supplemental code "U"), it is recommended to use the values 1mm smaller than the values in the table. However for the models of size 9 with under seal, 0.8 mm is recommended.

Remark: A typical identification number is indicated, but is applied to all models of the same size.

## Mounting Bolt

For LWL(F) series, track rail mounting bolt of slide unit and tapped rail specification shown in Table 17 and Table 18 are available. If these parts are necessary, please contact **IKO**.

Table 17 Cross-recessed pan head screw for precision equipment

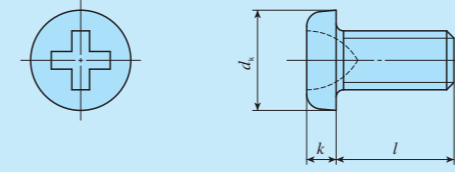

unit: mm

Bolt size $(d)$	Pitch of screw $P$	$d_k$	$k$	$l$
M1	0.25	1.8	0.45	3, 4, 5
M1.4 <sup>(1)</sup>	0.3	2.5	0.8	2.5, 3, 4
M1.6 <sup>(1)</sup>	0.35	2.8	0.85	4, 5, 6
M2 <sup>(1)</sup>	0.4	3.5	1	3, 4, 5

Note <sup>(1)</sup> Based on cross-recessed head screw for precision equipment (Number 0) in Japan Camera Industry Standard JCIS 10-70.

Remark: The dimensions are different from the appended track rail mounting bolts.

Table 18 Hexagon socket head bolt

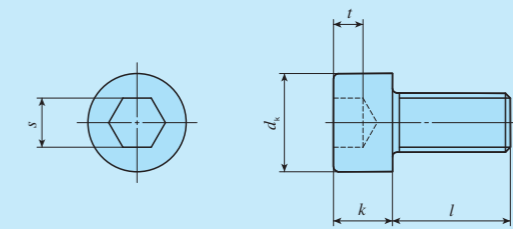

unit: mm

Bolt size $(d)$	Pitch of screw $P$	$d_k$	$k$	$s$	$t$	$l$
M1.4	0.3	2.6	1.4	1.3	0.6	2.5, 3, 4
M1.6 <sup>(1)</sup>	0.35	3	1.6	1.5	0.7	4, 5, 6
M2 <sup>(1)</sup>	0.4	3.8	2	1.5	1	3, 4, 5

Note <sup>(1)</sup> Based on hexagon socket head bolts equivalent to JIS B 1176.

# IKO C-Lube Linear Way ML

Standard type											
Shape	<b>ML • LWL</b>										
Size	<table border="1"> <tr> <td>1</td> <td>2</td> <td>3</td> <td>5</td> <td>7</td> </tr> <tr> <td>9</td> <td>12</td> <td>15</td> <td>20</td> <td>25</td> </tr> </table>	1	2	3	5	7	9	12	15	20	25
1	2	3	5	7							
9	12	15	20	25							

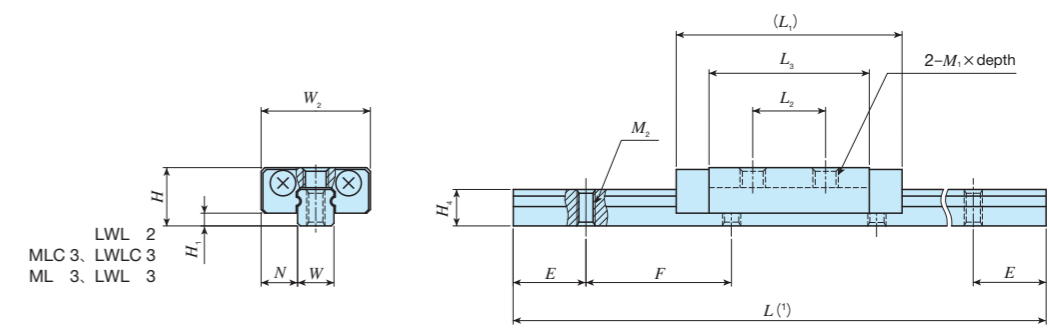
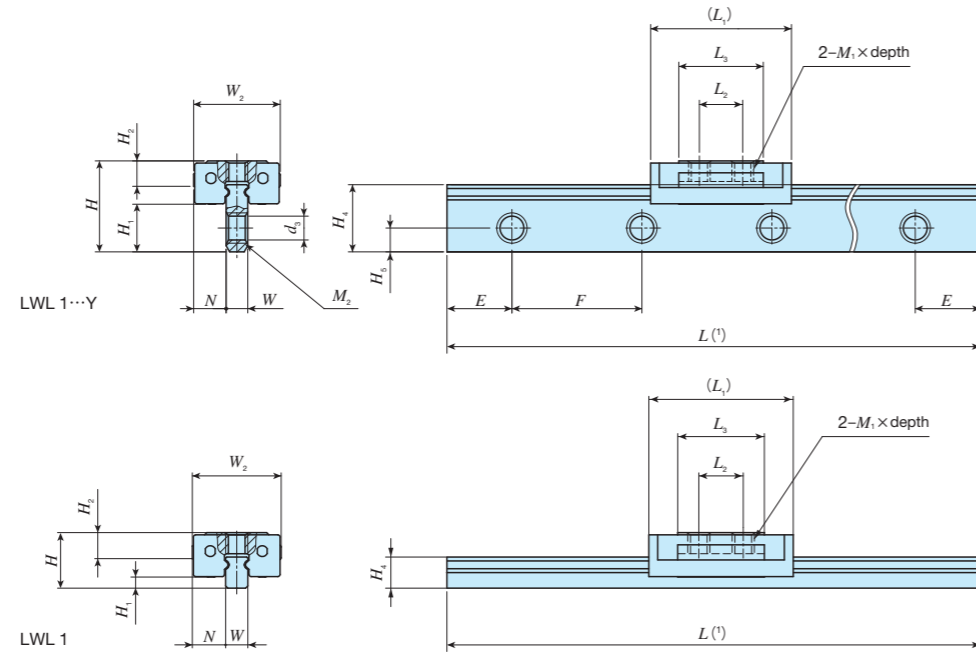

Identification number	Interchangeable	Mass (Ref.) g		Dimensions of assembly mm			Dimensions of slide unit mm						Dimensions of track rail mm						Mounting bolt for track rail (2) mm	Basic dynamic load rating (5) C N	Basic static load rating (5) C <sub>0</sub> N	Static moment rating (5) N·m				
		Slide unit	Track rail (per 100 mm)	H	H <sub>1</sub>	N	W <sub>2</sub>	L <sub>1</sub>	L <sub>2</sub>	L <sub>3</sub>	M <sub>1</sub> × depth	H <sub>2</sub>	W	H <sub>4</sub>	H <sub>5</sub>	M <sub>2</sub>	d <sub>3</sub>	E				F	Bolt size × ℓ	T <sub>0</sub>	T <sub>x</sub>	T <sub>y</sub>
—	LWL 1...Y	—	0.16	2.1	4.2	2.2	1.5	4	6.5	2	3.9	M1 × 0.9	1.2	—	—	—	—	—	—	—	M1 × ℓ or M1.4 × ℓ (3)	66.8	113	0.06	0.07	0.56
—	LWL 1	—	—	1.0	2.5	0.5	—	—	—	—	—	—	—	—	—	—	—	—	—	—	—	—	—	—	—	
—	LWL 2	—	0.9	2.8	3.2	0.7	2	6	12.5	4	8.8	M1.4 × 1.1	—	—	—	—	—	—	—	—	M1 × ℓ (4)	211	381	0.42	0.54	0.64
MLC 3	LWLC 3	—	0.9	5.3	4	1	2.5	8	10.5	3.5	7	M1.6 × 1.3	—	—	—	—	—	—	—	—	M1.6 × ℓ (4)	272	406	0.65	0.49	0.58
—	LWLC 3	—	1.0						11.5		6.7											2.7	0.47	3.2		
ML 3	LWL 3	—	1.3	5.3	4	1	2.5	8	14.5	5.5	11	M2 × 1.3	—	—	—	—	—	—	—	—	M1.6 × ℓ (4)	371	632	1.0	1.1	1.3
—	LWL 3	—	1.6						15.5		10.7											5.6	6.6			

- Notes (1) Track rail lengths *L* are shown in Table 3.1 on page II-10.  
 (2) Track rail mounting bolts are not appended.  
 (3) Prepare screws according to mounting structure.  
 (4) Choose screws whose dimension allow fixing thread depth into track rail *ℓ* to be less than *H<sub>4</sub>*.  
 (5) The direction of basic dynamic load rating (*C*), basic static load rating (*C<sub>0</sub>*), and static moment rating (*T<sub>0</sub>*, *T<sub>x</sub>*, *T<sub>y</sub>*) are shown in the sketches below.  
 The upper values of *T<sub>x</sub>* and *T<sub>y</sub>* are for one slide unit and the lower values are for two slide units in close contact.
- Remarks 1. Metal parts are made of stainless steel.  
 2. Do not disassemble a slide unit from the track rail because steel balls are not retained. No end seal is attached.  
 3. The specification of small size mounting bolts (M2 and less) are show on page II-22. If needed, please contact IKO.

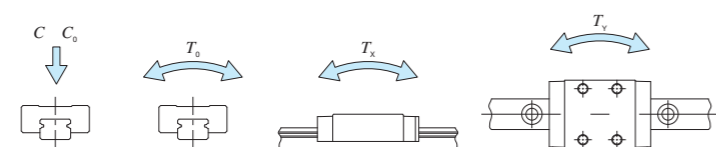

**Example of identification number of assembled set**

Model code	Dimensions	Part code	Model code	Preload symbol	Classification symbol	Supplemental code
LWL	2	C2 R80		T <sub>0</sub>	P	/D
①	②	③	④	⑤	⑥	⑦

① Model	③ Size	⑥ Preload amount	⑧ Special specification
ML LWL LWL...Y	1, 2, 3	T <sub>0</sub> Clearance	BS, D, E, I, W, Y
② Length of slide unit	④ Number of slide unit (2)	⑦ Accuracy class	
C No symbol		No symbol H P	Ordinary High Precision
Standard	⑤ Length of track rail (80 mm)		

# IKO C-Lube Linear Way ML

Standard type											
Shape	ML • LWL										
Size	<table border="1"> <tr> <td>1</td> <td>2</td> <td>3</td> <td>5</td> <td>7</td> </tr> <tr> <td>9</td> <td>12</td> <td>15</td> <td>20</td> <td>25</td> </tr> </table>	1	2	3	5	7	9	12	15	20	25
1	2	3	5	7							
9	12	15	20	25							

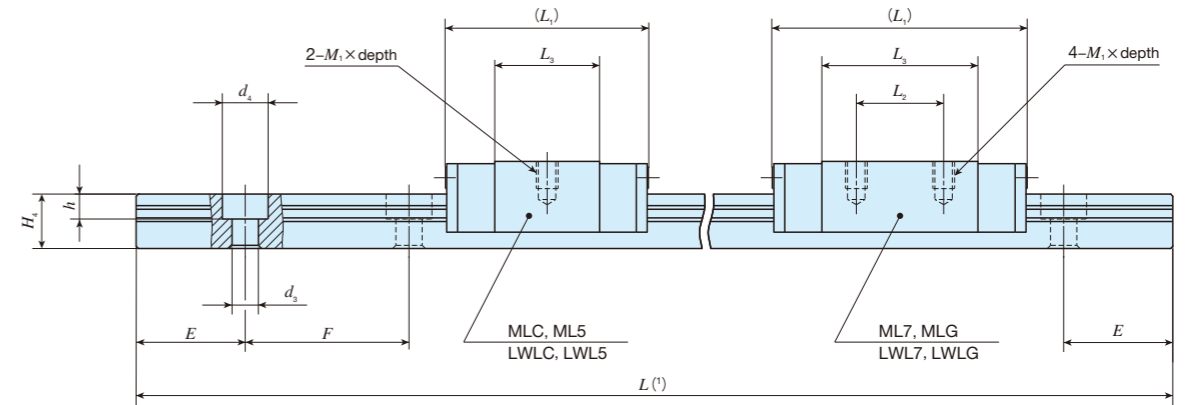
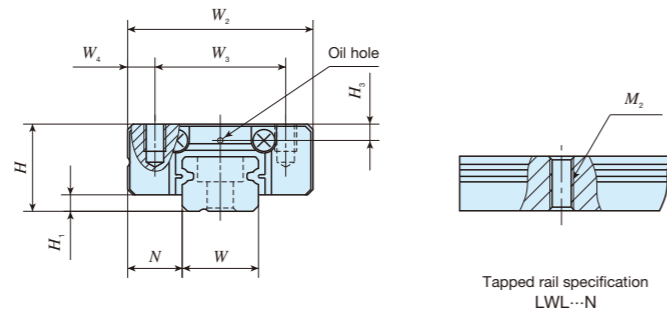

Identification number	Interchangeable	Mass (Ref.) g		Dimensions of assembly mm			Dimensions of slide unit mm							Dimensions of track rail mm						Appended mounting bolt for track rail mm	Basic dynamic load rating (4) C N	Basic static load rating (4) C0 N	Static moment rating (4) N·m																												
		Slide unit	Track rail (per 100 mm)	H	H1	N	W2	W3	W4	L1	L2	L3	M1 × depth	H3	W	H4	M2	d3	d4				h	E	F	T0	Tx	Ty																							
MLC 5	LWLC 5...B	○	3.4	12	6	1	3.5	12	8	2	16	-	9.6	M2 × 1.5	1.2	5	3.7	-	2.4	3.6	0.8	7.5	15	Cross-recessed pan head screw for precision equipment M2 × 6	562	841	2.2	1.4 8.5	1.2 7.2																						
MLC 5...N*	LWLC 5...N*	-	13																																																
ML 5	LWL 5...B	○	4.3	12																																								Cross-recessed pan head screw for precision equipment M2 × 6	676	1 090	2.9	2.3 12.8	1.9 10.8		
ML 5...N*	LWL 5...N*	-	4.4	13																																															
MLC 7	LWLC 7...B	○	6.7	22	8	1.5	5	17	12	2.5	19	-	9.6	M2 × 2.5	1.5	7	5	-	2.4	4.2	2.3	7.5	15	Hexagon socket head bolt M2 × 6	937	1 140	4.1	1.8 14.9	1.5 12.5																						
MLC 7...N*	LWLC 7...N*	-	6.7	24																																								Hexagon socket head bolt M2 × 6	1 330	1 890	6.9	4.7 28.2	3.9 23.6		
ML 7	LWL 7...B	○	9.1	22																																															
ML 7...N*	LWL 7...N*	-	9.1	24																																															
MLG 7	LWLG 7...B	○	13	22							31	12	21.6	-	-	-	-	-	-	-	-	7.5	15	Hexagon socket head bolt M2 × 6	1 690	2 650	9.7	8.8 50.7	7.4 42.5																						
MLG 7...N*	LWLG 7...N*	-	13	24																																															

Notes (1) Track rail lengths  $L$  are shown in Table 3.1 on page II - 10.  
 (2) The appended track rail mounting bolts are hexagon socket head bolts equivalent to JIS B 1176 or JCS10-70 cross-recessed pan head screw for precision equipment.  
 (3) Choose screws whose dimension allow fixing thread depth into track rail  $\ell$  to be less than  $H_4$ .  
 (4) The direction of basic dynamic load rating ( $C$ ), basic static load rating ( $C_0$ ), and static moment rating ( $T_0$ ,  $T_x$ ,  $T_y$ ) are shown in the sketches below.  
 The upper values of  $T_x$  and  $T_y$  are for one slide unit and the lower values are for two slide units in close contact.  
 If hybrid C-Lube Linear Way specification (supplemental code "/HB") is selected in MLC7, ML7, and MLG7, see Table 10 on page II - 17.

Remarks 1. The specification of oil hole is shown in Table 13 on page II - 18.  
 2. The identification numbers with \* are our semi-standard items.

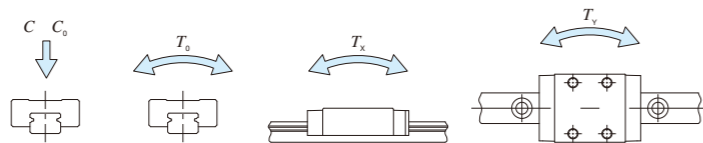

## Example of identification number of assembled set

Model code	Dimensions	Part code	Model code	Preload symbol	Classification symbol	Interchangeable code	Supplemental code
ML	C	7	C2	R120	T1	P	/D
1	2	3	4	5	6	7	8

① Model	ML LWL...B LWL...N	Standard type	③ Size	5, 7	⑥ Preload amount	T0 Clearance No symbol Standard T1 Light preload	⑧ Interchangeable	No symbol Non-interchangeable specification S1 S1 specification S2 S2 specification
② Length of slide unit	C Short No symbol Standard G Long		④ Number of slide unit (2)		⑦ Accuracy class	H High P Precision	⑨ Special specification	A, BS, D, E, HB, I, LR MN, N, Q, RE, S, W, Y

# IKO C-Lube Linear Way ML

Standard type					
Shape	ML • LWL				
	Size	1	2	3	5
	9	12	15	20	25

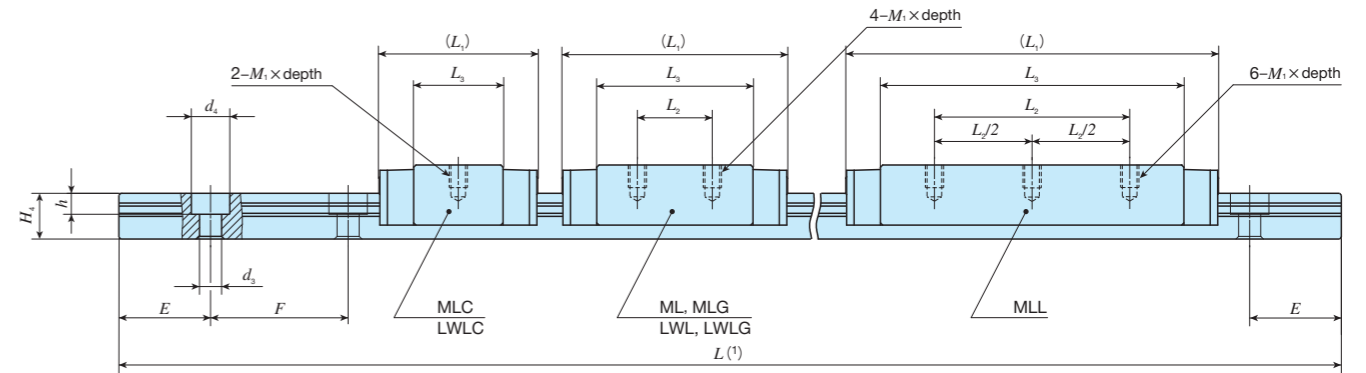
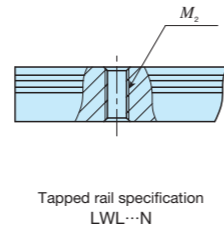
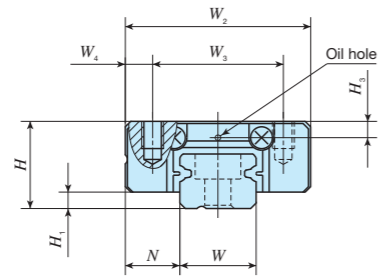

Identification number	Interchangeable	Mass (Ref.) g		Dimensions of assembly mm			Dimensions of slide unit mm							Dimensions of track rail mm						Appended mounting bolt for track rail mm Bolt size × ℓ	Basic dynamic load rating <sup>(4)</sup> C N	Basic static load rating <sup>(4)</sup> C <sub>0</sub> N	Static moment rating <sup>(4)</sup>												
		Slide unit	Track rail (per 100 mm)	H	H <sub>1</sub>	N	W <sub>2</sub>	W <sub>3</sub>	W <sub>4</sub>	L <sub>1</sub>	L <sub>2</sub>	L <sub>3</sub>	M <sub>1</sub> × depth	H <sub>3</sub>	W	H <sub>4</sub>	M <sub>2</sub>	d <sub>3</sub>	d <sub>4</sub>				h	E	F	T <sub>0</sub> N · m	T <sub>x</sub> N · m	T <sub>y</sub> N · m							
MLC 9	LWLC 9...B	○	11	35	10	2	5.5	20	15	2.5	M3×3	2.2	21.5	—	11.9	9	6	—	3.5	6	3.5	10	20	M3×8	1 180	1 480	6.9	2.9	2.4						
MLC 9...N*	LWLC 9...N*	—	11	37									30	10	20.8			M4 Through	—	—	—			M4 × ℓ <sup>(3)</sup> (Not appended)	1 810	2 760	12.8	9.1	7.6						
ML 9	LWL 9...B	○	18	35									40.5	15	30.9			—	3.5	6	3.5			M3×8	2 370	4 030	18.7	18.7	15.7						
—	LWL 9...BCS	○	19	35									50	26	40.4			—	3.5	6	3.5			M4 × ℓ <sup>(3)</sup> (Not appended)	2 870	5 300	24.6	31.9	26.7						
ML 9...N*	LWL 9...N*	—	18	37									M3×3.5	2.7	25			—	13	12	8			—	3.5	6.5	4.5	12.5	25	M3×8	2 210	2 380	14.8	5.3	4.5
MLG 9	LWLG 9...B	○	26	35											34			15	21.6					—	3.5	6.5	4.5	M4 × ℓ <sup>(3)</sup> (Not appended)	3 330	4 290	26.6	15.4	12.9		
MLG 9...N*	LWLG 9...N*	—	26	37											44			20	32					—	3.5	6.5	4.5	M3×8	4 310	6 200	38.4	30.6	25.7		
MLL 9	—	○	34	35											59.5			30	47.3					—	3.5	6.5	4.5	M4 × ℓ <sup>(3)</sup> (Not appended)	5 820	9 540	59.1	69.8	58.6		
MLL 9...N*	—	—	34	37											—			—	—					—	—	—	—	—	—	—	—	—	—	—	

- Notes (1) Track rail lengths  $L$  are shown in Table 3.1 on page II-10 and Table 3.3 on page II-12.  
 (2) The appended track rail mounting bolts are hexagon socket head bolts equivalent to JIS B 1176. For stainless steel model, stainless steel bolts are appended.  
 (3) Choose screws whose dimension allow fixing thread depth into track rail  $\ell$  to be less than  $H_4$ .  
 (4) The direction of basic dynamic load rating ( $C$ ), basic static load rating ( $C_0$ ), and static moment rating ( $T_0$ ,  $T_x$ ,  $T_y$ ) are shown in the sketches below.  
 The upper values of  $T_x$  and  $T_y$  are for one slide unit and the lower values are for two slide units in close contact.  
 If hybrid C-Lube Linear Way specification (supplemental code "/HB") is selected in ML series, see Table 10 on page II-17.

Remarks 1. The specification of oil hole is shown in Table 13 on page II-18.  
 2. The identification numbers with \* are our semi-standard items.

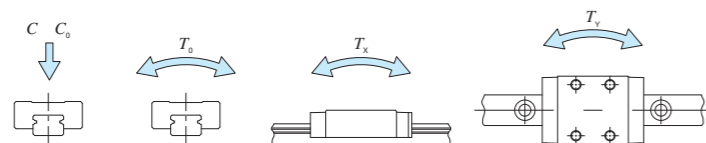

## Example of identification number of assembled set

Model code	Dimensions	Part code	Model code	Material code	Preload symbol	Classification symbol	Interchangeable code	Supplemental code
ML	G	9	C2	R160	T1	P		/D
1	2	3	4	5	6	7	8	9
1 Model	2 Length of slide unit	3 Size	4 Number of slide unit (2)	5 Length of track rail (160 mm)	6 Material type	7 Preload amount	8 Interchangeable	9 Accuracy class
ML LWL...B LWL...N	Standard type	9, 12	2	No symbol Stainless steel made CS High carbon steel made	T <sub>0</sub> Clearance No symbol Standard T <sub>1</sub> Light preload	No symbol Non-interchangeable specification S1 S1 specification S2 S2 specification	H High P Precision	A, BS, D, E, HB, I, LR, MN N, Q, RE, S, U, W, Y

# IKO C-Lube Linear Way ML

Standard type											
Shape	ML • LWL										
Size	<table border="1"> <tr> <td>1</td> <td>2</td> <td>3</td> <td>5</td> <td>7</td> </tr> <tr> <td>9</td> <td>12</td> <td>15</td> <td>20</td> <td>25</td> </tr> </table>	1	2	3	5	7	9	12	15	20	25
1	2	3	5	7							
9	12	15	20	25							

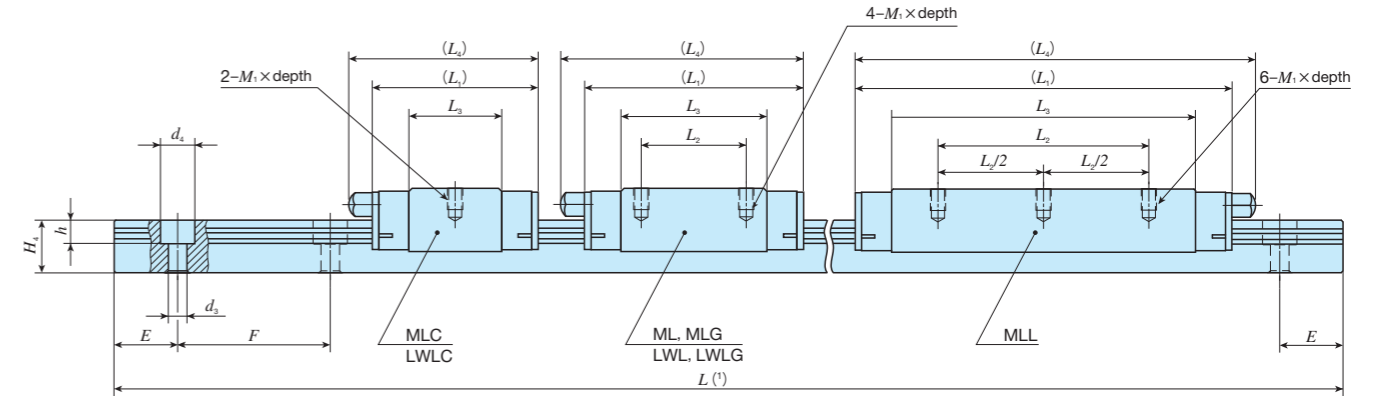
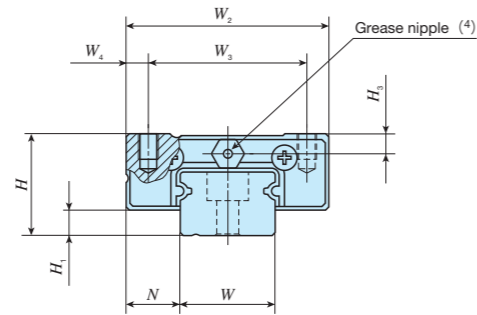

Identification number	Interchangeable	Mass (Ref.) g		Dimensions of assembly mm							Dimensions of slide unit mm					Dimensions of track rail mm						Appended mounting bolt for track rail (2) mm	Basic dynamic load rating (3) C N	Basic static load rating (3) C0 N	Static moment rating (3)			
		Slide unit	Track rail (per 100 mm)	H	H1	N	W2	W3	W4	L1	L2	L3	L4	M1 x depth	H3	W	H4	d3	d4	h	E				F	Bolt size x l	T0 N · m	Tx N · m
MLC 15	○	43	107	16	4	8.5	32	25	3.5	32	—	17.8	37	M3x4	3.1	15	10	3.5	6.5	4.5	20	40	M3x10	3 490	3 890	30.0	11.7 84.5	9.8 70.9
LWLC 15...B	○	42								42	20	27.8	47															
ML 15	○	63								42	20	27.8	47															
LWL 15...B	○	64								42	20	27.8	47															
LWL 15...BCS	○	64								42	20	27.8	47															
MLG 15	○	93								57	25	42.8	62															
LWLG 15...B	○	95	57	25	42.7	62																						
MLL 15	○	122	72	40	57.7	76																						
MLC 20	○	89	156	20	5	10	40	30	5	38	—	22.3	43	M4x6	4.2	20	11	6	9.5	5.5	30	60	M5x14	4 580	5 300	54.0	19.4 134	16.3 112
LWLC 20...B	○	89								50	25	34.6	55															
ML 20	○	130								50	25	34.6	55															
LWL 20...B	○	133								50	25	34.6	55															
LWL 20...BCS	○	133								50	25	34.6	55															
MLG 20	○	189								68	30	52.3	73															
LWLG 20...B	○	196	68	30	52.3	73																						
MLC 25	○	189	243	25	5	12.5	48	35	6.5	54.5	—	31.9	64	M6x7	5	23	15	7	11.0	9.0	30	60	M6x16	9 120	10 600	128	57.4 376	48.1 316
LWLC 25...B	○	190								78	35	55.7	88															
ML 25	○	305								78	35	55.7	88															
LWL 25...B	○	310								78	35	55.7	88															
MLG 25	○	405	98	40	75.5	108																						
LWLG 25...B	○	413	98	40	75.5	108																						

- Notes (1) Track rail lengths  $L$  are shown in Table 3.1 on page II-10 and Table 3.3 on page II-12.  
 (2) The appended track rail mounting bolts are hexagon socket head bolts equivalent to JIS B 1176. For stainless steel model, stainless steel bolts are appended.  
 (3) The direction of basic dynamic load rating ( $C$ ), basic static load rating ( $C_0$ ), and static moment rating ( $T_0$ ,  $T_x$ ,  $T_y$ ) are shown in the sketches below. The upper values of  $T_x$  and  $T_y$  are for one slide unit and the lower values are for two slide units in close contact. If hybrid C-Lube Linear Way specification (supplemental code "/HB") is selected in MLC15, ML15, MLG15, and MLL15, see Table 10 on page II-17.  
 (4) The shapes of grease nipple vary by size. The specifications are shown in Table 14 on page II-18.

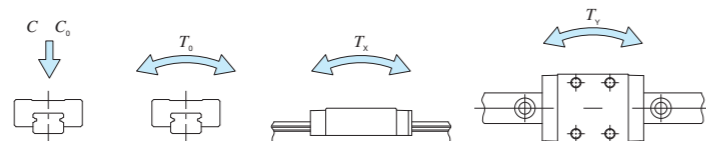

### Example of identification number of assembled set

Model code: ML G 15 C2 R320  
 Dimensions: 15, 20, 25  
 Part code: C2 R320  
 Model code: ML G 15 C2 R320  
 Material code: —  
 Preload symbol: T1  
 Classification symbol: P  
 Interchangeable code: —  
 Supplemental code: /D

① Model ML LWL...B Standard type	③ Size 15, 20, 25	⑦ Preload amount T0 Clearance No symbol Standard T1 Light preload	⑨ Interchangeable No symbol Non-interchangeable specification S1 S1 specification S2 S2 specification
② Length of slide unit C Short No symbol Standard G Long L Extra high rigidity long	④ Number of slide unit (2)	⑧ Accuracy class H High P Precision	⑩ Special specification A, BS, D, E, HB, I, LR, MN N, O, RE, S, U, W, Y
⑤ Length of track rail (320 mm)	⑥ Material type No symbol Stainless steel made CS High carbon steel made		



# IKO C-Lube Linear Way ML

Wide type				
Shape	MLF • LWLF			
Size	4	6	10	14
	18	24	30	42

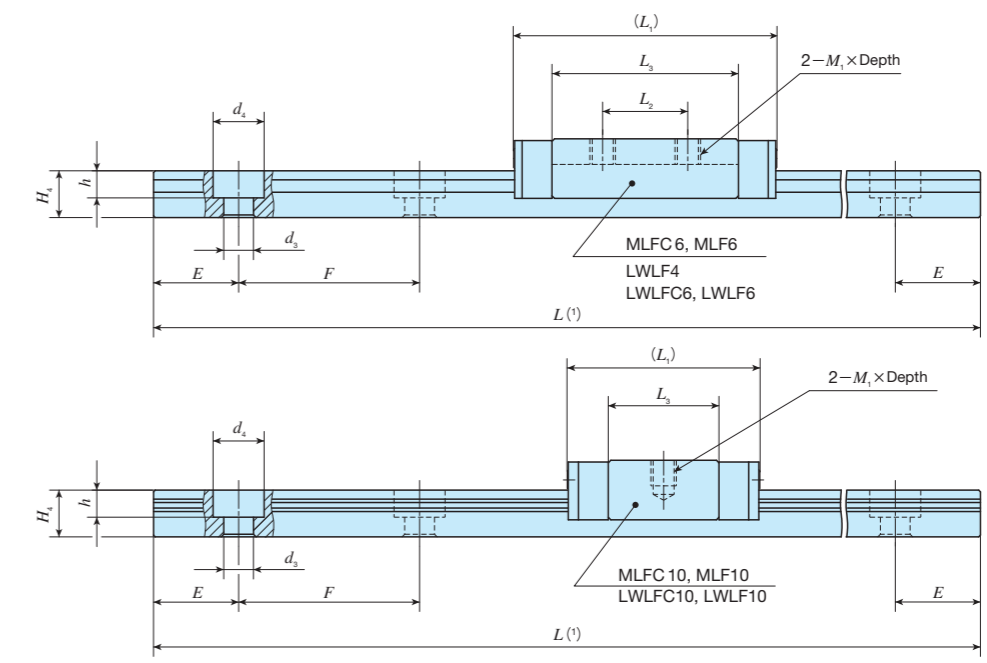
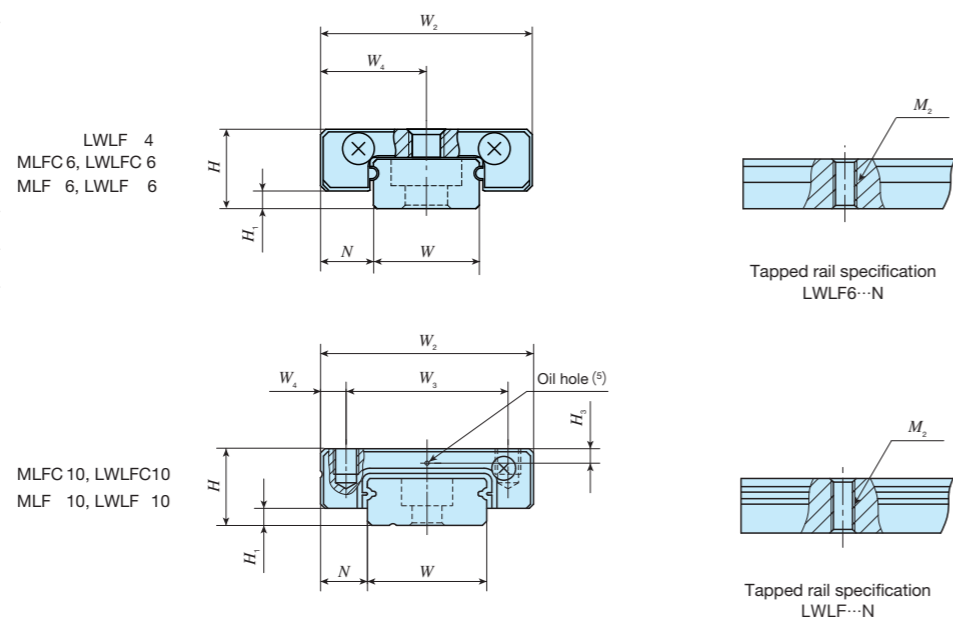

Identification number		Interchangeable	Mass (Ref.) g		Dimensions of assembly mm			Dimensions of slide unit mm							Dimensions of track rail mm							Appended mounting bolt for track rail mm Bolt size $\times$ $\ell$	Basic dynamic load rating (4) C N	Basic static load rating (4) C <sub>0</sub> N	Static moment rating (4)																													
MLF series	LWLF series (No C-Lube)		Slide unit	Track rail (per 100 mm)	H	H <sub>1</sub>	N	W <sub>2</sub>	W <sub>3</sub>	W <sub>4</sub>	L <sub>1</sub>	L <sub>2</sub>	L <sub>3</sub>	M <sub>1</sub> $\times$ depth	H <sub>3</sub>	W	H <sub>4</sub>	M <sub>2</sub>	d <sub>3</sub>	d <sub>4</sub>	h				E	F	T <sub>0</sub> N · m	T <sub>x</sub> N · m	T <sub>y</sub> N · m																									
—	LWLF 4 <sup>(2)</sup>	—	2.1	6.8	4	1	3	10	—	5	17	6.5	11.9	M2 $\times$ 1.3	—	4	2.6	—	1.8	2.8	0.75	5	10	Cross-recessed pan head screw for precision equipment M1.6 $\times$ 5	390	677	1.4	1.3 7.1	1.5 8.4																									
MLFC 6 <sup>(2)</sup>	LWLF 6 <sup>(2)</sup>	—	2.1	13	4.5	1	3	12	—	6	15	4.5	9.8	M2 $\times$ 1.6	—	6	2.8	—	2.4	4	1.5	7.5	15	Cross-recessed pan head screw for precision equipment M2 $\times$ 4	334	542	1.7	0.84 5.1	1.0 6.1																									
MLFC 6...N <sup>(2)*</sup>	LWLF 6...N <sup>(2)*</sup>	—	2.1	12																				—						—	—	—	—	—	—	—	—	—	—	—	—	—	—	—	—	—	—	—	—	—	—	—	—	
MLF 6 <sup>(2)</sup>	LWLF 6 <sup>(2)</sup>	—	3.1	13																				—						—	—	—	—	—	—	—	—	—	—	—	—	—	—	—	—	—	Cross-recessed pan head screw for precision equipment M2 $\times$ 4	443	813	2.5	1.8 9.9	2.2 11.8		
MLF 6...N <sup>(2)*</sup>	LWLF 6...N <sup>(2)*</sup>	—	3.4	12																				—						—	—	—	—	—	—	—	—	—	—	—	—	—	—	—	—	—	—						—	—
MLFC 10	LWLF 10...B	○	6.1	28	6.5	1.5	3.5	17	13	2	20.5	—	13.6	M2.5 $\times$ 1.5	1.3	10	4	—	2.9	4.8	1.6	10	20	Cross-recessed pan head screw for precision equipment M2.5 $\times$ 7	712	1 180	6.1	2.6 14.9	2.2 12.5																									
MLFC 10...N*	LWLF 10...N*	—	6.1	29																				—						—	—	—	—	—	—	—	—	—	—	—	—	—	—	—	—	—	—	—	—	—	—	—	—	
MLF 10	LWLF 10...B	○	7.6	28																				—						—	—	—	—	—	—	—	—	—	—	—	—	—	—	—	—	—	—	—	—	—	—	—	—	—
MLF 10...N*	LWLF 10...N*	—	7.6	29																				—						—	—	—	—	—	—	—	—	—	—	—	—	—	—	—	—	—	—	Cross-recessed pan head screw for precision equipment M2.5 $\times$ 7	849	1 510	7.8	4.2 22.4	3.5 18.8	
MLF 10...N*	LWLF 10...N*	—	7.5	29	—	—	—	—	—	—	—	—	—	—	—	—	—	—	—	—	—	—	—	—	—	—	—	—	—																									

Notes (1) Track rail lengths  $L$  are shown in Table 3.2 on page II - 11.  
 (2) Size 4 and 6 are non-retained-ball type. No end seal is attached.  
 (3) Choose screws whose dimension allow fixing thread depth into track rail  $\ell$  to be less than  $H_4$ .  
 (4) The direction of basic dynamic load rating ( $C$ ), basic static load rating ( $C_0$ ), and static moment rating ( $T_0$ ,  $T_x$ ,  $T_y$ ) are shown in the sketches below.  
 The upper values of  $T_x$  and  $T_y$  are for one slide unit and the lower values are for two slide units in close contact.  
 (5) No oil hole is prepared for size 4 and 6.  
 The specification of oil hole for size 10 is shown in Table 13 on page II - 18.

Remark: The identification numbers with \* are our semi-standard items.

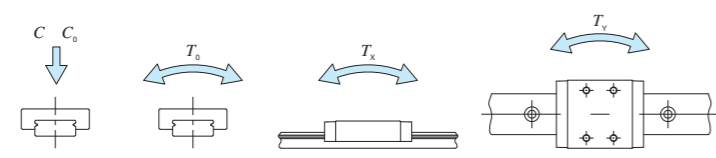

**Example of identification number of assembled set**

Model code: MLF C 10 C2 R120  
 Dimensions: 1 2 3  
 Part code: 4 5  
 Model code: 1  
 Preload symbol: T<sub>0</sub> 6  
 Classification symbol: P 7  
 Interchangeable code: 8  
 Supplemental code: /D 9

① Model MLF LWLF(...B) LWLF...N	Wide type	③ Size 4, 6, 10	⑥ Preload amount T <sub>0</sub> Clearance No symbol Standard	⑧ Interchangeable No symbol Non-interchangeable specification S1 S1 specification S2 S2 specification
② Length of slide unit C Short No symbol Standard	⑤ Length of track rail (120 mm)	⑦ Accuracy class H High P Precision	⑨ Special specification A, BS, D, E, I, MN, N, Q RE, S, W, Y	

Wide type				
Shape	MLF • LWLF			
Size	4	6	10	14
	18	24	30	42

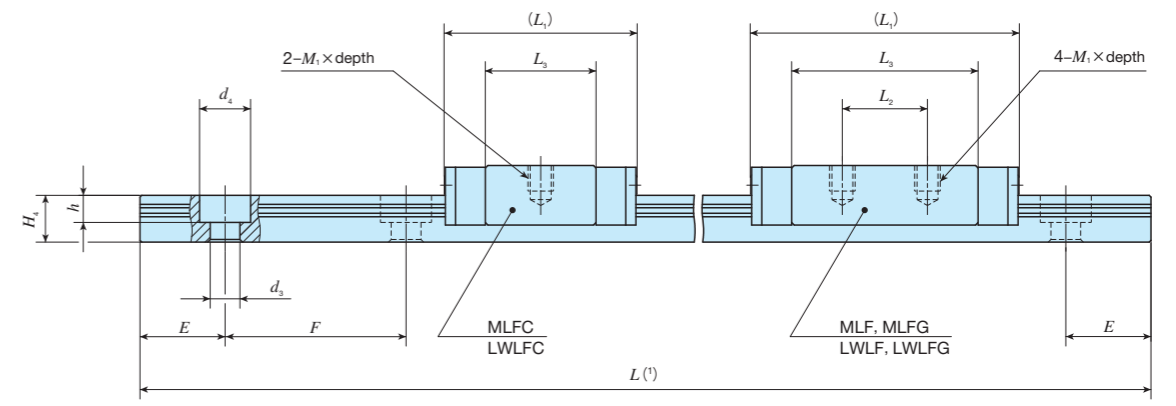
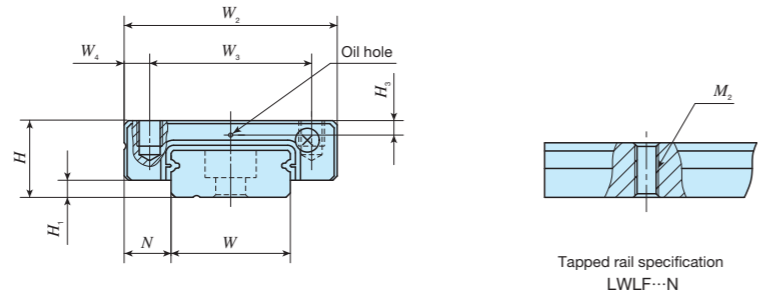

Identification number	Interchangeable	Mass (Ref.) g		Dimensions of assembly mm			Dimensions of slide unit mm							Dimensions of track rail mm							Appended mounting bolt for track rail (2) mm	Basic dynamic load rating (4) C N	Basic static load rating (4) C0 N	Static moment rating (4)													
		Slide unit	Track rail (per 100 mm)	H	H1	N	W2	W3	W4	L1	L2	L3	M1 × depth	H3	W	H4	M2	d3	d4	h				E	F	T0 N · m	Tx N · m	Ty N · m									
MLFC 14	LWLFC 14...B	○	13	54	9	2	5.5	25	19	3	31.5	10	22	M3×3	1.7	14	5.5	-	3.5	6	3.2	15	30	M3×8	1 240	1 700	12.2	3.8 24.6	3.2 20.7								
MLFC 14...N*	LWLFC 14...N*	-	56	22.5																				-						13	M4 Through	M4 × ℓ (3) (Not appended)					
MLF 14	LWLF 14...B	○	20	54																				42	19	32.5	-	3.5	6	3.2	M3×8	1 770	2 840	20.3	10.1 54.7	8.4 45.9	
MLF 14...N*	LWLF 14...N*	-	21	56																																	M4 Through
MLFG 14	LWLFG 14...B	○	29	54																												M3×8	2 320	4 160	29.8	21.0 104	17.6 87.6
MLFG 14...N*	LWLFG 14...N*	-	31	56																																	

Notes (1) Track rail lengths  $L$  are shown in Table 3.2 on page II - 11.  
 (2) The appended track rail mounting bolts are hexagon socket head bolts equivalent to JIS B 1176.  
 (3) Choose screws whose dimension allow fixing thread depth into track rail  $\ell$  to be less than  $H_4$ .  
 (4) The direction of basic dynamic load rating ( $C$ ), basic static load rating ( $C_0$ ), and static moment rating ( $T_0$ ,  $T_x$ ,  $T_y$ ) are shown in the sketches below.  
 The upper values of  $T_x$  and  $T_y$  are for one slide unit and the lower values are for two slide units in close contact.  
 Remarks 1. The specification of oil hole is shown in Table 13 on page II - 18.  
 2. The identification numbers with \* are our semi-standard items.

**Example of identification number of assembled set**

Model code	Dimensions	Part code	Model code	Preload symbol	Classification symbol	Interchangeable code	Supplemental code
MLF	G	14	C2	R240	T1	P	/D
1	2	3	4	5	6	7	8

**① Model**

MLF	Wide type
LWLFC...B	
LWLF...N	

**② Length of slide unit**

C	Short
No symbol	Standard
G	Long

**③ Size**

14
----

**④ Number of slide unit (2)**

**⑤ Length of track rail (240 mm)**

**⑥ Preload amount**

T0	Clearance
No symbol	Standard
T1	Light preload

**⑦ Accuracy class**

H	High
P	Precision

**⑧ Interchangeable**

No symbol	Non-interchangeable specification
S1	S1 specification
S2	S2 specification

**⑨ Special specification**

A, BS, D, E, I, LR, MN
N, Q, RE, S, W, Y

Wide type				
Shape	MLF • LWLF			
Size	4	6	10	14
	18	24	30	42

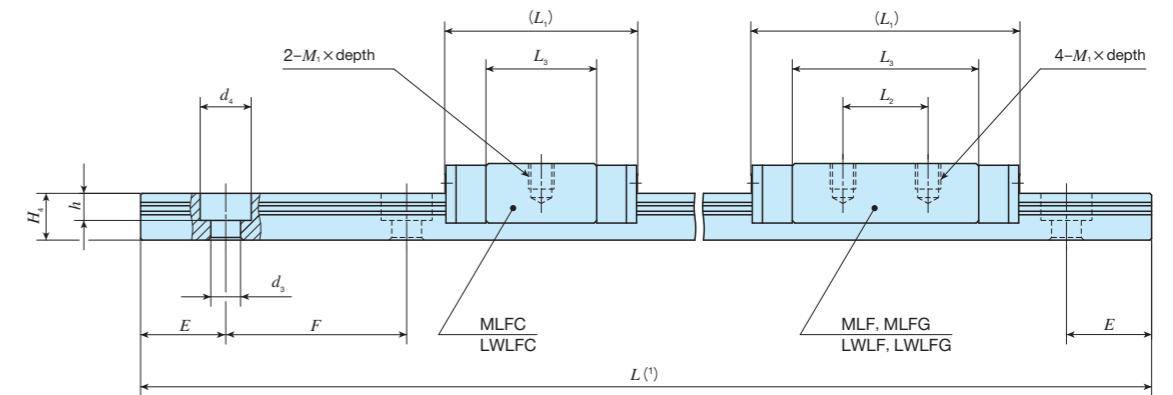
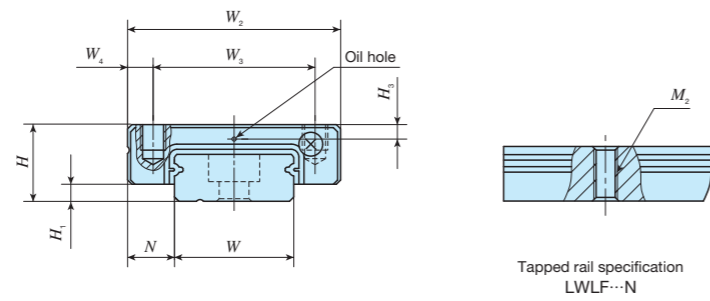

Identification number		Interchangeable	Mass (Ref.) g		Dimensions of assembly mm			Dimensions of slide unit mm						Dimensions of track rail mm						Appended mounting bolt for track rail (2) mm	Basic dynamic load rating (4) C	Basic static load rating (4) Co	Static moment rating (4)																													
MLF series	LWLF series (No C-Lube)		Slide unit	Track rail (per 100 mm)	H	H1	N	W2	W3	W4	L1	L2	L3	M1 x depth	H3	W	H4	M2	d3	d4	h	E	F	Bolt size x l	N	N	To	Tx	Ty																							
MLFC 18	LWLF 18...B	○	26	90	12	3	6	30	21	4.5	38.5	12	28.6	M3x3	2.5	18	7	-	3.5	6.5	4.5	15	30	M3x8	1 510	2 120	19.4	5.5 35.9	4.7 30.1																							
MLFC 18...N*	LWLF 18...N*	-	92	M4 Through														-	-	-	M4 x l (3) (Not appended)																															
MLF 18	LWLF 18...B	○	44	90														23	3.5	50.5	24			40.4	M3x3.5	3.2	-	3.5	6.5	4.5	M3x8	2 280	3 810	34.9	16.9 88.8	14.2 74.5																
-	LWLF 18...BCS	○	42	92																							M4 Through	-	-	-	M4 x l (3) (Not appended)																					
MLFG 18	LWLF 18...B	○	59	90					14	3	8	40	28	6	44			15	31	M3x3.5	3.2			24	8	-	3.5	6.5	4.5	20	40	M3x8	2 870	5 300	48.5	31.9 159	26.7 134															
MLFG 18...N*	LWLF 18...N*	-	59	92																						M4 Through	-	-	-			M4 x l (3) (Not appended)																				
MLFC 24	LWLF 24...B	○	46	90																						14	3	8	40			28	6	44	15	31	M3x3.5	3.2	24	8	-	4.5	8	4.5	20	40	M4x10	4 310	6 200	75.6	30.6 168	25.7 141
MLF 24	LWLF 24...B	○	74	92																																					M4 Through	-	-	-			M4 x l (3) (Not appended)					
-	LWLF 24...BCS	○	76	92	59	28	46.3	M3x3.5	3.2	M4 x l (3) (Not appended)																																										
MLFG 24	LWLF 24...B	○	108	92							5 620	9 060	111	63.3 321	53.1 270																																					

Notes (1) Track rail lengths  $L$  are shown in Table 3.2 on page II - 11 and Table 3.3 on page II - 12.  
 (2) The appended track rail mounting bolts are hexagon socket head bolts equivalent to JIS B 1176. For stainless steel model, stainless steel bolts are appended.  
 (3) Choose screws whose dimension allow fixing thread depth into track rail  $l$  to be less than  $H_4$ .  
 (4) The direction of basic dynamic load rating ( $C$ ), basic static load rating ( $C_0$ ), and static moment rating ( $T_0$ ,  $T_x$ ,  $T_y$ ) are shown in the sketches below.  
 The upper values of  $T_x$  and  $T_y$  are for one slide unit and the lower values are for two slide units in close contact.  
 Remarks 1. The specification of oil hole is shown in Table 13 on page II - 18.  
 2. The identification numbers with \* are our semi-standard items.

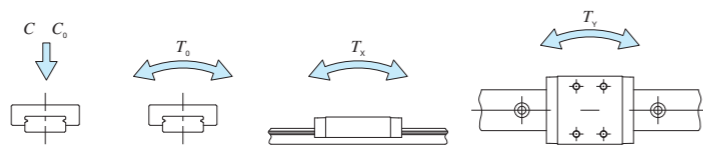

### Example of identification number of assembled set

Model code	Dimensions	Part code	Model code	Material code	Preload symbol	Classification symbol	Interchangeable code	Supplemental code	
MLF	G	18	C2	R300	T1	P	-	/D	
①	②	③	④	⑤	⑥	⑦	⑧	⑨	
① Model MLF LWLF...B LWLF...N Wide type	② Length of slide unit C Short No symbol Standard G Long	③ Size 18, 24	④ Number of slide unit (2)	⑤ Length of track rail (300 mm)	⑥ Material type No symbol Stainless steel made CS High carbon steel made	⑦ Preload amount To Clearance No symbol Standard T1 Light preload	⑧ Accuracy class H High P Precision	⑨ Interchangeable No symbol Non-interchangeable specification S1 S1 specification S2 S2 specification	⑩ Special specification A, BS, D, E, I, LR, MN N, Q, RE, S, U, W, Y

Wide type				
MLF • LWLF				
Shape				
Size	4	6	10	14
	18	24	30	42

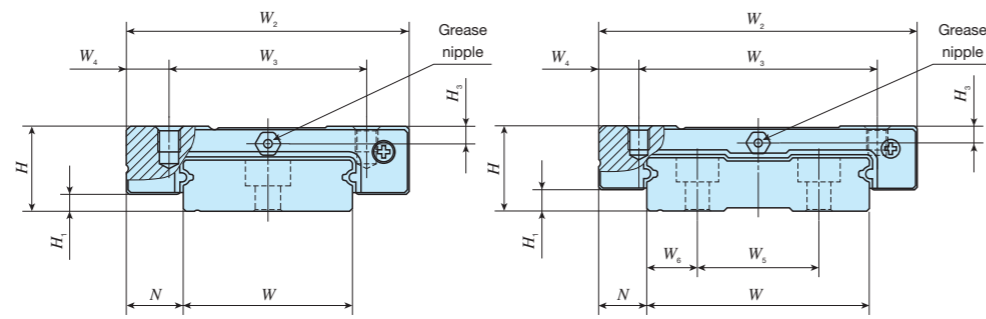

MLFC 42, LWLFC 42  
MLF 42, LWLF 42  
MLFG 42, LWLFG 42

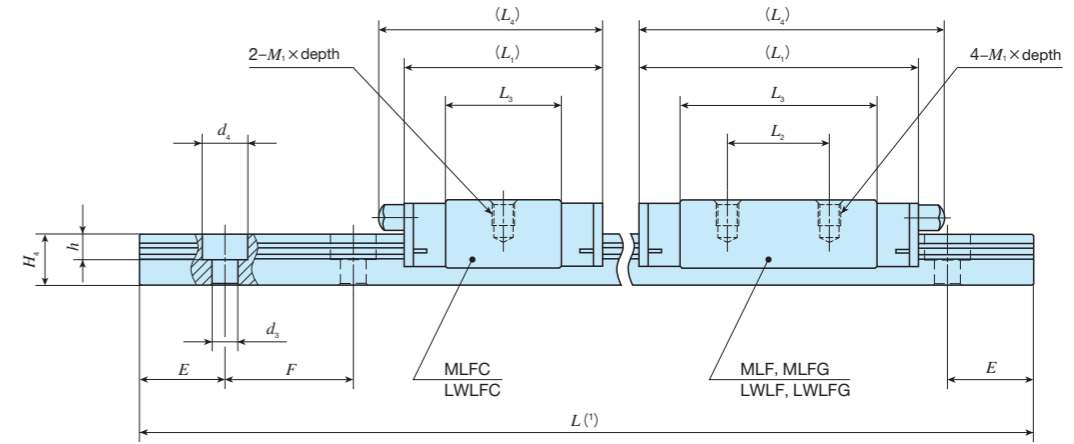

Identification number	Interchangeable	Mass (Ref.) g		Dimensions of assembly mm			Dimensions of slide unit mm							Dimensions of track rail mm						Appended mounting bolt for track rail mm Bolt size × ℓ	Basic dynamic load rating <sup>(2)</sup> C N	Basic static load rating <sup>(2)</sup> C <sub>0</sub> N	Static moment rating <sup>(3)</sup>								
		Slide unit	Track rail (per 100 mm)	H	H <sub>1</sub>	N	W <sub>2</sub>	W <sub>3</sub>	W <sub>4</sub>	L <sub>1</sub>	L <sub>2</sub>	L <sub>3</sub>	L <sub>4</sub>	M <sub>1</sub> × depth	H <sub>3</sub>	W	H <sub>4</sub>	W <sub>5</sub>	W <sub>6</sub>				d <sub>3</sub>	d <sub>4</sub>	h	E	F	T <sub>0</sub> N · m	T <sub>x</sub> N · m	T <sub>y</sub> N · m	
MLFC 30	LWLFC 30...B	○	70	198	15	3	10	50	35	7.5	35.5	—	20.5	40	M4×4.5	3.1	30	9	—	—	4.5	8	4.5	20	40	M4×12	3 890	4 540	69.1	15.4	13.0
MLF 30	LWLF 30...B	○	111								49.5	18	34.8	54															128	48.7	40.8
—	LWLF 30...BCS	○	112								68.5	35	53.8	73															187	100	84.3
MLFG 30	LWLFG 30...B	○	167								—	—	—	—															128	24.8	20.8
—	LWLFG 30...B	○	170								74.5	35	58.7	79															209	61.3	51.4
MLFC 42	LWLFC 42...B	○	95	294	16	4	9	60	45	7.5	41.5	—	25.7	46	M4×4.5	3.2	42	10	23	9.5	4.5	8	4.5	20	40	M4×12	5 440	6 810	144	30.8	25.8
—	LWLF 42...B	○	138								55	20	39.4	60															128	24.8	20.8
—	LWLF 42...BCS	○	140								74.5	35	58.7	79															209	61.3	51.4
MLFG 42	LWLFG 42...B	○	200								—	—	—	—															321	140	117
—	LWLFG 42...B	○	204								—	—	—	—															305	126	106

Notes (1) Track rail lengths  $L$  are shown in Table 3.2 on page II - 11 and Table 3.3 on page II - 12.  
 (2) The appended track rail mounting bolts are hexagon socket head bolts equivalent to JIS B 1176. For stainless steel model, stainless steel bolts are appended.  
 (3) The direction of basic dynamic load rating ( $C$ ), basic static load rating ( $C_0$ ), and static moment rating ( $T_0$ ,  $T_x$ ,  $T_y$ ) are shown in the sketches below.  
 The upper values of  $T_x$  and  $T_y$  are for one slide unit and the lower values are for two slide units in close contact.  
 Remark: The specifications of grease nipple are shown in Table 14 on page II - 18.

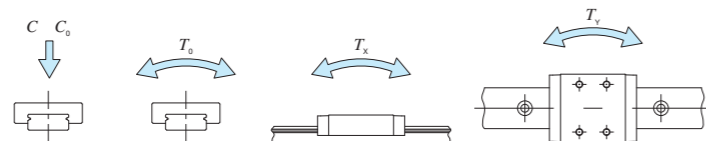

### Example of identification number of assembled set

Model code	Dimensions	Part code	Model code	Material code	Preload symbol	Classification symbol	Interchangeable code	Supplemental code	
MLF	G	42	C2	R320	T <sub>1</sub>	P	/D		
①	②	③	④	⑤	⑥	⑦	⑧	⑨	
① Model MLF LWLF...B Wide type	② Length of slide unit C Short No symbol Standard G Long	③ Size 30, 42	④ Number of slide unit (2)	⑤ Length of track rail (320 mm)	⑥ Material type No symbol Stainless steel made CS High carbon steel made	⑦ Preload amount T <sub>0</sub> Clearance No symbol Standard T <sub>1</sub> Light preload	⑧ Accuracy class H High P Precision	⑨ Interchangeable No symbol Non-interchangeable specification S1 S1 specification S2 S2 specification	⑩ Special specification A, BS, D, E, I, LR, MN N, Q, RE, S, U, W, Y

## C-Lube Linear Way MLV

MLV



# C-Lube Linear Way MLV

# MLV



Long term maintenance free compliant!

The aquamarine end plate is the symbol of maintenance free.

Track rail

Slide unit

Casing

Circulation pipe

C-Lube

Ball

End plate

Scraper

Ball retaining band

Oil hole

## Points

### 1 Extremely small size realized by simple structure

For details [P.I-19](#)

Super small-size linear motion rolling guide produced by two-row four-point contact simple structure and original small sizing technology.

### 2 Long term maintenance free

For details [P.I-11](#)

The built-in "C-Lube", the capillary lubricating element, in the ball circulation pipes of the slide unit makes it long term maintenance free.

Lubrication oil is continuously supplied to the surface of rolling elements by surface tension in the contact of the capillary lubricating element surface and rolling elements.

### 3 Cost performance

Preserving the basic performance of C-Lube Linear Way ML as is, lower cost has been achieved by reviewing the structure including the ball recirculation part.

### 4 Ball retained type for easy operation

The slide unit incorporates the ball retaining band, which prevents the ball from dropping down when the slide unit is removed from the track rail. This safety structure brings you an easy operation to the machines/equipment.

### 5 Stainless steel selections for excellent corrosion resistance

For details [P.I-41](#)

Stainless steel highly corrosion-resistant is used as the basic specification, so that the products are suitable for applications where rust prevention oil is not preferred, such as in cleanroom environment.

## Identification Number and Specification

### Example of an Identification Number

The specifications of the MLV series are indicated by the identification number. Indicate the identification number, consisting of a model code, dimensions, a part code, a classification symbol, and any supplemental codes for each specification to apply.

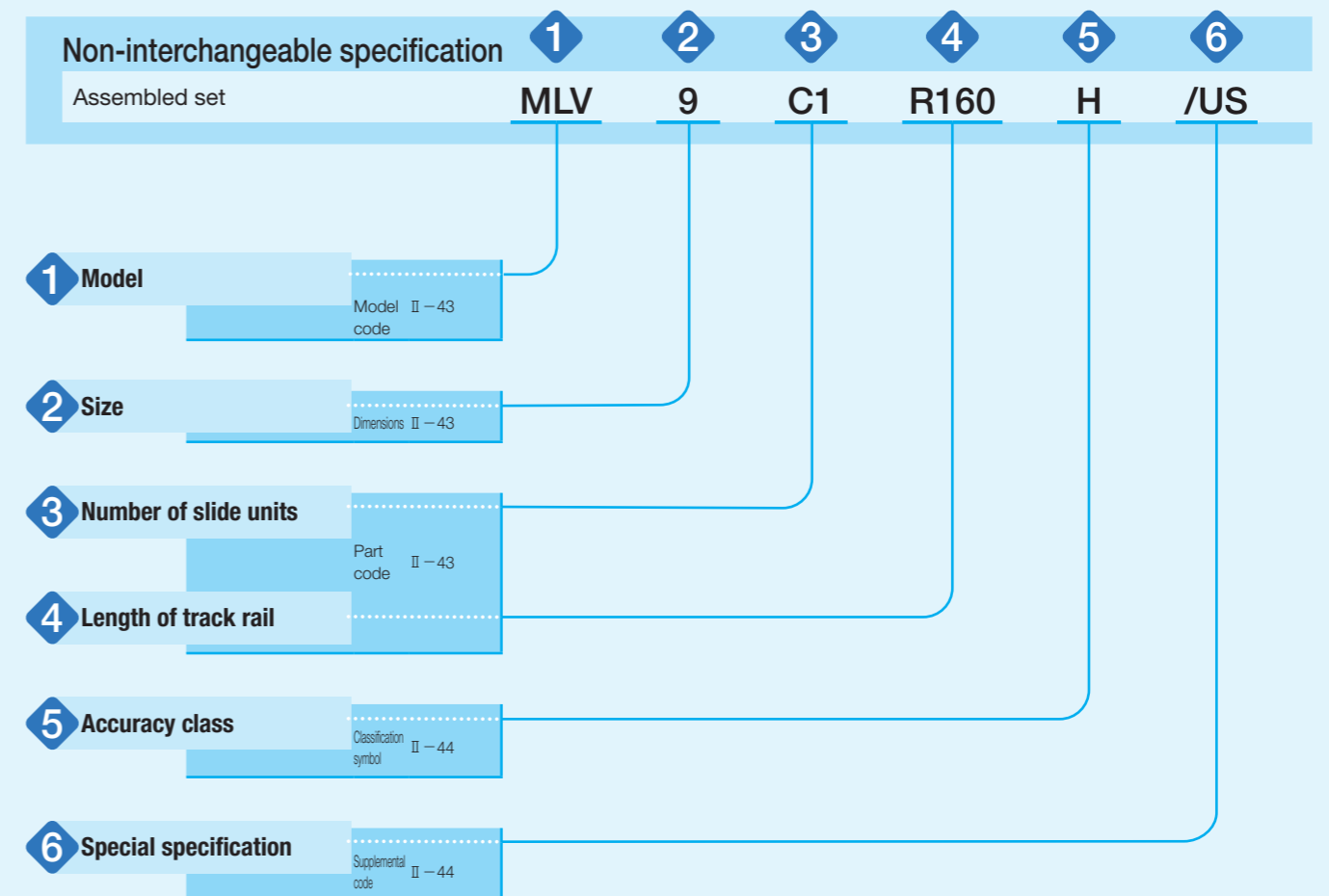

# Identification Number and Specification — Model · Size · Number of Slide Unit · Length of Track Rail —

<b>1 Model</b>	C-Lube Linear Way MLV (MLV series)	: MLV
<b>2 Size</b>	7, 9, 12	
<b>3 Number of slide units</b>		: C○ Indicates the number of slide units assembled on a track rail.
<b>4 Length of track rail</b>		: R○ Indicate the length of track rail in mm. For standard and maximum lengths, see Table 1.

**Table 1 Standard and maximum lengths of track rail**

unit: mm

Identification number	MLV 7	MLV 9	MLV 12
Standard length $L$ ( $n$ )	60 ( 4)	60 ( 3)	100 ( 4)
	90 ( 6)	80 ( 4)	150 ( 6)
	120 ( 8)	120 ( 6)	200 ( 8)
	150 (10)	160 ( 8)	275 (11)
	180 (12)	220 (11)	350 (14)
	240 (16)	280 (14)	475 (19)
Pitch of mounting holes $F$	15	20	25
$E$	7.5	10	12.5
Standard $E$ or higher dimensions below	4.5	4.5	5
Maximum length <sup>(1)</sup>	300 (990)	860 (1 200)	1 000 (1 450)

Note <sup>(1)</sup> Length up to the value in ( ) can be produced. If needed, please contact **IKO**.  
 Remark: If not directed,  $E$  dimensions for both ends will be the same within the range of standard  $E$  dimensions. To change the dimensions, indicate the specified rail mounting hole positions "/E" of special specification. For more information, see page III - 30.

# — Accuracy Class · Special Specification —

<b>5 Accuracy class</b>	High	: H	For details of accuracy class, see Table 2.
-------------------------	------	-----	---

**Table 2 Tolerance and allowance**

Item	Class (Classification symbol)	High (H)
Dim. $H$ tolerance		$\pm 0.020$
Dim. $N$ tolerance		$\pm 0.025$
Dim. variation of $H$ <sup>(1)</sup>		0.015
Dim. variation of $N$ <sup>(1)</sup>		0.020
Parallelism in operation of the slide unit C surface to A surface		See Fig. 1.
Parallelism in operation of the slide unit D surface to B surface		See Fig. 1.

Note <sup>(1)</sup> It means the size variation between slide units mounted on the same track rail.

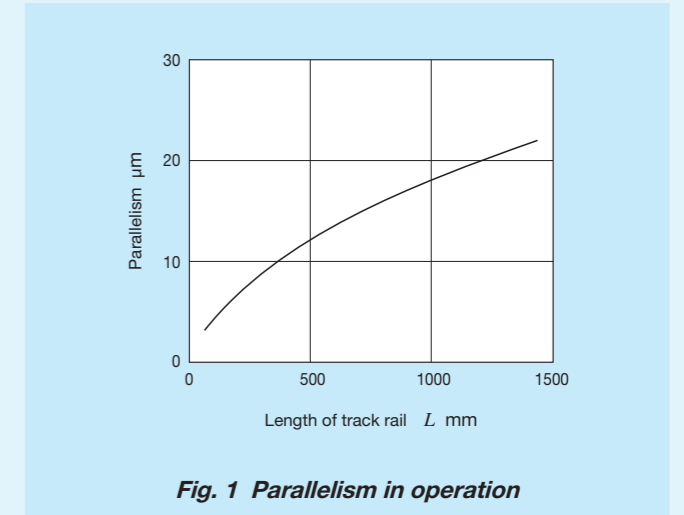

<b>6 Special specification</b>	/D, /E, /MN, /US, /W○, /YCG	For applicable special specifications, see Table 3. For combination of multiple special specifications, see Table 4. For details of special specifications, see page III - 29.
--------------------------------	-----------------------------	--

**Table 3 Application of special specifications**

Special specification	Supplemental code	Size		
		7	9	12
Opposite reference surfaces arrangement	/D	○	○	○
Specified rail mounting hole positions	/E	○	○	○
Without track rail mounting bolt	/MN	○	○	○
End seal	/US	○	○	○
A group of multiple assembled sets	/W○	○	○	○
Specified grease (Low Dust-Generation Grease for Clean Environment CG2)	/YCG	○	○	○

**Table 4 Combination of supplemental codes**

E	-				
MN	○	○			
US	○	○	○		
W	○	-	○	○	
YCG	○	○	○	○	○
	D	E	MN	US	W

Remarks: 1. The combination of "-" shown in the table is not available.  
 2. When using multiple types for combination, please indicate by arranging the symbols in alphabetical order.

# Preload

Preload for the MLV series is adjusted to have subtle clearance or minimal amount of preload.

# Lubrication

Lithium-soap base grease (MULTEMP PS No.2 [KYODO YUSHI CO., LTD.]) is pre-packed in MLV series. Additionally, MLV series has C-Lube placed in the recirculation part of balls, so that the interval for reapplying lubricant can be extended and maintenance works such as grease job can be reduced significantly.

MLV series have an oil hole. (See Table 5)

Dedicated supplying equipment (miniature greasers) fit to oil holes are also available. For order of these parts for lubrication, see Table 13 on Page III-23.

# Dust Protection

No end seal is provided for the MLV series. For applications in other than clean environment, cover the whole unit with a protective case, etc. to prevent harmful foreign substances such as dust and particles from entering.

We can also attach end seals (supplemental code "/US") on both sides of the slide unit. If needed, indicate the supplemental code.

Even with the use of the end seals to prevent dust from entering, if large amount of contaminants or dust are floating, or if large particles of foreign substances such as chips or sand may adhere to the track rail, it is recommended to attach a protective cover to the linear motion mechanism.

Table 5 Oil hole specifications

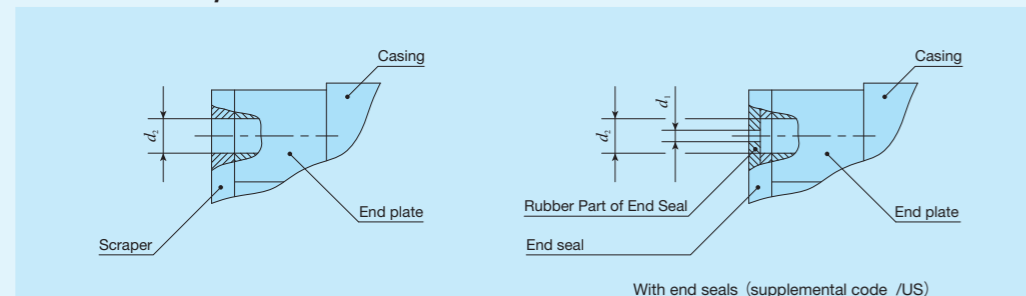

Size	$d_1$	$d_2$
7	0.5	1.2
9		1.5
12		2

unit: mm

# Precaution for Use



## 1 Handling

A strong grip on the circulation pipes of the MLV series slide unit, will distort the circulation path, which may affect the operating performance; handle with care.

## 2 Mounting surface, reference mounting surface and typical mounting structure

When mounting the MLV series, properly align the reference mounting surfaces B and D of the track rail and the slide unit with the reference mounting surface of the table and the bed and fix them. (See Fig.2)

The reference mounting surfaces B and D and mounting surfaces A and C are precisely ground. Machining the mounting surface of the table and bed, such as machine or device, to high accuracy and mounting them properly will ensure stable linear motion with high accuracy.

Reference mounting surface of the slide unit is the upper surface when you see the  mark on the C surface in normal position. The track rail reference mounting surface is identified by locating the  mark on the top surface of the track rail. It is the side surface above the mark (in the direction the arrow point). (See Fig.3)

## 3 Shoulder height and corner radius of the reference mounting surface

For the opposite corner of the mating reference mounting, it is recommended to have relieved fillet as indicated in Fig. 4. Recommended value for the shoulder height on the mating side is indicated in Table 6.

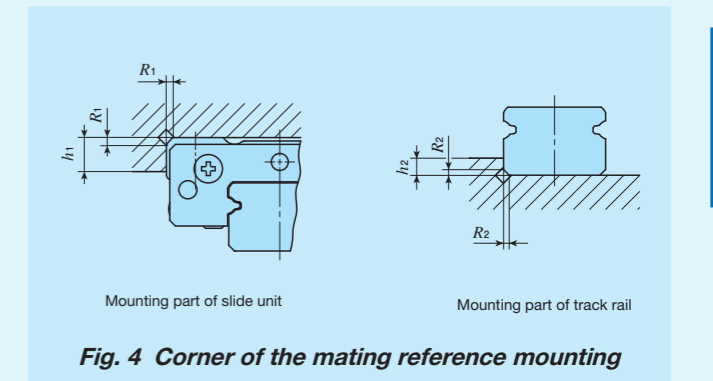

Table 6 Shoulder height and corner radius of the reference mounting surface

Size	Mounting part of slide unit		Mounting part of track rail	
	Shoulder height $h_1$	Corner radius $R_1$ (maximum)	Shoulder height $h_2$	Corner radius $R_2$ (maximum)
7	2.5	0.2	1.2	0.2
9	3	0.2	1.5	0.2
12	4	0.2	2.5	0.2

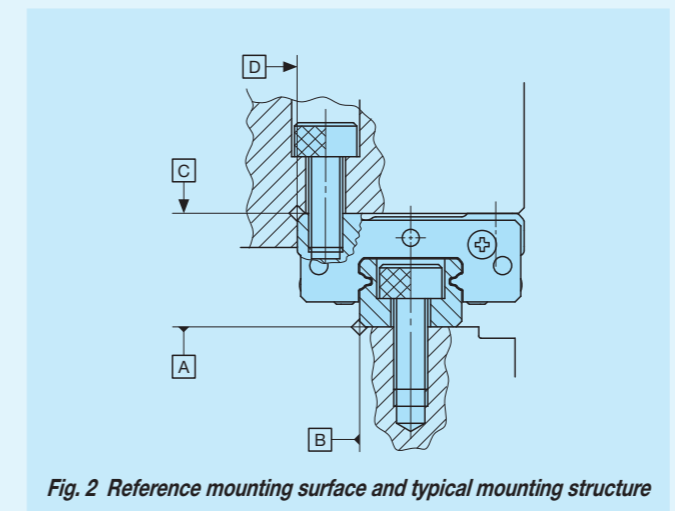

Fig. 2 Reference mounting surface and typical mounting structure

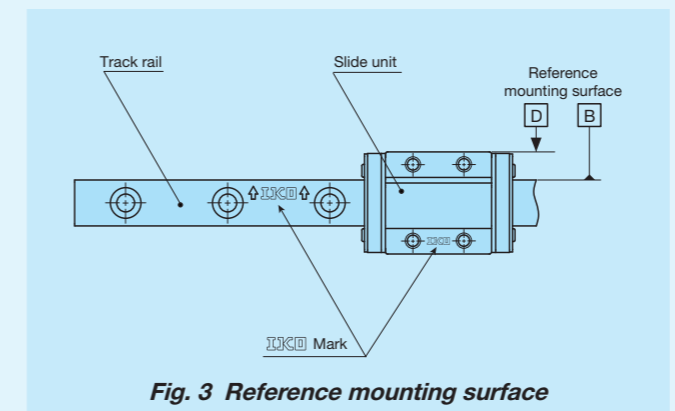

Fig. 3 Reference mounting surface

## 4 Tightening torque for fixing screw

Typical tightening torque for mounting of the MLV series to the steel mating member material is indicated in Table 7. When vibration and shock of the machine or device are large, fluctuating load is large, or moment load is applied, fix it by using the torque 1.2 to 1.5 times larger than the value indicated in the table as necessary. If the mating member material is cast iron or aluminum alloy, reduce the tightening torque depending on the strength characteristics of the mating member material.

Table 7 Tightening torque for fixing screw

Bolt size	Tightening torque N · m
	Stainless steel-made screw
M2×0.4	0.31
M3×0.5	1.1

Remark: The tightening torque is calculated based on the property division A2-70.



Standard type			
Shape	MLV		
Size	7	9	12

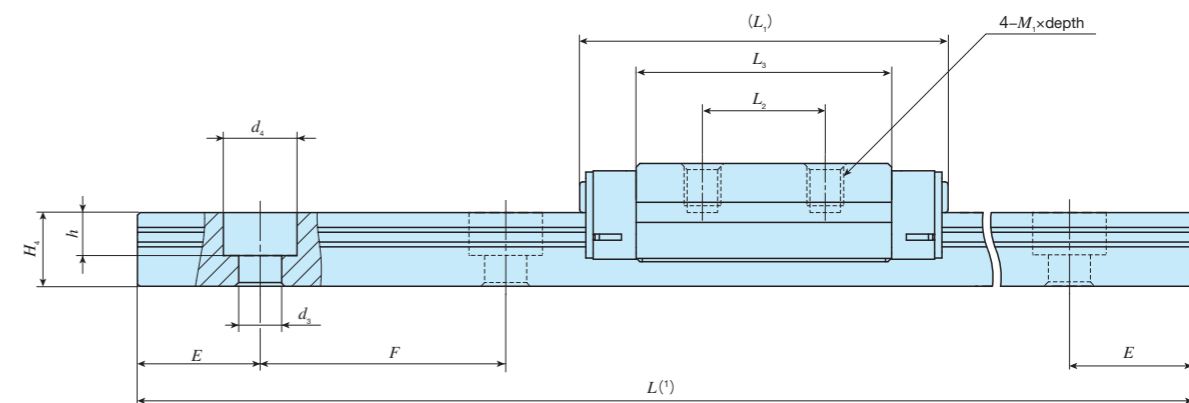
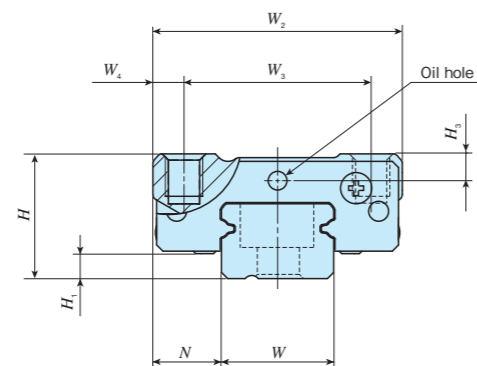

Identification number	Mass (Ref.) g		Dimensions of assembly mm			Dimensions of slide unit mm								Dimensions of track rail mm						Appended mounting bolt for track rail (2) mm Bolt size × ℓ	Basic dynamic load rating (3) C N	Basic static load rating (3) C <sub>0</sub> N	Static moment rating (3)			
	Slide unit	Track rail (Per 100 mm)	H	H <sub>1</sub>	N	W <sub>2</sub>	W <sub>3</sub>	W <sub>4</sub>	L <sub>1</sub>	L <sub>2</sub>	L <sub>3</sub>	M <sub>1</sub> × depth	H <sub>3</sub>	W	H <sub>4</sub>	d <sub>3</sub>	d <sub>4</sub>	h	E				F	T <sub>0</sub> N · m	T <sub>x</sub> N · m	T <sub>y</sub> N · m
MLV 7	8.4	22	8	1.5	5	17	12	2.5	23.5	8	14.3	M2×2	1.5	7	5	2.4	4.2	2.3	7.5	15	M2×6	1 330	1 890	6.9	4.7 28.2	3.9 23.6
MLV 9	17	35	10	2	5.5	20	15	2.5	30	10	20.8	M3×3	2.2	9	6	3.5	6	3.5	10	20	M3×8	1 810	2 760	12.8	9.1 51.1	7.6 42.9
MLV 12	31	65	13	3	7.5	27	20	3.5	34	15	21.6	M3×3.5	2.7	12	8	3.5	6.5	4.5	12.5	25	M3×8	3 330	4 290	26.6	15.4 93.1	12.9 78.2

Notes (1) Track rail lengths  $L$  are shown in Table 1 on page II-43.

(2) The appended track rail mounting bolts are stainless steel hexagon socket head bolts equivalent to JIS B 1176.

(3) The direction of basic dynamic load rating ( $C$ ), basic static load rating ( $C_0$ ), and static moment rating ( $T_0$ ,  $T_x$ ,  $T_y$ ) are shown in the sketches below.

The upper values of  $T_x$  and  $T_y$  are for one slide unit and the lower values are for two slide units in close contact.

Remark: The specification of oil holes is shown in Table 5 on page II-45.

1N=0.102 kgf

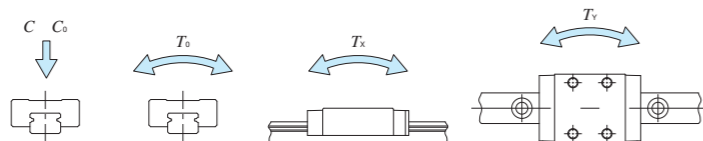

### Example of identification number of assembled set

Model code Dimensions Part code Classification symbol Supplemental code  
**MLV** **7** **C2** **R120** **H** **/US**  
 ① ② ③ ④ ⑤ ⑥

① Model MLV C-Lube Linear Way MLV	④ Length of Track Rail (120mm)
② Size 7, 9, 12	⑤ Accuracy class H High
③ Number of slide units (2)	⑥ Special specification D, E, MN, US, W, YCG

# C-Lube Linear Way MV

MV

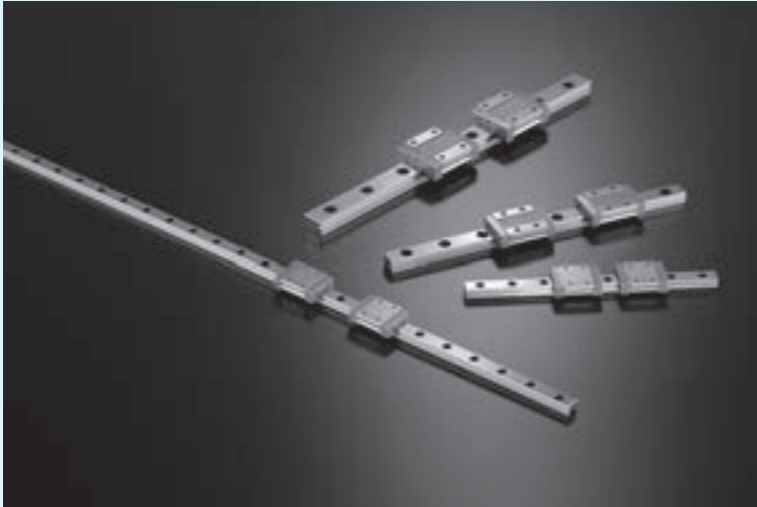

# C-Lube Linear Way MV

# MV



Long term maintenance free compliant!

The aquamarine end plate is the symbol of maintenance free.

Track rail

Slide unit

Casing

C-Lube

Ball

End plate

End seal

Ball retaining band

Grease nipple

## Points

### 1 Ultimate ball type linear motion rolling guide pursuing extra low profile and extra light weight

For details ▶ P.I-19

A linear motion rolling guide with extra low profile and extra light weight, achieved only because of the simple mechanism of two-row four-point contact structure.

### 2 High load capacity

Despite its extra low profile and extra light weight, it has the maximum load rating among the ball types and contributes to long life and increases safety of machine or device.

### 3 Long term maintenance free For details ▶ P.I-11

The built-in "C-Lube", the capillary lubricating element, in the ball circulation paths of the slide unit makes it long term maintenance free.

Lubrication oil is continuously supplied to the surface of rolling elements by surface tension in the contact of the capillary lubricating element surface and rolling elements.

### 4 Ball retained type for easy operation

The slide unit incorporates the ball retaining band, which prevents the ball from dropping down when the slide unit is removed from the track rail. This safety structure brings you an easy operation to the machines/equipment.

## Designation of Identification Number and Specification

### Example of an Identification Number

The specifications of the MV series are indicated by the identification number.

Indicate the identification number, consisting of a model code, dimensions, a part code, a preload symbol, a classification symbol, and any supplemental codes for each specification to apply.

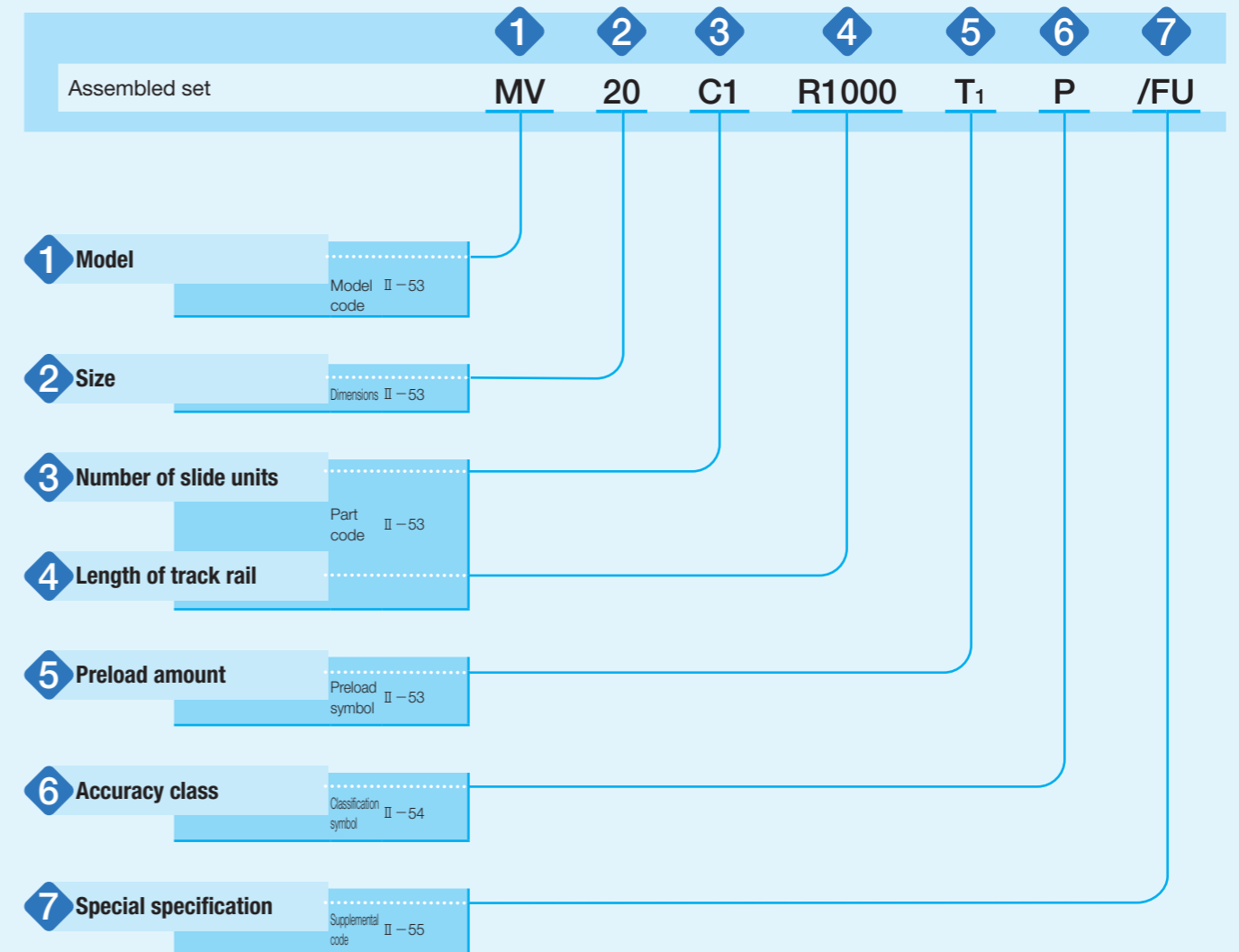

# Identification Number and Specification – Model · Size · Number of Slide Unit · Length of Track Rail · Preload amount –

<b>1 Model</b>	C-Lube Linear Way MV : MV (MV series)
<b>2 Size</b>	20, 25, 30
<b>3 Number of slide units</b>	: C○ Indicates the number of slide units assembled on a track rail.
<b>4 Length of track rail</b>	: R○ Indicate the length of track rail in mm. For standard and maximum lengths, see Table 1.

**Table 1 Standard and maximum lengths of track rail**

Item	MV 20	MV 25	MV 30
Standard length $L$ (n)	220 ( 4) 280 ( 5) 340 ( 6) 460 ( 8) 640 (11) 820 (14) 1 000 (17) 1 240 (21)	220 ( 4) 280 ( 5) 340 ( 6) 460 ( 8) 640 (11) 820 (14) 1 000 (17) 1 240 (21) 1 600 (27)	280 ( 4) 440 ( 6) 600 ( 8) 760 (10) 1 000 (13) 1 240 (16) 1 640 (21) 2 040 (26) 2 520 (32) 3 000 (38)
Pitch of mounting holes $F$	60	60	80
$E$	20	20	20
Standard $E$ or higher dimensions below	8 38	9 39	9 49
Maximum length <sup>(1)</sup>	2 200 (2 980)	2 980	3 000

Note <sup>(1)</sup> Length up to the value in ( ) can be produced. If needed, please contact **IKO**.  
Remark: If not directed,  $E$  dimensions for both ends will be the same within the range of  $E$  reference dimensions. To change the dimensions, indicate the specified rail mounting hole positions "/ $E$ " of special specification. For more information, see page III - 30.

<b>5 Preload amount</b>	Clearance : T <sub>c</sub> Standard : No symbol Light preload : T <sub>1</sub>	For details of the preload amount, see Table 2.
-------------------------	--	---

**Table 2 Preload amount**

Preload type	Preload symbol	Preload amount N	Operational conditions
Clearance	T <sub>c</sub>	0 <sup>(1)</sup>	<ul style="list-style-type: none"> <li>Very light motion</li> <li>To absorb slight errors</li> </ul>
Standard	(No symbol)	0 <sup>(2)</sup>	<ul style="list-style-type: none"> <li>Light and precise motion</li> </ul>
Light preload	T <sub>1</sub>	0.02C <sub>0</sub>	<ul style="list-style-type: none"> <li>Almost no vibrations</li> <li>Load is evenly balanced</li> <li>Light and precise motion</li> </ul>

Notes <sup>(1)</sup> Clearance of about 10 μm  
<sup>(2)</sup> Indicates zero or minimal amount of preload.  
Remark: C<sub>0</sub> indicates the basic static load rating.

# – Accuracy Class –

<b>6 Accuracy class</b>	Ordinary : No symbol High : H Precision : P Super precision : SP	For details of accuracy class, see Table 3. For applicable combinations of accuracy class and preload amount, see Table 4.
-------------------------	---	---

**Table 3 Tolerance and allowance**

Class (Classification symbol)	Ordinary (No symbol)	High (H)	Precision (P)	Super precision (SP)
Dim. $H$ tolerance	±0.080	±0.040	±0.020	±0.010
Dim. $N$ tolerance	±0.100	±0.050	±0.025	±0.015
Dim. variation of $H$ <sup>(1)</sup>	0.025	0.015	0.007	0.005
Dim. variation of $N$ <sup>(1)</sup>	0.030	0.020	0.010	0.007
Parallelism in operation of the slide unit C surface to A surface	See Fig. 1.			
Parallelism in operation of the slide unit D surface to B surface	See Fig. 1.			

Note <sup>(1)</sup> It means the size variation between slide units mounted on the same track rail.

**Table 4 Combination of accuracy class and preload**

Item (preload symbol)	Ordinary (No symbol)	High (H)	Precision (P)	Super precision (SP)
Clearance (T <sub>c</sub> )	○	—	—	—
Standard (no symbol)	○	○	○	○
Light preload (T <sub>1</sub> )	—	○	○	○

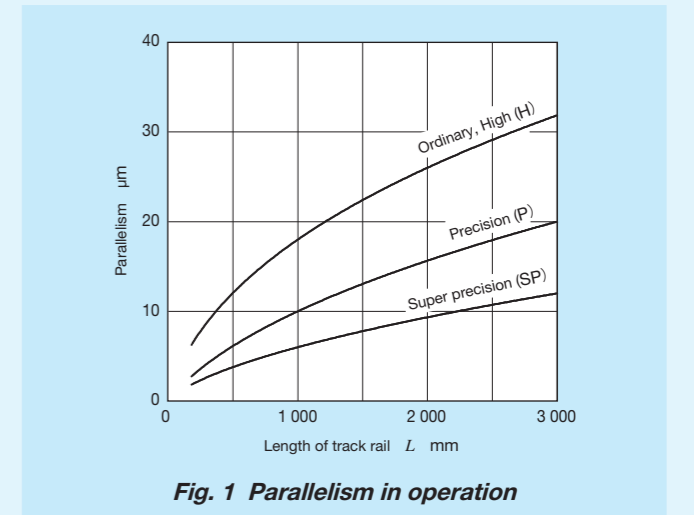

**Fig. 1 Parallelism in operation**

7 Special specification

/A, /D, /E, /F, /I, /LO, /LFO, /MA, /N, /U, /VO, /WO, /YCG, /ZO

For applicable special specifications, see Table 5.  
For combination of multiple special specifications, see Table 6.  
For details of special specifications, see page III-29.

Table 5 Application of special specifications

Special specification	Supplemental code
Butt-jointing track rails	/A
Opposite reference surfaces arrangement	/D
Specified rail mounting hole positions	/E
Caps for rail mounting holes	/F
Inspection sheet	/I
Black chrome surface treatment	/LO
Fluorine black chrome surface treatment	/LFO
With track rail mounting bolt	/MA
No seal	/N
Under seal	/U
Double seals	/VO
A group of multiple assembled sets	/WO
Specified grease (IKO Low Dust-Generation Grease for Clean Environment CG2)	/YCG
Scraper	/ZO

Table 6 Combination of supplemental codes

D	○													
E	-	-												
F	○	○	○											
I	○	○	○	○										
L	○	○	○	○	○									
LF	○	○	○	○	○	-								
MA	○	○	○	○	○	○								
N	○	○	○	-	○	○	○							
U	○	○	○	○	○	○	○	○						
V	○	○	○	○	○	○	○	○	-	○				
W	○	○	-	○	○	○	○	○	○	○				
YCG	○	○	○	○	○	○	○	○	○	○	○			
Z	○	○	○	○	○	○	○	○	-	○	○	○		
	A	D	E	F	I	L	LF	MA	N	U	V	W	YCG	Z

Remarks: 1. The combination of "-" shown in the table is not available.  
2. When using multiple types for combination, please indicate by arranging the symbols in alphabetical order.

Table 7 Track rail mounting bolt size (Supplemental code /MA)

Size	Bolt size for track rail
20	M5×14
25	M6×20
30	M6×20

Remark: Hexagon socket head bolts equivalent to JIS B 1176.

Table 8  $H_1$  dimension with under seal (Supplemental code: /U)

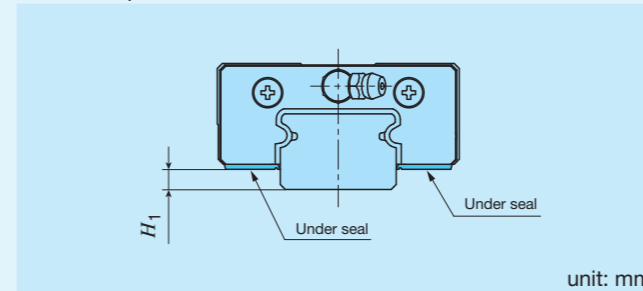

Size	$H_1$
20	4
25	4
30	4.5

Table 9 Dimension of slide unit with double end seals (Supplemental code /V /VV)

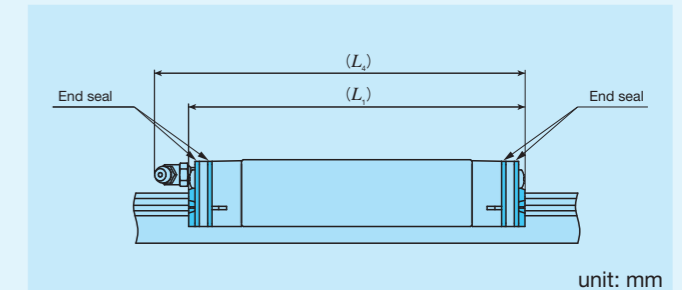

Size	$L_1$	$L_4$
20	81	83
25	101	111
30	125	141

Remark: The dimensions of the slide unit with double end seals at both ends are indicated.

Table 10 Dimension of slide unit with scrapers (Supplemental code: /Z /ZZ)

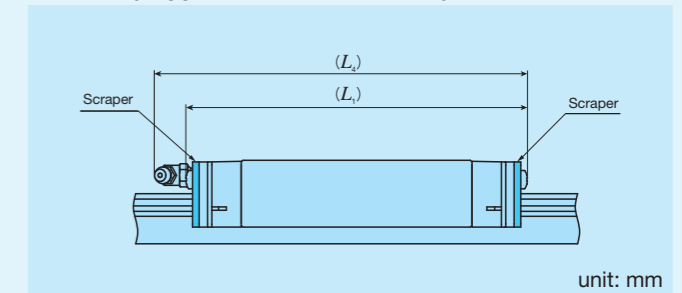

Size	$L_1$	$L_4$
20	82	84
25	103	112
30	127	142

Remark: The dimensions of the slide unit with scraper at both ends are indicated.

# Lubrication

Lithium-soap base grease with extreme-pressure additive (Alvania EP grease 2 [SHOWA SHELL SEKIYU K. K.]) is pre-packed in MV series. Additionally, MV series has C-Lube placed in the recirculation part of balls, so that the interval for reapplying lubricant can be extended and maintenance works such as grease job can be reduced significantly.

MV series has grease nipple as indicated in Table 11. Supply nozzles fit to each shapes of grease nipple are also available. When these parts are desired, see Tables 14.1 and 14.2 on page III-23 and Table 15 on page III-24 to order.

**Table 11 Parts for lubrication**

Size	Grease nipple type (1)	Applicable supply nozzle type	Bolt size of female threads for piping
20	A-M3	A-5120V A-5240V B-5120V B-5240V	—
25	B-M4	A-8120V B-8120V	M4
30	B-M6	Grease gun available on the market	M6

Note (1) For grease nipple specification, see Table 14.1 and 14.2 on page III-23.

Remark: Stainless steel grease nipple is also available. If needed, please contact **IKO**.

# Dust Protection

The slide units of MV series are equipped with end seals as standard for dust protection. However, if large amount of contaminant or dust are floating, or if large particles of foreign substances such as chips or sand may adhere to the track rail, it is recommended to cover the whole unit with bellows or telescope type shield, etc.

It is also effective to apply special specifications such as caps for rail mounting holes, under seal, double end seals and scrapers according to the use environment.

# Precaution for Use

## 1 Mounting surface, reference mounting surface and typical mounting structure

When mounting the MV series, properly align the reference mounting surface B and D of the track rail and slide unit with the reference mounting surface of the table and bed and fix them. (See Fig.2)

The reference mounting surfaces B and D and mounting surfaces A and C are precisely ground. Machining the mounting surface of the table and bed, such as machine or device, to high accuracy and mounting them properly will ensure stable linear motion with high accuracy.

Reference mounting surface of the slide unit is the opposite side of the **IKO** mark. The track rail reference mounting surface is identified by locating the **IKO** mark on the top surface of the track rail. It is the side surface above the mark (in the direction of the arrow). (See Fig.3)

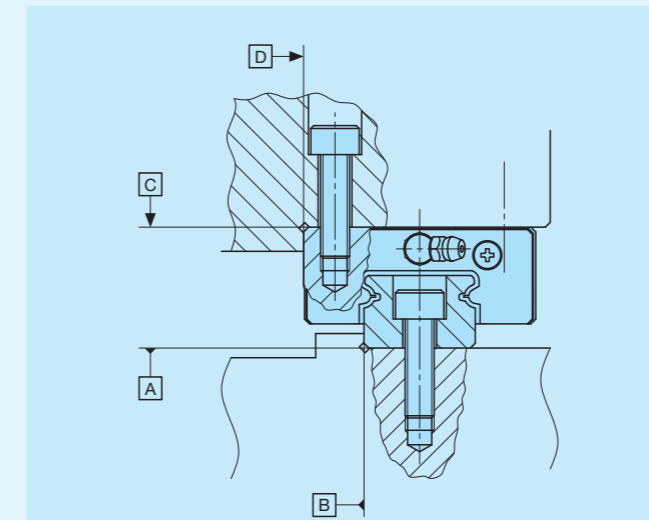

**Fig. 2 Reference mounting surface and typical mounting structure**

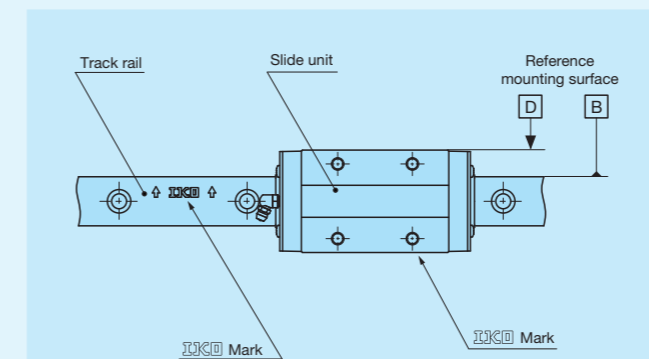

**Fig. 3 Reference mounting surface**

## 2 Shoulder height and corner radius of the reference mounting surface

For the opposite corner of the mating reference mounting, it is recommended to have relieved fillet as indicated in Fig.4. Recommended value for the shoulder height and corner radius on the mating side is indicated in Table 12.

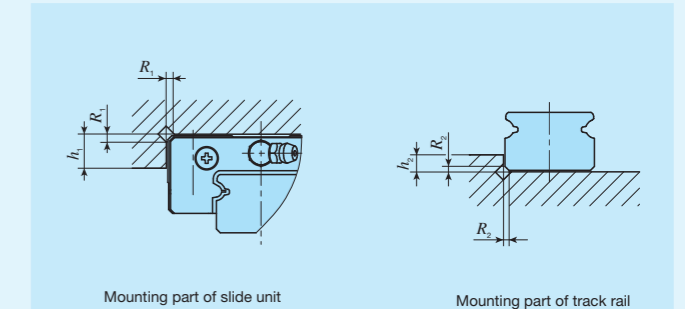

**Fig. 4 Corner of the mating reference mounting**

**Table 12 Shoulder height and corner radius of the reference mounting surface**

Size	Mounting part of slide unit		Mounting part of track rail	
	Shoulder height $h_1$	Corner radius $R_1$ (maximum)	Shoulder height $h_2$	Corner radius $R_2$ (maximum)
20	5	0.2	3	0.5
25	5	0.5	3	0.5
30	5	0.5	3	0.5

## 3 Tightening torque for fixing screw

Typical tightening torque for mounting of the MV series to the steel mating member material is indicated in Table 13. When vibration and shock of the machine or device are large, fluctuating load is large, or moment load is applied, fix it by using the torque 1.2 to 1.5 times larger than the value indicated in the table as necessary. If the mating member material is cast iron or aluminum alloy, reduce the tightening torque depending on the strength characteristics of the mating member material.

**Table 13 Tightening torque for fixing screw**

Bolt size	Tightening torque N · m	
	High carbon steel-made screw	Stainless steel-made screw
M5×0.8	8.0	5.0
M6×1	13.6	8.5
M8×1.25	32.7	20.4

Remark: The tightening torque is calculated based on strength division 12.9 and property division A2-70.

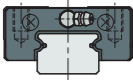
Standard type			
Shape	<b>MV</b>		
			
Size	20	25	30

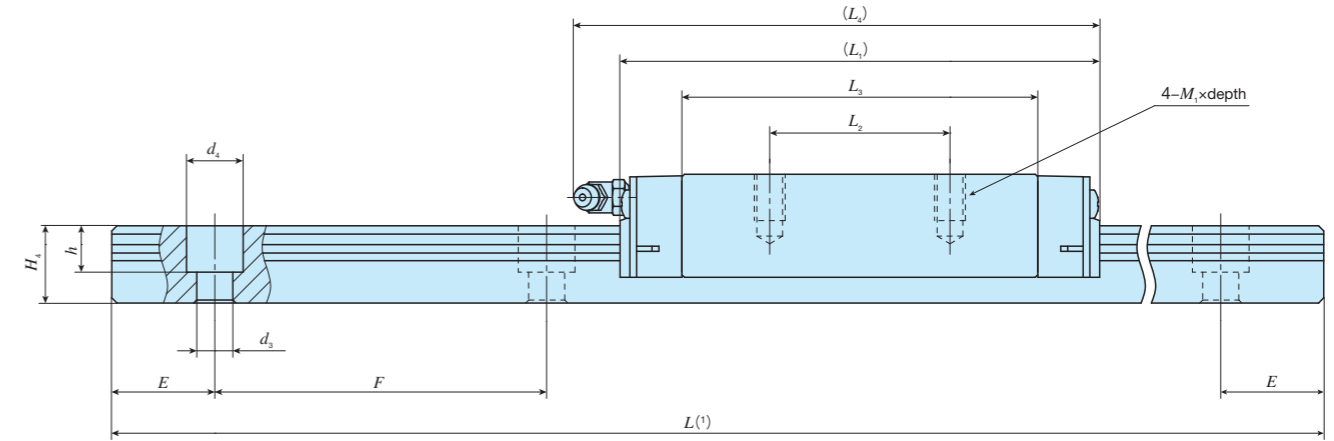
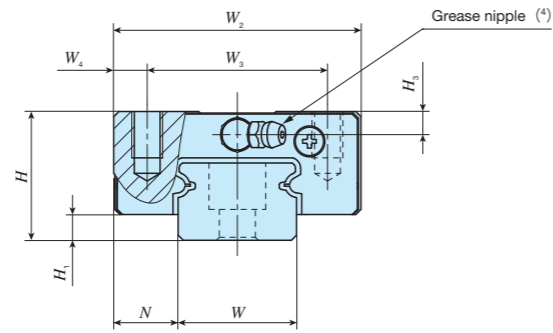

Identification number	Mass (Ref.)		Dimensions of assembly mm			Dimensions of slide unit mm									Dimensions of track rail mm							Appended mounting bolt for track rail (2) mm Bolt size × ℓ	Basic dynamic load rating (3) C N	Basic static load rating (3) C <sub>0</sub> N	Static moment rating (3)		
	Slide unit kg	Track rail kg/m	H	H <sub>1</sub>	N	W <sub>2</sub>	W <sub>3</sub>	W <sub>4</sub>	L <sub>1</sub>	L <sub>2</sub>	L <sub>3</sub>	L <sub>4</sub>	M <sub>1</sub> × depth	H <sub>3</sub>	W	H <sub>4</sub>	d <sub>3</sub>	d <sub>4</sub>	h	E	F				T <sub>0</sub> N · m	T <sub>x</sub> N · m	T <sub>y</sub> N · m
<b>MV 20</b>	0.18	1.66	20	5	11	42	32	5	73	32	51.2	76	M5×6	3.5	20	12	6	9.5	8.5	20	60	M5×14	19 600	25 600	138	115 624	102 555
<b>MV 25</b>	0.36	2.37	25	5	12.5	48	35	6.5	94	35	69.1	103	M6×9	4.5	23	15	7	11	9	20	60	M6×20	31 900	42 500	264	260 1 320	230 1 170
<b>MV 30</b>	0.72	3.33	30	6	16	60	40	10	116	40	86.6	126	M8×11	5	28	17	7	11	9	20	80	M6×20	46 300	61 800	468	467 2 350	414 2 090

Notes (1) Track rail lengths  $L$  are shown in Table 1 on page II-53.  
 (2) Track rail mounting bolts are not appended. Hexagon socket head bolts of JIS B 1176 with strength division 12.9 are recommended.  
 (3) The direction of basic dynamic load rating ( $C$ ), basic static load rating ( $C_0$ ), and static moment rating ( $T_0$ ,  $T_x$ ,  $T_y$ ) are shown in the sketches below. The upper values of  $T_x$  and  $T_y$  are for one slide unit and the lower values are for two slide units in close contact.  
 (4) For specifications of grease nipple, see Table 11 on page II-57.

MV

### Example of identification number of assembled set

Model code: **MV**    Dimensions: **25**    Part code: **C2**    Preload symbol: **R1000**    Classification symbol: **T1**    Supplemental code: **SP**    **/FU**

① Model  
MV C-Lube Linear Way MV

② Size  
20, 25, 30

③ Number of slide units (2)

④ Length of Track Rail (1000mm)

⑤ Preload amount	
T <sub>c</sub>	Clearance
No symbol	Standard
T <sub>1</sub>	Light preload

⑥ Accuracy class	
No symbol	Ordinary
H	High
P	Precision
SP	Super precision

⑦ Special specification  
A, D, E, F, I, L, LF, MA, N, U, V, W, YCG, Z

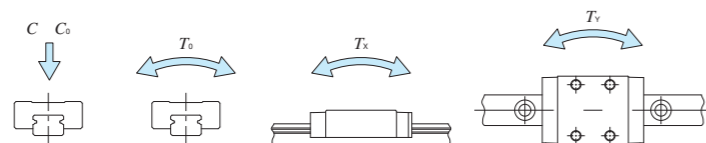

# C-Lube Linear Way ME Linear Way E

ME • LWE

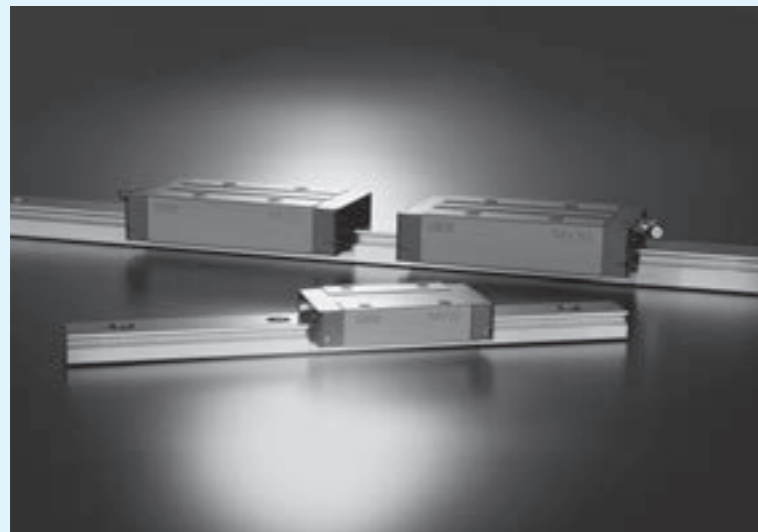



# C-Lube Linear Way ME

# ME



long term maintenance free supported!

The aquamarine end plate is the symbol of maintenance free.

Track rail

Slide unit

Casing

C-Lube

Ball

End plate

Ball retaining band

End seal

Grease nipple

Linear Way E

# LWE

## Points

### 1 Compact and versatile series with utility

Versatile linear motion rolling guide that has achieved utility pursuing compactness in every aspect.

### 2 Wide range of variations for your needs

For details [P.I-26](#)

As two shapes of slide unit, flange type and block type (with small width) and 3 types with different slide unit length with same section are available, you can select an optimal product for the specifications of your machine and device.

### 3 Stainless steel selections superior in corrosion resistance are listed on lineup.

For details [P.I-41](#)

Products made of stainless steel are highly resistant to corrosion, so that they are suitable for applications where rust prevention oil is not preferred, such as in cleanroom environment.

### 4 Achieved smooth and quiet motion Low Decibel Linear Way E

Due to resin separator built-in balls, Low Decibel Linear Way E achieved smooth and quiet motion by eliminating of direct contact of balls each other. This feature reduces noise level in factory and contributes to a human-friendly environment.

## Identification Number and Specification

### Example of an identification number

The specifications of ME and LWE (---Q) series are indicated by the identification number. Indicate the identification number, consisting of a model code, dimensions, a part code, a material code, a preload symbol, a classification symbol, an interchangeable code, and any supplemental codes for each specification to apply.

Non-interchangeable specification	1	2	3	4	5	6	7	8	9	10
Assembled set	ME	C	20	C1	R1000		T <sub>1</sub>	P		/FU
Interchangeable specification										
Single slide unit	ME	C	20	C1			T <sub>1</sub>	P	S1	/U
Single track rail (1)	LWE		20		R1000			P	S1	/F
Assembled set	ME	C	20	C1	R1000		T <sub>1</sub>	P	S1	/FU

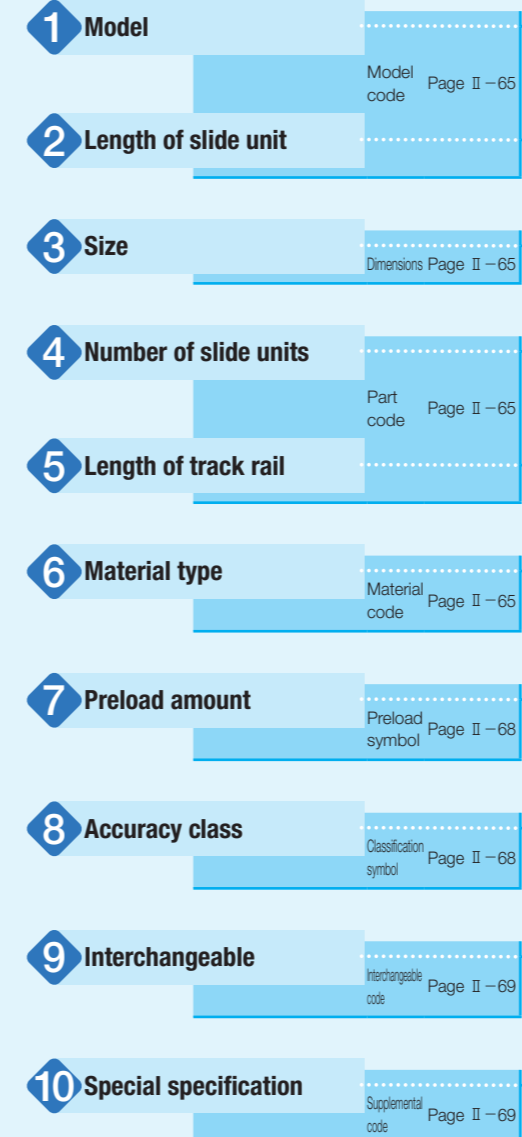

Note (1) Indicate "LWE" for the model code of the single track rail regardless of the series and the combination of slide unit model.

# Identification Number and Specification —Model · Length of Slide Unit · Size ·

<b>1 Model</b>	C-Lube Linear Way ME (ME series)	Flange type mounting from bottom : ME Flange type mounting from top : MET Block type mounting from top : MES
	Linear Way E <sup>(1)</sup> (LWE series)	Flange type mounting from bottom : LWE Flange type mounting from top : LWET Block type mounting from top : LWES
	Low Decibel Linear Way E <sup>(1)</sup> (LWE...Q series)	Flange type mounting from bottom : LWE...Q Flange type mounting from top : LWET...Q Block type mounting from top : LWES...Q
	For applicable models and sizes, see Table 1. Indicate "LWE" for the model code of single track rail regardless of the series and the slide unit model to be combined. Note <sup>(1)</sup> This model has no built-in C-Lube.	
<b>2 Length of slide unit</b>	Short : C Standard : No symbol Long : G	For applicable models and sizes, see Table 1.
<b>3 Size</b>	15,20,25,30,35,45	For applicable models and sizes, see Table 1.
<b>4 Number of slide units</b>	: C○	For an assembled set, indicates the number of slide units assembled on a track rail. For a single slide unit, only "C1" is specified.
<b>5 Length of track rail</b>	: R○	Indicate the length of track rail in mm. For standard and maximum lengths, see Tables 2.1 and 2.2.
<b>6 Material type</b>	High carbon steel made : No symbol Stainless steel made <sup>(2)</sup> : SL	For applicable models and sizes, see Table 1. Note <sup>(2)</sup> Mount a standard grease nipple (brass) on the stainless steel type, too. Stainless steel grease nipple is also available. If needed, please contact <b>IKO</b> .

# Number of Slide Unit · Length of Track Rail · Material—

Table 1 Models and sizes of ME and LWE (...Q) series

Material	Shape	Slide unit Length	Model	Size						
				15	20	25	30	35	45	
High carbon steel made	Flange type mounting from bottom	Short	MEC LWEC	○	○	○	○	○	—	
		Standard	ME LWE LWE...Q	○	○	○	○	○	○	
		Long	MEG LWEG	○	○	○	○	—	—	
		Flange type mounting from top	Short	METC LWETC	○	○	○	○	○	—
			Standard	MET LWET LWET...Q	○	○	○	○	○	○
			Long	METG LWETG	○	○	○	○	—	—
	Block type mounting from top	Short	MESC LWESC	○	○	○	○	○	—	
		Standard	MES LWES LWES...Q	○	○	○	○	○	○	
		Long	MESG LWESG	○	○	○	○	—	—	
		Flange type mounting from bottom	Short	MEC...SL LWEC...SL	○	○	○	○	—	—
			Standard	ME...SL LWE...SL	○	○	○	○	—	—
			Long	MEG...SL LWEG...SL	○	○	○	○	—	—
	Flange type mounting from top		Short	METC...SL LWETC...SL	○	○	○	○	—	—
			Standard	MET...SL LWET...SL	○	○	○	○	—	—
			Long	METG...SL LWETG...SL	○	○	○	○	—	—
	Block type mounting from top	Short	MESC...SL LWESC...SL	○	○	○	○	—	—	
		Standard	MES...SL LWES...SL	○	○	○	○	—	—	
		Long	MESG...SL LWESG...SL	○	○	○	○	—	—	

Remark: For the models indicated in  , the interchangeable specification is available.

Table 2.1 Standard and maximum lengths of high carbon steel track rails

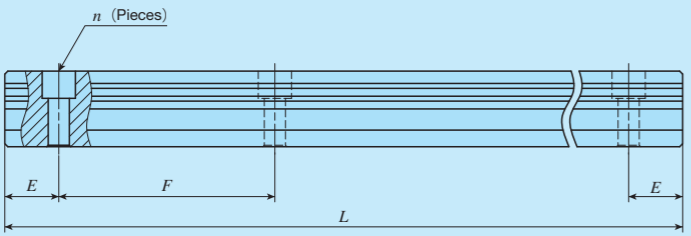

Item	Identification number	ME 15	ME 20	ME 25	ME 30	ME 35	ME 45
		LWE 15 LWE 15...Q	LWE 20 LWE 20...Q	LWE 25 LWE 25...Q	LWE 30 LWE 30...Q	LWE 35 LWE 35...Q	LWE 45
Standard length $L$ (n)		160 ( 3)	220 ( 4)	220 ( 4)	280 ( 4)	280 ( 4)	570 ( 6)
		220 ( 4)	280 ( 5)	280 ( 5)	440 ( 6)	440 ( 6)	885 ( 9)
		280 ( 5)	340 ( 6)	340 ( 6)	600 ( 8)	600 ( 8)	1 200 (12)
		340 ( 6)	460 ( 8)	460 ( 8)	760 (10)	760 (10)	1 620 (16)
		460 ( 8)	640 (11)	640 (11)	1 000 (13)	1 000 (13)	2 040 (20)
		640 (11)	820 (14)	820 (14)	1 240 (16)	1 240 (16)	2 460 (24)
	820 (14)	1 000 (17)	1 000 (17)	1 640 (21)	1 640 (21)	2 985 (29)	
		1 240 (21)	1 240 (21)	2 040 (26)	2 040 (26)		
			1 600 (27)	2 520 (32)	2 520 (32)		
				3 000 (38)	3 000 (38)		
Pitch of mounting holes $F$		60	60	60	80	80	105
$E$ (1)		20	20	20	20	20	22.5
Standard $E$ dimensions (2)	or higher	6	8	9	9	10	12
	below	36	38	39	49	50	64.5
Maximum length (3)		1 600 (2 980)	2 200 (2 980)	2 980 (4 000)	3 000 (3 960)	3 000 (3 960)	2 985 (3 930)

Notes (1) When specifying a butt-jointing track rail (supplemental code "/T"), pay attention to the  $E$  dimension at the butt-jointing part.  
 (2) Not applicable to the track rail with female threads for bellows (supplemental code "/J").  
 (3) Length up to the value in ( ) can be produced. If needed, please contact **IKO**. The values in ( ) is not applicable to LWE...Q series.

Remarks 1. A typical identification number is indicated, but is applied to all models of the same size.  
 2. Indicate "LWE" for the model code of single track rail regardless of the series and the slide unit model to be combined.  
 3. If not directed,  $E$  dimensions for both ends will be the same within the range of standard  $E$  dimensions. To change the dimensions, indicate the specified rail mounting hole positions "/E" of special specification. For more information, see page III - 30.

Table 2.2 Standard and maximum lengths of stainless steel track rails unit: mm

Item	Identification number	ME 15...SL	ME 20...SL	ME 25...SL	ME 30...SL
		LWE 15...SL	LWE 20...SL	LWE 25...SL	LWE 30...SL
Standard length $L$ (n)		160 ( 3)	220 ( 4)	220 ( 4)	280 ( 4)
		220 ( 4)	280 ( 5)	280 ( 5)	440 ( 6)
		280 ( 5)	340 ( 6)	340 ( 6)	600 ( 8)
		340 ( 6)	460 ( 8)	460 ( 8)	760 (10)
		460 ( 8)	640 (11)	640 (11)	1 000 (13)
		640 (11)	820 (14)	820 (14)	
	820 (14)	1 000 (17)	1 000 (17)		
Pitch of mounting holes $F$		60	60	60	80
$E$ (1)		20	20	20	20
Standard $E$ dimensions (2)	or higher	6	8	9	9
	below	36	38	39	49
Maximum length (3)		1 200 (1 600)	1 200 (1 960)	1 200 (1 960)	1 200 (1 960)

Notes (1) When specifying a butt-jointing track rail (supplemental code "/T"), pay attention to the  $E$  dimension at the butt-jointing part.  
 (2) Not applicable to the track rail with female threads for bellows (supplemental code "/J").  
 (3) Length up to the value in ( ) can be produced. If needed, please contact **IKO**.

Remarks 1. A typical identification number is indicated, but is applied to all models of the same size.  
 2. Indicate "LWE" for the model code of single track rail regardless of the series and the slide unit model to be combined.  
 3. If not directed,  $E$  dimensions for both ends will be the same within the range of standard  $E$  dimensions. To change the dimensions, indicate the specified rail mounting hole positions "/E" of special specification. For more information, see page III - 30.

7 Preload amount			
Clearance	: T <sub>c</sub>	Specify this item for an assembled set or a single slide unit.	
Standard	: No symbol	For details of the preload amount, see Table 3.	
Light preload	: T <sub>1</sub>	For applicable combinations of accuracy class and preload amount, see Table 4.	
Medium preload	: T <sub>2</sub>		

8 Accuracy class			
Ordinary	: No symbol	For interchangeable specification products, assemble a slide unit and a track rail of the same accuracy class.	
High	: H	For details of accuracy class, see Table 5.	
Precision	: P		
Super precision	: SP	For applicable combinations of accuracy class and preload amount, see Table 4.	

Table 3 Preload amount

Preload type	Item	Preload symbol	Preload amount N	Operational conditions
Clearance		T <sub>c</sub>	0 <sup>(1)</sup>	• Very light motion • To absorb slight errors
Standard		(No symbol)	0 <sup>(2)</sup>	• Light and precise motion
Light preload		T <sub>1</sub>	0.02C <sub>0</sub>	• Almost no vibrations • Load is evenly balanced • Light and precise motion
Medium preload		T <sub>2</sub>	0.05C <sub>0</sub>	• Medium vibration • Medium overhung load

Notes (1) Clearance of about 10 μm  
 (2) Indicates zero or minimal amount of preload  
 Remark: C<sub>0</sub> indicates the basic static load rating.

Table 4 Combination of accuracy class and preload

Preload type (preload symbol)	Classification (classification symbol)			
	Ordinary (No symbol)	High (H)	Precision (P)	Super precision (SP)
Clearance (T <sub>c</sub> ) (1)	○	—	—	—
Standard (no symbol)	○	○	○	○
Light preload (T <sub>1</sub> )	—	○	○	○
Medium preload (T <sub>2</sub> ) (1)	—	○	○	○

Note (1) Not applicable to LWE...Q series.  
 Remark: The mark   indicates that interchangeable specification products are available.

Table 5 Tolerance and allowance

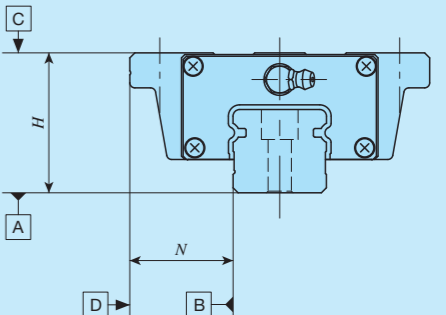

Item	Class (classification symbol)	Ordinary	High	Precision	Super precision
		(No symbol)	(H)	(P)	(SP)
Dim. $H$ tolerance		±0.080	±0.040	±0.020	±0.010
Dim. $N$ tolerance		±0.100	±0.050	±0.025	±0.015
Dim. variation of $H$ (1)		0.025	0.015	0.007	0.005
Dim. variation of $N$ (1)		0.030	0.020	0.010	0.007
Dim. variation of $H$ for multiple assembled sets (2)		0.045	0.035	0.025	—
Parallelism in operation of the slide unit C surface to A surface		See Fig. 1.			
Parallelism in operation of the slide unit D surface to B surface		See Fig. 1.			

Notes (1) It means the size variation between slide units mounted on the same track rail.  
 (2) Applicable to the interchangeable specification.

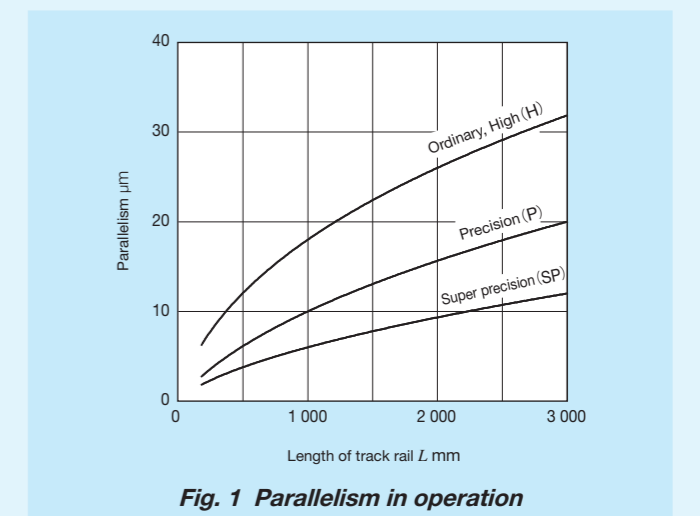

<b>9</b> <b>Interchangeable</b>	S1 specification : S1 S2 specification : S2 Non-interchangeable specification : No symbol	This is specified for the interchangeable specifications. Assemble a track rail and a slide unit with the same interchangeable code. Performance and accuracy of "S1" and "S2" are the same. For applicable models and sizes, see Table 1. "No symbol" is indicated for non-interchangeable specification.
---------------------------------	---	--

<b>10</b> <b>Special specification</b>	/A, /BS, /D, /E, /F, /I, /JO, /LO, /LFO, /MA, /M4, /N, /Q, /RE, /T, /U, /NO, /WO, /YO, /ZO	For applicable special specifications, see Tables 6.1, 6.2, 6.3, and 6.4. For combination of multiple special specifications, see Table 7. For details of special specifications, see page III -29.
--	--	---

**Table 6.1 Application of special specifications (Interchangeable specification, single slide unit)**

Special specification	Supplemental code	Size					
		15	20	25	30	35	45
Female threads for bellows <sup>(1)</sup>	/JO	○	○	○	○	○	○
No end seal	/N	○	○	○	○	○	○
With C-Lube plate <sup>(2)</sup>	/Q	○	○	○	○	○	○
Special environment seal <sup>(2)</sup>	/RE	○	○	○	○	×	×
Under seal	/U	○	○	○	○	○	○
Double end seals	/NO	○	○	○	○	○	○
Scrapers	/ZO	○	○	○	○	○	○

Notes <sup>(1)</sup> Not applicable to stainless steel made products.  
<sup>(2)</sup> Applicable to LWE series.

**Table 6.2 Application of special specifications (Interchangeable specification, single track rail)**

Special specification	Supplemental code	Size					
		15	20	25	30	35	45
Specified rail mounting hole positions	/E	○	○	○	○	○	○
Caps for rail mounting holes	/F	○	○	○	○	○	○
Female threads for bellows <sup>(1)</sup>	/JO	○	○	○	○	○	○
Black chrome surface treatment	/LR	○	○	○	○	○	○
With track rail mounting bolt	/MA	○	○	○	○	○	○
Changed size of mounting holes	/M4	○	×	×	×	×	×
Butt-jointing track rails	/T	○	○	○	○	○	○

Note <sup>(1)</sup> Not applicable to stainless steel made products.

**Table 6.3 Application of special specifications (Interchangeable specification, assembled set)**

Special specification	Supplemental code	Size					
		15	20	25	30	35	45
Stainless steel end plate <sup>(1)</sup>	/BS	○	○	○	○	×	×
Opposite reference surfaces arrangement	/D	○	○	○	○	○	○
Specified rail mounting hole positions	/E	○	○	○	○	○	○
Caps for rail mounting holes	/F	○	○	○	○	○	○
Female threads for bellows <sup>(2)</sup>	/JO	○	○	○	○	○	○
Black chrome surface treatment	/LO	○	○	○	○	○	○
Fluorine black chrome surface treatment	/LFO	○	○	○	○	○	○
With track rail mounting bolt	/MA	○	○	○	○	○	○
Changed size of mounting holes	/M4	○	×	×	×	×	×
No end seal	/N	○	○	○	○	○	○
With C-Lube plate <sup>(1)</sup>	/Q	○	○	○	○	○	○
Special environment seal <sup>(1)</sup>	/RE	○	○	○	○	×	×
Butt-jointing track rails	/T	○	○	○	○	○	○
Under seal	/U	○	○	○	○	○	○
Double end seals	/NO	○	○	○	○	○	○
Specified grease <sup>(3)</sup>	/YO	○	○	○	○	○	○
Scrapers	/ZO	○	○	○	○	○	○

Notes <sup>(1)</sup> Applicable to LWE series.  
<sup>(2)</sup> Not applicable to stainless steel made products.  
<sup>(3)</sup> ME series is applicable only to /YCG.

**Table 6.4 Application of special specifications (Non-interchangeable specification)**

Special specification	Supplemental code	Size					
		15	20	25	30	35	45
Butt-jointing track rails <sup>(1)</sup>	/A	○	○	○	○	○	○
Stainless steel end plate <sup>(2)</sup>	/BS	○	○	○	○	×	×
Opposite reference surfaces arrangement	/D	○	○	○	○	○	○
Specified rail mounting hole positions	/E	○	○	○	○	○	○
Caps for rail mounting holes	/F	○	○	○	○	○	○
Inspection sheet	/I	○	○	○	○	○	○
Female threads for bellows	/JO	○	○	○	○	○	○
Black chrome surface treatment	/LO	○	○	○	○	○	○
Fluorine black chrome surface treatment	/LFO	○	○	○	○	○	○
With track rail mounting bolt	/MA	○	○	○	○	○	○
Changed size of mounting holes	/M4	○	×	×	×	×	×
No end seal <sup>(1)</sup>	/N	○	○	○	○	○	○
With C-Lube plate <sup>(3)</sup>	/Q	○	○	○	○	○	○
Special environment seal <sup>(2)</sup>	/RE	○	○	○	○	×	×
Under seal <sup>(1)</sup>	/U	○	○	○	○	○	○
Double end seals	/NO	○	○	○	○	○	○
A group of multiple assembled sets	/WO	○	○	○	○	○	○
Specified grease <sup>(4)</sup>	/YO	○	○	○	○	○	○
Scrapers	/ZO	○	○	○	○	○	○

Notes <sup>(1)</sup> Not applicable to LWE...Q series.  
<sup>(2)</sup> Applicable to LWE series.  
<sup>(3)</sup> Applicable to LWE (...Q) series. / YCG is applicable to ME series.  
<sup>(4)</sup> ME series is applicable only to /YCG.

**Table 7 Combination of supplemental codes**

BS	○																		
D	○	○																	
E	-	○	-																
F	○	○	○	○															
I	○	○	○	○	○														
J	○	○	○	○	○	○													
L	○	○	○	○	○	○	○												
LF	○	○	○	○	○	○	○	-											
MA	○	○	○	○	○	○	○	○	○										
M4	○	○	○	○	○	○	○	○	○	○ <sup>(1)</sup>									
N	○	○	○	○	-	○	-	○	○	○	○								
Q	○	○	○	○	○	○	-	○	○	○	○	○							
RE	○	○	○	○	○	○	○	○	○	○	○	-	○						
T	-	○	○	○	○	-	-	○	○	○	○	○	○	○					
U	○	○	○	○	○	○	○	○	○	○	○	○	-	○	○				
V	○	○	○	○	○	○	●	○	○	○	○	○	-	-	○	○			
W	○	○	○	-	○	○	○	○	○	○	○	○	○	○	-	○	○		
Y	○	○	○	○	○	○	○	○	○	○	○	○	○	-	○	○	○	○	
Z	○	○	○	○	○	○	●	○	○	○	○	-	-	○	○	○	○	○	
	A	BS	D	E	F	I	J	L	LF	MA	M4	N	Q	RE	T	U	V	W	Y

Note <sup>(1)</sup> When combining "/MA" and "/M4", indicate "/MA4".  
Remarks 1. The combination of "-" shown in the table is not available.  
2. Contact **IKO** for the combination of the interchangeable specification marked with ●.  
3. When using multiple types for combination, please indicate by arranging the symbols in alphabetical order.

ME · LWE

Table 8 Dimension of female threads for bellows (Supplemental code Single unit: /J Assembled set: /J /JJ)

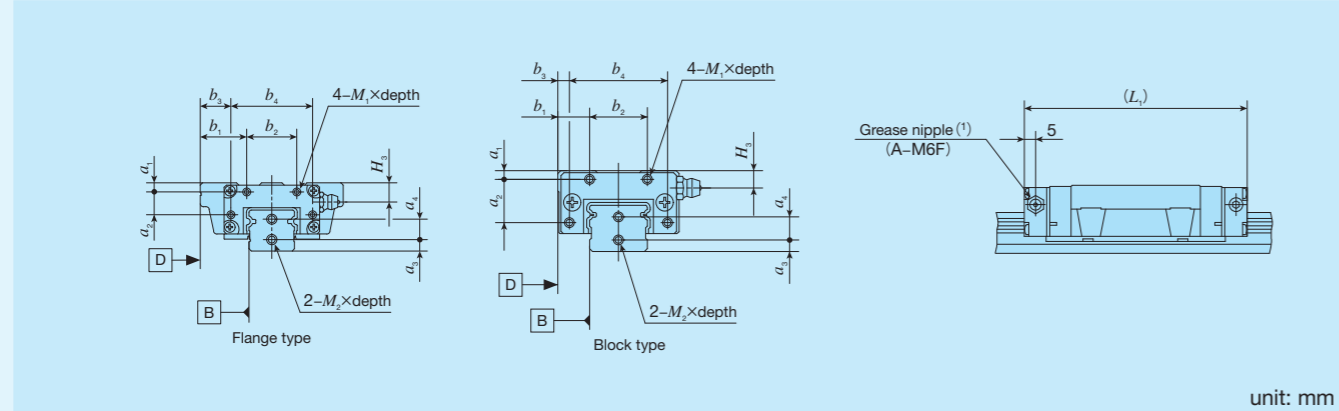

Identification number			Slide unit							Track Rail			
			a <sub>1</sub>	a <sub>2</sub>	b <sub>1</sub>	b <sub>2</sub>	b <sub>3</sub>	b <sub>4</sub>	M <sub>1</sub> ×depth	L <sub>1</sub> ( <sup>2</sup> )	H <sub>1</sub>	a <sub>3</sub>	a <sub>4</sub>
ME(T)C 15	LWE(T)C 15	—	3	12	18	12	28	M3×6	58	5.7	4	7	M3×6
ME(T) 15	LWE(T) 15	LWE(T) 15...Q			74								
ME(T)G 15	LWE(T)G 15	—			87								
MESC 15	LWESC 15	—	3	15	9	3	34	M3×6	58	6	4	8	M3×6
MES 15	LWES 15	LWES 15...Q			74								
MESG 15	LWESG 15	—			87								
ME(T)C 20	LWE(T)C 20	—	3.5	17	19.5	12.5	40	M3×6	64	7	5	9	M4×8
ME(T) 20	LWE(T) 20	LWE(T) 20...Q			83								
ME(T)G 20	LWE(T)G 20	—			99								
MESC 20	LWESC 20	—	5	17	11	4	50	M3×6	64	11	6	14	M4×8
MES 20	LWES 20	LWES 20...Q			83								
MESG 20	LWESG 20	—			99								
ME(T)C 25	LWE(T)C 25	—	5	17	23.5	16.5	50	M3×6	76	11	6	14	M4×8
ME(T) 25	LWE(T) 25	LWE(T) 25...Q			100								
ME(T)G 25	LWE(T)G 25	—			119								
MESC 25	LWESC 25	—	5	17	11	4	50	M3×6	76	11	6	14	M4×8
MES 25	LWES 25	LWES 25...Q			100								
MESG 25	LWESG 25	—			119								
ME(T)C 30	LWE(T)C 30	—	5	17	17	28	50	M3×6	83	11	6	14	M4×8
ME(T) 30	LWE(T) 30	—			112								
—	—	LWE(T) 30...Q			111								
ME(T)G 30	LWE(T)G 30	—	5	17	17	28	50	M3×6	144	11	6	14	M4×8
MESC 30	LWESC 30	—			83								
MES 30	LWES 30	—			112								
—	—	LWES 30...Q	5	17	17	13	50	M3×6	112	11	6	14	M4×8
MESG 30	LWESG 30	—			111								
MESG 30	LWESG 30	—			144								
ME(T)C 35	LWE(T)C 35	—	6	20	30	20	60	M3×6	93	13	7	15	M4×8
ME(T) 35	LWE(T) 35	—			126								
—	—	LWE(T) 35...Q			125								
MESC 35	LWESC 35	—	6	20	15	5	60	M3×6	93	13	7	15	M4×8
MES 35	LWES 35	—			126								
—	—	LWES 35...Q			125								
ME(T) 45	LWE(T) 45	—	7	26	35	23	74	M4×8	138	15	8	19	M5×10
MES 45	LWES 45	—			18	6			125				

Notes (1) The specification and mounting positions of grease nipple are different from those of the standard specification product. Provided grease nipple for size 15 models is NPB2 type (special specification).  
For details of dimensions, please contact **IKO**

(2) Dimensions of the specification that female threads for bellows are fitted to both ends of the slide unit are indicated.

Remark: This is also applicable to stainless steel models of the same size.

Table 9 Track rail mounting bolt size (Supplemental code /MA)

Size	Bolt size for track rail
15	M 3×16 M 4×16(1)
20	M 5×16
25	M 6×20
30	M 6×25
35	M 8×30
45	M10×35

Note (1) Applicable to the track rail of supplemental code "/M4" of special specification.

Remarks 1. Hexagon socket head bolts equivalent to JIS B 1176  
2. For stainless steel model, stainless steel made bolts are appended.

Table 10 Changed dimensions of mounting holes (Supplemental code /M4)

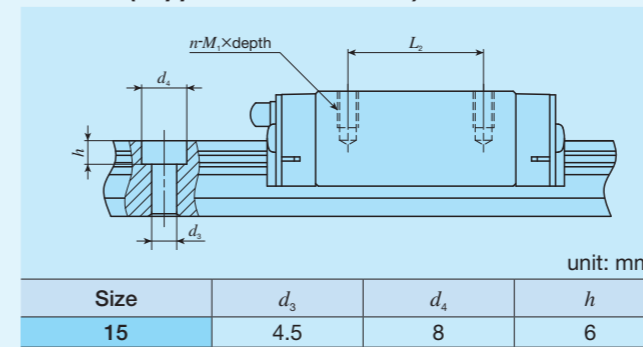
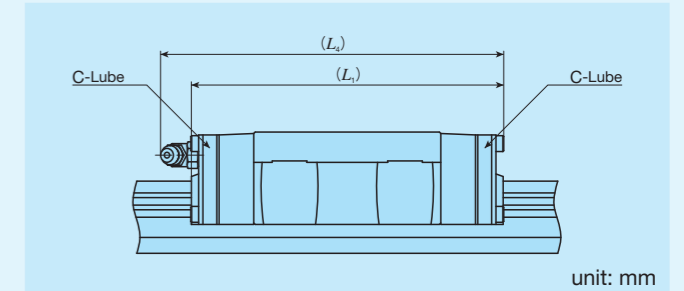

Table 11 Dimension of slide unit with C-Lube plate (Supplemental code /Q)



Identification number			L <sub>1</sub>	L <sub>2</sub>
LWEC 15	—	—	52	55
LWE 15	—	—	68	71
—	LWE15...Q	—		70
LWEG 15	—	—	81	83
LWEC 20	—	—	58	70
LWE 20	LWE20...Q	—	78	90
LWEG 20	—	—	94	105
LWEC 25	—	—	70	82
LWE 25	LWE25...Q	—	94	106
LWEG 25	—	—	113	125
LWEC 30	—	—	80	91
LWE 30	LWE30...Q	—	109	119
LWEG 30	—	—	141	151
LWEC 35	—	—	90	102
LWE 35	—	—	123	135
—	LWE35...Q	—	124	
LWE 45	—	—	138	148

Remarks 1. The dimensions of the slide unit with C-Lube at both ends are indicated.

2. A typical identification number is indicated, but is applied to all LWE (...Q) series models of the same size.

Table 12 H<sub>1</sub> dimension with under seal (Supplemental code /U)

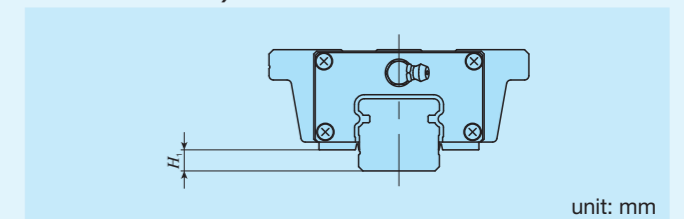

Identification number			H <sub>1</sub>
ME 15	LWE 15	—	5
ME 20	LWE 20	—	5
ME 25	LWE 25	—	6
ME 30	—	—	9
—	LWE 30	—	7
ME 35	—	—	10
—	LWE 35	—	8
ME 45	—	—	13
—	LWE 45	—	10

Remark: A typical identification number is indicated, but is applied to all models of the same size.

**Table 13 Dimension of slide unit with double end seals**  
(Supplemental code Single unit: /V  
Assembled set: /V /VV)

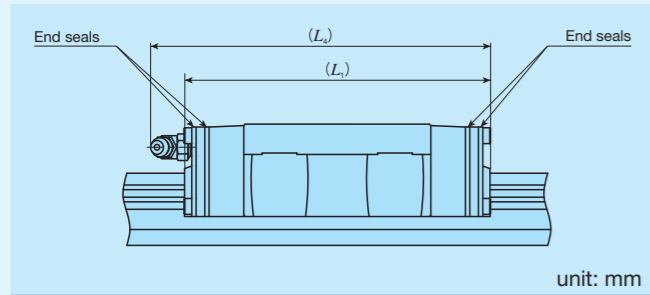

Identification number			L <sub>1</sub>	L <sub>4</sub>
MEC 15	LWEC 15	—	48	50
ME 15	LWE 15	LWE15...Q	64	66
MEG 15	LWEG 15	—	76	78
MEC 20	LWEC 20	—	54	68
ME 20	LWE 20	LWE20...Q	73	87
MEG 20	LWEG 20	—	89	103
MEC 25	LWEC 25	—	67	80
ME 25	LWE 25	LWE25...Q	91	104
MEG 25	LWEG 25	—	110	123
MEC 30	LWEC 30	—	78	89
ME 30	LWE 30	LWE30...Q	107	118
MEG 30	LWEG 30	—	138	150
MEC 35	LWEC 35	—	88	101
ME 35	LWE 35	LWE35...Q	121	134
ME 45	LWE 45	—	137	148

Remarks 1. The dimensions of the slide unit with double end seals at both ends are indicated.  
2. A typical identification number is indicated, but is applied to all models of the same size.

**Table 14 Dimension of slide unit with scrapers**  
(Supplemental code Single unit: /Z  
Assembled set: /Z /ZZ)

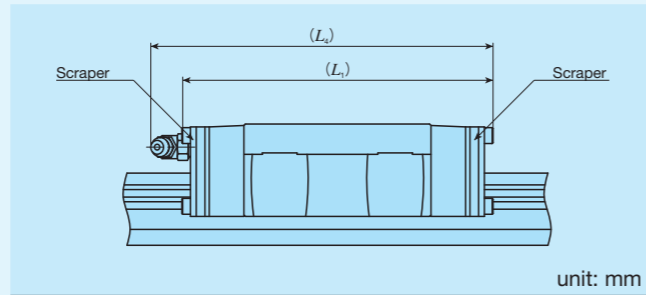

Identification number			L <sub>1</sub>	L <sub>4</sub>
MEC 15	LWEC 15	—	48	50
ME 15	LWE 15	LWE15...Q	64	66
MEG 15	LWEG 15	—	77	79
MEC 20	LWEC 20	—	55	69
ME 20	LWE 20	LWE20...Q	75	88
MEG 20	LWEG 20	—	91	104
MEC 25	LWEC 25	—	69	81
ME 25	LWE 25	LWE25...Q	93	105
MEG 25	LWEG 25	—	112	124
MEC 30	LWEC 30	—	79	90
ME 30	LWE 30	—	108	119
—	—	LWE30...Q	109	119
MEG 30	LWEG 30	—	140	151
MEC 35	LWEC 35	—	89	101
ME 35	LWE 35	—	122	134
—	—	LWE35...Q	123	135
ME 45	LWE 45	—	138	148

Remarks 1. The dimensions of the slide unit with scraper at both ends are indicated.  
2. A typical identification number is indicated, but is applied to all models of the same size.

## Lubrication

Lithium-soap base grease with extreme-pressure additive (Alvania EP grease 2 [SHOWA SHELL SEKIYU K. K.]) is pre-packed in ME and LWE (...Q) series. Additionally, ME series has C-Lube placed in the recirculation part of balls, so that the interval for reapplying lubricant can be extended and maintenance works such as grease job can be reduced significantly.

ME and LWE (...Q) series have grease nipple as indicated in Table 15. Supply nozzles fit to each shapes of grease nipple are also available. For order of these parts for lubrication, see Table 14.1 on page III-23 and Table 15 on page III-24.

**Table 15 Parts for lubrication**

Size	Grease nipple type (1)	Applicable supply nozzle type	Bolt size of female threads for piping
15	A-M4	A-5120V A-5240V B-5120V B-5240V	M4
20	B-M6	Grease gun available on the market	M6
25			
30	JIS type 4		PT1/8
35			
45			

Note (1) For grease nipple specification, see Tables 14.1 and 14.2 on page III-23.  
Remark: Stainless steel grease nipple is also available. If needed, please contact IKO.

## Dust Protection

The slide units of ME and LWE (...Q) series are equipped with end seals as standard for dust protection. However, if large amount of contaminant or dust are floating, or if large particles of foreign substances such as chips or sand may adhere to the track rail, it is recommended to cover the whole unit with bellows or telescope type shield, etc.



ME series and LWE (...Q) series are provided with specific bellows. The bellows are easy to mount and provide excellent dust protection. If needed, please refer to III-26 for ordering.

## Precaution for Use

### 1 Mounting surface, reference mounting surface, and typical mounting structure

When mounting the ME and LWE (...Q) series, properly align the reference mounting surface B and D of the track rail and slide unit with the reference mounting surface of the table and bed and fix them. (See Fig.2)

The reference mounting surfaces B and D and mounting surfaces A and C are precisely ground. Machining the mounting surface of the table and bed, such as machine or device, to high accuracy and mounting them properly will ensure stable linear motion with high accuracy.

Reference mounting surface of the slide unit is the opposite side of the  mark. The track rail reference mounting surface is identified by locating the  mark on the top surface of the track rail. It is the side surface above the mark (in the direction of the arrow). (See Fig. 3.)

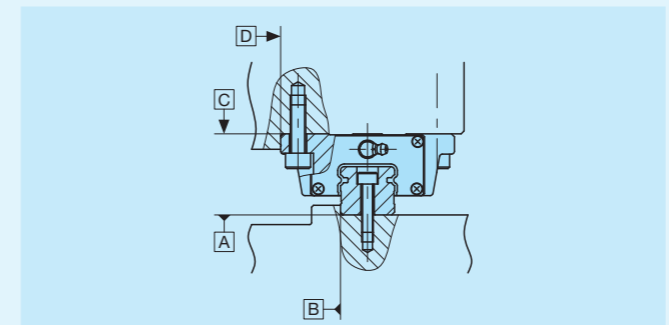

**Fig. 2 Reference mounting surface and typical mounting structure**

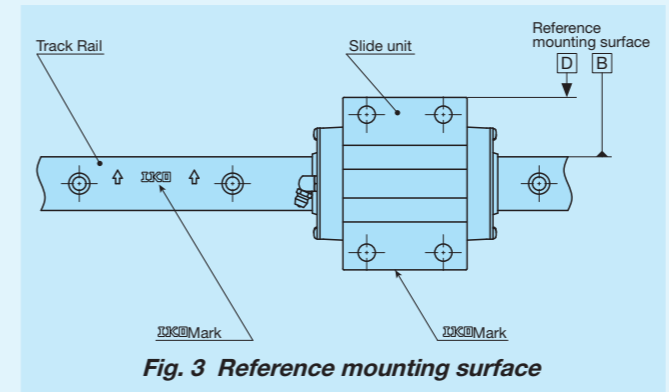

**Fig. 3 Reference mounting surface**

### 2 Shoulder height and corner radius of the reference mounting surface

For the opposite corner of the mating reference mounting, it is recommended to have relieved fillet as indicated in Fig. 4. Recommended value for the shoulder height on the mating side is indicated in Table 17.

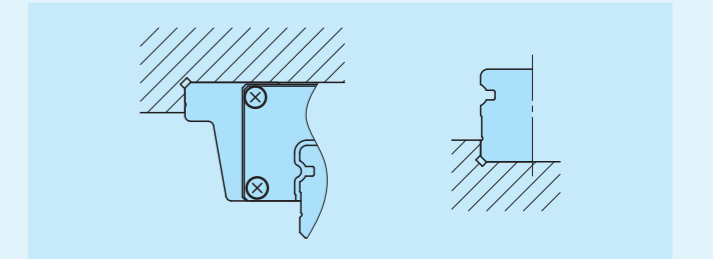

**Fig. 4 Corner of the mating reference mounting**

### 3 Tightening torque for fixing screw

Typical tightening torque for mounting of the ME or LWE (...Q) series to the steel mating member material is indicated in Table 16. When vibration and shock of the machine or device are large, fluctuating load is large, or moment load is applied, fix it by using the torque 1.2 to 1.5 times larger than the value indicated in the table as necessary. If the mating member material is cast iron or aluminum alloy, reduce the tightening torque depending on the strength characteristics of the mating member material.

**Table 16 Tightening torque for fixing screw**

Bolt size	Tightening torque N · m	
	High carbon steel-made screw	Stainless steel-made screw
M 3×0.5	1.8	1.1
M 4×0.7	4.1	2.5
M 5×0.8	8.0	5.0
M 6×1	13.6	8.5
M 8×1.25	32.7	20.4
M10×1.5	63.9	—
M12×1.75	110	—

Remark: The tightening torque is calculated based on strength division 12.9 and property division A2-70.

**Table 17 Shoulder height and corner radius of the reference mounting surface**

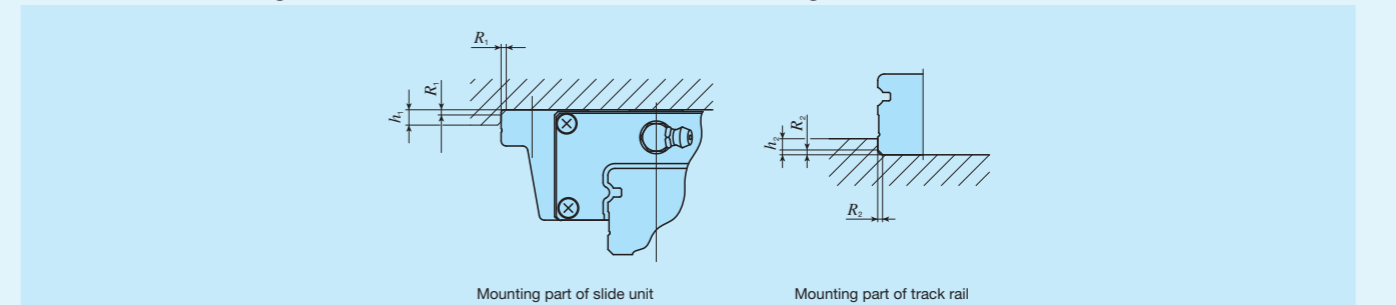

Size	Mounting part of slide unit		Mounting part of track rail	
	Shoulder height h <sub>1</sub>	Corner radius R <sub>1</sub> (maximum)	Shoulder height h <sub>2</sub>	Corner radius R <sub>2</sub> (maximum)
15	4	1 (0.5) (1)	3	0.5
20	5	1 (0.5) (1)	3	0.5
25	6	1	4	1
30	8	1	5	1
35	8	1	6	1
45	8	1.5	7	1.5

Note (1) The values in ( ) are applied to MES and LWES (...Q).

1N=0.102kgf=0.2248lbs.  
1mm=0.03937inch

# IKO C-Lube Linear Way ME

## Flange type mounting from bottom

Shape	ME · LWE		
Size	15	20	25
	30	35	45

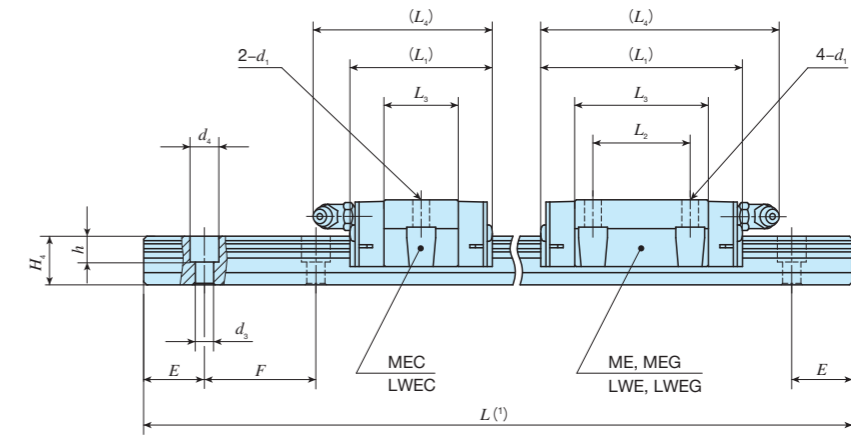
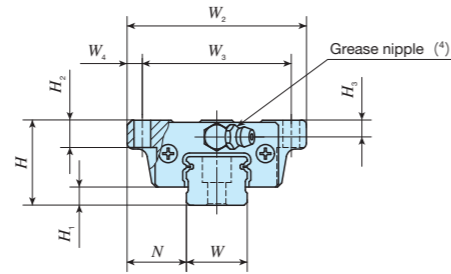

Identification number	Interchangeable	Mass (Ref.)		Dimensions of assembly mm			Dimensions of slide unit mm							Dimensions of track rail mm						Recommended mounting bolt for track rail (2) mm Bolt size × ℓ	Basic dynamic load rating (3) C N	Basic static load rating (3) C <sub>0</sub> N	Static moment rating (3)										
		Slide unit kg	Track rail kg/m	H	H <sub>1</sub>	N	W <sub>2</sub>	W <sub>3</sub>	W <sub>4</sub>	L <sub>1</sub>	L <sub>2</sub>	L <sub>3</sub>	L <sub>4</sub>	d <sub>1</sub>	H <sub>2</sub>	H <sub>3</sub>	W	H <sub>4</sub>	d <sub>3</sub>				d <sub>4</sub>	h	E	F	T <sub>0</sub> N · m	T <sub>x</sub> N · m	T <sub>y</sub> N · m				
MEC 15	LWEC 15	0.11	1.57	24	5.8	18.5	52	41	5.5	41	—	22.4	45	4.5	7	4.5	15	14.5	3.6 (4.5)	6.5 (8)	4.5 (6)	20	60	M3×16 (M4×16)	5 240	5 480	43.8	21.3 149	21.3 149				
MEC 15...SL	LWEC 15...SL									57	26	38.4	61												38.3	61	7 640	9 390	75.1	57.6 333	57.6 333		
ME 15	LWE 15									5	38.3	61	38.3												61	6 550	8 610	68.9	53.0 307	53.0 307			
ME 15...SL	LWE 15...SL									5	38.3	61	38.3												61	6 550	8 610	68.9	53.0 307	53.0 307			
—	LWE 15...Q									5	38.3	61	38.3												61	6 550	8 610	68.9	53.0 307	53.0 307			
MEG 15	LWEG 15	0.24	1.57	24	5.8	18.5	52	41	5.5	70	36	51.1	73	4.5	7	4.5	15	14.5	3.6 (4.5)	6.5 (8)	4.5 (6)	20	60	M3×16 (M4×16)	9 340	12 500	100	99.5 533	99.5 533				
MEG 15...SL	LWEG 15...SL									70	36	51.1	73												99.5 533	99.5 533							
MEC 20	LWEC 20	0.18	2.28	28	6	19.5	59	49	5	47	—	24.7	58	5.5	9	5.5	20	16	6	9.5	8.5	20	60	M5×16	7 580	7 340	78.9	31.5 235	31.5 235				
MEC 20...SL	LWEC 20...SL									47	—	24.7	58												7 340					78.9	31.5 235	31.5 235	
ME 20	LWE 20									44	44	44	78												11 600					13 400	145	95.6 566	95.6 566
ME 20...SL	LWE 20...SL									44	44	44	78												11 600					13 400	145	95.6 566	95.6 566
—	LWE 20...Q	5	44	44	78	10 500	13 400	145	5	100	100																						
MEG 20	LWEG 20	83	45	60.1	94	100				100																							
MEG 20...SL	LWEG 20...SL	83	45	60.1	94	100				100																							
MEG 20...SL	LWEG 20...SL	0.40	2.28	28	6	19.5	59	49	5	83	45	60.1	94	5.5	9	5.5	20	16	6	9.5	8.5	20	60	M5×16	14 400	18 300	197	172 930	172 930				
MEG 20...SL	LWEG 20...SL									83	45	60.1	94												172 930	172 930							

Notes (1) Track rail lengths  $L$  are shown in Tables 2.1 and 2.2 on page II-67.  
 (2) Track rail mounting bolts are not appended. Hexagon socket head bolts of JIS B 1176 with strength division 12.9 are recommended.  
 (3) The direction of basic dynamic load rating ( $C$ ), basic static load rating ( $C_0$ ), and static moment rating ( $T_0$ ,  $T_x$ ,  $T_y$ ) are shown in the sketches below. The upper values of  $T_x$  and  $T_y$  are for one slide unit and the lower values are for two slide units in close contact.  
 (4) The shapes of grease nipple vary by size. The specifications are shown in Table 15 on page II-73.  
 Remark: Values in ( ) represent dimensions when the track rail mounting hole is "M4". Indicate the identification number with "/M4" at the end.

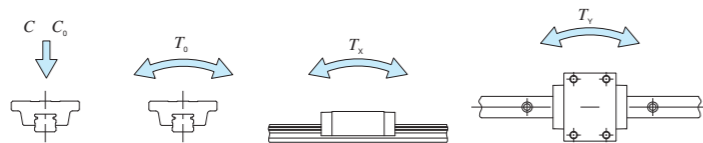

### Example of identification number of assembled set

Model code	Dimensions	Part code	Model code	Material code	Preload symbol	Classification symbol	Interchangeable code	Supplemental code
ME	G	15	C2	R340	T1	P	/U	
1	2	3	4	5	6	7	8	9

① Model	③ Size	⑦ Preload amount	⑨ Interchangeable
ME LWE LWE...Q	15, 20	T <sub>0</sub> Clearance No symbol Standard T <sub>1</sub> Light preload T <sub>2</sub> Medium preload	No symbol Non-interchangeable specification S1 S1 specification S2 S2 specification
② Length of slide unit	④ Number of slide unit (2)	⑧ Accuracy class	⑩ Special specification
C Short No symbol Standard G Long		No symbol Ordinary H High P Precision SP Super precision	A, BS, D, E, F, I, J, L, LF, MA M4, N, Q, RE, T, U, V, W, Y, Z
⑤ Length of track rail (340 mm)	⑥ Material type		
	No symbol High carbon steel made SL Stainless steel made		

# IKO C-Lube Linear Way ME

## Flange type mounting from bottom

Shape	ME · LWE		
Size	15	20	25
	30	35	45

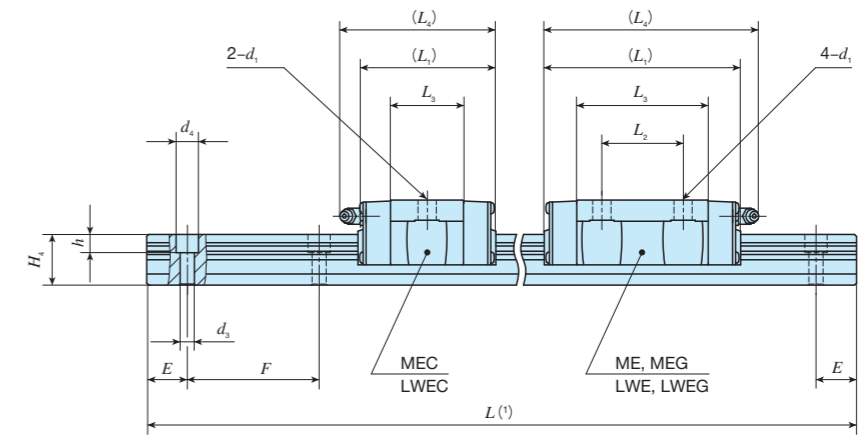
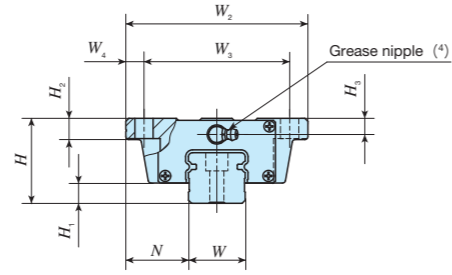

Identification number	Interchangeable	Mass (Ref.)		Dimensions of assembly mm			Dimensions of slide unit mm							Dimensions of track rail mm							Recommended mounting bolt for track rail mm Bolt size × ℓ	Basic dynamic load rating <sup>(3)</sup> C N	Basic static load rating <sup>(3)</sup> C <sub>0</sub> N	Static moment rating <sup>(3)</sup>						
		Slide unit kg	Track rail kg/m	H	H <sub>1</sub>	N	W <sub>2</sub>	W <sub>3</sub>	W <sub>4</sub>	L <sub>1</sub>	L <sub>2</sub>	L <sub>3</sub>	L <sub>4</sub>	d <sub>1</sub>	H <sub>2</sub>	H <sub>3</sub>	W	H <sub>4</sub>	d <sub>3</sub>	d <sub>4</sub>				h	E	F	T <sub>0</sub> N · m	T <sub>x</sub> N · m	T <sub>y</sub> N · m	
MEC 25	LWEC 25	○	0.33	3.09	33	7	25	73	60	6.5	83	35	56	94	7	10	6.5	23	19	7	11	9	20	60	M 6×20	12 400	12 300	153	71.8 480	71.8 480
MEC 25...SL	LWEC 25...SL	○																												
ME 25	LWE 25	○																												
ME 25...SL	LWE 25...SL	○																												
—	LWE 25...Q	—																												
MEG 25	LWEG 25	○	0.56	3.09	33	6	25	73	60	6.5	83	35	56	94	7	10	6.5	23	19	7	11	9	20	60	M 6×20	18 100	21 100	262	195 1 090	195 1 090
MEG 25...SL	LWEG 25...SL	○																												
MEC 30	LWEC 30	○																												
MEC 30...SL	LWEC 30...SL	○																												
ME 30	LWE 30	○																												
ME 30...SL	LWE 30...SL	○	0.58	5.09	42	10	31	90	72	9	97	40	64.8	107	9	10	8	28	25	7	11	9	20	80	M 6×25	20 600	18 800	287	129 855	129 855
MEC 30...SL	LWEC 30...SL	○																												
ME 30	LWE 30	○																												
ME 30...SL	LWE 30...SL	○																												
—	LWE 30...Q	—																												
MEG 30	LWEG 30	○	0.73	5.09	42	10	31	90	72	9	97	40	64.8	107	9	10	8	28	25	7	11	9	20	80	M 6×25	29 500	31 300	479	328 1 920	328 1 920
MEG 30...SL	LWEG 30...SL	○																												
MEC 30	LWEC 30	○																												
MEC 30...SL	LWEC 30...SL	○																												
ME 30	LWE 30	○																												
ME 30...SL	LWE 30...SL	○	0.97	5.04	42	10	31	90	72	9	96	40	106	106	9	10	8	28	25	7	11	9	20	80	M 6×25	21 600	26 400	398	278 1 580	278 1 580
MEG 30	LWEG 30	○																												
MEG 30...SL	LWEG 30...SL	○																												
MEC 35	LWEC 35	○																												
MEC 35	LWEC 35	○																												
ME 35	LWE 35	○	1.50	5.09	48	11	33	100	82	9	78	—	41.6	90	9	13	10	34	28	9	14	12	20	80	M 8×30	29 900	26 800	412	176 1 190	162 1 100
MEC 35	LWEC 35	○																												
ME 35	LWE 35	○																												
ME 35	LWE 35	○																												
—	LWE 35...Q	—																												
ME 45	LWE 45	○	0.84	6.85	48	11	33	100	82	9	111	50	74.6	123	9	13	10	34	28	9	14	12	20	80	M 8×30	42 900	44 700	686	448 2 660	412 2 450
ME 45	LWE 45	○																												
ME 45	LWE 45	○																												
ME 45	LWE 45	○																												
—	LWE 45...Q	—																												
ME 45	LWE 45	○	1.53	6.84	60	14	37.5	120	100	10	125	60	81.4	136	11	15	13	45	34	11	17.5	14	22.5	105	M10×35	61 100	60 200	1 210	672 4 070	618 3 750
ME 45	LWE 45	○																												
ME 45	LWE 45	○																												
ME 45	LWE 45	○																												
—	LWE 45...Q	—																												

- Notes (1) Track rail lengths  $L$  are shown in Tables 2.1 and 2.2 on page II - 67.  
 (2) Track rail mounting bolts are not appended. Hexagon socket head bolts of JIS B 1176 with strength division 12.9 are recommended.  
 (3) The direction of basic dynamic load rating ( $C$ ), basic static load rating ( $C_0$ ), and static moment rating ( $T_0$ ,  $T_x$ ,  $T_y$ ) are shown in the sketches below. The upper values of  $T_x$  and  $T_y$  are for one slide unit and the lower values are for two slide units in close contact.  
 (4) The shapes of grease nipple vary by size. The specifications are shown in Table 15 on page II - 73.

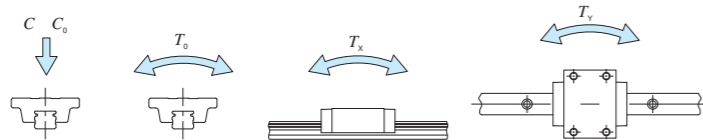

### Example of identification number of assembled set

Model code	Dimensions	Part code	Model code	Material code	Preload symbol	Classification symbol	Interchangeable code	Supplemental code
ME	G	30	C2	R440	T1	P	—	/U
1	2	3	4	5	7	8	9	10

① Model	③ Size	⑦ Preload amount	⑨ Interchangeable
ME LWE LWE...Q Flange type mounting from bottom	25, 30, 35, 45	T <sub>0</sub> Clearance No symbol Standard T <sub>1</sub> Light preload T <sub>2</sub> Medium preload	No symbol Non-interchangeable specification S1 S1 specification S2 S2 specification
② Length of slide unit	④ Number of slide unit (2)	⑧ Accuracy class	⑩ Special specification
C Short No symbol Standard G Long		No symbol Ordinary H High P Precision SP Super precision	A, BS, D, E, F, I, J, L, LF, MA N, Q, RE, T, U, V, W, Y, Z
⑤ Length of track rail (440 mm)	⑥ Material type		
	No symbol High carbon steel made SL Stainless steel made		



# IKO C-Lube Linear Way ME

## Flange type mounting from top

Shape	MET · LWET		
Size	15	20	25
	30	35	45

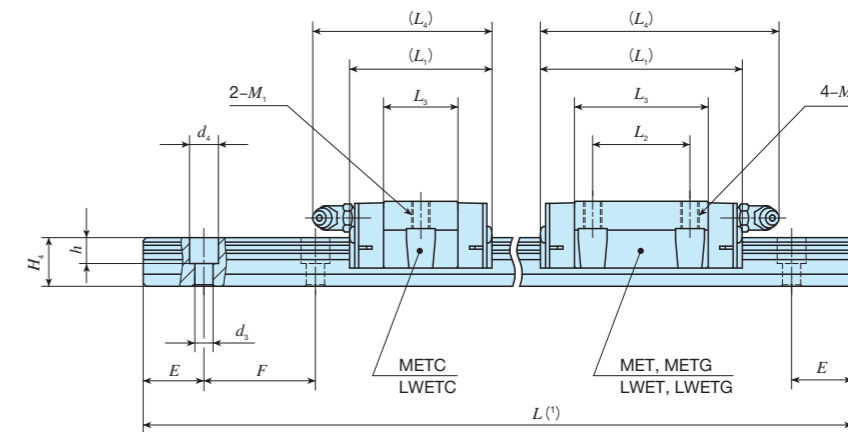
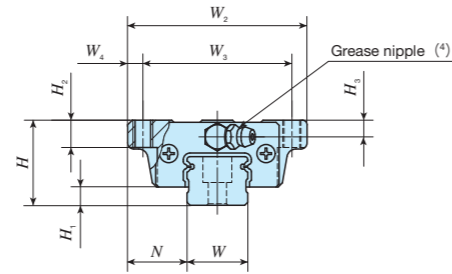

Identification number	Interchangeable	Mass (Ref.)		Dimensions of assembly mm			Dimensions of slide unit mm					Dimensions of track rail mm						Recommended mounting bolt for track rail (2) mm	Basic dynamic load rating (3) C N	Basic static load rating (3) C <sub>0</sub> N	Static moment rating (3)								
		Slide unit kg	Track rail kg/m	H	H <sub>1</sub>	N	W <sub>2</sub>	W <sub>3</sub>	W <sub>4</sub>	L <sub>1</sub>	L <sub>2</sub>	L <sub>3</sub>	L <sub>4</sub>	M <sub>1</sub>	H <sub>2</sub>	H <sub>3</sub>	W				H <sub>4</sub>	d <sub>3</sub>	d <sub>4</sub>	h	E	F	T <sub>0</sub> N·m	T <sub>x</sub> N·m	T <sub>y</sub> N·m
METC 15	LWETC 15	0.11	1.57	24	5.8	18.5	52	41	5.5	41	—	22.4	45	M5	7	4.5	15	14.5	3.6 (4.5)	6.5 (8 )	4.5 (6 )	20	60	M3×16 (M4×16)	5 240	5 480	43.8	21.3 <sup>3</sup> 149	21.3 <sup>3</sup> 149
METC 15...SL	LWETC 15...SL									57	26	38.4	61												57.6 <sup>3</sup> 333	57.6 <sup>3</sup> 333			
MET 15	LWET 15									5	38.3	61	57.6 <sup>3</sup> 333												57.6 <sup>3</sup> 333				
MET 15...SL	LWET 15...SL									5	38.3	61	57.6 <sup>3</sup> 333												57.6 <sup>3</sup> 333				
METG 15	LWETG 15	0.24			5.8					70	36	51.1	73											9 340	12 500	100	99.5 <sup>3</sup> 533	99.5 <sup>3</sup> 533	
METG 15...SL	LWETG 15...SL									70	36	51.1	73											99.5 <sup>3</sup> 533	99.5 <sup>3</sup> 533				
METC 20	LWETC 20	0.18								47	—	24.7	58											7 580	7 340	78.9	31.5 <sup>3</sup> 235	31.5 <sup>3</sup> 235	
METC 20...SL	LWETC 20...SL									47	—	24.5	58											31.5 <sup>3</sup> 235					31.5 <sup>3</sup> 235
MET 20	LWET 20									44	—	24.7	58											31.5 <sup>3</sup> 235					31.5 <sup>3</sup> 235
MET 20...SL	LWET 20...SL									44	—	24.5	58											31.5 <sup>3</sup> 235					31.5 <sup>3</sup> 235
METG 20	LWETG 20	0.30	2.28	28	6	19.5	59	49	5	67	32	44.2	78	M6	9	5.5	20	16	6	9.5	8.5	20	60	M5×16	11 600	13 400	145	95.6 <sup>3</sup> 566	95.6 <sup>3</sup> 566
METG 20...SL	LWETG 20...SL									67	32	44.2	78												95.6 <sup>3</sup> 566			95.6 <sup>3</sup> 566	
MET 20	LWET 20									44	—	44	78												95.6 <sup>3</sup> 566			95.6 <sup>3</sup> 566	
MET 20...SL	LWET 20...SL									44	—	44	78												95.6 <sup>3</sup> 566			95.6 <sup>3</sup> 566	
METG 20	LWETG 20	0.40			6					83	45	60.1	94												14 400	18 300	197	172 <sup>3</sup> 930	172 <sup>3</sup> 930
METG 20...SL	LWETG 20...SL									83	45	59.9	94												172 <sup>3</sup> 930			172 <sup>3</sup> 930	

Notes (1) Track rail lengths  $L$  are shown in Tables 2.1 and 2.2 on page II - 67.  
 (2) Track rail mounting bolts are not appended. Hexagon socket head bolts of JIS B 1176 with strength division 12.9 are recommended.  
 (3) The direction of basic dynamic load rating ( $C$ ), basic static load rating ( $C_0$ ), and static moment rating ( $T_0$ ,  $T_x$ ,  $T_y$ ) are shown in the sketches below. The upper values of  $T_x$  and  $T_y$  are for one slide unit and the lower values are for two slide units in close contact.  
 (4) The shapes of grease nipple vary by size. The specifications are shown in Table 15 on page II - 73.  
 Remark: Values in ( ) represent dimensions when the track rail mounting hole is "M4". Indicate the identification number with "/M4" at the end.

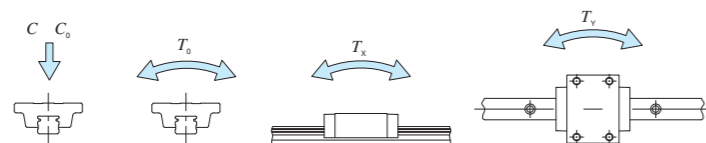

### Example of identification number of assembled set

Model code: MET G 15 C2 R340  
 Dimensions: 15, 20  
 Part code: C2  
 Model code: R340  
 Material code: —  
 Preload symbol: T1  
 Classification symbol: P  
 Interchangeable code: —  
 Supplemental code: /U

① Model MET LWET LWET...Q Flange type mounting from top	③ Size 15, 20	⑦ Preload amount T <sub>0</sub> Clearance No symbol Standard T <sub>1</sub> Light preload T <sub>2</sub> Medium preload	⑨ Interchangeable No symbol Non-interchangeable specification S1 S1 specification S2 S2 specification
② Length of slide unit C Short No symbol Standard G Long	④ Number of slide unit (2)	⑧ Accuracy class No symbol Ordinary H High P Precision SP Super precision	⑩ Special specification A, BS, D, E, F, I, J, L, LF, MA M4, N, Q, RE, T, U, V, W, Y, Z
⑤ Length of track rail (340 mm)	⑥ Material type No symbol High carbon steel made SL Stainless steel made		

## Flange type mounting from top

Shape	MET · LWET		
Size	15	20	25
	30	35	45

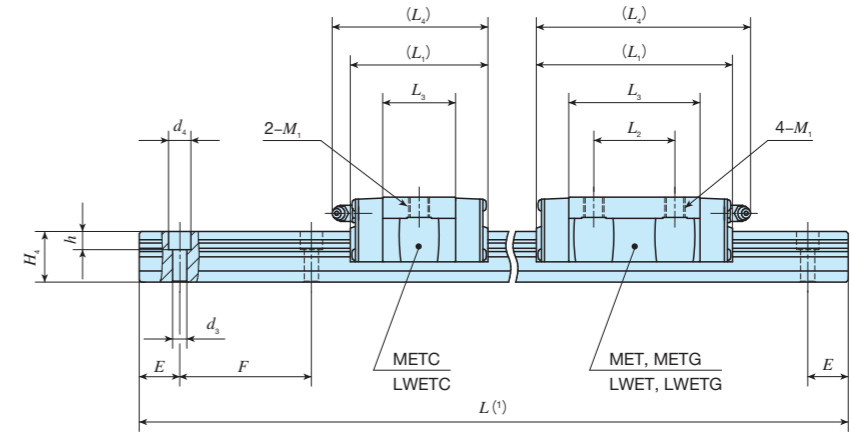
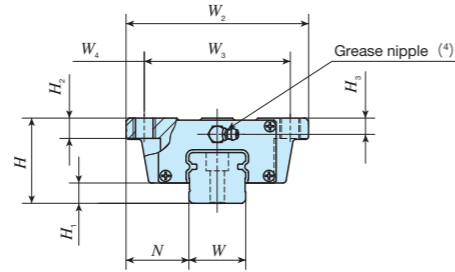

Identification number	Interchangeable	Mass (Ref.)		Dimensions of assembly mm			Dimensions of slide unit mm					Dimensions of track rail mm						Recommended mounting bolt for track rail mm Bolt size × ℓ	Basic dynamic load rating <sup>(3)</sup> C N	Basic static load rating <sup>(3)</sup> C <sub>0</sub> N	Static moment rating <sup>(3)</sup>									
		Slide unit kg	Track rail kg/m	H	H <sub>1</sub>	N	W <sub>2</sub>	W <sub>3</sub>	W <sub>4</sub>	L <sub>1</sub>	L <sub>2</sub>	L <sub>3</sub>	L <sub>4</sub>	M <sub>1</sub>	H <sub>2</sub>	H <sub>3</sub>	W				H <sub>4</sub>	d <sub>3</sub>	d <sub>4</sub>	h	E	F	T <sub>0</sub> N · m	T <sub>x</sub> N · m	T <sub>y</sub> N · m	
METC 25	LWETC 25	○	0.33	3.09	33	7	25	73	60	6.5	83	35	56	94	M 8	10	6.5	23	19	7	11	9	20	60	M 6×20	12 400	12 300	153	71.8 <sup>8</sup> 480	71.8 <sup>8</sup> 480
METC 25...SL	LWETC 25...SL	○																								18 100	21 100	262	195 1 090	195 1 090
MET 25	LWET 25	○																								15 500	19 400	240	175 1 010	175 1 010
MET 25...SL	LWET 25...SL	○																								22 200	28 200	349	336 1 740	336 1 740
METG 25	LWETG 25	○	0.73																											
METG 25...SL	LWETG 25...SL	○																												
METC 30	LWETC 30	○	0.58	5.09	42	10	31	90	72	9	68	40	64.8	107	M10	10	8	28	25	7	11	9	20	80	M 6×25	20 600	18 800	287	129 855	129 855
METC 30...SL	LWETC 30...SL	○																								29 500	31 300	479	328 1 920	328 1 920
MET 30	LWET 30	○																								21 600	26 400	398	278 1 580	278 1 580
MET 30...SL	LWET 30...SL	○																								39 200	47 000	718	704 3 690	704 3 690
METG 30	LWETG 30	○	1.50	5.09																										
METG 30...SL	LWETG 30...SL	○																												
METC 35	LWETC 35	○	0.84	6.85	48	11	33	100	82	9	78	50	41.6	90	M10	13	10	34	28	9	14	12	20	80	M 8×30	29 900	26 800	412	176 1 190	162 1 100
MET 35	LWET 35	○																								42 900	44 700	686	448 2 660	412 2 450
MET 35...Q	LWET 35...Q	○																								30 500	37 600	687	482 2 550	482 2 550
MET 45	LWET 45	○	2.46	11.2	60	14	37.5	120	100	10	125	60	81.4	136	M12	15	13	45	34	11	17.5	14	22.5	105	M10×35	61 100	60 200	1 210	672 4 070	618 3 750

- Notes (1) Track rail lengths  $L$  are shown in Tables 2.1 and 2.2 on page II - 67.  
 (2) Track rail mounting bolts are not appended. Hexagon socket head bolts of JIS B 1176 with strength division 12.9 are recommended.  
 (3) The direction of basic dynamic load rating ( $C$ ), basic static load rating ( $C_0$ ), and static moment rating ( $T_0$ ,  $T_x$ ,  $T_y$ ) are shown in the sketches below. The upper values of  $T_x$  and  $T_y$  are for one slide unit and the lower values are for two slide units in close contact.  
 (4) The shapes of grease nipple vary by size. The specifications are shown in Table 15 on page II - 73.

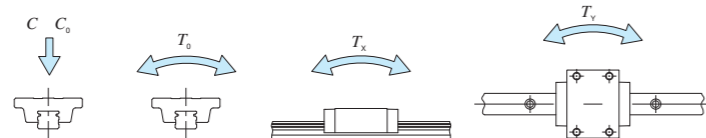

### Example of identification number of assembled set

Model code	Dimensions	Part code	Model code	Material code	Preload symbol	Classification symbol	Interchangeable code	Supplemental code
<b>MET</b>	<b>G</b>	<b>30</b>	<b>C2</b>	<b>R440</b>	<b>T1</b>	<b>P</b>	<b>/U</b>	
1	2	3	4	5	6	7	8	9

<b>① Model</b> MET LWET LWET...Q Flange type mounting from top	<b>③ Size</b> 25, 30, 35, 45	<b>⑦ Preload amount</b> T <sub>0</sub> Clearance No symbol Standard T <sub>1</sub> Light preload T <sub>2</sub> Medium preload	<b>⑨ Interchangeable</b> No symbol Non-interchangeable specification S1 S1 specification S2 S2 specification
<b>② Length of slide unit</b> C Short No symbol Standard G Long	<b>④ Number of slide unit (2)</b>	<b>⑧ Accuracy class</b> No symbol Ordinary H High P Precision SP Super precision	<b>⑩ Special specification</b> A, BS, D, E, F, 1, J, L, LF, MA N, Q, RE, T, U, V, W, Y, Z
<b>⑤ Length of track rail (440 mm)</b>	<b>⑥ Material type</b> No symbol High carbon steel made SL Stainless steel made		

# IKO C-Lube Linear Way ME

## Block type mounting from top

Shape	MES · LWES		
Size	15	20	25
	30	35	45

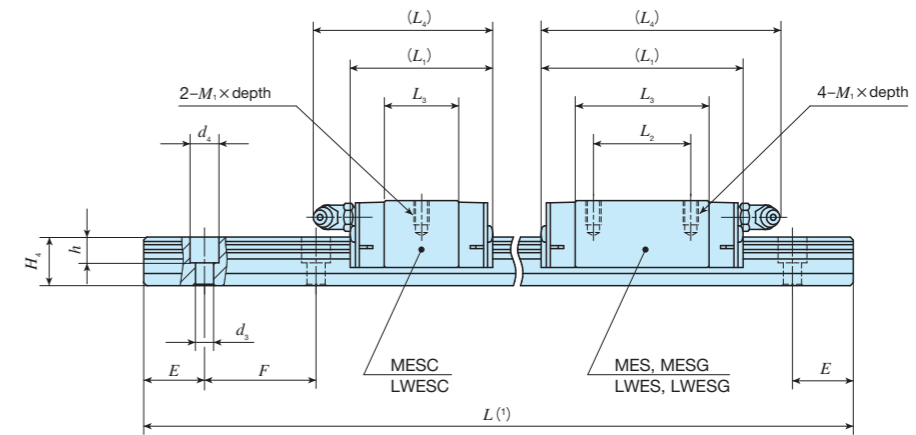
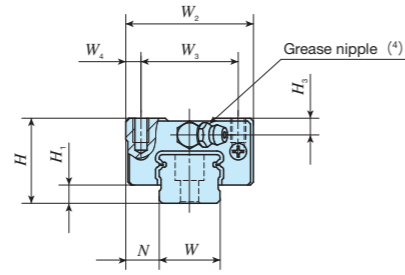

Identification number	ME series	LWE series (No C-Lube)	Interchangeable	Mass (Ref.)		Dimensions of assembly mm					Dimensions of slide unit mm					Dimensions of track rail mm						Recommended mounting bolt for track rail (2) mm	Bolt size x l	Basic dynamic load rating (3) C N	Basic static load rating (3) C0 N	Static moment rating (3)						
				Slide unit kg	Track rail kg/m	H	H1	N	W2	W3	W4	L1	L2	L3	L4	M1 x depth	H3	W	H4	d3	d4					h	E	F	T0 N·m	Tx N·m	Ty N·m	
MESC 15	LWESC 15		○	0.09	1.57	24	5.8	9.5	34	26	4	41	-	22.4	45	M4 x 7	4.5	15	14.5	3.6 (4.5)	6.5 (8)	4.5 (6)	20	60	M3 x 16 (M4 x 16)	5 240	5 480	43.8	21.3 149	21.3 149		
MESC 15...SL	LWESC 15...SL	○	57									26	38.4	61	7 640											9 390	75.1	57.6 333	57.6 333			
MES 15	LWES 15	○	5									38.3	61	6 550	8 610											68.9	53.0 307	53.0 307				
MES 15...SL	LWES 15...SL	○	70									36	51.1	73	9 340											12 500	100	99.5 533	99.5 533			
MESC 20	LWESC 20		○	0.15	2.28	28	6	11	42	32	5	47	-	24.7	58	M5 x 8	5.5	20	16	6	9.5	8.5	20	60	M5 x 16	7 580	7 340	78.9	31.5 235	31.5 235		
MESC 20...SL	LWESC 20...SL	○	44									44	78	11 600	13 400											145					95.6 566	95.6 566
MES 20	LWES 20	○	44									78	10 500													100 562					100 562	
MES 20...SL	LWES 20...SL	○	83									45	60.1	94	14 400											18 300					197	172 930
MESC 20	LWESC 20		○	0.25	2.28	28	6	11	42	32	5	67	32	44.2	78	M5 x 8	5.5	20	16	6	9.5	8.5	20	60	M5 x 16	11 600	13 400	145	95.6 566	95.6 566		
MESC 20...SL	LWESC 20...SL	○	44									78	10 500													100 562					100 562	
MES 20	LWES 20	○	44									78	10 500													100 562					100 562	
MES 20...SL	LWES 20...SL	○	83									45	60.1	94	14 400											18 300					197	172 930
MESC 20	LWESC 20		○	0.33	2.28	28	6	11	42	32	5	67	32	44.2	78	M5 x 8	5.5	20	16	6	9.5	8.5	20	60	M5 x 16	11 600	13 400	145	95.6 566	95.6 566		
MESC 20...SL	LWESC 20...SL	○	44									78	10 500													100 562					100 562	
MES 20	LWES 20	○	44									78	10 500													100 562					100 562	
MES 20...SL	LWES 20...SL	○	83									45	60.1	94	14 400											18 300					197	172 930
MESC 20	LWESC 20		○	0.33	2.28	28	6	11	42	32	5	67	32	44.2	78	M5 x 8	5.5	20	16	6	9.5	8.5	20	60	M5 x 16	11 600	13 400	145	95.6 566	95.6 566		
MESC 20...SL	LWESC 20...SL	○	44									78	10 500													100 562					100 562	
MES 20	LWES 20	○	44									78	10 500													100 562					100 562	
MES 20...SL	LWES 20...SL	○	83									45	60.1	94	14 400											18 300					197	172 930

Notes (1) Track rail lengths  $L$  are shown in Tables 2.1 and 2.2 on page II - 67.  
 (2) Track rail mounting bolts are not appended. Hexagon socket head bolts of JIS B 1176 with strength division 12.9 are recommended.  
 (3) The direction of basic dynamic load rating ( $C$ ), basic static load rating ( $C_0$ ), and static moment rating ( $T_0$ ,  $T_x$ ,  $T_y$ ) are shown in the sketches below. The upper values of  $T_x$  and  $T_y$  are for one slide unit and the lower values are for two slide units in close contact.  
 (4) The shapes of grease nipple vary by size. The specifications are shown in Table 15 on page II - 73.  
 Remark: Values in ( ) represent dimensions when the track rail mounting hole is "M4". Indicate the identification number with "/M4" at the end.

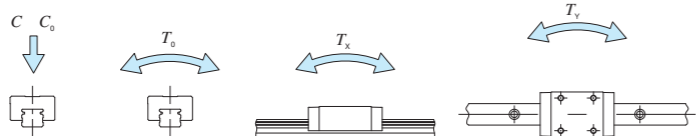

### Example of identification number of assembled set

Model code: MES G 15 C2 R340  
 Dimensions: 15, 20  
 Part code: C2  
 Model code: R340  
 Material code: (blank)  
 Preload symbol: T1  
 Classification symbol: P  
 Interchangeable code: (blank)  
 Supplemental code: /U

① Model MES LWES...Q Block type mounting from top	③ Size 15, 20	⑦ Preload amount T0 Clearance No symbol Standard T1 Light preload T2 Medium preload	⑨ Interchangeable No symbol Non-interchangeable specification S1 S1 specification S2 S2 specification
② Length of slide unit C Short No symbol Standard G Long	④ Number of slide unit (2)	⑧ Accuracy class No symbol Ordinary H High P Precision SP Super precision	⑩ Special specification A, BS, D, E, F, 1, J, L, LF, MA M4, N, Q, RE, T, U, V, W, Y, Z

# IKO C-Lube Linear Way ME

## Block type mounting from top

Shape	MES · LWES		
Size	15	20	25
	30	35	45

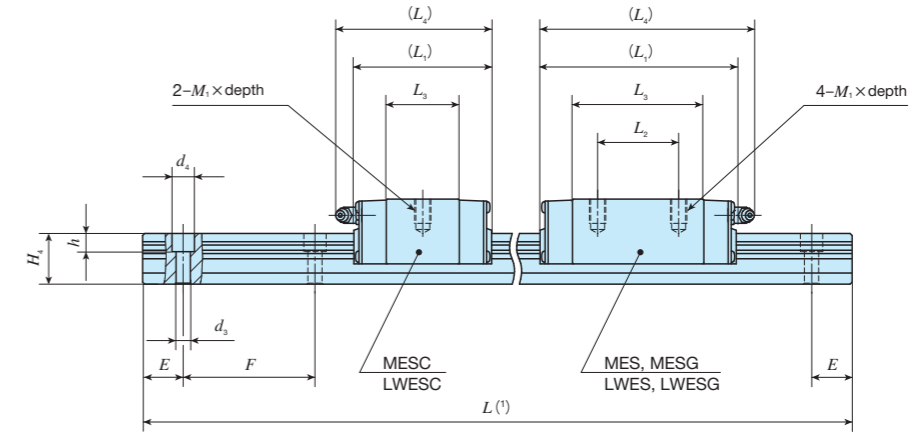
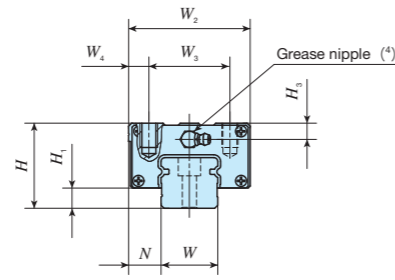

Identification number	Interchangeable	Mass (Ref.)		Dimensions of assembly mm			Dimensions of slide unit mm					Dimensions of track rail mm						Recommended mounting bolt for track rail (2) mm	Basic dynamic load rating (3) C N	Basic static load rating (3) C0 N	Static moment rating (3)								
		Slide unit kg	Track rail kg/m	H	H1	N	W2	W3	W4	L1	L2	L3	L4	M1 x depth	H3	W	H4				d3	d4	h	E	F	Bolt size x l	T0 N·m	Tx N·m	Ty N·m
MESC 25	LWESC 25	○	0.26	3.09	33	7	12.5	48	35	6.5	59	—	32	70	M 6×9	6.5	23	19	7	11	9	20	60	M 6×20	12 400	12 300	153	71.8	71.8
MESC 25...SL	LWESC 25...SL	○									83	35	56	94											18 100	21 100	262	195	195
MES 25	LWES 25	○									6	15 500	19 400	240											175	175			
MES 25...SL	LWES 25...SL	○									7	22 200	28 200	349											336	336			
—	LWES 25...Q	—	0.43	5.09	42	10	16	60	40	10	102	50	75	113	8	28	25	7	11	9	20	80	M 6×25	20 600	18 800	287	129	129	
MESG 25	LWESG 25	○	0.55	5.09	42	10	16	60	40	10	68	—	36	78	M 8×12	8	28	25	7	11	9	20	80	M 6×25	29 500	31 300	479	328	328
MESG 25...SL	LWESG 25...SL	○									97	40	64.8	107											21 600	26 400	398	278	278
—	LWES 30...Q	—									0.75	5.04	96	106											39 200	47 000	718	704	704
MESC 30	LWESC 30	○									1.13	5.09	129	60											96.5	139	29 900	26 800	412
MESC 30...SL	LWESC 30...SL	○	0.46	5.09	48	11	18	70	50	10	78	—	41.6	90	M 8×12	10	34	28	9	14	12	20	80	M 8×30	42 900	44 700	686	448	412
MES 30	LWES 30	○									111	50	74.6	123											30 500	37 600	687	482	482
—	LWES 30...Q	—									0.78	5.04	110	122											61 100	60 200	1 210	672	618
MESC 30	LWESG 30	○	1.21	6.85	60	14	20.5	86	60	13	78	—	41.6	90	M 10×15	13	45	34	11	17.5	14	22.5	105	M10×35	61 100	60 200	1 210	672	618
MESG 30	LWESG 30	○									129	60	96.5	139											4 070	3 750			
MESC 30	LWESC 30	○	1.20	6.84	60	14	20.5	86	60	13	111	50	74.6	123	M 8×12	10	34	28	9	14	12	20	80	M 8×30	42 900	44 700	686	448	412
MES 30	LWES 30	○									110	122	30 500	37 600											687	482	482		
MES 30...SL	LWES 30...SL	○	1.20	6.84	110	122	30 500	37 600	687	482	482																		
MES 45	LWES 45	○	2.05	11.2	60	14	20.5	86	60	13	125	60	81.4	136	M10×15	13	45	34	11	17.5	14	22.5	105	M10×35	61 100	60 200	1 210	672	618

Notes (1) Track rail lengths L are shown in Tables 2.1 and 2.2 on page II - 67.  
 (2) Track rail mounting bolts are not appended. Hexagon socket head bolts of JIS B 1176 with strength division 12.9 are recommended.  
 (3) The direction of basic dynamic load rating (C), basic static load rating (C0), and static moment rating (T0, Tx, Ty) are shown in the sketches below. The upper values of Tx and Ty are for one slide unit and the lower values are for two slide units in close contact.  
 (4) The shapes of grease nipple vary by size. The specifications are shown in Table 15 on page II - 73.

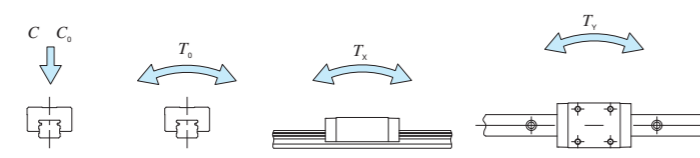

### Example of identification number of assembled set

Model code	Dimensions	Part code	Model code	Material code	Preload symbol	Classification symbol	Interchangeable code	Supplemental code
MES	G	30	C2	R440	T1	P	—	/U
①	②	③	④	⑤	⑦	⑧	⑨	⑩

① Model

MES	Block type mounting from top
LWES	
LWES...Q	

② Length of slide unit

C	Short
No symbol	Standard
G	Long

③ Size

25, 30, 35, 45
----------------

④ Number of slide unit (2)

⑤ Length of track rail (440 mm)

⑥ Material type

No symbol	High carbon steel made
SL	Stainless steel made

⑦ Preload amount

T0	Clearance
No symbol	Standard
T1	Light preload
T2	Medium preload

⑧ Accuracy class

No symbol	Ordinary
H	High
P	Precision
SP	Super precision

⑨ Interchangeable

No symbol	Non-interchangeable specification
S1	S1 specification
S2	S2 specification

⑩ Special specification

A, BS, D, E, F, I, J, L, LF, MA, N, Q, RE, T, U, V, W, Y, Z
---

## C-Lube Linear Way MH Linear Way H



# C-Lube Linear Way MH

# MH



The aquamarine end plate is the symbol of maintenance free.

Track rail

Slide unit

Casing

C-Lube

Ball

End plate

Under seal

Ball retaining band

End seal

Grease nipple

Linear Way H

# LWH

## Points

- **High rigidity series with the largest-class load rating among ball types**

High rigidity linear motion rolling guides designed to evenly support high load capacity by incorporating large-diameter balls.

- **Wide range of variations for your needs** For details ▶ P.I-26

As the lineup of 5 types of slide unit shape including the flange type, block type with small width and side mounting type, etc., and 3 types with different slide unit length with same section are available, you can select an optimal product for the specifications of your machine and device.

- **Stainless steels selections superior in corrosion resistance are listed on lineup.** For details ▶ P.I-41

Products made of stainless steel are highly resistant to corrosion, so that they are suitable for applications where rust prevention oil is not preferred, such as in cleanroom environment.

- **Series of ultra seal specification for excellent dust protection performance**

Products of ultra seal specifications have excellent dust protection performance thanks to the combination of the dedicated track rail finished with total ground and slide unit with end seal and under seal of special shapes. Special specification with inner seal further improves dust protection property of the ball circulation section against foreign substances from the upper surface of the track rail.

## Identification Number and Specification

### Example of an identification number

The specifications of MH and LWH series are indicated by the identification number. Indicate the identification number, consisting of a model code, dimensions, a part code, a dust protection code, a material code, a preload symbol, a classification symbol, an interchangeable code, and any supplemental codes for each specification to apply.

Non-interchangeable specification	1	2	3	4	5	6	7	8	9	10	11
Assembled set	MHT	G	20	C1	R840				T <sub>1</sub>	P	/FV
Interchangeable specification											
Single slide unit	MHT	G	20	C1					T <sub>1</sub>	P	S1 /V
Single track rail (1)	LWH		20		R840	B				P	S1 /F
Assembled set	MHT	G	20	C1	R840				T <sub>1</sub>	P	S1 /FV

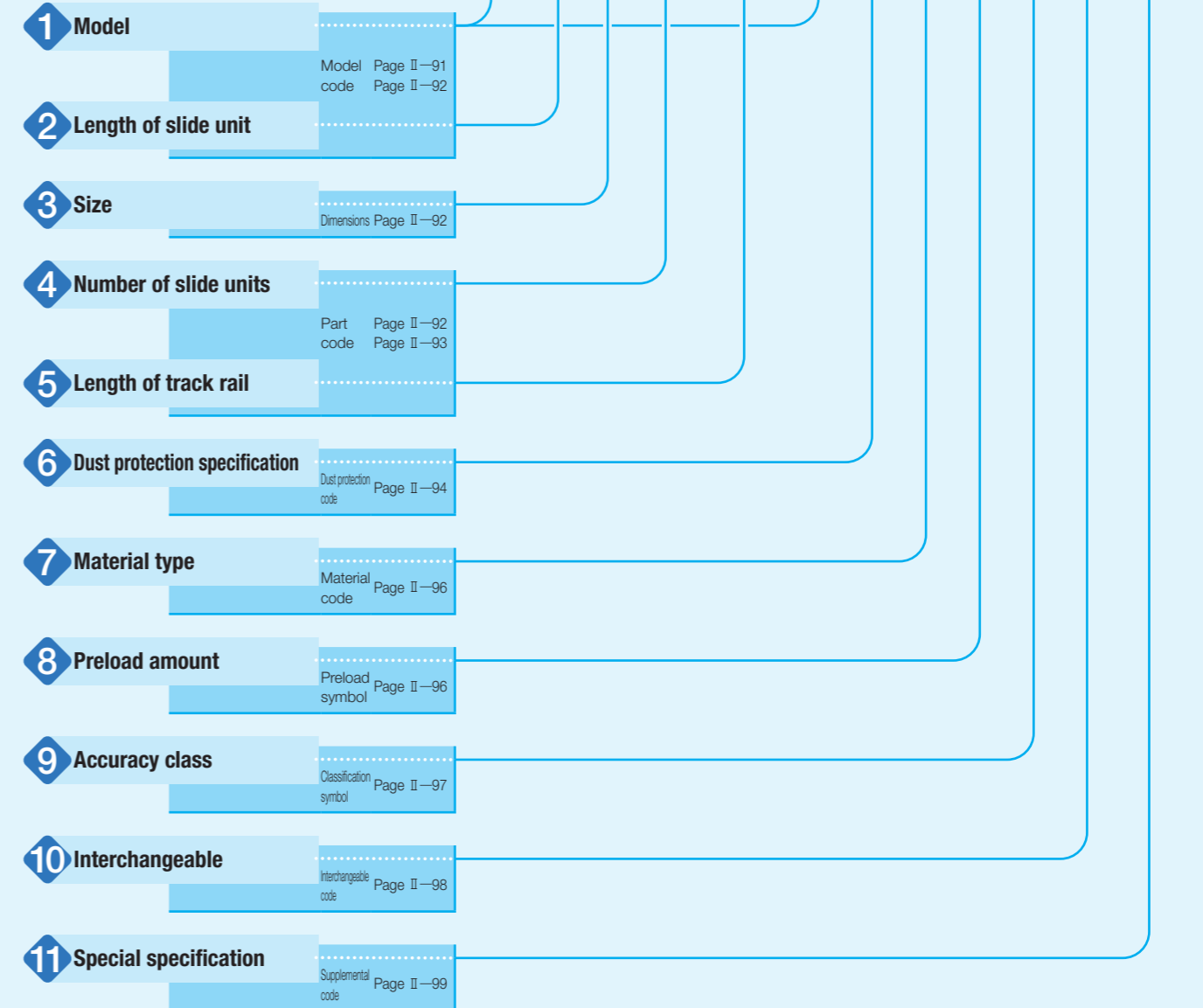

Note (1) Indicate "LWH...B" or "LWH" for the model code of the single track rail regardless of the series and the combination of slide unit models.

# Identification Number and Specification — Model —

<b>1 Model</b>	C-Lube Linear Way MH (MH series)	Flange type mounting from bottom : MH Flange type mounting from top <sup>(2)</sup> : MHT Block type mounting from top : MHD Compact block type mounting from top : MHS
	Linear Way H <sup>(1)</sup> (LWH series)	Flange type mounting from bottom : LWH (...B) Flange type mounting from top <sup>(2)</sup> : LWHT (...B) Block type mounting from top : LWHD (...B) Compact block type mounting from top : LWHS (...B) Side mounting type : LWHY

For applicable models and sizes, see Table 1.1 and Table 1.2.  
Indicate "LWH...B" or "LWH" for the model code of the single track rail regardless of the series and the combination of slide unit models.

Notes <sup>(1)</sup> This model has no built-in C-Lube.  
<sup>(2)</sup> Some models may be mounted upward.

**Table 1.1 Models and sizes of MH and LWH series**

Material	Shape	Length of slide unit	Model	Size										
				8	10	12	15	20	25	30	35	45	55	65
High carbon steel made	Flange type mounting from bottom	Standard	MH	—	—	—	○	○	○	○	○	○	—	—
			LWH...B	—	—	—	○	○	○	○	○	○	—	—
		Long	MH...M (U)	—	—	—	—	—	○	○	—	—	—	—
			LWH...M (U)	—	—	—	○	○	○	○	○	—	—	—
	Flange type mounting from top	Standard	MHG	—	—	—	—	○	○	○	○	○	—	—
			LWHG	—	—	—	—	○	○	○	○	○	—	—
		MHT	MHT	—	—	○ <sup>(1)</sup>	○	○	○	○	○	○	—	—
			LWHT...B	—	—	○ <sup>(1)(2)</sup>	○	○	○	○	○	○	—	—
		MHT...M (U)	MHT...M (U)	—	—	—	—	—	○	○	—	—	—	—
			LWHT...M (U)	—	—	—	—	—	○	○	○	○	—	—
		Long	MHTG	—	—	—	○ <sup>(1)</sup>	○	○	○	○	○	—	—
			LWHTG	—	—	—	—	○	○	○	○	○	—	—
	Extra long	MHTL <sup>(1)</sup>	—	—	—	—	—	○	○	○	—	—		
	Block type mounting from top	Standard	MHD	—	—	○	○	—	○	○	○	○	—	—
			LWHD...B	—	—	○ <sup>(2)</sup>	○	—	○	○	○	○	—	—
		MHD...M (U)	MHD...M (U)	—	—	—	—	—	○	○	—	—	—	—
			LWHD...M (U)	—	—	—	—	—	○	○	○	○	—	—
		Long	MHDG	—	—	—	—	—	○	○	○	○	—	—
			LWHDG	—	—	—	—	—	○	○	○	○	—	—
		Extra long	MHDL	—	—	—	—	—	○	○	○	—	—	
Compact block type mounting from top		Standard	MHS	—	—	—	○	○	○	○	—	—	—	
	LWHS...B		—	—	—	○	○	○	○	—	—	—		
	MHS...M (U)	MHS...M (U)	—	—	—	—	—	○	○	—	—	—		
		LWHS...M (U)	—	—	—	—	—	○	○	○	○	—	—	
Long	MHSG	—	—	—	○	○	○	○	—	—	—			
	LWHSG	—	—	—	—	—	○	○	○	○	—	—		
Side mounting type	Standard	LWHY	—	—	—	○	○	○	○	○	—	—		

Notes <sup>(1)</sup> This may be mounted upward.

<sup>(2)</sup> "...B" is not included in the model code.

Remark: For the models indicated in  , the interchangeable specification is available.

# — Length of Slide Unit · Size · Number of Slide Unit —

<b>2 Length of slide unit</b>	Short	: C	For applicable models and sizes, see Table 1.1 and Table 1.2.
	Standard	: No symbol	
	Long	: G	
	Extra long	: L	
<b>3 Size</b>	8, 10, 12, 15, 20, 25, 30, 35, 45, 55, 65		For applicable models and sizes, see Table 1.1 and Table 1.2.
	<b>4 Number of slide units</b>	: C○	For an assembled set, indicates the number of slide units assembled on a track rail. For a single slide unit, only "C1" is specified.

**Table 1.2 Models and sizes of MH and LWH series**

Material	Shape	Slide unit Length	Model	Size										
				8	10	12	15	20	25	30	35	45	55	65
Stainless steel made	Flange type mounting from bottom	Standard	LWH...SL	—	—	—	○	○	○	○	—	—	—	
			MHT...SL	○ <sup>(1)</sup>	○ <sup>(1)</sup>	○ <sup>(1)</sup>	○	○	○	○	—	—	—	
	Flange type mounting from top	Standard	LWHT...SL	○ <sup>(1)</sup>	○ <sup>(1)</sup>	○ <sup>(1)</sup>	○	○	○	○	—	—	—	
			MHDC...SL	○	○	○	—	—	—	—	—	—	—	
	Block type mounting from top	Standard	LWDC...SL	○	○	○	—	—	—	—	—	—	—	
			MHD...SL	○	○	○	—	—	—	—	—	—	—	
		Long	LWHD...SL	○	○	○	—	—	—	—	—	—	—	
			MHDG...SL	○	○	○	—	—	—	—	—	—	—	
	Compact block type mounting from top	Standard	MHS...SL	—	—	—	○	○	○	○	—	—	—	
			LWHS...SL	—	—	—	○	○	○	○	—	—	—	

Note <sup>(1)</sup> This may be mounted upward.

Remark: For the models indicated in  , the interchangeable specification is available.

**5 Length of track rail**

: R O Indicate the length of track rail in mm.  
For standard and maximum length, see Table 2.1 and Table 2.2.

**Table 2.1 Standard and maximum length of high carbon steel track rail**

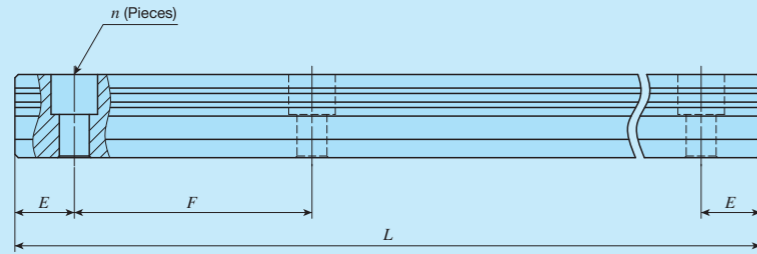

unit: mm

Item	Identification number	MH 12 LWH12	MH 15 LWH15...B	MH 20 LWH20...B	MH 25 LWH25...B	MH 30 LWH30...B
Standard length <i>L</i> ( <i>n</i> )		80 ( 2)	180 ( 3)	240 ( 4)	240 ( 4)	480 ( 6)
		160 ( 4)	240 ( 4)	480 ( 8)	480 ( 8)	640 ( 8)
		240 ( 6)	360 ( 6)	660 (11)	660 (11)	800 (10)
		320 ( 8)	480 ( 8)	840 (14)	840 (14)	1 040 (13)
		400 (10)	660 (11)	1 020 (17)	1 020 (17)	1 200 (15)
		480 (12)	900 (15)	1 200 (20)	1 200 (20)	1 520 (19)
		560 (14)	1 200 (20)	1 500 (25)	1 500 (25)	2 000 (25)
		640 (16)			1 980 (33)	
		720 (18)				
Pitch of mounting holes <i>F</i>		40	60	60	60	80
<i>E</i>		20	30	30	30	40
Standard <i>E</i> or higher dimensions <sup>(1)</sup> below		5.5	7	8	9	10
Maximum length <sup>(2)</sup>		1 480	1 500 (3 000)	1 980 (3 000)	3 000 (3 960)	2 960 (4 000)
Item	Identification number	MH 35 LWH35...B	MH 45 LWH45...B	LWH55...B	LWH65...B	
Standard length <i>L</i> ( <i>n</i> )		480 ( 6)	840 ( 8)	840 ( 7)	1 500 (10)	
		640 ( 8)	1 050 (10)	1 200 (10)	1 950 (13)	
		800 (10)	1 260 (12)	1 560 (13)	3 000 (20)	
		1 040 (13)	1 470 (14)	1 920 (16)		
		1 200 (15)	1 995 (19)	3 000 (25)		
		1 520 (19)				
Pitch of mounting holes <i>F</i>		80	105	120	150	
<i>E</i>		40	52.5	60	75	
Standard <i>E</i> or higher dimensions <sup>(1)</sup> below		10	12.5	15	17	
Maximum length <sup>(2)</sup>		2 960 (4 000)	2 940 (3 990)	3 000 (3 960)	3 000 (3 900)	

Notes <sup>(1)</sup> This does not apply to female threads for bellows (supplemental code "/J").

<sup>(2)</sup> Length up to the value in ( ) can be produced. If needed, please contact **IKO**.

Remarks 1. A typical identification number is indicated, but is applied to all models of the same size.

2. Indicate "LWH" for series of size 12 or "LWH...B" for series of size 15 or above for the model code of the single track rail regardless of the series and the combination of slide unit models.

3. For ultra seal specifications, refer to Table 2.3 and Table 2.4.

4. If not directed, *E* dimensions for both ends will be the same within the range of standard *E* dimensions. To change the dimensions, indicate the specified rail mounting hole positions "/E" of special specification. For more information, see page III - 30.

**6 Dust protection specification**

Standard specification : No symbol For applicable models and sizes, see Table 1.1 and Table 1.2.  
Ultra seal specification : M Each specification of ultra seal specification with track rail mounting from bottom is in compliance to the ultra seal specification.  
Ultra seal specification with track rail mounting from bottom : MU Ultra seal specification with track rail mounting from bottom applies to products to fix the track rail on the mounting surface side by pressing in the aluminum alloy caps for rail mounting holes to the mounting hole of the track rail in advance. As the upper surface of the track rail is flat, adhesion to the seal is high and dust protection effect is improved further.  
For track rail specifications, see Table 2.3 and Table 2.4.

**Table 2.2 Standard and maximum length of stainless steel track rail**

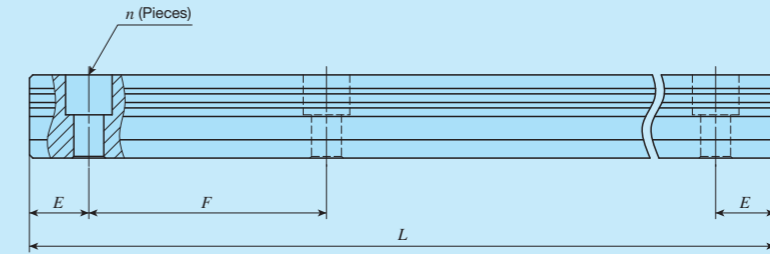

unit: mm

Item	Identification number	MH 8...SL LWH8...SL	MH 10...SL LWH10...SL	MH 12...SL LWH12...SL	MH 15...SL LWH15...SL	MH 20...SL LWH20...SL	MH 25...SL LWH25...SL	MH 30...SL LWH30...SL
Standard length <i>L</i> ( <i>n</i> )		40 ( 2)	50 ( 2)	80 ( 2)	180 ( 3)	240 ( 4)	240 ( 4)	480 ( 6)
		80 ( 4)	100 ( 4)	160 ( 4)	240 ( 4)	480 ( 8)	480 ( 8)	640 ( 8)
		120 ( 6)	150 ( 6)	240 ( 6)	360 ( 6)	660 (11)	660 (11)	800 (10)
		160 ( 8)	200 ( 8)	320 ( 8)	480 ( 8)	840 (14)	840 (14)	1 040 (13)
		200 (10)	250 (10)	400 (10)	660 (11)			
		240 (12)	300 (12)	480 (12)				
		280 (14)	350 (14)	560 (14)				
			400 (16)	640 (16)				
			450 (18)	720 (18)				
Pitch of mounting holes <i>F</i>		20	25	40	60	60	60	80
<i>E</i>		10	12.5	20	30	30	30	40
Standard <i>E</i> or higher dimensions <sup>(1)</sup> below		4.5	5	5.5	7	8	9	10
Maximum length <sup>(2)</sup>		480 (1 000)	850 (1 000)	1 000 (1 480)	1 200 (1 500)	1 200 (3 000)	1 200 (3 000)	1 200 (2 960)

Notes <sup>(1)</sup> This does not apply to female threads for bellows (supplemental code "/J").

<sup>(2)</sup> Length up to the value in ( ) can be produced. If needed, please contact **IKO**.

Remarks 1. A typical identification number is indicated, but is applied to all models of the same size.

2. Indicate "LWH" for the model code of the single track rail regardless of the series and the combination of slide unit models.

3. If not directed, *E* dimensions for both ends will be the same within the range of standard *E* dimensions. To change the dimensions, indicate the specified rail mounting hole positions "/E" of special specification. For more information, see page III - 30.



—Length of Track Rail—

Table 2.3 Standard and maximum length of ultra seal specification high carbon steel track rail

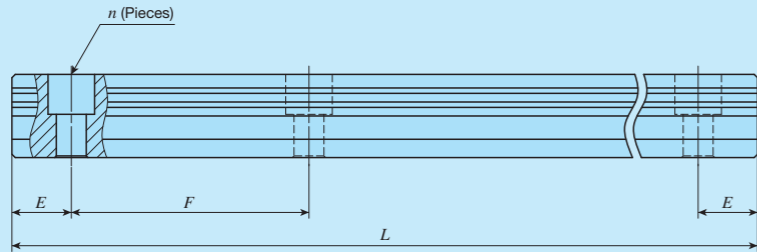

unit: mm

Item	Identification number	LWH15...M	LWH20...M	MH 25...M LWH25...M	MH 30...M LWH30...M	LWH35...M	LWH45...M
Standard length $L$ (n)		180 ( 3)	240 ( 4)	240 ( 4)	480 ( 6)	480 ( 6)	840 ( 8)
		240 ( 4)	480 ( 8)	480 ( 8)	640 ( 8)	640 ( 8)	1 050 (10)
		360 ( 6)	660 (11)	660 (11)	800 (10)	800 (10)	1 260 (12)
		480 ( 8)	840 (14)	840 (14)	1 040 (13)	1 040 (13)	1 470 (14)
		660 (11)	1 020 (17)	1 020 (17)	1 200 (15)	1 200 (15)	1 995 (19)
		1 200 (20)	1 200 (20)	1 520 (19)	1 520 (19)		
Pitch of mounting holes $F$		60	60	60	80	80	105
$E$		30	30	30	40	40	52.5
Standard $E$ or higher dimensions (1) below		7	8	9	10	10	12.5
		37	38	39	50	50	65
Maximum length		1 500	1 980	3 000	2 960	2 960	2 940
Maximum number of butt-jointing track rails		3	3	3	3	3	3
Maximum length of butt-jointing track rail		4 200	5 640	8 700	8 480	8 480	8 295

Note (1) This does not apply to female threads for bellows (supplemental code "/J").

Remarks 1. A typical identification number is indicated, but is applied to all models of the same size.

2. If not directed,  $E$  dimensions for both ends will be the same within the range of standard  $E$  dimensions. To change the dimensions, indicate the specified rail mounting hole positions "/E" of special specification. For more information, see page III -30.

Table 2.4 Standard and maximum length of ultra seal specification with track rail mounting from bottom

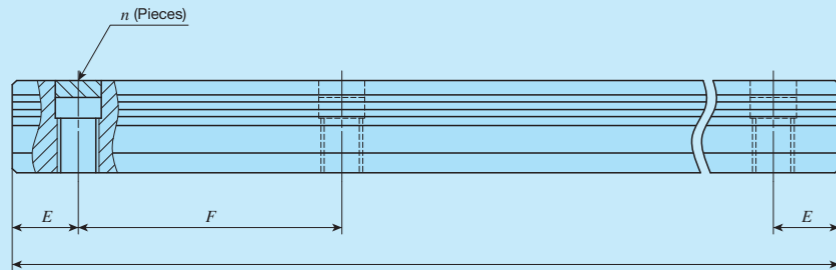

unit: mm

Item	Identification number	LWH15...MU	LWH20...MU	MH 25...MU LWH25...MU	MH 30...MU LWH30...MU	LWH35...MU	LWH45...MU
Standard length $L$ (n)		180 ( 3)	240 ( 4)	240 ( 4)	480 ( 6)	480 ( 6)	840 ( 8)
		240 ( 4)	480 ( 8)	480 ( 8)	640 ( 8)	640 ( 8)	1 050 (10)
		360 ( 6)	660 (11)	660 (11)	800 (10)	800 (10)	1 260 (12)
		480 ( 8)	840 (14)	840 (14)	1 040 (13)	1 040 (13)	1 470 (14)
		660 (11)	1 020 (17)	1 020 (17)	1 200 (15)	1 200 (15)	1 995 (19)
		1 200 (20)	1 200 (20)	1 520 (19)	1 520 (19)		
Pitch of mounting holes $F$		60	60	60	80	80	105
$E$		30	30	30	40	40	52.5
Standard $E$ or higher dimensions (1) below		7	8	9	10	10	12.5
		37	38	39	50	50	65
Maximum length		1 500	1 980	3 000	2 960	2 960	2 940
Maximum number of butt-jointing track rails		3	3	3	3	3	3
Maximum length of butt-jointing track rail		4 200	5 640	8 700	8 480	8 480	8 295

Note (1) This does not apply to female threads for bellows (supplemental code "/J").

Remarks 1. A typical identification number is indicated, but is applied to all models of the same size.

2. Track rail mounting bolt is not included.

3. If not directed,  $E$  dimensions for both ends will be the same within the range of standard  $E$  dimensions. To change the dimensions, indicate the specified rail mounting hole positions "/E" of special specification. For more information, see page III -30.

—Material Type · Preload Amount—

7 Material type

High carbon steel made : No symbol For applicable models and sizes, see Table 1.1 and Table 1.2.  
Stainless steel made (1) : SL

Note (1) Mount a standard grease nipple (brass) on the stainless steel type, too.  
Stainless steel grease nipple is also available. If needed, please contact **IKO**.

8 Preload amount

Clearance :  $T_0$  Specify this item for an assembled set or a single slide unit.  
Standard : No symbol For details of the preload amount, see Table 3.  
Light preload :  $T_1$  For applicable preload types, see Table 4.  
Medium preload :  $T_2$   
Heavy preload :  $T_3$

Table 3 Preload amount

Item	Preload symbol	Preload amount N	Operational conditions
Clearance	$T_0$	0 <sup>(2)</sup>	· Very light motion
Standard	(No symbol)	0 <sup>(3)</sup>	· Light and precise motion
Light preload	$T_1$	0.02 $C_0$	· Almost no vibrations · Load is evenly balanced · Light and precise motion
Medium preload	$T_2$	0.05 $C_0$	· Medium vibration · Medium overhung load
Heavy preload	$T_3$	0.08 $C_0$	· Operation with vibration and/or shock · Overhanging load applied · Heavy cutting

Notes (2) There is zero or subtle clearance.

(3) Indicates zero or minimal amount of preload.

Remark:  $C_0$  indicates the basic static load rating.

Table 4 Application of preload

Size	Preload type (preload symbol)				
	Clearance ( $T_0$ )	Standard (No symbol)	Light preload ( $T_1$ )	Medium preload ( $T_2$ )	Heavy preload ( $T_3$ )
8	○	○	○	—	—
10	○	○	○	—	—
12	○	○	○	—	—
15	—	○	○	○	○
20	—	○	○	○	○
25	—	○	○	○	○
30	—	○	○	○	○
35	—	○	○	○	○
45	—	○	○	○	○
55	—	○	○	○	○
65	—	○	○	○	○

Remark: The mark  indicates that interchangeable specification products are available.

<b>9 Accuracy class</b>	High	: H	For interchangeable specification products, assemble a slide unit and a track rail of the same accuracy class. For details of accuracy class, see Table 5.1 and Table 5.2. For applicable accuracy class, see Table 6.
	Precision	: P	
	Super precision	: SP	

**Table 5.1 Tolerance and allowance (Series of size 15 or higher)**

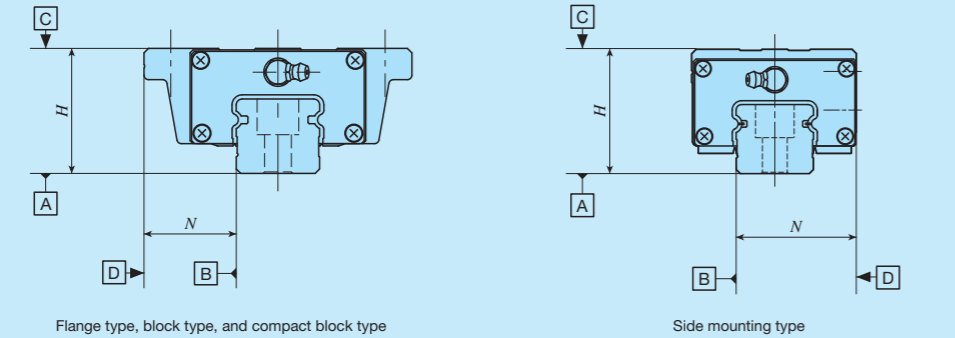

Item	Class (classification symbol)	High (H)	Precision (P)	Super precision (SP)
Dim. <i>H</i> tolerance		±0.040	±0.020	±0.010
Dim. <i>N</i> tolerance		±0.050	±0.025	±0.015
Dim. variation of <i>H</i> <sup>(1)</sup>		0.015	0.007	0.005
Dim. variation of <i>N</i> <sup>(1)</sup>		0.020	0.010	0.007
Dim. variation of <i>H</i> for multiple assembled sets <sup>(2)</sup>		0.035	0.025	—
Slide unit against the A surface Parallelism during running on the C surface		See Fig. 1.1		
Slide unit against the B surface Parallelism during running on the D surface		See Fig. 1.1		

Notes <sup>(1)</sup> It means the size variation between slide units mounted on the same track rail.  
<sup>(2)</sup> Applicable to the interchangeable specifications.

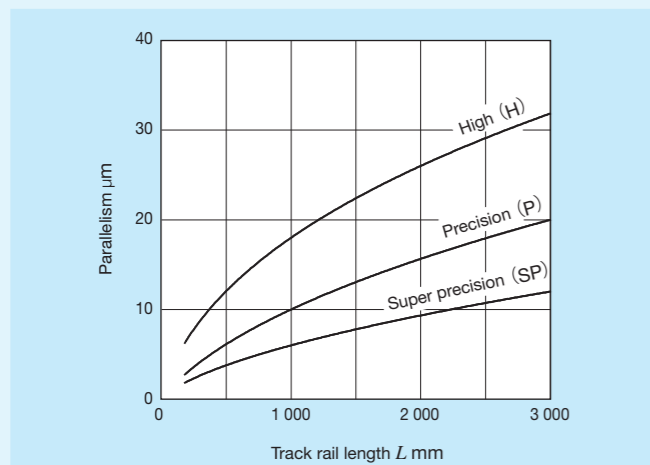

**Fig. 1.1 Parallelism in operation (series of Size 15 or higher)**

**Table 5.2 Tolerance and allowance (Series of size 8 to 12)**

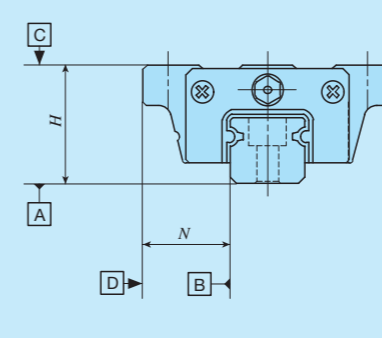

Item	Class (classification symbol)	High (H)	Precision (P)
Dim. <i>H</i> tolerance		±0.020	±0.010
Dim. <i>N</i> tolerance		±0.025	±0.015
Dim. variation of <i>H</i> <sup>(1)</sup>		0.015	0.007
Dim. variation of <i>N</i> <sup>(1)</sup>		0.020	0.010
Dim. variation of <i>H</i> for multiple assembled sets <sup>(2)</sup>		0.030	0.020
Parallelism in operation of the slide unit C surface to A surface		See Fig. 1.2	
Parallelism in operation of the slide unit D surface to B surface		See Fig. 1.2	

Notes <sup>(1)</sup> It means the size variation between slide units mounted on the same track rail.  
<sup>(2)</sup> Applicable to the interchangeable specifications.

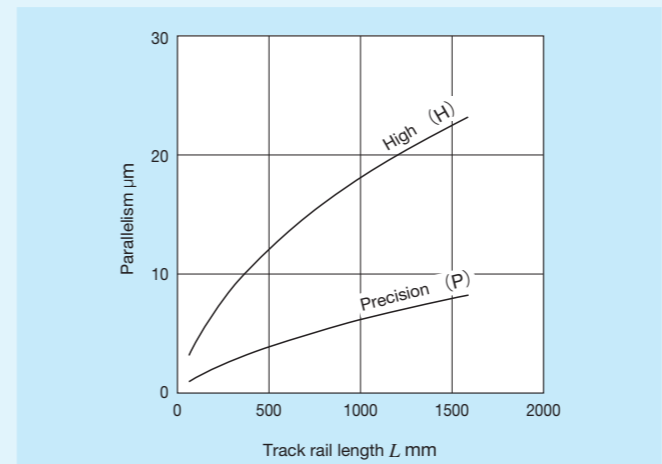

**Fig. 1.2 Parallelism in operation (Series of size 8 to 12)**

**Table 6 Application of accuracy class**

Size	Class (classification symbol)		
	High (H)	Precision (P)	Super precision (SP)
8	○	○	—
10	○	○	—
12	○	○	—
15	○	○	○
20	○	○	○
25	○	○	○
30	○	○	○
35	○	○	○
45	○	○	○
55	○	○	○
65	○	○	○

Remark: The mark  indicates that interchangeable specification products are available.

<b>10 Interchangeable</b>	S1 specification	: S1	This is specified for the interchangeable specifications. Assemble a track rail and a slide unit with the same interchangeable code. Performance and accuracy of "S1" and "S2" are the same. For applicable models and sizes, see Table 1.1 and Table 1.2. "No symbol" is indicated for non-interchangeable specification.
	S2 specification	: S2	
	Non-interchangeable specification	: No symbol	



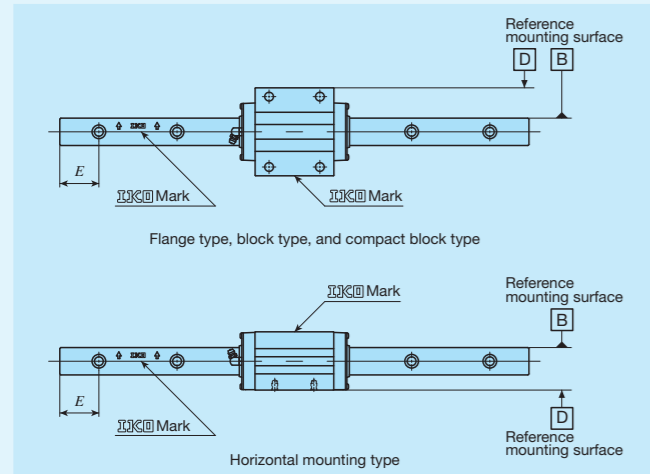

Fig. 2 Specified rail mounting hole positions (Supplemental code /E)

Remark: For details of specified rail mounting hole positions (supplemental code /E), see page III-30.

Table 9.1 Dimension of female threads for bellows (Supplemental code Single unit: /J Assembled set: /J /JJ)

Identification number		Slide unit								Track rail			
		a <sub>1</sub>	a <sub>2</sub>	b <sub>1</sub>	b <sub>2</sub>	b <sub>3</sub>	b <sub>4</sub>	M <sub>1</sub> ×depth	L <sub>1</sub> <sup>(2)</sup>	H <sub>3</sub>	a <sub>3</sub>	a <sub>4</sub>	M <sub>2</sub> ×depth
MH(T) 15	LWH(T) 15...B	3	7	15.5	16	9.5	28	M3×6	83	6.5	4	8	M3×6
-	LWH(T) 15...M								86				
MHTG 15	-								99				
MH(T) 20	LWH(T) 20...B	4	10	20.5	22	13.5	36	M3×6	99	8.5	5	9	M4×8
-	LWH(T) 20...M(U)								103				
MH(T)G 20	LWH(T)G 20								128				
MH(T) 25	LWH(T) 25...B	4	13	22	26	15	40	M3×6	110	8.5	5	12	M4×8
MH(T) 25...M(U)	LWH(T) 25...M(U)								115				
MH(T)G 25	LWH(T)G 25								133				
MH(T) 30	LWH(T) 30...B	5	17	28	34	20	50	M3×6	128	11	6	14	M4×8
MH(T) 30...M(U)	LWH(T) 30...M(U)								133				
MH(T)G 30	LWH(T)G 30								154				
MHTL 30	-								200				
MH(T) 35	LWH(T) 35...B	6	20	30	40	20	60	M3×6	137	13	7	15	M4×8
-	LWH(T) 35...M(U)								143				
MH(T)G 35	LWH(T)G 35								165				
MHTL 35	-								213				
MH(T) 45	LWH(T) 45...B	7	26	35	50	23	74	M4×8	160	15	8	19	M5×10
-	LWH(T) 45...M(U)								167				
MH(T)G 45	LWH(T)G 45								203				
MHTL 45	-								251				
-	LWH(T) 55...B	7	32	40	60	27	86	M4×8	196	17	8	25	M5×10
-	LWH(T)G 55								248				
-	LWH(T) 65...B	10	46	50	70	32	106	M5×10	240	20	10	28	M6×12
-	LWH(T)G 65								314				

Notes (1) The specification and mounting positions of grease nipple are different from those of the standard specification product. Provided grease nipple for size 15 models is NPB2 type (special specification). For details of dimensions, contact **IKO**.

(2) Dimensions of the specification that female threads for bellows are fitted to both ends of the slide unit are indicated.

Remark: This is also applicable to stainless steel models of the same size.

Table 9.2 Dimension of female threads for bellows (Supplemental code Single unit: /J Assembled set: /J /JJ)

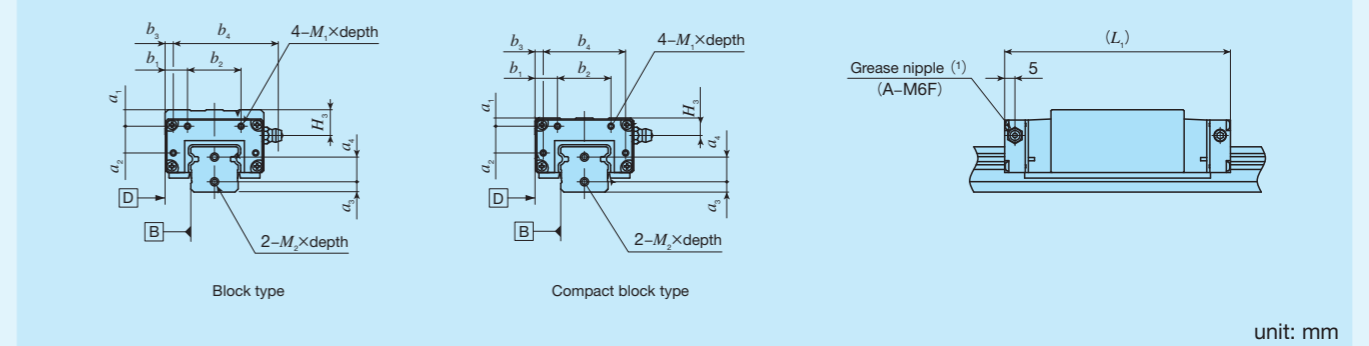

unit: mm

Identification number		Slide unit								Track rail			
		a <sub>1</sub>	a <sub>2</sub>	b <sub>1</sub>	b <sub>2</sub>	b <sub>3</sub>	b <sub>4</sub>	M <sub>1</sub> ×depth	L <sub>1</sub> <sup>(2)</sup>	H <sub>3</sub>	a <sub>3</sub>	a <sub>4</sub>	M <sub>2</sub> ×depth
MHD 15	LWHD 15...B	7	7	9	16	3	28	M3×6	83	10.5	4	8	M3×6
-	LWHD 15...M								86				
MHS 15	LWHS 15...B	3	7	9	16	3	28	M3×6	83	6.5	4	8	M3×6
-	LWHS 15...M(U)								86				
MHSG 15	-								99				
MHS 20	LWHS 20...B	4	10	11	22	4	36	M3×6	99	8.5	5	9	M4×8
-	LWHS 20...M(U)								103				
MHSG 20	LWHS 20								128				
MHD 25	LWHD 25...B	8	13	11	26	4	40	M3×6	110	12.5	5	12	M4×8
MHD 25...M(U)	LWHD 25...M(U)								115				
MHDG 25	LWHDG 25								133				
MHS 25	LWHS 25...B	4	13	11	26	4	40	M3×6	110	8.5	5	12	M4×8
MHS 25...M(U)	LWHS 25...M(U)								115				
MHSG 25	LWHS 25								133				
MHD 30	LWHD 30...B	8	17	13	34	5	50	M3×6	128	14	6	14	M4×8
MHD 30...M(U)	LWHD 30...M(U)								133				
MHDG 30	LWHDG 30								154				
MHDL 30	-								200				
MHS 30	LWHS 30...B	5	17	13	34	5	50	M3×6	128	11	6	14	M4×8
MHS 30...M(U)	LWHS 30...M(U)								133				
MHSG 30	LWHS 30								154				
MHD 35	LWHD 35...B	13	20	15	40	5	60	M3×6	137	20	7	15	M4×8
-	LWHD 35...M(U)								143				
MHDG 35	LWHDG 35								165				
MHDL 35	-								213				
MHD 45	LWHD 45...B	17	26	18	50	6	74	M4×8	160	25	8	19	M5×10
-	LWHD 45...M(U)								167				
MHDG 45	LWHDG 45								203				
MHDL 45	-								251				
-	LWHD 55...B	17	32	20	60	7	86	M4×8	196	27	8	25	M5×10
-	LWHDG 55								248				
-	LWHD 65...B	10	46	28	70	10	106	M5×10	240	20	10	28	M6×12
-	LWHDG 65								314				

Notes (1) The specification and mounting positions of grease nipple are different from those of the standard specification product. Provided grease nipple for size 15 models is NPB2 type (special specification). For details of dimensions, contact **IKO**.

(2) Dimensions of the specification that female threads for bellows are fitted to both ends of the slide unit are indicated.

Remark: This is also applicable to stainless steel models of the same size.

**Table 10 Dimension of slide unit with C-Lube plate (Supplemental code /Q)**

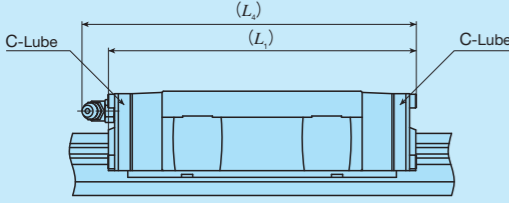

Identification number	$L_1$	$L_4$
LWHDC 8...SL	26	—
LWHT 8...SL	32	—
LWHD 8...SL		
LWHDG 8...SL	38.5	—
LWHDC 10...SL	34	—
LWHT 10...SL	42	—
LWHD 10...SL		
LWHDG 10...SL	50	—
LWHDC 12...SL	44	48
LWHT 12	56	60
LWHD 12		
LWHDG 12...SL	68	72
LWH 15...B	75	78
LWH 20...B	92	105
LWHG 20	121	134
LWH 25...B	105	116
LWHG 25	127	139
LWH 30...B	125	135
LWHG 30	151	161
LWH 35...B	134	146
LWHG 35	162	174
LWH 45...B	160	170
LWHG 45	203	214
LWH 55...B	196	207
LWHG 55	248	258
LWH 65...B	246	253
LWHG 65	321	328

Remarks 1. The dimensions of the slide unit with C-Lube at both ends are indicated.  
2. A typical identification number is indicated, but is applied to all LWH series models of the same size.

**Table 11  $H_1$  dimension with under seal (Supplemental code /U)**

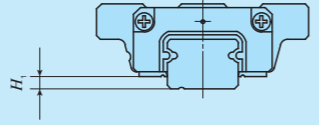

Size	$H_1$
8	1.5
10	1.8
12	3.2 <sup>(1)</sup>

Note <sup>(1)</sup> The dimensions are the same as those before mounting of under seal.

**Table 12 Dimension of slide unit with double end seals (Supplemental code Single unit: /V Assembled set: /VV)**

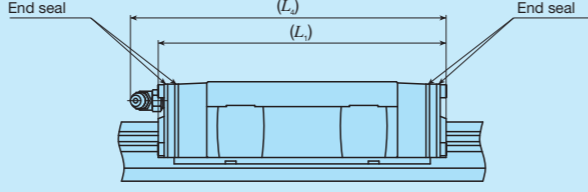

Identification number	$L_1$	$L_4$	
MH 15	LWH 15...B	72	77
—	LWH 15...M(U)	71	76
MHTG 15	—	88	93
MH 20	LWH 20...B	91	104
—	LWH 20...M(U)	90	103
MHG 20	LWHG 20	119	133
MH 25	LWH 25...B	104	116
MH 25...M(U)	LWH 25...M(U)	103	115
MHG 25	LWHG 25	127	139
MH 30	LWH 30...B	122	134
MH 30...M(U)	LWH 30...M(U)	121	
MHG 30	LWHG 30	148	160
MHL 30	—	194	206
MH 35	LWH 35...B	133	146
—	LWH 35...M(U)		
MHG 35	LWHG 35	161	173
MHL 35	—	209	222
MH 45	LWH 45...B	159	170
—	LWH 45...M(U)	158	
MHG 45	LWHG 45	202	213
MHL 45	—	251	261
—	LWH 55...B	195	206
—	LWHG 55	247	258
—	LWH 65...B	241	251
—	LWHG 65	316	325

Remarks 1. The dimensions of the slide unit with double end seals at both ends are indicated.  
2. A typical identification number is indicated, but is applied to all models of the same size.

**Table 13 Dimension of slide unit with scrapers (Supplemental code Single unit: /Z Assembled set: /ZZ)**

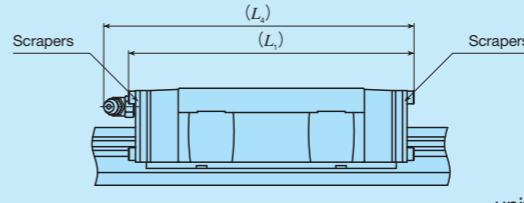

Identification number	$L_1$	$L_4$	
MH 15	LWH 15...B	73	75
—	LWH 15...M(U)	72	74
MHTG 15	—	89	91
MH 20	LWH 20...B	91	104
—	LWH 20...M(U)	90	100
MHG 20	LWHG 20	119	133
MH 25	LWH 25...B	104	116
MH 25...M(U)	LWH 25...M(U)	103	112
MHG 25	LWHG 25	126	138
MH 30	LWH 30...B	124	135
MH 30...M(U)	LWH 30...M(U)	123	131
MHG 30	LWHG 30	150	161
MHL 30	—	196	206
MH 35	LWH 35...B	133	146
—	LWH 35...M(U)		
MHG 35	LWHG 35	161	174
MHL 35	—	209	222
MH 45	LWH 45...B	160	170
—	LWH 45...M(U)	159	
MHG 45	LWHG 45	203	214
MHL 45	—	251	262
—	LWH 55...B	196	207
—	LWHG 55	248	258
—	LWH 65...B	242	251
—	LWHG 65	317	326

Remarks 1. The dimensions of the slide unit with scraper at both ends are indicated.  
2. A typical identification number is indicated, but is applied to all models of the same size.

**Table 15 Parts for lubrication**

Size	Grease nipple type <sup>(1)</sup>	Applicable supply nozzle type	Bolt size of female threads for piping
8	Oil hole	Miniature greaser	—
10			—
12			M4
15	A-M3	A-5120V A-5240V	M4
20	A-M4	B-5120V B-5240V	
25	B-M6	Grease gun available on the market	M6
30			
35			
45			
55			
65	JIS type 4	PT1/8	

Note <sup>(1)</sup> For grease nipple specification, see Table 14.1 and Table 14.2 on page III-23.  
Remark: Stainless steel grease nipple is also available. If needed, please contact **IKO**.

In the series of size 8 to 12 of MH series and LWH series, lithium-soap base grease (MULTEMP PS No.2, KYODO YUSHI) is pre-packed, and in the series of size 15 to 65, lithium-soap base grease with extreme-pressure additive (Alvania EP grease 2, [SHOWA SHELL SEKIYU K. K.]) is pre-packed. Additionally, MH series has C-Lube placed in the recirculation part of balls, so that the interval for reapplying lubricant can be extended and maintenance works such as grease job can be reduced significantly.

MH series and LWH series have grease nipple or oil hole as indicated in Table 15. Supply nozzles fit to each shapes of grease nipple and dedicated supplying equipment (miniature greasers) fit to oil holes are also available. For order of these parts for lubrication, see Table 13 and Table 14.1 on Page III-23, and Table 15 on page III-24.

**Table 14 Oil hole specifications**

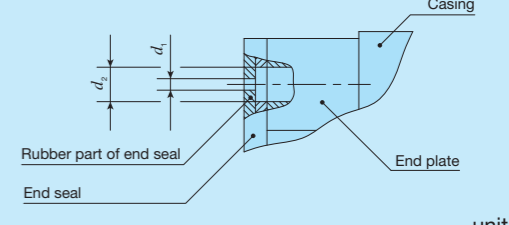

Size	$d_1$	$d_2$
8	0.5	1.5
10		

# Dust Protection

The slide units of MH series and LWH series are equipped with end seals and under seals as standard for dust protection. However, if large amount of contaminant or dust are floating, or if large particles of foreign substances such as chips or sand may adhere to the track rail, it is recommended to cover the whole unit with bellows or telescope type shield, etc. MH series and LWH series are provided with specific bellows. The bellows are easy to mount and provide excellent dust protection. If needed, please refer to III-26 for ordering. And, track rail mounting from bottom with no mounting hole on the upper surface of the track rail (Figure 3) is also available. If needed, contact **IKO**.

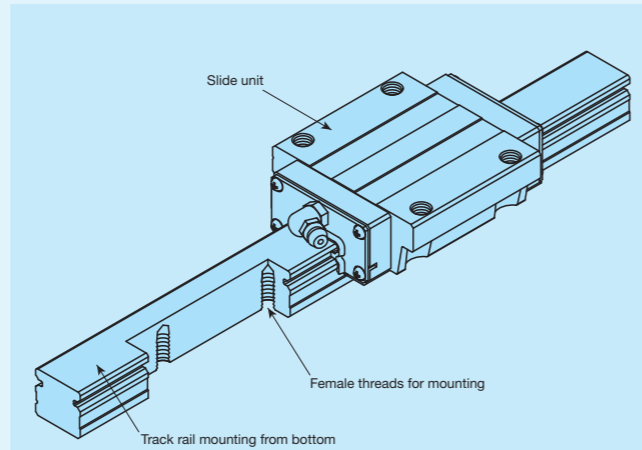

Fig. 3 Track rail mounting from bottom specification

# Precaution for Use

## 1 Mounting surface, reference mounting surface and typical mounting structure

When mounting the MH series and LWH series, properly align the reference mounting surfaces B and D of the track rail and slide unit with the reference mounting surface of the table and bed and fix them. (See Fig. 4.)

The reference mounting surfaces B and D and mounting surfaces A and C are precisely ground. Machining the mounting surface of the table and bed, such as machine or device, to high accuracy and mounting them properly will ensure stable linear motion with high accuracy.

Reference mounting surface of the slide unit is the opposite side of the **IKO** mark. The track rail reference mounting surface is identified by locating the **IKO** mark on the top surface of the track rail. It is the side surface above the mark (in the direction of the arrow). (See Fig. 5.)

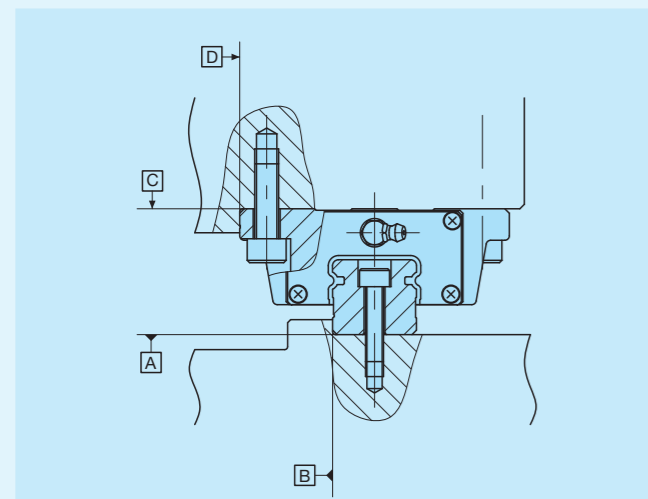

Fig. 4 Reference mounting surface and typical mounting structure

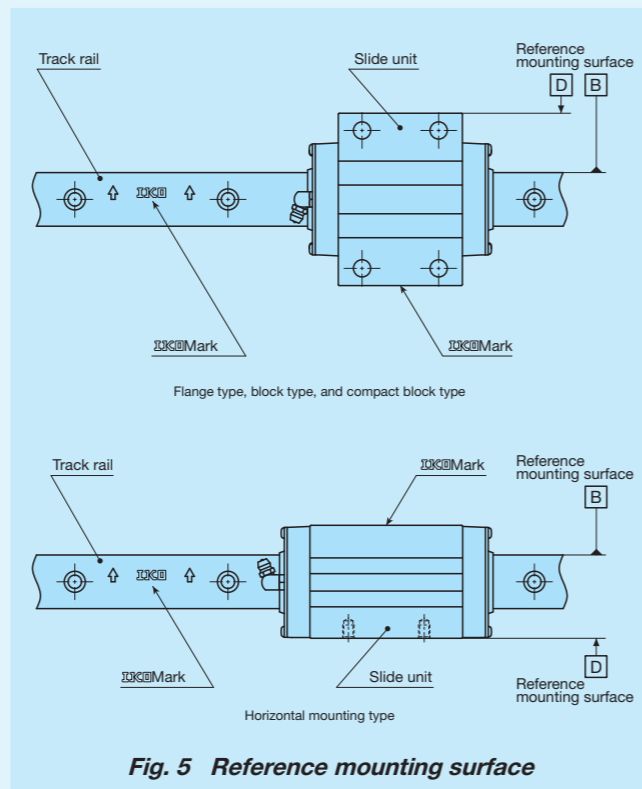

Fig. 5 Reference mounting surface

## 2 Shoulder height and corner radius of the reference mounting surface

For the opposite corner of the mating reference mounting, it is recommended to have relieved fillet as indicated in Fig. 6. Recommended value for the shoulder height and corner radius on the mating side is indicated in Table 16.

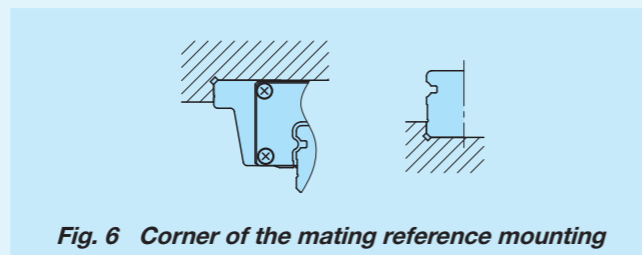

Fig. 6 Corner of the mating reference mounting

Table 16 Shoulder height and corner radius of the reference mounting surface

Size	Mounting part of slide unit		Mounting part of track rail	
	Shoulder height $h_1$	Corner radius $R_1$ (Maximum)	Shoulder height $h_2$	Corner radius $R_2$ (Maximum)
8	3.5(4) <sup>(1)</sup>	0.5	1.6 <sup>(2)</sup>	0.2
10	4.5(5) <sup>(1)</sup>	0.5	1.9 <sup>(2)</sup>	0.2
12	6	0.5	2.7 <sup>(2)</sup>	0.7
15	4	0.5	3	0.5
20	5	0.5	3	0.5
25	6	1	4	1
30	8	1	5	1
35	8	1	6	1
45	8	1.5	7	1.5
55	10	1.5	8	1.5
65	10	1.5	10	1.5

unit: mm

Notes <sup>(1)</sup> The values in ( ) are applied to MHD and LWHD.

<sup>(2)</sup> For models with under seals (supplemental code "/U"), it is recommended to use the values 0.6 mm smaller than the values in the table.

## 3 Tightening torque for fixing screw

Typical tightening torque for mounting of the MH series and LWH series to the steel mating member material is indicated in Table 17. When vibration and shock of the machine or device are large, fluctuating load is large, or moment load is applied, fix it by using the torque 1.2 to 1.5 times larger than the value indicated in the table as necessary. If the mating member material is cast iron or aluminum alloy, reduce the tightening torque depending on the strength characteristics of the mating member material.

Table 17 Tightening torque for fixing screw

Bolt size	Tightening torque N · m		
	High carbon steel-made screw		Stainless steel-made screw
	Size: 12	Size: 15 to 65	
M 1.6×0.35	—	—	0.15
M 2 ×0.4	—	—	0.31
M 2.3×0.4	—	—	0.49
M 2.6×0.45	—	—	0.70
M 3 ×0.5	1.3	—	1.1
M 4 ×0.7	2.9	4.1	2.5
M 5 ×0.8	—	8.0	5.0
M 6 ×1	—	13.6	8.5
M 8 ×1.25	—	32.7	20.4
M10 ×1.5	—	63.9	40.0
M12 ×1.75	—	110	—
M14 ×2	—	175	—
M16 ×2	—	268	—

Remark: The tightening torque is calculated based on strength division 8.8 for high carbon steel bolts in product size 12, strength division 12.9 for carbon steel bolts in product size 15 to 65, and property division A2-70 for stainless steel bolts.

# IKO C-Lube Linear Way MH

Flange type mounting from bottom

Shape	MH · LWH			
Size	15	20	25	30
	35	45	55	65

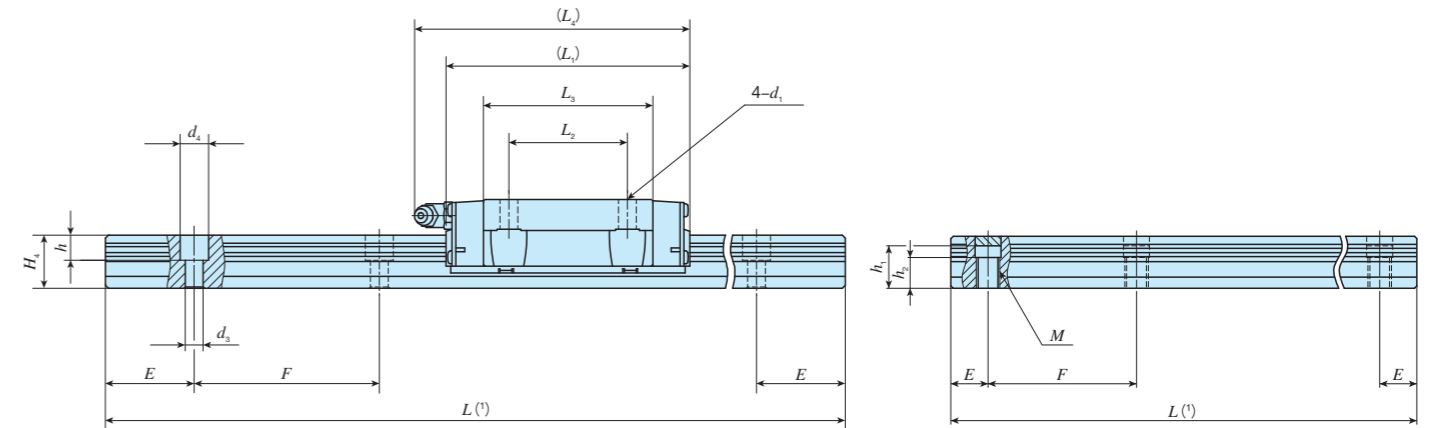
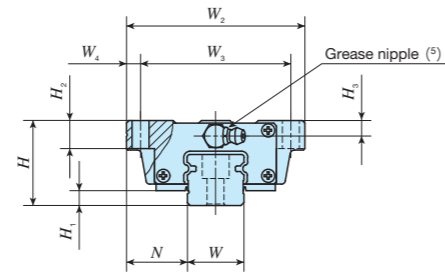

Ultra seal specification with track rail mounting from bottom

Identification number	Interchangeable	Mass (Ref.) Slide unit kg	Track rail kg/m	Dimensions of assembly mm			Dimensions of slide unit mm										Dimensions of track rail mm						Appended mounting bolt for track rail (3) mm	Basic dynamic load rating (4) N	Basic static load rating (4) N	Static moment rating (4)								
				H	H <sub>1</sub>	N	W <sub>2</sub>	W <sub>3</sub>	W <sub>4</sub>	L <sub>1</sub>	L <sub>2</sub>	L <sub>3</sub>	L <sub>4</sub>	d <sub>1</sub>	H <sub>2</sub>	H <sub>3</sub>	W	H <sub>4</sub>	d <sub>3</sub>	d <sub>4</sub>	h	M				h <sub>1</sub> (2)	h <sub>2</sub>	E	F	Bolt size × ℓ	C	C <sub>0</sub>	T <sub>0</sub>	T <sub>x</sub>
MH 15	○	0.22	1.47	24	4.5	16	47	38	4.5	66	30	44.2	69	4.5	7	4.5	15	15	4.5	8	6	-	-	-	30	60	M4×16	11 600	13 400	112	95.6	556	95.6	556
LWH 15...B	○																																	
LWH 15...SL	○																																	
LWH 15...M*	-																																	
MH 20	○	0.48	2.56	30	5	21.5	63	53	5	83	40	56	94	6	10	5.5	20	18	6	9.5	8.5	-	-	-	30	60	M5×18	18 100	21 100	232	195	1 090	195	1 090
LWH 20...B	○																																	
LWH 20...SL	○																																	
LWH 20...M*	-																																	
MHG 20	○	0.71								112		84.8	122																					
LWHG 20	○											86																						
MH 25	○	0.70	3.50	36	6.5	23.5	70	57	6.5	95	45	63.9	105	7	10	6.5	23	22	7	11	9	-	-	-	30	60	M6×22	25 200	28 800	362	309	1 690	309	1 690
LWH 25...B	○																																	
LWH 25...SL	○																																	
LWH 25...M*	-																																	
MH 25...MU*	-										118		86.6	128																				
LWHG 25	○												87.4																					

Notes (1) Track rail lengths  $L$  are shown in Table 2.1 on page II-93, Table 2.2 on page II-94, and Tables 2.3 and 2.4 on page II-95.

(2) Choose bolts whose dimension allow fixing thread depth into track rail to be less than  $h_1$ .

(3) The appended track rail mounting bolts are hexagon socket head bolts equivalent to JIS B 1176. For stainless steel model, stainless steel bolts are appended.

In an assembled set of MH series and LWH...MU model, track rail mounting bolts are not appended.

(4) The direction of basic dynamic load rating ( $C$ ), basic static load rating ( $C_0$ ), and static moment rating ( $T_0$ ,  $T_x$ ,  $T_y$ ) are shown in the sketches below. The upper values of  $T_x$  and  $T_y$  are for one slide unit and the lower values are for two slide units in close contact.

(5) The shapes of grease nipple vary by size. The specifications are shown in Table 15 on page II-104.

Remark: The identification numbers with \* are our semi-standard items.

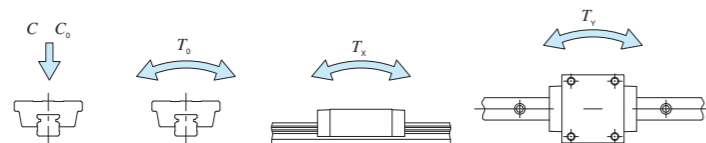

### Example of identification number of assembled set

Model code	Dimensions	Part code	Model code	Dust protection code	Material code	Preload symbol	Classification symbol	Interchangeable code	Supplemental code
MH	G	20	C2	R480		T1	P		N
1	2	3	4	5	6	7	8	9	10

① Model	MH Flange type mounting from bottom	⑤ Length of track rail (480 mm)	R480	⑧ Preload amount	T1 Light preload	⑩ Interchangeable	No symbol Non-interchangeable specification
② Length of slide unit	G Standard	⑥ Dust protection code	M Ultra seal specification	T2 Medium preload	S1 S1 specification	⑪ Special specification	A, BS, D, E, F, I, J, L, LF, MA, MN, N, PS, Q, RE, T, UR, V, W, Y, Z
③ Size	15, 20, 25	MU Ultra seal specification with track rail mounting from bottom		T3 Heavy preload	S2 S2 specification		
④ Number of slide unit (2)		⑦ Material type	SL Stainless steel made	⑨ Accuracy class	SP Super precision		

# IKO C-Lube Linear Way MH

Flange type mounting from bottom

Shape	MH · LWH			
Size	15	20	25	30
	35	45	55	65

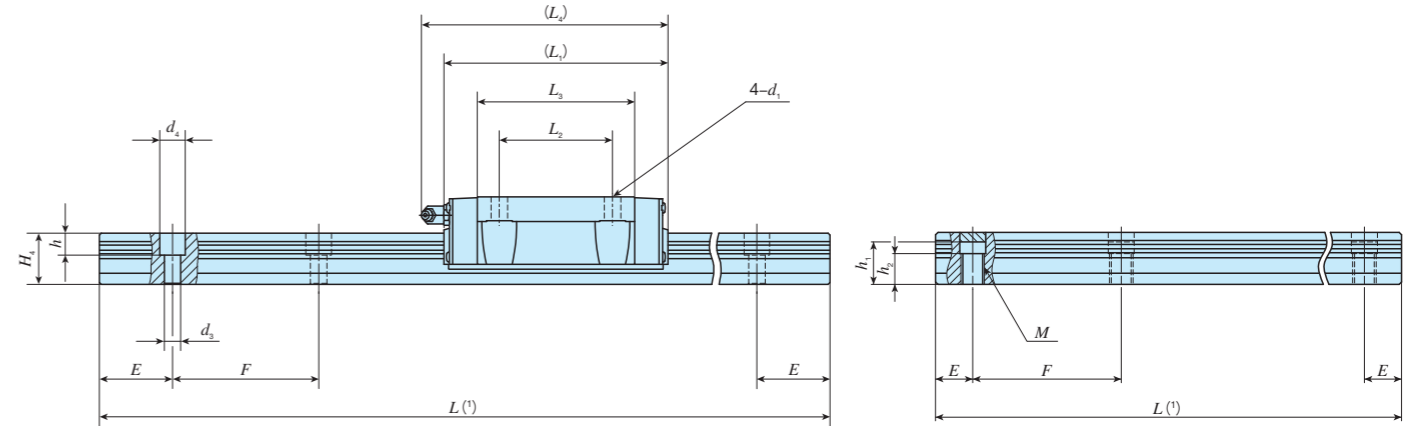
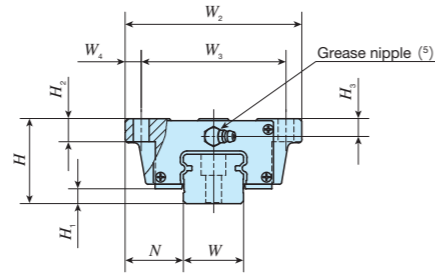
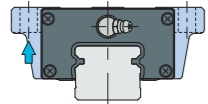

Ultra seal specification with track rail mounting from bottom

Identification number	Interchangeable	Mass (Ref.) Slide unit kg / Track rail kg/m	Dimensions of assembly mm			Dimensions of slide unit mm											Dimensions of track rail mm						Appended mounting bolt for track rail (3) mm Bolt size × ℓ	Basic dynamic load rating (4) C N	Basic static load rating (4) C <sub>0</sub> N	Static moment rating (4) T <sub>0</sub> , T <sub>x</sub> , T <sub>y</sub> N · m						
			H	H <sub>1</sub>	N	W <sub>2</sub>	W <sub>3</sub>	W <sub>4</sub>	L <sub>1</sub>	L <sub>2</sub>	L <sub>3</sub>	L <sub>4</sub>	d <sub>1</sub>	H <sub>2</sub>	H <sub>3</sub>	W	H <sub>4</sub>	d <sub>3</sub>	d <sub>4</sub>	h	M	h <sub>1</sub> (2)				h <sub>2</sub>	E	F	T <sub>0</sub>	T <sub>x</sub>	T <sub>y</sub>	
MH 30	○	1.28	4.82	42	7	31	90	72	9	113	52	80.6	123	9	10	8	28	25	9	14	12	-	-	-	40	80	M 8×28	35 400	40 700	623	536 2 820	536 2 820
LWH 30...B	○																															
LWH 30...SL	○																															
LWH 30...M*	-																															
MH 30...MU*	-	1.69	4.82	42	7	31	90	72	9	113	52	80.6	123	9	10	8	28	25	9	14	12	-	-	-	40	80	M 8×28	35 400	40 700	623	536 2 820	536 2 820
LWH 30...MU*	-																															
MHG 30	○																															
LWHG 30	○																															
MH 35	○	1.79	6.85	48	8	33	100	82	9	123	62	86.2	135	9	13	10	34	28	9	14	12	-	-	-	40	80	M 8×28	48 700	53 700	823	631 3 480	579 3 190
LWH 35...B	○																															
LWH 35...M*	-																															
LWH 35...MU*	-																															
MHG 35	○	2.35	6.85	48	8	33	100	82	9	123	62	86.2	135	9	13	10	34	28	9	14	12	-	-	-	40	80	M 8×28	48 700	53 700	823	631 3 480	579 3 190
LWHG 35	○																															
LWHG 35	○																															
LWHG 35	○																															
MH 45	○	3.17	10.7	60	10	37.5	120	100	10	147	80	103.4	158	11	15	13	45	34	14	20	17	-	-	-	52.5	105	M12×35	74 600	80 200	1 610	1 150 6 190	1 060 5 690
LWH 45...B	○																															
LWH 45...M*	-																															
LWH 45...MU*	-																															
MHG 45	○	4.34	10.7	60	10	37.5	120	100	10	147	80	103.4	158	11	15	13	45	34	14	20	17	-	-	-	52.5	105	M12×35	74 600	80 200	1 610	1 150 6 190	1 060 5 690
LWHG 45	○																															
LWHG 45	○																															
LWHG 45	○																															

Notes (1) Track rail lengths  $L$  are shown in Table 2.1 on page II-93, Table 2.2 on page II-94, and Tables 2.3 and 2.4 on page II-95.

(2) Choose bolts whose dimension allow fixing thread depth into track rail to be less than  $h_1$ .

(3) The appended track rail mounting bolts are hexagon socket head bolts equivalent to JIS B 1176. For stainless steel model, stainless steel bolts are appended.

In an assembled set of MH series and LWH...MU model, track rail mounting bolts are not appended.

(4) The direction of basic dynamic load rating ( $C$ ), basic static load rating ( $C_0$ ), and static moment rating ( $T_0$ ,  $T_x$ ,  $T_y$ ) are shown in the sketches below. The upper values of  $T_x$  and  $T_y$  are for one slide unit and the lower values are for two slide units in close contact.

(5) The shapes of grease nipple vary by size. The specifications are shown in Table 15 on page II-104.

Remark: The identification numbers with \* are our semi-standard items.

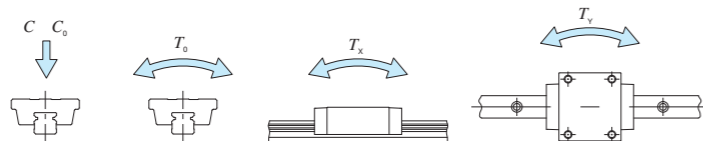

## Example of identification number of assembled set

Model code	Dimensions	Part code	Model code	Dust protection code	Material code	Preload symbol	Classification symbol	Interchangeable code	Supplemental code
MH	G	35	C2	R800		T1	P		N
1	2	3	4	5	6	7	8	9	10

① Model	MH Flange type mounting from bottom	⑤ Length of track rail (800 mm)	R800	⑧ Preload amount	T1 Light preload	⑩ Interchangeable	No symbol Non-interchangeable specification
② Length of slide unit	No symbol Standard	⑥ Dust protection code	M Standard specification	T2 Medium preload	S1 S1 specification	⑪ Special specification	A, BS, D, E, F, I, J, L, LF, MA, MN, N, PS, Q, RE, T, UR, V, W, Y, Z
③ Size	30, 35, 45	MU Ultra seal specification with track rail mounting from bottom		T3 Heavy preload	S2 S2 specification		
④ Number of slide unit (2)		⑦ Material type	No symbol High carbon steel made		⑨ Accuracy class		
		SL Stainless steel made		H High			
				P Precision			
				SP Super precision			



# IKO C-Lube Linear Way MH

## Flange type mounting from bottom

Shape	LWH			
Size	15	20	25	30
	35	45	55	65

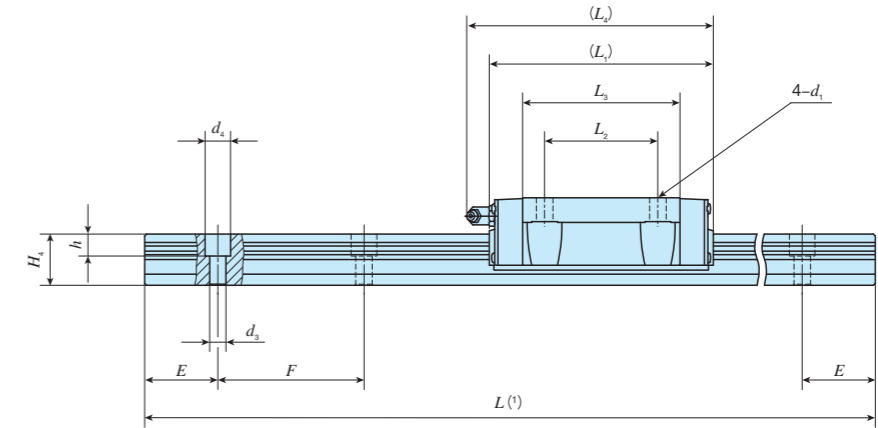
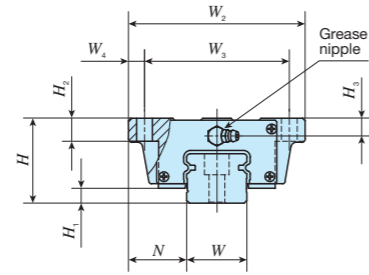

Identification number		Interchangeable	Mass (Ref.)		Dimensions of assembly mm			Dimensions of slide unit mm										Dimensions of track rail mm						Appended mounting bolt for track rail (2) mm	Basic dynamic load rating (3) N	Basic static load rating (3) N	Static moment rating (3)				
MH series	LWH series (No C-Lube)		Slide unit kg	Track rail kg/m	H	H <sub>1</sub>	N	W <sub>2</sub>	W <sub>3</sub>	W <sub>4</sub>	L <sub>1</sub>	L <sub>2</sub>	L <sub>3</sub>	L <sub>4</sub>	d <sub>1</sub>	H <sub>2</sub>	H <sub>3</sub>	H <sub>5</sub>	W	H <sub>4</sub>	d <sub>3</sub>	d <sub>4</sub>	h	E	F	Bolt size × ℓ	C	C <sub>0</sub>	T <sub>0</sub>	T <sub>x</sub>	T <sub>y</sub>
—	LWH 55-B	○	5.30	15.5	70	13	43.5	140	116	12	183	95	132	194	14	17	14	—	53	41	16	23	20	60	120	M14×45	113 000	121 000	2 870	2 210	2 030
—	LWHG 55	○	7.40								235		183.6	246													3 970	4 120	3 780		
—	LWH 65-B	○	12.3	22.2	90	14	53.5	170	142	14	229	110	164	239	16	23	20	—	63	48	18	26	22	75	150	M16×50	176 000	184 000	5 180	4 130	3 790
—	LWHG 65	○	17.6								303		238.8	313													7 560	8 530	7 810		

Notes (1) Track rail lengths  $L$  are shown in Table 2.1 on page II-93.

(2) The appended track rail mounting bolts are hexagon socket head bolts equivalent to JIS B 1176.

(3) The direction of basic dynamic load rating ( $C$ ), basic static load rating ( $C_0$ ), and static moment rating ( $T_0$ ,  $T_x$ ,  $T_y$ ) are shown in the sketches below. The upper values of  $T_x$  and  $T_y$  are for one slide unit and the lower values are for two slide units in close contact.

Remark: The specifications of grease nipple are shown in Table 15 on page II-104.

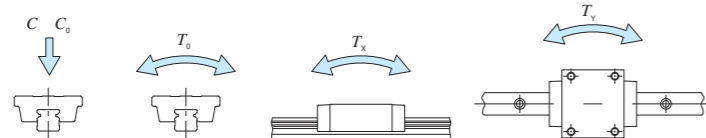

### Example of identification number of assembled set

Model code Dimensions Part code Model code Preload symbol Classification symbol Interchangeable code Supplemental code

**LWH** **G** **55** **C2 R1200** **T1** **P** **N**

① ② ③ ④ ⑤ ⑥ ⑦ ⑧ ⑨

① Model LWH(---B) Flange type mounting from bottom.	③ Size 55, 65	⑥ Preload amount No symbol Standard T1 Light preload T2 Medium preload T3 Heavy preload	⑧ Interchangeable No symbol Non-interchangeable specification S1 S1 specification S2 S2 specification
② Length of slide unit No symbol Standard G Long	④ Number of slide unit (2)	⑦ Accuracy class H High P Precision SP Super precision	⑨ Special specification A, D, E, F, I, J, L, LF, MN N, PS, Q, T, V, W, Y, Z
⑤ Length of track rail (1,200 mm)			

# IKO C-Lube Linear Way MH

## Flange type mounting from top

Shape	MHT · LWHT					
Size	8	10	12	15	20	25
	30	35	45	55	65	

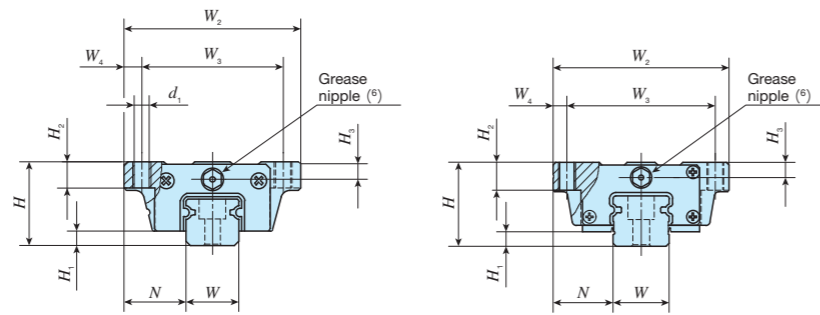

MHT 8 ...SL, LWHT 8 ...SL  
 MHT 10 ...SL, LWHT 10 ...SL  
 MHT 12 (...SL), LWHT 12 (...SL)  
 MHTG 15

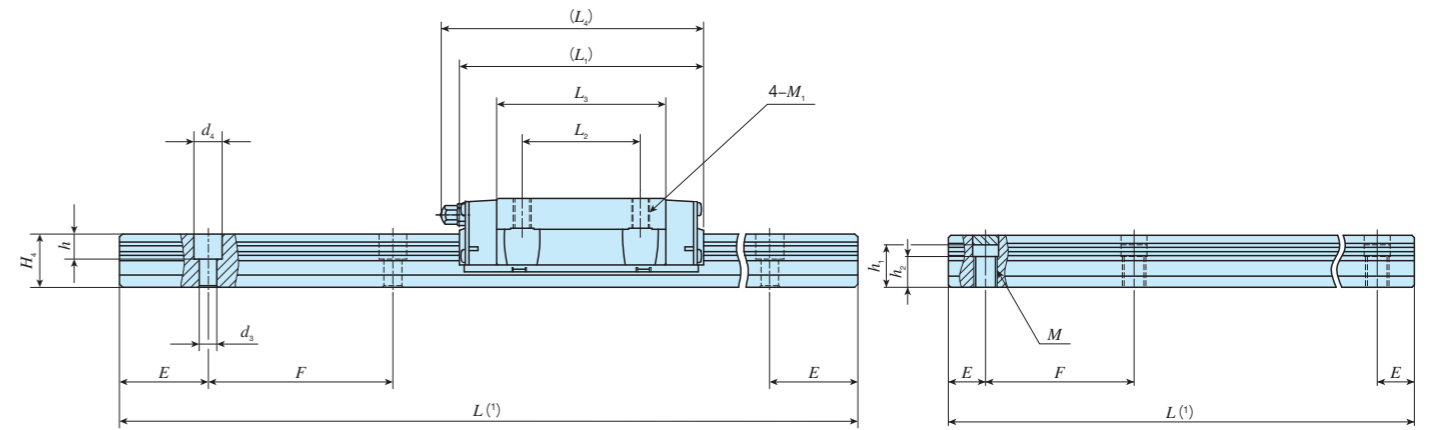

Ultra seal specification with track rail mounting from bottom

Identification number	Interchangeable	Mass (Ref.)		Dimensions of assembly mm			Dimensions of slide unit mm											Dimensions of track rail mm						Appended mounting bolt for track rail (4) mm	Basic dynamic load rating (5) N	Basic static load rating (5) N	Static moment rating (5)								
		Slide unit kg	Track rail kg/m	H	H <sub>1</sub>	N	W <sub>2</sub>	W <sub>3</sub>	W <sub>4</sub>	L <sub>1</sub>	L <sub>2</sub>	L <sub>3</sub>	L <sub>4</sub>	d <sub>1</sub> (2)	M <sub>1</sub>	H <sub>2</sub>	H <sub>3</sub>	W	H <sub>4</sub>	d <sub>3</sub>	d <sub>4</sub>	h	M				h <sub>1</sub> (3)	h <sub>2</sub>	E	F	T <sub>0</sub>	T <sub>x</sub>	T <sub>y</sub>		
MHT 8...SL	LWHT 8...SL	○	0.015	0.32	10	2.1	8	24	19	2.5	24	10	15.3	-	1.9	M2.3	3.5	2	8	6	2.4	4.2	2.3	-	-	-	10	20	M2×8	1 510	2 120	8.8	5.5 32.0	4.7 26.9	
MHT 10...SL	LWHT 10...SL	○	0.031	0.47	12	2.4	10	30	24	3	32	12	21.4	-	2.6	M3	4.5	2.5	10	7	3.5	6	3.5	-	-	-	12.5	25	M3×8	2 640	3 700	19.2	13.3 73.8	11.1 61.9	
MHT 12	LWHT 12	○	0.108	0.86	19	3.2	14	40	32	4	46	15	31.6	50	3.4	M4	6	4	12	10.5	3.5	6	4.5	-	-	-	20	40	M3×12	6 260	8 330	51.6	44.7 237	37.5 199	
MHT 12...SL	LWHT 12...SL	○	0.108																																
MHT 15	LWHT 15...B	○	0.22	1.47	24	4.5	16	47	38	4.5	66	30	44.2	69	-	M5	7	4.5	15	15	4.5	8	6	6	-	-	-	30	60	M4×16	11 600	13 400	112	95.6 556	95.6 556
MHT 15...SL	LWHT 15...SL	○											44.6																						
-	LWHT 15...M*	-											44.2																						
-	LWHT 15...MU*	-											44.6																						
MHTG 15	-	○	0.29	-	-	-	-	-	-	-	82	60.1	85	4.4	-	-	-	-	-	-	-	-	-	-	-	-	-	-	-	-	-	-	-	-	

Notes (1) Track rail lengths  $L$  are shown in Table 2.1 on page II-93, Table 2.2 on page II-94, and Tables 2.3 and 2.4 on page II-95.

(2) Series of size 8 to 12 and MHTG15 can also be mounted in upward direction.

(3) Choose bolts whose dimension allow fixing thread depth into track rail to be less than  $h_1$ .

(4) The appended track rail mounting bolts are hexagon socket head bolts equivalent to JIS B 1176. For stainless steel model, stainless steel bolts are appended.

In an assembled set of MH series and LWHT...MU model, track rail mounting bolts are not appended.

(5) The direction of basic dynamic load rating ( $C$ ), basic static load rating ( $C_0$ ), and static moment rating ( $T_0$ ,  $T_x$ ,  $T_y$ ) are shown in the sketches below. The upper values of  $T_x$  and  $T_y$  are for one slide unit and the lower values are for two slide units in close contact.

(6) Series of size 8 and 10 are provided with an oil hole. The specifications of oil holes are shown in Table 14 on page II-104.

The shapes of grease nipples of size 12 and 15 vary by size. The specifications are shown in Table 15 on page II-104.

Remark: The identification numbers with \* are our semi-standard items.

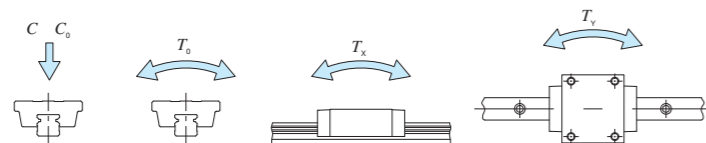

### Example of identification number of assembled set

Model code	Dimensions	Part code	Model code	Dust protection code	Material code	Preload symbol	Classification symbol	Interchangeable code	Supplemental code
MHT	G	15	C2	R900		T1	P		N
1	2	3	4	5	6	7	8	9	10

<b>① Model</b> MHT LWHT (...B)	<b>⑤ Length of track rail (900 mm)</b> R900	<b>⑧ Preload amount</b> T <sub>1</sub>	<b>⑩ Interchangeable</b> No symbol Non-interchangeable specification S1 S1 specification S2 S2 specification
<b>② Length of slide unit</b> No symbol Standard G Long	<b>⑥ Dust protection code</b> No symbol Standard specification M Ultra seal specification MU Ultra seal specification with track rail mounting from bottom	<b>⑨ Accuracy class</b> H High P Precision SP Super precision	<b>⑪ Special specification</b> A, BS, D, E, F, 1, J, L, LF, MA MN, N, Q, RE, T, U, V, W, Y, Z
<b>③ Size</b> 8, 10, 12, 15	<b>⑦ Material type</b> No symbol High carbon steel made SL Stainless steel made		
<b>④ Number of slide unit (2)</b>			

# IKO C-Lube Linear Way MH

## Flange type mounting from top

Shape	MHT · LWHT					
Size	8	10	12	15	20	25
	30	35	45	55	65	

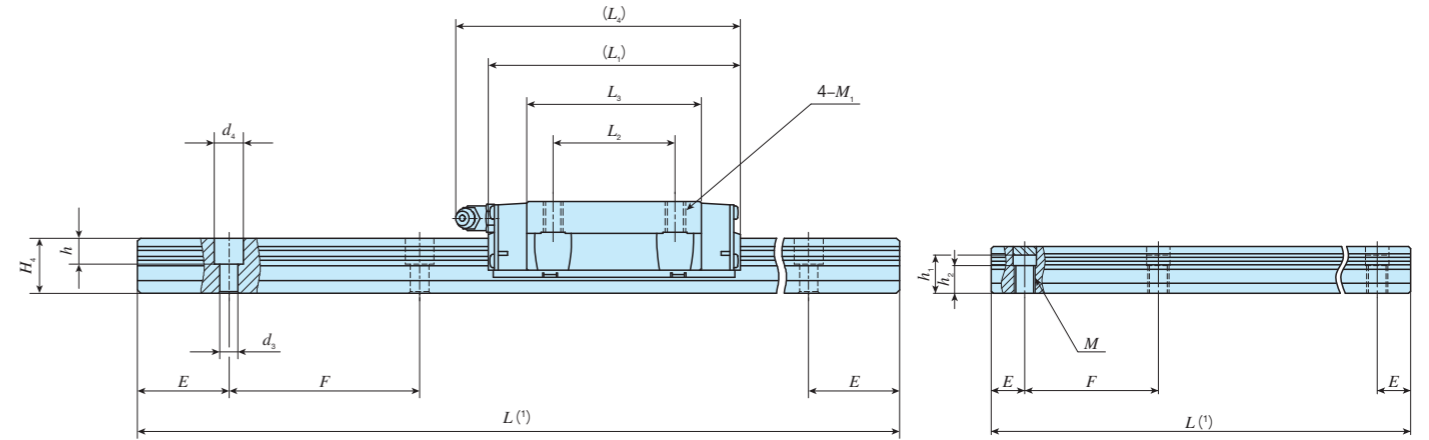
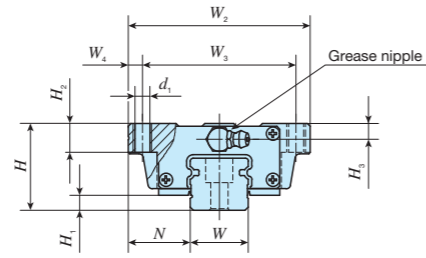

Ultra seal specification with track rail mounting from bottom

Identification number	Interchangeable	Mass (Ref.)		Dimensions of assembly mm			Dimensions of slide unit mm										Dimensions of track rail mm								Appended mounting bolt for track rail (3) mm	Basic dynamic load rating (4) C N	Basic static load rating (4) C0 N	Static moment rating (4)								
		Slide unit kg	Track rail kg/m	H	H1	N	W2	W3	W4	L1	L2	L3	L4	d1	M1	H2	H3	W	H4	d3	d4	h	M	h1(2)				h2	E	F	Bolt size × ℓ	T0 N·m	Tx N·m	Ty N·m		
MHT 20	○	0.48	2.56	30	5	21.5	63	53	5	83	40	56	94	-	M6	10	5.5	20	18	6	9.5	8.5	-	-	-	30	60	M5×18	18 100	21 100	232	1 090	1 090			
LWHT 20...B	○											57.2																								
MHT 20...SL	○											56																								
LWHT 20...SL	○											57.2																								
LWHT 20...M*	-																																			
MHTG 20	○	0.71								112	84.8	122																								
LWHTG 20	○										86																									
MHT 25	○	0.70	3.50	36	6.5	23.5	70	57	6.5	95	45	63.9	105	-	M8	10	6.5	23	22	7	11	9	-	-	-	30	60	M6×22	25 200	28 800	362	1 690	1 690			
LWHT 25...B	○											64.7																								
MHT 25...SL	○											63.9																								
LWHT 25...SL	○											64.7																								
MHT 25...M*	-											63.9																								
LWHT 25...M*	-											64.7																								
MHT 25...MU*	-											63.9																								
LWHT 25...MU*	-	64.7																																		
MHTG 25	○	0.93								118	86.6	128																								
LWHTG 25	○										87.4																									

Notes (1) Track rail lengths  $L$  are shown in Table 2.1 on page II-93, Table 2.2 on page II-94, and Tables 2.3 and 2.4 on page II-95.  
 (2) Choose bolts whose dimension allow fixing thread depth into track rail to be less than  $h_1$ .  
 (3) The appended track rail mounting bolts are hexagon socket head bolts equivalent to JIS B 1176. For stainless steel model, stainless steel bolts are appended.  
 In an assembled set of MH series and LWHT...MU model, track rail mounting bolts are not appended.  
 (4) The direction of basic dynamic load rating ( $C$ ), basic static load rating ( $C_0$ ), and static moment rating ( $T_0$ ,  $T_x$ ,  $T_y$ ) are shown in the sketches below. The upper values of  $T_x$  and  $T_y$  are for one slide unit and the lower values are for two slide units in close contact.  
 Remarks 1. The specifications of grease nipple are shown in Table 15 on page II-104.  
 2. The identification numbers with \* are our semi-standard items.

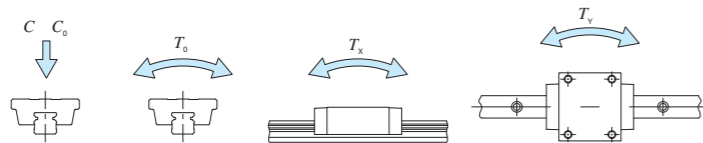

### Example of identification number of assembled set

Model code	Dimensions	Part code	Model code	Dust protection code	Material code	Preload symbol	Classification symbol	Interchangeable code	Supplemental code
MHT	G	25	C2	R840		T1	P		/N
1	2	3	4	5	6	7	8	9	10

① Model MHT LWHT (...B) Flange type mounting from top	⑤ Length of track rail (840 mm)	⑧ Preload amount No symbol Standard T1 Light preload T2 Medium preload T3 Heavy preload	⑩ Interchangeable No symbol Non-interchangeable specification S1 S1 specification S2 S2 specification
② Length of slide unit No symbol Standard G Long	⑥ Dust protection code No symbol Standard specification M Ultra seal specification MU Ultra seal specification with track rail mounting from bottom	⑨ Accuracy class H High P Precision SP Super precision	⑪ Special specification A, BS, D, E, F, 1, J, L, LF, MA MN, N, PS, Q, RE, T, UR, V, W, Y, Z
③ Size 20, 25	⑦ Material type No symbol High carbon steel made SL Stainless steel made		

# IKO C-Lube Linear Way MH

## Flange type mounting from top

Shape	MHT · LWHT					
Size	8	10	12	15	20	25
	30	35	45	55	65	

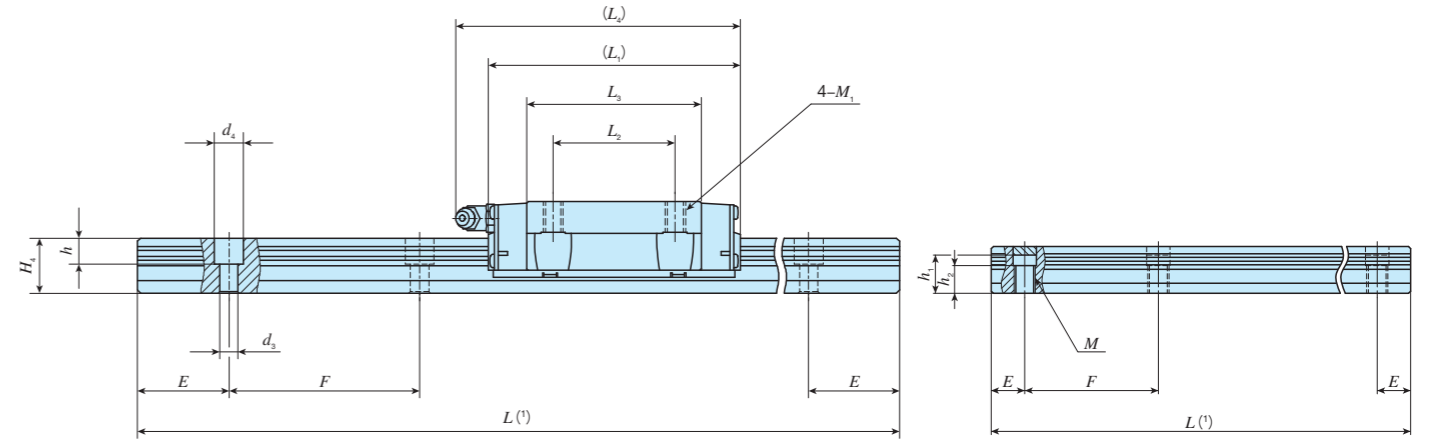
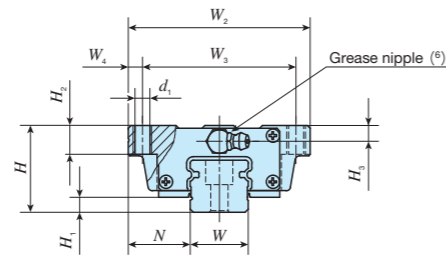

Ultra seal specification with track rail mounting from bottom

Identification number	Interchangeable	Mass (Ref.)		Dimensions of assembly mm			Dimensions of slide unit mm										Dimensions of track rail mm						Appended mounting bolt for track rail (4) mm	Basic dynamic load rating (5) C N	Basic static load rating (5) C <sub>0</sub> N	Static moment rating (5) N·m								
		Slide unit kg	Track rail kg/m	H	H <sub>1</sub>	N	W <sub>2</sub>	W <sub>3</sub>	W <sub>4</sub>	L <sub>1</sub>	L <sub>2</sub>	L <sub>3</sub>	L <sub>4</sub>	d <sub>1</sub> (2)	M <sub>1</sub>	H <sub>2</sub>	H <sub>3</sub>	W	H <sub>4</sub>	d <sub>3</sub>	d <sub>4</sub>	h				M	h <sub>1</sub> (3)	h <sub>2</sub>	E	F	Bolt size × ℓ	T <sub>0</sub>	T <sub>x</sub>	T <sub>y</sub>
MHT 30	○	1.28	4.82	42	7	31	90	72	9	113	52	80.6	123	-	M10	10	8	28	25	9	14	12	-	-	-	40	80	M 8×28	35 400	40 700	623	536 2 820	536 2 820	
LWHT 30...B	○																																	7
MHT 30...SL	○																																	9
LWHT 30...SL	○																																	
MHT 30...M*	-																																	
LWHT 30...M*	-																																	
MHT 30...MU*	-																																	
LWHT 30...MU*	-																																	
MHTG 30	○	1.69	4.82	42	7	31	90	72	9	113	52	80.6	123	-	M10	10	8	28	25	9	14	12	-	-	-	40	80	M 8×28	42 700	53 200	814	894 4 460	894 4 460	
LWHTG30	○																																	139
MHTL 30	○																																	185
MHT 35	○	1.79	6.85	48	8	33	100	82	9	123	62	86.2	135	-	M10	13	10	34	28	9	14	12	-	-	-	40	80	M 8×28	48 700	53 700	823	631 3 480	579 3 190	
LWHT 35...B	○																																	
LWHT 35...M*	-																																	
LWHT 35...MU*	-																																	
MHTG 35	○	2.35	6.85	48	10	33	100	82	9	151	62	114	163	-	M10	13	10	34	28	9	14	12	-	-	-	40	80	M 8×28	59 500	71 600	1 100	1 090 5 570	1 000 5 110	
LWHTG35	○																																	
MHTL 35	○	3.24	6.85	48	8	33	100	82	9	199	62	162.2	211	8.5	M10	13	10	34	28	9	14	12	-	-	-	40	80	M 8×28	76 700	103 000	1 580	2 200 10 400	2 010 9 490	

- Notes (1) Track rail lengths  $L$  are shown in Table 2.1 on page II-93, Table 2.2 on page II-94, and Tables 2.3 and 2.4 on page II-95.  
 (2) MHTL30 and MHTL35 can also be mounted in upward direction.  
 (3) Choose bolts whose dimension allow fixing thread depth into track rail to be less than  $h_1$ .  
 (4) The appended track rail mounting bolts are hexagon socket head bolts equivalent to JIS B 1176. For stainless steel model, stainless steel bolts are appended.  
 In an assembled set of MH series and LWHT...MU model, track rail mounting bolts are not appended.  
 (5) The direction of basic dynamic load rating ( $C$ ), basic static load rating ( $C_0$ ), and static moment rating ( $T_0$ ,  $T_x$ ,  $T_y$ ) are shown in the sketches below. The upper values of  $T_x$  and  $T_y$  are for one slide unit and the lower values are for two slide units in close contact.  
 (6) The shapes of grease nipple vary by size. The specifications are shown in Table 15 on page II-104.  
 Remark: The identification numbers with \* are our semi-standard items.

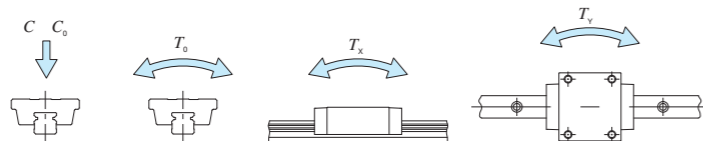

### Example of identification number of assembled set

Model code	Dimensions	Part code	Model code	Dust protection code	Material code	Preload symbol	Classification symbol	Interchangeable code	Supplemental code
MHT	G	35	C2	R1040		T1	P		N
1	2	3	4	5	6	7	8	9	10

① Model MHT LWHT (...B) Flange type mounting from top	⑤ Length of track rail (1,040 mm)	⑧ Preload amount No symbol Standard T1 Light preload T2 Medium preload T3 Heavy preload	⑩ Interchangeable No symbol Non-interchangeable specification S1 S1 specification S2 S2 specification
② Length of slide unit No symbol Standard G Long L Extra long	⑥ Dust protection code No symbol Standard specification M Ultra seal specification MU Ultra seal specification with track rail mounting from bottom	⑨ Accuracy class H High P Precision SP Super precision	⑪ Special specification A, BS, D, E, F, 1, J, L, LF, MA MN, N, PS, Q, RE, T, UR, V, W, Y, Z
③ Size 30, 35	⑦ Material type No symbol High carbon steel made SL Stainless steel made		
④ Number of slide unit (2)			

# IKO C-Lube Linear Way MH

## Flange type mounting from top

Shape	MHT · LWHT					
Size	8	10	12	15	20	25
	30	35	45	55	65	

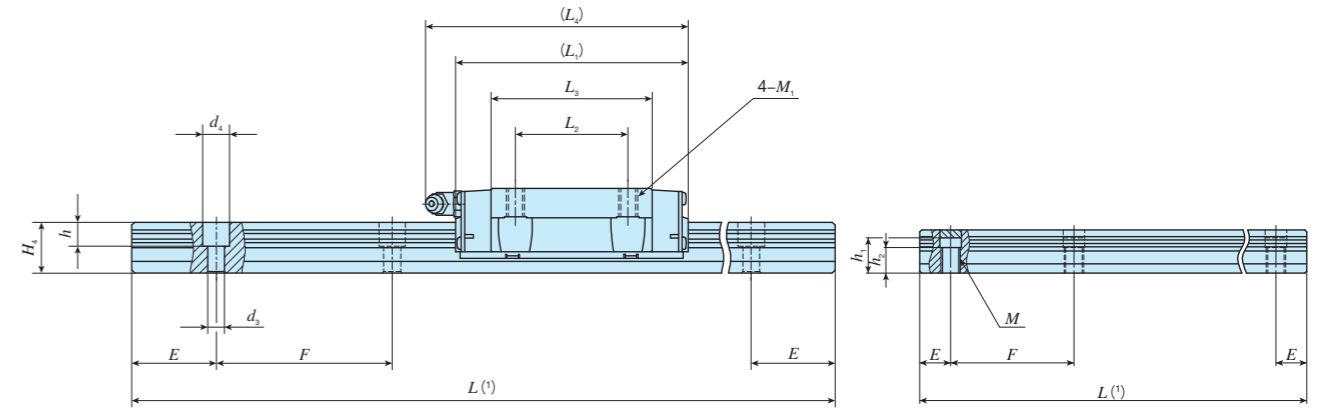
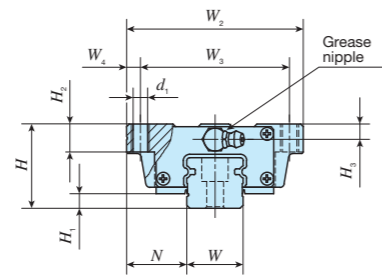

Identification number	Interchangeable	Mass (Ref.)		Dimensions of assembly mm			Dimensions of slide unit mm										Dimensions of track rail mm										Appended mounting bolt for track rail (4) mm	Basic dynamic load rating (5) C N	Basic static load rating (5) C0 N	Static moment rating (5)			
		Slide unit kg	Track rail kg/m	H	H1	N	W2	W3	W4	L1	L2	L3	L4	d1(2)	M1	H2	H3	H5	W	H4	d3	d4	h	M	h1(3)	h2				E	F	Bolt size × ℓ	T0 N·m
MHT 45	○	3.17	10.7	60	13	120	100	10	147	80	103.4	158	-	M12	15	13	-	45	34	14	20	17	-	-	-	52.5	105	M12×35	74 600	80 200	1 610	1 150	1 060
LWHT 45...B	○				10																												
LWHT 45...M*	-				37.5																												
MHTG 45	○	4.34	10.7	60	13	120	100	10	190	80	146.6	201	-	M12	15	13	-	45	34	14	20	17	-	-	-	52.5	105	M12×35	95 200	114 000	2 280	2 240	2 050
LWHTG45	○				10																												
MHTL 45	○	5.70	15.5	70	10	140	116	12	238	95	194.8	249	10.5	M14	17	14	-	53	41	16	23	20	-	-	-	60	120	M14×45	113 000	121 000	2 870	3 680	3 370
LWHT 55...B	○	5.30			13																							43.5					
LWHTG55	○	7.40	22.2	90	13	170	142	14	235	110	183.6	246	-	M14	17	14	-	53	41	16	23	20	-	-	-	60	120	M14×45	142 000	168 000	3 970	4 120	3 780
LWHT 65...B	○	12.3			14																							53.5					
LWHTG65	○	17.6	22.2	90	14	170	142	14	303	110	238.8	313	-	M16	23	20	-	63	48	18	26	22	-	-	-	75	150	M16×50	229 000	269 000	7 560	8 530	7 810
LWHTG65	○	17.6			14																							53.5					

- Notes (1) Track rail lengths  $L$  are shown in Table 2.1 on page II-93 and Tables 2.3 and 2.4 on page II-95.  
 (2) MHTL45 can also be mounted in upward direction.  
 (3) Choose bolts whose dimension allow fixing thread depth into track rail to be less than  $h_1$ .  
 (4) The appended track rail mounting bolts are hexagon socket head bolts equivalent to JIS B 1176.  
 In an assembled set of MH series and LWHT...MU model, track rail mounting bolts are not appended.  
 (5) The direction of basic dynamic load rating ( $C$ ), basic static load rating ( $C_0$ ), and static moment rating ( $T_0$ ,  $T_x$ ,  $T_y$ ) are shown in the sketches below. The upper values of  $T_x$  and  $T_y$  are for one slide unit and the lower values are for two slide units in close contact.  
 Remarks 1. The specifications of grease nipple are shown in Table 15 on page II-104.  
 2. The identification numbers with \* are our semi-standard items.

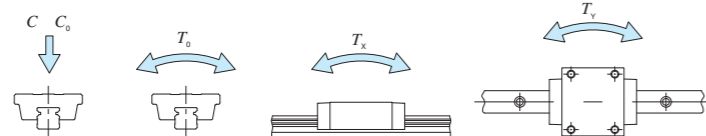

**Example of identification number of assembled set**

Model code: MHT G 45 C2 R1260 T1 P N

Dimensions: G 45 C2 R1260

Part code: T1 P N

Model code: MHT G 45 C2 R1260

Dust protection code: T1

Preload symbol: P

Classification symbol: N

Interchangeable code: N

Supplemental code: N

① Model MHT LWHT (...B) Flange type mounting from top	⑤ Length of track rail (1,260 mm)	⑦ Preload amount No symbol Standard T1 Light preload T2 Medium preload T3 Heavy preload	⑨ Interchangeable No symbol Non-interchangeable specification S1 S1 specification S2 S2 specification
② Length of slide unit No symbol Standard G Long L Extra long	⑥ Dust protection code No symbol Standard specification M Ultra seal specification MU Ultra seal specification with track rail mounting from bottom	⑧ Accuracy class H High P Precision SP Super precision	⑩ Special specification A, BS, D, E, F, 1, J, L, LF, MA MN, N, PS, Q, RE, T, V, W, Y, Z
③ Size 45, 55, 65	④ Number of slide unit (2)		

# IKO C-Lube Linear Way MH

## Block type mounting from top

Shape	MHD · LWHD				
Size	8	10	12	15	25
	30	35	45	55	65

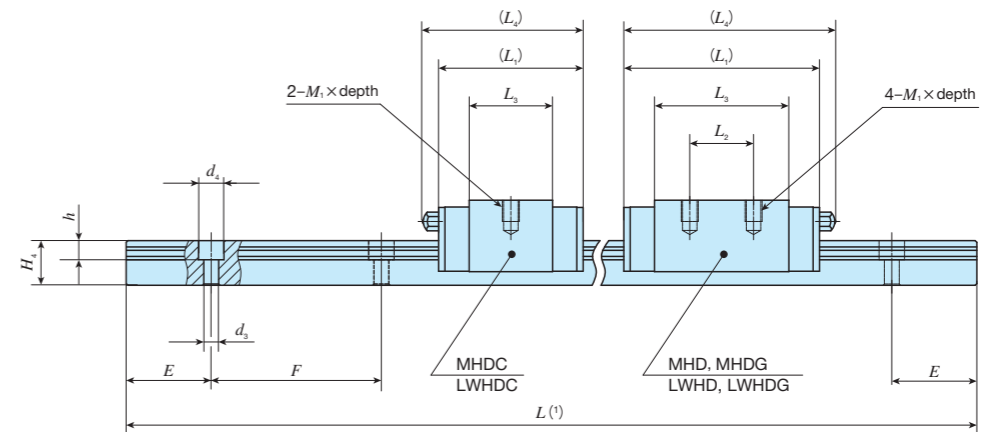
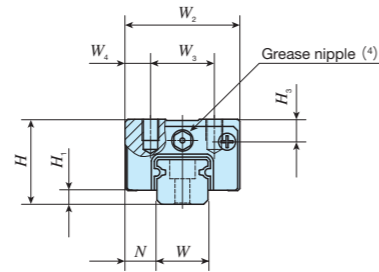

Identification number	Interchangeable	Mass (Ref.)		Dimensions of assembly mm			Dimensions of slide unit mm							Dimensions of track rail mm						Appended mounting bolt for track rail (2) mm	Basic dynamic load rating (3) N	Basic static load rating (3) N	Static moment rating (3)																						
		Slide unit kg	Track rail kg/m	H	H <sub>1</sub>	N	W <sub>2</sub>	W <sub>3</sub>	W <sub>4</sub>	L <sub>1</sub>	L <sub>2</sub>	L <sub>3</sub>	L <sub>4</sub>	M <sub>1</sub> × depth	H <sub>3</sub>	W	H <sub>4</sub>	d <sub>3</sub>	d <sub>4</sub>				h	E	F	Bolt size × ℓ	C	C <sub>0</sub>	T <sub>0</sub>	T <sub>x</sub>	T <sub>y</sub>														
MHDC 8...SL	LWHDC 8...SL	○	0.008	0.32	11	2.1	4	16	10	3	18	—	9.0	—	M2 × 2.5	3	8	6	2.4	4.2	2.3	10	20	M2 × 8	1 050	1 270	5.3	2.2	1.8																
MHD 8...SL	LWHD 8...SL	○	0.013								24	10	15.3												—	—	—	—	—	—	—	—	—	—	—	—	—	—	—	—	—	—	—	—	—
MHDG 8...SL	LWHDG 8...SL	○	0.018								30.5	10	21.7												—	—	—	—	—	—	—	—	—	—	—	—	—	—	—	—	—	—	—	—	—
MHDC 10...SL	LWHDC 10...SL	○	0.018	0.47	13	2.4	5	20	13	3.5	24	—	13.4	—	M2.6 × 3	3.5	10	7	3.5	6	3.5	12.5	25	M3 × 8	1 920	2 350	12.2	5.8	4.8																
MHD 10...SL	LWHD 10...SL	○	0.026								32	12	21.4												—	—	—	—	—	—	—	—	—	—	—	—	—	—	—	—	—	—	—	—	—
MHDG 10...SL	LWHDG 10...SL	○	0.035								40	12	29.4												—	—	—	—	—	—	—	—	—	—	—	—	—	—	—	—	—	—	—	—	—
MHDC 12...SL	LWHDC 12...SL	○	0.057	0.86	20	3.2	7.5	27	15	6	34	—	19.6	—	M4 × 5	5	12	10.5	3.5	6	4.5	20	40	M3 × 12	4 560	5 300	32.8	19.4	16.3																
MHD 12	LWHD 12	○	0.089								46	15	31.6												50	—	—	—	—	—	—	—	—	—	—	—	—	—	—	—	—	—	—	—	—
MHDG 12...SL	LWHDG 12...SL	○	0.115								58	15	43.6												62	—	—	—	—	—	—	—	—	—	—	—	—	—	—	—	—	—	—	—	—
MHDG 12...SL	LWHDG 12...SL	○	0.118	—	—	—	—	—	—	—	—	—	—	—	—	—	—	—	—	—	—	—	—	—	—	—	—	—																	

Notes (1) Track rail lengths  $L$  are shown in Table 2.1 on page II-93 and Table 2.2 on page II-94.

(2) The appended track rail mounting bolts are hexagon socket head bolts equivalent to JIS B 1176. For stainless steel model, stainless steel bolts are appended.

In an assembled set of MH series, track rail mounting bolts are not appended.

(3) The direction of basic dynamic load rating ( $C$ ), basic static load rating ( $C_0$ ), and static moment rating ( $T_0$ ,  $T_x$ ,  $T_y$ ) are shown in the sketches below. The upper values of  $T_x$  and  $T_y$  are for one slide unit and the lower values are for two slide units in close contact.

(4) Series of size 8 and 10 are provided with an oil hole. The specifications of oil holes are shown in Table 14 on page II-104. The specification of grease nipple for size 12 is shown in Table 15 on page II-104.

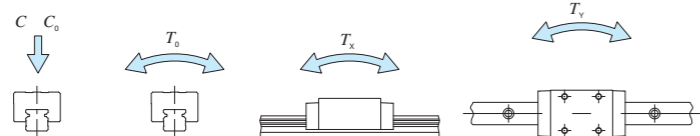

### Example of identification number of assembled set

Model code	Dimensions	Part code	Material code	Preload symbol	Classification symbol	Interchangeable code	Supplemental code
MHD	G	12	C2	R320	SL	T1	P
1	2	3	4	5	6	7	8
							9
							10

① Model MHD LWHD Block type mounting from top	④ Number of slide unit (2)	⑦ Preload amount T <sub>0</sub> Clearance No symbol Standard T <sub>1</sub> Light preload	⑩ Interchangeable No symbol Non-interchangeable specification S1 S1 specification S2 S2 specification
② Length of slide unit C Short No symbol Standard G Long	⑤ Length of track rail (320 mm)	⑧ Accuracy class H High P Precision	⑪ Special specification A, D, E, F, I, LR, MA MN, N, Q, U, W, Y
③ Size 8, 10, 12	⑥ Material type No symbol High carbon steel made SL Stainless steel made		

# IKO C-Lube Linear Way MH

## Block type mounting from top

Shape	MHD · LWHD				
Size	8	10	12	15	25
	30	35	45	55	65

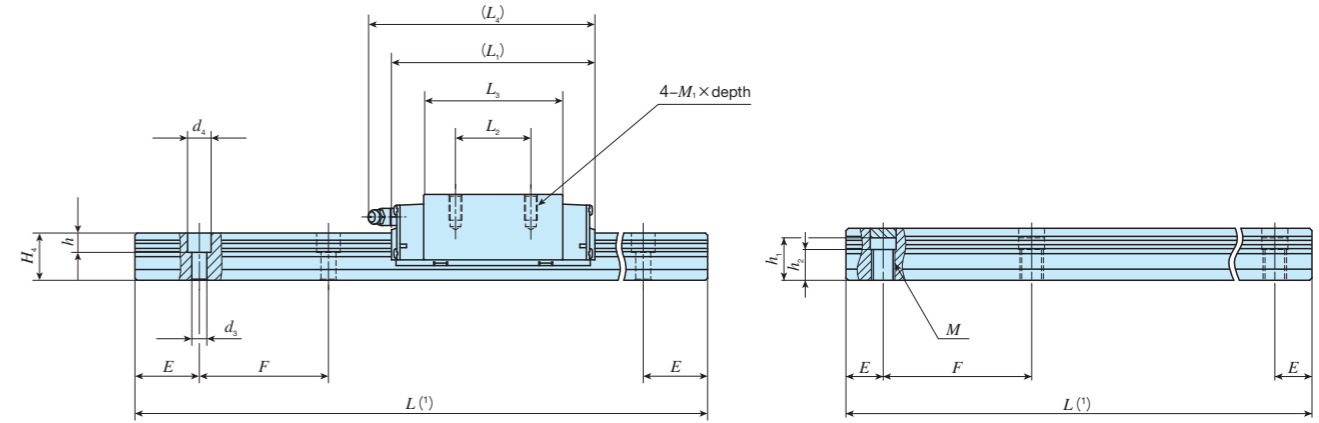
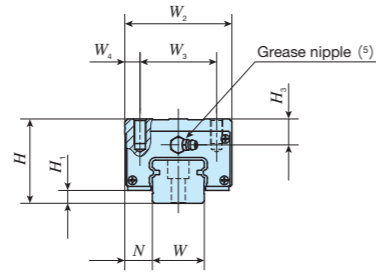

Ultra seal specification with track rail mounting from bottom

Identification number	Interchangeable	Mass (Ref.)		Dimensions of assembly mm			Dimensions of slide unit mm								Dimensions of track rail mm										Appended mounting bolt for track rail (3) mm	Basic dynamic load rating (4) C N	Basic static load rating (4) C0 N	Static moment rating (4) N·m			
		Slide unit kg	Track rail kg/m	H	H1	N	W2	W3	W4	L1	L2	L3	L4	M1×depth	H3	W	H4	d3	d4	h	M	h1(2)	h2	E				F	T0	Tx	Ty
MHD 15	○	0.23	1.47	28	4.5	9.5	34	26	4	66	26	44.2	69	M4×10	8.5	15	15	4.5	8	6	-	-	-	30	60	M4×16	11 600	13 400	112	95.6 556	95.6 556
LWHD 15···B	○																														
LWHD 15···M*	-																														
MHD 25	○	0.65	3.50	40	6.5	12.5	48	35	6.5	95	35	63.9	105	M6×12	10.5	23	22	7	11	9	-	-	-	30	60	M6×22	25 200	28 800	362	309 690	309 690
LWHD 25···B	○																														
LWHD 25···M*	-																														
LWHD 25···MU*	-																														
LWHD 25···MU*	-																														
MHDG 25	○	0.80	LWHDG25	9	7	16	60	40	10	118	50	86.6	128	M8×16	11	28	25	9	14	12	-	-	-	40	80	M8×28	35 400	40 700	623	536 2 820	536 2 820
MHD 30	○																														
MHD 30···M*	-	1.12	4.82	45	7	16	60	40	10	113	40	80.6	123	M8×16	11	28	25	-	-	-	M12	20	13	40	80	-	42 700	53 200	814	894 4 460	894 4 460
MHD 30···MU*	-																														
LWHD 30···MU*	-																														
MHDG 30	○	1.44	LWHDG30	9	7	16	60	40	10	139	60	106.6	149	M8×16	11	28	25	9	14	12	-	-	-	40	80	M8×28	42 700	53 200	814	894 4 460	894 4 460
MHD 30	○																														
MHDL 30	○	1.92	-	7	7	16	60	40	10	185	60	152.2	194	M8×16	11	28	25	9	14	12	-	-	-	40	80	M8×28	54 400	75 100	1 150	1 740 8 240	1 740 8 240

Notes (1) Track rail lengths  $L$  are shown in Table 2.1 on page II-93 and Tables 2.3 and 2.4 on page II-95.  
 (2) Choose bolts whose dimension allow fixing thread depth into track rail to be less than  $h_1$ .  
 (3) The appended track rail mounting bolts are hexagon socket head bolts equivalent to JIS B 1176. In an assembled set of MH series and LWHD···MU model, track rail mounting bolts are not appended.  
 (4) The direction of basic dynamic load rating ( $C$ ), basic static load rating ( $C_0$ ), and static moment rating ( $T_0$ ,  $T_x$ ,  $T_y$ ) are shown in the sketches below. The upper values of  $T_x$  and  $T_y$  are for one slide unit and the lower values are for two slide units in close contact.  
 (5) The shapes of grease nipple vary by size. The specifications are shown in Table 15 on page II-104.

Remark: The identification numbers with \* are our semi-standard items.

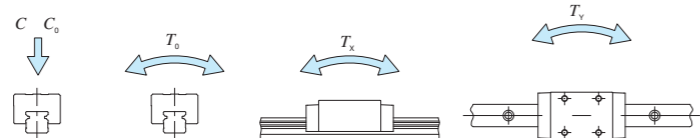

### Example of identification number of assembled set

Model code	Dimensions	Part code	Model code	Dust protection code	Preload symbol	Classification symbol	Interchangeable code	Supplemental code
MHD	G	25	C2	R840		T1	P	N
1	2	3	4	5	6	7	8	9

① Model MHD LWHD(···B) Block type mounting from top	④ Number of slide unit (2)	⑦ Preload amount No symbol Standard T1 Light preload T2 Medium preload T3 Heavy preload	⑩ Interchangeable No symbol Non-interchangeable specification S1 S1 specification S2 S2 specification
② Length of slide unit No symbol Standard G Long L Extra long	⑤ Length of track rail (840 mm)	⑧ Accuracy class H High P Precision SP Super precision	⑨ Special specification A, BS, D, E, F, I, J, L, LF, MA MN, N, PS, Q, RE, T, UR, V, W, Y, Z
③ Size 15, 25, 30	⑥ Dust protection code No symbol Standard specification M Ultra seal specification MU Ultra seal specification with track rail mounting from bottom		

# IKO C-Lube Linear Way MH

## Block type mounting from top

Shape	MHD · LWHD				
Size	8	10	12	15	25
	30	35	45	55	65

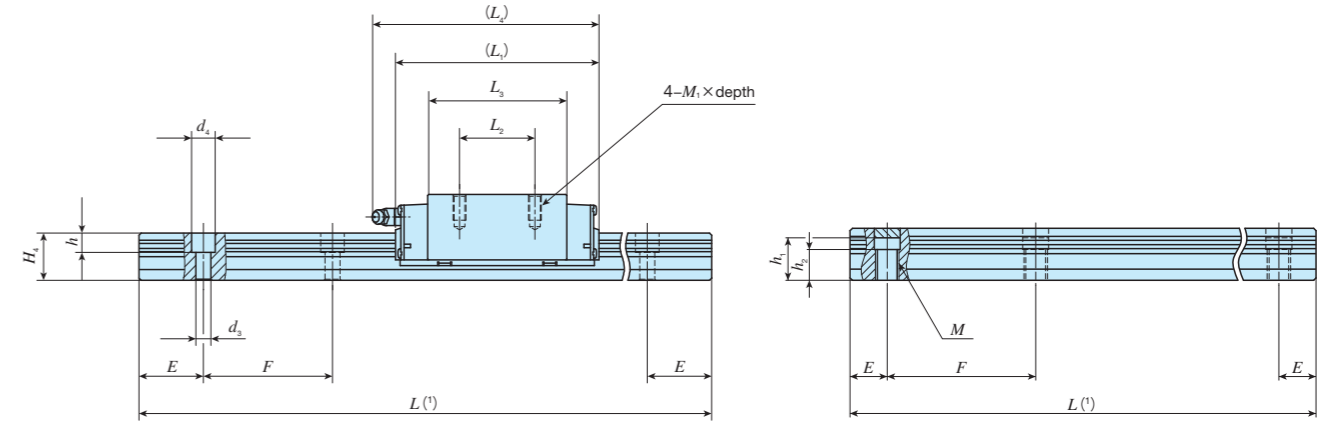
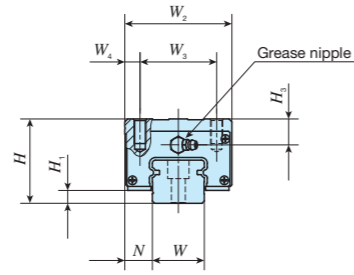

Ultra seal specification with track rail mounting from bottom

Identification number	Interchangeable	Mass (Ref.)		Dimensions of assembly mm		Dimensions of slide unit mm										Dimensions of track rail mm										Appended mounting bolt for track rail (3) mm	Basic dynamic load rating (4) C N	Basic static load rating (4) C0 N	Static moment rating (4) N·m		
		Slide unit kg	Track rail kg/m	H	H1	N	W2	W3	W4	L1	L2	L3	L4	M1 × depth	H3	W	H4	d3	d4	h	M	h1(2)	h2	E	F				Bolt size × ℓ	T0	Tx
MHD 35	○	1.74	6.85	55	10	70	50	10	123	50	86.2	135	M 8×16	17	34	28	9	14	12	-	-	-	40	80	M 8×28	48 700	53 700	823	631 3 480	579 3 190	
LWHD 35...B	○				8																										
LWHD 35...M*	-				18																										
MHDG 35	○	2.26	6.85	55	10	70	50	10	151	72	114	163	M 8×16	17	34	28	9	14	12	-	-	-	40	80	M 8×28	59 500	71 600	1 100	1 090 5 570	1 000 5 110	
LWHDG35	○				8																										
MHDL 35	○	3.08	6.85	55	9	70	50	10	199	72	162.2	211	M 8×16	17	34	28	9	14	12	-	-	-	40	80	-	59 500	71 600	1 100	1 090 5 570	1 000 5 110	
MHD 45	○	3.30	10.7	70	13	86	60	13	147	60	103.4	158	M10×20	23	45	34	14	20	17	-	-	-	52.5	105	M12×35	74 600	80 200	1 610	1 150 6 190	1 060 5 690	
LWHD 45...B	○				14																										
LWHD 45...M*	-				10																										
MHDG 45	○	4.57	10.7	70	13	86	60	13	190	80	146.6	201	M10×20	23	45	34	14	20	17	-	-	-	52.5	105	M12×35	95 200	114 000	2 280	2 240 11 100	2 050 10 200	
LWHDG45	○				14																										
MHDL 45	○	5.85	10.7	70	12	86	60	13	238	80	194.8	249	M10×20	23	45	34	14	20	17	-	-	-	52.5	105	-	114 000	147 000	2 960	3 680 17 800	3 370 16 300	
LWHD 55...B	○	5.36	15.5	80	17	23.5	100	75	12.5	183	75	132	194	M12×25	24	53	41	16	23	20	-	-	-	60	120	M14×45	113 000	121 000	2 870	2 210 11 600	2 030 10 600
LWHDG55	○	7.20																								235					
LWHD 65...B	○	9.80	22.2	90	18	31.5	126	76	25	229	70	164	239	M16×30	20	63	48	18	26	22	-	-	-	75	150	M16×50	176 000	184 000	5 180	4 130 22 000	3 790 20 200
LWHDG65	○	14.3																								303					

Notes (1) Track rail lengths  $L$  are shown in Table 2.1 on page II-93 and Tables 2.3 and 2.4 on page II-95.  
 (2) Choose bolts whose dimension allow fixing thread depth into track rail to be less than  $h_1$ .  
 (3) The appended track rail mounting bolts are hexagon socket head bolts equivalent to JIS B 1176. In an assembled set of MH series and LWHD...MU model, track rail mounting bolts are not appended.  
 (4) The direction of basic dynamic load rating ( $C$ ), basic static load rating ( $C_0$ ), and static moment rating ( $T_0$ ,  $T_x$ ,  $T_y$ ) are shown in the sketches below. The upper values of  $T_x$  and  $T_y$  are for one slide unit and the lower values are for two slide units in close contact.  
 Remarks 1. The specifications of grease nipple are shown in Table 15 on page II-104.  
 2. The identification numbers with \* are our semi-standard items.

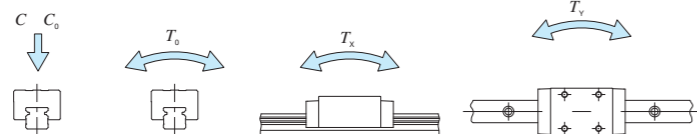

### Example of identification number of assembled set

Model code	Dimensions	Part code	Model code	Dust protection code	Preload symbol	Classification symbol	Interchangeable code	Supplemental code
MHD	G	45	C2	R1260	T1	P	N	
1	2	3	4	5	6	7	8	9

① Model MHD LWHD(...B) Block type mounting from top	④ Number of slide unit (2)	⑦ Preload amount No symbol Standard T1 Light preload T2 Medium preload T3 Heavy preload	⑩ Interchangeable No symbol Non-interchangeable specification S1 S1 specification S2 S2 specification
② Length of slide unit No symbol Standard G Long L Extra long	⑤ Length of track rail (1,260 mm)	⑧ Accuracy class H High P Precision SP Super precision	⑨ Special specification A, D, E, F, I, J, L, LF, MA MN, N, PS, Q, T, V, W, Y, Z
③ Size 35, 45, 55, 65	⑥ Dust protection code No symbol Standard specification M Ultra seal specification MU Ultra seal specification with track rail mounting from bottom		



# IKO C-Lube Linear Way MH

Compact block type mounting from top

Shape	MHS · LWHS			
Size	15	20	25	30

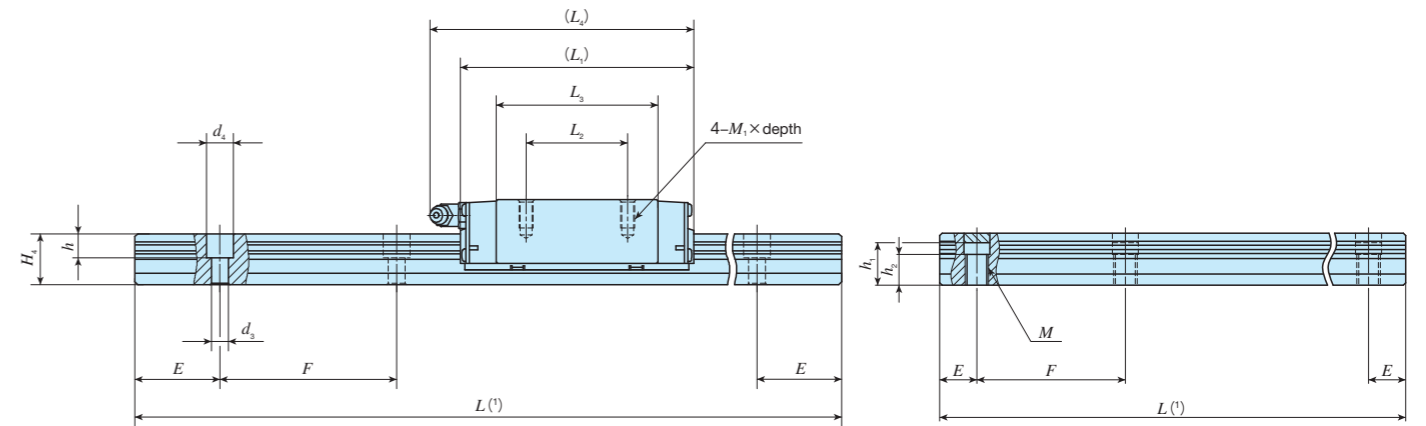
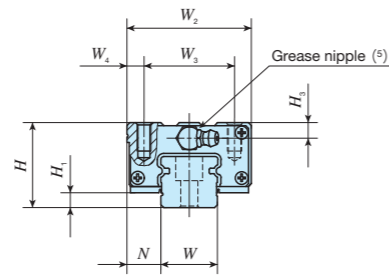

Identification number	Interchangeable	Mass (Ref.)		Dimensions of assembly mm			Dimensions of slide unit mm							Dimensions of track rail mm							Appended mounting bolt for track rail (3) mm	Basic dynamic load rating (4) C N	Basic static load rating (4) C0 N	Static moment rating (4) N·m							
		Slide unit kg	Track rail kg/m	H	H1	N	W2	W3	W4	L1	L2	L3	L4	M1×depth	H3	W	H4	d3	d4	h				M	h1(2)	h2	E	F	T0	Tx	Ty
MHS 15	○	0.18	1.47	24	4.5	9.5	34	26	4	66	26	44.2	69	M4×8	4.5	15	15	4.5	8	6	-	-	-	30	60	M4×16	11 600	13 400	112	95.6 556	95.6 556
LWHS 15···B	○											44.6																			
MHS 15···SL	○											44.2																			
LWHS 15···SL	○											44.6																			
LWHS 15···M*	-											-																			
LWHS 15···MU*	-	-																													
MHSG 15	○	0.25	-	-	-	-	-	-	-	82	-	60.1	85	-	-	-	4.5	8	6	-	-	-	-	-	M4×16	14 400	18 300	153	172 918	172 918	
MHS 20	○	0.36	2.56	30	5	12	44	32	6	83	36	56	94	M5×10	5.5	20	18	6	9.5	8.5	-	-	-	30	60	M5×18	18 100	21 100	232	195 1 090	195 1 090
LWHS 20···B	○											57.2																			
MHS 20···SL	○											56																			
LWHS 20···SL	○											57.2																			
LWHS 20···M*	-											-																			
LWHS 20···MU*	-	-																													
MHSG 20	○	0.53	-	-	-	-	-	-	-	112	50	84.8 86	122	-	-	-	6	9.5	8.5	-	-	-	-	-	M5×18	24 100	31 700	349	421 2 140	421 2 140	

Notes (1) Track rail lengths  $L$  are shown in Table 2.1 on page II-93, Table 2.2 on page II-94, and Tables 2.3 and 2.4 on page II-95.  
 (2) Choose bolts whose dimension allow fixing thread depth into track rail to be less than  $h_1$ .  
 (3) The appended track rail mounting bolts are hexagon socket head bolts equivalent to JIS B 1176. For stainless steel model, stainless steel bolts are appended.  
 In an assembled set of MH series and LWHS···MU model, track rail mounting bolts are not appended.  
 (4) The direction of basic dynamic load rating ( $C$ ), basic static load rating ( $C_0$ ), and static moment rating ( $T_0$ ,  $T_x$ ,  $T_y$ ) are shown in the sketches below. The upper values of  $T_x$  and  $T_y$  are for one slide unit and the lower values are for two slide units in close contact.  
 (5) The shapes of grease nipple vary by size. The specifications are shown in Table 15 on page II-104.  
 Remark: The identification numbers with \* are our semi-standard items.

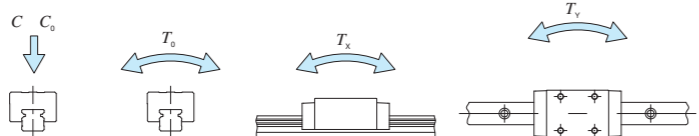

**Example of identification number of assembled set**

Model code	Dimensions	Part code	Model code	Dust protection code	Material code	Preload symbol	Classification symbol	Interchangeable code	Supplemental code
MHS	G	20	C2	R480		T1	P		N
1	2	3	4	5	6	7	8	9	10

① Model	⑤ Length of track rail (480 mm)	⑧ Preload amount	⑩ Interchangeable
MHS Compact block type mounting from top	⑥ Dust protection code	No symbol Standard	No symbol Non-interchangeable specification
LWHS(···B)	No symbol Standard specification	T1 Light preload	S1 S1 specification
② Length of slide unit	M Ultra seal specification	T2 Medium preload	S2 S2 specification
No symbol Standard	MU Ultra seal specification with track rail mounting from bottom	T3 Heavy preload	
G Long			
③ Size	⑦ Material type	⑨ Accuracy class	⑪ Special specification
15, 20	No symbol High carbon steel made	H High	A, BS, D, E, F, 1, J, L, LF, MA
④ Number of slide unit (2)	SL Stainless steel made	P Precision	MN, N, Q, RE, T, V, W, Y, Z
		SP Super precision	

MH · LWHS

# IKO C-Lube Linear Way MH

Compact block type mounting from top

Shape	MHS · LWHS			
Size	15	20	25	30

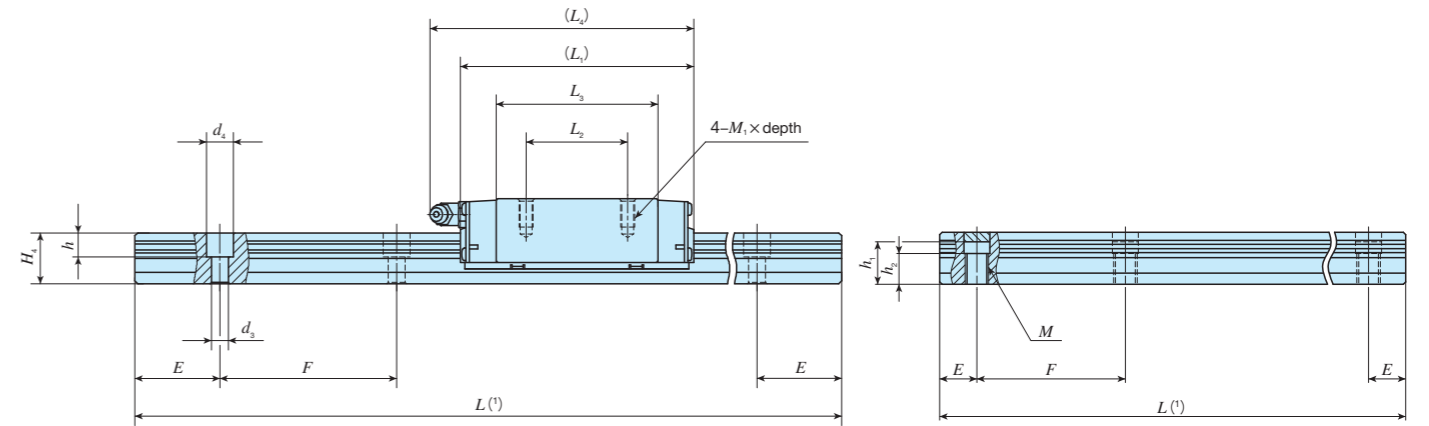
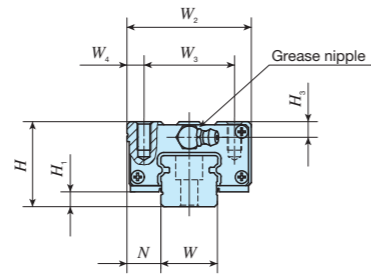

Ultra seal specification with track rail mounting from bottom

Identification number	Interchangeable	Mass (Ref.)		Dimensions of assembly mm			Dimensions of slide unit mm							Dimensions of track rail mm								Appended mounting bolt for track rail (3) mm	Basic dynamic load rating (4) C N	Basic static load rating (4) C0 N	Static moment rating (4) N·m						
		Slide unit kg	Track rail kg/m	H	H1	N	W2	W3	W4	L1	L2	L3	L4	M1×depth	H3	W	H4	d3	d4	h	M				h1(2)	h2	E	F	T0	Tx	Ty
MHS 25	○	0.55	3.50	36	6.5	12.5	48	35	6.5	95	35	63.9	105	M6×12	6.5	23	22	7	11	9	-	-	-	30	60	M6×22	25 200	28 800	362	1 309	1 690
LWHS 25...B	○											64.7																			
MHS 25...SL	○											63.9																			
LWHS 25...SL	○											64.7																			
MHS 25...M*	-											63.9																			
LWHS 25...M*	-											64.7																			
MHS 25...MU*	-	63.9																													
LWHS 25...MU*	-	64.7																													
MHSG 25	○	0.67								118	50	86.6	128												M6×22	30 800	38 300	483	533	2 740	
LWHS 25	○											87.4																			
MHS 30	○	1.00	4.82	42	7	16	60	40	10	113	40	80.6	123	M8×16	8	28	25	9	14	12	-	-	-	40	80	M8×28	35 400	40 700	623	536	2 820
LWHS 30...B	○											9																			
MHS 30...SL	○											7																			
LWHS 30...SL	○											9																			
MHS 30...M*	-											7																			
LWHS 30...M*	-											7																			
MHS 30...MU*	-	7																													
LWHS 30...MU*	-	7																													
MHSG 30	○	1.29								139	60	106.6	149												M8×28	42 700	53 200	814	894	4 460	
LWHS 30	○											9																			
LWHS 30	○	7																													

Notes (1) Track rail lengths  $L$  are shown in Table 2.1 on page II-93, Table 2.2 on page II-94, and Tables 2.3 and 2.4 on page II-95.  
 (2) Choose bolts whose dimension allow fixing thread depth into track rail to be less than  $h_1$ .  
 (3) The appended track rail mounting bolts are hexagon socket head bolts equivalent to JIS B 1176. For stainless steel model, stainless steel bolts are appended.  
 In an assembled set of MH series and LWHS...MU model, track rail mounting bolts are not appended.  
 (4) The direction of basic dynamic load rating ( $C$ ), basic static load rating ( $C_0$ ), and static moment rating ( $T_0$ ,  $T_x$ ,  $T_y$ ) are shown in the sketches below. The upper values of  $T_x$  and  $T_y$  are for one slide unit and the lower values are for two slide units in close contact.  
 Remarks 1. The specifications of grease nipple are shown in Table 15 on page II-104.  
 2. The identification numbers with \* are our semi-standard items.

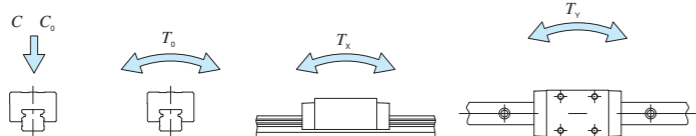

### Example of identification number of assembled set

Model code	Dimensions	Part code	Model code	Dust protection code	Material code	Preload symbol	Classification symbol	Interchangeable code	Supplemental code
MHS	G	30	C2	R480		T1	P		N
1	2	3	4	5	6	7	8	9	10

① Model MHS LWHS(...B)	Compact block type mounting from top	⑤ Length of track rail (480 mm)	⑧ Preload amount No symbol Standard T1 Light preload T2 Medium preload T3 Heavy preload	⑩ Interchangeable No symbol Non-interchangeable specification S1 S1 specification S2 S2 specification
② Length of slide unit No symbol Standard G Long	⑥ Dust protection code No symbol Standard specification M Ultra seal specification MU Ultra seal specification with track rail mounting from bottom	⑦ Material type No symbol High carbon steel made SL Stainless steel made	⑨ Accuracy class H High P Precision SP Super precision	⑪ Special specification A, BS, D, E, F, 1, J, L, LF, MA MN, N, PS, Q, RE, T, UR, V, W, Y, Z

MH · LWHS

# IKO C-Lube Linear Way MH

Side mounting type			
Shape	LWHY		
Size	15	20	25
	30	35	45

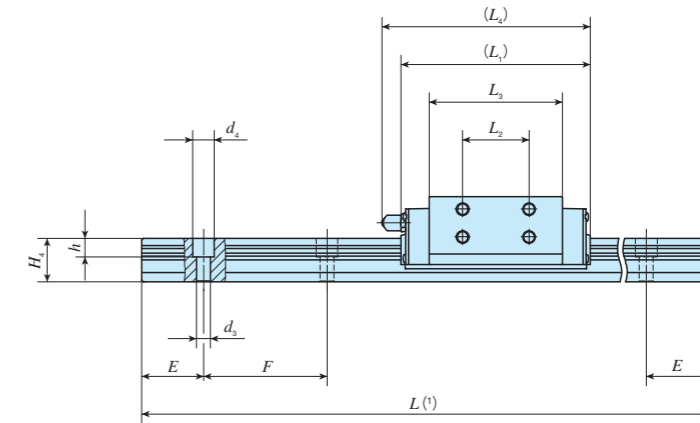
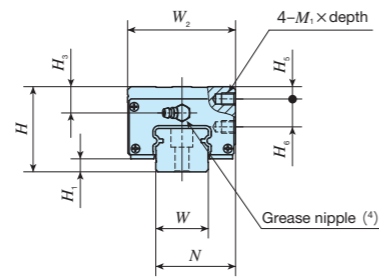

Identification number		Interchangeable	Mass (Ref.)		Dimensions of assembly mm			Dimensions of slide unit mm							Dimensions of track rail mm						Appended mounting bolt for track rail (2) mm	Basic dynamic load rating (3) N	Basic static load rating (3) N	Static moment rating (3)					
MH series	LWH series (No C-Lube)		Slide unit kg	Track rail kg/m	H	H1	N	W2	L1	L2	L3	L4	M1 x depth	H3	H5	H6	W	H4	d3	d4				h	E	F	Bolt size x l	C	C0
-	LWHY 15*	-	0.23	1.47	28	4.5	24.3	34	66	18	44.6	69	M 4 x 4	8.5	4	9	15	15	4.5	8	6	30	60	M 4 x 16	9 360	13 900	116	99.2	99.2
-	LWHY 20*	-	0.36	2.56	30	5	31.5	43.7	83	25	57.2	94	M 5 x 5	5.5	4	10	20	18	6	9.5	8.5	30	60	M 5 x 18	14 500	21 900	241	202	202
-	LWHY 25*	-	0.65	3.50	40	6.5	35	47.7	95	30	64.7	105	M 6 x 6	10.5	6	12	23	22	7	11	9	30	60	M 6 x 22	20 100	29 800	376	320	320
-	LWHY 30*	-	1.12	4.82	45	7	43.5	59.7	113	40	80.6	123	M 6 x 7	11	8	14	28	25	9	14	12	40	80	M 8 x 28	28 100	42 200	646	556	556
-	LWHY 35*	-	1.74	6.85	55	8	51.5	69.7	123	43	86.2	135	M 8 x 9	17	8	18	34	28	9	14	12	40	80	M 8 x 28	31 200	43 500	878	665	601
-	LWHY 45*	-	3.30	10.7	70	10	65	85.7	147	55	103.4	158	M10 x 11	23	10	22	45	34	14	20	17	52.5	105	M12 x 35	47 600	65 000	1 720	1 200	1 100

Notes (1) Track rail lengths  $L$  are shown in Table 2.1 on page II-93.  
 (2) The appended track rail mounting bolts are hexagon socket head bolts equivalent to JIS B 1176.  
 (3) The direction of basic dynamic load rating ( $C$ ), basic static load rating ( $C_0$ ), and static moment rating ( $T_0$ ,  $T_x$ ,  $T_y$ ) are shown in the sketches below. The upper values of  $T_x$  and  $T_y$  are for one slide unit and the lower values are for two slide units in close contact.  
 (4) The shapes of grease nipple vary by size. The specifications are shown in Table 15 on page II-104.  
 Remark: The identification numbers with \* are our semi-standard items.

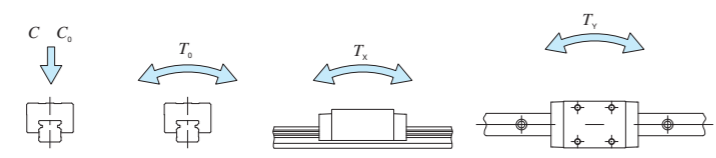

**Example of identification number of assembled set**

Model code	Dimensions	Part code	Preload symbol	Classification symbol	Supplemental code
LWHY	30	C2 R480	T1	P	/N
①	②	③	④	⑤	⑥

① Model  
LWHY Side mounting type

② Size  
15, 20, 25, 30, 35, 45

③ Number of slide unit (2)

④ Length of track rail (480 mm)

⑤ Preload amount  
No symbol Standard  
T1 Light preload  
T2 Medium preload  
T3 Heavy preload

⑥ Accuracy class  
H High  
P Precision  
SP Super precision

⑦ Special specification  
A, E, F, I, L, LF, MA, N, PS, RE, Y, Z

## Linear Way F



# Linear Way F

# LWFF

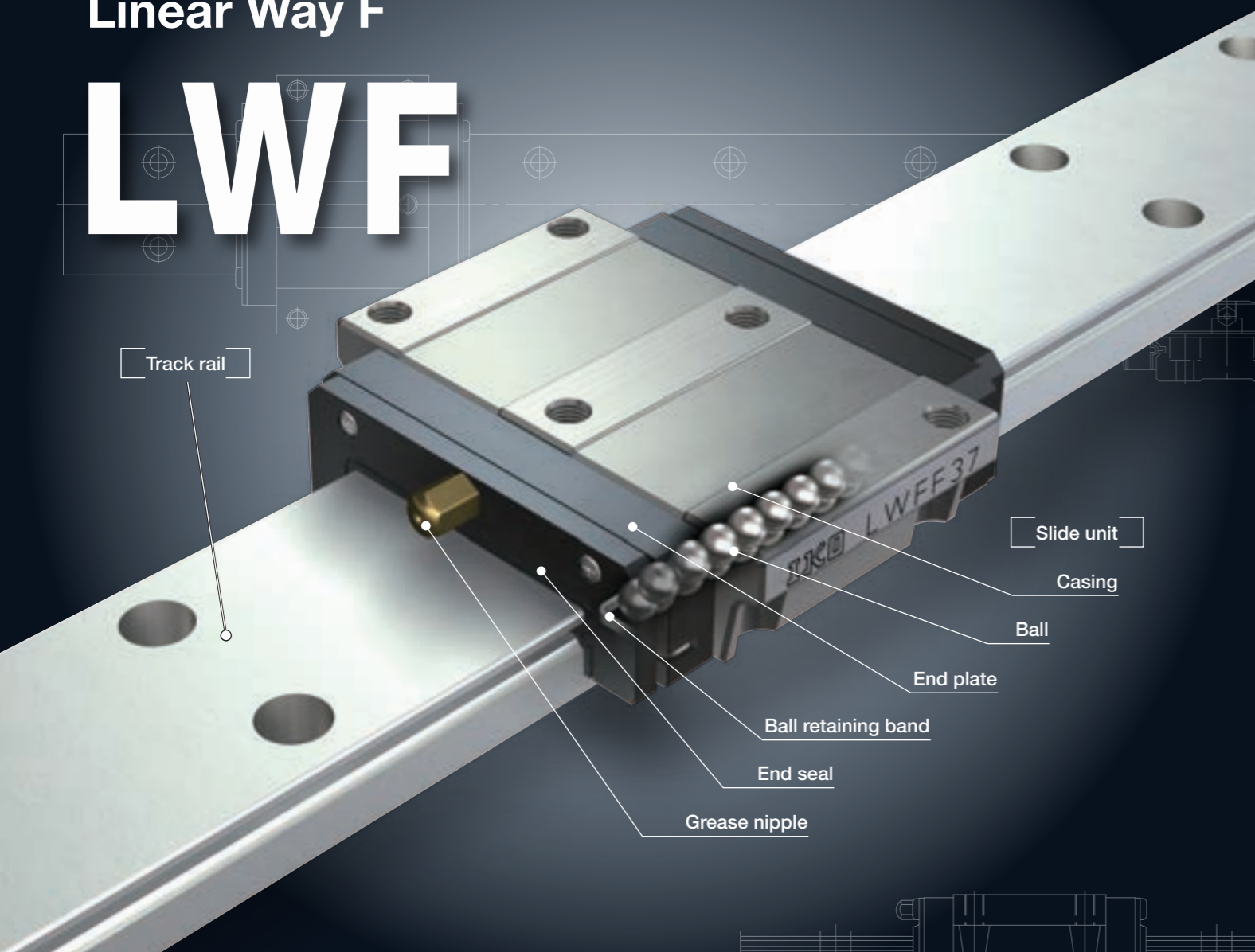

## Points

### 1 Wide rail type series resistant to moment load

As track rail width is wide and distance between moment load points is long, this is a linear motion rolling guide resistant to moment load and complex load and suitable for serial use.

### 2 Slide unit shapes for various usage

As the lineup of three types of slide unit shape including two flange types with different dimensional series and block type with small width are available, you can select an optimal product for the specifications of your machine and device.

### 3 Stainless steel selections superior in corrosion resistance are listed on lineup. For details P.I-41

Products made of stainless steel are highly resistant to corrosion, so that they are suitable for applications where rust prevention oil is not preferred, such as in a cleanroom environment.

## Identification Number and Specification

### Example of an identification number

The specification of LWF series is indicated by the identification number. Indicate the identification number, consisting of a model code, dimensions, a part code, a material code, a preload symbol, a classification symbol, an interchangeable code, and any supplemental codes for each specification to apply.

	1	2	3	4	5	6	7	8	9
<b>Non-interchangeable specification</b>									
Assembled set	LWFF	37	C1	R800		T <sub>1</sub>	P		/FZ
<b>Interchangeable specification</b>									
Single slide unit	LWFF	37	C1			T <sub>1</sub>	P	S1	/Z
Single track rail <sup>(1)</sup>	LWFF	37		R800			P	S1	/F
Assembled set	LWFF	37	C1	R800		T <sub>1</sub>	P	S1	/FZ

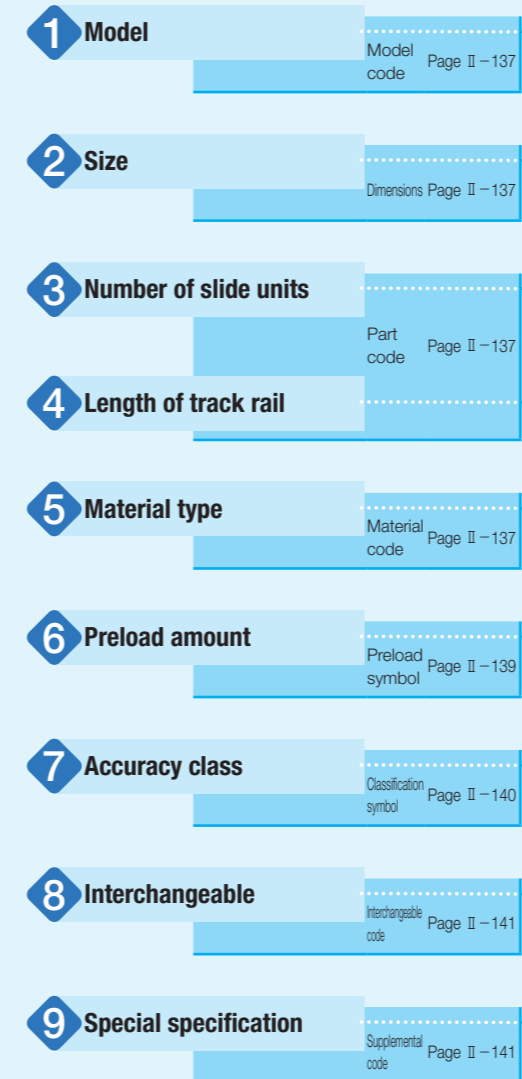





Note (1) Indicate "LWFF" for the model code of the single track rail of block type LWFS mounting from top.

# Identification Number and Specification — Model · Size · Number of Slide Unit ·

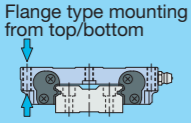
<b>1 Model</b>	Linear Way F <sup>(1)</sup> (LWF series)	Flange type mounting from top / bottom	: LWFH : LWFF
		Block type mounting from top	: LWFS
For applicable models and sizes, see Table 1. Indicate "LWFF" for the model code of the single track rail of block type LWFS mounting from top. Note <sup>(1)</sup> This model has no built-in C-Lube.			
<b>2 Size</b>	33,37,40,42,60,69,90	For applicable models and sizes, see Table 1.	
<b>3 Number of slide units</b>	: C○	For an assembled set, indicates the number of slide units assembled on a track rail. For a single slide unit, only "C1" is specified.	
<b>4 Length of track rail</b>	: R○	Indicate the length of track rail in mm. For standard and maximum length, see Table 2.1 and Table 2.2.	
<b>5 Material type</b>	High carbon steel made	: No symbol	For applicable models and sizes, see Table 1.
	Stainless steel made <sup>(2)</sup>	: SL	
Note <sup>(2)</sup> Mount a standard grease nipple (brass) on the stainless steel type, too. Stainless steel grease nipple is also available. If needed, please contact <b>IKO</b> .			

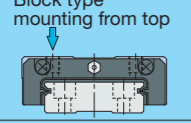
Table 1 Models and sizes of LWF series

Material	Shape	Model	Size						
			33	37	40	42	60	69	90
High carbon steel made	Flange type mounting from top/bottom 	LWFH	—	—	○	—	○	—	○
	Flange type mounting from top/bottom 	LWFF	○	○	—	○	—	○	—
	Block type mounting from top 	LWFS	○	○	—	—	—	—	—
Stainless steel made	Block type mounting from top 	LWFS...SL	○	○	—	○	—	—	—

Remark: For the models indicated in  , the interchangeable specification is available.

# Length of Track Rail · Material Type—

Table 2.1 Standard and maximum length of high carbon steel track rail

unit: mm

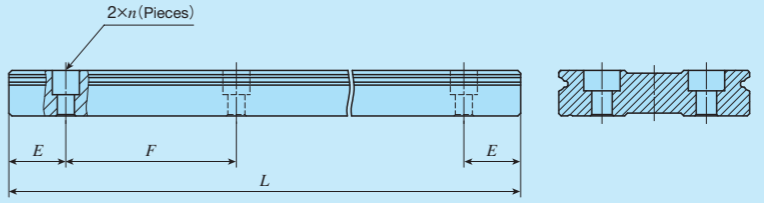

Identification number	LWFH40	LWFH60	LWFH90	
Item				
Standard length $L$ ( $n$ )	180 ( 3)	240 ( 3)	480 ( 6)	
	240 ( 4)	480 ( 5)	640 ( 8)	
	360 ( 6)	640 ( 8)	800 (10)	
	480 ( 8)	800 (10)	1 040 (13)	
	660 (11)	1 040 (13)	1 200 (15)	
	840 (14)		1 520 (19)	
Pitch of mounting holes $F$	60	80	80	
$E$	30	40	40	
Standard $E$ dimensions <sup>(1)</sup>	or higher	8	10	
	below	38	50	
Maximum length <sup>(2)</sup>	1 500	1 520	1 520	
Identification number	LWFF33 LWFS33	LWFF37 LWFS37	LWFF42	LWFF69
Item				
Standard length $L$ ( $n$ )	120 ( 3)	150 ( 3)	180 ( 3)	320 ( 4)
	200 ( 5)	250 ( 5)	240 ( 4)	480 ( 6)
	320 ( 8)	400 ( 8)	360 ( 6)	800 (10)
	480 (12)	500 (10)	480 ( 8)	1 040 (13)
	560 (14)	600 (12)	660 (11)	1 280 (16)
		800 (16)	840 (14)	1 600 (20)
Pitch of mounting holes $F$	40	50	60	80
$E$	20	25	30	40
Standard $E$ dimensions <sup>(1)</sup>	or higher	7	7	9
	below	27	32	49
Maximum length <sup>(2)</sup>	1 600	2 000	1 980	2 000

Notes <sup>(1)</sup> This does not apply to female threads for bellows (supplemental code "/J").

<sup>(2)</sup> We can produce products longer than the maximum length. If needed, please contact **IKO**.

Remarks 1. Indicate "LWFF" for the model code of the single track rail of block type LWFS mounting from top.

2. If not directed,  $E$  dimensions for both ends will be the same within the range of standard  $E$  dimensions. To change the dimensions, indicate the specified rail mounting hole positions " $E$ " of special specification. For more information, see page III-30.

Table 2.2 Standard and maximum length of stainless steel track rail

unit: mm

Identification number	LWFS33...SL	LWFS37...SL	LWFS42...SL
Item			
Standard length $L$ ( $n$ )	120 ( 3)	150 ( 3)	180 ( 3)
	200 ( 5)	250 ( 5)	240 ( 4)
	320 ( 8)	400 ( 8)	360 ( 6)
	480 (12)	500 (10)	480 ( 8)
	560 (14)	600 (12)	660 (11)
		800 (16)	840 (14)
Pitch of mounting holes $F$	40	50	60
$E$	20	25	30
Standard $E$ dimensions <sup>(1)</sup>	or higher	7	7
	below	27	32
Maximum length <sup>(2)</sup>	1 200	1 200	1 200

Notes <sup>(1)</sup> This does not apply to female threads for bellows (supplemental code "/J").

<sup>(2)</sup> We can produce products longer than the maximum length. If needed, please contact **IKO**.

Remarks 1. Indicate "LWFF" for the model code of the single track rail.

2. If not directed,  $E$  dimensions for both ends will be the same within the range of standard  $E$  dimensions. To change the dimensions, indicate the specified rail mounting hole positions " $E$ " of special specification. For more information, see page III-30.

—Preload Amount—

<b>6</b>	<b>Preload amount</b>	Standard	: No symbol	Specify this item for an assembled set or a single slide unit.
		Light preload	: T <sub>1</sub>	For details of the preload amount, see Table 3.
		Medium preload	: T <sub>2</sub>	For applicable preload types, see Table 4.

**Table 3 Preload amount**

Preload type	Item	Preload symbol	Preload amount N	Operational conditions
Standard	(No symbol)	0 <sup>(1)</sup>	· Light and precise motion	
Light preload	T <sub>1</sub>	0.02C <sub>0</sub>	· Almost no vibrations · Load is evenly balanced · Light and precise motion	
Medium preload	T <sub>2</sub>	0.05C <sub>0</sub>	· Medium vibration · Medium overhung load	

Note <sup>(1)</sup> Indicates zero or minimal amount of preload.  
Remark: C<sub>0</sub> indicates the basic static load rating.

**Table 4 Application of preload**

Size	Preload type (preload symbol)		
	Standard (No symbol)	Light preload (T <sub>1</sub> )	Medium preload (T <sub>2</sub> )
33	○	○	○
37	○	○	○
40	○	○	○
42	○	○	○
60	○	○	○
69	○	○	○
90	○	○	○

Remark: The mark  indicates that interchangeable specification products are available.

—Accuracy Class—

<b>7</b>	<b>Accuracy class</b>	High	: H	For interchangeable specification products, assemble a slide unit and a track rail of the same accuracy class.
		Precision	: P	For details of accuracy class, see Table 5.
		Super precision	: SP	For applicable accuracy class, see Table 6.

**Table 5 Tolerance and allowance**

unit: mm

Item	Class (classification symbol)		
	High (H)	Precision (P)	Super precision (SP)
Dim. H tolerance	±0.040	±0.020	±0.010
Dim. N tolerance	±0.050	±0.025	±0.015
Dim. variation of H <sup>(1)</sup>	0.015	0.007	0.005
Dim. variation of N <sup>(1)</sup>	0.020	0.010	0.007
Dim. variation of H for multiple assembled sets <sup>(2)</sup>	0.035	0.025	—
Parallelism in operation of the slide unit C surface to A surface	See Fig. 1		
Parallelism in operation of the slide unit D surface to B surface	See Fig. 1		

Notes <sup>(1)</sup> It means the size variation between slide units mounted on the same track rail.  
<sup>(2)</sup> Applicable to the interchangeable specifications.

**Table 6 Application of accuracy class**

Size	Class (classification symbol)		
	High (H)	Precision (P)	Super precision (SP)
33	○	○	○
37	○	○	○
40	○	○	○
42	○	○	○
60	○	○	○
69	○	○	○
90	○	○	○

Remark: The mark  indicates that interchangeable specification products are available.

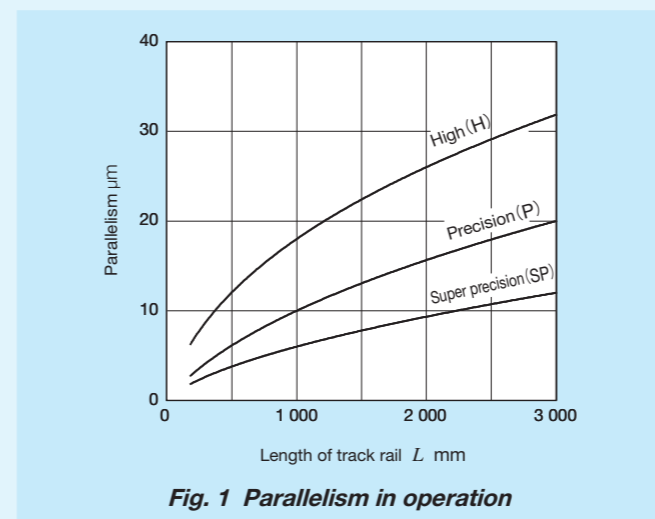

<b>8 Interchangeable</b>	S1 specification : S1	This is specified for the interchangeable specifications.
	S2 specification : S2	Assemble a track rail and a slide unit with the same interchangeable code. Performance and accuracy of "S1" and "S2" are the same.
	Non-interchangeable specification : No symbol	No symbol is indicated for non-interchangeable specification.
<b>9 Special specification</b>	/A, /C, /D, /E, /F, /I, /JO, /LO, /LFO, /MN, /N, /Q, /U, /VO, /WO, /YO, /ZO	For applicable special specifications, see Tables 7.1, 7.2, 7.3, and 7.4. For combination of multiple special specifications, see Table 8. For details of special specifications, see page III - 29.

**Table 7.1 Application of special specifications (Interchangeable specification, single slide unit)**

Special specification	Supplemental code	Size						
		33	37	40	42	60	69	90
Female threads for bellows (1)	/JO	○	○	○	○	○	○	○
No end seal	/N	○	○	○	○	○	○	○
With C-Lube plate	/Q	○	○	○	○	○	○	○
Under seal	/U	○	○	○	○	○	○	○
Double end seals	/VO	○	○	×	○	×	○	×
Scrapers	/ZO	○	○	○	○	○	○	○

Note (1) Not applicable to stainless steel made products.

**Table 7.2 Application of special specifications (Interchangeable specification, single track rail)**

Special specification	Supplemental code	Size						
		33	37	40	42	60	69	90
Specified rail mounting hole positions	/E	○	○	○	○	○	○	○
Caps for rail mounting holes	/F	○	○	○	○	○	○	○
Female threads for bellows (1)	/JO	○	○	○	○	○	○	○
Without track rail mounting bolt	/MN	○	○	○	○	○	○	○

Note (1) Not applicable to stainless steel made products.

**Table 7.3 Application of special specifications (Interchangeable specification and assembled set)**

Special specification	Supplemental code	Size						
		33	37	40	42	60	69	90
Opposite reference surfaces arrangement	/D	○	○	○	○	○	○	○
Specified rail mounting hole positions	/E	○	○	○	○	○	○	○
Caps for rail mounting holes	/F	○	○	○	○	○	○	○
Female threads for bellows (1)	/JO	○	○	○	○	○	○	○
Black chrome surface treatment	/LO	○	○	○	○	○	○	○
Fluorine black chrome surface treatment	/LFO	○	○	○	○	○	○	○
Without track rail mounting bolt	/MN	○	○	○	○	○	○	○
No end seal	/N	○	○	○	○	○	○	○
With C-Lube plate	/Q	○	○	○	○	○	○	○
Under seal	/U	○	○	○	○	○	○	○
Double end seals	/VO	○	○	×	○	×	○	×
Specified grease	/YO	○	○	○	○	○	○	○
Scrapers	/ZO	○	○	○	○	○	○	○

Note (1) Not applicable to stainless steel made products.

**Table 7.4 Application of special specifications (Non-interchangeable specification)**

Special specification	Supplemental code	Size						
		33	37	40	42	60	69	90
Butt-jointing track rails	/A	○	○	○	○	○	○	○
Chamfered reference surface	/CO	×	×	○	×	○	×	○
Opposite reference surfaces arrangement	/D	○	○	○	○	○	○	○
Specified rail mounting hole positions	/E	○	○	○	○	○	○	○
Caps for rail mounting holes	/F	○	○	○	○	○	○	○
Inspection sheet	/I	○	○	○	○	○	○	○
Female threads for bellows	/JO	○	○	○	○	○	○	○
Black chrome surface treatment	/LO	○	○	○	○	○	○	○
Fluorine black chrome surface treatment	/LFO	○	○	○	○	○	○	○
Without track rail mounting bolt	/MN	○	○	○	○	○	○	○
No end seal	/N	○	○	○	○	○	○	○
With C-Lube plate	/Q	○	○	○	○	○	○	○
Under seal	/U	○	○	○	○	○	○	○
Double end seals	/VO	○	○	×	○	×	○	×
A group of multiple assembled sets	/WO	○	○	○	○	○	○	○
Specified grease	/YO	○	○	○	○	○	○	○
Scrapers	/ZO	○	○	○	○	○	○	○

**Table 8 Combination of supplemental codes**

C	○																		
D	○	○																	
E	-	○	-																
F	○	○	○	○															
I	○	○	○	○	○														
J	○	○	○	○	○	○													
L	○	○	○	○	○	○	○												
LF	○	○	○	○	○	○	○	-											
MN	○	○	○	○	○	○	○	○	○										
N	○	○	○	○	-	○	-	○	○	○									
Q	○	○	○	○	○	○	-	○	○	○	○								
U	○	○	○	○	○	○	○	○	○	○	-	○							
V	○	-	○	○	○	○	○	○	○	○	-	-	○						
W	○	○	○	-	○	○	○	○	○	○	○	○	○	○					
Y	○	○	○	○	○	○	○	○	○	○	○	-	○	○	○				
Z	○	○	○	○	○	○	○	○	○	○	○	○	-	-	○	○	○		
	A	C	D	E	F	I	J	L	LF	MN	N	Q	U	V	W	Y			

Note (1) Contact **IKO** for the case of LWFH.

Remarks 1. The combination of "-" shown in the table is not available.

2. Contact **IKO** for the combination of the interchangeable specification marked with ●.

3. When using multiple types for combination, please indicate by arranging the symbols in alphabetical order.



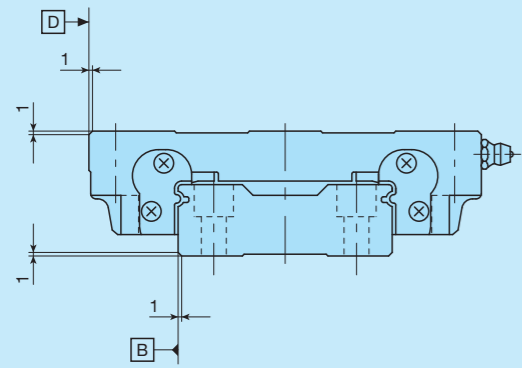
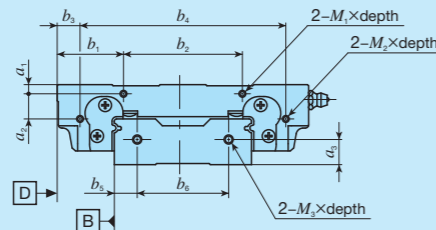

Fig. 2 Dimension of chamfered reference surface (Supplemental code /C /CC)

Remark: Add chamfer to the reference mounting surface of the slide unit and track rail.  
For corner R of the mounting section, see Table 17.2 on page II - 148.

Table 9 Dimension of female threads for bellows (Supplemental code Single unit: /J Assembled set: /J /JJ)



unit: mm

Identification number	Slide unit								Track rail			
	$a_1$	$a_2$	$b_1$	$b_2$	$b_3$	$b_4$	$M_1 \times \text{depth}$	$M_2 \times \text{depth}$	$a_3$	$a_5$	$a_6$	$M_3 \times \text{depth}$
LWFH 40	3	—	23.5	35	—	—	M3×6	—	9	8	24	M3×6
LWFH 60	4	11	29	52	10	90	M3×6	M3×3	11	10	40	M4×8
LWFH 90	6	17	41	80	13	136	M3×5	M3×5	13	15	60	M4×8

Table 10 Dimension of female threads for bellows (Supplemental code Single unit: /J Assembled set: /J /JJ)

Size 33, 37

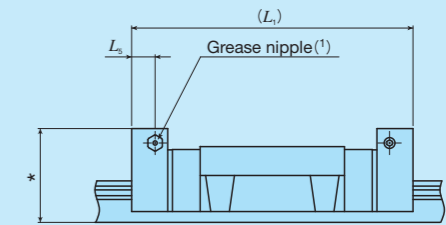
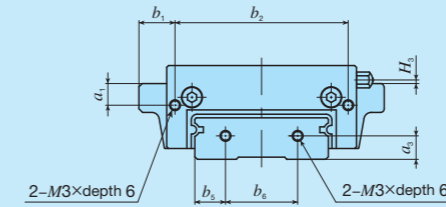

Size 42

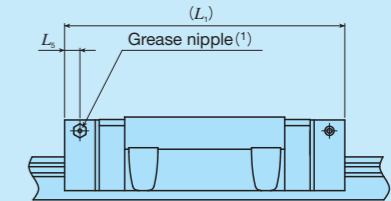
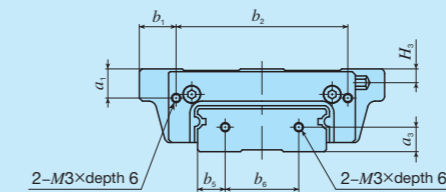

Size 69

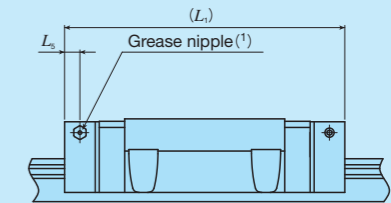
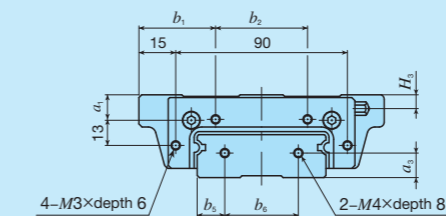

unit: mm

Identification number	Slide unit						Track rail		
	$a_1$	$b_1$	$b_2$	$L_1^{(2)}$	$L_2$	$H_3$	$a_3$	$b_5$	$b_6$
LWFF 33	4	8.25	43.5	71	5	1	6	7.5	18
LWFS 33(...SL)		3.25							
LWFF 37	6	10	48	78	5	1	6.5	8.5	20
LWFS 37(...SL)		3							
LWFF 42	9.5	12	56	92	7	4.5	8	9	24
LWFS 42...SL		3							
LWFF 69	9	35	50	125	7	5	11	14.5	40

Notes (1) Grease nipple specifications and mounting position are different from standard specifications. Provided grease nipple is A-M3 for size 37 and 42 models, and A-M4 for size 69 model. For grease nipple specification, see Table 15 on page II - 146.

(2) Dimensions of the specification that female threads for bellows are fitted to both ends of the slide unit are indicated.

Remark: Dimensions indicated by \* mark for series of size 33 and Size 37 is higher than the  $H$  dimension of Linear Way F. For details, contact **IKO**.

**Table 11 Dimension of slide unit with C-Lube plate (Supplemental code /Q)**

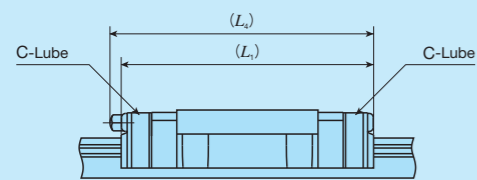

unit: mm

Size	$L_1$	$L_4$
33	64	66
37	73	75
40	78	—
42	86	98
60	98	—
69	121	132
90	131	—

Remark: The dimensions of the slide unit with C-Lube at both ends are indicated.

**Table 12  $H_1$  dimension with under seal (Supplemental code /U)**

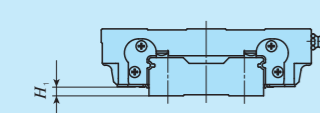

unit: mm

Size	$H_1$
40	3
60	4
90	5

Remark:  $H_1$  dimensions of series of the Size 33, 37, 42, and 69 are the same as dimensions before mounting of under seal.

**Table 13 Dimension of slide unit with double end seals (Supplemental code Single unit: /V Assembled set: /V /VV)**

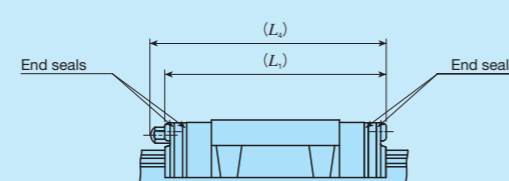

unit: mm

Size	$L_1$	$L_4$
33	61	64
37	70	74
42	82	96
69	117	130

Remark: The dimensions of the slide unit with double end seals at both ends are indicated.

**Table 14 Dimension of slide unit with scrapers (Supplemental code Single unit: /Z Assembled set: /Z /ZZ)**

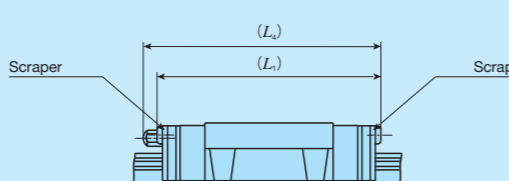

unit: mm

Size	$L_1$	$L_4$
33	62	64
37	71	75
40	80	—
42	84	97
60	100	—
69	119	131
90	130	—

Remark: The dimensions of the slide unit with scraper at both ends are indicated.

## Lubrication

Lithium-soap base grease with extreme-pressure additive (Alvania EP grease 2 [SHOWA SHELL SEKIYU K. K.]) is pre-packed in LWF series.

LWF series has grease nipple as indicated in Table 15. Supply nozzles fit to each shapes of grease nipple are also available. For order of these parts for lubrication, see Table 14.1 on page III-23 and Table 15 on page III-24.

**Table 15 Parts for lubrication**

Size	Grease nipple type <sup>(1)</sup>	Applicable supply nozzle type	Bolt size of female threads for piping
33	A-M3	A-5120V A-5240V	—
37	A-M4	B-5120V B-5240V	M4
40	JIS type 1	Grease gun available on the market	M6
42	B-M6		
60	JIS type 1		
69	B-M6		
90	JIS type 1		

Note <sup>(1)</sup> For grease nipple specification, see Table 14.1 and Table 14.2 on page III-23.

Remark: Stainless steel grease nipple is also available. If needed, please contact **IKO**.

## Dust Protection

The slide units of LWF series are equipped with end seals as standard for dust protection. However, if large amount of contaminant or dust are floating, or if large particles of foreign substances such as chips or sand may adhere to the track rail, it is recommended to cover the whole unit with bellows or telescope type shield, etc.



LWF series is provided with specific bellows. The bellows are easy to mount and provide excellent dust protection. If needed, please refer to III-26 for ordering.

# Precaution for Use

## ① Mounting surface, reference mounting surface and typical mounting structure

When mounting the LWF series, properly align the reference mounting surface B and D of the track rail and slide unit with the reference mounting surface of the table and bed and fix them. (See Fig. 3.)

The reference mounting surfaces B and D and mounting surfaces A and C are precisely ground. Machining the mounting surface of the table and bed, such as machine or device, to high accuracy and mounting them properly will ensure stable linear motion with high accuracy.

Reference mounting surface of the slide unit is the opposite side of the  mark. The track rail reference mounting surface is identified by locating the  mark on the top surface of the track rail. It is the side surface above the mark (in the direction of the arrow). (See Fig. 4)

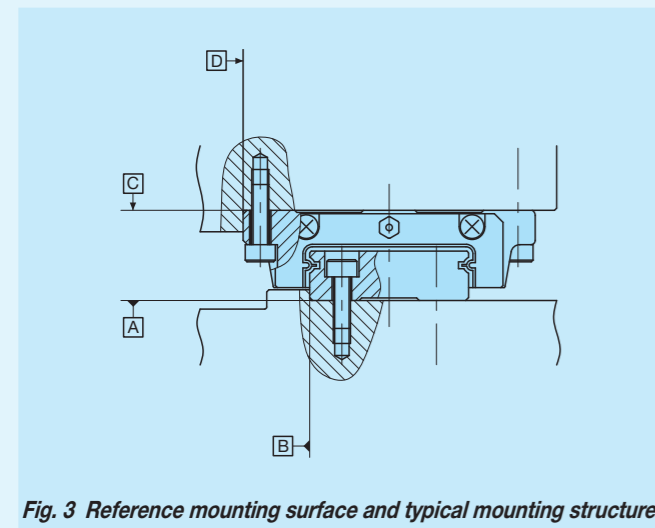

Fig. 3 Reference mounting surface and typical mounting structure

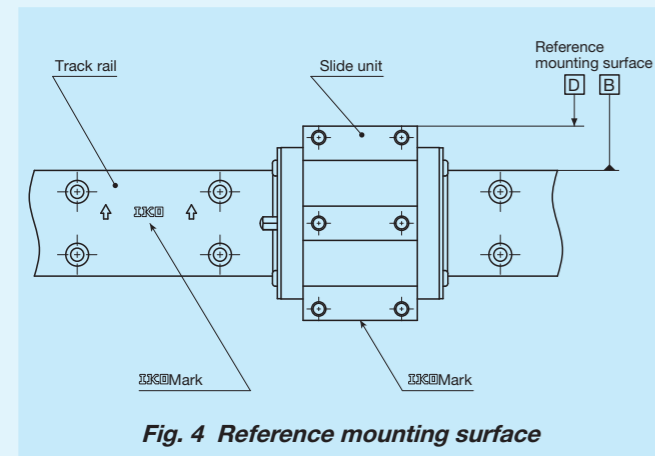

Fig. 4 Reference mounting surface

## ② Shoulder height and corner radius of the reference mounting surface

For the opposite corner of the mating reference mounting, it is recommended to have relieved fillet as indicated in Fig. 5. Recommended value for the shoulder height and corner radius on the mating side is indicated in Table 17.1 and Table 17.2.

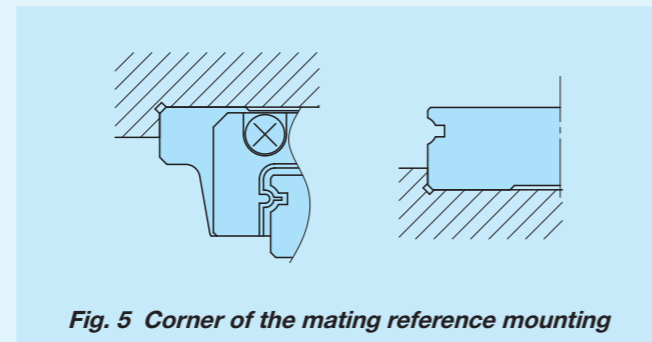

Fig. 5 Corner of the mating reference mounting

## ③ Tightening torque for fixing screw

Typical tightening torque for mounting of the LWF series to the steel mating member material is indicated in Table 16. When vibration and shock of the machine or device are large, fluctuating load is large, or moment load is applied, fix it by using the torque 1.2 to 1.5 times larger than the value indicated in the table as necessary. If the mating member material is cast iron or aluminum alloy, reduce the tightening torque depending on the strength characteristics of the mating member material.

Table 16 Tightening torque for fixing screw

Bolt size	Tightening torque N · m	
	High carbon steel-made screw	Stainless steel-made screw
M 4×0.7	4.1	2.5
M 5×0.8	8.0	5.0
M 6×1	13.6	8.5
M 8×1.25	32.7	—
M10×1.5	63.9	—

Remark: The tightening torque is calculated based on strength division 12.9 and property division A2-70.

Table 17.1 Shoulder height and corner radius of the reference mounting surface

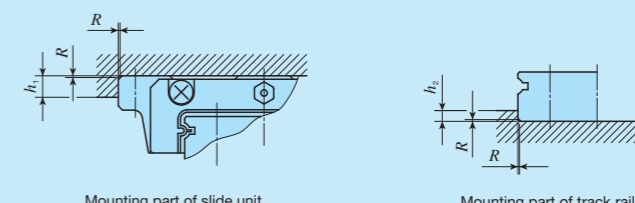

Size	Mounting part of slide unit		Mounting part of track rail	
	Shoulder height $h_1$	Corner radius $R$ (Maximum)	Shoulder height $h_2$	Corner radius $R$ (Maximum)
33	4	0.4	2	0.4
37	5	0.4	2.5	0.4
42	5	0.4	2.5	0.4
69	5	0.8	3.5	0.8

unit: mm

Table 17.2 Shoulder height and corner radius of the reference mounting surface

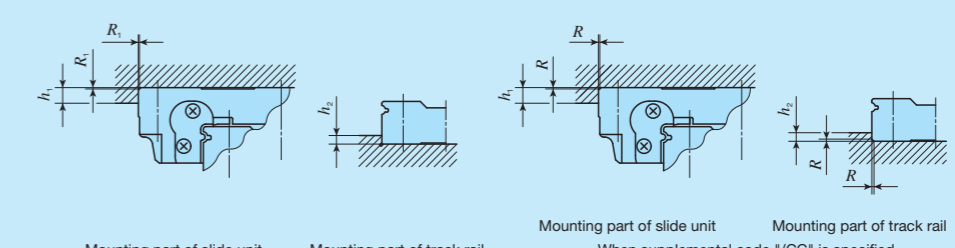

Size	Mounting part of slide unit		Mounting part of track rail	Corner radius when supplemental code "CC" is specified $R$ (Maximum)
	Shoulder height $h_1$	Corner radius $R$ (Maximum)	Shoulder height $h_2$	
40	4	0.3	3	1
60	6	0.5	4	1
90	8	0.5	6	1

unit: mm

## Flange type mounting from top / bottom

Shape			
Size	40	60	90

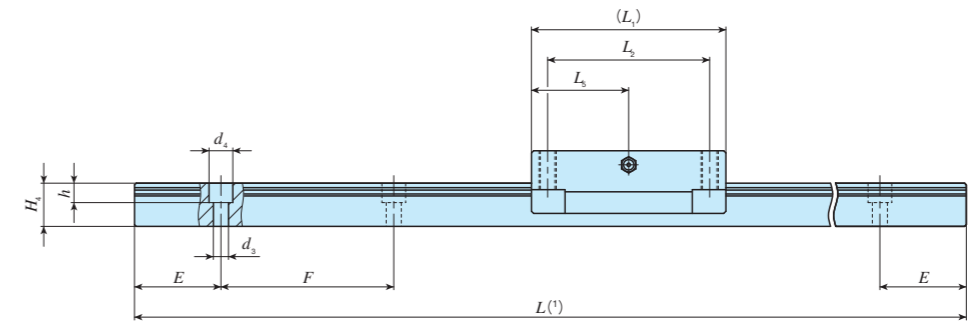
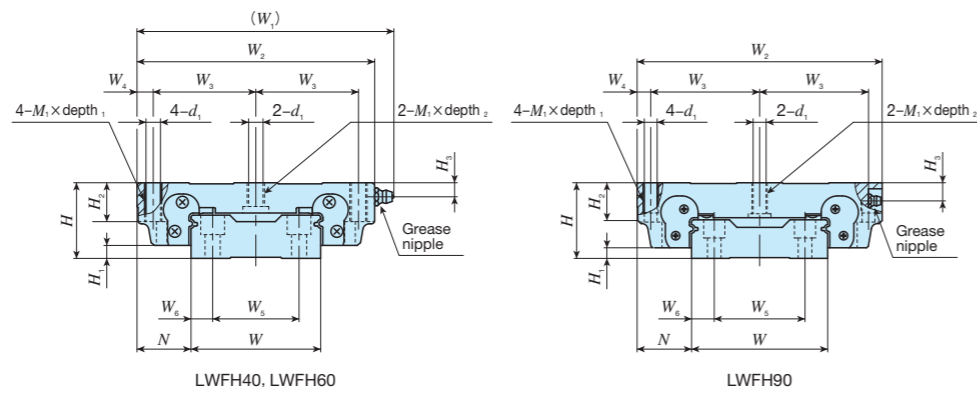

Identification number	Interchangeable	Mass(Ref.)		Dimensions of assembly			Dimensions of slide unit										Dimensions of track rail						Appended mounting bolt for track rail (2) mm	Basic dynamic load rating (3) C	Basic static load rating (3) C <sub>0</sub>	Static moment rating (3)							
		Slide unit kg	Track rail kg/m	H	H <sub>1</sub>	N	W <sub>1</sub>	W <sub>2</sub>	W <sub>3</sub>	W <sub>4</sub>	L <sub>1</sub>	L <sub>2</sub>	L <sub>3</sub>	d <sub>1</sub>	M <sub>1</sub> ×depth <sub>1</sub>	depth <sub>2</sub>	H <sub>2</sub>	H <sub>3</sub>	W	H <sub>4</sub>	W <sub>5</sub>	W <sub>6</sub>				d <sub>3</sub>	d <sub>4</sub>	h	E	F	Bolt size×ℓ	N	N
LWFH 40	○	0.58	4.60	27	5	21	91	82	37	4	70	60	27.5	4.3	M 5×14	8	14	6.5	40	16	24	8	4.5	7.2	6	30	60	M4×16	12 600	16 600	280	108 612	99.3 563
LWFH 60	○	1.29	8.60	35	6	25	119	110	47.5	7.5	90	75	45	6.7	M 8×18	11	18	6.5	60	20	40	10	7	11	9	40	80	M6×22	16 100	23 500	600	210 1 090	193 998
LWFH 90	○	4.06	16.5	50	7	36	-	162	72	9	120	100	60	8.6	M10×20	20.5	26	12	90	25.5	60	15	9	14	12	40	80	M8×28	31 600	43 300	1 650	513 2 680	470 2 460

Notes (1) Track rail lengths  $L$  are shown in Table 2.1 on page II - 138.  
 (2) The appended track rail mounting bolts are hexagon socket head bolts equivalent to JIS B 1176.  
 (3) The direction of basic dynamic load rating ( $C$ ), basic static load rating ( $C_0$ ), and static moment rating ( $T_0$ ,  $T_x$ ,  $T_y$ ) are shown in the sketches below. The upper values of  $T_x$  and  $T_y$  are for one slide unit and the lower values are for two slide units in close contact.  
 Remark: The specifications of grease nipple are shown in Table 15 on page II - 146.

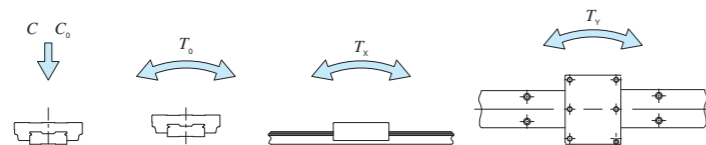

### Example of identification number of assembled set

Model code Dimensions Part code Preload symbol Classification symbol Interchangeable code Supplemental code

**LWFH** **60** **C2** **R800** **T1** **P** **/U**

① ② ③ ④ ⑤ ⑥ ⑦ ⑧

① Model	LWFH Flange type mounting from top / bottom	⑤ Preload amount	No symbol Standard T1 Light preload T2 Medium preload	⑦ Interchangeable	No symbol Non-interchangeable specification S1 S1 specification S2 S2 specification
② Size	40, 60, 90	⑥ Accuracy class	H High P Precision SP Super precision	⑧ Special specification	A, C, D, E, F, I, J, L, LF MN, N, Q, U, W, Y, Z
③ Number of slide unit (2)					
④ Length of track rail (800 mm)					

## Flange type mounting from top / bottom

Shape				
Size	33	37	42	69

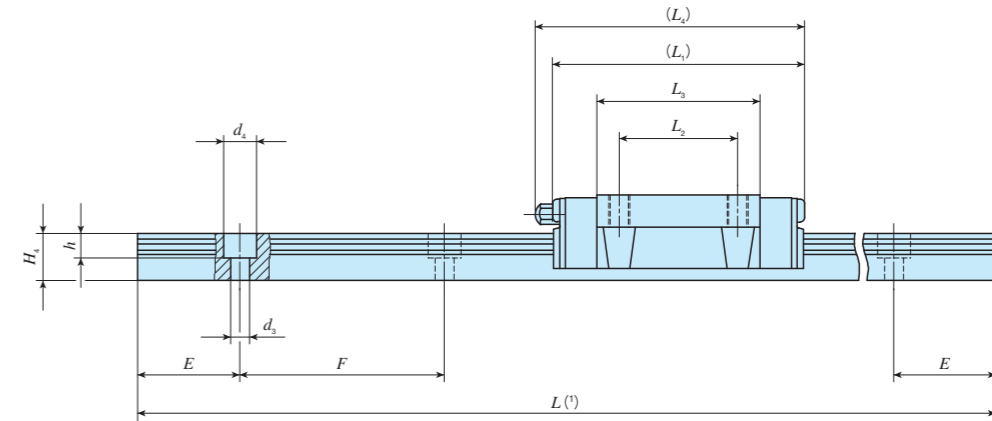
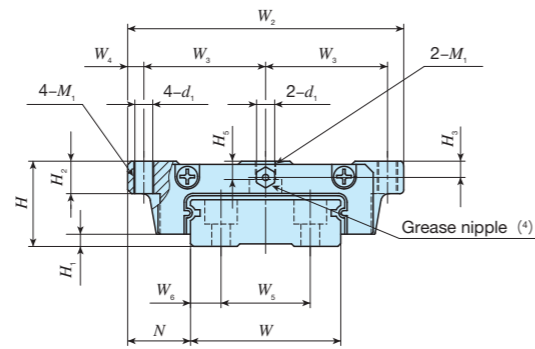

Identification number	Interchangeable	Mass(Ref.)		Dimensions of assembly			Dimensions of slide unit											Dimensions of track rail						Appended mounting bolt for track rail (2) mm	Basic dynamic load rating (3) N	Basic static load rating (3) N	Static moment rating (3)						
		Slide unit kg	Track rail kg/m	H	H <sub>1</sub>	N	W <sub>2</sub>	W <sub>3</sub>	W <sub>4</sub>	L <sub>1</sub>	L <sub>2</sub>	L <sub>3</sub>	L <sub>4</sub>	d <sub>1</sub>	M <sub>1</sub>	H <sub>2</sub>	H <sub>3</sub>	H <sub>5</sub>	W	H <sub>4</sub>	W <sub>5</sub>	W <sub>6</sub>	d <sub>3</sub>				d <sub>4</sub>	h	E	F	T <sub>0</sub>	T <sub>x</sub>	T <sub>y</sub>
LWFF 33	○	0.14	2.41	17	2.5	13.5	60	26.5	3.5	54	26	35.3	56	3.3	M4	6	3.2	3.7	33	10	18	7.5	4.6	8	6	20	40	M4×10	6 530	8 610	146	49.0 292	49.0 292
LWFF 37	○	0.23	3.05	21	3	15.5	68	30	4	62	29	40	66	4.4	M5	8	4	4.5	37	11.5	22	7.5	4.6	8	6	25	50	M4×12	9 840	12 200	235	80.0 480	80.0 480
LWFF 42	○	0.49	4.30	27	3	19	80	35	5	75	40	52.2	86	5.3	M6	10	6	7	42	14	24	9	4.6	8	6	30	60	M4×16	15 500	19 400	424	165 904	165 904
LWFF 69	○	1.40	9.51	35	4	25.5	120	53.5	6.5	109	60	79.5	120	7	M8	14	8	8	69	19.5	40	14.5	7	11	9	40	80	M6×22	34 900	44 100	1 560	581 2 940	488 2 460

Notes (1) Track rail lengths  $L$  are shown in Table 2.1 on page II – 138.

(2) The appended track rail mounting bolts are hexagon socket head bolts equivalent to JIS B 1176.

(3) The direction of basic dynamic load rating ( $C$ ), basic static load rating ( $C_0$ ), and static moment rating ( $T_0$ ,  $T_x$ ,  $T_y$ ) are shown in the sketches below. The upper values of  $T_x$  and  $T_y$  are for one slide unit and the lower values are for two slide units in close contact.

(4) The shapes of grease nipple vary by size. The specifications are shown in Table 15 on page II – 146.

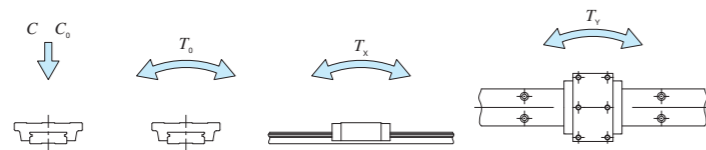

### Example of identification number of assembled set

Model code Dimensions Part code Preload symbol Classification symbol Interchangeable code Supplemental code

**LWFF** **37** **C2** **R800** **T1** **P** **/U**

① ② ③ ④ ⑤ ⑥ ⑦ ⑧

① Model

LWFF Flange type mounting from top / bottom

② Size

33, 37, 42, 69

③ Number of slide unit (2)

④ Length of track rail (800 mm)

⑤ Preload amount

No symbol Standard  
T1 Light preload  
T2 Medium preload

⑥ Accuracy class

H High  
P Precision  
SP Super precision

⑦ Interchangeable

No symbol Non-interchangeable specification  
S1 S1 specification  
S2 S2 specification

⑧ Special specification

A, D, E, F, I, J, L, LF  
MN, N, Q, U, V, W, Y, Z

## Block type mounting from top

Shape			
Size	33	37	42

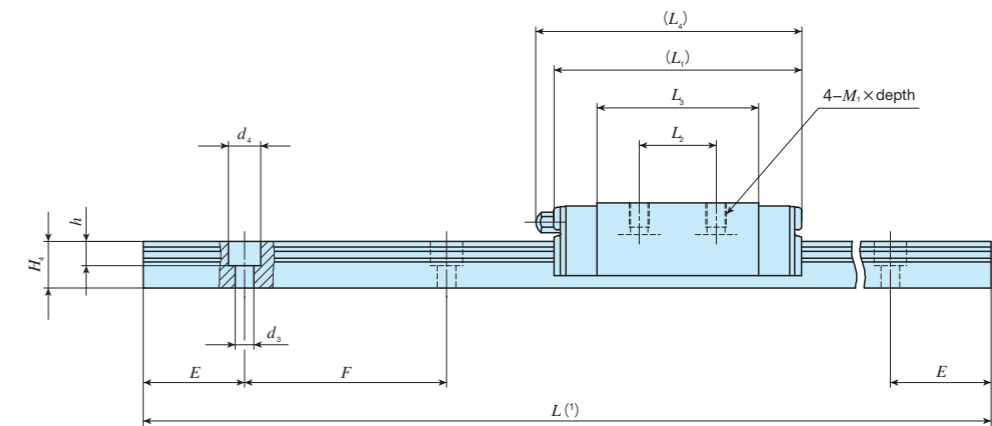
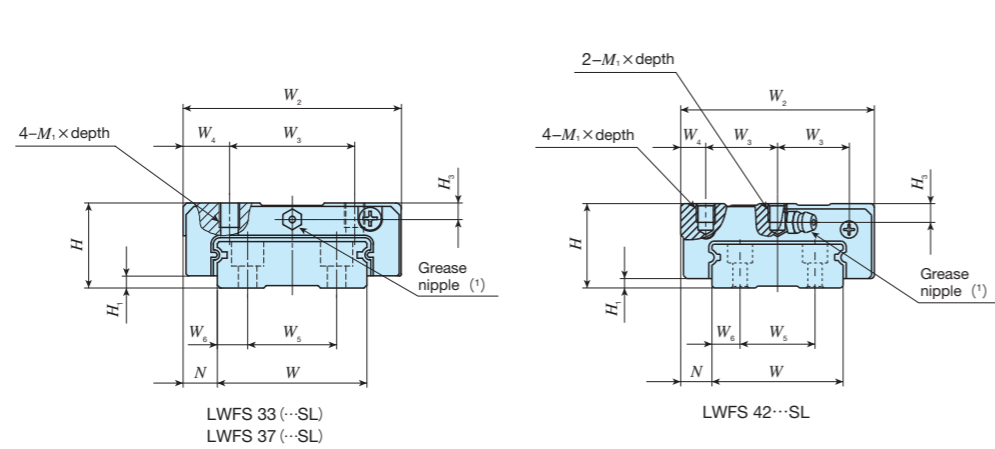

Identification number	Interchangeable	Mass(Ref.)		Dimensions of assembly			Dimensions of slide unit									Dimensions of track rail						Appended mounting bolt for track rail (2) mm	Basic dynamic load rating (3) N	Basic static load rating (3) N	Static moment rating (3)					
		Slide unit kg	Track rail kg/m	H	H <sub>1</sub>	N	W <sub>2</sub>	W <sub>3</sub>	W <sub>4</sub>	L <sub>1</sub>	L <sub>2</sub>	L <sub>3</sub>	L <sub>4</sub>	M <sub>1</sub> × depth	H <sub>3</sub>	W	H <sub>4</sub>	W <sub>5</sub>	W <sub>6</sub>	d <sub>3</sub>	d <sub>4</sub>				h	E	F	T <sub>0</sub>	T <sub>x</sub>	T <sub>y</sub>
LWFS 33	○	0.13	2.41	17	2.5	8.5	50	29	10.5	54	15	35.3	56	M4×5	3.2	33	10	18	7.5	4.6	8	6	20	40	M4×10	6 530	8 610	146	49.0 292 <sup>0</sup>	49.0 292 <sup>0</sup>
LWFS 33··SL	○			21	3	8.5	54	31	11.5	62	19	40	66	M5×6	4	37	11.5	22	7.5	4.6	8	6	25	50	M4×12	9 840	12 200	235	80.0 480 <sup>0</sup>	80.0 480 <sup>0</sup>
LWFS 37	○	0.20	3.05	27	3	10	62	23	8	75	32	52.2	86	M6×6	6	42	14	24	9	4.6	8	6	30	60	M4×16	15 500	19 400	424	165 904	165 904
LWFS 37··SL	○			27	3	10	62	23	8	75	32	52.2	86	M6×6	6	42	14	24	9	4.6	8	6	30	60	M4×16	15 500	19 400	424	165 904	165 904
LWFS 42··SL	○	0.40	4.30	27	3	10	62	23	8	75	32	52.2	86	M6×6	6	42	14	24	9	4.6	8	6	30	60	M4×16	15 500	19 400	424	165 904	165 904

Notes (1) Track rail lengths  $L$  are shown in Tables 2.1 and 2.2 on page II - 138.  
 (2) The appended track rail mounting bolts are hexagon socket head bolts equivalent to JIS B 1176. For stainless steel model, stainless steel bolts are appended.  
 (3) The direction of basic dynamic load rating ( $C$ ), basic static load rating ( $C_0$ ), and static moment rating ( $T_0$ ,  $T_x$ ,  $T_y$ ) are shown in the sketches below. The upper values of  $T_x$  and  $T_y$  are for one slide unit and the lower values are for two slide units in close contact.  
 (4) The shapes of grease nipple vary by size. The specifications are shown in Table 15 on page II - 146.

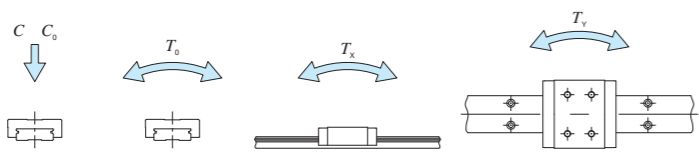

### Example of identification number of assembled set

Model code: LWFS    Dimensions: 37    Part code: C2    Material code: R800    Preload symbol: T1    Classification symbol: P    Interchangeable code: /U

① Model	③ Number of slide unit (2)	⑥ Preload amount	⑧ Interchangeable
LWFS    Block type mounting from top	No symbol    Standard	No symbol    Non-interchangeable specification	No symbol    Non-interchangeable specification
② Size	④ Length of track rail (800 mm)	T1    Light preload	S1    S1 specification
33, 37, 42	No symbol    Standard	T2    Medium preload	S2    S2 specification
⑤ Material type	⑦ Accuracy class	⑨ Special specification	
No symbol    High carbon steel made	H    High	A, D, E, F, I, J, L, LF	
SL    Stainless steel made	P    Precision	MN, N, Q, U, V, W, Y, Z	
	SP    Super precision		

# C-Lube Linear Way MUL Linear Way U



# C-Lube Linear Way MUL

# MUL



long term maintenance free supported!

The aquamarine end plate is the symbol of maintenance free.

Track rail

Slide unit

Casing

C-Lube

Ball

End plate

Ball retaining band

End seal

Oil hole

Linear Way U

# LWU

## Points

### 1 Original U-shaped track rail

MUL and LWU series are the linear motion rolling guides adopting the U-shaped track rail to greatly increase rigidity of track rail under moment load and torsion.

### 2 Expanded freedom of design for use as a structure beam

Because of the high rigidity of the track rail, the track rail can be used as a structure beam, such as a cantilever or both-end support in the machine and equipment. Therefore, freedom of design is expanded for user.

### 3 Additional machining available for corresponding to needs

High carbon steel track rail can be machined additionally to fix mechanical components such as a driving mechanism on the track rail directly at user.

### 4 Stainless steel selections superior in corrosion resistance are listed on lineup. For details P.I-41

The main metal components made of corrosion-resistant stainless steel are available for small size of 25 mm and 30 mm of track rail width. They are suitable for applications where rust prevention oil is not preferred, such as in a cleanroom environment.

## Identification Number and Specification

### Example of an identification number

The specifications of MUL and LWU series are indicated by the identification number. Indicate the identification number, consisting of a model code, dimensions, a part code, a preload symbol, a classification symbol, and any supplemental codes for each specification to apply.

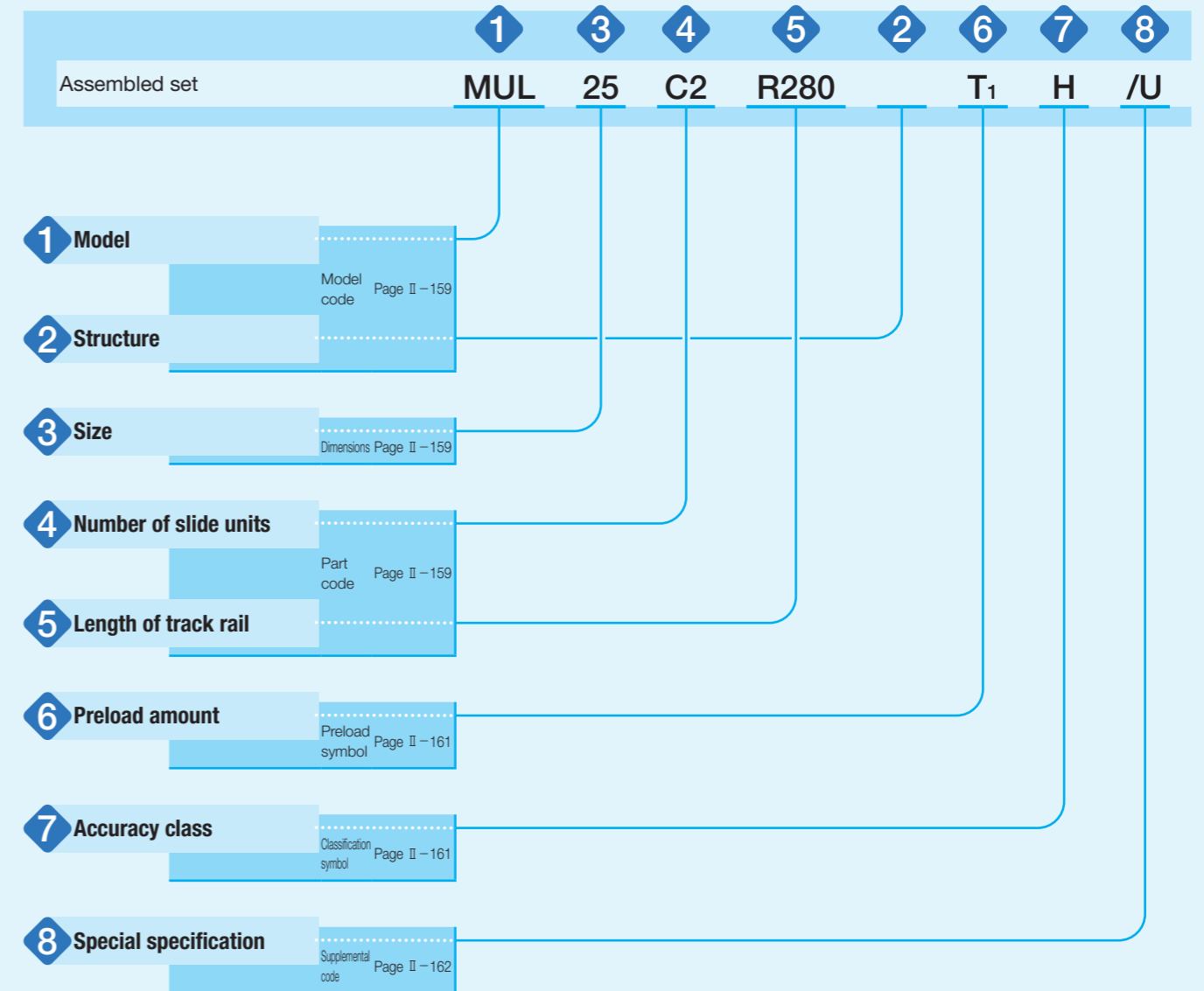



MUL · LWU



# Identification Number and Specification — Model · Structure · Size · Number of Slide unit ·

<b>1 Model</b>	C-Lube Linear Way MUL (MUL series)	Small type	: MUL
	Linear Way U <sup>(1)</sup> (LWU series)	Small type Standard type	: LWUL : LWU
For applicable models and sizes, see Table 1.			
Note <sup>(1)</sup> This model has no built-in C-Lube.			
<b>2 Structure</b>	Ball retained type	: B	For applicable models and sizes, see Table 1.
	Ball non-retained type	: No symbol	
<b>3 Size</b>	25,30,40,50,60,86,100,130	For applicable models and sizes, see Table 1.	
<b>4 Number of slide units</b>	: C○	Indicates the number of slide units assembled on a track rail.	
<b>5 Length of track rail</b>	: R○	Indicate the length of track rail in mm. For standard and maximum lengths, see Table 2.	

Table 1 Models and sizes of MUL and LWU series

Shape	Material	Model	Size							
			25	30	40	50	60	86	100	130
Small type 	Stainless steel made	MUL	○	○	—	—	—	—	—	—
		LWUL...B	○	○	—	—	—	—	—	—
Standard type 	High carbon steel made	LWU...B	—	—	○	○	○	○	—	—
		LWU	—	—	○	○	○	○	○	○

## Length of Track Rail —

Table 2 Standard and maximum lengths of track rail

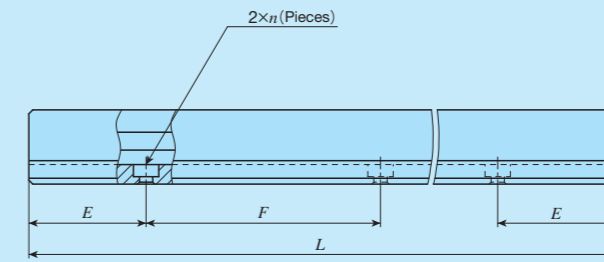

unit: mm

Item	MUL25 LWUL25...B	MUL30 LWUL30...B	LWU40...B LWU40	LWU50...B LWU50
	Standard length $L$ (n)	105 (3) 140 (4) 175 (5) 210 (6) 245 (7) 280 (8)	120 (3) 160 (4) 200 (5) 240 (6) 280 (7) 320 (8)	180 (3) 240 (4) 300 (5) 360 (6) 420 (7) 480 (8)
Pitch of mounting holes $F$	35	40	60	80
$E$	17.5	20	30	40
Standard $E$ dimensions or higher below	4.5 22	4.5 24.5	— —	— —
Maximum length <sup>(1)</sup>	420 (840)	480 (960)	720	800
Item	LWU60...B LWU60	LWU86...B LWU86	LWU100	LWU130
	Standard length $L$ (n)	300 (3) 400 (4) 500 (5) 600 (6) 700 (7) 800 (8)	300 (3) 400 (4) 500 (5) 600 (6) 700 (7) 800 (8)	450 (3) 600 (4) 750 (5) 900 (6) 1 050 (7) 1 200 (8)
Pitch of mounting holes $F$	100	100	150	150
$E$	50	50	75	75
Maximum length <sup>(1)</sup>	1 000	1 200	1 500	1 500

Note <sup>(1)</sup> Length up to the value in ( ) can be produced. If needed, please contact **IKO**.

Remarks 1. M8 female threads for hanging bolt are provided on the track rail of size 100 model. And M10 female threads for hanging bolt are provided on the track rail of size 130 model.

2. If not directed,  $E$  dimensions for both ends will be the same within the range of standard  $E$  dimensions. To change the dimensions, indicate the specified rail mounting hole positions "/ $E$ " of special specification. For more information, see page III-30.

— Preload Amount · Accuracy Class —

<b>6</b> Preload amount	Standard	: No symbol	For details of the preload amount, see Table 3.
	Light preload	: T <sub>1</sub>	

Table 3 Preload amount

Preload type	Preload symbol	Preload amount N	Operational conditions
Standard	(No symbol)	0 <sup>(1)</sup>	· Light and precise motion
Light preload	T <sub>1</sub>	0.02C <sub>0</sub>	· Almost no vibrations · Load is evenly balanced · Light and precise motion

Note <sup>(1)</sup> Indicates zero or minimal amount of preload.  
Remark: C<sub>0</sub> indicates the basic static load rating.

<b>7</b> Accuracy class	Ordinary	: No symbol	For details of accuracy class, see Table 4.
	High	: H	

Table 4 Tolerance and allowance

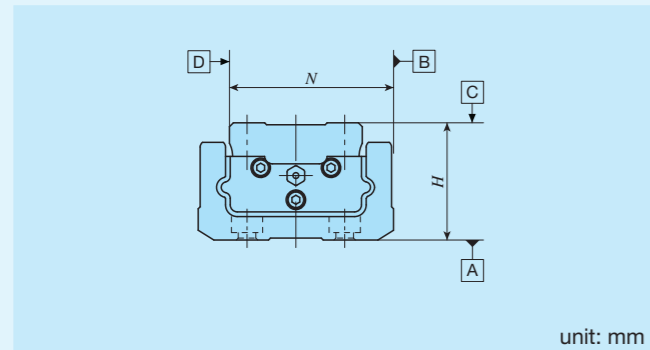

unit: mm

Item	Class (classification symbol)	
	Ordinary (No symbol)	High (H)
Dim. H tolerance	±0.100	±0.050
Dim. N tolerance	±0.100	±0.050
Dim. variation of H <sup>(1)</sup>	0.050	0.040
Dim. variation of N <sup>(1)</sup>	0.050	0.040
Parallelism in operation of the slide unit C surface to A surface	See Fig. 1	
Parallelism in operation of the slide unit D surface to B surface	See Fig. 1	

Note <sup>(1)</sup> It means the size variation between slide units mounted on the same track rail.

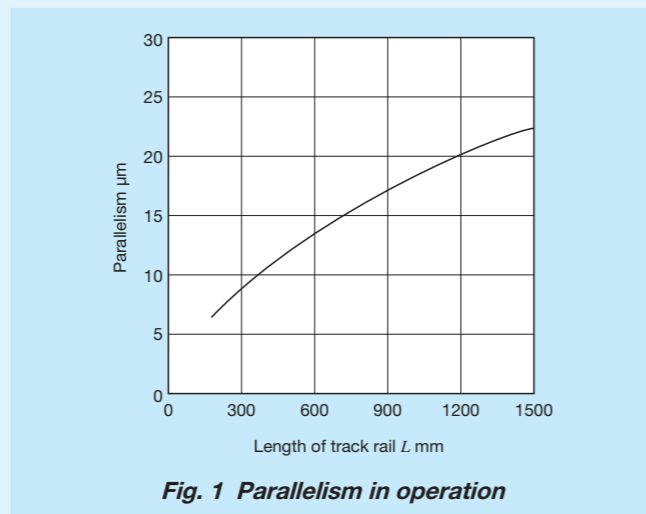

Fig. 1 Parallelism in operation

— Special Specification —

<b>8</b> Special specification	/E, /LO, /MA, /MN, /Q, /UO, /WO	For applicable special specifications, see Table 5. For combination of multiple special specifications, see Table 6. For details of special specifications, see page III-29.
--------------------------------	---------------------------------	--

Table 5 Application of special specifications

Special specification	Supplemental code	Size							
		25	30	40	50	60	86	100	130
Specified rail mounting hole positions	/E	○	○	×	×	×	×	×	×
Black chrome surface treatment	/LO	○ <sup>(1)</sup>	○ <sup>(1)</sup>	○	○	○	○	○	○
With track rail mounting bolt	/MA	○ <sup>(2)</sup>	○ <sup>(2)</sup>	○	○	○	○	○	○
Without track rail mounting bolt <sup>(3)</sup>	/MN	○	○	×	×	×	×	×	×
With C-Lube plate <sup>(3)</sup>	/Q	×	×	○	○	○	○	○	○
Upper seal	/U	○	○	×	×	×	×	×	×
A group of multiple assembled sets	/WO	○	○	○	○	○	○	○	○

Notes <sup>(1)</sup> Applicable only to "/LR".  
<sup>(2)</sup> Applicable to MUL series.  
<sup>(3)</sup> Applicable to LWU series.

Table 6 Combination of supplemental codes

L	○					
MA	○	○				
MN	○	○	—			
Q	—	○	○	○		
U	○	○	○	○	—	
W	—	○	○	○	○	○
	E	L	MA	MN	Q	U

Remarks 1. The combination of "—" shown in the table is not available.  
2. When using multiple types for combination, please indicate by arranging the symbols in alphabetical order.

**Table 7 Dimension of slide unit with C-Lube plate (Supplemental code /Q)**

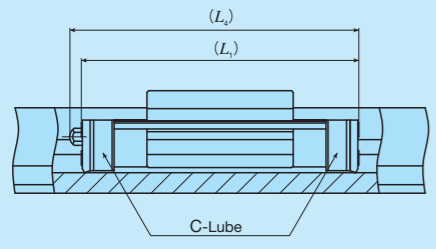

unit: mm

Size	$L_1$	$L_4$
40	67	68
50	82	83
60	95	100
86	142	146
100	166	170
130	190	194

Remark: The dimensions of the slide unit with C-Lube at both ends are indicated.

**Table 8 Dimension of slide unit with upper seal (Supplemental code /U)**

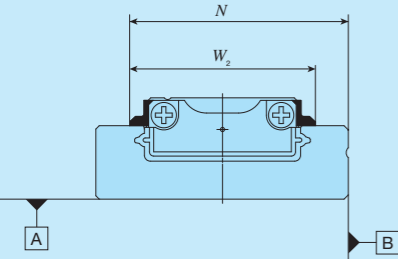

unit: mm

Size	$N$	$W_2$
25	21.4	18
30	25.9	22

## Moment of Inertia of Sectional Area

High rigidity design of C-Lube linear way MUL and LWU are achieved by adopting a U-shaped track rail. The moment of inertia of sectional area of track rails are shown in Table 9.

**Table 9 Moment of inertia of sectional area of track rails**

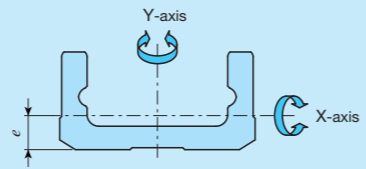

Identification number	Moment of inertia of sectional area $\text{mm}^4$		Center of gravity $e$ mm
	$I_x$	$I_y$	
MUL 25 LWUL 25...B	$3.7 \times 10^2$	$7.5 \times 10^3$	2.6
MUL 30 LWUL 30...B	$9.3 \times 10^2$	$1.7 \times 10^4$	3.3
— LWU 40...B	$1.0 \times 10^4$	$6.8 \times 10^4$	6.6
— LWU 40		$6.9 \times 10^4$	
— LWU 50...B	$2.8 \times 10^4$	$1.7 \times 10^5$	8.7
— LWU 50			
— LWU 60...B	$6.3 \times 10^4$	$3.9 \times 10^5$	10.7
— LWU 60			
— LWU 86...B	$2.4 \times 10^5$	$1.6 \times 10^6$	14.6
— LWU 86			
— LWU 100	$5.9 \times 10^5$	$3.3 \times 10^6$	18.8
— LWU 130	$1.4 \times 10^6$	$8.8 \times 10^6$	23.0

## Lubrication

In the series of size 25 and 30 of MUL series and LWU series, lithium-soap base grease (MULTEMP PS No.2, KYODO YUSHI) is pre-packed, and in the series of size 40 to 130, lithium-soap base grease with extreme-pressure additive (Alvania EP grease 2 [SHOWA SHELL SEKIYU K. K.]) is pre-packed. Additionally, MUL series has C-Lube placed in the recirculation part of balls, so that the interval for reapplying lubricant can be extended and maintenance works such as grease job can be reduced significantly.

MUL series and LWU series have grease nipple or oil hole as indicated in Table 11. Supply nozzles fit to each shapes of grease nipple and dedicated supplying equipment (miniature greasers) fit to oil holes are also available. For order of these parts for lubrication, see Table 13 and Table 14.1 on page III-23, and Table 15 on page III-24.

**Table 10 Oil hole specifications**

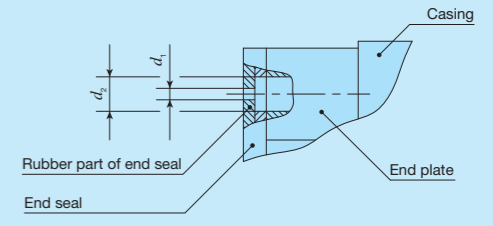

unit: mm

Size	$d_1$	$d_2$
25	0.5	1.2
30		1.5

**Table 11 Lubrication parts and position of grease nipple**

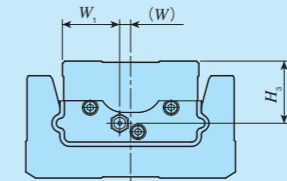

Size	Grease nipple type <sup>(1)</sup>	Applicable supply nozzle type	Bolt size of female threads for piping	Grease nipple position mm		
				$W_1$	$W$	$H_3$
25	Oil hole	Miniature greaser	—	7	0	2.9
30				9	0	3.75
40	A-M4	A-5120V	M4	13	0	10.5
50		B-5120V		17	0	13.5
60	JIS type 1	Grease gun available on the market	M6	19	0	14.5
86				23.5	4.5	25.5
100				28.5	4	29
130				44	0	35.5

Note <sup>(1)</sup> For grease nipple specification, see Tables 14.1 and 14.2 on page III-23.

Remark: Stainless steel grease nipple is also available. If needed, please contact **IKO**.

# Dust Protection

The slide units of MUL series and LWU series are equipped with end seals and upper seals as standard for dust protection. However, if large amount of contaminant or dust are floating, or if large particles of foreign substances such as chips or sand may adhere to the track rail, it is recommended to attach a protective cover to the linear motion mechanism.

# Precaution for Use

## ① Mounting surface, reference mounting surface and typical mounting structure

When mounting the MUL series and LWU series, properly align the reference mounting surfaces B and D of the track rail and slide unit with the reference mounting surface of the table and bed and fix them. (See Fig. 2)

The reference mounting surfaces B and D and mounting surfaces A and C are precisely ground. Machining the mounting surface of the table and bed, such as machine or device, to high accuracy and mounting them properly will ensure stable linear motion with high accuracy.

Reference mounting surfaces of slide unit and track rail of the MUL series and LWU series are the opposite side of the  mark. (See Fig. 3)

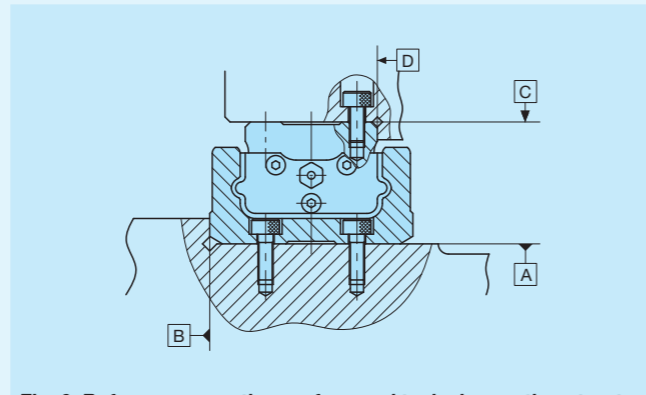

Fig. 2 Reference mounting surface and typical mounting structure

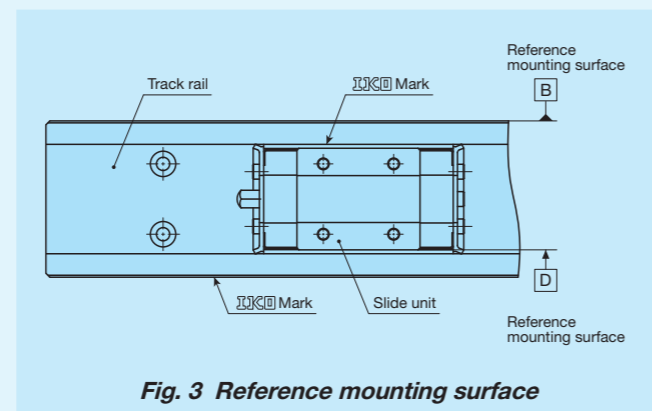

Fig. 3 Reference mounting surface

## ② Shoulder height and corner radius of the reference mounting surface

For the opposite corner of the mating reference mounting, it is recommended to have relieved fillet as indicated in Fig. 4. Recommended value for the shoulder height and corner radius on the mating side is indicated in Table 13.

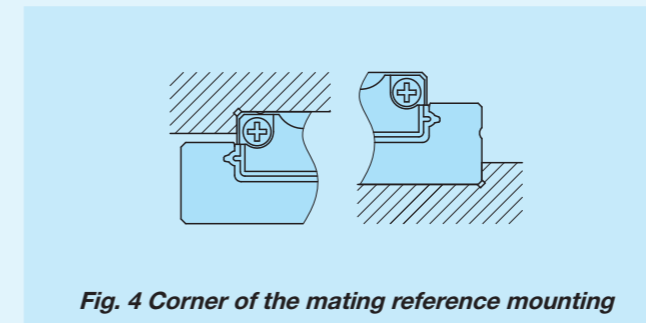

Fig. 4 Corner of the mating reference mounting

## ③ Tightening torque for fixing screw

Typical tightening torque for mounting of the MUL series and LWU series to the steel mating member material is indicated in Table 12. When vibration and shock of the machine or device are large, fluctuating load is large, or moment load is applied, fix it by using the torque 1.2 to 1.5 times larger than the value indicated in the table as necessary. If the mating member material is cast iron or aluminum alloy, reduce the tightening torque depending on the strength characteristics of the mating member material.

Table 12 Tightening torque for fixing screw

Bolt size	Tightening torque N · m	
	Stainless steel-made screw	High carbon steel-made screw
M 2.5×0.45	0.62	—
M 3 ×0.5	1.1	1.8
M 4 ×0.7	2.5	4.1
M 5 ×0.8	—	8.0
M 6 ×1	—	13.6
M 8 ×1.25	—	32.7
M10 ×1.5	—	63.9

Note (1) The tightening torque is calculated based on strength division 12.9 and property division A2-70.

Table 13 Shoulder height and corner radius of the reference mounting surface

Size	Mounting part of slide unit		Mounting part of track rail	
	Shoulder height $h_1$	Corner radius $R_1$ (Maximum)	Shoulder height $h_2$	Corner radius $R_2$ (Maximum) (1)
25	1.5	0.2	2.5	—
30	2.5	0.2	3	—
40	3	0.5	5	1
50	3	0.5	7	2
60	3	0.5	9	2
86	4	0.5	11	2
100	4	0.5	13	1
130	5	1	14	2

unit: mm

Note (1) In sizes 25 and 30, provide a relieved fillet as shown in Fig. 4.

# IKO C-Lube Linear Way MUL

Small type	
Shape	MUL · LWUL
Size	25    30
Standard type	
Shape	LWU (...B)
Size	40    50    60 86    100    130

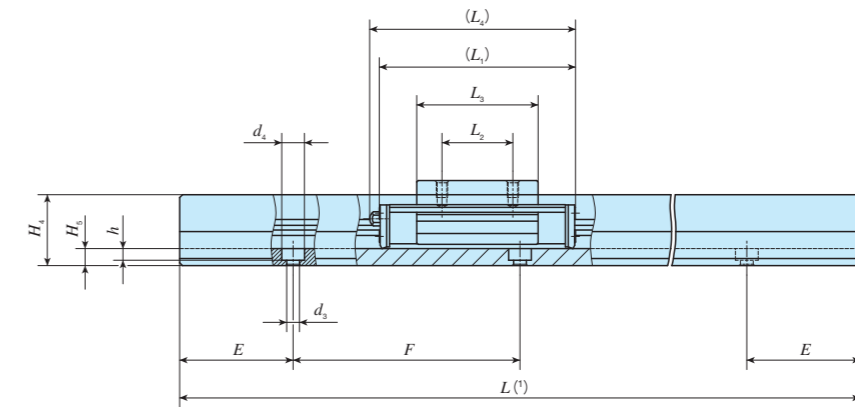
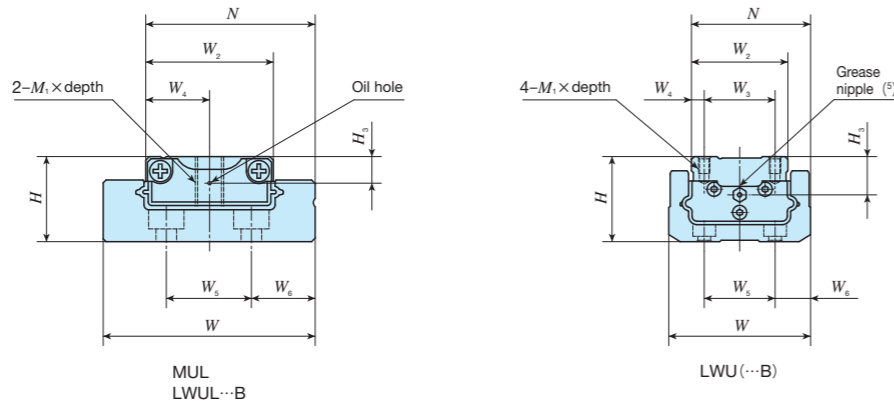

Identification number		Interchangeable	Mass(Ref.)		Dimensions of assembly mm		Dimensions of slide unit mm										Dimensions of track rail mm							Appended mounting bolt for track rail (3) mm Bolt size × ℓ	Basic dynamic load rating (4) C N	Basic static load rating (4) C <sub>0</sub> N	Static moment rating (4)				
MUL series	LWU series (No C-Lube)		Slide unit kg	Track rail kg/m	H	N	W <sub>2</sub>	W <sub>3</sub>	W <sub>4</sub>	L <sub>1</sub>	L <sub>2</sub>	L <sub>3</sub>	L <sub>4</sub>	M <sub>1</sub> × depth	H <sub>3</sub>	W	H <sub>4</sub>	H <sub>5</sub>	W <sub>5</sub>	W <sub>6</sub>	d <sub>3</sub>	d <sub>4</sub>	h				E	F	T <sub>0</sub> N · m	T <sub>x</sub> N · m	T <sub>y</sub> N · m
MUL 25	LWUL 25...B	-	0.013	0.87	9	19.4	14	-	7	31	12	22	-	M 3 × 5	2.9	24.9	6.7	3.2	9	8	2.9	4.8	1.6	17.5	35	Cross-recessed pan head screw for precision equipment M 2.5 × 6	1 770	2 840	20.3	10.1 53.7	8.4 45.0
MUL 30	LWUL 30...B	-	0.028	1.39	12	23.9	18	-	9	38	14	28.6	-	M 4 × 7	3.75	29.9	8.7	4.5	12	9	2.9	5	2.7	20	40	M 2.5 × 6	2 280	3 810	34.9	16.9 87.5	14.2 73.4
-	LWU 40...B	-	0.12	2.65	24	33	26	18	4	55	18	31.5	59	M 3 × 5	10.5	40	19	5	18	11	3.4	6.5	3.1	30	60	M 3 × 8 (Not appended)	8 410	9 780	134	53.0 351	53.0 351
-	LWU 40(2)	-	0.12	2.66	24	33	26	18	4	55	18	31.5	59	M 3 × 5	10.5	40	19	5	18	11	3.4	6.5	3.1	30	60	M 3 × 8 (Not appended)	8 410	9 780	134	53.0 351	53.0 351
-	LWU 50...B	-	0.27	4.06	30	42	34	25	4.5	70	25	42.8	73	M 4 × 6	13.5	50	25	6	25	12.5	4.5	8	4.1	40	80	M 4 × 10 (Not appended)	13 500	15 800	280	114 711	114 711
-	LWU 50(2)	-	0.27	4.08	30	42	34	25	4.5	70	25	42.8	73	M 4 × 6	13.5	50	25	6	25	12.5	4.5	8	4.1	40	80	M 4 × 10 (Not appended)	13 500	15 800	280	114 711	114 711
-	LWU 60...B	-	0.40	6.66	35	49	38	28	5	83	28	52.4	88	M 5 × 8	14.5	60	30	8	28	16	5.5	9.5	5.4	50	100	M 5 × 12 (Not appended)	18 800	21 600	425	181 1 150	181 1 150
-	LWU 60(2)	-	0.40	6.69	35	49	38	28	5	83	28	52.4	88	M 5 × 8	14.5	60	30	8	28	16	5.5	9.5	5.4	50	100	M 5 × 12 (Not appended)	18 800	21 600	425	181 1 150	181 1 150
-	LWU 86...B	-	1.32	14.1	48	71	56	46	5	130	46	93	134	M 6 × 12	25.5	86	42	13	46	20	7	11	7	50	100	M 6 × 16 (Not appended)	41 400	51 500	1 470	764 4 120	764 4 120
-	LWU 86(2)	-	1.32	14.1	48	71	56	46	5	130	46	93	134	M 6 × 12	25.5	86	42	13	46	20	7	11	7	50	100	M 6 × 16 (Not appended)	41 400	51 500	1 470	764 4 120	764 4 120
-	LWU 100(2)	-	2.20	21.5	58	82	65	50	7.5	154	50	111	158	M 8 × 15	29	99.5	52	17	50	24.5	9	14	9	75	150	M 8 × 20 (Not appended)	54 600	68 500	2 230	1 210 6 460	1 210 6 460
-	LWU 130(2)	-	4.49	33.0	72	109	88	70	9	178	70	132	182	M10 × 20	35.5	130	65	20	70	30	11	17.5	10.6	75	150	M10 × 25 (Not appended)	70 300	88 800	3 920	1 830 9 630	1 830 9 630

Notes (1) Track rail lengths L are shown in Table 2 on page II - 160.

(2) The balls are not retained.

(3) The appended track rail mounting bolts are hexagon socket head bolts equivalent to JIS B 1176 or JCS10-70 cross-recessed pan head screw for precision equipment. For the size 25 and 30 series, stainless steel bolts are appended. Track rail mounting bolts are not appended for MUL series.

(4) The direction of basic dynamic load rating (C), basic static load rating (C<sub>0</sub>), and static moment rating (T<sub>0</sub>, T<sub>x</sub>, T<sub>y</sub>) are shown in the sketches below. The upper values of T<sub>x</sub> and T<sub>y</sub> are for one slide unit and the lower values are for two slide units in close contact.

(5) The shapes of grease nipple vary by size. The specifications are shown in Table 11 on page II - 164.

Remark: The specification of oil hole is shown in Table 10 on page II - 164.

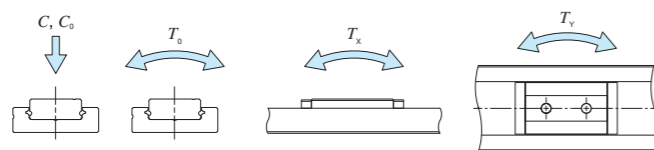

## Example of identification number of assembled set

Model code    Dimensions    Part code    Model code    Preload symbol    Classification symbol    Supplemental code

**MUL**    **25**    **C2**    **R280**       **T1**    **H**    **/Q**

①    ②    ③    ④    ⑤    ⑥    ⑦    ⑧

① Model  
MUL  
LWUL...B  
LWU...B

② Size  
25, 30, 40, 50, 60, 86, 100, 130

③ Number of slide unit (2)  
④ Length of track rail (280 mm)

⑤ Structure  
B Ball retained type  
No symbol Ball non-retained type

⑥ Preload amount  
No symbol Standard  
T1 Light preload

⑦ Accuracy class  
No symbol Ordinary  
H High

⑧ Special specification  
E, LR, MA, MN, Q, U, W

## C-Lube Linear Roller Way Super MX Linear Roller Way Super X



# C-Lube Linear Roller Way Super MX

# MX



long term maintenance free supported!

The aquamarine end plate is the symbol of maintenance free.

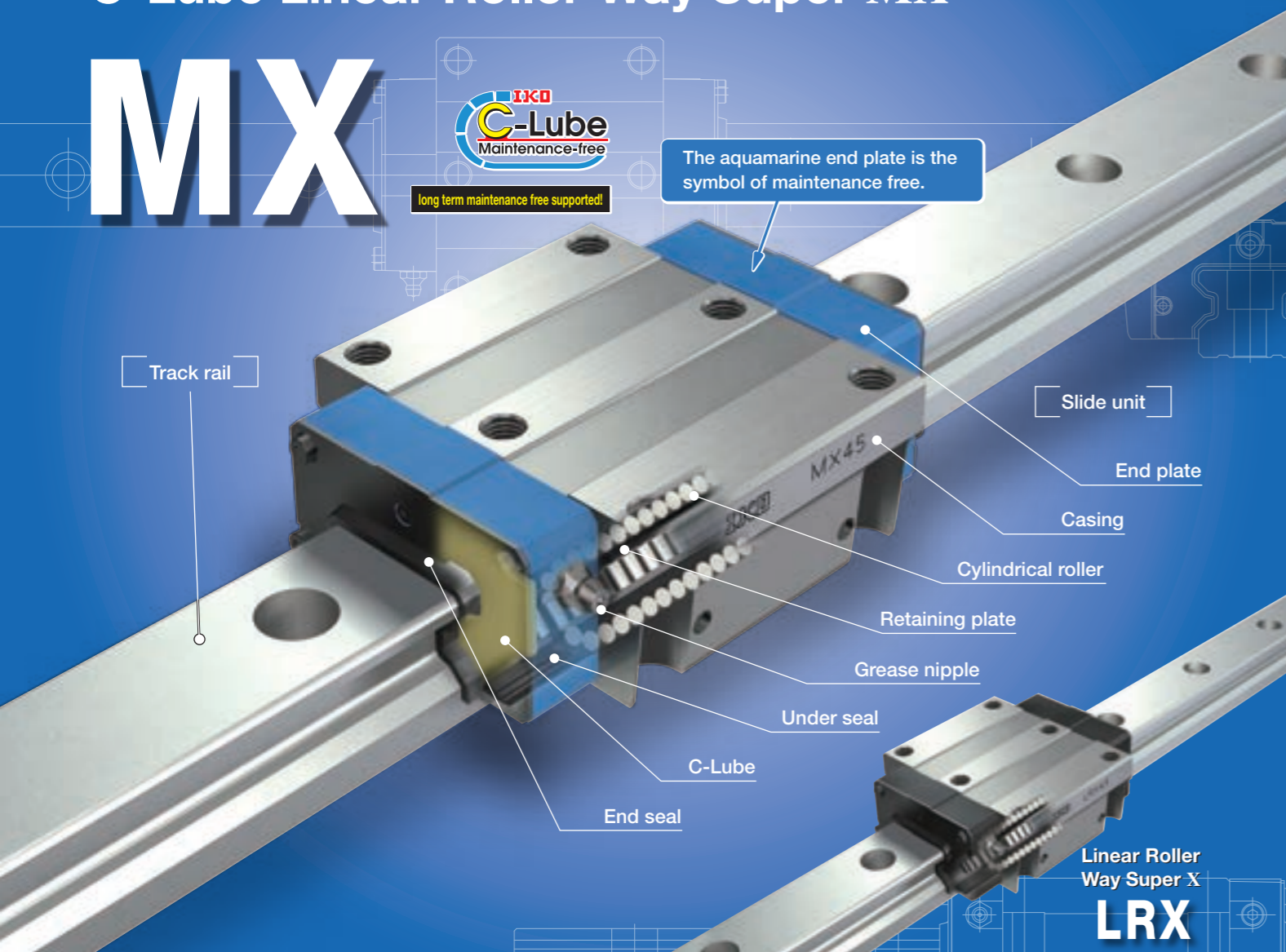

## Points

- **Roller type linear motion rolling guides having the highest level of rolling guide performance** For details ▶ P.I-21

Linear motion rolling guide that has achieved the highest level of performance in all characteristics, including load capacity, rigidity, friction characteristics and accuracy, brought about by utilizing the roller's excellent characteristic.

- **Wide range of variations for your needs** For details ▶ P.I-28

A wide variety of products, including five types of different slide unit shape such as the flange type, low profile flange type and low profile block type with low cross sectional height, etc., and four types of different slide unit length with varying lengths with same section are available. You can select an optimal product for the specifications of your machine and device.

- **Extra long unit** For details ▶ P.I-29

Extra long slide unit series having the length 1.4 to 1.5 times of standard type is now available. With more rollers built into the slide units, the new series not only have the enhanced load capacity and rigidity but also exhibit super accuracy running performance.

- **Stainless steels selections superior in corrosion resistance are listed on lineup.** For details ▶ P.I-41

A series of stainless steel products is available from the miniature size of track rail width 10 mm. They are highly corrosion-resistant and suitable for applications where rust prevention oil is not preferred, such as in cleanroom environment.

- **Easy replacement from ball type** For details ▶ P.I-24

Mounting dimensions are compatible with MH / LWH series of ball type. Therefore, replacement to roller type is possible without major design changes of machine and device.

## Identification Number and Specification

### Example of an identification number

The specifications of MX and LRX series are indicated by the identification number. Indicate the identification number, consisting of a model code, dimensions, a part code, a material code, a preload symbol, a classification symbol, an interchangeable code, and any supplemental codes for each specification to apply.

Non-interchangeable specification	1	2	3	4	5	6	7	8	9	10
Assembled set	MX	G	15	C2	R240		T <sub>1</sub>	P		/Z
Interchangeable specification										
Single slide unit	MX	G	15	C1			T <sub>1</sub>	P	S1	/Z
Single track rail (*)	LRX		15		R240			P	S1	
Assembled set	MX	G	15	C2	R240		T <sub>1</sub>	P	S1	/Z

- 1 **Model** Model code Page II - 173
- 2 **Length of slide unit**
- 3 **Size** Dimensions Page II - 173
- 4 **Number of slide units** Part code Page II - 174
- 5 **Length of track rail**
- 6 **Material type** Material code Page II - 174
- 7 **Preload amount** Preload symbol Page II - 177
- 8 **Accuracy class** Classification symbol Page II - 178
- 9 **Interchangeable** Interchangeable code Page II - 179
- 10 **Special specification** Supplemental code Page II - 179

Note (\*) Indicate "LRX" for the model code of the single track rail regardless of the series and the combination of slide unit model.

# Identification Number and Specification — Model · Length of Slide Unit · Size —

**1 Model**

C-Lube Linear Roller Way Super MX (MX series) Flange type mounting from top / bottom : MX <sup>(2)</sup>  
 Block type mounting from top : MXD  
 Compact block type mounting from top : MXS  
 Low profile flange type mounting from top : MXN  
 Low profile block type mounting from top : MXNS

Linear Roller Way Super X <sup>(1)</sup> (LRX series) Flange type mounting from top / bottom : LRX <sup>(2)</sup>  
 Block type mounting from top : LRXD  
 Compact block type mounting from top : LRXS

For applicable models and sizes, see Table 1.1 and Table 1.2.  
 Indicate "LRX" for the model code of the single track rail regardless of the series and the combination of slide unit models.

Notes <sup>(1)</sup> This model has no built-in C-Lube.  
<sup>(2)</sup> Series of size 20 can only be mounted by the bolts from top. The models with the same dimensions allowing mounting from bottom are "MXH" and "LRXH."

**2 Length of slide unit**

Short : C For applicable models and sizes, see Table 1.1 and Table 1.2.  
 Standard : No symbol  
 Long : G  
 Extra long : L

**3 Size**

10, 12, 15, 20, 25, 30, 35, 45, 55, 65, 85, 100 For applicable models and sizes, see Table 1.1 and Table 1.2.

Table 1.1 Models and sizes of MX and LRX series

Material	Shape	Slide unit Length	Model	Size																									
				10	12	15	20	25	30	35	45	55	65	85	100														
High carbon steel made	Flange type mounting from top / bottom	Short	MXC	-	○	○	○ <sup>(1)</sup>	○	○	○	○	○	○	-	-	LRXC	-	○	○	○ <sup>(1)</sup>	○	○	○	○	○	○	-	-	
			MX	-	○	○	○ <sup>(1)</sup>	○	○	○	○	○	○	○	-	-	LRX	-	○	○	○ <sup>(1)</sup>	○	○	○	○	○	○	-	-
		Long	MXG	-	○	○	○ <sup>(1)</sup>	○	○	○	○	○	○	○	-	-	LRXG	-	○	○	○ <sup>(1)</sup>	○	○	○	○	○	○	-	-
			MXL	-	-	-	○ <sup>(1)</sup>	○	○	○	○	○	○	○	-	-	LRXL	-	-	-	-	-	-	-	-	-	○	-	-
		Extra long	MXDC	-	○	○	○	○	○	○	○	○	○	○	-	-	LRXDC	-	○	○	○	○	○	○	○	○	○	-	-
			Standard	MXD	-	○	○	○	○	○	○	○	○	○	-	-	LRXD	-	○	○	○	○	○	○	○	○	○	-	-
		Long		MXDG	-	○	○	○	○	○	○	○	○	○	-	-	LRXDG	-	○	○	○	○	○	○	○	○	○	-	-
			Extra long	MXDL	-	-	-	○	○	○	○	○	○	○	-	-	LRXDL	-	-	-	-	-	-	-	-	-	○	-	-
	Block type mounting from top	Short		MXS	-	-	○	○	○	○	○	○	○	○	-	-	LRXS	-	-	○	○	○	○	○	○	○	○	-	-
			MXSG	-	-	○	○	○	○	○	○	○	○	-	-	LRXSG	-	-	○	○	○	○	○	○	○	○	-	-	
		Standard	MXNS	-	-	-	-	-	○	○	○	○	○	-	-	MXNSL	-	-	-	-	-	○	○	○	○	-	-	-	
			MXNSG	-	-	-	-	-	○	○	○	○	○	-	-	MXNSL	-	-	-	-	-	○	○	○	○	-	-	-	
		Long	MXNG	-	-	-	-	-	○	○	○	○	○	-	-	MXNGL	-	-	-	-	-	○	○	○	○	-	-	-	
			MXNL	-	-	-	-	-	○	○	○	○	○	-	-	MXNGL	-	-	-	-	-	○	○	○	○	-	-	-	
Stainless steel made	Block type mounting from top	Short	LRXDC...SL	-	○	○	○	○	○	○	○	-	-	MXD...SL	○	○	○	○	○	○	-	-	-	-	-	-			
		Standard	LRXD...SL	○	○	○	○	○	○	○	○	○	-	-	LRXD...SL	○	○	○	○	○	○	-	-	-	-	-	-		
		Long	LRXDG...SL	-	○	○	○	○	○	○	○	○	-	-	LRXDG...SL	-	○	○	○	○	○	-	-	-	-	-	-		

Note <sup>(1)</sup> MXC20, MX20, MXG20, MXL20, LRXC20, LRX20 and LRXG20 can only be mounted by the bolts from top.  
 The models with the same dimensions allowing mounting from bottom are MXHC20, MXH20, MXHG20, MXHL20, LRXHC20, LRXH20 and LRXHG20.  
 Remark: For the models indicated in  , the interchangeable specification is available.

# — Number of Slide Unit · Length of Track Rail · Material Type —

**4 Number of slide units** : C○ For an assembled set, indicates the number of slide units assembled on a track rail. For a single slide unit, only "C1" is specified.

**5 Length of track rail** : R○ Indicate the length of track rail in mm. For the standard and maximum lengths, see Table 2.1, Table 2.2, Table 2.3 and Table 2.4.

**6 Material type**  
 High carbon steel made : No symbol For applicable models and sizes, see Table 1.1 and Table 1.2.  
 Stainless steel made <sup>(1)</sup> : SL

Note <sup>(1)</sup> Mount a standard grease nipple (brass) on the stainless steel type, too.  
 Stainless steel grease nipple is also available. If needed, please contact **IKO**.

Table 1.2 Models and sizes of MX and LRX series

Material	Shape	Slide unit Length	Model	Size																								
				10	12	15	20	25	30	35	45	55	65	85	100													
High carbon steel made	Compact block type mounting from top	Short	MXSC	-	-	○	○	○	○	○	○	○	-	-	LRXSC	-	-	○	○	○	○	○	○	○	○	-	-	
			MXS	-	-	○	○	○	○	○	○	○	○	-	-	LRXS	-	-	○	○	○	○	○	○	○	○	-	-
		Long	MXSG	-	-	○	○	○	○	○	○	○	○	-	-	LRXSG	-	-	○	○	○	○	○	○	○	○	-	-
			MXSL	-	-	-	○	○	○	○	○	○	○	-	-	MXSL	-	-	-	○	○	○	○	○	○	-	-	-
		Extra long	MXN	-	-	-	-	-	○	○	○	○	○	-	-	MXNL	-	-	-	-	-	○	○	○	○	-	-	-
			MXNG	-	-	-	-	-	○	○	○	○	○	-	-	MXNL	-	-	-	-	-	○	○	○	○	-	-	-
		Low profile flange type mounting from top	Standard	MXNS	-	-	-	-	-	○	○	○	○	-	-	MXNSL	-	-	-	-	-	○	○	○	○	-	-	-
			Long	MXNSG	-	-	-	-	-	○	○	○	○	-	-	MXNSL	-	-	-	-	-	○	○	○	○	-	-	-
	Extra long	MXNSL	-	-	-	-	-	○	○	○	○	○	-	-	MXNSL	-	-	-	-	-	○	○	○	○	-	-	-	
		MXNSL	-	-	-	-	-	○	○	○	○	○	-	-	MXNSL	-	-	-	-	-	○	○	○	○	-	-	-	
	Stainless steel made	Block type mounting from top	Short	LRXDC...SL	-	○	○	○	○	○	○	○	-	-	MXD...SL	○	○	○	○	○	○	-	-	-	-	-	-	
			Standard	LRXD...SL	○	○	○	○	○	○	○	○	○	-	-	LRXD...SL	○	○	○	○	○	○	-	-	-	-	-	-
			Long	LRXDG...SL	-	○	○	○	○	○	○	○	○	-	-	LRXDG...SL	-	○	○	○	○	○	-	-	-	-	-	-

Remark: For the models indicated in  , the interchangeable specification is available.





—Preload Amount—

<b>7 Preload amount</b>	Standard	: No symbol	Specify this item for an assembled set or a single slide unit.
	Light preload	: T <sub>1</sub>	
	Medium preload	: T <sub>2</sub>	For details of the preload amount, see Table 3.
	Heavy preload	: T <sub>3</sub>	For applicable preload types, see Table 4.

Table 3 Preload amount

Preload type	Item	Preload symbol	Preload amount N	Operational conditions
Standard	(No symbol)		0 <sup>(1)</sup>	• Light and precise motion
Light preload	T <sub>1</sub>		0.02 C <sub>0</sub>	• Almost no vibrations • Load is evenly balanced • Light and precise motion
Medium preload	T <sub>2</sub>		0.05 C <sub>0</sub>	• Medium vibration • Medium overhung load
Heavy preload	T <sub>3</sub>		0.08 C <sub>0</sub>	• Operation with vibration and/or shock • Overhanging load applied • Heavy cutting

Note <sup>(1)</sup> Indicates zero or minimal amount of preload.  
Remark: C<sub>0</sub> indicates the basic static load rating.

Table 4 Application of preload

Size	Preload type (preload symbol)			
	Standard (No symbol)	Light preload (T <sub>1</sub> )	Medium preload (T <sub>2</sub> )	Heavy preload (T <sub>3</sub> )
10	○	○	—	—
12	○	○	○	○
15	○	○	○	○
20	○	○	○	○
25	○	○	○	○
30	○	○	○	○
35	○	○	○	○
45	○	○	○	○
55	○	○	○	○
65	○	○	○	○
85	○	○	○	○
100	○	○	○	○

Remark: The mark  indicates that interchangeable specification products are available.

—Accuracy Class—

<b>8 Accuracy class</b>	High	: H	For interchangeable specification products, assemble a slide unit and a track rail of the same accuracy class.
	Precision	: P	For details of accuracy class, see Table 5.
	Super precision	: SP	
	Ultra precision	: UP	For applicable accuracy class, see Table 6.

Table 5 Tolerance and allowance

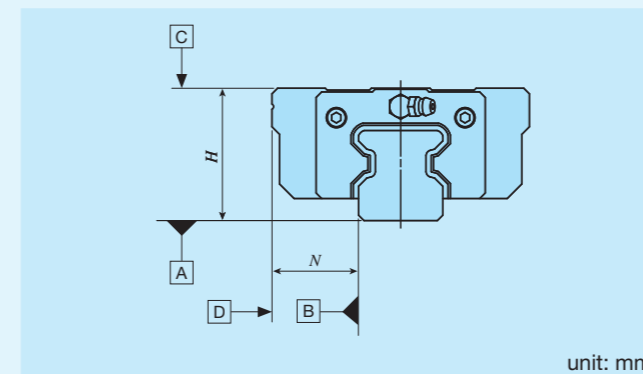

Class (classification symbol)	High (H)	Precision (P)	Super precision (SP)	Ultra precision (UP)
Item				
Dim. H tolerance	±0.040	±0.020	±0.010	±0.008
Dim. N tolerance	±0.050	±0.025	±0.015	±0.010
Dim. variation of H <sup>(1)</sup>	0.015	0.007	0.005	0.003
Dim. variation of N <sup>(1)</sup>	0.020	0.010	0.007	0.003
Dim. variation of H for multiple assembled sets <sup>(2)</sup>	0.035	0.025	—	—
Parallelism in operation of the slide unit C surface to A surface	See Fig. 1			
Parallelism in operation of the slide unit D surface to B surface	See Fig. 1			

Notes <sup>(1)</sup> It means the size variation between slide units mounted on the same track rail.  
<sup>(2)</sup> Applicable to the interchangeable specification.

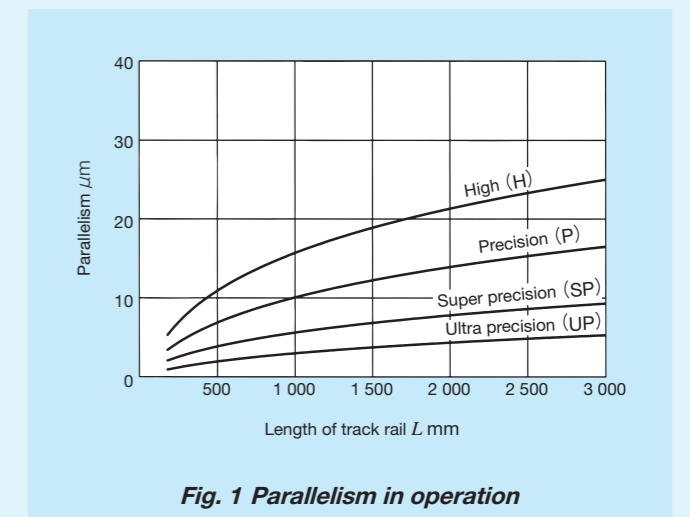

Table 6 Application of accuracy class

Size	Class (classification symbol)			
	High (H)	Precision (P)	Super precision (SP)	Ultra precision (UP)
10	○	○	○	○
12	○	○	○	○
15	○	○	○	○
20	○	○	○	○
25	○	○	○	○
30	○	○	○	○
35	○	○	○	○
45	○	○	○	○
55	○	○	○	○
65	○	○	○	○
85	○	○	○	○
100	○	○	○	○

Remark: The mark  indicates that interchangeable specification products are available.

<b>9 Interchangeable</b>	S1 specification	: S1	This is specified for the interchangeable specifications.
	S2 specification	: S2	Assemble a track rail and a slide unit with the same interchangeable code. Performance and accuracy of "S1" and "S2" are the same.
	Non-interchangeable specification	: No symbol	For applicable models and sizes, see Table 1.1 and Table 1.2. "No symbol" is indicated for non-interchangeable specification.
<b>10 Special specification</b>	/A, /D, /E, /F, /GE, /HP, /I, /JO, /LO, /LFO, /MA, /MN, /N, /PS, /Q, /RCO, /T, /UR, /VO, /WO, /YO, /ZO		For applicable special specifications, see Tables 7.1, 7.2, 7.3, and 7.4. For combination of multiple special specifications, see Table 8. For details of special specifications, see page III – 29.

Table 7.1 Application of special specifications (Interchangeable specification, single slide unit)

Special specification	Supplemental code	Size											
		10	12	15	20	25	30	35	45	55	65	85	100
Changed pitch of slide unit middle mounting holes <sup>(1)</sup>	/GE	–	×	○	○	○	○	○	○	○	○	–	–
Female threads for bellows <sup>(2)</sup>	/JO	–	×	○	○	○	○	○	○	○	○	–	–
No end seal <sup>(3)</sup>	/N	–	○	○	○	○	○	○	○	×	×	–	–
With C-Lube plate <sup>(4)</sup>	/Q	–	○	○	○	○	○	○	○	○	○	–	–
Double end seals	/VO	–	○	○	○	○	○	○	○	○	○	–	–
Scrapers	/ZO	–	○	○	○	○	○	○	○	○	○	–	–

Notes <sup>(1)</sup> Applicable to flange type (MX, MXG, MXH20, MXHG20, LRX, LRXG, LRXH20, LRXHG20).  
<sup>(2)</sup> Not applicable to stainless steel made products.  
<sup>(3)</sup> Not applicable to low profile flange type (MXN, MXNG, MXNL) and low profile block type (MXNS, MXNSG, MXNSL).  
<sup>(4)</sup> Applicable to LRX series.

Table 7.2 Application of special specifications (Interchangeable specification, single track rail)

Special specification	Supplemental code	Size											
		10	12	15	20	25	30	35	45	55	65	85	100
Specified rail mounting hole positions	/E	–	○	○	○	○	○	○	○	○	○	–	–
Caps for rail mounting holes	/F	–	○	○	○	○	○	○	○	○	○	–	–
Half pitch mounting holes for track rail	/HP	–	○	○	○	○	○	○	○	○	○	–	–
Female threads for bellows <sup>(1)</sup>	/JO	–	×	○	○	○	○	○	○	○	○	–	–
Black chrome surface treatment	/LR	–	○	○	○	○	○	○	○	○	○	–	–
Without track rail mounting bolt	/MN	–	○	○	○	○	○	○	○	○	○	–	–
Butt-jointing track rails	/T	–	○	○	○	○	○	○	○	○	○	–	–

Note <sup>(1)</sup> Not applicable to stainless steel made products.

Table 7.3 Application of special specifications (Interchangeable specification, assembled set)

Special specification	Supplemental code	Size												
		10	12	15	20	25	30	35	45	55	65	85	100	
Opposite reference surfaces arrangement	/D	–	○	○	○	○	○	○	○	○	○	–	–	
Specified rail mounting hole positions	/E	–	○	○	○	○	○	○	○	○	○	–	–	
Caps for rail mounting holes	/F	–	○	○	○	○	○	○	○	○	○	–	–	
Changed pitch of slide unit middle mounting holes <sup>(1)</sup>	/GE	–	×	○	○	○	○	○	○	○	○	–	–	
Half pitch mounting holes for track rail	/HP	–	○	○	○	○	○	○	○	○	○	–	–	
Female threads for bellows <sup>(2)</sup>	/JO	–	×	○	○	○	○	○	○	○	○	–	–	
Black chrome surface treatment	/LO	–	○	○	○	○	○	○	○	○	○	–	–	
Fluorine black chrome surface treatment	/LFO	–	○	○	○	○	○	○	○	○	○	–	–	
With track rail mounting bolt <sup>(3)</sup>	/MA	–	○	○	○	○	○	○	○	○	○	–	–	
Without track rail mounting bolt <sup>(4)</sup>	/MN	–	○	○	○	○	○	○	○	○	○	–	–	
No end seal <sup>(5)</sup>	/N	–	○	○	○	○	○	○	○	○	×	×	–	–
With C-Lube plate <sup>(4)</sup>	/Q	–	○	○	○	○	○	○	○	○	○	–	–	
Butt-jointing track rails	/T	–	○	○	○	○	○	○	○	○	○	–	–	
Double end seals	/VO	–	○	○	○	○	○	○	○	○	○	–	–	
Specified grease <sup>(6)</sup>	/YO	–	○	○	○	○	○	○	○	○	○	–	–	
Scrapers	/ZO	–	○	○	○	○	○	○	○	○	○	–	–	

Notes <sup>(1)</sup> Applicable to flange type (MX, MXG, MXH20, MXHG20, LRX, LRXG, LRXH20, LRXHG20).  
<sup>(2)</sup> Not applicable to stainless steel made products.  
<sup>(3)</sup> Applicable to MX series.  
<sup>(4)</sup> Applicable to LRX series.  
<sup>(5)</sup> Not applicable to low profile flange type (MXN, MXNG, MXNL) and low profile block type (MXNS, MXNSG, MXNSL).  
<sup>(6)</sup> MX series is applicable only to /YCG.

Table 7.4 Application of special specifications (Non-interchangeable specification)

Special specification	Supplemental code	Size											
		10	12	15	20	25	30	35	45	55	65	85	100
Butt-jointing track rails	/A	○	○	○	○	○	○	○	○	○	○	○	○
Opposite reference surfaces arrangement	/D	○	○	○	○	○	○	○	○	○	○	○	○
Specified rail mounting hole positions	/E	○	○	○	○	○	○	○	○	○	○	○	○
Caps for rail mounting holes	/F	×	○	○	○	○	○	○	○	○	○	○	○
Changed pitch of slide unit middle mounting holes <sup>(1)</sup>	/GE	×	×	○	○	○	○	○	○	○	○	×	○
Half pitch mounting holes for track rail	/HP	×	○	○	○	○	○	○	○	○	○	○	×
Inspection sheet	/I	○	○	○	○	○	○	○	○	○	○	○	○
Female threads for bellows	/JO	×	×	○	○	○	○	○	○	○	○	○	×
Black chrome surface treatment	/LO	×	○	○	○	○	○	○	○	○	○	×	×
Fluorine black chrome surface treatment	/LFO	×	○	○	○	○	○	○	○	○	○	×	×
With track rail mounting bolt <sup>(2)</sup>	/MA	○	○	○	○	○	○	○	○	○	○	×	×
Without track rail mounting bolt <sup>(3)</sup>	/MN	○	○	○	○	○	○	○	○	○	○	○	○
No end seal <sup>(4)</sup>	/N	○	○	○	○	○	○	○	○	○	×	×	×
Rail cover plate for track rail <sup>(3)</sup>	/PS	×	×	×	×	×	×	○	○	○	×	×	×
With C-Lube plate <sup>(3)</sup>	/Q	○	○	○	○	○	○	○	○	○	○	○	×
C-Wiper <sup>(2)</sup> <sup>(5)</sup>	/RCO	×	×	×	○	○	○	○	○	○	○	×	×
Inner seal <sup>(2)</sup>	/UR	×	×	×	○	○	○	○	○	○	○	×	×
Double end seals	/VO	×	○	○	○	○	○	○	○	○	○	○	○
A group of multiple assembled sets	/WO	○	○	○	○	○	○	○	○	○	○	×	×
Specified grease <sup>(6)</sup>	/YO	○	○	○	○	○	○	○	○	○	○	○	○
Scrapers	/ZO	×	○	○	○	○	○	○	○	○	○	○	○

Notes <sup>(1)</sup> Applicable to flange type (MX, MXG, MXH20, MXHG20, LRX, LRXG, LRXH20, LRXHG20).  
<sup>(2)</sup> Applicable to MX series.  
<sup>(3)</sup> Applicable to LRX series.  
<sup>(4)</sup> Not applicable to low profile flange type (MXN, MXNG, MXNL) and low profile block type (MXNS, MXNSG, MXNSL).  
<sup>(5)</sup> Since inner seal and scraper are mounted simultaneously, indication of "/UR" or "/Z" is not necessary.  
<sup>(6)</sup> MX series is applicable only to /YCG.



Table 10.2 Dimension of female threads for bellows (Supplemental code Single unit: /J Assembled set: /J /JJ)

Identification number		Slide unit								Track rail										
		$a_1$	$a_2$	$b_1$	$b_2$	$b_3$	$b_4$	$M_1 \times \text{depth}$	$L_1^{(1)}$	$a_3$	$a_4$	$M_2 \times \text{depth}$								
MXC 35	LRXC 35	6	16	30	20	60	M3 × 6	M3 × 6	99	8	16	M4 × 8								
MX 35	LRX 35								131											
MXG 35	LRXG 35								159											
MXL 35	—			191																
MXDC 35	LRXDC 35			99																
MXD 35	LRXD 35			131																
MXDG 35	LRXDG 35	13	15	5	60	M3 × 6	M3 × 6	159	8	16	M4 × 8									
MXDL 35	—							191												
MXS 35	—							131												
MXSG 35	—	7	21	35	23	74	M4 × 8	M4 × 8	159	10	19	M5 × 10								
MXC 45	LRXC 45								123											
MX 45	LRX 45								163											
MXG 45	LRXG 45			203																
MXL 45	—			243																
MXDC 45	LRXDC 45			123																
MXD 45	LRXD 45	17	18	6	74	M4 × 8	M4 × 8	163	10	19	M5 × 10									
MXDG 45	LRXDG 45							203												
MXDL 45	—							243												
MXS 45	—	7	27	40	26	88	M4 × 8	M4 × 8	163	10	24	M5 × 10								
MXSG 45	—								203											
MXC 55	LRXC 55								145											
MX 55	LRX 55			193																
MXG 55	LRXG 55			247																
MXL 55	—			301																
MXDC 55	LRXDC 55	17	20	6	88	M4 × 8	M4 × 8	145	10	24	M5 × 10									
MXD 55	LRXD 55							193												
MXDG 55	LRXDG 55							247												
MXDL 55	—	8.7	37	47.5	31	108	M5 × 10	M5 × 10	301	14	28	M6 × 12								
MXS 55	—								193											
MXSG 55	—								247											
MXC 65	—			15	45				62.5				90	140	M6 × 10	M6 × 10	191	14.5	38	M6 × 12
—	LRXC 65																192			
MX 65	—																255			
—	LRX 65	15	45	38	90	140	M6 × 10	M6 × 10	256	14.5	38	M6 × 12								
MXG 65	—								319											
—	LRXG 65								320											
MXL 65	—	15	45	90	13				140				M6 × 10	M6 × 10	391	14.5	38	M6 × 12		
MXDC 65	LRXDC 65														191					
MXD 65	—														192					
—	LRXD 65	15	45	90	13	140	M6 × 10	M6 × 10		255	14.5	38			M6 × 12					
MXDG 65	—									256										
—	LRXDG 65									319										
MXDL 65	—	15	45	90	13				140	M6 × 10			M6 × 10	320		14.5	38	M6 × 12		
—	LRX 85													391						
—	LRXG 85													334						
—	LRXL 85	15	45	90	13	140	M6 × 10	M6 × 10			406	14.5		38	M6 × 12					
—	LRXD 85										505									
—	LRXDG 85										334									
—	LRXDL 85	15	45	90	13				140	M6 × 10	M6 × 10		406			14.5	38	M6 × 12		
—	—												505							
—	—												505							

Note (1) Dimensions of the specification that female threads for bellows are fitted to both ends of the slide unit are indicated.

Table 10.3 Dimension of female threads for bellows (Supplemental code Single unit: /J Assembled set: /J /JJ)

Identification number	Slide unit								Track rail				
	$a_1^{(1)}$	$a_2$	$b_1$	$b_2$	$b_3$	$b_4$	$M_1 \times \text{depth}$	$L_1^{(2)}$	$H_3$	$a_3$	$a_4$	$M_2 \times \text{depth}$	
MXN 30	14.5	—	20	50	—	—	M3 × 6	M3 × 6	128	0.8	7	14	M4 × 8
MXNG 30									149				
MXNL 30									177				
MXNS 30			128										
MXNSG 30			149										
MXNSL 30			177										
MXN 35	2	16	30	40	60	M3 × 6	M3 × 6	M3 × 6	131	—	8	16	M4 × 8
MXNG 35									159				
MXNL 35									191				
MXNS 35			131										
MXNSG 35			159										
MXNSL 35			191										
MXN 45	1	21	35	50	74	M4 × 8	M4 × 8	M4 × 8	163	—	10	19	M5 × 10
MXNG 45									203				
MXNL 45									243				
MXNS 45			163										
MXNSG 45			203										
MXNSL 45			243										
MXN 55	0	27	40	60	88	M4 × 8	M4 × 8	M4 × 8	193	—	10	24	M5 × 10
MXNG 55									247				
MXNL 55									301				
MXNS 55			193										
MXNSG 55			247										
MXNSL 55			301										

Notes (1)  $a_1$  shows the dimension between mounting surface C and upper female thread.

(2) Dimensions of the specification that female threads for bellows are fitted to both ends of the slide unit are indicated.

Remark: The dimension of \* is higher than the dimensions of assembly H. For details of dimensions, contact IJKO.

**Table 11.1 Dimension of slide unit with C-Lube plate (Supplemental code /Q)**

Size: 10, 12, 15, 20, 25, 30

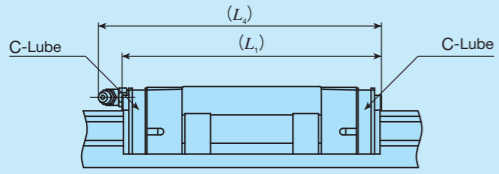

unit: mm

Identification number	$L_1$	$L_4$
LRXD 10...SL	44	—
LRXC 12	47	50
LRX 12	57	60
LRXG 12	68	71
LRXC 15	63	64
LRX 15	79	80
LRXG 15	95	96
LRXC 20	76	84
LRX 20	96	104
LRXG 20	116	124
LRXC 25	85	93
LRX 25	109	117
LRXG 25	124	132
LRXC 30	96	107
LRX 30	124	135
LRXG 30	145	156

Remarks 1. The dimensions of the slide unit with C-Lube at both ends are indicated.  
2. A typical identification number is indicated, but is applied to all LRX series models of the same type.

**Table 11.2 Dimension of slide unit with C-Lube plate (Supplemental code /Q)**

Size: 35, 45, 55, 65, 85

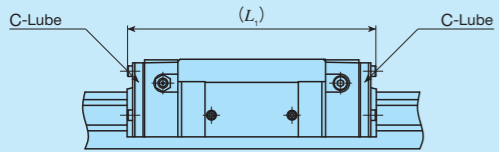

unit: mm

Identification number	$L_1$
LRXC 35	103
LRX 35	135
LRXG 35	163
LRXC 45	127
LRX 45	167
LRXG 45	207
LRXC 55	149
LRX 55	197
LRXG 55	251
LRXC 65	198
LRX 65	262
LRXG 65	326
LRX 85	341
LRXG 85	413
LRXL 85	512

Remarks 1. The dimensions of the slide unit with C-Lube at both ends are indicated.  
2. A typical identification number is indicated, but is applied to all LRX series models of the same type.

**Table 12.1 Dimension of slide unit with C-Wiper (Supplemental code Assembled set: /RC /RCC)**

Size: 20, 25, 30

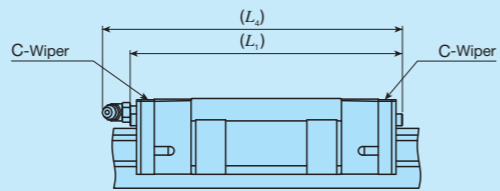

unit: mm

Identification number	$L_1$	$L_4$
MXC 20	80	90
MX 20	100	110
MXG 20	120	130
MXL 20	142	153
MXC 25	89	99
MX 25	113	123
MXG 25	128	138
MXL 25	152	162
MXC 30	100	113
MX 30	128	141
MXN 30	—	138
MXG 30	149	162
MXNG 30	—	159
MXL 30	—	190
MXNL 30	177	187

Remarks 1. The dimensions of the slide unit with C-Wiper at both ends are indicated.  
2. A typical identification number is indicated, but is applied to all MX series models of the same size.

**Table 12.2 Dimension of slide unit with C-Wiper (Supplemental code Assembled set: /RC /RCC)**

Size: 35, 45, 55, 65

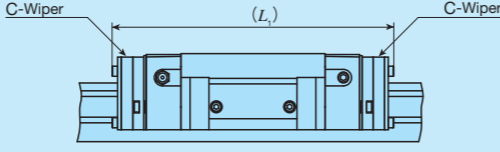

unit: mm

Identification number	$L_1$
MXC 35	123
MX 35	155
MXG 35	183
MXL 35	215
MXC 45	149
MX 45	189
MXG 45	229
MXL 45	269
MXC 55	172
MX 55	220
MXG 55	274
MXL 55	328
MXC 65	223
MX 65	287
MXG 65	351
MXL 65	423

Remarks 1. The dimensions of the slide unit with C-Wiper at both ends are indicated.  
2. A typical identification number is indicated, but is applied to all MX series models of the same size.

**Table 13.1 Dimension of slide unit with double end seals (Supplemental code Single unit: /V Assembled set: /V /VV)**

Size: 12, 15, 20, 25, 30

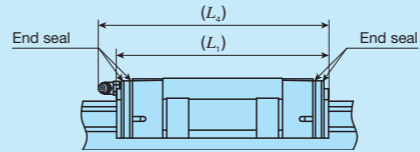

unit: mm

Identification number	$L_1$	$L_4$
MXC 12	—	49
—	LRXC 12	44
MX 12	—	58
—	LRX 12	54
MXG 12	—	70
—	LRXG 12	65
MXC 15	LRXC 15	58
MX 15	LRX 15	74
MXG 15	LRXG 15	90
MXC 20	LRXC 20	73
MX 20	LRX 20	93
MXG 20	LRXG 20	113
MXL 20	—	135
MXC 25	LRXC 25	83
MX 25	LRX 25	107
MXG 25	LRXG 25	122
MXL 25	—	146
MXC 30	LRXC 30	93
MX 30	LRX 30	121
MXN 30	—	—
MXG 30	LRXG 30	142
MXNG 30	—	—
MXL 30	—	170
MXNL 30	—	180

Remarks 1. The dimensions of the slide unit with double end seals at both ends are indicated.  
2. A typical identification number is indicated, but is applied to all models of the same size.

**Table 13.2 Dimension of slide unit with double end seals (Supplemental code Single unit: /V Assembled set: /V /VV)**

Size: 35, 45, 55, 65, 85, 100

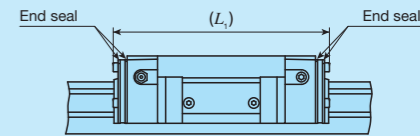

unit: mm

Identification number	$L_1$	
MXC 35	LRXC 35	101
MX 35	LRX 35	133
MXG 35	LRXG 35	161
MXL 35	—	193
MXC 45	LRXC 45	127
MX 45	LRX 45	167
MXG 45	LRXG 45	207
MXL 45	—	247
MXC 55	LRXC 55	149
MX 55	LRX 55	197
MXG 55	LRXG 55	251
MXL 55	—	305
MXC 65	—	192
—	LRXC 65	193
MX 65	—	256
—	LRX 65	257
MXG 65	—	320
—	LRXG 65	321
MXL 65	—	392
—	LRX 85	338
—	LRXG 85	410
—	LRXL 85	509
—	LRXG 100	376

Remarks 1. The dimensions of the slide unit with double end seals at both ends are indicated.  
2. A typical identification number is indicated, but is applied to all models of the same size.

**Table 14.1 Dimension of slide unit with scrapers**  
(Supplemental code Single unit: /Z  
Assembled set: /Z /ZZ)

Size: 12, 15, 20, 25, 30

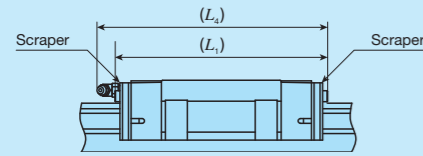

unit: mm

Identification number		$L_1$	$L_2$
MXC 12	—	50	53
—	LRXC 12	45	48
MX 12	—	60	63
—	LRX 12	56	58
MXG 12	—	71	74
—	LRXG 12	66	69
MXC 15	LRXC 15	60	61
MX 15	LRX 15	76	77
MXG 15	LRXG 15	92	93
MXC 20	LRXC 20	74	83
MX 20	LRX 20	94	103
MXG 20	LRXG 20	114	123
MXL 20	—	137	146
MXC 25	LRXC 25	85	93
MX 25	LRX 25	109	117
MXG 25	LRXG 25	124	132
MXL 25	—	148	156
MXC 30	LRXC 30	96	107
MX 30	LRX 30	124	135
MXN 30	—	—	132
MXG 30	LRXG 30	145	156
MXNG 30	—	—	153
MXL 30	—	173	184
MXNL 30	—	—	181

Remarks 1. The dimensions of the slide unit with scraper at both ends are indicated.  
2. A typical identification number is indicated, but is applied to all models of the same size.

**Table 14.2 Dimension of slide unit with scrapers**  
(Supplemental code Single unit: /Z  
Assembled set: /Z /ZZ)

Size: 35, 45, 55, 65, 85, 100

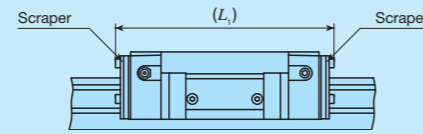

unit: mm

Identification number		$L_1$
MXC 35	LRXC 35	103
MX 35	LRX 35	135
MXG 35	LRXG 35	163
MXL 35	—	195
MXC 45	LRXC 45	129
MX 45	LRX 45	169
MXG 45	LRXG 45	209
MXL 45	—	249
MXC 55	LRXC 55	151
MX 55	LRX 55	199
MXG 55	LRXG 55	253
MXL 55	—	307
MXC 65	LRXC 65	194
MX 65	LRX 65	258
MXG 65	LRXG 65	322
MXL 65	—	394
—	LRX 85	339
—	LRXG 85	411
—	LRXL 85	510
—	LRXG 100	378

Remarks 1. The dimensions of the slide unit with scraper at both ends are indicated.  
2. A typical identification number is indicated, but is applied to all models of the same size.

## Lubrication

Lithium-soap base grease with extreme-pressure additive (Alvania EP grease 2 [SHOWA SHELL SEKIYU K. K.]) is pre-packed in MX series and LRX series. Additionally, MX series has C-Lube placed in the recirculation part of cylindrical roller, so that the interval for reapplying lubricant can be extended and maintenance works such as grease job can be reduced significantly.

MX series and LRX series have grease nipple or oil hole as indicated in Table 15. Supply nozzles fit to each shapes of grease nipple and dedicated supplying equipment (miniature greasers) fit to oil holes are also available. For order of these parts for lubrication, see Table 13 and Table 14.1 on Page III-23, and Table 15 on page III-24.

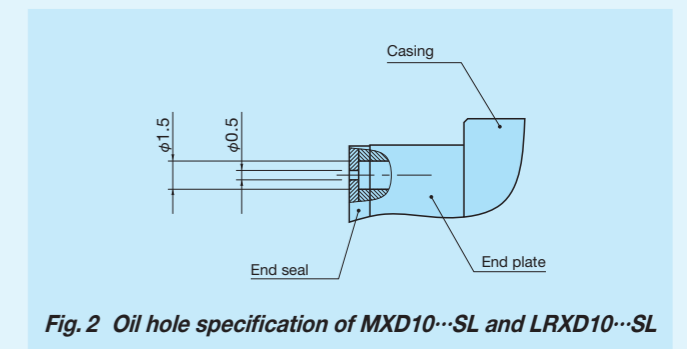

Fig. 2 Oil hole specification of MXD10...SL and LRXD10...SL

**Table 15 Parts for lubrication**

Size	Grease nipple type <sup>(1)</sup>	Applicable supply nozzle type	Bolt size of female threads for piping
10	Oil hole	Miniature greaser	—
12	A-M3	A-5120V A-5240V	—
15 <sup>(2)</sup>	A-M4	B-5120V B-5240V	M4
20 <sup>(2)</sup>	B-M4	A-8120V	
25 <sup>(2)</sup>		B-8120V	
30 <sup>(3) (4)</sup>	B-M6	Grease gun available on the market	M6
35 <sup>(5)</sup>	JIS1 type		PT1/8
45 <sup>(6)</sup>	JIS2 type		
55			
65			
85	A-PT1/4		PT1/4
100	A-PT1/4		PT1/4

Notes <sup>(1)</sup> For grease nipple specification, see Table 14.1 and Table 14.2 in page III-23.

<sup>(2)</sup> The grease nipple when female threads for bellows (supplemental code "J") is specified is A-M3.

<sup>(3)</sup> The grease nipple when female threads for bellows (supplemental code "J") is specified is A-M4.

<sup>(4)</sup> The grease nipple for MXN30 is B-M4. The grease nipple when female threads for bellows (supplemental code "J") is specified is A-M4.

<sup>(5)</sup> The size of the grease nipple mounting thread hole for MXN35 in the slide unit travelling direction is smaller than that of the crosswise direction. When the grease nipple is mounted along the travelling direction, contact **IKO**.

<sup>(6)</sup> The grease nipple for MXN45 is JIS type1.

Remark: Stainless steel grease nipple is also available. If needed, please contact **IKO**.

# Dust Protection

The slide units of MX series and LRX series are equipped with end seals and under seals as standard for dust protection. However, if large amount of contaminant or dust are floating, or if large particles of foreign substances such as chips or sand may adhere to the track rail, it is recommended to cover the whole unit with bellows or telescope type shield, etc. MX series and LRX series are provided with specific bellows. The bellows are easy to mount and provide excellent dust protection. If needed, please refer to III-26 for ordering. Also the rail cover sheet to cover the mounting hole of track rail (Fig. 3) and track rail mounting from bottom with no mounting hole on the upper surface (Fig.4) are available. If needed, please contact **IKO**.

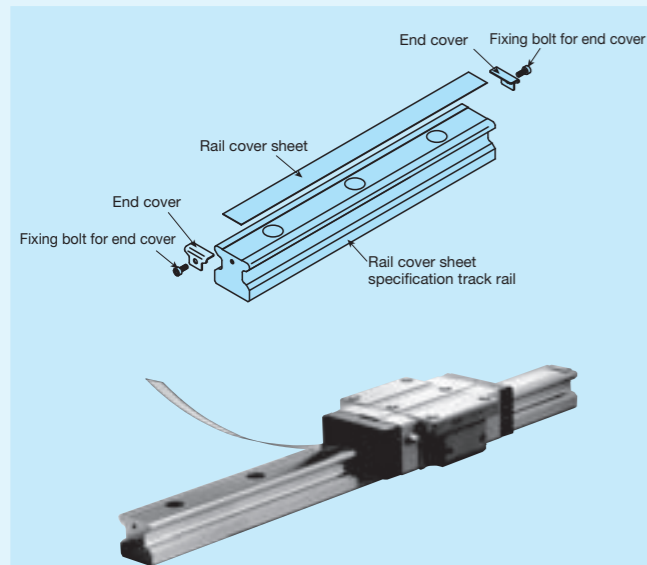

Fig. 3 Rail cover sheet

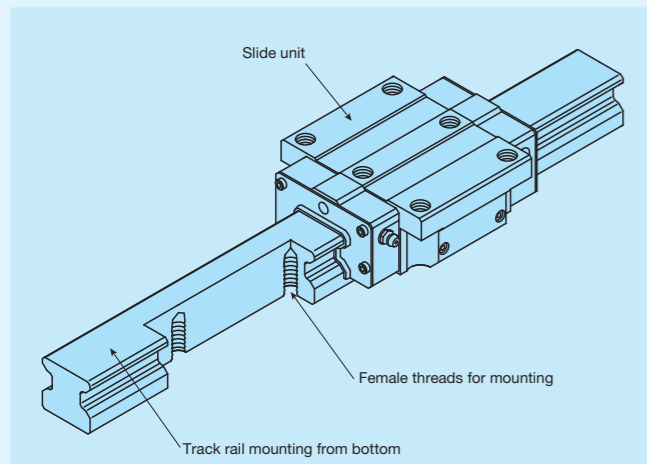

Fig. 4 Track rail mounting from bottom specification

# Precaution for Use

## 1 Mounting surface, reference mounting surface and typical mounting structure

When mounting the MX series and LRX series, properly align the reference mounting surfaces B and D of the track rail and slide unit with the reference mounting surface of the table and bed and fix them. (See Fig. 5.)

The reference mounting surfaces B and D and mounting surfaces A and C are precisely ground. Machining the mounting surface of the table and bed, such as machine or device, to high accuracy and mounting them properly will ensure stable linear motion with high accuracy.

Reference mounting surface of the slide unit is the opposite side of the **IKO** mark. The track rail reference mounting surface is identified by locating the **IKO** mark on the top surface of the track rail. It is the side surface above the mark (in the direction of the arrow). (See Fig. 6.)

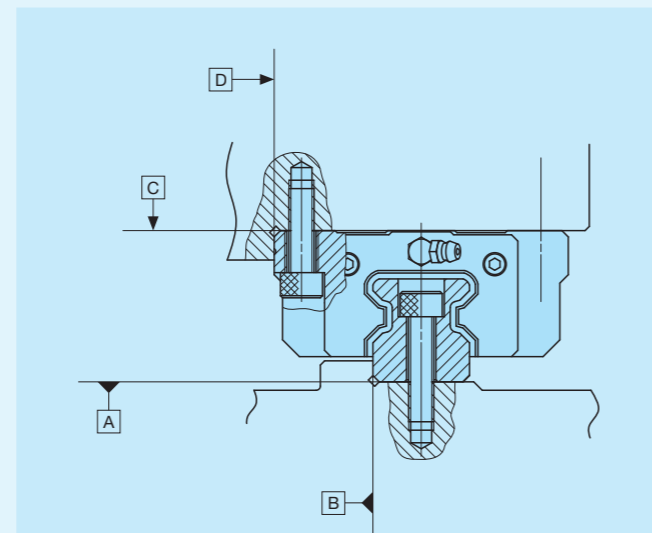

Fig. 5 Reference mounting surface and typical mounting structure

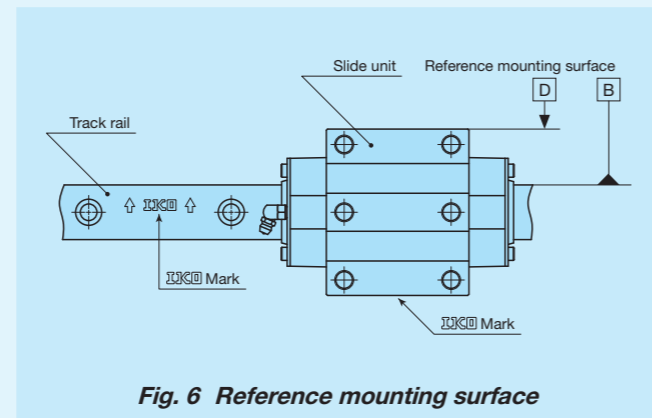

Fig. 6 Reference mounting surface

## 2 Fixing the slide unit

Slide unit is also provided with mounting holes in the middle of width direction (see Fig.7) and some products have the arrangement to receive the applied load in a good balance. When designing machines or equipment, consider the arrangement so that the mounting holes in the middle of slide unit can also be used to fix the units, to use the highest performance out of the product. To fix the slide unit of compact block type or low profile block type, we recommend to secure the fixing thread depth of Table 16.1 and Table 16.2. Also, with the low profile flange type and low profile block type, make sure that the fixing thread depth for the mounting screw in the middle of slide unit width direction should be less than the maximum fixing thread depth of the dimension table.

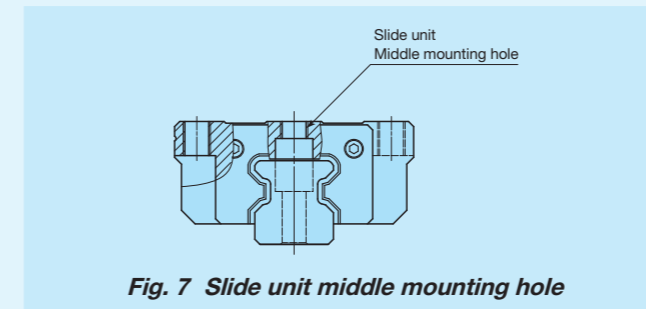

Fig. 7 Slide unit middle mounting hole

Table 16.1 Fixing thread depth for slide unit mounting hole of compact block type unit: mm

Identification number	Recommended minimum fixing thread depth	
MXS 15	LRXS 15	4.5
MXS 20	LRXS 20	5.5
MXS 25	LRXS 25	7
MXS 30	LRXS 30	9

Remark: A typical identification number is indicated, but is applied to all compact block types of the same size.

Table 16.2 Fixing thread depth for slide unit mounting hole of low profile block type unit: mm

Identification number	Recommended minimum fixing thread depth
MXNS 30	8
MXNS 35	8.5
MXNS 45	10.5
MXNS 55	14

Remark: A typical identification number is indicated, but is applied to all low profile block types of the same size.

## 3 Shoulder height and corner radius of the reference mounting surface

For the opposite corner of the mating reference mounting, it is recommended to have relieved fillet as indicated in Fig. 8, but you may also use it with providing corner radius  $R$  as shown in Table 17. Recommended value for the shoulder height and corner radius on the mating side is indicated in Table 17.

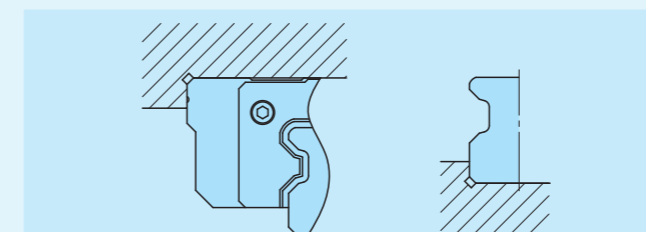

Fig. 8 Corner of the mating reference mounting

Table 17 Shoulder height and corner radius of the reference mounting surface

Size	Shoulder height of slide unit mounting part $h_1$	Shoulder height of track rail mounting part $h_2$	Corner radius $R$ (Maximum)
10	4	1	0.3
12	4	2	0.5
15	4	3	0.5
20	5	4	0.5
25	6	5	1
30	8	5.5	1
35	8	5.5	1
45	8	7	1.5
55	10	8	1.5
65	10	10	1.5
85	14	14	2.5 (Slide unit) 1.5 (Track rail)
100	14	13	2.5

## 4 Tightening torque for fixing screw

Typical tightening torque for mounting of the MX series and LRX series to the steel mating member material is indicated in Table 18. When vibration and shock of the machine or device are large, fluctuating load is large, or moment load is applied, fix it by using the torque 1.2 to 1.5 times larger than the value indicated in the table as necessary. If the mating member material is cast iron or aluminum alloy, reduce the tightening torque depending on the strength characteristics of the mating member material.

Table 18 Tightening torque for fixing screw

Bolt size	Tightening torque N · m		
	High carbon steel-made screw	Stainless steel-made screw	
	Size 12 to 65	Size 85 and 100	
M 2.6×0.45	—	—	0.70
M 3 ×0.5	1.8	—	1.1
M 4 ×0.7	4.1	—	2.5
M 5 ×0.8	8.0	—	5.0
M 6 ×1	13.6	—	8.5
M 8 ×1.25	32.7	—	20.4
M10 ×1.5	63.9	—	—
M12 ×1.75	110	—	—
M14 ×2	175	—	—
M16 ×2	268	—	—
M20 ×2.5	522	—	—
M24 ×3	—	749	—
M30 ×3.5	—	1 490	—

Remarks 1. The tightening torque is calculated based on strength division 12.9 for product size 12 to 65, strength division 10.9 for product sizes 85 and 100, and property division A2-70 for stainless steel bolts.

2. It is recommended that the tightening torque of slide unit middle mounting holes for size 15, 20, 25, 30, 35 of flange type (MXC, MX, MXG, MXL, LRXC, LRX, LRXG) is to be 70 to 80% of the values in the table.

1N=0.102kgf=0.2248lbs.  
1mm=0.03937inch



# IKO C-Lube Linear Roller Way Super MX

Flange type mounting from top / bottom

Shape	MX • LRX				
Size	12	15	20	25	30
	35	45	55	65	85

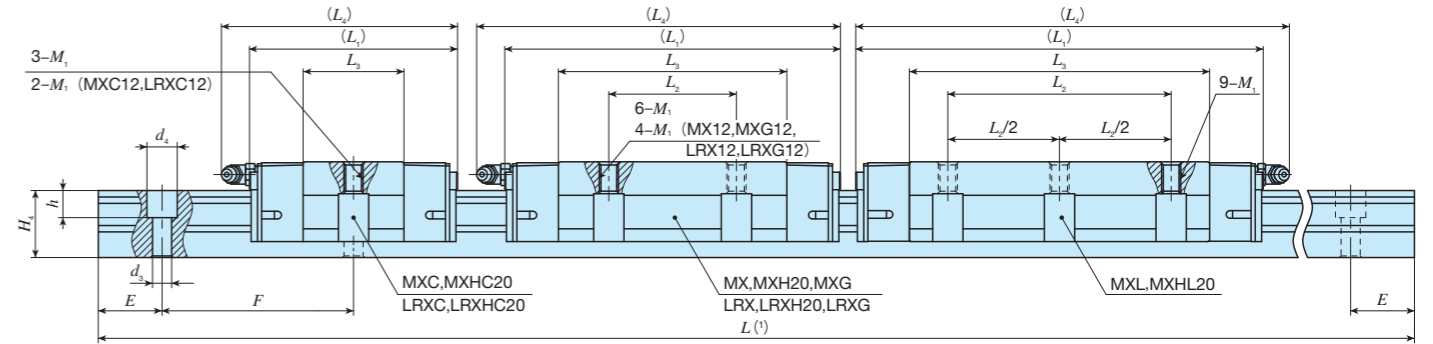
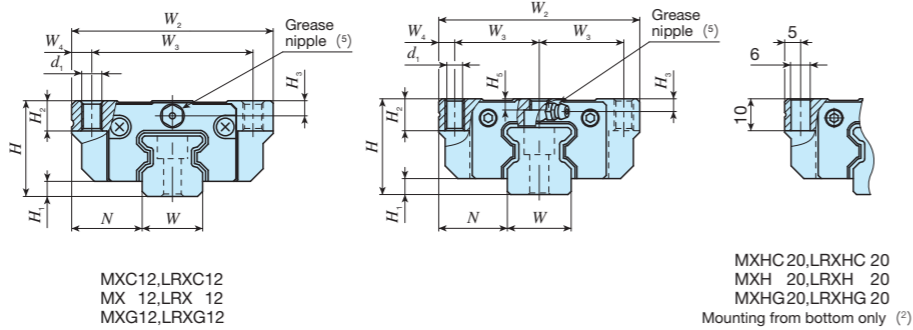

Identification number	Interchangeable	Mass (Ref.)	Dimensions of assembly mm	Dimensions of slide unit mm												Dimensions of track rail mm						Appended mounting bolt for track rail (3)	Basic dynamic load rating (4)	Basic static load rating (4)	Static moment rating (4)										
				Slide unit kg	Track rail kg/m	H	H <sub>1</sub>	N	W <sub>2</sub>	W <sub>3</sub>	W <sub>4</sub>	L <sub>1</sub>	L <sub>2</sub>	L <sub>3</sub>	L <sub>4</sub>	d <sub>1</sub>	M <sub>1</sub>	H <sub>2</sub>	H <sub>3</sub>	H <sub>5</sub>	W				H <sub>4</sub>	d <sub>3</sub>	d <sub>4</sub>	h	E	F	Bolt size × ℓ	C	C <sub>0</sub>	T <sub>0</sub>	T <sub>x</sub>
MXC 12	LRXC 12	0.058									40	—	15.8	44																	4 250	6 500	49.4	18.6 196	18.6 196
MX 12	LRX 12	0.092	0.92	19	3	14	40	32	4	50	—	25.4	53	3.4	M4	6	3	—	12	12	3.5	6	4.5	20	40	M3×12	6 120	10 400	79.1	45.8 371	45.8 371				
MXG 12	LRXG 12	0.13								47	15	25.3	50																	5 890	78.7	45.2 343	45.2 343		
MXC 15	LRXC 15	0.13								61	—	36.6	64																	8 120	15 000	114	92.7 628	92.7 628	
MX 15	LRX 15	0.20	1.65	24	4	16	47	19	4.5	58	30	35.8	61	4.4	M5	7	3.5	3	15	16.5	4.5	8	6	30	60	M4×16	7 710	14 600	111	88.6 581	88.6 581				
MXG 15	LRXG 15	0.28								84	—	56	87																	14 900	28 000	263	262 1 590	262 1 590	
MXC 20 <sup>(2)</sup>	LRXC 20 <sup>(2)</sup>	0.29								66	—	31.6	74																	16 100	26 400	341	150 1 260	150 1 260	
MX 20 <sup>(2)</sup>	LRX 20 <sup>(2)</sup>	0.44								86	—	51.6	94	— <sup>(2)</sup>	M6 <sup>(2)</sup>	10	4	3.5	20	21	6	9.5	8.5	30	60	M5×20	23 400	42 700	550	379 2 520	379 2 520				
MXG 20 <sup>(2)</sup>	LRXG 20 <sup>(2)</sup>	0.61								106	—	71.6	114																	30 100	58 900	760	713 4 200	713 4 200	
MXL 20 <sup>(2)</sup>	—	0.80								128	70	94.1	137																	37 200	77 200	996	1 210 6 560	1 210 6 560	

Notes (1) Track rail lengths *L* are shown in Table 2.1 on page II - 175 and Table 2.3 on page II - 176 .  
 (2) The mounting bolt can be mounted only in downward direction. The models with the same dimensions allowing mounting from bottom are MXHC20, MXH20, MXHG20, MXHL20, LRXHC20, LRXH20, and LRXH20.  
 (3) The appended track rail mounting bolts are hexagon socket head bolts equivalent to JIS B 1176. In an assembled set of MX series, track rail mounting bolts are not appended.  
 (4) The direction of basic dynamic load rating (*C*), basic static load rating (*C<sub>0</sub>*), and static moment rating (*T<sub>0</sub>*, *T<sub>x</sub>*, *T<sub>y</sub>*) are shown in the sketches below. The upper values of *T<sub>x</sub>* and *T<sub>y</sub>* are for one slide unit and the lower values are for two slide units in close contact.  
 (5) The shapes of grease nipple vary by size. The specifications are shown in Table 15 on page II - 188.

Remark: A grease nipple mounting thread hole is provided on the right and left end plates respectively.

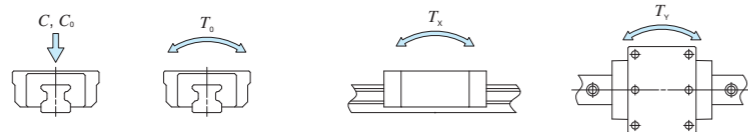

## Example of identification number of assembled set

Model code Dimensions Part code Preload symbol Classification symbol Interchangeable code Supplemental code

**MX** **G** **15** **C2** **R360** **T1** **P** **/F**

① ② ③ ④ ⑤ ⑥ ⑦ ⑧ ⑨

① Model MX Flange type mounting from top / bottom LRX	② Length of slide unit C Short No symbol Standard G Long L Extra long	③ Size 12, 15, 20	④ Number of slide unit (2)	⑤ Length of track rail (360 mm)	⑥ Preload amount No symbol Standard T1 Light preload T2 Medium preload T3 Heavy preload	⑦ Accuracy class H High P Precision SP Super precision UP Ultra precision	⑧ Interchangeable No symbol Non-interchangeable specification S1 S1 specification S2 S2 specification	⑨ Special specification A, D, E, F, GE, HP, I, J, L LF, MA, MN, N, Q, RC, T UR, V, W, Y, Z
---	---	----------------------	----------------------------	---------------------------------	---	---	--	---

# IKO C-Lube Linear Roller Way Super MX

Flange type mounting from top / bottom

Shape	MX • LRX				
Size	12	15	20	25	30
	35	45	55	65	85

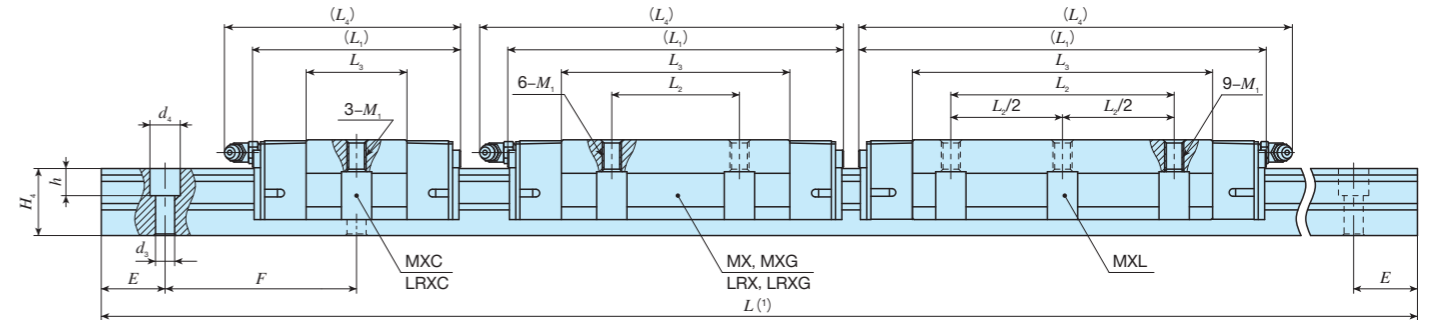
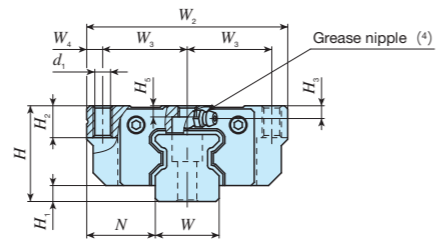

Identification number	Interchangeable	Mass (Ref.)		Dimensions of slide unit mm											Dimensions of track rail mm						Appended mounting bolt for track rail (2)	Basic dynamic load rating (3)	Basic static load rating (3)	Static moment rating (3)								
		Slide unit kg	Track rail kg/m	H	H <sub>1</sub>	N	W <sub>2</sub>	W <sub>3</sub>	W <sub>4</sub>	L <sub>1</sub>	L <sub>2</sub>	L <sub>3</sub>	L <sub>4</sub>	d <sub>1</sub>	M <sub>1</sub>	H <sub>2</sub>	H <sub>3</sub>	H <sub>5</sub>	W	H <sub>4</sub>				d <sub>3</sub>	d <sub>4</sub>	h	E	F	Bolt size × ℓ	C	C <sub>0</sub>	T <sub>0</sub>
MXC 25	LRXC 25	○	0.44	3.59	36	6	23.5	70	28.5	6.5	74	—	36	83	7	M 8	10	5	5	23	24.5	7	11	9	30	60	M6×25	21 600	33 800	500	213	213
MX 25	LRX 25	○	0.67								98	45	60	107														885	885			
MXG 25	LRXG 25	○	0.84								113	75	122	5 380														5 380				
MXL 25	—	—	1.08								137	70	99	146														8 480	8 480			
MXC 30	LRXC 30	○	0.78	5.01	42	6.5	31	90	36	9	85	—	42.4	95	8.5	M10	10	6.5	5.5	28	28	9	14	12	40	80	M8×28	29 200	44 600	808	329	329
MX 30	LRX 30	○	1.20								113	52	70.4	123														883	883			
MXG 30	LRXG 30	○	1.58								134	91.4	144	5 780														5 780				
MXL 30	—	—	2.03								162	80	119.4	172														8 740	8 740			

Notes (1) Track rail lengths  $L$  are shown in Table 2.1 on page II-175 and Table 2.3 on page II-176.  
 (2) The appended track rail mounting bolts are hexagon socket head bolts equivalent to JIS B 1176. In an assembled set of MX series, track rail mounting bolts are not appended.  
 (3) The direction of basic dynamic load rating ( $C$ ), basic static load rating ( $C_0$ ), and static moment rating ( $T_0$ ,  $T_x$ ,  $T_y$ ) are shown in the sketches below. The upper values of  $T_x$  and  $T_y$  are for one slide unit and the lower values are for two slide units in close contact.  
 (4) The shapes of grease nipple vary by size. The specifications are shown in Table 15 on page II-188.  
 Remark: A grease nipple mounting thread hole is provided on the right and left end plates respectively.

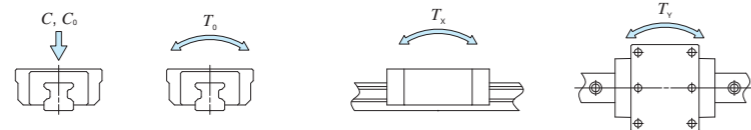

## Example of identification number of assembled set

Model code Dimensions Part code Preload symbol Classification symbol Interchangeable code Supplemental code

**MX G 25 C2 R840 T1 P /F**

① ② ③ ④ ⑤ ⑥ ⑦ ⑧ ⑨

① Model MX Flange type mounting from top / bottom LRX	② Length of slide unit C Short No symbol Standard G Long L Extra long	③ Size 25, 30	④ Number of slide unit (2)	⑤ Length of track rail (840 mm)	⑥ Preload amount No symbol Standard T1 Light preload T2 Medium preload T3 Heavy preload	⑦ Accuracy class H High P Precision SP Super precision UP Ultra precision	⑧ Interchangeable No symbol Non-interchangeable specification S1 S1 specification S2 S2 specification	⑨ Special specification A, D, E, F, GE, HP, I, J, L LF, MA, MN, N, Q, RC, T UR, V, W, Y, Z
---	---	------------------	----------------------------	---------------------------------	---	---	--	---

# IKO C-Lube Linear Roller Way Super MX

Flange type mounting from top / bottom

Shape	MX • LRX				
Size	12	15	20	25	30
	35	45	55	65	100

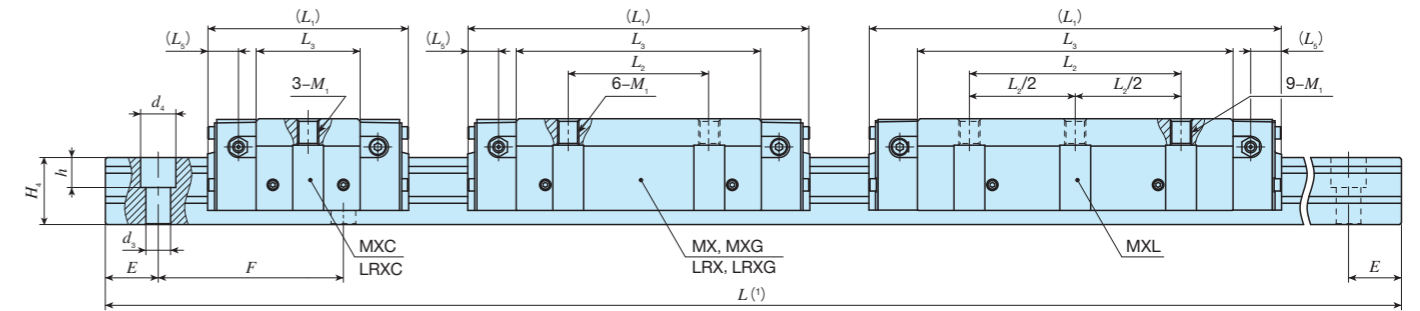
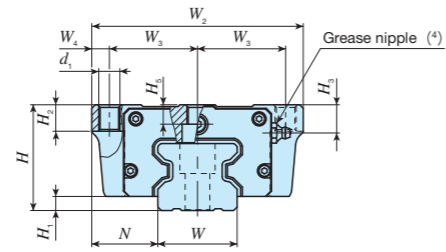

Identification number	Interchangeable	Mass (Ref.)		Dimensions of assembly mm			Dimensions of slide unit mm							Dimensions of track rail mm							Appended mounting bolt for track rail (2)	Basic dynamic load rating (3)	Basic static load rating (3)	Static moment rating (3)							
		Slide unit kg	Track rail kg/m	H	H <sub>1</sub>	N	W <sub>2</sub>	W <sub>3</sub>	W <sub>4</sub>	L <sub>1</sub>	L <sub>2</sub>	L <sub>3</sub>	L <sub>5</sub>	d <sub>1</sub>	M <sub>1</sub>	H <sub>2</sub>	H <sub>3</sub>	H <sub>5</sub>	W	H <sub>4</sub>				d <sub>3</sub>	d <sub>4</sub>	h	E	F	Bolt size × ℓ	C	C <sub>0</sub>
MXC 35	○	1.13	6.88	48	6.5	33	100	41	9	92	—	46.6	12.7	8.5	M10	13	13	7	34	32	9	14	12	40	80	M 8×35	39 500	60 000	1 300	506	506
LRXC 35	○	12.5								12.7	12.5	12.7	8 470														8 470				
MX 35	○	1.76								124	62	78.6	1360														1360				
LRX 35	○	12.5								12.7	12.5	12.7	8 470														8 470				
MXG 35	○	2.41	10.8	60	8	37.5	120	50	10	152	—	106.6	12.7	10.5	M12	15	16	11	45	38	14	20	17	52.5	105	M12×40	74 200	135 000	2 930	2 440	2 440
LRXG 35	○	12.5								12.7	12.5	12.7	13 800														13 800				
MXL 35	—	3.00								184	100	138.6	4 060														4 060				
LRXC 35	○	12.5								12.7	12.5	12.7	21 300														21 300				
MXC 45	○	2.11	10.8	60	8	37.5	120	50	10	114	—	59	12.7	10.5	M12	15	16	11	45	38	14	20	17	52.5	105	M12×40	64 100	95 600	2 660	1 010	1 010
LRXC 45	○	12.5								12.7	12.5	12.7	7 800														7 800				
MX 45	○	3.26								154	80	99	2 700														2 700				
LRX 45	○	12.5								12.7	12.5	12.7	16 800														16 800				
MXG 45	○	4.60	10.8	60	8	37.5	120	50	10	194	80	139	12.7	10.5	M12	15	16	11	45	38	14	20	17	52.5	105	M12×40	124 000	223 000	6 200	5 220	5 220
LRXG 45	○	12.5								12.7	12.5	12.7	29 000														29 000				
MXL 45	—	5.66								234	120	179	8 560														8 560				
LRXC 45	○	12.5								12.7	12.5	12.7	44 400														44 400				

Notes (1) Track rail lengths  $L$  are shown in Table 2.1 on page II-175 and Table 2.3 on page II-176.  
 (2) The appended track rail mounting bolts are hexagon socket head bolts equivalent to JIS B 1176. In an assembled set of MX series, track rail mounting bolts are not appended.  
 (3) The direction of basic dynamic load rating ( $C$ ), basic static load rating ( $C_0$ ), and static moment rating ( $T_0$ ,  $T_x$ ,  $T_y$ ) are shown in the sketches below. The upper values of  $T_x$  and  $T_y$  are for one slide unit and the lower values are for two slide units in close contact.  
 (4) The shapes of grease nipple vary by size. The specifications are shown in Table 15 on page II-188.  
 Remark: Three grease nipple mounting thread holes are provided on the right and left end plates respectively.

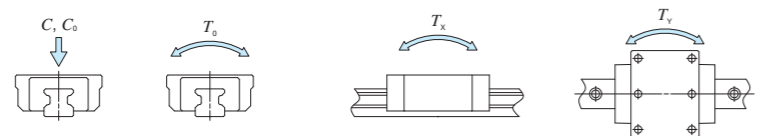

**Example of identification number of assembled set**

Model code: MX G 35 C2 R1200 T2 P /F

Dimensions: G 35 C2 R1200 T2 P /F

Part code: MX G 35 C2 R1200 T2 P /F

Preload symbol: T2

Classification symbol: P

Interchangeable code: /F

Supplemental code: /F

① Model	MX: Flange type mounting from top / bottom	③ Size	35, 45	⑥ Preload amount	No symbol: Standard T1: Light preload T2: Medium preload T3: Heavy preload	⑧ Interchangeable	No symbol: Non-interchangeable specification S1: S1 specification S2: S2 specification
② Length of slide unit	C: Short No symbol: Standard G: Long L: Extra long	④ Number of slide unit (2)	2	⑦ Accuracy class	H: High P: Precision SP: Super precision UP: Ultra precision	⑨ Special specification	A, D, E, F, GE, HP, I, J, L LF, MA, MN, N, PS, Q RC, T, UR, V, W, Y, Z
⑤ Length of track rail (1,200 mm)							

# IKO C-Lube Linear Roller Way Super MX

Flange type mounting from top / bottom

Shape	MX • LRX				
Size	12	15	20	25	30
	35	45	55	65	85

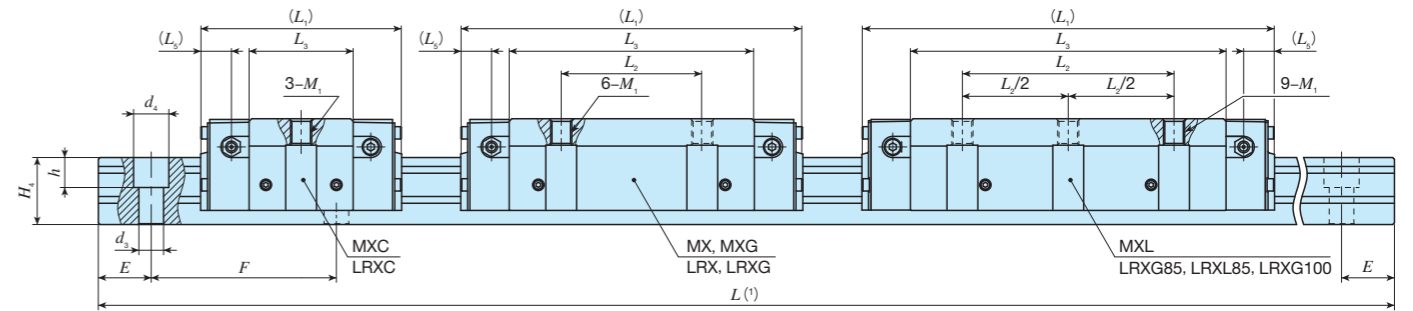
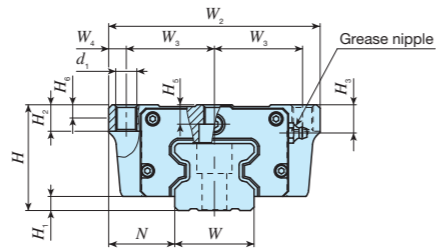

Identification number	Interchangeable	Mass (Ref.)		Dimensions of assembly mm											Dimensions of slide unit mm											Dimensions of track rail mm						Appended mounting bolt for track rail (2)	Basic dynamic load rating (3) C N	Basic static load rating (3) C0 N	Static moment rating (3) N·m		
		Slide unit kg	Track rail kg/m	H	H1	N	W2	W3	W4	L1	L2	L3	L5	d1	M1	H2	H3	H5	H6	W	H4	d3	d4	h	E	F	T0	Tx	Ty								
MXC 55	LRXC 55	○	3.49	14.1	70	9	43.5	140	58	12	136	—	72	20	12.5	M14	17	16	14	—	53	43	16	23	20	60	120	M14×45	99 700	149 000	4 830	1 880	1 880				
MX 55	LRX 55	○	5.42								184	—	120																5 040	5 040							
MXG 55	LRXG 55	○	7.93								238	—	174																10 400	10 400							
MXL 55	—	—	10.1								292	150	228																17 700	17 700							
MXC 65	LRXC 65	○	7.18	22.6	90	12	53.5	170	71	14	180	—	95	26.3	14.5	M16	23	18	18.5	—	63	56	18	26	22	75	150	M16×60	174 000	249 000	9 790	4 200	4 200				
MX 65	LRX 65	○	11.5								181	—	26.6	32 000															32 000								
MXG 65	LRXG 65	○	16.0								244	—	26.3	4 200															4 200								
MXL 65	—	—	20.8								245	110	26.6	11 300															11 300								
—	LRX 85	—	25.4	36.7	110	16	65	215	92.5	15	323	140	232	27.5	17.8	M20	35	22	25.5	20	85	67	26.5	39	30	90	180	M24×70	440 000	753 000	38 900	29 500	29 500				
—	LRXG 85	—	32.7								395	200	304																163 000	163 000							
—	LRXL 85	—	44.0								494	280	403																50 000	50 000							
—	LRXG 100*	—	43.0								43.2	120	15																75	250	110	15	362	200	262	29.7	17.8

Notes (1) Track rail lengths  $L$  are shown in Table 2.1 on page II-175 and Table 2.3 on page II-176.  
 (2) The appended track rail mounting bolts are hexagon socket head bolts equivalent to JIS B 1176. In an assembled set of MX series, track rail mounting bolts are not appended.  
 (3) The direction of basic dynamic load rating ( $C$ ), basic static load rating ( $C_0$ ), and static moment rating ( $T_0$ ,  $T_x$ ,  $T_y$ ) are shown in the sketches below. The upper values of  $T_x$  and  $T_y$  are for one slide unit and the lower values are for two slide units in close contact.

Remarks 1. The specifications of grease nipple are shown in Table 15 on page II-188.  
 2. Three grease nipple mounting thread holes are provided on the right and left end plates respectively.  
 3. The identification numbers with \* are our semi-standard items.

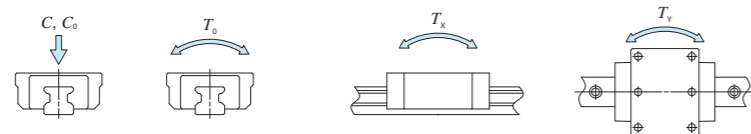

### Example of identification number of assembled set

Model code Dimensions Part code Preload symbol Classification symbol Interchangeable code Supplemental code

**MX G 55 C2 R3000 T2 P /F**

① ② ③ ④ ⑤ ⑥ ⑦ ⑧ ⑨

① Model MX Flange type mounting from top / bottom LRX	② Length of slide unit C Short No symbol Standard G Long L Extra long	③ Size 55, 65, 85, 100	④ Number of slide unit (2)	⑤ Length of track rail (3,000 mm)	⑥ Preload amount No symbol Standard T1 Light preload T2 Medium preload T3 Heavy preload	⑦ Accuracy class H High P Precision SP Super precision UP Ultra precision	⑧ Interchangeable No symbol Non-interchangeable specification S1 S1 specification S2 S2 specification	⑨ Special specification A, D, E, F, GE, HP, I, J, L LF, MA, MN, PS, Q, RC T, UR, V, W, Y, Z
---	---	---------------------------	----------------------------	-----------------------------------	---	---	--	--

# IKO C-Lube Linear Roller Way Super MX

## Block type mounting from top

Shape	MXD • LRXD					
Size	10	12	15	20	25	30
	35	45	55	65	85	

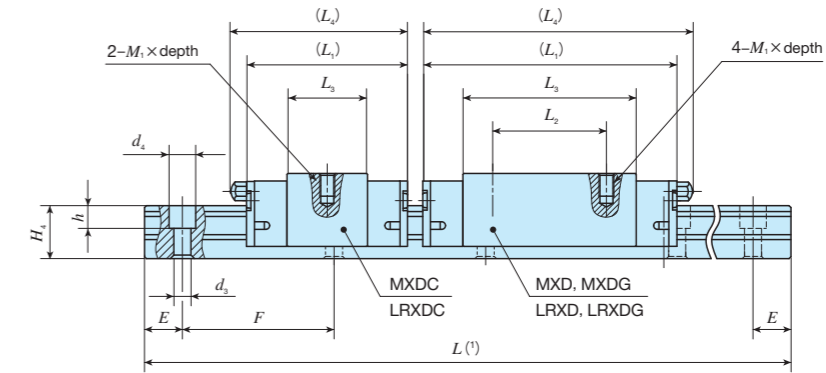
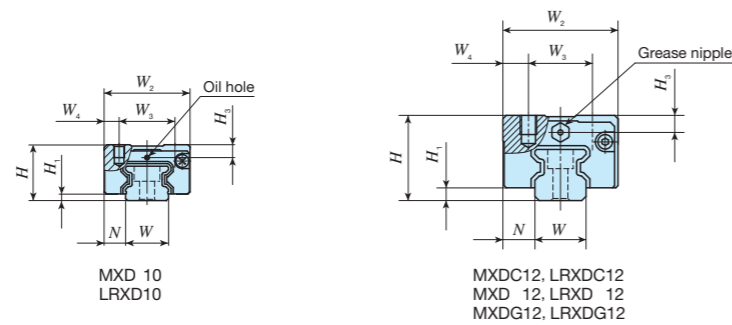

Identification number	Interchangeable	Mass (Ref.)		Dimensions of assembly mm			Dimensions of slide unit mm							Dimensions of track rail mm						Appended mounting bolt for track rail (2)	Basic dynamic load rating (3)	Basic static load rating (3)	Static moment rating (3)					
		Slide unit kg	Track rail kg/m	H	H1	N	W2	W3	W4	L1	L2	L3	L4	M1 x depth	H3	W	H4	d3	d4				h	E	F	Bolt size x l	C N	C0 N
MXD 10...SL	—	0.028	0.48	13	1.5	5	20	13	3.5	36	12	20.8	—	M2.6 x 3	3	10	8	3.5	6	3.5	12.5	25	M3 x 10	3 200	5 880	37.9	20.9	20.9
LRXD 10...SL	—																										147	147
MXDC 12	○	0.045	0.92	20	3	7.5	27	15	6	40	—	15.8	44	M4 x 4.5	4	12	12	3.5	6	4.5	20	40	M3 x 12	4 250	6 500	49.4	18.6	18.6
LRXDC 12	○																										196	196
—	○	0.072	0.92	20	3	7.5	27	15	6	37	—	14.8	40	M4 x 4.5	4	12	12	3.5	6	4.5	20	40	M3 x 12	3 900	6 090	46.3	16.3	16.3
LRXDC 12...SL	○																										170	170
MXD 12	○	0.072	0.92	20	3	7.5	27	15	6	50	—	25.4	53	M4 x 4.5	4	12	12	3.5	6	4.5	20	40	M3 x 12	6 120	10 400	79.1	45.8	45.8
LRXD 12	○																										371	371
MXD 12...SL	○	0.072	0.92	20	3	7.5	27	15	6	47	15	25.3	50	M4 x 4.5	4	12	12	3.5	6	4.5	20	40	M3 x 12	5 890	10 400	78.7	45.2	45.2
LRXD 12...SL	○																										343	343
MXDG 12	○	0.097	0.92	20	3	7.5	27	15	6	50	—	25.4	53	M4 x 4.5	4	12	12	3.5	6	4.5	20	40	M3 x 12	6 120	15 000	114	92.7	92.7
LRXDG 12	○																										628	628
—	○	0.097	0.92	20	3	7.5	27	15	6	61	—	36.6	64	M4 x 4.5	4	12	12	3.5	6	4.5	20	40	M3 x 12	8 120	14 600	111	88.6	88.6
LRXDG 12...SL	○																										581	581

Notes (1) Track rail lengths  $L$  are shown in Tables 2.1 and 2.2 on page II-175 and Tables 2.3 and 2.4 on page II-176.  
 (2) The appended track rail mounting bolts are hexagon socket head bolts equivalent to JIS B 1176. For stainless steel model, stainless steel bolts are appended.  
 In an assembled set of MX series, track rail mounting bolts are not appended.  
 (3) The direction of basic dynamic load rating ( $C$ ), basic static load rating ( $C_0$ ), and static moment rating ( $T_0$ ,  $T_x$ ,  $T_y$ ) are shown in the sketches below. The upper values of  $T_x$  and  $T_y$  are for one slide unit and the lower values are for two slide units in close contact.  
 Remarks 1. The specification of oil hole is shown in Fig. 2 on page II-188.  
 2. The specifications of grease nipple are shown in Table 15 on page II-188.  
 3. For size 12 series, a grease nipple mounting thread hole is provided on the right and left end plates respectively.

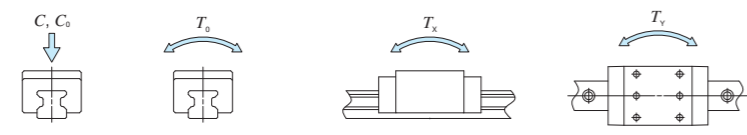

### Example of identification number of assembled set

Model code	Dimensions	Part code	Material code	Preload symbol	Classification symbol	Interchangeable code	Supplemental code
<b>MXD</b>	<b>G</b>	<b>12</b>	<b>C2</b>	<b>R560</b>	<b>T1</b>	<b>P</b>	<b>/F</b>
①	②	③	④	⑤	⑥	⑦	⑧

① Model	④ Number of slide unit (2)	⑦ Preload amount	⑩ Interchangeable
MXD LRXD Block type mounting from top		No symbol Standard T1 Light preload T2 Medium preload T3 Heavy preload	No symbol Non-interchangeable specification S1 S1 specification S2 S2 specification
② Length of slide unit	⑤ Length of track rail (560 mm)	⑧ Accuracy class	⑩ Special specification
C Short No symbol Standard G Long		H High P Precision SP Super precision UP Ultra precision	A, D, E, F, HP, I, L, LF MA, MN, N, Q, T, V, W Y, Z
③ Size			
10, 12			

# IKO C-Lube Linear Roller Way Super MX

## Block type mounting from top

Shape	MXD • LRXD					
Size	10	12	15	20	25	30
	35	45	55	65	85	

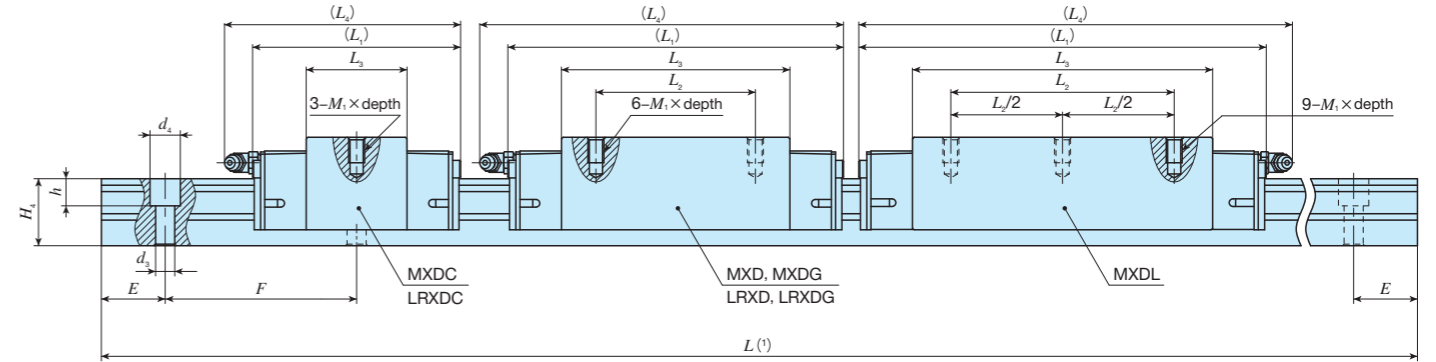
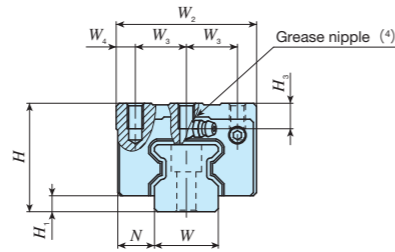

Identification number	LRX series (No C-Lube)	Interchangeable	Mass (Ref.)		Dimensions of assembly mm										Dimensions of slide unit mm						Dimensions of track rail mm						Appended mounting bolt for track rail (2)	Basic dynamic load rating (3)	Basic static load rating (3)	Static moment rating (3)		
			Slide unit kg	Track rail kg/m	H	H1	N	W2	W3	W4	L1	L2	L3	L4	M1 × depth	H3	W	H4	d3	d4	h	E	F	Bolt size × ℓ	C N	C0 N				T0 N · m	Tx N · m	Ty N · m
MXDC 15	LRXDC 15	○	0.13	1.65	28	4	9.5	34	13	4	52	—	24	55	M4 × 8	7.5	15	16.5	4.5	8	6	30	60	M4 × 16	7 730	12 000	113	50.6	50.6			
—	LRXDC 15··SL	○	0.19								68	26	40	71											136	136						
MXD 15	LRXD 15	○	0.26								84	56	87	1 262											1 262							
MXD 15··SL	LRXD 15··SL	○	0.25								66	—	31.6	74											150	150						
MXDG 15	LRXDG 15	○	0.38								86	36	51.6	94											2 379	2 379						
—	LRXDG 15··SL	○	0.52								106	50	71.6	114											4 713	4 713						
MXDC 20	LRXDC 20	○	0.67	2.73	34	5	12	44	16	6	66	—	31.6	74	M5 × 8	8	20	21	6	9.5	8.5	30	60	M5 × 20	37 200	77 200	996	1 210	1 210			
—	LRXDC 20··SL	○	0.13								52	—	24	55											50.6	50.6						
MXD 20	LRXD 20	○	0.19								68	26	40	71											136	136						
MXD 20··SL	LRXD 20··SL	○	0.26								84	56	87	1 262											1 262							
MXDG 20	LRXDG 20	○	0.25	66	—	31.6	74	150	150																							
—	LRXDG 20··SL	○	0.38	86	36	51.6	94	2 379	2 379																							
MXDL 20	—	—	0.52	106	50	71.6	114	4 713	4 713																							
			0.67	128	70	94.1	137	1 210	1 210																							

Notes (1) Track rail lengths  $L$  are shown in Tables 2.1 and 2.2 on page II - 175 and Tables 2.3 and 2.4 on page II - 176.  
 (2) The appended track rail mounting bolts are hexagon socket head bolts equivalent to JIS B 1176. For stainless steel model, stainless steel bolts are appended.  
 In an assembled set of MX series, track rail mounting bolts are not appended.  
 (3) The direction of basic dynamic load rating ( $C$ ), basic static load rating ( $C_0$ ), and static moment rating ( $T_0$ ,  $T_x$ ,  $T_y$ ) are shown in the sketches below. The upper values of  $T_x$  and  $T_y$  are for one slide unit and the lower values are for two slide units in close contact.  
 (4) The shapes of grease nipple vary by size. The specifications are shown in Table 15 on page II - 188.  
 Remark: A grease nipple mounting thread hole is provided on the right and left end plates respectively.

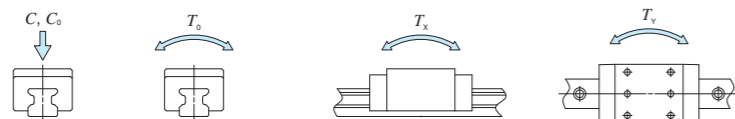

### Example of identification number of assembled set

Model code	Dimensions	Part code	Material code	Preload symbol	Classification symbol	Interchangeable code	Supplemental code
MXD	G	20	C2	R840	T1	P	/F
①	②	③	④	⑤	⑥	⑦	⑧

① Model MXD Block type mounting from top LRXD	② Length of slide unit C Short No symbol Standard G Long L Extra long	③ Size 15, 20	④ Number of slide unit (2)	⑤ Length of track rail (840 mm)	⑥ Material type No symbol High carbon steel made SL Stainless steel made	⑦ Preload amount No symbol Standard T1 Light preload T2 Medium preload T3 Heavy preload	⑧ Accuracy class H High P Precision SP Super precision UP Ultra precision	⑨ Interchangeable No symbol Non-interchangeable specification S1 S1 specification S2 S2 specification	⑩ Special specification A, D, E, F, HP, I, J, L, LF MA, MN, N, Q, RC, T, UR V, W, Y, Z
---	---	------------------	----------------------------	---------------------------------	--	---	---	--	---

# IKO C-Lube Linear Roller Way Super MX

## Block type mounting from top

MXD • LRXD

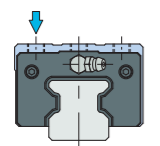

Size	10	12	15	20	25	30
	35	45	55	65	85	

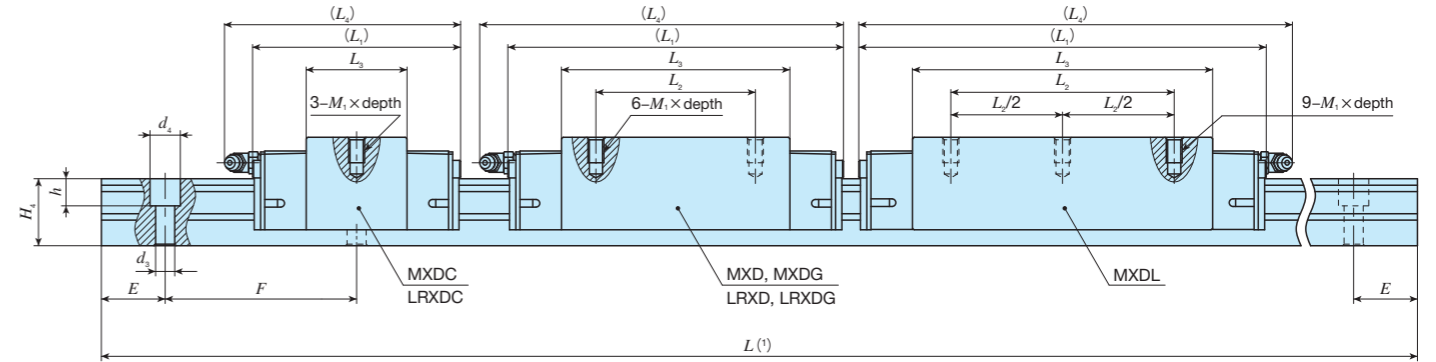
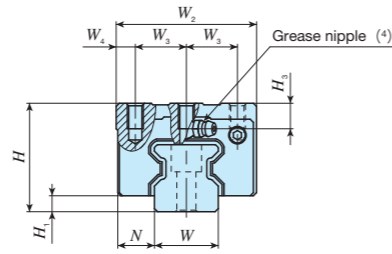

Identification number	Interchangeable	Mass (Ref.)		Dimensions of assembly mm							Dimensions of slide unit mm					Dimensions of track rail mm						Appended mounting bolt for track rail (2)	Basic dynamic load rating (3) C N	Basic static load rating (3) C0 N	Static moment rating (3)																										
		Slide unit kg	Track rail kg/m	H	H1	N	W2	W3	W4	L1	L2	L3	L4	M1 x depth	H3	W	H4	d3	d4	h	E				F	Bolt size x l	T0 N · m	Tx N · m	Ty N · m																						
MXDC 25	LRXDC 25	○	0.36	3.59	40	6	12.5	48	17.5	6.5	74	—	36	83	M6 x 12	9	23	24.5	7	11	9	30	60	M6 x 25	21 600	33 800	500	213 1 810	213 1 810																						
—	LRXDC 25-SL	○	0.55								40	6	12.5	48											17.5	6.5	98	35	60	107	573 3 800	573 3 800																			
MXD 25	LRXD 25	○																									113	50	75	122	885 5 380	885 5 380																			
MXD 25-SL	LRXD 25-SL	○																									137	70	99	146	1 040	1 530 8 480	1 530 8 480																		
MXDG 25	LRXDG 25	○																									0.68	—	—	—	—	—	—	—	—	—	—	—	—	—	—	—	—	—	—	—	—	—	—	—	—
MXDL 25	—	—	0.88	—	—	—	—	—	—	—	—	—	—	—	—	—	—	—	—	—	—	—	—	—	—	—	—	—																							
MXDC 30	LRXDC 30	○	0.60	5.01	45	6.5	16	60	20	10	85	—	42.4	95	M8 x 12	9.5	28	28	9	14	12	40	80	M8 x 28	29 200	44 600	808	329 2 740	329 2 740																						
—	LRXDC 30-SL	○	0.92								45	6.5	16	60											20	10	113	40	70.4	123	883 5 780	883 5 780																			
MXD 30	LRXD 30	○																									134	60	91.4	144	1 350	1 470 8 740	1 470 8 740																		
MXD 30-SL	LRXD 30-SL	○																									1.18	—	—	—	—	—	—	—	—	—	—	—	—	—	—	—	—	—	—	—	—	—	—	—	—
MXDG 30	LRXDG 30	○																									1.52	—	—	—	—	—	—	—	—	—	—	—	—	—	—	—	—	—	—	—	—	—	—	—	—
MXDL 30	—	—	1.52	—	—	—	—	—	—	—	—	—	—	—	—	—	—	—	—	—	—	—	—	—	—	—	—	—																							

Notes (1) Track rail lengths  $L$  are shown in Tables 2.1 and 2.2 on page II - 175 and Tables 2.3 and 2.4 on page II - 176.  
 (2) The appended track rail mounting bolts are hexagon socket head bolts equivalent to JIS B 1176. For stainless steel model, stainless steel bolts are appended.  
 In an assembled set of MX series, track rail mounting bolts are not appended.  
 (3) The direction of basic dynamic load rating ( $C$ ), basic static load rating ( $C_0$ ), and static moment rating ( $T_0$ ,  $T_x$ ,  $T_y$ ) are shown in the sketches below. The upper values of  $T_x$  and  $T_y$  are for one slide unit and the lower values are for two slide units in close contact.  
 (4) The shapes of grease nipple vary by size. The specifications are shown in Table 15 on page II - 188.  
 Remark: A grease nipple mounting thread hole is provided on the right and left end plates respectively.

### Example of identification number of assembled set

Model code   Dimensions   Part code   Material code   Preload symbol   Classification symbol   Interchangeable code   Supplemental code

**MXD**   **G**   **25**   **C2**   **R840**   —   **T1**   **P**   —   **/F**

①   ②   ③   ④   ⑤   ⑥   ⑦   ⑧   ⑨   ⑩

① Model MXD LRXD Block type mounting from top	② Length of slide unit C Short No symbol Standard G Long L Extra long	③ Size 25, 30	④ Number of slide unit (2)	⑤ Length of track rail (840 mm)	⑥ Material type No symbol High carbon steel made SL Stainless steel made	⑦ Preload amount No symbol Standard T1 Light preload T2 Medium preload T3 Heavy preload	⑧ Accuracy class H High P Precision SP Super precision UP Ultra precision	⑨ Interchangeable No symbol Non-interchangeable specification S1 S1 specification S2 S2 specification	⑩ Special specification A, D, E, F, HP, I, J, L, LF MA, MN, N, Q, RC, T, UR V, W, Y, Z
--	---	------------------	----------------------------	---------------------------------	--	---	---	--	---

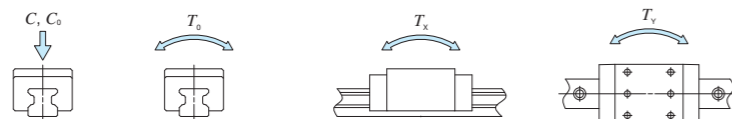

# IKO C-Lube Linear Roller Way Super MX

## Block type mounting from top

Shape	MXD • LRXD					
Size	10	12	15	20	25	30
	35	45	55	65	85	

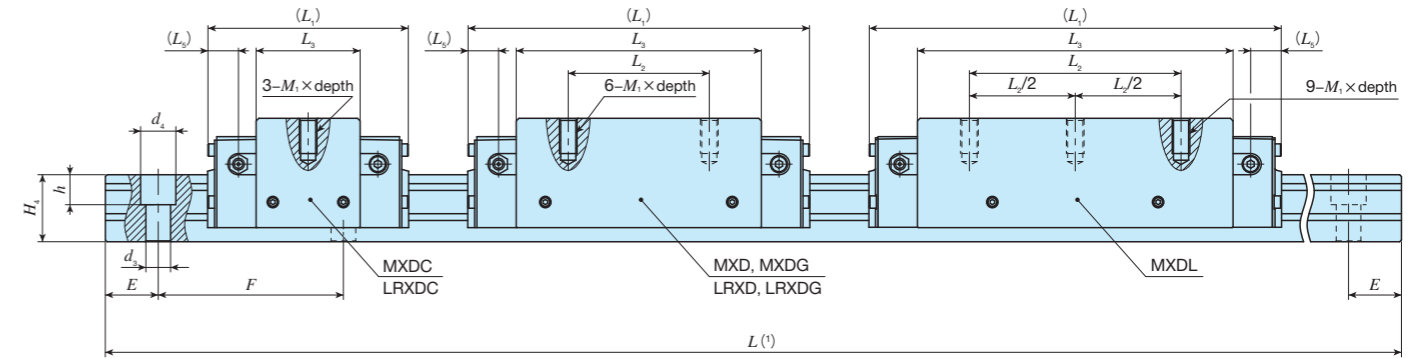
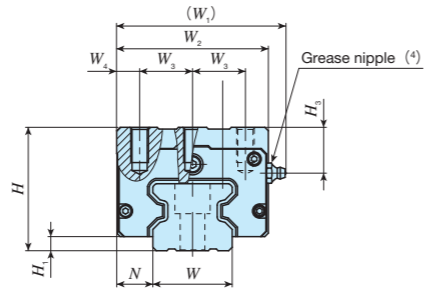

Identification number	Interchangeable	Mass (Ref.)		Dimensions of assembly mm								Dimensions of slide unit mm					Dimensions of track rail mm					Appended mounting bolt for track rail (2)	Basic dynamic load rating (3)	Basic static load rating (3)	Static moment rating (3)					
		Slide unit kg	Track rail kg/m	H	H1	N	W1	W2	W3	W4	L1	L2	L3	L4	M1 × depth	H3	W	H4	d3	d4	h				E	F	C	C0	T0	Tx
MXDC 35	○	0.97	6.88	55	6.5	18	78	70	25	10	92	—	46.6	12.7	M 8 × 16	20	34	32	9	14	12	40	80	M 8 × 35	39 500	60 000	1 300	506	506	
LRXDC 35	○										12.5	3 950	3 950																	
MXD 35	○										1.52	124	50	78.6											12.7	58 700	100 000	2 170	1 360	1 360
LRXD 35	○										12.5	8 470	8 470																	
MXDG 35	○	2.02	10.8	70	8	20.5	96	86	30	13	152	72	106.6	12.7	M 10 × 20	26	45	38	14	20	17	52.5	105	M 12 × 40	74 200	135 000	2 930	2 440	2 440	
LRXDG 35	○										12.5	13 800	13 800																	
MXDL 35	—										2.55	184	100	138.6											12.7	90 800	175 000	3 800	4 060	4 060
—	—										—	—	—	—											—	—	—	—	—	—
MXDC 45	○	2.01	10.8	70	8	20.5	96	86	30	13	114	—	59	17.5	M 10 × 20	26	45	38	14	20	17	52.5	105	M 12 × 40	64 100	95 600	2 660	1 010	1 010	
LRXDC 45	○										12.5	7 800	7 800																	
MXD 45	○										3.13	154	60	99											17.5	95 400	159 000	4 430	2 700	2 700
LRXD 45	○										12.5	16 800	16 800																	
MXDG 45	○	4.29	10.8	70	8	20.5	96	86	30	13	194	80	139	17.5	M 10 × 20	26	45	38	14	20	17	52.5	105	M 12 × 40	124 000	223 000	6 200	5 220	5 220	
LRXDG 45	○										12.5	29 000	29 000																	
MXDL 45	—	5.36	234	120	179	12.7	151 000	287 000	7 980	8 560	8 560																			

Notes (1) Track rail lengths  $L$  are shown in Table 2.1 on page II-175 and Table 2.3 on page II-176.  
 (2) The appended track rail mounting bolts are hexagon socket head bolts equivalent to JIS B 1176. In an assembled set of MX series, track rail mounting bolts are not appended.  
 (3) The direction of basic dynamic load rating ( $C$ ), basic static load rating ( $C_0$ ), and static moment rating ( $T_0$ ,  $T_x$ ,  $T_y$ ) are shown in the sketches below. The upper values of  $T_x$  and  $T_y$  are for one slide unit and the lower values are for two slide units in close contact.  
 (4) The shapes of grease nipple vary by size. The specifications are shown in Table 15 on page II-188.  
 Remark: Three grease nipple mounting thread holes are provided on the right and left end plates respectively.

### Example of identification number of assembled set

Model code	Dimensions	Part code	Preload symbol	Classification symbol	Interchangeable code	Supplemental code
<b>MXD</b>	<b>G</b>	<b>35</b>	<b>C2</b>	<b>R1200</b>	<b>T2</b>	<b>P</b>
						<b>/F</b>

① Model MXD LRXD Block type mounting from top	③ Size 35, 45	⑥ Preload amount No symbol Standard T1 Light preload T2 Medium preload T3 Heavy preload	⑧ Interchangeable No symbol Non-interchangeable specification S1 S1 specification S2 S2 specification
② Length of slide unit C Short No symbol Standard G Long L Extra long	④ Number of slide unit (2)	⑦ Accuracy class H High P Precision SP Super precision UP Ultra precision	⑨ Special specification A, D, E, F, HP, I, J, L, LF MA, MN, N, PS, Q, RC, T UR, V, W, Y, Z

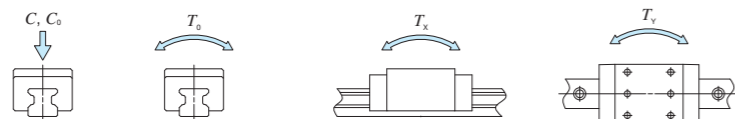



# IKO C-Lube Linear Roller Way Super MX

## Block type mounting from top

MXD • LRXD

Shape



Size

10	12	15	20	25	30
35	45	55	65	85	

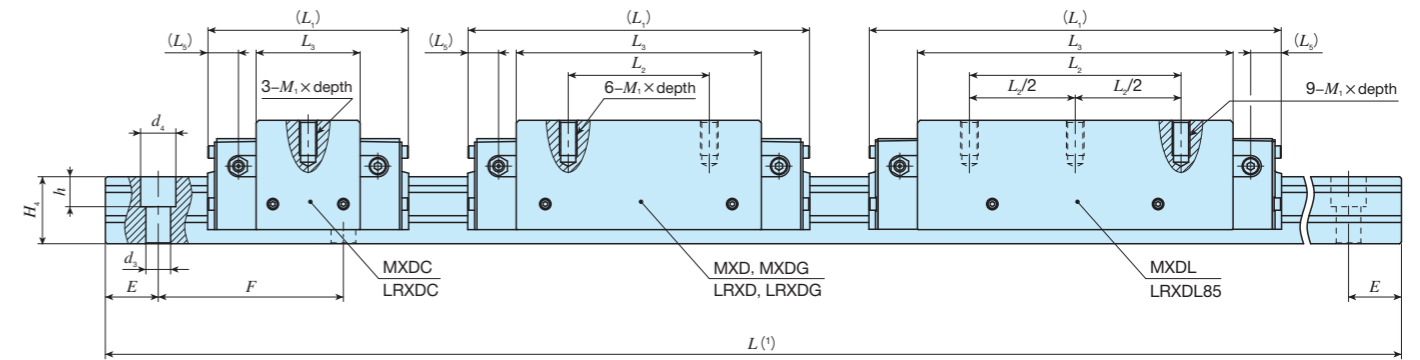
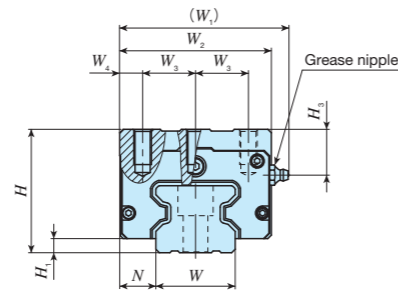

Identification number	Interchangeable	Mass (Ref.)		Dimensions of assembly mm								Dimensions of slide unit mm					Dimensions of track rail mm						Appended mounting bolt for track rail (2)	Basic dynamic load rating (3) C N	Basic static load rating (3) C <sub>0</sub> N	Static moment rating (3)				
		Slide unit kg	Track rail kg/m	H	H <sub>1</sub>	N	W <sub>1</sub>	W <sub>2</sub>	W <sub>3</sub>	W <sub>4</sub>	L <sub>1</sub>	L <sub>2</sub>	L <sub>3</sub>	L <sub>5</sub>	M <sub>1</sub> × depth	H <sub>3</sub>	W	H <sub>4</sub>	d <sub>3</sub>	d <sub>4</sub>	h	E				F	Bolt size × ℓ	T <sub>0</sub> N · m	T <sub>x</sub> N · m	T <sub>y</sub> N · m
MXDC 55	LRXDC 55	○	3.17	14.1	80	9	23.5	110	100	37.5	12.5	136	—	72	20	M12 × 25	26	53	43	16	23	20	60	120	M14 × 45	99 700	149 000	4 830	1 880	1 880
MXD 55	LRXD 55	○	4.97									184	75	120												5 040	5 040			
MXDG 55	LRXDG 55	○	7.06									238	95	174												10 400	10 400			
MXDL 55	—	—	9.08									292	150	228												17 700	17 700			
MXDC 65	LRXDC 65	○	5.52	22.6	90	12	31.5	135	126	38	25	180	—	95	26.3	M16 × 25	18	63	56	18	26	22	75	150	M16 × 60	174 000	249 000	9 790	4 200	4 200
MXD 65	LRXD 65	○	8.70									244	70	159												11 300	11 300			
MXDG 65	LRXDG 65	○	12.1									308	120	223												21 800	21 800			
MXDL 65	—	—	15.5									309	200	295												29 500	29 500			
MXDC 85	LRXDC 85	○	19.9	36.7	110	16	40.5	175	166	60	23	323	140	232	27.5	M20 × 30	22	85	67	26.5	39	30	90	180	M24 × 70	440 000	753 000	38 900	50 000	50 000
MXD 85	LRXD 85	○	25.5									395	200	304												163 000	163 000			
MXDG 85	LRXDG 85	○	34.1									494	280	403												257 000	257 000			
MXDL 85	LRXDL 85	○	34.1									—	—	—												422 000	422 000			

Notes (1) Track rail lengths  $L$  are shown in Table 2.1 on page II-175 and Table 2.3 on page II-176.  
 (2) The appended track rail mounting bolts are hexagon socket head bolts equivalent to JIS B 1176. In an assembled set of MX series, track rail mounting bolts are not appended.  
 (3) The direction of basic dynamic load rating ( $C$ ), basic static load rating ( $C_0$ ), and static moment rating ( $T_0$ ,  $T_x$ ,  $T_y$ ) are shown in the sketches below. The upper values of  $T_x$  and  $T_y$  are for one slide unit and the lower values are for two slide units in close contact.

Remarks 1. The specifications of grease nipple are shown in Table 15 on page II-188.  
 2. Three grease nipple mounting thread holes are provided on the right and left end plates respectively.

## Example of identification number of assembled set

Model code Dimensions Part code Preload symbol Classification symbol Interchangeable code Supplemental code

**MXD** **G** **55** **C2** **R3000** **T<sub>2</sub>** **P** **—** **/F**

① ② ③ ④ ⑤ ⑥ ⑦ ⑧ ⑨

① Model MXD LRXD Block type mounting from top	③ Size 55, 65, 85	⑥ Preload amount No symbol Standard T <sub>1</sub> Light preload T <sub>2</sub> Medium preload T <sub>3</sub> Heavy preload	⑧ Interchangeable No symbol Non-interchangeable specification S1 S1 specification S2 S2 specification
② Length of slide unit C Short No symbol Standard G Long L Extra long	④ Number of slide unit (2)	⑦ Accuracy class H High P Precision SP Super precision UP Ultra precision	⑨ Special specification A, D, E, F, HP, I, J, L, LF MA, MN, PS, Q, RC, T UR, V, W, Y, Z
⑤ Length of track rail (3,000 mm)			

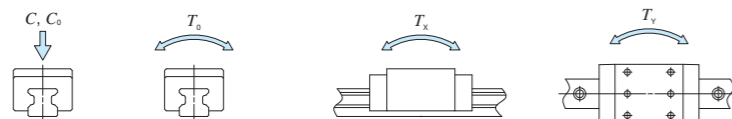

# IKO C-Lube Linear Roller Way Super MX

Compact block type mounting from top

Shape	MXS • LRXS			
Size	15	20	25	30
	35	45	55	

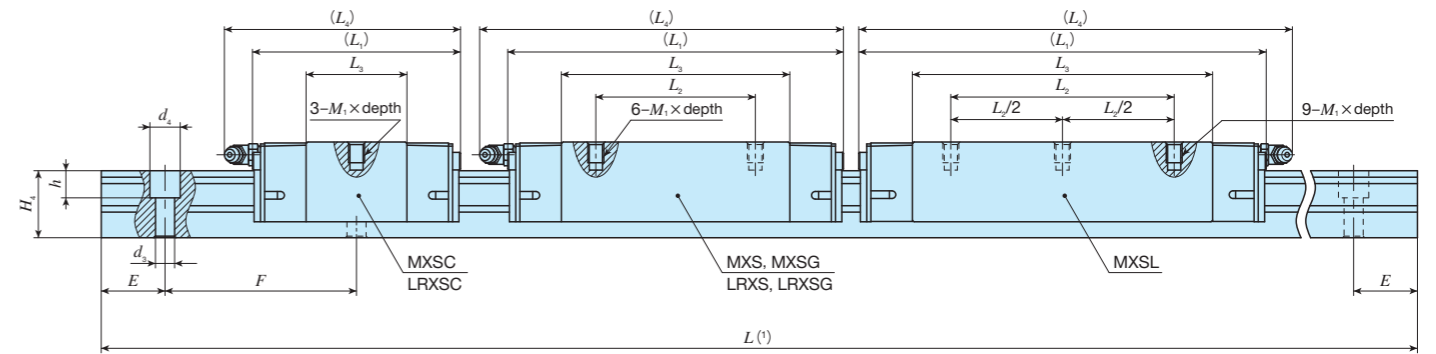
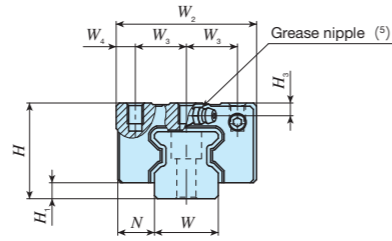

Identification number	Interchangeable	Mass (Ref.)		Dimensions of assembly mm					Dimensions of slide unit mm					Dimensions of track rail mm					Appended mounting bolt for track rail (3)	Basic dynamic load rating (4)	Basic static load rating (4)	Static moment rating (4)							
		Slide unit kg	Track rail kg/m	H	H1	N	W2	W3	W4	L1	L2	L3	L4	M1 × depth (2)	H3	W	H4	d3				d4	h	E	F	Bolt size × ℓ	C N	C0 N	T0 N · m
MXSC 15	LRXSC 15	○	0.099	1.65	24	4	9.5	34	13	4	52	—	24	55	M4 × 5.5	3.5	15	16.5	4.5	8	6	30	60	M4 × 16	7 730	12 000	113	50.6	50.6
MXS 15	LRXS 15	○	0.15								68	26	40	71											136	136			
MXSG 15	LRXSG 15	○	0.21								84	56	87	262											262				
MXSC 20	LRXSC 20	○	0.21	2.73	30	5	12	44	16	6	66	—	31.6	74	M5 × 6.5	4	20	21	6	9.5	8.5	30	60	M5 × 20	16 100	26 400	341	150	150
MXS 20	LRXS 20	○	0.31								86	36	51.6	94											379	379			
MXSG 20	LRXSG 20	○	0.42								106	50	71.6	114											2 520	2 520			
MXSL 20	—	—	0.55								128	70	94.1	137											4 200	4 200			
MXSC 25	LRXSC 25	○	0.30	3.59	36	6	12.5	48	17.5	6.5	74	—	36	83	M6 × 9	5	23	24.5	7	11	9	30	60	M6 × 25	21 600	33 800	500	213	213
MXS 25	LRXS 25	○	0.47								98	35	60	107											3 800	3 800			
MXSG 25	LRXSG 25	○	0.57								113	50	75	122											5 380	5 380			
MXSL 25	—	—	0.74								137	70	99	146											8 480	8 480			
MXSC 30	LRXSC 30	○	0.54	5.01	42	6.5	16	60	20	10	85	—	42.4	95	M8 × 11	6.5	28	28	9	14	12	40	80	M8 × 28	29 200	44 600	808	329	329
MXS 30	LRXS 30	○	0.83								113	40	70.4	123											5 780	5 780			
MXSG 30	LRXSG 30	○	1.05								134	60	91.4	144											8 740	8 740			
MXSL 30	—	—	1.37								162	80	119.4	172											13 600	13 600			

Notes (1) Track rail lengths  $L$  are shown in Table 2.1 on page II-175 and Table 2.3 on page II-176.  
 (2) For the fixing thread depth of the slide unit mounting hole, the value indicated in Table 16.1 on page II-190 is recommended.  
 (3) The appended track rail mounting bolts are hexagon socket head bolts equivalent to JIS B 1176. In an assembled set of MX series, track rail mounting bolts are not appended.  
 (4) The direction of basic dynamic load rating ( $C$ ), basic static load rating ( $C_0$ ), and static moment rating ( $T_0$ ,  $T_x$ ,  $T_y$ ) are shown in the sketches below. The upper values of  $T_x$  and  $T_y$  are for one slide unit and the lower values are for two slide units in close contact.  
 (5) The shapes of grease nipple vary by size. The specifications are shown in Table 15 on page II-188.  
 Remark: A grease nipple mounting thread hole is provided on the right and left end plates respectively.

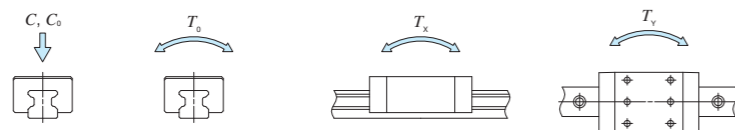

### Example of identification number of assembled set

Model code Dimensions Part code Preload symbol Classification symbol Interchangeable code Supplemental code

**MXS G 25 C2 R840 T1 P /F**

① ② ③ ④ ⑤ ⑥ ⑦ ⑧ ⑨

① Model MXS Compact block type mounting from top LRXS	② Length of slide unit C Short No symbol Standard G Long L Extra long	③ Size 15, 20, 25, 30	④ Number of slide unit (2)	⑤ Length of track rail (840 mm)	⑥ Preload amount No symbol Standard T1 Light preload T2 Medium preload T3 Heavy preload	⑦ Accuracy class H High P Precision SP Super precision UP Ultra precision	⑧ Interchangeable No symbol Non-interchangeable specification S1 S1 specification S2 S2 specification	⑨ Special specification A, D, E, F, HP, I, J, L, LF MA, MN, N, Q, RC, T, UR V, W, Y, Z
---	---	--------------------------	----------------------------	---------------------------------	---	---	--	---

# IKO C-Lube Linear Roller Way Super MX

Compact block type mounting from top

Shape	<b>MXS</b>			
Size	<b>15</b>	<b>20</b>	<b>25</b>	<b>30</b>
	<b>35</b>	<b>45</b>	<b>55</b>	

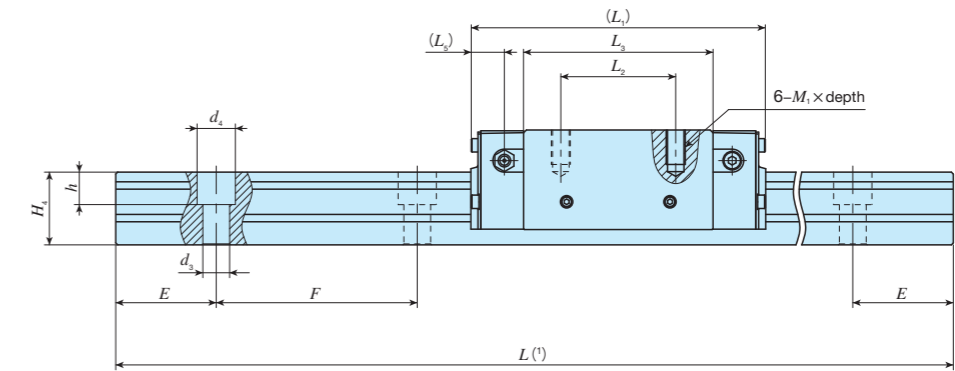
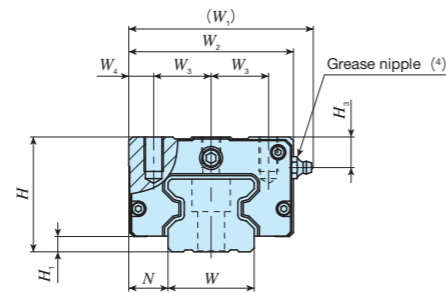

Identification number	Interchangeable	Mass (Ref.)		Dimensions of assembly mm				Dimensions of slide unit mm								Dimensions of track rail mm						Mounting bolt for track rail (2)	Basic dynamic load rating (3)	Basic static load rating (3)	Static moment rating (3)				
		Slide unit kg	Track rail kg/m	H	H <sub>1</sub>	N	W <sub>1</sub>	W <sub>2</sub>	W <sub>3</sub>	W <sub>4</sub>	L <sub>1</sub>	L <sub>2</sub>	L <sub>3</sub>	L <sub>5</sub>	M <sub>1</sub> × depth	H <sub>3</sub>	W	H <sub>4</sub>	d <sub>3</sub>	d <sub>4</sub>	h				E	F	Bolt size × ℓ	C	C <sub>0</sub>
MXS 35	—	1.22	6.88	48	6.5	18	78	70	25	10	124	50	78.6	12.7	M 8×12	13	34	32	9	14	12	40	80	M 8×35	58 700	100 000	2 170	1 360	1 360
MXSG 35	—	1.61	6.88	48	6.5	18	78	70	25	10	152	72	106.6												8 470	8 470	2 440	2 440	
MXS 45	—	2.37	10.8	60	8	20.5	96	86	30	13	154	60	99	17.5	M10×18	16	45	38	14	20	17	52.5	105	M12×40	95 400	159 000	4 430	2 700	2 700
MXSG 45	—	3.27	10.8	60	8	20.5	96	86	30	13	194	80	139												16 800	16 800	5 220	5 220	
MXS 55	—	3.96	14.1	70	9	23.5	110	100	37.5	12.5	184	75	120	20	M12×20	16	53	43	16	23	20	60	120	M14×45	148 000	248 000	8 040	5 040	5 040
MXSG 55	—	5.63	14.1	70	9	23.5	110	100	37.5	12.5	238	95	174												31 100	31 100	10 400	10 400	

Notes (1) Track rail lengths  $L$  are shown in Table 2.1 on page II-175 and Table 2.3 on page II-176.  
 (2) Track rail mounting bolts are not appended.  
 (3) The direction of basic dynamic load rating ( $C$ ), basic static load rating ( $C_0$ ), and static moment rating ( $T_0$ ,  $T_x$ ,  $T_y$ ) are shown in the sketches below. The upper values of  $T_x$  and  $T_y$  are for one slide unit and the lower values are for two slide units in close contact.  
 (4) The shapes of grease nipple vary by size. The specifications are shown in Table 15 on page II-188.  
 Remark: Three grease nipple mounting thread holes are provided on the right and left end plates respectively.

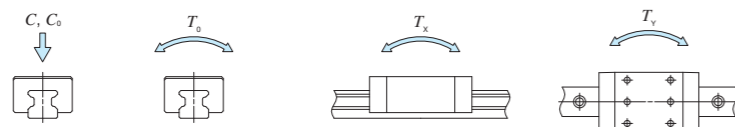

## Example of identification number of assembled set

Model code Dimensions Part code Preload symbol Classification symbol Interchangeable code Supplemental code

**MXS G 45 C2 R1470 T1 P /F**

① ② ③ ④ ⑤ ⑥ ⑦ ⑧ ⑨

① Model	MXS Compact block type mounting from top	③ Size	35, 45, 55	⑥ Preload amount	No symbol Standard T1 Light preload T2 Medium preload T3 Heavy preload	⑧ Interchangeable	No symbol Non-interchangeable specification S1 S1 specification S2 S2 specification
② Length of slide unit	No symbol Standard G Long	④ Number of slide unit (2)		⑦ Accuracy class	H High P Precision SP Super precision UP Ultra precision	⑨ Special specification	A, D, E, F, HP, I, J, L, LF MA, N, RC, T, UR, V, W, Z
⑤ Length of track rail (1,470 mm)							

# IKO C-Lube Linear Roller Way Super MX

Low profile flange type mounting from top

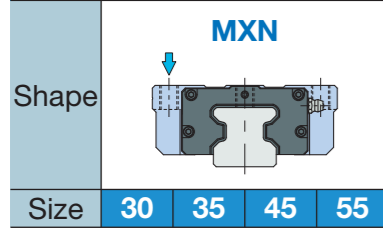

MXN 30  
MXNG 30  
MXNL 30

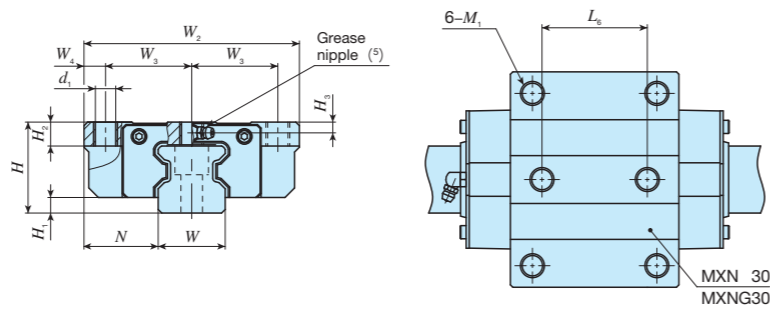

MXN  
MXNG  
MXNL

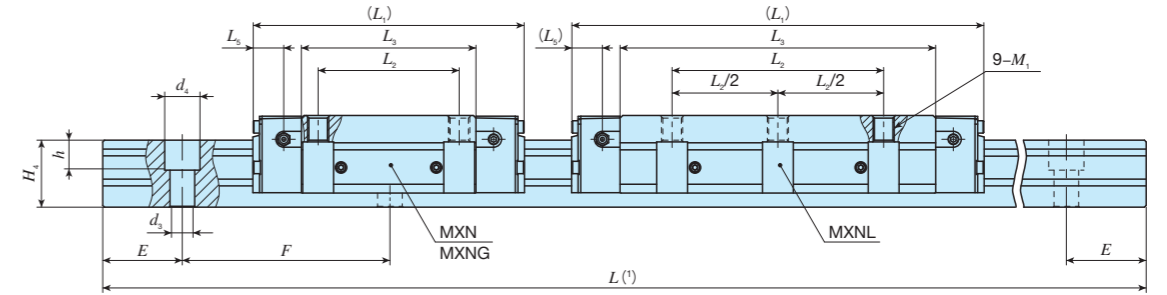
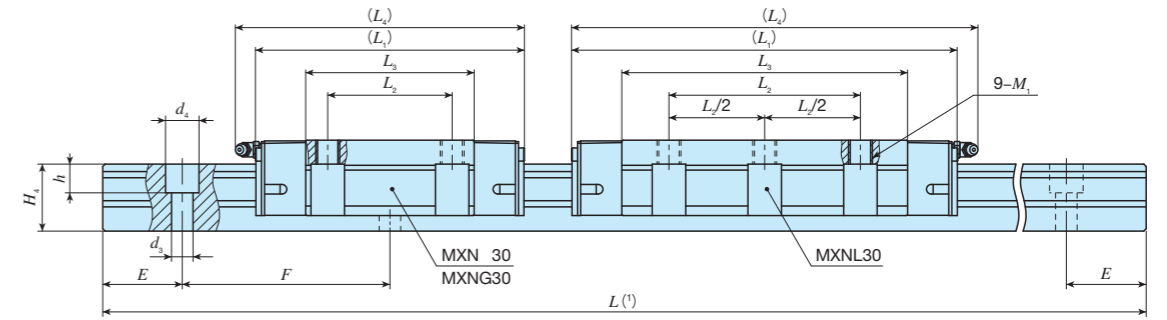
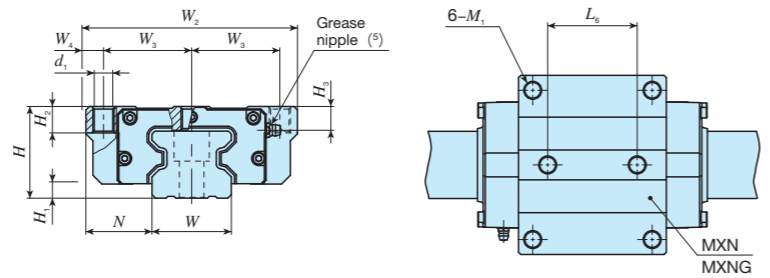

Identification number	Interchangeable	Mass (Ref.)	Dimensions of assembly mm	Dimensions of slide unit mm														Dimensions of track rail mm						Mounting bolt for track rail (3)	Basic dynamic load rating (4)	Basic static load rating (4)	Static moment rating (4)																
				Slide unit kg	Track rail kg/m	H	H1	N	W2	W3	W4	L1	L2	L3	L4	L5	L6	d1	M1	Maximum fixing thread depth (2)	H2	H3	W				H4	d3	d4	h	E	F	Bolt size x l	C	C0	T0	Tx	Ty					
MXN 30	-	1.05	5.01	38	6.5	31	90	36	9	113	52	70.4	121	-	44	8.5	M10	9	10	4.5	28	28	9	14	12	40	80	M 8x28	43 400	74 400	1 350	883	883										
MXNG 30	-	1.38								134		91.4	142																8.5	10	4.5	28	28	9	14	12	40	80	53 200	96 700	1 750	1 470	1 470
MXNL 30	-	1.75								162		119.4	170																80	10	4.5	28	28	9	14	12	40	80	65 600	126 000	2 290	2 500	2 500
MXN 35	-	1.55	6.88	44	6.5	33	100	41	9	124	62	78.6	-	52	8.5	M10	11	13	11	34	32	9	14	12	40	80	M 8x35	58 700	100 000	2 170	1 360	1 360											
MXNG 35	-	2.13								152		106.6																127	8.5	13	11	34	32	9	14	12	40	80	74 200	135 000	2 930	2 440	2 440
MXNL 35	-	2.71								184		138.6																100	10	11	34	32	9	14	12	40	80	90 800	175 000	3 800	4 060	4 060	
MXN 45	-	2.58	10.8	52	8	37.5	120	50	10	154	80	99	-	60	10.5	M12	13	15	13.5	45	38	14	20	17	52.5	105	M12x40	95 400	159 000	4 430	2 700	2 700											
MXNG 45	-	3.73								194		139																17.5	10.5	15	13.5	45	38	14	20	17	52.5	105	124 000	223 000	6 200	5 220	5 220
MXNL 45	-	4.72								234		179																120	10	13.5	45	38	14	20	17	52.5	105	151 000	287 000	7 980	8 560	8 560	
MXN 55	-	4.61	14.1	63	9	43.5	140	58	12	184	95	120	-	70	12.5	M14	19	17	16	53	43	16	23	20	60	120	M14x45	148 000	248 000	8 040	5 040	5 040											
MXNG 55	-	6.94								238		174																20	12.5	17	16	53	43	16	23	20	60	120	198 000	359 000	11 700	10 400	10 400
MXNL 55	-	8.87								292		150																228	12	16	53	43	16	23	20	60	120	244 000	470 000	15 300	17 700	17 700	

Notes (1) Track rail lengths L are shown in Table 2.1 on page II-175 and Table 2.3 on page II-176.

(2) The fixing thread depth of mounting screw in the middle of the way in the slide unit width direction should be less than the maximum fixing thread depth.

(3) Track rail mounting bolts are not appended.

(4) The direction of basic dynamic load rating (C), basic static load rating (C0), and static moment rating (T0, Tx, Ty) are shown in the sketches below. The upper values of Tx and Ty are for one slide unit and the lower values are for two slide units in close contact.

(5) The shapes of grease nipple vary by size. The specifications are shown in Table 15 on page II-188.

Remarks 1. For size 30 series, a grease nipple mounting thread hole is provided on the right and left end plates respectively.

2. For size 35, 45, and 55 series, three grease nipple mounting thread holes are provided on the right and left end plates respectively.

However, the size of thread hole for size 35 in the slide unit travelling direction is smaller than that of the crosswise direction.

When the grease nipple is mounted along the travelling direction, contact IKO.

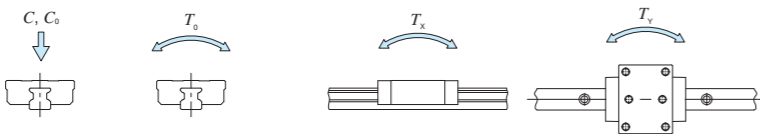

## Example of identification number of assembled set

Model code Dimensions Part code Preload symbol Classification symbol Interchangeable code Supplemental code

**MXN G 55 C2 R3000 T2 P /F**

① ② ③ ④ ⑤ ⑥ ⑦ ⑧ ⑨

① Model	MXN Low profile flange type mounting from top
② Length of slide unit	No symbol Standard G Long L Extra long

③ Size	30, 35, 45, 55
④ Number of slide unit (2)	
⑤ Length of track rail (3,000 mm)	

⑥ Preload amount	No symbol Standard T1 Light preload T2 Medium preload T3 Heavy preload
⑦ Accuracy class	H High P Precision SP Super precision UP Ultra precision

⑧ Interchangeable	No symbol Non-interchangeable specification S1 S1 specification S2 S2 specification
⑨ Special specification	A, D, E, F, HP, I, J, L, LF MA, RC, T, UR, V, W, Z

# IKO C-Lube Linear Roller Way Super MX

Low profile block type mounting from top

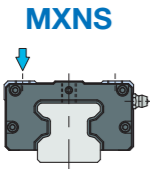
Shape				
Size	30	35	45	55

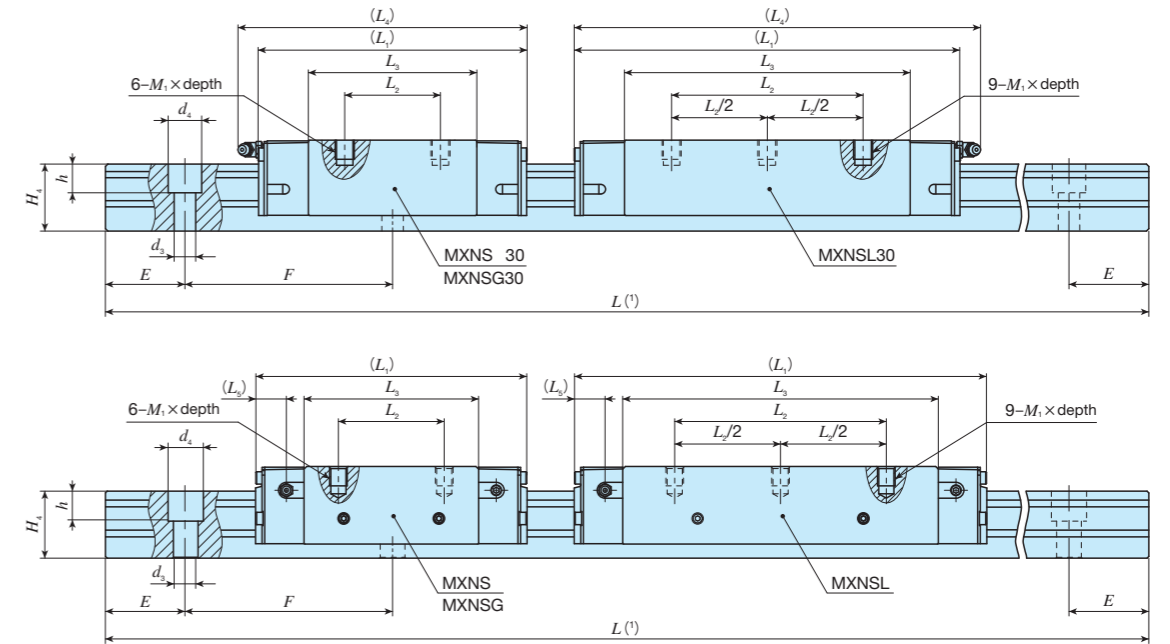
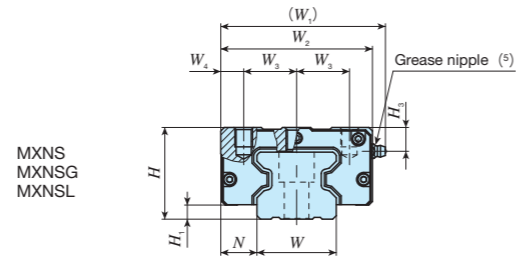
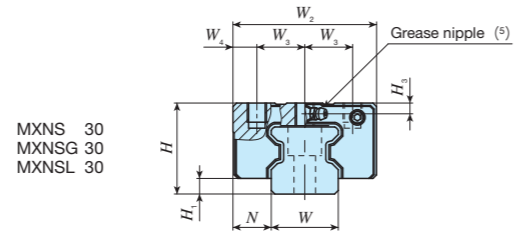

Identification number	LRX series (No C-Lube)	Interchangeable	Mass (Ref.) Slide unit kg / Track rail kg/m	Dimensions of assembly mm														Maximum fixing thread depth (2)	Dimensions of track rail mm						Mounting bolt for track rail (3) Bolt size x l	Basic dynamic load rating (4) C N	Basic static load rating (4) C0 N	Static moment rating (4)				
				H	H1	N	W1	W2	W3	W4	L1	L2	L3	L4	L5	M1 x depth (2)	H3		W	H4	d3	d4	h	E				F	T0 N·m	Tx N·m	Ty N·m	
MXNS 30	-	○	0.70	5.01	38	6.5	16	-	60	20	10	113	40	70.4	121	-	M 8 x 8	9	4.5	28	28	9	14	12	40	80	M 8 x 28	43 400	74 400	1 350	883 5 780	883 5 780
MXNSG 30	-	○	0.90	5.01	38	6.5	16	-	60	20	10	134	60	91.4	142	-	M 8 x 8	9	4.5	28	28	9	14	12	40	80	M 8 x 28	53 200	96 700	1 750	1 470 8 740	1 470 8 740
MXNSL 30	-	-	1.14	5.01	38	6.5	16	-	60	20	10	162	80	119.4	170	-	M 8 x 8	9	4.5	28	28	9	14	12	40	80	M 8 x 28	65 600	126 000	2 290	2 500 13 600	2 500 13 600
MXNS 35	-	○	1.08	6.88	44	6.5	18	78	70	25	10	124	50	78.6	-	12.7	M 8 x 9	11	11	34	32	9	14	12	40	80	M 8 x 35	58 700	100 000	2 170	1 360 8 470	1 360 8 470
MXNSG 35	-	○	1.42	6.88	44	6.5	18	78	70	25	10	152	72	106.6	-	12.7	M 8 x 9	11	11	34	32	9	14	12	40	80	M 8 x 35	74 200	135 000	2 930	2 440 13 800	2 440 13 800
MXNSL 35	-	-	1.81	6.88	44	6.5	18	78	70	25	10	184	100	138.6	-	12.7	M 8 x 9	11	11	34	32	9	14	12	40	80	M 8 x 35	90 800	175 000	3 800	4 060 21 300	4 060 21 300
MXNS 45	-	○	1.84	10.8	52	8	20.5	94	86	30	13	154	60	99	-	17.5	M10 x 11	13	13.5	45	38	14	20	17	52.5	105	M12 x 40	95 400	159 000	4 430	2 700 16 800	2 700 16 800
MXNSG 45	-	○	2.58	10.8	52	8	20.5	94	86	30	13	194	80	139	-	17.5	M10 x 11	13	13.5	45	38	14	20	17	52.5	105	M12 x 40	124 000	223 000	6 200	5 220 29 000	5 220 29 000
MXNSL 45	-	-	3.29	10.8	52	8	20.5	94	86	30	13	234	120	179	-	17.5	M10 x 11	13	13.5	45	38	14	20	17	52.5	105	M12 x 40	151 000	287 000	7 980	8 560 44 400	8 560 44 400
MXNS 55	-	○	3.31	14.1	63	9	23.5	110	100	37.5	12.5	184	75	120	-	20	M12 x 15	19	16	53	43	16	23	20	60	120	M14 x 45	148 000	248 000	8 040	5 040 31 100	5 040 31 100
MXNSG 55	-	○	4.83	14.1	63	9	23.5	110	100	37.5	12.5	238	95	174	-	20	M12 x 15	19	16	53	43	16	23	20	60	120	M14 x 45	198 000	359 000	11 700	10 400 57 000	10 400 57 000
MXNSL 55	-	-	6.28	14.1	63	9	23.5	110	100	37.5	12.5	292	150	228	-	20	M12 x 15	19	16	53	43	16	23	20	60	120	M14 x 45	244 000	470 000	15 300	17 700 90 700	17 700 90 700

Notes (1) Track rail lengths L are shown in Table 2.1 on page II-175 and Table 2.3 on page II-176.  
 (2) For the fixing thread depth of the slide unit mounting hole, the value indicated in Table 16.2 on page II-190 is recommended.  
 The fixing thread depth of mounting screw in the middle of the way in the slide unit width direction should be less than the maximum fixing thread depth.  
 (3) Track rail mounting bolts are not appended.  
 (4) The direction of basic dynamic load rating (C), basic static load rating (C0), and static moment rating (T0, Tx, Ty) are shown in the sketches below. The upper values of Tx and Ty are for one slide unit and the lower values are for two slide units in close contact.  
 (5) The shapes of grease nipple vary by size. The specifications are shown in Table 15 on page II-188.

Remarks 1. For size 30 series, a grease nipple mounting thread hole is provided on the right and left end plates respectively.  
 2. For size 35, 45, and 55 series, three grease nipple mounting thread holes are provided on the right and left end plates respectively. However, the size of thread hole for size 35 in the slide unit travelling direction is smaller than that of the crosswise direction.  
 When the grease nipple is mounted along the travelling direction, contact IKO.

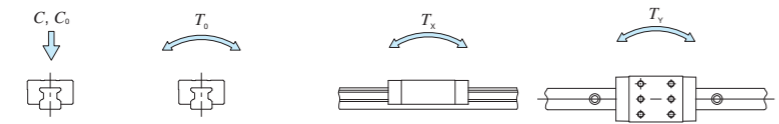

**Example of identification number of assembled set**

Model code	Dimensions	Part code	Preload symbol	Classification symbol	Interchangeable code	Supplemental code
MXNS G	55	C2 R3000	T2	P	-	/F
①	②	③	④	⑤	⑥	⑦

① Model	③ Size	⑥ Preload amount	⑧ Interchangeable
MXNS Low profile block type mounting from top	30, 35, 45, 55	No symbol Standard T1 Light preload T2 Medium preload T3 Heavy preload	No symbol Non-interchangeable specification S1 S1 specification S2 S2 specification
② Length of slide unit	④ Number of slide unit (2)	⑦ Accuracy class	⑨ Special specification
No symbol Standard G Long L Extra long		H High P Precision SP Super precision UP Ultra precision	A, D, E, F, HP, I, J, L, LF MA, RC, T, UR, V, W, Z
⑤ Length of track rail (3,000 mm)			

## Linear Roller Way X

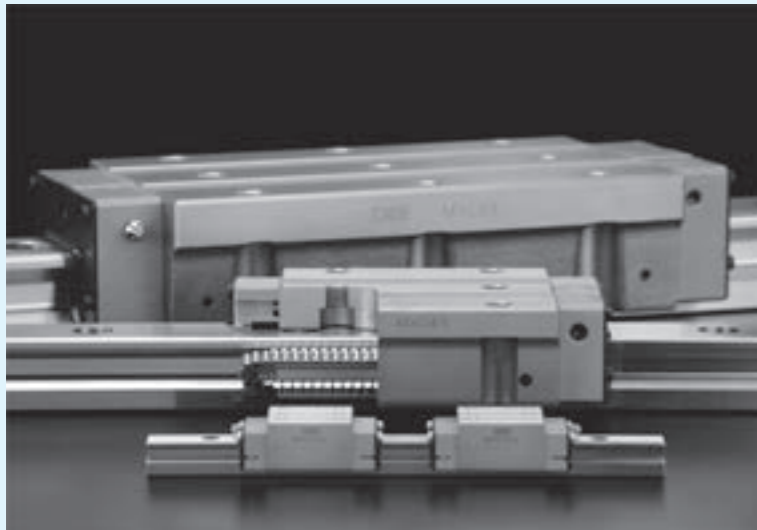

# Linear Roller Way X

# LRWX

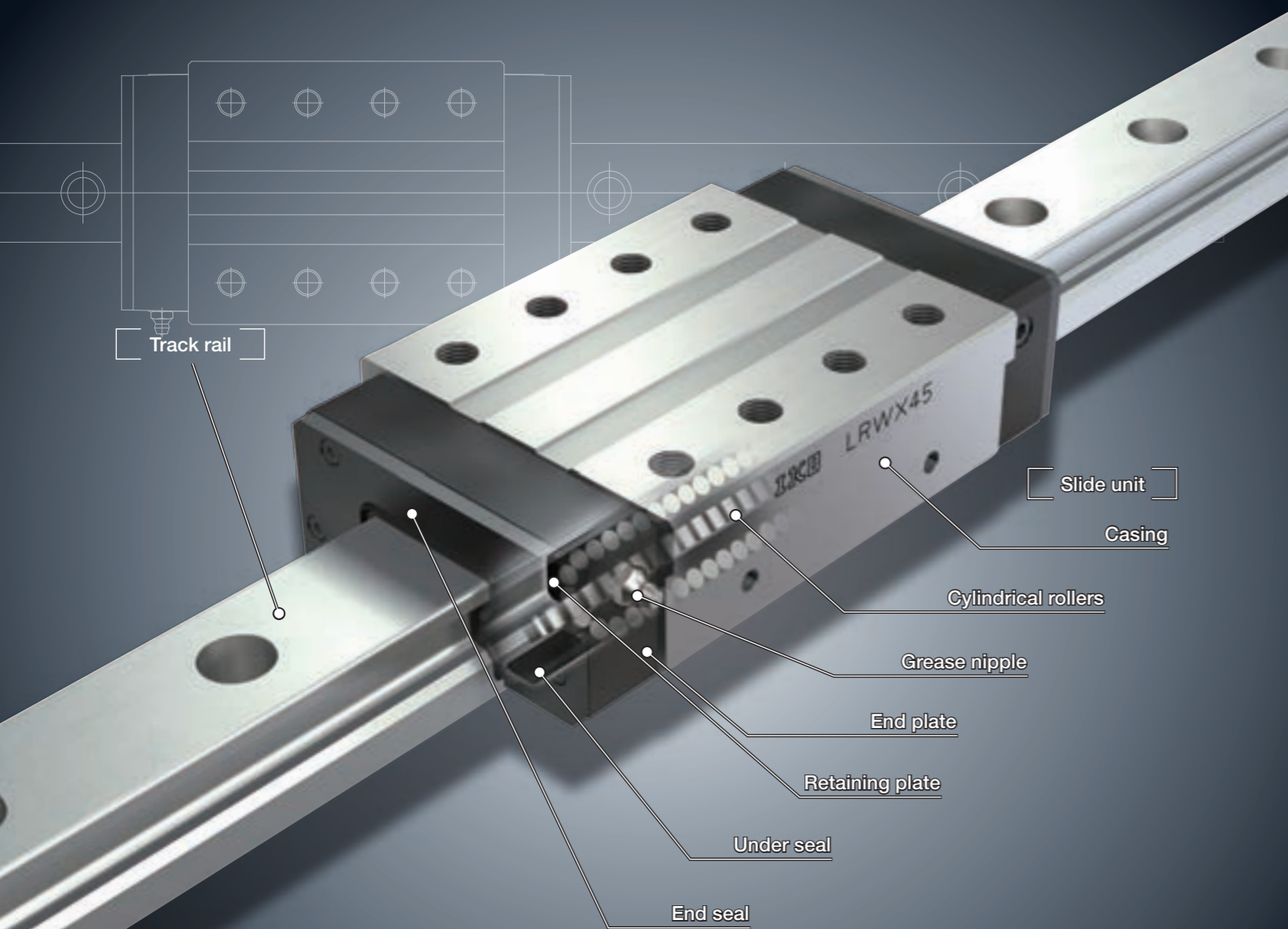
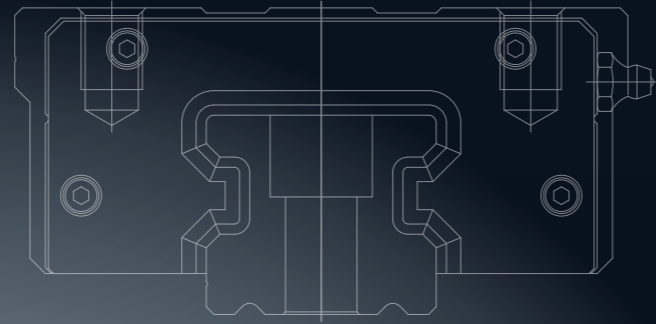

**Roller type linear motion rolling guide  
with cylindrical rollers in four-rows!**

**Well-balanced roller arrangement  
enabling equal resistance to all direction loads!**

**Slide unit shape block type and flange type are available  
and can be selected according to the application!**

## Identification Number and Specification

### Example of an identification number

The specification of LRWX series is indicated by the identification number. Indicate the identification number, consisting of a model code, dimensions, a part code, a preload symbol, a classification symbol, and any supplemental codes for each specification to apply.

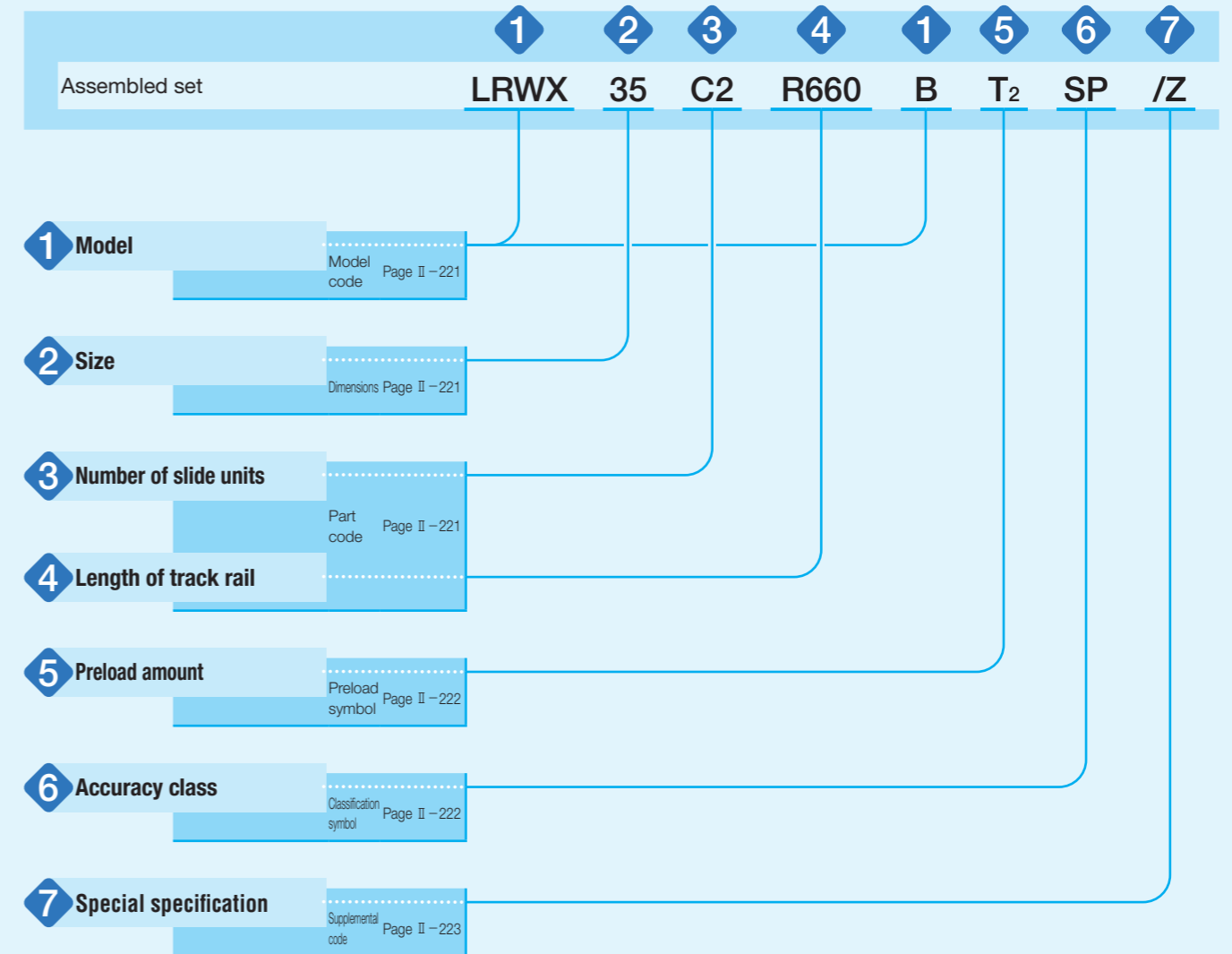

# Identification Number and Specification – Model · Size · Number of Slide Unit · Length of Track Rail –

<b>1 Model</b>	Linear Roller Way X <sup>(1)</sup> (LRWX series)	Block type mounting from top : LRWX...B Flange type mounting from bottom : LRWXH
	For applicable models and sizes, see Table 1. Note <sup>(1)</sup> This model has no built-in C-Lube.	
<b>2 Size</b>	25,35,45,55,75	For applicable models and sizes, see Table 1.
<b>3 Number of slide units</b>	: C○	Indicates the number of slide units assembled on a track rail.
<b>4 Length of track rail</b>	: R○	Indicate the length of track rail in mm. For standard and maximum lengths, see Table 2.

**Table 1 Models and sizes of LRWX series**

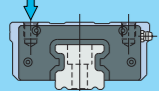
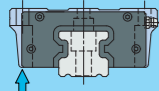
Shape	Model	Size				
		25	35	45	55	75
Block type mounting from top 	LRWX...B	○	○	○	○	○
Flange type mounting from bottom 	LRWXH	—	○	○	○	○

**Table 2 Standard and maximum lengths of track rail**

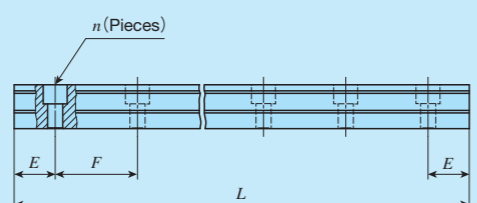

Item	Identification number	LRWX25...B	LRWX25...B/HP <sup>(3)</sup>	LRWX 35...B LRWXH35	LRWX 45...B LRWXH45	LRWX 55...B LRWXH55	LRWX 75...B LRWXH75
		Standard length $L$ ( $n$ )		480 ( 8) 660 (11) 840 (14) 1020 (17) 1200 (20) 1500 (25)	480 (16) 660 (22) 840 (28) 1020 (34) 1200 (40) 1500 (50)	480 ( 8) 660 (11) 840 (14)	800 (10) 1040 (13) 1200 (15) 1520 (19) 1920 (24)
Pitch of mounting holes $F$		60	30	60	80	100	120
$E$		30	15	30	40	50	60
Standard $E$ or higher dimensions <sup>(1)</sup> below		9	9	12	15	18	23
Maximum length <sup>(2)</sup>		1980 (3000)	1980 (3000)	3000 (3960)	2960 (4000)	3000 (4000)	3000 (3960)

Notes <sup>(1)</sup> Not applicable to female threads for bellows (supplemental code "J").

<sup>(2)</sup> Length up to the value in ( ) can be produced. If needed, please contact **IKO**.

<sup>(3)</sup> This indicates the dimension for the half pitch mounting holes specification of track rail.

Remark: If not directed,  $E$  dimensions for both ends will be the same within the range of standard  $E$  dimensions. To change the dimensions, indicate the specified rail mounting hole positions "E" of special specification. For more information, see page III-30.

# – Preload Amount · Accuracy Class –

<b>5 Preload amount</b>	Standard : No symbol Light preload : T <sub>1</sub> Medium preload : T <sub>2</sub> Heavy preload : T <sub>3</sub>	For details of the preload amount, see Table 3.
<b>6 Accuracy class</b>	High : H Precision : P Super precision : SP Ultra precision : UP	For details of accuracy class, see Table 4.

**Table 3 Preload amount**

Preload type	Item	Preload symbol	Preload amount N	Operational conditions
Standard	(No symbol)		0 <sup>(1)</sup>	· Light and precise motion
Light preload	T <sub>1</sub>		0.02 C <sub>0</sub>	· Almost no vibrations · Load is evenly balanced · Light and precise motion
Medium preload	T <sub>2</sub>		0.05 C <sub>0</sub>	· Medium vibration · Medium overhung load
Heavy preload	T <sub>3</sub>		0.08 C <sub>0</sub>	· Operation with vibration and / or shock · Overhanging load applied · Heavy cutting

Note <sup>(1)</sup> Indicates zero or minimal amount of preload.

Remark: C<sub>0</sub> indicates the basic static load rating.

**Table 4 Tolerance and allowance**

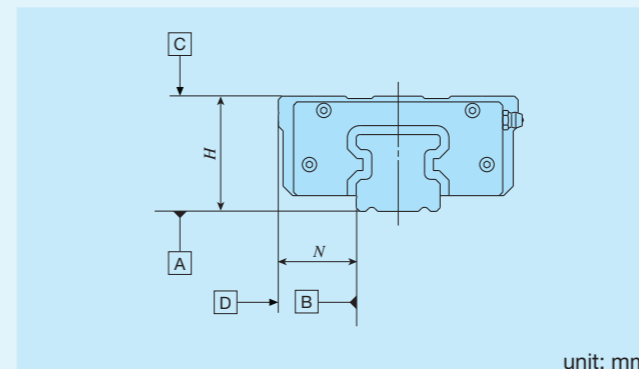

Item	Class (classification symbol)			
	High (H)	Precision (P)	Super precision (SP)	Ultra precision (UP)
Dim. $H$ tolerance	±0.040	±0.020	±0.010	±0.008
Dim. $N$ tolerance	±0.050	±0.025	±0.015	±0.010
Dim. variation of $H$ <sup>(1)</sup>	0.015	0.007	0.005	0.003
Dim. variation of $N$ <sup>(1)</sup>	0.020	0.010	0.007	0.003
Dim. variation of $H$ for multiple assembled sets	0.035	0.025	—	—
Parallelism in operation of the slide unit C surface to A surface	See Fig. 1			
Parallelism in operation of the slide unit D surface to B surface	See Fig. 1			

Note <sup>(1)</sup> It means the size variation between slide units mounted on the same track rail.

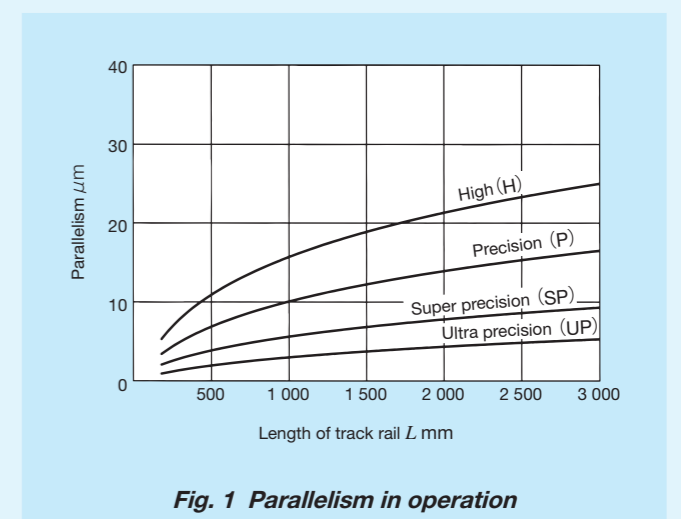

**Fig. 1 Parallelism in operation**



7 Special specification

/A, /D, /E, /F, /HP, /I, /JO, /LO, /LFO, /Q, /VO, /WO, /YO, /ZO

For applicable special specifications, see Table 5.  
For combination of multiple special specifications, see Table 6.  
For details of special specifications, see page III -29.

Table 5 Application of special specifications

Special specification	Supplemental code	Size				
		25	35	45	55	75
Butt-jointing track rails	/A	○	○	○	○	○
Opposite reference surfaces arrangement	/D	○	○	○	○	○
Specified rail mounting hole positions	/E	○	○	○	○	○
Caps for rail mounting holes	/F	○	○	○	○	○
Half pitch mounting holes for track rail	/HP	○	×	×	×	×
Inspection sheet	/I	○	○	○	○	○
Female threads for bellows	/JO	○	○	○	○	○
Black chrome surface treatment	/LO	○	○	○	○	○
Fluorine black chrome surface treatment	/LFO	○	○	○	○	○
With C-Lube plate	/Q	○	○	○	○	○
Double seals	/VO	○	×	×	×	×
A group of multiple assembled sets	/WO	○	○	○	○	○
Specified grease	/YO	○	○	○	○	○
Scrapers	/ZO	○	○	○	○	○

Table 6 Combination of supplemental codes

D	○												
E	-	-											
F	○	○	○										
HP	-	○	-	○									
I	○	○	○	○	○								
J	○	○	○	○	○	-	○						
L	○	○	○	○	○	○	○						
LF	○	○	○	○	○	○	○	-					
Q	○	○	○	○	○	○	-	○	○				
V	○	○	○	○	○	○	○	○	-				
W	○	○	-	○	○	○	○	○	○	○			
Y	○	○	○	○	○	○	○	○	-	○	○		
Z	○	○	○	○	○	○	-	○	○	-	○	○	○
A	D	E	F	HP	I	J	L	LF	Q	V	W	Y	

Remarks 1. The combination of "-" shown in the table is not available.  
2. When using multiple types for combination, please indicate by arranging the symbols in alphabetical order.

Table 7 Dimension of female threads for bellows (Supplemental code: /J /JJ)

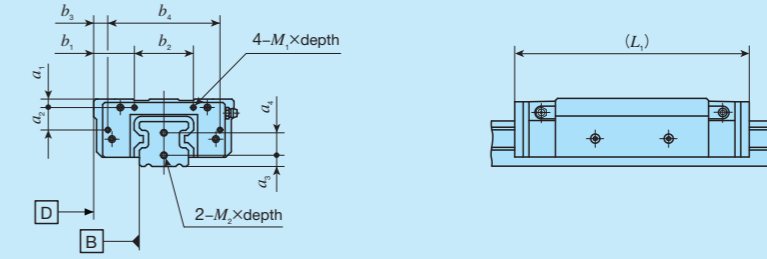

Identification number	Slide unit							Track rail			
	$a_1$	$a_2$	$b_1$	$b_2$	$b_3$	$b_4$	$M_1 \times \text{depth}$	$L_1^{(1)}$	$a_3$	$a_4$	$M_2 \times \text{depth}$
LRWX 25...B	5	12	15	33	7	49	M3×6	116	7	12	M4×8
LRWX 35...B	6	16	29	42	10	80	M3×6	166	8	16	M4×8
LRWXH 35			31		12						
LRWX 45...B	8	20	34	52	12	96	M4×8	221	10	19	M5×10
LRWXH 45			38		16						
LRWX 55...B	9	24	36	68	15	110	M5×10	282	12	23	M6×12
LRWXH 55			43		22						
LRWX 75...B	10	35	35	110	15.5	149	M5×10	366	15	30	M6×12
LRWXH 75			42		22.5						

Note (1) Dimensions of the specification that female threads for bellows are fitted to both ends of the slide unit are indicated.

Table 8 Dimension of slide unit with C-Lube plate (Supplemental code /Q)

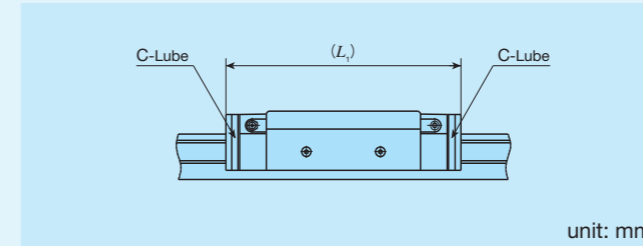

Size	$L_1$
25	120
35	166
45	218
55	275
75	364

Remark: The dimensions of the slide unit with C-Lube at both ends are indicated.

Table 9 Dimension of slide unit with scrapers (Supplemental code: /Z /ZZ)

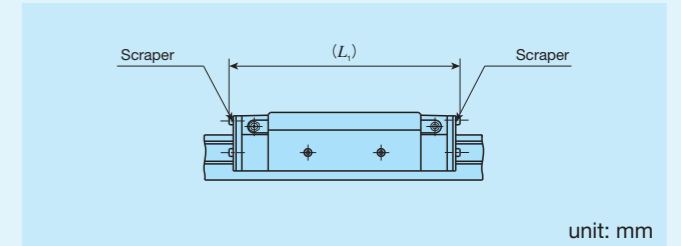

Size	$L_1$
25	120
35	164
45	217
55	275
75	361

Remark: The dimensions of the slide unit with scraper at both ends are indicated.

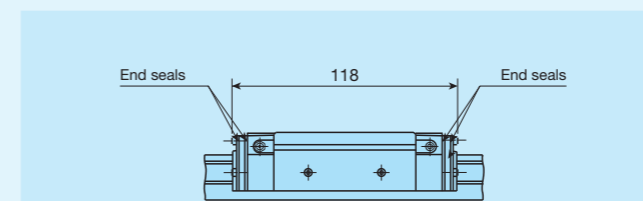

Fig. 2 Dimensions of slide unit with double seals (Size 25) (Supplemental code: /V /VV)

Remark: The dimensions of the slide unit with double end seals at both ends are indicated.

# Lubrication

Lithium-soap base grease with extreme-pressure additive (Alvania EP Grease 2 [SHOWA SHELL SEKIYU K. K.]) is pre-packed in LRWX series. LRWX series has grease nipple as indicated in Table 10.

**Table 10 Parts for lubrication**

Size	Grease nipple type (1)	Applicable supply nozzle type	Bolt size of female threads for piping
25	JIS type 1	Grease gun available on the market	M6
35			
45			
55	JIS type 2		PT1/8
75			

Note (1) For grease nipple specification, see Table 14.2 on page III-23.  
Remark: Stainless steel grease nipple is also available. If needed, please contact **IKO**.

# Dust Protection

The slide units of LRWX series are equipped with end seals and under seals as standard for dust protection. However, if large amount of contaminant or dust are floating, or if large particles of foreign substances such as chips or sand may adhere to the track rail, it is recommended to cover the whole unit with bellows or telescope type shield, etc. LRWX series is provided with specific bellows. The bellows are easy to mount and provide excellent dust protection. If

needed, please refer to III-26 for ordering.

# Precaution for Use

## 1 Mounting surface, reference mounting surface and typical mounting structure

When mounting the LRWX series, properly align the reference mounting surfaces B and D of the track rail and slide unit with the reference mounting surface of the table and bed and fix them. (See Fig. 3)

Reference mounting surfaces B and D and mounting surfaces A and C are ground precisely. Machining the mounting surface of the table and bed, such as machine or device, to high accuracy and mounting them properly will ensure stable linear motion with high accuracy.

Reference mounting surface of the slide unit is the opposite side of the **IKO** mark. The track rail reference mounting surface is identified by locating the **IKO** mark on the top surface of the track rail. It is the side surface above the mark (in the direction of the arrow). (See Fig. 4)

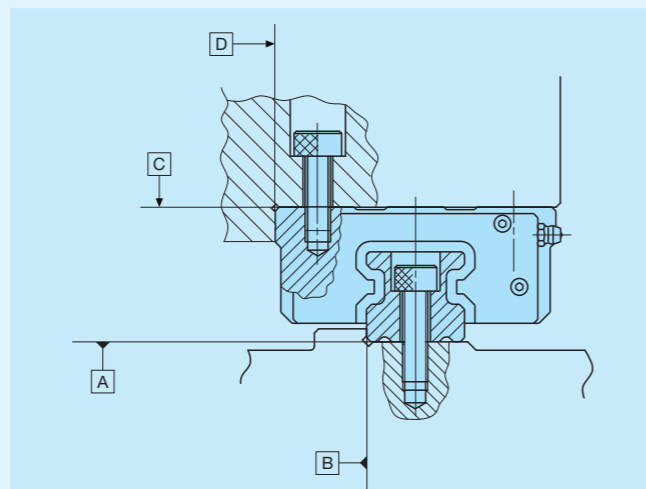

**Fig. 3 Reference mounting surface and typical mounting structure**

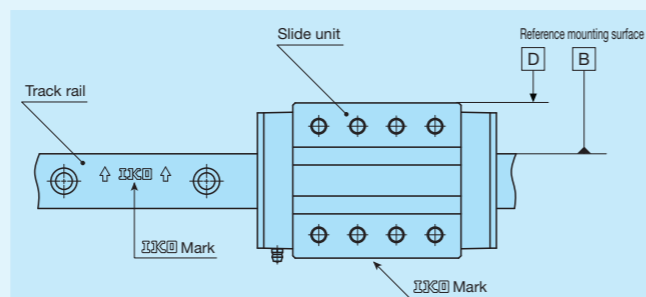

**Fig. 4 Reference mounting surface**

## 2 Fixing the slide unit

Slide unit of LRWX25... B and LRWXH is also provided with mounting holes in the middle of width direction (see Fig. 5) and has the arrangement to receive the applied load in a good balance. When designing machines or equipment, consider the arrangement so that the mounting holes in the middle of slide unit can also be used to fix the units, to use the highest performance out of the product.

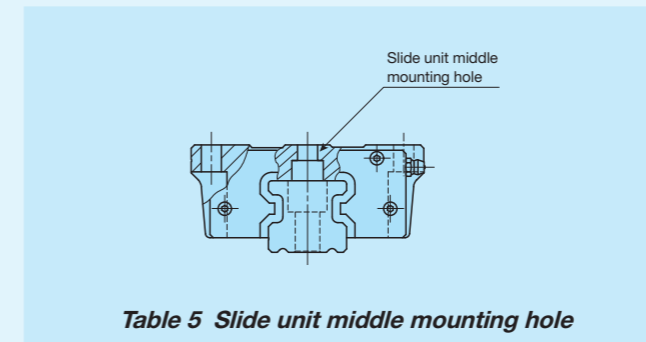

**Table 5 Slide unit middle mounting hole**

## 3 Shoulder height and corner radius of the reference mounting surface

For the opposite corner of the mating reference mounting, it is recommended to have relieved fillet as indicated in Fig. 6, but you may also use it with providing corner radius  $R$  as shown in Table 11. Recommended value for the shoulder height and corner radius on the mating side is indicated in Table 11.

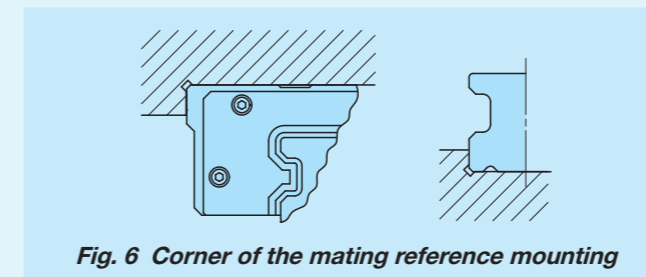

**Fig. 6 Corner of the mating reference mounting**

**Table 11 Shoulder height and corner radius of the reference mounting surface**

Size	Shoulder height of slide unit mounting part	Shoulder height of track rail mounting part	Corner radius
	$h_1$	$h_2$	$R$ (Maximum)
25	6	4	1
35	8	5.5	1
45	8	6	1
55	10	8	1.5
75	10	8	1.5

unit: mm

## 4 Tightening torque for fixing screw

Typical tightening torque for mounting of the LRWX series to the steel mating member material is indicated in Table 12. When vibration and shock of the machine or device are large, fluctuating load is large, or moment load is applied, fix it by using the torque 1.2 to 1.5 times larger than the value indicated in the table as necessary. If the mating member material is cast iron or aluminum alloy, reduce the tightening torque depending on the strength characteristics of the mating member material.

**Table 12 Tightening torque for fixing screw**

Bolt size	Tightening torque N · m
	High carbon steel-made screw
M 6×1	13.6
M 8×1.25	32.7
M10×1.5	63.9
M12×1.75	110
M16×2	268
M24×3	749

Remark: The tightening torque is calculated based on strength division 12.9 for product size up to 55, and strength division 10.9 for product size 75.

# IKO Linear Roller Way X

## Block type mounting from top

Shape	LRWX...B				
Size	25	35	45	55	75

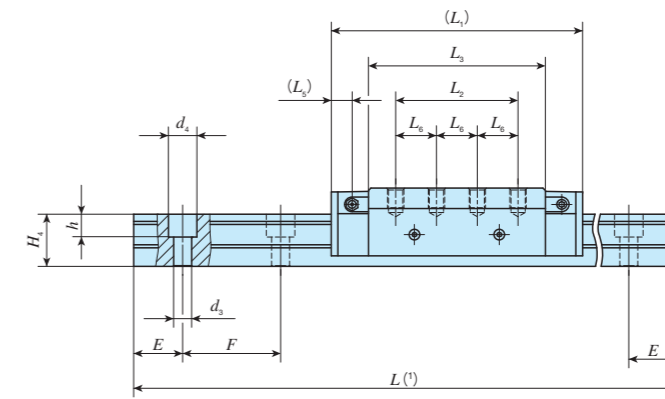
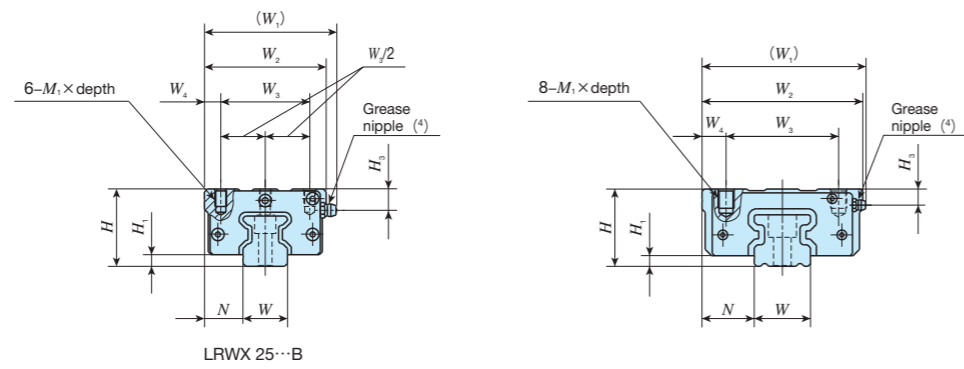

Identification number	Mass (Ref.)		Dimensions of assembly mm			Dimensions of slide unit mm										Dimensions of track rail mm						Appended mounting bolt for track rail (2)	Basic dynamic load rating (3)	Basic static load rating (3)	Static moment rating (3)				
	LRWX series (No C-Lube)	Slide unit kg	Track rail kg/m	H	H <sub>1</sub>	N	W <sub>1</sub>	W <sub>2</sub>	W <sub>3</sub>	W <sub>4</sub>	L <sub>1</sub>	L <sub>2</sub>	L <sub>3</sub>	L <sub>5</sub>	L <sub>6</sub>	M <sub>1</sub> × depth	H <sub>3</sub>	W	H <sub>4</sub>	d <sub>3</sub>	d <sub>4</sub>				h	E	F	Bolt size × ℓ	C
LRWX 25...B	0.93	3.70	40	6	20	69	63	46	8.5	109	45	74.4	11	-	M 6 × 9	11	23	26	7	11	9	30	60	M 6 × 28	32 700	70 300	1 110	885 5 170	885 5 170
LRWX 35...B	2.65	6.66	48	6.5	32.5	103	100	70	15	154	75	108.4	12.8	25	M10 × 12	10	35	32	11	17.5	14	30	60	M10 × 35	49 900	91 100	2 150	1 660 9 450	1 660 9 450
LRWX 45...B	5.32	10.3	60	8	37.5	125	120	82	19	205	105	144	18.5	35	M12 × 16	14.5	45	39	14	20	16	40	80	M12 × 40	93 300	167 000	5 000	4 030 23 000	4 030 23 000
LRWX 55...B	9.09	15.3	70	9	42.5	142	140	95	22.5	262	135	189	24.5	45	M12 × 18	16	55	47	18	26	21	50	100	M16 × 50	186 000	330 000	12 200	10 700 57 900	10 700 57 900
LRWX 75...B	19.0	25.1	90	10	52.5	190	180	123	28.5	346	180	240	45	60	M16 × 25	20	75	57	26	39	30	60	120	M24 × 60	298 000	518 000	25 200	20 900 121 000	20 900 121 000

- Notes (1) Track rail lengths  $L$  are shown in Table 2 on page II-221.  
 (2) The appended track rail mounting bolts are hexagon socket head bolts equivalent to JIS B 1176.  
 (3) The direction of basic dynamic load rating ( $C$ ), basic static load rating ( $C_0$ ), and static moment rating ( $T_0$ ,  $T_x$ ,  $T_y$ ) are shown in the sketches below. The upper values of  $T_x$  and  $T_y$  are for one slide unit and the lower values are for two slide units in close contact.  
 (4) The shapes of grease nipple vary by size. The specifications are shown in Table 10 on page II-225.

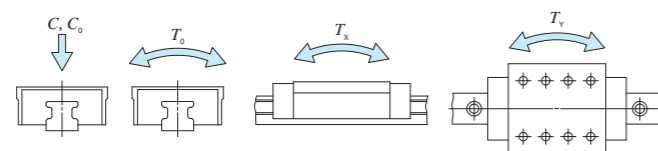

### Example of identification number of assembled set

Model code	Dimensions	Part code	Model code	Preload symbol	Classification symbol	Supplemental code
LRWX	35	C2	R840	B	T <sub>1</sub>	P /W2
①	②	③	④	⑤	⑥	⑦
① Model LRWX...B Block type mounting from top	② Size 25, 35, 45, 55, 75	③ Number of slide unit (2)	④ Length of track rail (840 mm)	⑤ Preload amount No symbol Standard T <sub>1</sub> Light preload T <sub>2</sub> Medium preload T <sub>3</sub> Heavy preload	⑥ Accuracy class H High P Precision SP Super precision UP Ultra precision	⑦ Special specification A, D, E, F, HP, I, J L, LF, O, V, W, Y, Z

# IKO Linear Roller Way X

## Flange type mounting from bottom

Shape	LRWXH			
				
Size	35	45	55	75

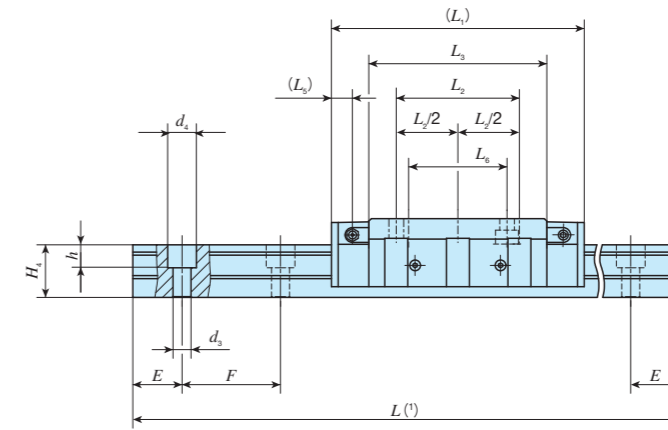
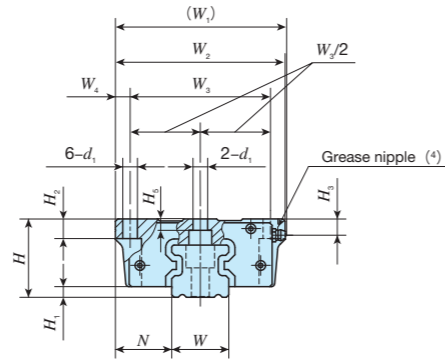

Identification number	Mass (Ref.)		Dimensions of assembly mm			Dimensions of slide unit mm										Dimensions of track rail mm						Appended mounting bolt for track rail <sup>(2)</sup>	Basic dynamic load rating <sup>(3)</sup>	Basic static load rating <sup>(3)</sup>	Static moment rating <sup>(3)</sup>						
	LRWX series (No C-Lube)	Slide unit kg	Track rail kg/m	H	H <sub>1</sub>	N	W <sub>1</sub>	W <sub>2</sub>	W <sub>3</sub>	W <sub>4</sub>	L <sub>1</sub>	L <sub>2</sub>	L <sub>3</sub>	L <sub>5</sub>	L <sub>6</sub>	d <sub>1</sub>	H <sub>2</sub>	H <sub>3</sub>	H <sub>5</sub>	W	H <sub>4</sub>	d <sub>3</sub>	d <sub>4</sub>	h	E	F	Bolt size × l	C N	C <sub>0</sub> N	T <sub>0</sub> N · m	T <sub>x</sub> N · m
LRWXH 35	2.51	6.66	48	6.5	34.5	105	104	86	9	154	75	108.4	12.8	60	9	12	10	7	35	32	11	17.5	14	30	60	M10×35	49 900	91 100	2 150	1 660 9 450	1 660 9 450
LRWXH 45	5.18	10.3	60	8	41.5	129	128	108	10	205	105	144	18.5	80	11	15	14.5	10	45	39	14	20	16	40	80	M12×40	93 300	167 000	5 000	4 030 23 000	4 030 23 000
LRWXH 55	9.08	15.3	70	9	49.5	—	154	130	12	262	135	189	24.5	106	14	18	16	10	55	47	18	26	21	50	100	M16×50	186 000	330 000	12 200	10 700 57 900	10 700 57 900
LRWXH 75	19.7	25.1	90	10	59.5	197	194	164	15	346	180	240	45	134	18	24	20	16	75	57	26	39	30	60	120	M24×60	298 000	518 000	25 200	20 900 121 000	20 900 121 000

- Notes <sup>(1)</sup> Track rail lengths *L* are shown in Table 2 on page II-221.  
<sup>(2)</sup> The appended track rail mounting bolts are hexagon socket head bolts equivalent to JIS B 1176.  
<sup>(3)</sup> The direction of basic dynamic load rating (*C*), basic static load rating (*C*<sub>0</sub>), and static moment rating (*T*<sub>0</sub>, *T*<sub>x</sub>, *T*<sub>y</sub>) are shown in the sketches below. The upper values of *T*<sub>x</sub> and *T*<sub>y</sub> are for one slide unit and the lower values are for two slide units in close contact.  
<sup>(4)</sup> The shapes of grease nipple vary by size. The specifications are shown in Table 10 on page II-225.

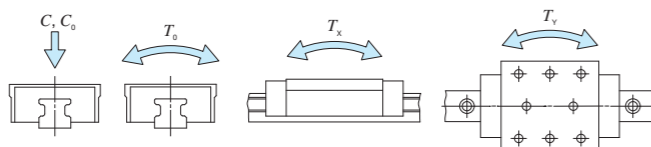

### Example of identification number of assembled set

Model code	Dimensions	Part code	Preload symbol	Classification symbol	Supplemental code
<b>LRWXH</b>	<b>35</b>	<b>C2</b>	<b>R840</b>	<b>T1</b>	<b>P /W2</b>
①	②	③	④	⑤	⑥ ⑦
① Model LRWXH Flange type mounting from bottom	② Size 35, 45, 55, 75	③ Number of slide unit (2)	④ Length of track rail (840 mm)	⑤ Preload amount No symbol Standard T <sub>1</sub> Light preload T <sub>2</sub> Medium preload T <sub>3</sub> Heavy preload	⑥ Accuracy class H High P Precision SP Super precision UP Ultra precision
					⑦ Special specification A, D, E, F, HP, I, J L, LF, Q, V, W, Y, Z

# Linear Way Module

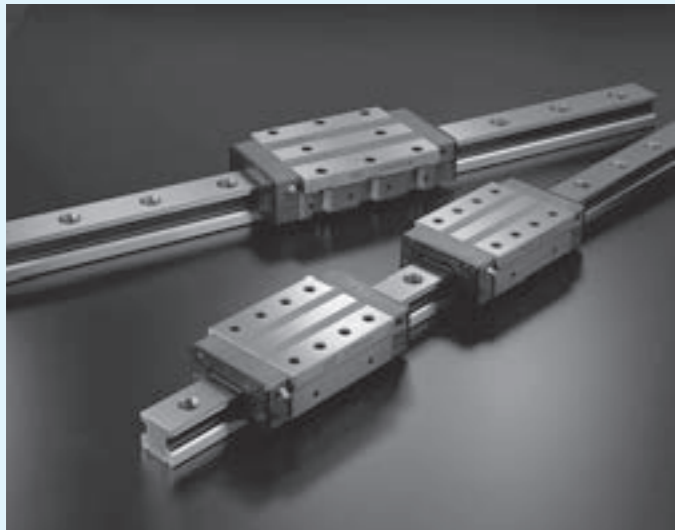

# Linear Way Module

# LWLM LWM



# LRWM

## Points

### ● Compact module type

Compact linear motion rolling guides consisting of a set of track rail and slide member which forms the smallest unit of linear motion mechanism.

### ● Models for various usage

Three models are available; LWLM and LWM using the ball for rolling elements, and LRWM using the roller.

### ● Stainless steel selections for excellent corrosion resistance

LWLM is made of stainless steel of excellent corrosion resistance. They are suitable for applications where rust prevention oil is not preferred, such as in cleanroom environment.

## Identification Number and Specification

### Example of an identification number

The specification of Linear Way Module series is indicated by the identification number. Indicate the identification number, consisting of a model code, dimensions, a part code, a classification symbol, and any supplemental codes for each specification to apply.

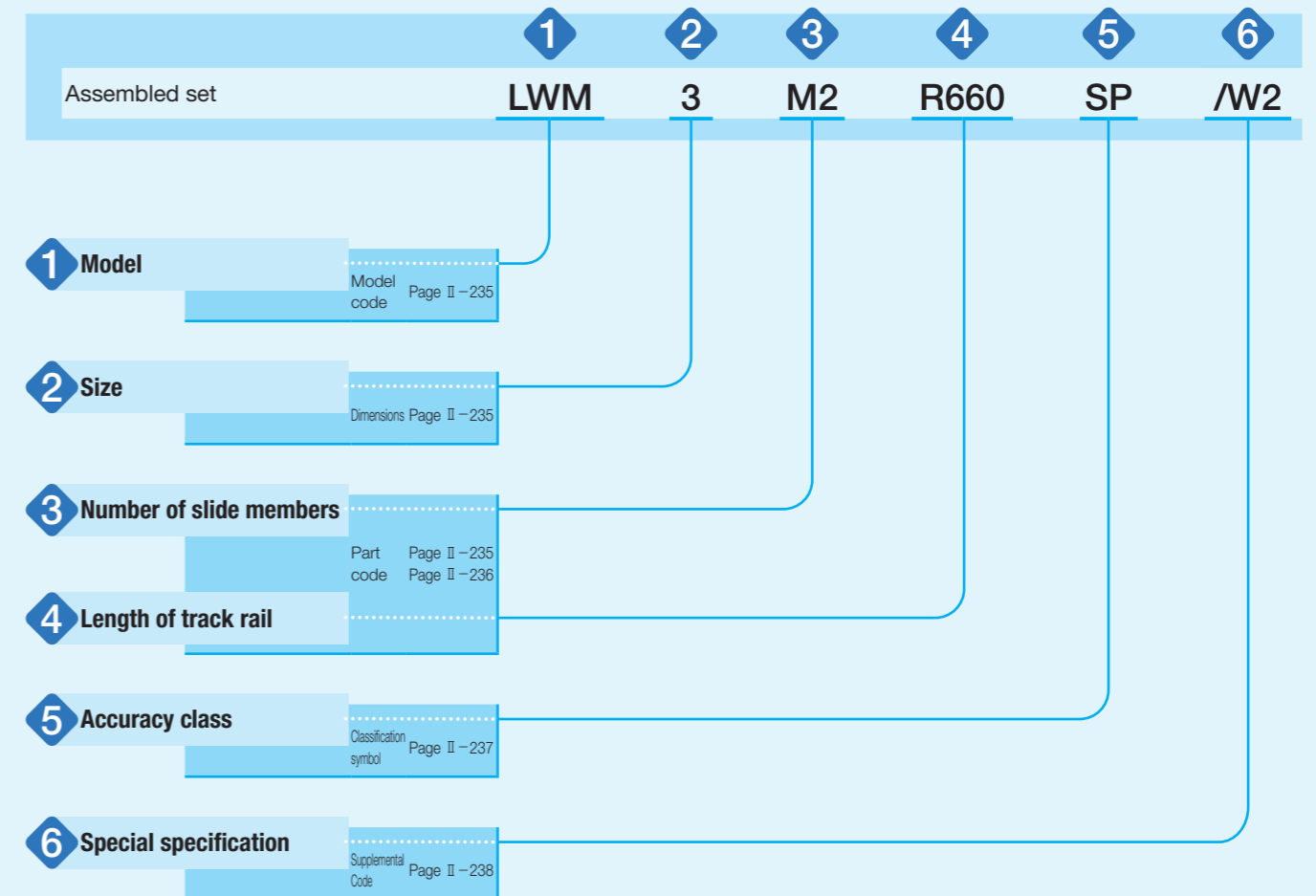

# Identification Number and Specification —Model · Size · Number of Slide Member—

<b>1 Model</b>	Linear Way Module	Linear Way LM <sup>(1)</sup>	: LWLM
		Linear Way M <sup>(1)</sup>	: LWM
		Linear Roller Way M <sup>(1)</sup>	: LRWM
For applicable models and sizes, see Table 1.1, 1.2 and 1.3.			
Note <sup>(1)</sup> This model has no built-in C-Lube.			
<b>2 Size</b>	7, 9, 11	For applicable models and sizes, see Table 1.1, 1.2 and 1.3.	
	1, 2, 3, 4, 5, 6		
<b>3 Number of slide members</b>		: M○	Indicates the number of slide members assembled on a track rail.

**Table 1.1 Model and sizes of LWLM series**

Shape	Model	Size		
		7	9	11
	LWLM	○	○	○

**Table 1.2 Model and sizes of LWM series**

Shape	Model	Size					
		1	2	3	4	5	6
	LWM	○	○	○	○	○	○

**Table 1.3 Model and sizes of LRWM series**

Shape	Model	Size				
		2	3	4	5	6
	LRWM	○	○	○	○	○

# —Length of Track Rail—

<b>4 Length of track rail</b>	: R○	Indicate the length of track rail in mm. For standard and maximum lengths, see Table 2.
-------------------------------	------	--

**Table 2 Standard and maximum lengths of track rail**

unit: mm

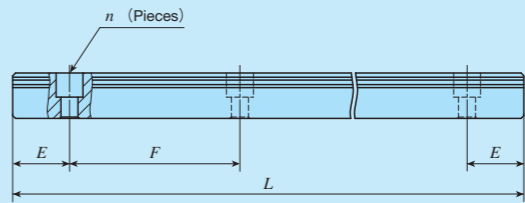

Item	Identification number	LWLM7	LWLM9	LWLM11			
Standard length $L$ ( $n$ )		60 ( 3)	100 ( 4)	160 ( 4)			
		80 ( 4)	150 ( 6)	240 ( 6)			
		120 ( 6)	200 ( 8)	320 ( 8)			
		160 ( 8)	275 (11)	440 (11)			
Pitch of mounting holes $F$		20	25	40			
$E$	Standard $E$ dimensions	10	12.5	20			
	or higher below	4.5	5	5.5			
Maximum length <sup>(1)</sup>		240 (500)	350 (900)	520 (1 000)			
Item	Identification number	LWM1	LWM2	LWM3	LWM4	LWM5	LWM6
Standard length $L$ ( $n$ )		240 ( 6)	240 ( 4)	480 ( 8)	800 (10)	800 ( 8)	1 200 (10)
		360 ( 9)	360 ( 6)	660 (11)	1 040 (13)	1 200 (12)	1 920 (16)
		480 (12)	480 ( 8)	840 (14)	1 200 (15)	1 500 (15)	2 520 (21)
Pitch of mounting holes $F$		40	60	60	80	100	120
$E$	Standard $E$ dimensions	20	30	30	40	50	60
	or higher below	7	8	9	10	12	13
Maximum length		27	38	39	50	62	73
Maximum length		1 240	1 260	1 260	1 520	1 500	2 520
Item	Identification number	LRWM2	LRWM3	LRWM4	LRWM5	LRWM6	
Standard length $L$ ( $n$ )		480 ( 8)	480 ( 8)	800 (10)	800 ( 8)	1 200 (10)	
		660 (11)	660 (11)	1 040 (13)	1 200 (12)		
		840 (14)	840 (14)	1 200 (15)	1 500 (15)		
Pitch of mounting holes $F$		60	60	80	100	120	
$E$	Standard $E$ dimensions	30	30	40	50	60	
	or higher below	8	9	10	12	13	
Maximum length		38	39	50	62	73	
Maximum length		1 800	1 860	1 920	1 600	1 200	

Note <sup>(1)</sup> Length up to the value in ( ) can be produced. If needed, please contact **IKO**.  
Remark: If not directed,  $E$  dimensions for both ends will be the same within the range of standard  $E$  dimensions. To change the dimensions, indicate the specified rail mounting hole positions "/ $E$ " of special specification. For more information, see page III-30.

<b>5 Accuracy class</b>	High	: H	For details of accuracy class, see Table 3.
	Precision	: P	
	Super precision	: SP	

Table 3 Tolerance and allowance

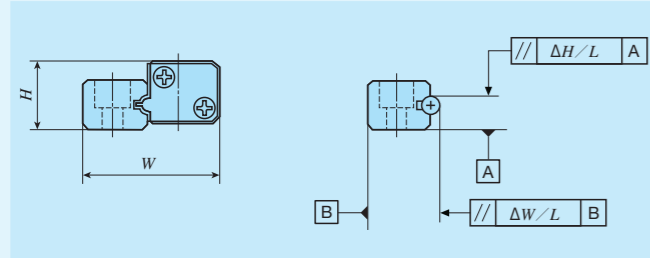

unit: mm			
Class (classification symbol)	High (H)	Precision (P)	Super precision (SP)
Item			
Dim. <i>H</i> tolerance	±0.040	±0.020	±0.010
Dim. <i>W</i> tolerance	±0.050	±0.025	±0.015
Dim. variation of <i>H</i> <sup>(1)</sup>	0.015	0.007	0.005
Dim. variation of <i>W</i> <sup>(1)</sup>	0.020	0.010	0.007
Track rail parallelism Δ <i>H</i>	See Fig. 1.1 and Fig. 1.2		
Track rail parallelism Δ <i>W</i>	See Fig. 1.1 and Fig. 1.2		

Note (1) It means the size variation between slide members mounted on the same track rail.

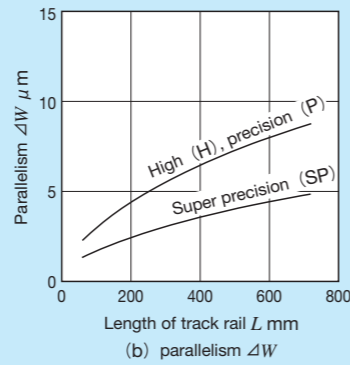
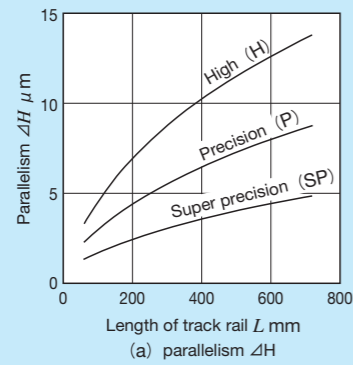

Fig.1.1 Track rail parallelism for LWLM

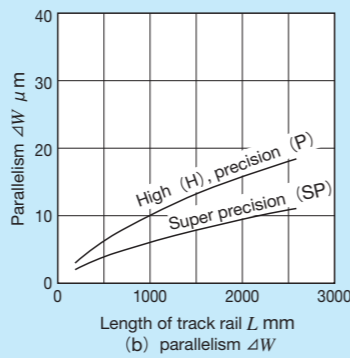
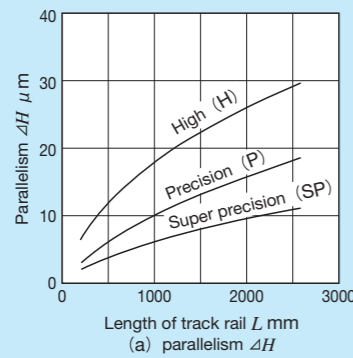

Fig.1.2 Track rail parallelism for LWM and LRWM

<b>6 Special specification</b>	/A, /E, /F, /I, /LR, /LFR, /MN, /W, /YO	For applicable special specifications, see Table 4. For combination of multiple special specifications, see Table 5. For details of special specifications, see page III-29.

Table 4 Application of special specifications

Special specification	Supplemental code	Model and size								
		LWLM			LWM, LRWM					
		7	9	11	1	2	3	4	5	6
Butt-jointing track rails	/A	×	×	×	○	○	○	○	○	○
Specified rail mounting hole positions	/E	○	○	○	○	○	○	○	○	○
Caps for rail mounting holes	/F	×	×	×	○	○	○	○	○	○
Inspection sheet	/I	○	○	○	○	○	○	○	○	○
Black chrome surface treatment	/LR	×	×	×	○	○	○	○	○	○
Fluorine black chrome surface treatment	/LFR	×	×	×	○	○	○	○	○	○
Without track rail mounting bolt	/MN	○	○	○	○ <sup>(1)</sup>	○ <sup>(1)</sup>	○ <sup>(1)</sup>	○ <sup>(1)</sup>	○ <sup>(1)</sup>	○ <sup>(1)</sup>
A group of multiple assembled sets	/W	○	○	○	○	○	○	○	○	○
Specified grease	/YO	○	○	○	○	○	○	○	○	○

Note (1) None of mounting bolts for slide member and track rail are appended.

Table 5 Combination of supplemental codes

E	-								
F	○	○							
I	○	○	○						
LR	○	○	○	○					
LFR	○	○	○	○	-				
MN	○	○	○	○	○				
W	○	-	○	○	○	○			
Y	○	○	○	○	○	○	○		
	A	E	F	I	LR	LFR	MN	W	

Remarks 1. The combination of "-" shown in the table is not available.

2. When using multiple types for combination, please indicate by arranging the symbols in alphabetical order.

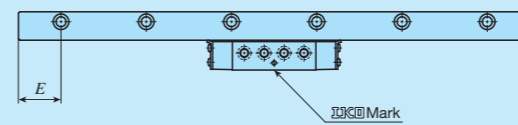

Fig.2 Specified rail mounting hole positions (Supplemental code /E)

Remark: For details of specified rail mounting hole positions (supplemental code /E), see page III-30.



# Lubrication

Lithium-soap base grease with extreme-pressure additive (Alvania EP Grease 2 [SHOWA SHELL SEKIYU K. K.]) is pre-packed in Linear Way Module series.

Though grease nipples are not appended to Linear Way Module series, oil holes are provided to slide member so that the grease or lubrication oil supplied from machines / devices is directly guided to the rolling elements recirculation route. Lubrication is easily conducted by providing the supply route in the machines / devices as shown in Fig. 3.

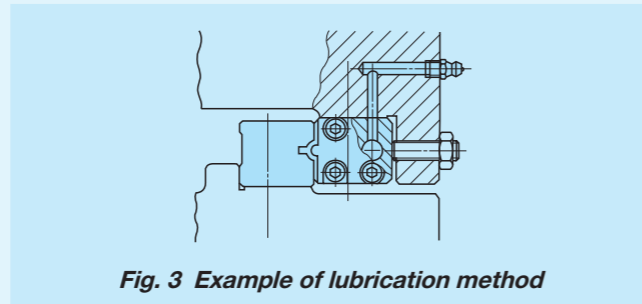

Fig. 3 Example of lubrication method

# Dust Protection

The slide members of Linear Way Module series are equipped with end seals as standard for dust protection. However, if large amount of contaminant or dust are floating, or if large

particles of foreign substances such as chips or sand may adhere to the track rail, it is recommended to cover the whole unit with bellows or telescope type shield, etc.

# Precaution for Use

## 1 Mounting surface, reference mounting surface and typical mounting structure

When mounting the Linear Way Module series, properly align the reference mounting surfaces B and D of the track rail and slide member with the reference mounting surface of the table and bed and fix them. (See Fig. 4) The reference mounting surfaces B and D and mounting surfaces A and C are precisely ground. Machining the mounting surface of the table and bed, such as machine or device, to high accuracy and mounting them properly will ensure stable linear motion with high accuracy.

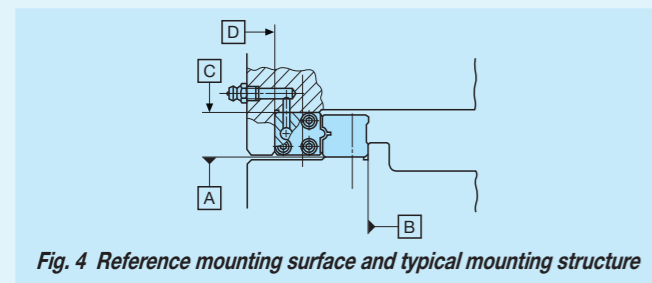

Fig. 4 Reference mounting surface and typical mounting structure

## 2 Fixing the slide member

Typical mounting structure of Linear Way Module series is shown in Fig. 5. As a convenient means to eliminate play or to give preload in linear motion rolling mechanism, preload adjusting screws are often used.

Set the preload adjusting screws at the positions of fixing bolts of slide member and in the middle of the height of slide member, and then press the slide member by tightening the screw.

For mounting the slide member of Linear Way Module LWLM, it is recommended to fix the slide member from the table side, because the allowance for the preload adjustment in the bolt hole of slide member is small. In this case, the bolt hole and the counterbore in the table should be made larger to give the adjustment allowance.

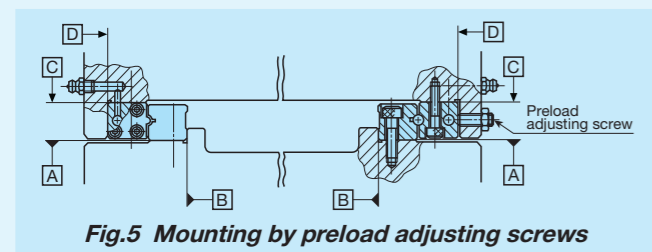

Fig. 5 Mounting by preload adjusting screws

Preload amount varies depending on operational conditions of your machine and device. However, as excessive preload may lead to short life and damage on the raceway, it is typically ideal to adjust to zero clearance or slight preload state.

## 3 Shoulder height and corner radius of the reference mounting surface

For the opposite corner of the mating reference mounting, it is recommended to have relieved fillet as indicated in Fig. 6. Recommended value for the shoulder height and corner radius on the mating side is indicated in Table 7.1, Table 7.2 and Table 7.3.

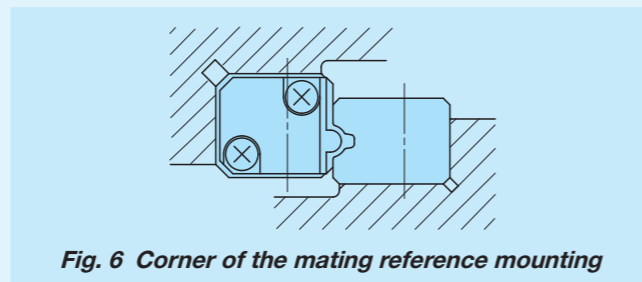

Fig. 6 Corner of the mating reference mounting

## 4 Tightening torque for fixing screw

Typical tightening torque for mounting of Linear Way Module series to the steel mating member material is indicated in Table 6. When vibration and shock of the machine or device are large, fluctuating load is large, or moment load is applied, fix it by using the torque 1.2 to 1.5 times larger than the value indicated in the table as necessary. If the mating member material is cast iron or aluminum alloy, reduce the tightening torque depending on the strength characteristics of the mating member material.

Table 6 Tightening torque for fixing screw

Bolt size	Tightening torque N · m	
	High carbon steel-made screw	Stainless steel-made screw
M 2.6×0.45	—	0.7
M 3 ×0.5	1.8	1.1
M 4 ×0.7	4.1	—
M 5 ×0.8	8.0	—
M 6 ×1	13.6	—
M 8 ×1.25	32.7	—
M10 ×1.5	63.9	—
M12 ×1.75	110	—

Remark: The tightening torque is calculated based on strength division 12.9 and property division A2-70.

Table 7.1 Shoulder height of the reference mounting surface for LWLM

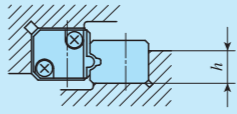

unit: mm

Size	Mounting part of track rail shoulder height $h$
7	4
9	5
11	6

Table 7.2 Shoulder height and corner radius of the reference mounting surface for LWM

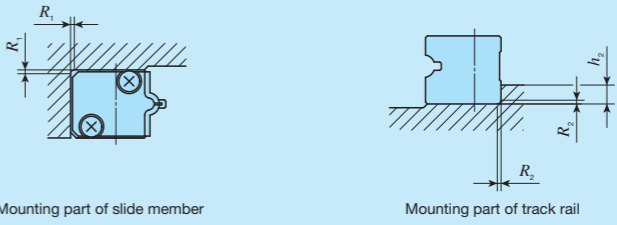

unit: mm

Size	Mounting part of slide member Corner radius $R_1$ (Maximum)	Mounting part of track rail	
		Shoulder height $h_2$	Corner radius $R_2$ (Maximum)
1	0.8	4	0.8
2	1	5	1
3	1	5	1
4	1.5	6	1
5	1.5	6	1
6	1.5	8	1.5

Table 7.3 Shoulder height and corner radius of the reference mounting surface for LRWM



unit: mm

Size	Mounting part of slide member		Mounting part of track rail	
	Shoulder height $h_1$	Corner radius $R_1$ (Maximum)	Shoulder height $h_2$	Corner radius $R_2$ (Maximum)
2	7	1	5	1
3	8.5	1	6	1
4	10.5	1.5	6	1
5	12.5	1.5	8	1
6	14.5	2	8	1.5

# IKO Linear Way Module

Linear Way LM			
Shape	LWLM		
Size	7	9	11

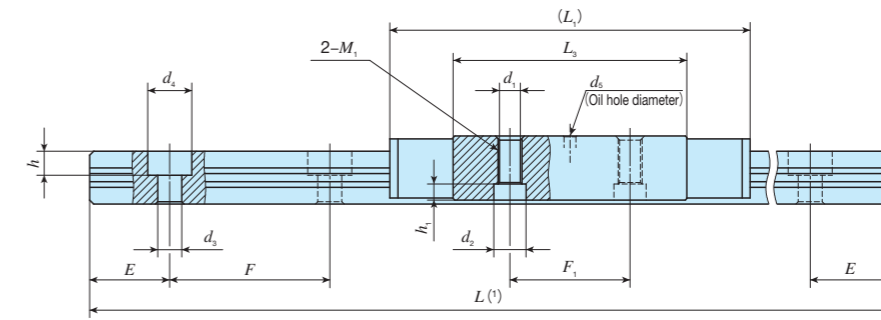
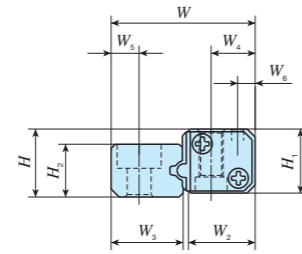

Identification number	Mass (Ref.)		Dimensions of assembly mm		Dimensions of slide member mm										Dimensions of track rail mm						Appended mounting bolt for track rail <sup>(2)</sup>	Basic dynamic load rating <sup>(3)</sup>	Basic static load rating <sup>(3)</sup>				
	Slide member g	Track rail g/m	H	W	H <sub>1</sub>	W <sub>2</sub>	W <sub>4</sub>	W <sub>6</sub>	L <sub>1</sub>	L <sub>3</sub>	F <sub>1</sub>	d <sub>1</sub>	d <sub>2</sub>	h <sub>1</sub>	M <sub>1</sub>	d <sub>5</sub>	H <sub>2</sub>	W <sub>3</sub>	W <sub>5</sub>	d <sub>3</sub>				d <sub>4</sub>	h	E	F
LWLM 7*	10	210	7	15	6.6	7.8	5	2.5	38	24	12	—	—	—	M2.6	1	4.8	6.8	3.3	3 <sup>(4)</sup>	— <sup>(4)</sup>	— <sup>(4)</sup>	10	20	M2.6 × 8 <sup>(4)</sup>	1 730	2 020
LWLM 9*	16	390	8.5	18	8	8.6	5.5	2.2	45	29.2	15	—	—	—	M3	1.5	6.6	9	3.5	3	5.5	3	12.5	25	M2.6 × 8	2 780	3 150
LWLM 11*	32	590	11	23	10	11.8	7	3	52	32.8	15	2.55	5	3	M3	2	8	10.8	5	3.5	6	4.5	20	40	M3 × 8	4 080	4 240

Notes <sup>(1)</sup> Track rail lengths  $L$  are shown in Table 2 on page II-236.

<sup>(2)</sup> The appended mounting bolts are stainless steel hexagon socket head bolts equivalent to JIS B 1176.

<sup>(3)</sup> The direction of basic dynamic load rating ( $C$ ) and basic static load rating ( $C_0$ ) are shown in the sketch below.

<sup>(4)</sup> Track rail mounting holes have no counterbore.

When the appended track rail mounting bolts are used, the height from track rail bottom surface to bolt head is 7.4 mm.

Remarks 1. Slide member mounting bolts are not appended.

2. The identification numbers with \* are our semi-standard items.

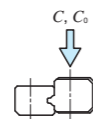

## Example of identification number of assembled set

Model code	Dimensions	Part code	Classification symbol	Supplemental code
<b>LWLM</b>	<b>9</b>	<b>M2 R200</b>	<b>P</b>	<b>/W2</b>
①	②	③	④	⑤
① Model LWLM Linear Way LM	② Size 7, 9, 11	③ Number of slide member (2)	④ Length of track rail (200 mm)	⑤ Accuracy class H High P Precision SP Super precision
				⑥ Special specification E, I, MN, W, Y

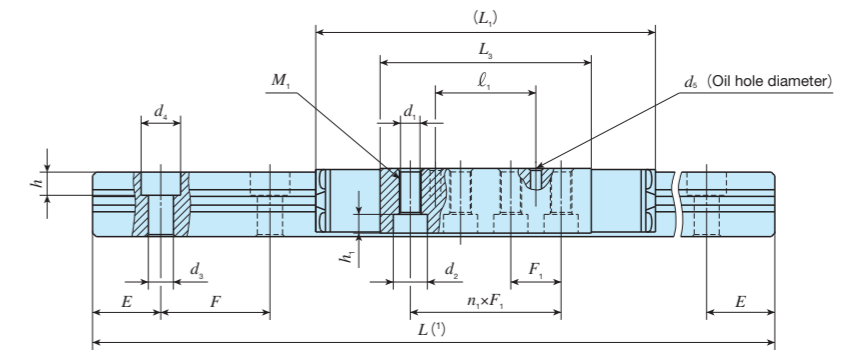
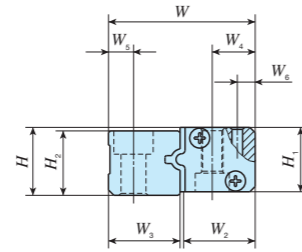
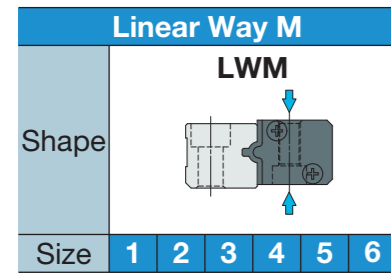

Identification number	Mass (Ref.)		Dimensions of assembly mm		Dimensions of slide member mm										Appended mounting bolt for slide member <sup>(2)</sup>	Dimensions of track rail mm							Appended mounting bolt for track rail <sup>(2)</sup>	Basic dynamic load rating <sup>(3)</sup> C N	Basic static load rating <sup>(3)</sup> C <sub>0</sub> N				
	Slide member kg	Track rail kg/m	H	W	H <sub>1</sub>	W <sub>2</sub>	W <sub>4</sub>	W <sub>6</sub>	L <sub>1</sub>	L <sub>3</sub>	n <sub>1</sub> × F <sub>1</sub>	d <sub>1</sub>	d <sub>2</sub>	h <sub>1</sub>		M <sub>1</sub>	ℓ <sub>1</sub>	d <sub>5</sub>	Bolt size × ℓ	H <sub>2</sub>	W <sub>3</sub>	W <sub>5</sub>				d <sub>3</sub>	d <sub>4</sub>	h	E
LWM 1*	0.07	1.20	14	28	13	14.6	9	4	64	41.2	2 × 13	3.4	6.5	3.1	M 4	13	2	M3 × 14	13	13	5.5	4.5	8	4.5	20	40	M 4 × 14	4 720	6 410
LWM 2*	0.11	1.93	17	35	16	17	10	4	75	47.2	2 × 15	4.4	8	4.1	M 5	15	3	M4 × 18	16	17	6	6	9.5	5.4	30	60	M 5 × 18	7 150	9 240
LWM 3*	0.17	2.71	19	41	18	20	12	5	95	58.8	3 × 14	5.4	9.5	5.2	M 6	—	3	M5 × 20	18	20	7	7	11	6.5	30	60	M 6 × 20	13 700	16 600
LWM 4*	0.32	3.49	21	51	20	25	15	6	122	80.6	3 × 20	6.8	11	6.2	M 8	—	3	M6 × 22	20	25	9	9	14	9	40	80	M 8 × 22	23 200	27 400
LWM 5*	0.56	5.25	25	63	24	30	18	8	145	94.8	4 × 20	6.8	11	6.2	M 8	20	3	M6 × 28	24	31	12	11	17.5	11	50	100	M10 × 25	35 300	41 000
LWM 6*	1.35	7.56	31	78	30	40	24	11	180	131	5 × 22	8.6	14	8.2	M10	—	3	M8 × 35	30	36	14	14	20	13	60	120	M12 × 35	74 100	80 900

Notes <sup>(1)</sup> Track rail lengths *L* are shown in Table 2 on page II-236.

<sup>(2)</sup> The appended mounting bolts are hexagon socket head bolts equivalent to JIS B 1176.

<sup>(3)</sup> The direction of basic dynamic load rating (*C*) and basic static load rating (*C<sub>0</sub>*) are shown in the sketch below.

Remark: The identification numbers with \* are our semi-standard items.

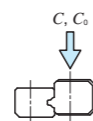

### Example of identification number of assembled set

Model code: LWM    Dimensions: 3    Part code: M2 R660    Classification symbol: P    Supplemental code: /W2

- ① Model: LWM Linear Way M
- ② Size: 1, 2, 3, 4, 5, 6
- ③ Number of slide member (2)
- ④ Length of track rail (660 mm)
- ⑤ Accuracy class:
 

H	High
P	Precision
SP	Super precision
- ⑥ Special specification: A, E, F, I, LR, LFR, MN, W, Y

Linear Roller Way M						
Shape	LRWM					
Size	2	3	4	5	6	

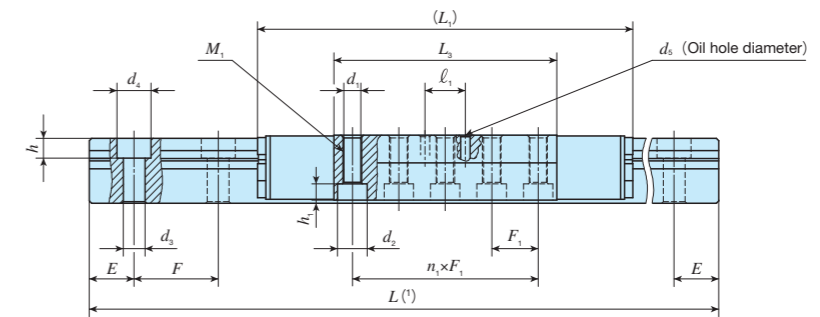
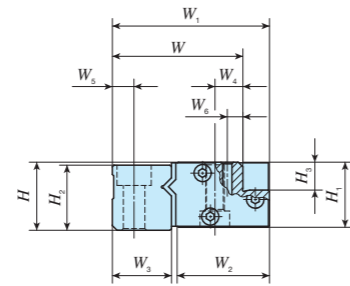

Identification number	Mass (Ref.)		Dimensions of assembly mm			Dimensions of slide member mm																Appended mounting bolt for slide member <sup>(2)</sup>	Dimensions of track rail mm										Appended mounting bolt for track rail <sup>(2)</sup>	Basic dynamic load rating <sup>(3)</sup> C N	Basic static load rating <sup>(3)</sup> C <sub>0</sub> N
	Slide member kg	Track rail kg/m	H	W	W <sub>1</sub>	H <sub>1</sub>	H <sub>3</sub>	W <sub>2</sub>	W <sub>4</sub>	L <sub>1</sub>	L <sub>3</sub>	n×F <sub>1</sub>	M <sub>1</sub>	d <sub>1</sub>	d <sub>2</sub>	h <sub>1</sub>	W <sub>6</sub>	ℓ <sub>1</sub>	d <sub>5</sub>	Bolt size × ℓ	H <sub>2</sub>		W <sub>3</sub>	W <sub>5</sub>	d <sub>3</sub>	d <sub>4</sub>	h	E	F	Bolt size × ℓ					
LRWM 2*	0.26	1.98	19	33	39.6	18	7.5	22.9	8	105	63	4×12	M 5	4.4	8	4.1	4	10	3	M4×20	18	15	6	6	9.5	5.4	30	60	M 5×20	9 700	10 800				
LRWM 3*	0.46	2.92	22	42	50.6	21	9	29.8	9	122	72	4×15	M 6	5.4	9.5	5.2	5	13	3	M5×25	21	19	7	7	11	6.5	30	60	M 6×25	18 500	20 300				
LRWM 4*	0.98	4.64	28	56	65.6	27	11	39.4	13	157	96	5×16	M 8	6.8	11	6.2	6	—	3	M6×32	27	24	9	9	14	8.6	40	80	M 8×32	36 500	39 800				
LRWM 5*	2.03	6.85	33	70	81.6	32	13	49.1	16	212	140	5×24	M10	8.6	14	8.2	7	—	3	M8×35	32	30	12	11	17.5	10.8	50	100	M10×35	67 900	75 500				
LRWM 6*	3.42	9.25	38	83	96.6	37	15	58.6	21	256	168	6×25	M10	8.6	14	8.2	8	28	3	M8×40	37	35	14	14	20	13	60	120	M12×40	99 800	109 000				

Notes <sup>(1)</sup> Track rail lengths *L* are shown in Table 2 on page II-236.  
<sup>(2)</sup> The appended mounting bolts are hexagon socket head bolts equivalent to JIS B 1176.  
<sup>(3)</sup> The direction of basic dynamic load rating (*C*) and basic static load rating (*C<sub>0</sub>*) are shown in the sketch below.  
 Remark: The identification numbers with \* are our semi-standard items.

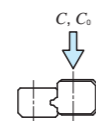

### Example of identification number of assembled set

Model code	Dimensions	Part code	Classification symbol	Supplemental code
<b>LRWM</b>	<b>3</b>	<b>M2 R660</b>	<b>P</b>	<b>/W2</b>
①	②	③	④	⑤
① Model LRWM Linear Roller Way M	② Size 2, 3, 4, 5, 6	③ Number of slide member (2)	④ Length of track rail (660 mm)	⑤ Accuracy class H High P Precision SP Super precision
				⑥ Special specification A, E, F, I, LR, LFR MN, W, Y

## General Explanation



# Selection Procedure

Selection of Linear Way and Linear Roller Way should be considered from the most important required matter to details in order. Typical procedure is shown below.

## Example of Linear Way and Linear Roller Way selection procedure

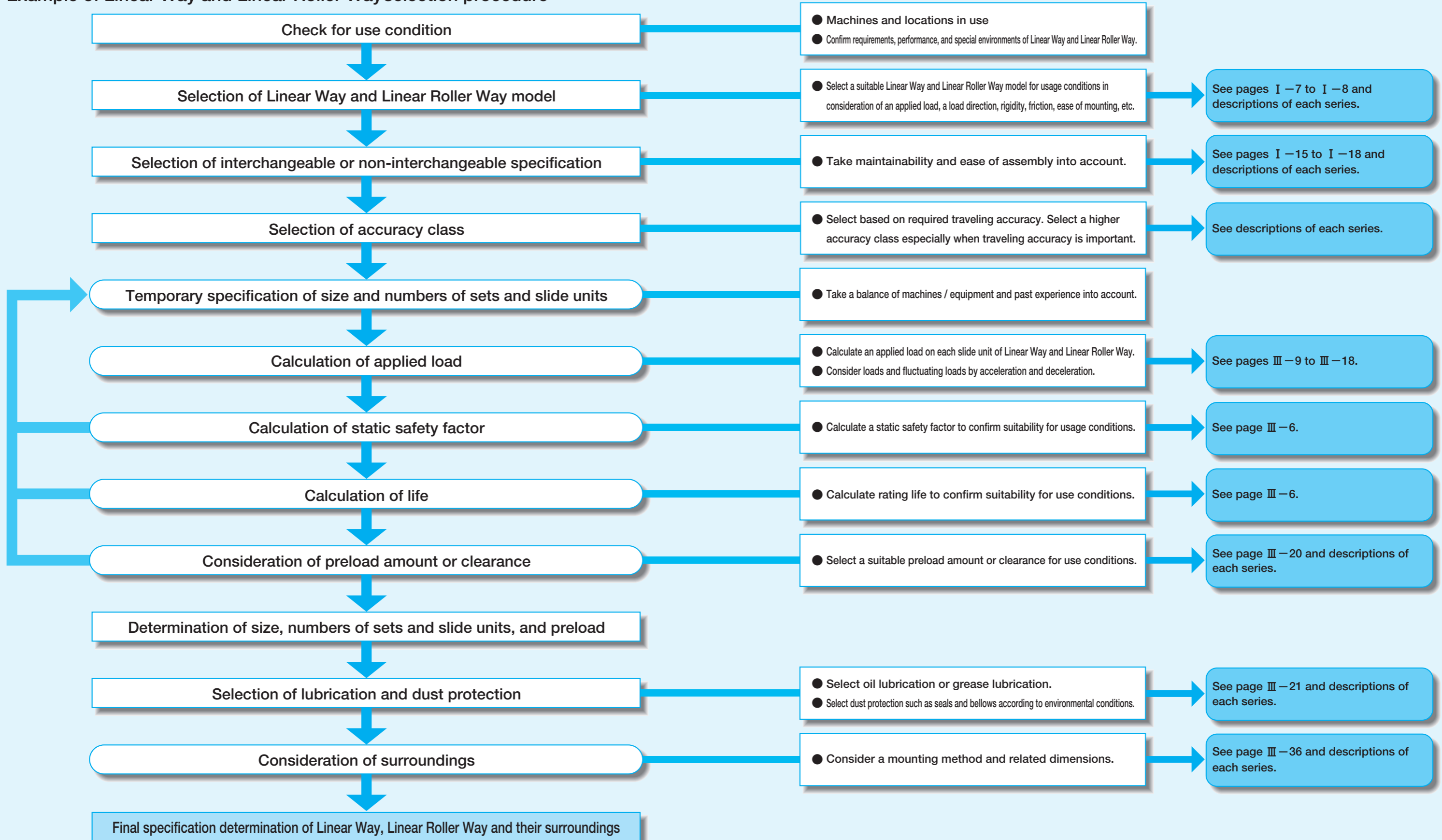

# Load Rating and Life

## Life of linear motion rolling guides

Even in normal operational status, a linear motion rolling guide will reach the end of its life after a certain period of operations. As repeated load is constantly applied onto a raceway and rolling elements of the linear motion rolling guide, this leads to leprous damage (scale-like wear fragments) called fatigue flaking due to rolling contact fatigue of materials, it will be unusable at the end. Total traveling distance before occurrence of this fatigue flaking on a raceway or rolling elements is called the life of linear motion rolling guide.

As the life of linear motion rolling guide may vary depending on material fatigue phenomenon, rating life based on statistic calculation is used.

## Rating life

Rating life of linear motion rolling guide refers to the total traveling distance 90% of a group of the same linear motion rolling guide can operate without linear motion rolling guide material damages due to rolling contact fatigue when they are operated individually under the same conditions.

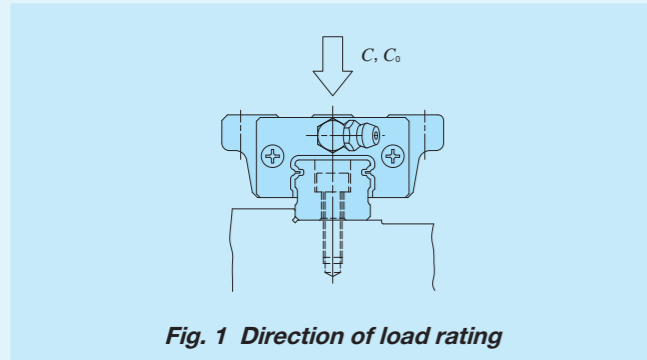

Fig. 1 Direction of load rating

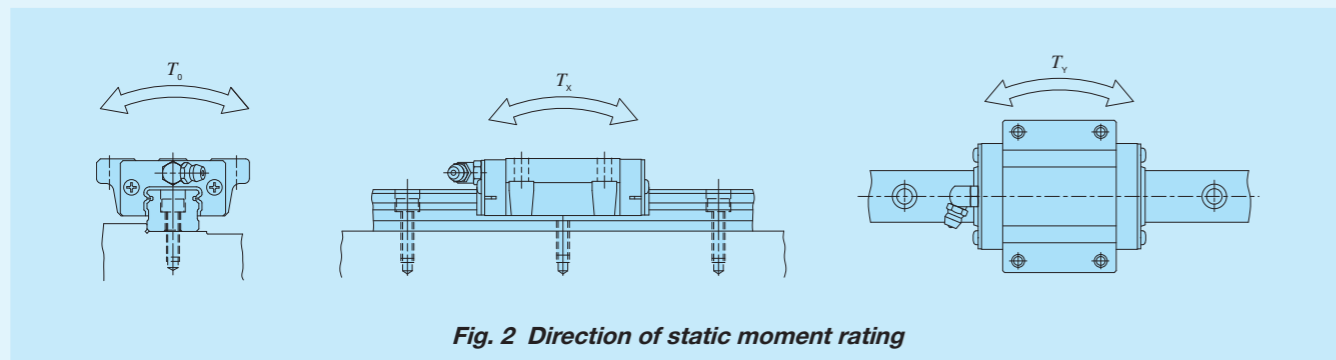

Fig. 2 Direction of static moment rating

## Basic dynamic load rating $C$

Complying with ISO 14728-1

Basic dynamic load rating refers to load with certain direction and size that is logically endurable for rating life of  $50 \times 10^3$  m when a group of the same linear motion rolling guides is operated individually under the same conditions.

## Basic static load rating $C_0$

Complying with ISO 14728-2

Basic static load rating refers to static load generating a certain contact stress at the center of contact part of the rolling elements and a raceway under maximum load, which is the load at the allowable limit for normal rolling motion. Generally, it is used considering static safety factor.

## Static moment rating $T_0, T_x, T_y$

Static moment rating refers to static moment load generating a certain contact stress at the center of contact parts of rolling elements and a raceway under the maximum load when the moment load shown in Fig. 2 is loaded, which is the moment load at the allowable limit for normal rolling motion. Generally, it is used considering static safety factor.

## Calculating formula of life

The rating life calculation formulas are shown below.

Linear Way  

$$L = 50 \left( \frac{C}{P} \right)^3 \dots \dots \dots (1)$$

Linear Roller Way  

$$L = 50 \left( \frac{C}{P} \right)^{10/3} \dots \dots \dots (2)$$

where,  $L$ : Rating life,  $10^3$  m  
 $C$ : Basic dynamic load rating, N  
 $P$ : Dynamic equivalent load, N

Life time can be calculated by applying a stroke length and a number of strokes per minute to the formula below.

$$L_h = \frac{10^6 L}{2Sn_1 \times 60} \dots \dots \dots (3)$$

where,  $L_h$ : Rating life in hours, h  
 $S$ : Stroke length, mm  
 $n_1$ : Number of strokes per minute, cpm

## Load factor

Load applied to a linear motion rolling guide can be larger than theoretical load due to machine vibration or shock. Generally, the applied load is obtained by multiplying it by the load factor indicated in Table 1.

Table 1 Load factor

Operating conditions	$f_w$
Smooth operation free from shock	1 ~ 1.2
Normal operation	1.2 ~ 1.5
Operation with shock load	1.5 ~ 3

## Static safety factor

Generally, basic static load rating and static moment rating is considered as load at the allowable limit for normal rolling motion. However, static safety factor must be considered according to operating conditions and required performance of the linear motion rolling guide.

Static safety factor can be obtained by the following equation and typical values are indicated in Tables 2.1 and 2.2.

Equation (6) is a representative equation for a moment load. Moment load and static moment rating in each direction is applied for the calculation.

$$f_s = \frac{C_0}{P_0} \dots \dots \dots (5)$$

$$f_s = \frac{T_0}{M_0} \dots \dots \dots (6)$$

where,  $f_s$ : Static safety factor  
 $C_0$ : Basic static load rating, N  
 $P_0$ : Static equivalent load, N  
 $T_0$ : Static moment rating, N · m  
 $M_0$ : Moment load in each direction, N · m (maximum moment load)

Table 2.1 Static safety factor for Linear Way

Operational conditions	$f_s$
Operation with vibration and / or shock	3 ~ 5
High operating performance	2 ~ 4
Normal operating conditions	1 ~ 3

Table 2.2 Static safety factor for Linear Roller Way

Operational conditions	$f_s$
Operation with vibration and / or shock	4 ~ 6
High operating performance	3 ~ 5
Normal operating conditions	2.5 ~ 3

Dynamic equivalent load

When a load is applied in a direction other than that of the basic dynamic load rating or a complex load is applied, the dynamic equivalent load must be calculated to obtain the basic rating life.

Obtain the downward and lateral conversion loads from the loads and moments in various directions.

$$F_{re} = k_r |F_r| + \frac{C_0}{T_0} |M_0| + \frac{C_0}{T_x} |M_x| \dots\dots\dots(7)$$

$$F_{ae} = k_a |F_a| + \frac{C_0}{T_y} |M_y| \dots\dots\dots(8)$$

- where,  $F_{re}$  : Downward conversion load, N
- $F_{ae}$  : Lateral conversion load, N
- $F_r$  : Downward load, N
- $F_a$  : Lateral load, N
- $M_0$  : Moment load in the  $T_0$  direction, N · m
- $M_x$  : Moment load in the  $T_x$  direction, N · m
- $M_y$  : Moment load in the  $T_y$  direction, N · m
- $k_r, k_a$  : Conversion factors for load direction (See Table 3)
- $C_0$  : Basic static load rating, N
- $T_0$  : Static moment rating in the  $T_0$  direction, N · m
- $T_x$  : Static moment rating in the  $T_x$  direction, N · m
- $T_y$  : Static moment rating in the  $T_y$  direction, N · m

Table 3 Conversion factor for load direction

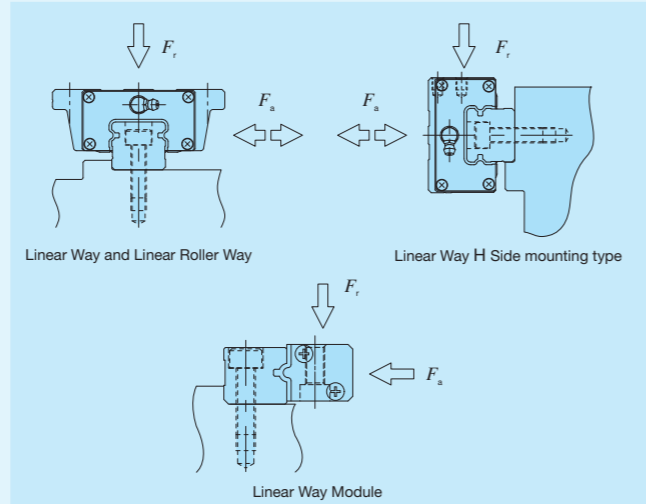

Series name and size		Conversion factor		
		$k_r$		$k_a$
		$F_r \geq 0$	$F_r < 0$	
C-Lube Linear Way ML Linear Way L	Ball retained type	1	1	1.19
	Ball non-retained type	1	1	0.84
C-Lube Linear Way MLV		1	1	1.19
C-Lube Linear Way MV		1	1.23	1.35
C-Lube Linear Way ME Linear Way E	15~30	1	1	1
	35~45	1	1.19	1.28
Low Decibel Linear Way E		1	1	1
C-Lube Linear Way MH Linear Way H	8~12	1	1	1.19
	15~30	1	1	1
	35~65	1	1.19	1.28
Linear Way H Horizontal mounting type	15~30	1	1	1
	35~45 <sup>(1)</sup>	1	1	0.84 0.95
Linear Way F	33~42	1	1	1
	69	1	1	1.19
	LWFH	1	1.19	1.28
C-Lube Linear Way MUL Linear Way U	25, 30	1	1	1.19
	40~130	1	1	1
C-Lube Linear Roller Way Super MX Linear Roller Way Super X		1	1	1
Linear Roller Way X		1	1	1
Linear Way Module	LWLM	1	1	0.73
	LWM	1~5	1	1.13
		6	1	1.28
	LRWM	1	1	0.58

Note <sup>(1)</sup> The upper value of  $k_a$  columns represents the right direction and the lower value represents the left direction.

Obtain the dynamic equivalent load from the downward and lateral conversion loads.

$$P = XF_{re} + YF_{ae} \dots\dots\dots(9)$$

- where,  $P$  : Dynamic equivalent load, N
- $X, Y$  : Dynamic equivalent load factor (See Table 4)
- $F_{re}$  : Downward conversion load, N
- $F_{ae}$  : Lateral conversion load, N

Table 4 Dynamic equivalent load factor

Class	X	Y
$ F_{re}  \geq  F_{ae} $	1	0.6
$ F_{re}  <  F_{ae} $	0.6	1

Static equivalent load

When a load is applied in a direction other than that of the basic static load rating or a complex load is applied, the static equivalent load must be calculated to obtain the static safety factor.

$$P_0 = k_{or} |F_r| + k_{oa} |F_a| + \frac{C_0}{T_0} |M_0| + \frac{C_0}{T_x} |M_x| + \frac{C_0}{T_y} |M_y| \dots\dots(10)$$

- where,  $P_0$  : Static equivalent load, N
- $F_r$  : Downward load, N
- $F_a$  : Lateral load, N
- $M_0$  : Moment load in the  $T_0$  direction, N · m
- $M_x$  : Moment load in the  $T_x$  direction, N · m
- $M_y$  : Moment load in the  $T_y$  direction, N · m
- $k_{or}, k_{oa}$  : Conversion factors for load direction (See Table 5)
- $C_0$  : Basic static load rating, N
- $T_0$  : Static moment rating in the  $T_0$  direction, N · m
- $T_x$  : Static moment rating in the  $T_x$  direction, N · m
- $T_y$  : Static moment rating in the  $T_y$  direction, N · m

Table 5 Conversion factor for load direction

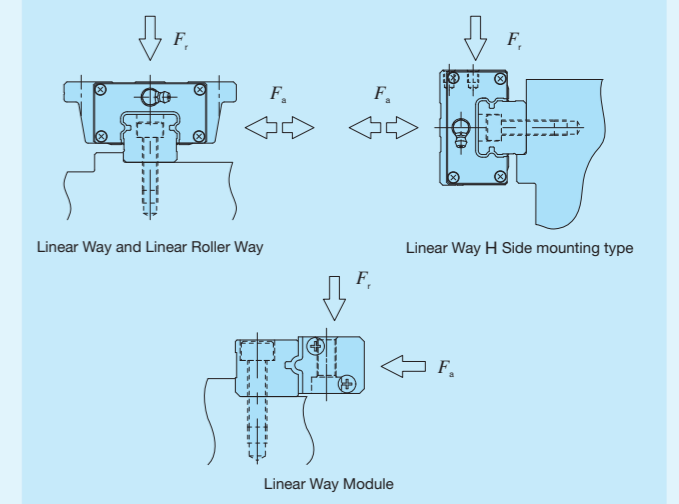

Series name and size		Conversion factor		
		$k_{or}$		$k_{oa}$
		$F_r \geq 0$	$F_r < 0$	
C-Lube Linear Way ML Linear Way L	Ball retained type	1	1	1.19
	Ball non-retained type	1	1	0.84
C-Lube Linear Way MLV		1	1	1.19
C-Lube Linear Way MV		1	1.88	2.08
C-Lube Linear Way ME Linear Way E	15~30	1	1	1
	35~45	1	1.19	1.28
Low Decibel Linear Way E		1	1	1
C-Lube Linear Way MH Linear Way H	8~12	1	1	1.19
	15~30	1	1	1
	35~65	1	1.19	1.28
Linear Way H Horizontal mounting type	15~30	1	1	1
	35~45 <sup>(1)</sup>	1	1	0.78 0.93
Linear Way F	33~42	1	1	1
	69	1	1	1.19
	LWFH	1	1.19	1.28
C-Lube Linear Way MUL Linear Way U	25, 30	1	1	1.19
	40~130	1	1	1
C-Lube Linear Roller Way Super MX Linear Roller Way Super X		1	1	1
Linear Roller Way X		1	1	1
Linear Way Module	LWLM	1	1	0.60
	LWM	1~5	1	1.19
		6	1	1.43
	LRWM	1	1	0.50

Note <sup>(1)</sup> The upper value of  $k_{oa}$  columns represents the right direction and the lower value represents the left direction.



# Calculated Load

Examples of calculation for the loads applied to Linear Way and Linear Roller Way that is incorporated in machine / equipment is shown in Table 6.1 to Table 6.6.

**Table 6.1 One track rail and one slide unit**

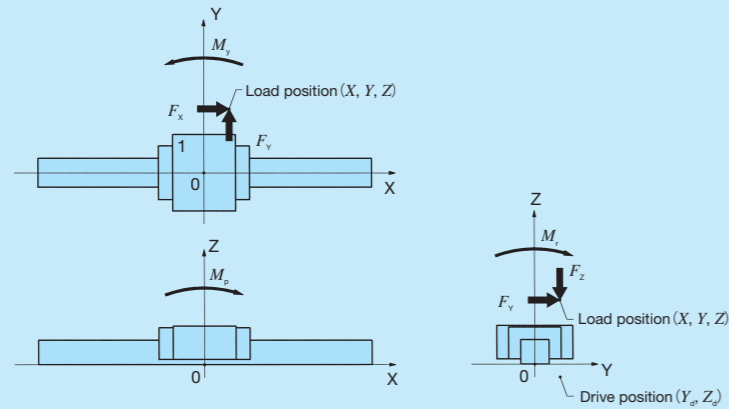

Slide unit No.	Load applied on the slide unit				
	Downward load $F_r$	Lateral load $F_a$	Moment load in the $T_0$ direction $M_0$	Moment load in the $T_x$ direction $M_x$	Moment load in the $T_y$ direction $M_y$
1	$F_z$	$F_y$	$M_r$	$M_p$	$M_y$

Remark: The moment loads in each direction  $M_x, M_p, M_y$  can be obtained by the following equation.

$$M_r = F_y Z + F_z Y$$

$$M_p = F_x (Z - Z_d) + F_z X$$

$$M_y = -F_x (Y - Y_d) + F_y X$$

**Table 6.2 One track rail and two slide units**

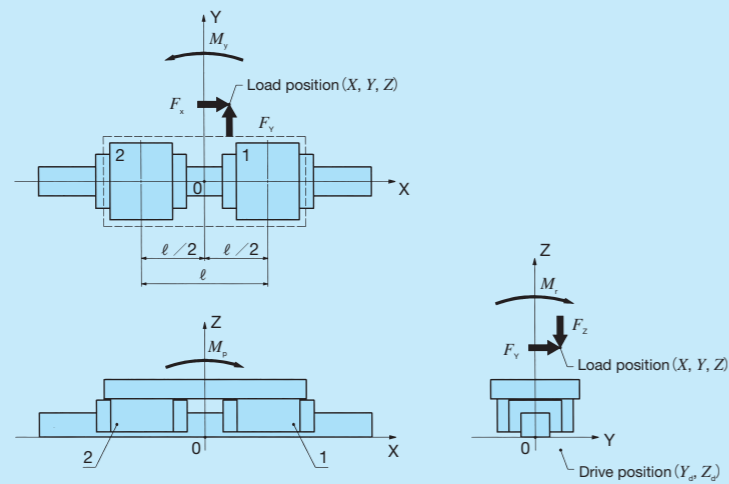

Slide unit No.	Load applied on the slide unit		
	Downward load $F_r$	Lateral load $F_a$	Moment load in the $T_0$ direction $M_0$
1	$\frac{F_z}{2} + \frac{M_p}{l}$	$\frac{F_y}{2} + \frac{M_y}{l}$	$\frac{M_r}{2}$
2	$\frac{F_z}{2} - \frac{M_p}{l}$	$\frac{F_y}{2} - \frac{M_y}{l}$	$\frac{M_r}{2}$

Remark: The moment loads in each direction  $M_x, M_p, M_y$  can be obtained by the following equation.

$$M_r = F_y Z + F_z Y$$

$$M_p = F_x (Z - Z_d) + F_z X$$

$$M_y = -F_x (Y - Y_d) + F_y X$$

**Table 6.3 Two track rails and one slide unit**

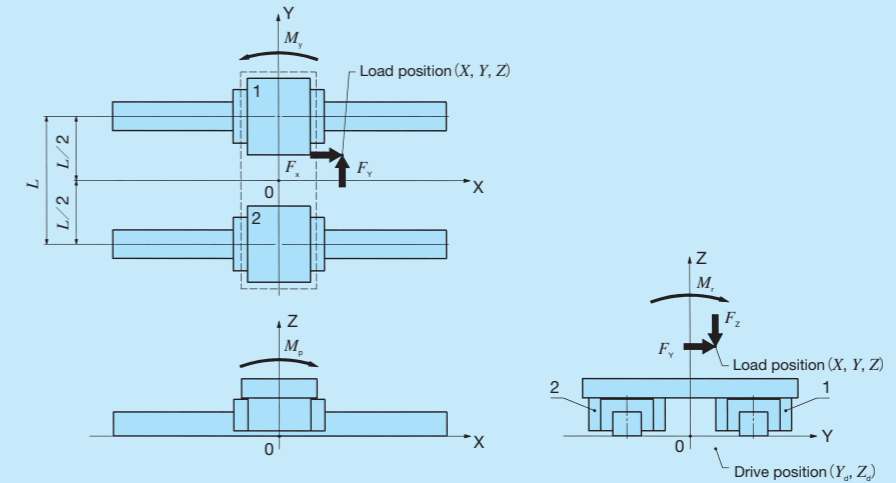

Slide unit No.	Load applied on the slide unit			
	Downward load $F_r$	Lateral load $F_a$	Moment load in the $T_x$ direction $M_x$	Moment load in the $T_y$ direction $M_y$
1	$\frac{F_z}{2} + \frac{M_r}{L}$	$\frac{F_y}{2}$	$\frac{M_p}{2}$	$\frac{M_y}{2}$
2	$\frac{F_z}{2} - \frac{M_r}{L}$	$\frac{F_y}{2}$	$\frac{M_p}{2}$	$\frac{M_y}{2}$

Remark: The moment loads in each direction  $M_x, M_p, M_y$  can be obtained by the following equation.

$$M_r = F_y Z + F_z Y$$

$$M_p = F_x (Z - Z_d) + F_z X$$

$$M_y = -F_x (Y - Y_d) + F_y X$$

Table 6.4 Two track rails and two slide units

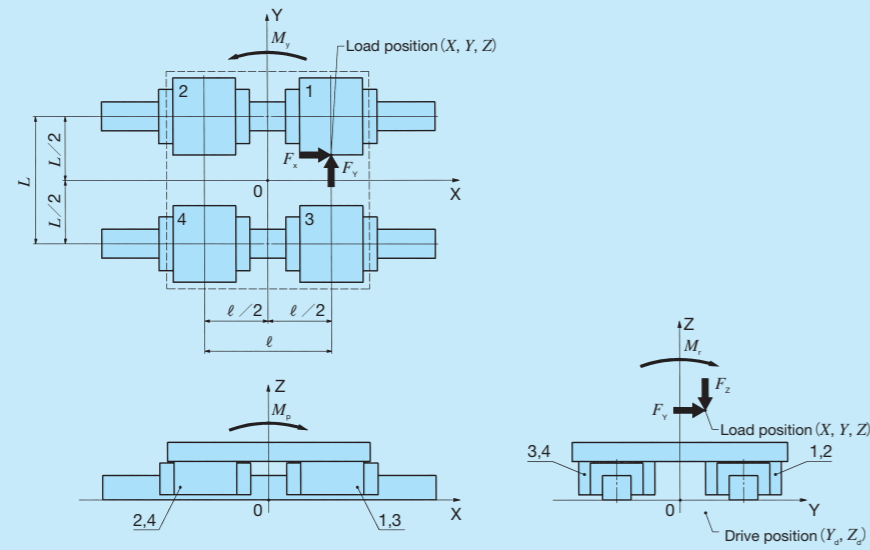

Slide unit No.	Load applied on the slide unit	
	Downward load $F_r$	Lateral load $F_a$
1	$\frac{F_z}{4} + \frac{M_r}{2L} + \frac{M_p}{2l}$	$\frac{F_y}{4} + \frac{M_y}{2l}$
2	$\frac{F_z}{4} + \frac{M_r}{2L} - \frac{M_p}{2l}$	$\frac{F_y}{4} - \frac{M_y}{2l}$
3	$\frac{F_z}{4} - \frac{M_r}{2L} + \frac{M_p}{2l}$	$\frac{F_y}{4} + \frac{M_y}{2l}$
4	$\frac{F_z}{4} - \frac{M_r}{2L} - \frac{M_p}{2l}$	$\frac{F_y}{4} - \frac{M_y}{2l}$

Remark: The moment loads in each direction  $M_r$ ,  $M_p$ ,  $M_y$  can be obtained by the following equation.

$$M_r = F_y Z + F_z Y$$

$$M_p = F_x (Z - Z_d) + F_z X$$

$$M_y = -F_x (Y - Y_d) + F_y X$$

Table 6.5 Two track rails and three slide units

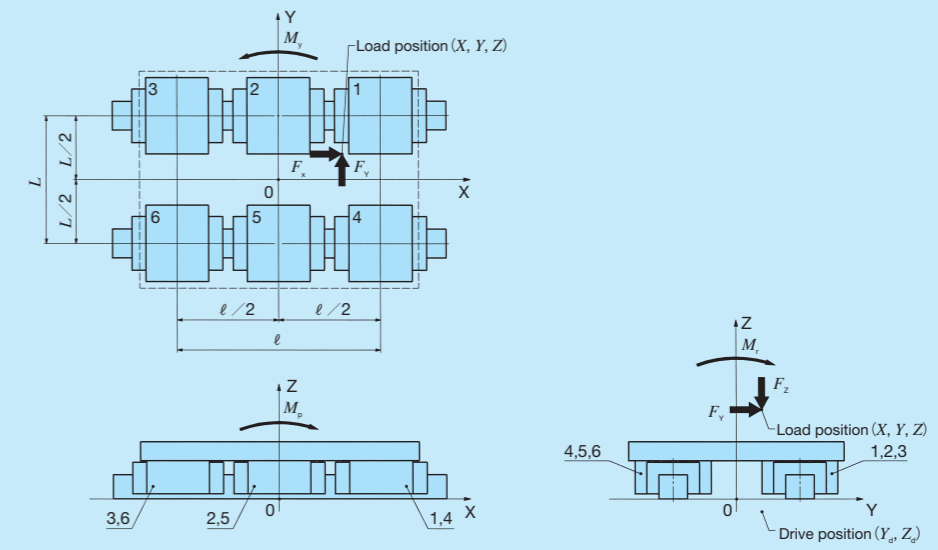

Slide unit No.	Load applied on the slide unit	
	Downward load $F_r$	Lateral load $F_a$
1	$\frac{F_z}{6} + \frac{M_r}{3L} + \frac{M_p}{2l}$	$\frac{F_y}{6} + \frac{M_y}{2l}$
2	$\frac{F_z}{6} + \frac{M_r}{3L}$	$\frac{F_y}{6}$
3	$\frac{F_z}{6} + \frac{M_r}{3L} - \frac{M_p}{2l}$	$\frac{F_y}{6} - \frac{M_y}{2l}$
4	$\frac{F_z}{6} - \frac{M_r}{3L} + \frac{M_p}{2l}$	$\frac{F_y}{6} + \frac{M_y}{2l}$
5	$\frac{F_z}{6} - \frac{M_r}{3L}$	$\frac{F_y}{6}$
6	$\frac{F_z}{6} - \frac{M_r}{3L} - \frac{M_p}{2l}$	$\frac{F_y}{6} - \frac{M_y}{2l}$

Remark: The moment loads in each direction  $M_r$ ,  $M_p$ ,  $M_y$  can be obtained by the following equation.

$$M_r = F_y Z + F_z Y$$

$$M_p = F_x (Z - Z_d) + F_z X$$

$$M_y = -F_x (Y - Y_d) + F_y X$$

Table 6.6 Two track rails and four slide units

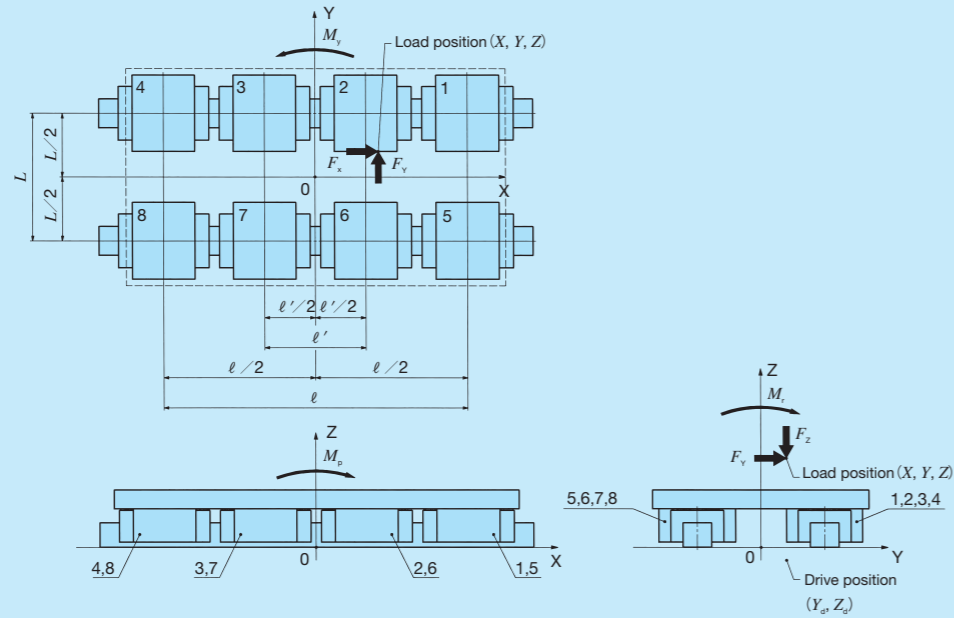

Slide unit No.	Load applied on the slide unit	
	Downward load $F_r$	Lateral load $F_a$
1	$\frac{F_z}{8} + \frac{M_r}{4L} + \frac{M_p}{2} \frac{\ell}{\ell^2 + \ell'^2}$	$\frac{F_y}{8} + \frac{M_y}{2} \frac{\ell}{\ell^2 + \ell'^2}$
2	$\frac{F_z}{8} + \frac{M_r}{4L} + \frac{M_p}{2} \frac{\ell'}{\ell^2 + \ell'^2}$	$\frac{F_y}{8} + \frac{M_y}{2} \frac{\ell'}{\ell^2 + \ell'^2}$
3	$\frac{F_z}{8} + \frac{M_r}{4L} - \frac{M_p}{2} \frac{\ell'}{\ell^2 + \ell'^2}$	$\frac{F_y}{8} - \frac{M_y}{2} \frac{\ell'}{\ell^2 + \ell'^2}$
4	$\frac{F_z}{8} + \frac{M_r}{4L} - \frac{M_p}{2} \frac{\ell}{\ell^2 + \ell'^2}$	$\frac{F_y}{8} - \frac{M_y}{2} \frac{\ell}{\ell^2 + \ell'^2}$
5	$\frac{F_z}{8} - \frac{M_r}{4L} + \frac{M_p}{2} \frac{\ell}{\ell^2 + \ell'^2}$	$\frac{F_y}{8} + \frac{M_y}{2} \frac{\ell}{\ell^2 + \ell'^2}$
6	$\frac{F_z}{8} - \frac{M_r}{4L} + \frac{M_p}{2} \frac{\ell'}{\ell^2 + \ell'^2}$	$\frac{F_y}{8} + \frac{M_y}{2} \frac{\ell'}{\ell^2 + \ell'^2}$
7	$\frac{F_z}{8} - \frac{M_r}{4L} - \frac{M_p}{2} \frac{\ell'}{\ell^2 + \ell'^2}$	$\frac{F_y}{8} - \frac{M_y}{2} \frac{\ell'}{\ell^2 + \ell'^2}$
8	$\frac{F_z}{8} - \frac{M_r}{4L} - \frac{M_p}{2} \frac{\ell}{\ell^2 + \ell'^2}$	$\frac{F_y}{8} - \frac{M_y}{2} \frac{\ell}{\ell^2 + \ell'^2}$

Remark: The moment loads in each direction  $M_r$ ,  $M_p$ ,  $M_y$  can be obtained by the following equation.

$$M_r = F_y Z + F_z Y$$

$$M_p = F_x (Z - Z_d) + F_z X$$

$$M_y = -F_x (Y - Y_d) + F_y X$$

## Mean Equivalent Load for Fluctuating Load

When the load on the Linear Way and Linear Roller Way varies, instead of dynamic equivalent load  $P$ , the mean equivalent load  $P_m$  is used for calculating formula of life. The mean equivalent load is a load converted to give life equal to that for fluctuating load. It is obtained by the following formula:

$$P_m = \sqrt[p]{\frac{1}{L} \int_0^L P_n^p dL} \dots \dots \dots (11)$$

- where,  $P_m$  : Mean equivalent load, N
- $L$  : Total traveling distance, m
- $P_n$  : Fluctuating load, N
- $p$  : Exponent (ball type: 3, roller type: 10/3)

Table 7 gives calculation examples of the mean equivalent load for typical fluctuating loads.

Table 7 Mean equivalent load for fluctuating load

Example	Mean equivalent load
<p>① Stepwise changing load</p>	$P_m = \sqrt[p]{\frac{1}{L} (P_1^p L_1 + P_2^p L_2 + \dots + P_n^p L_n)}$ <p>where, <math>L_1</math> : Total traveling distance receiving the load <math>P_1</math>, m  <math>L_2</math> : Total traveling distance receiving the load <math>P_2</math>, m  <math>L_n</math> : Total traveling distance receiving the load <math>P_n</math>, m</p>
<p>② Monotonously changing load</p>	$P_m \doteq \frac{1}{3} (2P_{max} + P_{min})$ <p>where, <math>P_{max}</math> : Maximum value of fluctuating load, N  <math>P_{min}</math> : Minimum value of fluctuating load, N</p>

# Examples of Load and Life Calculation

## Example 1

Linear Way Model.....ME 25 C2 R640 H	Work mass..... $m_2 = 10$ kg
Basic dynamic load rating..... $C = 18100$ N	Position of center of gravity of work..... $X_3 = 75$ mm
Basic static load rating..... $C_0 = 21100$ N	..... $Y_3 = 80$ mm
Applied load..... $F_{x1} = 1000$ N	..... $Z_3 = 68$ mm
..... $F_{y1} = 2000$ N	Number of strokes per minute..... $n_1 = 5$ cpm
..... $F_{z1} = 1000$ N	Stroke length..... $S = 100$ mm
Load position..... $X_1 = 60$ mm	Distance between slide units..... $\ell = 100$ mm
..... $Y_1 = 50$ mm	Distance between the track rails..... $L = 150$ mm
..... $Z_1 = 83$ mm	Drive position..... $Y_d = 150$ mm
Table mass..... $m_1 = 10$ kg	..... $Z_d = 10$ mm
Position of the center of gravity of table..... $X_2 = 0$ mm	
..... $Y_2 = 0$ mm	
..... $Z_2 = 43$ mm	

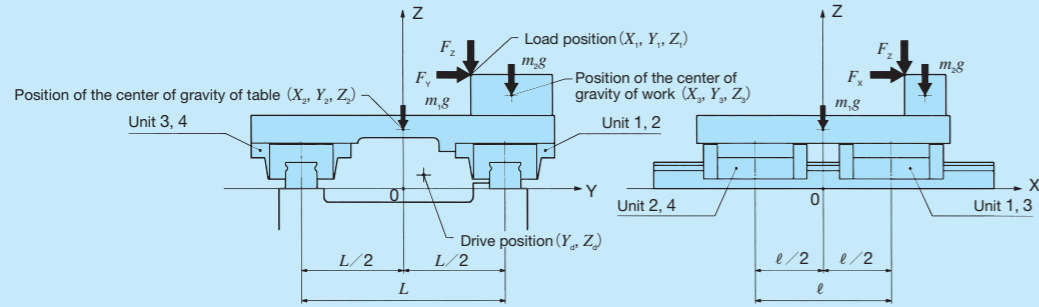

The life and static safety factor in the case of Example 1 is calculated. Load factor  $f_w$  is assumed to be 1.5.

### ① Calculation of load on the slide unit

Due to the applied load and the table weight, moment load occurs around each coordinate axis of the Linear Way as shown below.

$$M_r = \Sigma (F_y Z) + \Sigma (F_z Y) = F_{y1} Z_1 + F_{z1} Y_1 + m_1 g Y_2 + m_2 g Y_3$$

$$= 2000 \times 83 + 1000 \times 50 + 10 \times 9.8 \times 0 + 10 \times 9.8 \times 80$$

$$\approx 224000$$

$$M_p = \Sigma \{F_x (Z - Z_d)\} + \Sigma (F_z X) = F_{x1} (Z_1 - Z_d) + F_{z1} X_1 + m_1 g X_2$$

$$+ m_2 g X_3$$

$$= 1000 \times (83 - 10) + 1000 \times 60 + 10 \times 9.8 \times 0 + 10 \times 9.8 \times 75$$

$$\approx 140000$$

$$M_y = -\Sigma \{F_x (Y - Y_d)\} + \Sigma (F_y X) = -F_{x1} (Y_1 - Y_d) + F_{y1} X_1$$

$$= -1000 \times (50 - 150) + 2000 \times 60 = 220000$$

where,  $M_r$ : Moment load in the rolling direction, N · mm  
 $M_p$ : Moment load in the pitching direction, N · mm  
 $M_y$ : Moment load in the yawing direction, N · mm

The loads applied on each slide unit are calculated according to Table 6.4 on page III - 11.

$$F_{r1} = \frac{\Sigma F_z}{4} + \frac{M_r}{2L} + \frac{M_p}{2\ell} = \frac{F_{z1} + m_1 g + m_2 g}{4} + \frac{M_r}{2L} + \frac{M_p}{2\ell}$$

$$= \frac{1000 + 10 \times 9.8 + 10 \times 9.8}{4} + \frac{224000}{2 \times 150} + \frac{140000}{2 \times 100}$$

$$\approx 1750$$

$$F_{r2} = \frac{\Sigma F_z}{4} + \frac{M_r}{2L} - \frac{M_p}{2\ell} = \frac{F_{z1} + m_1 g + m_2 g}{4} + \frac{M_r}{2L} - \frac{M_p}{2\ell} \approx 346$$

$$F_{r3} = \frac{\Sigma F_z}{4} - \frac{M_r}{2L} + \frac{M_p}{2\ell} = \frac{F_{z1} + m_1 g + m_2 g}{4} - \frac{M_r}{2L} + \frac{M_p}{2\ell} \approx 252$$

$$F_{r4} = \frac{\Sigma F_z}{4} - \frac{M_r}{2L} - \frac{M_p}{2\ell} = \frac{F_{z1} + m_1 g + m_2 g}{4} - \frac{M_r}{2L} - \frac{M_p}{2\ell}$$

$$\approx -1150$$

$$F_{a1} = F_{a3} = \frac{\Sigma F_y}{4} + \frac{M_y}{2\ell} = \frac{F_{y1}}{4} + \frac{M_y}{2\ell}$$

$$= \frac{2000}{4} + \frac{220000}{2 \times 100} = 1600$$

$$F_{a2} = F_{a4} = \frac{\Sigma F_y}{4} - \frac{M_y}{2\ell} = \frac{F_{y1}}{4} - \frac{M_y}{2\ell} = -600$$

### ② Calculating of rating life

The upward / downward load and lateral load are converted by formula (7) and (8) on page III - 7.

$$F_{re1} = k_r |F_{r1}| = 1 \times 1750 = 1750$$

$$F_{re2} = k_r |F_{r2}| = 1 \times 346 = 346$$

$$F_{re3} = k_r |F_{r3}| = 1 \times 252 = 252$$

$$F_{re4} = k_r |F_{r4}| = 1 \times 1150 = 1150$$

$$F_{ae1} = k_a |F_{a1}| = 1 \times 1600 = 1600$$

$$F_{ae2} = k_a |F_{a2}| = 1 \times 600 = 600$$

$$F_{ae3} = k_a |F_{a3}| = 1 \times 1600 = 1600$$

$$F_{ae4} = k_a |F_{a4}| = 1 \times 600 = 600$$

where,  $k_r, k_a$ : Conversion factors for load direction (See Table 3 on page III - 7.)

The dynamic equivalent load is calculated by formula (9) on page III - 7.

$$P_1 = X |F_{re1}| + Y |F_{ae1}| = 1 \times 1750 + 0.6 \times 1600 = 2710$$

$$P_2 = X |F_{re2}| + Y |F_{ae2}| = 0.6 \times 346 + 1 \times 600 \approx 808$$

$$P_3 = X |F_{re3}| + Y |F_{ae3}| = 0.6 \times 252 + 1 \times 1600 \approx 1750$$

$$P_4 = X |F_{re4}| + Y |F_{ae4}| = 1 \times 1150 + 0.6 \times 600 = 1510$$

The basic rating life of slide unit 1 receiving the largest dynamic equivalent load is calculated. The basic rating life is obtained by the formula (1) given on the page III - 6 considering the load factor  $f_w$  (see Table 1 on page III - 6).

$$L_1 = 50 \left( \frac{C}{f_w P_1} \right)^3 = 50 \times \left( \frac{18100}{1.5 \times 2710} \right)^3 \approx 4410$$

$$L_{h1} = \frac{10^6 L_1}{2S n_1 \times 60} = \frac{10^6 \times 4410}{2 \times 100 \times 5 \times 60} \approx 73500$$

As the result of calculation above, the basic rating life is about 73,500 hours.

### ③ Calculating of static safety factor

The static equivalent load is calculated from the upward / downward load and lateral load by formula (10) on page III - 8.

$$P_{01} = k_{or} |F_{r1}| + k_{oa} |F_{a1}| = 1 \times 1750 + 1 \times 1600 = 3350$$

$$P_{02} = k_{or} |F_{r2}| + k_{oa} |F_{a2}| = 1 \times 346 + 1 \times 600 = 946$$

$$P_{03} = k_{or} |F_{r3}| + k_{oa} |F_{a3}| = 1 \times 252 + 1 \times 1600 = 1852$$

$$P_{04} = k_{or} |F_{r4}| + k_{oa} |F_{a4}| = 1 \times 1150 + 1 \times 600 = 1750$$

where,  $k_{or}, k_{oa}$ : Conversion factors for load direction (See Table 5 on page III - 8.)

The static safety factor of slide unit 1 receiving the largest static equivalent load is calculated. The static safety factor is calculated by formula (5) on page III - 6.

$$f_{s1} = \frac{C_0}{P_{01}} = \frac{21100}{3350} \approx 6.3$$

As the result of calculation above, the static safety factor is about 6.3.

**Example 2**

Linear Way Model.....	MH 45 C2 R1050 H	Distance between slide units... $\ell$	= 200 mm
Basic dynamic load rating.....	$C = 74600$ N	Stroke length.....	$S = 500$ mm
Basic static load rating.....	$C_0 = 80200$ N	Number of strokes per minute...	$n_1 = 6$ cpm
Static moment rating in the $T_0$ direction...	$T_0 = 1610$ N · m	Maximum traveling velocity...	$V = 100$ mm/s
Table mass.....	$m_1 = 100$ kg	Time spent for acceleration...	$t_1 = 0.1$ s
Position of the center of gravity of table...	$X_1 = 50$ mm	Time spent during constant speed motion...	$t_2 = 4.9$ s
.....	$Y_1 = 0$ mm	Time spent for deceleration...	$t_3 = 0.1$ s
.....	$Z_1 = 80$ mm	Drive position.....	$Y_d = 60$ mm
Work mass.....	$m_2 = 1000$ kg	.....	$Z_d = -20$ mm
Position of center of gravity of work...	$X_2 = 200$ mm		
.....	$Y_2 = 10$ mm		
.....	$Z_2 = 130$ mm		

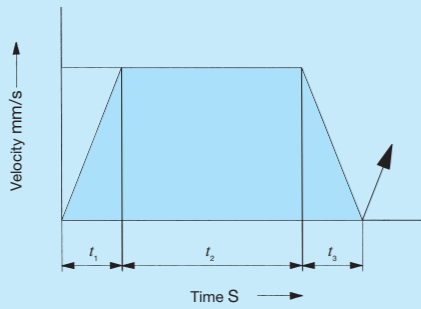
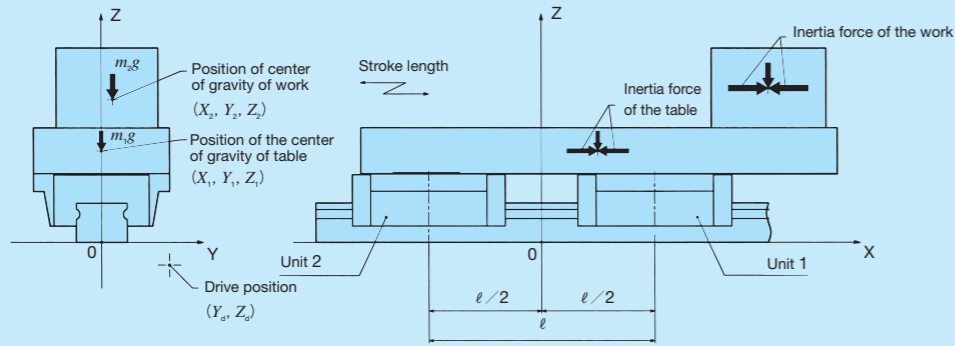

The life and static safety factor in the case of Example 2 is calculated. Load factor  $f_w$  is assumed to be 1.5.

**① Calculation of load on the slide unit**

Due to the applied load and the table mass and inertia force, moment load occurs around each coordinate axis of the Linear Way as shown below.

(During acceleration at the start of motion)

$$M_r = \sum (F_y Z) + \sum (F_z Y) = m_1 g Y_1 + m_2 g Y_2 = 100 \times 9.8 \times 0 + 1000 \times 9.8 \times 10 \approx 98000$$

$$M_p = \sum \{F_x (Z - Z_d)\} + \sum (F_z X)$$

$$= m_1 \frac{V_{max}}{1000 \times t_1} (Z_1 - Z_d) + m_2 \frac{V_{max}}{1000 \times t_1} (Z_2 - Z_d) + m_1 g X_1 + m_2 g X_2$$

$$= 100 \times \frac{100}{1000 \times 0.1} \times (80 + 20) + 1000 \times \frac{100}{1000 \times 0.1} \times (130 + 20) + 100 \times 9.8 \times 50 + 1000 \times 9.8 \times 200 \approx 2169000$$

$$M_y = -\sum \{F_x (Y - Y_d)\} + \sum (F_z Y)$$

$$= -m_1 \frac{V_{max}}{1000 \times t_1} (Y_1 - Y_d) - m_2 \frac{V_{max}}{1000 \times t_1} (Y_2 - Y_d)$$

$$= -100 \times \frac{100}{1000 \times 0.1} \times (0 - 60) - 1000 \times \frac{100}{1000 \times 0.1} \times (10 - 60) \approx 56000$$

(During constant speed motion)

$$M_r = m_1 g Y_1 + m_2 g Y_2 \approx 98000$$

$$M_p = m_1 g X_1 + m_2 g X_2 \approx 2010000$$

$$M_y = 0$$

(During deceleration at the end of motion)

$$M_r = m_1 g Y_1 + m_2 g Y_2 \approx 98000$$

$$M_p = -m_1 \frac{V_{max}}{1000 \times t_3} (Z_1 - Z_d) - m_2 \frac{V_{max}}{1000 \times t_3} (Z_2 - Z_d) + m_1 g X_1 + m_2 g X_2 \approx 1850000$$

$$M_y = m_1 \frac{V_{max}}{1000 \times t_3} (Y_1 - Y_d) + m_2 \frac{V_{max}}{1000 \times t_3} (Y_2 - Y_d) \approx -56000$$

where,  $M_r$ : Moment load in the rolling direction, N · mm  
 $M_p$ : Moment load in the pitching direction, N · mm  
 $M_y$ : Moment load in the yawing direction, N · mm

The loads applied on each slide unit are calculated according to Table 6.2 on page III-9.

(During acceleration at the start of motion)

$$F_{r1} = \frac{\sum F_z + M_p}{\ell} = \frac{m_1 g + m_2 g}{\ell} + \frac{M_p}{\ell}$$

$$= \frac{100 \times 9.8 + 1000 \times 9.8}{200} + \frac{2169000}{200} \approx 16200$$

$$F_{r2} = \frac{\sum F_z + M_p}{\ell} = \frac{m_1 g + m_2 g}{\ell} - \frac{M_p}{\ell} \approx -5460$$

$$F_{a1} = \frac{\sum F_y + M_y}{\ell} = 280$$

$$F_{a2} = \frac{\sum F_y - M_y}{\ell} = -280$$

$$M_{01} = M_{02} = \frac{M}{\ell} = 49000$$

(During constant speed motion)

$$F_{r1} = \frac{100 \times 9.8 + 1000 \times 9.8}{200} + \frac{2010000}{200} \approx 15400$$

$$F_{r2} \approx -4660$$

$$F_{a1} = F_{a2} = 0$$

$$M_{01} = M_{02} = 49000$$

(During deceleration at the end of motion)

$$F_{r1} = \frac{100 \times 9.8 + 1000 \times 9.8}{200} + \frac{1850000}{200} \approx 14600$$

$$F_{r2} \approx -3860$$

$$F_{a1} \approx -280$$

$$F_{a2} \approx 280$$

$$M_{01} = M_{02} = 49000$$

**② Calculating of rating life**

The upward / downward load, lateral load and the moment load along  $T_0$  direction are calculated by the formula (7) and (8) on page III-7, and the dynamic equivalent load is calculated by formula (9).

(During acceleration at the start of motion)

$$F_{re1} = k_r |F_{r1}| + \frac{C_0}{T_0} |M_{01}| = 1 \times 16200 + \frac{80200}{1610} \times \frac{49000}{1000} \approx 18600$$

$$F_{re2} = 1 \times 5460 + \frac{80200}{1610} \times \frac{49000}{7900} \approx 7900$$

$$F_{ae1} = k_a |F_{a1}| = 1.28 \times 280 \approx 358$$

$$F_{ae2} = 1.28 \times 280 \approx 358$$

$$P_{1a} = X F_{re1} + Y F_{ae1} = 1 \times 18600 + 0.6 \times 358 \approx 18800$$

$$P_{2a} = X F_{re2} + Y F_{ae2} = 1 \times 7900 + 0.6 \times 358 \approx 8110$$

(During constant speed motion)

$$F_{re1} = 1 \times 15400 + \frac{80200}{1610} \times \frac{49000}{1000} \approx 17800$$

$$F_{re2} = 1 \times 4660 + \frac{80200}{1610} \times \frac{49000}{1000} \approx 7100$$

$$F_{ae1} = 0$$

$$F_{ae2} = 0$$

$$P_{1b} = 17800$$

$$P_{2b} = 7100$$

(During deceleration at the end of motion)

$$F_{re1} = 1 \times 14600 + \frac{80200}{1610} \times \frac{49000}{1000} \approx 17000$$

$$F_{re2} = 1 \times 3860 + \frac{80200}{1610} \times \frac{49000}{1000} \approx 6300$$

$$F_{ae1} = 1.28 \times 280 \approx 358$$

$$F_{ae2} = 1.28 \times 280 \approx 358$$

$$P_{1c} = 1 \times 17000 + 0.6 \times 358 \approx 17200$$

$$P_{2c} = 1 \times 6300 + 0.6 \times 358 \approx 6510$$

Because the dynamic equivalent load changes stepwise along the traveling distance, the mean equivalent load is calculated from ① in Table 7 on page III-14.

$$P_{m1} = \sqrt[3]{\frac{1}{S} (P_{1a}^3 \frac{V_{max} t_1}{2} + P_{1b}^3 V_{max} t_2 + P_{1c}^3 \frac{V_{max} t_3}{2})}$$

$$= \left\{ \frac{1}{500} \times \left( 18800^3 \times \frac{100 \times 0.1}{2} + 17800^3 \times 100 \times 4.9 + 17200^3 \times \frac{100 \times 0.1}{2} \right) \right\}^{1/3} \approx 17800$$

$$P_{m2} = \left\{ \frac{1}{500} \times \left( 8110^3 \times \frac{100 \times 0.1}{2} + 7100^3 \times 100 \times 4.9 + 6510^3 \times \frac{100 \times 0.1}{2} \right) \right\}^{1/3} \approx 7110$$

The basic rating life of slide unit 1 receiving the largest dynamic equivalent load is calculated. The basic rating life is obtained by the formula (1) given on the page III-6 considering the load factor  $f_w$  (see Table 1 on page III-6).

$$L_1 = 50 \left( \frac{C}{f_w P_{m1}} \right)^3 = 50 \left( \frac{74600}{1.5 \times 17800} \right)^3 \approx 1090$$

$$L_{h1} = \frac{10^6 L_1}{2S n_1 \times 60} = \frac{10^6 \times 1090}{2 \times 500 \times 6 \times 60} \approx 3030$$

As the result of calculation above, the basic rating life is about 3,030 hours.

**③ Calculating of static safety factor**

The static equivalent load is calculated from the upward / downward load and lateral load by formula (10) on page III-8.

(During acceleration at the start of motion)

$$P_{01a} = k_{0r} |F_{r1}| + k_{0a} |F_{a1}| + \frac{C_0}{T_0} |M_{01}| = 1 \times 16200 + 1.28 \times 280 + \frac{80200}{1610} \times \frac{49000}{1000} \approx 19000$$

$$P_{02a} = k_{0r} |F_{r2}| + k_{0a} |F_{a2}| + \frac{C_0}{T_0} |M_{02}| = 1.19 \times 5460 + 1.28 \times 280 + \frac{80200}{1610} \times \frac{49000}{1000} \approx 9300$$

(During constant speed motion)

$$P_{01b} = 1 \times 15400 + 1.28 \times 0 + \frac{80200}{1610} \times \frac{49000}{1000} \approx 19000$$

$$P_{02b} = 1.19 \times 4660 + 1.28 \times 0 + \frac{80200}{1610} \times \frac{49000}{1000} \approx 7990$$

(During deceleration at the end of motion)

$$P_{01c} = 1 \times 14600 + 1.28 \times 280 + \frac{80200}{1610} \times \frac{49000}{1000} \approx 17400$$

$$P_{02c} = 1.19 \times 3860 + 1.28 \times 280 + \frac{80200}{1610} \times \frac{49000}{1000} \approx 7390$$

The static safety factor of slide unit 1 during acceleration at the start of motion receiving the largest static equivalent load is calculated. The static safety factor is calculated by formula (5) on page III-6.

$$f_s = \frac{C_0}{P_{01a}} = \frac{80200}{19000} \approx 4.2$$

As the result of calculation above, the static safety factor is about 4.2.

# Accuracy

Five classes of accuracy, ordinary, high, precision, super precision, and ultra precision are specified for Linear Way and Linear Roller Way.

The outline of applicable accuracy classes is shown in Table 8. For details, see an explanation of each series.

**Table 8 Accuracy classes and series**

Series name	Class (classification symbol)	Ordinary (No symbol)	High (H)	Precision (P)	Super precision (SP)	Ultra precision (UP)
C-Lube Linear Way ML Linear Way L		—	○	○	—	—
C-Lube Linear Way MLV		—	○	—	—	—
C-Lube Linear Way MV		○	○	○	○	—
C-Lube Linear Way ME Linear Way E		○	○	○	○	—
C-Lube Linear Way MH Linear Way H		—	○	○	○	—
Linear Way F		—	○	○	○	—
C-Lube Linear Way MUL Linear Way U		○	○	—	—	—
C-Lube Linear Roller Way Super MX Linear Roller Way Super X		—	○	○	○	○
Linear Roller Way X		—	○	○	○	○
Linear Way Module		—	○	○	○	—

# Preload

## Objectives of preload

In some cases, the linear motion rolling guide is used with clearance given to the linear motion rolling guide when light motion with small load is required. However, for some applications, it may be used with play in the guiding mechanism removed or with preload to increase rigidity.

Preload is applied to the contact parts of a raceway and rolling elements with internal stress generated in advance. When an external load is applied on the preloaded linear motion rolling guide, shock absorbing with this internal stress makes elastic deformation smaller, and its rigidity is increased. (See Fig. 3)

## Preload setting

Preload amount is determined by considering the characteristics of the machines or equipments on which the linear motion rolling guide is mounted and the nature of load acting on the linear motion rolling guide. The standard amount of preload for linear motion rolling guides is, in general, approx. 1/3 of load when the rolling elements are balls (steel balls) and approx. 1/2 of load when they are rollers (cylindrical rollers). If the linear motion rolling guides are required to have very high rigidity to withstand vibration or fluctuating load, a larger preload may be applied. For applicable preload amount, see Table 9. For details, see an explanation of each series.

## Precaution for preload selection

Even when high rigidity must be required, excessive preload should be avoided, because it will produce an excessive stress between rolling elements and raceways, and eventually result in short life of linear motion rolling guides. It is important to apply a proper amount of preload, considering the operational conditions. When using with a large preload, contact **IKO**.

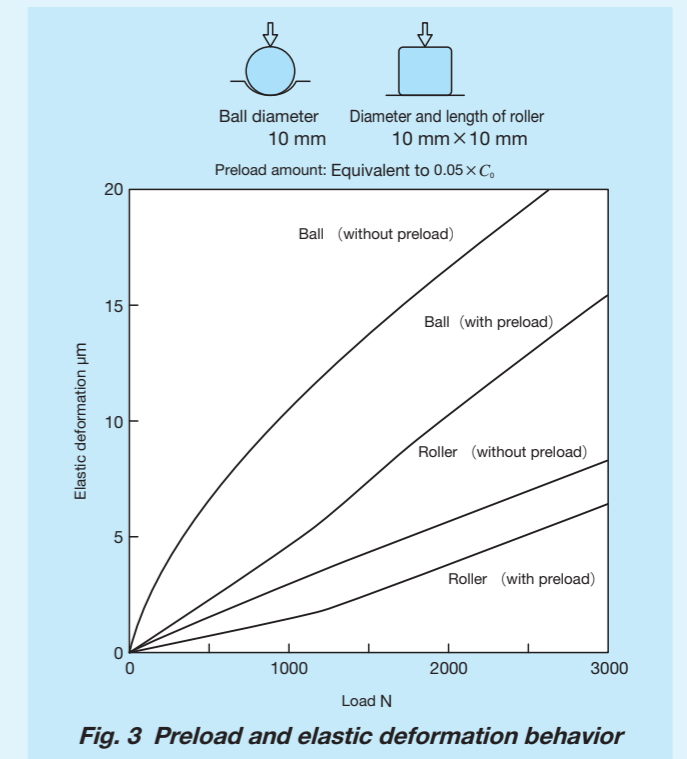

**Table 9 Series and preload amount**

Series name	Preload (preload symbol)	Clearance (T <sub>c</sub> )	Clearance (T <sub>0</sub> )	Standard (No symbol)	Light preload (T <sub>1</sub> )	Medium preload (T <sub>2</sub> )	Heavy preload (T <sub>3</sub> )
C-Lube Linear Way ML Linear Way L		—	○	○	○	—	—
C-Lube Linear Way MLV <sup>(1)</sup>		—	—	—	—	—	—
C-Lube Linear Way MV		○	—	○	○	—	—
C-Lube Linear Way ME Linear Way E		○	—	○	○	○	—
C-Lube Linear Way MH Linear Way H		—	○	○	○	○	○
Linear Way F		—	—	○	○	○	—
C-Lube Linear Way MUL Linear Way U		—	—	○	○	—	—
C-Lube Linear Roller Way Super MX Linear Roller Way Super X		—	—	○	○	○	○
Linear Roller Way X		—	—	○	○	○	○

Note <sup>(1)</sup> Preload is adjusted to have subtle clearance or minimal amount of preload.

## Friction of linear motion rolling guide

The static friction (start-up friction) of linear motion rolling guides is much lower than that of conventional plain guides. Also, the difference between static friction and dynamic friction is small, and frictional resistance varies little when velocity changes. These are excellent features of linear motion rolling guides, and account for their ability to reduce power consumption, suppress operating temperature rise, and increase traveling speed.

Since frictional resistance and variation are small, high-speed response characteristics to motion commands and high accuracy positioning can be achieved.

## Friction coefficient

The frictional resistance of linear motion rolling guides varies with their model, applied load, velocity and characteristics of lubricant. Generally, lubricant or seals are major factors in determining the frictional resistance in light load or high-speed operation, while the amount of load is the major factor in heavy load or low speed operation. The frictional resistance of linear motion rolling guides depends on various factors, but generally the following formula is used.

$$F = \mu P \dots\dots\dots(11)$$

where,  $F$ : Frictional resistance, N  
 $\mu$ : Dynamic friction coefficient  
 $P$ : Applied load, N

For sealed guides, seal resistance is added to the above value, but this resistance varies greatly depending on the interference amount of seal lip and lubrication conditions.

Where the lubrication and mounting condition are correct and the load is moderate, the friction coefficients of Linear Way and Linear Roller Way in operation are within the range shown in Table 10. Generally, friction coefficient is large under small load.

**Table 10 Friction coefficient**

Series name	Dynamic friction coefficient $\mu$ <sup>(1)</sup>
Linear Way	0.0040~0.0060
Linear Roller Way	0.0020~0.0040

Note <sup>(1)</sup> These friction coefficients do not include seal.

## Objectives of lubrication

The objectives of applying lubricant for linear motion rolling guides is to keep raceways, rolling elements, etc. in a linear motion rolling guide from metal contact, and thereby reduce friction and wear preventing heat generation and seizure. When an adequate oil film is formed at the rolling contact area between the raceways and rolling elements, the contact stress due to load can be reduced. To manage the formation of adequate oil film is important for ensuring the reliability of linear motion rolling mechanism.

## Selection of lubricant

To obtain the full performance of linear motion rolling guides, it is necessary to select an appropriate lubricant and lubrication method by considering the model, load and velocity of each linear motion rolling guide. However, as compared with plain guides, lubrication of linear motion rolling guides is much simpler. Only a small amount of lubrication oil is needed and replenishment interval is longer, so maintenance can be greatly reduced. Grease and oil are the two most commonly used lubricants for linear motion rolling guides.

## Grease lubrication

For linear motion rolling guides, lithium-soap base grease (Consistency No.2 of JIS) is commonly used. For rolling guides operating under heavy load conditions, grease containing extreme pressure additives is recommended.

In clean and high-vacuum environments, where low dust generating performance and low vaporization characteristics are required, greases containing a synthetic-base oil or a soap other than the lithium-soap base are used. For applications in these environments, due consideration is necessary to select a grease that is suitable for the operating conditions of linear motion rolling guide and achieves satisfactory lubrication performance at the same time.

**Table 11 Pre-packed grease list**

Series name	Pre-packed grease
C-Lube Linear Way ML Linear Way L	MULTEMP PS No.2 [KYODO YUSHI CO., LTD.]
C-Lube Linear Way MLV	
C-Lube Linear Way MV	
C-Lube Linear Way ME Linear Way E	Alvania EP Grease 2 [SHOWA SHELL SEKIYU K. K.]
C-Lube Linear Way MH <sup>(1)</sup> Linear Way H <sup>(1)</sup>	
Linear Way F	
C-Lube Linear Way MUL Linear Way U <sup>(2)</sup>	MULTEMP PS No.2 [KYODO YUSHI CO., LTD.]
C-Lube Linear Roller Way Super MX Linear Roller Way Super X	Alvania EP Grease 2 [SHOWA SHELL SEKIYU K. K.]
Linear Roller Way X	
Linear Way Module	

Notes <sup>(1)</sup> MULTEMP PS No.2 is pre-packed in size 8 to 12 series.  
<sup>(2)</sup> Alvania EP Grease 2 is pre-packed in size 40 to 130 series.

## Grease replenishment interval

The quality of any grease will gradually deteriorate as operating time passes. Therefore, periodic replenishment is necessary. Grease replenishment interval varies depending on the operating conditions. A six month interval is generally recommended, and if the machine operation consists of reciprocating motions with many cycles and long strokes, replenishment every three month is recommended.

In addition, linear motion rolling guides in which the lubrication part "C-Lube" is built deliver long-term maintenance free performance. This eliminates the need for lubrication mechanism and workload which used to be necessary for linear motion rolling guides and significantly reduces maintenance cost.

## Grease replenishment method

New grease must be supplied through a grease feed device such as a grease nipple until old grease is discharged. After grease is replenished, running-in is performed and excess grease will be discharged to outside of the linear motion rolling guide. Discharged grease must then be removed before starting the operation. The amount of grease required for standard replenishment is about 1/3 to 1/2 of the free space inside the linear motion rolling guide. When grease is supplied from a grease nipple for the first time, there will be grease lost in the replenishment path. The amount lost should be taken into consideration.

Generally, immediately after grease is replenished, frictional resistance tends to increase. If additional running-in is performed for 10 to 20 reciprocating cycles after excess grease is discharged, frictional resistance becomes small and stable.

For applications where low frictional resistance is required, the replenishment amount of grease may be reduced, but it must be kept to an appropriate level so as not to give a bad influence on the lubrication performance.

**Table 12 Grease brands used in linear motion rolling guide**

Brand	Base oil	Thickener	Range of operating temperature <sup>(2)</sup> °C	Usage
Alvania EP Grease 2	[SHOWA SHELL SEKIYU K. K.] Mineral oil	Lithium	-20~110	General application with extreme-pressure additive
Alvania Grease S2	[SHOWA SHELL SEKIYU K. K.] Mineral oil	Lithium	-25~120	General application
MULTEMP PS No.2	[KYODO YUSHI CO., LTD.] Synthetic oil, Mineral oil	Lithium	-50~130	General application
<b>IKO</b> Low Dust-Generation Grease for Clean Environment CG2	[NIPPON THOMPSON CO., LTD.] Synthetic oil	Urea	-40~200	For clean environment Long life
<b>IKO</b> Low Dust-Generation Grease for Clean Environment CGL	[NIPPON THOMPSON CO., LTD.] Synthetic oil, Mineral oil	Lithium / Calcium	-30~120	For clean environment Low sliding
DEMNUM™ Grease L-200 <sup>(1)</sup>	[DAIKIN INDUSTRIES, LTD.] Synthetic oil	Ethylene tetra-fluoride	-60~300	For clean environment
FOMBLIN® Y-VAC3 <sup>(1)</sup>	[SOLVAY SOLEXIS] Synthetic oil	Ethylene tetra-fluoride	-20~250	For vacuum
<b>IKO</b> Anti-Fretting Corrosion Grease AF2	[NIPPON THOMPSON CO., LTD.] Synthetic oil	Urea	-50~170	Fretting-proof
6459 Grease N	[SHOWA SHELL SEKIYU K. K.] Mineral oil	Poly-urea	—	Fretting-proof

Notes <sup>(1)</sup> Set replenishment intervals to short.  
<sup>(2)</sup> The ranges of operating temperature are quoted from the grease manufacturer's cataloged values, but do not guarantee regular use under high temperature environment.  
 Remarks 1. FOMBLIN® is a registered trademark of SOLVAY SOLEXIS.  
 2. Check with the chosen grease manufacturer's catalog before use.  
 For grease for use other than listed, contact **IKO**.

## Mixing of different type of grease

Mixing different types of grease may result in changing the properties of base oil, soap base, or additives used, and, in some cases, severely deteriorate the lubrication performance or cause trouble due to chemical changes of additives. Old grease should therefore be removed thoroughly before filling with new grease.

## Lubrication part "C-Lube"

C-Lube is a porous resin with molding formed fine resin powder. It is a lubrication part impregnated with a large amount of lubrication oil in its open pores by capillary inside.

Lubrication oil is supplied directly to balls (steel balls) or rollers (cylindrical rollers), not to the track rail. When the balls or rollers have contact with C-Lube built in the slide unit, lubrication oil is supplied to the surface of the balls or rollers. As the balls or rollers circulate, the lubricant is distributed to the loading area along the track rail. This results in adequate lubrication oil being properly maintained in the loading area and lubrication performance will last for a long time.

The surface of C-Lube is always covered with the lubrication oil. Lubrication oil is continuously supplied to the surface of balls or rollers by surface tension in the contact of C-Lube surface and balls or rollers.

## Oil lubrication

For oil lubrication, heavy load requires high oil viscosity and high velocity requires low oil viscosity. Generally, for linear motion rolling guides operating under heavy load, lubrication oil with a viscosity of about 68 mm<sup>2</sup>/s is used. For linear motion rolling guides under light load at high-speed operation, lubrication oil with a viscosity of about 13 mm<sup>2</sup>/s is used.

### Miniature greaser

The miniature greaser is specially prepared for grease replenishment for Linear Way and Linear Roller Way with an oil hole. Table 13 shows types of grease and specifications of miniature greasers.



Table 13 Grease type and miniature greaser

Identification number	Grease name	Amount	Outer diameter of grease feed needle
MG10 / MT2	MULTEMP PS No.2 [KYODO YUSHI CO., LTD.]	10 ml	φ 1 mm
MG10 / CG2	IKO Low Dust-Generation Grease for Clean Environment CG2		
MG2.5 / EP2	Alvania EP Grease 2 [SHOWA SHELL SEKIYU K. K.]	2.5 ml	
MG2.5 / CG2	IKO Low Dust-Generation Grease for Clean Environment CG2		
MG2.5 / CGL	IKO Low Dust-Generation Grease for Clean Environment CGL		
MG2.5 / AF2	IKO Anti-Fretting Corrosion Grease AF2		

### Grease nipple and supply nozzle

Tables 14.1 and 14.2 show the specifications of grease nipples and applicable types of supply nozzles, and Table 15 shows the specifications of supply nozzles.

Table 14.1 Grease nipple and applicable supply nozzle type

Grease nipple		Applicable supply nozzle type	
Type	Dimensions and shape	Type	Shape
A-M3		A-5120V A-5240V B-5120V B-5240V	Straight type 
A-M4			Straight type with angle 
B-M4		A-8120V B-8120V	

Table 14.2 Grease nipple and applicable supply nozzle type

Grease nipple		Applicable supply nozzle type	
Type	Dimensions and shape	Type	Shape
B-M6		Products available on the market	Straight type 
JIS type 1			
JIS type 2			
JIS type 4			
A-PT 1/4			

Note (1) For straight type, chuck type and hose type supply nozzles available on the market, it is recommended to use one with an outer diameter  $D$  of 13 mm or less.

Table 15 Types and dimensions of supply nozzle

Type	Dimensions and shape
A-5120V	
A-5240V	
B-5120V	
B-5240V	
A-8120V	
B-8120V	

Remark: The supply nozzles shown in the table can be mounted on the main body of a common grease gun available on the market shown below. If needed, specify the supply nozzle type and place an order to **IKO**.

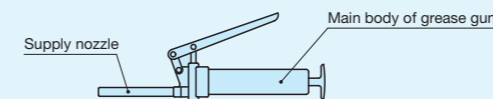

### Piping joint

When applying centralized grease or oil lubrication, detach the grease nipple or plug from the slide unit, and replace them with piping joints, which are prepared for various female threads for piping. Use them after confirming the dimensions of the piping joints and  $H_3$  dimensions in the dimensions table of each models, because the top face of some piping joints is at the same or higher level than the top face of slide unit. Fig. 4.1 and 4.2 and Tables 16.1, 16.2, 16.3, and 16.4 show identification number and dimensions of piping joints. Note that some of them are not applicable for the slide units of special specifications. Piping joints can be mounted on Linear Way and Linear Roller Way prior to delivery upon request. If needed, please contact **IKO**.

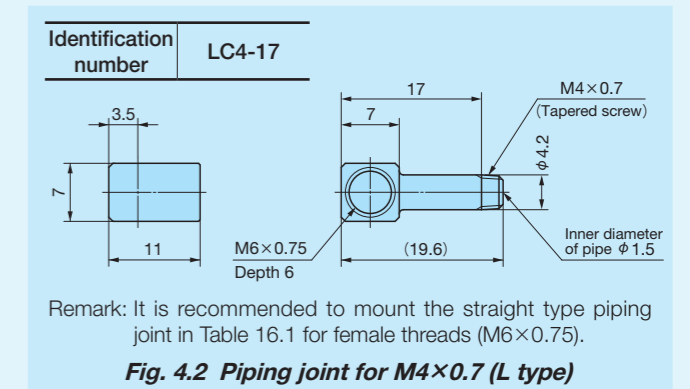
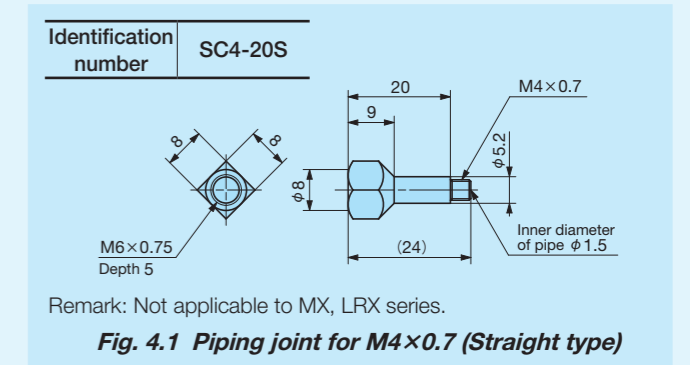
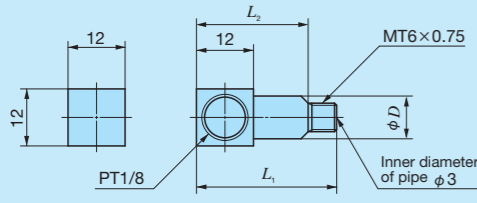

Table 16.1 Piping joint for M6x0.75 (Straight type)

Identification number	unit: mm			
	$L_1$	$L_2$	$L_3$	$D$
SC6-16	22	12.4	16	9
SC6-22S	28	12	22	6
SC6-25S	31	12	25	6

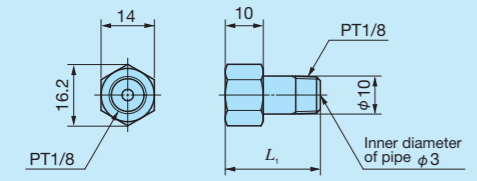

Table 16.2 Piping joint for M6×0.75 (L type)



Identification number	L <sub>1</sub>	L <sub>2</sub>	D
LC6-18	25	18	9
LC6-22S	28	—	6
LC6-24	30.5	23.5	9
LC6-25S	31	—	6

Table 16.3 Piping joint for PT1/8 (Straight type)



Identification number	L <sub>1</sub>
SC1/8-19S	25
SC1/8-34S	40

Table 16.4 Piping joint for PT1/8 (L type)

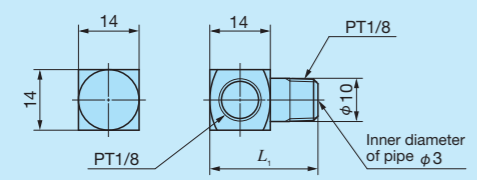

Identification number	L <sub>1</sub>
LC1/8-19S	25
LC1/8-34S	40

## Dust Protection

### Purpose of dust protection

To obtain the full performance of linear motion rolling guides, it is important to protect them from the intrusion of dust and other harmful foreign substances. Select an effective sealing or dust-protection device to withstand any operating conditions that might be imposed.

### Method of dust protection

Linear Way and Linear Roller Way have end seals as a standard specification. In addition, double seals or scrapers are provided as special specifications for improvement in dust protection performance. Also caps and a rail cover sheet to cover the mounting hole of track rail (Fig. 5) and track rail mounting from bottom with no mounting hole on the upper surface (Fig. 6) will further increase the reliability of dust protection.

However, if large amount of contaminant or dust are floating, or if large particles of foreign substances such as chips or sand may adhere to the raceway, complete dust protection becomes difficult. In this case, it is recommended to cover the whole unit with bellows (Fig. 7), telescope type shield, etc. When rail cover sheet or track rails mounting from bottom specification is needed, please contact **IKO**.

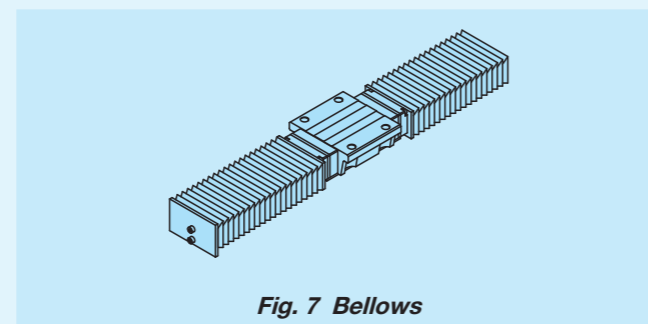
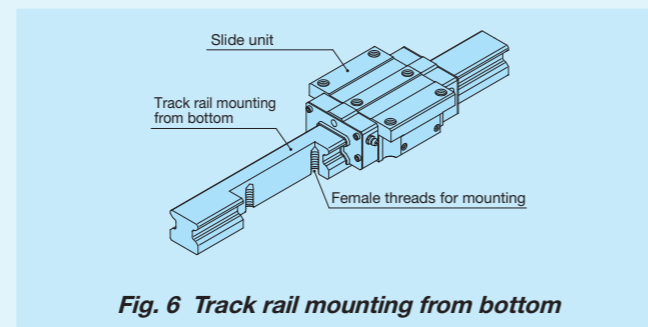
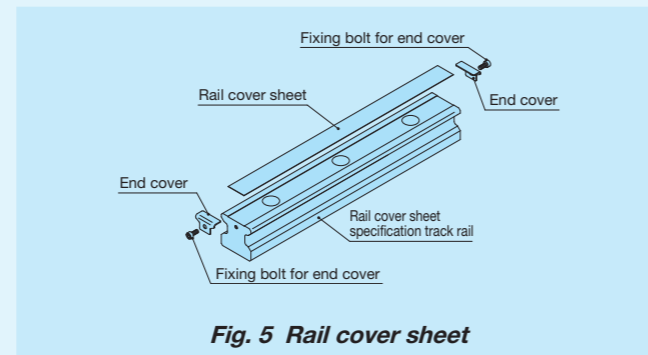

### Specific bellows

The specific bellows are manufactured to match the dimensions of Linear Way and Linear Roller Way for easy mounting and excellent dust protection. If special bellows to be used in an upside-down position or those made of heat-resistant material are needed, please contact **IKO**.

### Identification number of bellows

The identification number of bellows consists of a model code, dimensions, and any supplemental codes. Its standard arrangement is shown below.

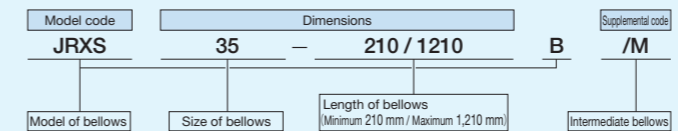

### Calculation of minimum length of bellows

The minimum necessary length of specific bellows is determined, by first calculating the necessary number of accordion pleats as follows.

$$ns = \frac{S}{\ell s_{\max} - \ell s_{\min}}$$

where,  $ns$ : Number of pleats (Raise decimal fractions)  
 $S$ : Stroke length, mm  
 $\ell s_{\max}$ : Maximum length of one pleat (See Tables 18.1 and 18.2)  
 $\ell s_{\min}$ : Minimum length of one pleat (See Tables 18.1 and 18.2)

$$L_{\min} = ns \times \ell s_{\min} + m \times 5 + 10$$

$$L_{\max} = S + L_{\min}$$

where,  $L_{\min}$ : Minimum length of bellows, mm  
 $L_{\max}$ : Maximum length of bellows, mm  
 $m$ : Number of internal guide plates (See Table 17)

Table 17 Number of internal guide plates for bellows

Model	P dimensions of specific bellows (1) mm		Number of internal guide plates $m$
	Above	Below	
JEF JRES	—	35	$m = \frac{ns}{7} - 1$
JES JHS JFS JRXS···B JFFS	—	22	$m = \frac{ns}{16}$ when $ns \leq 20$ , then $m=0$
	22	25	$m = \frac{ns}{12}$ when $ns \leq 18$ , then $m=0$
	25	35	$m = \frac{ns}{8}$

Note (1) For P dimensions, see Table 18.1 and Table 18.2.  
 Remark: In calculating the number of internal guide plates  $m$ , raise the decimal fractions for JEF and JRES and omit the decimal fractions for others.

### Intermediate bellows

Since different type of mounting plate is used for mounting bellows between slide units, add supplemental code "/M" onto the identification number when ordering. Reinforced bellows are also available, which are specially designed for use on long track rails or for lateral mounting. The width  $A$  of reinforced bellows is greater than that of standard type bellows. If needed, please contact **IKO**.

Table 18.1 Dimensions of bellows and applicable models

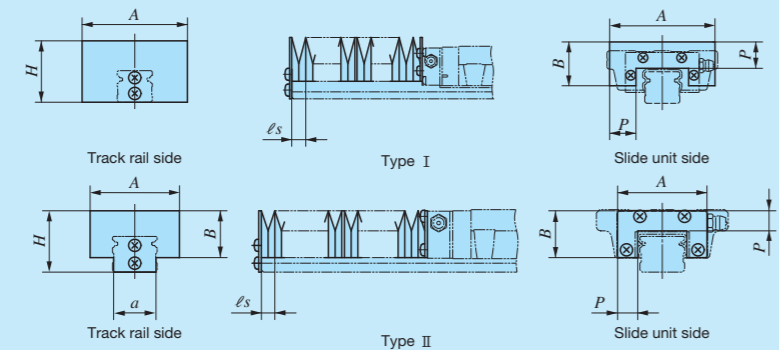

Series name	Size	Bellows model code	Type	H	A	a	B	P	$\ell_{s_{min}}$	$\ell_{s_{max}}$
C-Lube Linear Way ME Linear Way E	15	JEF 15	II	23.5	34	14	17	8	2	9
	20	JEF 20		27.5	40	19	21	9	2	10
	25	JEF 25		32	46	22	24	10	2	11
	30	JES 30		42	70	27	35	15	2	14
	35	JES 35		48	85	33	40	18	2	18.5
	45	JES 45		60	105	44	50	22	2	23.5
C-Lube Linear Way MH Linear Way H <sup>(1)</sup>	15	JHS 15	I	31 <sup>(2)</sup>	55	—	19.5	15	2	14
	20	JHS 20		35 <sup>(2)</sup>	60	—	25	15	2	14
	25	JHS 25		39 <sup>(2)</sup>	64	—	29.5	15	2	14
	30	JHS 30		42	70	—	35	15	2	14
	35	JHS 35		48	85	—	40	18	2	18.5
	45	JHS 45		60	105	—	50	22	2	23.5
	55	JHS 55		70	120	—	57	25	2	28
	65	JHS 65		90	158	—	76	35	2	42
Linear Way F	33	JFFS 33	II	26 <sup>(2)</sup>	66 <sup>(3)</sup>	—	23	15	2	15
	37	JFFS 37	II	27.5 <sup>(2)</sup>	70 <sup>(3)</sup>	—	24	15	2	15
	40	JFS 40	I	32 <sup>(2)</sup>	80	—	27	15	2	14
	42	JFFS 42	II	30.5 <sup>(2)</sup>	76 <sup>(3)</sup>	—	27.5	15	2	15
	60	JFS 60	I	36 <sup>(2)</sup>	100	—	30	15	2	14
	69	JFFS 69	II	36 <sup>(2)</sup>	106	—	31.5	15	2	15
90	JFS 90	I	50	150	—	43	22	2	23.5	

Notes (1) Not applicable to horizontal mounting type LWHY.  
 (2) The height of bellows may become higher than the height  $H$  of dimensions of assembly of slide units. Check  $H$  dimensions of each series in dimension table.  
 (3) The width of bellows may become larger than the  $W_2$  dimensions of slide units. Check with  $W_2$  dimensions of each series in dimension table.

Table 18.2 Dimensions of bellows and applicable models

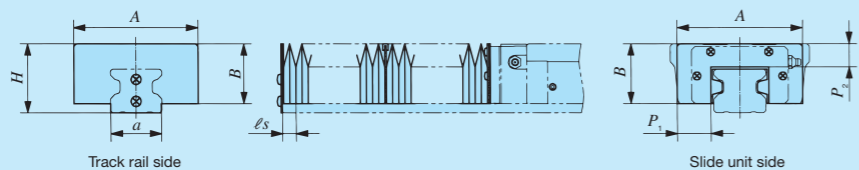

Series name	Size	Bellows model code	H	A	a	B	$P_1$	$P_2$	$\ell_{s_{min}}$	$\ell_{s_{max}}$
C-Lube Linear Roller Way Super MX Linear Roller Way Super X	15	JRES 15	34 <sup>(1)</sup>	55 <sup>(2)</sup>	14	30	17.5	15	2	15
	20	JRES 20	39 <sup>(1)</sup>	60 <sup>(2)</sup>	19	34	15	15	2	15
	25	JRES 25	42 <sup>(1)</sup>	65 <sup>(2)</sup>	22	36	16.5	15	2	15
	30	JRES 30	46 <sup>(1)</sup>	70 <sup>(2)</sup>	27	39.5	15	15	2	15
	35	JRES 35	48	88 <sup>(2)</sup>	33	41.5	24	15	2	15
	45	JRES 45	60	108 <sup>(2)</sup>	44	52	29	20	2	21
	55	JRES 55	70	122 <sup>(2)</sup>	52	61	31	22	2	23.5
	65	JRES 65	88	140 <sup>(2)</sup>	61	76	25	25	2	30
Linear Roller Way X	25	JRXS 25...B	40	60	22	34	15	12	2	10
	35	JRXS 35...B	48	88	34	41.5	24	15	2	14
	45	JRXS 45...B	60	108	44	52	29	20	2	21
	55	JRXS 55...B	70	122	54	61	31	22	2	23.5
	75	JRXS 75...B	90	160	74	80	40	30	2	36

Notes (1) The height of bellows may become higher than the height  $H$  of dimensions of assembly of slide units. Check  $H$  dimensions of each series in dimension table.  
 (2) The width of bellows may become larger than the  $W_2$  dimensions of slide units. Check  $W_2$  dimensions of each series in dimension table.

# Identification number and quantity for ordering

To order a set of Linear Way and Linear Roller Way, please specify the number of sets based on the number of track rails. For slide units of the interchangeable specification or single track rails, please specify the number of units.

## Non-interchangeable specification

Assembled set

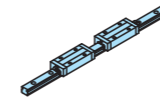

(When 1 set is needed)

Example of identification number indication  
**LWESG 25 C2 R640 SL T1 P /FU**

Order quantity

1 set

## Interchangeable specification

Single slide unit

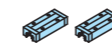

(When 2 pieces are needed)

Example of identification number indication  
**LWESG 25 C1 SL T1 P SO /U**

Order quantity

2 pieces

Only C1 is specified. Please specify S1 or S2.

Single track rail

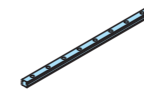

(When 1 unit is needed)

Example of identification number indication  
**LWE 25 R640 SL P SO /F**

Order quantity

1 unit

Please specify S1 or S2.

Assembled set

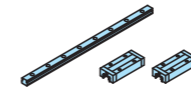

(When 1 set is needed)

Example of identification number indication  
**LWESG 25 C2 R640 SL T1 P SO /FU**

Order quantity

1 set

Please specify S1 or S2.

## Specification with 1 multiple assembled sets as 1 assembled group (Special specification /W)

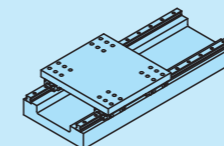

Linear Way and Linear Roller Way

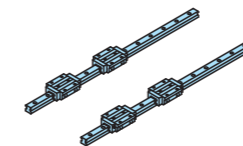

(When 2 sets as 1 assembled group is needed)

Example of identification number indication  
**LRX 45 C2 R1260 T3 SP /W2**

Order quantity

2 sets

Linear Way Module

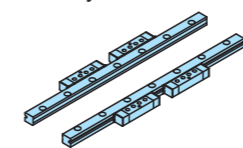

(When 2 sets as 1 assembled group is needed)

Example of identification number indication  
**LWM 2 M2 R480 P /W2**

Order quantity

2 set

# Special Specification

For Linear Way and Linear Roller Way, special specification described in pages III-29 through III-35 is available. There is limitation on applicable special specification. For details, see an explanation of each series.

## Butt-jointing track rails /A

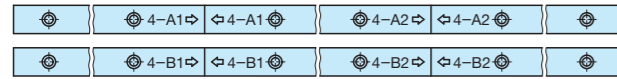

When the track rail of non-interchangeable specification is longer than the maximum length, two or more track rails should be butted in a linear motion direction. For length and number of track rails to butt, contact **IKO**.

## Stainless steel end plate /BS

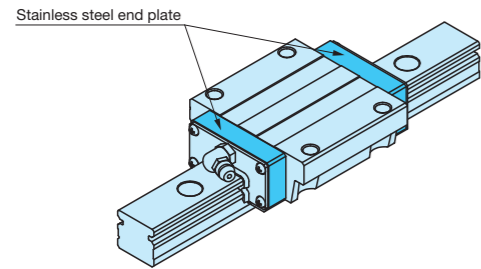

The standard synthetic resin end plates are replaced with stainless steel end plates. The total length of the slide unit remains unchanged. In addition, for improvement of heat resistance, it is recommended to use "No end seal (supplemental code /N)" together.

## Chamfered reference surface /C /CC

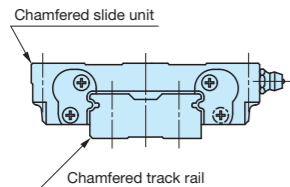

Add chamfer to the reference mounting surface of the slide unit and track rail.

- ① /C Add chamfer to the reference mounting surface of the track rail.
- ② /CC Add chamfer to the reference mounting surface of the slide unit and track rail.

## Opposite reference surfaces arrangement /D

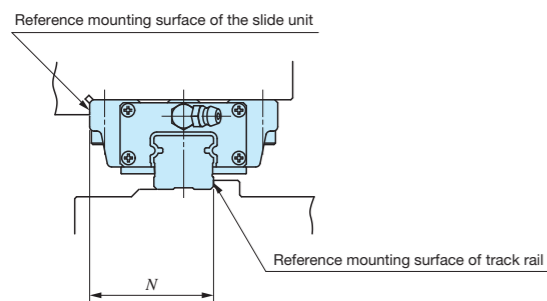

Reference mounting surface of the track rail should be the opposite of the standard position. Accuracy of  $N$  dimensions and parallelism during operation remain unchanged.

## Specified rail mounting hole positions /E

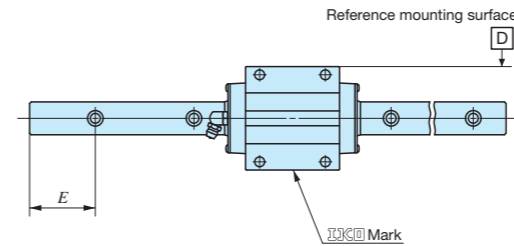

By specifying  $E$  dimensions from the mounting hole at the track rail left end to the left end surface when seen from **IKO** mark of the slide unit, specify the position of track rail mounting hole. Specify the dimensions (in mm) after "/E". In addition,  $E$  dimension range is limited. For details, please contact **IKO**. For Linear Way H horizontal mounting type and Linear Way Module series, see an explanation of each series.

## Caps for rail mounting holes /F

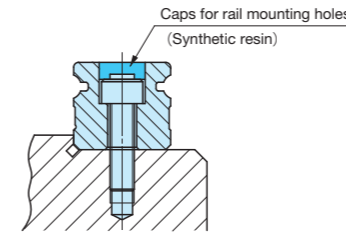

Dedicated caps for rail mounting holes are included. They close track rail mounting holes to improve sealing property in a motion direction. Contact **IKO** for aluminum alloy caps for rail mounting holes.

## Changed pitch of slide unit middle mounting holes /GE

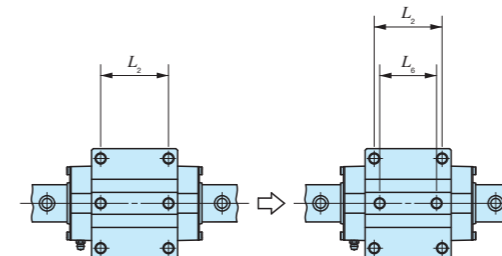

Change the dimension between mounting holes at the slide unit center.

## Hybrid C-Lube Linear Way /HB

Change the material of rolling elements built into the slide unit to silicon nitride ceramics.

## Half pitch mounting holes for track rail /HP

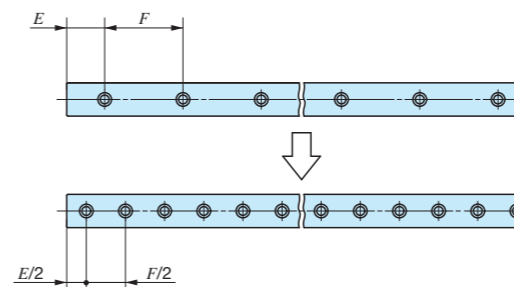

Set the pitch of track rail mounting holes to a half of the standard  $F$  dimension. The specification with bolts for track rail mounting holes are supplied with the required number of bolts.



**Inspection sheet / I**

Inspection sheet of *H* dimension, *N* dimension and parallelism during slide unit operation are appended in each set.

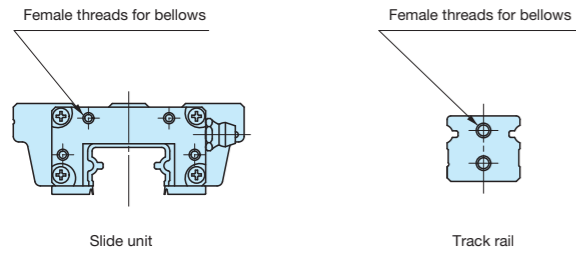
**Female threads for bellows (Single unit) /J /JR /JL**



For single slide unit or single track rail of the interchangeable specification, fit female threads for bellows.

- ① /J Fit female threads to both ends of the slide unit or track rail.
- ② /JR Fit female threads to a right end surface of the slide unit seen from  mark of the slide unit.
- ③ /JL Fit female threads to a left end surface of the slide unit seen from  mark of the slide unit.

**Female threads for bellows (Assembled set) /J /JJ /JR /JS /JJS**

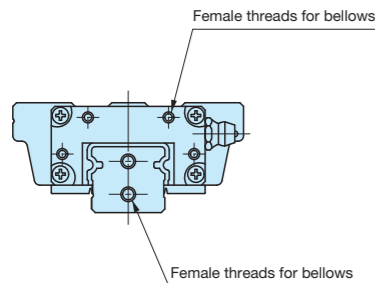

For assembled set of the interchangeable specification or a non-interchangeable specification product, fit female threads for bellows to the slide unit and track rail.

- ① /J Fit female threads to both ends of the track rail and to slide unit end nearest to both ends of the track rail. (When only one slide unit is used, fit them to both ends of the track rail)
- ② /JJ When two or more slide units are used, fit female threads to both ends of the track rail and to both ends of each slide unit. (When only one slide unit is used, specify "/J")
- ③ /JR Fit female threads to both ends of the track rail.
- ④ /JS Fit female threads to slide unit end nearest to both ends of the track rail. (When only one slide unit is used, they are fitted to both ends of the track rail)
- ⑤ /JJS When two or more slide units are used, fit female threads to both ends of each slide unit. (When only one slide unit is used, specify "/JS")

**Black chrome surface treatment /LC /LR /LCR**

Acrylate resin coating is applied to improve the rust prevention property after black impregnated chrome surface treatment.

- ① /LC Perform casing treatment.
- ② /LR Perform track rail treatment.
- ③ /LCR Perform casing and track rail treatment.

**Fluorine black chrome surface treatment /LFC /LFR /LFCR**

Fluorinated resin coating is applied to improve the rust prevention property after black impregnated chrome surface treatment. In addition, this prevent foreign substances from sticking to the surface.

- ① /LFC Perform casing treatment.
- ② /LFR Perform track rail treatment.
- ③ /LFCR Perform casing and track rail treatment.

**With track rail mounting bolt /MA**

Recommended track rail mounting bolt is included. For bolt size, see the dimension table.

**Without track rail mounting bolt /MN**

Track rail mounting bolt is not included.

**Changed size of mounting holes /M4**

Set the M3 track rail mounting hole for ME15 to M4. For combination with track rail mounting bolt (supplemental code "/MA"), specify "/MA4".

**No end seal /N**

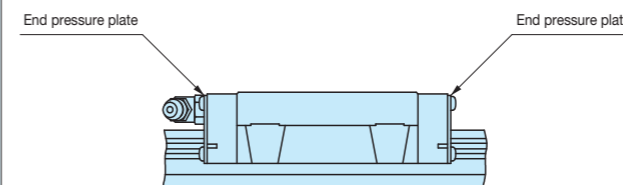

End seals at both ends of the slide unit can be replaced with end pressure plates, which do not come in contact with the track rail, to reduce frictional resistance. No under seal is attached. This specification is not effective for dust protection.

**Rail cover plate for track rail /PS**

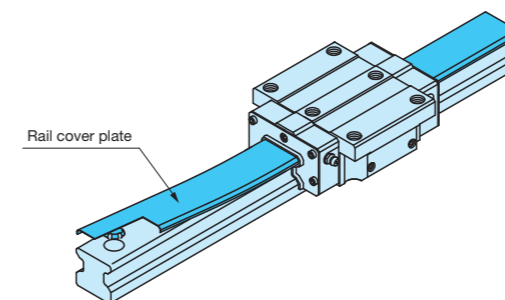

Deliver with the track rail cover plate mounted. Covering the upper surface with U-shape stainless steel thin plate after assembly of the track rail improves the sealing property further. Change the end seal to dedicated one. In addition, see the supplied rail cover plate instruction manual for mounting of rail cover plate.

**With C-Lube plate /Q**

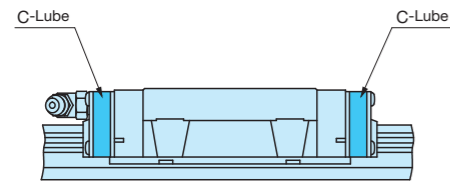

The C-Lube impregnated with lubricant is attached inside the end seal of the slide unit, so that the interval for reapplying lubricant can be extended.

**C-Wiper /RC /RCC**

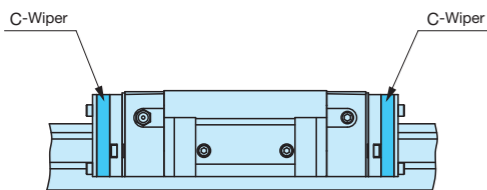

C-Wiper is mounted on the slide unit end to improve dust protection property. In addition, the slide unit with C-Wiper is equipped with inner seal (/UR) and scraper (/Z) together.

- ① /RC Fit C-Wiper to slide unit end nearest to both ends of the track rail. When only one slide unit is used, fit them to both ends of the track rail.
- ② /RCC When two or more slide units are used, fit C-Wiper to both ends of each slide unit.

**Special environment seal /RE**

The standard end seal and under seal are replaced with seals for special environment that can be used at high temperatures.

**Track rail with stopper pins /S**

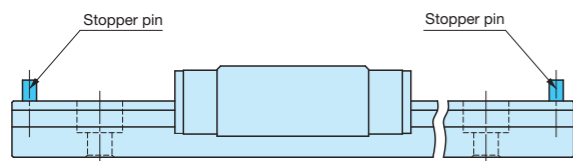

Mount stopper pins to both ends of the track rail as slide unit retainers.

**Butt-jointing track rails (Interchangeable specification) /T**

Finish the butted parts at both ends so as to set the interchangeable specification track rail in a linear motion direction. Butt the same interchangeable code for track rails. For non-interchangeable specification, specify butt-jointing track rails "/A".

**Under seal <sup>(1)</sup> /U**

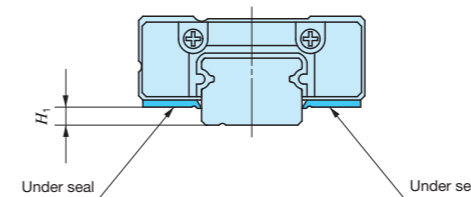

The seal is attached to the bottom of the slide unit to prevent foreign substances from entering from underneath.

Note <sup>(1)</sup> For C-Lube Linear Way UL and Linear Way U, attach "upper seal". The seal is attached to the upper end of the slide unit to prevent foreign substances from entering from above.

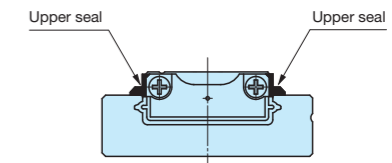

**Inner seal /UR**

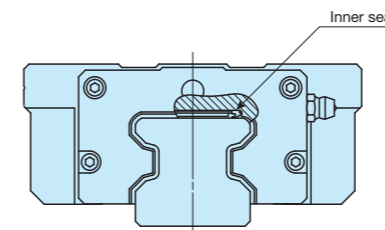

Attach the inner seal to the inside of the slide unit. Inner seal improves dust protection property of the cylindrical roller circulation part against foreign substances from the upper surface of the track rail.

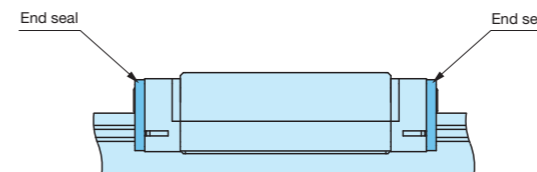

**End seal /US**



Attach end seals instead of scrapers on both sides of the slide unit in order to improve the dust protection performance.

**Double seals (Single unit) /V /VR /VL**

Double end seals are mounted to the interchangeable specification slide unit to improve the dust protection property.

- ① /V Apply double seals to both ends of the slide unit.
- ② /VR Apply double seals to a right end surface of the slide unit seen from the  mark of the slide unit.
- ③ /VL Apply double seals to a left end surface of the slide unit seen from the  mark of the slide unit.

**Double seals (Assembled set) /N /NV**

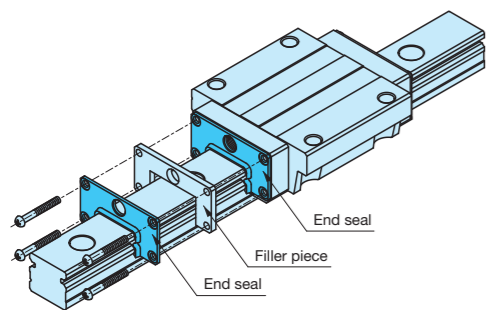

Double end seals are mounted to the interchangeable specification assembled set or non-interchangeable specification product's slide unit to improve the dust protection property.

- ① /N Apply double seals to slide unit end nearest to both ends of the track rail. When only one slide unit is used, fit them to both ends of the track rail.
- ② /NV When two or more slide units are used, apply double seals to both ends of each slide unit.

**A group of multiple assembled sets /W**

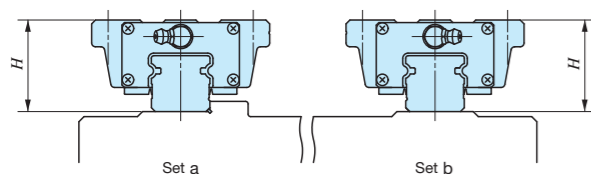

Set the variation of *H* dimensions of the Linear Way and Linear Roller Way of multiple assembled sets on the same flat surface in the standard range. The variation of *H* dimensions of the multiple assembled sets is the same as the accuracy of one set. Indicate the number of sets after "/W" based on the number of units when specify.



**Specified grease /YCG /YCL /YAF /YBR /YNG**

The type of pre-packed grease can be changed by the supplemental code.

- ① /YCG Low Dust-Generation Grease for Clean Environment CG2 is pre-packed.
- ② /YCL Low Dust-Generation Grease for Clean Environment CGL is pre-packed.
- ③ /YAF Anti-Fretting Corrosion Grease AF2 is pre-packed.
- ④ /YBR MOLYCOTE BR2- Plus Grease [Dow Corning] is pre-packed.
- ⑤ /YNG No grease is pre-packed.

**Scraper (Single unit) /Z /ZR /ZL**

Mount a metal scraper to the interchangeable specification slide unit. The scraper is non-contact type and effectively eliminate large foreign substances adhering to the track rail.

- ① /Z Mount scrapers to both ends of the slide unit.
- ② /ZR Fit a scraper to a right end surface of the slide unit seen from  mark of the slide unit.
- ③ /ZL Fit a scraper to a left end surface of the slide unit seen from  mark of the slide unit.

**Scraper (Assembled set) /Z /ZZ**

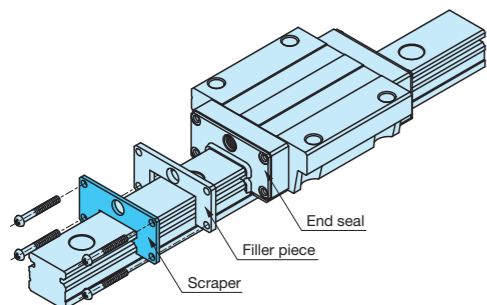

Mount a metal scraper to the interchangeable specification assembled set or non-interchangeable specification product's slide unit. The scraper is non-contact type and effectively eliminate large foreign substances adhering to the track rail.

- ① /Z Fit a scraper to slide unit end nearest to both ends of the track rail. When only one slide unit is used, fit them to both ends of the track rail.
- ② /ZZ When two or more slide units are used, fit scrapers to both ends of each slide unit.

**Precaution for Use**

**Operating temperature**

The maximum operating temperature for linear motion rolling guide with integrated C-Lube is 80°C. The maximum operating temperature for linear motion rolling guide without integrated C-Lube is 120°C and temperature up to 100°C is allowed for continuous operation. When the temperature exceeds 100°C, contact **IKO**. When specifying special specification with C-Lube plate (supplemental code "/Q"), utilize it below 80°C.

**Multiple slide units used in close proximity**

When using multiple slide units in close proximity, greater load may be applied than the calculated value depending on the deviation of slide unit mounting accuracy for the machine or device. In such cases, allowance for greater applied load than the calculated value should be made.

**Lateral or upside-down mounting**

For lateral or upside-down mounting of the Linear Way E and Linear Way F, specify the special specification (supplemental code "/U") with under seal as necessary to prevent foreign substances from entering into the slide unit.

**Operation velocity**

Operation velocity limit value of the Linear Way and Linear Roller Way depends on operation conditions such as motion characteristics, applied load, lubrication status, mounting accuracy and environment temperature. Reference values based on actual performance and experienced values as a reference of maximum velocity under typical operating conditions are indicated in Table 19.

Table 19 Reference maximum velocity

Size	Maximum velocity m/min
35	180
45	120
55	100
65	75

**Cleaning and removing fat**

Never clean up a linear motion rolling guide with integrated C-Lube with organic solvent or white kerosene with property of removing fat.

**Lubrication oil supply point for oil lubrication**

If the lubrication oil is supplied by a gravity drip system, enough lubrication oil may not be supplied to ways above the supply point, so lubrication path and supply point must be considered. For such applications, contact **IKO**.

**Precaution for Mounting**

**When mounting multiple assembled sets at the same time**

- Interchangeable specification products For interchangeable specification products, assemble a slide unit and a track rail with the same interchangeable code ("S1" or "S2").
- Non-interchangeable specification products Do not change the combination of delivered slide unit and track rail.
- Product including multiple assembled sets For special specification (supplemental code "/W") products with multiple assembled sets, the delivered combination is managed as a group for variation. So do not mix with different group for mounting.

**Assembling of slide unit and track rail**

When assembling the slide unit on the track rail, correctly fit the grooves of the slide unit and the track rail and move the slide unit softly in parallel direction. Rough handling may result in damaging of seals or dropping of steel balls and cylindrical roller. For product including a dummy rail as a standard accessory, operation of the slide unit to the track rail can be made easier by using the dummy rail. Though the dummy rail is included as an accessory of products indicated in Table 21.1 and Table 21.2, it is also available for other products. If these parts are necessary, please contact **IKO**.

**Mounting accuracy**

Deviation of accuracy of Linear Way and Linear Roller Way mounting surface or deviation of accuracy in mounting may generate large load over the calculated value. Note that such load could affect the life adversely. It enhances the reliability of Linear Way and Linear Roller Way to ensure high machining accuracy and assembly accuracy depending on operational conditions of the track rail and slide unit such as required motion accuracy and rigidity and to consider mounting structure that can maintain the accuracy and performance. Typical reference values for mounting parallelism between multiple assembled sets used are shown in Table 20.

Table 20 Parallelism between two mounting surfaces unit: μm

Classification	Ordinary (No symbol)	High (H)	Precision (P)	Super precision (SP)	Ultra precision (UP)
Parallelism	30	20	10	6	

**Shoulder height and corner radius of the reference mounting surface**

For the shape of opposite corner of the reference surface, it is recommended to have relieved fillet as indicated in Fig. 8, but you may also use it with providing radius at the corner. For recommended values for the shoulder height and corner radius of the reference mounting surface, see an explanation of each series.

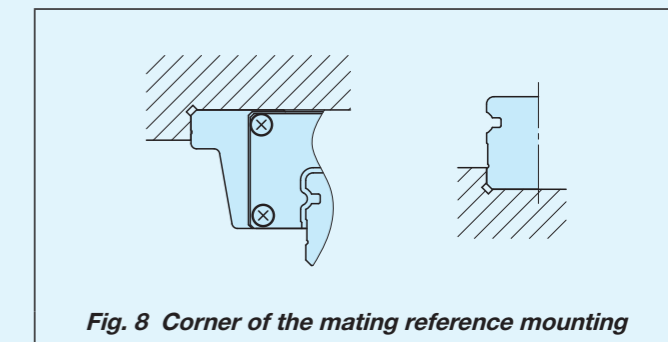

## Precaution for Mounting

Table 21.1 Products appended with dummy rail

Series name and size	Interchangeable		Non-interchangeable specification Assembled set
	Single unit	Assembled set	
C-Lube Linear Way ML Linear Way L	○	See Table 21.2	See Table 21.2
C-Lube Linear Way MLV	—	—	—
C-Lube Linear Way MV	—	—	—
C-Lube Linear Way ME Linear Way E	○	—	—
C-Lube Linear Way MH Linear Way H	8~12	○	○
	15~65	○	—
	Extra long	○	○
Linear Way F	○	—	—
C-Lube Linear Way MUL Linear Way U	25, 30	—	○
	40~130	—	—
C-Lube Linear Roller Way Super MX Linear Roller Way Super X	10~30	○	○
	35~65	○	—
	Extra long	○	○
85, 100	—	—	—
Linear Roller Way X	—	—	—

○: Appended

Table 21.2 Appended dummy rail model number for C-Lube Linear Way ML, C-Lube Linear Way MLV and Linear Way L

C-Lube Linear Way ML		C-Lube Linear Way MLV	Linear Way L	
Standard type	Wide type	Standard type	Standard type	Wide type
—	—	—	LWL 2	LWLF 4
MLC 3	MLFC 6	—	LWLC 3	LWLFC 6
ML 3	MLF 6	—	LWL 3	LWLF 6
MLC 5	MLFC 10	—	LWLC 5··B	LWLFC 10··B
ML 5	MLF 10	—	LWL 5··B	LWLF 10··B
MLC 7	MLFC 14	MLV 7	LWLC 7··B	LWLFC 14··B
ML 7	MLF 14	—	LWL 7··B	LWLF 14··B
MLG 7	MLFG 14	—	LWLG 7··B	LWLFG 14··B
MLC 9	MLFC 18	MLV 9	LWLC 9··B	LWLFC 18··B
ML 9	MLF 18	—	LWL 9··B	LWLF 18··B
MLG 9	MLFG 18	—	LWLG 9··B	LWLFG 18··B
MLL 9	—	—	LWLG 12··B	LWLFG 24··B
MLG 12	MLFG 24	—	LWLG 15··B	LWLFG 30··B
MLL 12	—	—	LWLG 20··B	LWLFG 42··B
MLG 15	MLFG 30	—	LWLG 25··B	—
MLL 15	—	—	—	—
MLG 20	MLFG 42	—	—	—
MLG 25	—	—	—	—

## Cleanup of mounting surface

Remove burrs and blemishes by using oil-stone, etc. and wipe off rust prevention oil and dust with clean cloth from mounting surface and reference mounting surface of the machine or device to which the Linear Way or Linear Roller Way are mounted.

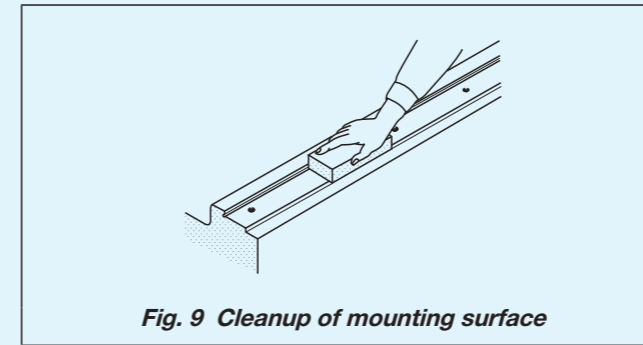

Fig. 9 Cleanup of mounting surface

## Mounting of caps for rail mounting holes

When mounting the special specification caps for rail mounting holes (supplemental code "/F") on the track rail, use a flat applicator and stamp it by bits until it becomes plane with the track rail upper surface.

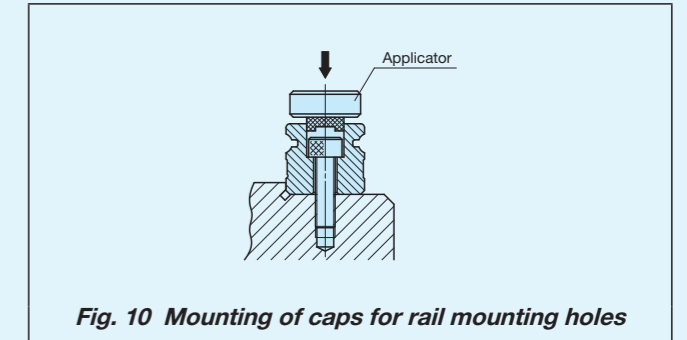

Fig. 10 Mounting of caps for rail mounting holes

## Tightening torque for fixing screw

Typical fixing screw tightening torque to mount the Linear Way and Linear Roller Way is indicated in Table 22. When vibration and shock of the machine or device are large, fluctuating load is large, or moment load is applied, fix it by using the torque 1.2 to 1.5 times larger than the value indicated as necessary.

If the mating member material is cast iron or aluminum alloy, reduce the tightening torque depending on the strength characteristics of the mating member material.

For details, see an explanation of each series.

Though the track rail mounting bolts are appended as an accessory of products indicated in Table 23, it is also available for other products. If these parts are necessary, please contact **IKO**.

Table 22 Tightening torque for fixing screw

Bolt size	Tightening torque N · m			
	High carbon steel-made screw (Strength division 8.8)	High carbon steel-made screw (Strength division 10.9)	High carbon steel-made screw (Strength division 12.9)	Stainless steel-made screw (Property division A2-70)
M 1 ×0.25	—	—	—	0.04
M 1.4×0.3	—	—	—	0.10
M 1.6×0.35	—	—	—	0.15
M 2 ×0.4	—	—	—	0.31
M 2.3×0.4	—	—	—	0.49
M 2.5×0.45	—	—	—	0.62
M 2.6×0.45	—	—	—	0.70
M 3 ×0.5	1.3	—	1.8	1.1
M 4 ×0.7	2.9	—	4.1	2.5
M 5 ×0.8	5.7	—	8.0	5.0
M 6 ×1	—	—	13.6	8.5
M 8 ×1.25	—	—	32.7	20.4
M10 ×1.5	—	—	63.9	—
M12 ×1.75	—	—	110	—
M14 ×2	—	—	175	—
M16 ×2	—	—	268	—
M20 ×2.5	—	—	522	—
M24 ×3	—	749	—	—
M30 ×3.5	—	1 490	—	—

1N=0.102kgf=0.2248lbs.  
1mm=0.03937inch

Table 23 Specifications of appended track rail mounting bolts

Series	Specifications of appended bolts				
	Size	Material type	Type	Material	Class
C-Lube Linear Way ML Standard type <sup>(1)</sup>	1~ 3 <sup>(2)</sup>	Stainless steel made	JCIS 10-70 Cross-recessed pan head screw for precision equipment	Stainless steel made	—
Linear Way L Standard type <sup>(1)</sup>	5	Stainless steel made	JCIS 10-70 Cross-recessed pan head screw for precision equipment	Stainless steel made	—
	7~ 25	Stainless steel made	JIS B 1176 Hexagon socket head bolt	Stainless steel made	Property division A2-70
	9~ 20	High carbon steel made	JIS B 1176 Hexagon socket head bolt	High carbon steel made	Strength division 8.8
C-Lube Linear Way ML Wide type <sup>(1)</sup>	4~ 10	Stainless steel made	JCIS 10-70 Cross-recessed pan head screw for precision equipment	Stainless steel made	—
Linear Way L Wide type <sup>(1)</sup>	14~ 42	Stainless steel made	JIS B 1176 Hexagon socket head bolt	Stainless steel made	Property division A2-70
	18~ 42	High carbon steel made	JIS B 1176 Hexagon socket head bolt	High carbon steel made	Strength division 8.8
C-Lube Linear Way MLV		Stainless steel made	JIS B 1176 Hexagon socket head bolt	Stainless steel made	Property division A2-70
C-Lube Linear Way MV <sup>(3)</sup>		High carbon steel made	JIS B 1176 Hexagon socket head bolt	High carbon steel made	Strength division 12.9
C-Lube Linear Way ME <sup>(3)</sup>		Stainless steel made	JIS B 1176 Hexagon socket head bolt	Stainless steel made	Property division A2-70
		High carbon steel made	JIS B 1176 Hexagon socket head bolt	High carbon steel made	Strength division 12.9
Linear Way E <sup>(3)</sup>	8~ 30	Stainless steel made	JIS B 1176 Hexagon socket head bolt	Stainless steel made	Property division A2-70
	12	High carbon steel made	JIS B 1176 Hexagon socket head bolt	High carbon steel made	Strength division 8.8
	15~ 65	High carbon steel made	JIS B 1176 Hexagon socket head bolt	High carbon steel made	Strength division 12.9
C-Lube Linear Way MH <sup>(4)</sup>		Stainless steel made	JIS B 1176 Hexagon socket head bolt	Stainless steel made	Property division A2-70
		High carbon steel made	JIS B 1176 Hexagon socket head bolt	High carbon steel made	Strength division 12.9
Linear Way H <sup>(5)</sup>		Stainless steel made	JIS B 1176 Hexagon socket head bolt	Stainless steel made	Property division A2-70
		High carbon steel made	JIS B 1176 Hexagon socket head bolt	High carbon steel made	Strength division 12.9
Linear Way F		Stainless steel made	JIS B 1176 Hexagon socket head bolt	Stainless steel made	Property division A2-70
		High carbon steel made	JIS B 1176 Hexagon socket head bolt	High carbon steel made	Strength division 12.9
C-Lube Linear Way MUL <sup>(3)</sup>	25	Stainless steel made	JCIS 10-70 Cross-recessed pan head screw for precision equipment	Stainless steel made	—
	30	Stainless steel made	JIS B 1176 Hexagon socket head bolt	Stainless steel made	Property division A2-70
Linear Way U	25	Stainless steel made	JCIS 10-70 Cross-recessed pan head screw for precision equipment	Stainless steel made	—
	30	Stainless steel made	JIS B 1176 Hexagon socket head bolt	Stainless steel made	Property division A2-70
	40~130 <sup>(2)</sup>	High carbon steel made	JIS B 1176 Hexagon socket head bolt	High carbon steel made	Strength division 12.9
C-Lube Linear Roller Way Super MX <sup>(4)</sup>	10~ 65	Stainless steel made	JIS B 1176 Hexagon socket head bolt	Stainless steel made	Property division A2-70
		High carbon steel made	JIS B 1176 Hexagon socket head bolt	High carbon steel made	Strength division 12.9
	85~100	High carbon steel made	JIS B 1176 Hexagon socket head bolt	High carbon steel made	Strength division 10.9
Linear Roller Way X	25~ 55	High carbon steel made	JIS B 1176 Hexagon socket head bolt	High carbon steel made	Strength division 12.9
	75	High carbon steel made	JIS B 1176 Hexagon socket head bolt	High carbon steel made	Strength division 10.9
Linear Way LM <sup>(6)</sup>		Stainless steel made	JIS B 1176 Hexagon socket head bolt	Stainless steel made	Property division A2-70
Linear Way M <sup>(7)</sup>		High carbon steel made	JIS B 1176 Hexagon socket head bolt	High carbon steel made	Strength division 12.9
Linear Roller Way M <sup>(7)</sup>		High carbon steel made	JIS B 1176 Hexagon socket head bolt	High carbon steel made	Strength division 12.9

Notes (1) The bolts are not appended for tapped rail specification.

(2) The bolts are not appended. Specifications in the table are the ones prepared by **IKO**.

(3) The bolts are not appended. Specifications in the table are the ones when special specification "/MA" (with track rail mounting bolts) is specified.

(4) The bolts are not appended in an assembled set. Specifications in the table are the ones when special specification "/MA" (with track rail mounting bolts) is specified.

(5) The bolts are not appended in LWH...MU.

(6) Slide member mounting bolts are not appended.

(7) Slide member mounting bolts are also appended.

### Mounting surface, reference mounting surface and typical mounting structure

When mounting Linear Way and Linear Roller Way, properly align the reference mounting surface B and D of the track rail and slide unit with the reference mounting surface of the table and bed and fix them. (See Fig. 11)

The reference mounting surfaces B and D and mounting surfaces A and C are precisely ground. Machining the mounting surface of the table and bed, such as machine or device, to high accuracy and mounting them properly will ensure stable linear motion with high accuracy.

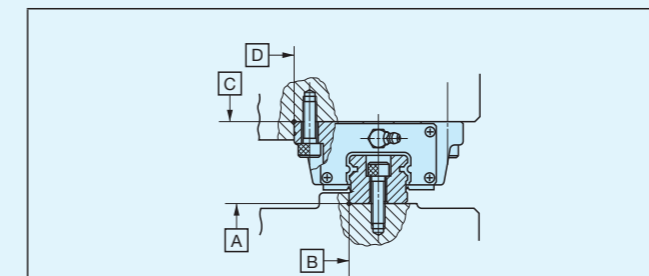

Fig. 11 Reference mounting surface and typical mounting structure of Linear Way and Linear Roller Way

Reference mounting surface of the slide unit is the opposite side of the **IKO** mark. The track rail reference mounting surface is identified by locating the **IKO** mark on the top surface of the track rail. It is the side surface above the mark (in the direction of the arrow). (See Fig. 12.)

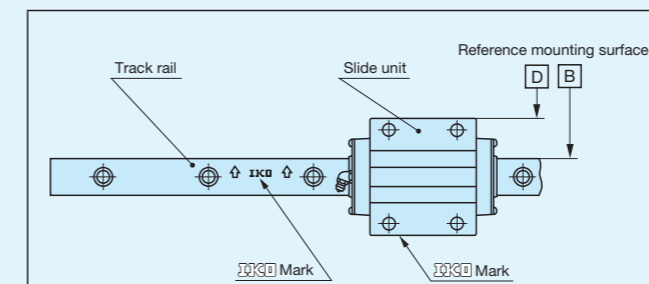

Fig. 12 Position of reference mounting surface of Linear Way and Linear Roller Way (Representative example)

### Load direction and mounting structure

When lateral load, alternate load, or fluctuating load is applied onto the Linear Way or Linear Roller Way, securely fix the ends of slide unit and track rail as indicated in the Fig. 13 and Fig. 14.

When the load is small or operational conditions are not harsh, mounting methods indicated in Fig. 15 and Fig. 16 may be used.

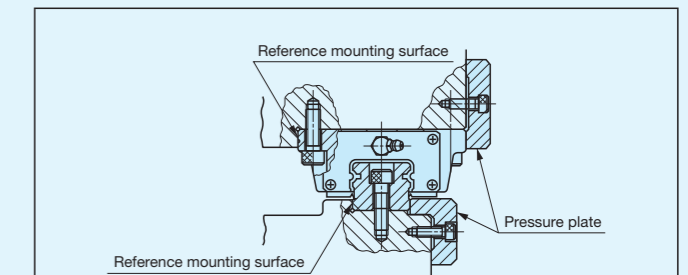

Fig. 13 Mounting example with pressure plate

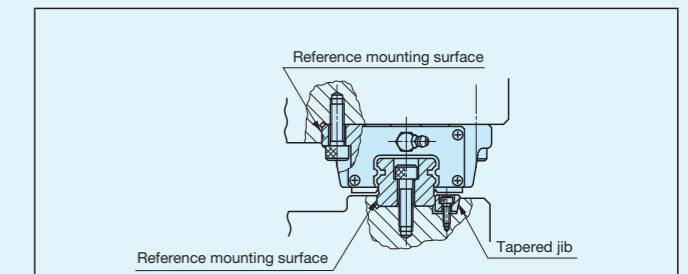

Fig. 14 Mounting example with tapered jib

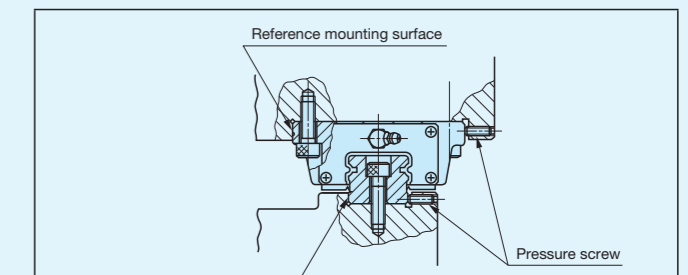

Fig. 15 Mounting example with pressure screw

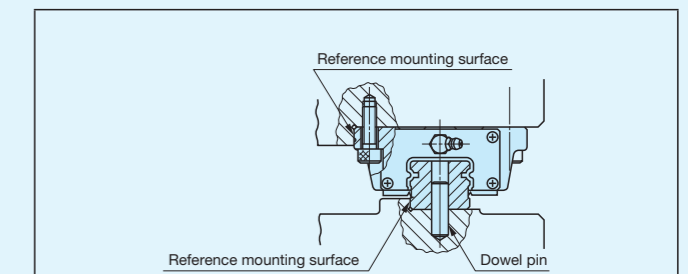

Fig. 16 Mounting example with dowel pin



# Mounting Examples

Typical procedures to mount Linear Way and Linear Roller Way are described in Examples 1 to 4 using a Linear Way as a representative case.

## Example 1. Typical operation

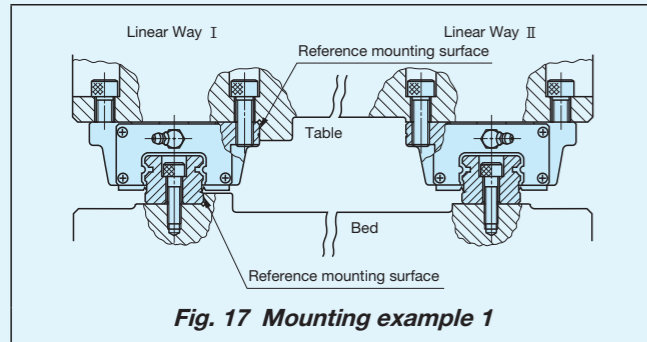

Fig. 17 Mounting example 1

For typical application without shock, reference mounting surface is prepared on each bed and table on the reference side. The mounting procedures are as follows. (See Fig. 17)

### 1 Cleanup of mounting surface and reference mounting surface

- Remove burrs and blemishes by using oil-stone, etc. from reference mounting surface and mounting surface of the machine or the device to which Linear Way is mounted and wipe off with clean cloth. (see Fig. 18)
- Wipe off rust prevention oil and dust on the reference mounting surface and the mounting surface of the Linear Way with clean cloth.

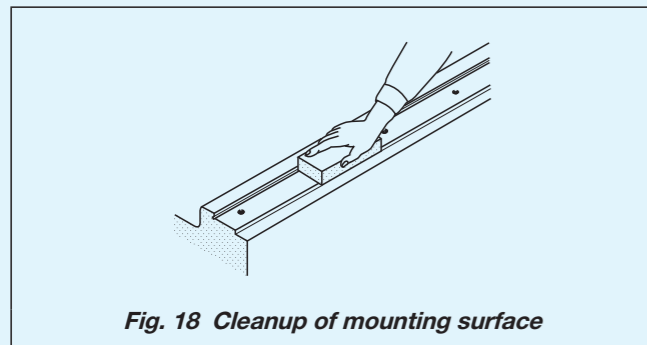

Fig. 18 Cleanup of mounting surface

### 2 Temporary fixing of Linear Way I and II track rails

- Align and temporarily fix them with reference mounting surface of each Linear Way track rail. (See Fig. 19)
- At this point, ensure that the fixing bolt does not interfere with the mounting hole.
- Fix the Linear Way II track rail to the bed.

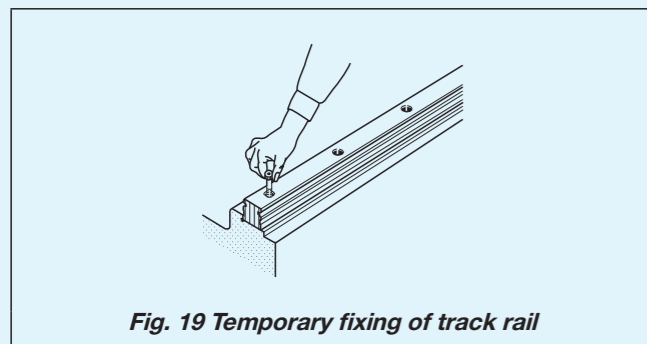

Fig. 19 Temporary fixing of track rail

### 3 Fixing of Linear Way I track rail

- Use small type vise or the like to stick track rail reference mounting surface to the reference mounting surface of the bed and tighten the fixing bolt at the same position. Repeat this method from one end to fix the track rail in order. (See Fig. 20)
- Linear Way II track rail should be left temporarily fixed.

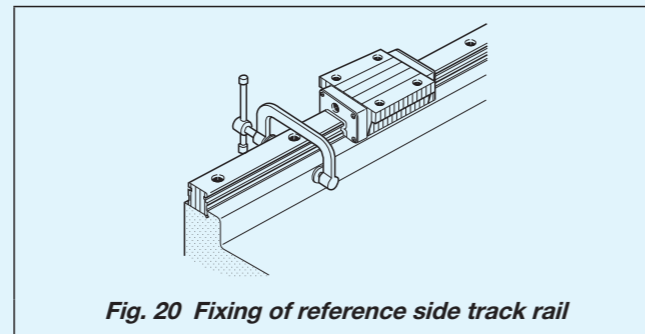

Fig. 20 Fixing of reference side track rail

### 4 Temporary fixing of Linear Way I and II slide units

- Align the Linear Way with the mounting position of the table and load the table gently.
- Temporarily fix the Linear Way I and II slide units to the table.

### 5 Fixing of Linear Way I slide unit

- Align the reference mounting surface of the Linear Way I slide unit with the reference mounting surface of the table correctly and fix them.

### 6 Fixing of Linear Way II slide unit

- Fix one of the Linear Way II slide units in a motion direction correctly and leave the other slide units temporarily fixed. (See Fig. 21)

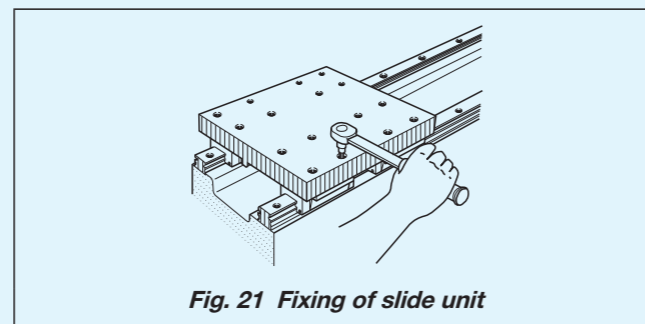

Fig. 21 Fixing of slide unit

### 7 Fixing of Linear Way II track rail

- Move the table and fix the Linear Way II track rail ensuring smooth motion status. At this point, tighten each fixing bolt immediately after the fixed slide unit of the Linear Way II passes on each of it. Repeat this method from one end to fix the track rail in order. (See Fig. 22)

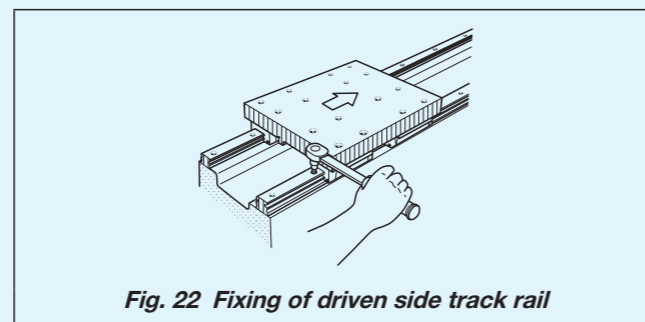

Fig. 22 Fixing of driven side track rail

### 8 Fixing of Linear Way II slide unit

- Fix the rest of the Linear Way II slide units.

## Example 2. Operation for linear motion with accuracy and rigidity

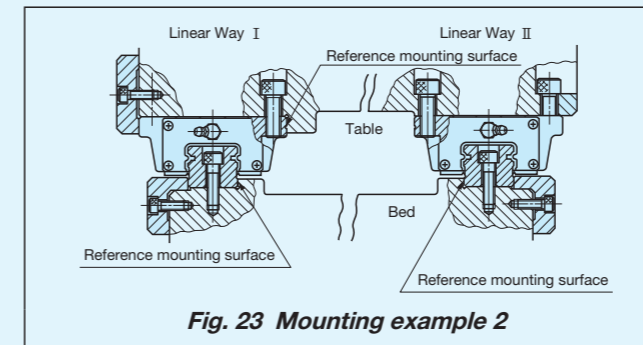

Fig. 23 Mounting example 2

If accuracy and rigidity of linear motion are required, prepare two reference mounting surfaces on the bed and one reference mounting surface on the table. The mounting procedures are as follows. (See Fig. 23)

### 1 Cleanup of mounting surface and reference mounting surface

- Remove burrs and blemishes by using oil-stone, etc. from reference mounting surface and mounting surface of the machine or the device to which Linear Way is mounted and wipe off with clean cloth. (see Fig. 24)
- Wipe off rust prevention oil and dust on the reference mounting surface and the mounting surface of the Linear Way with clean cloth.

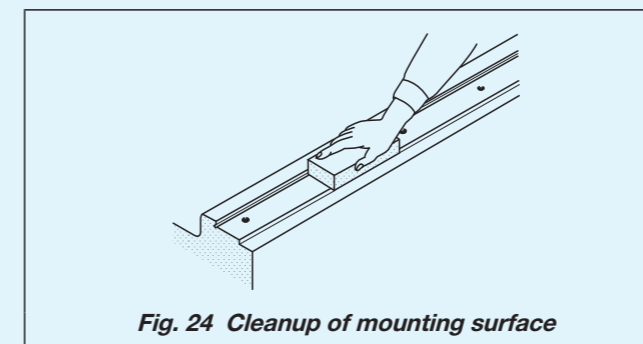

Fig. 24 Cleanup of mounting surface

### 2 Temporary fixing of Linear Way I and II track rails

- Align and temporarily fix them with reference mounting surface of each Linear Way track rail. (See Fig. 25)
- At this point, ensure that the fixing bolt does not interfere with the mounting hole.

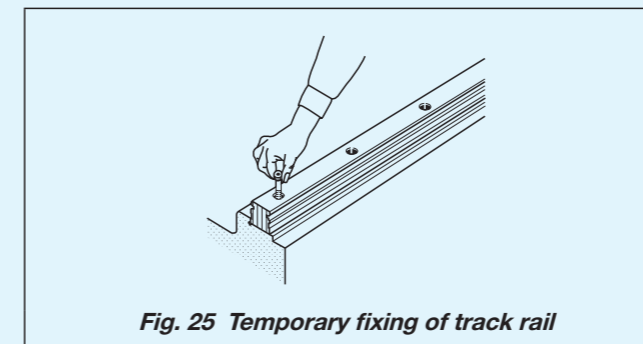

Fig. 25 Temporary fixing of track rail

### 3 Fixing of Linear Way I and II track rails

- Stick the track rail reference mounting surface of the Linear Way I to the reference mounting surface of the bed with pressure plate or pressure screws and tighten the track rail fixing bolt at the same position. Repeat this method from one end to fix the track rail in order. (See Fig. 26)

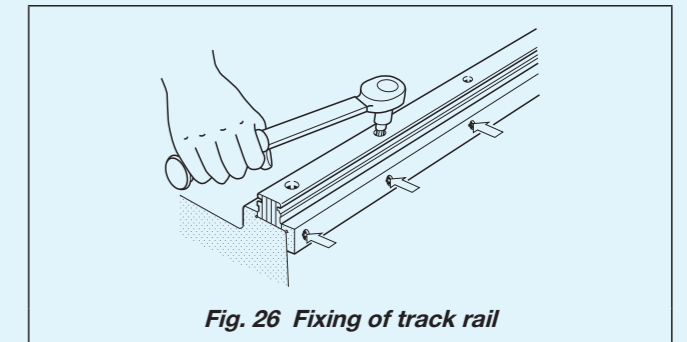

Fig. 26 Fixing of track rail

### 4 Temporary fixing of Linear Way I and II slide units

- Align the slide unit with the mounting position of the table and load the table gently. Temporarily fix the Linear Way I and II slide units to the table.

### 5 Fixing of Linear Way I slide unit

- Align the reference mounting surface of the Linear Way I slide unit with the reference mounting surface of the table correctly and fix them with pressure plate or pressure screws.

### 6 Fixing of Linear Way II slide unit

- Move the table ensuring smooth motion status, and fix the Linear Way II slide unit. (See Fig. 27)

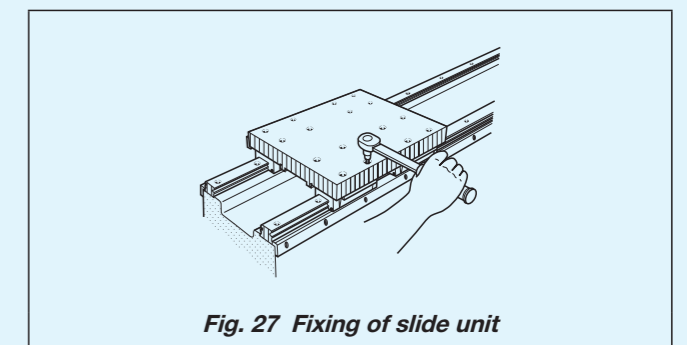
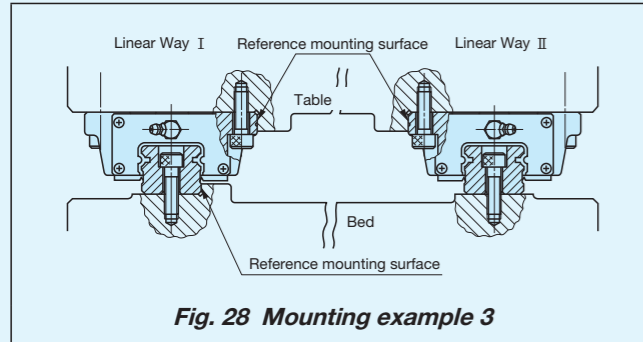

Fig. 27 Fixing of slide unit

### Example 3 Operation in case the slide unit is fixed separated from the track rail



If it cannot be fixed securely with the table loaded, prepare one reference mounting surface on the bed and two reference mounting surfaces on the table. The mounting procedures are as follows. (See Fig. 28)

#### 1 Cleanup of mounting surface and reference mounting surface

- Remove burrs and blemishes by using oil-stone, etc. from reference mounting surface and mounting surface of the machine or the device to which Linear Way is mounted and wipe off with clean cloth. (see Fig. 29)
- Wipe off rust prevention oil and dust on the reference mounting surface and the mounting surface of the Linear Way with clean cloth.

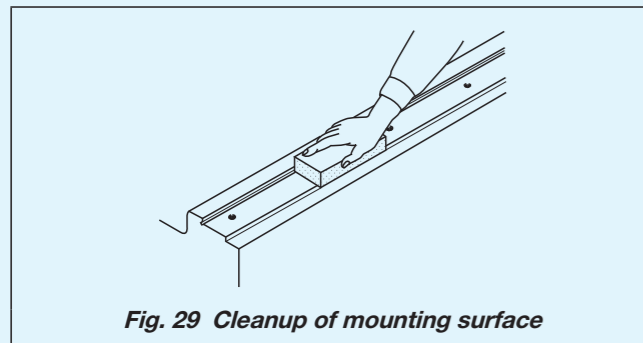

#### 2 Temporary fixing of Linear Way I and II track rails

- Align and temporarily fix them with reference mounting surface of each Linear Way track rail. (See Fig. 30)
- At this point, ensure that the fixing bolt does not interfere with the mounting hole.

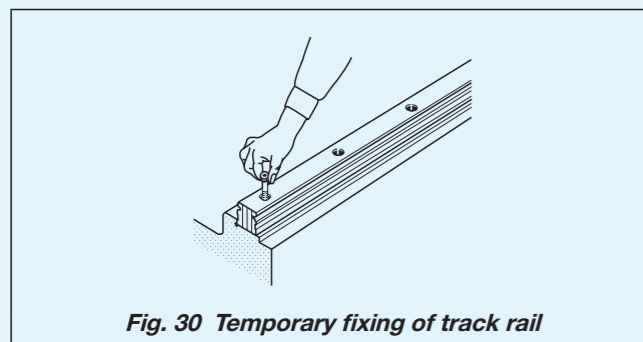

#### 3 Fixing of Linear Way I track rail

- Use small type vise or the like to stick track rail reference mounting surface to the reference mounting surface of the bed and tighten the fixing bolt at the same position. Repeat this method from one end to fix the track rail in order. (See Fig. 31)
- Linear Way II track rail should be left temporarily fixed.

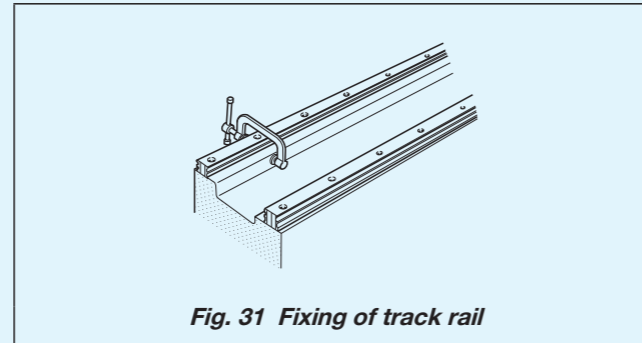

#### 4 Separation of track rail and slide unit

- After checking the combination and positions of Linear Way I and II track rails and slide units, separate each slide unit from the track rail.

#### 5 Fixing of Linear Way I and II slide units

- Align with the reference mounting surface of the Linear Way I and II slide units correctly, and fix them. (See Fig. 32)

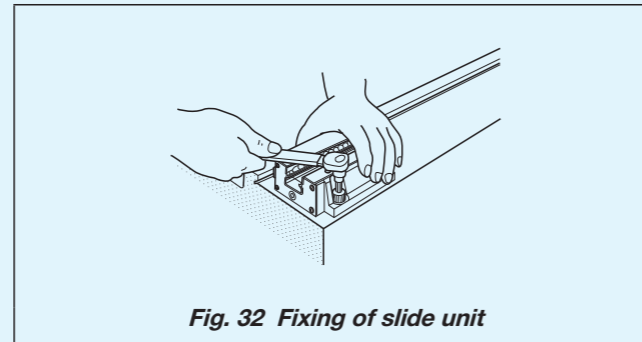

#### 6 Setting of track rail and slide unit

- Insert and assemble the slide unit fixed to the table slowly with care while aligning it with the track rail fixed and temporarily fixed to the bed to maintain parallelism.

#### 7 Fixing of Linear Way II track rail

- Move the table and fix the Linear Way II track rail ensuring smooth motion status. At this point, tighten each fixing bolt immediately after the fixed slide unit of the Linear Way II passes on each of it. Repeat this method from one end to fix the track rail in order.

### Example 4. Operation of Linear Way Module

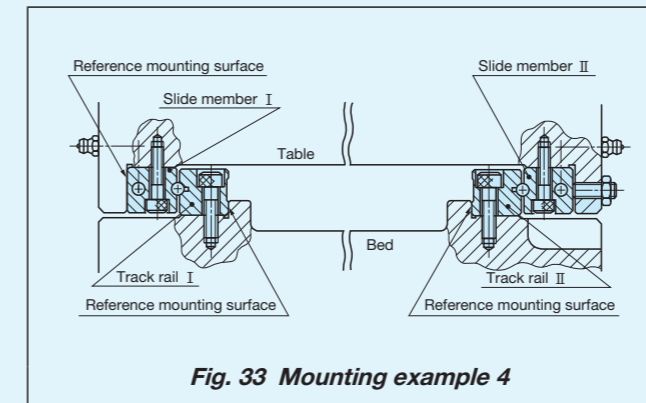

For the Linear Way Module, normally 2 sets are used in parallel as indicated in Fig. 33. For the mounting, typically follow the procedure below (see Fig. 33).

#### 1 Cleanup of mounting surface and reference mounting surface

- Remove burrs and blemishes by using oil-stone, etc. from reference mounting surface and mounting surface of the machine or the device to which Linear Way Module is mounted and wipe off with clean cloth (see Fig. 34).
- Wipe off rust prevention oil and dust on the reference mounting surface and the mounting surface of the Linear Way Module with clean cloth.

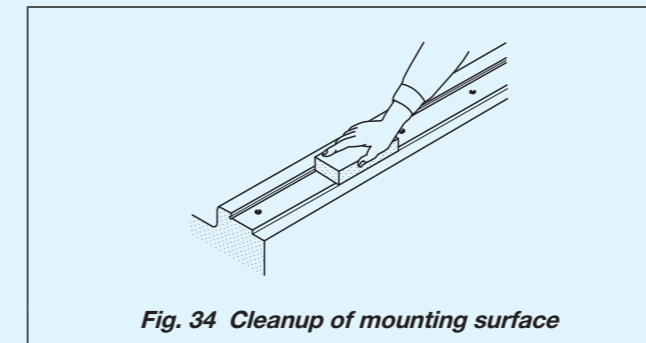

#### 2 Fixing of track rail

- Align the reference mounting surfaces of track rails I and II with the reference mounting surfaces of the bed correctly, stick them by using small type vise, and tighten the fixing bolts at the same position (see Fig. 35).

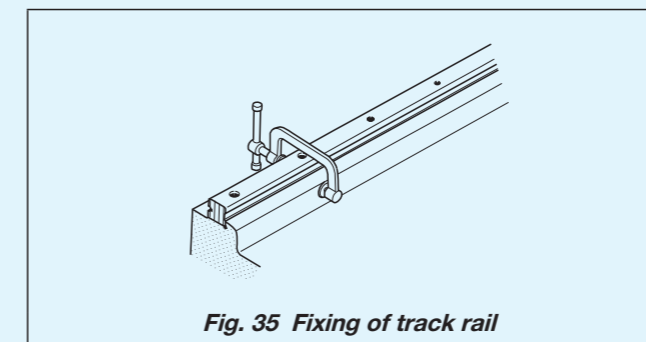

#### 3 Fixing the slide member

- Align the reference mounting surface of the slide member I with the reference mounting surface of the table correctly, tighten the fixing bolt to fix them, and temporarily fix the slide member II (see Fig. 36).

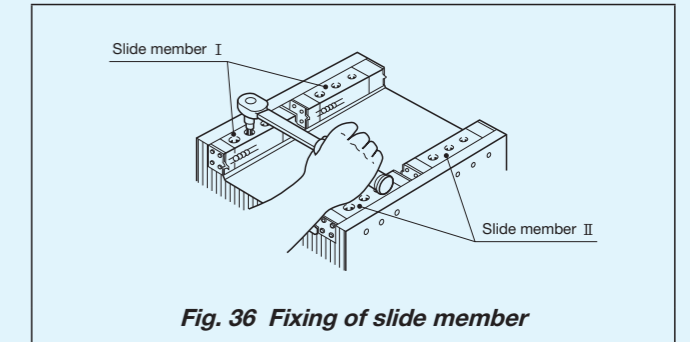

#### 4 Setting of table and bed

- Insert and assemble the slide member fixed to the table slowly with care while aligning it with the track rail fixed to the bed to maintain parallelism.

#### 5 Fixing the slide member II

- As indicated in Fig. 37, tighten the preload adjusting screw at the center first and then all the rest preload adjusting screws in order while measuring the clearance by using the dial gauge.
- The position where the dial gauge deflection stops after moving the table to right and left indicates zero preload or slight preload state.
- After preload adjustment, tighten the fixing bolt to fix them.

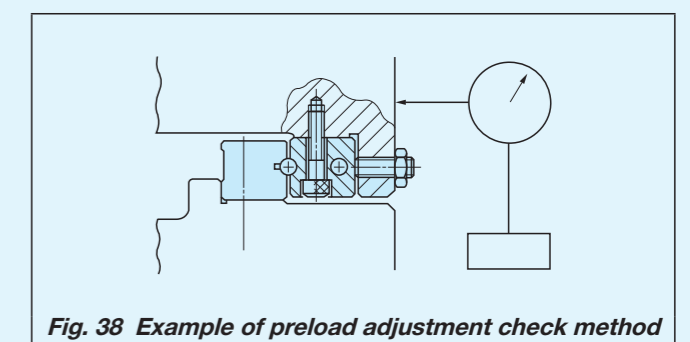
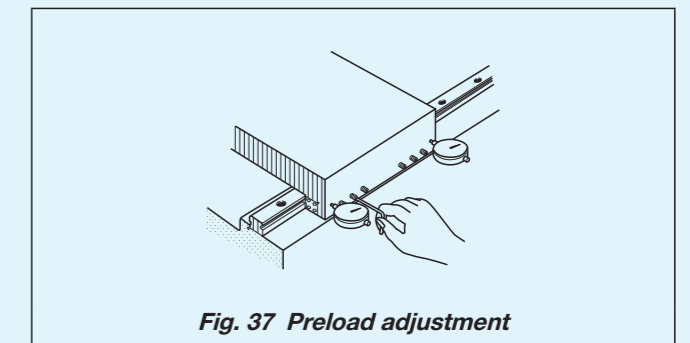

### Mounting of reference side track rail

Mounting methods of reference side track rail are indicated below. Select a method suitable for the specifications of your machine or device.

**1 Method to use reference mounting surface**

· Stick track rail reference mounting surface to the reference mounting surface of the bed by using a pressure plate or small type vise, and tighten the fixing bolt at the same position. Repeat this method from one end to fix the track rail in order.

**2 Method to use temporary reference surface**

· Prepare temporary reference surface around the mounting surface of the bed, temporarily fix the track rail, fix the measurement stand on the upper surface of the slide unit as indicated in Fig. 39, place an indicator onto the temporary reference surface, and fix them from one end of the track rail in order while maintaining straightness.

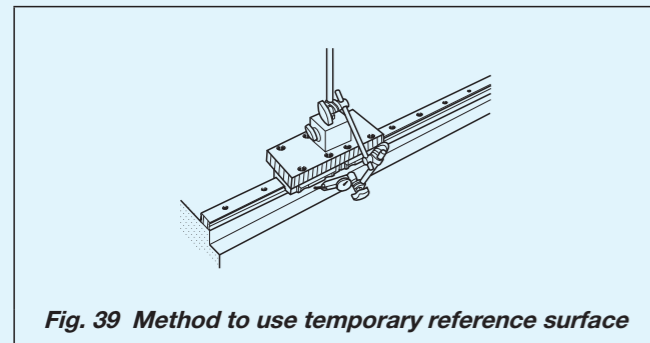

**3 Method with straight-edge**

· After temporary fixing of the track rail, apply an indicator to the reference mounting surface of the track rail as indicated in Fig. 40 and fix them from one end of the track rail in order referring to the straight-edge while maintaining straightness.

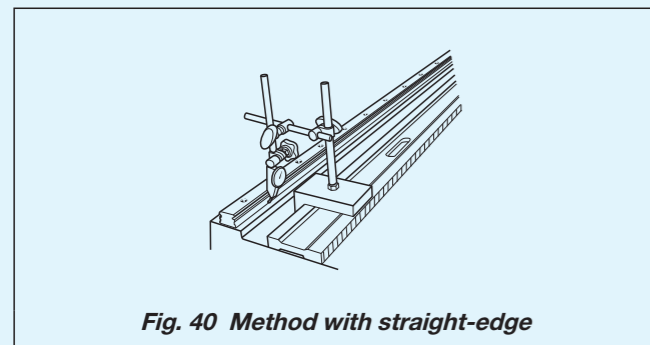

### Mounting of driven side track rail

Mounting methods of driven side track rail are indicated below. Select a method suitable for the specifications of your machine or device.

**1 Method to use reference mounting surface**

· Stick track rail reference mounting surface to the reference mounting surface of the bed by using a pressure plate or small type vise, and tighten the fixing bolt at the same position. Repeat this method from one end to fix the track rail in order.

**2 Method to follow the reference side track rail**

· Correctly mount the reference side track rail and one of the driven slide units in motion direction, temporarily fix the rest of slide units and track rails, and fix them from one end of the driven side track rail in order ensuring smooth motion status.

**3 Method with straight-edge**

· After temporary fixing of the track rail, apply an indicator to the reference mounting surface of the track rail as indicated in Fig. 40 and fix them from one end of the track rail in order referring to the straight-edge while maintaining straightness.

**4 Method to use reference side Linear Way**

· Fix a measurement stand onto the upper surface of the reference side slide unit as indicated in Fig. 41, place an indicator onto the reference mounting surface of the driven side track rail, and fix them from one end in order while maintaining parallelism.

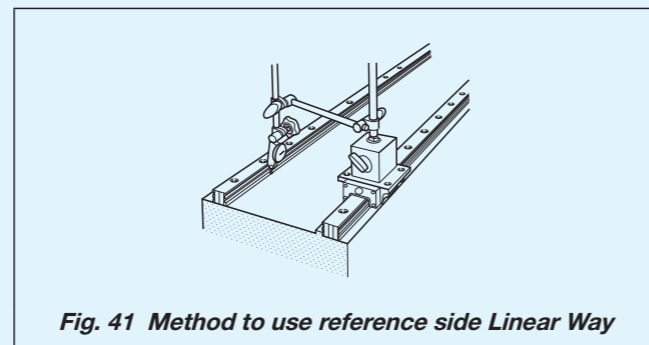

### Mounting procedures when track rails are butt-jointed

When multiple track rails are butt-jointed, it is necessary to specify special specification butted track rails (non-interchangeable specification, supplemental code "/A") or butt-jointing track rails (interchangeable specification, supplemental code "/T").

Butt-jointing track rails have a butt-jointing mark on the track rail end surface as indicated in Fig. 42. Typical method to butt-joint the track rails is as follows.

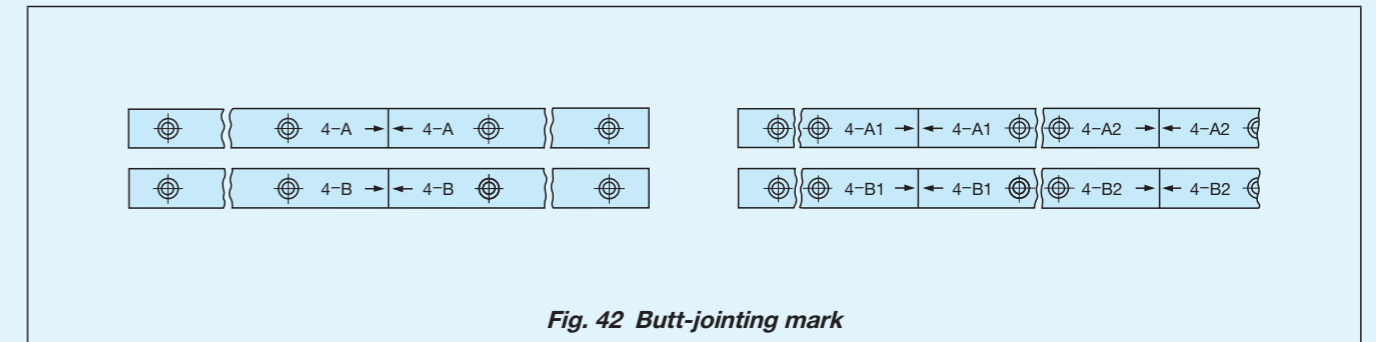

**1** Align the butt-jointing mark on the track rail end surface and temporarily fix it. Since butt-jointing track rails are interchangeable, no butt-jointing position is specified.

**2** Correctly align the reference mounting surface of the track rail with that of the bed in order. At this point, use a small type vise or the like to stick the reference mounting surfaces of the bed and track rail together so as to eliminate any step at the joint part of the track rail. (See Fig. 43)

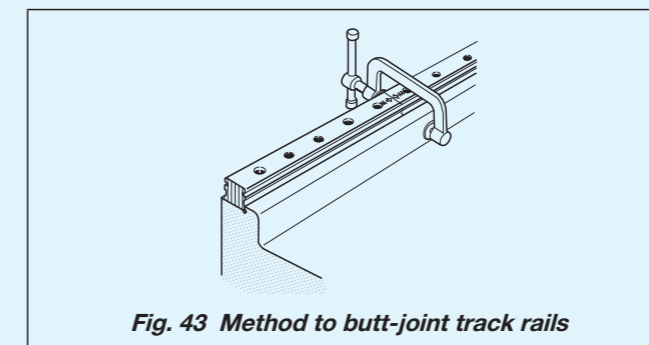

# Statements

## ● Unit Conversion Rate Table

SI, CGS series and gravity system unit cross-reference table

Amount Unit system	Length	Mass	Time	Acceleration	Force	Stress and pressure
SI	m	kg	s	m/s <sup>2</sup>	N	Pa
CGS series	cm	g	s	Gal	dyn	dyn/cm <sup>2</sup>
Gravity system	m	kgf·s <sup>2</sup> /m	s	m/s <sup>2</sup>	kgf	kgf/m <sup>2</sup>

### SI unit conversion

Amount	Unit name	Code	SI conversion rate	SI unit name	Code
Angle	D	°	$\pi/180$	Radian	rad
	Min	'	$\pi/10\ 800$		
	Sec	"	$\pi/648\ 000$		
Length	Meter	m	1	Meter	m
	Micron	$\mu$	$10^{-6}$		
	Angstrom	Å	$10^{-10}$		
	X ray unit		$\approx 1.002\ 08 \times 10^{-13}$		
	Nautical mile	n mile	1852		
Area	Square meter	m <sup>2</sup>	1	Square meter	m <sup>2</sup>
	Are	a	$10^2$		
	Hectare	ha	$10^4$		
Volume	Cubic meter	m <sup>3</sup>	1	Cubic meter	m <sup>3</sup>
	Liter	l, L	$10^{-3}$		
Mass	Kilogram	kg	1	Kilogram	kg
	Ton	t	$10^3$		
	Atomic mass unit	u	$\approx 1.660\ 57 \times 10^{-27}$		
Time	Sec	s	1	Sec	s
	Min	min	60		
	Hr	h	3 600		
	Day	d	86 400		
Velocity	Meter per second	m/s	1	Meter per second	m/s
	Knot	kn	$1\ 852/3\ 600$		
Frequency and vibration	Number of cycle	s <sup>-1</sup>	1	Hertz	Hz
Number of rotations	Rotation per minute	rpm	1/60	Per second	s <sup>-1</sup>
Angular velocity	Radian per second	rad/s	1	Radian per second	rad/s
Acceleration	Meter per second	m/s <sup>2</sup>	1	Meter per second	m/s <sup>2</sup>
	G	G	9.806 65		
Force	Weight in kg	kgf	9.806 65	Newton	N
	Weight in ton	tf	9 806.65		
	Dyne	dyn	$10^{-5}$		
Force moment load	Weight in kg meter	kgf·m	9.806 65	Newton meter	N·m
Stress and pressure	Weight in kg per square meter	kgf/m <sup>2</sup>	9.806 65	Pascal	Pa
	Weight in kg per square cm	kgf/cm <sup>2</sup>	$9.806\ 65 \times 10^4$		
	Weight in kg per square mm	kgf/mm <sup>2</sup>	$9.806\ 65 \times 10^6$		

Energy	Power	Temperature	Viscosity	Kinetic viscosity	Flux	Flux density	Magnetic field intensity
J	W	K	Pa·s	m <sup>2</sup> /s	Wb	T	A/m
erg	erg/s	°C	P	St	Mx	Gs	Oe
kgf·m	kgf·m/s	°C	kgf·s/m <sup>2</sup>	m <sup>2</sup> /s	—	—	—

Amount	Unit name	Code	SI conversion rate	SI unit name	Code
Pressure	Meter water column	mH <sub>2</sub> O	9 806.65	Pascal	Pa
	millimeter of mercury column	mmHg	$101\ 325/760$		
	Torr	Torr	$101\ 325/760$		
	Air pressure	atm	101 325		
	Bar	bar	$10^5$		
Energy	Erg	erg	$10^{-7}$	Joule	J
	IT calorie	cal <sub>IT</sub>	4.186 8		
	Weight in kg meter	kgf·m	9.806 65		
	Kilowatt per hour	kW·h	$3.600 \times 10^6$		
	French horse-power per hour	PS·h	$\approx 2.647\ 79 \times 10^6$		
Electron volt	eV	$\approx 1.602\ 19 \times 10^{-19}$			
Power and motivity	Watt	W	1	Watt	W
	French horse-power	PS	$\approx 735.5$		
	Weight in kg meter per second	kgf·m/s	9.806 65		
Viscosity	Poise	P	$10^{-1}$	Pascal second	Pa·s
	Centipoise	cP	$10^{-3}$		
	Weight in kg second per square meter	kgf·s/m <sup>2</sup>	9.806 65		
Kinetic viscosity	Stokes	St	$10^{-4}$	Square meter per second	m <sup>2</sup> /s
	Centistokes	cSt	$10^{-6}$		
Temperature	D	°C	+273.15	Kelvin	K
Radioactivity	Curie	Ci	$3.7 \times 10^{10}$	Becquerel	Bq
	Exposure radiation dose	Roentgen	$2.58 \times 10^{-4}$		
Absorbed dose	Rad	rad	$10^{-2}$	Gray	Gy
	Dose equivalent	Rem	$10^{-2}$		
Flux	Maxwell	Mx	$10^{-8}$	Weber	Wb
Flux density	Gamma	$\gamma$	$10^{-9}$	Tesla	T
	Gauss	Gs	$10^{-4}$		
Magnetic field intensity	Oersted	Oe	$10^3/4\pi$	Ampere per meter	A/m
Electric charge	Coulomb	C	1	Coulomb	C
	Electric potential difference	Volt	1		
Capacitance	Farad	F	1	Farad	F
	(Electric) Resistance	Ohm	1		
(Electric) Conductance	Siemens	S	1	Siemens	S
	Inductance	Henry	1		
Current	Ampere	A	1	Ampere	A

● Inch-mm Conversion Table

1 inch=25.4mm

inch		0"	1"	2"	3"	4"	5"	6"	7"	8"
Fractional number	Decimal number									
0	0		25.400	50.800	76.200	101.600	127.000	152.400	177.800	203.200
1 / 64"	0.015625	0.397	25.797	51.197	76.597	101.997	127.397	152.797	178.197	203.597
1 / 32"	0.031250	0.794	26.194	51.594	76.994	102.394	127.794	153.194	178.594	203.994
3 / 64"	0.046875	1.191	26.591	51.991	77.391	102.791	128.191	153.591	178.991	204.391
1 / 16"	0.062500	1.588	26.988	52.388	77.788	103.188	128.588	153.988	179.388	204.788
5 / 64"	0.078125	1.984	27.384	52.784	78.184	103.584	128.984	154.384	179.784	205.184
3 / 32"	0.093750	2.381	27.781	53.181	78.581	103.981	129.381	154.781	180.181	205.581
7 / 64"	0.109375	2.778	28.178	53.578	78.978	104.378	129.778	155.178	180.578	205.978
1 / 8"	0.125000	3.175	28.575	53.975	79.375	104.775	130.175	155.575	180.975	206.375
9 / 64"	0.140625	3.572	28.972	54.372	79.772	105.172	130.572	155.972	181.372	206.772
5 / 32"	0.156250	3.969	29.369	54.769	80.169	105.569	130.969	156.369	181.769	207.169
11 / 64"	0.171875	4.366	29.766	55.166	80.566	105.966	131.366	156.766	182.166	207.566
3 / 16"	0.187500	4.762	30.162	55.562	80.962	106.362	131.762	157.162	182.562	207.962
13 / 64"	0.203125	5.159	30.559	55.959	81.359	106.759	132.159	157.559	182.959	208.359
7 / 32"	0.218750	5.556	30.956	56.356	81.756	107.156	132.556	157.956	183.356	208.756
15 / 64"	0.234375	5.953	31.353	56.753	82.153	107.553	132.953	158.353	183.753	209.153
1 / 4"	0.250000	6.350	31.750	57.150	82.550	107.950	133.350	158.750	184.150	209.550
17 / 64"	0.265625	6.747	32.147	57.547	82.947	108.347	133.747	159.147	184.547	209.947
9 / 32"	0.281250	7.144	32.544	57.944	83.344	108.744	134.144	159.544	184.944	210.344
19 / 64"	0.296875	7.541	32.941	58.341	83.741	109.141	134.541	159.941	185.341	210.741
5 / 16"	0.312500	7.938	33.338	58.738	84.138	109.538	134.938	160.338	185.738	211.138
21 / 64"	0.328125	8.334	33.734	59.134	84.534	109.934	135.334	160.734	186.134	211.534
11 / 32"	0.343750	8.731	34.131	59.531	84.931	110.331	135.731	161.131	186.531	211.931
23 / 64"	0.359375	9.128	34.528	59.928	85.328	110.728	136.128	161.528	186.928	212.328
3 / 8"	0.375000	9.525	34.925	60.325	85.725	111.125	136.525	161.925	187.325	212.725
25 / 64"	0.390625	9.922	35.322	60.722	86.122	111.522	136.922	162.322	187.722	213.122
13 / 32"	0.406250	10.319	35.719	61.119	86.519	111.919	137.319	162.719	188.119	213.519
27 / 64"	0.421875	10.716	36.116	61.516	86.916	112.316	137.716	163.116	188.516	213.916
7 / 16"	0.437500	11.112	36.512	61.912	87.312	112.712	138.112	163.512	188.912	214.312
29 / 64"	0.453125	11.509	36.909	62.309	87.709	113.109	138.509	163.909	189.309	214.709
15 / 32"	0.468750	11.906	37.306	62.706	88.106	113.506	138.906	164.306	189.706	215.106
31 / 64"	0.484375	12.303	37.703	63.103	88.503	113.903	139.303	164.703	190.103	215.503
1 / 2"	0.500000	12.700	38.100	63.500	88.900	114.300	139.700	165.100	190.500	215.900

1 inch=25.4mm

inch		0"	1"	2"	3"	4"	5"	6"	7"	8"
Fractional number	Decimal number									
33 / 64"	0.515625	13.097	38.497	63.897	89.297	114.697	140.097	165.497	190.897	216.297
17 / 32"	0.531250	13.494	38.894	64.294	89.694	115.094	140.494	165.894	191.294	216.694
35 / 64"	0.546875	13.891	39.291	64.691	90.091	115.491	140.891	166.291	191.691	217.091
9 / 16"	0.562500	14.288	39.688	65.088	90.488	115.888	141.288	166.688	192.088	217.488
37 / 64"	0.578125	14.684	40.084	65.484	90.884	116.284	141.684	167.084	192.484	217.884
19 / 32"	0.593750	15.081	40.481	65.881	91.281	116.681	142.081	167.481	192.881	218.281
39 / 64"	0.609375	15.478	40.878	66.278	91.678	117.078	142.478	167.878	193.278	218.678
5 / 8"	0.625000	15.875	41.275	66.675	92.075	117.475	142.875	168.275	193.675	219.075
41 / 64"	0.640625	16.272	41.672	67.072	92.472	117.872	143.272	168.672	194.072	219.472
21 / 32"	0.656250	16.669	42.069	67.469	92.869	118.269	143.669	169.069	194.469	219.869
43 / 64"	0.671875	17.066	42.466	67.866	93.266	118.666	144.066	169.466	194.866	220.266
11 / 16"	0.687500	17.462	42.862	68.262	93.662	119.062	144.462	169.862	195.262	220.662
45 / 64"	0.703125	17.859	43.259	68.659	94.059	119.459	144.859	170.259	195.659	221.059
23 / 32"	0.718750	18.256	43.656	69.056	94.456	119.856	145.256	170.656	196.056	221.456
47 / 64"	0.734375	18.653	44.053	69.453	94.853	120.253	145.653	171.053	196.453	221.853
3 / 4"	0.750000	19.050	44.450	69.850	95.250	120.650	146.050	171.450	196.850	222.250
49 / 64"	0.765625	19.447	44.847	70.247	95.647	121.047	146.447	171.847	197.247	222.647
25 / 32"	0.781250	19.844	45.244	70.644	96.044	121.444	146.844	172.244	197.644	223.044
51 / 64"	0.796875	20.241	45.641	71.041	96.441	121.841	147.241	172.641	198.041	223.441
13 / 16"	0.812500	20.638	46.038	71.438	96.838	122.238	147.638	173.038	198.438	223.838
53 / 64"	0.828125	21.034	46.434	71.834	97.234	122.634	148.034	173.434	198.834	224.234
27 / 32"	0.843750	21.431	46.831	72.231	97.631	123.031	148.431	173.831	199.231	224.631
55 / 64"	0.859375	21.828	47.228	72.628	98.028	123.428	148.828	174.228	199.628	225.028
7 / 8"	0.875000	22.225	47.625	73.025	98.425	123.825	149.225	174.625	200.025	225.425
57 / 64"	0.890625	22.622	48.022	73.422	98.822	124.222	149.622	175.022	200.422	225.822
29 / 32"	0.906250	23.019	48.419	73.819	99.219	124.619	150.019	175.419	200.819	226.219
59 / 64"	0.921875	23.416	48.816	74.216	99.616	125.016	150.416	175.816	201.216	226.616
15 / 16"	0.937500	23.812	49.212	74.612	100.012	125.412	150.812	176.212	201.612	227.012
61 / 64"	0.953125	24.209	49.609	75.009	100.409	125.809	151.209	176.609	202.009	227.409
31 / 32"	0.968750	24.606	50.006	75.406	100.806	126.206	151.606	177.006	202.406	227.806
63 / 64"	0.984375	25.003	50.403	75.803	101.203	126.603	152.003	177.403	202.803	228.203

● Hardness Conversion Table (Reference)

Rockwell C scale hardness Load 1471N HRC	Vickers hardness HV	Brinell hardness		Rockwell hardness		Shore hardness HS
		Standard ball	Tungsten Carbide ball	A scale	B scale	
				Load 588.4N Diamond circular cone	Load 980.7N Diameter 1/16in ball	
68	940	—	—	85.6	—	97
67	900	—	—	85.0	—	95
66	865	—	—	84.5	—	92
65	832	—	(739)	83.9	—	91
64	800	—	(722)	83.4	—	88
63	772	—	(705)	82.8	—	87
62	746	—	(688)	82.3	—	85
61	720	—	(670)	81.8	—	83
60	697	—	(654)	81.2	—	81
59	674	—	(634)	80.7	—	80
58	653	—	615	80.1	—	78
57	633	—	595	79.6	—	76
56	613	—	577	79.0	—	75
55	595	—	560	78.5	—	74
54	577	—	543	78.0	—	72
53	560	—	525	77.4	—	71
52	544	(500)	512	76.8	—	69
51	528	(487)	496	76.3	—	68
50	513	(475)	481	75.9	—	67
49	498	(464)	469	75.2	—	66
48	484	451	455	74.7	—	64
47	471	442	443	74.1	—	63
46	458	432	432	73.6	—	62
45	446	421	421	73.1	—	60
44	434	409	409	72.5	—	58
43	423	400	400	72.0	—	57
42	412	390	390	71.5	—	56
41	402	381	381	70.9	—	55
40	392	371	371	70.4	—	54
39	382	362	362	69.9	—	52

Rockwell C scale hardness Load 1471N HRC	Vickers hardness HV	Brinell hardness		Rockwell hardness		Shore hardness HS
		Standard ball	Tungsten Carbide ball	A scale	B scale	
				Load 588.4N Diamond circular cone	Load 980.7N Diameter 1/16in ball	
38	372	353	353	69.4	—	51
37	363	344	344	68.9	—	50
36	354	336	336	68.4	(109.0)	49
35	345	327	327	67.9	(108.5)	48
34	336	319	319	67.4	(108.0)	47
33	327	311	311	66.8	(107.5)	46
32	318	301	301	66.3	(107.0)	44
31	310	294	294	65.8	(106.0)	43
30	302	286	286	65.3	(105.5)	42
29	294	279	279	64.7	(104.5)	41
28	286	271	271	64.3	(104.0)	41
27	279	264	264	63.8	(103.0)	40
26	272	258	258	63.3	(102.5)	38
25	266	253	253	62.8	(101.5)	38
24	260	247	247	62.4	(101.0)	37
23	254	243	243	62.0	100.0	36
22	248	237	237	61.5	99.0	35
21	243	231	231	61.0	98.5	35
20	238	226	226	60.5	97.8	34
(18)	230	219	219	—	96.7	33
(16)	222	212	212	—	95.5	32
(14)	213	203	203	—	93.9	31
(12)	204	194	194	—	92.3	29
(10)	196	187	187	—	90.7	28
(8)	188	179	179	—	89.5	27
(6)	180	171	171	—	87.1	26
(4)	173	165	165	—	85.5	25
(2)	166	158	158	—	83.5	24
(0)	160	152	152	—	81.7	24

# ● Tolerances of Shaft Dimensions

Classification of diameter mm		b12		c12		d6		e6		e12		f5		f6		g5	
Above	Below	H	L	H	L	H	L	H	L	H	L	H	L	H	L	H	L
—	3	-140	-240	-60	-160	-20	-26	-14	-20	-14	-114	-6	-10	-6	-12	-2	-6
3	6	-140	-260	-70	-190	-30	-38	-20	-28	-20	-140	-10	-15	-10	-18	-4	-9
6	10	-150	-300	-80	-230	-40	-49	-25	-34	-25	-175	-13	-19	-13	-22	-5	-11
10	18	-150	-330	-95	-275	-50	-61	-32	-43	-32	-212	-16	-24	-16	-27	-6	-14
18	30	-160	-370	-110	-320	-65	-78	-40	-53	-40	-250	-20	-29	-20	-33	-7	-16
30	40	-170	-420	-120	-370	-80	-96	-50	-66	-50	-300	-25	-36	-25	-41	-9	-20
40	50	-180	-430	-130	-380												
50	65	-190	-490	-140	-440	-100	-119	-60	-79	-60	-360	-30	-43	-30	-49	-10	-23
65	80	-200	-500	-150	-450												
80	100	-220	-570	-170	-520	-120	-142	-72	-94	-72	-422	-36	-51	-36	-58	-12	-27
100	120	-240	-590	-180	-530												
120	140	-260	-660	-200	-600	-145	-170	-85	-110	-85	-485	-43	-61	-43	-68	-14	-32
140	160	-280	-680	-210	-610												
160	180	-310	-710	-230	-630												
180	200	-340	-800	-240	-700	-170	-199	-100	-129	-100	-560	-50	-70	-50	-79	-15	-35
200	225	-380	-840	-260	-720												
225	250	-420	-880	-280	-740												
250	280	-480	-1000	-300	-820	-190	-222	-110	-142	-110	-630	-56	-79	-56	-88	-17	-40
280	315	-540	-1060	-330	-850												
315	355	-600	-1170	-360	-930	-210	-246	-125	-161	-125	-695	-62	-87	-62	-98	-18	-43
355	400	-680	-1250	-400	-970												
400	450	-760	-1390	-440	-1070	-230	-270	-135	-175	-135	-765	-68	-95	-68	-108	-20	-47
450	500	-840	-1470	-480	-1110												

Classification of diameter mm		h12		js5		j5		js6		j6		j7		k5		k6	
Above	Below	H	L	H	L	H	L	H	L	H	L	H	L	H	L	H	L
—	3	0	-100	+2	-2	+2	-2	+3	-3	+4	-2	+6	-4	+4	0	+6	0
3	6	0	-120	+2.5	-2.5	+3	-2	+4	-4	+6	-2	+8	-4	+6	+1	+9	+1
6	10	0	-150	+3	-3	+4	-2	+4.5	-4.5	+7	-2	+10	-5	+7	+1	+10	+1
10	18	0	-180	+4	-4	+5	-3	+5.5	-5.5	+8	-3	+12	-6	+9	+1	+12	+1
18	30	0	-210	+4.5	-4.5	+5	-4	+6.5	-6.5	+9	-4	+13	-8	+11	+2	+15	+2
30	40	0	-250	+5.5	-5.5	+6	-5	+8	-8	+11	-5	+15	-10	+13	+2	+18	+2
40	50																
50	65	0	-300	+6.5	-6.5	+6	-7	+9.5	-9.5	+12	-7	+18	-12	+15	+2	+21	+2
65	80																
80	100	0	-350	+7.5	-7.5	+6	-9	+11	-11	+13	-9	+20	-15	+18	+3	+25	+3
100	120																
120	140	0	-400	+9	-9	+7	-11	+12.5	-12.5	+14	-11	+22	-18	+21	+3	+28	+3
140	160																
160	180																
180	200	0	-460	+10	-10	+7	-13	+14.5	-14.5	+16	-13	+25	-21	+24	+4	+33	+4
200	225																
225	250																
250	280	0	-520	+11.5	-11.5	+7	-16	+16	-16	+16	-16	+26	-26	+27	+4	+36	+4
280	315																
315	355	0	-570	+12.5	-12.5	+7	-18	+18	-18	+18	-18	+29	-28	+29	+4	+40	+4
355	400																
400	450	0	-630	+13.5	-13.5	+7	-20	+20	-20	+20	-20	+31	-32	+32	+5	+45	+5
450	500																

unit:  $\mu m$

Classification of diameter mm		g6		h5		h6		h7		h8		h9		h10		h11	
Above	Below	H	L	H	L	H	L	H	L	H	L	H	L	H	L	H	L
—	3	-2	-8	0	-4	0	-6	0	-10	0	-14	0	-25	0	-40	0	-60
3	6	-4	-12	0	-5	0	-8	0	-12	0	-18	0	-30	0	-48	0	-75
6	10	-5	-14	0	-6	0	-9	0	-15	0	-22	0	-36	0	-58	0	-90
10	18	-6	-17	0	-8	0	-11	0	-18	0	-27	0	-43	0	-70	0	-110
18	30	-7	-20	0	-9	0	-13	0	-21	0	-33	0	-52	0	-84	0	-130
30	40	-9	-25	0	-11	0	-16	0	-25	0	-39	0	-62	0	-100	0	-160
40	50																
50	65	-10	-29	0	-13	0	-19	0	-30	0	-46	0	-74	0	-120	0	-190
65	80																
80	100	-12	-34	0	-15	0	-22	0	-35	0	-54	0	-87	0	-140	0	-220
100	120																
120	140	-14	-39	0	-18	0	-25	0	-40	0	-63	0	-100	0	-160	0	-250
140	160																
160	180																
180	200	-15	-44	0	-20	0	-29	0	-46	0	-72	0	-115	0	-185	0	-290
200	225																
225	250																
250	280	-17	-49	0	-23	0	-32	0	-52	0	-81	0	-130	0	-210	0	-320
280	315																
315	355	-18	-54	0	-25	0	-36	0	-57	0	-89	0	-140	0	-230	0	-360
355	400																
400	450	-20	-60	0	-27	0	-40	0	-63	0	-97	0	-155	0	-250	0	-400
450	500																

unit:  $\mu m$

Classification of diameter mm		m5		m6		n5		n6		p6	
Above	Below	H	L	H	L	H	L	H	L	H	L
—	3	+6	+2	+8	+2	+8	+4	+10	+4	+12	+6
3	6	+9	+4	+12	+4	+13	+8	+16	+8	+20	+12
6	10	+12	+6	+15	+6	+16	+10	+19	+10	+24	+15
10	18	+15	+7	+18	+7	+20	+12	+23	+12	+29	+18
18	30	+17	+8	+21	+8	+24	+15	+28	+15	+35	+22
30	40	+20	+9	+25	+9	+28	+17	+33	+17	+42	+26
40	50										
50	65	+24	+11	+30	+11	+33	+20	+39	+20	+51	+32
65	80										
80	100	+28	+13	+35	+13	+38	+23	+45	+23	+59	+37
100	120										
120	140	+33	+15	+40	+15	+45	+27	+52	+27	+68	+43
140	160										
160	180										
180	200	+37	+17	+46	+17	+51	+31	+60	+31	+79	+50
200	225										
225	250										
250	280	+43	+20	+52	+20	+57	+34	+66	+34	+88	+56
280	315										
315	355	+46	+21	+57	+21	+62	+37	+73	+37	+98	+62
355	400										
400	450	+50	+23	+63	+23	+67	+40	+80	+40	+108	+68
450	500										

### ● Tolerances of Housing Hole Dimensions

Classification of diameter mm		B12		E7		E11		E12		F6		F7		G6		G7	
Above	Below	H	L	H	L	H	L	H	L	H	L	H	L	H	L	H	L
—	3	+240	+140	+24	+14	+74	+14	+114	+14	+12	+6	+16	+6	+8	+2	+12	+2
3	6	+260	+140	+32	+20	+95	+20	+140	+20	+18	+10	+22	+10	+12	+4	+16	+4
6	10	+300	+150	+40	+25	+115	+25	+175	+25	+22	+13	+28	+13	+14	+5	+20	+5
10	18	+330	+150	+50	+32	+142	+32	+212	+32	+27	+16	+34	+16	+17	+6	+24	+6
18	30	+370	+160	+61	+40	+170	+40	+250	+40	+33	+20	+41	+20	+20	+7	+28	+7
30	40	+420	+170	+75	+50	+210	+50	+300	+50	+41	+25	+50	+25	+25	+9	+34	+9
40	50	+430	+180														
50	65	+490	+190	+90	+60	+250	+60	+360	+60	+49	+30	+60	+30	+29	+10	+40	+10
65	80	+500	+200														
80	100	+570	+220	+107	+72	+292	+72	+422	+72	+58	+36	+71	+36	+34	+12	+47	+12
100	120	+590	+240														
120	140	+660	+260	+125	+85	+335	+85	+485	+85	+68	+43	+83	+43	+39	+14	+54	+14
140	160	+680	+280														
160	180	+710	+310														
180	200	+800	+340	+146	+100	+390	+100	+560	+100	+79	+50	+96	+50	+44	+15	+61	+15
200	225	+840	+380														
225	250	+880	+420														
250	280	+1000	+480	+162	+110	+430	+110	+630	+110	+88	+56	+108	+56	+49	+17	+69	+17
280	315	+1060	+540														
315	355	+1170	+600	+182	+125	+485	+125	+695	+125	+98	+62	+119	+62	+54	+18	+75	+18
355	400	+1250	+680														
400	450	+1390	+760	+198	+135	+535	+135	+765	+135	+108	+68	+131	+68	+60	+20	+83	+20
450	500	+1470	+840														

unit: μm

Classification of diameter mm		H6		H7		H8		H9		H10		H11		JS6		J6		Classification of diameter mm	
Above	Below	H	L	H	L	H	L	H	L	H	L	H	L	H	L	H	L	Above	Below
—	3	+6	0	+10	0	+14	0	+25	0	+40	0	+60	0	+3	-3	+2	-4	—	3
3	6	+8	0	+12	0	+18	0	+30	0	+48	0	+75	0	+4	-4	+5	-3	3	6
6	10	+9	0	+15	0	+22	0	+36	0	+58	0	+90	0	+4.5	-4.5	+5	-4	6	10
10	18	+11	0	+18	0	+27	0	+43	0	+70	0	+110	0	+5.5	-5.5	+6	-5	10	18
18	30	+13	0	+21	0	+33	0	+52	0	+84	0	+130	0	+6.5	-6.5	+8	-5	18	30
30	40	+16	0	+25	0	+39	0	+62	0	+100	0	+160	0	+8	-8	+10	-6	30	40
40	50																	40	50
50	65	+19	0	+30	0	+46	0	+74	0	+120	0	+190	0	+9.5	-9.5	+13	-6	50	65
65	80																	65	80
80	100	+22	0	+35	0	+54	0	+87	0	+140	0	+220	0	+11	-11	+16	-6	80	100
100	120																	100	120
120	140	+25	0	+40	0	+63	0	+100	0	+160	0	+250	0	+12.5	-12.5	+18	-7	120	140
140	160																	140	160
160	180																	160	180
180	200	+29	0	+46	0	+72	0	+115	0	+185	0	+290	0	+14.5	-14.5	+22	-7	180	200
200	225																	200	225
225	250																	225	250
250	280	+32	0	+52	0	+81	0	+130	0	+210	0	+320	0	+16	-16	+25	-7	250	280
280	315																	280	315
315	355	+36	0	+57	0	+89	0	+140	0	+230	0	+360	0	+18	-18	+29	-7	315	355
355	400																	355	400
400	450	+40	0	+63	0	+97	0	+155	0	+250	0	+400	0	+20	-20	+33	-7	400	450
450	500																	450	500

Classification of diameter mm		JS7		J7		K5		K6		K7		M6		M7		N6	
Above	Below	H	L	H	L	H	L	H	L	H	L	H	L	H	L	H	L
—	3	+5	-5	+4	-6	0	-4	0	-6	0	-10	-2	-8	-2	-12	-4	-10
3	6	+6	-6	+6	-6	0	-5	+2	-6	+3	-9	-1	-9	0	-12	-5	-13
6	10	+7	-7	+8	-7	+1	-5	+2	-7	+5	-10	-3	-12	0	-15	-7	-16
10	18	+9	-9	+10	-8	+2	-6	+2	-9	+6	-12	-4	-15	0	-18	-9	-20
18	30	+10	-10	+12	-9	+1	-8	+2	-11	+6	-15	-4	-17	0	-21	-11	-24
30	40	+12	-12	+14	-11	+2	-9	+3	-13	+7	-18	-4	-20	0	-25	-12	-28
40	50																
50	65	+15	-15	+18	-12	+3	-10	+4	-15	+9	-21	-5	-24	0	-30	-14	-33
65	80																
80	100	+17	-17	+22	-13	+2	-13	+4	-18	+10	-25	-6	-28	0	-35	-16	-38
100	120																
120	140	+20	-20	+26	-14	+3	-15	+4	-21	+12	-28	-8	-33	0	-40	-20	-45
140	160																
160	180																
180	200	+23	-23	+30	-16	+2	-18	+5	-24	+13	-33	-8	-37	0	-46	-22	-51
200	225																
225	250																
250	280	+26	-26	+36	-16	+3	-20	+5	-27	+16	-36	-9	-41	0	-52	-25	-57
280	315																
315	355	+28	-28	+39	-18	+3	-22	+7	-29	+17	-40	-10	-46	0	-57	-26	-62
355	400																
400	450	+31	-31	+43	-20	+2	-25	+8	-32	+18	-45	-10	-50	0	-63	-27	-67
450	500																

unit: μm

Classification of diameter mm		N7		P6		P7		R7		S7		Classification of diameter mm	
Above	Below	H	L	H	L	H	L	H	L	H	L	Above	Below
—	3	-4	-14	-6	-12	-6	-16	-10	-20	-14	-24	—	3
3	6	-4	-16	-9	-17	-8	-20	-11	-23	-15	-27	3	6
6	10	-4	-19	-12	-21	-9	-24	-13	-28	-17	-32	6	10
10	18	-5	-23	-15	-26	-11	-29	-16	-34	-21	-39	10	18
18	30	-7	-28	-18	-31	-14	-35	-20	-41	-27	-48	18	30
30	40	-8	-33	-21	-37	-17	-42	-25	-50	-34	-59	30	40
40	50											40	50
50	65	-9	-39	-26	-45	-21	-51	-30	-60	-42	-72	50	65
65	80											65	80
80	100	-10	-45	-30	-52	-24	-59	-38	-73	-58	-93	80	100
100	120											100	120
120	140	-12	-52	-36	-61	-28	-68	-48	-88	-77	-117	120	140
140	160											140	160
160	180											160	180
180	200	-14	-60	-41	-70	-33	-79	-60	-106	-105	-151	180	200
200	225											200	225
225	250											225	250
250	280	-14	-66	-47	-79	-36	-88	-74	-126	-138	-190	250	280
280	315											280	315
315	355	-16	-73	-51	-87	-41	-98	-87	-144	-169	-226	315	355
355	400											355	400
400	450	-17	-80	-55	-95	-45	-108	-103	-166	-209	-272	400	450
450	500											450	500



## Model Code Index

Model code	Series name	Catalog name	Page	Model code	Series name	Catalog name	Page
<b>B</b>				LM...F AJ	Linear Bushing	RED	II-181
<b>B</b>				LM...F OP	Linear Bushing	RED	II-181
BG	Stroke Rotary Cage	RED	II-212	LM...F UU	Linear Bushing	RED	II-183
BK...A	Miniature Stroke Rotary Bushing	RED	II-207	LM...F UU AJ	Linear Bushing	RED	II-183
BSP...SL	Precision Linear Slide Unit	RED	II- 89	LM...F UU OP	Linear Bushing	RED	II-183
BSPG...SL	Precision Linear Slide Unit	RED	II- 91	LM...N	Linear Bushing	RED	II-167
BSR...SL	Precision Linear Slide Unit	RED	II- 93	LM...N AJ	Linear Bushing	RED	II-167
BSU...A	Linear Slide Unit	RED	II- 99	LM...N F	Linear Bushing	RED	II-181
BWU	High Rigidity Precision Linear Slide Unit	RED	II- 81	LM...N F AJ	Linear Bushing	RED	II-181
<b>C</b>				LM...N F OP	Linear Bushing	RED	II-181
<b>C</b>				LM...N F UU	Linear Bushing	RED	II-183
CRW	Crossed Roller Way	RED	II- 33	LM...N F UU AJ	Linear Bushing	RED	II-183
CRW...SL	Crossed Roller Way	RED	II- 33	LM...N F UU OP	Linear Bushing	RED	II-183
CRWG	Anti-Creep Cage Crossed Roller Way	RED	II- 27	LM...N OP	Linear Bushing	RED	II-167
CRWG...H	Anti-Creep Cage Crossed Roller Way H	RED	II- 31	LM...N UU	Linear Bushing	RED	II-171
CRWM	Crossed Roller Way	RED	II- 49	LM...N UU AJ	Linear Bushing	RED	II-171
CRWU	Crossed Roller Way Unit	RED	II- 63	LM...N UU OP	Linear Bushing	RED	II-171
CRWU...R	Crossed Roller Way Unit	RED	II- 67	LM...OP	Linear Bushing	RED	II-167
CRWU...RS	Crossed Roller Way Unit	RED	II- 71	LM...UU	Linear Bushing	RED	II-171
CRWUG	Anti-Creep Cage Crossed Roller Way Unit	RED	II- 61	LM...UU AJ	Linear Bushing	RED	II-171
<b>F</b>				LM...UU OP	Linear Bushing	RED	II-171
<b>F</b>				LMB	Linear Bushing	RED	II-179
FT	Flat Roller Cage	RED	II-231	LMB...AJ	Linear Bushing	RED	II-179
FT...N	Flat Roller Cage	RED	II-231	LMB...N	Linear Bushing	RED	II-179
FT...V	Flat Roller Cage	RED	II-231	LMB...N AJ	Linear Bushing	RED	II-179
FTW...A	Flat Roller Cage	RED	II-232	LMB...N OP	Linear Bushing	RED	II-179
FTW...VA	Flat Roller Cage	RED	II-232	LMB...OP	Linear Bushing	RED	II-179
<b>G</b>				LME	Linear Bushing	RED	II-175
<b>G</b>				LME...AJ	Linear Bushing	RED	II-175
GSN	Roller Way	RED	II-223	LME...F	Linear Bushing	RED	II-185
<b>L</b>				LME...F AJ	Linear Bushing	RED	II-185
<b>L</b>				LME...F OP	Linear Bushing	RED	II-185
LM	Linear Bushing	RED	II-167	LME...F UU	Linear Bushing	RED	II-187
LM...AJ	Linear Bushing	RED	II-167	LME...F UU AJ	Linear Bushing	RED	II-187
LM...F	Linear Bushing	RED	II-181	LME...F UU OP	Linear Bushing	RED	II-187
<b>L</b>				LME...N	Linear Bushing	RED	II-175
<b>L</b>				LME...N AJ	Linear Bushing	RED	II-175
<b>L</b>				LME...N F	Linear Bushing	RED	II-185
<b>L</b>				LME...N F AJ	Linear Bushing	RED	II-185

Note: BLUE denotes CAT-1560E, while RED denotes CAT-1561E.

## Model Code Index

Model code	Series name	Catalog name	Page	Model code	Series name	Catalog name	Page
LME...N F OP	Linear Bushing	RED	II-185	LRXS	Linear Roller Way Super X	BLUE	II-209
LME...N F UU	Linear Bushing	RED	II-187	LRXSC	Linear Roller Way Super X	BLUE	II-209
LME...N F UU AJ	Linear Bushing	RED	II-187	LRXSG	Linear Roller Way Super X	BLUE	II-209
LME...N F UU OP	Linear Bushing	RED	II-187	LS	Stroke Ball Spline	RED	II-149
LME...N OP	Linear Bushing	RED	II-175	LSAG	Linear Ball Spline G	RED	II-123
LME...N UU	Linear Bushing	RED	II-177	LSAGF	Linear Ball Spline G	RED	II-127
LME...N UU AJ	Linear Bushing	RED	II-177	LSAGFL	Linear Ball Spline G	RED	II-127
LME...N UU OP	Linear Bushing	RED	II-177	LSAGFLT	Linear Ball Spline G	RED	II-127
LME...OP	Linear Bushing	RED	II-175	LSAGFT	Linear Ball Spline G	RED	II-127
LME...UU	Linear Bushing	RED	II-177	LSAGL	Linear Ball Spline G	RED	II-123
LME...UU AJ	Linear Bushing	RED	II-177	LSAGLT	Linear Ball Spline G	RED	II-123
LME...UU OP	Linear Bushing	RED	II-177	LSAGT	Linear Ball Spline G	RED	II-123
LMG	Linear Bushing G	RED	II-159	LSB	Block Type Linear Ball Spline	RED	II-141
LMGT	Linear Bushing G	RED	II-159	LSB...SL	Block Type Linear Ball Spline	RED	II-141
LMS	Miniature Linear Bushing	RED	II-192	LSBT	Block Type Linear Ball Spline	RED	II-141
LMS...F	Miniature Linear Bushing	RED	II-192	LST	Stroke Ball Spline	RED	II-149
LMS...F UU	Miniature Linear Bushing	RED	II-192	LWE	Linear Way E	BLUE	II- 75
LMS...UU	Miniature Linear Bushing	RED	II-192	LWE...Q	Low Decibel Linear Way E	BLUE	II- 75
LMSL	Miniature Linear Bushing	RED	II-192	LWE...SL	Linear Way E	BLUE	II- 75
LMSL...F	Miniature Linear Bushing	RED	II-192	LWEC	Linear Way E	BLUE	II- 75
LMSL...F UU	Miniature Linear Bushing	RED	II-192	LWEC...SL	Linear Way E	BLUE	II- 75
LMSL...UU	Miniature Linear Bushing	RED	II-192	LWEG	Linear Way E	BLUE	II- 75
LRWM	Linear Way Module	BLUE	II-245	LWEG...SL	Linear Way E	BLUE	II- 75
LRWX...B	Linear Roller Way X	BLUE	II-227	LWES	Linear Way E	BLUE	II- 83
LRWXH	Linear Roller Way X	BLUE	II-229	LWES...Q	Low Decibel Linear Way E	BLUE	II- 83
LRX	Linear Roller Way Super X	BLUE	II-191	LWES...SL	Linear Way E	BLUE	II- 83
LRXC	Linear Roller Way Super X	BLUE	II-191	LWESC	Linear Way E	BLUE	II- 83
LRXD	Linear Roller Way Super X	BLUE	II-199	LWESC...SL	Linear Way E	BLUE	II- 83
LRXD...SL	Linear Roller Way Super X	BLUE	II-199	LWESG	Linear Way E	BLUE	II- 83
LRXDC	Linear Roller Way Super X	BLUE	II-199	LWESG...SL	Linear Way E	BLUE	II- 83
LRXDC...SL	Linear Roller Way Super X	BLUE	II-199	LWET	Linear Way E	BLUE	II- 79
LRXDG	Linear Roller Way Super X	BLUE	II-199	LWET...Q	Low Decibel Linear Way E	BLUE	II- 79
LRXDG...SL	Linear Roller Way Super X	BLUE	II-199	LWET...SL	Linear Way E	BLUE	II- 79
LRXDL	Linear Roller Way Super X	BLUE	II-207	LWETC	Linear Way E	BLUE	II- 79
LRXG	Linear Roller Way Super X	BLUE	II-191	LWETC...SL	Linear Way E	BLUE	II- 79
LRXH	Linear Roller Way Super X	BLUE	II-191	LWETG	Linear Way E	BLUE	II- 79
LRXHC	Linear Roller Way Super X	BLUE	II-191	LWETG...SL	Linear Way E	BLUE	II- 79
LRXHG	Linear Roller Way Super X	BLUE	II-191	LWFF	Linear Way F	BLUE	II-151
LRXL	Linear Roller Way Super X	BLUE	II-197	LWFH	Linear Way F	BLUE	II-149

Note: BLUE denotes CAT-1560E, while RED denotes CAT-1561E.

## Model Code Index

Model code	Series name	Catalog name	Page	Model code	Series name	Catalog name	Page
<b>L</b>				LWLF...BCS	Linear Way L	BLUE	II- 35
LWFS	Linear Way F	BLUE	II-153	LWLF...N	Linear Way L	BLUE	II- 31
LWFS...SL	Linear Way F	BLUE	II-153	LWLFC	Linear Way L	BLUE	II- 31
LWH...B	Linear Way H	BLUE	II-107	LWLFC...B	Linear Way L	BLUE	II- 31
LWH...M	Linear Way H	BLUE	II-107	LWLFC...N	Linear Way L	BLUE	II- 31
LWH...MU	Linear Way H	BLUE	II-107	LWLFG...B	Linear Way L	BLUE	II- 33
LWH...SL	Linear Way H	BLUE	II-107	LWLFG...N	Linear Way L	BLUE	II- 33
LWHD	Linear Way H	BLUE	II-121	LWLGG...B	Linear Way L	BLUE	II- 25
LWHD...B	Linear Way H	BLUE	II-123	LWLGG...N	Linear Way L	BLUE	II- 25
LWHD...M	Linear Way H	BLUE	II-123	LWLM	Linear Way Module	BLUE	II-241
LWHD...MU	Linear Way H	BLUE	II-123	LWM	Linear Way Module	BLUE	II-243
LWHD...SL	Linear Way H	BLUE	II-121	LWU	Linear Way U	BLUE	II-167
LWHDC...SL	Linear Way H	BLUE	II-121	LWU...B	Linear Way U	BLUE	II-167
LWHDG	Linear Way H	BLUE	II-123	LWUL...B	Linear Way U	BLUE	II-167
LWHDG...SL	Linear Way H	BLUE	II-121	<b>M</b>			
LWHG	Linear Way H	BLUE	II-107	MAG	C-Lube Linear Ball Spline MAG	RED	II-123
LWHS...B	Linear Way H	BLUE	II-127	MAGF	C-Lube Linear Ball Spline MAG	RED	II-127
LWHS...M	Linear Way H	BLUE	II-127	MAGFT	C-Lube Linear Ball Spline MAG	RED	II-127
LWHS...MU	Linear Way H	BLUE	II-127	MAGL	C-Lube Linear Ball Spline MAG	RED	II-123
LWHS...SL	Linear Way H	BLUE	II-127	MAGLT	C-Lube Linear Ball Spline MAG	RED	II-123
LWHSBG	Linear Way H	BLUE	II-127	MAGT	C-Lube Linear Ball Spline MAG	RED	II-123
LWHT	Linear Way H	BLUE	II-113	ME	C-Lube Linear Way ME	BLUE	II- 75
LWHT...B	Linear Way H	BLUE	II-113	ME...SL	C-Lube Linear Way ME	BLUE	II- 75
LWHT...M	Linear Way H	BLUE	II-113	MEC	C-Lube Linear Way ME	BLUE	II- 75
LWHT...MU	Linear Way H	BLUE	II-113	MEC...SL	C-Lube Linear Way ME	BLUE	II- 75
LWHT...SL	Linear Way H	BLUE	II-113	MEG	C-Lube Linear Way ME	BLUE	II- 75
LWHTG	Linear Way H	BLUE	II-115	MEG...SL	C-Lube Linear Way ME	BLUE	II- 75
LWHY	Linear Way H	BLUE	II-131	MES	C-Lube Linear Way ME	BLUE	II- 83
LWL	Linear Way L	BLUE	II- 23	MES...SL	C-Lube Linear Way ME	BLUE	II- 83
LWL...B	Linear Way L	BLUE	II- 25	MESC	C-Lube Linear Way ME	BLUE	II- 83
LWL...B CS	Linear Way L	BLUE	II- 27	MESC...SL	C-Lube Linear Way ME	BLUE	II- 83
LWL...N	Linear Way L	BLUE	II- 25	MESG	C-Lube Linear Way ME	BLUE	II- 83
LWL...Y	Linear Way L	BLUE	II- 23	MESG...SL	C-Lube Linear Way ME	BLUE	II- 83
LWLC	Linear Way L	BLUE	II- 23	MET	C-Lube Linear Way ME	BLUE	II- 79
LWLC...B	Linear Way L	BLUE	II- 25	MET...SL	C-Lube Linear Way ME	BLUE	II- 79
LWLC...N	Linear Way L	BLUE	II- 25	METC	C-Lube Linear Way ME	BLUE	II- 79
LWLF	Linear Way L	BLUE	II- 31	METC...SL	C-Lube Linear Way ME	BLUE	II- 79
LWLF...B	Linear Way L	BLUE	II- 31				

Note: **BLUE** denotes CAT-1560E, while **RED** denotes CAT-1561E.

## Model Code Index

Model code	Series name	Catalog name	Page	Model code	Series name	Catalog name	Page
METG	C-Lube Linear Way ME	BLUE	II- 79	MXDC	C-Lube Linear Roller Way Super MX	BLUE	II-199
METG...SL	C-Lube Linear Way ME	BLUE	II- 79	MXDG	C-Lube Linear Roller Way Super MX	BLUE	II-199
MH	C-Lube Linear Way MH	BLUE	II-107	MXDL	C-Lube Linear Roller Way Super MX	BLUE	II-201
MH...M	C-Lube Linear Way MH	BLUE	II-107	MXG	C-Lube Linear Roller Way Super MX	BLUE	II-191
MH...MU	C-Lube Linear Way MH	BLUE	II-107	MXH	C-Lube Linear Roller Way Super MX	BLUE	II-191
MHD	C-Lube Linear Way MH	BLUE	II-121	MXHC	C-Lube Linear Roller Way Super MX	BLUE	II-191
MHD...M	C-Lube Linear Way MH	BLUE	II-123	MXHG	C-Lube Linear Roller Way Super MX	BLUE	II-191
MHD...MU	C-Lube Linear Way MH	BLUE	II-123	MXHL	C-Lube Linear Roller Way Super MX	BLUE	II-191
MHD...SL	C-Lube Linear Way MH	BLUE	II-121	MXL	C-Lube Linear Roller Way Super MX	BLUE	II-191
MHDC...SL	C-Lube Linear Way MH	BLUE	II-121	MXN	C-Lube Linear Roller Way Super MX	BLUE	II-213
MHDG	C-Lube Linear Way MH	BLUE	II-123	MXNG	C-Lube Linear Roller Way Super MX	BLUE	II-213
MHDG...SL	C-Lube Linear Way MH	BLUE	II-121	MXNL	C-Lube Linear Roller Way Super MX	BLUE	II-213
MHDL	C-Lube Linear Way MH	BLUE	II-123	MXNS	C-Lube Linear Roller Way Super MX	BLUE	II-215
MHG	C-Lube Linear Way MH	BLUE	II-107	MXNSG	C-Lube Linear Roller Way Super MX	BLUE	II-215
MHS	C-Lube Linear Way MH	BLUE	II-127	MXNSL	C-Lube Linear Roller Way Super MX	BLUE	II-215
MHS...M	C-Lube Linear Way MH	BLUE	II-129	MXS	C-Lube Linear Roller Way Super MX	BLUE	II-209
MHS...MU	C-Lube Linear Way MH	BLUE	II-129	MXSC	C-Lube Linear Roller Way Super MX	BLUE	II-209
MHS...SL	C-Lube Linear Way MH	BLUE	II-127	MXSG	C-Lube Linear Roller Way Super MX	BLUE	II-209
MHSG	C-Lube Linear Way MH	BLUE	II-127	MXSL	C-Lube Linear Roller Way Super MX	BLUE	II-209
MHT	C-Lube Linear Way MH	BLUE	II-113	<b>O</b>			
MHT...M	C-Lube Linear Way MH	BLUE	II-115	OR...A	Miniature Stroke Rotary Bushing	RED	II-207
MHT...MU	C-Lube Linear Way MH	BLUE	II-115	<b>R</b>			
MHT...SL	C-Lube Linear Way MH	BLUE	II-113	RW	Roller Way	RED	II-221
MHTG	C-Lube Linear Way MH	BLUE	II-113	RWB	Roller Way	RED	II-222
MHTL	C-Lube Linear Way MH	BLUE	II-117	<b>S</b>			
ML	C-Lube Linear Way ML	BLUE	II- 25	SF...A	Miniature Stroke Rotary Bushing	RED	II-207
MLC	C-Lube Linear Way ML	BLUE	II- 25	SR	Roller Way	RED	II-223
MLF	C-Lube Linear Way ML	BLUE	II- 31	ST	Stroke Rotary Bushing	RED	II-199
MLFC	C-Lube Linear Way ML	BLUE	II- 31	ST...B	Stroke Rotary Bushing	RED	II-199
MLFG	C-Lube Linear Way ML	BLUE	II- 33	ST...UU	Stroke Rotary Bushing	RED	II-201
MLG	C-Lube Linear Way ML	BLUE	II- 25	ST...UU B	Stroke Rotary Bushing	RED	II-201
MLL	C-Lube Linear Way ML	BLUE	II- 27	STS	Miniature Stroke Rotary Bushing	RED	II-207
MLV	C-Lube Linear Way MLV	BLUE	II- 47	STSI	Miniature Stroke Rotary Bushing	RED	II-207
MUL	C-Lube Linear Way MUL	BLUE	II-167				
MV	C-Lube Linear Way MV	BLUE	II- 59				
MX	C-Lube Linear Roller Way Super MX	BLUE	II-191				
MXC	C-Lube Linear Roller Way Super MX	BLUE	II-191				
MXD	C-Lube Linear Roller Way Super MX	BLUE	II-199				
MXD...SL	C-Lube Linear Roller Way Super MX	BLUE	II-199				

Note: **BLUE** denotes CAT-1560E, while **RED** denotes CAT-1561E.

# IKO Linear Motion Rolling Guide Series,

# Configuration of General Catalog

IKO Linear Motion Rolling Guide Series General Catalog Consists of **BLUE** (CAT-1560E) and

**RED** (CAT-1561E), the two volumes.

## BLUE



CAT-1560E

### 【Models】

- Rail Guide Type
- Endless Linear Motion Type

C-Lube Linear Way ML Linear Way L C-Lube Linear Way MLV C-Lube Linear Way MV Linear Way E C-Lube Linear Way ME Linear Way H C-Lube Linear Way MH

ML · LWL

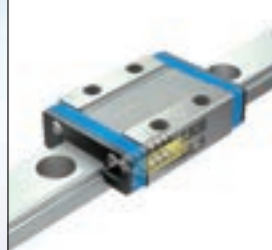

MLV

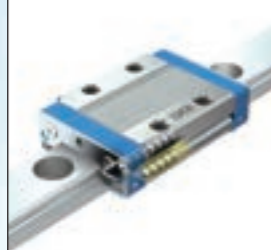

MV



ME · LWE



MH · LWH



Linear Way F



C-Lube Linear Way MUL Linear Way U

MUL · LWU



C-Lube Linear Roller Way Super MX Linear Roller Way Super X

MX · LRX



Linear Roller Way X



Linear Way Module



LWLM · LWM  
LRWM

## RED

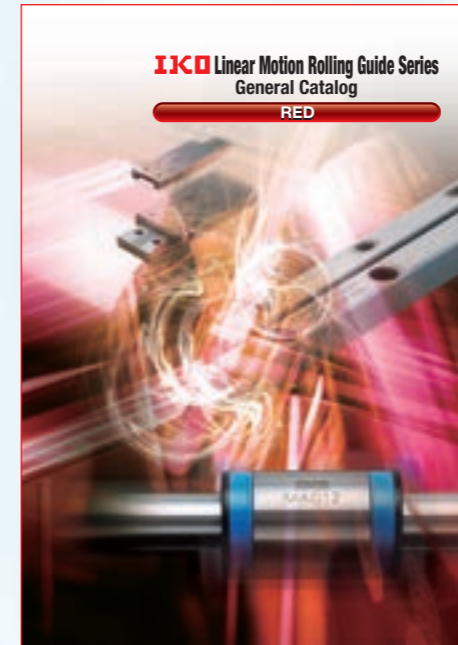

CAT-1561E

### 【Models】

- Rail Guide Type
- Limited Linear Motion Type
- Shaft Guide Type
- Endless Linear Motion Type
- Limited Linear Motion Type
- Limited Linear Motion Type + Rolling Motion Type
- Flat Guide Type
- Endless Linear Motion Type
- Limited Linear Motion Type

Rail Guide Type  
Crossed Roller Way

CRW(G)(···H)  
CRWU(G)



Rail Guide Type  
Linear Slide Unit

BWU · BSP(G)  
BSU···A



Shaft Guide Type  
Linear Ball Spline

MAG · LSAG  
LSB · LS



Shaft Guide Type  
Linear Bushing

LMG · LM · LMS



Shaft Guide Type  
Stroke Rotary Bushing

ST · STSI · BG



Flat Guide Type  
Roller Way & Flat Roller Cage

RW · SR · GSN  
FT · FTW···A



# IKO Introduction of Technical Service Site

"IKO Technical Service Site" can be accessed from our home page **IKO**. The site also distributes various tools, etc., to select Linear ways/Linear roller ways, and please utilize the site for the assistance to select products. Additionally the site also provides CAD data and product catalog of needle series, linear motion rolling guide series and mechatronics series for you to download. Please consider to use for enhancing your design efficiency.

<http://www.ikont.co.jp/eg/>



## 1. Technical calculations

For Linear Way/Linear Roller Way load and life calculation, you can obtain the calculated load and the rating life by entering the operating conditions.

Also you can derive the motor torque required for operation and the effective propulsion force during operation in the sections of motor torque calculation and calculation of effective propulsion force of linear motor tables respectively, and output the calculation results in PDF format, as well as save the histories.

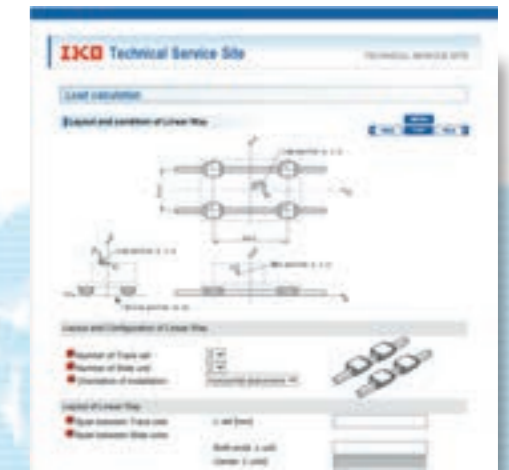

## 2. Selection of Identification Number

By selecting such specification as model code, dimensions, part code, material code, preload symbol, classification symbol, interchangeable code and supplemental code of Linear ways/Linear roller ways, you can easily specify the identification number used for ordering.

Also you can browse the CAD data of the selected products, calculate the load, and output the selection results in PDF format, as well as save the histories.



## 3. Downloading CAD data

### 2-dimensional CAD data (DXF file)

There are two types of figures, brief figure and detailed figure. The brief figure shows only the external view lines, and the detailed figure shows the detailed lines. The drawing consists of three drawings: front view, side view and plain view. The scale shows only the original size (1:1), and it does not show dimension lines.

### 3-dimensional CAD data

It is linked to the mechanical parts CAD library "PART community". Entering the rail dimension and option contents to the detail, you can view the 2D/3D CAD data suitable for the specification for free of charge.

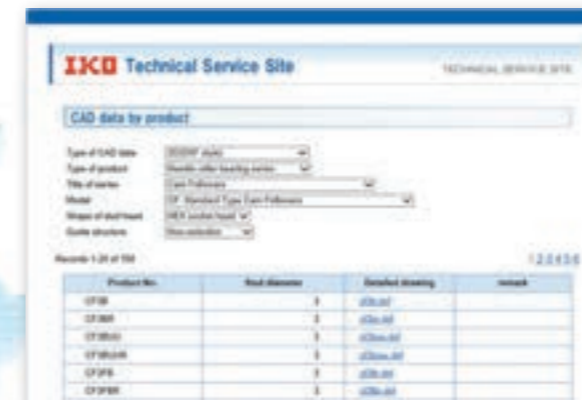

## 4. Downloading Catalog and Operation Manual

You can download product catalogs of needle series, linear motion rolling guide series and mechatronics series, operation manuals of precision positioning tables and various electrical components in PDF format, as well as support software for precision positioning tables. If you would like a copy of our catalog, please visit the **IKO** official website and apply for the catalog, or contact our regional office or sales office nearby.

# Oil Minimum

## IKO Gentle to The Earth

Nippon Thompson Co., Ltd. is working to develop global environment-friendly products.

It is committed to developing products that make its customers' machinery and equipment more reliable, thereby contributing to preserving the global environment.

This development stance manifests well in the keyword "Oil Minimum."

Our pursuit of Oil Minimum has led to the creation of  
**IKO's** proprietary family of lubricating parts as "C-Lube."

### IKO Products Underpin Sustain Technology Leaps

Nippon Thompson Co., Ltd. was the first Japanese manufacturer to develop needle bearings on its own and has since expanded into the arena of linear motion rolling guides (Linear Motion Series and Mechatro Series) on the support of its advanced expertise. The company now offers a vast assortment of ingenious products, including the world's first C-Lube maintenance-free series, to address increasingly diversified customer needs and thus sustain technology leaps.

### C-Lube Maintenance-Free Series Products Evolving from the "Oil Minimum" Concept

We have developed lubricating parts impregnated with a large amount of lubricant as C-Lube Series to save the customer's oiling management workload and built them into bearings and linear motion rolling guides. The C-Lube Series not only keeps products maintenance-free for long by giving them an optimal and minimal amount of a lubricant for an extended period of time but also contributes greatly to preserving the global environment.

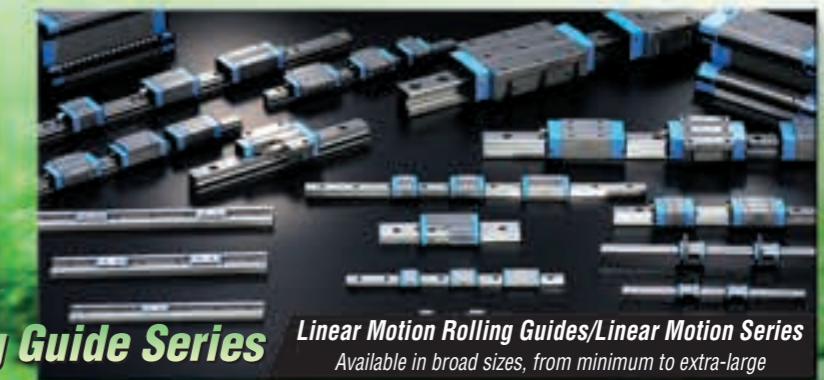

- **IKO** Linear Motion Rolling Guides are manufactured through a control system that alleviates their impact on the global environment to meet the quality requirements of ISO 14001 in compliance with the quality requirements level of ISO 9001 for quality improvement.
- The standard products listed in this catalog comply with the specifications of the six hazardous materials mentioned cited in the European RoHS Directive.