

1693
RLC Digibridge
User and Service Manual



Copyright © 2015 IET Labs, Inc.
Visit www.ietlabs.com for manual revision updates

1693 im/September 2015



IET LABS, INC.

www.ietlabs.com
Email: info@ietlabs.com
TEL: (516) 334-5959 • FAX: (516) 334-5988

WARRANTY

We warrant that this product is free from defects in material and workmanship and, when properly used, will perform in accordance with applicable IET specifications. If within one year after original shipment, it is found not to meet this standard, it will be repaired or, at the option of IET, replaced at no charge when returned to IET. Changes in this product not approved by IET or application of voltages or currents greater than those allowed by the specifications shall void this warranty. IET shall not be liable for any indirect, special, or consequential damages, even if notice has been given to the possibility of such damages.

THIS WARRANTY IS IN LIEU OF ALL OTHER WARRANTIES, EXPRESSED OR IMPLIED, INCLUDING BUT NOT LIMITED TO, ANY IMPLIED WARRANTY OF MERCHANTABILITY OR FITNESS FOR ANY PARTICULAR PURPOSE.



WARNING



OBSERVE ALL SAFETY RULES
WHEN WORKING WITH HIGH VOLTAGES OR LINE VOLTAGES.

**Dangerous voltages may be present inside this instrument. Do not open the case
Refer servicing to qualified personnel**

HIGH VOLTAGES MAY BE PRESENT AT THE TERMINALS OF THIS INSTRUMENT

WHENEVER HAZARDOUS VOLTAGES (> 45 V) ARE USED, TAKE ALL MEASURES TO
AVOID ACCIDENTAL CONTACT WITH ANY LIVE COMPONENTS.

USE MAXIMUM INSULATION AND MINIMIZE THE USE OF BARE
CONDUCTORS WHEN USING THIS INSTRUMENT.

Use extreme caution when working with bare conductors or bus bars.

WHEN WORKING WITH HIGH VOLTAGES, POST WARNING SIGNS AND
KEEP UNREQUIRED PERSONNEL SAFELY AWAY.



CAUTION



DO NOT APPLY ANY VOLTAGES OR CURRENTS TO THE TERMINALS OF THIS
INSTRUMENT IN EXCESS OF THE MAXIMUM LIMITS INDICATED ON
THE FRONT PANEL OR THE OPERATING GUIDE LABEL.

Table of Contents

Safety Information

General safety information	xi
----------------------------------	----

Abbreviated Specifications

Features.....	xiii
Applications.....	xiii
Specifications.....	xiii
Condensed operating instructions.....	xx

Chapter 1 Introduction

1.1 Purpose	1
1.2 General Description	2
1.2.1 1693 RLC Digibridge Overview	2
1.2.2 References	2
1.3 Controls, Indicators, and Connectors	2
1.4 Accessories	6
1.4.1 Supplied accessories.....	6
1.4.2 Optional Accessories	6

Chapter 2 Installation

2.1 Unpacking and Inspection	8
2.2 Dimensions	8
2.3 Power Line Connection	8
2.4 Line-Voltage Regulation.....	8
2.5 Test-Fixture Connections.....	9
2.6 Bias Voltage for the DUT	9
2.6.1 Internal Bias	9
2.6.2 External Bias	9
2.7 IEEE-488 Interface	10
2.7.1 Description	10
2.7.2 Signal Identification	10
2.7.3 Codes and addresses.....	10
2.8 Environment	12
2.9 Rack Mount Option	12

Chapter 3 Operation

3.1	Basic Operation	13
3.1.1	Overview	13
3.1.2	Startup	13
3.1.3	Zeroing	14
3.1.4	Routine Measurement.....	17
3.2	Connecting the DUT.....	18
3.2.1	Overview	18
3.2.2	The 1689-9600 Remote Test Fixture (with 1689-9602 BNC Cable)	18
3.2.3	Using the Test-Fixture Adaptors for Axial-Lead DUT	19
3.2.4	1657-9600 Banana Plug Extender Cable.....	20
3.2.5	The 1689-9602 Extender Cable with bnc-to-Banana-Plug Adaptors	21
3.2.6	The Effects of Cable and Fixture Capacitances	21
3.2.7	7000-05 Tweezers.....	22
3.2.8	1700-03 Kelvin Clip Cable.....	23
3.2.9	7000-04 Alligator Clip Leads	24
3.2.10	Connection to HACS-Z High Accuracy Decade Capacitor	25
3.2.11	Connection to 1482 Inductance Standard.....	27
3.2.12	Connection to 1409 Capacitance Standards	28
3.2.13	Connection to 1404 Reference Standard Capacitor	29
3.2.14	Connection to 1417 Capacitance Standard.....	30
3.2.15	Connection to the 1433 Decade Resistor	31
3.3	Measurement Parameters, Result Displays, and Outputs.....	33
3.3.1	Parameters (R/Q,L/Q, C/D,C/R,R/X,G/B,Z/ANG,Y/ANG)	33
3.3.2	Equivalent Circuits - Series, Parallel.....	34
3.3.3	Results Displayed	37
3.3.4	Units, Multipliers, and Blank Displays	39
3.3.5	D, Q, ANG in PPM.....	40
3.3.6	Ratio Displays, Virtual Range Extensions, and Conductance Measurements.....	41
3.4	Principal Test Conditions.....	42
3.4.1	Test Frequency.....	42
3.4.2	Test Voltage	43
3.4.3	Constant Voltage Source.....	44
3.4.4	Constant Current Source	44
3.4.5	Other Conditions	44

3.5	Measurement Time and Measurement Ranges	45
3.5.1	General	45
3.5.2	Measure Rate Selection at Keyboard	45
3.5.3	Settling Time or Programmed Delay, in Triggered Measure Mode	46
3.5.4	Measure Mode and Display Selection, Effects on Measurement Time	46
3.5.5	Integration-Time Factor (a Special Function)	46
3.5.6	Ranges and Range Changing.....	47
3.5.7	Range Holding.....	48
3.5.8	Time Required for Obtaining Median Values and Averaging	49
3.5.9	Time Required if IEEE-488 Output is Enabled.....	50
3.5.10	Effect of Selecting a Low Test Frequency on Measurement Time.....	50
3.5.11	Measurement Time Summary.....	51
3.6	Accuracy, The Limits of Errors	52
3.6.1	General	52
3.6.2	Accuracy for Some Typical Conditions.....	53
3.6.3	Averaging to Improve Accuracy	54
3.6.4	Selection of Median Value for Better Accuracy	55
3.6.5	Accuracy Enhancement for Large or Small Impedances at Particular Frequencies.....	55
3.6.6	Accuracy Enhancement by Special Attention to Short-Circuit Inductance.....	56
3.6.7	Cable-Related Errors and How to Correct for them.....	57
3.6.8	Use of Signal Reversing (Special Function) for Tests at Power Frequencies	58
3.6.9	Accuracy When Holding a Non-Optimum Range.....	59
3.7	Bias for the DUT	59
3.7.1	Internal Bias	59
3.7.2	External Bias	60
3.7.3	Suppression or Transients.....	62
3.8	Bin Sorting and Go/No-Go Results	62
3.8.1	Introduction to Binning (Sorting Based on Limit Comparisons).....	62
3.8.2	Sorting Methods	62
3.8.3	Limit Entry Procedure.....	63
3.8.4	Verification of Nominal and Limit Values.....	64
3.8.5	Examples of Limit Entry	65
3.8.6	Notes on Limit Entries in General.....	66
3.8.7	Go/No-Go and Bin Assignment Results.....	67
3.8.8	Bin Sum Information.....	67
3.8.9	Binning and Ratio Measurement Simultaneously	67

3.9	Keyboard Lock, Function Map, and Summary of Integrations	69
3.9.1	Keyboard Lock	69
3.9.2	Function Map	69
3.9.3	Summary of Interrogations	70
3.10	Special Functions	71
3.11	Data Output and Programming via IEEE 488 and RS-232 Interface	72
3.11.1	Overview	72
3.11.2	Configuration	72
3.11.3	Talk-Listen / Talk-Only Toggle Switch	72
3.11.4	GPIB Address DIP Switch	73
3.11.5	Jumpers	73
3.11.6	RS-232 Serial Interface (Currently Not Implemented)	73
3.11.7	Instrument Program Commands	74
3.11.8	Legacy Digibridge IEEE-488 Commands	75
3.11.9	IEEE 488.2/SCPI Digibridge Command Summary	77
3.11.10	IEEE 488.2 / SCPI Digibridge Command Reference	80
3.11.11	Example Programming	91
3.11.12	Talk-Only Use, for Data Output	91
3.11.13	Talk/Listen Use, for Remote Programming and Data Transfers	94
3.11.14	Data Output in Compacted Binary Format	97
3.12	Sample IEEE Programs	100
3.12.1	Programming Hints	100
3.12.2	National Instruments GPIB-PCII Card With the PC	100
3.13	Self-checks and Failure Displays (Error codes)	101
3.13.1	Power-up Self-Check	101
3.13.2	Failure Display due to Signal Overload	102
3.13.3	Failure Display due to Abnormal Measurement Cycle	102
3.13.4	Failure Display due to LC Resonance	102

Chapter 4 Theory

4.1	Introduction	104
4.1.1	General	104
4.1.2	Brief Description of the 1693 Digibridge	104
4.1.3	Block Diagram	105
4.2	Principal Functions	107
4.2.1	Elementary Measurement Circuit	107
4.2.2	Frequency and Time Source	107

4.2.3	Sine-Wave Generation.....	107
4.2.4	The Dual-Slope Integrating Detector and Converter	109
Chapter 5 Service and Maintenance		
5.1	Safety.....	110
5.2	Customer Service.....	111
5.3	Instrument Return.....	111
5.3.1	Packaging	111
5.3.2	Repair and Replacement of Circuit Boards.....	111
5.4	Performance Verification.....	112
5.4.1	Overview	112
5.4.2	Performance Verification Procedure.....	112
5.4.3	Measurement-Time Checkout.....	115
5.5	Disassembly and Access.....	116
5.5.1	Relocation of bnc Connector Bracket	119
5.5.2	Major internal components.....	120
5.5.3	Interface Options	121
5.5.4	Removal of Multiple-Pin Packages.....	122
5.6	Periodic Maintenance	122
5.6.1	Care of Test Fixtures	122
5.6.2	Care of the Display Panel.....	122
5.7	Trouble Analysis.....	123
5.7.1	Overview	123
5.7.2	Power-Up Self check and Certain Aborted Measurements	124
5.7.3	Internal Fuse Replacement.....	127
5.7.4	Power Supply and Regulator Board.....	128
5.7.5	Sinewave Generator Checks.....	129
5.7.6	Front End Amplifiers and Switches.....	129
5.8	Accuracy Verification	130
5.8.1	General	130
5.8.2	Capacitance Measurement Accuracy (Ranges 1-3).....	131
5.8.3	Capacitance Measurement Accuracy.....	132
5.8.4	Resistance Measurement Accuracy	134
5.8.5	Inductance Measurement Accuracy.....	135
5.8.6	D Measurement Accuracy	137
5.8.7	Limit Comparison Bins	138

5.9 Recalibration..... 140

5.9.1 Preparation..... 140

5.9.2 Zeroing and Selecting “DQ in PPM” 141

5.9.3 Recalibration for Range 4..... 141

5.9.4 Recalibration for Range 3..... 142

5.9.5 Recalibration for Range 2..... 142

5.9.6 Recalibration for Range 1..... 143

5.9.7 Frequency Calibration 143

5.9.8 Frequency Correction K Factor Procedure..... 144

5.10 Internal Address Settings for IEEE-488 Interface 146

Figures and Tables

Figure-A: Source Impedance Factors.....xv

Figure 1-1: 1693 RLC Digibridge, front view 2

Figure 1-2: 1693 Front Display..... 3

Figure 1-3: 1693 Keyboard 3

Figure 1-4: Rear controls and connectors on 1693 Digibridge..... 5

Figure 1-5: Typical operating guide attached to 1693..... 7

Figure 2-1: Input power module with a drawer for the input fuse..... 8

Figure 2-2: IEEE-488 interface..... 10

Figure 2-3: DIP switch set to Decimal Address 3 11

Figure 3-1: Open and short measurements with banana plugs..... 14

Figure 3-2: Open and short measurements with Kelvin cables..... 15

Figure 3-3: Open and short measurements with bnc-to-bnc cables..... 15

Figure 3-4: Open and short measurements with GR874 connectors..... 16

Figure 3-5: Chip component tweezers..... 16

Figure 3-6: Open and short measurements in 1689-9600..... 17

Figure 3-7: Connecting remote test fixture to RLC Digibridge..... 18

Figure 3-8: 1689-9600 Remote Test Fixture..... 19

Figure 3-9: 1689-9600 Remote Test Fixture with 1657-5995 Test Clips..... 19

Figure 3-10: Banana plugs on the 1657-9600 cable..... 20

Figure 3-11: Connecting remote test fixture and the Extender cable to RLC Digibridge 20

Figure 3-12: 1689-9602 Extender Cable with bnc-to-banana-plug adapters..... 21

Figure 3-13: 7000-05 Chip Component Tweezers..... 22

Figure 3-14: 1700-03 Kelvin Cables 23

Figure 3-15: 7000-04 Alligator Clip Leads..... 24

Figure 3-16: Connecting alligator clips 24

Figure 3-17: Connection to HACS-Z BP terminals with 1689-9602 cable and 1894 & 4684 adapters... 25

Figure 3-18: Connection to HACS-Z BP terminals with 1657-9600 Extender Cable or 7000-04 cable (without alligator clips) 25

Figure 3-19: Connection to HACS-Z bnc terminals with 1689-9602 cable with 6700 adapters 26

Figure 3-20: Connecting 1693 to 6-terminal 1482 27

Figure 3-21: Direct connection of 1693 and 1482 27

Figure 3-22: Connecting 1693 to a 3-terminal 1482 28

Figure 3-23: Connection to 1409 Standard Capacitor..... 28

Figure 3-24: Connecting 1693 to a 1404 29

Figure 3-25: Connecting to a 1417 30

<i>Figure 3-26: Connection to 1433 via 7000-04 cable.....</i>	<i>31</i>
<i>Figure 3-27: Connection to 1433 via 1657-9600 cable.....</i>	<i>32</i>
<i>Figure 3-28: Phase relationships</i>	<i>37</i>
<i>Figure 3-29: Relationships of Measurement Time.....</i>	<i>51</i>
<i>Figure 3-30: General view of the tradeoffs between measurement time and accuracy</i>	<i>53</i>
<i>Figure 3-31: Approximate RLC Accuracy vs Test Frequency.....</i>	<i>54</i>
<i>Figure 3-32: Recommended Wire Shapes for Zeroing.....</i>	<i>56</i>
<i>Figure 3-33: Nested limits for sorting.....</i>	<i>63</i>
<i>Figure 3-34: Sequential limits for sorting.....</i>	<i>63</i>
<i>Figure 3-35: Keyboard Map.....</i>	<i>69</i>
<i>Figure 4-1: Block diagram of the 1693 RLC Digibridge</i>	<i>106</i>
<i>Figure 4-2: Elementary Measurement Circuit.....</i>	<i>108</i>
<i>Figure 4-3: Frequency and timing source</i>	<i>108</i>
<i>Figure 4-4: Sine wave generator</i>	<i>108</i>
<i>Figure 5-1: Screws holding the interface assembly on the rear panel</i>	<i>117</i>
<i>Figure 5-2: Interior top view of 1693 Digibridge</i>	<i>118</i>
<i>Figure 5-3: Analog and Control Board Assembly (1689-4702)</i>	<i>120</i>
<i>Figure 5-4: Display Board Assembly (1689-4705).....</i>	<i>120</i>
<i>Figure 5-5: Keyboard Assembly (1687-4200)</i>	<i>121</i>
<i>Figure 5-6: Power Supply Assembly (700011)</i>	<i>121</i>
<i>Figure 5-7: IEEE interface (1689-9640), front view</i>	<i>121</i>
<i>Figure 5-8: IEEE interface (1689-9640), top view.....</i>	<i>121</i>
<i>Figure 5-9: Screws holding the interface assembly on the rear panel</i>	<i>122</i>
<i>Figure 5-10: Timing diagram of the power-up self check.</i>	<i>124</i>
<i>Figure 5-11: Location of internal fuse.....</i>	<i>127</i>
<i>Figure 5-12: Power Supply and Regulator Board Test Points</i>	<i>128</i>
<i>Figure 5-13: Series connections of standards for D accuracy checks</i>	<i>137</i>
<i>Figure 5-14: Calculating the K factor.....</i>	<i>145</i>
<i>Figure 5-15: IEEE-488 interface on the rear panel</i>	<i>146</i>

This page is intentionally left blank.

SAFETY INFORMATION

General safety information

Safety Summary

The following general safety precautions must be observed during all phases of operation, service and repair of this instrument. Failure to comply with these precautions or specific WARNINGS given elsewhere in this manual will violate safety standards of the design, manufacturing, and intended use of the instrument. IET Labs. assumes no liability for the customer's failure to comply with these requirements.

Before Applying Power

Verify that the power is set to match the rated input of this instrument.

Protective Ground

Make sure to connect the protective ground to prevent an electric shock before turning on the power.

Necessity of Protective Grounding

Never cut off the internal or external protective ground wire, or disconnect the wiring of the protective grounding terminal. Cutting the protective ground could cause a potential shock hazard and result in injury to a person.

Fuses

Only fuses with the required rated current, voltage and specified type (normal blow, time delay, etc.) should be used. Do not use repaired fuses or short-circuited fuse holders. Using the wrong fuse could cause a shock or fire hazard.

Do not operate in an explosive atmosphere

Do not operate this instrument in the presence of flammable gases or fumes.

Do not remove the cover of the instrument

Operating personnel must not remove the cover of this instrument. Component replacements and internal adjustments can be done only by qualified service personnel. Dangerous voltages may be present inside this instrument. Do not open the case. Refer servicing to qualified personnel.









Disposal

Do not dispose of electrical appliances as unsorted municipal waste, use separate collection facilities. Contact your local government for information regarding the collection systems available. If electrical appliances are disposed of in landfills or dumps, hazardous substances can leak into the groundwater and get into the food chain, damaging your health and well-being. When replacing old appliances with new one, the retailer is legally obligated to take back your old appliances for disposal.



Safety Symbols

The product is marked with the following safety symbols.

Safety Symbols	
 WARNING 	The WARNING sign denotes a hazard to the user. It calls attention to a procedure, practice, or the like, which, if not correctly performed or followed, could result in personal injury. Do not proceed beyond a WARNING sign until the indicated conditions are fully understood and met.
 CAUTION 	The CAUTION sign denotes a hazard to the equipment. It calls attention to procedures, practices and conditions, which, if not observed, could result in damage to the equipment or invalidating a procedure and/or test results.
	Alternating Current
	Direct Current
	On (Power Supply)
	Off (Power Supply)
	Protective grounding terminal: Protects against electrical shock in case of a fault. This symbol indicates the terminal must be connected to the ground wire before operating the equipment.

Material Contents Declaration

A regulatory requirement of The United States of America defined by specification SJ/T 11364-2006 mandates that manufacturers provide a material contents declaration of electronic products. IET's materials are listed below.

Part Name	Hazardous Substances					
	Lead	Mercury	Cadmium	Hexavalent Chromium	Polybrominated Biphenyls	Polybromodiphenyl Ethers
	Pb	Hg	Cd	Cr ⁶⁺	PBB	PBDE
PCBA	X	O	O	O	O	O
CHASSIS	X	O	O	O	O	O
ACCESSORY	X	O	O	O	O	O
PACKAGE	O	O	O	O	O	O
<p><i>“O” indicates that the level of the specified chemical substance is less than the threshold level specified in the standards.</i></p> <p><i>“X” indicates that the level of the specified chemical substance exceeds the threshold level specified in the standards.</i></p> <p><i>IET Labs. has not fully transitioned to lead-free solder assembly at this moment; however, most of the components used are RoHS compliant.</i></p> <p><i>The environment-friendly usage period of the product is assumed under the operating environment specified in each product's specification.</i></p>						

ABBREVIATED SPECIFICATIONS

Features

- The world's de facto standard for ac resistance, low-frequency inductance, and capacitance measurement
- 0.02% accuracy for R,L,C, G, Z, and Y
- 0.0001 accuracy for Dissipation and Q
- 11 Impedance Parameters
- Programmable test frequencies from 12 Hz to 200 kHz for testing versatility
- Programmable test voltages from 5 mV to 1.275 V
- Dual display featuring 5-digit readout for RLC and 4-digit readout for D and Q
- Extremely reliable: over 30 years of history
- Optional IEEE-488 interface allows test protocols and results to be stored in PC's

Applications

- High-end metrology applications
- Measuring impedance (inductance, capacitance, and resistance)
- Testing and sorting electrical components based on 11 possible parameters
- Optional IEEE-488 interface allows test protocols and results to be stored in PC's

Specifications

Measurement parameters:

Eight combinations of parameters are measured: R and Q, C and D, L and Q, C and R, R and X, G and B, Z(magnitude) and angle and Y (magnitude) and angle as selected by the R/Q, C/D, L/Q, or C/R keys, or the SHIFT key and the R/X, G/B, Z/ang/ or Y/ang keys. Either series or parallel equivalent circuit values are measured for R, C, and L as selected by the EQUIVALENT CIRCUIT key. Series values are measured for R and X combination and parallel values are measured for G and B. Parameter selection is initially made automatically based on the DDT being measuring. Automatic selection is inhibited once a specific parameter key has been selected by the operator (but may be restored).

Display format:

Dual display featuring 5 full digit LED for RLCGZY and full digit LED for DQRXB θ . Automatically positioned decimal points and minus signs where appropriate. Individual LED indicators for parameters, and measurement units

MEASURE displays:

When the MEASURE function has been selected, either VALUE, Δ RLC, Δ % or BIN NO. may be displayed.

VALUE display:

The VALUE display provides five digits for measured primary parameter (first quantity in each pair given above) four digits for secondary quantity

(second parameter in each pair) with automatically positioned decimal points, units of measurement and minus signs when appropriate.

The ΔRLC display:

The ΔRLC display indicates the difference between the measured R, L or C and a nominal value entered by the user with appropriate units (Ω, μF etc.). The R, L, or C difference display has five digits with a simultaneous four digit direct reading display of D, Q, or R with automatically positioned decimal points and minus signs when appropriate.

The Δ% display:

The Δ% display indicates the % deviation of the measured primary quantity and the stored nominal value. The display is five digits with a maximum resolution of one part per million with minus sign when appropriate. The resolution of the DQ and angle displays may also be increased by using the DQ in PPM key which gives D or Q in ppm or angle in microdegrees.

The BIN NO. display:

The BIN NO. display provides a single digit bin assignment number based on the measured value and user entered bin limits.

Measurement modes and rates:

There are two test modes, CONTINUOUS and TRIGGERED. The CONTINUOUS mode makes successive measurements continually, updating the display after each measurement. TRIGGERED measurements are initiated by the START button or remotely from the IEEE bus and the result held until another measurement is started.

There are three measurement rates selected by single keys; SLOW, MEDIUM and FAST whose measurement times depend on the test frequency (see table below for C and D, L and Q, or R and Q speeds). Other measurement rates may be selected by programming the integration time, AVERAGING to 255 measurements or adding a programmed DELAY of 1 to 99999 ms.

The measurement times in the following table were obtained with the use of the high-speed measurement option, continuous measurement mode, bin number display, and without IEEE-Bus data output. For other conditions refer to the notes below the table.

If the measurement mode is triggered, programmed delay (settling time), if any, should be added. Normal power up conditions include a programmed delay of 7/f to 12/f ms depending upon measurement rate. This delay can be programmed to zero or any value up to 100 s.

Measurement Rate	12 Hz	100 Hz	120 Hz	1 kHz	10 kHz	100 kHz	200 kHz
SLOW	899 ms	944 ms	944 ms	974 ms	944 ms	944 ms	944 ms
MEDIUM	694 ms	144 ms	194 ms	204 ms	194 ms	194 ms	194 ms
FAST	694 ms	129 ms	114 ms	89 ms	79 ms	79 ms	79 ms
MAXIMUM	672 ms	113 ms*	98 ms*	44 ms	34 ms	34 ms	34 ms

*These times can be shortened by 14ms by using the special quick acquisition routine.

Notes:

1. If the display is value, Δ% or ΔRLC, add 3 to 5 ms.
2. If data is output via the IEEE Bus, add 3 to 6 ms.
3. Speed in the table for C with D, L with Q or R with Q measurements.

Table-A: Measurement Rate

Test frequencies:

Over five hundred test frequencies between 12 Hz and 200 kHz may be selected by keyboard entry.

These are:

$$f = 200 \text{ kHz}/n, \text{ where } n = 1 \text{ to } 13$$

$$f = 60 \text{ kHz}/n, \text{ where } n = 4 \text{ to } 256$$

$$f = 3 \text{ kHz}/n, \text{ where } n = 13 \text{ to } 250$$

For example frequencies that can be selected:

$$200 \text{ kHz}/1 = 200 \text{ kHz}$$

$$200 \text{ kHz}/2 = 100 \text{ kHz}$$

....

$$200 \text{ kHz}/13 = 15.384.6 \text{ kHz}$$

If the exact frequency selected is not available, the nearest available frequency is used. The accuracy of the test frequency is better than .01%.

Applied Voltages:

5 mV to 1.275 V (programmable in 5 mV steps).

The open circuit voltage accuracy is (5% + 2mV) (1 + .001f²) where f is the frequency in kHz.

This voltage has a source impedance that depends on the range. A CONSTANT VOLTAGE mode can be selected which provides a low source impedance (25 ohms) in order to maintain a constant ac test level over a wider impedance range.

Range	Source Resistance/ Impedance
1	97.4 kΩ
2	6.4 kΩ
3	400 Ω
4	25 Ω
Constant Voltage	25 Ω

Table-B: Range versus internal source resistance

The programmed level is obtained under an open circuit condition. The actually applied voltage can be determined as follows.

A source resistance (R_s, internal to the meter) is effectively connected in series with the AC output and there is a voltage drop across this resistor. When a test device is connected, the voltage applied to the device depends on the value of the source resistor (R_s) and the impedance value of the device. As an example, where Range 4 is used which has a source impedance R_s of 25 ohms and the programmed voltage is 1 V but the voltage to the DUT is 0.5 V.

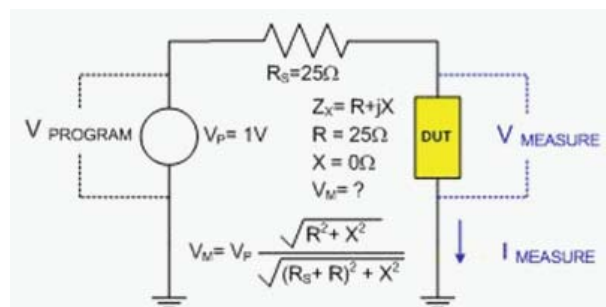

Figure-A: Source Impedance Factors

Internal dc bias is 2 V. External dc bias of up to 60 V may be applied.

Calibrations

An OPEN circuit zero calibration can be performed to remove the effects of stray capacitance and conductance shunting the internal test fixture or any other fixture or cable connection. A similar SHORT circuit zero calibration can be performed to remove the effects of resistance and inductance in series in the test connections. New zero calibrations should be made to obtain best accuracy whenever the test frequency or the fixture geometry is changed. A complete recalibration of the internal standards for each measurement range may be performed by using the optional 1689-9604 Calibration Kit and either a 1689-9600 Test Fixture.

Impedance Ranges:

The direct reading display ranges for R, L, C, G, |Z| and |Y| are given in Table A. These ranges may be extended by using the RATIO mode which multiplies or divides the measured result by an entered number but does not display a unit. These extended ranges are also shown. These ranges exceed by far any practical values and the accuracy capability of the instrument. The D and Q ranges are not changed by the RATIO mode, nor is the range of R when displayed with C, X with R or B with G.

Parameter	Direct Reading Range	Ratio and DQ in PPM
R and [Z]	0.00001 Ω to 99999 kΩ	0.00010 Ω to 9999.9 GΩ
L	0.00001 mH to 99999 H	0.00010 nH to 9999.9 MH
C	0.00001 pF to 99999 μF	0.00010 aF to 9999.9 F
G and [Y]	0.00001 μS to 99999 S	0.00010 pS to 9999.9 MS
R with C	0.0001 Ω to 9999 kΩ	not extended
X with R	0.0001 Ω to 9999 kΩ	not extended
B with G	0.0001 μS to 9999 S	not extended
D with C	0.0001 to 9999	1 to 9999 ppm
Q with R or L	0.0001 to 9999	1 to 9999 ppm
Angle	±0.0001° to 180°	±1 to 999 microdegrees

Table-C: Impedance ranges

Range selection:

Autoranging with manual hold

Basic accuracy*:

Basic RLCGZY: ±0.02%

Basic QD: ±0.0002 (±0.0001 in PPM mode)

Basic RXB: ±0.02%

Θ: ±0.01°

*See accuracy formulas below for actual accuracy based upon instrument configuration and DUT.

Limit of error (accuracy):

The specified limit of error is given below for all conditions (except constant voltage, for this condition add 2 inside the brackets). Rx, Cx, Lx etc. are the measured values, f is the frequency in kHz. The range constants Rmax, Lmax, Cmin, Gmin etc are given in Table-D. The constants Ks and Kfv are given in Tables 0 and D. Note that for SLOW measurements at 1kHz and 1 V with non constant voltage these K constants are all zero and that f=1.

Accuracy of primary parameters (left readout):

$$R: \pm (0.01\% * \left[1 + \frac{Rx}{Rmax} + \frac{3\Omega}{Rx}\right] * (1 + Q) * (1 + Ks + Kfv) + 0.01\%)$$

$$L: \pm (0.01\% * \left[1 + \frac{fLx}{Lmax} + \frac{500\mu H}{fLx}\right] * \left(1 + \frac{1}{Q}\right) * (1 + Ks + Kfv) + 0.01\%)$$

$$C: \pm (0.01\% * \left[1 + \frac{fCx}{50\mu F} + \frac{Cmin}{fCx}\right] * (1 + D) * (1 + Ks + Kfv) + 0.01\%)$$

$$G: \pm (0.01\% * \left[1 + \frac{Gx}{300mS} + \frac{Gmin}{Gx}\right] * (1 + D) * (1 + Ks + Kfv) + 0.01\%)$$

$$Z: \pm (0.01\% * \left[1 + \frac{Zx}{Zmax} + \frac{3\Omega}{Zx}\right] * (1 + Ks + Kfv) + 0.01\%)$$

$$Y: \pm (0.01\% * \left[1 + \frac{Yx}{300mS} + \frac{Ymin}{Yx}\right] * (1 + Ks + Kfv) + 0.01\%)$$

To obtain accuracy, IET offers a convenient tool at: http://www.ietlabs.com/notes/digibridge_accuracy_calculator. This tool is equivalent to the calculations shown for both primary and secondary parameters.

Note: This calculation tool is applicable for both 1689 and 1693 Digibridge modles.

Accuracy of secondary parameters (right readout):

$$Q \text{ of } R: \pm (0.0001 * \left[1 + \frac{Rx}{R_{max}} + \frac{3\Omega}{Rx}\right] * (1 + Q^2) * (1 + Ks + Kfv) + 0.0001\sim)$$

$$Q \text{ of } L: \pm (0.0001 * \left[1 + \frac{fLx}{L_{max}} + \frac{500\mu H}{fLx}\right] * (1 + Q^2) * (1 + Ks + Kfv) + 0.0001\sim)$$

$$D \text{ of } C: \pm (0.0001 * \left[1 + \frac{fCx}{50\mu F} + \frac{C_{min}}{fCx}\right] * (1 + D^2) * (1 + Ks + Kfv) + 0.0001\sim)$$

$$R: \pm (0.01\% * \left[1 + \frac{Rx}{R_{max}} + \frac{3\Omega}{Rx}\right] * (1 + Q) * (1 + Ks + Kfv) + 1 \text{ count})$$

$$X: \pm (0.01\% * \left[1 + \frac{Xx}{X_{max}} + \frac{3\text{ohms}}{Xx}\right] * \left(1 + \frac{1}{Q}\right) * (1 + Ks + Kfv) + 1 \text{ count})$$

$$B: \pm (0.01\% * \left[1 + \frac{Bx}{300mS} + \frac{B_{min}}{Bx}\right] * (1 + D) * (1 + Ks + Kfv) + 0.01\% + 1 \text{ count})$$

$$\text{Angle with } Z: \pm \left(0.01 * \left[1 + \frac{Zx}{Z_{max}} + \frac{3\Omega}{Zx}\right] * (1 + Ks + Kfv)\right) \text{ Degrees}$$

$$\text{Angle with } Y: \pm \left(0.01 * \left[1 + \frac{Yx}{300mS} + \frac{Y_{min}}{Yx}\right] * (1 + Ks + Kfv)\right) \text{ Degrees}$$

~ Remove this term of 0.0001, if DQ in PPM mode is used.

Notes :

1. It is assumed that both that OPEN and SHORT zeroing calibrations are made at the test frequency used.
2. Accuracy applies for measurements made using the 1689-9602 Extender Cable with or without the 1689-9600 or 1689-9605 Test Fixture.

High-Impedance range constants vs frequency:

Constants	12 Hz to 20 kHz	>20 kHz to 200 kHz
Rmax, Zmax, Xmax:	1 MΩ	60 kΩ
Lmax	160 H	10 H
Cmin	160 pF	3 nF
Gmin, Ymin, Bmin	1 μS	15 μS

Ks as a function of measurement rate:

Measurement Rate	Ks
Slow	0
Medium	3
Fast	8
Maximum*	23

* = Maximum is FAST measurement mode with minimum integration time.

Kfv as a Function of Frequency and RMS Voltage:

Frequency											
12 Hz to <30 Hz	30 Hz to <100 Hz	100 Hz to <250 Hz	250 Hz to <1 kHz	1 kHz	>1 kHz to 3 kHz	>3 kHz to 6 kHz*	>6 kHz to 10 kHz*	>10 kHz to 20 kHz*	>20 kHz to 50 kHz*	>50 kHz to 100 kHz*	200 kHz
1 V to 1.275 V AC Applied Voltage											
5	3	2	1	0	1	1*	3*	5*	8	18	70
0.25 V to < 1 V AC Applied Voltage											
8	5	3	2	1	2	2*	4*	6*	12	25	80
0.1 V to < 0.25 V AC Applied Voltage											
12	8	6	5	4	5	6*	8*	10*	20	50	100
0.03 V to < 0.1 V AC Applied Voltage											
35	30	25	20	14	15	15*	20*	25*	40	100	**
0.01 V to < 0.03 V AC Applied Voltage											
90	80	70	60	50	50	50*	50*	60*	70	**	**

* Multiply Kfv values by 5 from 3kHz to 20kHz for Range 1 (Z > 25 kohms)

** Not Specified

Measurement ranges and source impedance/resistance:

The 1693 has 4 measurement ranges, Range 1 to Range 4, that have specific source resistance. The Ranges can be automatically or manually selected. The source resistance does reduce the AC signal applied to the DUT.

AUTORANGING MEASUREMENT RANGES AND SOURCE RESISTANCES

Range	Source Resistance	Principal Measured Parameter		
		Resistance	Capacitance	Inductance
1	97.4 kohms	max 99999 K	min .00001 pF	max 99999 H *
		mid 102 K	mid 1600 pF/f	mid 16 H/f
		min 25.6 K	max 6400 pF/f	min 4.1 H/f
2	6.4 kohms	max 25.6 K	min 6.4 nF/f	max 4100 mH/f
		mid 6.4 K	mid 25.3 nF/f	mid 1025 mH/f
		min 1.6 K	max 100. nF/f	min 256 mH/f
3	400 ohms	max 1600 ohms	min 100 nF/f	max 256 mH/f
		mid 400 ohms	mid 400 nF/f	mid 64 mH/f
		min 100 ohms	max 1600 nF/f	min 16 mH/f
4	25 ohms	max 100 ohms	min 1.6 uF/f	max 16 mH/f
		mid 25 ohms	mid 6.4 uF/f	mid 4 mH/f
		min .00001 ohm	max 99999 uF	min .00001 mH

* "K" is kilohms; "f" is equal to the test frequency in kHz.

Binning:

Pass bins: 13 pass bins for RLCGZY

Fail bins: 2 fail bins, RLCGZY⊖

Sorting capabilities:

Bin number, Delta RLC, Delta %, Value

DUT connections:

The 1693 has four BNC connections to make four-terminal (Kelvin) connections to the device under test. These connections are shielded and the instrument ground has a guard for three-terminal measurements. 1689-9602 1-meter BNC Cable Set is provided. Various test fixtures and other accessories are available.

Front of 1693	Description	1689-9602 BNC Cable	1689-9600 Remote Test Fixture*
IL	Drive -	IL/Black Band	I+
PL	Potential -	PL/Black and White Band	P+
PH	Potential +	PH/Red and White Band	P-
IH	Drive +	IH/Red Band	I-

**High and Low Reversed for correct operation*

Charged capacitor protection:

The instrument is protected from damage due to the connection of charged capacitors with up to 1 joule of stored energy: Stored Energy = $\frac{1}{2}CV^2$ Joules

Keyboard lock:

The keyboard can be locked to prevent inadvertent changes to test conditions and sorting routines.

Parameter storage:

All keyboard settings and programmed nominal values and bin limits can be stored in non-volatile memory for automatic reentry upon power up .

Self-Check diagnostics:

Self-tests are performed during power-up to verify proper operation and validity of calibration. Coded error signals on the display notify the operator if a problem is encountered.

Special functions:

Several special features may be selected including:

- Direct Range Setting
- Range Extension (RATIO mode)
- Integration Time
- Blanking of lesser digits
- Signal reversal for hum removal under adverse conditions
- A Median value routine
- Automatic parameter selection
- Quick acquisition routine
- Choice of data output on IEEE bus
- Interface Option: IEEE-488 Bus (1689-9640)

Zeroing:

Open and short circuit compensation

Power:

90-250 Vac

50-60 Hz

60 W max

Environmental conditions:

Operating conditions: 0° to +50°C, <85% RH

Storage conditions: -45°C to +75°C

Dimensions:

43.8 cm W x 14.3 cm H x 38.5 cm D (17.3" x 5.6" x 15.2")

Weight:

6.4 kg (14 lbs)

Supplied accessories:

Power cable

1689-9602 bnc-to-bnc extender cable, 1-meter

Instruction manual

Calibration certificate traceable to SI

Optional accessories:

1700-03 Kelvin Test Leads

7000-04 Alligator Clip Leads, 1 Meter

7000-05 Chip Component Tweezers

1689-9602-2 bnc-bnc Extender Cable, 2-Meter

1689-9600 Remote Test Fixture

1689-9640 IEEE Digibridge Interface

1689-9604 Digibridge Calibration Kit

1689-9611 Rackmount Kit

1657-9600 Banana-Plug Extender Cable

1658-2450 Bias cable

Calibration certificate accredited to ISO17025

Condensed operating instructions

1. General Information

The 1693 RLC Digibridge is a microprocessor-controlled, automatic RLC meter.

Measurement parameters: R/Q, L/Q, C/D (series or parallel), R/X (series), G/B (parallel), Z/Angle or Y/Angle

Ranges:

Parameter	Direct Reading Range	Ratio and DQ in PPM
R and [Z]	0.00001 Ω to 99999 k Ω	0.00010 Ω to 9999.9 G Ω
L	0.00001 mH to 99999 H	0.00010 nH to 9999.9 MH
C	0.00001 pF to 99999 μ F	0.00010 aF to 9999.9 F

Test frequencies: Over 500 selectable test frequencies ranging from 12 Hz to 200 kHz

Applied voltage: 5 mV to 1.275 V (programmable in 5 mV steps)

Measurement speed: Up to 19 measurements per second

Bias: Internal: 2.0 Vdc; **External:** 60 Vdc max

Accuracy: Basic RLCGZY: $\pm 0.02\%$

Starting up

- If the Digibridge includes an optional IEEE-488 interface, set [TALK] switch (rear panel) to **TALK ONLY** (unless instructions are to be received through the IEEE-488 bus).
 - Make sure the [EXTERNAL BIAS] is in the **OFF** position.
 - Press the [POWER] button.
The unit runs a brief self-check on start-up.
 - Wait until keyboard lights indicate **MEASURE**, **VALUE**, **SLOW**, **TRIGGERED**, **SERIES**.
If a fault is detected, measurements are blocked and an error code remains displayed. See manual, paragraph 3.13. If keyboard lights remain dark, keyboard is locked. To unlock it, see manual paragraph 3.9.
- To switch power off, press the [POWER] button.

Maintaining optimal accuracy during zeroing

Before making measurements, zero the Digibridge as follows: (Note: For best accuracy, repeat this procedure every day, after each change of frequency, and after any change of test-fixture adaptors.)

- Attach extender cables or whichever test fixture/adaptor is appropriate.
- Create an open circuit by having the spacing between + and - cable ends match the spacing of the DUT terminals. See the figure.
If the spacing of DUT terminals is unknown, make sure that the + and - ends of the cable are at least 0.75" (19 mm) apart.
- Confirm that **MEASURE** keyboard light is lit.
- Press [MEASURE MODE] key to select **TRIGGERED** mode
- Press the following keys: [1] [6] [9] [3] [=] [SHIFT] [OPEN].
- Press [START] and wait for the green **GO** light.
- Create a short circuit across test terminals by connecting all cable ends together as shown in the figure.
- Press the following keys: [1] [6] [9] [3] [=] [SHIFT] [SHORT].
- Press [START] and wait for the green **GO** light.
At this point, the unit should be ready for taking measurements. If something goes wrong during the zeroing process, the procedure should be repeated.

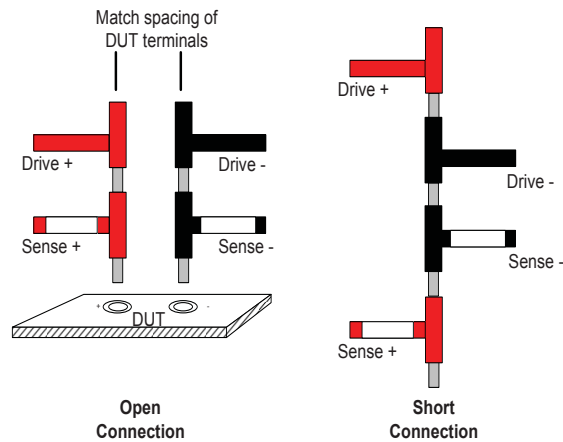

4. Taking measurements

- Select measurement conditions as follows:
 - [FUNCTION] key selects **MEASURE** mode
 - [DISPLAY] key selects **VALUE**, $\Delta\%$, or **BIN NO**
 - [MEASURE RATE] key selects **SLOW**, **MEDIUM**, or **FAST**
 - [MEASURE MODE] key selects **CONTINUOUS** or **TRIGGERED**
 - [EQUIVALENT CIRCUIT] key selects **SERIES** or **PARALLEL**
- Select impedance to be measured as follows
 - [R/Q] key to show Resistance in the primary display and Quality factor in the secondary display
 - [L/Q] key to show Inductance in the primary display and Quality factor in the secondary display
 - [C/D] key to show Capacitance in the primary display and Dissipation in the secondary display
 - [C/R] key to show Capacitance in the primary display and Resistance in the secondary display
 - To select other parameters, press and hold [SHIFT] key and select as appropriate

c. Connect component to be tested to the test terminals as appropriate.

d. If in the **TRIGGERED** mode, press [START].

Keep hands and objects at least 10 cm (4 in) from test fixture.

*If **NEG RLC** lights, the selected parameter is not appropriate for the DUT and another parameter should be selected. For example, if the Digirbridge is set to measure capacitance, and **NEG RLC** is lit, that means that the DUT is inductive.*

To view relative measurements, the nominal value and the bin limits must be first programmed. (See section 5 below.) Once the values have been programmed, select one of the following options by pressing the [DISPLAY] key:

- % difference from the nominal value: $\Delta\%$ must be lit
- Difference from nominal in original units (pF, mH, etc.): **VALUE** and $\Delta\%$ must both be lit
- Assigned bin number: **BIN NO** must be lit

The following programmable functions are available:

Parameter	Range	Default	Sample setting adjustment	Cancel	View Current Setting
Test frequency	12 Hz to 200 kHz	1 kHz	Programming 400 Hz: [FUNCTION] [.] [4] [=] [SHIFT] [FREQUENCY]	NA	[SHIFT] [FREQUENCY]
Test voltage	5 mV to 1.275 V	1 V	Programming 15 mV: [FUNCTION] [.] [0] [1] [5] [=] [SHIFT] [VOLTAGE]	NA	[SHIFT] [VOLTAGE]
Averaging	1 to 256	1	Programming 25 measurements: [FUNCTION] [2] [5] [=] [SHIFT] [AVERAGE]	[FUNCTION] [1] [=] [SHIFT] [AVERAGE]	[SHIFT] [AVERAGE]
Delay	0 to 99,999 ms	0	Programming a delay of 200 ms: [FUNCTION] [2] [0] [0] [=] [SHIFT] [DELAY]	[FUNCTION] [0] [=] [SHIFT] [DELAY]	[SHIFT] [DELAY]
Internal Bias	2 V	OFF	[SHIFT] [INT BIAS]	[SHIFT] [INT BIAS] again	NA
D and Q in PPM	NA	OFF	[SHIFT] [DQ in PPM]	[SHIFT] [DQ in PPM] again	NA
Hold constant voltage	NA	OFF	[SHIFT] [CONST V]	[SHIFT] [CONST V] again	NA
Hold constant range	NA	OFF	Select the desired range then [SHIFT] [HOLD RNG]	[SHIFT] [HOLD RNG] again	NA

5. Setting limits for GO/NO GO testing and sorting into bins

- Make sure the appropriate **VALUE** is selected by pressing [DISPLAY] key as necessary.
- Make sure to select **ENTER** by pressing the [FUNCTION] key.
- Select the desired range and multipliers.
- Select bins and limits as follows:

Option	Sample setting	Sample setting adjustment	Closing the bin
QDRXB0 limits (always bin 0)	Limit of 85	[8] [5] [=] [SHIFT] [BIN NO] [0] [0]	For D,R(series),X,B,Q/R: [9] [9] [9] [9] [=] [SHIFT] [BIN NO] [0] [0] For R(parallel),Q/L: [0] [=] [SHIFT] [BIN NO] [0] [0]
Symmetrical percentage tolerances for RLCGZY (nested bins)	Nominal value of 123.4 with $\pm 0.2\%$ limits in bin 1	[1] [2] [3] [.] [4] [=] [SHIFT] [NOM VAL], [.] [2] [%] [=] [SHIFT] [BIN NO] [0] [1], enter tolerances for more bins if necessary	[0] [=] [SHIFT] [BIN NO] [0] [1]
Multiple tolerances (bucket sort)*	Nominal value of 14.75 Ω with $\pm 0.5 \Omega$ limits in bin 2	[1] [4] [.] [7] [5] [=] [SHIFT] [NOM VAL], [.] [5] [=] [SHIFT] [BIN NO] [0] [2], enter tolerances for more bins if necessary	[0] [=] [SHIFT] [BIN NO] [0] [2]
Asymmetrical tolerances	+20%/-80% limits for bin 6	[2] [0] [%] [-] [8] [0] [%] [=] [SHIFT] [BIN NO] [0] [6] (upper limit should always come first)	[0] [=] [SHIFT] [BIN NO] [0] [6]

**Overlapping values will always get assigned into the lower-numbered bin*

- Press [FUNCTION] key to select **MEASURE** mode.
- Press [DISPLAY] key as needed to select the desired mode. (See Section 4 above.)
- Connect component to be tested to the test terminals and press [START].

If the DUT falls into the limits of one of the active bins, the bin number will be displayed and the GO LED will be lit.

If the DUT falls outside the limits of the active bins, display will show bin 14 and the NO GO LED will be lit.

This page is intentionally left blank.

Chapter 1

INTRODUCTION

1.1 Purpose

The 1693 RLC Digibridge™ is a microprocessor-controlled, automatic, programmable RLC measuring instrument that provides high accuracy, convenience, speed, and reliability at low cost. Limit comparison, binning, and internal bias are provided; both test frequency and voltage are selectable. With an interface option, the Digibridge tester can communicate with other equipment via IEEE-488 bus and respond to remote control.

The versatile, adaptable test fixture, lighted keyboard, and informative display panel makes the Digibridge tester convenient to use. Measurement results are clearly shown with decimal points and units, which are automatically presented to assure correctness. Display resolution is 5 full digits for R, L, C, G, Z, and Y (4 full digits for D, Q, X, B, and ANG. Notice that R is also known as ESR (equivalent series resistance).

The basic accuracy is 0.02%. Long-term accuracy and reliability are assured by the measurement system, which makes these accurate analog measurements over many decades of impedance without any critical internal adjustments. Calibration to account for any change of test-fixture parameters is semiautomatic; the operator needs to provide only open-circuit and short-circuit conditions in the procedure. The Digibridge tester normally autoranges and automatically identifies the principal measurement parameter.

The optional test fixture 1689-9600, with a pair of plug-in adaptors, receives any common component part (axial-lead or radial-lead), so easily that insertion of the device under test (DUT) is a one-hand operation. True 4-terminal connections are made automatically. Extender cables are available for measurements at a moderate distance from the instrument.

Limit comparisons facilitate sorting into 13 *GO* and 2 *NO-GO* bins.

- Test frequencies from 12 Hz to 200 kHz
- Test voltages from 5 mV to 1.275 V; bias (2 V)
- Delay (before data acquisition) from zero to 99999 ms
- Measurement speeds up to 30 per second
- Multi-measurement routines with automatic averaging and/or median taking of 2 to 255 measurements.
- Displays: measured values, percentages, differences, ratios, *GO/NO-GO*, binning
- Automatic output of value, bin number, bin summary and other results via IEEE-488 bus

Bias can be applied to capacitors being measured, either by programming the selection of an internal supply (2 V) or by sliding a switch to connect an external voltage source (up to 60 V).

A choice between two interface options provides full “talker/listener” and “talker only” capabilities consistent with the standard IEEE-488 bus. (Refer to the IEEE Standard 488-1978, Standard Digital Interface for Programmable Instrumentation.)

1.2 General Description

1.2.1 1693 RLC Digibridge Overview

The basic features of the 1693 are provided on the vertical front panel. These include the keypad, display, and the power OK/OFF button. The set of four bnc connectors for connection to the test fixture is supplied on the front panel, but can be relocated to the rear if that is preferred. The display-panel and keyboard indicators serve to inform and guide the operator in manipulating the simple controls, or to indicate that remote control is in effect.

The 1693 instrument also stands on a table or bench, where the bail provided under its front edge can be used to tilt it back for operator convenience. This model goes particularly well in a rack, with its vertical front panel and cable connection (from either front or rear) to a suitable test fixture. The sturdy metal cabinet is durably finished, in keeping with the long-life circuitry inside. Glass-epoxy circuit boards interconnect and support high-quality components to assure years of dependable performance.

Adaptability to any common ac power line is assured by the removable power cord and the convenient line voltage switch. Safety is enhanced by the fused isolating power transformer and the 3-wire connection.

1.2.2 References

Electrical and physical characteristics are listed in Specifications at the front of this manual. Interface connections and instrument dimensions are given in Installation, Chapter 1. Controls are described below in Chapter 1; their use, in Operation, Chapter 3. A functional description is given in Theory, Chapter 4.

1.3 Controls, Indicators, and Connectors

Figure 1-1 shows the front of the 1693 instrument. Figure 1-2 shows the display on the front panel and Figure 1-3 shows the controls. Table 1-1 identifies them with descriptions and functions. Similarly, Figure 1-4 shows the controls and connectors on the rear of the 1693. Table 1-2 identifies them.



Figure 1-1: 1693 RLC Digibridge, front view

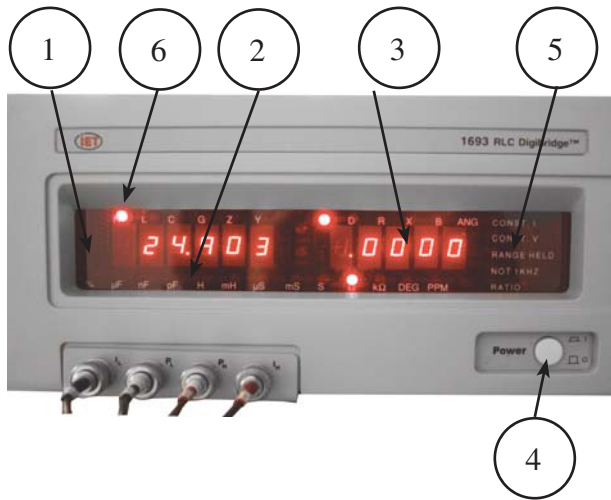

Figure 1-2: 1693 Front Display

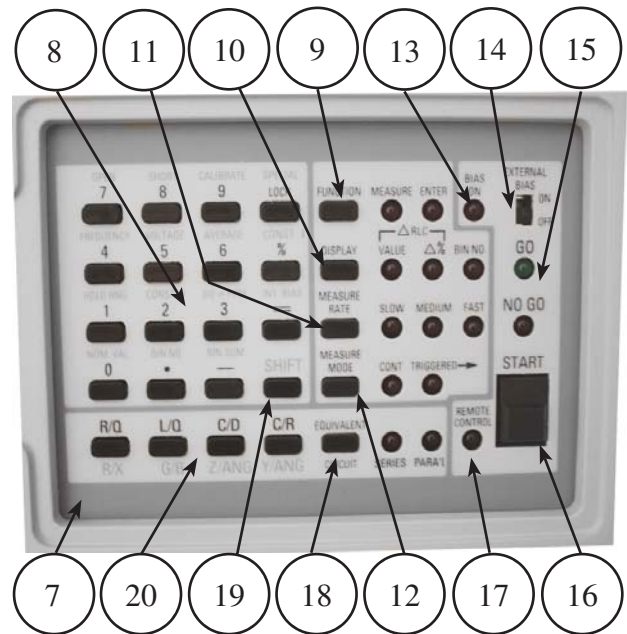

Figure 1-3: 1693 Keyboard

Reference	Name	Description	Function
1	RLCGZY Display	Digital display, 5 numerals with decimal points and negative sign (-) when applicable.	Display of the principal measured value. If function is MEASURE and display section is VALUE, Number indicates R, L, C, G, Z, or Y. If display selection is delta% or delta RLC, indicates percentage difference or value difference respectively of R, L, C, G, Z, or Y compared to stored nominal value. If display selection is BIN NO., indicates bin assignment is measured DUT. If function is ENTER, displays are indications of programmed entries, special functions, bin sum, status in calibration sequences, etc.
2	Units and multipliers	LED indicators	Indicates measurement units associated with the primary and secondary display. Indicates “%” if display selection is delta%. Indicates “PPM” if Q or D display selection is parts per million.
3	QDRXBAng Display	Digital display, 5 numerals with decimal points and negative sign (-) when applicable.	If function is MEASURE, display of secondary measured value of if display is BIN NO. blank. If function is ENTER, RLC, QDR display together indicate programmed entries, special functions, status in calibration sequences, etc.
4	POWER switch	Pushbutton (push again to release)	Switches the Digibridge ON, button in and Off, button out. OFF position breaks both sides of the power circuit.
5	Other display panel indicators	LED indicators	CONST I indicates that a fixed current has been selected. CONST V indicates that measurement source resistance is fixed at 25 ohms. RANGE HELD indicates that the autoranging is disabled. NOT 1kHz indicates that a frequency other than 1kHz has been selected. RATIO indicates that the ratio mode has been selected.
6	Selected Parameter	LED indicators	Indicated parameter selected for primary and secondary QDRXBAng display.

Reference	Name	Description	Function
7	Keyboard	Group of keys, indicators and 2 other switches	Manual programming and control. Refer to items 7 through 19 for more detail.
8	Programming Keys	Set of 16 keys, generally labeled with black and gray	Multipurpose input of programming instruction, selections, and data. Dual purposes of keys are indicated by color: Black labels apply normally. Gray labels apply immediately after you press and release the [SHIFT] key.
9	[FUNCTION] key	Indicators MEASURE and ENTER	Selection of function. MEASURE enables measurement and some routines that cannot be done in ENTER such as "ZERO" calibrations, keyboard lock or unlock, and part of full recalibration. ENTER enables programming of all special functions, current, frequency, voltage, averaging, delay, nominal value, and binning instructions. Either function allows selection of hold range, constant voltage, DQ in ppm, internal bias, parameter, equivalent circuit, measure mode, measure rate, and display.
10	[DISPLAY] key	Indicators: VALUE, delta%, BIN NO.	Selection of displays for MEASURE function; refer to items 1, 2, and 3 for description of displays. Two indicators are lit simultaneously for delta RLC. This key has no effect on ENTER-function displays.
11	[MEASURE RATE] key	Indicators: SLOW, MED, FAST	Selection of measurement speed as indicated. Speed is also affected by many other choices. Use SLOW for better accuracy and FAST for increased measurement speed.
12	[MEASURE MODE] key	Indicators: CONT, TRIGGERED	Mode selection: CONT, continuously repeating measurement; TRIGGERED, single measurement initiated by START button.
13	BIAS ON Indicator	LED indicator	Indicates that internal bias is on, or EXTERNAL BIAS switch is ON.
14	EXTERNAL BIAS switch	Slide switch, 2 positions: ON and OFF	To connect and disconnect the external bias circuit. External bias is applied via rear connector and optional bias cable.
15	GO/NO-GO indicators	Pair of LED indicators	GO means measured value is acceptable, based on the limits previously stored. NO-GO means RLC or QDR value or both are unacceptable. Indicator remains lighted during next measurement.
16	START button	Pushbutton switch	Starts measurement sequence, aborting any measurement that may be in process. Normally used in TRIGGERED measurement mode.
17	REMOTE CONTROL indicator	LED Indicator	Indicates when remote control is established by external command. Functions only if an IEEE interface option is installed.
18	EQUIVALENT CIRCUIT key	Indicators: SERIES and PARALLEL	Selection of equivalent circuit for R/Q, C/D, L/Q or C/R. R/X is also series, G/B is always parallel, Z/Ang and Y/Ang are magnitude.
19	SHIFT Key	Key labeled SHIFT	Pressing this shifts the role of any key labeled in both black and gray FROM the BLACK TO the gray label. Do NOT hold the [SHIFT] key down, press it first and then the other key.
20	Parameter keys	Set of 4 keys, labeled: R/Q, C/D, L/Q, C/R, R/X, G/B, Z/Ang, Y/Ang	Selection of principal and secondary measurement parameters. In the ENTER mode, repeated pushing of any one parameter key changes the range in sequence 1 2 3 4 And hence measurement values.

Table 1-1: Front controls and indicators

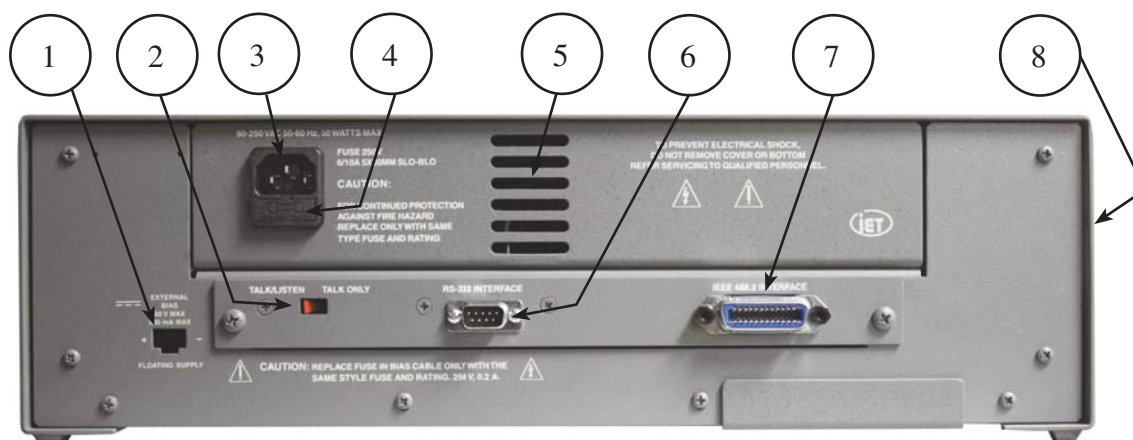

Figure 1-4: Rear controls and connectors on 1693 Digibridge

Reference	Name	Description	Function
1	EXTERNAL BIAS Connector	Connector, 2 pins, labeled 60V max, 200mA max, + -.	For External Bias supply. Optional cable available 1658-2450. Cable comes with a fuse (2/10 A, 250V, 3AG type, fast blow).
2	TALK switch*	Toggle switch	Selection of mode of IEEE-488 interface: TALK/LISTEN or TALK ONLY as labeled.
3	Power Connector	Shrouded 3-wire receptable labeled 90-250VAC, 50-60 Hz, 60W MAX.	AC power input
4	Fuse	Fuse in power input module drawer (6/10 A, 250V, 5x20mm, slow blow)	Short-circuit protection. Replace only with the same rating. To replace, press up on the release tab to remove fuse drawer.
5	Side Vent	Air passage	Ventilation
6	RS-232 Interface	RS-232 Interface for updating firmware of IEEE Card	Firmware can be updated using standard RS232 cable and software from IET.
7	IEEE-488 Interface connector	Socket, 24-pin. Received IEEE-488 interface cable.	Input/Output connections according to IEEE-488 standard. Functions: complete remote control. Output of selected results with or without PC.
8	Vent	Air passage	Ventilation
Not shown	Internal Fuse	1/4 A, plug-in type, sub-miniature, quick acting.	Protects instrument circuitry from damage by charged capacitors.

*TALK switch and IEEE connectors are supplied with the IEEE interface option only. Otherwise blank panel is installed.

Table 1-2: Rear controls and connectors

1.4 Accessories

IET makes several accessories that enhance the usefulness of each Digibridge. A choice of extender cables facilitates connection to a parts handler or to any DUT that does not readily fit the test fixture. Extender cables are available with your choice of banana plugs, BNC, or type 874 connectors. Each cable has 4 separate connectors for true 4-terminal connections (and guard) to the device being measured, without appreciable reduction in measurement accuracy. A remote test fixture is available to receive hand-inserted components at a distance from the Digibridge

1.4.1 Supplied accessories

- Extender cable, bnc-to-bnc (1-meter long)
- Power cable
- Instruction manual
- Calibration certificate traceable to SI

1.4.2 Optional Accessories



Remote Test Fixture 1689-9600



Kelvin Test Leads 1700-03



Alligator Clip Leads, 1 Meter 7000-04
(May also be used as bnc-to-banana-plug connector)



Digibridge Calibration Kit 1689-9604
(Requires Remote Test Fixture: 1689-9600)



bnc-bnc Extender Cable, 2-Meter 1689-9602-2



Chip Component Tweezers 7000-05



IEEE Digibridge Interface 1689-9640



Rackmount Kit 1689-9611



1657-9600 Banana-Plug Extender Cable
(Requires Remote Test Fixture: 1689-9600)

Operating Guide for Model 1693 RLC Digibridge

1. General Information

The 1693 RLC Digibridge is a microprocessor-controlled, automatic RLC meter.

Measurement parameters: R/Q, L/Q, C/D (series or parallel), R/X (series), G/B (parallel), Z/Angle or Y/Angle Ranges:

Parameter	Direct Reading Range	Ratio and DQ in PPM
R and Z	0.00001 Ω to 99999 kΩ	0.00010 Ω to 9999.9 GΩ
L	0.00001 mH to 99999 H	0.00010 mH to 9999.9 MH
C	0.00001 pF to 99999 μF	0.00010 pF to 9999.9 F

Test frequencies: Over 500 selectable test frequencies ranging from 12 Hz to 200 kHz

Applied voltage: 5 mV to 1.275 V (programmable in 5 mV steps)

Measurement speed: Up to 19 measurements per second

Bias: Internal: 2.0 Vdc; External: 60 Vdc max

Accuracy: Basic RLCGZY: ±0.02%

2. Starting-up

- If the Digibridge includes an optional IEEE-488 interface, set [TALK] switch (rear panel) to **TALK ONLY** (unless instructions are to be received through the IEEE-488 bus).
- Make sure the [EXTERNAL BIAS] is in the **OFF** position.
- Press the [POWER] button.
- The unit runs a brief self-check on start-up.
- If a fault is detected, measurements are blocked and an error code remains displayed. See manual, paragraph 3.13.
- If keyboard lights remain dark, keyboard is locked. To unlock it, see manual paragraph 3.9.

3. Obtaining optimal accuracy by zeroing

Before making measurements, zero the Digibridge as follows: (Note: For best accuracy, repeat this procedure every day, after each change of frequency, and after any change of test-fixture adaptors.)

- Attach extender cables or whichever test fixture/adaptor is appropriate.
- Create an open circuit by having the spacing between + and - cable ends match the spacing of the DUT terminals. See the figure.

If the spacing of DUT terminals is unknown, make sure that the + and - ends of the cable are at least 0.75" (19 mm) apart.

- Confirm that MEASURE keyboard light is lit.
- Press [MEASURE MODE] key to select TRIGGERED mode
- Press the following keys: [1] [6] [9] [3] [=] [SHIFT] [OPEN].
- Press [START] and wait for the green GO light.
- Create a short circuit across test terminals by connecting all cable ends together as shown in the figure.
- Press the following keys: [1] [6] [9] [3] [=] [SHIFT] [SHORT].
- Press [START] and wait for the green GO light.
- At this point, the unit should be ready for taking measurements. If something goes wrong during the zeroing process, the procedure should be repeated.

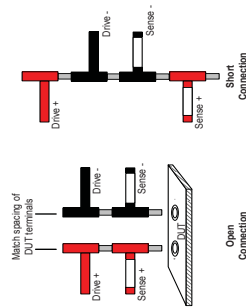

Observe all safety rules when working with high voltages or line voltages. Connect the (G) terminal to earth ground in order to maintain the case at a safe voltage. Whenever hazardous voltages (>45 V) are used, take all measures to avoid accidental contact with any live components: a) Use maximum insulation and minimize the use of bare conductors. b) Remove power when adjusting switches. c) Post warning signs and keep personnel safely away.



IET LABS, INC.
CAGE CODE: 62015
www.ietlabs.com

• 534 Main Street, Westbury, NY 11590 • (516) 334-5959 • Fax: (516) 334-5988

Figure 1-5: Typical operating guide attached to 1693

4. Taking measurements

a. Select measurement conditions as follows:

- [FUNCTION] key selects **MEASURE** mode
 - [DISPLAY] key selects **VALUE**, $\Delta\%$, or **BIN NO**
 - [MEASURE RATE] key selects **SLOW**, **MEDIUM**, or **FAST**
 - [MEASURE MODE] key selects **CONTINUOUS** or **TRIGGERED**
 - [EQUIVALENT CIRCUIT] key selects **SERIES** or **PARALLEL**
- b. Select impedance to be measured as follows
- [RIQ] key to show Resistance in the primary display and Quality factor in the secondary display
 - [LQI] key to show Inductance in the primary display and Quality factor in the secondary display
 - [CDI] key to show Capacitance in the primary display and Dissipation in the secondary display
 - [CR] key to show Capacitance in the primary display and Resistance in the secondary display
 - to select other parameters, press and hold [SHIFT] key and select as appropriate
- c. Connect component to be tested to the test terminals as appropriate.
- d. If in the **TRIGGERED** mode, press [START].

Keep hands and objects at least 10 cm (4 in) from test fixture. If NEG RLC lights, the selected parameter is not appropriate for the DUT and another parameter should be selected. For example, if the Digibridge is set to measure capacitance, and NEG RLC is lit, that means that the DUT is inductive.

To view relative measurements, the nominal value and the bin limits must be first programmed. (See section 5 below.) Once the values have been programmed, select one of the following options by pressing the [DISPLAY] key:

- % difference from the nominal value: $\Delta\%$ must be lit
- Difference from nominal in original units (pF, mH, etc.): **VALUE** and $\Delta\%$ must both be lit
- Assigned bin number: **BIN NO** must be lit

The following programmable functions are available:

Parameter	Range	Default	Sample setting adjustment	Cancel	View Current Setting
Test frequency	12 Hz to 200 kHz	1 kHz	Programming 400 Hz: [FUNCTION] [1] [4] [=] [SHIFT] [FREQUENCY]	NA	[SHIFT] [FREQUENCY]
Test voltage	5 mV to 1.275 V	1 V	Programming 15 mV: [FUNCTION] [1] [0] [1] [9] [=] [SHIFT] [VOLTAGE]	NA	[SHIFT] [VOLTAGE]
Averaging	1 to 256	1	Programming 25 measurements: [FUNCTION] [2] [5] [=] [SHIFT] [AVERAGE]	[FUNCTION] [1] [=] [SHIFT] [AVERAGE]	[SHIFT] [AVERAGE]
Delay	0 to 99.999 ms	0	Programming a delay of 200 ms: [FUNCTION] [2] [0] [0] [=] [SHIFT] [DELAY]	[FUNCTION] [0] [=] [SHIFT] [DELAY]	[SHIFT] [DELAY]
Internal Bias	2 V	OFF	[SHIFT] [INT BIAS]	[SHIFT] [INT BIAS] again	NA
D and Q in PPM	NA	OFF	[SHIFT] [DQ in PPM]	[SHIFT] [DQ in PPM] again	NA
Hold constant voltage	NA	OFF	[SHIFT] [CONST V]	[SHIFT] [CONST V] again	NA
Hold constant range	NA	OFF	Select the desired range then [SHIFT] [HOLD RNG]	[SHIFT] [HOLD RNG] again	NA

Model: 1693-9700

SN: 9090035011

WARNING

Observe all safety rules when working with high voltages or line voltages. Connect the (G) terminal to earth ground in order to maintain the case at a safe voltage. Whenever hazardous voltages (>45 V) are used, take all measures to avoid accidental contact with any live components: a) Use maximum insulation and minimize the use of bare conductors. b) Remove power when adjusting switches. c) Post warning signs and keep personnel safely away.



Chapter 2

INSTALLATION

2.1 Unpacking and Inspection

This instrument was carefully inspected before shipment. It should be in proper electrical and mechanical order upon receipt.

An OPERATING GUIDE is attached to the instrument to provide ready reference to specifications and operating information.

If the shipping carton is damaged, inspect the instrument for damage (scratches, dents, broken parts, etc). If the instrument is damaged or fails to meet specifications, notify the carrier and IET Labs for RMA number. Retain the shipping carton and the packing material for carrier's inspection.

2.2 Dimensions

Width = 440 mm (17.3")

Height = 147 mm (5.8")

Depth = 377 mm (14.8")

2.3 Power Line Connection

This instrument uses a standard IEC input module.

The input fuse is located in the drawer above the input power module. If it has to be replaced, be sure to use a "slow blow" fuse, 250 V, 6/10 A, 5x20 mm. See Figure 2-1.



Figure 2-1: Input power module with a drawer for the input fuse

2.4 Line-Voltage Regulation

The accuracy of measurements accomplished with precision electronic test equipment operated from ac line sources can often be seriously degraded by fluctuations in primary input power. Line-voltage variations of $\pm 15\%$ are commonly encountered, even in laboratory environments. Although most modern electronic instruments incorporate some degree of regulation, possible power-source problems should be considered for every instrumentation setup. The

use of line-voltage regulators between power lines and the test equipment is recommended as the only sure way to rule out the effects on measurement data of variations in line voltage.

2.5 Test-Fixture Connections

An external test fixture or cables are always required, because connection from the 1693 Digibridge to the DUT is provided via BNC cables (from connectors that can be positioned at either front or rear of the instrument, as described in Chapter 5). For general purposes, the recommended test fixture, cable, and their connections are as follows. Refer to paragraphs 1.4 and 3.2 for more information about accessories.

On 1693	Description	Cable	On
IL	Drive -	Black Band	I+
PL	Potential -	Black and White Band	P+
PH	Potential +	Red and White Band	P-
IH	Drive +	Red Band	I-

COMMENT: It is important that the IL and PL leads connect to the same end of the DUT (and that PH and IH connect to the other end). Also, connecting IL/PL to the test-fixture connectors labeled “+” (and IH/PH to “-”) assures that the test fixture’s “+” and “0” labels agree with the bias polarity.

NOTE: In the cable’s color code, RED is associated with “hot” leads, which have dc voltage, negative with respect to ground, when bias is used.

2.6 Bias Voltage for the DUT

2.6.1 Internal Bias

No external connections are required for the internal 2-volt bias. 2V bias is supplied internally by the instrument.

2.6.2 External Bias

External bias can be provided by connecting a suitable current-limited, floating dc voltage source, as follows.

- Be sure that the voltage is never more than 60 V, max.
- A current limiting voltage supply is recommended; set the limit at 200 mA, max.
- Be sure that the bias supply is floating; DO NOT connect either lead to ground.
- A well-filtered supply is recommended. Bias-supply hum can affect some measurements, particularly if test frequency is the power frequency.
- Generally the external circuit must include switching for both application of bias after each DUT is in the test fixture and discharge before it is removed.
- Connect the external bias voltage supply and switching circuit, using the optional 1658-2450 cable, via the rear-panel EXTERNAL BIAS connector. Observe polarity marking on the rear panel; connect the supply accordingly.

2.7 IEEE-488 Interface

2.7.1 Description

If you have the IEEE Interface option 1689-9640 (see Figure 2-2), you can use this instrument as part of a system comprised of other test instruments, printers and a PC, with each assigned its own bus address. The simplest system could consist of this instrument and just a printer. The documentation of each instrument describes the details of how to communicate with it, and how it communicates with other instruments, as appropriate.



Figure 2-2: IEEE-488 interface

All instruments are inter-connected using standard IEEE-488 cables, in nearly any combination of hub and daisy-chain connections, subject only to length-of-run restrictions. Standard IEEE-488 connectivity uses a 24-pin connector carrying 16 signal lines plus several ground connections and a shield.

This instrument will function as either TALK/LISTEN or a TALK ONLY device in the system, depending on the position of the TALK switch. “TALK/LISTEN” denotes full programmability and is suited for use in a system that has a controller or computer to manage the data flow. The “handshake” routine assures that the active talker proceeds slowly enough for the slowest listener that is active, but not limited by any inactive (unaddressed) listener. “TALK” is suited to a simpler system -- e.g. Digibridge and printer -- with no controller and no other talker. Either mode provides measurement results to the active listeners in the system.

2.7.2 Signal Identification

For a key to signal names, functions, and pin numbers. Further explanation is found in the IEEE-488.2 Standard.

2.7.3 Codes and addresses

General. The device-dependent messages, such as instrument programming commands and measurement data (which the digital interface exists to facilitate), have to be coded in a way that is compatible between talkers and listeners. They have to use the same language. Addresses have to be assigned, except in the case of a single “talker only” with one or more “listeners” always listening. The Standard sets ground rules for these codes and addresses.

In this instrument, codes for input and output data have been chosen in accordance with the IEEE-488.2 rules. The address (for both talker and listener functions) is user selectable, as explained below.

Instrument Program Commands. The set of commands used in remote programming is an input data code to which the instrument will respond as a “talker/listener”, after being set to a remote code and addressed to listen to device-dependent command strings. The set includes all of the keyboard functions except switching external bias ON/OFF and full recalibration, which are not remotely programmable.

Refer to paragraph 3.11.7 for a table of the commands used in programming.

Address. The initial setting of address, provided by the factory, is binary 00011, decimal 3. Consequently, the talk address command (MTA) is C in ASCII code and, similarly, the listen-address command (MIA) is #. If a different address pair is desired, set it manually using the following procedure.



**Shock hazard and static electricity
can cause damage.**

**Disassembly should be preformed by
qualified personnel only.**

1. Take the Digibridge to a qualified electronic technician who has the necessary equipment for minor disassembly and adjustment. Have the electronic technician remove the interface option assembly, as described in his 1693 Digibridge Service instructions.
There is no need to remove the top cover first.
2. Have the electronic technician set the switches in “DIP” switch assembly S2 to the desired address, which is a 5-bit binary number. (See below.)



Figure 2-3: DIP switch set to Decimal Address 3

3. Have the electronic technician replace the interface option assembly in its former place. Notice that S2 is located at the end of the interface option board, about 3 cm (1 in.) from the TALK switch S1.

If S2 is covered

- A. Lift the cover off, exposing the “DIP” switch, which has 5 tiny switches, numbered 1 thru 5.
- B. To enter logical 1’s, depress the side of each switch nearest the end of the board (switch open).
- C. To enter logical 0’s, depress the other side of the switch (switch closed). The address is read from 5 to 1.

Thus, for example, to set up the address 00011, enter 0’s at positions 5, 4, 3; enter 1’s at positions 2 and 1. (This makes the talk address “C” and the listen address “#”.)

Strictly speaking, the address includes more; S2 determines only the device-dependent bits of the address. You cannot choose talk and listen addresses separately, only as a pair. The list of possible pairs is shown in Table 2-1.

The GPIB Address of the Digibridge is set by the SW2 DIP Switch. The numeric value is set by setting the switch on or off for the corresponding bit with the OFF position for binary 1 and ON position for binary 0. Depress the rocker toward the OFF marking for OFF and toward the numeric marking for the corresponding ON position.

Decimal Address	Switch Settings				
	S1	S2	S3	S4	S5
0	ON	ON	ON	ON	ON
1	OFF	ON	ON	ON	ON
2	ON	OFF	ON	ON	ON
3	OFF	OFF	ON	ON	ON
4	ON	ON	OFF	ON	ON
5	OFF	ON	OFF	ON	ON
6	ON	OFF	OFF	ON	ON
7	OFF	OFF	OFF	ON	ON
8	ON	ON	ON	OFF	ON
9	OFF	ON	ON	OFF	ON
10	ON	OFF	ON	OFF	ON
11	OFF	OFF	ON	OFF	ON
12	ON	ON	OFF	OFF	ON
13	OFF	ON	OFF	OFF	ON
14	ON	OFF	OFF	OFF	ON
15	OFF	OFF	OFF	OFF	ON
16	ON	ON	ON	ON	OFF
17	OFF	ON	ON	ON	OFF
18	ON	OFF	ON	ON	OFF
19	OFF	OFF	ON	ON	OFF
20	ON	ON	OFF	ON	OFF
21	OFF	ON	OFF	ON	OFF
22	ON	OFF	OFF	ON	OFF
23	OFF	OFF	OFF	ON	OFF
24	ON	ON	ON	OFF	OFF
25	OFF	ON	ON	OFF	OFF
26	ON	OFF	ON	OFF	OFF
27	OFF	OFF	ON	OFF	OFF
28	ON	ON	OFF	OFF	OFF
29	OFF	ON	OFF	OFF	OFF
30	ON	OFF	OFF	OFF	OFF
31	Not Used				

Table 2-1: IEEE-488 address settings

In the above example, the remote message codes: MLA and MTA are X0100011 and X1000011, respectively. Thus, the listen address and the talk address are distinguished, although they contain the same set of device-dependent bits, which you set into S2.

Data Output: Data (results of measurements) are provided on the D101...D107 lines as serial strings of characters. Each character is a byte, coded according to the 7-bit ASCII code, as explained above. The alphanumeric characters used are appropriate to the data, for convenience in reading printouts. The character strings are always provided in the same sequence as that tabulated in paragraph 3.11.13; for example: RLC value, QDR value, bin number - if all 3 were selected (by the X7 command). The carriage-return and line-feed characters at the end of each string provide a printer (for example) with the basic commands to print each string on a separate line.

For example, if the measurement was 0.54321 μF (1 kHz, range 4 held), the character string for RLC value is:

U(space)C(space) μF (2 spaces)0.54321(CR)(LF)

If the D measurement was .001, the character string for QDR value is:

(2 spaces)D(5 spaces)00.0010(CR)(LF)

If the measurement falls into bin 9, the character string for bin number is:

F(space)BIN(2 spaces)9(CR)(LF)

The character string for RLC value has the length of 17 characters; for QDR value, 17 characters; for bin number, 10 characters - including spaces, carriage-return, and line-feed characters. Refer to the format tables in Section 3.11.12 for details.

2.8 Environment

The Digibridge can be operated in nearly any environment that is comfortable for the operator. Keep the instrument and all connections to the parts under test away from electromagnetic fields that may interfere with measurements.

Position the instrument with consideration for ample air flow to the side and rear ventilation holes. The recommended space around the instrument is at least 3" (75 mm). The surrounding environment should be free from excessive dust to prevent contamination of electric circuits.

Refer to the Specifications at the front of this manual for temperature and humidity tolerances. To safeguard the instrument during storage or shipment, use protective packaging. Service personnel refer to Section 5.

When the Digibridge is mounted in a rack or other enclosed location, make sure that the ambient temperature inside the rack does not exceed the limits specified under "Environment" in the Specifications at the front of this manual, and that air can circulate freely past all air inlet and outlet vents.

2.9 Rack Mount Option

To rack mount the unit, place the instrument on the shelf (1689-9611) so that its feet drop through the large holes.

Then position this assembly in the rack as desired and secure with four 10-32 screws. If the rack does not have threaded holes, use the supplied clip nuts.

Chapter 3

OPERATION

3.1 Basic Operation

3.1.1 Overview

For initial familiarization with the Digibridge™ RLC tester, follow the procedure carefully. After that, refer back to this section as required. Condensed operating instructions are provided near the front of this manual as well as on the unit itself.

3.1.2 Startup



Before the unit is powered up, the internal temperature of the Digibridge must be above 0°C. Otherwise, the instrument may be damaged by thermal shock.

1. Plug in the unit.
2. If the Digibridge tester includes an optional IEEE-488 interface, set TALK switch (rear panel) to TALK ONLY (unless instructions are to be received through the IEEE-488 bus).
3. Switch EXTERNAL BIAS OFF (front panel).
4. Press -the POWER button “in”, so that it stays in the depressed position.

Self-check codes will show briefly, indicating that the instrument is automatically executing a power-up routine that includes self checks.

5. (To turn the instrument off, push and release the POWER button and leave it in the “out” position.)
6. Wait until keyboard lights indicate MEASURE, VALUE, SLOW, CONT (or TRIGGERED), SERIES. If they do not, there are two possible explanations: self-check fault and keyboard lock.

If a fault is detected in the self-check, measurements are blocked and an error code remains displayed. Under some conditions, the block to operation can be bypassed. (See paragraph 3.13.) If the keyboard is locked, all of those keyboard indicators remain unlit except MEASURE and/or REMOTE CONTROL - and all previously programmed test conditions, limits, etc are reestablished. To unlock it, see paragraph 3.9.

3.1.3 Zeroing

In the zeroing process, the instrument automatically measures stray parameters and retains the data, which it uses to correct measurements so that results represent parameters of the DUT alone, without (for example) test-fixture or adaptor capacitance.

Before measurement, zero the Digibridge as follows.:

1. Set conditions: SLOW measure rate, 1 V test voltage (default), RANGE HELD indicator NOT lit.
2. To measure open circuit
 - A. Press [FUNCTION] key (if necessary) to select MEASURE function.
 - B. Press [MEASURE MODE] key (if necessary) to select TRIGGERED mode.
 - C. Connect the remote test fixture or at least the BNC cables and adaptors that will contact the DUT.
 - D. Be sure that the test fixture is open circuited.

If you want this “zero” process to echo a display of 0 00000, press the [C/D] key. However doing so will disable automatic parameter selection. (See paragraph 3.1.4, step 2.).

- E. Press the following keys: [1] [6] [9] [3] [=] [SHIFT] [OPEN]

Note: the GO indicator being lit and two zeros confirm the previous step. Watch the GO indicator on the keyboard; not one on any remote test fixture.

- F. Keep hands and objects at least 10 cm (4 in.) from test fixture.
- G. Press the START button.

The GO indication disappears.

- H. Wait for the GO indicator to be lit again.

3. To measure short circuit:
 - A. Short the fixture with a clean copper wire (AWG 18 to 30), length 5 to 8 cm.
 - B. Press the following keys: [1] [6] [9] [3] [=] [SHIFT] [SHORT].

Note: the GO indicator being lit and two fives confirm the previous step.

- C. Press the START button.

The GO indication disappears.

- D. • Wait for the GO indicator to be lit again.
- E. • Remove the short circuit.

Note: For best accuracy, repeat this procedure daily and after changing test-fixture adaptors or frequency..

3.1.3.1 Zeroing with various test fixtures

This section contains information on proper open and short connections for various types of cables for use with the 1693 Digibridge.

7000-04 Banana and 1657-9600 Extender Cables

Open and short should be performed as shown in Figure 3-1 below when using banana plugs. When performing Open the spacing between the pairs should be the same as the spacing of the terminals on the DUT or if unknown a minimum of 0.75". Short should be performed as shown and it is important to keep senses and drives in the correct order.

Geometry:

If is important to maintain the spacing between the leads during the open compensation at exactly the same distance as the spacing is when the banana plugs are connected to the DUT. If the spacing is not exactly the same there will be an error in the measured value. This is due to the fact that the four terminal Kelvin connection stops at the connection between Drive and Sense. The banana plugs are two-terminal so the capacitance between the parallel spaced banana plugs will be measured as part of the overall measurement unless open compensation is performed to eliminate this additional capacitance.

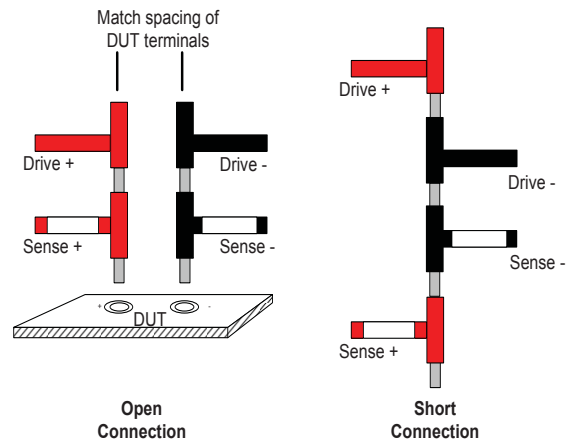

Figure 3-1: Open and short measurements with banana plugs

1700-03 Kelvin Cables

Open and short should be performed as shown in Figure 3-2 below when using Kelvin cables. When performing an open jaws of clips must be closed. During short it is important to match drives and sense exactly as shown.

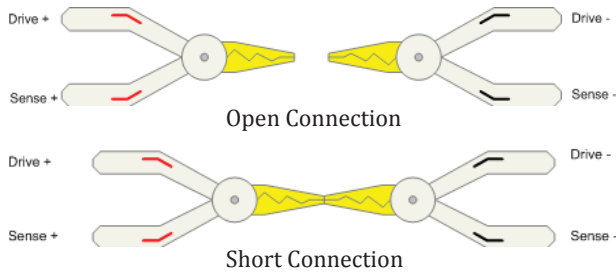

Figure 3-2: Open and short measurements with Kelvin cables

1689-9602 and 1689-9602-2 bnc-to-bnc Cables with bnc-T

Open and short should be performed as shown in Figure 3-3 below when using bnc-to-bnc cables with bnc-T connectors. During short connection two Pomona 3283 bnc (F)-(F) adapters are used to connect potential together and drives together.

Geometry:

It is important to maintain the spacing between the leads during the open compensation at exactly the same distance as the spacing is when the banana plugs are connected to the DUT. If the spacing is not exactly the same there will be an error in the measured value. This is due to the fact that the four terminal Kelvin connection stops at the connection between Drive and Sense. The banana plugs are two-terminal so the capacitance between the parallel spaced banana plugs will be measured as part of the overall measurement unless open compensation is performed to eliminate this additional capacitance.

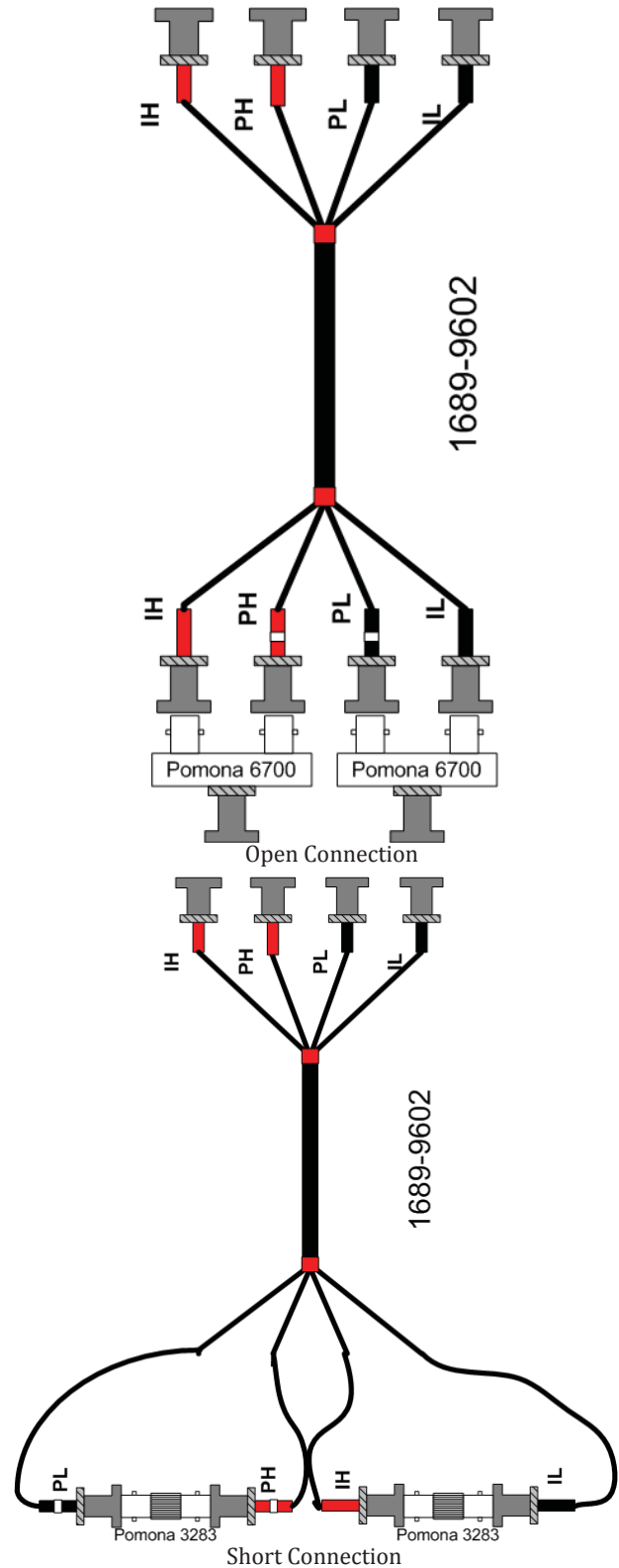

Figure 3-3: Open and short measurements with bnc-to-bnc cables

1689-9602 and 1689-9602-2 bnc-to-bnc Cables with bnc-T and GR874 Connectors

Open and short should be performed as shown in Figure 3-4 below when using bnc-to-bnc cables with bnc-T connectors and the GR874 adapters. During short connection connect the two GR874 connectors together. During open compensation spacing similar to the DUT or at least 0.75" should be maintained to minimize capacitance between the GR874 connectors.

Geometry:

If is important to maintain the spacing between the leads during the open compensation at exactly the same distance as the spacing is when the banana plugs are connected to the DUT. If the spacing is not exactly the same there will be an error in the measured value. This is due to the fact that the four terminal Kelvin connection stops at the connection between Drive and Sense. The banana plugs are two-terminal so the capacitance between the parallel spaced banana plugs will be measured as part of the overall measurement unless open compensation is performed to eliminate this additional capacitance.

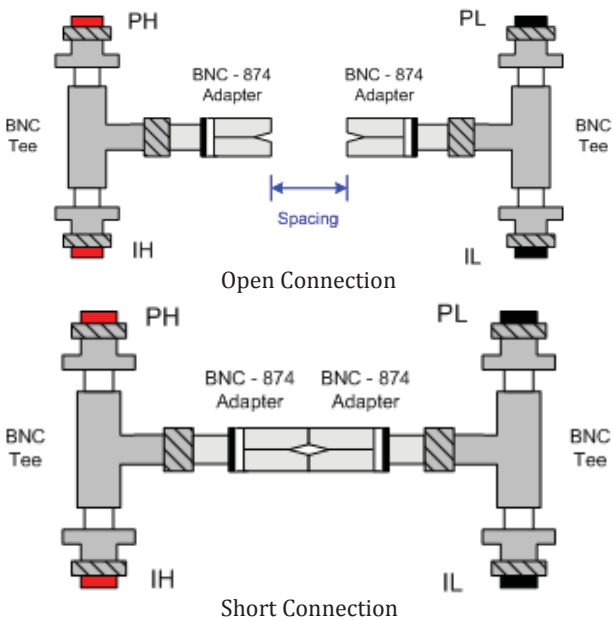

Figure 3-4: Open and short measurements with GR874 connectors

7000-05 Tweezers

The small amounts of residual-tip resistance and inductance can be automatically corrected by using the Digibridge shorting function with the tips pressed together. Guard shields between the tweezer blades minimize capacitance between them. A correction for this small capacitance can be made using Digibridge open circuit test with the tips held at a spacing equal to that of the component's contact spacing.

Measurement accuracy is very sensitive to connection geometry. The same connection geometry must be used for open/short compensation as for connection to the device under test.

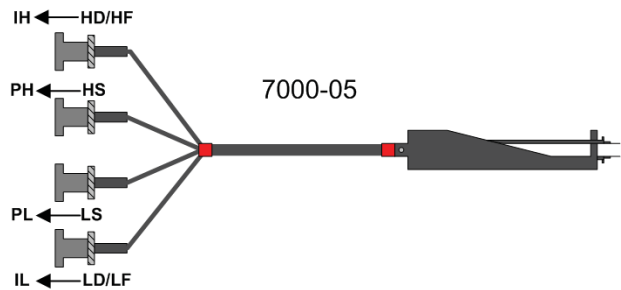

Figure 3-5: Chip component tweezers

1689-9600 Test Fixture

Ideally zeroing with the 1689-9600 should be performed with the 1689-9604 Digibridge Calibration kit.

The alternate method for performing open and short using two 18 AWG bus wires for the open and one loop of 18 AWG bus wire for a short. Two wires should be used to perform an open to ensure that the pairs of contacts in the 1689-9600 are connected. See Figure 3-6 below.

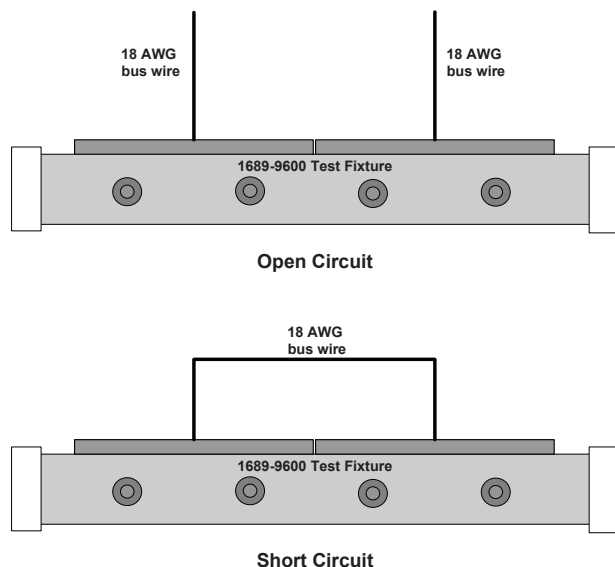

Figure 3-6: Open and short measurements in 1689-9600

3.1.4 Routine Measurement

- Verify or select measurement conditions as follows (indicated by keyboard lights); press the adjacent key to change a selection.
 - Function: MEASURE ([FUNCTION] key), a necessary selection
 - Display: VALUE ([DISPLAY] key), for normal RLC/QDR results
 - Measure rate: SLOW ([MEASURE RATE] key), for best accuracy
 - Measure mode: TRIGGERED ([MEASURE MODE] key), optional
 - Equivalent circuit: SERIES ([EQUIVALENT CIRCUIT] key) - see paragraph 3.3.

If you are in doubt about how to connect the device to be tested with the Digibridge, refer to paragraph 3.2, below.

- To measure any passive component (without knowing whether it is essentially a resistor, inductor, or capacitor), use “automatic parameter selection”.

This feature is provided at power-up and remains enabled as long as you do NOT select any particular parameter. (Automatic parameter selection can be disabled by pressing the [C/D] key, for example. Once disabled, this feature can be enabled again by selecting the ENTER function and then pressing these keys:

[I]=[SHIFT][SPECIAL][7]

- Place DUT in test fixture. Press START. (See note below.)

The RLC display and units indicator show the principal measured value and the basic parameter, thus identifying the DUT. The QDR display shows the measured Q if the principal units are ohms or henries; the measured 0 if they are farads.

- To measure G and D of a Capacitor (C Range .00001 pF to 99999 μ F, 0 range .0001 to 9999):
 - Press [C/D].
 - Place capacitor in test fixture.
 - Press START.

The RLC display shows C_s (series capacitance) and units (μ F, nF, pF); the QDR display shows D (dissipation factor). {If RLCGZY is negative, the DUT is inductive.}

- To measure C and R of a Capacitor (C Range .00001 nF to 99999 μ F, R range .0001 ohm to 9999 kilohm):
 - Press [C/R].
 - Place capacitor in test fixture.
 - Press START.

The RLC display shows O_s (series capacitance) and units (μ F, nF); the QDR display shows R_s (equivalent series resistance) and units (ohms, kilohms). {If RLCGZY is negative, DUT is inductive.}

- To measure L and Q of an Inductor (L range .00001 mH to 99999 H, Q range .0001 to 9999):
 - Press [L/Q].
 - Place inductor in test fixture.
 - Press START.

The RLC display shows L_s (series inductance) and units (mH, H); the QDR display shows Q (quality factor). {If RLCGZY is negative, DUT is capacitive.}

- To measure R and Q of a Resistor (R range .00001 ohm to 99999 kilohms, Q range .0001 to 9999):
 - Press [R/Q].
 - Place resistor in test fixture.
 - Press START.

The RLC display shows R_s (series resistance) and units (ohms, kilohms); the QDR display shows Q (quality factor). {If QDRXBang is negative, DUT is capacitive; if not DUT is inductive.}

8. To measure R and X of a component (R range .00001 Ω to 99999 k Ω , X range .0001 Ω to 9999 k Ω):

- A. Press [SHIFT][R/X].
- B. Place component in test fixture.
- C. Press START.

The RLCGZY display shows R (series resistance) and units (ohms, kohms); the QDRXB Angle display shows X (series reactance) and units (ohms, kohms). {If QDRXB Angle is negative, DUT is capacitive.}

9. To measure G and B of a component (G range .00001 μ S to 99999 S, B range .0001 μ S to 9999 S):

- A. Press [SHIFT][G/B].
- B. Place component in test fixture .
- C. Press START.

The RLCGZY display shows (parallel conductance) and units (μ S, mS, S); the QDRXB Angle display shows B (parallel susceptance) and units (μ S, mS, S). {If QDRXB Angle is negative, DUT is inductive.}

10. To measure Z and Angle of a component (Z range .00001 ohms to 99999 kohms, Angle range .0001 $^\circ$ to 180 $^\circ$):

- A. Press [SHIFT][Z/ANG].
- B. Place component in test fixture
- C. Press START.

The RLCGZY display shows Z (impedance) and units (ohms, kohms); the QDRXB Angle display shows Angle and units (degrees). {If QDRXB Angle is negative, DUT is capacitive.}

11. To measure Y and Angle of a component (Y range .00001 μ S to 99999 S, Angle range .0001 $^\circ$ to 180 $^\circ$):

- A. Press [SHIFT][Y/ANG].
- B. Place component in test fixture.
- C. Press START.

The RLCGZY display shows Y (admittance) and units (μ S, mS, S); the QDRXB Angle display shows Angle and units (degrees). {If QDRXB Angle is negative, DUT is inductive.}

NOTE: This procedure is basic; there are many alternatives described later. You can select and program for other equivalent circuits, types of results displayed, test conditions, measurement rate, and bin sorting, etc.

3.2 Connecting the DUT

3.2.1 Overview



DANGER

Charged capacitors can be dangerous, even lethal. Never handle their terminals if they have been charged to more than 60 V. Routine discharging procedures may not be perfectly dependable.

NOTE: Clean the leads of the DUT if they are noticeably Dirty, even though the test-fixture contacts will usually bite through a film of wax to provide adequate connections. 3-4

Connect the “device under test” (DUT), whose parameters are to be measured, as outlined in the next sections.

3.2.2 The 1689-9600 Remote Test Fixture (with 1689-9602 BNC Cable)

Connection of the DUT at a remote test fixture normally requires:

- Remote Test Fixture 1689-9600, or equivalent fixture or cable
- BNC Cable Assembly 1689-9602 - supplied with 1693 Digibridge

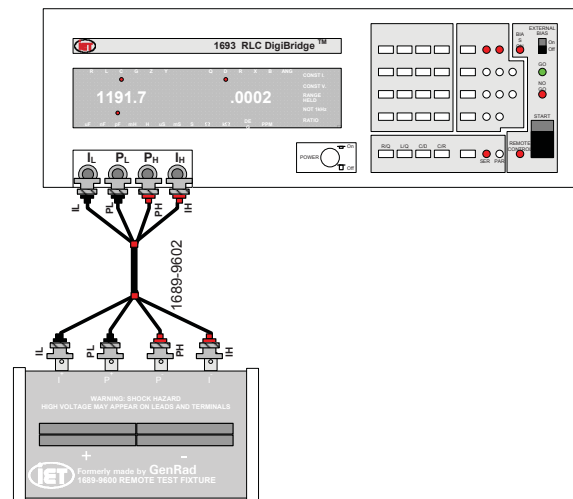

Note: The H connectors on the cable are deliberately connected to the “-” terminals on the test fixture and vice versa.

Figure 3-7: Connecting remote test fixture to RLC Digibridge

This remote test fixture provides that true “Kelvin” connections are made at the points of contact with the DUT leads. The recommended cable should be used (rather than any randomly chosen BNC patch cords) because the known cable parameters enable you to make corrections for best accuracy. Install the remote test fixture as follows.

1. Remove any adaptors, cables, etc, if present, from the DUT port of the instrument.
2. Connect the BNC cable assembly to the Digibridge and to the remote test fixture as indicated in Table 3-1.

Note that red designates leads that may be “hot”. (When bias is applied, they carry the negative voltage with respect to ground.)

On 1693	Bias Polarity	Description	1689-9602 Cable	On 1689-9600
IL	+	Drive -	Black Band	I+
PL	+	Potential -	Black and White Band	P+
PH	-	Potential +	Red and White Band	P-
IH	-	Drive +	Red Band	I-

Table 3-1: Connection of Remote Test Fixture to 1693 with 1689-9602 cable.

3. Before making measurements, be sure to repeat the zeroing procedure (open circuit and short circuit), as described in paragraph 3.1.3. *For notes on cable and fixture capacitance and zeroing, see paragraph 3.1.3, below.*
4. If the DUT is a radial-lead component or has parallel leads at one side, insert them into the Digibridge remote test-fixture slots as described below.

The test fixture provides convenient, reliable, guarded 4-terminal connection to any common radial-lead or axial-lead component part (using adaptors, 1657-5995). an axial-lead component part. The slots in the test fixture accommodate wires with diameters from 0.25 mm (.01 in., AWG 30) to 1 mm (.04 in., AWG 18), spaced from 4 to 98 mm apart (0.16 to 3.9 in.) or equivalent strip conductors. Each “radial” wire must be at least 4 mm long (0.16 in.). The divider between the test slots contains a shield, at guard potential, with its edges semi-exposed. The tapped holes (6-32 thread) at the left and right ends of the test fixture are also grounded, to connect the shields of extender cables.



Figure 3-8: 1689-9600 Remote Test Fixture

3.2.3 Using the Test-Fixture Adaptors for Axial-Lead DUT

If the DUT is an axial-lead component or has leads at opposite ends, insert the leads into the test-fixture adaptor’s slots as shown in Figure 3-9. Install the test-fixture adaptors as shown below; put one in each slot of the test fixture, by pushing vertically downward. Slide the adaptors together or apart so the body of the DUT will fit easily between them.



Figure 3-9: 1689-9600 Remote Test Fixture with 1657-5995 Test Clips

Note that the contacts inside the adaptor are off center; be sure to orient the adaptors so the contacts are close to the body of the DUT, especially if it has short or fragile leads.

The adaptors accommodate wires with diameters up to 1.5 mm (.06 in., AWG 15). The body of the DUT that will fit between these adaptors can be 80 mm long and 44 mm diameter (3.1 x 1.7 in.) maximum. Each

“axial” wire must be at least 3 mm long (0.12 in.]. The overall length of the DUT, including the axial wires must be at least 22 mm (0.866 in.).

Insert the DUT so that one lead makes connection on the left side of the test fixture, the other lead on the right side. Insertion and removal are smooth, easy operations and connections are reliable if leads are reasonably clean and straight. Press the DUT down so that the leads enter the slots in the adaptors as far as they go easily.

Be sure to remove any obvious dirt from leads before inserting them. The test-fixture contacts will wipe through a film of wax, but can become clogged and ineffectual if dirty leads are inserted repeatedly. Be sure to insert only one thing into each half of the test fixture, at anyone time. (If any object is inserted into the same slot with a DUT lead, it will probably NOT make true “Kelvin” connections.)

NOTE: For a DUT with very short leads, it is important to orient each adaptor so that its internal contacts (which are off center) are close to the DUT. To remove each adaptor, lift with a gentle tilt left or right (never forward or back) .

3.2.4 1657-9600 Banana Plug Extender Cable

The 1657-9600 is a male banana plug extender cable with shielded 4-terminal Kelvin connections and guard (3 feet in length) for connecting to 1659, 1689-9700, 1692 Digibridges and 1689-9600 Remote Test Fixture. Terminated with 5 banana plugs and includes 5 alligator clip. Each banana plug has a different color banana plug, red for high and black for low. White bands for potentials and green band for ground see Figure 3-10 below.

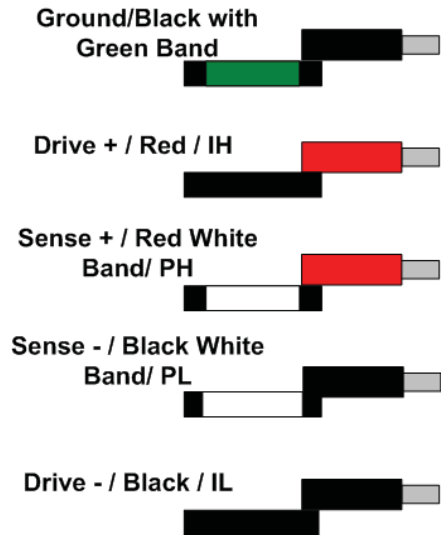
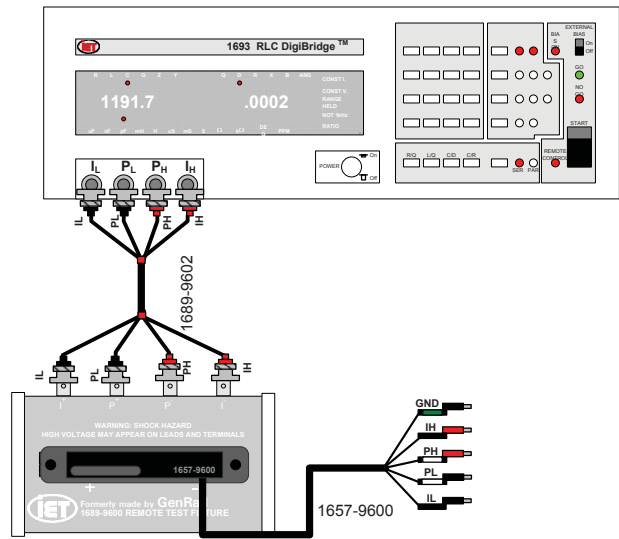

Figure 3-10: Banana plugs on the 1657-9600 cable



Note: The H connectors on the 1689-9602 cable are deliberately connected to the “-” terminals on the test fixture and vice versa.

Figure 3-11: Connecting remote test fixture and the Extender cable to RLC Digibridge

3.2.5 The 1689-9602 Extender Cable with bnc-to-Banana-Plug Adaptors

To connect to DUT's that are multi-terminal, physically large, or otherwise unsuited for remote test fixtures, connect bnc-to-banana-plug adaptors to the extender cable (See Figure 3-12). This is particularly convenient for DUT's with binding posts. This accessory cable (1689-9602), as well as the Pomona 1894 and 4684 adaptors, are available from IET Labs. Also see 7000-04 Alligator Clip Leads.

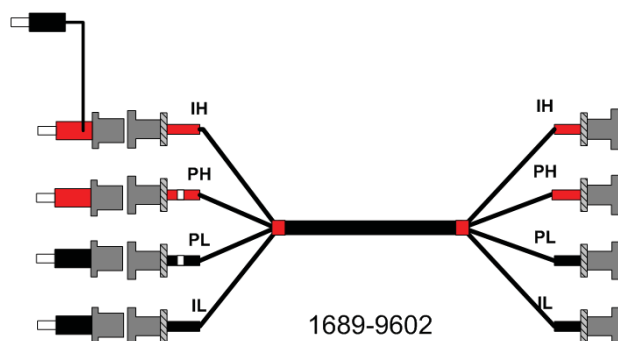

Figure 3-12: 1689-9602 Extender Cable with bnc-to-banana-plug adaptors

To use this cable with the adaptors, proceed as follows:

1. Connect 1689-9602 bnc cable to the 1693 Digibridge as specified in Table 3-1 on page 19.
2. Connect the set of four bnc-to-banana-plug adaptors to the free ends of the cables. One of these adaptors has a "pigtail" for connecting GUARD.
3. Zero the Digibridge. (See Section 3.1.3 on page 14.)
4. Connect the banana plugs (and GUARD, if appropriate) to the DUT.



Avoid contact between the shells of bnc connectors. Otherwise, measurements at high test frequencies may have errors that result from the changing mutual inductances between cable shields.

3.2.6 The Effects of Cable and Fixture Capacitances

It is important to use very low-capacitance shielded wire for cables, not only for accuracy, but also to minimize resonance effects in the measurement of large inductance at high frequency.

The Capacitance that are Most Liable to Affect Accuracy. Any test fixture extension cable adds a bit of capacitance in parallel with the DUT (because shielding of the leads is imperfect) and more between each terminal and ground. The zeroing process (Section 3.1.3) will compensate fully for the capacitances between cables in any normal test setup.

However, capacitance between ground and the "low" connections at the DUT (C from ground to **IL** and C from ground to **PL**, in parallel, designated C_{sn}) can affect measurement accuracy of very-high-impedance DUTs at high frequencies.

Zeroing. Be sure to repeat either the entire power-up procedure or at least the open-circuit and short-circuit zeroing procedure after any change in test fixtures or their cable connections.

Calculating the Capacitance Loading Error. The error due to this capacitance C_{sn} is designated A_{ld} ("additional error due to loading"). The magnitude of A_{ld} can be calculated so that you know how significant it is and so that measurements can be corrected if desired. Refer to paragraph 3.6.7.

3.2.7 7000-05 Tweezers

The 7000-05 tweezers combine the two functions:

- They handle chip components, up to 0.5 in. (12 mm) thick.
- Serve as a test fixture for measuring these components, if their terminals are on opposite faces.

The 7000-05 Chip Component Tweezers can handle small unleaded “chips” or SMDs (surface mounted devices), passive sensors, and components for testing on the Digibridge. A four-terminal Kelvin connection extends to the tip of the tweezers where the measurement becomes two-terminal, therefore series impedance of the connecting cables and internal tweezer connections do not affect the measurement. The small amounts of residual-tip resistance and inductance can be automatically corrected by using the Digibridge shorting function with the tips pressed together. Guard shields between the tweezer blades minimize capacitance between them. A correction for this small capacitance can be made using Digibridge open circuit test with the tips held at a spacing equal to that of the component’s contact spacing.

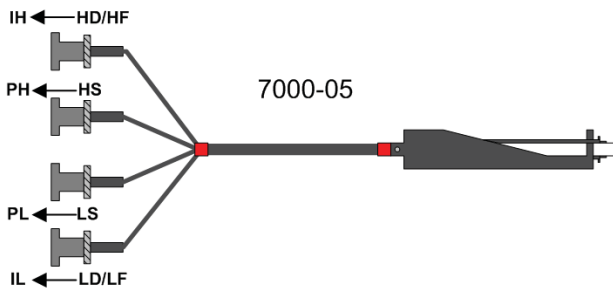

Figure 3-13: 7000-05 Chip Component Tweezers

For this accessory an additional accuracy (for parameters listed) must be added to the standard instrument accuracy as defined by AutoAcc.

$$C: \pm 1.5 \text{ pF} \quad R: \pm 10 \text{ m}\Omega \quad L: \pm 100 \text{ nH}$$

$$Q: \text{ for } R > 100 \Omega, \pm(9 * \text{Freq} * R * 10^{-12} \text{ ppm})$$

$$Q: \text{ for } R \leq 100 \Omega, \pm((R/\text{Freq}) * 10^{-6} \text{ ppm})$$

Measurement accuracy is very sensitive to connection geometry. The same connection geometry must be used for open/short compensation as for connection to the device under test.

Connection to Digibridge:

Connect to Digibridge	Cable Marking	Connection to DUT
PH (potential, high)	HS	to positive (+) terminal of DUT
IH (current, high)	HD/HF	
PL (potential, low)	LS	to negative (-) terminal of DUT
IL (current, low)	LD/LF	

The PH (HS) and IH (HD/HF) cables connect to the fixed arm of the tweezers (+) and the PL (LS) and IL (LD/LF) cables connect to the movable arm of the tweezers (-). To ensure valid measurements it is especially important to observe the correct polarity when DC bias is to be used.

If dc bias is used (see paragraph 3.7), note that the fixed arm of the tweezers is positive and the movable arm is negative.

3.2.8 1700-03 Kelvin Clip Cable

The 1700-03 Kelvin Clip Cable provides a means for easily making four terminal (Kelvin) connections to passive components. This cable is especially useful for testing low impedance devices or devices with large non-standard terminations, such as electrolytic capacitors or inductors.



Figure 3-14: 1700-03 Kelvin Cables

To attach Kelvin Clips as follows to the Digibridge, first remove any adaptors, cables, etc., if present, from the DUT port of the instrument. Then connect the bnc ends of the Kelvin Clips to the Digibridge as follows:

On 1693	Bias Polarity	Description	1700-03 Cable
IL	+	Drive -	LCUR (black)
PL	+	Potential -	LPOT (black)
PH	-	Potential +	HPOT (red)
IH	-	Drive +	HCUR (red)

Table 3-2: Digibridge to 1700-03 cable connections

Zero the Digibridge as instructed in Section 3.1.3 on page 14.

Note that red designates leads that may be “hot.” (When bias is applied, they carry negative voltage with respect to ground).

If dc bias is used (see paragraph 3.7), notice that the faces of the Kelvin Clips are labeled “+” and “-” to indicate bias polarity.

NOTE: It is important to be aware that if **DC BIAS** is used, that it is a negative voltage and that it is applied to the **IH** lead from the instrument.

For this accessory an additional accuracy (for parameters listed) must be added to the standard instrument accuracy.

C: ± 1.5 pF R: ± 10 m Ω L: ± 100 nH

Q: for $R > 100 \Omega$, $\pm(9 * \text{Freq} * R * 10^{-12}$ ppm)

Q: for $R < 100 \Omega$, $\pm((R/\text{Freq}) * 10^{-6}$ ppm)

Measurement accuracy is very sensitive to connection geometry. The same connection geometry must be used for open/short compensation as for connection to the device under test.

3.2.9 7000-04 Alligator Clip Leads

To connect to DUT's that are multi-terminal, physically large, or otherwise unsuited for remote test fixtures, connect bnc-to-banana-plug adaptors to the Digibridge. This is particularly convenient for DUT's with binding posts, when the alligator clips are removed.



Figure 3-15: 7000-04 Alligator Clip Leads

To use this cable, connect 7000-04 cable to the 1693 Digibridge as specified in Table 3-3.

On 1693	Bias Polarity	Description	7000-04 Cable
IL	+	Drive -	IL (black)
PL	+	Potential -	PL (black)
PH	-	Potential +	PH (red)
IH	-	Drive +	IH (red)

Table 3-3: Digibridge to 7000-04 cable connections

Connect the alligator clips if desired, and zero the Digibridge as instructed in Section 3.1.3 on page 14.

When connecting alligator clips to wire or other devices use the following connection to minimize errors.

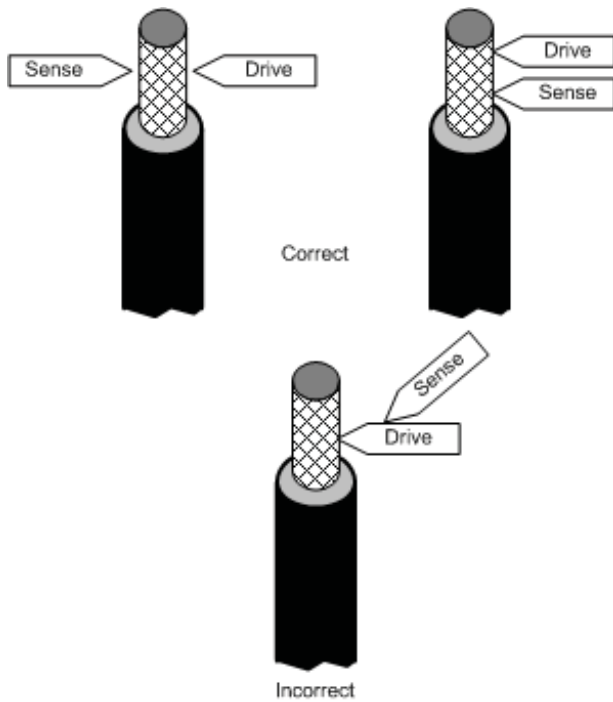

Figure 3-16: Connecting alligator clips

It is important that sense terminals be closest to the DUT and not to intermix high and low connections.

3.2.10 Connection to HACS-Z High Accuracy Decade Capacitor

The HACS-Z has two types of connections: one via 2 bnc connectors and the other via 5 binding posts. This section shows the connection to both types. It is important to perform open and short corrections as described previously in section 3.1.3 for the cables being used.

Connecting to HACS-Z with binding post terminals

Use one of the following options:

- 1689-9602 (bnc-to-bnc Extender Cable) in combination with Pomona 1894 & 4684 bnc-to-banana adapters (see Figure 3-17)
- 1657-9600 Extender Cable or 7000-04 Alligator Clip Leads (see Figure 3-18)

Note that the alligator clips are removed for direct connection to the binding posts.

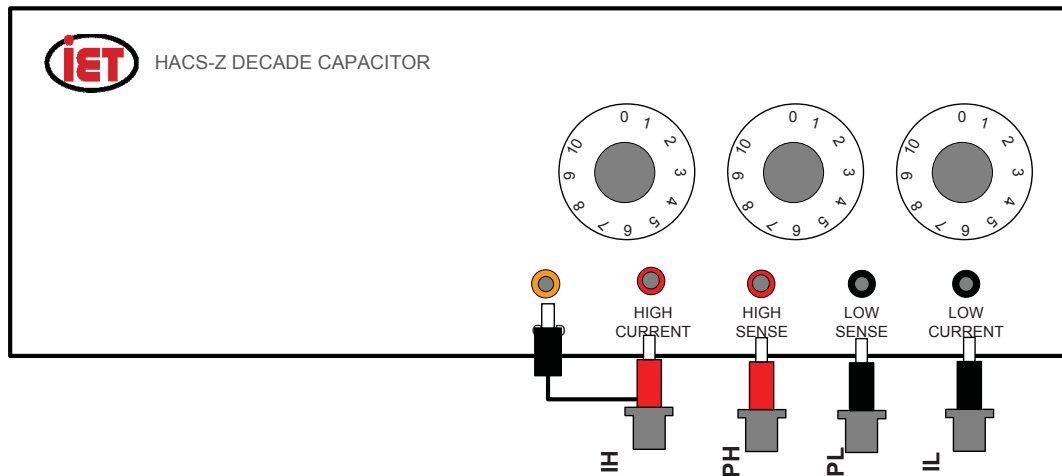

Figure 3-17: Connection to HACS-Z BP terminals with 1689-9602 cable and 1894 & 4684 adapters

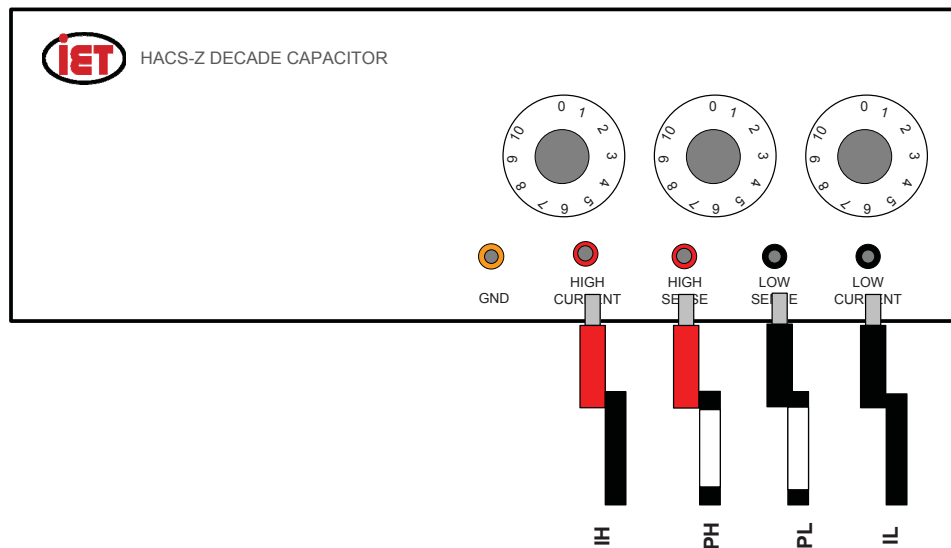

Figure 3-18: Connection to HACS-Z BP terminals with 1657-9600 Extender Cable or 7000-04 cable (without alligator clips)

Connecting to HACS-Z with bnc terminals

Connect using 1689-9602 bnc-to-bnc extender cable in combinations with 6700 bnc-T adapters (see Figure 3-19). Geometry should be maintained to reduce errors after the zeroing procedure has been performed.

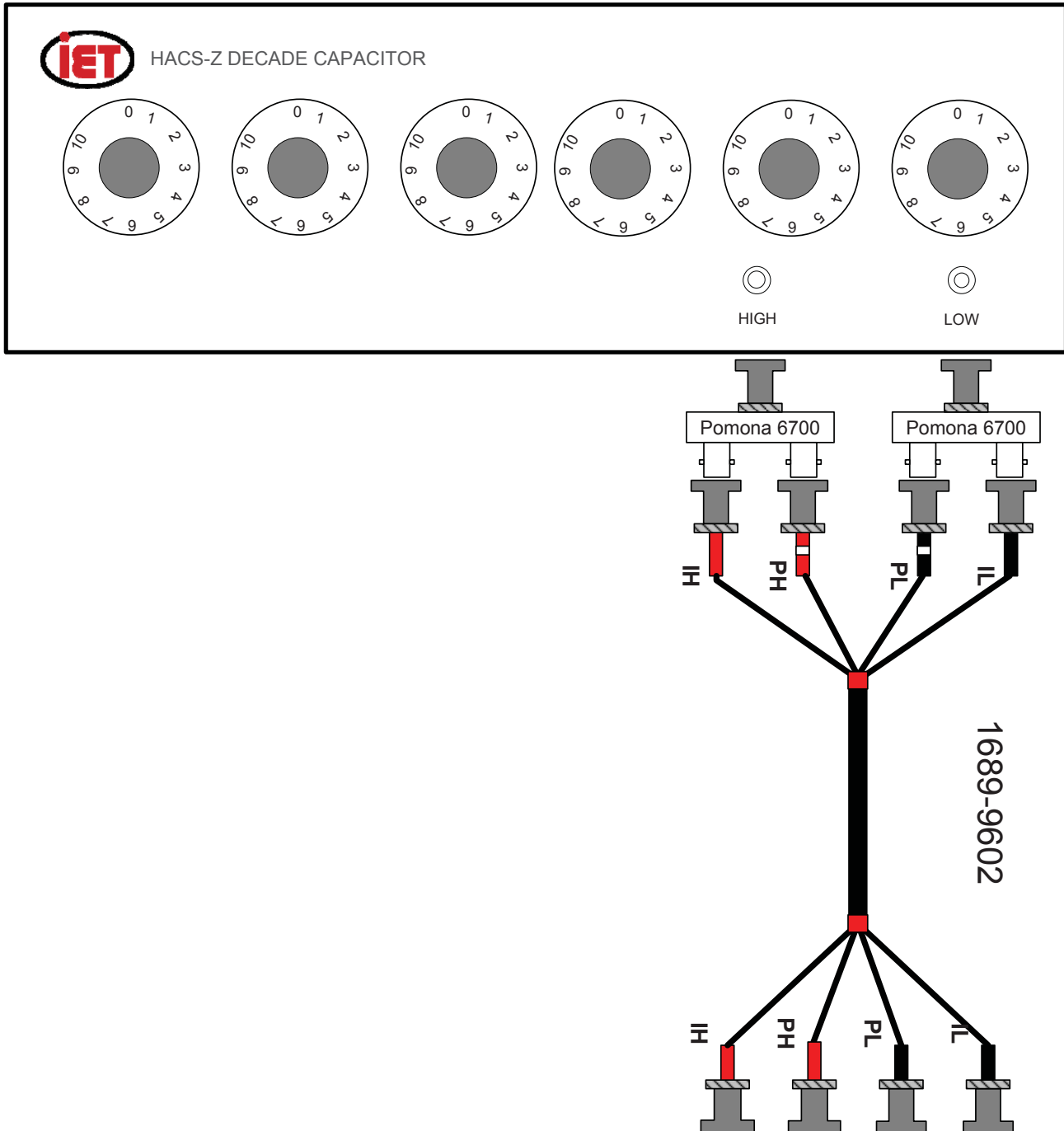

Figure 3-19: Connection to HACS-Z bnc terminals with 1689-9602 cable with 6700 adapters

3.2.11 Connection to 1482 Inductance Standard

Two methods that can be used when calibrating a 1482 Inductance standard is a direct method and a transfer method, both are described below.

3.2.11.1 Transfer Methods

6-Terminal Transfer method: When lead inductance is not sufficiently constant, its effect can be eliminated by another method of comparison. The two six terminal inductors can be connected in series to the bridge. A first measurement is made with the short of one inductor in the L position while that of the other is in the L₀ position on the reference terminals. A second measurement is then made with both links moved to the opposite terminals. The measured difference is the difference between the two inductance changes at the reference terminals and is independent of the internal lead inductances because they appear in both measurements and cancel in the difference.

The 1693 Digibridge is connected to the 1482-A Inductance Standard as illustrated in Figure 3-20. A 14-gauge piece of bus wire is used to connect between the high terminals of both known and unknown standards. **PH** and **IH** are connected to the low side of the known and **PL** and **IL** are connected to the low side of the unknown. Shorting bars should short between low and guard terminals for each standard.

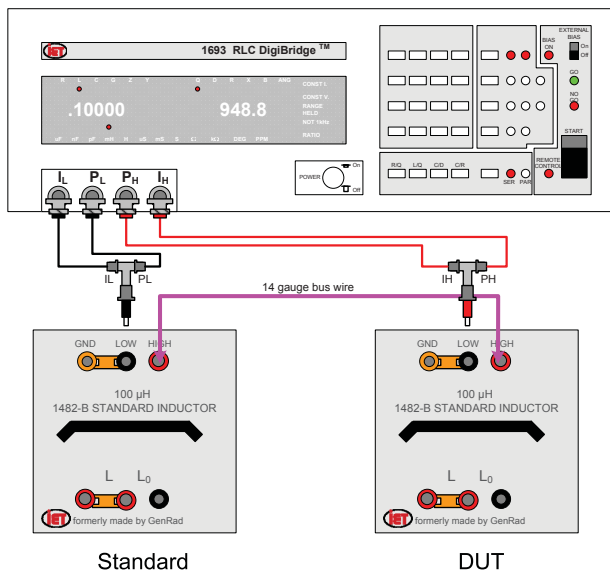

Figure 3-20: Connecting 1693 to 6-terminal 1482

3-terminal transfer method: Two measurements are performed with a 14 gauge bus wire moved so that the inductance of the DUT is made and then the bus wire is moved so that the measurement of the standard is made. The formula below can then be used to determine the value of DUT.

$$\text{Actual Value DUT} = \frac{\text{Known Value of Std}}{\text{Measured Value of Std}} * \text{Measured Value of DUT}$$

See Figure 3-22 for the 3-terminal transfer method. Ratio measurements of 2:1, made on a 1689, on the same range and using the delta% readout, typically have errors totaling less than 20 ppm. This allows comparisons of inductors of intermediate value (those values starting with a 2 or 5) to be compared against the even decade values with negligible added error.

3.2.11.2 Direct Measurement Method

The 1482 Inductor can be directly measured on the Digibridge. A combination of the 1689-9602 BNC to BNC cable, two BNC T adapters and Pomona 1894 adaptors are used for connection. Open and Short compensation should be performed. Spacing should be maintained when performing open compensation. To minimize noise the high leads are connected to the low terminal of the 1482 and the low terminals to the high terminal of the 1482.

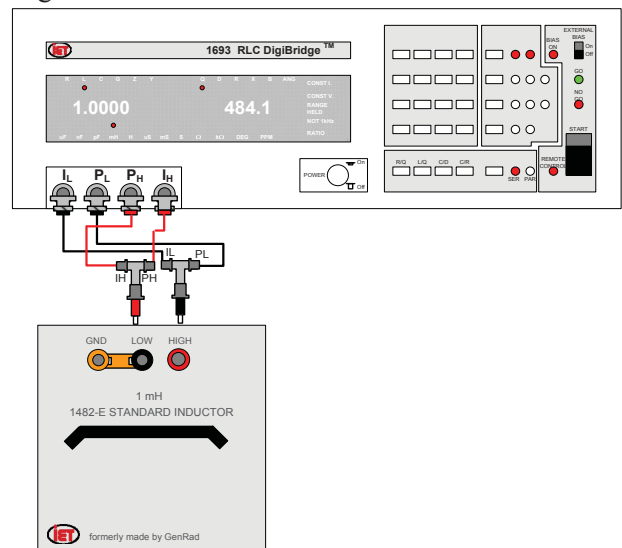

Figure 3-21: Direct connection of 1693 and 1482

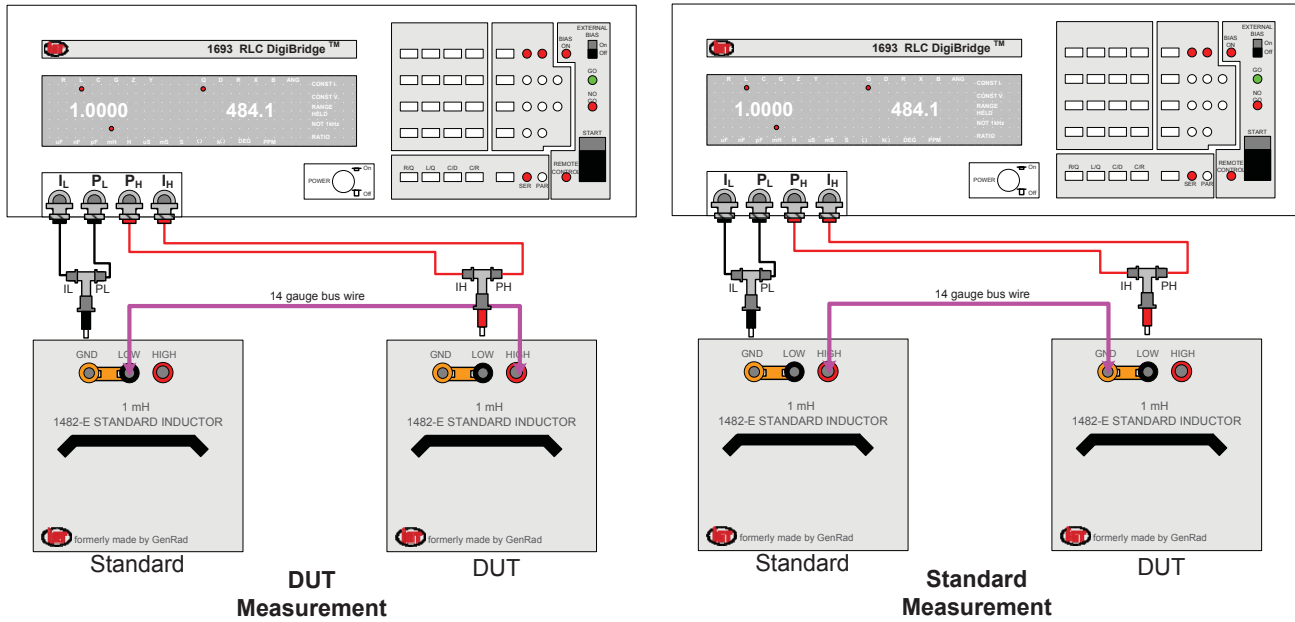

Figure 3-22: Connecting 1693 to a 3-terminal 1482

3.2.12 Connection to 1409 Capacitance Standards

Connection to the 1409 Capacitance standard can be accomplished using the 1657-9600 Extender cables or 7000-04 Alligator Clip Leads. Open and Short compensation should be performed. When measuring two terminal capacitance standards, such as type 1409, that are calibrated in a two terminal configuration care must be taken to keep exact cable geometries so as not to introduce error due to stray capacitance. This is extremely importance on low value of capacitance.

The connection shown below is for a two terminal measurement on the 1409 with ground strap connected between Lo and ground. The green guard lead is not used in this measurement. Measurements made with this connection will compare favorably with measurements made on the IET Labs's 1620 Capacitance Bridge. The configuration of having the drive connections on one side and the potentials on the other side minimizes connection resistance which can affect dissipation factor measurements.

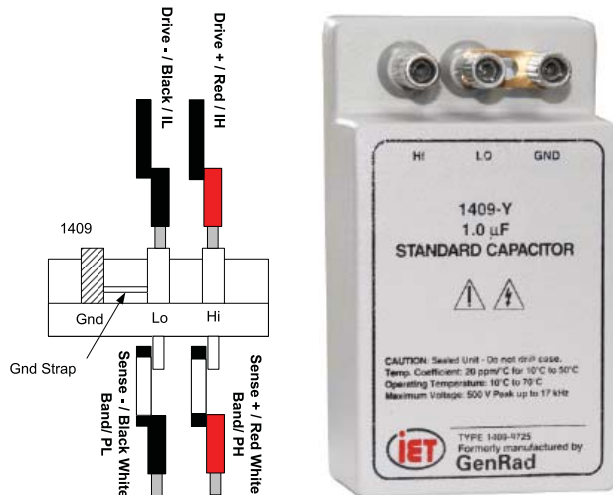

Figure 3-23: Connection to 1409 Standard Capacitor

3.2.13 Connection to 1404 Reference Standard Capacitor

Note: These same instructions also apply to 1403, 1408, and 1422.

Connection to the 1404 Reference Standard Capacitor can be accomplished using the 1689-9602 BNC to BNC cables, two BNC-T connectors and two GR 874 adapters, if applicable. Open and Short compensation should be performed. The connections shown are applicable for 1403, 1408 and 1422 Standard Capacitors as well.

Measurement of capacitor standards is similar to measurements of inductors using a direct comparison method. The unknown is simply compared to a standard capacitor of almost equal value that has a NIST calibration and the measured difference is used to obtain the value of the unknown. This technique is straight forward when dealing with three or four terminal standards as cable geometry and stray capacitance issues are negligible.

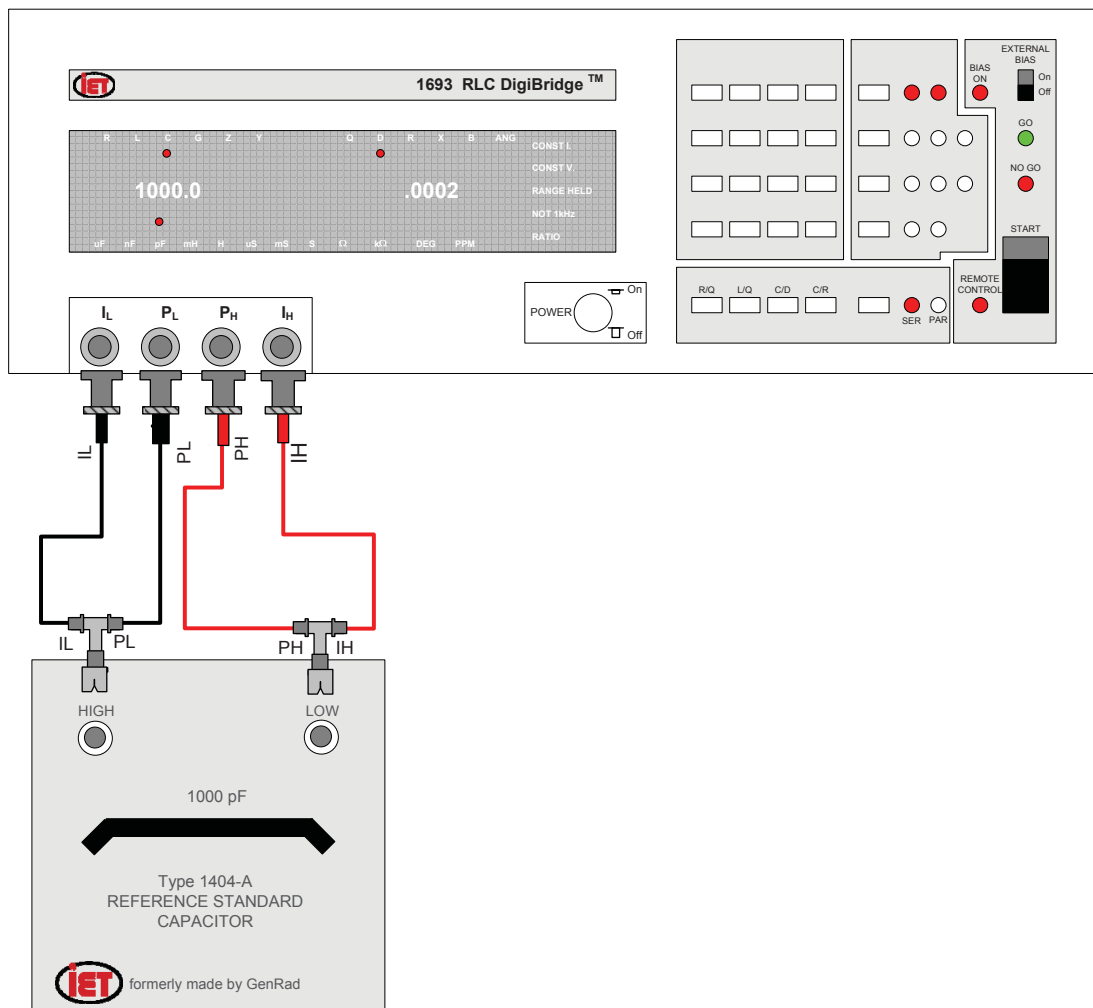

Figure 3-24: Connecting 1693 to a 1404

3.2.14 Connection to 1417 Capacitance Standard

Connection to the 1417 Capacitance Standard can be accomplished using the 1657-9600 Extender cables or 7000-04 Alligator Clip Leads. A four terminal connection should be made to the 1417 as shown below. The Digibridge may have a slight dc voltage so a blocking capacitor, greater than 200 μF , should be connected in series with the **H** Current terminal.

Open compensation should be performed as normal. Short compensation should be performed as follows; with cables connected as above with exception of plugging Red White/PH lead into Black White/PL lead. Set the 1417 to a capacitance value of 1F and frequency of 1kHz and then perform short on the Digibridge. Return Red White/PH lead to H Potential connection on 1417 when short is complete. Note: It can be beneficial to twist potential leads together and twist the current leads together to minimize coupling.

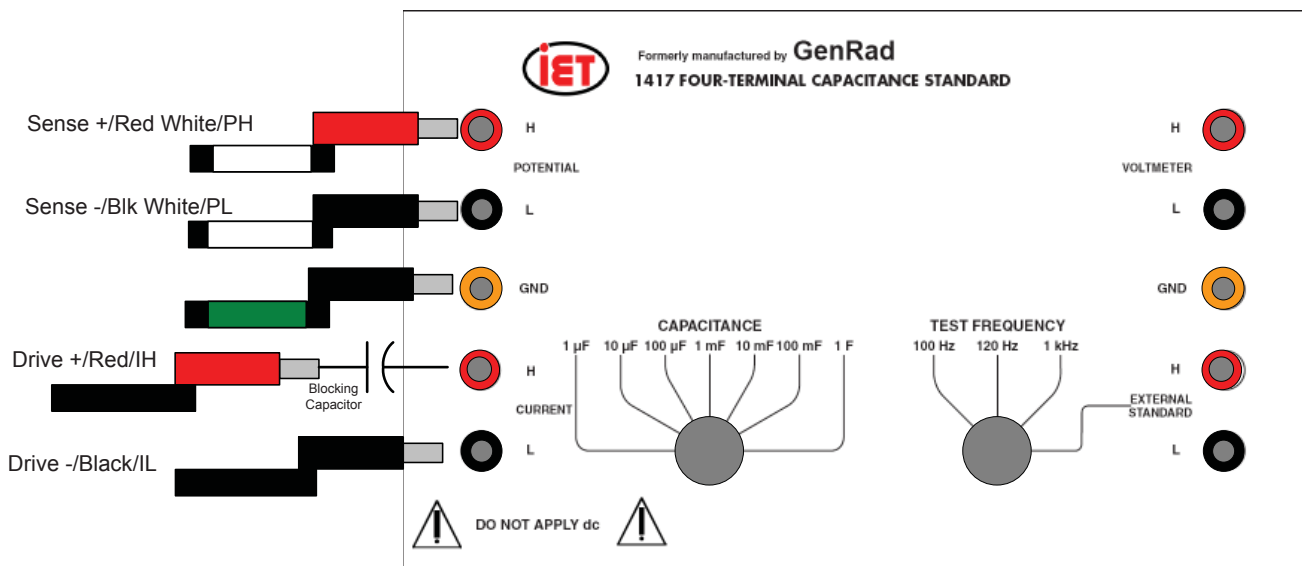

Figure 3-25: Connecting to a 1417

3.2.15 Connection to the 1433 Decade Resistor

Note: The procedure for connecting the HARS-X High-Accuracy Resistance Substituter is exactly the same.

Connection to the 1433 or HARS Decade Resistors can be accomplished using the 1657-9600 Extender cables or 7000-04 Alligator Clip Leads.

The connection via the 7000-04 cable is shown in Figure 3-26. When using 7000-04 Alligator Clip Leads the alligator clips should be removed. The simplest connection is a two-terminal measurement on the 1433/HARS with ground strap connected between **LOW** and **GND**. But to minimize the noise from the resistor decade, a three-terminal connection might be preferable. The three-terminal connection may be implemented by removing the ground strap and attaching a separate lead between **GND** and DigiBridge chassis ground.

The connection via the 1657-9600 Extender Cable is shown in Figure 3-27. It is for a three-terminal measurement on the 1433/HARS with ground strap *not* connected between **LOW** and **GND**. The green guard lead is used in this measurement to minimize noise.

Open and Short compensation should be performed as described. Set the DigiBridge to the required frequency. Open compensation should be performed as normal with the red pair and black pair separated by at least 6 inches. Short compensation should be performed as follows:

1. Connect the cables to the 1433/HARS as shown.
2. Set the 1433/HARS to zero ohms.
3. Perform short on the DigiBridge.

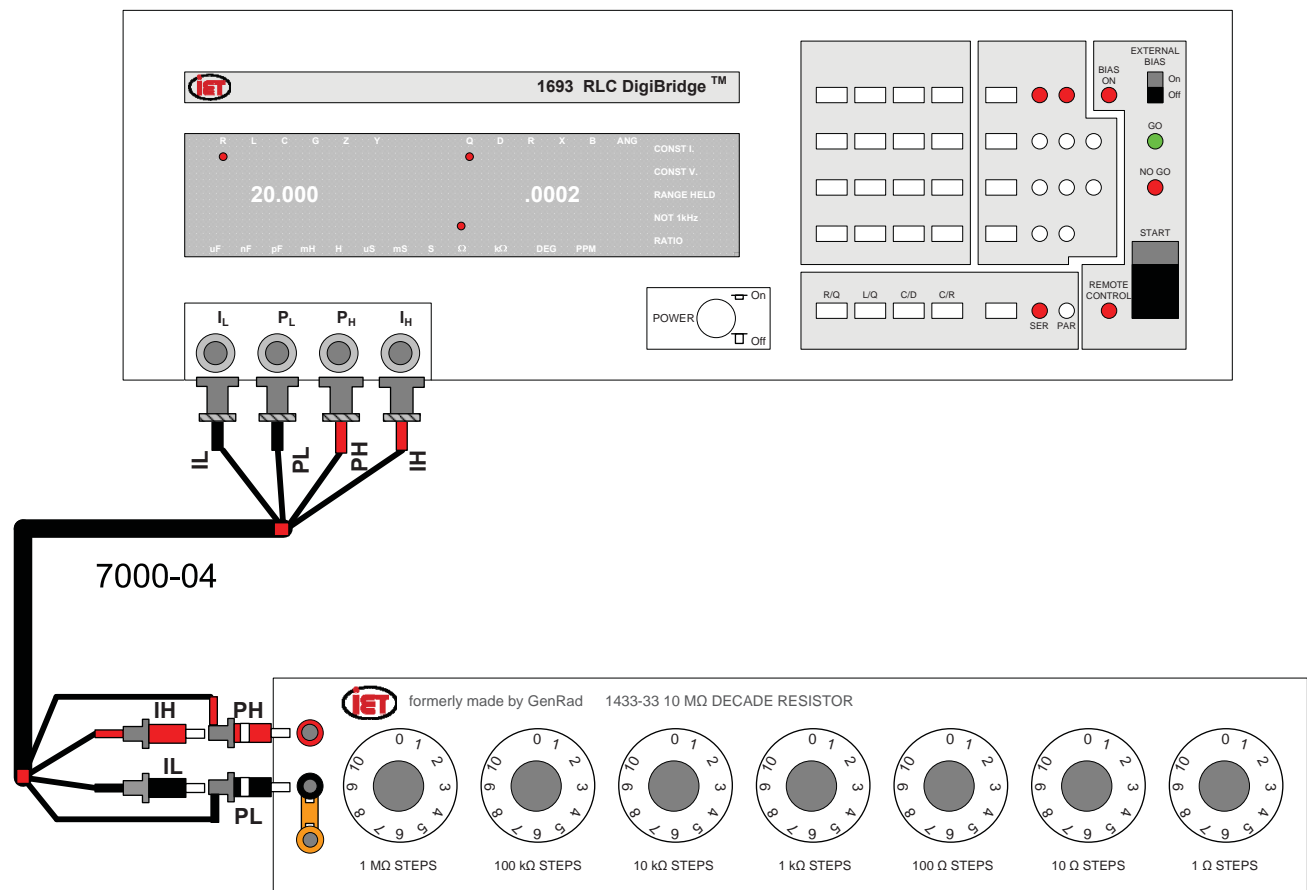

Figure 3-26: Connection to 1433 via 7000-04 cable

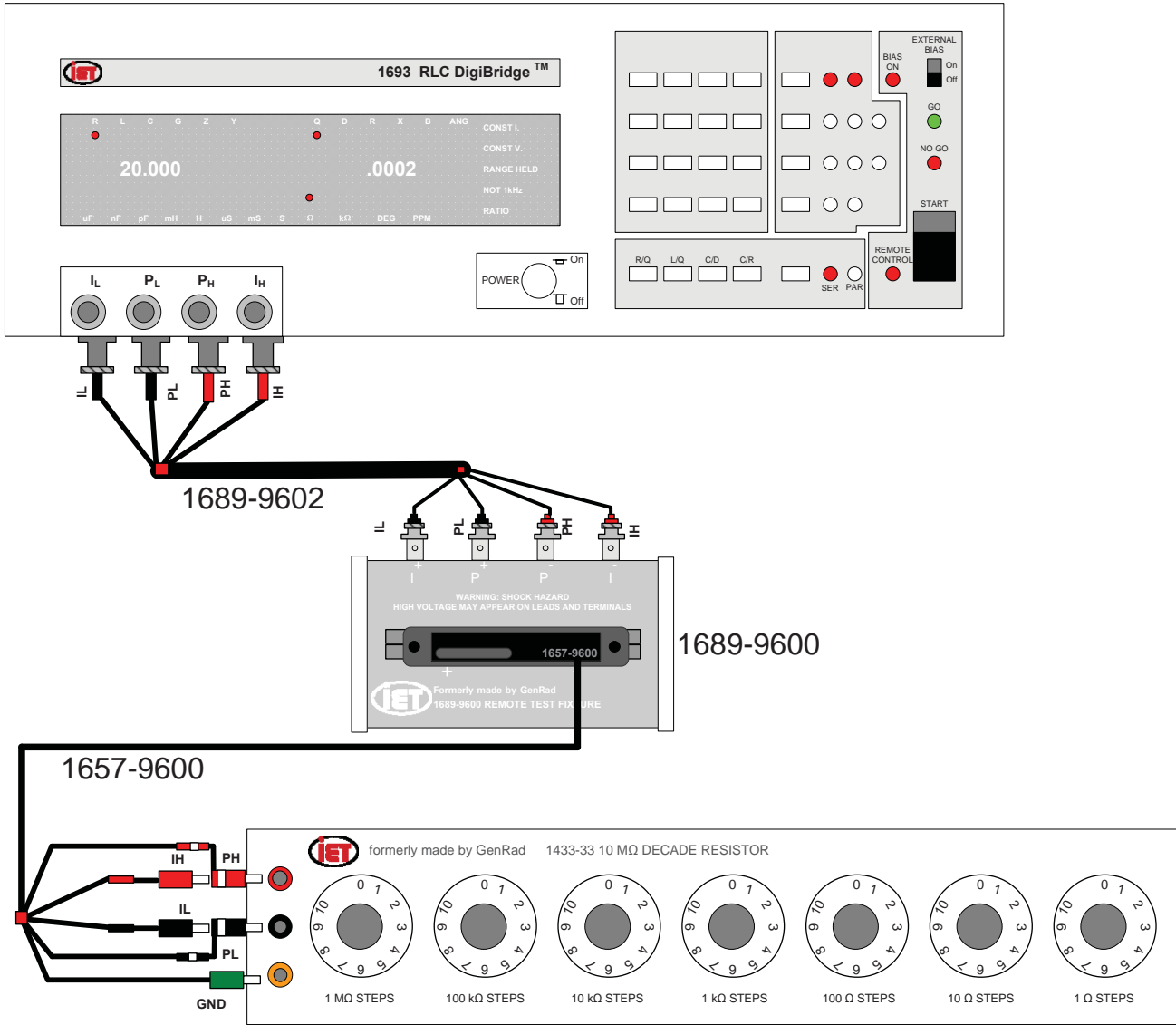

Figure 3-27: Connection to 1433 via 1657-9600 cable

3.3 Measurement Parameters, Result Displays, and Outputs

3.3.1 Parameters (R/Q,L/Q, C/D,C/R,R/X,G/B,Z/ANG,Y/ANG)

Automatic Selection. The Digibridge as powered up provides you with automatic selection of parameters (unless keyboard has been locked with a particular parameter selected).

This feature enables you to measure any passive component (without knowing whether it is essentially a resistor, inductor or capacitor). It is provided at power-up and remains enabled as long as you do NOT select any particular parameter.

Automatic parameter selection can be disabled by pressing any parameter key, such as the [C/D] key, for example. Once disabled, this feature can be enabled again by selecting the ENTER function and then pressing these keys:

[1][=][SHIFT][SPECIAL][7]

To select parameter automatically, the Digibridge calculates Q; if $|Q| < 0.125$, R is selected, otherwise, for positive Q, L is selected and for negative Q, C is selected. (The sign of Q is the same as the sign of the reactive component of impedance.)

Manual Selection: To select the parameter to be measured manually:

1. Press one of the 4 parameter keys:

[R/Q, L/Q, C/D, C/R]

or

[SHIFT][R/X, G/B, Z/ANG, Y/ANG]

The LEDs above the display will indicate which parameter is selected.

2. Use the [EQUIVALENT CIRCUIT] key to select SERIES or PARALLEL. See Table 3-4.

Key	Series	Parallel	Parameter Measured	Units
R/Q	Rs/Q	Rp/Q	Resistance/ Quality	Ohms/ none
L/Q	Ls/Q	Lp/Q	Inductance/ Quality	Henries/ none
C/D	Cs/D	Cp/D	Capacitance/ Dissipation	Farads/ none
C/R	Cs/Rs	Cp/Rp	Capacitance/ Resistance	Farads/ Ohms
R/X	Rs/Xs	*	Resistance/ Reactance	Ohms/ Ohms
G/B	*	Gp/Bp	Conductance/ Susceptance	Siemens/ Siemens
Z/ANG	*	*	Impedance/ Angle	Ohms/ Degrees
Y/ANG	*	*	Admittance/ Angle	Siemens/ Degrees

**Equivalent circuits are discussed below in paragraph 3.3.2.*

Table 3-4: Selecting Measurement Parameter

For an inductor select L/Q; for a capacitor, either C/D or C/R; for a resistor, R/Q. There will be an immediate confirmation on the display panel, where appropriate parameter and unit indicators will be lit. (However, do not attempt to select the unit multiplier.) The Digibridge will automatically switch to the appropriate multiplier - from μF to pF for example - , unless RANGE is HELD, when it makes a measurement. The result will be displayed in terms of the parameters and equivalent circuit that you select, (even if the DUT has the opposite kind of reactance - see below).

Note: Observing the results displays can be helpful in deciding whether you have made the best parameter selection. (See below.) Displays are discussed further in paragraph.

Negative RLC. If RLC is negative with an L or C value displayed, the DUT reactance is opposite to the selected parameter. As a rule, you should change parameter (usually select L instead of C or vice versa) so that a positive L or C value display can be obtained. However, the displayed negative value of L or C is mathematically correct and (without the minus sign) is in fact the value that will resonate with the DUT at the test frequency.

Notice that the appearance of a device can be misleading. (For example, an inductor is capacitive if test frequency is above resonance; or a component part can be mislabeled or unlabeled.)

For more information about both a negative RLC and negative QDR, see paragraph 3.3.3.

3.3.2 Equivalent Circuits - Series, Parallel

The results of R, L, or C measurements of many components depend on which of two equivalent circuits is chosen to represent it - series or parallel.

The more nearly “pure” the resistance or reactance, the more nearly identical are the “series” and “parallel” values of the principal parameter. However, if D is high or Q low, Cs differs substantially from Cp and Ls differs substantially from Lp; and these values are frequency dependent. Usually several measurements at frequencies near the desired evaluation will reveal that either series measurements are less frequency dependent than parallel, or the converse. The equivalent circuit that is less frequency dependent is the better model of the actual device.

We first give general rules for selection of measurement parameters, then some of the theory.

Making the Selection. The power-up selection is “series”, confirmed by the SERIES indicator being lit, on the keyboard. To change the selection, press the [EQUIVALENT CIRCUIT] key.

Specifications. The manufacturer or principal user of the DUT probably specifies how to measure it. (Usually “series” is specified.) Refer also to the applicable: MIL or EIA specifications, Select “parallel” or “series” and the test frequency according to the applicable specifications. If there are none known, be sure to specify with your results whether they are “parallel” or “series” and what the measurement frequency was.

3.3.2.1 Suggested Test Conditions:

- Capacitors less than 10 pF: Parallel, 10 kHz.
- Capacitors from 10 to 400 pF: Series or Parallel, 10 kHz.
- Capacitors from 400 pF to 1 μ F: Series, 1 kHz.
- Capacitors greater than 1 μ F: Series, 0.1 or 0.12 kHz.

Unless otherwise specified or for special reasons, always select “series” for capacitors and inductors. This has traditionally been standard practice. For very small capacitance, select a higher measurement frequency for best accuracy. (Refer to paragraph 3.6.) Conversely, for very large capacitance, select a lower measurement frequency for best accuracy.

- Inductors less than 10 μ H: Series, 100 kHz.
- Inductors from 10 μ H to 1 mH. Series, 10 kHz.
- Inductors from 1 mH to 1 H: Series, 1 kHz.
- Inductors greater than 1 H: Series, 0.1 kHz.

Select “series” as explained above. For very small inductance, select a higher measurement frequency for best accuracy. Conversely, for very large inductance, select a lower measurement frequency for best accuracy.

- Resistors, below about 1 k Ω Series, 1 kHz.
Usually the specifications call for dc resistance, so select a low test frequency to minimize ac effects. Select “series” because the reactive component most likely to be present in a low resistance resistor is series inductance, which has no effect on the measurement of series R.
- Between 1 k Ω and 10 M Ω : Parallel, 0.250 kHz.
- Resistors greater than 10 M Ω : Parallel, 0.030 kHz.

As explained above, select a low test frequency. Select “parallel” because the reactive component most likely to be present in a high-resistance resistor is shunt capacitance, which has no effect on the measurement of parallel R. If the Q is less than 0.1, the measured Rp is probably very close to the d DC resistance.

3.3.2.2 Theory -- Series and Parallel Parameters

An impedance that is neither pure reactance nor a pure resistance can be represented at any specific frequency by either a series or a parallel combination of resistance and reactance. The values of resistance and reactance used in the equivalent circuit depend on whether a series or parallel combination is used. Keeping this concept in mind will be valuable in operation of the instrument and interpreting its measurements.

The equivalent circuits are shown in Table 3-5, together with useful equations relating them. Notice that the Digibridge measures the equivalent series components R_s , L_s , or C_s , if you select SERIES EQUIVALENT CIRCUIT. It measures the parallel equivalent components R_p , L_p , or C_p if you select PARALLEL. D and Q have the same value regardless whether series or parallel equivalent circuit is calculated.



Resistance and Inductance			Resistance and Capacitance		
$X = \omega L$			$X_s = -\frac{1}{\omega C_s}$		
$Z = R_s + j\omega L_s$	$Z = \frac{j\omega L_p R_p}{R_p + j\omega L_p}$	$Z = \frac{R_p + Q^2 \omega L_p}{R_p + j\omega L_p}$	$Z = R_s - \frac{j}{\omega C_s}$	$Z = \frac{R_p}{1 + j\omega R_p C_p}$	$Z = \frac{D^2 R_p + 1(j\omega C_p)}{1 + D^2}$
$Q = -\frac{1}{D} = \tan \theta$	$Q = \frac{\omega L_s}{R_s}$	$Q = \frac{R_p}{\omega L_p}$	$D = -\frac{1}{Q} = \tan \delta$	$D = \omega R_s C_s$	$D = \frac{1}{\omega R_p C_p}$
$L_s = \frac{Q^2}{1 + Q^2} L_p$	$L_s = \frac{Q^2}{1 + Q^2} L_p$		$C_s = C_p(1 + D^2)$	$C_p = C_s \frac{1}{1 + D^2}$	
$L_p = L_s \left(\frac{1 + Q^2}{Q^2}\right)$	$L_p = (1 + D^2) R_s$		$R_s = \frac{D^2}{1 + D^2} R_p$	$R_s = \frac{1 + D^2}{D^2} R_p$	
$R_s = \frac{\omega L_s}{Q}$	$R_s = Q \omega L_p$	$R_p = \frac{1}{G_p}$	$R_s = \frac{D}{\omega C_s}$	$R_p = \frac{1}{\omega C_p D}$	$R_p = \frac{1}{G_p}$
$B_p = \frac{1}{\omega L_s}$	$Y = G_p - j \frac{1}{\omega C_s}$		$B_p = \omega C_p$	$Y = G_p + j \omega C_p$	
					

Table 3-5: Equivalent Circuits

Polar Form: Magnitude and Phase. A complex number may be expressed in polar form as well as in the Cartesian form used so far. For impedance and admittance the relationships are:

$$Z = R_s + jX_s = |Z| e^{j\theta} \text{ and } Y = G_p + jB_p = |Y| e^{j\phi}$$

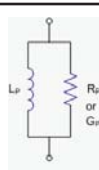
where $|Z|$ and $|Y|$ are the magnitudes and θ (*theta*) and ϕ (*phi*)

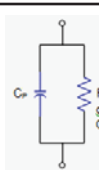
are the phase angle in radians (see Figure 3-28).

The magnitude of a complex number is the square root of the sum of the squares of the two parts so that

$$|Z| = \sqrt{R_s^2 + X_s^2} \text{ and } |Y| = \sqrt{G_p^2 + B_p^2}$$

Note that $|Z| = 1/|Y|$

The phase angle of an impedance or an admittance is the angle whose tangent is the ratio of the imaginary part to the real part so that

$$\theta = \arctan (X/R) = \arctan Q, \text{ or } \tan \theta = Q$$

and

$$\phi = \arctan (G/B) = \arctan Q, \text{ or } \tan \phi = Q$$

The size of the phase angle of an admittance is the same as that of the corresponding impedance, but if we use the convention that a positive angle is one in the counterclockwise direction then the angle of an admittance is the negative of that of the corresponding impedance, as one can see from the equation

$$Y = \frac{1}{Z} = \frac{1}{|Z| e^{j\theta}} = \frac{Y}{e^{j\theta}} = |Y| e^{-j\theta} = |Y| e^{j\phi}$$

Euler's formula,

$$e^{jX} = \cos X + j \sin X,$$

is useful when dealing with imaginary exponents and can be used to show that

$$R_s = |Z| \cos \theta, \text{ and that } X_s = |Z| \sin \theta$$

These phase relationships can be understood better using the diagrams of Figure 3-28 which show both inductive and capacitive impedance phasors (or planar vectors) on both the Z and Y planes. Here the angle is measured from the positive real axis (+ r or + G) and the angle δ (*delta*) is defined as the complement of θ and ϕ so one can see that:

$$\delta \text{ (delta) is defined as the complement of } \theta \text{ and } \phi$$

So one can see that:

$$\tan \delta = \cot \theta = \frac{R_s}{X_s} = \frac{G_p}{B_p} = D.$$

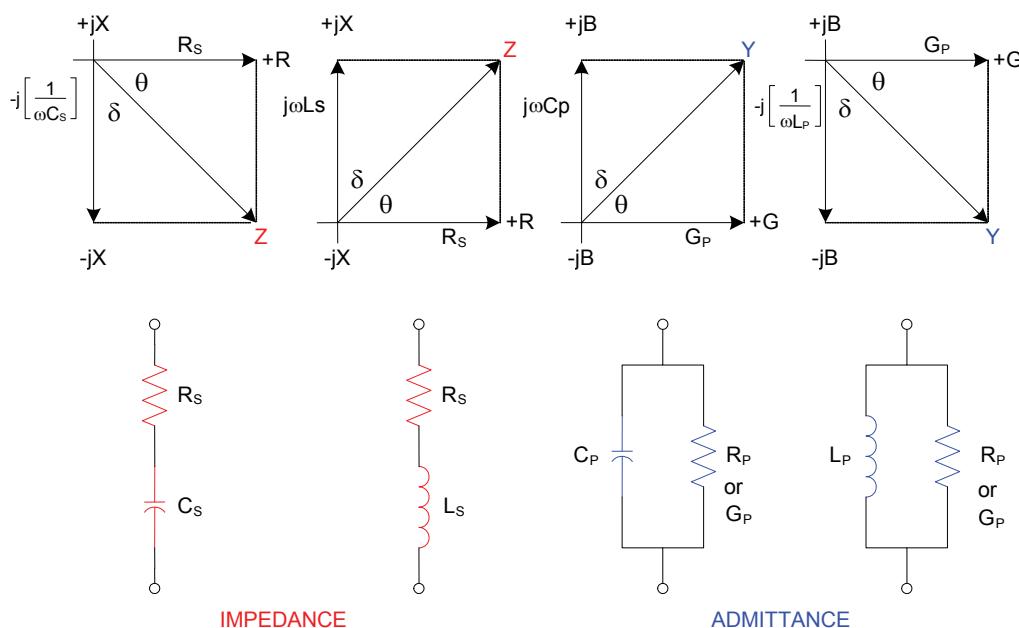

Figure 3-28: Phase relationships

ESR for Capacitors. The total loss of a capacitor can be expressed in several ways, including D and “ESR”, which stands for “equivalent series resistance” and which is designated “ R_s ” in the preceding paragraph. To obtain ESR, be sure that the SERIES indicator is lit; if you want ESR displayed simultaneously with C , push the $[C_s/R_s]$ parameter key; if you want the 5-place resolution for ESR, push the $[R_s/Q]$ key.

“Equivalent series resistance” is typically much larger than the actual “ohmic” series resistance of the wire leads and foils that are physically in series with the heart of a capacitor, because ESR includes also the effect of dielectric loss. ESR is related to D by the formula

$$ESR = R_s = D / \omega C_s$$

Parallel Equivalent Circuits for Inductors. Even though it is customary to measure series inductance of inductors, there are situations in which the parallel equivalent circuit better represents the physical device. For small “air-core” inductors, the significant loss mechanism is usually “ohmic” or “copper loss” in the wire; and the series circuit is appropriate.

However, if there is an iron core, the significant loss mechanism may be “core loss” (caused by eddy currents and hysteresis); and the parallel equivalent circuit is appropriate, being a better model of the inductor. Whether this is true at any particular frequency should be determined by an understanding of the DUT, but probably it is so if the following is true: that measurements of L_p at two frequencies near the frequency of interest differ from each other less than do measurements of L_s at the same two frequencies.

3.3.3 Results Displayed

3.3.3.1 Principal Measurement Results

The principal Digibridge measurement will be presented on the left (RLCGZY) part of the display panel in one of four ways; VALUE, deltaRLC, delta%, or BIN No., (only one way for any single measurement).

VALUE, Selected by the [DISPLAY] Key. This measurement provides two displays: the principal one is R, L, C, G, Z or Y and the secondary one is Q, D, R, X, B or DEG . The VALUE selection is the power-up

default and one of the selections of the [DISPLAY] key. For purposes of simplicity, the left display will be called the RLC and the right display called the QDR.

Read the measurement on the main displays. The RLC display is the principal measurement, complete with decimal point, parameter and units which are indicated by the light spots in the upper and lower part of the display panel. The QDR display is the secondary measurement, complete with decimal point, parameter and units indicated. Leading zeroes before the decimal point are automatically eliminated in most cases by positioning of the decimal point. Otherwise, such zeroes are blanked out.

Negative RLC. If the RLC is negative with an L or C value displayed, the DUT reactance is opposite to the selected parameter. Generally, you should change parameter (usually select L instead of C or vice versa) so that a positive L or C value display can be obtained. See paragraph 3.3.1.

DELTA PERCENT Displays, Selected by the [DISPLAY] Key. This presents the principal measurement (RLC) in terms of a percent difference above or below the nominal value last entered (i.e., a previously stored reference). Use this procedure.

1. Select ENTER with the [FUNCTION] key.
2. Select appropriate parameter and units with [EQUIVALENT CIRCUIT] and [R/Q, L/Q, C/D, C/R or [SHIFT] R/X, G/B, Z/ANG, Y/ANG) key.

Pressing the button multiple times changes unit multipliers.

3. Enter the reference for delta percent by pressing:
(N)[=][SHIFT][NOM VALVEI
in which (N) represents 1 to 6 numerical keys and (optionally) the decimal point key, depressed in sequence.

Confirmation is shown (up to 5 digits) on the RLC display.

4. MEASURE with the [FUNCTION] key and delta% with the [DISPLAY] key.

Observe that the RLC display will now be in percent, not an electrical measurement unit. It is the difference of the measured principal value from the nominal value (the stored reference), expressed as a percent of the nominal value.

The secondary measurement result appears in the QDR display area, just as it would if the principal display were VALUE.

NOTE: If you wish to see the delta% display simultaneously with bin sorting (data output to IEEE-488 bus), enter the bin limits first, as described in paragraph 3.8. Then (unless the last setting of nominal value happens to be the desired reference for percent difference) use the above procedure for setting up delta% displays.

DELTA RLC DISPLAY, Selected by the [DISPLAY] Key . This selection is indicated by lighting BOTH indicators together: VALUE and delta.%. The deltaRLC display is a difference from the stored nominal value, measured in the indicated electrical units, such as ohms, millihenries, or picofarads. If RLC is negative, the measured value is less than reference. The procedure for selecting deltaRLC displays is like the delta% procedure, above, except that the [DISPLAY] key is pressed repeatedly until two DISPLAY indicators (together labeled deltaRLC) are lit.

The secondary measurement result appears in the QDR display area, just as it would if the principal display were VALUE.

Bin No. Selected by using the [DISPLAY] key. When measurement is completed, the bin assignment will be shown on the left (RLC) display only, as a one-digit or two-digit number, with the following significance:

- 0 = No-Go because of the secondary (QDR) limit
- 1 = Go, bin 1
- 2 = Go, bin 2
- ... = Go, bin 3, 4, 5, ... 12, or 13, as indicated.
- 14 = No-go by default (suits no other bin).

Ratio Displays. The Digibridge can be programmed to display a ratio instead of either measured value or delta percentage. Refer to paragraph 3.3.6.

3.3.3.2 Secondary Measurement Results

The secondary Digibridge measurement will be presented on the right (QDR) display panel, for each measurement if the DISPLAY selection is VALUE, delta%, or deltaRLC. There is no secondary display if the selection is BIN NO.

Negative QDR. A negative QDR has the following meanings:

Parameter Selection	+ QDR	-QDR
R/X, G/B, Z/ANG,	DUT is inductive	DUT is capacitive
L/Q, C/D, C/R	Q, D, or R is Positive	Q, D, or R is negative see below
G/B, Y/ANG	DUT is capacitive	DUT is inductive

If the secondary measurement is Q, D, or R and is negative - then there are two likely possibilities. If the Q or D value (whichever is being displayed) is very small, a small (acceptable) calibration and/or measurement error can lead to a negative result. (It should of course fall within the specified accuracy of the instrument.)

Measurement error can be reduced by choice of measurement conditions, averaging, etc. Another possibility is that the DUT (as seen by the Digibridge) really does have a negative loss factor. This situation might occur when you are measuring certain kinds of multi-terminal networks or active devices.

NOTE: Improper connection of extender cables can cause a false indication of negative QDR.

D, Q or ANG IN PPM, Selected by the [SHIFT][DQ in PPM] Keys. For D, Q or ANG values less than .0100, selecting DQ in PPM improves the resolution by a factor of 100. For example, if the displayed D values of two capacitors are both 0.0001, changing to DQ in PPM might distinguish them by providing a reading of 138 ppm for one and 87 ppm for the other.

The "DQ in PPM" selection applies to the Q, D or ANG result only, and is effective for all selections of the [DISPLAY] key except BIN NO, and for all parameter selections except C/R, R/X, and G/B.

When this selection is in effect: the DQ INPPM indicator is lit; the display is always parts per million, without decimal point; if the display is blank, the D or Q value is greater than 9999 ppm (to obtain the value, cancel "DQ in PPM").

To cancel this selection, use the same keystrokes again: [SHIFT][DQ in PPM].

3.3.3.3 Go/No-Go Indicators

If comparison is enabled, by a non-zero entry for "nominal value" and limits in at least one bin, a GO or NO-GO indication is provided on the keyboard, for every measurement. GO means the measurement falls in bin 1 through 13; NO-GO means bin 0 or 14.

3.3.4 Units, Multipliers, and Blank Displays

Units of R, L, C, G, Z, and Y are determined entirely by your selection of parameter. Units multipliers are fixed by parameter, range, and frequency, except that selection of delta% changes the RLC display to a percentage. See Table 3-6.

Units of D and Q are dimensionless and are expressed as a decimal ratio, without multiplier - unless you select "DQ IN PPM", in which case D or Q is expressed in parts per million (see below). To obtain D or Q in percent, from the regular display, move the decimal point two places to the right. For example, a regular display of D = .0045 is equivalent to 0.45%

Parameter	Freq: Up to 0.1kHz				From 0.1 to 6kHz				From 6+ to 20kHz				Above 20kHz			
	1	2	3	4	1	2	3	4	1	2	3	4	1	2	3	4
R,Z	K	K	ohm	ohm*	K	K	ohm	ohm	K	K	ohm	ohm	**	K	ohm	ohm
L	H	H	H	mH	H	H	mH	mH	H	mH	mH	mH	**	mH	mH	mH
C/D	nF	nF	uF	uF	pF	nF	nF	uF	pF	nF	nF	nF	**	pF	nF	nF
C/R***	nF	nF	uF	uF	nF	nF	nF	uF	nF	nF	nF	uF	**	nF	nF	nF
G, Y	uS	mS	mS	S	uS	mS	mS	S	uS	mS	mS	S	**	mS	mS	S

* K represents "kilohms".
 ** Range 1 is not used if frequency is above 20kHz.
 *** For C in nF, R is in kilohms. For C in uF, R is in ohms.

Table 3-6: Units and Multipliers for Each Range

Decimal Point Position. The decimal point is automatically positioned for maximum resolution (i.e., so that the first significant digit or the first zero after the decimal point is in the first position in the display) with a few exceptions, as listed below. Of course, displays on low underrange or low extension of a held range may have a number of necessary zeros to right of the decimal point (and therefore reduced number of significant digits compared to the display area) because units and multipliers are fixed on anyone range. The above-mentioned exceptions are:

- DQ IN PPM is always displayed without a decimal point, in ppm.
- Delta% displays can resolve no less than 0.0001% (i.e., 1 ppm).
- Hysteresis is provided to reduce flickering, as explained below.

If the first digit of the measurement is 9, the decimal point for any measured-value display is left unchanged from its previous position, provided that so doing places that 9 in either the first or second position in the display area. (Notice that a number like 09XXX has resolution almost as fine as a number like 10xxx.)

For example, if the measured value is 99.985 nF, the display is a full 5 digits if the previous measured-value display was 12.345, 99.984, or 99.999; but the display is rounded off to 099.98 nF if the previous measured-value display was 100.02 or 1234.5 nF. Hysteresis is provided on both measured-value displays (RLC and QDR).

Blanks in Measured-Value Displays. If a measurement exceeds the capability of the display (99999 for RLC display, 9999 for QDR), the display is blank. If a measurement is less than 1 right-hand digit, the display is all zeros. If any leading zero before the decimal point must occupy a position in the display, that zero is blanked out.

3.3.5 D, Q, ANG in PPM

The Digibridge can easily be programmed to display the secondary test result - when it is either D, Q or ANG - in parts per million. To choose this display, press:

[SHIFT][DQ in PPM]

so that the PPM indicator is lit. To disable this option, repeat the same keystrokes so that the indicator is NOT lit. Units of D and Q in PPM are dimensionless and are expressed as a decimal ratio, with the multiplier of 1,000,000 understood. To obtain D or Q in percent, from the DQ in PPM display, place a decimal point four places to the left of its "understood" position at the right-hand end of the display. For example, a "DQ in PPM" display of D = 120 ppm is equivalent to 0.012%.

3.3.6 Ratio Displays, Virtual Range Extensions, and Conductance Measurements

The Digibridge can easily be programmed to display the principal test result (R, L, C, G, Z, Y) in the form of a ratio instead of the actual measured value. The ratio is either (measured value / stored nominal value) or the reciprocal of that. By suitable choice of the nominal value, you can obtain virtual range extensions for measurement of very large values or for fine resolution in measurement of very small values.

One use of the ratio display capability is to obtain results in terms of a multiple of some reference, which can be obtained if desired by measuring a real reference DUT.

For Very Large R, L, or G. Another use of the ratio display is to obtain measurements of very high values (in high overrange, i.e., exceeding 99999 of the highest range). For example, consider the measurement of capacitors with values near 200 mF [i.e., 0.2 farad). Any value greater than 99999 μ F (99.999 mF) normally causes a blank display (because the unit multiplier on the highest C range is fixed and the display is limited to 5 digits).

However, if you enter a nominal value of 1000 μ F, and enable calculation and display of the ratio “measurement/nominal”, then measurement results can be interpreted as though they were in units of mF (although the ratio is really dimensionless and the unit indicators remain unlit) . In this example, the measurement results can then be 199.99, 200.00, 200.01, etc. For much larger capacitance the Digibridge will automatically move the decimal point, up to 99999 mF [i.e., 99.999 farads). For still larger values, you can make the nominal value larger.

For Very Small R, L, or C. Another use of the ratio display is to obtain better resolution of very small values (Otherwise the resolution can be no better than .00001 on the lowest range.) For example, consider the measurement of some inductors with values near 20 nH. Because the minimum measured value, and

the resolution limit also, is .00001 mH. the normal measurement results can only be .00000, .00001, .00002, .00003 mH. etc, i.e., steps of 50% of the 20 nH value . However, if you enter a nominal value of .001 mH. and enable calculation and display of the ratio “measurement /nominal”, then measurement results can be interpreted as though they were in units of μ H (although the ratio is really dimensionless and the unit indicators remain unlit). In this example, the measurement results can then be .01999, .02000, .02001, etc, i.e., steps of .05%, which is very fine resolution. By selecting a sufficiently small nominal value, you can obtain resolution that is better than the repeatability of measurements.

Procedure. To program the Digibridge for ratio displays: enter desired nominal value in appropriate units of measurement; enable the special function, as follows.

1. With the [FUNCTION] key, select ENTER.
2. Using the appropriate parameter key, select the units of the nominal value to be stored.

If the Digibridge has just completed a measurement of a DUT, so that the principal display already indicates the appropriate units of measurement, Step 2 can be skipped.

3. Enter the desired nominal value. For example, if the units displayed on the panel are μ F and you want to set up a ratio display that can be interpreted as mF, press:

[0][0][0][0][=][SHIFT][NOM VALUE]

4. Enable the desired special function, the pertinent commands are:

- To display measurement/nominal: [2][=][SHIFT][SPECIAL][6]
- To display nominal/measurement: [1][=][SHIFT][SPECIAL][6]
- To disable ratio displays: [0] [=] [SHIFT] [SPECIAL] [6]

If ratio is selected, the ‘RATIO’ indicator will light on the display window

5. To enable measurements, select MEASURE with the [FUNCTION] key.
6. To display the ratio in the left-hand display area, select VALUE with the [DISPLAY] key.

After measurement, the right-hand display will be QDR, as usual; however, if the parameter selection is C/R, the units for R will NOT be indicated. If the parameter selection is C/R, the ratio display in the left-hand display area is accompanied by a resistance value in the QDR display area, without units indication. If the ambiguity in units (ohms or kilohms) must be resolved, the following method is suggested. The units can be determined for a typical DUT by temporarily disabling ratio display. While ratio is disabled, make measurements also with parameter selection C/D and observe the typical value of D. Now you are prepared to measure a batch of similar capacitors with ratio display. For any of them, a temporary change of parameter selection from C/R to C/D and another measurement will provide a quick check on whether its loss is similar to the loss of the typical DUT. If it is similar, for similar value of C at the same frequency, the R value is similar also. However if its D is much higher, the value of Rs is higher and Rp is lower, in approximate proportion to D.

3.4 Principal Test Conditions

3.4.1 Test Frequency

Power-up frequency is 1 kHz, unless the keyboard has been locked with some other choice. There are 504 available frequencies, as detailed below. If a frequency other than 1 kHz is selected, the “NOT 1 KHZ” indicator will light on the display window.

Selection. To select the test frequency, simply key in the desired frequency as follows, and the Digibridge will automatically obtain the nearest available one.

1. Select ENTER with the [FUNCTION] key.
2. Enter the desired frequency in kilohertz and press [=][SHIFT][FREQUENCY] in sequence, as follows. For example, to select 500 Hz, press:

[.][5][=][SHIFT][FREQUENCY]

Up to 6 digits and decimal point are valid in entry of desired frequency. For another example, if the desired frequency is 2300 Hz, key in:

[2][.][3][=][SHIFT][FREQUENCY]

The actual frequency obtained appears immediately in the left (RLC) display area. In the example of desired frequency 2300 Hz, the display is 2.3077. The actual frequency obtained is always the closest one of the 504 available frequencies, which can be calculated from the following formulas, where n is always an integer in the range indicated:

(3 kHz)(C/n) where n range is: 13 250 (freq .012000 to 0.23077 kHz)

(60 kHz)(C/n) where n range is: 4 256 (freq 0.23438 to 15.000 kHz)

(200 kHz)(C/n) where n range is: 1...13 (freq 15.385 to 200.00 kHz)

and where $C = 1 + c$, where c is a very small number between - .000099 and + .000099

The “nominal value” of an available frequency can be calculated from the appropriate one of the three formulas, the appropriate value of integer n, and by assuming that $c = 0$. The “corrected value” is more accurate, and is calculated in the same way except for using the true value of c.

The value of e is determined individually for each Digibridge as part of its factory calibration. If you want to find out what e is for your instrument, do the following. (The value will be in the range : -99 to 99 ppm.)

Select ENTER with the (FUNCTION] key. Then press:

[SHIFT][SPECIAL][0]

Indication. Frequency display is the nominal value, to 5-digit resolution. This display is shown when frequency is selected (as described above) or by interrogation as follows: select ENTER function and then press:

[SHIFT](FREQUENCY]

3.4.2 Test Voltage

The power-up test voltage is 1.0 volt rms, unless the keyboard has been locked with some other choice. There are a total of 255 choices: .005 to 1.275 V in increments of .005 V. To program the test voltage:

1. Select ENTER with the [FUNCTION] key.
2. Enter the desired voltage in volts and press [=][SHIFTT](VOLTAGE), in sequence as follows. For example, to select 750 mV rms, press:
[.][7][5][=][SHIFT][VOLTAGE]

The accuracy of the programmed source voltage is:

$$\pm[(5\%+2\text{mV})(1+0.001*f^2)]$$

where f = value of test frequency in kHz.

The actual voltage across the DUT is never more than the source voltage, and depends on the DUT impedance and the source resistance of the Digibridge, for the range in use. The DUT voltage is close to the source voltage at the high-impedance end of each

measurement range and lower at the low-impedance end. Normally, the smallest voltage across the DUT (if its impedance is 6.25 ohms or more) will be 20% of the source voltage; this is the case for resistors measured at the low end of each range. Refer to Table 3-7 for details. (This table is similar to the table of range constants in the specifications. However, the extreme limits are given here, on ranges 1 and 4.)

For example, what is the voltage across the DUT if it is a 1 μF capacitor. Assume the test frequency is 1 kHz, the test voltage is 1.0 V, the CONSTANT VOLTAGE indicator is NOT lit and the RANGE HELD indicator is NOT lit. The Digibridge will measure on range 3, with 1.0 V behind source resistance of 400 ohms. The DUT reactance is 159 ohms and the voltage across it is 370 mV.

For comparison, what is the voltage across the same DUT if you select CONSTANT VOLTAGE (see paragraph 3.4.3) or if range 4 is held. In either case, the source, 1.0 V, is behind 25 ohms, The voltage across the DUT is 988 mV.

Range	Source Resistance	----- Resistance	Principal Measured Parameter Capacitance	----- Inductance
1	97.4 kohms	max 99999 K mid 102 K min 25.6 K	min .00001 pF mid 1600 pF/f max 6400 pF/f	max 99999 H * mid 16 H/f min 4.1 H/f
2	6.4 kohms	max 25.6 K mid 6.4 K min 1.6 K	min 6.4 nF/f mid 25.3 nF/f max 100. nF/f	max 4100 mH/f mid 1025 mH/f min 256 mH/f
3	400 ohms	max 1600 ohms mid 400 ohms min 100 ohms	min 100 nF/f mid 400 nF/f max 1600 nF/f	max 256 mH/f mid 64 mH/f min 16 mH/f
4	25 ohms	max 100 ohms mid 25 ohms min .00001 ohm	min 1.6 uF/f mid 6.4 uF/f max 99999 uF	max 16 mH/f mid 4 mH/f min .00001 mH

* "K" is kilohms; "f" is equal to the test frequency in kHz.

Table 3-7: Autoranging Measurement Ranges and Source Resistance

3.4.3 Constant Voltage Source

If it is important to measure the DUT at a particular test voltage, then select the constant-voltage feature as follows. Press:

[SHIFT] [CONSTANT VOLTAGE]

so that the CONSTANT VOLTAGE indicator is lit. The Digibridge now retains a source resistance of 25 ohms for all ranges. The voltage is constant for any DUT impedance significantly larger than 25 ohms. An example is given in the preceding paragraph. Choosing this feature causes a reduction in measurement accuracy by a factor of three, as accounted for by Kcv in the accuracy specifications. (To disable the constant-voltage feature, press the same keys again.)

3.4.4 Constant Current Source

If it is important to measure the DUT with a particular test current applied, then select the constant current feature as follows.

1. Select ENTER with the [FUNCTION] key.
2. Enter the desired current in milliamps.

For example, to enter .2 mA press [.] [2] [=] [SHIFT] [CONST I].

To disable Const. I, press: [0] [=] [SHIFT] [CONST I]. Refer to Table 3-8 for a listing of constant-current source values.

CURRENT RANGE	51 nA – 13.1 μA	13.2 μA - 198 μA	200 μA - 3.195 mA	3.2 mA - 51 mA
SOURCE RESISTANCE	97.4 k	5.6 k	400 ohms	25 ohms
RANGE	1	2	3	4

Table 3-8: Current Range and Source Resistance

When Const. I is enabled, the following procedure can be used to determine the current, voltage, and range set.

1. Select ENTER with the [FUNCTION] key.
2. For current, press: [SHIFT][CONST I], current will be displayed in mA.
3. For voltage, press: [SHIFT][VOLTAGE], voltage will be displayed in V.
4. For range, press: [SHIFT][SPECIAL][1], the range will be displayed.

To calculate the actual current through the DUT, use:
 $I = V / (R_s + Z_{dut})$.

3.4.5 Other Conditions

Other test conditions are described in other parts of this manual.

Delay (programmable settling time before acquisition of data) - paragraph 3.5.3.

Averaging (selection of number of measurements to be averaged) - paragraph 3.6.3

Bias applied to the DUT (if it is a capacitor) - refer to paragraph 3.7

Special functions - refer to paragraph 3.10.

3.5 Measurement Time and Measurement Ranges

3.5.1 General

Selection of MEASURE RATE (SLOW, MEDIUM, and FAST) obviously relates to measurement time, providing the user with an easily made choice. (The slower rates provide greater accuracy.) Programming a DELAY (typically because the normal setting time is insufficient for a particular handler or biasing routine) also obviously affects measurement time. In this paragraph, the many items that affect measurement time are explained. The measurement time (required to complete a measurement and display the results) depends not only on the selected measure rate, and programmed delay, but also on the presence or absence of the high-speed measurement option, test conditions, choice of display, whether data is being sent out to other devices, etc. The best combination of conditions for any particular job should be selected recognizing their effects on speed and accuracy. The following examples are representative; some of the numbers are approximate.

NOTE: Except where stated otherwise (as in paragraph 3.5.10), measurement time is given for the condition that the “quick acquisition” special function is NOT selected. So accuracy is as specified. (See page xiii at the front of the manual.)

1693 Digibridge. The minimum measurement time is about 34 ms (30 meas/sec). The corresponding conditions are: measure rate = fast, IT factor set to 0.25 (integration time factor - paragraph 3.5.5), test frequency = 10 kHz to 100 kHz, display selection = bin no., measure mode = continuous (which eliminates the settling time that is normal with triggered mode), no data output via IEEE-488 bus.

For test frequency = 1 kHz, the minimum is about 44 ms (23 measurements per second).

Surprisingly Long Times. Please be aware of the long time periods that can be required by this very fast measuring instrument.

NOTE: Under some conditions, testing can consume so much time that the operator might wonder whether the Digibridge is really operating. See below.

The longest single measurement cycle (including programmable delay set to 99999 ms and the special-function selection of “median value”) is about 5 minutes. The Digibridge will execute up to 255 full-length cycles if you select maximum averaging, for a total of about 22 hours from START to display of measured result.

3.5.2 Measure Rate Selection at Keyboard

Choose one of 3 basic measurement rates with the [MEASURE RATE] key: SLOW, MEDIUM, or FAST. The continuous-mode rates are respectively about 1, 4, and 8 measurements per second, if the other test conditions and programmable selections are left at normal power-up defaults.

The tradeoff is speed vs. accuracy. The Digibridge will make a more precise and accurate measurement at a slower rate. For the above conditions, in very simplified terms, the basic accuracy is 0.02%, and the tradeoff is as follows:

- SLOW rate: 1 measurement per second, 0.02% accuracy (or better);
- MEDIUM rate: 4 measurements per second, 0.05% accuracy (or better);
- FAST rate: 8 measurements per second, 0.12% accuracy (or better).

For details on accuracy, refer to the specifications. In the accuracy formulas, the effect of measure rate selection appears as the term “Ks.”

3.5.3 Settling Time or Programmed Delay, in Triggered Measure Mode

For accurate measurements, it is often helpful to have a time delay between the START signal and the beginning of the first voltage measurement within the process of data conversion. Because such a delay allows time for switching transients to settle, and because more time is required for low test frequencies, the Digibridge normally incorporates “settling time” as follows.

- If measure mode is CONTINUOUS, settling time = zero, programmed delay is disabled.
- If measure mode is TRIGGERED, with measure rate FAST, settling time = 7 ms/f
- If measure mode is TRIGGERED, with measure rate MEDIUM, settling time = 10 ms/f
- If measure mode is TRIGGERED, with measure rate SLOW, settling time = 12 ms/f,

where f is equal to the test frequency in kHz. NOTE: the three times given above are verifiable in the ENTER function by pressing [SHIFT][SPECIAL][4].

If measure mode is TRIGGERED, you can program any desired delay (from 0 to 99999 milliseconds) for transient voltages to settle, for mechanical handling to be completed and contacts to settle, etc. The Digibridge will pause for this much time after each START signal, before actually starting to take data. Any programmed delay replaces the default “settling time”; and affects measurements only in TRIGGERED measure mode.

For example, you can set delay to 25 ms by selecting ENTER with the [FUNCTION] key and pressing [2][5][=] [SHIFT][SPECIAL][4]

Programmed delay is typically required for measurement of capacitors with bias, if the measure mode is TRIGGERED. Refer to paragraph 3.7.

NOTE: In the CONTINUOUS measurement mode, there will be no settling time or programmed delay; the speed of the Digibridge makes it reasonable to disregard the first displayed result (which is liable to be

in error for several reasons), and observe subsequent displays for consistency, which indicates that any transients have settled.

3.5.4 Measure Mode and Display Selection, Effects on Measurement Time

Measure Mode TRIGGERED. Selection of TRIGGERED mode introduces a settling time or delay between the START signal (which is necessary in this mode) and the beginning of data acquisition. Refer to paragraph 3.5.3, above.

Measure Mode CONTINUOUS. Selection of CONTINUOUS measure mode eliminates the delay described above. Notice that in continuous mode, the measurement being made when the DUT is connected to the Digibridge is erroneous. Subsequent measurements have the benefit of any effective “delay” furnished by the preceding ones.

Display Selection. The selection of BIN NO. display cuts 6 to 10 ms from the measurement time, compared to any other choice of display.

3.5.5 Integration-Time Factor (a Special Function)

The length of time that the Digibridge spends integrating analog voltages in the process of data acquisition can be varied by programming a number called the “integration-time factor”, if the measure rate is selected to be FAST or MEDIUM. In general, programming the I-T factor to a larger value allows the Digibridge to integrate over more cycles of the test signal, thus increasing the measurement time and enhancing the accuracy. (If the measure rate is SLOW integration time is automatically fixed at a relatively large value, so that any programmed I-T factor has no effect on measurement time.)

The I-T factor is normally 1. You can program it to values in the range from 0.25 to 6. For I-T factor = 0.25, if measurement rate is FAST, the integration time is set to 1 mS if the test frequency is above 1kHz, or to one period of the test signal if test frequency is

less than 1 kHz. The following tabulation indicates the integration time for several combinations of I-T factor and measurement rate, for test frequency of 1 kHz.

I-T Factor	0.25	1	6
FAST	1 ms	4 ms	24 ms
MEDIUM	4 ms	17 ms	100 ms
SLOW Not affected by I-T factor	100 ms	100 ms	100 ms

Table 3-9: Effects of Integration-Time factor on Measure Rates

Programming the I-T factor is a special function, which is under keyboard control only if you have selected ENTER function. Then, for example, press these keys:

[.] [2] [5] [=] [SHIFT] [SPECIAL] [5] (to make the IT factor 0.25)

NOTE: “Max” rate is defined as the combination of FAST measure rate with I-T factor programmed to be 0.25. (The quick- acquisition special function is NOT used. See paragraph 3.10. With it, the measure rate would be even higher.)

The accuracy of measurement is affected by the value of I-T factor (in combination with measure rate and other conditions). The tradeoff is illustrated as follows, for I-kHz test frequency, display = BIN NO., measurement mode = CONTINUOUS.

- I-T factor = any value, SLOW rate, 0.02% accuracy, 1 measurement per second;
- I-T factor = 1, MEDIUM rate, 0.05% accuracy, 4 measurements per second;
- I-T factor = 1, FAST rate, 0.12% accuracy, 8 measurements per second.
- I-T factor = 0.25, FAST rate (“Max”), 0.25% accuracy, 23 measurements/second.

For details about accuracy, refer to the specifications, where the effect of programming I-T factor to be 0.25 and selecting FAST rate is designated as “maximum measurement rate” in the table of values for the term “Ks.”

3.5.6 Ranges and Range Changing

Descriptions of ranges, range extensions, and decimal point control are explained below.

Basic Ranges. The 4 basic ranges are numbered 1, 2, 3, 4, in order of decreasing impedance. Each basic range is approximately a factor of 16 wide. Refer to Table 3-7.

The word “upper” as used below refers to increasing measured value (which is the direction of increasing range number only if the principal measured parameter is capacitance). Similarly, the word “lower” as used below refers to decreasing measured value (which is the direction of decreasing range number only if the principal measured parameter is capacitance).

Extensions. Each of the 4 ranges goes beyond its basic range, with both upper and lower range extensions (also called overrange and underrange). Most of these extensions are seldom used because they overlap basic portions of other ranges and the Digibridge will automatically select the basic range unless you have selected “hold range” (see RANGE HELD indicator). Measurement units and multipliers in any range extension are the same as in the basic range. The fact that range definition depends on frequency causes a considerable variation in the width of range extensions. The lower limit is generally .00001, with all-zeros next; the upper limit is 99999, with all blanks next. Blanks in the measurement display are discussed below. In general, for any measurement within the specifications of the Digibridge, if a measurement can be displayed, it will be.

The only range extensions that are valid with autorangeing are low underrange and high overrange, explained below.

Low Underrange. The “low” extension of the low range goes down to 1 count, with reduced accuracy. The smallest “f-count” increment in the display is the minimum measured value, given in the specifications in the front of this manual. Any measurement smaller than 1 count is displayed as all zeros.

NOTE: If the measured value is very small (even below one count) or very large (even over 99999), high resolution measurements are possible using the ratio display. Refer to paragraph 3.3.6 or 3.10

High Overrange. The “high” extension of the high range goes up to the maximum display (all 9’s, with the decimal point at the right), and finally to blank, with reduced accuracy. The high overrange is used for the very large values of RLC that exceed the basic high range.

Autoranging. Autoranging is normal; it is inhibited only if you select RANGEHELD. There is a slight hysteresis in the changeover from range to range to eliminate a possible cause of display flickering.

Time Required to Change Range. The Digibridge must almost complete a measurement cycle in the previously established range before starting measurement in the range to which it changes. The Digibridge completes the data acquisition and a large part of the calculation process before “deciding” whether the present range is best for the measured value. (If you have selected “median value”, a special function, the Digibridge will go through basically three measurement cycles so that it has the median value for making the decision whether to change ranges.) Thus, measuring a lot of components that straddle a range boundary requires almost double the regular measurement time for every DUT that is on the opposite side of the boundary from its predecessor. (Note : if the Digibridge starts in range 1 to measure in range 4, four almost complete measurement cycles are required before the desired result appears.) Therefore (at least in some measurement situations), maximum measurement speed requires range holding.

3.5.7 Range Holding

Why Hold Range? The most important use of the range holding capability is to avoid range changes when the component is removed from the fixture when in the CONTINUOUS mode. With no component connected, the instrument will autorange to range 1. Thus, if range 1 is not selected when the component is in place, considerable time is lost by unnecessary

autoranging. Another use of the range hold occurs when measuring components of the same nominal value whose actual values spread across the boundary between two ranges . If allowed to autorange, the units and decimal point may change with range which may be confusing to the operator. There are other uses for holding a range, such as obtaining the correct bias current or getting better guard capability. When a range is held that is not the range that autoranging would select, the accuracy may be sacrificed (see paragraph 3.6.9).

To inhibit autoranging, select the “range held” mode (RANGE HELD indicator lit) as described below - four methods.

To Hold Present Range. If the present range (as indicated by the measurement display) is the desired one, press [SHIFT][HOLD RANGE] to light the RANGE HELD indicator. (To return to the normal autoranging feature, press the same two keys again, making the RANGE HELD indicator unlit.)

To Hold the Range of a Sample DUT. One way to get into the desired range is to measure a DUT known to be in that range, thus:

1. Measure the DUT as usual.
2. Verify that the desired range is confirmed by the measurement display.
3. Press: [SHIFT][HOLD RANGE] to light the RANGE HELD indicator.

(To return to the normal autoranging feature, press the same two keys again, making the RANGE HELD indicator unlit.)

To Hold the Range selected by Use of a Parameter Key. Another way to get into the desired range is to use a parameter key, thus:

1. Select ENTER function with the [FUNCTION] key.
2. Press the appropriate parameter key (such as Cs/D) repeatedly, watching the units indicators.

The range advances with each repetition, enabling you to determine the present range by the pattern of changes. Notice that there is not always a change of unit multiplier with each range change. (Refer to Table 3-6 on page 40.)

3. Press: [SHIFT][HOLD RANGE] to light the RANGE HELD indicator.

(To return to the normal autoranging feature, press the same two keys again, making the RANGE HELD indicator unlit.)

To Hold Range by Number. If you know the desired range number (see Table 3-7 on page 43), use the special function key as follows:

1. Select ENTER with the [FUNCTION] key.
2. For range 1, press: [1][=][SHIFT][SPECIAL][1]
3. For range 2, press: [2][=][SHIFT][SPECIAL][1]
4. For range 3, press: [3][=][SHIFT][SPECIAL][1]
5. For range 4, press: [4][=][SHIFT][SPECIAL][1]

Note: for autoranging, press: [0][=][SHIFT][SPECIAL][1].

3.5.8 Time Required for Obtaining Median Values and Averaging

Accuracy can be enhanced, at the cost of increased measurement time, by either or both of these methods. The time considerations and a brief instruction for selecting each method (while in the ENTER FUNCTION) are given here.

Median Value. This measurement time is somewhat less than triple the single measurement time, because three nearly complete measurements are made, from which the Digibridge selects the median for final results. To be more specific, each median-value measurement requires approximately as much time as three single measurements MINUS two of the three settling or delay time intervals and also MINUS about half of the calculation time. (The relative magnitudes of settling time, delay time, and calculation time in the single measurement cycle are illustrated in paragraph 3.5.10.)

Enabling and disabling median-value selection is a special function (paragraph 3.10). The enabling command is [1][=][SHIFT][SPECIAL][8] (See paragraph 3.6.4.)

Averaging. The measurement time is multiplied by the number of measurements (2 to 255), specified when averaging was programmed. To program the Digibridge to average, for example, 8 measurements, press [8][=][SHIFT][AVERAGE] (See paragraph 3.6.3.)

Both. If both median value and averaging are enabled together, the measurement time is multiplied by almost three times the number specified when averaging was programmed. (The Digibridge finds the medians of groups of three measurements and then calculates the average of the medians.)

3.5.9 Time Required if IEEE-488 Output is Enabled

If data output is enabled, via IEEE-488 bus, additional time - about 2 ms to 12 ms - is required per measurement. This time requirement depends on the selected display and what data is being sent out, approximately as follows. (Refer to explanation of operation with the IEEE-488 interface, paragraph 3.12.)

Output data:	Regular Output Data Format							CBF*
	BIN	RLC	QDR	RLC, QDR	BIN, RLC	BIN, QDR	BIN, RLC, QDR	
Display = BIN NO.	2	6	8	10	10	10	12	< 2 ms
Display = other	2	2	2	4	4	4	6	< 2 ms

* *Compacted Binary Format. If the compacted binary format is selected, data output requires less than 2 ms.*

3.5.10 Effect of Selecting a Low Test Frequency on Measurement Time

Selection of a test frequency near or below 0.1 kHz affects measurement time in two ways: both settling time and data acquisition time depend on the period of the test signal. (Selection of test frequency near and above 1 kHz has little effect on measurement time, particularly if the integration time factor is left at default or set to a larger value.)

In general, measurement time includes the following two terms, which are additive. (Note: f is equal to the test frequency in kHz.)

- Settling time (if measure mode is TRIGGERED and you have not programmed any DELAY) is $[7 \text{ to } 12 \text{ ms}][1/f]$. In other words, approximately 10 periods.
- Data-acquisition time is generally more than 9 periods (15 periods at SLOW Measure rate), although the relationship is not linear. (Refer to the summary below and to theory, Chapter 4.)

Notice that you can select a shorter DELAY and you can select the “quick-acquisition” feature. The latter saves more than one test-frequency period (with some reduction in accuracy).

NOTE: If a special function is selected that simplifies or eliminates data output for PASS results, the additional time described above is accordingly reduced or eliminated, except for FAIL results.

3.5.11 Measurement Time Summary

To summarize the relationships of measurement time to a representative set of the many possible test conditions and operating selections, refer to Table 3-10 and Figure 3-29.

DELAY	DATA ACQUISITION	CALCULATION	DISPLAY	OUTPUT VIA IEEE-488 BUS
CONTINUOUS MODE: 0ms	(IRREGULAR, GENERALLY LESS THAN:)			NO OUTPUT: 0 ms
DEFAULT SETTING TIME FAST: (1/f) 7 ms MEDIUM: (1/f) 10 ms SLOW: (1/f) 12 ms	FAST: [9/f + 36 (ITF)] ms	WITH HI-SPEED OPT (ITF < 1): 13 ms (ITF ≥ 1): 17 ms	BIN NO: 0 ms	IF DISPLAY IS BIN NO. ONE { BIN: 1 ms RLC: 3 ms QDR: 4 ms ANY TWO: 5 ms ALL THREE: 6 ms
PROGRAMMED DELAY 0 TO 99999 ms	MEDIUM: [9/f + 160 (ITF)] ms	WITHOUT HI-SPEED OPT (ITF < 1): 25 ms (ITF ≥ 1): 35 ms	VALUE OR DELTA	IF DISPLAY IS VALUE OR DELTA. ANY ONE: 1 ms ANY TWO: 2 ms ALL THREE: 3 ms
	SLOW: [950 + 15/f] ms		3 TO 5 ms	

60046.0

Figure 3-29: Relationships of Measurement Time

Meas Rate	Display = BIN				Display = VALUE				Display = BIN				Display = VALUE			
	Test Freq (kHz)				Test Freq (kHz)				Test Freq (kHz)				Test Freq (kHz)			
	0.1	1	10	100	0.1	1	10	100	0.1	1	10	100	0.1	1	10	100
"Max"	123	50	44	43	131	58	52	51 ms	193	57	45	43	201	65	53	51ms
FAST	128	83	76	75	136	91	84	83 ms	198	90	77	75	206	98	85	83ms
MED	137	209	193	189	147	217	201	197 ms	237	219	194	189	245	227	202	197
SLOW	962	964	954	919	970	972	962	927 ms	1082	976	955	919	1090	984	963	927ms

* No entry for delay. When measure mode is CONTINUOUS, settling time is zero.

** No entry for delay. When measure mode is TRIGGERED, settling time is 7, 10, 12 ms/f defaults for measure rate = FAST, MED, SLOW, respectively; where f = test freq in kHz. Any programmed delay (can be 0 to 99999 ms) would replace the default settling time.

Table 3-10: Typical Measurement Times vs Frequency and Measurement Rate

NOTE: Table 3-6 differs slightly from the table of typical measurement times given in the Specifications at the front of this manual (and data in paragraphs 3.5.1, 3.5.2, 3.5.5), although the tables are reasonably accurate. The differences underscore that these “typical” numbers are not specifications and that several test conditions and selections in addition to those stated for the tables affect measurement time. For example, selections of parameter and equivalent circuit affect calculation time.

3.6 Accuracy, The Limits of Errors

3.6.1 General

Refer to the Specifications, at the front of this manual. The specifications apply at an ambient temperature of 23 degrees C (unless recalibration has been done at some other temperature), in low humidity, if the OPEN and SHORT zeroing procedures have been executed properly (paragraph 3.1.3), and the quick-acquisition feature is NOT selected. These specifications are valid when autoranging is used or the option range is set and held. When a non-optimum range is set and held, the accuracy may decrease (see paragraph 3.6.9).

Typical accuracy is described below, for convenience in obtaining a birds-eye view of the way it relates to the principal test conditions, instrument programming, averaging, and median-value selection.

Refinement of the zeroing procedure to enhance accuracy for certain kinds of measurements is described in paragraphs 3.6.5 and 3.6.6. Cable-related errors and their correction are described in paragraph 3.6.7. Paragraph 3.6.8 describes the use of signal reversing (a special function) to enhance accuracy whenever test frequency is the same as power-line frequency.

To obtain accuracy, and the limits of errors, IET offers a convenient tool at http://www.ietlabs.com/product_support/limits_of_error_calculator. This tool is equivalent to the calculation below for both primary and secondary parameters.

3.6.2 Accuracy for Some Typical Conditions

For convenience in comparing the tradeoffs between speed and accuracy, the accuracy is tabulated in Table 3-11 for the same frequencies, and the results tabulated in the same arrangement, as the measurement time tables. The data also appear as a graph of speed vs accuracy for several frequencies, Figure 3-30.

Each curve shows the tradeoff for one test frequency. Operating points are labeled according to the selected measure rate (FAST, MEDIUM, SLOW). All of these curves apply to the following conditions: R, L, or C within basic ranges, $D < < \text{or } Q > > 1$, display is BIN NO., test voltage $\Rightarrow 1.0 \text{ V}$, constant voltage NOT selected, delay NOT programmed, measure mode is CONTINUOUS, and the high-speed option used (except for the dashed curve, which shows approximately the difference that this option makes). NOTE: for display of VALUE, add 6 to 10 ms to the time.

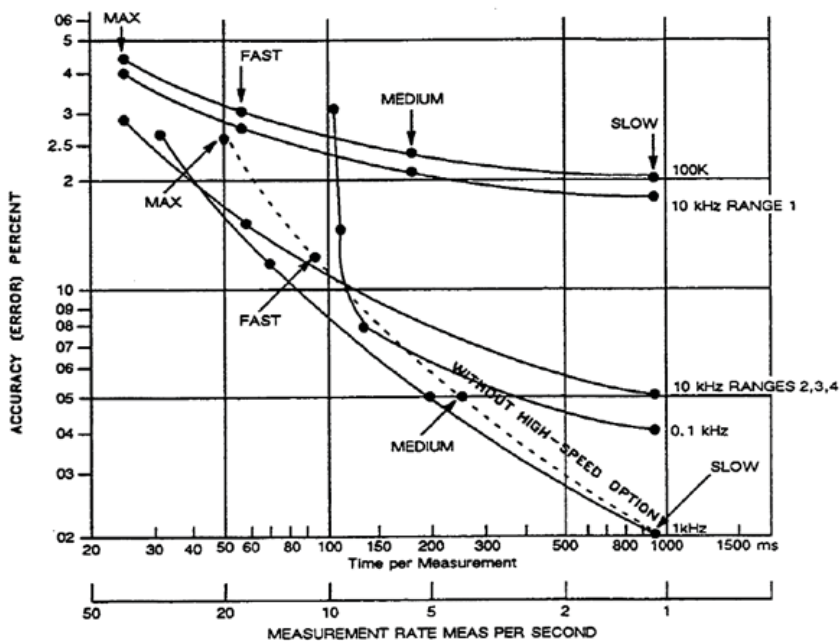

Figure 3-30: General view of the tradeoffs between measurement time and accuracy

---- Range 1 (Basic Range) ** ----					---- Ranges 2, 3, 4 (Basic) *** ----				
Meas Rate	Test Freq (kHz)	0.1	1	10 100	Meas Rate	Test Freq (kHz)	0.1	1	10 100
"Max"	.29	.26	.43	xx %	"Max"	.28	.26	.29	.45 %
FAST	.14	.12	.28	xx %	FAST	.14	.12	.15	.30 %
MED	.07	.05	.21	xx %	MED	.07	.05	.08	.23 %
SLOW	.04	.02	.18	xx %	SLOW	.04	.02	.05	.20 %

* With test voltage = 1 to 1.275 V, CONSTANT VOLTAGE indicator NOT lit, autoranging, RLC value within basic ranges (see below), and $Q < < 1$ with R, $Q > > 1$ with L, $D < < 1$ with C.

** (R) 25.6 to 410 kilohm
 (L) $4.1/f$ to $65/f$ H
 (C) $400/f$ to $6400/f$ pF
 (G) 39 to 2.44 uS
 (Z) 25.6 to 410 kilohm
 (Y) 39 to 2.44 uS

*** (R) 6.25 ohms to 25.6 kilohm
 (L) $1/f$ mH to $4100/f$ mH
 (C) $6.4/f$ nF to $25/f$ uF
 (G) 0.39 mS to .16 S
 (Z) 6.25 ohms to 25.6 kilohm
 (Y) .039 mS to .16 S

Table 3-11: Accuracy for Conditions Comparable to Table 3-10

3.6.3 Averaging to Improve Accuracy

The accuracy of measuring each DUT can be enhanced automatically by the Digibridge if you program it to make several measurements and average them before reporting the final result (See Figure 3-31). Thus, errors due to electrical noise and other effects that are just as likely to make the measurement too high as too low are largely canceled. (This is true regardless of the display selection, VALUE, BIN NO., etc.) Of course, the time required to complete a measurement with averaging set to 10 (for example) is 10 times as long as the time for a single measurement.

Averaging can be set to any integer up to 255. To select 8 for example, select ENTER with the [FUNCTION] key, then press [8][=][SHIFT][AVERAGE]

Similarly, to inhibit averaging, select ENTER function and press [1][=][SHIFT][AVERAGE]. This is the default situation (no averaging).

Displays of averaged measurements depend on the measure mode.

If the measure mode is TRIGGERED, the display is repeatedly updated to be the running average, until the programmed number of measurements have been made; then the final average remains displayed until the next START command.

If the measure mode is CONTINUOUS, averaging proceeds without any change of display until the programmed number of measurements have been made; then the final average is displayed and remains until replaced by another final average.

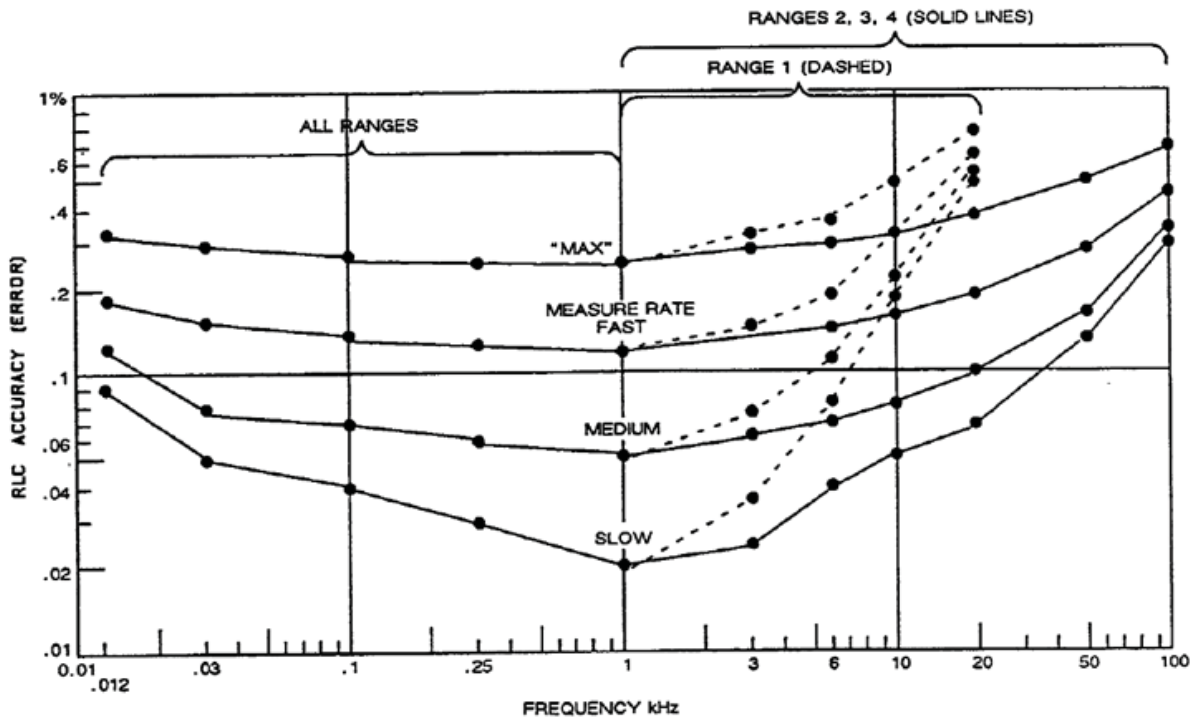

Figure 3-31: Approximate RLC Accuracy vs Test Frequency

3.6.4 Selection of Median Value for Better Accuracy

The Digibridge can be programmed to make measurements in one or more groups of three and take for results the median value in each group. If you also select averaging (of 5 for example), the median values of (5) groups will be averaged. Examples of uses for the median-value capability are given below.

If the “median-value” capability is enabled, the Digibridge makes three measurements, discards the highest and lowest results, and uses the median result for further calculations (if any), such as averaging. This capability is a special function. To enable it, press the following keys: [1][=][SHIFT][SPECIAL][8].

To disable “median value”, press: [0][=][SHIFT][SPECIAL][8]

An example of a use for the median value capability is to greatly reduce the likelihood of displaying an erroneous “transitory” measurement in CONTINUOUS measure mode. This erroneous measurement is typically caused by insertion or switching of the DUT at some indeterminate time during a measurement cycle. Typically, this erroneous measurement is preceded and followed by valid ones. (The next several measurements are correct until the DUT is changed again). If median value capability is enabled, the Digibridge displays the median of three measurements, only one of which is liable to be erroneous. Because the erroneous one is commonly quite different from the other two, the median is very likely to be one of the correct ones. Consequently, you see only one change in the value displayed, from “before” to “after” the DUT change.

Another example of a use for the median value capability is for measuring in the presence of occasional noise that pollutes some measurements - particularly noise spikes or bursts that can occasionally be coupled from electrical equipment (through power line to Digibridge circuits or via inductive or capacitive coupling to the DUT itself). Such noise pollutes a measurement now and then, among a majority of measurements that are correct. This noise

is non-random, i.e., not “white” noise, but it may be repetitive. Obviously you would prefer to have only the correct results displayed and/or output via the interfaces to other devices. If the duration of the noise spike is typically small compared to the length of a measurement cycle and the noise repetition rate is small compared to the Digibridge measurement rate, then it is likely that any polluted measurement will be one of three measurements in the median taking, the other two being valid and practically identical. The median of any three consecutive measurements is therefore very likely to be correct.

3.6.5 Accuracy Enhancement for Large or Small Impedances at Particular Frequencies

Regular Zeroing at Test Frequency. When measuring very large or small values of impedance, the Digibridge will provide much better accuracy than the specifications, if the OPEN and SHORT zeroing procedure has been recently repeated ‘with test frequency set to the actual test condition.

Examples of the accuracy that is typically obtained with measure rate = SLOW, after using the actual test frequency when zeroing:

At 30 Hz: $R = 100 \text{ megohms} \pm 1\%$
(range-1 extension, a factor of 240 over Rmax)

At 120 Hz: $C = 0.1 \text{ farad} \pm 1\%$
(range-4 extension, a factor of 480 over Cmax)

At 10 kHz: $C = 0.1 \text{ pF} \pm 1\%$
(range-1 extension, a factor of 400 below Cmin)

At 100 kHz: $L = 0.1 \text{ } \mu\text{H} \pm 1\%$
(range-4 extension, a factor of 100 below Lmin).

NOTE: Even better accuracy is possible if several measurements are averaged. See paragraph 3.6.3, above. Use of the “ratio display” special function is recommended when you measure very large values (which otherwise cannot be displayed) or very small values (for which ratio display can provide greatly improved resolution). See paragraph 3.3.6.

3.6.6 Accuracy Enhancement by Special Attention to Short-Circuit Inductance

The ratio display (paragraph 3.3.6) enables very high-resolution measurements of low inductance and high capacitance - even beyond the limits of normal RLC displays. If such measurements are planned, especially if the test frequency is high, the inductance of the "short circuit" used in the normal zeroing procedure should be considered.

The short circuit provided by a wire inserted into the Digibridge test fixture (paragraph 3.1.3) has an effective inductance in series with its very low resistance. This inductance typically has a magnitude of several nanohenries. To enhance accuracy of measurements in which a few nanohenries of inductance are significant, use a properly chosen shape, size, and orientation of wire for the short circuit. For greatest accuracy, particularly for axial-lead DUTs, also correct the measured value by suitable calculation.

Accuracy Enhancement Procedures. Three methods are described. See Figure 3-32.

If measurements are to be made without any adaptors (radial-lead DUT), use a piece of no. 18 (AWG) wire, 2.2 cm long (7/8 in.), bent into a hair-pin shape as shown in "A". Press this wire fully down into the Digibridge test fixture, keeping the straight sides of the wire vertical. Measurement results now depend on the geometry of the DUT leads, but will typically

contain a related error less than 10 nH. For even smaller error, correct inductance measurements by adding 5 nH to the displayed value.

If measurements are to be made with adaptors (axial-lead DUT), for most situations, make the short-circuit calibration **WITHOUT** the adaptors. Use a piece of no. 18 (AWG) wire, 5 cm long (2 in.), bent into a rectangular shape as shown in "B". Press this wire fully down into the Digibridge test fixture, keeping the center of the wire above the center of the fixture and the straight sides of the wire vertical. Measurement results (with adaptors) will typically contain a related error of less than 5 nH, which can be verified by measuring a OUT consisting of a straight wire of known inductance - refer to one of the accompanying tables of inductances. (Wire length is measured between points of contact in the adaptors.)

If measurements are to be made with adaptors (axial-lead DUT), for greatest accuracy (requiring a manual calculation for every measurement), make the short-circuit calibration **WITH** adaptors spaced exactly as they will be for the DUT. Use any piece of straight wire having a known self inductance L_a - refer to Table 3-12. Measure the DUT using the series equivalent circuit. Then make the following calculation for each measurements:

- For an inductor: $L_s = L_m + L_o$
- For a capacitor: $C_s = C_m / (1 - \omega^2 L_o C_m) = \text{approx } C_m (1 + \omega^2 L_o C_m)$

where L_s and C_s are the corrected series values, L_m and C_m are the measured series values, ω represents $\omega = 2 \pi$ times frequency, and L_o is defined above. (Refer to the specification: MIL 0-39010.)

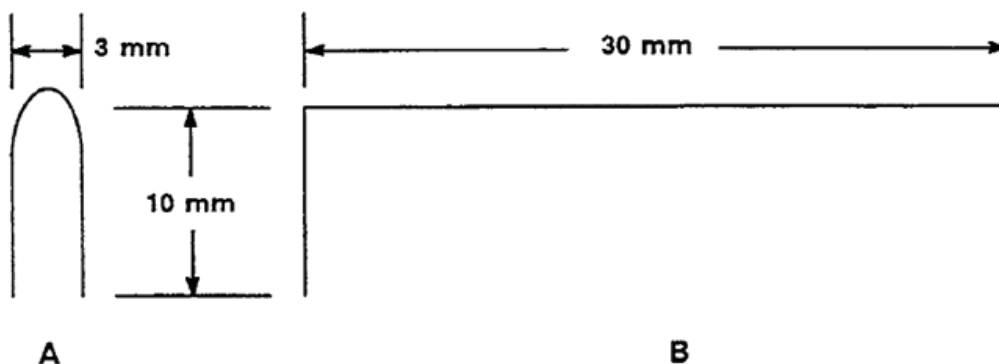

Figure 3-32: Recommended Wire Shapes for Zeroing

(Body of Table = Inductance in nH)*																
Wire Size	For frequency = 100 kHz								For low frequency							
	Wire Length in Centimeters								Wire Length in Centimeters							
	2	3	4	5	6	7	8	Delta	2	3	4	5	6	7	8	Delta
16	13.0	22.0	31.6	41.7	52.3	63.1	74.3	.13	13.5	22.7	32.6	42.9	53.7	64.8	76.2	.25
18	14.1	23.5	33.7	44.3	55.4	67.3	78.5	.16	14.4	24.1	34.4	45.2	56.4	68.1	79.9	.25
20	15.1	25.1	35.8	47.0	58.5	70.5	82.7	.19	15.4	25.5	36.3	47.6	59.3	71.3	83.6	.25
22	16.2	26.7	37.9	49.6	61.7	74.1	86.9	.22	16.3	26.9	38.1	49.9	62.1	74.6	87.3	.25

*From the formula $L=2l[\log_n(2l/\rho)-1+\delta]$ nanohenries, where l =length (cm), ρ =radius (cm), \log_n =natural logarithm, δ =skin-effect correction (tabulated). Reference: R. E. Terman, Radio Engineers' Handbook, McGraw Hill.

Table 3-12: Inductance of Straight Round Wires

3.6.7 Cable-Related Errors and How to Correct for them

Test-fixture extension can introduce measurement error so that specified accuracy may not be met. In other words, some of the series impedances and ground capacitances associated with connecting a remote DUT can be large enough to introduce terms that add significantly to the error permitted by the accuracy specifications. In this paragraph, we discuss the cable-related sources of error, how to estimate it, and how to correct for it.

NOTE: We define the "normal DUT interface" here as the 1689-9600 remote test fixture attached via 1689-9602 BNC cable to the 1693 Digibridge.

The Digibridge automatically compensates for capacitance between "high" terminals and "low" in the zero calibration. Also the 5-terminal "Kelvin" circuitry is designed to minimize the effect of other cable and test-fixture impedances on measurement accuracy. However, the following terms can be significant under some circumstances, particularly if a long extender cable is used to reach beyond the "normal DUT interface".

- A_{cm} , common-mode accuracy term, most significant on range 4.
- A_{ld} , capacitive-loading accuracy term, most significant on range 1, at high frequency.

Formulas and typical constants are given below for obtaining useful approximations to these terms.

Common-Mode Accuracy Term. (Applies to any extension beyond instrument.)

$$A_{cm} = \pm[(.05) (r + jx) / Z] \% \text{ of measured impedance}$$

where $(r + jx)$ is the series impedance in the IL lead including the cable, and Z is the DUT impedance.

However, if you have selected SERIES EQUIV CKT, it is more useful to split A_{cm} into the following 2 components, for treating L_s and C_s errors separately from R_s error:

$$A_{cmx} = \pm[(.05) (x) / (\text{DUT reactance})] \% \text{ of measured } L_s \text{ or } C_s$$

$$A_{cmr} = \pm[(.05) (r) / (R_s)] \% \text{ of measured } R_s$$

If either of these is significant, one can calculate and use it to correct each corresponding measured value. However, first make careful measurements with a known low-impedance DUT, to determine whether each correction should be positive or negative for your particular test fixture.

Capacitive-Loading Error Term

$$A_{ld} = [(.003) (K_{range}) (f_2)(C_{sn} / 1000 \text{ pf})] \% \text{ of principal measured value}$$

where Krange is: for range 1, 1; for range 2, .0625; for range 3, .0040; for range 4, .00024. Factor f is frequency in kilohertz. Csn is total capacitance from the low [IL and PL) terminals to ground (in cable and test fixture, beyond the “normal DUT interface” - see notes above and below).

NOTE: If the 7000-05 tweezers (or other extension having capacitance of about 200 to 300 pF) is connected directly to the 1693 Digibridge (without any other cable) the difference from “normal DUT interface” is trivial, and Ald error is negligible.

If Ald is significant, one can calculate and use it to correct each measured C, L, or (if the DUT is a resistor) R. The effect on D or Q is negligible.

For C, the Digibridge reads high; use a negative correction.

For L or R, the Digibridge reads low; use a positive correction.

The following table is used in the preceding formulas:

Cable	R	Lc*	Csn
1689-9602 bnc Cable, with 1689-9600 Remote Test Fixture	.33 Ω	1.1 μH	0 pF
1657-9600 Extender cable with banana plugs	.37 Ω	2.20 μH	475 pF

* The formulas for Ac and Acmx contain x, which is $2(\pi)fLc$, where pi is 3.1416, where f is expressed in Hz, and inductance Lc is tabulated above.

Table 3-13: Typical parameters for Digibridge Extender Cables

Refer to Table 3-14 for some representative examples of accuracy (error) terms related to cables, for certain range and frequency selections. Notice that the addition of an) unspecified cable and/or “homemade” remote test fixture will probably increase each of these parameters and error terms. Also, cable and test fixture capacitance can aggravate a resonance problem in measurement of large values of inductance at high frequency; refer to paragraph 3.13.

Accuracy Term*	1657-9600 Banana	1689-9602 bnc-to-bnc	Units
Acmx for 1kHz	.00069/Xdut	.00034/Xdut	% of Ls or Cs
Acmx for 20kHz	.0069/Xdut	.0088/Xdut	% of Ls or Cs
Acmr any frequency	.002/Rsdut	.020/Rsdut	% of meas Rs
Range 1, 1kHz	Zero **	.00021	% of meas value
Range 1, 20kHz	Zero **	.084	% of meas value
Range 2, 20kHz	Zero **	.0052	% of meas value
Range 2, 100kHz	Zero **	.13	% of meas value
Range 3, 20kHz	Zero **	.00033	% of meas value

* Xdut and Rsdut represent the DUT's series reactance and resistance respectively

** Ald error is significant only for extension beyond “normal DUT interface”, where the system software applies compensation.

Table 3-14: Typical Cable-Related Accuracy (Error) Terms

3.6.8 Use of Signal Reversing (Special Function) for Tests at Power Frequencies

The special “signal reversing” function is primarily for use whenever the test frequency is 60 or 120Hz (if your power frequency is 60 Hz) or whenever it is 50 or 100 Hz (if your power frequency is 50 Hz). However, it is also useful whenever the test frequency is equal to or very close to the frequency of any constant external signal that can be coupled to the low terminal(s) of the DUT (IL and PL).

If this disturbance is strong enough, it can degrade the accuracy of normal measurements. However if the disturbance is not so very strong that the Digibridge sensing circuits are overdriven, then “signal reversing” will typically restore specified accuracy. This special function enables a test routine in which the phase of the test signal is periodically reversed and the Digibridge senses both phases additively. However, the constant- phase disturbance component of the sensed signal is canceled by subtraction. This capability is a special function. To enable it, press [1][=][SHIFT][SPECIAL][3].

To disable “signal reversing”, for fastest measurements, press [0][=][SHIFT][SPECIAL][3].

3.6.9 Accuracy When Holding a Non-Optimum Range

The accuracy specifications are valid when the optimum range is used for any given impedance value. The optimum range is selected by the autoranging capability. If some other range is selected and held by the operator, the specified accuracy will be poorer. This accuracy may be calculated by multiplying the impedance ratio terms in the accuracy specifications by factors given in Table 3-11.

	Range 1	Range 2	Range 3	Range 4
Rx, Lx, Zx or Xx in numerator	1	20	300	5000
Cx, Yx, Gx or Bx in numerator	5000	300	20	1
Second Ratio Term				
Rx, Lx, Zx or Xx in denominator	5000	300	20	1
Cx, Yx, Gx or Bx in denominator	1	20	300	5000

Table 3-15: Multiplying Factors for Impedance Ratio Terms

3.7 Bias for the DUT

NOTE Keep the EXTERNAL BIAS switch OFF and the BIAS ON indicator unlit, for all measurements of inductors and resistors, and also for capacitors unless they are to be measured with dc bias applied.

3.7.1 Internal Bias

To measure capacitors with the internally available 2-volt dc bias voltage applied, use the following procedure. (The FUNCTION can be either MEASURE or ENTER.)

1. Press [SHIFT][INT BIAS] keys so that the BIAS ON indicator is lit.

NOTE: This indication, for internal bias, is somewhat dimmer than the other keyboard indicators.

2. To enable the special shorting routine (see paragraph 3.7.3):
 - A. Select ENTER function
 - B. Press [2][=][SHIFT][SPECIAL][3]
 - C. Select MEASURE function

3. Wait at least 1 second before initiating measurement, to allow for settling of internal circuits.

In the CONTINUOUS mode, disregard displays during this interval.

This delay is associated with enabling the internal bias; it applies to each DUT only if internal bias is disabled for each change of DUT.

4. Observe correct polarity when inserting DUT into test fixture.

Bias POSITIVE polarity is at the LEFT ("low" terminals) of the remote test fixture 1689-9600.

Bias NEGATIVE polarity is at the RIGHT.

5. For each DUT, in the CONTINUOUS measure mode, disregard the first displayed result and read the second. Notice enough of the subsequent results to verify that the DUT has stabilized. Use the stable result.
6. In the TRIGGERED measure mode, each measurement cycle includes the normal settling time (7 to 12 ms for 1-kHz measurements), or a programmed delay. See paragraph 3.5.3. Remeasure enough DUTs to be sure that they are stabilized in the first measurement so that any subsequent differences are well within the error permitted by your needs. If not, program in a longer delay.

NOTE: There are two effects to be aware of in watching for stabilization of the DUT: voltage and capacitance. Besides charging to a “final” voltage, there is also the stabilization of capacitance value itself. For example, some aluminum electrolytic capacitors respond slowly to a change in applied voltage, therefore the DUT capacitance can be settling long after the voltage is essentially stable.

Normally, the delay for internal bias measurements should be about 0 Rstd Cx seconds

(If the internal bias is being switched off during each change of DUT - by remote control perhaps - this delay should be 1 second larger: 1 + 10 Rstd Cx.)

NOTE: Rstd is 102400 for range 1, 6400 for range 2, 400 for range 3, 25 for range 4. (see Table 3-7 on page 43.) Cx is the capacitance of the DUT in farads:

For example, measuring 2000 pF at 1 kHz (range 1), this delay time should be about $(10)(102\ 400)(.000\ 000\ 002) = \text{approx } .002$ seconds. (Normal settling time is adequate.)

7. After biased measurements are completed, remember to disable the shorting routine:
 - A. Select the ENTER function
 - B. Press [0][=][SHIFT][SPECIAL][3]
8. Remove internal bias by pressing the [SHIFT][INT BIAS] keys, so that the BIAS ON indicator is NOT lit.

NOTE: The BIAS ON indicator serves to indicate whether internal bias is connected or disconnected only if the EXTERNAL BIAS is switched OFF. (See below for external bias.)

Notice that repeating the same keyboard sequence will cyclically enable and disable internal bias. For best results, after removing bias and before making further measurements, allow least 2 seconds for internal circuit discharge and settling.

3.7.2 External Bias

If bias is required at some other voltage than the 2-V internal bias, use external bias as described below. Also:

- Be sure that the voltage is never more than 60 V, max.
- A current-limiting power supply is recommended; set the current limit at 200 mA.
- Be sure that the bias supply is floating; DO NOT connect either lead to ground.
- Generally the external circuit must include switching for application of bias after each DUT is in the test fixture, and discharge before it is removed.
- A well-filtered power supply is recommended. Bias-supply hum can affect some measurements, particularly if a test frequency is the same as the power frequency.

Setup Procedure.

1. Connect the external bias voltage supply and switching circuit to the rear-panel EXTERNAL BIAS connector using a purchased or fabricated cable assembly. Observe polarity marking on the rear panel.
2. Set the external supply to limit current (<200 mA).
3. Set the external bias supply to the desired voltage (<60 V).
4. If the Digibridge power is off, switch its POWER ON, and wait for completion of the self-check routine before the next step.
5. Switch the EXTERNAL BIAS ON (switch is at right of keyboard) and verify that the BIAS ON indicator is lit - see below.

If polarity is inverted, the indicator will not be lit as brightly as normal.

6. If the bias cable fuse must be replaced, use a 200 mA fast-acting fuse.
7. Switch the bias off using an external switch, so that the DUT can be inserted before bias is applied to it. Refer to the Operating Procedure below.

NOTE: The BIAS ON indicator serves to indicate that the EXTERNAL BIAS is switched ON, NOT NECESSARILY the presence of external bias.

When the EXTERNAL BIAS switch is ON, the BIAS ON indicator is lit as long as the Digibridge POWER is ON. (The indicator brightness depends somewhat on the external bias voltage.) Also, when the EXTERNAL BIAS switch is ON, but the POWER is switched OFF, this indicator is lit by external bias voltages above about 3 V.

POWER ON. This is generally necessary to permit the power-up self checks to pass.

Protection. The Digibridge is internally protected from damage from charged capacitors with stored energy up to 1 joule at any voltage up to 60 V.

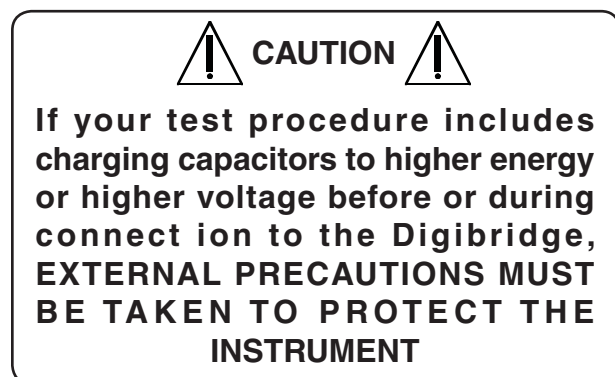

Operating Procedure.

1. If TRIGGERED measure mode is to be used, calculate the delay that is suitable for the largest value capacitor in the group to be measured with external bias, thus:

$$\text{Delay} = (C_x V_{\text{bias}}) / I_{\text{max}} + 10 R_{\text{std}} C_x \text{ seconds}$$

NOTE: C_x is the capacitance of the DUT in farads. V_{bias} is the external bias voltage in volts. I_{max} is the maximum current from the external supply (usually 0.2) amperes. R_{std} is 102400 for range 1, 6400 for range 2, 400 for range 3, 25 for range 4. (see Table 3-7 on page 43.) If the calculated delay is greater than the normal settling time (7 to 12 ms for 1-kHz measurements), then program the Digibridge to use this delay. See paragraph 3.5.3.

2. To enable the special shorting routine (see paragraph 3.7.3):

- A. Select ENTER function
- B. Press [2][=][SHIFT][SPECIAL][3]

3. Observe correct polarity when inserting DUT into test fixture.

Bias POSITIVE polarity is at the LEFT ("low" terminals) of the remote test fixture 1689-9600.

Bias NEGATIVE polarity is at the RIGHT.

4. Use the external switches (user-supplied) to remove bias from the test fixture (recommended when using external bias):

- A. Apply bias after the DUT is in place
- B. Remove bias after measurement
- C. Short the DUT before its removal

However, for occasional (non-production)

measurements, if the capacitances being measured are less than 200 μF and the bias voltage less than 30 V, an optional procedure is to leave the external bias circuitry "on" during measurements and to use the Digibridge EXTERNAL BIAS switch to apply bias to the DUT (ON) and to remove it and discharge the DUT (OFF).

5. For each DUT, in the CONTINUOUS measure mode, disregard the first displayed result and read the second. Notice enough of the subsequent results to verify that the DUT has stabilized. Use the stable result.
6. In the TRIGGERED measure mode, each measurement cycle includes the normal settling time (7 to 12 ms for 1-kHz measurements), or a programmed delay. Remeasure enough DUTs to be sure that they are stabilized in the first measurement so that any subsequent differences are well within the error permitted by your needs. If not, program in a longer delay.

NOTE: There are two effects to be aware of in watching for stabilization of the DUT: voltage and capacitance. Besides charging to a "final" voltage, there is also the stabilization of capacitance value itself. For example, some aluminum electrolytic capacitors respond slowly to a change in applied voltage, therefore the DUT capacitance can be settling long after the voltage is essentially stable.

7. After biased measurements are completed, remove all bias by sliding the EXTERNAL BIAS switch OFF and if necessary pressing the [SHIFT][INT BIAS] keys, so that the BIAS ON indicator is NOT lit. Disable the shorting routine. (See below.)

3.7.3 Suppression or Transients

When measuring biased capacitors, the time required for settling of transients in the measuring circuitry can usually be reduced by selecting the automatic shorting routine (a special function), as follows. Select ENTER function and press [2] [=][SHIFT][SPECIAL][3].

However, if there is no bias, the normal routine is faster. To obtain it, select ENTER function and press [0][=][SHIFT][SPECIAL][3].

NOTE: This automatic shorting routine DOES NOT discharge the capacitor DUT. It does short a capacitance in the measurement circuit to help terminate the transient that results from connecting a DUT with bias.

3.8 Bin Sorting and Go/No-Go Results

3.8.1 Introduction to Binning (Sorting Based on Limit Comparisons)

If a group of similar DUTs are to be measured, it is often convenient to use the limit-comparison capability of the Digibridge to categorize the parts. This can be done in lieu of or in addition to recording the measured value of each part. For example, the instrument can be used to sort a group of nominally 2.2- μ F capacitors into bins of 2%, 5%, 10%, 20%, lossy rejects, and other rejects. Or it can assign DUTs to bins of (for example) a 5% series such as 1.8, 2.0, 2.2, 2.4, 2.7 μ F, etc. The bin assignments can be displayed, for guidance in hand sorting. Up to 13 regular bins are provided for categories of the prin-

cipal measurement (RLC), in addition to a bin for rejects in the secondary measurement (QDR), and a bin for all other rejects; total = 15 bins.

Manually entered limits are normally entered in pairs (defining the upper and lower limits of a bin), in the form of “nominal value” and “percent” above and below that nominal. If only one “percent” value is entered for a bin, the limit pair is symmetrical (such as +/- 2%). To set up a non-symmetrical pair of limits, two “percent” values must be entered, the higher one first. Any overlapping portion of 2 bins is automatically assigned to the lower numbered bin.

For simple *GO/NO-GO* testing, set up a QDR limit and one regular bin. Entry of limits in additional bins will define additional GO conditions. Be sure the unused bins are dosed. (Bins 0 thru 13 are initially zero, at power-up. This means that the default QDR limit is “all fail” for D, Rs, and Q with R; it is “all pass” for Rp or Q with L; and that bins 1 through 13 are initially closed.)

The test frequency can be selected after limits are entered, before any particular measurement.

3.8.2 Sorting Methods

The figures illustrate 2 basic methods of sorting: nested and sequential. Nested limits are the natural choice for sorting by tolerance around a single nominal value. The lower numbered bins must be narrower than the higher numbered ones. Symmetrical limit pairs are shown; but unsymmetrical ones are possible. (For example, range AB could be assigned to bin 3 and range FG to bin 4 by use of unsymmetrical limit pairs in these bins.) Sequential limits, on the other hand, are the natural choice for sorting by nominal value. Any overlap is assigned to the lower numbered bin; any gap between bins defaults to bin 14. The usual method of entry uses a redefined nominal value for each bin, with a symmetrical pair of limits. If it is necessary to define bins without overlap or gaps, use a single nominal value and unsymmetrical limit pairs. It is possible to set up one or more, tighter tolerance bins within each member of a sequence.

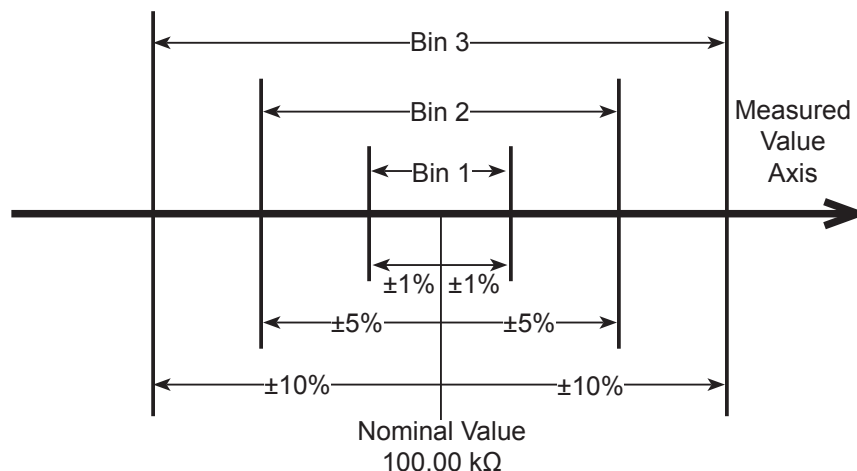

A single nominal value is used and all limit pairs are symmetrical in this basic plan.

Figure 3-33: Nested limits for sorting

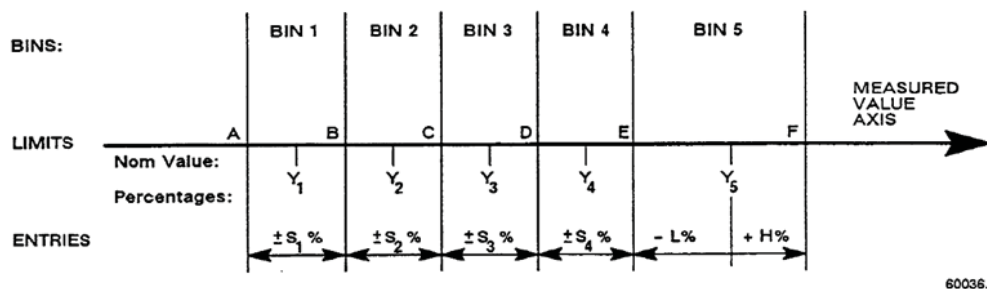

A different nominal value is entered for each bin and all limit pairs are symmetrical except for the unsymmetrical pair shown for example in bin 5.

Figure 3-34: Sequential limits for sorting

Bucket sorting means sorting into bins that are not nested. The usual method is that mentioned above, sequential limits. However, there is no requirement that the bins be adjacent. Any of them can be defined with its own specific limits, which may be overlapping, adjacent, or isolated from any other bin.

3.8.3 Limit Entry Procedure

To enable comparisons (unless the keyboard is locked), must enter limits as follows. This procedure makes use of limit entry keys, (at the left of the [SHIFT] key), with gray (or yellow) labels that apply only when the selected FUNCTION is ENTER.

1. Press [DISPLAY] key to select VALUE.
2. Press [FUNCTION] key to select ENTER

3. To enter a single QDR limit (always bin 0): press the parameter key (such as [Cs/D]) appropriate to DDT.

4. To change range and unit multipliers, press the same parameter key repeatedly.

Refer to Table 3-6 on page 40 for units and multipliers, which indicates the sequence of multipliers that will appear.

5. To enter limits:

A. Enter the maximum limit of D or Rs or Q with R.

B. Enter the minimum limit of Rp or Q with L.

For example, to enter a Q limit of 85 press [8][5][=][SHIFT][BIN NO][0][0].

The value first appears in left-hand display. To confirm storage of the limit, the value moves to the right-hand display.

Note: if you make a mistake, press the parameter key again and repeat the entry.

6. To enter RLC limits for bins 1-13, three methods are given:

Symmetrical percentage tolerances (nested bins).

- A. Enter the nominal value or DUTs to be sorted.

The value appears on the RLC display.

For example, to enter 123.40 as the nominal value, press [1][2][3][.][4][=][SHIFT][NOM VAL].

- B. Enter for bin 1 the narrowest percent tolerance to be sorted.

For example, for a tolerance of $\pm 0.2\%$ press [.] [2][%][=][SHIFT][BIN NO][0][1].

The numerical limits for RLC are automatically computed and rounded off values appear on the Digibridge displays (upper limit at the left, lower at the right).

- C. For bin 2, enter the next wider tolerance, similarly.

Be sure to use 2 digits for the bin number.

- D. Repeat the procedure for bins 3, 4, 5, ... up to a maximum of 13 bins.

Various nominal values (bucket sort). Plan for non-overlapping bins, each with a nominal value and limits defined by percent tolerance.

- A. For bin 1, enter nominal value and tolerance as described above.
 B. For each successive bin, similarly enter a new nominal value, then the tolerance and bin number.

Changing the nominal value does not affect limits already stored.

Any DUT that qualifies for 2 overlapping bins will automatically be assigned to the lower bin.

Unsymmetrical tolerances:

To enter unsymmetrical limits, for example +2% -5% in bin 6, press [2][%][-][5][%][=][SHIFT][BIN NO][0][6].

Two percentages of the same sign can be entered.

Always enter the more positive tolerance first.

7. You can close any bin that has been opened:
- For RLC bins (closing bin 8 as an example), press [0][=][SHIFT][BIN NO][0][8].
 - For D or Rs or Q with R (closing bin 0), press [9][9][9] [9][=][SHIFT][BIN NO][0][0].
 - For Rp or Q with L (closing bin 0), press [0][=][SHIFT][BIN NO][0][0].

8. To enable GO/NO-GO lights after opening at least one bin, leave "nominal value" at any non-zero value.

9. To disable GO/NO-GO and all bin sorting, press [0][=][SHIFT][NOM VAL].

Note: To see the present numerical limits for bin 3 (for example), press [SHIFT][BIN NO][0][3]. Similarly, to see the nominal value, press [SHIFT][NOM VAL].

10. To measure a DUT with bin sorting:

- Press the [FUNCTION] key to select MEASURE.
- Press the [DISPLAY] key to select BIN NO.
- Insert the DUT.
- If the measure mode is TRIGGERED, press the START button.
- Observe GO/NO-GO and bin-number results.

NO-GO indicates either QDR failure (bin 0) or RLC failure (bin 14). See also paragraph 3.1.4.

For continued operation of the Digibridge, in MEASURE function, using the limits entered as above, you can select any desired display, such as VALUE, or BIN No., with the [DISPLAY] key. (If you have the interface option, the available output data are not limited to the display selection.) The GO/NO-GO lights will operate unless you inhibit comparisons. (See below.)

3.8.4 Verification of Nominal and Limit Values

While the function is ENTER, the exact values entered into the Digibridge can be seen by either of 2 methods, as follows.

During the Entry Process: A confirming display is automatically provided immediately after the [mal] keystroke of each entry step. For example, after the [NOM VALUE] keystroke, the entered value appears on the RLC display. After the (BIN NO) and number keystrokes, the actual limits of RLC value (not percentages) appear across the full display area: upper limit on the regular RLC display, lower limit (4 most significant digits) in the regular RLC display area. For bin 0, the QDR limit appears in the QDR area.

Upon Demand. To see the current “nominal value”, depress the [NOM VALUE] key (while the ENTER indicator is lit). To see the limits in any particular bin (or to verify that it has been closed), depress [SHIFT][BIN NO] and the desired number, similarly. Displays selected in this way are limited by the units that are shown on the panel. For example, if the bin-3 limits are 162 and 198 nF, but the display units are pF, when you press [BIN No.][0][3], the display will go blank. Select either nF or μ F (instead of pF) to obtain a display of these limits. However, any “nominal values” previous to the current one are lost and cannot be displayed (unless entered again). Bin limits are not lost until replaced by new entries in the particular bin; but they are normally lost when POWER is switched OFF. To prevent loss, lock the keyboard; see paragraph 3.9.

For comments on how bin sorting information is displayed, see paragraph 3.3.3

3.8.5 Examples of Limit Entry

Nested Limits. To enter a set of nested limits, operate the keyboard as described below for the example of inductors having $Q > 21$, $L_s = 33$ mH $\pm 0.35\%$, $\pm 1\%$, $\pm 5\%$, $\pm 7-9\%$.

1. With [FUNCTION] key, select ENTER.
2. With [EQUIVALENT CIRCUIT] key, select SERIES.
3. With parameter key [Ls/Q], select RLC units: mH.
4. Enter Q limit thus: [2][1][=][SHIFT][BIN No.][0][0].
5. Enter nominal RLC value : [3][3][=][SHIFT][NOM VALUE].
6. Set bin 1 limits: [1][3][5][%][=][SHIFT][BIN No.][0][1].
7. Set bin 2 limits: [1][%][=][SHIFT][BIN No.][0][2].
8. Set bin 3 limits: [5][%][=][SHIFT][BIN No.][0][3].
9. Set bin 4 limits: [7][%][-][9][%][=][SHIFT][BIN No.][0][4].
10. Close bin 5 (if open): [0][%][=][SHIFT][BIN No.][0][5].
11. Close bins 6 through 13, similarly, if used before.

Sequential Limits. Sequential limits can be entered by either of the following methods; use the method that fits your application.

Method 1, changing the nominal value for each bin.

Advantage: Straightforward definition of each bin in terms of percentages of the bin’s nominal value.

Disadvantage: overlaps or gaps in coverage among several bins are not obvious. (Remember that overlaps default to the lower-numbered bin; gaps default to bin 14.)

Example: For sorting capacitors into part of the standard 5% series, setting $D < .005$, and nominal values for the bins at $C_s = 0.91, 1.0, 1.1, 1.2, 1.3$ μ F.

1. With [FUNCTION] key, select ENTER.
2. With [EQUIVALENT CIRCUIT] key, select SERIES.
3. With parameter key [Cs/D], select units: μ F.
4. Enter D limit: [.] [0] [0] [5] [=] [SHIFT] [BIN No.] [0] [0].
5. Enter nominal C value: [.] [9] [1] [=] [SHIFT] [NOM VALUE].
6. Set bin 1 limits: [5][%][=][SHIFT][BIN No.][0][1].
7. Redefine nominal: [1][=][SHIFT][NOM VALUE].
8. Set bin 2 limits: [5][%][=][SHIFT][BIN No.][0][2].
9. Redefine nominal: [1][.] [1] [=] [SHIFT] [NOM VALUE].
10. Set bin 3 limits: [5][%][=][SHIFT][BIN No.][0][3].
11. Redefine nominal: [1][.] [2] [=] [SHIFT] [NOM VALUE].
12. Set bin 4 limits: [5][%][=][SHIFT][BIN No.][0][4].
13. Redefine nominal: [1][.] [3] [=] [SHIFT] [NOM VALUE].
14. Set bin 5 limits: [5][%][=][SHIFT][BIN No.][0][5].
15. Close bin 6 (if open): [0][%][=][SHIFT][BIN No.][0][6].
16. Close bins 7 through 13, similarly (if used before).

NOTE: Because there are overlaps, bin numbers affect the binning (if a DDT satisfies two bins, it goes into “the lower-numbered bin”): for example, 1.046 μF will go into the 1.0- μF bin (No.2) because it is numbered lower than the 1.1- μF bin (No.3).

Method 2, using one nominal value for the set of bins.

Advantage: All bin limits are related to the same nominal value, making it easy to define bins exactly adjacent to each other without overlaps or gaps.

Disadvantage: Each bin is not readily defined in terms of its own nominal value.

Example: For sorting capacitors into six adjacent “1%” bins from -3% to +3%, setting $D < .005$, and nominal value of the six bins at $C_s = 1.0 \mu\text{F}$.

1. With [FUNCTION] key, select ENTER.
2. With [EQUIVALENT CIRCUIT] key, select SERIES.
3. With parameter key [Cs/D], select units: μF .
4. Enter D limit: [.] [0] [0] [5] [=] [SHIFT] [BIN No.] [0] [0].
5. Enter nominal C value: [1] [=] [SHIFT] [NOM VALUE].
6. Set bin 1 limits: [-] [2] [%] [-] [3] [%] [=] [SHIFT] [BIN No.] [0] [1].
7. Set bin 2 limits: [-] [1] [%] [-] [2] [%] [=] [[SHIFT] BIN No.] [0] [2].
8. Set bin 3 limits: [0] [%] [-] [1] [%] [=] [SHIFT] [BIN No.] [0] [3].
9. Set bin 4 limits: [1] [%] [0] [%] [=] [SHIFT] [BIN No.] [0] [4].
10. Set bin 5 limits: [2] [%] [1] [%] [=] [SHIFT] [BIN No.] [0] [5].
11. Set bin 6 limits: [3] [%] [2] [%] [=] [SHIFT] [BIN No.] [0] [6].
12. Close bin 7 (if open): [0] [%] [=] [SHIFT] [BIN No.] [0] [7].
13. Close bins 8 through 13, similarly (if used before).

NOTE: For any bin the less negative or more positive percentage must be entered first as shown clearly in steps 6 and 11. Because there are no overlaps, there will be no “default assignment to the lower-numbered bin”. Bin number sequence is immaterial.

3.8.6 Notes on Limit Entries in General

For additional detail, refer to the condensed instructions on the reference card under the Digibridge, and to the following notes.

Frequency. It is NOT necessary to select the test frequency first. Comparison results are valid even if the test frequency is changed later in the entry/measurement procedure.

Bin 0. The limit entered in bin 0 is always QDR. It is an upper or lower limit on the secondary measured value, depending on the parameter selection, as tabulated:

Rs/Q (upper)	Ls/Q (lower)	Cs/D (upper)	Cs/Rs (upper)
Rp/Q (upper)	Lp/Q (lower)	Cp/D (upper)	Cp/Rp (lower)

Unsymmetrical Limit Pairs. Enter 2 percentages for the bin. One or both may be + (unspecified sign) or -. Enter first the one that yields the larger absolute value of RLC.

Unused Bins. Initially, at power-up, bins 1 through 13 are closed so that unused ones can be ignored. Every unused bin that has previously been used (except 14) must be closed by entering 0%, as in the above examples. Once closed, it will stay closed until non-zero percent limits are inserted.

Allowable Limits. Max of 6 significant figures for nominal value and percent up to 99999.9. Bin Order. Optional except for nested bins; be sure the narrower limit pairs go into lower numbered bins (because all overlap goes to the lower numbered bin).

Inhibiting Comparisons. To inhibit all comparisons, set nominal value to zero. (Then GO/NO-GO indicators stay off.) Subsequent setting of nominal value to any number except zero enables all comparisons as previously set up. To inhibit QDR comparisons, set bin 0 to the “all-pass” extreme, i.e., to 0000 for Rp, or Q with L; to 9999 for D or Rs or Q with R.

NOTE: When POWER is switched ON - if the keyboard is not locked - nominal value is initialized at zero. Therefore, all bin sorting is initially inhibited.

Changing Entries: Enter new value(s) - or a zero.- to delete obsolete or erroneous nominal value or bin limits. Do not attempt to change or enter a single separate upper or lower limit in a bin, because any single percentage entered for a bin will be interpreted as a symmetrical pair of limits. Changing nominal value does not change any limits, but does determine the base for subsequent limit entries for specific bins. [After function is changed to MEASURE, this nominal value will also serve as reference for delta percent measurements.)

RLC Unit Selection. In limit entry procedures, it is NOT necessary to select the range that the Digibridge will use in measuring. Just be sure that the number you enter for nominal value is suited to the units and unit multiplier indicated on the display panel. For example, nominal values of .033 H, and 33 mH are equivalent.

3.8.7 Go/No-Go and Bin Assignment Results

If comparison (binning) is enabled, the GO/NO-GO indicators will provide the following information after each measurement:

GO - The DUT passed, in bin 1, 2, 3, ... 13

NO-GO - The DUT failed, in bin 0 (QDR failure) or bin 14 (RLC failure).

If the display selection is BIN NO., the bin assignment will be shown in the left display area.

3.8.8 Bin Sum Information

If comparison (binning) is enabled, the Digibridge automatically keeps totals of the number of measurements assigned to each bin since power-up (or reset of the count to zero). The sums can be called up onto

the display or sent out over the IEEE-488 bus. To make use of the bin-sum feature use these keystroke sequences:

- [SHIFT][BIN SUM][0][0] - requests the sum for bin 0
- [SHIFT][BIN SUM][0][1] - requests the sum for bin 1
- [SHIFT][BIN SUM][0][2] - requests the sum for bin 2
- (etc) Note: sum appears at left, bin number at right.
- [SHIFT][BIN SUM][LOCK] - sends the sums out via the IEEE-488 bus
- [=][SHIFT][BIN SUM][0][0][1][4] - resets all sums to zero

3.8.9 Binning and Ratio Measurement Simultaneously

In order to bin-sort component parts whose values lie beyond the normal measurement range of the Digibridge, you must combine ratio measurement (paragraph 3.3.6) with limit comparisons and binning (paragraph 3.8). You should first become familiar with both ratio measurement and binning procedures because the combined procedure (as follows) can be somewhat tricky. Just as the display is a dimensionless number in ratio measurement, so the limit comparisons are made on dimensionless ratios in this combined procedure.

Plan ahead so that you have in mind what the ratio display will be like for any given measurement. For entering bin limits, each nominal ratio is the ratio display that would be expected if a corresponding nominal valued DUT were measured.

General Procedure.

1. Select units appropriate for the component you plan to measure and a range that uses the largest unit multiplier. (This is necessary even if the measured value of the DUT is very small.) Select ENTER function.
2. Enter the nominal ratio (see above) as the bin-limit “nominal value”. Ignore units and multiplier (although those selected in step 1 will still be displayed); the number entered will be used by the Digibridge as a ratio reference.
3. Enter (as usual) the desired set of tolerances for bin sorting. (If sequential limits are desired, also enter another nominal ratio, limits for other bins, etc.)
4. If you plan to measure large-value components, make no change in range. (However, if you plan to measure small-valued components select a range that uses a small unit multiplier.)
5. Enter the nominal value to be used by the Digibridge in the ratio calculations. Notice that units and multiplier are displayed. You can calculate what to enter as follows:

(expected typical measurement)/(corresponding ratio to be displayed) = nominal value to be entered

6. Enable ratio measurement (measured value /nominal) as usual.

NOTE: if you want the other ratio (nominal / measured value) instead, then the calculation in step 5 has to be the product (expected measurement)(corresponding ratio).*

7. Select MEASURE function and proceed with measurements. Display selections VALUE, delta%, and deltaRLC will all display the ratio; BIN NO. will display the bin assignment. With a few strokes of the [DISPLAY] key, it is easy to obtain both ratio and bin number for each DUT (even without using the IEEE-488 interface).

Example 1. To sort 200-mF capacitors in bins of $\pm 5\%$, 10%, and 20%. Displays to be ratios that can be interpreted as Cp values in mF and dissipation factor D.

1. Select units appropriate for the component:
 - A. Select PARALLEL equivalent circuit and ENTER function.
 - B. Press [C/D]
 - C. Hold range 4 by pressing [4][=][SHIFT][SPECIAL][1]
2. Set up nominal ratio to look like 200 mF by pressing [2][0][0][=][SHIFT][NOM VAL]
3. Set up symmetrical bins as stated above:
 - A. [5][%][=][SHIFT][BIN NO][0][1]
 - B. [1][0][%][=][SHIFT][BIN NO][0][2]
 - C. [2][0][%][=][SHIFT][BIN NO][0][3]
4. No action is required; range is correct.
5. Enter the nominal value:
 - A. Calculate: $(200\ 000\ \mu\text{F}) / (200) = 1000$
 - B. Press [1][0][0][0][=][SHIFT][NOM VAL]
6. Enable the ratio mode (measurement/nominal) by pressing [2][=][SHIFT][SPECIAL][6].
7. Select MEASURE function and make measurements as usual.

If you enable VALUE display, the ratio shown can be interpreted as value in mF, and the measured D is also displayed. If you enable BIN NO. display, the bin number only will be shown.

Example 2. To sort 1 m Ω resistors in bins of $\pm 1\%$, 5%, and 10%. Displays to be ratios that can be interpreted as Rs values in m Ω (with better resolution than displays in ohms) and Q. NOTE: If the display resolution were not important, normal binning procedures would be sufficient; ratio measurement is not necessary for this binning.

1. Select units appropriate for the component:
 - A. Select SERIES equivalent circuit and ENTER function.
 - B. Press [R/Q].
 - C. Hold range 1 by pressing [1][=][SHIFT][SPECIAL][1].
2. Set up nominal ratio to look like 1 m Ω by pressing [1][=][SHIFT][NOM VAL].
3. Set up symmetrical bins as stated above:
 - A. [1][%][=][SHIFT][BIN NO][0][1]
 - B. [5][%][=][SHIFT][BIN NO][0][2]
 - C. [1][0][%][=][SHIFT][BIN NO][0][3]

4. Change from largest-value range to smallest-value range by pressing [4][=][SHIFT][SPECIAL][1]
5. Enter the nominal value:
 - A. Calculate: $(.001 \text{ ohm}) / (1) = .001$
 - B. Press [.] [0] [0] [1] [=][SHIFT][NOM VAL]
6. Enable the ratio mode (measurement/nominal) by pressing [2][=][SHIFT][SPECIAL][6].
7. Select MEASURE function and make measurements as usual.

If you enable VALUE display, the ratio shown can be interpreted as value in mF, and the measured D is also displayed. If you enable BIN NO. display, the bin number only will be shown.

Indications of the unlocked or locked state are as follows:

- Unlocked - several keyboard indicators lit.
- Locked - NO keyboard indicators lit, except possibly MEASURE, BIAS ON and /or REMOTE CONTROL.

To lock the keyboard, first select MEASURE function. Then, press the following keys deliberately: [1][6][9][3][=][LOCK]. The command sequence is the same to lock and to unlock.

NOTE: If the REMOTE CONTROL indicator is lit, the keyboard may have been deactivated by remote command, in which case the way to deactivate it is by remote command. Refer to paragraph 3.11.

3.9 Keyboard Lock, Function Map, and Summary of Integrations

3.9.1 Keyboard Lock

Locking the keyboard provides security against unintentional or unauthorized change in the keyboard selectable test conditions, as well as preserving them during the time that POWER is switched OFF.

3.9.2 Function Map

Figure 3-35 shows graphically (like a map of the keyboard) which programming keys are enabled in the MEASURE function and which ones in the ENTER function. Notice that one row of keys inside the square 16-key area and all of the keys outside of that square are enabled *regardless* of any selection by the [FUNCTION] key.

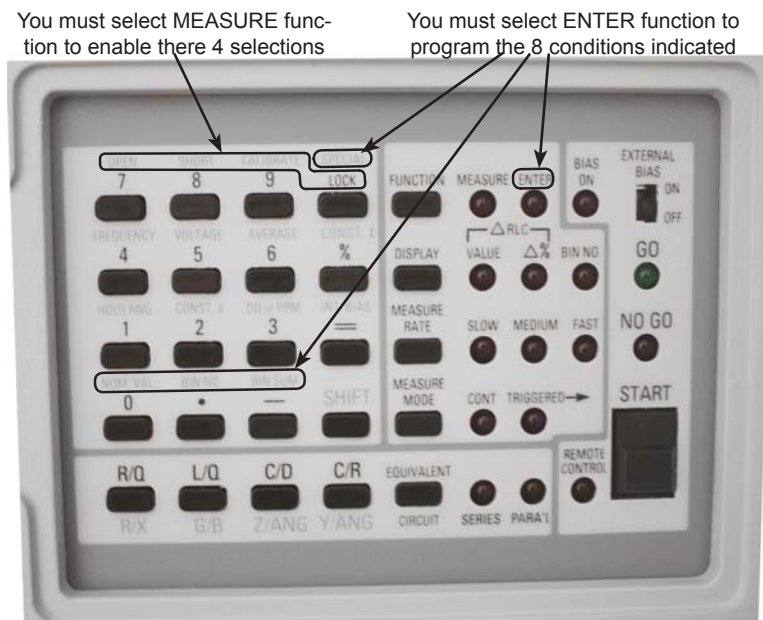

Other selections and programming can be made in either function

Figure 3-35: Keyboard Map

3.9.3 Summary of Interrogations

Certain status (and results) information is indicated automatically on the display panels. For example:

Indicators above and below RLC display – parameter and /or units of measurement.

RANGE HELD – autoranging is disabled.

CONST VOLT – source resistance held to 25 ohms (accuracy compromised).

PPM – units of D or Q, ANG (not R or X) are parts per million.

CONST I – short circuit current set .

NOT 1KHZ – frequency is other than 1 kHz.

RATIO – ratio mode is enabled.

Hardly any keyboard indicators lit – keyboard is locked.

Left display “0”, right also “0”, GO – open-circuit zeroing enabled.

Left display “5”, right also “5”, GO – short-circuit zeroing enabled.

Left display “6”, right also “6”, GO – calibration enabled.

Left display “0 14 ‘, right “blank” – measurement signal overload .

Left display “22222”, right “1111” – convertor/detector malfunction.

Left display “22222”, right “2222” - convertor/detector malfunction.

The preceding three lines are explained in paragraph 3.13. Indicators on the keyboard provide important information, NOT summarized here.

The following interrogations will work only if you select ENTER function:

[SHIFT] [NOM VAL]	stored nominal value (appears displayed at left).
[SHIFT] [BIN NO] [0] [1]	limits for bin 1 (both displayed , left and right) .
[SHIFT] [BIN NO] [1] [2]	limits for bin 12 (both displayed).
[SHIFT] [BIN SUM] [0] [3]	count in bin (left) ; bin number (right) .
[SHIFT] [FREQUENCY]	test frequency , kHz (displayed at left).
[SHIFT] [CONST I]	short circuit current if selected .
[SHIFT] [VOLTAGE]	test voltage that is applied behind source resistance .
[SHIFT] [AVERAGE]	number of measurements (or medians) averaged per result .

The following special functions are explained more fully in paragraph 3.10.

Each response display is: detailed code at left and special-function number at right.

Interrogation	Detail Code
[SHIFT][SPECIAL][1]	present range number
[SHIFT][SPECIAL][2]	Code for data output via IEEE-488 bus
[SHIFT][SPECIAL][3]	Measurement routine
[SHIFT][SPECIAL][4]	Milliseconds of delay after start before data is acquired
[SHIFT][SPECIAL][5]	Integration time factor (normal: 1)
[SHIFT][SPECIAL][6]	Displays – meas/nom: 2, nom/meas: 1, normal: 0
[SHIFT][SPECIAL][7]	Parameter selection – auto: 1, normal: 0
[SHIFT][SPECIAL][8]	If median of 3 meas taken: 1, normal: 0
[SHIFT][SPECIAL][9]	Version number of Digibridge internal firmware
[SHIFT][SPECIAL][0]	ppm offset of source frequency from nominal
[SHIFT][SPECIAL][.]	IEEE-488 address (2 digit) when this option is installed

The following interrogation will work only if you select MEASURE function:

[SHIFT][SPECIAL] (hold key down) – All special functions

Expect 0,1,4 and 9 (see above) that are NOT set to “0”. For example, under default (power up) conditions, the display is **** *7* (where * represents “blank”)

NOTE: special function 7 is initially set to 1; see Table 2-12. If you set special functions 2 through 8 each to 1, this display will be 2315 678. If you set these special functions each to 0, this display will be **** *** (blank).

3.10 Special Functions

Most of the special functions are described in more detail in other parts of the manual. Refer to Table 3-12 for a brief summary of the special functions and how to operate the [SPECIAL] key. Programming of special functions can be done only in ENTER function.

Purpose	Specific Selection	Keystrokes	Re Para
1. Setting the Range	Autorange (normal) Hold range 1 Hold range 2 Hold range 3 Hold range 4	[0]= [SHIFT][SPECIAL][1] [1]= [SHIFT][SPECIAL][1] [2]= [SHIFT][SPECIAL][1] [3]= [SHIFT][SPECIAL][1] [4]= [SHIFT][SPECIAL][1]	3.5.6
2. Output via IEEE-488 Bus	No Output (max meas speed) Bin numbers only QDR results only QDR and bin numbers RLC results only RLS and bin numbers RLC and QDR results RLS, QDR and bin numbers = full data No data on PASS, Full data on FAIL BIN No. on PASS, full data on FAIL	[0]= [SHIFT][SPECIAL][2] [1]= [SHIFT][SPECIAL][2] [2]= [SHIFT][SPECIAL][2] [3]= [SHIFT][SPECIAL][2] [4]= [SHIFT][SPECIAL][2] [5]= [SHIFT][SPECIAL][2] [6]= [SHIFT][SPECIAL][2] [7]= [SHIFT][SPECIAL][2] [8]= [SHIFT][SPECIAL][2] [9]= [SHIFT][SPECIAL][2]	3.5.9
3. Special Measurement Routines	Normal Signal reversing (useful when test frequency coincides with power frequency) Shorting in measurement circuit (useful when measuring biased capacitors) Both reversing and shorting Quick acquisition meas routine (MED and FAST only; useful at low frequencies) Quick acquisition and shorting (MED and FAST only; useful at low frequencies)	[0]= [SHIFT][SPECIAL][3] [1]= [SHIFT][SPECIAL][3] [2]= [SHIFT][SPECIAL][3] [3]= [SHIFT][SPECIAL][3] [4]= [SHIFT][SPECIAL][3] [5]= [SHIFT][SPECIAL][3]	3.6.8
4. Delay	Milliseconds of delay after start before data is acquired, "d"=msec.	[d]= [SHIFT][SPECIAL][4]	3.5.3
5. Integration Time Factor	Multiplies integration time by factor f (0.25 to 6), normally 1. Reducing f decreases accuracy and reduced measurement time. Increasing f does the converse.	[f]= [SHIFT][SPECIAL][5]	3.5.5
6. Ratio Displays (RLC only)	Normal displays Ratio Displayed: nominal/meas value meas value/nominal	[0]= [SHIFT][SPECIAL][6] [1]= [SHIFT][SPECIAL][6] [2]= [SHIFT][SPECIAL][6]	3.3.6
7. Man/auto Parameter Section Reset	Manual selection of parameter Automatic selection of parameter (R/Q, L/Q, or C/D); default Reset	[0]= [SHIFT][SPECIAL][7] [1]= [SHIFT][SPECIAL][7] [2]= [SHIFT][SPECIAL][7]	3.3.1
8. Median Result	Normal, no median found Display is median of 3 meas	[0]= [SHIFT][SPECIAL][8] [1]= [SHIFT][SPECIAL][8]	3.6.4
9. Version	Displays the software version	[SHIFT][SPECIAL][9]	
10. Frequency Correction	Displays the correction "c"	[SHIFT][SPECIAL][0]	3.4.1
11. IEEE Address	Display the LISTEN address of the IEEE interface	[SHIFT][SPECIAL][.]	

Table 3-16: Special Functions

3.11 Data Output and Programming via IEEE 488 and RS-232 Interface

3.11.1 Overview

The optional Digibridge IEEE-488.2 interface board provides IEEE-488.2 (GPIB) and RS 232 Serial interfaces to the Digibridge 1689/1693 series instruments via 24-pin GPIB and 9-pin male serial connectors. The interface can be used to connect directly to a controller or to a bus comprising of multiple instruments and a controller. All instruments on the IEEE-488.2 bus must meet the IEEE Standard 488.2-1987 (Standard Digital Interface for Programmable Instrumentation).

The IEEE-488 interface board supports the IEEE-488.2 and SCPI interface standard and communication protocol. The physical, electrical, signal and protocol standards of the IEEE 488.1-1987, IEEE 488.2-1987 and SCPI-1999 standards are supported.

The following IEEE-488 functions are implemented:

- AH1 Acceptor Handshake (Listener)
- SH1 Source Handshake (Talker)
- T5 Talker with normal and talk-only modes (for systems without a controller), switch selectable on the rear panel.
- L4 Listener.
- SR1 Service Request (to request service when measurement is complete and the instrument is not addressed to talk).
- RL2 Remote/Local (no local lockout, no return-to-local switch).
- PP0 No Parallel Poll.
- DC1 Device Clear.
- DT1 Device Trigger (to start measurement).
- C0 No controller functions.
- E2 Electrical Interface.

3.11.2 Configuration

The Digibridge IEEE-488.2 interface board has two switches for setting operating configuration, SW1, the Talk-Listen / Talk-Only toggle switch, and S2, the GPIB Address selection DIP switch.

3.11.3 Talk-Listen / Talk-Only Toggle Switch

The SW1 red toggle switch is used to select between the Talk-Listen and the Talk-Only operating modes. If no controller (or PC) will be used to control the Digibridge via either the IEEE 488 or RS 232 interfaces, then the SW1 toggle switch should be set to Talk-Only. For controlling the Digibridge externally via either interface, the SW1 toggle switch should be set to Talk-Listen.

3.11.4 GPIB Address DIP Switch

The GPIB Address of the Digibridge is set by the SW2 DIP Switch. The numeric value is set by setting the switch on or off for the corresponding bit with the OFF position for binary 1 and ON position for binary 0. Depress the rocker toward the OFF marking for OFF and toward the numeric marking for the corresponding ON position.

SW2 DIP switch setting for selecting Digibridge GPIB address:

Decimal Address	Switch Settings				
	S1	S2	S3	S4	S5
0	ON	ON	ON	ON	ON
1	OFF	ON	ON	ON	ON
2	ON	OFF	ON	ON	ON
3	OFF	OFF	ON	ON	ON
4	ON	ON	OFF	ON	ON
5	OFF	ON	OFF	ON	ON
6	ON	OFF	OFF	ON	ON
7	OFF	OFF	OFF	ON	ON
8	ON	ON	ON	OFF	ON
9	OFF	ON	ON	OFF	ON
10	ON	OFF	ON	OFF	ON
11	OFF	OFF	ON	OFF	ON
12	ON	ON	OFF	OFF	ON
13	OFF	ON	OFF	OFF	ON
14	ON	OFF	OFF	OFF	ON
15	OFF	OFF	OFF	OFF	ON
16	ON	ON	ON	ON	OFF
17	OFF	ON	ON	ON	OFF
18	ON	OFF	ON	ON	OFF
19	OFF	OFF	ON	ON	OFF
20	ON	ON	OFF	ON	OFF
21	OFF	ON	OFF	ON	OFF
22	ON	OFF	OFF	ON	OFF
23	OFF	OFF	OFF	ON	OFF
24	ON	ON	ON	OFF	OFF
25	OFF	ON	ON	OFF	OFF
26	ON	OFF	ON	OFF	OFF
27	OFF	OFF	ON	OFF	OFF
28	ON	ON	OFF	OFF	OFF
29	OFF	ON	OFF	OFF	OFF
30	ON	OFF	OFF	OFF	OFF
31	Not Used				

Table 3-17: Digibridge GPIB address

GPIB Address 31 is not a valid GPIB Address and setting the SW2 DIP switch to this setting (all switches in the OFF position) will disable the GPIB interface, with all communication possible only via the RS 232 serial interface.

By convention, GPIB Address 0 is normally used by the controller.

3.11.5 Jumpers

The Digibridge IEEE-488.2 interface board has three jumpers, JP1, JP2, and JP3. For normal operation, all three jumpers should be open (no shorting blocks inserted).

JP1 enables the RS 232 interface driver auto power off.

JP2 forces firmware update mode via RS 232 serial interface. If JP2 is set, the board will be forced to await firmware update and the Digibridge will be held in reset state.

JP3 enables flash write protect. If JP3 is set, certain onboard flash will be prevented from being updated. Since multiple safeguards are in place to prevent unintentional flash overwriting, the use of JP3 is not needed.

All other headers, populated and non-populated, are intended only for manufacturing test or future use. Do insert connectors or shorting blocks into these headers as the board may malfunction or permanent damage may result.

3.11.6 RS-232 Serial Interface (Currently Not Implemented)

The RS-232 Serial Interface implements a standard 9 wire DTE serial interface requiring the use of a standard 9-pin Female-to-Female Null Modem cable for connection to a PC. In normal use, either the IEEE-488 interface or the RS232 interface is used. Using both interfaces at the same time is possible, but will degrade overall communication speed and can lead to communication conflicts.

3.11.7 Instrument Program Commands

The set of commands used in remote programming is an input data code to which the instrument will respond as a “talker/listener”, after being put into a remote-control mode via the bus (see Table 3-25 on page 95) and addressed to listen to device-dependent command strings.

Refer to Table 3-19. The programming command set includes all of the keyboard functions except switching external bias ON/OFF and Cull recalibration, which are not remotely programmable. Keyboard functions are explained above, particularly in paragraphs 3.3, 3.4, 3.8, 3.9, 3.10; and most of these commands are related to them in an obvious way.

Zero calibration by remote control is similar to the manual procedure. The “Z1” command is equivalent to manually keying [1][6][9][3][=][SHIFT][OPEN].

It is necessary to allow the Digibridge to reach range 1. (It must not be held on another range.) The test fixture must be physically open-circuited. Zero calibration is initiated by a “G0” command (equivalent to pressing START), which should not be followed by other commands until the Digibridge responds with “SRQ”. (The purpose of the “Z0” command is to defeat the preceding “Z1” command, as you might wish to do if the “Z1” was sent by mistake.)

Limit entry commands are interpreted in relation to the previously established parameter; send the “M” command first. Use the limit entry commands in the tabulated sequence, except that nominal value need not be repeated after once being entered.

Notice that f, n, h, and l in the table are “E-notation” numbers, containing any number of digits, with optional use of decimal point and optional use of power-of-ten multiplier. Do NOT omit the semicolon after each of these. (Refer to the table.) The letter n in the table is nominal value in base units (ohms, farads, or henries). For example, nominal value can be set to 543.21 pF by the command:

```
N543.21E-12;
```

Limits for bins 1 thru 13 are entered using percentages, referred to the current nominal value. For example, Bin No.1 (designated 01) is set to +1.5%, -.05% by the command sequence:

```
B01H1.5;L-5E-2;
```

However, the limit for Bin Zero (the desired upper limit for D or Rs or Q with R, lower limit for Rp or Q with L) is entered as a value (dimensionless for D or Q, ohms for R). For example, Bin Zero is set to 250 ppm (with parameter selection C/D) by the command:

```
B00H250E-6;
```

Frequency is entered in kilohertz. *H* the desired frequency is (for example) 3.25 kHz, the following command will select the nearest available frequency, which is 3.3333 kHz:

```
F3.25;
```

There are three types of commands: two-byte, three-byte, and floating-point, as described below. Each byte is coded according to the 7-bit ASCII code, using the DI01...DI07 lines. The most significant bit is DI07, as recommended by the Standard. (The eighth bit – DI08 – is ignored.) Thus, for example, the command for “MEASURE FUNCTION” is P0, having octal code 120 followed by 060. The two 7-bit binary bytes are therefore: 1 010 000 and 0 110 000.

Note: The ASCII code - “X3.4-1968, Code for “Information Interchange” - is available from American National Standards Institute, 1430 Broadway, New York, N.Y. 10018. This code can be written out as follows. For the numerals 0, 1, 2 ... 9, write the series of octal numbers 060, 061, 062 ... 071; for the alphabet A, B, C ... Z, write the series 101, 102, 103 ... 132. (Refer also to the table in the paragraph about “Address”, in 2.8.4.) The ASCII code conforms to the 7-bit code ISO 646 used internationally.

Two Byte and Three Byte Entries. These command entries, as shown in Table 3-20, are simple ASCII character sequences of two or three characters. The first character is a letter which designates the category of the entry. The following ASCII character - or two characters if this is a three-byte entry - are decimal

digits (0 to 9) which convey information about the selection within the category. For example, the ASCII sequence D2 means “in DISPLAY category, select VALUE.” The command is like pressing the [DISPLAY] key to select VALUE.

Floating Point Entries. These entries (also shown in the table) are ASCII character sequences of arbitrary length, always terminated with a semicolon (;). The first character is a letter which designates the category of the entry. The following ASCII characters - before the semicolon - define a floating-point number including at least one decimal digit (0 to 9) and optional characters (+ - . e E). Any space character is ignored. The character e or E is recognized as “exponent” in E-format notation. For example, any of the following three entries will set the test frequency to 100 Hz:

F0.1; F1e-1; F100.0E-3;

NOTE: The 2-byte command P2 is recommended as the first command in a remote programming sequence because it resets all selections to their power-up (default) conditions.

3.11.8 Legacy Digibridge IEEE-488 Commands

The legacy IEEE-488.1 Digibridge commands are supported by the IEEE-488 interface board for compatibility with software and drivers written for the original Digibridge IEEE-488.1 interface boards.

Category	Description	Type	Code
Display	Bin #	2 byte	D0
	Delta %	2 byte	D1
	Value	2 byte	D2
	Delta RLC	2 byte	D3
	Ratio: nominal value / RLC value	2 byte	D4
	Ratio: RLC value / nominal value	2 byte	D5
	Bin on ratio: nominal value / RLC value	2 byte	D6
	Bin on ratio: RLC value / nominal value	2 byte	D7
Measurement Rate	Fast	2 byte	S0
	Medium	2 byte	S1
	Slow	2 byte	S2

Category	Description	Type	Code
Measurement Voltage	Constant, off	2 byte	Y0
	Constant, on	2 byte	Y1
	Value (in volts) = v	Floating point	Vv;
Function	Measure	2 byte	P0
	Enter	2 byte	P1
Reset	Turn-On Conditions	2 byte	P2
	Diagnostics	2 byte	P3
Measurement Mode	Triggered	2 byte	T0
	Continuous	2 byte	T1
	Triggered median value	2 byte	T2
	Continuous median value	2 byte	T3
Parameter	Inductance (L/Q)	2 byte	M0
	Capacitance (C/D)	2 byte	M1
	Capacitance (C/R)	2 byte	M2
	Resistance (R/Q)	2 byte	M3
	Inductance L/Q) ppm	2 byte	M4
	Capacitance (C/D) ppm	2 byte	M5
	Capacitance (C/R) ppm	2 byte	M6
	Resistance (R/Q) ppm	2 byte	M7
	Automatic selection of R/Q, C/D, or L/Q	2 byte	M8
	<i>Resistance (R/X)</i>	2 byte	K2
	<i>Conductance (G/B)</i>	2 byte	K3
	<i>Impedance (Z/ANG)</i>	2 byte	K4
	<i>Admittance (Y/ANG)</i>	2 byte	K5
	<i>Impedance (Z/ANG) ppm</i>	2 byte	K6
<i>Admittance (Y/ANG) ppm</i>	2 byte	K7	
Equivalent Circuit	Parallel	2 byte	C0
	Series	2 byte	C1
Range Control	Hold range	2 byte	R0
	Hold range 1	2 byte	R1
	Hold range 2	2 byte	R2
	Hold range 3	2 byte	R3
	Hold range 4	2 byte	R4
	Autorange	2 byte	R5
Frequency	Value (in kHz) = f	Floating point	Ff;
Zero Calibration	Disable	2 byte	Z0
	Enable open	2 byte	Z1
	Enable short	2 byte	Z2
Output Format	Normal (not compacted)	2 byte	x0 *
	Compacted binary format	2 byte	x1 *

Category	Description	Type	Code
Data Output	None	2 byte	X0
	Bin #	2 byte	X1
	QDR	2 byte	X2
	QDR, Bin #	2 byte	X3
	RLC	2 byte	X4
	RLC, Bin #	2 byte	X5
	RLC, QDR	2 byte	X6
	RLC, QDR, Bin #	2 byte	X7
	RLC, QDR, Bin # on FAIL only	2 byte	X8
	Same on FAIL; Bin # on PASS	2 byte	X9
Nominal Value	Value (in ohms, henries, farads) = n	Floating point	Nn;
Limit Entry	Bin #	3 byte	Bbb
	High limit (in %) = h	Floating point	Hh;
	Low limit (in %) = l	Floating point	Ll;
Initiation	Start a measurement (like start switch)	2 byte	G0
Manual Start	Enable switch	2 byte	W0
	Disable switch	2 byte	W1
Keyboard Lock	Unlock	2 byte	K0
	Lock	2 byte	K1
Average	# of measurements = a	Floating point	Aa;
Internal Bias	Off	2 byte	U0
	On	2 byte	U1
Bin Summary	Disable output	2 byte	E0
	Enable output	2 byte	E1
	Reset bin summary to 0	2 byte	E2
Measurement Routine	Normal routine (highest speed)	2 byte	Q0
	Signal reversal (use for low frequency hum rejection)	2 byte	Q1
	Shorting between measurements (used for reducing transient-recovery time within measuring circuit, when measuring with bias; NOT FOR DISCHARGING THE DUT)	2 byte	Q2
	Signal reversal and shorting between measurements	2 byte	Q3
	Quick-acquisition feature	2 byte	Q4
	Quick-acquisition & shorting	2 byte	Q5
iokfDisplay Digit Blanking	Eliminate (a) digits from RLC, (b) digits from QDR	3 byte	Oab

Category	Description	Type	Code
Integration-Time Multiplying Factor	Value (i) multiplies MEDIUM and FAST integration times	Floating point	li;
Delay	Value (in ms) = j	Floating point	Jj; **
Constant Current	Value (in mA) = #	Floating point	i#; ***

Table 3-18: Legacy IEEE-488.1 Digibridge Commands

Notes:

- Parameters in **bold** are default power-on or P2 reset settings.
- Commands in *italic* are available only on the Digibridge 1693 model.
- * Indicates lower-case character.
- ** Delay command must be entered after frequency command. (Inverting this sequence will cause delay to revert to its default value.)
- *** Lower-case i.

3.11.9 IEEE 488.2/SCPI Digibridge Command Summary

The IEEE-488.2 / SCPI commands are used to communicate with the Digibridge via the IEEE-488 or RS232 serial interfaces replacing and/or supplementing the legacy commands.

Command	Parameter(s)	Description	Legacy
CONFigure:			
PARAmeter	Selects the measured parameter		
	LQ	Inductance (L/Q)	M0
	CD	Capacitance (C/D)	M1
	CR	Capacitance (C/R)	M2
	RQ	Resistance (R/Q)	M3
	LQPPm	Inductance (L/Q) ppm	M4
	CDPPm	Capacitance (C/D) ppm	M5
	CRPPm	Capacitance (C/R) ppm	M6
	RQPPm	Resistance (R/Q) ppm	M7
	AUTO	Automatic selection of R/Q, C/D, or L/Q	M8
	<i>RX</i>	<i>Resistance (R/X)</i>	K2
	<i>GB</i>	<i>Conductance (G/B)</i>	K3
	<i>ZANG</i>	<i>Impedance (Z/ANG)</i>	K4
	<i>YANG</i>	<i>Admittance (Y/ANG)</i>	K5
	<i>ZAPPm</i>	<i>Impedance (Z/ANG) ppm</i>	K6
	<i>YAPPm</i>	<i>Admittance (Y/ANG) ppm</i>	K7
	CIRCUit	Selects the measured equivalent circuit	
PARAllel		Parallel	C0
SERies		Series	C1
APERture	Measure rate		
	FAST	Fast	S0
	MEDium	Medium	S1
	SLOW	Slow	S2

Command	Parameter(s)	Description	Legacy
MODE	Sets the measure mode		
	TRIGgered	Triggered	T0
	CONTinuous	Continuous	T1
	MTRiggered	Triggered median value	T2
	MCONTinuous	Continuous median value	T3
DISPlay	Results to display on the front panel		
	BIN	Bin #	D0
	DELTA	Delta %	D1
	VALue	Value	D2
	DRLC	Delta RLC	D3
:RATio	NOMValue	Ratio: nominal value / RLC value	D4
	VALNominal	Ratio: RLC value / nominal value	D5
:BINRatio	NOMValue	Bin on ratio: nominal value / RLC value	D6
	VALNominal	Bin on ratio: RLC value / nominal value	D7
FUNCTION	Sets function mode to measure or entry setting		
	MEASure	Measure	P0
	ENTer	Enter mode for setting configuration	P1
RANGe	Sets the measurement range		
	HOLD	Hold range	R0
	1	Hold range 1	R1
	2	Hold range 2	R2
	3	Hold range 3	R3
	4	Hold range 4	R4
	AUTO	Autorange	R5
DELAy	Sets the trigger delay time		
	<numeric>	Real value in ms	J<numeric>;
ITFACTOR	Sets the integration-time multiplying factor		
	<numeric>	Real value multiplies Medium and Fast integration times	I<numeric>;
AVERAge	Sets the number of measurements to average		
	<numeric>	# of measurements	A<numeric>;
FREQUency	Sets the frequency used for measurement		
	<numeric>	Real value in kHz	F<numeric>;
VOLTage:	Sets the measurement signal voltage		

Command	Parameter(s)	Description	Legacy
CONStant	OFF	Constant voltage off	Y0
	ON	Constant voltage on	Y1
LEVel	<numeric>	Real value in volts	V<numeric>;
CURRent	Sets constant current		
	<numeric>	Real value in mA	i<numeric>;
BIAS	Enables or disables DC bias		
	OFF	Off	U0
	ON	On	U1
ROUTine	Sets the measurement routine		
	NORMal	Normal routine (highest speed)	Q0
	REVersal	Signal reversal (for low freq hum rejection)	Q1
	SHORting	Shorting between measurements	Q2
	REVShorting	Signal reversal and shorting	Q3
	QUICK	Quick-acquisition feature	Q4
	QSHorting	Quick-acquisition & shorting	Q5
NOMinal	Sets the nominal value		
	<numeric>	Real value in ohms, henries, farads	N<numeric>;
BLANking	Front panel display digit blanking		
	<a> 	Eliminate <a> digits from RLC and digits from QDR	O<a>
BIN:	Sets the limit entries for binning		
NUM	<numeric>	Bin #	B<numeric>
HIGH	<numeric>	Real value high limit in %	H<numeric>;
LOW	<numeric>	Real value low limit in %	L<numeric>;
BINSummary	Enables or disables bin summary output		
	DISable	Disable output	E0
	ENABle	Enable output	E1
	RESet	Reset bin summary to 0	E2

Command	Parameter(s)	Description	Legacy
OUTPut	Sets the data to output via GPIB / RS-232		
	NONE	None	X0
	BIN	Bin #	X1
	QDR	QDR	X2
	QBIN	QDR, Bin #	X3
	RLC	RLC	X4
	RBIN	RLC, Bin #	X5
	RQDR	RLC, QDR	X6
	RQBin	RLC, QDR, Bin #	X7
	RQBFail	RLC, QDR, Bin # on FAIL only	X8
RQBPass	Same on FAIL, Bin # on PASS	X9	
DATAformat	Selects GPIB / RS-232 output data format		
	ASCIi	Normal ASCII (not compacted)	x0
	BINary	Compacted binary format	x1
SYSTem:			
SWITch	Enables or disables the manual start switch		
	ENABle	Enable switch	W0
	DISable	Disable switch	W1
KEYPad	Enables or disables the front panel keypad		
	ENABle	Unlock (enable keypad)	K0
DISable	Lock (disable keypad)	K1	
RESet		Resets settings to turn-on conditions	P2
REStart		Restarts and reruns power-on diagnostics	P3
CALibration	Zero calibration		
	DISable	Disable	Z0
	OPEN	Perform open circuit calibration	Z1
	SHORt	Perform short circuit calibration	Z2
COMMunicate:			
GPIB:			
ADDRess?		Reads the instrument GPIB address	
CONFigure	Enables or disables the GPIB interface		
	ENABle	Enable GPIB interface	
DISable	Disable GPIB interface (if using RS-232)		
SERial:			

Command	Parameter(s)	Description	Legacy
CONFigure	Enables or disables the RS-232 serial interface		
	ENABLe	Enable RS-232 interface	
	DISABle	Disable RS-232 interface (if using GPIB)	
BAUDrate	Sets the RS-232 interface baud rate		
	9600		
	19200		
	38400		
	57600		
PARity	Sets the RS-232 interface parity		
	NONe	No parity	
	EVEN	Even parity	
	ODD	Odd parity	
STOPbits	Sets the RS-232 interface stop bits		
	1	One stop bit	
	2	Two stop bits	
HANDshake	Sets the RS-232 interface handshake		
	NONe	No handshake	
	XON	XOn/XOff software handshake	
	HARDware	Hardware handshake	
MODem	Modem handshake		
ERRor?		Reads the error message from error queue	
[:NEXT?]		Reads the error message from error queue	
VERSion?		Reads the interface version	
STATus:			
OPERation?		Reads the Event Register	
OPERation:			
[EVENT]?		Reads the Event Register	
CONDition?		Reads the Condition Register	
ENABLe	<numeric>	Sets the Enable Mask Register	
ENABLe?		Reads the Enable Mask Register	
QUESTionable?		Reads the Event Register	
QUESTionable:			

Command	Parameter(s)	Description	Legacy
[EVENT]?		Reads the Event Register	
CONDition?		Reads the Condition Register	
ENABLe	<numeric>	Sets the Enable Mask Register	
ENABLe?		Reads the Enable Mask Register	
PRESet		Enables all required event reporting	
MEASure		Initiates a measurement (like start switch)	G0
*CLS		Clear Status Register	
*ESE	<numeric>	Sets Standard Event Status Enable	
*ESE?		Reads Standard Event Status Enable	
ESR?		Reads the Standard Event Status Register	
*IDN?		Reads the instrument identification information	
*OPC		Sets the OPC bit in the Standard Event Status	
*OPC?		Reads the OPC bit	
*RST		Resets buffers	
*SRE	<numeric>	Sets the Service Request Enable Register	
*SRE?		Reads the Service Request Enable Register	
*STB?		Reads the Status Byte Register	
*TST?		Self-test query	
*WAI		Waits until all commands have completed	

Table 3-19: IEEE-488/SCPI commands

Notes:

- Parameters in **bold** are default power-on or SYSTEM:RESet (P2) settings.
- Commands in *italic* are available only on the Digibridge 1693 model.

3.11.10 IEEE 488.2 / SCPI Digibridge Command Reference

Note: Parameters in *italic* are available only on the Digibridge 1693-9700 model.

:CONFigure:PARAmeter

Syntax:

```
:CONFigure:PARAmeter {LQ|CD|CR|RQ|
LQPPm|CDPPm|CRPPm|RQPPm|AUTo|
RX|GB|ZANG|YANG|ZAPPm|YAPPm}
```

Description:

Sets the measured parameter.

Parameter:

Value	Description
LQ	Inductance (L/Q)
CD	Capacitance (C/D)
CR	Capacitance (C/R)
RQ	Resistance (R/Q)
LQPPm	Inductance (L/Q) ppm
CDPPm	Capacitance (C/D) ppm
CRPPm	Capacitance (C/R) ppm
RQPPm	Resistance (R/Q) ppm
AUTo (default)	Automatic selection of R/Q, C/D, or L/Q
<i>RX</i>	<i>Resistance (R/X)</i>
<i>GB</i>	<i>Conductance (G/B)</i>
<i>ZANG</i>	<i>Impedance (Z/ANG)</i>
<i>YANG</i>	<i>Admittance (Y/ANG)</i>
<i>ZAPPm</i>	<i>Impedance (Z/ANG) ppm</i>
<i>YAPPm</i>	<i>Admittance (Y/ANG) ppm</i>

Equivalent legacy command:

M0, M1, M2, M3, M4, M5, M6, M7, **M8**, K2, K3, K4, K5, K6, K7

Equivalent key:

select appropriate parameter key(s)

:CONFigure:CIRCuit

Syntax:

```
:CONFigure:CIRCuit {PARAllel|SERies}
```

Description:

Sets the measurement equivalent circuit.

Parameter:

Value	Description
PARAllel	Parallel equivalent circuit
SERies	Series equivalent circuit

Equivalent legacy command:

C0, C1

Equivalent key:

[EQUIVALENT CIRCUIT]

:CONFigure:APERture

Syntax:

```
:CONFigure:APERture {FAST|MEDIum|SLOW }
```

Description:

Sets the measure rate.

Parameter:

Value	Description
FAST	Sets measurement rate to fast
MEDIum	Sets measurement rate to medium
SLOW	Sets measurement rate to slow

Equivalent legacy command:

S0, S1, S2

Equivalent key:

[MEASURE RATE]

:CONFigure:MODE

Syntax:

```
:CONFigure:MODE {TRIGgered|CONTInuous|M
TRiggered|MCONtinuous}
```

Description:

Sets the measure mode.

Parameter:

Value	Description
TRIGgered	Set measurement mode to triggered
Continuous	Set measurement mode to continuous
MTRiggered	Set measurement mode to triggered median value
MCONtinuous	Set measurement mode to continuous median value

Equivalent legacy command:

T0, T1, T2, T3

Equivalent key:
[MEASURE MODE]

:CONFigure:DISPlay

Syntax:
:CONFigure:DISPlay {BIN|DELTA|VALue|RLC}

Description:
Set measurement displayed on Digibridge front panel.

Parameter:

Value	Description
BIN	Display Bin #
DELTA	Display Delta %
VALue	Display Value
DRLC	Display Delta RLC

Equivalent legacy command:
D0, D1, **D2**, D3

Equivalent key:
[DISPLAY]

:CONFigure:DISPlay:RATio

Syntax:
:CONFigure:DISPlay:RATio
{NOMValue|VALNominal}

Description:
Set Digibridge front panel to display measurement ratio.

Parameter:

Value	Description
NOMValue	Display Ratio: nominal value / RLC value
VALNominal	Display Ratio: RLC value / nominal value

Equivalent legacy command:
D4, D5

Equivalent key:
[DISPLAY] + nominal value

:CONFigure:DISPlay:BINRatio

Syntax:
:CONFigure:DISPlay:BINRatio
{NOMValue|VALNominal}

Description:
Set Digibridge front panel to display measurement bin on ratio.

Parameter:

Value	Description
NOMValue	Display Bin on ratio: nominal value / RLC value
VALNominal	Display Bin on ratio: RLC value / nominal value

Equivalent legacy command:
D6, D7

Equivalent key:
[DISPLAY] + nominal value

:CONFigure:FUNCTioN

Syntax:
:CONFigure:FUNCTioN {MEASure|ENTER}

Description:
Set function mode to measurement or setting entry. This command affects user keyboard entry.

Parameter:

Value	Description
MEASure	Set function to Measure
ENTER	Set function to Enter (enable setting configuration)

Equivalent legacy command:
P0, P1

Equivalent key:
[MEASURE] key, current state indicated by MEASURE and ENTER LEDs.

:CONFigure:RANGe

Syntax:
:CONFigure:RANGe {HOLD|1|2|3|4|AUTO}

Description:
Set the measurement range.

Value	Description
HOLD	Hold range
1	Hold range 1
2	Hold range 2
3	Hold range 3
4	Hold range 4
AUTO	Autorange

Equivalent legacy command:
R0, R1, R2, R3, R4, **R5**

Equivalent key:
([1] or [2] or [3] or [4]) [=] [SHIFT] [SPECIAL] [1]

:CONFigure:DElay

Syntax:
:CONFigure:DElay <numeric>

Description:
Sets the trigger delay time.

Parameter:

Value	Description
<numeric>	Delay time real value in ms

Equivalent legacy command:
J<numeric>;

Equivalent key:
(delay in ms) [=] [SHIFT] [SPECIAL] [4]

:CONFigure:ITFactor

Syntax:
:CONFigure:ITFactor <numeric>

Description:
Set the integration-time multiplying factor. Value <numeric> multiplies MEDIUM and FAST integration times.

Parameter:

Value	Description
<numeric>	Integration-Time Multiplying Factor real value

Equivalent legacy command:
I<numeric>;

Equivalent key:
(IT factor in m) [=] [SHIFT] [SPECIAL] [5]

:CONFigure:FREquency

Syntax:
:CONFigure:FREquency <numeric>

Description:
Sets the frequency used for measurement signal.

Parameter:

Value	Description
<numeric>	Frequency real value in kHz

Equivalent legacy command:
F<numeric>;

Equivalent key:
(frequency) [=] [SHIFT] [FREQUENCY]

:CONFigure:VOLTagE:CONStant

Syntax:
:CONFigure:VOLTagE:CONStant {**OFF**|**ON**}

Description:
Set the measurement signal voltage.

Parameter:

Value	Description
OFF	Set constant voltage off
ON	Set constant voltage on

Equivalent legacy command:
Y0, Y1

Equivalent key:
[1] [=] [SHIFT] [CONST V]

:CONFigure:VOLTagE:LEVel

Syntax:
:CONFigure:VOLTagE:LEVel <numeric>

Description:
Set the measurement signal voltage level.

Parameter:

Value	Description
<numeric>	Set measurement voltage level to real value (in volts)

Equivalent legacy command:
V<numeric>;

Equivalent key:
(voltage) [=] [SHIFT] [VOLTAGE]

:CONFigure:CURRent

Syntax:

:CONFigure:CURRent <numeric>

Description:

Set the measurement constant current level.

Parameter:

Value	Description
<numeric>	Set measurement current to real value (in mA)

Equivalent legacy command:

i<numeric>;

Equivalent key:

(current) [=] [SHIFT] [CONST I]

:CONFigure:BIAS

Syntax:

:CONFigure:BIAS {OFF|ON|0|1}

Description:

Enables or disables DC bias.

Parameter:

Value	Description
OFF or 0	Disables the DC bias
On or 1	Enables the DC bias

Equivalent legacy command:

U0, U1

Equivalent key:

([0] or [1]) [=] [SHIFT] [SPECIAL] [INT BIAS]

:CONFigure:ROUTine

Syntax:

:CONFigure:ROUTine {NORMal|REVersal|SHORTing|REVShortint|QUICK|QSHorting}

Description:

Set the measurement routine.

Parameter:

Value	Description
NORMal	Normal routine (highest speed)
REVersal	Signal reversal (use for low frequency hum rejection)
SHORTing	Shorting between measurements (used for reducing transient-recovery time within measuring circuit, when measuring with bias; NOT FOR DISCHARGING THE DUT)
REVShorting	Signal reversal and shorting between measurements
QUICK	Quick-acquisition feature
QSHorting	Quick-acquisition & shorting

Equivalent legacy command:

Q0, Q1, Q2, Q3, Q4, Q5

Equivalent key:

none

:CONFigure:NOMinal

Syntax:

:CONFigure:NOMinal <numeric>

Description:

Set the nominal real value <numeric> in ohms, henries, or farads.

Parameter:

Value	Description
<numeric>	Nominal real value

Equivalent legacy command:

N<numeric>;

Equivalent key:

nominal value + [=] [SHIFT] [NOMINAL]

:CONFigure:BLANKing

Syntax:

:CONFigure:BLANKing <a numeric> <b numeric>

Description:

Set display digit blanking. Eliminate <a numeric> digits from RLC and <b numeric> digits from QDR displays on Digibridge front

Parameter:
<a numeric>

Value	Description
0 to 5	Number of digits to eliminate from RLC display

<b numeric>

Value	Description
0 to 4	Number of digits to eliminate from QDR display

Equivalent legacy command:
O<a numeric><b numeric>

Equivalent key:
none

:CONFigure:BIN:NUM

Syntax:
:CONFigure:BIN:NUM <numeric>

Description:
Set the limit entry bin number.

Parameter:

Value	Description
<numeric>	Bin #, range 0 to 15

Equivalent legacy command:
B<numeric>

Equivalent key:
none

:CONFigure:BIN:HIGH

Syntax:
:CONFigure:BIN:HIGH <numeric>

Description:
Set the limit entry bin high limit (in %).

Parameter:

Value	Description
<numeric>	Real value high limit in %

Equivalent legacy command:
Hh;

Equivalent key:
none

:CONFigure:BIN:LOW

Syntax:
:CONFigure:BIN:LOW <numeric>

Description:
Set the limit entry bin low limit (in %).

Parameter:

Value	Description
<numeric>	Real value low limit in %

Equivalent legacy command:
L<numeric>;

Equivalent key:
none

:CONFigure:BINSummary

Syntax:
:CONFigure:BINSummary
{DISable|ENABle|RESet}

Description:
Enables or disables bin summary output.

Parameter:

Value	Description
DISable	Disable output
ENABle	Enable output
RESet	Reset bin summary to 0

Equivalent legacy command:
E0, E1, E2

Equivalent key:
none

:CONFigure:OUTPut

Syntax:
:CONFigure:OUTPut {NONE|BIN|QDR|QBIN|RLC|RBIN|RQDR|RQBin|RQBFail|RQBPass}

Description:
Selects the data that is output.

Parameter:

Value	Description
NONE	No data output
BIN	Bin #
QDR	QDR
QBIN	QDR, Bin #
RLC	RLC
RBIN	RLC, Bin #
RQDR	RLC, QDR
RQBin	RLC, QDR, Bin #
RQBFail	RLC, QDR, Bin # on FAIL only
RQBPass	Same on FAIL; Bin # on PASS

Equivalent legacy command:

X0, X1, X2, X3, X4, X5, X6, X7, X8, X9

Equivalent key:

none

:CONFigure:DATAformat

Syntax:

:CONFigure:DATAformat {**ASCii**|**BINary**}

Description:

Selects the GPIB / RS-232 output data transfer format.

Parameter:

Value	Description
ASCii	Set output format to normal ASCII text
BINary	Set output format to compacted binary

Equivalent legacy command:

x0, x1

Equivalent key:

none

:SYSTem:KEYPad

Syntax:

:SYSTem:KEYPad {**ENABLE**|**DISable**}

Description:

Enables or disables the front panel keypad.

Parameter:

Value	Description
ENABLE	Unlock (enable) keypad
DISable	Lock (disable keypad)

Equivalent legacy command:

K0, K1

Equivalent key:

none

:SYSTem:RESet

Syntax:

:SYSTem:RESet

Description:

Resets the Digibridge configuration to turn-on conditions.

Equivalent legacy command:

P2

Equivalent key:

[POWER]

:SYSTem:REStart

Syntax:

:SYSTem:REStart

Description:

Resets the Digibridge and re-runs power-on diagnostics.

Equivalent legacy command:

P3

Equivalent key:

none

:SYSTem:CALibration

Syntax:

:SYSTem:CALibration {**DISable**|**OPEN**|**SHORT**}

Description:

Enables open or short zero calibration. The :SYSTem:CALibration? query reads current status.

Parameter:

Value	Description
DISable	Disable
OPEN	Enable open circuit calibration
SHORt	Enable short circuit calibration

Equivalent legacy command:

Z0, Z1, Z2

Equivalent key:

[1693] [=] [SHIFT] [OPEN]

[1693] [=] [SHIFT] [SHORT]

:SYSTem:COMMunicate:GPIB:ADDRess?

Syntax:

:SYSTem:COMMunicate:GPIB:ADDRess

Description:

Reads the GPIB address of the Digibridge. (Query Only) The GPIB address can only be changed by changing the SW2 DIP switch setting on the Digibridge IEEE.2 Communication board.

Parameter:

Value	Description
1 to 30	Numeric value range
3 (default)	Default GPIB address

Equivalent legacy command:

none

Equivalent key:

none

:SYSTem:COMMunicate:GPIB:CONFigure

Syntax:

:SYSTem:COMMunicate:GPIB:CONFigure

{**ENABLE**|DISable}

Description:

Enable or disable the GPIB interface. The GPIB interface can be disabled to prevent interference with or slowing down of measurements if using another interface, such as the RS-232 serial interface, for communicating with the Digibridge instrument.

Parameter:

Value	Description
ENABLE	Enable GPIB interface.
DISable	Disable GPIB interface (if using RS-232).

Equivalent legacy command:

none

Equivalent key:

none

:SYSTem:COMMunicate:SERial:CONFigure

Syntax:

:SYSTem:COMMunicate:SERial:CONFigure

{**ENABLE**|DISable}

Description:

Enable or disable the RS-232 serial interface. The RS-232 serial interface can be disabled to prevent interference with or slowing down of measurements if using another interface for communicating with the Digibridge instrument.

Parameter:

Value	Description
ENABLE	Enable RS-232 serial interface.
DISable	Disable RS-232 serial interface.

Equivalent legacy command:

none

Equivalent key:

none

:SYSTem:COMMunicate:SERial:BAUDrate

Syntax:

:SYSTem:COMMunicate:SERial:BAUDrate

{9600|**19200**|38400|57600|115200}

Description:

Set the RS-232 serial interface baud rate.

Parameter:

Value	Description
9600	9600 BAUD
19200	19200 BAUD
38400	38400 BAUD
57600	57600 BAUD
115200	115200 BAUD

Equivalent legacy command:

none

Equivalent key:

none

:SYSTem:COMMunicate:SERial:STOPbits

Syntax:

:SYSTem:COMMunicate:SERial:STOPbits {1|2}

Description:

Set the number of RS-232 serial interface stop bits.

Parameter:

Value	Description
1	1 stop bit
2	2 stop bits

Equivalent legacy command:

none

Equivalent key:

none

:SYSTem:COMMunicate:SERial:HANDshake

Syntax:

:SYSTem:COMMunicate:SERial:HANDshake
{NONE|XON|HARDware|MODem}

Description:

Set the RS-232 serial interface handshake.

Parameter:

Value	Description
NONE	No handshake
XON	XOn/XOff software handshake
HARDware	Hardware handshake
MODem	Modem handshake

Equivalent legacy command:

none

Equivalent key:

none

:SYSTem:ERRor[:NEXT]?

Syntax:

:SYSTem:ERRor[:NEXT]?

Description:

Reads the error message. (Query only)

Equivalent legacy command:

none

Equivalent key:

none

:SYSTem:VERSion?

Syntax:

:SYSTem:VERSion?

Description:

Reads the instrument version. (Query only)

Equivalent legacy command:

none

Equivalent key:

none

:STATus:OPERation[:EVENT]?

Syntax:

:STATus:OPERation[:EVENT]?

Description:

Reads the value of the Operation Status Event Register. (Query Only)

Equivalent legacy command:

none

Equivalent key:

none

:STATus:OPERation:CONDition?

Syntax:
:STATus:OPERation:CONDition?

Description:
Reads the value of the Operation Status Condition Register. (Query Only)

Equivalent legacy command:
none

Equivalent key:
none

:STATus:OPERation:ENABLE

Syntax:
:STATus:OPERation:ENABLE <numeric>:STATus:OPERation:ENABLE?

Description:
Sets the Operation Enable Mask Register to specified numeric value. :STATus:OPERation:ENABLE? reads the current value of the Operation Enable Mask Register without clearing the register value.

Parameter:

Value	Description
0 to 255	Numeric value range

Equivalent legacy command:
none

Equivalent key:
none

:STATus:QUEStionable[:EVENT]?

Syntax:
:STATus:QUEStionable[:EVENT]?

Description:
Reads the value of the Questionable Status Event Register. (Query Only)

Equivalent legacy command:
none

Equivalent key:
none

:STATus:QUEStionable:CONDition?

Syntax:
:STATus:QUEStionable:CONDition?

Description:
Reads the value of the Questionable Status Condition Register. (Query Only)

Equivalent legacy command:
none

Equivalent key:
none

:STATus:QUEStionable:ENABLE

Syntax:
:STATus:QUEStionable:ENABLE <numeric>:STATus:QUEStionable:ENABLE?

Description:
Sets the Questionable Enable Mask Register to specified numeric value. :STATus:QUEStionable:ENABLE? reads the current value of the Questionable Enable Mask Register without clearing the register value.

Parameter:

Value	Description
0 to 255	Numeric value range

Equivalent legacy command:
none

Equivalent key:
none

:STATus:PRESet

Syntax:
:STATus:PRESet

Description:
Enables all required event reporting.

Equivalent legacy command:
none

Equivalent key:
none

:MEASure

Syntax:
:MEASure

Description:
Start a measurement upon read (like pressing the start switch).

Equivalent legacy command:
G0

Equivalent key:
[START] key

***CLS**

Syntax:
*CLS

Description:
Clears the following:

- Error Queue
- Status Byte Register
- Standard Event Status Register
- Operation Status Event Register
- Questionable Status Event Register (No Query)
- Resets to Turn-On Conditions (legacy P2 command)

Equivalent legacy command:
P2

Equivalent key:
none

***ESE**

Syntax:
*ESE <numeric>
*ESE?

Description:
Sets the value of the Standard Event Status Enable Register to specified numeric value. *ESE? reads the current value of the Standard Event Status Enable Register without clearing the register value.

Parameter:

Value	Description
0 to 255	Numeric value range

Equivalent legacy command:
none

Equivalent key:
none

***ESR?**

Syntax:
*ESR?

Description:
Reads out the value of the Standard Event Status Register. Executing this command clears the Standard Event Status Register value.

Equivalent legacy command:
none

Equivalent key:
none

***IDN?**

Syntax:
*IDN?

Description:
Reads out the Digibridge instrument information (manufacturer, model number, serial number, FPGA version number, firmware version number) of the Digibridge.
Example: "IET Labs, 1693M, 20110228, 1.0, 1.0"

Equivalent legacy command:
none

Equivalent key:
none

***OPC**

Syntax:
*OPC

Description:
Sets the OPC bit (bit 0) of the Standard Event Status Register when all pending operations have completed or ended.

Equivalent legacy command:
none

Equivalent key:
none

***RST**

Syntax:
*RST

Description:
Resets Digibridge settings to Turn-On Conditions.

Equivalent legacy command:
P2

Equivalent key:
none

***SRE**

Syntax:
SRE <numeric>
*SRE?

Description:
Sets the value of the Service Request Enable Register. *SRE? reads the current value of the Service Request Enable Register.

Parameter:

Value	Description
0 to 255	Numeric value range

Equivalent legacy command:
none

Equivalent key:
none

***STB?**

Syntax:
*STB?

Description:
Reads the value of the Status Byte register.

Equivalent legacy command:
none

Equivalent key:
none

***TST?**

Syntax:
*TST?

Description:
Initiates self-test and returns 0 if all tests passed or error code if any test failed.

Equivalent legacy command:
none

Equivalent key:
none

***WAI**

Syntax:
*WAI

Description:
Waits until all commands previously sent have completed.

Equivalent legacy command:
none

Equivalent key:
none

3.11.11 Example Programming

Zero-Open

```
ibwrt "SYST:RES"
ibwrt "CONF:PAR CD"
ibwrt "CONF:OUTP RLC"
ibwrt "CONF:CIRC PAR"
ibwrt "CONF:AVER 10"
ibwrt "SYST:CAL OPEN"
ibwrt "MEAS"
ibrd 100
```

Zero-Short

```
ibwrt "SYST:RES"
ibwrt "CONF:PAR RQ"
ibwrt "CONF:OUTP RLC"
ibwrt "CONF:CIRC SER"
ibwrt "CONF:AVER 10"
ibwrt "SYST:CAL SHORT"
ibwrt "MEAS"
ibrd 100
```

3.11.12 Talk-Only Use, for Data Output

This pertains to a relatively simple system, with the Digibridge outputting data to one or more "listen-only" (IEEE-488 compatible) devices such as a printer.

1. Set the TALK switch to TALK ONLY.
2. Program the Digibridge to send out results automatically after each measurement. (Refer to paragraph 3.11.3.)

The "special" commands for this purpose can be executed only in ENTER function, as follows.

Bin numbers only	[1]= [SHIFT][SPECIAL][2]
QDR results only	[2]= [SHIFT][SPECIAL][2]
QDR and bin numbers	[3]= [SHIFT][SPECIAL][2]
RLC results only	[4]= [SHIFT][SPECIAL][2]
RLS and bin numbers	[5]= [SHIFT][SPECIAL][2]
RLC and QDR results	[6]= [SHIFT][SPECIAL][2]
RLS, QDR and bin numbers = full data	[7]= [SHIFT][SPECIAL][2]
No data on PASS, Full data on FAIL	[8]= [SHIFT][SPECIAL][2]
BIN No. on PASS, full data on FAIL	[9]= [SHIFT][SPECIAL][2]
For no data output via IEEE-488 bus	[0]= [SHIFT][SPECIAL][2]

Operate the Digibridge in the usual way (manually). The system may constrain operation in some way. For example, a slow printer will limit the measurement rate because it requires a certain time to print one value before it can accept the next.

Refer to Table 3-20 for examples of the interface message code for data transfer. This table shows typical codes, but does not repeat the entire ASCII code. (There is a more complete table, in paragraph Table 2-1 on page 11.)

NOTE: For a description of the compacted binary data output format (which saves time), refer to paragraph 3.11.14.

Character ASCII	Decimal Equivalent	DI08	DI07	DI06	DI05	DI04	DI03	DI02	DI01
A	65	0	1	0	0	0	0	0	1
B	66	0	1	0	0	0	0	1	0
C	67	0	1	0	0	0	0	1	1
*** etc ***									
1	49	0	0	1	1	0	0	0	1
2	50	0	0	1	1	0	0	1	0
3	51	0	0	1	1	0	0	1	1
*** etc ***									

Table 3-20: Abbreviated interface message code for "TALK-ONLY" data transfer

Character Sequence	Purpose	Allowed Characters	Meaning
1	Status	(space) U O E I	Normal Operation Underrange held (reduced accuracy)* Ovrange held (reduced accuracy)* End extension of range 1 or 1 (reduced accuracy)** Invalid measurement due to signal overload
2	Value of delta RLC or ratio	(space) - /	Normal display Delta RLC Mode Ratio Mode: Nominal Value/RLC Value
3	Parameter	L C R G Z Y	Inductance Capacitance Resistance Conductance Impedance Admittance
4	Normal or ratio mode	(space) -/	Normal mode (one of 3 describe above) Ratio Mode: RLC Value/Nominal Value
5,6	Units	(space)H mH uF nF (space)S mS uS (space)% (space) Ω k Ω	Henries Millihenries Microfarads Nanofarads Siemens Millisiemens Microsiemens Percent difference from nominal value Ohms kiloohms
7	Format	(space)	
8	Sign	(space) -	Positive Value Negative Value
9...15	Number	0123456789. (space)	Measured number, right justified in format field, like the RLC display except the zero before the decimal point is explicitly provided and this number can be as long as seven characters. ***
16		(CR)	The standard "carriage return" and "line feed" characters; end of string.
17		(LF)	

Table 3-21: Data output format for RLC value, delta%, deltaRLC, or RATIO

* Underrange generally occurs when the measured impedance is lower than the nominal low limit (for automatic range change) and there is a lower-impedance range. Ovrange generally occurs when the measured impedance is higher than the nominal high limit (for automatic range change) and there is a higher-impedance range. In either case, an appropriate range change will improve accuracy. If there is no appropriate range to change to, the status is "range end extension"; see below. Range limits are different if CONSTANT VOLTAGE OR CONSTANT CURRENT has been selected; see paragraph 3.5.6.

** Range 1 end extension if DUT impedance exceeds that of the largest R or L (smallest 0) in basic range 1. Range 4 end extension if DUT impedance is less than that of the smallest R or L (largest 0) in basic range 4. No possibility of changing range to improve accuracy.

*** If the measurement is outside of the display range (display goes blank), 9999999 is output in this numeric field.

Character Sequence	Purpose	Allowed Characters	Meaning
1	Status	(space) O I	Normal Operation Overrange held (reduced accuracy)* Invalid measurement due to signal overload
2	Format	(space)	
3	Parameter	Q D R X B A	Quality factor Dissipation factor Resistance Reactance Susceptance Angle
4	Format	(space)	
5..7	Units	(2 space) Ω (space)k Ω (2 space)S (space)mS (space) μ S deg ppm (3 space)kO	Ohms Kiloohms Siemens Millisiemens Microsiemens Degrees Part per million (for D, Q or Angle) Dimensionless (for Q or D)
7	Format	(space)	
8	Sign	(space) -	Positive Value Negative Value
9..15	Number	0123456789. (space)**	Measured number, right justified in format field, like the QDR display except the zero before the decimal point is explicitly provided and this number can be as long as six characters. *
16		(CR)	The standard "carriage return" and "line feed" characters; end of string.
17		(LF)	

Table 3-22: QDR-Value data output format

* If measurement is overrange (display goes blank), 999999 is output in this field.

** Two leading zeros will precede the decimal point on values less than 1. Two spaces will precede the value on values greater than 1.

Character Sequence	Purpose	Allowed Characters	Meaning
1	Pass/fail	(space) F	Go (bins 01 to 13) No-Go (bins 00 or 14)
2	Format	(space)	
3	Label	B	The word "BIN"
4		I	
5		N	
6	Format	(space)	
7,8	Bin Number	123456789	Bin number assignment, 00 to 14
9		(CR)	The standard "carriage return" and "line feed" characters; end of string.
10		(LF)	

Table 3-23: BIN-Number data output format

Character Sequence	Purpose	Allowed Characters	Meaning
1	Pass/fail	(space)	Go (bins 01 to 13)
		F	No-Go (bins 00 or 14)
2	Format	(space)	
3	Label	B	The word "BINSUM"
4		I	
5		N	
6		S	
7		U	
8		M	
9	Format	(space)	
10,11	Bin Number	123456789	Bin number assignment, 00 to 14
12	Equivalence	=	Equals
13-17	Sum	123456789	Total number counted in this bin, the bin-summary number.
18		(CR)	The standard "carriage return" and "line feed" characters; end of string.
19		(LF)	

Table 3-24: BIN summary data output format

Bin Summary Output Format, Table 3-24. The bin summary output can be enabled by the [SHIFT][BIN SUM] [LOCK] sequence from the keyboard. (It can also be enabled by the El command from the bus. See paragraph 3.11.12.) The bin summary output consists of 15 lines, one apiece for the 15 bins (00 through 14). Each line has the format shown in the table.

3.11.13 Talk/Listen Use, for Remote Programming and Data Transfers

Observe the REMOTE CONTROL indicator light. If it is lit, there is no opportunity for manual operation (except switching EXTERNAL BIAS ON and OFF and use of the START button if manual start is enabled.) The displays may be observed then, but their content is controlled by the system controller, via the IEEE-488 bus. Details of test program preparation are beyond the scope of this manual. Refer to Table 3-21 for an example of message activity during a control sequence in which the controller says "start" and the Digibridge (after a measurement) says "C μF 1.2345".

Programming Guidelines. If the Digibridge is to be programmed (TALK switch set to TALK/LISTEN), keep the following suggestions in mind.

- An "unlisten" command is required before measurement is possible.
- If not addressed to talk, the Digibridge sends a service request (SRQ low) when it has data ready to send.
- Then SRQ will not go false (high) until the Digibridge has been addressed to talk or has been serially polled. A typical program might include these features:
- * Initial Setup: with ATN true, "untalk unlisten, my listen address (of Digibridge), my talk address (of CPU)"; then with ATN false, measurement conditions.
- Measurement Enabling Sequence, for example: untalk the Digibridge, send a GET, unlisten the Digibridge.
- After the CPU receives the SRQ, necessary enabling of data transfer: with ATN true, "untalk, unlisten, my listen address (of CPU), my talk address (of Digibridge)"; then ATN false.

Serial Poll -- Status Byte -- Table 9-19. When the bus is in the serial poll mode and the Digibridge is addressed to talk, the Digibridge responds with a status byte, which is encoded as shown in the table and sent on the data lines DI01 through DI08.

Message Code	Note *	Character ASCII	Decimal Equivalent **	DI08	DI07	DI06	DI05	DI04	DI03	DI02	DI01
MLA	SET	#	35	X	0	1	0	0	0	1	1
	TOT	(SP) TO >	32 TO 62	X	0	1	<MSB – device – address – LSB>				
MTA	SET	C	67	X	1	0	0	0	0	1	1
	TOT	@ TO ****	64 TO 94	X	1	0	<MSB – device – address – LSB>				
SPD	--	(EM)	25	X	0	0	1	1	0	0	1
SPE	--	(CAN)	24	X	0	0	1	1	0	0	1
UNL	--	?	63	X	0	1	1	1	1	1	1
UNT	--	--	95	X	1	0	1	1	1	1	1
Because the following messages are addressed commands, they will affect the Digibridge operation only while it is addressed to listen***											
GET	--	(BS)	8	X	0	0	0	1	0	0	0
GTL	--	(SOH)	1	X	0	0	0	0	0	0	1

Table 3-25: Interface message for remote control

* Set = address setting as supplied by factory. Tot = total range of choice. See paragraph 2.7 for address changing procedure.

** Decimal equivalent makes DI08 (which is in material) a zero. Logical 1 is low state (true), logical 0 is high state.

*** Digibridge is addressed to listen by MLA message containing its device address (see para. 2.7). It terminates this condition when it receives UNL command, which is necessary before it can make measurements or recognize its own keyboard.

**** Mnemonic key to codes:

MLA = my listen address

MTA = my talk address

SPD = serial poll disable

SPE = serial poll enable

UNL = unlisten

UNT = untalk

GET = group execute trigger

GIL = go to local

Line	Significance of a "1" (Low)	Significance of a "0" (High)
DI08	Remote	Local
DI07	Request for service, RQS	No request by this Digibridge
DI06	Recalibration Required	Normal Operation
DI05	Busy, measurement in process	Measurement Completed
DI04	Limits were tested	Limits were not tested
DI03	RLC measured value is available	RLC value is not available
DI02	QDR measured value is available	QDR value is not available
DI01	Bin No. assignment is available	Bin No. assignment is not available

Table 3-26: Status Code

MESSAGE ACTIVITY ON IEEE-488 BUS DURING A SIMPLE EXAMPLE OF REMOTE CONTROL

Byte order	Message*	ATN line	Comment
1	(UNT)	true	Untalk all devices.
2	(UNL)	true	Unlisten all devices.
3**	(MLA 3)	true	Set Digibridge (address 3) to listen.
4	(MTA n)	true	Set controller (address n) to talk.
5	G	false	Typical device-dependent message: START. (See
6	0	false	Table 3-20 for "program commands".)
7	(UNL)	true	Unlisten Digibridge (must for measurement).
-	--	--	Digibridge makes measurement, asserts SRQ line to indicate completion.
8	(MLA n)	true	Set controller to listen.
9**	(MTA 3)	true	Set Digibridge to talk.
10	(space)		Typical data stream from Digibridge in
11	(space)		the format of Tables 3-14, 3-15, 3-16 sent to
12	C		controller, which will execute
13	(space)		some kind of read command
14	u		(specified by programmer) according to
15	F		destination (such as a printer).
16	(space)		
17	(space)		
18	(space)		
19	1		
20	.		
21	2		
22	3		
23	4		
24	5		
25	(CR)		
26	(LF)		

Table 3-27: Message activity on IEEE-488 bus during sample example of remote control

*Message on DI01 ...DI08 lines is coded and interpreted differently depending on simultaneous state of AIN line (true = asserted = low, false = high).

**Bytes 3 and 4 can be programmed in a single command to controller; bytes 8 and 9 similarly. Notice that we refer to factory-set address as "3" by reading a 5-bit binary number (lines DI05 ...DI01).

3.11.14 Data Output in Compacted Binary Format

The compacted binary format for data output can be selected to save time. Selection must be made via IEEE-488 bus, not via the keyboard. The time saving is indicated by the fact that this format conveys a full set of test results in 8 binary bytes, compared to 44 binary bytes required by the regular format. Fewer characters are sent if you select less than complete results (such as bin number only, output only for FAIL, etc).

The data stream for one measurement consists of two to eight 8-bit bytes, depending on what output is programmed. The format is explained partly in truth Table 3-28, and partly in the text that follows.

NOTE: The 8 bits in each byte are 76543210, where 0 is LSB (least significant bit). The vertical line or space between bytes is for clarity only, not present in data.

The full eight bytes are sent only if RLC, QDR, and Bin information is needed (i.e., only if status" bits 2,1,0 are logic 111. Otherwise, the data word is shortened, as follows.

If QDR data are NOT needed, the data format uses 5 bytes as follows.

If both QDR and BIN data are not needed, the "OTHER" byte is omitted.

Name :	STATUS	RLC, e	RLC, mantissa	OTHER	
Byte Number:	byte 1	byte 2	byte 3 byte 4	byte 5	
-----	-----	-----	-----	-----	-----

If RLC data are NOT needed, the data format uses 5 bytes as follows.

If both RLC and BIN data are not needed, the "OTHER" byte is omitted.

Name :	STATUS	QDR, e	QDR, mantissa	OTHER	
Byte Number:	byte 1	byte 2	byte 3 byte 4	byte 5	
-----	-----	-----	-----	-----	-----

If only BIN data are needed, the data format uses only 2 bytes, as follows.

If RLC, QDR, and BIN data are all NOT needed, no data output occurs.

Name :	STATUS	OTHER	
Byte Number:	byte 1	byte 2	
-----	-----	-----	-----

The RLC,e byte (except for bit 7) conveys the RLC exponent (2s complement).

The RLC,mantissa bytes (all 16 bits) convey the RLC mantissa (base 2).

The QDR,e byte (except for bit 7) conveys the QDR exponent (2s complement).

The QDR,mantissa bytes (3.1116 bits) convey the Q..DR mantissa (base 2).

The binary exponent and mantissa define a binary floating-point number, as follows:

$$(\text{sign})(2^{(\text{exponent})}) * (\text{mantissa})$$

Name:	STATUS	RLC, e	RLC, mantissa	QDR, e	QDR, mantissa	OTHER
Byte Number:	byte 1	byte 2	byte 3 byte 4	byte 5	byte 6 byte 7	byte 8
	76543210	7		7		76543210
Normal meas.	00 *					
Overrange	01					
Underrange	10					
Invalid meas.	11					
Range 1	00					
Range 2	01					
Range 3	10					
Range 4	11					
Bin Number	001					
QDR	010					
QDR & bin no.	011					
RLC	100					
RLC & bin no.	101					
RLC,QDR,bin#	111					
RLC value is+	0					
RLC value is-	1					
QDR value is+				0		
QDR value is-				1		
Parameter L/Q						00
Parameter C/D						01
Parameter C/R						10
Parameter R/Q, R/X, G/B, Y/ANG, Z/ANG						11
Ratio(either)						00
Delta percent						01
Value(default)						10
Delta RLC						11
BIN 0						0000
BIN 1						0001
BIN 2						0010
BIN 3						0011
BIN 4						0100
(etc)						
BIN 13						1101
BIN 14						1110

* Bit 3 of STATUS byte does not convey data.

Table 3-28: Truth table of compacted binary format for output data

The following examples illustrate how to obtain ordinary (base-10) numbers from the compacted binary data.

EXAMPLE 1. (Bytes are shown separated by spaces.)

STATUS	RLC, e	RLC, mantissa		QDR, e	QDR, mantissa		OTHER
byte 1	byte 2	byte 3	byte 4	byte 5	byte 6	byte 7	byte 8
76543210	76543210	76543210	76543210	76543210	76543210	76543210	76543210
0001x111	01100101	11100001	00001001	01110101	10100000	00000000	01100111

Byte 1: Normal measurement. Range 2. RLC, QDR, and bin number data are needed.

Byte 2, bit 7: Sign of C value is +

Byte 2, other bits: C exponent is 1100101 in 2s complement notation, which is the same as a negative exponent of 011011 (i.e., -27, base 10).

NOTE 1: bit 6 is always 1 for a negative exponent, 0 for a positive exponent. Bytes 3, 4: C mantissa is .879044 (directly from the 16-bit binary number).

NOTE 2: In the mantissa, the first bit has the weight of 0.5, the next bit 0.25, the next bit 0.125, and each other bit half of the one before it, to the 16th bit.

Therefore, the C value is $+(2 \text{ to the } -27\text{th power}) * (.879044) = (7.45058) * (10 \text{ to the } -9 \text{ power}) * (.879044) = 6.54939 * 10 \text{ e}(-9) \text{ farads} = 6.5494 \text{ nF}$.

Bytes 5, 6, and 7 (by the same method as bytes 2, 3, and 4): D = .0003

Byte 8: Parameters are C/D. Data numbers are values (normal). Bin 7 assignment.

EXAMPLE 2. (Bytes are shown separated by spaces.)

STATUS	RLC, e	RLC, mantissa	
byte 1	byte 2	byte 3	byte 4
76543210	76543210	76543210	76543210
0010x010	00001010	10100011	00011100

The example-2 interpretation is as follows:

Byte 1: Normal measurement. Range 3. RLC data are needed.

Byte 2, bit 7: Sign of R value is +.

Byte 2, other bits: R exponent is 0001010 in 2s complement notation, which is the same as a positive exponent of 001010 (i.e., +10, base 10). (See NOTE 1, above.) Bytes 3,4: R mantissa is .637146 (from the 16-bit binary number; see NOTE 2, above).

Therefore, the R value is $+(2 \text{ to the } +10\text{th power}) * (.637146) = (1024) * (.637146) = 652.44 \text{ ohms}$.

3.12 Sample IEEE Programs

Below are three sample IEEE-488 programs using three different IEEE controllers. These programs are intentionally very short and are intended as aids to demonstrate to the programmer how to operate a Digibridge using a typical controller. It is assumed that the Digibridge address is set to 3.

3.12.1 Programming Hints

- The initiation (start) command is "G0". That is the number 0, not the letter O.
- It is good practice to begin a new program with a "P2" command. This will reset all parameters to the known turn-on state. If "P2" is used later in the program, it will reset everything, including Nominal Value and any Bin Limits that may be set.

```

100 '*****INITIALIZE BRIDGE*****
110 ADAP$="GPIB0" : DIGI$="DIGI":V%=1
120 CALL IBFIND (ADAP$,GPIB0%):CALL IBSIC (GPIB0%)
130 IF IBSTA% < 0 THEN GOTO 120
140 CALL IBGTS (GPIB0%,V%)
150 CALL IBFIND (DIGI$,DIGI%)
160 CLS '*****MEASURE AND DISPLAY DATA*****
170 C$=SPACE$(20):D$=SPACE$(20)
180 SET$="P2X6G0" ' bridge setup string
190 CALL IBWRT (DIGI%,SET$) ' send string to bridge
200 CALL IBRD (DIGI%,C$): CALL IBRD (DIGI%,D$) ' read measurement results
' display results
210 PRINT C$;D$
220 CALL IBLOC (DIGI%) : CALL IBGTS (GPIB0%,V%) ' return to local control
230 END
Ok

```

- An "X" command must be sent to enable data output.
- The string "P2A10;M3X4Z2G0" should be sent for the Short Circuit Zero. A frequency other than 1 kHz can be sent, if needed.
- The string "P2A10;M1X4Z1G0" should be sent for the Open Circuit Zero. A frequency other than 1 kHz can be sent, if needed.
- All commands sent to the Digibridge must be followed by an UNL (unlisten) and then ATN (attention) must be unasserted. *H* the instrument is set to TALK, this should happen automatically

3.12.2 National Instruments GPIB-PCII Card With the PC

3.13 Self-checks and Failure Displays (Error codes)

3.13.1 Power-up Self-Check

Every time the instrument is switched ON or the line voltage reappears after an interruption, the Digibridge keeps itself busy for a short time going through an automatic self-check routine. The RLC and QDR displays indicate in code which check is being performed. It is possible to halt the diagnostic routine and hold the displayed code by pressing and holding the [SHIFT] key or other key. Normally these displays follow one another rapidly.

However, if one of them persists, there has been a failure in the self check. The nature of the failure and the proper remedy for each are indicated below. Normal operation is inhibited in each of these cases.

NOTE: Operation can usually be enabled (in spite of failure messages other than 88888 or 33333) by pressing START button. This action is useful to enable measurements using a test fixture with very large capacitance or for certain transfer impedance measurements. But, it IS NOT RECOMMENDED unless you are well aware of what caused the self-check failure.

88888888. The random-access-memory read/write exercise was imperfect. Try power-up again; otherwise the remedy is beyond the operator's control; repair service is required.

77777 xxxx. The detector test was not completed satisfactorily. Be sure that the EXTERNAL BIAS switch is OFF; try power-up again. Otherwise the remedy is beyond the operator's control; repair service is required. (The QDR display provides some service information indicating in code which of 4 important digital signals is stuck, and whether high or low.)

66666 xxxx. The detector scale test failed. CPU will loop on failure. Switch POWER OFF and ON again. If these remedies are ineffective, repair service is required.

555 D xxxx. A signal-strength check failed: When D is 1...4, it indicates the range being checked (with voltage = 1.275 V). When D is 5, the range is 4, with voltage = .075 V. CPU will loop on failure. Be sure that the EXTERNAL BIAS switch is OFF and check to make sure that the charged capacitor protective fuse has not blown (Item 11, Figure 1-3). Recycle power OFF and ON to exit from loop.

444 E xxxx. A check on test frequency and waveform failed. For E of 1, 2, 3, 4, 5, 6, the frequency being checked is 6.06, 6.0, 1.2, 0.48, .0968, .0118 kHz, respectively. CPU will loop on failure; recycle power OFF and ON to exit from loop.

33333 xxxx. PROM data checksum test. XXXX = checksum, which must be zero to pass the test.

222 F XXXX. Calibration constants test. XXXX = normalized value of constant, which must be within the limits of 1.000000 +/- 0.78125 to pass the test. For F = 0, the constant is frequency correction factor. For F = 1, 2, 3, or 4, it is the conductance of range 1, 2, 3, or 4, respectively.

You can proceed from this power-up self-check failure (222 F XXXX) and operate the Digibridge. To do so, press the [C/D] key. Of course, the measured results are liable to be erroneous; you should then proceed to obtain service to repair the fault and/or recalibrate.

1111 1111. Failure of the high-speed math chip on the 1689-9620 high-speed measurement and IEEE/handler interface option. (This check is performed only if that option is present.)

You can proceed from this power-up self-check failure (1111 1111) and operate the Digibridge. To do so, press the [C/D] key. Interface functions can be expected to work properly. However, the Digibridge will operate at its regular speed (as though the high-speed option were absent) if it has this failure.

3.13.2 Failure Display due to Signal Overload

“014” (right display blank) Occurrence of an unrecoverable signal overload during the last measurement. This means that a signal overload occurred during RANGE HELD or while measuring on Range 4. Otherwise (if a signal overload occurs on range 1, 2, or 3 and range is NOT held), this failure display is not shown; instead, the Digibridge will change to the next higher-numbered range and try again.

Signal overload can result from any of five causes:

- RANGE HELD and CONSTANT VOLTAGE with impedance value too low for the range.
- Transient voltage from charged capacitor.
- Transient due to application of bias voltage.
- Hardware failure.
- LC resonance effect (measuring inductance).

3.13.3 Failure Display due to Abnormal Measurement Cycle

2222 zzzz. The Digibridge will abort the measurement and provide this display if there is (even once during a measurement) a converter/detector malfunction such that the integrator’s conversion cannot be completed. There are two versions of this failure.

2222 2222. The cycle is “too long”. Integrator voltage does not return to zero in reasonable time.

2222 1111. The cycle is “too short”. Integrator voltage was already zero (or wrong polarity) when conversion began.

3.13.4 Failure Display due to LC Resonance

A display of “0 14” or 2222 1111 can occur, in place of the expected L and Q, because the inductor being measured resonates with measuring circuit capacitance. (Resonance can cause an overload of the converter/detector.) The Digibridge thus presents an easily noticed failure display rather than an invalid measurement result.

When Expected. This resonance effect can be expected when large values of inductance are being measured at high frequency. In particular, if the Digibridge is autoranging, this effect can be expected in range 1 under any of the following 4 equivalent conditions. (A representative value of L that will cause selection of range 1 is indicated in parentheses beside each condition.)

- Without extender cable: $f > 3.8 \text{ kHz}$ ($L > 1 \text{ H}$ at 4 kHz).
- With 1657-9600 cable (banana plugs): $f > 1.1 \text{ kHz}$ ($L > 3 \text{ H}$ at 1.2 kHz).
- With 1689-9602 cable (BNC/BNC): $f > 2 \text{ kHz}$ ($L > 2 \text{ H}$ at 2 kHz).
- With any other cable and remote test fixture, use the following formula: $f > 770 / (200 + C)$, where f is in kHz, C is stray capacitance outside of the Digibridge, from the high (Ih, Ph) terminal to ground (guard), expressed in pF. (Measurement will be on range 1 if $L > 4/f$.)

This resonance effect can also be expected under some conditions of high-frequency measurement with range 1 held but the inductance of the DUT appropriate for range 2. The effect is NOT expected with autoranging in ranges 2, 3, 4, unless stray capacitance is considerably larger than that of the 1657-9600 extender cable.

It is possible for valid measurement, with a slight reduction in accuracy, to be made under conditions very close to those that will trigger the LC resonance failure display. Such a measurement can be expected to meet accuracy specifications if it is displayed at all.

Recommended Procedure. If this LC-resonance failure display appears, in the course of otherwise normal measurements, the instrument is functioning normally. Valid measurements can usually be made by taking one or more of the following steps:

1. Select low source impedance, by pressing [SHIFT][CONST VOLTAGE] so that the CONSTANT VOLTAGE indicator lights up.
2. Select a low-impedance range. For example, if measurement is normally in range 1, try holding range 2; or if range 1 has been held, select autorange.

3. Reduce the measurement frequency.
4. If cable and test fixture capacitance can be reduced, do so.
5. If this resonance effect is not easily avoided, consider that the DUT may be self-resonant. If so, unqualified measurements of apparent inductance are misleading. Try a set of measurements of apparent inductance at several frequencies sufficiently low (or high) to avoid the resonance failure display. NOTE: If RLC is negative, with indicated units of mH or H, the measured reactance is capacitive, although the RLC display is a number of millihenries or henries.

Chapter 4

THEORY

4.1 Introduction

4.1.1 General

This instrument uses an unusual method of measurement, which is quite different from those used in most previous impedance meters or bridges. A thorough understanding of this method will be helpful in unusual applications of the instrument. The following paragraph gives a brief overall description outlining the measurement technique to one familiar with impedance measurement methods. A more detailed description of operation, specific circuitry, and control signals is given later.

4.1.2 Brief Description of the 1693 Digibridge

The Digibridge RLC tester uses a patented measurement technique, in which a microprocessor calculates the desired impedance parameters from a series of 6 or 8 voltage measurements (6 for FAST, 6 for MED, and 8 for SLOW measurement rates). These measurements include quadrature (90 degree) and inverse (180 degree) vector components of the voltages across the device under test Z_x (the DUT), and across a standard resistor R_s carrying the same current as the DUT. Each of these voltage measurements is meaningless by itself, because the reference signals have no particular phase relationship to the measured analog signals, and because the current through Z_x is not controlled. Each set of voltage measurements is made in rapid sequence with the same phase-sensitive detector and analog-to-digital converter. Therefore properly chosen differences between these measurements subtract

out fixed offset errors, and ratios between them cancel out the value of the common current, the scale factor of the detector-converter, and the effect of the relative reference-to-signal phase angle.

The phase-sensitive detector uses 4 reference signals, precisely 90 degrees apart, that have exactly the same frequency as the test signal, but whose phase relationship to any of the analog voltages or currents (such as the current through Z_x and R_s) is incidental. Therefore, no precise analog phase shifter or waveform squaring circuit is required. Correct phase relationships are maintained by generating test signal and reference signals from the same high-frequency source.

Because of the measurement technique and circuitry, the only calibration adjustment in the Digibridge is the factory setting of the test-voltage-level reference. The only precision components in this instrument are four standard resistors and a quartz-crystal stabilized oscillator. There is no reactance standard. For example, C and D are calculated by the microprocessor from the set of voltage measurements, the predetermined frequency, and the calibrated R and Q of the applicable standard resistor.

In these calculations, the microprocessor automatically removes from the measured result the parameters of the test connection (“stray” capacitance and conductance and series resistance and inductance), if simple open circuit and short-circuit “ZERO” calibration measurements have been performed by the opera-

tor. The values obtained during “ZERO” calibration are stored in Digibridge memory and retained during power-down and power up.

The impedance of each internal standard resistor is similarly stored in memory for use by the microprocessor in the calculation of parameters being measured. (For this purpose, the Digibridge measures its own internal standard resistors against an external standard during factory calibration - and recalibration, if any.) Therefore, the impedances of the internal resistance standards are known at the calibration frequency (usually 1 kHz), and are computed by the microprocessor for other test frequencies.

The Digibridge also stores the frequency error of its crystal-referenced oscillator (actual vs nominal frequency, expressed in parts per million) so that the microprocessor uses a corrected frequency value in each calculation of capacitance or inductance from measured impedance. This frequency correction is programmed into the Digibridge during factory calibration - and recalibration, if any.

The microprocessor controls the measurement sequence, according to programs in the read-only memory, using stored operator selections that are made available through keyboard control or (if you have the interface option) by remote-control command. Selections include for example - parameters: R and Q, L and Q, C and D, or C and R; test voltage: .005 to 1.275 V; equivalent circuit: series or parallel; test rate: SLOW, MEDIUM:, or FAST; frequency:

programmable from 12 Hz to 200 kHz in 504 steps; delay: up to 99999 ms; and averaging: 2 to 255 measurements; etc.

The instrument normally autoranges to find the correct range; but operation can be restricted to any of the four ranges (1, 2, 3,4), under keyboard control. Each range is 4 octaves wide (16:1), with reduced-accuracy extensions both above and below. Leading zeroes before the decimal point are blanked out of the RLC and QDR displays.

4.1.3 Block Diagram

The block diagram shows the microprocessor in the upper center connected by data and address buses to digital circuitry including memories (RAM and ROM) and peripheral interface adaptors (PIAs).

Analog circuitry is shown in the lower part of the diagram, where Z_x is supplied with a test signal at frequency f from a sine-wave generator, driven by a crystal-controlled digital frequency divider circuit. The P/I signal selector and instrumentation amplifier supply an analog signal that represents 2 impedances alternately: the appropriate internal resistance standard, R_s , and the DUT, Z_x .

The phase-sensitive (dual-slope) detector and measurement counters convert this analog signal into digital form. See circuit descriptions below.

From this information and criteria selected by the keyboard (or remote control) , the microprocessor calculates the RLC and QDR values for display, averaging, bin assignments, etc.

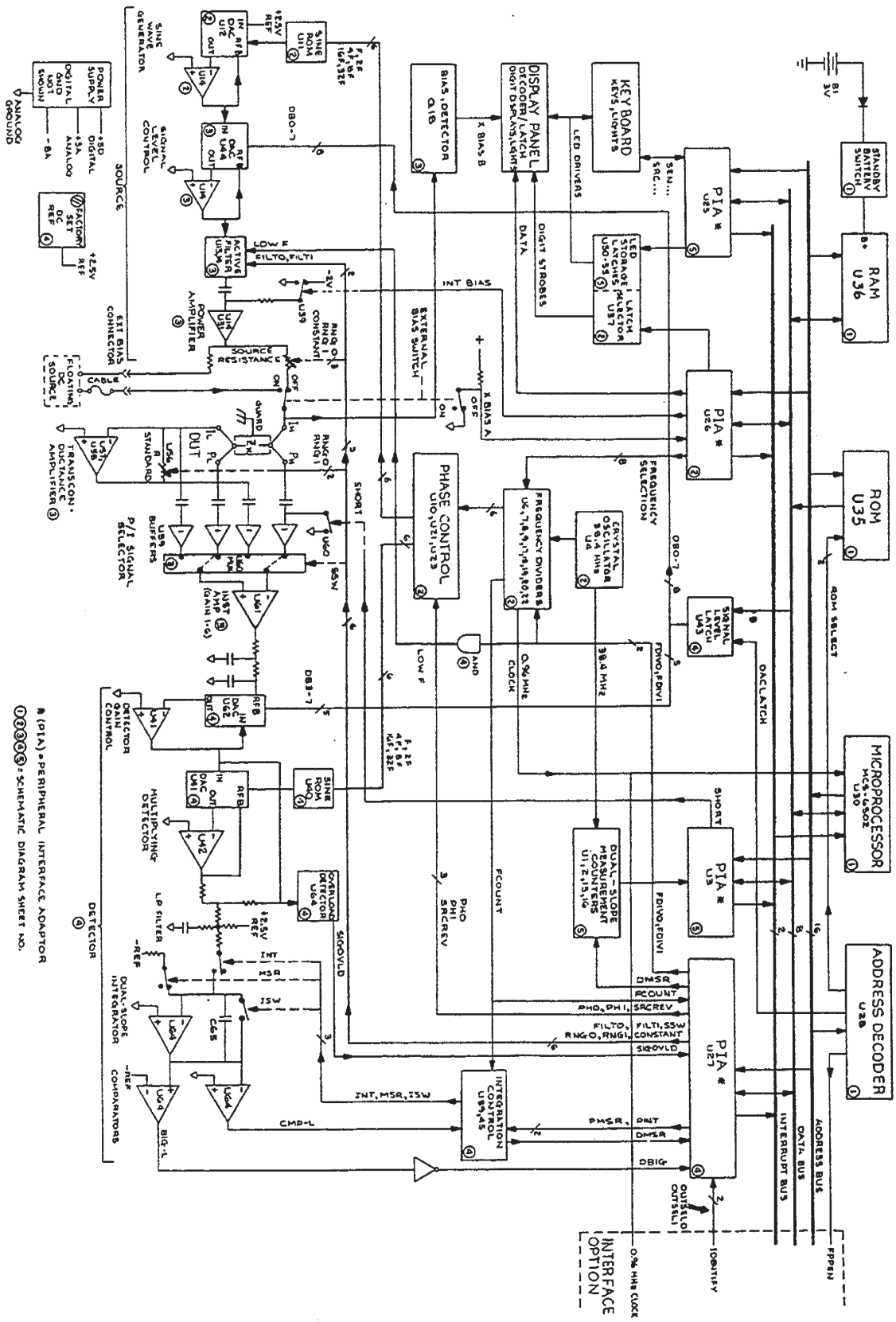

Figure 4-1: Block diagram of the 1693 RLC Digibridge

①②③④⑤ = PERIPHERAL INTERFACE ADAPTOR
 ①②③④⑤ = SCHEMATIC DIAGRAM SHEET NO.

4.2 Principal Functions

4.2.1 Elementary Measurement Circuit

The measurement technique is illustrated in Figure 4-2 by the accompanying simplified diagram, which can be correlated with the previous (block) diagram. A sine-wave generator drives current I_x through the DUT Z_x and standard resistor R_s in series. Two differential amplifiers with the same gain K produce voltages e_1 and e_2 . Simple algebra, some of which is shown in the figure, leads to the expression for the “unknown” impedance:

$$Z_x = R_s [e(1)/e(2)]$$

Notice that this ratio is complex. Two values (such as C and D or L and Q) are automatically calculated by the microprocessor from Z_x , frequency, and other information.

4.2.2 Frequency and Time Source

A necessary standard for accuracy is the frequency of the test signal; and equally important are the generation of multi-phase references for detection and clocks for the microprocessor. Frequency and timing requirements are implemented by derivation from a single very accurate oscillator, operating at 38.4 MHz. Digital dividers and logic circuitry provide the many clocks and triggers, as well as driving the sine-wave generator described below.

Figure 4-3 shows several clocks and synchronizing pulses as well as the measurement signal f are derived from the accurate time-base signal.

4.2.3 Sine-Wave Generation

Source of the Test Signal. Starting with a digital signal at 64 times the selected test frequency, the sine wave generator provides the test signal that drives a small but essential current through the DUT. The sine wave is generated as follows.

Binary dividers count down from 64 I , providing signals at 32 f , 16 f , ... 2 f , f . This set of signals is used to address a read-only memory which contains a 64-step approximation to a sine function. The RO:-.1 output (as an 8-bit binary number) is converted by a D/A converter to a stepped approximation of a sine-wave, which is then smoothed by filtering before its use in the measurement of a DUT. The filter is switched appropriately, according to the selected test frequency.

Source of the Reference Sine Wave for the Multiplying Detector. Another sine-function ROM is addressed by the same digital signals (64 f through f) to produce another stepped approximation of a sine wave at 0 degrees. Suitable inversions of signals 2 f and/or f serve to shift the phase of the output sine wave, under microprocessor control, by 90, 180, or 270 degrees.

Figure 4-4 shows how given square waves at frequencies of 64 f , 32 f , 16 t , 8 f , 4 f , 2 f , and I , a ROM containing the mathematical sine function drives a D/A converter to form a finely stepped approximation to a sine wave at frequency f . The filter provides smoothing of the test signal.

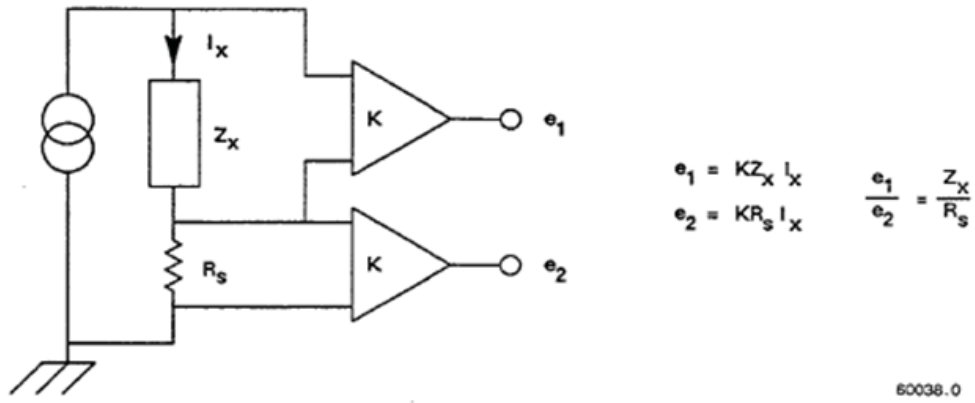

Figure 4-2: Elementary Measurement Circuit

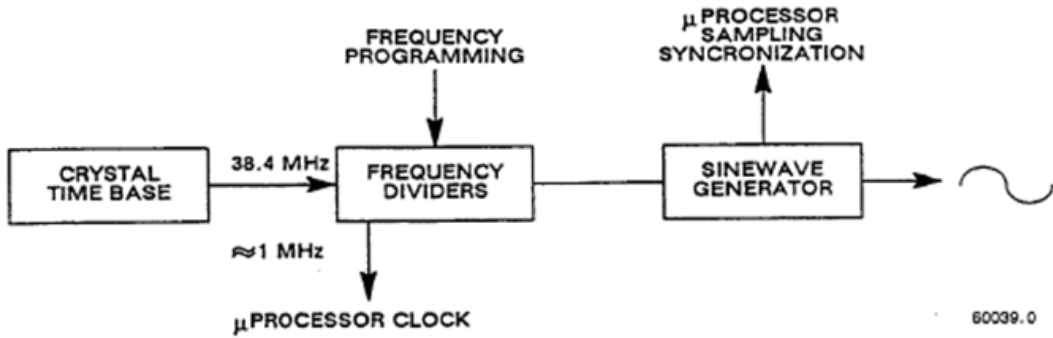

Figure 4-3: Frequency and timing source

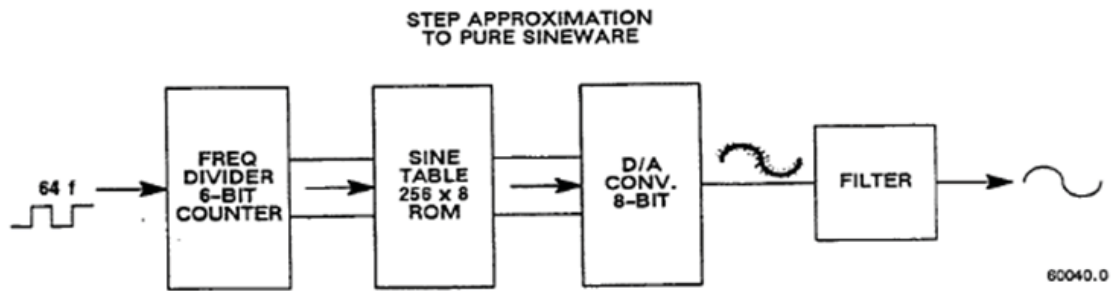

Figure 4-4: Sine wave generator

4.2.4 The Dual-Slope Integrating Detector and Converter

Circuitry. Refer back to Figure 4-1 on page 106 and note that the phase-sensitive detector/converter circuit consists of a multiplier whose dc output is measured by a dual-slope converter, providing the measurement in digital form. The multiplier is a multiplying D/A converter whose “reference” input is the test signal and whose digital controls are signals representing a stepwise approximation of a reference sine wave at the test frequency. The dc value of the multiplier output is proportional to the product of signal magnitude multiplied by the cosine of the phase angle between the test signal and the reference sine wave.

The dual-slope converter includes these three stages: dual-slope integrator, comparator, and counter (all controlled by the microprocessor through PIAs). In the dual-slope integrator, a capacitor is charged for a controlled integration time interval (sampling) at a rate proportional to the multiplier output voltage. This capacitor is then discharged at a fixed rate (the deintegration slope) to zero voltage, a condition that is sensed by a comparator. (See signal name “CMP-L” on the block diagram.) Thus, the integrator and comparator transform the sampled dc output from the multiplier into a precise interval of time.

The dual-slope measurement counter is gated by this time interval, thus converting it into a digital number, which is a principal data input to the microprocessor.

If the integration time is relatively long, so that the integration capacitor voltage reaches a certain reference level, another comparator triggers the beginning of the return (deintegration) slope before sampling has been completed. (See signal name “BIG-L” on block diagram.) The detector is then sampling and converting simultaneously for a portion of the dual-slope conversion cycle.

Data Acquisition Time. Data acquisition time includes pauses for synchronization, and several integration/deintegration cycles.

A pause for synchronization varies depending on timing relationships among the START signal, length of settling time or programmed delay, length of the previous integration/deintegration cycle, and the Digibridge clocks (particularly FCOUNT, shown on block diagram). This pause can be as much as one test-frequency period for high frequencies or up to 1/32 of the test-frequency period for low frequencies.

The integration (sampling, gate, or capacitor charging) time of the dual-slope integrator is the number of full periods of the test frequency whose sum is closest to $(4 \text{ ms}) \times (\text{integration-time factor})$ for FAST, closest to but not over $(16.7 \text{ ms}) \times (\text{integration-time factor})$ for MEDIUM, or closest to but not over 100 ms for SLOW measurement rate. (The integration-time factor is normally 1.0 but can be programmed between 0.25 and 6.)

The return (deintegration) time depends on the dc voltage being converted and whether “BIG-L” has been triggered (see above); therefore, this time requirement varies in a complex manner.

Data acquisition includes several complete dual-slope conversion cycles, with the reference sine wave at 3 or 4 different phases, exactly 90 degrees apart, as follows:

For FAST and MEDIUM rates, 6 cycles (2 each with reference phases of 0, 90, and 180).

For FAST and MEDIUM rates if “quick acquisition” special function is enabled, 5 cycles.

For SLOW measurement rate, 8 cycles (2 each with ref phases of 0, 90, 180, and 270).

Therefore, data acquisition time is a complex, discontinuous function of test frequency, the selected measurement rate, programmed integration-time factor, enabling or disabling of “quick acquisition”, and pauses for synchronization.

Chapter 5

SERVICE AND MAINTENANCE

5.1 Safety



These servicing instructions are for use by qualified personnel only. To avoid electrical shock, do not perform any servicing, other than that contained in the operating instructions, unless you are qualified to do so.



For continued protection against fire hazard, replace fuse only with same type and rating as shown on rear panel and in parts list. Service personnel, observe the following precautions whenever you handle a circuit board or integrated circuit in this instrument.

Handling Electronic Devices that Might Get Damaged by Static Electricity

Place instrument or system component to be serviced, spare parts in conductive (anti-static) envelopes or carriers, hand tools, etc., on a work surface defined as follows. The work surface, typically a bench top,

must be conductive and reliably connected to earth ground through a safety resistance of approximately 250 kilohms to 500 kilohms. Also, for personnel safety, the surface must NOT be metal. (A resistivity of 30 to 300 kilohms per square is suggested.) Avoid placing tools or electrical parts on insulators, such as books, paper, rubber pads, plastic bags, or trays.

Ground the frame of any line-powered equipment, test instruments, lamps, drills, soldering iron s, etc., directly to earth ground. Accordingly, (to avoid shorting out the safety resistance) be sure that grounded equipment has rubber feet or other means of insulation from the work surface. The instrument or system component being serviced should be similarly insulated while grounded through the power-cord ground wire, but must be connected to the work surface before, during, and after any disassembly or other procedure in which the line cord is disconnected.

Exclude any hand tools and other items that can generate a static charge . (Examples of forbidden items are non-conductive plunger-type solder suckers and rolls of tape.)

Ground yourself reliably, through a resistance , to the work surface ; use, for example, a conductive strap or cable with a wrist cuff . The cuff must make electrical contact directly with your skin; do NOT wear it over clothing. (Resistance between skin contact and work surface through a commercially available personnel grounding device is typically in the range of 250 k Ω to 1 M Ω .)

If any circuit boards or IC packages are to be stored or transported, enclose them in conductive envelopes and/or carriers. Remove the items from such envelopes only with the above precautions; handle IC packages without touching the contact pins.

Avoid circumstances that are likely to produce static charges, such as wearing clothes of Synthetic material, sitting on a plastic-covered or rubber-footed stool (particularly while wearing wool), combing your hair, or making extensive erasures. These circumstances are most significant when the air is dry.

When testing static-sensitive devices, be sure dc power is on before, during, and after application of test signals. Be sure all pertinent voltages have been switched off while boards or components are removed or inserted, whether hard wired or plugged in.

The symbol shown below may appear on circuit boards and/or schematic diagrams to call attention to static sensitive component parts. However, the absence of such a symbol does NOT assure the absence of static sensitive devices.



5.2 Customer Service

Our warranty (at the front of this manual) attests the quality of materials and workmanship in our products. If a malfunction does occur, our service engineers are available for technical telephone assistance. If the difficulty cannot be eliminated by use of the following service instructions, please contact IET and provide information about any problems and steps taken to remedy them. Describe the instrument by model number and serial number.

Products provided by IET Labs are thoroughly tested and calibrated to meet product specifications. A Certificate of Calibration (which certifies that the product meets its specifications and that its calibration is traceable to appropriate SI) is supplied.

5.3 Instrument Return

Before returning an instrument to IET Labs for service, contact our sales department. See below.

5.3.1 Packaging

To safeguard your instrument during storage and shipment, please use packaging that is adequate to protect it from damage, i.e., equivalent to the original packaging. Contract packaging companies in many cities can provide dependable custom packaging on short notice. Mark the box "Delicate Instrument."

5.3.2 Repair and Replacement of Circuit Boards

This instruction manual contains information to guide an experienced and skillful electronic technician in fault-analysis and repair of some circuits in this instrument. Contact IET Labs if additional help is required:

IET Labs, Inc
534 Main Street
Westbury, NY 11590
Phone: (800)899-8438
Fax: (516) 334-5988
Email: sales@ietlabs.com

5.4 Performance Verification

5.4.1 Overview

This procedure is recommended for verifying that the Digibridge is performing normally. No other check is generally necessary because this procedure checks operation of nearly all of the circuitry. If the Digibridge passes this performance verification, it is safe to assume that the instrument is functional. (However, to insure accuracy, refer to section 5.8, Accuracy Verification.)

All tests are done at 1 kHz, 1 volt NOT CONSTANT, and at SLOW measure rate so that basic bridge accuracy is realized. The accuracy of each verification is therefore $\pm 0.02\%$ plus the tolerance of the verifying DUT, which is discussed below. Table 5-1 lists the necessary resistors, capacitors, and inductors. The most accurate ones available should be used; tolerances listed are the “best” commonly catalogued. There are no calibrations and only one adjustment that may be required; and the internal standards are very stable. This procedure checks at least one point on each of the four measurement ranges.

Value	Component	Accuracy	Suggested IET Product
Resistance			
49.9 Ω	Metal Film Resistors	$\pm 0.1\%$	RS-201
499 Ω			
4.99 k Ω			
49.9 k Ω			
499 k Ω			
Capacitance			
10 μF	Metalized Polyester Polystyrene Capacitors	$\pm 5\%$	CS-C-6-100pF-WC
0.33 μF		$\pm 0.5\%$	
0.033 μF		$\pm 0.5\%$	
0.0033 μF		$\pm 0.5\%$	
Inductance			
1 mH	Ferrite core Inductors	$\pm 2\%$	LS-400A
100 mH			

Table 5-1: Components needed for performance verification

5.4.2 Performance Verification Procedure

1. After the line voltage switch has been set to correspond to the input line voltage, connect the line cord and switch the POWER ON.

The Digibridge then enters an automatic self-check routine and displays a sequence of codes. If one of these displays persists, a check failure has occurred and further checks or measurements are inhibited. (See paragraph 3.13.)

Normally, upon completion of the power-up self check, the following preset or default conditions are established, lighting a vertical line of indicators. (However, if the keyboard is locked, the locked-in conditions are re-established and most of the keyboard indicators are dark.) Normal:

[FUNCTION] - MEASURE
 [DISPLAY] - VALUE
 I MEASURE RATE} - SLOW
 I MEASURE MODE] - CONT*
 [EQUIVALENT CIRCUIT] - SERIES

* NOTE: If interface option is installed, MEASURE MODE will indicate TRIGGERED and display blank.

The main panel displays and indicators (RLC and QDR) will normally come up with random, meaningless readings; ignore them.

2. If the keyboard is locked, and the MEASURE indicator is lit, to unlock it, press [1][6][9][3][=][LOCK].

If you have the interface option, it is possible that the FUNCTION is locked at ENTER. Then the use of remote control signals is required either to unlock the keyboard or to select the MEASURE function, which is a prerequisite for unlocking from the keyboard.

3. Confirm or select the following measurement conditions on the Digibridge:
[FUNCTION] - ENTER (necessary for determining test frequency)
[DISPLAY] - VALUE
[MEASURE RATE] - SLOW
[MEASURE MODE] - TRIGGERED (necessary for zeroing)
[EQUIVALENT CIRCUIT] - SERIES
EXTERNAL BIAS - OFF (slide switch)
4. Verify that the test frequency is 1 kHz (the power-up default) by pressing [SHIFT][FREQUENCY].
The left-hand display should read 1.0000. If any other reading is observed press [1][=][SHIFT][FREQUENCY]
5. Verify that the test voltage is 1 volt by pressing [SHIFT][VOLTAGE].
The left-hand display should read 1.0000. If any other reading is observed, press [1][=][SHIFT][VOLTAGE].
6. Press the [FUNCTION] key to select MEASURE function.
7. If the Digibridge has an interface option (which has two 24-pin interface connectors on the rear panel), be sure that the TALK switch (rear panel) is set to TALK ONLY.
8. Zero the Digibridge as follows, before making measurements.
Make sure that the MEASURE and TRIGGERED keyboard indicators are lit.
 - A. Install the BNC cable and the Remote Test Fixture (or whatever cable is appropriate) as described in paragraph 3.2.
Note: make sure the test setup can accommodate all components needed for performance verification. See Table 5-1.
 - B. Press the [C/D] key.
 - C. Press: [1][6][9][3][=][SHIFT][OPEN].
 - D. Keep hands and all objects at least 10 cm from fixture contacts.
 - E. Press START to initialize zeroing operation.
 - F. Wait until the GO indicator lights.
 - G. Press [1][6][9][3][=][SHIFT][SHORT].
 - H. Press START to initialize zeroing operation.
 - I. Wait until the GO indicator lights again.
NOTE: For maximum accuracy, this zeroing procedure should be performed at the start of each day and every time the fixture configuration is changed.
9. Press the [MEASURE MODE] key to select CONT. (continuous measurements).
10. Press [R/Q].
11. Insert, as DUT, the first resistor specified in Table 5-2.
12. Verify that the displays are within the extremes shown for check number 1 in Table 5-2, if the resistor is within the tolerance listed in Table 5-1.

NOTE ON TOLERANCES: Acceptable performance of the instrument is bracketed by the set of display “extremes” in Table 5-2. These are defined as the nominal (ideal) measurements plus-or-minus the sum of the instrument accuracy tolerances and the DDT accuracy tolerance (or slightly more). If the accuracy of your DDT is different from the recommendation, revise the acceptable “extremes” accordingly. Notice that this performance verification is NOT intended to prove the accuracy of the instrument.

NOTE ON INSIGNIFICANT FIGURES: The right-hand digit(s) of the display may be expected to flicker and change (with the automatically repeating measurements) if they are not significant for the specified accuracy of the instrument. (See further comment with step 21 below.)

13. Similarly, make the other checks indicated in Table 5-2, under the R/Q parameter (checks number 2, 3, 4, 5).
14. Press [C/D].
15. Insert as DUT the first capacitor specified in Table 5-2 (check number 6).
16. Verify that the displays are within the extremes shown for check number 6 in Table 5-2, if the capacitor is within the tolerance listed in Table 5-1.
17. Similarly, make the other checks indicated in Table 5-2 under the C/D parameter (checks number 6, 7, 8, 9).

In check number 8, verify that the fifth digit is reasonably stable, as follows. (Notice that the fourth digit is the last significant one in the readout, for 0.02 percent accuracy.) In check number 8, the flickering of the fifth digit should stay typically between 2 counts. For example, if the display is 330.1X μ F, the “X”

might flicker between 2 and 4. If, for example, ‘X’ is flickering between 9 and 11, it will of course cause a flickering of the preceding digit (330.19 and 330.21). In such a case, the correct readout is the larger 4-digit number (330.2) and the fifth digit is acceptably stable.

18. Press [L/Q].
19. Insert as DUT the first inductor specified in Table 5-2 (check number 10).
20. Verify that the displays are within the extremes shown for check number 10 in Table 5-2, if the inductor is within the tolerance specified by Table 5-1.
21. Similarly check the inductor specified in check number 11.

Check Number	Parameter	DUT	RLC Display Extremes	QDR Display Extremes
1	R/Q	49.9 ohms	49.840 to 49.959 ohms	*
2		499 ohms	498.40 to 499.59 ohms	
3		4.99 kilohms	4.9840 to 4.9959K ohms	
4		49.9 kilohms	49.840 to 49.959K ohms	*
5		499 kilohms	498.40 to 499.59K ohms	
6	C/D	0.0033 uF	3282.8 to 3317.2 pF	.0000 to .0100
7		0.033 uF	32.828 to 33.172 nF	.0000 to .0100
8		0.33 uF	328.28 to 331.72 nF	.0000 to .0100
9		10 uF	9.498 to 10.502 uF	.0000 to .0300
10	L/D	1000 uH	.9498 to 1.0502 mH	*
11		100 mH	89.98 to 110.02 mH	*

 * The right hand display (QDR) can be expected to change frequently; accuracy of that display is not significant in these performance checks.

Table 5-2: Performance Verification

5.4.3 Measurement-Time Checkout

This procedure verifies that the 1693 measurement rate is functioning properly. All measurements are made with the default (power-up) values of test frequency and test voltage (1 kHz and 1 V). The procedure determines the time required per measurement for several operating conditions, without and then with the high-speed option board. Make a note of each calculated result for final comparisons to verify the speed.

Equipment Required:

- 1693 Digibridge without high-speed option. (To remove it, see paragraph 5.5.3.)
- 1689-9620 high-speed measurement option board (retrofit or just removed).
- Watch or clock with digital display of seconds or a sweep second hand
- A suitable DUT such as the 24.9-ohm Calibration Resistor (used in the examples, see below).

NOTE: The readings can be expected to vary $\pm 5\%$ from the examples given, mostly because the manual timing method is liable to such errors. The method is adequate for the purpose intended.

1. Switch the POWER ON. Perform the zeroing procedure (both open circuit and short circuit), as described in paragraph 5.4.2 of the recalibration procedure.
2. Insert the DUT (24.9 ohms $\pm 0.1\%$ for example) in the test fixture
 - A. Press: [FUNCTION] key to select ENTER function.
 - B. Press: [2] [4] [.] [9] [=] [SHIFT] [NOM. VALUE]
 - C. Press: [.] [2] [%] [=] [SHIFT] [BIN NO.] [0] [1]
 - D. Press: [MEASURE RATE] (if necessary) to select SLOW rate.
 - E. Press: [MEASURE MODE] to select CONTINUOUS mode.

3. With the watch or clock, time the interval between the next two keystrokes. The number of measurements made while the function is MEASURE will automatically be stored in "bin sum" for bin 01.
 - A. Press: [FUNCTION] key to select MEASURE function.
 - B. Wait 60 seconds.
 - C. Press: [FUNCTION] key to select ENTER function.
 - D. Press: [SHIFT] [BIN SUM] [0] [1].
4. Read the left-hand display, which is the number of measurements made in 60 seconds. ($\pm 5\%$ accuracy of timing is assumed.) Use this number as "x" in the following formula; retain these results. Note: the right-hand display should be 1, the bin number being reported.

Measurement time = $T = 60,000 \text{ milliseconds} / x$
 For example, if $x = 58$, then $T = 1034 \text{ ms} \pm 5\%$.

5. Clear all "bin sum" registers by pressing [=] [SHIFT] [BIN SUM] [0] [0] [1] [4]
Note: The Digibridge should confirm the clearing action by displaying in the left-hand display area.
6. Press: [MEASURE RATE] key to select MEDIUM rate. Repeat the procedure of steps 3, 4, 5 (as summarized below), for this rate
 - A. Time the interval between the next two keystrokes.
 - B. Press: [FUNCTION] key to select MEASURE function. Wait 60 seconds.
 - C. Press: [FUNCTION] key to select ENTER function.
 - D. Press: [SHIFT] [BIN SUM] [0] [1].
 - E. Read the left-hand display, the number of measurements made in 60 s.
 - F. Use this number as "x" in the following formula.

$T = 60,000 \text{ milliseconds} / x$
 For example, if $x = 250$, then $T = 240 \text{ DIS} \pm 5\%$.

- G. Clear "bin sum" registers by pressing [=] [SHIFT] [BIN SUM] [0] [0] [1] [4]

7. Press: [MEASURE RATE] key to select FAST rate. Repeat the procedure of steps 3, 4, 5 (as summarized below), for this rate
 - A. Time the interval between the next two keystrokes.
 - B. Press: [FUNCTION] key to select MEASURE function. Wait 60 seconds.
 - C. Press: [FUNCTION] key to select ENTER function.
 - D. Press: [SHIFT] [BIN SUM] [0] [1].
 - E. Read the left-hand display, the number of measurements made in 60 s.
 - F. Use this number as “x” in the following formula.

$$T = 60,000 \text{ milliseconds} / x$$

For example, if $x = 493$, then $T = 122 \text{ ms} \pm 5\%$.

- G. Clear “bin sum” registers by pressing [=] [SHIFT][BIN SUM][0][0][1][4]
8. Select “Max” measurement rate by pressing [.] [2] [5] [=] [SHIFT][SPECIAL][5]. Repeat the procedure of steps 3, 4, 5 (as summarized below), for “Max” rate.

Note: Indicated measure rate must be FAST. For explanation, see paragraph 3.5.5.

- A. Time the interval between the next two keystrokes.
 - B. Press: [FUNCTION] key to select MEASURE function. Wait 60 seconds.
 - C. Press: [FUNCTION] key to select ENTER function.
 - D. Press: [SHIFT] [BIN SUM] [0] [1].
 - E. Read the left-hand display, the number of measurements made in 60 s.
 - F. Use this number as “x” in the following formula.

$$T = 60,000 \text{ milliseconds} / x$$

For example, if $x = 771$, then $T = 78 \text{ ms} \pm 5\%$.

- G. Clear “bin sum” registers by pressing [=] [SHIFT][BIN SUM][0][0][1][4]

5.5 Disassembly and Access



WARNING



If disassembly or servicing is necessary, it should be performed only by qualified personnel familiar with the electrical shock hazards inherent to the high voltage circuits inside the cabinet.



CAUTION



Observe precautions against damage by static electricity whenever you handle a circuit board or integrated circuit in this instrument. Refer to the Safety section (Section 5.1). Use the following procedure for access to replaceable parts and contact points used in trouble analysis.

1. Disconnect the power cord. Optionally, remove the bail from the front feet by bending it temporarily. (It is springy enough to resume its former shape.)
2. For access to the bottom of the main board, without further disassembly, remove the access panel from the bottom of the instrument. Note: this panel is held by ten screws and covers a major part of the bottom area.
3. Remove the four rubber or plastic feet (one screw for each rear foot, two screws for each front foot). Notice that the front feet are not interchangeable.
4. Slide the instrument forward (or cover to the rear) until they are separated. (Reassembly note: slide the cover on until the rear feet mounting holes in the cover are aligned with corresponding holes in the chassis.)



Figure 5-1: Screws holding the interface assembly on the rear panel

5. If there is an interface option, remove it by removing the two large screws (see Figure 5-1) and sliding the interface assembly out. (If the panel held by these screws is blank, leave it in place.)

Reassembly note: align the board contacts with the internal connector, and push it firmly into position. Refer also to section 5.5.2.

6. For access to the desired areas on top of the main board, remove the power supply as follows:



Disconnect the power cord before proceeding so that dangerous voltages will not be present on wires and terminals that will be exposed in the following steps.

- A. Unplug the cable connecting the Power Supply to the Power Switch.
- B. Unplug the ribbon cable leading from Voltage Regulator Board to the Main Board (at J5).
- C. Remove four screws at the corners of the power supply.

NOTE: The obvious parts of this assembly are the plastic bezel (at the very front), the subpanel (to which the other parts are attached), the display board, the display window in front of the board, and the keyboard module Behind and below the display board is

the display connector board. Behind the keyboard is the keyboard mount (a wide bracket with clearance holes for cables).

- D. Remove the two screws from the bnc-connector bracket (or blank bracket, whichever is at the front).
- E. Remove the Retainer Bracket at the front panel.
- F. Disconnect the cables connecting the Display Board and Keyboard to the Main Board.



For reassembly, be sure that the Keyboard cables are both oriented with the white markings facing up at the Keyboard and facing left at the Main Board. On the two Display-Board cables the red edges must face left.

- G. Place a small spacer (such as a pad of paper) under the chassis at each side, but not under the front panel assembly.
- H. Remove four screws (2 at left, 2 at right) that pass through the sides of the chassis (just behind the rear edge of the bezel) into flanges of the subpanel. Pull the Front Panel Assembly forward and tilt it face down.

Notice that moving the bezel forward leaves the POWER ON/OFF push rod unsupported at the front. For reassembly, be sure to check that this push rod

is attached (via a short piece of rubber tubing) to the power switch. Guide the front end of this rod through its hole in the bezel while bringing the front panel assembly into position. (The bottom access panel should be out of the way during this procedure.)

Notice also that (if the BNC connector bracket is at the front) its shielded cables must be kept to the left of the display-panel connector board during reassembly (to avoid pinching the cables).

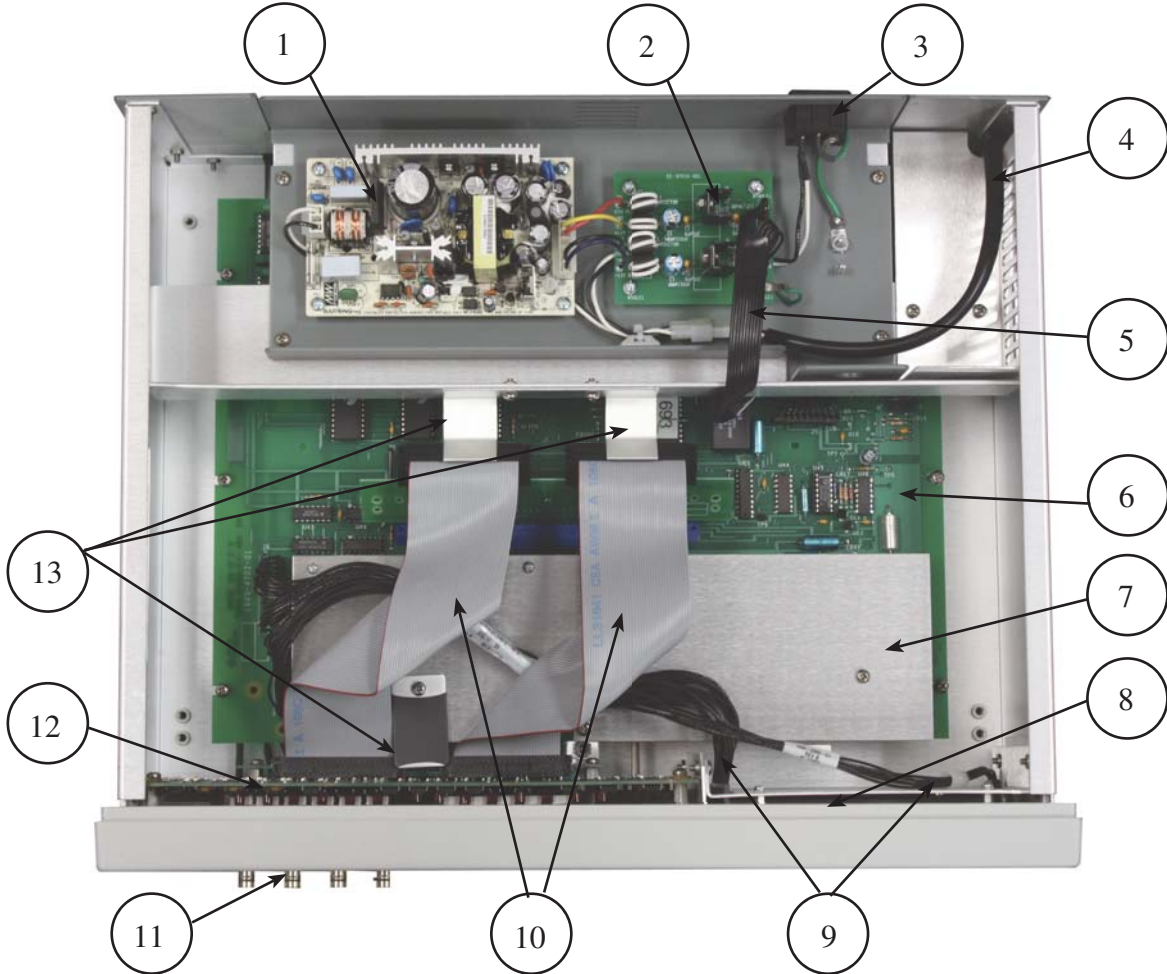

Figure 5-2: Interior top view of 1693 Digibridge

Item	Description
1	Power Supply
2	Regulator Board
3	ac power connector
4	Cable connecting Power Supply to Power Switch
5	Ribbon cable connecting Regulator Board to Main Board
6	Analog and Control board
7	Shield Plate
8	Keyboard assembly
9	Cables connecting Main Board to Keyboard
10	Ribbon cables connecting Main Board to Display Panel
11	bnc Bracket assembly
12	Display board assembly
13	Retainer brackets for cable connectors

7. To remove the keyboard module:
 - A. Remove the four screws (all with their heads to the right) that hold the keyboard assembly to the subpanel at the right and the keyboard bracket at the left. Remove this assembly.
 - B. To separate the keyboard, remove 4 screws that pass through the mounting plate.

Reassembly note: Be sure that all keys and switches of the keyboard are properly located in their holes in the subpanel before tightening the four screws in the subpanel and bracket. Also, plug the two cables into the keyboard before attaching the front-panel assembly to the chassis.

IMPORTANT: each of these cables plugs onto a row of pins, without any keying. Be sure that the cable is oriented correctly (with color marked edges up at the keyboard and toward the rear at the main board. Also be sure that each cable connector engages its full set of pins and does NOT miss the first or last one.

8. To remove the display board:
 - A. Remove the two screws that pass through the display board, into spacers on the subpanel (not the two screws that fasten the associated connector board).
 - B. Slide the display board upwards, to unplug it from the connectors below.
9. To remove the main board:
 - A. Disconnect the cables that connect this board with display, keyboard, and power supply. (See above.)
 - B. Remove the two screws from below that attach the bnc-connector bracket (at the front or rear panel).
 - C. Remove eight screws from above that fasten the main board to the chassis and the stiffener below this board. Note: One of these screws is accessed after first removing the air deflector (2 screws) near the right rear air vent.
 - D. Remove the main board, forward and upwards. If removal is obstructed by the front-panel assembly, that can be removed first. (See above.)

5.5.1 Relocation of bnc Connector Bracket

The bnc connectors that interface (via cables) with the DUT test fixture can be located at the lower part of either front or rear panel. The four bnc connectors remain mounted on their bracket and cabled to the main board during relocation from front to rear, or vice versa. To relocate this bracket from front to rear:

1. Loosen generously (but do NOT remove) the two right-side screws that fasten the front-panel assembly into the chassis. Stand the instrument on its right side. Remove the two left-side screws that are opposite to the ones just loosened. Now the front-panel assembly can be tipped away from the instrument an inch or two (as required in the next step).

Note: the display and keyboard cables remain connected.

2. Remove the blank bracket (2 screws) from the rear bnc-connector position.
3. Remove the two screws that fasten the bnc connector bracket to the main chassis, below the front panel.
4. Holding the front-panel assembly tipped away from the instrument slightly, snake the bnc connector bracket between the main board and the nearby part of the chassis, until free from its front position. Return the front-panel assembly to its normal position and secure it with its two screws. *If necessary, loosen but DO NOT REMOVE the screws holding the mother board.*
5. Snake the bnc connector bracket carefully into the rear position (where the blank bracket was).



Handle the shielded cable assembly with care and be sure that it is dressed neatly, with a minimum of twist or stress in its new position.

6. Fasten the bnc connector bracket in the rear position and the blank bracket in the front position.
7. Reassemble the instrument and verify normal operation. To relocate the bnc connector bracket to the front again, reverse this procedure.

5.5.2 Major internal components

The following figures show the major internal components of the 1693 Digibridges.

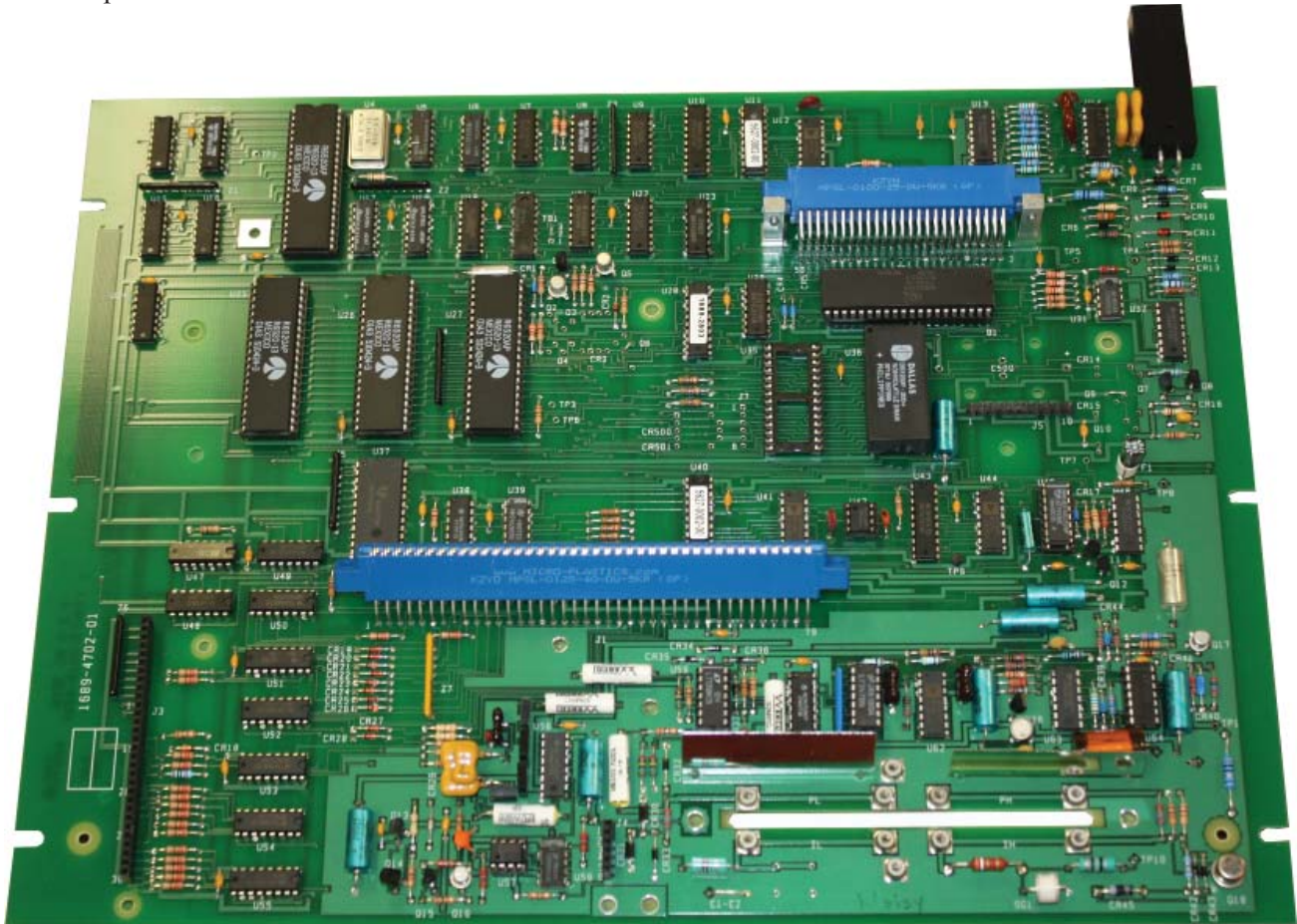

Figure 5-3: Analog and Control Board Assembly (1689-4702)

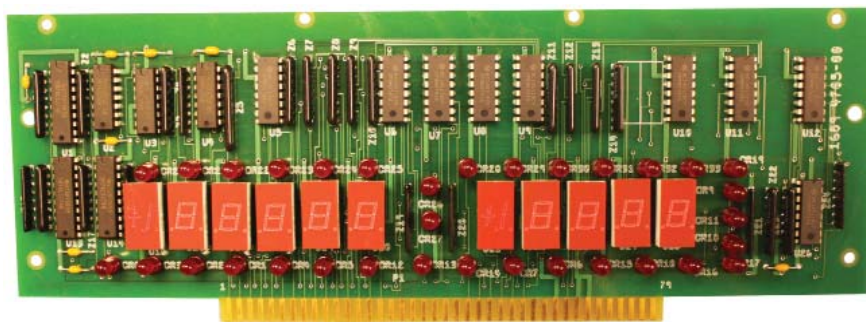

Figure 5-4: Display Board Assembly (1689-4705)



Figure 5-5: Keyboard Assembly (1687-4200)

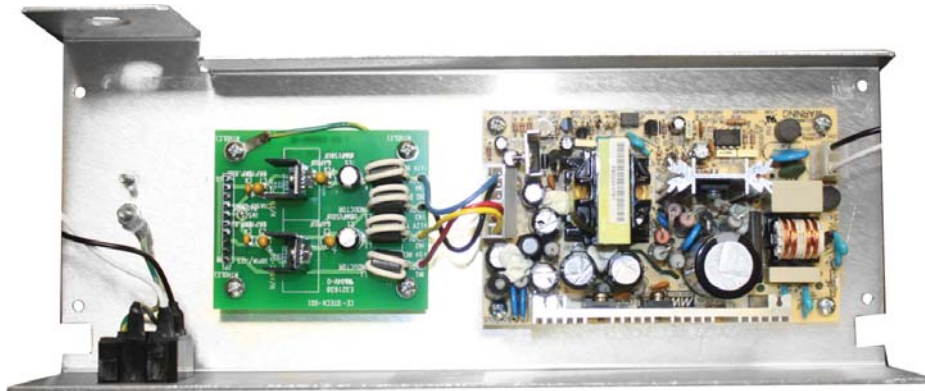

Figure 5-6: Power Supply Assembly (700011)

5.5.3 Interface Options

If the Digibridge has the IEEE interface option, it can be connected via either the RS232 interface or the IEEE 488.2 interface.



Figure 5-7: IEEE interface (1689-9640), front view



Figure 5-8: IEEE interface (1689-9640), top view

To remove the IEEE board:

1. Switch POWER OFF and disconnect power cord from Digibridge.
2. Place the instrument in the normal position (flat on table or in rack). Looking at the rear panel, remove the two screws that hold the interface from the Digibridge. See Figure 5-9 below.

Note: if the IEEE option is not installed, there will be a blank plate to cover the opening.



Figure 5-9: Screws holding the interface assembly on the rear panel

3. Remove the interface option (or the blank cover plate) horizontally, directly away from the front panel.



CAUTION

Observe precautions while handling the interface option. Because there are static sensitive parts on the board, DO NOT TOUCH THE CIRCUITS or ICs. Refer to Section 5 of this manual, for recommended handling procedure.

To install the interface option, proceed as follows:

1. Hold the interface option by its rear panel, so that the labels near the connectors read “right-side up.”
If you look through the opening in the rear, you will see an open connector. The contact edge of the interface board is going to have to slide in there.
2. Press the interface fully into the Digibridge by hand, confirming that alignment is correct.
3. Reinstall the screws.

5.5.4 Removal of Multiple-Pin Packages

Use caution when removing a plug-in integrated-circuit or other multiple-pin part, not to bend pins nor stress the circuit board. Withdraw the part straight away from the board. Unless an IC is known NOT to be a static sensitive type, place it immediately on a conductive pad (pins in the pad) or into a conductive envelope.

DO NOT attempt to remove a soldered-in IC package unless you have the proper equipment and skills to do so without damage.

5.6 Periodic Maintenance

5.6.1 Care of Test Fixtures

For best results and minimum maintenance effort, the operator must remove any obvious dirt from leads of DUTs before inserting them into any test fixture. Test fixture contacts will wipe through a thin film of wax, but they can become clogged and ineffectual if the operator is careless about cleanliness. The unit should be cleaned monthly with a soft brush and isopropyl alcohol. Avoid getting excess alcohol on painted surfaces to avoid possible damage. The test fixture and its axial adaptors should be cleaned once a year as follows:

1. Use compressed air to blow away any dust on the surface as well as inside the fixture.
2. Clean the contact surfaces and blades of the axial-lead adaptors with isopropyl alcohol. Rub with a cotton swab (Q-tip). Remove any remaining alcohol with compressed air, and remove any remaining cotton fibers with tweezers.

5.6.2 Care of the Display Panel

Use caution when cleaning the display window, not to scratch it or to get cleaning substances into the instrument. Use a soft cloth, a lint-free wiper, or absorbent cotton moistened with a mild glass cleaner, such as plain Windex. **DO NOT** use paper towels.

If it becomes necessary to place marks on the window, use paper-based masking tape (NOT any kind of marking pen, which could be abrasive or react chemically with the plastic). To minimize retention of any gummy residue, remove the tape within a few weeks.

5.7 Trouble Analysis

5.7.1 Overview



Only well-qualified personnel should attempt trouble analysis. Be sure power is OFF during disassembly and setting up for tests. Carefully observe the HANDLING PRECAUTIONS given at the beginning of Section 5.

Resources: Refer to Section 4 for a good understanding of the theory of operation. Section 4 provides block diagrams and discussion for the necessary background, which can generally save time in trouble analysis.

Abnormal digital signal levels. Most digital signal levels in this instrument are normally near zero (logic low), about +3.5 to + 5 V (logic high), or rapidly switching between these states. Failure of a digital source often produces a dc voltage of about +2 V on a signal line. Use high-impedance probes in measuring. Use a scope as well as a voltmeter, because an average of 2 V may be normal for a digital signal that has a duty cycle near 50%.

Duplicated circuit and resistor networks. Some circuits, as in the display board for example, are duplicated several times. The ICs can usually be exchanged between a faulty circuit and a functional one, to identify a “bad” IC. Notice, also, that the resistor networks DB-Z2..DB-Z10 are simply compact packages of 220 ohm resistors. If one resistor is open, it is not necessary to replace the entire package. Use a 5% resistor.

Circuit board replacement. Refer to paragraph 5.3 for recommended procedures to obtain replacements.

Power-Up Self Check. Upon power-up, the Digibridge performs a self-check sequence as explained in paragraph 3.13. If a self-check failure occurs, the instrument display will indicate the nature of the failure. For more detail, refer to paragraph 5.7.2 below.

Telltale symptoms. Scan the following group of symptoms for a preliminary analysis of trouble and suggestions for more detailed procedures if applicable.

Display. A perpetually blank digit or decimal point may be caused by a fault in the directly associated circuit on the display board. (Refer to comments above.)

D Error. A large D error may be caused by faulty “protection” diodes in the analog front end. Check MECR30, CR31, CR32, CR33 on 1689-4702 Analog & Control board.

Reactance Error. If C or L measurements are not accurate, the test signal source may be at fault. In checking it, verify that the frequency is within $\pm 0.01\%$ of the specified nominal frequency. Refer to paragraph 3.4.1.

Keyboard Malfunction. If the instrument passes its power-up self-check and proceeds to measure DUT has no (or only a few) keyboard indicators lit, and the keys on the keyboard don’t function normally: the fault is probably in the 30-wire cable connection between keyboard and main board. If the keyboard has been disconnected, check for misalignment of the connector that plugs directly into the keyboard. If only one key or indicator malfunctions, check that portion of the keyboard assembly (1687-4200).

Test Signal. To check performance of the test-signal source, use a scope to look at the open-circuit signal at the IH terminal of the test fixture (right front contact - be sure there is no DUT) . The signal on each range should be an undistorted sine wave at the selected frequency, with the top of the waveform about +3.4 V and the trough about + 0.85 V. Range should be locked to Range 4 if checking signal level accuracy.

5.7.2 Power-Up Self check and Certain Aborted Measurements

The following outline of failure displays includes comments on some of the self check routines, significance of the displays, and some suggestions for appropriate service procedures.

For the most rigorous self check, in servicing, repeat the power-up self check several times, at least once with a abort circuit as "DUT" in the test fixture and once with the test fixture empty (open circuit). A normally functional Digibridge should pass both ways.

Keen observation of the fleeting displays associated with the tests that pass, before the one that fails, are sometimes useful. Pressing any key, such as [SHIFT] will halt the self-test routine and bold the display until the key is released. Look for trends or tests that pass only marginally.

SELF-CHECK (FAILURE) DISPLAYS

88888 8888. RAM read/write exercise failure; Digibridge hangs up. PROCEDURE: Switch POWER OFF and ON to clear hang up and repeat self check. Check RAM circuitry and data and address buses on 1689-4702 Analog & Control board.

77777 XXXX. Detector test failure ; Digibridge hangs up. PROCEDURE: Switch POWER OFF and ON to clear hang up and repeat self check. Be sure that the EXTERNAL BIAS switch is OFF. 1689-4702 Analog & Control board requires service by trained personnel.

77777 7777. DBIG (U27 pin 2) is stuck low. Integration failure. 1689-4702 Analog & Control board requires service by trained personnel.

77777 6666. DMSR (U27 pin 8) is stuck high . Integration failure 1689-4702 Analog & Control board requires service by trained personnel.

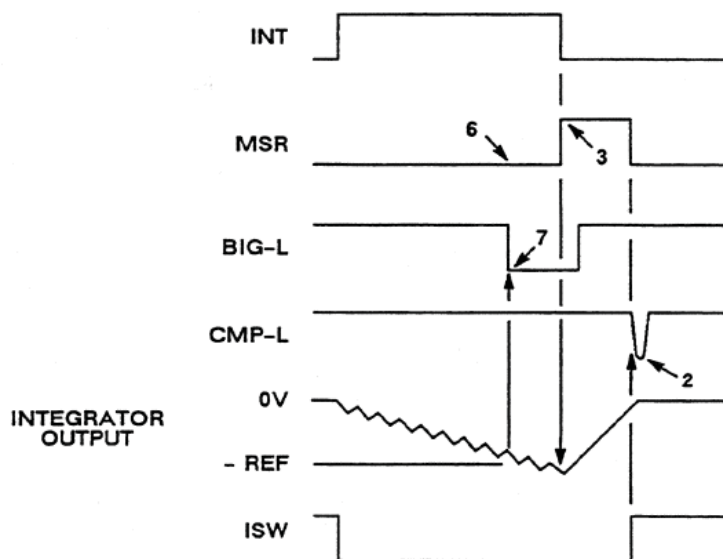

Figure 5-10: Timing diagram of the power-up self check.

77777 5555. FCOUNT is not toggling (U27 pins 9, 40). 1689-4702 Analog & Control board requires service by trained personnel.

77777 3333. DMSR (U27 pin 8) is stuck low. Integration failure. 1689-4702 Analog & Control board requires service by trained personnel.

77777 2222. CMP-L (U64 pin 8) is stuck high . Deintegration failure. 1689-4702 Analog & Control board requires service by trained personnel.

77777 1111. DBIG (U27 pin 2) is stuck high. Deintegration failure. 1689-4702 Analog & Control board requires service by trained personnel.

66666 XXXX. Stuck key or detector scale factor and zero bias test failure; the Digibridge will loop, automatically repeating the test and updating the display. XXXXX is the magnitude of “zero” measurement, normalized to 1.

COMMENT: The “zero” measurement includes a sequence of five dual-slope conversions (measurements of voltage coming into the detector from the instrumentation amplifier) . Frequency is 1 kHz; test signal level is 75 mV. The signal component is removed by averaging the results of two dual-slope conversions, sampled in opposite phases. The detector is supposed to be biased so that its “zero” output is essentially in the center of its operating range. For convenience, the CPU divides the “zero” measurement by its normal value and displays the result. Consequently, the ideal value for XXXXX is 1.000. If it is less than 0.875 or more than 1.125, the test fails.

Verify that all keys on the keypad are working. If no fault in the keypad is found, 1689-4702 Analog & Control board requires service by trained personnel.

ANALYSIS PROCEDURE: Check the following circuits:

555 D XXXX. Signal strength check failure; the Digibridge will loop, automatically repeating the test and updating the display. The digit D indicates the range and voltage level used. (See below.) Test frequency is 1 kHz.

COMMENT: Possible cause is having EXTERNAL BIAS switch ON during power-up. The effect depends on what is connected to the EXTERNAL BIAS connector and what is in the test fixture. This switch must be OFF to assure normal power-up routines. Check to make sure that the charged capacitor protective fuse F1 has not blown, the effect is similar (see section 5.7.3). Remove all DUT from Digibridge during power up. The ideal value for XXXX is about 0.64. If it is less than 0.250 or more than 1.000, this test fails

ANALYSIS PROCEDURE: See below; depends on the failure display, which is coded to indicate test voltage (high or low) and range of the failed test.

5555 5 0000. (Confirming symptoms: If you press START repeatedly until the instrument completes its self check, the BIAS ON indicator will be lit even though the EXTERNAL BIAS switch is OFF, no bias is applied, and INT BIAS has not been selected.) The fault is probably in the 6-wire connection between keyboard and main board. Check to be sure that the cable connector properly engages all 6 pins at the keyboard.

555 5 XXXX. Low voltage (75 mVrms), range 4. 1689-4702 Analog & Control board requires service by trained personnel.

5554 XXXX. High voltage (1.275 V), range 4.

555 3 XXXX. High voltage (1.275 V), range 3.

555 2 XXXX. High voltage (1.275 V), range 2.

555 1 XXXX. High voltage (1.275 V), range 1.

444 E XXXX Test frequency and waveform check failure; the Digibridge will loop, automatically repeating the test and updating the display. The digit E indicates the frequency used in the test. (See below.) High voltage test signal is used, on range 4.

COMMENT: Measurement, summing of squares, and normalization are exactly as described for 555 D XXXX. Also the failure limits for XXXX are the same (0.250 and 1.00), except for tests 1 and 2, which have the limits: 0.125 and 1.000.

ANALYSIS PROCEDURE: Check for the generation of the proper frequency (indicated in code by failure display, see below).

- 444 6 XXXX .0118 kHz.
- 444 5 XXXX .0968 kHz.
- 444 4: XXXX. 0.480 kHz.
- 444 3 XXXX. 1.200 kHz.
- 444 2 XXXX. 6.000 kHz.
- 444 1 XXXX 6.0606 kHz.

1689-4702 Analog & Control board requires service by trained personnel.

33333 XXXX. PROM data checksum failure. If the checksum XXXX is not 0000, check all digital circuitry, starting with the 6502 microprocessor U30. Any error on the address or data bus could cause a checksum error check ROM U35; check RAM U36; check all of the PLAs U3, U25, U26, U27. Make sure all socketed chips are seated, otherwise contact trained personnel to service the Analog & Control board (1689-4702).

222 F XXXX. Calibration constants check failure; Digibridge hangs up, but will respond to keyboard inputs. The digit F is the range in question.

COMMENT: Each check consists of a comparison between the stored calibration data for the range and the normal, expected values. The calibration can be expressed (essentially) as the conductance of the internal standard resistor. The Digibridge normalizes this conductance by dividing it by the nominal conductance of the standard, and displays the result,

XXXX, which should be very close to 1.000. (See Table 3-7 on page 43.) If XXXX is less than 0.2187 or more than 1.781, this test fails.

ANALYSIS PROCEDURE: depends upon display; see below.

NOTE: This is a non-catastrophic failure. If you press the [C/D] key, the Digibridge will proceed with the self-check routine. The instrument can be operated as usual, but results may be erroneous. To restore accuracy, recalibrate, as described in paragraph 5.9.

222 4 XXXX. Range 4 may be incorrectly calibrated. Refer to paragraph 5.9 for recalibration procedure. If calibration is accomplished correctly, but this failure display appears when POWER is cycled OFF and ON, the calibration data is stored in the "Dallas Chip" (U36) which should be replaced.

2223 XXXX. Range 3. Be sure that recalibration has been done correctly.

222 2 XXXX. Range 2. Same comment as for range 3.

222 1 XXXX. Range 1. Same comment as for range 3.

222 0 XXXX. Frequency correction factor. ANALYSIS PROCEDURE: Refer to 444 E XXXX.

11111 1111. Math chip operational check failure. COMMENT: This test is performed only if you have the high-speed interface option 1689-9620 installed.

NOTE: This is a non-catastrophic failure. If you press the [C/D] key, the Digibridge can be operated as usual, but measurement time will be typical of an instrument WITHOUT the high-speed option.

5.7.3 Internal Fuse Replacement



Take appropriate safety precautions when servicing the unit.

If at power-up, there is a failure display of 555 5:XXXX (see Self Check paragraph 3.13.1 and Trouble Analysis paragraph 3.7.1) replacement of the capacitor discharge fuse may be necessary.

1. Remove the top and bottom covers.
2. This fuse is located in a socket on the main board and behind the power switch. Unplug the fuse (using needle nose pliers) and replace.
3. Install top and bottom covers.

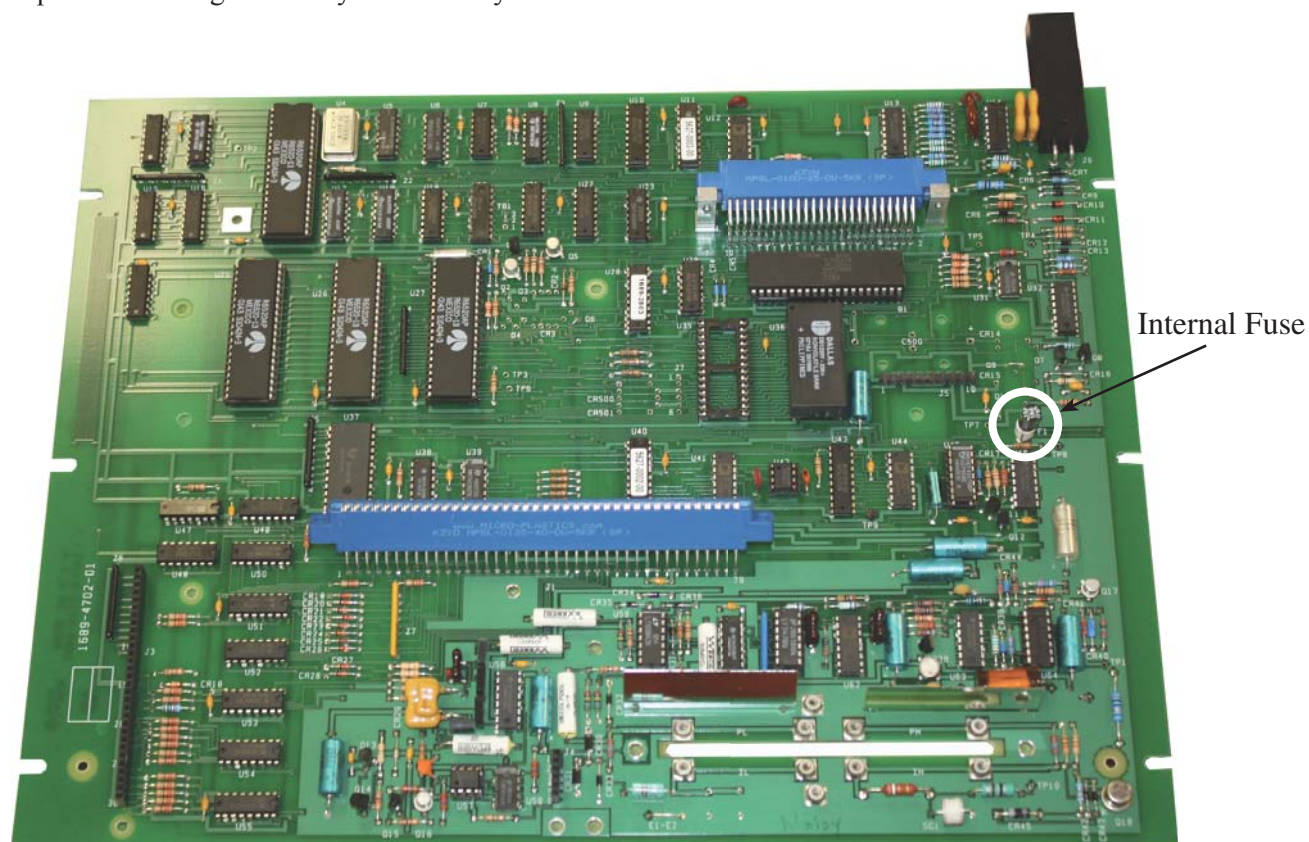

Figure 5-11: Location of internal fuse

5.7.4 Power Supply and Regulator Board

To verify that the power supply (700011-4) is working properly, confirm the following voltage outputs (See Figure 5-12).

- Red to black wire = +5 V (± 0.2 V)
- Yellow to black wire = +12 V (± 0.8 V)
- Blue to black wire = -12 V (± 0.6 V)

To verify that the regulator board (750023) is working properly, confirm the following voltage outputs (See Figure 5-12).

+5 V values (± 0.2 V)

- Pin 1 to Pin 2
- Pin 3 to Pin 5
- Pin 8 to Pin 6
- Pin 10 to Pin 9

-8 V values (± 0.4 V)

- Pin 4 to Pin 5
- Pin 7 to Pin 6

⚠ CAUTION ⚠
To prevent damage to the unit, avoid short-circuiting the pins.

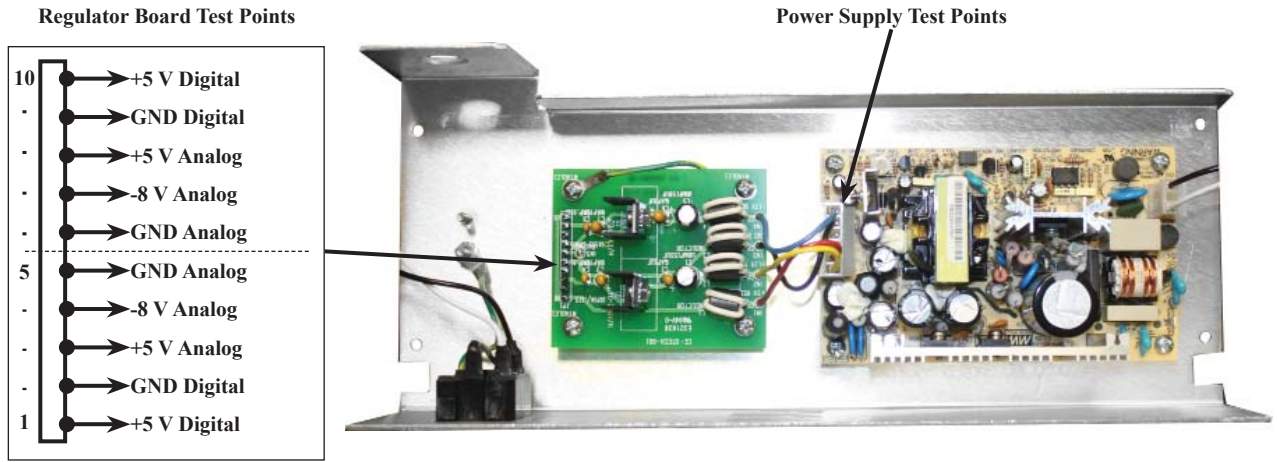

Figure 5-12: Power Supply and Regulator Board Test Points

For replacement Power Supply Assembly, contact IET Labs.

5.7.5 Sinewave Generator Checks

Check the MB-board circuits that supply the test signals to the OUT, as follows.

1. Perform the zeroing procedure (both open circuit and short circuit), as described in paragraph 5.9.2 of the recalibration procedure.
2. Make the following test setup and keyboard selections.

[FUNCTION] - MEASURE
 [DISPLAY] - VALUE
 [MEASURE RATE] - SLOW
 [MEASURE MODE] - CONT.
 [EQUIVALENT CIRCUIT] – SERIES

3. Install a 10 kilohm resistor as the DUT.
4. Use an oscilloscope to verify that the signal at the right-hand end of the DUT in the test fixture is a sine wave, as follows . (For scope ground return, connect to the ground plane on the circuit board or via a 6-32 screw to the tapped hole in the left-hand end of the test fixture.)

Frequency: 1 kHz,
 Amplitude: approx 1.5 Vpk-pk,

5.7.6 Front End Amplifiers and Switches

If a discrepancy is found, check similarly at the R-Std signal check point - as described in Table 5-4. The signal should be the same as listed in step 4 above for U59 pin 14, for the particular DUT and range.

RNG1	Control Signals		Range	Nom Source Resistance	Signal Source Check Point
	RNG0	LSRC			
0	0	0	4	25 ohm	U32 pin 12
0	1	1	3	400 ohm	U32 pin 14
1	0	1	2	6.4 kohm	U32 pin 15
1	1	1	1	97.4 kohm	U32 pin 11

Table 5-3: Source range switching checks

RNG1	Control Signals		Range	Nominal Standard Resistance	R-Std Signal Check Point
	RNG0	LSTD			
0	0	0	4	25 ohm	U56 pin 12
0	1	1	3	400 ohm	U56 pin 14
1	0	1	2	5.97 kohm	U56 pin 15
1	1	1	1	97.4 kohm	U56 pin 11

Table 5-4: Detector (standard) resistor range switching checks

5.8 Accuracy Verification

5.8.1 General

This procedure is a more rigorous alternative to the performance verification described above. Precision standards of impedance are required for this procedure, which checks the accuracy as well as the overall performance of the instrument. It will be controlled from the front panel, without disassembly. Table 5-5 lists the recommended standards and associated equipment. For the C accuracy checks, the standard is a precision decade capacitor.

Calibration of Standard. The acceptable RLC readout (min to max range) may have to be modified if the actual (calibrated) value of your standard or its accuracy (either or both) is different from the tabulated value(s).

Test Fixture. This procedure requires that a remote test fixture (1689-9600) be connected to the 1693.

For example, if your 10-pF standard is known to be 10.18 ± 0.25 pF, then compute the new tolerance as follows: Digibridge accuracy ± 0.02 percent. The limits are, therefore, 9.92 to 10.44 pF.

Verify that the instrument meets performance specifications as follows.

Name	Requirements	Recommended
Capacitor	Decade, 3-terminal, 1pF to 1 μ F, Accuracy: $\pm 0.05\%$ ± 0.5 pF	IET 1413
Capacitor	Decade, 50pF to 1.111115 μ F Accuracy: $\pm 0.5\%$	IET 1412
Capacitor	Four-terminal, ratio type, 10 μ F to 100 μ F, accuracy: $\pm 0.25\%$	IET 1417
Capacitor	DC, 500 μ F, 10 V blocking	any
Capacitor	Three-terminal, 1 μ F, accuracy: $\pm 0.02\%$, uncertainty within $\pm 0.03\%$ including effects of aging since last calibration	IET 1409-Y
Resistor	Decade, 3-terminal, 10 ohm to 1 Mohm, accuracy: $\pm 0.01\%$	HARS-X-7-1
Inductors	Fixed, 2-terminal 1 mH, $\pm 0.1\%$ 100 mH, $\pm 0.1\%$ 1 H, $\pm 0.1\%$ 10 H, $\pm 0.1\%$	1482-E 1482-L 1482-P 1482-T

Table 5-5: Equipment for accuracy verification

5.8.2 Capacitance Measurement Accuracy (Ranges 1-3)



Be sure the line voltage switch, rear panel, is correctly set for your power line voltage.

Make the test setup and verify instrument performance as follows:

1. After the line voltage switch has been set to correspond to the input line voltage, connect the power cord and switch POWER ON.
2. Connect the 1689-9602 extender cable with GR874 connectors as shown in section 3.2.13 on page 29.
3. Connect the “high” leads (red and red white) to one of the 874 Tee connectors. Connect the “low” leads (black and black/white) to the other 874 tee.
4. Before measurement, zero the Digibridge as follows:

In this process, the Digibridge automatically measures stray parameters and retains the data, which it uses to correct measurements so that results represent parameters of the DUT alone, without (for example) test-fixture or adaptor capacitance.

- A. Be sure that MEASURE RATE is SLOW and that the RANGE HELD indicator is NOT lit. DO NOT have test voltage programmed to other than 1 V, nor frequency to other than 1 kHz.
- B. Leave the two type 874 tees connected to the 1689-9602 extender cable, but not connected to each other.
- C. Press [FUNCTION] key (if necessary) to select MEASURE function.
- D. Press [MEASURE MODE] key (if necessary) to select TRIGGERED mode.
- E. Press these keys deliberately: [1] [6] [9] [3] [=] [SHIFT] [OPEN].
- F. Confirm that the GO indicator is lit. Press the START button.
- G. Keep hands and objects at least 10 cm (4 in.) from test fixture.
- H. Wait for the GO indicator to be lit
- I. Connect the two type 874 tees together.

- J. Press these keys deliberately: [1] [6] [9] [3] [=] [SHIFT] [SHORT].
- K. Confirm that the GO indicator is lit. Press the START button.
- L. Wait for the GO indicator to be lit again, on the keyboard (not on any remote test fixture).
- M. Disconnect the two type 874 tees from each other.

5. Connect the type 874 tee with the red cables to the **HIGH** terminal of the HACS-Z capacitance substituter. Connect the other tee (black cables) to the **LOW** terminal of this capacitor.
6. Set the decade capacitor dials to 00000 pF.
 - A. Press the C/D key.
 - B. Press these keys deliberately: [1] [6] [9] [3] [=] [SHIFT] [OPEN].
 - C. Confirm that the GO indicator is lit. Press the START button.
 - D. Wait for the GO light. The RLC display should be .00000 pF.
 - E. Press [MEASURE MODE] key to select CONT.
 - F. Press [EQUIVALENT CIRCUIT] key to select SERIES.
7. Set the decade capacitor to 10 pF . If necessary, press the START button. Verify that the C and D measurements subsequently displayed on the Digibridge are within the limits given in the first line of Table 5-6.
8. Similarly, for each line in the table, set the capacitor and the Digibridge measurement rate, and verify that the resulting measurements are satisfactory.
9. Disconnect the 1689-9600, BNC-T GR874 connectors extender cable from the capacitor and the Digibridge

NOTE: Whenever doing short-circuit or open-circuit zeroing, remember that the GO light to watch is the one on the keyboard (not on any remote test fixture, for example).

For more information on connecting to a HACS-Z capacitance substituter see section 3.2.10.

HACS-Z		1693 Digibridge					
Setting	Accuracy	Range	Measure Rate	Accuracy	Lower Limit*	Upper Limit*	QDR Max**
10 pF	5.05%	1	SLOW	0.22%	9.4730	10.527	6100 ppm
100 pF	0.55%		SLOW	0.04%	99.410	100.59	2500 ppm
1500 pF	0.083%		SLOW	0.021%	1498.4	1501.6	700 ppm
1500 pF	0.083%		MED	0.053%	1497.9	1502.1	1000 ppm
1500 pF	0.083%		FAST	0.128%	1496.8	1503.2	1700 ppm
6400 pF	0.058%		SLOW	0.020%	6395.0	6405.0	500 ppm
10 nF	0.055%	2	SLOW	0.020%	9.9925	10.008	500 ppm
25 nF	0.052%		SLOW	0.020%	24.982	25.018	500 ppm
25 nF	0.052%		MED	0.050%	24.974	25.026	800 ppm
25 nF	0.052%		FAST	0.120%	24.957	25.043	1500 ppm
100 nF	0.051%		SLOW	0.020%	99.929	100.07	500 ppm
200 nF	0.05%	3	SLOW	0.020%	199.86	200.14	600 ppm
400 nF	0.05%		SLOW	0.020%	399.72	400.28	600 ppm
400 nF	0.05%		MED	0.050%	399.60	400.40	900 ppm
400 nF	0.05%		FAST	0.120%	399.32	400.68	1600 ppm
1000 pF	0.05%		SLOW	0.020%	999.30	1000.7	600 ppm

* These ranges of acceptable displays are based on specified accuracy of decade capacitor that has recently been calibrated. If the capacitor values are known to higher accuracy by special calibration of lesser accuracy because of long-term drift, the acceptable upper and lower limits must be revised accordingly.

** Based on the stated dissipation values of the HACS-Z capacitors, If the dissipation values are known more accurately, the acceptable QDR display criteria can be reduced accordingly.

Alternative capacitance standards are available for checking the Digibridge. Models available from IET include:

1413 Precision Decade Capacitor
SCA Series

Table 5-6: Capacitance accuracy checks (Ranges 1-3)

5.8.3 Capacitance Measurement Accuracy

This procedure follows after paragraph 5.8.2. (Leave the test frequency at 1 kHz, the test voltage at 1 V, the measure rate SLOW, the selected parameter Cs/D, and the RANGE HELD indicator NOT lit.)

- Connect the 1657-9600 extender cable (with banana plugs) to the Digibridge test fixture. Hand-tighten the screws, to provide the ground (guard) connection.
- Connect the “high” leads (red and red/white) together. Separately connect the “low” leads (black and black white) together.
- Before measurement, zero the Digibridge as follows:
 - Leave the high (red) banana plug stack disconnected from the low (black) stack
 - Press [FUNCTION] key (if necessary) to select MEASURE.
 - Press [MEASURE MODE] key (if necessary) to select TRIGGERED mode.
 - Press the following keys: [1] [6] [9] [3] [=] [SHIFT] [OPEN].
 - Confirm that the GO indicator is lit.
 - Keep hands and objects at least 10 cm (4 in.) from test fixture,
 - Press the START button.
 - Wait for the GO indicator to be lit. The RLC display should be .000000 pF.
 - Connect the two banana plug stacks together; leave the guard (black/green) open.
 - Press the following keys: [1] [6] [9] [3] [=] [SHIFT] [SHORT].

- K. Confirm that the GO indicator is lit.
 L. Press the START button.
 M. Wait for the GO indicator to be lit. The RLC display should be .00000 ohms .
 N. Press the [MEASURE MODE] key to select CONT.
4. Connect the three-terminal 1- μ F capacitance standard (GR 1409-Y) as follows.
This standard should be certified to an accuracy of $\pm .03\%$ including the effects of aging .
- | | |
|---------------|--|
| RED | IH : capacitor H binding post with end of blocking |
| RED & WHITE | PH: stacked on the red banana plug |
| BLACK | IL: capacitor L binding post |
| BLACK & WHITE | PL: stacked on the black banana plug |
| BLACK & GREEN | G: capacitor G, NOT linked to L |
5. Verify that the RLC display agrees with the certified value of the standard (corrected for temperature if appropriate) within $\pm .0005 \mu\text{F}$ which is the sum of .03% for the standard and 0.02% for the Digibridge.
 6. Calculate the difference D1, as shown above, and retain it for future use $D1 = (\text{displayed measurement}) - (\text{value of standard}) \mu\text{F}$
 7. Remove the 1- μ F standard and connect the 4-terminal ratio-type capacitance standard (GR 1417) and the blocking capacitor (500 μF) as shown above. Be sure that the dc blocking capacitor is fully discharged before connecting it. Notice that only the left-hand terminals of the standard are used.
 8. Set the dials on the capacitance standard thus:
 - CAPACITANCE: 1 μF
 - TEST FREQUENCY: 1 kHz
9. Read the RLC display, which should be close to the nominal value of the standard: 1 μF .
 10. Calculate the difference D2, as follows, and retain it for future use:
 $D2 = (1.0000 \mu\text{F}) - (\text{displayed measurement}) \mu\text{F}$
NOTE: The DQ display should show D = .0085 to .0115.
 11. Calculate the calibration factor K as follows.
 $K = D1 + D2 (\mu\text{F})$
- Example: Suppose that in step 5, the display is 1.0013, and the value of the standard is 1.0006. Then $D1 = +.0001 \mu\text{F}$. In step 9, the nominal is 1.0000. Suppose that the display is 1.0024; then $D2 = -.0024 \mu\text{F}$. The correction K would therefore be $+ .0007 -.0024 = -.0017 (\mu\text{F})$.
12. Reset the capacitance-standard dial to CAPACITANCE 10 μF .
 13. Read the RLC display and correct it by adding 10k. (For example, if the display is 10.023 μF and if $K = -.0017$, the corrected measurement is 10.006 μF .) Verify that the corrected measurement is within the acceptable extremes for the 10- μF setting in Table 5-7.
 14. Reset the capacitance-standard dial to CAPACITANCE = 100 μF . Read the RLC display and correct it by adding 1k. As in step 13, verify that the corrected measurement is within the acceptable extremes shown in Table 5-7.

For more information on connecting to a 1417 Capacitance Standard see section 3.2.14.

Capacitor Setting	Digibridge Accuracy	St'd C Accuracy	RLC Display (Uncorrected)		RLC Display Correction (See text)	Acceptable D	
			Min	Max		Min	Max
1 μF	--	--	(Used to determine K)		+10K	.0085	.0115
10 μF	.022%	.07%	9.991	10.009	+10K	.0085	.0115
100 μF	.040%	.07%	99.89	100.11	+100K	.0085	.0115

Table 5-7: Capacitance accuracy checks (Range 4)

5.8.4 Resistance Measurement Accuracy

This procedure follows after paragraph 5.8.3. (Thus, test frequency = 1 kHz, test voltage = 1 V, measure rate = SLOW, range held indicator is NOT lit, and parameter Cs/D is specified.)

1. With the Digibridge still connected to the 1657-9600 extender cable, zero the Digibridge as follows:
 - A. Leave the high (red) banana plug stack disconnected from the low (black) stack
 - B. Press [FUNCTION] key (if necessary) to select MEASURE.
 - C. Press [MEASURE MODE] key (if necessary) to select TRIGGERED mode.
 - D. Press the [Rs/Q] key.
 - E. Press the following keys: [1] [6] [9] [3] [=] [SHIFT] [OPEN].
 - F. Confirm that the GO indicator is lit.
 - G. Keep hands and objects at least 10 cm (4 in.) from test fixture,
 - H. Press the START button.
 - I. Wait for the GO indicator to be lit.
 - J. Connect the banana plugs to the 1433-33 Decade Resistor as follows:
 - “High” leads (red and red/white) to the **H** binding post
 - “Low” leads (black and black/white) to the **L** binding post
 - Guard lead (black/green) to the **G** binding post.
 - White bands should always be close to 1433 terminals.
 - K. Disconnect any link between the **G** and **L** binding posts.
 - L. Set the decade resistor dials to 00000 ohms.
 - M. Press the following keys: [1] [6] [9] [3] [=] [SHIFT] [SHORT].
 - N. Confirm that the GO indicator is lit. Press the START button.
 - O. Wait for the GO indicator to be lit again. The RLC display should be .00000 ohms.
 - P. Press [MEASURE MODE] key to select CONT.
2. Refer to Table 5-8. Set the decade resistor dials to 0000010, as indicated in the first line of the table and verify that the RLC display is between the extremes listed. Repeat for each line of the table, setting the decade resistor dials, Digibridge equivalent circuit, and measurement rate, and verifying the results, as tabulated.

For more information on connecting to a 1433 Series Decade Resistor see section 3.2.15.

Standard Resistor Setting	Equivalent Circuit	Measure Rate	Typical Standard Accuracy*	Digibridge Accuracy	RLC Display Acceptable Extremes*
10.00 ohms	Series	SLOW	.03%	.022%	9.995 to 10.005
25.00 ohms	Series	SLOW	.018%	.021%	24.990 to 25.010
25.00 ohms	Series	MED	.018%	.052%	24.983 to 25.018
25.00 ohms	Series	FAST	.018%	.125%	24.964 to 25.036
90.00 ohms	Series	SLOW	.012%	.020%	89.971 to 90.029
200.0 ohms	Series	SLOW	.011%	.020%	199.94 to 200.06
400.0 ohms	Series	SLOW	.01%	.020%	399.88 to 400.12
400.0 ohms	Series	MED	.01%	.050%	399.76 to 400.24
400.0 ohms	Series	FAST	.01%	.120%	399.48 to 400.52
1500 ohms	Parallel	SLOW	.01%	.020%	1499.5 to 1500.5
2000 ohms	Parallel	SLOW	.01%	.020%	1999.4 to 2000.6
6400 ohms	Parallel	SLOW	.01%	.020%	6398.1 to 6401.9
6400 ohms	Parallel	MED	.01%	.050%	6396.2 to 6403.8
6400 ohms	Parallel	FAST	.01%	.120%	6391.6 to 6408.4
24 kilohms	Parallel	SLOW	.01%	.020%	23.993 to 24.007
30 kilohms	Parallel	SLOW	.01%	.020%	29.991 to 30.009
100 kilohms	Parallel	SLOW	.01%	.021%	99.97 to 100.03
100 kilohms	Parallel	MED	.01%	.053%	99.94 to 100.06
100 kilohms	Parallel	FAST	.01%	.126%	99.86 to 100.14

* If the calibrated value of the resistance standard is slightly different from the nominal value, or if the standard's accuracy is different from the typical accuracy, correct the "acceptable extremes" accordingly.

Table 5-8: Resistance accuracy checks at 1 kHz

5.8.5 Inductance Measurement Accuracy

This procedure follows after paragraph 5.8.4. (Thus, test frequency = 1 kHz, test voltage = 1 V, measure rate = SLOW, range held indicator is NOT lit, and parameter Rs/Q is specified.)

1. Connect the 1657-9600 extender cable to the Digibridge test fixture. Hand tighten the screws, to provide ground (guard) connection.
2. Connect the "high" leads (red and red/white) together and separately connect the "low" leads (black and black/white) together.
3. Before measurement, zero the Digibridge as follows:
 - A. Keep the "high" banana-plug stack separated from the "low" stack.
 - B. Press [FUNCTION] key (if necessary) to select MEASURE function.
 - C. Press [MEASURE MODE] key (if necessary) to select TRIGGERED mode.
 - D. Press the following keys: [1] [6] [9] [3] [=] [SHIFT] [OPEN].
 - E. Confirm that the GO indicator is lit.
 - F. Keep hands and objects at least 10 cm (4 in.) from test fixture.
 - G. Press the START button.
 - H. Wait for the GO indicator to be lit again. The RLC display should be .00000pF.
 - I. Connect the 2 banana plug stacks together, leave the guard (black /green) open.
 - J. Press the following keys: [1] [6] [9] [3] [=] [SHIFT] [SHORT].

- K. Confirm that the GO indicator is lit.
 - L. Press the START button.
 - M. Wait for the GO indicator to be lit again. The RLC display should be .00000 ohms.
 - N. Press the [MEASURE MODE] key to select CONT.
4. Connect the banana plugs of the 1687-9600 extender cable to the 1-mH inductance standard (1482-E) as follows:
 - “High” leads (red and red/white) to the **LOW** binding post
 - “Low” leads (black and black/white) to the **HIGH** binding post
 - Guard lead (black/green) hanging free.
 - White bands should always be closest to 1482 terminals.
 5. Disconnect any link between ground and **LOW** binding posts.
 6. Press the [L/Q] key to select inductance parameter. Press the [EQUIVALENT CIRCUIT] key (if necessary) to select SERIES.
 7. Refer to Table 5-9 and verify that the RLC display is between the extremes listed for 1 mH, SLOW measurement rate [first line of table).
 8. Repeat steps 4 through 7 with the other inductance standards (1 mH, 100 mH, 1 H, and 10 H) as indicated in the LS column, and with the indicated measurement rate, verify that the RLC display is acceptable for each line or the table, for ranges 4, 3, 2, and 1.

For more information on connecting to 1482 Series Inductance standards, see section 3.2.11.

Standard Inductor (LS)	Measure Range	Digibridge Rate	Digibridge Accuracy	Typical Standard Accuracy	RLC Display* Acceptable Extremes	Expected Q**
1 mH	4	SLOW	.027%	0.1%	.9987 to 1.0013	7.5
		MED	.068%	0.1%	.9983 to 1.0017	---
		FAST	.163%	0.1%	.9974 to 1.0026	---
100 mH	3	SLOW	.023%	0.1%	99.88 to 100.12	7.5
		MED	.057%	0.1%	99.84 to 100.16	---
		FAST	.136%	0.1%	99.76 to 100.24	---
1 H	2	SLOW	.022%	0.1%	.9988 to 1.0012	10
		MED	.055%	0.1%	.9984 to 1.0016	---
		FAST	.133%	0.1%	.9977 to 1.0023	---
10 H	1	SLOW	.023%	0.1%	9.988 to 10.012	10
		MED	.058%	0.1%	9.984 to 10.016	---
		FAST	.139%	0.1%	9.976 to 10.024	---

* These ranges of acceptable displays are based on specific accuracy of decade inductors, recently calibrated. If the inductance values are known to higher accuracy by special calibration or lesser because of long-term drift, the “acceptable RLC extremes” must be revised accordingly.

** Based on Q of Type 1482 Standard Inductor; as stated in IET Labs documentation. If inductor Q values are known more accurately, the Q can be checked to tighter tolerances.

Table 5-9: Inductance accuracy checks at 1 kHz

5.8.6 D Measurement Accuracy

Verify D-measurement accuracy with the following procedure. Dissipation-factor checks will be made using series equivalent circuit, with corresponding connections of resistance and capacitance standards.

This procedure follows after paragraph 5.8.5. (Thus, test frequency = 1 kHz, test voltage = 1 V, measure rate = SLOW, range held indicator is NOT lit, and parameter L/Q is specified.)

1. Connect the 1657-9600 extender cable to the Digibridge remote test fixture. Hand tighten the screws, to provide ground (guard) connection.
2. Connect the “high” leads (red and red/white) together and separately connect the “low” leads (black and black/white) together.
3. Press [FUNCTION] key to select ENTER function.
4. To select 100 Hz, press [.] [1] [=] [SHIFT] [FREQUENCY].
5. Before measurement, zero the Digibridge as follows:
 - A. Keep the “high” banana-plug stack separated from the “LOW” stack.
 - B. Press [FUNCTION] key (if necessary) to select MEASURE function .
 - C. Press [MEASURE MODE] key (if necessary) to select TRIGGERED mode.
 - D. Press the following keys: [1] [6] [9] [3] [=] [SHIFT] [OPEN].
 - E. Confirm that the GO indicator is lit.
 - F. Keep hands and objects at least 10 cm (4 in.) from test fixture.
 - G. Press the START button.
 - H. Wait for the GO indicator to be lit again. The RLC display should be .00000 pF.
 - I. Connect the 2 banana-plug stacks together, leave the guard (black/green) open.
 - J. Press the following keys: [1] [6] [9] [3] [=] [SHIFT] [SHORT].
 - K. Confirm that the GO indicator is lit.
 - L. Press the START button.
 - M. Wait for the GO indicator to be lit again. The RLC display should be .00000 ohms.
 - N. Press the [MEASURE MODE] key to select CONT.

6. Using the extender cable and plain bus wire, connect the decade Rand C standards in series, as DUT to the Digibridge, as shown in Figure 5-13 and tabulated below.

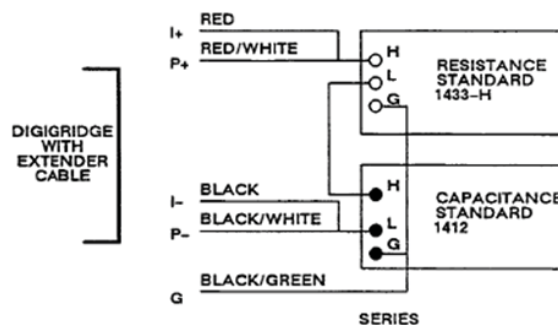

Figure 5-13: Series connections of standards for D accuracy checks

RED, I+:	stack on P+
RED & WHITE, P+:	resistor H
BLACK, I- :	stack on P-
BLACK & WHITE, P- :	capacitor L, center
BLACK&GREEN, G:	resistor G, capacitor H side post, and capacitor L side post

Also connect with a short jumper from resistor L to capacitor H, center post.

7. Confirm or select measurement conditions on the Digibridge thus:

DISPLAY	VALUE
MEASURE RATE	SLOW
EQUIVALENT CIRCUIT	SERIES
FREQUENCY	100 Hz
MEASURE MODE	CONT
HOLD RANGE	AUTORANGE
PARAMETER	C/D
EXIT BIAS	OFF

8. Set the resistance and capacitance standards to the values given in line 1 of Table 5-10. Verify that the DQ display is within the range given, inclusive. Lock in this range on the 1693 by pressing [SHIFT][HOLD RNG].

Resistance Standard	Capacitance Standard	DQ Display (Min to Max)
50 Ω	0.1592 μF	.0046 to .0054
100 Ω	0.1592 μF	.0096 to .0104
500 Ω	0.1592 μF	.0496 to 0.504
1 k Ω	0.1592 μF	.0996 to .1004
5 k Ω	0.1592 μF	.4995 to .5005
10 k Ω	0.1592 μF	.9994 to 1.001
50 k Ω	0.1592 μF	4.992 to 5.008
90 k Ω	0.1592 μF	8.975 to 9.025

Table 5-10: D-Accuracy Check

9. Continue down the table, verifying each line. Because the capacitance in the series equivalent circuit is different from the decade capacitor setting when the series resistance is large, use the RLC readout to indicate capacitance in those lines of the table.

5.8.7 Limit Comparison Bins

Verify the Digibridge performance with regard to limit comparison and bin assignments as follows. The resistance standard 1433-33 or equivalent is required for this test.

1. Confirm or select measurement conditions on the Digibridge as listed:

FUNCTION	ENTER
DISPLAY	VALUE
MEASURE RATE	SLOW
EQUIVALENT CIRCUIT	SERIES
FREQUENCY	1 kHz
MEASURE MODE	CONT
RANGE	Select range 3 by pressing [R/Q] for the first k Ω range and then press [SHIFT] [HOLD RANGE], if necessary to hold.
EXIT BIAS	OFF

2. Connect the 1657-9600 extender cable from the Digibridge remote test fixture as follows:
 - “high” leads (red and red/white) to resistor **H**
 - “low” leads (black and black/white) to resistor **L**
 - “ground” lead (black/green) to resistor **G**
3. Refer to Table 5-11. After making the sequence of key-strokes (using the appropriate limit entry keys) shown under “Entry”, verify that the Digibridge numerical displays are like the numbers tabulated in the same row of the table under “Displays”. Make all entries as tabulated.
4. Select on the Digibridge:
 - FUNCTION: MEASURE
 - DISPLAY: BIN No.
5. Refer to Table 5-12 For each setting of the resistance standard, verify that the DQR display is blank, the bin (RLC) display is a single digit as tabulated, and the GO/NO-GO lights work as tabulated.

Entry		RLC Display	DQ Display
(none)		(blank)	(blank)
[5]	[=] [SHIFT] [NOM VALUE]	5.0000	(blank)
[.]	[1] [=] [SHIFT] [BIN No.] [0] [0]	(blank)	.1000
[1]	[%] [=] [SHIFT] [BIN No.] [0] [1]	5.0500	4.950
[2]	[%] [=] [SHIFT] [BIN No.] [0] [2]	5.1000	4.900
[3]	[%] [=] [SHIFT] [BIN No.] [0] [3]	5.1500	4.850
[4]	[%] [=] [SHIFT] [BIN No.] [0] [4]	5.2000	4.800
[5]	[%] [=] [SHIFT] [BIN No.] [0] [5]	5.2500	4.750
[6]	[%] [=] [SHIFT] [BIN No.] [0] [6]	5.3000	4.700
[7]	[%] [=] [SHIFT] [BIN No.] [0] [7]	5.3500	4.650
[8]	[%] [=] [SHIFT] [BIN No.] [0] [8]	5.4000	4.600
[9]	[%] [=] [SHIFT] [BIN No.] [0] [9]	5.4500	4.550
[10]	[%] [=] [SHIFT] [BIN No.] [0] [10]	5.5000	4.500
[11]	[%] [=] [SHIFT] [BIN No.] [0] [11]	5.5500	4.450
[12]	[%] [=] [SHIFT] [BIN No.] [0] [12]	5.6000	4.400
[13]	[%] [=] [SHIFT] [BIN No.] [0] [13]	5.6500	4.350

Table 5-11: Entry of limits

Resistance Standard Set To	GO/NO-GO	Bin Display
5000 Ω	GO	1
5057 Ω	GO	2
5107 Ω	GO	3
5157 Ω	GO	4
5207 Ω	GO	5
5257 Ω	GO	6
5307 Ω	GO	7
5357 Ω	GO	8
5407 Ω	GO	9
5457 Ω	GO	10
5507 Ω	GO	11
5557 Ω	GO	12
5607 Ω	GO	13
5657 Ω	NO-GO	14
0000 Ω	NO-GO	0
5000 Ω	GO	1

Table 5-12: Bin assignment check

5.9 Recalibration

5.9.1 Preparation

Introduction. This service procedure requires a set of external calibration resistors whose Rand Q values are exactly known and generally requires a frequency counter. (Table 5-13) For the frequency correction, the counter makes a measurement; but for the four internal resistance standards, the Digibridge makes the measurements. After recalibration, the Digibridge retains in RAM the corrections that the microprocessor needs to compensate for the small errors in the actual values of test frequency and internal standard resistor parameters.

(Therefore, the Digibridge calculates its measurement results correctly, accomplishing by calculation the same result that would be obtained if the recalibration process actually trimmed the internal standards exactly to their nominal values.]

Required Equipment. Refer to Table 5-13.

Decision "Whether Frequency Calibration is Needed. The frequency calibration (paragraph 5.9.7) is necessary - and should be completed before recalibrating any range - if any of the following is true:

- If the "Dallas Chip" has been replaced.
- If oscillator U4 has been replaced.

Procedure

1. Remove any adaptor that may be in the test fixture. Inspect the Digibridge test fixture for cleanliness. If it is dirty or if it is scheduled for periodic cleaning soon, clean the test fixture as described in paragraph 5.6.
2. Place all equipment including the Digibridge(s) to be recalibrated in the temperature stabilized room, normally at 23°C.
3. Switch Digibridge(s) ON, and if frequency calibration is needed (see above), switch the counter power ON. Allow all equipment to warm up for at least two hours. Leave the Digibridge test conditions at the defaults.
4. If frequency calibration is needed (see "Decision ..." above), skip to the procedure of paragraph 5.9.7 before zeroing and recalibrating ranges 4, 3, 2, and 1.

Decision whether K Factor Calibration Is Needed. The K Factor Calibration (paragraph 5.9.8) is necessary and should be completed before recalibrating any range, if the "Dallas Chip" has been replaced.

GenRad No.	Description	Requirements
---	Temperature stabilized room	23 degrees C (73.4 F) recommended
1689-9604	Kit of four calibration resistors with nominal resistances of 24.9, 374 ohms; 5.97, 95.3 kilohms, and calibration "open" and "short".	R and Q values known at 1 kHz, R accuracy +/- .002%, calibration traceable to SI ; Q calibrated to +/- 10 ppm. *
---	Universal counter/timer, with ground strap **	Accuracy better than +/-10 ppm (+/-2 ppm preferred) in averaging multiple period measurement
---	Screw, bright plated brass **	Size: 0.138-32 x 0.5 (diam-thds/in. x length, in.)

* Refer to calibration certificate (Form No. 1689-8204) supplied with the kit.		
** Counter and screw are needed for frequency calibration only.		

Table 5-13: Equipment required for calibration

5.9.2 Zeroing and Selecting “DQ in PPM”

This zeroing procedure is like the routine procedure in Operation, Chapter 3. In this process, the Digibridge automatically measures stray parameters related to the test fixture and associated circuits and retains the data, which it uses in each recalibration step below to correct measurements so that results most accurately represent parameters of the external calibration resistor alone. *NOTE: Leave the I-T factor at 1 (the power-up default) or more, NOT less.* (See para 3.5.5.)

1. Press [FUNCTION] key (if necessary) to select MEASURE function .
2. Press [MEASURE MODE] key (if necessary) to select TRIGGERED mode.
3. Press the following keys: [1][6][9][3][=][SHIFT][OPEN].
4. Confirm that the GO indicator is lit.
5. Keep hands and objects at least 10 cm (4 in.) from test fixture.
6. Press the START button.
7. Wait for the GO indicator to be lit again.
8. Press the following keys: [1][6][9][3][=][SHIFT][SHORT].
9. Confirm that the GO indicator is lit.
10. Press the START button.
11. Wait for the GO indicator to be lit again. The RLC display should be .00000 ohms.
12. Disconnect the short circuit.

DQ in PPM. Press [SHIFT][DQ in PPM] keys if necessary to light this indicator. Select “k Ω .” Press [R/Q] key. The k Ω indicator will light

5.9.3 Recalibration for Range 4

1. Connect the 24.9-ohm calibration resistor to the Digibridge test fixture .
2. Enter the known parameters of the calibration resistor as in the following example, based on the values R = 24.895 ohms and Q= 15 ppm.
NOTES: The Digibridge will accept six digits for R, even though only five will be displayed. The Q is associated with ‘b in 00’, and its value must be preceded with “-” if the known Q is negative.)

- A. Select ENTER with [FUNCTION] key and CONTINUOUS with [MEASURE MODE] key.
- B. Press [4][=][SHIFT][SPECIAL][1]
- C. Press [2][4][.][8][9][5][=][SHIFT][NOM VALUE]

NOTE: The calibration resistance value should appear in the left display. The DQ in PPM indicator must be lit.

- D. Press [1][5][=][SHIFT][BIN NO][0][0]

NOTE: The calibration Q value should appear in the right-hand display.

3. Enable and execute the recalibration for this range as follows. (The following keystrokes are the same for any range.)
 - A. Select MEASURE with the [FUNCTION] key and TRIGGERED with [MEASURE MODE] key.
 - B. Press [1][6][9][3][=][1][SHIFT][CALIBRATE]

NOTE: The GO indicator being lit and a 6 in the left and a 6 in the right displays confirm that calibration is enabled.

 - C. Press START (The GO indicator remains unlit while calibration proceeds.) Keeping hands away from the test fixture, wait until the GO indicator is lit again.

This completes recalibration of one range.

4. Select CONTINUOUS with the [MEASURE MODE] key and check that the Digibridge operates properly with the recalibration.
 - The Digibridge should measure the calibration resistor like any ordinary resistor and display its R and Q (ppm) values.
 - The Q display can be expected to “jump” a bit. (precision and repeatability are in the order of 5 ppm).
 - The NO-GO indicator will probably be lit; this is normal.
5. Disconnect the calibration resistor from the test fixture.

5.9.4 Recalibration for Range 3

1. Connect the 374-ohm calibration resistor to the Digibridge test fixture.
2. Enter the known parameters of the calibration resistor as in the following example, based on the values $R = 374.06$ ohms and $Q = 5$ ppm.

NOTES: The Digibridge will accept six digits for R, even though only five will be displayed. The Q is associated with "bin 00", and its value must be preceded with "-" if the known Q is negative.

- A. Select ENTER with [FUNCTION] key and verify that measure mode is CONT.
- B. Press [3][=][SHIFT][SPECIAL][1]
- C. Press [3][7][4][.][0][6][=][SHIFT][NOM VALUE]

NOTE: the calibration resistance value should appear in the left display. The DQ in PPM indicator must be lit.

- D. Press [5][=][SHIFT][BIN NO][0][0]

NOTE: the calibration Q value should appear in the right-hand display.

3. Enable and execute the recalibration for this range as follows. (The following keystrokes are the same for any range.)
 - A. Select MEASURE with the [FUNCTION] key and TRIGGERED with [MEASURE MODE] key.
 - B. Press [1][6][9][3][=][1][SHIFT][CALIBRATE]

NOTE: The GO indicator being lit and a 6 in the left and a 6 in the right displays confirm that calibration is enabled.

- C. Press START (The GO indicator remains unlit while calibration proceeds.)
- D. Keeping hands away from the test fixture, wait until the GO indicator is lit again.

This completes recalibration of one range.

4. Select CONTINUOUS with the [MEASURE MODE] key and check as follows that the Digibridge operates properly with the recalibration.
 - The Digibridge should measure the calibration resistor like any ordinary resistor and display its R and Q (ppm) values.
 - The Q display can be expected to "jump" a bit. (Precision and repeatability are in the order of 5 ppm).
 - The NO-GO indicator will probably be lit; this is normal.
5. Disconnect the calibration resistor from the test fixture.

5.9.5 Recalibration for Range 2

1. Connect the 5.97-kilohm calibration resistor to the Digibridge test fixture.
2. Enter the known parameters of the calibration resistor as in the following example, based on the values $R = 5.9581$ kilohms and $Q = -22$ ppm.

NOTES: The Digibridge will accept six digits for R, even though only five will be displayed. The Q is associated with "bin 00", and its value must be preceded with "-" if the known Q is negative.)

- A. Select ENTER with [FUNCTION] key and verify that measure mode is CONT.
- B. Press [2][=][SHIFT][SPECIAL][1]
- C. Press [5][.][9][5][8][1][=][SHIFT][NOM VALUE]

NOTE: The calibration resistance value should appear in the left display. The DQ in PPM indicator must be lit.

- D. Press [-][2][2][=][SHIFT][BIN NO][0][0]

NOTE: The calibration Q value should appear in the right-hand display.

3. Enable and execute the recalibration for this range as follows. (The following keystrokes are the same for any range.)
 - A. Select MEASURE with the [FUNCTION] key and TRIGGERED with [MEASURE MODE] key.
 - B. Press [1][6][9][3][=][1][SHIFT][CALIBRATE]

NOTE: The GO indicator being lit and a 6 in the left and a 6 in the right displays confirm that calibration is enabled.

- C. Press START (The GO indicator remains unlit while calibration proceeds.)
- D. Keeping hands away from the test fixture, wait until the GO indicator is lit again.

This completes recalibration of one range.

4. Select CONTINUOUS with the [MEASURE MODE] key and check as follows that the Digibridge operates properly with the recalibration.
 - The Digibridge should measure the calibration resistor like any ordinary resistor and display its R and Q (ppm) values.
 - The Q display can be expected to "jump" a bit. (precision and repeatability are in the order of 5 ppm).
 - The NO-GO indicator will probably be lit; this is normal.
5. Disconnect the calibration resistor from the test fixture.

5.9.6 Recalibration for Range 1

1. Connect the 95.3-kilohm calibration resistor to the Digibridge test fixture.
2. Enter the known parameters of the calibration resistor as in the following example, based on the values $R = 94.986$ kilohms and $Q = -280$ ppm.

NOTES: The Digibridge will accept six digits for R, even though only five will be displayed. The Q is associated with "bin 00", and its value must be preceded with "-" if the known Q is negative.)

- A. Select ENTER with [FUNCTION] key and verify that measure mode is CONT.
- B. Press [1][=][SHIFT][SPECIAL][1]
- C. Press [9][4][.][9][8][6][=][SHIFT][NOM VALUE]

NOTE: The calibration resistance value should appear in the left display. The DQ in PPM indicator must be lit.

- D. Press [-][2][8][0][=][SHIFT][BIN NO] [0][0]

NOTE: The calibration Q value should appear in the right-hand display.

3. Enable and execute the recalibration for this range as follows. (The following keystrokes are the same for any range.)
 - A. Select MEASURE with the [FUNCTION] key and TRIGGERED with [MEASURE MODE] key.
 - B. Press [1][6][9][3][=][1][SHIFT] [CALIBRATE]

NOTE: The GO indicator being lit and a 6 in the left and a 6 in the right displays confirm that calibration is enabled.

 - C. Press START (The GO indicator remains unlit while calibration proceeds.)
 - D. Keeping hands away from the test fixture, wait until the GO indicator is lit again.

This completes recalibration of one range.

4. Select CONTINUOUS with the [MEASURE MODE] key and check as follows that the Digibridge operates properly with the recalibration.
 - The Digibridge should measure the calibration resistor like any ordinary resistor and display its Rand Q (ppm) values.
 - The Q display can be expected to "jump" a bit. (precision and repeatability are in the order of 5 ppm).
 - The NO-GO indicator will probably be lit; this is normal.
5. Disconnect the calibration resistor from the test fixture.

5.9.7 Frequency Calibration

If frequency calibration is not necessary (refer to "Decision ...," in paragraph 5.8.1), omit the procedures of paragraph 5.8.7. If necessary at all, these steps should be done before paragraphs 5.8.2 through 5.8.6.

1. Connect the counter as follows to measure the period of the test frequency, nominally 1 kHz.

If the Digibridge is not disassembled, provide for a ground connection as follows. (Otherwise, see NOTE below.)

 - A. Insert a 6-32 (1/2 - inch long) screw into the tapped hole at the right-hand end of the Digibridge's test fixture (tighten gently).
 - B. Connect the ground return of the counter's probe to this screw.
 - C. Insert the short-circuit wire used above (for example) into the right-hand slot of the test fixture only.
 - D. Connect the counter's probe to this wire.

NOTE: If calibration is being done with the main board out of the cabinet, a more convenient ground connection is found near the front edge of the board at a guard-jumper terminal labeled E1 on the board (DUT CONNECTOR GND on the schematic diagram).

2. Measure the test signal frequency, preferably as a period and calculate its reciprocal.

For example, if the period is 1.000007 ms, the frequency is 0.999993 kHz.
3. Calculate the frequency correction "c" (error) in ppm, as follows.

$$c = \frac{(\text{measured frequency}) - 1.000000 \text{ kHz}}{1 \text{ kHz}} \times 1,000,000$$

For example, if the period is 1.000007 ms, the frequency is 0.999993 kHz.

4. Enter the frequency correction "c" (error) in ppm, as follows. The allowable range of entry is -99 to +99.

For example, if the value of "c" is -7 ppm

- A. Select ENTER function and press [-] [7] [=][SHIFT][SPECIAL][0].

Notice that the correction "c" appears in the left display, followed by a decimal point. The correction has NOT been entered yet.

- B. Confirm the value.
- C. Continue the entry process by pressing [1][6][9][3]

The decimal point should disappear, indicating that the correction has been entered.

5. Confirm normalcy as follows.
 - A. Press [1][=][SHIFT][FREQUENCY] (The left display should now be 1).
 - B. Press [1][=][SHIFT] [VOLTAGE] (The left display should be 1).
6. Now continue with the zeroing and range recalibration procedures, starting at paragraph 5.8.2.

5.9.8 Frequency Correction K Factor Procedure

The Frequency K Factor correction is for small changes related to loading errors and timing errors with respect to frequency. There is one K factor for each of the four ranges.

These corrections are determined during initial calibration and the procedure is not necessary to repeat unless the contents of RAM have been lost due to issue with Dallas chip or other corruption.

This procedure is not recommended during normal recalibration (see paragraphs 5.9.1 through 5.9.6).

Procedure:

1. Reset K factors to typical values. (required as a starting reference)
 - A. Press [FUNCTION] to ENTER
 - B. Press [1] [6] [9] [3] [.] [9] [SHIFT] [SPECIAL] [SHIFT]
 - C. Press [START] (to initiate storage of K factors)
2. Check K factors:
 - A. Press [R/Q]
 - B. For RANGE 1 press [1] [6] [9] [3] [.] [5] [SHIFT] [SPECIAL] [SHIFT]
if units are ohms display will be -238.42
(= -238.42×10^{-9})
if units are Kohms display will be -.23842
(= $-.23842 \times 10^{-6}$)
 - C. For RANGE 2 press [1] [6] [9] [3] [.] [6] [SHIFT] [SPECIAL] [SHIFT]
ohms = -11.176
Kohms = -.01118

- D. For RANGE 3 press [1] [6] [9] [3] [.] [7] [SHIFT] [SPECIAL] [SHIFT]
ohms = 4.6000
Kohms = .00460
- E. For RANGE 4 press [1] [6] [9] [3] [.] [8] [SHIFT] [SPECIAL] [SHIFT]
ohms = 5.5879
Kohms = .00559

3. Calibrate 4 ranges of the Digibridge as described in paragraphs 5.9.2 through 5.9.6.

4. Determine new K factors

In order to calculate the K factor it is necessary to measure the delta% value of the calibration resistors from 1 kHz to 20 kHz for range 1 and from 1 kHz to 100 kHz for ranges 2, 3, and 4.

- A. Select:
FUNCTION ---- ENTER
DISPLAY ---- VALUE
MEASURE RATE SLOW
MEASURE MODE --- CONTINUOUS
- B. Select the frequency of 1 kHz by pressing [1] [=] [SHIFT] [FREQUENCY]
- C. Select the range to be calibrated by pressing [x] [=] [SHIFT] [SPECIAL] [1] (where x=1,2,3, or 4)
- D. Select: FUNCTION --- MEASURE
- E. Insert the calibration resistor for the range to be calibrated.
Range 1: 95 k Ω
Range 2: 1.6 k Ω
Range 3: 374 Ω
Range 4: 25 Ω

Note: For range 1 only, the 95 k Ω standard may only give 4 digits of resolution. To get 5 digits, perform the following:

- Select: FUNCTION ---- ENTER
 - Enter a nominal value by pressing [9] [5] [=] [SHIFT] [NOM VAL]
 - Select:
FUNCTION ---- MEASURE
DISPLAY DELTA%
DISPLAY ---- VALUE
- F. Record the average value standard resistor as indicated on the Digibridge display. (For example: for range 1 the reading might be 95.286 k Ω).
 - G. Select: FUNCTION ---- ENTER
 - H. Enter as a nominal value the reading noted above. (For example, range 1 Press [2][0] [=] [SHIFT] [FREQUENCY])

5.10 Internal Address Settings for IEEE-488 Interface

Each device (instrument) in a system linked by an IEEE-488 bus must have its own address (except in the simple case of a single “talker only” with one or more “listeners” that are always listening). The initial setting of address, provided by the factory, in the interface option of this Digibridge, is 00011. If the requirements of a system installation make it necessary to change the Digibridge address, use the following procedure. Refer to paragraph 2.8.4 for further comments and a table of possible addresses.

1. Remove the interface option , after removing the 2 large screws with resilient washers in the rear panel. See Figure 5-15



CAUTION

Observe the handling precautions given at the beginning of the Service Section.

2. Find S2 which is located at the end of the interface option board, about 3 cm (1 in.) from the TALK switch S1. If S2 is covered, lift the cover off, exposing the “DIP” switch, which has 2 rows of 6 tiny square pads with numbers 1 thru 6 between the rows. The five device-dependent bits of the address are set by this switch.
3. Set in the desired bits as follows. To enter logical 1’s, depress pads nearest the end of the board. To enter logical 0’s, depress pads on the other side of the “DIP” switch, the side marked with a + sign. The address is read from 5 to 1 (not using 6). Thus, for example, to set up the address 00011, enter 0’s at positions 5, 4, 3; enter 1’s at positions 2, 1. (This makes the talk address “0” and the listen address “#”.)
4. Replace the interface option assembly in its former place. Reassembly note: align board edges carefully with connector and guide that are inside of instrument, while pushing interface option into position.



Figure 5-15: IEEE-488 interface on the rear panel

