

IBM Storwize V5100

*Quick Installation Guide for MTM
2078-424, 2078-12F, 2078-24F,
2078-92F, and 2078-U5B*



Note

Before using this information and the product it supports, read the following information:

- The general information in [“Notices” on page 111](#)
- The information in the [“Safety and environmental notices” on page xiii](#)
- The information in the *IBM Environmental Notices and User Guide* (provided on a DVD)

This edition applies to version 8, release 3, modification 0, and to all subsequent modifications until otherwise indicated in new editions.

© **Copyright International Business Machines Corporation 2019.**

US Government Users Restricted Rights – Use, duplication or disclosure restricted by GSA ADP Schedule Contract with IBM Corp.

Contents

- Figures..... V**
- Tables..... ix**
- Compliance standards..... xi**
- Safety and environmental notices..... xiii**
 - Safety notices and labels..... xiii
 - Caution notices for the system..... xiv
 - Danger notices for the system xvii
 - Special caution and safety notices..... xviii
 - General safety..... xviii
 - Handling static-sensitive devices..... xix
 - Environmental notices..... xix
- About this guide.....xxi**
 - Who should use this guide..... xxi
 - Publications and related libraries..... xxi
 - Related websites..... xxii
 - Sending your comments.....xxii
 - Know how to report a problem.....xxii
- Chapter 1. Before you begin the installation..... 1**
 - Reviewing your packing slip.....3
 - Identifying the hardware components..... 5
 - Identifying Storwize V5100 node canisters..... 8
 - Verify environmental requirements..... 9
 - Review enclosure location guidelines..... 9
- Chapter 2. Installing the system hardware..... 11**
 - Installation overview..... 11
 - Unpacking the Storwize V5100 control enclosure12
 - Installing support rails for the control enclosures13
 - Installing a Storwize V5100 control enclosure.....14
 - Unpacking a 2U expansion enclosure 16
 - Installing support rails for 2U expansion enclosures 17
 - Installing an optional 2U SAS expansion enclosure 20
 - Unpacking an optional 5U expansion enclosure20
 - Installing an optional 5U SAS expansion enclosure..... 23
 - Safety notices and considerations: 2077-92F, 2077-A9F23
 - Weight considerations: 5U SAS expansion enclosure.....27
 - Identify the hardware components: 2077-92F, 2077-A9F 32
 - Unpacking and installing the enclosure: 2077-92F, 2077-A9F35
 - Removing the top cover: 2077-92F, 2077-A9F 38
 - Installing the support rails: 2077-92F, 2077-A9F 39
 - Installing or replacing the fascia: 2077-92F, 2077-A9F43
 - Installing or replacing a drive: 2077-92F, 2077-A9F 44
 - Installing or replacing the top cover: 2077-92F, 2077-A9F 48
 - Installing an optional 5U SAS expansion enclosure..... 49

Installing or replacing the cable-management arm: 2077-92F, 2077-A9F	51
Removing and installing a SAS cable: 2077-92F, 2077-A9F	55
Connecting optional SAS expansion enclosures: 2078-92F, 2078-A9F	57
Powering on the 2077-92F, 2077-A9F expansion enclosure.....	59
Powering off the expansion enclosure: 2077-92F, 2077-A9F	62
Storwize V5100 2078-92F, 2078-A9F expansion enclosure LEDs and indicators.....	63
Storwize V5100 5U expansion enclosure parts	68
Connecting the components	70
Connecting Ethernet cables to the node canisters.....	71
Connecting Fibre Channel cables to the control enclosure.....	71
Connecting optional expansion enclosures to the control enclosure	72
Powering on the optional 2U SAS expansion enclosures.....	75
Powering on the 2077-92F, 2077-A9F expansion enclosure.....	76
Powering on the system.....	79
Chapter 3. Configuring the system.....	81
Checking your web browser settings for the management GUI.....	81
Initializing the control enclosure.....	83
Completing the initial system setup.....	84
Verify and update the system firmware and software.....	85
Chapter 4. Adding an expansion enclosure to an existing system.....	87
Chapter 5. Adding a control enclosure to an existing system	89
Appendix A. Accessibility features for the system.....	91
Appendix B. Where to find the Statement of Limited Warranty.....	93
Appendix C. Control enclosure requirements.....	95
Appendix D. SAS expansion enclosure requirements.....	101
Notices.....	111
Trademarks.....	112
Homologation statement.....	113
Electromagnetic compatibility notices.....	113
Canada Notice.....	113
European Community and Morocco Notice.....	113
Germany Notice.....	113
Japan Electronics and Information Technology Industries Association (JEITA) Notice.....	114
Japan Voluntary Control Council for Interference (VCCI) Notice	115
Korea Notice.....	115
People's Republic of China Notice.....	115
Russia Notice.....	115
Taiwan Notice.....	115
United States Federal Communications Commission (FCC) Notice.....	116
Index.....	117

Figures

- 1. Label showing the orientation of the node canisters and PSUs 5
- 2. Orientation of ports on node canister 1 (top) 5
- 3. Orientation of ports on node canister 2 (bottom).....6
- 4. Rear view of a 2077/2078-424 / 2077/2078-AF4 2077 expansion enclosure.....7
- 5. SAS ports and LEDs in rear view of an expansion canister for 2077/2078-424 / 2077/2078-AF47
- 6. Expansion enclosure support rails 8
- 7. Rear of the Storwize V5100 enclosure..... 8
- 8. Control enclosure support rails..... 13
- 9. Hole locations in the front of the rack..... 13
- 10. Removing enclosure end caps..... 15
- 11. Inserting the enclosure.....15
- 12. Securing the front of the enclosure..... 15
- 13. Expansion enclosure support rails..... 17
- 14. Hole locations in the front of the rack..... 18
- 15. Opening the hinge brackets..... 19
- 16. Closing the hinge brackets.....19
- 17. Tray containing expansion enclosure parts..... 21
- 18. Packaging materials..... 22
- 19. Packaging for fascia..... 22
- 20. Features on the front of the 2077-92F, 2077-A9F expansion enclosure..... 32
- 21. Front fascia of the 2077-92F, 2077-A9F expansion enclosure..... 33
- 22. Features on the rear of the 2077-92F, 2077-A9F expansion enclosure..... 33
- 23. 2077-92F, 2077-A9F support rails..... 34

24. 2077-92F, 2077-A9F CMA assemblies.....	35
25. Tray containing expansion enclosure parts.....	36
26. Packaging materials.....	37
27. Packaging for fascia.....	38
28. Releasing the 5U expansion enclosure cover	39
29. Removing the 5U expansion enclosure cover.....	39
30. Support rails.....	40
31. Detaching the inner rail section.....	40
32. Screw locations to attach the inner rail to the enclosure.....	41
33. Attaching the inner rail section to the enclosure.....	41
34. Installing the rail assembly to the rack frame.....	42
35. Example of the required rack space.....	42
36. Fascia components on the expansion enclosure	43
37. Replace fascia components on the expansion enclosure	44
38. Drive assembly.....	45
39. Drive locations in a 5U expansion enclosure.....	45
40. Correct drive installation.....	46
41. Incorrect drive installation.....	46
42. Replace the drive	47
43. Aligning the 2077-92F, 2077-A9F top cover.....	48
44. Replacing the 2077-92F, 2077-A9F top cover.....	49
45. Locking the top cover.....	49
46. Example installation of the enclosure in the rack.....	50
47. Replacing the 2077-92F, 2077-A9F enclosure in the rack.....	51
48. Upper and lower cable-management arms.....	52

49. Upper and lower cable-management arms.....	52
50. Connectors for the cable management arm.....	53
51. Install the inner connector of the upper CMA to the inner member of the support rail.....	53
52. Install the outer connector of the upper CMA to the outer member of the support rail.....	53
53. Attach the support rail connector of the upper CMA to the right support rail.....	54
54. Comparing the location of the components of the CMA assemblies.....	54
55. Correct orientation for SAS cable connectors.....	56
56. Example of SAS cables routed through the cable management arms.....	56
57. SAS cable correctly inserted into the SAS port	57
58. SAS cable connector orientation.....	57
59. Connecting the SAS cables.....	58
60. SAS port orientation on expansion enclosures.....	59
61. Features on the front of the 2077-92F, 2077-A9F expansion enclosure.....	60
62. Secure power cables	61
63. Power and SAS cable connections on the back of the enclosure	61
64. Features on the rear of the 2077-92F, 2077-A9F expansion enclosure.....	62
65. LEDs on the front of the expansion enclosure.....	63
66. LEDs on the front of a power supply unit.....	64
67. LEDs on a drive assembly	65
68. LEDs on a secondary expansion module.....	66
69. LEDs on the back of the expansion enclosure.....	67
70. LEDs on the back of the expansion canister.....	67
71. Fibre Channel adapters in the node canisters.....	71
72. Connecting the SAS cables.....	73
73. SAS cable connectors.....	74

74. Connecting the SAS cables.....	75
75. Expansion enclosure LEDs.....	76
76. Features on the front of the 2077-92F, 2077-A9F expansion enclosure.....	77
77. Secure power cables	78
78. Power and SAS cable connections on the back of the enclosure	78
79. Features on the rear of the 2077-92F, 2077-A9F expansion enclosure.....	79
80. Technician ports.....	83
81. Rack space requirements for the 2078-92F models.....	98
82. Acoustical Declaration with Noise Hazard Notice.....	99
83. Rack space requirements for the 2077/2078-24F , 2077-92F, 2077-A9F and 2078-92F, 2078-A9F expansion enclosures.....	106

Tables

1. IBM websites for help, services, and information.....	xxi
2. Storwize V5100 library.....	xxii
3. IBM websites for help, services, and information.....	xxiii
4. Storwize V5100 control and expansion enclosures.....	3
5. Summary of onboard Ethernet ports.....	6
6. Selecting bracket pins for your rack.....	14
7. Selecting bracket pins for your rack.....	18
8. Weight of expansion enclosure parts.....	28
9. Weight of an enclosure with 92 SAS drives.....	29
10. Enclosure weight as FRUs are installed.....	29
11. Examples of supported SAS chain combinations.....	59
12. Display panel LEDs.....	63
13. Power supply unit LEDs.....	64
14. LED indicators on drives.....	65
15. LED indicators on secondary expansion modules.....	66
16. Expansion canister and SAS port LEDs	68
17. Supported expansion enclosure SAS drives.....	69
18. Other expansion enclosure parts.....	69
19. Power specifications per power supply.....	96
20. Temperature requirements.....	97
21. Physical characteristics of the enclosures.....	97
22. Rack space requirements for the 2077-424 or 2078-U5B control enclosure.....	98
23. Clearances.....	98

24. Drive specifications.....	98
25. Shock testing results.....	99
26. Vibration testing results.....	99
27. Power specifications per power supply.....	101
28. Power consumption examples per enclosure.....	102
29. Temperature requirements.....	104
30. Physical characteristics of the expansion enclosures.....	105
31. Rack space requirements for the 2077/2078-24F , 2077-92F, 2077-A9F and 2078-92F, 2078-A9F expansion enclosures.....	107
32. Clearances.....	107
33. Drive specifications.....	108
34. Acoustical specifications for 2077/2078-24F SAS expansion enclosures.....	108
35. Declared noise emissions for 2077-92F, 2077-A9F and 2078-92F, 2078-A9F SAS expansion enclosures in accordance with ISO 9296.....	109
36. Shock testing results.....	109
37. Vibration testing results.....	109

Compliance standards

Note: This product was designed, tested, manufactured, and certified for safe operation. It complies with IEC 60950-1 and/or IEC 62368-1 and where required, to relevant national differences/deviations (NDs) to these IEC base standards. This includes, but is not limited to: EN (European Norms including all Amendments under the Low Voltage Directive), UL/CSA (North America bi-national harmonized and marked per accredited NRTL agency listings), and other such derivative certifications according to corporate determinations and latest regional publication compliance standardized requirements.

- Regulatory Model ID (RMID, for control system base platform): FBIII
- RMID (for 2U expansion option unit): ESLS
- RMID (for 5U expansion option unit): 5U-92

(Relevant Machine Type - Models (MT-Ms) may also be used to supplement identification (ID) for worldwide (WW) co-compliance filings or registrations with regulatory bodies.)

Safety and environmental notices

Review all safety notices, environmental notices, and electronic emission notices before you install and use the product.

Suitability for telecommunication environment: This product is not intended to connect directly or indirectly by any means whatsoever to interfaces of public telecommunications networks.

To find the translated text for a caution or danger notice, complete the following steps.

1. Look for the identification number at the end of each caution notice or each danger notice. In the following examples, the numbers (C001) and (D002) are the identification numbers.



CAUTION: A caution notice indicates the presence of a hazard that has the potential of causing moderate or minor personal injury. (C001)



DANGER: A danger notice indicates the presence of a hazard that has the potential of causing death or serious personal injury. (D002)

2. Locate the with the user publications that were provided with your system hardware.
3. Find the matching identification number in the . Then, review the topics about the safety notices to ensure that you are in compliance.
4. (Optional) Read the multilingual safety instructions on the system website.
 - a. Go to www.ibm.com/support
 - b. Search for ""
 - c. Click the documentation link.

Safety notices and labels

Review the safety notices and safety information labels before you use this product.

To view a PDF file, you need Adobe Acrobat Reader. You can download it at no charge from the Adobe website:

www.adobe.com/support/downloads/main.html

IBM Systems Safety Notices

This publication contains the safety notices for the IBM Systems products in English and other languages. Anyone who plans, installs, operates, or services the system must be familiar with and understand the safety notices. Read the related safety notices before you begin work.

Note: The *IBM System Safety Notices* document is organized into two sections. The danger and caution notices without labels are organized alphabetically by language in the "Danger and caution notices by language" section. The danger and caution notices that are accompanied with a label are organized by label reference number in the "Labels" section.

Note: You can find and download the multilingual *IBM System Safety Notices* by searching for Publication number **G229-9054** in the [IBM Publications Center](#). You can also find and download the PDF by searching for **Systems Safety Notices** on the [IBM site](#) or the [IBM Support site](#).

The following notices and statements are used in IBM documents. They are listed in order of decreasing severity of potential hazards.

Danger notice definition

A special note that emphasizes a situation that is potentially lethal or extremely hazardous to people.

Caution notice definition

A special note that emphasizes a situation that is potentially hazardous to people because of some existing condition, or to a potentially dangerous situation that might develop because of some unsafe practice.

Note: In addition to these notices, labels might be attached to the product to warn of potential hazards.

Finding translated notices

Each safety notice contains an identification number. You can use this identification number to check the safety notice in each language.

To find the translated text for a caution or danger notice:

1. In the product documentation, look for the identification number at the end of each caution notice or each danger notice. In the following examples, the numbers (D002) and (C001) are the identification numbers.



DANGER: A danger notice indicates the presence of a hazard that has the potential of causing death or serious personal injury. (D002)



CAUTION: A caution notice indicates the presence of a hazard that has the potential of causing moderate or minor personal injury. (C001)

2. After you download the *IBM System Safety Notices* document, open it.
3. Under the language, find the matching identification number. Review the topics about the safety notices to ensure that you are in compliance.

Caution notices for the system

Ensure that you understand the caution notices for the system.

Use the reference numbers in parentheses at the end of each notice (for example, D005) to find the matching translated notice in .



CAUTION:

33.6-46.3 kg (74-102 lbs)	46.3-61.7 kg (102-136 lbs)	≥61.7-100 kg (136-220 lbs)

snc01053

The weight of this part or unit is more than 55 kg (121.2 lb). It takes specially trained persons, a lifting device, or both to safely lift this part or unit. (C011)



CAUTION: To avoid personal injury, before lifting this unit, remove all appropriate subassemblies per instructions to reduce the system weight. (C012)



CAUTION: CAUTION regarding IBM provided VENDOR LIFT TOOL:

- Operation of LIFT TOOL by authorized personnel only
- LIFT TOOL intended for use to assist, lift, install, remove units (load) up into rack elevations. It is not to be used loaded transporting over major ramps nor as a replacement for such designated tools like pallet jacks, walkies, fork trucks and such related relocation practices. When this is not practicable, specially trained persons or services must be used (for instance, riggers or movers). Read and completely understand the contents of LIFT TOOL operator's manual before using.
- Read and completely understand the contents of LIFT TOOL operator's manual before using. Failure to read, understand, obey safety rules, and follow instructions may result in property damage and/or personal injury. If there are questions, contact the vendor's service and support. Local paper manual must remain with machine in provided storage sleeve area. Latest revision manual available on vendor's website.
- Test verify stabilizer brake function before each use. Do not over-force moving or rolling the LIFT TOOL with stabilizer brake engaged.
- Do not raise, lower or slide platform load shelf unless stabilizer (brake pedal jack) is fully engaged. Keep stabilizer brake engaged when not in use or motion.
- Do not move LIFT TOOL while platform is raised, except for minor positioning.
- Do not exceed rated load capacity. See LOAD CAPACITY CHART regarding maximum loads at center versus edge of extended platform.
- Only raise load if properly centered on platform. Do not place more than 200 lb (91 kg) on edge of sliding platform shelf also considering the load's center of mass/gravity (CoG).
- Do not corner load the platform tilt riser accessory option. Secure platform riser tilt option to main shelf in all four (4x) locations with provided hardware only, prior to use. Load objects are designed to slide on/off smooth platforms without appreciable force, so take care not to push or lean. Keep riser tilt option flat at all times except for final minor adjustment when needed.
- Do not stand under overhanging load.
- Do not use on uneven surface, incline or decline (major ramps).
- Do not stack loads. (C048, part 1 of 2)

- **Do not operate while under the influence of drugs or alcohol.**
- **Do not support ladder against LIFT TOOL.**
- **Tipping hazard. Do not push or lean against load with raised platform.**
- **Do not use as a personnel lifting platform or step. No riders.**
- **Do not stand on any part of lift. Not a step.**
- **Do not climb on mast.**
- **Do not operate a damaged or malfunctioning LIFT TOOL machine.**
- **Crush and pinch point hazard below platform. Only lower load in areas clear of personnel and obstructions. Keep hands and feet clear during operation.**
- **No Forks. Never lift or move bare LIFT TOOL MACHINE with pallet truck, jack or fork lift.**
- **Mast extends higher than platform. Be aware of ceiling height, cable trays, sprinklers, lights, and other overhead objects.**
- **Do not leave LIFT TOOL machine unattended with an elevated load.**
- **Watch and keep hands, fingers, and clothing clear when equipment is in motion.**
- **Turn Winch with hand power only. If winch handle cannot be cranked easily with one hand, it is probably over-loaded. Do not continue to turn winch past top or bottom of platform travel. Excessive unwinding will detach handle and damage cable. Always hold handle when lowering, unwinding. Always assure self that winch is holding load before releasing winch handle.**
- **A winch accident could cause serious injury. Not for moving humans. Make certain clicking sound is heard as the equipment is being raised. Be sure winch is locked in position before releasing handle. Read instruction page before operating this winch. Never allow winch to unwind freely. Freewheeling will cause uneven cable wrapping around winch drum, damage cable, and may cause serious injury. (C048, part 2 of 2)**



CAUTION: Removing components from the upper positions in the rack cabinet improves rack stability during a relocation. Follow these general guidelines whenever you relocate a populated rack cabinet within a room or building.

- Reduce the weight of the rack cabinet by removing equipment starting at the top of the rack cabinet. When possible, restore the rack cabinet to the configuration of the rack cabinet as you received it. If this configuration is not known, you must observe the following precautions.
 - Remove all devices in the 32U position and above.
 - Ensure that the heaviest devices are installed in the bottom of the rack cabinet.
 - Ensure that there are no empty U-levels between devices installed in the rack cabinet below the 32U level.
- If the rack cabinet you are relocating is part of a suite of rack cabinets, detach the rack cabinet from the suite.
- If the rack cabinet you are relocating was supplied with removable outriggers they must be reinstalled before the cabinet is relocated.
- Inspect the route that you plan to take to eliminate potential hazards.
- Verify that the route that you choose can support the weight of the loaded rack cabinet. Refer to the documentation that comes with your rack cabinet for the weight of a loaded rack cabinet.
- Verify that all door openings are at least 760 x 230 mm (30 x 80 in.).
- Ensure that all devices, shelves, drawers, doors, and cables are secure.
- Ensure that the four leveling pads are raised to their highest position.
- Ensure that there is no stabilizer bracket installed on the rack cabinet during movement.
- Do not use a ramp inclined at more than 10 degrees.
- When the rack cabinet is in the new location, complete the following steps:

- Lower the four leveling pads.
- Install stabilizer brackets on the rack cabinet.
- If you removed any devices from the rack cabinet, repopulate the rack cabinet from the lowest position to the highest position.
- If a long-distance relocation is required, restore the rack cabinet to the configuration of the rack cabinet as you received it. Pack the rack cabinet in the original packaging material, or equivalent. Also lower the leveling pads to raise the casters off the pallet and bolt the rack cabinet to the pallet. (R002)

Danger notices for the system

Ensure that you are familiar with the danger notices for your system.

Use the reference numbers in parentheses at the end of each notice (for example, D005) to find the matching translated notice in .



DANGER: When working on or around the system, observe the following precautions:

Electrical voltage and current from power, telephone, and communication cables are hazardous. To avoid a shock hazard:

- If IBM supplied a power cord(s), connect power to this unit only with the IBM provided power cord. Do not use the IBM provided power cord for any other product.
- Do not open or service any power supply assembly.
- Do not connect or disconnect any cables or perform installation, maintenance, or reconfiguration of this product during an electrical storm.
- The product might be equipped with multiple power cords. To remove all hazardous voltages, disconnect all power cords.
- Connect all power cords to a properly wired and grounded electrical outlet. Ensure that the outlet supplies proper voltage and phase rotation according to the system rating plate.
- Connect any equipment that will be attached to this product to properly wired outlets.
- When possible, use one hand only to connect or disconnect signal cables.
- Never turn on any equipment when there is evidence of fire, water, or structural damage.
- Disconnect the attached power cords, telecommunications systems, networks, and modems before you open the device covers, unless instructed otherwise in the installation and configuration procedures.
- Connect and disconnect cables as described in the following procedures when installing, moving, or opening covers on this product or attached devices.

To disconnect:

1. Turn off everything (unless instructed otherwise).
2. Remove the power cords from the outlets.
3. Remove the signal cables from the connectors.
4. Remove all cables from the devices.

To connect:

1. Turn off everything (unless instructed otherwise).
 2. Attach all cables to the devices.
 3. Attach the signal cables to the connectors.
 4. Attach the power cords to the outlets.
 5. Turn on the devices.
- Sharp edges, corners and joints might be present in and around the system. Use care when handling equipment to avoid cuts, scrapes and pinching. (D005)



DANGER: Heavy equipment–personal injury or equipment damage might result if mishandled. (D006)



DANGER: DANGER: Serious injury or death can occur if loaded lift tool falls over or if a heavy load falls off the lift tool. Always completely lower the lift tool load plate and properly secure the load on the lift tool before moving or using the lift tool to lift or move an object. (D010)



DANGER: Racks with a total weight of > 227 kg (500 lb.), Use Only Professional Movers! (R003)



DANGER: Do not transport the rack via fork truck unless it is properly packaged, secured on top of the supplied pallet. (R004)

DANGER:



Main Protective Earth (Ground):

This symbol is marked on the frame of the rack.

The **PROTECTIVE EARTHING CONDUCTORS** should be terminated at that point. A recognized or certified closed loop connector (ring terminal) should be used and secured to the frame with a lock washer using a bolt or stud. The connector should be properly sized to be suitable for the bolt or stud, the locking washer, the rating for the conducting wire used, and the considered rating of the breaker. The intent is to ensure the frame is electrically bonded to the **PROTECTIVE EARTHING CONDUCTORS**. The hole that the bolt or stud goes into where the terminal conductor and the lock washer contact should be free of any non-conductive material to allow for metal to metal contact. All **PROTECTIVE EARTHING CONDUCTORS** should terminate at this main protective earthing terminal or at points marked with . (R010)

Special caution and safety notices

This information describes special safety notices that apply to the system. These notices are in addition to the standard safety notices that are supplied; they address specific issues that are relevant to the equipment provided.

General safety

When you service the Storwize® V5100 , follow general safety guidelines.

Use the following general rules to ensure safety to yourself and others.

- Observe good housekeeping in the area where the devices are kept during and after maintenance.
- Follow the guidelines when lifting any heavy object:
 1. Ensure that you can stand safely without slipping.
 2. Distribute the weight of the object equally between your feet.
 3. Use a slow lifting force. Never move suddenly or twist when you attempt to lift.
 4. Lift by standing or by pushing up with your leg muscles; this action removes the strain from the muscles in your back. *Do not attempt to lift any objects that weigh more than 18 kg (40 lb) or objects that you think are too heavy for you.*
- Do not perform any action that causes a hazard or makes the equipment unsafe.
- Before you start the device, ensure that other personnel are not in a hazardous position.
- Place removed covers and other parts in a safe place, away from all personnel, while you are servicing the unit.
- Keep your tool case away from walk areas so that other people cannot trip over it.

- Do not wear loose clothing that can be trapped in the moving parts of a device. Ensure that your sleeves are fastened or rolled up above your elbows. If your hair is long, fasten it.
- Insert the ends of your necktie or scarf inside clothing or fasten it with a nonconducting clip, approximately 8 cm (3 in.) from the end.
- Do not wear jewelry, chains, metal-frame eyeglasses, or metal fasteners for your clothing.

Remember: Metal objects are good electrical conductors.

- Wear safety glasses when you are hammering, drilling, soldering, cutting wire, attaching springs, using solvents, or working in any other conditions that might be hazardous to your eyes.
- After service, reinstall all safety shields, guards, labels, and ground wires. Replace any safety device that is worn or defective.
- Reinstall all covers correctly after you have finished servicing the unit.

Handling static-sensitive devices

Ensure that you understand how to handle devices that are sensitive to static electricity.



Attention: Static electricity can damage electronic devices and your system. To avoid damage, keep static-sensitive devices in their static-protective bags until you are ready to install them.

To reduce the possibility of electrostatic discharge, observe the following precautions:

- Limit your movement. Movement can cause static electricity to build up around you.
- Handle the device carefully, holding it by its edges or frame.
- Do not touch solder joints, pins, or exposed printed circuitry.
- Do not leave the device where others can handle and possibly damage the device.
- While the device is still in its antistatic bag, touch it to an unpainted metal part of the system unit for at least 2 seconds. (This action removes static electricity from the package and from your body).
- Remove the device from its package and install it directly into your system, without putting it down. If it is necessary to put the device down, place it onto its static-protective bag. (If your device is an adapter, place it component-side up.) Do not place the device onto the cover of the system or onto a metal table.
- Take additional care when you handle devices during cold weather. Indoor humidity tends to decrease in cold weather, causing an increase in static electricity.

Environmental notices

This information contains all the required environmental notices for IBM Systems products in English and other languages.

The *Environmental Notices and User Guide* includes statements on limitations, product information, product recycling and disposal, battery information, flat panel display, refrigeration and water-cooling systems, external power supplies, and safety data sheets.

About this guide

This publication provides information that helps you install and initialize the system.

Unless otherwise stated, references to 2077-424 are assumed to include 2078-424 , 2077-AF4 , 2078-AF4 , and 2078-U5B .

Who should use this guide

This guide is intended for installers of Storwize V5100 systems.

Before configuring your system, ensure that you follow the procedures as listed. Be sure to gather IP addresses that you will need before you begin the installation.

Publications and related libraries

Product manuals, other publications, and websites that contain information that is related to your system are available.

IBM Knowledge Center for Storwize V5100

The information collection in the IBM Knowledge Center contains all of the information that is required to install, configure, and manage the system. The information collection in the IBM Knowledge Center is updated between product releases to provide the most current documentation. The information collection is available at the following website:

[Knowledge Center](#)

IBM websites for help, services, and information

Table 1 on page [xxi](#) lists websites where you can find help, services, and more information.

Website	Address
Directory of worldwide contacts	http://www.ibm.com/planetwide
Support for Storwize V5100 [2077 (1-year warranty) or 2078 (3-year warranty)]	www.ibm.com/support
IBM Redbooks® publications	www.redbooks.ibm.com/

Publications in the Knowledge Center

Each PDF publication in the library is available in the IBM Knowledge Center by clicking the title in the "Link to PDF" column:

Table 2. Storwize V5100 library

Title	Description	Link to PDF file
<p><i>IBM Spectrum Virtualize Software Command-Line Interface User's Guide</i></p> <p><i>For IBM Spectrum Virtualize as Software Only, IBM Spectrum Virtualize for Public Cloud, IBM SAN Volume Controller, IBM Storwize V7000, IBM Storwize V5000, IBM Storwize V5000E, IBM Storwize V5100, IBM FlashSystem 5000, IBM FlashSystem 5100, IBM FlashSystem V9000, and IBM FlashSystem 9100</i></p>	<p>The guide describes the commands that you can use from the Storwize V5100 command-line interface (CLI).</p>	<p>Command-Line Interface User's Guide</p>

Related accessibility information

To view a PDF file, you need Adobe Reader, which can be downloaded from the Adobe website:

www.adobe.com/support/downloads/main.html

Related websites

The following websites provide information about the system, related products, or technologies.

Type of information	Website
Storwize V5100 support	www.ibm.com/support
Technical support for IBM storage products	www.ibm.com/support
IBM Electronic Support registration	www-01.ibm.com/support/electronicssupport/

Sending your comments

Your feedback is important in helping to provide the most accurate and highest-quality information.

To submit any comments, send your comments by email to ibmkc@us.ibm.com. Include the following information in your email:

- Exact publication title and version.
- Page, table, or illustration numbers that you are commenting on.
- A detailed description of any information that needs to be changed.

How to get information, help, and technical assistance

If you need help, service, technical assistance, or want more information about IBM products, you can find a wide variety of sources available from IBM to assist you.

Information

IBM maintains pages on the web where you can get information about IBM products and fee services, product implementation and usage assistance, break and fix service support, and the latest technical information. For more information, refer to this table.

Table 3. IBM websites for help, services, and information

Website	Address
IBM home page	http://www.ibm.com
Directory of worldwide contacts	http://www.ibm.com/planetwide
Support for products	www.ibm.com/support

Note: Available services, telephone numbers, and web links are subject to change without notice.

Help and service

When you call from the US or Canada, choose the **storage** option.

Getting help online

You can find information about products, solutions, partners, and support on the IBM website.

To find up-to-date information about products, services, and partners, visit the IBM website at www.ibm.com/support.

Before you call

Make sure that you take steps to try to solve the problem yourself before you call. Some suggestions for resolving the problem before you call IBM Support include:

- Check all cables to make sure that they are connected.
- Use the troubleshooting information in your system documentation. The troubleshooting section of IBM Knowledge Center contains procedures to help you diagnose problems.

Using the documentation

Sign up for the Support Line Offering

If you have questions about how to use and configure the machine, sign up for the IBM Support Line offering to get a professional answer.

The maintenance that is supplied with the system provides support when there is a problem with a hardware component or a fault in the system machine code. At times, you might need expert advice about using a function that is provided by the system or about how to configure the system. Purchasing the IBM Support Line offering gives you access to this professional advice for your system, and in the future.

Contact your local IBM sales representative or your support group for availability and purchase information.

Chapter 1. Before you begin the installation

Before you can begin installing your system, you must unpack and verify your order and make other preparations.

The *Quick Installation Guide* contains a set of instructions to help you unpack and install your system. The guide is divided into chapters and appendixes.

1. The steps in [Chapter 1, “Before you begin the installation,” on page 1](#) (the chapter you are now reading) involve verifying your order, becoming familiar with the hardware component terminology, and ensuring that you have met the environmental requirements.
2. The steps in [Chapter 2, “Installing the system hardware,” on page 11](#) involve installing the hardware and attaching the data cables and power cords.
3. [Chapter 3, “Configuring the system,” on page 81](#) helps you create your configuration file and access the management GUI. The management GUI guides you through the initial configuration process.
4. [Chapter 4, “Adding an expansion enclosure to an existing system,” on page 87](#) describes how to add an expansion enclosure to an existing system by using the management GUI to update the system configuration.
5. [Chapter 5, “Adding a control enclosure to an existing system,” on page 89](#) describes how to add a control enclosure to an existing system, beginning with installing the control enclosure in the rack and then connecting it to the system through a zone in the SAN.
6. [Appendix A, “Accessibility features for the system,” on page 91](#) is an appendix that describes IBM's commitment to accessibility for all customers.
7. [Appendix B, “Where to find the Statement of Limited Warranty,” on page 93](#) is an appendix that describes where to find Warranty information.
8. [Appendix C, “Control enclosure requirements,” on page 95](#) is an appendix that describes the environmental requirements that you must meet to install and operate a 2077/2078-AF4/424/U5B control enclosure.
9. [Appendix D, “SAS expansion enclosure requirements,” on page 101](#) is an appendix that describes the environmental requirements that you must meet to install and operate a 2U 2077/2078-12F or 2077/2078-24F expansion enclosure, or a 5U 2077/2078-92F/A9F expansion enclosure. The examples that are shown for a 2U enclosure are for the 2077-24F / 2078-24F .

Important information:

- This guide presumes that you have read the planning information regarding your physical environment that is available in the IBM Knowledge Center.
- Ensure that any cables that you are supplying are available for installation.

Installation scenarios

Depending on your order, this documentation steps you through setting up your system for the following scenarios:

- **Setting up a new system that consists of a control enclosure only.** In this case, you are not installing any expansion enclosures.
- **Setting up a new system that consists of a control enclosure and one or more expansion enclosures.**
- **Adding an expansion enclosure to an existing system.** In this case, you initially installed a control enclosure (and, optionally, one or more expansion enclosures). You want to add an expansion enclosure to your existing system. You do not need to power off the system. You can add an expansion enclosure while the system is operational.

- **Adding a control enclosure (either by itself or with one or more expansion enclosures) to an existing system.** You do not need to power off the system. You can add a control enclosure while the system is operational.
- **Setting up a new system that consists of more than one control enclosure.** Install the first control enclosure and then the required expansion enclosures. For each additional control enclosure, complete the setup as if you were adding it to an existing system.

Be familiar with the following information

- See “Caution notices for the system” on page xiv and “Danger notices for the system ” on page xvii for a summary of the situations that can be potentially hazardous to you. Before installing, read and understand the following caution and danger statements.
- Use safe practices when lifting. The fully populated enclosure weighs about 45 kg (99 lbs). At least three people are required to lift and install the enclosure into the rack or to remove an enclosure from the rack.



CAUTION: Use safe practices when lifting.

		
33.6-46.3 kg (74-102 lbs)	46.3-61.7 kg (102-136 lbs)	≥61.7-100 kg (136-220 lbs)

svc01053

(27B)

Also keep in mind that a rack full of equipment is extremely heavy.



DANGER: Heavy equipment–personal injury or equipment damage might result if mishandled. (D006)

- The following general precautions should be observed, even though the power-on steps differ slightly from the directions that you will follow for this product:



DANGER: When working on or around the system, observe the following precautions:

Electrical voltage and current from power, telephone, and communication cables are hazardous. To avoid a shock hazard:

- If IBM supplied a power cord(s), connect power to this unit only with the IBM provided power cord. Do not use the IBM provided power cord for any other product.
- Do not open or service any power supply assembly.
- Do not connect or disconnect any cables or perform installation, maintenance, or reconfiguration of this product during an electrical storm.
- The product might be equipped with multiple power cords. To remove all hazardous voltages, disconnect all power cords.
- Connect all power cords to a properly wired and grounded electrical outlet. Ensure that the outlet supplies proper voltage and phase rotation according to the system rating plate.
- Connect any equipment that will be attached to this product to properly wired outlets.
- When possible, use one hand only to connect or disconnect signal cables.
- Never turn on any equipment when there is evidence of fire, water, or structural damage.
- Disconnect the attached power cords, telecommunications systems, networks, and modems before you open the device covers, unless instructed otherwise in the installation and configuration procedures.
- Connect and disconnect cables as described in the following procedures when installing, moving, or opening covers on this product or attached devices.

To disconnect:

1. Turn off everything (unless instructed otherwise).
2. Remove the power cords from the outlets.
3. Remove the signal cables from the connectors.
4. Remove all cables from the devices.

To connect:

1. Turn off everything (unless instructed otherwise).
 2. Attach all cables to the devices.
 3. Attach the signal cables to the connectors.
 4. Attach the power cords to the outlets.
 5. Turn on the devices.
- Sharp edges, corners and joints might be present in and around the system. Use care when handling equipment to avoid cuts, scrapes and pinching. (D005)

Tools needed

A flat-blade screwdriver with a 7 mm (1/4 inch) head is the only tool needed for installation.

Reviewing your packing slip

After you open your shipment, you must verify the contents against the packing slip.

In each box, locate the packing slip. Verify that the items that are listed in the packing slip match what is in the box, and that any optional items that you ordered are included in the list. Your shipment might contain extra items, depending on the order.

Note: If you purchased your equipment through a reseller, some of the options might be preinstalled. Contact your supplier for details.

Use the following checklist to check off the items in your order as you verify that they are included in your shipment.

___ • Control enclosure or expansion enclosures:

<i>Table 4. Storwize V5100 control and expansion enclosures</i>		
Machine type / model	Warranty	Description
2077-424	1 year	IBM Storwize V5100 NVMe Control Enclosure
2078-424	3 years	IBM Storwize V5100 NVMe Control Enclosure
2078-U5B	3 years	IBM Storwize V5100 Utility NVMe Control Enclosure
2077-12F	1 year	IBM Storwize V5100 12-slot Expansion Enclosure for 3.5-inch drives
2078-12F	3 years	IBM Storwize V5100 12-slot Expansion Enclosure for 3.5-inch drives
2077-24F	1 year	IBM Storwize V5100 24-slot Expansion Enclosure for 2.5-inch drives
2078-24F	3 years	IBM Storwize V5100 24-slot Expansion Enclosure for 2.5-inch drives
2077-92F	1 year	IBM Storwize V5100 92-slot Expansion Enclosure for 3.5-inch drives

Machine type / model	Warranty	Description
2078-92F	3 years	IBM Storwize V5100 92-slot Expansion Enclosure for 3.5-inch drives
2077-A9F	3 years	IBM Storwize V5100 92-slot Expansion Enclosure for 2.5-inch drives
2078-A9F	3 years	IBM Storwize V5100 92-slot Expansion Enclosure for 2.5-inch drives

- ___ • Rack-mounting hardware kit:
 - ___ – Two rails (right and left assembly)
 - ___ – Silver screw pins for use with racks with square mounting holes (12 and 24 drive enclosures only)
 - ___ – Black rack mounting screws
- ___ • Two power cords for connection to rack-mounted power distribution units
- ___ • Drive bay blanking plates (installed in the enclosure for 12 and 24 drive enclosures only)
- ___ • Publications package

Options applicable to control enclosures

Note: All options other than cables are preinstalled.

- ___ • Cache memory sequential upgrades to enhance 32 GB base system memory (2 x 16 GB DIMMs):
 - 96 GB total system memory – adds 4 x 16 GB DIMMs
 - 288 GB total system memory – (requires 96 GB total memory option and) adds 6 x 32 GB DIMMs
- ___ • From 0 - 1 of the following host interface adapter options for the two available card slots:
 - Four-port 32 Gbps Fibre Channel with four small form-factor pluggable (SFP) transceivers installed
 - Four-port 16 Gbps Fibre Channel that supports NVMe over Fabrics (NVMe-oF) with four small form-factor pluggable (SFP) transceivers installed
 - Two-port 25 Gbps Ethernet iWARP with iSER support that is NVMe-oF ready when the software supports it
 - Two-port 25 Gbps Ethernet RoCE with iSER support that is NVMe-oF ready when the software supports it
 - Two-port 12 Gbps SAS expansion adapter
- ___ • Fibre Channel cables
- ___ • SAS cables
- ___ • Drive options for the 24 available drive bays:
 - Self-compressing, self-encrypting 2.5-inch NVMe-attached IBM FlashCore Modules with the following storage capacities: 4.8 TB, 9.6 TB, and 19.2 TB.
 - Industry-standard 2.5-inch NVMe-attached SSD drive options with the following storage capacities: 1.92 TB, 3.84 TB, 7.68 TB, and 15.36 TB.
- ___ • Power cords for connection to wall sockets

Options applicable to expansion enclosures

Note: All options other than cables are preinstalled.

- ___ • Expansion enclosure attachment cables

- ___ • Drives
- ___ • Power cords for connection to wall sockets

Identifying the hardware components

The following graphics identify hardware components and port locations for the control enclosures and expansion enclosures of the system.

Control enclosure components

The control enclosure contains two node canisters. A label on the control enclosure identifies each node canister and power supply unit (PSU). As [Figure 1 on page 5](#) shows, node canister 1 is on top and node canister 2 is on the bottom. Because the node canisters are inverted, the location of the ports and the numbering of the ports are oriented differently on each node canister. It is important to remember this orientation when you are installing adapters and cables.

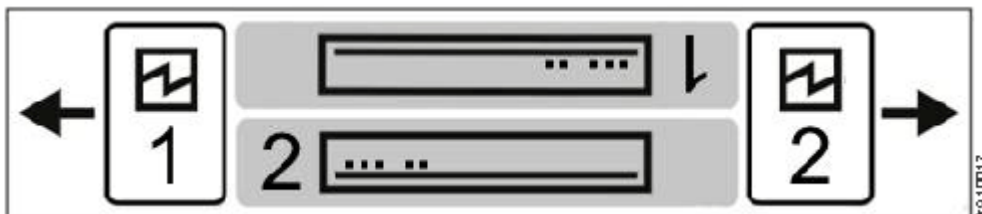

Figure 1. Label showing the orientation of the node canisters and PSUs

For example, [Figure 2 on page 5](#) shows the top node canister. On this canister, the numbering of the PCIe slots and ports goes from right to left. PCIe adapter slot 1 contains a 4-port 12 Gbps SAS adapter and slot 2 contains a 4-port 16 Gbps Fibre Channel adapter. The onboard Ethernet and USB ports are also shown.

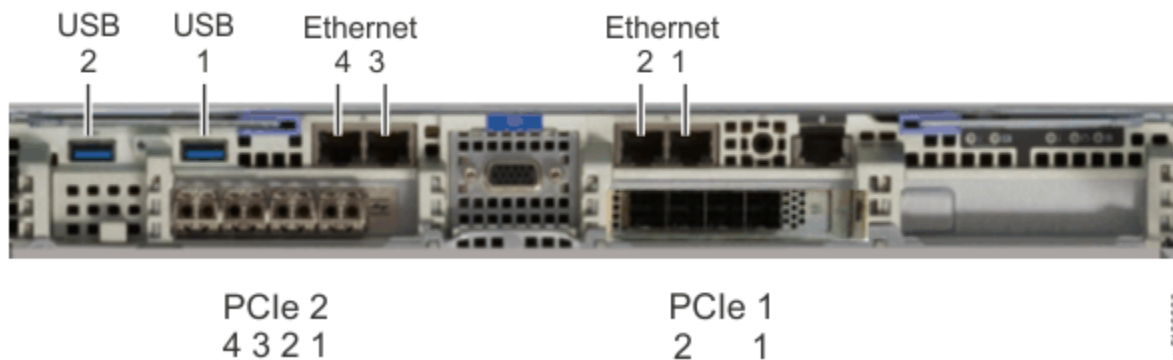

Figure 2. Orientation of ports on node canister 1 (top)

[Figure 3 on page 6](#) shows the bottom node canister. This node canister has the same type and number of adapters installed. However, on the bottom canister, the numbering of the PCI slots and the ports goes from left to right.

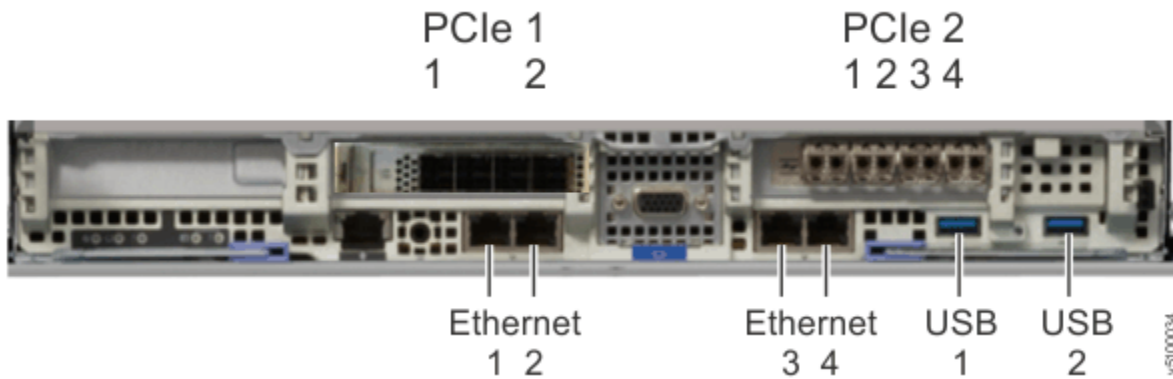

Figure 3. Orientation of ports on node canister 2 (bottom)

Data ports

Four 10 Gbps Ethernet ports on each node canister provide system management connections and iSCSI host connectivity. The onboard 10 Gbps Ethernet ports use RJ-45 connections, not optical connections. The 10 Gbps ports operate at 1 Gbps when connected to a 1 Gbps switch. A separate technician port provides access to initialization and service assistant functions. [Table 5 on page 6](#) describes each port.

Table 5. Summary of onboard Ethernet ports

Onboard Ethernet Port	Speed	Function
1	10 Gbps	Management IP, Service IP, Host I/O
2	10 Gbps	Secondary Management IP, Host I/O
3	10 Gbps	Host I/O
4	10 Gbps	Host I/O
T	1 Gbps	Technician Port - DHCP/DNS for direct attach service management

Control enclosure support rails

The left and right control enclosure support rails are designed specifically for installation of a control enclosure.

- The ledge on the inside of the rails supports the entire length of a control enclosure.
- At the rear end of the control enclosure support rail, the top edge curves over to capture the top edge of an inserted control enclosure. This prevents the installed control enclosure bouncing when the rack is subjected to quake or vibration.
- The control enclosure support rails adjust to fit racks from 685 mm to 765 mm deep, measured between the front and rear rack rails.

Expansion enclosure components

[Figure 4 on page 7](#) shows the location of the power supply units and expansion canisters.

- **1** Expansion canisters
- **2** Power supply units

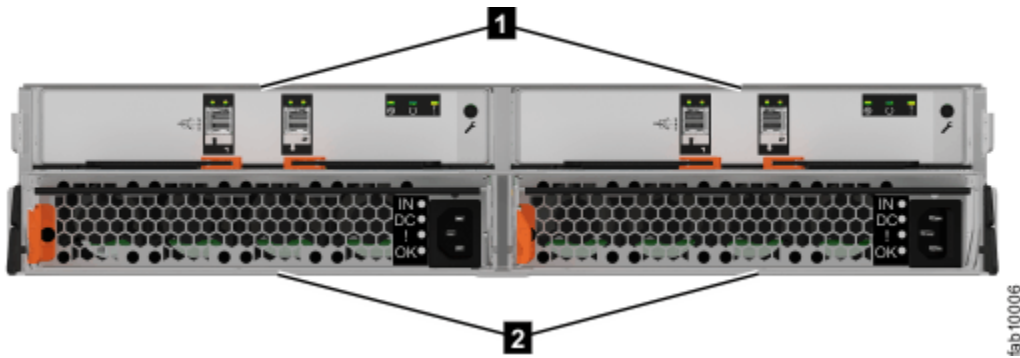

Figure 4. Rear view of a 2077/2078-424 / 2077/2078-AF4 2077 expansion enclosure

Figure 5 on page 7 shows the LEDs and SAS port locations from the rear view of an expansion canister.

- **1** LEDs
- **2** SAS ports

Each canister has two SAS ports that are numbered 1 on the left and 2 on the right. Port 1 is used to connect to a SAS expansion port on a node canister or port 2 of another expansion canister.

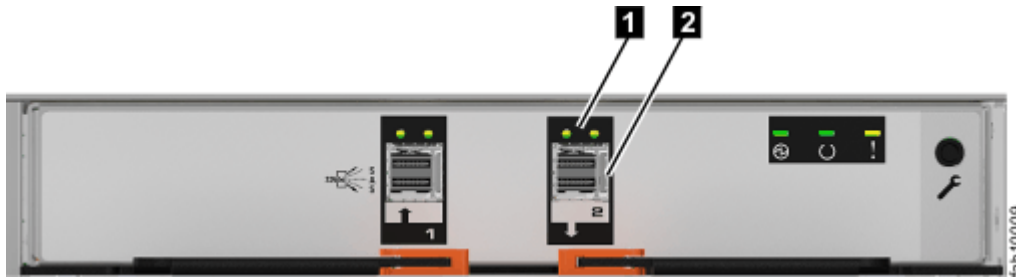

Figure 5. SAS ports and LEDs in rear view of an expansion canister for 2077/2078-424 / 2077/2078-AF4

Expansion enclosure support rails

The left and right expansion enclosure support rails (Figure 6 on page 8) are designed specifically for installation of an expansion enclosure.

- The ledge on the inside of each rail supports the entire length of an expansion enclosure.
- The expansion enclosure support rails capture the left and right rear edges of an inserted expansion enclosure. This prevents the installed control enclosure bouncing when the rack is subjected to quake or vibration.
- The expansion enclosure support rails adjust to fit racks from 595 mm to 755 mm deep, measured between the front and rear rack rails.

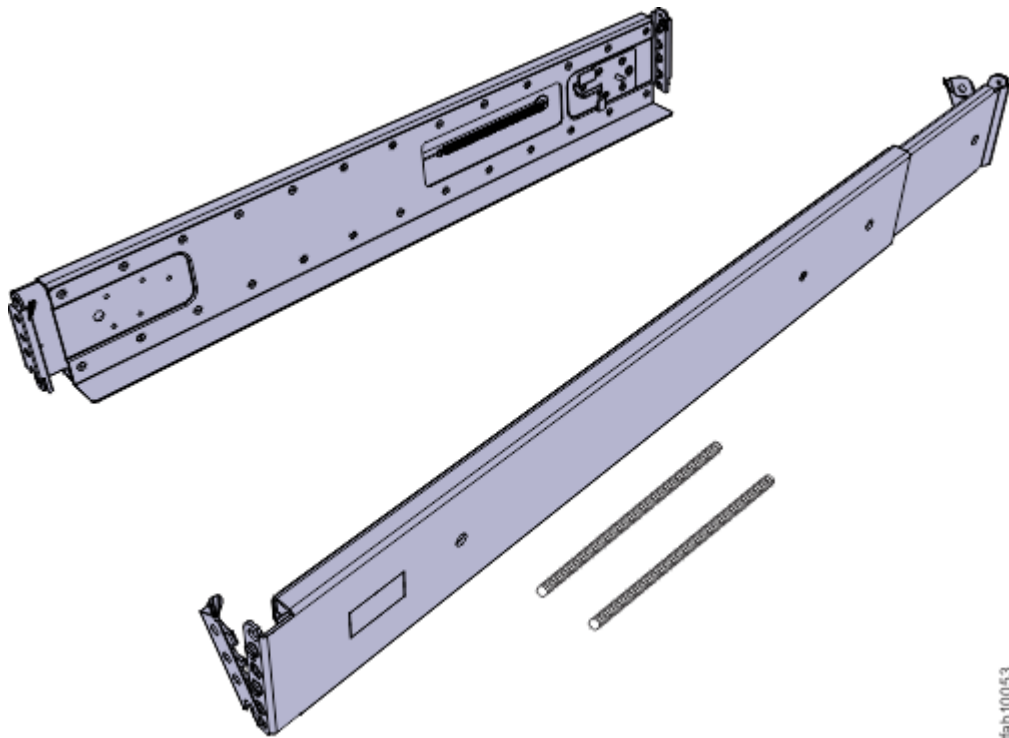

Figure 6. Expansion enclosure support rails

Identifying Storwize V5100 node canisters

The Storwize V5100 node canisters include hardware changes that significantly differ from earlier model node canisters. The differences help distinguish the types of node canisters. The main difference is that Storwize V5100 node canisters are not side by side in the control enclosure, but each is the full width (minus the width of both power supplies) and half the height of the control enclosure, sitting one above the other in an inverted orientation.

Figure 7 on page 8 shows the canister release levers extended to either remove or replace the bottom of the two node canisters in a Storwize V5100 control enclosure. The inverted (upside down) upper node canister is also shown in the illustration.

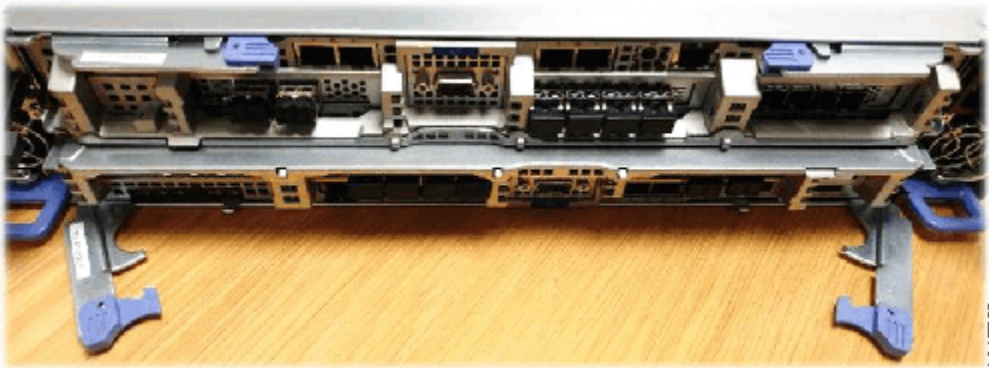

Figure 7. Rear of the Storwize V5100 enclosure

Other differences between Storwize V5100 control enclosures and earlier control enclosures are numerous:

- New Intel CPU platform: Intel Xeon Bronze 8 core 1.7GHz processor with 16 Hyperthreads per node canister
- Removable Trusted Platform Module (TPM)

- From 4 to 12 DDR4 (288p socket) DIMMs in 12 DIMM slots in each node canister, supported as base memory and cumulative, sequential upgrades:
 - 32 GB per node canister as 2 x 16 GB DIMMs (default base installation)
 - 96 GB per node canister as 6 x 16 GB DIMMs (the first upgrade of 64 GB raises the cumulative total to 96 GB total memory per canister)
 - 288 GB per node canister as 6 x 16 GB DIMMs and 6 x 32 GB DIMMs (the second upgrade of 192 GB raises the cumulative total to 288 GB total memory per canister)

Note: The control enclosure has two canisters. To reach the system total cache of 576 GB, multiply the above figure of 288 GB by two.

For other differences, see the system overview in the Knowledge Center.

Verify environmental requirements

The environmental and electrical requirements for the physical site must be met to ensure that your system works reliably.

Before you install a system, you must verify that adequate space in a suitable rack is available. You must also ensure that the requirements for power and environmental conditions are met.

The quick installation guide assumes that you have completed the physical planning for the environment of your system. If you have not done the environmental planning for your system, see the "physical installation planning" topic in the IBM Knowledge Center for the product. Complete the planning tasks and worksheets before you install and initialize your system.

If your system contains more than one control enclosure, configure a Fibre Channel switch for correct zoning between control enclosures for best results. See the configuring topics in IBM Knowledge Center that contain information about zoning rules and zoning details.

To verify that your environment can support 2077-424 , see [Appendix C, "Control enclosure requirements,"](#) on page 95.

To verify that your environment can support expansion enclosures for 2077-424 , see [Appendix D, "SAS expansion enclosure requirements,"](#) on page 101.

Review enclosure location guidelines

Installing a control enclosure only

If you are installing a control enclosure only, follow these guidelines.

- Position the enclosure in the rack so that you can easily view it and access it for servicing.
- Locate the enclosure low enough for the rack to remain stable.

A fully assembled enclosure, containing drives, node canisters, power supplies units, and all possible features weighs approximately 45 kg (99 lb), requiring three people to lift. For installation by a single person, reduce the system down to manageable components by removing the drives from the front of the enclosure and node canisters and power supply units from the rear of the enclosure before you attempt to move the enclosure.

Installing a control enclosure and one or more expansion enclosures

If you are installing a control enclosure plus one or more expansion enclosures, follow these guidelines.

- A system can support up to 1520 drives that are installed into control and expansion enclosures. Each enclosure requires 2U of rack space.
- Each assembled enclosure weighs more than 36 kg. Provide sufficient space at the front of the rack for three persons to carry the enclosure safely.
- Each 2U expansion enclosure, including drives, can weigh approximately 29 kg, requiring two persons to lift. For a single person installation, separate the drives from the enclosure. Installation of the 5U expansion enclosure requires additional care. For more information, see the following chapter.
- Each system can consist of up to two control enclosures. Each control enclosure can be connected to up to 20 expansion enclosures (two SAS chains of up to 10 expansion enclosures each).
- For best performance, divide the total number of expansion enclosures to be installed among the control enclosures in the system.
- Where expansion enclosures are to be installed, distribute them evenly into rack space above and below the control enclosure to which they are to connect. Do not leave gaps between the enclosures. Such placement aids cabling and serviceability.
- Leave space in the rack for future expansion enclosures, but otherwise install all enclosures that constitute one system in adjacent or nearby rack space.
- If a rack is to be only partially filled, install the enclosures low enough for the rack to remain stable and enable easy access to the enclosures for servicing.

Adding an expansion enclosure chain to an existing system

If you are adding an expansion enclosure chain to an existing system, follow these guidelines.

- You do not need to power off the system. You can add an expansion enclosure while the system is operational.
- Add the first expansion enclosure directly below the control enclosure.
- Add the second expansion enclosure directly above the control enclosure.
- Add the third expansion enclosure directly below the first.
- Add the fourth expansion directly above the second, and so on.

Chapter 2. Installing the system hardware

After verification that you have all of the hardware components that you require, you can install them.

You completed the initial steps of verifying the shipping contents and becoming familiar with the hardware components. You verified that the power and environmental requirements are met and planned the location of the enclosures. You are now ready to begin installing the hardware components and connecting the data cables and power cords.

Installation overview

The installation and initial configuration of your system is your responsibility, following the plan that you created using the planning information in the Knowledge Center.

Hardware installation tasks that you must complete

To install the Storwize V5100 hardware, you must complete the following tasks:

Important: You must complete the planning tasks and have completed worksheets so that you can proceed with installing and initializing your system.

1. You must unpack and install the Storwize V5100 control enclosures and any optional SAS expansion enclosures in the rack.
2. Referring to the worksheets that you created, you must complete the cabling.

Note:

If you intend to add the Storwize V5100 control enclosure to an existing system, you simply install the control enclosure, because the existing system is already initialized.

Initial setup tasks that you must complete

After the hardware is installed, connect a workstation to the technician port of one of the node canisters in the Storwize V5100 control enclosure and complete the following tasks:

1. Configure the system with a name and management and service IP addresses.

Note:

If you intend to add the Storwize V5100 control enclosure to an existing system, you simply install the control enclosure, because the existing system is already initialized.

2. Log in to the control enclosure using the management GUI, and complete the system setup wizard using information from the worksheets you created.

First customer tasks

After you complete the service setup process, you can log in to the Storwize V5100 management GUI and complete the following tasks using the customer setup wizard:

1. Change the system password.
2. Set the date and time.
3. Create I/O groups (if applicable).
4. Confirm the Call Home settings that you entered during the installation.
5. Configure licensed functions.
6. Create storage pools.

At the completion of the setup wizard, the setup wizard creates storage arrays and assigns the MDisks to the storage pools.

After the installation and initial configuration of the hardware is complete, IBM strongly recommends that you check to see whether a later level of firmware and software is available and update to that level.

Unpacking the Storwize V5100 control enclosure

Before you unpack the Storwize V5100 control enclosure, ensure that you review and follow all related instructions.

Before you begin

The control enclosure and related parts are shipped in a single box, containing the following:

- Control enclosure with the following components preinstalled:
 - Two node canisters with adapters, SFPs, and memory feature codes preinstalled
 - Two power supplies and two power interposers
 - A combination of 24 NVMe drives and drive blanks

The specific number of drives and drive blanks will vary, depending on the number of drives that were specified in the product order. For example, if 12 drives were ordered, they will be preinstalled in the control enclosure along with 12 drive blanks. All drive bays must contain a drive or a drive blank.

- Rail kit including left and right rails, eight securing screws, and eight locating pins
- Two power cables
- Optional OM3 fiber cables

Note: You will need a box knife to unpack the control enclosure.

About this task



CAUTION: To lift the assembled enclosure requires three persons unless suitable lifting equipment is available or the enclosure is unpacked and dismantled as described in the procedure.

Procedure

1. Cut the box tape and open the lid of the shipping carton.
2. Remove the rail kit box and set it aside in a safe location.
3. Lift the front and rear foam packing pieces from the carton.
4. Remove the four corner reinforcement pieces from the carton.
5. Using the box knife, carefully cut the four corners of the carton from top to bottom.
6. Fold the sides and back of the carton down to uncover the rear of the control enclosure.
If necessary, carefully cut along the lower fold line of the sides and remove them.
7. Carefully cut the raised section of the foam packing away from the rear of the enclosure.
8. Carefully cut open the bag covering the rear of the enclosure.
9. Remove the left power supply unit (PSU) from the enclosure.
10. Record the last six digits of the serial number on the back of the power supply, and then set the power supply aside.
11. Remove the right PSU, record its serial number, and set it aside.
12. Remove the upper node canister from the enclosure.
13. Record the serial number on the canister release handle, and then set the canister aside.
14. Remove the lower node canister, record its serial number, and set it aside.
15. Lift the enclosure from the shipping carton.

Installing support rails for the control enclosures

Before you install the control enclosure into the rack, you must first install the support rails for it.

Procedure

To install the support rails for the control enclosure, complete the following steps.

1. Locate the control enclosure rails, as shown in [Figure 8 on page 13](#).

The rail assembly consists of two rails that must be installed in the rack cabinet.

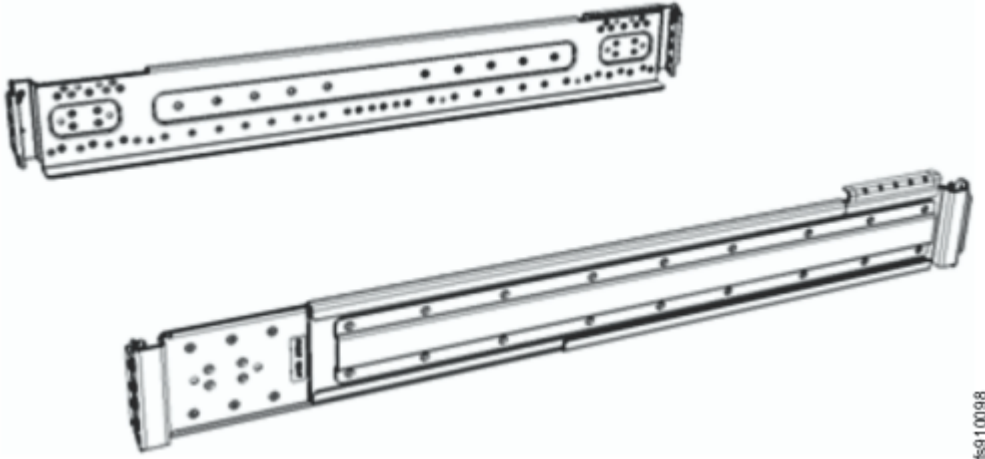

Figure 8. Control enclosure support rails

2. Working at the front of the rack cabinet, identify the two standard rack units (2U) of space in the rack into which you want to install the support rails.

[Figure 9 on page 13](#) shows two rack units with the front mounting holes identified.

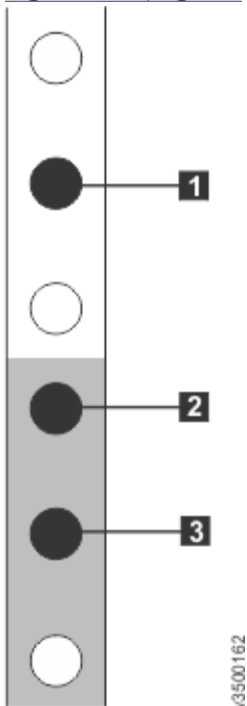

Figure 9. Hole locations in the front of the rack

- **1** Upper rail-mounting bracket pin
- **2** Lower rail-mounting bracket pin

- **3** Rack mounting screw hole
3. Ensure that the appropriate bracket pins are installed in the front and rear bracket of each rail.
Each rail comes with four medium pins preinstalled (two in the front bracket and two in the rear bracket). Large pins are provided separately. Use the pins that are appropriate for the mounting holes in your rack, as described in [Table 6 on page 14](#).

<i>Table 6. Selecting bracket pins for your rack</i>	
Mounting holes	Bracket pins
Round, unthreaded	Use the preinstalled medium pins.
Square	Unscrew the medium pins and replace with the large pins that are supplied with the rails.

4. At each end of the rail, grasp the tab **1** and pull *firmly* to open the hinge bracket.
5. Align the holes in the rail bracket with the holes on the front and rear rack cabinet flanges.
Ensure that the rails are aligned on the inside of the rack cabinet.
6. On the rear of the rail, press the two bracket pins into the holes in the rack flanges.
7. Close the rear hinge bracket to secure the rail to the rack cabinet flange.
8. On the front of the rail, press the two bracket pins into the holes in the rack flanges.
9. Close the front hinge bracket to secure the rail to the rack cabinet flange.
10. Secure the rear of the rail to the rear rack flange with two black M5 screws.
11. Repeat the steps to secure the opposite rail to the rack cabinet.
12. Repeat the procedure to install rails for each additional control enclosure.

Installing a Storwize V5100 control enclosure

Following your enclosure location plan, install each control enclosure.

About this task



CAUTION:

- To lift a control enclosure requires at least three people.
- Install a control enclosure only onto the control enclosure rails supplied with the enclosure.
- Load the rack from the bottom up to ensure rack stability. Empty the rack from the top down.

Procedure

To install an enclosure, complete the following steps.

1. On either side of the drive assemblies, remove the enclosure end caps by grasping the handle and pulling the bottom of the end cap free, then clearing the tab on the top of the enclosure.
See [Figure 10 on page 15](#).

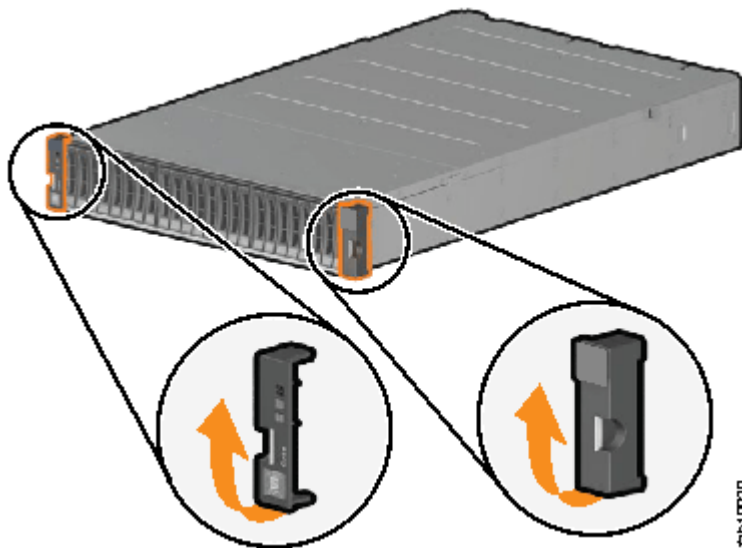

Figure 10. Removing enclosure end caps

2. Align the enclosure with the front of the rack cabinet.
3. Slide the enclosure into the rack along the rails until the enclosure is fully inserted. See [Figure 11](#) on page 15.

Note: The rails are not designed to hold an enclosure that is partially inserted. The enclosure must always be in a fully inserted position. Control enclosures must be installed only on the supplied control enclosure rails.

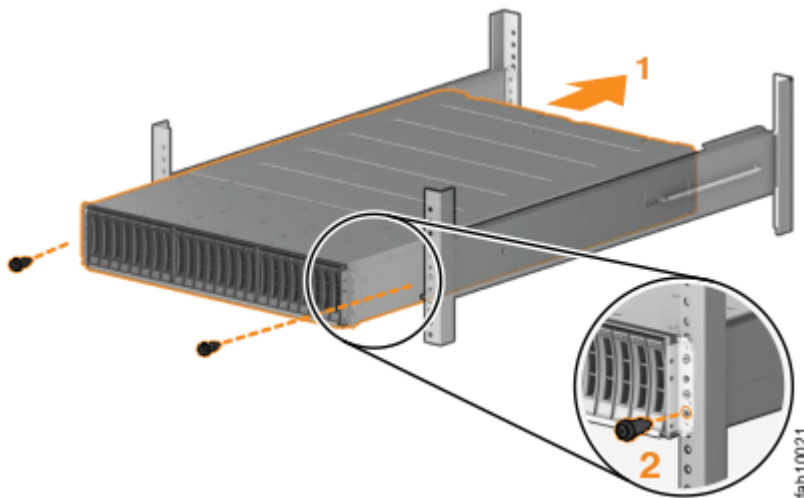

Figure 11. Inserting the enclosure

4. Secure the enclosure with screws in the rack mounting screw holes on each side of the enclosure. See [Figure 12](#) on page 15.

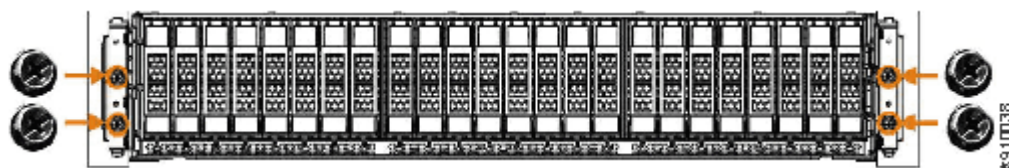

Figure 12. Securing the front of the enclosure

5. Reinstall the left and right end caps.

The left end cap has indicator windows that align with the status LEDs (light-emitting diodes) on the edge of the enclosure.

- a) Ensure that the serial number on the left end cap matches the serial number on the left flange ("ear") on the front of the enclosure.
- b) Fit the slot on the top of the end cap over the tab on the flange.
- c) Rotate the end cap down until it snaps into place.
- d) Ensure that the inside surface of the end cap is flush with the flange.

Unpacking a 2U expansion enclosure

Before you unpack the optional 2U expansion enclosure, ensure that you review and follow all related instructions.

Before you begin

The expansion enclosure and related parts are included in a single box that contains the following items:

- Expansion enclosure with the following components preinstalled:
 - Two power supplies
 - Drives and drive blanks
- Rail kit, which includes left and right rails, black M5 screws, and alternative silver screw pins for other rack types
- Two power cables

Note: You will need a box knife to unpack the expansion enclosure.

About this task



CAUTION: To lift the assembled enclosure requires three persons unless suitable lifting equipment is available or the enclosure is unpacked and dismantled as described in the procedure.

Procedure

1. Cut the box tape and open the lid of the shipping carton.
2. Remove the rail kit box and set it aside in a safe location.
3. Lift the front and back foam packing pieces from the carton.
4. Remove the four corner reinforcement pieces from the carton.
5. Using the box knife, carefully cut the four corners of the carton from top to bottom.
6. Fold the sides and back of the carton down to uncover the front of the expansion enclosure.
If necessary, carefully cut along the lower fold lines and remove each of the sides.
7. Carefully cut the foam packing away from the front of the enclosure.
8. Carefully cut open the bag that covers the front of the enclosure.
9. Remove the leftmost drive or drive filler. Note its location (and its serial number, if it is a drive) and set it aside.
10. Repeat until all drives or drive fillers are removed from the enclosure.
11. Lift the enclosure from the shipping carton. Note that the rear half of the enclosure is heavier than the front half.

Note: With the drives removed, the enclosure weighs approximately 17 kg (37 lb).

Installing support rails for 2U expansion enclosures

Before you install 2U expansion enclosures, you must first install support rails.

Procedure

To install the support rails, complete the following steps.

1. Locate the expansion enclosure rails ([Figure 13 on page 17](#)).

The rail assembly consists of two rails that must be installed in the rack cabinet.

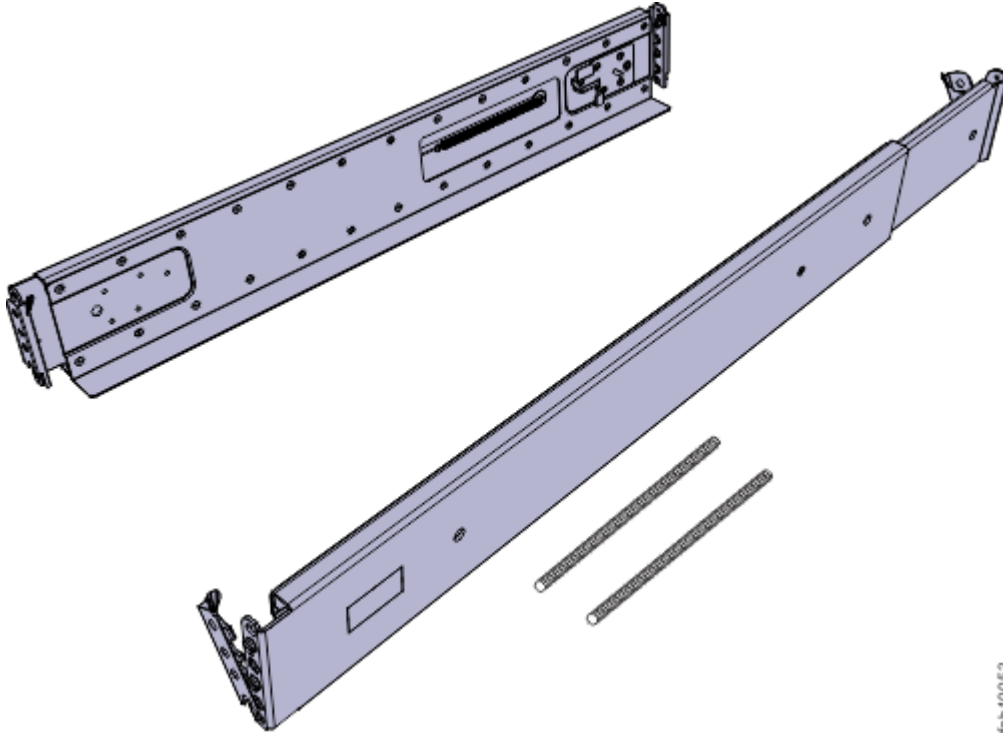

Figure 13. Expansion enclosure support rails

2. Locate the hardware that is used to install the rails, including two rail springs, two sets of eight bracket pins, and two M5 screws.

Set the hardware aside for use later in the installation process.

3. Install a spring on each rail.
 - a) Extend the rail to its full length.
 - b) Push one looped end of a spring over one stud on the inside of the rail.
 - c) Stretch the spring slightly and push the other looped end of the spring onto the other stud on the inside of the rail.
4. Working at the front of the rack cabinet, identify the two standard rack units (2U) of space in the rack into which you want to install the support rails.

[Figure 14 on page 18](#) shows two rack units with the front mounting holes identified.

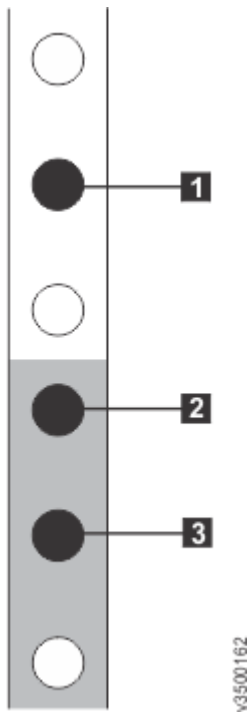

Figure 14. Hole locations in the front of the rack

- **1** Upper rail mounting bracket pin
 - **2** Lower rail mounting bracket pin
 - **3** Rack mounting screw hole
5. Ensure that the appropriate bracket pins are installed in the front and rear bracket of each rail. Each rail comes with four medium pins preinstalled (two in the front bracket and two in the rear bracket). Large and small pins are provided separately. Use the pins that are appropriate for the mounting holes in your rack. See [Table 7 on page 18](#).

Mounting holes	Bracket pins
Round, unthreaded	Use the preinstalled medium pins.
Round, threaded	Unscrew the medium pins and replace with the smaller pins that are supplied with the rails.
Square	Unscrew the medium pins and replace with the large pins that are supplied with the rails.

6. At each end of the rail, grasp the tab **1** and pull *firmly* to open the hinge bracket (see [Figure 15 on page 19](#)).

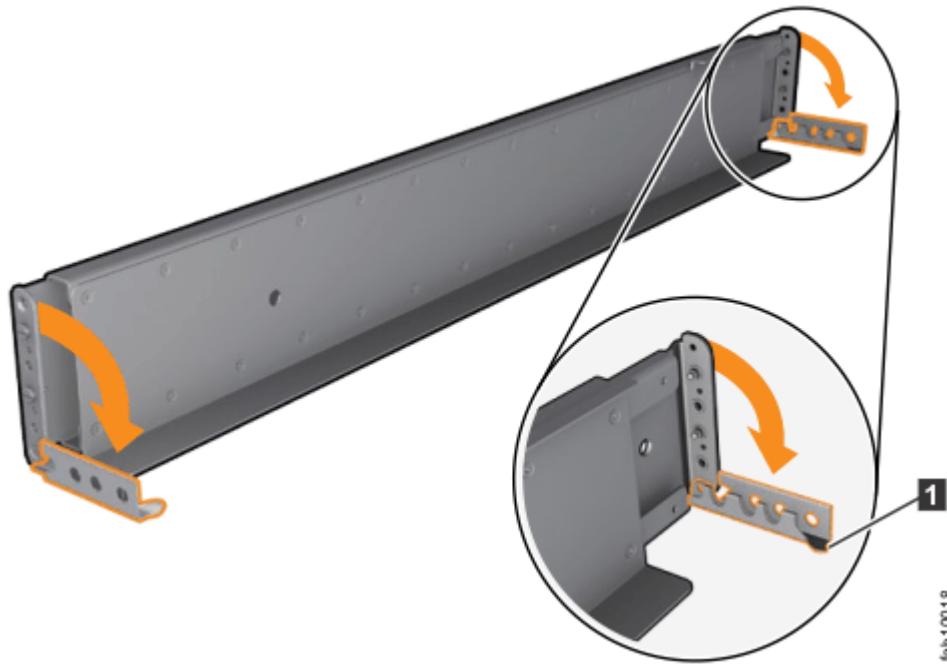

Figure 15. Opening the hinge brackets

7. Align the holes in the rail bracket with the holes on the front and rear rack cabinet flanges. Ensure that the rails are aligned on the inside of the rack cabinet.
8. On the rear of the rail, press the two bracket pins into the holes in the rack flanges.
9. Close the rear hinge bracket to secure the rail to the rack cabinet flange.
(See [Figure 16 on page 19.](#))

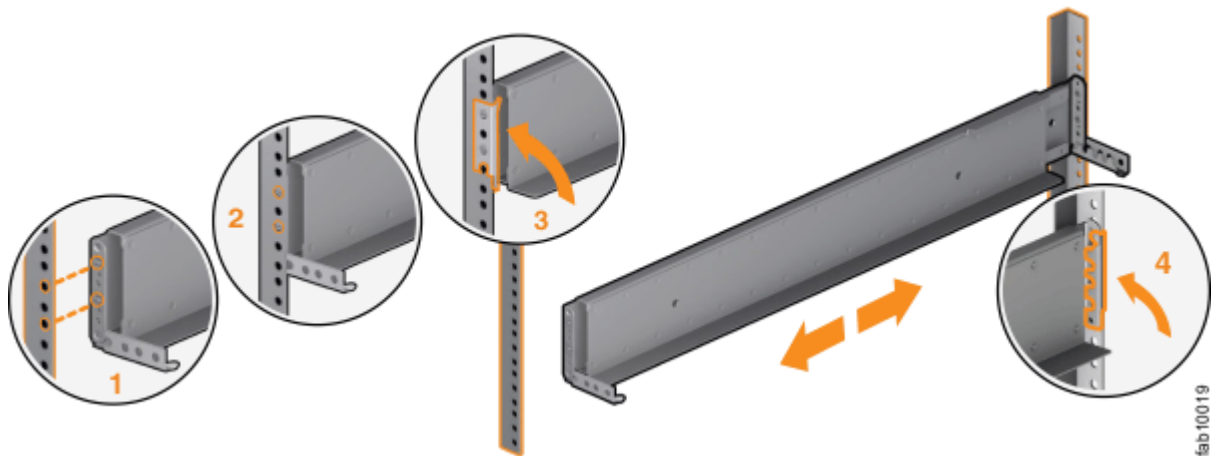

Figure 16. Closing the hinge brackets

10. On the front of the rail, press the two bracket pins into the holes in the rack flanges.
11. Close the front hinge bracket to secure the rail to the rack cabinet flange.
See [Figure 16 on page 19.](#)
12. Secure the rear of the rail to the rear rack flange with an M5 screw that is provided with the rack kit.
13. Repeat the steps to secure the opposite rail to the rack cabinet.
14. Repeat the procedure to install rails for each additional expansion enclosure.

Installing an optional 2U SAS expansion enclosure

The 2U SAS expansion enclosures are installed in the same rack as the control enclosure.

About this task



CAUTION:

- To lift and install the 2U SAS expansion enclosure into the rack requires at least two people.
- Install a 2U SAS expansion enclosure only onto the rails that are supplied with the enclosure.
- Load the rack from the bottom up to ensure rack stability. Empty the rack from the top down.

Procedure

To install an optional 2U SAS expansion enclosure, complete the following steps.

1. Remove the two enclosure end caps by grasping the handle and pulling the bottom of the end cap free, then clearing the tab on the top of the enclosure.
2. Align the enclosure with the front of the rack cabinet.
3. Carefully slide the enclosure into the rack along the rails until the enclosure is fully inserted.
4. Secure the enclosure with screws in the rack mounting screw holes.
5. Reinstall the left and right end caps.

The left end cap has indicator windows that align with the status LEDs (light-emitting diodes) on the edge of the enclosure.

- a) Ensure that the serial number of the end cap matches the serial number on the rear of the enclosure.
 - b) Fit the slot on the top of the end cap over the tab on the chassis flange.
 - c) Rotate the end cap down until it snaps into place.
 - d) Ensure that the inside surface of the end cap is flush with the chassis.
6. If you are installing additional 2U SAS expansion enclosures, repeat the previous steps to complete the installation.

Unpacking an optional 5U expansion enclosure

Before you unpack an optional 5U expansion enclosure, ensure that you review and follow all related instructions and safety notices.

Before you begin



CAUTION:

		
33.6-46.3 kg (74-102 lbs)	46.3-61.7 kg (102-136 lbs)	≥61.7-100 kg (136-220 lbs)

svc01053

The weight of this part or unit is more than 55 kg (121.2 lb). It takes specially trained persons, a lifting device, or both to safely lift this part or unit. (C011)



CAUTION: To avoid personal injury, before you lift this unit, remove all appropriate subassemblies per instructions to reduce the system weight. (C012)

Important: Before you unpack, move, install, or service the 2077-92F, 2077-A9F expansion enclosure and its parts, always complete the following tasks:

- Read and follow the safety notices and instructions, as described in [“Safety notices and considerations: 2077-92F, 2077-A9F”](#) on page 23.
- Read and follow the guidelines that are described in [“Weight considerations: 5U SAS expansion enclosure”](#) on page 27.
- Ensure that a suitably rated mechanical lift is available to support the weight of the expansion enclosure when it is inserted into the rack for installation.

About this task

The 2077-92F, 2077-A9F expansion enclosure and most parts are shipped together in one large box. A tray on top of the enclosure contains the front fascia (1U and 4U pieces), the cable management arm (CMA), and the slide rail kit. [Figure 17 on page 21](#) shows how the enclosure is packaged for shipment.



Figure 17. Tray containing expansion enclosure parts

- 1 Slide rail kit
- 2 Cable management arm
- 3 Fascia

Note: Drives are not included in installation package for the enclosure; they are provided in a separate package.

Procedure

1. Remove the cardboard tray that contains the slide rails, cable management arm, and fascia from cardboard box in which the expansion enclosure was shipped.
2. Remove the foam end pieces from the top of the 2077-92F, 2077-A9F expansion enclosure.
3. Cut the corners of the shipping box and fold them down to uncover the sides and faces of the expansion enclosure, as shown in [Figure 18 on page 22](#).

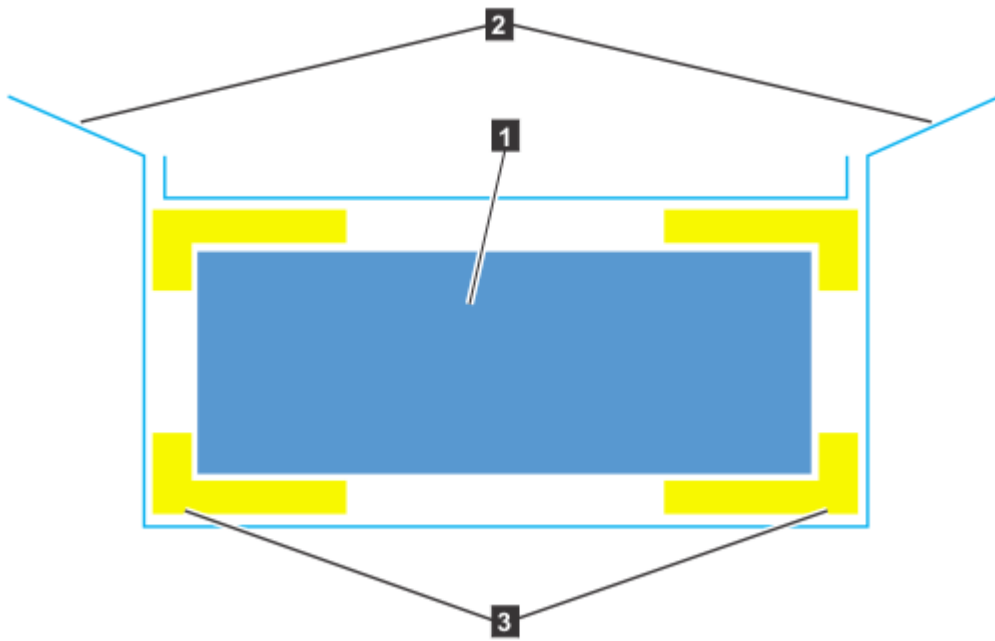

svc01064

Figure 18. Packaging materials

- 1 Enclosure
 - 2 Top of shipping box, folded back
 - 3 Foam protectors
4. With four or more persons, push the expansion enclosure sideways onto an adjacent flat bed lift. Keep the remaining foam block protectors attached to the enclosure.
 5. Remove the support rail kit from the box in which it was shipped (1, as shown in [Figure 17 on page 21](#)).
 6. Remove the 4U and 1U fascia from the boxes in which they were shipped, as shown in [Figure 19 on page 22](#).



svc01062

Figure 19. Packaging for fascia

- 1 4U fascia (front)

- 2 1U fascia (power supply units)
7. Remove the cable management arm assembly from its packaging (2 in Figure 17 on page 21).

Installing an optional 5U SAS expansion enclosure

Before you install the optional 5U SAS expansion enclosure, review the following guidelines:

The expansion enclosure is supported on Storwize V7000 2076-724 and 2077-424 systems that have Spectrum Virtualize 8.2.0 or later with the latest fix packs. If the system is not running that level of software, do not connect it to an enclosure.

Safety notices and considerations: 2077-92F, 2077-A9F

Before you install, service, or move the expansion enclosure, always read and follow the safety notices and guidelines.

Safety notices

Use the reference numbers in parentheses at the end of each notice (for example, D005) to find the matching translated notice in .

 **DANGER:** DANGER: Serious injury or death can occur if loaded lift tool falls over or if a heavy load falls off the lift tool. Always completely lower the lift tool load plate and properly secure the load on the lift tool before moving or using the lift tool to lift or move an object. (D010)

 **DANGER:** Multiple power cords. The product might be equipped with multiple power cords. To remove all hazardous voltages, disconnect all power cords. (L003)

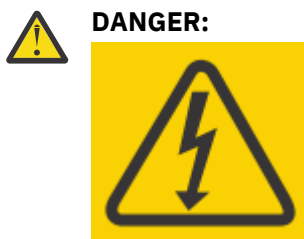
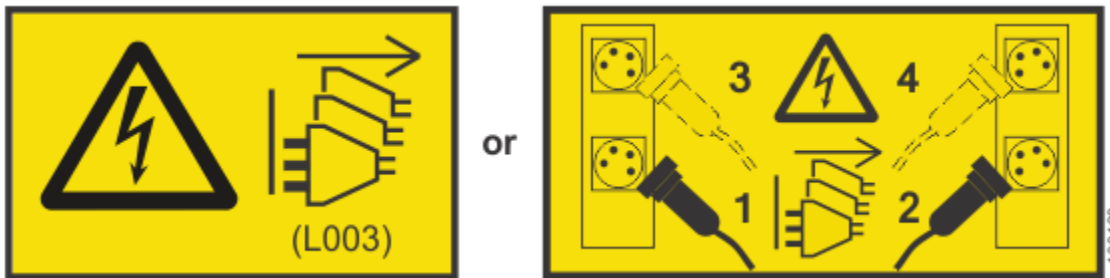

Hazardous voltage present. Voltages present constitute a shock hazard, which can cause severe injury or death. (L004)



Hazardous energy present. Voltages with hazardous energy might cause heating when shorted with metal, which might result in splattered metal, burns, or both. (L005)

DANGER:

Observe the following precautions when working on or around your IT rack system:

- Heavy equipment—personal injury or equipment damage might result if mishandled.
- Always lower the leveling pads on the rack cabinet.
- Always install stabilizer brackets on the rack cabinet.
- To avoid hazardous conditions due to uneven mechanical loading, always install the heaviest devices in the bottom of the rack cabinet. Always install servers and optional devices starting from the bottom of the rack cabinet.
- Rack-mounted devices are not to be used as shelves or work spaces. Do not place objects on top of rack-mounted devices.



- Each rack cabinet might have more than one power cord. Be sure to disconnect all power cords in the rack cabinet when directed to disconnect power during servicing.
- Connect all devices installed in a rack cabinet to power devices installed in the same rack cabinet. Do not plug a power cord from a device installed in one rack cabinet into a power device installed in a different rack cabinet.
- An electrical outlet that is not correctly wired could place hazardous voltage on the metal parts of the system or the devices that attach to the system. It is the responsibility of the customer to ensure that the outlet is correctly wired and grounded to prevent an electrical shock. (R001 part 1 of 2)



CAUTION:

- Do not install a unit in a rack where the internal rack ambient temperatures will exceed the manufacturer's recommended ambient temperature for all your rack-mounted devices.
- Do not install a unit in a rack where the air flow is compromised. Ensure that air flow is not blocked or reduced on any side, front, or back of a unit used for air flow through the unit.
- Consideration should be given to the connection of the equipment to the supply circuit so that overloading of the circuits does not compromise the supply wiring or overcurrent protection. To provide the correct power connection to a rack, refer to the rating labels located on the equipment in the rack to determine the total power requirement of the supply circuit.
- (For sliding drawers) Do not pull out or install any drawer or feature if the rack stabilizer brackets are not attached to the rack. Do not pull out more than one drawer at a time. The rack might become unstable if you pull out more than one drawer at a time.
- (For fixed drawers) This drawer is a fixed drawer and must not be moved for servicing unless specified by the manufacturer. Attempting to move the drawer partially or completely out of the rack might cause the rack to become unstable or cause the drawer to fall out of the rack. (R001 part 2 of 2)



CAUTION: Removing components from the upper positions in the rack cabinet improves rack stability during a relocation. Follow these general guidelines whenever you relocate a populated rack cabinet within a room or building.

- Reduce the weight of the rack cabinet by removing equipment starting at the top of the rack cabinet. When possible, restore the rack cabinet to the configuration of the rack cabinet as you received it. If this configuration is not known, you must observe the following precautions.
 - Remove all devices in the 32U position and above.
 - Ensure that the heaviest devices are installed in the bottom of the rack cabinet.
 - Ensure that there are no empty U-levels between devices installed in the rack cabinet below the 32U level.

- If the rack cabinet you are relocating is part of a suite of rack cabinets, detach the rack cabinet from the suite.
- If the rack cabinet you are relocating was supplied with removable outriggers they must be reinstalled before the cabinet is relocated.
- Inspect the route that you plan to take to eliminate potential hazards.
- Verify that the route that you choose can support the weight of the loaded rack cabinet. Refer to the documentation that comes with your rack cabinet for the weight of a loaded rack cabinet.
- Verify that all door openings are at least 760 x 230 mm (30 x 80 in.).
- Ensure that all devices, shelves, drawers, doors, and cables are secure.
- Ensure that the four leveling pads are raised to their highest position.
- Ensure that there is no stabilizer bracket installed on the rack cabinet during movement.
- Do not use a ramp inclined at more than 10 degrees.
- When the rack cabinet is in the new location, complete the following steps:
 - Lower the four leveling pads.
 - Install stabilizer brackets on the rack cabinet.
 - If you removed any devices from the rack cabinet, repopulate the rack cabinet from the lowest position to the highest position.
- If a long-distance relocation is required, restore the rack cabinet to the configuration of the rack cabinet as you received it. Pack the rack cabinet in the original packaging material, or equivalent. Also lower the leveling pads to raise the casters off the pallet and bolt the rack cabinet to the pallet. (R002)



DANGER: Racks with a total weight of > 227 kg (500 lb.), Use Only Professional Movers! (R003)



DANGER: Do not transport the rack via fork truck unless it is properly packaged, secured on top of the supplied pallet. (R004)

DANGER:





Main Protective Earth (Ground):

This symbol is marked on the frame of the rack.

The **PROTECTIVE EARTHING CONDUCTORS** should be terminated at that point. A recognized or certified closed loop connector (ring terminal) should be used and secured to the frame with a lock washer using a bolt or stud. The connector should be properly sized to be suitable for the bolt or stud, the locking washer, the rating for the conducting wire used, and the considered rating of the breaker. The intent is to ensure the frame is electrically bonded to the **PROTECTIVE EARTHING CONDUCTORS**. The hole that the bolt or stud goes into where the terminal conductor and the lock washer contact should be free of any non-conductive material to allow for metal to metal contact. All **PROTECTIVE EARTHING CONDUCTORS** should terminate at this main protective earthing terminal or at points marked with . (R010)



CAUTION:

		
33.6-46.3 kg (74-102 lbs)	46.3-61.7 kg (102-136 lbs)	≥61.7-100 kg (136-220 lbs)

swc01053

The weight of this part or unit is more than 55 kg (121.2 lb). It takes specially trained persons, a lifting device, or both to safely lift this part or unit. (C011)



CAUTION: To avoid personal injury, before lifting this unit, remove all appropriate subassemblies per instructions to reduce the system weight. (C012)



CAUTION: CAUTION regarding IBM provided VENDOR LIFT TOOL:

- Operation of LIFT TOOL by authorized personnel only
- LIFT TOOL intended for use to assist, lift, install, remove units (load) up into rack elevations. It is not to be used loaded transporting over major ramps nor as a replacement for such designated tools like pallet jacks, walkies, fork trucks and such related relocation practices. When this is not practicable, specially trained persons or services must be used (for instance, riggers or movers). Read and completely understand the contents of LIFT TOOL operator's manual before using.
- Read and completely understand the contents of LIFT TOOL operator's manual before using. Failure to read, understand, obey safety rules, and follow instructions may result in property damage and/or personal injury. If there are questions, contact the vendor's service and support. Local paper manual must remain with machine in provided storage sleeve area. Latest revision manual available on vendor's website.
- Test verify stabilizer brake function before each use. Do not over-force moving or rolling the LIFT TOOL with stabilizer brake engaged.
- Do not raise, lower or slide platform load shelf unless stabilizer (brake pedal jack) is fully engaged. Keep stabilizer brake engaged when not in use or motion.
- Do not move LIFT TOOL while platform is raised, except for minor positioning.
- Do not exceed rated load capacity. See LOAD CAPACITY CHART regarding maximum loads at center versus edge of extended platform.
- Only raise load if properly centered on platform. Do not place more than 200 lb (91 kg) on edge of sliding platform shelf also considering the load's center of mass/gravity (CoG).
- Do not corner load the platform tilt riser accessory option. Secure platform riser tilt option to main shelf in all four (4x) locations with provided hardware only, prior to use. Load objects are designed to slide on/off smooth platforms without appreciable force, so take care not to push or lean. Keep riser tilt option flat at all times except for final minor adjustment when needed.
- Do not stand under overhanging load.
- Do not use on uneven surface, incline or decline (major ramps).
- Do not stack loads. (C048, part 1 of 2)

- Do not operate while under the influence of drugs or alcohol.
- Do not support ladder against LIFT TOOL.
- Tipping hazard. Do not push or lean against load with raised platform.
- Do not use as a personnel lifting platform or step. No riders.
- Do not stand on any part of lift. Not a step.
- Do not climb on mast.
- Do not operate a damaged or malfunctioning LIFT TOOL machine.
- Crush and pinch point hazard below platform. Only lower load in areas clear of personnel and obstructions. Keep hands and feet clear during operation.
- No Forks. Never lift or move bare LIFT TOOL MACHINE with pallet truck, jack or fork lift.
- Mast extends higher than platform. Be aware of ceiling height, cable trays, sprinklers, lights, and other overhead objects.
- Do not leave LIFT TOOL machine unattended with an elevated load.
- Watch and keep hands, fingers, and clothing clear when equipment is in motion.
- Turn Winch with hand power only. If winch handle cannot be cranked easily with one hand, it is probably over-loaded. Do not continue to turn winch past top or bottom of platform travel. Excessive unwinding will detach handle and damage cable. Always hold handle when lowering, unwinding. Always assure self that winch is holding load before releasing winch handle.
- A winch accident could cause serious injury. Not for moving humans. Make certain clicking sound is heard as the equipment is being raised. Be sure winch is locked in position before releasing handle. Read instruction page before operating this winch. Never allow winch to unwind freely. Freewheeling will cause uneven cable wrapping around winch drum, damage cable, and may cause serious injury. (C048, part 2 of 2)



CAUTION: If the System slide rails are installed above EIA location 29U, the [ServerLIFT®] tool (or other qualified lift tool) must be used as a safety precaution for servicing. Position the lift tool platform slightly below the bottom of the System drawer to account for the slight downward flex when the drawer is extended out fully on its slides. Then gently raise the lift tool platform to stably contact the bottom of the drawer, minding not to over force it as it could put upward stress to the slide rails. A service-qualified ladder may have to be used to reach or properly work around the System at such heights. While using a ladder, do not lean on or against the system drawer or lift tool during service, and follow safe practices. (C051)

Weight considerations: 5U SAS expansion enclosure

Before you install, move, or perform service on a 5U SAS expansion enclosure, you must be prepared to handle the weight of the enclosure and its parts.

Safety notices and considerations

Important: Always read and follow the safety notices and instructions before you install, move, or service the expansion enclosure and its parts. See [“Safety notices and considerations: 2077-92F, 2077-A9F”](#) on page 23 for information.

- Do not exceed the specified maximum load of the rack where the enclosure is to be installed.
- Do not exceed any load limit of the building and flooring where the enclosure is to be installed.
- Always use a suitably rated mechanical lift or four persons when you are performing any of the following tasks:
 - Removing the expansion enclosure from its packing material
 - Lifting and installing the expansion enclosure in the rack for the first time
 - Reinstalling the expansion enclosure after you complete a service task (for example, replacing the enclosure FRU).

- At least three persons are required to move the enclosure while it is in the rack (if you are moving the enclosure off the rails). Even after the drives, power supply units, secondary expander modules, canisters, fans, and top cover are removed, the enclosure weighs approximately 43 kg (95 lbs).
- To maximize rack stability, always install the expansion enclosure in the lowest possible position in the rack.

Weight of expansion enclosure parts

Table 8 on page 28 summarizes the weight and quantity of the parts (FRUs) that are shipped with the 5U expansion enclosure.

FRU description	FRU part number	Weight per unit		Quantity shipped	Total weight	
		kg	lbs		kg	lb
Enclosure FRU	01LJ607 (replaces enclosure FRU P/N 01LJ112)	42.5	93.696	1	42.500	93.696
Rail kit	01LJ114	9.231	20.351	1	9.231	20.351
Front fascia (4U front cover)	01LJ116	0.303	0.668	1	0.303	0.668
Display panel assembly	01LJ118	0.020	0.044	1	0.020	0.044
PSU fascia (1U cover)	01LJ120	0.010	0.022	1	0.010	0.022
Power supply unit (PSU)	01LJ122	3.335	7.352	2	6.670	14.705
Secondary expansion module	01LJ860 (for use with enclosure FRU P/N 01LJ607) 01LJ124 (for use with enclosure FRU P/N 01LJ112)	0.826	1.821	2	1.652	3.642
Fan module	01LJ126	0.890	1.962	4	3.560	7.848
Expansion canister	01LJ128	1.588	3.501	2	3.176	7.002
Cable management arm (lower and upper arms)	01LJ130	1.373	3.027	1	1.373	3.027
Top cover	01LJ132	3.720	8.201	1	3.720	8.201

Table 8. Weight of expansion enclosure parts (continued)

FRU description	FRU part number	Weight per unit		Quantity shipped	Total weight	
		kg	lbs		kg	lb
Fan interface board	01LJ134	0.118	0.260	1	0.236	0.260

Weight of expansion enclosure SAS drives

The SAS drives are shipped in a separate package from the 5U expansion enclosure. The enclosure can support up to 92 SAS drives; however, the quantity varies depending on the number of drives ordered.

Weight increases as FRUs are installed

The 5U expansion enclosure supports up to 92 SAS drives. As [Table 9 on page 29](#) shows, substantial weight is added to the enclosure when all drives are installed.

Table 9. Weight of an enclosure with 92 SAS drives

FRU description	Approximate weigh per unit		Maximum supported	Approximate extra weight	
	kg	lb		kg	lb
2.5-inch tier 0 flash drive	0.224	0.494	92	20.608	45.433
2.5-inch tier 1 flash drive					
2.5-inch hard disk drive	0.304	0.670	92	27.968	61.659
3.5-inch Near-Line SAS hard disk drive	0.876	1.931	92	80.592	177.675

As you install or replace FRUs, the overall weight of the expansion enclosure increases. For example, [Table 10 on page 29](#) shows the weight progression as different combinations of FRUs are installed.

Table 10. Enclosure weight as FRUs are installed

Enclosure assembly		Approximate weight	
FRUs installed	FRUs not installed	kg	lb
<ul style="list-style-type: none"> Enclosure (01LJ607 or 01LJ112) 	<ul style="list-style-type: none"> Secondary expansion modules Fascia (1U and 4U) PSUs Expansion canisters Fan modules Fan interface board Display assembly Drives Cover 	42.5	93.7

Table 10. Enclosure weight as FRUs are installed (continued)

Enclosure assembly		Approximate weight	
FRUs installed	FRUs not installed	kg	lb
<ul style="list-style-type: none"> • Enclosure (01LJ607 or 01LJ112) • Secondary expansion modules 	<ul style="list-style-type: none"> • Fascia (1U and 4U) • PSUs • Expansion canisters • Fan modules • Fan interface board • Display assembly • Drives • Cover 	44.3	97.7
<ul style="list-style-type: none"> • Enclosure (01LJ607 or 01LJ112) • Secondary expansion modules • Fascia (1U and 4U) • PSUs • Expansion canisters • Fan modules • Fan interface board • Display assembly 	<ul style="list-style-type: none"> • Drives • Cover 	58	127.9
<p>Note: The following FRUs are installed when the enclosure is initially shipped.</p> <ul style="list-style-type: none"> • Enclosure (01LJ607 or 01LJ112) • Secondary expansion modules • PSUs • Expansion canisters • Fan modules • Fan interface board • Display assembly • Cover 	<ul style="list-style-type: none"> • Fascia (1U and 4U) • Drives 	61.5	135.4

Table 10. Enclosure weight as FRUs are installed (continued)

Enclosure assembly		Approximate weight	
FRUs installed	FRUs not installed	kg	lb
<ul style="list-style-type: none"> • Enclosure (01LJ607 or 01LJ112) • Secondary expansion modules • Fascia (1U and 4U) • PSUs • Expansion canisters • Fan modules • Fan interface boards • 92 2.5-inch tier 1 flash drives 	<ul style="list-style-type: none"> • Cover 	78.6	173.3
<ul style="list-style-type: none"> • Enclosure (01LJ607 or 01LJ112) • Secondary expansion modules • Fascia • PSUs • Expansion canisters • Fan modules • Fan interface board • 92 2.5-inch hard disk drives 	<ul style="list-style-type: none"> • Cover 	86	189.6
<ul style="list-style-type: none"> • Enclosure (01LJ607 or 01LJ112) • Secondary expansion modules • Fascia • PSUs • Expansion canisters • Fan modules • Fan interface board • 92 3.5-inch Near-Line SAS hard disk drives 	<ul style="list-style-type: none"> • Cover 	138.6	305.6

Conversely, the overall weight of the expansion enclosure is reduced as you remove parts. However, even with parts removed, the 5U expansion enclosure is heavy. Depending on the number of parts that remain, you might need four persons or a mechanical lift to support the weight of the expansion enclosure.

Identify the hardware components: 2077-92F, 2077-A9F

You should become familiar with the external components of the 2077-92F, 2077-A9F expansion enclosure.

Components on the front of the enclosure

Figure 20 on page 32 shows the front of the 2077-92F, 2077-A9F expansion enclosure. In the figure, all parts are installed in the enclosure.

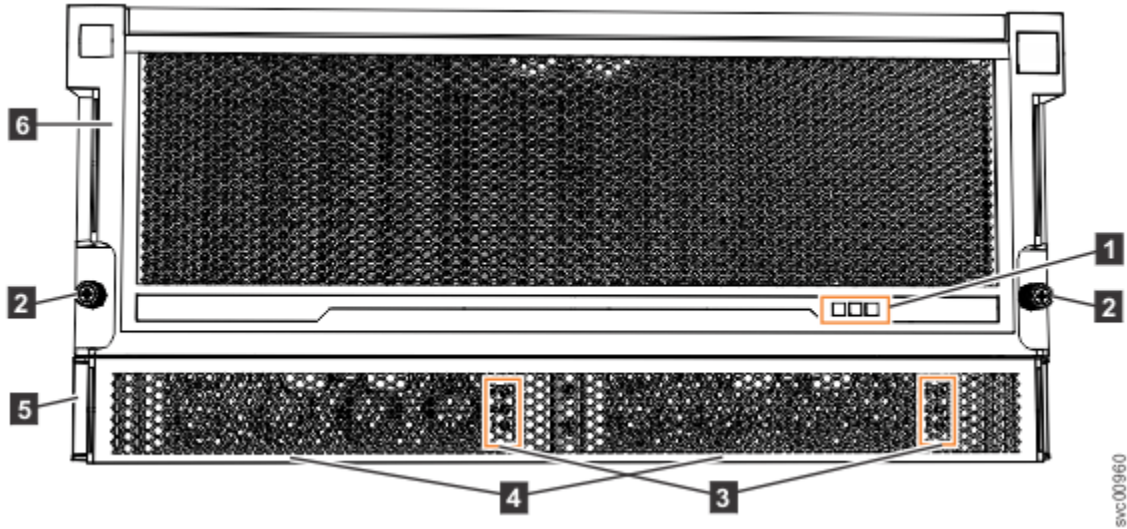

Figure 20. Features on the front of the 2077-92F, 2077-A9F expansion enclosure

- 1 Display panel indicators
- 2 Rack retention thumb screws
- 3 Power supply unit indicators
- 4 Power supply units (PSUs)
- 5 PSU fascia (1U)
- 6 Front fascia (4U)

However, as Figure 21 on page 33 shows, the 4U and 1U fascias are packaged separately. You must attach them to the front of the 2077-92F, 2077-A9F expansion enclosure as part of the initial installation process.

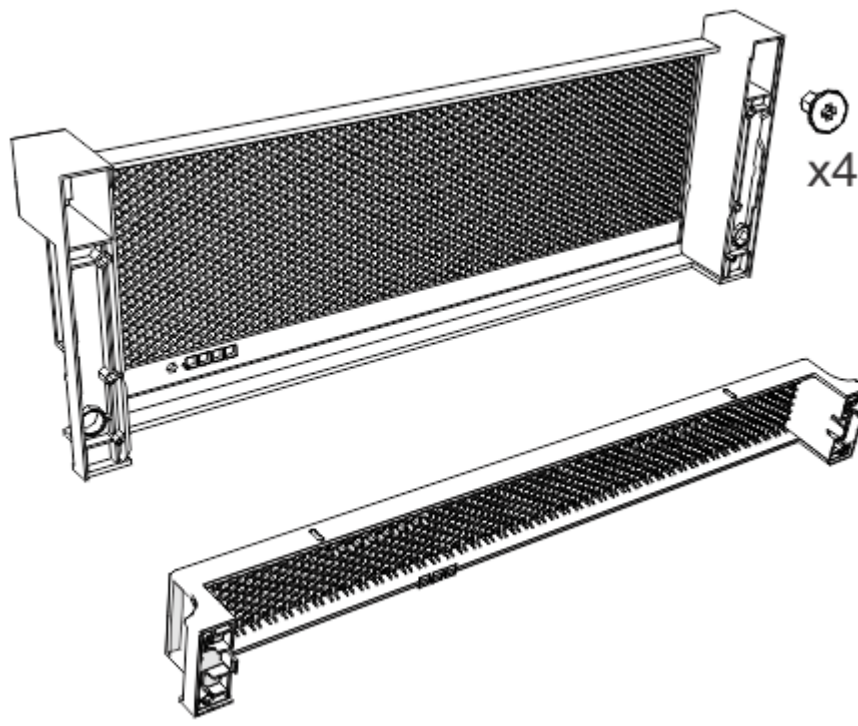

Figure 21. Front fascia of the 2077-92F, 2077-A9F expansion enclosure

Components on the rear of the enclosure

Figure 22 on page 33 shows the components on the rear of the 2077-92F, 2077-A9F expansion enclosure. Four fan modules and two expansion enclosures are accessible from the back of the enclosure.

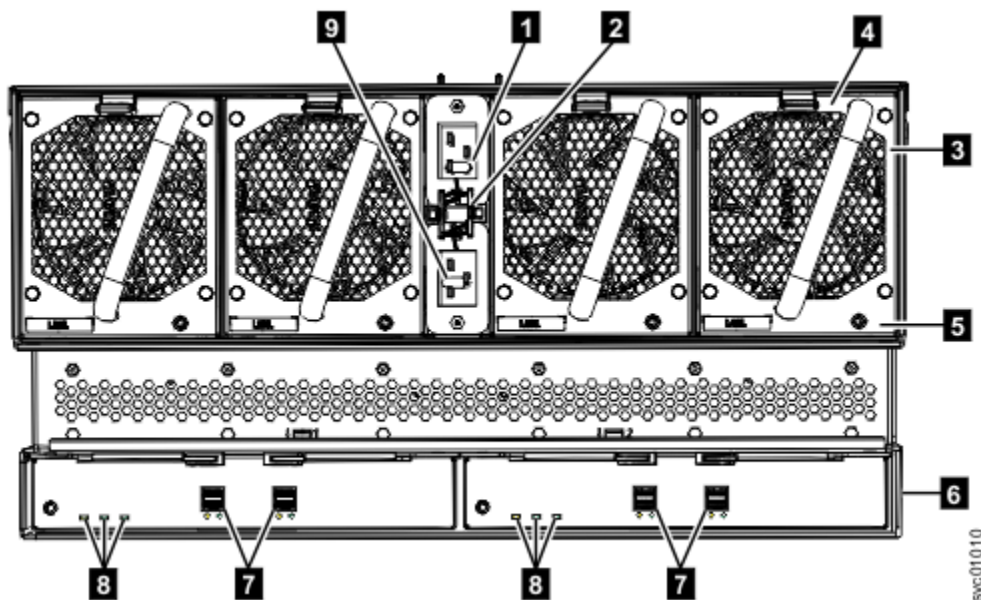

Figure 22. Features on the rear of the 2077-92F, 2077-A9F expansion enclosure

- 1** Power cable connector for PSU 2
- 2** Power cable retention clamps
- 3** Fan module
- 4** Fan release latch
- 5** Fan fault indicator

- 6 Expansion canister
- 7 SAS ports and indicators
- 8 Expansion canister indicators
- 9 Power cable connector for PSU 1

Support rails

Figure 23 on page 34 shows the support rails for the expansion enclosure. The support rails are packaged separately from the expansion enclosure.

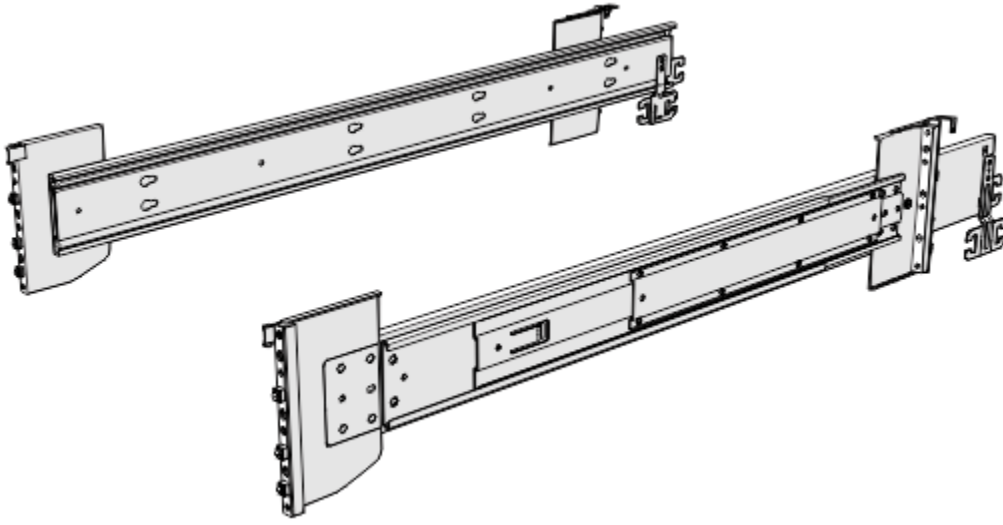

svc00962

Figure 23. 2077-92F, 2077-A9F support rails

Cable management arm

The cable management arm (CMA), which consists of an upper and lower assembly, are packaged separately from the expansion enclosure. As [Figure 24 on page 35](#) shows, each CMA assembly is attached to the rear end of the support rails.

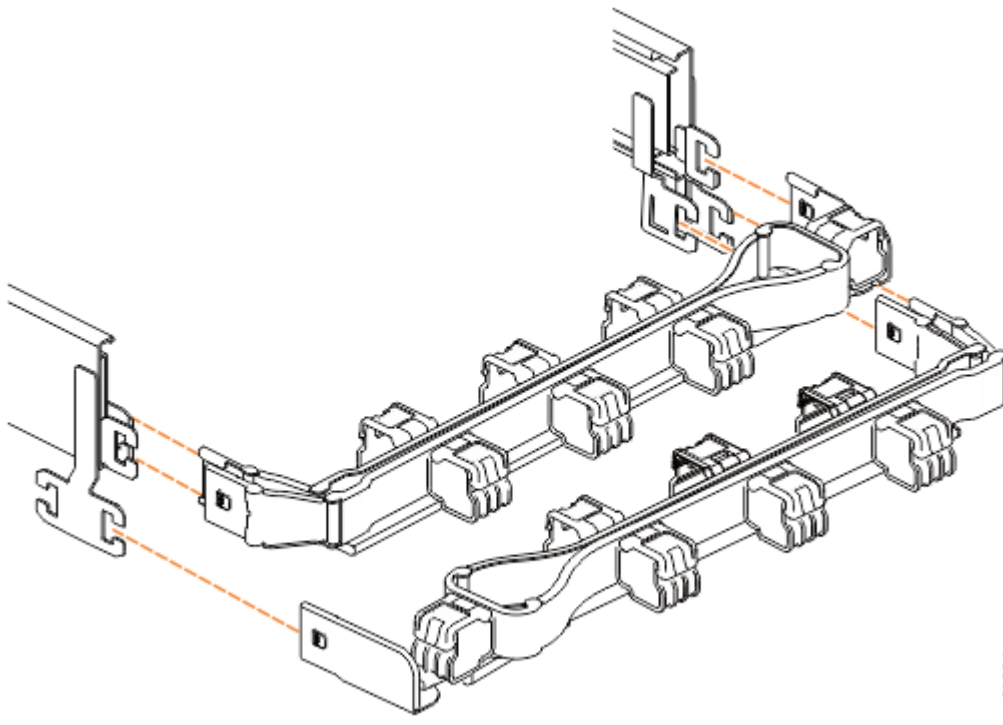

Figure 24. 2077-92F, 2077-A9F CMA assemblies

Unpacking and installing the enclosure: 2077-92F, 2077-A9F

Before you unpack and install the 2077-92F, 2077-A9F expansion enclosure, ensure that you review and follow the installation checklist and safety notices.

Before you begin



CAUTION:

		
33.6-46.3 kg (74-102 lbs)	46.3-61.7 kg (102-136 lbs)	≥61.7-100 kg (136-220 lbs)

The weight of this part or unit is more than 55 kg (121.2 lb). It takes specially trained persons, a lifting device, or both to safely lift this part or unit. (C011)



CAUTION: To avoid personal injury, before lifting this unit, remove all appropriate subassemblies per instructions to reduce the system weight. (C012)

Important: Before you unpack, move, install, or service the 2077-92F, 2077-A9F expansion enclosure and its parts, always complete the following tasks:

- Read and follow the safety notices and instructions, as described in [“Safety notices and considerations: 2077-92F, 2077-A9F”](#) on page 23.
- Read and follow the guidelines that are described in [“Weight considerations: 5U SAS expansion enclosure”](#) on page 27.
- Ensure that a suitably rated mechanical lift is available to support the weight of the expansion enclosure as it is inserted into the rack for installation.

About this task

The 2077-92F, 2077-A9F expansion enclosure and most parts are shipped together in one large box. A tray on the top of the enclosure contains the front fascia (1U and 4U pieces), the cable management arm (CMA), and the slide rail kit; you must install these parts. [Figure 25 on page 36](#) shows how the enclosure is packaged for shipment.

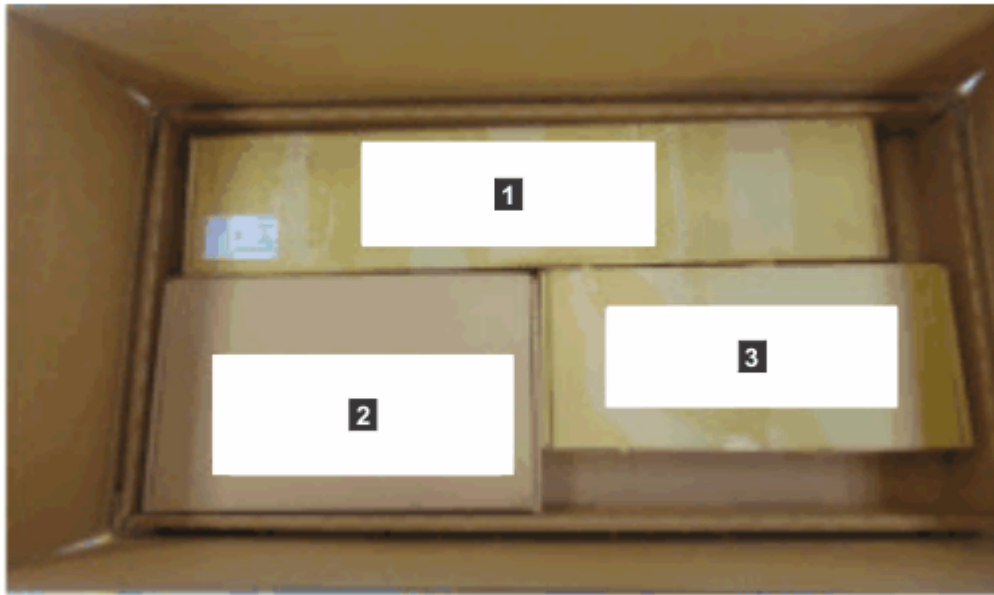

Figure 25. Tray containing expansion enclosure parts

- 1 Slide rail kit
- 2 Cable management arm
- 3 Fascia

Other parts, such as the cover, secondary expander modules, and fans, are installed in the enclosure. However, due to weight considerations, you must remove some parts and then reinstall them as part of the initial installation process.

Note: Drives are not included in installation package for the enclosure; they are provided in a separate package.

Procedure

1. Remove the cardboard tray that contains the slide rails, cable management arm, and fascia from cardboard box in which the expansion enclosure was shipped.
2. Remove the foam end pieces from the top of the 2077-92F, 2077-A9F expansion enclosure.
3. Cut the corners of the shipping box and fold them down to uncover the sides and faces of the expansion enclosure, as shown in [Figure 26 on page 37](#).

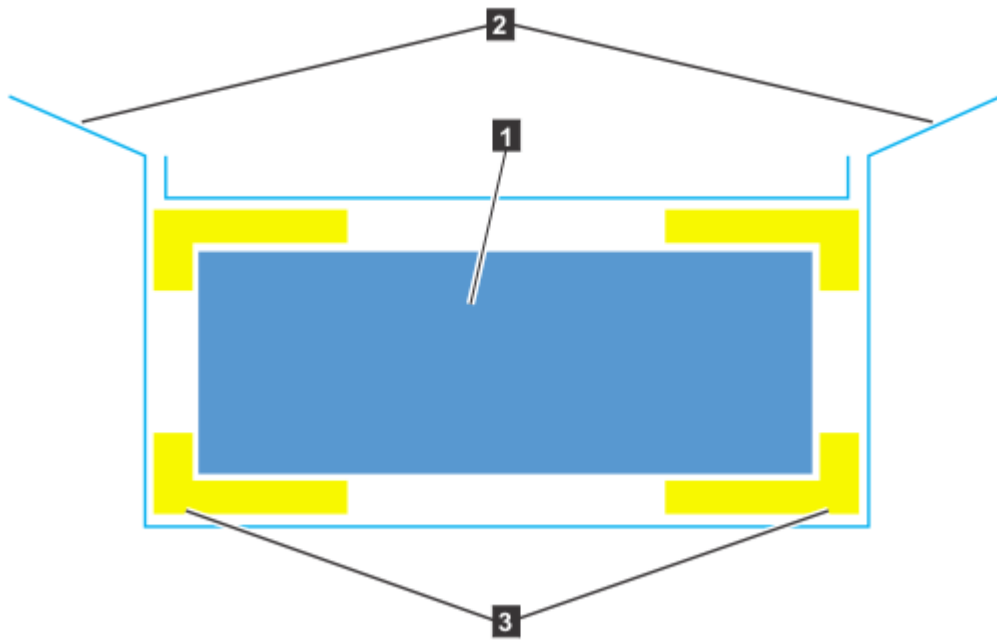

Figure 26. Packaging materials

- 1** Enclosure
 - 2** Top of shipping box, folded back.
 - 3** Foam protectors
4. Remove the top cover, as described in [“Removing the top cover: 2077-92F, 2077-A9F”](#) on page 38.
 5. With two or more persons, push the expansion enclosure sideways onto an adjacent flat bed lift. Keep the remaining foam block protectors attached to the enclosure.
 6. Remove the support rail kit from the box in which it was shipped (**1**), as shown in [Figure 25](#) on page 36).
 7. Separate the inner section of the support rails and attach them to each side of the expansion enclosure, as described in steps [“3”](#) on page 40 through [“5”](#) on page 41 in [“Installing the support rails: 2077-92F, 2077-A9F”](#) on page 39.
 8. Attach the remaining sections of the support rails to the rack, as described in step [“6”](#) on page 41 in [“Installing the support rails: 2077-92F, 2077-A9F”](#) on page 39.
 9. Move the mechanical lift to the front of the rack. Align the inner section of the rails with the mid section of the rails that are extending from the rack.
 10. On each side, push the inner section and middle section of the rails together until they click and will no longer separate, as described in step [“1”](#) on page 50 in [“Installing an optional 5U SAS expansion enclosure”](#) on page 49.
 11. Remove the 4U and 1U fascia from the boxes in which they were shipped, as shown in [Figure 27](#) on page 38.



Figure 27. Packaging for fascia

- 1 4U fascia (front)
- 2 1U fascia (power supply units)

12. Attach the 4U and 1U fascia to the front of the enclosure, as described in [“Installing or replacing the fascia: 2077-92F, 2077-A9F”](#) on page 43.
13. Install the drives, as described in [“Installing or replacing a drive: 2077-92F, 2077-A9F”](#) on page 44.
14. Replace the top cover, as described in [“Installing or replacing the top cover: 2077-92F, 2077-A9F”](#) on page 48.
15. Lower the mechanical lift so that you can remove the remaining foam blocks away from the expansion enclosure.
16. Slide the latch on the side of each rail and push the expansion enclosure securely into the rack, as described in steps [“5”](#) on page 51 through [“7”](#) on page 51 in [“Installing an optional 5U SAS expansion enclosure”](#) on page 49.
17. Remove the cable management arm assembly from its packaging (**2** in Figure 25 on page 36).
18. Attach the cable management arm, as described in [“Installing or replacing the cable-management arm: 2077-92F, 2077-A9F”](#) on page 51.
19. Connect the SAS cables, as described in [“Removing and installing a SAS cable: 2077-92F, 2077-A9F”](#) on page 55.
20. Connect the power cables.

Removing the top cover: 2077-92F, 2077-A9F

To complete some service tasks, you might need to remove the top cover from a 2077-92F, 2077-A9F (5U) expansion enclosure.

Before you begin

Important: You can remove the cover without powering off the expansion enclosure. However, to maintain operating temperature, replace the cover within 15 minutes of its removal. When the cover is removed, the reduction in airflow through the enclosure might cause the enclosure or its components to shut down to protect from overheating.

Procedure

1. Slide the release latch (1) in the direction that is shown in [Figure 28 on page 39](#).

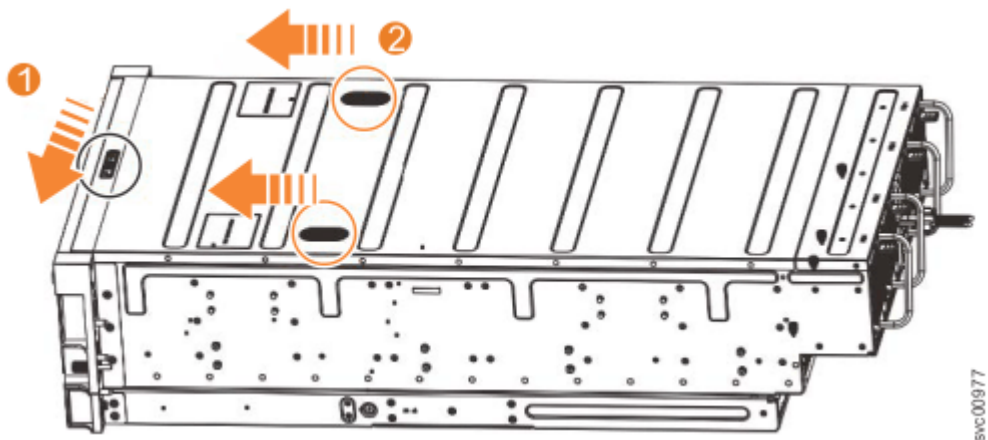

Figure 28. Releasing the 5U expansion enclosure cover

2. Slide the cover toward the front of the expansion enclosure (2), as shown in [Figure 28 on page 39](#).
3. Carefully lift the cover up, as shown in [Figure 29 on page 39](#).

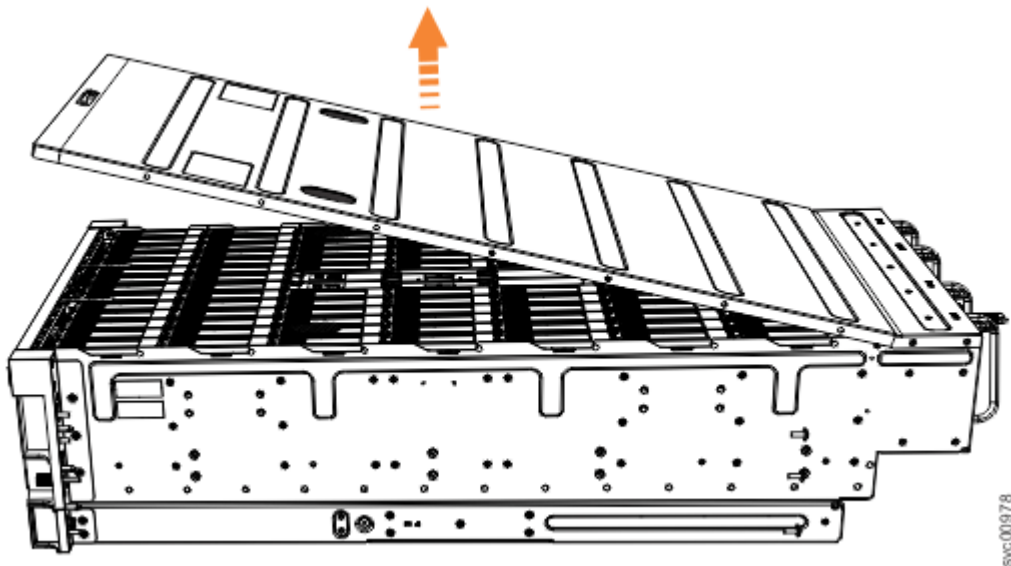

Figure 29. Removing the 5U expansion enclosure cover

4. Place the cover in a safe location.

Replace the cover

5. To reinstall the cover, or replace it with one from FRU stock, follow the procedure in [“Installing or replacing the top cover: 2077-92F, 2077-A9F” on page 48](#).

Installing the support rails: 2077-92F, 2077-A9F

You must install the support rails before you can install a 2077-92F, 2077-A9F expansion enclosure in a rack.

Procedure

1. Locate the hardware that is used to install the rails, including the M4xL6 and M5xL13 screws.
Set the hardware, which is shown in [Figure 30 on page 40](#), aside for use later in the installation process.

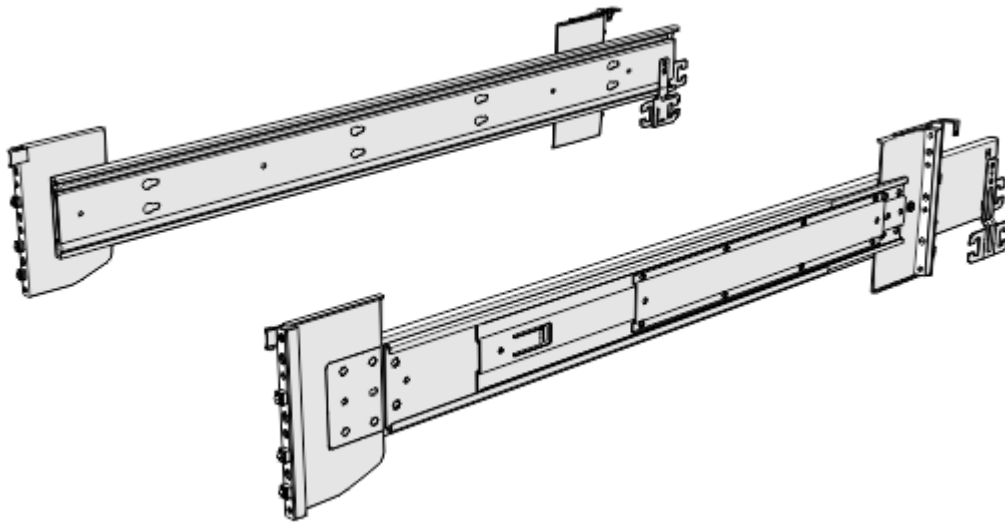

svc00962

Figure 30. Support rails

2. Select an available 5U space in your rack to install the expansion enclosure.

Important notes:

- When you select a rack location, ensure that the enclosure and its parts are easily accessible. Allow enough space for the lid to be easily removed and for internal components, such as drives and secondary expansion modules, to be serviced.
- When all components and drives are installed, the expansion enclosure is heavy. Install the support rails and enclosure at the lowest available position. Do not install the rails and enclosure above position U25 in the rack.

3. Remove the inner member of the rail. Push the tab (a) and slide the middle rail member back, as shown in Figure 31 on page 40.

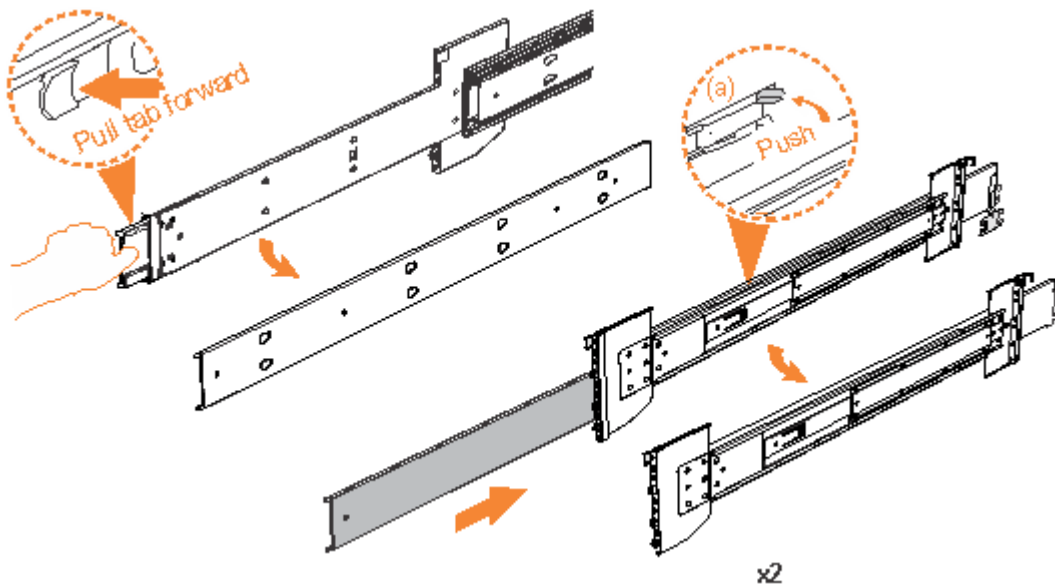

svc01050

Figure 31. Detaching the inner rail section

4. Use four M4 screws to attach the inner rail to the side of the enclosure. Figure 32 on page 41 shows the screw locations.

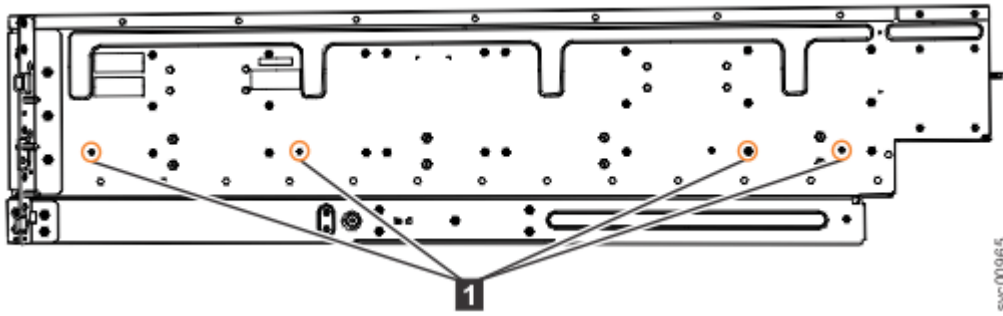

Figure 32. Screw locations to attach the inner rail to the enclosure

5. Install the inner section of the rail onto each side of the expansion enclosure, as shown in [Figure 33 on page 41](#).

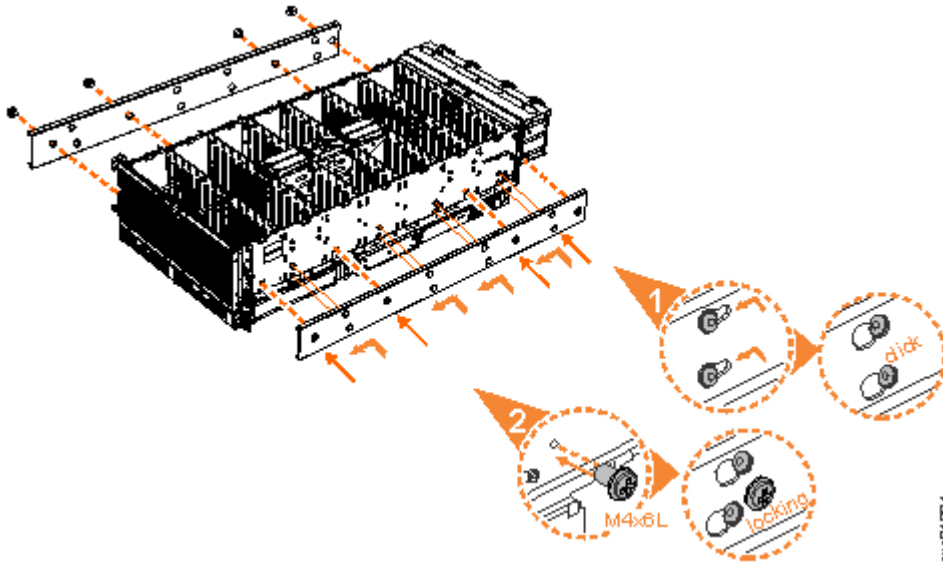

Figure 33. Attaching the inner rail section to the enclosure

6. Use the M5 screws to install the outer rail member and bracket assembly to the rack, as shown in [Figure 34 on page 42](#).

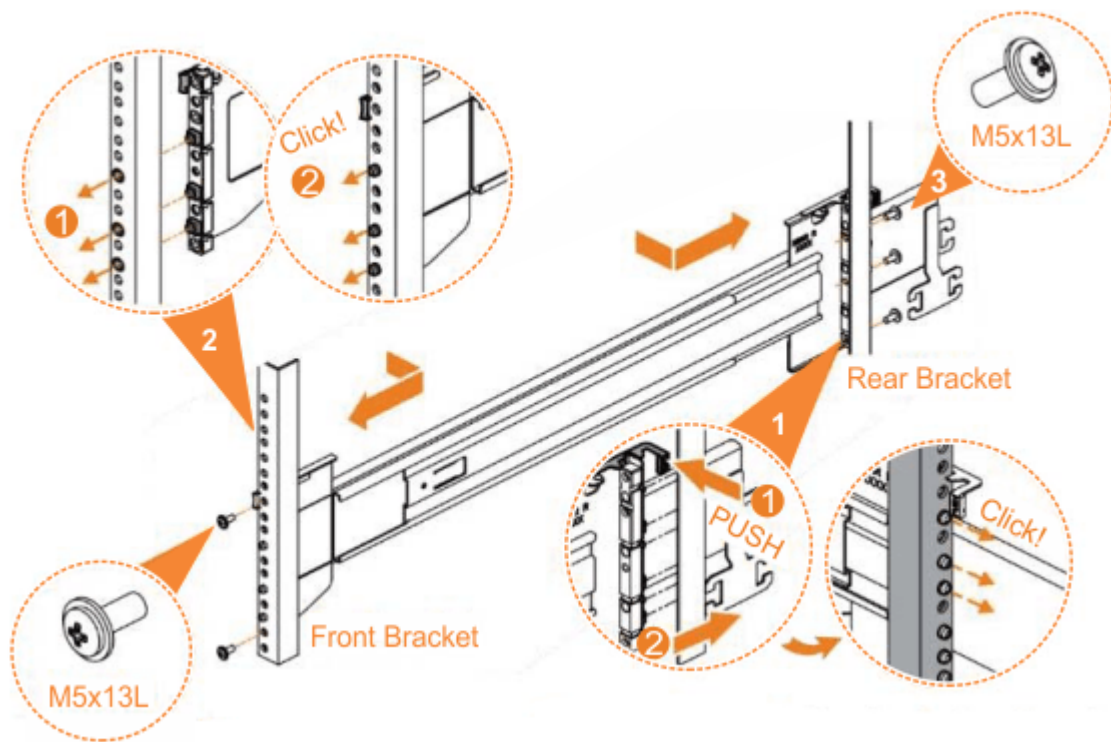

Figure 34. Installing the rail assembly to the rack frame

For example, [Figure 35 on page 42](#) shows the front of the rail that is attached to the frame.



Figure 35. Example of the required rack space

7. Repeat steps “5” on page 41 through “6” on page 41 to install the opposite rail.
8. Install the expansion enclosure in the rack, as described in “Installing an optional 5U SAS expansion enclosure” on page 49.

Installing or replacing the fascia: 2077-92F, 2077-A9F

During the initial installation process or after you perform service, you can install the fascia components on the front of a 2077-92F, 2077-A9F expansion enclosure.

About this task

The 4U fascia covers the display panel of the expansion enclosure. It is attached to the enclosure by four screws. The bottom 1U fascia covers both of the power supply units (PSUs) on the enclosure. As [Figure 36 on page 43](#) shows, the fascias are independent; you can remove or replace one without having to remove or replace the other.

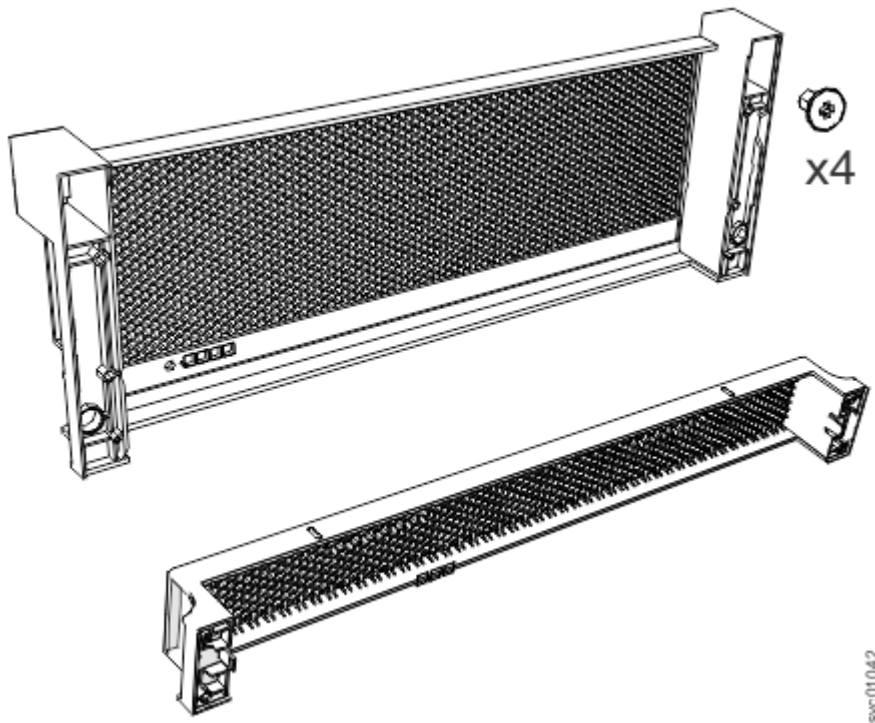

Figure 36. Fascia components on the expansion enclosure

Note: When the expansion enclosure is shipped, the 4U and 1U fascia are not installed. You must install them as part of the initial installation process.

Procedure

Attach the front (4U) fascia

1. Align the front 4U fascia with the enclosure so that the thumbscrews go through the holes on each side. As [Figure 37 on page 44](#) shows, this action aligns the screw holes on the back of the fascia with the screw holes on the front flange of the enclosure.
2. Replace the four screws to reattach the 4U fascia. Secure the screws from the back of the flange and into the rear of the fascia. Each side of the 4U fascia contains two screws.

Attach the bottom (1U) fascia

3. Reattach the bottom 1U fascia that covers the power supply units (PSUs). Align the fascia with the enclosure and gently push it until it clicks into place on the chassis, as shown in [Figure 37 on page 44](#).

Align the tab on each side of the 1U fascia with the corresponding slots on the enclosure flange. Pins on each flange must also align with a hole in each side of the 1U fascia.

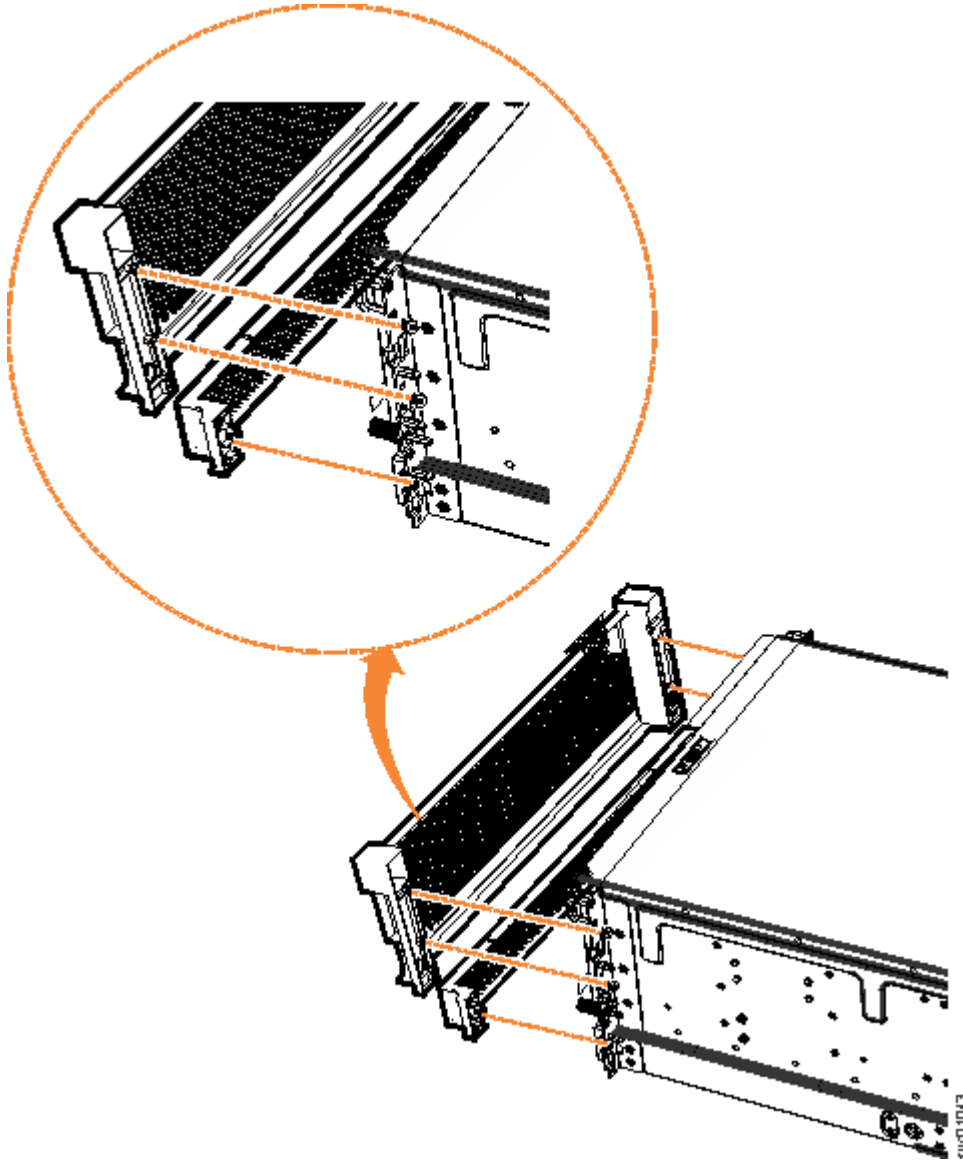

Figure 37. Replace fascia components on the expansion enclosure

Installing or replacing a drive: 2077-92F, 2077-A9F

Use the following procedure to install a drive for the first time or to replace a faulty drive in a 2077-92F, 2077-A9F expansion enclosure with a new one received from FRU stock.

Before you begin

Important:

- You can replace a drive assembly without powering off the expansion enclosure. However, to maintain operating temperature, do not keep the cover off an operational enclosure for more than 15 minutes. The reduction in airflow through the enclosure might cause the enclosure or its components to shut down to protect from overheating.
- Ensure that the drive that you are replacing is not a spare or a member of an array. The drive status is shown in **Pools > Internal Storage** in the management GUI. If the drive is a member of an array, follow the fix procedures in the management GUI. The fix procedures minimize the risk of losing data or access to data; the procedures also manage the system's use of the drive.

About this task

The 2077-92F, 2077-A9F expansion enclosure supports 92 drives. [Figure 38 on page 45](#) shows an example of a drive assembly.

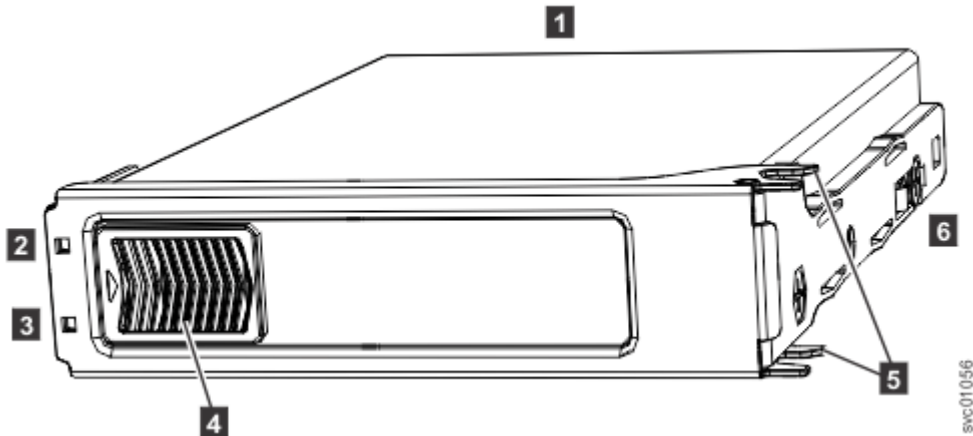

Figure 38. Drive assembly

- 1 Disk drive
- 2 Online indicator
- 3 Fault indicator
- 4 Release latch
- 5 Drive latch toes
- 6 Drive carrier

Procedure

1. Read all of the available safety information.
2. Remove the cover, as described in [“Removing the top cover: 2077-92F, 2077-A9F”](#) on page 38.
3. Locate the empty drive slot to receive the new drive or that contains the faulty drive that you want to replace.

Note: When a drive is faulty, the amber fault indicator is lit (3 in Figure 38 on page 45). Do not replace a drive unless the drive fault indicator is on or you are instructed to do so by a fix procedure.

A label on the enclosure cover (Figure 39 on page 45) shows the drive locations in the enclosure. The drive slots are numbered 1-14 from left to right and A-G from the back to the front of the enclosure.

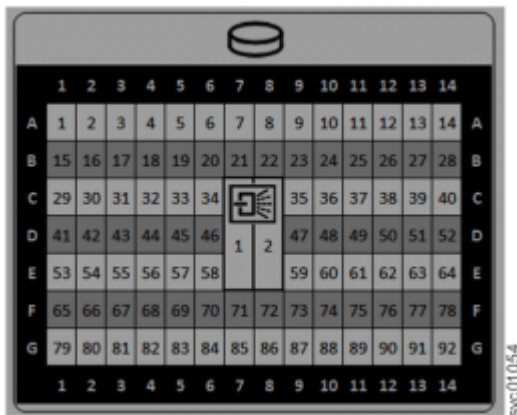

Figure 39. Drive locations in a 5U expansion enclosure

The drive slots must be populated sequentially, starting from the back-left corner position (slot 1, grid A1). Sequentially install the drive in the slots from left to right and back row to front. Always complete a full row before you install drives in the next row. For example, in [Figure 40 on page 46](#), the drives are installed correctly. Drives are installed in slots 1 -14 of row A and the installation continues in slot 15 in row B.

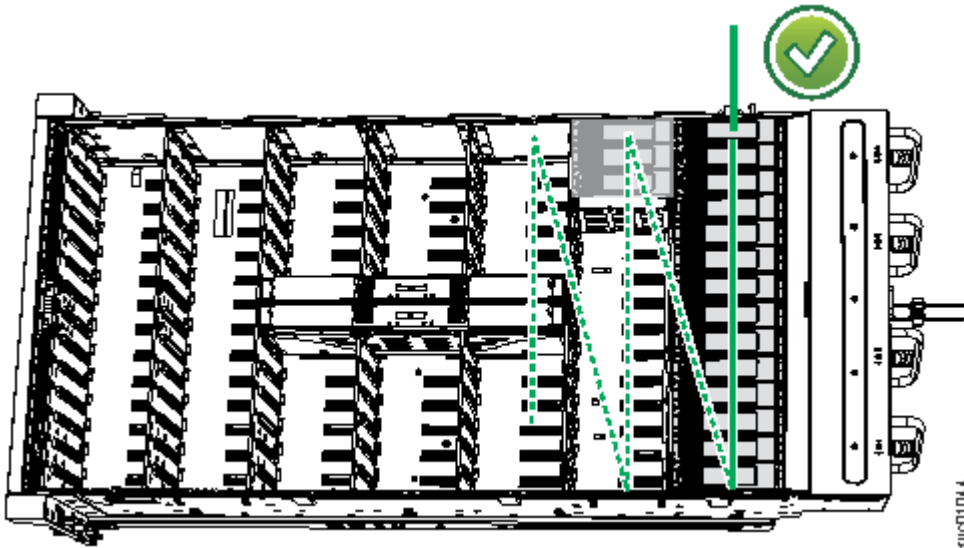

Figure 40. Correct drive installation

In [Figure 41 on page 46](#), the drives are not installed correctly. Slot 1 (A1) does not contain a drive. In addition, drives are installed in row B even though row A contains empty drive slots.

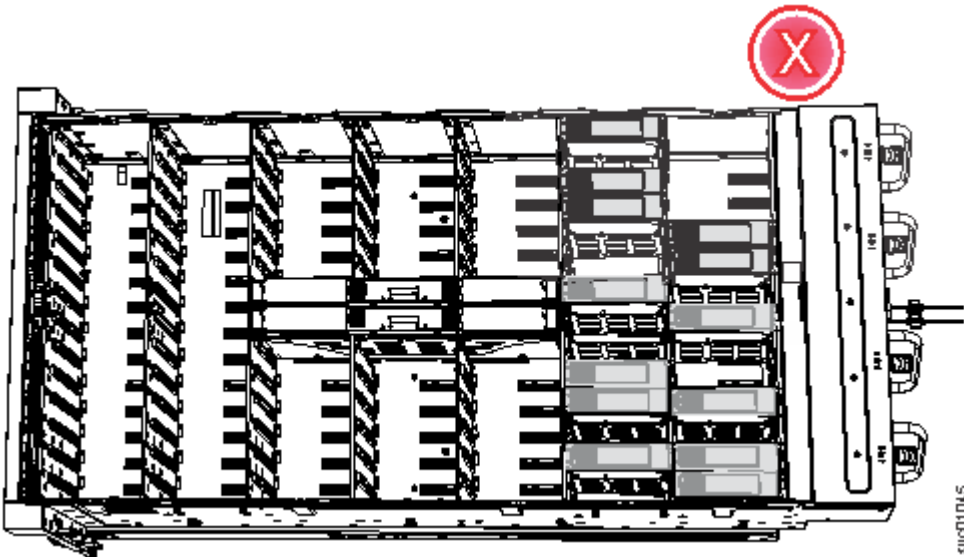

Figure 41. Incorrect drive installation

4. Touch the static-protective package that contains the drive to any unpainted metal surface on the enclosure. Wear an anti-static wrist strap to remove the drive from the package.
5. Ensure that the drive handle (❶ in [Figure 42 on page 47](#)) of the drive assembly is in the open (unlocked) position.
6. Align the drive carrier into the appropriate drive slot.
7. Gently push the drive down until it stops and the bottom of the latch is aligned with the top of the partition. Ensure that the handle is not open more than 45 degrees from the drive carrier. (❷ in [Figure 42 on page 47](#)).

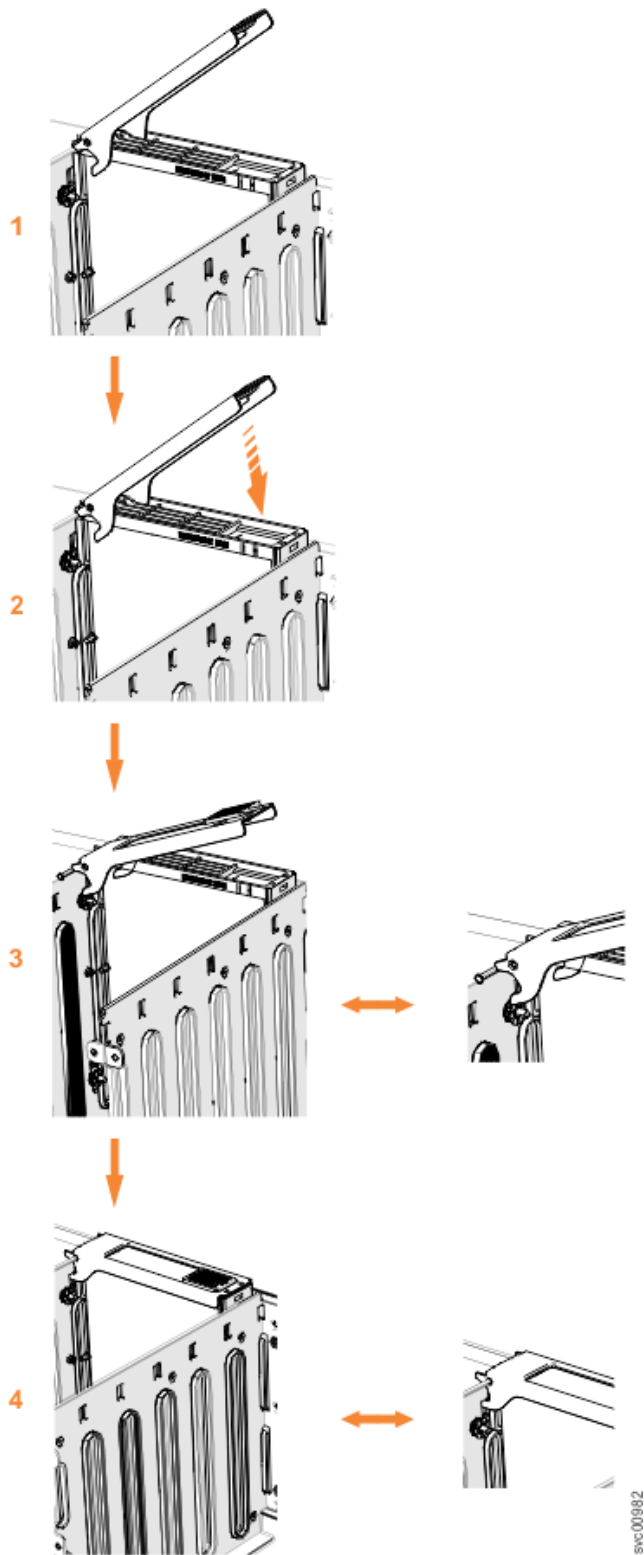

Figure 42. Replace the drive

8. Rotate the handle down to lock the drive assembly into the chassis (**3** in Figure 42 on page 47).
9. Ensure the toe on the bottom of the latch is fully engaged with the partition in the chassis.
10. Ensure that the top toe of the latch is also fully engaged (**4** in Figure 42 on page 47).
11. Repeat steps “4” on page 46 through “10” on page 47 for each drive you are replacing.

12. Replace the cover, as described in [“Installing or replacing the top cover: 2077-92F, 2077-A9F”](#) on page 48.
13. Slide the expansion enclosure back into the rack, as described in [“Installing an optional 5U SAS expansion enclosure”](#) on page 49.

Installing or replacing the top cover: 2077-92F, 2077-A9F

You can replace the top cover on a 2077-92F, 2077-A9F expansion enclosure during the installation process or after you complete a service task.

Before you begin

Important: You can install the cover while the expansion enclosure is powered on. To maintain operating temperature, replace the cover within 15 minutes of completing other service tasks. When the cover is removed, the reduction in airflow through the enclosure might cause the enclosure or its components to shut down to protect from overheating.

About this task

To install or replace the top cover on the 2077-92F, 2077-A9F expansion enclosure, complete the following steps.

Procedure

1. Carefully lower the cover and ensure that it is aligned correctly with the back of the enclosure, as shown in [Figure 43](#) on page 48.

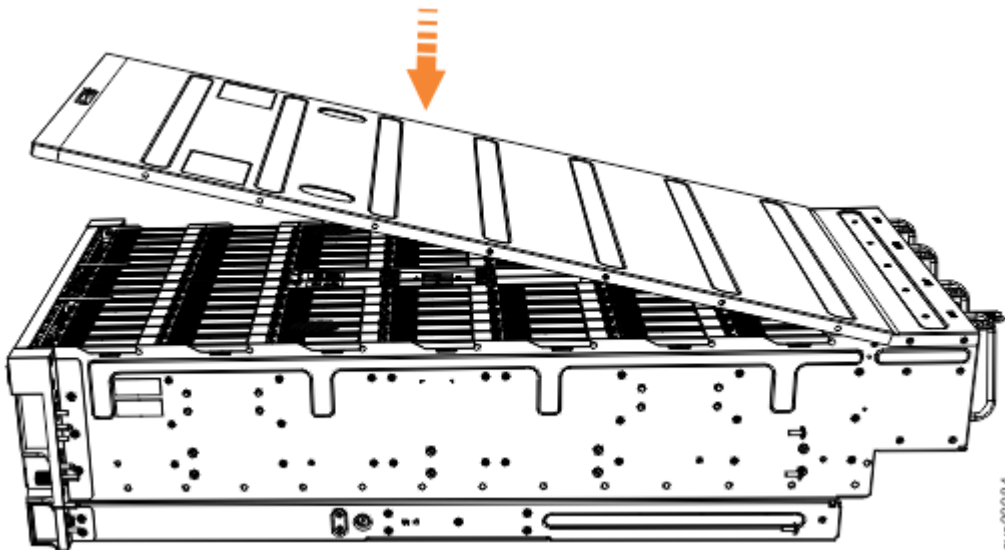

Figure 43. Aligning the 2077-92F, 2077-A9F top cover

2. Push the cover release lever to the side (2) as shown in [Figure 44](#) on page 49.
3. Slide the cover towards the back of the enclosure (3) back until it stops, as shown in [Figure 44](#) on page 49.

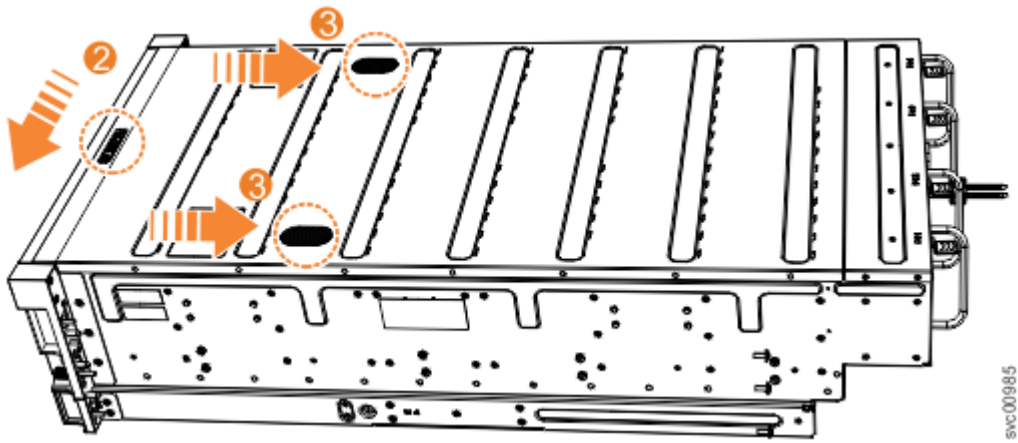

Figure 44. Replacing the 2077-92F, 2077-A9F top cover

4. Verify that the cover correctly engages the cover release latch and all of the inset tabs on the expansion enclosure.
5. Lock the cover into position by sliding the release lever **4**, as shown in [Figure 45 on page 49](#)

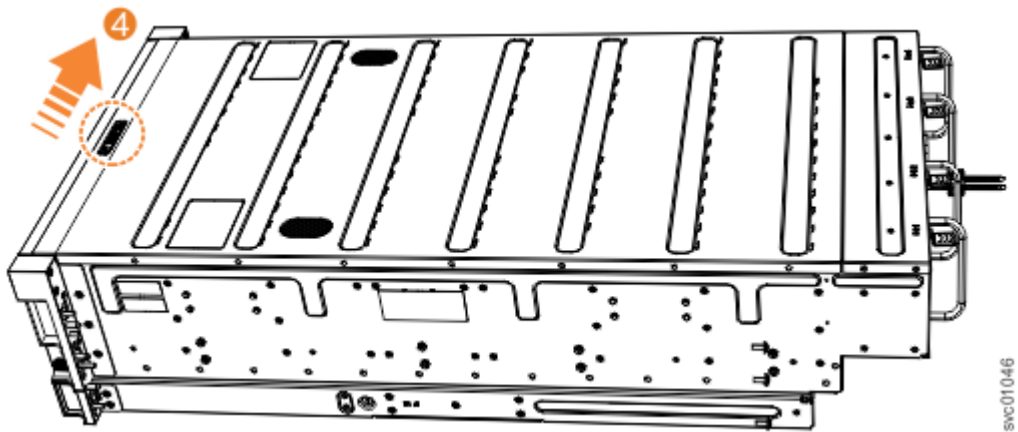

Figure 45. Locking the top cover

Installing an optional 5U SAS expansion enclosure

Use the following procedure to place the 2077-92F, 2077-A9F expansion enclosure in a rack during the installation process. To complete some service tasks, you might also need to slide the enclosure back in to the rack.

About this task

Important: The 2077-92F, 2077-A9F expansion enclosure is heavy. Before you install the expansion enclosure in the rack for the first time or replace it in the rack to complete a service task, review and implement the following tasks:

- Always use a suitably rated mechanical lift or four persons to raise the enclosure to install it in the rack. Even after the drives, power supply units, secondary expander modules, canisters, fans, and top cover are removed, the enclosure weighs 43 kg (95 lbs).
- Install the expansion enclosure in the lowest position in the rack. [Figure 46 on page 50](#) shows an example.

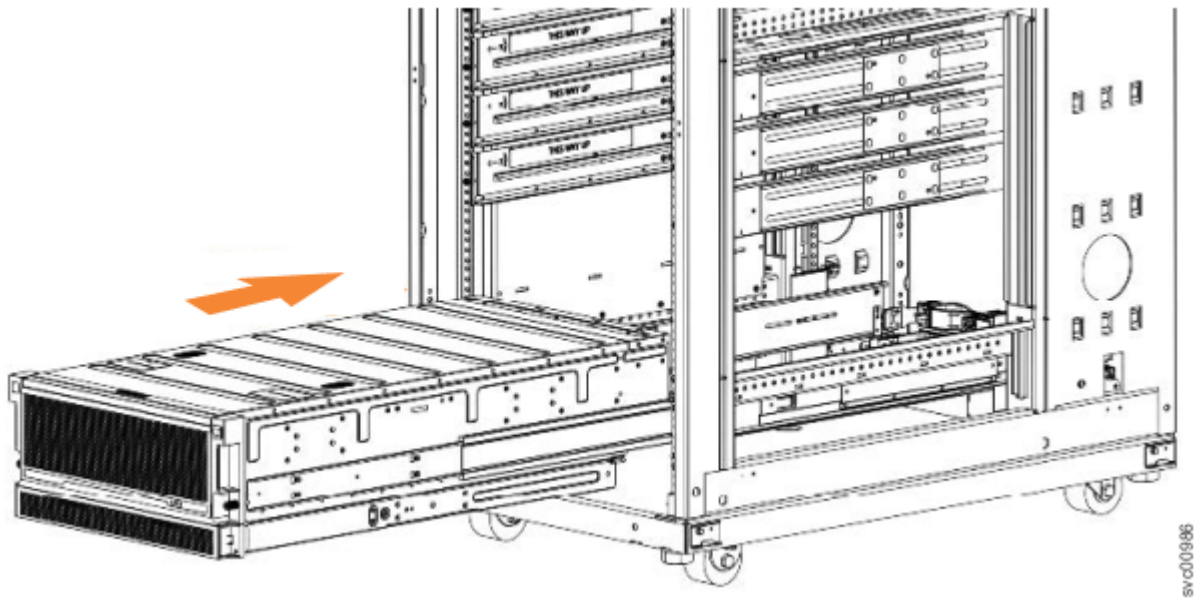

Figure 46. Example installation of the enclosure in the rack

- Ensure that the drives are easily accessible. Avoid installing the 2077-92F, 2077-A9F expansion enclosure above position 22U in the rack.

If you are reinstalling the expansion enclosure in the rack after you performed a service task (for example, replacing the enclosure), you must also perform the following tasks:

- Reinstall all of the following parts:
 - Cover
 - Drives
 - Fan modules
 - Power supply units and 1U fascia
 - Secondary expander modules
 - Expansion canisters (and SAS cables)
- Reconnect both power cables to the expansion enclosure.

Procedure

1. Fully extend the left and right drawer sections from the rack to lock the rails in the extended position (1 in Figure 47 on page 51).

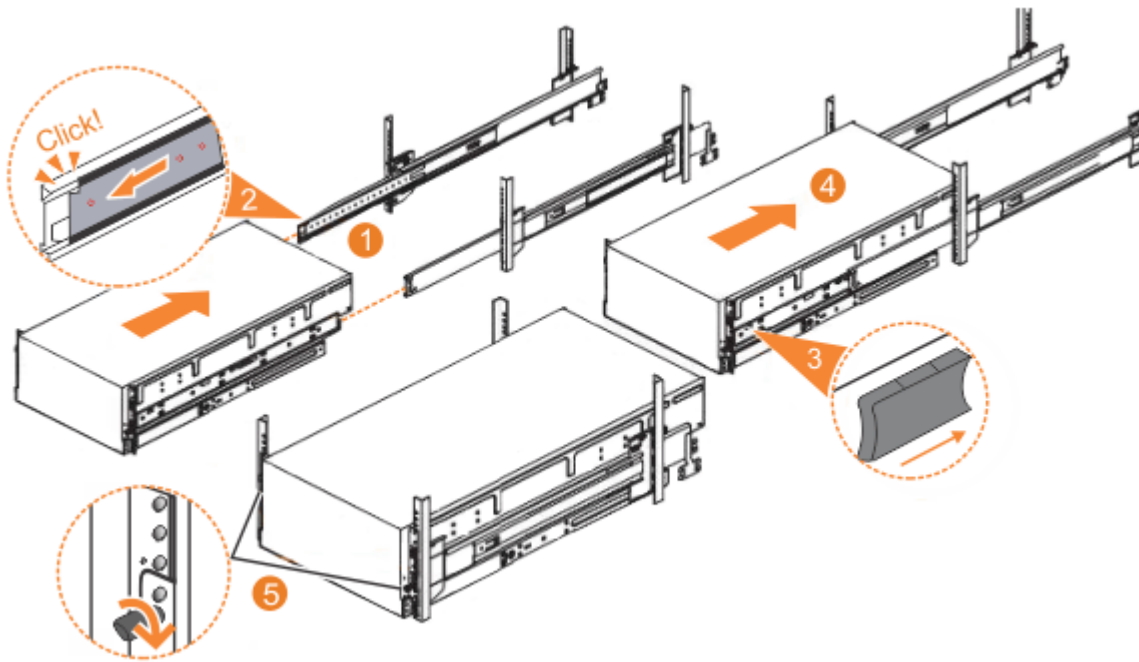

svc00969

Figure 47. Replacing the 2077-92F, 2077-A9F enclosure in the rack

2. Ensure that the ball bearing retainer clicks into place inside the front of the left and right drawer sections (2 in Figure 47 on page 51).

Reinstalling parts into the enclosure

3. Replace the top cover, as described in [“Installing or replacing the top cover: 2077-92F, 2077-A9F”](#) on page 48.
4. Reinstall the remaining enclosure parts, as described in the following topics. You can reinstall the parts in any order.
 - [“Installing or replacing the fascia: 2077-92F, 2077-A9F”](#) on page 43
 - [“Removing and installing a SAS cable: 2077-92F, 2077-A9F”](#) on page 55

Sliding the enclosure into the rack

5. Locate the left and right blue release tabs near the front of the enclosure. Press both release tabs forward to unlock the drawer mechanism (3 in Figure 47 on page 51).
6. Push the enclosure firmly into the rack (4 in Figure 47 on page 51).
7. Tighten the locking thumb screws (5 in Figure 47 on page 51) to secure the enclosure in the rack.
8. Reconnect power to the expansion enclosure.

Installing or replacing the cable-management arm: 2077-92F, 2077-A9F

Use these procedures to install the cable-management arm (CMA) for the 2077-92F, 2077-A9F expansion enclosure. You can also use these procedures to replace a faulty CMA assembly.

About this task

As part of the initial installation of the 2077-92F, 2077-A9F expansion enclosure, you must attach the CMA. You might also need to replace a faulty CMA with a new one from FRU stock.

The cable management arm (CMA) consists of an upper arm and a lower arm assembly, as [Figure 48](#) on page 52 shows.

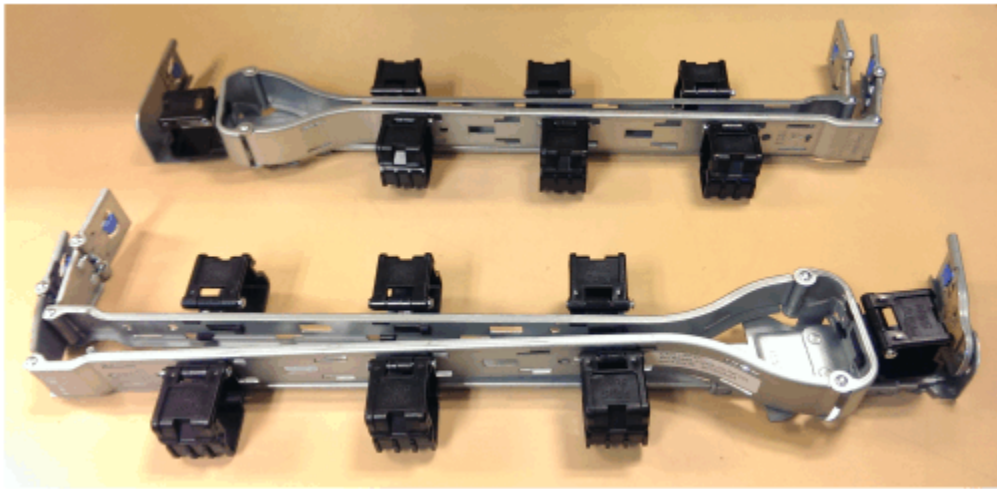

Figure 48. Upper and lower cable-management arms

As Figure 49 on page 52 shows, the support rail connectors of each CMA assembly are installed on the rail hooks at the end of the support rails.

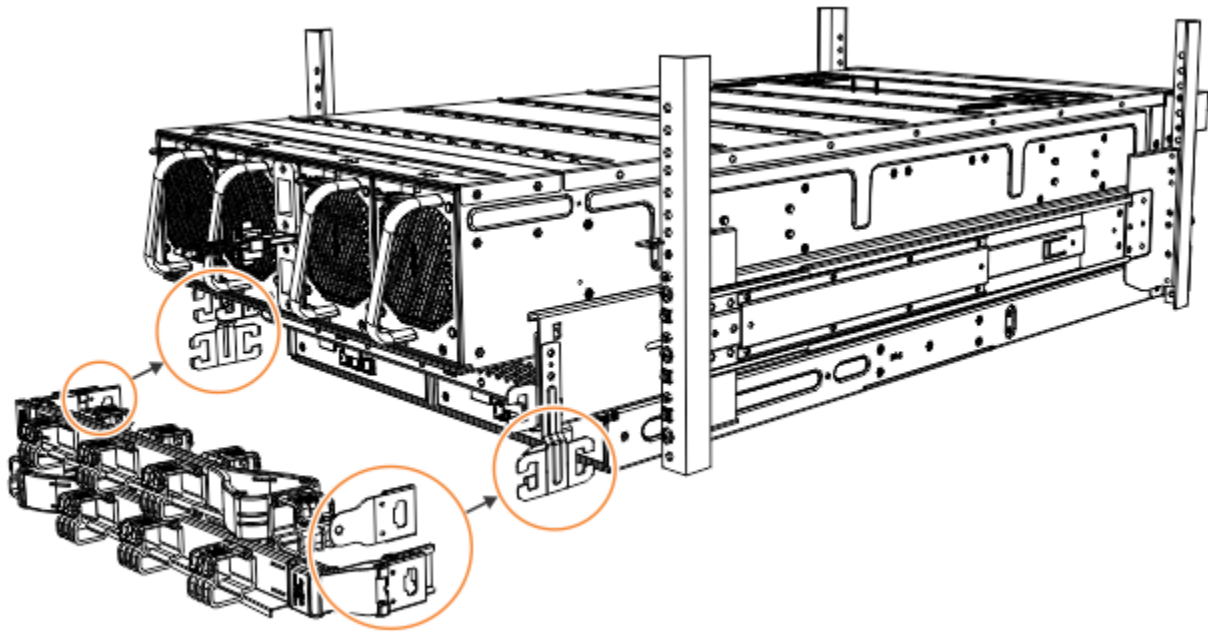

Figure 49. Upper and lower cable-management arms

Procedure

1. Remove the loop straps from the upper and lower CMA assemblies. The straps are used only for shipping.

Installing the upper CMA assembly

Figure 50 on page 53 shows the connectors on the upper CMA assembly.

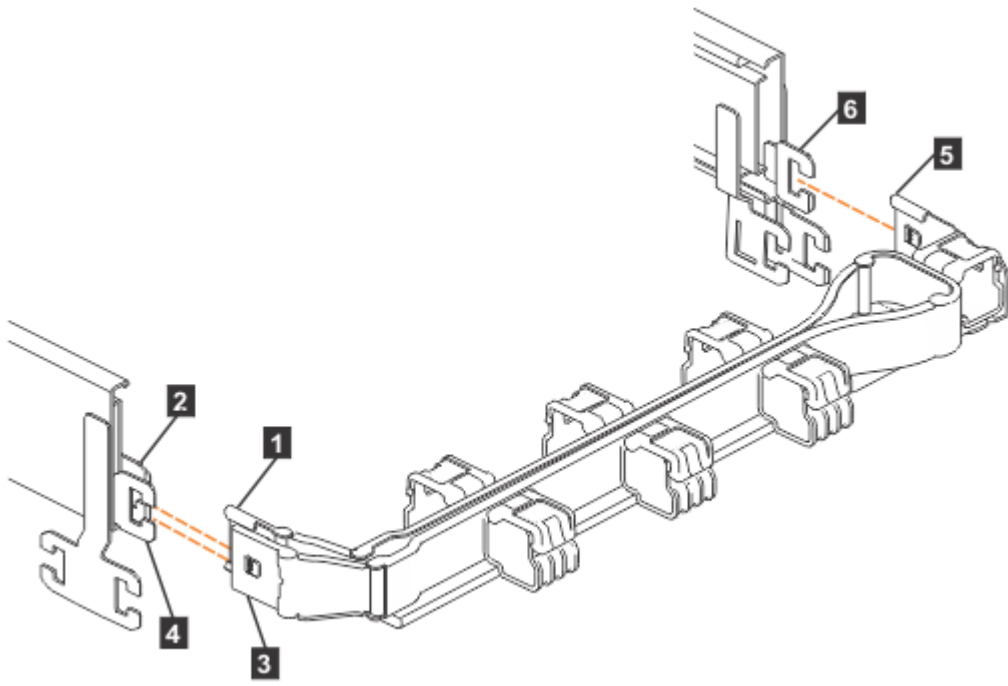

Figure 50. Connectors for the cable management arm

- 1** Inner connector on upper CMA
- 2** Connector base on inner rail member
- 3** Outer connector on upper CMA
- 4** Connector base on outer rail member
- 5** Support rail connector on upper CMA
- 6** Connector base on outer rail member

2. Install the inner connector of the upper CMA assembly (**1**) to the inner member of the left support rail (**2**), as shown in [Figure 51](#) on page 53.

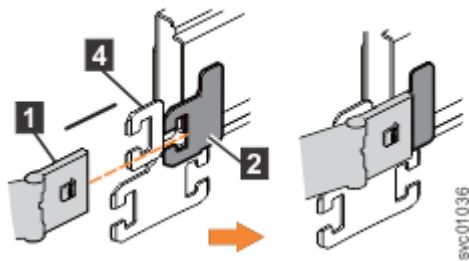

Figure 51. Install the inner connector of the upper CMA to the inner member of the support rail

3. Install the outer connector of the upper CMA assembly (**3**) to the outer member of the left support rail (**4**), as shown in [Figure 52](#) on page 53.

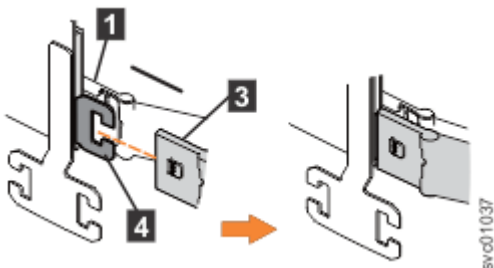

Figure 52. Install the outer connector of the upper CMA to the outer member of the support rail

- Attach the support rail connector on the upper CMA assembly (5) to the connector base on the right support rail (6), as shown in Figure 53 on page 54.

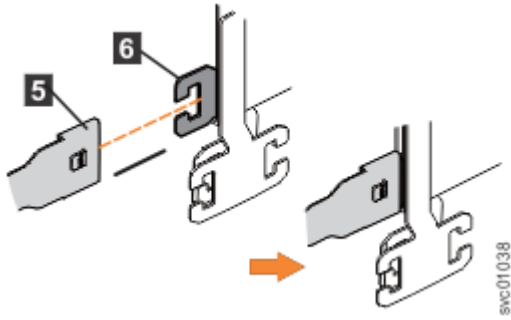

Figure 53. Attach the support rail connector of the upper CMA to the right support rail

Ensure the cable-management arm connector attaches securely to the hooks on the rails.

Installing the lower CMA assembly

Note: The procedure for attaching the lower CMA assembly is the same as the procedure to attach the upper CMA assembly. However, the connector locations are reversed. For comparison, Figure 54 on page 54 shows the upper and lower CMA assemblies as they are aligned to the support rails. The support rail connector of the upper CMA attaches to the right rail. The support rail connector of the lower CMA (11) attaches to the left rail.

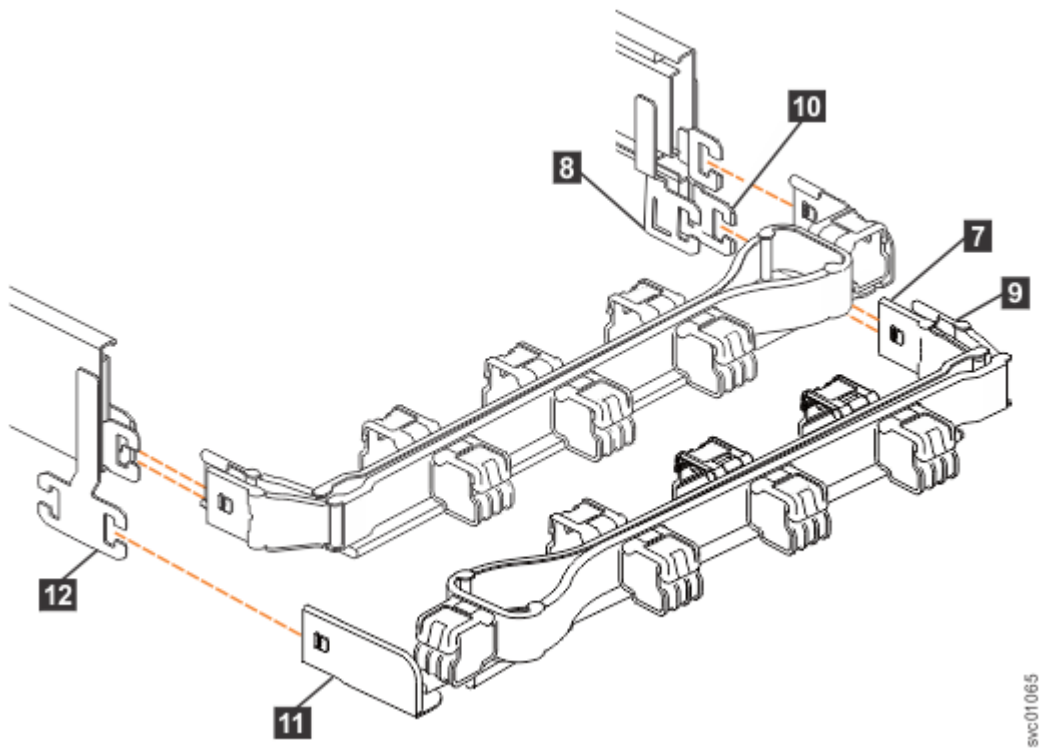

Figure 54. Comparing the location of the components of the CMA assemblies

- 7 Inner connector on lower CMA
- 8 Connector base on inner rail member
- 9 Outer connector on lower CMA
- 10 Connector base on outer rail member
- 11 Support rail connector the lower CMA
- 12 Connector base on outer rail member

- Install the inner connector of the lower CMA assembly (7) to the inner member of the right support rail (8), as shown in Figure 54 on page 54).

6. Install the outer connector of the lower CMA assembly (9) to the outer member of the right support rail (10), as shown in [Figure 54 on page 54](#).
7. Attach the support rail connector on the lower CMA assembly (11) to the connector on the left support rail (12), as shown in [Figure 54 on page 54](#).
Ensure that the lower CMA assembly is securely attached to the hooks on the end of the support rails.
8. Route the cables and power cords on the CMA. If needed, secure them with cable ties or hook-and-loop fasteners.

Notes:

- Use the cable straps that are provided on the rear of the system to retain the cables and prevent them from sagging.
 - Allow slack in all of the cables to avoid tension in the cables as the CMA moves.
9. Reconnect the power cords and other cables, as needed.

Removing and installing a SAS cable: 2077-92F, 2077-A9F

Use the following procedures to attach SAS cables to the 2077-92F, 2077-A9F enclosure during the initial installation process. You can also remove a faulty SAS cable and replace it with a new one received from FRU stock.

About this task

Be careful when you are replacing the hardware components that are located in the back of the system. Do not inadvertently disturb or remove any cables that you are not instructed to remove.

If you replace more than one cable, record which two ports, canisters, and enclosures each cable connects, so you can match the connections with the replacement cables. The system cannot operate if the SAS cabling to the expansion enclosure is incorrect.

When the 2077-92F, 2077-A9F expansion enclosure is installed in the rack, the expansion canisters are upside down. The input cable connects to the right port (port 1) on the expansion canister. The output cable connects to the left port (port 2) on the canister.

Procedure

Removing a SAS cable

1. Locate the connector at the end of the SAS cable that is to be removed from the expansion enclosure.
2. Grasp the connector by its blue tag. Pull the tag.
3. Release the connector and slide it out of the SAS port.
4. Repeat steps “2” on [page 55](#) and “3” on [page 55](#) on the other end of the SAS cable.

Replacing a SAS cable

5. Ensure that the SAS connector is oriented correctly, as shown in [Figure 55 on page 56](#). The blue tab must face towards the top of the enclosure canister.

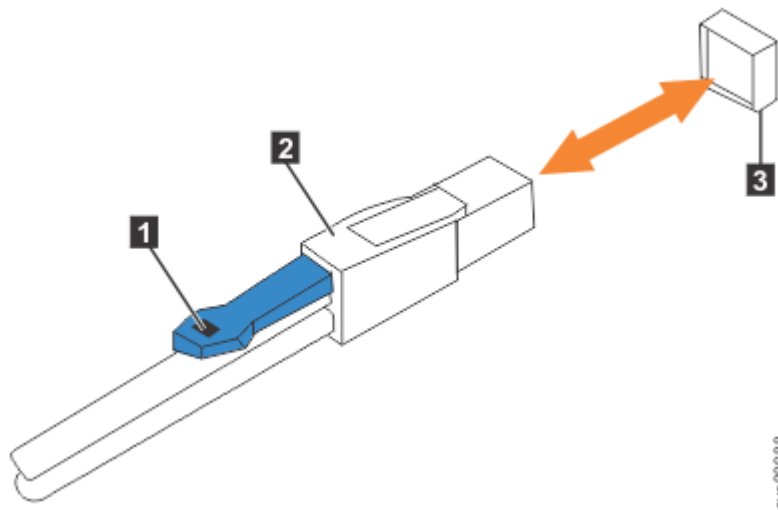

- 1 Blue pull tab
- 2 SAS cable
- 3 SAS port

Figure 55. Correct orientation for SAS cable connectors

6. Insert the SAS cable into the SAS port until you hear or feel a click. When the cable is successfully inserted, you cannot disconnect the cable without pulling on the blue tag.

Connecting to a Storwize V5100 node

7. Connect the SAS cable to the SAS port with blue tab **above** the connector (that is, facing towards the top of the node).

You hear or feel a click when the cable is successfully inserted. You cannot disconnect the cable without pulling on the blue tag.

8. Route the SAS cables through the cable management arms, as shown in [Figure 56 on page 56](#).

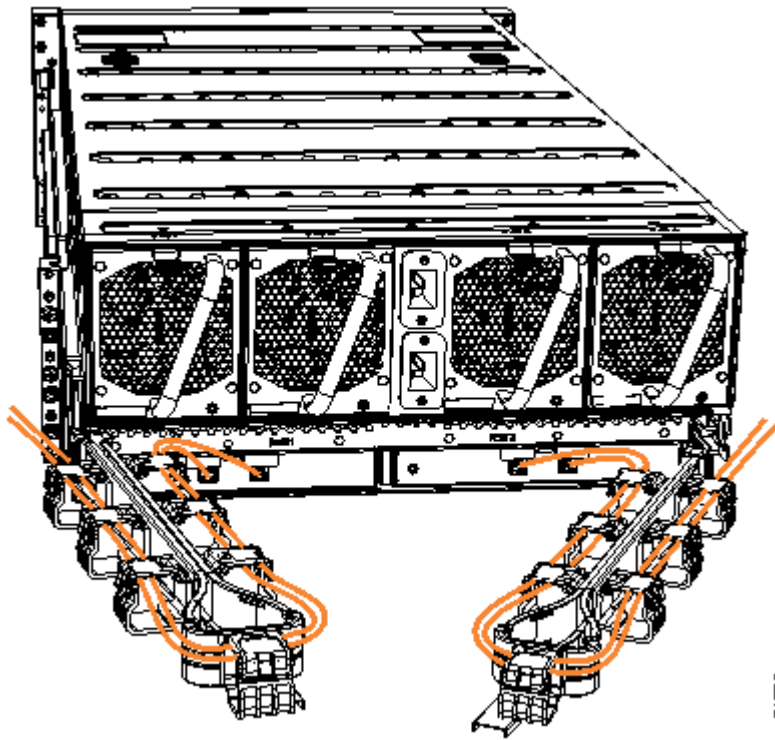

Figure 56. Example of SAS cables routed through the cable management arms

9. When both ends of a SAS cable are correctly connected, the green link-LED next to the connected SAS ports are lit.

For example, Figure 57 on page 57 shows the LEDs of expansion canister 1 on a 2077-92F, 2077-A9F expansion enclosure. The SAS cable is successfully inserted in to port 1 (input); port 2 (output) does not contain a SAS cable.

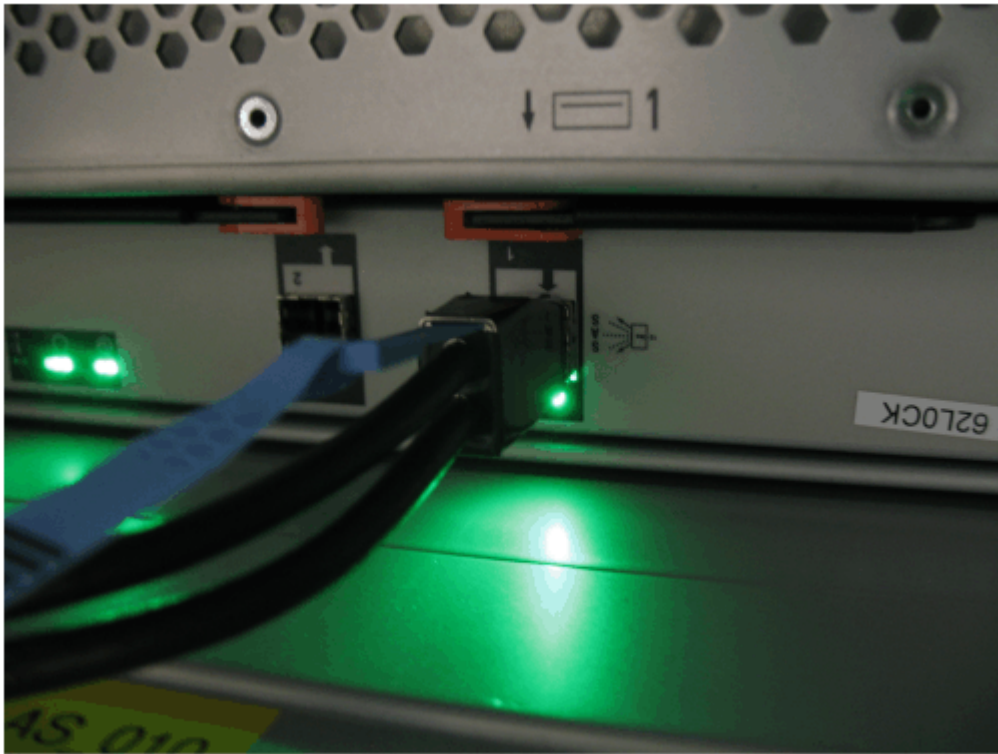

Figure 57. SAS cable correctly inserted into the SAS port

Connecting optional SAS expansion enclosures: 2078-92F, 2078-A9F

After you install 5U expansion enclosures into the rack, you must connect them to each system that will use them. The system requires software version 7.8.0 or later. Do not connect the expansion enclosure if software version 7.8.0 is not installed on the system.

About this task

This task applies if you are installing a 2078-92F, 2078-A9F expansion enclosure.

Note: When you insert SAS cables, ensure that the connector is oriented correctly to the control enclosure and expansion enclosure.

- For systems, IBM Storwize V5100 control enclosures, and 2077-24F 2U expansion enclosures, the blue pull tab must be below the cable (1 in Figure 58 on page 57).

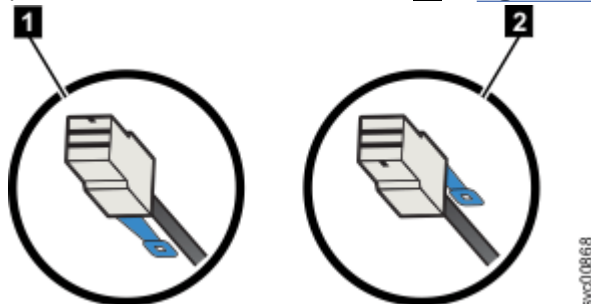

Figure 58. SAS cable connector orientation

- For 2078-92F, 2078-A9F 5U expansion enclosures, the blue pull tab must be above the connector (2 in Figure 58 on page 57).
- Insert the connector gently until it clicks into place. If you feel resistance, the connector is probably oriented the wrong way. Do not force it.
- When inserted correctly, the connector can be removed only by pulling the tab.

Be aware of the following guidelines when you attach the cables to the SAS ports.

- No cable can be connected between a port on a left canister and a port on a right canister of the expansion enclosures.
- Ensure that cables are installed in an orderly way to reduce the risk of cable damage when replaceable units are removed or inserted.
- SAS cables must be routed through the cable management arms to reduce the risk of disconnecting the nodes from their storage arrays. This step also helps to protect the SAS cables from getting damaged if you slide the node or enclosure out of the rack while they are attached. Arrange your cables to provide access to the following components:
 - Ethernet ports, including the technician port. The technician port is used for initial setup of the system by directly attaching to a personal computer. It can also be used to complete service actions for the system.
 - USB ports.
 - Fibre Channel ports. If your system has an optionally installed Fibre Channel adapter for host and external storage attachment, ensure that these ports are accessible.
 - The nodes and the enclosures themselves. Access is required to the hardware for servicing and for safely removing and replacing components by using two or more people.

Procedure

1. Install the cables, as shown in [Figure 59 on page 58](#).

Note: Figure 59 on page 58 shows the cable connections between the SAS enclosures and the control enclosure. It does not imply or represent the precise racking order for the enclosures in a rack. However, due to its size and weight, always place the 2078-92F, 2078-A9F enclosure near the bottom of the rack.

Figure 59. Connecting the SAS cables

2. If more I/O groups are configured, repeat the cabling procedure for the other I/O groups. Each system can have a maximum of four I/O groups, with two chains of expansion enclosures attached to each I/O group. Two chains of expansion enclosures can be attached to each I/O group. On each SAS chain, the systems can support up to a SAS chain weight of 10.

Combining 2U and 5U expansion enclosures

About this task

You can combine 2U and 5U expansion enclosures in a SAS chain. The limiting factor is the combined *chain weight* of the various components. The maximum SAS chain weight that can be attached to a node SAS port is 10:

- 2078-92F, 2078-A9F enclosures have a chain weight of 2.5
- 2077-24F and 2077/2078-12F enclosures have a chain weight of 1.

Example

[Table 11 on page 59](#) shows example of different combinations of SAS weights.

2077/2078-12F Enclosures	2077-24F Enclosures	2078-92F, 2078-A9F Enclosures	Combined chain weight
2	0	3	9.5
2	3	2	10
0	7	1	9.5
1	1	1	4.5

In addition, the orientation of the Input and Output SAS ports on the 2U and 5U SAS enclosures differs. Figure 60 on page 59 shows the SAS ports on the 2U and 5U expansion enclosures.

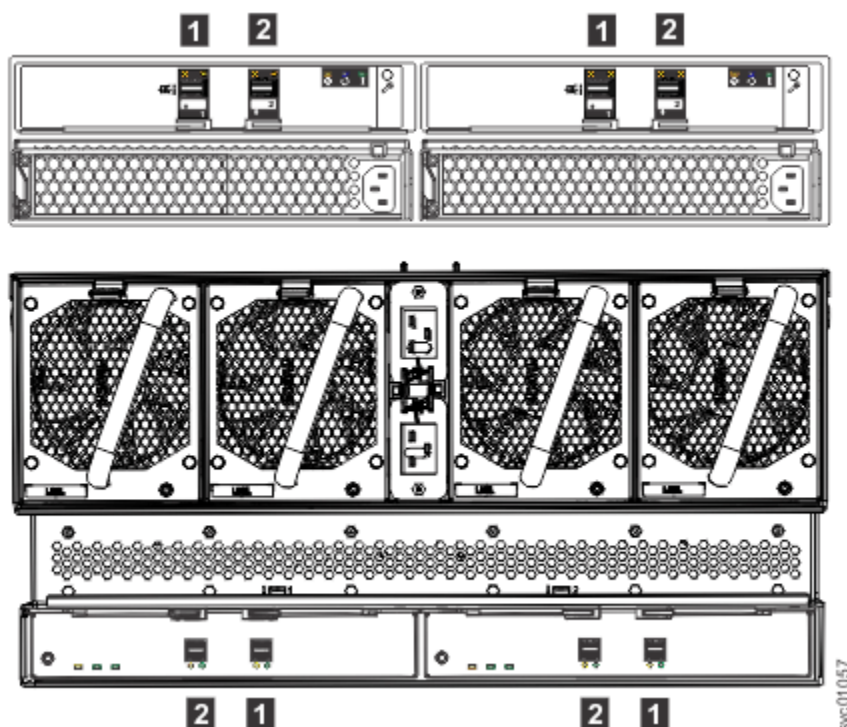

Figure 60. SAS port orientation on expansion enclosures

- 1 Input SAS port
- 2 Output SAS port

Powering on the optional 2077-92F, 2077-A9F expansion enclosures

Use the following procedure to provide power to the 2077-92F, 2077-A9F expansion enclosure as part of the initial installation process or after a service procedure.

Before you begin

Important:

- Before you connect the power cables to the rear of the enclosure, always check that the expansion enclosure is secured in the rack. If needed, tighten the thumbscrews on the front of the enclosure (2 in Figure 61 on page 60) to ensure that the enclosure drawer does not roll open.

About this task

The 2077-92F, 2077-A9F expansion enclosure has two power supply units (PSUs) that are accessible from the front of the enclosure (4 in Figure 61 on page 60). As the figure also shows, the PSUs are covered by the 1U fascia (5).

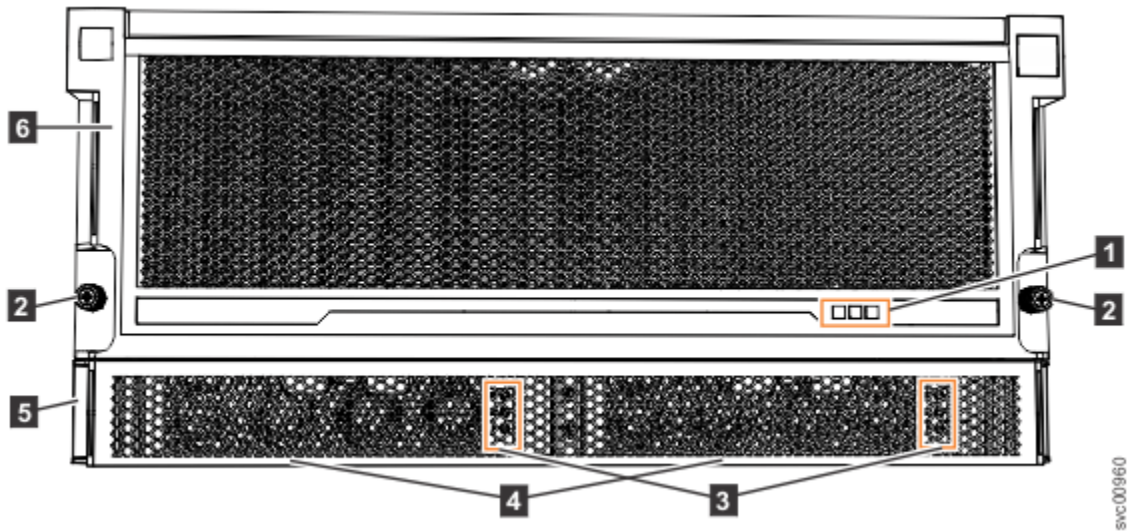

Figure 61. Features on the front of the 2077-92F, 2077-A9F expansion enclosure

- 1 Display panel LEDs
- 2 Rack retention thumb screws
- 3 Power supply unit LEDs
- 4 Power supply units (PSUs)
- 5 PSU fascia (1U)
- 6 Front fascia (4U)

Each PSU has a power supply connector and power cable, which are accessible from the back of the enclosure. Power is provided by plugging a C19-C20 power cable into each power supply unit and, if necessary, turning on the power source. The expansion enclosure does not have a power button.

Procedure

1. Connect the C19-C20 power cables to the power connectors on the rear of the expansion enclosure. The enclosure automatically powers on and begins its Power On Self-Tests (POST).
2. Secure the power cables in the cable retainer at each power connector on the rear of the enclosure, as shown in Figure 62 on page 61. Also, ensure that each cable is installed along one of the cable management arms. The cable management arms also support the SAS cables.

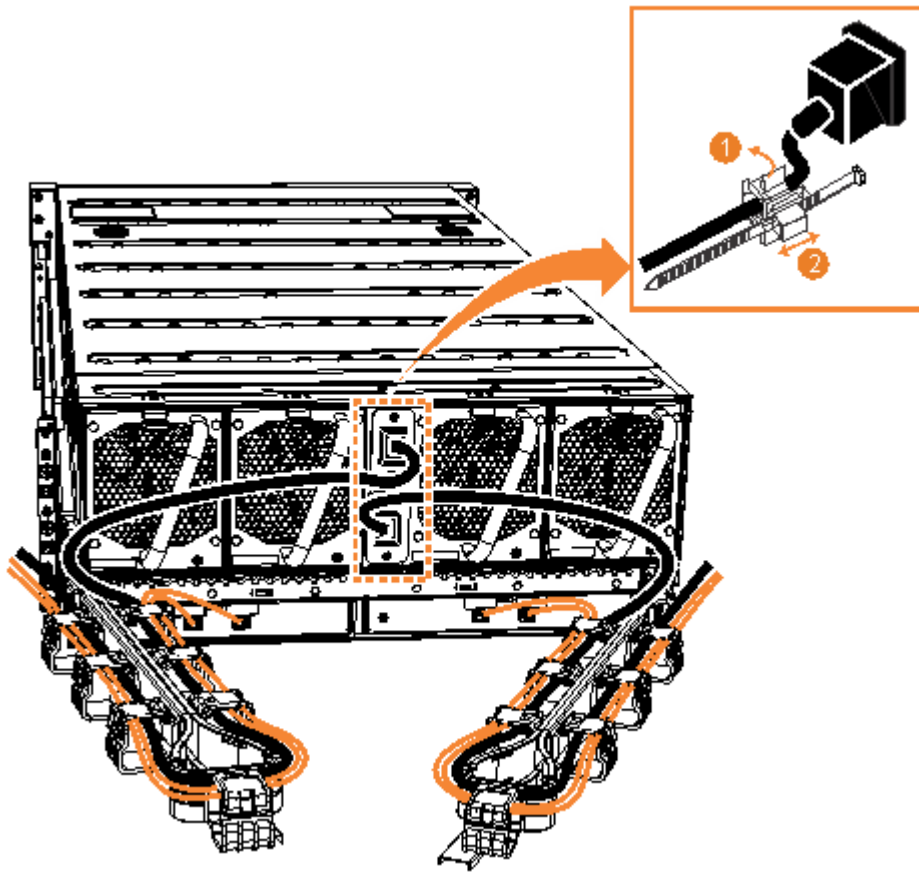

Figure 62. Secure power cables

Important: Always secure each power cable with a cable retainer and ensure that the cable is installed along one of the cable management arms. When secured, the power and SAS cables stay connected when you slide the expansion enclosure out of the rack to perform service tasks.

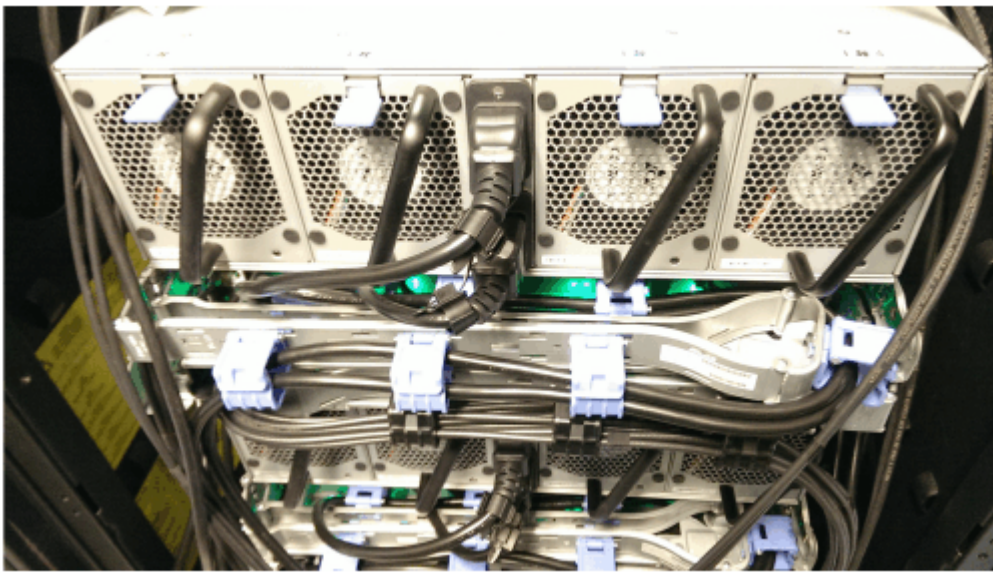

Figure 63. Power and SAS cable connections on the back of the enclosure

3. Verify that the expansion enclosure and its components are operating as expected.

On the back of the expansion enclosure, all four fans and the expansion canister indicators (3 and 8 in Figure 64 on page 62) become active when the power is connected.

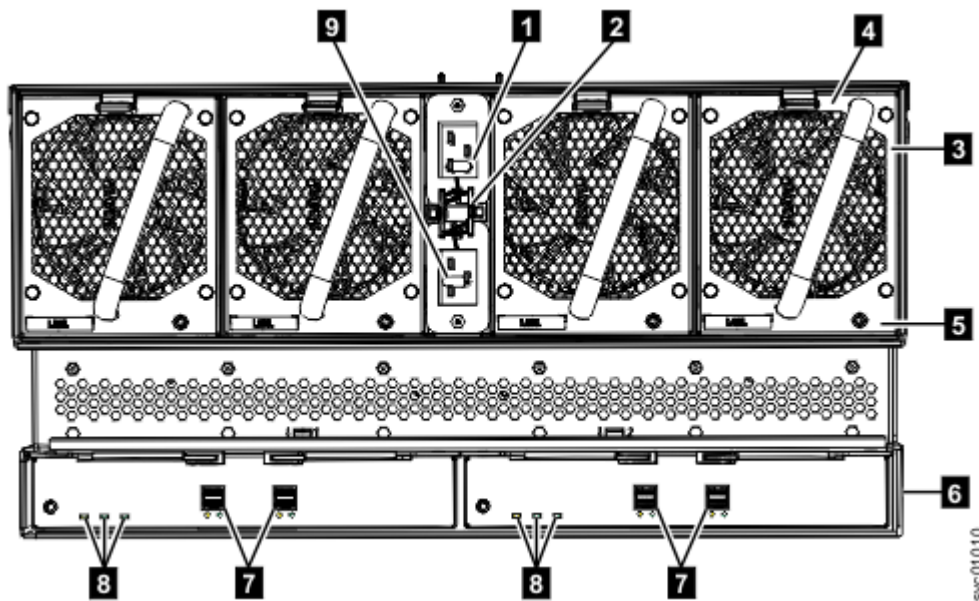

Figure 64. Features on the rear of the 2077-92F, 2077-A9F expansion enclosure

- 1 Power cable connector for PSU 2
- 2 Power cable retention clamps
- 3 Fan module
- 4 Fan release latch
- 5 Fan fault indicator
- 6 Expansion canister
- 7 SAS ports and indicators
- 8 Expansion canister indicators
- 9 Power cable connector for PSU 1

4. Verify that the system recognizes the expansion enclosure.

In the management GUI, view information about the system status and the expansion enclosure.

- If a new expansion enclosure was installed, make sure that the enclosure was discovered by the system. A newly recognized expansion enclosure is visible in the management GUI.
- If the expansion enclosure was powered off as part of a service procedure, view the information in the management GUI to confirm that the enclosure is operating as expected. You can also access the Event Log to view enclosure and component events and complete any remaining fix procedures.

Powering off the expansion enclosure: 2077-92F, 2077-A9F

Before you power down a 2077-92F, 2077-A9F expansion enclosure, review the following procedure.

Before you begin

When you power off an expansion enclosure, the drives in that enclosure are no longer available to the control enclosure. The SAS chain also breaks. Any expansion enclosures that are beyond the enclosure that is powered down are also disconnected from the control enclosure.

Before you power off an enclosure, use the management GUI to show the volumes that depend on that enclosure. In the system view, select the expansion enclosure to be powered off. Then, select **Dependent Volumes**. If no configuration changes are made, other volumes remain available to the system.

Procedure

1. Stop all I/O to the system from hosts that access the expansion enclosure.
2. Unmount any associated file systems.

3. Wait 5 minutes for all write data to be flushed to the drives.
4. Unplug both of the power cords from the rear of the expansion enclosure to remove all power from the enclosure.

Storwize V5100 2078-92F, 2078-A9F expansion enclosure LEDs and indicators

The 2078-92F, 2078-A9F (5U) expansion enclosure has several sets of LEDs that provide information about the overall status of the enclosure, power, drives, fans, canisters, and SAS connections.

A 2078-92F, 2078-A9F expansion enclosure has sets of LEDs on the front and rear of the enclosure. Inside of the expansion enclosure, LEDs also indicate the status of the drives and each secondary expander module.

LEDs on the front of the expansion enclosure

As [Figure 65 on page 63](#) shows, the front of the 2077-92F, 2077-A9F expansion enclosure contains LEDs for the display panel (1) and for each of the power supply units (3).

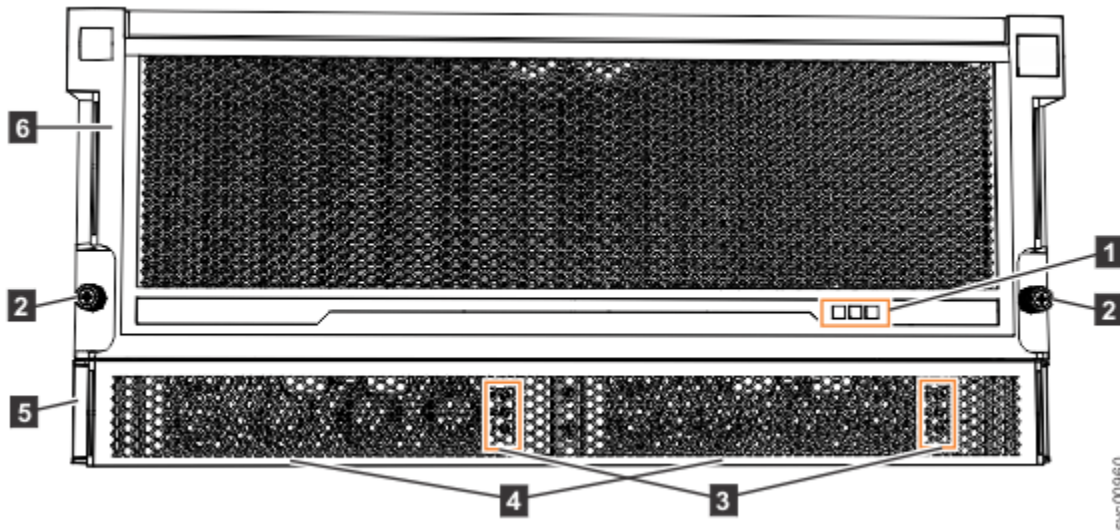

Figure 65. LEDs on the front of the expansion enclosure

- 1 Display panel LEDs
- 2 Rack retention thumb screws
- 3 Power supply unit LEDs
- 4 Power supply units (PSUs)
- 5 PSU fascia (1U)
- 6 Front fascia (4U)

The display panel (1) contains three LEDs that describe the operational status of the expansion enclosure. [Table 12 on page 63](#) describes the function and meaning of the LEDs on the front display panel.

Function	Color	Status	Description
Power	Green	On	The expansion enclosure power is on; this LED is controlled by the expansion enclosure.
		Off	The expansion enclosure power is off.

Table 12. Display panel LEDs (continued)

Function	Color	Status	Description
Identify	Blue	On	Identifies the expansion enclosure; this LED is controlled by the system. Use the management GUI or service interface to identify an enclosure.
		Off	The expansion enclosure is operating normally.
Enclosure fault	Amber	On	The expansion enclosure is coming up or a fault is detected against a component within the enclosure.
		Off	No faults are detected.

The 2077-92F, 2077-A9F expansion enclosure contains two PSUs (4 in Figure 65 on page 63) that are accessible from the front of the enclosure. Each PSU has its own a set of LEDs, as shown in Figure 66 on page 64.

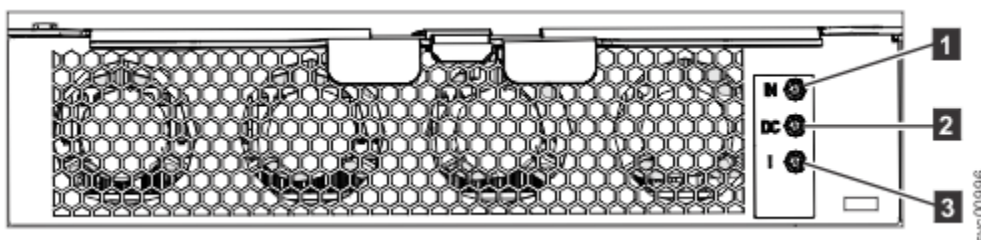

Figure 66. LEDs on the front of a power supply unit

- 1 Input power
- 2 DC power
- 3 Fault indicator

Table 13 on page 64 explains the function and status that is indicated by each of the LEDs. The power cords for each PSU are accessible from the rear of the expansion enclosure (1), as shown in Figure 69 on page 67.

Table 13. Power supply unit LEDs

Function	Color	Status	Description
1 Input power	Green	On	The input voltage is within specification.
		Off	No power input detected.
2 DC power	Green	On	DC power outputs are within specification.
		Off	DC power is not available.
3 Fault	Amber	On	A fault is detected in the PSU.
		Off	No faults are detected.

LEDs inside of the expansion enclosure

Each of the drives and secondary expansion modules within the 2077-92F, 2077-A9F expansion enclosure has two LED indicators. To view the drives and secondary expansion modules, you must remove the cover of the enclosure, as described in [“Removing the top cover: 2077-92F, 2077-A9F”](#) on page 38.

Figure 67 on page 65 shows the components of a drive assembly. Each drive has an online indicator (2) and fault indicator (3).

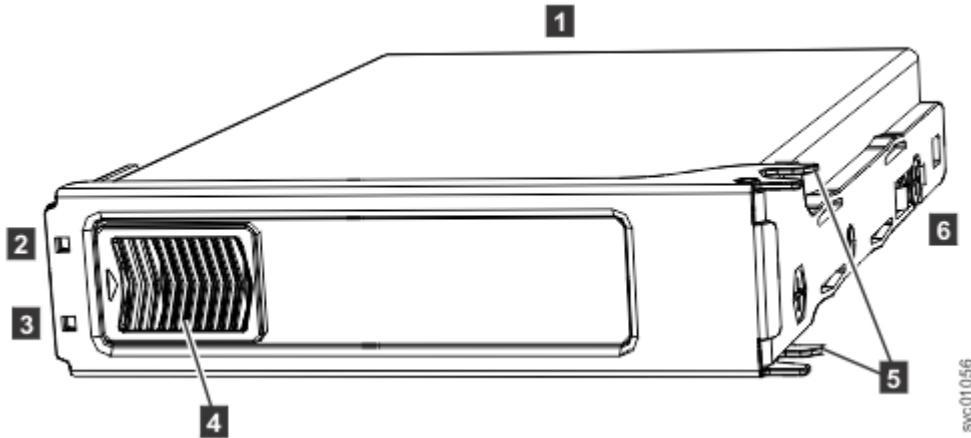

Figure 67. LEDs on a drive assembly

Table 14 on page 65 describes the meaning of the LEDs on each drive.

Function	Color	Status	Description
2 Activity	Green	On	The drive is ready to be used.
		Flashing	The drive is operating and I/O is occurring.
		Off	The drive is not installed or an installed drive is not ready to be used.
3 Fault	Amber	On	A fault occurred on the drive. The LED is turned off when the drive is removed and replaced.
		Flash	The drive is being identified, a fault might or might not be detected.
		Off	The installed drive is operating normally.

Figure 68 on page 66 shows the LEDs on a secondary expansion module.

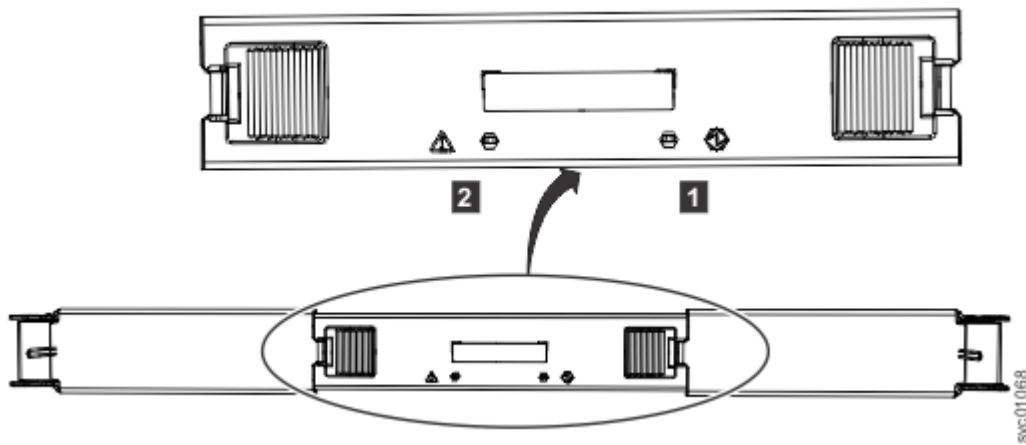

Figure 68. LEDs on a secondary expansion module

- 1 Online indicator
- 2 Fault indicator

Table 15 on page 66 describes the meaning of the LEDs on each secondary expansion module.

Table 15. LED indicators on secondary expansion modules

Function	Color	Status	Description
1 Power	Green	On	The secondary expansion module is receiving power.
		Flashing	Not used.
		Off	The secondary expansion module is not receiving power.
2 Fault	Amber	On	Not used.
		Flash	The secondary expansion module is being identified.
		Off	The secondary expansion module is operating normally.

LEDs on the rear of the expansion enclosure

Figure 69 on page 67 shows the rear view of a 2077-92F, 2077-A9F expansion enclosure. LEDs on the rear of the enclosure provide information about each fan module, each expansion canister, and SAS links.

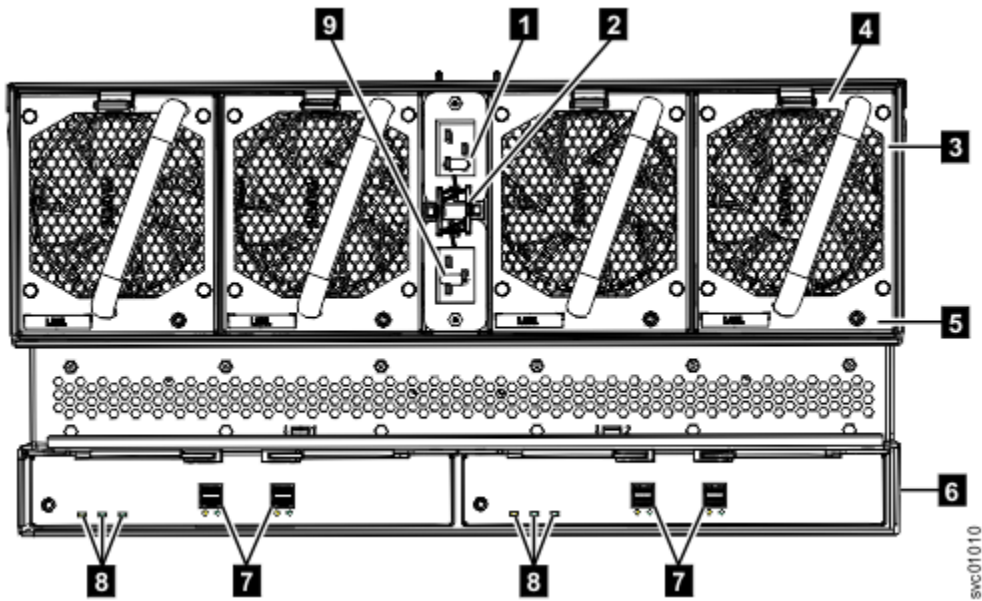

Figure 69. LEDs on the back of the expansion enclosure

The expansion enclosure has four fans. Each fan has one LED; for example, [Figure 69 on page 67](#) shows the location of the LED (5) for fan number four. When a fan is operating normally, the LED is not lit. If a fault is detected, the amber LED is lit.

As [Figure 69 on page 67](#) also shows, the expansion enclosure contains two expansion canisters. Each expansion canister contains its own set of LEDs, as shown in [Figure 70 on page 67](#). The LEDs provide status information about the expansion canister itself and the SAS connections.

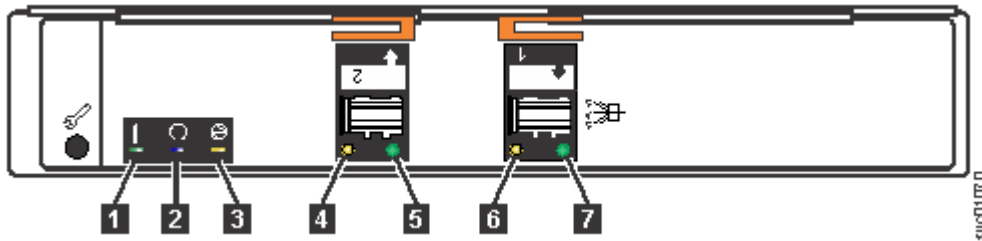

Figure 70. LEDs on the back of the expansion canister

- 1 Canister fault
- 2 Canister status
- 3 Canister power
- 4 and 6 SAS link fault
- 5 and 7 SAS link operational
- 8 Canister release handles

[Table 16 on page 68](#) describes the values and meaning of each LED.

Table 16. Expansion canister and SAS port LEDs

Name	Color	State	Meaning
1 Canister fault	Amber	Off	Normal operation.
		On	A fault was detected.
		Flashing	The expansion canister is being identified. A fault might or might not be detected.
2 Canister status	Green	Off	Canister is off.
		On	Normal operation.
		Flashing	A vital product data (VPD) error occurred.
3 Canister power	Green	Off	Canister is off.
		On	Canister is receiving power.
4 and 6 SAS link fault	Amber	Off	No faults are detected. All four phys have a link connection.
		On	Several error conditions are possible: <ul style="list-style-type: none"> • Only 1, 2, or 3 phys are connected, but not all 4. • The phys are not operating at the same speed. • All phys are not connected to the same remote port. One or more of the connected lanes are attached to a different address.
5 and 7 SAS link operational	Green	Off	No link connection on any lane. The connection is down.
		On	The SAS link is active. At least one of the four lanes is connected.

Storwize V5100 5U expansion enclosure parts

On the (5U) expansion enclosure, all replaceable parts are customer-replaceable units (CRUs).

Expansion enclosure drives

Table 17 on page 69 summarizes the part numbers and feature codes for the 2077-92F, 2077-A9F expansion enclosure, which is supported by all Storwize V5100 systems.

Table 17. Supported expansion enclosure SAS drives

Description	FRU part number	Comments
600 GB 15 K disk drive	01LJ037	
1.2 TB 10 K disk drive	01LJ038	
1.8 TB 10 K disk drive	01LJ039	
6 TB 7.2 K Near-Line SAS disk drive	01LJ040	
8 TB 7.2 K Near-Line SAS disk drive	01LJ041	
10 TB 7.2 K Near-Line SAS disk drive	01LJ042	
12 TB 7.2 K Near-Line SAS disk drive	01YM235	
1.6 TB tier 0 flash drive	01LJ043	For systems with a 1-year warranty (2077-xxx).
		For systems with a 3-year warranty (2078-xxx).
3.2 TB tier 0 flash drive	01LJ044	For systems with a 1-year warranty (2077-xxx).
		For systems with a 3-year warranty (2078-xxx).
1.92 TB tier 1 flash drive	01LJ045	For systems with a 1-year warranty (2077-xxx).
		For systems with a 3-year warranty (2078-xxx).
3.84 TB tier 1 flash drive	01LJ046	For systems with a 1-year warranty (2077-xxx).
		For systems with a 3-year warranty (2078-xxx).
7.68 TB tier 1 flash drive	01LJ047	For systems with a 1-year warranty (2077-xxx).
		For systems with a 3-year warranty (2078-xxx).
15.36 TB tier 1 flash drive	01LJ048	For systems with a 1-year warranty (2077-xxx).
		For systems with a 3-year warranty (2078-xxx).

Other expansion enclosure parts

Table 18 on page 69 summarizes the part numbers and feature codes for other parts. The values are the same for all Storwize V5100 systems that support the 2077-92F, 2077-A9F expansion enclosure.

Table 18. Other expansion enclosure parts

FRU Part Number	Description	Comments
00AR317	3 m 12 Gb SAS Cable (mSAS HD)	

<i>Table 18. Other expansion enclosure parts (continued)</i>		
FRU Part Number	Description	Comments
00AR439	6 m 12 Gb SAS Cable (mSAS HD)	
01LJ114	Rail kit	
01LJ116	Front fascia (4U front cover)	
01LJ118	Display panel assembly	
01LJ120	PSU fascia (1U cover)	The fascia must be removed to access the power supply units.
01LJ122	Power supply unit (PSU)	The expansion enclosure contains 2 PSUs. Each PSU requires a C19/C20 power cord.
01LJ124 (for use with enclosure FRU P/N 01LJ112) 01LJ860 (for use with enclosure FRU P/N 01LJ607)	Secondary expansion module	The expansion enclosure supports two-secondary expansion modules.  CAUTION: Use caution when you are removing or replacing a secondary expansion module from an enclosure with FRU part number 01LJ112. Avoid contact with the connectors on the main board.
01LJ126	Fan module	The expansion enclosure contains four fan modules.
01LJ128	Expansion canister	
01LJ130	Cable management arms (CMA)	The part contains the upper and lower CMA.
01LJ132	Top cover	
01LJ134	Fan interface board	
01LJ607 Note: Replaces enclosure FRU P/N 01LJ112.	Enclosure	Includes the drive board, signal interconnect board, and internal power cables, in an otherwise empty enclosure.
39M5388	16A power cord C19/C20 2 m	

Connecting the components

After installing the rails and enclosures in the rack, the Storwize V5100 control enclosures are connected to power, the network, and any optional expansion enclosures.

After all cabling connections are completed, the system components are powered on.

Connecting Ethernet cables to the node canisters

To provide system management connectivity for the system, connect Ethernet cables to Ethernet port 1 of both node canisters in the control enclosure.

Procedure

To install the Ethernet cables, complete the following steps.

1. Connect Ethernet port 1 of each node canister in the system to the IP network that will provide connection to the system management interfaces.

This port can also be used for iSCSI connectivity to the system by hosts on the network. Where more than one control enclosure is present in the system, ensure port 1 of every node canister is connected to the same network to provide access if the configuration node fails.

2. Optionally, connect Ethernet port 2 of each node canister in the system to a second IP network that will provide redundant connection to the system management interfaces.

This port can also be used for iSCSI connectivity to the system by hosts on the network. If there is more than one control enclosure in the system, ensure that port 2 of every node canister is connected to the same network to provide access if the configuration node fails.

Connecting Fibre Channel cables to the control enclosure

If your system has one or more Fibre Channel adapters installed, use Fibre Channel cables to connect the two node canisters in the enclosure to the switches in the Fibre Channel SAN.

Before you begin

Refer to the "Planning" section of the IBM Knowledge Center for instructions on determining the number of required cables and their intended port locations.

Procedure

To install the cables, complete the following steps.

1. Referring to the "Planning" section of the documentation, connect the required number of Fibre Channel cables to the node canisters in the control enclosure

Note: Both canisters must have the same number of cables connected.

Figure 71 on page 71 shows the location of optional Fibre Channel adapters in adapter slot 2 of each of the two node canisters. The port numbers are also shown.

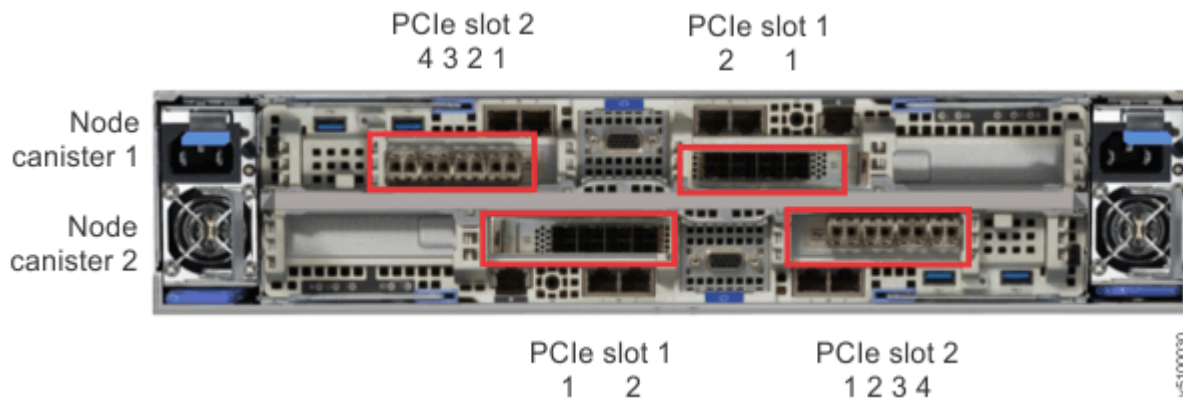

Figure 71. Fibre Channel adapters in the node canisters

2. To connect additional Fibre Channel cables, connect the same number of cables to each canister.

Connecting optional expansion enclosures to the control enclosure

If you have installed expansion enclosures in the rack, you must connect them to the control enclosure.

About this task

This task applies if you are installing one or more expansion enclosures. Each control enclosure in the system can manage two chains of expansion enclosures; each chain can consist of a maximum of 10 2U expansion enclosures. Therefore, each control enclosure can support up to 20U of expansion enclosures. A system that contains two control enclosures can support up to 40U of expansion enclosures.

Note: When connecting SAS cables between enclosures, you must follow a list of guidelines to ensure that your configuration is valid. Do not begin connecting the cables until you have read [Figure 72 on page 73](#).

Procedure

To install the cables, complete the following steps.

1. Using the supplied SAS cables, connect the control enclosure to the expansion enclosure at rack position 1, as shown in [Figure 72 on page 73](#).
 - a) Connect SAS port 1 of the upper node canister in the control enclosure to SAS port 1 of the left expansion canister in the first expansion enclosure.
 - b) Connect SAS port 1 of the lower node canister in the control enclosure to SAS port 1 of the right expansion canister in the first expansion enclosure.

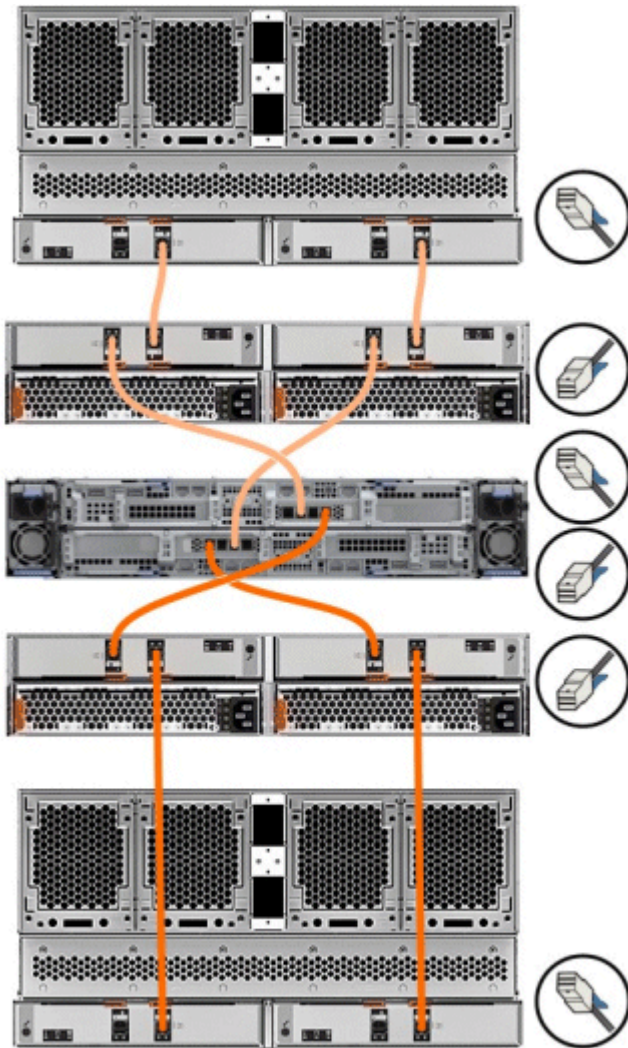

Figure 72. Connecting the SAS cables

2. To add a second expansion enclosure chain to the control enclosure, use the supplied SAS cables to connect the control enclosure to the expansion enclosure at rack position 2. Refer to [Figure 72 on page 73](#) for an example.
3. If additional expansion enclosures are installed, connect each one to the previous expansion enclosure in a chain. Use two Mini SAS HD to Mini SAS HD cables, as shown in [Figure 72 on page 73](#).

Note: A control enclosure can support up to 20U of expansion enclosures in two chains: 10U in the upper chain (above the control enclosure) and 10U in the lower chain.

4. If additional control enclosures are installed, repeat this cabling procedure on each control enclosure and its expansion enclosures.

When using more than one control enclosure, divide the total number of expansion enclosures among the control enclosures to enhance performance.

SAS cabling guidelines

When connecting SAS cables between 2U expansion enclosures, you must follow a list of guidelines to ensure that your configuration is valid.

Orienting the connector

When inserting SAS cables, make sure the connector ([Figure 73 on page 74](#)) is oriented correctly.

- The orientation of the connector must match the orientation of the port before you push the connector into the port. The cable connector and socket are keyed, and it is important that you have proper alignment of the keys when the cable is inserted.

Note: On Storwize V5100 control enclosures, node canister 1 is inverted from node canister 2. Because the orientation of the ports differ, you must ensure that the orientation of the SAS cables is also correct for each canister.

- For ports in the upper canister (canister 1), the blue pull tab must be **above** the connector. For ports in the lower canister (canister 2), the blue pull tab must be **below** the connector.
- Insert the connector **gently** until it clicks into place. If you feel resistance, the connector is probably oriented the wrong way. Do **not** force it.
- When inserted correctly, the connector can only be removed by pulling the tab.
- When both ends of a SAS cable are inserted correctly, the green link LEDs next to the connected SAS ports are lit.

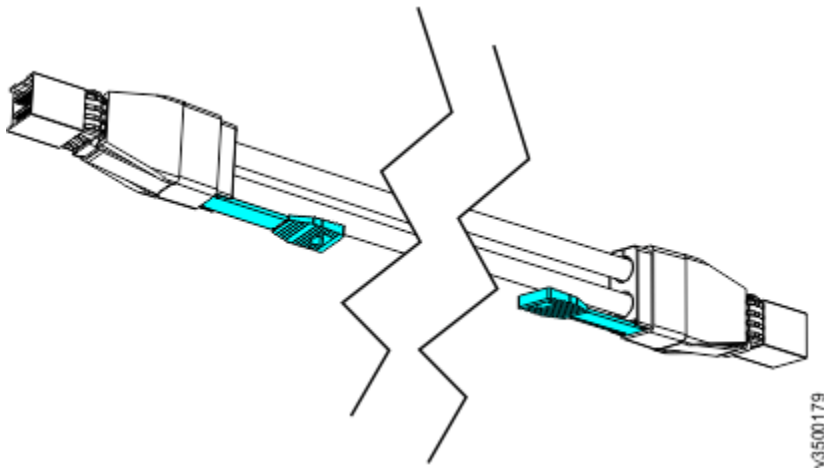

Figure 73. SAS cable connectors

Guidelines

Be aware of the following guidelines when you connect a 2077-424 control enclosure to the SAS ports in 2U and 5U expansion enclosures.

- 2077-424 systems support 4-port SAS interface adapters.
- No more than ten 2U expansion enclosures can be chained to SAS port 1 of a node canister. The expansion enclosures in this chain should be installed below the control enclosure, as shown in [Figure 74 on page 75](#).
- No cable can be connected between a port on a left expansion canister and a port on a right expansion canister.
- A cable must not be connected between ports in the same enclosure.
- A connected port on the node canister must connect to a single port on an expansion canister. Cables that split the connector out into separate physical connections are not supported.
- Attach cables serially between enclosures; do not skip an enclosure.
- The last expansion enclosure in a chain must not have cables in port 1 of canister 1 or port 1 of canister 2.
- Ensure that cables are installed in an orderly way to reduce the risk of cable damage when replaceable units are removed or inserted.

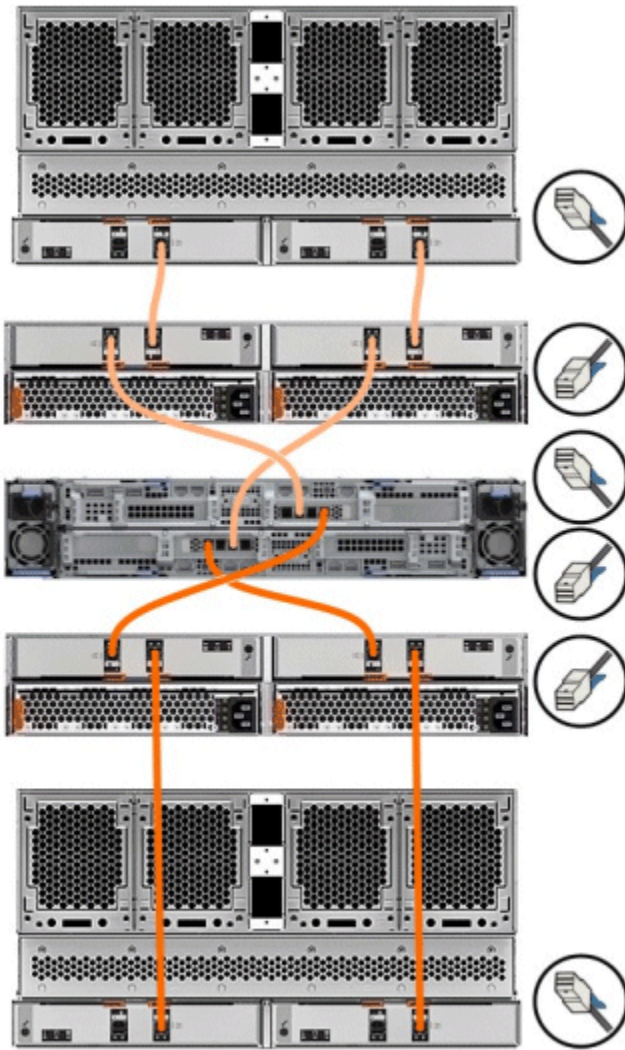

Figure 74. Connecting the SAS cables

Powering on the optional 2U SAS expansion enclosures

After you install all the hardware components, power on the optional 2U SAS expansion enclosures and check their status.

About this task



Attention: Do not power on an expansion enclosure with any open bays or slots.

- Every unused drive bay must be occupied by a filler panel.
- Filler panels must be installed in all empty host interface adapter slots.

Open bays or slots disrupt the internal air flow, causing the drives to receive insufficient cooling.

Procedure

To power on the 2U SAS expansion enclosures, complete the following steps.

1. Use the supplied power cords to connect both power supply units of the first expansion enclosure to their power sources.

If the power sources have circuit breakers or switches, ensure that they are turned on. The expansion enclosure does not have power switches. Repeat this step for each expansion enclosure in the system.

Note: Each enclosure has two power supply units. To provide power failure redundancy, connect the two power cords to separate power circuits.

2. From the rear of the rack, check the LEDs on each expansion enclosure (see [Figure 75 on page 76](#)).

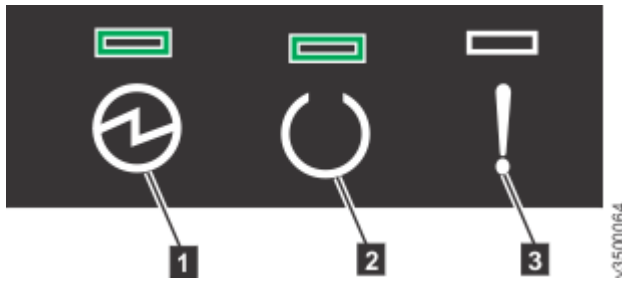

Figure 75. Expansion enclosure LEDs

- 1 Power
- 2 Status
- 3 Fault

The canister is ready with no critical errors when **Power** is illuminated, **Status** is on, and **Fault** is off.

3. Wait for all expansion canisters to finish powering on before you proceed with the system installation process.

Powering on the optional 2077-92F, 2077-A9F expansion enclosures

Use the following procedure to provide power to the 2077-92F, 2077-A9F expansion enclosure as part of the initial installation process or after a service procedure.

Before you begin

Important:

- Before you connect the power cables to the rear of the enclosure, always check that the expansion enclosure is secured in the rack. If needed, tighten the thumbscrews on the front of the enclosure (2 in [Figure 76 on page 77](#)) to ensure that the enclosure drawer does not roll open.

About this task

The 2077-92F, 2077-A9F expansion enclosure has two power supply units (PSUs) that are accessible from the front of the enclosure (4 in [Figure 76 on page 77](#)). As the figure also shows, the PSUs are covered by the 1U fascia (5).

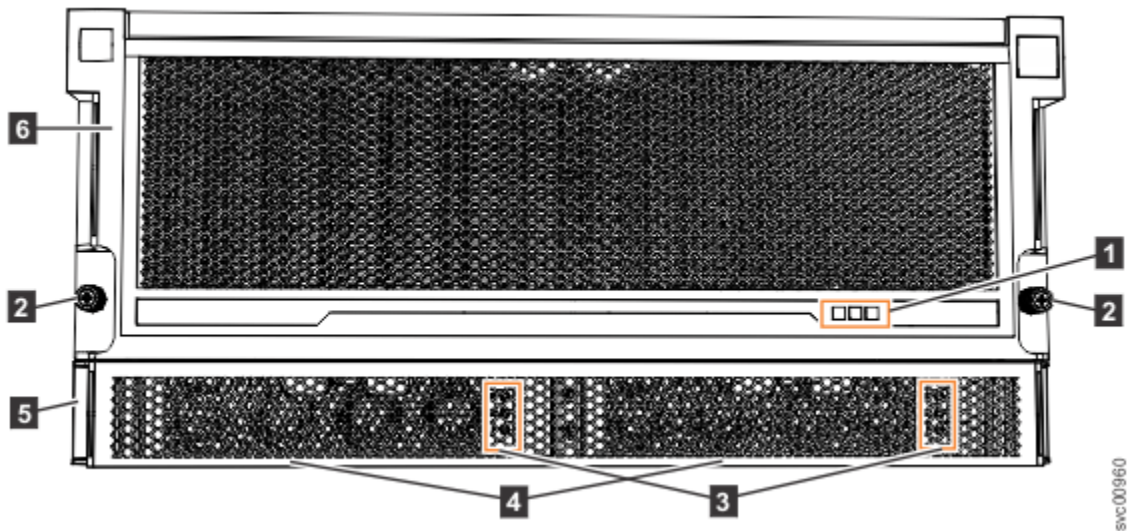

Figure 76. Features on the front of the 2077-92F, 2077-A9F expansion enclosure

- 1 Display panel LEDs
- 2 Rack retention thumb screws
- 3 Power supply unit LEDs
- 4 Power supply units (PSUs)
- 5 PSU fascia (1U)
- 6 Front fascia (4U)

Each PSU has a power supply connector and power cable, which are accessible from the back of the enclosure. Power is provided by plugging a C19-C20 power cable into each power supply unit and, if necessary, turning on the power source. The expansion enclosure does not have a power button.

Procedure

1. Connect the C19-C20 power cables to the power connectors on the rear of the expansion enclosure. The enclosure automatically powers on and begins its Power On Self-Tests (POST).
2. Secure the power cables in the cable retainer at each power connector on the rear of the enclosure, as shown in [Figure 77](#) on page 78. Also, ensure that each cable is installed along one of the cable management arms. The cable management arms also support the SAS cables.

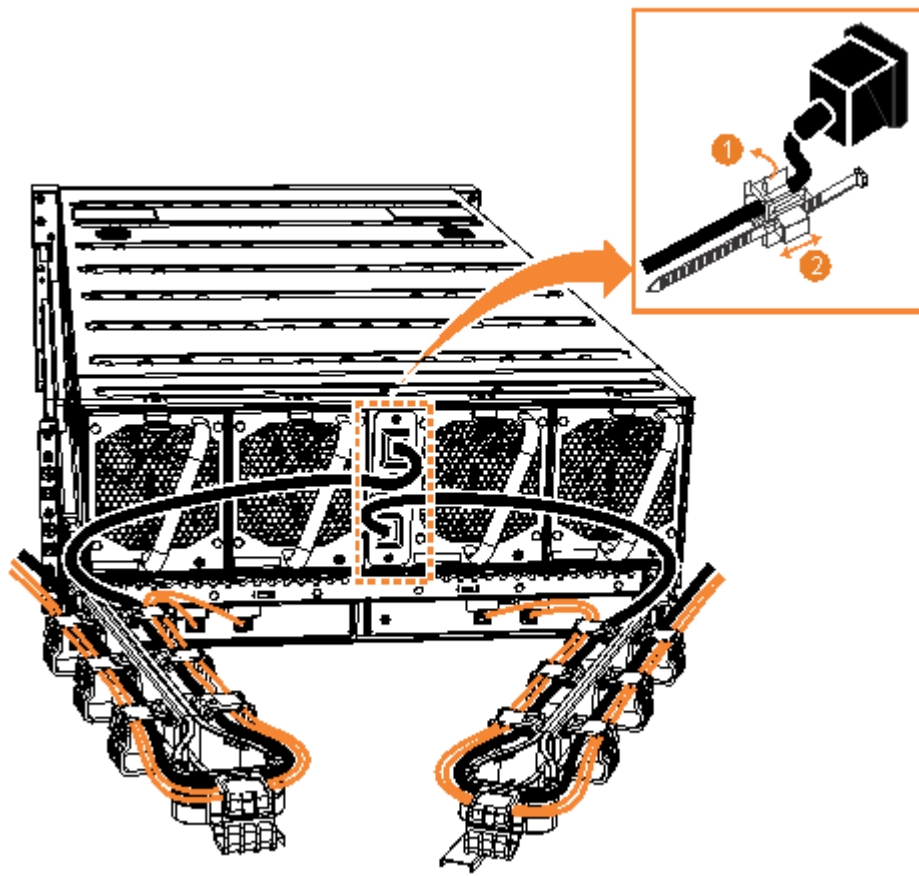

Figure 77. Secure power cables

Important: Always secure each power cable with a cable retainer and ensure that the cable is installed along one of the cable management arms. When secured, the power and SAS cables stay connected when you slide the expansion enclosure out of the rack to perform service tasks.

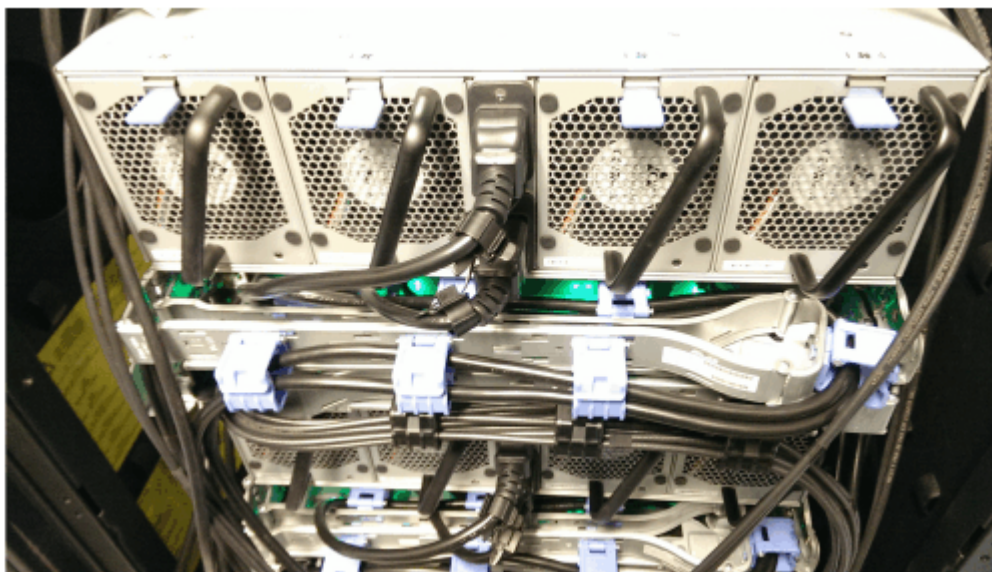

Figure 78. Power and SAS cable connections on the back of the enclosure

3. Verify that the expansion enclosure and its components are operating as expected.

On the back of the expansion enclosure, all four fans and the expansion canister indicators (3 and 8 in Figure 79 on page 79) become active when the power is connected.

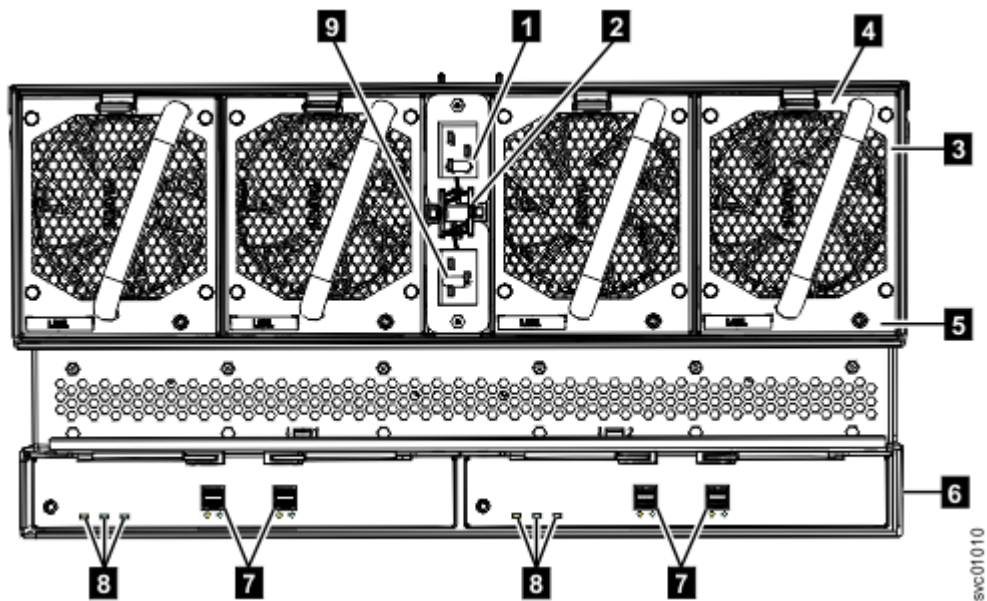

Figure 79. Features on the rear of the 2077-92F, 2077-A9F expansion enclosure

- 1 Power cable connector for PSU 2
- 2 Power cable retention clamps
- 3 Fan module
- 4 Fan release latch
- 5 Fan fault indicator
- 6 Expansion canister
- 7 SAS ports and indicators
- 8 Expansion canister indicators
- 9 Power cable connector for PSU 1

4. Verify that the system recognizes the expansion enclosure.

In the management GUI, view information about the system status and the expansion enclosure.

- If a new expansion enclosure was installed, make sure that the enclosure was discovered by the system. A newly recognized expansion enclosure is visible in the management GUI.
- If the expansion enclosure was powered off as part of a service procedure, view the information in the management GUI to confirm that the enclosure is operating as expected. You can also access the Event Log to view enclosure and component events and complete any remaining fix procedures.

Powering on the system

After you install all hardware components, you must power on the system and check its status.

About this task



Attention: Do not power on the system with any open bays or slots. Open bays or slots disrupt the internal air flow, causing the drives to receive insufficient cooling.

- Every unused drive bay must be occupied by a filler panel.
- Filler panels must be installed in all empty host interface adapter slots.

Procedure

To power on the system, complete the following steps.

1. All expansion enclosures should already be powered on.
2. Wait for all expansion enclosures to finish powering on.

3. Power on the control enclosure. Use the supplied power cords to connect both power supply units of the enclosure to their power sources.

If the power sources have circuit breakers or switches, ensure that they are turned on. The enclosure does not have power switches.

Notes:

- Each enclosure has two power supply units. To provide power failure redundancy, connect the two power cords to separate power circuits.
- Ensure that each power cable is secured to each PSU on the back of the enclosure.

What to do next

Next, you will connect an Ethernet cable to the technician port on the control enclosure, and initialize the system.

Chapter 3. Configuring the system

After installing and connecting the enclosures, you can initialize the control enclosure by using the technician port.

- To use the enclosure hardware, the system software must be configured. Your web browser is used to access the system's initialization and configuration interfaces. [“Checking your web browser settings for the management GUI” on page 81](#) describes how to ensure that you are using a supported web browser.
- Each control enclosure supports the connection of SAS expansion enclosures. These can be added by following the procedure in [Chapter 4, “Adding an expansion enclosure to an existing system,” on page 87](#).

Checking your web browser settings for the management GUI

To access the management GUI, you must ensure that your web browser is supported and that the appropriate settings are enabled.

Before you begin

The management GUI supports the following HTML5-compliant browsers:

- Mozilla Firefox 66
- Mozilla Firefox Extended Support Release (ESR) 60
- Microsoft Internet Explorer (IE) 11 and Microsoft Edge 44
- Google Chrome 74

Note: The minimum viewpoint for browser window for the management GUI is 1024 x 768. Scaling browser view to less than those dimensions affects readability of data on management GUI pages.

IBM supports higher versions of the browsers if the vendors do not remove or disable function that the product relies upon. For browser levels higher than the versions that are certified with the product, customer support accepts usage-related and defect-related service requests. If the support center cannot re-create the issue, support might request the client to re-create the problem on a certified browser version. Defects are not accepted for cosmetic differences between browsers or browser versions that do not affect the functional behavior of the product. If a problem is identified in the product, defects are accepted. If a problem is identified with the browser, IBM might investigate potential solutions or work-arounds that the client can implement until a permanent solution becomes available.

Procedure

To configure your web browser, follow these steps:

1. Enable JavaScript for your web browser.

For Mozilla Firefox, JavaScript is enabled by default and requires no additional configuration.

For Microsoft Internet Explorer (IE) 11 and Microsoft Edge running on Microsoft Windows 10, JavaScript is enabled by default and requires no additional configuration.

For Microsoft Internet Explorer (IE) running on Microsoft Windows 7, complete the following steps:

- a. In Internet Explorer, click **Tools > Internet Options**.
- b. Click **Security Settings**.
- c. Click **Internet** to choose the internet zone.
- d. Click **Custom Level**.
- e. Scroll down to the **Scripting** section, and then in **Active Scripting**, click **Enable**.

- f. Click **OK** to close **Security Settings**.
- g. Click **Yes** to confirm the change for the zone.
- h. Click **OK** to close **Internet Options**.
- i. Refresh your browser.

For Microsoft Internet Explorer (IE) running on Microsoft Windows Server 2008, complete the following steps:

- a. In Internet Explorer, click **Tools > Internet Options**.
- b. Click **Security**.
- c. Click **Trusted sites**.
- d. On the **Trusted sites** window, verify that the web address for the management GUI is correct and click **Add**.
- e. Verify that the correct web address was added to the **Trusted sites** window.
- f. Click **Close** on the **Trusted sites** window.
- g. Click **OK**.
- h. Refresh your browser.

For Google Chrome, complete the following steps:

- a. On the menu bar in the Google Chrome browser window, click **Settings**.
- b. Click **Show advanced settings**.
- c. In the **Privacy** section, click **Content settings**.
- d. In the **JavaScript** section, select **Allow all sites to run JavaScript**.
- e. Click **OK**.
- f. Refresh your browser.

2. Enable cookies in your web browser.

For Microsoft Internet Explorer (IE) 11 and Microsoft Edge running on Microsoft Windows 10, cookies are enabled by default and require no additional configuration.

For Mozilla Firefox, complete the following steps:

- a. On the menu bar in the Firefox browser window, click **Tools > Options**.
- b. On the **Options** window, select **Privacy**.
- c. Set "Firefox will" to **Use custom settings for history**.
- d. Select **Accept cookies from sites** to enable cookies.
- e. Click **OK**.
- f. Refresh the browser.

For Microsoft Internet Explorer, complete the following steps:

- a. In Internet Explorer, click **Tools > Internet Options**.
- b. Click **Privacy**. Under **Settings**, move the slider to the bottom to allow all cookies.
- c. Click **OK**.
- d. Refresh your browser.

For Google Chrome, complete the following steps:

- a. On the menu bar in the Google Chrome browser window, click **Settings**.
- b. Click **Show advanced settings**.
- c. In the **Privacy** section, click **Content settings**.
- d. In the **Cookies** section, select **Allow local data to be set**.
- e. Click **OK**.

- f. Refresh your browser.
3. Enable file download on IE 11 running on Windows 2012.
 - a. In Internet Explorer, click **Tools > Internet Options**.
 - b. On the **Internet Options** window, select the **Security** tab.
 - c. On the **Security** tab, click the **Internet zone**.
 - d. Click **Custom level** to customize the security level for this zone.
 - e. Scroll down to **Downloads** and select **Enable** under File download.
 - f. Click **OK**.
 - g. Click **Yes** to confirm.
 - h. Click **OK** to close the **Internet Options** window.

For Microsoft Internet Explorer (IE) 11 and Microsoft Edge running on Microsoft Windows 10, file download is enabled by default and requires no additional configuration.

4. Enable scripts to disable or replace context menus (Mozilla Firefox only).

For Mozilla Firefox, complete the following steps:

- a. On the menu bar in the Firefox browser window, click **Tools > Options**.
- b. On the **Options** window, select **Content**.
- c. Click **Advanced** by the **Enable JavaScript** setting.
- d. Select **Disable or replace context menus**.
- e. Click **OK** to close the **Advanced** window.
- f. Click **OK** to close the **Options** window.
- g. Refresh your browser.

Initializing the control enclosure

Before you initiate the system, you must connect an Ethernet cable to the technician port on the 2077/2078-424 / 2077/2078-AF4 control enclosure. To initialize the system, you connect a computer to a technician port of the control enclosure by using an Ethernet cable, and then open a wizard in a supported web browser.

Before you begin

Procedure

1. Locate the technician ports on the control enclosure, as shown in the following figure:

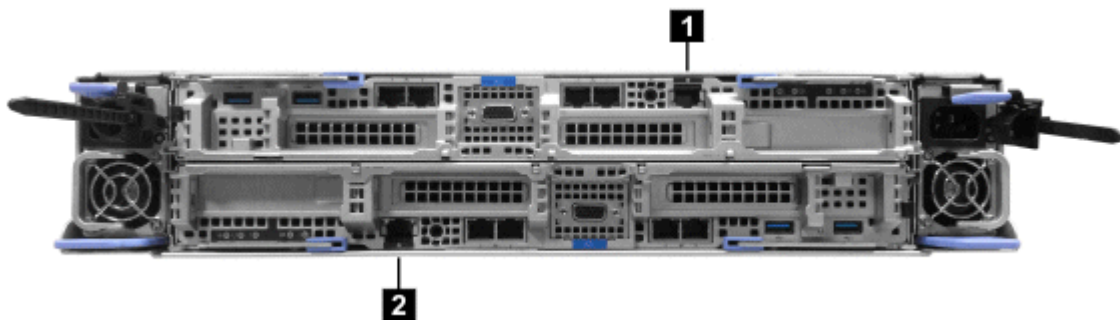

Figure 80. Technician ports

- 1 Node canister 1 technician port
- 2 Node canister 2 technician port

2. Connect an Ethernet cable to a technician port. The cable must be long enough to connect easily to a notebook computer.
3. Open a new web browser page.
4. If the node canisters will communicate with each other via RDMA over Ethernet, then browse to address `http://service` or press the wrench icon on the initialization page to access the Service Assistant Tool. Use the **Change node IP** tab of the Service Assistant Tool to configure the node IP settings for the node as provided by the customer on the worksheet. Repeat this step for each node canister that will be in the system.
5. Using the initialization GUI, enter the requested information by using the worksheets that you created during the planning phase, including the management IP address and service IP addresses.

Completing the initial system setup

After the service setup of the new system is complete, use the management GUI to do the initial system setup.

Before you begin

Have the following information on hand:

- The management IP address of the system
- Licensed key information
- The worksheets that were completed during the system planning process

Procedure

To do the initial setup of your system, use the management GUI to complete the following high-level tasks.

1. Use a web browser to open: `https://your_management_IP`
2. Log in to the management GUI for the first time by using ID `superuser` and password `passwd`.

After you log in, the initial setup wizard helps you get started.

Use the information on your worksheets to inform your inputs.

- a) Choose and create a new password.
- b) Configure licensed functions.
 - If encryption was purchased, you can activate it now or later by opening the management GUI and selecting **Settings > Security > Encryption**.
 - The base license entitles 2077-424 to all licensed functions such as Virtualization, FlashCopy®, Global Mirroring, and Metro Mirroring. (Real-Time Compression is not supported.)

You need an External Virtualization license for storage that is not Storwize V5100 . This license is based on a per capacity unit of metric. Because subcapacity licensing applies, the amount of storage FlashCopy or Remote Mirror licenses does not always match the quantity of externally virtualized storage licenses.
- c) If you already use IBM Storage Insights, log in to Storage Insights, select **Add Storage System** and register the new system by using the IP address.

Important: If you do not use IBM Storage Insights, you were registered during the initial system setup. When your Storage Insights interface is ready to use, you receive an email notification. IBM® Storage Insights is an *IBM Cloud™™™ software as a service* offering that can help you monitor and optimize the storage resources in the system and across your data center.
- d) If errors exist, you are prompted to resolve them.
- e) Review the system summary page, then click **Finish**.

The Initial Setup Wizard closes.

3. If there is more than one control enclosure for your system, go to **Monitoring > System > System--Overview** and click **Add Enclosure**.

Add Enclosure is shown only when a candidate control enclosure exists.

4. Use the **System update** page of the management GUI to check whether software updates are available for this system. Use the management GUI to help you install any updates.

During the automatic update process, each node canister in the system is updated one at a time. After all the nodes in the system are successfully restarted with the new code level, the new level is automatically committed.

5. Start the wizard to configure drives and pools.
6. Referring to the Call Home and Storage Insights configuration worksheet, use the following URL to register the new system:

`https://call-home.w3ibm.mybluemix.net/activate`

7. If you activated an encryption license, click **Enable Encryption** to complete the encryption setup wizard.
8. If exactly two control enclosures are in the system, you must set up a quorum disk or application outside of the system. If the two control enclosures lose communication with each other, the quorum disk prevents both I/O groups from going offline. For more information, see the "Configuring quorum" topic in the IBM Knowledge Center.

Results

You completed the initial setup of your system as the final part of installation.

What to do next

You are ready to migrate data from another system and configure your system.

Verify and update the system firmware and software

After the installation and initial configuration of the hardware is complete, IBM strongly suggests that you check to see whether a later level of firmware and software is available, and update to that level.

To download updated drive firmware, system software, and other applicable software, go to <https://www.ibm.com/support/fixcentral> and follow the instructions there.

Chapter 4. Adding an expansion enclosure to an existing system

When you add an expansion enclosure to an existing system, you must use the management GUI to update the system configuration.

About this task

The management GUI requires a supported web browser (see [“Checking your web browser settings for the management GUI”](#) on page 81).

Procedure

To add an expansion enclosure to your system, complete the following steps.

1. Install support rails for the new enclosure.
2. Install the new enclosure in the rack.
3. Connect the expansion enclosure attachment cables.
4. Connect the power cables and wait for the SAS light-emitting diodes (LEDs) to illuminate.
5. Start the management GUI.
6. Go to **Monitoring > System**.
7. In the management GUI, select **Monitoring > System**. On the **System -- Overview** page, select **Add Enclosure**. When a new enclosure is cabled correctly to the system, the **Add Enclosure** action automatically displays on the **System -- Overview** page. If this action does not appear, review the installation instructions to ensure the new enclosure is cabled correctly. You can also add a new enclosure by selecting **Add Enclosure** from the **System Actions** menu.
8. Continue to follow the on-screen instructions.

Chapter 5. Adding a control enclosure to an existing system

To add a control enclosure to an existing system, you must first install it in the rack. Then, you must connect it to the system through a zone in the SAN.

About this task

The management GUI requires a supported web browser. (See [“Checking your web browser settings for the management GUI”](#) on page 81.)

Note: You cannot add a second control enclosure to another IBM Storwize V5100 system.

Procedure

To add a control enclosure to an existing system, complete the following steps.

1. Install the support rails for the new enclosure.
2. Install the new enclosure in the rack.
3. Connect the node canisters to the storage area network.
4. Configure the zoning on the SAN switches.
The correct zoning provides a way for the Fibre Channel ports to connect to each other.
5. Start the management GUI on the existing system.
6. In the management GUI, select **Monitoring > System**. On the **System -- Overview** page, select **Add Enclosure**. When a new enclosure is cabled correctly to the system, the **Add Enclosure** action automatically displays on the **System -- Overview** page. If this action does not appear, review the installation instructions to ensure the new enclosure is cabled correctly. You can also add a new enclosure by selecting **Add Enclosure** from the **System Actions** menu.
7. Complete the instructions in the **Add Enclosures** wizard until the control enclosure is added to the system.
8. If only two control enclosures are in the system, you must set up a quorum disk or application outside of the system. If the two control enclosures lose communication with each other, the quorum disk prevents both I/O groups from going offline. For more information, see the "Configuring quorum" topic in the IBM Knowledge Center.

Appendix A. Accessibility features for the system

Accessibility features help users who have a disability, such as restricted mobility or limited vision, to use information technology products successfully.

Accessibility features

These are the major accessibility features for the system:

- You can use screen-reader software and a digital speech synthesizer to hear what is displayed on the screen. HTML documents are tested by using JAWS version 15.0.
- This product uses standard Windows navigation keys.
- Interfaces are commonly used by screen readers.
- Industry-standard devices, ports, and connectors.

The system online documentation and its related publications are accessibility-enabled. The accessibility features of the online documentation are described in

Keyboard navigation

You can use keys or key combinations for operations and to initiate menu actions that can also be done through mouse actions. You can go to the system online documentation from the keyboard by using the keyboard shortcuts for your browser or screen-reader software. See your browser or screen-reader software Help for a list of keyboard shortcuts that it supports.

IBM and accessibility

See the [IBM Human Ability and Accessibility Center](#) for more information about the commitment that IBM has to accessibility.

Appendix B. Where to find the Statement of Limited Warranty

The *Statement of Limited Warranty* is available in both hardcopy format and in the Storwize V5100 IBM Knowledge Center.

The *Statement of Limited Warranty* is included (in hardcopy form) with your product. It can also be ordered from IBM.

Appendix C. Control enclosure requirements

Before you install a system, your physical environment must meet certain requirements. This includes verifying that adequate space is available and that requirements for power and environmental conditions are met.

Safety notices

Use the following general safety information for all rack-mounted devices:

DANGER:

Observe the following precautions when working on or around your IT rack system:

- **Heavy equipment—personal injury or equipment damage might result if mishandled.**
- **Always lower the leveling pads on the rack cabinet.**
- **Always install stabilizer brackets on the rack cabinet.**
- **To avoid hazardous conditions due to uneven mechanical loading, always install the heaviest devices in the bottom of the rack cabinet. Always install servers and optional devices starting from the bottom of the rack cabinet.**
- **Rack-mounted devices are not to be used as shelves or work spaces. Do not place objects on top of rack-mounted devices.**



- **Each rack cabinet might have more than one power cord. Be sure to disconnect all power cords in the rack cabinet when directed to disconnect power during servicing.**
- **Connect all devices installed in a rack cabinet to power devices installed in the same rack cabinet. Do not plug a power cord from a device installed in one rack cabinet into a power device installed in a different rack cabinet.**
- **An electrical outlet that is not correctly wired could place hazardous voltage on the metal parts of the system or the devices that attach to the system. It is the responsibility of the customer to ensure that the outlet is correctly wired and grounded to prevent an electrical shock. (R001 part 1 of 2)**



CAUTION:

- Do not install a unit in a rack where the internal rack ambient temperatures will exceed the manufacturer's recommended ambient temperature for all your rack-mounted devices.
- Do not install a unit in a rack where the air flow is compromised. Ensure that air flow is not blocked or reduced on any side, front, or back of a unit used for air flow through the unit.
- Consideration should be given to the connection of the equipment to the supply circuit so that overloading of the circuits does not compromise the supply wiring or overcurrent protection. To provide the correct power connection to a rack, refer to the rating labels located on the equipment in the rack to determine the total power requirement of the supply circuit.
- (For sliding drawers) Do not pull out or install any drawer or feature if the rack stabilizer brackets are not attached to the rack. Do not pull out more than one drawer at a time. The rack might become unstable if you pull out more than one drawer at a time.
- (For fixed drawers) This drawer is a fixed drawer and must not be moved for servicing unless specified by the manufacturer. Attempting to move the drawer partially or completely out of the rack might cause the rack to become unstable or cause the drawer to fall out of the rack. (R001 part 2 of 2)

Important: In addition, remember:

- The rack design must support the total weight of the installed enclosures and incorporate stabilizing features suitable to prevent the rack from tipping or being pushed over during installation or normal use.
- The rack must not exceed the maximum enclosure operating ambient temperature of 35-degrees C (95-degrees Fahrenheit). Air is drawn through the control enclosure by fans in each node canister and each power supply.

In particular, the rack front and rear doors must be at least 60% perforated to enable sufficient airflow through the enclosure. If there is less airflow, additional mechanisms are required to cool the enclosure. An appropriate IBM rack configuration would be the 7014-T42 IBM Rack Model T42, with standard rear door and feature code 6069 Front Door For 2.0 Meter Rack (High Perforation).

- The rack must have a safe electrical distribution system. It must provide over-current protection for the enclosure and must not be overloaded by the total number of enclosures installed. The electrical power consumption rating that is shown on the nameplate should be observed.
- The electrical distribution system must provide a reliable ground for each enclosure in the rack.

Power requirements for each power supply (two per enclosure)

Ensure that your environment meets the following power requirements.

To aid in power and cooling requirements planning, [Table 19 on page 96](#) lists the rating of each power supply unit (PSU) by enclosure.

The power that is used by the system depends on various factors, including the number of enclosures and drives in the system and the ambient temperature.

Model and type	PSU	Input power requirements	Maximum input current	Maximum power output
2077/2078-424 / 2077/2078-AF4 Control Enclosure	2000 W (2)	200 V to 240 V single phase AC At a frequency of 50 Hz or 60 Hz IEC C14 standardized	10A (x2)	2000 W
2078-U5B Control Enclosure	2000 W (2)	200 V to 240 V single phase AC At a frequency of 50 Hz or 60 Hz IEC C14 standardized	10A (x2)	2000 W

Note: One or more C19 power distribution units (PDU) are needed in the rack to connect power to 2078-92F power supplies.

Each Storwize V5100 enclosure contains two PSUs for redundancy. The total power consumption values represent the total power that is drawn by both PSUs.

Environmental requirements

System airflow is from the front to the rear of each enclosure:

- Airflow passes between drive carriers and through each enclosure.
- Airflow for the upper 4U of the 5U enclosure enters the front, passes between the disk drives, and exits through the large fans in the rear of the enclosure.
- Airflow for the lower 1U of the 5U enclosure is driven through the power supplies via 40 mm X 56 mm fans. Air continues through the chassis cooling the ESMs or controllers and exits the rear of the enclosure.
- The combined power and cooling module exhausts air from the rear of each canister.

Ensure that your environment falls within the ranges that are shown in [Table 20 on page 97](#).

Environment	Ambient temperature	Altitude	Relative humidity	Maximum wet bulb temperature
Operating	5°C to 35°C (41°F to 95°F)	0 - 3048 m (0 - 10000 ft)	8% to 80% noncondensing	23°C (73°F)
Non-operating	1°C to 50°C (34°F to 122°F)	-305 to 12192 m (-1000 to 40000 ft)	8% to 80% noncondensing	27°C (80°F)
Storage	1°C to 60°C (34°F to 140°F)		5% to 80% noncondensing	29°C (84°F)
Shipping	-40°C to 60°C (-40°F to 140°F)		5% to 100% condensing, but not precipitating	

Dimensions and weight requirements for rack installation

Ensure that space is available in a standard 19" rack that is capable of supporting the enclosure. The rack rail kit supports racks with either threaded round or square rail mounting holes. The following table lists the dimensions and weights of the enclosures.

Enclosure	Height	Width	Depth	Maximum weight	
				Drive ready (without drive modules)	Fully configured (with drive modules)
2077-424 and 2078-U5B Control Enclosures with 24 drive slots	87 mm (3.46 in.)	483 mm (19.0 in.)	850 mm (33.5 in.)	44.85 kg (98.87 lb)	49.65 kg (109.46 lb)



Warning: The 2078-92F model needs 968 mm from the rack front post to the back of the cable management arm (CMA). Some racks do not provide sufficient space to close the rear door. In addition, allow 905 mm from the front post to the back of the enclosure. To allow space for the power cables, provide 60 to 70 mm from the back of the enclosure.

[Figure 81 on page 98](#) shows the rack space requirements for the 2078-92F models.

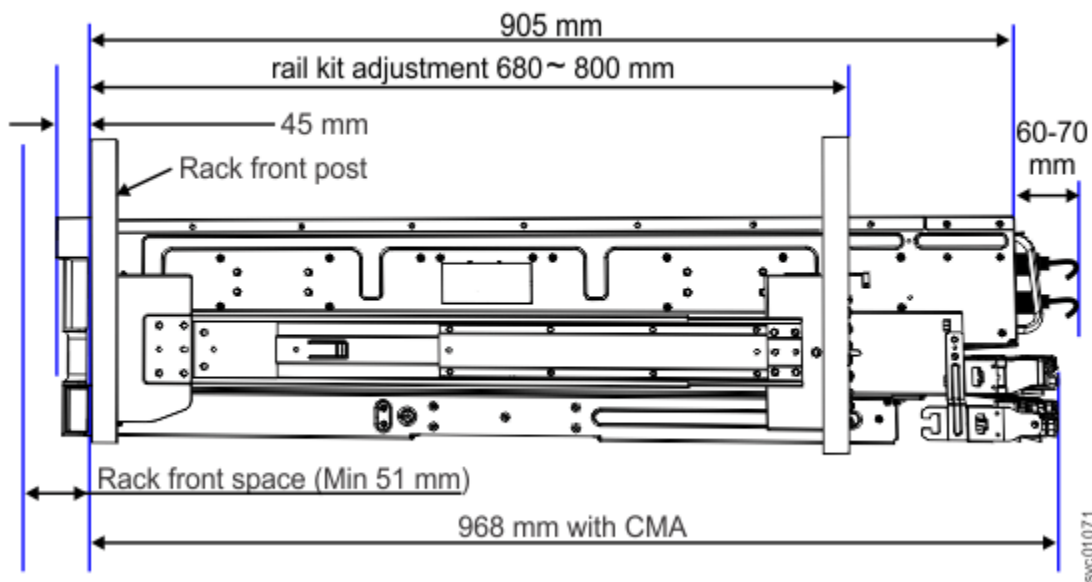

Figure 81. Rack space requirements for the 2078-92F models

The following table shows the rack space requirements for the control enclosure in tabular form.

Minimum rail length	Maximum rail depth
685 mm (27 in.)	765 mm (30.1 in.)

Additional space requirements

Ensure that these additional space requirements, as shown in [Table 23 on page 98](#), are available around the enclosures.

Location	Additional space requirements	Reason
Left and right sides	50 mm (2 in.)	Cooling air flow
Back	Minimum: 100 mm (4 in.)	Cable exit

Supported drives

[Table 24 on page 98](#) provides drive specifications for your Storwize V5100 system.

Model and type	3.5-inch drives	2.5-inch drives
2077-424 or 2078-U5B Control Enclosure with 24 2.5-inch drive slots	-	24 dual port NVMe drives (1.92 TB, 3.84 TB, 7.68 TB, 15.36 TB), or 24 dual port FCM NVMe drives (4.8 TB, 9.6 TB, 19.2 TB)

Acoustical specifications for NVMe drives for each Storwize V5100 enclosure

The noise emission level that is stated is the declared (upper limit) sound power level, in decibels, for a random sample of machines. All measurements are made in accordance with ISO 7779 and reported in conformance with ISO 9296.

Acoustical Declaration with Noise Hazard Notice

Figure 82 on page 99 indicates the declared noise emissions values in accordance with ISO 9296.

Figure 82. Acoustical Declaration with Noise Hazard Notice

Shock and vibration specifications for Storwize V5100 enclosures

Table 25 on page 99 and Table 26 on page 99 provide the shock and vibration testing results for your Storwize V5100 system.

<i>Table 25. Shock testing results</i>		
Shock categories	Test level	Performance
Operational	5 g 10 ms 1/2 Sine	<=25 g 10 ms
Non-operational	30 g 10 ms 1/2 Sine	<=75 g 11 ms

<i>Table 26. Vibration testing results</i>		
Vibration categories	Test level	Performance
Operational	0.21 grms 5-500 Hz Random	Throughput loss <=10% FCAL <= 0.68 grms
Non-operational	1.04 grms 2-200 Hz Random	<=3.12 grms
Shipping	0.3 g 2-200 Hz Sine	<=5 g
Rotational vibration	Normal operation performance measurements in enclosure with no external vibration.	Throughput loss for all drives of the same type within performance profile.

Appendix D. SAS expansion enclosure requirements

Before you install a Storwize V5100 2077/2078-12F , 2077/2078-24F , 2077-92F, 2077-A9F or 2078-92F, 2078-A9F SAS expansion enclosure, your physical environment must meet certain requirements. This includes verifying that adequate space is available and that requirements for power and environmental conditions are met.

Power requirements for each power supply (two per enclosure)

Ensure that your environment meets the following power requirements.

To aid in power and cooling requirements planning, [Table 27 on page 101](#) lists the rating of each power supply unit (PSU) by enclosure.

The power that is used by the system depends on several factors, including the number of enclosures and drives in the system and the ambient temperature.

Table 27. Power specifications per power supply

Model and type	PSU	Input power requirements	Maximum input current	Maximum power output	Caloric value (BTU/hr)
2077/2078-12F or 2077/2078-24F or 2077/2078-AFF	764 W (2)	100 V to 240 V single phase AC at a frequency of 50 Hz to 60 Hz	10A for 100V 6A for 240V	764W	2607

Table 27. Power specifications per power supply (continued)

Model and type	PSU	Input power requirements	Maximum input current	Maximum power output	Caloric value (BTU/hr)
2077-92F, 2077-A9F	2400 W (2)	AC 200-240 V~, (nominal; +/- 10% tolerant)	12 A (x2 - per inlet redundancy)	2400W	8189
2078-92F, 2078-A9F		50/60 Hz (nominal; 47-63 Hz tolerant)	Requires an IEC C20 appliance coupler (16-20A branch circuit or C19 power socket PDU)		

Note: One or more C19 power distribution units (PDU) are needed in the rack to connect power to 2078-92F, 2078-A9F power supplies.

The power and thermal measurements that are shown in [Table 28 on page 102](#) were obtained in the specific operating environment and under the conditions described. These measurements are presented as an illustration; measurements that are obtained in other operating environments might vary. Conduct your own testing to determine specific measurements for your environment.

Table 28. Power consumption examples per enclosure

Model and type	Configuration	Total power consumption
2077/2078-12F or 2077/2078-24F or 2077/2078-AFF	1 enclosure with 24 2.5-inch flash drives	151 W

Model and type	Configuration	Total power consumption
2077-92F, 2077-A9F	1 enclosure with 92 15 TB tier 1 flash drives	748 W
2078-92F, 2078-A9F		

Each SAS expansion enclosure contains two PSUs for redundancy. The total power consumption values represent the total power that is drawn by both PSUs.

Environmental requirements

System airflow is from the front to the rear of each enclosure:

- Airflow passes between drive carriers and through each enclosure.
- Airflow for the upper 4U of the 5U enclosure enters the front, passes between the disk drives, and exits through the large fans in the rear of the enclosure.
- Airflow for the lower 1U of the 5U enclosure is driven through the power supplies via 40mm X 56mm fans. Air continues through the chassis cooling the ESMs or controllers and exits the rear of the enclosure.
- The combined power and cooling module exhausts air from the rear of each canister.

Ensure that your environment falls within the ranges that are shown in [Table 29 on page 104](#).

Environment	Ambient temperature	Altitude	Relative humidity	Maximum wet bulb temperature
Operating	5°C to 35°C (5°C to 40°C for 2077/2078-24F) 41°F to 95°F (41°F to 104°F for 2077/2078-24F)	0 - 2133 m (0 - 7000 ft)	8% to 80% noncondensing	23°C (73°F)
	5°C to 30°C (41°F to 86°F)	2134 - 3048 m (7001 - 10000 ft)		

Table 29. Temperature requirements (continued)

Environment	Ambient temperature	Altitude	Relative humidity	Maximum wet bulb temperature
Non-operating	1°C to 50°C (34°F to 122°F)	-305 to 12192 m (-1000 to 40000 ft)	8% to 80% noncondensing	27°C (80°F)
Storage	1°C to 60°C (34°F to 140°F)		5% to 80% noncondensing	29°C (84°F)
Shipping	-40°C to 60°C (-40°F to 140°F)		5% to 100% condensing, but not precipitating	

Dimensions and weight requirements for rack installation

Ensure that space is available in a standard 19" rack that is capable of supporting the enclosure. The rack rail kits support racks with either threaded round or square rail mounting holes. The following table lists the dimensions and weights of the expansion enclosures.

Table 30. Physical characteristics of the expansion enclosures

Enclosure	Height	Width	Depth	Maximum weight	
				Drive ready (without drive modules)	Fully configured (with drive modules)
2077/2078-12F or 2077/2078-24F or 2077/2078-AFF	87 mm (3.46 in.)	483 mm (19.0 in.)	556 mm (21.9 in.)	16.7 kg (36.8 lb)	25.0 kg (55.1 lb)

Table 30. Physical characteristics of the expansion enclosures (continued)

Enclosure	Height	Width	Depth	Maximum weight	
				Drive ready (without drive modules)	Fully configured (with drive modules)
2077-92F, 2077-A9F	222.2 mm (8.75 in.)	483 mm (19.0 in.)	968 mm (38.1 in.)	67 kg (147.7 lb)	135 kg (297 lb)
2078-92F, 2078-A9F					



Warning: Some racks will not provide sufficient space to close the rear door. 2077-92F, 2077-A9F and 2078-92F, 2078-A9F model enclosures need 968 mm from the rack front post to the back of the cable management arm (CMA). In addition, allow 905 mm from the front post to the back of the enclosure. To allow space for the power cables, provide 60 to 70 mm from the back of the enclosure.

Figure 83 on page 106 shows the rack space requirements for the 2077/2078-24F , 2077-92F, 2077-A9F and 2078-92F, 2078-A9F expansion enclosures.

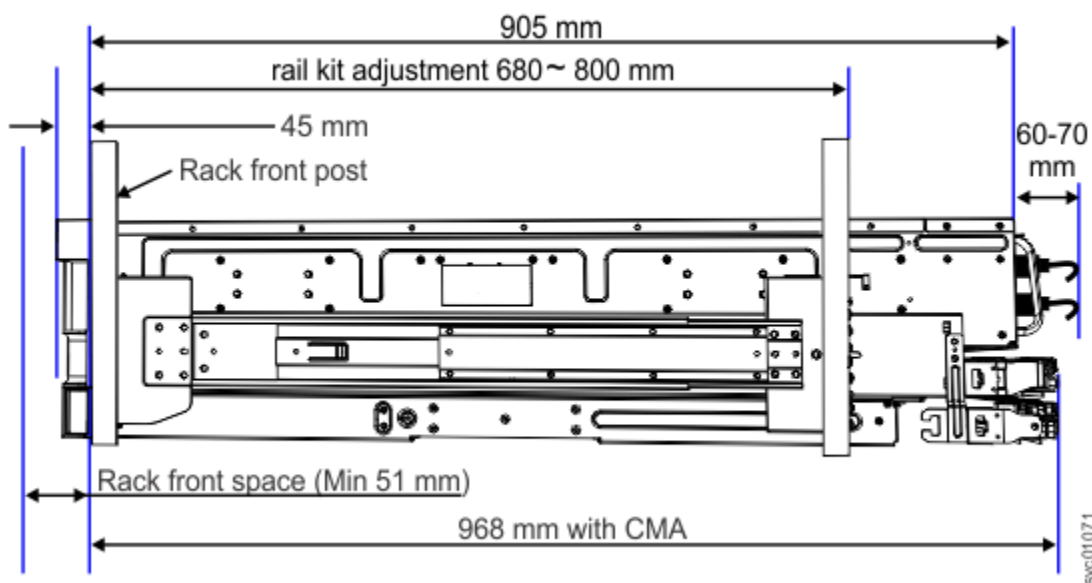

Figure 83. Rack space requirements for the 2077/2078-24F , 2077-92F, 2077-A9F and 2078-92F, 2078-A9F expansion enclosures

The following table shows the rack space requirements for the expansion enclosures in tabular form.

<i>Table 31. Rack space requirements for the 2077/2078-24F, 2077-92F, 2077-A9F and 2078-92F, 2078-A9F expansion enclosures</i>		
Enclosure	Minimum rail length	Maximum rail depth
2077/2078-12F or 2077/2078-24F or 2077/2078-AFF	595 mm (23.4 in.)	795 mm (31.3 in.)
2077-92F, 2077-A9F	680 mm (26.8 in.)	800 mm (31.5 in.)
2078-92F, 2078-A9F		

Additional rack space requirements

Ensure that these additional space requirements, as shown in [Table 32 on page 107](#), are available around the enclosures.

<i>Table 32. Clearances</i>		
Location	Additional space requirements	Reason
Left and right sides	50 mm (2 in.)	Cooling air flow
Back	Minimum: 100 mm (4 in.) This space is not needed for 2077-92F, 2077-A9F or 2078-92F, 2078-A9F models.	Cable exit

Supported drives for Storwize V5100 SAS expansion enclosures

Table 33 on page 108 provides drive specifications for Storwize V5100 SAS expansion enclosures.

All drives are dual-port and hot-swappable. Drives of the same form factor and connector type can be intermixed within an enclosure.

Model and type	3.5-inch drives	2.5-inch drives
2077/2078-12F or 2077/2078-24F or 2077/2078-AFF	-	<ul style="list-style-type: none"> • 2.5" Flash Drive 200 GB, 400 GB, 800 GB, 1.6 TB • 2.5" 15 K RPM HDD 300 GB, 600 GB • 2.5" 10K RPM HDD 600 GB, 900 GB, 1.2 TB, 1.8 TB, 2.4 TB • 2.5" 7.2 K RPM HDD 2 TB
2077-92F, 2077-A9F	-	<ul style="list-style-type: none"> • 2.5" Flash Drive 1.6 TB, 1.92 TB, 3.2 TB, 3.84 TB, 7.68 TB, 15.36 TB
2078-92F, 2078-A9F	-	

Acoustical specifications for Storwize V5100 SAS expansion enclosures

The following table provides the acoustical specifications for the 2077/2078-24F SAS expansion enclosures.

Model and type	Acoustical output per enclosure
2077/2078-24F	Less than 6.3 B LWA -- Operating (40% Average seek rate) @ 23°C ambient

The noise emission level that is stated is the declared (upper limit) sound power level, in decibels, for a random sample of machines. All measurements are made in accordance with ISO 7779 and reported in conformance with ISO 9296.

Table 35 on page 109 provides the acoustical specifications for the 2077-92F, 2077-A9F and 2078-92F, 2078-A9F SAS expansion enclosures in accordance with ISO 9296^(1,2,3).

Important: Hearing conservation program (HCP) procedures are required for field service personnel servicing a 2077-92F, 2077-A9F or 2078-92F, 2078-A9F SAS expansion enclosure.

<i>Table 35. Declared noise emissions for 2077-92F, 2077-A9F and 2078-92F, 2078-A9F SAS expansion enclosures in accordance with ISO 9296</i>				
Model and type	Declared A-Weighted Sound Power Level, L_{WAd} (B)		Declared A-Weighted Sound Pressure Level, L_{pAm} (dB)	
	Operating	Idling	Operating	Idling
Fully configured expansion enclosure, MTM/ Model 2077-92F, 2077-A9F, 2078-92F, 2078-A9F	8.5	8.5	85	85
<p>Notes:</p> <ol style="list-style-type: none"> 1. Declared level L_{WAd} is the upper-limit A-weighted sound power level. Declared level L_{pAm} is the mean A-weighted sound pressure level measured at the 1-meter bystander positions. 2. All measurements are made in conformance with ISO 7779 and declared in conformance with ISO 9296. 3. "B" and "dB" are abbreviations for bels and decibels, respectively. 1 B = 10 dB. <p>Important: Government regulations (such as those prescribed by OSHA or European Community Directives) may govern noise level exposure in the workplace and may apply to you and your server installation. This system is available with an optional acoustical door feature that can help reduce the noise emitted from this system. The actual sound pressure levels in your installation depend upon a variety of factors, including the number of racks in the installation; the size, materials, and configuration of the room where you designate the racks to be installed; the noise levels from other equipment; the room ambient temperature, and employees' location in relation to the equipment. Further, compliance with such government regulations also depends upon a variety of additional factors, including the duration of employees' exposure and whether employees wear hearing protection. IBM recommends that you consult with qualified experts in this field to determine whether you are in compliance with the applicable regulations.</p>				

Shock and vibration specifications for Storwize V5100 SAS expansion enclosures

Table 36 on page 109 and Table 37 on page 109 provide the shock and vibration testing results for Storwize V5100 SAS expansion enclosures.

<i>Table 36. Shock testing results</i>		
Shock categories	Test level	Performance
Operational	5 g 10 ms 1/2 Sine	≤ 25 g 10 ms
Non-operational	30 g 10 ms 1/2 Sine	≤ 75 g 11 ms

<i>Table 37. Vibration testing results</i>		
Vibration categories	Test level	Performance
Operational	0.21 grms 5-500Hz Random	Throughput loss $\leq 10\%$ FCAL ≤ 0.68 grms
Non-operational	1.04 grms 2-200Hz Random	≤ 3.12 grms

Table 37. Vibration testing results (continued)

Vibration categories	Test level	Performance
Shipping	0.3 g 2-200Hz Sine	<=5 g
Rotational vibration	Normal operation performance measurements in enclosure with no external vibration.	Throughput loss for all drives of the same type within performance profile.

Notices

This information was developed for products and services offered in the US. This material might be available from IBM in other languages. However, you may be required to own a copy of the product or product version in that language in order to access it.

IBM may not offer the products, services, or features discussed in this document in other countries. Consult your local IBM representative for information on the products and services currently available in your area. Any reference to an IBM product, program, or service is not intended to state or imply that only that IBM product, program, or service may be used. Any functionally equivalent product, program, or service that does not infringe any IBM intellectual property right may be used instead. However, it is the user's responsibility to evaluate and verify the operation of any non-IBM product, program, or service.

IBM may have patents or pending patent applications covering subject matter described in this document. The furnishing of this document does not grant you any license to these patents. You can send license inquiries, in writing, to:

*IBM Director of Licensing
IBM Corporation
North Castle Drive
Armonk, NY 10504-1785
U.S.A.*

For license inquiries regarding double-byte character set (DBCS) information, contact the IBM Intellectual Property Department in your country or send inquiries, in writing, to:

*Intellectual Property Licensing
Legal and Intellectual Property Law
IBM Japan, Ltd.
19-21, Nihonbashi-Hakozakicho, Chuo-ku
Tokyo 103-8510, Japan*

INTERNATIONAL BUSINESS MACHINES CORPORATION PROVIDES THIS PUBLICATION "AS IS" WITHOUT WARRANTY OF ANY KIND, EITHER EXPRESS OR IMPLIED, INCLUDING, BUT NOT LIMITED TO, THE IMPLIED WARRANTIES OF NON-INFRINGEMENT, MERCHANTABILITY OR FITNESS FOR A PARTICULAR PURPOSE. Some jurisdictions do not allow disclaimer of express or implied warranties in certain transactions, therefore, this statement may not apply to you.

This information could include technical inaccuracies or typographical errors. Changes are periodically made to the information herein; these changes will be incorporated in new editions of the publication. IBM may make improvements and/or changes in the product(s) and/or the program(s) described in this publication at any time without notice.

Any references in this information to non-IBM websites are provided for convenience only and do not in any manner serve as an endorsement of those websites. The materials at those websites are not part of the materials for this IBM product and use of those websites is at your own risk.

IBM may use or distribute any of the information you provide in any way it believes appropriate without incurring any obligation to you.

Licensees of this program who wish to have information about it for the purpose of enabling: (i) the exchange of information between independently created programs and other programs (including this one) and (ii) the mutual use of the information which has been exchanged, should contact:

*IBM Director of Licensing
IBM Corporation
North Castle Drive, MD-NC119
Armonk, NY 10504-1785*

US

Such information may be available, subject to appropriate terms and conditions, including in some cases, payment of a fee.

The licensed program described in this document and all licensed material available for it are provided by IBM under terms of the IBM Customer Agreement, IBM International Program License Agreement or any equivalent agreement between us.

The performance data discussed herein is presented as derived under specific operating conditions. Actual results may vary.

Information concerning non-IBM products was obtained from the suppliers of those products, their published announcements or other publicly available sources. IBM has not tested those products and cannot confirm the accuracy of performance, compatibility or any other claims related to non-IBM products. Questions on the capabilities of non-IBM products should be addressed to the suppliers of those products.

Statements regarding IBM's future direction or intent are subject to change or withdrawal without notice, and represent goals and objectives only.

All IBM prices shown are IBM's suggested retail prices, are current and are subject to change without notice. Dealer prices may vary.

This information is for planning purposes only. The information herein is subject to change before the products described become available.

This information contains examples of data and reports used in daily business operations. To illustrate them as completely as possible, the examples include the names of individuals, companies, brands, and products. All of these names are fictitious and any similarity to the names and addresses used by an actual business enterprise is entirely coincidental.

COPYRIGHT LICENSE:

This information contains sample application programs in source language, which illustrate programming techniques on various operating platforms. You may copy, modify, and distribute these sample programs in any form without payment to IBM, for the purposes of developing, using, marketing or distributing application programs conforming to the application programming interface for the operating platform for which the sample programs are written. These examples have not been thoroughly tested under all conditions. IBM, therefore, cannot guarantee or imply reliability, serviceability, or function of these programs. The sample programs are provided "AS IS", without warranty of any kind. IBM shall not be liable for any damages arising out of your use of the sample programs.

If you are viewing this information softcopy, the photographs and color illustrations may not appear.

Trademarks

IBM, the IBM logo, and ibm.com[®] are trademarks or registered trademarks of International Business Machines Corp., registered in many jurisdictions worldwide. Other product and service names might be trademarks of IBM or other companies. A current list of IBM trademarks is available on the web at www.ibm.com/legal/copytrade.shtml.

Adobe, the Adobe logo, PostScript, and the PostScript logo are either registered trademarks or trademarks of Adobe Systems Incorporated in the United States, and/or other countries.

Java and all Java-based trademarks and logos are trademarks or registered trademarks of Oracle and/or its affiliates.

Linux[®] and the Linux logo is a registered trademark of Linus Torvalds in the United States, other countries, or both.

Microsoft, Windows, and the Windows logo are trademarks of Microsoft Corporation in the United States, other countries, or both.

Other product and service names might be trademarks of IBM or other companies.

Homologation statement

This product may not be certified in your country for connection by any means whatsoever to interfaces of public telecommunications networks. Further certification may be required by law prior to making any such connection. Contact an IBM representative or reseller for any questions.

Electromagnetic compatibility notices

The following Class A statements apply to IBM products and their features unless designated as electromagnetic compatibility (EMC) Class B in the feature information.

When attaching a monitor to the equipment, you must use the designated monitor cable and any interference suppression devices that are supplied with the monitor.

Canada Notice

CAN ICES-3 (A)/NMB-3(A)

European Community and Morocco Notice

This product is in conformity with the protection requirements of Directive 2014/30/EU of the European Parliament and of the Council on the harmonization of the laws of the Member States relating to electromagnetic compatibility. IBM cannot accept responsibility for any failure to satisfy the protection requirements resulting from a non-recommended modification of the product, including the fitting of non-IBM option cards.

This product may cause interference if used in residential areas. Such use must be avoided unless the user takes special measures to reduce electromagnetic emissions to prevent interference to the reception of radio and television broadcasts.

Warning: This equipment is compliant with Class A of CISPR 32. In a residential environment this equipment may cause radio interference.

Germany Notice

Deutschsprachiger EU Hinweis: Hinweis für Geräte der Klasse A EU-Richtlinie zur Elektromagnetischen Verträglichkeit

Dieses Produkt entspricht den Schutzanforderungen der EU-Richtlinie 2014/30/EU zur Angleichung der Rechtsvorschriften über die elektromagnetische Verträglichkeit in den EU-Mitgliedsstaaten und hält die Grenzwerte der EN 55032 Klasse A ein.

Um dieses sicherzustellen, sind die Geräte wie in den Handbüchern beschrieben zu installieren und zu betreiben. Des Weiteren dürfen auch nur von der IBM empfohlene Kabel angeschlossen werden. IBM übernimmt keine Verantwortung für die Einhaltung der Schutzanforderungen, wenn das Produkt ohne Zustimmung von IBM verändert bzw. wenn Erweiterungskomponenten von Fremdherstellern ohne Empfehlung von IBM gesteckt/eingebaut werden.

EN 55032 Klasse A Geräte müssen mit folgendem Warnhinweis versehen werden:

"Warnung: Dieses ist eine Einrichtung der Klasse A. Diese Einrichtung kann im Wohnbereich Funk-Störungen verursachen; in diesem Fall kann vom Betreiber verlangt werden, angemessene Maßnahmen zu ergreifen und dafür aufzukommen."

Deutschland: Einhaltung des Gesetzes über die elektromagnetische Verträglichkeit von Geräten

Dieses Produkt entspricht dem "Gesetz über die elektromagnetische Verträglichkeit von Geräten (EMVG)." Dies ist die Umsetzung der EU-Richtlinie 2014/30/EU in der Bundesrepublik Deutschland.

Zulassungsbescheinigung laut dem Deutschen Gesetz über die elektromagnetische Verträglichkeit von Geräten (EMVG) (bzw. der EMC Richtlinie 2014/30/EU) für Geräte der Klasse A

Dieses Gerät ist berechtigt, in Übereinstimmung mit dem Deutschen EMVG das EG-Konformitätszeichen - CE - zu führen.

Verantwortlich für die Einhaltung der EMV-Vorschriften ist der Hersteller:

International Business Machines Corp.
New Orchard Road
Armonk, New York 10504
Tel: 914-499-1900

Der verantwortliche Ansprechpartner des Herstellers in der EU ist:

IBM Deutschland GmbH
Technical Relations Europe, Abteilung M456
IBM-Allee 1, 71139 Ehningen, Germany
Tel: +49 800 225 5426
e-mail: Halloibm@de.ibm.com

Generelle Informationen:

Das Gerät erfüllt die Schutzanforderungen nach EN 55024 und EN 55032 Klasse A.

Japan Electronics and Information Technology Industries Association (JEITA) Notice

(一社) 電子情報技術産業協会 高調波電流抑制対策実施
要領に基づく定格入力電力値 : Knowledge Centerの各製品の
仕様ページ参照

This statement applies to products less than or equal to 20 A per phase.

高調波電流規格 JIS C 61000-3-2 適合品

This statement applies to products greater than 20 A, single phase.

高調波電流規格 JIS C 61000-3-2 準用品

本装置は、「高圧又は特別高圧で受電する需要家の高調波抑制対策ガイドライン」対象機器（高調波発生機器）です。

- 回路分類 : 6 (単相、PFC回路付)
- 換算係数 : 0

This statement applies to products greater than 20 A per phase, three-phase.

高調波電流規格 JIS C 61000-3-2 準用品

本装置は、「高圧又は特別高圧で受電する需要家の高調波抑制対策ガイドライン」対象機器（高調波発生機器）です。

- 回路分類 : 5 (3相、PFC回路付)
- 換算係数 : 0

Japan Voluntary Control Council for Interference (VCCI) Notice

この装置は、クラスA情報技術装置です。この装置を家庭環境で使用すると電磁妨害を引き起こすことがあります。この場合には使用者が適切な対策を講ずるよう要求されることがあります。

VCCI-A

Korea Notice

이 기기는 업무용 환경에서 사용할 목적으로 적합성평가를 받은 기기로서 가정용 환경에서 사용하는 경우 전파간섭의 우려가 있습니다.

People's Republic of China Notice

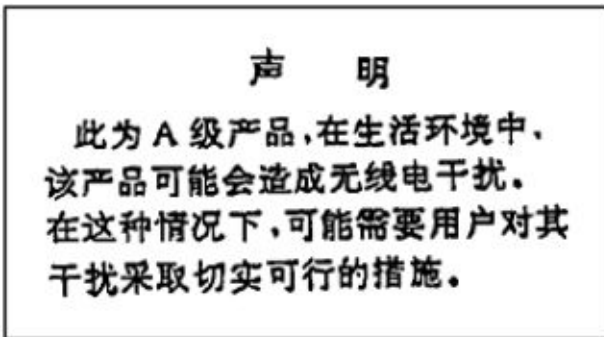

Russia Notice

ВНИМАНИЕ! Настоящее изделие относится к классу А.
В жилых помещениях оно может создавать радиопомехи, для снижения которых необходимы дополнительные меры

rusent

Taiwan Notice

警告使用者：
此為甲類資訊技術設備，
於居住環境中使用時，
可能會造成射頻擾動，在此種情況下，
使用者會被要求採取某些適當的對策。

IBM Taiwan Contact Information:



United States Federal Communications Commission (FCC) Notice

This equipment has been tested and found to comply with the limits for a Class A digital device, pursuant to Part 15 of the FCC Rules. These limits are designed to provide reasonable protection against harmful interference when the equipment is operated in a commercial environment. This equipment generates, uses, and can radiate radio frequency energy and, if not installed and used in accordance with the instruction manual, may cause harmful interference to radio communications. Operation of this equipment in a residential area is likely to cause harmful interference, in which case the user will be required to correct the interference at his own expense.

Properly shielded and grounded cables and connectors must be used in order to meet FCC emission limits. IBM is not responsible for any radio or television interference caused by using other than recommended cables and connectors, or by unauthorized changes or modifications to this equipment. Unauthorized changes or modifications could void the user's authority to operate the equipment.

This device complies with Part 15 of the FCC Rules. Operation is subject to the following two conditions:

(1) this device might not cause harmful interference, and (2) this device must accept any interference received, including interference that might cause undesired operation.

Index

Numerics

2077-92F, 2077-A9F
cable-management arm [51](#)
2077-92F, 2077-A9F 2078-92F, 2078-A9F
replacing in rack [49](#)

A

air flow [79](#)

B

browsers, *See* web browsers

C

cable-management arm
replacing [51](#)
comments [xxii](#)
configuration
web browsers
settings [81](#)
control enclosure
data ports [6](#)
location [guidelines 9](#)
power cords [80](#)
cooling [79](#)

D

drive
requirements [98](#)

E

environmental notices [xix](#)
environmental requirements [9](#)
Ethernet
ports [6](#)
expansion canister
data ports [7](#)
expansion enclosure
adding to an existing system [87](#)
attachment cables [57, 73](#)
LEDs [76](#)
location [guidelines 9, 10](#)
power cords [75](#)
rails [17](#)
expansion enclosure SAS cable
2077-92F, 2077-A9F [55](#)
replacing [55](#)

F

feedback [xxii](#)

H

homologation statement [113](#)

L

LEDs
expansion enclosure [76](#)

M

management GUI
adding an expansion enclosure [87](#)

N

notices
environmental [xix](#)

P

power
requirements
system [96](#)
power cords [75, 80](#)
powering on the system [79](#)

R

rails
expansion enclosure [17](#)
reader feedback [xxii](#)
replacing
2077-92F, 2077-A9F [55](#)
cable-management arm [51](#)
expansion enclosure SAS cable [55](#)
requirements
additional space [98](#)
drives [98](#)
electrical [96](#)
environmental [96](#)
power [96](#)
space [97](#)

S

SAS cables [57, 73](#)
SAS expansion enclosure
installing [20](#)
send a comment [xxii](#)
shock
specifications [99](#)
space requirements
Storwize V5100 [98](#)
specifications
shock [99](#)

specifications (*continued*)

vibration [99](#)

static-sensitive devices [xix](#)

Storwize V5100

acoustic output of drives [98](#), [99](#)

additional space requirements [98](#)

air temperature without redundant AC power [96](#)

dimensions and weight [97](#)

enclosures

acoustic output [98](#), [99](#)

humidity without redundant AC power [96](#)

power requirements for each PSU [96](#)

weight and dimensions [97](#)

T

technician port [83](#)

trademarks [112](#)

V

vibration

specifications [99](#)

W

web browsers

configuring [81](#)

requirements [81](#)



Part Number: 02YC382

(1P) P/N: 02YC382

