

IBM Storage Networking SAN64B-7
MTM Service information: 8960-P64, R64

Installation, Service, and User Guide



Read Before Using

This product contains software that is licensed under written license agreements. Your use of such software is subject to the license agreements under which they are provided.

Before you use the information in this publication, be sure to read the general information under “Notices” on page 73.

Copyright

Portions Copyright © 2020 Broadcom, Inc. All Rights Reserved.

© Copyright International Business Machines Corporation 2020.

US Government Users Restricted Rights – Use, duplication or disclosure restricted by GSA ADP Schedule Contract with IBM Corp.

Contents

- Figures..... vii**

- Tables..... ix**

- Read this first..... xi**
 - Getting help..... xi
 - Accessibility features..... xi
 - Feedback.....xii

- Safety and environmental notices..... xiii**
 - Safety notices and labels..... xiii
 - Cautions..... xiii
 - Danger notices..... xiv
 - Safety labels..... xiv
 - Attention notices..... xv
 - ESD precautions..... xv
 - Rack safety.....xvi
 - Rack installation.....xvi
 - Rack relocation (19" rack)..... xvi
 - Product recycling and disposal..... xvii

- About this document..... xix**
 - Product documentation.....xix
 - Brocade documents..... xix
 - IBM and Brocade product matrix..... xix

- Chapter 1. Device overview.....1**
 - License options..... 2
 - Port-Side view of the device..... 2
 - Nonport-side view of the device..... 3
 - Device management options..... 4

- Chapter 2. Preparing for installation..... 7**
 - Safety precautions..... 7
 - General precautions..... 7
 - ESD precautions..... 7
 - Power precautions..... 8
 - Lifting and weight-related precautions..... 8
 - Laser precautions..... 8
 - Facility requirements..... 9
 - Quick installation checklist..... 9
 - Shipping carton contents..... 12

- Chapter 3. Mounting the switch.....13**
 - Precautions specific to mounting..... 13
 - Stand-alone installation13
 - Installing the universal four-post rack kit..... 14
 - Time and items required..... 14
 - Parts List..... 14

Flush-front mounting.....	16
Flush-rear (recessed) mounting.....	21
Installing the universal two-post rack kit	27
Time and items required.....	27
Parts list.....	28
Flush-front mounting.....	28
Mid-mounting.....	32
Chapter 4. Initial setup and verification.....	37
Items required.....	37
Providing power to the device.....	37
Establishing a first-time serial connection.....	38
Configuring the IP address.....	39
Using DHCP to set the IP address.....	39
Setting a static IP address.....	39
Setting the date and time.....	40
Setting the time zone.....	40
Synchronizing the local time with an external source.....	41
Customizing the chassis name and switch name.....	41
Establishing an Ethernet connection.....	42
Setting the domain ID.....	42
Verifying correct operation.....	43
Backing up the configuration.....	44
Powering down the device.....	45
Chapter 5. Installing transceivers and cables.....	47
Precautions specific to transceivers and cables.....	47
Cleaning the fiber-optic connectors.....	47
Managing cables.....	47
Installing an SFP+ transceiver.....	48
Replacing an SFP+ Transceiver.....	48
Verifying the operation of new transceivers.....	49
Chapter 6. Monitoring the switch.....	51
Interpreting port-side LEDs.....	51
System power LED.....	52
System status LED.....	53
Management port LEDs	53
FC port status LEDs.....	53
Interpreting nonport-side LEDs.....	54
Interpreting POST results.....	55
Interpreting Boot results.....	56
Running diagnostic tests.....	56
Chapter 7. Power supply and fan assembly.....	57
Precautions specific to the power supply and fan assemblies.....	58
Identifying the airflow direction.....	58
AIR_FLOW and ENCR error monitoring.....	58
Power supply and fan assembly fault indicators.....	59
Power supply and fan assembly task guide.....	59
Time and items required.....	60
Recording critical information about the power supply and fan assembly	60
Removing a power supply and fan assembly.....	60
Inserting a new power supply and fan assembly.....	61
Verifying the operation of the power supply and fan assemblies.....	62
Chapter 8. Chassis replacement.....	63

Customer replacement responsibilities.....	63
Determining the need to replace the chassis.....	63
Chassis replacement overview.....	64
Reconnecting system to the network and fabric.....	68
Downloading the configuration.....	68
Verifying correct operation of system.....	69
Verifying correct configuration of the fabric.....	70
IBM service replacement responsibilities.....	71
Disconnecting the cables.....	71
Remove the old switch chassis and install the new switch chassis.....	71
Notices.....	73
Trademarks.....	74
Homologation statement.....	74
Electromagnetic compatibility notices.....	74
United States Federal Communications Commission (FCC) Notice.....	74
Canada Notice.....	75
Australia and New Zealand Class A Statement.....	75
European Community and Morocco Notice.....	75
Germany Notice.....	75
People's Republic of China Notice.....	76
Taiwan Notice.....	76
Taiwan Contact Information.....	76
Japan Voluntary Control Council for Interference (VCCI) Notice	77
Japan Electronics and Information Technology Industries Association (JEITA) Notice.....	77
Korea Notice.....	78
Russia Notice.....	78
Index.....	79

Figures

- 1. Port-Side View..... 3
- 2. Nonport-Side View with AC Power Supply and Fan Assembly Units..... 4
- 3. Universal Four-Post Rack Kit Parts..... 15
- 4. Attaching the Front Brackets..... 17
- 5. Attaching the Extension Brackets to the Device..... 18
- 6. Positioning the Device in the Rack..... 19
- 7. Attaching the Rear Brackets to the Extensions..... 20
- 8. Attaching the Rear Brackets to the Rack Posts..... 21
- 9. Attaching the Front Brackets to the Rear of the Device..... 22
- 10. Attaching the Extensions to the Device..... 23
- 11. Positioning the Device in the Rack..... 24
- 12. Attaching the Rear Brackets to the Extensions at the Front of the Device..... 25
- 13. Attaching the Short or Long Rear Brackets to the Extensions..... 26
- 14. Attaching the Rear Brackets to the Front Rack Posts..... 27
- 15. Universal Two-Post Rack Kit Parts..... 28
- 16. Attaching the Front Brackets..... 29
- 17. Attaching the Front Brackets to the Rack..... 30
- 18. Attaching the Rear Brackets to the Rack..... 31
- 19. Attaching the Rear Brackets to the Device..... 32
- 20. Attaching the Front Brackets..... 33
- 21. Attaching the Front Brackets to the Rack..... 34
- 22. Attaching the Rear Brackets to the Rack..... 35
- 23. Attaching the Rear Brackets to the Device..... 36

24. Installing an SFP+ Transceiver into a Port.....	48
25. Replacing an SFP+ Optical Transceiver in an Upper Port.....	49
26. SAN64B-7 Switch Port-Side LEDs - Left Side.....	51
27. SAN64B-7 Port-Side LEDs - Right Side.....	52
28. AC Power Supply and Fan Assembly.....	57
29. AC Power Supply and Fan Assembly.....	61
30. Inserting an AC Power Supply and Fan Assembly.....	62

Tables

- 1. Brocade and IBM product and model number matrix..... xix
- 2. Management Options for the Device..... 4
- 3. Facility Requirements 9
- 4. Installation Prerequisites..... 9
- 5. Installation and Basic System Configuration 10
- 6. Space Requirements..... 14
- 7. tsTimeZone Command Parameter Selection for the U.S. Time Zones..... 40
- 8. System Power LED Patterns during Normal Operation..... 52
- 9. System Status LED Patterns during Normal Operation..... 53
- 10. Management Port LED Patterns during Normal Operation..... 53
- 11. FC Port Status LED Patterns during Normal Operation..... 54
- 12. Power Supply and Fan Assembly Status LED Patterns during Normal Operation..... 55
- 13. Critical information checklist 65

Read this first

Summary of changes

This is the first edition of the IBM® Storage Networking SAN64B-7 Installation, Service, and User Guide.

Getting help

For the latest version of your product documentation, visit the IBM Publications Center at www.ibm.com/shop/publications/order. Search by form number or title.

For more information about IBM Storage Networking products, go to www.ibm.com/systems/storage/san/.

IBM Redbooks® often provide in depth information about product best practices, configurations, and more technical information. For redbooks associated with this product, enter search terms on the following Web site: www.redbook.ibm.com.

For support information for this and other IBM products, see the IBM Support Portal www.ibm.com/supportportal. Search for the product Machine type or product name.

For Fabric OS Release Notes and access to Fabric OS firmware downloads, go to the IBM Support Portal www.ibm.com/supportportal. Search for the product Machine type or product name, and then follow links for **Downloads**. More detailed instructions are available through the **Accessing firmware updates and OS documentation updates** link on the product documentation CD that is shipped with this product.

You can also contact IBM within the United States at 1-800-IBMSERV (1-800-426-7378). For support outside the United States, you can find the service number through the IBM contacts directory website at www.ibm.com/planetwide/.

Visit the IBM contact website www.ibm.com/contact for contact information for your country or region.

For information about storage and networking industry standards, see the Storage Networking Industry Association (SNIA) website at www.snia.org/.

For details regarding FICON and z Systems support, please refer to the qualification letters published on IBM ResourceLink at <https://www.ibm.com/servers/resourcelink/svc03100.nsf?OpenDatabase>

Note: New users may need to register for a free IBMid and request access.

Accessibility features

Accessibility features help users who have a disability, such as restricted mobility or limited vision, to use information technology products successfully.

Accessibility features

The following list includes the major accessibility features in this product:

- Light emitting diodes (LEDs) that flash at different rates, to represent the same information as the colors of the LEDs
- Industry-standard devices for ports and connectors
- Management of the product through management applications is available through Web and Graphical User Interface (GUI) options

Keyboard navigation

This product does not have an attached or integrated keyboard. Any keyboard navigation is provided through the management software and GUI.

Vendor software

This product includes certain vendor software that is not covered under the IBM license agreement. IBM makes no representation about the accessibility features of these products. Contact the vendor for the accessibility information about its products.

Related accessibility information

You can view the publications for this product in Adobe Portable Document Format (PDF) using the Adobe Acrobat Reader. The PDFs are provided on a product documentation CD-ROM that is packaged with the product. The CD-ROM also includes an accessible HTML version of this document.

IBM and accessibility

See the IBM Human Ability and Accessibility Center website at www.ibm.com/able/ for more information about the commitment that IBM has to accessibility.

Sending comments

Your feedback is important in helping to provide the most accurate and highest quality information.

Procedure

To submit any comments about this publication or any other IBM storage product documentation:

- Send your comments by email to ibmkc@us.ibm.com. Be sure to include the following information:
 - Exact publication title and version
 - Publication form number (for example, GA32-1234-00)
 - Page, table, or illustration numbers that you are commenting on
 - A detailed description of any information that should be changed

Safety and environmental notices

This section contains information about:

- [“Safety notices and labels” on page xiii](#)
- [“Rack safety” on page xvi](#)
- [“Product recycling and disposal” on page xvii](#)

Safety notices and labels

When using this product, observe the danger, caution, and attention notices contained in this guide. The notices are accompanied by symbols that represent the severity of the safety condition. The danger and caution notices are listed in numerical order based on their IDs, which are displayed in parentheses, for example (D004), at the end of each notice. Use this ID to locate the translation of these danger and caution notices in the Safety Notices publication that is shipped with this product.

The following notices and statements are used in IBM documents. They are listed below in order of increasing severity of potential hazards. Follow the links for more detailed descriptions and examples of the danger, caution, and attention notices in the sections that follow.

- **Note:** These notices provide important tips, guidance, or advice.
- **“Attention notices” on page xv:** These notices indicate potential damage to programs, devices, or data.
- **“Cautions” on page xiii:** These statements indicate situations that can be potentially hazardous to you.
- **“Danger notices” on page xiv:** These statements indicate situations that can be potentially lethal or extremely hazardous to you. Safety labels are also attached directly to products to warn of these situations.
- In addition to these notices, [“Safety labels” on page xiv](#) may be attached to the product to warn of potential hazards.

Cautions

A Caution statement alerts you to situations that can be potentially hazardous to you or cause damage to hardware, firmware, software, or data.

General Cautions



CAUTION: Changes or modifications made to this device that are not expressly approved by the party responsible for compliance could void the user's authority to operate the equipment.



CAUTION: Do not install the device in an environment where the operating ambient temperature might exceed 40°C (104°F).



CAUTION: Make sure the airflow around the front and back of the device is not restricted.

Electrical Cautions



CAUTION: Before plugging a cable into any port, be sure to discharge the voltage stored on the cable by touching the electrical contacts to ground surface.



CAUTION: Static electricity can damage the chassis and other electronic devices. To avoid damage, keep static-sensitive devices in their static-protective packages until you are ready to install them.



CAUTION: If you do not install a module or a power supply in a slot, you must keep the slot filler panel in place. If you run the chassis with an uncovered slot, the system will overheat.



CAUTION: Carefully follow the mechanical guides on each side of the power supply slot and make sure the power supply is properly inserted in the guides. Never insert the power supply upside down.



CAUTION: The power supply switch must be in the off position when you insert the power supply into the chassis. Damage to the switch can result if a live power supply is installed.

Danger notices

General Dangers



DANGER: The procedures in this manual are for qualified service personnel.



DANGER: Be careful not to accidentally insert your fingers into the fan tray while removing it from the chassis. The fan may still be spinning at a high speed.

Electrical Dangers



DANGER: For safety reasons, the ESD wrist strap should contain a series 1 megaohm resistor.



DANGER: Make sure that the power source circuits are properly grounded, and then use the power cord supplied with the device to connect it to the power source.



DANGER: Remove both power cords before servicing.



DANGER: Disconnect the power cord from all power sources to completely remove power from the device.



DANGER: To avoid high voltage shock, do not open the device while the power is on.



DANGER: Batteries used for RTC/NVRAM backup are not located in operator-access areas. There is a risk of explosion if a battery is replaced by an incorrect type. Dispose of used components with batteries according to local ordinance and regulations.

Dangers Related to Equipment Weight



DANGER: Make sure the rack housing the device is adequately secured to prevent it from becoming unstable or falling over.

Laser Dangers



DANGER: All fiber-optic interfaces use Class 1 lasers.



DANGER: Use only optical transceivers that are qualified by Broadcom and comply with the FDA Class 1 radiation performance requirements defined in 21 CFR Subchapter I, and with IEC 60825 and EN60825. Optical products that do not comply with these standards might emit light that is hazardous to the eyes.

Safety labels

As an added precaution, safety labels are often installed directly on products or product components to warn of potential hazards. These can be either danger or caution notices, depending upon the level of the hazard.

The actual product safety labels may differ from these sample safety labels:



DANGER: Hazardous voltage, current, or energy levels are present inside any component that has this label attached. Do not open any cover or barrier that contains this label. (L001)



DANGER: Rack-mounted devices are not to be used as a shelf or work space. (L002)



DANGER: Multiple power cords. The product might be equipped with multiple power cords. To remove all hazardous voltages, disconnect all power cords. (L003)



DANGER: Hazardous voltage present. Voltages present constitute a shock hazard, which can cause severe injury or death. (L004)



CAUTION: Hazardous moving parts nearby. (L008)

Attention notices

An attention notice indicates the possibility of damage to a program, device, or system, or to data. An exclamation point symbol may accompany an attention notice, but is not required. A sample attention notice follows:



Attention: Do not bend a fibre cable to a radius less than 5 cm (2 in.); you can damage the cable. Tie wraps are not recommended for optical cables because they can be easily overtightened, causing damage to the cable.

ESD precautions



Attention: Many of the field replaceable units (FRUs) are sensitive to electrostatic discharge (ESD), and can potentially be damaged by improper handling. When working with any FRU, use correct ESD precautions:

- Attach ground to the indicated area on the chassis
- Wear a wrist grounding strap connected to chassis ground (if the switch is plugged in) or a bench ground.

Note: For safety reasons, the ESD wrist strap should contain a series 1 megaohm resistor.

- Store ESD-sensitive components in antistatic packaging

Rack safety

Rack installation



DANGER: Observe the following precautions when working on or around your IT rack system:

- Heavy equipment—personal injury or equipment damage might result if mishandled.
- Always lower the leveling pads on the rack cabinet.
- Always install stabilizer brackets on the rack cabinet.
- To avoid hazardous conditions due to uneven mechanical loading, always install the heaviest devices in the bottom of the rack cabinet. Always install servers and optional devices starting from the bottom of the rack cabinet.
- Rack-mounted devices are not to be used as shelves or work spaces. Do not place objects on top of rack-mounted devices.



- Each rack cabinet might have more than one power cord. Be sure to disconnect all power cords in the rack cabinet when directed to disconnect power during servicing.
- Connect all devices installed in a rack cabinet to power devices installed in the same rack cabinet. Do not plug a power cord from a device installed in one rack cabinet into a power device installed in a different rack cabinet.
- An electrical outlet that is not correctly wired could place hazardous voltage on the metal parts of the system or the devices that attach to the system. It is the responsibility of the customer to ensure that the outlet is correctly wired and grounded to prevent an electrical shock.

(R001 part 1 of 2)



CAUTION:

- Do not install a unit in a rack where the internal rack ambient temperatures will exceed the manufacturer's recommended ambient temperature for all your rack-mounted devices.
- Do not install a unit in a rack where the air flow is compromised. Ensure that air flow is not blocked or reduced on any side, front, or back of a unit used for air flow through the unit.
- Consideration should be given to the connection of the equipment to the supply circuit so that overloading of the circuits does not compromise the supply wiring or overcurrent protection. To provide the correct power connection to a rack, refer to the rating labels located on the equipment in the rack to determine the total power requirement of the supply circuit.
- *(For sliding drawers)* Do not pull out or install any drawer or feature if the rack stabilizer brackets are not attached to the rack. Do not pull out more than one drawer at a time. The rack might become unstable if you pull out more than one drawer at a time.
- *(For fixed drawers)* This drawer is a fixed drawer and must not be moved for servicing unless specified by the manufacturer. Attempting to move the drawer partially or completely out of the rack might cause the rack to become unstable or cause the drawer to fall out of the rack.

(R001 part 2 of 2)

Rack relocation (19" rack)



CAUTION: Removing components from the upper positions in the rack cabinet improves rack stability during relocation. Follow these general guidelines whenever you relocate a populated rack cabinet within a room or building:

- Reduce the weight of the rack cabinet by removing equipment starting at the top of the rack cabinet. When possible, restore the rack cabinet to the configuration of the rack cabinet as you received it. If this configuration is not known, you must complete these steps:
 - Remove all devices in the 32U position and above.
 - Ensure that the heaviest devices are installed in the bottom of the rack cabinet.
 - Ensure that there are no empty U-levels between devices installed in the rack cabinet below the 32U level.
 - If the rack cabinet you are relocating is part of a suite of rack cabinets, detach the rack cabinet from the suite.
 - Inspect the route that you plan to take when moving the rack to eliminate potential hazards.
 - Verify that the route that you choose can support the weight of the loaded rack cabinet. Refer to the documentation that came with your rack cabinet for the weight of a loaded rack cabinet.
 - Verify that all door openings are at least 760 x 2030 mm (30 x 80 in.).
 - Ensure that all devices, shelves, drawers, doors, and cables are secure.
 - Ensure that the four leveling pads are raised to their highest position.
 - Ensure that there is no stabilizer bracket installed on the rack cabinet during movement.
 - Do not use a ramp inclined at more than 10 degrees.
 - Once the rack cabinet is in the new location, do the following:
 - Lower the four leveling pads.
 - Install stabilizer brackets on the rack cabinet.
 - If you removed any devices from the rack cabinet, repopulate the rack cabinet from the lowest position to the highest position.
 - If a long distance relocation is required, restore the rack cabinet to the configuration of the rack cabinet as you received it. Pack the rack cabinet in the original packaging material, or equivalent. Also, lower the leveling pads to raise the casters off of the pallet and bolt the rack cabinet to the pallet.

(R002)

Product recycling and disposal

Refer to the *IBM Systems Environmental Notices and User Guide (Z125-5823)* for translated environmental statements and information regarding product recycling and disposal. This document may be provided either in printed version or on the product documentation CD. A more current version may be available through this link ftp://public.dhe.ibm.com/systems/support/warranty/envnotices/environmental_notices_and_user_guide.pdf.

About this document

This document is intended for use by systems administrators and technicians experienced with networking, Fibre Channel, and storage area network (SAN) technologies. It describes how to install, service, and use the IBM Storage Networking SAN64B-7 (machine type-models 8960-P74, R64 Switch). Throughout this document, the product is referred to as the *SAN64B-7*, or simply the *switch*.

This document has been created to include information specific to SAN64B-7 switches running on Fabric OS version 9.0.0 or later. This document does not support all Fabric OS versions. It is specific to Fabric OS 9.0.0 or later. Refer to the Fabric OS Release Notes for more information.

Product documentation

The following documents contain information related to this product:

- *IBM Storage Networking SAN64B-7 Installation, Service, and User Guide*, (this document)
- *IBM Systems Safety Notices, G229–9054*

Brocade documents

IBM b-type switches use software licensed from Brocade Communications Systems, Inc. You can find information related to the software that supports the switch in the following documents on the CD-ROM supplied with this product:

Brocade Fabric OS

- *EZSwitchSetup Administrator's Guide*
- *Fabric OS Administrator's Guide*
- *Fabric OS Command Reference Manual*
- *Fabric OS MIB Reference Manual*
- *Fabric OS Message Reference Manual*
- *Fabric OS Troubleshooting and Diagnostics Guide*

Brocade Fabric OS optional features

- *Fabric Watch Administrator's Guide*
- *Web Tools Administrator's Guide*

IBM and Brocade product matrix

The product matrix provides a cross-reference between the comparable IBM and Brocade product models.

When you use any of the Brocade documents, such as Fabric Operating System (FOS) publications, you will notice that the model numbers reflect the corresponding Brocade products. Table 1 on page xix provides a product matrix to correlate the Brocade products and models to the IBM product names and machine types and model numbers. Products withdrawn from marketing are not listed.

Brocade product name	IBM product name	IBM machine type and model number
Brocade 7810	IBM Storage Networking SAN18B-6	8960 Model R18

Table 1. Brocade and IBM product and model number matrix (continued)

Brocade product name	IBM product name	IBM machine type and model number
Brocade G630	IBM Storage Networking SAN128B-6	8960 Models F96/F97 and N96/N97
Brocade G620	IBM Storage Networking SAN64B-6	8960 Models F64/F65 and N64/N65
Brocade G610	IBM Storage Networking SAN24B-6	8960 Models F24
Brocade G720	IBM Storage Networking SAN64B-7	8960 Models P64 and R64
Brocade X7-4 Director	IBM Storage Networking SAN256B-7	8961 Model F74
Brocade X7-8 Director	IBM Storage Networking SAN512B-7	8961 Model F78
Brocade X6-4 Director	IBM Storage Networking SAN256B-6	8961 Model F04
Brocade X6-8 Director	IBM Storage Networking SAN512B-6	8961 Model F08
Brocade 6520	IBM System Networking SAN96B-5	2498 Models F96 and N96
Brocade 6505	IBM System Networking SAN24B-5	2498 Model F24, 249824G
Brocade 6510	IBM System Storage SAN48B-5	2498 Model F48
Brocade DCX 8510-4	IBM System Storage SAN384B-2	2499 Model 416
Brocade DCX 8510-8	IBM System Storage SAN768B-2	2499 Model 816
Brocade 7800	IBM System Storage SAN06B-R	2498 Model R06
Brocade 7840	IBM System Storage SAN42B-R	2498 Model R42
Brocade 300	IBM System Storage SAN24B-4	2498 Models B24 and 24E

Chapter 1. Device overview

The IBM SAN64B-7 Switch offers the following features and capabilities:

Note: The SAN64B-7 Switch is secure-booted.

- Enterprise class 56-port Gen 7 Fibre Channel switch supported with FOS v9.0.0 that offers 56 x 64Gb/s SFP+ ports in a 1U form-factor.
- Each of the 56 SFP+ ports supports 8, 10, 16, 32 and 64Gb/s Fibre Channel speeds.
- 64Gb/s autosensing Fibre Channel switch and router ports.
 - A 64Gb/s optical transceiver can autonegotiate to 64Gb/s, 32Gb/s, or 16Gb/s.
 - A 32Gb/s optical transceiver can autonegotiate to 32Gb/s, 16Gb/s, or 8Gb/s.
 - A 10Gb/s optical transceiver can autonegotiate to 10Gb/s.

Note: The port speed is determined by the maximum speed supported by the optical transceiver at the other end of the link.

- 10Gb/s manually set capability on FC ports.
 - 10Gb/s performance is enabled by 10Gb/s SFP+ transceivers.
 - Ports can be configured for 10Gb/s for metro connectivity.
- Dynamic Ports on Demand (Dynamic-POD) scaling from a base configuration of 24 ports to 56 ports (four 8-port SFP+ PODs).
- Universal ports self-configure as a E_Ports, F_Ports, N_Ports, or D_Ports. EX_Ports can be activated on a per-port basis with the optional Integrated Routing license.
 - A Diagnostic Port (D_Port) provides diagnostics, troubleshooting, and verification services for the physical media.
- In-flight 64Gb/s data compression and encryption provide efficient link utilization and security. The following table lists the number of ports that can be enabled with compression and encryption.

Port Speed	Encryption Only	Compression-Only	Compression and Encryption
64Gb/s (*)	4 ports	4 ports	4 ports
32Gb/s (*)	4 ports	4 ports	4 ports
16Gb/s (*)	4 ports	4 ports	4 ports
10Gb/s (*)	4 ports	4 ports	4 ports
8Gb/s	4 ports	4 ports	4 ports
* = supported on SFP ports			

- Support for port-side exhaust or nonport-side exhaust airflow for cooling.
- Hardware-enabled input and output (I/O) latency statistics collection.
- Hardware-enabled VM support.
- Small form-factor pluggable plus (SFP+) optical transceivers support any combination of Short Wavelength (SWL) and Long Wavelength (LWL) optical media among the switch ports.
- Extended distance Fibre Channel to support long-distance native FC connectivity.
- 10Gb/s Fibre Channel integration on any selected port provides DWDM metro connectivity on the same switch.
- Port-to-port latency is minimized to 460 ns (including FEC) is minimized by using cut-through frame switching.

- High performance T1022E processor with two cores operating at 1.2 GHz delivers high performance, scalability, and advanced Fabric Vision functionality.
- One 1000/100Mb/s RJ-45 connector for the Ethernet management connection. In conjunction with EZSwitchSetup, this port supports switch IP address discovery and configuration, eliminating the need to attach a serial cable to configure the switch IP address.
- One internal e-USB module provides 2 GB of persistent storage, increased serviceability, and error logging functionality by facilitating easier firmware upgrades and downloads of the system log files.
- One external USB connector.
- Two hot-swappable redundant integrated 350W AC power supplies and fan assembly field-replaceable units.
- 56 hot-pluggable SFP+ optical transceiver slots.
- 48 LEDs (green/amber) for the first 48 SFP+ ports and 8 LEDs (green/amber/light-blue) for the last 8 SFP+ ports.
- One green LED to indicate valid system power.
- One bicolor (green/amber) LED to indicate the system status.
- Two Ethernet LEDs: one green LED to indicate link speed of 1000/100/10Mb/s and one green LED to indicate activity.
- SEEPROM for switch identification.
- Console port. One RS-232 (UART), for terminal access via mini-USB
- Encryptable SEEPROM
- Secure encryptable SEEPROM
 - Note:** The License ID is protected by the secure encryptable SEEPROM.
- Secure boot.
- Real-time power monitoring.
- Real-time voltage monitoring.
- Real-time fan monitoring including airflow direction.
- Real-time digital thermometers for temperature monitoring.
- Real-time clock (RTC) with battery.

License options

The SAN64B-7 Switch uses a capacity-based Ports on Demand (POD) license method. An Integrated Routing (IR) license is required to enable EX_Ports on this device. A license for software release is also required. Refer to the *Fabric OS Software Licensing Guide* for more details.

Port-Side view of the device

The following illustration shows the port-side view of the SAN64B-7 Fibre Channel switch.

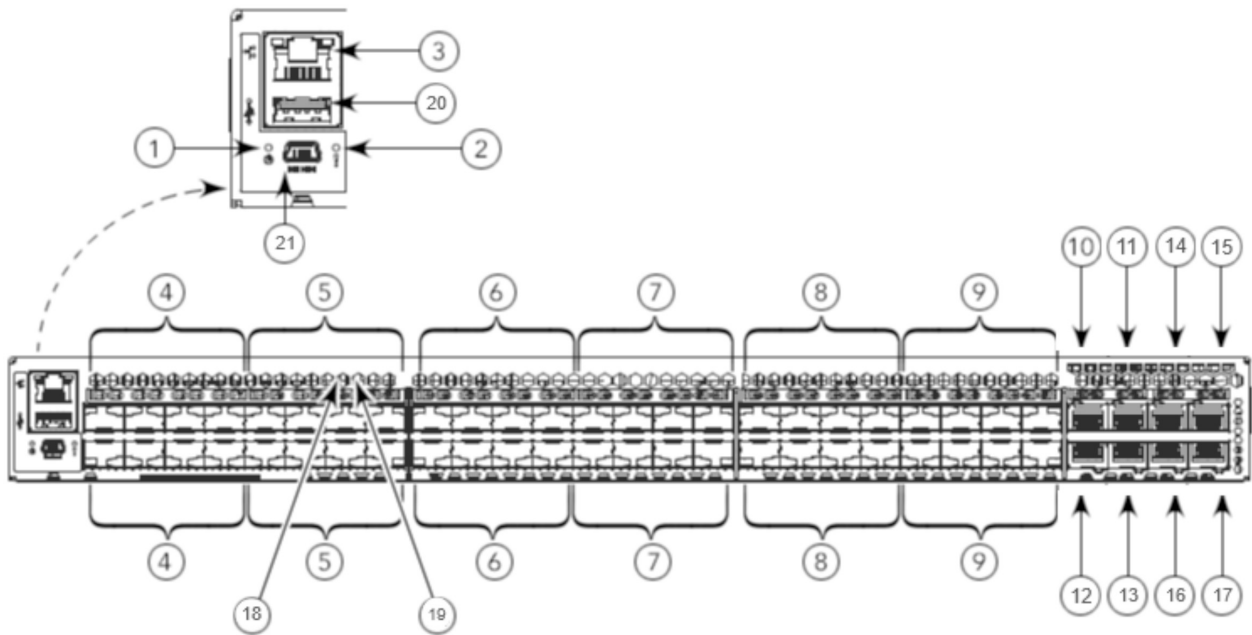

Figure 1. Port-Side View

1. System Power LED
2. System Status LED
3. Management Ethernet Port
4. SFP+ FC (upper and lower) Ports 0–7
5. SFP+ FC (upper and lower) Ports 8–15
6. SFP+ FC (upper and lower) Ports 16–23
7. SFP+ FC (upper and lower) Ports 24–31
8. SFP+ FC (upper and lower) Ports 32–39
9. SFP+ FC (upper and lower) Ports 40–47
10. SFP+ upper Port 48
11. SFP+ upper Port 50
12. SFP+ lower Port 52
13. SFP+ lower Port 54
14. SFP+ upper Port 56
15. SFP+ upper Port 58
16. SFP+ lower Port 60
17. SFP+ lower Port 62
18. SFP+ (lower) Port 14 Status LED
19. SFP+ (upper) Port 10 Status LED
20. USB Port
21. UART mini-USB Serial Console Port

Note: All the ports are connected to a single ASIC.

Nonport-side view of the device

The following illustration shows the nonport-side view of the SAN64B-7 FC switch.

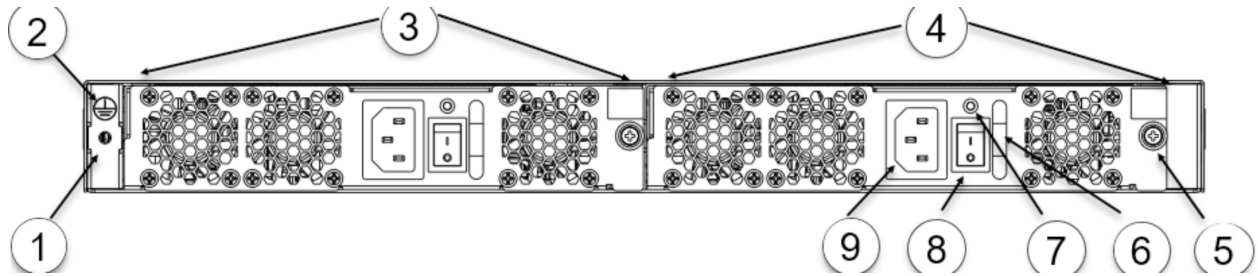

Figure 2. Nonport-Side View with AC Power Supply and Fan Assembly Units

1. #6-32 for Screw Mounting of the Ground Cable
2. Ground Marking
3. Power Supply and Fan Assembly 2
4. Power Supply and Fan Assembly 1
5. Captive Screw
6. Handle
7. Power Supply and Fan Assembly Status LED
8. Power-On Switch
9. Power Supply Receptacle

Device management options

You can use the management functions built into the device to monitor the fabric topology, port status, physical status, and other information to help you analyze switch performance and to accelerate system debugging. The device automatically performs a power-on self-test (POST) each time it is turned on. A RASlog message is generated for any detected startup errors.

You can manage the device using any of the management options listed in the following table.

Management Tool	Out-of-Band Support	Reference Documents
Command line interface (CLI) Up to two admin sessions and four user sessions simultaneously.	Ethernet or serial connection	<i>Fabric OS Administration Guide</i> <i>Fabric OS Command Reference Manual</i>
Brocade EZSwitchSetup EZSwitchSetup helps to complete the basic configuration for single-switch setup.	Ethernet or serial connection	<i>EZSwitchSetup Software Installation Guide</i> <i>EZSwitchSetup Administrator's Guide</i>
Brocade Web Tools	Ethernet or serial connection	<i>Fabric OS Web Tools Administration Guide</i>
Standard SNMP applications	Ethernet or serial connection	<i>Fabric OS MIB Reference Manual</i>
Management Server	Ethernet or serial connection	<i>Fabric OS Administration Guide</i> <i>Fabric OS Command Reference Manual</i>

Table 2. Management Options for the Device (continued)

Management Tool	Out-of-Band Support	Reference Documents
IBM SANnav IBM SANnav must be purchased separately.	Ethernet or serial connection	IBM SANnav documentation set

Chapter 2. Preparing for installation

Use the following precautions and requirements for successful installation and operation of the switch.

Safety precautions

When using this product, observe all danger, caution, and attention notices in this manual. The safety notices are accompanied by symbols that represent the severity of the safety condition.

See “Safety and environmental notices” on page xiii for a complete list of safety notices for this product.

General precautions



DANGER: The procedures in this manual are for qualified service personnel.



DANGER: Before beginning the installation, see the precautions in “Power Precautions.”



DANGER: Be careful not to accidentally insert your fingers into the fan tray while removing it from the chassis. The fan may still be spinning at a high speed.



CAUTION: Changes or modifications made to this device that are not expressly approved by the party responsible for compliance could void the user's authority to operate the equipment.



CAUTION: Disassembling any part of the power supply and fan assembly voids the warranty and regulatory certifications. There are no user-serviceable parts inside the power supply and fan assembly.



CAUTION: Make sure the airflow around the front and back of the device is not restricted.



CAUTION: Ensure that the airflow direction of the power supply unit matches that of the installed fan tray. The power supplies and fan trays are clearly labeled with either a green arrow with an "E" or an orange arrow with an "I."



CAUTION: Never leave tools inside the chassis.



CAUTION: To protect the serial port from damage, keep the cover on the port when not in use.



CAUTION: If you do not install a module or a power supply in a slot, you must keep the slot filler panel in place. If you run the chassis with an uncovered slot, the system will overheat.



CAUTION: Do not install the device in an environment where the operating ambient temperature might exceed 40°C (104°F).

ESD precautions



DANGER: For safety reasons, the ESD wrist strap should contain a series 1 megaohm resistor.



CAUTION: Before plugging a cable into any port, be sure to discharge the voltage stored on the cable by touching the electrical contacts to ground surface.



CAUTION: Static electricity can damage the chassis and other electronic devices. To avoid damage, keep static-sensitive devices in their static-protective packages until you are ready to install them.

Note: Wear a wrist grounding strap connected to the chassis ground (if the device is plugged in) or to a bench ground.

Power precautions



DANGER: Make sure that the power source circuits are properly grounded, and then use the power cord supplied with the device to connect it to the power source.



DANGER: If the installation requires a different power cord than the one supplied with the device, make sure that you use a power cord displaying the mark of the safety agency that defines the regulations for power cords in your country. The mark is your assurance that the power cord can be used safely with the device.



DANGER: This device might have more than one power cord. To reduce the risk of electric shock, disconnect all power cords before servicing.



DANGER: Remove both power cords before servicing.



DANGER: Disconnect the power cord from all power sources to completely remove power from the device.



DANGER: To avoid high voltage shock, do not open the device while the power is on.



DANGER: Batteries used for RTC/NVRAM backup are not located in operator-access areas. There is a risk of explosion if a battery is replaced by an incorrect type. Dispose of used components with batteries according to local ordinance and regulations.



CAUTION: Use a separate branch circuit for each power cord, which provides redundancy in case one of the circuits fails.



CAUTION: Ensure that the device does not overload the power circuits, wiring, and over-current protection. To determine the possibility of overloading the supply circuits, add the ampere (amp) ratings of all devices installed on the same circuit as the device. Compare this total with the rating limit for the circuit. The maximum ampere ratings are usually printed on the devices near the input power connectors.



CAUTION: The power supply switch must be in the off position when you insert the power supply into the chassis. Damage to the switch can result if a live power supply is installed.



CAUTION: Carefully follow the mechanical guides on each side of the power supply slot and make sure the power supply is properly inserted in the guides. Never insert the power supply upside down.

Note: Device control processors and management modules may contain batteries for RTC or NVRAM backup. Dispose of components containing batteries as required by local ordinances and regulations.

Lifting and weight-related precautions



DANGER: Use safe lifting practices when moving the product.



DANGER: Mount the devices you install in a rack as low as possible. Place the heaviest device at the bottom and progressively place lighter devices above.



DANGER: Make sure the rack housing the device is adequately secured to prevent it from becoming unstable or falling over.



CAUTION: Do not use the port cover tabs to lift the module. They are not designed to support the weight of the module, which can fall and be damaged.



CAUTION: To prevent damage to the chassis and components, never attempt to lift the chassis using the fan or power supply handles. These handles were not designed to support the weight of the chassis.

Laser precautions



DANGER: All fiber-optic interfaces use Class 1 lasers.



DANGER: Use only optical transceivers that are qualified by Broadcom and comply with the FDA Class 1 radiation performance requirements defined in 21 CFR Subchapter I, and with IEC 60825 and EN60825. Optical products that do not comply with these standards might emit light that is hazardous to the eyes.

Facility requirements

Before installing the device, be sure that the following facilities requirements are met:

Type	Requirements
Electrical	<ul style="list-style-type: none"> Adequate supply circuit, line fusing, and wire size, as specified by the electrical rating on the switch nameplate. Circuit protected by a circuit breaker and grounded in accordance with local electrical codes. <p>See the technical specifications at the end of this guide for complete power supply specifications.</p>
Thermal	<ul style="list-style-type: none"> A Maximum airflow of 170 cubic meters/hour (100 cubic ft/min.) available in the immediate vicinity of the switch. Minimal would be 120 cubic meters/hour (71 cubic ft/min). <p>Note: Although this airflow may exceed the airflow maximum listed in the device technical specifications, the additional airflow is recommended to pressurize the inlet (cool isle) side of rack installations relative to the exhaust side to minimize recirculation of hot air back to the inlet side.</p> <ul style="list-style-type: none"> Ambient air temperature not exceeding 40°C (104°F) while the switch is operating.
Rack (when rack-mounted)	<ul style="list-style-type: none"> One rack unit (1U) in a 48.3 cm (19 in.) rack. All equipment in the rack grounded through a reliable branch circuit connection. Additional weight of the switch not to exceed the rack's weight limits. Rack secured to ensure stability in case of unexpected movement.

Quick installation checklist

The following checklists provide a high-level overview of the basic installation process from the planning stage to the point where the device comes online and is ready to be deployed. Completing all the tasks in the suggested order ensures successful installation. Print these checklists and take them to the installation site.

Preinstallation Tasks

Review all installation requirements ahead of time as part of your site preparation. Careful planning and site preparation ensures seamless installation, especially when installing multiple devices.

Task	Task Details or Additional Information	Completed
Unpack the device.	Take an inventory of the hardware components included in your shipment. See "Shipping carton contents" on page 12.	

Task	Task Details or Additional Information	Completed
Gather necessary components and required tools.	Review the time and items required at the beginning of each chapter to ensure that you have gathered all necessary components required for the following installation tasks: <ul style="list-style-type: none"> • Chapter 3, “Mounting the switch,” on page 13 • Chapter 5, “Installing transceivers and cables,” on page 47 • Chapter 7, “Power supply and fan assembly,” on page 57 	
Review the safety precautions.	See “Safety precautions” on page 7 . For translations, see “Safety and environmental notices” on page xiii at the end of this guide.	
Plan the installation.	Decide whether you want to install the unit on a flat surface or in a rack. For rack installation, obtain the appropriate rack mount kit. See Chapter 3, “Mounting the switch,” on page 13 .	
Review and verify installation requirements.	Verify that the following requirements are met. See “Facility requirements” on page 9 . <ul style="list-style-type: none"> • Power requirements • Environmental requirements • Clearance for stand-alone or rack installation 	
Gather network configuration parameters.	<ul style="list-style-type: none"> • IP address: • Subnet mask: • Default gateway: • Domain ID: • Time zone: 	

Installation and Initial Configuration

The initial setup includes mounting the device on a flat surface or in a rack and completing the configuration tasks necessary to bring the device online and verify the operation.

Task	Task Details or Additional Information	Completed
Mount the device.	Choose one of the following mounting options: <ul style="list-style-type: none"> • Mount the device as a stand-alone unit. See “Stand-alone installation” on page 13. • Mount the device in a four-post rack. See “Installing the universal four-post rack kit” on page 14. • Mount the device in a two-post rack. See “Installing the universal two-post rack kit” on page 27. 	
Check the airflow of the power supply and fan assembly.	The airflow direction of the power supply and fan should match. The power supplies and fan trays are clearly labeled with either a green arrow with an "E", or an orange arrow with an "I." For more details, see “Identifying the airflow direction” on page 58 .	

Table 5. Installation and Basic System Configuration (continued)

Task	Task Details or Additional Information	Completed
Gather all components required for the initial setup.	See “Items required” on page 37.	
Provide power to the device.	See “Providing power to the device” on page 37.	
Attach a management station, establish a serial connection, and change the default passwords (optional).	See “Establishing a first-time serial connection” on page 38. After completing this task, log on to the serial port to configure the device.	
Set the IP address, subnet mask, and the default gateway IP address.	Use the <code>ipaddress</code> command to configure a static device IP address, subnet mask, and gateway IP address, or you can use a DHCP server to obtain the information dynamically. See “Configuring the IP address” on page 39.	
Set the date and time.	<ul style="list-style-type: none"> • Use the <code>date</code> command to display and set the date and time. • Use the <code>timezone</code> command to display and set the time zone. • Use the <code>clockserver</code> command to synchronize the time with an external NTP server. See “Setting the date and time” on page 40 for more information.	
Customize the switch name and chassis name.	<ul style="list-style-type: none"> • Use the <code>switchname</code> command to change the default switch name. • Use the <code>chassisname</code> command to change the default chassis name. See “Customizing the chassis name and switch name” on page 41 for more information.	
Establish an Ethernet connection.	By establishing an Ethernet connection, you can complete the device configuration using a serial session, Telnet, or management application, such as SANnav. See “Establishing an Ethernet connection” on page 42.	
Optional: Configure the DNS service.	Use the <code>dnsconfig</code> command to create DNS server entries. Refer to the <i>Fabric OS Administration Guide</i> .	
Optional: Customize the domain ID.	Use the <code>configure</code> command to change the domain ID (default ID is 1). See “Setting the domain ID” on page 42 for more information.	

Table 5. Installation and Basic System Configuration (continued)

Task	Task Details or Additional Information	Completed
Verify that the device operates correctly.	<ul style="list-style-type: none"> • Check the LEDs to verify operation of functional parts. See “Interpreting port-side LEDs” on page 51 and “Interpreting nonport-side LEDs” on page 54. • The following commands can be useful to establish an operational baseline for the device. Refer to the <i>Fabric OS Command Reference Manual</i> for more information on these commands. <ul style="list-style-type: none"> – errdump – fanshow – historyshow – psshow – tempshow 	
Back up the configuration.	Use the interactive <code>configupload</code> command to back up the configuration. See “Backing up the configuration” on page 44 for more information.	
Optional: Power off the devices.	Enter the shutdown command and wait for the device to power down, and then unplug the power cords. See “Powering down the device” on page 45 for more information.	

Shipping carton contents

When unpacking the device, verify that the contents of the shipping carton are complete. Save the shipping carton and packaging in the event you need to return the shipment.

- The SAN64B-7 switch
- An accessory kit containing the following items:
 - mini USB cable
 - Two 1.82m (6 ft) power cords
 - *Download Instructions for Fibre Channel Networking Software and Documents*
- Inner foam

Note: Transceivers may be shipped in the accessory tray instead of installed in switch ports.

Chapter 3. Mounting the switch

You can install the device in several ways:

- As a stand-alone unit on a flat surface, for example, a table top. Use the rubber feet included with the shipment to secure the device on the surface. No other equipment is required for desktop installation.
- In a four-post EIA rack: You will need a Universal Four-Post Rack Kit to install devices in EIA racks that are between L-13.7 cm to 81.28 cm deep (L-5.0 in. to 32.0 in.), where L is the chassis depth.
- In a two-post Telco rack: You will need a Universal Two-Post Rack Kit to install 1U and 2U devices in a two-post telecommunications (Telco) rack.

Note: Review the following precautions before mounting the device.

Precautions specific to mounting

The following precautions apply to mounting the device.



DANGER: Use safe lifting practices when moving the product.



DANGER: Mount the devices you install in a rack as low as possible. Place the heaviest device at the bottom and progressively place lighter devices above.



CAUTION: Make sure the airflow around the front and back of the device is not restricted.



CAUTION: Never leave tools inside the chassis.



CAUTION: Do not use the port cover tabs to lift the module. They are not designed to support the weight of the module, which can fall and be damaged.



CAUTION: To prevent damage to the chassis and components, never attempt to lift the chassis using the fan or power supply handles. These handles were not designed to support the weight of the chassis.

Stand-alone installation

About this task

Complete the following steps to install the device as a stand-alone unit on a table.

Procedure

1. Unpack the device and verify that the items listed under [“Shipping carton contents”](#) on page 12 are present and undamaged.
2. Apply the adhesive rubber feet to the underside of the device. The rubber feet help prevent the device from sliding off the supporting surface.
 - a) Clean the indentations at each corner of the bottom of the device to ensure that they are free of dust or other debris that might lessen the adhesion of the feet.
 - b) With the adhesive side against the chassis, place one rubber foot in each indentation and press into place.
3. Place the device on a sturdy flat surface.
4. Provide power to the device as described in [“Providing power to the device”](#) on page 37.

Note: Do not connect the device to the network until the IP address is set correctly. For instructions on how to set the IP address, see [“Configuring the IP address”](#) on page 39.

Installing the universal four-post rack kit

Use the following instructions to install 1U and 2U devices in EIA racks that are from L-12.7 cm to 81.28 cm (L-5.0 in. to 32.0 in.) deep, where L is the chassis depth, using the Universal Four-Post Rack Kit (XBR-R000296).

You can mount the device in a four-post rack in two ways:

- With the port side flush with the front posts.
- With the nonport side flush with the rear posts in a recessed position. A recessed position allows a more gradual bend in the fiber-optic cables connected to the switch and less interference in the aisle at the front of the rack.

Chassis with Port-Side Side Vents	Notes	Chassis Depth	Minimum Rack Depth	Maximum Rack Depth
No	Applicable to port-side and nonport-side flush mounts.	L	L-12.7 cm (L-5 in.)	81.28 cm (32 in.)
Yes	Applicable to port-side flush mounts.	L	L-12.7 cm (L-5 in.)	81.28 cm (32 in.)
Yes	Applicable to nonport-side flush mounts.	L	L	81.28 cm (32 in.)

If the chassis depth (L) is less than 40.64 cm (16 in.), the chassis will not fit into a rack with a maximum depth of 81.28 cm (32 in.) using the Universal Four-Post Rack Kit. The maximum rack depth for a chassis less than 40.64 cm (16 in.) is 81.28 cm (32 in.) minus the difference between the chassis depth and 40.64 cm (16 in.). For example, a chassis with a depth (L) of 35.56 cm (14 in.) is 5.08 cm (2 in.) smaller than 40.64 cm (16 in.), so it will install into a rack with a maximum depth of 81.28 cm (32 in.) – 5.08 cm (2 in.), which equals 76.2 cm (30 in.).

Observe the following when mounting the device:

- Two people are required to install the device in a rack. One person holds the device, while the other screws in the front and rear brackets.
- Before mounting your device, review any specific installation and facility requirements in the hardware installation guide for the device.
- Hardware devices illustrated in these procedures are for reference only and may not depict the device that you are installing into the rack.

Time and items required

Allow 15 to 30 minutes to complete the installation.

The following items are required to install the device using the Universal Four-Post Rack Kit:

- No. 2 Phillips torque screwdriver
- 1/4-in. slotted-blade torque screwdriver

Parts List

The following parts are provided with the 1U, 1.5U, and 2U Universal Four-Post Rack Kit:

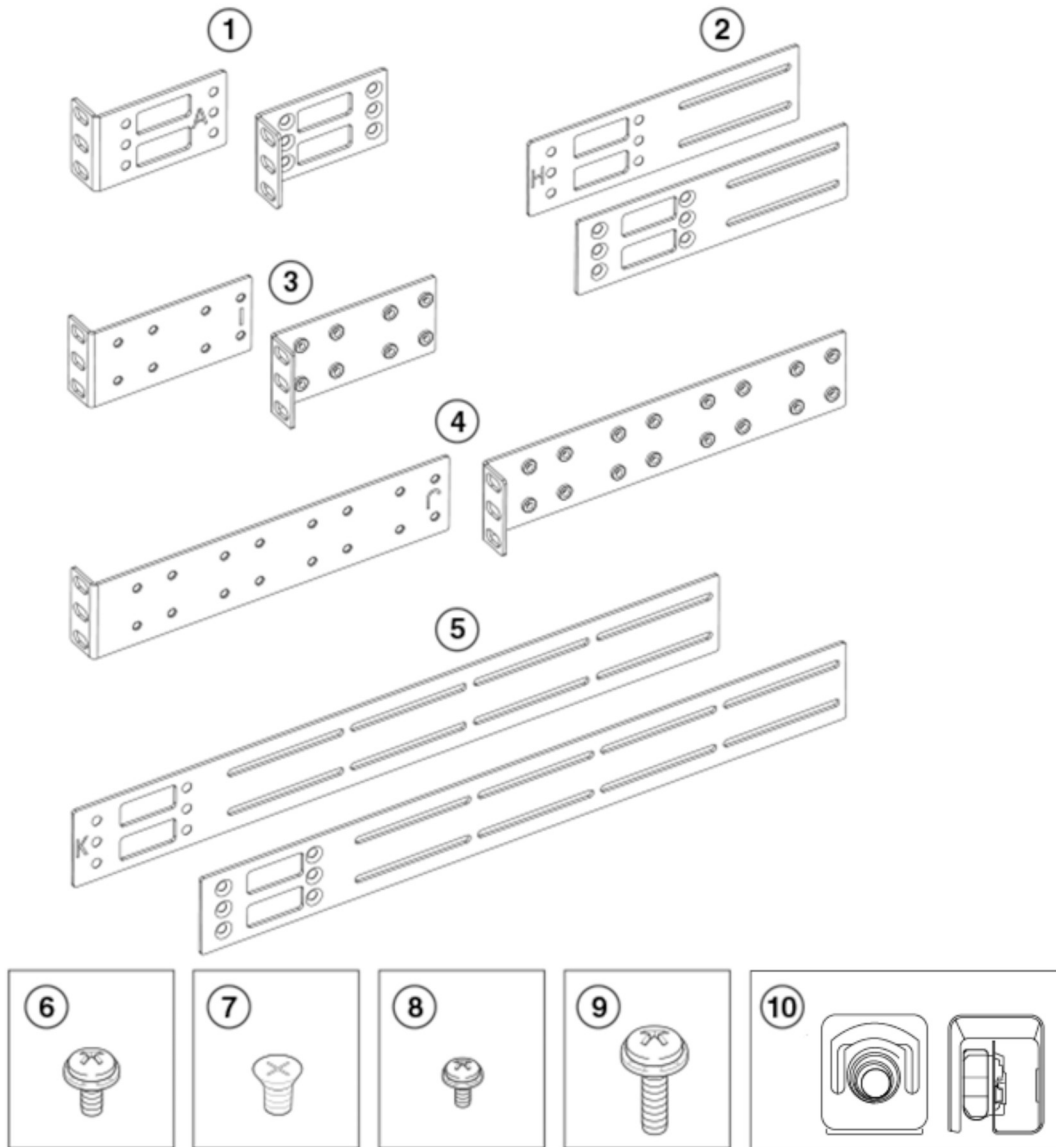

Figure 3. Universal Four-Post Rack Kit Parts

1. Front Brackets (2)
2. Extension Brackets, Medium (2)
3. Rear Brackets, Short (2)
4. Rear Brackets, Long (2)
5. Bracket Extensions, Long (2)
6. Screw, 8-32 x 5/16-in. Panhead Phillips (8)
7. Screw, 8-32 x 5/16-in. Flathead Phillips (16)
8. Screw, 6-32 x 1/4-in. Panhead Phillips (8)
9. Screw, 10-32 x 5/8-in. Panhead Phillips (8)
10. Retainer Nut, 10-32 (8)

Ensure that the items listed and illustrated are included in the kit. Note that not all parts may be used with certain installations depending on the device type.



CAUTION: Use the screws specified in the procedure. Using longer screws can damage the device.

Flush-front mounting



CAUTION: The device must be turned off and disconnected from the fabric during this procedure.

Note: The illustrations in the rack installation procedures are for reference only and may not show the device that you are installing.

Complete the following tasks to install the device in a four-post rack.

1. [Attaching the Front Brackets](#)
2. [Attaching the Extension Brackets to the device](#)
3. [Installing the Device in the Rack](#)
4. [Attaching the Rear Brackets to the Extensions](#)
5. [Attaching the Rear Brackets to the Rack Posts](#)

Attaching the front brackets

About this task

Complete the following steps to attach the front brackets to the device.

Procedure

1. Position the right front bracket with the flat side against the right side of the device at the front of the device, as shown in [Figure 4](#).
2. Insert four 8-32 x 5/16-in. flathead screws through the vertically aligned holes in the bracket and then into the holes on the side of the device. Use the upper and lower screw holes, leaving the center holes empty.
3. Repeat Step 1 and Step 2 to attach the left front bracket to the left side of the device.
4. Tighten all 8-32 x 5/16-in. screws to a torque of 17 cm·kg (15 in.-lb).

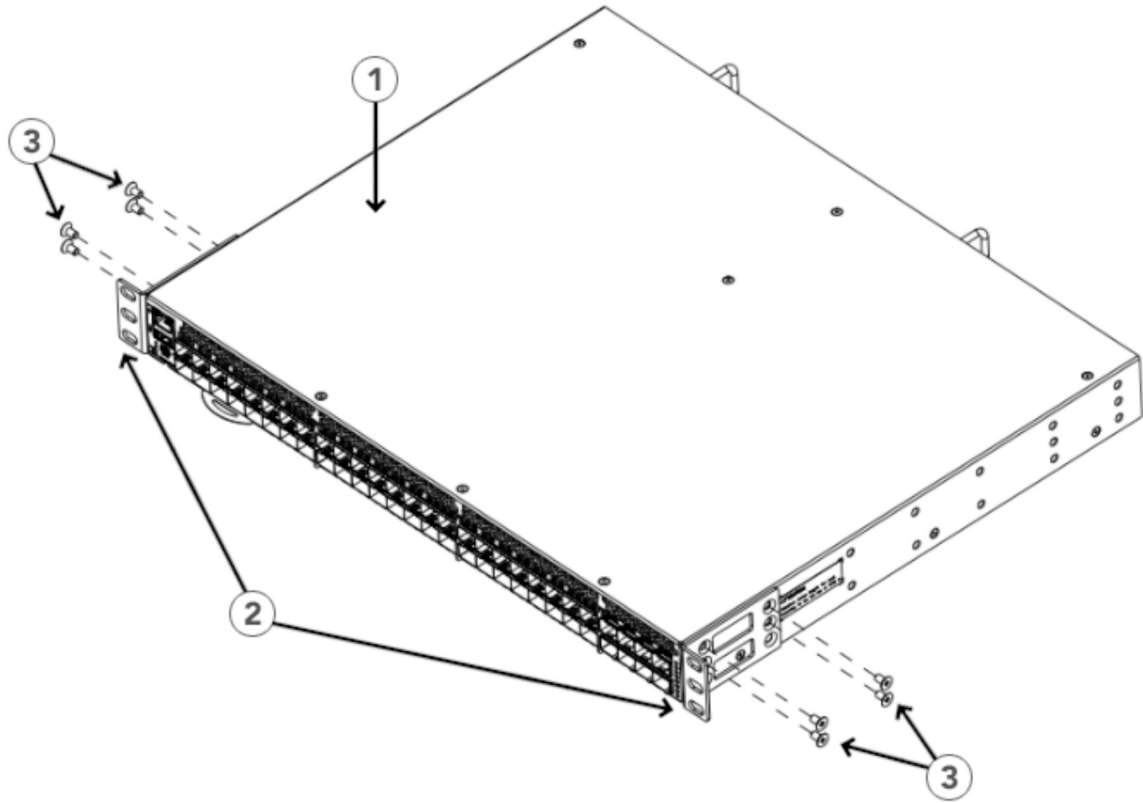

Figure 4. Attaching the Front Brackets

1. SAN64B-7 Device
2. Front Brackets
3. Screws, 8-32 x 5/16-in. Flathead Phillips

Attaching the extension brackets to the device

About this task

Complete the following steps to attach the extension brackets to the device. You can use medium and long extension brackets for this task.

Procedure

1. Select the proper length extension bracket for your rack depth.
2. Position the right extension bracket along the side of the device as shown in Figure 5.
3. Insert four 8-32 x 5/16-in. flathead screws through the vertically aligned holes in the bracket extension and then into the holes on the side of the device. Use the upper and lower screw holes, leaving the center holes empty.
4. Repeat Steps 2 and 3 to attach the left extension bracket to the left side of the device.
5. Tighten all 8-32 x 5/16-in. screws to a torque of 17 cm·kg (15 in.-lb).

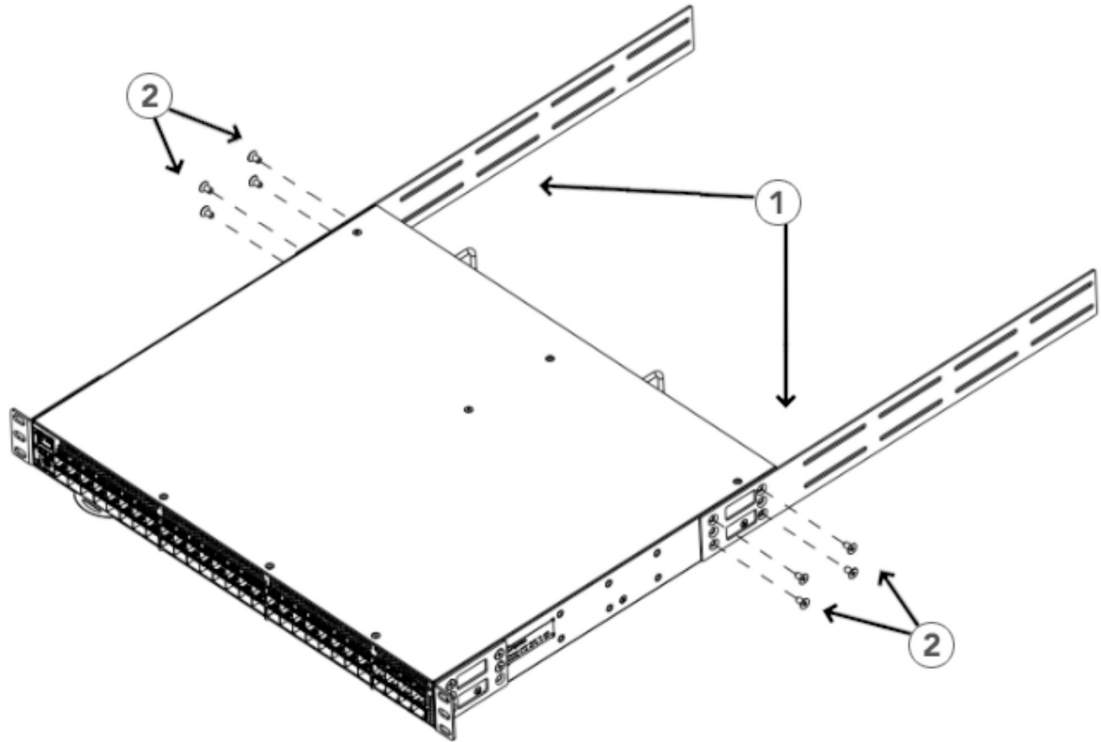

Figure 5. Attaching the Extension Brackets to the Device

Installing the device in the rack

About this task

Complete the following steps to install the device in the rack.

Procedure

1. Position the device in the rack, as shown Figure 6. Provide temporary support under the device as you secure the rail kit to the rack.
2. Attach the right front bracket to the right front rack post using two 10-32 x 5/8-in. panhead screws and two retainer nuts. Use the upper and lower holes in the bracket.
3. Tighten all 10-32 x 5/8-in. screws to a torque of 29 cm·kg (25 in.-lb).

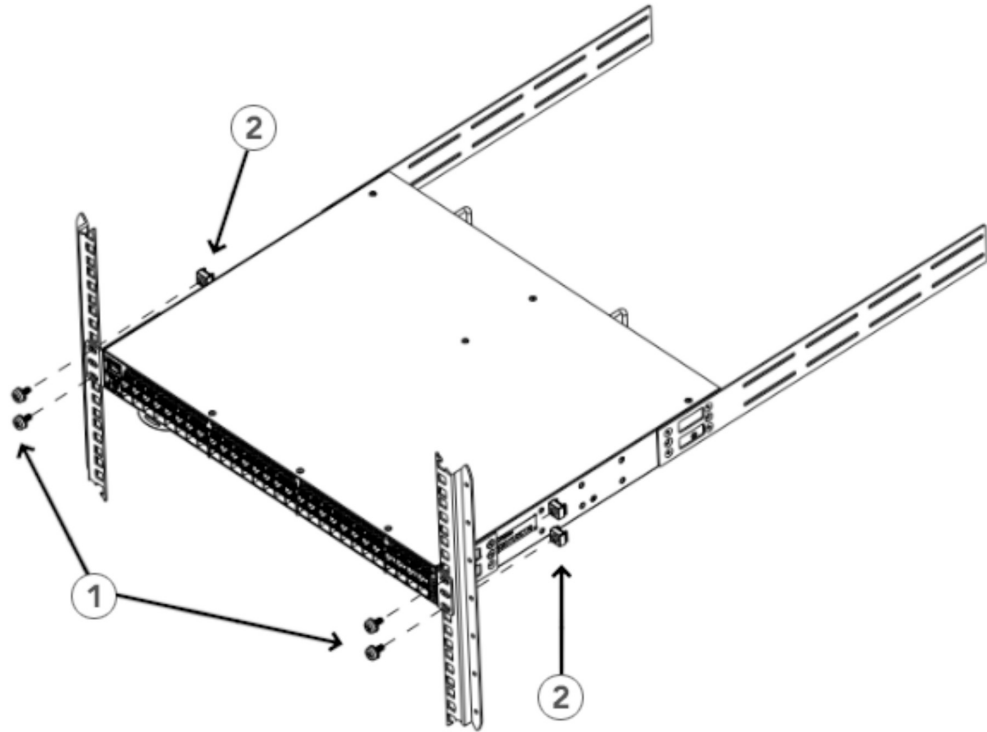

Figure 6. Positioning the Device in the Rack

Attaching the rear brackets to the extensions

About this task

Complete the following steps to attach the rear brackets to the extensions. You can use short or long rear brackets for this task, depending on the depth of your rack.

Procedure

1. Select the proper length rear bracket for your rack depth.
2. Slide the right rear bracket onto the right extension bracket, as shown in Figure 7.
3. Attach the brackets using four 6-32 x 1/4-in. panhead screws.
If possible, leave at least one empty vertical pair of holes between the screws for better support.
4. Repeat Step 2 and 3 to attach the left rear bracket to the left extension bracket.
5. Adjust the brackets to the rack depth and tighten all 6-32 x 1/4-in. screws to a torque of 10 cm·kg (9 in.-lb).

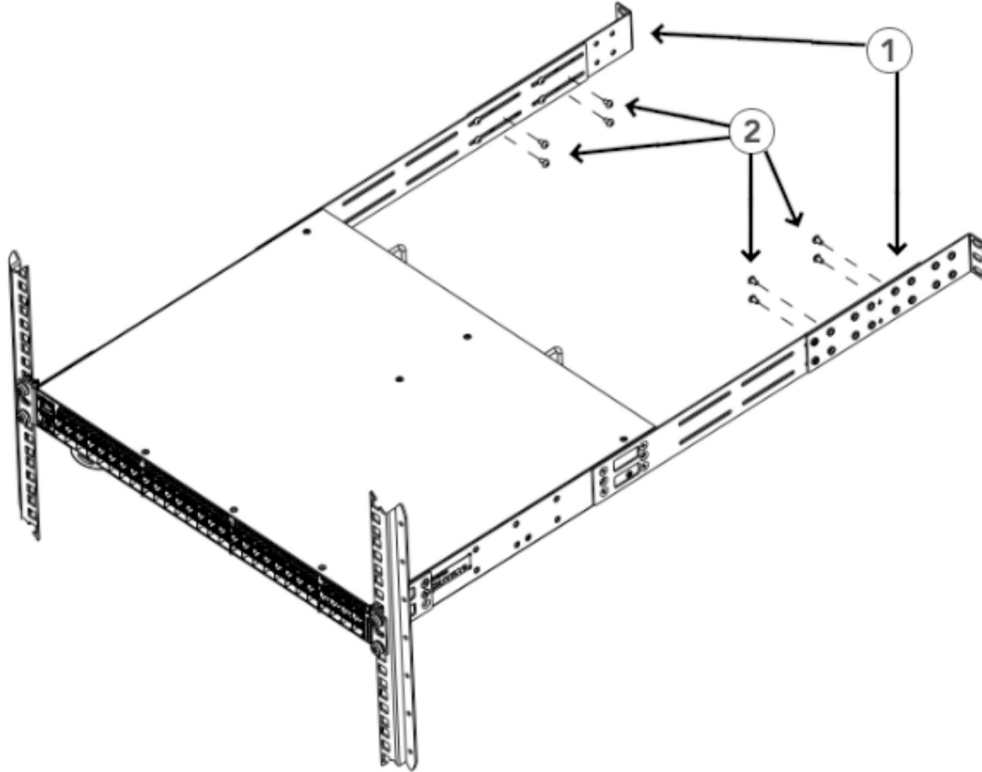

Figure 7. Attaching the Rear Brackets to the Extensions

Attaching the rear brackets to the rack posts

About this task

Complete the following steps to attach the rear brackets to the rack posts.

Procedure

1. Attach the right rear bracket to the right rear rack post using two 10-32 x 5/8-in. panhead screws and two retainer nuts, as shown in Figure 8. Use the upper and lower holes in the bracket.
2. Attach the left rear bracket to the left rear rack post using two 10-32 x 5/8-in. panhead screws and two retainer nuts. Use the upper and lower holes in the bracket.
3. Tighten all 10-32 x 5/8-in. screws to a torque of 29 cm·kg (25 in.-lb).

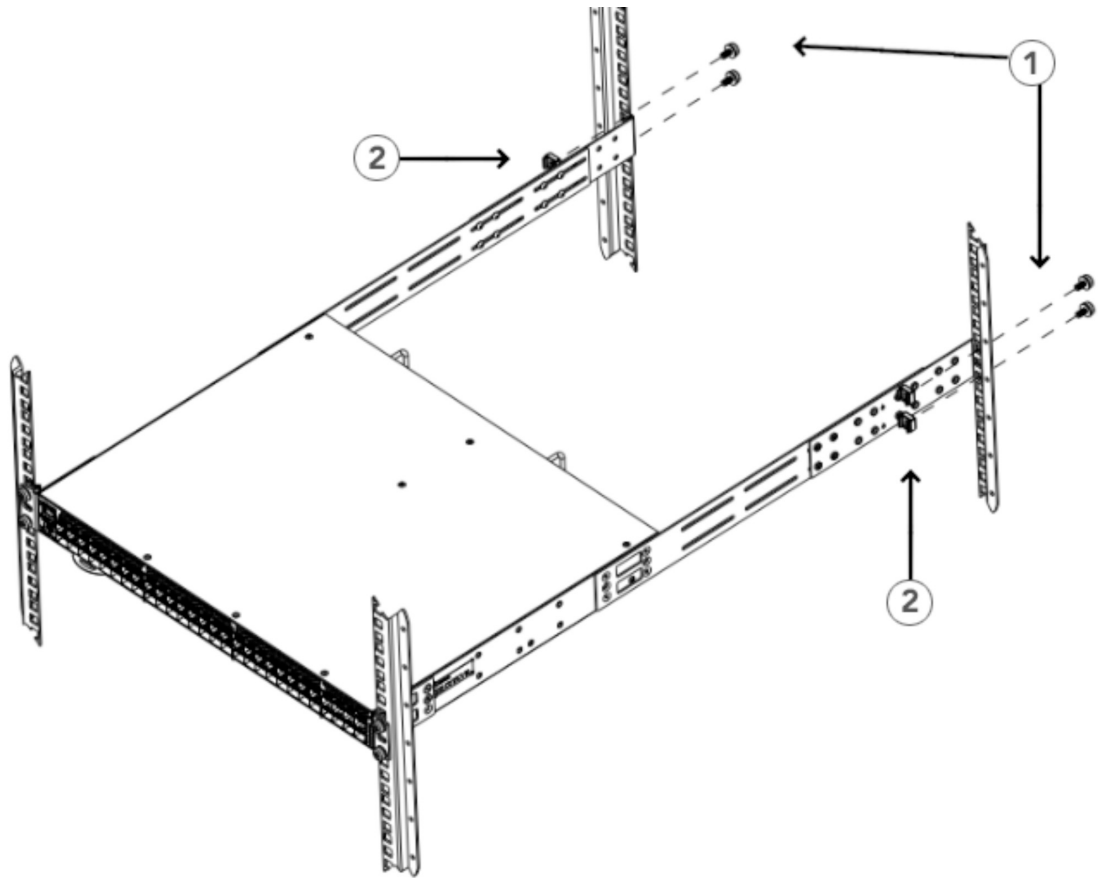

Figure 8. Attaching the Rear Brackets to the Rack Posts

Flush-rear (recessed) mounting

Flush-rear (recessed) mounting is similar to flush-front mounting except that the brackets are reversed on the device.



CAUTION: The device must be turned off and disconnected from the fabric during this procedure.

Note: The illustrations in the rack installation procedures show a 1U device, but the instructions are the same for a 2U device. The illustrations in the rack installation procedures are for reference only and may not show the actual device.

Complete the following tasks to install the device in a four-post rack:

1. Attaching the front brackets to the rear of the device
2. Attaching the extensions to the front of the device
3. Installing the device in the rack
4. Attaching the rear brackets to the extensions at the front of the device
5. Attaching the rear brackets to the front rack posts

Attaching the front brackets to the rear of the device

About this task

Note: In this installation, the brackets are named as listed in the parts list even though the installation of the brackets is reversed from the flush-front installation.

Complete the following steps to attach the front brackets to the rear of the device.

Procedure

1. Position the right front bracket with the flat side against the right rear side of the device, as shown Figure 9.
2. Insert four 8-32 x 5/16-in. flathead screws through the vertically aligned holes in the bracket and then into the holes on the side of the device. Use the upper and lower screw holes, leaving the center holes empty.
3. Repeat Steps 1 and 2 to attach the left front bracket to the left side of the device.
4. Tighten all 8-32 x 5/16-in. screws to a torque of 17 cm·kg (15 in.-lb).

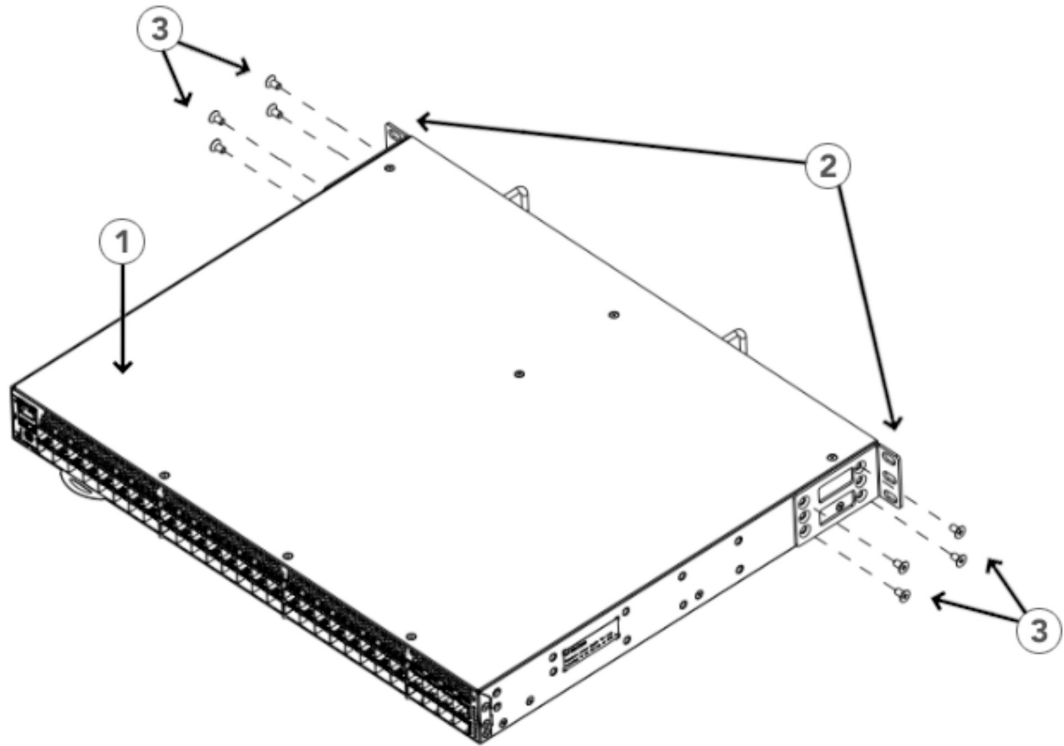

Figure 9. Attaching the Front Brackets to the Rear of the Device

Attaching the extensions to the front of the device

About this task

Complete the following steps to attach the extension brackets to the front of the device. You can use medium or long extension brackets for this task, depending on your rack depth.

Procedure

1. Select the proper length extension bracket for your rack depth.
2. Position the right extension bracket along the side of the device as shown Figure 10.
3. Insert four 8-32 x 5/16-in. flathead screws through the vertically aligned holes in the extension brackets and then into the holes on the side of the device. Use the upper and lower screw holes, leaving the center holes empty.

4. Repeat Steps 2 and 3 to attach the left front extension bracket to the left side of the device.
5. Tighten all the 8-32 x 5/16-in. screws to a torque of 17 cm-kg (15 in.-lb).

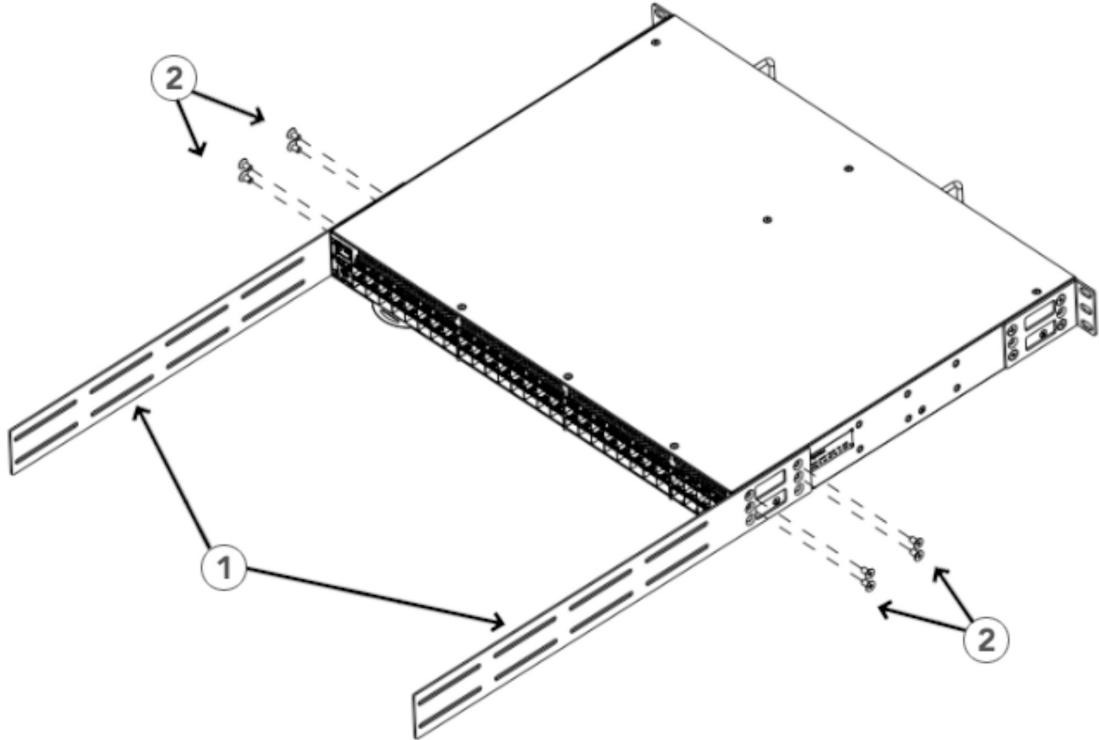

Figure 10. Attaching the Extensions to the Device

Installing the device in the rack

About this task

Complete the following steps to install the device in the rack.

Procedure

1. Position the device in the rack, as shown Figure 11, providing temporary support under the device until the rail kit is secured to the rack.
2. Attach the right front bracket to the right rear rack post using two 10-32 x 5/8-in. panhead screws and two retainer nuts. Use the upper and lower holes in the bracket.
3. Tighten all 10-32 x 5/8-in. screws to a torque of 29 cm-kg (25 in.-lb).

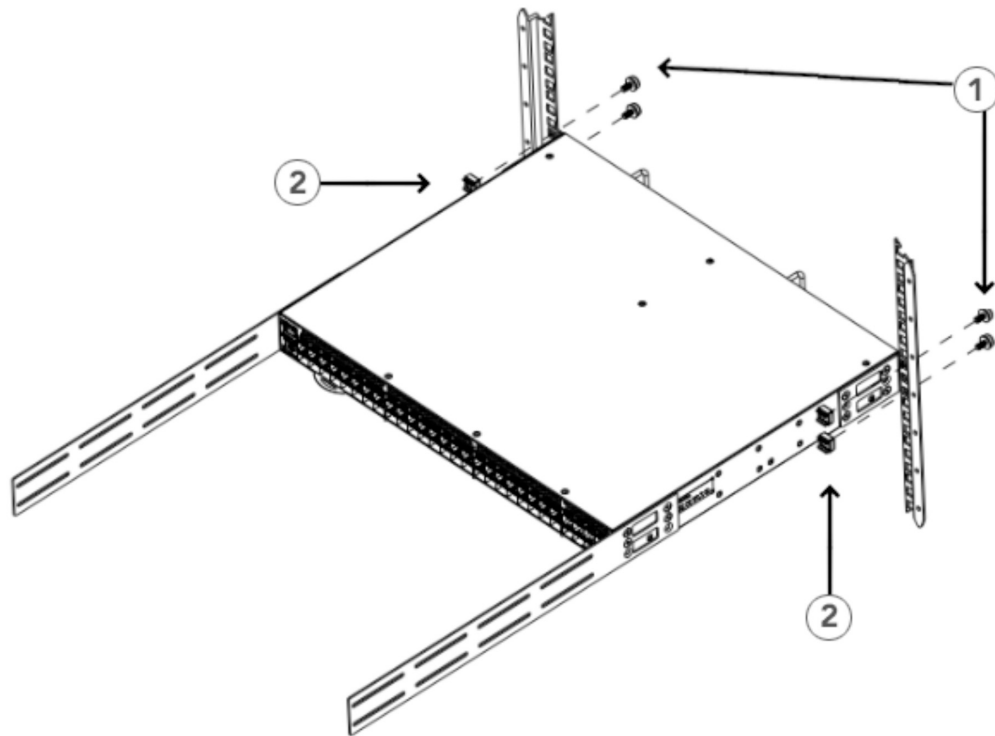

Figure 11. Positioning the Device in the Rack

- a. 1. Screws, 10-32 x 5/8-in. Panhead Phillips
- b. 2. Retainer Nuts, 10-32

Attaching the rear brackets to the extensions at the front of the device

About this task

Complete the following steps to attach the rear brackets to the extensions. Rack depth determines use of short or long brackets.

Procedure

1. Select the proper length rear bracket for your rack depth.
2. Slide the right rear bracket onto the right extension.

The short rear brackets are shown in Figure 12. Use the first and third vertical pairs of holes for the screws.

See Figure 13 for the positioning of the short or long brackets and screws.

3. Attach the brackets using four 6-32 x 1/4-in. panhead screws.
4. Repeat Steps 2 and 3 to attach the left rear bracket to the left extension.
5. Adjust the brackets to the rack depth, and tighten all 6-32 x 1/4-in. screws to a torque of 10 cm-kg (9 in.-lb).

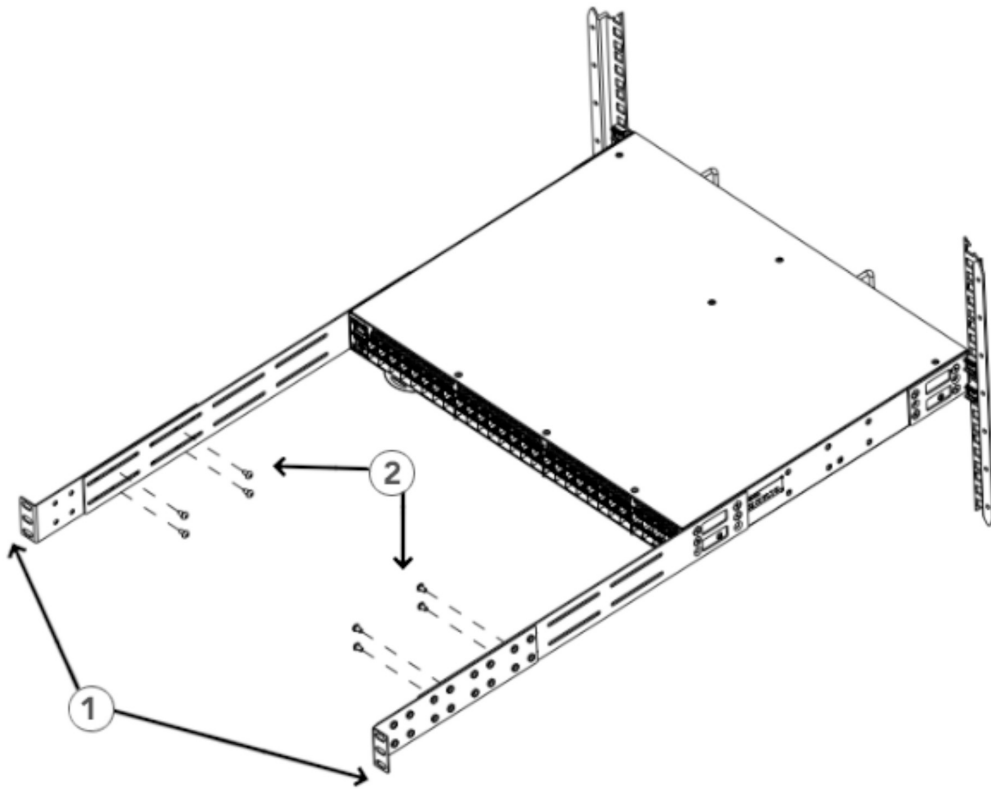

Figure 12. Attaching the Rear Brackets to the Extensions at the Front of the Device

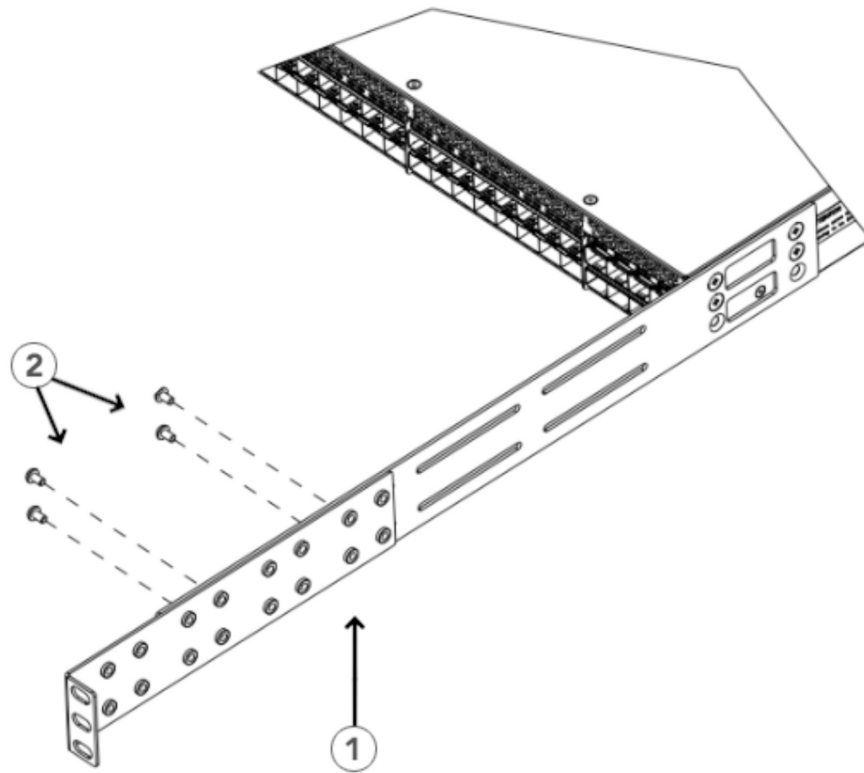

Figure 13. Attaching the Short or Long Rear Brackets to the Extensions

Attaching the rear brackets to the front rack posts

About this task

Complete the following steps to attach the rear brackets to the front rack posts.

Procedure

1. Attach the right rear bracket to the right front rack post using two 10-32 x 5/8-in. screws and two retainer nuts, as shown Figure 14. Use the upper and lower holes in the bracket.
2. Attach the left rear bracket to the left front rack post using two 10-32 x 5/8-in. screws and two retainer nuts. Use the upper and lower holes in the bracket.
3. Tighten all 10-32 x 5/8-in. screws to a torque of 29 cm-kg (25 in.-lb).

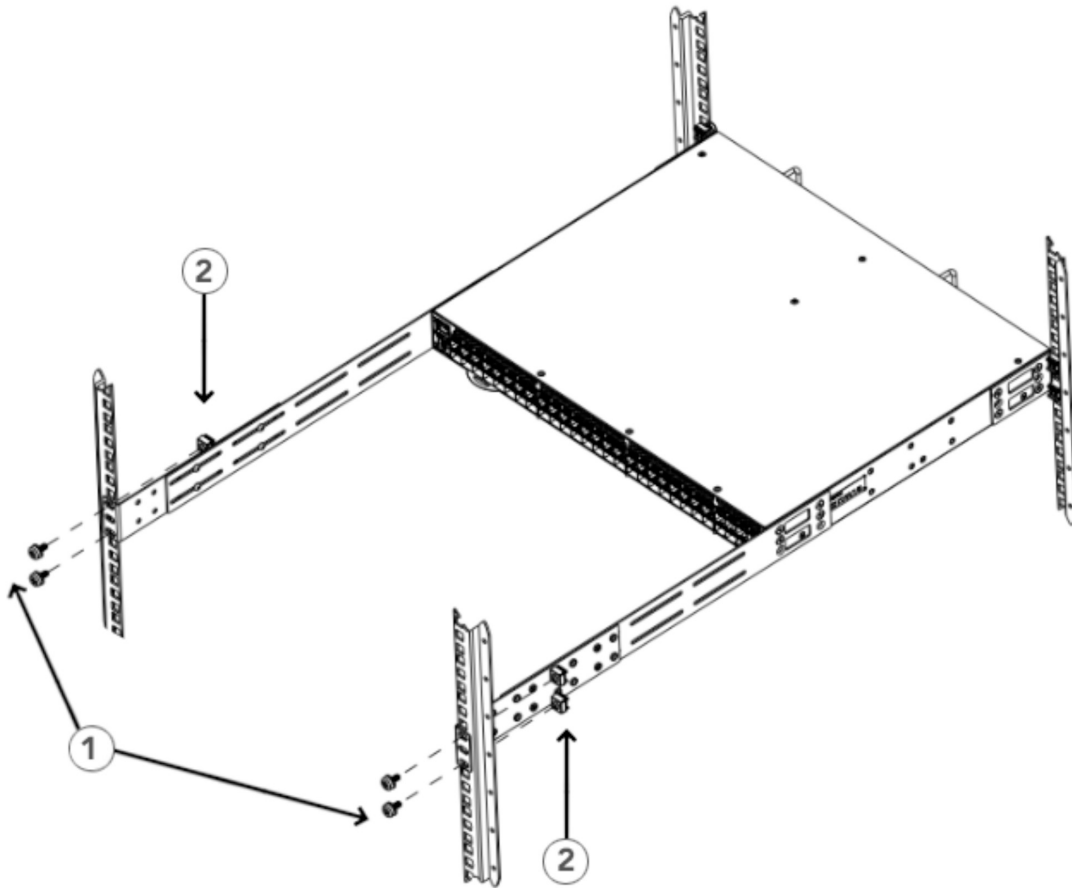

Figure 14. Attaching the Rear Brackets to the Front Rack Posts

Installing the universal two-post rack kit

Use the following instructions to install a 1U or 2U device in a two-post telecommunications (Telco) rack using the Universal Two-Post Rack Kit.

You can mount the device in a two-post rack in two ways:

- With the port side flush with the front posts
- With the posts mounted to the mid-section of the device

Observe the following when mounting this device:

- Two people are required to install the device in a rack. One person should hold the device, while the other while the other screws in the front and rear brackets.
- Before mounting your device, review any specific installation and facility requirements in the hardware installation guide for the device.
- Hardware devices illustrated in these procedures are for reference only and may not depict the device that you are installing into the rack.

Time and items required

Allow 15 to 30 minutes to complete the installation.

The following items are required to install the device using the Universal Two-Post Rack Kit:

- No. 2 Phillips torque screwdriver
- 1/4-in. slotted-blade torque screwdriver

Parts list

The following parts are provided with the Universal Two-Post Rack Kit:

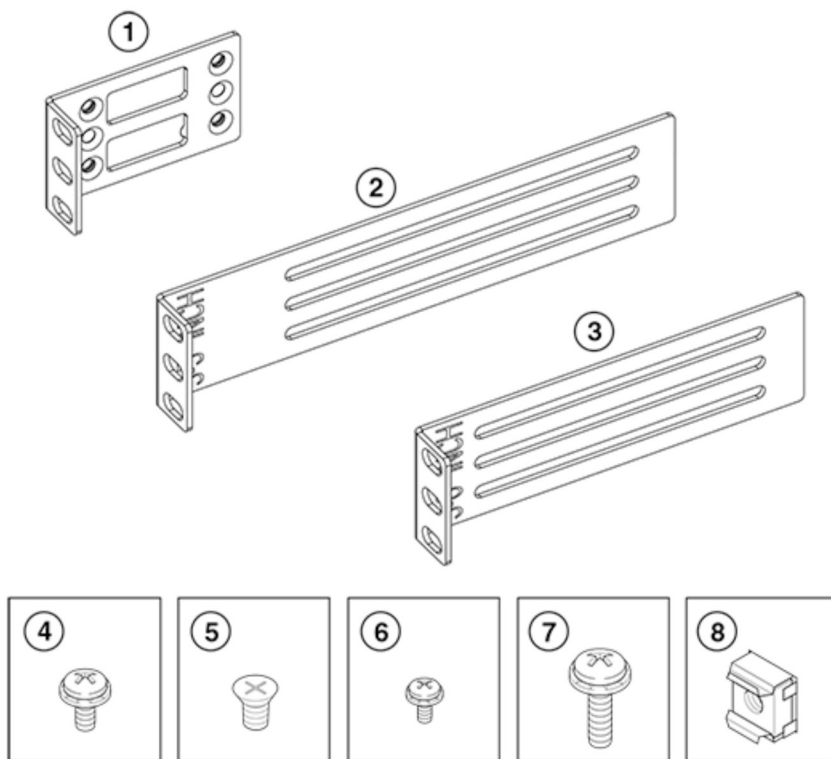

Figure 15. Universal Two-Post Rack Kit Parts

1. Front Brackets (2)
2. Rear Brackets, 5–6-in. Post (2)
3. Rear Brackets, 3–5-in. Post (2)
4. Screw, 8-32 x 5/16-in. Panhead Phillips (8)
5. Screw, 8-32 x 5/16-in. Flathead Phillips (16)
6. Screw, 8-32 x 1/4-in. Panhead Phillips (8)
7. Screw, 10-32 x 5/8-in. Panhead Phillips (8)
8. Retainer Nut, 10-32 (8)

Ensure that the items listed and illustrated in the preceding figure are included in the kit.

Note: Not all parts may be used with certain installations depending on the device type.

Flush-front mounting

Observe the following notes when performing this procedure:

- The device must be turned off and disconnected from the fabric during this procedure.
- The figures in this document show a 1U device, but the instructions are the same for a 2U device.
- The figures for this procedure show a two-post rack with narrow posts (3-in. to 5-in.) as an example.
- The figures in the rack installation procedures are for reference only and may not show the actual device.



CAUTION: Use the screws specified in the procedure. Using longer screws can damage the device.

Complete the following tasks to install the device in the rack:

1. [“Attaching the front brackets to the device” on page 29](#)
2. [“Attaching the front brackets to the rack” on page 30](#)
3. [“Attaching the rear brackets to the rack” on page 30](#)
4. [“Attaching the rear brackets to the device” on page 31](#)

Attaching the front brackets to the device

About this task

Complete the following steps to attach the front brackets to the device.

Procedure

1. Position the right front bracket with the flat side against the right side of the device, as shown Figure 16.
2. Insert four 8-32 x 5/16-in. flathead screws through the vertically aligned holes in the bracket and then into the holes on the side of the device. Use the upper and lower screw holes, leaving the center holes empty.
3. Repeat Steps 1 and 2 to attach the left front bracket to the left side of the device.
4. Tighten all the 8-32 x 5/16-in. screws to a torque of 17 cm·kg (15 in.-lb).

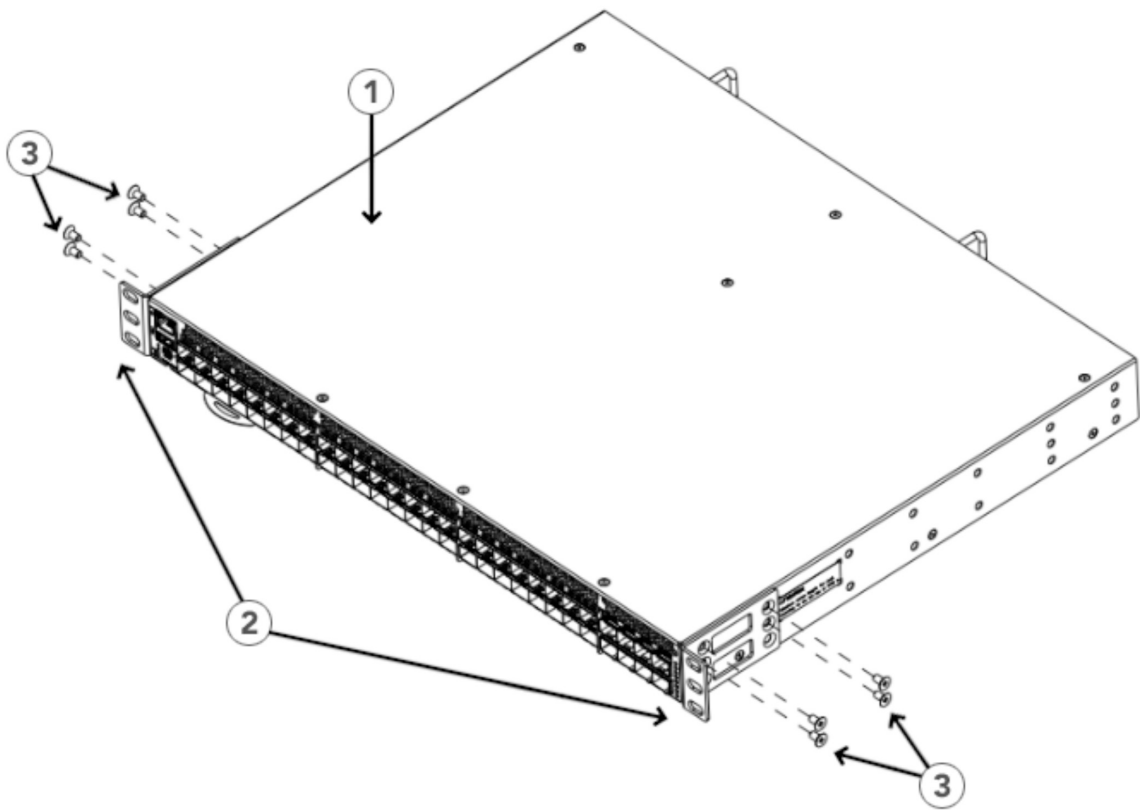

Figure 16. Attaching the Front Brackets

Attaching the front brackets to the rack

About this task

Complete the following steps to install the device in the rack.

Procedure

1. Position the device in the rack, as shown in Figure 17, providing temporary support under the device until the rack kit is fully secured to the rack.
2. Attach the right front bracket to the right rack upright using two 10-32 x 5/8-in. panhead screws and two retainer nuts. Use the upper and lower holes in the bracket.
3. Attach the left front bracket to the left rack upright using two 10-32 x 5/8-in. panhead screws and two retainer nuts.

Use the upper and lower holes in the bracket.

4. Tighten all the 10-32 x 5/8-in. screws to a torque of 29 cm-kg (25 in.-lb).

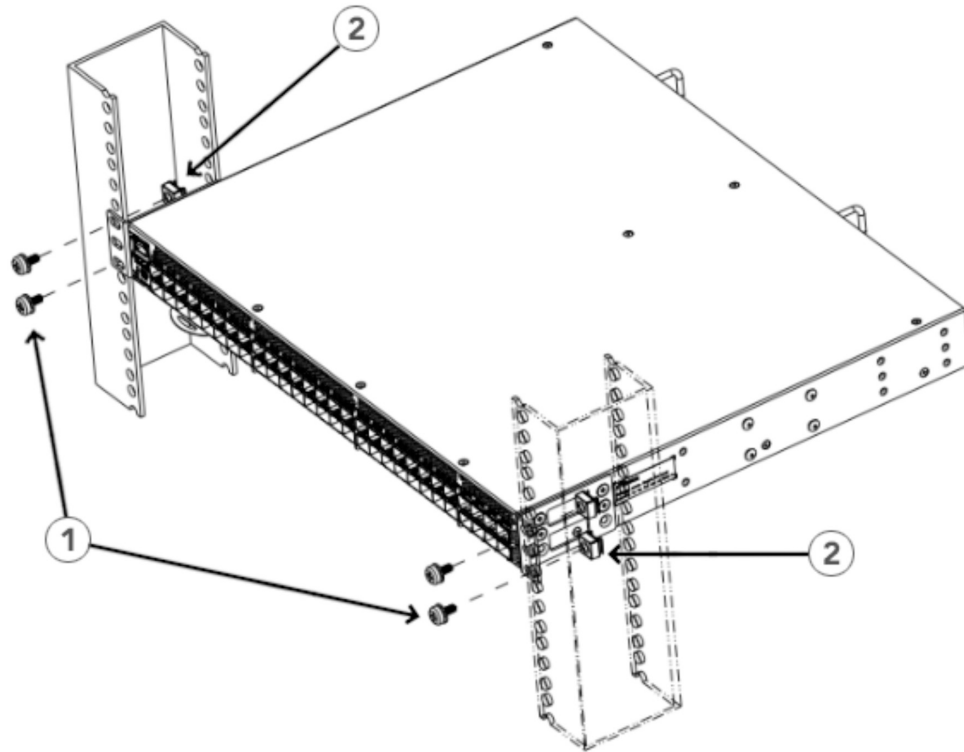

Figure 17. Attaching the Front Brackets to the Rack

Attaching the rear brackets to the rack

About this task

Complete the following steps to attach the rear brackets to the rack.

Procedure

1. Select the proper length bracket for your post width. If your posts are 3 inches to 5 inches wide, use the brackets marked 3-5 INCH. If your posts are 5 to 6 inches wide, use the brackets marked 5-6 INCH.
2. Position the right rear bracket in the right rear of the device, as shown in Figure 18.
3. Attach the bracket to the right rack upright using two 10-32 x 5/8-in. panhead screws and two retainer nuts. Use the upper and lower holes in the bracket.
4. Repeat Steps 2 and 3 to attach the left rear bracket to the left rack upright.
5. Tighten all the 10-32 x 5/8-in. screws to a torque of 29 cm-kg (25 in.-lb).

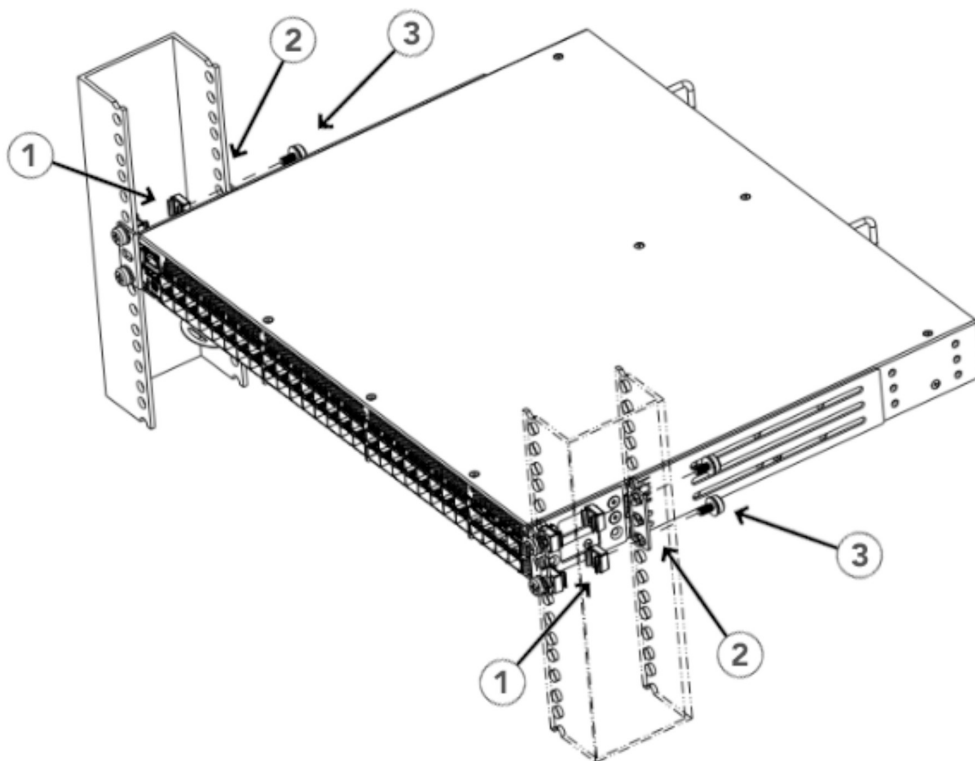

Figure 18. Attaching the Rear Brackets to the Rack

Attaching the rear brackets to the device

About this task

Complete the following steps to attach the rear brackets to the device.

Procedure

1. Align the right rear bracket to the right rear of the device and use four 8-32 x 5/16-in. panhead screws to attach the bracket to the device, as shown in Figure 19. Be sure to insert the screws through the upper and lower slots in the bracket.
2. Align the left rear bracket to the left rear of the device and use four 8-32 x 5/16-in. panhead screws to attach the bracket to the device. Again, use the upper and lower slots in the bracket.
3. Tighten all the 8-32 x 5/16-in. screws to a torque of 17 cm-kg (15 in.-lb).

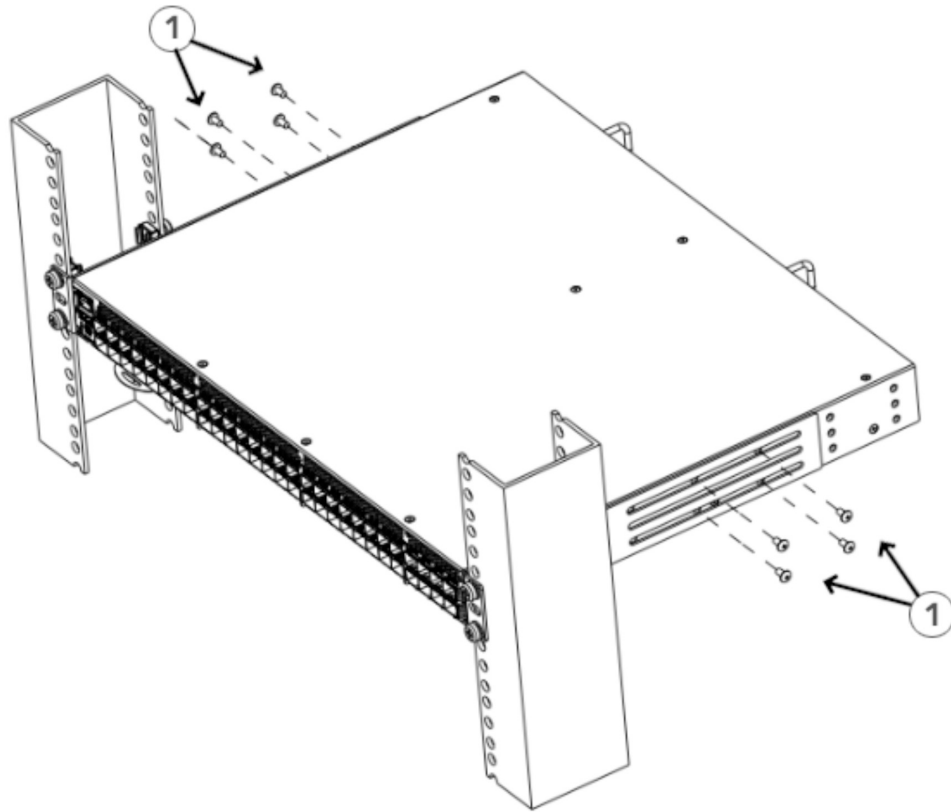

Figure 19. Attaching the Rear Brackets to the Device

Mid-mounting

Observe the following notes when performing this procedure:

- The device must be turned off and disconnected from the fabric during this procedure.
- The illustrations in this document show a 1U device, but the instructions are the same for a 2U device.
- The illustrations in the rack installation procedures are for reference only and may not show the actual device.

Complete the following tasks to install the device in the rack:

1. [“Attaching the front brackets to the device” on page 32](#)
2. [“Attaching the front brackets to the rack” on page 33](#)
3. [“Attaching the rear brackets to the rack” on page 34](#)
4. [“Attaching the rear brackets to the device” on page 35](#)

Attaching the front brackets to the device

About this task

Complete the following steps to attach the front brackets to the device.

Procedure

1. Position the right front bracket with the flat side against the right side of the device, as shown in Figure 20.

2. Insert four 8-32 x 5/16-in. flathead screws through the vertically aligned holes in the bracket and then into the holes on the side of the device. Use the upper and lower screw holes, leaving the center holes empty.
3. Repeat Steps 1 and 2 to attach the left front bracket to the left side of the device.
4. Tighten all 8-32 x 5/16-in. screws to a torque of 17 cm·kg (15 in.-lb).

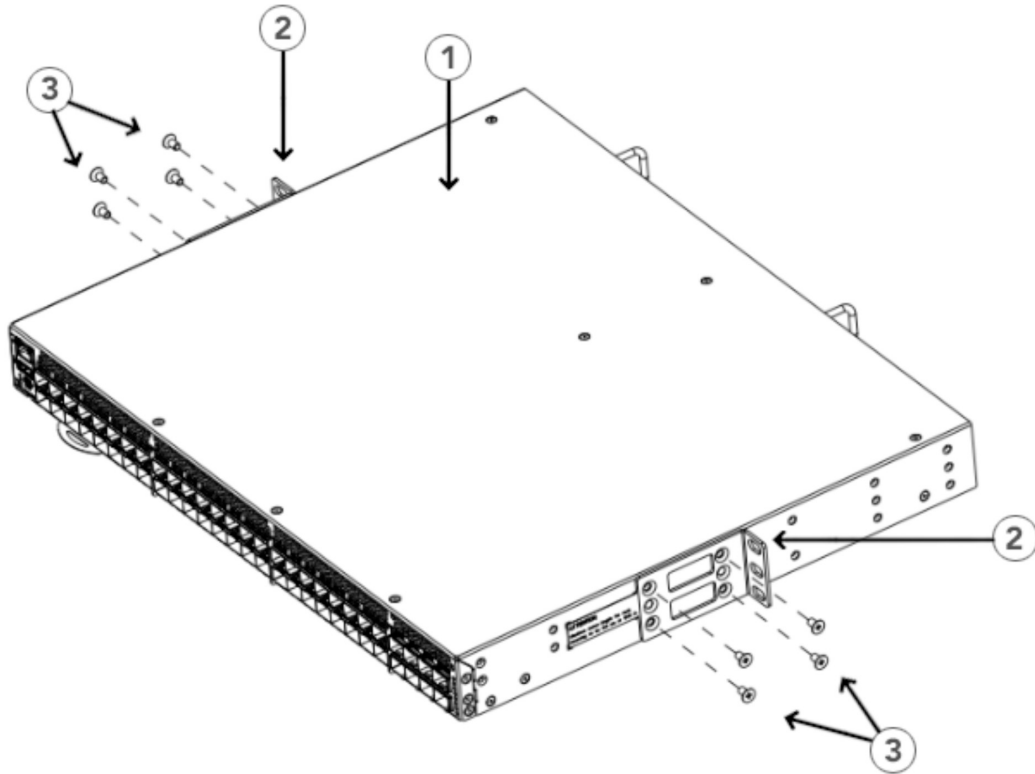

Figure 20. Attaching the Front Brackets

Attaching the front brackets to the rack

About this task

Complete the following steps to install the front brackets to the rack.

Procedure

1. Position the device in the rack, as shown in Figure 21, providing temporary support under the device until the rack kit is fully secured to the rack.
2. Attach the right front bracket to the right rack upright using two 10-32 x 5/8-in. screws and two retainer nuts. Use the upper and lower holes in the bracket.
3. Attach the left front bracket to the left rack upright using two 10-32 x 5/8-in. screws and two retainer nuts. Use the upper and lower holes in the bracket.
4. Tighten all 10-32 x 5/8-in. screws to a torque of 29 cm·kg (25 in.-lb).

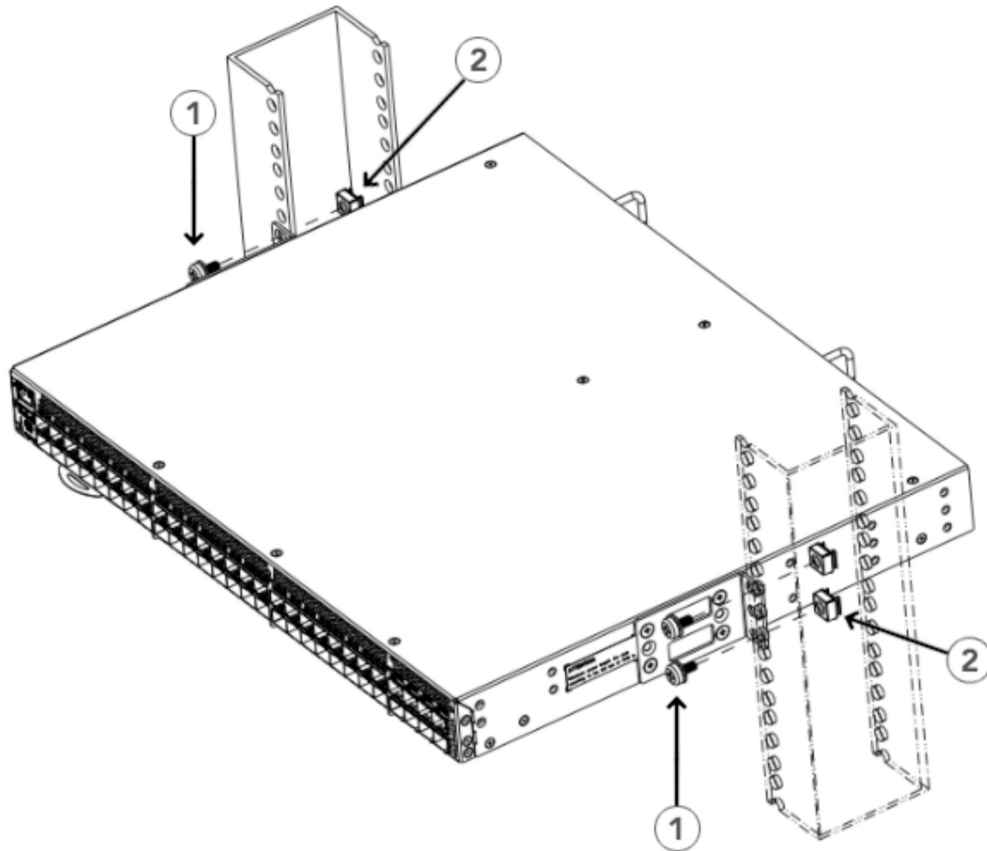

Figure 21. Attaching the Front Brackets to the Rack

Attaching the rear brackets to the rack

About this task

Complete the following steps to attach the rear brackets to the rack.

Procedure

1. Select the proper length bracket for your post width. If your posts are 3 in. to 5 in. wide, use the brackets marked 3-5 INCH. If your posts are 5 in. to 6 in. wide, use the brackets marked 5-6 INCH as shown in Figure 22.
2. Position the right rear bracket in the right rear of the device, as shown in Figure 22. Whether you are using the 3-5 INCH or the 5-6 INCH bracket, the rear end of the bracket will be flush with the back of the device.
3. Attach the brackets to the right rack upright using two 10-32 x 5/8-in. panhead screws and two retainer nuts.
4. Repeat Step 2 and Step 3 to attach the left rear bracket to the left rack upright.
5. Tighten all 10-32 x 5/8-in. screws to a torque of 29 cm·kg (25 in.-lb).

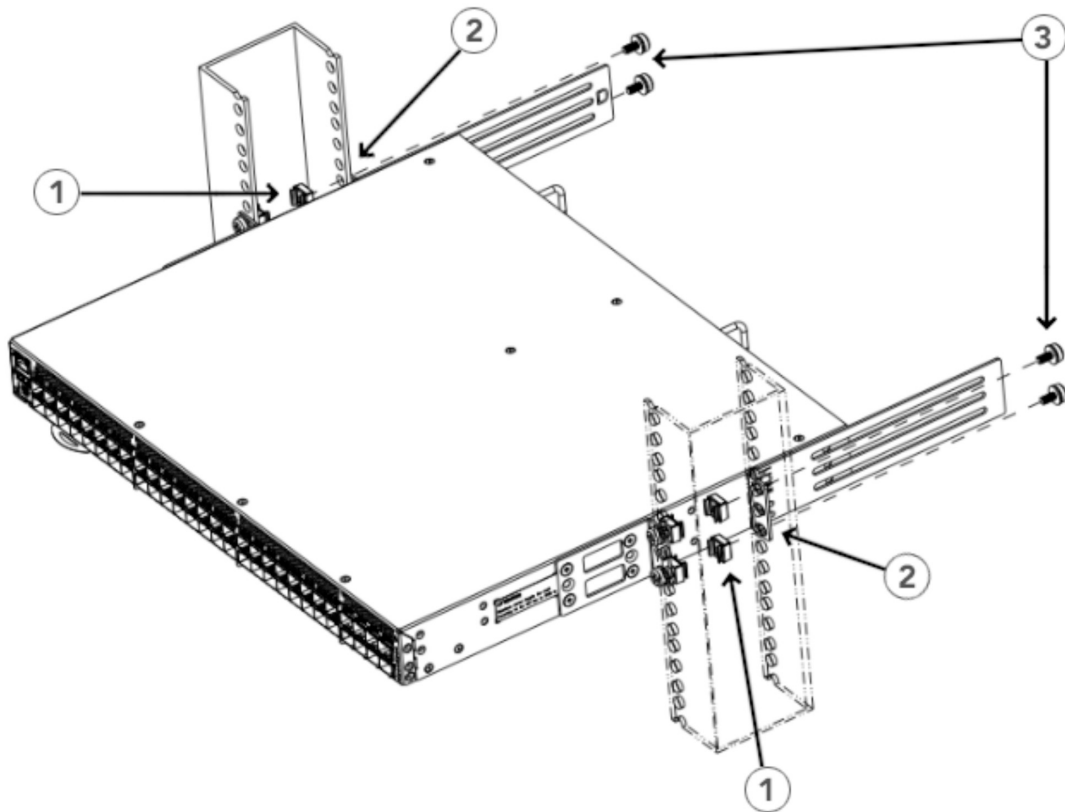

Figure 22. Attaching the Rear Brackets to the Rack

Attaching the rear brackets to the device

About this task

Complete the following steps to attach the rear brackets to the device.

Procedure

1. Align the right rear bracket to the right rear of the device, and use four 8-32 x 5/16-in. panhead screws to attach the bracket to the device, as shown Figure 23. Be sure to insert the screws through the upper and lower slots in the bracket.
2. Align the left rear bracket to the left rear of the device, and use four 8-32 x 5/16-in. panhead screws to attach the bracket to the device. Again, use the upper and lower slots in the bracket.
3. Tighten all 8-32 x 5/16-in. screws to a torque of 17 cm·kg (15 in.-lb).

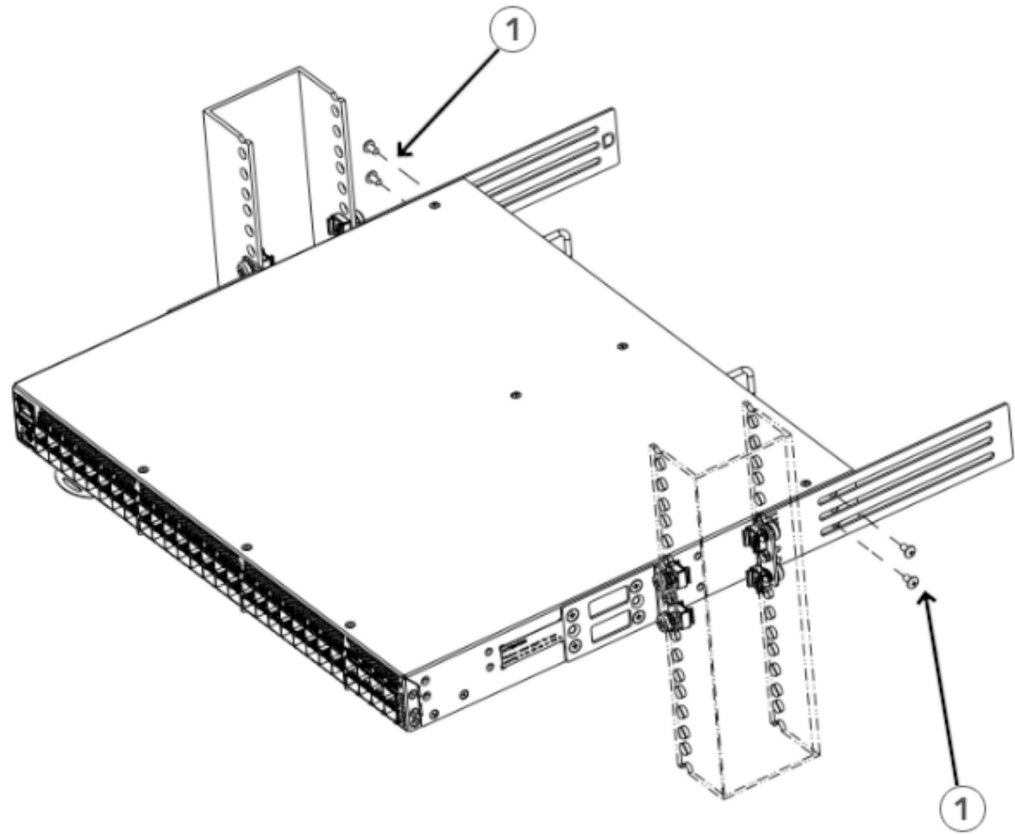

Figure 23. Attaching the Rear Brackets to the Device

Chapter 4. Initial setup and verification

Once you have set up the SAN64B-7 in a rack or as a standalone switch, it is time to attach power and set up a basic configuration. If you are going to use the SAN64B-7 in a single-switch setup, you can use EZSwitchSetup to complete the basic configuration.

See the *EZSwitchSetup CD*, included with the switch, for more information. You can also use the *SAN64B-7 Quick Start Guide*. If you do not want to use EZSwitchSetup, follow the instructions in this section.

Items required

The following items are required for initial setup and verification of the device:

- The device, mounted and connected to a power source, with the required power supply, fan assemblies, transceivers, and cables installed.
- A workstation computer with a terminal emulator application installed, such as PuTTY, XShell, or SecureCRT on Windows.
- An unused IP address with a corresponding subnet mask and gateway address.
- A serial cable with an RJ-45 connector.
- An Ethernet cable.
- Access to an FTP server or USB device for uploading (backing up) or downloading the device configuration (optional).

Note: It is recommended that you use a USB drive that has been test validated (verified):

- SanDisk 32 CZ48 USB 3.0 Flash Drive (SDCZ48-032G-UAM46)
- SanDisk 16 CZ48 USB 3.0 Flash Drive (SDCZ48-016G-UAM46)
- Kingston 32GB DataTraveler 100 G3 USB 3.0 Flash Drive (DT100G3/32GB)
- Kingston 32GB DataTraveler G4 USB 3.0 Flash Drive (DTIG4/32GB)
- PNY Attache 3.0 4 USB 32GB Flash Drive
- PNY Attache 3.0 4 USB 16GB Flash Drive

These drives are not orderable from IBM but are generically-branded and can be purchased from other suppliers.

Providing power to the device

About this task

Perform the following steps to provide power to the device.

Procedure

1. Connect the power cords to both power supplies, and then to power sources on separate circuits to protect against power failure. Ensure that the power cords have a minimum service loop of 6 in. available and that they are routed to avoid stress.
2. Power on the power supplies by flipping both switches to the on position (the "I" symbol). The power supply LEDs display amber until the power-on self-test (POST) is complete, and then the LEDs change to green. The switch usually requires several minutes to boot and complete the POST.

Note: Power is supplied to the device as soon as the first power supply is connected and turned on.

3. After the POST completes, verify that the switch power and switch status LEDs are green.

For more information about how to interpret the POST, boot, and diagnostics tests, see [Monitoring the Device](#).

Establishing a first-time serial connection

About this task

Perform the following steps to log on to the device through a serial connection.

Procedure

1. Connect the mini USB of the console cable to the device and the RJ-45 of the cable to the RS-232 serial port on the workstation.

If the serial port on the workstation is RJ-45 instead of RS-232, remove the adapter on the end of the serial cable and insert the exposed RJ-45 connector into the RJ-45 serial port on the workstation.

2. Disable any serial communication programs running on the workstation, such as synchronization programs.
3. Open a terminal emulator application, such as PuTTY, XShell, or SecureCRT on a Windows PC, or TERM, TIP, or C-Kermit in a Linux environment, and configure the application as follows:
 - In a Windows environment, use the following values:

Parameter	Value
Bits per second	9600
Data bits	8
Parity	None
Stop bits	1
Flow control	None (must be disabled on the host side)

Note: Flow control is not supported on the serial connection when attached to a remote terminal and must be disabled on the customer-side remote terminal server in addition to the host-side clients.

- In a UNIX environment using TIP, enter the following string at the prompt:

```
tip /dev/ttyb -9600
```

If ttyb is already in use, use ttya instead and enter the following string at the prompt:

```
tip /dev/ttya -9600
```

4. When the terminal emulator application stops reporting information, press Enter to display the login prompt.

```
Switch Console Login:
```

5. Log on to the device as admin, using the default password (password). You are prompted to change the default user name and password at initial logon. Make sure to write down the new credentials and keep this information in a secure location.

```
Fabric OS (swDir)
swDir login: admin
Password:
Please change your passwords now.
```

```
Use Control-C to exit or press 'Enter' key to proceed.
swDir:admin>
```

6. Modify the credentials. To cancel, press `Ctrl+C`.

Note: Initial passwords can be 8 to 40 characters long. They must begin with an alphabetic character. They can include numeric characters, the period (`.`), and the underscore (`_`) only. Passwords are case-sensitive, and they are not displayed when you enter them on the command line.

Configuring the IP address

About this task

You can configure the device with a static IP address, or you can use a Dynamic Host Configuration Protocol (DHCP) server to set the IP address of the switch. DHCP is enabled by default. The device supports both IPv4 and IPv6 addresses.

Using DHCP to set the IP address

About this task

When using DHCP, the switch obtains its IP address, subnet mask, and default gateway address from the DHCP server. The DHCP client can connect only to a DHCP server that is on the same subnet as the switch. If your DHCP server is not on the same subnet as the switch, use a static IP address.

Setting a static IP address

About this task

To set a static IP address for the device, complete the following steps.

Procedure

1. Log on to the device as admin.
2. Use the `ipaddrset` command to set the Ethernet IP address.
 - If you will use an IPv4 address, enter the IP address in dotted decimal notation as prompted.

```
Ethernet IP Address: [192.168.74.102]
```

- If you will use an IPv6 address, enter the network information in colon-separated notation as prompted.

```
device:admin> ipaddrset -ipv6 --add 1080::8:800:200C:417A/64
IP address is being changed...Done.
```

3. Complete the rest of the network information as prompted (IPv4 format shown).

```
Ethernet Subnetmask: [255.255.255.0]
Ethernet IP Address: [192.168.74.102]
Gateway IP Address: [192.168.74.1]
```

4. Enter `off` to disable DHCP when prompted.

```
DHCP [OFF]: off
```

Setting the date and time

About this task

The date and time settings are used for event logging, error detection, and troubleshooting. However, device operation does not depend on the date and time; a device with incorrect date or time values still functions properly.

You can synchronize the local time of the principal or primary fabric configuration server (FCS) device to that of an external Network Time Protocol (NTP) server.

Perform the following steps to set the date and time:

Procedure

1. Log on to the device as admin.
2. Enter the date ["*new-date*"] command at the command line.

The "*new-date*" variable specifies the new date and time and is enclosed in double quotation marks. This variable is optional; if omitted, the current date and time are displayed. The date and time are specified as a string in *mmdhmmyy* format:

- *mm*: Specifies the month. Valid values are 01 to 12.
- *dd*: Specifies the date. Valid values are 01 to 31.
- *hh*: Specifies the hour. Valid values are 00 to 23.
- *mm*: Specifies the minutes. Valid values are 00 to 59.
- *yy*: Specifies the year. Valid values are 00 to 37 and 70 to 99. Year values from 70 to 99 are interpreted as 1970 to 1999; year values from 00 to 37 are interpreted as 2000 to 2037.

```
device:admin> date
Thu Dec 22 14:05:10 UTC 2016
device:admin> date "1222150617"
Thu Dec 22 15:06:00 UTC 2017
```

Setting the time zone

About this task

The default time zone is Coordinated Universal Time (UTC). The time zone must be set only once because the value is stored in nonvolatile memory. Use the following procedure to set the time zone.

Procedure

1. Log on as admin.
2. Use the `tsTimeZone --interactive` command and follow the prompts, or enter the `tsTimeZone -[hour-offset,minute-offset]` command as follows:

For Pacific Standard Time, enter `tsTimeZone -8,0`.

For Central Standard Time, enter `tsTimeZone -6,0`.

For Eastern Standard Time, enter `tsTimeZone -5,0`.

Local Time	tsTimeZone Parameter (Difference from UTC)
Atlantic Standard	-4,0

Table 7. tsTimeZone Command Parameter Selection for the U.S. Time Zones (continued)	
Local Time	tsTimeZone Parameter (Difference from UTC)
Atlantic Daylight	-3,0
Eastern Standard	-5,0
Eastern Daylight	-4,0
Central Standard	-6,0
Central Daylight	-5,0
Mountain Standard	-7,0
Mountain Daylight	-6,0
Pacific Standard	-8,0
Pacific Daylight	-7,0
Alaskan Standard	-9,0
Alaskan Daylight	-8,0
Hawaiian Standard	-10,0

Synchronizing the local time with an external source

About this task

Perform the following steps to synchronize the local time of the principal or primary FCS device with that of an external NTP server:

Procedure

1. Log on as admin.
2. Enter the `tsClockServer [ipaddr]` command.

The `ipaddr` variable represents the IP address of the NTP server that the device can access. This variable is optional; by default, the value is LOCL.

```
switch:admin> tsclockserver 192.168.126.60
Updating Clock Server configuration...done.
Updated with the NTP servers
```

Customizing the chassis name and switch name

About this task

Changing the chassis and switch names is important for uniquely distinguishing and identifying the device and for accurate tracking of logs and errors. The messages that appear in the log are labeled with the switch name or chassis name, which makes tracking the errors much easier. Specify an easily understandable and meaningful name for the chassis and switch.

Perform the following steps to change the chassis name and then the switch name:

Procedure

1. Log on to the device through Telnet using the admin account.
2. Change the chassis name by using the `chassisName` command.

```
device:admin> chassisname Chassis_001
```

3. Change the switch name by using the `switchName` command.

```
device:admin> switchname Switch_001
Committing configuration...
Done
Switch name has been changed. Please re-login to the switch for the change to applied
```

Establishing an Ethernet connection

About this task

Perform the following steps to establish an Ethernet connection to the device:

Procedure

1. Remove the plug from the Ethernet port.
2. Connect an Ethernet cable to the device Ethernet port and to the workstation or to an Ethernet network that connects the workstation.

Note: At this point, the device can be accessed remotely, using either the command line or Brocade Web Tools. Ensure that the device is not being modified from any other connections during the remaining tasks in this chapter. The Ethernet management port also supports Auto MDI/MDIX.

Setting the domain ID

About this task

Perform the following steps to set the switch domain ID:

Procedure

1. Log on to the switch through Telnet using the admin account.
2. Modify the domain ID if required.

The default domain ID is 1. If the switch is not powered on until after it is connected to the fabric and the default domain ID is already in use, the domain ID for the new switch is automatically reset to a unique value. If the switch is connected to the fabric after it has been powered on and the default domain ID is already in use, the fabric segments. To find the domain IDs that are currently in use, enter the `fabricShow` command on another switch in the fabric.

Perform the following steps to modify the domain ID:

- a) Disable the switch by entering the `switchDisable` command.
- b) Enter the `configure` command. The command prompts display sequentially; enter a new value or press `Enter` to accept each default value.
- c) Enter `y` after the `Fabric param` prompt.

```
Fabric param (yes, y, no, n): [no] y
```

- d) Enter a unique domain ID (such as the domain ID used by the previous switch, if still available).

Domain: (1..239) [1] 3

- e) Complete the remaining prompts or press Ctrl+D to accept the remaining settings without completing all the prompts.
- f) Re-enable the switch by entering the switchEnable command.

Verifying correct operation

About this task

Perform the following steps to verify correct operation of the device:

Procedure

1. Check the LEDs to verify that all components are functional.
2. Verify the correct operation of the device by entering the following commands from the workstation.

Command	Description
errDump	Displays any errors
fanShow	Displays fans status and information
historyShow	Displays the device history
psShow	Displays power supply status and information
switchShow	Displays switch status and information
tempShow	Displays temperature status and information

The switchShow command provides the following information about the device and ports status.

```
G720switch:admin> switchshow
switchName:      E_Cassian_146155_C5c
switchType:      181.0
switchState:     Online
switchMode:      Native
switchRole:      Subordinate
switchDomain:    155
switchId:        fffc9b
switchWwn:       10:00:d8:1f:cc:03:44:40
zoning:          ON (fos6k)
switchBeacon:    OFF
FC Router:       OFF
Fabric Name:     012345_fid128
HIF Mode:        OFF
Allow XISL Use:  OFF
LS Attributes:   [FID: 128, Base Switch: No, Default Switch: Yes, Ficon Switch: No, Address
Mode 0]
Index Port Address Media Speed State Proto
=====
  0  0  9b0000 id N32 Online FC F-Port 10:00:00:10:9b:8f:2d:1c
  1  1  9b0100 id N32 Online FC F-Port 10:00:00:10:9b:8f:2d:1b
  2  2  9b0200 id N32 Online FC F-Port 10:00:00:10:9b:8f:2d:e8
  3  3  9b0300 id N32 Online FC F-Port 10:00:00:10:9b:8f:2d:e7
  4  4  9b0400 id N32 Online FC F-Port 10:00:00:10:9b:8f:2c:e2
  5  5  9b0500 id N32 Online FC F-Port 10:00:00:10:9b:8f:2c:e1
  6  6  9b0600 id N32 Online FC F-Port 10:00:00:10:9b:8c:54:6a
  7  7  9b0700 id N32 Online FC F-Port 10:00:00:10:9b:8c:54:69
  8  8  9b0800 id N32 Online FC F-Port 10:00:00:10:9b:8f:29:46
  9  9  9b0900 id N32 Online FC F-Port 10:00:00:10:9b:8f:29:45
 10 10 9b0a00 id N32 Online FC F-Port 10:00:00:10:9b:8f:2c:e5
 11 11 9b0b00 id N32 Online FC F-Port 10:00:00:10:9b:8f:2c:e4
 12 12 9b0c00 id N32 Online FC F-Port 10:00:00:10:9b:8f:2c:ca
 13 13 9b0d00 id N32 Online FC F-Port 10:00:00:10:9b:8f:2c:c9
 14 14 9b0e00 id N32 Online FC F-Port 10:00:00:10:9b:8f:2f:88
 15 15 9b0f00 id N32 Online FC F-Port 10:00:00:10:9b:8f:2f:87
 16 16 9b1000 id N32 Online FC F-Port 10:00:00:10:9b:8f:2e:1c
 17 17 9b1100 id N32 Online FC F-Port 10:00:00:10:9b:95:46:f6
```

```

18 18 9b1200 id N32 Online FC F-Port 10:00:00:10:9b:95:46:f7
19 19 9b1300 id N32 Online FC F-Port 10:00:00:10:9b:8f:2d:2d
20 20 9b1400 id N32 Online FC F-Port 10:00:00:10:9b:8f:2e:1b
21 21 9b1500 id N32 Online FC F-Port 10:00:00:10:9b:95:47:dc
22 22 9b1600 id N32 Online FC F-Port 10:00:00:10:9b:95:47:db
23 23 9b1700 id N32 Online FC F-Port 10:00:00:10:9b:8f:2d:2e
24 24 9b1800 id N16 Online FC F-Port 10:00:8c:7c:ff:1b:d3:00
(truncated)

```

The tempshow command shows the current temperature of the EM sensors.

```

switch:admin> tempshow
Sensor ID|Sensor Index|State          |Centigrade |Fahrenheit |
-----|-----|-----|-----|-----|
1         |0         |Ok          |30 |86
2         |1         |Ok          |34 |93
3         |2         |Ok          |29 |84
4         |3         |Ok          |30 |86
5         |4         |Ok          |30 |86
6         |5         |Ok          |32 |89
7         |6         |Ok          |29 |84
8         |7         |Ok          |36 |96
9         |8         |Ok          |39 |102
10        |9         |Ok          |28 |82
11        |10        |Ok          |30 |86
12        |11        |Ok          |N/A |N/A
13        |12        |Ok          |43 |109

```

Backing up the configuration

About this task

Back up the configuration on a regular basis to ensure that a complete configuration is available for downloading to a replacement switch. Perform the following steps:

Procedure

1. Log on to the device as the admin user.
2. Back up the device configuration to an FTP server by entering the configUpload command as shown in the following example.

```

E_Cassian_146155_C5c:FID128:admin> configupload
Protocol (scp, ftp, sftp, local) [ftp]:
Server Name or IP Address [host]: 10.154.5.40
User Name [user]: anonymous
Path/File name [(home dir>/config.txt): dumps/supportsaves/am01/fo9k/jakku/cass-d155-vf-b1d85
Section (all|chassis|FID# [all]):

configUpload complete: All selected config parameters are uploaded
2020/03/05-23:57:59, [CONF-1001], 130, FID 128, INFO, E_Cassian_146155_C5c, configUpload
completed successfully for all.

```

This command uploads the device configuration to the server, making it available for downloading to a replacement device if necessary.

Note: If Virtual Fabrics (VF) is enabled, you need to use the configupload -vf command only once to upload configuration for the virtual fabric (all logical switches configured on the device). You might want to refer to the discussion of configupload/download in the *Fabric OS Administration Guide, 9.0x*.

Powering down the device

About this task

Perform the following steps to power down the device:

Procedure

1. Shut down the Fabric OS software using the `sysShutdown` command.
2. Identify the power-on switches in the nonport-side of the device.
3. Power off both power supplies by setting each power switch to the “O” position.
4. Unplug the power cables from the power source before servicing the device or FRUs.

Results

All devices are returned to their initial state the next time the switch is powered on.

Chapter 5. Installing transceivers and cables

Complete the steps in the following topics to install the transceivers and then to connect the cables.

Precautions specific to transceivers and cables



DANGER: All fiber-optic interfaces use Class 1 lasers.



DANGER: Use only optical transceivers that are qualified by Broadcom and comply with the FDA Class 1 radiation performance requirements defined in 21 CFR Subchapter I, and with IEC 60825 and EN60825. Optical products that do not comply with these standards might emit light that is hazardous to the eyes.



CAUTION: Before plugging a cable into any port, be sure to discharge the voltage stored on the cable by touching the electrical contacts to ground surface.

Cleaning the fiber-optic connectors

About this task

To avoid problems with the connection between the fiber-optic transceiver (SFP+ or QSFP) and the fiber cable connectors, clean both connectors *each time you disconnect and reconnect them*. Dust can accumulate on the connectors and cause problems such as reducing the optic launch power.

To clean the fiber cable connectors, use a fiber-optic reel-type cleaner. When not using an SFP+ or QSFP connector, make sure to keep the protective covering in place.

Managing cables

The minimum bend radius for a 50-micron cable is 2 inches under a full tensile load and 1.2 inches with no tensile load. Cables can be organized and managed in a variety of ways, for example, using cable channels on the sides of the rack or patch panels to minimize cable management. Follow these recommendations:

Note: You should not use tie wraps with optical cables because they are easily overtightened and can damage the optic fibers.



CAUTION: Before plugging a cable into any port, be sure to discharge the voltage stored on the cable by touching the electrical contacts to ground surface.

- Plan for the proper rack space required for cable management before installing the switch.
- Leave at least 1m (3.28 ft) of slack for each port cable. This slack provides room to remove and replace the switch, allows for inadvertent movement of the rack, and helps prevent the cables from being bent to less than the minimum bend radius.
- If you are using Inter-Switch Link (ISL) Trunking, consider grouping cables by trunking groups. The cables used in trunking groups must meet specific requirements, as described in the *Fabric OS Administration Guide*.
- For easier maintenance, label the fiber-optic cables and record the devices to which they connect.
- Keep LEDs visible by routing port cables and other cables away from the LEDs.
- Use hook-and-loop style straps to secure and organize fiber-optic cables.

Installing an SFP+ transceiver

About this task

The device supports only transceivers qualified for Brocade products. For current information on qualified transceivers supported by this device, refer to the *Transceiver Support Matrix* and *Transceiver Modules* on www.broadcom.com. If you use an unqualified transceiver, the `switchshow` command output shows the port in a `Mod_Inv` state. The issue is also logged in the system error log.

To insert an SFP+ transceiver, complete the following steps:

Note: The 16Gb/s and 32Gb/s SFP+ transceivers do not have bails. Always use the pull tab to insert or remove the transceivers, since the SFP might be hot.

Procedure

1. Use the pull tab on the 16Gb/s and 32Gb/s SFP+ transceivers to help push the transceiver into the port. Transceivers are keyed so that they can be inserted only with the correct orientation. If a transceiver does not slide in easily, ensure that it is correctly oriented. Push the transceiver into the port until it is firmly seated and the latching mechanism clicks.

Note: Each SFP+ transceiver has a 10-pad gold-plated PCB-edge connector on the bottom. The correct position to insert an SFP+ transceiver into an upper row of ports is with the gold edge down. The correct position to insert an SFP+ transceiver into a lower row of ports is with the gold edge up.

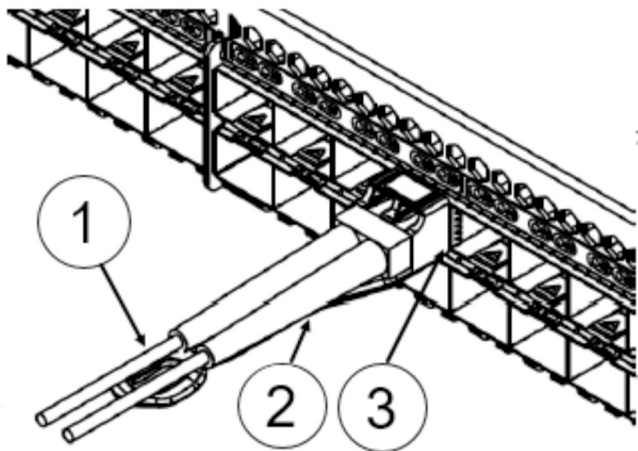

Figure 24. Installing an SFP+ Transceiver into a Port

2. Position a cable so that the key (the ridge on one side of the cable connector) is aligned with the slot in the transceiver. Insert the cable into the transceiver until the latching mechanism clicks.

Note: Cables are keyed so that they can be inserted in only one way. If a cable does not slide in easily, ensure that it is correctly oriented. Do not insert any unsupported cable intended for an other type of transceiver into a regular SFP+ transceiver. You may damage the cable as well as the transceiver.

Replacing an SFP+ Transceiver

About this task

Complete the following steps to remove an SFP+ transceiver and then install a new SFP+ transceiver.

Note: Replacing an SFP+ transceiver may cause disruption in the fabric or to the attached device.

Note: 16Gb/s and 32Gb/s SFP+ transceivers have pull tabs instead of bails. Always use the pull tab to insert or remove the SFP+ transceivers, since the SFP might be hot.

Procedure

1. Remove any cables that are inserted into the transceiver.
2. Grasp the SFP+ transceiver pull tab and pull the tab straight out.

Note: Grasp the tab near the body of the transceiver to reduce the chances of bending the pull tab. Because the SFP may be hot, avoid touching it.

3. To insert the replacement transceiver, use the pull tab on the SFP+ transceiver to carefully push the transceiver into the port. Transceivers are keyed so that they can be inserted only with the correct orientation. If a transceiver does not slide in easily, ensure that it is correctly oriented.

Note: Each SFP+ transceiver has a 10-pad gold-plated PCB-edge connector on the bottom. The correct position to insert an SFP+ transceiver into the upper row of ports is with the gold edge down. The correct position to insert an SFP+ transceiver into the lower row of ports is with the gold edge up.

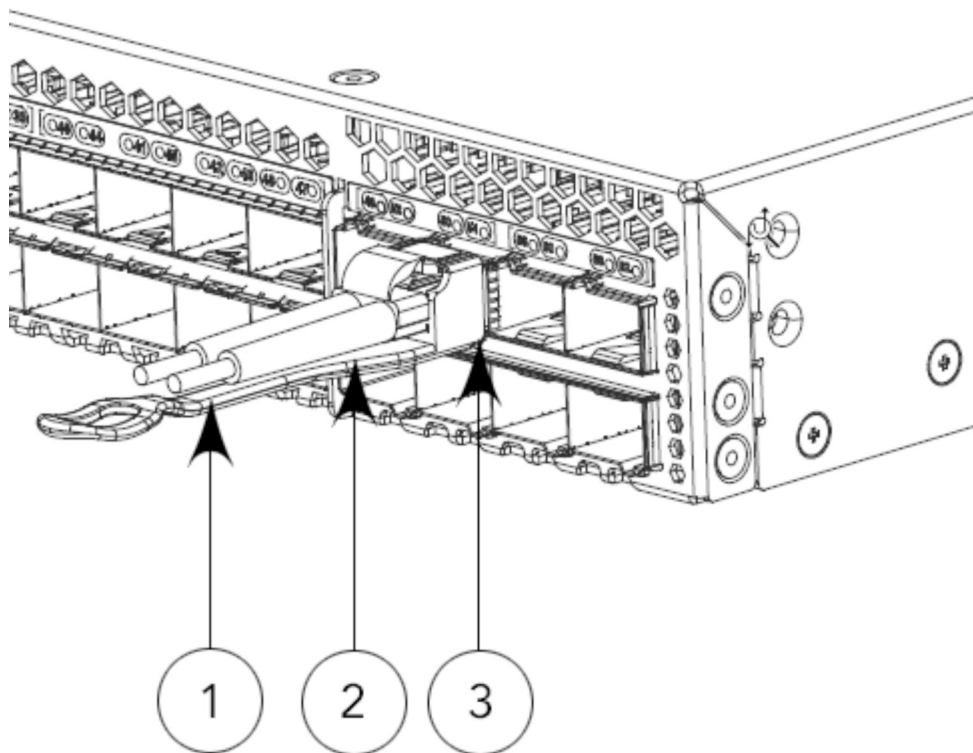

Figure 25. Replacing an SFP+ Optical Transceiver in an Upper Port

4. Position a cable so that the key (the ridge on one side of the cable connector) is aligned with the slot in the transceiver. Insert the cable into the transceiver until the latching mechanism clicks.

Cables are keyed so that they can be inserted in only one way. If a cable does not slide in easily, ensure that it is correctly oriented.

Verifying the operation of new transceivers

About this task

You can use the following commands to verify if the transceivers are working correctly:

- `errDump`
- `fabricShow`

- sfpShow
- switchShow

Refer to the *Fabric OS Command Reference Manual* for output examples and descriptions.

Chapter 6. Monitoring the switch

System activity and status can be determined through the activity of the LEDs on the switch. There are three possible LED states: no light, a steady light, and a flashing light. Flashing lights may be slow, fast, or flickering. The lights are green or amber. Sometimes, the LEDs may flash either of the colors during boot, POST, or other diagnostic tests. This is normal; it does not indicate a problem unless the LEDs do not indicate a healthy state after all boot processes and diagnostic tests are complete.

Interpreting port-side LEDs

System activity and status can be determined through the activity of the LEDs on the switch.

One LED per SFP port to indicate status.

There are 48 LEDs (green/amber) for the first 48 SFP+ ports and 8 tri-color LEDs (green/amber/light-blue) for the last 8 SFP+ ports 48, 50, 52, 54, 56, 60, and 62. The last set of LEDs pulse once in light-blue, before indicating the FC port status in green or amber. All functionalities pertaining to the green/amber colors for the last 8 LEDs remain the same as the first 48 LEDs.

There are three possible LED states: no light, a steady light, and a flashing light. Flashing lights may be slow, fast, or flickering.

Sometimes, the LEDs may flash either of the colors during boot, POST, or other diagnostic tests. This is normal; it only indicates a problem if the LEDs indicate an unhealthy state after all boot processes and diagnostic tests complete.

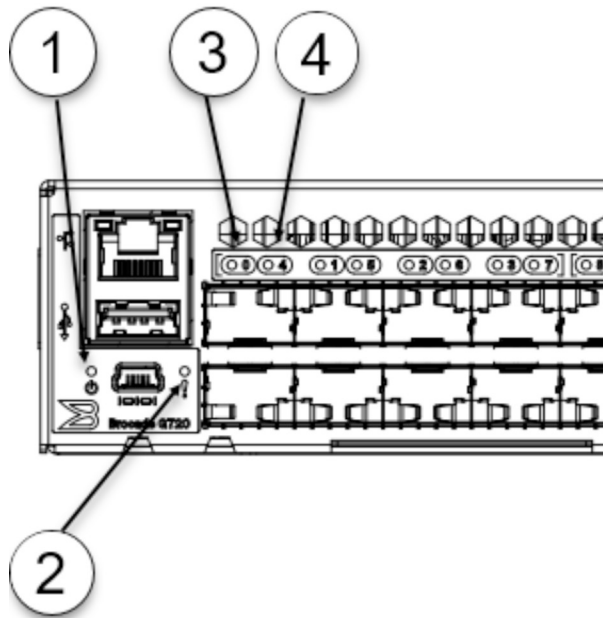

Figure 26. SAN64B-7 Switch Port-Side LEDs - Left Side

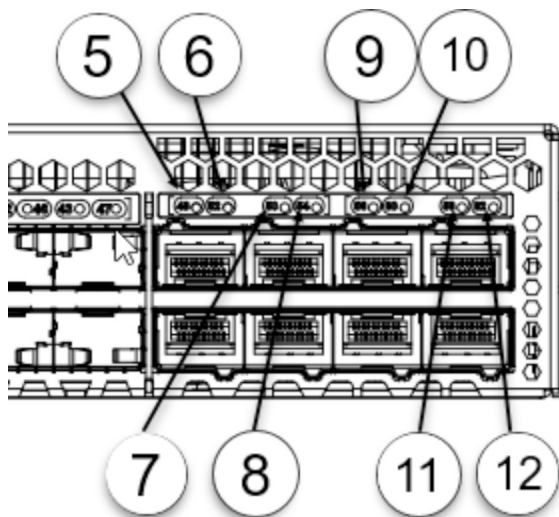

Figure 27. SAN64B-7 Port-Side LEDs - Right Side

1. System Power LED
2. System Status LED
3. SFP+ (Upper) Port 0 Status LED
4. SFP+ (Lower) Port 4 Status LED
5. SFP+ upper Port 48
6. SFP+ upper Port 50
7. SFP+ lower Port 52
8. SFP+ lower Port 54
9. SFP+ upper Port 56
10. SFP+ upper Port 58
11. SFP+ lower Port 60
12. SFP+ lower Port 62

System power LED

Use the following table to interpret the system power LED.

LED Color	Status of Hardware	Recommended Action
No light	The system is off, or there is an internal power supply failure.	Verify that the system is powered on, that the power cables are attached, and that your power source is live. If the system power LED is not green, the unit may be faulty. Contact your solution provider.
Steady green	The system is on, and power supplies are functioning properly.	No action is required.

System status LED

Use the following table to interpret the system status LED.

LED Color	Status of Hardware	Recommended Action
No light	The system is off or there is no power.	Verify that the system is on and has completed booting.
Steady green	The POST and initialization have completed. The system is on and functioning properly.	No action is required.
Steady amber (for more than 5 seconds—can take over a minute to complete the POST)	System is going through the power-up process.	No action is required.
Steady amber (for more than a few minutes)	Unknown state, boot failed, or faulty system. Note: When the POST completes and the switch has failed, a steady amber color may result.	Perform the following steps: 1. Connect a serial cable to the system. 2. Reboot the system. 3. Check the failure indicated on the system console. 4. Contact your solution provider.
Flashing amber and green	Attention is required. A number of variables can cause this status, including a single power supply failure, a fan failure, or one or more environmental ranges being exceeded.	Check the management interface and the error log for details on the cause of the status. Contact your solution provider.

Management port LEDs

Use the following table to interpret the management port LEDs.

LED Function/State	Status of Hardware
Link/Speed—Green LED is on	1000Mb/s link
Link/Speed—LED is off	100Mb/s link
Activity—Green LED is blinking	Presence of activity

FC port status LEDs

On the SAN64B-7 switch, you find 48 LEDs (green/amber) for the first 48 SFP+ ports and 8 tri-color LEDs (green/amber/light-blue) for the last 8 SFP+ ports 48, 50, 52, 54, 56, 60, and 62. The tri-color LEDs pulse once in light-blue, before indicating the FC port status in green or amber. All functions pertaining to the green/amber colors for the last set of 8 LEDs remain the same as the first 48 LEDs.

Use the following table to interpret the FC port status LEDs.

Table 11. FC Port Status LED Patterns during Normal Operation

LED Color	Status of Hardware	Recommended Action
No light	Indicates one of the following: <ul style="list-style-type: none"> No signal or light carrier (media or cable) detected. The device may be currently initializing. The connected device is configured in an offline state. 	<ul style="list-style-type: none"> Verify that the power LED is on, and check the SFP+ and cable. Verify that the device is not currently being initialized. Verify the status of the connected device.
Steady green	The port is online (connected to an external device) but has no traffic.	No action is required.
Slow-flashing green (on for 1 second; then off for 1 second)	The port is online but is segmented because of a loopback cable or incompatible device connection.	Verify that the correct device is attached to the switch.
Fast-flashing green (on for 1/4 second; then off for 1/4 second)	The port is online, and an internal loopback diagnostic test is running.	No action is required.
Flickering green	The port is online, and frames are flowing through the port.	No action is required.
Steady amber	The port is receiving light or signal carrier, but it is not online yet.	No action is required.
Slow-flashing amber (on for 2 seconds; then off for 2 seconds)	The port is disabled because of diagnostics or the <code>portDisable</code> command.	Reset the port. The <code>portCfgPersistentDisable</code> command is persistent across reboots.
Fast-flashing amber (on for 1/2 second; then off for 1/2 second)	The SFP+ or port is faulty.	Reset the port. Replace the SFP+. Must be a Brocade-branded SFP+.

Interpreting nonport-side LEDs

Use the following table to interpret the power supply and fan assembly status LED during normal operation.

Table 12. Power Supply and Fan Assembly Status LED Patterns during Normal Operation

LED Color	Description	Action Required
No light	The power supply and fan assembly is not receiving power, or is off.	Verify that the power supply and fan assembly is on and seated and that the power cord is connected to a functioning power source.
Steady green	The power supply and fan assembly is operating normally.	No action is required.
Flashing green (for more than 5 seconds)	<p>The power supply and fan assembly is faulty for one of the following reasons:</p> <ul style="list-style-type: none"> • The assembly is switched off (flashing for ~ 5 seconds, then off). • The power cable is disconnected (flashing for ~ 5 seconds, then off). • The power supply and fan assembly has failed. <p>Note: When the device is first powered on, the power supply and fan assembly status LED flashes until the POST has completed.</p>	<p>Try one of the following:</p> <ul style="list-style-type: none"> • Check the power cable connection. • Verify that the assembly is powered on. • Replace the power supply and fan assembly.

Interpreting POST results

About this task

Each time the switch is powered on, rebooted, or reset, it performs a power-on self-test (POST). The total boot time with the POST can be several minutes. The POST can be omitted after subsequent reboots by using the `fastboot` command or entering the `diagDisablePost` command to persistently disable the POST. The success or failure results of the diagnostic tests that run during the POST can be monitored through LED activity, the error log, or the command line interface. During the POST, the LEDs flash different colors.

The POST performs the following tasks:

- Conducts preliminary POST diagnostics.
- Initializes the operating system.
- Initializes the hardware.
- Runs diagnostic tests on several functions, including the circuitry, port functionality, memory, statistics counters, and serialization.

Perform the following steps to determine whether the POST completed successfully and whether any errors were detected:

Procedure

1. Verify that the LEDs on the device indicate that all components are healthy. If one or more LEDs do not display a healthy state:
 - a) Verify that the LEDs are not set to "beacon" (this can be determined through the `switchShow` command or Web Tools).
 - b) Follow the recommended action for the observed LED behavior.
2. Verify that the `diagShow` command displays that the diagnostic status for all ports in the device is OK.
3. Review the system log for errors. Errors detected during the POST are written to the system log, which can be viewed by using the `errShow` command.

Interpreting Boot results

About this task

Boot performs the following tasks after POST is complete:

- Performs universal port configuration.
- Initializes links.
- Analyzes the fabric. If any ports are connected to other switches, the switch participates in a fabric configuration.
- Obtains a domain ID and assigns port addresses.
- Constructs unicast routing tables.
- Enables normal port operation.

Running diagnostic tests

About this task

In addition to the POST, switch firmware includes diagnostic tests to help you troubleshoot the hardware and firmware. These diagnostics test the internal connections and circuitry, the fixed media, and the transceivers and cables in use.

The tests are implemented by command, either through a Telnet session or through a terminal setup for a serial connection to the device. Some tests require that the ports be connected by external cables to allow diagnostics to verify the serializer or deserializer interface, transceiver, and cable. Some tests require loopback plugs.

Diagnostic tests are run at supported link speeds depending on the speed of the link being tested and the type of port.

Note: Diagnostic tests may temporarily lock the transmit and receive speed of the links.

Note: Power-cycle the device after completing offline diagnostics tests.

Chapter 7. Power supply and fan assembly

The SAN64B-7 chassis has two 350W power supplies and three fans, which operate at three speeds: Low, Normal, and High.

The power supply and fan assembly units in the SAN64B-7 chassis can be removed and replaced without special tools. The device can continue operating during the replacement.

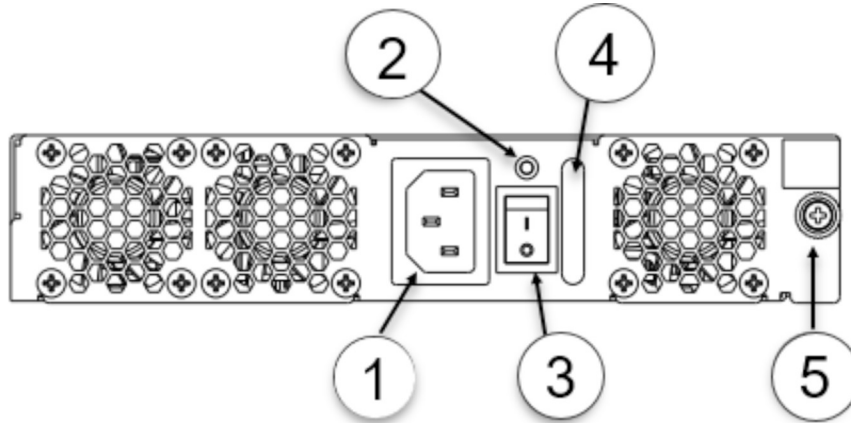

Figure 28. AC Power Supply and Fan Assembly

1. AC Power Cable Receptacle
2. Power Supply and Fan Assembly Status LED
3. Power-On/Off Switch
4. Power Supply and Fan Assembly Handle
5. Captive Screw

The device supports the following types of power supplies. (DC power is not supported.)

- AC power supply with nonport-side air exhaust. This unit moves the air from the port side to the nonport side of the device.
- AC power supply with nonport-side air intake. This unit moves the air from the nonport side to the port side of the device.

Note: The two power supply and fan assemblies concurrently installed in the chassis must be of the same power type, model (airflow direction), and part number. If the airflow directions are different, an error is generated on the console.

Note: The power supply and fan assembly units are hot-swappable if they are replaced one at a time. They are identical and fit into either slot.

Note: The device can operate all the ports with one power supply and fan assembly unit if you do not require redundancy.

The device fans are fixed inside the combined power supply and fan assemblies to provide necessary airflow to cool the whole system. The system software sets the fan speed and measures it through the tachometer interface.

The Optic Environmental Monitor (EM) Policy, a new feature for Gen7 platforms introduced in Fabric OS 9.0.0, monitors the temperature of the SFP optics that are inserted on the switch against the defined thresholds for that specific optic type (Vendor PN). The fan speed is adjusted based on the temperature of the SFP and the EM thresholds.

Precautions specific to the power supply and fan assemblies



DANGER: Make sure that the power source circuits are properly grounded, and then use the power cord supplied with the device to connect it to the power source.



DANGER: If the installation requires a different power cord than the one supplied with the device, make sure that you use a power cord displaying the mark of the safety agency that defines the regulations for power cords in your country. The mark is your assurance that the power cord can be used safely with the device.



CAUTION: Disassembling any part of the power supply and fan assembly voids the warranty and regulatory certifications. There are no user-serviceable parts inside the power supply and fan assembly.



CAUTION: Ensure that the airflow direction of the power supply unit matches that of the installed fan tray. The power supplies and fan trays are clearly labeled with either a green arrow with an "E" or an orange arrow with an "I."



CAUTION: If you do not install a module or a power supply in a slot, you must keep the slot filler panel in place. If you run the chassis with an uncovered slot, the system will overheat.



CAUTION: Use a separate branch circuit for each power cord, which provides redundancy in case one of the circuits fails.



CAUTION: To prevent damage to the chassis and components, never attempt to lift the chassis using the fan or power supply handles. These handles were not designed to support the weight of the chassis.

Note: The equipment installation must meet NEC/CEC code requirements. Consult local authorities for regulations.

Note: If the ambient temperature is above the recommended operational limits, the power supply units shutdown, which in turn shuts down the device without any warning message.

Identifying the airflow direction

The power supply and fan assemblies are identified by the following airflow directions:

- **Intake power supply and fan assembly with an orange "I" label or without any label:** Pulls air from the nonport side of the switch and exhausts it out the port side.

	<ul style="list-style-type: none"> – Nonport-side air intake – Port-side air exhaust – Back-to-front (nonport-side to port-side) airflow – Part numbers ending with -R
---	--

- **Exhaust power supply and fan assembly with a green "E" label:** Pulls air from the port side of the switch and exhausts it out the nonport side.

	<ul style="list-style-type: none"> – Nonport-side air exhaust – Port-side air intake – Front-to-back (port-side to nonport-side) airflow – Part numbers ending with -F
---	--

AIR_FLOW and ENCR error monitoring

Starting with FOS 9.0.0, MAPS added support for the following monitoring systems:

- FAN_AIRFLOW_MISMATCH
- ENCR_BLK
- ENCR_DISC
- ENCR_SHRT_FRM

Power supply and fan assembly fault indicators

Use one of the following fault indicators to determine the status of the power supply and fan assemblies:

- Power supply and fan assembly status LED. See [“Interpreting nonport-side LEDs”](#) on page 54 to interpret the meaning of LED operation.
- The **Power Status** icon in Web Tools. Click the icon to display status.
- The psShow command displays the power supply and fan assembly status, as shown in the following example:

```
Device:admin> psshow
Power Supply #1 is OK
Power Supply #2 is OK
```

Power supply and fan assembly task guide

You can perform an easy set of steps to install or replace one or both assemblies. By default, both power supply and fan assemblies are installed in the device.

Installing an Additional Power Supply and Fan Assembly (Hot-Install)

If your device is up and running with a single power supply and fan assembly and you want to install an additional power supply, complete the following steps.

1. Remove the existing filler panel.
2. Insert the new power supply and fan assembly.
3. Tighten the captive screws to ensure the power supply is fully seated.
4. Power on the power supply and fan assembly.
5. Verify the power supply and fan assembly status LED.

Replacing a Power Supply and Fan Assembly (Hot-Swap)

If your device is up and running with two power supply and fan assemblies, but one of them must be replaced, complete the following steps to replace it.

1. Power down the power supply and fan assembly that needs replaced.

Note: Setting the power switch to the "O" position will not shut down the fans in the power supply and fan assembly.

2. Insert the new power supply and fan assembly.
3. Remove the power supply and fan assembly that you are replacing.
4. Tighten the captive screws to ensure the power supply is fully seated.
5. Power on the power supply and fan assembly.
6. Verify the power supply and fan assembly status LED.

Replacing Both Power Supply and Fan Assemblies (Cold-Swap)

If your device is up and running with both power supply and fan assemblies, but you want to replace both of them, complete the following steps.

1. Shut down the system using the sysShutdown command.

2. Insert the new power supply and fan assembly.
3. Power down both power supply and fan assemblies.
4. Remove the old/failed power supply and fan assemblies.
5. Tighten the captive screws to ensure the power supply is fully seated.
6. Power on both power supply and fan assemblies.
7. Verify operation using the power supply and fan assembly status LEDs.

Time and items required

Installing or removing and replacing a power supply and fan assembly should require less than 5 minutes to complete.

The following items are required to replace a power supply and fan assembly:

- New power supply and fan assembly (must have the same airflow direction as the power supply and fan assembly being replaced)
- #1 Phillips-head screwdriver

Recording critical information about the power supply and fan assembly

About this task

You can use the following commands to record the power supply and fan assembly configuration and operation information:

- `chassisshow`
- `fanshow`
- `historyshow`
- `psshow`
- `sensorshow`
- `tempshow`

Refer to the *Fabric OS Command Reference Manual* for output examples and descriptions.

Removing a power supply and fan assembly

About this task

Complete the following steps to remove a faulty power supply and fan assembly.

Procedure

1. To leave the device in service while removing a power supply and fan assembly, verify that the other power supply and fan assembly (the one not being replaced) has been powered on for at least four seconds and has a steady green LED.

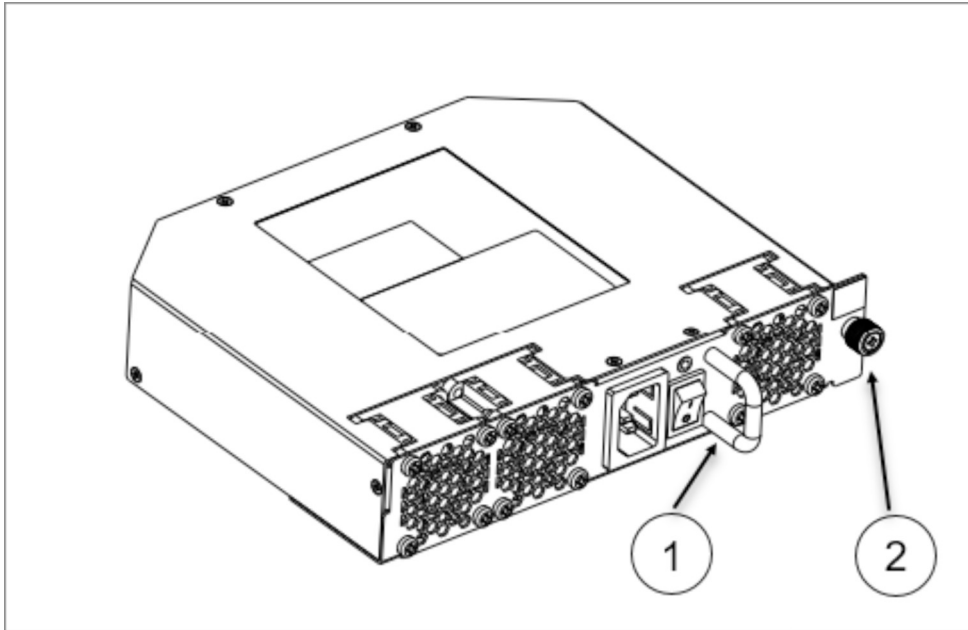

Figure 29. AC Power Supply and Fan Assembly

2. Power off the power supply to be replaced by flipping the AC power switch to the off position (the “O” symbol). The fans in the other power supply will automatically switch to high speed to maintain adequate cooling.
3. Unplug the power cord from the power supply and fan assembly that is being replaced.
4. Using a Phillips screwdriver, unscrew the captive screw.
5. Remove the power supply and fan assembly from the chassis by pulling the handle out and away from the chassis.

Inserting a new power supply and fan assembly

About this task

Complete the following steps to insert a new power supply and fan assembly into the chassis.



CAUTION: The power supply switch must be in the off position when you insert the power supply into the chassis. Damage to the switch can result if a live power supply is installed.

The new power supply and fan assembly must have the same part number and airflow label (or lack thereof) as the power supply and fan assembly already installed.

Procedure

1. To leave the device in service while installing a power supply and fan assembly, verify that the other power supply and fan assembly (the one already installed) has been powered on for at least four seconds and has a steady green LED.
2. Using a Phillips screwdriver, unscrew the captive screw of the filler panel that is located in the empty power supply and fan assembly slot.
3. Orient the new power supply and fan assembly with the captive screw on the right, as shown in the following figure.

Do not force the installation. If the power supply and fan assembly does not slide in easily, ensure that it is correctly oriented before continuing.



CAUTION: Carefully follow the mechanical guides on each side of the power supply slot and make sure the power supply is properly inserted in the guides. Never insert the power supply upside down.

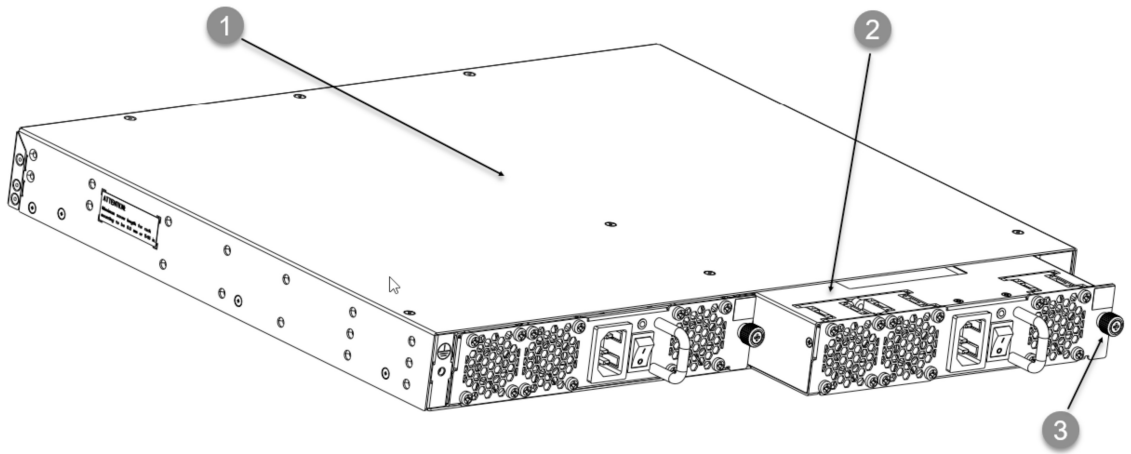

Figure 30. Inserting an AC Power Supply and Fan Assembly

4. Gently push the power supply and fan assembly into the chassis until it is firmly seated.
5. Using the Phillips screwdriver, secure the power supply and fan assembly to the chassis by tightening the captive screw.
6. Plug the power cord into the power supply and fan assembly and power on the unit by flipping the PSU power switch to the on position (the “I” symbol).
7. Verify that the LED on the new power supply and fan assembly displays a steady green light while the device is operating. If the LED is not a steady green, ensure that the power supply is securely installed and seated properly.
8. Optional: Enter `psShow` to display the PSU status. The power supply and fan assembly status can also be viewed using Web Tools.

Verifying the operation of the power supply and fan assemblies

About this task

You can use the following commands to verify that the power supply and fan assemblies are operational:

- `errDump`
- `fanShow`
- `psShow`
- `switchShow`

Refer to the *Fabric OS Command Reference Manual* for output examples and descriptions.

Chapter 8. Chassis replacement

The SAN64B-7 chassis is highly reliable and unlikely to fail. However, the chassis is available as a FRU and can be replaced using the following basic tasks. Since chassis replacement is a collaborative process between customers and SSRs please review the information provided in [“Customer replacement responsibilities” on page 63](#) and [“IBM service replacement responsibilities” on page 71](#) to gain an understanding of your specific responsibilities for this procedure.

1. [“Determining the need to replace the chassis” on page 63](#)
2. [“Chassis replacement overview” on page 64](#)
3. [“Preparing for replacement” on page 64](#)
4. [“Recording critical device and SAN information” on page 65](#)
5. [“Powering down the switch” on page 68](#)
6. [“Disconnecting the cables” on page 71](#)
7. [“Remove the old switch chassis and install the new switch chassis” on page 71](#)
8. [“Reconnecting system to the network and fabric” on page 68](#)
9. [“Downloading the configuration” on page 68](#)
10. [“Verifying correct operation of system” on page 69](#)
11. [“Verifying correct configuration of the fabric” on page 70](#)

Customer replacement responsibilities

Chassis replacement is a combined effort between the customer and the IBM System Services Representative (SSR). Before the IBM SSR can perform the physical replacement and labeling procedures, you must prepare your environment for chassis replacement by performing the following tasks:

- [“Determining the need to replace the chassis” on page 63](#)
- [“Preparing for replacement” on page 64](#)
- [“Recording critical device and SAN information” on page 65](#)
- [“Powering down the switch” on page 68](#)
- [“Disconnecting the cables” on page 71](#)
- [“Reconnecting system to the network and fabric” on page 68](#)
- [“Downloading the configuration” on page 68](#)
- [“Verifying correct operation of system” on page 69](#)
- [“Verifying correct configuration of the fabric” on page 70](#)

Determining the need to replace the chassis

Before replacing the chassis, verify that the replacement is necessary. Ensure that the components are firmly seated when troubleshooting. Contact IBM support if you have any questions about whether the chassis should be replaced. Any of the following events might indicate that the chassis requires replacement:

- One or more components do not function properly.
- The **psShow** or **fanShow** commands continue to show a faulty component even though the component has been replaced.

Chassis replacement overview

Use the following information to help prepare for a chassis replacement. Do not remove components without following procedures in this section exactly as you will need to save critical device and SAN information for these components before disconnecting the chassis from the network, fabric, and power to begin removal procedures. After you reinstall components in the new chassis, follow exact procedures to reconnect to the network, fabric and power, and then download firmware if necessary and verify system operation and configuration.

Before beginning these procedures, perform the following tasks:

- Place the replacement chassis in close proximity to the old chassis.
- Provide a surface on which to place the old chassis, such as a second lift or the pallet originally provided with the chassis.
- Obtain all tools and other materials listed below.



Attention: Refer to [“Safety notices and labels”](#) on page xiii and [“ESD precautions”](#) on page xv before performing any removal or installation procedures.

Time and items required

The chassis replacement procedure takes approximately 1 hour to complete, depending on number of SFPs and cables installed.

The following items are required for the chassis replacement procedure:

- Replacement chassis
- ESD grounding strap
- Phillips #2 screwdriver
- 1/4 in. straight slot screwdriver

Preparing for replacement

Before beginning replacement procedures you must run a series of Fabric OS commands and record device information for safekeeping that may be required for installing and configuring the new chassis. This includes information on licenses, IP address, WWN, serial numbers, switch ID, location of configuration files, and fabric details. It also includes information that might be required by Technical Support. [“Recording critical device and SAN information”](#) on page 65 instructs you to run the following commands and record specific output:

- supportShow
- configUpload
- configupload -vf
- ipAddrShow
- chassisShow
- nsShow
- nsAllShow
- switchShow
- fabricShow
- licenseShow

Before beginning replacement, you must also properly shut down the device and disconnect from the fabric and power using procedures under [“Powering down the switch”](#) on page 68.

Recording critical device and SAN information

About this task

Perform the following steps. All commands must be entered from a CLI session (telnet or serial) to the active CP blade unless otherwise indicated.

Procedure

1. Run **supportShow**, which includes most of the information in the following table and more. Be sure to record the location of the .txt files that you create in this procedure that are not called out in the **supportShow** results.

For detailed information about Fabric OS commands, refer to the *Fabric OS Command Reference*. Use a checklist to ensure that all required information is recorded.

<i>Table 13. Critical information checklist</i>		
Checked?	Data	Notes
Configuration information		
	Location of "config-switch.txt" file	
	Location of "config-miscinfo.txt" file	
	IP address, subnet mask	
	WWN for the device	
SAN profile		
	Location of "SANbefor.txt" file	
	Notes regarding nsshow output	
	Notes regarding nsallshow output	
	Notes regarding switchshow output	
	Notes regarding fabricshow output	
Output from chassisshow command		
Important: The information displayed for Part Num and Serial Num are critical when replacing a chassis. This information allows the replacement chassis to assume the identity of the old chassis.		
Output from licenseshow command		
	License keys and other licensing data for licensed products enabled on device.	

Table 13. Critical information checklist (continued)		
Checked?	Data	Notes
Output from supportshow command		
	Location of "spptshow.txt" file	
	Notes regarding supportshow output	
Information about the new chassis		
	New factory serial number	
	New serial number (if available)	

- Open a telnet session and log into the device as `admin`. The default password is `password`. Enable the logging function on your telnet or serial console connection.
- Back up the current configuration by entering **configUpload**. Enter the requested information at the prompts.

Note: If you are using the Virtual Fabric feature, run **configupload -vf** before running the **configupload** command to save the logical switch configuration.

This **configUpload** command uploads the device configuration to the customer-defined FTP server, making it available for downloading. Alternatively, you can save the configuration file to a USB device. For more information about this command, refer to the *Fabric OS Command Reference*.

```
switch:admin> configupload
Protocol (scp, ftp, sftp, local) [ftp]: ftp
Server Name or IP Address [host]: 123.123.123.123
User Name [user]: Admin24
Path/Filename [<home dir>/config.txt]: config-switch0.txt
Section (all|chassis|switch [all]): all
Password:
Upload complete
switch: admin>
```

- Record the WWN value: Enter **wwn**, and then copy the command output into a file named `config-miscinfo.txt`.

```
switch:admin> wwn
10:00:00:60:69:00:00:0a
```

- Enter **ipAddrShow**, and then copy the command output into the `config-miscinfo.txt` file.

```
switch:admin> ipaddrshow

SWITCH
Ethernet IP Address: 14.25.60.14
Ethernet Subnetmask: 255.55.0.0
Gateway IP Address: 14.25.43.1
DHCP: Off
```

- Display and record the manufacturer serial numbers.

Enter **chassisShow**, and then copy the command output into the `config-miscinfo.txt` file.

"Factory Serial Num" and "Serial Num" are listed under "Chassis/WWN Unit 1" and "Chassis/WWN Unit 2". If the current WWN cards are the original cards, the factory serial number listed is the same as the chassis serial number.

```
CHASSIS/WWN Unit: 1
Header Version: 2
```

```

Power Usage:          -288W
Factory Part Num:    40-1000864-11
Factory Serial Num:  CWA2551K00V
Manufacture:         Day:  1  Month: 11  Year: 2014
Update:              Day: 29  Month:  6  Year: 2017
Time Alive:          774 days
Time Awake:          17 days
ID:                  IBM0000CA
Part Num:            0024980000R42
Serial Num:          10450TC

```

7. Create a SAN "profile" by entering and recording the information provided by the following commands:

- **nsShow**
- **nsAllShow**
- **switchShow**
- **fabricShow**

Copy the command output into a text file named "SANbefor.txt." After the device is restored to the fabric, this information can be used to verify that no unintentional changes have occurred to the fabric.

```

switch:admin> nsshow
Enter Pid COS PortName NodeName TTL
<output truncated>
switch:admin> nsallshow
    12 Nx_Ports in the Fabric
<output truncated>
switch:admin> switchshow
switchName: switch
<output truncated>
switch:admin> fabricshow
Switch ID Worldwide Name Enet IP Addr FC IP Addr Name
<output truncated>
switch:admin>

```

8. Enter **licenseShow**, and then copy the command output into a text file named "licenseshow.txt."

```

switch:admin> licenseshow
S9bddb9SQbTAceeC:
Fabric license
eezeRRySff0fSe:
Remote Switch license
bzbzRcbcSc0c0SY:
Remote Fabric license
dSeR9RcSeeTfSAq:
Extended Fabric license
RyeSzRScycTzft09:
Entry Fabric license
RyeSzRScycazft0G:
Trunking license
RyeSzRScycS0ft09:
4 Domain Fabric license

```

9. Enter **supportShow**; then copy the command output into a text file named "spptshow.txt."

Note: The **supportShow** command has a very long output and time for completion. It may last 20 minutes or longer depending on the size of the SAN.

This file provides a backup of all the information that might be required by Technical Support. The information can be used after the device is restored to the fabric to verify that no unintentional changes have occurred to the fabric.

```

switch:admin> supportshow
version: 8.0.1
<output truncated>
switch:admin>

```

10. Record the cable connections between the chassis and the target device and ports.

11. Run **supportSave** on the active CP blade. The information recorded can be very important in case you have difficulties during the replacement process.

Powering down the switch

If the switch is functioning at all, it must be disconnected from the network and fabric. To disconnect the switch from the network and fabric shut down the system by entering the **sysShutdown** command.

Reconnecting system to the network and fabric

About this task

Complete the following steps to reconnect the device to the network and fabric.

Procedure

1. Connect the switch to the local area network.

- a) Insert the appropriate Ethernet cables into the Ethernet port.
- b) Connect the other ends to an appropriate Ethernet LAN, if not already connected.

Note: The device can be accessed by remote connection using any of the available management tools, such as Telnet or Web Tools. Ensure that the device is not modified using other connections during the rest of this procedure.

2. Reconnect the transceivers and cables to the port.

Note: The ports and cables used in trunking groups must meet specific requirements. For a list of these requirements, refer to the *Fabric OS Administrator's Guide*.

- a) Position one of the transceivers so that the key is oriented correctly to the port and insert the transceiver into the port until it is firmly seated and the latching mechanism clicks.
- b) Select the cable that corresponds to the port and position it so that the key (the ridge on one side of the cable connector) is aligned with the slot in the transceiver. Insert the cable into the transceiver until the latching mechanism clicks.
- c) Repeat step a and step b for the remaining ports.
- d) Organize the cables as required.

Note: Do not route cables in front of the air exhaust vents.

What to do next

Allow the customer to [“Downloading the configuration”](#) on page 68 and [“Verifying correct operation of system”](#) on page 69 and then proceed with [“Reconnecting system to the network and fabric”](#) on page 68.

Downloading the configuration

About this task

Once the chassis and its various components have been reassembled and powered back on, use the **configDownload** command to restore the original configuration. The **configDownload** command can be entered through a Telnet or serial session, but the device must have an Ethernet connection to the server name or IP address of the host for the download process to complete. For more information, refer to the **help configdownload** command or the *Fabric OS Command Reference*.

Complete the following steps to download the configuration.

Procedure

1. Log in to the device as admin.

```
switch:admin> login
login: admin
password: xxxxxxxx
switch:admin>
```

Note: If you are using the Virtual Fabric feature, you must run **configdownload -vf** before running the **configdownload** command to restore the logical switch configuration.

2. Enter the **chassisDisable** command.
3. Enter the **configDownload** command.

```
switch:admin> configdownload
Protocol (scp, ftp, sftp, local) [ftp]: ftp
Server Name or IP Address [host]: 123.123.123.123
User Name [user]: Admin24
Path/Filename [<home dir>/config.txt]: config-switch.txt
Section (all|chassis|switch [all]): all
```



CAUTION: This command is used to download a back-up configuration for a specific switch. If you use a file from a different switch, its configuration settings will override current switch settings. Downloading a configuration file that was uploaded from a different type of switch, can cause this switch to fail.

Reboot the system for the configuration to take effect.

```
configDownload operation may take several minutes to complete for large files.
Do you want to continue [y/n]: y
Password:
```

4. Reboot the device.
5. Enter the **chassisEnable** command to enable all user ports and enable a virtual fabric-aware chassis.

Verifying correct operation of system

About this task

Complete the following steps to verify the correct operation of the device.

Procedure

1. Log in to the device as admin.

```
switch:admin> login
login: admin
password: xxxxxxxx
switch:admin>
```

2. Enter the **chassisShow** command to verify that airflow direction set on WWN cards matches airflow direction for fans in fan and power supply assemblies installed in device.

Airflow direction of fans and power supplies displays as "Fan Direction" under each fan or power supply unit. System airflow direction displays as "System Airflow" under the WWN card unit. The following example shows mismatch of system airflow and airflow direction in installed fan and power supply.

```
POWER SUPPLY Unit: 1
Power Source:      AC
Fan Direction:     Non-portside Intake
...
FAN Unit: 2
Fan Direction:     Non-portside Intake
...
WWN Unit: 1
System AirFlow:   Non-portside Exhaust
...
WWN Unit: 2
System AirFlow:   Non-portside Exhaust
```

The WWN units should indicate "Non-portside Intake." If there is a mismatch of airflow direction, RAS log messages will indicate a mismatch between system airflow direction and airflow direction of fan in

power supply or fan assembly refer to the Hardware Installation Guide for your product for more details.

3. Verify that the device is functioning correctly by entering **switchShow** or **switchStatusShow**.

This **switchShow** command displays the device and port status information.

```
switch0:admin> switchshow
switchName:      sw0
switchType:      165.0
switchState:     Online
switchMode:      Native
switchRole:      Principal
switchDomain:     130
switchId:        fffc82
switchWwn:       10:00:00:05:31:03:2c:00
zoning:          ON (ZONE_CONFIG_NAME)
switchBeacon:    OFF
FC Router:       OFF
HIF Mode:        OFF
Allow XISL Use:  OFF
LS Attributes:   [FID: 128, Base Switch: No, Default Switch: Yes,
Address Mode 0]
Index Slot Port Address Media  Speed  State  Proto
=====
   64   4   0   014000  --   N32   Online FC F-Port 10:00:00:05:1e:f8:a0:b4
   65   4   1   014100  --   N32   Online FC F-Port 10:00:00:05:33:26:0e:65
   66   4   2   014200  --   N32   Online FC F-Port 10:00:00:05:33:48:5e:f5
   67   4   3   014300  --   N32   Online FC F-Port 10:00:00:05:1e:f8:a0:b3
   68   4   4   014400  --   N32   Online FC F-Port 10:00:00:05:1e:f8:a0:b6
(output truncated)
```

4. Verify that all the IP address information is correct by entering **ipAddrShow** and checking the results against the IP information recorded in the config-miscinfo.txt file.

```
switch:admin> ipaddrshow

SWITCH
Ethernet IP Address: 14.25.60.14
Ethernet Subnetmask: 255.55.0.0
Gateway IP Address: 14.25.43.1
DHCP: Off
```

Verifying correct configuration of the fabric

About this task

Copying the command outputs from this section into a file is recommended. You must be logged in with Admin privileges.

Procedure

1. Create an "after" SAN profile by entering the following commands and copying the output to a text file named SANafter.txt:

- **nsShow**
- **nsAllShow**
- **switchShow**
- **fabricShow**
- **lscfg --show** (if using the Virtual Fabric feature)

```
switch:admin> nsshow
Type Pid  COS      PortName NodeName TTL(sec)
N      020f00;  3;10:00:00:01:73:00:29:46;10:00:00:01:73:00:29:46; na
Fabric Port Name: 20:0f:00:60:69:90:03:f0
<output truncated>
```

```

switch:admin> nsallshow
{
  020f00 021fda 021fdc 021fe0 021fe1
  5 Nx_Ports in the Fabric}
switch:admin> switchshow
switchName: rs18-st03-01
<output truncated>
switch:admin> fabricshow
Switch ID Worldwide Name Enet IP Addr FC IP Addr Name
<output truncated>
switch:admin>lscfg --show
Created switches: 128(ds) 1 2(bs)
Port      0   1   2   3   4   5   6   7   8   9
-----
FID       1 | 1 | 1 | 1 | 1 | 128 | 128 | 128 | 128 | 128 |
<output truncated>
switch:admin>

```

2. Determine any differences between the information in the SANafter.txt file and the information in the SANbefor.txt file created earlier. In particular, look for differences in the following:
 - Device types
 - Number of devices
 - ISL and port states
 - Number of switches in the fabric
3. Resolve any issues or unintentional changes to the device or fabric:
 - If there are any mechanical problems, try reseating the associated component.
 - If the configuration information is not correct for the device, modify as required.
 - If other issues exist, contact your support provider.

IBM service replacement responsibilities

IBM System Services Representatives (SSR) are responsible for the physical replacement and labeling of the chassis. The SSR performs the following tasks during the replacement:

1. [“Disconnecting the cables” on page 71](#)
2. [“Remove the old switch chassis and install the new switch chassis” on page 71](#)

Disconnecting the cables

Procedure

1. Power off the chassis by disconnecting both power cords from the power supplies and the power sources. Set the cords aside for use with the new installation.
2. After ensuring that the cables are properly labeled, and the port connection information is recorded, disconnect the cables and transceivers from the ports. Use the pull tab on the 16 Gbps SFP+ transceivers to remove the fiber cable and the attached SFP+ at the same time (see [“Installing an SFP + transceiver” on page 48](#)).
3. Group the cables together and position them safely away from the switch to avoid damage during the chassis replacement process.

Remove the old switch chassis and install the new switch chassis

About this task

Follow these steps to remove the switch chassis from the cabinet. The rack mount hardware from the old chassis will be used for installing the new chassis in the cabinet. Depending on how the switch chassis was installed, you will need to complete the appropriate instructions in reverse to remove the chassis from the cabinet and the rack mounting kit hardware from the old chassis. Then complete the appropriate instructions from the beginning to attach the rack mounting kit hardware to the new chassis and install it into the cabinet. Refer to [Chapter 3, “Mounting the switch,” on page 13](#) for more information.

Procedure

Complete these steps after the new chassis is installed in the cabinet.

1. Reconnect all transceivers and fiber cables.
2. Connect the two power cables to the power sources. The switch will begin to power up and start the POST as soon as the first power cable is connected.
3. Once POST has completed, the switch is ready to restore the saved configurations. Refer to the *Fabric OS Command Reference* for more information on the CLI commands.

What to do next

Work with the customer to perform the steps for [“Reconnecting system to the network and fabric” on page 68](#).

Notices

This information was developed for products and services offered in the USA.

IBM may not offer the products, services, or features discussed in this document in other countries. Consult your local IBM representative for information on the products and services currently available in your area. Any reference to an IBM product, program, or service is not intended to state or imply that only that IBM product, program, or service may be used. Any functionally equivalent product, program, or service that does not infringe on any IBM intellectual property right may be used instead. However, it is the user's responsibility to evaluate and verify the operation of any non-IBM product, program, or service.

IBM may have patents or pending patent applications covering subject matter described in this document. The furnishing of this document does not give you any license to these patents. You can send license inquiries, in writing to:

*IBM Director of Licensing
IBM Corporation
North Castle Drive
Armonk, N.Y. 10504-1785
U.S.A.*

For additional information, visit the web at: www.ibm.com/ibm/licensing/contact/

The following paragraph does not apply to the United Kingdom or any other country where such provisions are inconsistent with local law: INTERNATIONAL BUSINESS MACHINES CORPORATION PROVIDES THIS PUBLICATION "AS IS" WITHOUT WARRANTY OF ANY KIND, EITHER EXPRESS OR IMPLIED, INCLUDING, BUT NOT LIMITED TO, THE IMPLIED WARRANTIES OF NON-INFRINGEMENT, MERCHANTABILITY OR FITNESS FOR A PARTICULAR PURPOSE. Some states do not allow disclaimer of express or implied warranties in certain transactions, therefore, this statement may not apply to you.

This information could include technical inaccuracies or typographical errors. Changes are periodically made to the information herein; these changes will be incorporated in new editions of the publication. IBM may make improvements and/or changes in the product(s) and/or the program(s) described in this publication at any time without notice.

Any references in this information to non-IBM web sites are provided for convenience only and do not in any manner serve as an endorsement of those web sites. The materials at those web sites are not part of the materials for this IBM product and use of those web sites is at your own risk.

IBM may use or distribute any of the information you supply in any way it believes appropriate without incurring any obligation to you.

Any performance data contained herein was determined in a controlled environment. Therefore, the results obtained in other operating environments may vary significantly. Some measurements may have been made on development-level systems and there is no guarantee that these measurements will be the same on generally available systems. Furthermore, some measurement may have been estimated through extrapolation. Actual results may vary. Users of this document should verify the applicable data for their specific environment.

Information concerning non-IBM products was obtained from the suppliers of those products, their published announcements or other publicly available sources. IBM has not tested those products and cannot confirm the accuracy of performance, compatibility or any other claims related to non-IBM products. Questions on the capabilities of non-IBM products should be addressed to the suppliers of those products.

If you are viewing this information in softcopy, the photographs and color illustrations may not appear.

Trademarks

IBM, the IBM logo, and [ibm.com](http://www.ibm.com)[®] are trademarks or registered trademarks of International Business Machines Corp., registered in many jurisdictions worldwide. Other product and service names might be trademarks of IBM or other companies. A current list of IBM trademarks is available on the web at Copyright and trademark information at www.ibm.com/legal/copytrade.shtml

Adobe, the Adobe logo, PostScript, and the PostScript logo are either registered trademarks or trademarks of Adobe Systems Incorporated in the United States, and/or other countries.

Java[™] and all Java-based trademarks and logos are trademarks or registered trademarks of Oracle and/or its affiliates.

Linux[®] is a registered trademark of Linus Torvalds in the United States, other countries, or both.

Microsoft, Windows, Windows NT, and the Windows logo are trademarks of Microsoft Corporation in the United States, other countries, or both.

UNIX is a registered trademark of The Open Group in the United States and other countries.

Other product and service names might be trademarks of IBM or other companies.

Homologation statement

This product may not be certified in your country for connection by any means whatsoever to interfaces of public telecommunications networks. Further certification may be required by law prior to making any such connection. Contact an IBM representative of reseller for any questions.

Electromagnetic compatibility notices

The following Class A statements apply to IBM products and their features unless designated as electromagnetic compatibility (EMC) Class B in the feature information.

When attaching a monitor to the equipment, you must use the designated monitor cable and any interference suppression devices that are supplied with the monitor.

United States Federal Communications Commission (FCC) Notice

This equipment has been tested and found to comply with the limits for a Class A digital device, pursuant to Part 15 of the FCC Rules. These limits are designed to provide reasonable protection against harmful interference when the equipment is operated in a commercial environment. This equipment generates, uses, and can radiate radio frequency energy and, if not installed and used in accordance with the instruction manual, may cause harmful interference to radio communications. Operation of this equipment in a residential area is likely to cause harmful interference, in which case the user will be required to correct the interference at his own expense.

Properly shielded and grounded cables and connectors must be used in order to meet FCC emission limits. IBM is not responsible for any radio or television interference caused by using other than recommended cables and connectors, or by unauthorized changes or modifications to this equipment. Unauthorized changes or modifications could void the user's authority to operate the equipment.

This device complies with Part 15 of the FCC Rules. Operation is subject to the following two conditions:

(1) this device might not cause harmful interference, and (2) this device must accept any interference received, including interference that might cause undesired operation.

Responsible Party:

International Business Machines Corporation

New Orchard Road

Armonk, NY 10504

Contact for FCC compliance information only: fccinfo@us.ibm.com

Canada Notice

CAN ICES-3 (A)/NMB-3(A)

Australia and New Zealand Class A Statement

Attention: This is a Class A product. In a domestic environment this product might cause radio interference in which case the user might be required to take adequate measures.

European Community and Morocco Notice

This product is in conformity with the protection requirements of Directive 2014/30/EU of the European Parliament and of the Council on the harmonization of the laws of the Member States relating to electromagnetic compatibility. IBM cannot accept responsibility for any failure to satisfy the protection requirements resulting from a non-recommended modification of the product, including the fitting of non-IBM option cards.

This product may cause interference if used in residential areas. Such use must be avoided unless the user takes special measures to reduce electromagnetic emissions to prevent interference to the reception of radio and television broadcasts.

Warning: This equipment is compliant with Class A of CISPR 32. In a residential environment this equipment may cause radio interference.

Germany Notice

Deutschsprachiger EU Hinweis: Hinweis für Geräte der Klasse A EU-Richtlinie zur Elektromagnetischen Verträglichkeit

Dieses Produkt entspricht den Schutzanforderungen der EU-Richtlinie 2014/30/EU zur Angleichung der Rechtsvorschriften über die elektromagnetische Verträglichkeit in den EU-Mitgliedsstaaten und hält die Grenzwerte der EN 55032 Klasse A ein.

Um dieses sicherzustellen, sind die Geräte wie in den Handbüchern beschrieben zu installieren und zu betreiben. Des Weiteren dürfen auch nur von der IBM empfohlene Kabel angeschlossen werden. IBM übernimmt keine Verantwortung für die Einhaltung der Schutzanforderungen, wenn das Produkt ohne Zustimmung von IBM verändert bzw. wenn Erweiterungskomponenten von Fremdherstellern ohne Empfehlung von IBM gesteckt/eingebaut werden.

EN 55032 Klasse A Geräte müssen mit folgendem Warnhinweis versehen werden:

"Warnung: Dieses ist eine Einrichtung der Klasse A. Diese Einrichtung kann im Wohnbereich Funk-Störungen verursachen; in diesem Fall kann vom Betreiber verlangt werden, angemessene Maßnahmen zu ergreifen und dafür aufzukommen."

Deutschland: Einhaltung des Gesetzes über die elektromagnetische Verträglichkeit von Geräten

Dieses Produkt entspricht dem "Gesetz über die elektromagnetische Verträglichkeit von Geräten (EMVG)." Dies ist die Umsetzung der EU-Richtlinie 2014/30/EU in der Bundesrepublik Deutschland.

Zulassungsbescheinigung laut dem Deutschen Gesetz über die elektromagnetische Verträglichkeit von Geräten (EMVG) (bzw. der EMC Richtlinie 2014/30/EU) für Geräte der Klasse A

Dieses Gerät ist berechtigt, in Übereinstimmung mit dem Deutschen EMVG das EG-Konformitätszeichen - CE - zu führen.

Verantwortlich für die Einhaltung der EMV-Vorschriften ist der Hersteller:

International Business Machines Corp.
New Orchard Road
Armonk, New York 10504
Tel: 914-499-1900

Der verantwortliche Ansprechpartner des Herstellers in der EU ist:

IBM Deutschland GmbH
Technical Relations Europe, Abteilung M456
IBM-Allee 1, 71139 Ehningen, Germany
Tel: +49 800 225 5426
e-mail: Halloibm@de.ibm.com

Generelle Informationen:

Das Gerät erfüllt die Schutzanforderungen nach EN 55024 und EN 55032 Klasse A.

People's Republic of China Notice

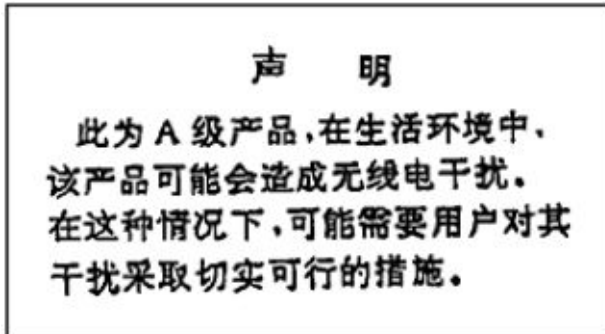

Taiwan Notice

警告使用者：

此為甲類資訊技術設備，
於居住環境中使用時，
可能會造成射頻擾動，在此種情況下，
使用者會被要求採取某些適當的對策。

IBM Taiwan Contact Information:

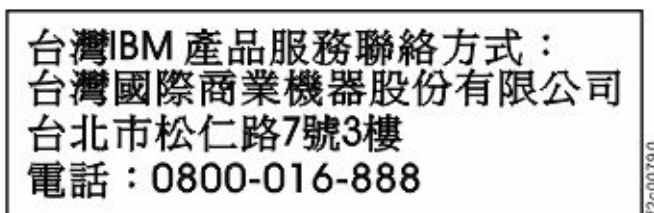

Taiwan Contact Information

This topic contains the product service contact information for Taiwan.

IBM Taiwan Product Service Contact Information:
IBM Taiwan Corporation
3F, No 7, Song Ren Rd., Taipei Taiwan
Tel: 0800-016-888

台灣IBM 產品服務聯絡方式：
台灣國際商業機器股份有限公司
台北市松仁路7號3樓
電話：0800-016-888

f2c00790

Japan Voluntary Control Council for Interference (VCCI) Notice

この装置は、クラスA情報技術装置です。この装置を家庭環境で使用すると電磁妨害を引き起こすことがあります。この場合には使用者が適切な対策を講ずるよう要求されることがあります。

VCCI-A

Japan Electronics and Information Technology Industries Association (JEITA) Notice

(一社) 電子情報技術産業協会 高調波電流抑制対策実施
要領に基づく定格入力電力値： Knowledge Centerの各製品の
仕様ページ参照

This statement applies to products less than or equal to 20 A per phase.

高調波電流規格 JIS C 61000-3-2 適合品

This statement applies to products greater than 20 A, single phase.

高調波電流規格 JIS C 61000-3-2 準用品

本装置は、「高圧又は特別高圧で受電する需要家の高調波抑制対策ガイドライン」対象機器（高調波発生機器）です。

- 回路分類：6（単相、PFC回路付）
- 換算係数：0

This statement applies to products greater than 20 A per phase, three-phase.

高調波電流規格 JIS C 61000-3-2 準用品

本装置は、「高圧又は特別高圧で受電する需要家の高調波抑制対策ガイドライン」対象機器（高調波発生機器）です。

- 回路分類：5（3相、PFC回路付）
- 換算係数：0

Korea Notice

이 기기는 업무용 환경에서 사용할 목적으로 적합성평가를 받은 기기로서 가정용 환경에서 사용하는 경우 전파간섭의 우려가 있습니다.

Russia Notice

ВНИМАНИЕ! Настоящее изделие относится к классу А.
В жилых помещениях оно может создавать радиопомехи, для снижения которых необходимы дополнительные меры

RUSSIAN

Index

A

about this document [xix](#)
accessibility
 features [xi](#)
attention notices [xv](#)

B

Brocade
 documents [xix](#)

C

chassis
 replacing [63](#)
comments, sending [xii](#)

D

director of licensing, address [73](#)
documentation
 Brocade [xix](#)
 Fabric Operating System (FOS) [xix](#)

E

electrostatic discharge
 precautions [xv](#)
environmental
 notices [xiii](#), [xvii](#)
 product recycling and disposal [xvii](#)
ESD
 precautions [xv](#)

F

Fabric Operating System (FOS)
 documents [xix](#)
Fabric OS
 documentation
 updates [xi](#)
 Release Notes [xi](#)
 updates [xi](#)
Fabric OS version [xix](#)
feedback, sending [xii](#)

G

getting help [xi](#)

H

help [xi](#)

I

IBM
 notices [73](#)
 trademarks [74](#)
IBM contacts [xi](#)
IBM Publications Center [xi](#)
IBM Support Portal [xi](#)
intellectual property [73](#)
intended audience [xix](#)

L

labels
 safety [xiv](#)
license, for patents [73](#)

N

notices
 attention [xv](#)
 environmental [xiii](#), [xvii](#)
 general [73](#)
 IBM [73](#)
 patents [73](#)
 safety [xiii](#)
 types [xiii](#)

P

patents [73](#)
precautions
 ESD [xv](#)
 rack installation [xvi](#)
 rack relocation [xvi](#)
product
 accessibility [xi](#)
 models [xix](#)
 support [xi](#)
product disposal [xvii](#)
product recycling [xvii](#)

R

rack
 safety precautions [xvi](#)
rack relocation
 safety [xvi](#)
Redbooks [xi](#)
replace
 chassis [63](#)

S

safety
 notices [xiii](#)

safety (*continued*)
 rack installation [xvi](#)
 rack relocation [xvi](#)
safety labels [xiv](#)
SAN64B-7
 library [xix](#)
support [xi](#)

T

trademarks [74](#)

W

Web sites [xi](#)



Part Number: 03GM386

SC28-3148-00

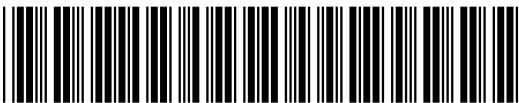

(1P) P/N: 03GM386

