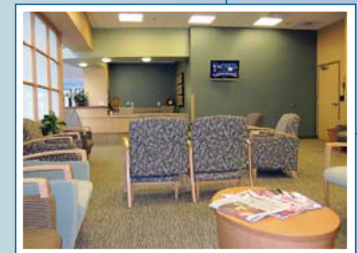


DRISTEEM[®]
The humidification experts



Vapormist[®]
Electric-to-Steam
Humidification System
PRODUCT CATALOG



Now with Vapor-logic[®]4 controller:

- Web-enabled access
- Interoperability via Modbus[®] or optional BACnet[®] MS/TP or LonTalk[®]

Versatility for finished spaces



DRI-STEEM® offers Space Distribution Units that match the Vapormist cabinet. See Page 13.

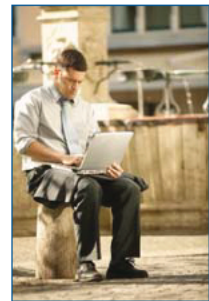
The Vapormist humidifier is a compact, cabinet-style unit compatible with all water types (tap, softened, deionized, reverse osmosis) and numerous dispersion options. Installation is a snap — just attach the frame to a supporting structure and connect electrical and water services.

Available matching Space Distribution Units disperse steam with no visible vapor trail, making Vapormist ideal for use in finished spaces.

Comprehensive control with Vapor-logic4

Vapormist with Vapor-logic4 sets new standards for control in electric steam humidification:

Interoperability allows communication with building automation systems via Modbus or with optional BACnet MS/TP or LonTalk protocols.



Safety presets initiate fill and drain cycles and keep the humidifier cool and safe if sensed conditions, though unlikely, could be hazardous.

Web-enabled control allows you to set up, view, and adjust humidifier functions via Ethernet, either directly or remotely through a network.

DRI-STEEM Vapor-logic4

STATUS ALARMS DIAGNOSTICS SETUP HELP

System Status **Wednesday, January 27, 2010 3:42:28 PM** Data stream is LIVE
View all humidifier settings below. Some settings can be changed here. Go to the Setup tab to change settings that cannot be changed from this page.

DEMAND	OUTPUT
0%	0%

RUN MODE: Local standby

TANK STATUS
Empty

Alarms
2 active alarms
[View Alarms](#)

Messages
2 active messages
[View Messages](#)

TANK STATUS:

Run Mode	Local standby	CHANGE
Input signal	18.2 VDC	
Steam output	0%	
Steam production	0 lbs/hr	
Duct HL switch	Closed	
Tank temperature	192.9°	
Tank temp signal	1623 Ohms	
High water probe	Water	
Md water probe	Water	
Low water probe	Water	
Fill valve	Open	
Drain valve	Open	
Airflow switch	Flow	
Interlock switch	Closed	
H2O until drain/flush	123454 lbs	
H2O until service	30000 lbs	
High probe signal	3874	
Md probe signal	3875	
Low probe signal	3873	

© Copyright 2009 DRI-STEEM Corporation. All rights reserved. Vapor-logic is a registered trademark of DRI-STEEM Corporation.

Vapormist features and benefits

Versatile

- Uses tap, softened, or DI/RO water
- Capacity from 6 to 102 lbs/hr (2.7 to 46 kg/h), link up to 16 units for capacity up to 1632 lbs/hr (740 kg/h)
- Disperses steam through ductwork with dispersion tubes or panels, or directly into a room with a Space Distribution Unit (SDU) mounted remotely or on top of the Vapormist

Flexible

- Control to $\pm 3\%$ RH
- On-off or time-proportioned (TP) control for application control in most environments; solid-state relay (SSR) option for tight control
- Electronically monitored water level ensures safe and reliable operation

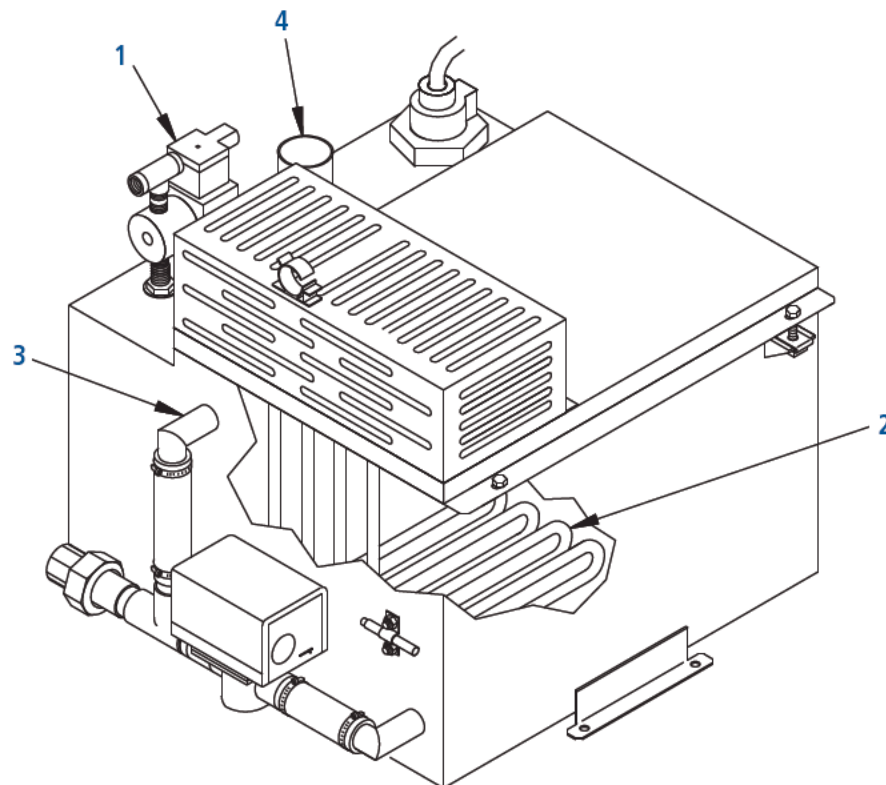
Easy to maintain

- Removable cover allows easy access to evaporating chamber and electrical connections
- Softened water significantly reduces maintenance requirements
- End-of-season autodrain minimizes microbial growth
- User-adjustable water skimmer skims off floating minerals
- Controller-operated drain and flush removes precipitated minerals from evaporating chamber
- Constant thermal expansion and contraction of heating elements continuously sheds mineral buildup

Vapormist principle of operation

Figure 5-1:
Vapormist principle of operation

Standard water system (shown with cover removed)



OM-2000

1. When the system is first activated, the fill valve opens and the evaporating chamber fills with water to the operating level.
2. On a call for humidity, the heating elements are energized, causing the water to boil. The fill valve opens and closes as needed to maintain the operating water level.
3. During refill in standard water systems, a portion of the surface water is skimmed off, carrying away precipitated minerals. DI/RO water systems (systems using deionized water or water that has been treated using reverse osmosis) do not require skimming.
4. Steam created in the evaporating chamber flows through vapor hose or piping to the dispersion assembly, where it is discharged into the airstream.

Vapormist components

Figure 6-1:
Vapor-logic4 keypad/display

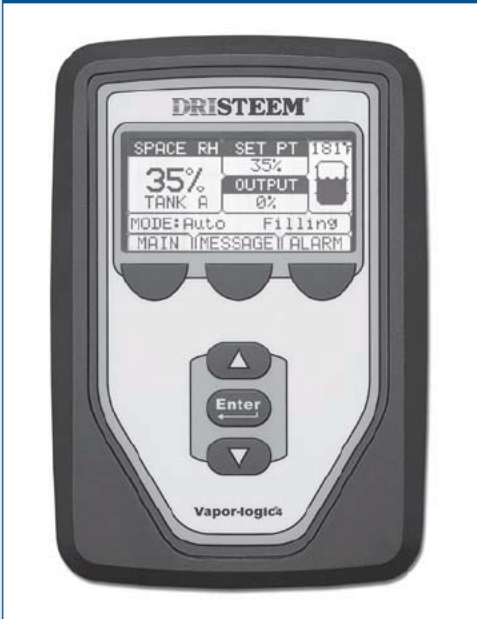
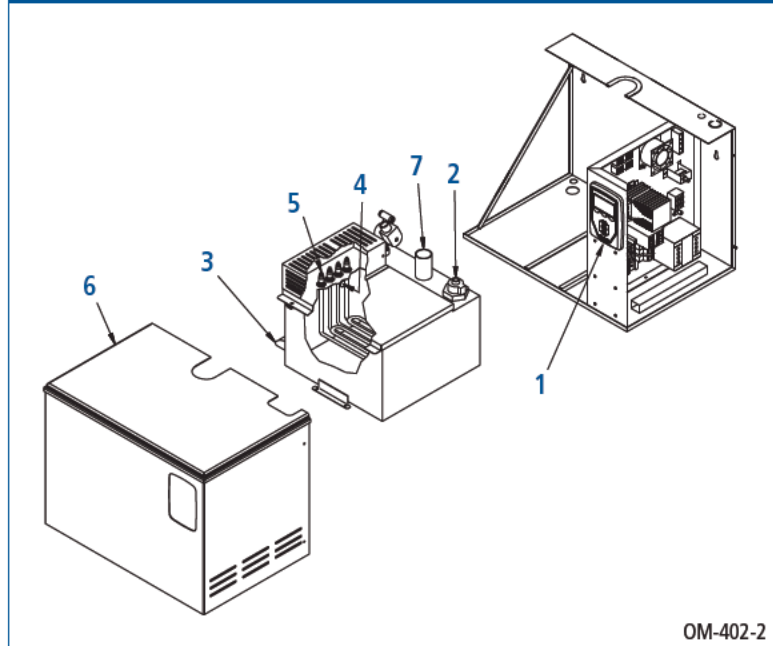


Figure 6-2:
Vapormist components



OM-402-2

1. Vapor-logic4 controller

Vapor-logic4 controls all humidifier functions and can connect to a building automation system via Modbus or optional BACnet MS/TP or LonTalk. See Page 4 for more information.

2. Water level control

Tap or softened water systems control water levels electronically using a three-rod probe (Figure 7-1).

DI/RO water systems control water levels using a float valve (Figure 7-2) and low-water cutoff switch.

3. Drain

Duration and frequency of draining are user adjustable. To avoid possible stagnant water and microbial growth, the humidifier automatically drains if there is no call for humidity after a user-defined time period (72-hour default).

Vapormist components

4. Water skimmer/overflow port

In standard water systems, the water skimmer reduces surface minerals in the evaporating chamber. Skimming occurs each time the humidifier fills. The skim time duration is user-adjustable.

DI/RO water systems do not require skimming. In DI/RO systems, the skimmer port functions as an overflow port.

5. Heating elements

Low-watt-density Incoloy-sheathed heating elements ensure operation for many seasons. Constant expansion and contraction of heating elements sheds mineral scale. In the unlikely event of heater failure, heating elements can be removed easily.

6. Removable cover

A removable cover allows easy access to the evaporating chamber, electrical connections, and drain.

7. Steam outlet

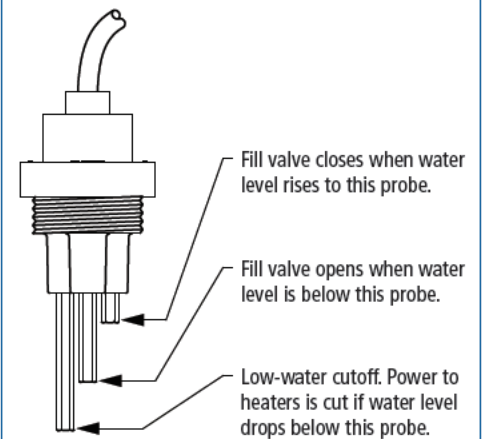
Steam generated in the humidifier rises through the steam outlet and travels to the dispersion assembly through vapor hose or piping.

8. Temperature sensor (not shown)

Mounted on the evaporating chamber, this sensor enables:

- Over-temperature protection
- Freeze protection
- Preheating, allowing rapid response to a call for humidity

Figure 7-1:
Water level control for standard-water humidifier

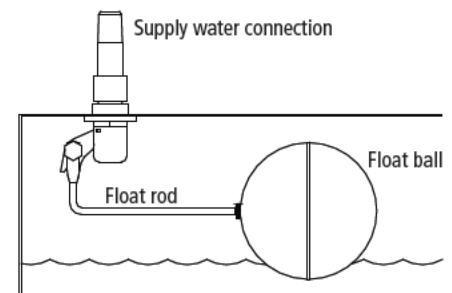


Humidifiers using tap or softened water control water levels electronically using a three-rod probe. The controller responds with the above actions when the water level reaches each rod.

mc_030910_1335

VLC-OM-030

Figure 7-2:
Water level control for DI/RO-water humidifier



Humidifiers using DI/RO water control water levels using a float valve and low-water cutoff switch.

OM-7396

Vapormist specifications

Table 8-1:
Vapormist capacities, electrical specifications, and weights

Model	Maximum steam capacity		Current draw (amps)											Weights ‡			
			Single-phase						Three-phase					Shipping		Operating	
kW	lbs/hr	kg/h	120V	208V*	240V*	277V	480V†	600V†	208V*	240V†	277V	480V†	600V†	lbs	kg	lbs	kg
VM-2	6	2.7	16.7	9.6	8.3	7.2	4.2	3.3	—	—	—	—	—	80	36	95	43
VM-4	12	5.4	33.3	19.2	16.7	14.4	8.3	6.7	16.7**	14.4**	12.5	7.2**	5.8**	80	36	95	43
VM-6	18	8.2	—	28.8	25.0	21.7	12.5	10.0	25.0**	21.7**	18.8	10.8**	8.7**	88	40	122	55
VM-8	24	10.9	—	38.5	33.3	28.9	16.7	13.3	33.3**	28.9**	25.0	14.4**	11.5**	88	40	122	55
VM-10	30	13.6	—	—	41.7	36.1**	20.8	16.7	29.1**	25.3**	21.9	12.6**	10.1**	93	42	139	63
VM-12	36	16.3	—	—	—	43.3	25.0	20.0	33.3	28.9	25.0	14.4	11.5	93	42	139	63
VM-14	42	19.1	—	—	—	—	29.2	23.3	38.9	33.7	29.2	16.8	13.5	93	42	139	63
VM-16	48	21.8	—	—	—	—	33.3	26.7	44.4	38.5	33.3	19.2	15.4	93	42	139	63
VM-21	63	28.6	—	—	—	—	43.8	35.0	—	—	43.8	25.3	20.2	95	43	152	69
VM-25	75	34.0	—	—	—	—	—	41.7	—	—	—	30.1	24.1	95	43	152	69
VM-30	90	40.9	—	—	—	—	—	—	—	—	—	36.1	28.9	101	46	156	71
VM-34	102	46.3	—	—	—	—	—	—	—	—	—	40.9	32.7	101	46	156	71

* On 208V/240V/single-phase/three-wire and on 208V/three-phase/four-wire supplies, the neutral line provides a separate 120V circuit for the SDU fan unit.

** For wire sizing, the highest leg draw is shown due to current imbalance.

† Add the following to Vapormist weights if using an SDU option (these weights are for additional control components housed within the Vapormist cabinet):

- SDU-I: 12 lbs (5.5 kg) (SDU-I shipping weight is 68 lbs [31 kg])
- SDU-E: 9 lbs (4 kg) (SDU-E shipping weight is 61 lbs [28 kg])

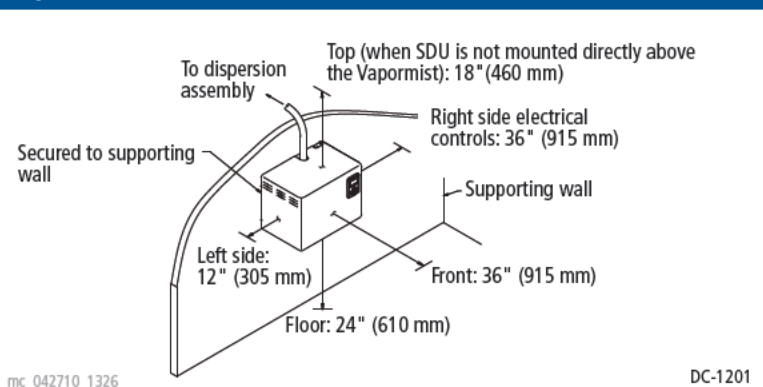
‡ Add the following if using the SSR option:

- For single-phase or three-phase models drawing less than 21.7 amps, add 2 lbs (1 kg)
- For three-phase models drawing more than 21.7 amps, add 4 lbs (2 kg)

All Vapormist models operate at 50/60 Hz.

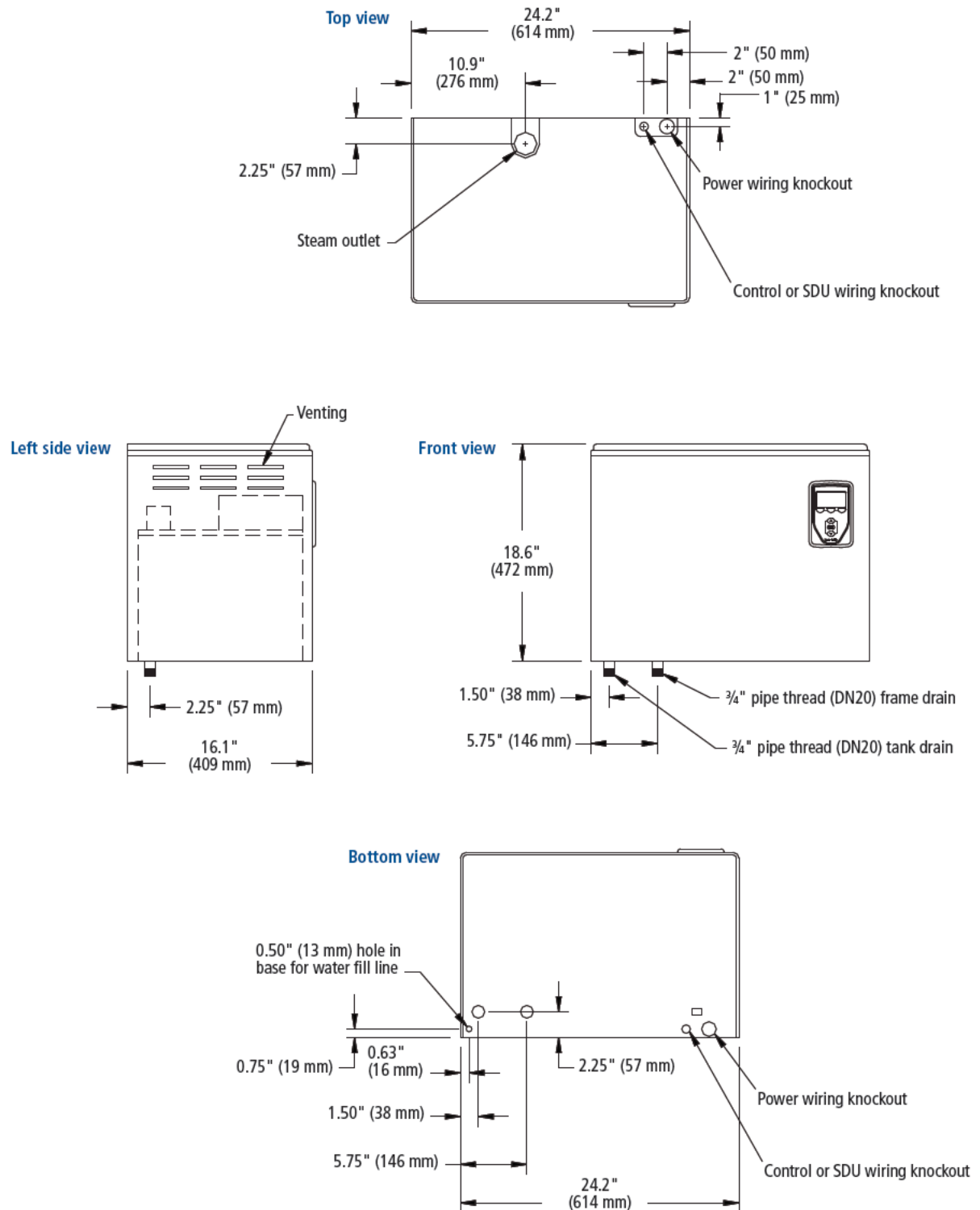
mc_042610_0900

Figure 8-1:
Vapormist clearance recommendations



Vapormist dimensions

**Figure 9-1:
Vapormist dimensions**

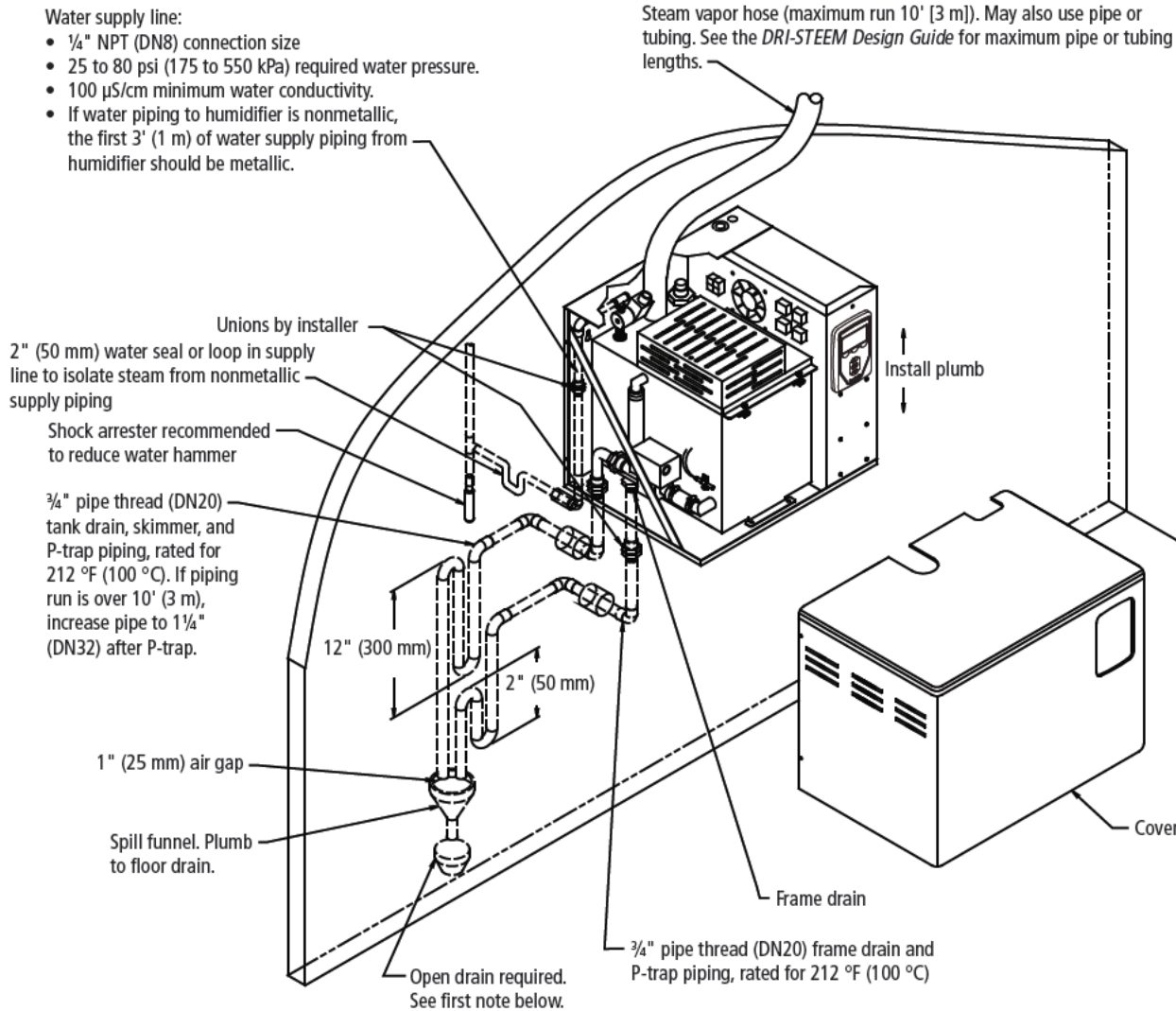


mc_042710_1325

DC-1167

Vapormist piping: Standard water

Figure 10-1:
Vapormist (standard water) field piping overview



DC-1136

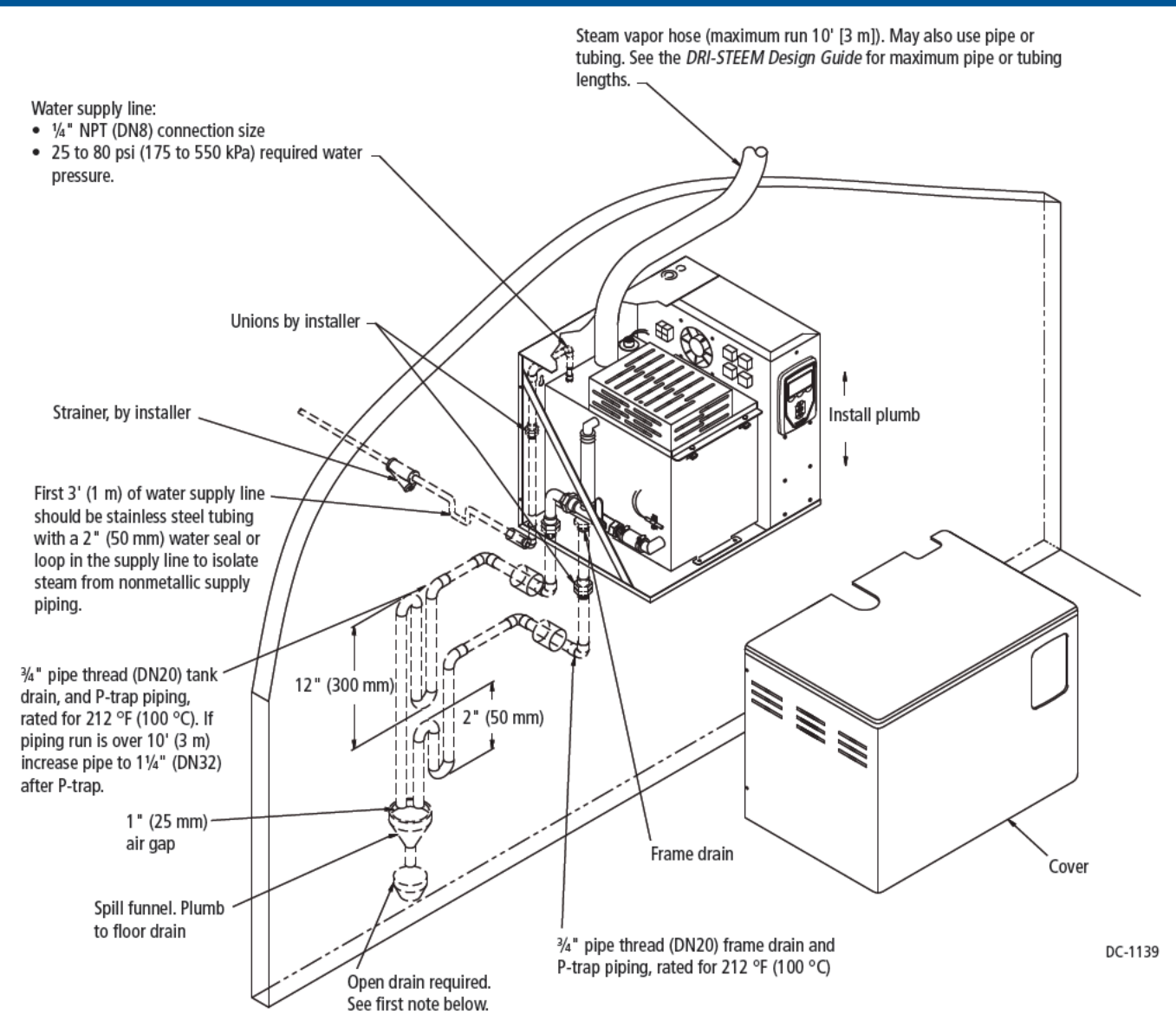
Notes:

- Locate air gap only in spaces with adequate temperature and air movement to absorb flash steam; otherwise, condensation may form on nearby surfaces. Refer to governing codes for drain pipe size and maximum discharge water temperature.
- Offset humidifier from spill funnel or floor drain to prevent flash steam from rising into cabinet.
- Dashed lines indicate provided by installer.
- Water supply inlet is more than 1" (25 mm) above skim/overflow port, eliminating the possibility of backflow or siphoning from tank. No additional backflow prevention is required; however, governing codes prevail.
- Install a union in water supply and drain lines as shown to allow tank removal.
- Damage caused by chloride corrosion is not covered by your DRI-STEEM warranty.

mc_042710_1327-VM

Vapormist piping: DI/RO water

Figure 11-1:
Vapormist (DI/RO water) field piping overview



DC-1139

Notes:

- Locate air gap only in spaces with adequate temperature and air movement to absorb flash steam; otherwise, condensation may form on nearby surfaces. Refer to governing codes for drain pipe size and maximum discharge water temperature.
- Offset humidifier from spill funnel or floor drain to prevent flash steam from rising into the cabinet.
- Dashed lines indicate provided by installer.
- The water supply inlet is more than 1" (25 mm) above the overflow port, eliminating the possibility of backflow or siphoning from the tank. No additional backflow prevention is required; however, governing codes prevail.
- Install a union in the water supply and drain lines as shown to allow tank removal.
- Damage caused by chloride corrosion is not covered by your DRI-STEEM warranty.

mc_042710_1328-VM

Drip-free dispersion basics

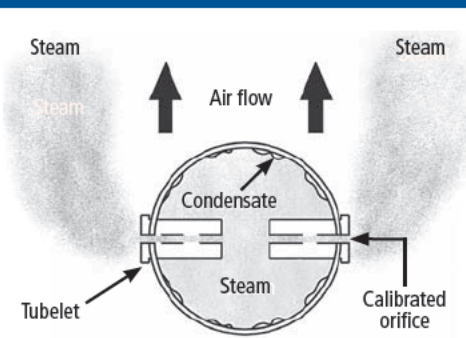
Figure 12-1:
DRI-STEEM dispersion tubes



DRI-STEEM's dispersion tubes are fitted with one or two rows of closely-spaced thermal-resin tubelets to evenly disperse steam across the airstream.

mc_042610_1555

Figure 12-2:
DRI-STEEM tubelets



DRI-STEEM's unique tubelets extend into the center of the tube so only the driest steam is discharged into the air.

mc_042610_1550

OM-150a

Guaranteed non-wetting distances

Using data collected in our on-site test lab, we have developed guaranteed steam absorption (non-wetting) distances. Performance charts allow you to confidently choose equipment that will accommodate any application.

Dry steam

Adding humidification to an airstream without creating wetness in the duct system is critical for the maintenance of a healthy environment. Wet areas in ducts are a threat to the health of building occupants since they moisten dust on duct floors, creating ideal breeding grounds for disease-producing microbes. In addition, water accumulating in ducts can drip and cause building damage.

Steam exits drip-free through tubelets

All DRI-STEEM evaporative dispersion tube units discharge steam through thermal-resin tubelets fitted into dispersion tubes. These tubelets extend from the center of the tube, where the steam is driest, through the tube wall, to the duct airstream. In essence, the tubelets provide a temperature-neutral exit tunnel for steam, allowing steam to cross over lower-temperature metal without condensing or dripping. Each tubelet contains a calibrated orifice sized for steam capacity. These tubelets are a DRI-STEEM exclusive, and are essential for drip-free steam dispersion.

Condensate drains away

Some condensation is inevitable in steam dispersion, but through careful design, condensate can be controlled and directed away from where it can cause problems.

For example, the Ultra-sorb dispersion panel has a unique double-header design that uses gravity to remove condensate. Steam enters the supply header, exits through the tubelets, and condensate drains out the return header. In the Rapid-sorb dispersion unit, steam enters one end of a single bottom header with velocities carefully managed so that condensate is not pushed out into the air along with the steam; it drains out at the opposite end of the header.

Reduce condensate, wasted energy with high-efficiency tubes

To significantly reduce condensate and wasted energy, use DRI-STEEM's high-efficiency tubes, which reduce dispersion-generated condensate and wasted energy by up to 85%. See "High-efficiency Tube option" on Page 13.

mc_042610_1630

Vapormist steam dispersion options

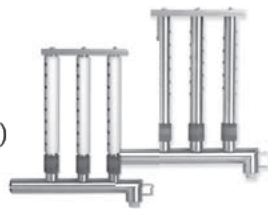
Ultra-sorb®

- Double-header design
- Shortest non-wetting distance; install within inches of upstream dampers, coils, or elbows without dripping
- Steam capacity up to 1,850 lbs/hr (839 kg/h)
- Factory assembled for easy installation
- High-efficiency tube option



Rapid-sorb®

- Single-header design
- Short non-wetting distance
- Steam capacity up to 800 lbs/hr (363 kg/h)
- Assembled on-site
- High-efficiency tube option



Single or multiple tubes

- Horizontal or vertical airflow
- Available with or without condensate drain
- Steam capacity up to 85 lbs/hr (39 kg/h)



High-efficiency Tube option

- Up to 85% reduction in wasted energy, airstream heat gain, and condensate production
- PVDF insulation is plenum-approved for in-duct installation
- Will not absorb water or support microbial growth; has a closed-cell structure
- Available on Ultra-sorb and Rapid-sorb



Ultra-sorb panel with high-efficiency tubes

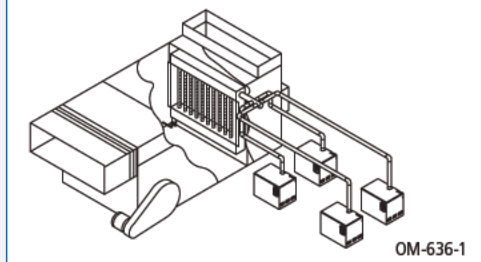
mc_042710_1345-NA

Space Distribution Units (SDU)

- Designed for use in finished spaces
- Disperse steam into large open spaces; useful where there are no air ducts
- SDU-E, external absorption, capacities up to 102 lbs/hr (46.3 kg/h)
- SDU-I, internal absorption, capacities up to 30 lbs/hr (13.6 kg/h)

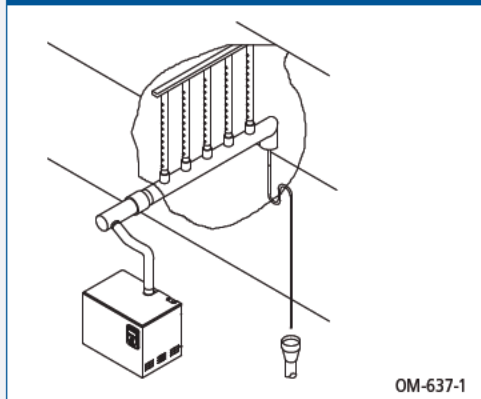


Figure 13-1:
Ultra-sorb dispersion



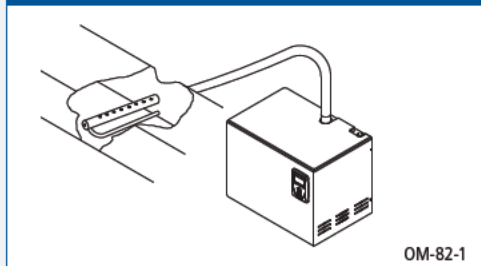
OM-636-1

Figure 13-2:
Rapid-sorb dispersion



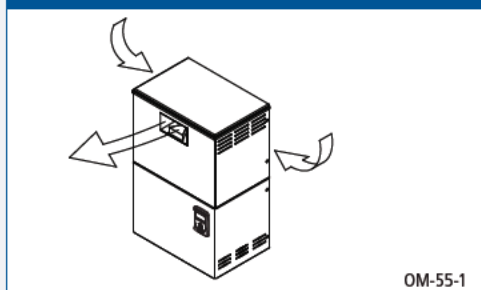
OM-637-1

Figure 13-3:
Single-tube dispersion



OM-82-1

Figure 13-4:
SDU-E mounted directly above Vapormist



OM-55-1

Calculating non-wetting distances

Guaranteed absorption

- Cataloged and guaranteed steam absorption distances
- Unique tubelets in dispersion tubes eliminate condensate drips
- Published absorption tables for sizing and selecting the correct dispersion option
- Dri-calc® software available for system selection and absorption distance calculations

Notes:

- Final equipment selection should account for condensate loss. See the *DRI-STEEM Design Guide* for steam loss tables.
- Dispersion assembly should accommodate maximum output capacity of humidifier.

Sample exercise

Read through this exercise to learn more about specifying a dispersion unit based on non-wetting distance. Assume you have chosen to use Ultra-sorb units because you want pre-assembled panels.

Assume the entering air is 20% RH, and the leaving air needs to be 70% RH. Design for a non-wetting distance of 24" (610 mm) maximum.

Solution

Refer to Figure 15-1. Find 20% entering RH. Proceed vertically until you intersect the 70% leaving RH line. Draw a line horizontally from that point to the right to see that for 24" (610 mm) of non-wetting distance, 6" (152 mm) tube spacing would be the closest match.

Verify capacity

From Table 15-1, note that for 6" (152 mm) spacing, maximum capacity is 18 lbs/hr/ft² (88 kg/h/m²). Multiply this value by the active face area of the Ultra-sorb to determine if the unit will produce adequate output capacity. If the capacity is inadequate, go to the next smaller tube spacing.

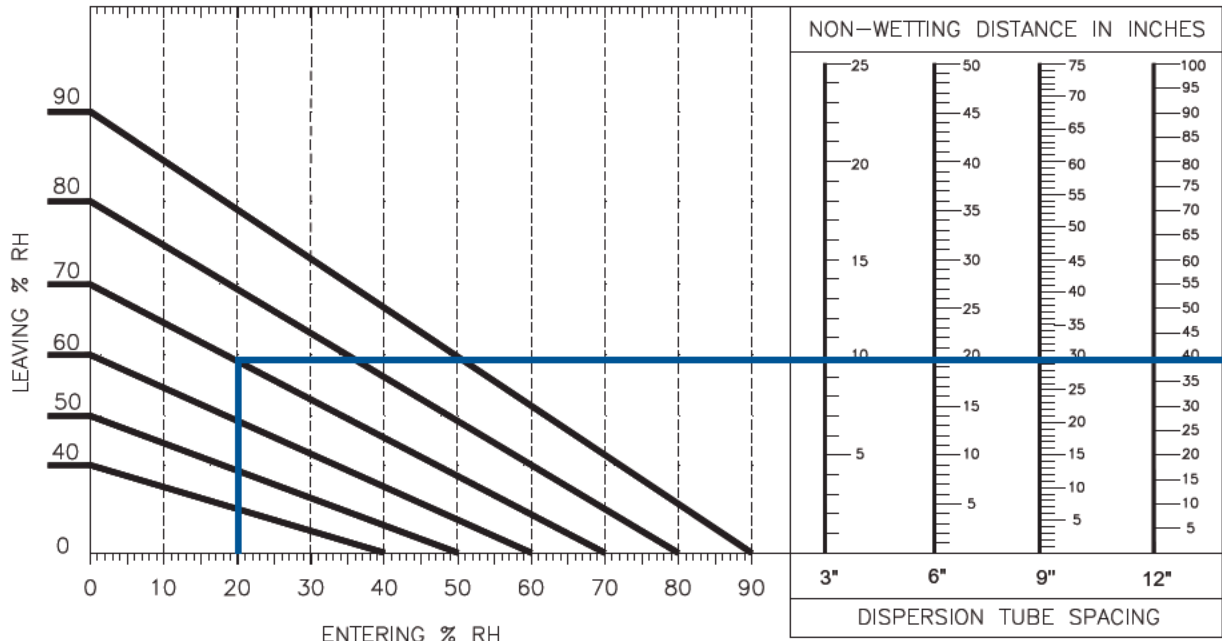
Steam absorption considerations

1. Non-wetting distance is the dimension downstream from the leaving side of the steam dispersion assembly to the point where wetting will not occur, although wisps of steam may be present. Solid objects at duct air temperature, such as coils, dampers, fans, etc., downstream of this dimension will remain dry.
2. **CAUTION!** Non-wetting distances described in this catalog do not apply when installing a steam dispersion assembly upstream of filter media. If you need to install a steam dispersion assembly upstream of filter media, consult your representative or DRI-STEEM directly for special recommendations.
3. Note that the rise (Δ) in RH (the difference between entering and leaving RH) has a direct bearing on the non-wetting distance. As the rise increases, more vapor needs to be dispersed into the air, and thus the non-wetting distance increases.
4. Uneven airflow over the cross-section of a dispersion assembly can result in nonuniform mixing of steam with air which, in turn, will adversely affect the non-wetting distance.

mc_042710_0850

Dispersion: Ultra-sorb

**Figure 15-1:
Ultra-sorb non-wetting distances**



Note:

The above data apply to all air velocities up to 1,500 fpm (7.6 m/s), and are based on air leaving the zone of humidification at conditions of 55 °F (13 °C) and the stated % RH. The blue lines in the graph refer to the sample exercise described on Page 14.

mc_042710_0900

**Table 15-1:
Ultra-sorb tube spacing and capacity**

Tube spacing		Maximum capacity	
inches	mm	lbs/hr/ft ²	kg/h/m ²
3	76	36	175
6	152	18	88
9	229	12	59
12	305	9	44

Note:

The above steam flow capacity data are based on pounds (kg) of steam per hour per square foot (meter) of face area, exclusive of headers, at various tube spacings.

mc_042710_0905

Dispersion: Ultra-sorb

Ultra-sorb LV

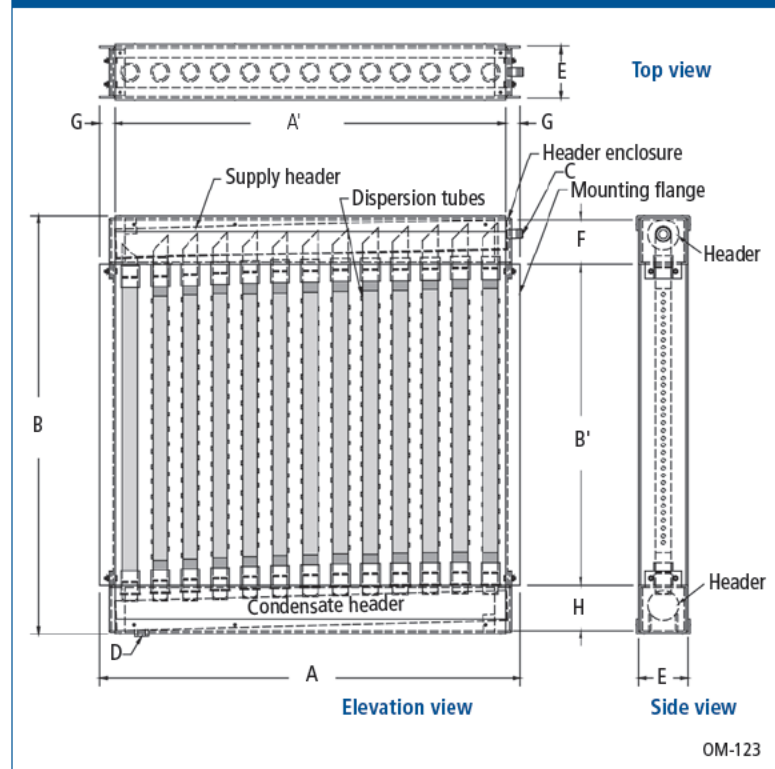
- Vertical dispersion tubes
- Suitable for AHUs or ductwork
- Use when duct height is greater than duct width
- May use with pressurized or evaporative steam (horizontal airflow only)

For Ultra-sorb Model LH (horizontal tubes), see the *Ultra-sorb Steam Dispersion Panels Product Catalog* (available at www.dristeem.com).

**Table 16-1:
Evaporative steam header capacities**

Header capacity		Header diameter	
lbs/hr	kg/h	inches	DN
300	135	3	80
600	270	4	100
1100	500	5	125
1850	820	6	150

**Figure 16-1:
Ultra-sorb LV dimensions**



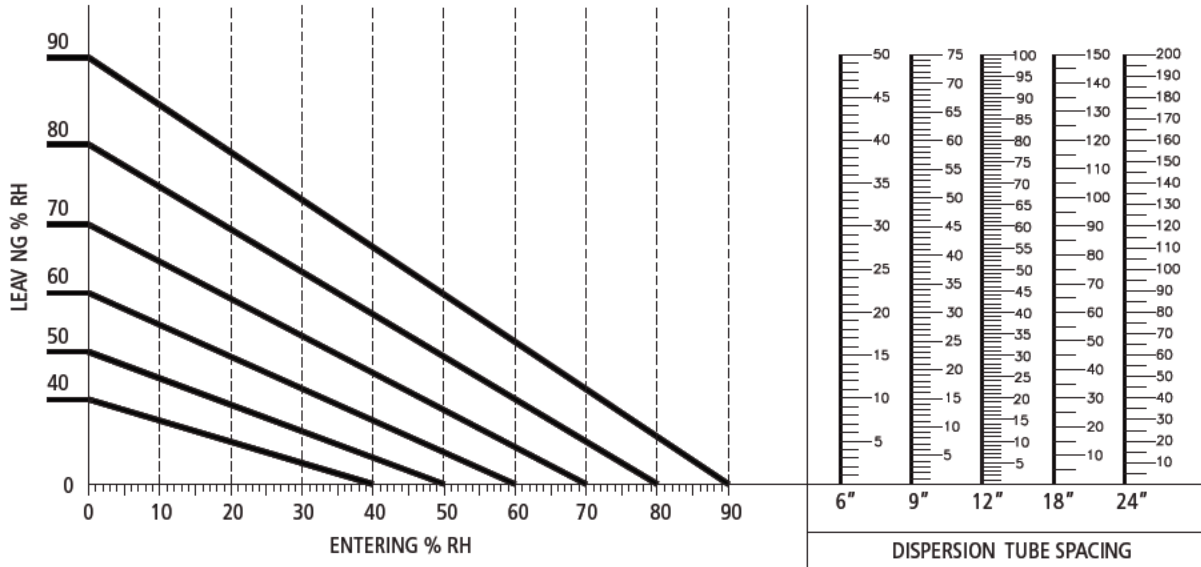
**Table 16-2:
Ultra-sorb LV dimensions**

Dimension	Inches (mm)
A Overall width	15" (380) min, 147" (3735) max, in 1" (25) increments
A' Face width	12" (305) min, 144" (3660) max, in 1" (25) increments
B Overall height	21" (530) min, 156" (3960) max, in 1" (25) increments Panels with overall height more than 98" (2490 mm) are shipped unassembled.
B' Face height	12" (305) min, 144" (3660) max, in 1" (25) increments
C Steam inlet diameter	Determined by maximum steam capacity
D Condensate drain	3/4" pipe thread (DN20)
E Header enclosure (front to back)	For 3" (DN80) and 4" (DN100) headers, E = 5" (127); for 5" (DN125) header, E = 6" (152); for 6" (DN150) header, E = 7" (178)
F Header enclosure (top to bottom)	For 3" (DN80) header F = 4.5" (114); for 4" (DN100) header, F = 5.5" (140); for 5" (DN125) header, F = 6.5" (165); for 6" (DN150) header F = 7.5" (191)
G Flange	1.5" (38)
H Condensate header enclosure	4.5" (114)

Note: Header dimensions are determined by capacity. See Table 16-1.

Dispersion: Rapid-sorb

Figure 17-1:
Rapid-sorb non-wetting distances



Note:

The above data apply to all air velocities up to 1,500 fpm (7.6 m/s) and are based on air leaving the zone of humidification at 55 °F (13 °C) and the stated % RH.

Table 17-1:
Rapid-sorb dispersion tube capacities*

Tube capacity		Tube diameter	
lbs/hr	kg/h	inches	DN
≤35	≤16	1½	40
36-70	17-32	2	50

* If duct height is <15" (381 mm), tube quantities may need to increase to compensate for reduced capacity of short tubes. Consult DRI-STEEM or see Dri-calc for the correct calculation.

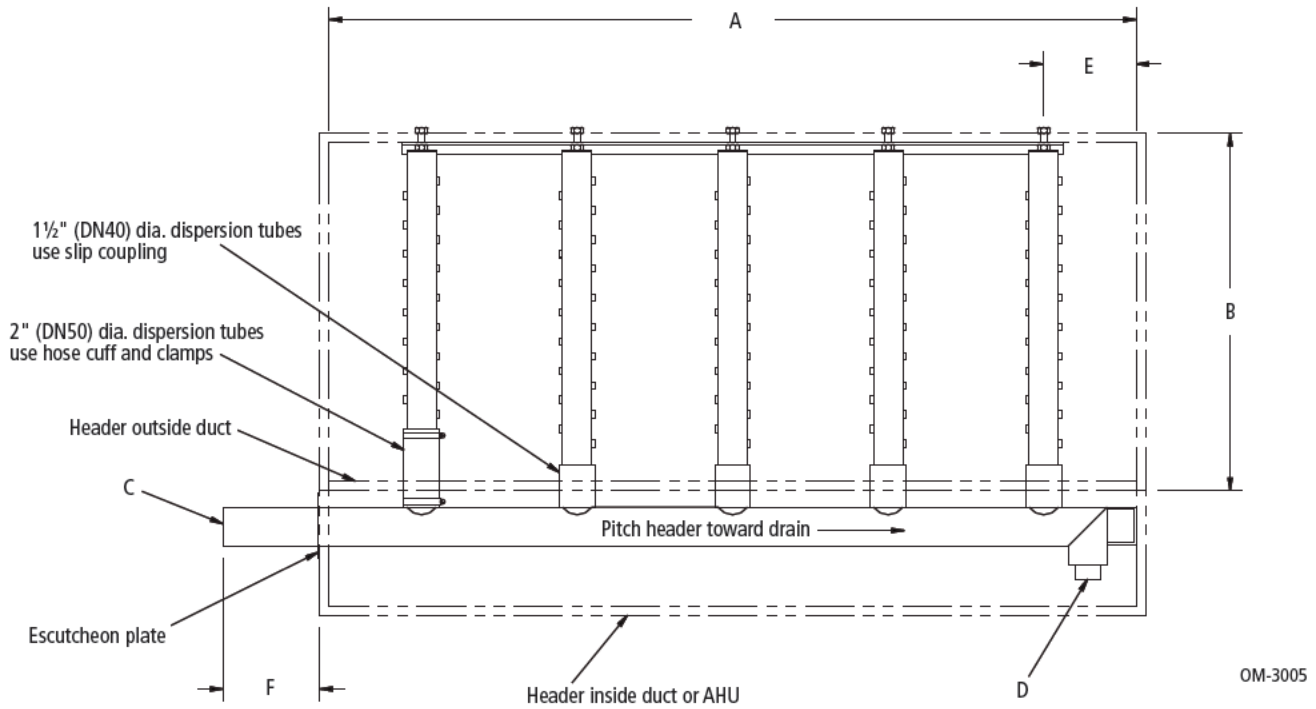
mc_042710_1410

Table 17-2:
Rapid-sorb header capacities

Header capacity		Header diameter	
lbs/hr	kg/h	inches	DN
≤250	≤113	2	50
251-500	114-227	3	80
501-800	228-363	4	100

Dispersion: Rapid-sorb

**Figure 18-1:
Rapid-sorb dimensions**



OM-3005

Note:
Add water seal to condensate drain as shown in the Dri-calc Installation Guides or the humidifier's Installation, Operation and Maintenance manual.

**Table 18-1:
Rapid-sorb dimensions**

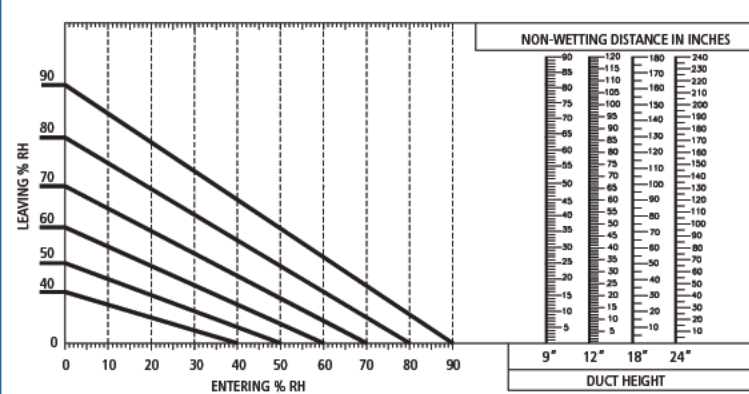
Dimension	Description	Inches (mm)
A	Face width	12" (305) minimum to 120" (3048) maximum in 1" (25) increments
B	Face height	12" (305) minimum to 120" (3048) maximum in 1" (25) increments
C	Steam inlet	Determined by supply steam pressure
D	Condensate drain	3/4" pipe thread (DN20)
E	Distance from tube center to inside of duct or AHU wall	4.5" (114) minimum
F	Distance from outside of duct or AHU wall to end of Rapid-sorb leader	4.5" (114) minimum

Note:
All Rapid-sorb units are custom-sized and field-assembled to fit the duct or air handler. Consult DRI-STEEM for sizes larger or smaller than those listed above.

mc_042710_1415

Dispersion: Single tube

Figure 19-1:
Single tube non-wetting distances



Note:
The above data apply to all air velocities up to 1,500 fpm (7.6 m/s), and are based on air leaving the zone of humidification at conditions of 55 °F (13 °C) and the stated % RH.

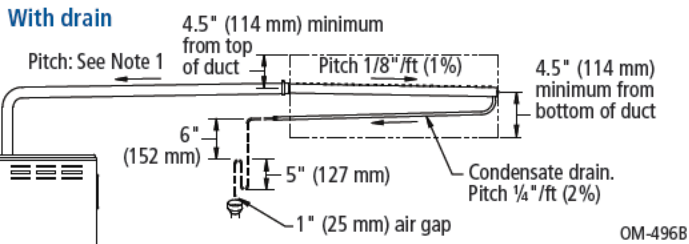
mc_042710_1417

Table 19-1:
Single tube capacities

Tube size		Maximum capacity of dispersion tube			
		Without drain		With drain	
inches	DN	lbs/hr	kg/h	lbs/hr	kg/h
1½	40	28.4	13	56.8	25.8
2	50	56.8	25.8	85.2	38.6

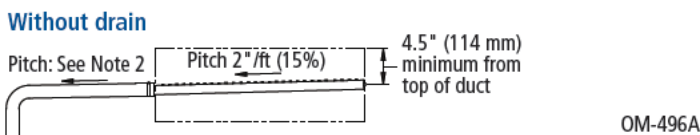
mc_042710_1416

Figure 19-2:
Single tube with and without condensate drain



Note 1:
Recommended pitch toward humidifier for interconnecting hose, tubing, or pipe:

- Vapor hose: 2" per ft (15%)
- 1½" tubing or pipe: ½" per ft (5%)
- 2" tubing or pipe: ¼" per ft (2%)



Note 2:
Recommended pitch toward humidifier for interconnecting hose, tubing, or pipe:

- Vapor hose: 2" per ft (15%)
- Tubing or pipe: 1/8" per ft (1%)

Table 19-2:
Hose kit sizing by model

Model	Hose kit (vapor hose, dispersion tube, and hardware)
VM 2-8	1½" (DN40) hose kit without drain
VM 10-16	1½" (DN40) hose kit with drain
	2" (DN50) hose kit without drain
VM 21-25	2" (DN50) hose kit with drain
VM 30-34	These models require multiple tube assemblies and cannot use a hose kit.

Dispersion: SDU

DRI-STEEM's SDUs match the Vapormist cabinet

SDU-I (Space Distribution Unit Internal Absorption) disperses steam without a visible vapor trail. This option is ideal for spaces where the presence of vapor creates either a visual problem or a condensation risk.

For larger capacities, choose the SDU-E (Space Distribution Unit External Absorption).

Both SDU models offer extremely quiet, reliable steam distribution.

Note: SDUs ship separate from the Vapormist.

Mount the Vapormist and SDU to wall studs using the template on the box. Two lag bolts are provided with each unit.

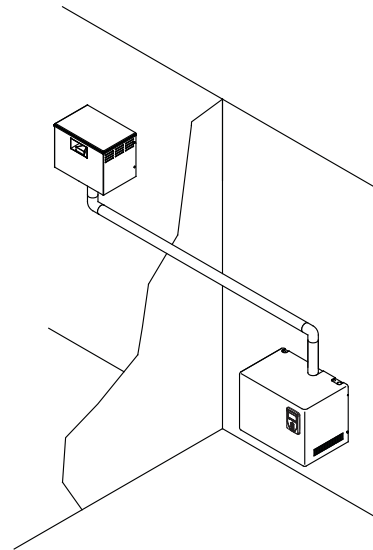
Provide at least 6" (152 mm) clearance on each side of an SDU when mounted remotely. For required SDU-E clearances see Table 22-1.

SDU-I is available for Vapormist humidifier models VM-2 through VM-8, and all VM-10 models except those using 240V, three-phase power with SSR control.

SDU-E is available for all Vapormist humidifiers except VM-2 and models using 240V, 277V, and 480V three-phase power with the SSR control option and drawing more than 21.7 amps.

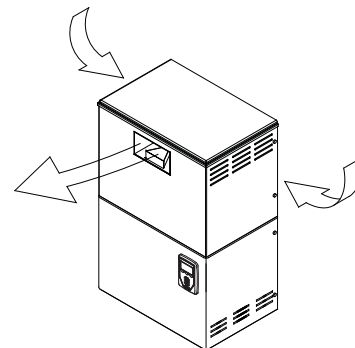
Figure 20-1:
SDU mounting options

Remote from Vapormist



OM-56-1

Directly above Vapormist



OM-55-1

Dispersion: SDU

Figure 21-1:
Wall-mounted Vapormist and SDU-I

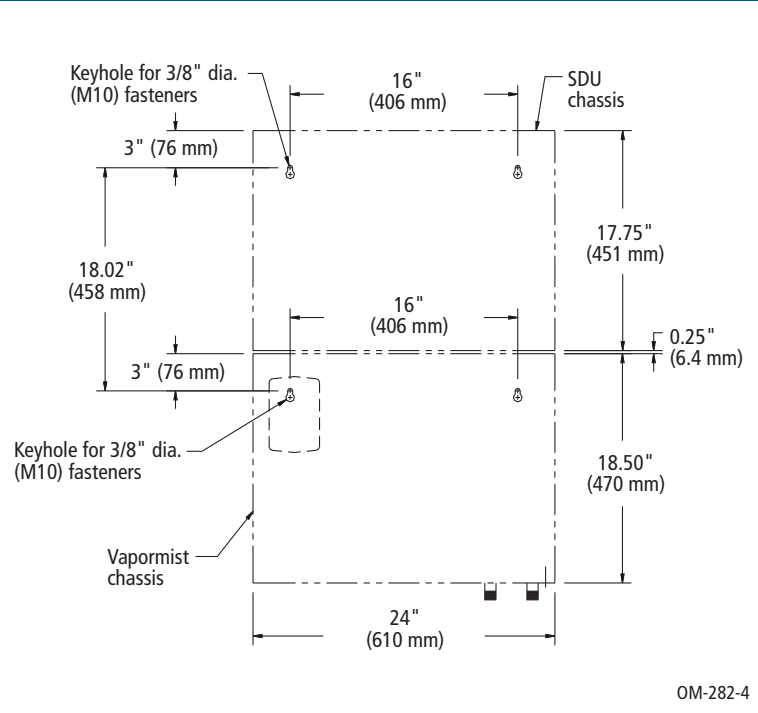
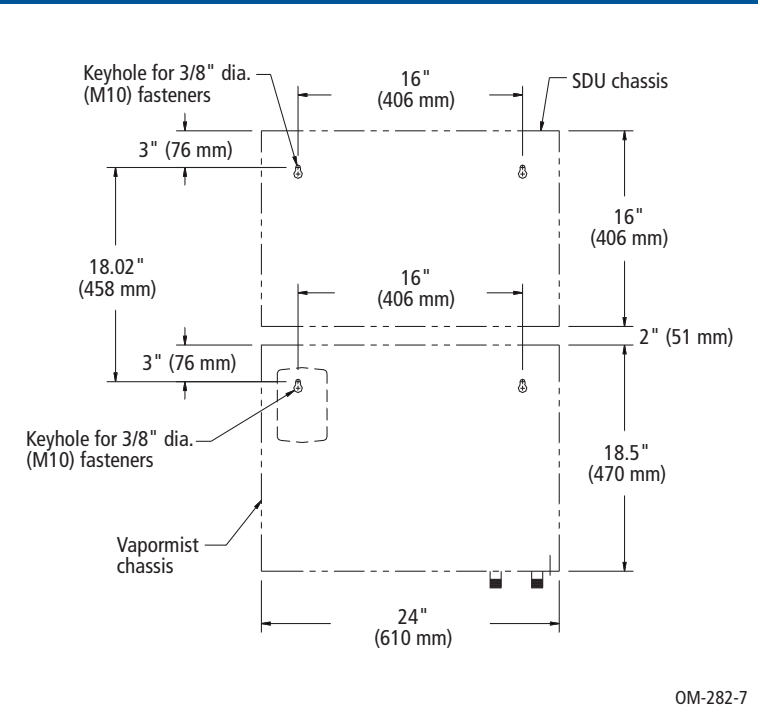
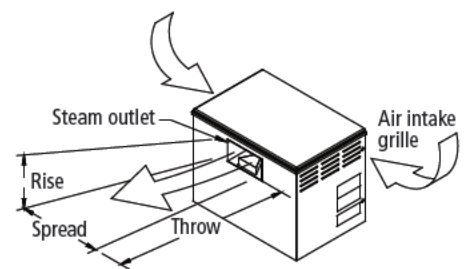


Figure 21-2:
Wall-mounted Vapormist with SDU-E



Dispersion: SDU

**Figure 22-1:
SDU-E rise, spread, and throw**



mc_042710_1435

DC-1027

As steam is discharged from the SDU-E, it quickly cools and turns to a visible fog that is lighter than air. As this fog is carried away from the SDU-E by the airstream, it tends to rise toward the ceiling. If this fog contacts solid surfaces (columns, beams, ceiling, pipes, etc.) before it disappears, it could collect and drip as water. The greater the space relative humidity, the more the fog will rise, throw and spread.

Table 22-1 lists the minimum rise, throw and spread non-wetting distances for SDU-E at 40%, 50% and 60% RH in the space. Surfaces cooler than ambient temperature, or objects located within this minimum dimension, can cause condensation and dripping. To avoid steam impingement on surrounding areas, observe the minimum non-wetting distances in Table 22-1.

The SDU-E contains a blower (120 V, single-phase, 60 Hz) and an airflow proving switch (field-wired to the humidifier electrical panel). A wiring diagram of the SDU-E is included with the unit.

On a call for humidity, the humidifier begins producing steam, and the start relay energizes the SDU-E blower. When the call for humidity is satisfied, the Vapor-logic4 controller keeps the blower running to disperse residual moisture using a time delay.

mc_042710_1255

**Table 22-1:
SDU-E minimum nonwetting distances**

kW	Maximum steam capacity		40% RH @ 70 °F (21 °C)						50% RH @ 70 °F (21 °C)						60% RH @ 70 °F (21 °C)					
			Rise		Spread		Throw		Rise		Spread		Throw		Rise		Spread		Throw	
	lbs/hr	kg/h	ft	m	ft	m	ft	m	ft	m	ft	m	ft	m	ft	m	ft	m	ft	m
2	6	2.7	1.0	0.3	1.0	0.3	5.0	1.5	1.5	0.5	1.5	0.5	6.5	2.0	2.5	0.8	2.5	0.8	7.5	2.3
4	12	5.4	1.0	0.3	1.0	0.3	5.0	1.5	1.5	0.5	1.5	0.5	6.5	2.0	2.5	0.8	2.5	0.8	7.5	2.3
6	18	8.2	1.0	0.3	1.0	0.3	5.0	1.5	1.5	0.5	1.5	0.5	6.5	2.0	2.5	0.8	2.5	0.8	7.5	2.3
8	24	10.9	1.0	0.3	1.0	0.3	5.5	1.7	1.5	0.5	1.5	0.5	6.5	2.0	2.5	0.8	2.5	0.8	7.5	2.3
10	30	13.6	1.5	0.5	1.5	0.5	6.0	1.8	2.0	0.6	2.0	0.6	7.0	2.1	3.0	1.0	3.0	1.0	8.0	2.5
12	36	16.3	1.5	0.5	1.5	0.5	6.0	1.8	2.0	0.6	2.0	0.6	7.0	2.1	3.0	1.0	3.0	1.0	8.0	2.5
14	42	19.1	2.0	0.6	2.0	0.6	7.0	2.1	2.0	0.6	2.0	0.6	7.0	2.1	3.0	1.0	3.0	1.0	9.0	2.7
16	48	21.8	2.0	0.6	2.0	0.6	7.0	2.1	2.0	0.6	2.0	0.6	7.0	2.1	3.0	1.0	3.0	1.0	9.0	2.7
21	63	28.6	2.0	0.6	2.0	0.6	7.5	2.3	2.5	0.8	2.5	0.8	10.0	3.0	3.0	1.0	3.0	1.0	12.0	3.7
25	75	34.0	2.0	0.6	2.0	0.6	8.0	2.5	2.5	0.8	2.5	0.8	10.5	3.2	3.5	1.1	3.5	1.1	12.5	3.8
30	90	40.9	2.0	0.6	2.0	0.6	8.0	2.5	2.5	0.8	2.5	0.8	10.5	3.2	3.5	1.1	3.5	1.1	12.5	3.8
34	102	46.3	2.0	0.6	2.0	0.6	8.0	2.5	2.5	0.8	2.5	0.8	10.5	3.2	3.5	1.1	3.5	1.1	12.5	3.8

Notes:

- Surfaces or objects directly in the path of vapor discharge may cause condensation and dripping.
- To avoid steam impingement on surrounding areas, observe the minimum nonwetting dimensions in this table.
- Rise: The minimum nonwetting height above the steam outlet of the SDU-E.
- Spread: The minimum nonwetting width from the steam outlet of the SDU-E.
- Throw: The minimum nonwetting horizontal distance from the steam outlet of the SDU-E.

mc_042710_1300

Dispersion: SDU

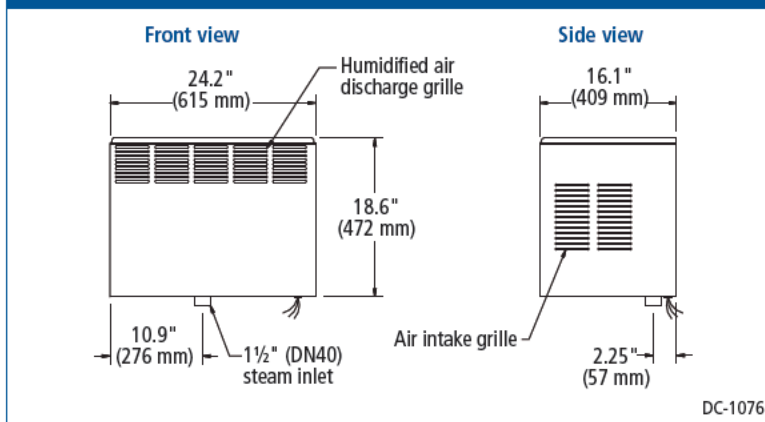
**Table 23-1:
SDU specifications****

SDU model	Maximum capacity		Shipping weight		Amps at 120V (50/60 Hz)	Horsepower	cfm	m³/s	dB*
	lbs/hr	kg/h	lbs	kg					
SDU-E	102	46.3	61	28	2.07	1/8	545	0.26	64
SDU-I	30	13.6	68	31	3.20	1/5	760	0.36	58

* Measurement taken 6.5' (2 m) in front of SDU cabinet.
 ** For visible vapor to be absorbed completely within the SDU-I unit before being discharged as humidified air, room air must be 45% RH or less. Trying to maintain greater than 45% RH will cause visible vapor and potential for moisture collection on the discharge grille.

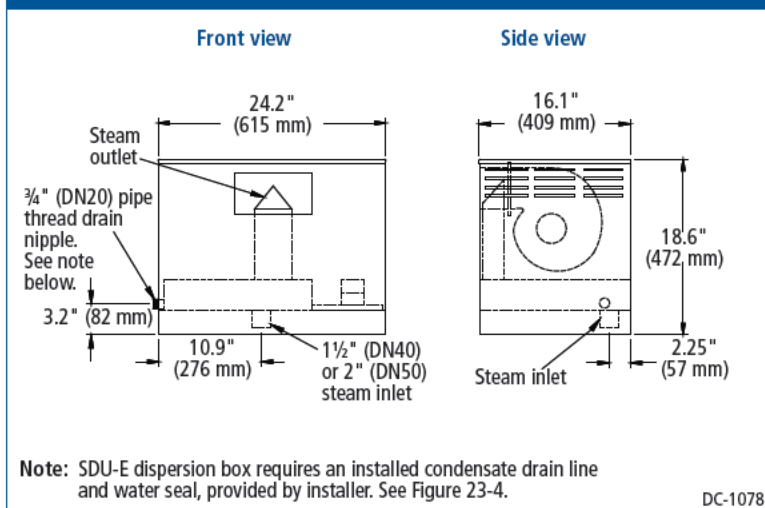
mc_042710_1440

**Figure 23-2:
SDU-I mechanical detail**



DC-1076

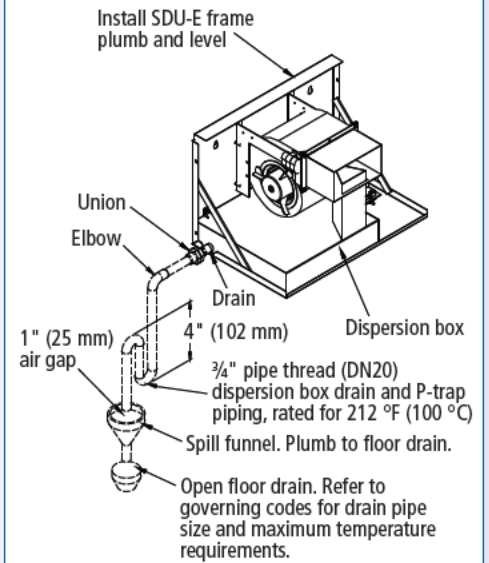
**Figure 23-3:
SDU-E mechanical detail**



Note: SDU-E dispersion box requires an installed condensate drain line and water seal, provided by installer. See Figure 23-4.

DC-1078

**Figure 23-4:
SDU-E drain line piping**



mc_042710_1445

OM-1245

Note: If using Vapormist models VM-10, VM-12, VM-14, or VM-16 with an SDU-E, the Vapormist steam outlet must be 2" to match the SDU-E steam inlet.

Conserving resources through better performance

Expect quality from the industry leader

For more than 45 years, DRI-STEEM has been leading the industry with creative and reliable humidification solutions. Our focus on quality is evident in the construction of the Vapormist humidifier, which features cleanable, stainless steel construction. DRI-STEEM also leads the industry with a Two-year Limited Warranty and optional extended warranty.

For more information

www.dristeem.com
sales@dristeem.com

For the most recent production information visit our web site:

www.dristeem.com

DRI-STEEM Corporation

An ISO 9001:2000 certified company

U.S. Headquarters:
14949 Technology Drive
Eden Prairie, MN 55344
800-328-4447 or 952-949-2415
952-229-3200 (fax)

European office:
Marc Briers
Grote Hellekensstraat 54 b
B-3520 Zonhoven
Belgium
+3211823595 (voice)
+3211817948 (fax)
E-mail: marc.briers@dristeem.com

Continuous product improvement is a policy of DRI-STEEM Corporation; therefore, product features and specifications are subject to change without notice.

DRI-STEEM, Dri-calc, Rapid-sorb, Ultra-sorb, Vapor-logic, and Vapormist are registered trademarks of DRI-STEEM Corporation and are filed for trademark registration in Canada and the European community.

Area-type and Drane-kooler are trademarks of DRI-STEEM Corporation.

Product and corporate names used in this document may be trademarks or registered trademarks. They are used for explanation only without intent to infringe.

Ultra-sorb is covered by the following Patents, with additional patents pending: United States Patent numbers 5,126,080; 5,277,849; 5,372,753; 5,376,312; 5,543,090

© 2010 DRI-STEEM Corporation



Form No. VM-CAT-0510

DRI-STEEM conserves resources by designing humidification systems that optimize performance. Systems that perform well save energy and water and, ultimately, cost less to operate and maintain.

Save energy

For applications requiring short absorption, high-efficiency dispersion tubes reduce wasted energy up to 85% by significantly reducing airstream heat gain and condensate production. Available for new and retrofit Ultra-sorb® and Rapid-sorb® steam dispersion panels.

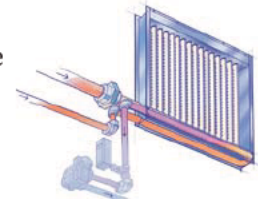


For warm, dry applications, DRI-STEEM's High-Pressure Atomizing System disperses unheated micro-fine water particles into airstreams or open spaces. As atomized water droplets evaporate, air temperature drops, reducing the cooling load. This provides significant energy savings when humidifying and cooling simultaneously.



Save water

Ultra-sorb Model XV eliminates water waste and reduces airstream heat gain, energy costs, and boiler chemical use. Available for all pressurized steam applications.



Optimize performance

DRI-STEEM's most advanced controller, Vapor-logic®4 continuously monitors space conditions to align humidifier output with demand. The result is accurate, responsive control.



Your DRI-STEEM representative is: