

**Contents:**

Section	Page
1) Purpose.....	1
2) Definitions and Notes.....	2
3) Container Assembly Numbers, Sizes, Weights and Hang Dimension.....	3
4) Container Dimension.....	12
5) Assembly Drawing Numbers.....	13

**1) Purpose**

This document provides information internal to Harrington for the selection of Steel Chain Container(Domestic production model) Part Assemblies. Steel Chain Container Assemblies are available for the following hoists:

- (N)ER2 001H – through - 200S
- (N)ER2M 001H – through - 200S
- (N)ER2P 001H – through - 200S
- (N)ER2G 001H – through - 200S

Information Provided:

- Container Assembly Part Number
- Maximum Lifts
- Weight
- Hang Dimension
- Physical Size of Chain Container

## 2) Definitions and Notes

1. Steel Chain Container Assembly = Chain Container(s), Hangers, includes Hook or Chain Container Trolley if required.
2. Part numbers for Steel Chain Container Assemblies begin with "SC2H" or "SC1H" followed by 3 digits "XXX".
3. Per capacity code (EX. 005S) the kits are the same for ER2 and NER2.
4. Weights refer to SCC kit weight only and do not include chain. For total system weight add steel chain container kit weight to hoist net weight plus additional feet of lift chain weight.

Hoist (Including Trolley) Net Weight + Weight For Additional Feet Of Lift + Steel Chain Container Kit Weight = Total System Weight

**Example:**

ER2M050L-L/S	439 lb
32 feet of Lift (total) (32-10standard lift) 22ft x 3.8 lb	83.6 lb
Steel Chain Container SC2H075	37.7 lb
<hr/>	
Total System Weight	560.3 lb

5. Hang Dimension is the distance from the bottom of the chain container to the saddle of the top hook or the where the trolley wheels rest on the beam. Refer to Figure 1 below for an illustration showing the hang dimension.

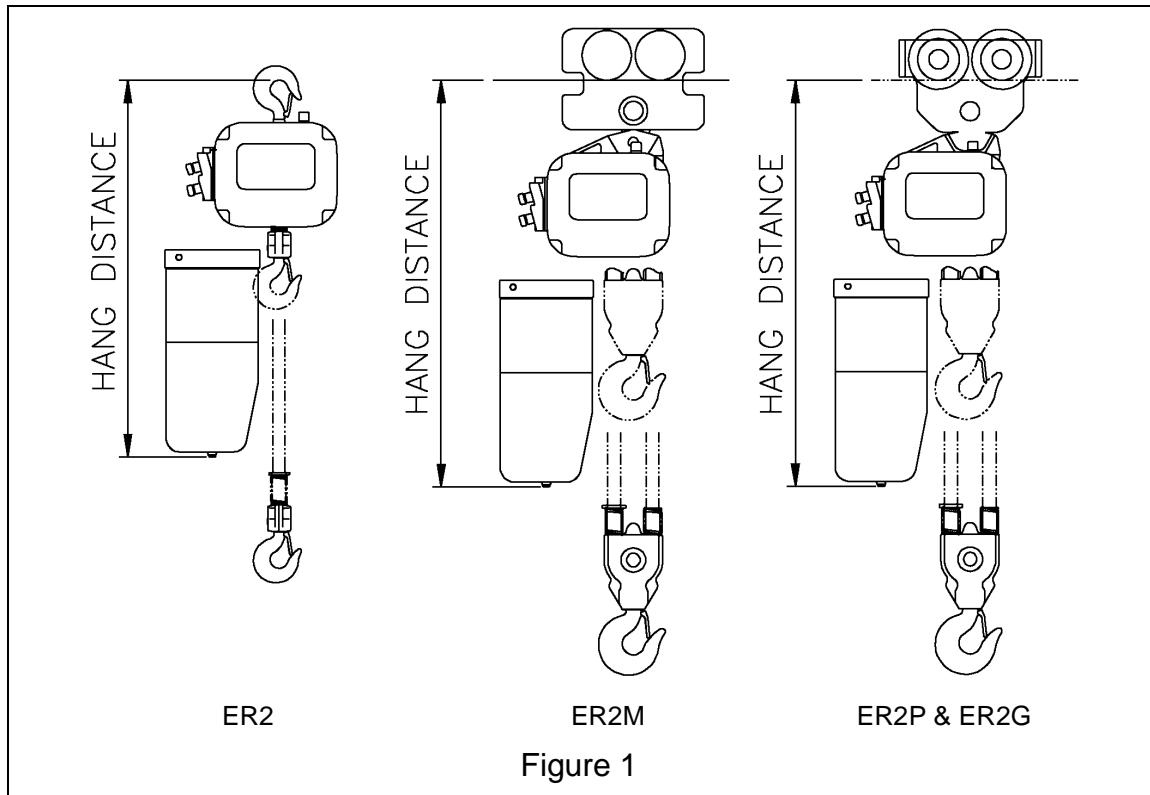

### 3) Container Assembly Numbers, Sizes, Weights and Hang Dimension

Hoist Capacity Code	Cont. Size	Lift		(N)ER2 SCC	(N)ER2M SCC	(N)ER2P/G SCC
		feet	meters	Weight (lbs) Hang Dim. (in)	Weight (lbs) Hang Dim. (in)	Weight (lbs) Hang Dim. (in)
001H 003S	AH	49	15	SC2H001 9.1 lbs 25.1 in	SC2H001 9.1 lbs 25.1 in	SC2H001 9.1 lbs 28 in
	B	141	43	SC2H011 20.7 lbs 29.6 in	SC2H028 33.5 lbs 30.8 in	SC2H045 33.5 lbs 30.4 in
	D	249	76	SC2H012 22.9 lbs 32.7 in	SC2H029 35.7 lbs 33.9 in	SC2H046 35.7 lbs 33.5 in
003H 005L 005S	AH	23	7	SC2H002 9.1 lbs 25.9 in	SC2H002 9.1 lbs 25.9 in	SC2H002 9.1 lbs 29 in
	BH	49	15	SC2H003 10.3 lbs 28.8 in	SC2H003 10.3 lbs 28.4 in	SC2H003 10.3 lbs 31.6 in
	B	78	24	SC2H013 20.7 lbs 30.4 in	SC2H030 33.5 lbs 31.2 in	SC2H047 33.5 lbs 31.2 in
	D	137	42	SC2H014 22.9 lbs 33.5 in	SC2H031 35.7 lbs 34.3 in	SC2H048 35.7 lbs 34.3 in
	F	252	77	SC2H015 24.3 lbs 35.4 in	SC2H032 37.0 lbs 36.2 in	SC2H049 37.0 lbs 36.2 in

Hoist Capacity Code	Cont. Size	Lift		(N)ER2 SCC Weight (lbs)	(N)ER2M SCC Weight (lbs)	(N)ER2P/G SCC Weight (lbs)
		feet	meters	Hang Dim. (in)	Hang Dim. (in)	Hang Dim. (in)
010L 010S	BH	26	8	SC2H004 10.3 lbs 30.4 in	SC2H004 10.3 lbs 29.6 in	SC2H004 10.3 lbs 32.4 in
	DH	49	15	SC2H005 12.5 lbs 33.2 in	SC2H005 12.5 lbs 32.4 in	SC2H005 12.5 lbs 35.5 in
	D	72	22	SC2H016 23.4 lbs 35.0 in	SC2H033 35.7 lbs 35.0 in	SC2H050 35.7 lbs 35.4 in
	F	134	41	SC2H017 25.4 lbs 37 in	SC2H034 37.7 lbs 37.4 in	SC2H051 37.7 lbs 37.4 in
	H	216	66	SC2H018 29.8 lbs 41.5 in	SC2H035 42.1 lbs 41.9 in	SC2H052 42.1 lbs 41.9 in
020C	BH	13	4	SC2H004 10.3lbs 32 in	SC2H004 10.3lbs 32 in	SC2H004 10.3lbs 31.8 in
	DH	24	7.5	SC2H005 12.5 lbs 34.7 in	SC2H005 12.5 lbs 34.7 in	SC2H005 12.5 lbs 34.5 in
	D	36	11	SC2H090 23.4 lbs 38.0 in	SC2H087 35.7 lbs 37.6 in	SC2H093 35.7 lbs 37.8 in
	F	67	20.5	SC2H091 25.4 lbs 40 in	SC2H088 37.7lbs 39.6 in	SC2H094 37.7 lbs 39.8 in
	H	108	33	SC2H092 29.8 lbs 44.5 in	SC2H089 42.1 lbs 44.1 in	SC2H095 42.1 lbs 44.3 in

Hoist Capacity Code	Cont. Size	Lift		(N)ER2 SCC	(N)ER2M SCC	(N)ER2P/G SCC
		feet	meters	Weight (lbs) Hang Dim. (in)	Weight (lbs) Hang Dim. (in)	Weight (lbs) Hang Dim. (in)
015S 020L 020S	CH	20	6	SC2H006 13.9 lbs 34.4 in	SC2H006 13.9 lbs 32.8 in	SC2H006 13.9 lbs 36.7 in
	EH	39	12	SC2H007 18.2 lbs 38.2 in	SC2H007 18.2 lbs 36.6 in	SC2H007 18.2 lbs 40.9 in
	F	78	24	SC2H019 25.6 lbs 39.8 in	SC2H036 37.7 lbs 40.2 in	SC2H053 37.7 lbs 40.2 in
	H	124	38	SC2H020 30.0 lbs 44.3 in	SC2H037 42.1 lbs 44.7 in	SC2H054 42.1 lbs 44.7 in
	K	252	77	SC2H021 38.8 lbs 52.8 in	SC2H038 50.5 lbs 52.8 in	SC2H055 50.5 lbs 52.8 in

Hoist Capacity Code	Cont. Size	Lift		(N)ER2 SCC Weight (lbs) Hang Dim. (in)	(N)ER2M SCC Weight (lbs) Hang Dim. (in)	(N)ER2P/G SCC Weight (lbs) Hang Dim. (in)
		feet	meters			
025S	DH	20	6	SC2H008 15.8 lbs 37.9 in	SC2H008 15.8 lbs 37.1 in	SC2H008 15.8 lbs 40.7 in
	FH	39	12	SC2H009 19.3 lbs 41.3 in	SC2H009 19.3 lbs 40.2 in	SC2H009 19.3 lbs 43.7 in
	F	65	20	SC2H025 25.6 lbs 41.3 in	SC2H039 37.7 lbs 41.7 in	SC2H059 37.7 lbs 41.7 in
	H	105	32	SC2H026 30.0 lbs 45.9 in	SC2H040 42.1 lbs 46.3 in	SC2H060 42.1 lbs 46.3 in
	K	210	64	SC2H027 38.8 lbs 54.4 in	SC2H041 50.5 lbs 54.4 in	SC2H061 50.5 lbs 54.4 in
030C	CH	10	3	SC2H006 13.9 lbs 38.3 in	SC2H006 13.9 lbs 35.5 in	SC2H006 13.9 lbs 38.3 in
	EH	20	6	SC2H007 18.2 lbs 42.1 in	SC2H007 18.2 lbs 39.4 in	SC2H007 18.2 lbs 42.5 in
	F	39	12	SC2H022 25.6 lbs 42.9 in	SC2H068 37.7 lbs 42.5 in	SC2H056 37.7 lbs 42.5 in
	H	62	19	SC2H023 30.0 lbs 47.4 in	SC2H069 42.1 lbs 47 in	SC2H057 42.1 lbs 47 in
	K	126	38.5	SC2H024 38.8 lbs 55.9 in	SC2H070 50.5 lbs 55.5 in	SC2H058 50.5 lbs 55.5 in
030L	FH	23	7	SC1H008 22.8 lbs 41.2 in	SC1H008 37.3 lbs 41.1 in	SC1H008 37.6 lbs 41.2 in
	F	49	15	SC1H134 28.3 lbs 42.2 in	SC1H135 42.8 lbs 42 in	SC1H136 43.1 lbs 42.2 in
	H	82	25	SC1H122 33.8 lbs 46.7 in	SC1H143 48.3 lbs 46.5 in	SC1H144 48.6 lbs 46.7 in
	K	164	50	SC1H202 50.6 lbs 55.3 in	SC1H203 65.1 lbs 55.1 in	SC1H204 65.4 lbs 55.3 in

Hoist Capacity Code	Cont. Size	Lift		(N)ER2 SCC Weight (lbs) Hang Dim. (in)	(N)ER2M SCC Weight (lbs) Hang Dim. (in)	(N)ER2P/G SCC Weight (lbs) Hang Dim. (in)
		feet	meters			
050L	DH	10	3	SC2H008 15.8 lbs 42.2 in	SC2H008 15.8 lbs 40.7 in	SC2H008 15.8 lbs 42.2 in
	FH	20	6	SC2H009 19.3 lbs 45.3 in	SC2H009 19.3 lbs 43.3 in	SC2H009 19.3 lbs 45.3 in
	F	32	10	SC2H065 25.6 lbs 44.9 in	SC2H042 37.7 lbs 44.9 in	SC2H062 37.7 lbs 45.3 in
	H	52	16	SC2H066 30.0 lbs 49.4 in	SC2H043 42.1 lbs 49.4 in	SC2H063 42.1 lbs 49.4 in
	K	105	32	SC2H067 38.8 lbs 57.5 in	SC2H044 50.5 lbs 58.3 in	SC2H064 50.5 lbs 58.3 in

**SCC KIT FOR 8 WHEEL CONFIGURATION DESIGN**

050L Patented Track	F	32	10		SC2H190 37.7 lbs 40.2 in	SC2H194 37.7 lbs 40.3 in
	H	52	16		SC2H192 42.1 lbs 44.7 in	SC2H195 42.1 lbs 44.7 in
	K	105	32		SC2H193 50.5 lbs 53.9 in	SC2H196 50.5 lbs 53.9 in

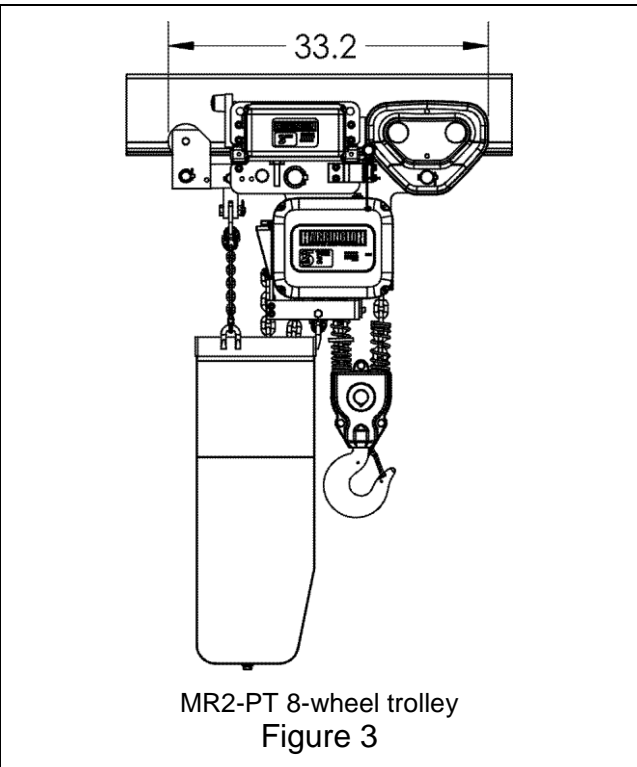
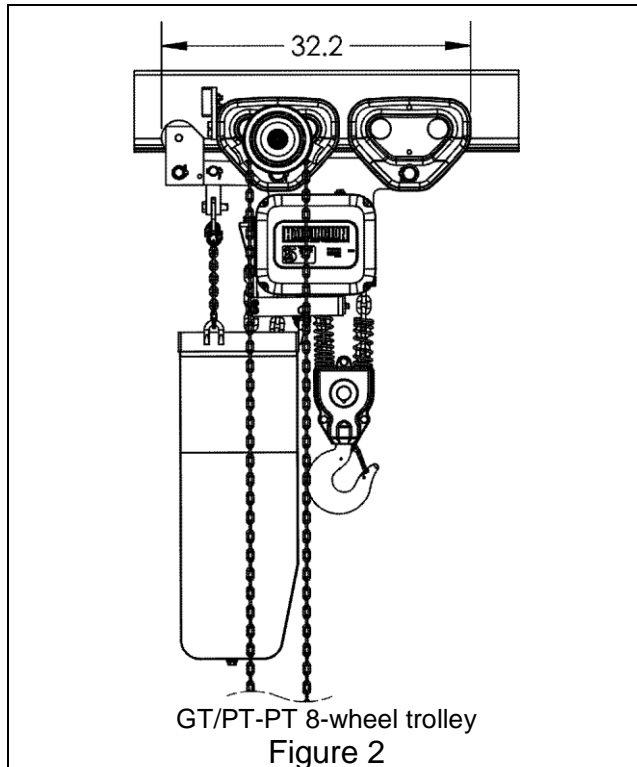

Chain container shown is for illustration only.

Hoist Capacity Code	Cont. Size	Lift		*(N)ER2 LUG-MT SCC Weight (lbs) Hang Dim. (in)	(N)ER2M SCC Weight (lbs) Hang Dim. (in)	(N)ER2P/G SCC Weight (lbs) Hang Dim. (in)
		feet	meters			
080S	F	21	6.6	SC2H071 24.9 lbs 43.3 in	SC2H074 37.7 lbs 48 in	SC2H096 37.7 lbs 48.8 in
	H	34	10.6	SC2H072 29.3 lbs 47.8 in	SC2H075 42.1 lbs 52.5 in	SC2H097 42.1 lbs 53.3 in
	K	70	21.3	N/A	SC2H076 50.5 lbs 61.4 in	SC2H098 50.5 lbs 61.4 in
100L	F	16	5	SC2H077 24.9 lbs 43.3 in	SC2H079 37.7 lbs 48 in	SC2H099 37.7 lbs 48.8 in
	H	26	8	SC2H078 29.3 lbs 47.8 in	SC2H080 42.1 lbs 52.5 in	SC2H100 42.1 lbs 53.3 in
	K	52	16	N/A	SC2H081 50.5 lbs 61.4 in	SC2H101 50.5 lbs 61.4 in

\* Hang distance for ER080S with out trolley is measured from center of lug hole to bottom of chain container.



Hoist Capacity Code	Cont. Size	Lift		(N)ER2 SCC Weight (lbs) Hang Dim. (in)	(N)ER2M SCC Weight (lbs) Hang Dim. (in)	(N)ER2P/G SCC Weight (lbs) Hang Dim. (in)
		feet	meters			
100S*	DH	10	3	SC2H082 31.5 lbs 50.5 in	SC2H082 31.5 lbs 43.4 in	SC2H082 31.5 lbs 43.4 in
	FH	20	6	SC2H083 38.6 lbs 53.5 in	SC2H083 38.6 lbs 46.5 in	SC2H083 38.6 lbs 46.5 in
	F	32	10	SC2H084 51.1 lbs 55.5 in	SC2H084 51.1 lbs 48.8 in	SC2H084 51.1 lbs 48.8 in
	H	52	16	SC2H085 60.0 lbs 60 in	SC2H085 60.0 lbs 53.3 in	SC2H085 60.0 lbs 53.3 in
	K	104	32	SC2H086 76.7 lbs 68.1 in	SC2H086 76.7 lbs 61.4 in	SC2H086 76.7 lbs 61.4 in
	(M)	164	50	Custom (Dwg: 70600)	Custom (Dwg: 70600)	Custom (Dwg: 70600)

\* Chain container assemblies for 100S, 150S and 200S include two containers to accommodate the dual hoist body configuration.

Hoist Capacity Code	Cont. Size	Lift		(N)ER2 SCC	(N)ER2M SCC	(N)ER2P/G SCC
		feet	meters	Weight (lbs) Hang Dim. (in)	Weight (lbs) Hang Dim. (in)	Weight (lbs) Hang Dim. (in)
150S*	FH	13	4	SC2H083 38.6 lbs 57.1 in	SC2H083 38.6 lbs 46.8 in	SC2H083 38.6 lbs 46.8 in
	F	21	6.6	SC2H084 51.1 lbs 59.4 in	SC2H084 51.1 lbs 48.8 in	SC2H084 51.1 lbs 48.8 in
	H	34	10.6	SC2H085 60.0 lbs 64 in	SC2H085 60.0 lbs 53.3 in	SC2H085 60.0 lbs 53.3 in
	K	68	21.3	SC2H086 76.7 lbs 72.1 in	SC2H086 76.7 lbs 61.8 in	SC2H086 76.7 lbs 61.8 in
	(M)	109	33.3	Custom (Dwg: 70600)	Custom (Dwg: 70600)	Custom (Dwg: 70600)
200S*	FH	9	3	SC2H083 38.6 lbs 60.2 in	SC2H083 38.6 lbs 46.8 in	SC2H083 38.6 lbs 46.8 in
	F	16	5	SC2H084 51.1 lbs 62.6 in	SC2H084 51.1 lbs 48.8 in	SC2H084 51.1 lbs 48.8 in
	H	26	8	SC2H085 60.0 lbs 67.1 in	SC2H085 60.0 lbs 53.3 in	SC2H085 60.0 lbs 53.3 in
	K	52	16	SC2H086 76.7 lbs 75.2 in	SC2H086 76.7 lbs 61.8 in	SC2H086 76.7 lbs 61.8 in
	(M)	82	25	Custom (Dwg: 70600)	Custom (Dwg: 70600)	Custom (Dwg: 70600)

\* Chain container assemblies for 100S, 150S and 200S include two containers to accommodate the dual hoist body configuration.

#### 4) Containers Dimensions

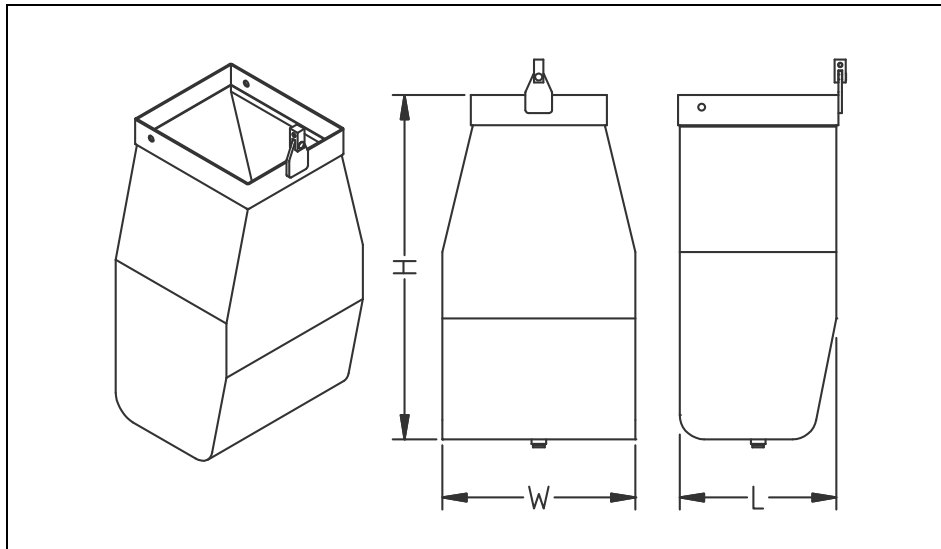

Container Size	H		L		W	
	mm	inch	mm	inch	mm	inch
AH	318	12.5	152	6	180	7
BH	381	15	152	6	180	7
CH	407	16	165	6.5	216	8.5
DH	457	18	178	7	216	8.5
EH	508	20	229	9	216	8.5
FH	534	21	229	9	216	8.5
B	432	17	254	10	216	8.5
D	508	20	254	10	216	8.5
F	559	22	254	10	322	12.7
H	673	26.5	260	10.3	322	12.7
K	864	34	311	12.3	407	16
(M)	1016	40	381	15	546	21.5

## 5) Assembly Drawing Numbers

Container Assy. No.	Drawing	Container Assy. No.	Drawing	Container Assy. No.	Drawing
SC2H001	70756	SC2H046	70843	SC2H091	70887
SC2H002	70757	SC2H047	70844	SC2H092	70896
SC2H003	70758	SC2H048	70845	SC2H093	70897
SC2H004	70759	SC2H049	70846	SC2H094	70898
SC2H005	70760	SC2H050	70847	SC2H095	70899
SC2H006	70761	SC2H051	70848	SC2H096	70900
SC2H007	70762	SC2H052	70849	SC2H097	70901
SC2H008	70763	SC2H053	70850	SC2H098	70902
SC2H009	70764	SC2H054	70851	SC2H099	70903
SC2H011	70765	SC2H055	70852	SC2H100	70904
SC2H012	70766	SC2H056	70853	SC2H101	70905
SC2H013	70767	SC2H057	70854	SC2H190	83247
SC2H014	70768	SC2H058	70855	SC2H192	83248
SC2H015	70803	SC2H059	70856	SC2H193	83249
SC2H016	70804	SC2H060	70857	SC2H194	83250
SC2H017	70805	SC2H061	70858	SC2H195	83251
SC2H018	70806	SC2H062	70859	SC2H196	83252
SC2H019	70816	SC2H063	70860	SC1H134	70908
SC2H020	70817	SC2H064	70861	SC1H135	70909
SC2H021	70818	SC2H065	70862	SC1H136	70910
SC2H022	70819	SC2H066	70863	SC1H122	70907
SC2H023	70820	SC2H067	70864	SC1H143	70911
SC2H024	70821	SC2H068	70865	SC1H144	70912
SC2H025	70822	SC2H069	70866	SC1H202	83174
SC2H026	70823	SC2H070	70867	SC1H008	70906
SC2H027	70824	SC2H071	70868	SC1H203	70913
SC2H028	70825	SC2H072	70869	SC1H204	70914
SC2H029	70826	SC2H074	70870		
SC2H030	70827	SC2H075	70871		
SC2H031	70828	SC2H076	70872		
SC2H032	70829	SC2H077	70873		
SC2H033	70830	SC2H078	70874		
SC2H034	70831	SC2H079	70875		
SC2H035	70832	SC2H080	70876		
SC2H036	70833	SC2H081	70877		
SC2H037	70834	SC2H082	70878		
SC2H038	70835	SC2H083	70879		
SC2H039	70836	SC2H084	70880		
SC2H040	70837	SC2H085	70881		
SC2H041	70838	SC2H086	70882		
SC2H042	70839	SC2H087	70883		
SC2H043	70840	SC2H088	70884		
SC2H044	70841	SC2H089	70885		
SC2H045	70842	SC2H090	70886		