

Feedthrough

SEMICONDUCTOR | ANALYTICAL EQUIPMENT | AEROSPACE | TELECOMMUNICATIONS



OIL EXPLORATION | R&D | HIGH ENERGY PHYSICS | MILITARY/DEFENSE | BIOTECHNOLOGY



*Advanced Ceramic-to-Metal &
Glass-Ceramic Sealing Technology*

Description

Feedthrough: An assembly which provides for the transfer of electrical power, gases or fluids from outside a hermetic chamber to the inside. Feedthroughs can provide both a hermetic seal and electrical isolation from the chamber wall. Feedthroughs are sometimes referred to as 'passthroughs.'

CeramTec feedthroughs provide the solutions for applications requiring hermeticity and electrical isolation. In addition to remaining leak-free in high and ultra-high vacuum, many of Ceramaseal® feedthroughs can accommodate:

- High temperatures
- Cryogenic temperatures
- High pressure
- Aggressive chemicals

A feedthrough is basically defined by the requirements for installation, insulation, and conductor material. The method of interconnection is flexible and left to the customer's discretion. A selection of push-on contacts can be found in the Accessories section of this catalog.

Standard Specifications

- Voltages to 100 kV
- Current to 1000 Amps
- Up to 41 conductors
- Temperature Range: -269° C to 450° C
- Internal Pressure 1 x 10⁻¹⁰ torr to 3000 psig

Extreme / Custom Design

- Multiple feedthrough flange assemblies
- 940-pin header assembly
- Corona-free designs to 180 kV DC
- Currents in excess of 2,500 Amps
- Pressures to 30,000 psig



Installation

Standard installation mountings include:

- Braze
- Weld (Pulse-TIG, TIG, Laser, E-Beam)
- ISO KF flange
- ConFlat flange
- NPT fitting (see Pressure section)
- 1" Baseplate

Applications

A few of the many applications in which these feedthroughs are commonly used are:

- Semiconductor processing equipment
- Particle accelerators
- Furnaces
- Analytical equipment
- In-vacuum coating
- Satellite instrumentation
- X-ray detection equipment









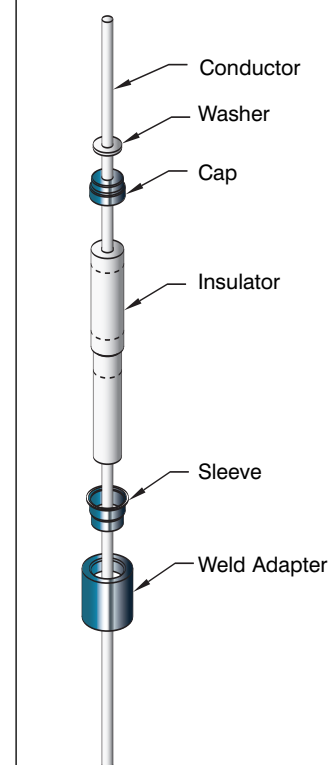

New Products

- New high-density, low current feedthroughs
- Micro & Mini HV (high voltage) feedthroughs with mating air side cable assemblies
- 40 & 50 kV feedthroughs with mating air side cable assemblies

- .154 & .250 Power Plugs for safe high voltage and high current connectivity

Typical Feedthrough Construction



Type	Voltage DC	Current (Amps per conductor)	# of Conductors	Conductor Size (in inches)	Sub-section	Section Pages
	to 2 kV	to 16 Amps	1 to 8	0.032 & 0.042	Instrumentation / Power	A.1 14-15
	to 6 kV	to 27 Amps	1 to 4	0.050	Power	A.2 16-17
	to 5 kV	5 Amps	4 to 10	0.062	Pin Header	A.3 18-19
	1 kV	5 Amps	3 to 41	0.040	Multipin Header	A.4 20-21
	to 15 kV	7.5 Amps	1 to 4	0.030 & 0.037	Micro & Mini HV	A.5 22-25
	to 25 kV	to 185 Amps	1 to 4	0.094, 0.154 & 0.250	Power Plug	A.6 26-35
	8 kV	to 1000 Amps	1 to 2	0.250, 0.500 & 0.750	High Power - Liquid Cooled	A.7 36-41
	to 100 kV	to 10 Amps	1	0.062 & 0.156	High Voltage	A.8 42-47
	to 14 kV	to 300 Amps	1 to 2	0.250	RF Power - Liquid Cooled	A.9 48-49
	to 15 kV	to 185 Amps	1 to 4	0.050, 0.094 & 0.250	Baseplate	A.10 50-51

Weld/Braze - Superthru

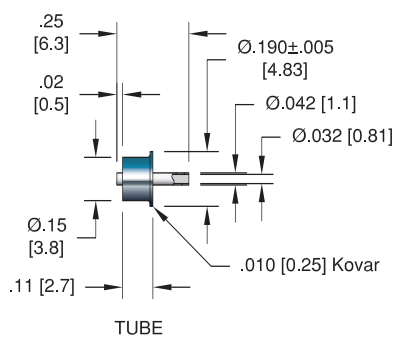
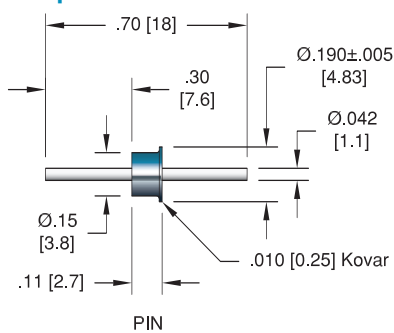

Weldable - One Conductor

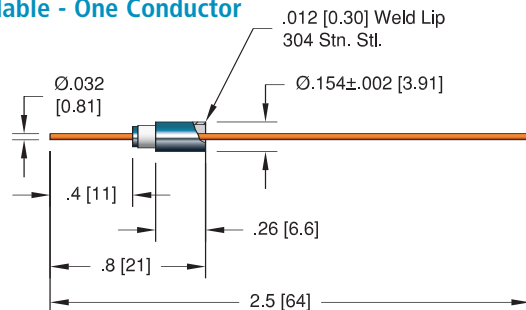

Weldable - 2, 4, & 8 Conductor

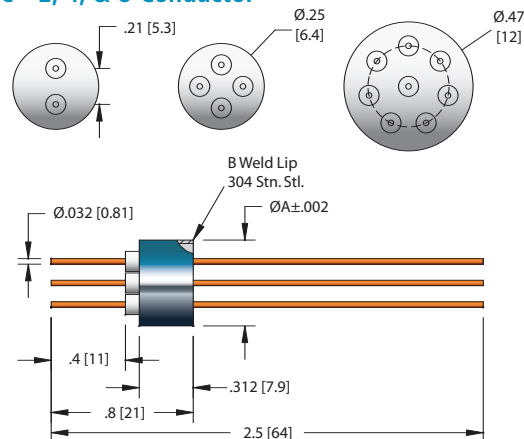

ISO KF - 2, 4, & 8 Conductor

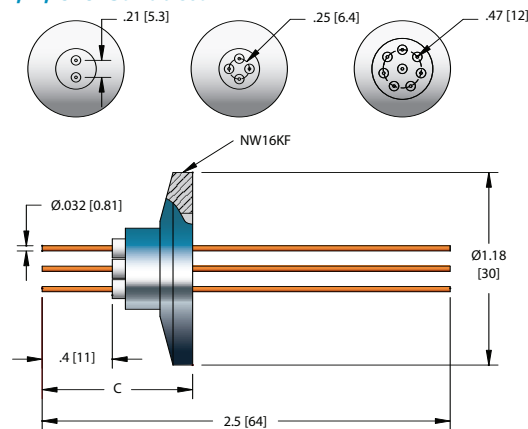

ConFlat - 2, 4, & 8 Conductor

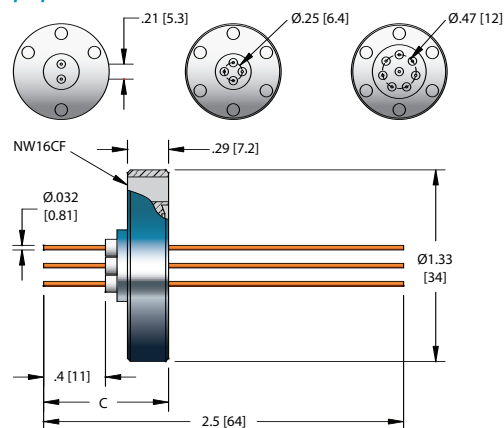

Specifications — Superthru

Materials

Housing: Kovar
Pin/Tube: Pin-Molybdenum, Tube-Kovar
Insulation: Alumina ceramic
Magnetic Materials: Yes

Voltage Rating 500 V DC

Current Rating See table

Temperature Range -80°C to 450°C

Pressure @ 20°C 2500 PSIG (172 Bar), ISO KF 0 PSIG

Specifications — 1, 2, 4, & 8 Conductor

Materials

Housing: 304 Stainless steel
Pin: See table
Insulation: Alumina ceramic
Magnetic Materials: See table

Voltage Rating See table

Current Rating See table

Temperature Range -269°C to 450°C, ISO KF -25°C to 205°C

Pressure @ 20°C ISO KF 0 PSIG

Single pin: 3500 PSIG (241 Bar)
2 & 4 pin: 1400 PSIG (96 Bar)
8 pin: 500 PSIG (34 Bar)



FEEDTHROUGH

Weld or Braze Superthru

INSTALLATION	VOLTAGE DC	CONDUCTOR AMPS*	MATERIAL	PART NUMBER
Weld or Braze	500	-	Kovar Tube	9809-01-W
Weld or Braze	500	11.5	Molybdenum	9809-02-W

*Current carrying capacity of the tubular feedthroughs varies based on the coolant used and the flow rate.

Weldable Single Pin

NO. PINS	INSTALLATION	VOLTAGE DC	CONDUCTOR AMPS	MATERIAL	A	DIMENSIONS B	C	MAGNETIC MATERIALS	PART NUMBER
1	Weld	1 kV	1.1	304 Stn. Stl.	-	-	-	No	9297-03-W
1	Weld	1 kV	5	Nickel	-	-	-	Yes	9297-01-W
1	Weld	1 kV	8.5	Molybdenum	-	-	-	No	9297-06-W
1	Weld	1 kV	16	Copper	-	-	-	No	9297-08-W
2	Weld	2 kV	1.1	304 Stn. Stl.	0.497 [12.62]	.020 [0.51]	-	No	9298-07-W
2	Weld	2 kV	5	Nickel	0.497 [12.62]	.020 [0.51]	-	Yes	9298-01-W
2	Weld	2 kV	8.5	Molybdenum	0.497 [12.62]	.020 [0.51]	-	No	9298-05-W
2	Weld	2 kV	16	Copper	0.497 [12.62]	.020 [0.51]	-	No	9298-06-W
4	Weld	2 kV	1.1	304 Stn. Stl.	0.497 [12.62]	.020 [0.51]	-	No	9299-05-W
4	Weld	2 kV	5	Nickel	0.497 [12.62]	.020 [0.51]	-	Yes	9299-01-W
4	Weld	2 kV	8.5	Molybdenum	0.497 [12.62]	.020 [0.51]	-	No	9299-04-W
4	Weld	2 kV	16	Copper	0.497 [12.62]	.020 [0.51]	-	No	9299-06-W
8	Weld	1.5 kV	1.1	304 Stn. Stl.	0.747 [18.97]	.035 [0.89]	-	No	9294-03-W
8	Weld	1.5 kV	5	Nickel	0.747 [18.97]	.035 [0.89]	-	Yes	9294-01-W
8	Weld	1.5 kV	8.5	Molybdenum	0.747 [18.97]	.035 [0.89]	-	No	9294-04-W
8	Weld	1.5 kV	16	Copper	0.747 [18.97]	.035 [0.89]	-	No	9294-08-W

Weldable 2, 4, & 8 Pin

ISO FLANGE

2	NW16KF	2 kV	1.1	304 Stn. Stl.	-	-	.9 [23]	No	17006-01-KF
2	NW16KF	2 kV	5	Nickel	-	-	.9 [23]	Yes	17006-02-KF
2	NW16KF	2 kV	8.5	Molybdenum	-	-	.9 [23]	No	17006-03-KF
2	NW16KF	2 kV	16	Copper	-	-	.9 [23]	No	17006-04-KF
4	NW16KF	2 kV	1.1	304 Stn. Stl.	-	-	.9 [23]	No	17007-01-KF
4	NW16KF	2 kV	5	Nickel	-	-	.9 [23]	Yes	17007-02-KF
4	NW16KF	2 kV	8.5	Molybdenum	-	-	.9 [23]	No	17007-03-KF
4	NW16KF	2 kV	16	Copper	-	-	.9 [23]	No	17007-04-KF
8	NW16KF	1.5 kV	1.1	304 Stn. Stl.	-	-	1.3 [34]	No	17008-01-KF
8	NW16KF	1.5 kV	5	Nickel	-	-	1.3 [34]	Yes	17008-02-KF
8	NW16KF	1.5 kV	8.5	Molybdenum	-	-	1.3 [34]	No	17008-03-KF
8	NW16KF	1.5 kV	16	Copper	-	-	1.3 [34]	No	17008-04-KF

ISO KF 2, 4, & 8 Pin

CONFLAT FLANGE

2	1 1/3" (NW16CF)	2 kV	1.1	304 Stn. Stl.	-	-	.9 [23]	No	17046-01-CF
2	1 1/3" (NW16CF)	2 kV	5	Nickel	-	-	.9 [23]	Yes	17046-02-CF
2	1 1/3" (NW16CF)	2 kV	8.5	Molybdenum	-	-	.9 [23]	No	17046-03-CF
2	1 1/3" (NW16CF)	2 kV	16	Copper	-	-	.9 [23]	No	17046-04-CF
4	1 1/3" (NW16CF)	2 kV	1.1	304 Stn. Stl.	-	-	.9 [23]	No	17048-01-CF
4	1 1/3" (NW16CF)	2 kV	5	Nickel	-	-	.9 [23]	Yes	17048-02-CF
4	1 1/3" (NW16CF)	2 kV	8.5	Molybdenum	-	-	.9 [23]	No	17048-03-CF
4	1 1/3" (NW16CF)	2 kV	16	Copper	-	-	.9 [23]	No	17048-04-CF
8	1 1/3" (NW16CF)	1.5 kV	1.1	304 Stn. Stl.	-	-	1.3 [34]	No	9340-06-CF
8	1 1/3" (NW16CF)	1.5 kV	5	Nickel	-	-	1.3 [34]	Yes	9340-01-CF
8	1 1/3" (NW16CF)	1.5 kV	8.5	Molybdenum	-	-	1.3 [34]	No	9340-04-CF
8	1 1/3" (NW16CF)	1.5 kV	16	Copper	-	-	1.3 [34]	No	9340-05-CF

ConFlat 2, 4, & 8 Pin

Contacts

TYPE	MATERIAL	DESCRIPTION	PART NUMBER
0.032 Crimp Contacts	Beryllium Copper	Accepts wire up to 0.032 [0.81]	11288-02-X†
0.042 Crimp Contacts	Stainless Steel - Gold Plated	Accepts wire up to 0.030 [0.76]	14461-04-A
Crimp Tool		For 0.025" - 0.075" Crimp Diameters	2840-05

*Contacts priced and sold in packages of 10. **Contacts priced and sold in packages of 5. †Shown in photo. See the Accessories section for more information on all accessories.



Specifications

Materials

Housing: 304 Stainless steel
 Pin/Tube: See table
 Insulation: Alumina ceramic
 Magnetic Materials: See table

Voltage Rating See table

Current Rating See table

Temperature Range -269°C to 450°C, ISO KF -25°C to 205°C

Pressure @ 20°C ISO KF 0 PSIG

Single Pin: 3500 PSIG (241 Bar)

2 & 4 Pin: 1250 PSIG (86 Bar)

Weldable - Single Pin

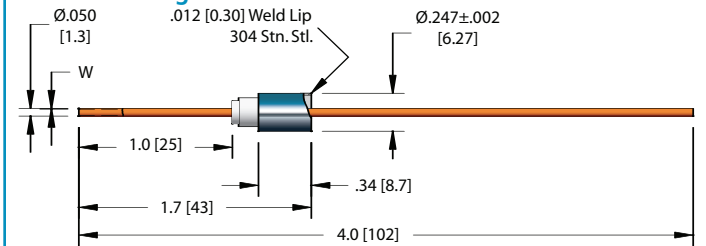

Weldable - 2 & 4 Pin

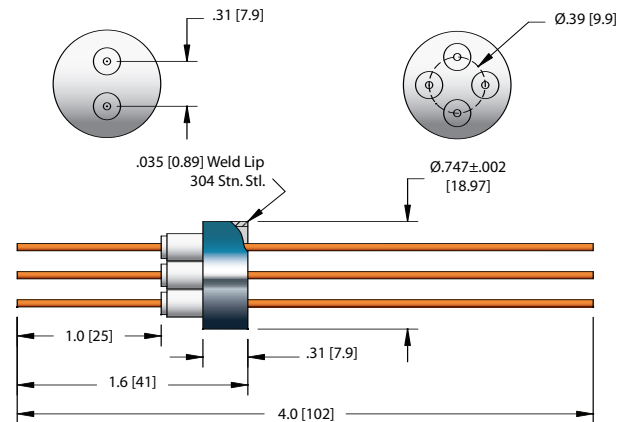

ISO KF - 2 & 4 Pin

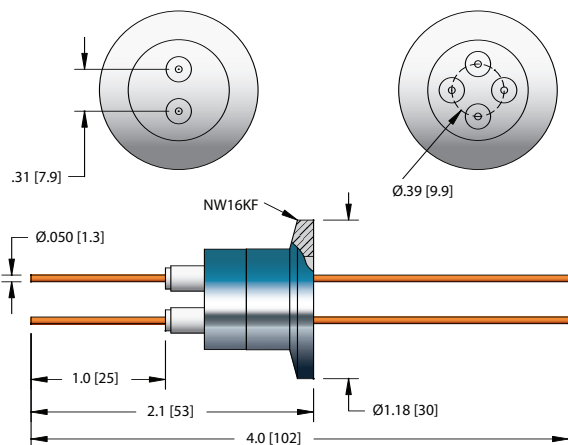

ConFlat - 2 & 4 Pin 6 kV

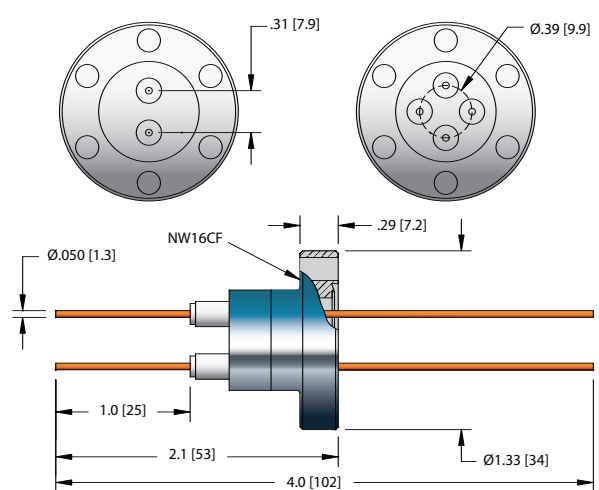



NO. PINS	INSTALLATION	VOLTAGE DC	AMPS*	CONDUCTOR MATERIAL	W	MAGNETIC MATERIALS	PART NUMBER
1	Weld	5 KV	1.8	304 Stn. Stl.	-	No	9791-04-W
1	Weld	5 KV	8.2	Nickel	-	Yes	9791-02-W
1	Weld	5 KV	27	Copper	-	No	9791-08-W
1	Weld	5 KV	-	Nickel Tube	.005	Yes	9791-06-W

*Current carrying capacity of the tubular feedthroughs varies based on the coolant used and the flow rate.

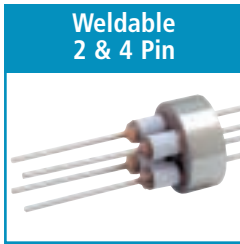

2	Weld	6 KV	1.8	304 Stn. Stl.	-	No	9215-04-W
2	Weld	6 KV	8.2	Nickel	-	Yes	9215-02-W
2	Weld	6 KV	27	Copper	-	No	9215-08-W
4	Weld	6 KV	1.8	304 Stn. Stl.	-	No	9216-04-W
4	Weld	6 KV	8.2	Nickel	-	Yes	9216-02-W
4	Weld	6 KV	27	Copper	-	No	9216-08-W

ISO FLANGE



2	NW16KF	6 KV	1.8	304 Stn. Stl.	-	No	17018-01-KF
2	NW16KF	6 KV	8.2	Nickel	-	Yes	17018-02-KF
2	NW16KF	6 KV	27	Copper	-	No	17018-04-KF
4	NW16KF	6 KV	1.8	304 Stn. Stl.	-	No	17019-01-KF
4	NW16KF	6 KV	8.2	Nickel	-	Yes	17019-02-KF
4	NW16KF	6 KV	27	Copper	-	No	17019-04-KF

CONFLAT FLANGE

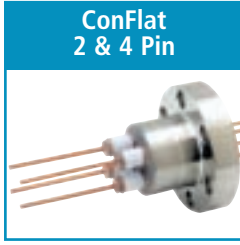

2	1 1/3" (NW16CF)	6 KV	1.8	304 Stn. Stl.	-	No	9871-02-CF
2	1 1/3" (NW16CF)	6 KV	8.2	Nickel	-	Yes	9871-01-CF
2	1 1/3" (NW16CF)	6 KV	27	Copper	-	No	9871-04-CF
4	1 1/3" (NW16CF)	6 KV	1.8	304 Stn. Stl.	-	No	9871-06-CF
4	1 1/3" (NW16CF)	6 KV	8.2	Nickel	-	Yes	9871-05-CF
4	1 1/3" (NW16CF)	6 KV	27	Copper	-	No	9871-08-CF

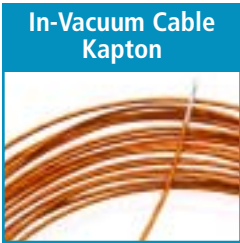

VOLTAGE DC	CONDUCTOR AMPS	GAUGE	TYPE	LENGTH	WIRE DIAMETER	INSULATION DIAMETER	PART NUMBER
850 V	2.5	28 AWG	Stranded	30'	7 x 0.005	Ø .028	21621-01-A
850 V	5	22 AWG	Stranded	30'	19 x 0.0063	Ø .035	21643-01-A
850 V	20	12 AWG	Stranded	15'	37 x 0.013	Ø .101	21702-02-A
Adjustable wire stripper, 20-30 AWG (.25-.80mm)							21128-01

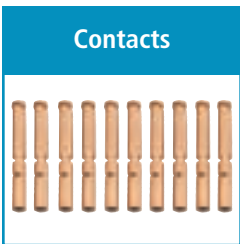

TYPE	MATERIAL	DESCRIPTION	PART NUMBER
0.050 Crimp Contacts	Beryllium Copper	Accepts wire up to 0.062 [1.6]	11911-02-X†
0.050 Set Screw Contacts	Beryllium Copper	Accepts wire up to 0.050 [1.3]	7429-02-A
0.050 Barrel Type Contacts	Beryllium Copper	Accepts wire up to 0.050 [1.3]	7332-02-A
Crimp Tool		For 0.025" - 0.075" Crimp Diameters	2840-05

*Contacts priced and sold in packages of 10. †Shown in photo. See the Accessories section for more information on all accessories.

FEEDTHROUGH





Specifications

Materials

Housing: 304 Stainless steel
 Pins: Alumel
 Insulation: Alumina ceramic
 Magnetic Materials: Yes

Voltage Rating See table

Current Rating 5 Amps per pin

Temperature Range -269°C to 450°C, ISO KF -25°C to 205°C

Pressure @ 20°C ISO KF 0 PSIG

4 Pin - 600 PSIG (41 Bar)

6 Pin - 550 PSIG (38 Bar)

10 Pin - 500 PSIG (34 Bar)

Weldable

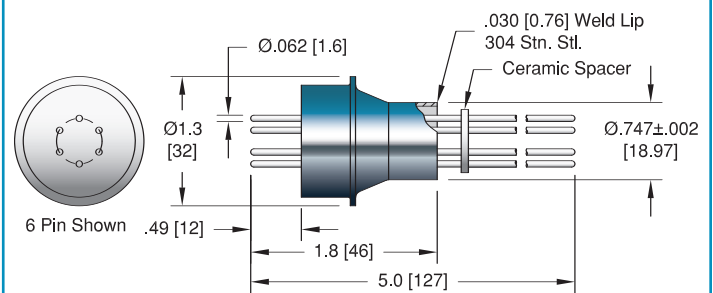
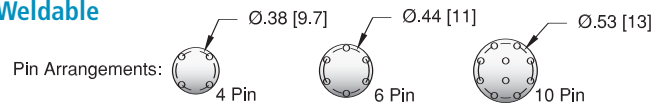

ISO KF

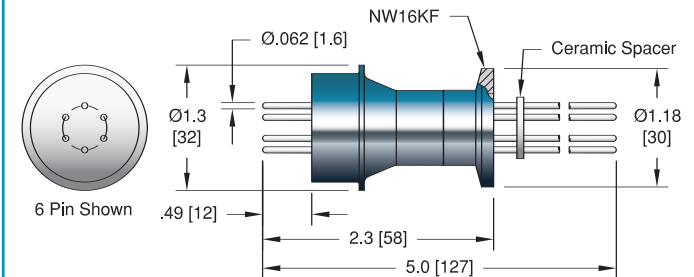
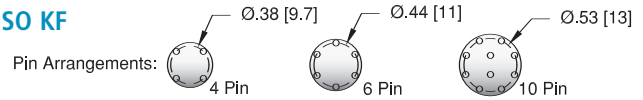

ConFlat - NW16CF

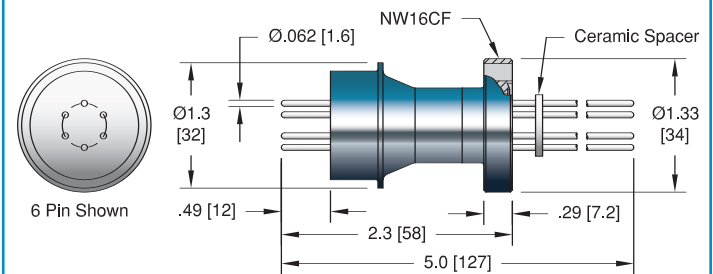
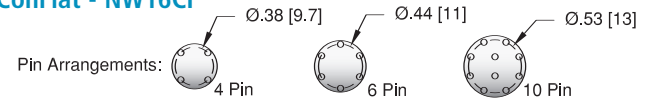

ConFlat - NW35CF

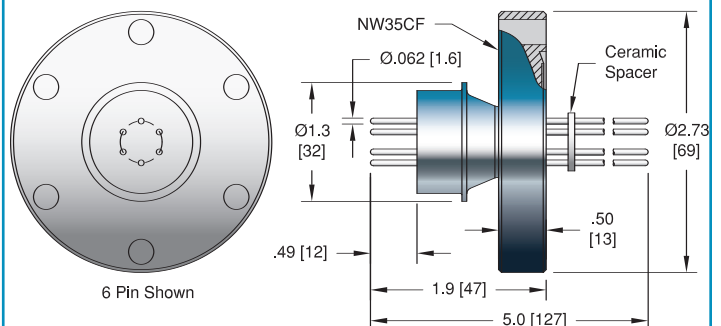
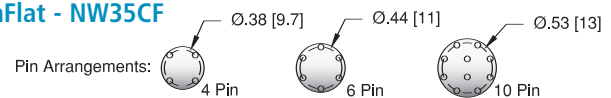



FEEDTHROUGH



NO. PINS	INSTALLATION	VOLTAGE DC	PART NUMBER
4	Weld	5 KV	10234-01-W
6	Weld	5 KV	10235-01-W
10	Weld	2 KV	10236-01-W



ISO FLANGE			
NO. PINS	INSTALLATION	VOLTAGE DC	PART NUMBER
4	NW16KF	5 KV	10234-13-KF
6	NW16KF	5 KV	10235-13-KF
10	NW16KF	2 KV	10236-15-KF



CONFLAT FLANGE			
NO. PINS	INSTALLATION	VOLTAGE DC	PART NUMBER
4	1 1/3" (NW16CF)	5 KV	10234-02-CF
6	1 1/3" (NW16CF)	5 KV	10235-02-CF
10	1 1/3" (NW16CF)	2 KV	10236-02-CF

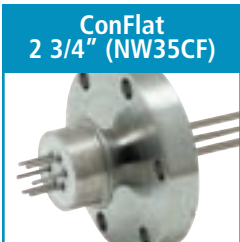

CONFLAT FLANGE			
NO. PINS	INSTALLATION	VOLTAGE DC	PART NUMBER
4	2 3/4" (NW35CF)	5 KV	10234-03-CF
6	2 3/4" (NW35CF)	5 KV	10235-03-CF
10	2 3/4" (NW35CF)	2 KV	10236-03-CF



VOLTAGE DC	CONDUCTOR AMPS	GAUGE	TYPE	WIRE LENGTH	WIRE DIAMETER	INSULATION DIAMETER	PART NUMBER
850 V	2.5	28 AWG	Stranded	30'	7 x 0.005	Ø .028	21621-01-A
850 V	5	22 AWG	Stranded	30'	19 x 0.0063	Ø .035	21643-01-A
850 V	20	12 AWG	Stranded	15'	37 x 0.013	Ø .101	21702-02-A
Adjustable wire stripper, 20-30 AWG (.25-.80mm)							21128-01



TYPE	MATERIAL	DESCRIPTION	PART NUMBER
0.062 Crimp Contacts Crimp Tool	Alumel	Accepts wire up to 0.050 [1.3] For 0.025" - 0.075" Crimp Diameters	11259-06-X† 2840-05

*Contacts priced and sold in packages of 5. †Shown in photo. See the Accessories section for more information on all accessories.



Straight Conductor Weldable

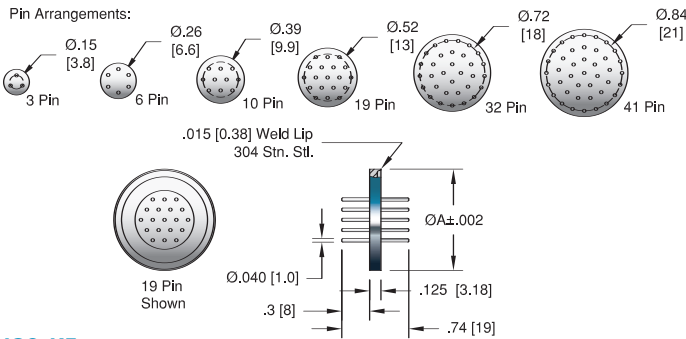

ISO KF

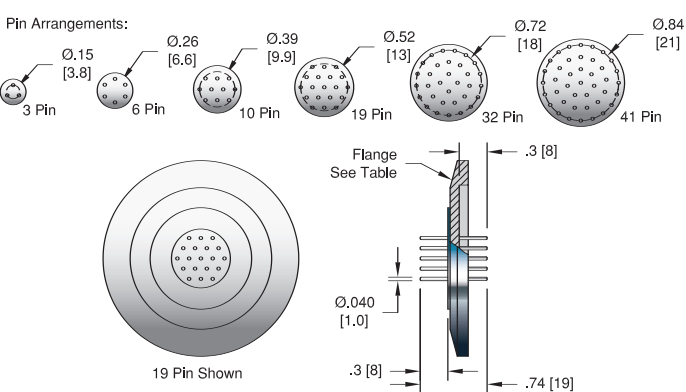

ConFlat

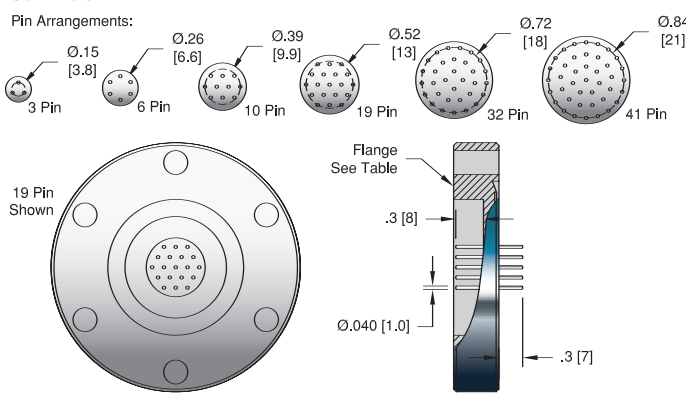

Straight/Solder Cup Conductor Weldable

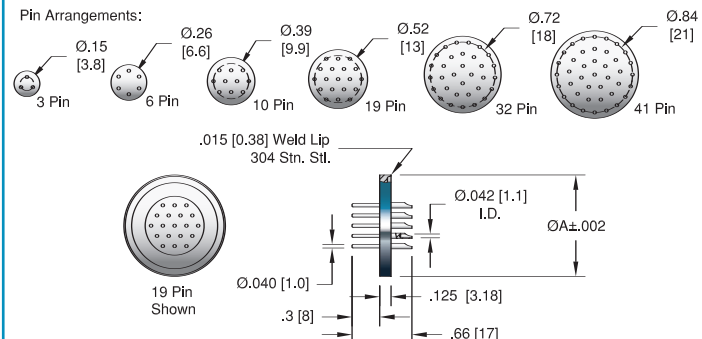

ISO KF

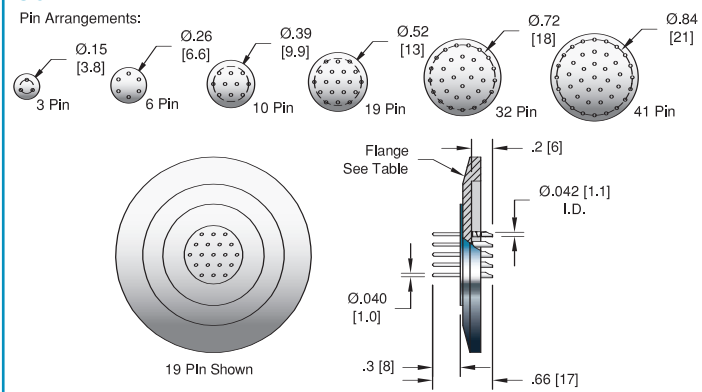

ConFlat

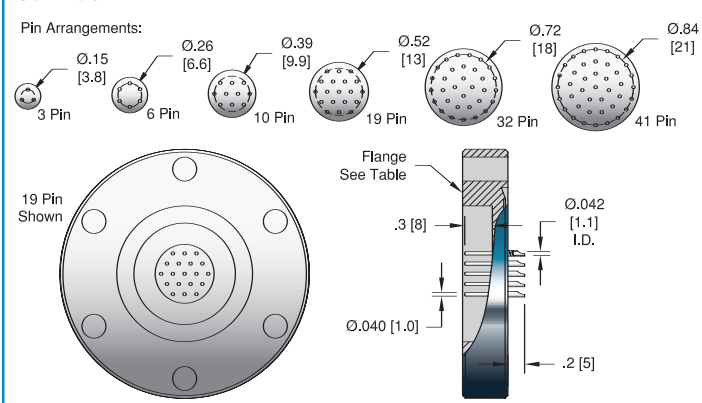

Specifications

Materials

- Housing: 304 Stainless steel
- Pins: 330 Stainless steel (Nickel plated)
- Insulation: Glass-ceramic
- Magnetic Materials: No

Voltage Rating 1 kV DC

Current Rating 5 Amps per pin

Temperature Range -269°C to 450°C, ISO KF -25°C to 205°C

Pressure @ 20°C ISO KF 0 PSIG

3 Pin: 550 PSIG (38 Bar)	19 Pin: 400 PSIG (28 Bar)
6 Pin: 500 PSIG (34 Bar)	32 Pin: 375 PSIG (26 Bar)
10 Pin: 450 PSIG (31 Bar)	41 Pin: 350 PSIG (24 Bar)



FEEDTHROUGH



NO. PINS	PIN TYPE	INSTALLATION	PART NUMBER
3	.040 [1.0] Straight	Weld	18840-01-W
6	.040 [1.0] Straight	Weld	18841-01-W
10	.040 [1.0] Straight	Weld	18842-01-W
19	.040 [1.0] Straight	Weld	18843-01-W
32	.040 [1.0] Straight	Weld	18844-01-W
41	.040 [1.0] Straight	Weld	18845-01-W



ISO FLANGE			
NO. PINS	PIN TYPE	INSTALLATION	PART NUMBER
3	.040 [1.0] Straight	NW25KF	17040-01-KF
6	.040 [1.0] Straight	NW40KF	17041-01-KF
10	.040 [1.0] Straight	NW40KF	17042-01-KF
19	.040 [1.0] Straight	NW40KF	17043-01-KF
32	.040 [1.0] Straight	NW40KF	17044-01-KF
41	.040 [1.0] Straight	NW50KF	17045-01-KF



CONFLAT FLANGE			
NO. PINS	PIN TYPE	INSTALLATION	PART NUMBER
3	.040 [1.0] Straight	2 3/4" (NW35CF)	17020-01-CF
6	.040 [1.0] Straight	2 3/4" (NW35CF)	17021-01-CF
10	.040 [1.0] Straight	2 3/4" (NW35CF)	17022-01-CF
19	.040 [1.0] Straight	2 3/4" (NW35CF)	17023-01-CF
32	.040 [1.0] Straight	2 3/4" (NW35CF)	17024-01-CF
41	.040 [1.0] Straight	3 3/8" (NW50CF)	17025-01-CF



3	.040 [1.0] Solder Cup	Weld	18850-01-W
6	.040 [1.0] Solder Cup	Weld	18851-01-W
10	.040 [1.0] Solder Cup	Weld	18852-01-W
19	.040 [1.0] Solder Cup	Weld	18853-01-W
32	.040 [1.0] Solder Cup	Weld	18854-01-W
41	.040 [1.0] Solder Cup	Weld	18855-01-W



ISO FLANGE			
NO. PINS	PIN TYPE	INSTALLATION	PART NUMBER
3	.040 [1.0] Solder Cup	NW25KF	17050-01-KF
6	.040 [1.0] Solder Cup	NW40KF	17051-01-KF
10	.040 [1.0] Solder Cup	NW40KF	17052-01-KF
19	.040 [1.0] Solder Cup	NW40KF	17053-01-KF
32	.040 [1.0] Solder Cup	NW40KF	17054-01-KF
41	.040 [1.0] Solder Cup	NW50KF	17055-01-KF



CONFLAT FLANGE			
NO. PINS	PIN TYPE	INSTALLATION	PART NUMBER
3	.040 [1.0] Solder Cup	2 3/4" (NW35CF)	17030-01-CF
6	.040 [1.0] Solder Cup	2 3/4" (NW35CF)	17031-01-CF
10	.040 [1.0] Solder Cup	2 3/4" (NW35CF)	17032-01-CF
19	.040 [1.0] Solder Cup	2 3/4" (NW35CF)	17033-01-CF
32	.040 [1.0] Solder Cup	2 3/4" (NW35CF)	17034-01-CF
41	.040 [1.0] Solder Cup	3 3/8" (NW50CF)	17035-01-CF



TYPE	MATERIAL	DESCRIPTION	PART NUMBER
0.040 Crimp Contacts	Copper Alloy - Gold Flash	Accepts wire up to 0.040 [1.0]	16167-03-A†
Crimp Tool		For 0.025" - 0.075" Crimp Diameters	2840-05

*Contacts priced and sold in packages of 5. †Shown in photo. See the Accessories section for more information on all accessories.



Weldable

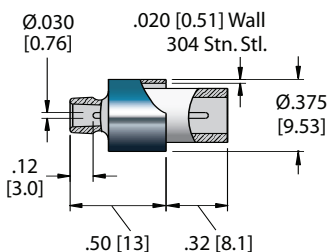

ISO KF - NW16KF

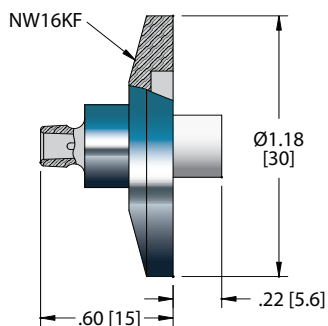

ConFlat - NW16CF

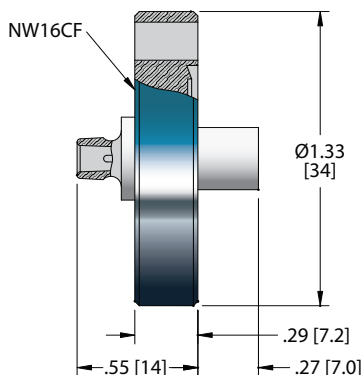

ISO KF - NW40KF

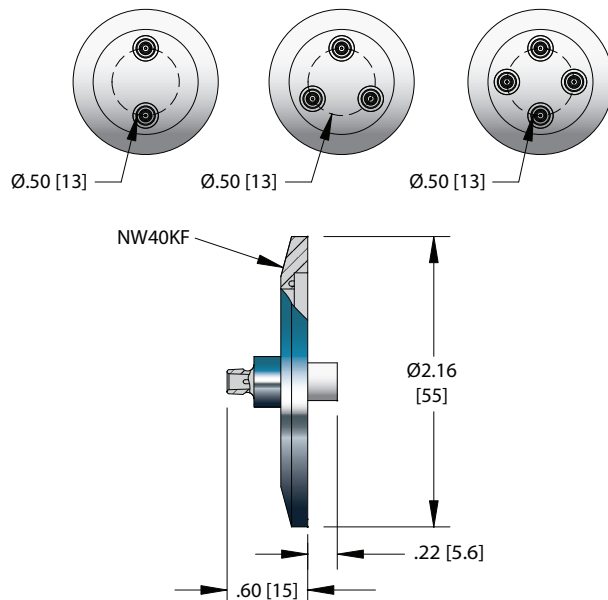

ConFlat - NW35CF

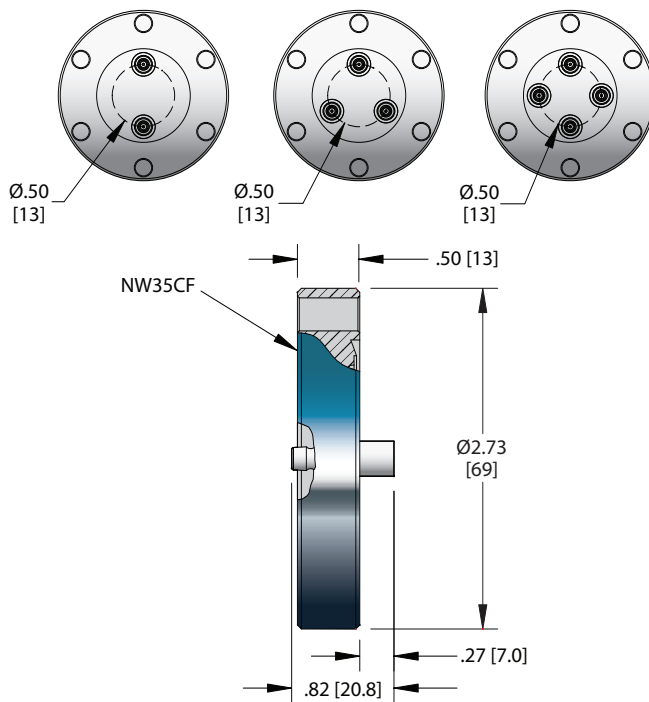

Micro HV Cable Assembly

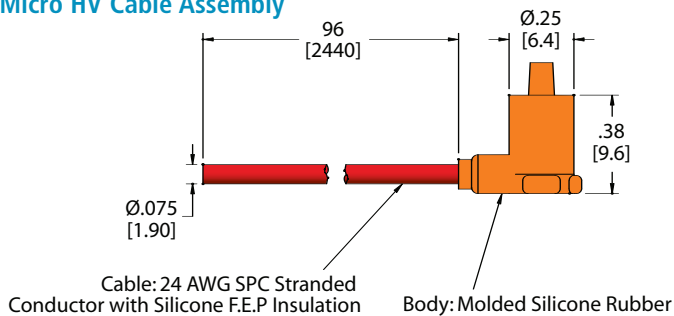

Specifications - Micro HV

Materials

- Housing: 304 Stainless steel
- Pin: Molybdenum (Gold plated)
- Insulation: Alumina ceramic
- Magnetic Materials: Yes

Voltage Rating 10 kV DC*

Current Rating 3 Amps

Temperature Range -269°C to 450°C, ISO KF -25°C to 205°C

Pressure @ 20°C 1395 PSIG (96 Bar), ISO KF 0 PSIG

*When used with air side cable assembly.



FEEDTHROUGH



Weldable

NO. PINS	INSTALLATION	PART NUMBER
1	Weld	21140-01-W



ISO KF

ISO FLANGE		
1	NW16KF	21211-01-KF
2	NW40KF	21215-01-KF
3	NW40KF	21216-01-KF
4	NW40KF	21217-01-KF

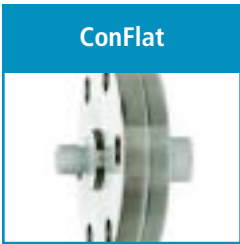

ConFlat

CONFLAT FLANGE		
1	1 1/3" (NW16CF)	21210-01-CF
2	2 3/4" (NW35CF)	21212-01-CF
3	2 3/4" (NW35CF)	21213-01-CF
4	2 3/4" (NW35CF)	21214-01-CF



Air Side Cable Assembly

TYPE	CABLE TYPE	LENGTH	VOLTAGE DC	CONDUCTOR AMPS	TEMPERATURE °C MIN	TEMPERATURE °C MAX	PART NUMBER
Micro HV Air Side	24 AWG	8'	10 kV	3	-55	125	21039-01-A

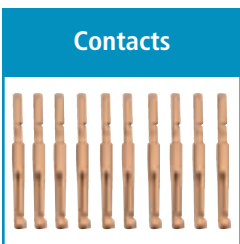

Contacts

TYPE	MATERIAL	DESCRIPTION	PART NUMBER
0.032 Crimp Type Contacts Crimp Tool	Beryllium Copper	Accepts wire up to 0.032 [0.81] For 0.025" - 0.075" Crimp Diameters	11288-02-X 2840-05

*When used with air side cable assembly. **Contacts priced and sold in packages of 10. See the Accessories section for more information on all accessories.

Weldable

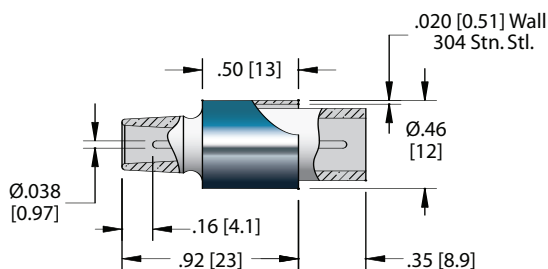

ISO KF - NW16KF

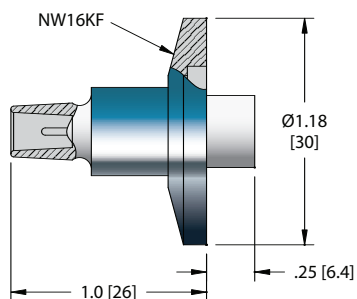

ConFlat - NW16CF

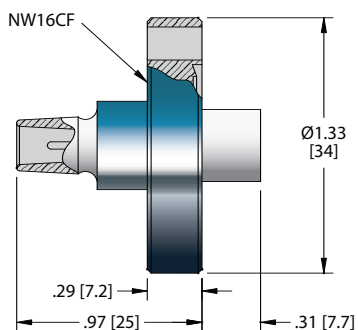

ISO KF - NW40KF

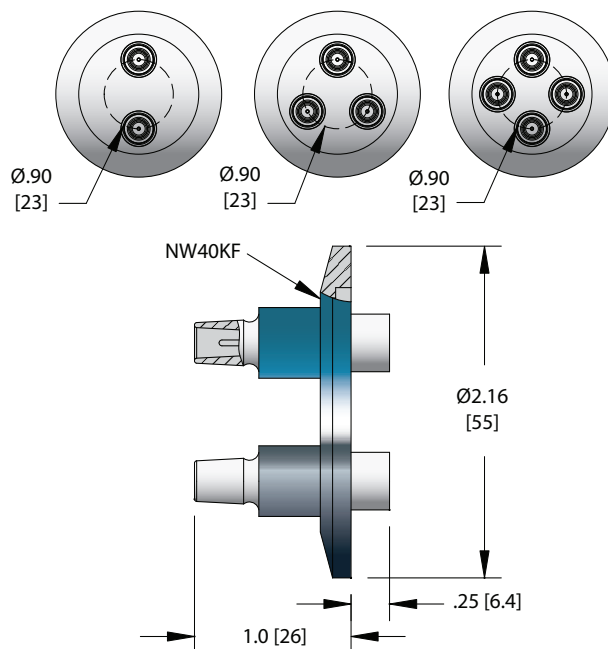

ConFlat - NW35CF

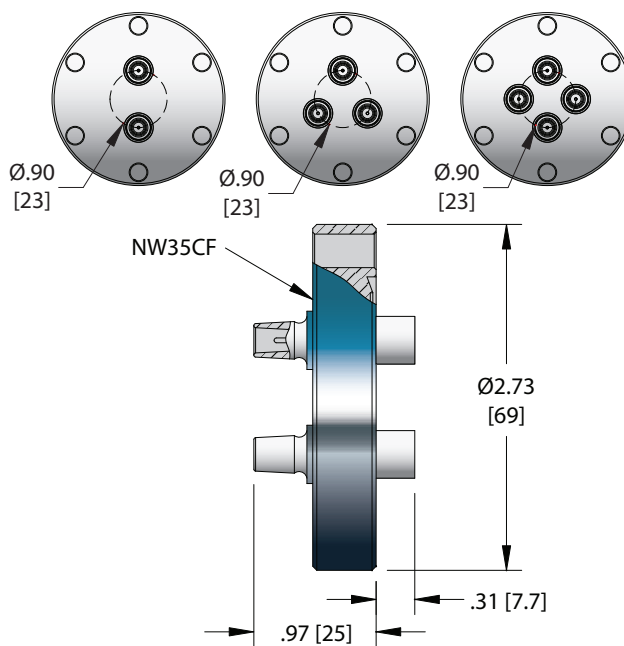

Mini HV Cable Assembly

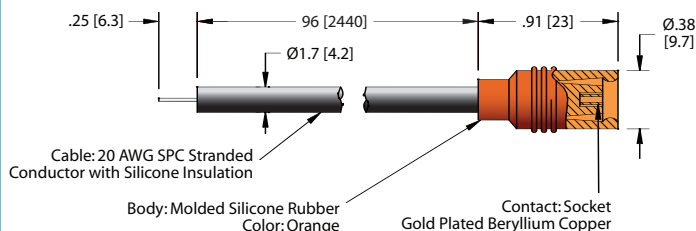

Specifications - Mini HV

Materials

- Housing: 304 Stainless steel
- Pin: Molybdenum (Gold plated)
- Insulation: Alumina ceramic
- Magnetic Materials: Yes

Voltage Rating 15 kV DC*

Current Rating 7.5 Amps

Temperature Range -269°C to 450°C, ISO KF -25°C to 205°C

Pressure @ 20°C 1100 PSIG (76 Bar), ISO KF 0 PSIG

*When used with air side cable assembly.



FEEDTHROUGH

Weldable

NO. PINS	INSTALLATION	PART NUMBER
1	Weld	21169-01-W

ISO KF

1	NW16KF	21227-01-KF
2	NW40KF	21231-01-KF
3	NW40KF	21232-01-KF
4	NW40KF	21233-01-KF

ConFlat

1	1 1/3" (NW16CF)	21226-01-CF
2	2 3/4" (NW35CF)	21228-01-CF
3	2 3/4" (NW35CF)	21229-01-CF
4	2 3/4" (NW35CF)	21230-01-CF

Air Side Cable Assembly

TYPE	CABLE TYPE	LENGTH	VOLTAGE DC	CONDUCTOR AMPS	TEMPERATURE °C MIN	TEMPERATURE °C MAX	PART NUMBER
Mini HV Air Side	20 AWG	8'	15 kV	7.5	-55	125	21119-01-A

Contacts

TYPE	MATERIAL	DESCRIPTION	PART NUMBER
0.040 Crimp Type Contacts	Copper Alloy - Gold Flash	Accepts wire up to 0.040 [1.0]	16757-02-A
Crimp Tool		For 0.025" - 0.075" Crimp Diameters	2840-05

*When used with air side cable assembly. **Contacts priced and sold in packages of 10. See the Accessories section for more information on all accessories.



Weldable

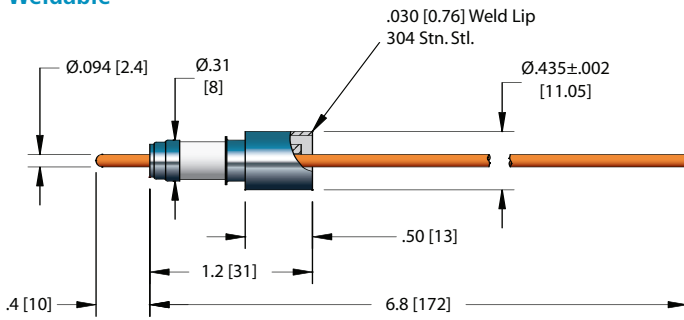

ISO KF - NW16KF

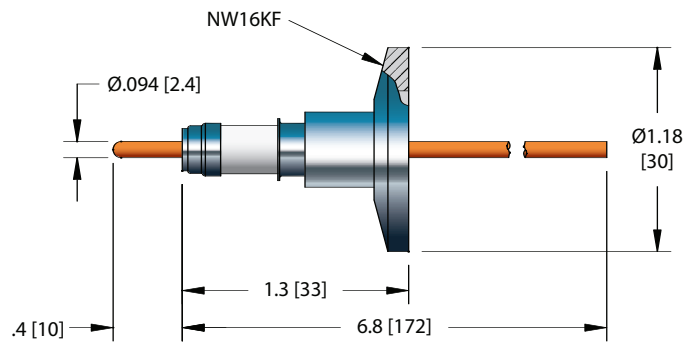

ConFlat - NW16CF

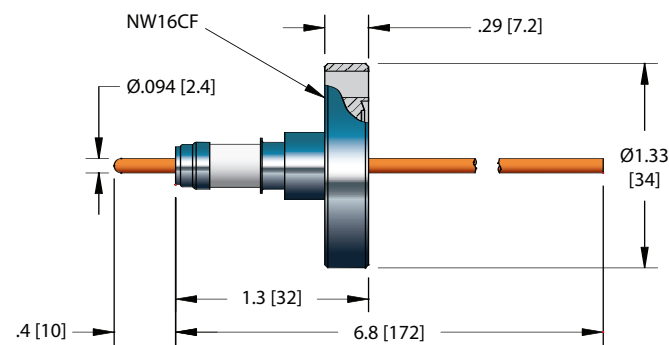

ISO KF - NW40KF

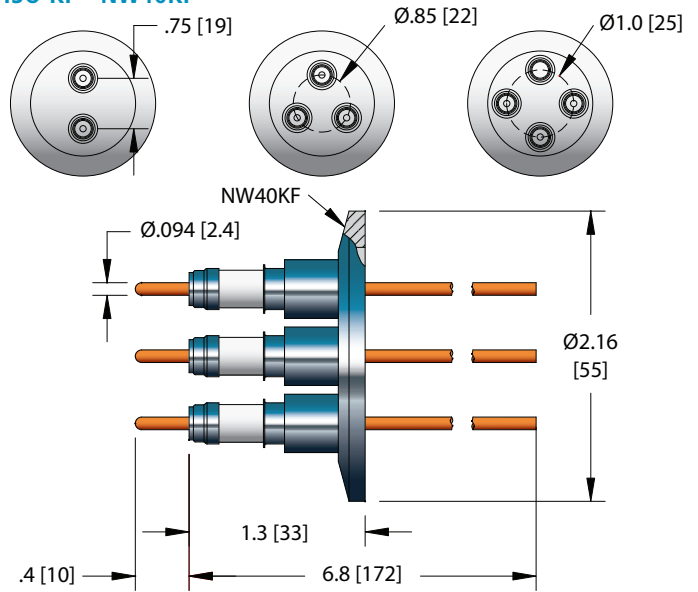

ConFlat - NW35CF

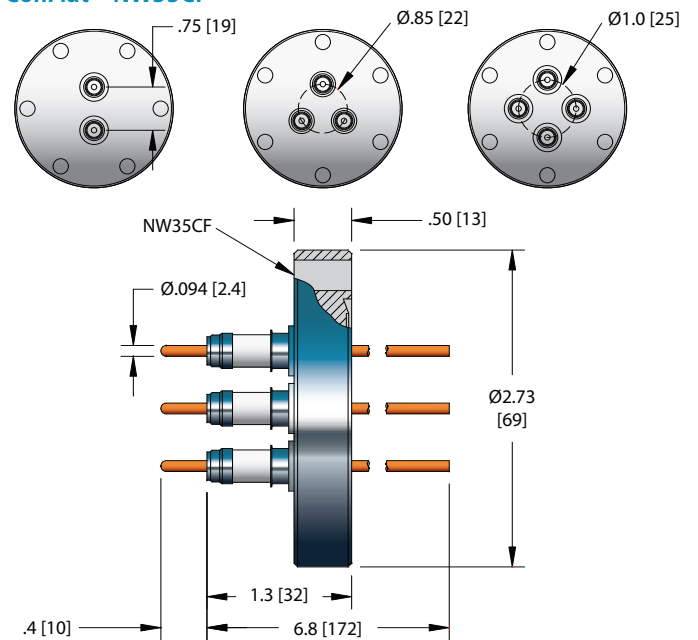

10 KV Power Plug

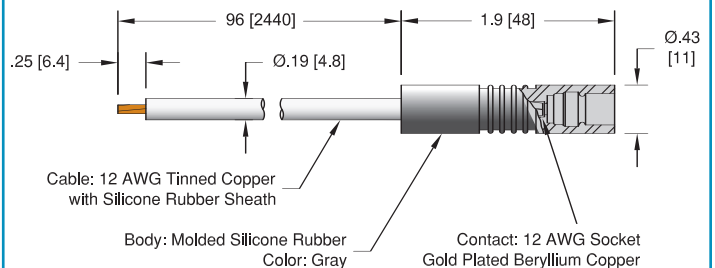

Specifications

Materials

- Housing: 304 Stainless steel
- Pin: See table
- Insulation: Alumina ceramic
- Magnetic Materials: See table

Voltage Rating 10 kV DC*

Current Rating See table

Temperature Range -269°C to 450°C, ISO KF -25°C to 205°C

Pressure @ 20°C 1500 PSIG (103 Bar), ISO KF 0 PSIG

*When used with air side cable assembly.



FEEDTHROUGH

Weldable

NO. PINS	CONDUCTOR AMPS	MATERIAL	INSTALLATION	MAGNETIC MATERIALS	PART NUMBER
1	3.6	304 Stn. Stl.	Weld	No	3888-08-W
1	16.5	Nickel	Weld	Yes	3888-09-W
1	55	Copper	Weld	No	3888-10-W

ISO KF

ISO FLANGE

1	3.6	304 Stn. Stl.	NW16KF	No	17026-05-KF
1	16.5	Nickel	NW16KF	Yes	17026-06-KF
1	55	Copper	NW16KF	No	17026-08-KF
2	3.6	304 Stn. Stl.	NW40KF	No	17027-05-KF
2	16.5	Nickel	NW40KF	Yes	17027-06-KF
2	55	Copper	NW40KF	No	17027-08-KF
3	3.6	304 Stn. Stl.	NW40KF	No	17067-05-KF
3	16.5	Nickel	NW40KF	Yes	17067-06-KF
3	55	Copper	NW40KF	No	17067-08-KF
4	3.6	304 Stn. Stl.	NW40KF	No	17028-05-KF
4	16.5	Nickel	NW40KF	Yes	17028-06-KF
4	55	Copper	NW40KF	No	17028-08-KF

ConFlat

CONFLAT FLANGE

1	3.6	304 Stn. Stl.	1 1/3" (NW16CF)	No	19542-07-CF
1	16.5	Nickel	1 1/3" (NW16CF)	Yes	19542-03-CF
1	55	Copper	1 1/3" (NW16CF)	No	19542-04-CF
2	3.6	304 Stn. Stl.	2 3/4" (NW35CF)	No	17060-05-CF
2	16.5	Nickel	2 3/4" (NW35CF)	Yes	17060-06-CF
2	55	Copper	2 3/4" (NW35CF)	No	17060-08-CF
3	3.6	304 Stn. Stl.	2 3/4" (NW35CF)	No	17064-05-CF
3	16.5	Nickel	2 3/4" (NW35CF)	Yes	17064-06-CF
3	55	Copper	2 3/4" (NW35CF)	No	17064-08-CF
4	3.6	304 Stn. Stl.	2 3/4" (NW35CF)	No	17069-05-CF
4	16.5	Nickel	2 3/4" (NW35CF)	Yes	17069-06-CF
4	55	Copper	2 3/4" (NW35CF)	No	17069-08-CF

Air Side Cable Assembly

TYPE	CABLE TYPE	LENGTH	CONDUCTOR AMPS	TEMPERATURE °C MIN	TEMPERATURE °C MAX	PART NUMBER
10 kV Power Plug	12 AWG	8'	30	-55	125	14418-02-A

Contacts

TYPE	MATERIAL	DESCRIPTION	PART NUMBER
0.094 Set Screw Type Contacts	Beryllium Copper	Accepts wire up to 0.050 [1.3]	7429-01-A
0.094 Barrel Type Contacts	Beryllium Copper	Accepts wire up to 0.094 [2.4]	7332-04-A†
Crimp Tool		For 0.025" - 0.075" Crimp Diameters	2840-05

*When used with air side cable assembly. **Contacts priced and sold in packages of 10. †Shown in photo. See the Accessories section for more information on all accessories.

FEEDTHROUGH

Weldable

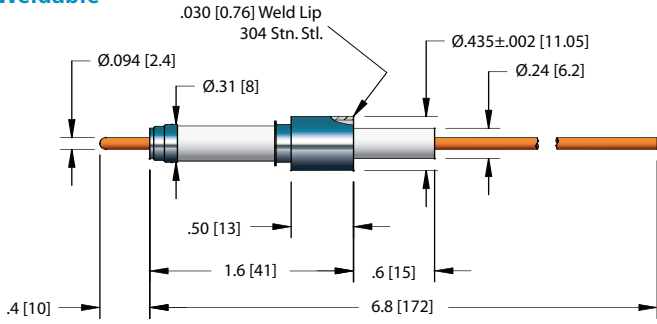

ISO KF - NW16KF

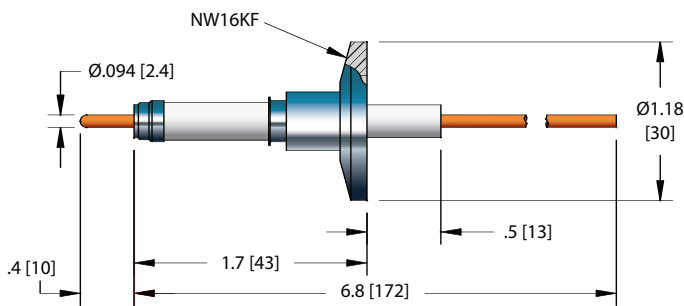

ConFlat - NW16CF

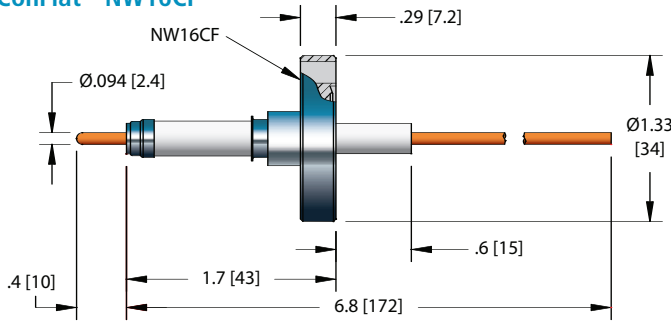

ISO KF - NW40KF

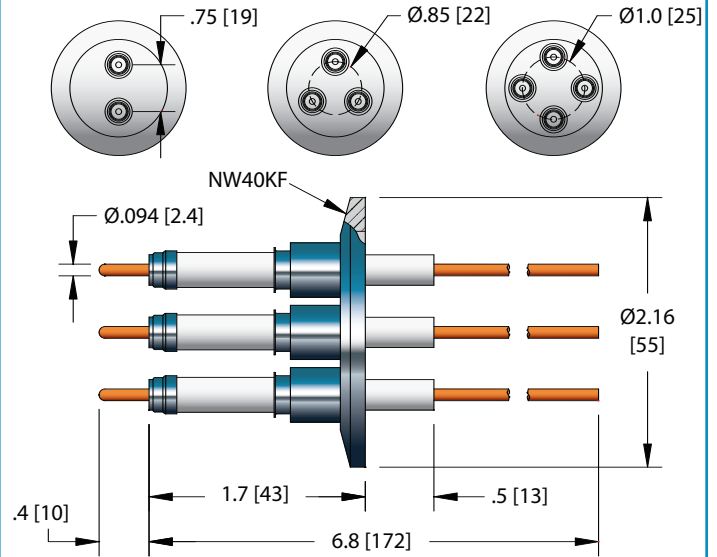

ConFlat - NW35CF

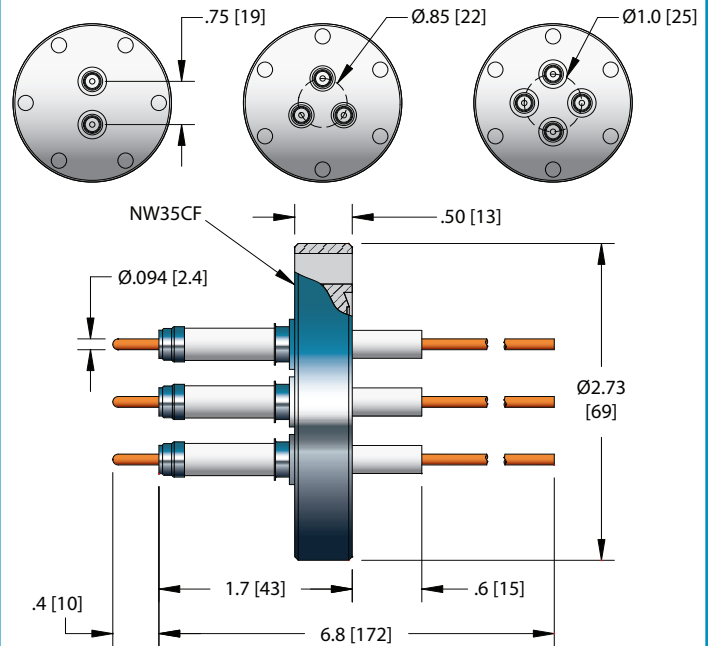

Specifications

Materials

- Housing: 304 Stainless steel
- Pin: See table
- Insulation: Alumina ceramic
- Magnetic Materials: See table

Voltage Rating 20 kV DC*

Current Rating See table

Temperature Range -269°C to 450°C, ISO KF -25°C to 205°C

Pressure @ 20°C 1500 PSIG (103 Bar), ISO KF 0 PSIG

*When used with air side cable assembly.

20 KV Power Plug

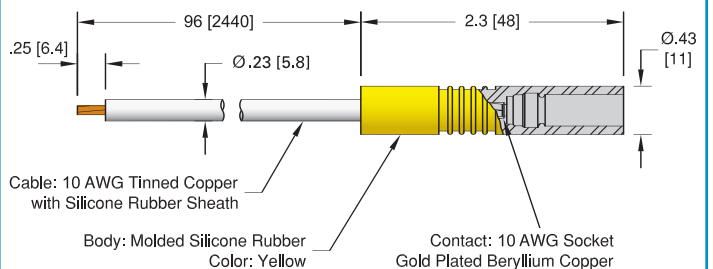



FEEDTHROUGH



Weldable

NO. PINS	CONDUCTOR AMPS	MATERIAL	INSTALLATION	MAGNETIC MATERIALS	PART NUMBER
1	3.6	304 Stn. Stl.	Weld	No	17575-03-W
1	16.5	Nickel	Weld	Yes	4275-22-W
1	55	Copper	Weld	No	4275-21-W



ISO KF

ISO FLANGE					
NO. PINS	CONDUCTOR AMPS	MATERIAL	INSTALLATION	MAGNETIC MATERIALS	PART NUMBER
1	3.6	304 Stn. Stl.	NW16KF	No	17036-05-KF
1	16.5	Nickel	NW16KF	Yes	17036-06-KF
1	55	Copper	NW16KF	No	17036-08-KF
2	3.6	304 Stn. Stl.	NW40KF	No	17037-05-KF
2	16.5	Nickel	NW40KF	Yes	17037-06-KF
2	55	Copper	NW40KF	No	17037-08-KF
3	3.6	304 Stn. Stl.	NW40KF	No	17068-05-KF
3	16.5	Nickel	NW40KF	Yes	17068-06-KF
3	55	Copper	NW40KF	No	17068-08-KF
4	3.6	304 Stn. Stl.	NW40KF	No	17038-05-KF
4	16.5	Nickel	NW40KF	Yes	17038-06-KF
4	55	Copper	NW40KF	No	17038-08-KF

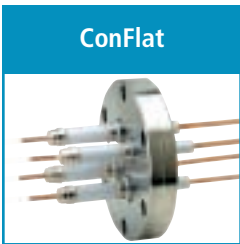

ConFlat

CONFLAT FLANGE					
NO. PINS	CONDUCTOR AMPS	MATERIAL	INSTALLATION	MAGNETIC MATERIALS	PART NUMBER
1	3.6	304 Stn. Stl.	1 1/3" (NW16CF)	No	19543-07-CF
1	16.5	Nickel	1 1/3" (NW16CF)	Yes	19543-03-CF
1	55	Copper	1 1/3" (NW16CF)	No	19543-04-CF
2	3.6	304 Stn. Stl.	2 3/4" (NW35CF)	No	10287-04-CF
2	16.5	Nickel	2 3/4" (NW35CF)	Yes	10287-05-CF
2	55	Copper	2 3/4" (NW35CF)	No	10287-03-CF
3	3.6	304 Stn. Stl.	2 3/4" (NW35CF)	No	17065-05-CF
3	16.5	Nickel	2 3/4" (NW35CF)	Yes	17065-06-CF
3	55	Copper	2 3/4" (NW35CF)	No	17065-08-CF
4	3.6	304 Stn. Stl.	2 3/4" (NW35CF)	No	16709-16-CF
4	16.5	Nickel	2 3/4" (NW35CF)	Yes	16709-08-CF
4	55	Copper	2 3/4" (NW35CF)	No	16709-10-CF



Air Side Cable Assembly

TYPE	CABLE TYPE	LENGTH	CONDUCTOR AMPS	TEMPERATURE °C MIN	TEMPERATURE °C MAX	PART NUMBER
20 kV Power Plug	10 AWG	8'	55	-55	125	14419-02-A

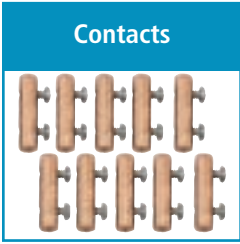

Contacts

TYPE	MATERIAL	DESCRIPTION	PART NUMBER
0.094 Set Screw Type Contacts	Beryllium Copper	Accepts wire up to 0.050 [1.3]	7429-01-A
0.094 Barrel Type Contacts	Beryllium Copper	Accepts wire up to 0.094 [2.4]	7332-04-A†

*When used with air side cable assembly. **Contacts priced and sold in packages of 10. †Shown in photo. See the Accessories section for more information on all accessories.



Weldable

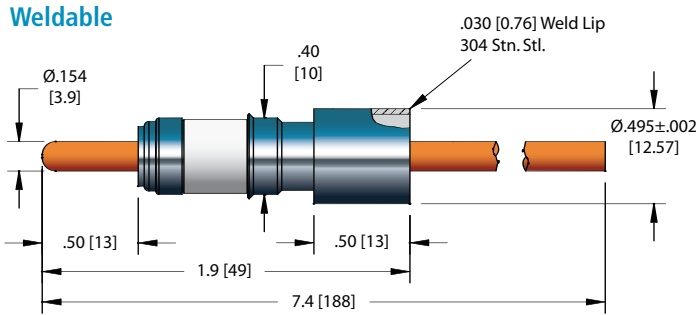

ISO KF - NW16KF

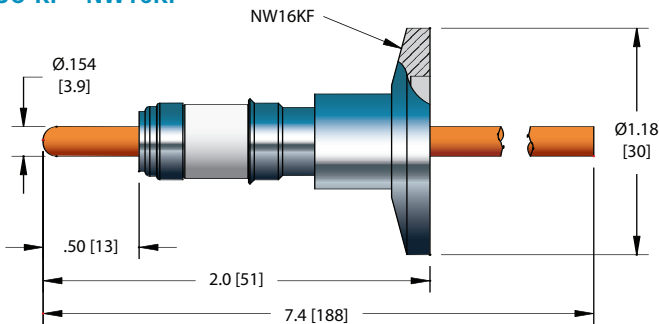

ConFlat - NW16CF

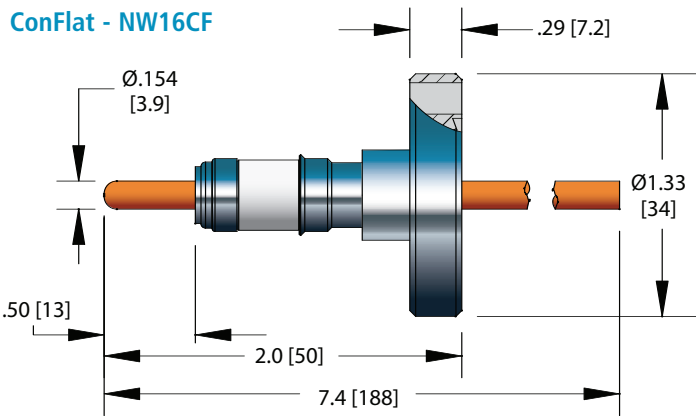

ISO KF - NW40KF

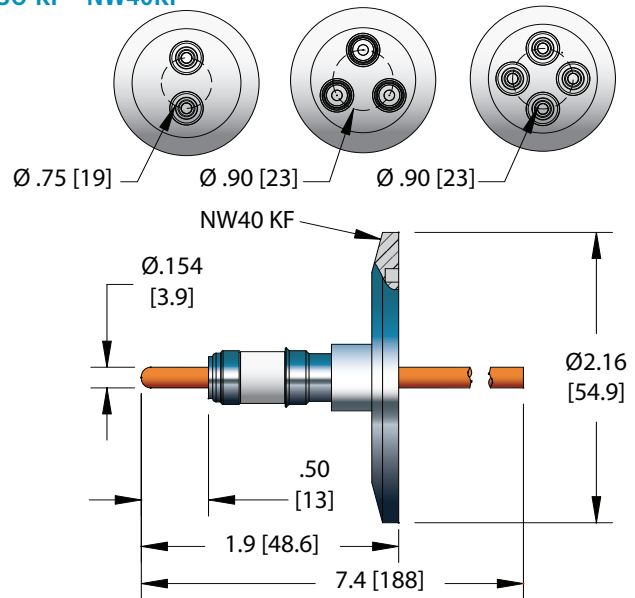

ConFlat - NW35CF

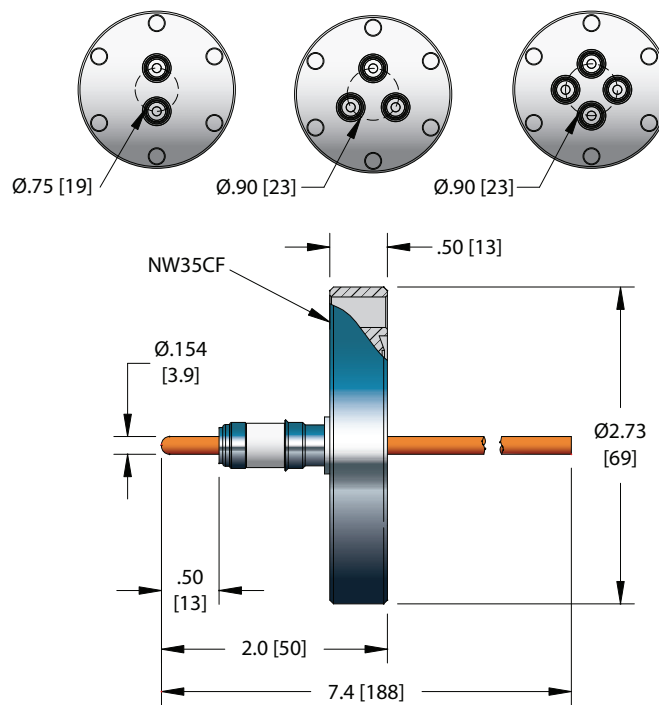

.154 Power Plug

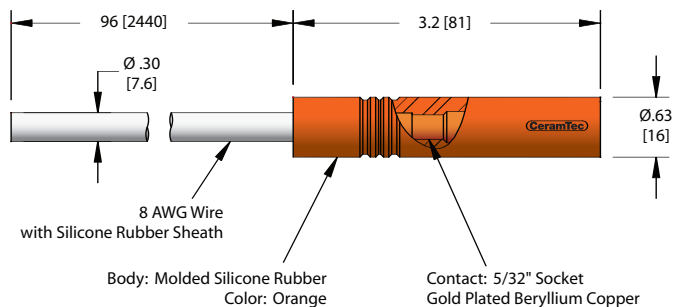

Specifications

Materials

- Housing: 304 Stainless steel
- Pin: See table
- Insulation: Alumina ceramic
- Magnetic Materials: Yes

Voltage Rating 10 kV DC*

Current Rating See table

Temperature Range -269°C to 450°C, ISO KF -25°C to 205°C

Pressure @ 20°C 1000 PSIG (69 Bar), ISO KF 0 PSIG

*When used with air side cable assembly.



FEEDTHROUGH



NO. PINS	AMPS	CONDUCTOR MATERIAL	INSTALLATION	PART NUMBER
1	30	Nickel	Weld	21032-02-W
1	100	Copper	Weld	21032-01-W

ISO FLANGE



1	30	Nickel	NW16KF	21134-02-KF
1	100	Copper	NW16KF	21134-01-KF
2	30	Nickel	NW40KF	21158-02-KF
2	100	Copper	NW40KF	21158-01-KF
3	30	Nickel	NW40KF	21159-02-KF
3	100	Copper	NW40KF	21159-01-KF
4	30	Nickel	NW40KF	21160-02-KF
4	100	Copper	NW40KF	21160-01-KF

CONFLAT FLANGE

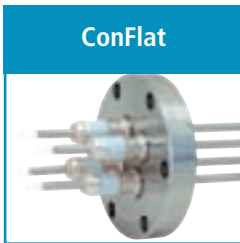

1	30	Nickel	1 1/3" (NW16CF)	21131-02-CF
1	100	Copper	1 1/3" (NW16CF)	21131-01-CF
2	30	Nickel	2 3/4" (NW35CF)	21154-02-CF
2	100	Copper	2 3/4" (NW35CF)	21154-01-CF
3	30	Nickel	2 3/4" (NW35CF)	21155-02-CF
3	100	Copper	2 3/4" (NW35CF)	21155-01-CF
4	30	Nickel	2 3/4" (NW35CF)	21156-02-CF
4	100	Copper	2 3/4" (NW35CF)	21156-01-CF



TYPE	CABLE TYPE	LENGTH	VOLTAGE DC	CONDUCTOR AMPS	TEMPERATURE °C MIN	TEMPERATURE °C MAX	PART NUMBER
.154 Power Plug	8 AWG	8'	10 kV	75	-55	125	21094-01-A

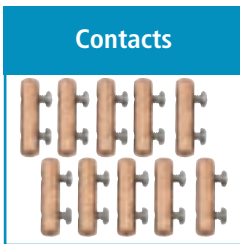

TYPE	MATERIAL	DESCRIPTION	PART NUMBER
0.154 Barrel Type Contacts	Beryllium Copper	Accepts wire up to 0.154 [3.9]	7332-07-A

*When used with air side cable assembly. **Contacts priced and sold in packages of 10. See the Accessories section for more information on all accessories.



Weldable

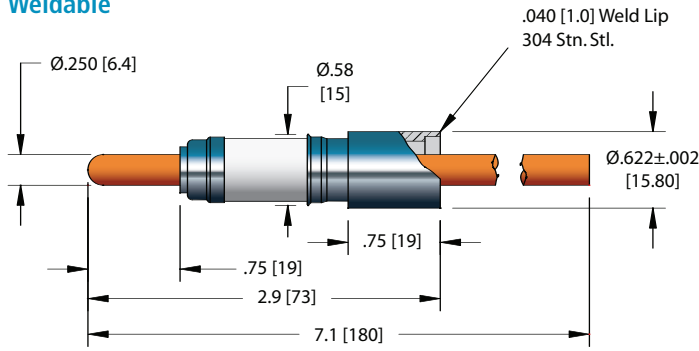

ISO KF - NW16KF

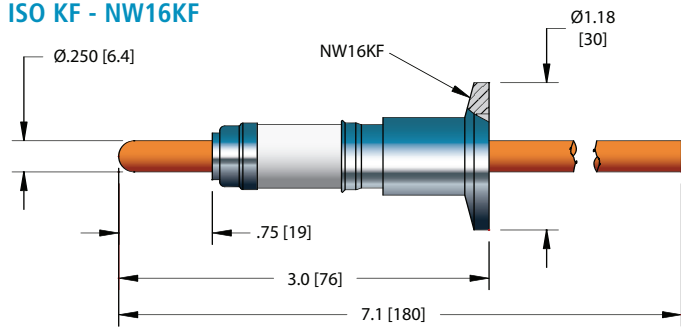

ConFlat - NW16CF

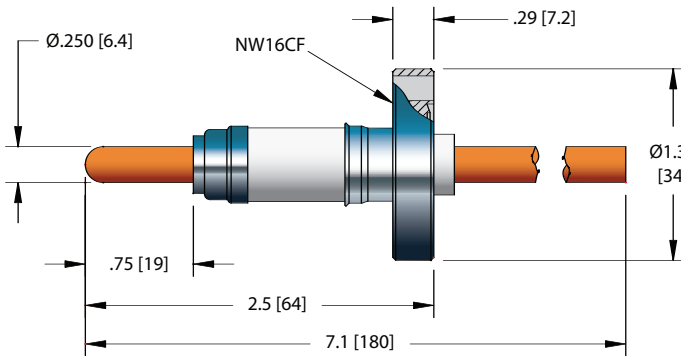

ISO KF

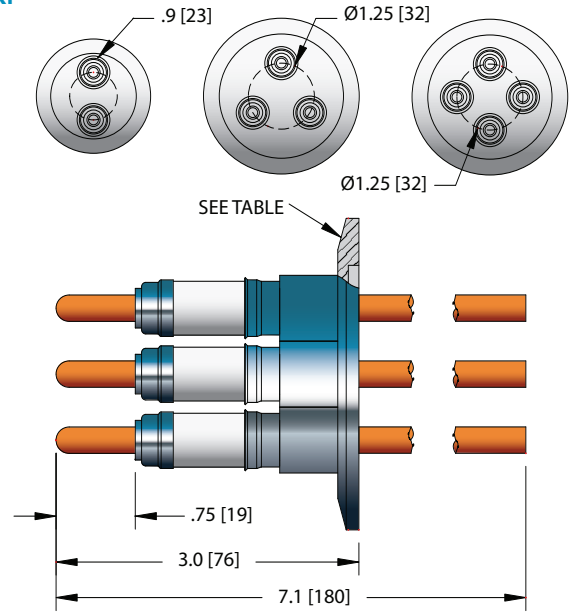

ConFlat

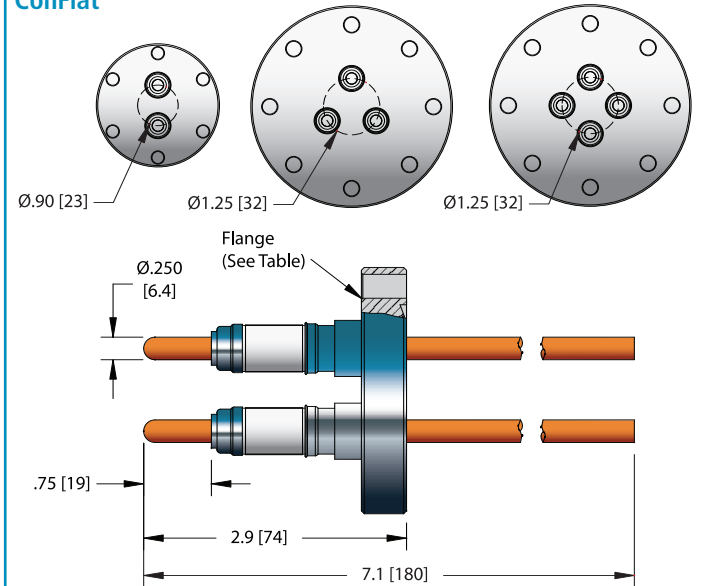

.250 Power Plug

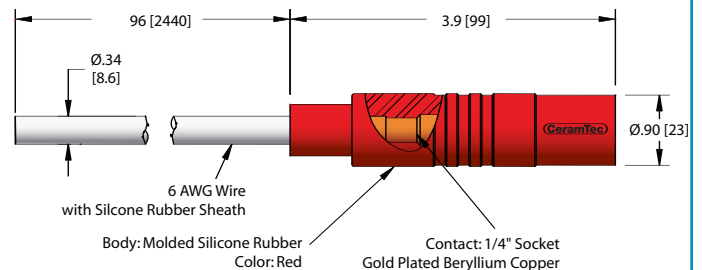

Specifications

Materials

- Housing: 304 Stainless steel
- Pin: See table
- Insulation: Alumina ceramic
- Magnetic Materials: Yes

Voltage Rating 15 kV DC*

Current Rating See table

Temperature Range -269°C to 450°C, ISO KF -25°C to 205°C

Pressure @ 20°C 750 PSIG (52 Bar), ISO KF 0 PSIG

*When used with air side cable assembly.



FEEDTHROUGH

Weldable

NO. PINS	AMPS	CONDUCTOR MATERIAL	INSTALLATION	PART NUMBER
1	56	Nickel	Weld	21414-07-W
1	185	Copper	Weld	21414-01-W

ISO KF

ISO FLANGE

1	56	Nickel	NW16KF	21308-02-KF
1	185	Copper	NW16KF	21308-01-KF
1	56	Nickel	NW40KF	21278-02-KF
1	185	Copper	NW40KF	21278-01-KF
2	56	Nickel	NW40KF	21278-04-KF
2	185	Copper	NW40KF	21278-03-KF
3	56	Nickel	NW50KF	21278-06-KF
3	185	Copper	NW50KF	21278-05-KF
4	56	Nickel	NW50KF	21278-08-KF
4	185	Copper	NW50KF	21278-07-KF

ConFlat

CONFLAT FLANGE

1	56	Nickel	1 1/3" (NW16CF)	21309-02-CF
1	185	Copper	1 1/3" (NW16CF)	21309-01-CF
1	56	Nickel	2 3/4" (NW35CF)	21280-02-CF
1	185	Copper	2 3/4" (NW35CF)	21280-01-CF
2	56	Nickel	2 3/4" (NW35CF)	21280-04-CF
2	185	Copper	2 3/4" (NW35CF)	21280-03-CF
3	56	Nickel	4 1/2" (NW63CF)	21280-06-CF
3	185	Copper	4 1/2" (NW63CF)	21280-05-CF
4	56	Nickel	4 1/2" (NW63CF)	21280-08-CF
4	185	Copper	4 1/2" (NW63CF)	21280-07-CF

Air Side Cable Assembly

TYPE	CABLE TYPE	LENGTH	VOLTAGE DC	CONDUCTOR AMPS	TEMPERATURE °C MIN	TEMPERATURE °C MAX	PART NUMBER
.250 Power Plug	6 AWG	8'	25 kV	100	-55	125	20956-02-A

Contacts

TYPE	MATERIAL	DESCRIPTION	PART NUMBER
0.250 Barrel Type Contacts	Beryllium Copper	Accepts wire up to 0.250 [6.4]	7332-06-A†
0.250 Clamp Type Contacts	Copper	Accepts wire up to 0.250 [6.4]	18740-01-A

*When used with air side cable assembly. **Contacts priced and sold in packages of 10. †Shown in photo. See the Accessories section for more information on all accessories.

Weldable

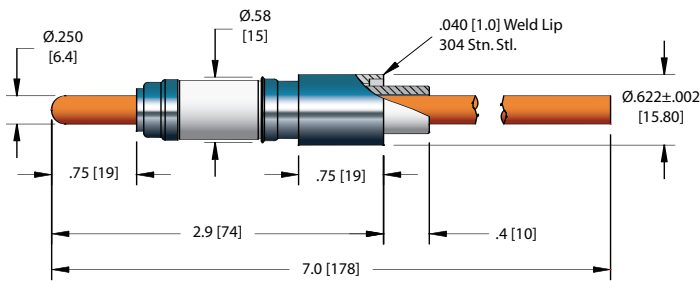

ISO KF - NW16KF

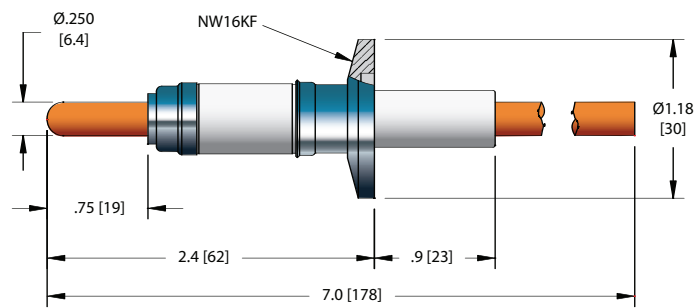

ConFlat - NW16CF

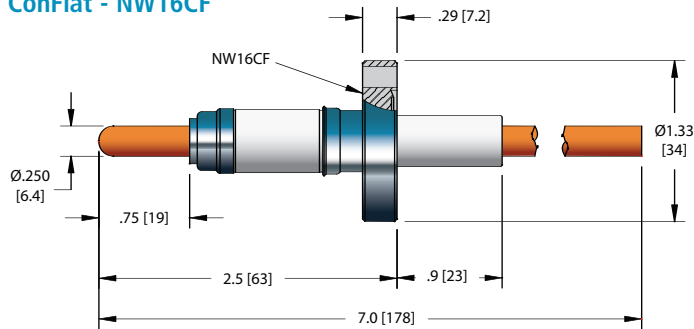

ISO KF

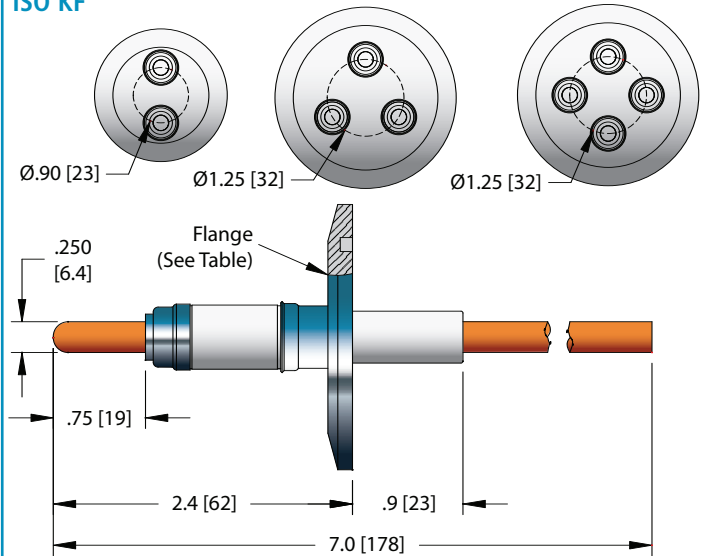

ConFlat

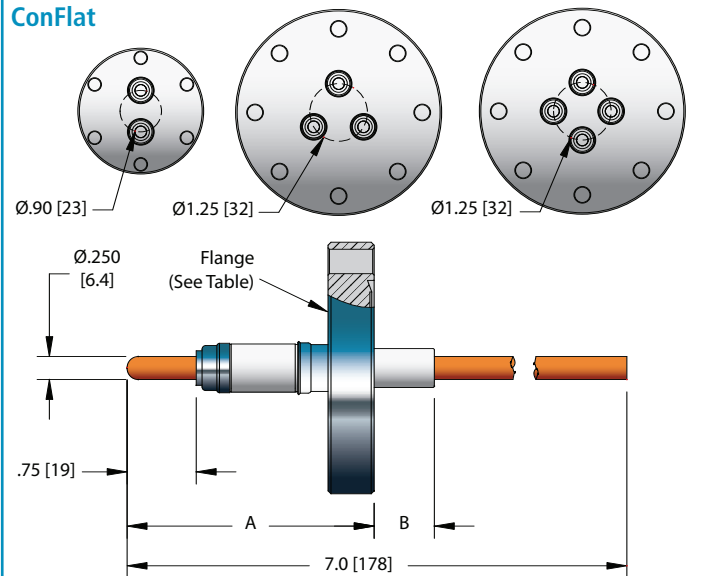

.250 Power Plug

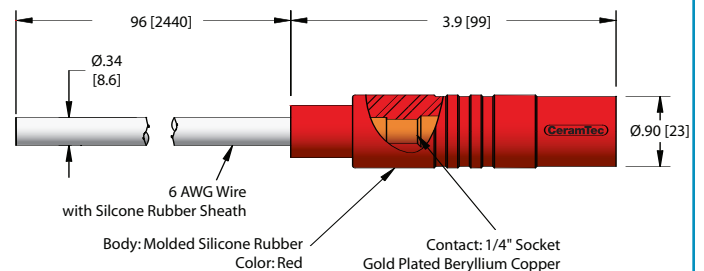

Specifications

Materials

- Housing: 304 Stainless steel
- Pin: See table
- Insulation: Alumina ceramic
- Magnetic Materials: Yes

Voltage Rating 25 kV DC*

Current Rating 185 Amps

Temperature Range -269°C to 450°C, ISO KF -25°C to 205°C

Pressure @ 20°C 750 PSIG (52 Bar), ISO KF 0 PSIG

*When used with air side cable assembly.



FEEDTHROUGH



NO. PINS	AMPS	CONDUCTORS MATERIAL	INSTALLATION	DIMENSIONS		PART NUMBER
				A	B	
1	185	Copper	Weld	-	-	20955-01-W
1	56	Nickel	Weld	-	-	20955-02-W

ISO FLANGE



1	185	Copper	NW16KF	-	-	21133-01-KF
1	56	Nickel	NW16KF	-	-	21133-02-KF
2	185	Copper	NW40KF	-	-	21149-01-KF
2	56	Nickel	NW40KF	-	-	21149-02-KF
3	185	Copper	NW50KF	-	-	21150-01-KF
3	56	Nickel	NW50KF	-	-	21150-02-KF
4	185	Copper	NW50KF	-	-	21151-01-KF
4	56	Nickel	NW50KF	-	-	21151-02-KF

CONFLAT FLANGE



1	185	Copper	1 1/3" (NW16CF)	-	-	21130-01-CF
1	56	Nickel	1 1/3" (NW16CF)	-	-	21130-02-CF
1	185	Copper	2 3/4" (NW35CF)	2.68 [68]	.65 [17]	21144-01-CF
1	56	Nickel	2 3/4" (NW35CF)	2.68 [68]	.65 [17]	21144-02-CF
2	185	Copper	2 3/4" (NW35CF)	2.68 [68]	.65 [17]	21145-01-CF
2	56	Nickel	2 3/4" (NW35CF)	2.68 [68]	.65 [17]	21145-02-CF
3	185	Copper	4 1/2" (NW63CF)	2.87 [73]	.47 [12]	21146-01-CF
3	56	Nickel	4 1/2" (NW63CF)	2.87 [73]	.47 [12]	21146-02-CF
4	185	Copper	4 1/2" (NW63CF)	2.87 [73]	.47 [12]	21147-01-CF
4	56	Nickel	4 1/2" (NW63CF)	2.87 [73]	.47 [12]	21147-02-CF



TYPE	CABLE TYPE	LENGTH	VOLTAGE DC	CONDUCTOR AMPS	TEMPERATURE °C MIN	TEMPERATURE °C MAX	PART NUMBER
.250 Power Plug	6 AWG	8'	25 kV	100	-55	125	20956-02-A

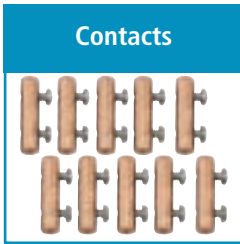

TYPE	MATERIAL	DESCRIPTION	PART NUMBER
0.250 Barrel Type Contacts	Beryllium Copper	Accepts wire up to 0.250 [6.4]	7332-06-A [†]
0.250 Clamp Type Contacts	Copper	Accepts wire up to 0.250 [6.4]	18740-01-A

*When used with air side cable assembly. **Contacts priced and sold in packages of 10. [†]Shown in photo. See the Accessories section for more information on all accessories.

FEEDTHROUGH

**.250 [6.4] Dia. Conductor
Weldable**

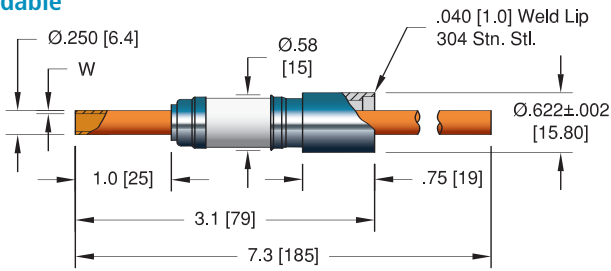

ISO KF - NW16KF

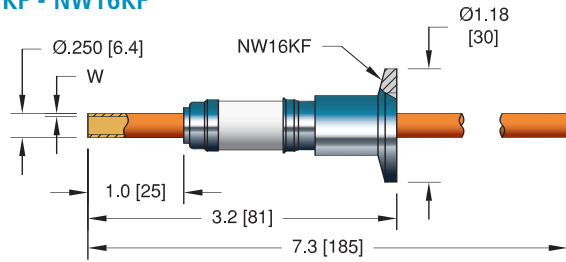

ConFlat - NW16CF

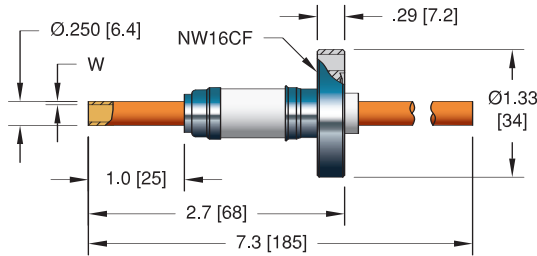

ISO KF - NW40KF

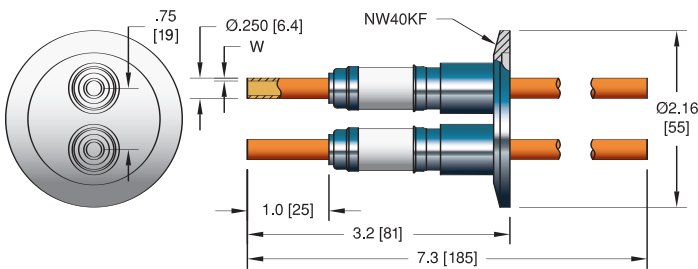

ConFlat - NW35CF

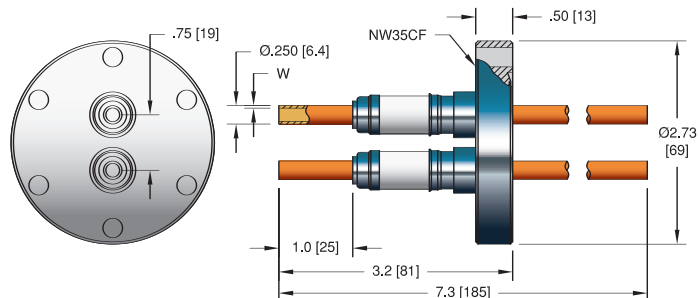

**.375 [9.5] Dia. Conductor
Weldable**

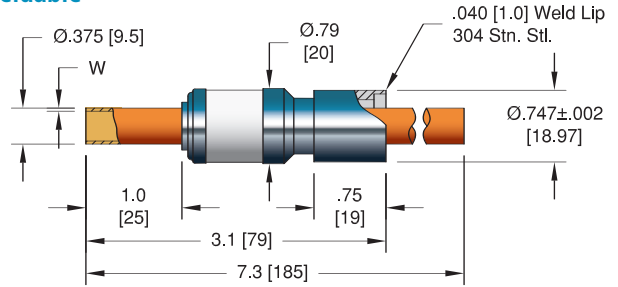

ISO KF - NW16KF

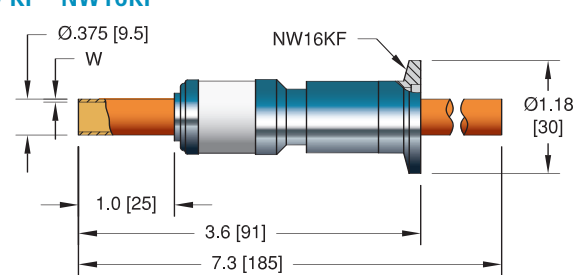

1 1/3" ConFlat (NW16CF)

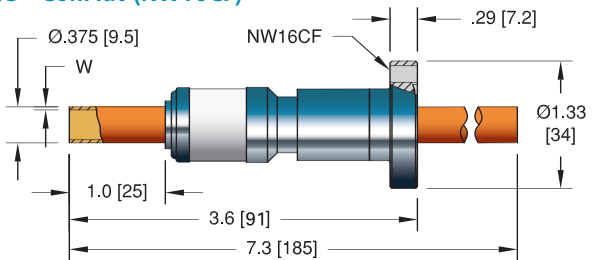

ISO KF - NW50KF

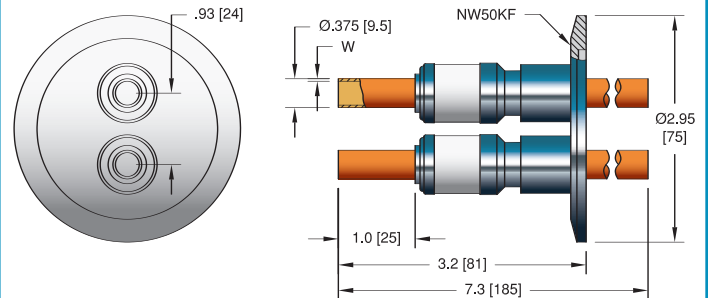

ConFlat - NW35CF

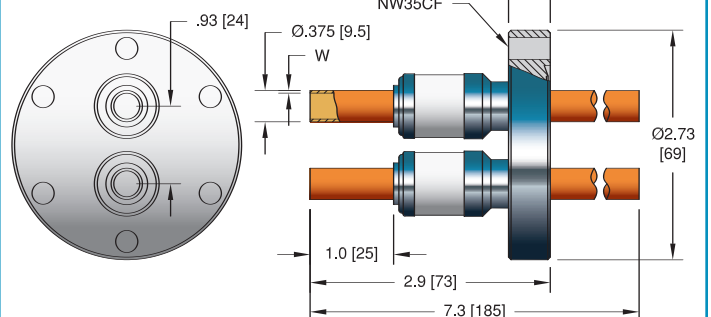



NO. PINS/TUBES	DIA.	CONDUCTOR W	AMPS*	MATERIAL	INSTALLATION	PART NUMBER
1	.250 [6.4]	.035 [0.89]	-	304 Stn. Stl. Tube	Weld	2779-06-W
1	.250 [6.4]	.032 [0.81]	-	Copper Tube	Weld	2779-02-W
1	.375 [9.5]	.035 [0.89]	-	304 Stn. Stl. Tube	Weld	2780-16-W
1	.375 [9.5]	.032 [0.81]	-	Copper Tube	Weld	2780-02-W
1	.375 [9.5]	-	330	Copper	Weld	2780-01-W



ISO FLANGE						
NO. PINS/TUBES	DIA.	CONDUCTOR W	AMPS*	MATERIAL	INSTALLATION	PART NUMBER
1	.250 [6.4]	.035 [0.89]	-	304 Stn. Stl. Tube	NW16KF	16614-02-KF
1	.250 [6.4]	.032 [0.81]	-	Copper Tube	NW16KF	16614-05-KF
2	.250 [6.4]	.035 [0.89]	-	304 Stn. Stl. Tube	NW40KF	14308-06-KF
2	.250 [6.4]	.032 [0.81]	-	Copper Tube	NW40KF	14308-05-KF
1	.375 [9.5]	.035 [0.89]	-	304 Stn. Stl. Tube	NW16KF	17091-05-KF
1	.375 [9.5]	.032 [0.81]	-	Copper Tube	NW16KF	17091-06-KF
1	.375 [9.5]	-	330	Copper	NW16KF	17091-04-KF
2	.375 [9.5]	.035 [0.89]	-	304 Stn. Stl. Tube	NW50KF	17093-05-KF
2	.375 [9.5]	.032 [0.81]	-	Copper Tube	NW50KF	17093-06-KF
2	.375 [9.5]	-	330	Copper	NW50KF	17093-04-KF

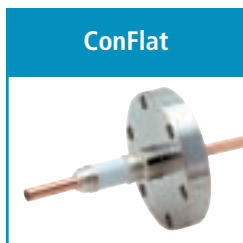

CONFLAT FLANGE						
NO. PINS/TUBES	DIA.	CONDUCTOR W	AMPS*	MATERIAL	INSTALLATION	PART NUMBER
1	.250 [6.4]	.035 [0.89]	-	304 Stn. Stl. Tube	1 1/3" (NW16CF)	7161-02-CF
1	.250 [6.4]	.032 [0.81]	-	Copper Tube	1 1/3" (NW16CF)	7161-05-CF
1	.250 [6.4]	.035 [0.89]	-	304 Stn. Stl. Tube	2 3/4" (NW35CF)	6700-08-CF
1	.250 [6.4]	.032 [0.81]	-	Copper Tube	2 3/4" (NW35CF)	6700-05-CF
2	.250 [6.4]	.035 [0.89]	-	304 Stn. Stl. Tube	2 3/4" (NW35CF)	16705-04-CF
2	.250 [6.4]	.032 [0.81]	-	Copper Tube	2 3/4" (NW35CF)	16705-02-CF
1	.375 [9.5]	.035 [0.89]	-	304 Stn. Stl. Tube	1 1/3" (NW16CF)	17099-01-CF
1	.375 [9.5]	.032 [0.81]	-	Copper Tube	1 1/3" (NW16CF)	17099-02-CF
1	.375 [9.5]	-	330	Copper	1 1/3" (NW16CF)	17099-06-CF
2	.375 [9.5]	.035 [0.89]	-	304 Stn. Stl. Tube	2 3/4" (NW35CF)	17092-05-CF
2	.375 [9.5]	.032 [0.81]	-	Copper Tube	2 3/4" (NW35CF)	17092-06-CF
2	.375 [9.5]	-	330	Copper	2 3/4" (NW35CF)	17092-04-CF

*Current carrying capacity of the tubular feedthroughs varies based on the coolant used and the flow rate.



TYPE	MATERIAL	DESCRIPTION	PART NUMBER
0.250 Barrel Type Contacts	Beryllium Copper	Accepts wire up to 0.250 [6.4]	7332-06-A
0.250 Clamp Type Contacts	Copper	Accepts wire up to 0.250 [6.4]	18740-01-A†
0.375 Clamp Type Contacts	Copper	Accepts wire up to 0.375 [9.5]	18737-01-A

**Contacts priced and sold in packages of 10. †Shown in photo. See the Accessories section for more information on all accessories.

Specifications

Materials

Housing: 304 Stainless steel
 Pin/Tube: See table
 Insulation: Alumina ceramic
 Magnetic Materials: Yes

Voltage Rating 8 kV DC

Current Rating See table

Temperature Range -269°C to 450°C, ISO KF -25°C to 205°C

Pressure @ 20°C ISO KF 0 PSIG

.250 [6.4] Dia. Conductor: 750 PSIG (52 Bar)
 .375 [9.5] Dia. Conductor: 500 PSIG (34 Bar)

FEEDTHROUGH

FEEDTHROUGH

**.500 [12.7] Dia. Conductor
Weldable**

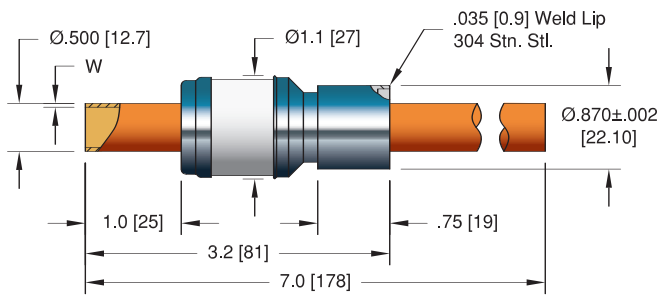

ISO KF

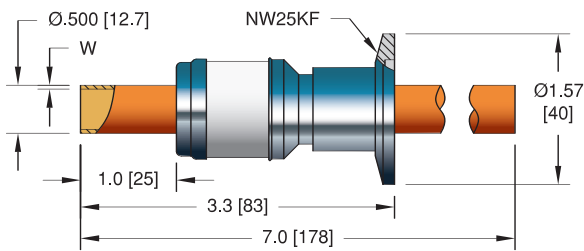

ConFlat

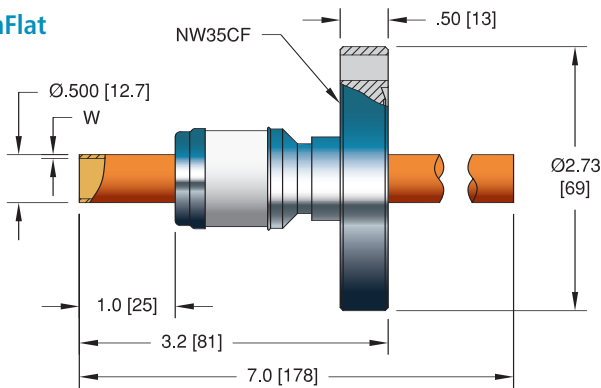

**.750 [19.0] Dia. Conductor
Weldable**

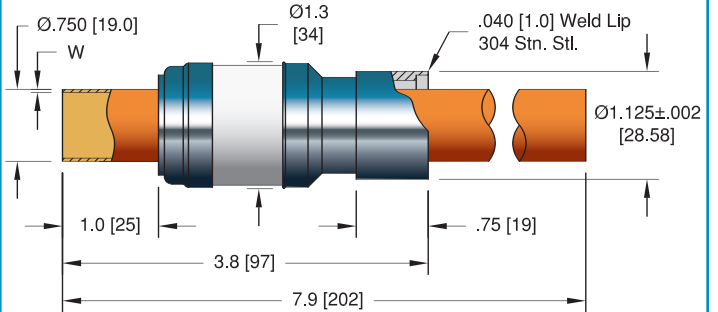

ISO KF

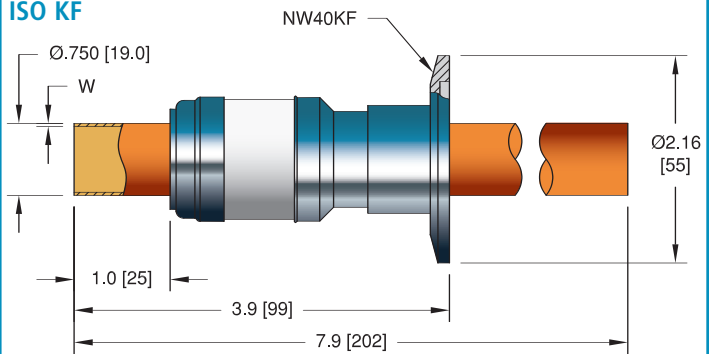

ConFlat

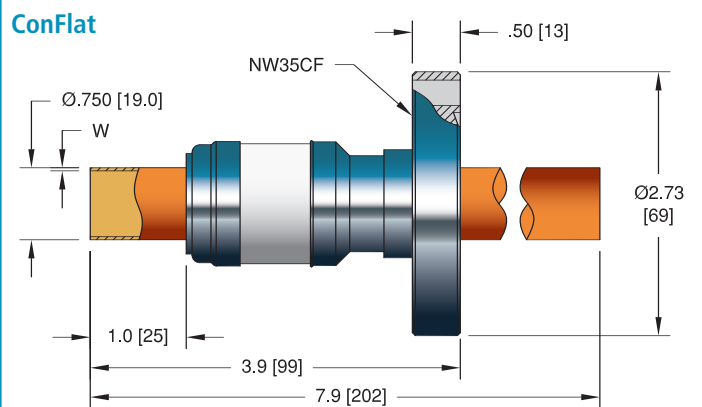

Specifications

Materials

- Housing: 304 Stainless steel
- Pin/Tube: See table
- Insulation: Alumina ceramic
- Magnetic Materials: Yes

Voltage Rating 8 kV DC

Current Rating See table

Temperature Range -269°C to 450°C, ISO KF -25°C to 205°C

Pressure @ 20°C ISO KF 0 PSIG

.500 [12.7] Dia. Conductor: 350 PSIG (24 Bar)

.750 [19.0] Dia. Conductor: 250 PSIG (17 Bar)



Weldable

NO. PINS/TUBES	DIA.	CONDUCTOR W	AMPS*	MATERIAL	INSTALLATION	PART NUMBER
1	.500 [12.7]	.032 [0.81]	-	Copper Tube	Weld	17095-06-W
1	.500 [12.7]	-	470	Copper	Weld	17095-04-W
1	.750 [19.0]	.032 [0.81]	-	Copper Tube	Weld	2781-02-W
1	.750 [19.0]	-	800	Copper	Weld	2781-01-W

ISO FLANGE



ISO KF

1	.500 [12.7]	.032 [0.81]	-	Copper Tube	NW25KF	17097-06-KF
1	.500 [12.7]	-	470	Copper	NW25KF	17097-04-KF
1	.750 [19.0]	.032 [0.81]	-	Copper Tube	NW40KF	17094-06-KF
1	.750 [19.0]	-	800	Copper	NW40KF	17094-04-KF

CONFLAT FLANGE

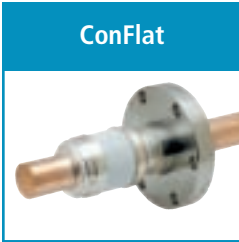

ConFlat

1	.500 [12.7]	.032 [0.81]	-	Copper Tube	2 3/4" (NW35CF)	17096-06-CF
1	.500 [12.7]	-	470	Copper	2 3/4" (NW35CF)	17096-04-CF
1	.750 [19.0]	.032 [0.81]	-	Copper Tube	2 3/4" (NW35CF)	16702-03-CF
1	.750 [19.0]	-	800	Copper	2 3/4" (NW35CF)	16702-01-CF

*Current carrying capacity of the tubular feedthroughs varies based on the coolant used and the flow rate.



Contacts

TYPE	MATERIAL	DESCRIPTION	PART NUMBER
0.500 Clamp Type Contact	Copper	Accepts wire up to 0.500 [12.7]	18738-01-A
0.750 Clamp Type Contact	Copper	Accepts wire up to 0.750 [19.0]	18739-01-A†

†Shown in photo. See the Accessories section for more information on all accessories.

FEEDTHROUGH

Specifications

Materials

- Housing: 304 Stainless steel
- Tube: Tellurium copper
- Fitting: Brass
- Insulation: Alumina ceramic
- Magnetic Materials: Yes

Voltage Rating 8 kV DC

Current Rating 1000 Amps

Temperature Range -269°C to 450°C, ISO KF -25°C to 205°C

Pressure @ 20°C 250 PSIG (17 Bar), ISO KF 0 PSIG

FEEDTHROUGH

**.750 [19.0] Dia. Conductor
Weldable**

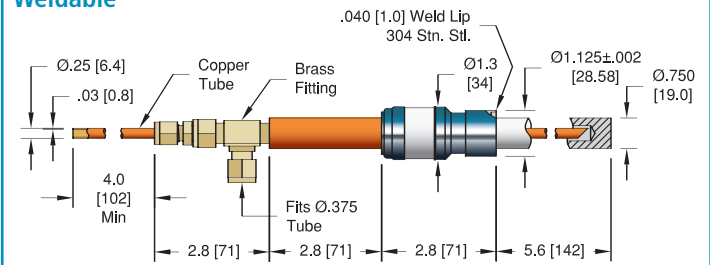

ISO KF

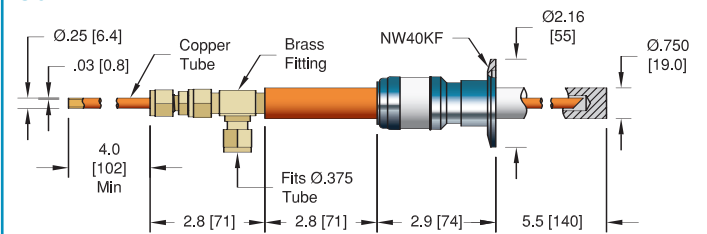

ConFlat

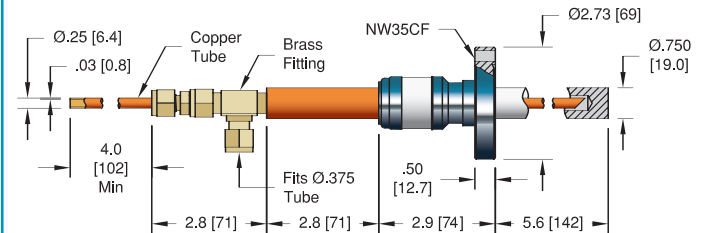

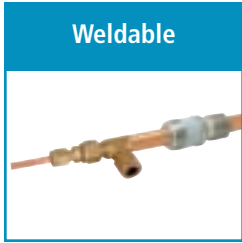

CONDUCTOR AMPS	MATERIAL	INSTALLATION	VOLTAGE DC	PART NUMBER
1000	Tellurium Copper	Weld	8 kV	17110-01-W

ISO FLANGE



1000	Tellurium Copper	NW40KF	8 KV	17111-01-KF
------	------------------	--------	------	-------------

CONFLAT FLANGE

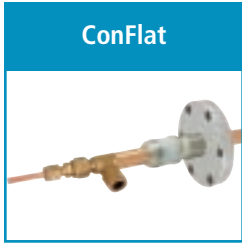

1000	Tellurium Copper	2 3/4" (NW35CF)	8 KV	17112-01-CF
------	------------------	-----------------	------	-------------

FEEDTHROUGH

40 KV Single Pin Weldable

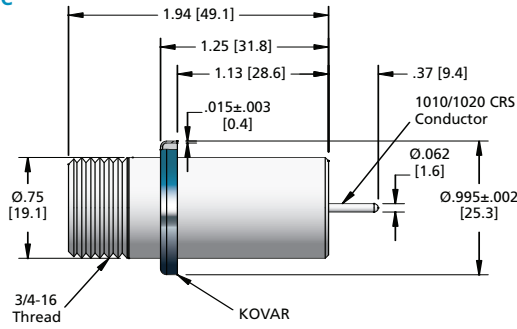

ISO KF

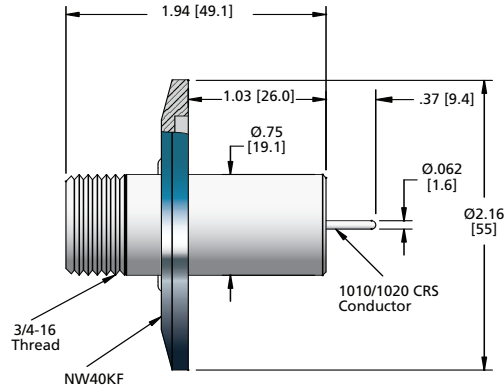

ConFlat

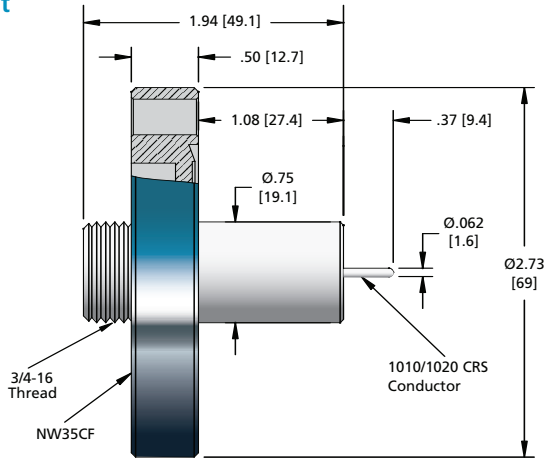

40 KV Cable Assembly

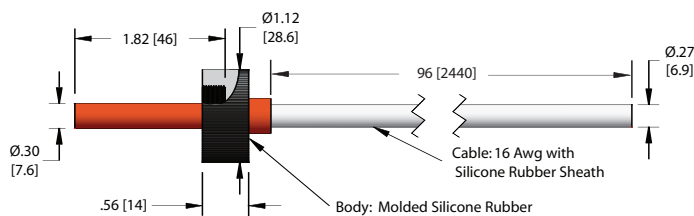

50 KV Single Pin Weldable

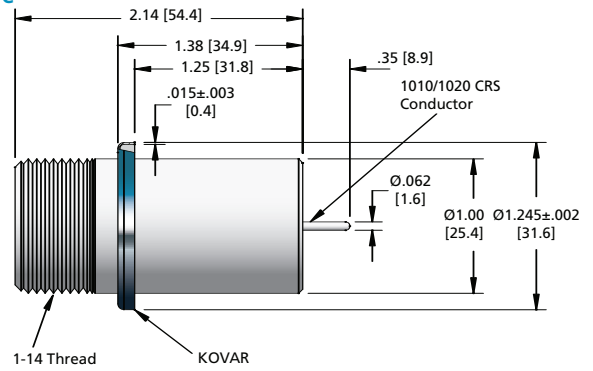

ISO KF

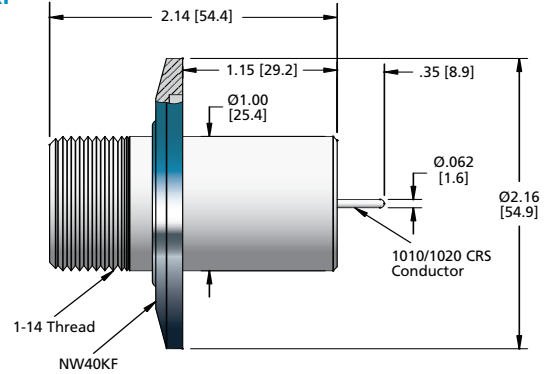

ConFlat

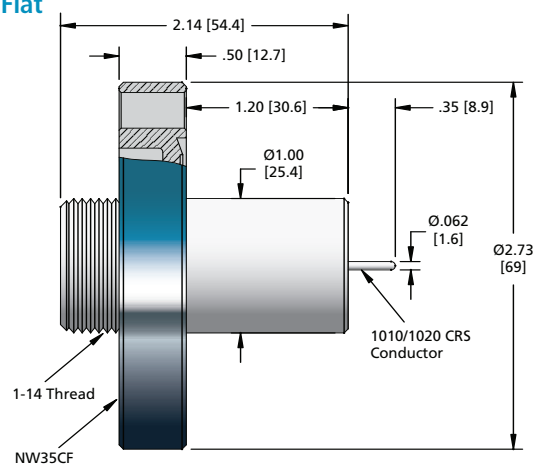

50 KV Cable Assembly

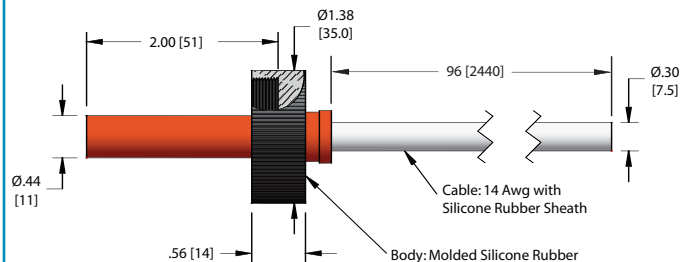



INSTALLATION	VOLTAGE DC	PART NUMBER
Weld	40 kV	21191-01-W
Weld	50 kV	21183-01-W



ISO FLANGE		
NW40KF	40 kV	21117-01-KF
NW40KF	50 kV	21185-01-KF



CONFLAT FLANGE		
2 3/4" (NW35CF)	40 kV	21194-01-CF
2 3/4" (NW35CF)	50 kV	21184-01-CF



VOLTAGE DC	CABLE TYPE	LENGTH	CURRENT CAPACITY	TEMPERATURE °C MIN	TEMPERATURE °C MAX	PART NUMBER
40 kV	16 AWG	8'	10 Amps	-55	125	21034-01-A
50 kV	14 AWG	8'	10 Amps	-55	125	21112-01-A

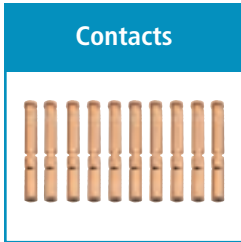

TYPE	MATERIAL	DESCRIPTION	PART NUMBER
0.062 Crimp Contacts	Beryllium Copper	Accepts wire up to 0.062 [1.6]	2044-02-A†
0.062 Crimp Contacts	Nickel Alloy	Accepts wire up to 0.062 [1.6]	0821-01-A
0.062 Barrel Type Contacts	Beryllium Copper	Accepts wire up to 0.062 [1.6]	7332-03-A
Crimp Tool		For 0.025" - 0.075" Crimp Diameters	2840-05

**Contacts priced and sold in packages of 10. †Shown in photo. See the Accessories section for more information on all accessories.

Specifications - 40 KV Single Pin

Materials

Housing: Kovar
Pin: Cold Rolled Steel (Nickel plated)
Insulation: Alumina ceramic
Magnetic Materials: Yes

Voltage Rating 40 kV DC*

Current Rating 10 Amps

Temperature Range -269°C to 450°C, ISO KF -25°C to 205°C

Pressure @ 20°C 400 PSIG (28 Bar), ISO KF 0 PSIG

Specifications - 50 KV Single Pin

Materials

Housing: Kovar
Pin: Cold Rolled Steel (Nickel plated)
Insulation: Alumina ceramic
Magnetic Materials: Yes

Voltage Rating 50 kV DC*

Current Rating 10 Amps

Temperature Range -269°C to 450°C, ISO KF -25°C to 205°C

Pressure @ 20°C 400 PSIG (28 Bar), ISO KF 0 PSIG

*When used with air side cable assembly. The use of silicone insulating grease is recommended for the air side cable assembly to feedthrough interface.

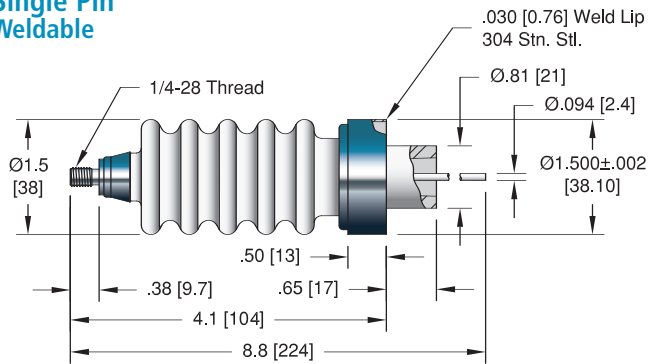
Single Pin
Weldable

ISO KF

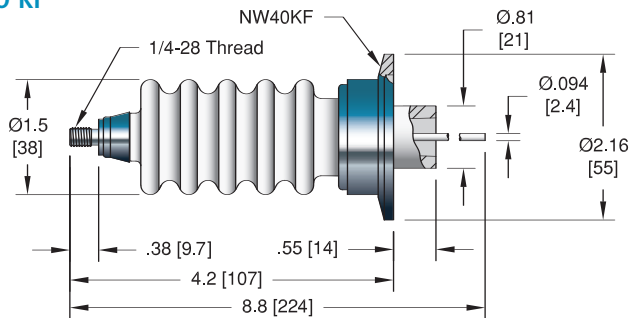

ConFlat

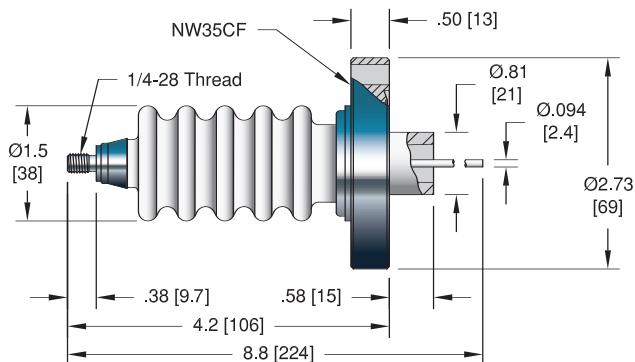
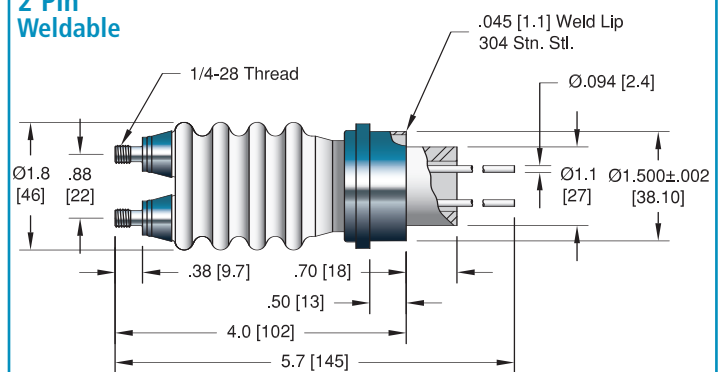
2 Pin
Weldable

ISO KF

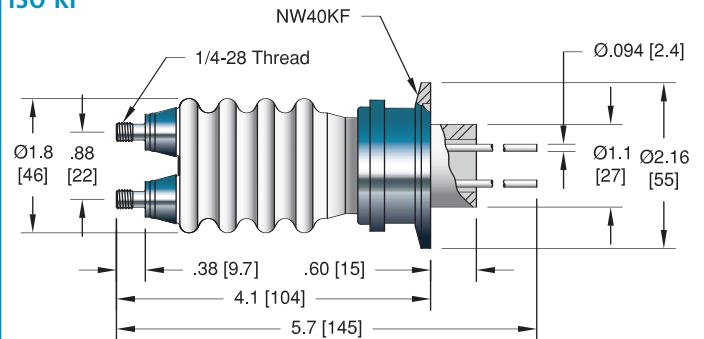

ConFlat

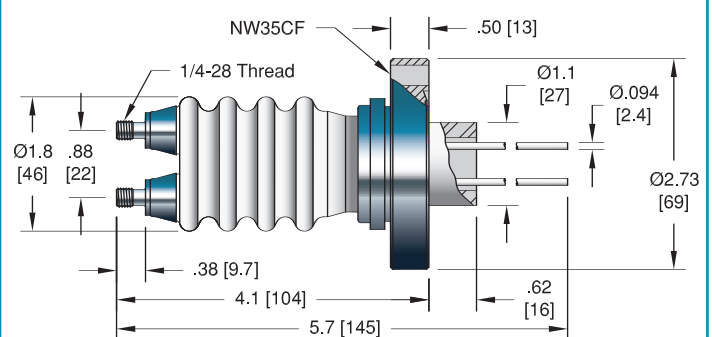

Specifications

Materials

Housing: 304 Stainless steel
Pin: 304 Stainless steel
Insulation: Alumina ceramic
Magnetic Materials: Yes

Voltage Rating 30 kV DC

Current Rating 4 Amps per pin

Temperature Range -269°C to 450°C, ISO KF -25°C to 205°C

Pressure @ 20°C 250 PSIG (17 Bar), ISO KF 0 PSIG



FEEDTHROUGH



NO. PINS	CONDUCTORS AMPS	MATERIAL	INSTALLATION	VOLTAGE DC	PART NUMBER
1	4	304 Stn. Stl.	Weld	30 kV	6530-03-W

ISO FLANGE



1	4	304 Stn. Stl.	NW40KF	30 kV	17100-01-KF
---	---	---------------	--------	-------	-------------

CONFLAT FLANGE



1	4	304 Stn. Stl.	2 3/4" (NW35CF)	30 kV	16729-03-CF
---	---	---------------	-----------------	-------	-------------



2	4	304 Stn. Stl.	Weld	30 kV	6532-05-W
---	---	---------------	------	-------	-----------

ISO FLANGE



2	4	304 Stn. Stl.	NW40KF	30 kV	17103-03-KF
---	---	---------------	--------	-------	-------------

CONFLAT FLANGE

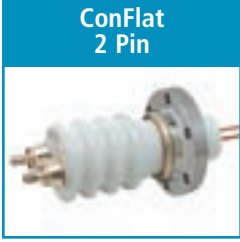

2	4	304 Stn. Stl.	2 3/4" (NW35CF)	30 kV	16764-06-CF
---	---	---------------	-----------------	-------	-------------

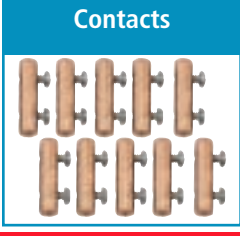

TYPE	MATERIAL	DESCRIPTION	PART NUMBER
0.094 Set Screw Type Contacts	Beryllium Copper	Accepts wire up to 0.050 [1.3]	7429-01-A
0.094 Barrel Type Contacts	Beryllium Copper	Accepts wire up to 0.094 [2.4]	7332-04-A [†]
Crimp Tool		For 0.025" - 0.075" Crimp Diameters	2840-05

*Contacts priced and sold in packages of 10. [†]Shown in photo. See the Accessories section for more information on all accessories.



**DC Voltage: 70 KV
Weldable**

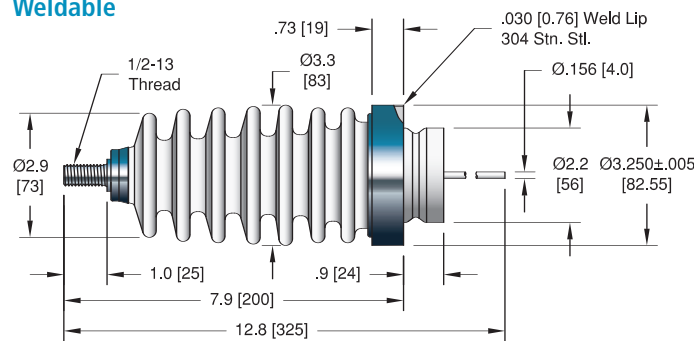

ConFlat

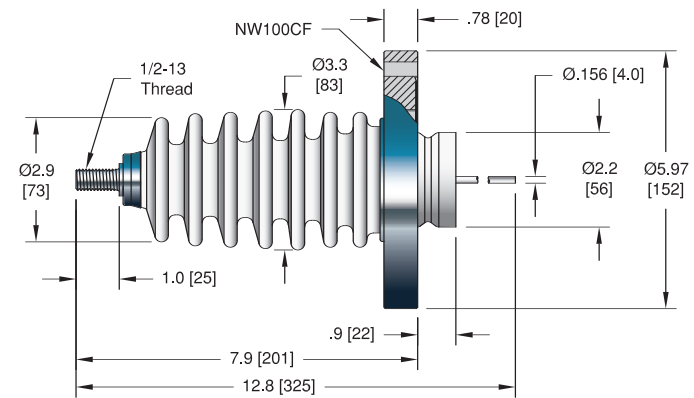

**DC Voltage: 100 KV
Weldable**

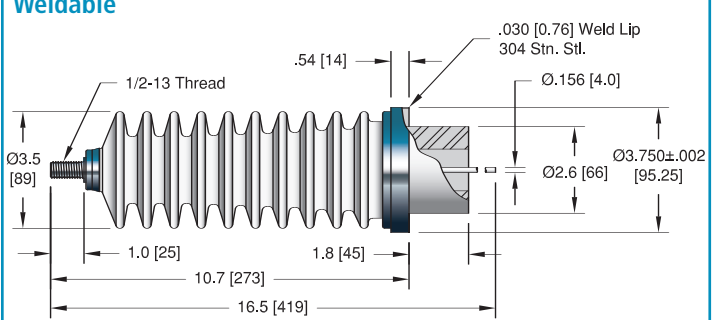

ConFlat

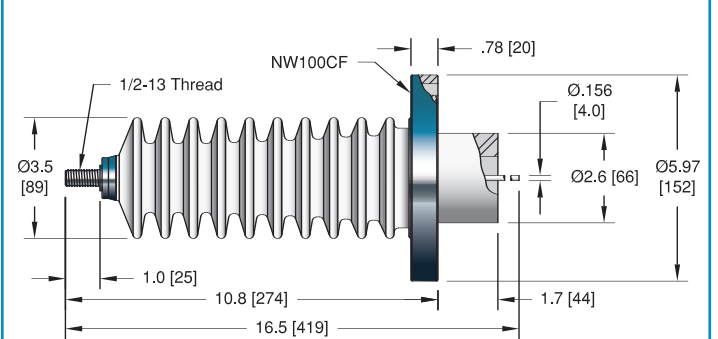

Specifications - 70 KV

Materials

- Housing: 304 Stainless steel
- Conductor: 304 Stainless steel
- Insulation: Alumina ceramic
- Magnetic Materials: Yes

Voltage Rating 70 kV DC

Current Rating 6.5 Amps

Temperature Range -269°C to 450°C

Pressure @ 20°C 125 PSIG (8.6 Bar), ISO KF 0 PSIG

Specifications - 100 KV

Materials

- Housing: 304 Stainless steel
- Conductor: 304 Stainless steel
- Insulation: Alumina ceramic
- Magnetic Materials: Yes

Voltage Rating 100 kV DC

Current Rating 6.5 Amps

Temperature Range -269°C to 450°C

Pressure @ 20°C 125 PSIG (8.6 Bar), ISO KF 0 PSIG



CONDUCTORS AMPS	MATERIAL	INSTALLATION	VOLTAGE DC	PART NUMBER
6.5	304 Stn. Stl.	Weld	70 kV	6526-01-W

CONFLAT FLANGE



6.5	304 Stn. Stl.	6" (NW100CF)	70 kV	7884-01-CF
-----	---------------	--------------	-------	------------



6.5	304 Stn. Stl.	Weld	100 kV	6523-01-W
-----	---------------	------	--------	-----------

CONFLAT FLANGE



6.5	304 Stn. Stl.	6" (NW100CF)	100 kV	6722-01-CF
-----	---------------	--------------	--------	------------

FEEDTHROUGH

Single Conductor Weldable

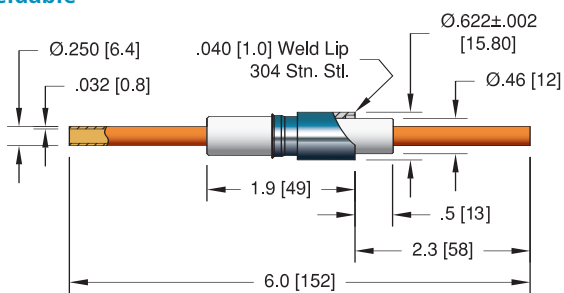

ISO KF

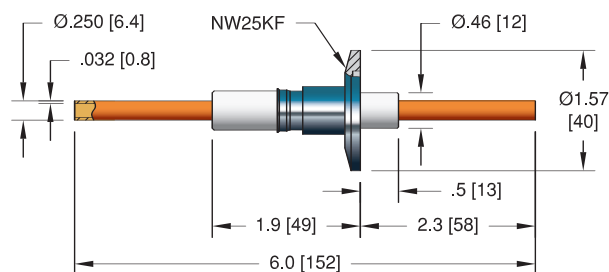

ConFlat

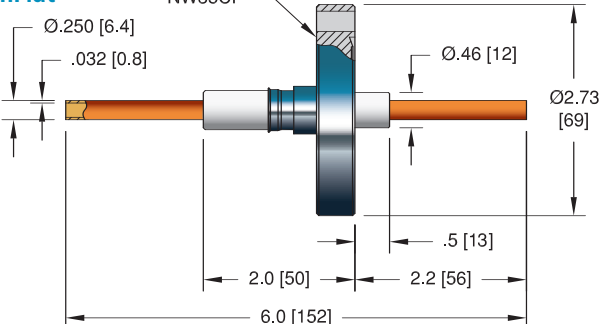

Dual Conductor Weldable

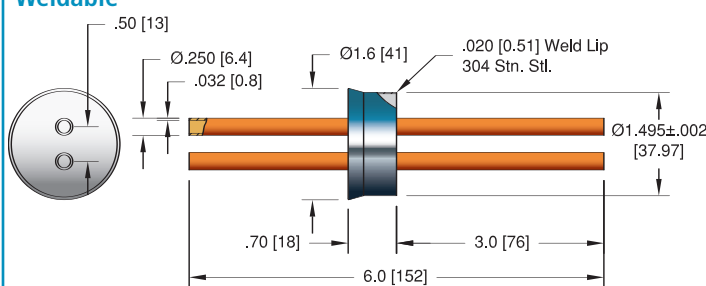

ISO KF

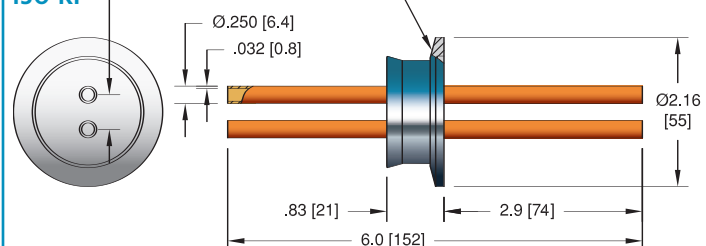

ConFlat

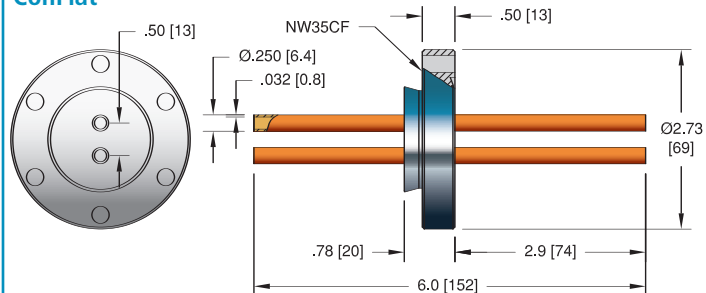

Specifications - Single Conductor

Materials

- Housing: 304 Stainless steel
- Conductor: Copper Tube
- Insulation: Alumina ceramic
- Magnetic Materials: No

Voltage Rating 14 kV DC

Current Rating 100 Amps

Temperature Range -55°C to 350°C, ISO KF -25°C to 205°C

Pressure @ 20°C 500 PSIG (35 Bar), ISO KF 0 PSIG

Specifications - Dual Conductor

Materials

- Housing: 304 Stainless steel
- Conductor: Copper Tube
- Insulation: Alumina ceramic
- Magnetic Materials: No

Voltage Rating 8 kV DC

Current Rating See table

Temperature Range -55°C to 350°C, ISO KF -25°C to 205°C

Pressure @ 20°C 125 PSIG (8.6 Bar), ISO KF 0 PSIG



FREQUENCY	CONDUCTOR AMPS	MATERIAL	INSTALLATION	PART NUMBER
13.56 MHz	100	Copper Tube	Weld	16476-01-W

ISO KF FLANGE



13.56 MHz	100	Copper Tube	NW25KF	16959-01-KF
-----------	-----	-------------	--------	-------------

CONFLAT FLANGE

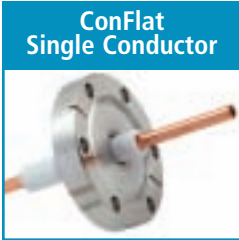

13.56 MHz	100	Copper Tube	2 3/4" (NW35CF)	16941-01-CF
-----------	-----	-------------	-----------------	-------------

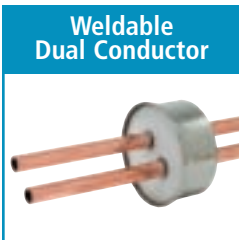

100 KHz	300	Copper Tube	Weld	16976-01-W
300 KHz	250			
450 KHz	200			
13.56 MHz	100			

ISO KF FLANGE



100 KHz	300	Copper Tube	NW40KF	17119-01-KF
300 KHz	250			
450 KHz	200			
13.56 MHz	100			

CONFLAT FLANGE

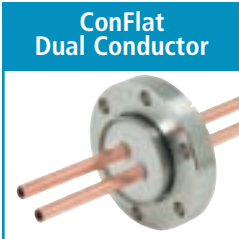

100 KHz	300	Copper Tube	2 3/4" (NW35CF)	16991-01-CF
300 KHz	250			
450 KHz	200			
13.56 MHz	100			



FEEDTHROUGH



Specifications

Materials

- Bolt: 304 Stainless steel
- O-Ring: Viton®
- Pin: See table
- Insulation: Alumina ceramic
- Magnetic Materials: See table

Voltage Rating See table

Current Rating See table

Temperature Range -25°C to 205°C

Pressure @ 20°C 200 PSIG (14 Bar) unless otherwise noted

FEEDTHROUGH

**Instrumentation/Power
Installation: 1" Bolt**

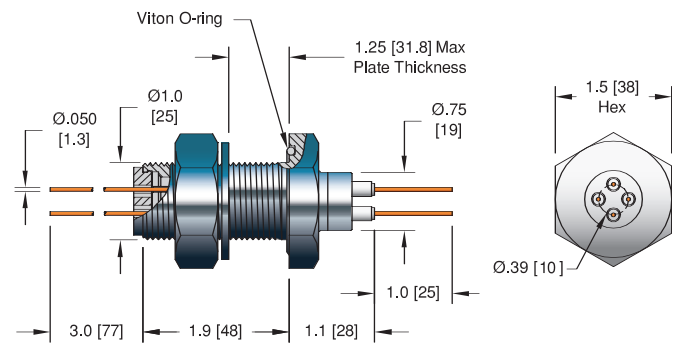

**Power
Installation: 1" Bolt**

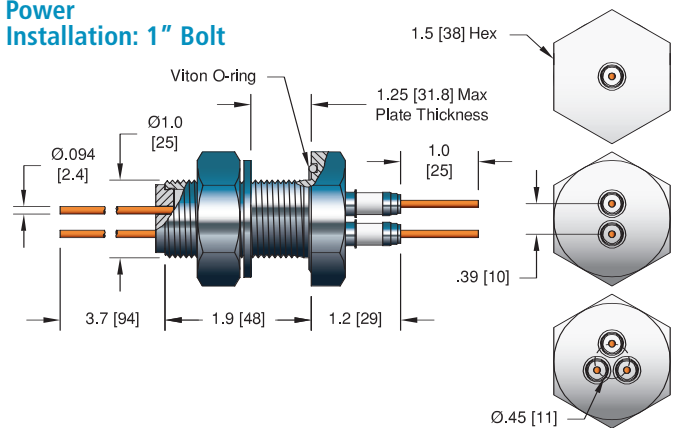

**High Power
Installation: 1" Bolt**

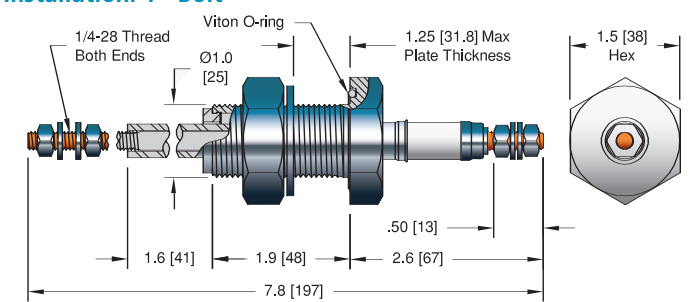

**High Voltage
Installation: 1" Bolt**

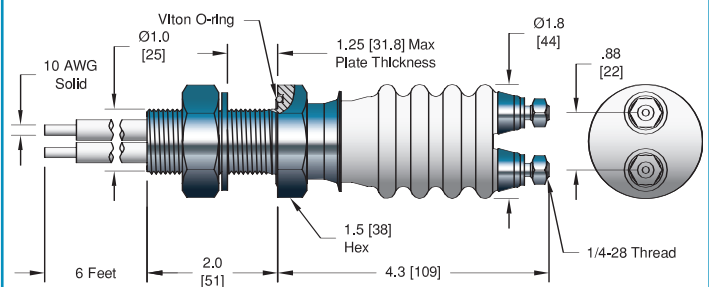



FEEDTHROUGH

Instrumentation/Power 1" Bolt



NO. PINS	VOLTAGE DC	CONDUCTOR AMPS	CONDUCTOR MATERIAL	MAGNETIC MATERIALS	PART NUMBER
4	2 kV	8.2	Nickel	Yes	15710-02-A
4	2 kV	27	Copper	No	15710-04-A

Power 1" Bolt

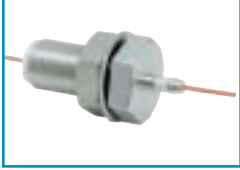

1	5 kV	55	Copper	No	15702-04-A
2	2 kV	27	Copper	No	15703-04-A
3	2 kV	27	Copper	No	15704-04-A

High Power 1" Bolt

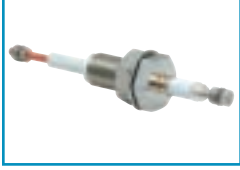

1	12 kV	185	Copper	Yes	15700-04-A
---	-------	-----	--------	-----	------------

High Voltage 1" Bolt



NO. PINS	VOLTAGE DC	CONDUCTOR AMPS	CONDUCTOR MATERIAL	PRESSURE @ 20°C PSIG	BAR	MAGNETIC MATERIALS	PART NUMBER
2	15 kV	185	Copper	125	8.6	Yes	9388-01-A

Teflon Shield



DESCRIPTION	PART NUMBER
PTFE Teflon Shield for use with part # 15700-04-A.	17413-01-A

Contacts

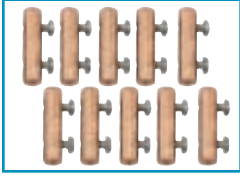

TYPE	MATERIAL	DESCRIPTION	PART NUMBER
0.050 Crimp Contacts	Beryllium Copper	Accepts wire up to 0.062 [1.6]	11911-02-X
0.050 Set Screw Type Contacts	Beryllium Copper	Accepts wire up to 0.050 [1.3]	7429-02-A
0.050 Barrel Type Contacts	Beryllium Copper	Accepts wire up to 0.050 [1.3]	7332-02-A [†]
0.094 Set Screw Type Contacts	Beryllium Copper	Accepts wire up to 0.050 [1.3]	7429-01-A
0.094 Barrel Type Contacts	Beryllium Copper	Accepts wire up to 0.094 [2.4]	7332-04-A
Crimp Tool		For 0.025" - 0.075" Crimp Diameters	2840-05

*Contacts priced and sold in packages of 10. [†]Shown in photo. See the Accessories section for more information on all accessories.



Multipin Connector

SEMICONDUCTOR | ANALYTICAL EQUIPMENT | AEROSPACE | TELECOMMUNICATIONS



OIL EXPLORATION | R&D | HIGH ENERGY PHYSICS | MILITARY/DEFENSE | BIOTECHNOLOGY



*Advanced Ceramic-to-Metal &
Glass-Ceramic Sealing Technology*

Description

CeramTec's multipin connector category of products describes hermetic feedthroughs of two or more conducting pins that accept plugs on the air side. Some connectors allow for plugs on the vacuum side as well.

Product variations include instrumentation Micro D (MIL-DTL-83513) type, Sub D (MIL-C-24308) type and circular connector types MIL-C-26482 and MIL-C-5015.

The products in this section are used primarily to provide instrumentation signals, voltage and/or current into an ultra-high vacuum environment, high pressure, or many other extreme environments, with an in-line connection to outside instrumentation. Designs adapt a Ceramaseal® feedthrough (receptacle) with an industry-standard plug.

The connector assembly is characterized by the Mil Spec designation, installation method and number of pins. In situations where voltage and current requirements are moderate, CeramTec is able to achieve a very high pin density using glass-ceramic technology. CeramTec's designs include both single-ended and double-ended connector assemblies.

Standard Specifications

- Voltages to 12 kV DC
- Current to 40 Amps per pin
- Temperature Range: -269° C to 450° C
- Internal Pressure 1 x 10⁻¹⁰ torr to 600 psig
- Up to 51 pins/conductors

Extreme / Custom Design

- 940-pin connector using thermocouple and instrumentation leads
- Combination multipin and coaxial connectors with a custom plug
- Multiple combinations of circular and D connectors in a flange
- Plugs bakeable to 650° C



Installation

Standard installation mountings include:

- Weld (Pulse-TIG, TIG, Laser, E-Beam)
- ISO KF flange
- ConFlat flange
- NPT fitting (see Pressure section)
- 1" Baseplate

For details and information on connector assembly installation, please refer to the Technical Reference section. For additional vacuum-side attachments, see the contacts and plugs in the Accessories section.

Applications

A few of the many applications in which these multipin connectors are commonly used are:





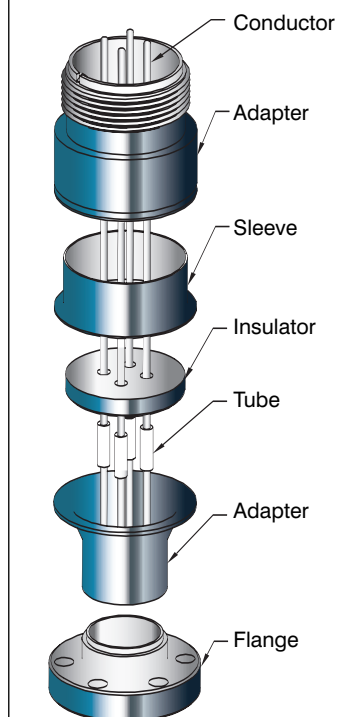

- Semiconductor processing equipment
- Analytical test and measurement equipment
- Pressure transducers
- Power generation: measurement and control
- Particle accelerators
- Furnaces
- Energy research
- Commercial & military aircraft

New Products

- Micro D connector product family

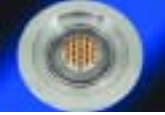
Typical Multipin Connector Construction



Type	Voltage DC	Current (Amps per conductor)	# of Conductors	Conductor Material	Sub-section	Section Pages
	375 V	1 Amp	9, 15, 25 and 51	Gold-Plated 300 Series Stainless Steel	Micro D Type MIL-DTL-83513	B.1 56-57
	500 V	5 Amps	9, 15, 25 and 50	Gold-Plated 300 Series Stainless Steel	Sub D Type MIL-C-24308	B.2 58-59
	1 kV	5 Amps	3, 6, 10, 19, 32 and 41	Gold-Plated 300 Series Stainless Steel	Circular Type MIL-C-26482	B.3 60-63
	700 V	7 Amps	4, 6, 10, 20, and 35	Alumel	Circular Type MIL-C-5015	B.4 64-65
	700 V	to 40 Amps	2 and 4	Nickel, Molybdenum	Circular Type Power: MIL-C-5015	B.5 66-69
	12 kV	13 Amps	2, 4, and 7	Molybdenum	High Voltage	B.6 70-71
	to 700 V	7 Amps	8 and 10	Alumel	Baseplate	B.7 72-73

MULTIPIN CONNECTOR



Micro D Type (MIL-DTL-83513) Connectors

CeramTec's hermetic Micro D type connectors are rugged and lightweight connectors that are designed to meet MIL-DTL-83513 specifications. Contacts are on .050 [1.27] centers, which provides a significant space and weight savings over other traditional Mil Spec connectors. Standard configurations include 9, 15, 25 and 51 gold plated pin/socket contacts, which are available as a weldable unit or in a ConFlat® or ISO flange. CeramTec uses a proprietary glass-ceramic sealing process to individually seal and electrically insulate each pin from the stainless steel housing. This allows for a very high pin/lead density and the extremely robust hermetic seal. These hermetic connectors are built for the most demanding environments and offer a much higher level of durability and reliability than any glass or elastomer sealed connector. These products are all RoHS compliant.

Mating air side cable assemblies with standard color coded 6" flying leads are offered for ease of installation. Custom PEEK thermoplastic plugs are offered for easy connectivity on the vacuum side of the connector. These PEEK plugs are fitted with gold plated 0.020 female crimp contacts, which mate to the male pins on the vacuum side of the Micro D connector and can be used with #26 through 30 AWG Kapton® wire. Typical applications for these hermetic Micro D connectors include military and commercial aircraft, IR cameras, laser-guided systems, MRI equipment and semiconductor testing & inspection equipment.

Specifications

Materials

Shell: 304 Stainless steel
Pins: 300 Series Stainless steel (Gold plated)
Insulation: Glass-ceramic
Magnetic Materials: No

Voltage Rating 375 V DC

Current Rating 1 Amp per pin

Temperature Range -269°C to 450°C, ISO KF -25°C to 205°C

Pressure @ 20°C ISO KF 0 PSIG

9 Pin - 1450 PSIG (100 Bar) 25 Pin - 1300 PSIG (89.6 Bar)
15 Pin - 1375 PSIG (94.8 Bar) 51 Pin - 1125 PSIG (77.6 Bar)

Vacuum Side Plug Specifications

Materials

Shell/Insulation: PEEK (polyether ether ketone)
Crimp Contacts: Copper alloy (Gold Plated)
Magnetic Materials: No

Voltage Rating 500 V DC

Current Rating 2 Amps per pin

Temperature Range -269°C to 200°C

Weldable

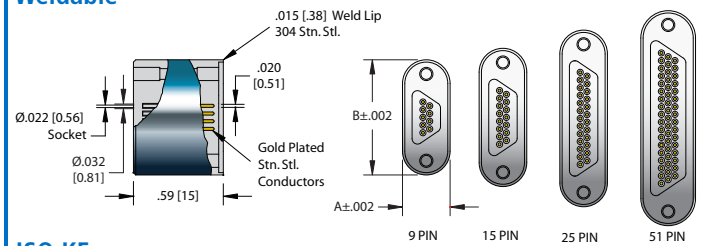

ISO KF

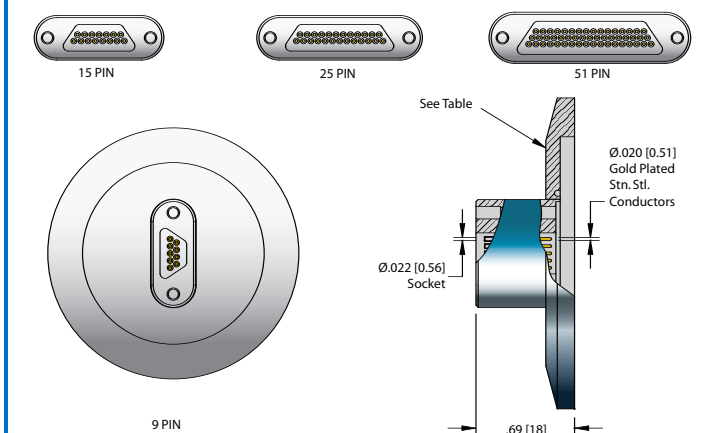

ConFlat

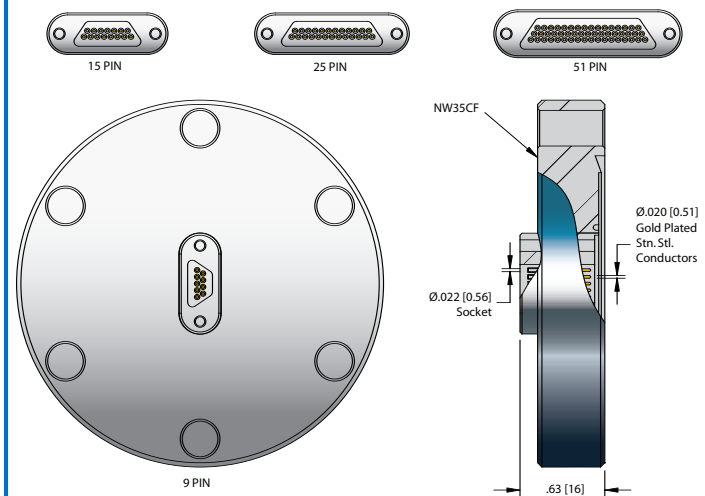

Ribbon Cable Specifications

Materials

Insulation: Kapton® Type FN
Weave: PEEK (polyether ether ketone) monofilament

Number of Conductors 9, 15, 25

Conductor

28 AWG 7 / 0.005" stranded silver plated copper

Voltage Rating 600 V AC, 850 V DC

Resistance @ 20°C 244 Ω/Km

Current Rating 2 Amps per conductor

Temperature Range -55°C to 200°C

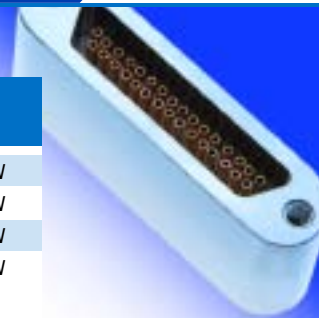

MULTIPIN CONNECTOR

Weldable

NO. PINS	INSTALLATION	DIMENSIONS		PART NUMBER
		A	B	
9	Weld	0.310 [7.9]	0.750 [19]	21270-01-W
15	Weld	0.310 [7.9]	0.900 [22.9]	21271-01-W
25	Weld	0.310 [7.9]	1.150 [29.2]	21272-01-W
51	Weld	0.356 [9.04]	1.400 [35.6]	21274-01-W

ISO FLANGE

9	NW25KF	-	-	21607-01-KF
15	NW40KF	-	-	21608-01-KF
25	NW40KF	-	-	21609-01-KF
51	NW40KF	-	-	21611-01-KF

CONFLAT FLANGE

9	2 3/4" (NW35CF)	-	-	21594-01-CF
15	2 3/4" (NW35CF)	-	-	21598-01-CF
25	2 3/4" (NW35CF)	-	-	21599-01-CF
51	2 3/4" (NW35CF)	-	-	21601-01-CF

ISO KF

ConFlat

Air Side Cable Assembly

TYPE	VOLTAGE DC	CONDUCTOR QTY	AMPS	MATERIAL	DIMENSIONS		TEMPERATURE °C		MAGNETIC MATERIALS	PART NUMBER
					W	H	MIN	MAX		
Air Side	500 V	9	3	Copper Alloy	0.775 [20]	0.298 [8]	-55	125	No	21585-01-A
Air Side	500 V	15	3	Copper Alloy	0.925 [23]	0.298 [8]	-55	125	No	21586-01-A
Air Side	500 V	25	3	Copper Alloy	1.175 [30]	0.298 [8]	-55	125	No	21587-01-A
Air Side	500 V	51	3	Copper Alloy	1.425 [36]	0.341 [9]	-55	125	No	21589-01-A

Vacuum Side Plug

TYPE	VOLTAGE DC	CONDUCTOR QTY	AMPS	MATERIAL	DIMENSIONS		TEMPERATURE °C		MAGNETIC MATERIALS	PART NUMBER
					W	H	MIN	MAX		
Vacuum Side	500 V	9	2	Beryllium Copper	0.790 [20]	0.390 [10]	-269	200	No	21573-01-A
Vacuum Side	500 V	15	2	Beryllium Copper	0.935 [24]	0.390 [10]	-269	200	No	21574-01-A
Vacuum Side	500 V	25	2	Beryllium Copper	1.185 [30]	0.390 [10]	-269	200	No	21575-01-A
Vacuum Side	500 V	51	2	Beryllium Copper	1.135 [36]	0.390 [10]	-269	200	No	21577-01-A

Note that contacts are included with all plugs.

Ribbon Cable 28 AWG

CONDUCTOR QUANTITY*	CABLE LENGTH	CABLE WIDTH	INSULATION DIAMETER	WIRE DIAMETER	PART NUMBER
9	19"	0.4	Ø .028	7 X 0.005	21622-19-WW
9	39"	0.4	Ø .028	7 X 0.005	21622-39-WW
15	19"	0.7	Ø .028	7 X 0.005	21623-19-WW
15	39"	0.7	Ø .028	7 X 0.005	21623-39-WW
25	19"	1.2	Ø .028	7 X 0.005	21624-19-WW
25	39"	1.2	Ø .028	7 X 0.005	21624-39-WW
Adjustable Wire Stripper For 20 - 30 AWG (0.25 - 0.80 mm) Cable					21128-01
Contact CeramTec for custom lengths.					

Contacts

TYPE	MATERIAL	DESCRIPTION	PART NUMBER
.020 Crimp Contacts	Beryllium Copper	Accepts wire up to 0.022 [.56]	21466-02-A

*Contacts priced and sold in packages of 5. See the Accessories section for more information on all accessories.

Sub D Type (MIL-C-24308) Connectors

CeramTec's hermetic Subminiature D type connectors are designed to meet MIL-C-24308 specifications. Standard configurations include 9, 15, 25, and 50 gold plated pin connectors, which are available as a weldable unit or in a ConFlat® or ISO flange. Custom configurations are commonplace and available upon request. CeramTec is able to achieve a very high pin/lead density (standard - up to 50 pins) using glass-ceramic sealing technology. The rugged stainless steel shell design is built to withstand severe environments and reduces seal failure due to overheating while welding. These connectors are used primarily to provide instrumentation signals, voltage and/or current into a high-vacuum or ultra-high vacuum environment, with an in-line connection to outside instrumentation.

In-Vacuum Ribbon Cable

CeramTec's in-vacuum ribbon cable is designed to complement our Sub D Type (MIL-C-24308) hermetic multipin connector product line and therefore cable configurations include 9, 15, or 25 conductor cable. Note that 50 conductor cables are created by using two 25 conductor cables. Each of the Kapton® wrapped (19 x 0.0063) 22 AWG silver plated copper conductors are woven with a PEEK (polyether ether ketone) monofilament in order to achieve the ribbon cable form. The multistranded wrapped cable offers the most flexible solution and has a temperature range up to 200° C. All ribbon cable assembly materials are ultra-high vacuum (UHV) compatible. The ribbon cables are vacuum baked out prior to shipping. Additional vacuum bake out prior to use is also recommended. All cable assembly components are sold separately.

Specifications

Materials

Shell: 304 Stainless steel
 Pins: 300 Series Stainless steel (Gold Plated)
 Insulation: Glass-ceramic
 Magnetic Materials: No

Voltage Rating 500 V DC

Current Rating 5 Amps per pin

Temperature Range -269°C to 450°C, ISO KF -25°C to 205°C

Pressure @ 20°C ISO KF 0 PSIG

9 Pin - 1350 PSIG (93.1 Bar)	25 Pin - 1200 PSIG (82.7 Bar)
15 Pin - 1250 PSIG (86.2 Bar)	50 Pin - 900 PSIG (62.1 Bar)

Vacuum Side Plug Specifications

Materials

Shell/Insulation: PEEK (polyether ether ketone)
 Crimp Contacts: Copper alloy (Gold Plated)
 Magnetic Materials: No

Voltage Rating 500 V DC

Current Rating 15 Amps

Temperature Range -269°C to 200°C

Weldable

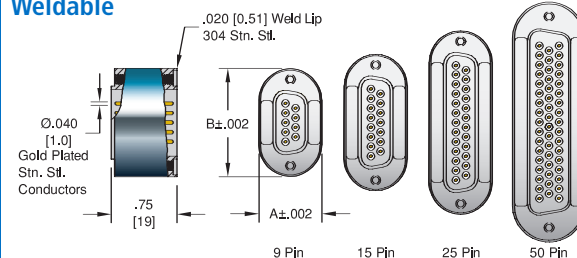

ISO KF

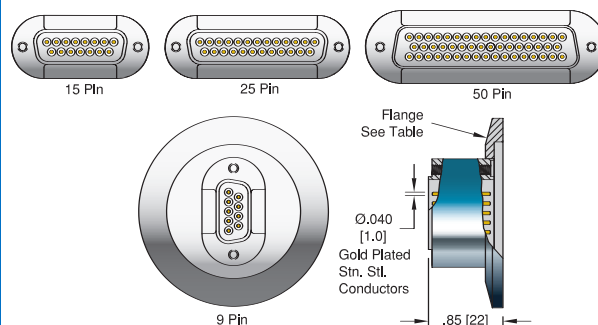

ConFlat

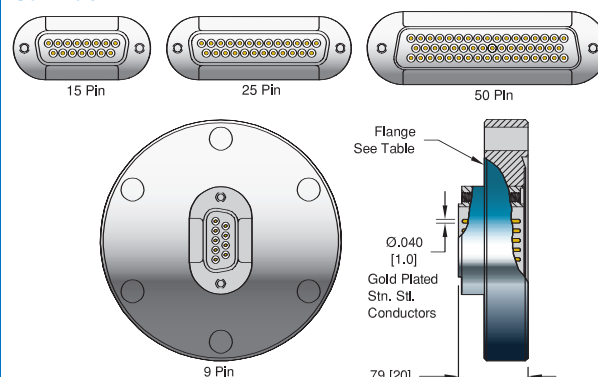

Ribbon Cable Specifications

Materials

Insulation: Kapton® Type FN
 Weave: PEEK (polyether ether ketone) monofilament

Number of Conductors 9, 15, 25

Conductor

22 AWG 19 / 0.0063" stranded silver plated copper

Voltage Rating 600 V AC, 850 V DC

Current Rating 5 Amps per conductor

Temperature Range -55°C to 200°C

Resistance @ 20°C 119Ω/km

Weldable



NO. PINS	INSTALLATION	DIMENSIONS		PART NUMBER
		A	B	
9	Weld	0.720 [18.29]	1.234 [31.34]	16800-01-W
15	Weld	0.720 [18.29]	1.562 [39.67]	16801-01-W
25	Weld	0.720 [18.29]	2.102 [53.39]	16802-01-W
50	Weld	0.832 [21.13]	2.738 [69.54]	16804-01-W

ISO KF



ISO FLANGE

9	NW40KF	-	-	18605-01-KF
15	NW50KF	-	-	18606-01-KF
25	NW63LF	-	-	20306-01-CLF
50	NW100LF	-	-	20307-01-CLF

ConFlat

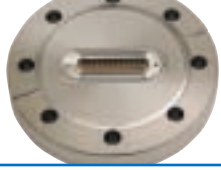

CONFLAT FLANGE

9	2 3/4" (NW35CF)	-	-	18607-01-CF
15	3 3/8" (NW50CF)	-	-	18608-01-CF
15	4 1/2" (NW63CF)	-	-	21108-01-CF
25	4 1/2" (NW63CF)	-	-	18609-01-CF
50 (2x25)	4 1/2" (NW63CF)	-	-	21109-01-CF
50	6" (NW100CF)	-	-	18610-01-CF
100 (2x50)	6" (NW100CF)	-	-	21641-01-CF

Air Side Plug



TYPE	VOLTAGE DC	QTY	CONTACTS		DIMENSIONS			TEMPERATURE °C		MAGNETIC MATERIALS	PART NUMBER
			AMPS	MATERIAL	D	W	H	MIN	MAX		
Air Side	500 V	9	5	Copper Alloy	1.7 [43]	1.2 [31]	0.6 [15]	-55	105	Yes	18076-01-A
Air Side	500 V	15	5	Copper Alloy	1.6 [41]	1.6 [41]	0.6 [15]	-55	105	Yes	18076-02-A
Air Side	500 V	25	5	Copper Alloy	1.9 [48]	2.2 [56]	0.6 [15]	-55	105	Yes	18076-03-A†
Air Side	500 V	50	5	Copper Alloy	2.0 [51]	2.6 [66]	0.7 [18]	-55	105	Yes	18076-04-A
Vacuum Side-Female	500 V	9	5	Copper Alloy	1.3 [33]	0.4 [11]	0.63 [16]	-200	200	No	16810-01-A
Vacuum Side-Female	500 V	15	5	Copper Alloy	1.6 [40]	0.4 [11]	0.63 [16]	-200	200	No	16811-01-A
Vacuum Side-Female	500 V	25	5	Copper Alloy	2.2 [55]	0.4 [11]	0.63 [16]	-200	200	No	16812-01-A†
Vacuum Side-Female	500 V	50	5	Copper Alloy	2.7 [69]	0.5 [14]	0.63 [16]	-200	200	No	16814-01-A
Vacuum Side-Male	500 V	9	5	Copper Alloy	1.3 [33]	0.4 [11]	0.63 [16]	-200	200	No	19827-01-A
Vacuum Side-Male	500 V	15	5	Copper Alloy	1.6 [40]	0.4 [11]	0.63 [16]	-200	200	No	19828-01-A
Vacuum Side-Male	500 V	25	5	Copper Alloy	2.2 [55]	0.4 [11]	0.63 [16]	-200	200	No	17411-01-A
Vacuum Side-Male	500 V	50	5	Copper Alloy	2.7 [69]	0.5 [14]	0.63 [16]	-200	200	No	19829-01-A

Note that contacts are included with all plugs.

Vacuum Side Plugs



Ribbon Cable 22 AWG



CONDUCTOR QUANTITY*	CABLE LENGTH	CABLE WIDTH	INSULATION DIAMETER	WIRE DIAMETER	PART NUMBER
9	19"	0.4	Ø .035	19 X 0.0063	20370-19-WW
9	39"	0.4	Ø .035	19 X 0.0063	20370-39-WW
15	19"	0.7	Ø .035	19 X 0.0063	20371-19-WW
15	39"	0.7	Ø .035	19 X 0.0063	20371-39-WW
25	19"	1.2	Ø .035	19 X 0.0063	20372-19-WW
25	39"	1.2	Ø .035	19 X 0.0063	20372-39-WW
Adjustable Wire Stripper	For 20 - 30 AWG (0.25 - 0.80 mm) Cable				21128-01

*The 50 conductor cables are created by using two 25 conductor cables. Contact CeramTec for custom lengths.

Contacts



TYPE	MATERIAL	DESCRIPTION	PART NUMBER
0.040 Female Crimp Contacts	Copper Alloy	Female accepts wire up to 0.040 [1.0]	16757-02-A
0.040 Male/Pin Crimp Contacts	Copper Alloy	Male/Pin contact - 0.040 [1.0] Pin	17412-02-A
Crimp Tool		For 0.025" - 0.075" Crimp Diameters	2840-05

**Contacts priced and sold in packages of 5. See the Accessories section for more information on all accessories.

Single Ended - Straight Pin Weldable

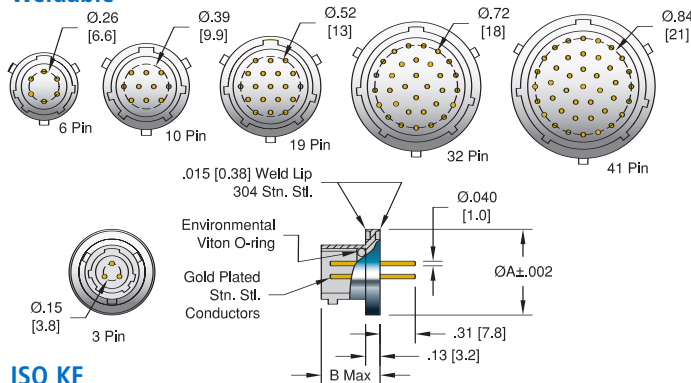

ISO KF

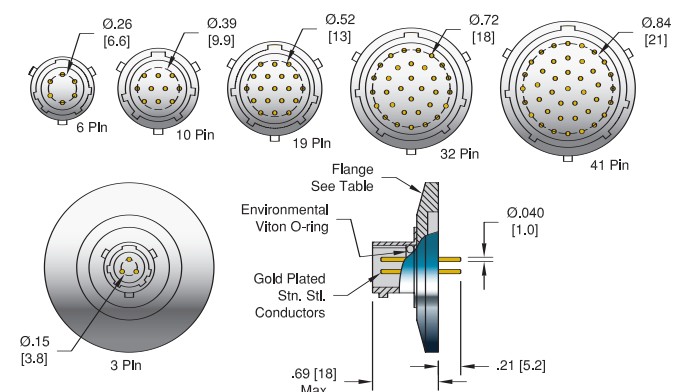

ConFlat

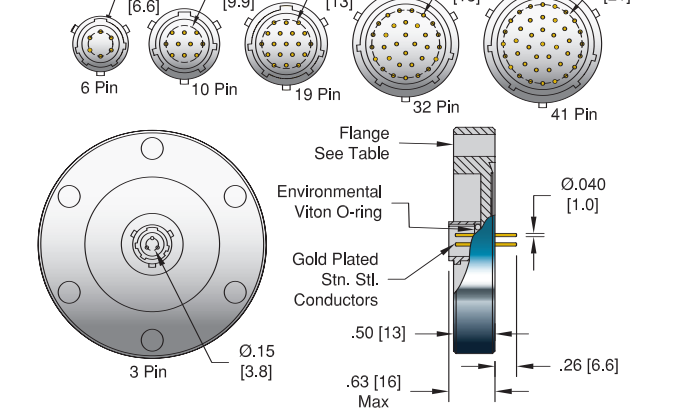

Single Ended - Solder Cup Weldable

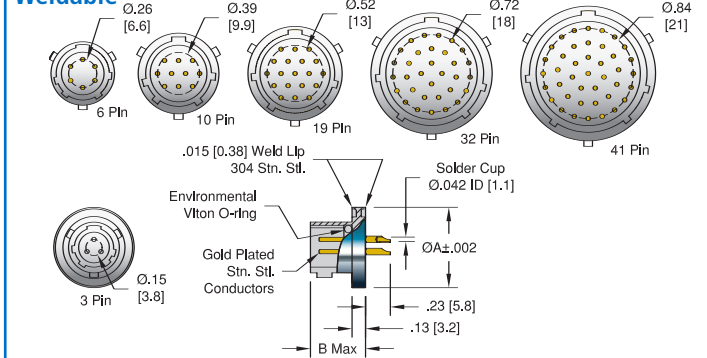

ISO KF

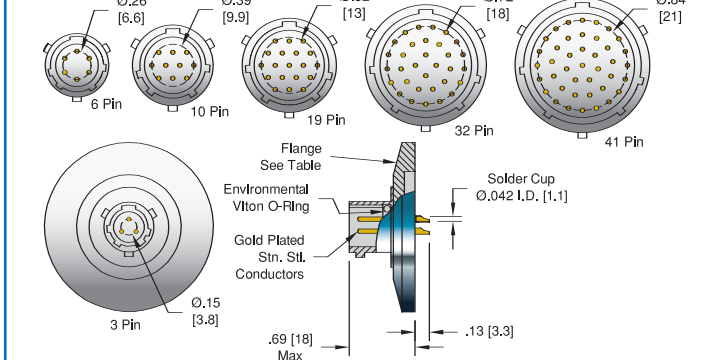

ConFlat

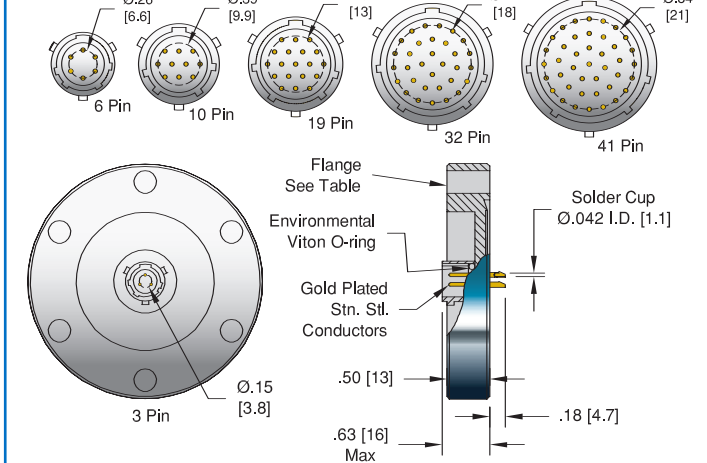

Specifications

Materials

- Shell: 304 Stainless steel
- Pins: 300 Series Stainless steel (Gold plated)
- Insulation: Glass-ceramic
- Magnetic Materials: No

Voltage Rating 1 kV DC

Current Rating 5 Amps per pin

Temperature Range -269°C to 450°C, ISO KF -25°C to 205°C

Pressure @ 20°C ISO KF 0 PSIG

3 Pin - 550 PSIG (38 Bar)	19 Pin - 400 PSIG (28 Bar)
6 Pin - 500 PSIG (34 Bar)	32 Pin - 375 PSIG (26 Bar)
10 Pin - 450 PSIG (31 Bar)	41 Pin - 350 PSIG (24 Bar)

MULTIPIN CONNECTOR



MULTIPIN CONNECTOR



NO. PINS	PIN TYPE	INSTALLATION	DIMENSIONS		PART NUMBER
			A	B	
3	Straight	Weld	0.745 [18.92]	0.51 [13.0]	16130-02-W
6	Straight	Weld	0.870 [22.10]	0.51 [13.0]	16131-02-W
10	Straight	Weld	0.995 [25.27]	0.51 [13.0]	16132-02-W
19	Straight	Weld	1.120 [28.45]	0.51 [13.0]	16133-02-W
32	Straight	Weld	1.370 [34.80]	0.51 [13.0]	16134-02-W
41	Straight	Weld	1.495 [37.97]	0.57 [14.5]	16135-02-W



ISO FLANGE					
NO. PINS	PIN TYPE	INSTALLATION	A	B	PART NUMBER
3	Straight	NW25KF	-	-	17160-01-KF
6	Straight	NW40KF	-	-	17161-01-KF
10	Straight	NW40KF	-	-	17162-01-KF
19	Straight	NW40KF	-	-	17163-01-KF
32	Straight	NW40KF	-	-	17164-01-KF
41	Straight	NW50KF	-	-	17165-01-KF



CONFLAT FLANGE					
NO. PINS	PIN TYPE	INSTALLATION	A	B	PART NUMBER
3	Straight	2 3/4" (NW35CF)	-	-	18894-01-CF
6	Straight	2 3/4" (NW35CF)	-	-	18895-01-CF
10	Straight	2 3/4" (NW35CF)	-	-	18896-01-CF
19	Straight	2 3/4" (NW35CF)	-	-	18897-01-CF
32	Straight	2 3/4" (NW35CF)	-	-	18898-01-CF
41	Straight	3 3/8" (NW50CF)	-	-	18899-01-CF
Female Crimp Contacts Female accepts wire up to 0.040 [1.0]					16757-02-A

*Contacts priced and sold in packages of 5.



NO. PINS	PIN TYPE	INSTALLATION	DIMENSIONS		PART NUMBER
			A	B	
3	Solder Cup	Weld	0.745 [18.92]	0.51 [13.0]	16010-02-W
6	Solder Cup	Weld	0.870 [22.10]	0.51 [13.0]	16011-02-W
10	Solder Cup	Weld	0.995 [25.27]	0.51 [13.0]	16012-02-W
19	Solder Cup	Weld	1.120 [28.45]	0.51 [13.0]	16013-02-W
32	Solder Cup	Weld	1.370 [34.80]	0.51 [13.0]	16014-02-W
41	Solder Cup	Weld	1.495 [37.97]	0.57 [14.5]	16015-02-W



ISO FLANGE					
NO. PINS	PIN TYPE	INSTALLATION	A	B	PART NUMBER
3	Solder Cup	NW25KF	-	-	17171-01-KF
6	Solder Cup	NW40KF	-	-	17172-01-KF
10	Solder Cup	NW40KF	-	-	17173-01-KF
19	Solder Cup	NW40KF	-	-	17174-01-KF
32	Solder Cup	NW40KF	-	-	17175-01-KF
41	Solder Cup	NW50KF	-	-	17176-01-KF



CONFLAT FLANGE					
NO. PINS	PIN TYPE	INSTALLATION	A	B	PART NUMBER
3	Solder Cup	2 3/4" (NW35CF)	-	-	17148-01-CF
6	Solder Cup	2 3/4" (NW35CF)	-	-	17343-01-CF
10	Solder Cup	2 3/4" (NW35CF)	-	-	17149-01-CF
19	Solder Cup	2 3/4" (NW35CF)	-	-	17787-01-CF
32	Solder Cup	2 3/4" (NW35CF)	-	-	17697-01-CF
41	Solder Cup	3 3/8" (NW50CF)	-	-	17156-01-CF



TYPE	VOLTAGE DC	CONDUCTOR AMPS	NO. CONTACTS	DIMENSIONS		PART NUMBER
				H	L	
Air Side	1 kV	1	3	0.8 [20]	1.9 [48]	16060-01-A
Air Side	1 kV	1	6	1.0 [25]	1.9 [48]	16060-02-A
Air Side	1 kV	1	10	1.0 [25]	1.9 [48]	16060-03-A
Air Side	1 kV	1	19	1.2 [31]	1.9 [48]	16060-04-A
Air Side	1 kV	1	32	1.4 [36]	2.1 [53]	16060-05-A
Air Side	1 kV	1	41	1.5 [38]	2.3 [58]	16060-06-A

Note that contacts are included with all plugs. See the Accessories section for more information on all accessories.





MULTIPIN CONNECTOR

Specifications

Materials

Shell: Stainless steel
 Pins: 300 Series Stainless steel (Gold plated)
 Insulation: Glass-ceramic
 Magnetic Materials: No

Voltage Rating 1 kV DC

Current Rating 5 Amps per pin

Temperature Range -269°C to 450°C, ISO KF -25°C to 205°C

Pressure @ 20°C ISO KF 0 PSIG

- 3 Pin - 550 PSIG (38 Bar)
- 6 Pin - 500 PSIG (34 Bar)
- 10 Pin - 450 PSIG (31 Bar)
- 19 Pin - 400 PSIG (28 Bar)
- 32 Pin - 375 PSIG (26 Bar)
- 41 Pin - 350 PSIG (24 Bar)

Vacuum Side Plug Specifications

Materials

Shell: 304 Stainless steel
 Crimp Contacts: Copper alloy (Gold plated)
 Insulation: PEEK (polyether ether ketone)
 Magnetic Materials: No

Voltage Rating 1 kV DC

Current Rating 5 Amps per pin

Temperature Range -269°C to 200°C

**Double Ended
Weldable**

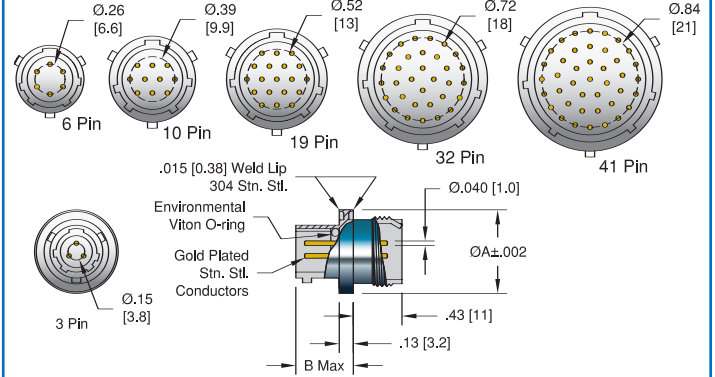

ISO KF

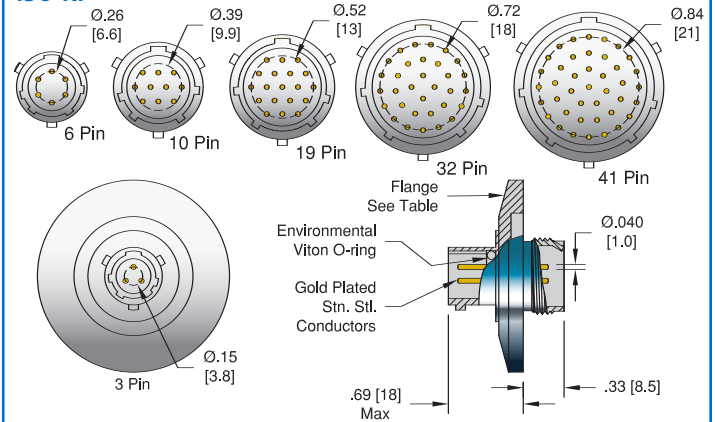

ConFlat

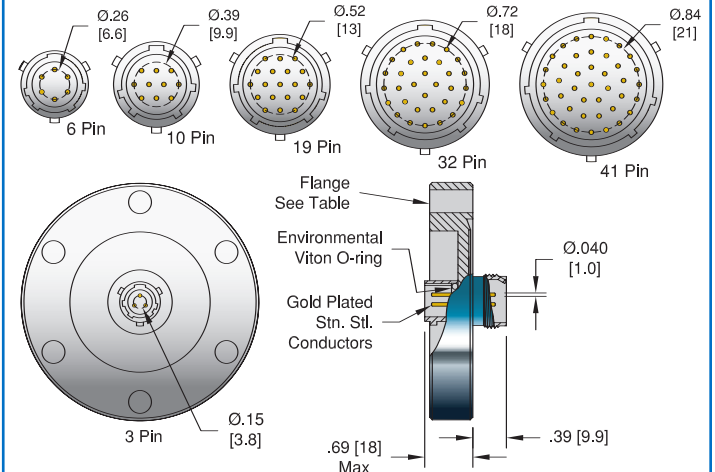



NO. PINS	INSTALLATION	DIMENSIONS		PART NUMBER
		A	B	
3	Weld	0.745 [18.92]	0.51 [13.0]	16000-02-W
6	Weld	0.870 [22.10]	0.51 [13.0]	16001-02-W
10	Weld	0.995 [25.27]	0.51 [13.0]	16002-02-W
19	Weld	1.120 [28.45]	0.51 [13.0]	16003-02-W
32	Weld	1.370 [34.80]	0.51 [13.0]	16004-02-W
41	Weld	1.495 [37.97]	0.57 [14.5]	16005-02-W



ISO FLANGE				
3	NW25KF	-	-	17180-01-KF
6	NW40KF	-	-	17181-01-KF
10	NW40KF	-	-	17182-01-KF
19	NW40KF	-	-	18900-01-KF
32	NW40KF	-	-	18901-01-KF
41	NW50KF	-	-	18902-01-KF

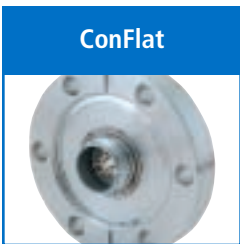

CONFLAT FLANGE				
3	2 3/4" (NW35CF)	-	-	18903-01-CF
6	2 3/4" (NW35CF)	-	-	18904-01-CF
10	2 3/4" (NW35CF)	-	-	18905-01-CF
19	2 3/4" (NW35CF)	-	-	18906-01-CF
32	2 3/4" (NW35CF)	-	-	18907-01-CF
41	3 3/8" (NW50CF)	-	-	18908-01-CF



TYPE	VOLTAGE DC	CONDUCTOR AMPS	NO. CONTACTS	DIMENSIONS		PART NUMBER
				H	L	
Air Side	1 kV	1	3	0.8 [20]	1.9 [48]	16060-01-A
Air Side	1 kV	1	6	1.0 [25]	1.9 [48]	16060-02-A
Air Side	1 kV	1	10	1.0 [25]	1.9 [48]	16060-03-A
Air Side	1 kV	1	19	1.2 [31]	1.9 [48]	16060-04-A
Air Side	1 kV	1	32	1.4 [36]	2.1 [53]	16060-05-A
Air Side	1 kV	1	41	1.5 [38]	2.3 [58]	16060-06-A



TYPE	VOLTAGE DC	CONDUCTOR AMPS	NO. CONTACTS	DIMENSIONS		PART NUMBER
				H	L	
Vacuum Side	1 kV	5	3	0.8 [19]	1.0 [25]	16026-02-A
Vacuum Side	1 kV	5	6	0.9 [22]	1.0 [25]	16027-02-A
Vacuum Side	1 kV	5	10	1.0 [25]	1.0 [25]	16028-02-A
Vacuum Side	1 kV	5	19	1.1 [28]	1.0 [25]	16029-02-A
Vacuum Side	1 kV	5	32	1.4 [34]	1.0 [25]	16030-02-A
Vacuum Side	1 kV	5	41	1.5 [37]	1.0 [25]	16031-02-A

Note that contacts are included with all plugs. See the Accessories section for more information on all accessories.



4, 6, & 10 Pin
Weldable

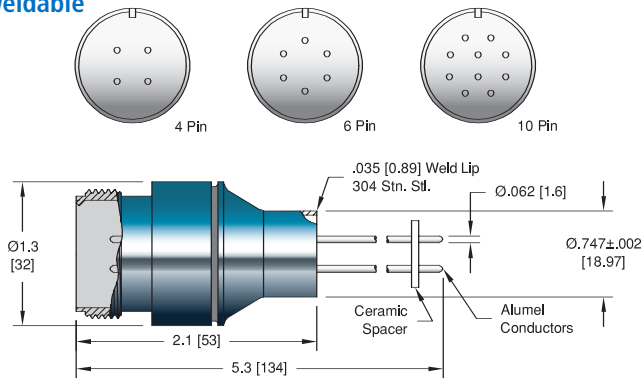

ISO KF - NW16KF

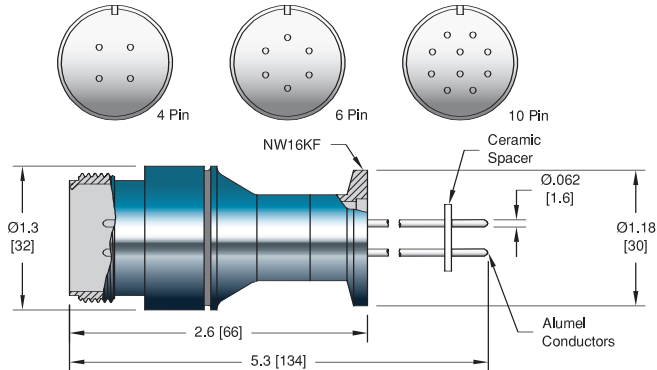

ConFlat - NW16CF

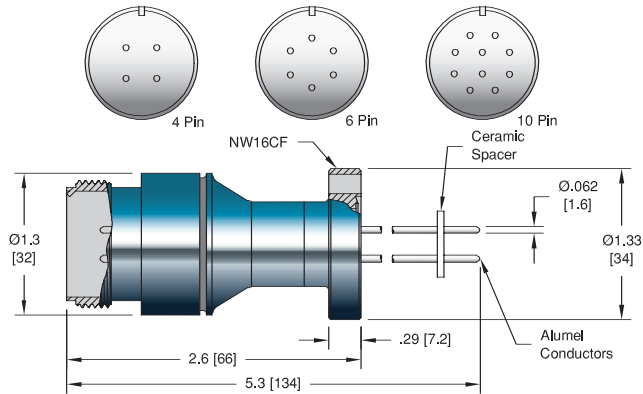

ConFlat - NW35CF

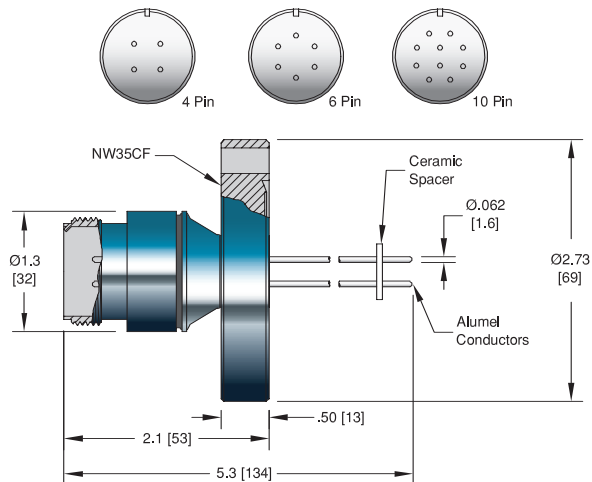

20 & 35 Pin
Weldable

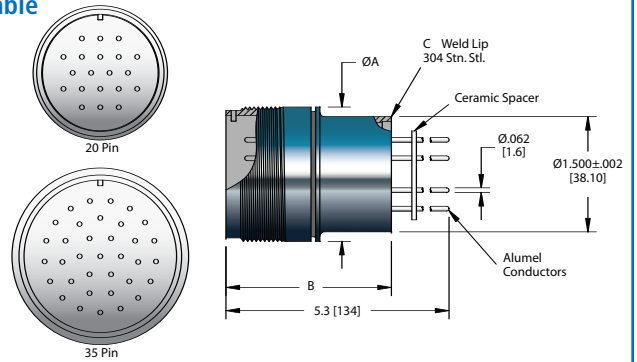

ISO KF

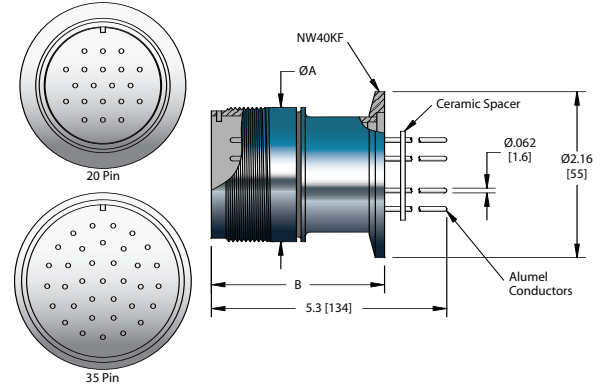

ConFlat

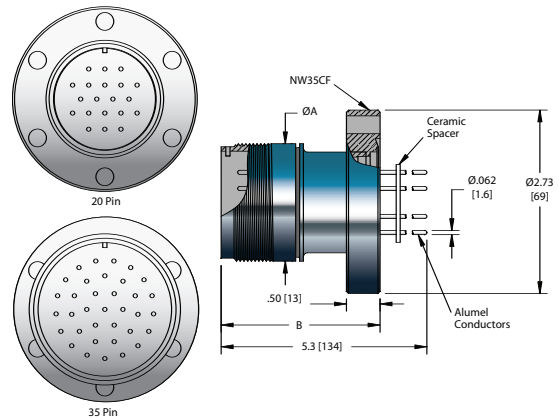

Specifications
Materials

- Shell: 304 Stainless steel
- Pins: Alumel
- Insulation: Alumina ceramic
- Magnetic Materials: Yes

Voltage Rating 700 V DC

Current Rating 7 Amps per pin

Temperature Range -269°C to 450°C, ISO KF -25°C to 205°C

Pressure @ 20°C ISO KF 0 PSIG

- 4 Pin - 600 PSIG (41 Bar)
- 6 Pin - 550 PSIG (38 Bar)
- 10 Pin - 500 PSIG (34 Bar)
- 20 Pin - 125 PSIG (8.6 Bar)
- 35 Pin - 50 PSIG (3.4 Bar)



NO. PINS	INSTALLATION	DIMENSIONS			PART NUMBER
		A	B	C	
4	Weld	-	-	-	10184-05-W
6	Weld	-	-	-	10185-05-W
10	Weld	-	-	-	10094-05-W
20	Weld	1.8 [44]	2.3 [57]	.065 [1.7]	10096-04-W
35	Weld	2.3 [57]	3.1 [79]	.060 [1.5]	10186-04-W



ISO FLANGE					
NO. PINS	INSTALLATION	A	B	C	PART NUMBER
4	NW16KF	-	-	-	17150-02-KF
6	NW16KF	-	-	-	17151-02-KF
10	NW16KF	-	-	-	17155-04-KF
20	NW40KF	1.8 [44]	2.3 [57]	-	13744-02-KF
35	NW40KF	2.3 [57]	3.2 [82]	-	15103-02-KF

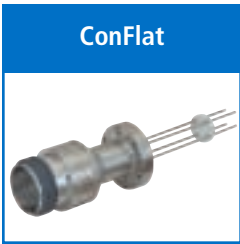

CONFLAT FLANGE					
NO. PINS	INSTALLATION	A	B	C	PART NUMBER
4	1 1/3" (NW16CF)	-	-	-	10184-06-CF
4	2 3/4" (NW35CF)	-	-	-	10184-07-CF
6	1 1/3" (NW16CF)	-	-	-	10185-06-CF
6	2 3/4" (NW35CF)	-	-	-	10185-07-CF
10	1 1/3" (NW16CF)	-	-	-	10094-06-CF
10	2 3/4" (NW35CF)	-	-	-	10094-09-CF
20	2 3/4" (NW35CF)	1.8 [44]	2.4 [60]	-	10096-03-CF
35	2 3/4" (NW35CF)	2.3 [57]	3.3 [84]	-	10186-03-CF



TYPE	VOLTAGE DC	CONDUCTOR AMPS	NO. CONTACTS	DIMENSIONS		TEMPERATURE °C		PART NUMBER
				H	L	MIN	MAX	
Air Side	700 V	13	4	1.4 [36]	4.4 [112]	-55	125	15910-01-A
Air Side	700 V	13	6	1.4 [36]	4.4 [112]	-55	125	15911-01-A
Air Side	700 V	13	10	1.4 [36]	4.4 [112]	-55	125	15912-01-A
Air Side	700 V	13	20	1.9 [49]	4.3 [109]	-55	125	15913-01-A
Air Side	700 V	13	35	2.5 [62]	4.2 [107]	-55	125	15914-01-A
Air Side: Hi-Temp PEEK	700 V	4.8	4	1.4 [36]	2.6 [65]	-55	260	15910-32-A
Air Side: Hi-Temp PEEK	700 V	4.8	6	1.4 [36]	2.6 [65]	-55	260	15911-32-A
Air Side: Hi-Temp PEEK	700 V	4.8	10	1.4 [36]	2.6 [65]	-55	260	15912-32-A

Note that contacts are included with all plugs.



VOLTAGE DC	CONDUCTOR AMPS	TYPE	LENGTH	WIRE DIAMETER	INSULATION DIAMETER	PART NUMBER
850 V	2.5	28 AWG Stranded	30'	7 x 0.005	Ø .028	21621-01-A
850 V	5	22 AWG Stranded	30'	19 x 0.0063	Ø .035	21643-01-A

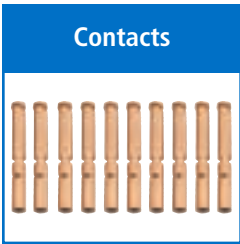

TYPE	MATERIAL	DESCRIPTION	PART NUMBER
0.062 Crimp Contacts	Beryllium Copper	Accepts .062 [1.6] Pin	2044-02-A†
0.062 Crimp Contacts	Nickel Alloy	Accepts .062 [1.6] Pin	0821-01-A
0.062 Barrel Type Contacts	Beryllium Copper	Accepts .062 [1.6] Pin	7332-03-A
Crimp Tool		For 0.025" – 0.075" Crimp Diameters	2840-05

*Contacts priced and sold in packages of 10. †Shown in photo. See the Accessories section for more information on all accessories.



Specifications

Materials

Shell: 304 Stainless steel
 Pins: Nickel or Molybdenum
 Insulation: Alumina ceramic
 Magnetic Materials: See table

Voltage Rating 700 V DC

Current Rating See table

Temperature Range -269°C to 450°C, ISO KF -25°C to 205°C

Pressure @ 20°C 475 PSIG (33 Bar), ISO KF 0 PSIG

MULTIPIN CONNECTOR

Ø .094 Conductor

Weldable

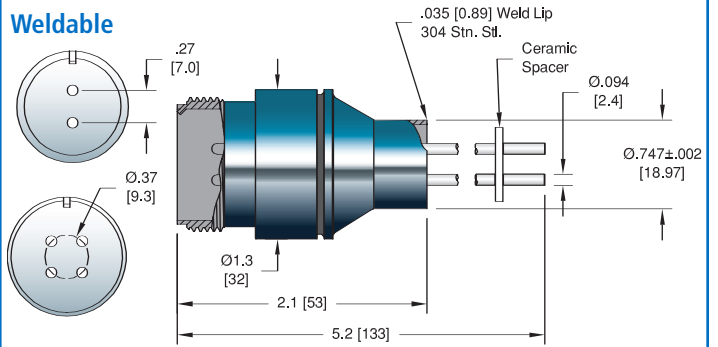

ISO KF

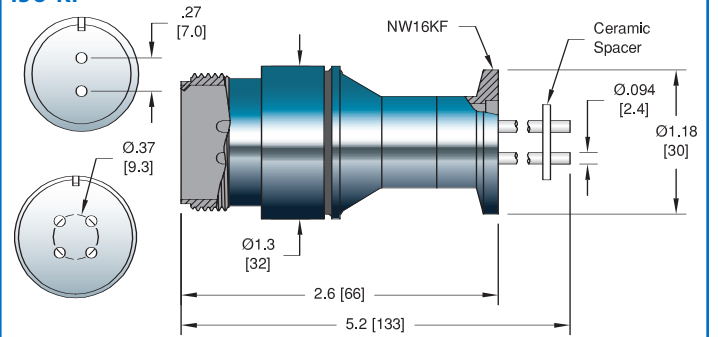

ConFlat - NW16CF

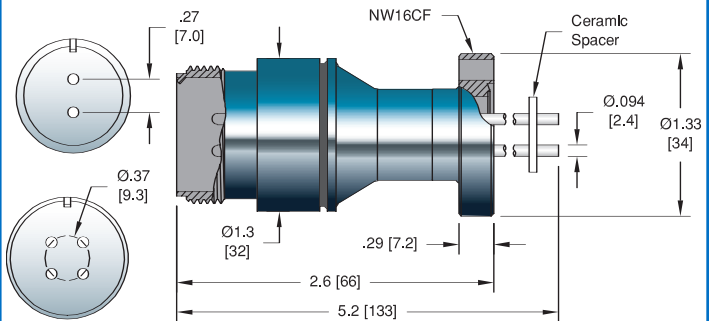

ConFlat - NW35CF

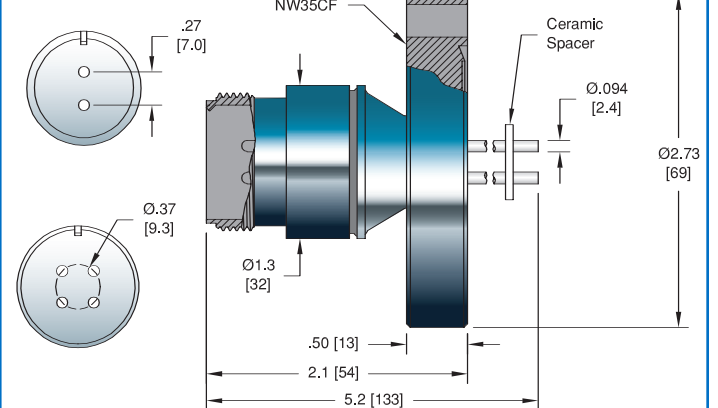



NO. PINS	CONDUCTORS AMPS	MATERIAL	INSTALLATION	MAGNETIC MATERIALS	PART NUMBER
2	16	Nickel	Weld	Yes	18093-02-W
2	28	Molybdenum	Weld	No	18093-04-W
4	16	Nickel	Weld	Yes	18093-06-W
4	28	Molybdenum	Weld	No	18093-08-W

ISO FLANGE



NO. PINS	CONDUCTORS AMPS	MATERIAL	INSTALLATION	MAGNETIC MATERIALS	PART NUMBER
2	16	Nickel	NW16KF	Yes	18094-02-KF
2	28	Molybdenum	NW16KF	No	18094-04-KF
4	16	Nickel	NW16KF	Yes	18094-06-KF
4	28	Molybdenum	NW40KF	No	18094-08-KF

CONFLAT FLANGE

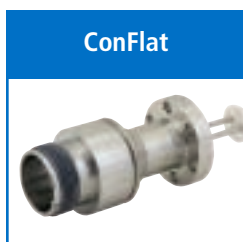

NO. PINS	CONDUCTORS AMPS	MATERIAL	INSTALLATION	MAGNETIC MATERIALS	PART NUMBER
2	16	Nickel	1 1/3" (NW16CF)	Yes	18095-02-CF
2	28	Molybdenum	1 1/3" (NW16CF)	No	18095-04-CF
2	16	Nickel	2 3/4" (NW35CF)	Yes	18096-02-CF
2	28	Molybdenum	2 3/4" (NW35CF)	No	18096-04-CF
4	16	Nickel	1 1/3" (NW16CF)	Yes	18095-06-CF
4	28	Molybdenum	1 1/3" (NW16CF)	No	18095-08-CF
4	16	Nickel	2 3/4" (NW35CF)	Yes	18096-06-CF
4	28	Molybdenum	2 3/4" (NW35CF)	No	18096-08-CF



TYPE	VOLTAGE DC	CONDUCTOR AMPS	NO. CONTACTS	DIMENSIONS H L		PART NUMBER
Air Side	700 V	23	2	2.5 [63]	1.2 [32]	18600-01-A
Air Side	700 V	23	4	2.6 [65]	1.4 [36]	18600-02-A

Note that contacts are included with all plugs.



VOLTAGE DC	CONDUCTOR AMPS	TYPE	LENGTH	WIRE DIAMETER	INSULATION DIAMETER	PART NUMBER
850 V	20	12 AWG Stranded	15'	37 x 0.013	Ø .101	21702-02-A

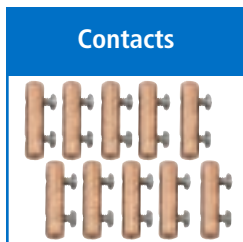

TYPE	MATERIAL	DESCRIPTION	PART NUMBER
0.094 Barrel Type	Beryllium Copper	Accepts .094 [2.4] Pin	7332-04-A†
0.094 Set Screw Type	Beryllium Copper	Accepts .094 [2.4] Pin	7429-01-A

*Contacts priced and sold in packages of 10. †Shown in photo. See the Accessories section for more information on all accessories.



Specifications

Materials

- Shell: 304 Stainless steel
- Pins: Nickel or molybdenum
- Insulation: Alumina ceramic
- Magnetic Materials: See table

Voltage Rating 700 V DC

Current Rating See table

Temperature Range -269°C to 450°C, ISO KF -25°C to 205°C

Pressure @ 20°C ISO KF 0 PSIG

- 2 Pin - 600 PSIG (41 Bar)
- 4 Pin - 500 PSIG (34 Bar)

MULTIPIN CONNECTOR

Ø .142 Conductor
Weldable

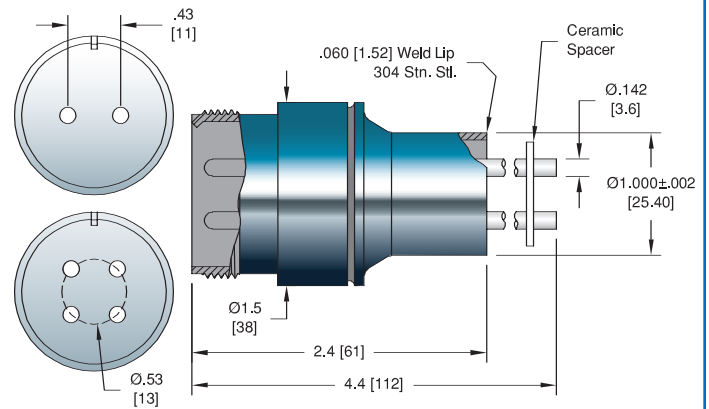

ISO KF

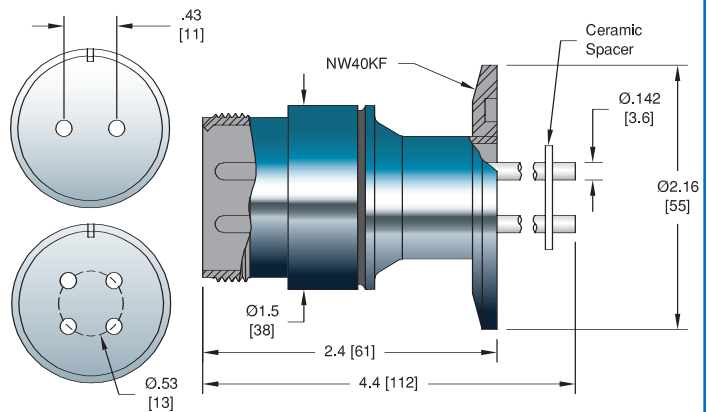

ConFlat

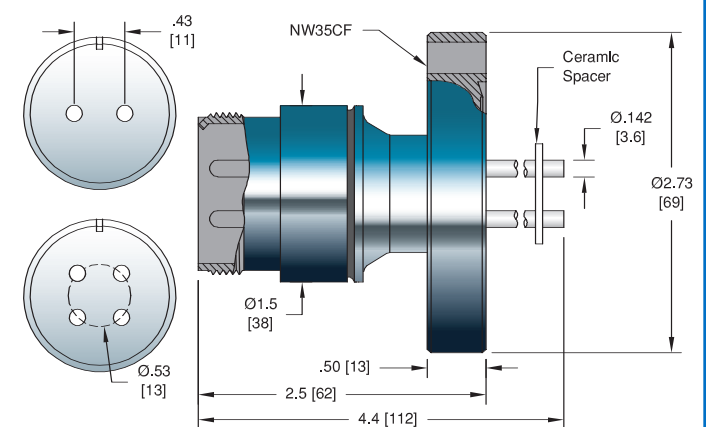



NO. PINS	CONDUCTORS AMPS	MATERIAL	INSTALLATION	MAGNETIC MATERIALS	PART NUMBER
2	25	Nickel	Weld	Yes	18097-02-W
2	46	Molybdenum	Weld	No	18097-04-W
4	25	Nickel	Weld	Yes	18097-06-W
4	46	Molybdenum	Weld	No	18097-08-W

ISO FLANGE



NO. PINS	CONDUCTORS AMPS	MATERIAL	INSTALLATION	MAGNETIC MATERIALS	PART NUMBER
2	25	Nickel	NW40KF	Yes	18098-02-KF
2	46	Molybdenum	NW40KF	No	18098-04-KF
4	25	Nickel	NW40KF	Yes	18098-06-KF
4	46	Molybdenum	NW40KF	No	18098-08-KF

CONFLAT FLANGE



NO. PINS	CONDUCTORS AMPS	MATERIAL	INSTALLATION	MAGNETIC MATERIALS	PART NUMBER
2	25	Nickel	2 3/4" (NW35CF)	Yes	18099-02-CF
2	46	Molybdenum	2 3/4" (NW35CF)	No	18099-04-CF
4	25	Nickel	2 3/4" (NW35CF)	Yes	18099-06-CF
4	46	Molybdenum	2 3/4" (NW35CF)	No	18099-08-CF



TYPE	VOLTAGE DC	CONDUCTOR AMPS	NO. CONTACTS	DIMENSIONS		PART NUMBER
				H	L	
Air Side	700 V	46	2	2.5 [63]	1.2 [32]	18601-01-A
Air Side	700 V	46	4	2.6 [65]	1.4 [36]	18601-02-A

Note that contacts are included with all plugs.



VOLTAGE DC	CONDUCTOR AMPS	TYPE	LENGTH	WIRE DIAMETER	INSULATION DIAMETER	PART NUMBER
850 V	20	12 AWG Stranded	15'	37 x 0.013	Ø .101	21702-02-A

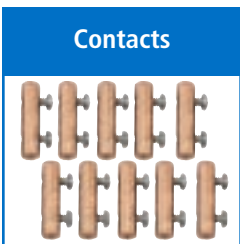

TYPE	MATERIAL	DESCRIPTION	PART NUMBER
0.154 Barrel Type	Beryllium Copper	Accepts 0.154 [3.9] Pin	7332-07-A

*Contacts priced and sold in packages of 10. See the Accessories section for more information on all accessories.

2 and 4 Pin Weldable

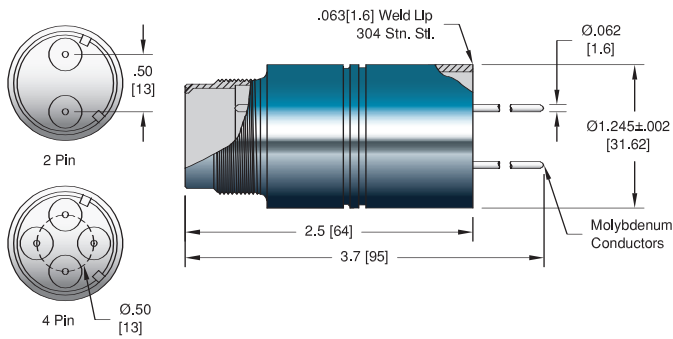

ISO KF

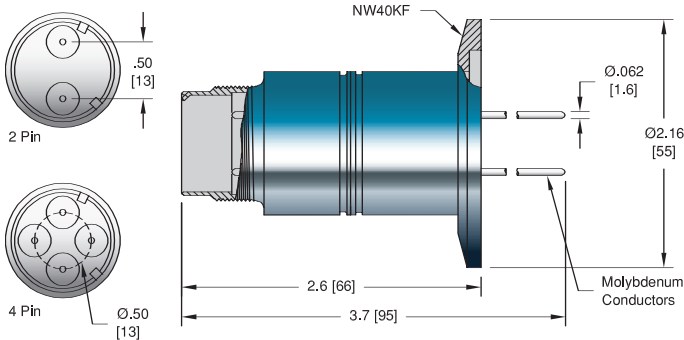

ConFlat

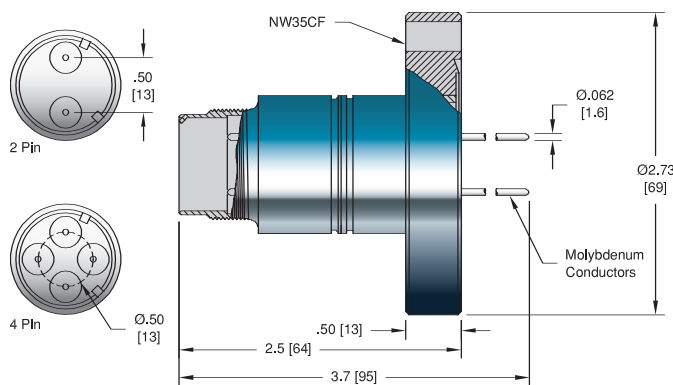

7 Pin Weldable

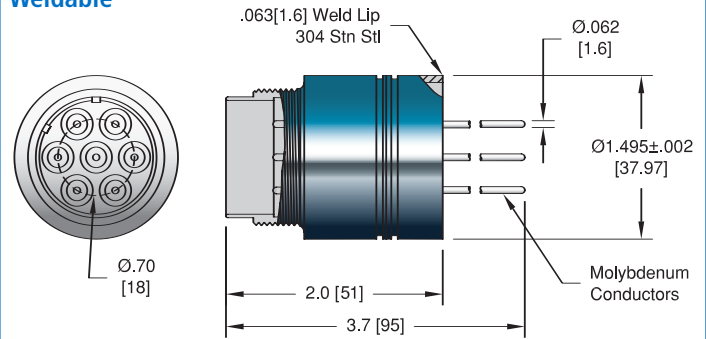

ISO KF

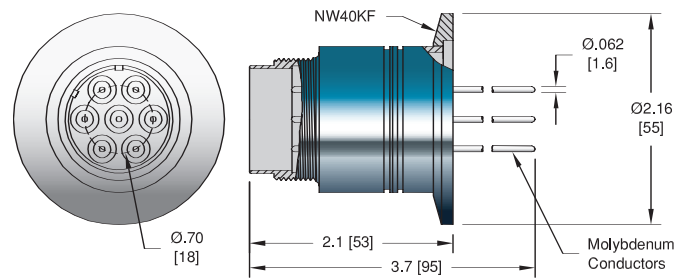

ConFlat

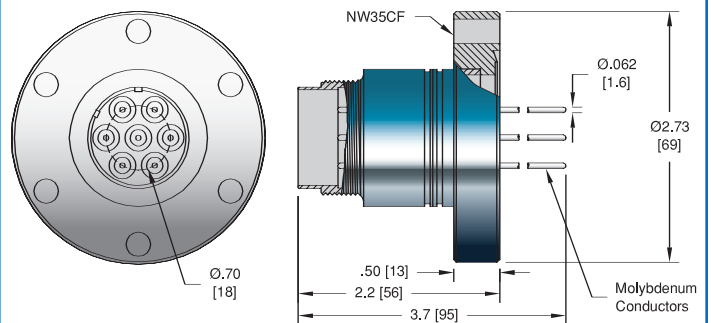

Specifications

Materials

- Shell: 304 Stainless steel
- Pins: Molybdenum (Nickel plated)
- Insulation: Alumina ceramic
- Magnetic Materials: Yes

Voltage Rating 12 kV DC (pin/pin and pin/shell)

Current Rating 13 Amps per pin

Temperature Range -269°C to 450°C, ISO KF -25°C to 205°C

Pressure @ 20°C ISO KF 0 PSIG

2 Pin - 400 PSIG (28 Bar)

4 Pin - 300 PSIG (20 Bar)

7 Pin - 200 PSIG (14 Bar)



MULTIPIN CONNECTOR

Weldable

NO. PINS	INSTALLATION	PART NUMBER
2	Weld	12475-03-W
4	Weld	12475-04-W
7	Weld	12867-06-W

ISO KF

ISO FLANGE

2	NW40KF	17157-02-KF
4	NW40KF	17158-02-KF
7	NW40KF	17159-02-KF

ConFlat

CONFLAT FLANGE

2	2 3/4" (NW35CF)	12476-03-CF
4	2 3/4" (NW35CF)	12476-04-CF
7	2 3/4" (NW35CF)	12867-07-CF

Air Side Plug

TYPE	VOLTAGE DC	CONDUCTOR AMPS	NO. CONTACTS	DIMENSIONS		PART NUMBER
				H	L	
Air Side	12 kV	13	2	1.3 [33]	1.6 [41]	2871-02-A
Air Side	12 kV	13	4	1.3 [33]	1.6 [41]	2871-03-A
Air Side	12 kV	13	7	1.4 [37]	3.3 [84]	2871-01-A

Note that contacts are included with all plugs.

Contacts

TYPE	MATERIAL	DESCRIPTION	PART NUMBER
0.062 Crimp Type Contacts	Beryllium Copper	Accepts .050 [1.3] Pin	11911-02-X†
0.062 Set Screw Type Contacts	Beryllium Copper	Accepts .062 [1.6] Pin	7429-02-A
0.062 Barrel Type Contacts	Beryllium Copper	Accepts .062 [1.6] Pin	7332-02-A
Crimp Tool		For 0.025" – 0.075" Crimp Diameters	2840-05

*Contacts priced and sold in packages of 10. †Shown in photo. See the Accessories section for more information on all accessories.



MIL-C-5015 Type
Installation: 1" Bolt

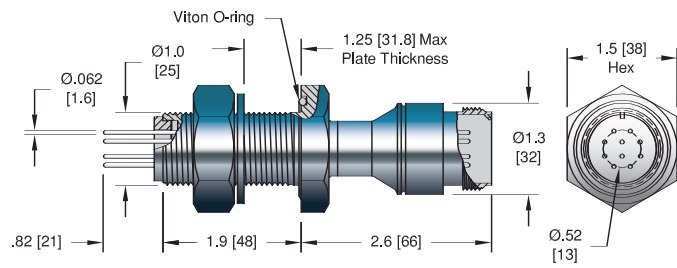

Octal Connector
Installation: 1" Bolt

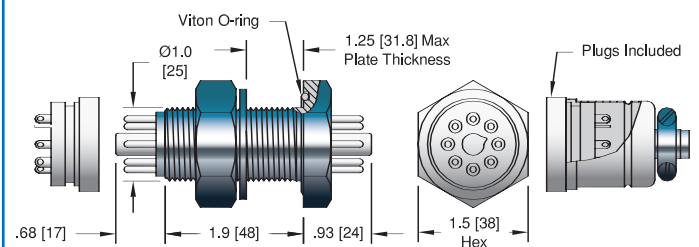

MIL-C-5015 Type Specifications

Materials

- Bolt: 304 Stainless steel
- Pins: Alumel
- Insulation: Alumina ceramic
- Magnetic Materials: Yes

Voltage Rating 700 V DC

Current Rating 7 Amps per pin

Temperature Range -25°C to 205°C

Pressure @ 20°C 200 PSIG (14 Bar)

Octal Connector Specifications

Materials

- Bolt: 304 Stainless steel
- Pins: Alumel
- Insulation: Glass-ceramic
- Magnetic Materials: Yes

Voltage Rating 350 V DC

Current Rating 7 Amps per pin

Temperature Range -25°C to 205°C

Pressure @ 20°C 200 PSIG (14 Bar)

MULTIPIN CONNECTOR



NO. PINS	INSTALLATION	PART NUMBER
10	1" Bolt	15717-01-A



8	1" Bolt	15730-01-A
---	---------	------------



TYPE	VOLTAGE DC	CONDUCTOR AMPS	NO. CONTACTS	DIMENSIONS		PART NUMBER
				H	L	
Air Side	700 V	13	10	1.4 [36]	4.4 [112]	15912-01-A

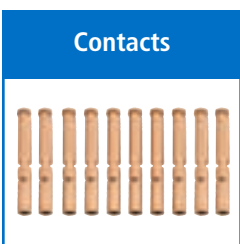

TYPE	MATERIAL	DESCRIPTION	PART NUMBER
0.062 Crimp Contacts	Beryllium Copper	Accepts wire up to 0.050 [1.3]	2044-02-A†
0.062 Crimp Contacts	Nickel Alloy	Accepts wire up to 0.062 [1.6]	0821-01-A
Crimp Tool		For 0.025" – 0.075" Crimp Diameters	2840-05

*Contacts priced and sold in packages of 10. †Shown in photo. See the Accessories section for more information on all accessories.

MULTIPIN CONNECTOR



Coaxial

SEMICONDUCTOR | ANALYTICAL EQUIPMENT | AEROSPACE | TELECOMMUNICATIONS



OIL EXPLORATION | R&D | HIGH ENERGY PHYSICS | MILITARY/DEFENSE | BIOTECHNOLOGY



*Advanced Ceramic-to-Metal &
Glass-Ceramic Sealing Technology*

Description

CeramTec coaxial connectors consist of two concentric conductors: a central conductor surrounded by and insulated from a second tubular conductor. The outside conductor is usually at ground potential but in some product variations may be floated off ground by employing an additional insulating ring. The outer conducting surface can prevent radio frequency noise from passing to or from the central conductor. CeramTec's Ceramaseal® product line includes a complete line of industry-standard coaxial connectors ranging from Microdot through SHV. These coaxial connectors are manufactured for high and ultra-high vacuum service.

Microdot connectors are the smallest standard threaded interface connectors we offer for use in Ultra-High Vacuum (UHV). CeramTec's standard Microdot connectors are available as single ended or double ended units.

SMA (Subminiature Type-A) connectors offer a threaded interface in a subminiature size. Matched impedance designs are also available and are ideally suited for high frequency signal transmission above 10 GHz. CeramTec's standard SMA connectors are available as single ended or double ended units.

SMB (Subminiature Type-B) connectors are designed for quick connecting and disconnecting. This is made possible by the SMB's spring retention connector. CeramTec's standard SMB connectors are single ended and available with a grounded shield or a floating shield configuration.

BNC connectors are the most popular miniature-sized connector and can accommodate up to 500 V DC. The BNC is characterized by its quick connect/disconnect bayonet coupling. Matched impedance designs are also available and are ideally suited for high frequency



signal transmission. CeramTec's standard BNC connectors are available as single or double ended units with a grounded shield or a floating shield.

MHV (Miniature High Voltage) connectors are designed for high-voltage applications of BNC connectors (DC voltage between 500 V and 5 kV). MHV connectors are sometimes referred to as "high-voltage BNCs." CeramTec's standard MHV connectors are available as single ended or double ended units with a floating shield or a grounded shield.

Type N series connectors are the most popular medium-sized connectors, accommodating voltages up to 1.5 kV. The threaded coupling provides low noise and increases resistance to shock and vibration. Matched impedance designs are also available and are ideally suited for high frequency signal transmission above 6 GHz. CeramTec's standard Type N connectors are available as single or double ended units.

HN series connectors are Type N series connectors that have been designed to take higher voltages (up to 7 kV). These matched impedance designs are ideally suited for high frequency signal transmission or fast rise time pulses for data transmission.

Standard Specifications

- Grounded and floating shield versions
- High frequency 50 ohm impedance matched connectors
- Connectors sold with or without air side plugs

Typical Coaxial Construction

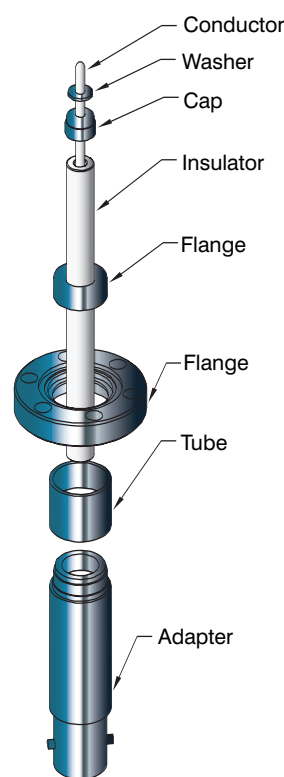

SHV (Safe High Voltage)

connectors feature an improved interface over the MHV. The SHV outer contact ground connection is maintained through the center contact mating cycle. The center contact is recessed to prevent shock hazard when disengaged. Four designs are included in this Product Guide covering DC voltages from 5 kV to as high as 20 kV. The BSHV version is a bakeable SHV connector that exhibits the safety level of the SHV. CeramTec's standard SHV connectors are single ended and available with a grounded shield or a floating shield (SHV 5 kV) configuration.

Extreme / Custom Design

- Multiple coaxial and multipin connectors in a flange
- Double ended 50 ohm coaxial connector with floating shield for a cryogenic application
- Coaxial connectors using a glass-ceramic seal for cryogenic and corrosive environments
- LC connector, TNC connector and other military style coaxial connectors

Installation

Standard installation mountings include:

- Weld (Pulse-TIG, TIG, Laser, E-Beam)
- ISO KF flange
- ConFlat flange
- NPT fitting (see Pressure section)

Applications

A few of the many applications in which these coaxial connectors are commonly used are:

- Telecommunications
- Semiconductor processing equipment
- Aerospace equipment
- Medical equipment

STANDARD SPECIFICATIONS					
Category	Classification	DC Voltage	Coupling	Current (amps)	Cable
Subminiature	Microdot®	1000V	Threaded	2	.08 dia. 50-ohm
	SMB (Subminiature-B)	375V	Push-on	1.4	RG-174/U
	SMA (Subminiature-A)	500V	Threaded	0.8 - 1.8	RG-58/U
Miniature	BNC	500V	Bayonet	3.6 - 4.4	RG-58/U
	MHV (Min. High-Voltage)	5000V	Bayonet	3.6	RG-59/U
	SHV-5KV (Safe High-Voltage)	5000V	Bayonet	10	RG-59/U
	SHV-10KV (Safe High-Voltage)	10,000V	Bayonet	2.2 - 10	RG-58/U
	SHV-20KV (Safe High-Voltage)	20,000V	Bayonet	16.5	RG-213/U
	BSHV (Bakeable Safe High-Voltage)	7500V	Threaded	8	RG-59/U
Medium-Sized	N	1500V	Threaded	0.8 - 5	RG-8/U RG-9/U RG-10/U
	HN	7000V	Threaded	7	RG-8/U RG-9/U RG-87/U RG-213/U RG-214/U RG-225/U

- Microwave
- In-vacuum coating
- Particle accelerators

New Products

- Floating SMA connector
- BNC to Microdot connector
- New 50 Ohm BNC connector design







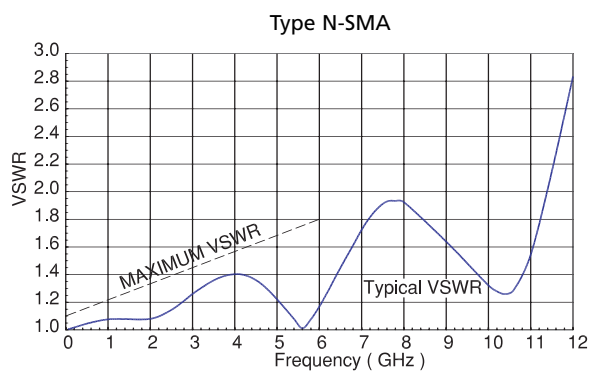
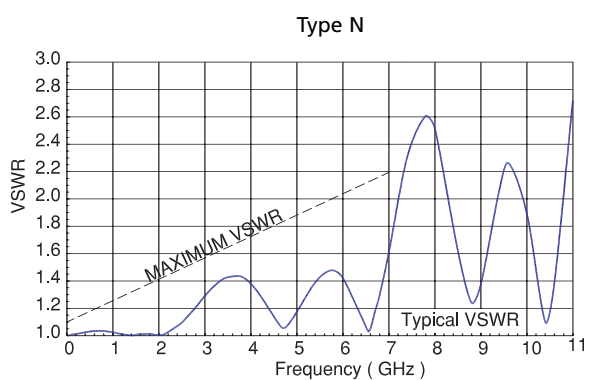
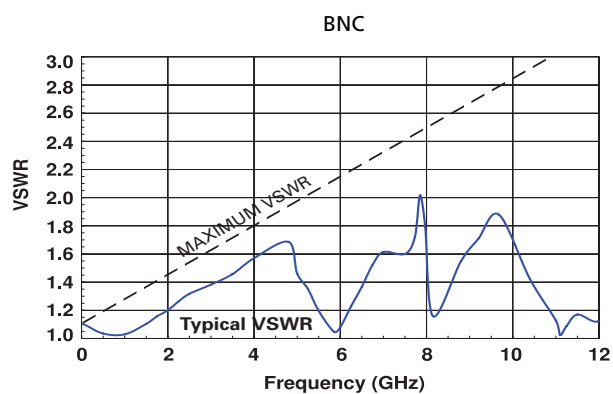
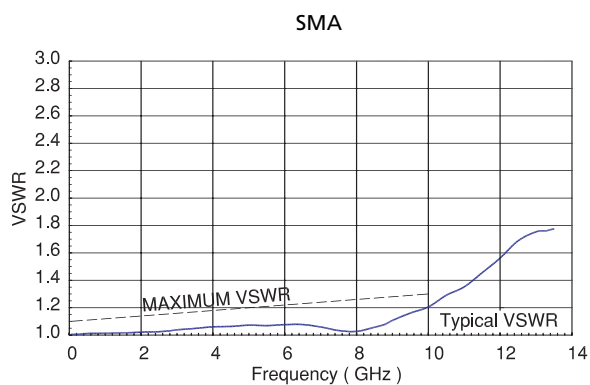





High Frequency 50 Ohm Designs

- SMA
- BNC
- Type N
- HN

VSWR vs. Frequency Charts



COAXIAL

Type	Voltage DC	Current	Impedance Rating	Sub-section	Section Pages
	1 kV	2 Amps	Non-Constant	Microdot	C.1 80-83
	375 V	1.4 Amps	Non-Constant	SMB	C.2 84-87
	500 V	to 1.8 Amps	50 Ohm & Non-Constant	SMA	C.3 88-95
	500 V	to 3.6 Amps	50 Ohm & Non-Constant	BNC	C.4 96-105
	5 kV	3.6 Amps	Non-Constant	MHV	C.5 106-113
	1.5 kV	to 5 Amps	50 Ohm & Non-Constant	Type N	C.6 114-117
	7 kV	7 Amps	50 Ohm	HN	C.7 118-119
	5 kV	10 Amps	Non-Constant	SHV 5 KV	C.8 120-125
	7.5 kV	8 Amps	Non-Constant	BSHV 7.5 KV	C.9 126-127
	10 kV	to 10 Amps	Non-Constant	SHV 10 KV	C.10 128-131
	20 kV	16.5 Amps	Non-Constant	SHV 20 KV	C.11 132-133
	1.5 kV	0.8 Amps	50 Ohm & Non-Constant	Between Series	C.12 134-137

Weldable

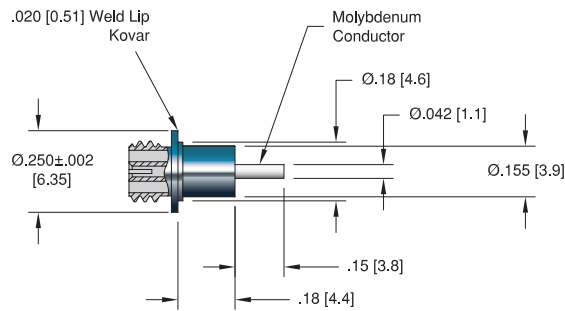

ISO KF - NW16KF

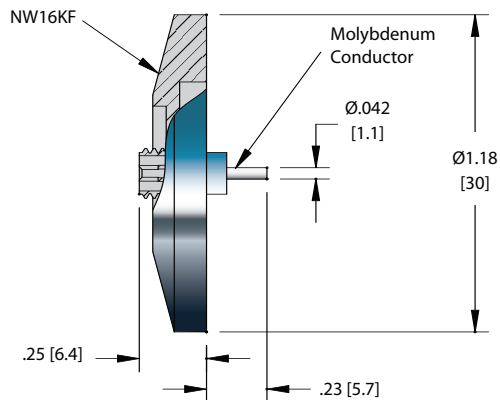

ConFlat - NW16CF

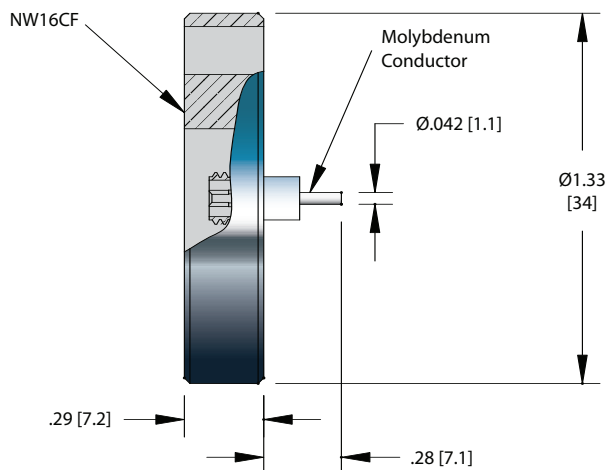

ISO KF - NW40KF

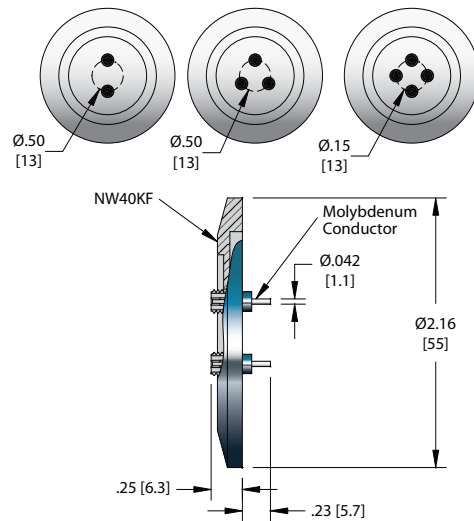

ConFlat - NW35CF

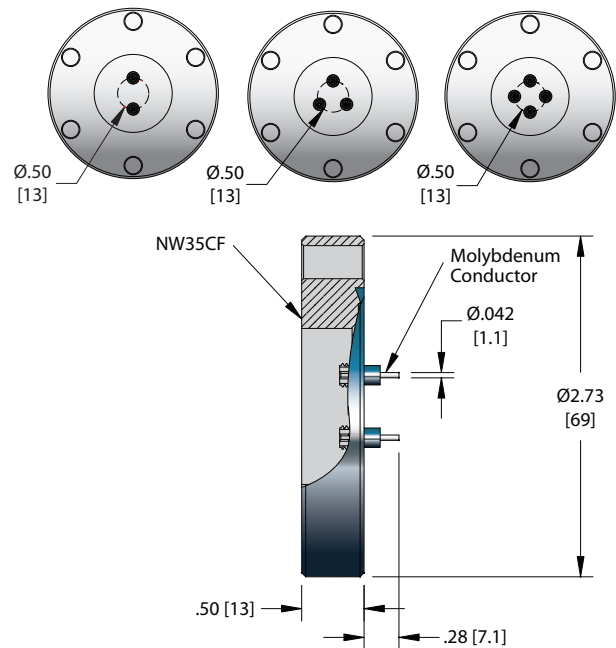

Specifications

Materials

Housing: Kovar
Pin: Molybdenum
Insulation: Alumina ceramic
Magnetic Materials: Yes

Voltage Rating 1 kV DC

Current Rating 2 Amps

Temperature Range -55°C to 450°C, ISO KF -25°C to 205°C

Pressure @ 20°C See table



NO. PINS	INSTALLATION	PRESSURE @ 20°C		PART NUMBER
		PSIG	BAR	
1	Weld	1600	110	17614-01-W

ISO FLANGE



1	NW16KF	-	-	21507-01-KF
2	NW40KF	-	-	21525-01-KF
3	NW40KF	-	-	21526-01-KF
4	NW40KF	-	-	21527-01-KF

CONFLAT FLANGE



1	1 1/3" (NW16CF)	1600	110	21505-01-CF
2	2 3/4" (NW35CF)	1500	103	21522-01-CF
3	2 3/4" (NW35CF)	1500	103	21523-01-CF
4	2 3/4" (NW35CF)	1500	103	21524-01-CF



TYPE	LENGTH	VOLTAGE DC	CONDUCTOR AMPS	TEMPERATURE		PART NUMBER
				MIN	MAX	
Microdot – Single Ended	10'	1 kV	2	-65°C	125°C	14544-01-A

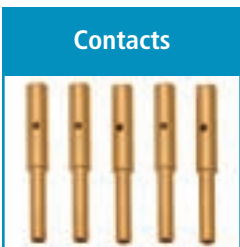

TYPE	MATERIAL	DESCRIPTION	PART NUMBER
0.042 Crimp Contacts Crimp Tool	Gold Plated 300 Series Stn. Stl.	Accepts wire up to 0.030 [0.76] For 0.025" – 0.075" Diameters	14461-04-A 2840-05

*Contacts priced and sold in packages of 5. See the Accessories section for more information on all accessories.

Weldable

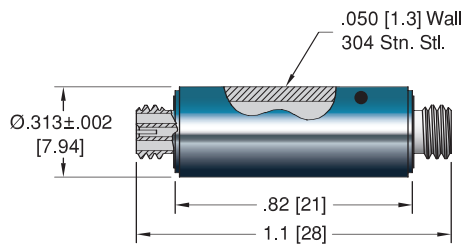

ISO KF - NW16KF

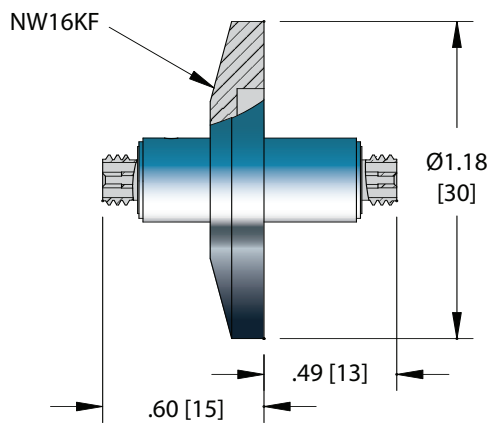

ConFlat - NW16CF

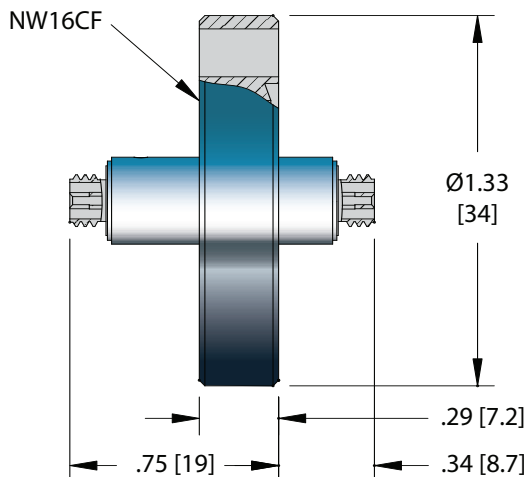

ISO KF - NW40KF

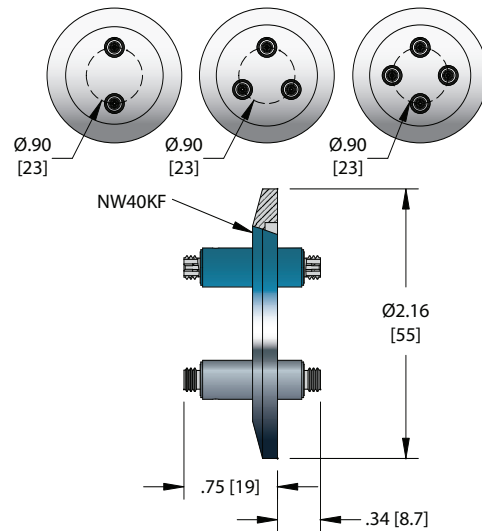

ConFlat - NW35CF

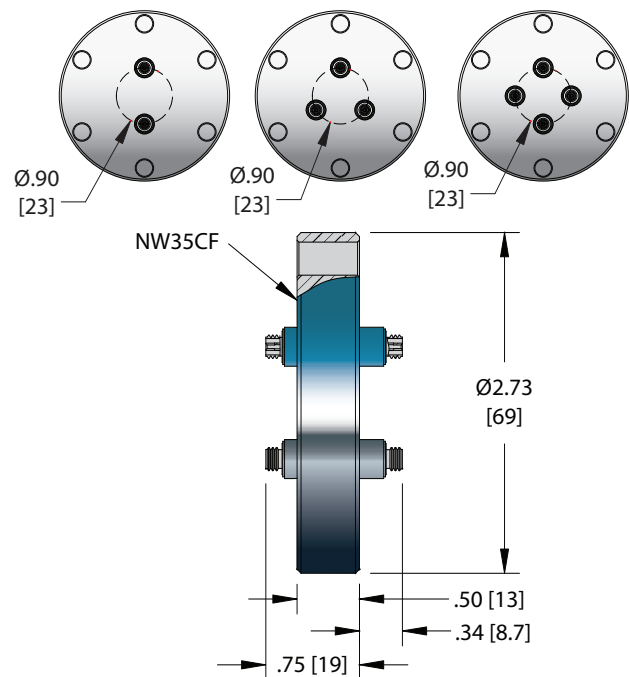

Specifications

Materials

Housing: 304 Stainless steel
 Contact: 304 Stainless steel
 Insulation: Alumina ceramic
 Magnetic Materials: Yes

Voltage Rating 1 kV DC

Current Rating 2 Amps

Temperature Range -55°C to 450°C, ISO KF -25°C to 205°C

Pressure @ 20°C See table

Weldable	NO. PINS	INSTALLATION	PRESSURE @ 20°C		PART NUMBER
			PSIG	BAR	
	1	Weld	1600	110	18044-02-W

ISO FLANGE

	1	NW16KF	-	-	21511-01-KF
	2	NW40KF	-	-	21517-01-KF
	3	NW40KF	-	-	21518-01-KF
	4	NW40KF	-	-	21519-01-KF

CONFLAT FLANGE

	1	1 1/3" (NW16CF)	1600	110	21509-01-CF
	2	2 3/4" (NW35CF)	1500	103	21514-01-CF
	3	2 3/4" (NW35CF)	1500	103	21515-01-CF
	4	2 3/4" (NW35CF)	1500	103	21516-01-CF

Air Side Cable Assembly	TYPE	LENGTH	VOLTAGE DC	CONDUCTOR AMPS	TEMPERATURE		PART NUMBER
					MIN	MAX	
	Microdot Air Side – Single Ended	10'	1 kV	2	-65°C	125°C	14544-01-A

Vacuum Side Cable Assembly	TYPE	LENGTH	VOLTAGE DC	CONDUCTOR AMPS	TEMPERATURE		PART NUMBER
					MIN	MAX	
	Microdot Vacuum Side – Double Ended	12"	500 V	2	-65°C	125°C	15767-12-A
	Microdot Vacuum Side – Double Ended	24"	500 V	2	-65°C	125°C	15767-24-A
	Microdot Vacuum Side – Double Ended	36"	500 V	2	-65°C	125°C	15767-36-A†

†Shown in photo. See the Accessories section for more information on all accessories.

Weldable

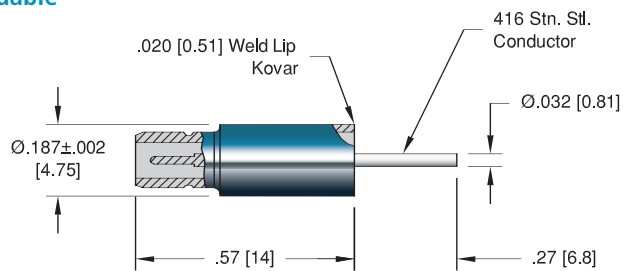

ISO KF - NW16KF

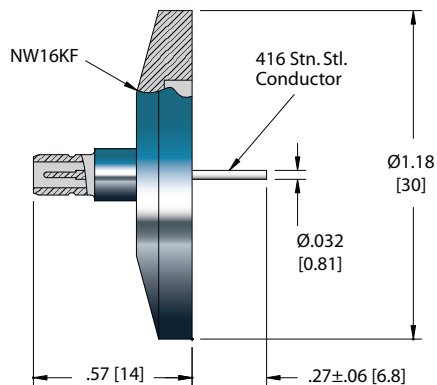

ConFlat - NW16CF

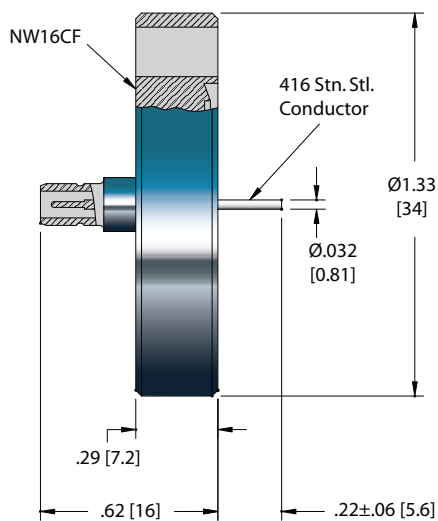

ISO KF - NW40KF

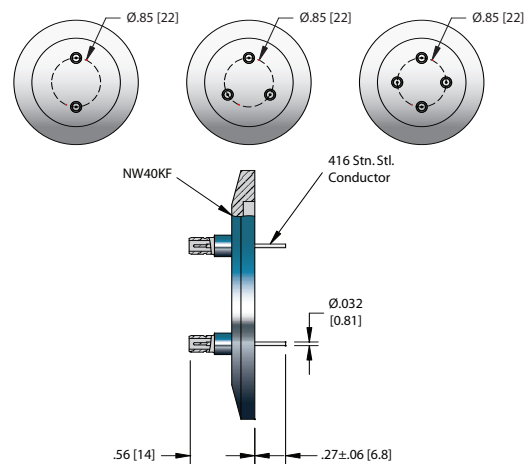

ConFlat - NW35CF

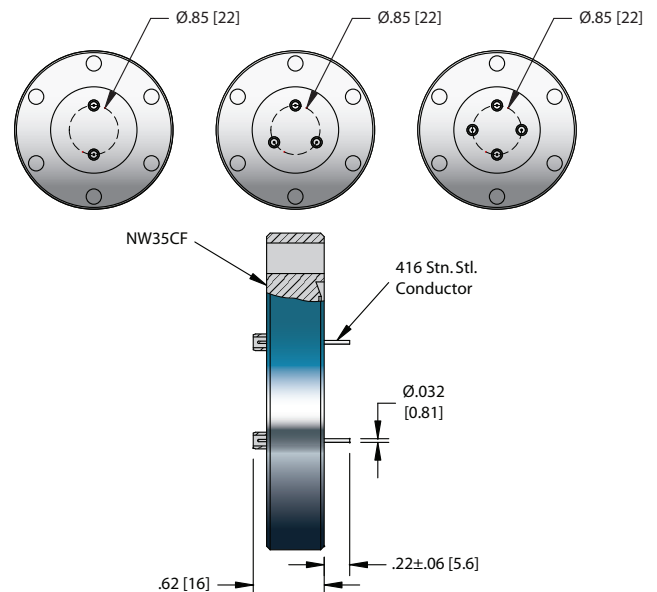

Specifications

Materials

Housing: Kovar
Pin: 416 Stainless steel
Insulation: Alumina ceramic
Magnetic Materials: Yes

Voltage Rating 500 V DC

Current Rating 1.4 Amps

Temperature Range -55°C to 450°C, ISO KF -25°C to 205°C

Pressure @ 20°C See table



Weldable

NO. PINS	INSTALLATION	PRESSURE @ 20°C		PART NUMBER
		PSIG	BAR	
1	Weld	3500	241	0713-02-W

ISO KF

ISO FLANGE

1	NW16KF	-	-	21371-01-KF
2	NW40KF	-	-	21379-01-KF
3	NW40KF	-	-	21381-01-KF
4	NW40KF	-	-	21383-01-KF

ConFlat

CONFLAT FLANGE

1	1 1/3" (NW16CF)	3000	207	21369-01-CF
2	2 3/4" (NW35CF)	1500	103	21373-01-CF
3	2 3/4" (NW35CF)	1500	103	21375-01-CF
4	2 3/4" (NW35CF)	1500	103	21377-01-CF

Air Side Plug

TYPE	VOLTAGE DC	CONDUCTOR AMPS	DIMENSIONS		DESCRIPTION	PART NUMBER
			H	L		
Air Side	375 V	5	0.25 [6.4]	0.71 [18]	SMB Plug	3095-12

Air Side Cable Assembly

TYPE	LENGTH	VOLTAGE DC	CONDUCTOR AMPS	TEMPERATURE		PART NUMBER
				MIN	MAX	
50 Ohm SMB – Double Ended	10'	500 V	2	-70	200	21618-01-A

Contacts

TYPE	MATERIAL	DESCRIPTION	PART NUMBER
0.032 Crimp Contacts Crimp Tool	Beryllium Copper	Accepts wire up to 0.032 [0.81] For 0.025" – 0.075" Diameters	11288-02-X 2840-05

*Contacts priced and sold in packages of 10. See the Accessories section for more information on all accessories.



Weldable

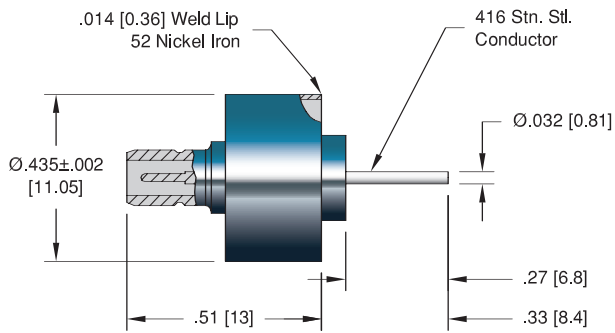

ISO KF - NW16KF

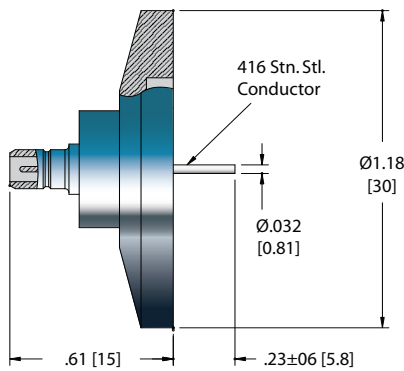

ConFlat - NW16CF

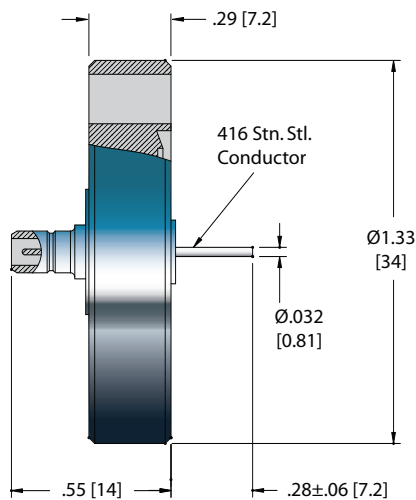

ISO KF - NW40KF

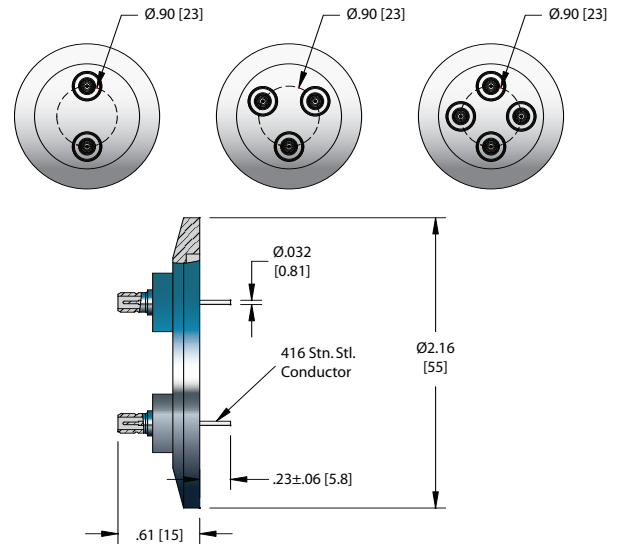

ConFlat - NW35CF

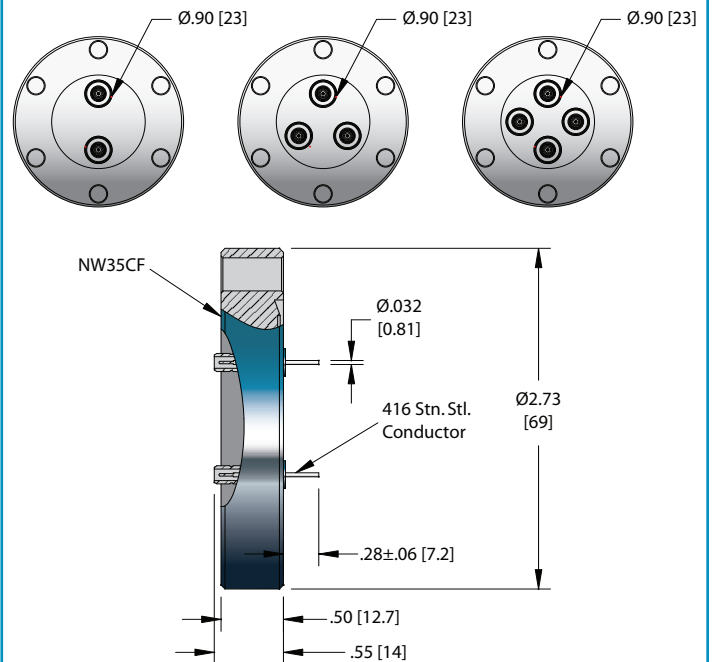

Specifications
Materials

- Housing: 52 Nickel Iron
- Pin: 416 Stainless steel
- Insulation: Alumina ceramic
- Magnetic Materials: Yes

Voltage Rating Pin/Shield: 500 V DC, Shield/Grd: 1 kV DC

Current Rating 1.4 Amps

Temperature Range -55°C to 450°C, ISO KF -25°C to 205°C

Pressure @ 20°C 500 PSIG (35 Bar), ISO KF 0 PSIG

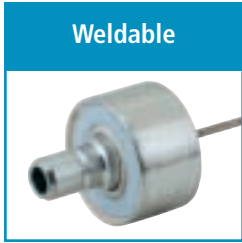

Weldable

NO. PINS	INSTALLATION	PART NUMBER
1	Weld	0714-02-W



ISO KF

ISO FLANGE		
1	NW16KF	21396-01-KF
2	NW40KF	21403-01-KF
3	NW40KF	21405-01-KF
4	NW40KF	21407-01-KF

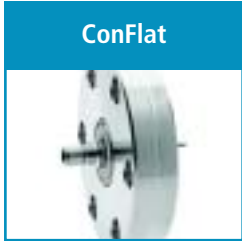

ConFlat

CONFLAT FLANGE		
1	1 1/3" (NW16CF)	21394-01-CF
2	2 3/4" (NW35CF)	21397-01-CF
3	2 3/4" (NW35CF)	21399-01-CF
4	2 3/4" (NW35CF)	21401-01-CF



Air Side Plug

TYPE	VOLTAGE DC	CONDUCTOR AMPS	DIMENSIONS H L		DESCRIPTION	PART NUMBER
Air Side	375 V	5	0.25 [6.4]	0.71 [18]	SMB Plug	3095-12



Air Side Cable Assembly

TYPE	LENGTH	VOLTAGE DC	CONDUCTOR AMPS	TEMPERATURE MIN	TEMPERATURE MAX	PART NUMBER
50 Ohm SMB – Double Ended	10'	500 V	2	-70	200	21618-01-A

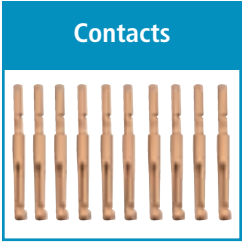

Contacts

TYPE	MATERIAL	DESCRIPTION	PART NUMBER
0.032 Crimp Contacts Crimp Tool	Beryllium Copper	Accepts wire up to 0.032 [0.81] For 0.025" – 0.075" Diameters	11288-02-X 2840-05

*Contacts priced and sold in packages of 10. See the Accessories section for more information on all accessories.

COAXIAL

Weldable

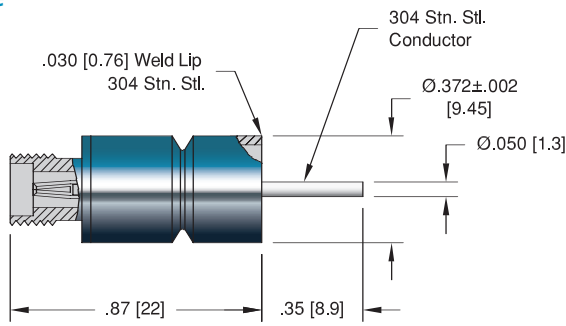

ISO KF - NW16KF

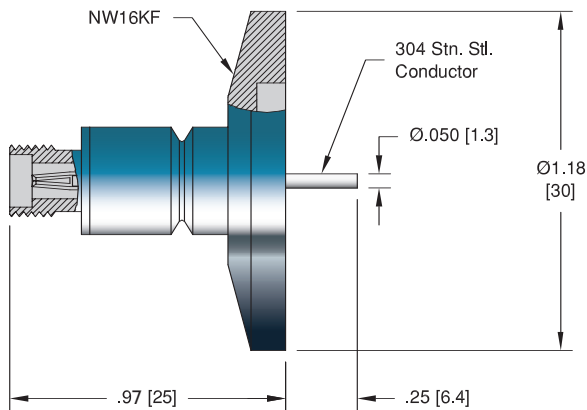

ConFlat - NW16CF

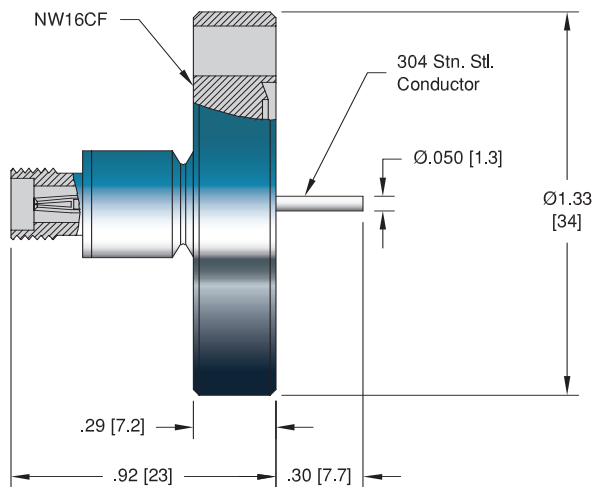

ISO KF - NW40KF

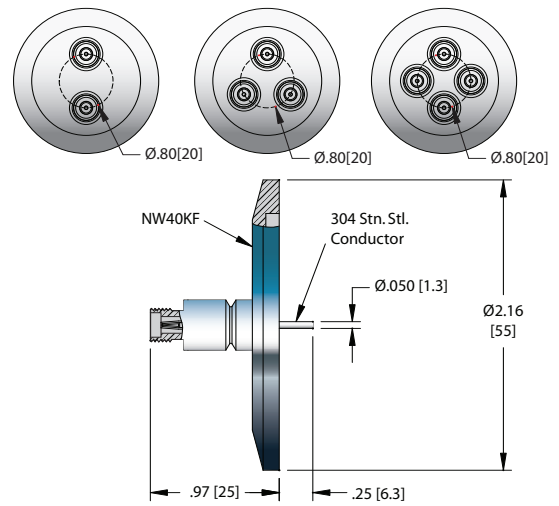

ConFlat - NW35CF

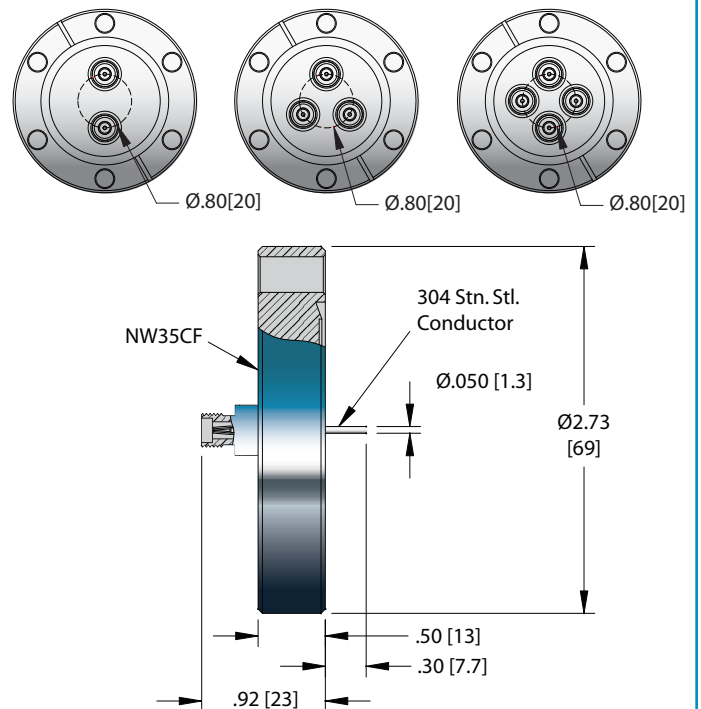

Specifications

Materials

- Housing: 304 Stainless steel
- Pin: 304 Stainless steel
- Insulation: Alumina ceramic
- Magnetic Materials: No

Voltage Rating 500 V DC

Current Rating 1.8 Amps

Temperature Range -269°C to 450°C, ISO KF -25°C to 205°C

Pressure @ 20°C See table



Weldable

NO. PINS	INSTALLATION	PRESSURE @ 20°C		PART NUMBER
		PSIG	BAR	
1	Weld	4000	276	8071-02-W

ISO KF

ISO FLANGE

1	NW16KF	-	-	18045-02-KF
2	NW40KF	-	-	21498-01-KF
3	NW40KF	-	-	21499-01-KF
4	NW40KF	-	-	21500-01-KF

ConFlat

CONFLAT FLANGE

1	1 1/3" (NW16CF)	3000	207	18046-02-CF
2	2 3/4" (NW35CF)	1500	103	21495-01-CF
3	2 3/4" (NW35CF)	1500	103	21496-01-CF
4	2 3/4" (NW35CF)	1500	103	21497-01-CF

Air Side Plug

TYPE	VOLTAGE DC	CONDUCTOR AMPS	DIMENSIONS		DESCRIPTION	PART NUMBER
			H	L		
Air Side	500 V	5	0.31 [7.9]	0.98 [25]	SMA Plug	6524-02

Air Side Cable Assembly

TYPE	LENGTH	VOLTAGE DC	CONDUCTOR AMPS	TEMPERATURE		PART NUMBER
				MIN	MAX	
50 Ohm SMA – Double Ended	10'	500 V	5	-70	200	21617-01-A

Contacts

TYPE	MATERIAL	DESCRIPTION	PART NUMBER
0.050 Crimp Contacts	Beryllium Copper	Accepts wire up to 0.062 [1.6]	11911-02-X†
0.050 Set Screw Type Contacts	Beryllium Copper	Accepts wire up to 0.050 [1.3]	7429-02-A
0.050 Barrel Type Contacts	Beryllium Copper	Accepts wire up to 0.050 [1.3]	7332-02-A
Crimp Tool		For 0.025" – 0.075" Diameters	2840-05

*Contacts priced and sold in packages of 10. †Shown in photo. See the Accessories section for more information on all accessories.

COAXIAL



Weldable

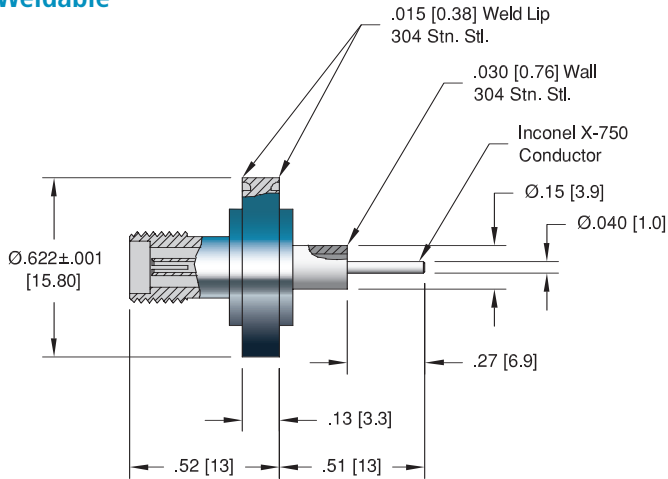

ISO KF – NW25KF

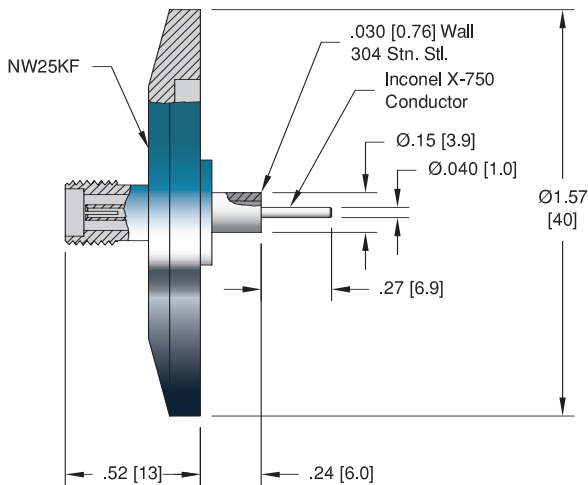

ConFlat – NW16CF

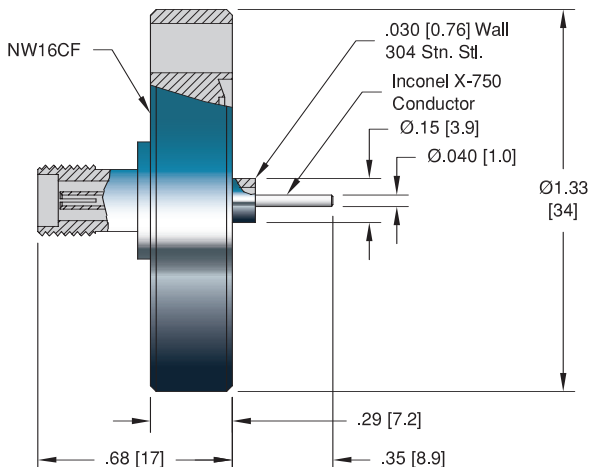

ISO KF

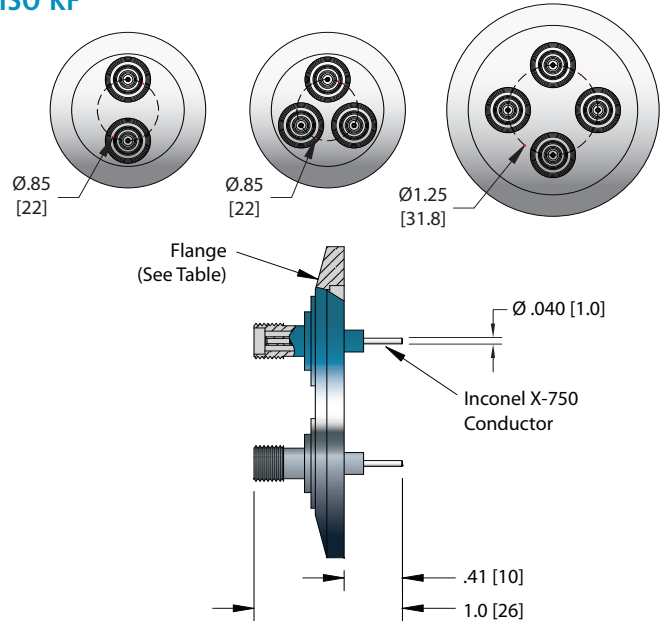

ConFlat

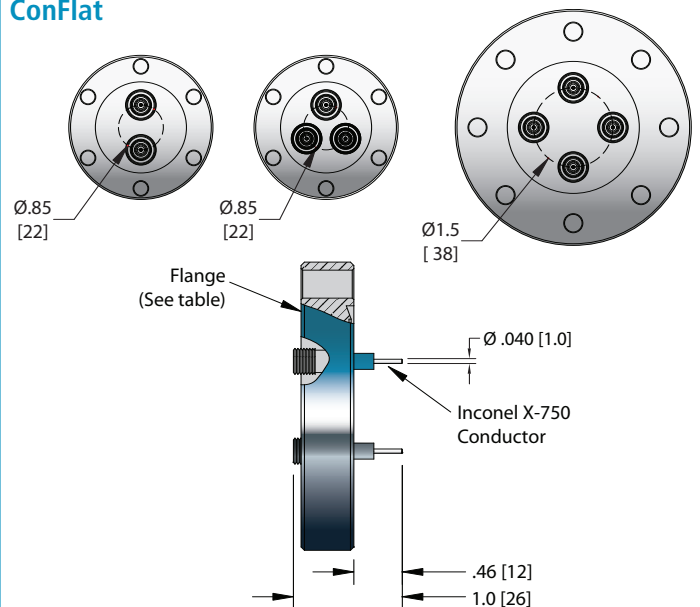

Specifications

Materials

Housing: 304 Stainless steel Insulation: Glass-ceramic
 Pin: Inconel X-750 Magnetic Materials: No
 Contacts: 300 Series Stn. Stl.

Voltage Rating 500 V DC

Current Rating 1 Amp

Temperature Range -269°C to 350°C, ISO KF -25°C to 205°C

Pressure @ 20°C 1400 PSIG (97 Bar), ISO KF 0 PSIG



Single Ended Weldable

NO. PINS	INSTALLATION	PART NUMBER
1	Weld	15310-03-W

Single Ended ISO KF

ISO FLANGE		
1	NW25KF	18053-02-KF
2	NW40KF	21356-01-KF
3	NW40KF	21357-01-KF
4	NW50KF	21361-01-KF

Single Ended ConFlat

CONFLAT FLANGE		
1	1 1/3" (NW16CF)	18054-02-CF
2	2 3/4" (NW35CF)	21353-01-CF
3	2 3/4" (NW35CF)	21358-01-CF
4	4 1/2" (NW63CF)	21360-01-CF

Air Side Plug

TYPE	VOLTAGE DC	CONDUCTOR AMPS	DIMENSIONS H L		DESCRIPTION	PART NUMBER
Air Side	500 V	5	0.31 [7.9]	0.98 [25]	SMA Plug	6524-02

Air Side Cable Assembly

TYPE	LENGTH	VOLTAGE DC	CONDUCTOR AMPS	TEMPERATURE MIN MAX		PART NUMBER
50 Ohm SMA – Double Ended	10'	500 V	5	-70	200	21617-01-A

See the Accessories section for more information on all accessories.

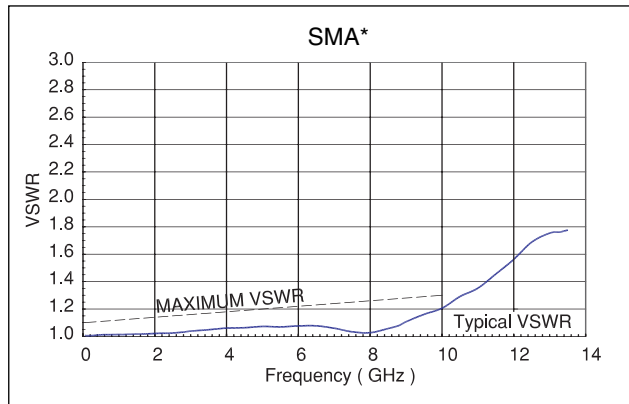

*Applies when properly mated to a 50 Ohm load.



Weldable

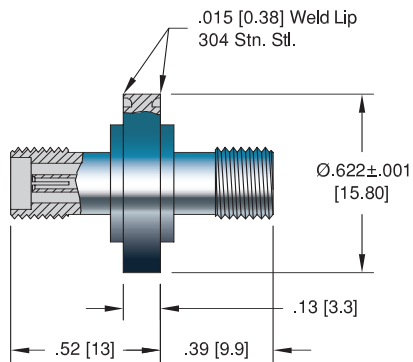

ISO KF – NW25KF

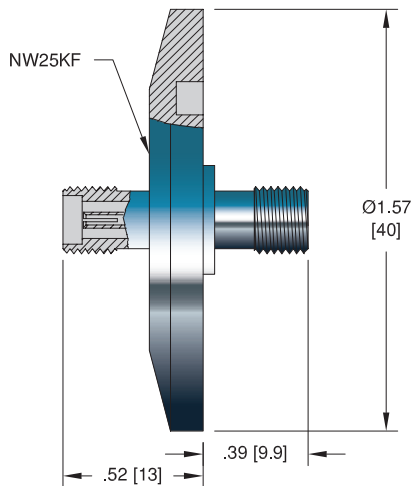

ConFlat – NW16CF

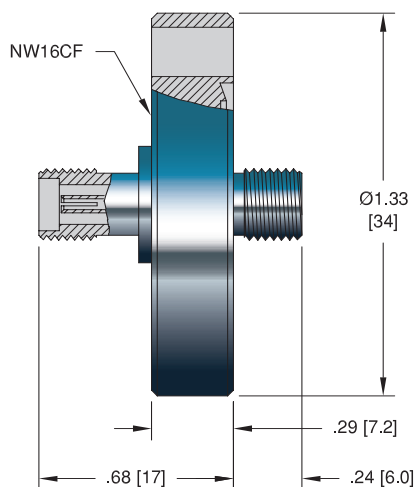

ISO KF

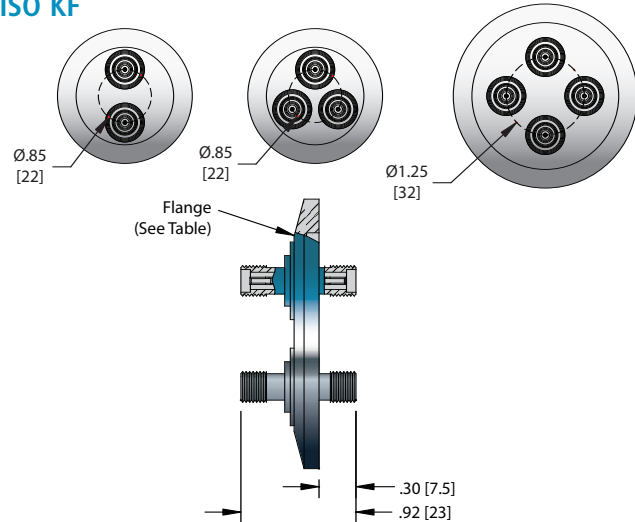

ConFlat

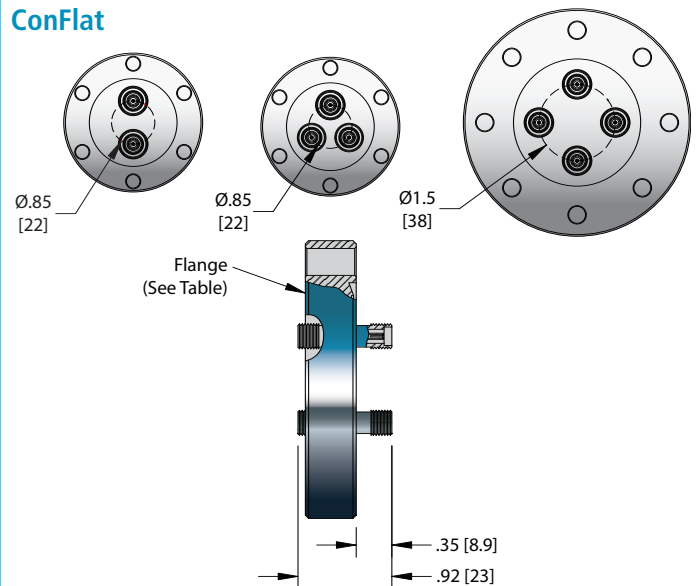

Specifications

Materials

Housing: 304 Stainless steel Insulation: Glass-ceramic
Pin: Inconel X-750 Magnetic Materials: No
Contacts: 300 Series Stn. Stl.

Voltage Rating 500 V DC

Current Rating 1 Amp

Temperature Range -269°C to 350°C, ISO KF -25°C to 205°C

Pressure @ 20°C 1400 PSIG (97 Bar), ISO KF 0 PSIG



NO. PINS	INSTALLATION	PART NUMBER
1	Weld	15263-03-W

ISO FLANGE



1	NW25KF	18055-02-KF
2	NW40KF	21365-01-KF
3	NW40KF	21366-01-KF
4	NW50KF	21367-01-KF

CONFLAT FLANGE



1	1 1/3" (NW16CF)	16545-01-CF
2	2 3/4" (NW35CF)	21362-01-CF
3	2 3/4" (NW35CF)	21363-01-CF
4	4 1/2" (NW63CF)	21364-01-CF



TYPE	VOLTAGE DC	CONDUCTOR AMPS	DIMENSIONS H L		DESCRIPTION	PART NUMBER
Air Side	500 V	5	0.31 [7.9]	0.98 [25]	SMA Plug	6524-02



TYPE	LENGTH	VOLTAGE DC	CONDUCTOR AMPS	TEMPERATURE MIN MAX		PART NUMBER
50 Ohm SMA – Double Ended	10'	500 V	5	-70	200	21617-01-A

See the Accessories section for more information on all accessories.

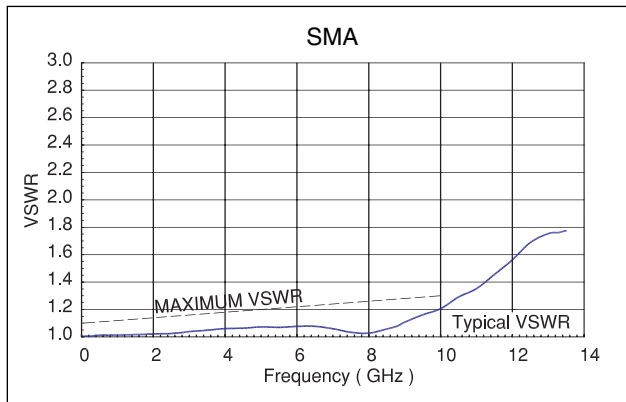

**Single Ended – Floating Shield
Weldable**

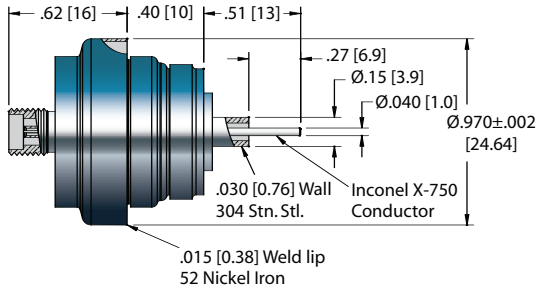

ISO KF

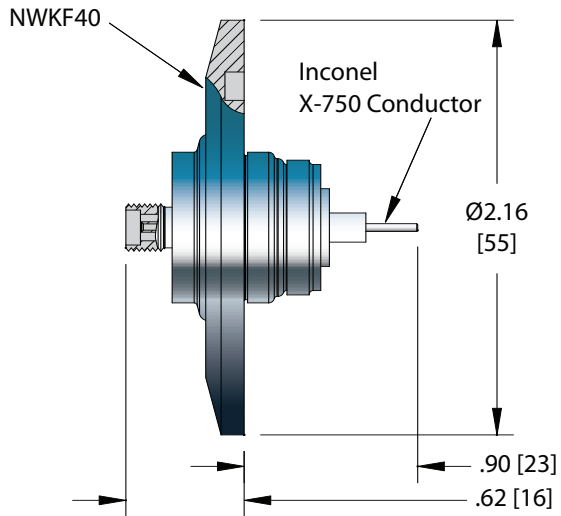

ConFlat

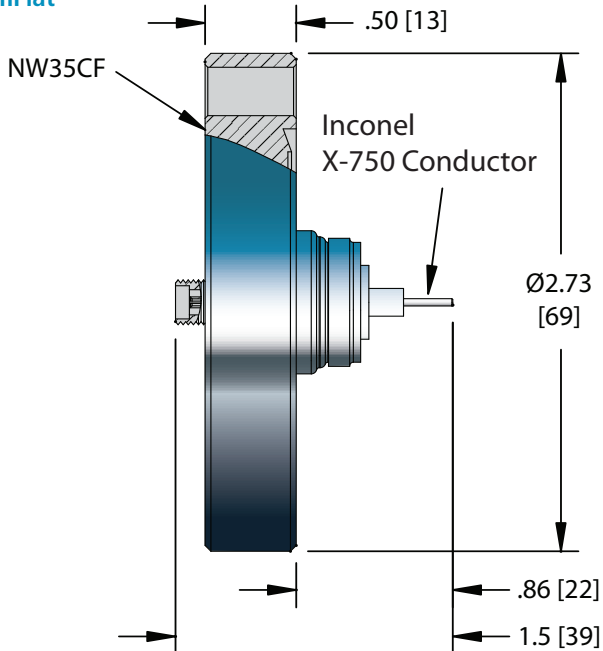

**Double Ended – Floating Shield
Weldable**

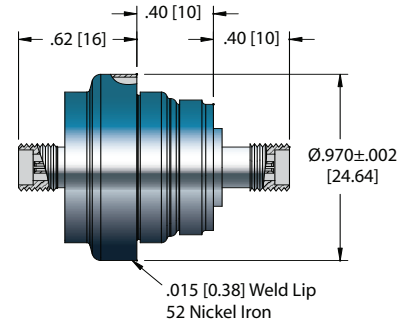

ISO KF

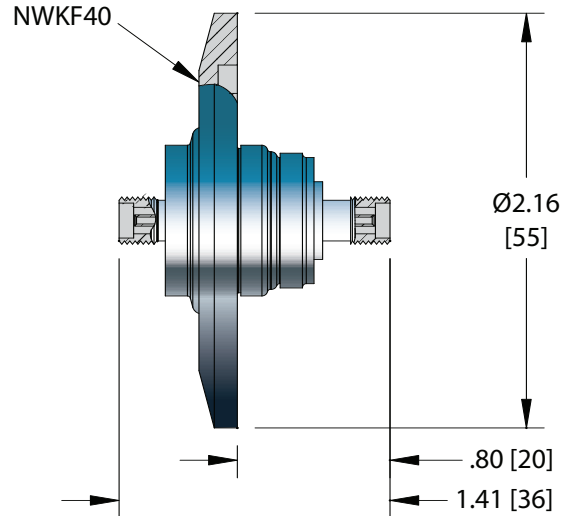

ConFlat

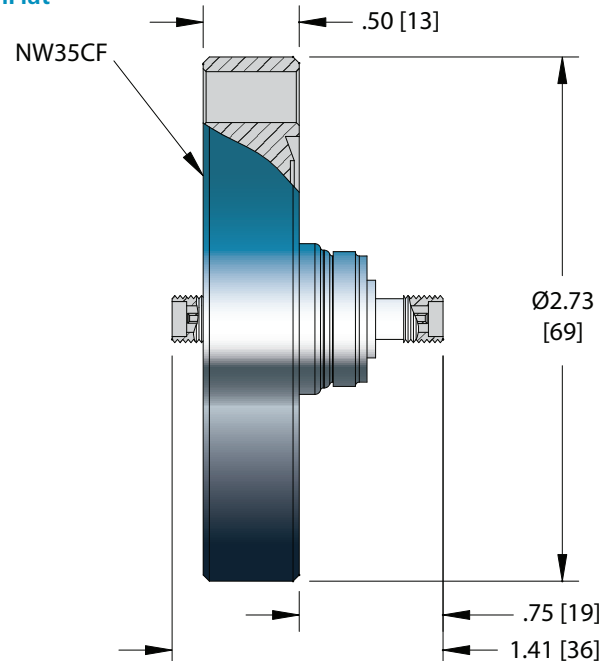

Single & Double Ended Weldable



STYLE	INSTALLATION	PART NUMBER
Single Ended	Weld	21283-01-W
Double Ended	Weld	19604-01-W†

Single & Double Ended ISO KF



ISO FLANGE		
STYLE	INSTALLATION	PART NUMBER
Single Ended	NW40KF	21285-01-KF
Double Ended	NW40KF	21287-01-KF†

Single & Double Ended ConFlat



CONFLAT FLANGE		
STYLE	INSTALLATION	PART NUMBER
Single Ended	2 3/4" (NW35CF)	21284-01-CF
Double Ended	2 3/4" (NW35CF)	21286-01-CF†

Air Side Plug



TYPE	VOLTAGE DC	CONDUCTOR AMPS	DIMENSIONS H L	DESCRIPTION	PART NUMBER
Air Side	500 V	5	0.31 [7.9] 0.98 [25]	SMA Plug	6524-02

Air Side Cable Assembly



TYPE	LENGTH	VOLTAGE DC	CONDUCTOR AMPS	TEMPERATURE MIN MAX	PART NUMBER
50 Ohm SMA – Double Ended	10'	500 V	5	-70 200	21617-01-A

Contacts

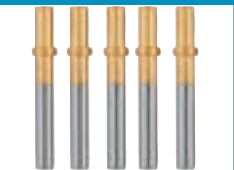

TYPE	MATERIAL	DESCRIPTION	PART NUMBER
0.040 Crimp Contacts	Copper Alloy - Gold Flash	Accepts wire up to 0.040 [1.0]	16167-03-A†
0.040 Set Screw Type Contacts	Beryllium Copper	Accepts wire up to 0.050 [1.3]	7429-03-A
0.040 Barrel Type Contacts	Beryllium Copper	Accepts wire up to 0.040 [1.0]	7332-01-A
Crimp Tool		For 0.025" – 0.075" Diameters	2840-05

*Contacts priced and sold in packages of 5. **Contacts priced and sold in packages of 10. †Shown in photo. See the Accessories section for more information on all accessories.

Specifications

Materials

Housing: 52 Nickel Iron Insulation: Glass-ceramic & Alumina ceramic

Pin: Inconel X-750 Magnetic Materials: Yes

Voltage Rating Pin/Shield: 500 V DC, Shield/Gnd: 2.5 kV DC

Current Rating 1 Amp

Temperature Range -269°C to 350°C, ISO KF -25°C to 205°C

Pressure @ 20°C 300 PSIG (20 Bar), ISO KF 0 PSIG

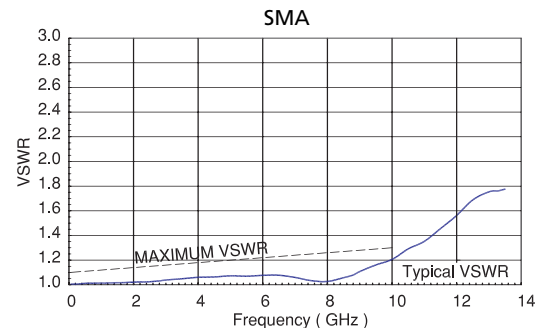

Weldable

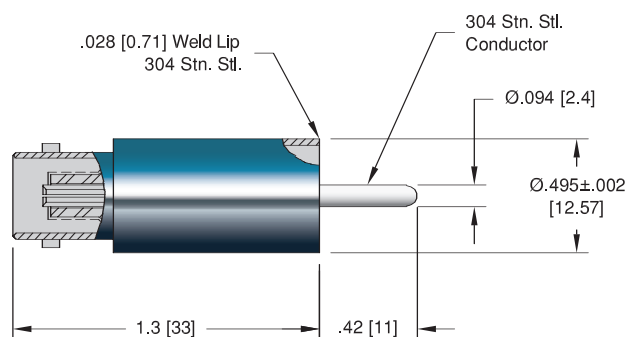

ISO KF - NW16KF

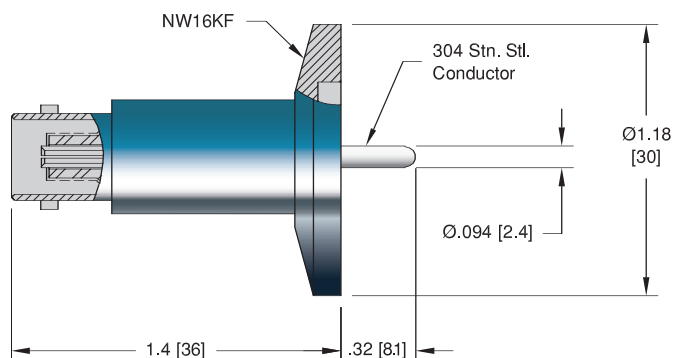

ConFlat - NW16CF

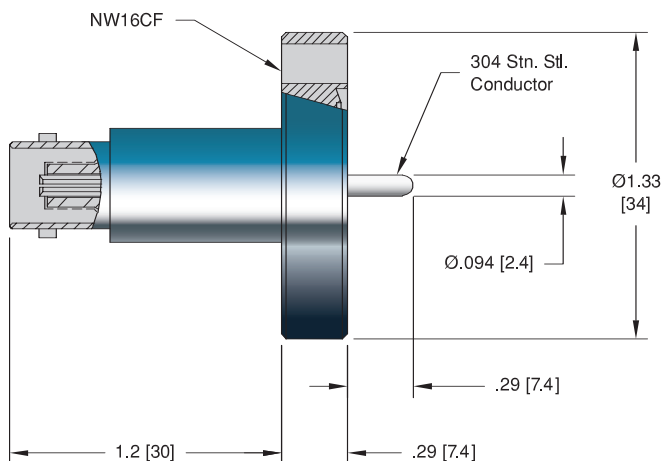

ISO KF - NW40KF

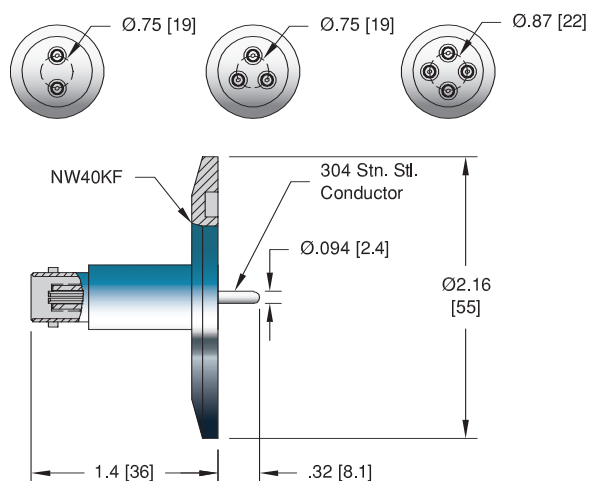

ConFlat - NW35CF

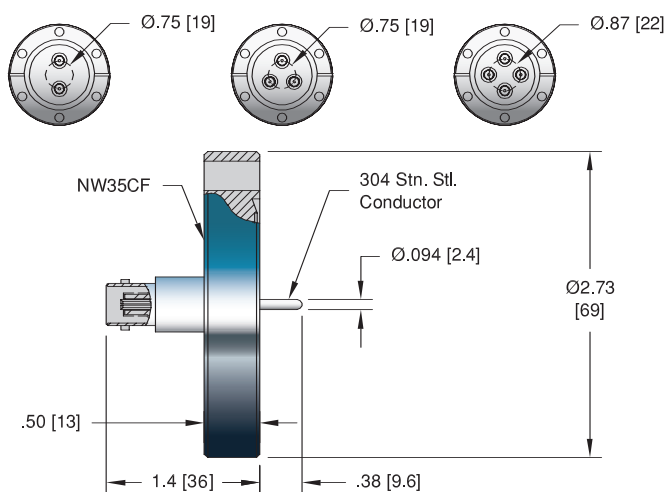

Specifications

Materials

Housing: 304 Stainless steel
 Pin: 304 Stainless steel
 Insulation: Alumina ceramic
 Magnetic Materials: No

Voltage Rating 500 V DC

Current Rating 3.6 Amps

Temperature Range -269°C to 450°C, ISO KF -25°C to 205°C

Pressure @ 20°C 1400 PSIG (97 Bar), ISO KF 0 PSIG



Single Ended Weldable

NO. PINS	INSTALLATION	PART NUMBER
1	Weld	7007-02-W

Single Ended ISO KF

ISO FLANGE

1	NW16KF	17114-01-KF
1	NW40KF	17114-05-KF
2	NW40KF	17136-01-KF
3	NW40KF	17137-01-KF
4	NW40KF	17138-01-KF

Single Ended ConFlat

CONFLAT FLANGE

1	1 1/3" ConFlat (NW16CF)	7593-02-CF
1	2 3/4" ConFlat (NW35CF)	7592-02-CF
2	2 3/4" ConFlat (NW35CF)	5822-04-CF
3	2 3/4" ConFlat (NW35CF)	6647-04-CF
4	2 3/4" ConFlat (NW35CF)	7184-05-CF

Air Side Plug

TYPE	VOLTAGE DC	CONDUCTOR AMPS	DIMENSIONS H L		DESCRIPTION	PART NUMBER
Air Side	500 V	5	0.56 [14]	1.1 [27]	BNC Plug	7116-02

Air Side Cable Assembly

TYPE	LENGTH	VOLTAGE DC	CONDUCTOR AMPS	TEMPERATURE MIN MAX		PART NUMBER
50 Ohm BNC – Double Ended	10'	500 V	5	-40	85	18921-01-A

Contacts

TYPE	MATERIAL	DESCRIPTION	PART NUMBER
0.094 Set Screw Type Contacts	Beryllium Copper	Accepts wire up to 0.050 [1.3]	7429-01-A†
0.094 Barrel Type Contacts	Beryllium Copper	Accepts wire up to 0.094 [2.4]	7332-04-A

*Contacts priced and sold in packages of 10. †Shown in photo. See the Accessories section for more information on all accessories.

COAXIAL



Weldable

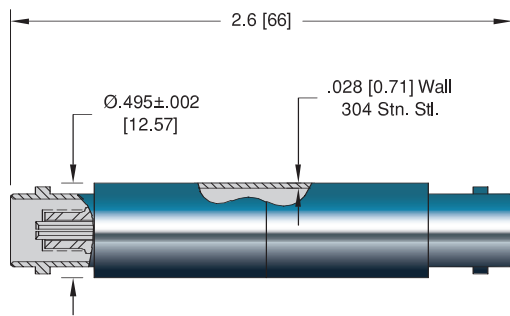

ISO KF - NW16KF

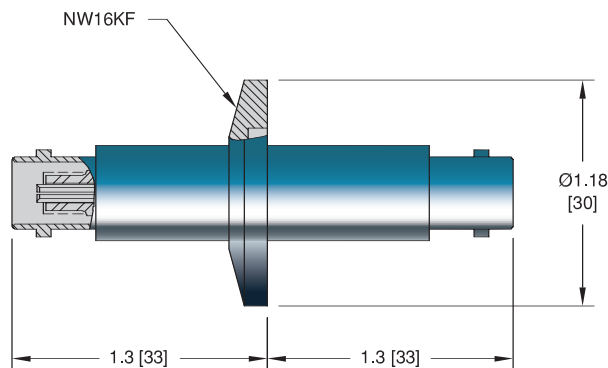

ConFlat - NW16CF

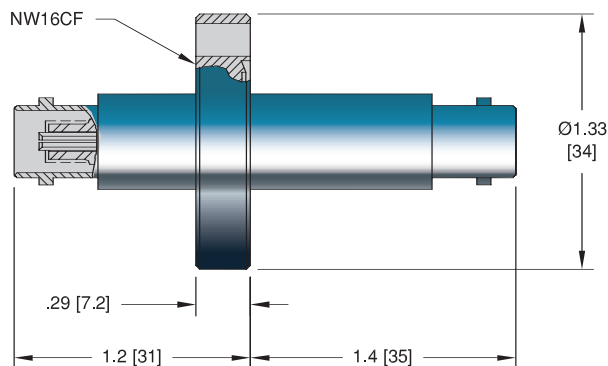

ISO KF

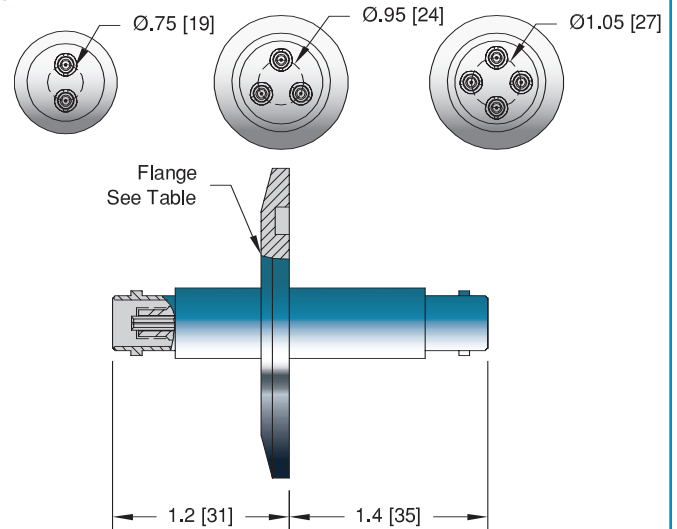

ConFlat

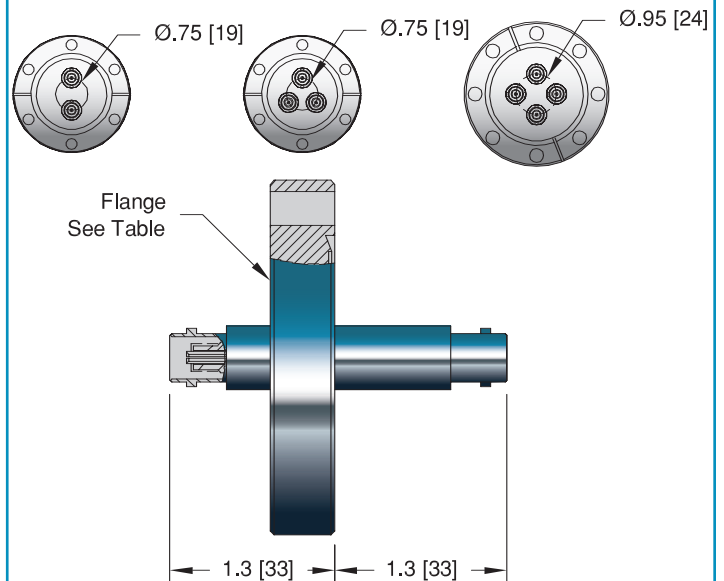

Specifications

Materials

Housing: 304 Stainless steel
 Pin: 304 Stainless steel
 Insulation: Alumina ceramic
 Magnetic Materials: No

Voltage Rating 500 V DC

Current Rating 3.6 Amps

Temperature Range -269°C to 450°C, ISO KF -25°C to 205°C

Pressure @ 20°C 1400 PSIG (97 Bar), ISO KF 0 PSIG



NO. PINS	INSTALLATION	PART NUMBER
1	Weld	17115-01-W



ISO FLANGE		
1	NW16KF	17116-01-KF
1	NW40KF	17118-01-KF
2	NW40KF	17118-05-KF
3	NW50KF	17122-01-KF
4	NW50KF	17139-01-KF

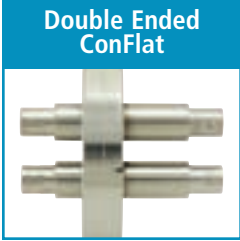

CONFLAT FLANGE		
1	1 1/3" ConFlat (NW16CF)	17117-01-CF
1	2 3/4" ConFlat (NW35CF)	18604-01-CF
2	2 3/4" ConFlat (NW35CF)	17187-01-CF
3	2 3/4" ConFlat (NW35CF)	17188-01-CF
4	3 3/8" ConFlat (NW50CF)	17189-01-CF



TYPE	VOLTAGE DC	CONDUCTOR AMPS	DIMENSIONS H L		DESCRIPTION	PART NUMBER
Air Side	500 V	5	0.56 [14]	1.1 [28]	BNC Plug	7116-02



TYPE	LENGTH	VOLTAGE DC	CONDUCTOR AMPS	TEMPERATURE MIN MAX		PART NUMBER
50 Ohm BNC – Double Ended	10'	500 V	5	-40	85	18921-01-A

See the Accessories section for more information on all accessories.

COAXIAL



Specifications

Materials

Housing: 52 Nickel Iron

Pin: 304 Stainless steel

Insulation: Alumina ceramic

Magnetic Materials: Yes

Voltage Rating Pin/Shield: 500 V DC, Shield/Gnd: 2.5 kV DC

Current Rating 3.6 Amps

Temperature Range -269°C to 450°C, ISO KF -25°C to 205°C

Pressure @ 20°C 300 PSIG (20 Bar), ISO KF 0 PSIG

Weldable

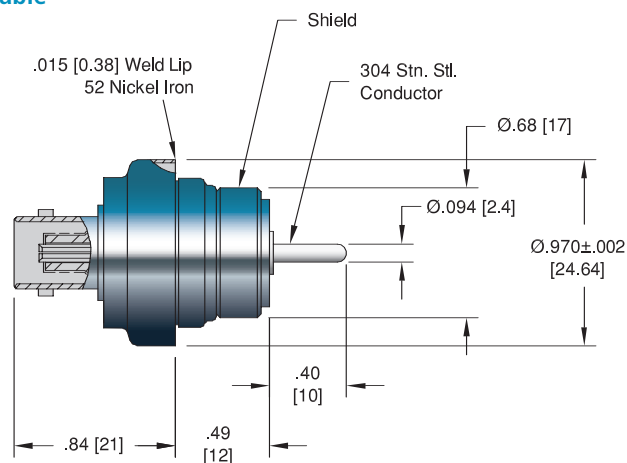

ISO KF

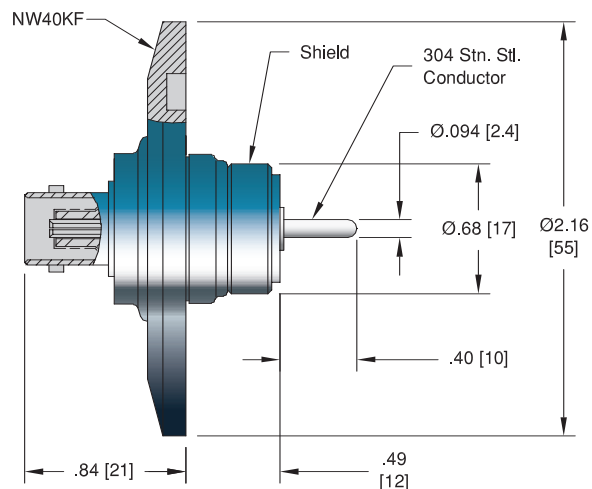

ConFlat

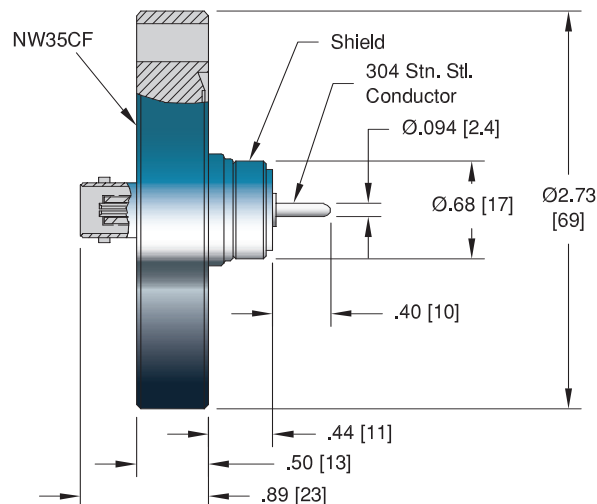



Single Ended Weldable

INSTALLATION	PART NUMBER
Weld	6511-03-W

Single Ended ISO KF

ISO FLANGE	PART NUMBER
NW40KF	17177-01-KF

Single Ended ConFlat

CONFLAT FLANGE	PART NUMBER
2 3/4" (NW35CF)	17178-01-CF

Air Side Plug

TYPE	VOLTAGE DC	CONDUCTOR AMPS	DIMENSIONS		DESCRIPTION	PART NUMBER
			H	L		
Air Side	500 V	5	0.56 [14]	1.1 [28]	BNC Plug	7116-02

Air Side Cable Assembly

TYPE	LENGTH	VOLTAGE DC	CONDUCTOR AMPS	TEMPERATURE		PART NUMBER
				MIN	MAX	
50 Ohm BNC – Double Ended	10'	500 V	5	-40	85	18921-01-A

Contacts

TYPE	MATERIAL	DESCRIPTION	PART NUMBER
0.094 Set Screw Type Contacts	Beryllium Copper	Accepts wire up to 0.050 [1.3]	7429-01-A [†]
0.094 Barrel Type Contacts	Beryllium Copper	Accepts wire up to 0.094 [2.4]	7332-04-A

*Contacts priced and sold in packages of 10. [†]Shown in photo. See the Accessories section for more information on all accessories.

COAXIAL



Weldable

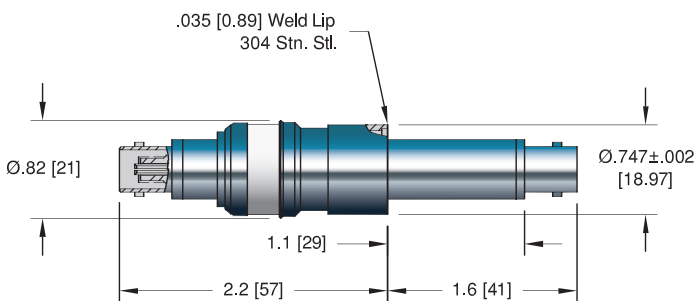

ISO KF - NW40KF

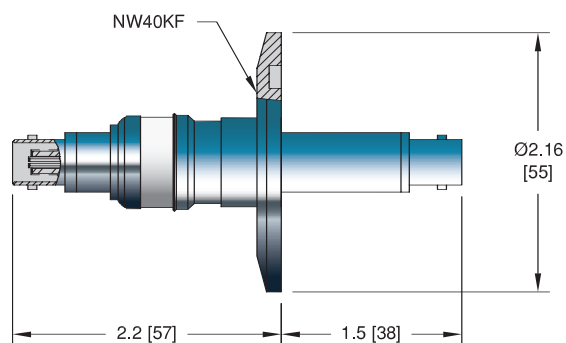

ISO KF - NW16KF

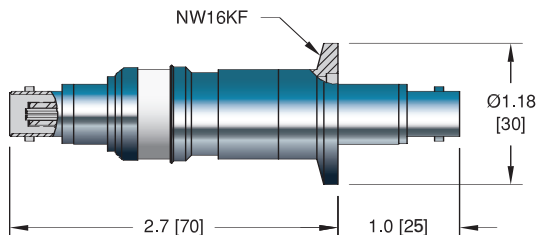

ConFlat - NW35CF

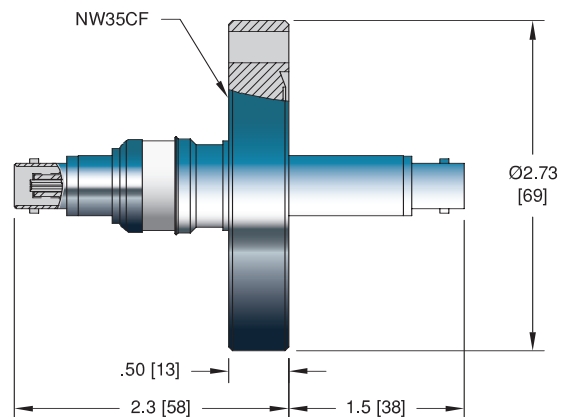

ConFlat - NW16CF

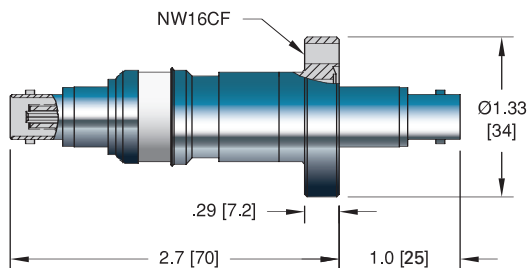

Specifications

Materials

Housing: 304 Stainless steel
 Pin: 304 Stainless steel
 Insulation: Alumina ceramic
 Magnetic Materials: Yes

Voltage Rating Pin/Shield: 500 V DC, Shield/Gnd: 2.5 kV DC

Current Rating 3.6 Amps

Temperature Range -269°C to 450°C, ISO KF -25°C to 205°C

Pressure @ 20°C 400 PSIG (28 Bar), ISO KF 0 PSIG



INSTALLATION
Weld

PART NUMBER
17190-01-W



ISO FLANGE
NW16KF
NW40KF

17191-01-KF
17191-05-KF



CONFLAT FLANGE
1 1/3" (NW16CF)
2 3/4" (NW35CF)

17192-01-CF
17193-01-CF



TYPE	LENGTH	VOLTAGE DC	CONDUCTOR AMPS	TEMPERATURE MIN	TEMPERATURE MAX	PART NUMBER
50 Ohm BNC – Double Ended	10'	500 V	5	-40	85	18921-01-A

18921-01-A



TYPE	VOLTAGE DC	CONDUCTOR AMPS	DIMENSIONS		DESCRIPTION	PART NUMBER
			H	L		
Air Side	500 V	5	0.56 [14]	1.1 [28]	BNC Plug	7116-02

7116-02

See the Accessories section for more information on all accessories.

COAXIAL

Single Ended - Grounded Shield
Weldable

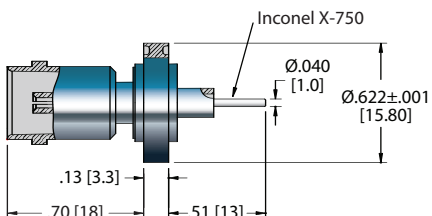

ISO KF

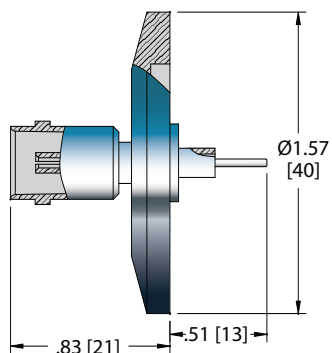

ConFlat

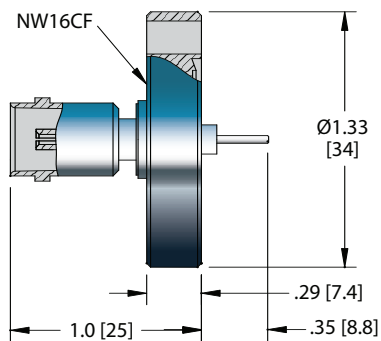

Double Ended - Grounded Shield
Weldable

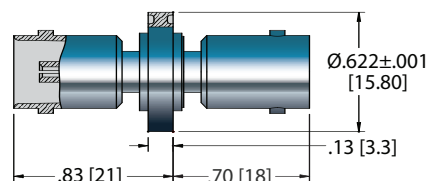

ISO KF

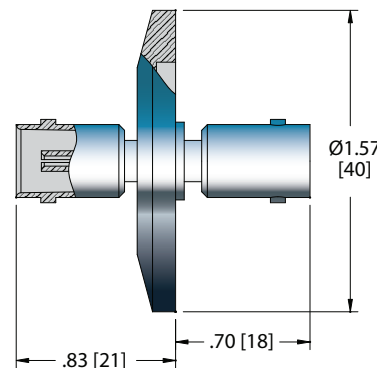

ConFlat

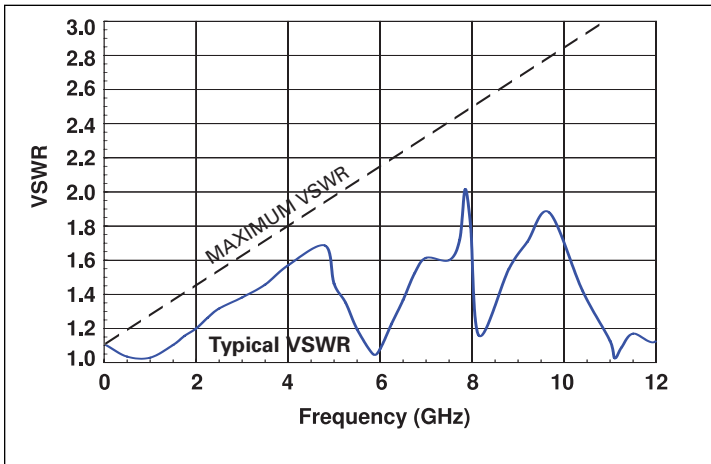
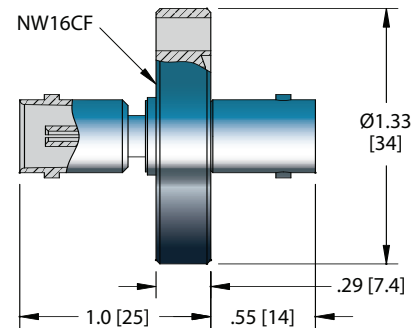

Specifications

Materials

- Housing: 304 Stainless steel
- Pin: Inconel X-750
- Insulation: Glass-ceramic
- Magnetic Materials: No

Voltage Rating 500 V DC

Current Rating 1 Amp

Temperature Range -269°C to 350°C, ISO KF -25°C to 205°C

Pressure @ 20°C 1400 PSIG (97 Bar), ISO KF 0 PSIG



Single & Double Ended Weldable



STYLE	INSTALLATION	PART NUMBER
Single Ended	Weld	21200-01-W
Double Ended	Weld	21201-01-W

ISO FLANGE

Single & Double Ended ISO KF



Single Ended	NW25KF	21205-01-KF
Double Ended	NW25KF	21207-01-KF

CONFLAT FLANGE

Single & Double Ended ConFlat



Single Ended	1 1/3" ConFlat (NW16CF)	21204-01-CF
Double Ended	1 1/3" ConFlat (NW16CF)	21206-01-CF

Air Side Plug



TYPE	VOLTAGE DC	CONDUCTOR AMPS	DIMENSIONS		DESCRIPTION	PART NUMBER
			H	L		
Air Side	500 V	5	0.56 [14]	1.1 [28]	BNC Plug	7116-02

Air Side Cable Assembly



TYPE	LENGTH	VOLTAGE DC	CONDUCTOR AMPS	TEMPERATURE		PART NUMBER
				MIN	MAX	
50 Ohm BNC – Double Ended	10'	500 V	5	-40	85	18921-01-A

Contacts



TYPE	MATERIAL	DESCRIPTION	PART NUMBER
Crimp Type Contacts	Copper Alloy - Gold Flash	Accepts wire up to 0.040 [1.0]	16167-03-A
Crimp Tool		For 0.025" – 0.075" Diameters	2840-05

*Contacts priced and sold in packages of 5. See the Accessories section for more information on all accessories.

Weldable

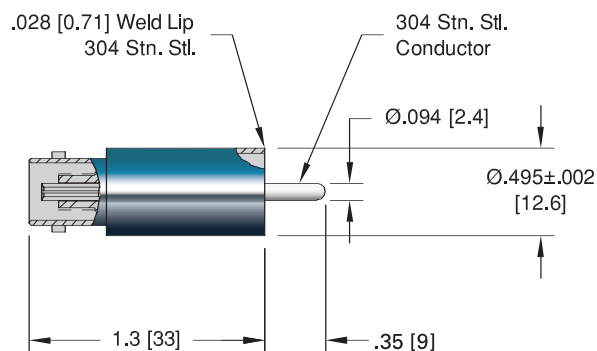

ISO KF - NW16KF

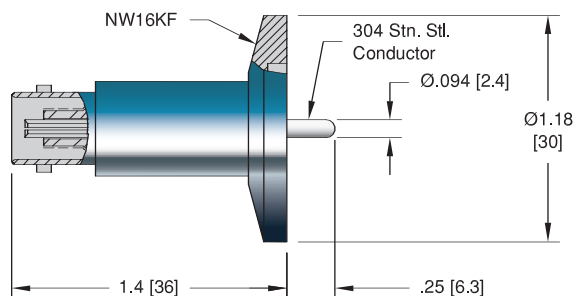

ConFlat - NW16CF

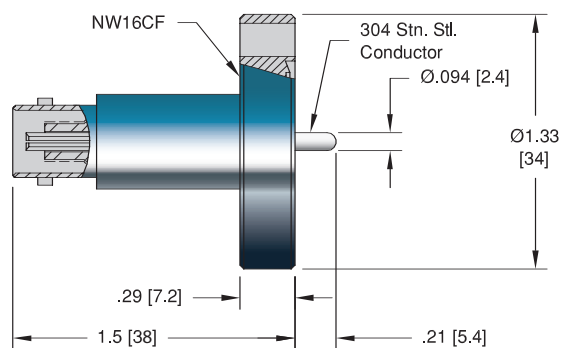

ISO KF - NW40KF

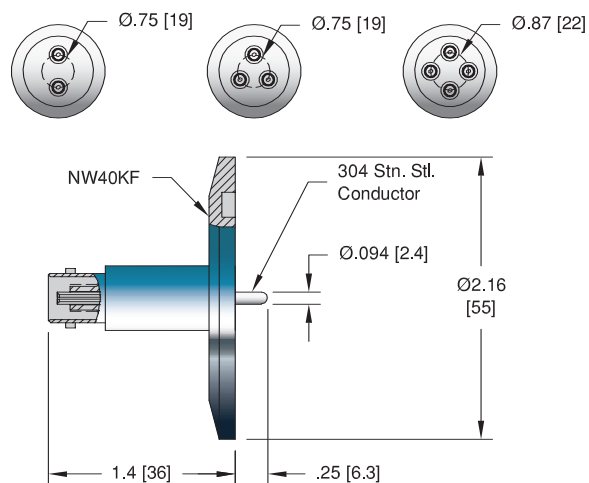

ConFlat - NW35CF

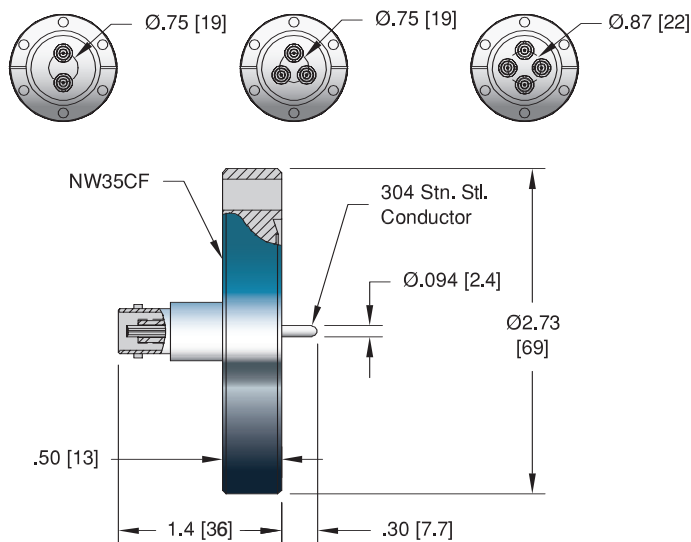

Specifications

Materials

Housing: 304 Stainless steel
Pin: 304 Stainless steel
Insulation: Alumina ceramic
Magnetic Materials: No

Voltage Rating 5 kV DC

Current Rating 3.6 Amps

Temperature Range -269°C to 450°C, ISO KF -25°C to 205°C

Pressure @ 20°C 1400 PSIG (97 Bar), ISO KF 0 PSIG



Single Ended Weldable

NO. PINS	INSTALLATION	PART NUMBER
1	Weld	5230-07-W

Single Ended ISO KF

ISO FLANGE

1	NW16KF	17114-03-KF
1	NW40KF	17114-07-KF
2	NW40KF	17136-03-KF
3	NW40KF	17137-03-KF
4	NW40KF	17138-03-KF

Single Ended ConFlat

CONFLAT FLANGE

1	1 1/3" ConFlat (NW16CF)	6924-03-CF
1	2 3/4" ConFlat (NW35CF)	7590-02-CF
2	2 3/4" ConFlat (NW35CF)	5822-05-CF
3	2 3/4" ConFlat (NW35CF)	6647-01-CF
4	2 3/4" ConFlat (NW35CF)	7184-06-CF

Air Side Plug

TYPE	VOLTAGE DC	CONDUCTOR AMPS	DIMENSIONS H L		DESCRIPTION	PART NUMBER
Air Side	5 kV	10	0.56 [14]	1.5 [38]	MHV Plug	7116-01

Air Side Cable Assembly

TYPE	LENGTH	VOLTAGE DC	CONDUCTOR AMPS	TEMPERATURE MIN MAX		PART NUMBER
52 Ohm MHV – Double Ended	10'	5 kV	10	-55	85	18921-02-A

Contacts

TYPE	MATERIAL	DESCRIPTION	PART NUMBER
0.094 Set Screw Type Contacts	Beryllium Copper	Accepts wire up to 0.050 [1.3]	7429-01-A [†]
0.094 Barrel Type Contacts	Beryllium Copper	Accepts wire up to 0.094 [2.4]	7332-04-A

*Contacts priced and sold in packages of 10. [†]Shown in photo. See the Accessories section for more information on all accessories.

Weldable

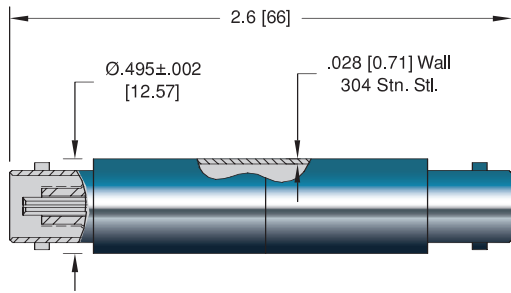

ISO KF - NW16KF

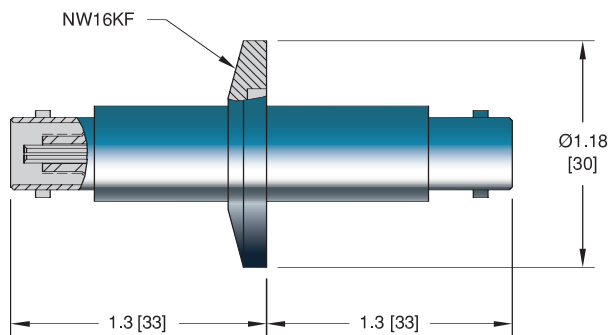

ConFlat - NW16CF

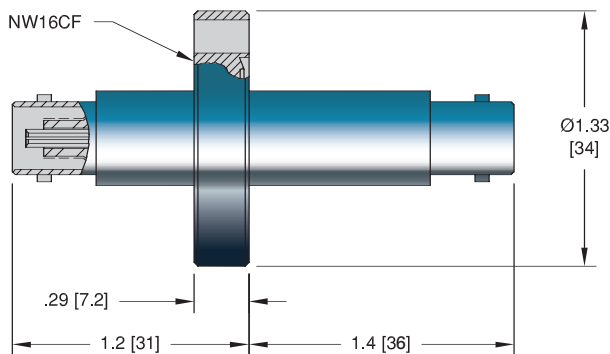

ISO KF

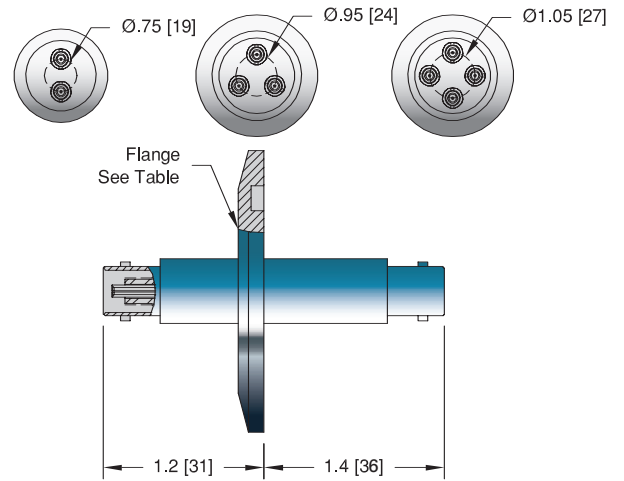

ConFlat

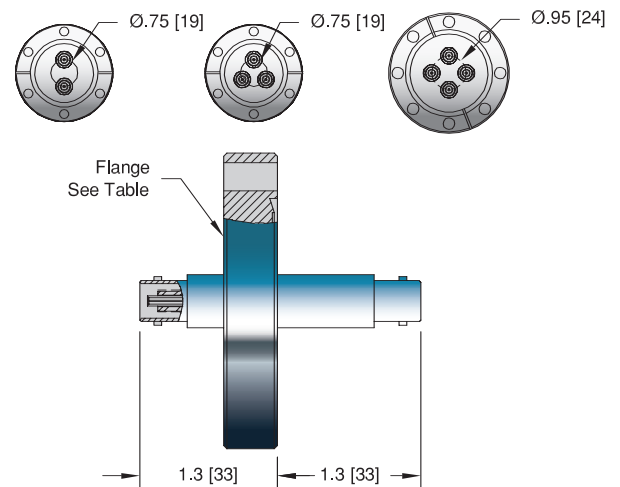

Specifications

Materials

- Housing: 304 Stainless steel
- Pin: 304 Stainless steel
- Insulation: Alumina ceramic
- Magnetic Materials: No

Voltage Rating 5 kV DC

Current Rating 3.6 Amps

Temperature Range -269°C to 450°C, ISO KF -25°C to 205°C

Pressure @ 20°C 1400 PSIG (97 Bar), ISO KF 0 PSIG



NO. PINS	INSTALLATION	PART NUMBER
1	Weld	17115-03-W



ISO FLANGE		
1	NW16KF	17116-03-KF
1	NW40KF	17118-03-KF
2	NW40KF	17118-07-KF
3	NW50KF	17122-03-KF
4	NW50KF	17139-03-KF

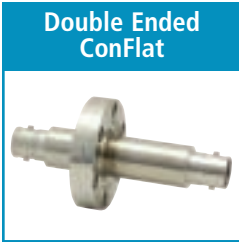

CONFLAT FLANGE		
1	1 1/3" ConFlat (NW16CF)	17117-03-CF
1	2 3/4" ConFlat (NW35CF)	18604-03-CF
2	2 3/4" ConFlat (NW35CF)	17187-03-CF
3	2 3/4" ConFlat (NW35CF)	17188-03-CF
4	3 3/8" ConFlat (NW50CF)	17189-03-CF



TYPE	VOLTAGE DC	CONDUCTOR AMPS	DIMENSIONS H L		DESCRIPTION	PART NUMBER
Air Side	5 kV	10	0.56 [14]	1.5 [38]	MHV Plug	7116-01



TYPE	LENGTH	VOLTAGE DC	CONDUCTOR AMPS	TEMPERATURE MIN MAX		PART NUMBER
52 Ohm MHV – Double Ended	10'	5 kV	10	-55	85	18921-02-A

See the Accessories section for more information on all accessories.



Specifications

Materials

Housing: 52 Nickel Iron
Pin: 304 Stainless steel
Insulation: Alumina ceramic
Magnetic Materials: Yes

Voltage Rating Pin/Shield: 5 kV DC, Shield/Gnd: 2.5 kV DC

Current Rating 3.6 Amps

Temperature Range -269°C to 450°C, ISO KF -25°C to 205°C

Pressure @ 20°C 300 PSIG (20 Bar), ISO KF 0 PSIG

Weldable

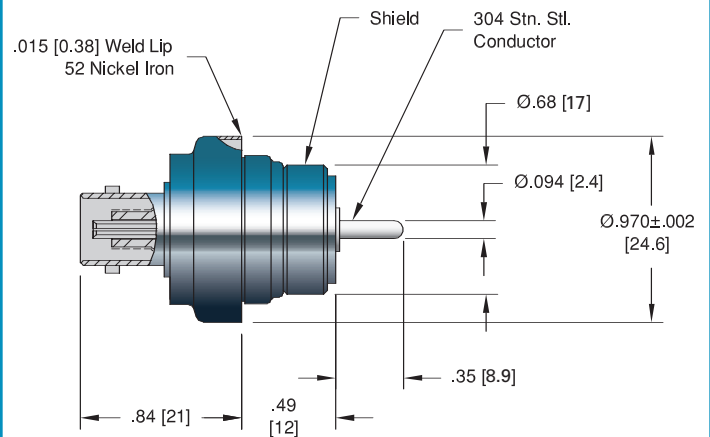

ISO KF

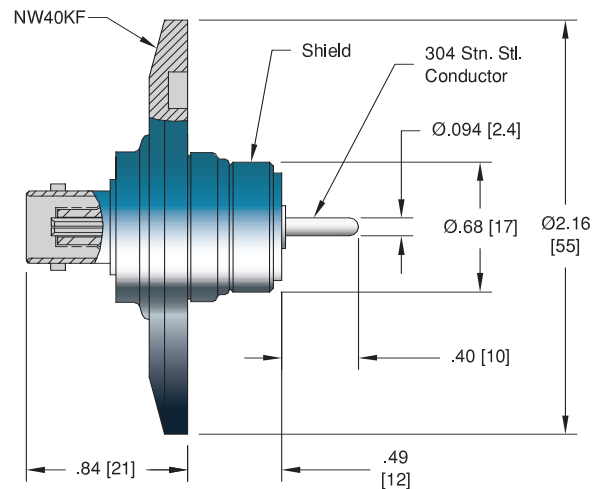

ConFlat

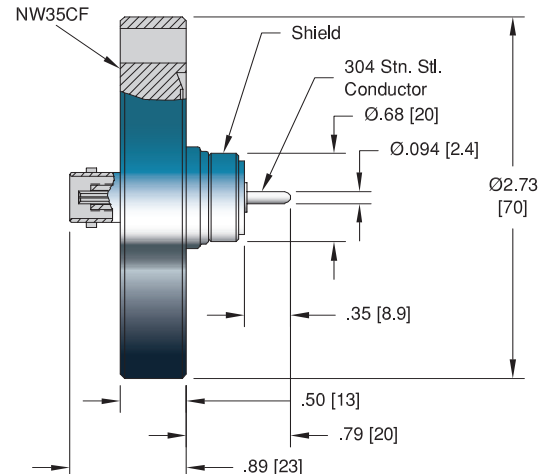



Single Ended Weldable

INSTALLATION	PART NUMBER
Weld	6511-04-W

Single Ended ISO KF

ISO FLANGE	PART NUMBER
NW40KF	17177-03-KF

Single Ended ConFlat

CONFLAT FLANGE	PART NUMBER
2 3/4" (NW35CF)	17178-03-CF

Air Side Plug

TYPE	VOLTAGE DC	CONDUCTOR AMPS	DIMENSIONS		DESCRIPTION	PART NUMBER
			H	L		
Air Side	5 kV	10	0.56 [14]	1.5 [38]	MHV Plug	7116-01

Air Side Cable Assembly

TYPE	LENGTH	VOLTAGE DC	CONDUCTOR AMPS	TEMPERATURE		PART NUMBER
				MIN	MAX	
52 Ohm MHV – Double Ended	10'	5 kV	10	-55	85	18921-02-A

Contacts

TYPE	MATERIAL	DESCRIPTION	PART NUMBER
0.094 Set Screw Type Contacts	Beryllium Copper	Accepts wire up to 0.050 [1.3]	7429-01-A [†]
0.094 Barrel Type Contacts	Beryllium Copper	Accepts wire up to 0.094 [2.4]	7332-04-A

*Contacts priced and sold in packages of 10. [†]Shown in photo. See the Accessories section for more information on all accessories.

COAXIAL

Weldable

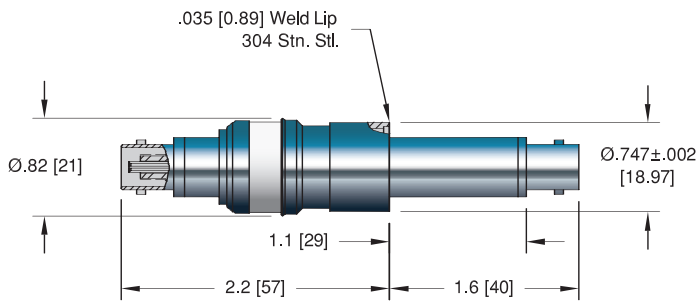

ISO KF - NW40KF

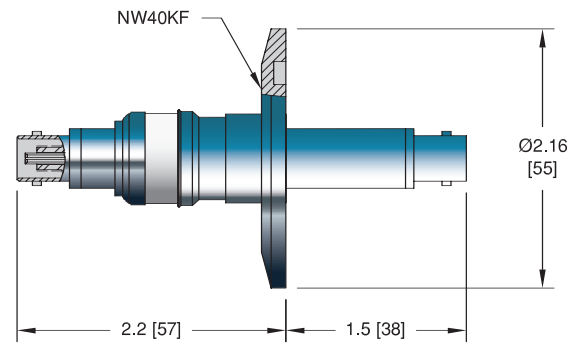

ISO KF - NW16KF

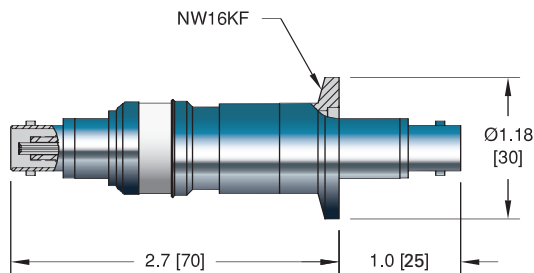

ConFlat - NW35CF

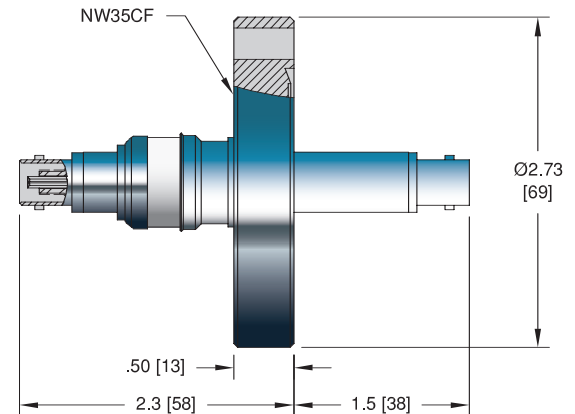

ConFlat - NW16CF

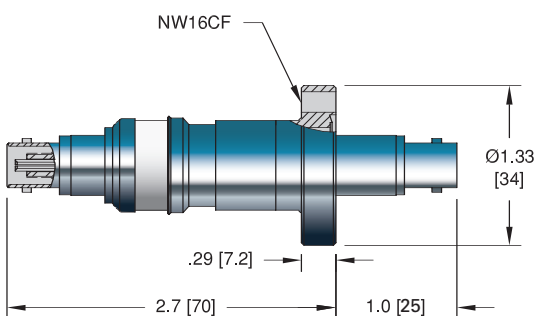

Specifications

Materials

Housing: 304 Stainless steel
Pin: 304 Stainless steel
Insulation: Alumina ceramic
Magnetic Materials: Yes

Voltage Rating Pin/Shield: 5 kV DC, Shield/Gnd: 2.5 kV DC

Current Rating 3.6 Amps

Temperature Range -269°C to 450°C, ISO KF -25°C to 205°C

Pressure @ 20°C 400 PSIG (28 Bar), ISO KF 0 PSIG



Double Ended Weldable

INSTALLATION	PART NUMBER
Weld	17190-03-W

Double Ended ISO KF

ISO FLANGE	PART NUMBER
NW16KF	17191-03-KF
NW40KF	17191-07-KF

Double Ended ConFlat

CONFLAT FLANGE	PART NUMBER
1 1/3" (NW16CF)	17192-03-CF
2 3/4" (NW35CF)	17193-03-CF

Air Side Plug

TYPE	VOLTAGE DC	CONDUCTOR AMPS	DIMENSIONS		DESCRIPTION	PART NUMBER
			H	L		
Air Side	5 kV	10	0.56 [14]	1.5 [38]	MHV Plug	7116-01

Air Side Cable Assembly

TYPE	LENGTH	VOLTAGE DC	CONDUCTOR AMPS	TEMPERATURE		PART NUMBER
				MIN	MAX	
52 Ohm MHV – Double Ended	10'	5 kV	10	-55	85	18921-02-A

See the Accessories section for more information on all accessories.

Single Ended – Grounded Shield Weldable

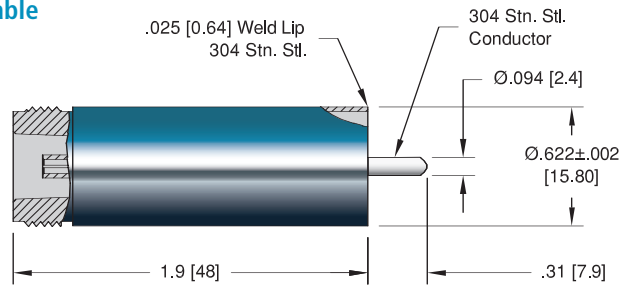

ISO KF

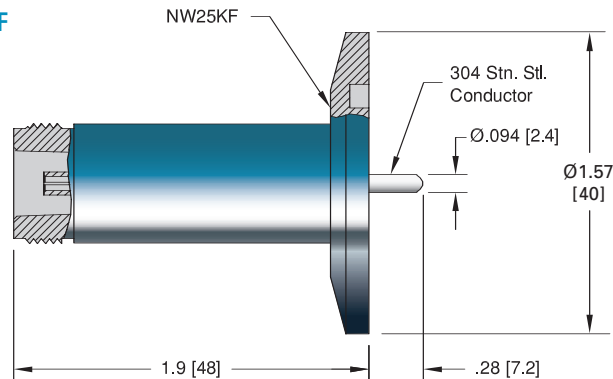

ConFlat - NW16CF

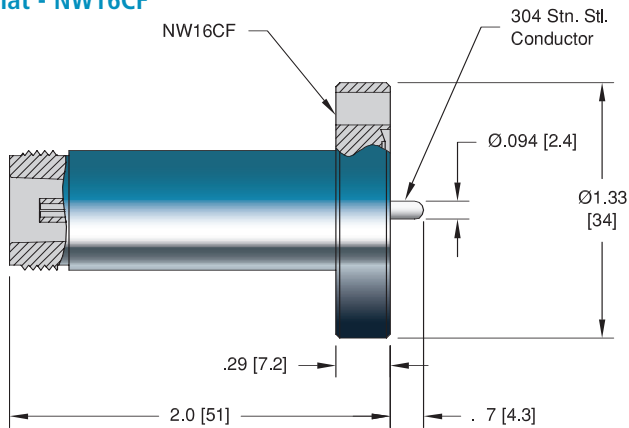

ConFlat - NW35CF

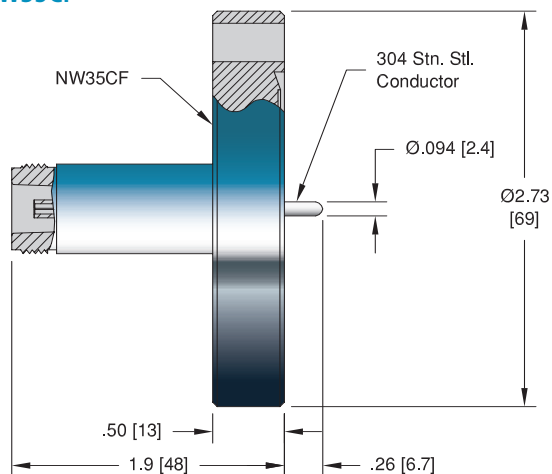

Double Ended – Grounded Shield Weldable

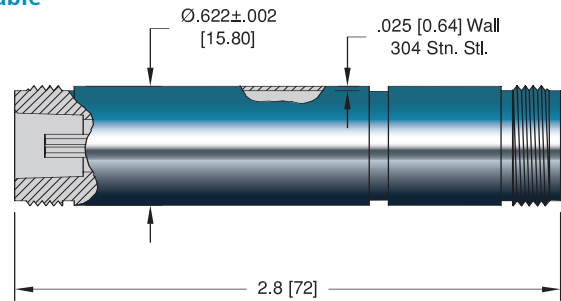

ISO KF

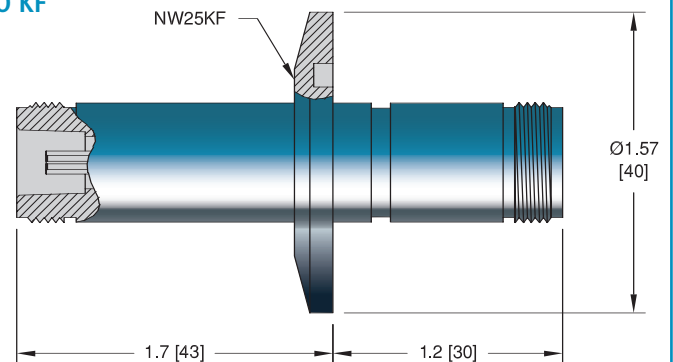

ConFlat

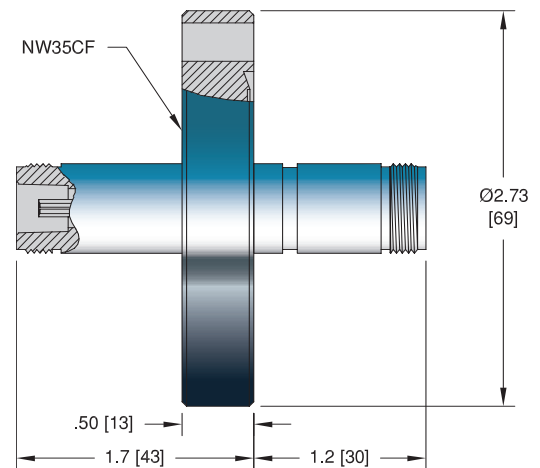

Specifications

Materials

Housing: 304 Stainless steel
Pin: 304 Stainless steel
Insulation: Alumina ceramic
Magnetic Materials: No

Voltage Rating 1.5 kV DC

Current Rating 3.6 Amps

Temperature Range -269°C to 450°C, ISO KF -25°C to 205°C

Pressure @ 20°C See table

Single & Double Ended
Weldable



STYLE	INSTALLATION	PRESSURE @ 20°C PSIG BAR		PART NUMBER
Single Ended	Weld	1800	124	7589-02-W [†]
Double Ended	Weld	1800	124	18077-02-W

ISO FLANGE

Single & Double Ended
ISO KF



Single Ended	NW25KF	-	-	18057-01-KF
Double Ended	NW40KF	-	-	18078-02-KF [†]

CONFLAT FLANGE

Single & Double Ended
ConFlat



Single Ended	1 1/3" (NW16CF)	1800	124	7588-02-CF [†]
Single Ended	2 3/4" (NW35CF)	1500	103	7587-02-CF
Double Ended	2 3/4" (NW35CF)	1500	103	18080-02-CF

Air Side Plug



TYPE	VOLTAGE DC	CONDUCTOR AMPS	DIMENSIONS H L		DESCRIPTION	PART NUMBER
Air Side	1.5 kV	5	0.81 [20]	1.5 [38]	Type N Plug	7707-01

Air Side Cable
Assembly



TYPE	LENGTH	VOLTAGE DC	CONDUCTOR AMPS	TEMPERATURE MIN MAX		PART NUMBER
50 Ohm Type N – Double Ended	10'	1.5 kV	5	-55	85	21619-01-A

Contacts

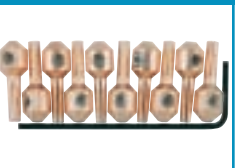

TYPE	MATERIAL	DESCRIPTION	PART NUMBER
0.094 Set Screw Type Contacts	Beryllium Copper	Accepts wire up to 0.050 [1.3]	7429-01-A [†]
0.094 Barrel Type Contacts	Beryllium Copper	Accepts wire up to 0.094 [2.4]	7332-04-A

*Contacts priced and sold in packages of 10. [†]Shown in photo. See the Accessories section for more information on all accessories.

Single Ended – Grounded Shield Weldable

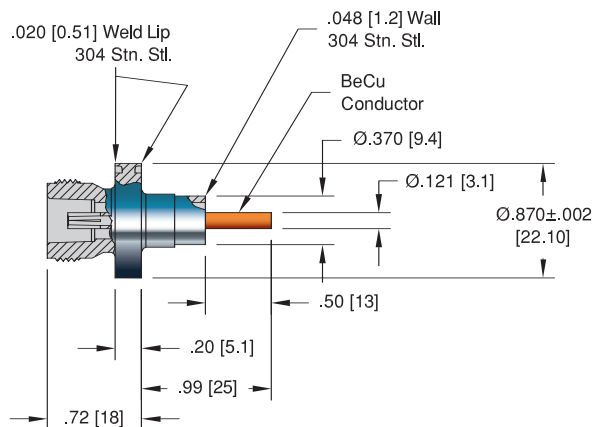

ISO KF

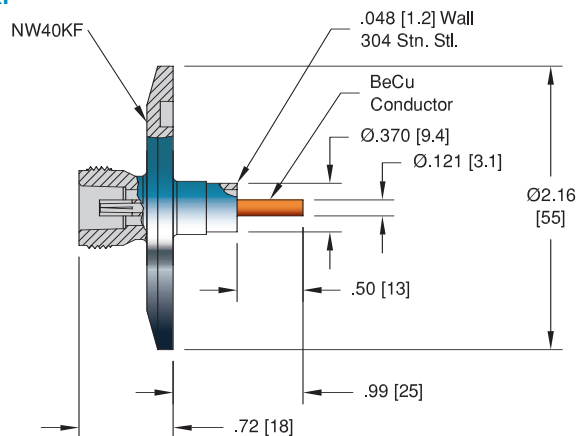

ConFlat

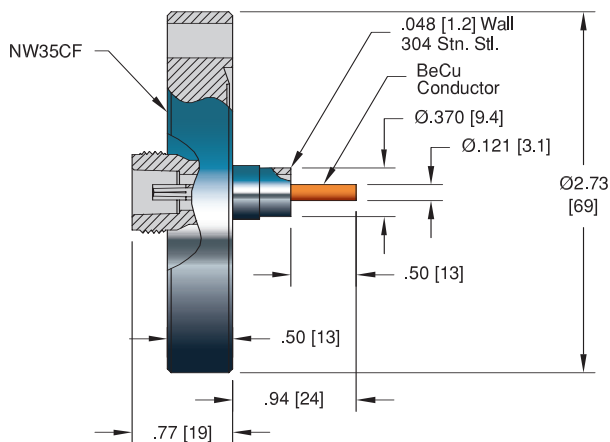

Double Ended – Grounded Shield Weldable

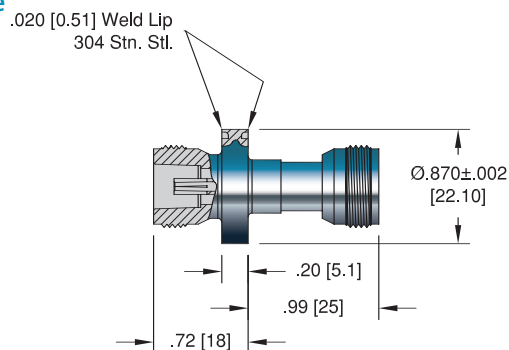

ISO KF

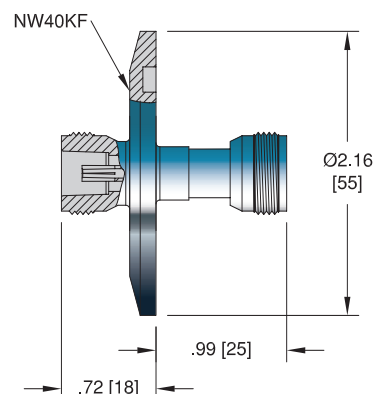

ConFlat

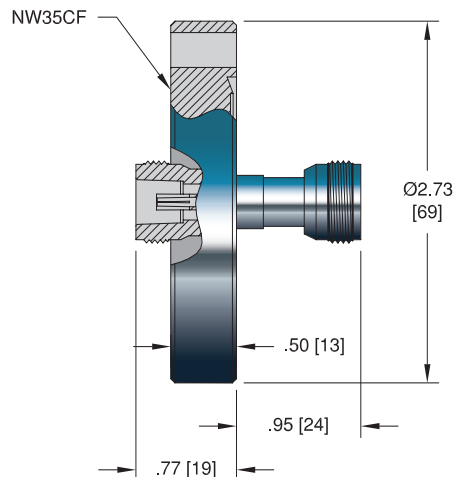

Specifications

Materials

Housing: 304 Stainless steel
Pin/Contact: Beryllium Copper
Insulation: Glass-ceramic
Magnetic Materials: No

Voltage Rating 1.5 kV DC

Current Rating 1 Amp

Temperature Range -200°C to 225°C, ISO KF -25°C to 205°C

Pressure @ 20°C 500 PSIG (34 Bar), ISO KF 0 PSIG



Single & Double Ended
Weldable

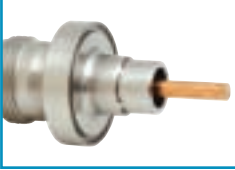

STYLE	INSTALLATION	PART NUMBER
Single Ended	Weld	18066-01-W†
Double Ended	Weld	18069-01-W

ISO FLANGE

Single & Double Ended
ISO KF



Single Ended	NW40KF	18067-01-KF
Double Ended	NW40KF	18070-01-KF†

CONFLAT FLANGE

Single & Double Ended
ConFlat

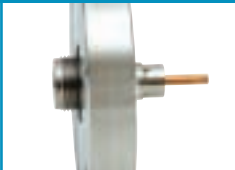

Single Ended	2 3/4" (NW35CF)	18068-01-CF†
Double Ended	2 3/4" (NW35CF)	18071-01-CF

Air Side Plug



TYPE	VOLTAGE DC	CONDUCTOR AMPS	DIMENSIONS H L		DESCRIPTION	PART NUMBER
Air Side	1.5 kV	5	0.81 [20]	1.5 [38]	Type N Plug	7707-01

Air Side Cable
Assembly



TYPE	LENGTH	VOLTAGE DC	CONDUCTOR AMPS	TEMPERATURE MIN MAX		PART NUMBER
50 Ohm Type N – Double Ended	10'	1.5 kV	5	-55	85	21619-01-A

†Shown in photo. See the Accessories section for more information on all accessories.

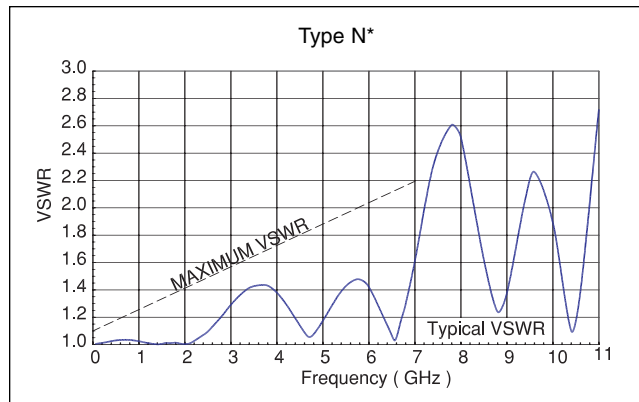

*Applies when properly mated to a 50 Ohm load.



Specifications

Materials

Housing: 304 Stainless steel
 Pin: 70/30 Copper Nickel
 Insulation: Alumina ceramic
 Magnetic Materials: No

Voltage Rating 7 kV DC

Current Rating 7 Amps

Temperature Range -269°C to 450°C, ISO KF -25°C to 205°C

Pressure @ 20°C 320 PSIG (22 Bar), ISO KF 0 PSIG

Single Ended – Grounded Shield Weldable

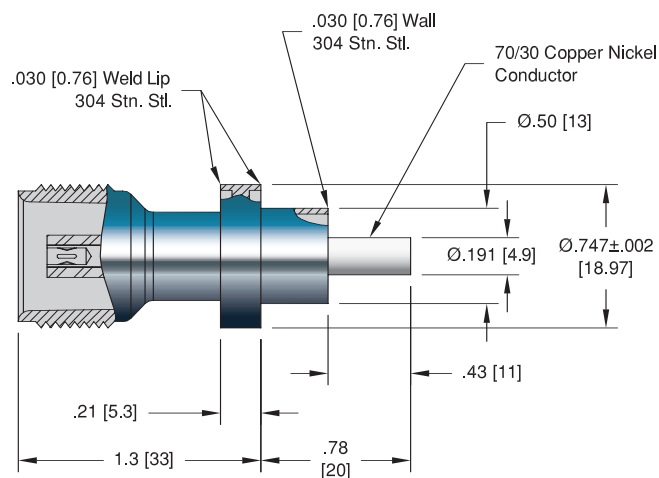

ISO KF

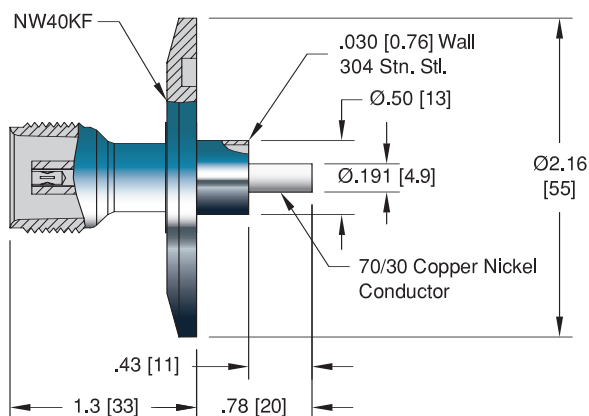

ConFlat

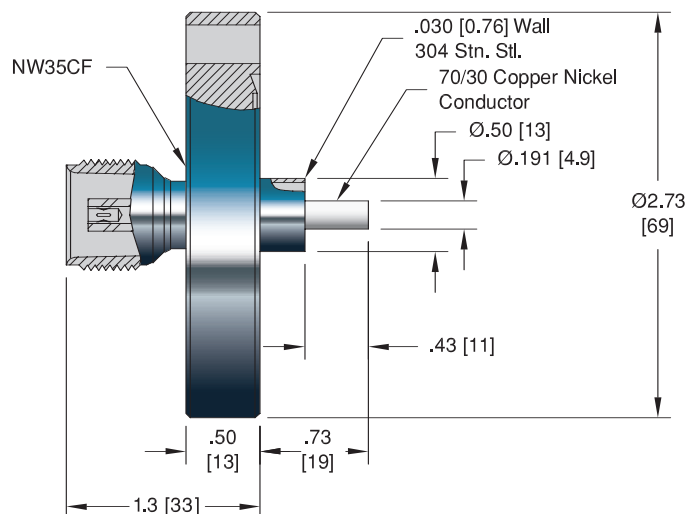



COAXIAL

Weldable

INSTALLATION
Weld

PART NUMBER
1084-01-W

ISO KF

ISO FLANGE
NW40KF

PART NUMBER
18072-01-KF

ConFlat

CONFLAT FLANGE
2 3/4" (NW35CF)

PART NUMBER
10339-02-CF

Air Side Plug

TYPE	VOLTAGE DC	CONDUCTOR AMPS	DIMENSIONS		DESCRIPTION
			H	L	
Air Side	7 kV	10	0.88 [22]	2.4 [61]	HN Plug

PART NUMBER
6524-05

Contacts

TYPE	MATERIAL	DESCRIPTION
0.250 Barrel Type Contacts	Beryllium Copper	Accepts wire up to 0.250 [6.4]

PART NUMBER
7332-06-A

*Contacts priced and sold in packages of 10. See the Accessories section for more information on all accessories.

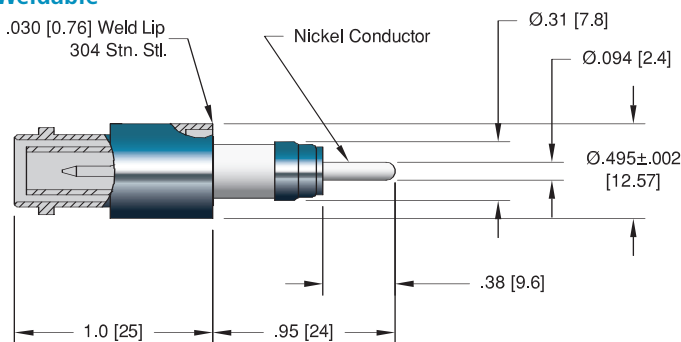
SHV 5 KV - Exposed
Weldable

ISO KF - NW16KF

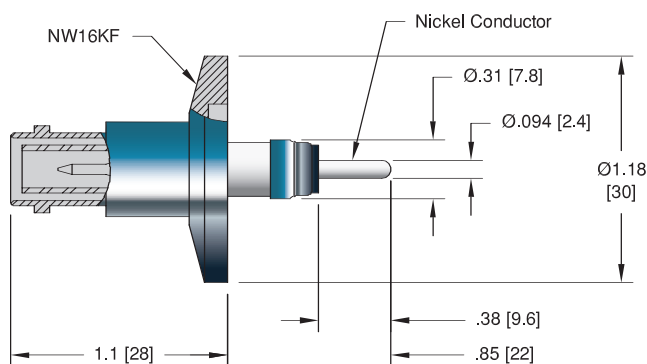

ConFlat - NW16CF

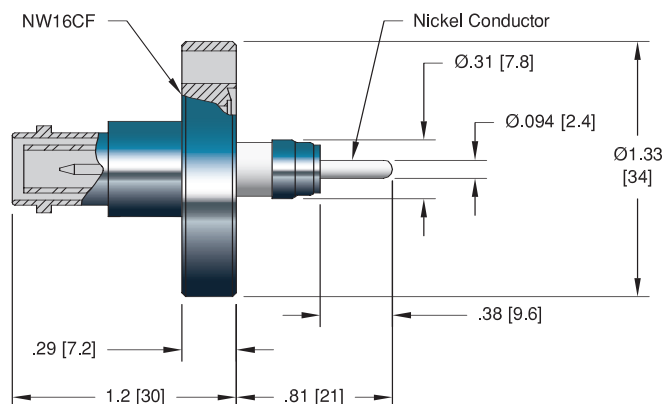
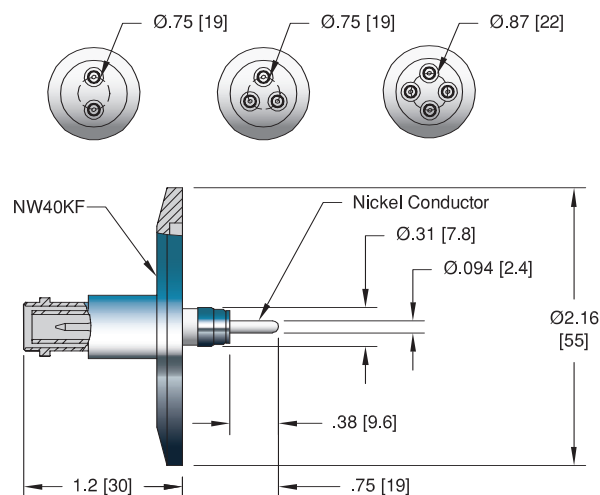
SHV 5 KV - Exposed
ISO KF - NW40KF

ConFlat - NW35CF

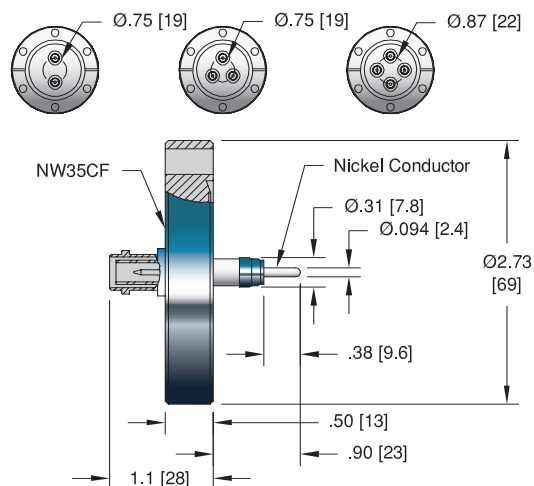

Specifications

Materials

Housing: 304 Stainless steel
Pin: Nickel
Insulation: Alumina ceramic
Magnetic Materials: Yes

Voltage Rating 5 kV DC

Current Rating 16.5 Amps

Temperature Range -269°C to 450°C, ISO KF -25°C to 205°C

Pressure @ 20°C See table



Weldable

NO. PINS	INSTALLATION	PRESSURE @ 20°C BAR		PART NUMBER
1	Weld	1600	110	8630-02-W

ISO KF

ISO FLANGE

1	NW16KF	-	-	17205-01-KF
1	NW40KF	-	-	17208-07-KF
2	NW40KF	-	-	17208-01-KF
3	NW40KF	-	-	17208-03-KF
4	NW40KF	-	-	17208-05-KF

ConFlat

CONFLAT FLANGE

1	1 1/3" (NW16CF)	1600	110	8880-02-CF
1	2 3/4" (NW35CF)	1500	103	14366-07-CF
2	2 3/4" (NW35CF)	1500	103	14366-03-CF
3	2 3/4" (NW35CF)	1500	103	14366-05-CF
4	2 3/4" (NW35CF)	1500	103	14366-01-CF

Air Side Plug

TYPE	VOLTAGE DC	CONDUCTOR AMPS	DIMENSIONS H L		DESCRIPTION	PART NUMBER
Air Side	5 KV	10	0.56 [14]	1.8 [46]	SHV 5 kV Plug	8058-01

Air Side Cable Assembly

TYPE	LENGTH	VOLTAGE DC	CONDUCTOR AMPS	TEMPERATURE MIN MAX		PART NUMBER
52 Ohm SHV – Double Ended	10'	5 kV	10	-55	85	18921-03-A

Contacts

TYPE	MATERIAL	DESCRIPTION	PART NUMBER
0.094 Set Screw Type Contacts	Beryllium Copper	Accepts wire up to 0.050 [1.3]	7429-01-A†
0.094 Barrel Type Contacts	Beryllium Copper	Accepts wire up to 0.094 [2.4]	7332-04-A

*Contacts priced and sold in packages of 10. †Shown in photo. See the Accessories section for more information on all accessories.

COAXIAL

SHV 5 KV - Recessed Weldable

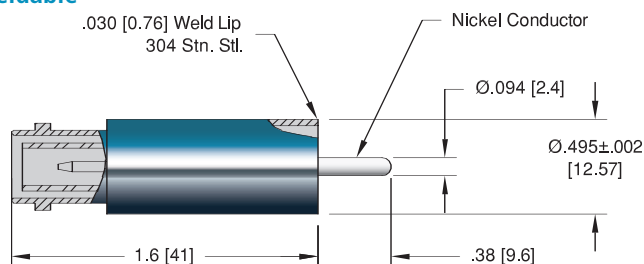

ISO KF - NW16KF

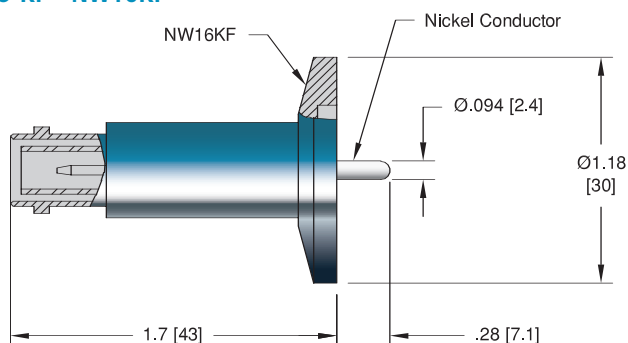

ConFlat - NW16CF

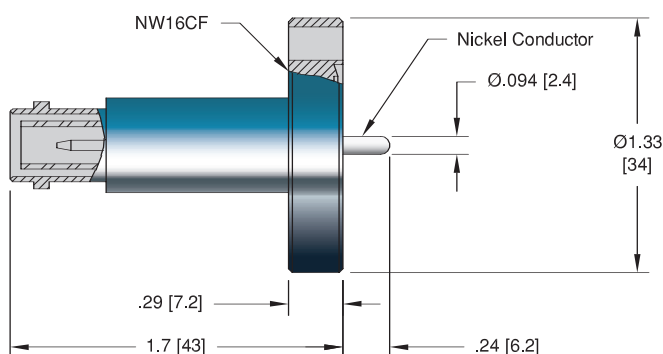

SHV 5 KV - Recessed ISO KF - NW40KF

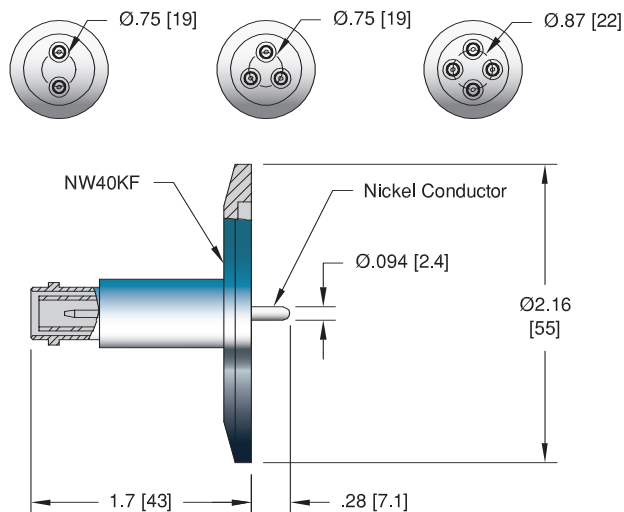

ConFlat - NW35CF

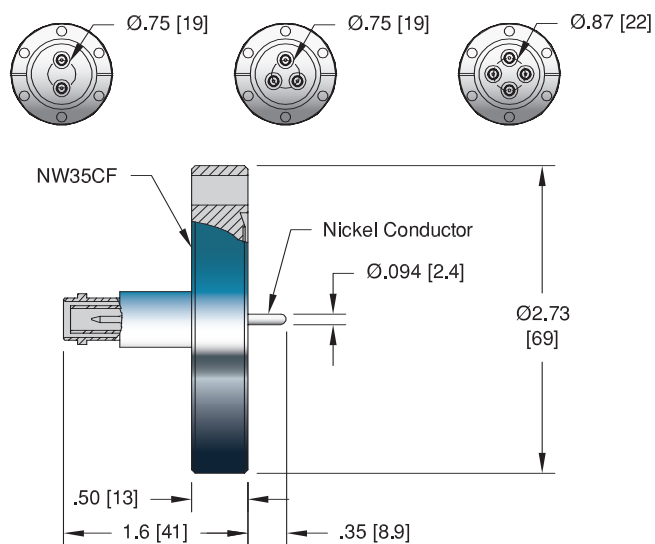

Specifications Materials

Housing: 304 Stainless steel
Pin: Nickel
Insulation: Alumina ceramic
Magnetic Materials: Yes

Voltage Rating 5 kV DC

Current Rating 16.5 Amps

Temperature Range -269°C to 450°C, ISO KF -25°C to 205°C

Pressure @ 20°C See table



COAXIAL

Weldable

NO. PINS	INSTALLATION	PRESSURE @ 20°C BAR		PART NUMBER
1	Weld	1600	110	8030-02-W

ISO KF

ISO FLANGE

1	NW16KF	-	-	17207-02-KF
1	NW40KF	-	-	17206-07-KF
2	NW40KF	-	-	17206-01-KF
3	NW40KF	-	-	17206-03-KF
4	NW40KF	-	-	17206-05-KF

ConFlat

CONFLAT FLANGE

1	1 1/3" (NW16CF)	1600	110	9485-02-CF
1	2 3/4" (NW35CF)	1500	103	11179-04-CF
2	2 3/4" (NW35CF)	1500	103	0268-02-CF
3	2 3/4" (NW35CF)	1500	103	1958-02-CF
4	2 3/4" (NW35CF)	1500	103	11179-02-CF

Air Side Plug

TYPE	VOLTAGE DC	CONDUCTOR AMPS	DIMENSIONS H L		DESCRIPTION	PART NUMBER
Air Side	5 kV	10	0.56 [14]	1.8 [46]	SHV 5 kV Plug	8058-01

Air Side Cable Assembly

TYPE	LENGTH	VOLTAGE DC	CONDUCTOR AMPS	TEMPERATURE MIN MAX		PART NUMBER
52 Ohm SHV – Double Ended	10'	5 kV	10	-55	85	18921-03-A

Contacts

TYPE	MATERIAL	DESCRIPTION	PART NUMBER
0.094 Set Screw Type Contacts	Beryllium Copper	Accepts wire up to 0.050 [1.3]	7429-01-A [†]
0.094 Barrel Type Contacts	Beryllium Copper	Accepts wire up to 0.094 [2.4]	7332-04-A

*Contacts priced and sold in packages of 10. [†]Shown in photo. See the Accessories section for more information on all accessories.



Specifications

Materials

Housing: 304 Stainless steel

Pin: Nickel

Insulation: Alumina ceramic

Magnetic Materials: Yes

Voltage Rating Pin/Shield: 5 kV DC, Shield/Gnd: 2.5 kV DC

Current Rating 16.5 Amps

Temperature Range -269°C to 450°C, ISO KF -25°C to 205°C

Pressure @ 20°C 300 PSIG (20 Bar), ISO KF 0 PSIG

Weldable

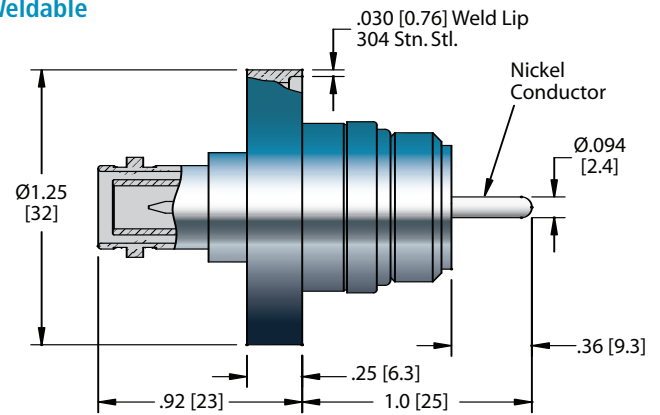

ISO KF

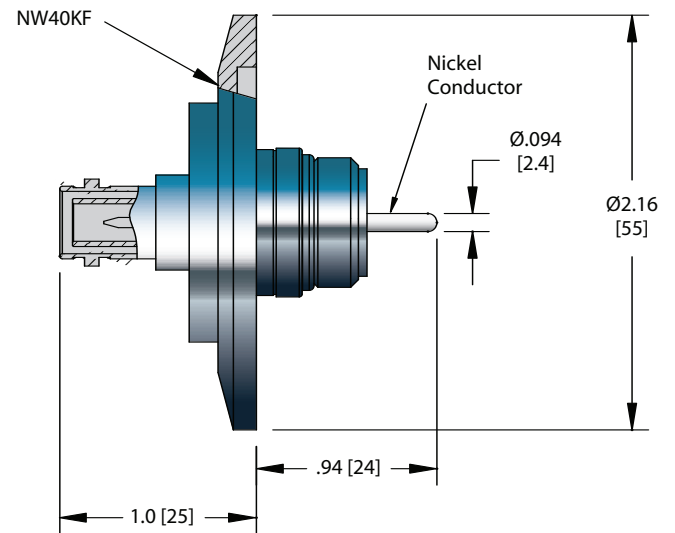

ConFlat

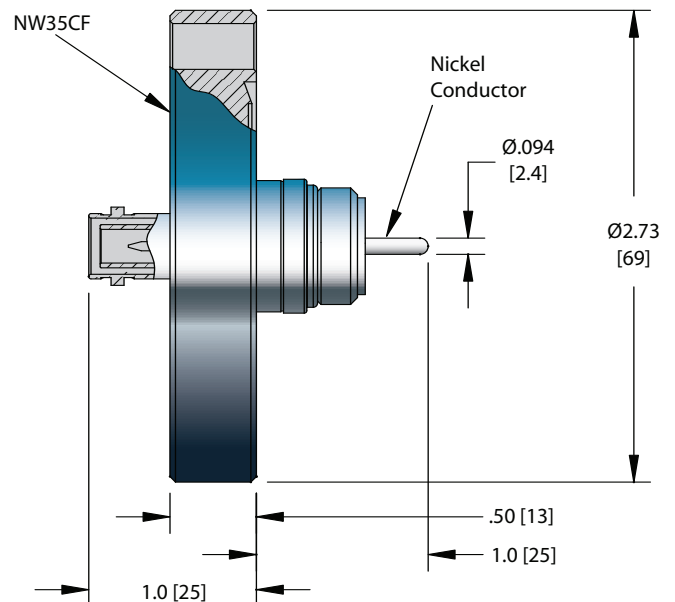



INSTALLATION
Weld

PART NUMBER
15619-01-W



ISO FLANGE
NW40KF

21303-01-KF

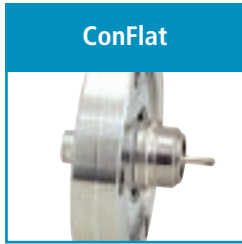

CONFLAT FLANGE
2 3/4" (NW35CF)

21304-01-CF



TYPE	VOLTAGE DC	CONDUCTOR AMPS	DIMENSIONS H L		DESCRIPTION
Air Side	5 kV	10	0.56 [14]	1.8 [46]	SHV 5 kV Plug

PART NUMBER
8058-01



TYPE	LENGTH	VOLTAGE DC	CONDUCTOR AMPS	TEMPERATURE MIN MAX	
52 Ohm SHV – Double Ended	10'	5 kV	10	-55	85

PART NUMBER
18921-03-A

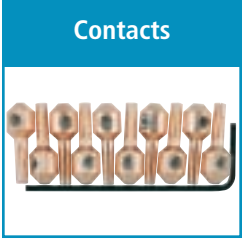

TYPE	MATERIAL	DESCRIPTION
0.094 Set Screw Type Contacts	Beryllium Copper	Accepts wire up to 0.050 [1.3]
0.094 Barrel Type Contacts	Beryllium Copper	Accepts wire up to 0.094 [2.4]

PART NUMBER
7429-01-A [†]
7332-04-A

*Contacts priced and sold in packages of 10. [†]Shown in photo. See the Accessories section for more information on all accessories.

Weldable

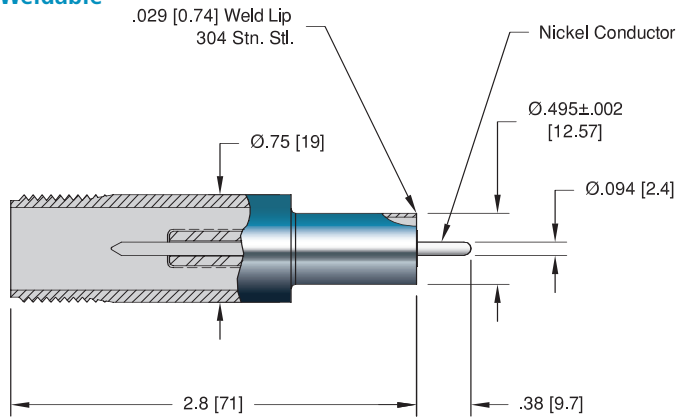

ConFlat - NW35CF

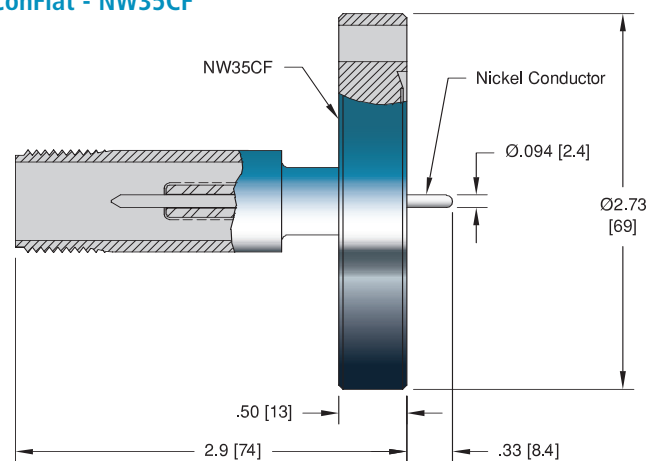

ISO KF

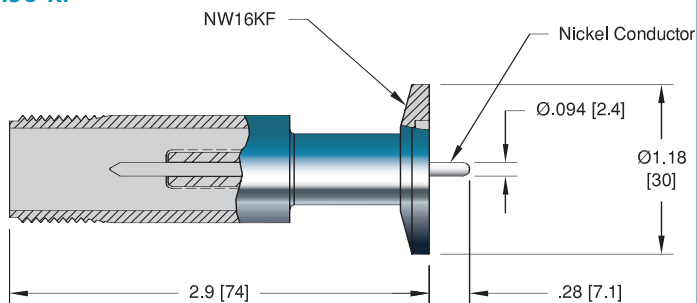

ConFlat - NW16CF

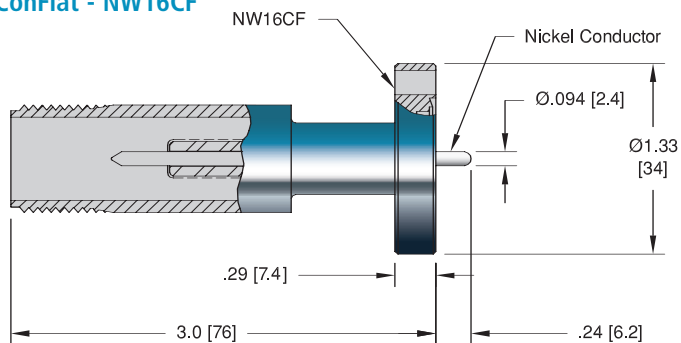

Specifications

Materials

Housing: 304 Stainless steel
Pin: Nickel
Insulation: Alumina ceramic
Magnetic Materials: Yes

Voltage Rating 7.5 kV DC

Current Rating 16.5 Amps

Temperature Range -269°C to 450°C, ISO KF -25°C to 205°C

Pressure @ 20°C See table

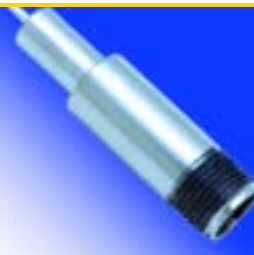

INSTALLATION	PRESSURE @ 20°C		PART NUMBER
	PSIG	BAR	
Weld	1600	110	7546-02-W

ISO FLANGE



NW16KF	-	-	18047-02-KF
--------	---	---	-------------

CONFLAT FLANGE



1 1/3" (NW16CF)	1600	110	7585-02-CF
2 3/4" (NW35CF)	1500	103	7584-02-CF



TYPE	VOLTAGE DC	CONDUCTOR AMPS	DIMENSIONS		DESCRIPTION	PART NUMBER
			H	L		
Air Side	7.5 kV	8	0.88 [22]	3.5 [88]	BSHV Plug	7604-01-A

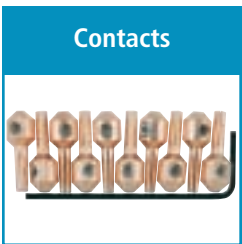

TYPE	MATERIAL	DESCRIPTION	PART NUMBER
0.094 Set Screw Type Contacts	Beryllium Copper	Accepts wire up to 0.050 [1.3]	7429-01-A†
0.094 Barrel Type Contacts	Beryllium Copper	Accepts wire up to 0.094 [2.4]	7332-04-A

*Contacts priced and sold in packages of 10. †Shown in photo. See the Accessories section for more information on all accessories.

SHV 10 KV - Exposed Weldable

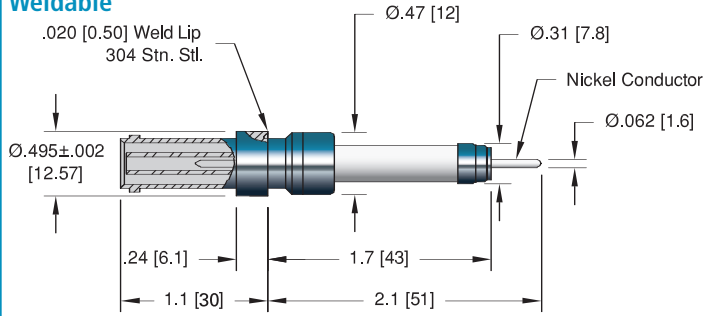

ISO KF - NW16KF

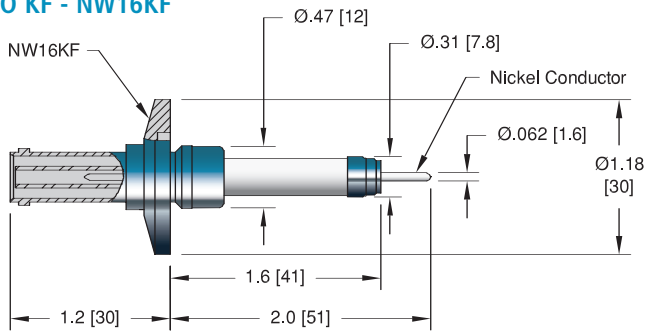

ConFlat - NW16CF

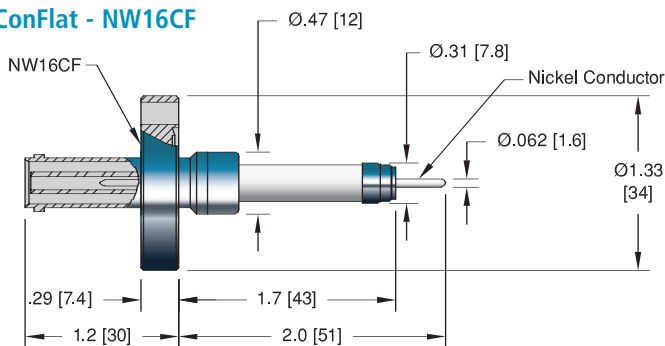

ISO KF

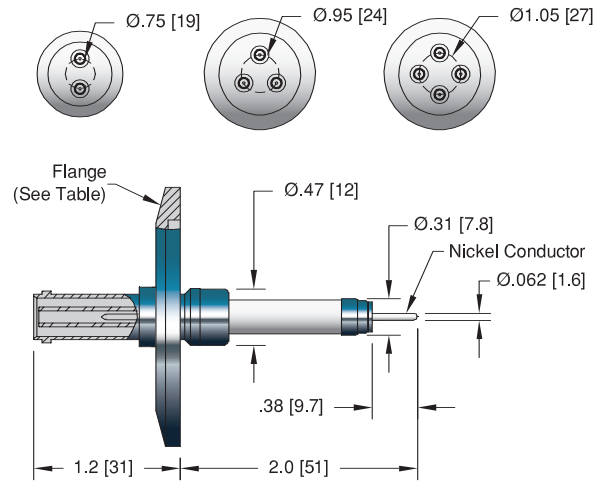

ConFlat

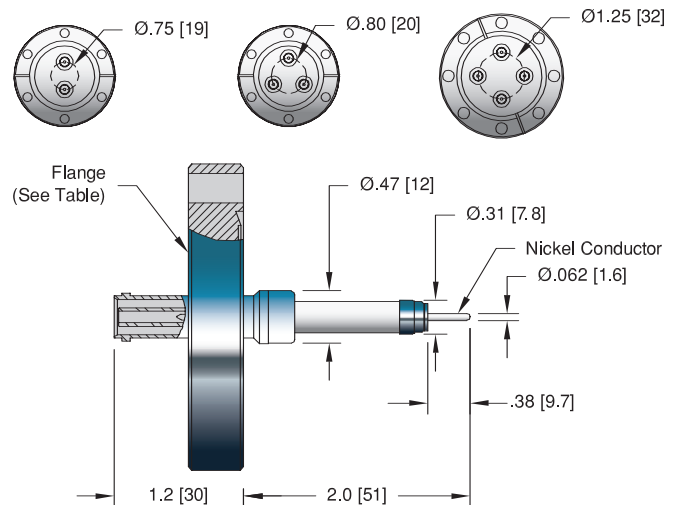

Specifications
Materials

- Housing: 304 Stainless steel
- Pin: Nickel
- Insulation: Alumina ceramic
- Magnetic Materials: Yes

Voltage Rating 10 kV DC

Current Rating 10 Amps

Temperature Range -269°C to 450°C, ISO KF -25°C to 205°C

Pressure @ 20°C 120 PSIG (8.3 Bar), ISO KF 0 PSIG



NO. PINS	INSTALLATION	PART NUMBER
1	Weld	17213-01-W



ISO FLANGE		
1	NW16KF	18043-01-KF
1	NW40KF	17215-07-KF
2	NW40KF	17215-01-KF
3	NW50KF	17215-03-KF
4	NW50KF	17215-05-KF



CONFLAT FLANGE		
1	1 1/3" (NW16CF)	17214-01-CF
1	2 3/4" (NW35CF)	17216-08-CF
2	2 3/4" (NW35CF)	17216-02-CF
3	2 3/4" (NW35CF)	17216-04-CF
4	3 3/8" (NW50CF)	17216-06-CF



TYPE	VOLTAGE DC	CONDUCTOR AMPS	DIMENSIONS		DESCRIPTION	PART NUMBER
			H	L		
Air Side	10 kV	10	0.56 [14]	1.8 [46]	SHV 10 kV Plug	8058-02



TYPE	MATERIAL	DESCRIPTION	PART NUMBER
0.062 Crimp Contacts	Nickel Alloy	Accepts wire up to 0.062 [1.6]	0821-01-A [†]
0.062 Crimp Contacts	Beryllium Copper	Accepts wire up to 0.062 [1.6]	2044-02-A
0.062 Barrel Type Contacts	Beryllium Copper	Accepts wire up to 0.062 [1.6]	7332-03-A
Crimp Tool		For 0.025" - 0.075" Diameters	2840-05

*Contacts priced and sold in packages of 10. [†]Shown in photo. See the Accessories section for more information on all accessories.

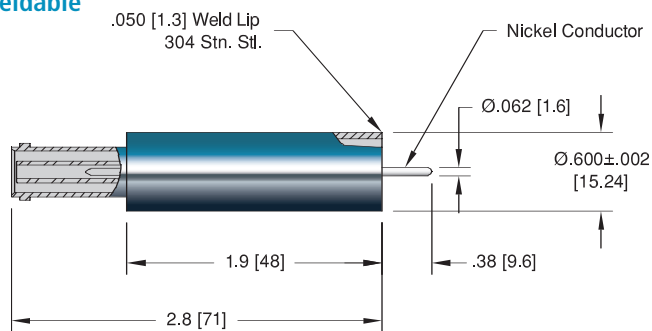
SHV 10 KV - Recessed Insulator
Weldable

ISO KF - NW16KF

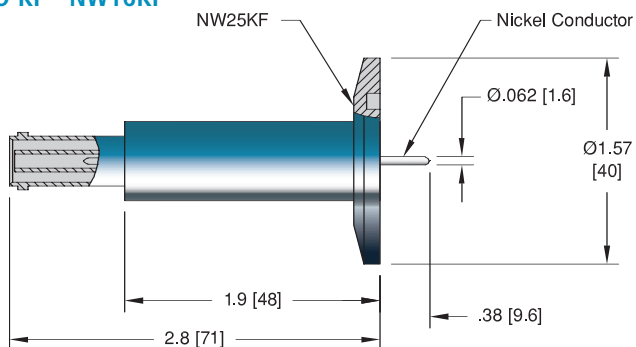

ConFlat - NW16CF

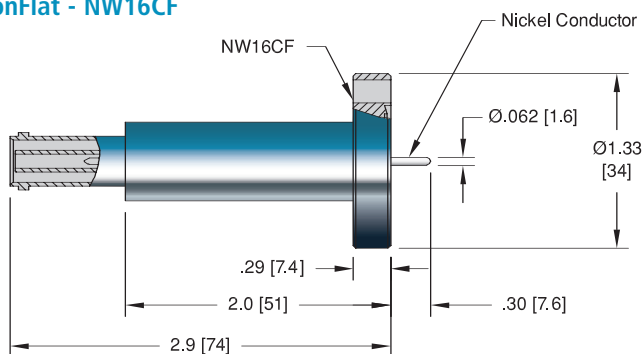

ISO KF

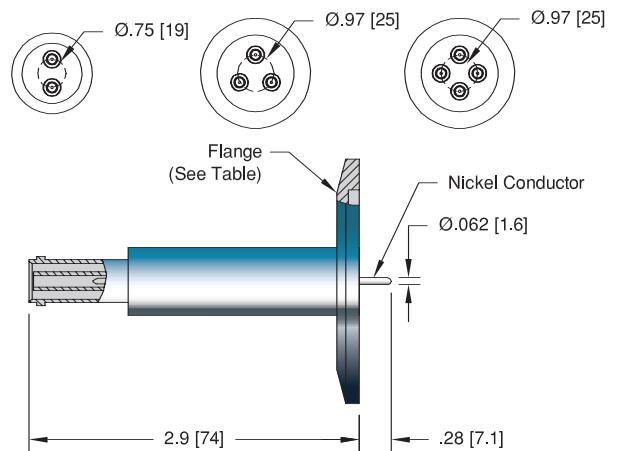

ConFlat

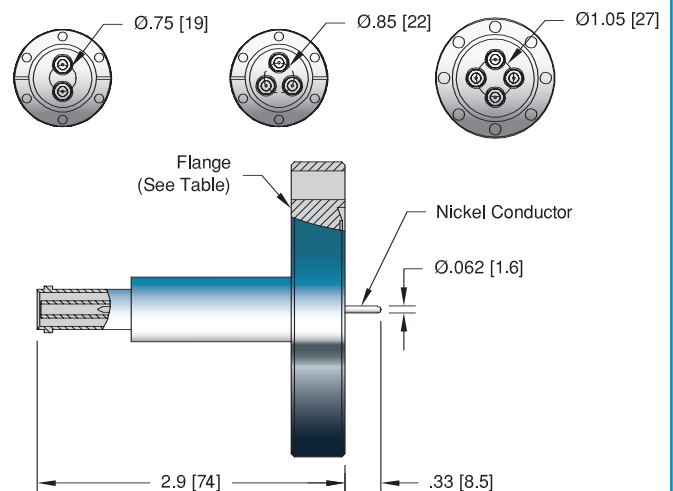
Specifications
Materials

Housing: 304 Stainless steel
Pin: Nickel
Insulation: Alumina ceramic
Magnetic Materials: Yes

Voltage Rating 10 kV DC

Current Rating 10 Amps

Temperature Range -269°C to 450°C, ISO KF -25°C to 205°C

Pressure @ 20°C 120 PSIG (8.3 Bar), ISO KF 0 PSIG



Weldable

NO. PINS	INSTALLATION	PART NUMBER
1	Weld	17217-01-W



ISO KF

ISO FLANGE		
1	NW25KF	17218-01-KF
1	NW40KF	18000-07-KF
2	NW40KF	18000-01-KF
3	NW50KF	18000-03-KF
4	NW50KF	18000-05-KF

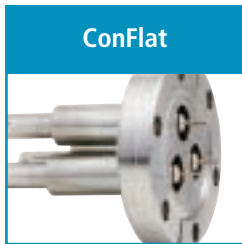

ConFlat

CONFLAT FLANGE		
1	1 1/3" (NW16CF)	17219-01-CF
1	2 3/4" (NW35CF)	18001-07-CF
2	2 3/4" (NW35CF)	18001-01-CF
3	2 3/4" (NW35CF)	18001-03-CF
4	3 3/8" (NW50CF)	18001-05-CF



Air Side Plug

TYPE	VOLTAGE DC	CONDUCTOR AMPS	DIMENSIONS		DESCRIPTION	PART NUMBER
			H	L		
Air Side	10 kV	10	0.56 [14]	1.8 [46]	SHV 10 kV Plug	8058-02



Contacts

TYPE	MATERIAL	DESCRIPTION	PART NUMBER
0.062 Crimp Contacts	Nickel Alloy	Accepts wire up to 0.062 [1.6]	0821-01-A [†]
0.062 Crimp Contacts	Beryllium Copper	Accepts wire up to 0.062 [1.6]	2044-02-A
0.062 Barrel Type Contacts	Beryllium Copper	Accepts wire up to 0.062 [1.6]	7332-03-A
Crimp Tool		For 0.025" - 0.075" Diameters	2840-05

*Contacts priced and sold in packages of 10. [†]Shown in photo. See the Accessories section for more information on all accessories.

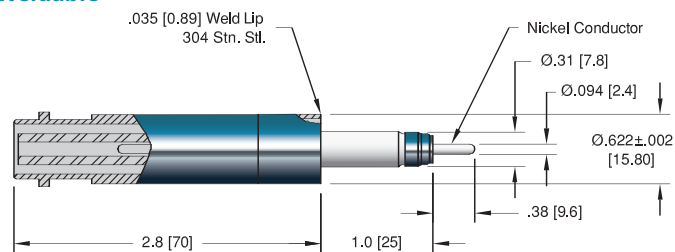
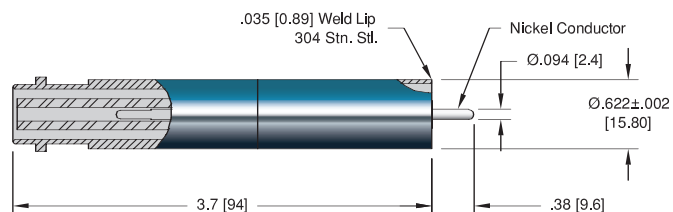
SHV 20 KV - Exposed Insulator
WeldableSHV 20 KV - Recessed Insulator
Weldable

ISO KF

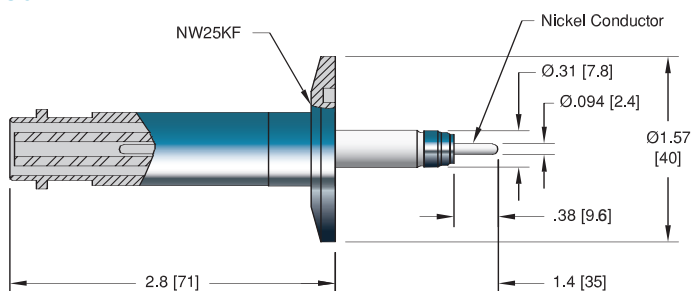

ISO KF

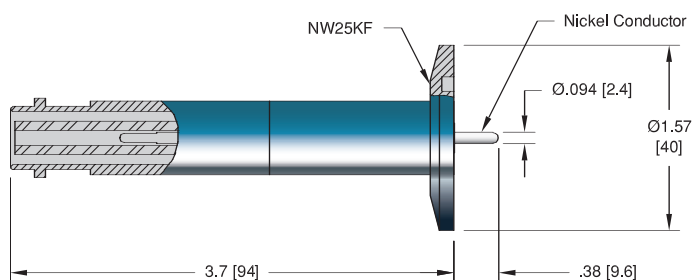

ConFlat

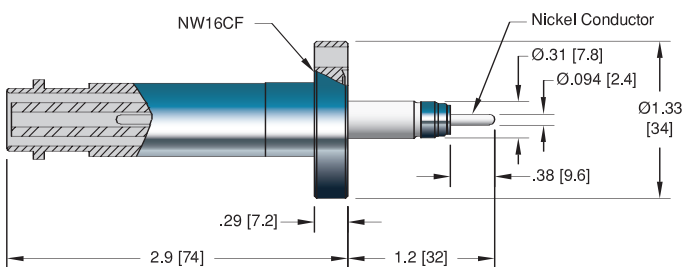

ConFlat

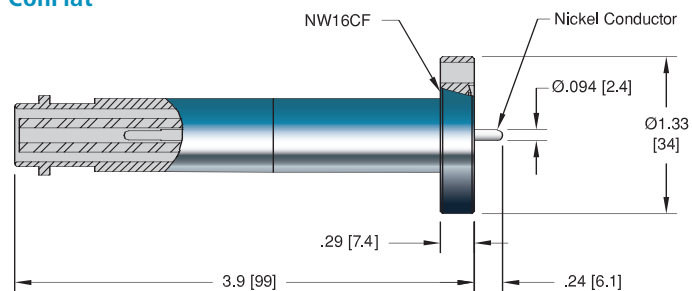

Specifications

Materials

Housing: 304 Stainless steel
Pin: Nickel
Insulation: Alumina ceramic
Magnetic Materials: Yes

Voltage Rating 20 kV DC

Current Rating 16.5 Amps

Temperature Range -269°C to 450°C, ISO KF -25°C to 205°C

Pressure @ 20°C 250 PSIG (17 Bar), ISO KF 0 PSIG



STYLE	INSTALLATION	PART NUMBER
Exposed Insulator	Weld	18086-01-W
Recessed Insulator	Weld	18089-01-W [†]



ISO FLANGE		
STYLE	INSTALLATION	PART NUMBER
Exposed Insulator	NW25KF	18087-01-KF [†]
Recessed Insulator	NW25KF	18090-01-KF

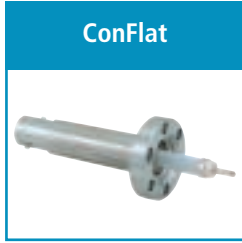

CONFLAT FLANGE		
STYLE	INSTALLATION	PART NUMBER
Exposed Insulator	1 1/3" (NW16CF)	18088-01-CF [†]
Recessed Insulator	1 1/3" (NW16CF)	18091-01-CF



TYPE	VOLTAGE DC	CONDUCTOR AMPS	DIMENSIONS		DESCRIPTION	PART NUMBER
			H	L		
Air Side	20 kV	20	0.75 [19]	4.5 [115]	SHV 20 kV Plug	8208-02

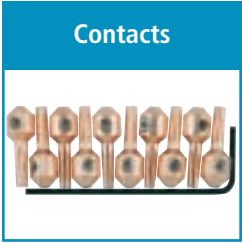

TYPE	MATERIAL	DESCRIPTION	PART NUMBER
0.094 Set Screw Type Contacts	Beryllium Copper	Accepts wire up to 0.050 [1.3]	7429-01-A [†]
0.094 Barrel Type Contacts	Beryllium Copper	Accepts wire up to 0.094 [2.4]	7332-04-A

*Contacts priced and sold in packages of 10. [†]Shown in photo. See the Accessories section for more information on all accessories.



Specifications

Materials

Housing: 304 Stainless steel
 Pin: Inconel X-750
 Contacts: 300 Series Stainless steel
 Insulation: Glass-ceramic
 Magnetic Materials: No

Voltage Rating 1.5 kV DC

Current Rating 1 Amp

Temperature Range -269°C to 350°C, ISO KF -25°C to 205°C

Pressure @ 20°C 1400 PSIG (97 Bar), ISO KF 0 PSIG

Weldable

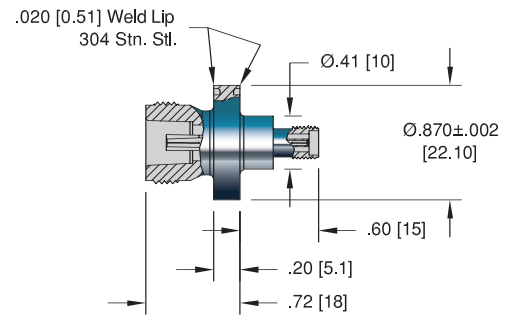

ISO KF

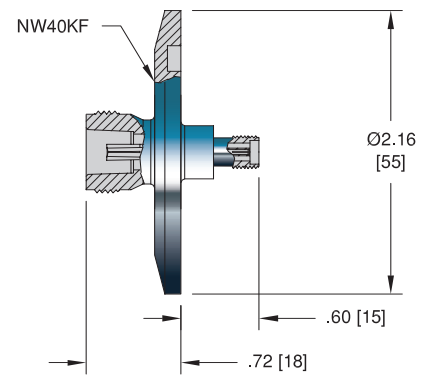

ConFlat

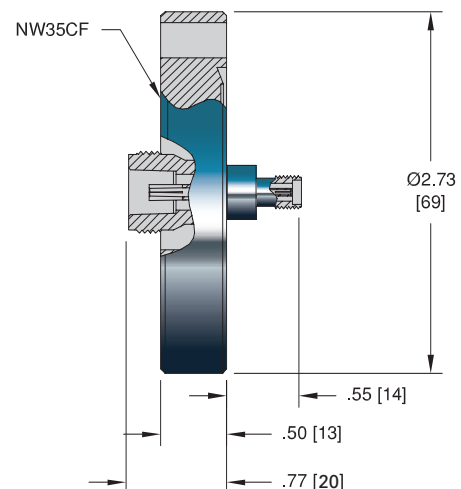



Weldable

INSTALLATION
Weld

PART NUMBER
15025-02-W



ISO KF

ISO FLANGE
NW40KF

PART NUMBER
18083-02-KF



ConFlat

CONFLAT FLANGE
2 3/4" (NW35CF)

PART NUMBER
18084-02-CF



Air Side Plug

TYPE	VOLTAGE DC	CONDUCTOR AMPS	DIMENSIONS		DESCRIPTION
			H	L	
Air Side	1.5 kV	5	0.81 [20]	1.5 [38]	Type N Plug

PART NUMBER
7707-01



Air Side Cable Assembly

TYPE	LENGTH	VOLTAGE DC	CONDUCTOR AMPS	TEMPERATURE	
				MIN	MAX
50 Ohm Type N – Double Ended	10'	1.5 kV	5	-55	85

PART NUMBER
21619-01-A

See the Accessories section for more information on all accessories.

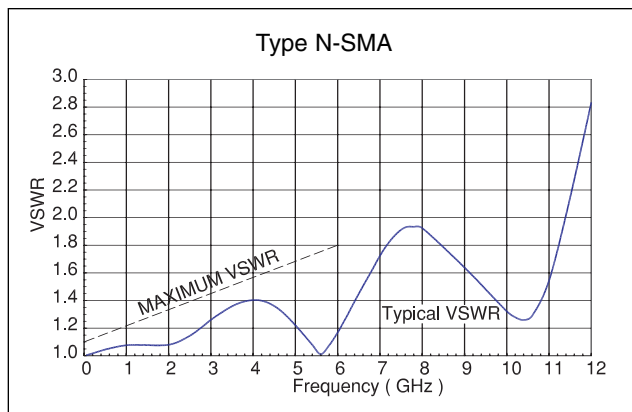

Weldable

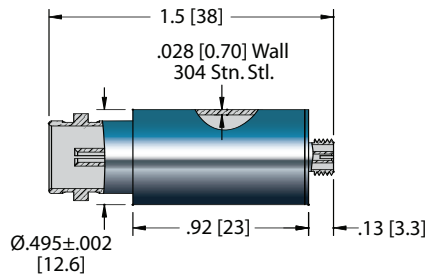

ISO KF - NW16KF

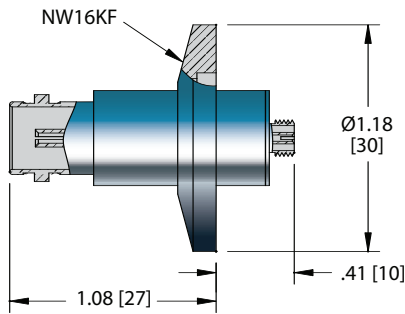

ConFlat - NW16CF

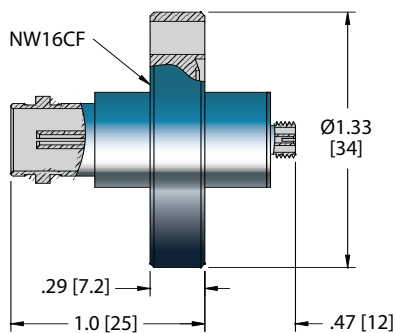

ISO KF - NW40KF

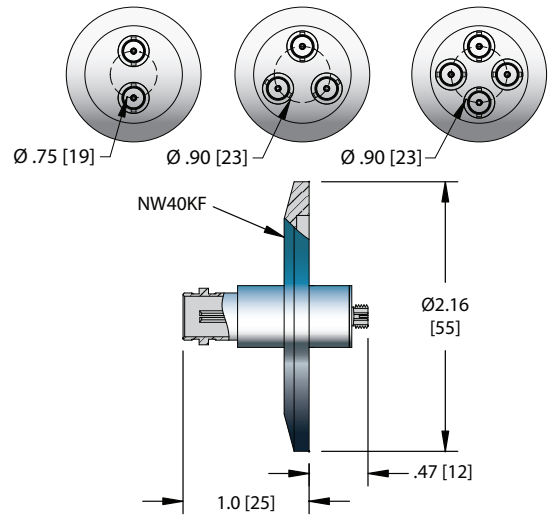

ConFlat - NW35CF

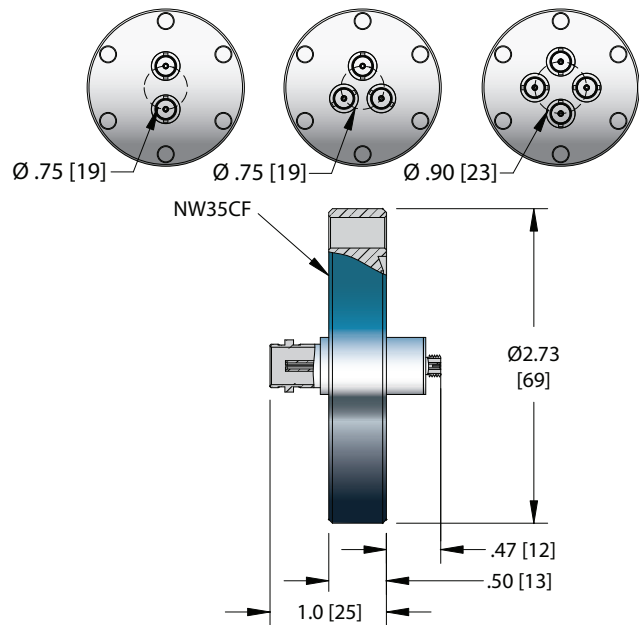

Specifications

Materials

- Housing: 304 Stainless steel
- Pin: 330 Stainless steel
- Insulation: Glass-ceramic
- Magnetic Materials: No

Voltage Rating 500 V DC

Current Rating 5 Amps

Temperature Range -269°C to 450°C, ISO KF -25°C to 205°C

Pressure @ 20°C 1400 PSIG (97 Bar), ISO KF 0 PSIG



Weldable

NO. PINS	INSTALLATION	PART NUMBER
1	Weld	21254-01-W



ISO KF

ISO FLANGE		
1	NW16KF	21256-01-KF
1	NW40KF	21292-01-KF
2	NW40KF	21261-01-KF
3	NW40KF	21262-01-KF
4	NW40KF	21263-01-KF



ConFlat

CONFLAT FLANGE		
1	1 1/3" (NW16CF)	21255-01-CF
1	2 3/4" (NW35CF)	21291-01-CF
2	2 3/4" (NW35CF)	21257-01-CF
3	2 3/4" (NW35CF)	21258-01-CF
4	2 3/4" (NW35CF)	21259-01-CF



Air Side Plug

TYPE	DIMENSIONS		DESCRIPTION	PART NUMBER
	H	L		
Air Side	0.56 [14]	1.1 [27]	BNC Plug	7116-02



Air Side Cable Assembly

TYPE	LENGTH	VOLTAGE DC	CONDUCTOR AMPS	TEMPERATURE		PART NUMBER
				MIN	MAX	
50 Ohm BNC – Double Ended	10'	500 V	5	-40	85	18921-01-A



Vacuum Side Cable Assemblies

TYPE	LENGTH	VOLTAGE DC	CONDUCTOR AMPS	TEMPERATURE		PART NUMBER
				MIN	MAX	
Microdot Vacuum Side – Double Ended	12"	500 V	2	-65°C	125°C	15767-12-A
Microdot Vacuum Side – Double Ended	24"	500 V	2	-65°C	125°C	15767-24-A
Microdot Vacuum Side – Double Ended	36"	500 V	2	-65°C	125°C	15767-36-A†

†Shown in photo. See the Accessories section for more information on all accessories.

Thermocouple

SEMICONDUCTOR | ANALYTICAL EQUIPMENT | AEROSPACE | TELECOMMUNICATIONS



OIL EXPLORATION | R&D | HIGH ENERGY PHYSICS | MILITARY/DEFENSE | BIOTECHNOLOGY



*Advanced Ceramic-to-Metal &
Glass-Ceramic Sealing Technology*

Description

Thermocouples are widely used to measure the temperature inside a vacuum or pressure chamber. CeramTec's thermocouple feedthroughs, manufactured with thermocouple materials or compensating material, transmit through the wall of the chamber the electromotive force (emf) generated by the application of heat to the thermocouple bead without introducing error. External instrumentation can then evaluate the strength of the emf that is proportional to the temperature at the thermocouple bead, thus yielding a temperature measurement. The Ceramaseal® thermocouple feedthroughs provide the necessary electrical isolation and a hermetic seal.

For refractory and noble metal thermocouples, Ceramaseal® products use compensating wires. The junction between the compensating wires and the true thermocouple conductor material must be thermally shielded and not exceed 250°C. A Thermocouple Application Chart is shown on the next page.

Standard Specifications

- Temperature Range: Cryogenic (-269°C) to 450°C
- Internal pressure from 10⁻¹⁰ torr to 3500 psig
- Thermocouple Type C, K, R, S, T
- Single to 10 pairs

Extreme / Custom Design

- 940-pin feedthrough using thermocouple materials
- Sub D connectors using thermocouple materials
- Single pair high-temperature cable end seal in a special plug design
- Type E, J and N thermocouples



Installation

Standard installation mountings include:

- Weld (Pulse-TIG, TIG, Laser, E-Beam)
- ISO KF flange
- ConFlat flange
- NPT fitting (see Pressure section)

For details and information on thermocouple assembly installation, refer to the Technical Reference section.

Applications

A few of the many applications in which these thermocouples are commonly used are:





- Furnaces
- Power generation measurement and control
- Aerospace equipment
- In-vacuum coating
- Semiconductor processing equipment
- Energy research
- Industrial equipment
- Telecommunications

New Products

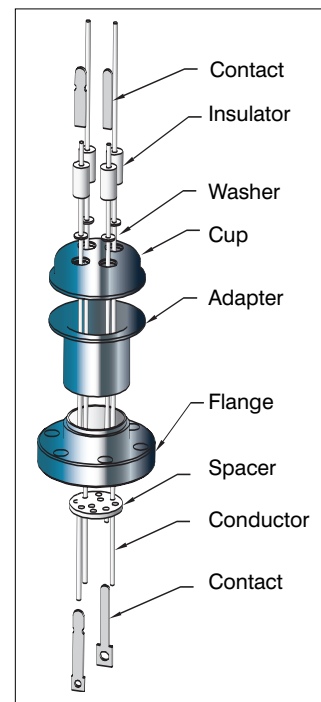
- Multipin spade type thermocouples
- Single conductor thermocouples in spade and loop type
- Thermocouples now available in ISO KF flanges

Typical Thermocouple Construction



Type	Voltage DC	Temperature Rating °C		Number of Pairs	Thermocouple Types	Sub-section	Section Pages
		Min	Max				
	NA	Thermocouple:	-269 450	Single, 1, 2	R, S, T (see table below)	Loop Type	D.1 142-143
	NA	Thermocouple: Air Side Plug:	-269 450 -73 650	Single, 1, 2, 3, 5	C, K (see table below)	Spade Type	D.2 144-147
	to 5 kV	Thermocouple: Air Side Plug:	-269 450 -73 650	1 Pair, 2 Conductors	C, K (see table below)	Spade & Power	D.3 148-149
	NA	Thermocouple: Air Side Plug:	-269 450 -55 125	3, 5, 10	K (see table below)	MIL-C-5015 Type	D.4 150-151

THERMOCOUPLE APPLICATION CHART

ANSI Type	Thermocouple	Polarity	Degrees C	emf (mV)
T	Copper Constantan	+ -	-200 to 350	-5.60 to 17.82
K	Chromel Alumel	+ -	-200 to 1250	-5.9 to 50.63
S	Platinum 10% Rhodium Platinum	+ -	0 to 1450	0 to 14.97
R	Platinum 13% Rhodium Platinum	+ -	0 to 1450	0 to 16.74
C*	Tungsten 5% Rhenium Tungsten 26% Rhenium	+ -	0 to 2315	0 to 37.06

*Not an ANSI symbol

THERMOCOUPLE



Single Conductor – Weldable

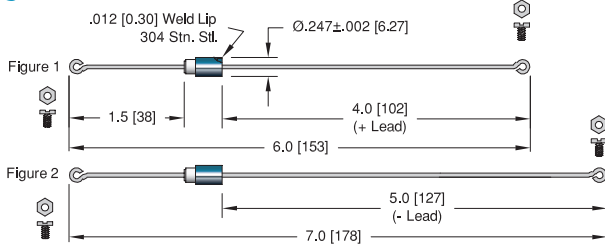

Single Pair – Weldable

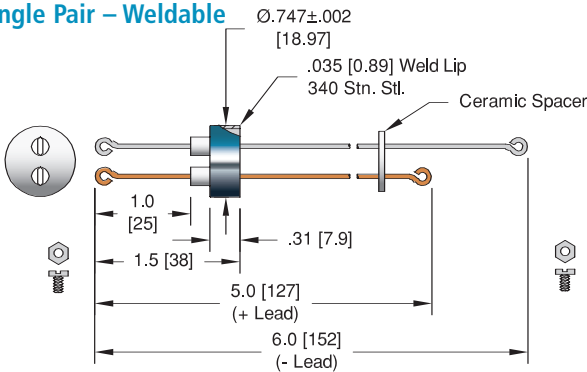

Single Pair – ISO KF - NW16KF

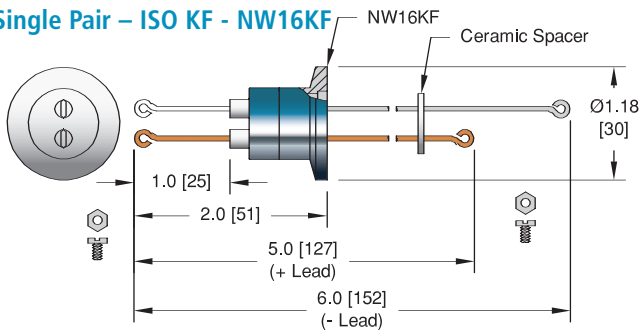

Single Pair – ConFlat - NW16CF

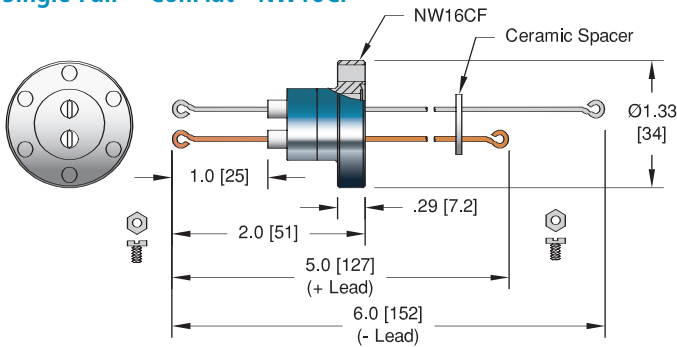

Single Pair – ConFlat - NW35CF

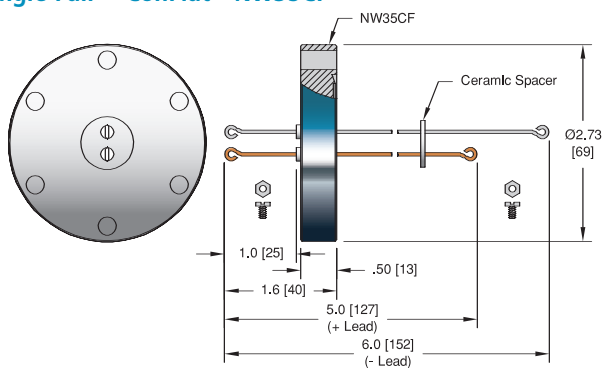

Two Pairs – Weldable

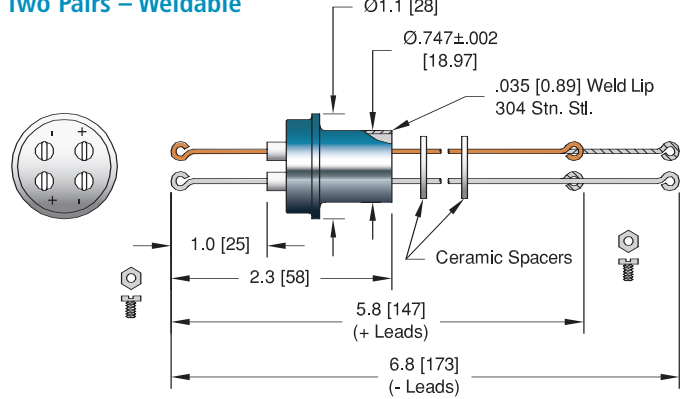

Two Pairs – ISO KF - NW16KF

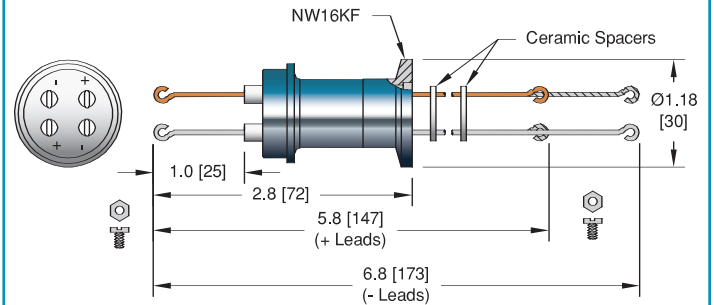

Two Pairs – ConFlat - NW16CF

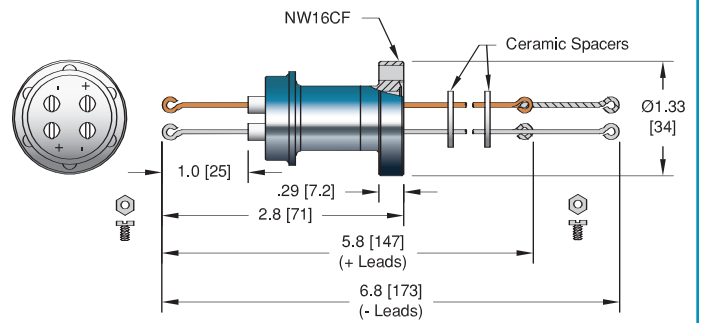

Two Pairs – ConFlat - NW35CF

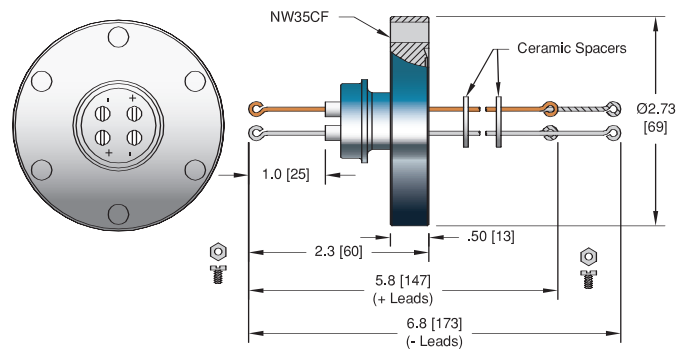



THERMOCOUPLE MATERIAL	FIGURE NUMBER	INSTALLATION	PART NUMBER
Copper	1	Weld	18085-13-W
Constantan	2	Weld	18085-14-W
Platinum-Rhodium*	2	Weld	18085-15-W

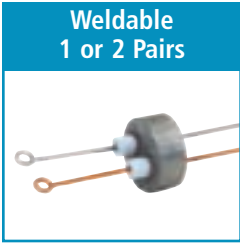

ANSI TYPE	THERMOCOUPLE MATERIALS	INSTALLATION	NO. OF PAIRS	PART NUMBER
T	Copper/Constantan	Weld	1	8900-02-W
R/S	Platinum-Rhodium*	Weld	1	8900-03-W
T	Copper/Constantan	Weld	2	8800-02-W
R/S	Platinum-Rhodium*	Weld	2	8800-03-W



ISO FLANGE

T	Copper/Constantan	NW16KF	1	18004-01-KF
R/S	Platinum-Rhodium*	NW16KF	1	18004-02-KF
T	Copper/Constantan	NW16KF	2	15108-01-KF
R/S	Platinum-Rhodium*	NW16KF	2	15108-02-KF

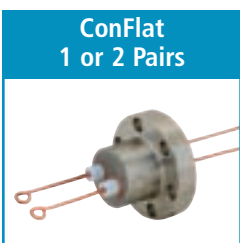

CONFLAT FLANGE

T	Copper/Constantan	1 1/3" (NW16CF)	1	9020-02-CF
R/S	Platinum-Rhodium*	1 1/3" (NW16CF)	1	9020-03-CF
T	Copper/Constantan	2 3/4" (NW35CF)	1	9806-02-CF
R/S	Platinum-Rhodium*	2 3/4" (NW35CF)	1	9806-01-CF
T	Copper/Constantan	1 1/3" (NW16CF)	2	8820-02-CF
R/S	Platinum-Rhodium*	1 1/3" (NW16CF)	2	8820-03-CF
T	Copper/Constantan	2 3/4" (NW35CF)	2	10584-02-CF
R/S	Platinum-Rhodium*	2 3/4" (NW35CF)	2	10584-03-CF

*Uses compensating wire. Maximum junction temperature 250° C.

Specifications - Single Conductor

Materials

Shell: 304 Stainless steel
 Thermocouple materials:
 Copper
 Constantan
 Platinum-Rhodium
 Insulation: Alumina ceramic
 Magnetic Materials: No

Temperature Range -269°C to 450°C

Pressure @ 20°C 3500 PSIG (241 Bar), ISO KF 0 PSIG

Specifications - 1 or 2 Pairs

Materials

Shell: 304 Stainless steel
 Thermocouple materials:
 Copper/Constantan (Type T)
 Platinum-Rhodium (Type R/S)
 Insulation: Alumina ceramic
 Magnetic Materials: No

Temperature Range -269°C to 450°C

Pressure @ 20°C ISO KF 0 PSIG

1 Pair: 1250 PSIG (86 Bar)
 2 Pairs: 800 PSIG (55 Bar)

THERMOCOUPLE

Single Conductor – Weldable

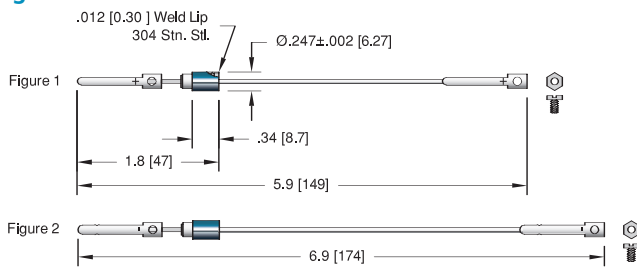

Single Pair – Weldable

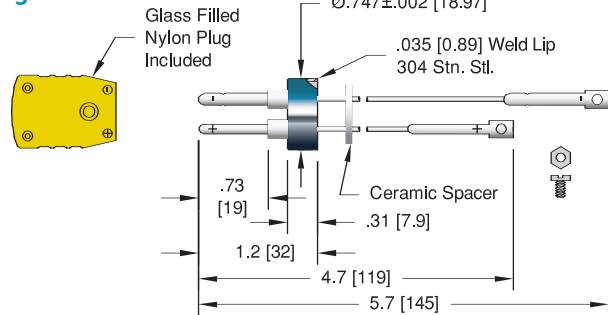

Single Pair – ISO KF - NW16KF

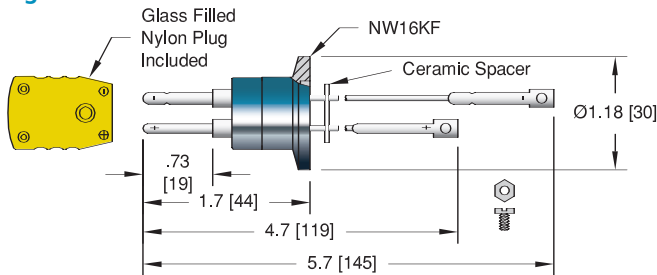

Single Pair – ConFlat - NW16CF

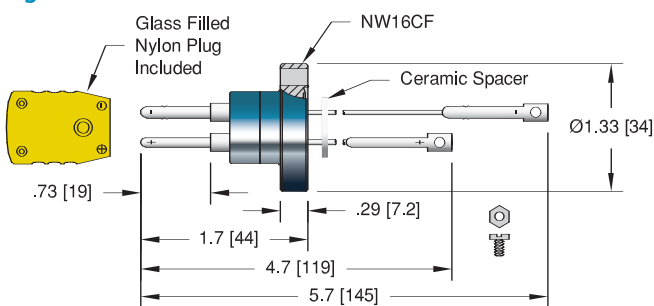

Single Pair – ConFlat - NW35CF

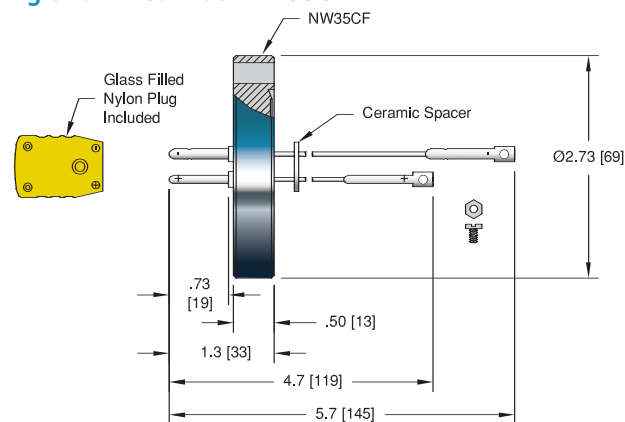

Single Conductor – Weldable

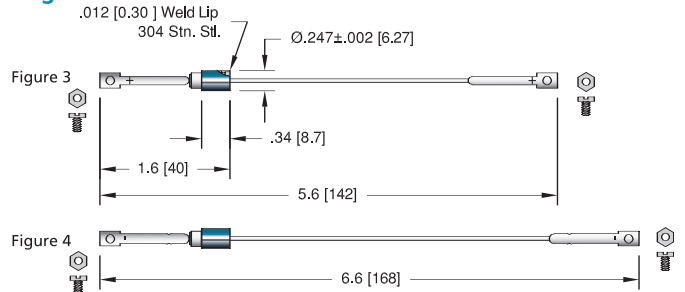

Two Pairs – Weldable

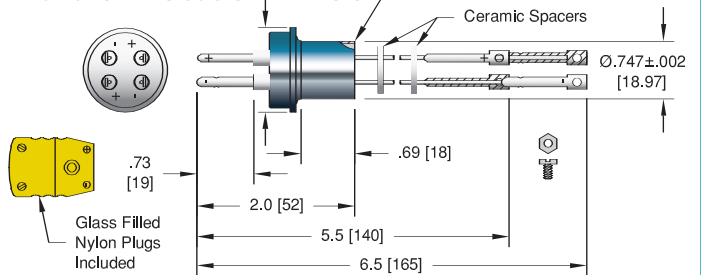

Two Pairs – ISO KF - NW16KF

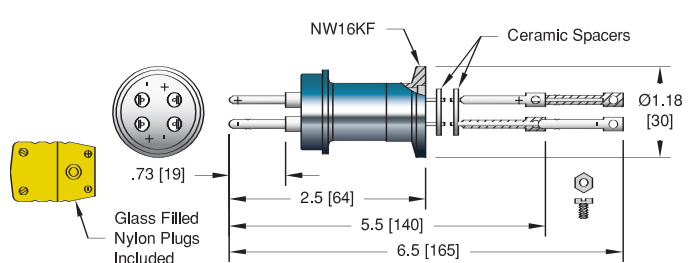

Two Pairs – ConFlat - NW16CF

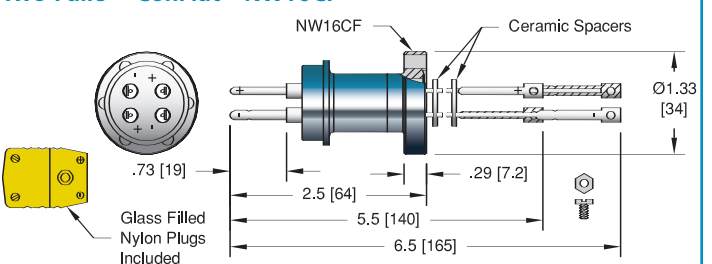

Two Pairs – ConFlat - NW35CF

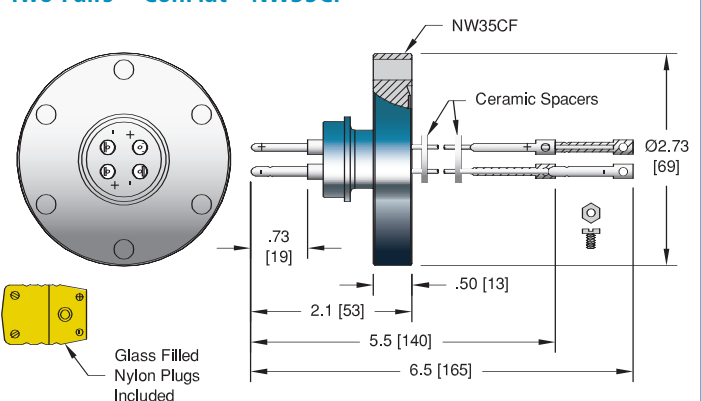

THERMOCOUPLE



THERMOCOUPLE MATERIALS	FIGURE NUMBER	INSTALLATION	PART NUMBER
Chromel	1	Weld	18085-02-W
Alumel	2	Weld	18085-06-W
Chromel	3	Weld	18085-08-W
Alumel	4	Weld	18085-12-W

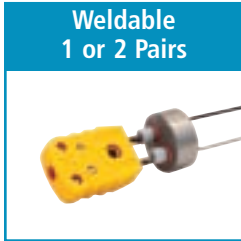

ANSI TYPE	THERMOCOUPLE MATERIALS	INSTALLATION	NO. OF PAIRS	PART NUMBER
K	Chromel/Alumel	Weld	1	8117-01-W
C	Tungsten-Rhenium*	Weld	1	8117-04-W
K	Chromel/Alumel	Weld	2	8233-01-W
C	Tungsten-Rhenium*	Weld	2	8233-04-W



ISO FLANGE				
ANSI TYPE	THERMOCOUPLE MATERIALS	INSTALLATION	NO. OF PAIRS	PART NUMBER
K	Chromel/Alumel	NW16KF	1	13563-01-KF
C	Tungsten-Rhenium*	NW16KF	1	13563-04-KF
K	Chromel/Alumel	NW16KF	2	18003-01-KF
C	Tungsten-Rhenium*	NW16KF	2	18003-03-KF

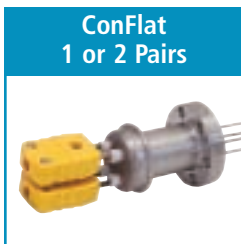

CONFLAT FLANGE				
ANSI TYPE	THERMOCOUPLE MATERIALS	INSTALLATION	NO. OF PAIRS	PART NUMBER
K	Chromel/Alumel	1 1/3" (NW16CF)	1	8118-01-CF
C	Tungsten-Rhenium*	1 1/3" (NW16CF)	1	8118-04-CF
K	Chromel/Alumel	2 3/4" (NW35CF)	1	10583-01-CF
C	Tungsten-Rhenium*	2 3/4" (NW35CF)	1	10583-03-CF
K	Chromel/Alumel	1 1/3" (NW16CF)	2	8232-01-CF
C	Tungsten-Rhenium*	1 1/3" (NW16CF)	2	8232-04-CF
K	Chromel/Alumel	2 3/4" (NW35CF)	2	8593-01-CF
C	Tungsten-Rhenium*	2 3/4" (NW35CF)	2	8593-04-CF



ANSI TYPE	THERMOCOUPLE MATERIALS	TYPE	MATERIALS	TEMPERATURE °C MIN MAX	COLOR CODE	PART NUMBER
K	Chromel/Alumel	Standard	Glass Filled Nylon	-29 218	Yellow	08151-01
K	Chromel/Alumel	High Temp	Ceramic	-73 650	Yellow	08151-09
C	Tungsten-Rhenium	Standard	Glass Filled Nylon	-29 218	Red	08151-04
C	Tungsten-Rhenium	High Temp	Ceramic	-73 250	Red	08151-07

*Uses compensating wire. Maximum junction temperature 250° C. See the Accessories section for more information on all accessories.

Specifications - Single Conductor

Materials

Shell: 304 Stainless steel
 Thermocouple materials:
 Chromel
 Alumel
 Insulation: Alumina ceramic
 Magnetic Materials:
 Chromel: No
 Alumel: Yes

Temperature Range -269°C to 450°C

Pressure @ 20°C 3500 PSIG (241 Bar), ISO KF 0 PSIG

Specifications - 1 or 2 Pairs

Materials

Shell: 304 Stainless steel
 Thermocouple materials:
 Chromel/Alumel (Type K)
 Tungsten-Rhenium (Type C)
 Insulation: Alumina ceramic
 Magnetic Materials: Yes

Temperature Range -269°C to 450°C

Pressure @ 20°C ISO KF 0 PSIG

1 Pair: 1250 PSIG (86 Bar)
 2 Pairs: 800 PSIG (55 Bar)

THERMOCOUPLE

Weldable

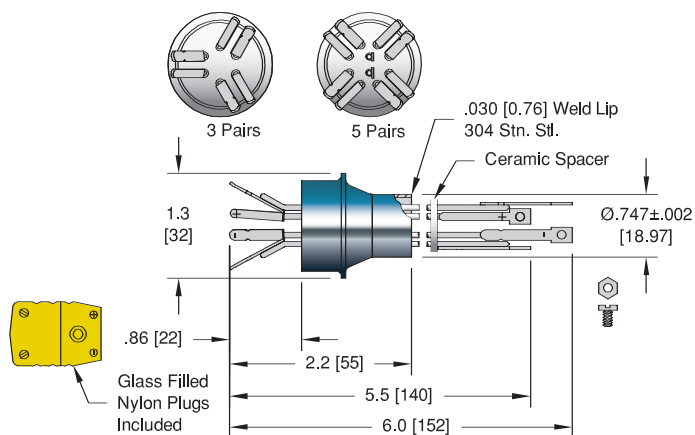

ISO KF

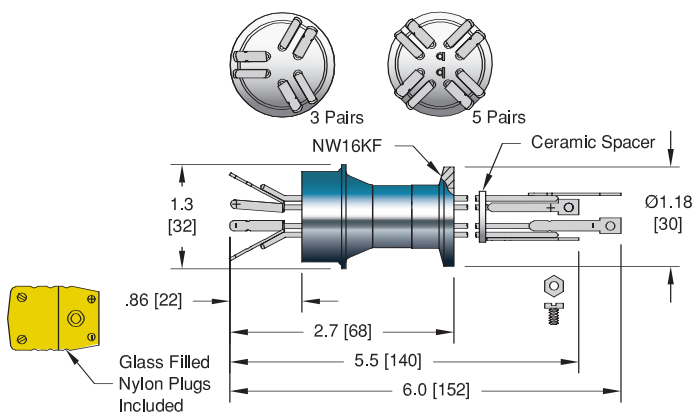

ConFlat – NW16CF

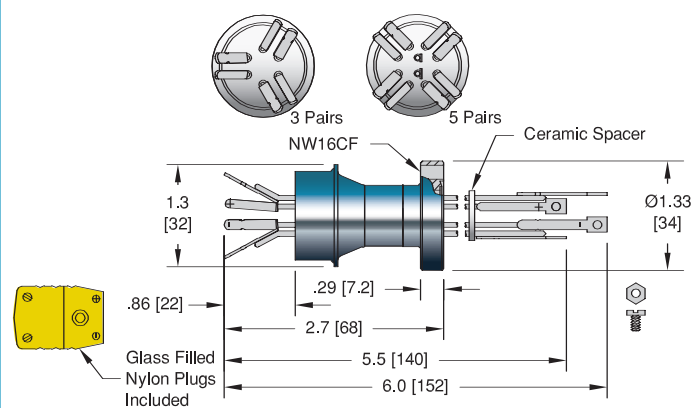

ConFlat – NW35CF

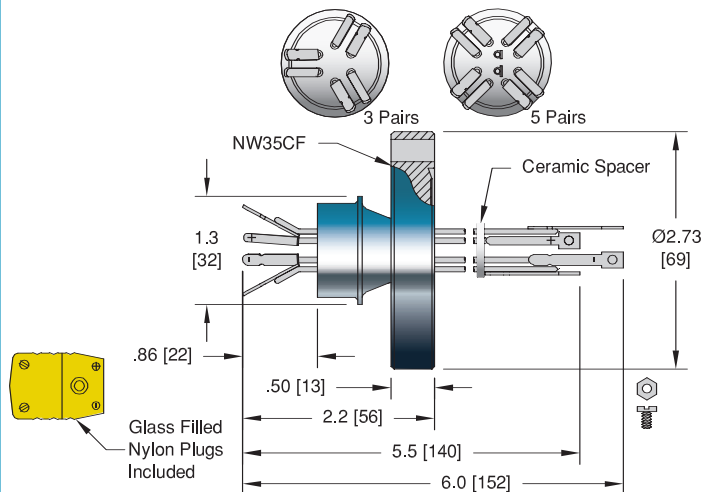

Specifications

Materials

Shell: 304 Stainless steel

Thermocouple materials:

Chromel/Alumel (Type K)

Insulation: Alumina ceramic

Magnetic Materials: Yes

Temperature Range -269°C to 450°C

Pressure @ 20°C ISO KF 0 PSIG

3 Pairs: 400 PSIG (28 Bar)

5 Pairs: 350 PSIG (24 Bar)

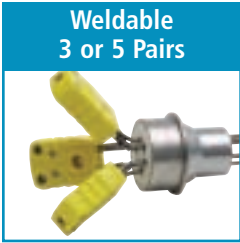

ANSI TYPE	THERMOCOUPLE MATERIALS	INSTALLATION	NO. OF PAIRS	PART NUMBER
K	Chromel/Alumel	Weld	3	18618-01-W
K	Chromel/Alumel	Weld	5	18619-01-W



ISO FLANGE				
ANSI TYPE	THERMOCOUPLE MATERIALS	INSTALLATION	NO. OF PAIRS	PART NUMBER
K	Chromel/Alumel	NW16KF	3	18618-02-KF
K	Chromel/Alumel	NW16KF	5	18619-02-KF

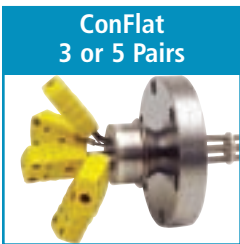

CONFLAT FLANGE				
ANSI TYPE	THERMOCOUPLE MATERIALS	INSTALLATION	NO. OF PAIRS	PART NUMBER
K	Chromel/Alumel	1 1/3" (NW16KF)	3	18618-03-CF
K	Chromel/Alumel	1 1/3" (NW16KF)	5	18619-03-CF
K	Chromel/Alumel	2 3/4" (NW35CF)	3	18618-04-CF
K	Chromel/Alumel	2 3/4" (NW35CF)	5	18619-04-CF



ANSI TYPE	THERMOCOUPLE MATERIALS	TYPE	MATERIALS	TEMPERATURE °C MIN	TEMPERATURE °C MAX	COLOR CODE	PART NUMBER
K	Chromel/Alumel	Standard	Glass Filled Nylon	-29	218	Yellow	08151-01
K	Chromel/Alumel	High Temp	Ceramic	-73	650	Yellow	08151-09

See the Accessories section for more information on all accessories.

THERMOCOUPLE





THERMOCOUPLE

Specifications

Materials

- Shell: 304 Stainless steel
- Thermocouple materials:
 - Chromel/Alumel (Type K)
 - Tungsten-Rhenium (Type C)
- Pins: Nickel or Copper
- Insulation: Alumina ceramic
- Magnetic Materials: Yes

Voltage Rating 5 kV DC

Current Rating See table

Temperature Range -269°C to 450°C

Pressure @ 20°C 500 PSIG (34 Bar), ISO KF 0 PSIG

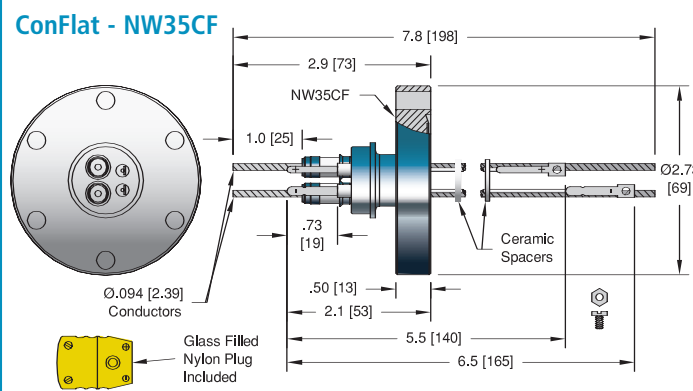
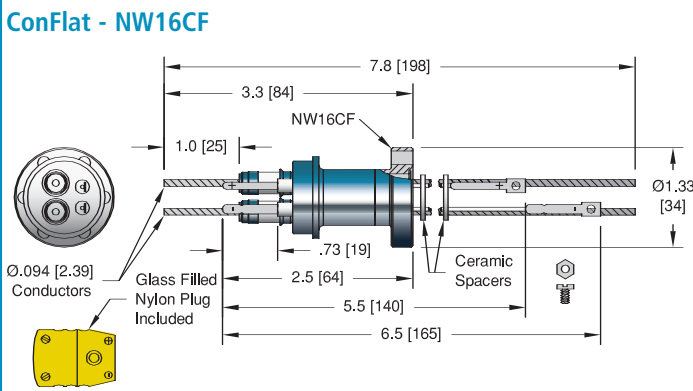
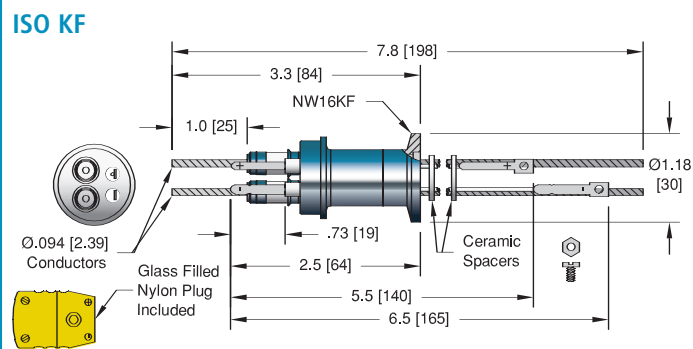
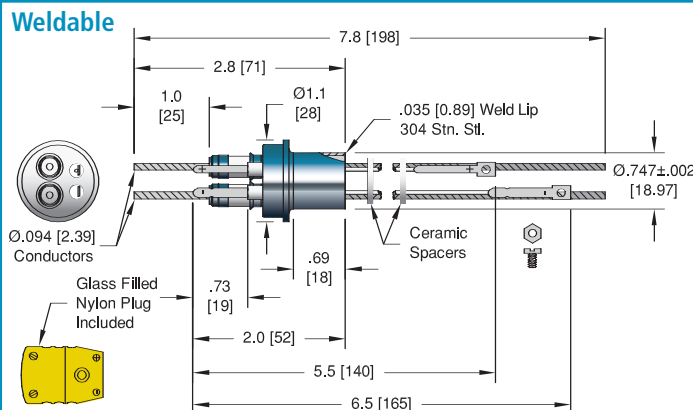



Weldable

ANSI TYPE	THERMOCOUPLE MATERIALS	INSTALLATION	CONDUCTOR AMPS	CONDUCTOR MATERIAL	PART NUMBER
K	Chromel/Alumel	Weld	16.5	Nickel	3181-02-W
K	Chromel/Alumel	Weld	55	Copper	3181-01-W
C	Tungsten-Rhenium**	Weld	16.5	Nickel	0572-02-W
C	Tungsten-Rhenium**	Weld	55	Copper	0572-01-W

ISO FLANGE



ISO KF

K	Chromel/Alumel	NW16KF	16.5	Nickel	18007-01-KF
K	Chromel/Alumel	NW16KF	55	Copper	18007-02-KF
C	Tungsten-Rhenium**	NW16KF	16.5	Nickel	18007-05-KF
C	Tungsten-Rhenium**	NW16KF	55	Copper	18007-06-KF

CONFLAT FLANGE

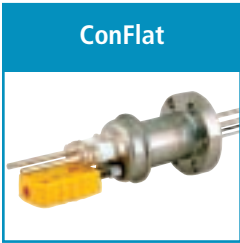

ConFlat

K	Chromel/Alumel	1 1/3" (NW16KF)	16.5	Nickel	8878-07-CF
K	Chromel/Alumel	1 1/3" (NW16KF)	55	Copper	8878-01-CF
C	Tungsten-Rhenium**	1 1/3" (NW16KF)	16.5	Nickel	8878-06-CF
C	Tungsten-Rhenium**	1 1/3" (NW16KF)	55	Copper	8878-02-CF
K	Chromel/Alumel	2 3/4" (NW35CF)	16.5	Nickel	10586-06-CF
K	Chromel/Alumel	2 3/4" (NW35CF)	55	Copper	10586-01-CF
C	Tungsten-Rhenium**	2 3/4" (NW35CF)	16.5	Nickel	10586-08-CF
C	Tungsten-Rhenium**	2 3/4" (NW35CF)	55	Copper	10586-02-CF



Air Side Plug

ANSI TYPE	THERMOCOUPLE MATERIALS	TYPE	MATERIALS	TEMPERATURE °C MIN	TEMPERATURE °C MAX	COLOR CODE	PART NUMBER
K	Chromel/Alumel	Standard	Glass Filled Nylon	-29	218	Yellow	08151-01
K	Chromel/Alumel	High Temp	Ceramic	-73	650	Yellow	08151-09
C	Tungsten-Rhenium**	Standard	Glass Filled Nylon	-29	218	Red	08151-04
C	Tungsten-Rhenium**	High Temp	Ceramic	-73	250	Red	08151-07

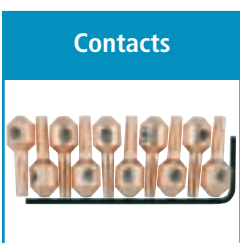

Contacts

TYPE	MATERIAL	DESCRIPTION	PART NUMBER
0.094 Set Screw Type Contacts	Beryllium Copper	Accepts wire up to 0.050 [1.3]	7429-01-A†
0.094 Barrel Type Contacts	Beryllium Copper	Accepts wire up to 0.094 [2.4]	7332-04-A

*Contacts priced and sold in packages of 10. **Uses compensating wire. Maximum junction temperature 250° C. †Shown in photo. See the Accessories section for more information on all accessories.

THERMOCOUPLE



THERMOCOUPLE

3 & 5 Pair Weldable

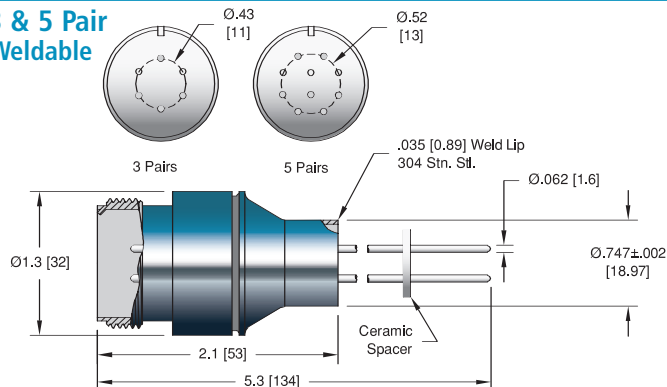

ISO KF

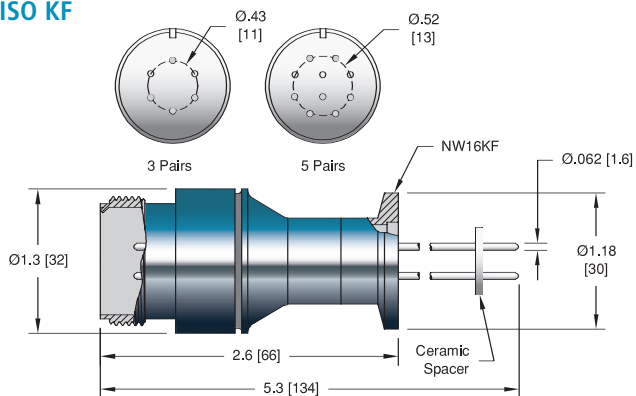

ConFlat - NW16CF

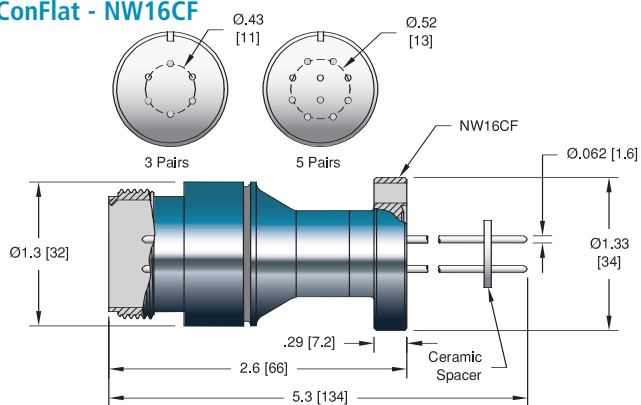

ConFlat - NW35CF

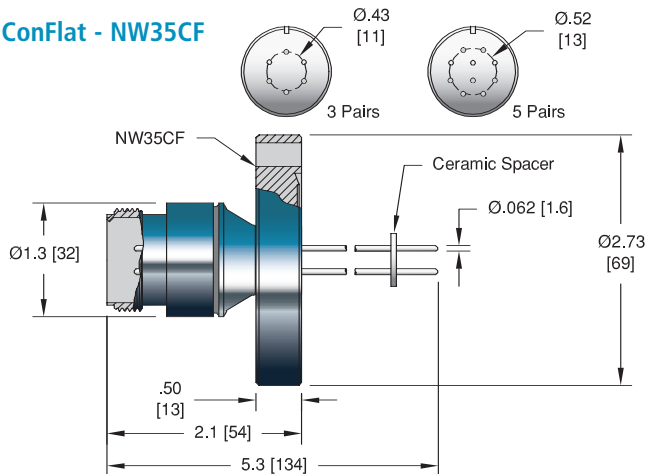

10 Pair Weldable

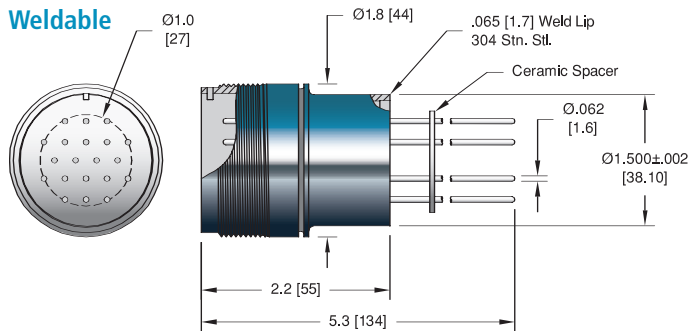

ISO KF

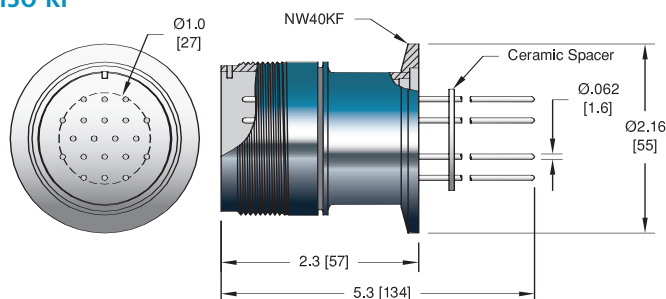

ConFlat

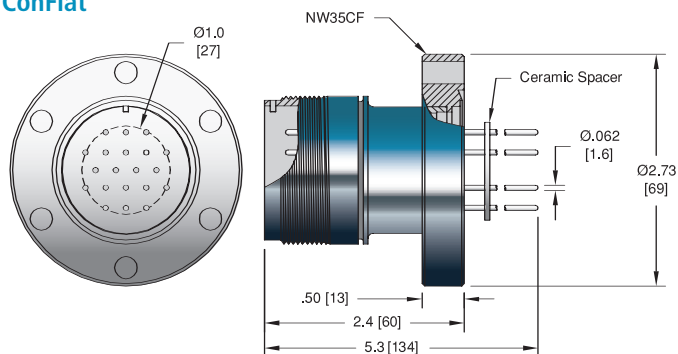

Specifications

Materials

- Shell: 304 Stainless steel
- Thermocouple materials:
Chromel/Alumel (Type K)
- Insulation: Alumina ceramic
- Magnetic Materials: Yes

Temperature Range -269°C to 450°C

Pressure @ 20°C ISO KF 0 PSIG

- 3 Pair: 400 PSIG (28 Bar)
- 5 Pair: 350 PSIG (24 Bar)
- 10 Pair: 125 PSIG (8.6 Bar)



ANSI TYPE	THERMOCOUPLE MATERIALS	INSTALLATION	T/C PAIRS	PART NUMBER
K	Chromel/Alumel	Weld	3	10084-05-W
K	Chromel/Alumel	Weld	5	11342-08-W
K	Chromel/Alumel	Weld	10	11343-07-W



ISO FLANGE				
ANSI TYPE	THERMOCOUPLE MATERIALS	INSTALLATION	T/C PAIRS	PART NUMBER
K	Chromel/Alumel	NW16KF	3	18008-02-KF
K	Chromel/Alumel	NW16KF	5	17155-02-KF
K	Chromel/Alumel	NW40KF	10	18010-02-KF



CONFLAT FLANGE				
ANSI TYPE	THERMOCOUPLE MATERIALS	INSTALLATION	T/C PAIRS	PART NUMBER
K	Chromel/Alumel	1 1/3" NW16CF	3	10084-06-CF
K	Chromel/Alumel	2 3/4" NW35CF	3	10084-07-CF
K	Chromel/Alumel	1 1/3" NW16CF	5	11342-09-CF
K	Chromel/Alumel	2 3/4" NW35CF	5	11342-10-CF
K	Chromel/Alumel	2 3/4" NW35CF	10	11343-05-CF



ANSI TYPE	THERMOCOUPLE MATERIALS	DIMENSIONS H	L	T/C PAIRS	PART NUMBER
K	Chromel/Alumel	1.4 [36]	4.4 [112]	3	15911-02-A
K	Chromel/Alumel	1.4 [36]	4.4 [112]	5	15912-02-A
K	Chromel/Alumel	1.9 [49]	4.3 [109]	10	15913-02-A

Note that thermocouple contacts are included with all plugs.



TYPE	MATERIAL	TEMPERATURE MIN	TEMPERATURE MAX	GROOVE	PART NUMBER
Crimp	Chromel	-269	350	Yes	11259-05-X
Crimp	Alumel	-269	350	No	11259-06-X
Crimp Tool					2840-05

*Contacts priced and sold in packages of 5. See the Accessories section for more information on all accessories.

THERMOCOUPLE



Isolator

SEMICONDUCTOR | ANALYTICAL EQUIPMENT | AEROSPACE | TELECOMMUNICATIONS



OIL EXPLORATION | R&D | HIGH ENERGY PHYSICS | MILITARY/DEFENSE | BIOTECHNOLOGY



*Advanced Ceramic-to-Metal &
Glass-Ceramic Sealing Technology*

Description

Electrical isolators, sometimes referred to as 'breaks' or 'envelopes', consist of metal sleeves brazed to each end of an insulating ceramic tube. These assemblies provide electrical isolation of system components that operate within a common environment. They can also be used to act as a conduit to introduce gases or liquids into hermetic systems.

- Cryogenic isolators are used to introduce cryogenic fluids into a system and to provide electrical isolation of line components.
- Water isolators are used to introduce water or other fluids into a system and to provide electrical isolation of line components.
- Vacuum isolators are used to provide an electrical break between the vacuum system and other external components.

Standard Specifications

- Voltages up to 75 kV DC
- Temperature Range: -269°C to 450°C
- Internal IDs to 8 inches
- Internal Pressure 1×10^{-10} torr to 1000 psig

Extreme / Custom Design

- Voltages in excess of 180 kV
- Pressures to 10,000 psig
- Insulator IDs in excess of 15 inches
- Special fittings
- Radiation resistant
- Non-circular geometries
- Fluted configurations



Installation

Standard installation mountings include:

- Weld (Pulse-TIG, TIG, Laser, E-Beam)
- ISO KF flange
- ConFlat flange

Applications

A few of the many applications in which these isolators are commonly used are:



- Semiconductor processing equipment
- Particle accelerators
- Furnaces
- Analytical equipment
- Beam line tubes
- Aerospace
- Telecommunications

New Products

- Newly designed water isolators with higher pressure ratings
- Standard non-magnetic isolators

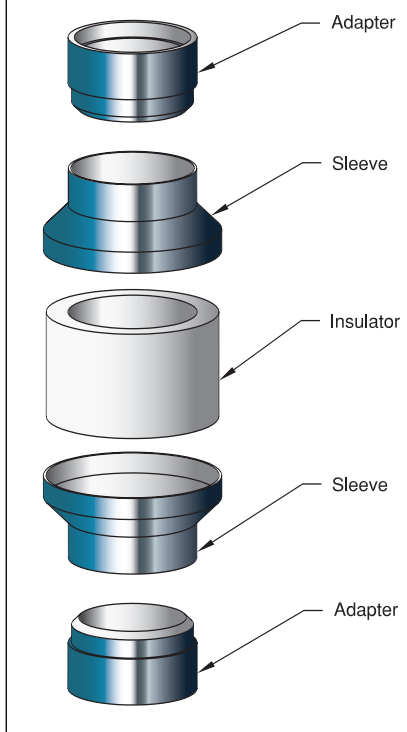
Typical Isolator Construction

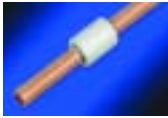

Type	Voltage DC	Pressure Rating (@ 20° C)	Temperature Range	Isolator ID (inches)	Sub-section	Section Pages
	to 13 kV	to 1000 psig	-269°C to 450°C	.11 to .41	Cryogenic	E.1 156-157
	5 kV	to 450 psig	0°C to 100°C	.32 to .57	Water	E.2 158-159
	to 75 kV	to 900 psig	-269°C to 450°C	.31 to 8.0	Vacuum	E.3 160-167





Cryogenic - ID: .11 [2.7]

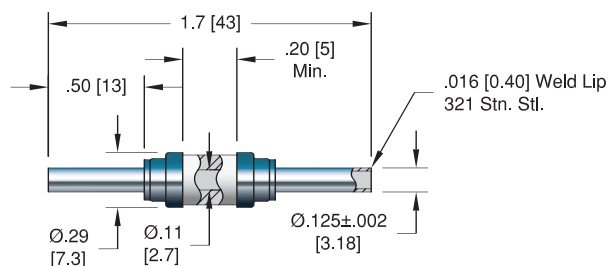

Cryogenic - ID: .25 [6.4]

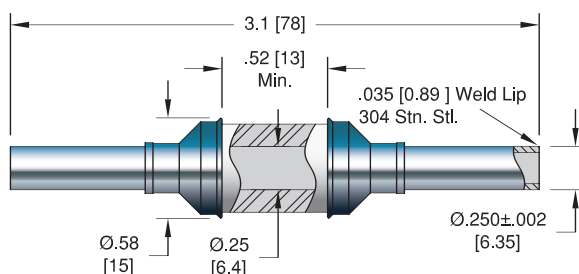

Cryogenic - ID: .25 [6.4]

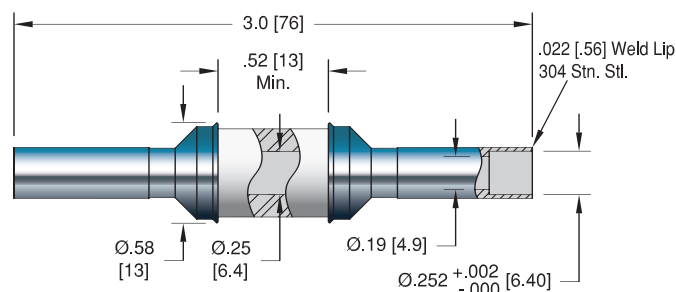

Cryogenic - ID: .41 [10]

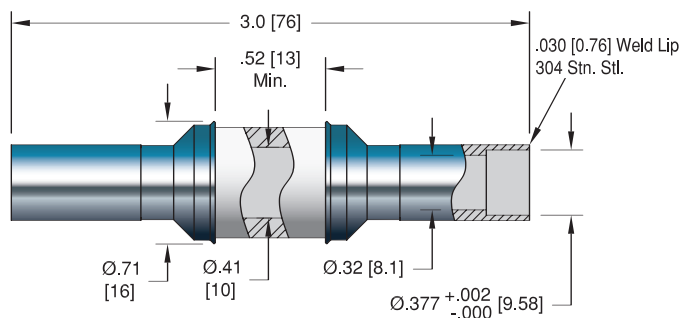

Specifications

Materials

Tube:

.11 ID: 321 Stainless steel

.25 ID: 304 Stainless steel

.41 ID: 304 Stainless steel

Cap: 42 Nickel iron

Insulation: Alumina ceramic

Magnetic Materials: Yes

Voltage Rating See table

Temperature Range -269°C to 450°C

Pressure @ 20°C See table



VOLTAGE DC	INSTALLATION	PRESSURE		PART NUMBER
		PSIG	BAR	
6 kV	Weld	1000	68	0858-01-W



13 kV	Weld	900	61	17108-01-W
-------	------	-----	----	------------

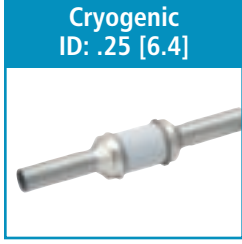

13 kV	Weld	900	61	8002-01-W
-------	------	-----	----	-----------

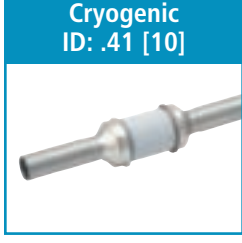

13 kV	Weld	400	27	8002-02-W
-------	------	-----	----	-----------



ISOLATOR





Water - ID: .26 [8.1]

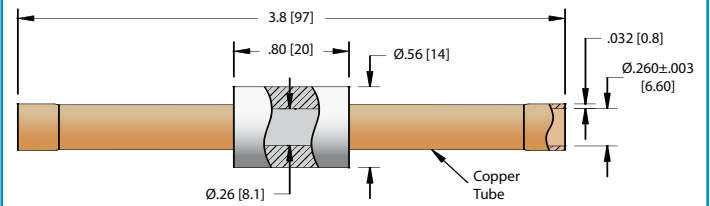

Water - ID: .38 [11]

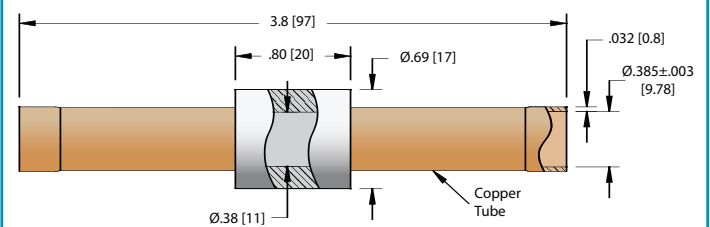

Water - ID: .51 [14]

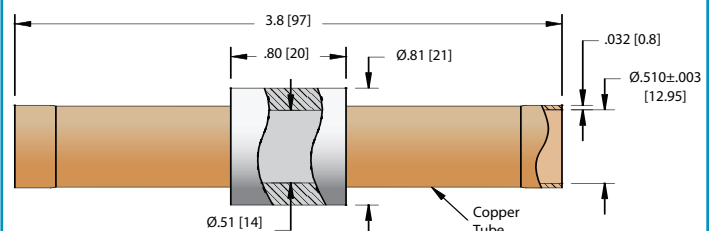

Specifications

Materials

Tube: Copper
 Insulation: Alumina ceramic
 Magnetic Materials: No

Voltage Rating 5 kV DC

Temperature Range 0°C to 100°C

Pressure @ 20°C See table

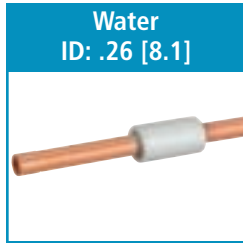

VOLTAGE DC	INSTALLATION	PRESSURE @ 20°C		PART NUMBER
		PSIG	BAR	
5 kV	Braze or Solder	450	30	17228-01-B

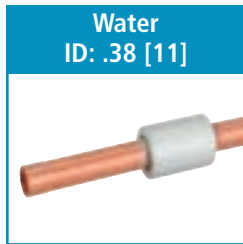

5 kV	Braze or Solder	300	20	17229-01-B
------	-----------------	-----	----	------------

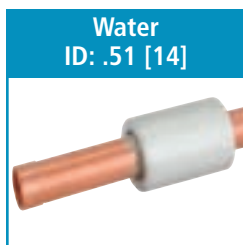

5 kV	Braze or Solder	200	13	17230-01-B
------	-----------------	-----	----	------------



ISOLATOR

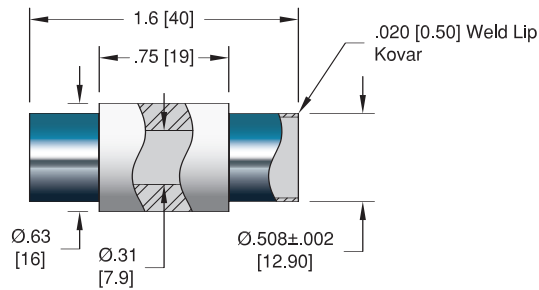
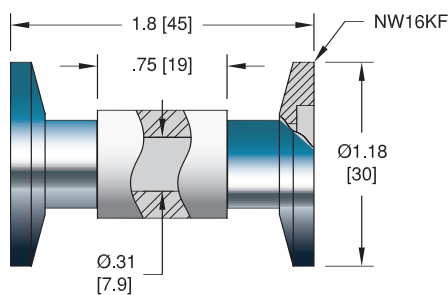
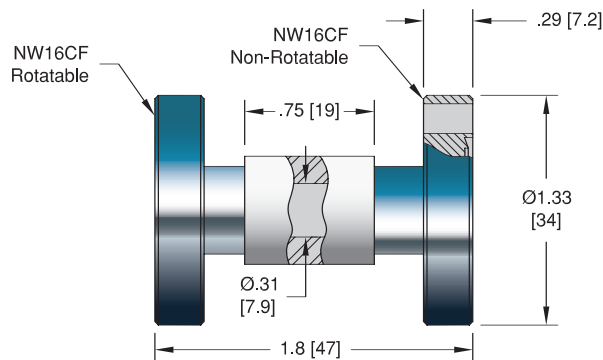
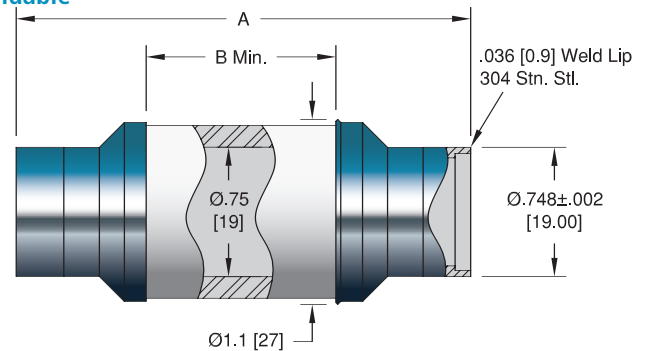
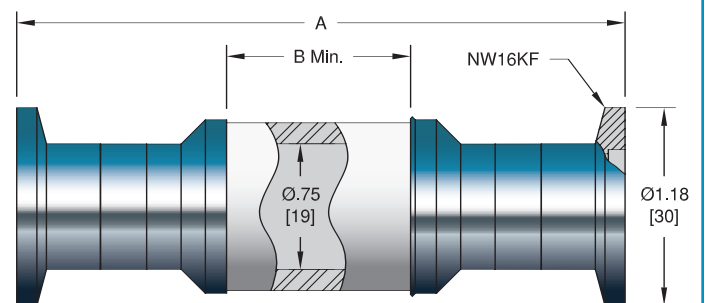
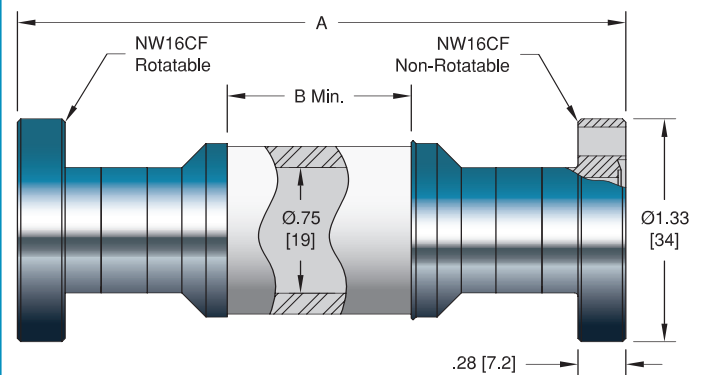

Insulator ID: .31 [7.9]**Weldable****ISO KF****ConFlat****Insulator ID: .75 [19]****Weldable****ISO KF****ConFlat****Specifications - Insulator ID: .31 [7.9]****Materials**

Tube: Kovar
 Insulation: Alumina ceramic
 Magnetic Materials: Yes

Voltage Rating 15 kV DC**Temperature Range** -55°C to 450°C, ISO KF -25°C to 205°C**Pressure @ 20°C** See table**Specifications - Insulator ID: .75 [19]****Materials**

Tube: Stainless steel
 Insulation: Alumina ceramic
 Magnetic Materials: See table

Voltage Rating See table**Temperature Range** See table**Pressure @ 20°C** See table



VOLTAGE DC	INSTALLATION	PRESSURE @ 20 °C		PART NUMBER
		PSIG	BAR	
15 kV	Weld	900	61	9997-05-W



ISO FLANGE				
15 kV	NW16KF	-	-	17235-01-KF

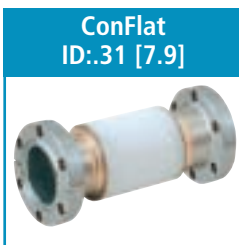

CONFLAT FLANGE				
15 kV	1 1/3" (NW16CF)	900	61	4511-01-CF



VOLTAGE DC	INSTALLATION	DIMENSIONS		PRESSURE @ 20 °C		TEMP °C		MAGNETIC MATERIALS	PART NUMBER
		A	B	PSIG	BAR	MIN	MAX		
6 kV	Weld	1.9 [48]	0.25 [6.3]	500	34	-55	450	Yes	9998-04-W
20 kV	Weld	2.6 [67]	1.0 [25]	500	34	-55	450	Yes	9998-01-W
35 kV	Weld	3.6 [92]	2.0 [51]	500	34	-55	450	Yes	9998-03-W
6 kV	Weld	1.9 [48]	0.25 [6.3]	350	24	-269	450	No	9998-06-W
20 kV	Weld	2.6 [67]	1.0 [25]	350	24	-269	450	No	9998-07-W
35 kV	Weld	3.6 [92]	2.0 [51]	350	24	-269	450	No	9998-08-W



ISO FLANGE									
6 kV	NW16KF	2.9 [73]	0.25 [6.3]	-	-	-25	205	Yes	17236-01-KF
20 kV	NW16KF	3.6 [92]	1.0 [25]	-	-	-25	205	Yes	17236-02-KF
35 kV	NW16KF	4.6 [118]	2.0 [51]	-	-	-25	205	Yes	17236-03-KF
6 kV	NW16KF	2.9 [73]	0.25 [6.3]	-	-	-25	205	No	17236-04-KF
20 kV	NW16KF	3.6 [92]	1.0 [25]	-	-	-25	205	No	17236-05-KF
35 kV	NW16KF	4.6 [118]	2.0 [51]	-	-	-25	205	No	17236-06-KF

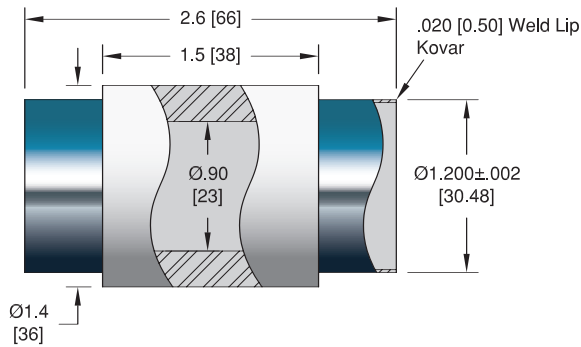
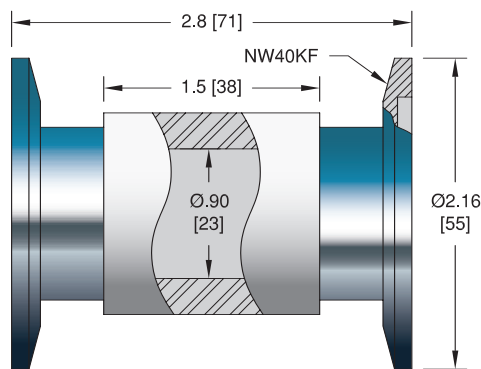
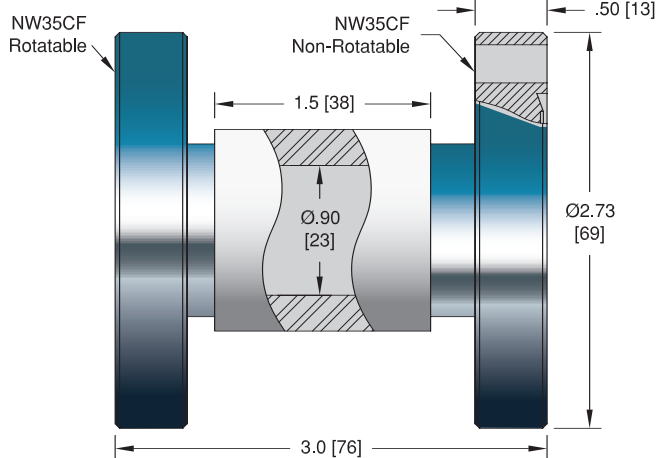
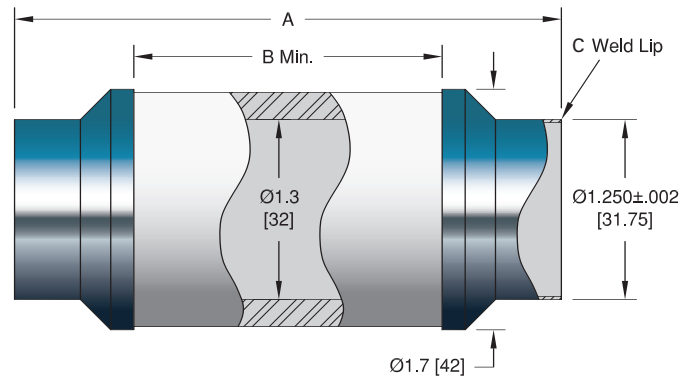
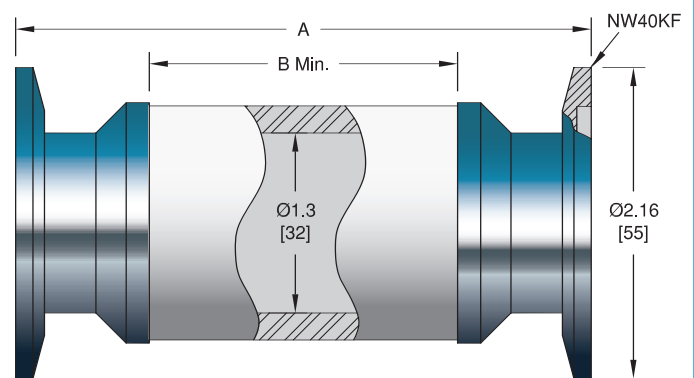
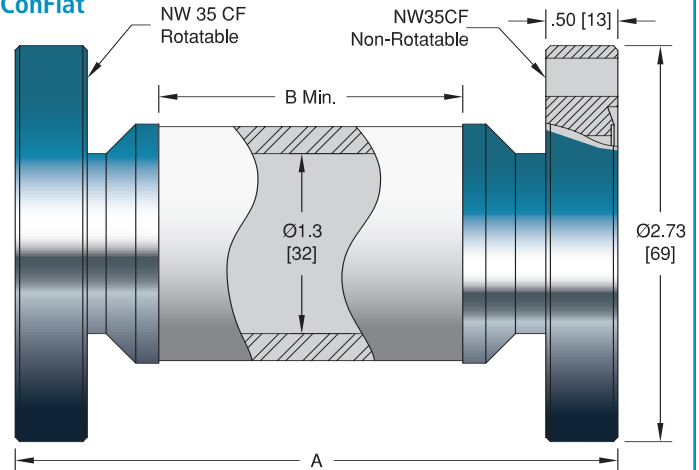

CONFLAT FLANGE									
6 kV	1 1/3" (NW16CF)	2.9 [73]	0.25 [6.3]	500	34	-55	450	Yes	8000-04-CF
20 kV	1 1/3" (NW16CF)	3.6 [92]	1.0 [25]	500	34	-55	450	Yes	8000-02-CF
35 kV	1 1/3" (NW16CF)	4.6 [118]	2.0 [51]	500	34	-55	450	Yes	8000-03-CF
6 kV	1 1/3" (NW16CF)	2.9 [73]	0.25 [6.3]	350	24	-269	450	No	8000-06-CF
20 kV	1 1/3" (NW16CF)	3.6 [92]	1.0 [25]	350	24	-269	450	No	8000-07-CF
35 kV	1 1/3" (NW16CF)	4.6 [118]	2.0 [51]	350	24	-269	450	No	8000-08-CF

Insulator ID: .90 [23]
Weldable

ISO KF

ConFlat

Insulator ID: 1.3 [32]
Weldable

ISO KF

ConFlat

Specifications - Insulator ID: .90 [23]
Materials

Tube: Kovar
 Insulation: Alumina ceramic
 Magnetic Materials: Yes

Voltage Rating 30 kV DC

Temperature Range -55°C to 450°C, ISO KF -25°C to 205°C

Pressure @ 20°C See table

Specifications - Insulator ID: 1.3 [32]
Materials

Tube: Kovar or 304 stainless steel
 Insulation: Alumina ceramic
 Magnetic Materials: See table

Voltage Rating See table

Temperature Range See table

Pressure @ 20°C See table



VOLTAGE DC	INSTALLATION	PRESSURE @ 20 °C		PART NUMBER
		PSIG	BAR	
30 kV	Weld	360	24	9997-09-W



ISO FLANGE				
30 kV	NW40KF	-	-	17237-01-KF



CONFLAT FLANGE				
30 kV	2 3/4" (NW35CF)	360	24	4511-02-CF



VOLTAGE DC	INSTALLATION	DIMENSIONS			PRESSURE @ 20 °C		TEMP °C		MAGNETIC MATERIALS	PART NUMBER	
		A	B	C	PSIG	BAR	MIN	MAX			
5 kV	Weld	1.9 [49]	0.6 [4.0]	.020 [0.50]	Kovar	350	24	-55	450	Yes	9999-03-W
35 kV	Weld	3.8 [96]	2.0 [50]	.020 [0.50]	Kovar	350	24	-55	450	Yes	9999-01-W
65 kV	Weld	5.7 [144]	3.9 [99]	.020 [0.50]	Kovar	350	24	-55	450	Yes	9999-04-W
5 kV	Weld	1.9 [49]	0.6 [4.0]	.035 [0.90]	Stn.Stl.	250	17	-269	450	No	17199-01-W
35 kV	Weld	3.8 [96]	2.0 [50]	.035 [0.90]	Stn.Stl.	250	17	-269	450	No	17199-02-W
65 kV	Weld	5.7 [144]	3.9 [99]	.035 [0.90]	Stn.Stl.	250	17	-269	450	No	17199-03-W



ISO FLANGE										
5 kV	NW40KF	2.1 [54]	0.16 [4.0]	-	-	-	-25	205	Yes	17238-01-KF
35 kV	NW40KF	4.0 [101]	2.0 [50]	-	-	-	-25	205	Yes	17238-02-KF
65 kV	NW40KF	5.9 [149]	3.9 [99]	-	-	-	-25	205	Yes	17238-03-KF
5 kV	NW40KF	2.1 [54]	0.16 [4.0]	-	-	-	-25	205	No	17238-04-KF
35 kV	NW40KF	4.0 [101]	2.0 [50]	-	-	-	-25	205	No	17238-05-KF
65 kV	NW40KF	5.9 [149]	3.9 [99]	-	-	-	-25	205	No	17238-06-KF



CONFLAT FLANGE										
5 kV	2 3/4"(NW35CF)	2.3 [59]	0.16 [4.0]	-	350	24	-55	450	Yes	8001-03-CF
35 kV	2 3/4"(NW35CF)	4.2 [107]	2.0 [50]	-	350	24	-55	450	Yes	8001-02-CF
65 kV	2 3/4"(NW35CF)	6.1 [155]	3.9 [99]	-	350	24	-55	450	Yes	8001-04-CF
5 kV	2 3/4"(NW35CF)	2.3 [59]	0.16 [4.0]	-	250	17	-269	450	No	8001-06-CF
35 kV	2 3/4"(NW35CF)	4.2 [107]	2.0 [50]	-	250	17	-269	450	No	8001-07-CF
65 kV	2 3/4"(NW35CF)	6.1 [155]	3.9 [99]	-	250	17	-269	450	No	8001-08-CF

ISOLATOR



Insulator ID: 2.0 [51] Weldable

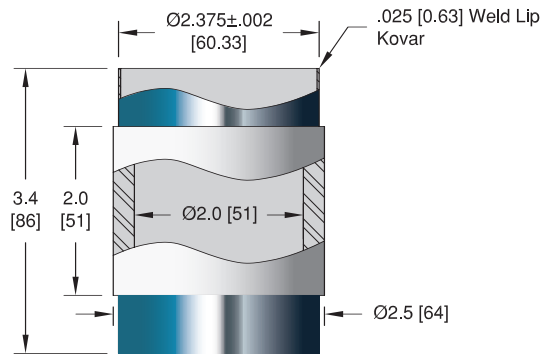

ConFlat

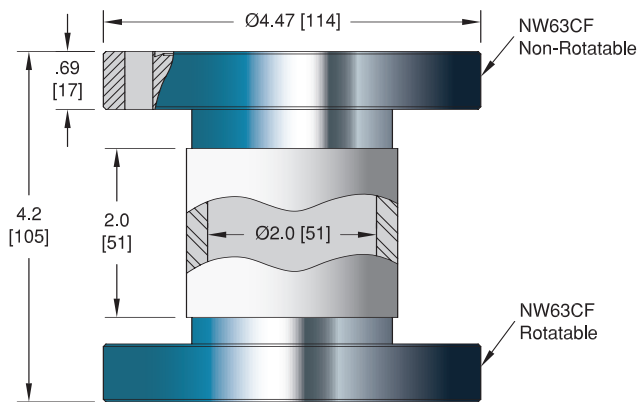

Insulator ID: 2.5 [64] Weldable

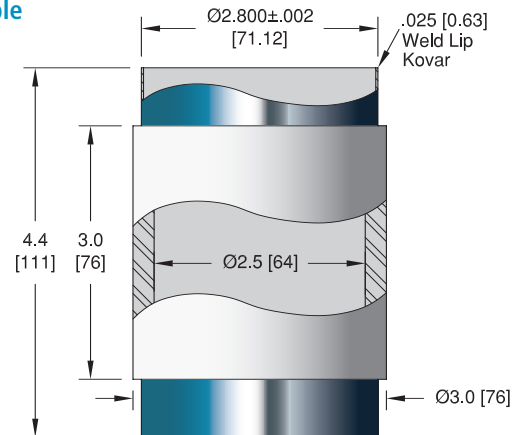

ConFlat

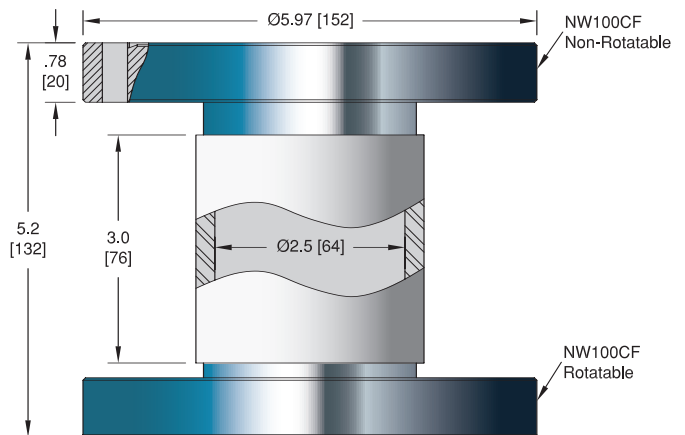

Weldable

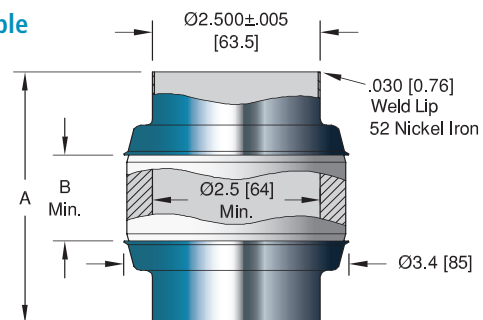

ConFlat

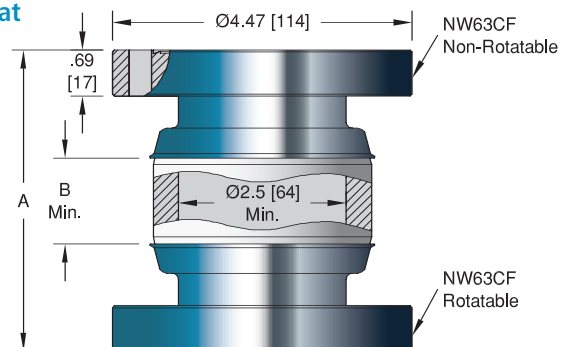

Specifications - Insulator ID: 2.0 [51]

Materials

Tube: Kovar
Insulation: Alumina ceramic
Magnetic Materials: Yes

Voltage Rating 40 kV DC

Temperature Range -55°C to 450°C

Pressure @ 20°C 180 PSIG (12 Bar)

Specifications - Insulator ID: 2.5 [64]

Materials

Tube: Kovar or 52 Nickel iron
Insulation: Alumina ceramic
Magnetic Materials: Yes

Voltage Rating See table

Temperature Range See table

Pressure @ 20°C See table



VOLTAGE DC	INSTALLATION
40 kV	Weld

PART NUMBER
9997-21-W

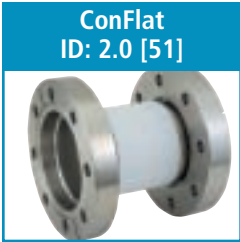

CONFLAT FLANGE		
40 kV	4 1/2" (NW63CF)	4511-03-CF



VOLTAGE DC	INSTALLATION	PRESSURE @ 20 °C		TEMP °C	
		PSIG	BAR	MIN	MAX
60 kV	Weld	150	10	-55	450

PART NUMBER
9997-25-W

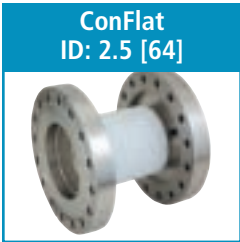

CONFLAT FLANGE		
60 kV	6" (NW100CF)	4511-05-CF



VOLTAGE DC	INSTALLATION	DIMENSIONS		PRESSURE @ 20 °C		TEMP °C	
		A	B	PSIG	BAR	MIN	MAX
20 kV	Weld	3.7 [95]	0.90 [22.8]	80	5	-269	450
60 kV	Weld	6.5 [165]	3.65 [92.7]	80	5	-269	450

PART NUMBER
17140-01-W
17140-02-W

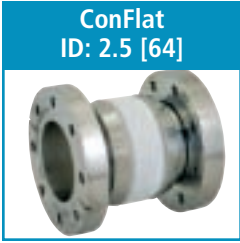

CONFLAT FLANGE		
20 kV	4 1/2" (NW63CF)	17144-01-CF
60 kV	4 1/2" (NW63CF)	17144-02-CF

ISOLATOR



Insulator ID: 4.0 [102] Weldable

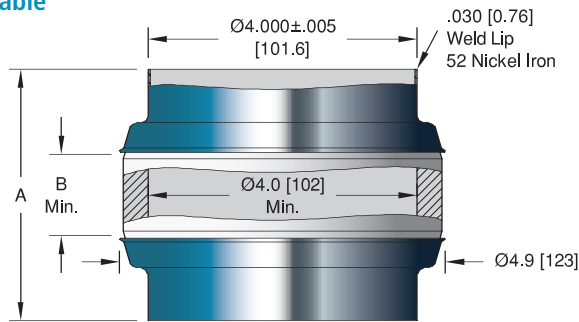

ConFlat

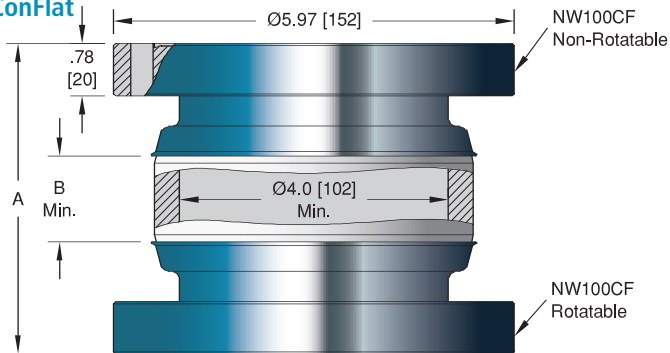

Insulator ID: 6.0 [152] Weldable

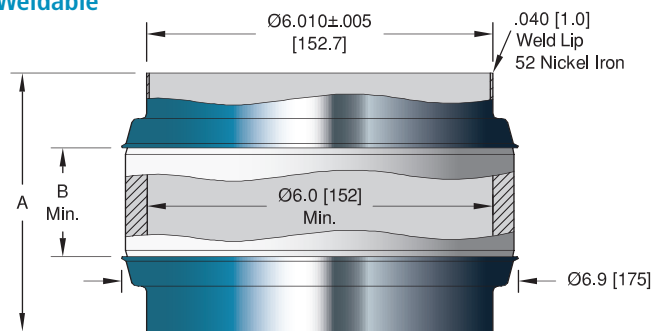

ConFlat

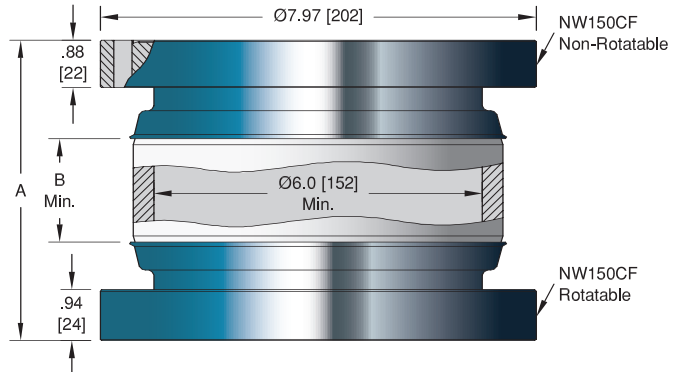

Specifications

Materials

Tube: 52 Nickel iron
Insulation: Alumina ceramic
Magnetic Materials: Yes

Voltage Rating See table

Temperature Range -269°C to 450°C

Pressure @ 20°C

Insulator ID: 4.0 [102] – 60 PSIG (4 Bar)
Insulator ID: 6.0 [152] – 40 PSIG (2.7 Bar)
Insulator ID: 8.0 [203] – 30 PSIG (2 Bar)

Insulator ID: 8.0 [203] Weldable

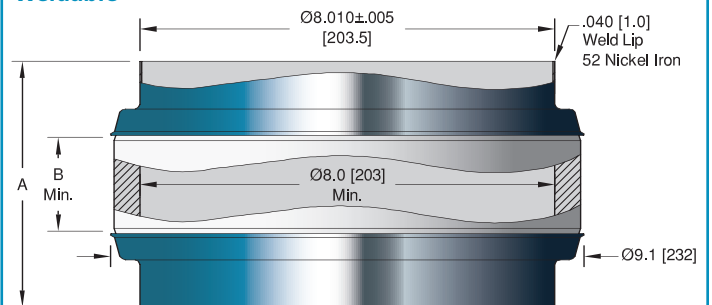

ConFlat

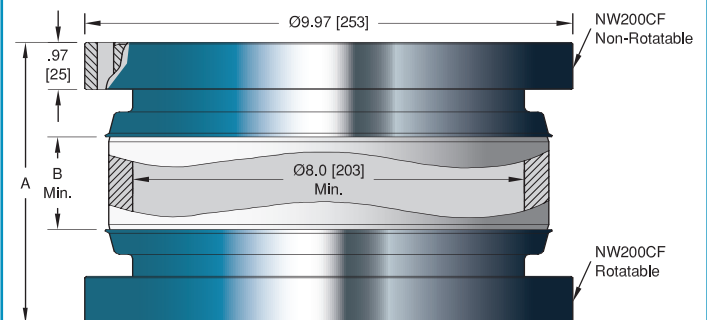



VOLTAGE DC	INSTALLATION	DIMENSIONS A B		PART NUMBER
20 kV	Weld	3.7 [95]	0.90 [22.8]	17141-01-W
60 kV	Weld	6.5 [165]	3.65 [92.7]	17141-02-W

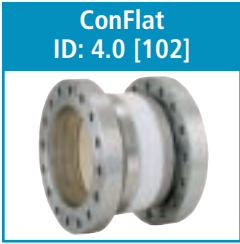

CONFLAT FLANGE

20 kV	6" (NW100CF)	4.6 [117]	0.90 [22.8]	17145-01-CF
60 kV	6" (NW100CF)	7.4 [187]	3.65 [92.7]	17145-02-CF



VOLTAGE DC	INSTALLATION	DIMENSIONS A B		PART NUMBER
30 kV	Weld	4.5 [114]	1.5 [38]	17142-01-W
55 kV	Weld	6.0 [152]	3.0 [76]	17142-02-W
75 kV	Weld	7.5 [191]	4.5 [114]	17142-03-W



CONFLAT FLANGE

30 kV	8" (NW150CF)	5.5 [140]	1.5 [38]	17146-01-CF
55 kV	8" (NW150CF)	7.0 [178]	3.0 [76]	17146-02-CF
75 kV	8" (NW150CF)	8.5 [216]	4.5 [114]	17146-03-CF



VOLTAGE DC	INSTALLATION	DIMENSIONS A B		PART NUMBER
30 kV	Weld	4.75 [121]	1.5 [38]	17143-01-W
55 kV	Weld	6.25 [159]	3.0 [76]	17143-02-W
75 kV	Weld	7.75 [197]	4.5 [114]	17143-03-W



CONFLAT FLANGE

30 kV	10" (NW200CF)	5.8 [146]	1.5 [38]	17147-01-CF
55 kV	10" (NW200CF)	7.3 [184]	3.0 [76]	17147-02-CF
75 kV	10" (NW200CF)	8.8 [222]	4.5 [114]	17147-03-CF

ISOLATOR

Viewport

SEMICONDUCTOR | ANALYTICAL EQUIPMENT | AEROSPACE | TELECOMMUNICATIONS



OIL EXPLORATION | R&D | HIGH ENERGY PHYSICS | MILITARY/DEFENSE | BIOTECHNOLOGY



*Advanced Ceramic-to-Metal &
Glass-Ceramic Sealing Technology*

Description

A viewport, sometimes referred to as a window, is an optical component that provides a means for visual, optical or broad-band energy transmission in and out of a vacuum system.

There are two types of viewports offered, zero-length and tubulated. A zero-length viewport has a thickness no larger than that of its mounting flange. This makes it easier to protect from accidental damage as there are no parts protruding from the mounting flange. It also allows for the best angle of view.

CeramTec's precision-engineered Ceramaseal® viewports are available with a choice of two viewport materials: sapphire or fused silica. Other viewport materials are available upon request.

CeramTec offers a UV grade fused silica viewport with a 1.37" view diameter that can be used for cryogenic applications.

Sapphire should be used in the most demanding applications, as this material provides extended transmission, temperature, pressure and wear resistance.

To select the right window for your applications, you should consider size, transmission requirements, temperature, pressure, and aggressiveness of environment.

Standard Specifications

Sapphire:

- Temperature Range: -269° C to 450° C
- Standard transmission range 0.25 to 4 microns
- Internal Pressure 1×10^{-10} torr to 400 psig
- Viewing diameters from .55" to 1.94"

Fused Silica:

- Temperature Range: -65° C to 200° C
- Standard Transmission Range 0.25 to 2 microns
- Internal Pressure 1×10^{-10} torr to 115 psig
- Viewing diameters from 1.13" to 3.81"

Extended Range:

- Optics: Zinc Selenide, Cleartran, Magnesium Fluoride, Calcium Fluoride
- Temperature Range: -8°C to 204°C

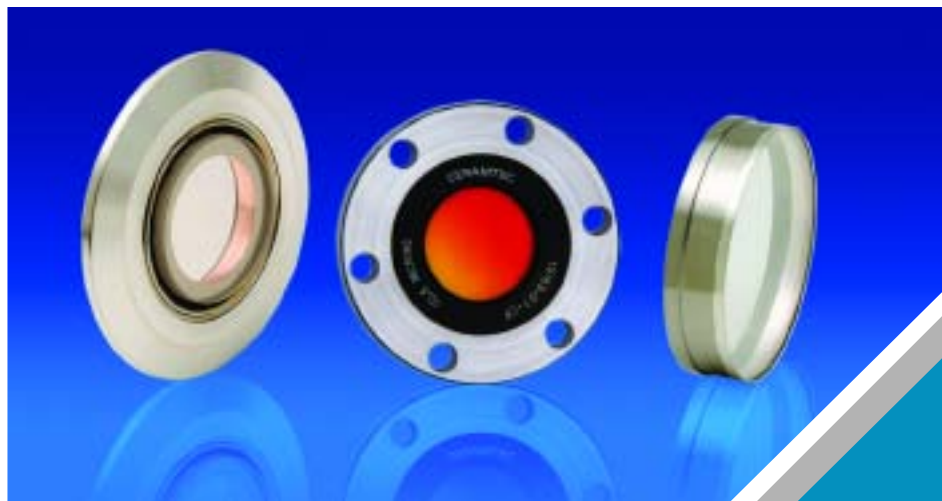

- Standard transmission ranges from 0.12 to 20 microns
- Viewing diameter of .50" or 1.1"
- Anti-reflective (AR) coatings are optional

Extreme / Custom Design

- Double viewports
- Viewing diameters exceeding 7 inches
- Internal pressures to 80,000 psig
- RF applications and special configuration requirements

Installation

Standard installation mountings include:

- Braze (sapphire only)
- Weld (Pulse-TIG, TIG, Laser, E-Beam)
- ConFlat flange
- ISO KF flange

Applications

A few of the many applications in which these viewports are commonly used are:





- Semiconductor processing equipment
- Accelerators
- Furnaces
- Instrumentation
- Analytical test and measurement equipment
- CO₂ lasers
- Multispectral applications
- Optical imaging
- Materials processing
- Thermometry
- Pyrometry

New Products

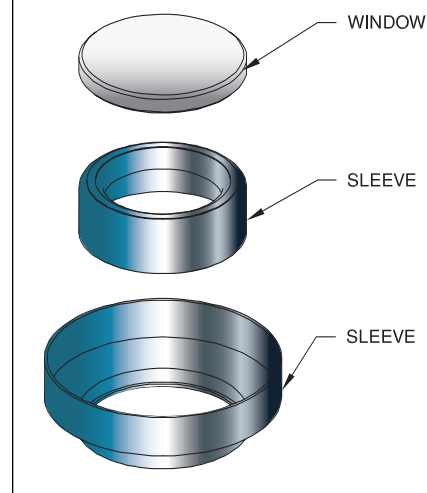
- Extended Range Viewports
- Differentially Pumped Viewports

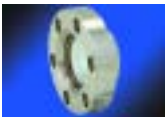
Typical Viewport Construction



Type	View Dia. (inches)	Internal Pressure Rating (@ 20 °C)	Temperature Range	Transmission Range	Sub-section	Section Pages
	0.55 to 1.94	to 400 psig	-269° C to 450° C	0.25 to 4 Microns	Sapphire	F.1 172-173
	1.13 to 3.81	to 115 psig	-269° C to 200° C	0.25 to 2 Microns	Fused Silica	F.2 174-175
	.50 to 1.10	–	-8° C to 204° C	0.12 to 18 Microns	Extended Range	F.3 176-177
	1.10	–	-8° C to 204° C	10.6 Micron Optimized	Differentially Pumped	F.4 178-179

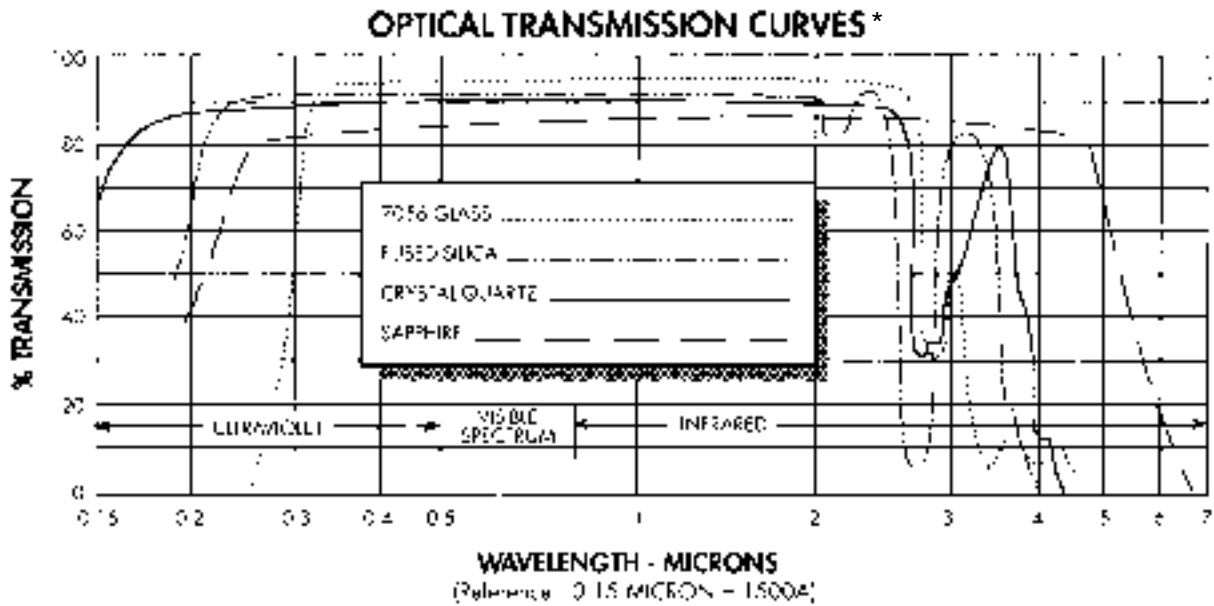

*The 7056 Glass, Fused Silica, and Crystal Quartz transmission curves are based on a thickness of 1 cm. The sapphire transmission curve is based on a thickness of 1 mm.

View Diameter: .55 [14]
Weldable

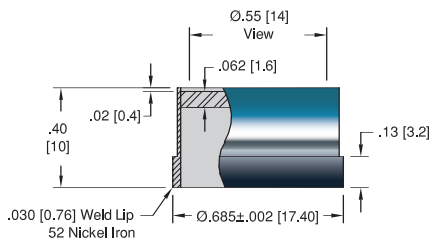

ISO KF

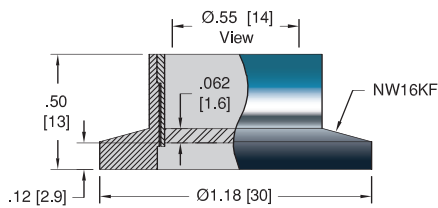

ConFlat

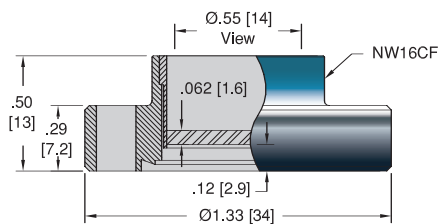

View Diameter: .94 [24]
Weldable

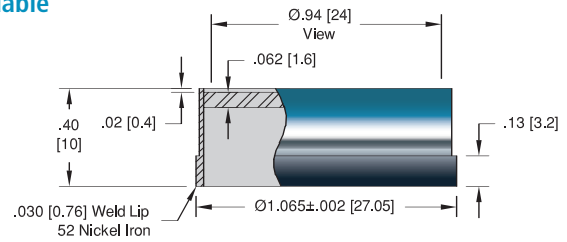

ISO KF

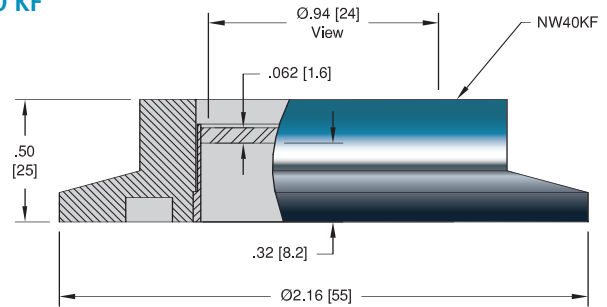

ConFlat

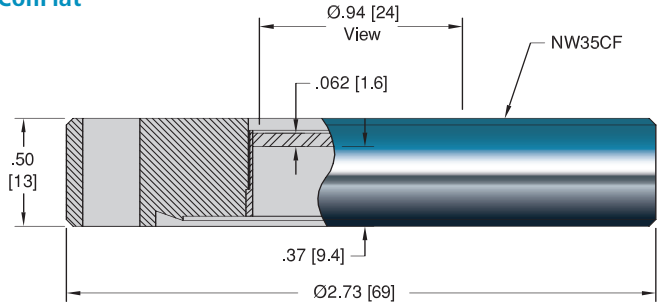

View Diameter: 1.94 [49.3]
Weldable

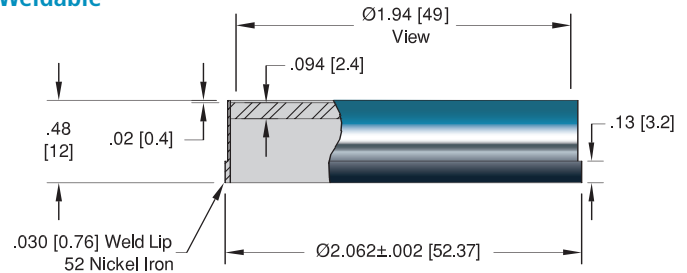

ConFlat

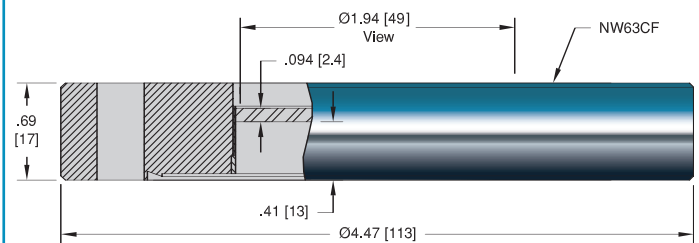

Specifications

Materials

Housing: 52 Nickel iron
Optic: Sapphire
Magnetic Materials: Yes

Transmission Range (80% Min) 0.25 to 4 Microns



Temperature Range -269°C to 450°C, ISO KF -25°C to 205°C

Pressure @ 20°C ISO KF 0 PSIG

.55 View Dia.: 400 PSIG (27.6 Bar)

.94 View Dia.: 160 PSIG (11 Bar)

1.94 View Dia.: 50 PSIG (3.4 Bar)

Weldable	VIEW DIAMETER	INSTALLATION	PART NUMBER
	.55 [14]	Weld	17105-01-W
	.94 [24]	Weld	17105-02-W
	1.94 [49]	Weld	17105-03-W
ISO FLANGE			
ISO KF 	.55 [14]	NW16KF	17106-01-KF
	.94 [24]	NW40KF	17106-02-KF
CONFLAT FLANGE			
ConFlat 	.55 [14]	1 1/3" (NW16CF)	9547-04-CF
	.94 [24]	2 3/4" (NW35CF)	18617-01-CF
	1.94 [49]	4 1/2" (NW63CF)	18617-02-CF



View Diameter: 1.13 [28.7]
Weldable

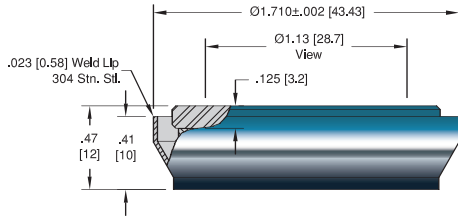

ISO KF

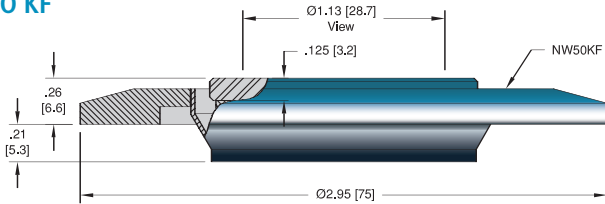

ConFlat

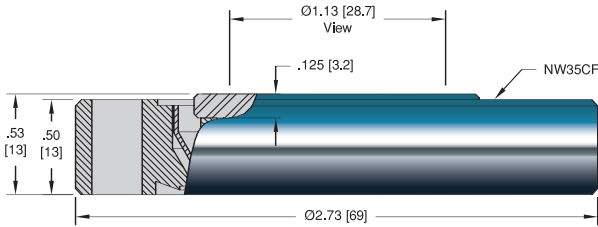

View Diameter: 3.81 [96.8]
Weldable

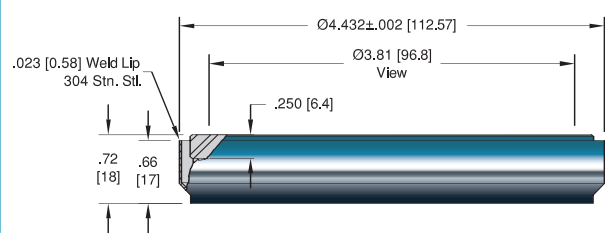

ConFlat

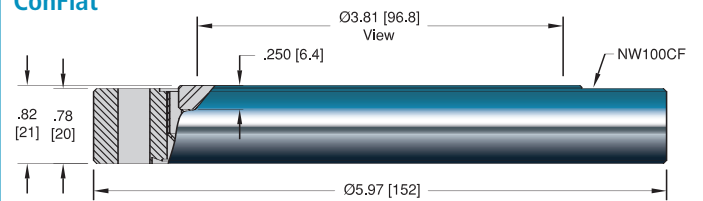

Cryogenic – View Diameter: 1.37 [35]
Weldable

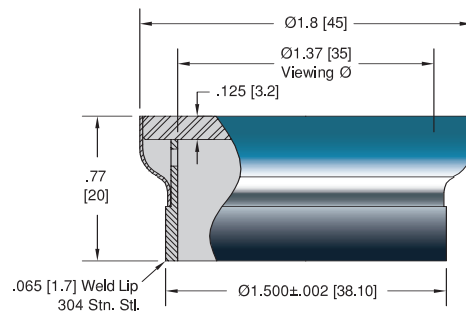

ConFlat

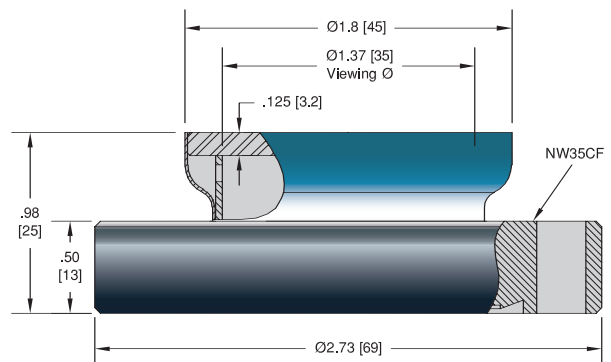

View Diameter: 2.37 [60.2]
Weldable

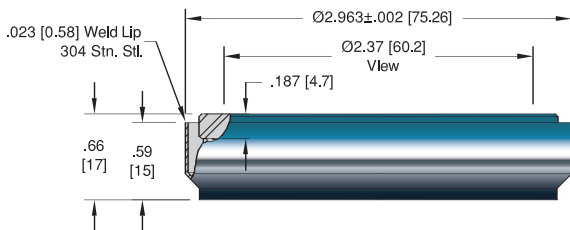

ConFlat

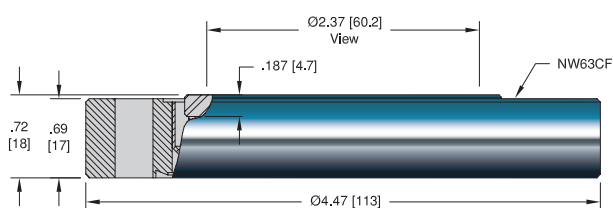



Weldable	VIEW	INSTALLATION	TEMPERATURE RANGE		MAGNETIC MATERIALS	PART NUMBER
	DIAMETER		MIN	MAX		
	1.13 [28.7]	Weld	-65	200	No	11466-09-W*
	2.37 [60.2]	Weld	-65	200	No	11466-10-W*
	3.81 [96.8]	Weld	-65	200	No	11466-11-W*

ISO FLANGE

	1.13 [28.7]	NW50KF	-25	200	No	17109-01-KF*
---	-------------	--------	-----	-----	----	--------------

CONFLAT FLANGE

	1.13 [28.7]	2 3/4" (NW35CF)	-65	200	No	11466-01-CF*
	2.37 [60.2]	4 1/2" (NW63CF)	-65	200	No	11466-02-CF*
	3.81 [96.8]	6" (NW100CF)	-65	200	No	11466-03-CF*

Cryogenic Weldable	VIEW	INSTALLATION	TEMPERATURE RANGE		MAGNETIC MATERIALS	PART NUMBER
	DIAMETER		MIN	MAX		
	1.37 [35]	Weld	-196	200	No	4901-01-W*
	1.37 [35]	Weld	-269	200	Yes	9600-01-W*

	1.37 [35]	2 3/4" (NW35CF)	-196	200	No	4900-01-CF*
	1.37 [35]	2 3/4" (NW35CF)	-269	200	Yes	4900-21-CF*

*This part is not RoHS compliant.

Specifications**Materials**

Housing: 304 Stainless steel
 Optic: UV Grade Fused Silica
 Magnetic Materials: See Table

Transmission Range (80% Min) 0.25 to 2 Microns

Temperature Range See Table

Pressure @ 20°C ISO KF 0 PSIG

1.13 View Dia.: 115 PSIG (7.9 Bar)
 1.37 View Dia.: 35 PSIG (2.4 Bar)
 2.37 View Dia.: 35 PSIG (2.4 Bar)
 3.81 View Dia.: 25 PSIG (1.7 Bar)



Description

Hermetic Extended Range Transmission Ports

As its name suggests, an extended range transmission port is an optical component that provides for transmission of radiation in either the ultra violet or infrared portion of the electromagnetic spectrum. Standard viewports made of either fused silica or sapphire have useful transmission from .25 microns to 2.5 or 5.0 microns respectively. Extended range window materials have a combined transmission range from .12 microns to 18 microns.

Of course no single window material can offer good transmission over the entire spectrum. Alkali halides such as calcium fluoride, CaF_2 , or magnesium fluoride, MgF_2 , offer excellent transmission in the deep ultraviolet. Polycrystalline CVD grown infrared transmitting materials such as Zinc Sulfide, ZnS, and Zinc Selenide, ZnSe, transmit radiation out to 14 and 18 microns respectively.

Many factors govern the selection of optical materials for the construction of a high and ultra high vacuum assembly. Whereas quartz and sapphire can be readily metalized and sealed to vacuum flanges by brazing, most optical materials are too weak to join to by the high temperature joining processes. Further, many optically transmitting materials are strongly hygroscopic (such as sodium chloride) or melt at low temperatures (such as glass). The physical and chemical properties of CeramTec's extended range transmission ports have been selected on the basis of optical transmission, vacuum compatibility, strength of materials and widespread usage by optical engineers.

Accordingly, the following materials are offered standard as extended range transmission ports:

Zinc Selenide – Best transmission available at 10.6 micron (CO_2 laser fundamental line) and in the visible. It has some absorption in the blue-green causing it to appear yellow. The index of refraction is high and thus requires anti-reflection coatings on both sides for optimum performance. This polycrystalline, CVD grown material is strong, though relatively soft compared to other crystalline, optical materials. It is non-hygroscopic. ZnSe sublimates at 300°C and reacts violently with strong mineral acids.

Cleartran™ Zinc Sulfide – Comparable to ZnSe in most respects, only slightly more absorbing at 10.6 microns. Advantage is the transmission in the visible is better, no absorption to only slight absorption in the blue-green thus appearing clear (i.e. not yellow). It is much harder than ZnSe and thus offers increased scratch resistance.

AR Coatings for both ZnSe and ZnS (Cleartran™) are standard and highly recommended for most applications. The exception is possibly for wide range pyrometry or spectrometry where artifacts from the coating materials leave a spectral "fingerprint" in regions beyond the useful transmission range of the coating. The standard coating has been specifically tailored to maximize transmission at 10.6 microns and will also transmit minimally 50% in the visible (i.e. remain at least partially transparent in the visible).

Calcium Fluoride – Best transmission by fluoride crystals in the UV (except very weak LiF). Relatively insoluble (non-to-very-low hygroscopic). Mechanically only slightly weaker than Zinc Selenide and slightly harder. Single crystal material with cubic symmetry, hence no birefringence. Calcium Fluoride is transparent in the visible (appears similar in color to quartz or glass) and in the UV down to 120nm, which services all excimer laser applications. Low index of refraction, which means that the windows rarely require anti-reflective coatings.

Magnesium Fluoride – Next best transmission of fluorides compared to CaF_2 and similar in all other characteristics with the following exceptions. MgF_2 is stronger and harder and is naturally, strongly birefringent.

View Diameter: .50 [13]

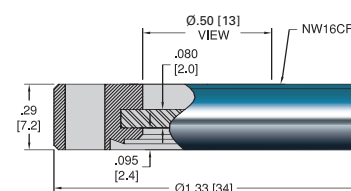

View Diameter: 1.10 [28]

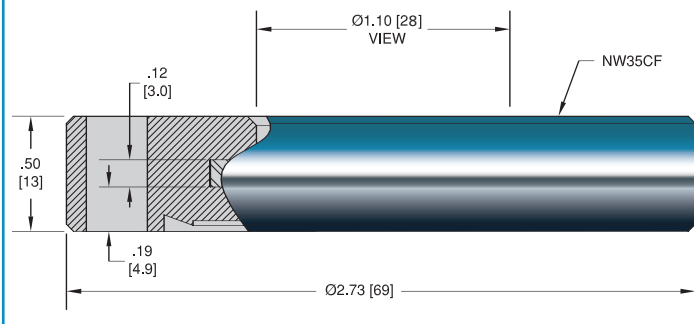

Specifications

Materials

Flange: 304 Stainless steel
O-ring: Viton®
Optics: See Table
Magnetic Materials: Yes

Transmission Range 0.12 to 20 Microns (See table)

Temperature Range -8°C to 204°C



MATERIAL	INSTALLATION	ANTI-REFLECTIVE COATINGS	TRANSMISSION RANGE	TRANSMISSION %MIN	PART NUMBER
Zinc Selenide	1 1/3" (NW16CF)	10.6 Micron	10.6 Micron optimized	98	19485-01-CF
Cleartran™	1 1/3" (NW16CF)	10.6 Micron	10.6 Micron optimized	98	19485-02-CF
Magnesium Fluoride	1 1/3" (NW16CF)	No	0.12 to 7 Microns	-	19485-03-CF
Calcium Fluoride	1 1/3" (NW16CF)	No	0.12 to 9 Microns	-	19485-04-CF
Zinc Selenide	1 1/3" (NW16CF)	No	0.55 to 18 Microns	-	19485-05-CF



Zinc Selenide	2 3/4" (NW35CF)	10.6 Micron	10.6 Micron optimized	98	19163-01-CF
Cleartran™	2 3/4" (NW35CF)	10.6 Micron	10.6 Micron optimized	98	19163-02-CF
Magnesium Fluoride	2 3/4" (NW35CF)	No	0.12 to 7 Microns	-	19163-03-CF
Calcium Fluoride	2 3/4" (NW35CF)	No	0.12 to 9 Microns	-	19163-04-CF
Zinc Selenide	2 3/4" (NW35CF)	No	0.55 to 18 Microns	-	19163-05-CF

Extended Range Transmission Curves

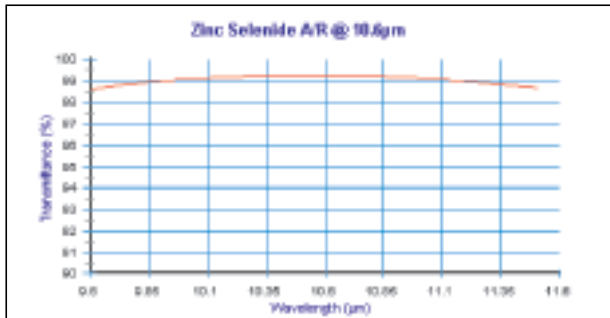
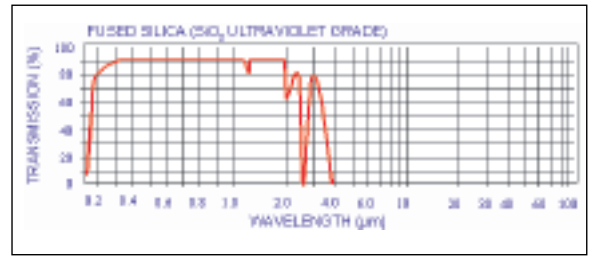
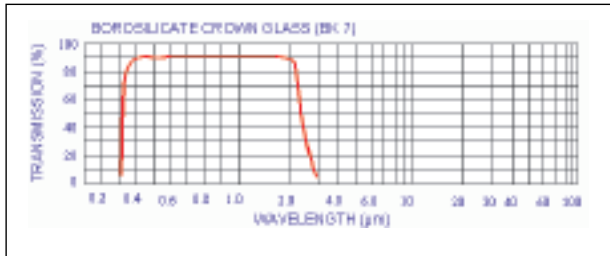
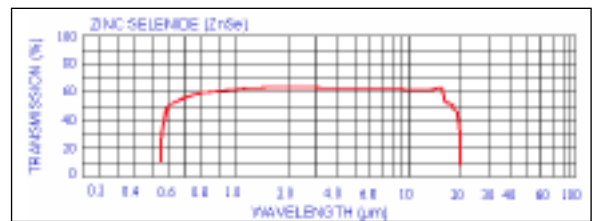
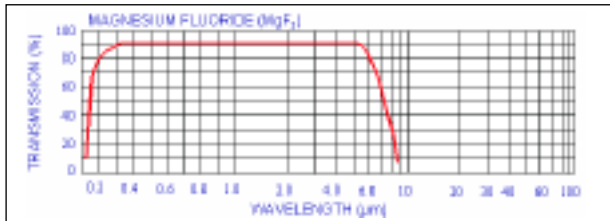
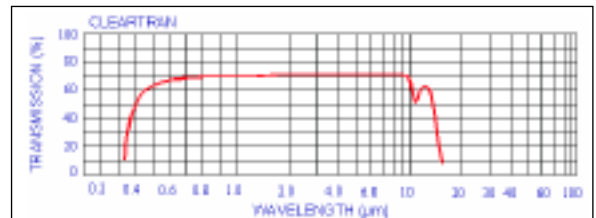
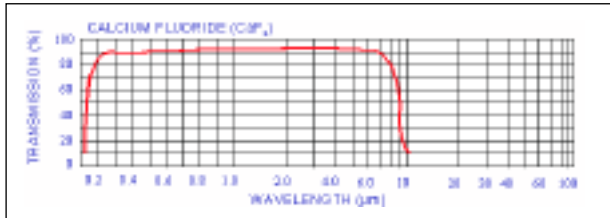

Transmission charts are for reference only. These transmission curves are based on a 10mm window thickness. Thermal gradient should not exceed 10°C/minute.

VIEWPORT



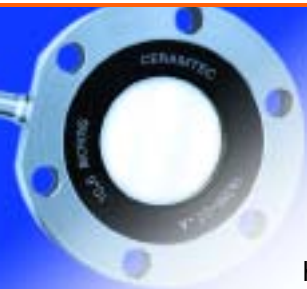

Description

Differentially Pumped, Extended Range, Viewports for Extreme High Vacuum (EHV) Applications

EHV applications demand exceedingly high seal reliability. These requirements for vacuum integrity lead to consideration of two limits to commercial leak detection. First, what is the typical helium sensitivity for commercially available leak detectors; and second, what are the practical limitations of helium mass spectrometer (MS) leak rate certification.

While helium MS leak detection systems are sensitive to leak rates less than 10^{-11} STD cc/sec, commercial vacuum seals are certified only for leak rates of less than 10^{-10} STD cc/sec. In these instances, the discrepancy between that achievable versus the reported sensitivity is not due to the presence of small, measurable leaks ($<10^{-11}$ STD cc/sec). Rather, the reduced certification is due to the difficulty of performing a reliable leak test with de-mountable hardware. An all metal welded joint to an MS leak detector, for example, could readily and reliably be certified to leak rates less than 10^{-11} . This type of joint is not practical for most de-mountable vacuum components. Even in the case of a copper gasket seal, the process of sealing is not only too time consuming but also would cosmetically alter the finished part.

In other instances, such as in inert gas chronology measurements, where the desired background levels due to atmospheric argon or helium are actually below the level of instrument sensitivity; it is not possible to measure with sensitivity at the desired leak rate with commercially available Helium MS leak detectors.

In both instances, a differentially pumped vacuum seal can ensure EHV reliability. Arranging two or more seals such that the space between the seals is accessible to an appended vacuum pump creates a differentially pumped seal. Typically, each seal is readily qualified to have leak rates $<10^{-10}$ STD cc/sec. By actively pumping the region between the seals, minute leakage through the atmospheric seal is further rarified to ensure that leakage through the inner seal is reduced by several orders of magnitude. Thus, differential pumping ensures EHV reliability.

CeramTec's differentially pumped, extended range, viewports have been designed specifically for such extreme high vacuum (EHV) applications including inert gas chronology.

Extreme / Custom Design

- Larger viewport view diameters to fit within a 4 1/2" ConFlat flange.

- Different optics are available upon request. For example, Silicon, Germanium, Zinc Sulfide
- Specialized coatings are also available.
- Custom pumping port termination options are available.

Installation

All of CeramTec's standard differentially pumped viewports are mounted within a 2 3/4" or 4 1/2" ConFlat flange. For information on ConFlat flange installation, refer to the Technical Reference section.

Applications

A few of the many applications in which these differentially pumped viewports are commonly used are:

- Geochronology
- Geology
- Argon Dating

View Diameter: 1.10 [28]

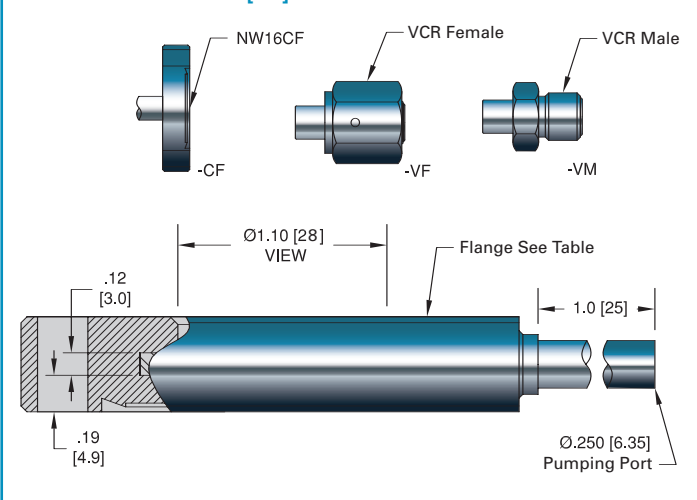

Specifications

Materials

Flange: 304 Stainless steel
 O-ring: Viton®
 Optics: Zinc Selenide or Cleartran
 Magnetic Materials: Yes

Transmission Range 10.6 Micron optimized

Anti-reflective Coating Yes

Temperature Range -8°C to 204°C

1.10 View Dia.
ConFlat

MATERIAL	INSTALLATION	TRANSMISSION RANGE	%MIN	TERMINATION OPTIONS	PART NUMBER
Zinc Selenide	2 3/4" (NW35CF)	10.6 Micron optimized	98	Tube	19286-01-A
Zinc Selenide	2 3/4" (NW35CF)	10.6 Micron optimized	98	1 1/3" ConFlat	19286-01-CF
Zinc Selenide	2 3/4" (NW35CF)	10.6 Micron optimized	98	Male VCR	19286-01-VM
Zinc Selenide	2 3/4" (NW35CF)	10.6 Micron optimized	98	Female VCR	19286-01-VF
Cleartran™	2 3/4" (NW35CF)	10.6 Micron optimized	98	Tube	19286-02-A
Cleartran™	2 3/4" (NW35CF)	10.6 Micron optimized	98	1 1/3" ConFlat	19286-02-CF
Cleartran™	2 3/4" (NW35CF)	10.6 Micron optimized	98	Male VCR	19286-02-VM
Cleartran™	2 3/4" (NW35CF)	10.6 Micron optimized	98	Female VCR	19286-02-VF
Zinc Selenide	4 1/2" (NW63CF)	10.6 Micron optimized	98	Tube	19781-01-A
Zinc Selenide	4 1/2" (NW63CF)	10.6 Micron optimized	98	1 1/3" ConFlat	19781-01-CF
Zinc Selenide	4 1/2" (NW63CF)	10.6 Micron optimized	98	Male VCR	19781-01-VM
Zinc Selenide	4 1/2" (NW63CF)	10.6 Micron optimized	98	Female VCR	19781-01-VF
Cleartran™	4 1/2" (NW63CF)	10.6 Micron optimized	98	Tube	19781-02-A
Cleartran™	4 1/2" (NW63CF)	10.6 Micron optimized	98	1 1/3" ConFlat	19781-02-CF
Cleartran™	4 1/2" (NW63CF)	10.6 Micron optimized	98	Male VCR	19781-02-VM
Cleartran™	4 1/2" (NW63CF)	10.6 Micron optimized	98	Female VCR	19781-02-VF



Pressure

SEMICONDUCTOR | ANALYTICAL EQUIPMENT | AEROSPACE | TELECOMMUNICATIONS



OIL EXPLORATION | R&D | HIGH ENERGY PHYSICS | MILITARY/DEFENSE | BIOTECHNOLOGY



*Advanced Ceramic-to-Metal &
Glass-Ceramic Sealing Technology*

Description

CeramTec's pressure feedthroughs are terminated in NPT (National Pipe Thread) fittings or other threaded fittings to allow for easy bulkhead installation. The NPT pressure units are designed to be sealed using Teflon tape or other acceptable sealants. All other designs use an o-ring seal.

These Ceramaseal® components are usually used in pressure vessels or industrial environments. High vacuum applications are also common but note that the use of threaded connections in a vacuum system should be minimized. The small spaces between the threads can cause virtual leaks.

CeramTec has been designing and manufacturing high pressure, high-reliability, ceramic-to-metal assemblies for more than 55 years.

The pressure feedthroughs in this section show capability in design for pressures up to 25,000 psig. In every design, the ceramic used is high-grade alumina or glass-ceramic, the NPT mounting members are 304 or 316 stainless steel and the ceramic-metal braze materials are silver, silver-copper or copper.

Standard Specifications

- 1/8" to 1/2" NPT fittings
- Internal pressures from 1×10^{-10} torr to 25,000 psig
- Feedthrough, multipin connector, coaxial, CeramTite and Tec-Seal units available
- 1 to 10 conductors

Extreme / Custom Design

- Different fittings: cone and thread, NPT, straight thread and weld designs
- Internal pressures from 1×10^{-10} torr to 40,000 psig



- Instrumentation, multipin connector, coaxial, and thermocouple units are available
- Precious metal braze alloys

Installation

CeramTec's high quality pressure feedthroughs mount easily through NPT fittings or other threaded fittings.

Applications

A few of the many applications in which these pressure feedthroughs are commonly used are:



- Undersea communications
- Geothermal energy exploration
- Power generation
- Furnaces

New Products

- Power Plug feedthroughs mounted in NPT fittings
- CeramTite™ glass-ceramic sealed high pressure feedthroughs
- Tec-Seal™ high pressure feedthroughs

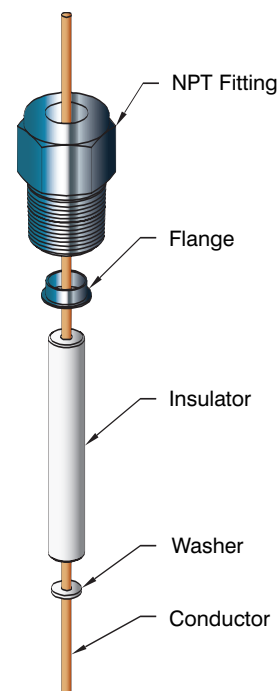
Typical Pressure Feedthrough Construction



Type	Voltage DC	Current (Amps per pin)	Pressure @ 20°C	Number of Conductors	Conductor Material	Sub-section	Section Pages
			PSIG (Bar)				
	to 25 kV	to 185 Amps	4000 (275)	1, 4, 6 & 10	Feedthrough: Copper Multipin: Alumel Coaxial: 304 Stn. Stl. or Nickel	NPT	G.1 184-187
	500 V	4 Amps	to 25,000 (1724)	1 to 3	Alumel	CeramTite™	G.2 188-189
	1.5 kV	15 Amps	to 25,000 (1724)	1	52 Nickel iron	Tec-Seal™	G.3 190-191

.050 [1.3] Dia. Conductor – 1/8" NPT

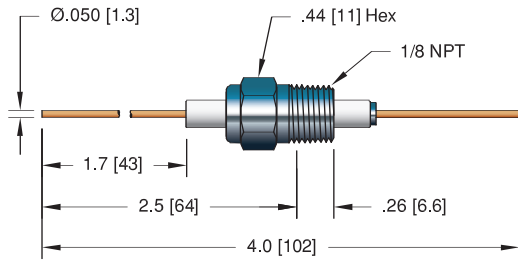

20 KV Power Plug – 1/8" NPT

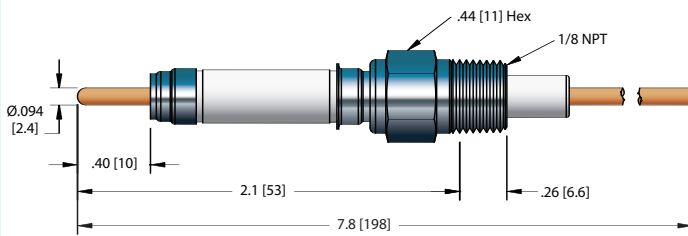

.154 Power Plug – 3/8" NPT

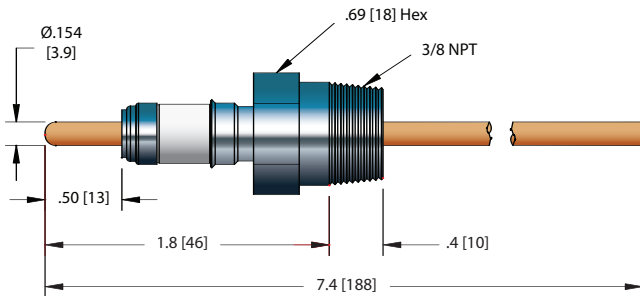

.250 Power Plug – 3/8" NPT

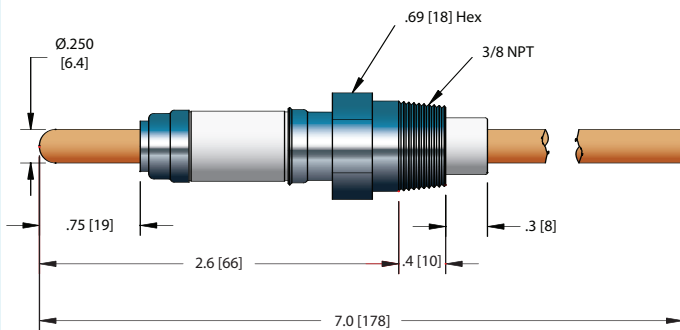

**Power Plug Cable Assemblies
20 kV Power Plug**

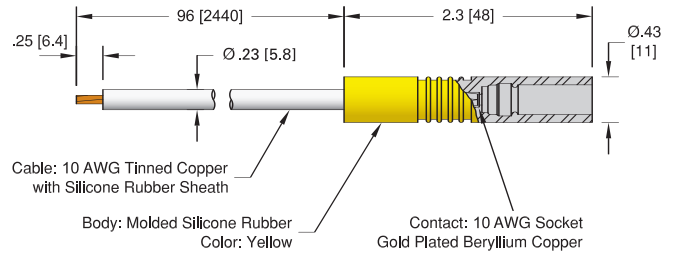

.154 Power Plug

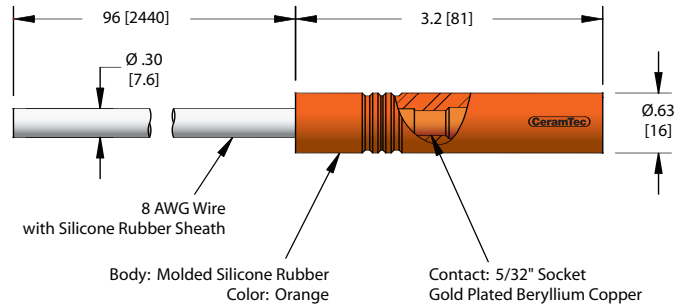

.250 Power Plug

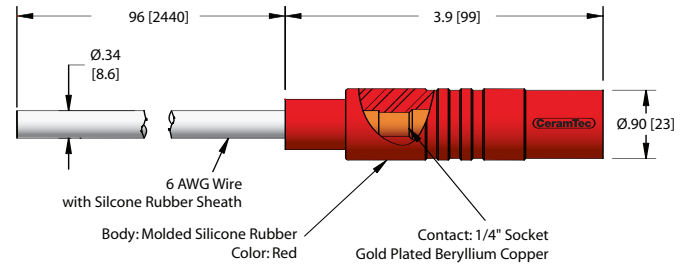

Feedthrough Specifications

Materials

- NPT Fitting: 316 Stainless steel
- Conductor: Copper or 304 Stainless steel
- Insulation: Alumina ceramic
- Magnetic Materials: See table

Voltage Rating See table

Current Rating See table

Temperature Range -269°C to 450°C

Pressure @ 20°C See table



.050 [1.3] Dia. Conductor, 1/8" NPT



VOLTAGE DC	CONDUCTOR AMPS	MATERIAL	INSTALLATION	PRESSURE@20°C PSIG	BAR	MAGNETIC MATERIALS	PART NUMBER
5 kV	27	Copper	1/8" NPT	4000	275	Yes	2846-01-A

20 KV Power Plug 1/8" NPT



20 kV*	3.6	304 Stn. Stl.	1/8" NPT	4000	275	No	21322-01-A
20 kV*	55	Copper	1/8" NPT	4000	275	No	21324-01-A

.154 Power Plug 3/8" NPT

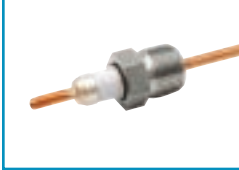

10 kV*	100	Copper	3/8" NPT	1000	69	Yes	21152-01-A
--------	-----	--------	----------	------	----	-----	------------

.250 Power Plug 3/8" NPT



25 kV*	185	Copper	3/8" NPT	1000	69	Yes	21143-01-A
--------	-----	--------	----------	------	----	-----	------------

Air Side Cable Assemblies



TYPE	CABLE TYPE	LENGTH	VOLTAGE DC	CONDUCTOR AMPS	TEMPERATURE °C MIN	MAX	PART NUMBER
20 kV Power Plug	10 AWG	8'	20 kV	55	-55	125	14419-02-A
.154 Power Plug	8 AWG	8'	10 kV	75	-55	125	21094-01-A
.250 Power Plug	6 AWG	8'	25 kV	100	-55	125	20956-02-A [†]

Contacts

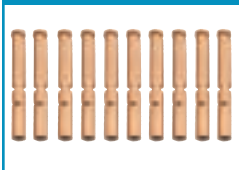

TYPE	MATERIAL	DESCRIPTION	PART NUMBER
0.050 Crimp Contacts	Beryllium Copper	Accepts wire up to 0.062 [1.6]	11911-02-X [†]
0.094 Set Screw Type Contacts	Beryllium Copper	Accepts wire up to 0.050 [1.3]	7429-01-A
0.094 Barrel Type Contacts	Beryllium Copper	Accepts wire up to 0.094 [2.4]	7332-04-A
0.154 Barrel Type Contacts	Beryllium Copper	Accepts wire up to 0.154 [3.9]	7332-07-A
0.250 Barrel Type Contacts	Beryllium Copper	Accepts wire up to 0.250 [6.4]	7332-06-A
Crimp Tool		For 0.025" - 0.075" Crimp Diameters	2840-05

*When used with airside cable assembly. **Contacts priced and sold in packages of 10. [†]Shown in photo. See the Accessories section for more information on all accessories. Note that voltage ratings are based on a minimum of 250 volts DC per mil dielectric strength on the pressure side.

PRESSURE

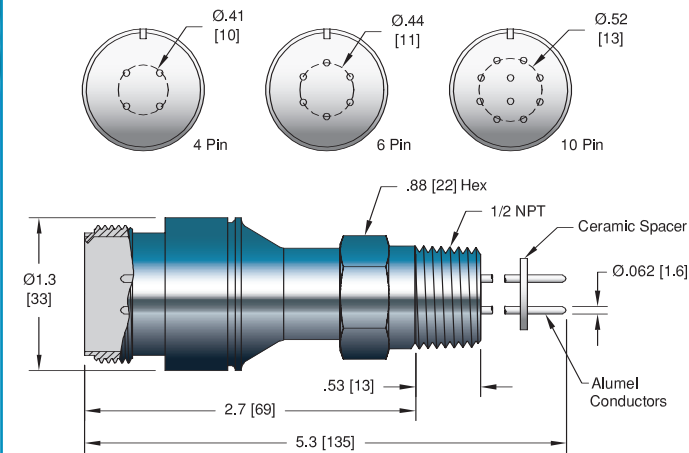
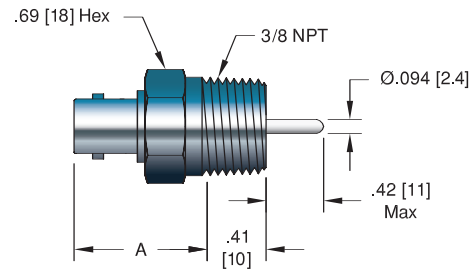

MIL-C-5015 Type – 1/2" NPT**Coaxial – 3/8" NPT****Specifications - Multipin Connector****Materials**

NPT Fitting: 316 Stainless steel
 Conductor: Alumel
 Insulation: Alumina ceramic
 Magnetic Materials: Yes

Voltage Rating 700 V DC

Current Rating 7 Amps per pin

Temperature Range -269°C to 450°C

Pressure @ 20°C

4 Pin: 600 (41 Bar)
 6 Pin: 550 (38 Bar)
 10 Pin: 500 (34 Bar)

Specifications - Coaxial Connector**Materials**

NPT Fitting: 316 Stainless steel
 Conductor:
 BNC: 304 Stainless steel
 MHV: 304 Stainless steel
 SHV: Nickel
 Insulation: Alumina ceramic
 Magnetic Materials:
 BNC: No
 MHV: No
 SHV: Yes

Voltage Rating BNC: 500 V, MHV: 5 kV, SHV: 5 kV DC

Current Rating

BNC: 3.6 Amps, MHV: 3.6 Amps, SHV: 16.5 Amps

Temperature Range -269°C to 450°C

Pressure @ 20°C

BNC: 1400 (97 Bar)
 MHV: 1400 (97 Bar)
 SHV: 1600 (110 Bar)



CONDUCTOR			INSTALLATION	PART NUMBER
QTY	AMPS			
4	7		1/2" NPT	10184-08-A†
6	7		1/2" NPT	10185-08-A
10	7		1/2" NPT	10094-11-A



NO. CONTACTS	VOLTAGE DC	CONDUCTOR AMPS	TYPE	DIMENSIONS		PART NUMBER
				H	L	
4	700 V	13	Air Side	1.4 [36]	4.4 [112]	15910-01-A†
6	700 V	13	Air Side	1.4 [36]	4.4 [112]	15911-01-A
10	700 V	13	Air Side	1.4 [36]	4.4 [112]	15912-01-A



COAXIAL TYPE	CONDUCTOR AMPS	CONDUCTOR MATERIAL	DIMENSION A	PART NUMBER
BNC	3.6	304 Stn. Stl.	0.90 [23]	9263-04-A†
MHV	3.6	304 Stn. Stl.	0.90 [23]	9263-03-A
SHV	16.5	Nickel	1.2 [30]	9263-06-A



TYPE	VOLTAGE DC	CONDUCTOR AMPS	DIMENSIONS		DESCRIPTION	PART NUMBER
			H	L		
Air Side	500 V	5	0.56 [14]	1.1 [28]	BNC Plug	7116-02†
Air Side	5 kV	10	0.56 [14]	1.5 [38]	MHV Plug	7116-01
Air Side	5 kV	10	0.56 [14]	1.8 [46]	SHV 5 kV Plug	8058-01†

†Shown in photo.



CeramTite™ High Pressure Feedthroughs

CeramTite™ feedthroughs consist of a Nickel plated Alumel pin bonded directly to the threaded bolt using our proprietary glass-ceramic sealing process. These hermetically sealed feedthroughs utilize an O-ring crush seal to make the external pressure seal. The hex bolt side is designed to be the high pressure side of the feedthrough. The temperature rating of the assembly is limited by the O-ring material. Viton® is the standard O-ring material used and this material has a high end temperature capability of 205° C.

CeramTite™ feedthroughs are typically used for low power or instrumentation applications in pressure vessels or oil systems. 100% of CeramTec's Ceramaseal® products are helium leak tested to meet or exceed 10⁻¹⁰ atm-cc/sec (He). Custom bolt sizes, pin configurations or sizes are available upon request.

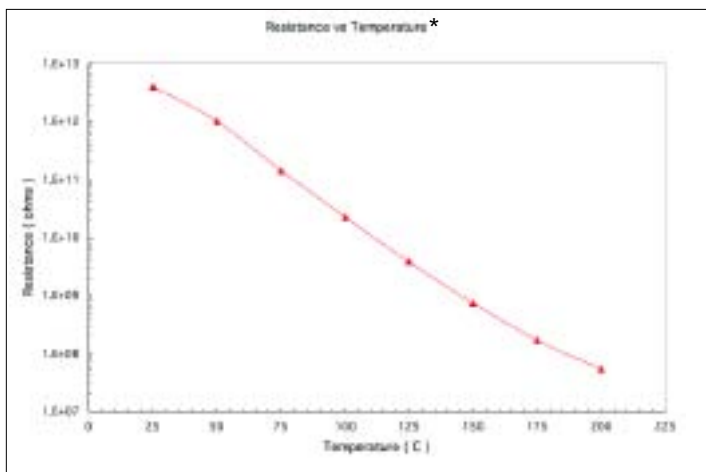

Specifications

Material

Body: 316 Stainless steel
 O-ring: Viton®
 Pin: Alumel (Nickel Plated)
 Insulation: Glass-ceramic & Alumina ceramic
 Magnetic Materials: Yes

Voltage Rating 500 V DC

Current Rating 4 Amps per pin

Temperature Range* -269° C to 450° C

Viton® O-ring: -25° C to 205° C

Pressure @ 20°C

Single Pin: 25,000 (1724 Bar)
 2 Pin: 20,000 (1379 Bar)
 3 Pin: 20,000 (1379 Bar)

*Maximum temperature ratings listed are for bakeout only. The insulation resistance at these temperatures may not be suitable for all applications.

Single Pin

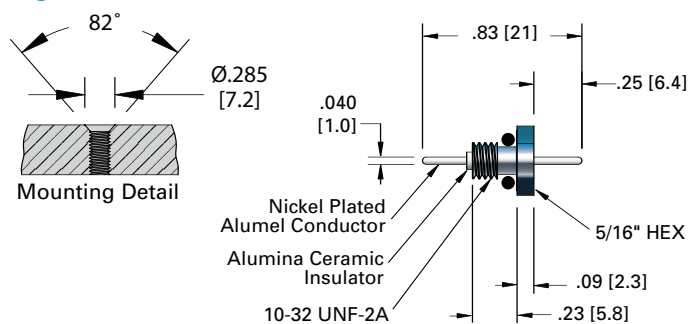

Two Pin

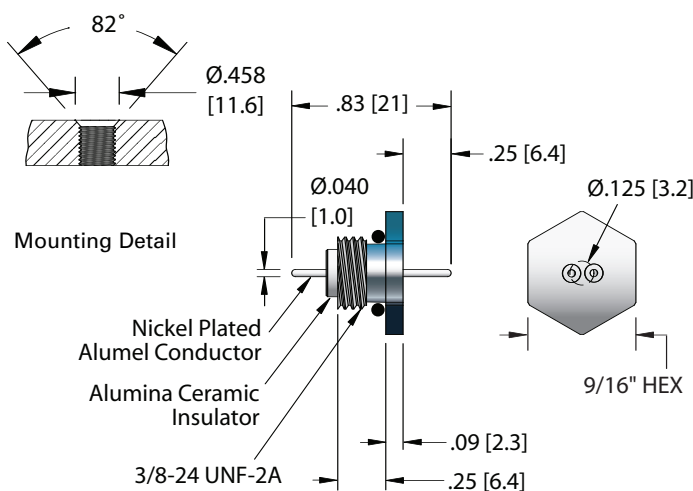

Three Pin

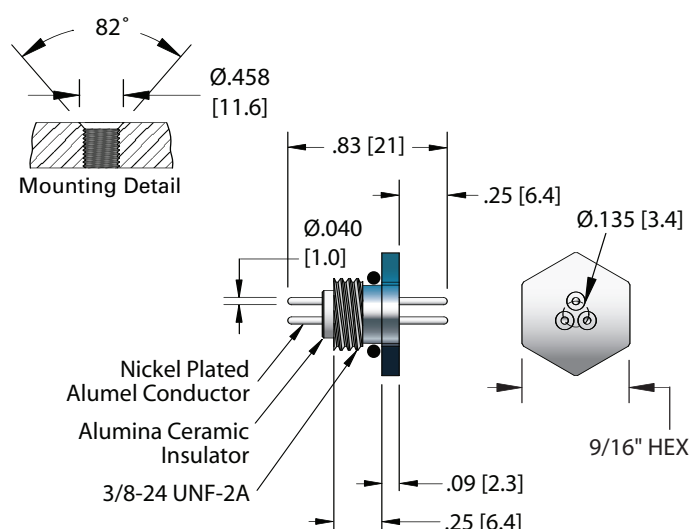



NO. PINS	INSTALLATION		PART NUMBER
	HEX	THREAD	
1	5/16	10-32	50039-01-A



2	9/16	3/8-24	50040-01-A
---	------	--------	------------



3	9/16	3/8-24	50041-01-A
---	------	--------	------------



Contacts	TYPE	MATERIAL	DESCRIPTION	PART NUMBER
	0.040 Crimp Contacts Crimp Tool	Copper Alloy - Gold Flash	Accepts wire up to 0.040 [1.0] For 0.025" - 0.075" Crimp Diameters	16167-03-A† 2840-05

*Contacts priced and sold in packages of 5. †Shown in photo. See the Accessories section for more information on all accessories.



Tec-Seal™ High Pressure Feedthroughs

Tec-Seal™ feedthrough products are built for extreme downhole environments. These rugged hermetic feedthroughs are rated for pressures up to 25,000 psi and temperatures up to 450° C. The Tec-Seal™ embedded seal design will maintain the seal integrity even if one or both sides of the feedthrough are sheared off, thus protecting the bulkhead electronics from damage. These standard designs are also built for dual pressure applications, which means that they can take 25,000 psi from either side. These designs are successfully tested to 50,000 psig but the assembly pressure rating is limited by the o-ring. There isn't a more reliable or durable feedthrough available.

The temperature rating of the assembly is limited by the O-ring material. Viton® is the standard O-ring material used and this material has a high end temperature capability of 205° C. 100% of CeramTec's Ceramaseal® products are helium leak tested to meet or exceed 10^{-10} atm-cc/sec (He). Custom bolt sizes, pin configurations or sizes are available upon request.

Specifications

Materials

Body: 304 Stainless steel
 O-ring: Viton®
 Pin: 52 Nickel iron (Gold Plated)
 Insulation: Alumina ceramic
 Magnetic Materials: Yes

Voltage Rating 1.5 kV DC

Current Rating 7.5 Amps

Temperature Range -269° C to 450° C
 Viton® O-ring: -25° C to 205° C

Pressure @ 20°C 25,000 PSIG (1724 Bar)

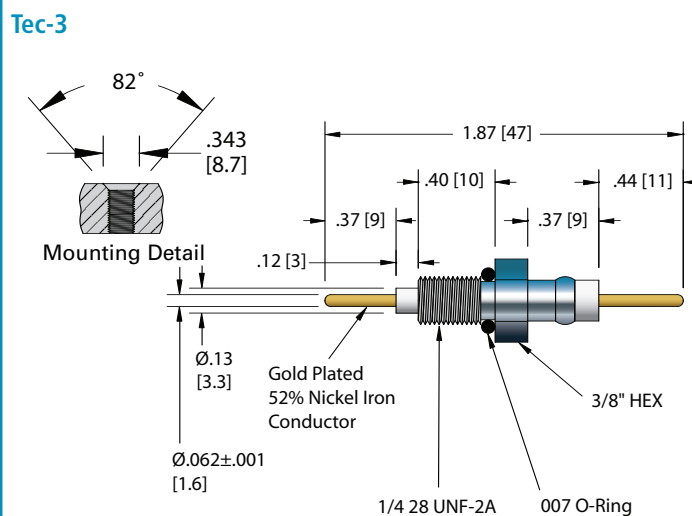
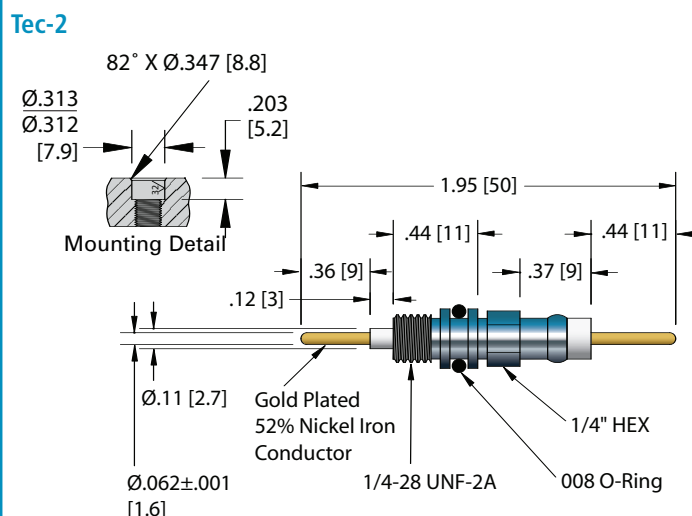
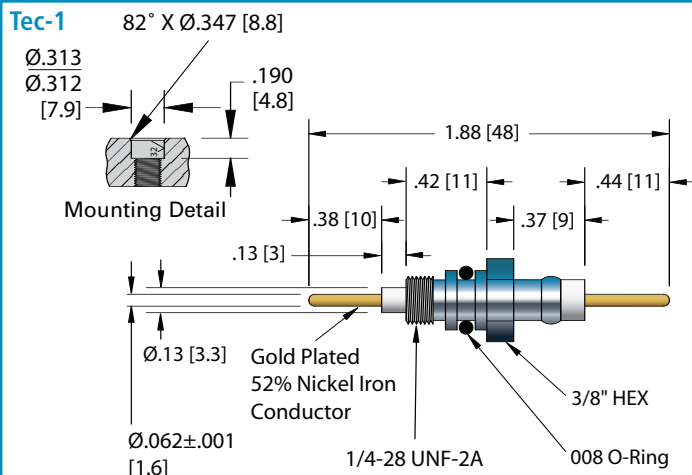



INSTALLATION		PART NUMBER
HEX	THREAD	
3/8	1/4-28	50015-01-A



1/4	1/4-28	50019-01-A
-----	--------	------------



3/8	1/4-28	50020-01-A
-----	--------	------------



TYPE	MATERIAL	DESCRIPTION	PART NUMBER
0.062 Crimp Contacts	Nickel Alloy	Accepts wire up to 0.062 [1.6]	0821-01-A†
0.062 Crimp Contacts	Beryllium Copper	Accepts wire up to 0.062 [1.6]	2044-02-A
0.062 Barrel Type Contacts	Beryllium Copper	Accepts wire up to 0.062 [1.6]	7332-03-A
Crimp Tool		For 0.025" - 0.075" Crimp Diameters	2840-05

*Contacts priced and sold in packages of 5. †Shown in photo. See the Accessories section for more information on all accessories.

Accessories

SEMICONDUCTOR | ANALYTICAL EQUIPMENT | AEROSPACE | TELECOMMUNICATIONS



OIL EXPLORATION | R&D | HIGH ENERGY PHYSICS | MILITARY/DEFENSE | BIOTECHNOLOGY



*Advanced Ceramic-to-Metal &
Glass-Ceramic Sealing Technology*

Description

Accessories is the product classification given by CeramTec for miscellaneous hardware that is used to connect, terminate, install, or isolate Ceramaseal® products.

Contacts

- Used to connect conductors for instrumentation, thermocouples and power in high-temperature vacuum systems, inert atmospheres or in air
- Operational to as high as 400° C
- Thermocouple contacts use thermocouple materials to minimize the induced error from dissimilar materials
- Can be used as direct replacement for the contacts in most of our standard plugs

Plugs

- All coaxial instrumentation and thermocouple plugs can be purchased separately
- All of the standard plugs can be found in the catalog section where they are used
- High voltage (up to 25 kV) and extended temperature range (up to 260° C) plugs are shown here in the Accessories section

In-Vacuum Cables

- Voltages up to 2 kV DC
- Current up to 25 Amps
- Suitable for UHV use
- Temperature ratings as high as 650° C
- Variety of terminations
- Can be used with many CeramTec feedthroughs
- Dual cables for instrumentation and thermocouple pairs

Ceramic Spacers

- Manufactured from high-alumina ceramics
- For use in UHV, inert atmospheres or air
- Can be subjected to the high temperatures associated with bake-out cycles
- Can be used in excess of 800° C, but are limited by thermal expansion differences of conductors



- Will accommodate up to 35 conductors while maintaining separation required to withstand instrumentation voltages

Ceramic Standoffs

- Manufactured from high-vacuum grade non-porous ceramic
- 300 series stainless steel washers and 400 series stainless steel bolts provided
- Can be used at temperatures up to 400° C
- Can be used to support cables, plates or samples at elevated voltages within a vacuum or pressure system
- Voltages to 40 kV in vacuum, 16 kV in air
- Refer to the dielectric strength vs. pressure charts in the Technical Reference section for the value associated with changes in pressure

Vacuum Flanges

- Manufactured to meet industry standards
- Made from 304 stainless steel specially processed to eliminate microscopic leak paths

ConFlat Flange

- Vacuum rating to 10⁻¹⁰ torr or better after repeated cycling from -196° C to 450° C
- Create a reliable seal by compressing a flat copper gasket between the seal surfaces of two compatible flanges.





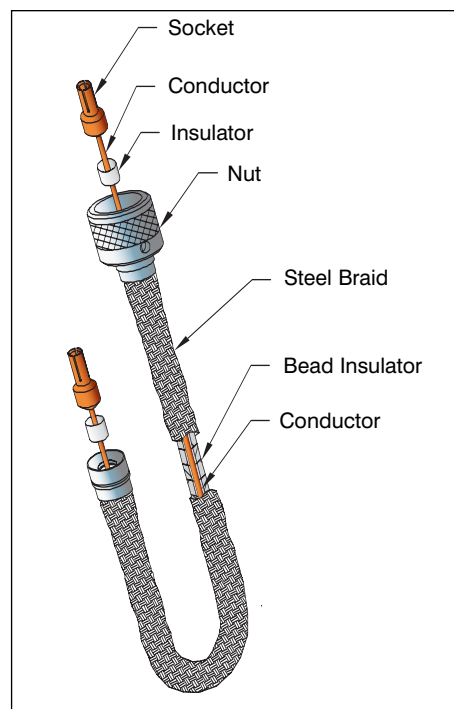

- Can also be used with an o-ring to make the seal

ISO-NW Flange

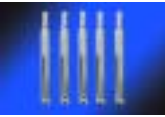
- Vacuum rating to 10⁻⁹ torr after sustained use to 150° C. Repeated bakeout to 200° C can cause deterioration of o-rings and require periodic replacement.
- Create a vacuum seal by closing an aluminum clamp to compress a Viton o-ring on a centering ring between mating flanges

Typical Cable Construction



Type	Voltage DC	Current	Temperature Rating °C		Material	Sub-section	Section Pages
			Min	Max			
	NA	to 1000 Amps	-269	400	Copper, Copper Alloy, Beryllium Copper, Nickel Alloy, Chromel, Alumel	Contacts	H.1 196-197
	to 12 kV	to 46 Amps	-269	260	See Drawings/Table	Plugs	H.2 198-203
	to 25 kV	to 100 Amps	-70	200	See Drawings/Table	Air Side Cables	H.3 204-207
	to 2 kV	to 25 Amps	-269	650	Kapton® Insulated, Stn. Stl. Braid & Alumina Bead Insulator	In-Vacuum Cables	H.4 208-215
	to 40 kV	NA	-269	800	Steatite, Ceramic – 85% Alumina	Standoffs & Spacers	H.5 216-217
	NA	NA	-269	450	304 Stn. Stl.	Flanges	H.6 218-219

Crimp Contacts

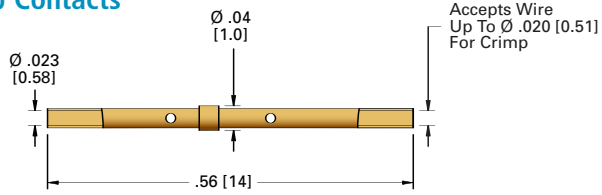

Figure 1

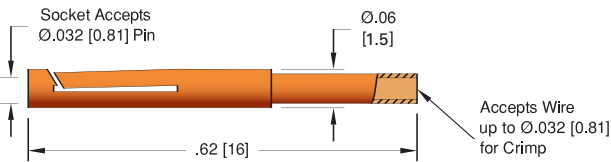

Figure 2

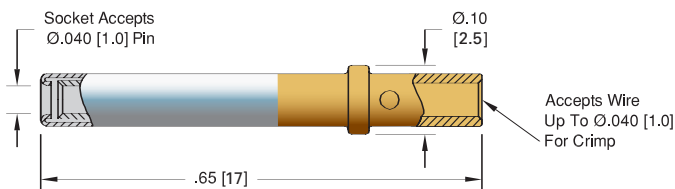

Figure 3

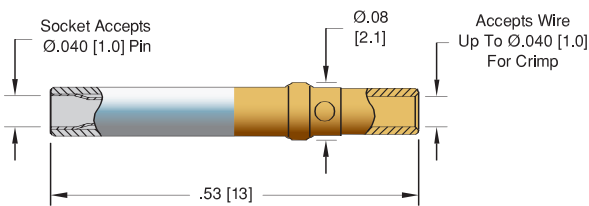

Figure 4

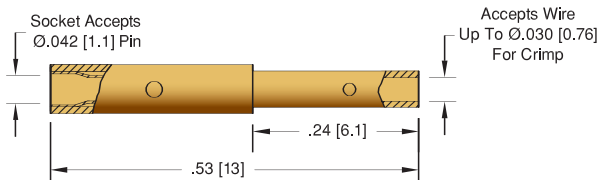

Figure 5

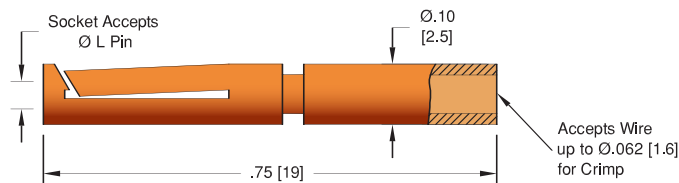

Figure 6

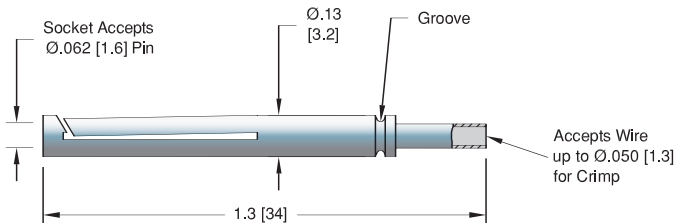

Figure 7

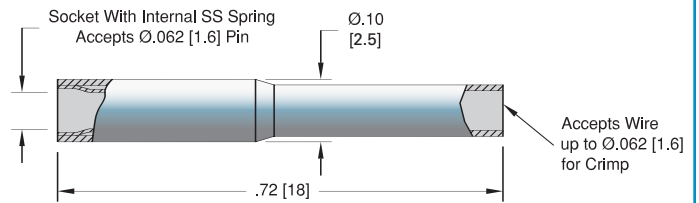

Figure 8

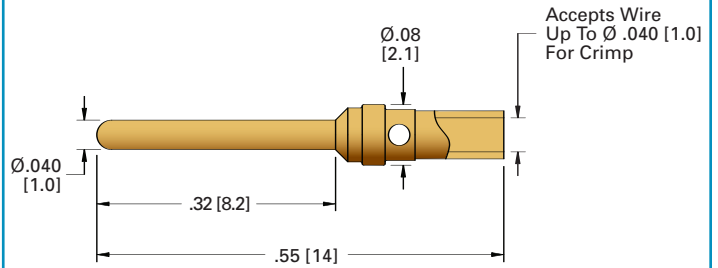

Figure 9

Set Screw Type Contacts

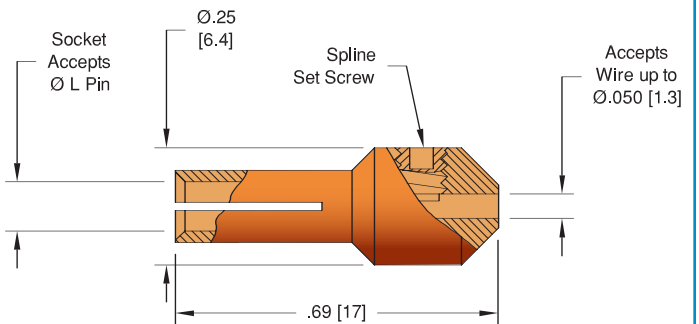

Figure 10

Barrel Type Contacts

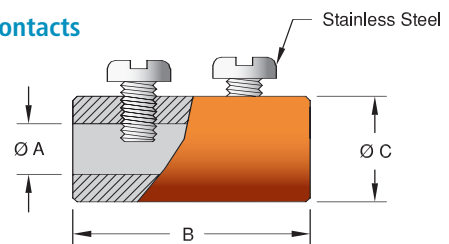

Figure 11

Clamp Type Contacts

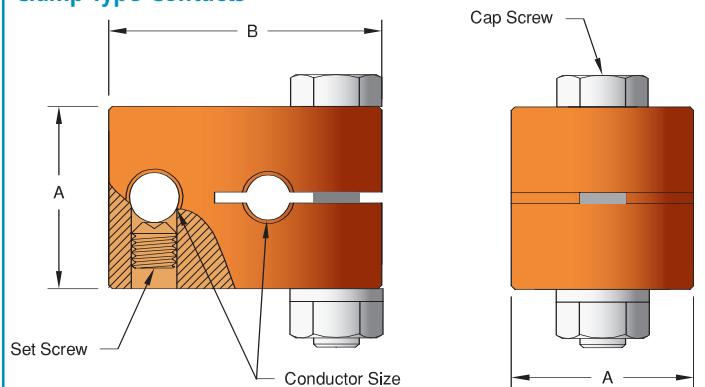

Figure 12

ACCESSORIES



ACCEPTS PIN DIA.	FIGURE	MATERIAL	CURRENT AMPS	TEMPERATURE MIN	TEMPERATURE MAX	GROOVE	GOLD PLATED	QTY/PK	PART NUMBER
.020 [0.51]	1	Beryllium Copper	2	-269	200	-	Yes	5/Pk	21466-02-A
.032 [0.81]	2	Beryllium Copper	16	-269	200	-	No	10/Pk	11288-02-X†
.040 [1.0]	3	Copper Alloy - Gold Flash	15	-200	200	-	No	5/Pk	16167-03-A
.040 [1.0]	4	Copper Alloy - Gold Flash	15	-200	200	-	No	5/Pk	16757-02-A
.042 [1.1]	5	Stainless Steel	2	-269	450	-	Yes	5/Pk	14461-04-A
.050 [1.3]	6	Beryllium Copper	20	-269	200	-	No	10/Pk	11911-02-X
.062 [1.6]	6	Beryllium Copper	20	-269	200	-	No	10/Pk	2044-02-A
.062 [1.6]	7	Chromel	-	-269	350	Yes	No	5/Pk	11259-05-X
.062 [1.6]	7	Alumel	-	-269	350	No	No	5/Pk	11259-06-X
.062 [1.6]	8	Nickel Alloy	10	-269	400	-	No	10/Pk	0821-01-A



MALE PIN DIA.	FIGURE	MATERIAL	CURRENT AMPS	TEMPERATURE MIN	TEMPERATURE MAX	GOLD PLATED	QTY/PK	PART NUMBER
.040 [1.0]	9	Copper Alloy	15	-200	200	Yes	5/Pk	17412-02-A



DIAMETER L	FIGURE	MATERIAL	CURRENT AMPS	TEMPERATURE MIN	TEMPERATURE MAX	QTY/PK	PART NUMBER
0.040 [1.0]	10	Beryllium Copper	20	-269	200	10	7429-03-A
0.050 [1.3]	10	Beryllium Copper	25	-269	200	10	7429-02-A
0.094 [2.4]	10	Beryllium Copper	25	-269	200	10	7429-01-A

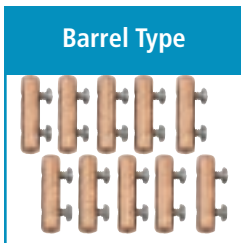

DIAMETER A	FIGURE	MATERIAL	CURRENT AMPS	DIMENSIONS B C		TEMPERATURE MIN	TEMPERATURE MAX	QTY/PK	PART NUMBER
0.040 [1.0]	11	Beryllium Copper	13	0.50 [12.7]	0.13 [3.2]	-269	400	10	7332-01-A
0.050 [1.3]	11	Beryllium Copper	20	0.50 [12.7]	0.19 [4.8]	-269	400	10	7332-02-A
0.062 [1.6]	11	Beryllium Copper	20	0.50 [12.7]	0.19 [4.8]	-269	400	10	7332-03-A
0.094 [2.4]	11	Beryllium Copper	25	0.56 [14.2]	0.25 [6.4]	-269	400	10	7332-04-A
0.125 [3.2]	11	Beryllium Copper	25	0.63 [16.0]	0.25 [6.4]	-269	400	10	7332-05-A
0.154 [3.9]	11	Beryllium Copper	30	0.75 [19.1]	0.33 [8.3]	-269	400	10	7332-07-A
0.250 [6.4]	11	Beryllium Copper	35	1.00 [25.4]	0.50 [12.7]	-269	400	10	7332-06-A



CONDUCTOR SIZE	FIGURE	MATERIAL	CURRENT AMPS	DIMENSIONS A B		TEMPERATURE MIN	TEMPERATURE MAX	PART NUMBER
0.250 [6.4]	12	Copper	350	1.0 [25]	1.5 [38]	-269	400	18740-01-A
0.375 [9.5]	12	Copper	400	1.0 [25]	2.4 [60]	-269	400	18737-01-A
0.500 [12.7]	12	Copper	500	1.0 [25]	2.4 [60]	-269	400	18738-01-A
0.750 [19.1]	12	Copper	1000	1.5 [38]	3.1 [79]	-269	400	18739-01-A



DESCRIPTION	PART NUMBER
Crimp tool for .025" - .075" crimp diameters	2840-05

†Shown in photo.



SMB

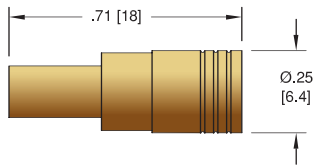

SMA

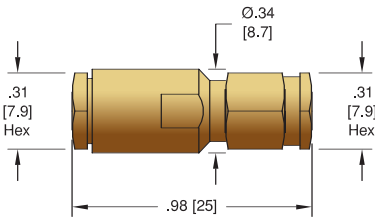

BNC

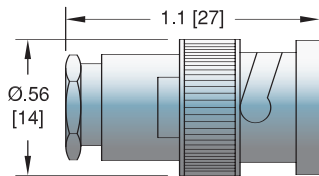

MHV

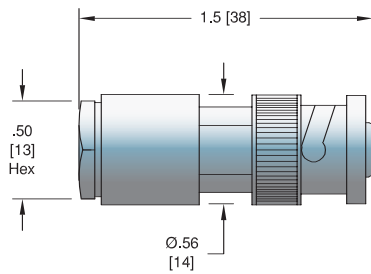

Type N

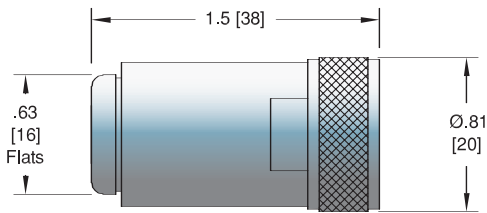

HN

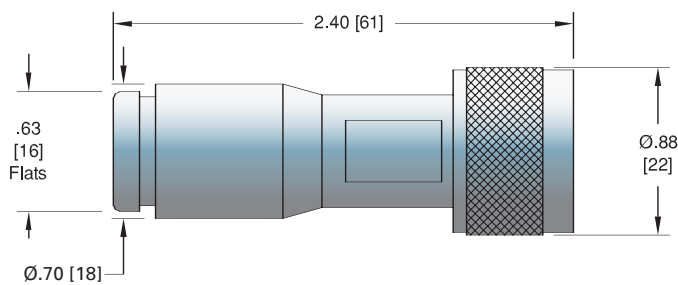

SHV – 5 KV

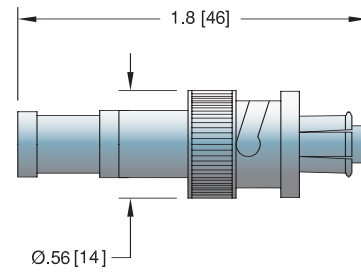

BSHV – 7.5 KV

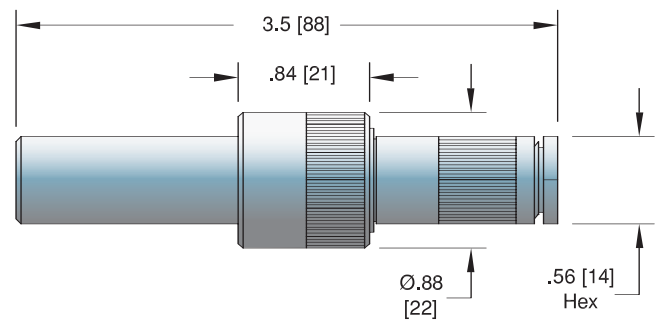

SHV – 10 KV

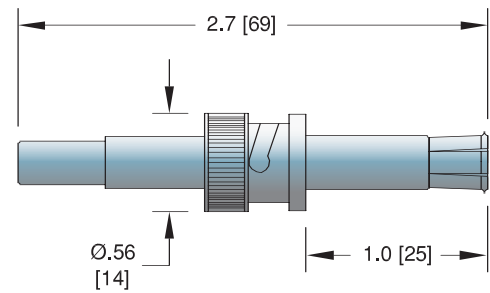

SHV – 20 KV

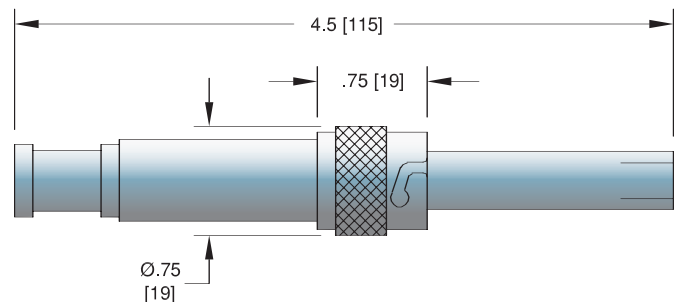



SMB

TYPE	VOLTAGE DC	CONDUCTOR AMPS	TEMPERATURE °C		MAGNETIC MATERIALS	PART NUMBER
			MIN	MAX		
SMB Plug: Air Side	375 V	5	-65	165	No	3095-12



SMA

SMA Plug: Air Side	500 V	5	-65	165	No	6524-02
--------------------	-------	---	-----	-----	----	---------



BNC & MHV

BNC Plug: Air Side	500 V	5	-65	165	No	7116-02 [†]
MHV Plug: Air Side	5 kV	10	-65	165	No	7116-01



Type N

Type N Plug: Air Side	1.5 kV	5	-65	165	No	7707-01
-----------------------	--------	---	-----	-----	----	---------



HN

HN Plug: Air Side	7 kV	10	-55	165	No	6524-05
-------------------	------	----	-----	-----	----	---------



BSHV – 7.5 kV

BSHV Plug: Air Side	7.5 kV	8	-65	400	Yes	7604-01-A
---------------------	--------	---	-----	-----	-----	-----------



SHV

SHV - 5 kV Plug: Air Side	5 kV	10	-65	165	No	8058-01 [†]
SHV - 10 kV Plug: Air Side	10 kV	10	-65	165	No	8058-02
SHV - 20 kV Plug: Air Side	20 kV	20	-20	125	No	8208-02

[†]Shown in photo.

MIL-DTL-83513 – Micro D Type Air Side Plug

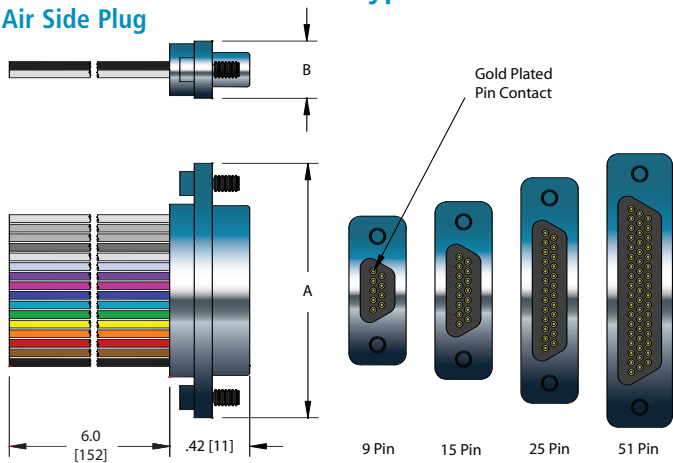

Vacuum Side Plug – PEEK

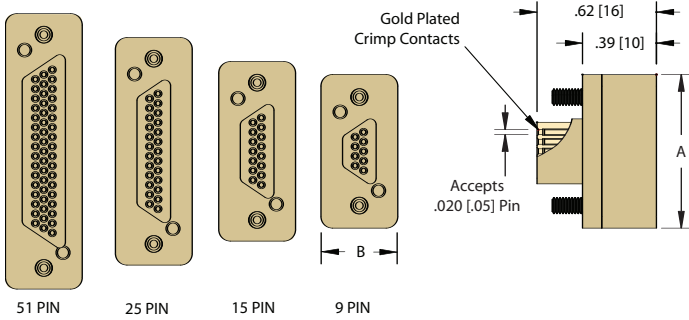

MIL-C-24308 – Sub D Type Air Side Plug

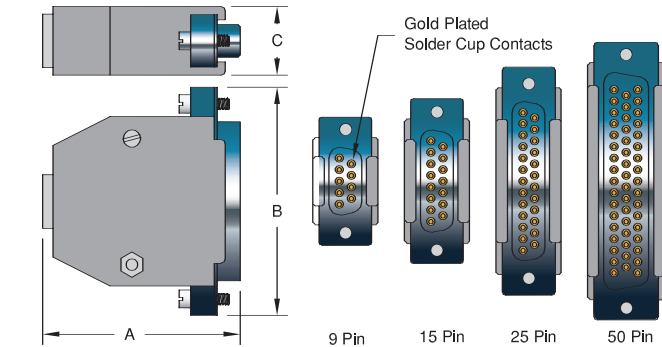

Vacuum Side Plug – PEEK

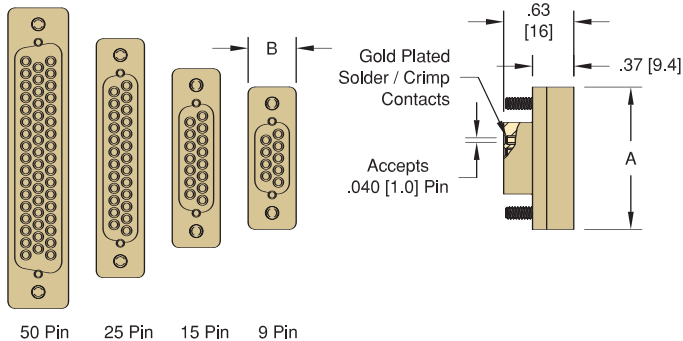

MIL-C-26482 Type Air Side Plug

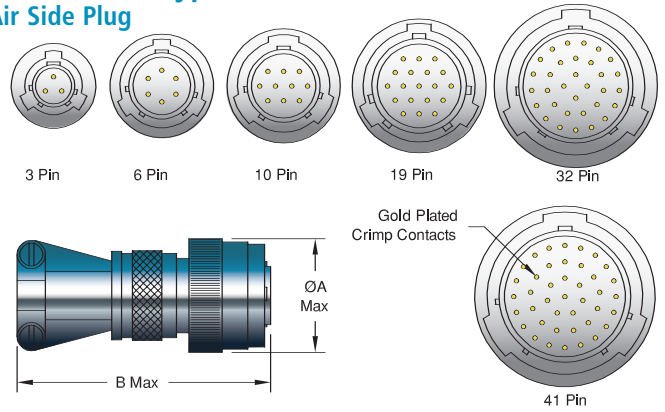

Vacuum Side Plug – PEEK

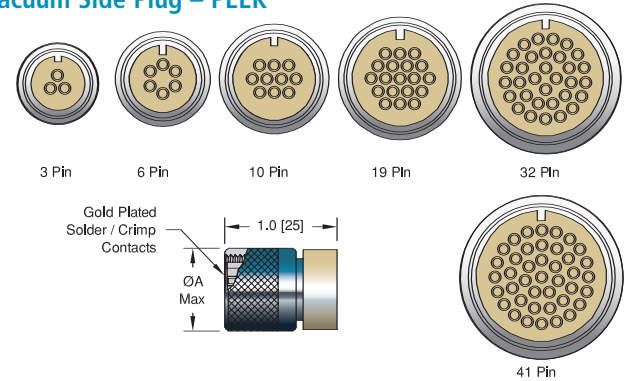

MIL-C-5015 Type Air Side Plug

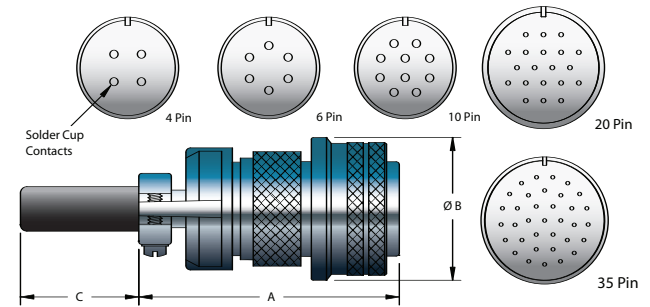

Power-MIL-C-5015 Type

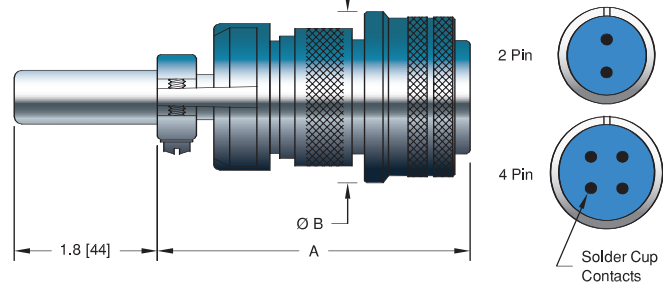



Micro D Type



TYPE	VOLTAGE DC	QTY	CONDUCTOR		DIMENSIONS		TEMPERATURE °C		MAGNETIC MATERIALS	PART NUMBER
			AMPS	MATERIAL	A	B	MIN	MAX		
Air Side	500 V	9	3	Copper Alloy	0.775 [20]	0.298 [8]	-55	125	No	21585-01-A
Air Side	500 V	15	3	Copper Alloy	0.925 [23]	0.298 [8]	-55	125	No	21586-01-A
Air Side	500 V	25	3	Copper Alloy	1.175 [30]	0.298 [8]	-55	125	No	21587-01-A†
Air Side	500 V	51	3	Copper Alloy	1.425 [36]	0.341 [9]	-55	125	No	21589-01-A
Vacuum Side	500 V	9	2	Beryllium Copper	0.790 [20]	0.390 [10]	-269	200	No	21573-01-A
Vacuum Side	500 V	15	2	Beryllium Copper	0.935 [24]	0.390 [10]	-269	200	No	21574-01-A
Vacuum Side	500 V	25	2	Beryllium Copper	1.185 [30]	0.390 [10]	-269	200	No	21575-01-A
Vacuum Side	500 V	51	2	Beryllium Copper	1.135 [36]	0.390 [10]	-269	200	No	21577-01-A

Sub D Type

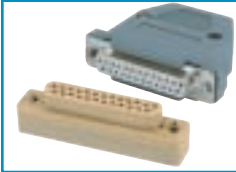

TYPE	VOLTAGE DC	QTY	CONTACTS		DIMENSIONS			TEMPERATURE °C		MAGNETIC MATERIALS	PART NUMBER
			AMPS	MATERIAL	A	B	C	MIN	MAX		
Air Side	500 V	9	5	Copper Alloy	1.7 [43]	1.2 [31]	0.6 [15]	-55	105	Yes	18076-01-A
Air Side	500 V	15	5	Copper Alloy	1.6 [41]	1.6 [41]	0.6 [15]	-55	105	Yes	18076-02-A
Air Side	500 V	25	5	Copper Alloy	1.9 [48]	2.2 [56]	0.6 [15]	-55	105	Yes	18076-03-A†
Air Side	500 V	50	5	Copper Alloy	2.0 [51]	2.6 [66]	0.7 [18]	-55	105	Yes	18076-04-A
Vacuum Side-Female	500 V	9	5	Copper Alloy	1.3 [33]	0.4 [11]	-	-200	200	No	16810-01-A
Vacuum Side-Female	500 V	15	5	Copper Alloy	1.6 [40]	0.4 [11]	-	-200	200	No	16811-01-A
Vacuum Side-Female	500 V	25	5	Copper Alloy	2.2 [55]	0.4 [11]	-	-200	200	No	16812-01-A†
Vacuum Side-Female	500 V	50	5	Copper Alloy	2.7 [69]	0.5 [14]	-	-200	200	No	16814-01-A
Vacuum Side-Male	500 V	9	5	Copper Alloy	1.3 [33]	0.4 [11]	-	-200	200	No	19827-01-A
Vacuum Side-Male	500 V	15	5	Copper Alloy	1.6 [40]	0.4 [11]	-	-200	200	No	19828-01-A
Vacuum Side-Male	500 V	25	5	Copper Alloy	2.2 [55]	0.4 [11]	-	-200	200	No	17411-01-A
Vacuum Side-Male	500 V	50	5	Copper Alloy	2.7 [69]	0.5 [14]	-	-200	200	No	19829-01-A

MIL-C-26482 Type



TYPE	VOLTAGE DC	QTY	CONTACTS		DIMENSIONS		TEMPERATURE °C		MAGNETIC MATERIALS	PART NUMBER
			AMPS	MATERIAL	A	B	MIN	MAX		
Air Side	1 kV	3	1	Copper Alloy	0.8 [20]	1.9 [48]	-55	200	No	16060-01-A†
Air Side	1 kV	6	1	Copper Alloy	1.0 [25]	1.9 [48]	-55	200	No	16060-02-A
Air Side	1 kV	10	1	Copper Alloy	1.0 [25]	1.9 [48]	-55	200	No	16060-03-A
Air Side	1 kV	19	1	Copper Alloy	1.2 [31]	1.9 [48]	-55	200	No	16060-04-A
Air Side	1 kV	32	1	Copper Alloy	1.4 [36]	2.1 [53]	-55	200	No	16060-05-A
Air Side	1 kV	41	1	Copper Alloy	1.5 [38]	2.3 [58]	-55	200	No	16060-06-A
Vacuum Side	1 kV	3	5	Copper Alloy	0.8 [20]	-	-200	200	No	16026-02-A†
Vacuum Side	1 kV	6	5	Copper Alloy	0.9 [22]	-	-200	200	No	16027-02-A
Vacuum Side	1 kV	10	5	Copper Alloy	1.0 [25]	-	-200	200	No	16028-02-A
Vacuum Side	1 kV	19	5	Copper Alloy	1.1 [28]	-	-200	200	No	16029-02-A
Vacuum Side	1 kV	32	5	Copper Alloy	1.4 [34]	-	-200	200	No	16030-02-A
Vacuum Side	1 kV	41	5	Copper Alloy	1.5 [37]	-	-200	200	No	16031-02-A

MIL-C-5015 Type



TYPE	VOLTAGE DC	QTY	CONTACTS		DIMENSIONS			TEMPERATURE °C		MAGNETIC MATERIALS	PART NUMBER
			AMPS	MATERIAL	A	B	C	MIN	MAX		
Air Side	700 V	4	13	Copper Alloy	2.6 [65]	1.4 [36]	1.8 [44]	-55	125	No	15910-01-A
Air Side	700 V	6	13	Copper Alloy	2.6 [65]	1.4 [36]	1.8 [44]	-55	125	No	15911-01-A
Air Side	700 V	10	13	Copper Alloy	2.6 [65]	1.4 [36]	1.8 [44]	-55	125	No	15912-01-A
Air Side	700 V	20	13	Copper Alloy	2.9 [74]	1.9 [49]	1.4 [36]	-55	125	No	15913-01-A†
Air Side	700 V	35	13	Copper Alloy	3.0 [77]	2.5 [62]	1.2 [30]	-55	125	No	15914-01-A
Air Side: Hi-Temp PEEK	700 V	4	4.8	Alumel	2.6 [65]	1.4 [36]	1.8 [44]	-55	260	Yes	15910-32-A
Air Side: Hi-Temp PEEK	700 V	6	4.8	Alumel	2.6 [65]	1.4 [36]	1.8 [44]	-55	260	Yes	15911-32-A
Air Side: Hi-Temp PEEK	700 V	10	4.8	Alumel	2.6 [65]	1.4 [36]	1.8 [44]	-55	260	Yes	15912-32-A
Power: .094 Contacts	700 V	2	23	Copper Alloy	2.5 [63]	1.2 [32]	-	-55	125	No	18600-01-A
Power: .094 Contacts	700 V	4	23	Copper Alloy	2.5 [63]	1.4 [36]	-	-55	125	No	18600-02-A
Power: .142 Contacts	700 V	2	46	Copper Alloy	2.6 [65]	1.6 [40]	-	-55	125	No	18601-01-A
Power: .142 Contacts	700 V	4	46	Copper Alloy	2.6 [65]	1.6 [40]	-	-55	125	No	18601-02-A

Note that contacts are included with all plugs. †Shown in photo.



High Voltage 2 & 4 Contacts

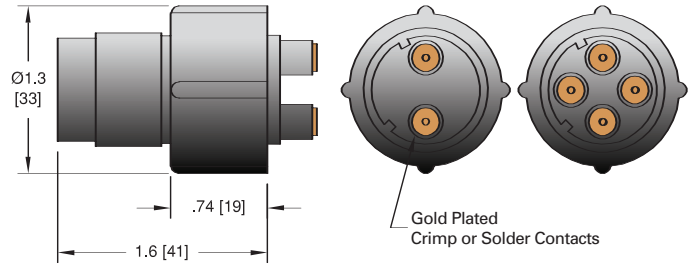

7 Contacts

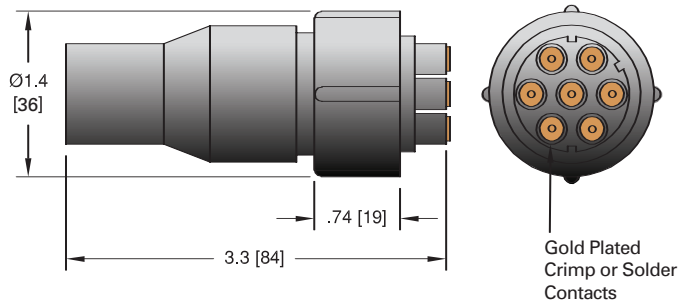

Thermocouple Spade Type

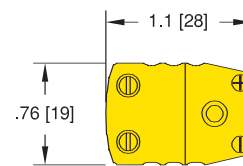

Thermocouple MIL-C-5015 Type

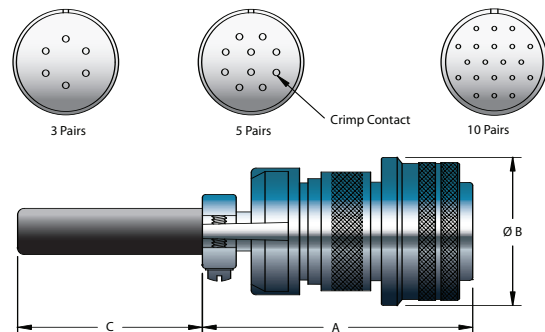

High Voltage



TYPE	VOLTAGE DC	QTY	CONTACTS AMPS	MATERIAL	TEMPERATURE °C		MAGNETIC MATERIALS	PART NUMBER
					MIN	MAX		
Air Side	12 kV	2	13	Copper Alloy	-15	85	No	2871-02-A [†]
Air Side	12 kV	4	13	Copper Alloy	-15	85	No	2871-03-A
Air Side	12 kV	7	13	Copper Alloy	-15	85	No	2871-01-A

Thermocouple Spade Type



ANSI TYPE	THERMOCOUPLE MATERIALS	TYPE	PLUG MATERIALS	TEMPERATURE °C		COLOR CODE	MAGNETIC MATERIALS	PART NUMBER
				MIN	MAX			
K	Chromel/Alumel	Standard	Glass Filled Nylon	-29	218	Yellow	Yes	08151-01 [†]
K	Chromel/Alumel	High Temp	Ceramic	-73	650	Yellow	Yes	08151-09
C	Tungsten - Rhenium	Standard	Glass Filled Nylon	-29	218	Red	Yes	08151-04
C	Tungsten - Rhenium	High Temp	Ceramic	-73	250	Red	Yes	08151-07

Thermocouple MIL-C-5015 Type



ANSI TYPE	T/C PAIRS	THERMOCOUPLE MATERIALS	DIMENSIONS			TEMPERATURE °C		MAGNETIC MATERIALS	PART NUMBER
			A	B	C	MIN	MAX		
K	3	Chromel/Alumel	2.6 [65]	1.4 [36]	1.8 [44]	-55	125	Yes	15911-02-A
K	5	Chromel/Alumel	2.6 [65]	1.4 [36]	1.8 [44]	-55	125	Yes	15912-02-A
K	10	Chromel/Alumel	2.9 [74]	1.9 [49]	1.4 [36]	-55	125	Yes	15913-02-A [†]

Note that contacts are included with all plugs. [†]Shown in photo.



Microdot

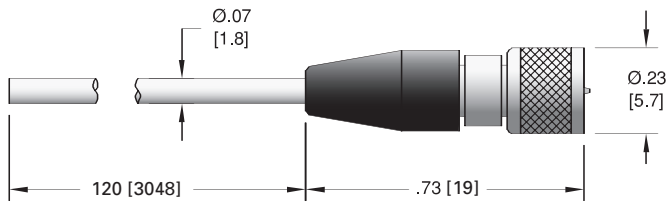

SMB

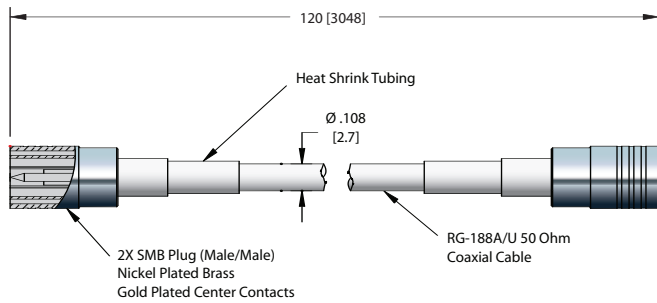

SMA

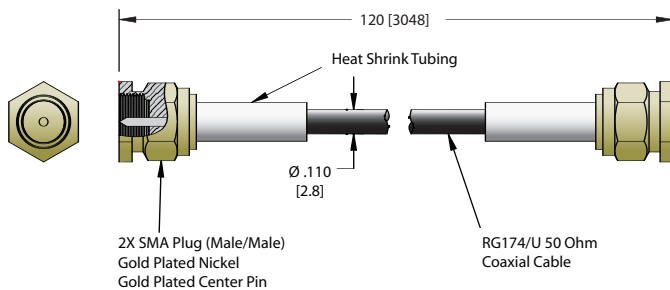

BNC

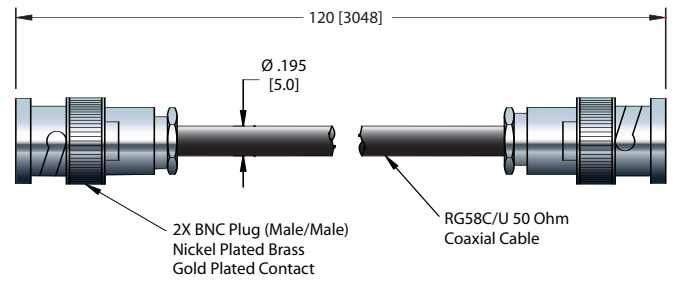

MHV

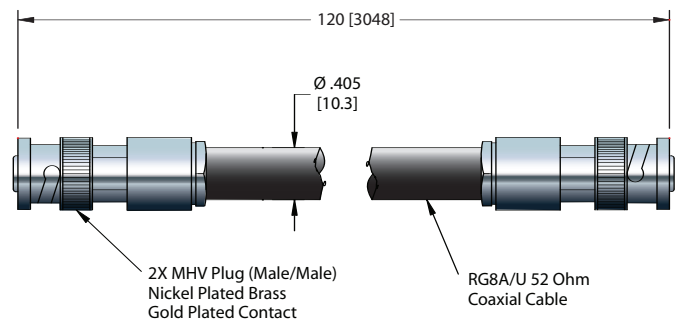

Type N

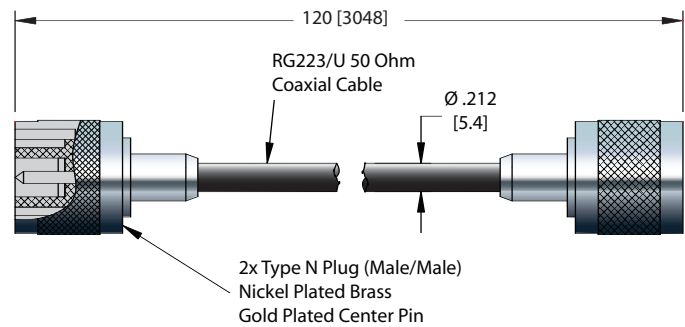

SHV - 5 KV

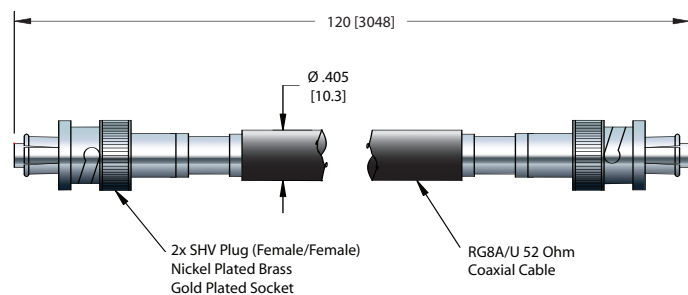



**Single Ended
Microdot**

TYPE	CABLE	CABLE LENGTH	VOLTAGE DC	CONDUCTOR AMPS	TEMPERATURE °C MIN	TEMPERATURE °C MAX	PART NUMBER
Microdot	RG196A/U	10'	1 kV	2	-65	125	14544-01-A



**Double Ended
SMB**

50 Ohm SMB	RG188A/U	10'	500 V	2	-70	200	21618-01-A
------------	----------	-----	-------	---	-----	-----	------------



**Double Ended
SMA**

50 Ohm SMA	RG174/U	10'	500 V	5	-45	75	21617-01-A
------------	---------	-----	-------	---	-----	----	------------



**Double Ended
BNC**

50 Ohm BNC	RG58C/U	10'	500 V	5	-40	85	18921-01-A
------------	---------	-----	-------	---	-----	----	------------



**Double Ended
MHV**

52 Ohm MHV	RG8A/U	10'	5 kV	10	-55	85	18921-02-A
------------	--------	-----	------	----	-----	----	------------



**Double Ended
Type N**

50 Ohm Type N	RG223/U	10'	1.5 kV	5	-40	60	21619-01-A
---------------	---------	-----	--------	---	-----	----	------------



**Double Ended
SHV - 5 KV**

52 Ohm SHV	RG8A/U	10'	5 kV	10	-55	85	18921-03-A
------------	--------	-----	------	----	-----	----	------------

Micro HV

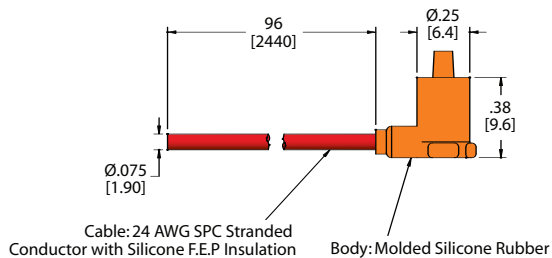

.250 Power Plug

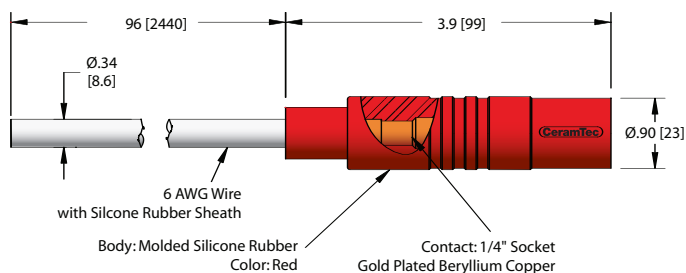

Mini HV

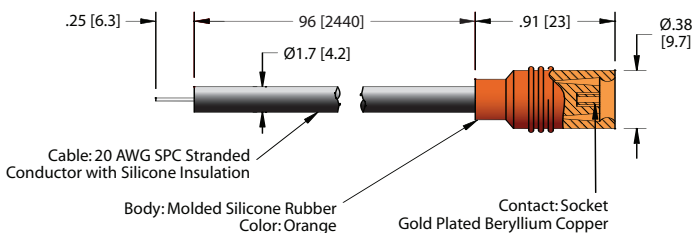

High Voltage – 40 KV

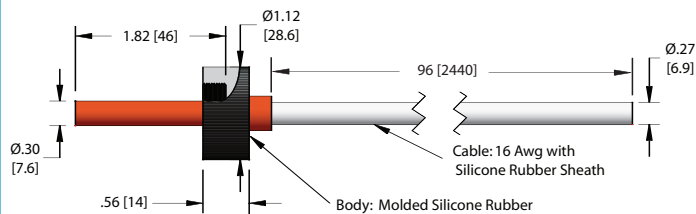

10 kV Power Plug

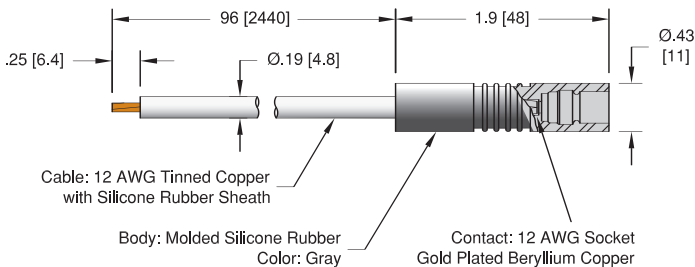

High Voltage – 50 KV

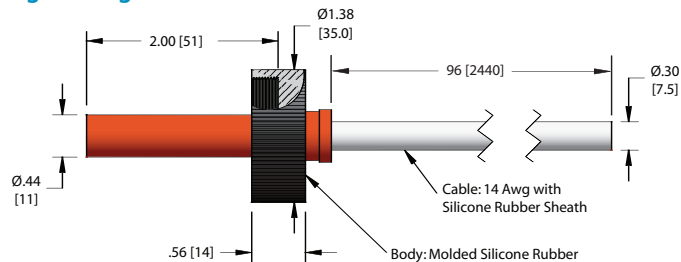

20 KV Power Plug

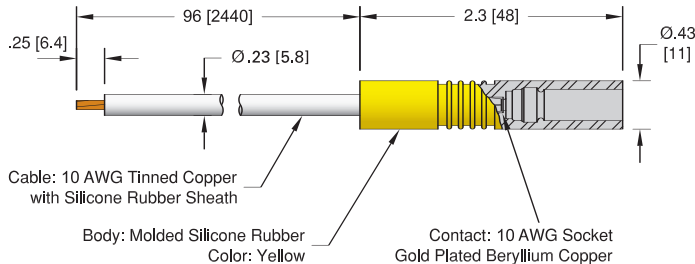

.154 Power Plug

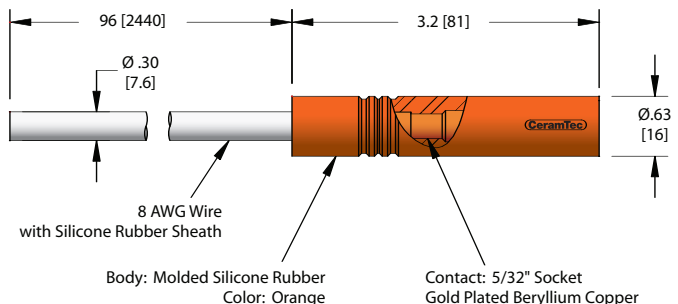



TYPE	CABLE TYPE	LENGTH	VOLTAGE DC	CONDUCTOR AMPS	TEMPERATURE °C		PART NUMBER
					MIN	MAX	
Micro HV	24 AWG	8'	10 kV	3	-55°C	125°C	21039-01-A



Mini HV	20 AWG	8'	15 kV	7.5	-55°C	125°C	21119-01-A
---------	--------	----	-------	-----	-------	-------	------------



10 kV Power Plug	12 AWG	8'	10 kV	30	-55°C	125°C	14418-02-A
20 kV Power Plug	10 AWG	8'	20 kV	55	-55°C	125°C	14419-02-A
.154 Power Plug	8 AWG	8'	10 kV	75	-55°C	125°C	21094-01-A
.250 Power Plug	6 AWG	8'	25 kV	100	-55°C	125°C	20956-02-A



40 kV Air Side	16 AWG	8'	40 kV	10	-55°C	125°C	21034-01-A
50 kV Air Side	14 AWG	8'	50 kV	10	-55°C	125°C	21112-01-A

**Duplex Shielded
.030 [0.76] Dia. Conductor**

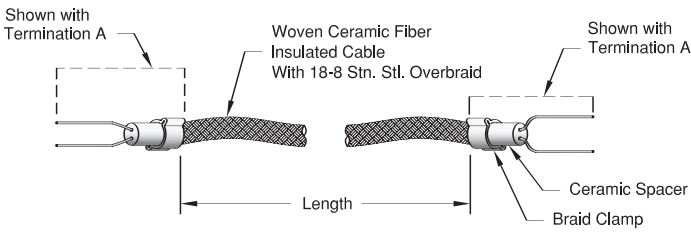

Termination A – Bare Conductor

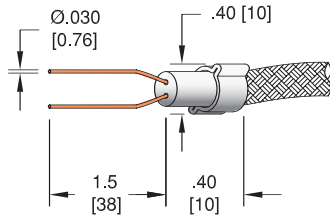

Termination B – Thermocouple Bead

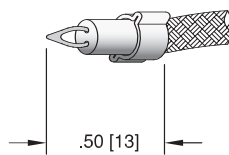

Termination C – BeCu Contacts

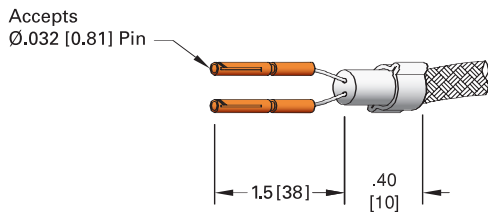

Termination D – Nickel Contacts

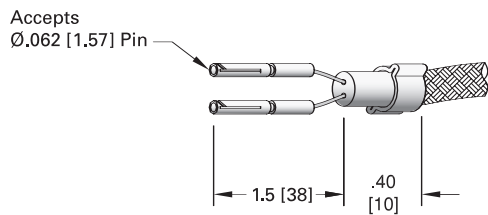

Termination E – Chromel/Alumel Contacts

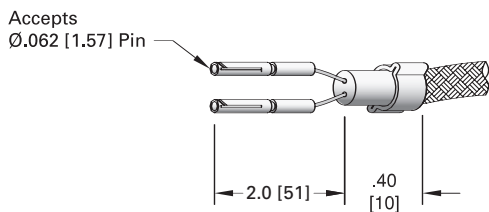

**Cable Components
Beads**

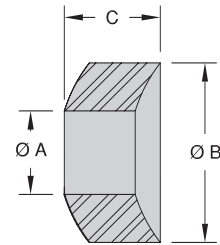

Conductor



Braid

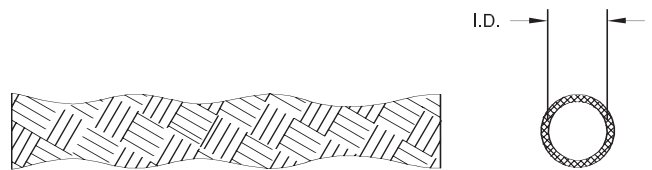

Duplex Shielded Two Conductors

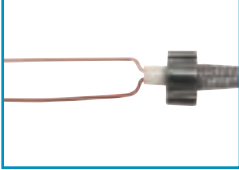

VOLTAGE DC	TERMINATION			CONDUCTOR AMPS	CONDUCTOR MATERIAL	CONTACT MATERIAL	TEMPERATURE °C		MAGNETIC MATERIALS	PART NUMBER
	END 1	END 2	LENGTH				MIN	MAX		
500 V	A	A	12"	15	Copper/Copper	-	-269	650	No	18682-12-AA
500 V	A	C	12"	15	Copper/Copper	BeCu	-269	200	No	18682-12-AC
500 V	A	D	12"	15	Copper/Copper	Nickel Alloy	-200	400	Yes	18682-12-AD
500 V	C	C	12"	15	Copper/Copper	BeCu	-269	200	No	18682-12-CC
500 V	D	D	12"	15	Copper/Copper	Nickel Alloy	-200	400	Yes	18682-12-DD
500 V	A	A	24"	15	Copper/Copper	-	-269	650	No	18682-24-AA
500 V	A	C	24"	15	Copper/Copper	BeCu	-269	200	No	18682-24-AC
500 V	A	D	24"	15	Copper/Copper	Nickel Alloy	-200	400	Yes	18682-24-AD
500 V	C	C	24"	15	Copper/Copper	BeCu	-269	200	No	18682-24-CC
500 V	D	D	24"	15	Copper/Copper	Nickel Alloy	-200	400	Yes	18682-24-DD
500 V	A	A	36"	15	Copper/Copper	-	-269	650	No	18682-36-AA
500 V	A	C	36"	15	Copper/Copper	BeCu	-269	200	No	18682-36-AC
500 V	A	D	36"	15	Copper/Copper	Nickel Alloy	-200	400	Yes	18682-36-AD
500 V	C	C	36"	15	Copper/Copper	BeCu	-269	200	No	18682-36-CC
500 V	D	D	36"	15	Copper/Copper	Nickel Alloy	-200	400	Yes	18682-36-DD

Duplex Shielded Thermocouple

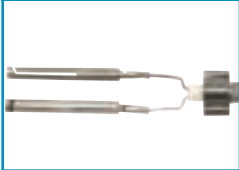

VOLTAGE DC	TERMINATION			ANSI TYPE	CONDUCTOR/CONTACT MATERIAL	TEMPERATURE °C		MAGNETIC MATERIALS	PART NUMBER
	END 1	END 2	LENGTH			MIN	MAX		
500 V	A	A	12"	K	Chromel/Alumel	-269	650	Yes	18684-12-AA
500 V	A	B	12"	K	Chromel/Alumel	-200	650	Yes	18684-12-AB
500 V	A	E	12"	K	Chromel/Alumel	-269	350	Yes	18684-12-AE
500 V	E	E	12"	K	Chromel/Alumel	-269	350	Yes	18684-12-EE
500 V	A	A	24"	K	Chromel/Alumel	-269	650	Yes	18684-24-AA
500 V	A	B	24"	K	Chromel/Alumel	-200	650	Yes	18684-24-AB
500 V	A	E	24"	K	Chromel/Alumel	-269	350	Yes	18684-24-AE
500 V	E	E	24"	K	Chromel/Alumel	-269	350	Yes	18684-24-EE
500 V	A	A	36"	K	Chromel/Alumel	-269	650	Yes	18684-36-AA
500 V	A	B	36"	K	Chromel/Alumel	-200	650	Yes	18684-36-AB
500 V	A	E	36"	K	Chromel/Alumel	-269	350	Yes	18684-36-AE
500 V	E	E	36"	K	Chromel/Alumel	-269	350	Yes	18684-36-EE

Beads



MATERIAL	DIMENSIONS			BEADS PER FOOT	TEMPERATURE °C		PART NUMBER
	A	B	C		MIN	MAX	
96% Min Alumina	0.056 [1.42]	0.110 [2.79]	0.110 [2.79]	120	-269	800	07424-01
Steatite Grade L3	0.068 [1.73]	0.170 [4.32]	0.170 [4.32]	84	-269	600	07424-03
Steatite Grade L3	0.087 [2.21]	0.180 [4.57]	0.100 [2.54]	120	-269	600	07424-06
Steatite Grade L3	0.092 [2.34]	0.200 [5.08]	0.200 [5.08]	72	-269	600	07424-02

Conductor

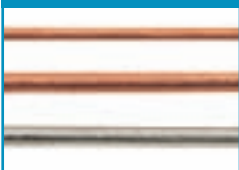

DIAMETER	CONDUCTOR MATERIAL	AMPS	PART NUMBER
0.032 [0.81]	Copper	16	18745-01
0.036 [0.91]	Zirconium Copper	17	18745-02
0.050 [1.3]	Nickel	8.2	18745-03
0.050 [1.3]	Zirconium Copper	30	18745-04
0.050 [1.3]	Copper	27	18745-05

Braid

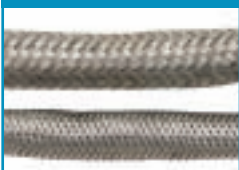

BRAID INSIDE DIAMETER	PART NUMBER
0.125 [3.18]	18746-01
0.250 [6.35]	18746-02

**Coaxial: 1/8" Diameter
.036 [0.91] Dia. Conductor**

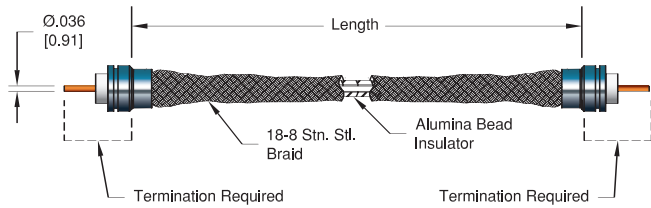

Termination A – Coaxial

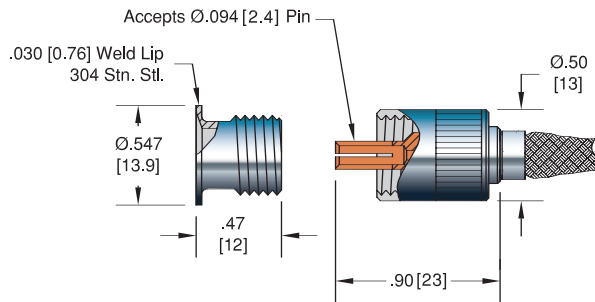

Termination B – Contact

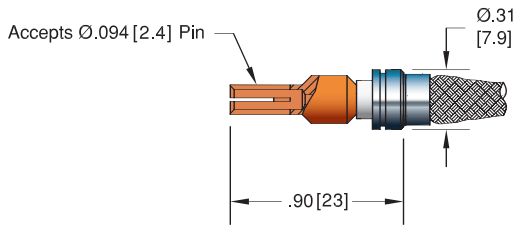

Termination C – In-Line

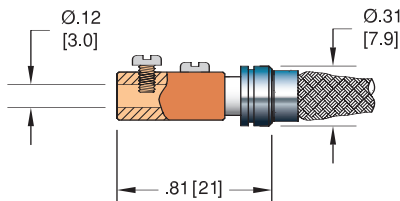

Termination – BNC & MHV

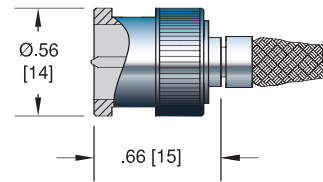

1/8" Cable Splice

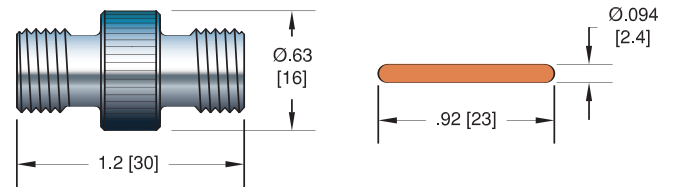

Microdot

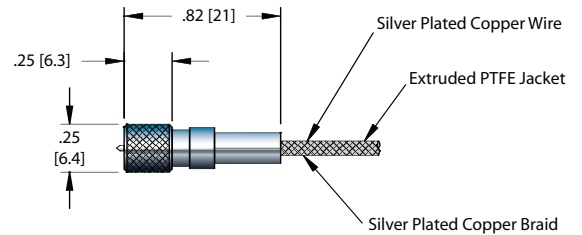

ACCESSORIES



VOLTAGE DC	TERMINATION		LENGTH	CONDUCTOR AMPS	CONDUCTOR MATERIAL	TEMPERATURE °C		MAGNETIC MATERIALS	PART NUMBER
	END 1	END 2				MIN	MAX		
1.5 V	A	A	12"	15	Zirconium Copper	-269	200	No	18680-12-AA
1.5 V	A	B	12"	15	Zirconium Copper	-269	200	No	18680-12-AB
1.5 V	A	C	12"	15	Zirconium Copper	-269	200	No	18680-12-AC
1.5 V	A	BNC	12"	15	Zirconium Copper	-269	200	No	18680-12-AE
1.5 V	A	MHV	12"	15	Zirconium Copper	-269	200	No	18680-12-AF
1.5 V	B	B	12"	15	Zirconium Copper	-269	200	No	18680-12-BB
1.5 V	B	C	12"	15	Zirconium Copper	-269	200	No	18680-12-BC
1.5 V	C	C	12"	15	Zirconium Copper	-269	350	No	18680-12-CC
1.5 V	A	A	24"	15	Zirconium Copper	-269	200	No	18680-24-AA
1.5 V	A	B	24"	15	Zirconium Copper	-269	200	No	18680-24-AB
1.5 V	A	C	24"	15	Zirconium Copper	-269	200	No	18680-24-AC
1.5 V	A	BNC	24"	15	Zirconium Copper	-269	400	No	18680-24-AE
1.5 V	A	MHV	24"	15	Zirconium Copper	-269	200	No	18680-24-AF
1.5 V	B	B	24"	15	Zirconium Copper	-269	400	No	18680-24-BB
1.5 V	B	C	24"	15	Zirconium Copper	-269	400	No	18680-24-BC
1.5 V	C	C	24"	15	Zirconium Copper	-269	350	No	18680-24-CC
1.5 V	A	A	36"	15	Zirconium Copper	-269	200	No	18680-36-AA
1.5 V	A	B	36"	15	Zirconium Copper	-269	200	No	18680-36-AB
1.5 V	A	C	36"	15	Zirconium Copper	-269	200	No	18680-36-AC
1.5 V	A	BNC	36"	15	Zirconium Copper	-269	400	No	18680-36-AE
1.5 V	A	MHV	36"	15	Zirconium Copper	-269	200	No	18680-36-AF
1.5 V	B	B	36"	15	Zirconium Copper	-269	400	No	18680-36-BB
1.5 V	B	C	36"	15	Zirconium Copper	-269	400	No	18680-36-BC
1.5 V	C	C	36"	15	Zirconium Copper	-269	350	No	18680-36-CC

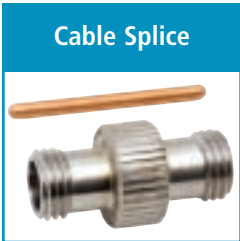

SIZE	VOLTAGE DC	CONDUCTOR AMPS	CONDUCTOR MATERIAL	TEMPERATURE °C MIN	TEMPERATURE °C MAX	MAGNETIC MATERIALS	PART NUMBER
1/8"	1.5 kV	15	Copper	-269	400	No	18727-01-A



VOLTAGE DC	TERMINATION END 1	TERMINATION END 2	LENGTH	CONDUCTOR AMPS	CONDUCTOR MATERIAL	TEMPERATURE °C MIN	TEMPERATURE °C MAX	MAGNETIC MATERIALS	PART NUMBER
500 V	Microdot	Microdot	12"	2	Silver Plated Copper	-65	125	No	15767-12-A
500 V	Microdot	Microdot	24"	2	Silver Plated Copper	-65	125	No	15767-24-A
500 V	Microdot	Microdot	36"	2	Silver Plated Copper	-65	125	No	15767-36-A†

†Shown in photo.



**Coaxial: 1/4" Diameter
.050 [1.3] Dia. Conductor**

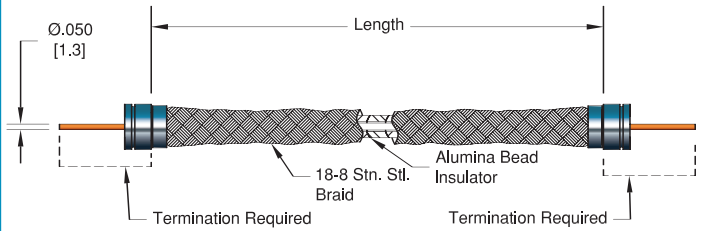

Termination A – Coaxial

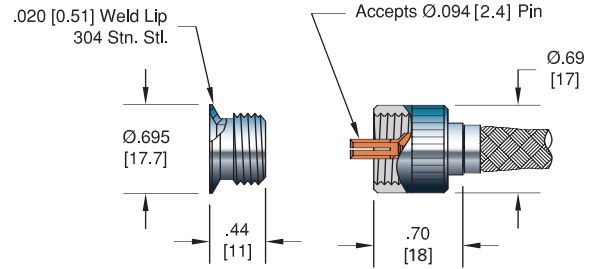

Termination B – Contact

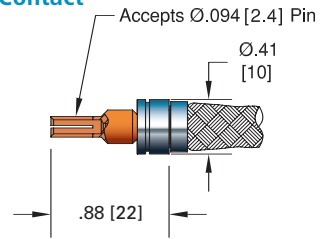

Termination C – In-Line

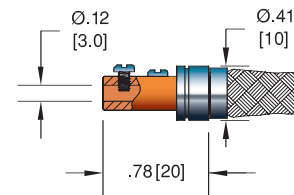

Termination – BNC & MHV

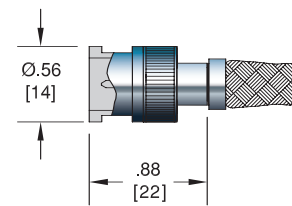

1/4" Cable Splice

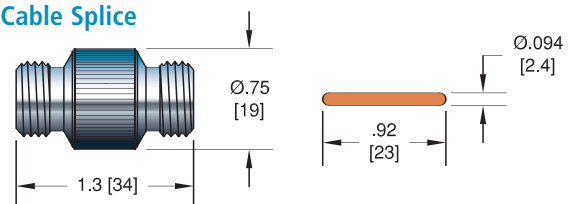

Coaxial Cables
1/4" Diameter

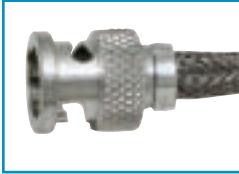

VOLTAGE DC	TERMINATION		LENGTH	AMPS	CONDUCTOR MATERIAL	TEMPERATURE °C		MAGNETIC MATERIALS	PART NUMBER
	END 1	END 2				MIN	MAX		
3 kV	A	A	12"	25	Zirconium Copper	-269	200	No	18681-12-AA
3 kV	A	B	12"	25	Zirconium Copper	-269	200	No	18681-12-AB
3 kV	A	C	12"	25	Zirconium Copper	-269	200	No	18681-12-AC
3 kV	A	BNC	12"	25	Zirconium Copper	-269	200	No	18681-12-AE
3 kV	A	MHV	12"	25	Zirconium Copper	-269	200	No	18681-12-AF
3 kV	B	B	12"	25	Zirconium Copper	-269	200	No	18681-12-BB
3 kV	B	C	12"	25	Zirconium Copper	-269	200	No	18681-12-BC
3 kV	C	C	12"	25	Zirconium Copper	-269	350	No	18681-12-CC
3 kV	BNC	BNC	12"	25	Zirconium Copper	-269	350	No	18681-12-EE
3 kV	MHV	MHV	12"	25	Zirconium Copper	-269	350	No	18681-12-FF
3 kV	A	A	24"	25	Zirconium Copper	-269	200	No	18681-24-AA
3 kV	A	B	24"	25	Zirconium Copper	-269	200	No	18681-24-AB
3 kV	A	C	24"	25	Zirconium Copper	-269	200	No	18681-24-AC
3 kV	A	BNC	24"	25	Zirconium Copper	-269	200	No	18681-24-AE
3 kV	A	MHV	24"	25	Zirconium Copper	-269	200	No	18681-24-AF
3 kV	B	B	24"	25	Zirconium Copper	-269	200	No	18681-24-BB
3 kV	B	C	24"	25	Zirconium Copper	-269	200	No	18681-24-BC
3 kV	C	C	24"	25	Zirconium Copper	-269	350	No	18681-24-CC
3 kV	BNC	BNC	24"	25	Zirconium Copper	-269	350	No	18681-24-EE
3 kV	MHV	MHV	24"	25	Zirconium Copper	-269	350	No	18681-24-FF
3 kV	A	A	36"	25	Zirconium Copper	-269	200	No	18681-36-AA
3 kV	A	B	36"	25	Zirconium Copper	-269	200	No	18681-36-AB
3 kV	A	C	36"	25	Zirconium Copper	-269	200	No	18681-36-AC
3 kV	A	BNC	36"	25	Zirconium Copper	-269	200	No	18681-36-AE
3 kV	A	MHV	36"	25	Zirconium Copper	-269	200	No	18681-36-AF
3 kV	B	B	36"	25	Zirconium Copper	-269	200	No	18681-36-BB
3 kV	B	C	36"	25	Zirconium Copper	-269	200	No	18681-36-BC
3 kV	C	C	36"	25	Zirconium Copper	-269	350	No	18681-36-CC
3 kV	BNC	BNC	36"	25	Zirconium Copper	-269	350	No	18681-36-EE
3 kV	MHV	MHV	36"	25	Zirconium Copper	-269	350	No	18681-36-FF

Cable Splice



SIZE	VOLTAGE DC	AMPS	CONDUCTOR MATERIAL	TEMPERATURE °C		MAGNETIC MATERIALS	PART NUMBER
				MIN	MAX		
1/4"	3 kV	25	Copper	-269	400	No	18728-01-A

In-Vacuum Ribbon Cable

CeramTec's in-vacuum ribbon cable is designed to complement our Micro D Type (MIL-DTL-83513) & Sub D Type (MIL-C-24308) hermetic multipin connector product lines and therefore cable configurations include 9, 15 or 25 conductor cable. Note that 50 conductor cables are created by using two 25 conductor cables. Each of the Kapton® wrapped stranded 28 AWG (7 x 0.005) or 22 AWG (19 x 0.0063) silver plated copper conductors are woven with a PEEK (polyether ether ketone) monofilament in order to achieve the ribbon cable form. The multistranded wrapped cable offers the most flexible solution and has a temperature range up to 200° C. All ribbon cable assembly materials are ultra-high vacuum (UHV) compatible. The ribbon cables are vacuum baked out prior to shipping. Additional vacuum bakeout is also recommended prior to use. All cable assembly components are sold separately.

28 AWG Ribbon Cable

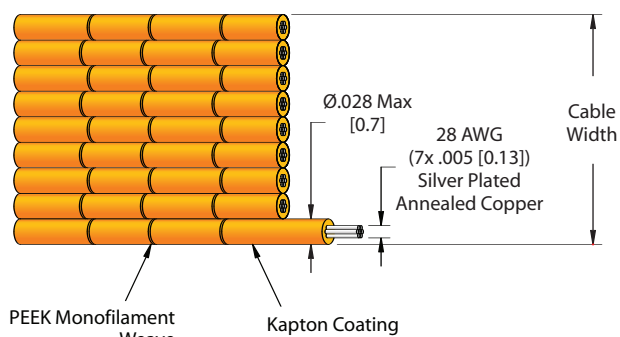

22 AWG Ribbon Cable

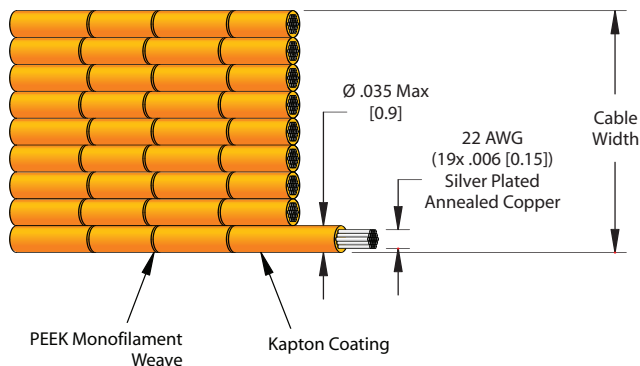

Single Conductor 28 AWG Stranded Wire

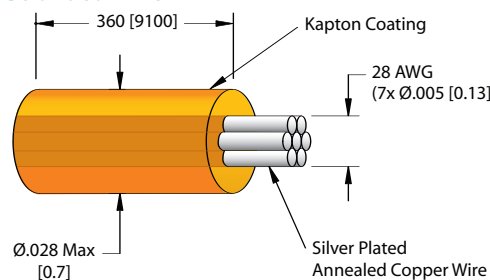

22 AWG Stranded Wire

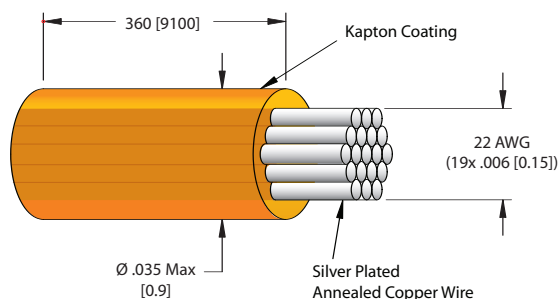

12 AWG Stranded Wire

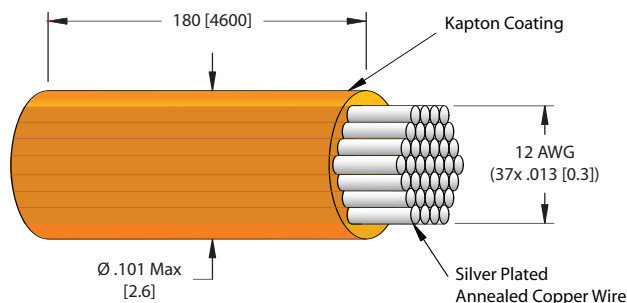

Specifications

Materials

Insulation: Kapton® Type FN
Weave: PEEK (polyether ether ketone) monofilament

Number of Conductors Single, 9, 15, 25

Conductor

28 AWG 7 / 0.005" stranded silver plated copper
22 AWG 19 / 0.0063" stranded silver plated copper
12 AWG 37 / 0.013" stranded silver plated copper

Voltage Rating 600 V AC, 850 V DC

Current Rating

28 AWG - 2.5 Amps per conductor
22 AWG - 5 Amps per conductor
12 AWG - 20 Amps per conductor

Temperature Range -55°C to 200°C

Resistance

28 AWG - 244Ω/km at 20°C max.
22 AWG - 119Ω/km at 20°C max.
12 AWG - 6.2Ω/km at 20°C max.



VOLTAGE DC	CONDUCTOR AMPS	TYPE	LENGTH	WIRE DIAMETER	INSULATION DIAMETER	PART NUMBER
850 V	2.5	Stranded	30'	7 x 0.005	Ø .028	21621-01-A



VOLTAGE DC	CONDUCTOR AMPS	TYPE	LENGTH	WIRE DIAMETER	INSULATION DIAMETER	PART NUMBER
850 V	5	Stranded	30'	19 x 0.0063	Ø .035	21643-01-A



VOLTAGE DC	CONDUCTOR AMPS	TYPE	LENGTH	WIRE DIAMETER	INSULATION DIAMETER	PART NUMBER
850 V	20	Stranded	15'	37 x 0.013	Ø .101	21702-02-A



NO. WIRES	CABLE LENGTH	CABLE WIDTH	WIRE DIAMETER	INSULATION DIAMETER	PART NUMBER
9	19"	0.4	7 x 0.005	Ø .028	21622-19-WW
9	39"	0.4	7 x 0.005	Ø .028	21622-39-WW
9	96"	0.4	7 x 0.005	Ø .028	21622-96-WW
15	19"	0.7	7 x 0.005	Ø .028	21623-19-WW
15	39"	0.7	7 x 0.005	Ø .028	21623-39-WW
15	96"	0.7	7 x 0.005	Ø .028	21623-96-WW
25	19"	1.2	7 x 0.005	Ø .028	21624-19-WW
25	39"	1.2	7 x 0.005	Ø .028	21624-39-WW
25	96"	1.2	7 x 0.005	Ø .028	21624-96-WW



NO. WIRES	CABLE LENGTH	CABLE WIDTH	WIRE DIAMETER	INSULATION DIAMETER	PART NUMBER
9	19"	0.4	19 X 0.0063	Ø .035	20370-19-WW
9	39"	0.4	19 X 0.0063	Ø .035	20370-39-WW
9	96"	0.4	19 X 0.0063	Ø .035	20370-96-WW
15	19"	0.7	19 X 0.0063	Ø .035	20371-19-WW
15	39"	0.7	19 X 0.0063	Ø .035	20371-39-WW
15	96"	0.7	19 X 0.0063	Ø .035	20371-96-WW
25	19"	1.2	19 X 0.0063	Ø .035	20372-19-WW
25	39"	1.2	19 X 0.0063	Ø .035	20372-39-WW
25	96"	1.2	19 X 0.0063	Ø .035	20372-96-WW

Note that 50 conductor cables are created by using two 25 conductor cables.



DESCRIPTION	PART NUMBER
Adjustable wire stripper, 20-30 AWG (.25 - .80mm)	21128-01

Standoffs

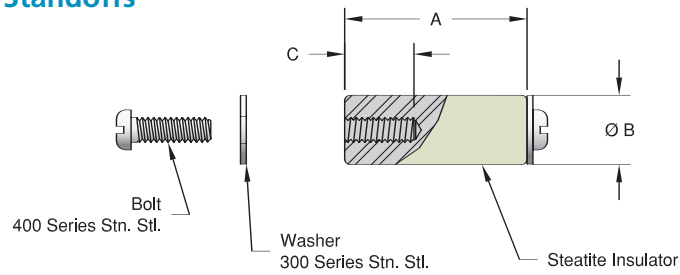

Ceramic Spacers

Number of Conductor Holes: 10

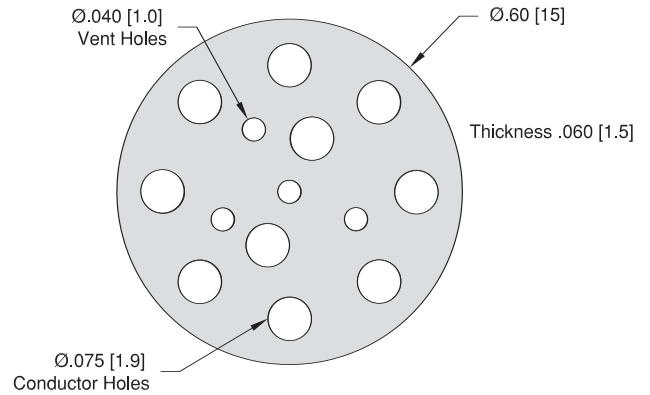

Number of Conductor Holes: 20

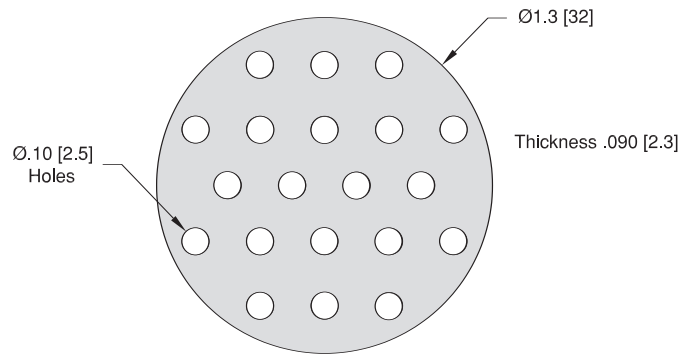

Number of Conductor Holes: 35

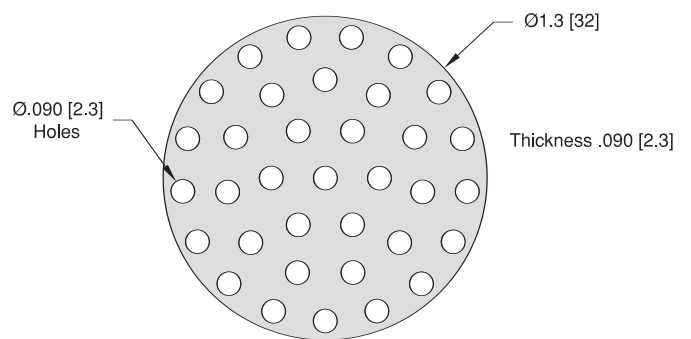



THREAD SIZE	VOLTAGE		A	DIMENSIONS			TEMPERATURE °C		PART NUMBER
	DC (Vac)	DC (Air)		B	C	MIN	MAX		
6 – 32	10 kV	4 kV	0.50 [12.7]	0.38 [9.7]	0.16 [4.1]	-200	400	10420-01-A	
8 – 32	12 kV	5 kV	0.63 [16.0]	0.50 [12.7]	0.19 [4.8]	-200	400	10420-03-A	
6 – 32	20 kV	8 kV	1.00 [25.4]	0.38 [9.7]	0.38 [9.7]	-200	400	10420-02-A	
8 – 32	20 kV	8 kV	1.00 [25.4]	0.50 [12.7]	0.38 [9.7]	-200	400	10420-04-A	
10 – 32	20 kV	8 kV	1.00 [25.4]	0.75 [19.0]	0.38 [9.7]	-200	400	10420-06-A	
1/4 – 20	25 kV	10 kV	1.25 [31.8]	1.00 [25.4]	0.44 [11]	-200	400	10420-08-A	
8 – 32	35 kV	14 kV	2.00 [50.8]	0.50 [12.7]	0.38 [9.7]	-200	400	10420-05-A	
10 – 32	35 kV	14 kV	2.00 [50.8]	0.75 [19.0]	0.38 [9.7]	-200	400	10420-07-A	
1/4 – 20	40 kV	16 kV	2.50 [63.5]	1.00 [25.4]	0.63 [16]	-200	400	10420-09-A	



NO. CONDUCTOR HOLES	TEMPERATURE °C		PART NUMBER
	MIN	MAX	
10	-269	800	3116-01-X
20	-269	800	1984-01-A
35	-269	800	10206-01



ConFlat Flanges
Size: 1 1/3" (NW16CF)

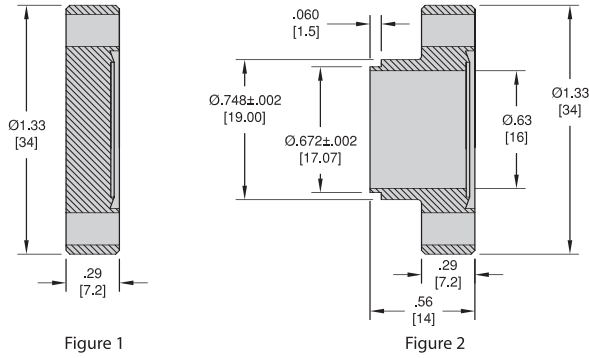

Size: 2 3/4" (NW35CF)

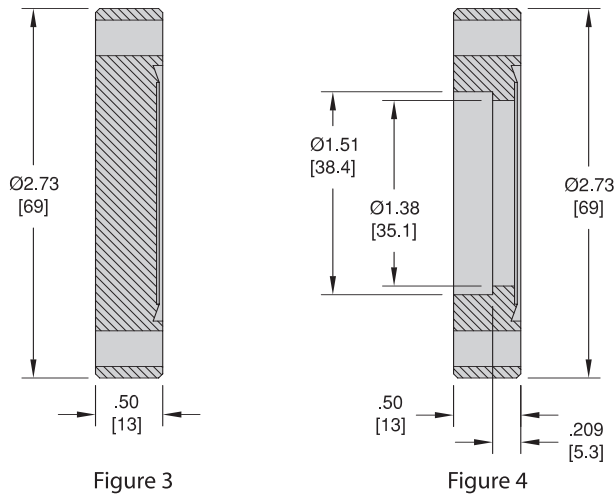

Size: 3 3/8" (NW50CF) & 4 1/2" (NW63CF)

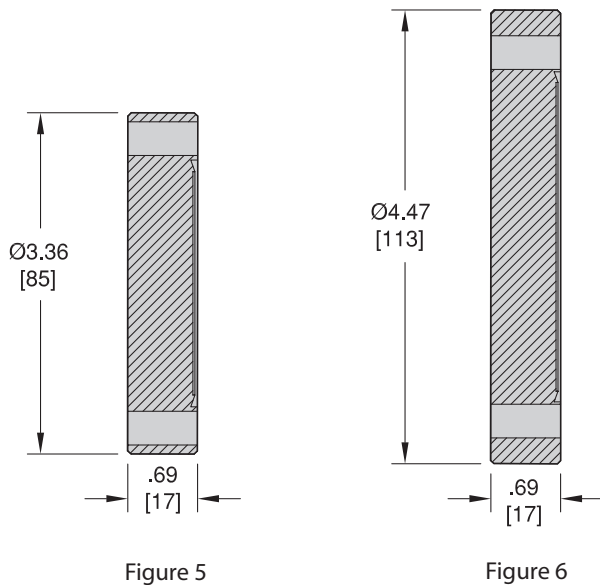

ISO KF Flanges
Type: Ported Weld Neck

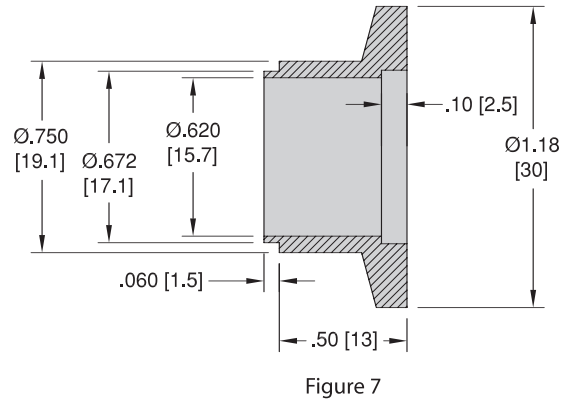

Type: Blank

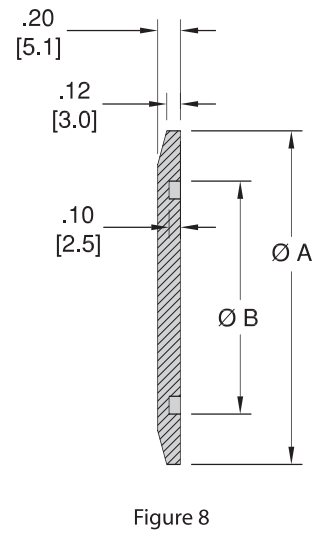



FLANGE CONFLAT	TYPE	FIGURE NUMBER	TEMPERATURE °C		PART NUMBER	PRICE
			MIN	MAX		
1 1/3" (NW16CF)	Blank	1	-269	450	6463-01	
1 1/3" (NW16CF)	Ported Weld Neck	2	-269	450	6863-01	
2 3/4" (NW35CF)	Blank	3	-269	450	02899-01	
2 3/4" (NW35CF)	Ported	4	-269	450	02899-02	
3 3/8" (NW50CF)	Blank	5	-269	450	02899-13	
4 1/2" (NW63CF)	Blank	6	-269	450	02899-03	



FLANGE ISO	TYPE	FIGURE	DIMENSIONS		TEMPERATURE °C		PART NUMBER	PRICE
			A	B	MIN	MAX		
NW16KF	Ported Weld Neck	7	.50 [13]	1.8 [30]	-25	205	17669-01	
NW16KF	Blank	8	1.18 [30]	0.68 [17.3]	-25	205	13499-02	
NW25KF	Blank	8	1.57 [40]	1.03 [26.2]	-25	205	13499-03	
NW40KF	Blank	8	2.16 [55]	1.62 [41.0]	-25	205	13499-04	
NW50KF	Blank	8	2.95 [75]	2.06 [52.3]	-25	205	13499-05	



Engineering Data	Cable/Plug Attachment	Installation
Good Vacuum Practice	221 Sub D (MIL-C-24308) Plugs	229 Installation Options 242
Magnetic Properties of Metals	222 Circular (MIL-C-26482) Plugs	229 Braze/Solder 243
Material Temperature Limitations	222 Circular Plug MIL-C-5015	229 Weld 243
Properties of Ceramic Insulators	223 Thermocouple Pin Orientation	230 ConFlat Flange 244
Thermal Expansion Curves	223 High Voltage	231 ISO-NW Flange 246
Pressure Conversion	224 Thermocouple, Spade Type	232 NPT Thread 246
Dielectric Strength vs. Pressure	224 Coaxial/Plug Attachments	233 Baseplate 246
Leak Rate Conversions	226 Vacuum Cable Termination Options	234 Miscellaneous 247
Vacuum Ranges	226	
Wire Gauge Conversion Chart	226	
Vapor Pressure	227	
Temperature Conversion Chart	228	

GOOD VACUUM PRACTICE

Working with vacuum systems requires good vacuum practice. CeramTec recommends that the user, at a minimum, address the following items:

- Cleanliness is very important when handling any vacuum equipment. The use of clean vinyl gloves is recommended at all times. Internal surfaces of vacuum equipment should never be touched without gloves as fingerprints will contaminate the system, resulting in decreased pumping efficiency.
- Vacuum grease should be used sparingly. Silicone-based oils or grease should not be used in a system with electronically charged plates; this could insulate the charged plates.
- System components should be made of smooth, oxide-resistant, high-strength materials. The components should be smooth to keep the surface area to a minimum. Rough surfaces provide locations where gases and other contaminants will adhere. Materials that readily oxidize should not be used because oxidation will increase the surface area. Increased surface area results in decreased pumping efficiency. High-strength materials should be used to withstand the wide temperature variations associated with vacuum bakeouts. A good example of a smooth, oxide-resistant, high-strength material is 304 stainless steel.
- Raw material manufacturing processes can influence a material’s compatibility with vacuum applications. CeramTec uses the best materials available. As an example, CeramTec products use ConFlat® flanges made from cross-forged or electroslag remelted 304 stainless steel. These materials provide the greatest reliability for leak free performance.

MAGNETIC PROPERTIES OF METAL

MAGNETIC (μ greater than 1.1)

Alloy 225
Alloy 405
Alloy 426
Alumel
Iron
Kovar
1010-1020 Low Carbon Steel
Monel
Nickel
42% Nickel Iron
52% Nickel Iron
430 Stainless Steel

NON-MAGNETIC (μ less than 1.1)

Alloy 11
Alloy 203
Aluminum
Constantan
Copper
Chromel
Inconel
Molybdenum
Platinum
Rhodium
302-304 Stainless Steel
Tantalum
Titanium
70% Copper-Nickel

$$\mu = \frac{\text{Absolute Permeability of Material}}{\text{Absolute Permeability of Empty Space}}$$

MATERIAL TEMPERATURE LIMITATIONS

	Maximum Load Bearing Temperature °C	Maximum Air Operating Temperature °C
Lead-Silver Solder	100	150
Silver Braze Alloys	250	450 (O ₂ permeation)
Copper Braze	300	400
Gold Braze Alloys	350	700
Copper	200	300
70% Copper-Nickel	400	500
Monel & Constantan	450	550
Nickel	500	750
Kovar (29 Ni, 17 Co, 53 Fe)	500	500
42% & 52% Nickel Iron	450	400
300 Series S.S. (304, 316, Etc.)	650	850
Inconel	550	1000
430 S.S.	500 (Vacuum, Argon)	500
Tantalum	1000 (Vacuum, Argon)	400
Molybdenum	1000 (Vacuum, Argon)	350

All of these charts should be used as a rough guideline to match materials with the individual application. For standard products in this catalog, the temperature ratings (limitations) can be attributed to both materials used and seal configuration.

PROPERTIES OF CERAMIC INSULATORS

	PROPERTY	UNIT	STEATITE	85% NOM. ALUMINA	94% NOM. ALUMINA	97.5% NOM. ALUMINA	99.5% NOM. ALUMINA	
Mechanical	Compressive Strength	psi, 25°C	90,000	>240,000	>300,000	>250,000	>300,000	
	Flexural Strength	psi, 25°C	21,000	46,000	50,000	43,000	45,000	
	Porosity	—	Vacuum Tight	Vacuum Tight	Vacuum Tight	Vacuum Tight	Vacuum Tight	
	Water Absorption	%	0.00	0.00	0.00	0.00	0.00	
	Hardness	Moh's Scale	7.5	8	9	9	9	
Thermal	Thermal Conductivity	cal/cm ² /sec/°C	0.008	0.035	0.049	0.064	0.070	
	Max. Operating Temp.	°C	1000	1400	1600	1650	1725	
	Thermal Expansion	in/in/°C	25-200°C	6.9×10^{-6}	5.4×10^{-6}	6.3×10^{-6}	6.9×10^{-6}	6.9×10^{-6}
	Linear Coefficient	25-600°C	7.8×10^{-6}	7.5×10^{-6}	8.0×10^{-6}	8.5×10^{-6}	8.3×10^{-6}	
Electrical	Dielectric Constant	10 MHz at 25°C	6.1	8.2	9.07	9.53	9.58	
		1 GHz at 25°C	—	8.2	9.04	9.00	9.30	
		8.5 GHz at 25°C	5.9	8.2	8.98	9.04	9.37	
	Dielectric Strength	V/mil, 60 Cycle	230	600	650	1100	800	
	Dielectric Loss Factor	10 MHz at 25°C	.0050	.0070	.00236	.00038	.00029	
		1 GHz at 25°C	—	.0100	.00560	.00270	.00130	
		8.5 GHz at 25°C	.012	—	.00700	.00407	.00084	
	Volume Resistivity	Ohms/cm ³ at 25°C	> 10^{14}	> 10^{14}	> 10^{14}	> 10^{14}	> 10^{14}	
300°C		10^{11}	10^{10}	10^{12}	10^{13}	10^{11}		
600°C		10^7	10^7	10^8	10^{10}	10^8		

THERMAL EXPANSION FOR INSULATORS

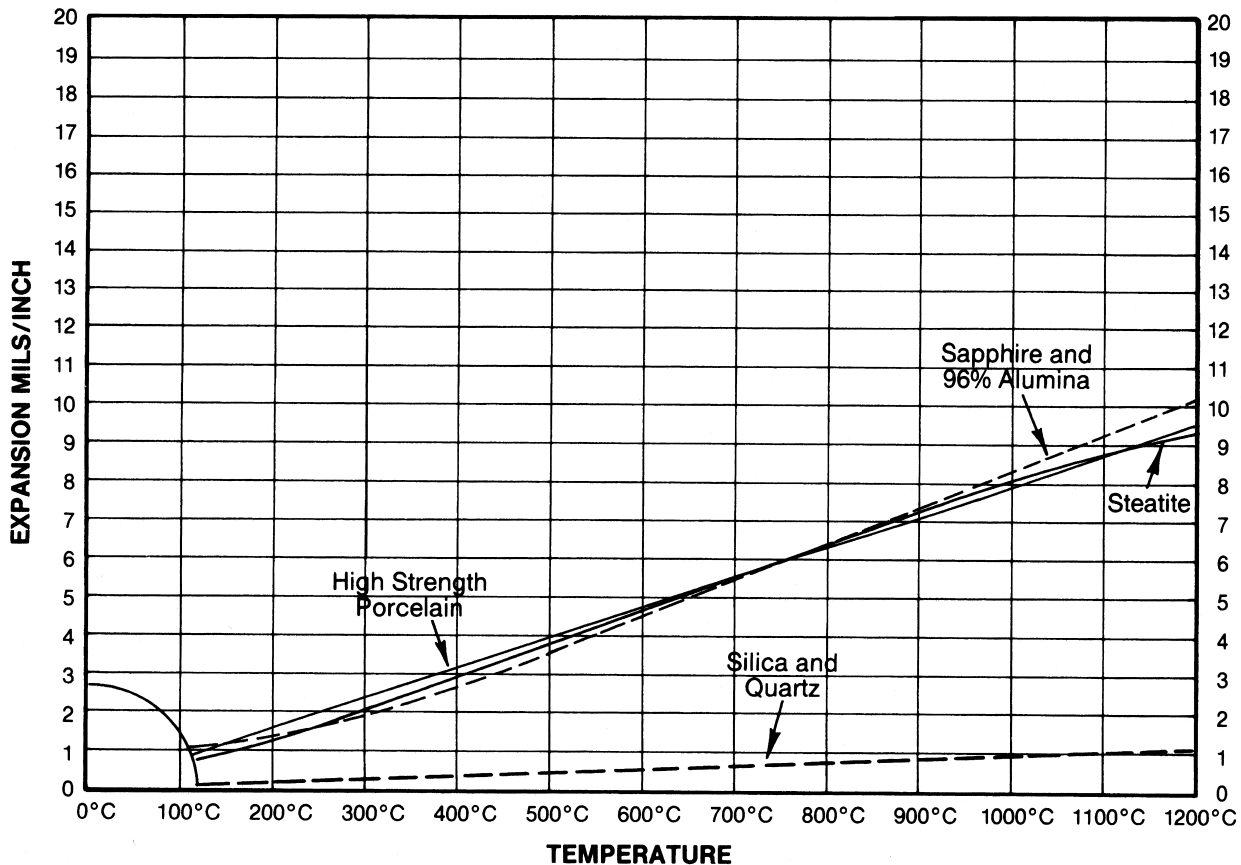

All of these charts should be used as a rough guideline to match materials with the individual application. For standard products in this catalog, the temperature ratings (limitations) can be attributed to both materials used and seal configuration.

THERMAL EXPANSION FOR MAGNETIC METALS

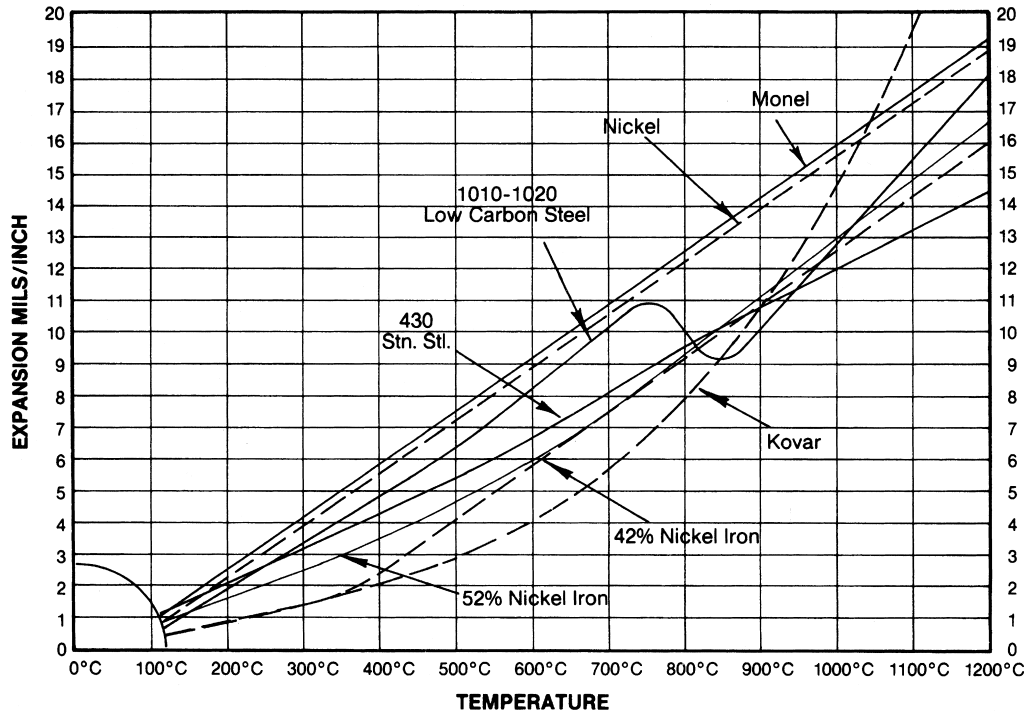

THERMAL EXPANSION FOR NON-MAGNETIC METALS

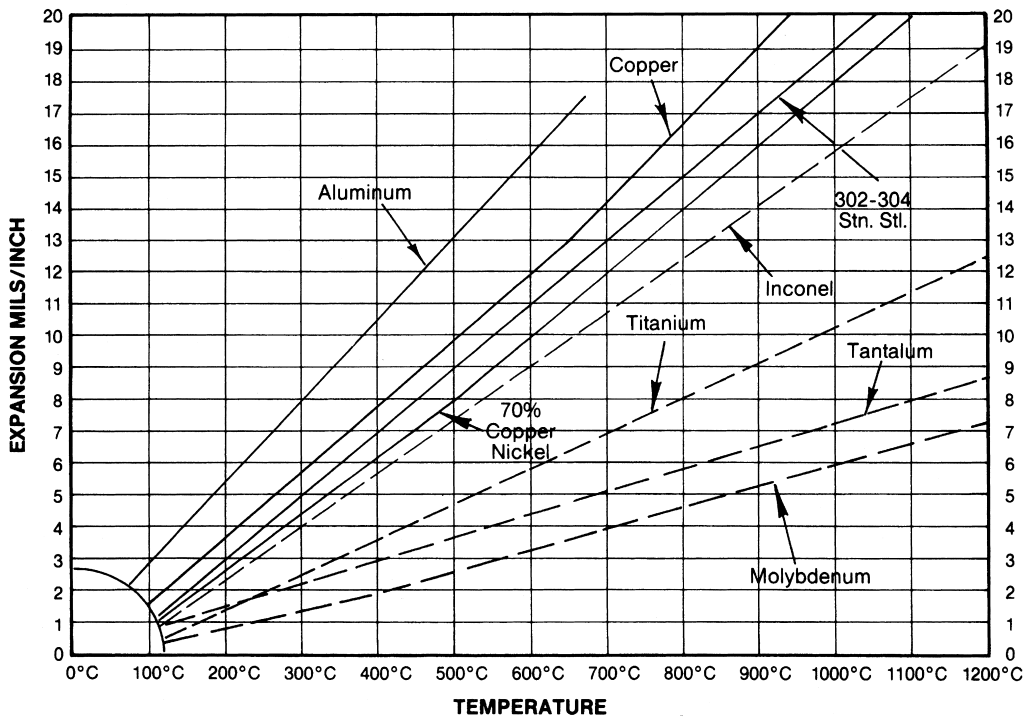

All of these charts should be used as a rough guideline to match materials with the individual application. For standard products in this catalog, the temperature ratings (limitations) can be attributed to both materials used and seal configuration.

PRESSURE CONVERSIONS

		Pa	torr	atm	mbar	psi	kg/cm ²	μ
Pascal	(newtons/m ²)	1	7.5 (10 ⁻³)	9.87 (10 ⁻⁶)	10 ⁻²	1.45 (10 ⁻⁴)	1.02 (10 ⁻⁵)	7.5
torr	(mm of mercury)	133	1	1.32 (10 ⁻³)	1.333	1.93 (10 ⁻²)	1.36 (10 ⁻³)	10 ³
atm	(atmosphere)	1.013 (10 ⁵)	760	1	1013	14.7	1.033	7.6 (10 ⁵)
mbar	(millibar)	100	0.75	9.87 (10 ⁻⁴)	1	1.45 (10 ⁻²)	1.02 (10 ⁻³)	750.1
psi	(lb/in ²)	6.89 (10 ³)	51.71	6.8 (10 ⁻²)	68.9	1	0.070	5.17 (10 ⁴)
kg/cm²		9.81 (10 ⁴)	735.6	0.968	981	14.2	1	7.35 (10 ⁵)
μ	(micron)	0.1333	10 ⁻³	1.32 (10 ⁻⁶)	1.333(10 ⁻³)	1.93 (10 ⁻⁵)	1.359 (10 ⁻⁶)	1

	kPa	lb/sq in	lb/sq ft	atm	kg/cm ²	mm Hg at 32°F	in Hg at 32°F	ft water at 39.2°F
1 kPa	1	0.145	20.92	9.9 (10 ⁻³)	0.0102	7.519	0.295	0.335
1 lb/sq in	6.895	1	144	...	0.0703	51.713	2.036	2.307
1 lb/sq ft	0.048	6.94 (10 ⁻³)	1	0.3591	0.014	0.016
1 atmosphere	101.3	14.696	2116.2	1	1.0333	760	29.921	33.9
1 kg/cm²	98.07	14.223	2048.1	0.9678	1	735.56	28.958	32.81
1 torr	0.133	0.0193	2.785	1	0.039	0.045
1 in mercury	3.387	0.4912	70.73	0.0334	0.0345	25.4	1	1.133
1 ft water	2.984	0.4335	62.42	...	0.0305	22.418	0.883	1

DIELECTRIC STRENGTH VS. PRESSURE

Pressure PSIG Chart#1

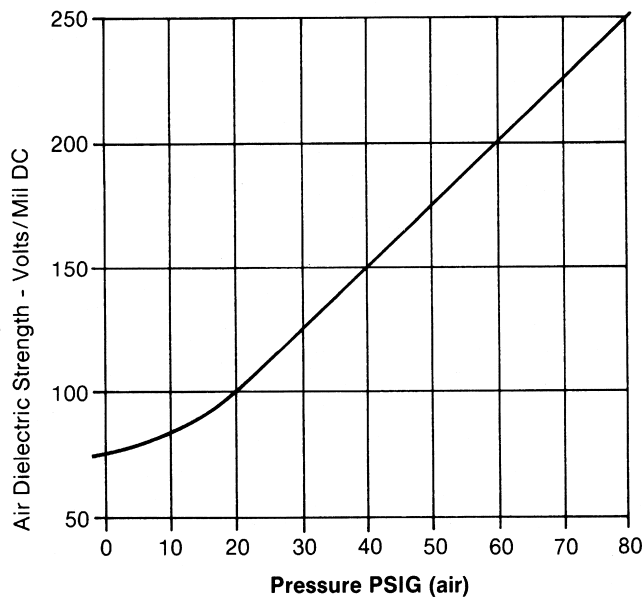

Pressure Torr Chart#2

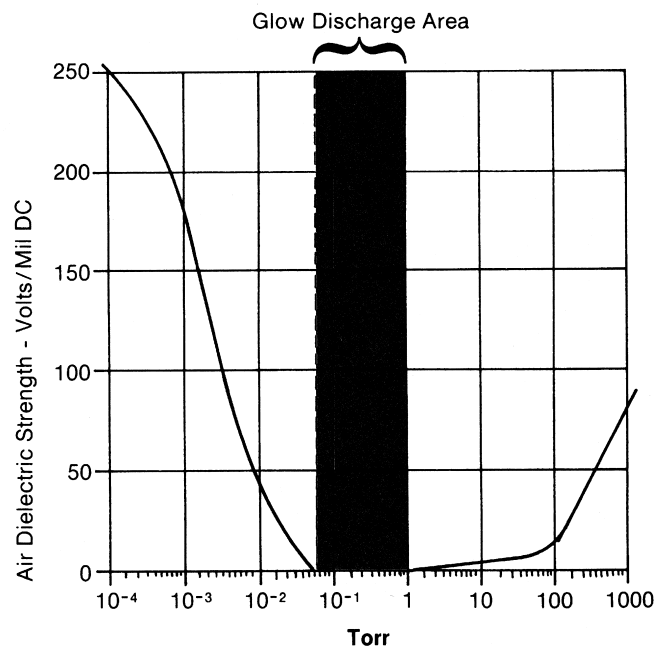

The voltage ratings are dependent upon system pressure. Catalog ratings are given at a system pressure of 10⁻⁴ torr or 80 PSIG air. For rating at system pressures between these points, the charts shown may be used to determine the approximate derating required. Voltage rating at pressures less than 10⁻⁴ torr or greater than 80 PSIG air is the same as at 10⁻⁴ torr or 80 PSIG since the voltage is limited by the external ambient air at normal atmospheric conditions.

TECHNICAL REFERENCE

THROUGHPUT AND LEAK RATE

	Pa•m ³ /s	torr•l/s	atm cm ³ /s or std cc/s	μl/s	ft ³ (STP)/h
1 Pa•m³/s	1.0	7.5	9.87	7.50 (10 ³)	1.26
1 torr•l/s	0.133	1.0	1.32	10 ³	0.168
1 atm cm³/s or 1 std cc/s	0.101	0.76	1.0	760	127 (10 ⁻³)
1 μl/s	1.3 (10 ⁻⁴)	10 ⁻³	1.32 (10 ⁻³)	1.0	11.68 (10 ⁻⁴)
1 ft³ (STP)/h	0.794	5.96	787	5960	1.0

VACUUM RANGES

Rough (Low) Vacuum	759 to 1 X 10 ⁻³ torr (approx.)
High Vacuum	1 X 10 ⁻³ to 1 X 10 ⁻⁸ torr (approx.)
Ultra-High Vacuum	Less than 1 X 10 ⁻⁸ torr

WIRE GAUGE CONVERSION CHART

S.W.G. (inches)	Wire No. (Gauge)	A.W.G. or B&S (inches)	A.W.G. Metric (MM)	S.W.G. (inches)	Wire No. (Gauge)	A.W.G. or B&S (inches)	A.W.G. Metric (MM)	S.W.G. (inches)	Wire No. (Gauge)	A.W.G. or B&S (inches)	A.W.G. Metric (MM)
0.500	0000000 (7/0)	0.0920	13	0.0720	1,829	0.0092	34	0.0063	0,1601
0.464	000000 (6/0)	0.580000	0.0800	14	0.0641	1,628	0.0084	35	0.0056	0,1422
0.432	00000 (5/0)	0.516500	0.0720	15	0.0571	1,450	0.0076	36	0.0050	0,1270
0.400	0000 (4/0)	0.460000	11,684	0.0640	16	0.0508	1,291	0.0068	37	0.0045	0,1143
0.372	000 (3/0)	0.409642	10,404	0.0560	17	0.0453	1,150	0.0060	38	0.0040	0,1016
0.348	00 (2/0)	0.364796	9,266	0.0480	18	0.0403	1,024	0.0052	39	0.0035	0,0889
0.324	0 (1/0)	0.324861	8,252	0.0400	19	0.0359	0,9119	0.0048	40	0.0031	0,0787
0.300	1	0.289297	7,348	0.0360	20	0.0320	0,8128	0.0044	41	0.0028	0,0711
0.276	2	0.257627	6,543	0.0320	21	0.0285	0,7239	0.0040	42	0.0025	0,0635
0.252	3	0.229423	5,827	0.0280	22	0.0253	0,6426	0.0036	43	0.0022	0,0559
0.232	4	0.2043	5,189	0.0240	23	0.0226	0,5740	0.0032	44	0.0020	0,0508
0.2120	5	0.1819	4,621	0.0220	24	0.0201	0,5106	0.0028	45	0.0018	0,0457
0.1920	6	0.1620	4,115	0.0200	25	0.0179	0,4547	0.0024	46	0.0016	0,0406
0.1760	7	0.1443	3,665	0.0180	26	0.0159	0,4038	0.0020	47	0.0014	0,0350
0.1600	8	0.1285	3,264	0.0164	27	0.0142	0,3606	0.0016	48	0.0012	0,0305
0.1440	9	0.1144	2,906	0.0148	28	0.0126	0,3200	0.0012	49	0.0011	0,0279
0.1280	10	0.1019	2,588	0.0136	29	0.0113	0,2870	0.0010	50	0.0010	0,0254
0.1160	11	0.0907	2,304	0.0124	30	0.0100	0,2540		51	0.00088	0,0224
0.1040	12	0.0808	2,052	0.0116	31	0.0089	0,2261		52	0.00078	0,0198
				0.0108	32	0.0080	0,2032		53	0.00070	0,0178
				0.0100	33	0.0071	0,1803		54	0.00062	0,0158
									55	0.00055	0,0140
									56	0.00049	0,0124

TECHNICAL REFERENCE

VAPOR PRESSURES OF ELEMENTS

Element	VAPOR PRESSURE (mm Hg)						mp (°C)
	10 ⁻⁵ at °C	10 ⁻⁴ at °C	10 ⁻³ at °C	10 ⁻² at °C	10 ⁻¹ at °C	1 at °C	
Aluminum	882	972	1082	1207	1347	1547	659
Antimony	382	427	477	542	617	757	630
Barium	417	467	537	617	727	867	710
Beryllium	902	987	1092	1212	1367	1567	1283
Bismuth	450	508	578	661	762	892	271
Cadmium	149	182	221	267	321	392	321
Calcium	402	452	517	592	687	817	850
Carbon	1977	2107	2247	2427	2627	2867	—
Cesium	46	75	110	152	206	277	30
Chromium	1062	1162	1267	1392	1557	1737	1903
Cobalt	1162	1262	1377	1517	1697	1907	1495
Copper	942	1032	1142	1272	1427	1622	1084
Gold	987	1082	1197	1332	1507	1707	1063
Indium	670	747	837	947	1077	1242	156
Iridium	1797	1947	2107	2307	2527	2827	2454
Iron	1107	1207	1322	1467	1637	1847	1539
Lead	487	551	627	719	832	977	328
Lithium	348	399	460	534	623	737	181
Magnesium	287	330	382	442	517	612	650
Manganese	697	767	852	947	1067	1227	1244
Mercury	-28	-8	16	45	81	125	-39
Molybdenum	1987	2167	2377	2627	2927	3297	2577
Nickel	1142	1247	1357	1497	1667	1877	1452
Osmium	2101	2264	2451	2667	2920	3221	2697
Palladium	1157	1262	1387	1547	1727	1967	1550
Platinum	1602	1742	1907	2077	2317	2587	1770
Potassium	91	123	162	208	266	341	64
Rubidium	64	95	133	176	228	300	39
Silicon	1177	1282	1357	1547	1717	1927	1415
Silver	757	832	922	1032	1167	1337	961
Sodium	158	195	238	290	355	437	98
Strontium	342	394	456	531	623	742	770
Tantalum	2397	2587	2807	3067	3372	3737	2997
Thorium	1686	1831	1999	2196	2431	2715	1827
Tin	882	977	1092	1227	1397	1612	232
Tungsten	2547	2757	3007	3297	3647	—	3377
Uranium	1442	1582	1737	1927	2157	2447	1130
Zinc	208	246	290	342	405	485	420
Zirconium	1837	2002	2187	2397	2647	2977	1852

Table reprinted from: *Basic Vacuum Practice*, third edition (1992), Varian Associates, Lexington, Mass.

NOTE: The numbers in **boldface** refer to the temperature in degrees, either Centigrade or Fahrenheit, which it is desired to convert into the other scale. If converting from F° to C°, the equivalent temperature will be found in the left column; while if converting from C° to F°, the answer will be found in the column on the right.

Centigrade	Fahrenheit	Centigrade	Fahrenheit	Centigrade	Fahrenheit	Centigrade	Fahrenheit	Centigrade	Fahrenheit				
-223.3	-370	-70.6	-95	-139	2.2	36	96.8	32.8	91	195.8	288	550	1022
-220.6	-365	-67.8	-90	-130	2.8	37	98.6	33.3	92	197.6	293	560	1040
-217.8	-360	-65.0	-85	-121	3.3	38	100.4	33.9	93	199.4	299	570	1058
-215.0	-355	-62.2	-80	-112.0	3.9	39	102.2	34.4	94	201.2	304	580	1076
-212.2	-350	-59.4	-75	-103.0	4.4	40	104.0	35.0	95	203.0	310	590	1094
-209.4	-345	-56.7	-70	-94.0	5.0	41	105.8	35.6	96	204.8	316	600	1112
-206.7	-340	-53.9	-65	-85.0	5.6	42	107.6	36.1	97	206.6	321	610	1130
-203.9	-335	-51.1	-60	-76.0	6.1	43	109.4	36.7	98	208.4	327	620	1148
-201.1	-330	-48.3	-55	-67.0	6.7	44	111.2	37.2	99	210.2	332	630	1166
-198.3	-325	-45.6	-50	-58.0	7.2	45	113.0	37.8	100	212.0	338	640	1184
-195.6	-320	-42.8	-45	-49.0	7.8	46	114.8	43	110	230	343	650	1202
-192.8	-315	-40.0	-40	-40.0	8.3	47	116.6	49	120	248	349	660	1220
-190.0	-310	-37.2	-35	-31.0	8.9	48	118.4	54	130	266	354	670	1238
-187.2	-305	-34.4	-30	-22.0	9.4	49	120.2	60	140	284	360	680	1256
-184.4	-300	-31.7	-25	-13.0	10.0	50	122.0	66	150	302	366	690	1274
-181.7	-295	-28.9	-20	-4.0	10.6	51	123.8	71	160	320	371	700	1292
-178.9	-290	-26.1	-15	5.0	11.1	52	125.6	77	170	338	377	710	1310
-176.1	-285	-23.3	-10	14.0	11.7	53	127.4	82	180	356	382	720	1328
-173.3	-280	-20.6	-5	23.0	12.2	54	129.2	88	190	374	388	730	1346
-170.6	-275	-17.8	0	32.0	12.8	55	131.0	93	200	392	393	740	1364
-167.8	-270	-17.2	1	33.8	13.3	56	132.8	99	210	410	399	750	1382
-165.0	-265	-16.7	2	35.6	13.9	57	134.6	100	212	414	404	760	1400
-162.2	-260	-16.1	3	37.4	14.4	58	136.4	104	220	428	410	770	1418
-159.4	-255	-15.6	4	39.2	15.0	59	138.2	110	230	446	416	780	1436
-156.7	-250	-15.0	5	41.0	15.6	60	140.0	116	240	464	421	790	1454
-153.9	-245	-14.4	6	42.8	16.1	61	141.8	121	250	482	427	800	1472
-151.1	-240	-13.9	7	44.6	16.7	62	143.6	127	260	500	432	810	1490
-148.3	-235	-13.3	8	46.4	17.2	63	145.4	132	270	518	438	820	1508
-145.6	-230	-12.8	9	48.2	17.8	64	147.2	138	280	536	443	830	1526
-142.8	-225	-12.2	10	50.0	18.3	65	149.0	143	290	554	449	840	1544
-140.0	-220	-11.7	11	51.8	18.9	66	150.8	149	300	572	454	850	1562
-137.2	-215	-11.1	12	53.6	19.4	67	152.6	154	310	590	460	860	1580
-134.4	-210	-10.6	13	55.4	20.0	68	154.4	160	320	608	466	870	1598
-131.7	-205	-10.0	14	57.2	20.6	69	156.2	166	330	626	471	880	1616
-128.9	-200	-9.4	15	59.0	21.1	70	158.0	171	340	644	477	890	1634
-126.1	-195	-8.9	16	60.8	21.7	71	159.8	177	350	662	482	900	1652
-123.3	-190	-8.3	17	62.6	22.2	72	161.6	182	360	680	488	910	1670
-120.6	-185	-7.8	18	64.4	22.8	73	163.4	188	370	698	493	920	1688
-117.8	-180	-7.2	19	66.2	23.3	74	165.2	193	380	716	499	930	1706
-115.0	-175	-6.7	20	68.0	23.9	75	167.0	199	390	734	504	940	1724
-112.2	-170	-6.1	21	69.8	24.4	76	168.8	204	400	752	510	950	1742
-109.4	-165	-5.6	22	71.6	25.0	77	170.6	210	410	770	516	960	1760
-106.7	-160	-5.0	23	73.4	25.6	78	172.4	216	420	788	521	970	1778
-103.9	-155	-4.4	24	75.2	26.1	79	174.2	221	430	806	527	980	1796
-101.1	-150	-3.9	25	77.0	26.7	80	176.0	227	440	824	532	990	1814
-98.3	-145	-3.3	26	78.8	27.2	81	177.8	232	450	842	538	1000	1832
-95.6	-140	-2.8	27	80.6	27.8	82	179.6	238	460	860	566	1050	1922
-92.8	-135	-2.2	28	82.4	28.3	83	181.4	243	470	878	593	1100	2012
-90.0	-130	-1.7	29	84.2	28.9	84	183.2	249	480	896	621	1150	2102
-87.2	-125	-1.1	30	86.0	29.4	85	185.0	254	490	914	649	1200	2192
-84.4	-120	-0.6	31	87.8	30.0	86	186.8	260	500	932	677	1250	2282
-81.7	-115	0.0	32	89.6	30.6	87	188.6	266	510	950	704	1300	2372
-78.9	-110	0.6	33	91.4	31.1	88	190.4	271	520	968	732	1350	2462
-76.1	-105	1.1	34	93.2	31.7	89	192.2	277	530	986	760	1400	2552
-73.3	-100	1.7	35	95.0	32.2	90	194.0	282	540	1004	788	1450	2642
											816	1500	2732

The formulas at the right may also be used for converting Centigrade or Fahrenheit degrees into the other scales.

Degrees Cent., C° = $\frac{5}{9} (F° + 40) - 40$

Degrees Fahr., F° = $\frac{5}{9} (C° + 40) - 40$

Degrees Kelvin, K° = C° + 273.18

Degrees Rankine, R° = F° + 459.72

SUB D MIL-C-24308 TYPE

Air Side Plug

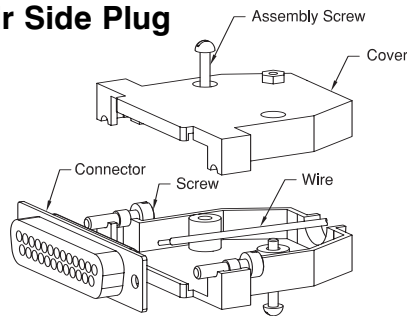

Solder wires to solder cup contacts. Insert connector between 2-piece housing. Assemble with included screws and nuts.

Vacuum Side Plug

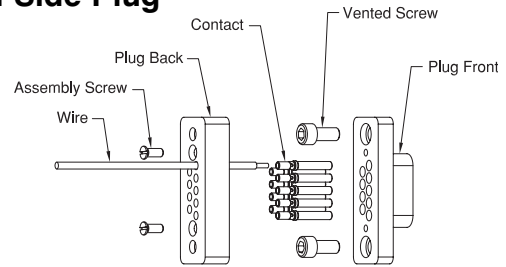

Feed wiring through plug back prior to crimping. Crimp wire to contact. Use crimp tool #2840-05. Insert two 4-40 vented socket head cap screws into counterbores in plug front. Insert contacts into holes in plug front. Align plug back with plug front. Insert assembly screws and tighten.

CIRCULAR MIL-C-26482 TYPE (200°C Max.)

Circular Multipin and Thermocouple

Air Side Plug

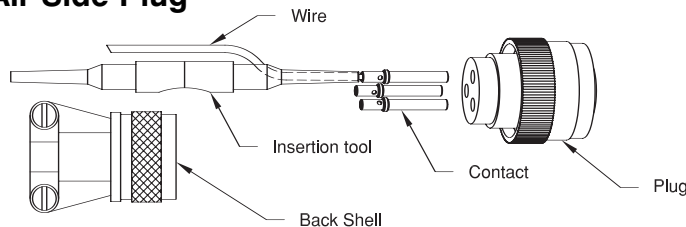

Crimp wire to contact and insert through back shell. Place wire / contact on end of insertion tool. Starting at center of plug insert contact / wire.

Vacuum Side Plug

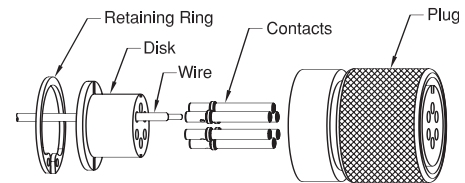

Insert wires through disk and crimp to contacts. Use crimp tool #2840-05. After crimping seat contacts on disk. Align contacts with holes in plug and insert. Insert retaining ring into back of plug to secure disk in place.

CIRCULAR MIL-C-5015 TYPE (125°C Max.)

Instrumentation

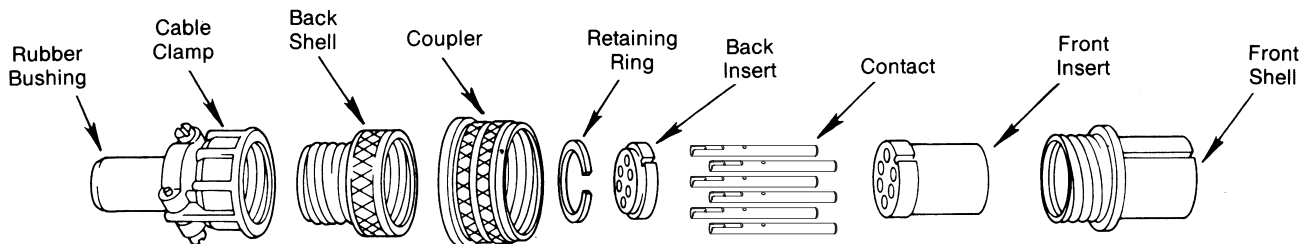

Note: Assembly instructions for the 4, 6, 10, 20 and 35 conductor and extended range plugs are identical.

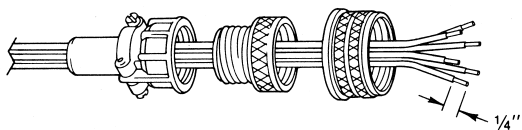

STEP 1 . . . Slide the cable clamp, rubber bushing, back shell and coupler over the cable. Strip the ends of the wires to the dimension shown.

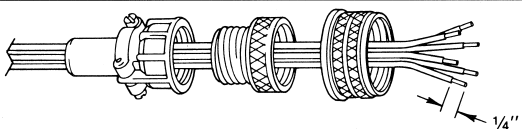

STEP 2 . . . Insert the proper wires into the contacts within the front shell and solder in place with the 60-40 rosin core solder. Snap ring and rear insulator can be removed, which would allow contacts to be more easily soldered.

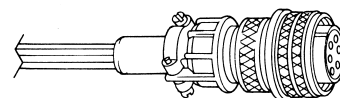

STEP 3 . . . Slide the coupler over the front shell, then thread the back shell onto the front shell and tighten. Slide the rubber bushing inside the cable clamp. Thread the cable clamp onto the back shell and tighten. Moderately tighten the clamp on the cable.

CIRCULAR MIL-C-5015 TYPE (125°C Max.)

Thermocouple

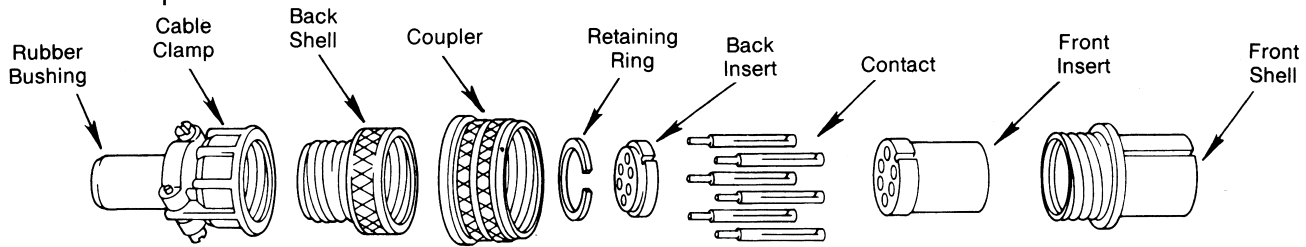

Note: Assembly instructions for the 2, 3, 5, and 10 pair thermocouple and extended range plugs are identical.

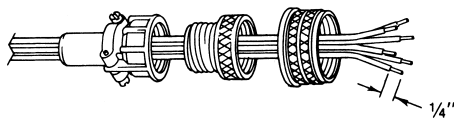

STEP 1 . . . Slide the cable clamp, rubber bushing, back shell and coupler over the cable. Strip the ends of the wires to the dimension shown.

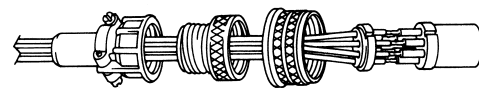

STEP 3 . . . Insert the contacts into the correct holes of the front insert. Notice that the alignment slots are in line upon assembly.

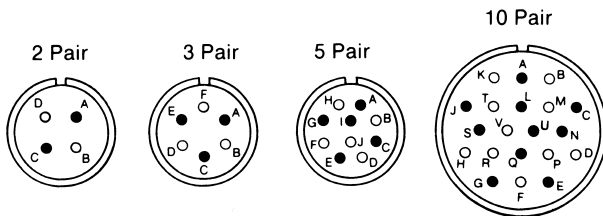

THERMOCOUPLE LEAD IDENTIFICATION
Darkened circles indicate placement of the positive (+) thermocouple leads and the empty circles indicate placement of the negative (-) thermocouple leads.

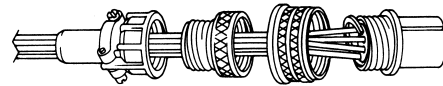

STEP 4 . . . Slide the front and back inserts together and insert them into the front shell. Secure them in place with the retaining ring.

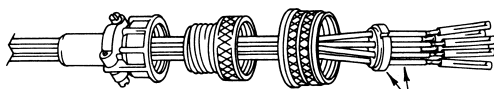

See Lead Orientation Charts Above

STEP 2 . . . Insert the proper thermocouple material into the properly identified holes in the back insert. Slide the proper contact on its corresponding conductor and crimp in place as shown.

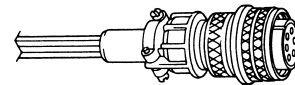

STEP 5 . . . Slide the coupler over the front shell, then thread the back shell onto the front shell and tighten. Slide the rubber bushing inside the cable clamp. Thread the cable clamp onto the back shell and tighten. Moderately tighten the clamp on the cable.

Thermocouple Header Pin Orientation

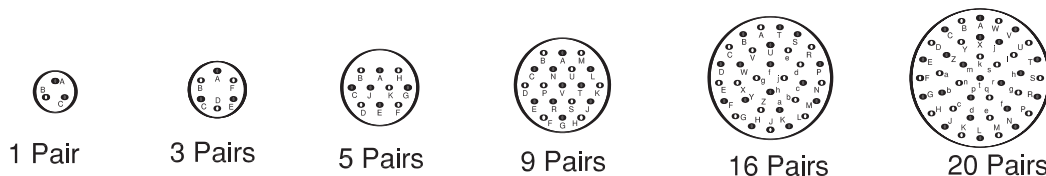

Darkened circles indicate placement of the positive (+) thermocouple leads and the empty circles indicate negative (-) thermocouple leads when viewed from the vacuum side.

TECHNICAL REFERENCE

High-Voltage Plug Attachment

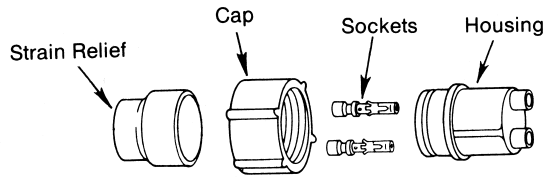

NOTE: Applies to 2, 4 and 7 pin high-voltage connectors.

Use Corona-Resistant High-Voltage Wire
 15KV Rating
 AWG #16 Max. Conductor
 .20 Max. Wire Insulation Diameter

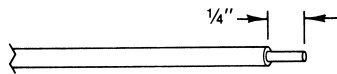

STEP 1 . . . Strip insulation back 1/4" from the end of all cables and pre-tin the conductor.

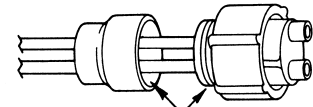

Apply cement at these locations

STEP 4 . . . Insert cable/socket assemblies in cavities of the housing until they lock into place, and moisture cure the "RTV-108" at 100% humidity and 140°F for 1 hour. This will seal cavities before final potting. Slip cap over housing and cement strain relief to the housing.

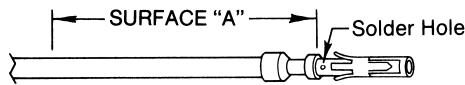

STEP 2 . . . Apply socket to the conductor by pushing it up against the insulation and solder onto the conductor. Clean SURFACE "A" (2 inches minimum) thoroughly with alcohol and apply a thin coating of "RTV-108" or equivalent.

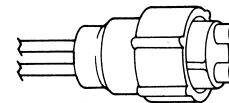

STEP 5 . . . Once the strain relief is attached, pot the strain relief and housing with Hysol #4215 or equivalent by pouring through the strain relief. (Potting mixture to be 100 parts of Hysol #4215 to 15 parts Hardener #3561.)

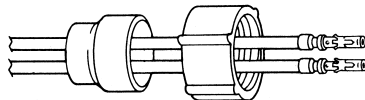

STEP 3 . . . Clean the inner surfaces of the housing and strain relief thoroughly with alcohol. Slide the strain relief and the cap over cables.

Thermocouple Plug Attachment

SPADE TYPE

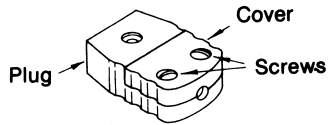

ANSI Type	Thermocouple Materials	Plug or Dot Color
K	Chromel /Alumel	Yellow
J	Iron/Constantan	Black
C†	Tungsten 5% Re/Tungsten 26% Re	Red
E	Chromel /Constantan	Violet
N†	Nicrosil/Nisil	Orange

† Not an ANSI symbol.

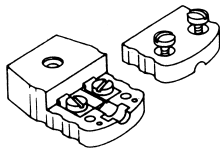

STEP 1 . . . Loosen the two screws in the cover and lift cover off plug.

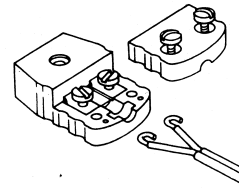

STEP 3 . . . Curve conductors clockwise as shown. Unscrew inner screws roughly 2-1/2 turns to allow the conductors to be fastened under the screw heads.

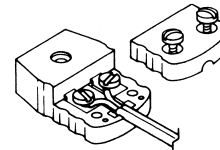

STEP 4 . . . Hook the conductors under the heads of the screws and tighten screws moderately.

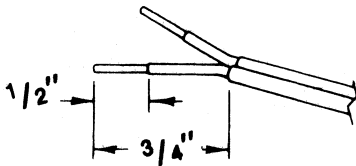

STEP 2 . . . Strip end of thermocouple wire to the dimensions shown.

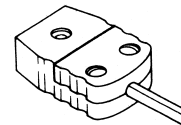

STEP 5 . . . Place cover back on the plug and tighten cover screws gently, being careful not to strip the threads in the cover.

TECHNICAL REFERENCE

Coaxial Cable/Plug Attachment

MICRODOT

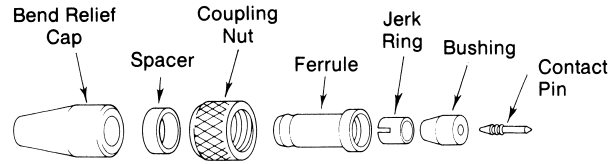

Coaxial Cable RG-196/U

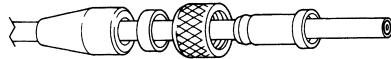

STEP 1 . . . Slide bend relief cap, spacer, coupling nut and ferrule over cable.

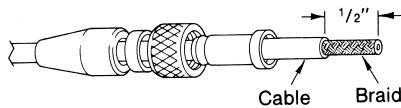

STEP 2 . . . Strip cable to the dimension shown.

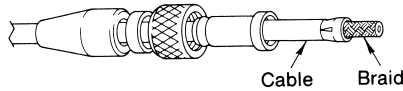

STEP 3 . . . Place jerk ring over shield, slotted end of ring should butt against cable jacket. Squeeze the ring snugly around the shield with a slight taper at the slotted end. Be careful not to squeeze the ring out of round.

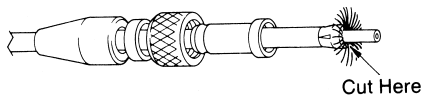

STEP 4 . . . Comb out braid and cut it close to the jerk ring as shown.

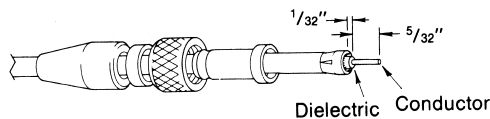

STEP 5 . . . Strip dielectric from end of conductor $5/32"$ and to $1/32"$ from the jerk ring (be careful not to nick conductor). If conductor is stranded it must be tinned.

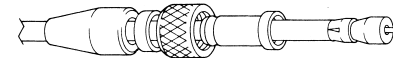

STEP 6 . . . Slip bushing over conductor and dielectric until bushing is against braid.

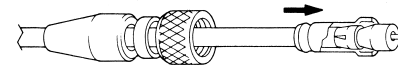

STEP 7 . . . Hold ferrule in one hand. With other hand push on the bushing until jerk ring and part of bushing start inside the ferrule.

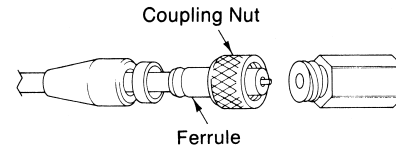

STEP 8 . . . Slide coupling nut over ferrule. Then screw coupling nut to Malco Tool, Part II.

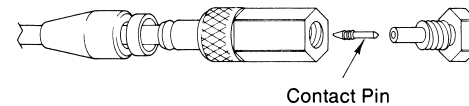

STEP 9 . . . Insert contact pin barbed end out, in small hole at the end of Malco Tool, Part 1, and screw into Part II as far as possible, thus forcing contact pin completely into bushing.



STEP 10 . . . Slide the bend relief cap up and over the end of the ferrule until it snaps into the groove. Remove Malco Tools, Part I and Part II.

Coaxial Cable/Plug Attachment

SMB

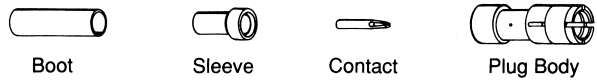

<p>STEP 1 . . . Dilate boot with Dilator (boot will remain dilated for approximately five minutes.) Slip boot over cable. When the optional black heat shrink tubing is used, activate with hot air gun after connector assembly. Trim outer jacket to indicated dimension.</p>	<p>STEP 4 . . . Slip cable assembly into body and trim excess braid.</p>
<p>STEP 2 . . . Slip sleeve over braid and against cable jacket. Fold braid back over sleeve and comb out braid to avoid bunching. Trim dielectric as indicated. Remaining dimension should be as shown; trim if necessary. Tin center conductor and remove excess solder.</p>	<p>STEP 5 . . . Crimp securely using Crimp Tool making sure that the contact does not protrude beyond insulator surface.</p>
<p>STEP 3 . . . Solder contact to inner conductor. Avoid excessive solder to permit insertion of contact into insulator. Avoid overheating, which could cause deformation of core. Contact must butt cable dielectric at point "x" to prevent contact from protruding beyond insulator surface.</p>	<p>STEP 6 . . . Slip boot over body as shown and use heat gun if required.</p>

SMA

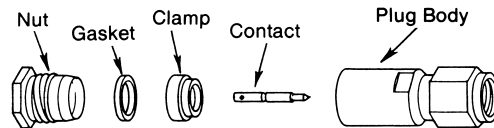

<p>STEP 1 . . . Place nut and gasket over cable and cut jacket to dimension shown.</p>	<p>STEP 4 . . . Trim dielectric 1/8" from the end of the cable. Do not nick center conductor.</p>
<p>STEP 2 . . . Comb out braid and taper forward toward the conductor.</p>	<p>STEP 5 . . . Solder contact in place so as to be seated squarely against dielectric. Clean all surfaces thoroughly.</p>
<p>STEP 3 . . . Place clamp over braid and push back against jacket. Fold braid back against clamp and trim as necessary so that wires do not touch shoulder of clamp.</p>	<p>STEP 6 . . . Thread connector assembly onto prepared cable assembly. Tighten to 20-25 in./lbs. torque.</p>

TECHNICAL REFERENCE

Coaxial Cable/Plug Attachment

BNC

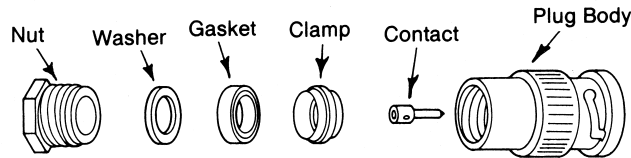

Coaxial Cables
 RG-58/U
 RG-140/U
 RG-141/U

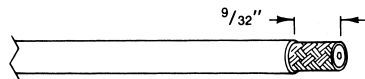

STEP 1 . . . Cut jacket and strip to dimension shown.

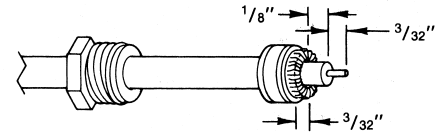

STEP 4 . . . With the clamp in place, fold back braid as shown and trim 3/32" from the end. Trim dielectric to the dimensions shown.

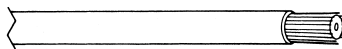

STEP 2 . . . Comb out braid and taper toward the center.

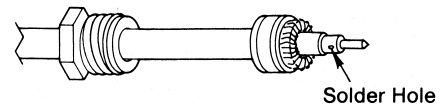

STEP 5 . . . Slip contact in place so it butts against the dielectric and solder in place. Remove excess solder from outside of contact. Be sure cable dielectric is not heated excessively and swollen so as to prevent dielectric from entering into connector body.

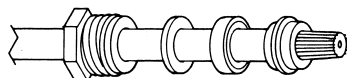

STEP 3 . . . Place the nut, washer, and gasket over the cable, then slide the clamp on over the braid so that the inner shoulder fits against the end of the cable jacket.

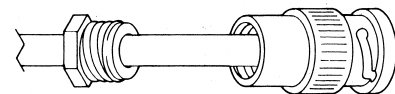

STEP 6 . . . Push assembly into body as far as it will go. Slide nut into body and screw in place with wrench until tight. For this operation, hold cable and shell rigidly and rotate nut.

TECHNICAL REFERENCE

Coaxial Cable/Plug Attachment

MHV

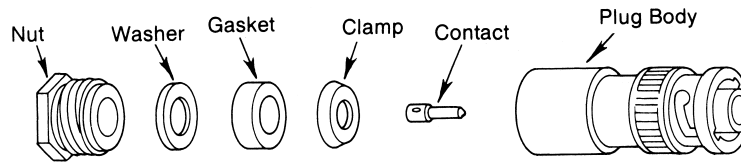

**Coaxial Cable
RG-59/U**

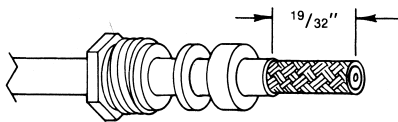

STEP 1 . . . Slide nut, washer and gasket over jacket, and cut off jacket 19/32" from end of cable as shown.

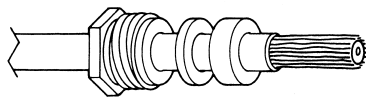

STEP 2 . . . Comb out braid, pull braid wires forward and taper toward conductor.

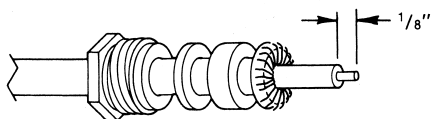

STEP 3 . . . Place clamp over braid and push back against cable jacket. Fold back braid wires as shown, trim to proper length and evenly form over clamp as shown. Cut dielectric to 1/8" dimension as shown. Tin exposed conductor using minimum amount of heat.

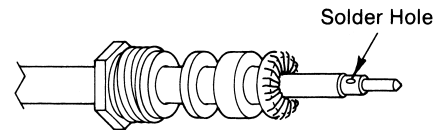

STEP 4 . . . Solder contact to conductor. Remove excess flux and solder from outside of contact.

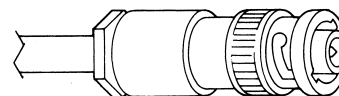

STEP 5 . . . Insert prepared cable termination into plug body. Tighten nut moderately, holding plug body stationary.

TECHNICAL REFERENCE

Coaxial Cable/Plug Attachment

SHV 5 KV

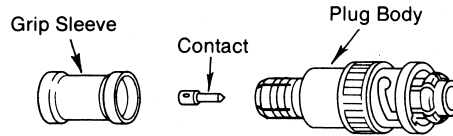

**Coaxial Cable
RG-59/U**

STEP 1 . . . Slide the grip sleeve over the cable. Trim the end of the cable to the dimensions shown.

STEP 3 . . . Push the assembled contact into the plug body until the dielectric bottoms against the shoulder within the plug body. At this point, the body grip fingers should be under the flared braid as shown.

STEP 2 . . . Tin end of the cable and inside of contact. Solder the contact to the center conductor. Flare out the braid without fraying.

STEP 4 . . . Slide the grip sleeve forward against the plug body, over the braid and crimp as shown. Use Kings Hand Crimp Tool #KTH-1000 and Crimp Die #KTH-2062.

SHV 10 & 20KV

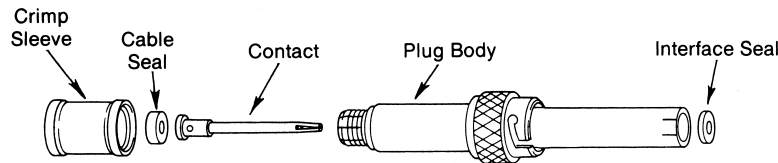

NOTE: Before assembly be sure you can distinguish between the cable seal and the interface seal. The cable seal has a .09" hole and is .10" thick. However, the interface seal has a .13" hole and is .07" thick. Do not interchange.

PART	Cable	A	B	C
10 KV	RG 58C/U	15/16	1 1/8	15/64
20 KV	RG-213/U	1 3/4	1 15/16	5/16

STEP 1 . . . Slide the crimp sleeve over the cable. Trim the end of the cable to the dimensions shown and tin the exposed conductor.

STEP 3 . . . Flare out braid without fraying the ends. Insert prepared cable assembly into the plug body carefully. DO NOT pinch or otherwise damage cable seal. Guide braid smoothly over the splined crimp area of the body until the contact shoulder butts against the inner insulator.

STEP 2 . . . Slip cable seal over center conductor then slide contact over conductor. Push contact against cable seal and maintain this slight pressure while soldering contact in place through solder hole.

STEP 4 . . . Slide the grip sleeve into position and crimp as shown. Use Ceramaseal's Crimping Tool #2840-02 or Thomas and Betts Crimping Tool #WT-540 with Crimping Die #5452. Make sure braid does not extend beyond the end of the grip sleeve. Insert interface seal into the open end of the plug. Carefully slide the interface seal over contact until it bottoms evenly around the contact.

TECHNICAL REFERENCE

Coaxial Cable/Plug Attachment

BSHV 7.5 KV

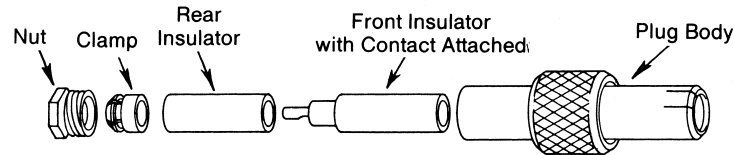

**Coaxial Cable
RG-59/U**

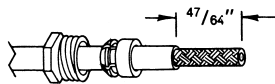

STEP 1 . . . Slide nut and clamp over cable. Cut the jacket to the dimension shown. Do not nick braid.



STEP 2 . . . Comb out braid and fold back against jacket. Cut dielectric to the dimension shown. Do not nick the conductor.

**Crimp Tool KTH-1000 & Die
(KTH 2001 or 2002)**

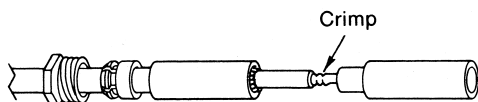

STEP 3 . . . Carefully slide rear insulator over cable just so it covers the braid. Insert the conductor into the crimp end of the front insulator and crimp as shown.

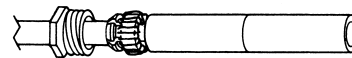

STEP 4 . . . Carefully slide the rear insulator up against the front insulator as shown. Fold braid out and slide clamp up to meet the braid. Fold the braid back over the clamp and trim so as to fit around the clamp as shown.

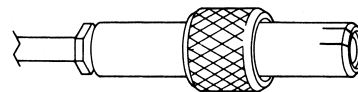

STEP 5 . . . Slide prepared cable end into plug body and tighten nut moderately.

TECHNICAL REFERENCE

Coaxial Cable/Plug Attachment

TYPE N

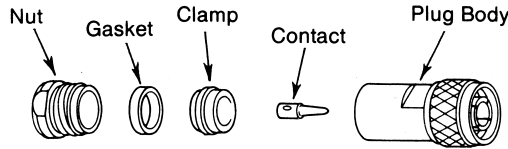

Coaxial Cable
 RG-8/U
 RG-9/U
 RG-213/U
 RG-214/U
 RG-225/U

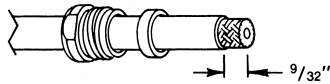

STEP 1 . . . Place nut and gasket with "V" groove toward clamp over cable and cut jacket to the dimension shown.

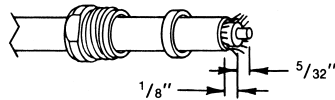

STEP 2 . . . Comb out braid and fold out. Cut off cable dielectric to the dimensions shown.

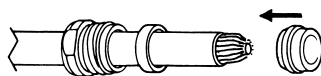

STEP 3 . . . Pull braid wires forward and taper toward conductor. Place clamp over braid so that the inner shoulder fits against the end of the cable jacket.

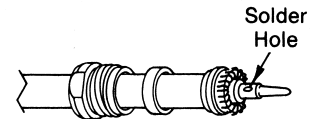

STEP 4 . . . Fold back braid as shown, trim to proper length and form over clamp as shown. Solder contact to center conductor.

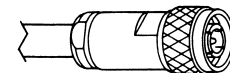

STEP 5 . . . Insert cable and parts into connector body. Make sure sharp edge of clamp seats properly in gasket. Tighten nut.

TECHNICAL REFERENCE

Coaxial Cable/Plug Attachment

HN

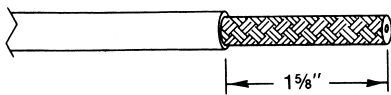
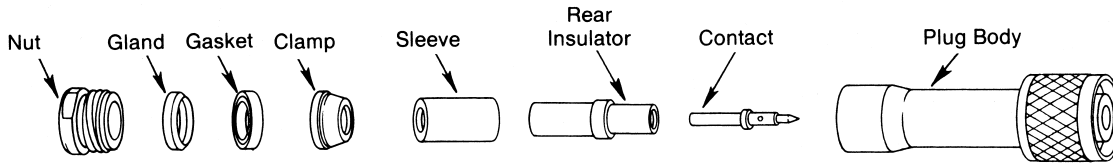

STEP 1 . . . Cut end of cable even. Strip off vinyl jacket to the dimension shown.

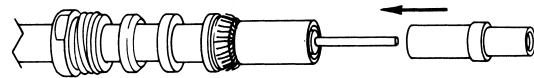

STEP 4 . . . Fold braid back over clamp and trim. Tin exposed center conductor using minimum amount of heat. Slide sleeve and rear insulator over cable dielectric.

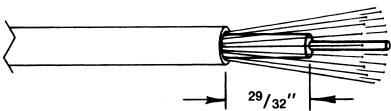

STEP 2 . . . Comb out braid and cut dielectric to the dimension shown.

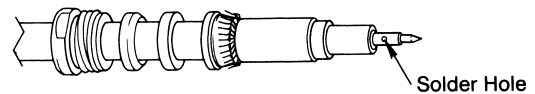

STEP 5 . . . Solder contact to center conductor. Rear insulator must seat against cable dielectric and contact shoulder must be flush with insulator face as shown. Coat cable dielectric and insulator mating surfaces with Amphenol #53-307 Silicone Compound or equal to achieve 5KV peak rating under operating conditions.

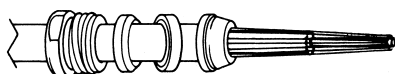

STEP 3 . . . Taper braid wires forward and slide nut and gland onto jacket. Make certain knife edge of gland is toward end of cable. Then slide gasket onto jacket with "V" groove toward gland. Clamp is now pushed over braid so that the internal shoulder butts flush against the cable jacket.

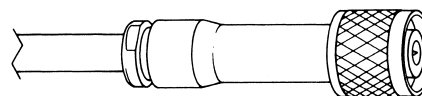

STEP 6 . . . Slide prepared cable terminations carefully into body. Be sure knife edge of gland remains in groove of gasket. Tighten nut with wrench, holding body stationary. Gasket should be cut in half during tightening.

TECHNICAL REFERENCE

Cable Terminations

Termination A - Coaxial

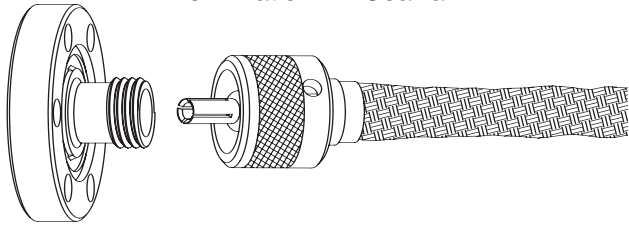

Termination B - Contact

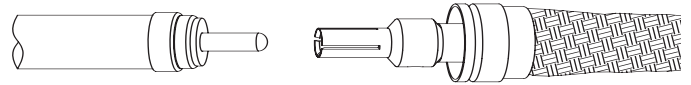

Termination C - In-Line

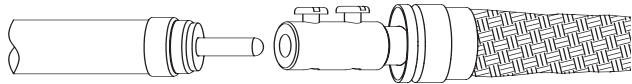

Termination D - Cable Splice

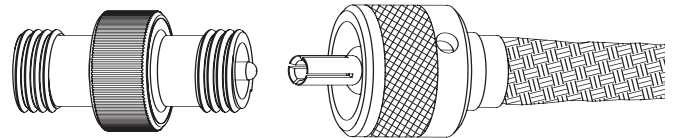

Termination E - BNC

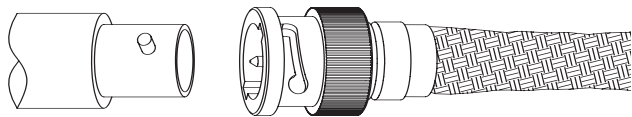

Termination F - MHV

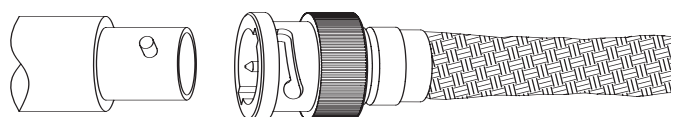

Termination G - Bare Conductor

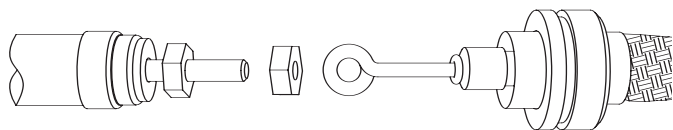

Termination H - Lug

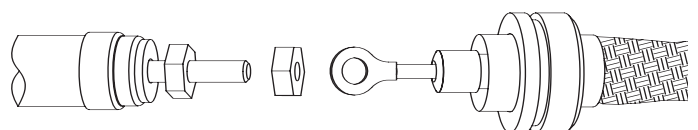

TECHNICAL REFERENCE

When choosing the best installation for your system, there are a number of considerations, including pressure, temperature and maintenance requirements of your system.

Pressure:

ConFlat flanges are recommended for low pressure applications. Because a ConFlat flange uses an OFE copper gasket, the outgassing range is very low. To reach very low pressures, the system hardware will probably have to be baked out.

Temperature:

ConFlat flanges can be baked to 450°C, while ISO-NW flanges may be baked to 205°C if Viton o-rings are used.

Maintenance:

Consider how often your system will require maintenance, since ConFlat flanges are more difficult to assemble and disassemble and require tools. ISO-NW flanges are easy to assemble and disassemble and require no tools.

INSTALLATION

Products in this catalog have been categorized by method of installation. Options include braze, solder, weld, NPT threaded, ConFlat flange, baseplate, and ISO-NW flange.

Braze:

Brazing is compatible for products that have mounting hardware made of nickel, copper-nickel, nickel-iron, Kovar, or stainless steel and that have been manufactured using higher temperature braze alloys. These items are identified in the tables throughout this catalog. Maximum braze temperature should not exceed 500°C without prior factory approval. Acceptable mounting configurations can be found on page L23.

Solder:

Soldering is acceptable for products that have mounting hardware made of copper, copper-nickel, nickel-iron or Kovar. Acceptable mounting configurations can be found on page L23.

Weld:

Products in this catalog identified for welding utilize Kovar, 52% nickel-iron, or stainless steel mounting hardware. Pulse-TIG, TIG, laser, or E-Beam welding are acceptable. It is important to minimize the heat concentration at seal areas to avoid thermal shock to the insulator. A number of suggested configurations can be found on page L23.

NPT Threaded:

NPT fittings provide reliable leak-free performance down to 10⁻⁶ torr. Use of Teflon sealing tape is recommended. Bakeouts are limited to 232°C. Refer to page L26.

ConFlat Flange:

ConFlat flanges are recommended for ultra-high-vacuum applications. They can be used either with a copper gasket for ConFlat to ConFlat mounting or with an o-ring for ConFlat to plate mounting. ConFlat mountings using the copper gasket can be baked to 450°C with very low outgassing. O-ring applications are limited in vacuum capability by the bakeout limitations of the o-ring. Viton o-ring applications can be baked to 205°C. See pages L24 - L25.

ISO-NW Flange:

ISO-NW flanges are recommended for vacuum applications down to 10⁻⁹ torr. Bakeout to 150°C is required to achieve this vacuum level. The advantage of using the ISO-NW flange mounting option is that installation and removal are quickly and easily accomplished. No tools are required. See page L26.

Baseplate:

Baseplate o-ring seals provide a quick and easy assembly to plates or housings for high-vacuum applications. Baseplates utilize a Viton o-ring and can be baked to 205°C. See page L26.

BRAZE/SOLDER

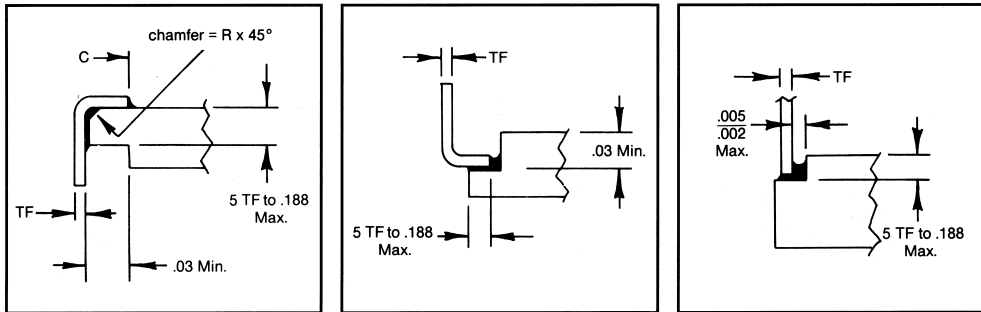

TF = Flange Thickness — Units with copper, copper nickel, nickel iron and Kovar can be soldered.
 C = Flange-Flat Diameter — Units with nickel, copper-nickel, nickel-iron, Kovar and stainless steel can be brazed.
 — Fit up to be at solder or braze temperature. Refer to thermal expansion curves on pages L4.

WELD

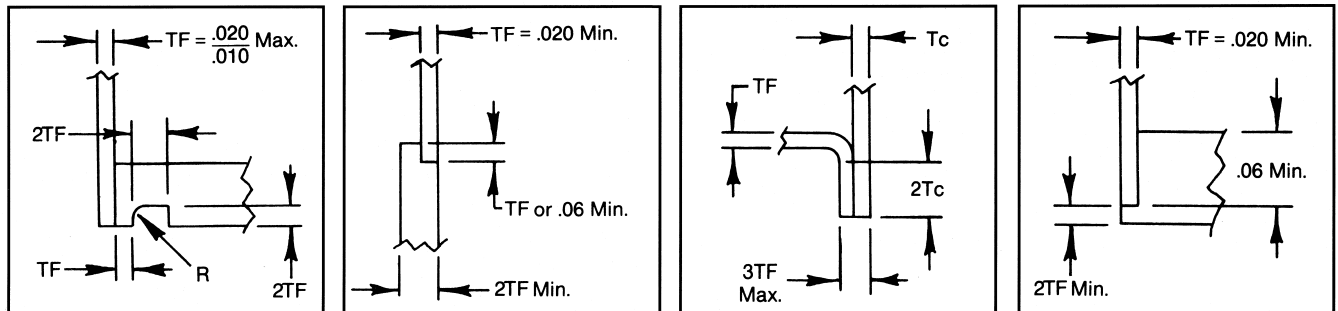

TF = Flange Thickness R = TF Tc = Mating Part Thickness

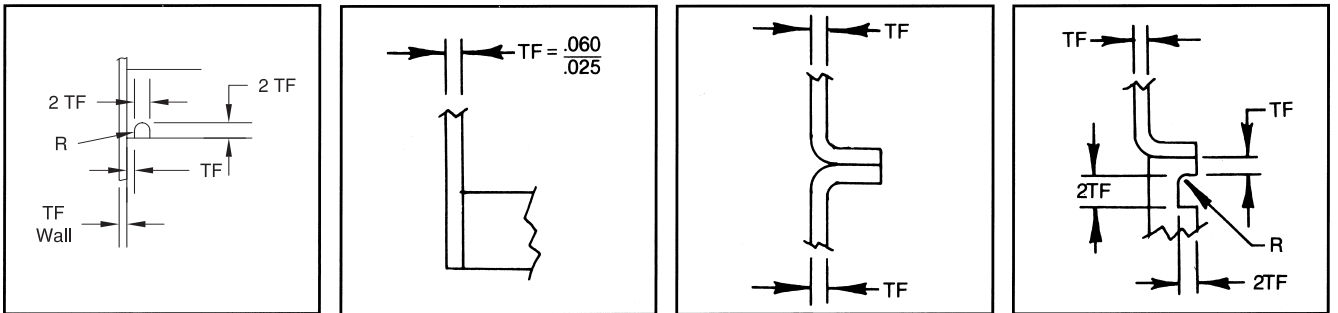

When welding components, the weld should be made on the vacuum side of the system to prevent virtual leaks from small spaces or gaps where the components mate. If both sides of the components need to be welded for strength, the vacuum side should be welded continuously and the welds on the outside of the system should be welded intermittently. All dimensions are in inches.

TECHNICAL REFERENCE

CONFLAT FLANGE

COPPER GASKET SEAL

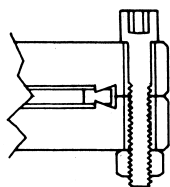
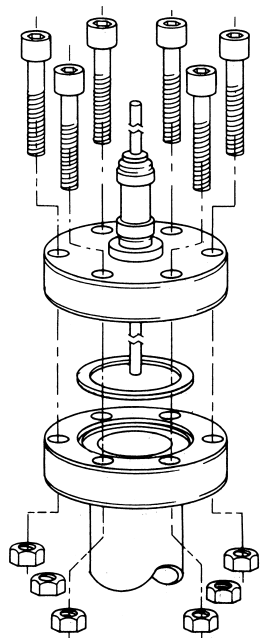

O-RING SEAL

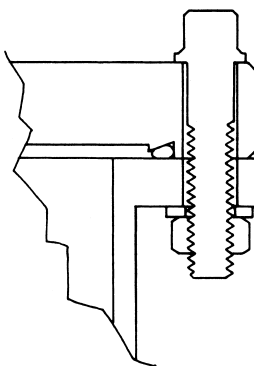
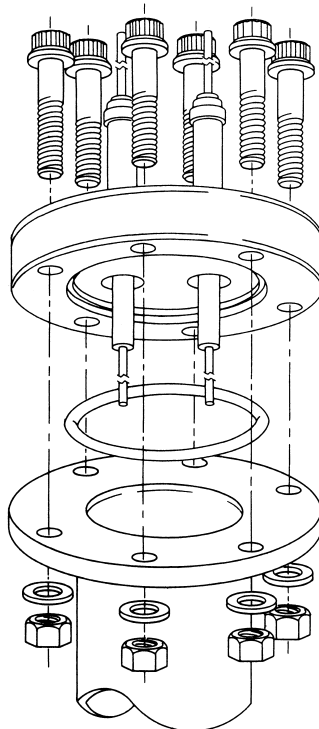

**Viton O-Ring Seal
Flange to Flange**

Flange Dia.	O-Ring Cross Section	Parker O-Ring Cat. No.
1.33	.103 Dia.	2-114
2.75	.139 Dia.	2-223
3.38	.139 Dia.	2-227
4.50	.139 Dia.	2-234
6.00	.139 Dia.	2-246
8.00	.139 Dia.	2-260
10.00	.139 Dia.	2-268

**Viton O-Ring Seal
Flange to Flat Plate**

Flange Dia.	O-Ring Cross Section	Parker O-Ring Cat. No.
1.33	.070 Dia.	2-17
2.75	.103 Dia.	2-130
3.38	.103 Dia.	2-139
4.50	.103 Dia.	2-151
6.00	.103 Dia.	2-157
8.00	.103 Dia.	2-165
10.00	.103 Dia.	2-173

Conflat Flange Assembly

- Finger-tighten all flange bolts, being certain they are evenly tightened.
- Torque the bolts using the torque pattern shown in the figure on page L25 in incremental steps with the final setting being the value listed in the table.

TECHNICAL REFERENCE

CONFLAT FLANGE: TIGHTENING SEQUENCE & BOLT HOLE LAYOUT

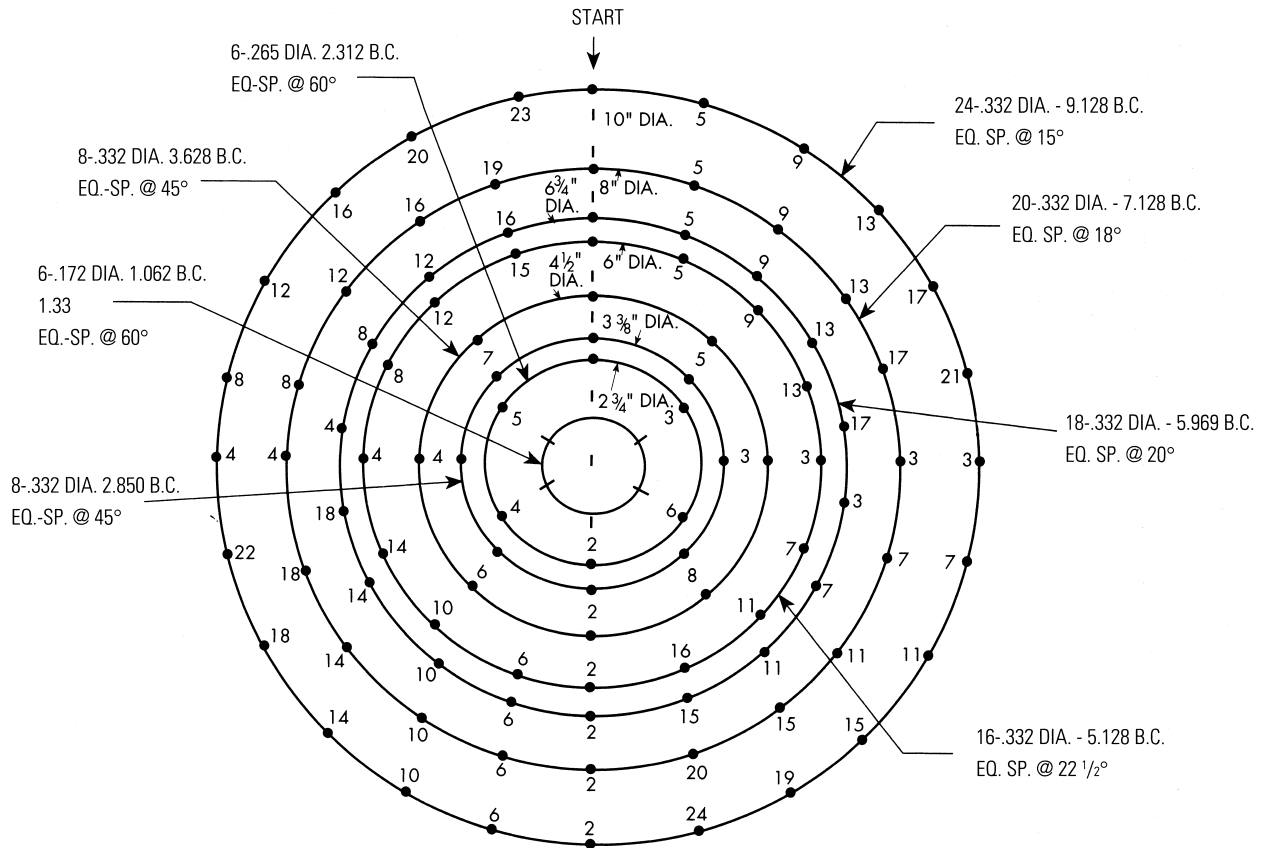

Schematic of bolt-hole locations, 1.33 in., 2-3/4 in., 3-3/8 in., 4-1/2 in., 6 in., 6-3/4 in., 8 in., 10 in. ultra-high-vacuum bakeable flanges numbered in sequence for completing seal.

Flange Bolt and Torque Data

Lubricated Bolt Torque	Bolt dia/thd	Flange Size (OD in.) and Number of Bolts						
		2 3/4	3 3/8	4 1/2	6	6 3/4	8	10
80 in.-lb (7 ft.-lb.) to 100 in.-lb max	1/4 in. -20	6	—	—	—	—	—	—
120 in.-lb (10 ft.-lb.) to 150 in.-lb max	5/16 in. -18	—	8	8	16	18	20	24

TECHNICAL REFERENCE

ISO NW FLANGE

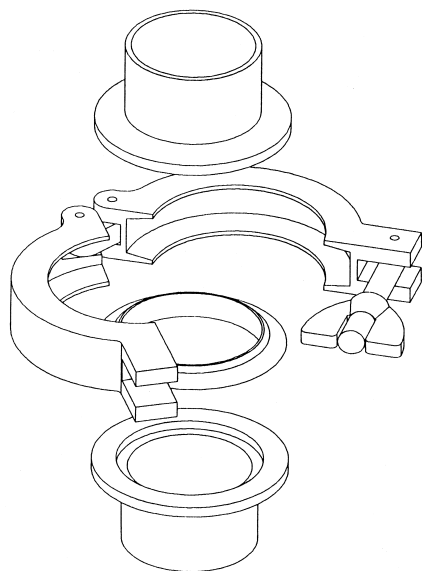

ISO-NW Flange Assembly

- Assemble the two flanges together with a clean O-ring and retainer between them. Place the mounted device in the proper orientation. Use of vacuum grease should not be required.
- Place the clamp around the flanges, positioning the clamp bolt and nut in an accessible position for tightening.
- Tighten down the nut. Hand tighten only. Do not use a wrench or pliers.

NPT THREAD

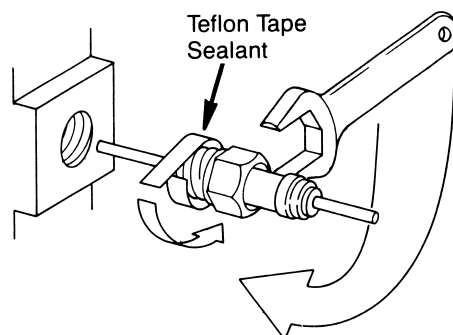

Use of threaded connections in a vacuum system should be minimized. The small spaces between the threads will cause virtual leaks. If threaded connection must be used, one of the connections should be slotted to permit rapid pumping of the threads and blind hole, if any.

BASEPLATE

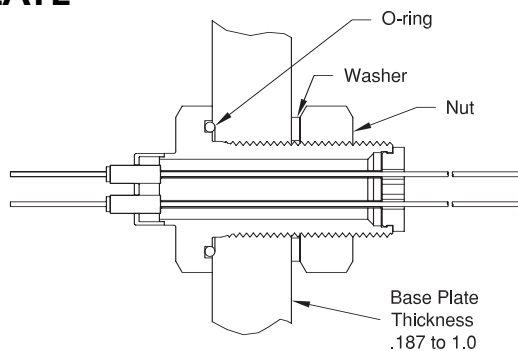

Install feedthrough with o-ring on vacuum or pressure side of the wall. Place washer and nut on air side of system. Tighten nut to compress o-ring.

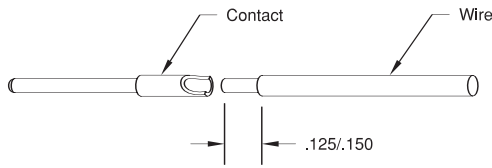

Solder Cup Contacts

Strip conductor to dimension shown. Tin the conductor. Place a small length of solder in the contact well. Insert tinned wire end into contact. Heat contact to melt solder and position the conductor.

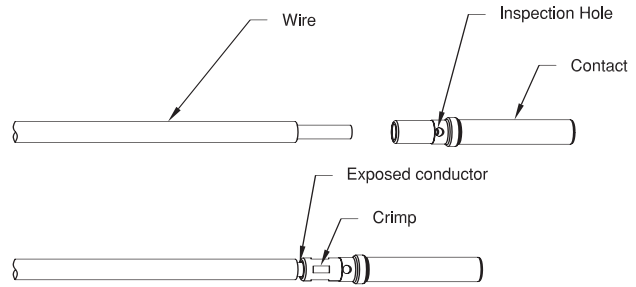

Crimp Contacts

Strip conductor to allow insertion of contact and a .010 to .030 maximum exposure between contact and wire insulation. Insert wire fully into contact, wire should be visible in inspection hole. Center crimp between end of contact and inspection hole. Refer to Chart on page K18 for crimp locator part number.

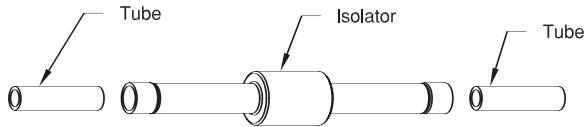

Water Isolators

Solder or Braze tube into isolator tube ends.

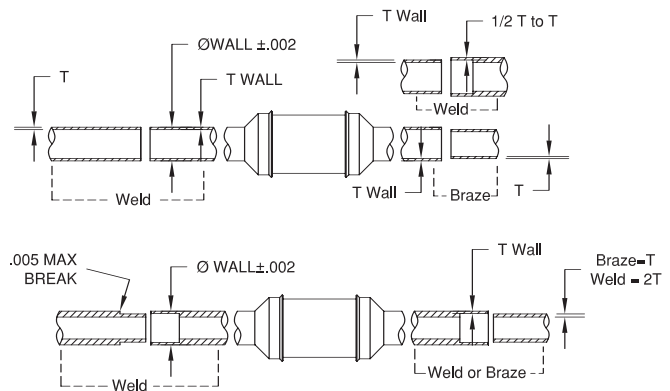

Isolators

Braze or Weld tube into isolator tube ends.

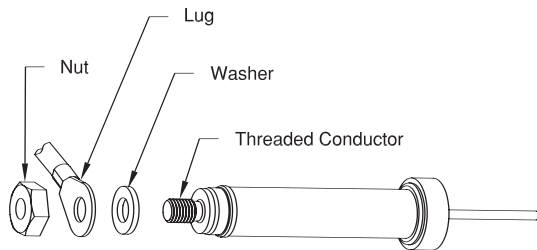

Threaded Conductor Feedthrough

Place washer on stud to limit torque on feedthrough. Put conductor termination over stud. Thread nut onto conductor to apply clamping force to termination.

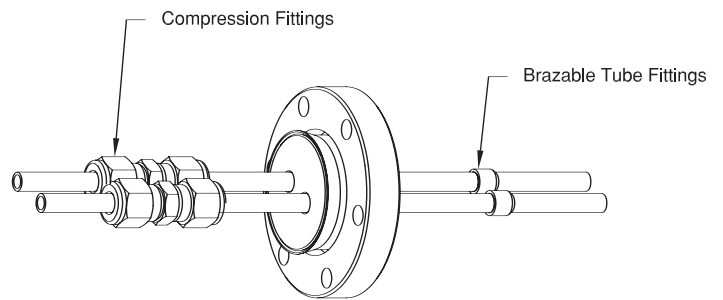

RF Feedthrough Installation

A variety of options can be used to attach to the tube/conductor depending on whether or not the joint or required components will couple with the RF field. Ceramaseal can make no general recommendation because of the large variety of systems and applications in various industries. Testing is recommended. Options include: vacuum brazing, soldering, compression fittings, and welding. Ceramaseal can offer designs with a short copper rod welded on the vacuum or air side of a tube to serve as a plug for those who do not need or want coolant fluid and want to attach with a clamp. Ceramaseal can also braze entire coils in a feedthrough and offer non-coil designs with return coolant paths.