

> IFP30 Series

Commercial Touch Display User Guide

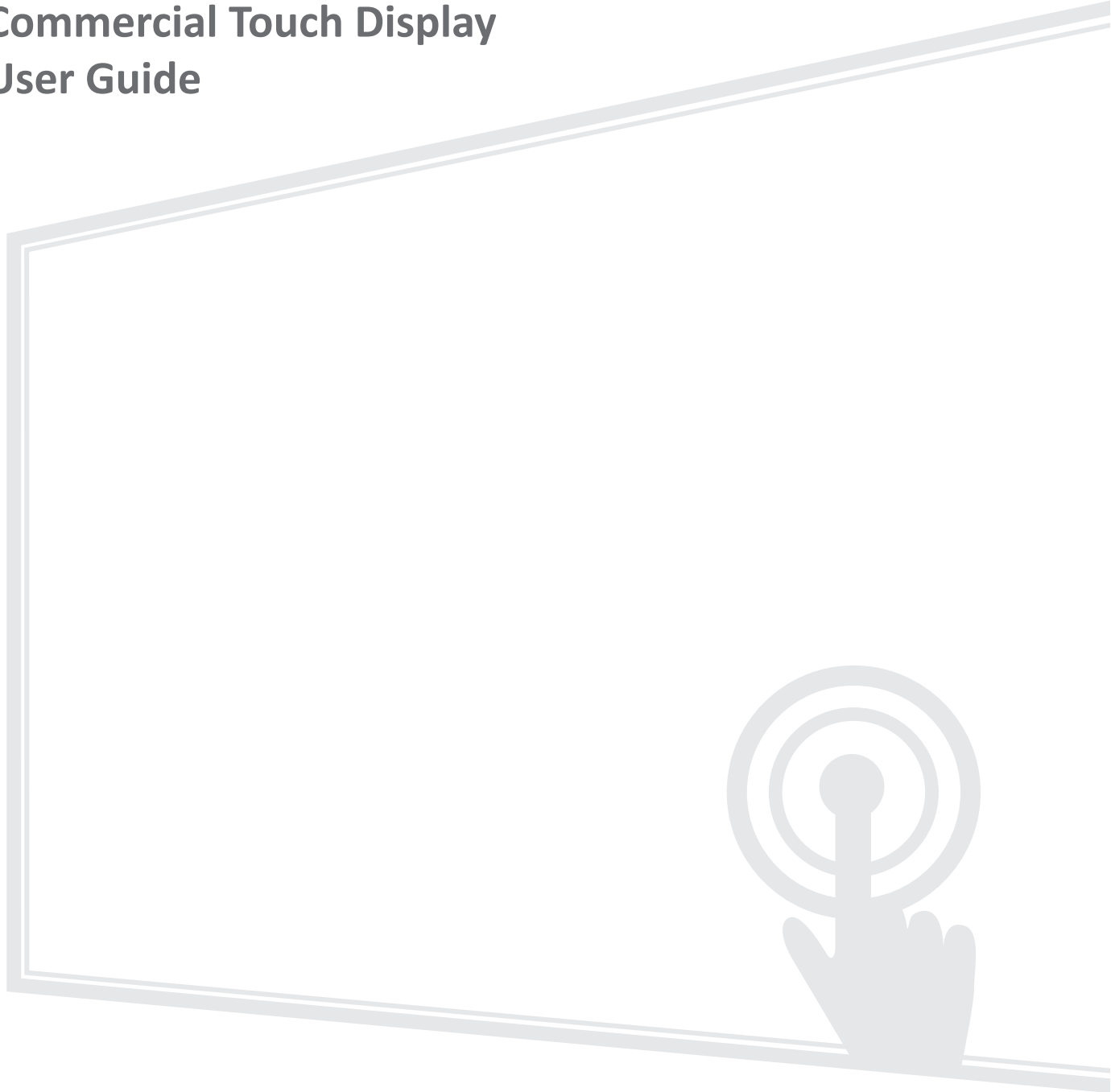

IMPORTANT: Please read this User Guide to obtain important information on installing and using your product in a safe manner, as well as registering your product for future service. Warranty information contained in this User Guide will describe your limited coverage from ViewSonic® Corporation, which is also found on our web site at <http://www.viewsonic.com> in English, or in specific languages using the Regional selection box in the upper right corner of our website. "Antes de operar su equipo lea cuidadosamente las instrucciones en este manual"

Model No. VS17775/VS17776
P/N: IFP6530/IFP7530

Thank you for choosing ViewSonic®

As a world-leading provider of visual solutions, ViewSonic® is dedicated to exceeding the world's expectations for technological evolution, innovation, and simplicity. At ViewSonic®, we believe that our products have the potential to make a positive impact in the world, and we are confident that the ViewSonic® product you have chosen will serve you well.

Once again, thank you for choosing ViewSonic®!

> Safety Precautions

Please read the following **Safety Precautions** before you start using the device.

- Keep this user guide in a safe place for later reference.
- Read all warnings and follow all instructions.
- Do not use the device near water. To reduce the risk of fire or electric shock, do not expose the device to moisture.
- Never remove the rear cover. This display contains high-voltage parts. You may be seriously injured if you touch them.
- Avoid exposing the device to direct sunlight or other sources of sustained heat.
- Do not install near any heat sources such as radiators, heat registers, stoves, or other devices (including amplifiers) that may increase the temperature of the device to dangerous levels.
- Use a soft, dry cloth to clean the external housing. For more information, refer to the "Maintenance" section on page 103.
- When moving the device, be careful not to drop or bump the device on anything.
- Do not place the device on an uneven or unstable surface. The device may fall over resulting in an injury or a malfunction.
- Do not place any heavy objects on the device or connection cables.
- If smoke, an abnormal noise, or a strange odor is present, immediately turn the device off and call your dealer or ViewSonic®. It is dangerous to continue using the device.
- The device is a monitor with an LED backlight intended for general office use.
- Do not attempt to circumvent the safety provisions of the polarized or grounding-type plug. A polarized plug has two blades with one wider than the other. A grounding-type plug has two blades and a third grounding prong. The wide blade and the third prong are provided for your safety. If the plug does not fit into your outlet, obtain an adapter and do not attempt to force the plug into the outlet.
- When connecting to a power outlet, DO NOT remove the grounding prong. Please ensure grounding prongs are NEVER REMOVED.
- Protect the power cord from being treaded upon or pinched, particularly at the plug, and at the point where it emerges from the equipment. Ensure that the power outlet is located near the equipment so that it is easily accessible.

- Only use attachments/accessories specified by the manufacturer.
- When a cart is used, use with caution when moving the cart/equipment combination to avoid injury from tipping over.
- Disconnect the power plug from the AC outlet if the device is not being used for a long period of time.
- Place the device in a well-ventilated area. Do not place anything on the device that prevents heat dissipation.

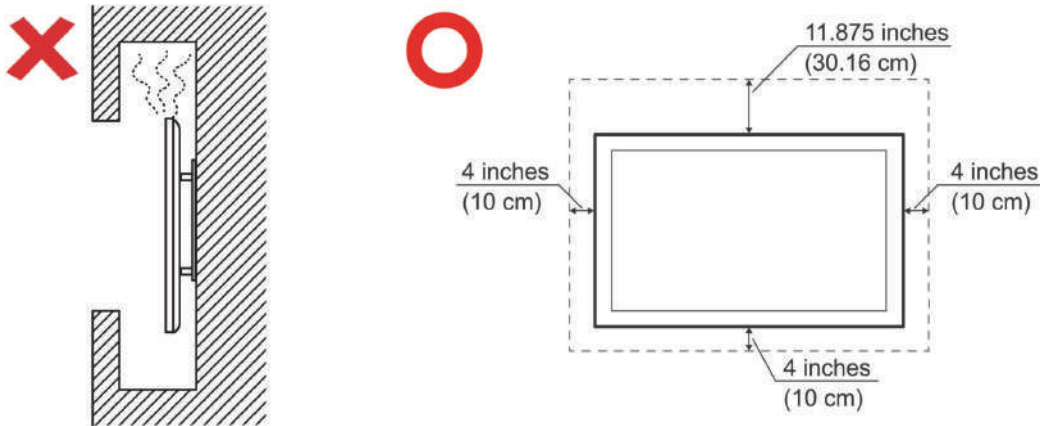

- Refer all servicing to qualified service personnel. Service will be required when the unit has been damaged in any way, such as:
 - » if the power supply cord or plug is damaged
 - » if liquid is spilled onto or objects fall in the unit
 - » if the unit is exposed to moisture
 - » if the unit does not operate normally or has been dropped

> Contents

Safety Precautions.....	3
Introduction	10
Package Contents	10
Wall Mount Kit Specifications (VESA)	11
Product Overview	12
Control Panel.....	12
I/O Panel.....	13
Remote Control	15
Using Gestures	19
Select and Deselect an Object (Clicking)	19
Display Menu Options (Right-Clicking)	19
Double-Clicking	19
Moving an Object	20
Erasing Digital Ink	20
Swipe Up for General Settings.....	20
Making Connections	21
Connecting External Devices and Touch Connection	21
DisplayPort Connection.....	21
HDMI Connection	21
VGA Connection	21
RS-232 Connection	22
USB and Networking Connections	23
Media Player Connection	24
SPDIF Connection	25
Video Output Connection	26

Using Your ViewBoard..... 27

Powering On/Off your ViewBoard.....	27
Initial Launch Setup	28
vLauncher - Customizable Welcome Screen.....	30
Customize Default Applications (vLauncher).....	31
Tool Bar	32
ViewBoard On-Screen Display (OSD) Menu	36
General Settings	37
Detailed Settings	39
Audio	39
Screen.....	40
Display	41
Adjust	42
Advanced Settings.....	43
Wireless & Networks.....	43
Wi-Fi	44
Ethernet	45
Wi-Fi Hotspot	46
Share	47
Device.....	48
Theme	48
Display.....	48
Wallpaper	49
ENERGY STAR® mode.....	50
HDMI EDID	51
HDMI OUT Resolution Setting	52
Auto Brightness.....	52
Burn-in Protection Interval.....	53
Storage	54
Sound	54
Security.....	55
Trusted Credentials.....	55
Clear Credentials	55
Languages & Input.....	56
Keyboard and Input Method	56
Android Keyboard.....	56
Language	58
Boot Setting.....	59

Startup Channel.....	59
Built-in PC startup option	59
Standby after Startup	60
Power On/Off Timer	60
No Signal Power Off.....	61
HDMI CEC	61
Password for Screen Lock.....	62
Channel Setting	63
Input Channel Alias Switch	63
Power On by Active Source	63
Signal Auto Search.....	63
Auto Switch to new Source	63
Side Tool Bar Channel.....	64
System	65
Date & Time	65
About Device	68
System Update	68
Advanced.....	71
Mode	72
App Info.....	72
Password	72
Reset.....	73

Embedded Applications and Settings.....	74
Embedded Digital Whiteboard App.....	74
myViewBoard	74
Floating Bar	74
Toolbar	74
ViewBoard Cast	76
Cast Sender from Windows-based Devices, Macbook, and Chrome devices.	77
Cast Sender from Mobile Devices: iOS-based (iPhone, iPad) and Android OS based phone/tablet.	78
Cast Out from a Mobile Device that Supports Annotation	79
vSweeper.....	80
Screen Lock	81
Chromium.....	82
WPS Office.....	82
Folders.....	83
RS-232 Protocol.....	84
Description	84
RS-232 Hardware Specification	84
LAN Hardware Specification.....	85
RS-232 Communication Setting.....	85
LAN Communication Setting	85
Command Message Reference.....	85
Protocol	86
Set-Function Listing.....	86
Get-Function Listing	90
Remote Control Pass-through Mode	95
Appendix.....	98
Specifications.....	98
Display Modes	99
VGA Mode	99
HDMI/OPS Mode.....	99
DisplayPort (DP) Mode.....	100
Troubleshooting	101
Maintenance.....	103
General Precautions.....	103
Cleaning the Screen.....	103
Cleaning the Case	103

Regulatory and Service Information	104
Compliance Information.....	104
CE Conformity for European Countries	104
Declaration of RoHS2 Compliance.....	104
ENERGY STAR® statement.....	105
Indian Restriction of Hazardous Substances	105
Product Disposal at End of Product Life	106
Copyright Information	107
Customer Service	108
Limited Warranty	109
Mexico Limited Warranty.....	112

> Introduction

Package Contents

- HDMI cable
- Power cable x 4
- Remote control
- AAA battery x 2
- USB touch cable
- Compliance Statement
- Touch Pen x 2
- Wall mount screws
- Quick Start Guide
- Webcam plate with screws
- Pen Tray and screws

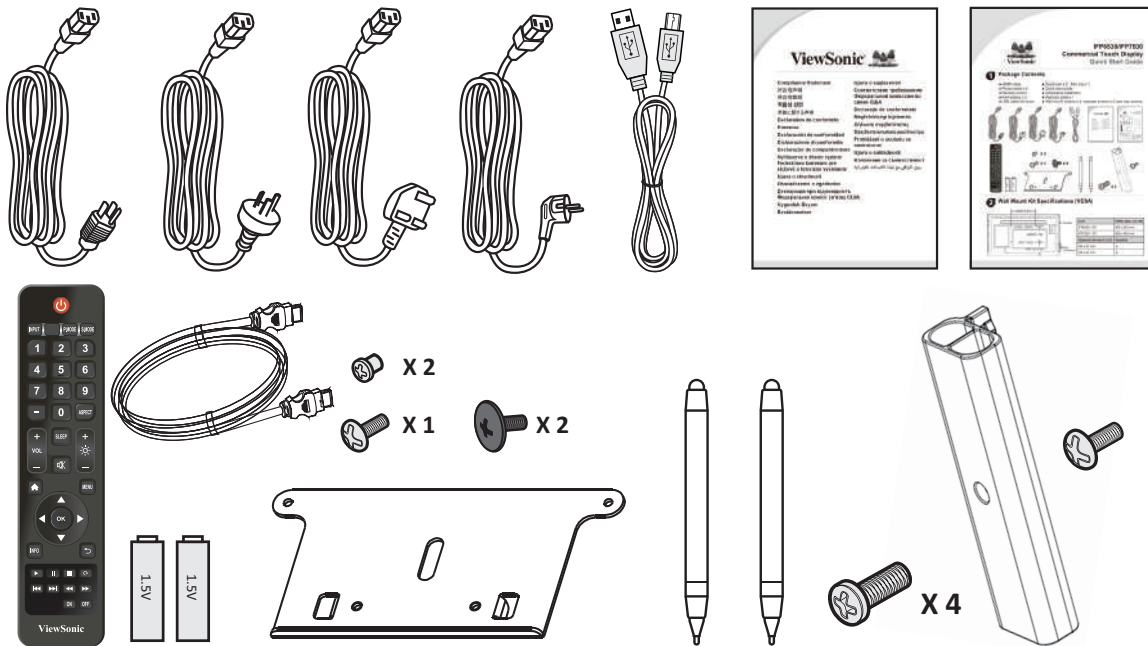

NOTE: The power cord and video cables included in your package may vary depending on your country. Please contact your local reseller for more information.

Wall Mount Kit Specifications (VESA)

NOTE: Please follow the instructions in the wall mount installation guide to install your wall mount or mobile mount bracket. If attaching to other building materials, please contact your nearest dealer.

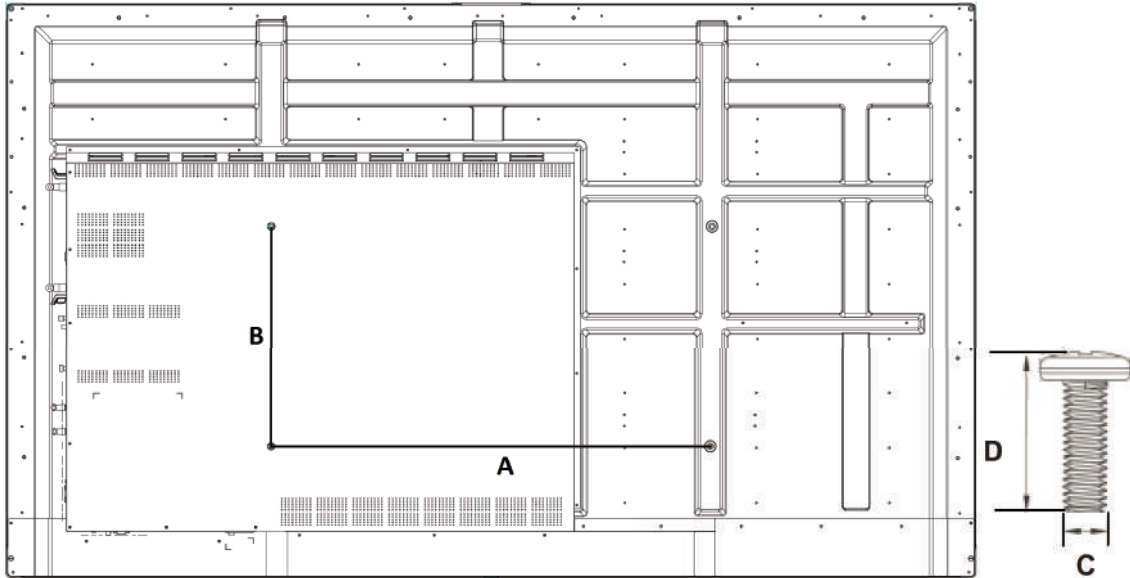







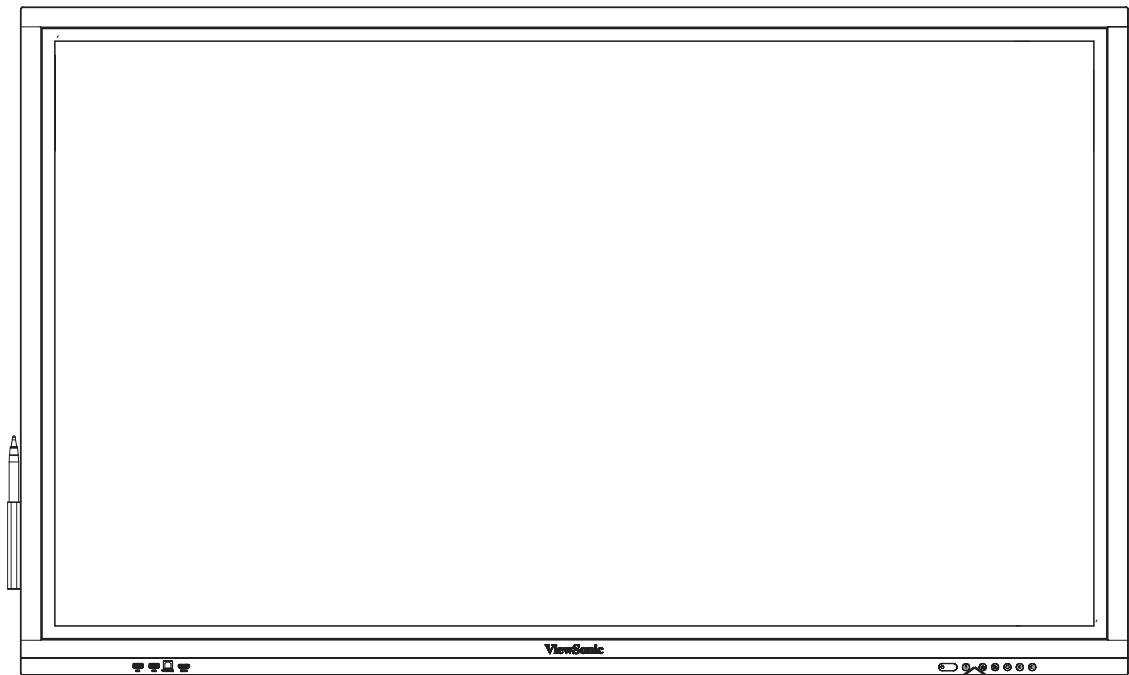

Model	VESA Spec. (A x B)	Standard Screw (C x D)	Quantity
IFP6530 - 65"	600 x 400 mm	M8 x 20 mm	4
IFP7530 - 75"	600 x 400 mm	M8 x 20 mm	4

NOTE: Do not use screws that are longer than the standard dimension, as they may cause damage to the inside of the display.

Product Overview

Control Panel

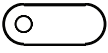

Item	Description
	Back to the Home screen
	Return to the previous screen
	Activate the Screen Freeze function
	Decrease the Volume
	Increase the Volume
	Turn on/off the device Tap to enter Energy Saving mode Press and hold for at least two (2) seconds to shut down
	Remote control receiver
	Ambient light sensor

I/O Panel

Front Left

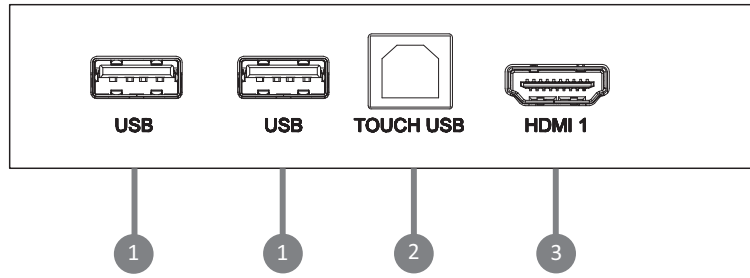

Side Left

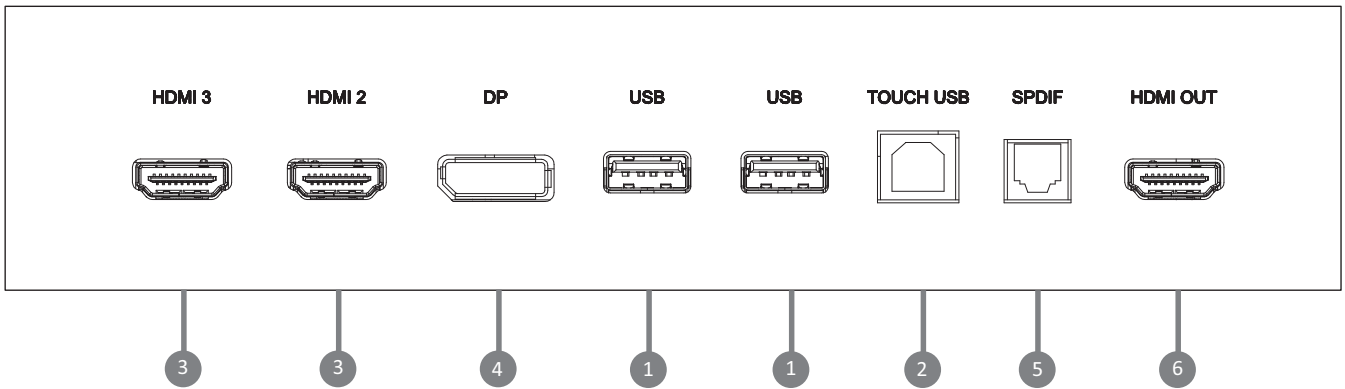



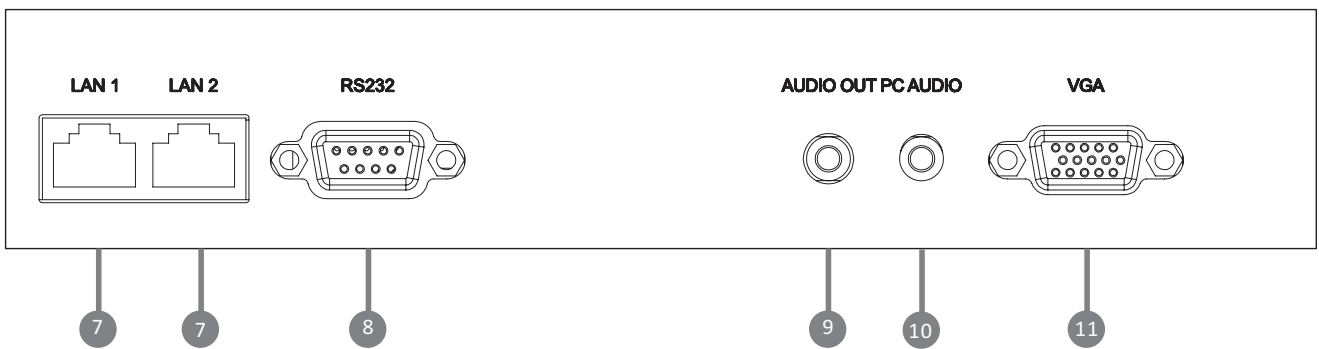

Bottom Left

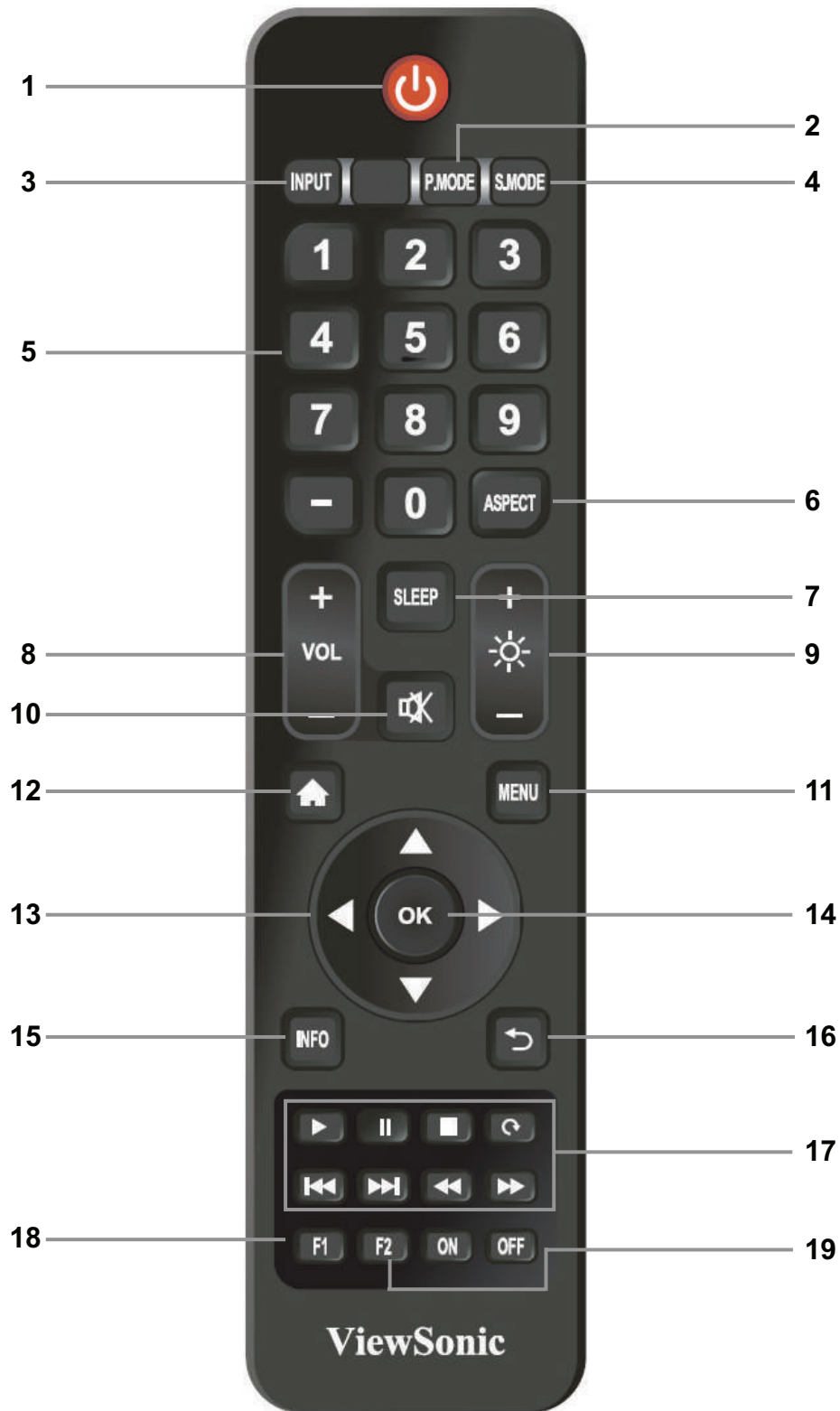

Number	Port	Description
1	USB 2.0	Connect USB devices such as hard disks, keyboard, mouse, etc. NOTE: Rear USB port is for Embed player only.
2	TOUCH USB	<ul style="list-style-type: none"> • Touch signal output to external PC • Network signal output to external PC • After connection (with external PC), the external PC's audio can be played through the ViewBoard, and the external PC's audio can be controlled by the audio button of the ViewBoard. • After connection (with external PC), the device connected to the USB port can be directly used by an external PC.
3	HDMI IN	High definition input; connect to PC with HDMI output, set-top box, or other video device.
4	DisplayPort	Connect to devices with DisplayPort output function.
5	SPDIF	Multichannel sound via optical signals
6	HDMI OUT	Extend content out to another display device
7	LAN	Standard RJ45 (10M/100M) Internet connection interface.
8	RS-232	Serial interface; used for mutual transfer of data between devices
9	AUDIO OUT	Audio output to an external speaker
10	PC AUDIO	External computer audio input
11	VGA	External computer image input

Remote Control



Number	Item	Description
1		Power on/off
2	P.MODE	Image adjustment menu for DP/HDMI/VGA
3	INPUT	Input source selection
4	S.MODE	Audio adjustment menu for DP/HDMI/VGA
5		Numeric input buttons
6	ASPECT	Adjust aspect ratio for DP/HDMI/VGA
7	SLEEP	Blank the screen. Press again to resume the screen
8	VOL+ / VOL-	Increase/Decrease volume
9	Brightness.+ Brightness.-	Brightness +/- 1
10		Mute/Unmute
11	MENU	Setting menu
12	HOME	Back to Embed player Home screen
13		Scroll up, left, right, down
14	OK	Confirm selection
15	INFO	Channel information
16	RETURN	Return to previous page
17		Media control
18	F1	Screen capture ¹
19	F2	Screen freeze

NOTE: All computer-related function keys are not available without a built-in computer.

1. The files will be saved in the embedded player under: System\Picture\Screenshots. When a USB is connected to a rear slot, pictures will save to the USB disk.

Inserting Remote Control Batteries

To insert batteries into the remote control:

1. Remove the cover on the rear of the remote control.
2. Insert two “AAA” batteries, ensuring the “+” symbol on the battery matches the “+” on the battery post.
3. Replace the cover by aligning it with the slot on the remote control and snapping the latch shut.

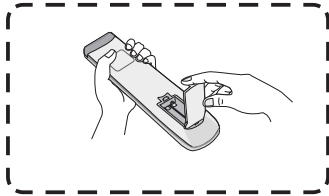

(1)

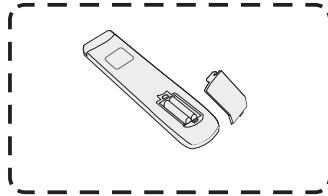

(2)

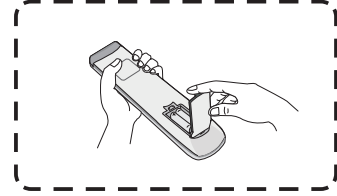

(3)

WARNING: There is a risk of explosion if batteries are replaced with the incorrect type.

NOTE:

- It is recommended that you do not mix battery types.
- Always dispose of old batteries in an environmentally friendly way. Contact your local government for more information on how to dispose of batteries safely.

Remote Control Receiver Range

The working range of the remote control is shown here. It has an effective range of 7 meters, 30° degrees left and right. Ensure there is nothing obstructing the remote control's signal to the receiver.



Using Gestures

Touch gestures allow the user to use pre-determined commands without using a keyboard or mouse. Using gestures on the ViewBoard, the user can select/deselect objects, change the location of an object, access settings, erase digital ink, and much more.

Select and Deselect an Object (Clicking)

Press and release the ViewBoard to select/deselect options or objects. This is like a single, standard left mouse click.

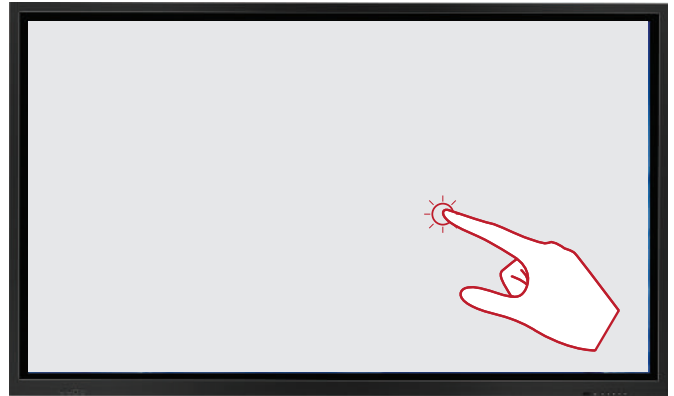

Display Menu Options (Right-Clicking)

Press and hold the ViewBoard with your finger. This is like a single, standard right mouse click.

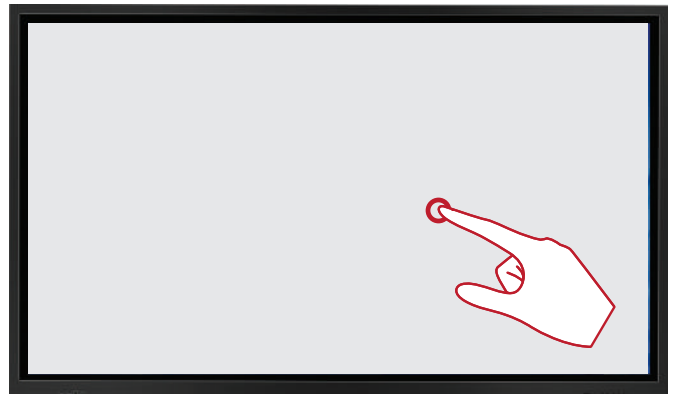

Double-Clicking

Quickly press and release twice in the same location on the ViewBoard. This is like a double, standard left mouse click.

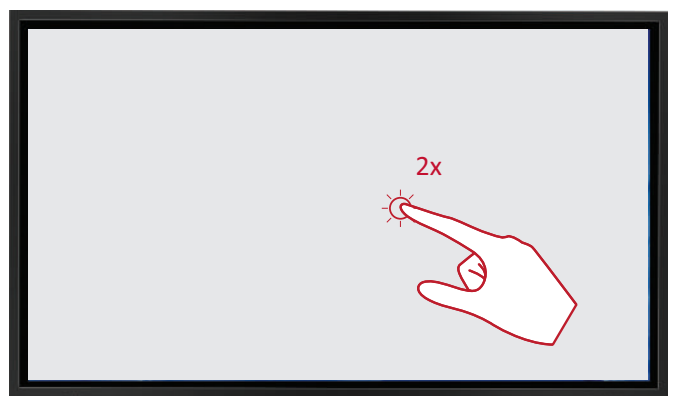

Moving an Object

Press and hold the object on the ViewBoard and slowly drag it with your finger to your desired location.

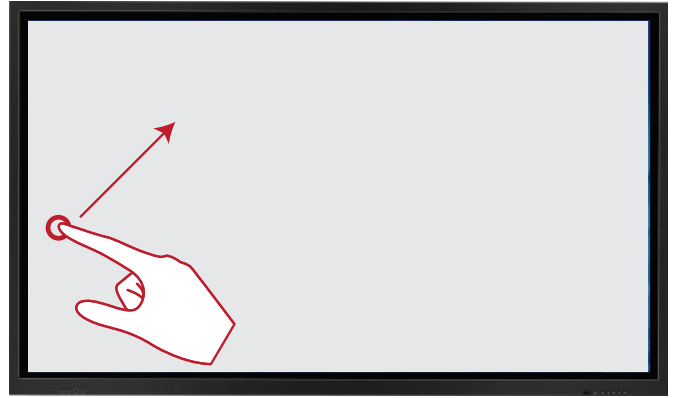

Erasing Digital Ink

Use your flattened hand, palm, or fist on the ViewBoard and move your hand across the area which you wish to erase.

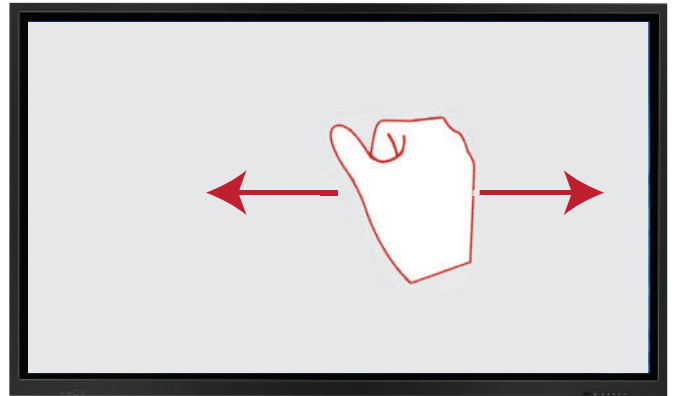

Swipe Up for General Settings

Swipe up from the bottom of the ViewBoard to launch the General Settings. To learn more, see page 36.

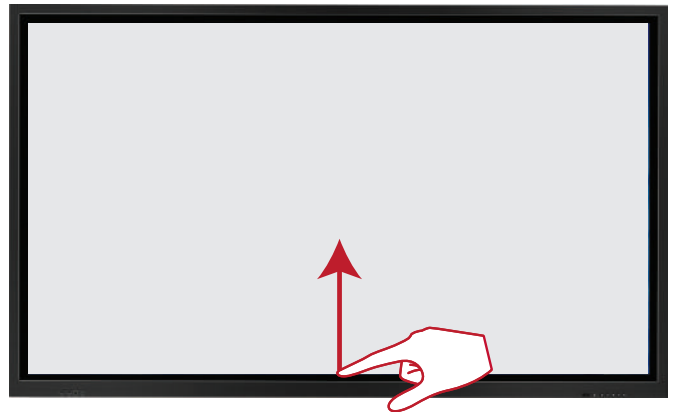

> Making Connections

Connecting External Devices and Touch Connection

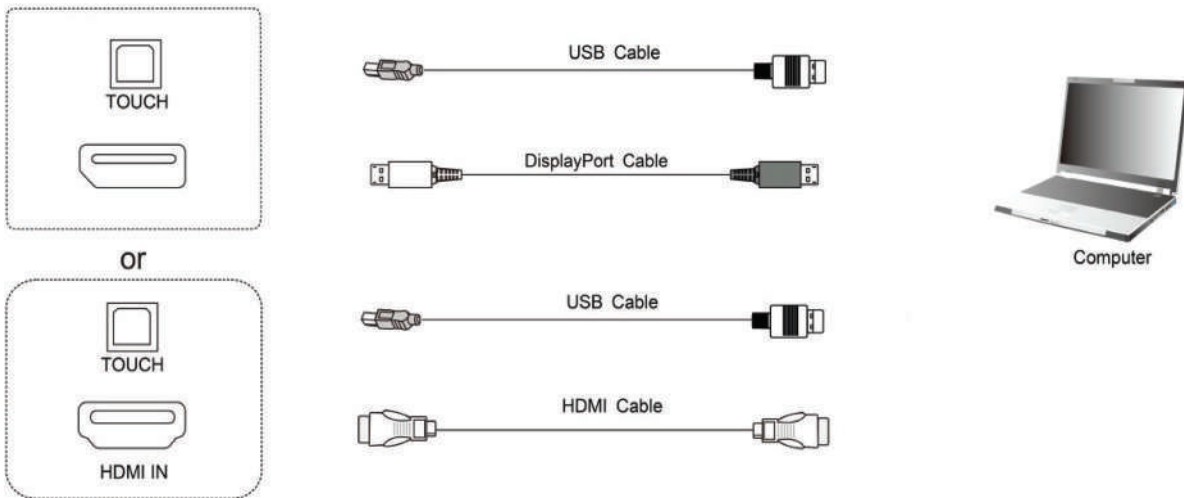

DisplayPort Connection

To connect via DisplayPort:

1. Connect a DisplayPort cable from your external device to the **DisplayPort** port on the ViewBoard.
2. Connect a USB cable to the external device from the **TOUCH** port of the ViewBoard.

HDMI Connection

To connect via HDMI:

1. Connect an HDMI cable from your external device to the **HDMI IN** port on the ViewBoard.
2. Connect a USB cable to the external device from the **TOUCH** port of the ViewBoard.

VGA Connection

To connect via VGA:

1. Connect a VGA cable from your external device to the **VGA** port on the ViewBoard.
2. Connect a USB cable to the external device from the **TOUCH** port of the ViewBoard.
3. For audio, connect an audio cable from the external device to the **PC Audio** port of the ViewBoard.

NOTE: The front **TOUCH** port is arranged to pair with **HDMI 1**; the rear **TOUCH** port is arranged to pair with **HDMI 2/3**, **DisplayPort**, and **VGA**.

RS-232 Connection

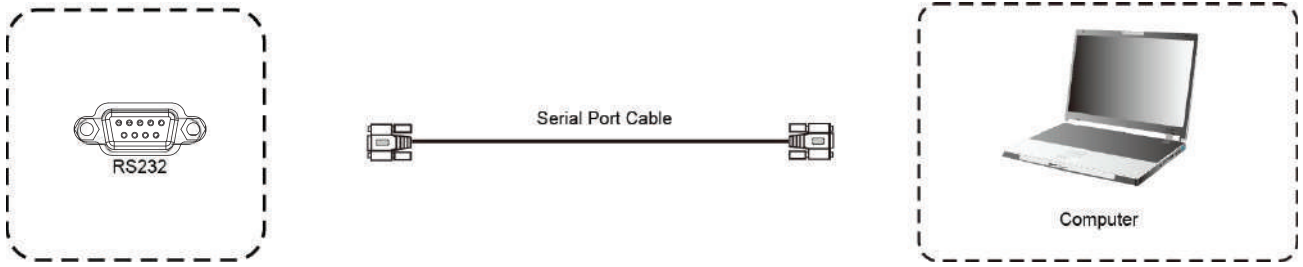

When you use a RS-232 serial port cable to connect your display to an external computer certain functions can be controlled remotely by the PC, including Power On/Off, Volume adjustment, Input select, Brightness, and more.

USB and Networking Connections

Just like any PC, it is easy to connect various USB devices and other peripherals to your ViewBoard.

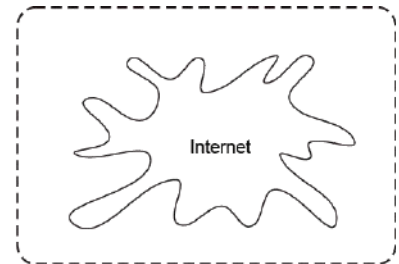
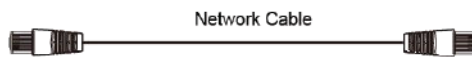
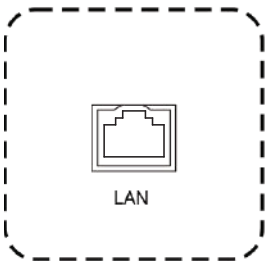
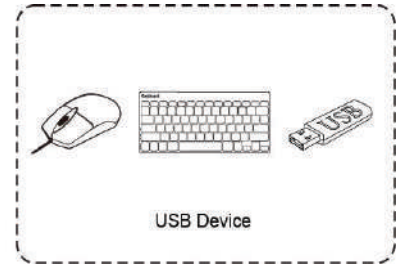
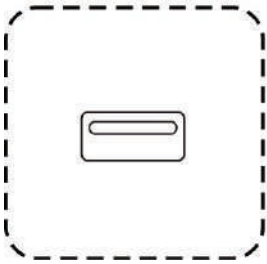

USB Peripherals

Plug the USB device cable into the **USB** port.

Networking and Modem cables

Plug the router cable into the **LAN** port.

Media Player Connection

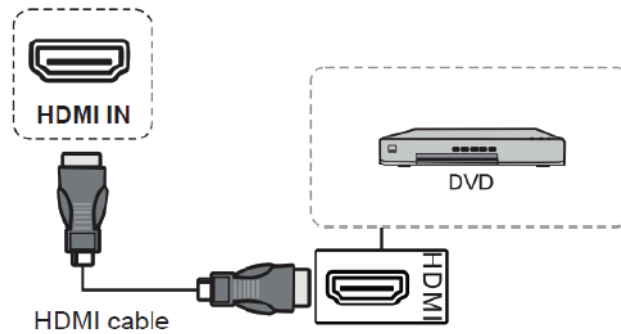

To connect to a media player:

1. Connect an HDMI cable to the **HDMI** ports (or connect a DisplayPort cable to the **DisplayPort** port) on your ViewBoard and peripheral device.
2. Plug in the power cord of your ViewBoard, and turn on the power supply switch.
3. Press the **Power** button on the right-hand side of the ViewBoard to turn the screen on.
4. Press the **INPUT** button on the remote control and switch to the “HDMI” input source.

NOTE:

- HDR is not supported on the IFP30 series.
- **HDMI 1/2/3** supports up to 3840 x 2160 @ 60Hz
- **DisplayPort** supports up to 3840 x 2160 @ 60Hz

SPDIF Connection

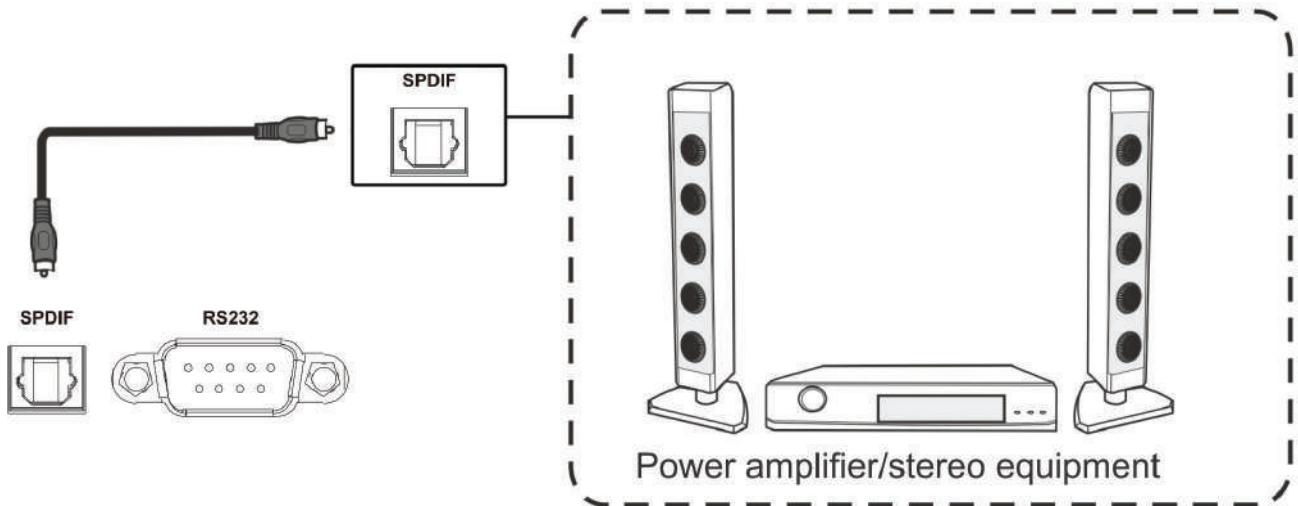

To connect to an external sound system:

1. Connect an optical cable from the **SPDIF** port to your sound system's optical connector.
2. Plug in the power cord of your ViewBoard, and turn on the power supply switch.
3. Press the **Power** button on the right-hand side of the ViewBoard to turn the screen on.

Video Output Connection

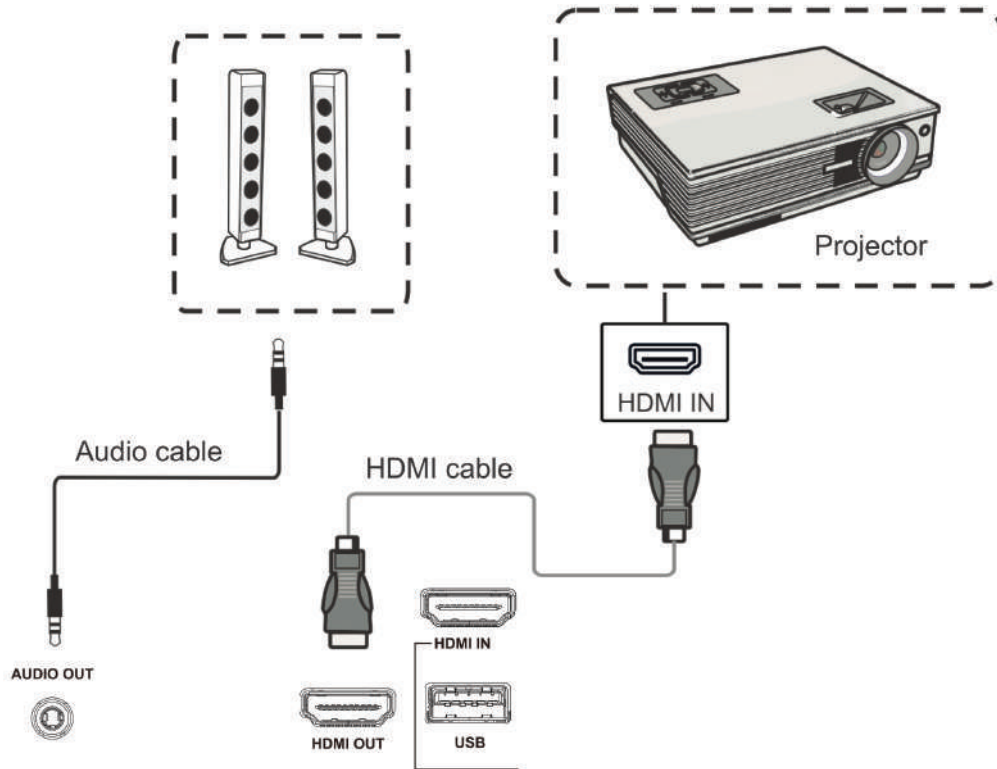

To output video via a display device:

1. Connect an HDMI cable to the **HDMI IN** port of your display device, and the other end to the **HDMI OUT** port of your ViewBoard.
2. For audio, connect one end of an audio cable to your ViewBoard's **AUDIO OUT** port (or **SPDIF**) and the other end to your speakers.
3. Plug in the power cord of your ViewBoard, and turn on the power supply switch.
4. Press the **Power** button on the right-hand side of the ViewBoard to turn the screen on.

> Using Your ViewBoard

Powering On/Off your ViewBoard

1. Ensure the power cord is connected, plugged into a power outlet, and the power switch is in the “On” position.

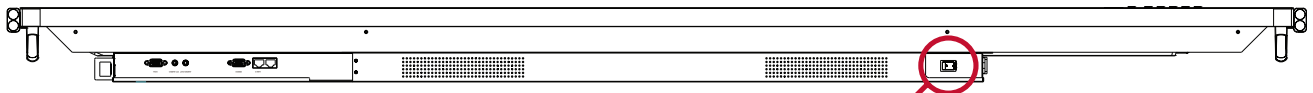

The Power switch is located at the bottom of the unit.

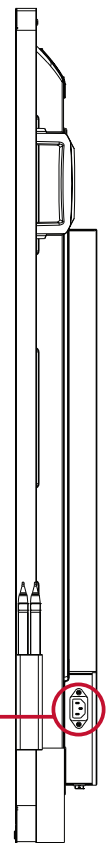

The AC Power input is located on the right side of the unit.

2. Press the **Power** button to turn on the ViewBoard.
3. To turn the ViewBoard off, press and hold the **Power** button on the device or press the **Power** button on the remote control.

Initial Launch Setup

When you first turn on your ViewBoard, an initial setup wizard will launch.

1. Select your Language:

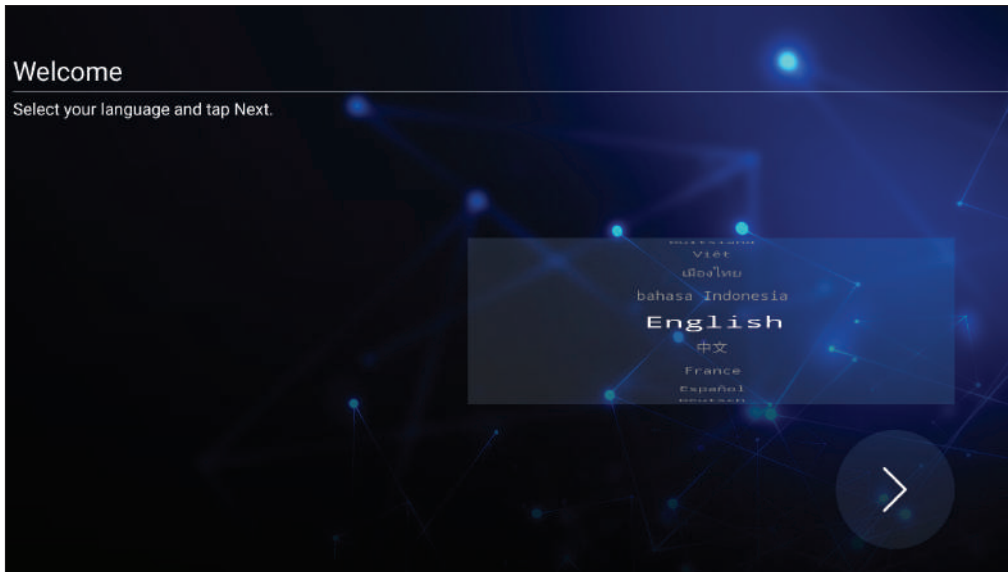

2. Setup and verify your LAN connection. DHCP is for regular network connection. Static IP is for a specific network environment.

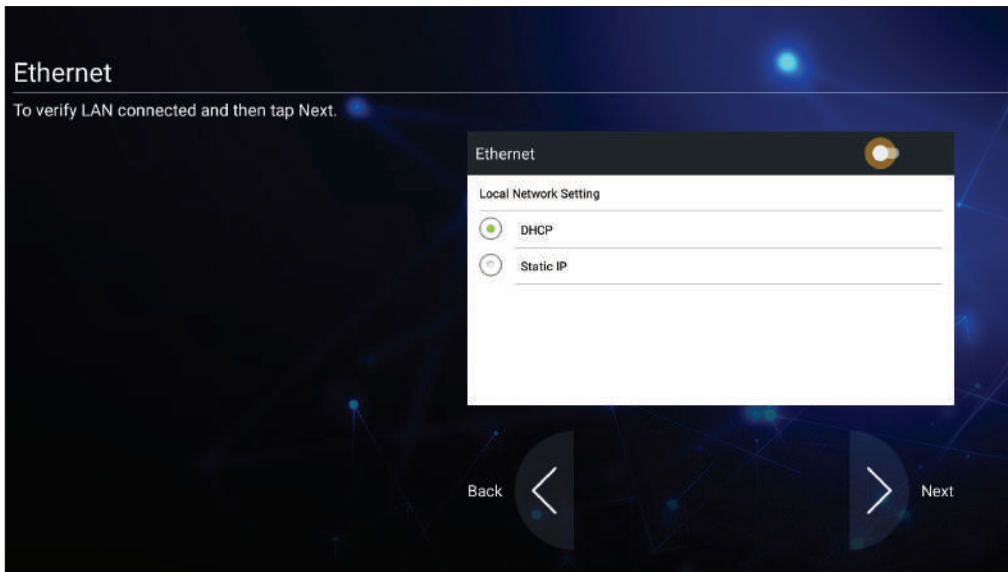

3. Select your Time Zone to set the Date and Time:

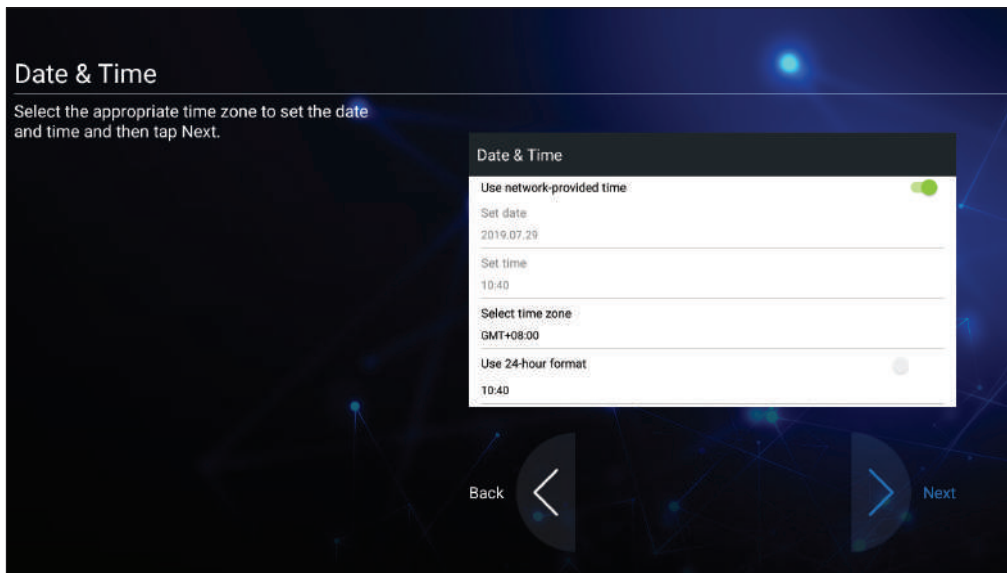

4. Select your preferred System Mode:

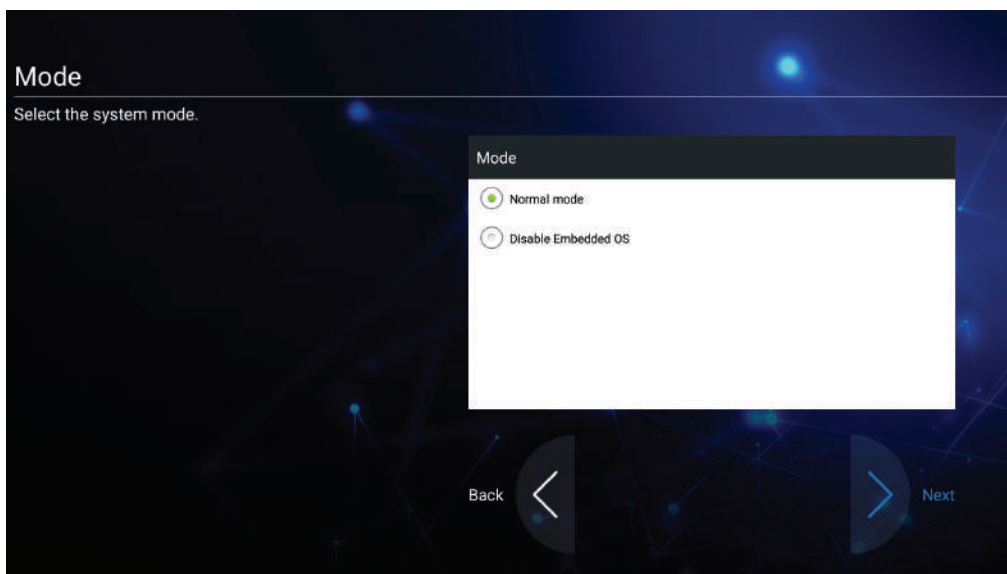



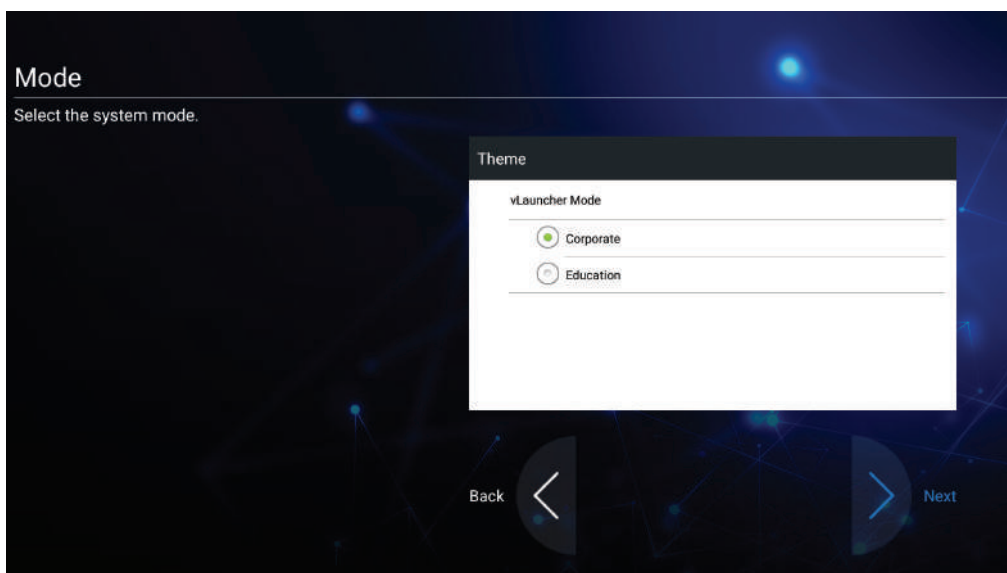

NOTE: For more information see page 72.

5. Select your preferred vLauncher mode:



vLauncher - Customizable Welcome Screen



Icon	Description
	myViewBoard annotation application
	Wireless screen sharing application, vCastReceiver
	Switch to slot-in PC source
	Open the web browser
	Application list

NOTE: ViewBoard offers two background themes, Corporate and Education.

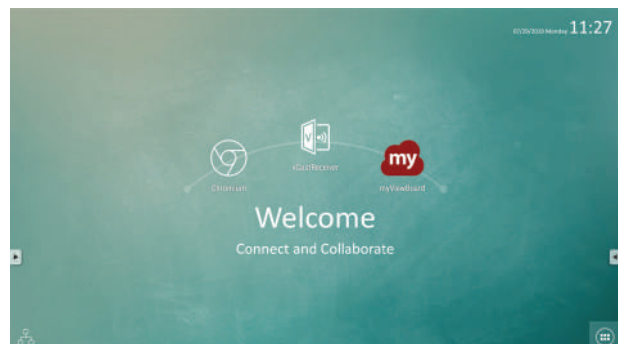
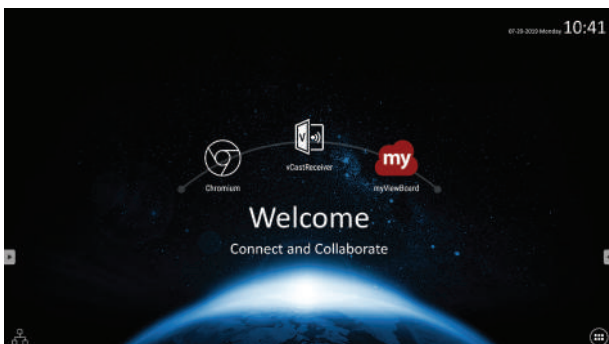

Customize Default Applications (vLauncher)

To add or customize your default applications on the vLauncher welcome screen:

1. Select the Application list icon () to view your installed applications.

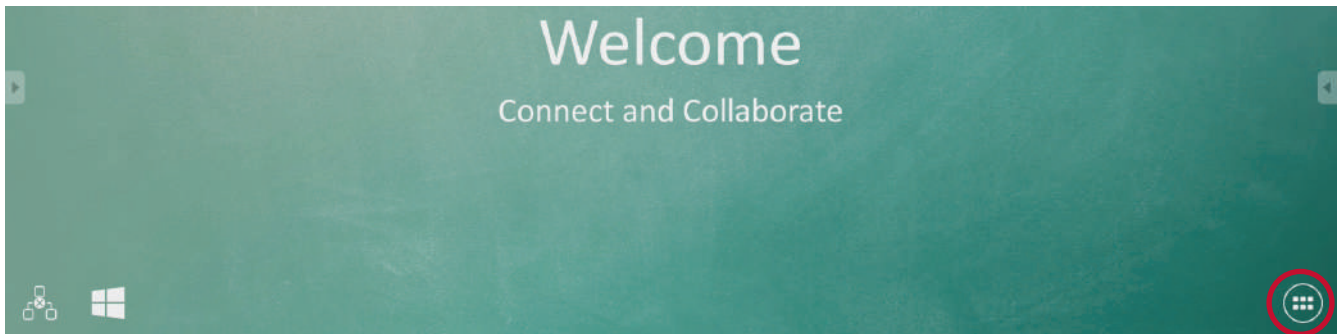

2. Tap and hold the preferred application icon and drag it to the launcher page.

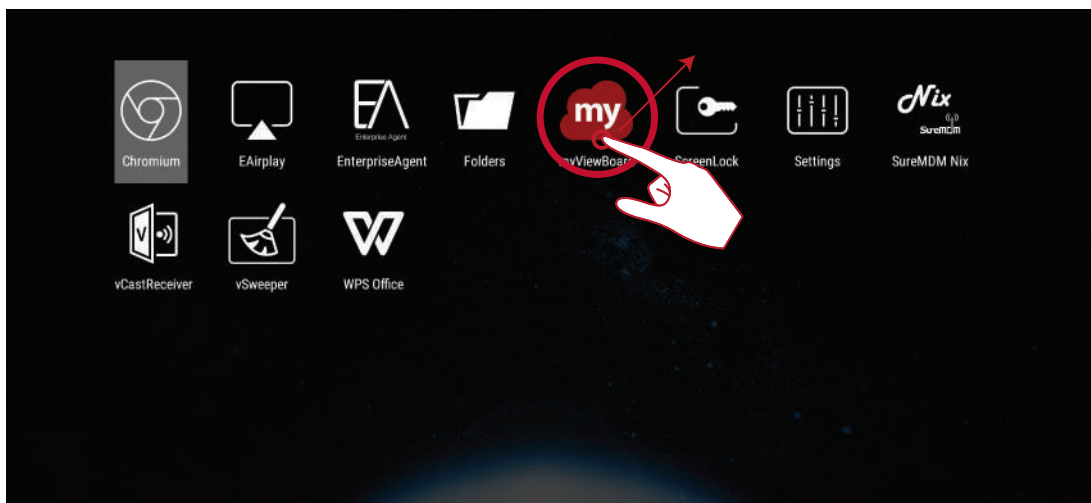

3. The chosen application will appear on the launcher welcome screen as a shortcut.



Tool Bar









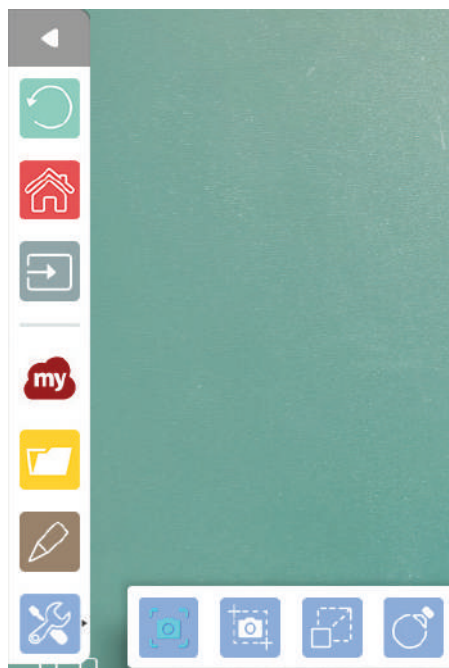







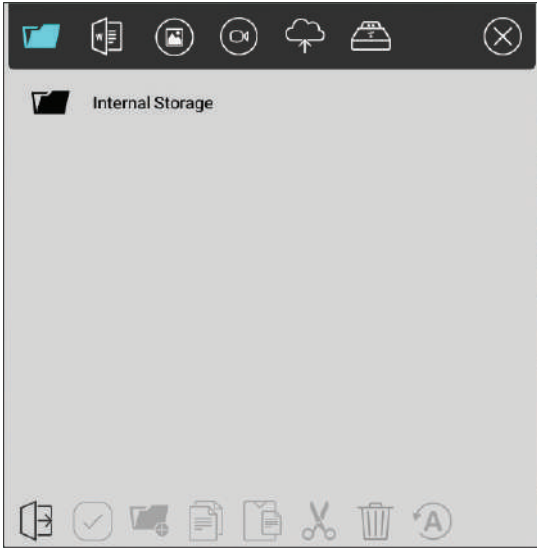



































Tool bar trigger icons are on the edge of the ViewBoard launcher providing access to your tools.







To launch a tool:







1. Tap a Tool bar trigger icon.
2. Tap on your desired tool icon.

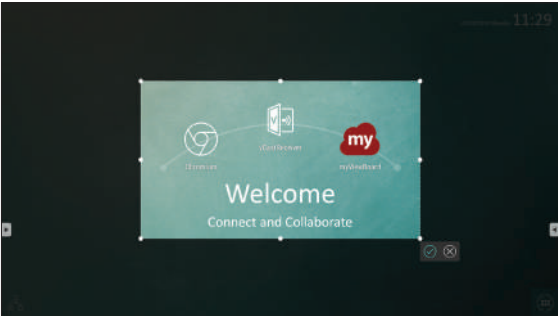

NOTE: The default tool bar setting is to be available for all input sources; however, users can adjust the options: (1) available for all input sources, (2) Embed player only, (3) available for all input sources, except for PC, and (4) disable the tool bar. For more information, see page 64.

Icon	Description					
	Return to the previous page					
	Return to the Home screen					
	Display the General Settings menu					
	Launch myViewBoard software					
	<p>Launch the File manager to manage files and storage</p> 					
	<table border="1"> <tr> <td data-bbox="344 1395 416 1469"></td> <td data-bbox="416 1395 866 1469">Browse files</td> </tr> </table>		Browse files	<table border="1"> <tr> <td data-bbox="882 1395 954 1469"></td> <td data-bbox="954 1395 1406 1469">Sort by documents</td> </tr> </table>		Sort by documents
		Browse files				
		Sort by documents				
	<table border="1"> <tr> <td data-bbox="344 1480 416 1554"></td> <td data-bbox="416 1480 866 1554">Sort by pictures</td> </tr> </table>		Sort by pictures	<table border="1"> <tr> <td data-bbox="882 1480 954 1554"></td> <td data-bbox="954 1480 1406 1554">Sort by videos</td> </tr> </table>		Sort by videos
		Sort by pictures				
		Sort by videos				
	<table border="1"> <tr> <td data-bbox="344 1559 416 1632"></td> <td data-bbox="416 1559 866 1632">Access cloud storage</td> </tr> </table>		Access cloud storage	<table border="1"> <tr> <td data-bbox="882 1559 954 1632"></td> <td data-bbox="954 1559 1406 1632">Access USB storage</td> </tr> </table>		Access USB storage
		Access cloud storage				
		Access USB storage				
<table border="1"> <tr> <td data-bbox="344 1637 416 1711"></td> <td data-bbox="416 1637 866 1711">Exit</td> </tr> </table>		Exit				
	Exit					
<table border="1"> <tr> <td data-bbox="344 1738 416 1812"></td> <td data-bbox="416 1738 866 1812">Exit</td> </tr> </table>		Exit	<table border="1"> <tr> <td data-bbox="882 1738 954 1812"></td> <td data-bbox="954 1738 1406 1812">Select file</td> </tr> </table>		Select file	
	Exit					
	Select file					
<table border="1"> <tr> <td data-bbox="344 1823 416 1897"></td> <td data-bbox="416 1823 866 1897">Create folder</td> </tr> </table>		Create folder	<table border="1"> <tr> <td data-bbox="882 1823 954 1897"></td> <td data-bbox="954 1823 1406 1897">Copy file</td> </tr> </table>		Copy file	
	Create folder					
	Copy file					
<table border="1"> <tr> <td data-bbox="344 1901 416 1975"></td> <td data-bbox="416 1901 866 1975">Paste file</td> </tr> </table>		Paste file	<table border="1"> <tr> <td data-bbox="882 1901 954 1975"></td> <td data-bbox="954 1901 1406 1975">Cut file</td> </tr> </table>		Cut file	
	Paste file					
	Cut file					
<table border="1"> <tr> <td data-bbox="344 1980 416 2054"></td> <td data-bbox="416 1980 866 2054">Delete file</td> </tr> </table>		Delete file	<table border="1"> <tr> <td data-bbox="882 1980 954 2054"></td> <td data-bbox="954 1980 1406 2054">Rename file</td> </tr> </table>		Rename file	
	Delete file					
	Rename file					

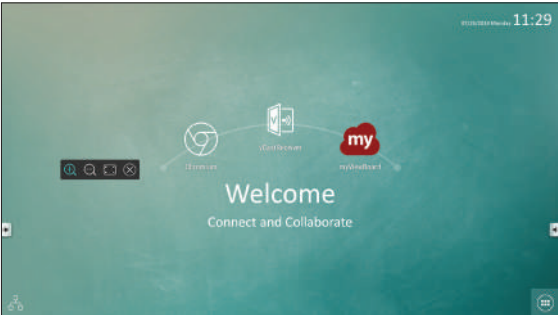
Icon	Description
	Access the pen, highlighter, clear digital ink, and save options 
	 <u>Digital Pen</u> Annotate the overlay of any input source with yellow, red, black, blue, or green ink.
	 <u>Digital Highlighter</u> Mark and highlight with: yellow, orange, red, blue, and green.
	 <u>Brush</u> Clears all the digital ink on the screen.
	 <u>Save As</u> Save the on-screen image/notes.
	 <u>Close</u> Close the annotation tool.

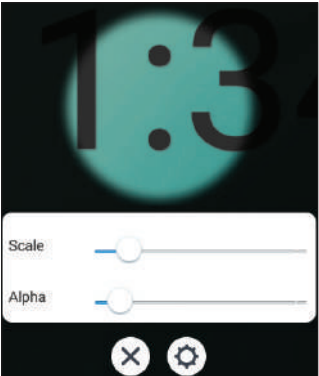
Icon	Description
	<p>View more applications within the ViewBoard tool bar</p> 
	<p> Capture Take a screenshot of the entire screen and save.</p>
	<p> Snip Select a specific area to take a screenshot and save.</p> 
	<p> Magnifier Zoom in and out of captured screen images.</p> 
	<p> Spotlight Highlight the focus content zone. Tap the setting icon to adjust the spotlight size and alpha blending effect.</p> 

ViewBoard On-Screen Display (OSD) Menu

The ViewBoard has three options for opening the OSD Menu:

Option 1 - Gesture

Swipe up from the bottom of the screen.



Option 2 - Remote

Press the **INPUT** button on the remote control.



Option 3 - Tool Bar

Select the icon from the Tool Bar.



General Settings

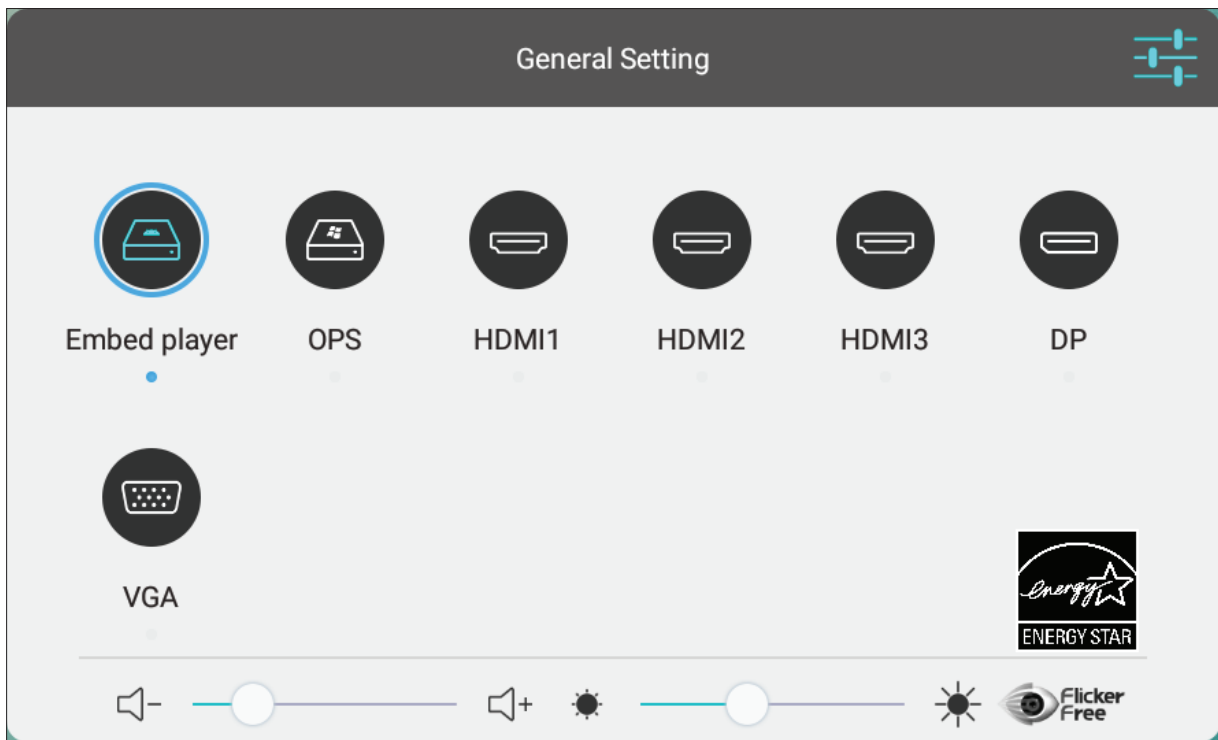

To select an Input Source:

1. Press **INPUT** on the remote control, gesture, or use the tool bar to display the **General Setting** menu.
2. Press **▼/▲/◀/▶** to select the input source you want.
3. Press **ENTER** on the remote control, or touch the input source.
4. Press **BACK** on the remote control, or touch a blank area outside of the menu to exit.

NOTE: PC source will only display when the slot-in computer is connected.



To adjust the Backlight and enable/disable Flicker-Free:

1. Press **INPUT** on the remote control, gesture, or use the tool bar to display the **General Setting** menu.
2. Drag the brightness slider directly to adjust the backlight value, and/or touch the Flicker-Free icon to enable/disable the function.
3. Press **BACK** on the remote control, or touch a blank area outside of the menu to exit.

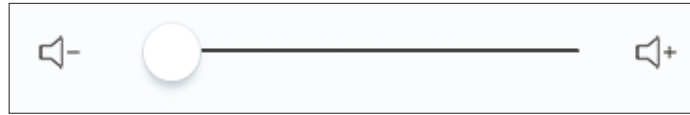

To adjust the Volume:

1. Press **INPUT** on the remote control, gesture, or use the tool bar to display the **General Setting** menu.
2. Drag the volume slider directly to adjust the value.
3. Press  (**Mute**) on the remote control to enable or disable the mute function.
4. Press **BACK** on the remote control, or touch a blank area outside of the menu to exit.

Detailed Settings

Press **MENU** on the remote control or select the  icon on the **General Setting** menu to launch the Detailed Settings menu. Detailed Settings include: **Audio**, **Screen**, **Display**, and **Adjust**.

NOTE: Only available when not on Embed Player.

Audio

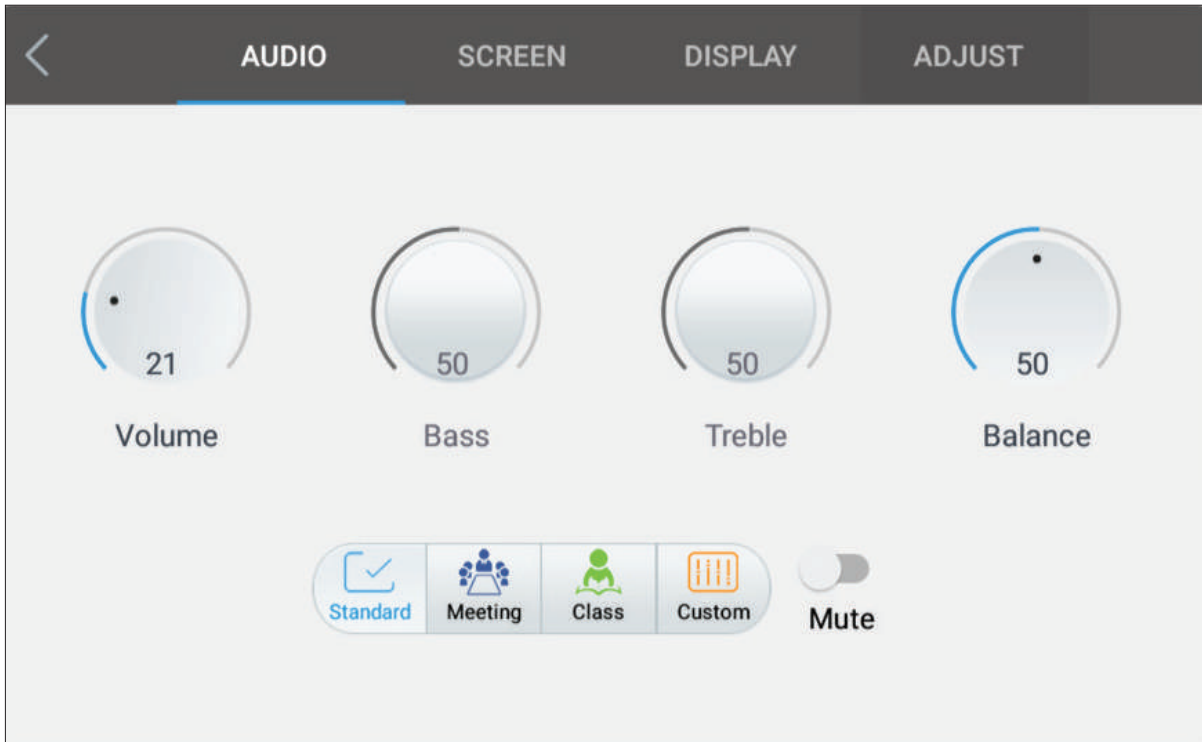

1. Press **▶** on the remote control and select the **Audio** menu.
2. Press **▼/▲/◀/▶** on the remote control or directly touch the option to select it.
3. Adjust the Volume, Bass, Treble, and Balance directly by touching and adjusting each value, or with the remote control by pressing **ENTER** and using **◀/▶** to adjust the option.
4. Additionally, you can select one of the preset audio profiles: Standard, Meeting, or Class.
5. Touch the Mute slider directly to enable/disable mute, or press  (**Mute**) on the remote control.
6. Press **BACK** on the remote control, or touch a blank area outside of the menu to exit.

Screen

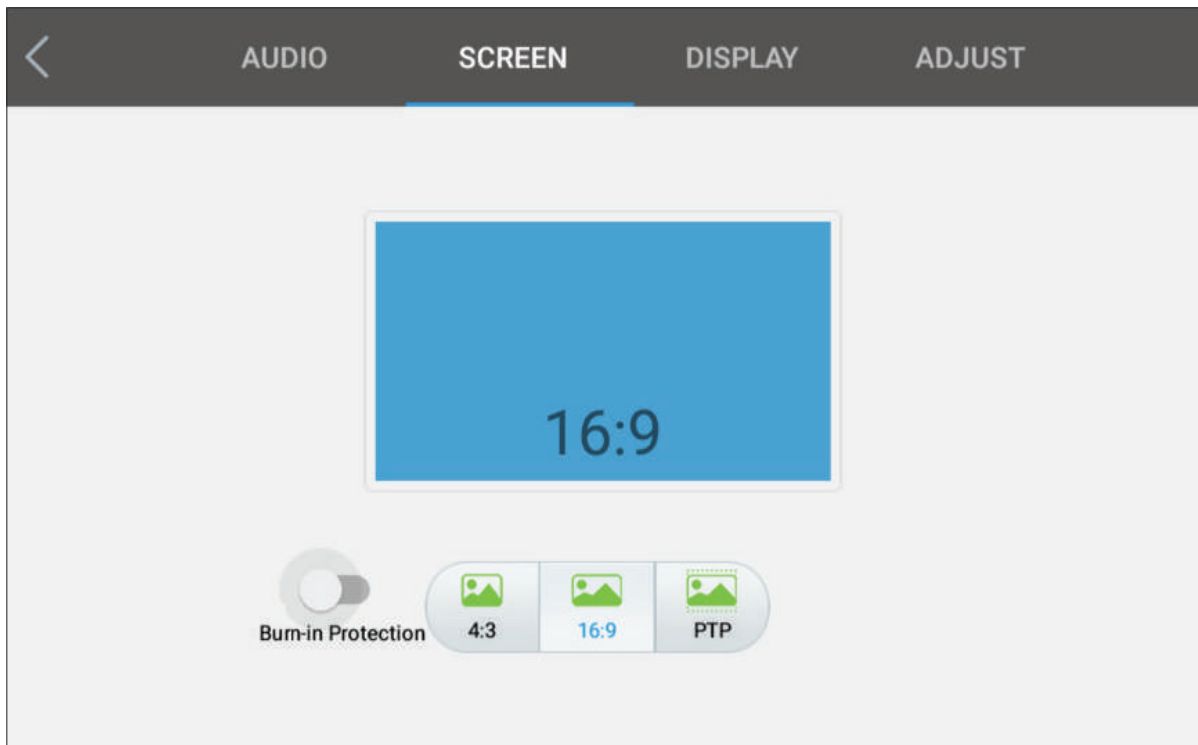

1. Press **▶** on the remote control and select the **Screen** menu.
2. Press **▼/▲/◀/▶** on the remote control or directly touch the option to select it.
3. Adjust your preference by touching each value directly, or with the remote control by pressing **ENTER**.
4. Press **BACK** on the remote control, or touch a blank area outside of the menu to exit.

NOTE:

- **Burn-in (Image Sticking) Protection**

To reduce the possibility of screen burn-in, this unit is equipped with image sticking protection technology.

If the screen displays a still image for a certain period of time you define, the device activates a screen saver to prevent the formation of burnt in ghost images on the screen.

Image sticking protection moves the picture slightly on the screen. The image sticking protection time setting allows you to program the time between movements of the picture in minutes. For more information, see page 53.

Display

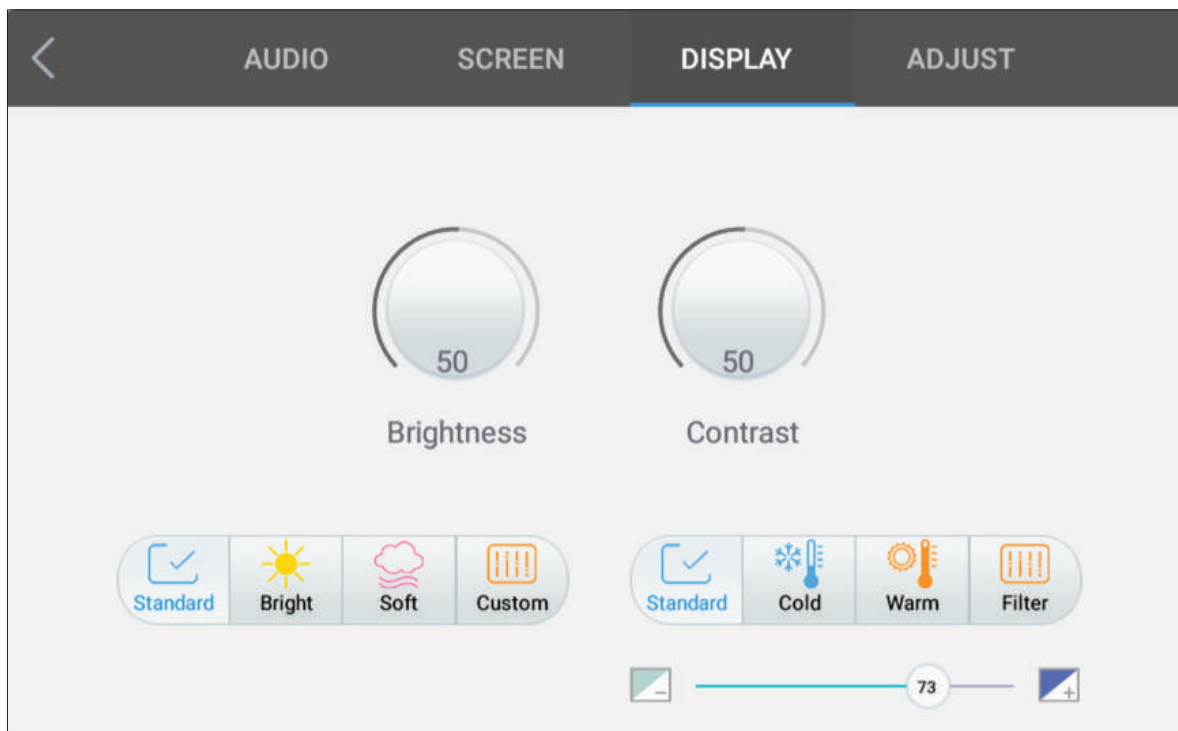

1. Press **▶** on the remote control and select the **Display** menu.
2. Press **▼/▲/◀/▶** on the remote control or directly touch the option to select it.
3. Adjust the Brightness and Contrast directly by touching and adjusting each value, or with the remote control by pressing **ENTER** and using **◀/▶** to adjust the option.
4. Additionally, you can select one of the preset display profiles.
5. Drag the blue light slider directly to adjust the blue light value.

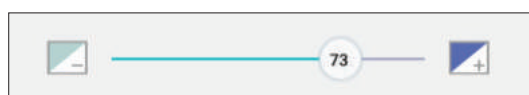

6. Press **BACK** on the remote control, or touch a blank area outside of the menu to exit.

Adjust

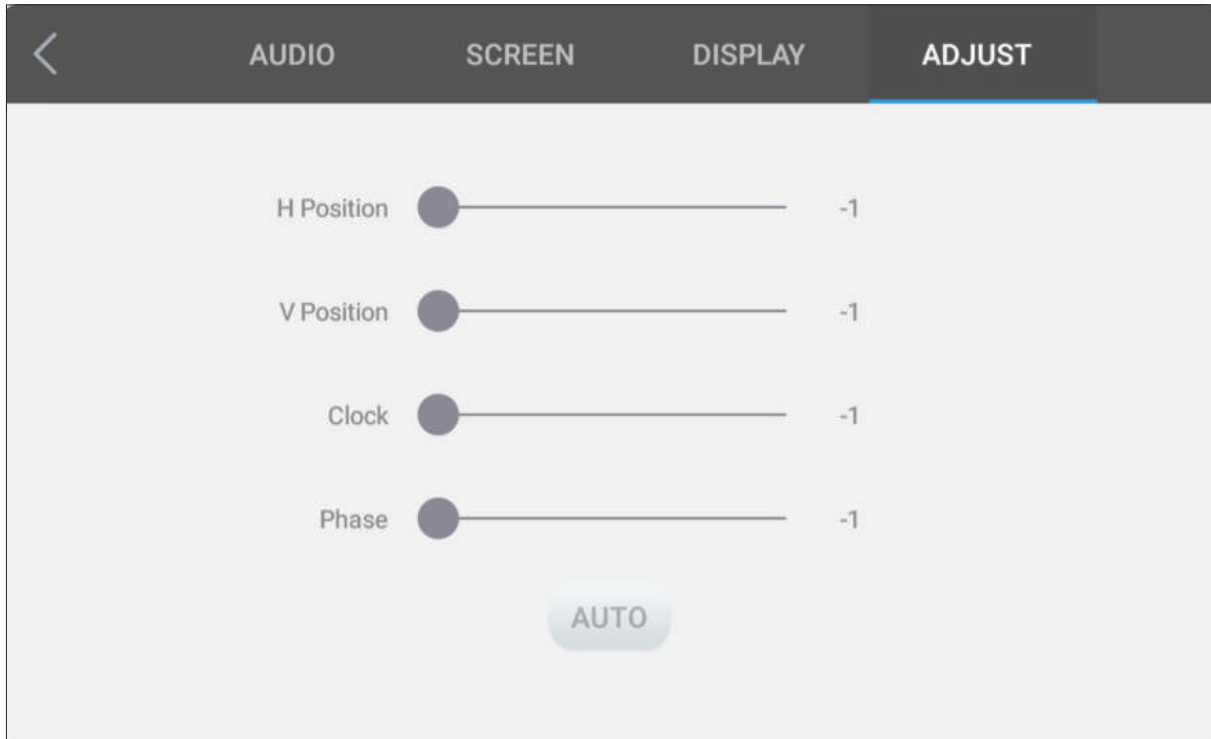

1. Press **▶** on the remote control and select the **Adjust** menu.
2. Press **▼/▲/◀/▶** on the remote control or directly touch the option to select it.
3. Adjust the H Position, V Position, Clock, or Phase directly by touching and adjusting each value, or with the remote control by pressing **ENTER** and using **◀/▶** to adjust the option.
4. Touch the **AUTO** button directly to automatically adjust the values.
5. Press **BACK** on the remote control, or touch a blank area outside of the menu to exit.

NOTE: These settings are only available when the input signal is VGA.

Advanced Settings

When the ViewBoard is in the Embed Player source, tap the  icon in the On-Screen Display (OSD) Menu, or press **MENU** on the remote control to enter the Advanced Settings Menu.

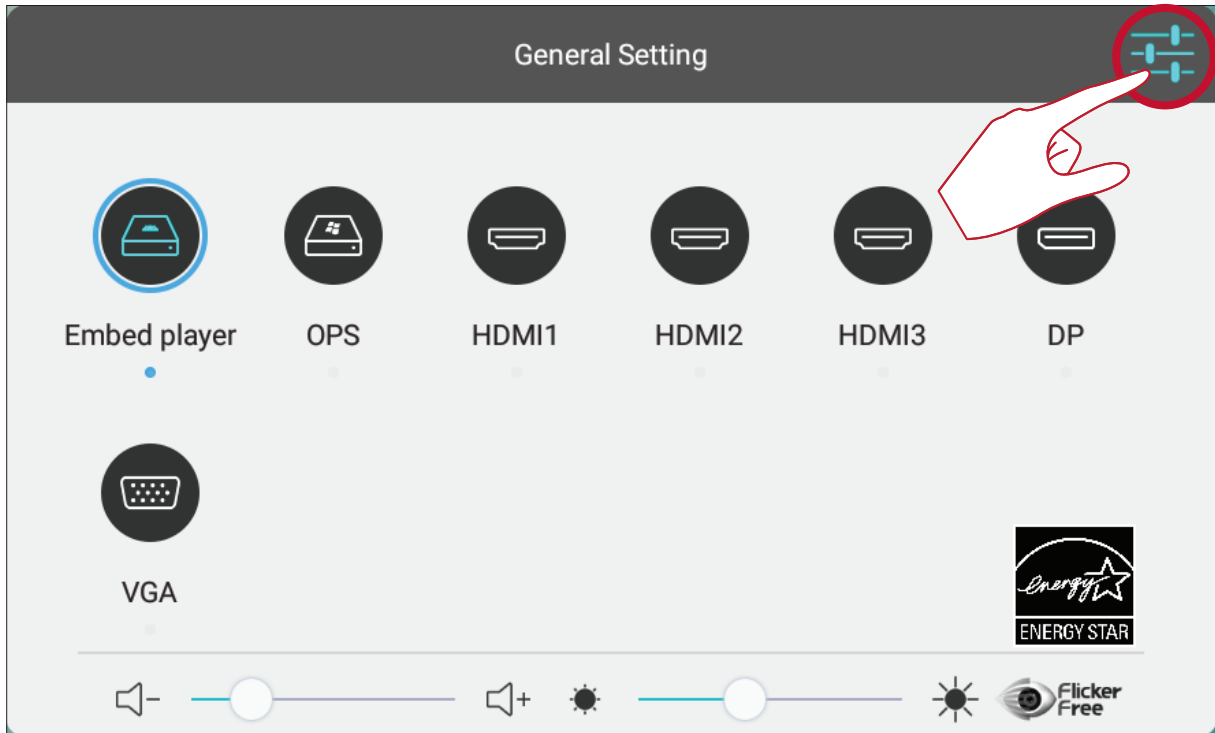

Wireless & Networks

Check current network connection status, Wi-Fi, and establish a Wireless hotspot.

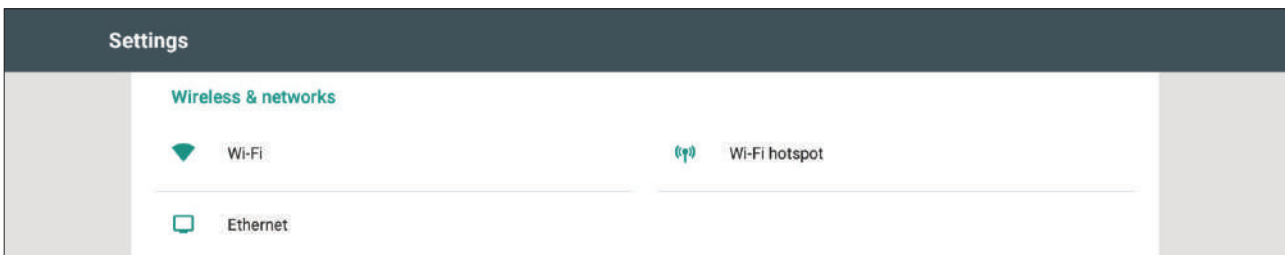

NOTE:

- Wi-Fi and Wireless hotspot settings will appear when a compatible wireless adapter has been installed.
- Ethernet will disable automatically when Wi-Fi is enabled. Wi-Fi will disable automatically when Ethernet is enabled. Wi-Fi will disable when Wireless hotspot is enabled.
- The device cannot connect to the Internet when Wireless hotspot is enabled.

Wi-Fi

Tap **On** to toggle Wi-Fi on or off.

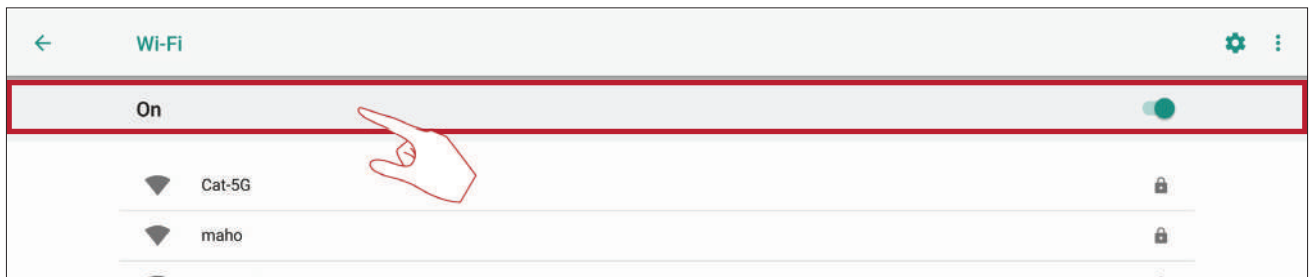

Tap the settings icon to: Add Network, view Saved Networks, Refresh the network list, or view Advanced settings.

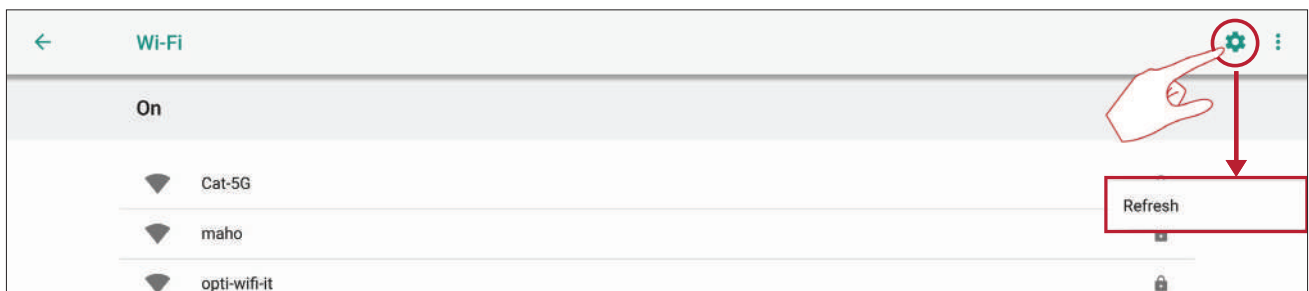

In Advanced settings, you can set Proxy and IP settings.

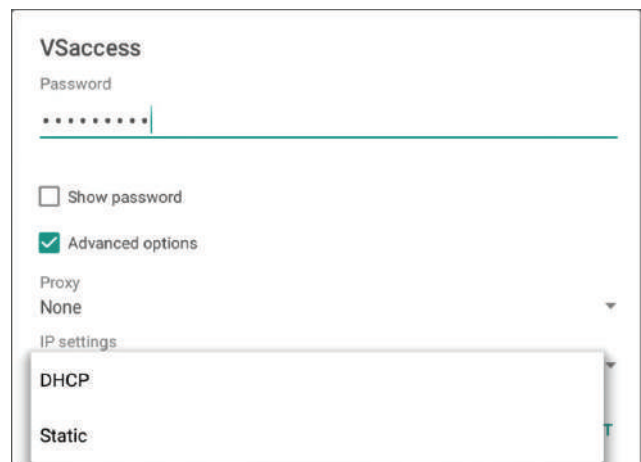
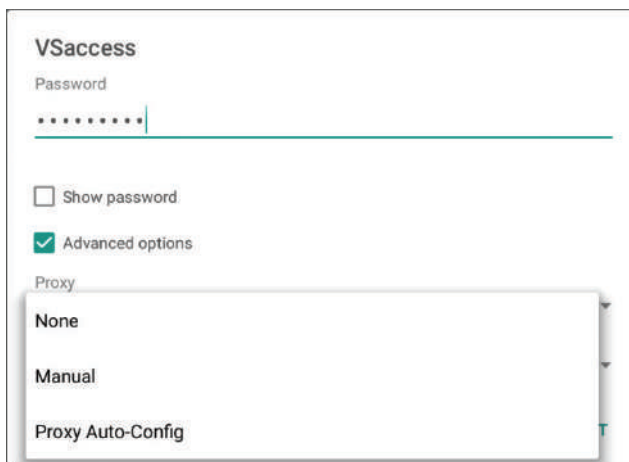

Ethernet

Tap **Connect** to toggle Ethernet on or off.



You can adjust Static IP and Proxy settings as well.



Wi-Fi Hotspot

Tap **Portable Wi-Fi hotspot** to turn it on or off.



Tap **Set up Wi-Fi hotspot** to set Network name, Security, and Password.

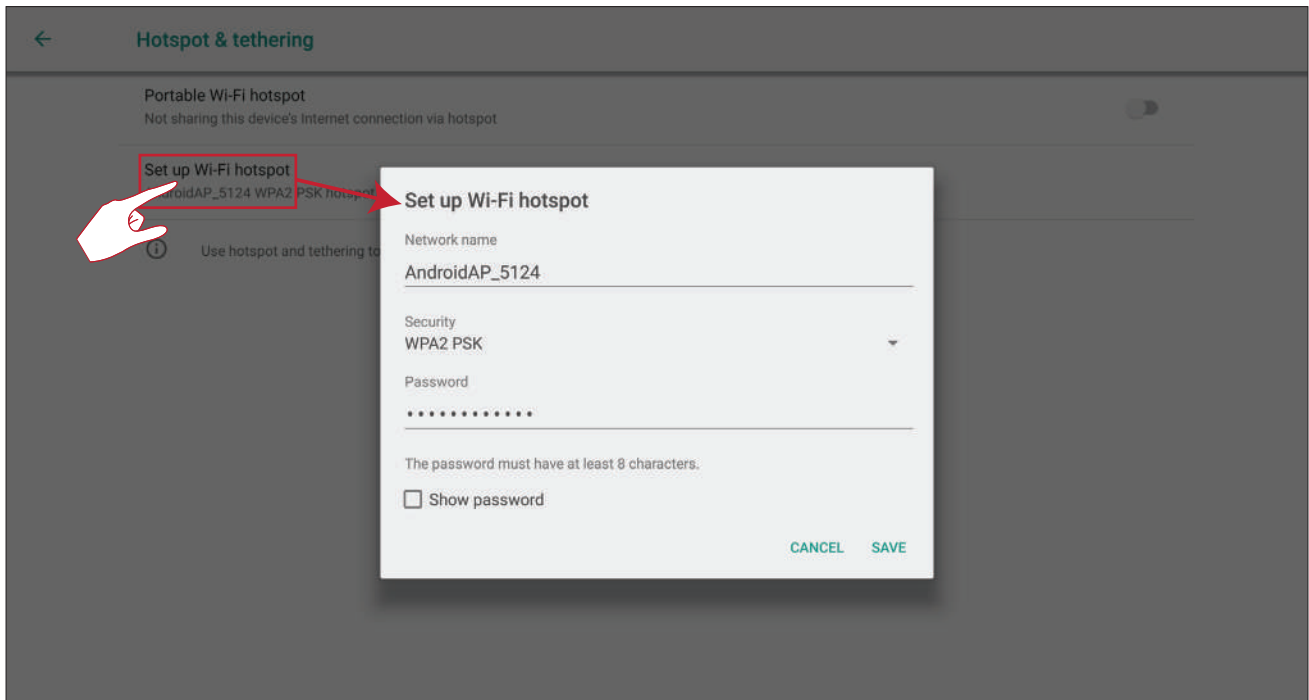

Share

Miracast allows for wireless sharing of multimedia and screens of connected devices. To access, go to: **Settings > Share > Miracast**.

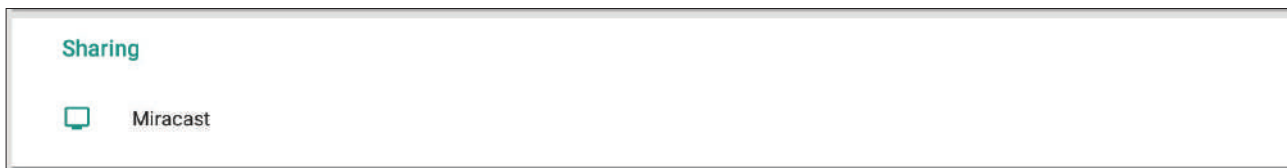

Device

Adjust the Theme, Display, Storage, Sound and other settings.

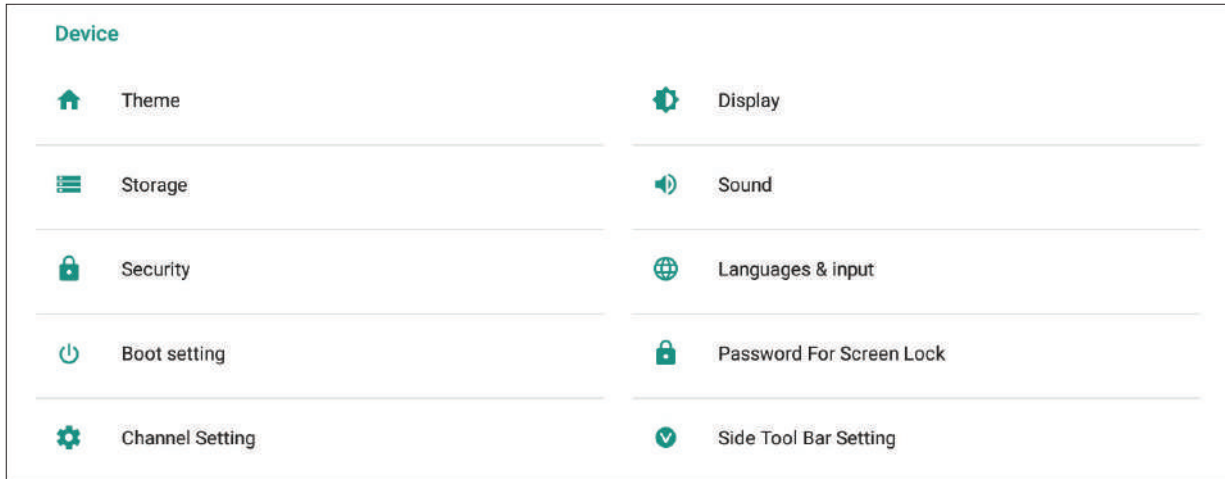

Theme

Users can change their home launcher theme for the Embedded player.

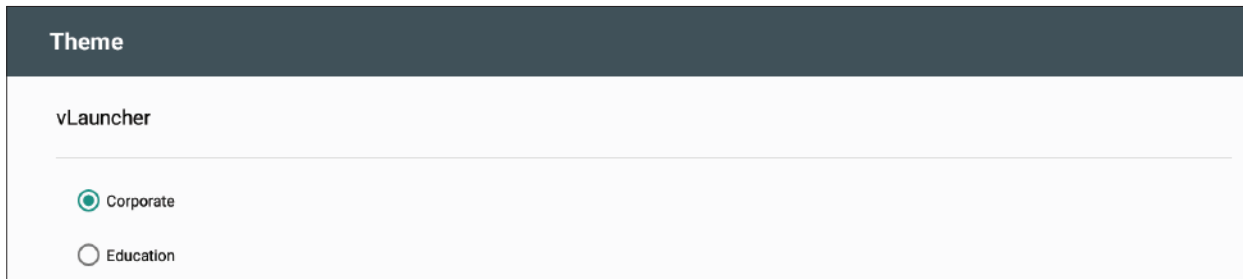

NOTE: vLauncher cannot be removed.

Display

Adjust the Wallpaper, ENERGY STAR® mode, HDMI EDID, HDMI Out Resolution, Auto Brightness, and Burn-in Protection Interval.

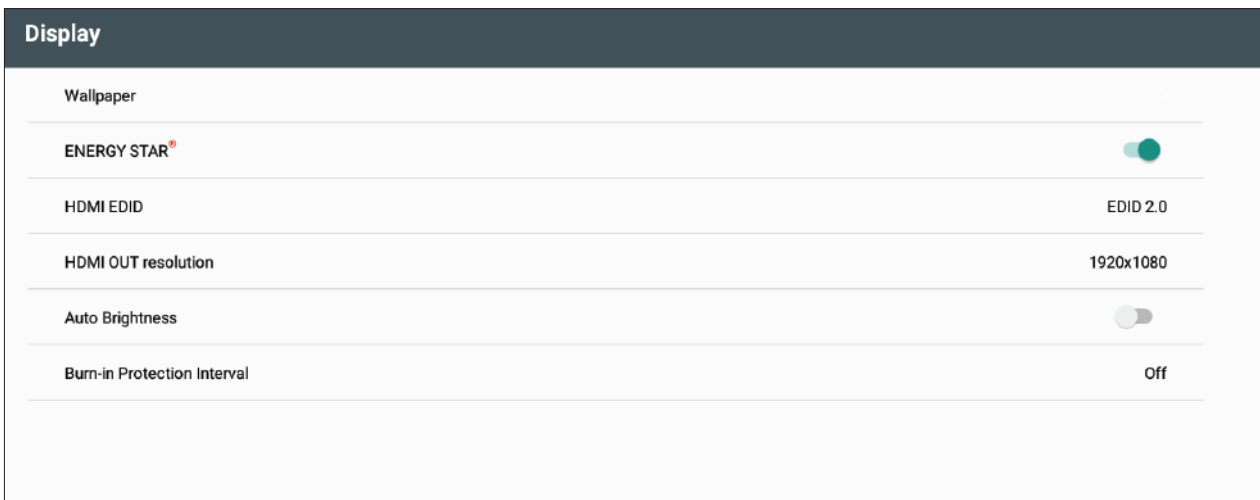

Wallpaper

Users can change their wallpaper with default images, or

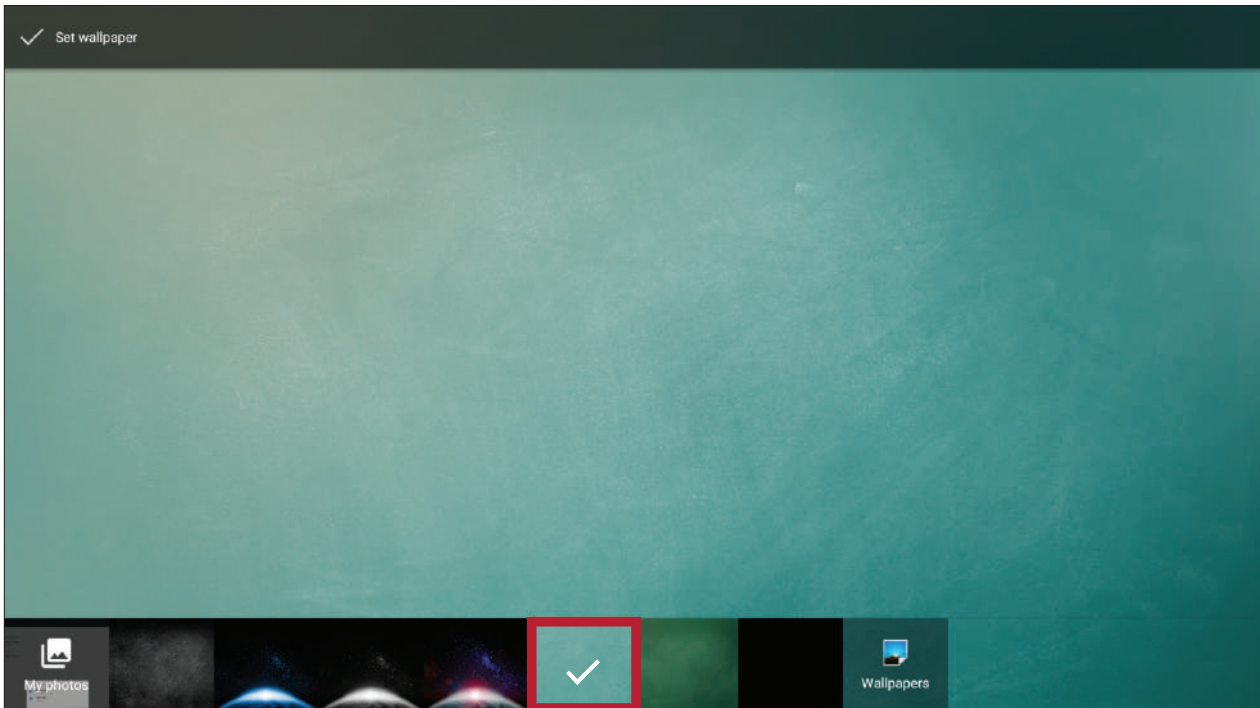

use their own by tapping **My photos** and selecting the image file.

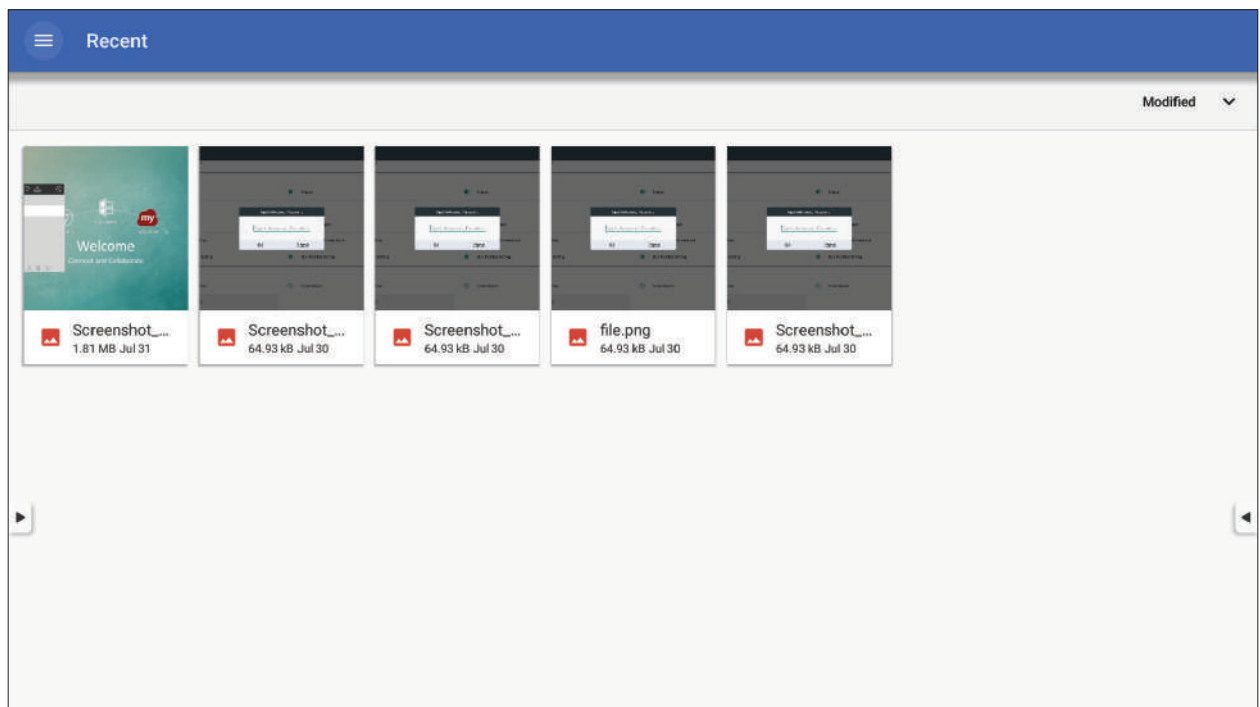

ENERGY STAR® mode

ENERGY STAR mode is On by default.

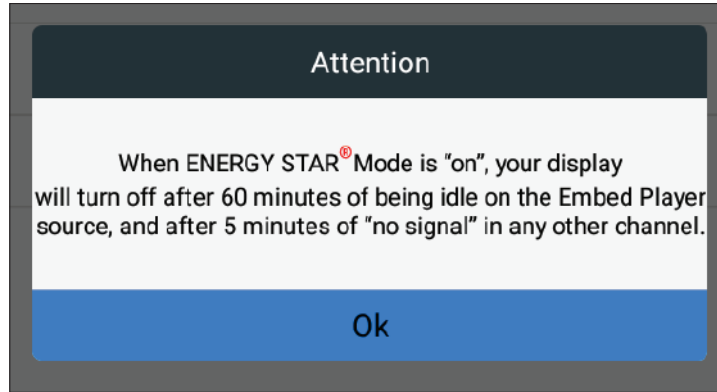

When On, the ENERGY STAR® logo will be present on the OSD Menu.

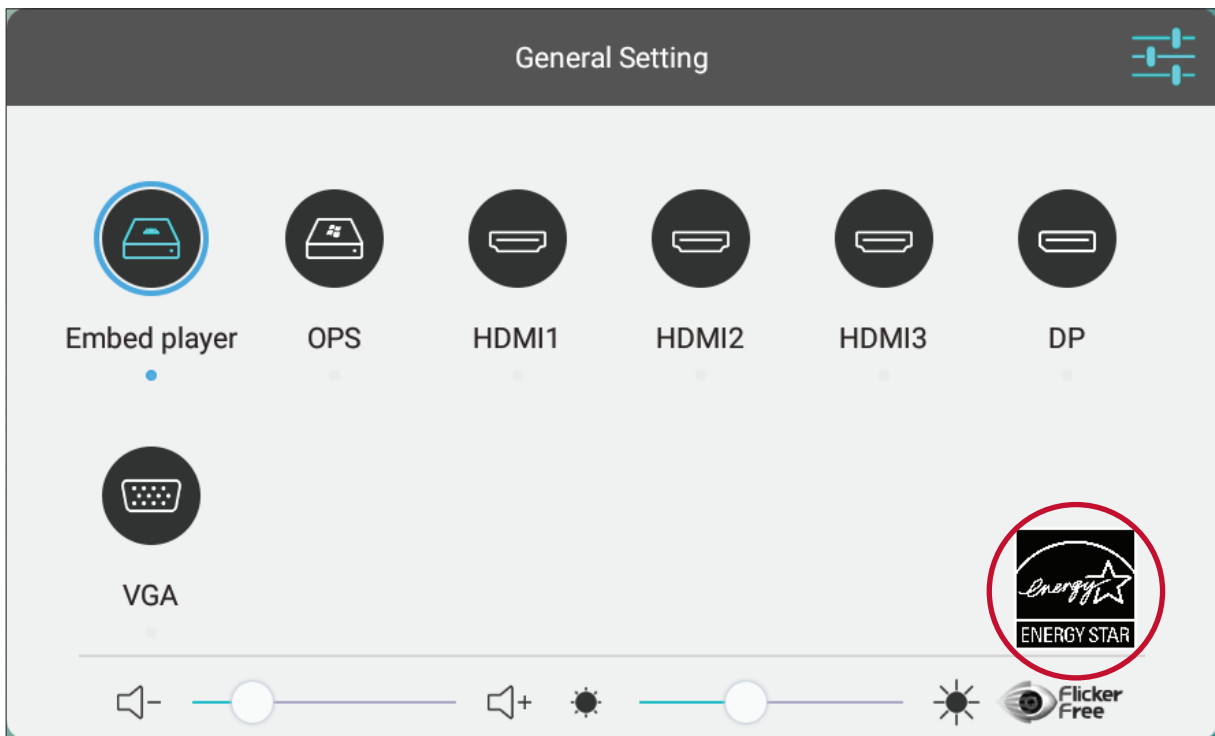

NOTE: When adjusting the backlight, enabling the ambient light sensor, or turning off the ENERGY STAR® feature the display may consume more power.

HDMI EDID

Choose between EDID 1.4 or 2.0 for your HDMI Extended Display Identification Data.

- EDID 1.4: supports up to 3840 x 2160 @ 30Hz
- EDID 2.0: supports up to 3840 x 2160 @ 60Hz

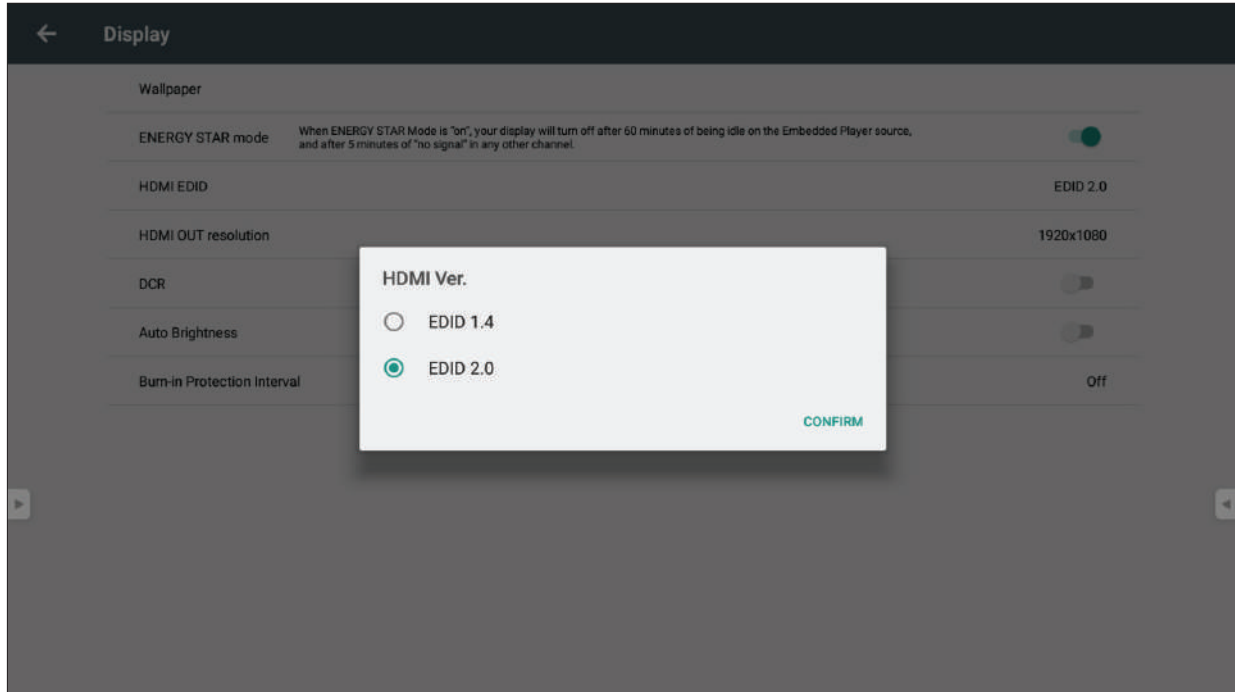

NOTE: Most laptop's HDMI only support 3480 x 2160 @ 30Hz. Please refer to the graphics card's or laptop's technical specifications for more information.

HDMI OUT Resolution Setting

Users can adjust their HDMI Out resolution preference.

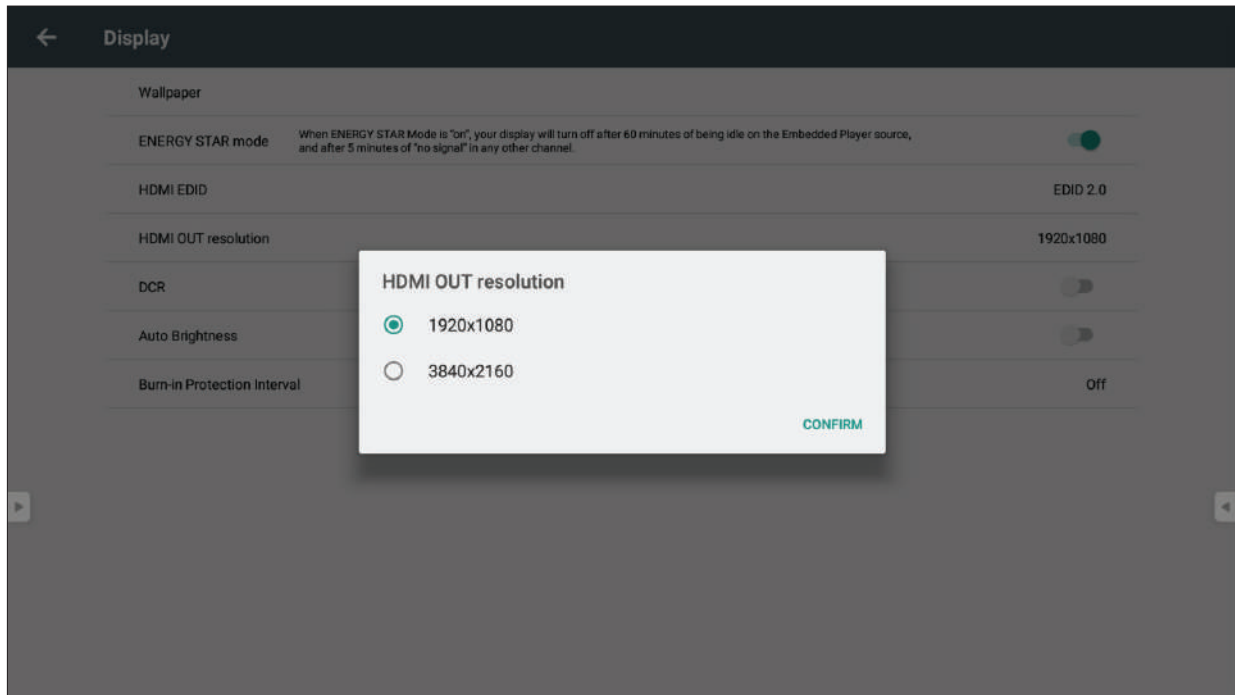

Auto Brightness

When enabled, the ambient light sensor will be activated. The ViewBoard will automatically adjust the panel backlight.



Ambient Light Sensor

Burn-in Protection Interval

This setting allows the user to program the time between movements of the picture in minutes.

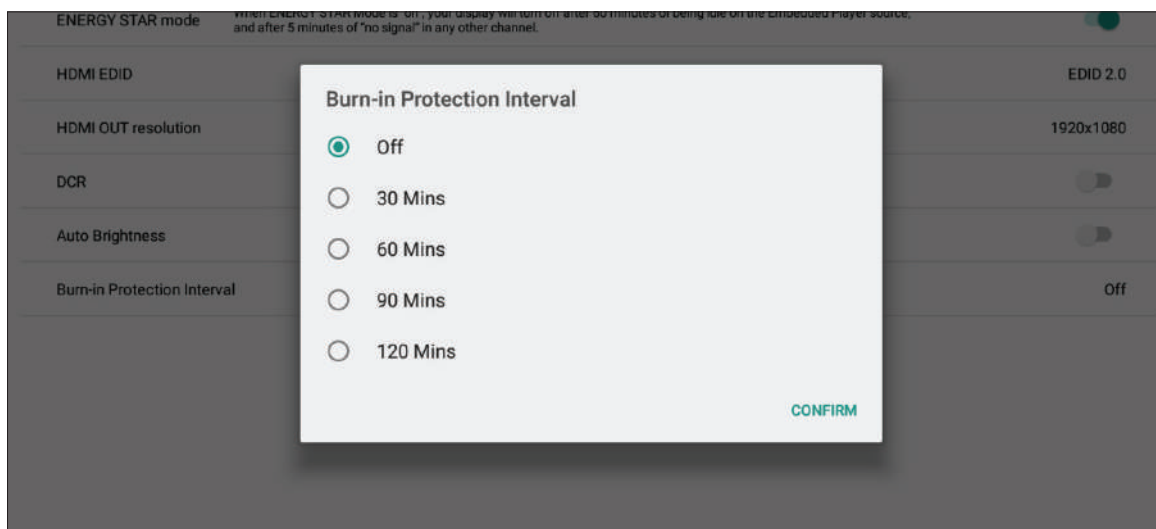

Storage

Users can check the storage status of their ViewBoard.



Sound

Users can enable/disable touch sounds, and adjust output settings.

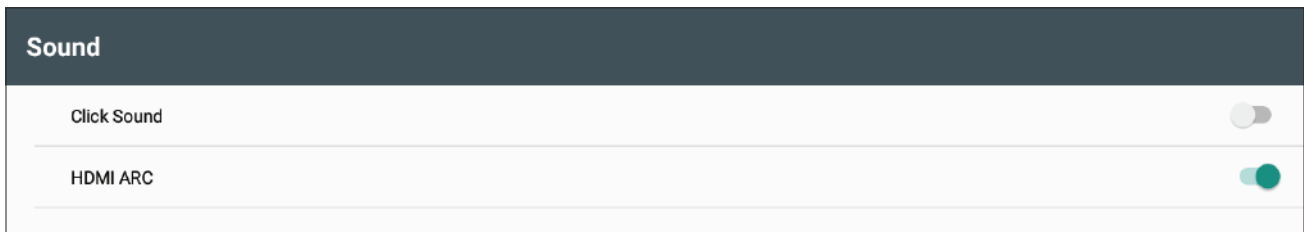

NOTE: Connect the display and amplifier through an HDMI cable for audio output. Only **HDMI 3** supports ARC.

Security

Review Credential storage and installation.

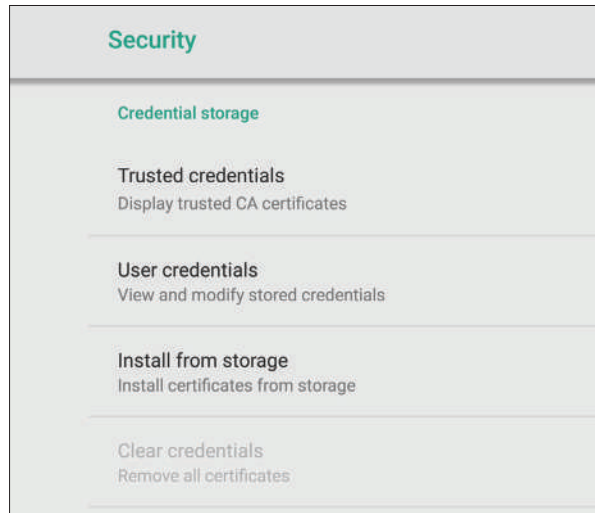

Trusted Credentials

Show and edit all trusted CA certificates that have been installed on the ViewBoard.

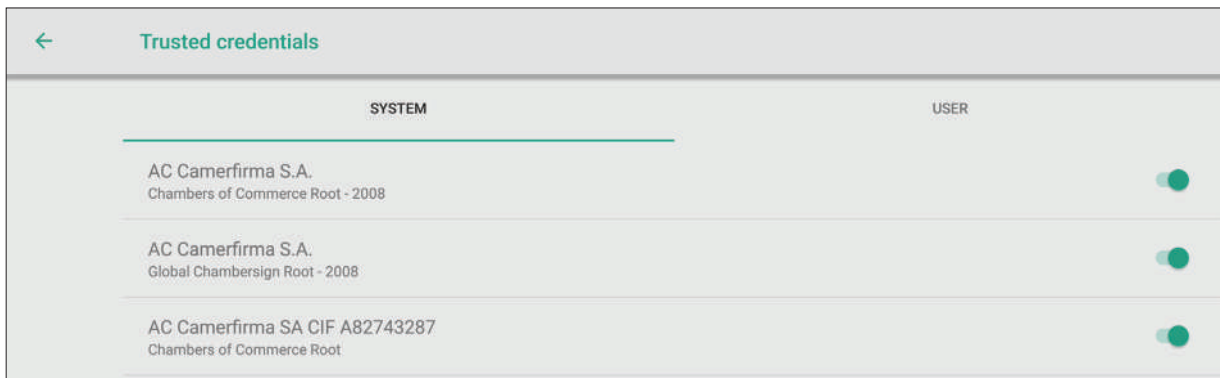

Clear Credentials

Clear any previously installed credentials.

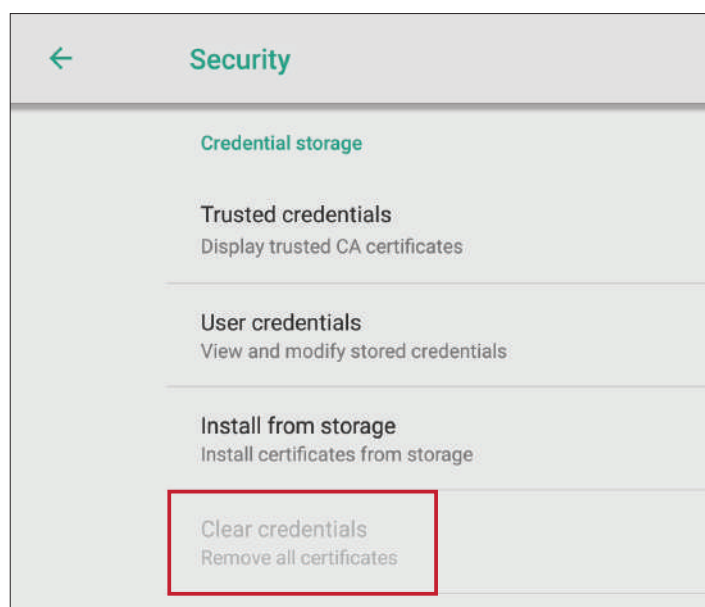

NOTE: Pre-loaded credentials cannot be cleared.

Languages & Input

Adjust the Language and Input method of the Embedded Player.

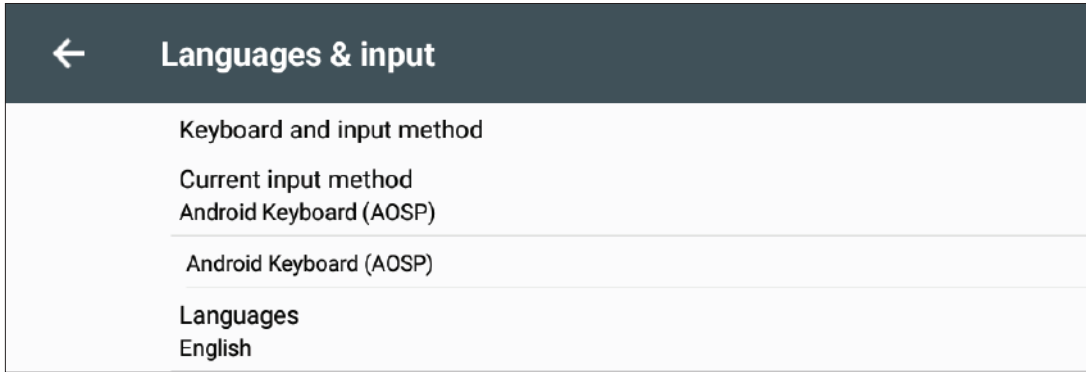

Keyboard and Input Method

Choose the preferred keyboard and input method.

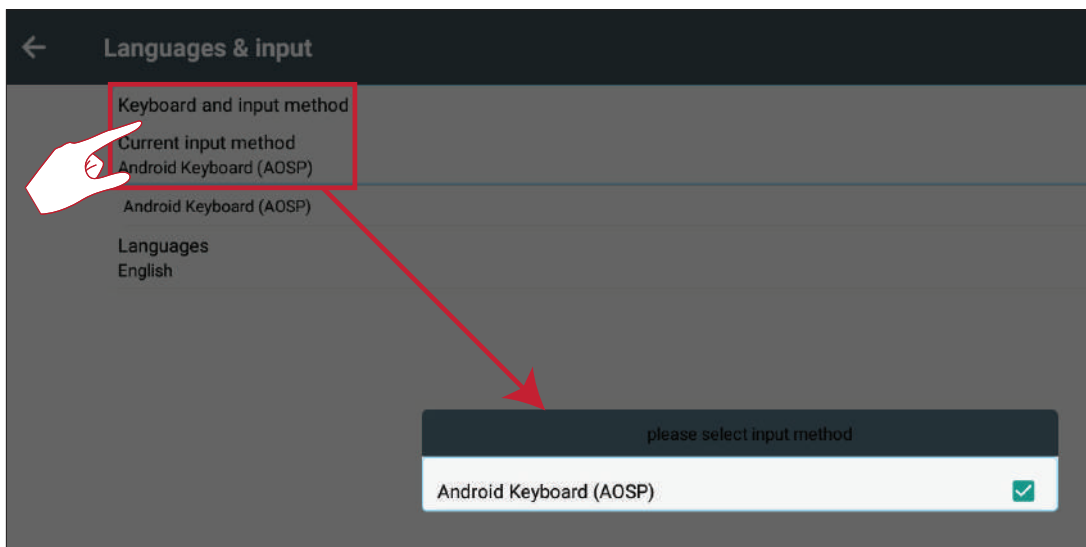

Android Keyboard

View and adjust entry settings: Languages, Preferences, Appearance & Layout, Gesture Typing, Text Correction, and Advanced.

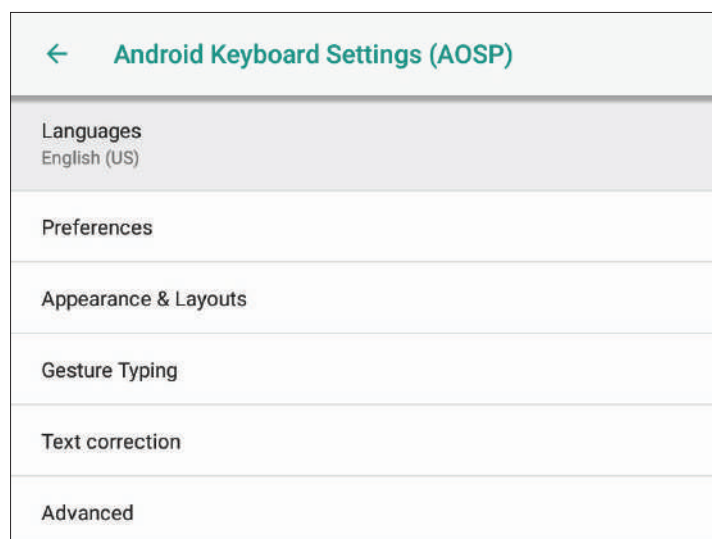

Preferences

Adjust: auto-capitalization, double-space period, and sound on keypress.

Auto-capitalization Capitalize the first word of each sentence	<input checked="" type="checkbox"/>
Double-space period Double tap on spacebar inserts a period followed by a space	<input checked="" type="checkbox"/>
Sound on keypress	<input checked="" type="checkbox"/>

Appearance and Layout

Personalize the theme, input style, and enable/disable split keyboard.

Theme Material Light	
Custom input styles German (QWERTY), French (QWERTZ)	
Enable split keyboard	<input type="checkbox"/>

Gesture Typing

Enable/disable gesture typing and adjust related settings.

Enable gesture typing Input a word by sliding through the letters	<input checked="" type="checkbox"/>
Dynamic floating preview See the suggested word while gesturing	<input checked="" type="checkbox"/>
Show gesture trail	<input checked="" type="checkbox"/>

Text Correction

Choose your preferred dictionary, block offensive words, and enable/disable various suggestions.

Personal dictionary	
Add-on dictionaries	
Block offensive words Do not suggest potentially offensive words	<input checked="" type="checkbox"/>
Auto-correction Spacebar and punctuation automatically correct mistyped words	<input checked="" type="checkbox"/>
Show correction suggestions Display suggested words while typing	<input checked="" type="checkbox"/>
Personalized suggestions Learn from your communications and typed data to improve suggestions	<input checked="" type="checkbox"/>
Suggest Contact names Use names from Contacts for suggestions and corrections	<input type="checkbox"/>
Next-word suggestions Use the previous word in making suggestions	<input checked="" type="checkbox"/>

Advanced

Adjust additional options and preferences.



Language

Choose from the available languages.

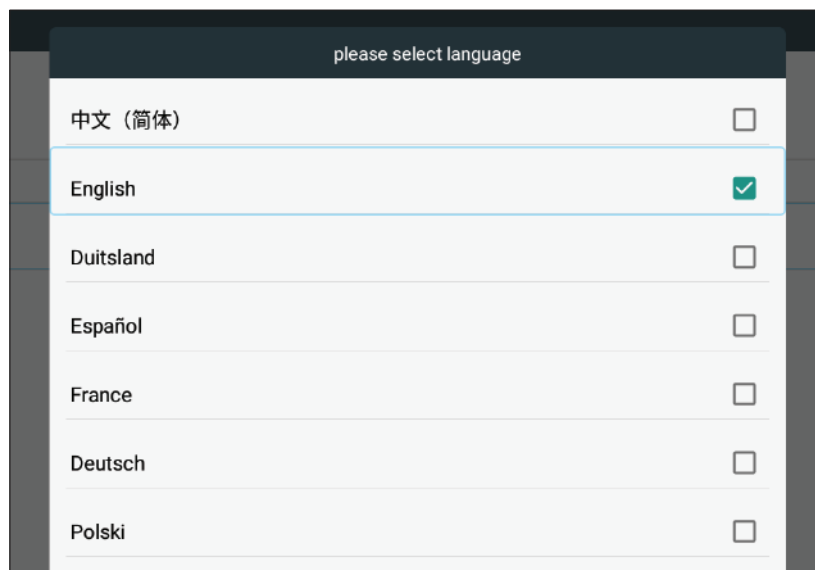

Boot Setting

Set the Startup channel, Built-in PC startup option, Standby after Startup, Power On/Off timer, and HDMI CEC.

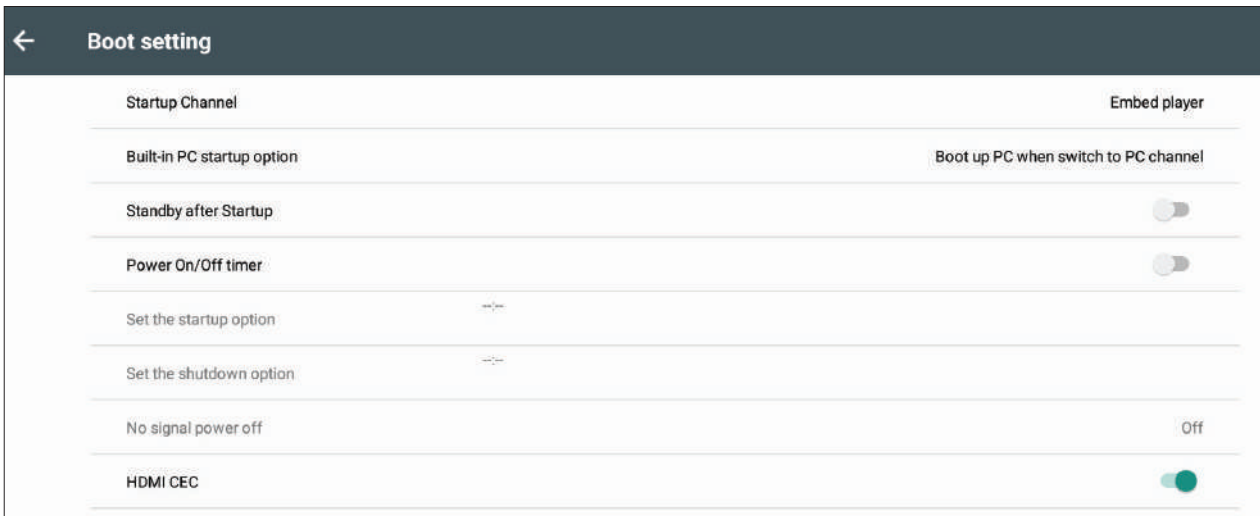

Startup Channel

Set the boot up channel from the last shutdown channel or a specific source.

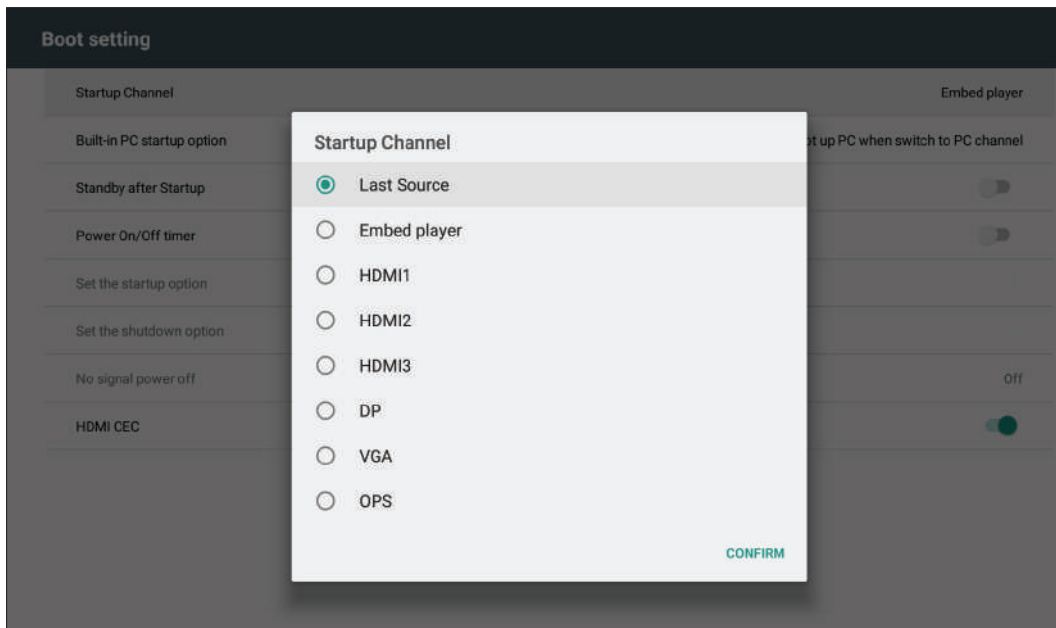

Built-in PC startup option

Set the PC module boot up options. The default setting is to boot up the PC when the source is changed to OPS.

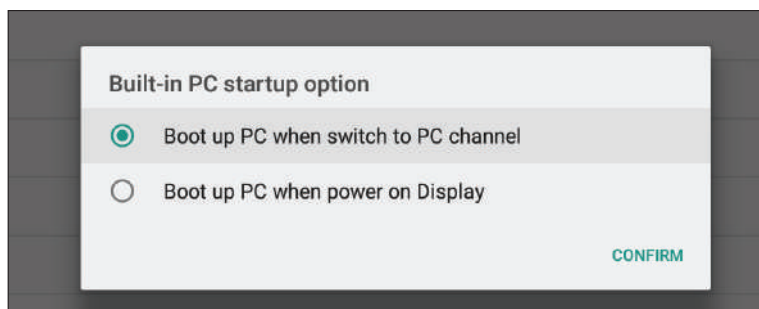

Standby after Startup

The ViewBoard will turn off the backlight automatically after booting up from Standby mode. To wake the display, press the **⏻ Power** button.

Power On/Off Timer

Set a power on and power off time for the ViewBoard. To setup:

1. Enable the feature by selecting “Power On/Off timer”.



2. Then select a startup and shutdown time.

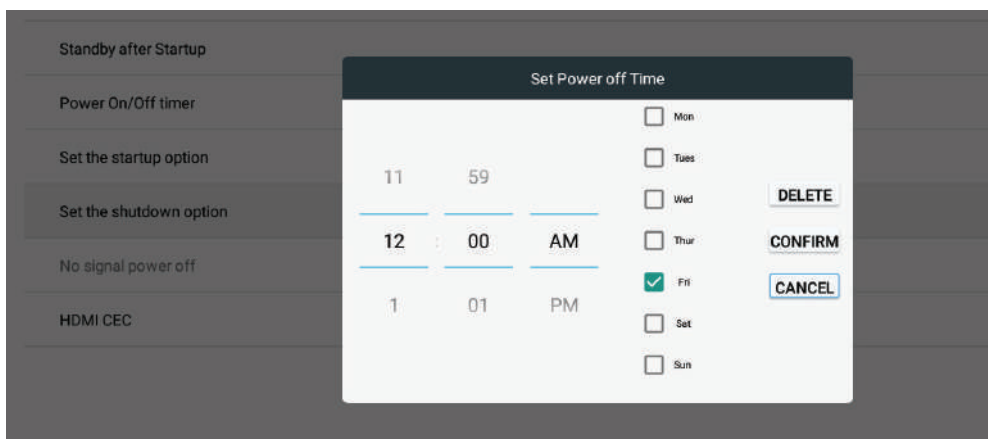

3. After selecting both times, the feature is ready to use.

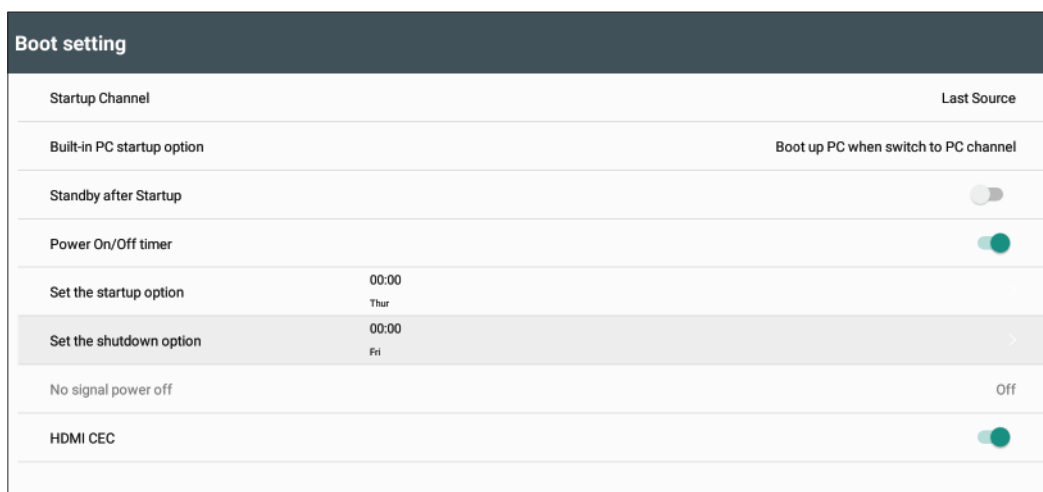

No Signal Power Off

When there is no signal for a specific amount of time the ViewBoard will turn off. By default the time is set to 10 minutes.

HDMI CEC

Only supported by the **HDMI 3** port, when the function is enabled the ViewBoard can be controlled On/Off by an HDMI CEC device.

NOTE: “Player off then display off” and “Display on then player on” are not standard CEC commands. ViewBoard may not be compatible with all players.

Password for Screen Lock

To set a screen lock password:

1. Select **SET**.

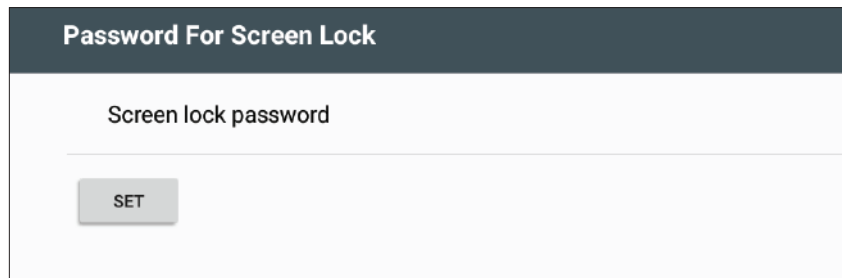

2. Input a password, and select **OK**.



3. If a password already exists you will be able to choose from **CHANGE** and **CLEAR**.

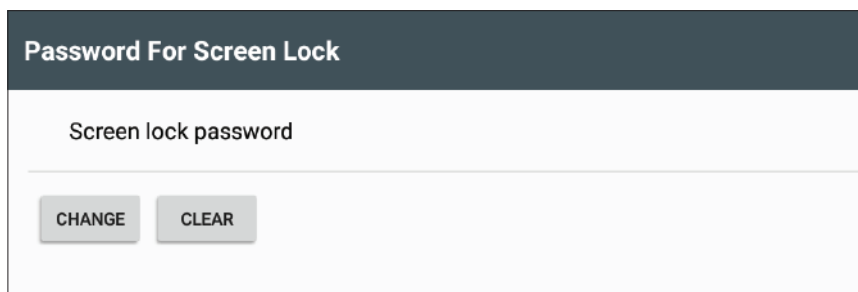

NOTE: Please contact your local service center if you forget the password.

After a password is set, when selecting “Screen Lock” from the application menu the lock screen will activate. Inputting the password will unlock the screen.

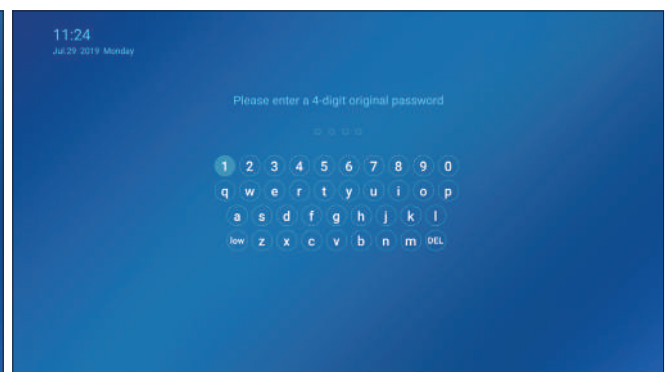
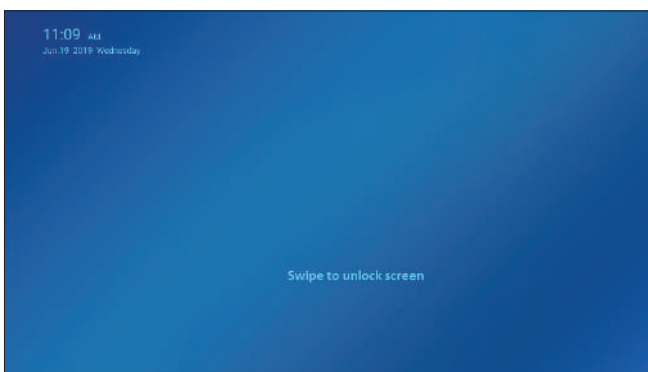

NOTE: For more information, see page 81.

Channel Setting

Enable/disable Input Alias Switch, Power On by Active Source, Signal Auto Switch, and Auto Switch to a New Source.

Input Channel Alias Switch

Once enabled, the user can edit input aliases and when the **Display** button is pressed the source information (located in the upper left side) will also be changed.

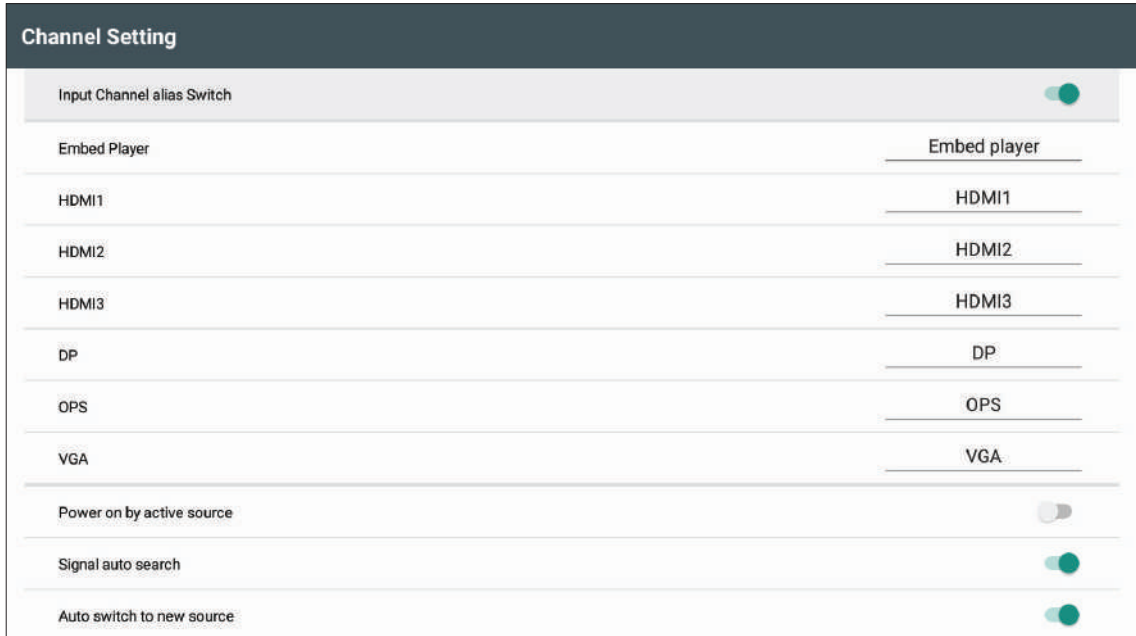

Power On by Active Source

The ViewBoard will detect active signals in Standby mode. If there is a signal output, the ViewBoard will power on automatically.

NOTE: Only supports **HDMI 3** and **VGA**.

Signal Auto Search

When enabled, if the ViewBoard loses its current input source signal, it will search for another input source automatically.

Auto Switch to new Source

When enabled, if the ViewBoard detects a new signal input it will switch the input source automatically.

Side Tool Bar Channel

Adjust the side tool bar availability. For more information, see page 32.

Side Tool Bar Setting

Side Toolbar Channel Setting

Available in all channels

Embedd player only

Except OPS channel

Disable Side toolbar

System

View and adjust Date & Time, About Device, and Advanced Settings.

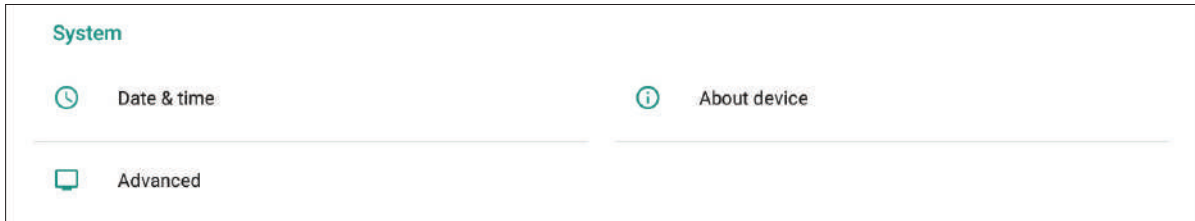

Date & Time

Set the system time and format.

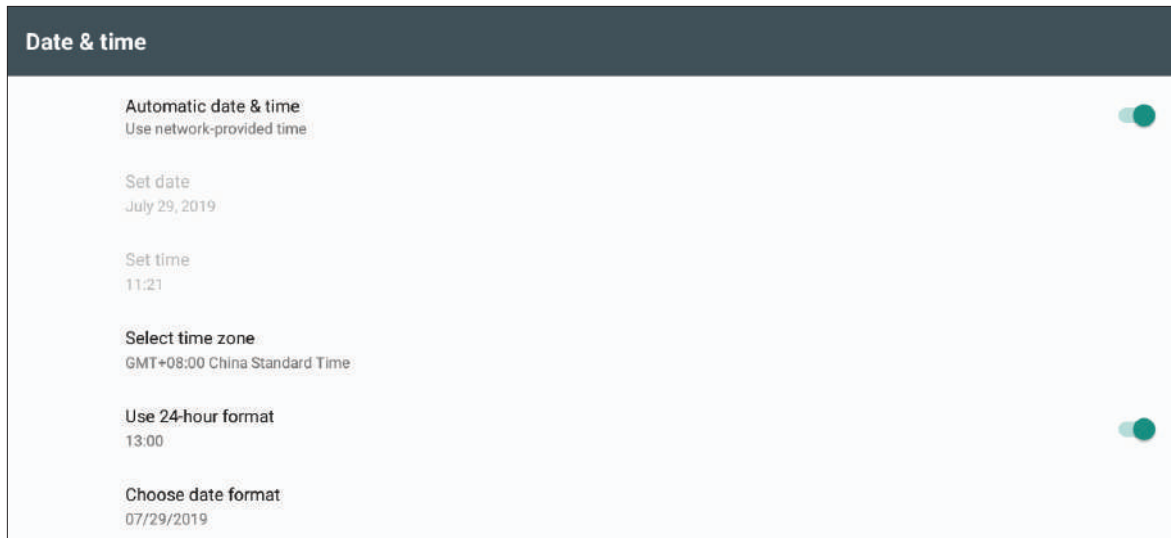

Automatic Date & Time

When enabled, the ViewBoard will automatically synchronize the date and time via the Internet.



NOTE: Ethernet or Wi-Fi connection is needed.

Set Date

Adjust the values, then select **OK** when finished.

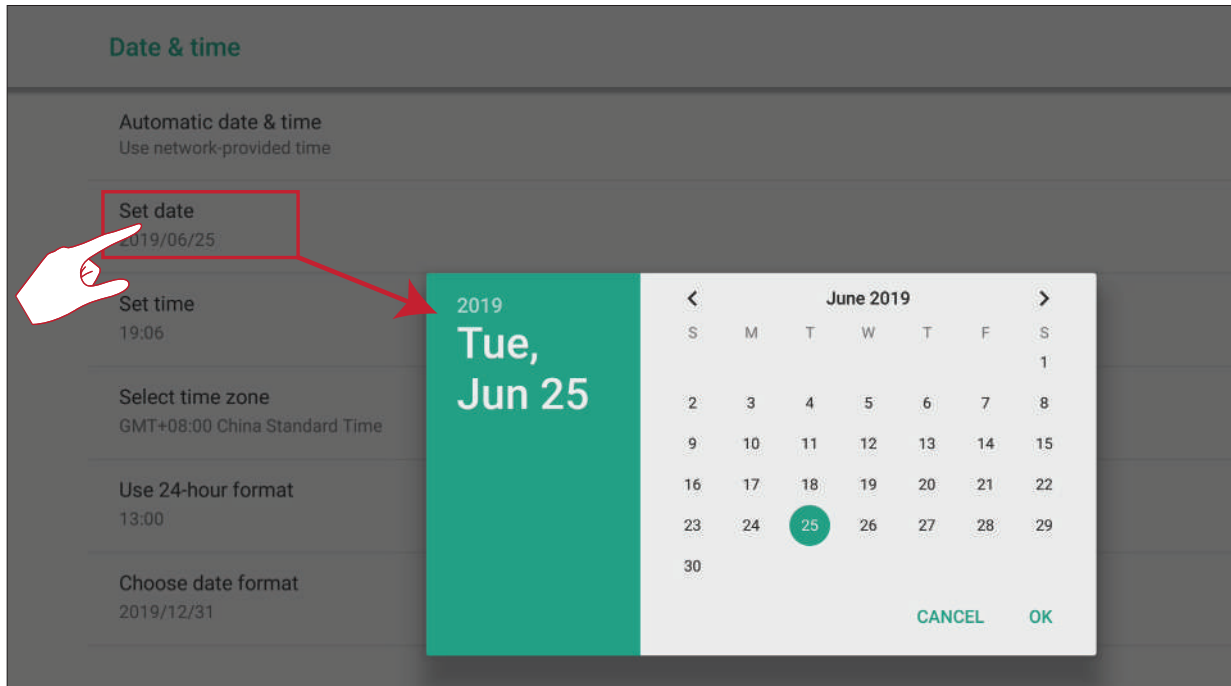

Set Time

Adjust the values, then select **OK** when finished.

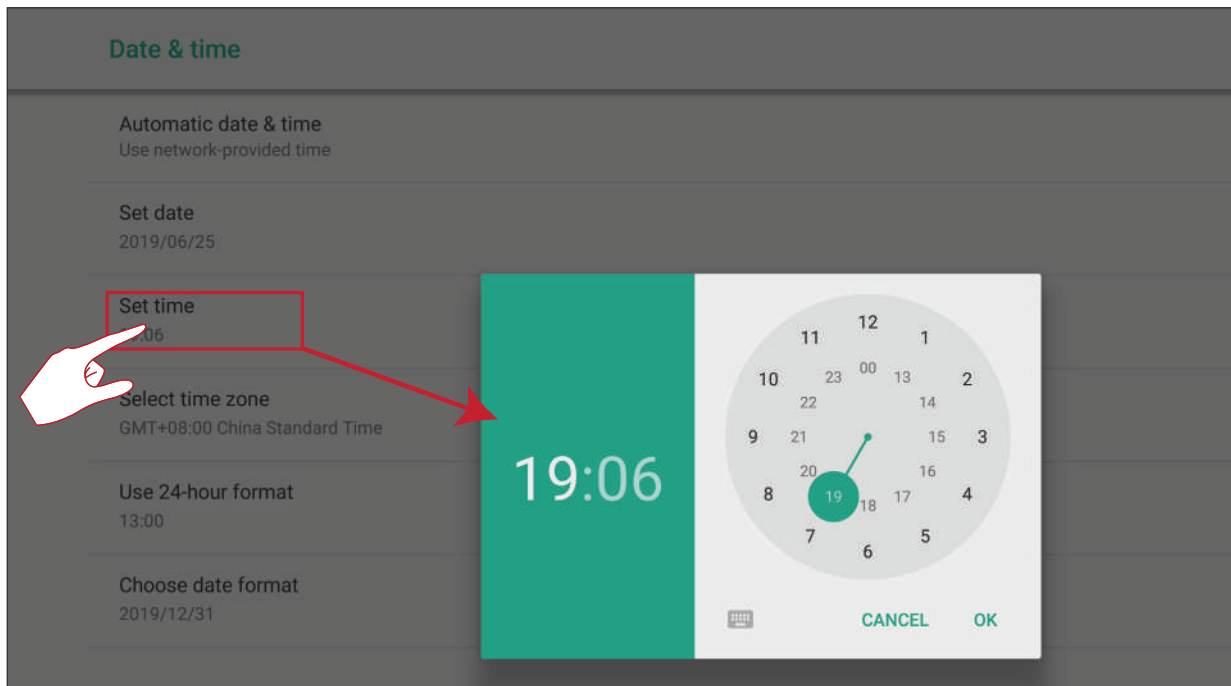

NOTE: Automatic Date & Time must be disabled to manually adjust the date and time.

Select Time Zone

Choose from the available time zones.

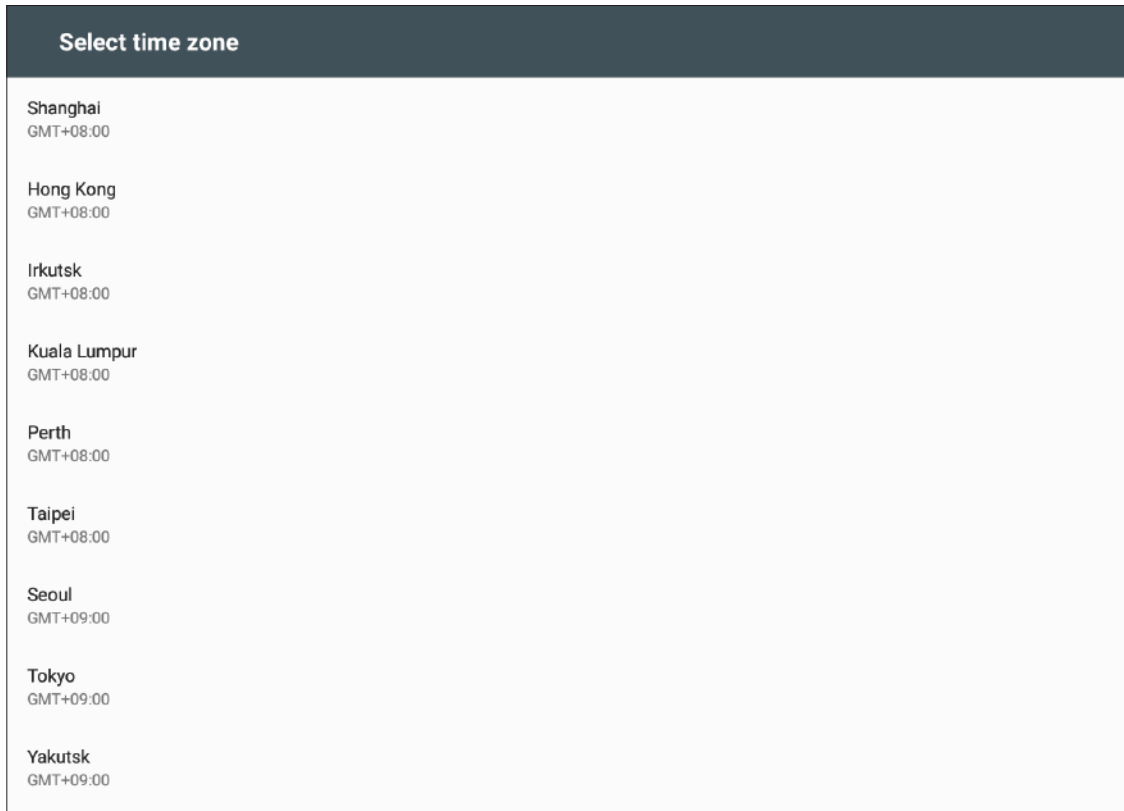

Select Time Format

Choose from 12 hour and 24 hour time format. Toggle 24-hour format on/off.



Choose Date Format

Select from the available date formats.

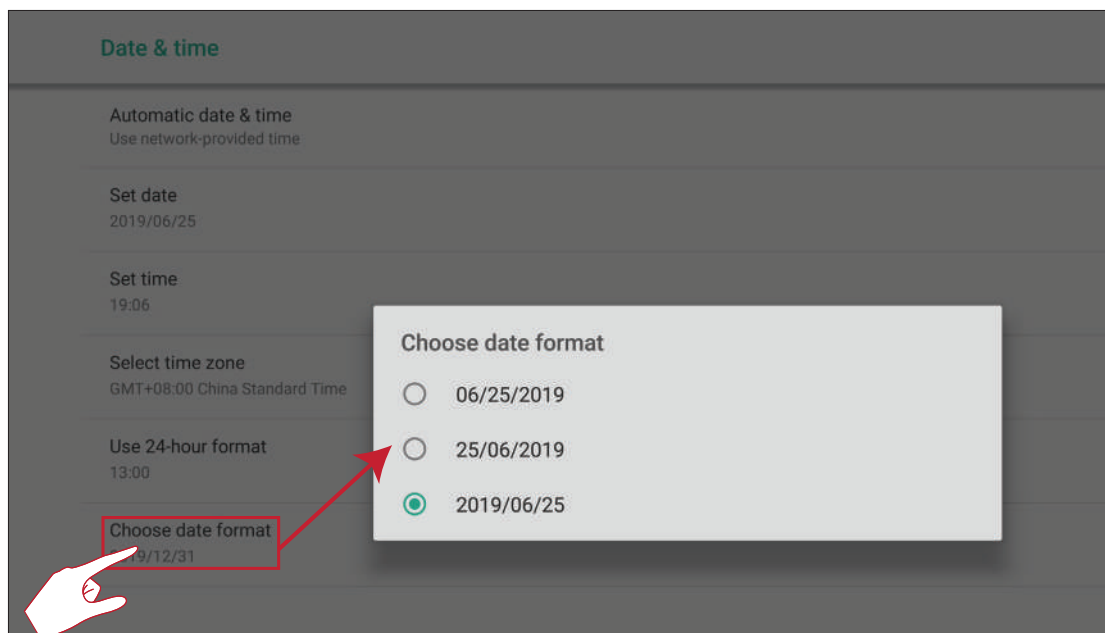

About Device

Display Embedded Player information, System Updates, Display ID Setting, and Asset Tag.

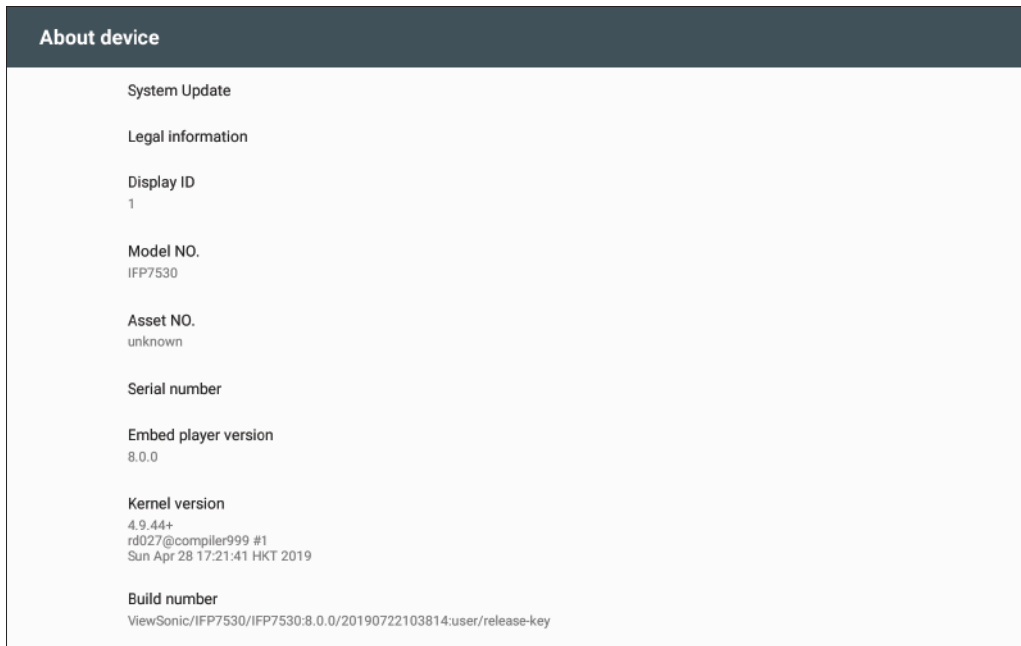

System Update

The ViewBoard automatically searches for software updates whenever connected to the Internet (OTA). With just one click, users can update their version of ViewBoard software.

OTA Service

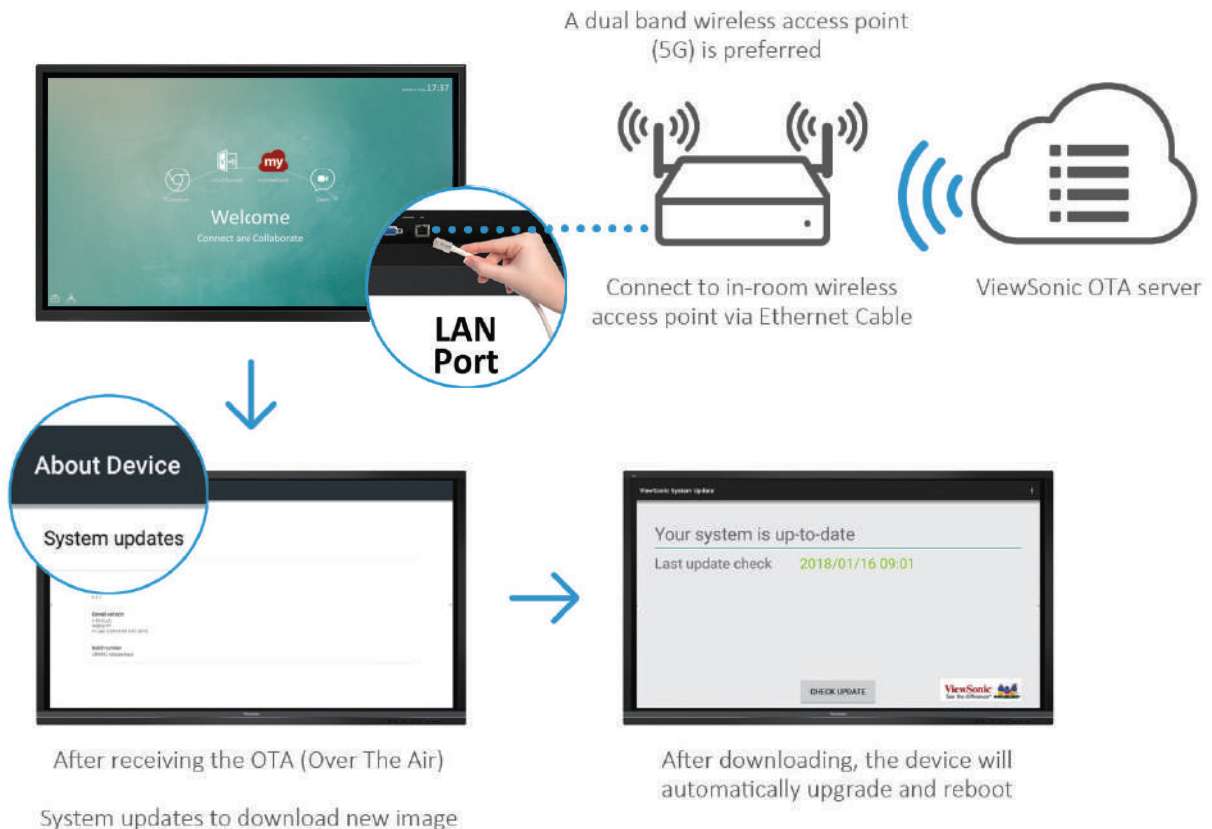

Update by USB

When an update BIN file is available on the ViewSonic website, users are able to download and update the system via USB.

To update via USB:

1. Download the upgrade package and unzip the file. You may get a file named “MstarUpgrade_848.bin”.
2. Copy the file to a FAT32 USB, then plug the USB into the rear USB port of the ViewBoard.
3. Proceed to update the system via USB: **Settings > System > About Device > System Update > USB Update.**

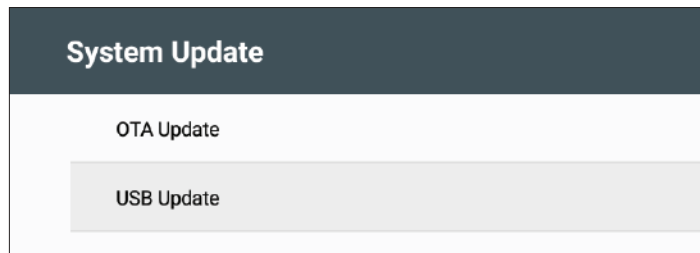

4. During the updating process do not power off the ViewBoard. The ViewBoard will automatically reboot after the updating process has completed.

NOTE: User data will be removed when updating the system by USB. The data in OPS/SDM will not be removed.

Legal Information

Check open source and System WebView licenses.

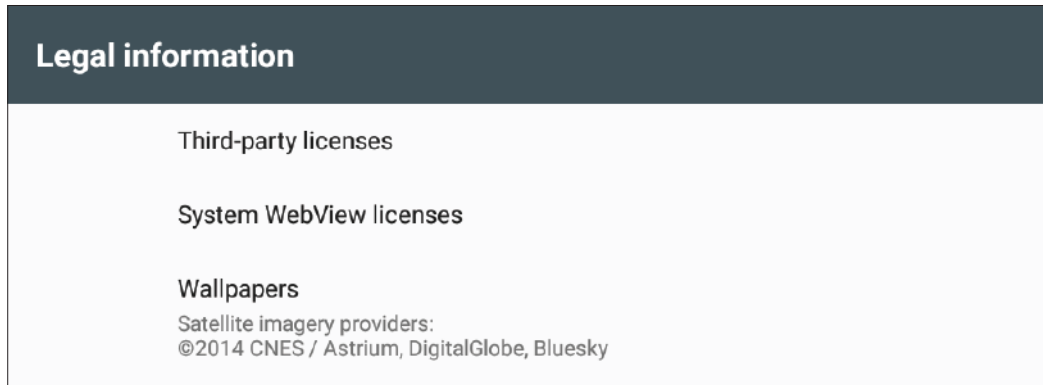

Display ID

Change the Display ID.

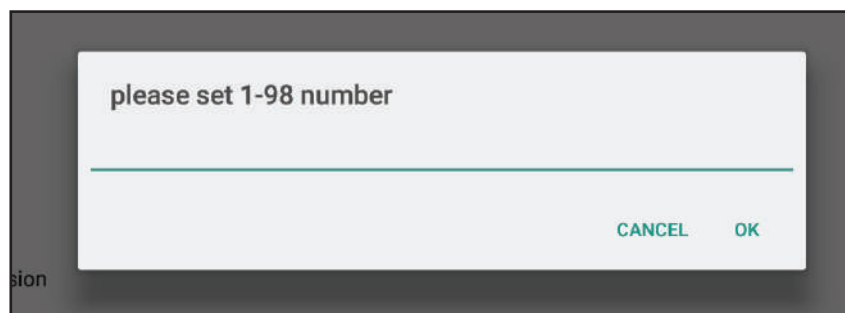

NOTE: The Display ID is for RS-232 users and LAN control, and the range is 01~98.

Asset Tag

Key in the asset information.

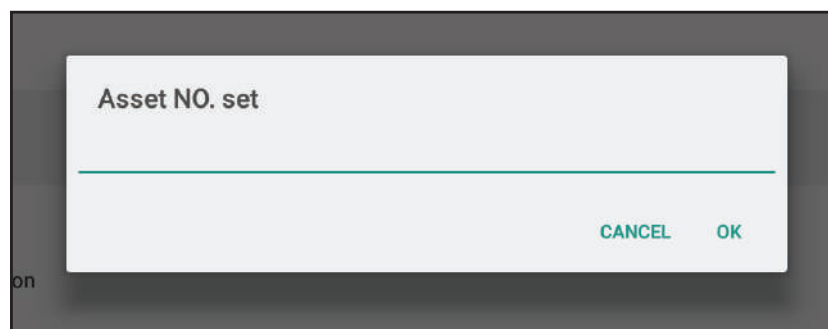

Advanced

Adjust the Mode, review Application information, change the access password, or Factory Reset the device.

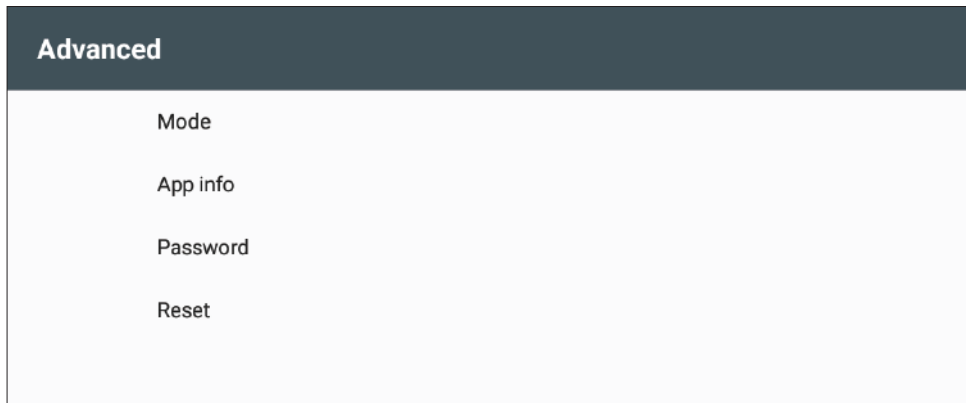

To view the Advanced settings:

1. After selecting **Advanced** under **Settings**, If an access password has not been set yet, one will need to be set;

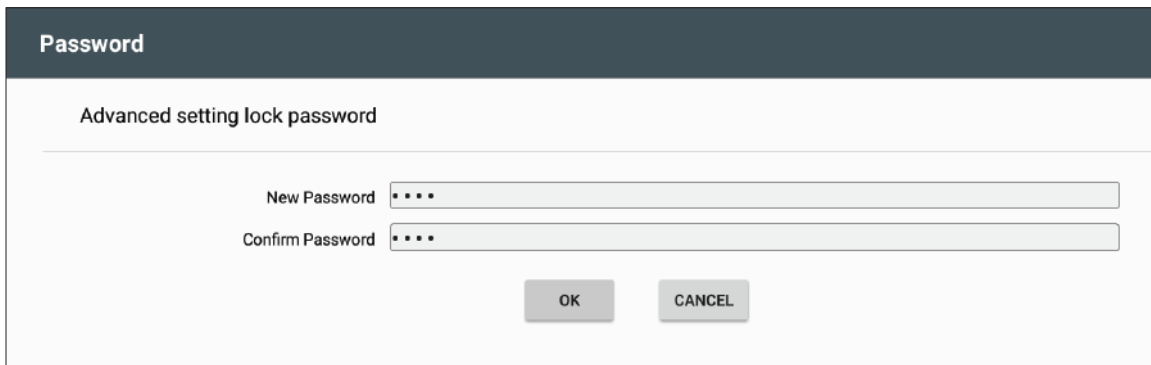

2. Or, if an access password has been set, you will need to input it.

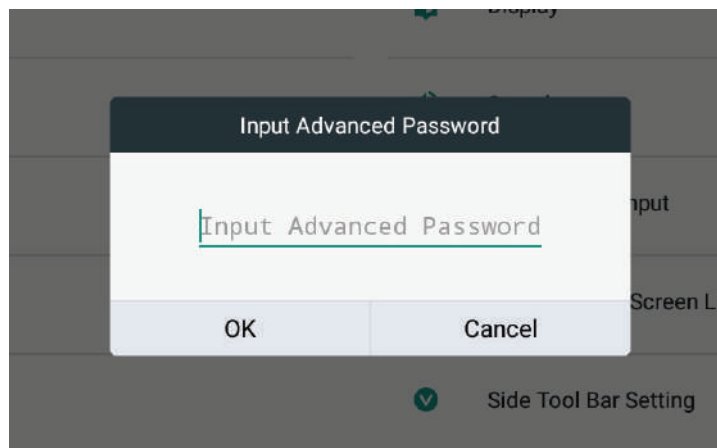

3. After an access password has been created or inputted the settings can be adjusted.

Mode

- **Normal Mode:** The embedded screen sharing apps will run normally.
- **Disable Embed OS:** The system will automatically reboot, and then the Embed OS will not appear.

Mode

Normal mode

Disable Embed OS

App Info

The user can view App information, force stop, and clear data, cache, and defaults.

App info

BootHome
32.77 kB

Chromium
7.55 MB

EAirplay
35.11 MB

EnterpriseAgent
3.93 MB

Folders
61.44 kB

myViewBoard
32.77 kB

ScreenLock
45.06 kB

Settings
270 kB

Password

Modify the **Advanced** setting access password.

Password

Advanced setting lock password

Current Password

New Password

Confirm Password

CHANGE CANCEL

Reset

Perform a Factory Data Reset.

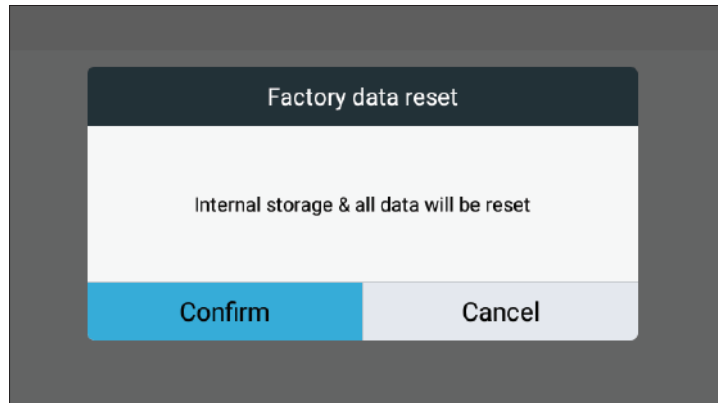

NOTE: All locally stored data will be deleted.

> Embedded Applications and Settings

Embedded Digital Whiteboard App

Within ViewBoard, ViewSonic offers the embedded digital whiteboarding app, myViewBoard.







myViewBoard

Floating Bar

		Move the Floating Bar.	
		Switch between presentation and preparation modes.	
		Paste from the clipboard onto the canvas.	
		Click to open the web browser	
		Go to the previous canvas.	1. New myViewBoard File 2. Open File 3. Save File
		Go to the next canvas.	
		Add a new canvas.	

Toolbar

		Full Screen Capture	
		Toolbar Move Button	Select and hold to move the toolbar to the left side, right side, or bottom of the screen.
	<p style="text-align: center;">File Button</p>		
		1. New myViewBoard File 2. Open File 3. Save File	4. Save as File 5. Export 6. Email
		Import resources (image, video, audio, etc.) to the whiteboard.	
		Infinite Canvas Button	Select – Use two hands to zoom in/out on/of the working panel.
		Selection Button	Select objects, text, and pictures to get other tools.
		Pen Button	Writing tools, changing colors, transparency, thickness, etc.
		Eraser to erase objects or clear the page.	
		Shape/Line Button	Create shapes, select shape colors, insert arrows.

	Text Box	Creates a Text box.
	Undo Button	Undo previous actions.
	Redo Button	Redo previous actions.
	Page Toggle Button	Select pages, sort pages, delete pages.
	Show or hide the current host information.	
	Whiteboard background management menu.	

ViewBoard Cast

Working with ViewBoard® Cast software, the vCastReceiver app, will allow the ViewBoard® to receive vCastSender laptop screens (Windows/Mac/Chrome) and mobile (iOS/Android) users' screens, photos, videos, annotations, and camera(s).

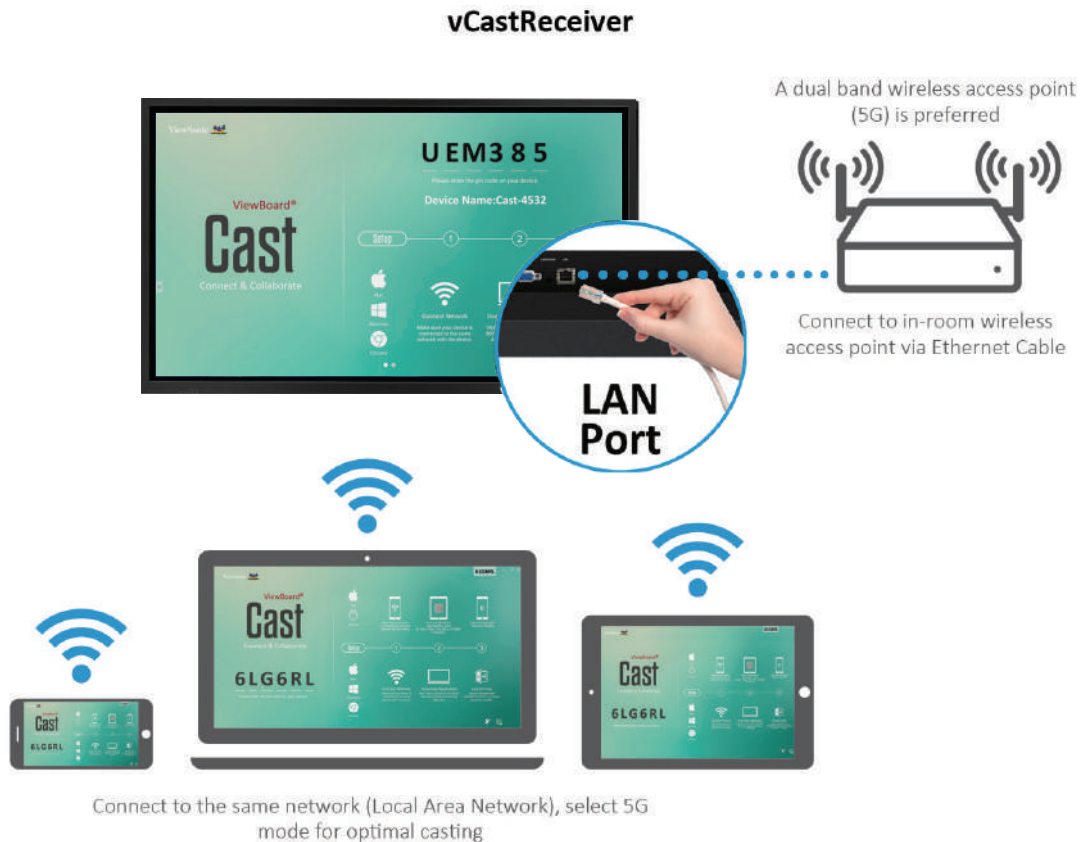

Network Information

- ViewBoard® Cast software, laptops, and mobile devices can connect to both the same subnet and across the subnet network.
- Connected devices will show up under “Device List” on the same subnet connection.
- If the device does not show up under “Device List”, users will need to key-in the on-screen PIN-code.

ViewBoard Cast is a wireless peer to peer data communication, therefore the below port settings are required:

Ports:

- CP: 56789, 25123, 8121, and 8000
- UDP: 48689 and 25123

Port and DNS activation:

- Port: 8001
- DNS: h1.ee-share.com

Cast Sender from Windows-based Devices, Macbook, and Chrome devices.



Mac, Windows, Chrome Devices:

1. Make sure your device is connected to the same network as the ViewBoard.
2. Visit the address that is shown on the ViewBoard to download the application.
3. Launch the application and click the **Connect** button next to the Device Name.

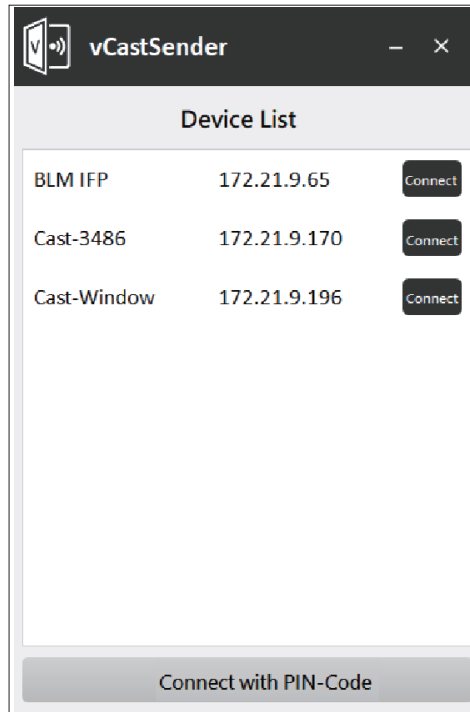

NOTE: If the device is not listed, click **Connect with PIN-Code** and input the pin-code displayed on the ViewBoard.

Cast Sender from Mobile Devices: iOS-based (iPhone, iPad) and Android OS based phone/tablet.



Android:







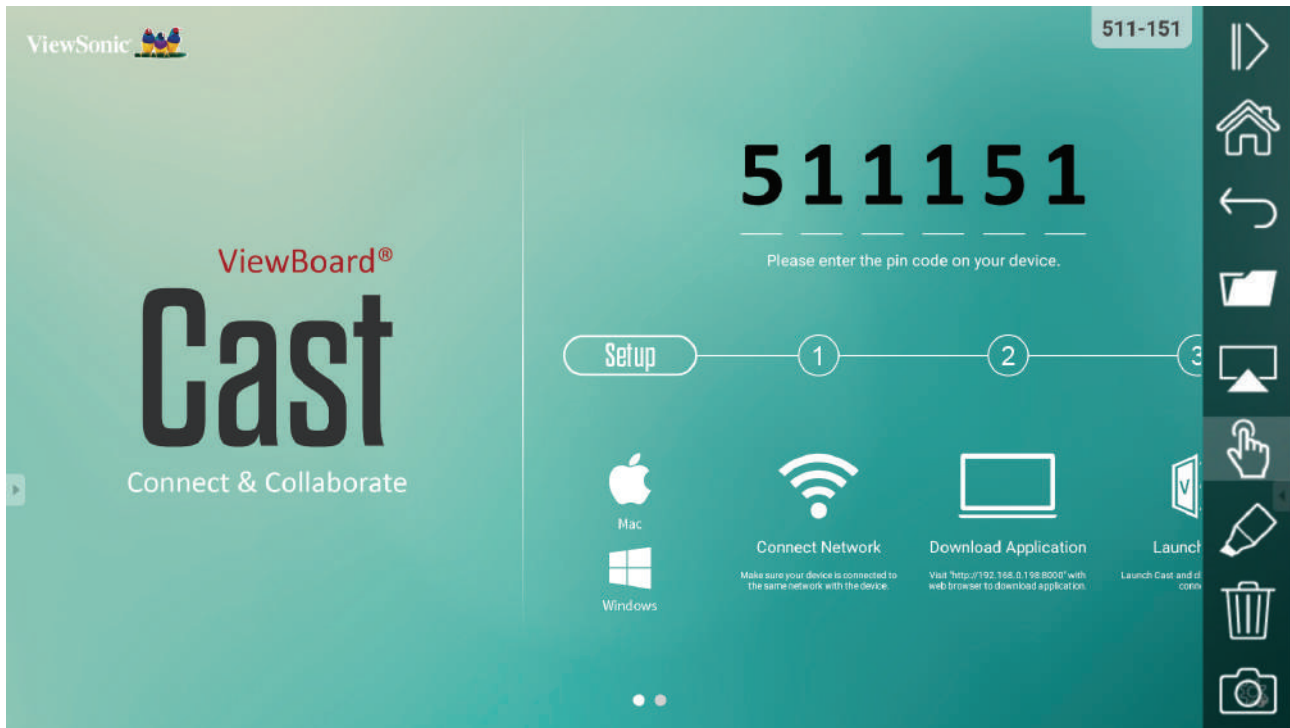

1. Make sure your device is connected to the same network as the ViewBoard.
2. Scan the QR Code that is shown on the ViewBoard, or key in the web address provided, to download the application.
3. Launch the application and select the correct Device Name and input the pin to connect. You can also directly input the pin-code displayed on the ViewBoard to connect.

iOS:

1. Make sure your device is connected to the same network as the ViewBoard.
2. Directly open AirPlay and select the Device Name to connect. Or,
3. Scan the QR Code that is shown on the ViewBoard, or key in the web address provided, to download the application.
4. Launch the application and select the correct Device Name and input the pin to connect. You can also directly input the pin-code displayed on the ViewBoard to connect.

Cast Out from a Mobile Device that Supports Annotation



Item	Description
 Toggle	Click to hide or display tool bar
 Home	Click to return to home interface
 Return	Click to return to previous operation interface
 Folder	Click to view or open mobile device internal file
 Screen sharing	Click to share screen (Android 5.0 above supported)
 Touch	Click to change to touch mode
 Pen	Click to make annotation in the picture Click to change color or thickness
 Clear	Click to clean all the elements
 Camera	Click to use camera then send the image to IFP50

vSweeper

Select the  icon to clear unnecessary data and unwanted files.

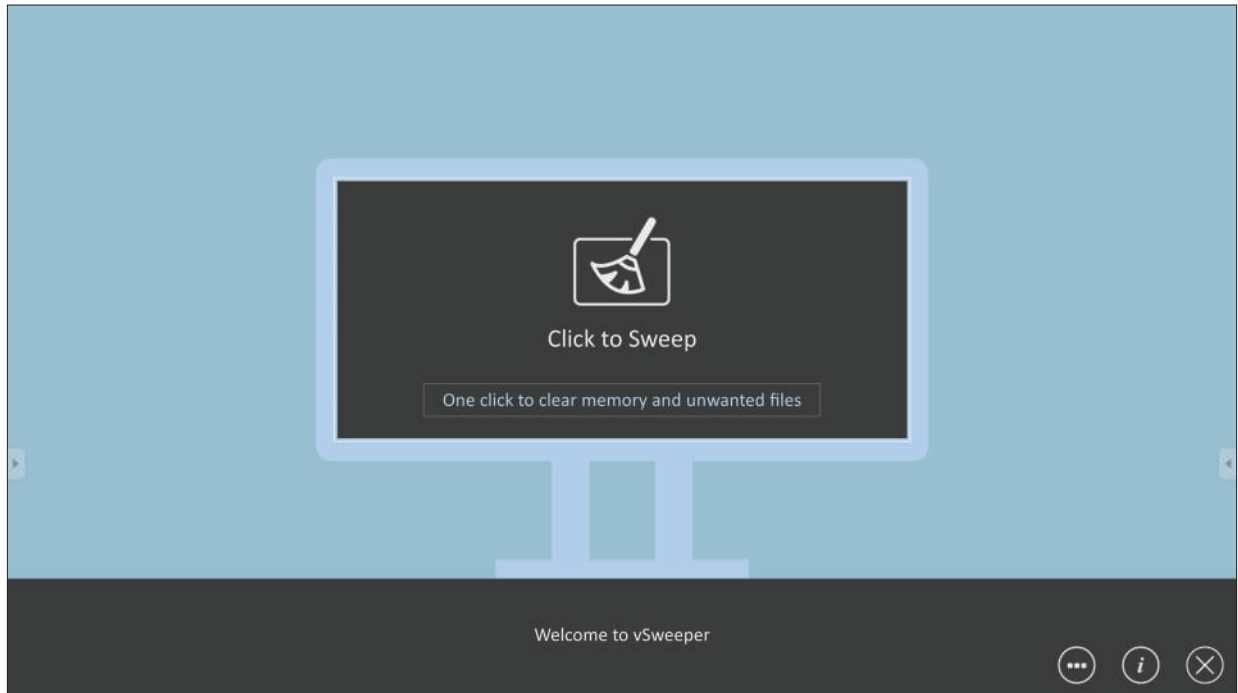

Advanced Settings can also be customized to the user's needs.

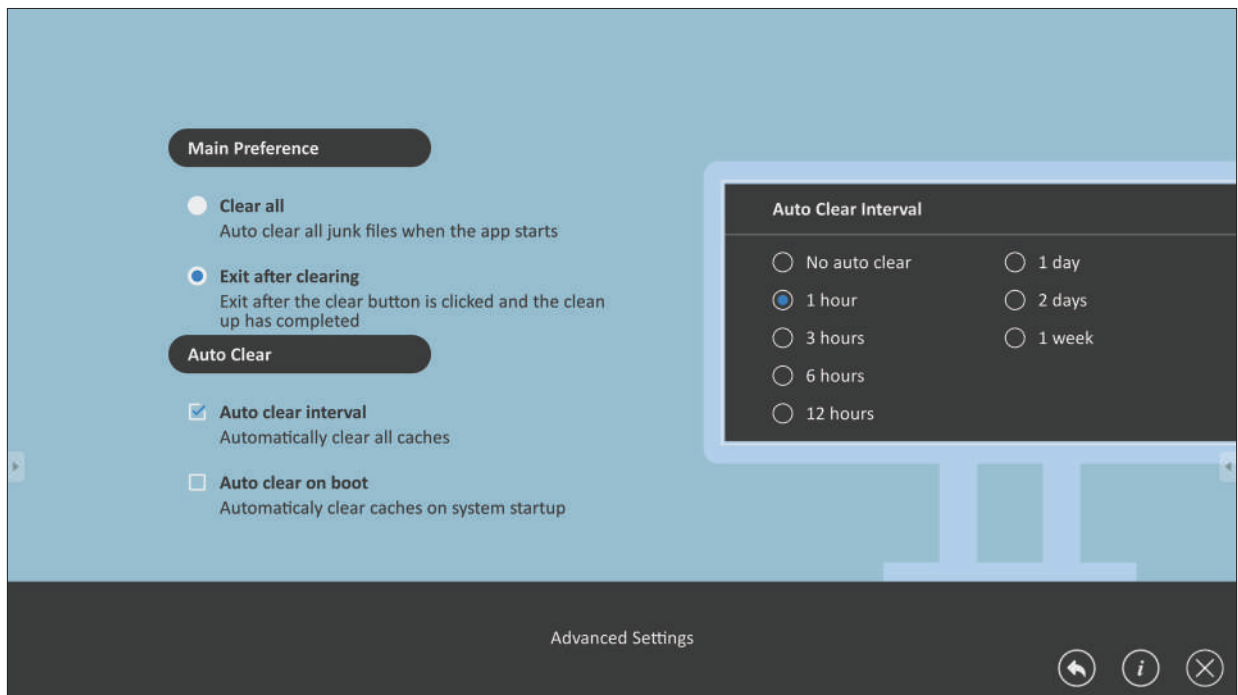

Screen Lock

Select the  icon to set a screen lock password and enable screen lock.

NOTE: If the user forgets the password, use the remote control and input “**ViewBoard**” to restore the password to default.

To set a screen lock password:

1. Go to: **Settings > Personal > Password for screen lock**, or select the  icon in the applications list.

NOTE: If you select the  icon and no password has been set, the below prompt will appear:

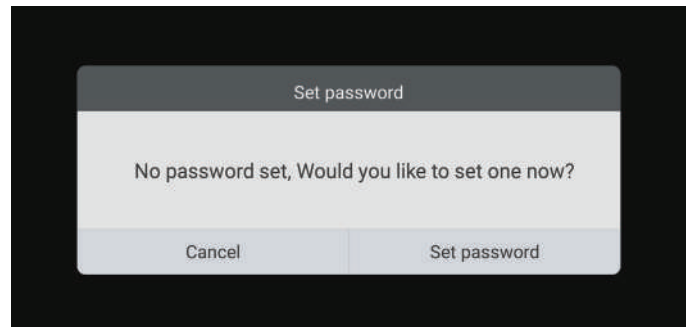

2. Select **SET**, and input a new four (4) digit password. Then select **OK**.

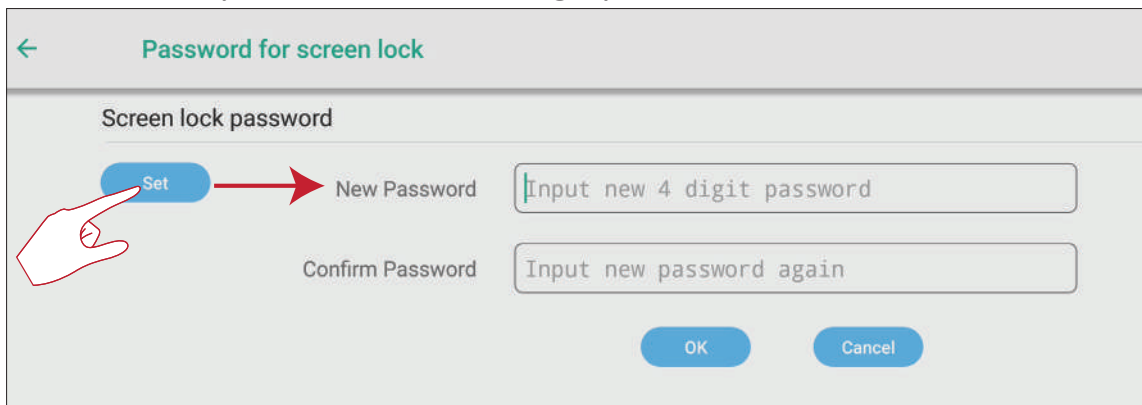

3. Now when selecting the  icon, the screen will be locked.

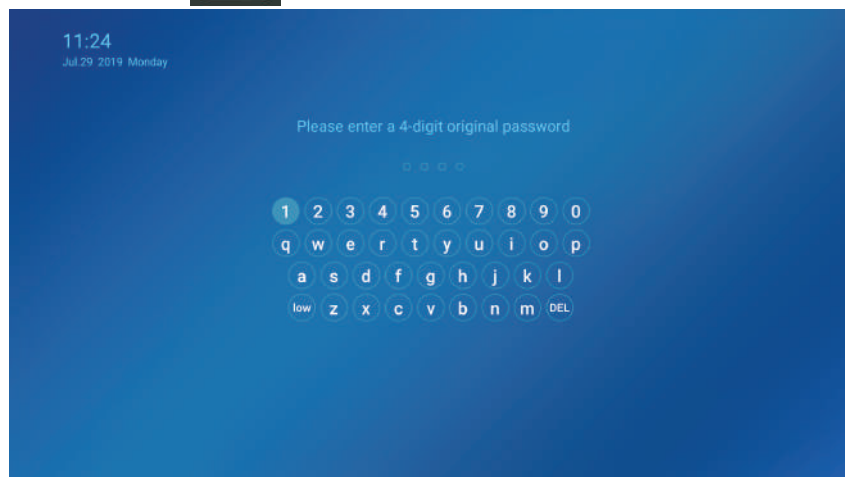

Chromium

Web browser for surfing the Internet.

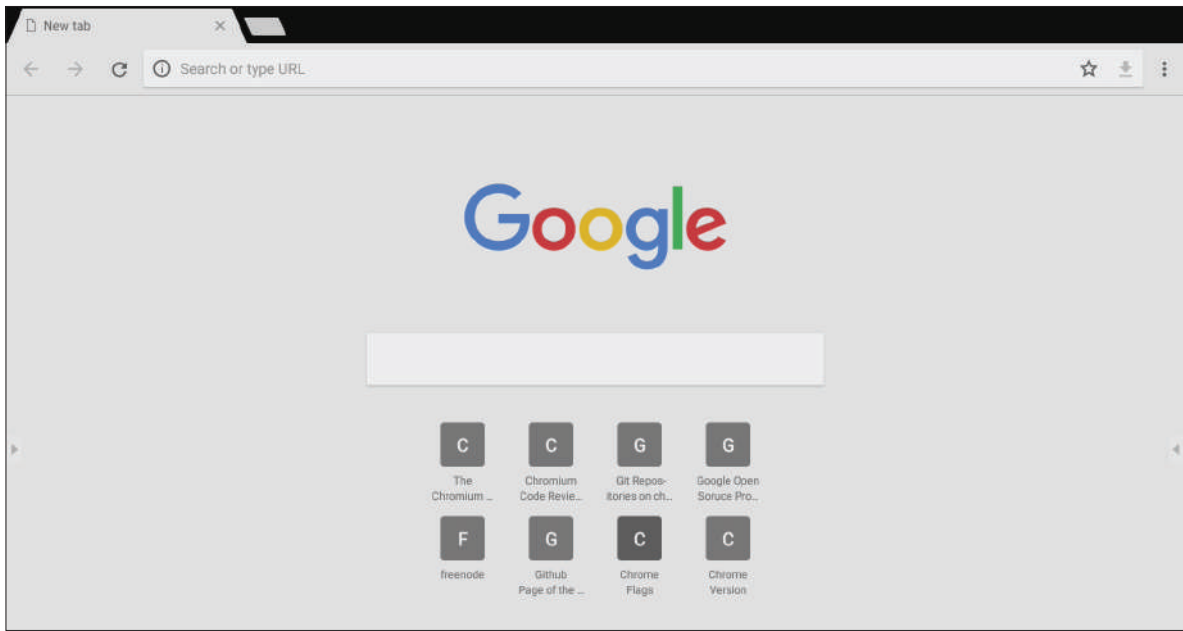

WPS Office

Create, edit, and view Documents, Memos, Presentations, and Spreadsheets.

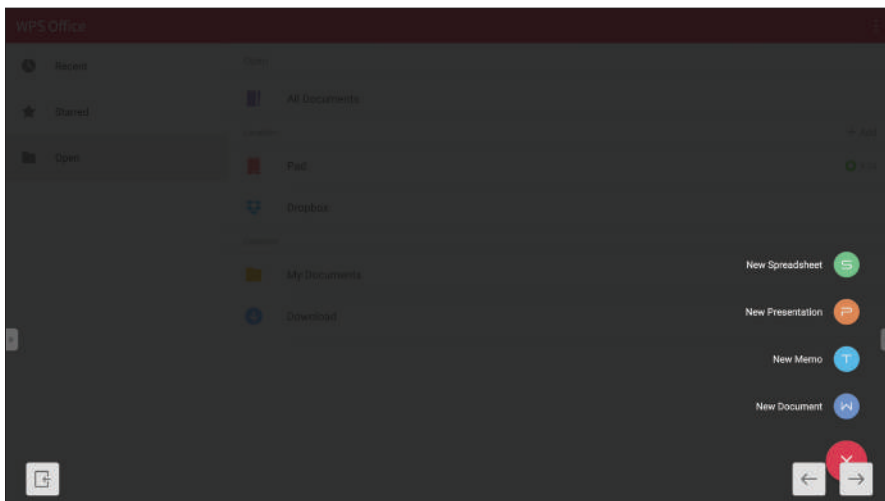
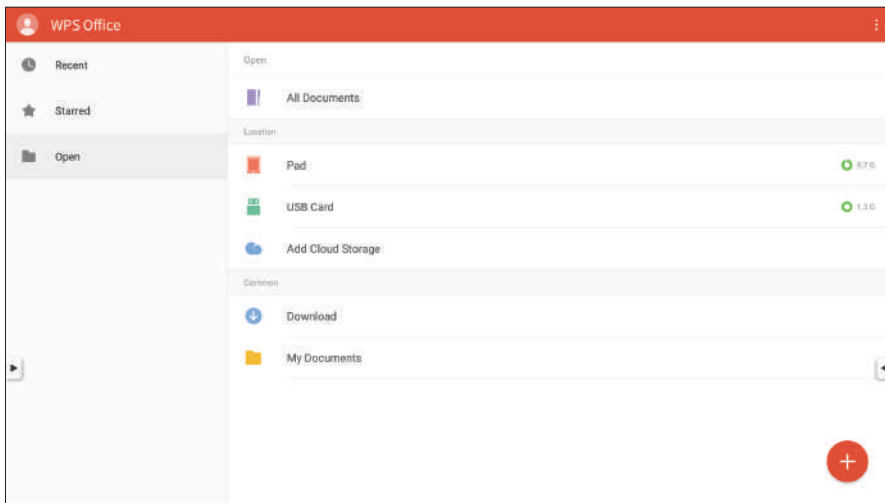

Folders

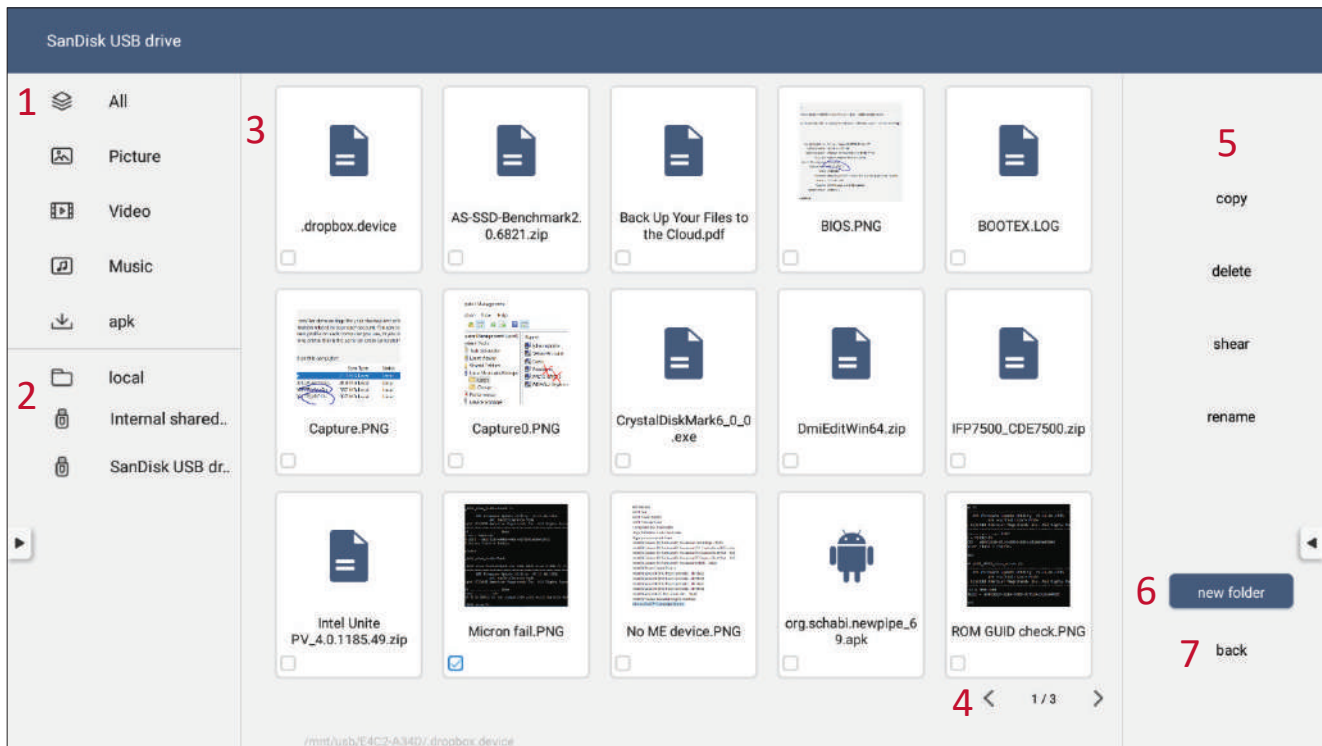

1. File Type Filter

2. Storage Location

3. File Browser

4. Next Page

5. Long press on a file or folder to: copy, delete, cut, or rename it.

6. Add a new folder

7. Exit the file manager.

> RS-232 Protocol

This document describes the hardware interface spec and software protocols of RS-232 interface communication between ViewSonic LFD and PC or other control units with RS-232 protocol.

The protocol contains three command sections:

- Set-Function
- Get-Function
- Remote control pass-through mode

NOTE: Below, “PC” represents all the control units that can send or receive the RS-232 protocol command.

Description

RS-232 Hardware Specification

ViewSonic LFD communication port on the rear side:

1. Connector type: DSUB 9-Pin Male (or 3.5 mm barrel connector)
2. Use of crossover (null modem) cable for connection
3. Pin Assignment:

Female DSUB 9-Pin

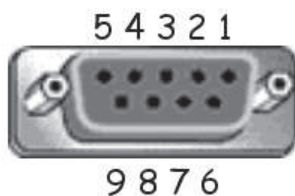

Male DSUB 9-Pin

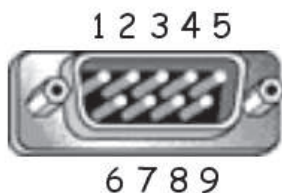

3.5 mm barrel connector (alternative for limited space)



Pin #	Signal	Remark
1	NC	
2	RXD	Input to Display
3	TXD	Output from Display
4	NC	
5	GND	
6	NC	
7	NC	
8	NC	
9	NC	Provide +5V/2A power for external specific dongle *3.0
frame	GND	

Item	Signal	Remark
Tip	TXD	Output from Display
Ring	RXD	Input to Display
Sleeve	GND	

LAN Hardware Specification

ViewSonic LFD communication port on the rear side:

1. Connector type: 8P8C RJ45
2. Pin Assignment:

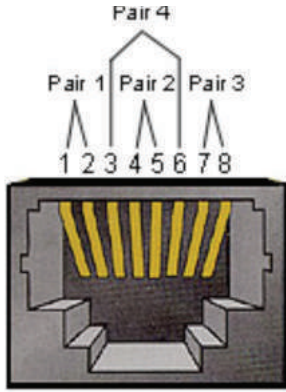

Pin #	Signal	Remark
1	TX+	Output from Display
2	TX-	Output from Display
3	RX+	Input to Display
4	BI_D3+	For 1G case
5	BI_D3-	For 1G case
6	RX-	Input to Display
7	BI_D4+	For 1G case
8	BI_D4-	For 1G case
frame	GND	

RS-232 Communication Setting

- Baud Rate Select: 9600bps (fixed)
- Data bits: 8 bits (fixed)
- Parity: None (fixed)
- Stop Bits: 1(fixed)

LAN Communication Setting

- Type: Ethernet
- Protocol: TCP/IP
- Port: 5000 (fixed)
- Cross subnet: No
- Logon Credentials: No

Command Message Reference

PC sends to LFD command packet followed by “CR”. Every time PC sends control command to Display, the Display shall respond as follows:

1. If the message is received correctly it will send “+” (02Bh) followed by “CR” (00Dh)
2. If the message is received incorrectly it will send “-” (02Dh) followed by “CR” (00Dh)

Protocol

Set-Function Listing

The PC can control the Display for specific actions. The Set-Function command allows you to control the Display behavior at a remote site through the RS-232 port. The Set-Function packet format consists of 9 bytes.

Set-Function Description:

- Length:** Total Byte of Message excluding "CR"
- LFD ID** Identification for each of Display (01~98; default is 01)
ID "99" means to apply the set command for all connected displays. Under such circumstances, only ID#1 display has to reply.
The LFD ID can be set via the OSD menu for each Display.
- Command Type** Identify command type,
"s" (0x73h): Set Command
"+" (0x2Bh): Valid command Reply
"- " (0x2Dh): Invalid command Reply
- Command:** Function command code: One byte ASCII code.
- Value[1~3]:** Three bytes ASCII that defines the value.
- CR** 0x0D

Set-Function Format

Send: (Command Type="s")

Name	Length	ID	Command Type	Command	Value1	Value2	Value3	CR
Byte Count	1 Byte	2 Byte	1 Byte	1 Byte	1 Byte	1 Byte	1 Byte	1 Byte
Bytes order	1	2~3	4	5	6	7	8	9

Reply: (Command Type="+" or "-")

Name	Length	ID	Command Type	CR
Byte Count	1 Byte	2 Byte	1 Byte	1 Byte
Bytes order	1	2~3	4	5

NOTE: When PC applies command to all displays (ID=99), only the #1 set needs to reply by the name of ID=1.

Example 1: Set Brightness as 76 for Display (#02) and this command is valid

Send (Hex Format)

Name	Length	ID	Command Type	Command	Value1	Value2	Value3	CR
Hex	0x38	0x30 0x32	0x73	0x24	0x30	0x37	0x36	0x0D

Reply (Hex Format)

Name	Length	ID	Command Type	CR
Hex	0x34	0x30 0x32	0x2B	0x0D

Example 2: Set Brightness as 75 for Display (#02) and this command is NOT valid

Send (Hex Format)

Name	Length	ID	Command Type	Command	Value1	Value2	Value3	CR
Hex	0x38	0x30 0x32	0x73	0x24	0x30	0x37	0x35	0x0D

Reply (Hex Format)

Name	Length	ID	Command Type	CR
Hex	0x34	0x30 0x32	0x2D	0x0D

Set-Function Table

A. Basic Function

Set Function	Length	ID	Command	Command		Value Range (Three ASCII bytes)	Comments
			Type (ASCII)	Code (ASCII)	Code (Hex)		
Power on/ off (standby)	8		s	!	21	000: STBY 001: ON	1. The Power-on via LAN control may work only under specific mode. To see display UG for details. *3.1.1 2. "WOL by MAC address" may available as alternative.*3.2.1
Input Select	8		s	"	22	000: TV 001: AV 002: S-Video 003: YPbPr 004: HDMI1 014: HDMI2 024: HDMI3 034: HDMI4 005: DVI 006: VGA1 016: VGA2 026: VGA3 007: Slot-in PC (OPS/SDM)/HDBT 008: Internal memory 009: DP 00A: Embedded/ Main (Android)	1. No need for USB 2. For the case of two more same sources, the 2nd digital is used to indicate the extension. 3. The HEX of 00A is 30 30 41.
Brightness	8		s	\$	24	000 ~ 100 900: Bright down (-1) 901: Bright up (+1) *3.1.1	
Backlight*3.2.0	8		A	B	42	000 ~ 100	1. For Android platform whose main mode is controlled by backlight and the other sources are controlled by brightness. 2. Derived from Color calibration. *3.2.0
Power lock	8		s	4	34	000: Unlock 001: Lock	*See note in details
Volume	8		s	5	35	000 ~ 100 900: Volume down(-1) 901:Volume up(+1)	
Mute	8		s	6	36	000: OFF 001: ON (mute)	

Button lock	8		s	8	38	000: Unlock 001: Lock	*See note in details
Menu lock	8		s	>	3E	000: Unlock 001: Lock	*See note in details
Number *3.1.1	8		s	@	40	000~009	
Key Pad *3.1.1	8		s	A	41	000: UP 001: DOWN 002: LEFT 003: RIGHT 004: ENTER 005: INPUT 006: MENU/(EXIT) 007: EXIT	
Remote Control	8		s	B	42	000: Disable 001: Enable 002: Pass through	Disable: RCU will be no function Enabled: RCU controls normally Pass through: Display will bypass the RC code to connected device via the RS-232 port, but not react itself.
Restore default	8		s	~	7E	000	Recover to factory setting

NOTE:

1. Behavior at Lock Modes

Lock Mode	Behavior
Button Lock	<ol style="list-style-type: none"> Lock all buttons on the front panel and RCU, except for "Power" All the SET functions should be workable via RS-232, even the ones with according hot key in RCU like Mute,...etc.
MENU Lock	<ol style="list-style-type: none"> Lock "MENU" key of front panel and RCU The Factory and Hospitality modes should not be blocked for the model using MENU-combined key to enter these two modes. Alternative approach will be indicated separately if any limitation by model.
POWER Lock	<ol style="list-style-type: none"> Lock "POWER" key on the front and RCU. The SET_POWER on/off should be workable via RS-232, but does not mean the POWER lock will be released under this case. Can not be unlocked by reset in OSD setting Will auto AC power-on in power-lock Under power-lock, the set will not enter power saving when no PC signal and neither not turn off when no other video signals after 15 minutes.
Remote control disable	Lock the RCU keys, but keep the front panel buttons workable.

2. Wake-on-LAN by MAC address as alternative for SET Power on

(Length=126 Bytes)

6 Bytes	6 Bytes (#1)	6 Bytes (#2)	...	6 Bytes (#16)	24 Bytes
0xFF FF ... FF	MAC address	MAC address	...	MAC address	0x00 00 ... 00

Get-Function Listing

The PC can interrogate the LFD for specific information. The Get-Function packet format consists of 9 bytes which is similar to the Set-Function packet structure. Note that the “Value” byte is always = 000.

Get-Function Description:

- Length:** Total Byte of Message excluding “CR”.
- TV/DS ID** Identification for each of TV/DS (01~98; default is 01).
- Command Type** Identify command type,
 “g” (0x67h) : Get Command
 “r” (0x72h) : Valid command Reply
 “-” (0x2Dh) : Invalid command Reply
- Command:** Function command code: One byte ASCII code.
- Value[1~3]:** Three bytes ASCII that defines the value.
- CR** 0x0D

Get-Function Format

Send: (Command Type=“g”)

Name	Length	ID	Command Type	Command	Value1	Value2	Value3	CR
Byte Count	1 Byte	2 Byte	1 Byte	1 Byte	1 Byte	1 Byte	1 Byte	1 Byte
Bytes order	1	2~3	4	5	6	7	8	9

Reply: (Command Type=“r” or “-”)

If the Command is valid, Command Type = “r”

Name	Length	ID	Command Type	Command	Value1	Value2	Value3	CR
Byte Count	1 Byte	2 Byte	1 Byte	1 Byte	1 Byte	1 Byte	1 Byte	1 Byte
Bytes order	1	2~3	4	5	6	7	8	9

If the Command is NOT valid, Command Type = “-”

Name	Length	ID	Command Type	CR
Byte Count	1 Byte	2 Byte	1 Byte	1 Byte
Bytes order	1	2~3	4	5

Example 1: Get Brightness from TV-05 and this command is valid. The Brightness value is 67.

Send (Hex Format)

Name	Length	ID	Command Type	Command	Value1	Value2	Value3	CR
Hex	0x38	0x30 0x35	0x67	0x62	0x30	0x30	0x30	0x0D

Reply (Hex Format)

Name	Length	ID	Command Type	Command	Value1	Value2	Value3	CR
Hex	0x38	0x30 0x35	0x72	0x62	0x30	0x36	0x37	0x0D

Example 2: Get Color from Display (#05), but the Color command is not supported by this model.

Send (Hex Format)

Name	Length	ID	Command Type	Command	Value1	Value2	Value3	CR
Hex	0x38	0x30 0x35	0x67	0x26	0x30	0x30	0x30	0x0D

Reply (Hex Format)

Name	Length	ID	Command Type	CR
Hex	0x34	0x30 0x35	0x2D	0x0D

Get-Function Table

A. Basic Function

Get Function	Length	ID	Command	Command		Response Range (Three ASCII bytes)	Comments
			Type (ASCII)	Code (ASCII)	Code (Hex)		
Get-Brightness	8		g	b	62	000 ~ 100	
Get-Backlight*3.2.0	8		a	B	42	000 ~ 100	1. For Android platform whose main mode is controlled by backlight and the other sources are controlled by brightness. 2. Derived from Color calibration. *3.2.0
Get-Volume	8		g	f	66	000 ~ 100	
Get-Mute	8		g	g	67	000: Off 001: On (muted)	
Get-Input select	8		g	j	6A	000~ 100~	1. 1st digit for signal detection: 0 means "no signal"; 1 means "signal detected" 2. 2nd & 3rd digit: See Set-function table
Get-Power status: ON/ STBY	8		g	l	6C	001: ON 000: STBY	
Get-Remote control	S		g	n	6E	000: Disable 001: Enable 002: Pass through	Get RCU mode status
Get-Power lock	8		g	o	6F	000: Unlock 001: Lock	
Get-Button lock	8		g	p	70	000: Unlock 001: Lock	
Get-Menu lock	8		g	l	6C	000: Unlock 001: Lock	
Get-ACK	8		g	z	7A	000	This command is used to test the communication link
Get-Thermal	8		g	0	30	000~100: 0~+100 deg C -01~-99: -1~-99 deg C	
Get-Operation time*3.2.0	8		g	1	31	000	1. Accumulated hours in 6-digit integer (000,001~999,999)*3.2.0 2. Can not be reset when FW update and Factory initiation*3.2.2 3. Reply in new 32-byte format*3.2.0
Get-Device name	8		g	4	34	000	Reply in new 32-byte format *3.2.0

Get-MAC address	8		g	5	35	000	(for the model with LAN) Reply in new 32-byte format*3.2.0
Get-IP address *3.2.0	8		g	6	36	000	(for the model with LAN) Reply in new 32-byte format*3.2.0
Get-Serial number *3.2.0	8		g	7	37	000	Reply in new 32-byte format *3.2.0
Get-FW version *3.2.0	8		g	8	38	000	Reply in new 32-byte format *3.2.0

NOTE:

1. Get Operation Hour example

Assumed the accumulated operation hour is 123,456 hrs

Send: 0x 38 30 31 67 31 30 30 30 0D (Get Operation hour)

Reply: 0x 32 30 31 72 31 31 32 33 34 35 36 00 00 ... 00 00 0D

2. Get Device Name example

Assumed the device name is CDE-5500

Send: 0x 38 30 31 67 34 30 30 30 0D (Get Device Name)

Reply: 0x 32 30 31 72 34 43 44 45 2D 35 35 30 30 00 00 ... 00 00 0D

Assumed the device name is "NMP-302#1"

Send: 0x 38 30 31 67 34 30 30 30 0D (Get Device Name)

Reply: 0x 32 30 31 72 34 4E 4D 50 2D 33 30 32 23 31 00 00 ...00 00 0D

3. Get MAC address example

Assumed the MAC address is 00:11:22:aa:bb:cc

Send: 0x 38 30 31 67 35 30 30 30 0D (Get MAC add)

Reply: 0x 32 30 31 72 35 30 30 31 31 32 32 61 61 62 62 63 63 00 00...00 00 0D

4. Get IP address example

Assumed the IP address is 192.168.100.2

Send: 0x 38 30 31 67 36 30 30 30 0D (Get IP address)

Reply: 0x 32 30 31 72 36 31 39 32 2E 31 36 38 2E 31 30 30 2E 32 00 00...00 00 0D

5. Get Serial number example

Assumed the Serial number is ABC180212345

Send: 0x 38 30 31 67 37 30 30 30 0D (Get Serial number)

Reply: 0x 32 30 31 72 37 41 42 43 31 38 30 32 31 32 33 34 35 00 00...00 00 0D

6. Get FW version example

Assumed the FW version is 3.02.001

Send: 0x 38 30 31 67 38 30 30 30 0D (Get FW version)

Reply: 0x 32 30 31 72 38 33 2E 30 32 2E 30 30 31 00 00...00 00 0D

Remote Control Pass-through Mode

When the PC sets the Display to Remote Control Pass through mode, the Display shall send a 7-byte packet (followed by “CR”) in response to remote control unit (RCU) button activation. In this mode the remote control shall have no effect on the Display function. For example: “Volume+” will not change the volume of the Display, but instead only sends the “Volume+” code to the PC over the RS-232 port.

IR Pass Through-Function format

Reply: (Command Type=“p”)

Name	Length	ID	Command Type	RCU Code1 (MSB)	RCU Code2 (LSB)	CR
Byte Count	1 Byte	2 Byte	1 Byte	1 Byte	1 Byte	1 Byte
Bytes order	1	2~3	4	5	6	7

Example 1: Remote Control Pass-through when “VOL+” key is pressed for Display (#5)

Send (Hex Format)

Name	Length	ID	Command Type	RCU Code1 (MSB)	RCU Code2 (LSB)	CR
Hex	0x36	0x30 0x35	0x70	0x31	0x30	0x0D

Key	Code (HEX)	Basic *3.1.1	Optional *3.1.1
1	01	V	
2	02	V	
3	03	V	
4	04	V	
5	05	V	
6	06	V	
7	07	V	
8	08	V	
9	09	V	
0	0A	V	
-	0B		V
RECALL (LAST)	0C		V
INFO (DISPLAY)	0D		V
	0E		
ASPECT (ZOOM, SIZE)	0F		V
VOLUME UP (+)	10	V	

VOLUME DOWN (-)	11	V	
MUTE	12	V	
CHANNEL/PAGE UP (+)/ BRIGHTNESS+	13		V
CHANNEL/PAGE DOWN (-)/ BRIGHTNESS-	14		V
POWER	15	V	
SOURCES (INPUTS)	16	V	
	17		
	18		
SLEEP	19		V
MENU	1A	V	
UP	1B	V	
DOWN	1C	V	
LEFT (-)	1D	V	
RIGHT (+)	1E	V	
OK (ENTER, SET)	1F	V	
EXIT	20	V	
	21		
	22		
	23		
	24		
	25		
	26		
	27		
	28		
	29		
	2A		
	2B		
RED ■ (F1)	2C		
GREEN ■ (F2)	2D		

NOTE:

1. This IR-pass-through code is different from the RCU key code.
2. Special control sequence for POWER key under IR-pass through mode.
 - 2-1. When Display is OFF and receives the IR POWER code: Display will turn itself on, then forward the POWER code to the host via RS-232.
 - 2-2. When Display is ON and receives the IR POWER code: Display will forward the POWER code to the host via RS-232, then turn off itself.

- 2-3. When SET-POWER LOCK is enabled, the Display will not respond to POWER key pressing.
3. The VOLUME UP and VOLUME DOWN code will repeatedly output when you press and hold the keys.

> Appendix

Specifications

Item	Category	Specifications	
Model		IFP6530	IFP7530
Screen Size		64.5"	74.5"
Input Signal		1 x VGA 3 x HDMI 2.0 (4K@60Hz) 1 x DisplayPort 1.2 1 x PC audio 1 x RJ45	
Output Signal		1 x HDMI 2.0 (1920 x 1080/3840 x 2160) 1 x Earphone Out 1 x SPDIF	
Speaker Output		16W x 2	
RS-232		RS-232 Communication	
Power	Voltage	100V-240V AC 50/60Hz	
Operating Conditions	Temperature	32° F to 104° F (0° C to 40° C)	
	Humidity	20%~80% non-condensing	
	Altitude	≤ 2,000 m	
Storage Conditions	Temperature	-4° F to 140° F (-20° C to 60° C)	
	Humidity	10%~90% non-condensing	
	Altitude	≤ 2,000 m	
Dimensions	Physical (mm)	1523.5 x 919.24 x 96.2	1753.1 x 1052.3 x 102.8
Weight	Physical (kg)	44.2	61.25
Power Consumption	On	129W	115W
	Off	<0.5W	<0.5W

NOTE: Product specifications are subject to change without notice.

Display Modes

VGA Mode

Resolution	Refresh Rate (@)
800 x 600	56Hz, 60Hz, 75Hz
1024 x 768	60Hz
1152 x 864	75Hz
1280 x 768	60Hz, 75Hz
1280 x 960	60Hz
1280 x 1024	60Hz, 75Hz
1360 x 768	60Hz
1366 x 768	60Hz
1440 x 900	60Hz
1600 x 1200	60Hz
1680 x 1050	60Hz
1920 x 1080	60Hz
1920 x 1200	60Hz

HDMI/OPS Mode

Resolution	Refresh Rate (@)
640 x 480	60Hz
800 x 600	60Hz
1024 x 768	60Hz
1280 x 720	60Hz
1280 x 960	60Hz
1280 x 1024	60Hz
1360 x 768	60Hz
1440 x 900	60Hz
1680 x 1050	60Hz
1920 x 1080	60Hz
3840 x 2160	30Hz, 60Hz
480i	60Hz
480p	60Hz
576i	50Hz
720p	50Hz, 60Hz
1080i	50Hz, 60Hz
1080p	50Hz, 60Hz

DisplayPort (DP) Mode

Resolution	Refresh Rate (@)
640 x 480	60Hz
720 x 480	60Hz
800 x 600	60Hz
1024 x 768	60Hz, 70Hz, 75Hz
1280 x 800	60Hz
1360 x 768	60Hz
1440 x 900	60Hz
1680 x 1050	60Hz
1920 x 1080	60Hz
3840 x 2160	30Hz, 60Hz

Troubleshooting

This section describes some common problems that you may experience when using the ViewBoard.

Problem or Issue	Possible Solutions
Remote Control is not working	<ol style="list-style-type: none">1. Check whether something is obstructing the display's remote control receiver.2. Check whether the batteries in the remote control are installed correctly.3. Check whether the batteries need to be replaced.
The unit turns off unexpectedly	<ol style="list-style-type: none">1. Check whether Sleep mode is enabled.2. Check if there is a power outage in your area.3. Turn on the display and see if the problem is with the signal and control system.

PC Mode

Problem or Issue	Possible Solutions
No PC signal	<ol style="list-style-type: none">1. Check the display settings.2. Check the display resolution.3. Adjust the Hs & Vs (synchronization) settings using the OSD menu.
Background streaking	<ol style="list-style-type: none">1. Choose auto adjust.2. Adjust clock and phase.
False color	<ol style="list-style-type: none">1. Check the VGA connection.2. Adjust the chroma, brightness, and contrast settings.
Unsupported format	<ol style="list-style-type: none">1. Choose auto adjust.2. Adjust clock and phase settings.

Touch Function

Problem or Issue	Possible Solutions
Touch function does not work	<ol style="list-style-type: none">1. Check that drivers are installed correctly.2. Reinstall driver(s).3. Check setup and align it.4. Check whether the touch pen is working properly.

Video Not Working Properly

Problem or Issue	Possible Solutions
No picture/ No sound	<ol style="list-style-type: none">1. Check the Power status.2. Check the signal cable.3. Check that the internal PC is installed correctly.
Picture is unclear or cuts in and out	<ol style="list-style-type: none">1. Check the signal cable.2. Check if other electronics are interrupting the signal.
Poor picture	<ol style="list-style-type: none">1. Adjust chroma, brightness, and contrast settings in the menu.2. Check the signal cable.

Audio Not Working Properly

Problem or Issue	Possible Solutions
No sound	<ol style="list-style-type: none">1. Press the Mute/Unmute button.2. Adjust the volume.3. Check the audio cable.
One speaker only	<ol style="list-style-type: none">1. Adjust the sound balance in the menu.2. Check the sound control panel settings of the computer.3. Check the audio cable.

Maintenance

General Precautions

- Make sure the device is turned off and the power cable is unplugged from the power outlet.
- Never spray or pour any liquid directly onto the screen or case.
- Handle the device with care, as a darker-colored device, if scuffed, may show marks more clearly than a lighter-colored device.
- Do not use the system continuously for long periods of time.

Cleaning the Screen

- Wipe the screen with a clean, soft, lint-free cloth. This removes dust and other particles.
- If the screen is still not clean, apply a small amount of non-ammonia, non-alcohol based glass cleaner onto a clean, soft, lint-free cloth; then wipe the screen.

Cleaning the Case

- Use a soft, dry cloth.
- If the case is still not clean, apply a small amount of non-ammonia, non-alcohol based, mild non-abrasive detergent onto a clean, soft, lint-free cloth, then wipe the surface.

Disclaimer

- ViewSonic® does not recommend the use of any ammonia or alcohol-based cleaners on the display screen or case. Some chemical cleaners have been reported to damage the screen and/or case of the device.
- ViewSonic® will not be liable for damage resulting from use of any ammonia or alcohol-based cleaners.

NOTE: If condensation appears between the glass and the panel, keep the display turned on until the moisture disappears.

> Regulatory and Service Information

Compliance Information

This section addresses all connected requirements and statements regarding regulations. Confirmed corresponding applications shall refer to nameplate labels and relevant markings on the unit.

CE Conformity for European Countries

CE The device complies with the EMC Directive 2014/30/EU and Low Voltage Directive 2014/35/EU.

The following information is only for EU-member states:

The mark shown to the right is in compliance with the Waste Electrical and Electronic Equipment Directive 2012/19/EU (WEEE). The mark indicates the requirement NOT to dispose of the equipment as unsorted municipal waste, but use the return and collection systems according to local law.



Declaration of RoHS2 Compliance

This product has been designed and manufactured in compliance with Directive 2011/65/EU of the European Parliament and the Council on restriction of the use of certain hazardous substances in electrical and electronic equipment (RoHS2 Directive) and is deemed to comply with the maximum concentration values issued by the European Technical Adaptation Committee (TAC) as shown below:

Substance	Proposed Maximum Concentration	Actual Concentration
Lead (Pb)	0.1%	< 0.1%
Mercury (Hg)	0.1%	< 0.1%
Cadmium (Cd)	0.01%	< 0.01%
Hexavalent Chromium (Cr6 ⁺)	0.1%	< 0.1%
Polybrominated biphenyls (PBB)	0.1%	< 0.1%
Polybrominated diphenyl ethers (PBDE)	0.1%	< 0.1%
Bis (2-ethylhexyl) phthalate (DEHP)	0.1%	< 0.1%
Butyl benzyl phthalate (BBP)	0.1%	< 0.1%
Dibutyl phthalate (DBP)	0.1%	< 0.1%
Diisobutyl phthalate (DIBP)	0.1%	< 0.1%

Certain components of products as stated above are exempted under the Annex III of the RoHS2 Directives as noted below:

- Copper alloy containing up to 4% lead by weight.
- Lead in high melting temperature type solders (i.e. lead-based alloys containing 85% by weight or more lead).
- Electrical and electronic components containing lead in a glass or ceramic other than dielectric ceramic in capacitors, e.g. piezoelectronic devices, or in a glass or ceramic matrix compound.
- Lead in dielectric ceramic in capacitors for a rated voltage of 125V AC or 250V DC or higher.

ENERGY STAR® statement

ENERGY STAR® is a U.S. Environmental Protection Agency voluntary program that helps businesses and individuals save money and protect our climate through superior energy efficiency. Products that earn the ENERGY STAR® prevent greenhouse gas emissions by meeting strict energy efficiency criteria or requirements set by the U.S. Environmental Protection Agency.

As an ENERGY STAR® Partner, ViewSonic is determined to meet the ENERGY STAR® Guidelines and mark all certified models with the ENERGY STAR® logo.

The following logo appears on all ENERGY STAR®-certified models:



NOTE: The power management features significantly reduce energy consumption when the product is not in use. Power management allows the device to automatically enter a low power “sleep” mode after a defined period of inactivity. And the power management features also enter Sleep Mode or Off Mode within 5 minutes of being disconnected from a host computer. Please note any change in energy settings will increase energy consumption.

Indian Restriction of Hazardous Substances

Restriction on Hazardous Substances statement (India). This product complies with the “India E-waste Rule 2011” and prohibits use of lead, mercury, hexavalent chromium, polybrominated biphenyls or polybrominated diphenyl ethers in concentrations exceeding 0.1 weight % and 0.01 weight % for cadmium, except for the exemptions set in Schedule 2 of the Rule.

Product Disposal at End of Product Life

ViewSonic® respects the environment and is committed to working and living green. Thank you for being part of Smarter, Greener Computing. Please visit the ViewSonic® website to learn more.

USA & Canada:

<http://www.viewsonic.com/company/green/recycle-program/>

Europe:

<http://www.viewsoniceurope.com/eu/support/call-desk/>

Taiwan:

<https://recycle.epa.gov.tw/>

Copyright Information

Copyright© ViewSonic® Corporation, 2019. All rights reserved.

Macintosh and Power Macintosh are registered trademarks of Apple Inc.

Microsoft, Windows, and the Windows logo are registered trademarks of Microsoft Corporation in the United States and other countries.

HDMI logo and High-Definition Multimedia Interface are trademarks of HDMI licensing LLC.

ViewSonic®, the three birds logo, OnView, ViewMatch, and ViewMeter are registered trademarks of ViewSonic® Corporation.

VESA is a registered trademark of the Video Electronics Standards Association. DPMS, DisplayPort, and DDC are trademarks of VESA.

Disclaimer: ViewSonic® Corporation shall not be liable for technical or editorial errors or omissions contained herein; nor for incidental or consequential damages resulting from furnishing this material, or the performance or use of this product.

In the interest of continuing product improvement, ViewSonic® Corporation reserves the right to change product specifications without notice. Information in this document may change without notice.

No part of this document may be copied, reproduced, or transmitted by any means, for any purpose without prior written permission from ViewSonic® Corporation.

Customer Service

For technical support or product service, see the table below or contact your reseller.

NOTE: You will need the product's serial number.

Country/ Region	Website	Country/ Region	Website
Asia Pacific & Africa			
Australia	www.viewsonic.com/au/	Bangladesh	www.viewsonic.com/bd/
中国 (China)	www.viewsonic.com.cn	香港 (繁體中文)	www.viewsonic.com/hk/
Hong Kong (English)	www.viewsonic.com/hk-en/	India	www.viewsonic.com/in/
Indonesia	www.viewsonic.com/id/	Israel	www.viewsonic.com/il/
日本 (Japan)	www.viewsonic.com/jp/	Korea	www.viewsonic.com/kr/
Malaysia	www.viewsonic.com/my/	Middle East	www.viewsonic.com/me/
Myanmar	www.viewsonic.com/mm/	Nepal	www.viewsonic.com/np/
New Zealand	www.viewsonic.com/nz/	Pakistan	www.viewsonic.com/pk/
Philippines	www.viewsonic.com/ph/	Singapore	www.viewsonic.com/sg/
臺灣 (Taiwan)	www.viewsonic.com/tw/	ประเทศไทย	www.viewsonic.com/th/
Việt Nam	www.viewsonic.com/vn/	South Africa & Mauritius	www.viewsonic.com/za/
Americas			
United States	www.viewsonic.com/us	Canada	www.viewsonic.com/us
Latin America	www.viewsonic.com/la		
Europe			
Europe	www.viewsonic.com/eu/	France	www.viewsonic.com/fr/
Deutschland	www.viewsonic.com/de/	Қазақстан	www.viewsonic.com/kz/
Россия	www.viewsonic.com/ru/	España	www.viewsonic.com/es/
Türkiye	www.viewsonic.com/tr/	Україна	www.viewsonic.com/ua/
United Kingdom	www.viewsonic.com/uk/		

Limited Warranty

ViewSonic® Smart White Board

What the warranty covers:

ViewSonic® warrants its products to be free from defects in material and workmanship during the warranty period. If a product proves to be defective in material or workmanship during the warranty period, ViewSonic® will, at its sole option, and as your sole remedy, repair or replace the product with a similar product. Replacement Product or parts may include remanufactured or refurbished parts or components. The repair or replacement unit or parts or components will be covered by the balance of the time remaining on the customer's original limited warranty and the warranty period will not be extended. ViewSonic® provides no warranty for any third-party software whether included with the product or installed by the customer, installation of any unauthorized hardware parts or components (e.g. Projector Lamps). (Please refer to: "What the warranty excludes and does not cover" section).

Who the warranty protects:

This warranty is valid only for the first consumer purchaser.

What the warranty excludes and does not cover:

- Any product on which the serial number has been defaced, modified, or removed.
- Damage, deterioration, or malfunction resulting from:
 - » Accident, misuse, neglect, fire, water, lightning, or other acts of nature, unauthorized product modification, or failure to follow instructions supplied with the product.
 - » Repair or attempted repair by anyone not authorized by ViewSonic®.
 - » Damage to or loss of any programs, data, or removable storage media.
 - » Normal wear and tear.
 - » Removal or installation of the product.
- Software or data loss occurring during repair or replacement.
- Any damage of the product due to shipment.
- Causes external to the product, such as electric power fluctuations or failure.
- Use of supplies or parts not meeting ViewSonic's specifications.
- Failure of owner to perform periodic product maintenance as stated in the User Guide.
- Any other cause which does not relate to a product defect.

- Damage caused by static (non-moving) images displayed for lengthy periods of time (also referred to as image burn-in).
- Software - Any third-party software included with the product or installed by the customer.
- Hardware/Accessories/Parts/Components – Installation of any unauthorized hardware, accessories, consumable parts or components (e.g. Projector Lamps).
- Damage to, or abuse of, the coating on the surface of the display through inappropriate cleaning as described in the product User Guide.
- Removal, installation, and set-up service charges, including wall-mounting of the product.

How to get service:

- For information about receiving service under warranty, contact ViewSonic® Customer Support (Please refer to the “Customer Service” page). You will need to provide your product’s serial number.
- To obtain warranty service, you will be required to provide: (a) the original dated sales slip, (b) your name, (c) your address, (d) a description of the problem, and (e) the serial number of the product.
- Take or ship the product, freight prepaid, in the original container to an authorized ViewSonic® service center or ViewSonic®.
- For additional information or the name of the nearest ViewSonic® service center, contact ViewSonic®.

Limitation of implied warranties:

There are no warranties, express or implied, which extend beyond the description contained herein including the implied warranty of merchantability and fitness for a particular purpose.

Exclusion of damages:

ViewSonic's liability is limited to the cost of repair or replacement of the product. ViewSonic® shall not be liable for:

- Damage to other property caused by any defects in the product, damages based upon inconvenience, loss of use of the product, loss of time, loss of profits, loss of business opportunity, loss of goodwill, interference with business relationships, or other commercial loss, even if advised of the possibility of such damages.
- Any other damages, whether incidental, consequential or otherwise.
- Any claim against the customer by any other party.
- Repair or attempted repair by anyone not authorized by ViewSonic®.

Effect of state law:

This warranty gives you specific legal rights, and you may also have other rights which vary from state to state. Some states do not allow limitations on implied warranties and/or do not allow the exclusion of incidental or consequential damages, so the above limitations and exclusions may not apply to you.

Sales outside the U.S.A. and Canada:

For warranty information and service on ViewSonic® products sold outside of the U.S.A. and Canada, contact ViewSonic® or your local ViewSonic® dealer.

The warranty period for this product in mainland China (Hong Kong, Macao, and Taiwan Excluded) is subject to the terms and conditions of the Maintenance Guarantee Card.

For users in Europe and Russia, full details of warranty provided can be found at: <http://www.viewsonic.com/eu/> under "Support/Warranty Information".

Mexico Limited Warranty

ViewSonic® Smart White Board

What the warranty covers:

ViewSonic® warrants its products to be free from defects in material and workmanship, under normal use, during the warranty period. If a product proves to be defective in material or workmanship during the warranty period, ViewSonic® will, at its sole option, repair or replace the product with a like product. Replacement product or parts may include remanufactured or refurbished parts or components & accessories.

Who the warranty protects:

This warranty is valid only for the first consumer purchaser.

What the warranty excludes and does not cover:

- Any product on which the serial number has been defaced, modified or removed.
- Damage, deterioration, or malfunction resulting from:
 - » Accident, misuse, neglect, fire, water, lightning, or other acts of nature, unauthorized product modification, unauthorized attempted repair, or failure to follow instructions supplied with the product.
 - » Causes external to the product, such as electrical power fluctuations or failure.
 - » Use of supplies or parts not meeting ViewSonic®'s specifications.
 - » Normal wear and tear.
 - » Any other cause which does not relate to a product defect.
- Any product exhibiting a condition commonly known as “image burn-in” which results when a static image is displayed on the product for an extended period of time.
- Removal, installation, insurance, and set-up service charges.

How to get service:

For information about receiving service under warranty, contact ViewSonic® Customer Support (Please refer to the attached “Customer Service” page). You will need to provide your product’s serial number, so please record the product information in the space provided below on your purchase for your future use. Please retain your receipt of proof of purchase to support your warranty claim.

For Your Records

Product Name: _____ Model Number: _____
Document Number: _____ Serial Number: _____
Purchase Date: _____ Extended Warranty Purchase? _____(Y/N)
If so, what date does warranty expire? _____

- To obtain warranty service, you will be required to provide (a) the original dated sales slip, (b) your name, (c) your address, (d) a description of the problem, and (e) the serial number of the product.
- Take or ship the product, in the original container packaging, to an authorized ViewSonic® service center.
- Round trip transportation costs for in-warranty products will be paid by ViewSonic®.

Limitation of implied warranties:

There are no warranties, express or implied, which extend beyond the description contained herein including the implied warranty of merchantability and fitness for a particular purpose.

Exclusion of damages:

ViewSonic®’s liability is limited to the cost of repair or replacement of the product. ViewSonic® shall not be liable for:

- Damage to other property caused by any defects in the product, damages based upon inconvenience, loss of use of the product, loss of time, loss of profits, loss of business opportunity, loss of goodwill, interference with business relationships, or other commercial loss, even if advised of the possibility of such damages.
- Any other damages, whether incidental, consequential or otherwise.
- Any claim against the customer by any other party.
- Repair or attempted repair by anyone not authorized by ViewSonic®.

Contact Information for Sales & Authorized Service (Centro Autorizado de Servicio) within Mexico:	
Name, address, of manufacturer and importers: México, Av. de la Palma #8 Piso 2 Despacho 203, Corporativo Interpalmas, Col. San Fernando Huixquilucan, Estado de México Tel: (55) 3605-1099 http://www.viewsonic.com/la/soporte/index.htm	
NÚMERO GRATIS DE ASISTENCIA TÉCNICA PARA TODO MÉXICO: 001.866.823.2004	
Hermosillo: Distribuciones y Servicios Computacionales SA de CV. Calle Juarez 284 local 2 Col. Bugambilias C.P: 83140 Tel: 01-66-22-14-9005 E-Mail: disc2@hmo.megared.net.mx	Villahermosa: Compumantenimientos Garantizados, S.A. de C.V. AV. GREGORIO MENDEZ #1504 COL, FLORIDA C.P. 86040 Tel: 01 (993) 3 52 00 47 / 3522074 / 3 52 20 09 E-Mail: compumantenimientos@prodigy.net.mx
Puebla, Pue. (Matriz): RENTA Y DATOS, S.A. DE C.V. Domicilio: 29 SUR 721 COL. LA PAZ 72160 PUEBLA, PUE. Tel: 01(52).222.891.55.77 CON 10 LINEAS E-Mail: datos@puebla.megared.net.mx	Veracruz, Ver.: CONEXION Y DESARROLLO, S.A DE C.V. Av. Americas # 419 ENTRE PINZÓN Y ALVARADO Fracc. Reforma C.P. 91919 Tel: 01-22-91-00-31-67 E-Mail: gacosta@qplus.com.mx
Chihuahua: Soluciones Globales en Computación C. Magisterio # 3321 Col. Magisterial Chihuahua, Chih. Tel: 4136954 E-Mail: Cefeo@soluglobales.com	Cuernavaca: Compusupport de Cuernavaca SA de CV Francisco Leyva # 178 Col. Miguel Hidalgo C.P. 62040, Cuernavaca Morelos Tel: 01 777 3180579 / 01 777 3124014 E-Mail: aquevedo@compusupportcva.com
Distrito Federal: QPLUS, S.A. de C.V. Av. Coyoacán 931 Col. Del Valle 03100, México, D.F. Tel: 01(52)55-50-00-27-35 E-Mail : gacosta@qplus.com.mx	Guadalajara, Jal.: SERVICRECE, S.A. de C.V. Av. Niños Héroes # 2281 Col. Arcos Sur, Sector Juárez 44170, Guadalajara, Jalisco Tel: 01(52)33-36-15-15-43 E-Mail: mmiranda@servicrece.com
Guerrero Acapulco: GS Computación (Grupo Sesicomp) Progreso #6-A, Colo Centro 39300 Acapulco, Guerrero Tel: 744-48-32627	Monterrey: Global Product Services Mar Caribe # 1987, Esquina con Golfo Pérsico Fracc. Bernardo Reyes, CP 64280 Monterrey N.L. México Tel: 8129-5103 E-Mail: aydeem@gps1.com.mx
MERIDA: ELECTROSER Av Reforma No. 403Gx39 y 41 Mérida, Yucatán, México CP97000 Tel: (52) 999-925-1916 E-Mail: rrrb@sureste.com	Oaxaca, Oax.: CENTRO DE DISTRIBUCION Y SERVICIO, S.A. de C.V. Murguía # 708 P.A., Col. Centro, 68000, Oaxaca Tel: 01(52)95-15-15-22-22 Fax: 01(52)95-15-13-67-00 E-Mail: gpotai2001@hotmail.com
Tijuana: STD Av Ferrocarril Sonora #3780 L-C Col 20 de Noviembr Tijuana, Mexico	FOR USA SUPPORT: ViewSonic® Corporation 381 Brea Canyon Road, Walnut, CA. 91789 USA Tel: 800-688-6688 E-Mail: http://www.viewsonic.com



ViewSonic®