

10-80 TONS

Reach Stackers for Your World



The environments, climate challenges, drivers' needs, lifting loads and heights of every lift truck driver are always different and special. By listening and observing carefully to learn about your world, it's possible to design and deliver the most ideal lift truck for your operation.

YOUR WORLD

"The toughest challenge in my job is to ensure a precise and safe handling of containers."

Arnold Bindemann
DCP Bremen, Germany



Built for your world

Here's a secret we know and understand: we all like to talk about ourselves, but the world that matters most to you is your world, not ours. We at Konecranes Lift Trucks listen to, learn from, design for, deliver to and support you to help you succeed in the unique world where you work.

Quality in every aspect

Excellence is a cornerstone of the Konecranes product design process and a hallmark of the Konecranes brand.

Excellence shows in our heavy-duty durability, modern cabin and all the little things that makes up the efficient, high-quality lift trucks that we proudly produce every day.

Continuous improvement

Our mission is to build and customize the hardest-working, longest-lasting, heavy-duty lift trucks for our customers' worlds. This has been our way ever since we made our very first lift truck in 1959 for a very special customer, and our customers still provide the most important input for the continuous improvement of our lift trucks.

Every lift truck goes through rigorous tests before delivery to check that your equipment always meets the highest possible product standards.

This publication is for general informational purposes only. Konecranes reserves the right at any time, without notice, to alter or discontinue the products and/or specifications referenced herein. This publication creates no warranty on the part of Konecranes, express or implied, including but not limited to any implied warranty or merchantability or fitness for a particular purpose.



Safety-first culture

We think that the pursuit of safety never stops. It's not about built-in safety features alone – it's about preventive maintenance, training and building a safety-first working culture. Konecranes is often the first to introduce new technology that improves safety.

Safety is in everything we do, all the way from R&D to all the customization possibilities and technological innovations we offer. Depending on your particular operations, we can meet your specific needs with a wide variety of preventive solutions to maximize the safety of your personnel.

Technology for safe operations

Our overload detection system helps prevent accidents by sending data on the use of each of your reach stackers for checking and analysis.

At Konecranes, the TRUCONNECT® Remote Monitoring service receives that data and can send alert notifications of overloads and overrides to designated personnel at your own facility.

Container weighing detects dangerous overweight conditions with accurate weight measurement to meet all local requirements for maritime and port safety.

First in safety

When working with material handling and heavy loads, you want to minimize safety risks to help maintain the well-being of your employees. You can do this by implementing new and improved preventive safety measures.

YOUR WORLD

Innovations like Work Zone geofencing and Konecranes weight verification system are not important because they are cutting-edge, but because they make your work environment safer. They protect your drivers and ground staff.

Work Zone for safer operations

Developed by Konecranes, Work Zone is a suite of location-based services designed to improve the safety of lift truck operations, especially in busy, high-traffic environments.

Work Zone uses GPS technology to create geofencing – invisible fences around real-world areas. You can remotely control lift trucks and their height limitations, speed limits and other safety matters inside computer-defined areas – virtual fences. Drivers can see selected alerts on their operating display and you can also send the alerts by SMS or email to chosen recipients.





Customization

Every operation must meet different challenges. Lift trucks need to be able to function anywhere from the blazing deserts of the Sahara to the frozen wastes of the Arctic. With optimal performance and the right combination of features and attachments, Konecranes reach stackers can help you maximize your operational efficiency.

YOUR WORLD

Every industry has its own special requirements. Our reach stackers must be customizable to your particular business, so you don't have to change your operations every time you buy new equipment.

Everything is possible

Listening to our customers and meeting their needs has been our way from the very start. Not only do we want to help you to lift loads, but we also want to help lift our customers' businesses. So we listen, learn and develop our products based on customer experience.

You provide us with the details of your operational needs and goals, and we design a lift truck that takes your requirements into account. With each vehicle you order, we aim to exceed your expectations.

The strength, performance and reliability of every Konecranes lift truck are based on the heart of our technology: a strong box-type chassis, efficient load-sensing hydraulics and intelligent electronic machine control (EMC) that monitors the lift truck's vital components and functions. Our tight organization and a close dialogue between sales and engineering ensure that we can provide for your customization needs in the best way possible.

OUR SOME EXAMPLES CUSTOMIZED REACH STACKER SOLUTIONS

- SMV 4535 TCX6, equipped with 45-degree tilting spreader
- SMV 4537 TC5, equipped with magnet for steel handling
- SMV 4545 TCXBH, world's biggest barge handler

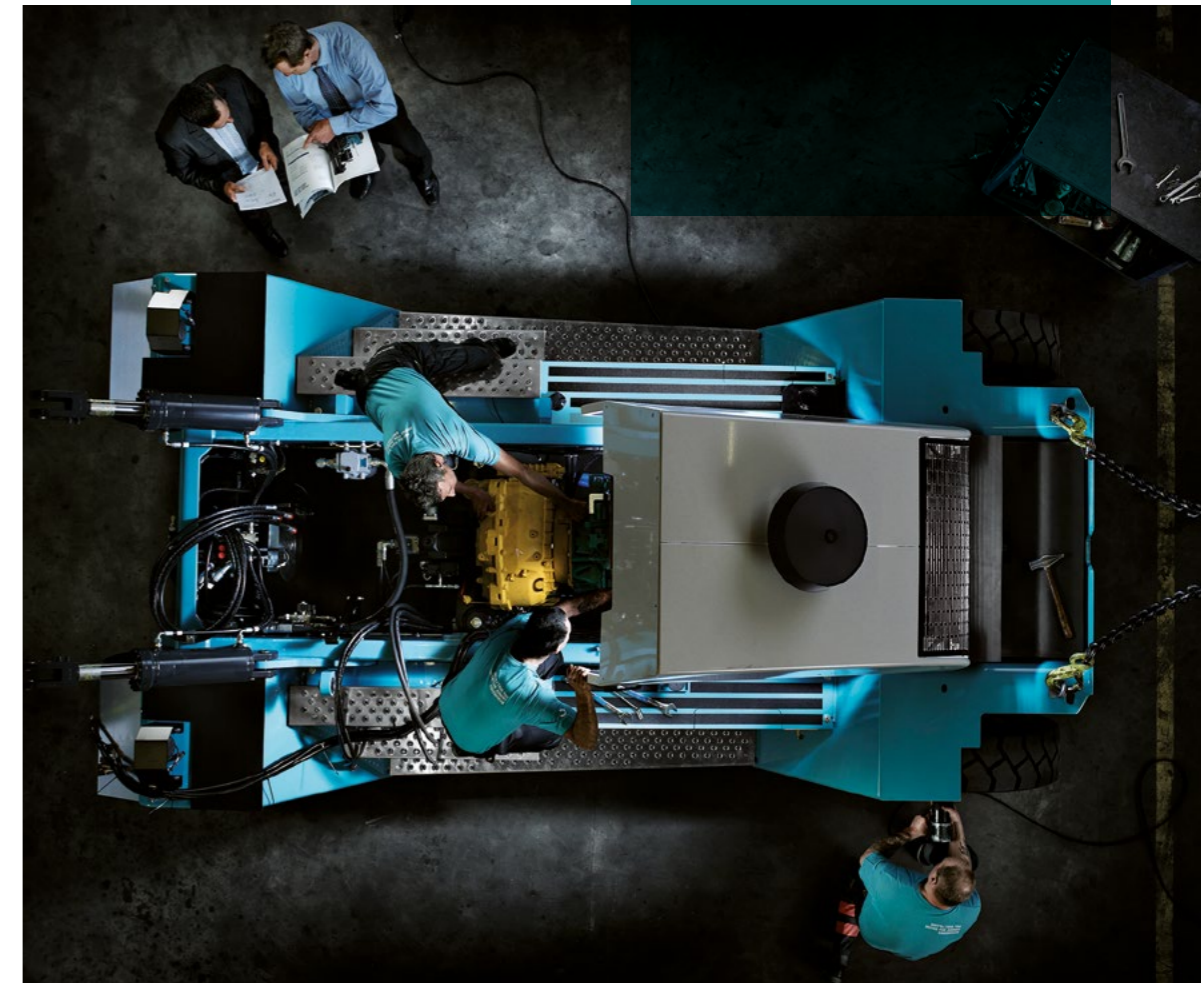

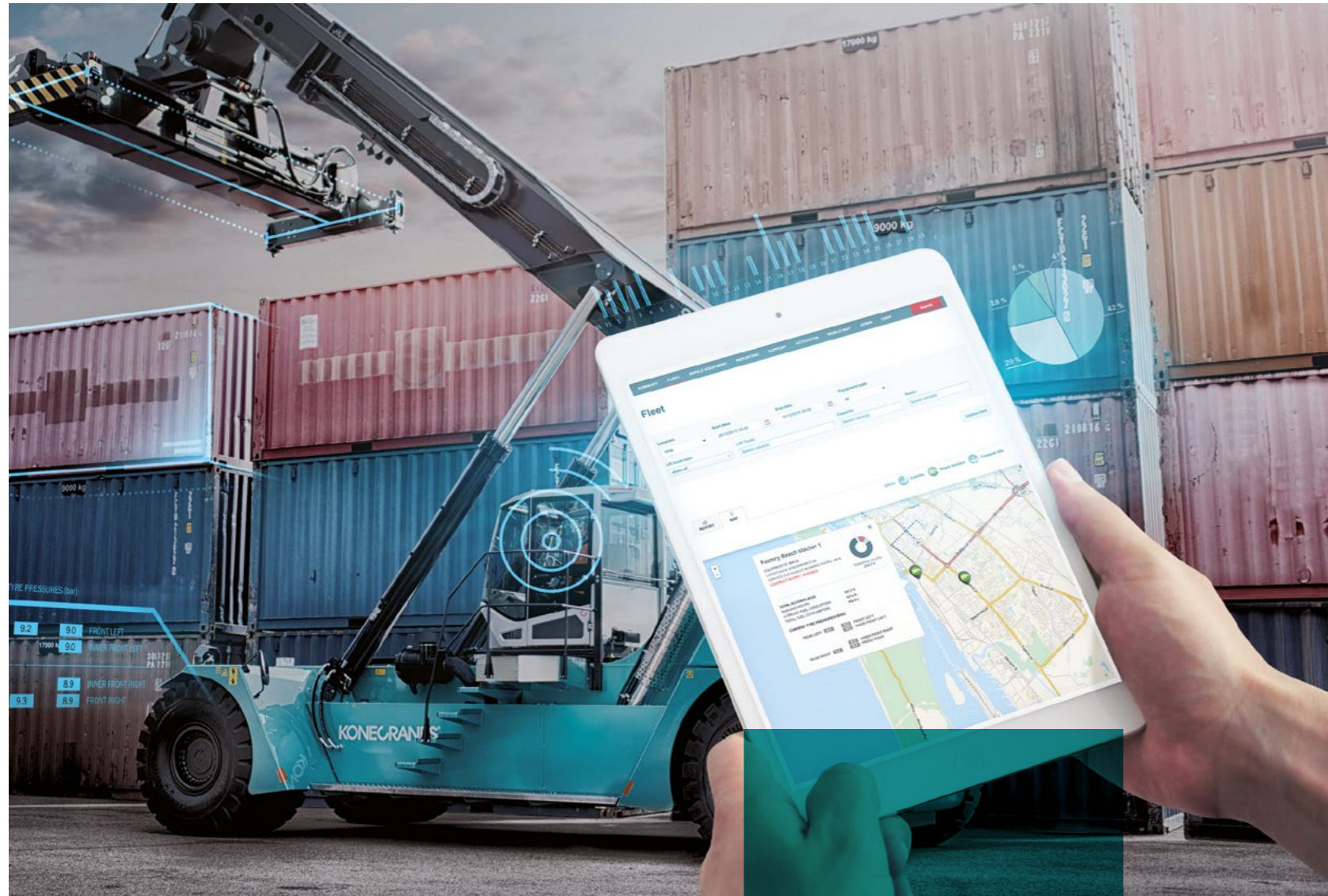

The lifetime advantage

Owning the perfect lift truck is not only about the machine itself. It's about maintaining high performance as the years go by, with services such as quality spare parts, preventive maintenance, support when you need it, or tailored training for in-house mechanics.

YOUR WORLD

"Even though our company is located in the far south of Thailand, we have no issues with technical support such as spare parts, on-site technicians and technical advice.

Konecranes and Sri Trang Logistics work together to ensure the highest uptime for our machines and our satisfaction."

**Apichart Parnitchkul
CEO, Sri Trang Logistics,
Thailand**

Smart Connected Lift Trucks

Konecranes Smart Connected Lift Trucks is a range of remote service applications that track the condition and usage of your lift trucks in real time, allowing you to use insights from this data to optimize the productivity of your operation. For example, you can better forecast and schedule maintenance, discover and improve weaknesses in safety and efficiency, or enhance driver performance by identifying training needs for more economical and ecological driving.

Listening to your lift truck

Is your maintenance at regular intervals, or do you plan it based on your actual needs? Do you order spare parts after a breakdown, or do you get them before they are needed? Do you know how your lift trucks are doing, or are you still guessing?

Knowledge is power, and when it comes to taking expert care of your lift truck, nothing beats knowing what will happen before it happens. So, what do your Smart Connected Lift Trucks want to tell you today?

Expert support when you need it

We have a unique service concept in the lift truck industry. It provides you with a seamless service experience, starting with the condition of the reach stacker, and producing all needed parts and work orders.

Being a global company, Konecranes is at the center of a huge network of service and distribution partners around the world. Our expert support helps you to maintain extended use cycles and give your equipment a longer lifetime. We also offer several related services, such as upgrades, safety and maintenance kits, e-learning platforms, recommended parts lists and more.

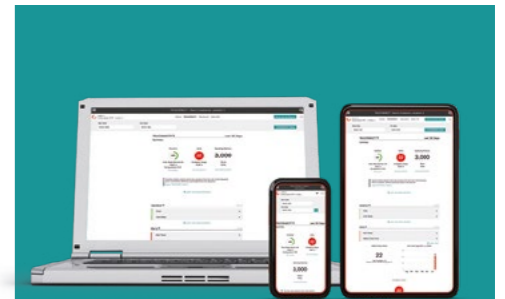

YOUR WORLD

"I can access the Konecranes web portal at any time to check on any machine in all of our branches. It is extremely valuable to have all that information at your fingertips."

**Atthapon Mebusaya
Sri Trang Logistics, Thailand**

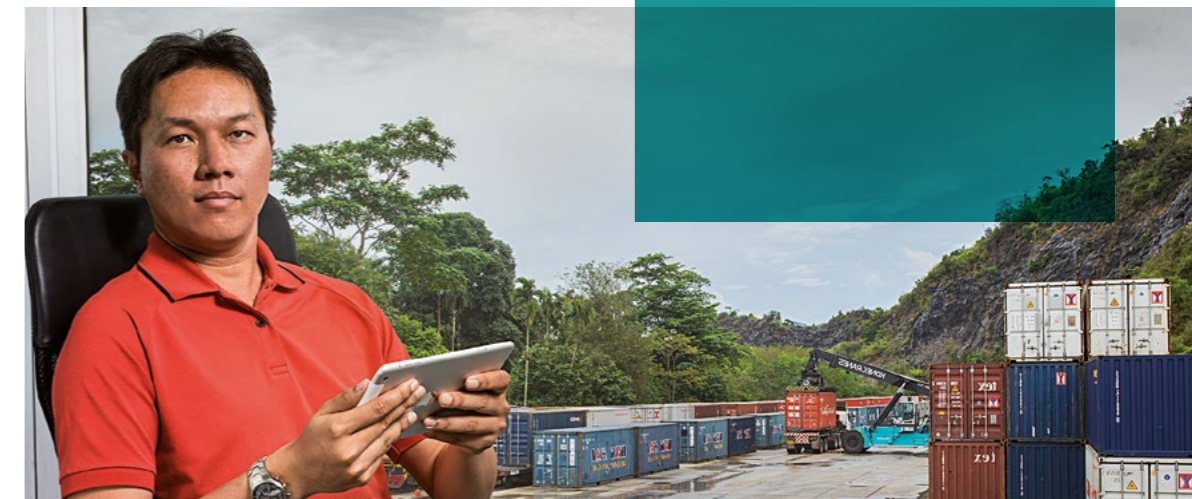



Powered by ECOLIFTING

Developing environmental solutions has been important to us for a very long time. In 2013, we released the world's first hybrid reach stacker, a vehicle that is fast becoming a leader in the next generation of sustainable lift trucks. We give you the opportunity simultaneously save money and help the environment by using less fossil fuels.

ECOLIFTING is a future-proof concept with new solutions continuously in development. In all of our products, true value lies in the small and intelligent details implemented with cutting-edge technology that make Konecranes Lift Trucks some of the world's most advanced lift trucks. Small things make a huge difference.

Go green with ECOLIFTING solutions

What's your goal in reducing emissions and fuel consumption? Pick the solution that fits your world to reduce environmental impact and your operational costs.

Indicative Emission Reductions

(tons of CO₂, accumulated)

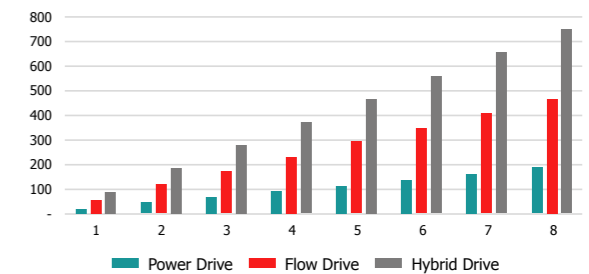

Eco-efficiency

To be able to make choices for a better tomorrow, you must find new ways to reduce costs without compromising performance. With the optimal combination of features and attachments, you can help protect the environment and still maximize your operational efficiency.

YOUR WORLD

Product advances like Powered by ECOLIFTING can make a big difference in operating costs without any decrease in performance. You don't have to choose between being "green" and being "great" – you can be both.



Power Drive

- reduce fuel consumption and emissions by up to 15%
- minimal capital investment and payback in less than a year
- same performance, less fuel consumption

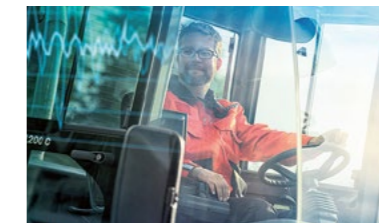

Flow Drive

- reduce fuel consumption and emissions by up to 25%
- enhance your drivers' experience, increase active operation time and improve your overall productivity



Hybrid Drive

- reduce fuel consumption and emissions by up to 40%
- world's first fully electric reach stacker
- higher productivity compared to non-hybrid reach stacker



Efficient operations with more savings and less emissions

Modern container handling terminal DIT offers a wide range of transport and storage services at Krupp Port in Duisburg, Germany. A Konecranes hybrid reach stacker has brought increased productivity and considerable cost savings to the company and has taken DIT closer to its goal of operations market leader in environmentally friendly cargo handling technology.

CUSTOMER STORY:

NAME:
DIT Duisburg Intermodal Terminal

INDUSTRY: Intermodal

COUNTRY: Germany

"We have reliable contacts in Konecranes sales and service. If we have any questions about optimization, we get direct answers from Konecranes staff."

Bernd Putens
Managing Director, DIT

Located at the intersection of major north, south and east-west cities, Duisburg Intermodal Terminal (DIT), with its international rail and barge services, fills a range of transportation needs. DIT stores 10,500 containers in a total working area of 200,000 m².

Challenge – reduce ecological footprint

The requirements for the business and technology of container handling are facing changes and improvements. At the same time, ecological and environmental issues are becoming more important for both customers and container handling companies alike. When DIT set a goal to provide green logistics for their customers and put more effort into corporate responsibility, they needed to find a reliable partner to support their ambition.

Solution – unique hybrid technology

Based on a long-standing partnership with Konecranes, DIT was sure that the introduction of the new, unique Konecranes Hybrid Drive technology for reach stackers would be beneficial.

"There were no better alternatives available than the hybrid reach stacker, and the service concept with insurance and backup solutions were customized precisely for our needs", says Bernd Putens, Managing Director, DIT.

Mr. Putens says that DIT was very satisfied with its involvement in the supply chain. "We have reliable contacts in Konecranes sales and service. If we have any questions about optimization, we get direct answers from Konecranes staff."

Results – save both money and environment

At Krupp Port, the hybrid reach stacker is used in load handling and container handling operations from the crane side. It runs on a three-shift system.

With its regenerative power feature, the hybrid reach stacker has cut down fuel consumption in everyday container handling and increased the productivity and cost-efficiency of DIT's operations. Due to electric motors and fewer complex mechanical components, maintenance has become faster and service costs have lowered significantly. With reduced noise levels and better lifting response, operator performance has improved. A significant decrease in carbon emissions is in line with the company's mission to provide sustainable transportation services. Maintaining the same level of performance, DIT will, according to their calculations, eliminate about 10% of emissions from their operations by 2020.

"The Konecranes hybrid reach stacker is better at materials handling than any other reach stacker we have, and it both helps the environment and saves our financial resources," says Mr. Putens. "We got the complete package, consisting of both machine and service. We have felt well looked after and understood in this Hybrid Drive project. Konecranes is a partner we want to continue to work with in the future."

Future – extend green lifting with high performance

Clearly, the hybrid reach stacker speaks for itself. Contargo Group, of which DIT is a part, has decided to continue to invest in Konecranes hybrid reach stackers, as it looks towards a greener future and more efficient container handling.

Driver-friendliness

For the driver spending countless hours in a lift truck, the most important thing is probably not the return on investment or the overall performance of the fleet. Drivers want to feel secure and comfortable, and have the opportunity to do their jobs with precision and effectiveness.

FEATURES FOR DRIVER-FRIENDLY OPERATIONS

CURVED GLASS GIVES REMARKABLE VISIBILITY

Drivers have an exceptional range of vision through very large, lowered windows with no corner posts, a thin but very strong roof crossmember, and curved panels.

OUTSTANDING ERGONOMICS

With driver-focused design, the OPTIMA cabin is one of the most spacious on the market. Everything is within easy reach.

ELECTRONIC MACHINE CONTROL, EMC MASTER

You can monitor vital components and functions on a 7" touch screen. CanBus technology increases engine and transmission reliability as well as hydraulic and joystick control.

FLOW DRIVE

Flow drive uses improved 2nd generation HVT technology together with Konecranes Lift Trucks software and engine re-configuration to produce lower cabin noise, a less "jerky" ride, and easier change of direction – all of which leads to more relaxed and productive drivers.

SMART LOAD-SENSING HYDRAULICS

Specially designed hydraulics sense the weight of the load and adapt lifting power accordingly. The truck provides maximum power only when really needed, so it consumes less fuel while reducing emissions and noise.

YOUR WORLD

People are your most valuable asset. Driver-friendly trucks facilitate the well-being and work of the drivers.

Cabins that are well-designed for long shifts and demanding conditions lead to relaxed and more effective drivers. Konecranes cabins put your drivers in a position to succeed – to be their best at what they do.



Meeting the needs of drivers

Cabin OPTIMA, designed and built by Konecranes Lift Trucks, offers comfort and superior visibility for your drivers. Both the cabin and the truck itself can be customized to fit your site requirements, so all of your operations on the ground can run more safely and smoothly.

Ergonomically advanced

Instrumentation is conveniently accessible to the right of and above the driver, improving driver posture and positioning during operation. If you need it, ask us to install extra equipment and add the controls as part of the instrumentation layout.

Solutions for comfort

An excellent seat with compressor suspension, cabin heating and ventilation, air conditioning – we aim to provide your drivers with every possible comfort. Optional ergonomic steering solutions improve your drivers' productivity.



WHAT DO YOU NEED TO LIFT?

We have the attachment

You'll find your lifting solution in our complete range of attachments for reach stackers.



CONTAINER HANDLING



ELME 517-MPS

Telescopic spreader for empty ISO containers with capacity up to 10 tons. Strong single beam spreader design, floating twistlock (± 10 mm) with hydraulic operation and mechanical safety locking. Hydraulic extension with 2 cylinders (20–40 ft), large sideshift (± 800 mm) with 1 hydraulic cylinder and full rotation ($-105/+195$ deg) with 1 hydraulic motor (turning) and 1 brake (holding). Spreader side tilt ± 2 deg (MPS = mechanical pile slope). The spreader frame and end beams are of strong heavy-duty design. Weight = appr. 4.8 tons.



ELME 817-MPS/OFL (folded)

With overheight folding legs for open-top containers and flat racks (extra high cargo). The foldable extension legs are 1600 or 2100 mm long and activated by 4 cylinders. Weight appr. 10.3–11.3 tons.



ELME 817-MPS

Telescopic spreader for laden ISO containers with capacity up to 45 tons. Strong parallel double beam spreader design, floating twistlock (± 10 mm) with hydraulic operation and mechanical safety locking. Hydraulic extension with 2 cylinders (20–40 ft), big sideshift (± 800 mm) with 2 hydraulic cylinders and full rotation ($-105/+195$ deg) with 1 hydraulic motor (turning) and 2 brakes (holding). Spreader side tilt with stroke of ± 2 deg (MPS = mechanical pile slope) and 4 lift eyes included for slings (45 tons). ELME 817-MPS with a stroke of ± 6 deg (HPS = hydraulic pile slope with 4 cylinders). The spreader frame and the end beams are of strong heavy-duty design. Weight 817-MPS/HPS = appr. 9.3/10.3 tons.



ELME 817-MPS/OFL in action

Legs shown in unfolded position with an open-top container with high cargo. Flat racks often have overheight cargo that must be lifted like this.

INTERMODAL HANDLING



ELME 857-HPS (folded)

Telescopic intermodal spreader (combi/piggyback) for laden ISO containers, swap bodies, and trailer handling with capacity up to 45 tons (in twistlocks / lift legs). Extension 20/B7/30/40 ft is included. The lift legs "fold in" and "fold out" in a sequence with sensors in each lift leg / lift shoe. Leg length = 3600 mm and leg opening = 1700–3200 mm. The package of spreader frame and legs is of strong heavy-duty design. All container functions as for ELME 817-MPS/OFL. Weight appr. 13.6 tons.



ELME 857-HPS in action

Legs shown in unfolded position with a trailer being lifted.

INDUSTRIAL HANDLING



ELME industrial tool carrier system

For connecting tools (connection points = 2500 x 760 mm). Strong single beam spreader design, floating twistlock (± 10 mm) with hydraulic operation and mechanical safety locking. Large sideshift (TC-50 = ± 500 mm / TC-65 = ± 300 mm) with 1 hydraulic cylinder and full rotation ($-105/+195$ deg) with 1 hydraulic motor (turning) and 2 brakes (holding). Spreader side tilt ± 2 deg (MPS) or ± 6 deg (HPS). The spreader frame and end beams are of strong heavy-duty design. Weight TC-50-MPS/TC-65-MPS = appr. 5.0–7.5 tons.



Hydraulic steel slab grab unit

Hydraulic steel slab grab unit with pairs of hydraulic lifting jaws. The grab can lift 1–4 slabs if the height adjustment function is included. Various slab width combinations are available, width min–max 700–1800/900–2000/1500–2600 mm. Capacities up to 50 tons (in grab unit). Grab weight = appr. 9.0–12.0 tons.

10 TO 80 TONS

Reach stackers for efficient and versatile handling of containers and cargo

When you buy a Konecranes reach stacker, you are investing in time-tested technology with innovative, eco-efficient features to enhance productivity and cut lifecycle costs. We offer a range of solutions and technologies to reduce engine, drive train

and tire wear to extend the functional life of your reach stacker and decrease your running expenses. When your lifting needs change, a well-maintained reach stacker also has high resale value.



For container handling 10 TO 45 TONS

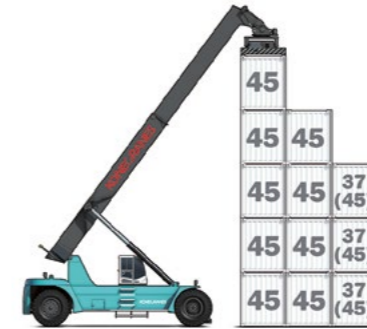

MODEL NAME	CAPACITY	WHEELBASE
SMV 108 TC6	10-8-5 tons	5000 mm
MODEL NAME	CAPACITY	WHEELBASE
SMV 2115 TC3	21-15-5 tons	5500 mm
SMV 2518 TC3	25-18-8 tons	5500 mm

MODEL NAME	CAPACITY	WHEELBASE
SMV 4127 TC5 (TC6)*	41-27-14 tons	6400 mm
SMV 4527 TC5 (TC6)*	45-27-14 tons	6400 mm
SMV 4531 TC5 (TC6)*	45-31-16 tons	6400 mm

MODEL NAME	CAPACITY	WHEELBASE
SMV 4535 TC5 (TC6)*	45-35-20 tons	6400 mm
SMV 4535 TCX5**	45-37-24 tons	6400 mm
SMV 4537 TC5	45-37-19 tons	6400 mm
SMV 4537 TCX5**	45-41-28 tons	6400 mm

MODEL NAME	CAPACITY	WHEELBASE
SMV 4542 TC5	45-42-24 tons	7250 mm
SMV 4542 TCX5**	45-44-30 tons	7250 mm
SMV 4543 TC5	45-42-25 tons	7500 mm
SMV 4543 TCX5**	45-44-34 tons	7500 mm

MODEL NAME	CAPACITY	WHEELBASE
SMV 4545 TC5	45-45-37 tons	8000 mm
SMV 4545 TCX5**	45-45-45 tons	8000 mm

*TC5 5 high, TC6 = 6 high
**TCX Capacity with support jacks engaged

For barge handling 45 TONS

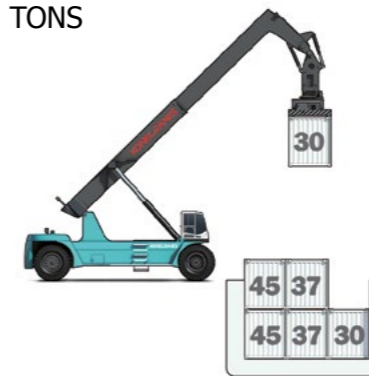

MODEL NAME	CAPACITY	WHEELBASE
SMV 4542 TC4 BH	45-37-23 tons (yard) 43-30-18 tons (barge)	7500 mm
SMV 4542 TCX4 BH**	45-41-31 tons (yard) 45-37-23 tons (barge)	7500 mm
SMV 4545 TC3 BH	45-45-35 tons (yard) 45-37-30 tons (barge)	9000 mm

BH** = Capacity with support jacks engaged

For intermodal handling 41 TO 45 TONS

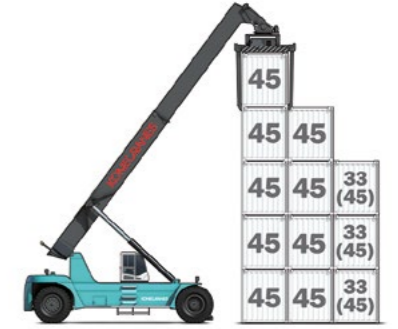

MODEL NAME	CAPACITY	WHEELBASE
SMV 4123 CC5	41-23-9 tons	6400 mm
SMV 4527 CC5	45-27-13 tons	6400 mm
SMV 4531 CC5	45-31-16 tons	6400 mm
SMV 4531 CCX5***	45-33-20 tons	6400 mm
SMV 4533 CC5	45-33-16 tons	6400 mm
SMV 4533 CCX5***	45-37-24 tons	6400 mm

MODEL NAME	CAPACITY	WHEELBASE
SMV 4537 CC5	45-37-22 tons	7250 mm
SMV 4537 CCX5	45-40-28 tons	7250 mm
SMV 4538 CC5	45-38-23 tons	7500 mm
SMV 4538 CCX5***	45-40-32 tons	7500 mm

MODEL NAME	CAPACITY	WHEELBASE
SMV 4545 CC5	45-45-33 tons	8000 mm
SMV 4545 CCX5***	45-45-45 tons	8000 mm

***CCX Capacity with support jacks engaged

For industrial handling 35 TO 80 TONS



MODEL NAME	CAPACITY	WHEELBASE
SMV 4127	35-50 tons	6400 mm
SMV 4527	35-50 tons	6400 mm
SMV 4531	35-50 tons	6400 mm
SMV 4535	35-50 tons	6400 mm
SMV 4542	40-60 tons	7250 mm
SMV 4545	40-60 tons	8000 mm

Other models upon request

Konecranes is a world-leading group of Lifting Businesses™, serving a broad range of customers, including manufacturing and process industries, shipyards, ports and terminals. Konecranes provides productivity-enhancing lifting solutions as well as services for lifting equipment of all makes. In 2017, Group sales totaled EUR 3,136 million. The Group has 16,200 employees at 600 locations in 50 countries. Konecranes shares are listed on Nasdaq Helsinki (symbol: KCR).

© 2018 Konecranes. All rights reserved. 'Konecranes', 'Lifting Businesses',  and 'TRUCONNECT' are either registered trademarks or trademarks of Konecranes Global Corporation.



**READ MORE STORIES ABOUT OUR
LIFT TRUCKS IN YOUR WORLD**

Customer stories

kclifttrucks.com/customer-stories

