

Forgotten Books

— www.forgottenbooks.com —

Copyright © 2016 FB &c Ltd.

All rights reserved. No part of this publication may be reproduced, distributed, or transmitted in any form or by any means, including photocopying, recording, or other electronic or mechanical methods, without the prior written permission of the publisher, except in the case of brief quotations embodied in critical reviews and certain other noncommercial uses permitted by copyright law.

THE LOEB CLASSICAL LIBRARY

FOUNDED BY JAMES LOEB, LL.D.

EDITED BY

† T. E. PAGE, C.H., LITT.D.

E. CAPPS, PH.D., LL.D.

† W. H. D. ROUSE, LITT.

L. A. POST, M.A.

E. H. WARMINGTON, M.A., F.R.HIST.SO

GREEK MATHEMATICS

SELECTIONS
ILLUSTRATING THE HISTORY OF
GREEK MATHEMATICS

WITH AN ENGLISH TRANSLATION BY
IVOR THOMAS

FORMERLY SCHOLAR OF ST. JOHN'S AND SENIOR DEMY
OF MAGDALEN COLLEGE, OXFORD

IN TWO VOLUMES

I

FROM THALES TO EUCLID

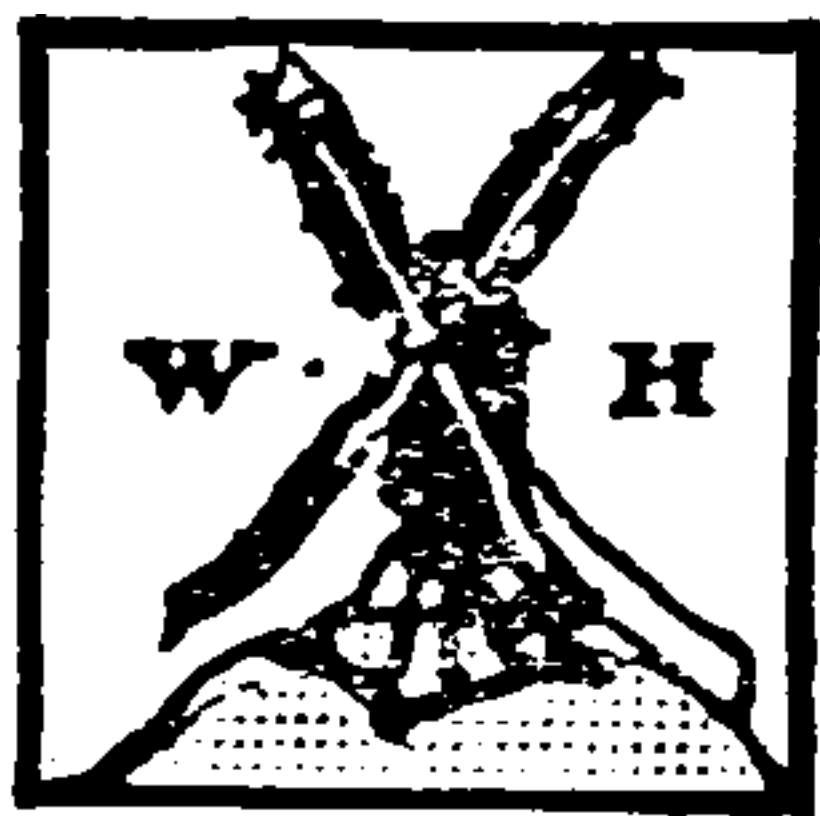

LONDON
WILLIAM HEINEMANN LTD
CAMBRIDGE, MASSACHUSETTS
HARVARD UNIVERSITY PRESS
MCMLVII

First printed 1939
Reprinted 1951, 1957

Printed in Great Britain

TO
M. E. B.

PREFACE

THE story of Greek mathematics is the tale of one of the most stupendous achievements in the history of human thought. It is my hope that these selections, which furnish a reasonably complete picture of the rise of Greek mathematics from earliest days, will be found useful alike by classical scholars, desiring easy access to a most characteristic aspect of the Greek genius, and by mathematicians, anxious to learn something about the origins of their science. In these days of specialization the excellent custom which formerly prevailed at Oxford and Cambridge whereby men took honours both in classics and in mathematics has gone by the board. It is now rare to find a classical scholar with even an elementary knowledge of mathematics, and the mathematician's knowledge of Greek is usually confined to the letters of the alphabet. By presenting the main Greek sources side by side with an English translation, reasonably annotated, I trust I have done something to bridge the gap.

For the classical scholar Greek mathematics is a brilliant after-glow which lightened the sky long after the sun of Hellas had set. Greek mathematics sprang from the same impulse as Greek philosophy, but Greek philosophy reached its maturity in the fourth century before Christ, the century of Plato and Aristotle, and thereafter never spoke with like con-

PREFACE

viction until the voice of Plato became reincarnate in the schools of Egypt. Yet such was the vitality of Hellenic thought that the autumn flowering of Greek philosophy in Aristotle was only the spring of Greek mathematics. It was Euclid, following hard on the heels of Aristotle in point of time, but teaching in distant Alexandria, who first transformed mathematics from a number of uncoordinated and loosely-proved theorems into an articulated and surely-grounded science; and in the succeeding hundred years Archimedes and Apollonius raised mathematics to heights not surpassed till the sixteenth century of the Christian era.

To the mathematician his Greek predecessors are deserving of study in that they laid the foundations on which all subsequent mathematical science is based. Names still in everyday use testify to this origin—Euclidean geometry, Pythagoras's theorem, Archimedes' axiom, the quadratrix of Hippias or Dinostratus, the cissoid of Diocles, the conchoid of Nicomedes. I cannot help feeling that mathematicians will welcome the opportunity of learning the reasons for these names, and that the extracts which follow will enable them to do so more easily than is now possible. In perusing these extracts they will doubtless be impressed by three features. The first is the rigour with which the great Greek geometers demonstrated what they set out to prove. This is most noticeable in their treatment of the indefinitely small, a subject whose pitfalls had been pointed out by Zeno in four arguments of remarkable acuteness. Archimedes, for example, carries out operations equivalent to the integral calculus, but he refuses to posit the existence of infinitesimal quanti-

PREFACE

ties, and avoids logical errors which infected the calculus until quite recent times. The second feature of Greek mathematics which will impress the modern student is the dominating position of geometry. Early in the present century there was a powerful movement for the "arithmetization" of all mathematics. Among the Greeks there was a similar impulse towards the "geometrization" of all mathematics. Magnitudes were from earliest times represented by straight lines, and the Pythagoreans developed a geometrical algebra performing operations equivalent to the solution of equations of the second degree. Later Archimedes evaluated by purely geometrical means the area of a variety of surfaces, and Apollonius developed his awe-inspiring geometrical theory of the conic sections. The third feature which cannot fail to impress a modern mathematician is the perfection of form in the work of the great Greek geometers. This perfection of form, which is another expression of the same genius that gave us the Parthenon and the plays of Sophocles, is found equally in the proof of individual propositions and in the ordering of those separate propositions into books; it reaches its height, perhaps, in the *Elements* of Euclid.

In making the selections which follow I have drawn not only on the ancient mathematicians but on many other writers who can throw light on the history of Greek mathematics. Thanks largely to the labours of a band of Continental scholars, admirable standard texts of most Greek mathematical works now exist, and I have followed these texts, indicating only the more important variants and emendations. In the selection of the passages, in their arrangement and at

PREFACE

innumerable points in the translation and notes I owe an irredeemable debt of gratitude to the works of Sir Thomas Heath, who has been good enough, in addition, to answer a number of queries on specific points. These works, covering almost every aspect of Greek mathematics and astronomy, are something of which English scholarship may justly feel proud. His *History of Greek Mathematics* is unexcelled in any language. Yet there may still be room for a work which will give the chief sources in the original Greek together with a translation and sufficient notes.

In a strictly logical arrangement the passages would, no doubt, be grouped wholly by subjects or by persons. But such an arrangement would not be satisfactory. I imagine that the average reader would like to see, for example, all the passages on the squaring of the circle together, but would also like to see the varied discoveries of Archimedes in a single section. The arrangement here adopted is a compromise for which I must ask the reader's indulgence where he might himself have made a different grouping. The contributions of the Greeks to arithmetic, geometry, trigonometry, mensuration and algebra are noticed as fully as possible, but astronomy and music, though included by the Greeks under the name mathematics, have had to be almost wholly excluded.

I am greatly indebted to Messrs. R. and R. Clark for the skill and care shown in the difficult task of making this book.

I. T.

ADELPHI, LONDON

April 1939

CONTENTS OF VOLUME I

	PAGE
I. INTRODUCTORY—	
(<i>a</i>) Mathematics and its divisions—	
(i) Origin of the name	2
(ii) The Pythagorean quadrivium	4
(iii) Plato's scheme	6
(iv) Logistic	16
(v) Later classification	18
(<i>b</i>) Mathematics in Greek Education	20
(<i>c</i>) Practical calculation—	
(i) Enumeration by fingers	28
(ii) The abacus	34
II. ARITHMETICAL NOTATION AND THE CHIEF ARITHMETICAL OPERATIONS—	
(<i>a</i>) English notes and examples	41
(<i>b</i>) Division	50
(<i>c</i>) Extraction of the square root	52
(<i>d</i>) Extraction of the cube root	60
III. PYTHAGOREAN ARITHMETIC—	
(<i>a</i>) First principles	66
(<i>b</i>) Classification of numbers	72
(<i>c</i>) Perfect numbers	74
	xi

CONTENTS

	PAGE
(<i>d</i>) Figured numbers—	
(i) General	86
(ii) Triangular numbers	90
(iii) Oblong and square numbers	94
(iv) Polygonal numbers	94
(v) Gnomons of polygonal numbers	98
(<i>e</i>) Some properties of numbers—	
(i) The “sieve” of Eratosthenes	100
(ii) Divisibility of squares	102
(iii) A theorem about cube numbers	104
(iv) A property of the <i>pythmen</i>	106
(<i>f</i>) Irrationality of the square root of 2	110
(<i>g</i>) The theory of proportion and means—	
(i) Arithmetic, geometric and harmonic means	110
(ii) Seven other means	114
(iii) Pappus’s equations between means	124
(iv) Plato on means between two squares or two cubes	128
(v) A theorem of Archytas	130
(<i>h</i>) Algebraic equations—	
(i) Side- and diameter-numbers	132
(ii) The “bloom” of Thymaridas	138
 IV. PROCLUS’S SUMMARY	 144
 V. THALES	 164
 VI. PYTHAGOREAN GEOMETRY—	
(<i>a</i>) General	172
(<i>b</i>) Sum of the angles of a triangle	176
(<i>c</i>) “Pythagoras’s theorem”	178

CONTENTS

	PAGE
(<i>d</i>) The application of areas	186
(<i>e</i>) The irrational	214
(<i>f</i>) The five regular solids	216
 VII. DEMOCRITUS	 228
 VIII. HIPPOCRATES OF CHIOS—	
(<i>a</i>) General	234
(<i>b</i>) Quadrature of lunes	234
(<i>c</i>) Two mean proportionals	252
 IX. SPECIAL PROBLEMS—	
1. Duplication of the Cube—	
(<i>a</i>) General	256
(<i>b</i>) Solutions given by Eutocius—	
(<i>i</i>) “Plato”	262
(<i>ii</i>) Heron	266
(<i>iii</i>) Diocles : the Cissoïd	270
(<i>iv</i>) Menaechmus : solution by conics	278
(<i>v</i>) Archytas : solution in three dimensions	284
(<i>vi</i>) Eratosthenes	290
(<i>vii</i>) Nicomedes : the Conchoid	296
 2. Squaring of the Circle—	
(<i>a</i>) General	308
(<i>b</i>) Approximation by polygons—	
(<i>i</i>) Antiphon	310
(<i>ii</i>) Bryson	314
(<i>iii</i>) Archimedes	316
(<i>c</i>) Solutions by higher curves—	
(<i>i</i>) General	334
(<i>ii</i>) The Quadratrix	336

CONTENTS

PAGE

3. Trisection of an Angle—

(a) Types of geometrical problems	346
(b) Solution by means of a verging	352
(c) Direct solutions by means of conics	356

X. ZENO OF ELEA	366
---------------------------	-----

XI. THEAETETUS—

(a) General	378
(b) The five regular solids	378
(c) The irrational	380

XII. PLATO—

(a) General	386
(b) Philosophy of mathematics	390
(c) The <i>diorismos</i> in the <i>Meno</i>	394
(d) The nuptial number	398
(e) Generation of numbers	400

XIII. EUDOXUS OF CNIDOS—

(a) Theory of proportion	408
(b) Volume of pyramid and cone	408
(c) Theory of concentric spheres	410

XIV. ARISTOTLE—

(a) First principles	418
(b) The infinite	424
(c) Proof differing from Euclid's	428
(d) Mechanics—	
(i) Principle of the lever	430
(ii) Parallelogram of velocities	432

CONTENTS

	PAGE
XV. EUCLID—	
(<i>a</i>) General	436
(<i>b</i>) The <i>Elements</i> —	
(i) Foundations	436
(ii) Theory of proportion	444
(iii) Theory of incommensurables	450
(iv) Method of exhaustion	458
(v) Régular solids	466
(<i>c</i>) The <i>Data</i>	478
(<i>d</i>) The <i>Porisms</i>	478
(<i>e</i>) The <i>Conics</i>	486
(<i>f</i>) The <i>Surface Loci</i>	490
(<i>g</i>) The <i>Optics</i>	502

ABBREVIATIONS

Heath, *H.G.M.* Sir Thomas Heath, *A History of Greek Mathematics*, 2 vols., Oxford 1921.

Diels, *Vors.*⁵ Hermann Diels, *Die Fragmente der Vorsokratiker*, 3 vols., 5th ed., edited by Walther Kranz, Berlin 1934–1937.

Both cited by volume and page.

References to modern editions of classical texts are by volume (where necessary), page and line, *e.g.*, Eucl. ed. Heiberg-Menge vii. 14. 1—16. 5 refers to *Euclidis Opera Omnia*, edited by I. L. Heiberg and H. Menge, vol. vii., page 14 line 1 to page 16 line 5.



THIS PAGE IS LOCKED TO FREE MEMBERS

Purchase full membership to immediately unlock this page

SAVE \$3,999,994

Did you know we sell
paperback books too?

To buy our entire catalog
in paperback would cost
over \$4,000,000

Access it all now for
\$8.99/month

*Fair usage policy applies

Continue

I. INTRODUCTORY

(a) MATHEMATICS AND ITS DIVISIONS

(i.) *Origin of the Name*

Anatolius ap. Her. *Def.*, ed. Heiberg 160. 8-162. 2

Ἐκ τῶν Ἀνατολίου . . .

“ Ἀπὸ τίνος δὲ μαθηματικὴ ὠνομάσθη;
“ Οἱ μὲν ἀπὸ τοῦ Περιπάτου φάσκοντες ῥητο-
ρικῆς μὲν καὶ ποιητικῆς συμπάσης τε τῆς δημώδους
μουσικῆς δύνασθαι τινα συνεῖναι καὶ μὴ μαθόντα,
τὰ δὲ καλούμενα ἰδίως μαθήματα οὐδένα εἰς εἶδησιν
λαμβάνειν μὴ οὐχὶ πρότερον ἐν μαθήσει γεγόμενον
τούτων, διὰ τοῦτο μαθηματικὴν καλεῖσθαι τὴν περὶ
τούτων θεωρίαν ὑπελάμβανον. θέσθαι δὲ λέγονται
τὸ τῆς μαθηματικῆς ὄνομα ἰδιαίτερον ἐπὶ μόνῃς
γεωμετρίας καὶ ἀριθμητικῆς οἱ ἀπὸ τοῦ Πυθα-
γόρου· τὸ γὰρ πάλαι χωρὶς ἑκάτερα τούτων ὠνομά-
ζετο, κοινὸν δὲ οὐδὲν ἦν ἀμφοῖν ὄνομα.”

^a Anatolius was bishop of Laodicea about A.D. 280. In a letter by Michael Psellus he is said to have written a concise treatise on the Egyptian method of reckoning.

^b *i.e.* singing or playing, as opposed to the mathematical study of musical intervals.

^c The word *μάθημα*, from *μαθεῖν*, means in the first place “that which is learnt.” In Plato it is used in the general sense for any subject of study or instruction, but with a tendency to restrict it to the studies now called mathematics. By the time of Aristotle this restriction had become established.

I. INTRODUCTORY

(a) MATHEMATICS AND ITS DIVISIONS

(i.) *Origin of the Name*

Anatolius, cited by Heron, *Definitions*, ed. Heiberg
160. 8–162. 2

From the works of Anatolius^a . . .

“ Why is mathematics so named ?

“ The Peripatetics say that rhetoric and poetry and the whole of popular music^b can be understood without any course of instruction, but no one can acquire knowledge of the subjects called by the special name *mathematics* unless he has first gone through a course of instruction in them ; and for this reason the study of these subjects was called *mathematics*.^c The Pythagoreans are said to have given the special name *mathematics* only to geometry and arithmetic ; previously each had been called by its separate name, and there was no name common to both.”^d

^a The esoteric members of the Pythagorean school, who had learnt the Pythagorean theory of knowledge in its entirety, are said to have been called *mathematicians* (μαθηματικοί), whereas the exoteric members, who merely knew the Pythagorean rules of conduct, were called *hearers* (ἀκουσματικοί). See Iamblichus, *De Vita Pythag.* 18. 81, ed. Deubner 46. 24 ff.

GREEK MATHEMATICS

(ii.) *The Pythagorean Quadrivium*

Archytas ap. Porphyr. in *Ptol. Harm.*, ed. Wallis, *Opera Math.* iii. 236. 40-237. 1; Diels, *Vors.* i⁵. 431. 26-432. 8

Παρακείσθω δὲ καὶ νῦν τὰ Ἀρχύτα τοῦ Πυθαγορείου, οὗ μάλιστα καὶ γνήσια λέγεται εἶναι τὰ συγγράμματα· λέγει δὲ ἐν τῷ *Ἡερὶ μαθηματικῆς εὐθὺς ἐναρχόμενος* τοῦ λόγου τάδε.

“Καλῶς μοι δοκοῦντι τοὶ περὶ τὰ μαθήματα διαγνώμεναι, καὶ οὐδὲν ἄτοπον ὀρθῶς αὐτοῦς, οἷά ἐντι, περὶ ἐκάστων φρονέειν· περὶ γὰρ τῆς τῶν ὄλων φύσιος καλῶς διαγνόντες ἔμελλον καὶ περὶ τῶν κατὰ μέρος, οἷά ἐντι, καλῶς ὀψείσθαι. περὶ τε δὴ τῆς τῶν ἄστρον ταχυτάτος καὶ ἐπιτολᾶν καὶ δυσίων παρέδωκαν ἡμῖν σαφῆ διάγνωσιν καὶ περὶ γαμετρίας καὶ ἀριθμῶν καὶ σφαιρικᾶς καὶ οὐχ ἥκιστα περὶ μωσικᾶς. ταῦτα γὰρ τὰ μαθήματα δοκοῦντι ἡμεν ἀδελφεά.”

^a Archytas lived in the first half of the fourth century B.C. at Taras (Tarentum) in Magna Graecia. He is said to have dissuaded Dionysius from putting Plato to death. For seven years he commanded the forces of his city-state, though the law forbade anyone to hold the post normally for more than one year, and he was never defeated. He is said to have been the first to write on mechanics, and to have invented a mechanical dove which would fly. For such of his mathematical discoveries as have survived, see pp. 112-115, 130-133, 284-289.

INTRODUCTORY

(ii.) *The Pythagorean Quadrivium*

Archytas, cited by Porphyry in his *Commentary on Ptolemy's Harmonics*, ed. Wallis, *Opera Mathematica* iii. 235. 40–237. 1; Diels, *Vors.* i⁵. 431. 26–432. 8

Let us now cite the words of Archytas ^a the Pythagorean, whose writings are said to be mainly authentic. In his book *On Mathematics* right at the beginning of the argument he writes thus :

“ The mathematicians seem to me to have arrived at true knowledge, and it is not surprising that they rightly conceive the nature of each individual thing ; for, having reached true knowledge about the nature of the universe as a whole, they were bound to see in its true light the nature of the parts as well. Thus they have handed down to us clear knowledge about the speed of the stars, and their risings and settings, and about geometry, arithmetic and sphaeric, and, not least, about music ; for these studies appear to be sisters.” ^b

^b *Sphaeric* is clearly identical with astronomy, and is aptly defined by Heath, *H.G.M.* i. 11 as “ the geometry of the sphere considered solely with reference to the problem of accounting for the motions of the heavenly bodies.” The same *quadrivium* is attributed to the Pythagoreans by Nicomachus, Theon of Smyrna and Proclus, but in the order arithmetic, music, geometry and sphaeric. The logic of this order is that arithmetic and music are concerned with number (*ποσόν*), arithmetic with number in itself and music with number in relation to sounds ; while geometry and sphaeric are concerned with magnitude (*πηλίκον*), geometry with magnitude at rest, sphaeric with magnitude in motion.

GREEK MATHEMATICS

(iii.) *Plato's Scheme*

Plat. *Rep.* vii. 525 A-530 D

(a) *Logistic and Arithmetic*

Ἄλλὰ μὲν λογιστικὴ τε καὶ ἀριθμητικὴ περὶ ἀριθμὸν πᾶσα.

Καὶ μάλα.

Ταῦτα δὲ γε φαίνεται ἀγωγὰ πρὸς ἀλήθειαν.

Ἵπερφυῶς μὲν οὖν.

Ὅν ζητοῦμεν ἄρα, ὡς ἔοικε, μαθημάτων ἂν εἴη· πολεμικῶ μὲν γὰρ διὰ τὰς τάξεις ἀναγκαῖον μαθεῖν ταῦτα, φιλοσόφῳ δὲ διὰ τὸ τῆς οὐσίας ἀπτέον εἶναι γενέσεως ἐξαναδύντι, ἢ μηδέποτε λογιστικῶ γενέσθαι. . . .

Τί οὖν οἶει, ὦ Γλαύκων, εἴ τις ἔροιτο αὐτούς· “Ὅ θαυμάσιοι, περὶ ποίων ἀριθμῶν διαλέγεσθε, ἐν οἷς τὸ ἐν οἷον ὑμεῖς ἀξιούτέ ἐστιν, ἴσον τε ἕκαστον πᾶν παντὶ καὶ οὐδὲ σμικρὸν διαφέρον, μόριόν τε ἔχον ἐν ἑαυτῶ οὐδέν;” τί ἂν οἶει αὐτοὺς ἀποκρίνασθαι;

Τοῦτο ἔγωγε, ὅτι περὶ τούτων λέγουσιν ὧν διανοηθῆναι μόνον ἐγχωρεῖ, ἄλλως δ' οὐδαμῶς μεταχειρίζεσθαι δυνατόν. . . .

Τί δέ; τόδε ἤδη ἐπεσκέψω, ὡς οἱ τε φύσει

^a The passage is taken from the section dealing with the education of the Guardians. The speakers in the dialogue are Socrates and Glaucon. It is made clear in *Rep.* 537 B-D that the Guardians would receive their chief mathematical training between the ages of twenty and thirty, after two or three years spent in the study of music and gymnastic and as a preliminary to five years' study of dialectic. Plato's scheme, it will be noticed, is virtually identical with the Pythagorean *quadrivium* except for the addition of stereo-

INTRODUCTORY

(iii.) *Plato's Scheme*

Plato, *Republic* vii. 525 A-530 D ^a

(a) *Logistic and Arithmetic*

Now logistic and arithmetic treat of the whole of number.

Yes.

And, apparently, they lead us towards truth.

They do, indeed.

It would appear, therefore, that they must be among the studies we seek ; for the soldier finds it necessary to learn them in order to draw up his troops, and the philosopher because he is bound to rise out of Becoming and cling to Being on pain of never becoming a reasoner. . . .^b

Now what would you expect, Glaucon, if someone were to ask them : " My good people, what kind of numbers are you discussing ? What are these numbers such as you describe, every unit being equal, each to each, without the smallest difference, and containing within itself no part ? " What answer would you expect them to make ?

I should expect them to say that the numbers they discuss are capable of being conceived only in thought, and can be dealt with in no other way. . . .

Again ; have you ever noticed that those who are metry ; and the addition is more formal than real since stereometrical problems were certainly investigated by the Pythagoreans—not least by Archytas—as part of geometry. Plato also distinguishes *logistic* from *arithmetic* (for which see the extract given below on pp. 16-19), and speaks of *harmonics* (ἁρμονία) not *music* (μουσική), thus avoiding confusion with *popular music* (τὸ δημῶδες μουσικόν).

^b There is a play on the Greek word, which could mean either " reasoner " or " calculator."

GREEK MATHEMATICS

λογιστικοὶ εἰς πάντα τὰ μαθήματα ὡς ἔπος εἰπεῖν ὀξεῖς φύονται, οἳ τε βραδεῖς, ἂν ἐν τούτῳ παιδευθῶσιν καὶ γυμνάσωνται, κὰν μηδὲν ἄλλο ὠφελθῶσιν, ὅμως εἰς γὰρ τὸ ὀξύτεροι αὐτοὶ αὐτῶν γίγνεσθαι πάντες ἐπιδιδόασιν;

Ἔστιν, ἔφη, οὕτω.

Καὶ μήν, ὡς ἐγῶμαι, ἃ γὰρ μείζω πόνον παρέχει μαθάνοντι καὶ μελετῶντι, οὐκ ἂν ῥαδίως οὐδὲ πολλὰ ἂν εὖροις ὡς τοῦτο.

Οὐ γὰρ οὖν.

Πάντων δὲ ἔνεκα τούτων οὐκ ἀφετέον τὸ μάθημα, ἀλλ' οἱ ἄριστοι τὰς φύσεις παιδευτέοι ἐν αὐτῷ.

Σύμφημι, ἦ δ' ὅς.

(β) Geometry

Τοῦτο μὲν τοίνυν, εἶπον, ἐν ἡμῖν κείσθω· δεύτερον δὲ τὸ ἐχόμενον τούτου σκεψώμεθα ἄρα τι προσήκει ἡμῖν.

Τὸ ποῖον; ἢ γεωμετρίαν, ἔφη, λέγεις;

Αὐτὸ τοῦτο, ἦν δ' ἐγώ.

Ὅσον μὲν, ἔφη, πρὸς τὰ πολεμικὰ αὐτοῦ τείνει, δῆλον ὅτι προσήκει. . . .

Ἄλλ' οὖν δὴ, εἶπον, πρὸς μὲν τὰ τοιαῦτα καὶ βραχὺ τι ἂν ἐξαρκοῖ γεωμετρίας τε καὶ λογισμῶν μόριον· τὸ δὲ πολὺ αὐτῆς καὶ πορρωτέρω προῖον σκοπεῖσθαι δεῖ εἴ τι πρὸς ἐκεῖνο τείνει, πρὸς τὸ ποιεῖν κατιδεῖν ῥᾶον τὴν τοῦ ἀγαθοῦ ἰδέαν. . . .

οὐ τοίνυν τοῦτό γε, ἦν δ' ἐγώ, ἀμφισβητήσουσιν ἡμῖν ὅσοι καὶ σμικρὰ γεωμετρίας ἔμπειροι, ὅτι



THIS PAGE IS LOCKED TO FREE MEMBERS

Purchase full membership to immediately unlock this page

FORGOTTEN BOOKS

FULL

MEMBERSHIP

797,885 Books!

All you can read

for only

\$8.99/month

Continue

*Fair usage policy applies



GREEK MATHEMATICS

αὕτη ἢ ἐπιστήμη πᾶν τούναντίον ἔχει τοῖς ἐν αὐτῇ λόγοις λεγομένοις ὑπὸ τῶν μεταχειριζομένων.

Πῶς; ἔφη.

Λέγουσι μὲν που μάλα γελοίως τε καὶ ἀναγκαίως· ὡς γὰρ πράττοντές τε καὶ πράξεως ἔνεκα πάντας τοὺς λόγους ποιούμενοι λέγουσιν τετραγωνίζειν τε καὶ παρατείνειν καὶ προστιθέναι καὶ πάντα οὕτω φθειγγόμενοι, τὸ δ' ἔστι που πᾶν τὸ μάθημα γνώσεως ἔνεκα ἐπιτηδευόμενον. . . .

(γ) Stereometry

Τί δέ; τρίτον θῶμεν ἀστρονομίαν; ἢ οὐ δοκεῖ;

Ἐμοὶ γοῦν, ἔφη. . . .

Νυνδὴ γὰρ οὐκ ὀρθῶς τὸ ἐξῆς ἐλάβομεν τῇ γεωμετρῖᾳ.

Πῶς λαβόντες; ἔφη.

Μετὰ ἐπίπεδον, ἦν δ' ἐγώ, ἐν περιφορᾷ ὄν ἤδη στερεὸν λαβόντες, πρὶν αὐτὸ καθ' αὐτὸ λαβεῖν· ὀρθῶς δὲ ἔχει ἐξῆς μετὰ δευτέραν αὐξήν τρίτην λαμβάνειν. ἔστι δέ που τοῦτο περὶ τὴν τῶν κύβων αὐξήν καὶ τὸ βάθος μετέχον.

Ἔστι γάρ, ἔφη· ἀλλὰ ταῦτά γε, ὦ Σώκρατες, δοκεῖ οὕπω ηὔρησθαι.

Διττὰ γάρ, ἦν δ' ἐγώ, τὰ αἴτια· ὅτι τε οὐδεμία πόλις ἐντίμως αὐτὰ ἔχει, ἀσθενῶς ζητεῖται χαλεπὰ ὄντα, ἐπιστάτου τε δέονται οἱ ζητοῦντες, ἄνευ οὗ οὐκ ἂν εὔροισεν, ὄν πρῶτον μὲν γενέσθαι χαλεπόν,

^a It is useful to know that these terms, which are regularly found in Euclid, were already in technical use in Plato's day.

^b Lit. "increase of cubes," where the word "increase" is the same as that translated above by "dimension."

INTRODUCTORY

science holds a position the very opposite from that implied in the language of those who practise it.

How so ? he asked.

They speak, I gather, in an exceedingly ridiculous and poverty-stricken way. For they fashion all their arguments as though they were engaged in business and had some practical end in view, speaking of squaring and producing and adding^a and so on, whereas in reality, I fancy, the study is pursued wholly for the sake of knowledge. . . .

(γ) *Stereometry*

Again ; shall we put astronomy third, or do you think otherwise ?

That suits me, he said. . . .

We were wrong just now in what we took as the study next in order after geometry.

What did we take ? he asked.

After dealing with plane surfaces, I replied, we proceeded to consider solids in motion before considering solids in themselves ; the correct procedure, after the second dimension, is to consider the third dimension. This brings us, I believe, to cubical increase^b and to figures partaking of depth.

Yes, he replied ; but these subjects, Socrates, do not appear to have been yet investigated.

The reasons, I said, are twofold. In the first place, no state holds them in honour and so, being difficult, they are investigated only in desultory manner. In the second place, the investigators lack a director, and without such a person they will make no discoveries. Now to find such a person is a diffi-

There is probably a playful reference to the problem of doubling the cube, for which see *infra*, pp. 256-309.

ἔπειτα καὶ γειομένου, ὡς νῦν ἔχει, οὐκ ἂν πείθοντο οἱ περὶ ταῦτα ζητητικοὶ μεγαλοφρονούμενοι. εἰ δὲ πόλις ὅλη συνεπιστατοῖ ἐντίμως ἄγουσα αὐτά, οὗτοί τε ἂν πείθοντο καὶ συνεχῶς τε ἂν καὶ ἐντόνως ζητούμενα ἐκφανῆ γένοιτο ὅπη ἔχει· ἐπεὶ καὶ νῦν ὑπὸ τῶν πολλῶν ἀτιμαζόμενα καὶ κολουόμενα, ὑπὸ δὲ τῶν ζητούντων λόγον οὐκ ἔχόντων καθ' ὅτι χρήσιμα, ὅμως πρὸς ἅπαντα ταῦτα βία ὑπὸ χάριτος αὐξάνεται, καὶ οὐδὲν θαυμαστὸν αὐτὰ φανῆναι.

Καὶ μὲν δὴ, ἔφη, τό γε ἐπίχαρι καὶ διαφερόντως ἔχει. ἀλλὰ μοι σαφέστερον εἶπέ ἃ νυνδὴ ἔλεγες. τὴν μὲν γάρ που τοῦ ἐπιπέδου πραγματείαν γεωμετρίαν ἐτίθεις.

Ναί, ἦν δ' ἐγώ.

Εἶτά γ', ἔφη, τὸ μὲν πρῶτον ἀστρονομίαν μετὰ ταύτην, ὕστερον δ' ἀνεχώρησας.

Σπεύδων γάρ, ἔφην, ταχὺ πάντα διεξελεῖν μᾶλλον βραδύνω· ἐξῆς γὰρ οὔσαν τὴν βάθους αὔξης μέθοδον, ὅτι τῇ ζητήσει γελοίως ἔχει, ὑπερβὰς αὐτὴν μετὰ γεωμετρίαν ἀστρονομίαν ἔλεγον, φορὰν οὔσαν βάθους.

Ὅρθῶς, ἔφη, λέγεις.

^a These words (ὡς νῦν ἔχει) can be taken either with what goes before or with what comes after. In the former case Plato (or Socrates) will be referring to a distinguished contemporary (such as Eudoxus or Archytas) who had already made discoveries in solid geometry.

^b This passage has been thought to have some bearing on the question whether the Socrates of the dialogue is meant to be the Socrates of history or not. The condition of stereometry, as described in the dialogue, certainly does not fit

INTRODUCTORY

cult task, and even supposing one appeared on the scene, as matters now stand,^a those who are investigating these problems, being swollen with pride, would pay no heed to him. But if a whole state were to honour this study and constitute itself the director thereof, they would pay heed, and the subject, being continuously and earnestly investigated, would be brought to light. For even now, neglected and curtailed as it is, not only by the many but even by professed students, who can suggest no use for it, nevertheless in the face of all these obstacles it makes progress on account of its elegance, and it would not be astonishing if it were fully unravelled.

It is certainly an exceedingly fascinating subject, he said. But pray tell me more clearly what you were saying just now. I think you defined geometry as the investigation of plane surfaces.

Yes, I said.

Then, he observed, you first placed astronomy after it, but later drew back.

The more I hasten to cover the ground, I said, the more slowly I travel; the study of solid bodies comes next in order, but because of the absurd way in which it is investigated I passed it over and spoke of astronomy, which involves the motion of solid bodies, as next after geometry.

You are quite right, he said.^b

Plato's generation, when Archytas and Eudoxus were making brilliant discoveries in solid geometry; but, even during the lifetime of Socrates, Democritus and Hippocrates had made notable contributions to the same science. This passage cannot help, therefore, towards the solution of that problem. All that Plato meant, it would appear, was that stereometry had not been made a formal element in the curriculum but was treated as part of geometry.

GREEK MATHEMATICS

(δ) *Astronomy*

Τέταρτον τοίνυν, ἣν δ' ἐγώ, τιθῶμεν μάθημα ἀστρονομίαν, ὡς ὑπαρχούσης τῆς νῦν παραλειπομένης, εἰς αὐτὴν πόλις μετίη. . . . ταῦτα μὲν τὰ ἐν τῷ οὐρανῷ ποικίλματα, ἐπεὶ ἐν ὁρατῷ πεποικίλται, κάλλιστα μὲν ἡγεῖσθαι καὶ ἀκριβέστατα τῶν τοιούτων ἔχειν, τῶν δὲ ἀληθινῶν πολὺ ἐνδεῖν, ἅς τὸ ὄν τάχος καὶ ἡ οὐσα βραδυτῆς ἐν τῷ ἀληθινῷ ἀριθμῷ καὶ πᾶσι τοῖς ἀληθέσι σχήμασι φοράς τε πρὸς ἄλληλα φέρεται καὶ τὰ ἐνόητα φέρει, ἃ δὴ λόγῳ μὲν καὶ διανοίᾳ ληπτὰ, ὅψει δ' οὐ· ἣ σὺ οἶει;

Οὐδαμῶς γε, ἔφη.

Οὐκοῦν, εἶπον, τῇ περὶ τὸν οὐρανὸν ποικιλίᾳ παραδείγμασι χρηστέον τῆς πρὸς ἐκεῖνα μαθήσεως ἕνεκα, ὁμοίως ὥσπερ ἂν εἴ τις ἐντύχοι ὑπὸ Δαιδάλου ἢ τινος ἄλλου δημιουργοῦ ἢ γραφέως διαφερόντως γεγραμμένοις καὶ ἐκπεπονημένοις διαγράμμασιν. . . . προβλήμασιν ἄρα, ἣν δ' ἐγώ, χρώμενοι ὥσπερ γεωμετρίαν οὕτω καὶ ἀστρονομίαν μέτιμεν, τὰ δ' ἐν τῷ οὐρανῷ ἐάσομεν, εἰ μέλλομεν ὄντως ἀστρονομίας μεταλαμβάνοντες χρήσιμον τὸ φύσει φρόνιμον ἐν τῇ ψυχῇ ἐξ ἀχρήστου ποιήσιν. . . .

• There seems little doubt that in this passage Plato wished astronomy to be regarded as the pure science of bodies in motion, of which the heavenly bodies could at best afford only one example. Burnet has made desperate efforts to save Plato from himself. According to his contention, Plato meant that astronomy should deal with the true, as opposed to the apparent, motions of the heavenly bodies; it is tempt-

INTRODUCTORY

(δ) *Astronomy*

Let us then put astronomy as the fourth study, regarding that now passed over as waiting only until some state shall take it up. . . . Those broideries yonder in the heaven, forasmuch as they are broidered on a visible ground, are rightly held to be the most beautiful and perfect of visible things, but they are nevertheless far inferior to those that are true, far inferior to those revolutions which absolute speed and absolute slowness, in true number and in all true forms, accomplish relatively to each other, carrying their contents with them—which can indeed be grasped by reason and intelligence, but not by sight. Or do you think otherwise ?

No, indeed, he replied.

Therefore, I said, we should use the broideries round the heaven as examples to help the study of those true objects, just as we might use, if we met with them, diagrams surpassingly well drawn and elaborated by Daedalus or any other artist. . . . Hence, I said, we shall approach astronomy, as we do geometry, by means of problems, but we shall leave the starry heavens alone, if we wish to obtain a real grasp of astronomy, and by that means to make useful, instead of useless, the natural intelligence of the soul. . . .^a

ing but difficult to reconcile this with the decisive language of the text. Fortunately Plato's own pupils in the Academy, notably Eudoxus and Heraclides of Pontus, adopted a different attitude, using mathematics to account for the actual motion of the heavenly bodies ; and Plato himself does not appear to have held consistently to the belief here expressed, for he is said to have put to his pupils the question by what combination of uniform circular revolutions the apparent movements of the heavenly bodies can be explained.

GREEK MATHEMATICS

(ε) *Harmonics*

Κινδυνεύει, ἔφην, ὡς πρὸς ἀστρονομίαν ὄμματα πέπηγεν, ὡς πρὸς ἐναρμόνιον φοράν ὦτα παγῆναι, καὶ αὐταὶ ἀλλήλων ἀδελφαὶ τινες αἱ ἐπιστῆμαι εἶναι, ὡς οἷ τε Πυθαγόρειοί φασι καὶ ἡμεῖς, ὦ Γλαύκων, συγχωροῦμεν.

(iv.) *Logistic*

Schol. in Plat. *Charm.* 165 E

Λογιστική ἐστὶ θεωρία τῶν ἀριθμητῶν, οὐχὶ δὲ τῶν ἀριθμῶν μεταχειριστική, οὐ τὸν ὄντως ἀριθμὸν λαμβάνουσα, ἀλλ' ὑποτιθεμένη τὸ μὲν ἐν ὡς μονάδα, τὸ δὲ ἀριθμητὸν ὡς ἀριθμὸν, οἷον τὰ τρία τριάδα εἶναι καὶ τὰ δέκα δεκάδα· ἐφ' ὧν ἐπάγει τὰ κατὰ ἀριθμητικὴν θεωρήματα. θεωρεῖ οὖν τοῦτο μὲν τὸ κληθὲν ὑπ' Ἀρχιμήδους βοεικὸν πρόβλημα, τοῦτο δὲ μηλίτας καὶ φιαλίτας ἀριθμούς, τοὺς μὲν ἐπὶ φιαλῶν, τοὺς δὲ ἐπὶ ποιίμνης· καὶ ἐπ' ἄλλων δὲ γενῶν τὰ πλήθη τῶν αἰσθητῶν σωμάτων σκοποῦσα, ὡς περὶ τελείων ἀποφαίνεται. ὕλη δὲ αὐτῆς πάντα τὰ ἀριθμητὰ· μέρη δὲ αὐτῆς αἱ Ἑλληνικαὶ καὶ Αἰγυπτιακαὶ καλούμεναι μέθοδοι ἐν πολλαπλασια-

^a See the fragment from Archytas, *supra*, pp. 4-5.

^b Socrates proceeds to censure the Pythagoreans for committing the same error as the astronomers: they investigate the numerical ratios subsisting between audible concords, but do not apply themselves to problems, in order to examine what numbers are consonant and what not, and to find out the reason for the difference (ἐπισκοπεῖν τίνες σύμφωνοι ἀριθμοὶ καὶ τίνες οὐ, καὶ διὰ τί ἑκάτεροι).

^c In the cattle-problem Archimedes sets himself to find the number of bulls and cows of each of four colours. The problem, stripped of its trimmings, is to find eight unknown



THIS PAGE IS LOCKED TO FREE MEMBERS

Purchase full membership to immediately unlock this page

SAVE \$3,999,994

Did you know we sell
paperback books too?

To buy our entire catalog
in paperback would cost
over \$4,000,000

Access it all now for
\$8.99/month

*Fair usage policy applies

Continue

σμοῖς καὶ μερισμοῖς, καὶ αἱ τῶν μορίων συγκεφα-
 λαιώσεις καὶ διαιρέσεις, αἷς ἰχνεύει τὰ κατὰ τὴν
 ὕλην ἐμφωλευόμενα τῶν προβλημάτων τῇ περὶ τοὺς
 τριγώνους καὶ πολυγώνους πραγματεία. τέλος
 δὲ αὐτῆς τὸ κοινωνικὸν ἐν βίῳ καὶ χρήσιμον ἐν
 συμβολαίοις, εἰ καὶ δοκεῖ περὶ τῶν αἰσθητῶν ὡς
 τελείων ἀποφαίνεσθαι.

(v.) *Later Classification*

Anatolius ap. Her. *Def.*, ed. Heiberg 164. 9-18

“ Πόσα μέρη μαθηματικῆς;

“ Τῆς μὲν τιμιωτέρας καὶ πρώτης ὀλοσχερέστερα
 μέρη δύο, ἀριθμητικὴ καὶ γεωμετρία, τῆς δὲ περὶ
 τὰ αἰσθητὰ ἀσχολουμένης ἕξ, λογιστικὴ, γεωδαι-
 σία, ὀπτική, κανονικὴ, μηχανικὴ, ἀστρονομικὴ.
 ὅτι οὔτε τὸ τακτικὸν καλούμενον οὔτε τὸ ἀρχιτε-
 κτονικὸν οὔτε τὸ δημῶδες μουσικὸν ἢ τὸ περὶ τὰς
 φάσεις, ἀλλ’ οὐδὲ τὸ ὁμωνύμως καλούμενον μηχαν-
 νικόν, ὡς οἴονταί τινες, μέρη μαθηματικῆς εἰσι,
 προϊόντος δὲ τοῦ λόγου σαφῶς τε καὶ ἐμμεθόδως
 δείξομεν.”

^a i.e., that which deals with non-sensible objects.

^b Geminus, according to Proclus in *Eucl.* i. (ed. Friedlein 38. 8-12), gives the same classification, only in the order

INTRODUCTORY

tion and splitting up of fractions, whereby it explores the secrets lurking in the subject-matter of the problems by means of the theory of triangular and polygonal numbers. Its aim is to provide a common ground in the relations of life and to be useful in making contracts, but it appears to regard sensible objects as though they were absolute.

(v.) *Later Classification*

Anatolius, cited by Heron, *Definitions*, ed. Heiberg
164. 9-18

“ How many branches of mathematics are there ?

“ There are two main branches of the prime and more honourable type of mathematics,^a arithmetic and geometry ; and there are six branches of that type of mathematics concerned with sensible objects, logistic, geodesy, optics, canonic, mechanics and astronomy.^b That the so-called study of tactics and architecture and popular music and the study of [lunar] phases,^c or even the mechanics so called homonymously,^d are not branches of mathematics, as some think, we shall show clearly and methodically as the argument proceeds.”

arithmetic, geometry, mechanics, astronomy, optics, geodesy, canonic, logistic. Geodesy means the practical measurement of surfaces and volumes ; canonic is the theory of musical intervals ; logistic is the art of calculation, as opposed to arithmetic, by which is meant what we should call the theory of numbers. Geminus proceeds to give an elaborate analysis of the various branches.

^a According to Heiberg, this means “ das Kalenderwesen.”

^d Heiberg interprets this as “ die praktische Mechanik, die sich im Namen von der theoretischen nicht unterscheidet.”

GREEK MATHEMATICS

(b) MATHEMATICS IN GREEK EDUCATION

Iambl. *De Vita Pythag.* 18. 89, ed. Deubner 52. 8-11

Λέγουσι δὲ οἱ Πυθαγόρειοι ἐξενηρέχθαι γεωμετρίαν οὕτως. ἀποβαλεῖν τινα τὴν οὐσίαν τῶν Πυθαγορείων· ὡς δὲ τοῦτο ἠτύχησε, δοθῆναι αὐτῶ χρηματίσασθαι ἀπὸ γεωμετρίας. ἐκαλεῖτο δὲ ἡ γεωμετρία πρὸς Πυθαγόρου ἱστορία.

Plat. *Leg.* vii. 817 E-820 D

ΑΘΗΝΑΙΟΣ ΞΕΝΟΣ. "Ἐτι δὴ τοίνυν τοῖς ἐλευθέροις ἔστιν τρία μαθήματα, λογισμοὶ μὲν καὶ τὰ περὶ ἀριθμοὺς ἐν μάθημα, μετρητικὴ δὲ μήκους καὶ ἐπιπέδου καὶ βάθους ὡς ἐν αὐτῷ δεύτερον, τρίτον δὲ τῆς τῶν ἄστρον περιόδου πρὸς ἄλληλα ὡς πέφυκεν πορεύεσθαι. ταῦτα δὲ σύμπαντα οὐχ ὡς ἀκριβείας ἐχόμενα δεῖ διαπονεῖν τοὺς πολλοὺς ἀλλὰ τινὰς ὀλίγους—οὓς δέ, προϊόντες ἐπὶ τῷ τέλει φράσομεν· οὕτω γὰρ πρέπον ἂν εἴη—τῷ πλήθει δέ, ὅσα αὐτῶν ἀναγκαῖα καὶ πῶς ὀρθότατα λέγεται μὴ ἐπίστασθαι μὲν τοῖς πολλοῖς αἰσχρὸν, δι' ἀκριβείας δὲ ζητεῖν πάντα οὔτε ῥάδιον οὔτε τὸ παράπαν δυνατόν. . . .

Τοσάδε τοίνυν ἐκάστων χρὴ φάναι μαθάνειν δεῖν τοὺς ἐλευθέρους, ὅσα καὶ πάμπολυς ἐν Αἰγύπτῳ παίδων ὄχλος ἅμα γράμμασι μαθάνει. πρῶτον μὲν γὰρ περὶ λογισμοὺς ἀτεχνῶς παισὶν ἐξηυρημένα μαθήματα μετὰ παιδιᾶς τε καὶ ἡδονῆς μαθάνειν,

^a Plato is thought to have redeemed this promise towards the end of the *Laws*, where he describes the composition of the Nocturnal Council, whose members are required to have considerable knowledge of mathematics.

^b The Greek word *gis* derived from the same root as the

INTRODUCTORY

(b) MATHEMATICS IN GREEK EDUCATION

Iamblichus, *On the Pythagorean Life* 18. 89, ed. Deubner
52. 8-11

The Pythagoreans say that geometry was divulged in this manner. A certain Pythagorean lost his fortune ; and when this befell him, he was permitted to make money from geometry. But geometry was called by Pythagoras “ inquiry.”

Plato, *Laws* vii. 817 E-820 D

ATHENIAN STRANGER. Then there are, of course, still three subjects for the freeborn to study. Calculations and the theory of numbers form one subject ; the measurement of length and surface and depth make a second ; and the third is the true relation of the movement of the stars one to another. To pursue all these studies thoroughly and with accuracy is a task not for the masses but for a select few—who these should be we shall say later towards the end of our argument, where it would be appropriate ^a—for the multitude it will be proper to learn so much of these studies as is necessary and so much as it can rightly be described a disgrace for the masses not to know, even though it would be hard, or altogether impossible, to pursue with precision all of those studies. . . .

Well then, the freeborn ought to learn as much of these things as a vast multitude of boys in Egypt learn along with their letters. First there should be calculations of a simple type devised for boys, which they should learn with amusement ^b and pleasure,

Greek word for “ boy,” and Plato is playing on the two words.

GREEK MATHEMATICS

μήλων τέ τινων διανομαὶ καὶ στεφάνων πλείοσιν ἅμα καὶ ἐλάττοσιν ἀρμοττόντων ἀριθμῶν τῶν αὐτῶν, καὶ πυκτῶν καὶ παλαιστῶν ἐφεδρείας τε καὶ συλλήξεως ἐν μέρει καὶ ἐφεξῆς καὶ ὡς πεφύκασι γίνεσθαι. καὶ δὴ καὶ παίζοντες, φιάλας ἅμα χρυσοῦ καὶ χαλκοῦ καὶ ἀργύρου καὶ τοιούτων τινῶν ἄλλων κεραυνύντες, οἱ δὲ καὶ ὅλας πως διαδιδόντες, ὅπερ εἶπον, εἰς παιδιὰν ἐναρμόττοντες τὰς τῶν ἀναγκαίων ἀριθμῶν χρήσεις, ὠφελοῦσι τοὺς μανθάνοντας εἰς τε τὰς τῶν στρατοπέδων τάξεις καὶ ἀγωγὰς καὶ στρατείας καὶ εἰς οἰκονομίας αὐτῶν, καὶ πάντως χρησιμωτέρους αὐτοὺς αὐτοῖς καὶ ἐγρηγορότας μᾶλλον τοὺς ἀνθρώπους ἀπεργάζονται· μετὰ δὲ ταῦτα ἐν ταῖς μετρήσεσιν, ὅσα ἔχει μήκη καὶ πλάτη καὶ βάθη, περὶ ἅπαντα ταῦτα ἐνοῦσάν τινα φύσει γελοίαν τε καὶ αἰσχρὰν ἄγνοιαν ἐν τοῖς ἀνθρώποις πᾶσιν, ταύτης ἀπαλλάττουσιν.

ΚΛΕΙΝΙΑΣ. Ποίαν δὴ καὶ τίνα λέγεις ταύτην;

ΑΘ. ὦ φίλε Κλεινία, παντάπασί γε μὴν καὶ αὐτὸς ἀκούσας ὀψέ ποτε τὸ περὶ ταῦτα ἡμῶν πάθος ἐθαύμασα, καὶ ἔδοξέ μοι τοῦτο οὐκ ἀνθρώπινον ἀλλὰ ὑηνῶν τινων εἶναι μᾶλλον θρεμμάτων, ἡσχύνθην τε οὐχ ὑπὲρ ἑμαυτοῦ μόνον, ἀλλὰ καὶ ὑπὲρ ἀπάντων τῶν Ἑλλήνων.

^a Heath (*H.G.M.* i. 20 n. 1) first satisfactorily explained the construction of this sentence.

^b The Athenian Stranger, generally taken to mean Plato

INTRODUCTORY

such as distributions of apples and crowns wherein the same numbers are divided among more or fewer, or distributions of the competitors in boxing and wrestling matches by the method of byes and drawings, or by taking them in consecutive order, or in any of the usual ways.^a Again, the boys should play with bowls containing gold, bronze, silver and the like mixed together, or the bowls may be distributed as wholes. For, as I was saying, to incorporate in the pupils' play the elementary applications of arithmetic will be of advantage to them later in the disposition of armies, in marches and in campaigns, as well as in household management, and will make them altogether more useful to themselves and more awake. After these things there should be measurements of objects having length, breadth and depth, whereby they would free themselves from that ridiculous and shameful ignorance on all these topics which is the natural condition of all men.

CLEINIAS. And in what, pray, does this ignorance consist?

ATHENIAN STRANGER. My dear Cleinias, when I heard, somewhat belatedly, of our condition in this matter,^b I also was astonished; such ignorance seemed to me worthy, not of human beings, but of swinish creatures, and I felt ashamed, not for myself alone, but for all the Greeks.

himself, proceeds to explain at length that he is referring to the problem of incommensurability. The Greek (*ἀκούσας ὀψέ ποτε*) could mean that he had only lately heard either of incommensurability itself or of the prevalent Greek ignorance about incommensurability. A. E. Taylor comments that in view of references to incommensurability in quite early dialogues it seems better to take the words in the latter sense.

GREEK MATHEMATICS

κλ. Τοῦ περί; λέγ' ὅτι καὶ φῆς, ὦ ξένε.

αθ. Λέγω δὴ· μάλλον δὲ ἐρωτῶν σοι δείξω.
καί μοι μικρὸν ἀποκρίναι· γινώσκεις πού
μῆκος;

κλ. Τί μῆν;

αθ. Τί δέ; πλάτος;

κλ. Πάντως.

αθ. Ἡ καὶ ταῦτα ὅτι δύο ἔστόν, καὶ τρίτον
τούτων βάθος;

κλ. Πῶς γὰρ οὐ;

αθ. Ἄρ' οὖν οὐ δοκεῖ σοι ταῦτα εἶναι πάντα
μετρητὰ πρὸς ἄλληλα;

κλ. Ναί.

αθ. Μῆκός τε οἶμαι πρὸς μῆκος, καὶ πλάτος
πρὸς πλάτος, καὶ βάθος ὡσαύτως δυνατὸν εἶναι
μετρεῖν φύσει.

κλ. Σφόδρα γε.

αθ. Εἰ δ' ἔστι μήτε σφόδρα μήτε ἡρέμα δυνατὰ
ἔνια, ἀλλὰ τὰ μὲν, τὰ δὲ μή, σὺ δὲ πάντα ἡγῆ, πῶς
οἶει πρὸς ταῦτα διακεῖσθαι;

κλ. Δῆλον ὅτι φαύλως.

αθ. Τί δ' αὖ μῆκός τε καὶ πλάτος πρὸς βάθος,
ἢ πλάτος τε καὶ μῆκος πρὸς ἄλληλα; ἄρ' οὐ
διανοούμεθα περὶ ταῦτα οὕτως "Ἕλληνες πάντες,
ὡς δυνατὰ ἔστι μετρεῖσθαι πρὸς ἄλληλα ἀμῶς
γέ πως;

κλ. Παντάπασι μὲν οὖν.

αθ. Εἰ δ' ἔστιν αὖ μηδαμῶς μηδαμῆ δυνατά,
πάντες δ', ὅπερ εἶπον, "Ἕλληνες διανοούμεθα ὡς
δυνατά, μῶν οὐκ ἄξιον ὑπὲρ πάντων αἰσχυθέντα
εἰπεῖν πρὸς αὐτούς· "ὦ βέλτιστοι τῶν Ἑλλήνων,
ἐν ἐκείνων τοῦτ' ἐστὶν ὧν ἔφαμεν αἰσχρὸν μὲν



THIS PAGE IS LOCKED TO FREE MEMBERS

Purchase full membership to immediately unlock this page

FORGOTTEN BOOKS

FULL

MEMBERSHIP

797,885 Books!

All you can read

for only

\$8.99/month

Continue

*Fair usage policy applies



GREEK MATHEMATICS

γεγονέναι τὸ μὴ ἐπίστασθαι, τὸ δ' ἐπίστασθαι
τὰναγκαῖα οὐδὲν πάνυ καλόν;''

κλ. Πῶς δ' οὐ;

αθ. Καὶ πρὸς τούτοις γε ἄλλα ἔστιν τούτων
συγγενῆ, ἐν οἷς αὐ πολλὰ ἁμαρτήματα ἐκείνων
ἀδελφὰ ἡμῖν ἐγγίγνεται τῶν ἁμαρτημάτων.

κλ. Ποῖα δὴ;

αθ. Τὰ τῶν μετρητῶν τε καὶ ἀμέτρων πρὸς
ἄλληλα ἦτινι φύσει γέγονεν· ταῦτα γὰρ δὴ σκο-
ποῦντα διαγιγνώσκειν ἀναγκαῖον ἢ παντάπασιν
εἶναι φαῦλον, προβάλλοντά τε ἀλλήλοις αἰεί, δια-
τριβὴν τῆς πεττείας πολὺ χαριεστέραν πρεσβυτῶν
διατρίβοντα, φιλονικεῖν ἐν ταῖς τούτων ἀξίαισι
σχολαῖς.

κλ. Ἴσως· ἔοικεν γοῦν ἢ τε πεττεία καὶ ταῦτα
ἀλλήλων τὰ μαθήματα οὐ πάμπου κεχωρίσθαι.

Isoc. Panathenaicus 26-28, 238 B-D

Τῆς μὲν οὖν παιδείας τῆς ὑπὸ τῶν προγόνων
καταλειφθείσης τοσοῦτου δέω καταφρονεῖν, ὥστε
καὶ τὴν ἐφ' ἡμῶν κατασταθεῖσαν ἐπαινῶ, λέγω δὲ

* Plato is probably censuring a belief that if two squares are commensurable, their sides are also commensurable; and if two cubes are commensurable, their surfaces and sides are also commensurable. The discovery that this is not necessarily so would arise in such problems as that propounded in *Meno* 82 B—85 B (doubling of a square) and in the duplication of the cube (see *infra*, pp. 256-309). The only difficulty is that commensurability is not always impossible (μηδαμῶς μηδαμῆ δυνατά). A belief that areas and volumes can be expressed in linear measure would meet this stipulation, but it seems too elementary to call for elaborate refutation by Plato.

INTRODUCTORY

to know such necessary matters is no great achievement " ? ^a

CLEIN. Certainly.

ATH. In addition to these, there are other related points, which often give rise to errors akin to those lately mentioned.

CLEIN. What kind of errors do you mean ?

ATH. The real nature of commensurables and incommensurables towards one another.^b A man must be able to distinguish them on examination, or must be a very poor creature. We should continually put such problems to each other—it would be a much more elegant occupation for old people than draughts—and give our love of victory an outlet in pastimes worthy of us.

CLEIN. Perhaps so ; it would seem that draughts and these studies are not so widely separated.

Isocrates, *Panegyric of Athens* 26-28, 238 B-D ^c

So far from despising the education handed down by our ancestors, I even approve that established in

^b According to A. E. Taylor, this means that " behind the more special problems of the commensurability of specific areas and volumes there lies the problem of constructing a general 'theory of incommensurables.' " He calls in the evidence of *Epinomis*, 990 B—991 B, for which see *infra*, pp. 400-405. For further references to the problem see *infra*, pp. 110-111, 214-215.

^c Isocrates began this last of his orations in his ninety-fourth year and it was published in his ninety-eighth. He expresses similar sentiments about mathematics in *Antidosis* §§ 261-268 ; see also Xenophon, *Memorabilia* iv. 7. 2 ff. Heath's dry comment (*H.G.M.* i. 22) is : " It would appear therefore that, notwithstanding the influence of Plato, the attitude of cultivated people in general towards mathematics was not different in Plato's time from what it is to-day."

GREEK MATHEMATICS

τὴν τε γεωμετρίαν καὶ τὴν ἀστρολογίαν καὶ τοὺς διαλόγους τοὺς ἐριστικούς καλουμένους, οἷς οἱ μὲν νεώτεροι μᾶλλον χαίρουσι τοῦ δέοντος, τῶν δὲ πρεσβυτέρων οὐδεὶς ἔστιν, ὅστις ἂν ἀνεκτοὺς αὐτοὺς εἶναι φήσειεν.

Ἄλλ' ὅμως ἐγὼ τοῖς ὠρμημένοις ἐπὶ ταῦτα παρακελεύομαι πονεῖν καὶ προσέχειν τὸν νοῦν ἅπασιν τούτοις, λέγων, ὡς εἰ καὶ μηδὲν ἄλλο δύναται τὰ μαθήματα ταῦτα ποιεῖν ἀγαθόν, ἀλλ' οὖν ἀποτρέπει γε τοὺς νεωτέρους πολλῶν ἄλλῶν ἀμαρτημάτων. τοῖς μὲν οὖν τηλικούτοις οὐδέποτ' ἂν εὐρεθῆναι νομίζω διατριβὰς ὠφελιμωτέρας τούτων οὐδὲ μᾶλλον πρεπούσας· τοῖς δὲ πρεσβυτέροις καὶ τοῖς εἰς ἄνδρας δεδοκιμασμένοις οὐκέτι φημὶ τὰς μελέτας ταύτας ἀρμόττειν. ὁρῶ γὰρ ἐνίους τῶν ἐπὶ τοῖς μαθήμασι τούτοις οὕτως ἀπηκριβωμένων ὥστε καὶ τοὺς ἄλλους διδάσκειν, οὗτ' εὐκαίρως ταῖς ἐπιστήμαις αἷς ἔχουσι χρωμένους, ἔν τε ταῖς ἄλλαις πραγματείαις ταῖς περὶ τὸν βίον ἀφρονεστέρους ὄντας τῶν μαθητῶν· ὁκνῶ γὰρ εἰπεῖν τῶν οἰκετῶν.

(c) PRACTICAL CALCULATION

(i.) Enumeration by Fingers

Aristot. *Prob.* xv. 3, 910 b 23–911 a 1

Διὰ τί πάντες ἄνθρωποι, καὶ βάρβαροι καὶ Ἕλληνες, εἰς τὰ δέκα καταριθμοῦσι, καὶ οὐκ εἰς ἄλλον ἀριθμόν, οἷον β̄, γ̄, δ̄, ε̄, εἶτα πάλιν ἐπαναδιπλοῦσιν, ἔν πέντε, δύο πέντε, ὥσπερ ἔνδεκα, δώδεκα; . . . ἢ ὅτι πάντες ὑπῆρξαν ἄνθρωποι ἔχοντες δέκα δακτύλους; οἷον οὖν ψήφους ἔχοντες

INTRODUCTORY

our own times—I mean geometry, astronomy, and the so-called eristic dialogues, in which our young men delight more than they ought, though there is not one of the older men who would pronounce them tolerable.

Nevertheless I urge those who are inclined to these disciplines to work hard and apply their mind to all of them, saying that even if these studies can do no other good, they at least keep the young out of many other things that are harmful. Indeed, for those who are at this age I maintain that no more helpful or fitting occupations can be found; but for those who are older and those admitted to man's estate I assert that these disciplines are no longer suitable. For I notice that some of those who have become so versed in these studies as to teach others fail to use opportunely the sciences they know, while in the other activities of life they are more unpractical than their pupils—I shrink from saying than their servants.

(c) PRACTICAL CALCULATION

(i.) *Enumeration by Fingers*

Aristotle, *Problems* xv. 3, 910 b 23–911 a 1

Why do all men, both barbarians and Greeks, count up to ten and not up to any other number, such as 2, 3, 4 or 5, whence they would start again, saying, for example, one *plus* five, two *plus* five, just as they say one *plus* ten, two *plus* ten? ^a . . . Is it that all men were born with ten fingers? Having the

^a The Greek words for 11 and 12 mean literally *one-ten*, *two-ten*.

τοῦ οἰκείου ἀριθμοῦ, τούτῳ τῷ πλήθει καὶ τὰ ἄλλα ἀριθμοῦσιν.

Nicolas Rhabdas, ed. Tannery, *Notices et extraits des manuscrits de la Bibliothèque Nationale*, vol. xxxii. pt. 1, pp. 146-152

Ἐκφασίς τοῦ δακτυλικοῦ μέτρου

Ἐν δὲ ταῖς χερσὶ καθέξεις τοὺς ἀριθμοὺς οὕτως· καὶ ἐν μὲν τῇ λαιᾷ, ὀφείλεις ἀεὶ τοὺς μοναδικούς καὶ δεκαδικούς κρατεῖν ἀριθμούς, ἐν δὲ τῇ δεξιᾷ τοὺς ἑκατονταδικούς καὶ χιλιονταδικούς, τοὺς δὲ ἐπέκεινα τούτων χαράττειν ἐν τινι· οὐ γὰρ ἔχεις ὅπως καθέξεις ἐν ταῖς χερσὶ.

Συστελλομένου τοῦ πρώτου καὶ μικροῦ δακτύλου, τοῦ μύωπος καλουμένου, τῶν δὲ τεσσάρων ἐκτεταμένων καὶ ἰσταμένων ὀρθίων, κατέχεις ἐν μὲν τῇ ἀριστερᾷ χειρὶ μονάδα μίαν, ἐν δὲ τῇ δεξιᾷ χιλιοντάδα μίαν.

Καὶ πάλιν συστελλομένου καὶ τούτου καὶ τοῦ μετ' αὐτὸν δευτέρου δακτύλου, τοῦ παραμέσου καὶ ἐπιβάτου καλουμένου, τῶν δὲ λοιπῶν τριῶν ὡς ἔφημεν ἠπλωμένων, κρατεῖς ἐν μὲν τῇ εὐωνύμῳ δύο, ἐν δὲ τῇ δεξιᾷ δισχίλια.

Τοῦ δ' αὖ τρίτου συστελλομένου, ἧτοι τοῦ σφακέλου καὶ μέσου, κειμένων καὶ τῶν ἑτέρων δύο, τῶν

^a The word πεμπάζειν ("to five"), used by Homer (*Od.* iv. 412) in the sense "to count," would appear to be a relic of a quinary system of reckoning. The Greek χεῖρ, like the Latin *manus*, is used to denote "a number" of men, e.g., Herodotus vii. 157, viii. 140; Thucydides iii. 96.

^b Nicolas Artavasdas of Smyrna, called Rhabdas, lived in the fourteenth century A.D. He is the author of two letters

INTRODUCTORY

equivalent of pebbles to the number of their own fingers, they came to use this number for counting everything else as well.^a

Nicolas Rhabdas,^b ed. Tannery, *Notices et extraits des manuscrits de la Bibliothèque Nationale*, vol. xxxii. pt. 1, pp. 146-152

Exposition of finger-notation^c

This is how numbers are represented on the hands: The left hand is always used for the units and tens, and the right hand for the hundreds and thousands, while beyond that some form of characters must be used, for the hands are not sufficient.

Closing the first finger—the little one, called *myope*—and keeping the other four stretched out straight, you have on the left hand 1 and on the right hand 1000.^d

Again, closing this finger together with that next after it—the second, called *next the middle* and *epibate*—and keeping the remaining three fingers open, as we said, you have on the left hand 2 and on the right hand 2000.

Once more, closing the third finger—called *spha-keles* and *middle*—and keeping the other two as

edited by Tannery, of which the second can be dated to the year 1341 by a calculation of Easter. He edited the arithmetical manual of the monk Maximus Planudes.

^b A similar system is explained by the Venerable Bede, *De temporum ratione*, c. i., “De computo vel loquela digitorum.” He implies that St. Jerome (*ob.* A.D. 420) was also acquainted with the system.

^d In the Greek the numerals are sometimes written in full, sometimes in the alphabetic notation, for which see *infra*, p. 43.

δὲ λοιπῶν δύο ἐκτεταμένων, τοῦ λιχανοῦ λέγω καὶ τοῦ ἀντίχειρος, εἰσὶν ἄπερ κρατεῖς ἐν μὲν τῇ λαιᾶ, γ̄, ἐν δὲ τῇ δεξιᾶ, γ̄.

Πάλιν συστελλομένων τῶν δύο, τοῦ μέσου καὶ παραμέσου, ἤγουν τοῦ δευτέρου καὶ τρίτου, καὶ τῶν ἄλλων ὄντων ἐξηπλωμένων, τοῦ ἀντίχειρος λέγω, τοῦ λιχανοῦ καὶ τοῦ μύωπος, εἰσὶν ἄπερ κρατεῖς ἐν μὲν τῇ λαιᾶ, δ̄, ἐν δὲ τῇ δεξιᾶ, δ̄.

Πάλιν τοῦ τρίτου, τοῦ καὶ μέσου, συνεσταλμένου, καὶ τῶν λοιπῶν τεσσάρων ἐκτεταμένων, δηλοῦσιν ἄπερ κρατεῖς (ἐν μὲν τῇ λαιᾶ)¹ ε̄, ἐν δὲ τῇ δεξιᾶ, ε̄.

Τοῦ ἐπιβάτου πάλιν, τοῦ καὶ δευτέρου, συνεσταλμένου καὶ τῶν λοιπῶν (τεσσάρων)² ἤπλωμένων, κρατεῖς ἐν μὲν τῇ εὐωνύμῳ ζ̄, ἐν δὲ τῇ ἑτέρα, ζ̄.

Τοῦ μύωπος πάλιν, τοῦ καὶ πρώτου, ἐκτεταμένου καὶ τῇ παλάμῃ προσψαύοντος, τῶν δὲ λοιπῶν ἰσταμένων ὀρθίως, εἰσὶν ἄπερ κατέχεις, ζ̄, ἐν δὲ τῇ ἄλλῃ, ζ̄.

Τοῦ δευτέρου πάλιν, τοῦ καὶ παραμέσου, ὁμοίως ἐκτεταμένου καὶ κλίνοντος ἄχρις οὗ τῇ κυάθῳ τελείως προσεγγίση, τῶν δὲ λοιπῶν τριῶν, τοῦ τρίτου, τοῦ τετάρτου καὶ τοῦ πέμπτου, ὡς προεῖρηται ἰσταμένων ὀρθίων, τὸ γεγόμενον σχῆμα ἐν μὲν τῇ λαιᾶ δηλοῖ η̄, ἐν δὲ τῇ δεξιᾶ, η̄.

Οὕτως οὖν καὶ τοῦ τρίτου γενομένου, κειμένων καὶ τῶν ἄλλων δύο, τοῦ πρώτου καὶ δευτέρου, κατὰ τὸ αὐτὸ σχῆμα, ἐν μὲν τῇ ἀριστερᾷ δηλοῦσιν θ̄, ἐν δὲ τῇ ἄλλῃ, θ̄.

Πάλιν τοῦ ἀντίχειρος ἤπλωμένου, οὐχὶ δ' ὑπερ-

¹ ἐν . . . λαιᾶ add. Morel.

² τεσσάρων add. Tannery.



THIS PAGE IS LOCKED TO FREE MEMBERS

Purchase full membership to immediately unlock this page

SAVE \$3,999,994

Did you know we sell
paperback books too?

To buy our entire catalog
in paperback would cost
over \$4,000,000

Access it all now for
\$8.99/month

*Fair usage policy applies

Continue

GREEK MATHEMATICS

αιρομένου, ἀλλὰ πλαγίως πως, καὶ τοῦ λιχανοῦ ὑποκλινομένου ἄχρις ἂν τῷ τοῦ ἀντίχειρος προτέρῳ ἄρθρῳ συμπέση, ἕως ἂν γένηται σίγματος σχῆμα, τῶν δὲ λοιπῶν τριῶν φυσικῶς ἠπλωμένων καὶ μὴ χωριζομένων ἀπ' ἀλλήλων, ἀλλὰ συνημμένων, τὸ τοιοῦτον ἐν μὲν τῇ εὐωνύμῳ χειρὶ σημαίνει δέκα, ἐν δὲ τῇ δεξιᾷ ῥ.

(ii.) *The Abacus*

Herod. ii. 36. 4

Γράμματα γράφουσι καὶ λογίζονται ψήφοισι Ἑλληνες μὲν ἀπὸ τῶν ἀριστερῶν ἐπὶ τὰ δεξιὰ φέροντες τὴν χεῖρα, Αἰγύπτιοι δὲ ἀπὸ τῶν δεξιῶν ἐπὶ τὰ ἀριστερά· καὶ ποιεῦντες ταῦτα αὐτοὶ μὲν φασὶ ἐπὶ δεξιὰ ποιέειν, Ἑλληνας δὲ ἐπ' ἀριστερά.

• It is perhaps unnecessary to follow this trifle to its end. Rhabdas proceeds to show how the tens from 20 to 90, and the hundreds from 200 to 900, can be represented in similar manner. Details are given in Heath, *H.G.M.* ii. 552.

I have not found it possible to give a satisfactory rendering of Rhabdas's names for the fingers. Possibly *μύωψ* should be translated *spur* (though this seems a more natural name for the thumb than the first finger) and *ἐπιβάτης rider*; *σφάκελος* (*σφάκελλος* in the mss.) can mean spasms or convulsions, and Mr. Colin Roberts tentatively suggests (to my mind convincingly) that the middle finger is so called because it is joined with the thumb in cracking the fingers.

• The only ancient abaci which have been preserved and can definitely be identified as such are Roman. It is disputed whether the famous Salaminian table, discovered by

INTRODUCTORY

cally but somewhat aslant, and the forefinger is bent until it touches the first joint of the thumb, so that they resemble the letter σ , while the remaining three fingers are kept open in their natural position and not separated from each other but kept together, the figure so formed will signify on the left hand 10 and on the right hand 100.^a

(ii.) *The Abacus*^b

Herodotus ii. 36. 4

In writing and in reckoning with pebbles the Greeks move the hand from left to right, but the Egyptians from right to left^c; in so doing they maintain that they move the hand to the right, and that it is the Greeks who move to the left.

Rangabé and described by him in 1846 (*Revue archéologique* iii.), is an abacus or a game-board; the table now lies in the Epigraphical Museum at Athens and is described and illustrated by Kubitschek (*Wiener numismatische Zeitschrift*, xxxi., 1899, pp. 393-398, with Plate xxiv.), Nagl (*Abhandlungen zur Geschichte der Mathematik*, ix., 1899, plate after p. 357) and Heath, *H.G.M.* i. 49-51. The essence of the Greek abacus, like the Roman, was an arrangement of the columns to denote different denominations, *e.g.*, in the case of the decimal system units, tens, hundreds, and thousands. The number of units in each denomination was shown by pebbles. When the pebbles collected in one column became sufficient to form one or more units of the next highest denomination, they were withdrawn and the proper number of pebbles substituted in the higher column.

^a This implies that the columns were vertical.

GREEK MATHEMATICS

Diog. Laert. i. 59

Ἔλεγε δὲ τοὺς παρὰ τοῖς τυράννοις δυναμένους παραπλησίους εἶναι ταῖς ψήφοις ταῖς ἐπὶ τῶν λογισμῶν. καὶ γὰρ ἐκείνων ἐκάστην ποτὲ μὲν πλείω σημαίνειν, ποτὲ δὲ ἥττω· καὶ τούτων τοὺς τυράννους ποτὲ μὲν ἕκαστον μέγαν ἄγειν καὶ λαμπρόν, ποτὲ δὲ ἄτιμον.

Polyb. *Histor.* v. 26. 13

Ὅντως γὰρ εἰσιν οὗτοι παραπλήσιοι ταῖς ἐπὶ τῶν ἀβακίων ψήφοις· ἐκεῖναί τε γὰρ κατὰ τὴν τοῦ ψηφίζοντος βούλησιν ἄρτι χαλκοῦν καὶ παραυτικά τάλαντον ἰσχύουσιν, οἳ τε περὶ τὰς αὐλὰς κατὰ τὸ τοῦ βασιλέως νεῦμα μακάριοι καὶ παρὰ πόδας ἐλεεινοὶ γίνονται.

INTRODUCTORY

Diogenes Laertius i. 59

He [Solon] used to say that men who surrounded tyrants were like the pebbles used in calculations ; for just as each pebble stood now for more, now for less, so the tyrants would treat each of their courtiers now as great and famous, now as of no account.

Polybius, *History* v. 26. 13

These men are really like the pebbles on reckoning-boards. For the pebbles, according to the will of the reckoner, have the value now of an eighth of an obol, and the next moment of a talent^a ; while courtiers, at the nod of the king, are now happy, and the next moment lying piteously at his feet.

^a In the Salaminian table (see *supra*, p. 34 n. b) the extreme denominations on one side are actually the talent and the χαλκοῦς ($\frac{1}{8}$ obol).

I. ARITHMETICAL NOTATION AND THE CHIEF ARITHMETI- CAL OPERATIONS



THIS PAGE IS LOCKED TO FREE MEMBERS

Purchase full membership to immediately unlock this page

FORGOTTEN BOOKS

FULL

MEMBERSHIP

797,885 Books!

All you can read

for only

\$8.99/month

Continue

*Fair usage policy applies



GREEK MATHEMATICS

four times. Four other symbols are formed by compounding two of the simple signs.

$$\text{Ϛ} (\text{Ϛ and } \Delta) = 50$$

$$\text{ϛ} (\text{Ϛ and H}) = 500$$

$$\text{Ϝ} (\text{Ϛ and X}) = 5000$$

$$\text{ϝ} (\text{Ϛ and M}) = 50000$$

By combinations of these signs it is possible to represent any number from 1 to 50000. For example, $\text{ϜXHHH}\Delta\Delta\text{Ϛ}|||| = 6329$.

Notwithstanding the opinion of Cantor,^a there is very little to be said for this cumbrous notation. A second system devised by the Greeks made use of the letters of the alphabet, with three added letters, as numerals. It is not certain when this system came into use,^b but it had completely superseded the older system long before the time of the writers with whom we shall be concerned, and for the purposes of this book it is the only system which need be noticed. In it an alphabet of 27 letters is used: the first nine letters represent the units from 1 to 9, the second nine represent the tens from 10 to 90, and the third nine represent the hundreds from 100 to 900. To show that a numeral is indicated, a horizontal stroke

^a *Vorlesungen über Geschichte der Mathematik*, i³, p. 129.

^b For a full consideration of the date given by Larfeld (end of eighth century B.C.) and that given by Keil (550–425 B.C.), see Heath, *H.G.M.* i. 33-34.

ARITHMETICAL NOTATION

is generally placed above the letter in cursive writing, as in the following scheme ^a

$\bar{\alpha} = 1$	$\bar{\iota} = 10$	$\bar{\rho} = 100$
$\bar{\beta} = 2$	$\bar{\kappa} = 20$	$\bar{\sigma} = 200$
$\bar{\gamma} = 3$	$\bar{\lambda} = 30$	$\bar{\tau} = 300$
$\bar{\delta} = 4$	$\bar{\mu} = 40$	$\bar{\upsilon} = 400$
$\bar{\epsilon} = 5$	$\bar{\nu} = 50$	$\bar{\phi} = 500$
$\bar{\varsigma} = 6$	$\bar{\xi} = 60$	$\bar{\chi} = 600$
$\bar{\zeta} = 7$	$\bar{\omicron} = 70$	$\bar{\psi} = 700$
$\bar{\eta} = 8$	$\bar{\pi} = 80$	$\bar{\omega} = 800$
$\bar{\theta} = 9$	$\bar{\varsigma} = 90$	$\bar{\xi} = 900$

The horizontal stroke is often omitted for convenience in printed texts.

In this system there are three letters ς (Stigma, a form of the digamma), ξ or φ (Koppa) and ξ (Sampi) which had been taken over by the Greeks from the Phoenician alphabet but had dropped out of literary use. As there is no record of this alphabet of 27 letters in this order being in use at any time, it seems to have been deliberately framed by someone for the purposes of mathematics.^b Though more concise than the Attic system, it suffers from the disadvantage of giving no indication of place-value; the connexion between $\bar{\epsilon}$, $\bar{\nu}$ and $\bar{\phi}$, for example, does not leap to the eye as in the Arabic notation 5, 50, 500.

^a In some texts the method of indicating that a letter stands for a numeral is an accent placed above the letter and to the right, in the following manner :

$$\alpha' = 1, \iota' = 10, \rho' = 100.$$

A double accent is used to indicate submultiples, e.g.,

$$\gamma'' = \frac{1}{3}, \lambda'' = \frac{1}{30}, \tau'' = \frac{1}{300}.$$

^b Gow, *A Short History of Greek Mathematics*, pp. 45-46.

GREEK MATHEMATICS

Opinions differ greatly on the facility with which it could be used, but the balance of opinion is in favour of the view that it was an obstacle to the development of arithmetic by the Greeks.

By combination of these letters, it is possible to represent any number from 1 to 999. Thus $\overline{\rho\nu\gamma} = 153$. For the thousands from 1000 to 9000 the letters α to θ are used again with a distinguishing mark, generally a stroke subscribed to the letter a little to the left, in addition to the horizontal stroke above the letter.

Thus $\overline{\alpha} = 1000, \overline{\beta} = 2000, \dots, \overline{\theta} = 9000$.

For tens of thousands the sign M is used, generally with the number of myriads written above it.

Thus $\overset{\alpha}{M} = 10000, \overset{\beta}{M} = 20000$, and so on (Eutocius).

Another method is to use the sign M or $\overset{\gamma}{M}$ for the myriad and to put the number of myriads after it, separated by a dot from the thousands.

Thus

$\overset{\gamma}{M}\overline{\rho\delta} \cdot \overline{\eta\phi\sigma} = 1048576$ (Diophantus vi. 22, ed. Tannery 446. 11).

In a third method the symbol M is not used, but the symbol representing the number of myriads has two dots placed over it.

Thus

$\ddot{\alpha}\overline{\eta\phi\zeta\sigma} = 18596$ (Heron, *Geometrica* xvii. 33, ed. Heiberg 348. 35).

Heron commonly wrote the word $\mu\nu\rho\iota\acute{\alpha}\delta\epsilon\varsigma$ in full.

To express still higher numbers, powers of myriads were used. Apollonius and Archimedes invented

ARITHMETICAL NOTATION

systems of "tetrads" and "octads" respectively to indicate powers of 10000 and 100000000.

There was no single Greek system for representing fractions. With submultiples, the orthodox method was to write the letter for the corresponding number with an accent instead of a horizontal dash, *e.g.*, $\delta' = \frac{1}{4}$. There were special signs, \angle' and C' , for $\frac{1}{2}$, and ω' for $\frac{2}{3}$. The Greeks, like the Egyptians, tried to express ordinary proper fractions as the sum of two or more submultiples. Thus $\angle' \delta' = \frac{1}{2} + \frac{1}{4} = \frac{3}{4}$, $\angle' \xi \delta' = \frac{1}{2} + \frac{1}{8} = \frac{5}{8}$ (Eutocius). There was a limit to what could be done in this way, and the Greeks devised several methods of representing ordinary proper fractions. The most convenient is that used by Diophantus, and occasionally by Heron. The numerator is written underneath the denominator, which is the reverse of our modern practice. Thus $\chi^{\circ 5}_{\iota \epsilon} = \frac{15}{878}$. A method commonly used in Heron's works was to write the denominator twice and with an accent, *e.g.*, $\bar{\delta} \zeta' \zeta' = \frac{4}{7}$, $\bar{\iota \beta} \zeta' \zeta' = \frac{12}{7}$. Sometimes the word $\lambda \epsilon \pi \tau \acute{\alpha}$ ("fractional parts") was added, *e.g.*, $\lambda \epsilon \pi \tau \grave{\alpha} \nu \alpha' \nu \alpha' \bar{\lambda \epsilon} = \frac{35}{51}$. There is no fixed order of preference for numerator and denominator. In Aristarchus of Samos we find $\delta \acute{\upsilon} \circ \mu \epsilon'$ for $\frac{2}{45}$ and in Archimedes $\bar{\iota} \circ \alpha'$ for $\frac{10}{71}$, where only the context will show that $10\frac{1}{71}$ is not intended.

Several fragments illustrating elementary mathematical operations have come to light among the Egyptian papyri.^a The following tables (2nd cent. A.D.) show how fractions can be represented as sums of submultiples. The Greek is set out in columns. The

^a I am indebted to Mr. Colin Roberts for drawing my attention to them.

GREEK MATHEMATICS

first two columns give the numerator of the fraction to be split up. The denominator is not explicitly announced in the table, but it is implicit in the first line. Fractions are marked with signs like accents, usually but not always over every letter. The sign Δ for $\frac{1}{4}$ will be noted. Dots under letters indicate doubtful readings.

Michigan Papyri, No. 145, vol. iii. (*Humanistic Series*, vol. xl.) p. 36

I, ii

A Table of Twenty-thirds

της	α	κ'γ'		
[των	β]	ι'β'	σο'ς'	
[των	γ]	ι'	μ'ς'	ρ'ι'ε'
[των	δ	ς']'	ρ'λ'η'	
[των	ε	ς'	κ'γ']'	ρλ'[η']

Equivalent in Arabic Notation

$$\begin{aligned} \frac{1}{23} &= \frac{1}{23} \\ \frac{2}{23} &= \frac{1}{12} + \frac{1}{278} \\ \frac{3}{23} &= \frac{1}{10} + \frac{1}{46} + \frac{1}{115} \\ \frac{4}{23} &= \frac{1}{8} + \frac{1}{138} \\ \frac{5}{23} &= \frac{1}{8} + \frac{1}{23} + \frac{1}{138} \end{aligned}$$

ii

A Table of Twenty-ninths

των	ιβ	Δ	η'	κθ'	σλ'β'	
[των]	ιγ	γ'	ι'ε'	[κ'θ'	π']ξ'	ι[λ'ε']
[των]	ιδ	Δ	ε'	[ν']η'	ρις'	ρμ'ε'
[των]	ιε	∠	ν'η'			
[των	ι]ς		[∠	κ']θ'	ν'η'	
[των	ιζ	∠		ι'β']	τ'μ'η'	

ARITHMETICAL NOTATION

Equivalent in Arabic Notation

$$\begin{aligned} \frac{12}{29} &= \frac{1}{4} + \frac{1}{8} + \frac{1}{29} + \frac{1}{232} \\ \frac{13}{29} &= \frac{1}{3} + \frac{1}{15} + \frac{1}{29} + \frac{1}{87} + \frac{1}{435} \\ \frac{14}{29} &= \frac{1}{4} + \frac{1}{5} + \frac{1}{58} + \frac{1}{116} + \frac{1}{145} \\ \frac{15}{29} &= \frac{1}{2} + \frac{1}{58} \\ \frac{16}{29} &= \frac{1}{2} + \frac{1}{29} + \frac{1}{58} \\ \frac{17}{29} &= \frac{1}{2} + \frac{1}{12} + \frac{1}{348} \end{aligned}$$

The Greeks had no sign corresponding to 0, and never rose to the conception of 0 as a number.^a Having no need of a sign to indicate decimal position, they wrote such a number as 1007 in only two letters— $\overline{\alpha\zeta}$.

By means of these devices the Greeks had a complete system of enumeration. Here are a few examples of complicated numbers taken from Eutocius :

$$\begin{array}{c} \rho\lambda\zeta \\ \text{M} \end{array} \overline{\gamma\lambda\mu\gamma} \angle' \xi\delta' = 1373943\frac{1}{2}\frac{1}{8}\frac{1}{4} = 1373943\frac{33}{84}.$$

$$\begin{array}{c} \phi\mu\zeta \\ \text{M} \end{array} \overline{\beta\varsigma} \angle' \iota\varsigma' = 5472090\frac{1}{2}\frac{1}{18} = 5472090\frac{9}{18}.$$

With these symbols the Greeks conducted the chief mathematical operations in much the same manner, and with much the same facility, as we do. The following is an example of multiplication from

^a In his sexagesimal notation, Ptolemy used the symbol **O** to stand for *οὐδεμία μοῖρα* or *οὐδὲν ἑξήκοστόν*. The diverse views which have been held on this symbol from the time of Delambre are summed up by Loria (*Le scienze esatte nell' antica Grecia*, p. 761) in the words: "In base ai documenti scoperti e decifrati sino ad oggi, siamo autorizzati a negare che i Greci usassero lo zero nel senso e nel modo in cui lo adoperiamo noi."

GREEK MATHEMATICS

Eutocius's commentary on Archimedes' *Measurement of a Circle* (Archim., ed. Heiberg iii. 242):

$\overline{\rho\nu\gamma}$	153		
$\acute{\epsilon}\pi\grave{\iota} \overline{\rho\nu\gamma}$	$\times 153$		
$\overset{\alpha}{\text{M}} \overline{\epsilon\tau}$	15300		
$\overline{\epsilon} \overline{\beta\phi} \overline{\rho\nu}$	5000	2500	150
$\overline{\tau} \overline{\rho\nu\theta}$		300	159
$\delta\mu\omicron\upsilon \overset{\beta}{\text{M}} \overline{\gamma\nu\theta}$	Total	23409	

The operation, it will be noticed, is split up into a number of simple operations. 153 is first multiplied by 100, then 100, 50 and 3 are separately multiplied by 50, and lastly 100 and 53 are separately multiplied by 3. The products are finally all added together to make the total of 23409.

Only one example of long division fully worked out survives in the whole of the extant corpus of Greek mathematical writings—in Theon's *Commentary on the Syntaxis of Ptolemy*. The same work contains an example of the extraction of a square root. Both passages will be reproduced, but as the notation is sexagesimal a few words of explanation are necessary.

The sexagesimal notation had its origin among the Babylonians and was used by the Greeks in astronomical calculations. It appears fully developed in the *Syntaxis* of Ptolemy and the *Commentaries* of Theon and Pappus.^a In this system the circumference of a

^a Theon of Alexandria (to be distinguished from Theon of Smyrna) is dated by Suidas in the reign of Theodosius I (A.D. 379–395). His commentary on Ptolemy's *Syntaxis* is in eleven books, and his famous daughter Hypatia assisted in its revision. Pappus of Alexandria flourished in the reign of



THIS PAGE IS LOCKED TO FREE MEMBERS

Purchase full membership to immediately unlock this page

SAVE \$3,999,994

Did you know we sell
paperback books too?

To buy our entire catalog
in paperback would cost
over \$4,000,000

Access it all now for
\$8.99/month

*Fair usage policy applies

Continue

GREEK MATHEMATICS

(b) DIVISION

Theon Alex. in Ptol. Math. Syn. Comm. i. 10, ed. Rome, *Studi e Testi*, lxxii. (1936), 461. 1-462. 17

Ἔστω δὲ καὶ ἀνάπαλιν δοθέντα ἀριθμὸν μερίσαι παρά τε μοίρας καὶ πρῶτα καὶ δεύτερα ἑξηκοστά. ἔστω ὁ δοθεὶς ἀριθμὸς ὁ $\overline{\alpha\phi\iota\epsilon\ \kappa\ \iota\epsilon}$. καὶ δεόν ἔστω μερίσαι αὐτὸν παρά τὸν $\overline{\kappa\epsilon\ \iota\beta\ \iota}$, τουτέστιν εὐρεῖν ποσάκις ἐστὶν ὁ $\overline{\kappa\epsilon\ \iota\beta\ \iota}$ ἐν τῷ $\overline{\alpha\phi\iota\epsilon\ \kappa\ \iota\epsilon}$.

Μερίζομεν αὐτὸν πρῶτον παρά τὸν ξ , ἐπειδήπερ ὁ παρά τὸν $\xi\alpha$ ὑπερπίπτει καὶ ἀφαιροῦμεν ἑξηκοντάκι τὸν τε $\overline{\kappa\epsilon}$ καὶ τὸν $\overline{\iota\beta}$, καὶ ἔτι τὸν $\overline{\iota}$. καὶ πρότερον τὸν $\overline{\kappa\epsilon}$, καὶ γίνονται $\overline{\alpha\phi}$. εἶτα ἐπὶ τῶν λοιπῶν μοιρῶν $\overline{\iota\epsilon\ \kappa\ \iota\epsilon}$ ἀναλύσαντες τὰς $\overline{\iota\epsilon}$ μοίρας εἰς πρῶτα ἑξηκοστά καὶ προσθέντες αὐτοῖς τὰ πρῶτα ἑξηκοστά $\overline{\kappa}$ ἀπὸ τῶν γενομένων $\overline{\lambda\kappa}$ πρῶτα πάλιν ἑξηκοστά ἀφαιροῦμεν ἑξηκοντάκις τὰ $\overline{\iota\beta}$, τουτέστιν $\overline{\psi\kappa}$. καὶ ἔτι ἀπὸ τῶν λοιπῶν πρῶτων ἑξηκοστῶν $\overline{\sigma}$ καὶ δευτέρων $\overline{\iota\epsilon}$ ἀφαιροῦμεν ἑξηκοντάκις πάλιν τὰ $\overline{\iota}$. γίνεται δεύτερα μὲν ἑξηκοστά

• We may exhibit Theon's working as follows :

$$\begin{array}{r}
 \text{1st division} \quad \underline{\underline{25^\circ 12' 10''}} \overline{\underline{1515^\circ}} \quad \underline{\underline{20' 15''}} \overline{\underline{60^\circ}} \\
 \quad \quad \quad \quad \quad \quad \quad \quad \underline{25^\circ \cdot 60^\circ = 1500^\circ} \\
 \quad \quad \quad \quad \quad \quad \quad \quad \quad \quad \underline{15^\circ = 900'} \\
 \quad \quad \quad \quad \quad \quad \quad \quad \quad \quad \quad \quad \underline{20'} \\
 \quad \quad \quad \quad \quad \quad \quad \quad \quad \quad \quad \quad \quad \underline{920'} \\
 \quad \quad \quad \quad \quad \quad \quad \quad \quad \quad \quad \underline{12' \cdot 60^\circ = 720'} \\
 \quad \quad \quad \quad \quad \quad \quad \quad \quad \quad \quad \quad \quad \underline{200'} \quad \underline{15''} \\
 \quad \quad \quad \quad \quad \quad \quad \underline{10'' \cdot 60^\circ = 10'}
 \end{array}$$

ARITHMETICAL NOTATION

(b) DIVISION

Theon of Alexandria, *Commentary on Ptolemy's Syntaxis*, i. 10, ed. Rome, *Studi e Testi*, lxxii. (1936), 461. 1-462. 17

Conversely, let it be required to divide a given number by a number expressed in degrees, minutes and seconds. Let the given number be $1515^{\circ} 20' 15''$; and let it be required to divide this by $25^{\circ} 12' 10''$, that is, to find how often $25^{\circ} 12' 10''$ is contained in $1515^{\circ} 20' 15''$.^a

We take 60° as the first quotient, for 61° is too big; and we subtract sixty times 25° and sixty times $12'$ and also sixty times $10''$. Firstly, we take away sixty times 25° , which is 1500° . In the remainder, $15^{\circ} 20' 15''$, we split up the 15° into minutes and add to them the $20'$; and from the resulting $920'$ we subtract sixty times $12'$, that is, $720'$. This leaves $200' 15''$, and we now subtract

2nd division

$$\begin{array}{r}
 25^{\circ} 12' 10'' \overline{) 190' \quad 15''} \underline{7'} \\
 \underline{25^{\circ}.7' = 175'} \\
 15' = 900'' \\
 \quad \quad \quad 15'' \\
 \quad \quad \quad \underline{\quad} \\
 \quad \quad \quad 915'' \\
 \quad \quad 12'.7' = \quad 84'' \\
 \quad \quad \quad \underline{\quad} \\
 \quad \quad \quad 831'' \\
 \quad 10''.7' = \quad 1'' 10'''
 \end{array}$$

3rd division

$$\begin{array}{r}
 25^{\circ} 12' 10'' \overline{) 829'' 50'''} \underline{33''} \\
 \underline{25^{\circ}.33'' = 825''} \\
 \quad \quad \quad \underline{\quad} \\
 \quad \quad \quad 4'' 50''' = 290''' \\
 \quad 12'.33'' = \quad \quad \quad \underline{396'''}
 \end{array}$$

GREEK MATHEMATICS

$\bar{\chi}$, πρῶτα δὲ $\bar{\iota}$. εἶτα πάλιν τὰ ὑπολιπέντα¹ πρῶτα
 ἐξηκοστὰ $\bar{\rho}\zeta$ καὶ δεύτερα $\bar{\iota}\epsilon$ μερίζομεν παρὰ τὸν
 $\bar{\kappa}\epsilon$, καὶ γίνεται ὁ μερισμὸς παρὰ $\bar{\zeta}$. ὑπερπίπτε
 γὰρ παρὰ τὸν $\bar{\eta}$. καὶ τὰ γενόμενα ἐκ τῆς παρα-
 βολῆς ἐξηκοστὰ πρῶτα $\bar{\rho}\sigma\epsilon$ ἀφείλομεν ἀπὸ τῶν
 $\bar{\rho}\zeta$ πρώτων ἐξηκοστῶν. ἔπειτα τὰ λοιπὰ $\bar{\iota}\epsilon$ πρῶτα
 ἐξηκοστὰ ἀναλύσαντες εἰς δεύτερα $\bar{\lambda}$ καὶ προσ-
 θέντες αὐτοῖς τὰ δεύτερα ἐξηκοστὰ $\bar{\iota}\epsilon$, ἀπὸ τῶν
 γενομένων $\bar{\lambda}\iota\epsilon$ ἀφαιροῦμεν ἑπτάκις τὰ $\bar{\iota}\beta$ πρῶτα
 ἐξηκοστά, τουτέστιν $\bar{\pi}\delta$ δεύτερα ἐξηκοστά, διὰ τὸ
 καὶ τὰ $\bar{\zeta}$ πρῶτα εἶναι ἐξηκοστά. καὶ ὑπολείπεται
 λοιπὰ $\bar{\omega}\lambda\alpha$ δεύτερα ἐξηκοστά. καὶ ἔτι ἀφελοῦμεν
 ὁμοίως ἑπτάκις καὶ τὰ $\bar{\iota}$ δεύτερα ἐξηκοστά, ἃ
 γίνεται τρίτα ἐξηκοστὰ $\bar{\sigma}$, τουτέστιν δεύτερον $\bar{\alpha}$
 καὶ τρίτα $\bar{\iota}$. καὶ λοιπὰ ὑπελίπη δεύτερα ἐξηκοστὰ
 $\bar{\omega}\kappa\theta$ καὶ τρίτα $\bar{\nu}$. ταῦτα πάλιν παρὰ τὸν $\bar{\kappa}\epsilon$. καὶ
 γίνεται ὁ μὲν μερισμὸς παρὰ τὸν $\bar{\lambda}\gamma$, ἐκ δὲ τῆς
 παραβολῆς $\bar{\omega}\kappa\epsilon$ δεύτερα ἐξηκοστά. καὶ λοιπὰ
 ὑπελίπη δεύτερα ἐξηκοστὰ $\bar{\delta}$, τρίτα δὲ $\bar{\nu}$, ὁμοῦ δὲ
 τρίτα $\bar{\sigma}\zeta$. ἔπειτα πάλιν ἀφείλομεν τὰ $\bar{\iota}\beta$ πρῶτα
 ἐξηκοστὰ τριακοντάκι καὶ τρίς καὶ γίνεται τρίτα
 $\bar{\tau}\zeta\varsigma$, ὡς ποιεῖν ἔγγιστα τὸν μερισμὸν τὸν $\bar{\alpha}\phi\iota\epsilon\ \bar{\kappa}\ \bar{\iota}\epsilon$
 παρὰ τὸν $\bar{\kappa}\epsilon$ $\bar{\iota}\beta$ $\bar{\iota}$, $\bar{\xi}$ $\bar{\zeta}$ $\bar{\lambda}\gamma$, ἐπεὶ καὶ ἐὰν ταῦτα
 πολλαπλασιάσωμεν ἐπὶ τὰ $\bar{\kappa}\epsilon$ $\bar{\iota}\beta$ $\bar{\iota}$ συνάγεται ὁ
 $\bar{\alpha}\phi\iota\epsilon\ \bar{\kappa}\ \bar{\iota}\epsilon$ ἔγγιστα.

$\bar{\alpha}\phi\iota\epsilon\ \bar{\kappa}\ \bar{\iota}\epsilon$ $\bar{\kappa}\epsilon\ \bar{\iota}\beta\ \bar{\iota}$ $\bar{\xi}\ \bar{\zeta}\ \bar{\lambda}\gamma$

(c) EXTRACTION OF SQUARE ROOT

Ibid. 469. 16-473. 8

Τούτων θεωρηθέντων, ἐξῆς ἂν εἴη διαλαβεῖν πῶς
 52

ARITHMETICAL NOTATION

sixty times $10''$; that is $600''$, or $10'$. The remainder is $190' 15''$, and, making a new start, we divide by 25° ; the quotient is $7'$, for $8'$ is too big. The number resulting from this division is $175'$, which we subtract from the $190'$. There is a remainder of $15'$, which we split up into $900''$ and to it add the $15''$; from the resulting $915''$ we subtract seven times $12'$, which is $84''$ on account of the seven being minutes; there is left a remainder $831''$. Similarly we subtract seven times $10''$, which is $70'''$, or $1'' 10'''$. The remainder is $829'' 50'''$. We divide this in turn by 25° . The quotient is $33''$, and the number resulting from the division is $825''$, leaving a remainder of $4'' 50'''$, or $290'''$. Next we subtract thirty-three times $12'$, which is $396'''$. Thus the quotient obtained by dividing $1515^\circ 20' 15''$ by $25^\circ 12' 10''$ is approximately $60^\circ 7' 33''$, inasmuch as, if we multiply this quotient by $25^\circ 12' 10''$, the result will be approximately $1515^\circ 20' 15''$.

$1515^\circ 20' 15''$

$25^\circ 12' 10''$

$60^\circ 7' 33''$

(c) EXTRACTION OF SQUARE ROOT

Ibid. 469. 16–473. 8

After this demonstration the next step is to inquire

¹ “Forme suspecte. Voir pourtant Hirt, *Handbuch der griechischen Laut- und Formenlehre*, 2^e éd., Heidelberg, 1912, p. 506.”—Rome.

GREEK MATHEMATICS

ἂν δοθέντος χωρίου τινὸς τετραγώνου μὴ ἔχοντος πλευρὰν μήκει ῥητὴν τὴν σύνεγγυς αὐτοῦ τετραγωνικὴν πλευρὰν ἐπιλογισώμεθα. καὶ ἔστιν τὸ τοιοῦτον δῆλον ἐπὶ ῥητὴν ἔχοντος πλευρὰν, ἐκ τοῦ δ' θεωρήματος τοῦ β' βιβλίου τῶν Στοιχείων, οὗ ἡ πρότασις ἐστὶν τοιαύτη· ἐὰν εὐθεῖα γραμμὴ τμηθῆ ὡς ἔτυχεν, τὸ ἀπὸ τῆς ὅλης τετράγωνον ἴσον ἐστὶν τοῖς τε ἀπὸ τῶν τμημάτων τετραγώνοις καὶ τῷ δις ὑπὸ τῶν τμημάτων περιεχομένῳ ὀρθογωνίῳ. ἐὰν γὰρ ἔχοντες δοθέντα ἀριθμὸν τετράγωνον ὡς τὸν $\overline{\rho\mu\delta}$, ῥητὴν ἔχοντα πλευρὰν ὡς τὴν AB εὐθεῖαν, καὶ λαβόντες αὐτοῦ ἐλάσσονα τετράγωνον τὸν $\overline{\rho}$, οὗ ἐστὶν πλευρὰ $\overline{\iota}$, καὶ ὑποθέμενοι τὴν AG $\overline{\iota}$, διπλασιάσαντες αὐτὴν [καὶ]¹ διὰ τὸ δις ὑπὸ τῶν AG , GB , <παρὰ>² τὰ γενόμενα $\overline{\kappa}$ παραβάλωμεν [παρὰ]³ τὰ λοιπὰ $\overline{\mu\delta}$, τῶν ὑπολειπομένων $\overline{\delta}$ ἔσται τὸ ἀπὸ τῆς GB , αὕτη δὲ μήκει $\overline{\beta}$. ἦν δὲ καὶ ἡ AG $\overline{\iota}$. καὶ ὅλη ἄρα ἡ AB ἔσται μοιρῶν $\overline{\iota\beta}$, ὅπερ ἔδει δεῖξαι.

¹ καὶ om. Rome.

² παρὰ add. Rome.

³ παρὰ om. Rome.

- The diagram will make the procedure clear. The square

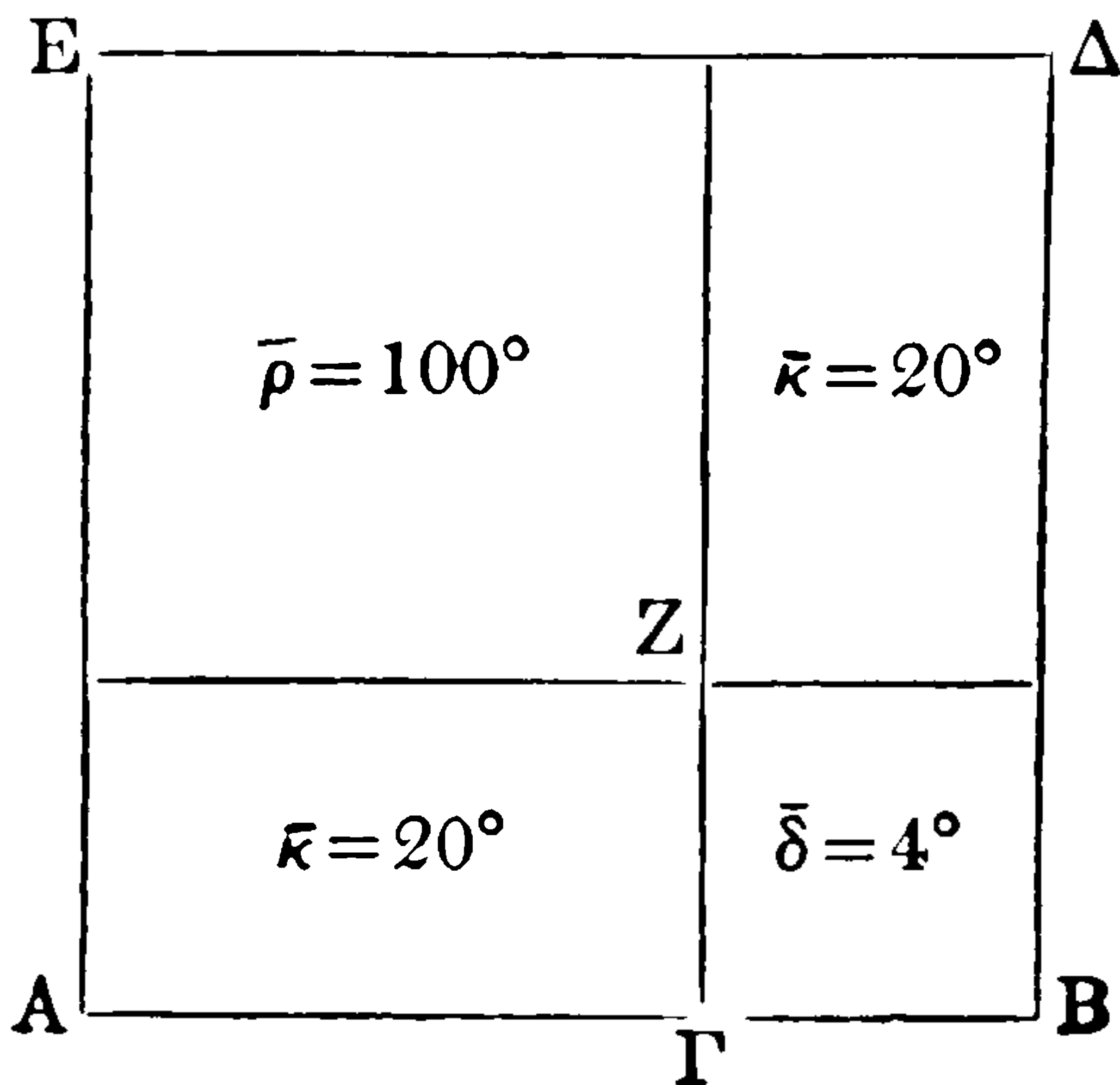

ARITHMETICAL NOTATION

in what manner, given the area of a square whose side is irrational, we may make an approximation to its side. In the case of a square with a rational side the method is clear from the fourth theorem of the second book of the *Elements*, whose enunciation is as follows : *If a straight line be cut at random, the square on the whole is equal to the squares on the segments, and twice the rectangle contained by the segments.* For if the given number is a square such as 144, having a rational side AB, we take the square 100, which is less than 144 and has 10 as its side, and make AΓ equal to 10. Doubling it, because the rectangle contained by AΓ, ΓB is taken twice, we get 20, and by this number we divide the remainder 44, obtaining a remainder 4 as the square on ΓB, whose length will therefore be 2. Now AΓ was 10, and therefore the whole AB is 12, which was to be proved.^a

AΔ is divided up into the squares EZ, BZ and the equal rectangles AZ, ZΔ.

Thus, square AΔ = square EZ + 2 rect. AZ + square BZ or $144 = 10^2 + 2 \cdot 10 \cdot 2 + 2^2$. Generally, if a given square number A is equal to $(a + x)^2$, where a^2 is a first approximation, then

$$A = a^2 + 2ax + x^2$$

and we find the value of x by dividing $2a$ into the remainder when a^2 is subtracted from A.

If A is not a square number, then this gives a method of finding an approximation, $a + x$, to the square root.

GREEK MATHEMATICS

ἵνα δὲ καὶ ἐπί τινος τῶν ἐν τῇ Συντάξει παρακειμένων ἀριθμῶν ὑπ' ὄψιν ἡμῶν γένηται ἢ τῆς κατὰ μέρος ἀφαιρέσεως διάκρισις, ποιησόμεθα τὴν ἀπόδειξιν ἐπὶ τοῦ $\overline{\delta\phi}$ ἀριθμοῦ, οὗ τὴν πλευρὰν ἐξέθετο μοιρῶν $\overline{\xi\zeta}$ δ' $\overline{\nu\epsilon}$. ἐκκείσθω χωρίον τετράγωνον τὸ ΑΒΓΔ, δυνάμει μόνον ῥητόν, οὗ τὸ ἐμβαδὸν ἔστω μοιρῶν $\overline{\delta\phi}$, καὶ δέον ἔστω τὴν σύνεγγυς αὐτοῦ

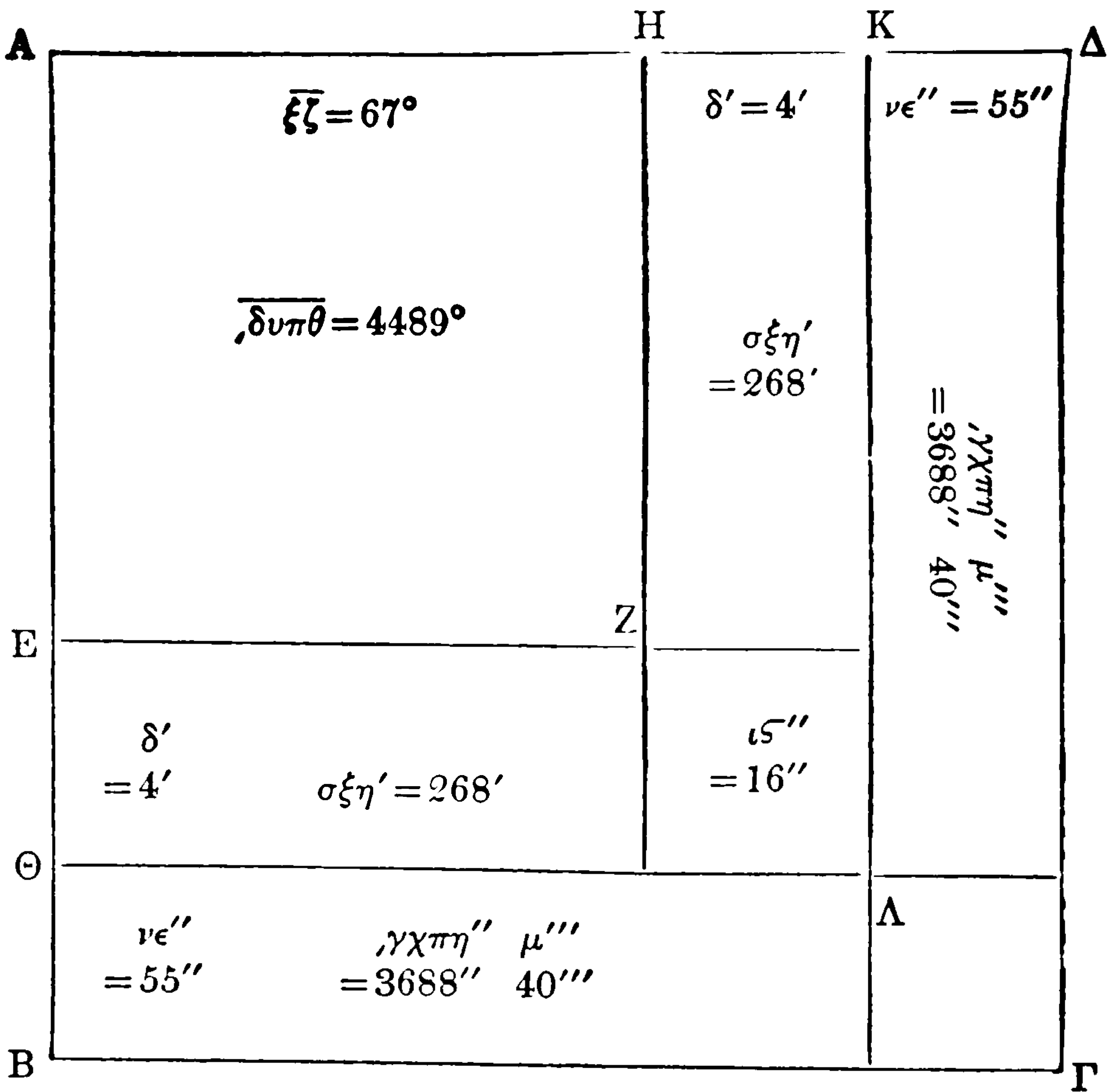

τετραγωνικὴν πλευρὰν ἐπιλογίσασθαι. ἐπεὶ οὖν ὁ

^a The method which Theon proposes to use may be summarized as follows. A first approximation to the square root 56



THIS PAGE IS LOCKED TO FREE MEMBERS

Purchase full membership to immediately unlock this page

FORGOTTEN BOOKS

FULL

MEMBERSHIP

797,885 Books!

All you can read

for only

\$8.99/month

Continue

*Fair usage policy applies



GREEK MATHEMATICS

σύνεγγυς τοῦ $\overline{\delta\phi}$ τετράγωνος ῥητὴν ἔχων πλευρὰν
 ὄλων μονάδων ἐστὶν $\overline{\delta\upsilon\pi\theta}$ ἀπὸ πλευρᾶς τοῦ $\overline{\xi\zeta}$,
 ἀφηρήσθω ἀπὸ τοῦ $\overline{ΑΒΓΔ}$ τετραγώνου τὸ $\overline{ΑΖ}$
 τετράγωνον μονάδων $\overline{\delta\upsilon\tau\theta}$ οὗ ἡ πλευρὰ ἔστω μονά-
 δων $\overline{\xi\zeta}$. ὁ λοιπὸς ἄρα ὁ $\overline{ΒΖΖΔ}$ γνώμων ἔσται
 μονάδων $\overline{\iota\alpha}$, ἃς ἀναλύσαντες εἰς πρῶτα ἐξηκοστὰ
 $\overline{\chi\psi}$ ἐκθησόμεθα. ἔπειτα διπλασιάσαντες τὴν $\overline{ΕΖ}$ διὰ
 τὸ δις ὑπὸ $\overline{ΕΖ}$, ὡσπερ ἐπ' εὐθείας τῆς $\overline{ΕΖ}$ τὴν $\overline{ΖΗ}$
 λαμβάνοντες, παρὰ τὰ γινόμενα $\overline{\rho\lambda\delta}$ παραβαλοῦμεν
 τὰ $\overline{\chi\psi}$ ἐξηκοστὰ πρῶτα, καὶ τῶν γενομένων ἐκ τῆς
 παραβολῆς δ πρώτων ἐξηκοστῶν ἔξομεν ἑκατέραν
 τῶν $\overline{ΕΘ}$, $\overline{ΗΚ}$. καὶ ἀναπληρώσαντες τὰ $\overline{ΘΖ}$, $\overline{ΖΚ}$
 παραλληλόγραμμα ἔξομεν καὶ αὐτὰ $\overline{\phi\lambda\sigma}$ πρώτων
 ἐξηκοστῶν, ἑκάτερον δὲ ὄν $\overline{\sigma\eta\eta}$. εἶτα πάλιν τὰ
 ὑπολιπέντα $\overline{\rho\kappa\delta}$ πρῶτα ἐξηκοστὰ ἀναλύσαντες εἰς
 δεύτερα $\overline{\zeta\upsilon\mu}$, ἀφελοῦμεν καὶ τὸ $\overline{ΖΛ}$ ἀπὸ πρώτων
 δ γινόμενον ἐξηκοστῶν δευτέρων $\overline{\iota\sigma}$, ἵνα γνώμονα
 περιθέντες τῷ ἐξ ἀρχῆς τετραγώνῳ τῷ $\overline{ΑΖ}$ ἔχωμεν
 τὸ $\overline{ΑΛ}$ τετράγωνον ἀπὸ πλευρᾶς $\overline{\xi\zeta}$ δ συναγόμενον
 μοιρῶν $\overline{\delta\upsilon\varsigma\zeta}$ $\overline{\nu\sigma}$ $\overline{\iota\sigma}$. καὶ λοιπὸν πάλιν τὸν $\overline{ΒΛΛΔ}$
 γνώμονα μοιρῶν $\overline{\beta}$ $\overline{\gamma}$ $\overline{\mu\delta}$, τουτέστιν δευτέρων
 ἐξηκοστῶν $\overline{\zeta\upsilon\kappa\delta}$. ἔτι δὲ πάλιν διπλασιάσαντες τὴν
 $\overline{ΘΛ}$ ὡς ἐπ' εὐθείας τυγχανούσης τῇ $\overline{ΘΛ}$ τῆς $\overline{ΛΚ}$,
 καὶ παρὰ τὰ γινόμενα $\overline{\rho\lambda\delta}$ $\overline{\eta}$ μερίσαντες τὰ $\overline{\zeta\upsilon\kappa\delta}$
 δεύτερα ἐξηκοστὰ, τῶν ἐκ τῆς παραβολῆς γενο-
 μένων $\overline{\nu\epsilon}$ ἔγγιστα δευτέρων ἐξηκοστῶν ἔχομεν

Euclid ii. 4 that $2\left(67 + \frac{4}{60}\right) \cdot \frac{y}{60^2} + \left(\frac{y}{60^2}\right)^2$ is approximately $\frac{7424}{60^2}$,

and we obtain a trial value for y by dividing $2\left(67 + \frac{4}{60}\right)$ or

ARITHMETICAL NOTATION

which approximates to 4500° but has a rational side and consists of a whole number of units is 4489° on a side of 67° , let the square AZ, with area 4489° and side 67° , be taken away from the square $AB\Gamma\Delta$. The remainder, the gnomon $BZZ\Delta$, will therefore be 11° , which we reduce to $660'$ and set out. Then we double EZ, because the rectangle on EZ has to be taken twice, as though we regarded ZH as on the straight line EZ, divide the result 134° into $660'$, and by the division get $4'$, which gives us each of $E\Theta$, HK . Completing the parallelograms ΘZ , ZK , we have for their sum $536'$, or $268'$ each. Continuing, we reduce the remainder, $124'$, into $7440''$, and subtract from it also the complement $Z\Lambda$, which is $16''$, in order that by adding a gnomon to the original square AZ we may have the square $A\Lambda$ on a side $67^\circ 4'$ and consisting of $4497^\circ 56' 16''$. The remainder, the gnomon $B\Lambda\Lambda\Delta$, consists of $2^\circ 3' 44''$, that is, $7424''$. Continuing the process, we double $\Theta\Lambda$, as though ΛK were in a straight line with $\Theta\Lambda$ and equal to it, divide the product $134^\circ 8'$ into $7424''$, and the result is approximately $55''$, which gives

$\left(134 + \frac{8}{60}\right)$ into 7424 , which yields $y = 55$. Putting $\frac{55}{60^2}$ as the

value of ΘB , $K\Lambda$, we get the value $\frac{3688}{60^2} + \frac{40}{60^3}$ for each of the

rects. $B\Lambda$, $\Lambda\Delta$, or $\frac{7377}{60^2} + \frac{20}{60^3}$ for their sum. Subtracting this

from $\frac{7424}{60^2}$ we get $\frac{46}{60^2} + \frac{40}{60^3}$, which Theon notes will be ap-

proximately the value of the square $\Lambda\Gamma$, or $\left(\frac{55}{60^2}\right)^2$. As a

matter of fact, $\frac{46}{60^2} + \frac{40}{60^3} = \frac{2800}{60^3} = \frac{16800}{60^4}$ while $\left(\frac{55}{60^2}\right)^2 = \frac{3025}{60^4}$.

ἔγγιστα ἑκατέραν τῶν ΘΒ, ΚΔ. καὶ συμπληρώσαντες τὰ ΒΛ, ΛΔ παραλληλόγραμμα, ἕξομεν καὶ αὐτὰ ἑξηκοστῶν δευτέρων μὲν ζτο καὶ τρίτων $\bar{\upsilon}\mu$, ἑκάτερον δὲ δευτέρων μὲν ἑξηκοστῶν γχπε καὶ τρίτων $\bar{\sigma}\kappa$.¹ καὶ λοιπὰ ὑπελίπη ἑξηκοστά δεύτερα $\bar{\mu}\bar{\varsigma}$ καὶ τρίτα $\bar{\mu}$, ἅπερ ἔγγιστα ποιεῖ τὸ ΛΓ τετράγωνον, ἀπὸ πλευρᾶς τυγχάνον $\bar{\nu}\bar{\epsilon}$ δευτέρων ἑξηκοστῶν, καὶ ἔσχομεν τὴν πλευρὰν τοῦ ΑΒΓΔ τετραγώνου, μοιρῶν τυγχάνοντος $\bar{\delta}\bar{\phi}$, $\bar{\xi}\bar{\zeta}$ δ $\bar{\nu}\bar{\epsilon}$ ἔγγιστα.

Ὡστε καὶ καθόλου εἰάν ζητῶμεν ἀριθμοῦ τινος τὴν τετραγωνικὴν πλευρὰν ἐπιλογίσασθαι, λαμβάνομεν πρῶτον τοῦ σύνεγγυς τετραγώνου ἀριθμοῦ τὴν πλευρὰν. εἶτα ταύτην διπλασιάσαντες καὶ παρὰ τὸν γινόμενον ἀριθμὸν μερίσαντες τὸν λοιπὸν ἀριθμὸν ἀναλυθέντα εἰς πρῶτα ἑξηκοστά, καὶ ἀπὸ τοῦ ἐκ τῆς παραβολῆς γενομένου ἀφελούμεν τετράγωνον, καὶ ἀναλύοντες πάλιν τὰ ὑπολειπόμενα εἰς δεύτερα ἑξηκοστά, καὶ μερίζοντες παρὰ τὸν διπλασίονα τῶν μοιρῶν καὶ ἑξηκοστῶν, ἕξομεν ἔγγιστα τὸν ἐπιζητούμενον τῆς πλευρᾶς τοῦ τετραγώνου χωρίου ἀριθμόν.

(d) EXTRACTION OF CUBE ROOT

Heron, *Metr.* iii. 20, ed. Schöne 178. 3-16

Ὡς δὲ δεῖ λαβεῖν τῶν $\bar{\rho}$ μονάδων κυβικὴν πλευρὰν $\bar{\nu}\bar{\upsilon}\bar{\nu}$ ἐρούμεν.

¹ So the oldest ms. In others the numbers are worked out to the equivalent forms ζτοζ''' κ''', γχπη'' μ'''.

^a In the Greek of the oldest ms. the numbers are given as 7370'' 440''' and 3685'' 220''', in which form Theon would first

ARITHMETICAL NOTATION

us an approximation to θB , $K\Delta$. Completing the parallelograms $B\Lambda$, $\Lambda\Delta$, we shall have for their joint area $7377'' 20'''$, or $3688'' 40'''$ each.^a The remainder is $46'' 40'''$, which approximates to the square $\Lambda\Gamma$ on a side of $55''$, and so we obtain for the side of the square $AB\Gamma\Delta$, consisting of 4500° , the approximation $67^\circ 4' 55''$.

In general, if we seek the square root of any number, we take first the side of the nearest square number, double it, divide the product into the remainder reduced to minutes, and subtract the square of the quotient; proceeding in this way we reduce the remainder to seconds, divide it by twice the quotient in degrees and minutes, and we shall have the required approximation to the side of the square area.^b

(d) EXTRACTION OF CUBE ROOT

Heron, *Metrics* iii. 20, ed. Schöne 178. 3-16

We shall now inquire into the method of extracting the cube root of 100.

obtain them. In other mss. the numbers are worked out to the form $7377'' 20'''$, $3688'' 40'''$.

^b In his Table of Chords Ptolemy gives the approximation

$$\sqrt[3]{3} = \frac{103}{60} + \frac{55}{60^2} + \frac{23}{60^3},$$

which is equivalent to 1.7320509 and is correct to six decimal places. This formula could be obtained by a slight adaptation of Theon's method.

Archimedes gives, without any explanation, the following approximation :

$$\frac{1351}{780} > \sqrt[3]{3} > \frac{265}{153}.$$

The formula opens up a wide field of conjecture. See Heath, *The Works of Archimedes*, pp. lxxx-xcix.

Λαβὲ τὸν ἔγγιστα κύβον τοῦ $\bar{\rho}$ τὸν τε ὑπερβάλλοντα καὶ τὸν ἐλλείποντα· ἔστι δὲ ὁ $\bar{\rho}\bar{\kappa}\bar{\epsilon}$ καὶ ὁ $\bar{\xi}\bar{\delta}$. καὶ ὅσα μὲν ὑπερβάλλει, μονάδες $\bar{\kappa}\bar{\epsilon}$, ὅσα δὲ ἐλλείπει, μονάδες $\bar{\lambda}\bar{\sigma}$. καὶ ποιήσον τὰ $\bar{\epsilon}$ ἐπὶ τὰ $\bar{\lambda}\bar{\sigma}$. γίγνεται $\bar{\rho}\bar{\pi}$. καὶ τὰ $\bar{\rho}$ γίγνεται $\bar{\sigma}\bar{\pi}$. (καὶ παράβαλε $\bar{\iota}\bar{\delta}'$

τὰ $\bar{\rho}\bar{\pi}$ παρὰ τὰ $\bar{\sigma}\bar{\pi}$.)¹ γίγνεται θ . πρόσβαλε τῇ [κατὰ] τοῦ ἐλάσσονος κύβου πλευρᾷ, τουτέστι τῷ $\bar{\iota}\bar{\delta}'$

$\bar{\delta}$. γίγνεται μονάδες $\bar{\delta}$ καὶ θ τοσοῦτων ἔσται ἢ τῶν $\bar{\rho}$ μονάδων κυβικὴ πλευρὰ ὡς ἔγγιστα.

¹ καὶ παράβαλε τὰ $\bar{\rho}\bar{\pi}$ παρὰ τὰ $\bar{\sigma}\bar{\pi}$ supplevit H. Schöne.

^a If p^3 and q^3 are the two cube numbers between which A lies, and $A = p^3 - a = q^3 + b$, then Heron's formula can be generalized as follows :

$$\sqrt[3]{A} = q + \frac{b\sqrt{a}}{A + b\sqrt{a}}$$

It is unlikely that Heron worked with this general formula ; his method was probably empirical. The subject is discussed

ARITHMETICAL NOTATION

Take the nearest cube in excess of 100 and also the nearest which is deficient ; they are 125 and 64. The excess of the former is 25, the deficiency of the latter 36. Now multiply 36 by 5 ; the result is 180 ; and adding 100 gives 280. Dividing 180 by 280 gives $\frac{9}{14}$. Add this to the side of the lesser cube, that is, to 4, and the result is $4\frac{9}{14}$. This ^a is the closest approximation to the cube root of 100.

by M. Curtze, *Quadrat- und Kubikwurzeln bei den Griechen nach Herons neu aufgefundenen Μετρικά* (*Zeitschrift f. Math. u. Phys.* xlii., 1897, *Hist.-lit. Abth.*, pp. 113-120), G. Wertheim, *Heron's Ausziehung der irrationalen Kubikwurzeln* (*ibid.* xliv., 1899, *Hist.-lit. Abth.*³, pp. 1-3), and G. Eneström, *Bibliotheca Mathematica*, viii., 1907-1908, pp. 412-413. The actual value of $(4\frac{9}{14})^3$ is $100\frac{225}{2744}$.

There is no example in Greek mathematics of the extraction of a cube root fully worked out by means of the formula $(a + x)^3 = a^3 + 3a^2x + 3ax^2 + x^3$, corresponding to Theon's method for square roots ; but by means of this formula Philon of Byzantium (*Mech. Synt.* iv. 6-7, ed. R. Schöne) appears to have approximated to the cube roots of 1500, 2000, 3000, 5000 and 6000. Heron (*Metrica* iii. 22, ed. H. Schöne 184. 1-2) gives without explanation 46 as the cube root of 97050.



THIS PAGE IS LOCKED TO FREE MEMBERS

Purchase full membership to immediately unlock this page

SAVE \$3,999,994

Did you know we sell
paperback books too?

To buy our entire catalog
in paperback would cost
over \$4,000,000

Access it all now for
\$8.99/month

*Fair usage policy applies

Continue

III. PYTHAGOREAN ARITHMETIC

(a) FIRST PRINCIPLES

Eucl. *Elem.* vii.

Ὅροι

α'. Μονάς ἐστίν, καθ' ἣν ἕκαστον τῶν ὄντων ἐν λέγεται.

β'. Ἄριθμός δὲ τὸ ἐκ μονάδων συγκείμενον πλῆθος.

γ'. Μέρος ἐστὶν ἀριθμὸς ἀριθμοῦ ὁ ἐλάσσων τοῦ μείζονος, ὅταν καταμετρῆ τὸν μείζονα.

δ'. Μέρη δέ, ὅταν μὴ καταμετρῆ.

ε'. Πολλαπλάσιος δὲ ὁ μείζων τοῦ ἐλάσσονος, ὅταν καταμετρῆται ὑπὸ τοῦ ἐλάσσονος.

ς'. Ἄρτιος ἀριθμὸς ἐστὶν ὁ δίχα διαιρούμενος.

ζ'. Περισσὸς δὲ ὁ μὴ διαιρούμενος δίχα ἢ [ὁ] μονάδι διαφέρων ἀρτίου ἀριθμοῦ.

η'. Ἄρτιάκις ἄρτιος ἀριθμὸς ἐστὶν ὁ ὑπὸ ἀρτίου ἀριθμοῦ μετρούμενος κατὰ ἄρτιον ἀριθμόν.

* The theory of numbers is treated by Euclid in Books vii.-x. The definitions prefixed to Book vii. are wholly Pythagorean in their outlook, though there are differences in
66

III. PYTHAGOREAN ARITHMETIC

(a) FIRST PRINCIPLES

Euclid, *Elements* vii.

DEFINITIONS ^a

1. A *unit* is that in virtue of which each of the things that exist is called one.

2. A *number* is a multitude composed of units.

3. A number is a *part* of a number, the less of the greater, when it measures the greater.

4. But *parts*, when it does not measure it.

5. The greater number is a *multiple* of the less when it is measured by the less.

6. An *even number* is one that is divisible into two equal parts.

7. An *odd number* is one that is not divisible into two equal parts, or that differs from an even number by a unit.

8. An *even-times even number*^b is one that is measured by an even number according to an even number.

detail. Heath's notes (*The Thirteen Books of Euclid's Elements*, vol. ii. pp. 279-295) are invaluable.

^b It is a consequence of this definition that an even-times even number may also be even-times odd, as 24 is both 6×4 and 8×3 (cf. Euclid ix. 34, where it is proved that this must be so for certain numbers). Three later writers, Nicomachus, Theon of Smyrna and Iamblichus, defined an even-times even number differently, as a number of the form 2^p .

GREEK MATHEMATICS

θ'. Ἄρτιάκις δὲ περισσός ἐστιν ὁ ὑπὸ ἀρτίου ἀριθμοῦ μετρούμενος κατὰ περισσὸν ἀριθμόν.

[ι'. Περισσάκις ἄρτιός ἐστιν ὁ ὑπὸ περισσοῦ ἀριθμοῦ μετρούμενος κατὰ ἄρτιον ἀριθμόν.]¹

ια'. Περισσάκις δὲ περισσὸς ἀριθμός ἐστιν ὁ ὑπὸ περισσοῦ ἀριθμοῦ μετρούμενος κατὰ περισσὸν ἀριθμόν.

ιβ'. Πρῶτος ἀριθμός ἐστιν ὁ μονάδι μόνῃ μετρούμενος.

ιγ'. Πρῶτοι πρὸς ἀλλήλους ἀριθμοί εἰσιν οἱ μονάδι μόνῃ μετρούμενοι κοινῶ μέτρῳ.

ιδ'. Σύνθετος ἀριθμός ἐστιν ὁ ἀριθμῶ τινι μετρούμενος.

ιε'. Σύνθετοι δὲ πρὸς ἀλλήλους ἀριθμοί εἰσιν οἱ ἀριθμῶ τινι μετρούμενοι κοινῶ μέτρῳ.

¹ ι'. περισσάκις . . . ἀριθμόν om. Heiberg.

^a Instead of Euclid's term ἀρτιάκις περισσός, Nicomachus, Theon and Iamblichus used the single word ἀρτιοπέριπτος. According to Nicomachus (*Arith. Introd.* i. 9) such a number, when divided by 2, leaves an odd number as the quotient, *i.e.*, it is of the form $2(2n+1)$. In this later subdivision an *odd-even* (περισσάρτιος) number is one which can be halved twice or more successively, but the final quotient is always an odd number and not unity, *i.e.*, a number of the form $2^{p+1}(2n+1)$. We thus have three mutually exclusive classes of even numbers: (1) *even-even*, of the form 2^p ; (2) *even-odd*, of the form $2(2n+1)$; and (3) *odd-even*, of the form $2^{p+1}(2n+1)$, where (1) and (3) are extremes and (2) partakes of the nature of both. The *odd-odd* is not defined by Nicomachus and Iamblichus, but according to a curious usage in Theon it is one of the names applied to prime numbers, for these have two odd factors, 1 and the number itself.

^b According to this definition, any even-times odd number would also be odd-times even. The definition appears to have been known to Iamblichus, but there can be little doubt

PYTHAGOREAN ARITHMETIC

9. An *even-times-odd number*^a is one that is measured by an even number according to an odd number.

[10. An *odd-times even number* is one that is measured by an odd number according to an even number.]^b

11. An *odd-times odd number* is one that is measured by an odd number according to an odd number.

12. A *prime number* is one that is measured by the unit alone.

13. Numbers *prime to one another* are those which are measured by a unit alone as a common measure.

14. A *composite number* is one that is measured by some number.

15. Numbers *composite to one another* are those which are measured by some number as a common measure.^c

that it is an interpolation. If both definitions are genuine, one is not only pointless but the enunciations of ix. 33 and ix. 34 become difficult to understand, and were, indeed, read differently by Iamblichus from what we find in our mss. We have to choose between accepting Iamblichus's reading in all three places and rejecting Def. 10 as interpolated. I agree with Heiberg (*Euklid-Studien*, pp. 198 *et seq.*) that the definition was probably interpolated by someone who was unaware of the difference between the Euclidean and the later Pythagorean classifications, but noticed the absence of a definition by Euclid of an odd-times even number and tried to supply one.

^c Euclid's definition of prime and composite numbers differs greatly from the classification of Nicomachus (*Arith. Introd.* i. 11-13) and Iamblichus. To match the three classes of even numbers, they devised three classes of odd numbers: (1) *πρῶτον καὶ ἀσύνθετον*, *prime and incomposite*, which is a prime number in the Euclidean sense; (2) *δευτερον καὶ σύνθετον*, *secondary and composite*, which appears to be the product of prime numbers; and (3) *ὁ καθ' ἑαυτὸ μὲν δευτερον καὶ σύνθετον, πρὸς ἄλλο δὲ πρῶτον καὶ ἀσύνθετον*, *that which is secondary and composite in itself, but prime and incomposite in relation to another*, where all the factors must

ις'. Ἄριθμός ἀριθμὸν πολλαπλασιάζειν λέγεται, ὅταν, ὅσαι εἰσὶν ἐν αὐτῷ μονάδες, τοσαυτάκις συντεθῆ ὁ πολλαπλασιαζόμενος, καὶ γένηταί τις.

ιζ'. Ὄταν δὲ δύο ἀριθμοὶ πολλαπλασιάσαντες ἀλλήλους ποιῶσί τινα, ὁ γενόμενος ἐπίπεδος καλεῖται, πλευραὶ δὲ αὐτοῦ οἱ πολλαπλασιάσαντες ἀλλήλους ἀριθμοί.

ιη'. Ὄταν δὲ τρεῖς ἀριθμοὶ πολλαπλασιάσαντες ἀλλήλους ποιῶσί τινα, ὁ γενόμενος στερεός ἐστιν, πλευραὶ δὲ αὐτοῦ οἱ πολλαπλασιάσαντες ἀλλήλους ἀριθμοί.

ιθ'. Τετράγωνος ἀριθμός ἐστιν ὁ ἰσάκις ἴσος ἢ [ὁ] ὑπὸ δύο ἴσων ἀριθμῶν περιεχόμενος.

κ'. Κύβος δὲ ὁ ἰσάκις ἴσος ἰσάκις ἢ [ὁ] ὑπὸ τριῶν ἴσων ἀριθμῶν περιεχόμενος.

κα'. Ἀριθμοὶ ἀνάλογόν εἰσιν, ὅταν ὁ πρῶτος τοῦ δευτέρου καὶ ὁ τρίτος τοῦ τετάρτου ἰσάκις ἢ πολλαπλάσιος ἢ τὸ αὐτὸ μέρος ἢ τὰ αὐτὰ μέρη ᾖσιν.

κβ'. Ὅμοιοι ἐπίπεδοι καὶ στερεοὶ ἀριθμοὶ εἰσιν οἱ ἀνάλογον ἔχοντες τὰς πλευράς.

κγ'. Τέλειος ἀριθμός ἐστιν ὁ τοῖς ἑαυτοῦ μέρεσιν ἴσος ᾧν.

be odd and prime. The classification is defective, as (2) includes (3). Another defect is that the term *composite* is restricted to odd numbers instead of being given, as by Euclid, its general signification. For an earlier and different use of the terms by Speusippus, see *infra*, p. 78 n. a.

° For figured numbers, see *infra*, pp. 86-99.

• “Ἀνάλογον, though usually written in one word, is equivalent to ἀνά λόγον, *in proportion*. It comes, however, in

PYTHAGOREAN ARITHMETIC

16. A number is said to *multiply* a number when that which is multiplied is added to itself as many times as there are units in the other, and so some number is produced.

17. And when two numbers have multiplied each other so as to make some number, the resulting number is called *plane*, and its sides are the numbers which have multiplied each other.^a

18. And when three numbers have multiplied each other so as to make some number, the resulting number is *solid*, and its sides are the numbers which have multiplied each other.

19. A *square number* is equal multiplied by equal, or one that is contained by two equal numbers.

20. And a *cube* is equal multiplied by equal and again by equal, or a number that is contained by three equal numbers.

21. Numbers are *proportional*^b when the first is the same multiple, or the same part, or the same parts, of the second as the third is of the fourth.

22. *Similar plane* and *solid* numbers are those which have their sides proportional.

23. A *perfect number*^c is one that is equal to [the sum of] its own parts.

Greek mathematics to be used practically as an indeclinable adjective. . . . Sometimes it is used adverbially ” (Heath, *The Thirteen Books of Euclid's Elements*, vol. ii. p. 129).

This definition, inasmuch as it depends on the notion of a part of a number, is applicable only to commensurable magnitudes. A new definition, applicable to incommensurable as well as commensurable magnitudes, and due in substance though not necessarily in form to Eudoxus, is given by Euclid in *Elements* v. Def. 5 (see *infra*, pp. 444-447).

^c The term “perfect number” was apparently not used in this sense before Euclid. The subject is treated *infra*, pp. 74-87.

GREEK MATHEMATICS

(b) CLASSIFICATION OF NUMBERS

Philolaus ap. Stob. *Ecl.* i. 21. 7c, ed. Wachsmuth 188. 9-12 ;
Diels, *Vors.* 1⁵. 408. 7-10

Ἐκ τοῦ Φιλολάου Περὶ κόσμου . . .

“Ὁ γὰρ μὲν ἀριθμὸς ἔχει δύο μὲν ἴδια εἶδη, περισσὸν καὶ ἄρτιον, τρίτον δὲ ἀπ’ ἀμφοτέρων μειχθέντων ἀρτιοπέριπτον· ἑκατέρω δὲ τῷ εἶδους πολλαὶ μορφαί, ὥς ἕκαστον αὐταυτὸ σημαίνει.”

Nicom. *Arith. Introd.* i. 7, ed. Hoche 13. 7-14. 12

Ἀριθμὸς ἐστὶ πλῆθος ὠρισμένον ἢ μονάδων σύστημα ἢ ποσότητος χύμα ἐκ μονάδων συγκείμενον, τοῦ δὲ ἀριθμοῦ πρώτη τομὴ τὸ μὲν ἄρτιον, τὸ δὲ περιπτόν. ἔστι δὲ ἄρτιον μὲν, ὃ οἶόν τε εἰς δύο ἴσα διαιρεθῆναι μονάδος μέσον μὴ παρεμπιπτούσης, περιπτόν δὲ τὸ μὴ δυνάμενον εἰς δύο ἴσα μερισθῆναι διὰ τὴν προειρημένην τῆς μονάδος μεσιτείαν. οὗτος μὲν οὖν ὁ ὅρος ἐκ τῆς δημώδους ὑπολήψεως· κατὰ δὲ τὸ Πυθαγορικὸν ἄρτιος ἀριθμὸς ἐστὶν ὃ τὴν εἰς τὰ μέγιστα καὶ τὰ ἐλάχιστα κατὰ ταῦτὸ τομὴν ἐπιδεχόμενος, μέγιστα μὲν πηλικότητι, ἐλάχιστα δὲ ποσότητι, κατὰ φυσικὴν τῶν δυὸ τούτων γενῶν ἀντιπεπόνθησιν, περισσὸς δὲ ὃ μὴ δυνάμενος τοῦτο παθεῖν, ἀλλ’ εἰς ἄνισα δύο τεμνόμενος. ἑτέρω δὲ τρόπῳ κατὰ τὸ παλαιὸν

^a The “even-odd” would seem to mean here the product of odd and even numbers. This agrees with Euclid’s usage in *Elem.* vii. Def. 9. For the later specialized Pythagorean meaning, see *supra*, p. 68 n. a.

^b If an odd number is set out as $2n + 1$ units in a straight line, then it can be divided into two sections of n units



THIS PAGE IS LOCKED TO FREE MEMBERS

Purchase full membership to immediately unlock this page

FORGOTTEN BOOKS

FULL

MEMBERSHIP

797,885 Books!

All you can read

for only

\$8.99/month

Continue

*Fair usage policy applies



GREEK MATHEMATICS

ἄρτιός ἐστιν ὁ καὶ εἰς δύο ἴσα τμηθῆναι δυνάμενος καὶ εἰς ἄνισα δύο, πλὴν τῆς ἐν αὐτῷ ἀρχοειδοῦς δυάδος θάτερον τὸ διχοτόμημα μόνον ἐπιδεχομένης τὸ εἰς ἴσα, ἐν ἧτινι οὖν τομῇ παρεμφαίνων τὸ ἕτερον εἶδος μόνον τοῦ ἀριθμοῦ, ὅπως ἂν διχασθῇ, ἀμέτοχον τοῦ λοιποῦ· περισσὸς δέ ἐστιν ἀριθμὸς ὁ καθ' ἧντιναοῦν τομὴν εἰς ἄνισα πάντως γινομένην ἀμφότερα ἅμα ἐμφαίνων τὰ τοῦ ἀριθμοῦ δυὸ εἶδη οὐδέποτε ἄκρατα ἀλλήλων, ἀλλὰ πάντοτε σὺν ἀλλήλοις. ἐν δὲ τῷ δι' ἀλλήλων ὄρω περιττός ἐστιν ἡ μονάδι ἐφ' ἑκάτερα διαφέρων ἀρτίου ἀριθμοῦ, τουτέστιν ἐπὶ τὸ μείζον καὶ ἔλαττον, ἄρτιος δὲ ὁ μονάδι διαφέρων ἐφ' ἑκάτερον περισσοῦ ἀριθμοῦ, τουτέστι μονάδι μείζων καὶ μονάδι ἐλάσσων.

(c) PERFECT NUMBERS

[Iambl.] *Theol. Arith.*, ed. de Falco 82. 10–85. 23 ; Diels, *Vors.* i⁵. 400. 22–402. 11

Ὅτι καὶ Σπεύσιππος, ὁ Πωτώνης μὲν υἱὸς τῆς τοῦ Πλάτωνος ἀδελφῆς, διάδοχος δὲ Ἀκαδημείας πρὸ Ξενοκράτου, ἐκ τῶν ἐξαιρέτως σπουδασθεισῶν αἰὲ Πυθαγορικῶν ἀκροάσεων, μάλιστα δὲ τῶν

^a It is probable that we have here a trace of an original conception according to which 2 (the dyad) was regarded as being, not a number, but the principle or beginning of the even, just as 1 was not regarded as a number, but the principle or beginning of number; for the qualification about the dyad seems clearly to be a later addition to the original definition. It must, however, have been pre-Platonic, for in *Parm.* 143 D Plato speaks of 2 as even. Aristotle, who adds (*Topics* Θ 2, 157 a 39) that 2 is the only even number which is prime, says (*Met.* A 5, 986 a 19) the Pythagoreans regarded the One as

PYTHAGOREAN ARITHMETIC

according to which it can be divided both into two equal parts and into two unequal parts, save in the case of the fundamental dyad, which can be divided only into two equal parts^a; but howsoever it be divided, it must have its two parts of the same kind,^b without partaking of the other kind; while the odd is that which, howsoever it be divided, always yields two unequal parts and so exhibits at one and the same time both species of number, never independent of one another but always together.^c To give a definition in terms one of another, the odd is that which differs from even number by a unit in both directions, that is, in the direction both of the greater and of the lesser, while the even is that which differs by a unit from odd number in either direction, that is, it is greater by a unit and less by a unit.

(c) PERFECT NUMBERS

[Iamblichus], *Theologumena Arithmeticae*, ed. de Falco
82. 10–85. 23; Diels, *Vors.* i⁵. 400. 22–402. 11

Speusippus, the son of Potone, sister of Plato, and his successor in the Academy before Xenocrates, was always full of zeal for the teachings of the Pythagoreans, and especially for the writings of Philolaus,

both odd and even. For this question, as well as many others arising in Greek arithmetic, the student may profitably consult *Nicomachus of Gerasa: Introduction to Arithmetic*, translated by Martin Luther D'Ooge, with studies in Greek arithmetic by Frank Egleston Robbins and Louis Charles Karpinski.

^b *i.e.* both odd or both even.

^c *i.e.* an odd number can be divided only into an odd number and an even number, never into two odd or two even numbers.

Φιλολάου συγγραμμάτων, βιβλίδιόν τι συντάξας γλαφυρόν ἐπέγραψε μὲν αὐτὸ Περὶ Πυθαγορικῶν ἀριθμῶν, ἀπ' ἀρχῆς δὲ μέχρι ἡμίσεως περὶ τῶν ἐν αὐτοῖς γραμμικῶν ἐμμελέστατα διεξελθὼν πολυγωνίων τε καὶ παντοίων τῶν ἐν ἀριθμοῖς ἐπιπέδων ἅμα καὶ στερεῶν, περί τε τῶν πέντε σχημάτων, ἃ τοῖς κοσμικοῖς ἀποδίδονται στοιχείοις, ἰδιότητός <τε>¹ αὐτῶν καὶ πρὸς ἄλληλα κοινότητος, <περὶ>² ἀναλογίας τε καὶ ἀντακολουθίας,³ μετὰ ταῦτα λοιπὸν θάτερον [τὸ]⁴ τοῦ βιβλίου ἡμισυ περὶ δεκάδος ἀντικρυς ποιεῖται, φυσικωτάτην αὐτὴν ἀποφαίνων καὶ τελεστικωτάτην τῶν ὄντων, οἷον εἶδος τι τοῖς κοσμικοῖς ἀποτελέσμασι τεχνικὸν ἀφ' ἑαυτῆς (ἀλλ' οὐχ ἡμῶν νομισάντων ἢ ὡς ἔτυχε) θεμέλιον ὑπάρχουσαν καὶ παράδειγμα παντελέστατον τῷ τοῦ παντός ποιητῇ θεῷ προεκκειμένην. λέγει δὲ τὸν τρόπον τοῦτον περὶ αὐτῆς.

“Ἔστι δὲ τὰ δέκα τέλειος <ἀριθμός>,⁵ καὶ ὀρθῶς τε καὶ κατὰ φύσιν εἰς τοῦτον καταντῶμεν παντοίως ἀριθμοῦντες Ἕλληνές τε καὶ πάντες ἄνθρωποι οὐδὲν αὐτοῖ ἐπιτηδεύοντες· πολλὰ γὰρ ἴδια ἔχει, ἃ προσήκει τὸν οὕτω τέλειον ἔχειν, πολλὰ δὲ ἴδια μὲν οὐκ ἔστιν αὐτοῦ, δεῖ δὲ ἔχειν αὐτὰ τέλειον.

“ Πρῶτον μὲν οὖν ἄρτιον δεῖ εἶναι, ὅπως ἴσοι ἐνῶσιν οἱ περιττοί τε καὶ ἄρτιοι, καὶ μὴ ἕτερομερῶς⁶· ἐπεὶ γὰρ πρότερος αἰεὶ ἔστιν ὁ περιττός τοῦ

¹ <τε> add. Diels.

² <περὶ> add. de Falco.

³ ἀντακολουθίας Lang; ἀνακολουθίας Ast, Tannery, Diels.

⁴ [τὸ] om. Diels.

⁵ ἀριθμός add. Diels.

⁶ ἕτερομερεῖς Diels.

^a For the five cosmic or Platonic figures, see *infra*, pp. 216-225.

PYTHAGOREAN ARITHMETIC

and he compiled a neat little book which he entitled *On the Pythagorean Numbers*. From the beginning up to half way he deals most elegantly with linear and polygonal numbers and with all the kinds of surfaces and solids in numbers ; with the five figures which he attributes to the cosmic elements,^a both in respect of their special properties and in respect of their similarity one to another ; and with proportion and reciprocity.^b After this he immediately devotes the other half of the book to the decad, showing it to be the most natural and most initiative of realities, inasmuch as it is in itself (and not because we have made it so or by chance) an organizing idea of cosmic events, being a foundation stone and lying before God the Creator of the universe as a pattern complete in all respects. He speaks about it to the following effect.

“Ten is a perfect number, and it is both right and according to Nature that we Greeks and all men arrive at this number in all kinds of ways when we count, though we make no effort to do so ; for it has many special properties which a number thus perfect ought to have, while there are many characteristics which, while not special to it, are necessary to its perfection.

“In the first place it must be even, in order that the odds and evens in it may be equal and not disparate. For since the odd is always prior to the even, unless

^b If, with Ast, Tannery and Diels we read *ἀνακολουθίας* for *ἀντακολουθίας*, the rendering is “proportion continuous and discontinuous,” but it is not easy to interpret this, though Tannery makes a valiant effort to do so. His French translation, notes and comments should be studied (*Pour l'histoire de la science hellène*, 2nd ed., pp. 374 seq., 386 seq., and *Mémoires scientifiques*, vol. i. pp. 281-289).

ἀρτίου, εἰ μὴ ἄρτιος εἶη ὁ συμπεραίνων, πλεονεκτῆσει ὁ ἕτερος.

“Εἶτα δὲ ἴσους ἔχειν χρή τοὺς πρώτους καὶ ἀσυνθέτους καὶ τοὺς δευτέρους καὶ συνθέτους· ὁ δὲ δέκα ἔχει ἴσους, καὶ οὐδεὶς ἂν ἄλλος ἐλάττων τῶν δέκα τοῦτο ἔπαθεν ἀριθμός, πλείων δὲ τάχα (καὶ γὰρ ὁ $\bar{\iota}\beta$ καὶ ἄλλοι τινές), ἀλλὰ πυθμὴν αὐτῶν ὁ δέκα· καὶ πρῶτος τοῦτο ἔχων καὶ ἐλάχιστος τῶν ἐχόντων τέλος τι ἔχει, καὶ ἰδιόν πως αὐτοῦ τοῦτο γέγονε τὸ ἐν πρώτῳ αὐτῷ ἴσους ἀσυνθέτους τε καὶ συνθέτους ὠφθαι.

“Ἐχων τε τοῦτο ἔχει πάλιν (ἴσους)¹ καὶ τοὺς πολλαπλασίους καὶ τοὺς ὑποπολλαπλασίους, ὧν εἰσι πολλαπλάσιοι· ἔχει μὲν γὰρ ὑποπολλαπλασίους τοὺς μεχρὶ πέντε, τοὺς δὲ ἀπὸ τῶν ἕξ μέχρι τῶν δέκα [οἶ]² πολλαπλασίους αὐτῶν· ἐπεὶ δὲ τὰ ζ οὐδενός, ἐξαιρετέον, καὶ τὰ δ ὡς πολλαπλάσια τοῦ $\bar{\beta}$, ὥστε ἴσους εἶναι πάλιν [δει].³

“Ἐτι πάντες οἱ λόγοι ἐν τῷ $\bar{\iota}$, ὃ τε τοῦ ἴσου καὶ τοῦ μείζονος καὶ τοῦ ἐλάττονος καὶ τοῦ ἐπι-

¹ ἴσους add. Lang.

² οἶ om. Diels.

³ δει om. Diels. He points out that the original reading may have been δ', indicating the fourth property of the decad.

• One of the most noteworthy features of this passage is the early use of the terms *πρῶτοι καὶ ἀσύνθετοι* (*prime and incomposite*), *δευτέροι καὶ σύνθετοι* (*secondary and composite*), for which see *supra*, p. 69 n. c. The use is different from that of Nicomachus and Iamblichus. It seems that *prime and incomposite* numbers are prime numbers in the ordinary sense, including 2, as is the case with Euclid and Aristotle (*Topics* Θ 2, 157 a 39). *Secondary and composite* numbers

PYTHAGOREAN ARITHMETIC

the even were joined with it the other would pre-
dominate.

“ Next it is necessary that the prime and incom-
posite and the secondary and composite ^a should be
equal ; now they are equal in the case of 10, and in
the case of no other number which is less than 10 is
this true, though numbers greater than 10 having
this property (such as 12 and certain others ^b) can
soon be found, but their base is 10. As the first
number with this property and the least of those
possessing it 10 has a certain perfection, and it is a
property peculiar to itself that it is the first number
in which the incomposite and the composite are equal.

“ In addition to this property it has an equal number
of multiples and submultiples of those multiples ; for
it has as submultiples the numbers up to 5, while
those from 6 to 10 are multiples of them ; since 7 is
a multiple of no number, it has to be omitted, but
4 must also be dropped as a multiple of 2, and so this
brings about equality once more.^c

“ Furthermore all the ratios are in 10, for the equal
and the greater and the less and the superparticular

are all composite numbers, the term not being limited to odd
numbers as with Nicomachus. There is no suggestion of a
third mixed class. The two equal classes according to
Speusippus are 1, 2, 3, 5, 7 and 4, 6, 8, 9, 10. According
to the later terminology the *prime and incomposite* numbers
would be 3, 5, 7, while the only *secondary and composite*
number would be 9.

^b Actually 10, 12 and 14 are the only numbers possessing
this property.

^c In the series 1, 2 . . . 10 the submultiples are 1, 2, 3, 5
and the multiples are 6, 8, 9, 10. It is curious that though 1
is counted as a submultiple, all the other numbers are not
counted as multiples of it ; to have admitted them as such
would have destroyed the scheme.

GREEK MATHEMATICS

μορίου καὶ τῶν λοιπῶν εἰδῶν ἐν αὐτῷ, καὶ οἱ γραμμικοὶ (καὶ)¹ οἱ ἐπίπεδοι καὶ οἱ στερεοί. τὸ μὲν γὰρ $\bar{\alpha}$ στιγμή, τὰ δὲ $\bar{\beta}$ γραμμή, τὰ δὲ $\bar{\gamma}$ τρίγωνον, τὰ δὲ $\bar{\delta}$ πυραμῖς· ταῦτα δὲ πάντα ἐστὶ πρῶτα καὶ ἀρχαὶ τῶν καθ' ἕκαστον ὁμογενῶν. καὶ ἀναλογιῶν δὲ πρώτη αὕτη ἐστὶν ἢ ἐν αὐτοῖς ὀφθειῖσα, ἢ τὸ ἴσον μὲν ὑπερέχουσα, τέλος δὲ ἔχουσα ἐν τοῖς δέκα. ἐν τε ἐπιπέδοις καὶ στερεοῖς πρῶτά ἐστι ταῦτα, στιγμή, γραμμή, τρίγωνον, πυραμῖς· ἔχει δὲ ταῦτα τὸν τῶν δέκα ἀριθμὸν καὶ τέλος ἴσχει. τετράς μὲν γὰρ ἐν πυραμίδος γωνίαις ἢ βάσεσιν, ἑξὰς δὲ ἐν πλευραῖς, ὥστε δέκα· τετράς δὲ πάλιν ἐν στιγμής καὶ γραμμῆς διαστήμασι καὶ πέρασι, ἑξὰς δὲ ἐν τριγώνου πλευραῖς καὶ γωνίαις, ὥστε πάλιν δέκα. καὶ μὴν καὶ ἐν τοῖς σχήμασι κατ' ἀριθμὸν σκεπτομένῳ συμβαίνει². πρῶτον γὰρ ἐστὶ τρίγωνον τὸ ἰσόπλευρον, ὃ ἔχει μίαν πῶς

¹ καὶ add. Lang.

² <ταὐτὸ> συμβαίνει Lang (in adn.), de Falco.

^a Speusippus asserts that among the numbers 1, 2 . . . 10 all the different kinds of ratio can be found. The *superparticular* ratio is the ratio of the whole + an aliquot fraction, $1 + \frac{1}{n}$ or $\frac{n+1}{n}$, typified by the ratio known as ἐπίτριτος, or $\frac{4}{3}$.

Tannery sees here an allusion to the ten kinds of proportion outlined by Nicomachus (see *infra*, pp. 114-124), and a proof of their ancient origin.

^b *i.e.*, 1, 2, 3, 4 form an arithmetical progression having 1 as the common difference and 10 as the sum.

^c *i.e.*, a pyramid has 4 angles (or 4 faces) and 6 sides, and so exhibits the number 10.

^d The reasoning is not very clear. Taking first a line and a point outside it, Speusippus notes that the line has 2 extremities and between the point and these 2 extremities are



THIS PAGE IS LOCKED TO FREE MEMBERS

Purchase full membership to immediately unlock this page

SAVE \$3,999,994

Did you know we sell
paperback books too?

To buy our entire catalog
in paperback would cost
over \$4,000,000

Access it all now for
\$8.99/month

*Fair usage policy applies

Continue

γραμμὴν καὶ γωνίαν· λέγω δὲ μίαν, διότι ἴσας ἔχει· ἄσχιστον γὰρ αἰεὶ καὶ ἔνοειδές τὸ ἴσον· δεύτερον δὲ τὸ ἡμιτετράγωνον· μίαν γὰρ ἔχον παραλλαγήν γραμμῶν καὶ γωνιῶν ἐν δυάδι ὁράται· τρίτον δὲ τὸ τοῦ ἰσοπλεύρου ἡμισυ τὸ καὶ ἡμιτρίγωνον· πάντως γὰρ ἄνισον καθ' ἕκαστον, τὸ δὲ πάντη¹ αὐτοῦ τρία ἐστί· καὶ ἐπὶ τῶν στερεῶν εὐρίσκοις ἂν ἄχρι τῶν τεττάρων προῖόν τὸ τοιοῦτο, ὥστε δεκάδος καὶ οὕτως φαύει· γίνεται γὰρ πως ἢ μὲν πρώτη πυραμὶς μίαν πως γραμμὴν τε καὶ ἐπιφάνειαν ἐν ἰσότητι ἔχουσα, ἐπὶ τοῦ ἰσοπλεύρου ἰσταμένη· ἢ δευτέρα δύο, ἐπὶ² τετραγώνου ἐνηγεμένη, μίαν παραλλαγήν ἔχουσα παρὰ τῆς ἐπὶ τῆς βάσεως γωνίας, ὑπὸ τριῶν ἐπιπέδων περιεχομένη, τὴν κατὰ κορυφήν ὑπὸ τεττάρων συγκλειομένη, ὥστε ἐκ τούτου δυάδι εἰκέναι· ἢ δὲ τρίτη τριάδι, ἐπὶ ἡμιτετραγώνου βεβηκυῖα καὶ σὺν τῇ ὀφθείσῃ μιᾷ ὡς ἐν ἐπιπέδῳ τῇ ἡμιτετραγώνῳ ἔτι καὶ ἄλλην ἔχουσα διαφορὰν τὴν τῆς κορυφαίας γωνίας, ὥστε τριάδι ἂν ὁμοιοῖτο, πρὸς ὀρθὰς τὴν γωνίαν ἔχουσα τῇ τῆς βάσεως μέσῃ πλευρᾷ· τετράδι δὲ ἢ τετάρτη κατὰ ταῦτά, ἐπὶ ἡμιτριγώνῳ³ βάσει συνισταμένη, ὥστε τέλος ἐν τοῖς δέκα λαμβάνειν τὰ λεχθέντα· τὰ αὐτὰ δὲ καὶ ἐν τῇ γενέσει· πρώτη μὲν γὰρ ἀρχὴ εἰς μέγεθος στιγμὴ, δευτέρα γραμμὴ, τρίτη ἐπιφάνεια, τέταρτον στερεόν·”

¹ πάντη Lang, de Falco; πᾶν [τι] Diels; Lang would like to read τὰ δὲ πάντα.

² ἐπὶ . . . ἔχουσα. Only one manuscript has these words; many emendations have been offered.

³ The manuscripts have ἡμιτετραγώνῳ, but ἡμιτριγώνῳ is required, as Tannery recognized.

PYTHAGOREAN ARITHMETIC

because they are equal ; for the equal is always indivisible and uniform. The second triangle is the half-square ; for with one difference in the sides and angles it corresponds to the dyad. The third is the half-triangle, which is half of the equilateral triangle ; for being completely unequal in every respect, its elements number three. In the case of solids, you would find this property also, but going up to four, so that the decad is reached in this way also. For the first pyramid, which is built upon an equilateral triangle, is in some sense unity, since by reason of its equality it has one side and one face ; the second pyramid, which is raised upon a square, has the angles at the base enclosed by three planes and that at the vertex by four, so that from this difference it resembles the dyad. The third resembles a triad, for it is set upon a half-square ; together with the one difference that we have seen in the half-square as a plane figure it presents another corresponding to the angle at the vertex ; there is therefore a resemblance between the triad and this pyramid, whose vertex lies on the perpendicular to the middle of the hypotenuse^a of the base. In the same way the fourth, rising upon a half-triangle as base, resembles a tetrad, so that the aforesaid figures find completion in the number 10. The same result is seen in their generation. For the first principle of magnitude is point, the second is line, the third is surface, the fourth is solid.”^b

^a Lit. “ side.”

^b The abrupt end suggests that the passage went on in this strain for some time ; but the historian of mathematics need not feel much disappointment.

GREEK MATHEMATICS

Theon Smyr., ed. Hiller 45. 9-46. 19

Ἔτι τε τῶν ἀριθμῶν οἱ μὲν τινες τέλειοι λέγονται, οἱ δ' ὑπερτέλειοι, οἱ δ' ἔλλιπεῖς. καὶ τέλειοι μὲν εἰσιν οἱ τοῖς αὐτῶν μέρεσιν ἴσοι, ὡς ὁ τῶν $\bar{5}$ · μέρη γὰρ αὐτοῦ ἡμισυ $\bar{\gamma}$, τρίτον $\bar{\beta}$, ἕκτον $\bar{\alpha}$, ἅτινα συντιθέμενα ποιεῖ τὸν $\bar{5}$. γεννῶνται δὲ οἱ τέλειοι τοῦτον τὸν τρόπον. εἰάν ἐκθῶμεθα τοὺς ἀπὸ μονάδος διπλασίους καὶ συντιθῶμεν αὐτούς, μέχρις οὗ ἂν γένηται πρῶτος καὶ ἀσύνθετος ἀριθμὸς, καὶ τὸν ἐκ τῆς συνθέσεως ἐπὶ τὸν ἔσχατον τῶν συντιθεμένων πολλαπλασιάσωμεν, ὁ ἀπογεννηθεὶς ἔσται τέλειος. οἷον ἐκκείσθωσαν διπλάσιοι $\bar{\alpha}$ $\bar{\beta}$ $\bar{\delta}$ $\bar{\eta}$ $\bar{\iota\varsigma}$. συνθῶμεν οὖν $\bar{\alpha}$ καὶ $\bar{\beta}$ · γίνεται $\bar{\gamma}$ · καὶ τὸν $\bar{\gamma}$ ἐπὶ τὸν ὑστερον τὸν ἐκ τῆς συνθέσεως πολλαπλασιάσωμεν, τουτέστιν ἐπὶ τὸν $\bar{\beta}$ · γίνεται $\bar{5}$, ὅς ἐστι πρῶτος τέλειος. ἂν πάλιν τρεῖς τοὺς ἐφεξῆς διπλασίους συνθῶμεν, $\bar{\alpha}$ καὶ $\bar{\beta}$ καὶ $\bar{\delta}$, ἔσται $\bar{\zeta}$ · καὶ τοῦτον ἐπὶ τὸν ἔσχατον τῶν τῆς συνθέσεως πολλαπλασιάσωμεν, τὸν $\bar{\zeta}$ ἐπὶ τὸν $\bar{\delta}$ · ἔσται ὁ $\bar{\kappa\eta}$, ὅς ἐστι δεύτερος τέλειος. σύγκειται ἐκ τοῦ ἡμίσεος τοῦ $\bar{\iota\delta}$, τετάρτου τοῦ $\bar{\zeta}$, ἑβδόμου τοῦ $\bar{\delta}$, τεσσαρακαιδεκάτου τοῦ $\bar{\beta}$, εἰκοστοῦ ὀγδόου τοῦ $\bar{\alpha}$.

Ἐπερτέλειοι δὲ εἰσιν ὧν τὰ μέρη συντεθέντα μείζονά ἐστι τῶν ὅλων, οἷον ὁ τῶν $\bar{\iota\beta}$ · τούτου γὰρ ἡμισύ ἐστιν $\bar{5}$, τρίτον $\bar{\delta}$, τέταρτον $\bar{\gamma}$, ἕκτον $\bar{\beta}$, δωδέκατον $\bar{\alpha}$, ἅτινα συντεθέντα γίνεται $\bar{\iota\varsigma}$, ὅς ἐστι μείζων τοῦ ἐξ ἀρχῆς, τουτέστι τῶν $\bar{\iota\beta}$.

Ἐλλιπεῖς δὲ εἰσιν ὧν τὰ μέρη συντεθέντα ἐλάττονα τὸν ἀριθμὸν ποιεῖ τοῦ ἐξ ἀρχῆς προτεθέντος

^a In other words, if $S_n = 1 + 2 + 2^2 + \dots + 2^{n-1}$, and S_n is prime, then $S_n \cdot 2^{n-1}$ is a perfect number. This is proved in



THIS PAGE IS LOCKED TO FREE MEMBERS

Purchase full membership to immediately unlock this page

FORGOTTEN BOOKS

FULL

MEMBERSHIP

797,885 Books!

All you can read

for only

\$8.99/month

Continue

*Fair usage policy applies



GREEK MATHEMATICS

ἀριθμοῦ, οἷον ὁ τῶν η . τούτου γὰρ ἡμισυ δ , τετάρτον β , ὄγδοον ϵ . τὸ αὐτὸ δὲ καὶ τῷ ι συμβέβηκεν, ὃν καθ' ἕτερον λόγον τέλειον ἔφασαν οἱ Πυθαγορικοί, περὶ οὗ κατὰ τὴν οἰκείαν χώραν ἀποδώσομεν. λέγεται δὲ καὶ ὁ γ τέλειος, ἐπειδὴ πρῶτος ἀρχὴν καὶ μέσα καὶ πέρασ ἔχει· ὁ δ' αὐτὸς καὶ γραμμὴ ἐστὶ καὶ ἐπίπεδον, τρίγωνον γὰρ ἰσόπλευρον ἐκάστην πλευρὰν δυεῖν μονάδων ἔχον, καὶ πρῶτος δεσμὸς καὶ στερεοῦ δύναμις· ἐν γὰρ τρισὶ διαστάσεσι τὸ στερεὸν νοεῖσθαι.

(d) FIGURED NUMBERS

(i.) General

Nicom. *Arith. Introd.* ii. 7. 1-3, ed. Hoche 86. 9-87. 6

Ἔστιν οὖν σημείον ἀρχὴ διαστήματος, οὐ διάστημα δέ, τὸ δ' αὐτὸ καὶ ἀρχὴ γραμμῆς, οὐ γραμμὴ

^a There were in use among the Greeks two ways of representing numbers geometrically. One, used by Euclid and implied in Plato, *Theaetetus* 147 D—148 B (see *infra*, p. 380), is to represent numbers by straight lines proportional in length to the numbers they represent. If two such lines are made adjacent sides of a rectangle, then the rectangle represents their product; if three such lines are made sides of a rectangular parallelepiped then the parallelepiped is the product. The other way of representing numbers was by dots or alphas for the units disposed along straight lines so as to form geometrical patterns, a method greatly developed by the Pythagoreans. Any number could be represented as a straight line, and prime numbers only as

PYTHAGOREAN ARITHMETIC

put forth, such as 8 ; for the half of this number is 4, the fourth 2, the eighth 1. The same property is shown by 10, which the Pythagoreans called perfect for a different reason, and this we shall discuss in the proper place. The number 3 is also called perfect, since it is the first number which has a beginning and middle and end. It is moreover both a line and a surface, for it is an equilateral triangle in which each side is two units, and it is the first bond and power of the solid ; for in three dimensions is the solid conceived.

(d) FIGURED NUMBERS ^a

(i.) *General*

Nicomachus, *Introduction to Arithmetic* ii. 7. 1-3,
ed. Hoche 86. 9-87. 6

Point is therefore the principle of dimension, but is not dimension, while it is also the principle of line,

straight lines, whence Thymaridas spoke of them as “rectilinear *par excellence*” (Plato would have represented a prime number such as 7 by 7×1 , an oblong). The unit, being the source of all number, can be taken as a triangle, a pentagon, a hexagon, and so on. The first number after 1 which can be represented as a triangle is 3, and the sum of the first n natural numbers can always be represented as a triangle; the adjoining figure, a famous Pythagorean symbol, shows how this is done for $1 + 2 + 3 + 4 = 10$.

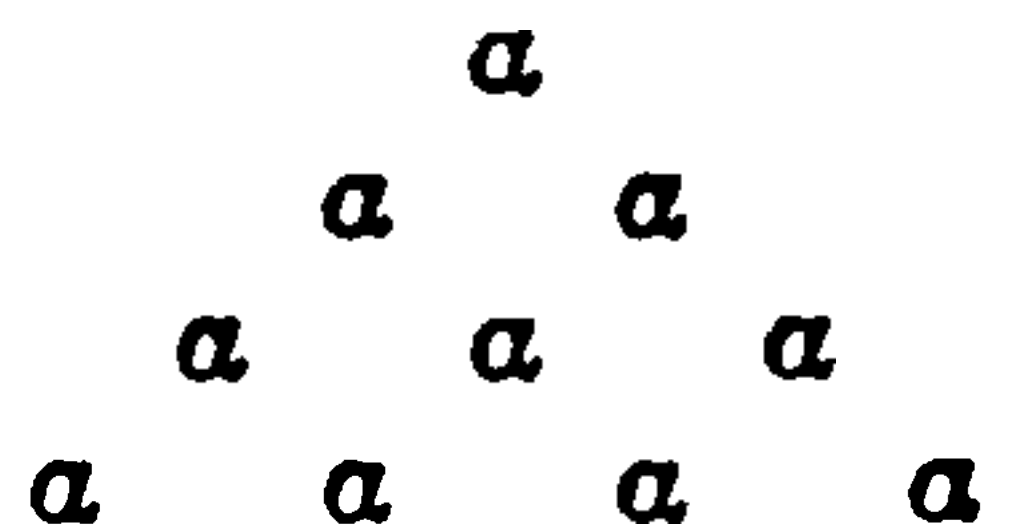

Square numbers can be represented in similar fashion, and the square of side $n + 1$ can be obtained from the square of side n by adding a gnomon of $2n + 1$ dots round the side (the term “gnomon” originally signified an upright stick which cast shadows on a plane or hemispherical surface, and so

GREEK MATHEMATICS

δέ· καὶ γραμμὴ ἀρχὴ ἐπιφανείας, οὐκ ἐπιφάνεια δέ, καὶ ἀρχὴ τοῦ διχῆ διαστατοῦ, οὐ διχῆ δὲ διαστατόν. καὶ εἰκότως ἢ ἐπιφάνεια ἀρχὴ μὲν σώματος, οὐ σῶμα δέ, καὶ ἢ αὐτὴ ἀρχὴ μὲν τοῦ τριχῆ διαστατοῦ, οὐ τριχῆ δὲ διαστατόν. οὕτως δὴ καὶ ἐν τοῖς ἀριθμοῖς ἢ μὲν μονὰς ἀρχὴ παντὸς ἀριθμοῦ ἐφ' ἓν διάστημα κατὰ μονάδα προβιβαζομένου, ὁ δὲ γραμμικὸς ἀριθμὸς ἀρχὴ ἐπιπέδου ἀριθμοῦ ἐφ' ἕτερον διάστημα ἐπιπέδως πλατυνομένου, ὁ δὲ ἐπίπεδος ἀριθμὸς ἀρχὴ στερεοῦ ἀριθμοῦ ἐπὶ τρίτον

could be used for telling the time ; it was later used of an

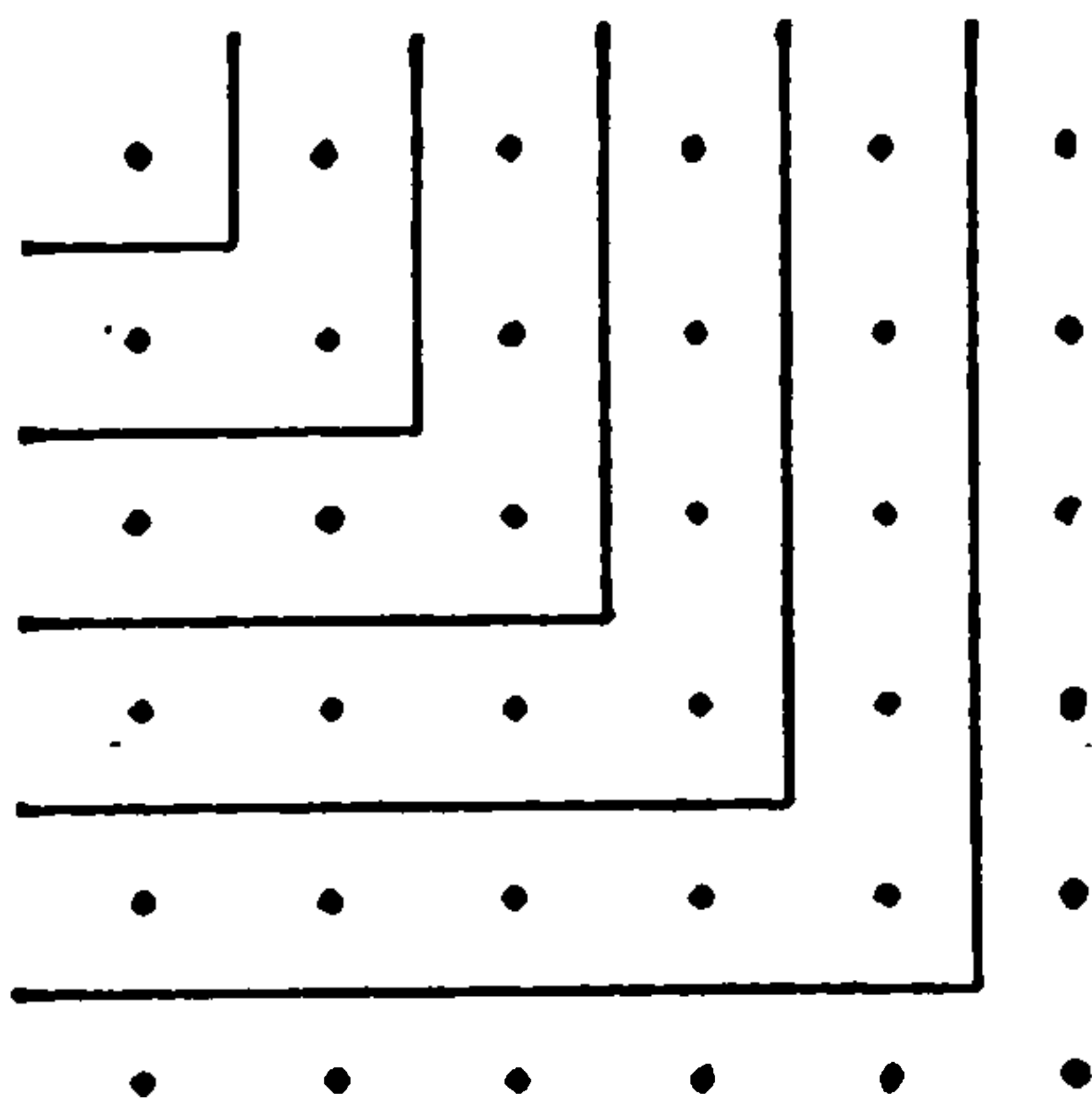

instrument for drawing right angles).

The first number after 1 which can be represented as a pentagon is 5. If it be represented as ABCDE, then we can form another pentagon AB'C'D'E, equivalent to 10, by adding the "gnomon of the pentagon," a row of an extra 7 dots arranged round three of the sides of the original pentagon. The gnomons to be added to form the successive pentagonal numbers 1, 5, 12, 22 . . . are respectively 4, 7, 10 . . ., or the successive terms of an arithmetical progression having 3 as the common difference. In the case of the hexagon the successive gnomonic numbers differ by 4, and in general, if n is the number of sides in the polygon, the successive gnomonic numbers differ by $n - 2$.



THIS PAGE IS LOCKED TO FREE MEMBERS

Purchase full membership to immediately unlock this page

SAVE \$3,999,994

Did you know we sell
paperback books too?

To buy our entire catalog
in paperback would cost
over \$4,000,000

Access it all now for
\$8.99/month

*Fair usage policy applies

Continue

GREEK MATHEMATICS

διάστημα πρὸς τὰ ἕξ ἀρχῆς βάθος τι προσκτω-
μένου· οἷον καθ' ὑποδιαίρεσιν γραμμικοὶ μὲν εἰσιν
ἀριθμοὶ ἀπλῶς ἅπαντες οἱ ἀπὸ δυάδος ἀρχόμενοι
καὶ κατὰ μονάδος πρόσθεσιν ἐπὶ ἓν καὶ τὸ αὐτὸ
προχωροῦντες διάστημα, ἐπίπεδοι δὲ οἱ ἀπὸ τριάδος
ἀρχόμενοι ἀρχικωτάτης ρίζης καὶ διὰ τῶν ἑξῆς
συνεχῶν ἀριθμῶν προϊόντες, λαμβάνοντες καὶ τὴν
ἐπωνυμίαν κατὰ τὴν αὐτὴν τάξιν· πρῶτιστοι γὰρ
τρίγωνοι, εἶτα μετ' αὐτοὺς τετράγωνοι, εἶτα μετ'
αὐτοὺς πεντάγωνοι, εἶτα ἐπὶ τούτοις ἑξάγωνοι καὶ
ἑπτάγωνοι καὶ ἐπ' ἄπειρον.

(ii.) *Triangular Numbers*

Luc. Vit. auct. 4

ΠΥΘΑΓΟΡΑΣ. Εἶτ' ἐπὶ τουτέοισιν ἀριθμέειν.

ΑΓΟΡΑΣΤΗΣ. Οἶδα καὶ νῦν ἀριθμεῖν.

ΠΥΘ. Πῶς ἀριθμέεις;

ΑΓΟ. Ἐν, δύο, τρία, τέτταρα.

ΠΥΘ. Ὅρᾶς; ἂ σὺ δοκέεις τέσσαρα, ταῦτα
δέκα ἐστὶ καὶ τρίγωνον ἐντελὲς καὶ ἡμέτερον
ὄρκιον.

Procl. in Eucl. i., ed. Friedlein 428. 7-429. 8

Παραδέδονται δὲ καὶ μέθοδοί τινες τῆς εὐρέσεως
τῶν τοιούτων τριγώνων, ὧν τὴν μὲν εἰς Πλάτωνα

* This celebrated Pythagorean symbol was known as the

PYTHAGOREAN ARITHMETIC

right angles] to the dimensions of the surface. For example, by subdivision linear numbers are all numbers without exception beginning from two and proceeding by the addition of a unit in one and the same dimension, while plane numbers begin from three as their fundamental root and advance through an orderly series of numbers, taking their designation according to their order. For first come triangles, then after them are squares, then after these are pentagons, then succeeding these are hexagons and heptagons and so on to infinity.

(ii.) *Triangular Numbers*

Lucian, *Auction of Souls* 4

PYTHAGORAS. After this you must count.

AGORASTES. Oh, I know how to do that already.

PYTH. How do you count?

AGO. One, two, three, four.

PYTH. Do you see? What you think is four is ten, a perfect triangle and our oath.^a

Proclus, *on Euclid* i., ed. Friedlein 428. 7-429. 8

There have been handed down certain methods for the discovery of such triangles,^b of which one is

τετρακτύς. It was alternatively called the "principle of health" (Lucian, *De Lapsu in Salutando* 5). The sum of any number of successive terms (beginning with the first) of the series of natural numbers $1 + 2 + 3 + \dots + n$ is therefore a triangular number, and the general formula for a triangular number is $\frac{1}{2}n(n+1)$.

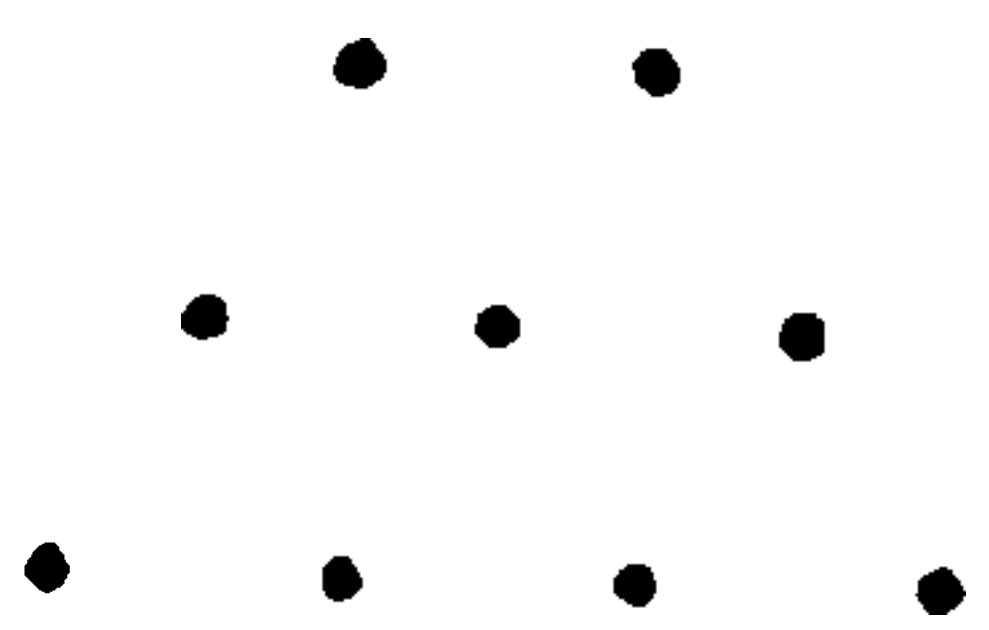

^b *i.e.*, triangles having the square on one side equal to the sum of the squares on the other two. Proclus is commenting on Euclid i. 47, for which see *infra*, pp. 178-185.

GREEK MATHEMATICS

ἀναπέμπουσι, τὴν δὲ εἰς Πυθαγόραν. καὶ ἡ μὲν Πυθαγορικὴ ἀπὸ τῶν περιττῶν ἐστὶν ἀριθμῶν. τίθησι γὰρ τὸν δοθέντα περιττὸν ὡς ἐλάσσονα τῶν περὶ τὴν ὀρθήν, καὶ λαβοῦσα τὸν ἀπ' αὐτοῦ τετράγωνον καὶ τούτου μονάδα ἀφελούσα τοῦ λοιποῦ τὸ ἥμισυ τίθησι τῶν περὶ τὴν ὀρθήν τὸν μείζονα· προσθεῖσα δὲ καὶ τούτῳ μονάδα τὴν λοιπὴν ποιεῖ τὴν ὑποτείνουσαν· οἷον τὸν τρία λαβοῦσα καὶ τετραγωνίσασα καὶ ἀφελούσα τοῦ ἐννέα μονάδα τοῦ ἦ λαμβάνει τὸ ἥμισυ τὸν δ, καὶ τούτῳ προστίθησι πάλιν μονάδα καὶ ποιεῖ τὸν ε, καὶ εὔρηται τρίγωνον ὀρθογώνιον ἔχον τὴν μὲν τριῶν, τὴν δὲ τεσσάρων, τὴν δὲ πέντε.

Ἡ δὲ Πλατωνικὴ ἀπὸ τῶν ἀρτίων ἐπιχειρεῖ. λαβοῦσα γὰρ τὸν δοθέντα ἄρτιον τίθησιν αὐτὸν ὡς μίαν πλευρὰν τῶν περὶ τὴν ὀρθήν, καὶ τοῦτον

^a i.e., if n is the given odd number, the sides of the triangle are

$$n, \frac{n^2 - 1}{2}, \frac{n^2 + 1}{2}$$

and the formula is an assertion that

$$n^2 + \left(\frac{n^2 - 1}{2}\right)^2 = \left(\frac{n^2 + 1}{2}\right)^2.$$



THIS PAGE IS LOCKED TO FREE MEMBERS

Purchase full membership to immediately unlock this page

FORGOTTEN BOOKS

FULL

MEMBERSHIP

797,885 Books!

All you can read

for only

\$8.99/month

Continue

*Fair usage policy applies



GREEK MATHEMATICS

διελούσα δίχα καὶ τετραγωνίσασα τὸ ἥμισυ, μονάδα μὲν τῷ τετραγώνῳ προσθείσα ποιεῖ τὴν ὑποτείνουσαν, μονάδα δὲ ἀφελούσα τοῦ τετραγώνου ποιεῖ τὴν ἑτέραν τῶν περὶ τὴν ὀρθήν· οἶον τὸν τέσσαρα λαβοῦσα καὶ τούτου τὸ ἥμισυ τὸν β̄ τετραγωνίσασα καὶ ποιήσασα αὐτὸν δ. ἀφελούσα μὲν μονάδα ποιεῖ τὸν γ̄, προσθείσα δὲ ποιεῖ τὸν ε̄, καὶ ἔχει τὸ αὐτὸ γινόμενον τρίγωνον, ὃ καὶ ἐκ τῆς ἑτέρας ἀπετελεῖτο μεθόδου. τὸ γὰρ ἀπὸ τούτου ἴσον τῷ ἀπὸ τοῦ γ̄ καὶ τῷ ἀπὸ τοῦ δ̄ συντεθείσιν.

(iii.) Oblong and Square Numbers

Aristot. *Phys.* Γ 4, 203 a 13-15

Περιτιθεμένων γὰρ τῶν γνωμόνων περὶ τὸ ἓν καὶ χωρὶς ὅτε μὲν ἄλλο αἰεὶ γίνεσθαι τὸ εἶδος, ὅτε δὲ ἓν.

(iv.) Polygonal Numbers

Nicom. *Arith. Introd.* ii. 12. 2-4, ed. Hoche 96. 11-97. 17

Δύο δὴ, οὓς ἂν θέλης, τριγώνους συνεχεῖς ἀλ-

^a *i.e.*, if $2n$ is the given even number, the sides of the triangle are $2n$, $n^2 + 1$, $n^2 - 1$, and the formula asserts that

$$(2n)^2 + (n^2 - 1)^2 = (n^2 + 1)^2.$$

Heath (*H.G.M.* i. 81) shows how this formula, like that of Pythagoras, could have been obtained from gnomons of dots. Both formulae can be deduced from Euclid ii. 5, a Pythagorean proposition (see *infra*, p. 194 n. a). A more general formula, including both the Pythagorean and Platonic methods, is given in the lemma to Euclid x. 28, which is equivalent to the assertion

$$m^2 n^2 p^2 q^2 + \left(\frac{mnp^2 - mnq^2}{2} \right)^2 = \left(\frac{mnp^2 + mnq^2}{2} \right)^2.$$

PYTHAGOREAN ARITHMETIC

this in two and squares the half, adds a unit to the square so as to make the hypotenuse and subtracts a unit from the square so as to make the other side about the right angle.^a For example, taking 4 and squaring the half, 2, it makes 4 again. Subtracting a unit it obtains 3, and adding one it makes 5, and yields the same triangle as that furnished by the other method. For the triangle constructed by this method is equal to that from 3 and from 4.

(iii.) *Oblong and Square Numbers*

Aristotle, *Physics* Γ 4, 203 a 13-15

For when gnomons are placed round 1 the resulting figures are in one case always different, in the other they preserve one form.^b

(iv.) *Polygonal Numbers*

Nicomachus, *Introduction to Arithmetic* ii. 12. 2-4,
ed. Hoche 96. 11-97. 17

By taking any two successive triangular numbers

^b As was indicated on p. 86 n. a, when gnomons consisting of an *odd* number of dots are placed round 1 the result is always a square. When gnomons consisting of an *even* number of dots are placed round 2 the result is an oblong, and the successive oblongs are always different in form. This is probably what Aristotle refers to, but he does not indicate that the starting-point is in one case 1 and in the other 2; and the interpretation is modern, Themistius and Simplicius having other (and less attractive) explanations. The subject is fully discussed by W. D. Ross in his notes *ad loc.* (*Aristotle's Physics*, pp. 542-544).

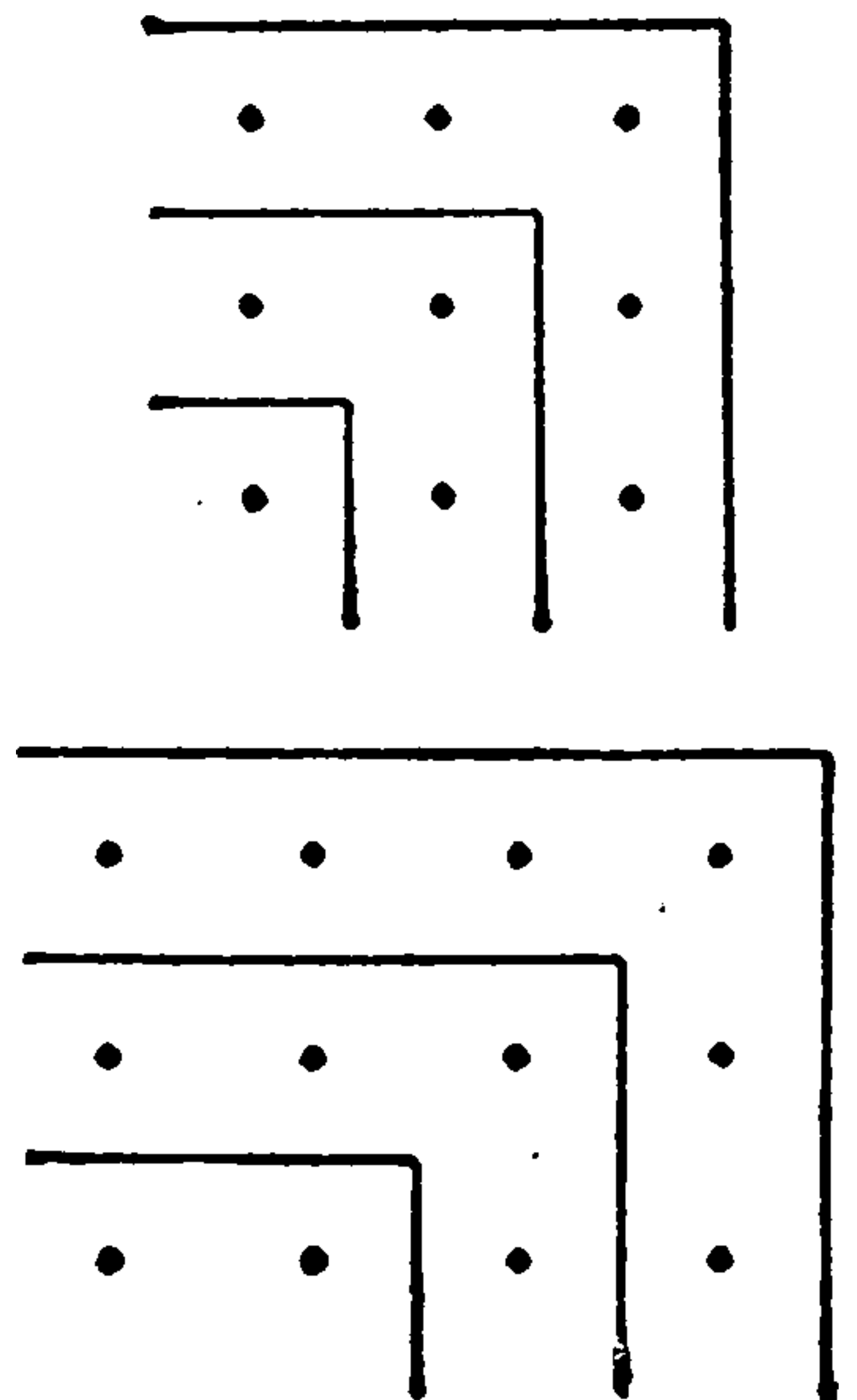

λήλοις συνθεῖς πάντως τετράγωνον ποιήσεις καὶ ὄντινοῦν τετράγωνον ἄρα διαλύσας δυνήσῃ δύο ἀπ' αὐτῶν τριγώνους ποιῆσαι· καὶ πάλιν παντὶ τετραγώνῳ σχήματι τρίγωνον προσζευχθὲν ὀθενοῦν πεντάγωνον ποιεῖ, οἷον τῷ δ τετραγώνῳ ὁ ᾱ τρίγωνος προσζευχθεὶς τὸν ε̄ πεντάγωνον ποιεῖ καὶ τῷ θ̄ τῷ ἐξῆς ὁ ἐξῆς προστεθείς, δηλονότι ὁ γ̄, πεντάγωνον τὸν ιβ̄ ποιεῖ, τῷ δὲ ις̄ ὄντι ἀκολουθῶ ὁ ε̄ ἀκόλουθος ἐπισυντεθείς τὸν κβ̄ ἀκόλουθον ἀποδίδωσιν καὶ τῷ κε̄ ὁ ῑ τὸν λε̄ καὶ αἰεὶ οὕτως. κατὰ δὲ τὰ αὐτὰ καὶν τοῖς πενταγώνοις οἱ τρίγωνοι προστιθοῖντο τῇ αὐτῇ τάξει, τοὺς εὐτάκτους γενήσουσιν ἑξαγώνους καὶ πάλιν ἐκείνοις οἱ αὐτοὶ προσπλεκόμενοι τοὺς ἐν τάξει ἑπταγώνους ποιήσουσι καὶ μετ' ἐκείνους τοὺς ὀκταγώνους καὶ τοῦτο ἐπ' ἄπειρον. πρὸς δὲ ὑπόμνησιν ἐκκείσθωσαν ἡμῖν πολυγώνων στίχοι παραλλήλως γεγραμμένοι οἶδε, ὁ πρῶτος τρίγωνων, ὁ μετ' αὐτὸν τετραγώνων, μετὰ δὲ ἀμφοτέρους πενταγώνων, εἶτα ἑξαγώνων, εἶτα ἑπταγώνων, εἶτα, εἰ ἐθέλοι τις, καὶ τῶν ἐξῆς πολυγώνων·

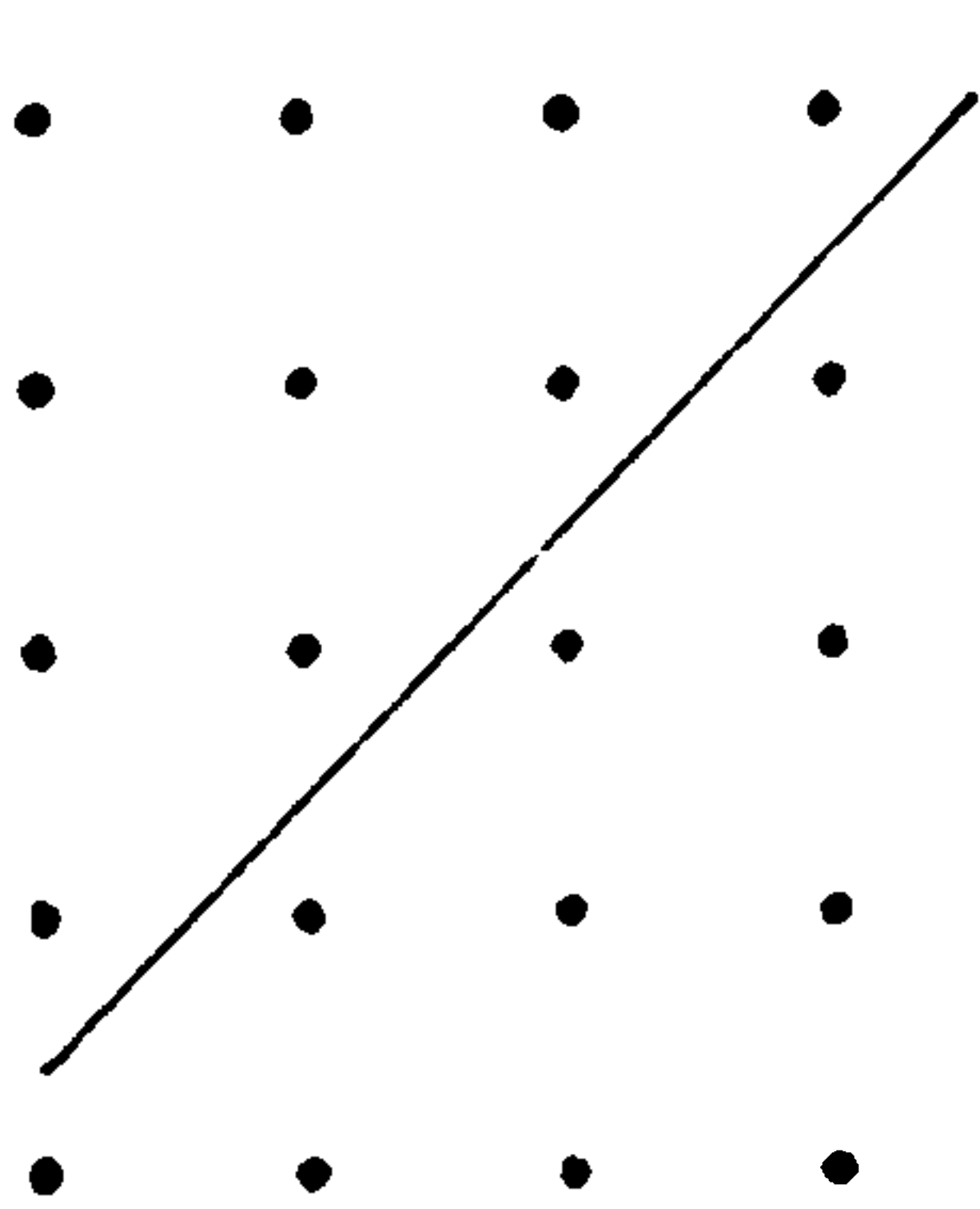

^a In other words $\frac{1}{2}(n-1)n + \frac{1}{2}n(n+1) = n^2$, as may easily be seen from an array of dots. Here the square, of side n , is split up into two triangular numbers of side $n-1$, n whose values are therefore $\frac{1}{2}(n-1)n$, $\frac{1}{2}n(n+1)$. Theon of Smyrna (ed. Hiller 41. 3-8) gives the same theorem.

^b The general formula for an a -gonal number of side n is $n + \frac{1}{2}n(n-1)(a-2)$,



THIS PAGE IS LOCKED TO FREE MEMBERS

Purchase full membership to immediately unlock this page

SAVE \$3,999,994

Did you know we sell
paperback books too?

To buy our entire catalog
in paperback would cost
over \$4,000,000

Access it all now for
\$8.99/month

*Fair usage policy applies

Continue

GREEK MATHEMATICS

μῆκος καὶ πλάτος

τρίγωνοι	α	γ	ς	ι	ιε	κα	κη	λς	με	νε
τετράγωνοι	α	δ	θ	ις	κε	λς	μθ	ξδ	πα	ρ
πεντάγωνοι	α	ε	ιβ	κβ	λε	να	ο	ςβ	ριζ	ρμε
έξάγωνοι	α	ς	ιε	κη	με	ξς	ςα	ρκ	ργγ	ρς
έπτάγωνοι	α	ζ	ιη	λδ	νε	πα	ριβ	ρμη	ρπθ	σλε

βάθος

(v.) Gnomons of Polygonal Numbers

Iambl. in Nicom. Arith. Introd., ed. Pistelli 62. 10-18

Καὶ ἐν τῇ σχηματογραφίᾳ δὲ τῶν πολυγώνων δύο μὲν ἐπὶ πάντων αἱ αὐταὶ μενοῦσι πλευραὶ μηκυνόμεναι καθ' ἕκαστον, αἱ δὲ παρὰ ταύτας ἐναποληφθήσονται τῇ τῶν γνωμόνων περιθέσει αἰεὶ ἀλλασσόμεναι, μία μὲν ἐν τριγώνῳ, δύο δὲ ἐν τετραγώνῳ καὶ τρεῖς ἐν πενταγώνῳ καὶ ὁμοίως ἐπ' ἄπειρον, κατὰ δυάδος κἀνταῦθα διαφορὰν τῆς κλήσεως τῶν πολυγώνων πρὸς τὴν ποσότητα τῶν ἀλλασσομένων γινομένης.

* i.e., the principle will be made clear from the figures for the gnomons of the square and pentagon given on pp. 86-89 n. a. The general formula is that in a polygon of a sides, the number of sides changed to form the next highest polygon

PYTHAGOREAN ARITHMETIC

BREADTH AND LENGTH

Triangles	1	3	6	10	15	21	28	36	45	55	depth
Squares	1	4	9	16	25	36	49	64	81	100	
Pentagons	1	5	12	22	35	51	70	92	117	145	
Hexagons	1	6	15	28	45	66	91	120	153	190	
Heptagons	1	7	18	34	55	81	112	148	189	235	

(v.) *Gnomons of Polygonal Numbers*

Iamblichus, *On Nicomachus's Introduction to Arithmetic*,
ed. Pistelli 62. 10-18

Now in the representation of the polygons two of the sides always remain the same but are produced, while the sides intercepted between them are continually changed when the gnomons are placed round, one being changed in the triangle, two in the square, three in the pentagon and so on to infinity, the difference between the designation of the polygons and the number of sides changed being two.^a

is $a - 2$. (This leads Iamblichus to introduce immediately Thymaridas's rule for solving n simultaneous equations, as the factor $a - 2$ occurs in this also. For this rule see *infra*, pp. 138-141).

From Iamblichus's account it follows that the successive gnomons to a polygon of a sides are

$$1, 1 + (a - 2), 1 + 2(a - 2), \dots, 1 + (r - 1)(a - 2),$$

and the a -gonal number of side n is the sum of n terms this series, or

$$n + \frac{1}{2}n(n - 1)(a - 2).$$

GREEK MATHEMATICS

(e) SOME PROPERTIES OF NUMBERS

(i.) *The "Sieve" of Eratosthenes*

Nicom. *Arith. Introd.* i. 13. 2-4, ed. Hoche 29. 17-32. 18

Ἡ δὲ τούτων γένεσις ὑπὸ Ἐρατοσθένους καλεῖται κόσκινον, ἐπειδὴ ἀναπεφυρμένους τοὺς περισσοὺς λαβόντες καὶ ἀδιακρίτους ἐξ αὐτῶν τῇ τῆς γενέσεως μεθόδῳ ταύτῃ διαχωρίζομεν, ὡς δι' ὀργάνου ἢ κοσκίνου τινὸς καὶ ἰδίᾳ μὲν τοὺς πρώτους καὶ ἀσυνθέτους, ἰδίᾳ δὲ τοὺς δευτέρους καὶ συνθέτους, χωρὶς δὲ τοὺς μικτοὺς εὐρίσκομεν. ἔστι δὲ ὁ τρόπος τοῦ κοσκίνου τοιοῦτος· ἐκθέμενος τοὺς ἀπὸ τριάδος πάντα ἐφεξῆς περισσοὺς ὡς δυνατόν μάλιστα ἐπὶ μήκιστον στίχον, ἀρξάμενος ἀπὸ τοῦ πρώτου ἐπισκοπῶ, τίνας οἷός τέ ἐστι μετρεῖν, καὶ εὐρίσκω δυνατόν ὄντα τοὺς δύο μέσους παραλείποντας μετρεῖν, μέχρις οὗ ἂν προχωρεῖν ἐθέλωμεν, οὐχ ὡς ἔτυχε δὲ καὶ εἰκῆ μετροῦντα, ἀλλὰ τὸν μὲν πρώτως κείμενον, τουτέστι τὸν δύο μέσους ὑπερβαίνοντα κατὰ τὴν τοῦ πρωτίστου ἐν τῷ στίχῳ κειμένου ποσότητα μετρήσει, τουτέστι κατὰ τὴν ἑαυτοῦ· τρὶς γάρ· τὸν δ' ἀπ' ἐκείνου δύο

^a Nicomachus has been discussing the different species of odd numbers, which are explained above on p. 69 n. c.

^b That is, Eratosthenes, for whom see p. 156 n. a, set out the odd numbers beginning with 3 in a column. For convenience we will set them out horizontally as follows :

3, 5, 7, 9, 11, 13, 15, 17, 19, 21, 23, 25, 27, 29, 31, 33, 35.



THIS PAGE IS LOCKED TO FREE MEMBERS

Purchase full membership to immediately unlock this page

FORGOTTEN BOOKS

FULL

MEMBERSHIP

797,885 Books!

All you can read

for only

\$8.99/month

Continue

*Fair usage policy applies



GREEK MATHEMATICS

διαλείποντα κατὰ τὴν τοῦ δευτέρου τεταγμένου πεντάκισ γάρ· τὸν δὲ περαιτέρω πάλιν δύο διαλείποντα κατὰ τὴν τοῦ τρίτου τεταγμένου· ἑπτάκισ γάρ· τὸν δὲ ἔτι περαιτέρω ὑπὲρ δύο κείμενον κατὰ τὴν τοῦ τετάρτου τεταγμένου· ἐνάκισ γάρ· καὶ ἐπ' ἄπειρον τῷ αὐτῷ τρόπῳ. εἶτα μετὰ τοῦτον ἀπ' ἄλλης ἀρχῆς ἐπὶ τὸν δεύτερον ἔλθων σκοπῶ, τίνας οἶός τέ ἐστι μετρεῖν, καὶ εὕρισκω πάντας τοὺς τετράδα διαλείποντας, ἀλλὰ τὸν μὲν πρῶτον κατὰ τὴν τοῦ ἐν τῷ στίχῳ πρώτου τεταγμένου ποσότητα· τρὶς γάρ· τὸν δὲ δεύτερον κατὰ τὴν τοῦ δευτέρου· πεντάκισ γάρ· τὸν δὲ τρίτον κατὰ τὴν τοῦ τρίτου· ἑπτάκισ γάρ· καὶ τοῦτο ἐφεξῆς αἰεί.

(ii.) *Divisibility of Squares*

Theon Smyr., ed. Hiller 35. 17–36. 2

Ἰδίως δὲ τοῖς τετραγώνοις συμβέβηκεν ἥτοι τρίτον ἔχειν ἢ μονάδος ἀφαιρεθείσης τρίτον ἔχειν πάντως, ἢ πάλιν τέταρτον ἔχειν ἢ μονάδος ἀφαιρεθείσης τέταρτον ἔχειν πάντως· καὶ τὸν μὲν μονάδος ἀφαιρεθείσης τρίτον ἔχοντα ἔχειν καὶ τέταρτον

-
- The numbers obtained by passing over four numbers are

15, 25, 35 . . .

and can all be divided by 5, leaving

3, 5, 7 . . .

which is the original series of odd numbers.

Nicomachus proceeds to pass over six numbers at a time, beginning from 7, but we need not follow him. Clearly in this way he will eventually be able to remove from the series of odd numbers all that are not prime. The general formula is that we obtain all multiples of a prime number n by skip-

PYTHAGOREAN ARITHMETIC

obtained by passing over two from that one according to the magnitude of the second number in order ; for it will measure it five times. The number obtained by passing over two numbers yet again it will measure according to the magnitude of the third number in order ; for it will measure it seven times. The number that lies yet two places beyond it will measure according to the magnitude of the fourth number in order ; for it will measure it nine times ; and we may proceed without limit in this manner. After this I make a fresh start with the second number in the series and examine which numbers it will measure, and I find it will measure all the numbers obtained by passing over four,^a and will measure the first number so obtained according to the magnitude of the first number in the column ; for it will measure it thrice. It will measure the second according to the magnitude of the second, that is, five times ; the third according to the magnitude of the third, that is, seven times ; and so on in order for ever.

(ii.) *Divisibility of Squares*

Theon of Smyrna, ed. Hiller 35. 17–36. 2

It is a property of squares to be divisible by three, or to become so divisible after subtraction of a unit ; likewise they are divisible by four, or become so divisible after subtraction of a unit ; even squares that after subtraction of a unit are divisible by three

ping $n - 1$ terms at a time. But to make sure that any odd number $2n + 1$ left in the series is prime we should have to try to divide it by all the prime numbers up to $\sqrt{2n + 1}$, and the method is not a practicable way of ascertaining whether any large number is prime.

GREEK MATHEMATICS

πάντως, ὡς ὁ δ, τὸν δὲ μονάδος ἀφαιρέσεως
τέταρτον ἔχοντα ἔχειν τρίτον πάντως, ὡς ὁ θ, ἢ
τὸν αὐτὸν πάλιν καὶ τρίτον ἔχειν καὶ τέταρτον, ὡς
ὁ λ̄ [ἢ μηδέτερον τούτων ἔχοντα τούτον μονάδος
ἀφαιρέσεως τρίτον ἔχειν πάντως],¹ ἢ μήτε τρίτον
μήτε τέταρτον ἔχοντα μονάδος ἀφαιρέσεως καὶ
τρίτον ἔχειν καὶ τέταρτον, ὡς ὁ κ̄.

(iii.) *A Theorem about Cube Numbers*

. Nicom. *Arith. Introd.* ii. 20. 5, ed. Hoche 119. 12-18

Ἐκτεθέντων γὰρ τῶν ἀπὸ μονάδος ἐπ' ἄπειρον
συνεχῶν περισσῶν ἐπισκόπει οὕτως, ὁ πρῶτος τὸν
δυνάμει κύβον ποιεῖ, οἱ δὲ δύο μετ' ἐκείνον συν-
τεθέντες τὸν δεύτερον, οἱ δὲ ἐπὶ τούτοις τρεῖς τὸν
τρίτον, οἱ δὲ συνεχεῖς τούτοις τέσσαρες τὸν τέ-
ταρτον, οἱ δὲ ἐφεξῆς τούτοις πέντε τὸν πέμπτον

¹ ἢ . . . πάντως om. Bullialdus, Hiller.

* Any number may be written as $3n$, $3n \pm 1$ or $3n \pm 2$, and its square takes the form

$$9n^2 \text{ or } 9n^2 \pm 6n + 1 \text{ or } 9n^2 \pm 12n + 4.$$

In the first case, the square is divisible by three; in the second and third cases it becomes so divisible after subtraction of a unit.



THIS PAGE IS LOCKED TO FREE MEMBERS

Purchase full membership to immediately unlock this page

SAVE \$3,999,994

Did you know we sell
paperback books too?

To buy our entire catalog
in paperback would cost
over \$4,000,000

Access it all now for
\$8.99/month

*Fair usage policy applies

Continue

GREEK MATHEMATICS

καὶ οἱ ἑξῆς ἕξ τὸν ἕκτον καὶ τοῦτο μέχρι αἰεί.

(iv.) *A Property of the Pythmen*

Iambl. in *Nicom. Arith. Introd.*, ed. Pistelli 103. 10-104. 13

Ἐπεὶ δὲ ἑξάδος ἀποτελεστική ἐστὶν ἢ πρώτη παρ' οὐδέν ἀπὸ μονάδος συζυγία, ἢ πρώτη $\bar{\alpha}$ $\bar{\beta}$ $\bar{\gamma}$ εἰδοποιήσῃ τὰς ἑξῆς αὐτῇ, μηδενὸς ὄρου κοινουῦ λαμβανομένου μηδὲ μὴν παρελειπομένου, ἀλλὰ μετὰ τὴν $\bar{\alpha}$ $\bar{\beta}$ $\bar{\gamma}$ λαμβανομένης τῆς $\bar{\delta}$ $\bar{\epsilon}$ $\bar{\zeta}$, εἶτα $\bar{\zeta}$ $\bar{\eta}$ $\bar{\theta}$ καὶ ἑξῆς ἀκολουθῶς. πᾶσαι γὰρ αὐταὶ ἑξάδες γενήσονται μεταλαμβάνουσης τὸν μονάδος τόπον αἰεί τῆς δεκάδος, τουτέστιν εἰς μονάδα ἀναγομένης· οὕτως γὰρ αὐτὴν καὶ δευτερωδομένην μονάδα καλεῖσθαι ἐλέγομεν πρὸς τῶν Πυθαγορείων,

^a That is to say, $1 = 1^3$, $3 + 5 = 2^3$, $7 + 9 + 11 = 3^3$, $13 + 15 + 17 + 19 = 4^3$, $21 + 23 + 25 + 27 + 29 = 5^3$, $31 + 33 + 35 + 37 + 39 + 41 = 6^3$, and so on to infinity, the general formula being

$\{n(n-1)+1\} + \{n(n-1)+3\} + \dots + \{n(n-1)+2n-1\} = n^3$.
By putting $n=1, 2, 3 \dots r$ in this formula and adding the results it is easily shown that

$$1^3 + 2^3 + 3^3 + \dots + r^3 = \left\{\frac{1}{2}r(r+1)\right\}^2,$$

a formula which was known to the Roman *agrimensores* and probably to Nicomachus. Heath (*H.G.M.* i. 109-110) shows how it was proved by the Arabian algebraist Alkarkhī in a book *Al-Fakhrī* written in the tenth or eleventh century. The proof depends on Nicomachus's theorem.

^b Iamblichus has been considering various groups of three numbers which can be formed from the series of natural numbers, by passing over a specified number of terms, so as to become polygonal numbers. Thus $1 + 2 + 3 = 6$ (triangle), $1 + 3 + 5 = 9$ (square), $3 + 4 + 5 = 12$ (pentagon), $1 + 4 + 7 = 12$ (pentagon), $1 + 5 + 9 = 15$ (hexagon).

PYTHAGOREAN ARITHMETIC

the next six in order make the sixth cube, and so on for ever.^a

(iv.) *A Property of the Pythmen*

Iamblichus, *On Nicomachus's Introduction to Arithmetio*,
ed. Pistelli 103. 10–104. 13

Since the first group,^b starting from the unit and omitting no term, is productive of the hexad, the first group, 1, 2, 3, will be a model of those that succeed it, the groups having no common term and leaving none on one side, but 1, 2, 3 being followed by 4, 5, 6, then by 7, 8, 9, and so on in order.^c For all these will become hexads when the unit takes the place of the decad in all cases, so reducing it to a unit. For after this manner we said 10 was called the unit of the second course ^d among the Pythagoreans, while 100

• In other words, Iamblichus asks us to consider any group of three consecutive numbers, the greatest of which is divisible by 3. We may represent such a group generally as $3p + 1, 3p + 2, 3p + 3$.

^d As Iamblichus had previously explained (*in Nicom.*, ed. Pistelli 75. 25—77. 4), the Pythagoreans looked upon a square number n^2 as a race course (*δίαυλος*) formed of successive numbers from 1 (as the *start*, *ὑσπληξ*) up to n (the *turning point*, *καμπτήρ*) and back again through $(n - 1)$, $(n - 2)$, and so on to 1 (as the *goal*, *νύσσα*), in this way:

$$\begin{array}{r}
 1 + 2 + 3 + \dots + (n - 1) \\
 + \\
 n \\
 + \\
 1 + 2 + 3 + \dots + (n - 1)
 \end{array}$$

As an example we have

$$1 + 2 + 3 + \dots + 10 + 9 + 8 + \dots + 3 + 2 + 1 = 10^2$$

and thence

GREEK MATHEMATICS

καὶ τριωδουμέναν τὴν ἑκατοντάδα, καὶ τετρωδου-
 μέναν τὴν χιλιάδα. ἡ μὲν γὰρ $\bar{\delta} \bar{\epsilon} \bar{\zeta}$ ποιεῖ ἀριθμὸν
 τὸν $\bar{\iota}\bar{\epsilon}$. ἀναγομένης δὲ τῆς δεκάδος εἰς μονάδα, ὁ
 πέντε προσλαβὼν αὐτὴν ἐξὰς γίνεται. πάλιν ἡ
 $\bar{\xi}$ ἢ $\bar{\theta}$ συνθεῖσα ποιεῖ τὸν $\bar{\kappa}\bar{\delta}$ ἀριθμόν, οὗ τὰ $\bar{\kappa}$
 εἰς δύο μονάδας ἀναγαγὼν προστίθῃμι τῷ $\bar{\delta}$, καὶ
 ἔχω πάλιν ἐξάδα. πάλιν $\bar{\iota}$ $\bar{\iota}\bar{\alpha}$ $\bar{\iota}\bar{\beta}$ συνθεῖς ποιῶ
 $\bar{\lambda}\bar{\gamma}$, ὧν τὰ $\bar{\lambda}$ τριάς ἐστίν, ἣν προσθεῖς τοῖς τρισὶν
 ἔχω ὁμοίως ἐξάδα, καὶ τοῦτο ὁμοίως ἔσται δι'
 ὄλου. καὶ ἡ μὲν πρώτη ἐξὰς οὐκ ἔχει μετάθεσιν
 δεκάδος εἰς μονάδα, ὡς ἂν εἶδοποιὸς καὶ στοιχεῖον
 τῶν μετ' αὐτὴν ὑπάρχουσα. ἡ δὲ δευτέρα μιᾶς
 μονάδος μετάθεσιν ἔξει, ἡ δὲ τρίτη δυεῖν καὶ ἡ
 τετάρτη τριῶν καὶ ἡ πέμπτη τεσσάρων καὶ ἐξῆς
 ἀκολουθῶς. ὅσαι δ' ἂν ὦσιν αἱ μετατιθέμεναι
 δεκάδες, τοσαῦται καὶ αἱ ἐννεάδες ἀφαιρεθήσονται
 ἐκ τοῦ ὄλου συστήματος, ἵνα τὸ λείπον ὁμοίως ἐξὰς
 ἦ. τοῦ γὰρ $\bar{\iota}\bar{\epsilon}$ μιᾶς δεκάδος ἔχοντος μετάθεσιν, εἰ
 ἀφέλω μίαν ἐννεάδα, λειφθήσεται ἐξὰς. τοῦ δὲ $\bar{\kappa}\bar{\delta}$
 δύο ἔχοντος δεκάδας τὰς μεταποιουμένας εἰ
 ἀφέλω δύο ἐννεάδας, λειφθήσεται πάλιν ἐξὰς, καὶ
 τοῦτο δι' ὄλου συμβήσεται.

$$\begin{aligned}
 &10 + 20 + 30 + \dots + 100 + 90 + 80 + \dots + 30 + 20 + 10 = 10^3 \\
 &100 + 200 + 300 + \dots + 1000 + 900 + 800 + \dots + 300 + 200 + 100 \\
 &= 10^4
 \end{aligned}$$

and so on. It was in virtue of these relations that the Pythagoreans spoke of 10 as the *unit of the second course* (δευτεροδουμένη μονάς), 100 as the *unit of the third course* (τριωδουμένη μονάς) and so on.

^a The truth of Iamblichus's proposition is proved generally by Loria (*Le scienze esatte nell' antica Grecia*, pp. 841-842) in the following manner.

Let
$$N = n_0 + 10n_1 + 10^2n_2 + \dots$$



THIS PAGE IS LOCKED TO FREE MEMBERS

Purchase full membership to immediately unlock this page

FORGOTTEN BOOKS

FULL

MEMBERSHIP

797,885 Books!

All you can read

for only

\$8.99/month

Continue

*Fair usage policy applies



GREEK MATHEMATICS

(f) IRRATIONALITY OF THE SQUARE ROOT OF 2

Aristot. *Anal. Pr.* i. 23, 41 a 26-27

Πάντες γὰρ οἱ διὰ τοῦ ἀδυνάτου περαίνοντες τὸ μὲν ψεῦδος συλλογίζονται, τὸ δ' ἐξ ἀρχῆς ἐξ ὑποθέσεως δεικνύουσιν, ὅταν ἀδύνατόν τι συμβαίη τῆς ἀντιφάσεως τεθείσης, οἷον ὅτι ἀσύμμετρος ἡ διάμετρος διὰ τὸ γίνεσθαι τὰ περιττὰ ἴσα τοῖς ἀρτίοις συμμέτρου τεθείσης. τὸ μὲν οὖν ἴσα γίνεσθαι τὰ περιττὰ τοῖς ἀρτίοις συλλογίζεται, τὸ δ' ἀσύμμετρον εἶναι τὴν διάμετρον ἐξ ὑποθέσεως δεικνύουσιν, ἐπεὶ ψεῦδος συμβαίνει διὰ τὴν ἀντίφασιν.

(g) THE THEORY OF PROPORTION AND MEANS

(i.) *Arithmetic, Geometric and Harmonic Means*

Iambl. in *Nicom. Arith. Introd.*, ed. Pistelli 100. 19-25

Μόνοι δὲ τὸ παλαιὸν τρεῖς ἦσαν μεσότητες ἐπὶ Πυθαγόρου καὶ τῶν κατ' αὐτὸν μαθηματικῶν, ἀριθ-

Now, if N is the sum of three consecutive numbers of which the greatest is divisible by 3, we can write

$$N = (3p + 1) + (3p + 2) + (3p + 3),$$

and the above congruence becomes

$$9p + 6 = N' \pmod{9}$$

so that $N' \equiv 6 \pmod{9}$, with the condition $N' \leq 9$. But the only number ≤ 9 which is divisible by 6 is 6 itself.

Therefore $N' = 6$.

^a It is generally believed that the Pythagoreans were aware of the irrationality of $\sqrt{2}$ (Theodorus, for example, when proving the irrationality of numbers began with $\sqrt{3}$), and that Aristotle has indicated the method by which they proved it. The proof, interpolated in the text of Euclid as

PYTHAGOREAN ARITHMETIC

(f) IRRATIONALITY OF THE SQUARE ROOT OF 2

Aristotle, *Prior Analytics* i. 23, 41 a 26-27

For all who argue *per impossibile* infer by syllogism a false conclusion, and prove the original conclusion hypothetically when something impossible follows from a contradictory assumption, as, for example, that the diagonal [of a square] is incommensurable [with the side] because odd numbers are equal to even if it is assumed to be commensurate. It is inferred by syllogism that odd numbers are equal to even, and proved hypothetically that the diagonal is incommensurate, since a false conclusion follows from the contradictory assumption.^a

(g) THE THEORY OF PROPORTION AND MEANS

(i.) *Arithmetic, Geometric and Harmonic Means*

Iamblichus, *On Nicomachus's Introduction to Arithmetic*,
ed. Pistelli 100. 19-25

In ancient days in the time of Pythagoras and the mathematicians of his school there were only three

x. 117 (Eucl., ed. Heiberg-Menge iii. 408-410), is roughly as follows. Suppose AC, the diagonal of a square, to be commensurable with its side AB, and let their ratio in its smallest terms be $a : b$.

Now $AC^2 : AB^2 = a^2 : b^2$

and $AC^2 = 2AB^2, a^2 = 2b^2.$

Hence a^2 , and therefore a , is even.

Since $a : b$ is in its lowest terms it follows that b is odd.

Let $a = 2c$. Then $4c^2 = 2b^2$, or $b^2 = 2c^2$, so that b^2 , and therefore b is even.

But b was shown to be odd, and is therefore odd and even, which is impossible. Therefore AC cannot be commensurable with AB.

μητική τε καὶ ἡ γεωμετρική καὶ ἡ ποτὲ μὲν ὑπεναντία λεγομένη τῇ τάξει τρίτη, ὑπὸ δὲ τῶν περὶ Ἀρχύταν αὐθις καὶ Ἰππασον ἁρμονικὴ μετακληθεῖσα, ὅτι τοὺς κατὰ τὸ ἡρμοσμένον καὶ ἐμμελὲς ἐφαίνετο λόγους περιέχουσα.

Archytas ap. Porph. in Ptol. Harm., ed. Wallis, Opera Math. iii. 267. 39–268. 9 ; Diels, Vors. i^b. 435. 18–436. 13

Ἀρχύτας δὲ περὶ τῶν μεσοτήτων λέγων γράφει ταῦτα·

“ Μέσαι δὲ ἐντι τρῖς τᾶ μουσικᾶ, μία μὲν ἀριθμητικά, δευτέρα δὲ γεωμετρικά, τρίτα δ’ ὑπεναντία, ἃν καλέοντι ἁρμονικάν. ἀριθμητικὰ μὲν, ὅκκα ἔωντι τρεῖς ὅροι κατὰ τὰν τοίαν ὑπεροχὰν ἀνὰ λόγον· ὧ πρῶτος δευτέρου ὑπερέχει, τωὐτῶ δεύτερος τρίτου ὑπερέχει. καὶ ἐν ταύτα τᾶ ἀναλογία συμπίπτει εἶμεν τὸ τῶν μειζόνων ὄρων διάστημα μείον, τὸ δὲ τῶν μειόνων μείζον. γεωμετρικὰ δέ, ὅκκα ἔωντι οἷος ὁ πρῶτος ποτὶ τὸν δεύτερον, καὶ ὁ δεύτερος ποτὶ τὸν τρίτον. τούτων δὲ οἱ μείζονες ὅροι ἴσον ποιοῦνται τὸ διάστημα καὶ οἱ μείους. ἃ δὲ ὑπεναντία, ἃν καλοῦμεν ἁρμονικάν, ὅκκα ἔωντι (τοῖοι· ὧ)¹ ὁ πρῶτος ὅρος ὑπερέχει τοῦ δευτέρου αὐταύτου μέρει, τωὐτῶ ὁ μέσος τοῦ τρίτου ὑπερ-

¹ τοῖοι ὧ add. Diels.

• i.e., b is the arithmetic mean between a and c if

$$a - b = b - c.$$

• The word διάστημα (*interval*) is here used in the musical sense; mathematically it must be understood as the *ratio*



THIS PAGE IS LOCKED TO FREE MEMBERS

Purchase full membership to immediately unlock this page

SAVE \$3,999,994

Did you know we sell
paperback books too?

To buy our entire catalog
in paperback would cost
over \$4,000,000

Access it all now for
\$8.99/month

*Fair usage policy applies

Continue

GREEK MATHEMATICS

ἔχει τοῦ τρίτου μέρει. γίνεται δὲ ἐν ταῦτα τῶ ἀναλογία τὸ τῶν μειζόνων ὄρων διάστημα μείζον, τὸ δὲ τῶν μειόνων μείον.”

(ii.) *Seven Other Means*

Nicom. *Arith. Introd.* ii. 28. 3-11, ed. Hoche 141. 4-144. 19

Τετάρτη μὲν ἢ καὶ ὑπεναντία λεγομένη διὰ τὸ ἀντικεῖσθαι καὶ ἀντιπεπονθέναι τῇ ἀρμονικῇ ὑπάρχει ὅταν ἐν τρισὶν ὄροις ὡς ὁ μέγιστος πρὸς τὸν ἐλάχιστον, οὕτως ἢ τῶν ἐλαττόνων διαφορά πρὸς τὴν τῶν μειζόνων ἔχη, οἷον

$$\bar{\gamma}, \bar{\epsilon}, \varsigma,$$

• *i.e.*, b is the harmonic mean between a and c if

$$\frac{a-b}{a} = \frac{b-c}{c},$$

which can be written $\frac{1}{c} - \frac{1}{b} = \frac{1}{b} - \frac{1}{a}$,

so that $\frac{1}{c}, \frac{1}{b}, \frac{1}{a}$

form an arithmetical progression, and Archytas goes on to assert that

$$\frac{a}{b} > \frac{b}{c}$$

• It is easily seen how the Pythagoreans would have observed the three means in their musical studies (see A. E. Taylor, *A Commentary on Plato's Timaeus*, p. 95). They would first have noticed that when they took three vibrating strings, of which the first gave out a note an octave below the second, while the second gave out a note an octave below the third, the lengths of the strings would be proportional to 4, 2, 1. Here the *διάστημα* is in each case an octave. The Pythagoreans would then have noticed that if they took three

PYTHAGOREAN ARITHMETIC

third by the same part of the third.^a In this proportion the interval between the greater terms is the greater, that between the lesser terms is the lesser.”^b

(ii.) *Seven Other Means*

Nicomachus, *Introduction to Arithmetic* ii. 28. 3-11,
ed. Hoche 141. 4-144. 19

The fourth mean, which is also called subcontrary by reason of its being reciprocal and antithetical to the harmonic, comes about when of three terms the greatest bears the same ratio to the least as the difference of the lesser terms bears to the difference of the greater,^c as in the case of

3, 5, 6,

strings sounding a given note, its major fourth and its upper octave, the lengths of the strings would be proportional to 12, 8, 6, which are in harmonic progression. Finally they would have observed that if they took three strings sounding a note, its major fifth and its upper octave, the lengths of the strings would be proportional to 12, 9, 6, which are terms in arithmetical progression. But the fact that the means are consistently given in the order arithmetic, geometric, harmonic, and that the name “harmonic” was substituted by Archytas for the older name “subcontrary” suggests that these means had already been arithmetically defined before they were seen to be exemplified in the fundamental intervals of the octave.

^c *i.e.*, b will be the subcontrary mean to a, c , if

$$\frac{c}{a} = \frac{b-a}{c-b}.$$

In this and the succeeding examples, following the practice of Nicomachus, it is assumed that a, b, c are in ascending order of magnitude.

GREEK MATHEMATICS

ἐν γὰρ διπλασίῳ τὰ συγκριθέντα ὁράται· φανερόν δέ, καθ' ἃ ἠναντίωται τῇ ἀρμονικῇ· τῶν γὰρ αὐτῶν ἄκρων ἀμφοτέραις ὑπαρχόντων καὶ ἐν διπλασίῳ γελόγω, ἐν μὲν τῇ πρὸ ταύτης ἢ τῶν μειζόνων ὑπεροχὴ πρὸς τὴν τῶν ἐλαττόνων τὸν αὐτὸν ἔσωζε λόγον, ἐν ταύτῃ δὲ ἀνάπαλιν ἢ τῶν ἐλαττόνων πρὸς τὴν τῶν μειζόνων· ἴδιον δὲ ταύτης ἰστέον ἐκεῖνο, τὸ διπλάσιον ἀποτελεῖσθαι τὸ ὑπὸ τοῦ μείζονος καὶ μέσου πρὸς τὸ ὑπὸ τοῦ μέσου καὶ ἐλαχίστου, τοῦ γὰρ πεντάκις $\bar{\gamma}$ διπλάσιον τὸ ἑξάκις $\bar{\epsilon}$.

Αἱ δὲ δύο μεσότητες πέμπτη καὶ ἕκτη παρὰ τὴν γεωμετρικὴν ἐπλάσθησαν ἀμφοτέραι, διαφέρουσι δ' ἀλλήλων οὕτως· ἢ μὲν πέμπτη ἔστιν, ὅταν ἐν τρισὶν ὅροις ὡς ὁ μέσος πρὸς τὸν ἐλάχιστον οὕτω καὶ ἢ αὐτῶν τούτων διαφορὰ πρὸς τὴν τοῦ μεγίστου πρὸς τὸν μέσον, οἷον

$$\bar{\beta}, \bar{\delta}, \bar{\epsilon}.$$

διπλάσιος γὰρ ὁ μὲν $\bar{\delta}$ τοῦ $\bar{\beta}$, μέσος ὅρος τοῦ ἐλάχιστου, ὁ δὲ $\bar{\beta}$ τοῦ $\bar{\alpha}$, ἐλαχίστων διαφορὰ πρὸς διαφορὰν μεγίστων· ὁ δ' ὑπεναντίον αὐτὴν τῇ

^a An elaborate classification of ratios is given by Nicom. *Arith. Introd.* i. 17-23. They are given in a convenient form for reference by Heath, *H.G.M.* i. 101-104, with the Latin names used by Boethius in his *De Institutione Arithmetica*, which is virtually a translation of Nicomachus's work.

^b *i.e.*, in the harmonic mean

$$\frac{c}{a} = \frac{c-b}{b-a}$$

and in the subcontrary mean

$$\frac{c}{a} = \frac{b-a}{c-b}.$$

^c This property happens to be true of the particular



THIS PAGE IS LOCKED TO FREE MEMBERS

Purchase full membership to immediately unlock this page

FORGOTTEN BOOKS

FULL

MEMBERSHIP

797,885 Books!

All you can read

for only

\$8.99/month

Continue

*Fair usage policy applies



GREEK MATHEMATICS

γεωμετρικῇ ποιεί, ἐκεῖνό ἐστιν, ὅτι ἐπὶ μὲν ἐκείνης ὡς ὁ μέσος πρὸς τὸν ἐλάττονα, οὕτως ἢ τοῦ μείζονος πρὸς τὸν μέσον ὑπεροχῇ πρὸς τὴν τοῦ μέσου πρὸς τὸν ἐλάττονα, ἐπὶ δὲ ταύτης ἀνάπαλιν ἢ τοῦ ἐλάττονος πρὸς τὴν τοῦ μείζονος· ἴδιον δ' ὅμως καὶ ταύτης ἐστὶ τὸ διπλάσιον γίνεσθαι τὸ ὑπὸ τοῦ μεγίστου καὶ μέσου τοῦ ὑπὸ τοῦ μεγίστου καὶ ἐλαχίστου, τὸ γὰρ πεντάκις δ' διπλάσιον τοῦ πεντάκις β̄.

Ἡ δὲ ἕκτη γίνεται, ὅταν ἐν τρισὶν ὄροις ἢ ὡς ὁ μέγιστος πρὸς τὸν μέσον, οὕτως ἢ τοῦ μέσου παρὰ τὸν ἐλάχιστον ὑπεροχῇ πρὸς τὴν τοῦ μεγίστου παρὰ τὸν μέσον, οἶον

$$\bar{a}, \delta, \bar{c},$$

ἐν ἡμιολίῳ γὰρ ἐκάτεροι λόγῳ· εἰκυῖα δ' αἰτία καὶ ταύτη τῆς πρὸς τὴν γεωμετρικὴν ὑπεναντιότητος, ἀναστρέφει γὰρ κἀνταῦθα ἢ τῶν λόγων ὁμοιότης ὡς ἐπὶ τῆς πέμπτης.

Καὶ αἱ μὲν παρὰ τοῖς πρόσθεν θρυλλούμεναι ἐξ μεσότητες αἶδε εἰσὶ, τρεῖς μὲν αἱ πρωτότυποι μέχρι

^a *i.e.*, if b is the geometric mean between a and c ,

$$\frac{b}{a} = \frac{c}{b} = \frac{c-b}{b-a},$$

while if b is the fifth mean between a and c ,

$$\frac{b}{a} = \frac{b-a}{c-b}.$$

The property which Nicomachus notes about this mean needs generalizing as in the case of his similar remark about the fourth mean, *i.e.*, if

$$\frac{b}{a} = \frac{b-a}{c-b} = \tau,$$

then

$$ac\tau = ac \times \frac{b}{a} = ba.$$

PYTHAGOREAN ARITHMETIC

What makes it subcontrary to the geometric mean is this property, that in the case of the geometric mean the middle term bears to the lesser the same ratio as the excess of the greater term over the middle bears to that of the middle term over the lesser, while in the case of this mean a contrary relation holds. It is a peculiar property of this mean that the product of the greatest and middle terms is double the product of the greatest and least, for five times four is double of five times two.^a

The sixth mean comes about when of three terms the greatest bears the same ratio to the middle term as the excess of the middle term over the least bears to the excess of the greatest term over the middle,^b as in the case of

1, 4, 6,

for in each case the ratio is the sesquialter (3 : 2). No doubt, it is called subcontrary to the geometric mean because the ratios are reversed, as in the case of the fifth mean.^c

These are then what are commonly called the six means, three prototypes which came down to Plato

^b *i.e.*, b is the sixth mean between a and b if

$$\frac{c}{b} = \frac{b-a}{c-b}$$

^c *i.e.*, if b is the geometric mean between a and c ,

$$\frac{c}{b} = \frac{c-b}{b-a},$$

while if b is the sixth mean between a and c ,

$$\frac{c}{b} = \frac{b-a}{c-b}.$$

GREEK MATHEMATICS

Ἄριστοτέλους καὶ Πλάτωνος ἄνωθεν ἀπὸ Πυθαγόρου διαμείνασαι, τρεῖς δ' ἕτεραι ἐκείναις ὑπεναντίαί τοῖς μετ' ἐκείνους ὑπομνηματογράφοις τε καὶ αἰρετισταῖς ἐν χρήσει γινόμεναι· τέσσαρας δέ τινες ἕτερας μετακινουῦντες τοὺς τούτων ὄρους τε καὶ διαφορὰς ἐπέξευρόν τινες οὐ πάνυ ἐμφανταζόμενας τοῖς τῶν παλαιῶν συγγράμμασιν, ἀλλ' ὡς περιεργότερον λελεπτολογημένας, ἅς ὅμως πρὸς τὸ μὴ δοκεῖν ἀγνοεῖν ἐπιτροχαστέον τῆδέ πη.

Πρώτη μὲν γὰρ αὐτῶν, ἑβδόμη δὲ ἐν τῇ πασῶν συντάξει ἔστιν, ὅταν ἦ ὡς ὁ μέγιστος πρὸς τὸν ἐλάχιστον, οὕτως καὶ ἡ τῶν αὐτῶν διαφορὰ πρὸς τὴν τῶν ἐλαττόνων, οἷον

$$\bar{\epsilon}, \bar{\eta}, \bar{\theta},$$

ἡμιόλιος γὰρ ὁ λόγος ἑκατέρου συγκρίσει ἐνορᾶται.

Ἐγδότη δὲ μεσότης, ἣτις τούτων δευτέρα ἔστι, γίνεται, ὅταν ὡς ὁ μέγιστος πρὸς τὸν ἐλάχιστον, οὕτως ἡ διαφορὰ τῶν ἄκρων πρὸς τὴν τῶν μειζόνων διαφορὰν, οἷον

$$\bar{\epsilon}, \bar{\zeta}, \bar{\theta}.$$

καὶ αὕτη γὰρ ἡμιολίους ἔχει τοὺς δύο λόγους.

Ἡ δὲ ἐνάτη μὲν ἐν τῇ τῶν πασῶν συντάξει, τρίτη δὲ ἐν τῷ τῶν ἐφευρημένων ἀριθμῷ ὑπάρχει, ὅταν τριῶν ὄρων ὄντων, ὃν λόγον ἔχει ὁ μέσος πρὸς

^a Iamblichus says (*in Nicom.*, ed. Pistelli 101. 1-5) that the school of Eudoxus discovered these means, but in other places (*ibid.* 116. 1-4, 113. 16-18) he gives the credit, in part at least, to Archytas and Hippasus.



THIS PAGE IS LOCKED TO FREE MEMBERS

Purchase full membership to immediately unlock this page

SAVE \$3,999,994

Did you know we sell
paperback books too?

To buy our entire catalog
in paperback would cost
over \$4,000,000

Access it all now for
\$8.99/month

*Fair usage policy applies

Continue

GREEK MATHEMATICS

τὸν ἐλάχιστον, τοῦτον καὶ ἡ τῶν ἄκρων ὑπεροχὴ
πρὸς τὴν τῶν ἐλαχίστων ἔχη, ὡς
 $\delta, \bar{\epsilon}, \zeta.$

Ἡ δὲ ἐπὶ πάσαις δεκάτῃ μὲν συλλήβδην, τετάρτῃ
δὲ ἐν τῇ τῶν νεωτερικῶν ἐκθέσει ὁράται, ὅταν ἐν
τρισὶν ὅροις ἢ ὡς ὁ μέσος πρὸς τὸν ἐλάχιστον,
οὕτως καὶ ἡ διαφορὰ τῶν ἄκρων πρὸς τὴν διαφορὰν
τῶν μειζόνων, οἷον

$\bar{\gamma}, \bar{\epsilon}, \bar{\eta}.$

ἐπιδιμερῆς γὰρ ὁ ἐν ἑκατέρᾳ συζυγίᾳ λόγος.

Ἐπὶ κεφαλαίου τοίνυν οἱ τῶν δέκα ἀναλογιῶν
ὅροι ἐκκείσθωσαν ὑφ' ἐν παράδειγμα πρὸς τὸ
εὐσύνοπτον,

πρώτης	$\bar{a}, \bar{\beta}, \bar{\gamma},$
δευτέρας	$\bar{a}, \bar{\beta}, \bar{\delta},$
τρίτης	$\bar{\gamma}, \bar{\delta}, \bar{\epsilon},$
τετάρτης	$\bar{\gamma}, \bar{\epsilon}, \bar{\zeta},$
πέμπτης	$\bar{\beta}, \bar{\delta}, \bar{\epsilon},$
ἕκτης	$\bar{a}, \bar{\delta}, \bar{\zeta},$

• *i.e.*, b is the ninth mean between a and c if

$$\frac{b}{a} = \frac{c-a}{b-a}.$$

• *i.e.*, b is the tenth mean between a and c if

$$\frac{b}{a} = \frac{c-a}{c-b}.$$

• Pappus (iii. 18, ed. Hultsch 84. 12-86. 14) gives a similar list, but in a different order after the sixth mean. Nos. 8, 9, 10 in Nicomachus's list are respectively Nos. 9, 10, 7 in that of Pappus. Moreover Pappus omits No. 7 in the list of Nicomachus and gives as No. 8 an additional mean equivalent to the formula $\frac{c-a}{c-b} = \frac{c}{b}$. The two lists thus give five means additional to the first six.

PYTHAGOREAN ARITHMETIC

middle bears to the least the same ratio as the difference between the extremes bears to the difference between the least terms,^a as

$$4, 6, 7.$$

Finally, the tenth in the complete series, and the fourth in the list set out by the moderns, is seen when in three terms the middle term bears to the least the same ratio as the difference between the extremes bears to the difference of the greater terms,^b as in the case of

$$3, 5, 8 ;$$

for the ratio in each couple is the superbipartient (5 : 3).

To sum up, then, let the terms of the ten proportions be set out in one figure so as to be taken in at a glance.^c

			$a < b < c$
First	1, 2, 3		$\frac{b-a}{c-b} = \frac{a}{a} = \frac{b}{b} = \frac{c}{c}$; arithmetic
Second	1, 2, 4		$\frac{b-a}{c-b} = \frac{b}{c} = \frac{a}{b}$; geometric
Third	3, 4, 6		$\frac{b-a}{c-b} = \frac{a}{c}$; harmonic
Fourth	3, 5, 6		$\frac{b-a}{c-b} = \frac{c}{a}$; subcontrary to harmonic
Fifth	2, 4, 5		} ; subcontrary to geometric
Sixth	1, 4, 6		

GREEK MATHEMATICS

ἑβδόμης	$\bar{\sigma}, \bar{\eta}, \bar{\theta},$
ὀγδόης	$\bar{\sigma}, \bar{\zeta}, \bar{\theta},$
ἐνάτης	$\delta, \bar{\epsilon}, \bar{\zeta},$
δεκάτης	$\bar{\gamma}, \bar{\epsilon}, \bar{\eta}.$

(iii.) Pappus's Equations between Means

Papp. Coll. iii. 18. 48, ed. Hultsch 88. 5-18

Τρεῖς ἀνάλογον ἔστωσαν ὄροι οἱ A, B, Γ καὶ συναμφοτέρω μὲν τῷ A, Γ μετὰ $\bar{\beta}$ τῶν B ἴσος ἐκκείσθω ὁ Δ , συναμφοτέρω δὲ τῷ B, Γ ὁ E , τῷ δὲ Γ ὁ Z . λέγω ὅτι καὶ οἱ Δ, E, Z ὄροι ἀνάλογόν εἰσιν.

Ἐπεὶ γὰρ ὡς ὁ A πρὸς τὸν B , οὕτως ὁ B πρὸς τὸν Γ , ἔσται καὶ συνθέντι ὡς συναμφοτέρος ὁ A, B πρὸς τὸν B , οὕτως συναμφοτέρος ὁ B, Γ πρὸς τὸν Γ . καὶ πάντες ἄρα οἱ ἡγούμενοι πρὸς πάντας τοὺς ἐπομένους εἰσὶν ἐν τῷ αὐτῷ λόγῳ ὡς συναμφοτέρος ὁ A, B μετὰ συναμφοτέρου τοῦ B, Γ πρὸς συναμφοτέρον τὸν B, Γ , οὕτως συναμφοτέρος ὁ B, Γ πρὸς τὸν Γ . καὶ ἔστιν συναμφοτέρω μὲν τῷ A, B μετὰ συναμφοτέρου τοῦ B, Γ ἴσος ὁ Δ , συναμφοτέρω δὲ



THIS PAGE IS LOCKED TO FREE MEMBERS

Purchase full membership to immediately unlock this page

FORGOTTEN BOOKS

FULL

MEMBERSHIP

797,885 Books!

All you can read

for only

\$8.99/month

Continue

*Fair usage policy applies



GREEK MATHEMATICS

τῶ Β, Γ ἴσος ὁ Ε, καὶ τῶ Γ ὁ Ζ. καὶ οἱ Δ, Ε, Ζ
ἄρα ἀνάλογόν εἰσιν.

Ibid. iii. 23. 57, ed. Hultsch 102

Μεσότητες	Α Β Γ	Οἱ περιέχοντες τὰς μεσότητας τρεῖς ἐλάχιστοι ἀριθμοί
ἀριθμητική	$\bar{\beta}$ $\bar{\gamma}$ $\bar{\alpha}$ $\bar{\alpha}$ $\bar{\beta}$ $\bar{\alpha}$ $\bar{\alpha}$ $\bar{\alpha}$	$\bar{\sigma}$ δ $\bar{\beta}$
γεωμετρική	$\bar{\alpha}$ $\bar{\beta}$ $\bar{\alpha}$ $\bar{\alpha}$ $\bar{\alpha}$ $\bar{\alpha}$	δ $\bar{\beta}$ α
ἀρμονική	$\bar{\beta}$ $\bar{\gamma}$ $\bar{\alpha}$ $\bar{\beta}$ $\bar{\alpha}$ $\bar{\alpha}$ $\bar{\alpha}$	$\bar{\sigma}$ $\bar{\gamma}$ $\bar{\beta}$
ὑπεναντία	$\bar{\beta}$ $\bar{\gamma}$ $\bar{\alpha}$ $\bar{\beta}$ $\bar{\beta}$ $\bar{\alpha}$ $\bar{\alpha}$ $\bar{\alpha}$	$\bar{\sigma}$ ϵ $\bar{\beta}$

^a This is one of a series of propositions given by Pappus to the following effect. If Δ, B, Γ are three terms in geometric proportion, it is possible to form from them three other terms Δ, E, Z , being linear functions of Δ, B, Γ , which satisfy the different proportions. In this case Δ, E, Z are also in geometric proportion, but in the other examples Δ, E, Z are made to satisfy the harmonic, the subcontrary, and the fifth, sixth, eighth, ninth and tenth means of Pappus's list. The problems are, of course, problems in indeterminate analysis of the second degree. Pappus does not include solutions for the arithmetic and seventh proportions. Tannery (*Mémoires scientifiques* i., pp. 97-98) suggests as the reason that in these cases the equations of the proportions, $\Delta + Z = 2E$ and, $\Delta = E + Z$, are already linear, there is no need to assume that

PYTHAGOREAN ARITHMETIC

$B + \Gamma$, $E = B + \Gamma$ and $Z = \Gamma$; and therefore Δ , E , Z are in [geometric] proportion.^a

Ibid. iii. 23. 57, ed. Hultsch 102

Means	Solution in terms of A, B, Γ	The three least numbers exhibiting the means
Arithmetic	$\Delta = 2A + 3B + \Gamma$ $E = A + 2B + \Gamma$ $Z = B + \Gamma$	6, 4, 2
Geometric	$\Delta = A + 2B + \Gamma$ $E = B + \Gamma$ $Z = \Gamma$	4, 2, 1
Harmonic	$\Delta = 2A + 3B + \Gamma$ $E = 2B + \Gamma$ $Z = B + \Gamma$	6, 3, 2
Subcontrary	$\Delta = 2A + 3B + \Gamma$ $E = 2A + 2B + \Gamma$ $Z = B + \Gamma$	6, 5, 2

$A\Gamma = B^2$, and consequently there is one indeterminate too many. But the complete results are shown in the table reproduced on these pages from Pappus (ed. Hultsch, p. 102, with explanation, pp. 100-104). The first column in the Greek table gives the means which Δ , E , Z are to satisfy. The second column gives the number of times A , B , Γ have to be taken to form Δ , E , Z respectively. In the case of the geometric progression already considered, the table shows that to form Δ we have to take A once, B twice and Γ once; to form E we have to take B once and Γ once; and to form Z we take Γ once. The third column gives the least integral values of Δ , E , Z satisfying the respective proportions (*i.e.* the values of Δ , E , Z , supposing A , B , Γ to be each unity); in the case of the geometric proportion the values are 4, 2, 1.

GREEK MATHEMATICS

Μεσότητες	A B Γ	Οί περιέχοντες τὰς μεσότητας τρεῖς ἐλάχιστοι ἀριθμοί
ε'	\bar{a} $\bar{\gamma}$ \bar{a} \bar{a} $\bar{\beta}$ \bar{a} \bar{a} \bar{a}	$\bar{\epsilon}$ $\bar{\delta}$ $\bar{\beta}$
ς'	\bar{a} $\bar{\gamma}$ $\bar{\beta}$ \bar{a} $\bar{\beta}$ \bar{a} \bar{a} \bar{a} \bar{a}	$\bar{\sigma}$ $\bar{\delta}$ \bar{a}
ζ'	\bar{a} \bar{a} \bar{a} \bar{a} \bar{a} \bar{a}	$\bar{\gamma}$ $\bar{\beta}$ \bar{a}
η'	$\bar{\beta}$ $\bar{\gamma}$ \bar{a} \bar{a} $\bar{\beta}$ \bar{a} $\bar{\beta}$ \bar{a}	$\bar{\sigma}$ $\bar{\delta}$ $\bar{\gamma}$
θ'	\bar{a} $\bar{\beta}$ \bar{a} \bar{a} \bar{a} \bar{a} \bar{a} \bar{a}	$\bar{\delta}$ $\bar{\gamma}$ $\bar{\beta}$
	\bar{a} \bar{a} \bar{a} \bar{a} \bar{a} \bar{a}	$\bar{\gamma}$ $\bar{\beta}$ \bar{a}

(iv.) *Plato on Means between two Squares or two Cubes*

Plat. *Tim.* 31 B-32 B

Δύο δὲ μόνω καλῶς συνίστασθαι τρίτου χωρὶς οὐ δυνατόν· δεσμὸν γὰρ ἐν μέσῳ δεῖ τινα ἀμφοῖν συναγωγὸν γίνεσθαι. . . . εἰ μὲν οὖν ἐπίπεδον μὲν, βάθος δὲ μηδὲν ἔχον ἔδει γίνεσθαι τὸ τοῦ παντὸς σῶμα, μία μεσότης ἂν ἐξήρκει τὰ τε μεθ'



THIS PAGE IS LOCKED TO FREE MEMBERS

Purchase full membership to immediately unlock this page

SAVE \$3,999,994

Did you know we sell
paperback books too?

To buy our entire catalog
in paperback would cost
over \$4,000,000

Access it all now for
\$8.99/month

*Fair usage policy applies

Continue

GREEK MATHEMATICS

αὐτῆς συνδεῖν καὶ ἑαυτήν, νῦν δὲ στερεοειδῆ γὰρ αὐτὸν προσῆκεν εἶναι, τὰ δὲ στερεὰ μία μὲν οὐδέποτε, δύο δὲ ἀεὶ μεσότητες συναρμόττουσιν.

(v.) *A Theorem of Archytas*

Archytas ap. Boeth. *De Inst. Mus.* iii. 11,
ed. Friedlein 285-286

Demonstratio Archytae superparticularem in aqua dividi non posse.

Superparticularis proportio scindi in aqua medio proportionaliter interposito numero non potest. Id vero posterius firmiter demonstrabitur. Quam enim demonstrationem ponit Archytas, nimium fluxa est. Haec vero est huiusmodi. Sit, inquit, superparticularis proportio $\cdot A \cdot B \cdot$, sumo in eadem proportione minimos $\cdot C \cdot DE \cdot$. Quoniam igitur sunt minimi in eadem proportione $\cdot C \cdot DE \cdot$ et sunt superparticulares, $\cdot DE \cdot$ numerus $\cdot C \cdot$ numerum parte una sua eiusque transcendit. Sit haec $\cdot D \cdot$. Dico, quoniam $\cdot D \cdot$ non crit numerus, sed unitas. Si enim est nu-

^a In other words, one mean is sufficient to connect in continuous proportion two square numbers, but two are required to connect cube numbers. Plato's remarks are equivalent to saying that

$$a^2 : ab = ab : b^2$$

and $a^3 : a^2b = a^2b : ab^2 = ab^2 : b^3$.

^b The *superparticularis ratio* (ἐπιμόριος λόγος) is the ratio in which one number contains the other and an aliquot part of it, *i.e.*, is the ratio $\frac{n+1}{n}$.

^c That is, a geometric mean. Archytas's proof as preserved by Boethius is substantially identical with that given by Euclid in his *Sectio Canonis*, prop. 3 (*Euclid*, ed. Heiberg-

PYTHAGOREAN ARITHMETIC

sufficed to bind together both itself and its fellow-terms ; but now it is otherwise—for it behoved it to be solid in shape, and what brings solids into harmony is never one mean, but always two.^a

(v.) *A Theorem of Archytas*

Archytas as quoted by Boethius, *On Music* iii. 11,
ed. Friedlein 285-286

Archytas's proof that a superparticular ratio cannot be divided into equal parts.

A superparticular ratio ^b cannot be divided into equal parts by a mean proportional ^c placed between. That will later be more conclusively proved. For the proof which Archytas gives is very loose. It is after this manner. Let there be, he says, a superparticular ratio $A : B$.^d I take $C, D + E$ the least numbers in the same ratio.^e Therefore, since $C, D + E$, are the least numbers in the same ratio and are superparticulars, the number $D + E$ exceeds the number C by an aliquot part of itself and of C . Let the excess be D .^f I say that D is not a number but a unit. For, if D is a number and an aliquot

Menge viii. 162. 7-26). It is subsequently used by Euclid (prop. 16), to show that the musical tone, whose numerical value is $9 : 8$, cannot be divided into two or more equal parts.

^d Archytas writes the smaller number first instead of second, as Euclid does.

^e In Archytas's proof $D + E$ is represented by DE . Euclid, following his usual practice, takes a straight line divided into two parts. To find $C, D + E$, presupposes Euclid vii. 33.

^f *i.e.*, E is supposed equal to C .

GREEK MATHEMATICS

merus $\cdot D \cdot$ et pars est eius, qui est $\cdot DE \cdot$ metitur $\cdot D \cdot$ numerus $\cdot DE \cdot$ numerum; quocirca et $\cdot E \cdot$ numerum metietur, quo fit, ut $\cdot C \cdot$ quoque metiatur. Utrumque igitur $\cdot C \cdot$ et $\cdot DE \cdot$ numeros metietur $\cdot D \cdot$ numerus, quod est impossibile. Qui enim sunt minimi in eadem proportione quibuslibet aliis numeris, hi primi ad se invicem sunt, et solam differentiam retinent unitatem. Unitas igitur est $\cdot D \cdot$. Igitur $\cdot DE \cdot$ numerus $\cdot C \cdot$ numerum unitate transcendit. Quocirca nullus incidit medius numerus, qui eam proportionem aequaliter scindat. Quo fit, ut nec inter eos, qui eandem his proportionem tenent, medius possit numerus collocari, qui eandem proportionem aequaliter scindat.

(h) ALGEBRAIC EQUATIONS

(i.) *Side- and Diameter-numbers*

Theon Smyr., ed. Hiller 42. 10–44. 17

Ὡσπερ δὲ τριγωνικοὺς καὶ τετραγωνικοὺς καὶ πενταγωνικοὺς καὶ κατὰ τὰ λοιπὰ σχήματα λόγους ἔχουσι δυνάμει οἱ ἀριθμοί, οὕτως καὶ πλευρικοὺς καὶ διαμετρικοὺς λόγους εὕρομεν ἂν κατὰ τοὺς σπερματικοὺς λόγους ἐμφανιζομένους τοῖς ἀριθμοῖς. ἐκ γὰρ τούτων ῥυθμίζεται τὰ σχήματα. ὥσπερ οὖν πάντων τῶν σχημάτων κατὰ τὸν ἀνωτάτω καὶ σπερματικὸν λόγον ἢ μονὰς ἄρχει, οὕτως καὶ τῆς διαμέτρου καὶ τῆς πλευρᾶς λόγος ἐν τῇ μονάδι εὕρισκεται. οἷον ἐκτίθενται δύο μονάδες, ὧν τὴν μὲν θῶμεν εἶναι διάμετρον, τὴν δὲ πλευράν, ἐπειδὴ

^a This presupposes Euclid vii. 22.

^b This is an inference from Euclid vii. 20. Heath (*H.G.M.*



THIS PAGE IS LOCKED TO FREE MEMBERS

Purchase full membership to immediately unlock this page

FORGOTTEN BOOKS

FULL

MEMBERSHIP

797,885 Books!

All you can read

for only

\$8.99/month

Continue

*Fair usage policy applies



GREEK MATHEMATICS

τὴν μονάδα, πάντων οὕσαν ἀρχήν, δεῖ δυνάμει καὶ πλευρὰν εἶναι καὶ διάμετρον. καὶ προστίθεται τῇ μὲν πλευρᾷ διάμετρος, τῇ δὲ διαμέτρῳ δύο πλευραί, ἐπειδὴ ὅσον ἢ πλευρὰ δις δύναται, ἢ διάμετρος ἅπαξ. ἐγένετο οὖν μείζων μὲν ἢ διάμετρος, ἐλάττων δὲ ἢ πλευρά. καὶ ἐπὶ μὲν τῆς πρώτης πλευρᾶς τε καὶ διαμέτρου εἶη ἄν τὸ ἀπὸ τῆς μονάδος διαμέτρου τετράγωνον μονάδι μιᾷ ἔλαττον ἢ διπλάσιον τοῦ ἀπὸ τῆς μονάδος πλευρᾶς τετραγώνου· ἐν ἰσότητι γὰρ αἱ μονάδες· τὸ δ' ἐν τοῦ ἐνὸς μονάδι ἔλαττον ἢ διπλάσιον. προσθῶμεν δὴ τῇ μὲν πλευρᾷ διάμετρον, τουτέστι τῇ μονάδι μονάδα· ἔσται ἢ πλευρὰ ἄρα δύο μονάδων· τῇ δὲ διαμέτρῳ προσθῶμεν δύο πλευράς, τουτέστι τῇ μονάδι δύο μονάδας· ἔσται ἢ διάμετρος μονάδων τριῶν· καὶ τὸ μὲν ἀπὸ τῆς δυάδος πλευρᾶς τετράγωνον δ, τὸ δ' ἀπὸ τῆς τριάδος διαμέτρου τετράγωνον θ· τὸ θ

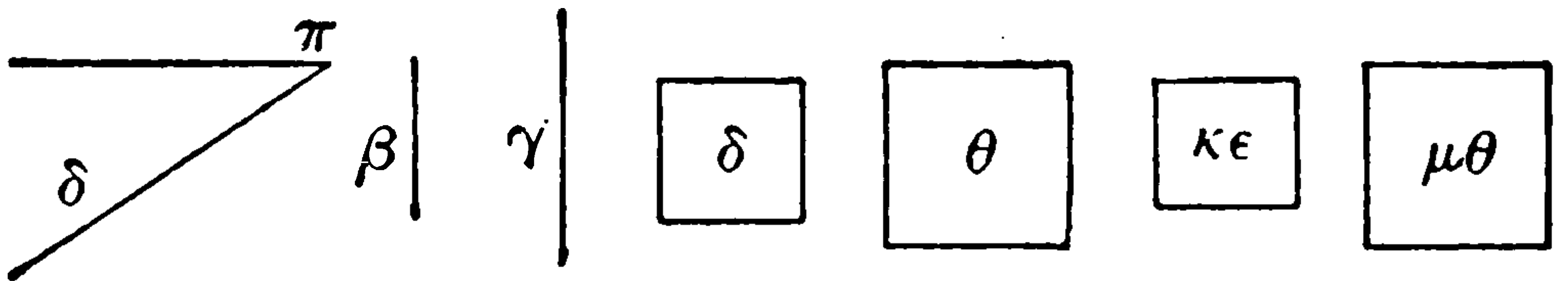

ἄρα μονάδι μείζων ἢ διπλάσιον τοῦ ἀπὸ τῆς β̄ πλευρᾶς.

Πάλιν προσθῶμεν τῇ μὲν β̄ πλευρᾷ διάμετρον τὴν τρίαδα· ἔσται ἢ πλευρὰ ε̄· τῇ δὲ τριάδι διαμέτρῳ β̄ πλευράς, τουτέστι δις τὰ β̄· ἔσται ζ̄· ἔσται τὸ μὲν ἀπὸ τῆς <ε̄> πλευρᾶς τετράγωνον κε, τὸ δὲ ἀπὸ τῆς ζ̄ <διαμέτρου> μθ· μονάδι ἔλασσον ἢ διπλάσιον τοῦ κε ἄρα τὸ μθ. πάλιν ἄν τῇ <ε̄> πλευρᾷ προσθῆς τὴν ζ̄ διάμετρον, ἔσται ιβ̄. κὰν τῇ ζ̄ διαμέτρῳ

PYTHAGOREAN ARITHMETIC

beginning of all things, must have it in its capacity to be both side and diameter. Now let there be added to the side a diameter and to the diameter two sides, for as often as the square on the diameter is taken once, so often is the square on the side taken twice. The diameter will therefore become the greater and the side will become the less. Now in the case of the first side and diameter the square on the unit diameter will be less by a unit than twice the square on the unit side; for units are equal, and 1 is less by a unit than twice 1. Let us add to the side a diameter, that is, to the unit let us add a unit; therefore the [second] side will be two units. To the diameter let us now add two sides, that is, to the unit let us add two units; the [second] diameter will therefore be three units. Now the square on the side of two units will be 4, while the square on the diameter of three units will be 9; and 9 is greater by a unit than twice the square on the side 2.

Again, let us add to the side 2 the diameter 3; the [third] side will be 5. To the diameter 3 let us add two sides, that is, twice 2; the third diameter will be 7. Now the square from the side 5 will be 25, while that from the diameter 7 will be 49; and 49 is less by a unit than twice 25. Again, add to the side 5 the diameter 7; the result will be 12. And to the

GREEK MATHEMATICS

προσθῆς δις τὴν $\bar{\epsilon}$ πλευράν, ἔσται $\bar{\iota\zeta}$. καὶ τοῦ ἀπὸ τῆς $\bar{\iota\beta}$ τετραγώνου τὸ ἀπὸ τῆς $\bar{\iota\zeta}$ μονάδι πλέον ἢ διπλάσιον. καὶ κατὰ τὸ ἐξῆς τῆς προσθήκης ὁμοίως γιγνομένης, ἔσται τὸ ἀνάλογον ἐναλλάξ· ποτὲ μὲν μονάδι ἔλαττον, ποτὲ δὲ μονάδι πλέον ἢ διπλάσιον τὸ ἀπὸ τῆς διαμέτρου τετράγωνον τοῦ ἀπὸ τῆς πλευρᾶς· καὶ ῥηταὶ αἱ τοιαῦται καὶ πλευραὶ καὶ διάμετροι.

Procl. in Plat. Remp., ed. Kroll ii. 27. 11-22

Προετίθεσαν δὲ οἱ Πυθαγόρειοι τούτου τοιόνδε

^a In algebraical notation, a pair of *side-* and *diameter-* numbers, a_n, d_n are such that

$$d_n^2 - 2a_n^2 = \pm 1,$$

and the law for the formation of any pair of such numbers from the preceding pair is

$$\begin{aligned} d_n &= 2a_{n-1} + d_{n-1} \\ a_n &= a_{n-1} + d_{n-1}. \end{aligned}$$

The general proof of the property of these numbers is not given by Theon (doubtless as being well known). It can be exhibited algebraically as follows :

$$\begin{aligned} d_n^2 - 2a_n^2 &= (2a_{n-1} + d_{n-1})^2 - 2(a_{n-1} + d_{n-1})^2 \\ &= 2a_{n-1}^2 - d_{n-1}^2 \\ &= -(d_{n-1}^2 - 2a_{n-1}^2) \\ &= +(d_{n-2}^2 - 2a_{n-2}^2), \end{aligned}$$

by similar reasoning, and so on. Starting with $a_1 = 1, d_1 = 1$ as the first pair of side and diameter numbers, we have

$$d_1^2 - 2a_1^2 = -1$$

and therefore by the above equation we have

$$\begin{aligned} d_2^2 - 2a_2^2 &= +1, \\ d_3^2 - 2a_3^2 &= -1, \end{aligned}$$

and so on, the positive and negative signs alternating. The



THIS PAGE IS LOCKED TO FREE MEMBERS

Purchase full membership to immediately unlock this page

SAVE \$3,999,994

Did you know we sell
paperback books too?

To buy our entire catalog
in paperback would cost
over \$4,000,000

Access it all now for
\$8.99/month

*Fair usage policy applies

Continue

θεώρημα γλαφυρόν περί τῶν διαμέτρων καὶ πλευρῶν, ὅτι ἢ μὲν διάμετρος προσλαβοῦσα τὴν πλευράν, ἢς ἐστὶν διάμετρος, γίνεται πλευρά, ἢ δὲ πλευρὰ ἑαυτῇ συντεθείσα καὶ προσλαβοῦσα τὴν διάμετρον τὴν ἑαυτῆς γίνεται διάμετρος. καὶ τοῦτο δείκνυται διὰ τῶν ἐν τῷ δευτέρῳ Στοιχείων γραμμικῶς ἀπ' ἐκείνου. εἰ ἐὺθεῖα τμηθῆ διχα, προσλάβη δὲ ἐὺθεῖαν, τὸ ἀπὸ τῆς ὅλης σὺν τῇ προσκειμένη καὶ τὸ ἀπὸ ταύτης μόνης τετράγωνα διπλάσια τοῦ ἀπὸ τῆς ἡμισείας καὶ τοῦ ἀπὸ τῆς συγκειμένης ἐκ τῆς ἡμισείας καὶ τῆς προσληφθείσης.

(ii.) *The "Bloom" of Thymaridas*

Iambl. in Nicom. Arith. Introd., ed. Pistelli 62. 18-63. 2

Ἐντεῦθεν καὶ ἡ ἔφοδος τοῦ Θυμαριδείου ἐπ-

^a This is Euclid ii. 10, which asserts that if AG is bisected at B



and produced to Δ , then

$$\Delta A^2 + \Delta \Gamma^2 = 2AB^2 + 2B\Delta^2.$$

If $AB = x$, $\Gamma A = y$, this gives

$$(2x + y)^2 + y^2 = 2x^2 + 2(x + y)^2$$

or
$$(2x + y)^2 - 2(x + y)^2 = 2x^2 - y^2.$$

Therefore, if (x, y) are a pair of numbers satisfying one of the equations $2x^2 - y^2 = \pm 1$,

then $(x + y)$, $(2x + y)$ are another pair of numbers satisfying the other equation.

Proclus is not quoting exactly the Euclidean enunciation, for which see Euclid, ed. Heiberg-Menge i. 146. 15-22.

^b Thymaridas was apparently an early Pythagorean, not

PYTHAGOREAN ARITHMETIC

about the diameters and sides, that when the diameter receives the side of which it is diameter it becomes a side, while the side, added to itself and receiving its diameter, becomes a diameter. And this is proved graphically in the second book of the *Elements* by him [sc. Euclid]. If a straight line be bisected and a straight line be added to it, the square on the whole line including the added straight line and the square on the latter by itself are together double of the square on the half and of the square on the straight line made up of the half and the added straight line.^a

(ii.) *The "Bloom" of Thymaridas*^b

Iamblichus, *On Nicomachus's Introduction to Arithmetic*,
ed. Pistelli 62. 18-63. 2

The method of the "bloom" of Thymaridas was

later than the time of Plato, who lived at Paros. The name *ἐπάνθημα* (*flower* or *bloom*) given to his method shows that it must have been widely known in antiquity, though the term is not confined to this particular proposition. It is presumably used to give a sense of distinction, much as we say "flower of the army." The Greek is unfortunately most obscure, but the meaning was successfully extracted by Nesselman (*Die Algebra der Griechen*, pp. 232-236), who is followed by Gow (*History of Greek Mathematics*, p. 97), Cantor (*Vorlesungen* i³. 158-159), Loria (*Le scienze esatte nell' antica Grecia*, pp. 807-809), and Heath (*H.G.M.*, i. 94-96, *Diophantus of Alexandria*, 2nd ed., pp. 114-116). The "bloom" is a rule for solving n simultaneous equations connecting n unknown quantities, and states in effect:

(1) if $x + x_1 + x_2 = S$,
while $x + x_1 = s_1$, $x + x_2 = s_2$,
then $x = s_1 + s_2 - S$;

GREEK MATHEMATICS

ανθήματος ἐλήφθη. ὠρισμένων γὰρ ἢ ἀορίστων μερισμένων ὠρισμένον τι καὶ ἐνὸς οὐτινοσοῦν τοῖς λοιποῖς καθ' ἕκαστον συντεθέντος, τὸ ἐκ πάντων ἀθροισθὲν πλῆθος ἐπὶ μὲν τριῶν μετὰ τὴν ἐξ ἀρχῆς ὀρισθεῖσαν ποσότητα ὅλον τῷ συγκριθέντι προσρέμει τ' ἀφ' οὗ τὸ λείπον καθ' ἕκαστον τῶν λοιπῶν ἀφαιρεθήσεται, ἐπὶ δὲ τεσσάρων τὸ ἥμισυ καὶ ἐπὶ πέντε τὸ τρίτον καὶ ἐπὶ ἕξ τὸ τέταρτον καὶ ἀεὶ ἀκολουθῶς, δυάδος κἀνταῦθα διαφορᾶς ἐπιφανομένης πρὸς τε τὴν ποσότητα τῶν μεριζομένων καὶ πρὸς τὴν τοῦ μορίου κλήσιν.

(2) if $x + x_1 + x_2 + x_3 = S,$
 while $x + x_1 = s_1, x + x_2 = s_2, x + x_3 = s_3,$
 then $x = \frac{s_1 + s_2 + s_3 - S}{2},$

(3) while generally, if $x + x_1 + x_2 + \dots + x_{n-1} = S,$
 while $x + x_1 = s_1, x + x_2 = s_2 \dots x + x_{n-1} = s_{n-1},$
 then $x = \frac{s_1 + s_2 + \dots + s_{n-1} - S}{n - 2}.$

Iamblichus goes on to show how other equations can be



THIS PAGE IS LOCKED TO FREE MEMBERS

Purchase full membership to immediately unlock this page

FORGOTTEN BOOKS

FULL

MEMBERSHIP

797,885 Books!

All you can read

for only

\$8.99/month

Continue

*Fair usage policy applies



IV. PROCLUS'S SUMMARY

IV. PROCLUS'S SUMMARY

Procl. *in Eucl.* i., ed. Friedlein 64. 16-70. 18

Ἐπεὶ δὲ χρὴ τὰς ἀρχὰς καὶ τῶν τεχνῶν καὶ τῶν ἐπιστημῶν πρὸς τὴν παροῦσαν περίοδον σκοπεῖν, λέγομεν, ὅτι παρ' Αἰγυπτίοις μὲν εὐρῆσθαι πρῶτον ἢ γεωμετρία παρὰ τῶν πολλῶν ἱστόρηται, ἐκ τῆς τῶν χωρίων ἀναμετρήσεως λαβοῦσα τὴν γένεσιν. ἀναγκαία γὰρ ἦν ἐκείνοις αὕτη διὰ τὴν ἄνοδον τοῦ Νείλου τοὺς προσήκοντας ὄρους ἐκάστοις ἀφανί-

^a The course of Greek geometry from the earliest days to the time of Euclid is reviewed in the few pages from Proclus's *Commentary on Euclid*, Book i., which are here reproduced. This "Summary" of Proclus has often been called the "Eudemian summary," on the assumption that it is extracted from the lost *History of Geometry* by Eudemos, the pupil of Aristotle. But the latter part dealing with Euclid cannot have been written by Eudemos, who preceded Euclid, nor is there any stylistic reason for attributing the earlier and later portions to different hands. Heath (*The Thirteen Books of Euclid's Elements*, i., pp. 37, 38, and *H.G.M.* i. 119, 120) gives arguments for believing that the author cannot have been Proclus himself, and suggests that the body of the summary was taken by Proclus from a compendium by some writer later than Eudemos, though the earlier portion was based, directly or indirectly, on Eudemos's *History*. The summary was written primarily for an understanding of the way in which the elements of geometry had come into being. The more advanced discoveries are therefore omitted or mentioned only in passing. Proclus himself lived from A.D. 410 to 485. On the death of Syrianus he became head of the



THIS PAGE IS LOCKED TO FREE MEMBERS

Purchase full membership to immediately unlock this page

SAVE \$3,999,994

Did you know we sell
paperback books too?

To buy our entire catalog
in paperback would cost
over \$4,000,000

Access it all now for
\$8.99/month

*Fair usage policy applies

Continue

GREEK MATHEMATICS

ζοντος. καὶ θαυμαστὸν οὐδὲν ἀπὸ τῆς χρείας ἄρξασθαι τὴν εὕρεσιν καὶ ταύτης καὶ τῶν ἄλλων ἐπιστημῶν, ἐπειδὴ πᾶν τὸ ἐν γενέσει φερόμενον ἀπὸ τοῦ ἀτελοῦς εἰς τὸ τέλειον πρόεισιν. ἀπὸ αἰσθήσεως οὖν εἰς λογισμὸν καὶ ἀπὸ τούτου ἐπὶ νοῦν ἢ μετάβασις γέειοιτο ἂν εἰκότως. ὥσπερ οὖν παρὰ τοῖς Φοίνιξιν διὰ τὰς ἐμπορείας καὶ τὰ συναλλάγματα τὴν ἀρχὴν ἔλαβεν ἢ τῶν ἀριθμῶν ἀκριβῆς γνῶσις, οὕτω δὴ καὶ παρ' Αἰγυπτίοις ἢ γεωμετρία διὰ τὴν εἰρημένην αἰτίαν εὔρηται.

Θαλῆς δὲ πρῶτον εἰς Αἴγυπτον ἐλθὼν μετήγαγεν εἰς τὴν Ἑλλάδα τὴν θεωρίαν ταύτην καὶ πολλὰ μὲν αὐτὸς εὔρεν, πολλῶν δὲ τὰς ἀρχὰς τοῖς μετ' αὐτὸν ὑφηγήσατο, τοῖς μὲν καθολικώτερον ἐπιβάλλων, τοῖς δὲ αἰσθητικώτερον. μετὰ δὲ τοῦτον Ἀμέριστος¹ ὁ Στησιχόρου τοῦ ποιητοῦ ἀδελφός, ὃς ἐφαψάμενος τῆς περὶ γεωμετρίαν σπουδῆς μνη-

¹ Μάμερκος Friedlein, following a correction in the oldest ms.

^a Thales (c. 624–547 B.C.), one of the “Seven Wise Men” of ancient Greece, is universally acknowledged as the founder of Greek geometry, astronomy and philosophy. His greatest fame in antiquity rested on his prediction of the total eclipse of the sun of May 28, 585 B.C., which led to the cessation of hostilities between the Medes and Lydians and a lasting

146

PROCLUS'S SUMMARY

everybody's proper boundaries. Nor is there anything surprising in that the discovery both of this and of the other sciences should have its origin in a practical need, since everything which is in process of becoming progresses from the imperfect to the perfect. Thus the transition from perception to reasoning and from reasoning to understanding is natural. Just as exact knowledge of numbers received its origin among the Phoenicians by reason of trade and contracts, even so geometry was discovered among the Egyptians for the aforesaid reason.

Thales^a was the first to go to Egypt and bring back to Greece this study; he himself discovered many propositions, and disclosed the underlying principles of many others to his successors, in some cases his method being more general, in others more empirical. After him Ameristus,^b the brother of the poet Stesichorus, is mentioned as having touched the study

peace (Herodotus i. 74); what Thales probably did was to predict the *year* in which the eclipse would take place, an achievement by no means beyond the astronomical powers of the age. Thales was noted for his political sense. He urged the separate states of Ionia, threatened by the encroachment of the Lydians, to form a federation with a capital at Teos; and his successful dissuasion of his fellow-Milesians from accepting the overtures of Croesus, king of the Lydians, may have had an influence on the favourable terms later granted to Miletus by Cyrus, king of the Persians, though the main reason for this preferential treatment was probably commercial. In philosophy Thales taught that the all is water. For his mathematical discoveries, see *infra*, pp. 164-169.

^b The name is uncertain. Friedlein, in suggesting Mamercus, observes that Suidas gives a brother of Stesichorus as Mamertinus, which could easily arise out of Mamercus. Another reading is Mamertius. Nothing more is known about him. Stesichorus, the lyric poet, flourished c. 611 B.C.

GREEK MATHEMATICS

μονεύεται, καὶ Ἰππίας ὁ Ἡλεῖος ἰστόρησεν ὡς ἐπὶ γεωμετρίᾳ δόξαν αὐτοῦ λαβόντος. ἐπὶ δὲ τούτοις Πυθαγόρας τὴν περὶ αὐτὴν φιλοσοφίαν εἰς σχῆμα παιδείας ἐλευθέρου μετέστησεν, ἄνωθεν τὰς ἀρχὰς αὐτῆς ἐπισκοπούμενος καὶ αὐλῶς καὶ νοερῶς τὰ θεωρήματα διερευνώμενος, ὅς δὴ καὶ τὴν τῶν ἀνὰ λόγον¹ πραγματείαν καὶ τὴν τῶν κοσμικῶν σχημάτων σύστασιν ἀνεῦρεν. μετὰ δὲ τοῦτον Ἀναξαγόρας ὁ Κλαζομένιος πολλῶν ἐφήψατο τῶν κατὰ γεωμετρίαν καὶ Οἰνοπίδης ὁ Χῖος, ὀλίγω νεώτερος ὢν Ἀναξαγόρου, ὢν καὶ ὁ Πλάτων ἐν τοῖς ἀντερασταῖς ἐμνημόμευσεν ὡς ἐπὶ τοῖς μαθήμασι δόξαν λαβόντων.

¹ τῶν ἀνὰ λόγον con. Diels ; τῶν ἀλόγων Friedlein.

^a The well-known Sophist, born about 460 B.C., whose various accomplishments are described in Plato's *Hippias Minor*. He claimed to have gone once to the Olympic Games with everything that he wore made by himself, as well as all kinds of works in prose and verse of his own composition. His system of mnemonics enabled him to remember any string of fifty names which he had heard once. The unmathematical Spartans, however, could not appreciate his genius, and from them he could get no fees. His chief mathematical discovery was the curve known as the quadratrix, which could be used for trisecting an angle or squaring the circle (see *infra*, pp. 336-347).

^b The life of Pythagoras is shrouded in mystery. He was probably born in Samos about 582 B.C. and migrated about 529 B.C. to Crotona, the Dorian colony in southern Italy, where a semi-religious brotherhood sprang up round him. This brotherhood was subjected to severe persecution in the fifth century B.C., and the Pythagoreans then took their



THIS PAGE IS LOCKED TO FREE MEMBERS

Purchase full membership to immediately unlock this page

FORGOTTEN BOOKS

FULL

MEMBERSHIP

797,885 Books!

All you can read

for only

\$8.99/month

Continue

*Fair usage policy applies



GREEK MATHEMATICS

Ἐφ' οἷς Ἱπποκράτης ὁ Χῖος ὁ τὸν τοῦ μηνίσκου τετραγωνισμὸν εὐρών, καὶ Θεόδωρος ὁ Κυρηναιῖος ἐγένοντο περὶ γεωμετρίαν ἐπιφανεῖς. πρῶτος γὰρ ὁ Ἱπποκράτης τῶν μνημονευομένων καὶ στοιχεῖα συνέγραψεν. Πλάτων δ' ἐπὶ τούτοις γενόμενος μεγίστην ἐποίησεν ἐπίδοσιν τὰ τε ἄλλα μαθήματα καὶ τὴν γεωμετρίαν λαβεῖν διὰ τὴν περὶ αὐτὰ σπουδήν, ὅς που δῆλός ἐστι καὶ τὰ συγγράμματα τοῖς μαθηματικοῖς λόγοις καταπυκνώσας καὶ πανταχοῦ τὸ περὶ αὐτὰ θαῦμα τῶν φιλοσοφίας ἀντεχομένων ἐπεγείρων. ἐν δὲ τούτῳ τῷ χρόνῳ καὶ Λεωδάμας ὁ Θάσιος ἦν καὶ Ἀρχύτας ὁ Ταραντῖνος καὶ Θεαίτητος ὁ Ἀθηναῖος, παρ' ὧν ἐπηυξήθη τὰ θεωρήματα καὶ προῆλθεν εἰς ἐπιστημονικωτέραν σύστασιν.

Λεωδάμαντος δὲ νεώτερος ὁ Νεοκλείδης καὶ ὁ τούτου μαθητῆς Λέων, οἱ πολλὰ προσευπόρησαν τοῖς πρὸ αὐτῶν, ὥστε τὸν Λέοντα καὶ τὰ στοιχεῖα συνθεῖναι τῷ τε πλήθει καὶ τῇ χρείᾳ τῶν δεικνυμένων ἐπιμελέστερον, καὶ διορισμοὺς εὐρεῖν, πότε δυνατόν ἐστι τὸ ζητούμενον πρόβλημα καὶ πότε ἀδύνατον. Εὐδόξος δὲ ὁ Κνίδιος, Λέοντος μὲν ὀλίγῳ νεώτερος, ἑταῖρος δὲ τῶν περὶ Πλάτωνα

^a Hippocrates was in Athens from about 450 to 430 B.C. For his mathematical achievements, see *infra*, pp. 234-253.

^b Our chief knowledge of Theodorus comes from the *Theaetetus* of Plato, whose mathematical teacher he is said to have been (Diog. Laert. ii. 103); see *infra*, pp. 380-383.

^c Proclus (*in Eucl.* i., ed. Friedlein 72 *et seq.*) explains that the *elements* in geometry are leading theorems having to those which follow the relation of an all-pervading principle; he compares them with the letters of the alphabet in relation

PROCLUS'S SUMMARY

After them Hippocrates of Chios,^a who discovered the quadrature of the lune, and Theodorus of Cyrene^b became distinguished in geometry. For Hippocrates is the first of those mentioned as having compiled *elements*.^c Plato,^d who came after them, made the other branches of mathematics as well as geometry take a very great step forward by his zeal for them; and it is obvious how he filled his writings with mathematical arguments and everywhere stirred up admiration for mathematics in those who took up philosophy. At this time also lived Leodamas of Thasos^e and Archytas of Taras^f and Theaetetus of Athens,^g by whom the theorems were increased and an advance was made towards a more scientific grouping.

Younger than Leodamas were Neoclides and his pupil Leon, who added many things to those known before them, so that Leon was able to make a collection of the *elements* in which he was more careful in respect both of the number and of the utility of the things proved; he also discovered *diorismi*, showing when the problem investigated can be solved and when not.^h Eudoxus of Cnidos, a little younger than Leon and an associate of Plato's school, was the first

to language; and they have, indeed, the same name in Greek.

^a See *infra*, pp. 386-405.

^e All we know about him is that Plato is said to have explained or communicated to him the method of analysis (Diog. Laert. iii. 24, Procl. *in Eucl.* i., ed. Friedlein 211. 19-23).

^f For Archytas, see *supra*, p. 4 n. a.

^g See *infra*, pp. 378-383.

^h We have no further knowledge of Neoclides and Leon. A good example of a *diorismos* is given in Plato, *Meno* 86 E—87 B (*infra*, pp. 394-397), which incidentally shows that Leon was not the first in this field.

GREEK MATHEMATICS

γενόμενος, πρῶτος τῶν καθόλου καλουμένων θεωρημάτων τὸ πλῆθος ἠϋξησεν καὶ ταῖς τρισὶν ἀναλογίαις ἄλλας τρεῖς προσέθηκεν καὶ τὰ περὶ τὴν τομὴν ἀρχὴν λαβόντα παρὰ Πλάτωνος εἰς πλῆθος προήγαγεν καὶ ταῖς ἀναλύσεσιν ἐπ' αὐτῶν χρησάμενος. Ἀμύκλας δὲ ὁ Ἡρακλεώτης, εἰς τῶν Πλάτωνος ἐταίρων καὶ Μέναιχμος ἀκροατῆς ὢν Εὐδόξου καὶ Πλάτωνι δὲ συγγεγονῶς καὶ ὁ ἀδελφὸς αὐτοῦ Δεινόστρατος ἔτι τελεωτέραν ἐποίησαν τὴν ὄλην γεωμετρίαν. Θεύδιος δὲ ὁ Μάγνης ἔν τε τοῖς μαθήμασιν ἔδοξεν εἶναι διαφέρων καὶ κατὰ τὴν ἄλλην φιλοσοφίαν· καὶ γὰρ τὰ στοιχεῖα καλῶς συνέταξεν καὶ πολλὰ τῶν μερικῶν¹ καθολικώτερα ἐποίησεν. καὶ μέντοι καὶ ὁ Κυζικηνὸς Ἀθήναιος κατὰ τοὺς αὐτοὺς γεγονῶς χρόνους καὶ ἐν τοῖς ἄλλοις μὲν μαθήμασι, μάλιστα δὲ κατὰ γεωμετρίαν ἐπιφανῆς ἐγένετο. διῆγον οὖν οὗτοι μετ' ἀλλήλων ἐν Ἀκαδημία κοινὰς ποιούμενοι τὰς ζητήσεις. Ἐρμότιμος δὲ ὁ Κολοφώνιος τὰ ὑπ' Εὐδόξου προηυπορημένα καὶ Θεαιτήτου προήγαγεν ἐπὶ πλέον

¹ ὀρικῶν Friedlein.

^a For Eudoxus, one of the great mathematicians of all time, see *infra*, pp. 408-415. He lived c. 408-355 B.C. What the "so-called general theorems" may be is uncertain; Heath (*H.G.M.* i. 323) suggests theorems which are "true of everything falling under the conception of magnitude, as are the definitions and theorems forming part of Eudoxus's own theory of proportion." The three means which Eudoxus is said to have added to those already known are the three sub-contrary means (*supra*, pp. 114-121). Iamblichus (*in Nicom.*, 101. 1-5) also attributes them to Eudoxus, but in other places (113. 16-18, 116. 1-4) he assigns them to Archytas and Hippasus. It is disputed whether the "section" to which Eudoxus devoted his attention means sections of solids



THIS PAGE IS LOCKED TO FREE MEMBERS

Purchase full membership to immediately unlock this page

SAVE \$3,999,994

Did you know we sell
paperback books too?

To buy our entire catalog
in paperback would cost
over \$4,000,000

Access it all now for
\$8.99/month

*Fair usage policy applies

Continue

GREEK MATHEMATICS

καὶ τῶν στοιχείων πολλὰ ἀνεῦρε καὶ τῶν τόπων
τινὰ συνέγραψεν. Φίλιππος ^ε ὁ Μεδμαῖος,¹
Πλάτωνος ὢν μαθητῆς καὶ ὑπ' ἐκείνου προτραπείς
εἰς τὰ μαθήματα, καὶ τὰς ζητήσεις ἐποιεῖτο κατὰ
τὰς Πλάτωνος ὑφηγήσεις καὶ ταῦτα προὔβαλλεν
ἑαυτῷ, ὅσα ᾤετο τῇ Πλάτωνος φιλοσοφίᾳ συν-
τελεῖν.

Οἱ μὲν οὖν τὰς ἱστορίας ἀναγράφαντες μέχρι
τούτου προάγουσι τὴν τῆς ἐπιστήμης ταύτης τε-
λείωσιν. οὐ πολὺ δὲ τούτων νεώτερός ἐστιν Εὐ-
κλείδης ὁ τὰ στοιχεῖα συναγαγὼν καὶ πολλὰ μὲν
τῶν Εὐδόξου συντάξας, πολλὰ δὲ τῶν Θεαιτήτου
τελεωσάμενος, ἔτι δὲ τὰ μαλακώτερον δεικνύμενα
τοῖς ἔμπροσθεν εἰς ἀνελέγκτους ἀποδείξεις ἀναγα-
γών. γέγονε δὲ οὗτος ὁ ἀνὴρ ἐπὶ τοῦ πρώτου
Πτολεμαίου· καὶ γὰρ ὁ Ἀρχιμήδης ἐπιβαλὼν καὶ
τῷ πρώτῳ μνημονεύει τοῦ Εὐκλείδου, καὶ μέντοι
καὶ φασιν ὅτι Πτολεμαῖος ἤρετό ποτε αὐτόν, εἴ τίς
ἐστιν περὶ γεωμετρίαν ὁδὸς συντομωτέρα τῆς
στοιχειώσεως· ὁ δὲ ἀπεκρίνατο, μὴ εἶναι βασιλικὴν
ἀτραπὸν ἐπὶ γεωμετρίαν· νεώτερος μὲν οὖν ἐστι τῶν
περὶ Πλάτωνα, πρεσβύτερος δὲ Ἐρατοσθένους καὶ

¹ Μενδαῖος Friedlein.

^a Almost certainly the same as Philippus of Opus, who is said to have revised and published the *Laws* of Plato and (wrongly) to have written the *Epinomis*. Suidas notes a number of astronomical and mathematical works by him.

^b Not much more is known about the life of Euclid than is contained in this passage (see Heath, *The Thirteen Books of Euclid's Elements*, vol. i., pp. 1-6 and *H.G.M.* i. 354-357). The summary of Euclid's achievement in the *Elements* is a very fair one, agreeing with the considered judgement of Heath (*H.G.M.* i. 217): "There is therefore probably little

PROCLUS'S SUMMARY

discovered many propositions in the *elements* and compiled some portion of the theory of loci. Philippus of Medma,^a a disciple of Plato and by him diverted to mathematics, not only made his investigations according to Plato's directions but set himself to do such things as he thought would fit in with the philosophy of Plato.

Those who have compiled histories carry the development of this science up to this point. Not much younger than these is Euclid, who put together the *elements*, arranging in order many of Eudoxus's theorems, perfecting many of Theaetetus's, and also bringing to irrefutable demonstration the things which had been only loosely proved by his predecessors. This man lived in the time of the first Ptolemy; for Archimedes, who came immediately after the first Ptolemy, makes mention of Euclid; and further they say that Ptolemy once asked him if there was in geometry a way shorter than that of the *elements*; he replied that there was no royal road to geometry.^b He is therefore younger than the pupils of Plato, but

in the whole compass of the *Elements* of Euclid, except the new theory of proportion due to Eudoxus and its consequences, which was not in substance included in the recognized content of geometry and arithmetic by Plato's time, although the form and arrangement of the subject-matter and the method employed in particular cases were different from what we find in Euclid" (*cf. H.G.M. i. 357*). As Plato died in 347 B.C., and Archimedes was born in 287 B.C., Euclid must have flourished about 300 B.C.; Ptolemy I reigned from 306 to 283 B.C. Had not the confusion been common in the Middle Ages, it would scarcely be necessary to point out that this Euclid is to be distinguished from Euclid of Megara, the philosopher, who lived about 400 B.C. A story about there being no royal road to geometry is also told of Menaechmus and Alexander (Stobaeus, *Ecl. ii. 31*, ed. Wachsmuth 115).

GREEK MATHEMATICS

Αρχιμήδους. οὔτοι γὰρ σύγχρονοι ἀλλήλοις, ὡς πού φησιν Ἐρατοσθένης. καὶ τῇ προαιρέσει δὲ Πλατωνικός ἐστι καὶ τῇ φιλοσοφίᾳ ταύτῃ οἰκεῖος, ὅθεν δὴ καὶ τῆς συμπάσης Στοιχειώσεως τέλος προεστήσατο τὴν τῶν καλουμένων Πλατωνικῶν σχημάτων σύστασιν. πολλὰ μὲν οὖν καὶ ἄλλα τοῦ ἀνδρὸς τούτου μαθηματικὰ συγγράμματα θαυμαστῆς ἀκριβείας καὶ ἐπιστημονικῆς θεωρίας μεστά. τοιαῦτα γὰρ καὶ τὰ Ὀπτικά καὶ τὰ Κατοπτρικά, τοιαῦται δὲ καὶ αἱ κατὰ μουσικὴν στοιχειώσεις, ἔτι δὲ τὸ Περὶ διαιρέσεων βιβλίον. διαφερόντως δ' ἄν τις αὐτὸν ἀγασθείη κατὰ τὴν Γεωμετρικὴν στοιχειώσιν τῆς τάξεως ἔνεκα καὶ τῆς ἐκλογῆς τῶν πρὸς τὰ στοιχεῖα πεποιημένων θεωρημάτων τε καὶ προβλημάτων. καὶ γὰρ οὐχ ὅσα ἐνεχώρει λέγειν ἀλλ' ὅσα στοιχειοῦν ἠδύνατο παρείληφεν, ἔτι δὲ τοὺς τῶν συλλογισμῶν παντοίους τρόπους, τοὺς μὲν

^a Eratosthenes was born about 284 B.C. His ability in many branches of knowledge, but failure to achieve the highest place in any, won for him the nicknames "Beta" and "Pentathlos." He became tutor to Philopator, son of Ptolemy Euergetes (see *infra*, pp. 256-257) and librarian at Alexandria. He wrote a book *Platonicus* and another *On Means* (both lost). For his *sieve* for finding successive prime numbers, see *supra*, pp. 100-103 and for his solution of the problem of doubling the cube, *infra*, pp. 290-297. His greatest achievement was his measurement of the circumference of the earth to a surprising degree of exactitude (see Heath, *H.G.M.* i. 106-108, *Greek Astronomy*, pp. 109-112).

^b It is true that the final book of the *Elements*, as written by Euclid, dealt with the construction of the cosmic, or Platonic, figures, but the whole work was certainly not designed with a view to their construction. Euclid, however, may quite well have been a Platonist.

^c Euclid's *Optics* survives and is available in the Teubner text in two recensions, one probably Euclid's own, the other



THIS PAGE IS LOCKED TO FREE MEMBERS

Purchase full membership to immediately unlock this page

FORGOTTEN BOOKS

FULL

MEMBERSHIP

797,885 Books!

All you can read

for only

\$8.99/month

Continue

*Fair usage policy applies



GREEK MATHEMATICS

ἀπὸ τῶν αἰτίων λαμβάνοντας τὴν πίστιν, τοὺς δὲ ἀπὸ τεκμηρίων ὠρμημένους, πάντας δὲ ἀνελέγκτους καὶ ἀκριβεῖς καὶ πρὸς ἐπιστήμην οἰκείους, πρὸς δὲ τούτοις τὰς μεθόδους ἀπάσας τὰς διαλεκτικάς, τὴν μὲν διαιρετικὴν ἐν ταῖς εὐρέσεσι τῶν εἰδῶν, τὴν δὲ ὀριστικὴν ἐν τοῖς οὐσιώδεσι λόγοις, τὴν δὲ ἀποδεικτικὴν ἐν τοῖς ἀπὸ ἀρχῶν εἰς τὰ ζητούμενα μεταβάσει, τὴν δὲ ἀναλυτικὴν ἐν ταῖς ἀπὸ τῶν ζητουμένων ἐπὶ τὰς ἀρχὰς ἀναστροφαῖς. καὶ μὴν καὶ τὰ ποικίλα τῶν ἀντιστροφῶν εἶδη τῶν τε ἀπλουστέρων καὶ τῶν συνθετωτέρων ἱκανῶς ἐστὶν ἐν τῇ πραγματείᾳ ταύτῃ διηκριβωμένα θεωρεῖν, καὶ τίνα μὲν ὅλα ὅλοις ἀντιστρέφειν δύναται, τίνα δὲ ὅλα μέρεσι καὶ ἀνάπαλιν, τίνα δὲ ὡς μέρη μέρεσιν. ἔτι δὲ λέγομεν τὴν συνέχειαν τῶν εὐρέσεων, τὴν οἰκονομίαν καὶ τὴν τάξιν τῶν τε προηγουμένων καὶ τῶν ἐπομένων, τὴν δύναμιν, μεθ' ἧς ἕκαστα παραδίδωσιν. ἢ καὶ τὸ τυχὸν προσθεῖς ἢ ἀφελὼν οὐκ ἐπιστήμης λανθάνεις ἀποπεσῶν καὶ εἰς τὸ ἐναντίον ψεῦδος καὶ τὴν ἄγνοιαν ὑπενεχθεῖς; ἐπειδὴ δὲ πολλὰ φαντάζεται μὲν ὡς τῆς ἀληθείας ἀντεχόμενα καὶ ταῖς ἐπιστημονικαῖς ἀρχαῖς ἀκολουθοῦντα, φέρεται δὲ εἰς τὴν ἀπὸ τῶν ἀρχῶν πλάνην καὶ τοὺς

^a Lit. "causes," but αἴτιον clearly means the same here as ἀρχή, as often in Aristotle, cf. *Met.* A 1, 1013 a 16, ἰσαχῶς δὲ καὶ τὰ αἴτια λέγεται πάντα γὰρ τὰ αἴτια ἀρχαί.

^b Geometrical conversion is to be distinguished from logical conversion, as described by Aristotle, *Cat.* xii. 6 and elsewhere. An analysis of the conversion of geometrical propositions is given by Proclus (*in Eucl.* i., ed. Friedlein, 252. 5 *et seq.*). In the leading form of conversion (ἡ προηγουμένη ἀντιστροφή, also called conversion *par excellence*, ἡ κυρίως ἀντιστροφή) the conversion is simple, the hypo-

PROCLUS'S SUMMARY

first principles,^a some setting out from demonstrative proofs, all being irrefutable and accurate and in harmony with science. In addition to these he used all the dialectical methods, the *divisional* in the discovery of figures, the *definitive* in the existential arguments, the *demonstrative* in the passages from first principles to the things sought, and the *analytic* in the converse process from the things sought to the first principles. And the various species of conversions,^b both of the simpler (propositions) and of the more complex, are in this treatise accurately set forth and skilfully investigated, what wholes can be converted with wholes, what wholes with parts and conversely, and what as parts with parts. Again, mention must be made of the continuity of the proofs, the disposition and arrangement of the things which precede and those which follow, and the power with which he treats each detail. Have you, adding or subtracting accidentally, fallen away unawares from science, carried into the opposite error and into ignorance? Since many things seem to conform with the truth and to follow from scientific principles, but lead away from the principles into error and

thesis and conclusion of one theorem becoming the conclusion and hypothesis of the converse theorem. The other form of conversion is more complex, being that where several hypotheses are combined into a single enunciation so as to lead to a single conclusion. In the converse proposition the conclusion of the original proposition is combined with the hypotheses of the original proposition, less one, so as to lead to the omitted hypothesis as the new conclusion. An example of the first species of conversion is Euclid i. 6, which is the converse of Euclid i. 5, and Heath's notes thereon are most valuable (*The Thirteen Books of Euclid's Elements*, vol. i. pp. 256-257); an example of partial conversion is given by Euclid i. 8, which is a converse to i. 4.

ἐπιπολαιότερους ἔξαπατᾶ, μεθόδους παραδέδωκεν καὶ τῆς τούτων διορατικῆς φρονήσεως, ἃς ἔχοντες γυμνάζειν μὲν δυνασόμεθα τοὺς ἀρχομένους τῆς θεωρίας ταύτης πρὸς τὴν εὕρεσιν τῶν παραλογισμῶν, ἀνεξαπάτητοι δὲ διαμένειν. καὶ τοῦτο δὴ τὸ σύγγραμμα, δι' οὗ τὴν παρασκευὴν ἡμῖν ταύτην ἐντίθησι, Ψευδαρίων ἐπέγραψεν, τρόπους τε αὐτῶν ποικίλους ἐν τάξει διαριθμησάμενος καὶ καθ' ἕκαστον γυμνάσας ἡμῶν τὴν διάνοιαν παντοίοις θεωρήμασι καὶ τῷ ψεύδει τὸ ἀληθὲς παραθεῖς καὶ τῇ πείρᾳ τὸν ἔλεγχον τῆς ἀπάτης συναρμόσας. τοῦτο μὲν οὖν τὸ βιβλίον καθαρτικόν ἐστι καὶ γυμναστικόν, ἢ δὲ Στοιχείωσις αὐτῆς τῆς ἐπιστημονικῆς θεωρίας τῶν ἐν γεωμετρίᾳ πραγμάτων ἀνελέγκτον ἔχει καὶ τελείαν ὑφήγησιν.



THIS PAGE IS LOCKED TO FREE MEMBERS

Purchase full membership to immediately unlock this page

SAVE \$3,999,994

Did you know we sell
paperback books too?

To buy our entire catalog
in paperback would cost
over \$4,000,000

Access it all now for
\$8.99/month

*Fair usage policy applies

Continue

V. THALES

V. THALES

The circle is bisected by its diameter

Procl. *in Eucl.* i., ed. Friedlein 157. 10-13

Τὸ μὲν οὖν διχοτομείσθαι τὸν κύκλον ὑπὸ τῆς διαμέτρου πρῶτον Θαλῆν ἐκείνον ἀποδείξαι φασιν, αἰτία δὲ τῆς διχοτομίας ἢ τῆς εὐθείας ἀπαρέγκλιτος διὰ τοῦ κέντρου χώρησις.

The angles at the base of an isosceles triangle are equal

Ibid. 250. 22-251. 2

Λέγεται γὰρ δὴ πρῶτος ἐκείνος ἐπιστῆσαι καὶ εἰπεῖν, ὡς ἄρα παντὸς ἰσοσκελοῦς αἱ πρὸς τῇ βάσει γωνίαι ἴσαι εἰσίν, ἀρχαικώτερον δὲ τὰς ἴσας ὁμοίας προσειρηκέναι.

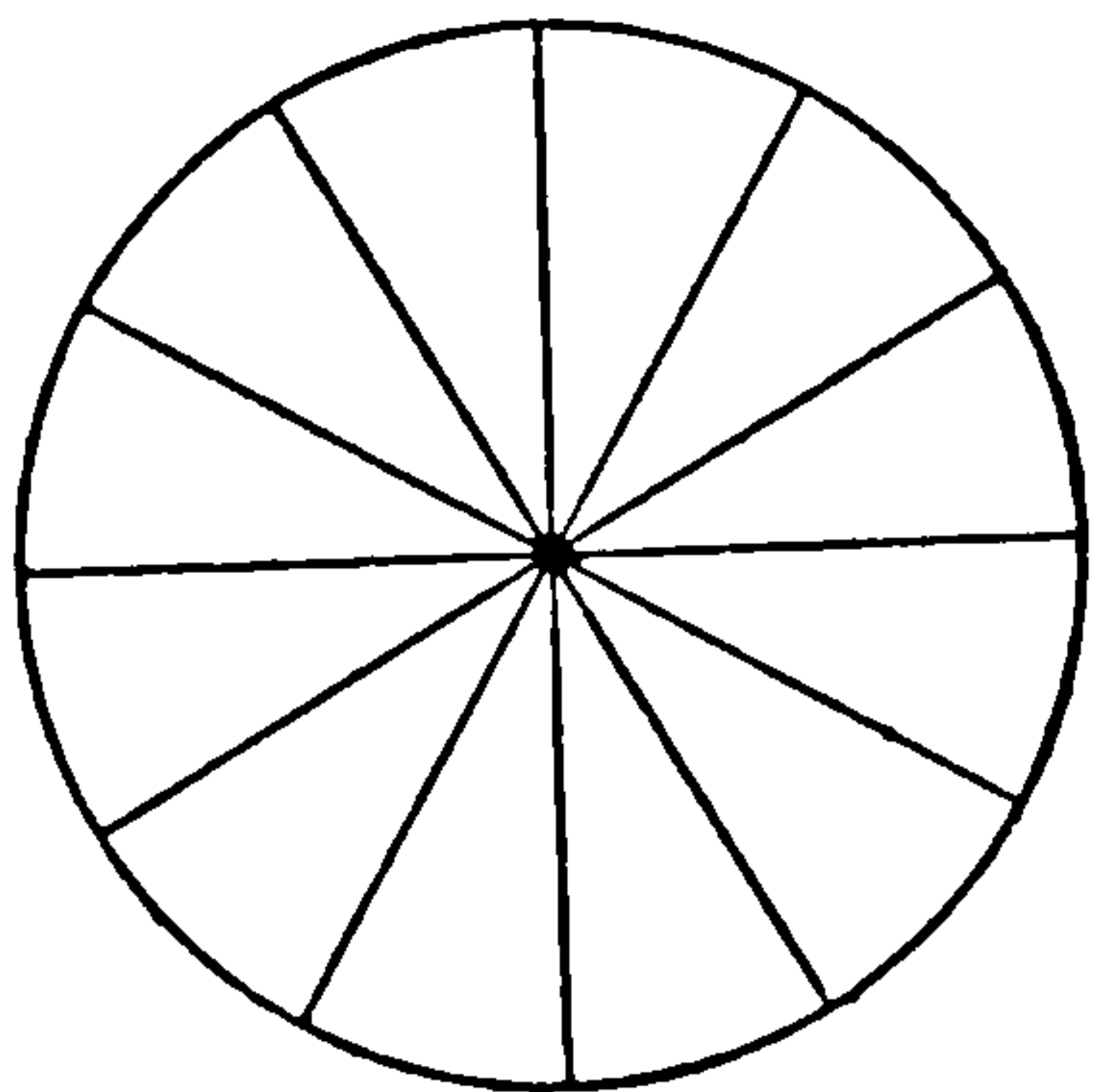

• The word “demonstrate” (ἀποδείξαι) must not be taken too literally. Even Euclid did not demonstrate this property of the circle, but stated it as the 17th definition of his first book. Thales probably was the first to point out this property. Cantor (*Gesch. d. Math.* i³., pp. 109, 140) and Heath (*H.G.M.* i. 131) suggest that his attention may have been drawn to it by figures of circles divided into equal sectors by a number of diameters. Such figures are found on Egyptian monuments



THIS PAGE IS LOCKED TO FREE MEMBERS

Purchase full membership to immediately unlock this page

FORGOTTEN BOOKS

FULL

MEMBERSHIP

797,885 Books!

All you can read

for only

\$8.99/month

Continue

*Fair usage policy applies



GREEK MATHEMATICS

The vertical and opposite angles are equal

Ibid. 299. 1-5

Τοῦτο τοίνυν τὸ θεώρημα δείκνυσιν, ὅτι δύο εὐθειῶν ἀλλήλας τεμνουσῶν αἱ κατὰ κορυφὴν γωνίαι ἴσαι εἰσίν, εὐρημένον μὲν, ὡς φησιν Εὐδήμος, ὑπὸ Θαλοῦ πρώτου, τῆς δὲ ἐπιστημονικῆς ἀποδείξεως ἡξιωμένου παρὰ τῷ Στοιχειωτῇ.

Equality of Triangles

Ibid. 352. 14-18

Εὐδήμος δὲ ἐν ταῖς γεωμετρικαῖς ἱστορίαις εἰς Θαλῆν τοῦτο ἀνάγει τὸ θεώρημα. τὴν γὰρ τῶν ἐν θαλάττῃ πλοίων ἀπόστασιν δι' οὗ τρόπου φασὶν αὐτὸν δεικνύναι τούτῳ προσχρῆσθαί φησιν ἀναγκαῖον.

The angle in a semicircle is a right-angle

Diog. Laert. i. 24-25

Παρά τε Αἰγυπτίων γεωμετρεῖν μαθόντα φησὶ Παμφίλη πρῶτον καταγράψαι κύκλου τὸ τρίγωνον

^a It is Eucl. i. 15.

^b The method by which Thales used the theorem referred to, Eucl. i. 26, to find the distance of a ship from the shore, has given rise to many conjectures. The most attractive is that of Heath (*The Thirteen Elements of Euclid's Elements*, i., p. 305, *H.G.M.* i. 133). He supposes that the observer had a rough instrument made of a straight stick and a cross-piece fastened to it so as to be capable of turning about the

THALES

The vertical and opposite angles are equal

Ibid. 299. 1-5

This theorem, that when two straight lines cut one another the vertical and opposite angles are equal, was first discovered, as Eudemus says, by Thales, though the scientific demonstration was improved by the writer of the *Elements*.^a

Equality of Triangles

Ibid. 352. 14-18

Eudemus in his *History of Geometry* attributes this theorem to Thales. For he says that the method by which Thales showed how to find the distance of ships at sea necessarily involves this method.^b

The angle in a semicircle is a right-angle

Diogenes Laertius i. 24-25

Pamphila says that, having learnt geometry from the Egyptians, he was the first to inscribe in a circle fastening in such a manner so that it could form any angle with the stick and would remain where it was put. The observer, standing on the top of a tower or some other eminence on the shore, would fix the stick in the upright position and direct the cross-piece towards the ship. Leaving the cross-piece at this angle, he would turn the stick round, keeping it vertical, until the cross-piece pointed to some object on the land, which would be noted. The distance between the foot of the tower and this object would, by Eucl. i. 26, be equal to the distance of the ship. Apparently this method is found in many practical geometries during the first century of printing.

GREEK MATHEMATICS

ὀρθογώνιον, καὶ θῦσαι βοῦν. οἱ δὲ Πυθαγόραν
φασίν, ὧν ἔστιν Ἀπολλόδωρος ὁ λογιστικός.

^a Pamphila was a female writer who lived in the reign of Nero and won much repute by her historical commonplace book (*Συμμίκτων ἱστορικῶν ὑπομνημάτων λόγοι*). She may have been right in ascribing to Thales the discovery that the angle in a semicircle is a right angle, but the passage bristles with difficulties. The reference to the sacrifice of an ox is suspiciously like the better-attested story that Pythagoras sacrificed oxen when he discovered a certain theorem. This story is told in a distich by Apollodorus reproduced below (p. 176). In reproducing that distich Plutarch says it is uncertain whether the theorem was that about the square on the hypotenuse of a right-angled triangle or that about the application of areas; he does not mention the theorem about the angle in a semicircle. Diogenes Laertius probably made a mistake in bringing in Apollodorus; the reference to the sacrifice of an ox made him think of Apollodorus's distich



THIS PAGE IS LOCKED TO FREE MEMBERS

Purchase full membership to immediately unlock this page

SAVE \$3,999,994

Did you know we sell
paperback books too?

To buy our entire catalog
in paperback would cost
over \$4,000,000

Access it all now for
\$8.99/month

*Fair usage policy applies

Continue

VI. PYTHAGOREAN GEOMETRY

VI. PYTHAGOREAN GEOMETRY

(a) GENERAL

Apollon. *Mirab.* 6 ; Diels, *Vors.* i⁵. 98. 29-31

Πυθαγόρας Μνησάρχου υἱὸς τὸ μὲν πρῶτον διεπονεῖτο περὶ τὰ μαθήματα καὶ τοὺς ἀριθμούς, ὕστερον δέ ποτε καὶ τῆς Φερεκύδου τερατοποιίας οὐκ ἀπέστη.

Aristot. *Met.* A 5, 985 b 23-26

Ἐν δὲ τούτοις καὶ πρὸ τούτων οἱ καλούμενοι Πυθαγόρειοι τῶν μαθημάτων ἀψάμενοι πρῶτοι ταῦτά τε προήγαγον, καὶ ἐντραφέντες ἐν αὐτοῖς τὰς τούτων ἀρχὰς τῶν ὄντων ἀρχὰς ᾤκηθησαν εἶναι πάντων.

Diog. Laert. viii. 24-25

Φησὶ δ' ὁ Ἀλέξανδρος ἐν ταῖς τῶν φιλοσόφων διαδοχαῖς καὶ ταῦτα εὐρηκέναι ἐν Πυθαγορικοῖς ὑπομνήμασιν. ἀρχὴν μὲν ἀπάντων μονάδα· ἐκ δὲ τῆς μονάδος ἀόριστον δυάδα ὡς ἂν ὕλην τῇ μονάδι αἰτίῳ ὄντι ὑποστήναι· ἐκ δὲ τῆς μονάδος καὶ τῆς ἀορίστου δυάδος τοὺς ἀριθμούς· ἐκ δὲ τῶν ἀριθμῶν τὰ σημεία· ἐκ δὲ τούτων τὰς γραμμάς, ἐξ ὧν τὰ



THIS PAGE IS LOCKED TO FREE MEMBERS

Purchase full membership to immediately unlock this page

FORGOTTEN BOOKS

FULL

MEMBERSHIP

797,885 Books!

All you can read

for only

\$8.99/month

Continue

*Fair usage policy applies



GREEK MATHEMATICS

ἐπίπεδα σχήματα· ἐκ δὲ τῶν ἐπιπέδων τὰ στερεὰ σχήματα· ἐκ δὲ τούτων τὰ αἰσθητὰ σώματα, ὧν καὶ τὰ στοιχεῖα εἶναι τέτταρα, πῦρ, ὕδωρ, γῆν, ἀέρα· μεταβάλλειν δὲ καὶ τρέπεσθαι δι' ὄλων, καὶ γίνεσθαι ἐξ αὐτῶν κόσμον ἔμψυχο, νοερόν, σφαιροειδῆ, μέσῃν περιέχοντα τὴν γῆν καὶ αὐτὴν σφαιροειδῆ καὶ περιρικουμένην.

Diog. Laert. viii. 11-12

Τοῦτον καὶ γεωμετρίαν ἐπὶ πέρας ἀγαγεῖν, Μοίριδος πρώτου εὐρόντος τὰς ἀρχὰς τῶν στοιχείων αὐτῆς, ὡς φησιν Ἀντικλείδης ἐν δευτέρῳ Περὶ Ἀλεξάνδρου. μάλιστα δὲ σχολάσαι τὸν Πυθαγόραν περὶ τὸ ἀριθμητικὸν εἶδος αὐτῆς τὸν τε κανόνα τὸν ἐκ μιᾶς χορδῆς εὐρεῖν. οὐκ ἠμέλησε δ' οὐδ' ἰατρικῆς. φησὶ δ' Ἀπολλόδωρος ὁ λογιστικὸς ἑκατόμβην θῦσαι αὐτόν, εὐρόντα ὅτι τοῦ ὀρθογωνίου τριγώνου ἡ ὑποτείνουσα πλευρὰ ἴσον δύναται ταῖς περιεχούσαις. καὶ ἔστιν ἐπίγραμμα οὕτως ἔχον·

ἦνίκα Πυθαγόρης τὸ περικλεῆς εὔρετο γράμμα,
κεῖν' ἐφ' ὅτῳ κλεινὴν ἤγαγε βουθυσίην.

Procl. in Eucl. i., ed. Friedlein 84. 13-23

Ἔσα δὲ πραγματειωδεστέραν ἔχει θεωρίαν καὶ συντελεῖ πρὸς τὴν ὄλην φιλοσοφίαν, τούτων προηγούμενην ποιησόμεθα τὴν ὑπόμνησιν, ζηλοῦντες τοὺς Πυθαγορείους, οἷς πρόχειρον ἦν καὶ τοῦτο σύμβολον “σχᾶμα καὶ βᾶμα, ἀλλ' οὐ σχᾶμα καὶ τριώβολον” ἐνδεικνυμένων, ὡς ἄρα δεῖ τὴν γεωμετρίαν ἐκείνην μεταδιώκειν, ἢ καθ' ἕκαστον

PYTHAGOREAN GEOMETRY

arise plane figures ; from planes, solid figures ; from these, sensible bodies, whose elements are four—fire, water, earth, air ; these elements interchange and turn into one another completely, and out of them arises a world which is animate, intelligent, spherical, and having as its centre the earth, which also is spherical and is inhabited round about.

Diogenes Laertius viii. 11-12

He [Pythagoras] it was who brought geometry to perfection, after Moeris had first discovered the beginnings of the elements of that science, as Anticleides says in the second book of his *History of Alexander*. He adds that Pythagoras specially applied himself to the arithmetical aspect of geometry and he discovered the musical intervals on the monochord ; nor did he neglect even medicine. Apollodorus the calculator says that he sacrificed a hecatomb on finding that the square on the hypotenuse of the right-angled triangle is equal to the squares on the sides containing the right angle. And there is an epigram as follows :

As when Pythagoras the famous figure found,
For which a sacrifice renowned he brought.

Proclus, *on Euclid* i., ed. Friedlein 84. 13-23

Whatsoever offers a more profitable field of research and contributes to the whole of philosophy, we shall make the starting-point of further inquiry, therein imitating the Pythagoreans, among whom there was prevalent this motto, "A figure and a platform, not a figure and sixpence," by which they implied that the geometry deserving study is that which, at each

GREEK MATHEMATICS

θεώρημα βῆμα τίθησιν εἰς ἄνοδον καὶ ἀπαίρει τὴν ψυχὴν εἰς ὕψος, ἀλλ' οὐκ ἐν τοῖς αἰσθητοῖς καταβαίνειν ἀφίησιν καὶ τὴν σύνοικον τοῖς θνητοῖς χρεῖαν ἀποπληροῦν καὶ ταύτης στοχαζομένην τῆς ἐντεῦθεν περιαγωγῆς καταμελεῖν.

Plut. *Non posse suav. vivi sec. Epic.* 11, 1094 B

Καὶ Πυθαγόρας ἐπὶ τῷ διαγράμματι βοῦν ἔθυσεν, ὡς φησιν Ἀπολλόδωρος·

ἠνίκα Πυθαγόρας τὸ περικλεῆς εὔρετο γράμμα κείν' ἐφ' ὅτῳ λαμπρὴν ἤγετο βουθυσίην.

εἴτε περὶ τῆς ὑποτεινοῦσης ὡς ἴσον δύναται ταῖς περιεχούσαις τὴν ὀρθήν, εἴτε πρόβλημα περὶ τοῦ χωρίου τῆς παραβολῆς.

Plut. *Quaest. Conv.* viii. 2. 4, 720 A

Ἔστι γὰρ ἐν τοῖς γεωμετρικωτάτοις θεωρήμασι, μᾶλλον δὲ προβλήμασι, τὸ δυεῖν εἰδῶν δοθέντων ἄλλο τρίτον παραβάλλειν τῷ μὲν ἴσον τῷ δ' ὅμοιον· ἐφ' ᾧ καὶ φασιν ἐξευρεθέντι θῦσαι τὸν Πυθαγόραν. πολὺ γὰρ ἀμέλει γλαφυρώτερον τοῦτο καὶ μουσικώτερον ἐκείνου τοῦ θεωρήματος, ὃ τὴν ὑποτείνουσαν ἀπέδειξε ταῖς περὶ τὴν ὀρθὴν ἴσον δυναμένην.

(b) SUM OF THE ANGLES OF A TRIANGLE

Procl. *in Eucl.* i., ed. Friedlein 379. 2-16

Εὐδῆμος δὲ ὁ περιπατητικὸς εἰς τοὺς Πυθαγορείους ἀναπέμπει τὴν τοῦδε τοῦ θεωρήματος εὔρεσιν, ὅτι τρίγωνον ἅπαν δυσὶν ὀρθαῖς ἴσας ἔχει



THIS PAGE IS LOCKED TO FREE MEMBERS

Purchase full membership to immediately unlock this page

SAVE \$3,999,994

Did you know we sell
paperback books too?

To buy our entire catalog
in paperback would cost
over \$4,000,000

Access it all now for
\$8.99/month

*Fair usage policy applies

Continue

GREEK MATHEMATICS

τὰς ἐντὸς γωνίας. καὶ δεικνύναι φησὶν αὐτοὺς οὕτως τὸ προκείμενον. ἔστω τρίγωνον τὸ ΑΒΓ, καὶ ἤχθω διὰ τοῦ Α τῇ ΒΓ παράλληλος ἡ ΔΕ. ἐπεὶ οὖν παράλληλοί εἰσιν αἱ ΒΓ, ΔΕ, καὶ αἱ ἐναλλάξ ἴσαι εἰσὶν, ἴση ἄρα ἡ μὲν ὑπὸ ΔΑΒ τῇ ὑπὸ ΑΒΓ, ἡ δὲ ὑπὸ ΕΑΓ τῇ ὑπὸ ΑΓΒ. κοινὴ προσκείσθω ἡ ΒΑΓ. αἱ ἄρα ὑπὸ ΔΑΒ, ΒΑΓ, ΓΑΕ, τουτέστιν αἱ ὑπὸ ΔΑΒ, ΒΑΕ, τουτέστιν αἱ δύο ὀρθαὶ ἴσαι εἰσὶ ταῖς τοῦ ΑΒΓ τριγώνου τρισὶ γωνίαις. αἱ ἄρα τρεῖς τοῦ τριγώνου δύοσιν ὀρθαῖς εἰσὶν ἴσαι.

(c) "PYTHAGORAS'S THEOREM"

Eucl. *Elem.* i. 47

Ἐν τοῖς ὀρθογωνίοις τριγώνοις τὸ ἀπὸ τῆς τὴν ὀρθὴν γωνίαν ὑποτεϊνούσης πλευρᾶς τετράγωνον ἴσον ἐστὶ τοῖς ἀπὸ τῶν τὴν ὀρθὴν γωνίαν περιεχουσῶν πλευρῶν τετραγώνοις.

Ἐστω τρίγωνον ὀρθογώνιον τὸ ΑΒΓ ὀρθὴν ἔχον τὴν ὑπὸ ΒΑΓ γωνίαν· λέγω ὅτι τὸ ἀπὸ τῆς ΒΓ τετράγωνον ἴσον ἐστὶ τοῖς ἀπὸ τῶν ΒΑ, ΑΓ τετραγώνοις.

PYTHAGOREAN GEOMETRY

angles. He says they proved the theorem in question

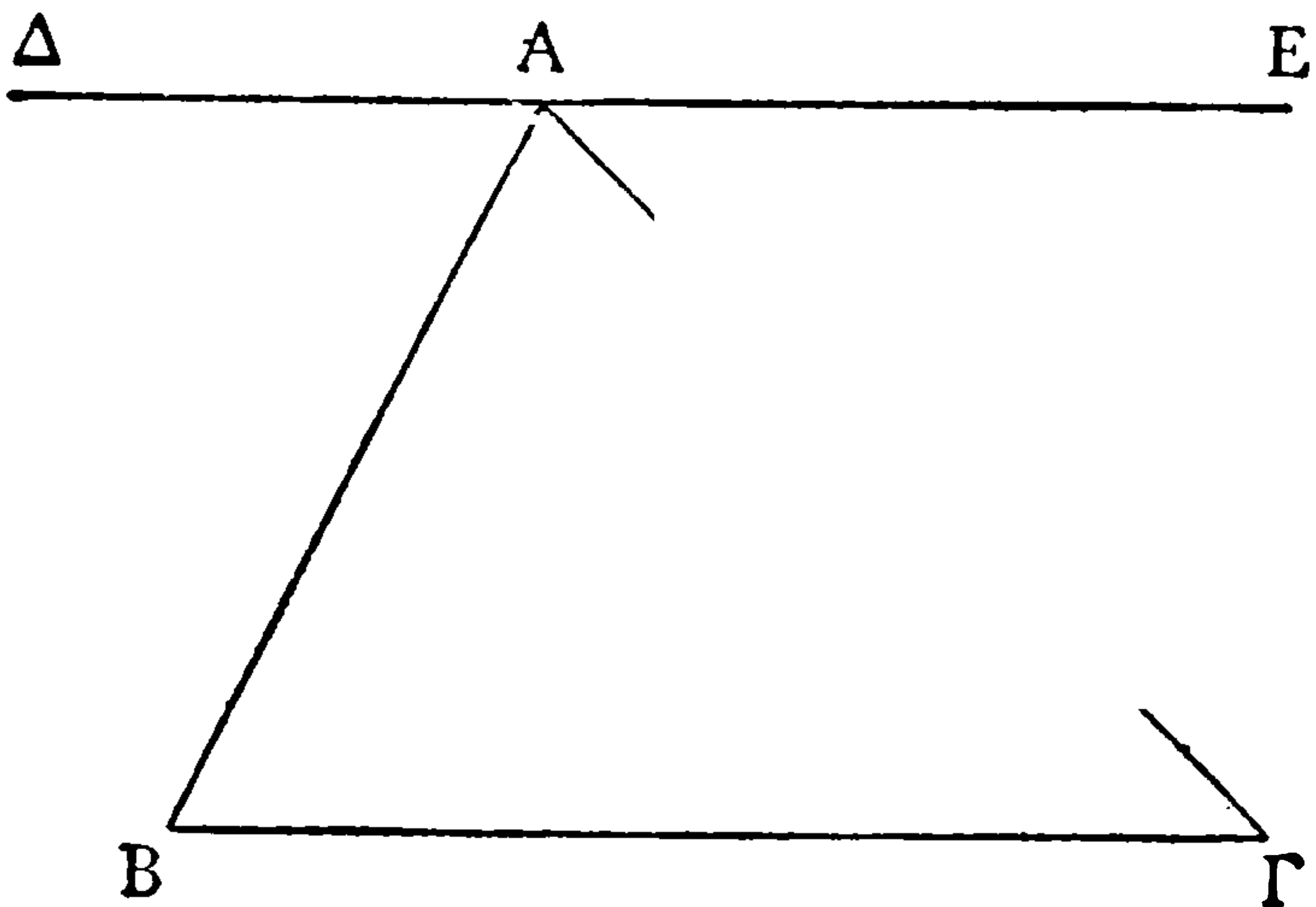

after this fashion. Let $AB\Gamma$ be a triangle, and through A let ΔE be drawn parallel to $B\Gamma$. Now since $B\Gamma$, ΔE are parallel, and the alternate angles are equal, the angle ΔAB is equal to the angle $AB\Gamma$, and $E A \Gamma$ is equal to $A \Gamma B$. Let $B A \Gamma$ be added to both. Then the angles ΔAB , $B A \Gamma$, $\Gamma A E$, that is, the angles ΔAB , $B A E$, that is, two right angles, are equal to the three angles of the triangle. Therefore the three angles of the triangle are equal to two right angles.

(c) "PYTHAGORAS'S THEOREM"

Euclid, *Elements* i. 47

In right-angled triangles the square on the side subtending the right angle is equal to the squares on the sides containing the right angle.

Let $AB\Gamma$ be a right-angled triangle having the angle $B A \Gamma$ right; I say that the square on $B\Gamma$ is equal to the squares on BA , $A\Gamma$.

Ἀναγεγράφθω γὰρ ἀπὸ μὲν τῆς ΒΓ τετράγωνον τὸ ΒΔΕΓ, ἀπὸ δὲ τῶν ΒΑ, ΑΓ τὰ ΗΒ, ΘΓ, καὶ διὰ τοῦ Α ὁποτέρᾳ τῶν ΒΔ, ΓΕ παράλληλος ἦχθω ἢ ΑΛ· καὶ ἐπεζεύχθωαν αἱ ΑΔ, ΖΓ. καὶ ἐπεὶ

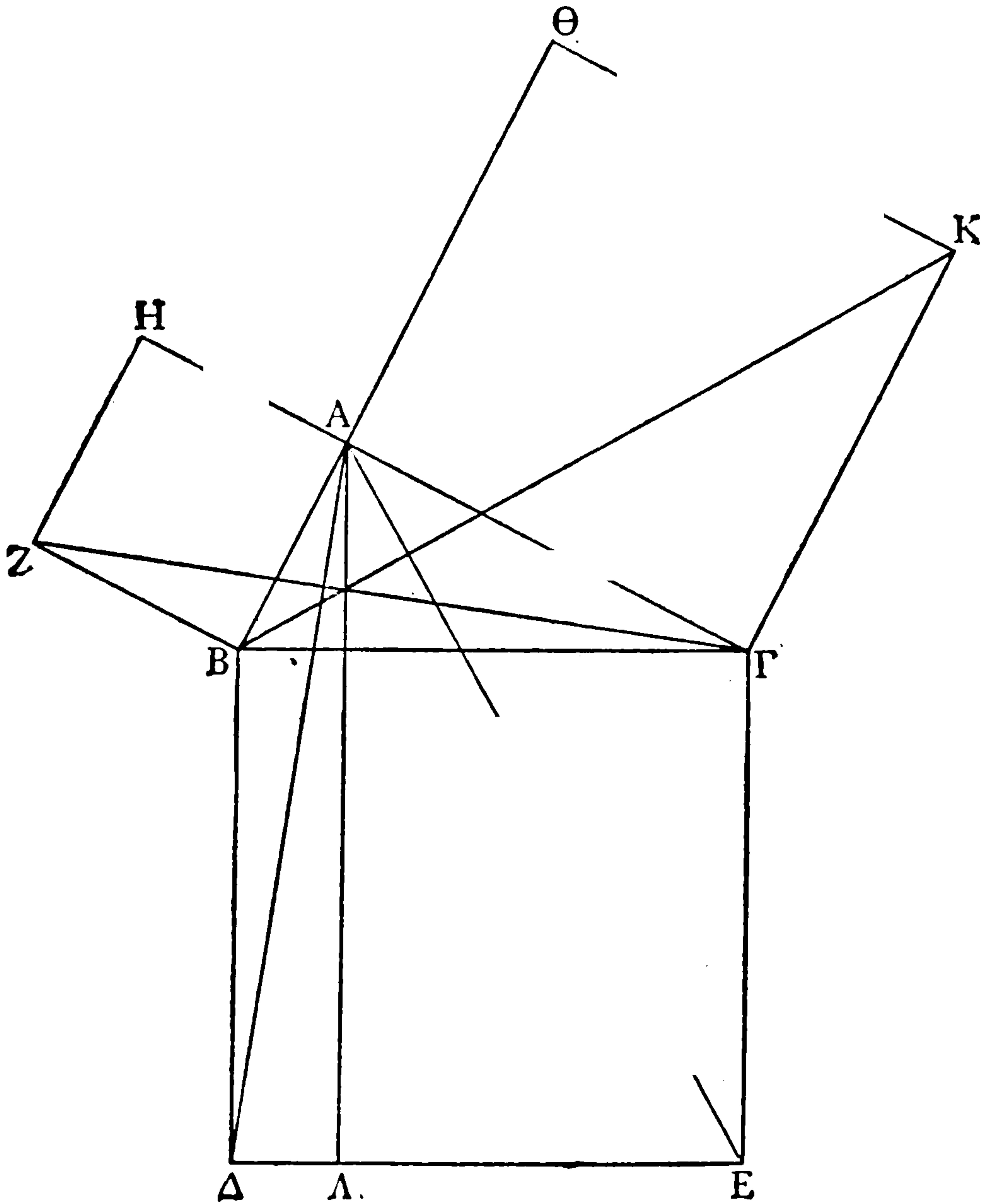



THIS PAGE IS LOCKED TO FREE MEMBERS

Purchase full membership to immediately unlock this page

FORGOTTEN BOOKS

FULL

MEMBERSHIP

797,885 Books!

All you can read

for only

\$8.99/month

Continue

*Fair usage policy applies



ὀρθή ἐστὶν ἑκάτερα τῶν ὑπὸ ΒΑΓ, ΒΑΗ γωνιῶν, πρὸς δὴ τινὶ εὐθείᾳ τῇ ΒΑ καὶ τῷ πρὸς αὐτῇ σημείῳ τῷ Α δύο εὐθεῖαι αἱ ΑΓ, ΑΗ μὴ ἐπὶ τὰ αὐτὰ μέρη κείμεναι τὰς ἐφεξῆς, γωνίας δὲ ὀρθαῖς ἴσας ποιοῦσιν· ἐπ' εὐθείας ἀρα ἐστὶν ἡ ΓΑ τῇ ΑΗ. διὰ τὰ αὐτὰ δὴ καὶ ἡ ΒΑ τῇ ΑΘ ἐστὶν ἐπ' εὐθείας. καὶ ἐπεὶ ἴση ἐστὶν ἡ ὑπὸ ΔΒΓ γωνία τῇ ὑπὸ ΖΒΑ· ὀρθή γὰρ ἑκάτερα· κοινὴ προσκείσθω ἡ ὑπὸ ΑΒΓ· ὅλη ἄρα ἡ ὑπὸ ΔΒΑ ὅλη τῇ ὑπὸ ΖΒΓ ἐστὶν ἴση. καὶ ἐπεὶ ἴση ἐστὶν ἡ μὲν ΔΒ τῇ ΒΓ, ἡ δὲ ΖΒ τῇ ΒΑ, δύο δὴ αἱ ΔΒ, ΒΑ δύο ταῖς ΖΒ, ΒΓ ἴσαι εἰσὶν ἑκάτερα ἑκάτερα· καὶ γωνία ἡ ὑπὸ ΔΒΑ γωνία τῇ ὑπὸ ΖΒΓ ἴση· βάσις ἄρα ἡ ΑΔ βάσει τῇ ΖΓ [ἐστὶν] ἴση, καὶ τὸ ΑΒΔ τρίγωνον τῷ ΖΒΓ τριγώνῳ ἐστὶν ἴσον· καὶ [ἐστὶ] τοῦ μὲν ΑΒΔ τριγώνου διπλάσιον τὸ ΒΛ παραλληλόγραμμον· βάσιν τε γὰρ τὴν αὐτὴν ἔχουσι τὴν ΒΔ καὶ ἐν ταῖς αὐταῖς εἰσι παραλλήλοις ταῖς ΒΔ, ΑΛ· τοῦ δὲ ΖΒΓ τριγώνου διπλάσιον τὸ ΗΒ τετράγωνον· βάσιν τε γὰρ πάλιν τὴν αὐτὴν ἔχουσι τὴν ΖΒ καὶ ἐν ταῖς αὐταῖς εἰσι παραλλήλοις ταῖς ΖΒ, ΗΓ. [τὰ δὲ τῶν ἴσων διπλάσια ἴσα ἀλλήλοις ἐστίν·]¹ ἴσον ἄρα ἐστὶ καὶ τὸ ΒΛ παραλληλόγραμμον τῷ ΗΒ τετραγώνῳ. ὁμοίως δὴ ἐπιζευγνυμένων τῶν ΑΕ, ΒΚ δειχθήσεται καὶ τὸ ΓΛ παραλληλόγραμμον ἴσον τῷ ΘΓ τετραγώνῳ· ὅλον ἄρα τὸ ΒΔΕΓ τετράγωνον δὲ τοῖς ΗΒ, ΘΓ τετραγώνοις ἴσον ἐστίν. καὶ ἐστὶ τὸ μὲν ΒΔΕΓ τετράγωνον ἀπὸ τῆς ΒΓ ἀναγραφέν, τὰ δὲ ΗΒ, ΘΓ ἀπὸ τῶν ΒΑ, ΑΓ. τὸ ἄρα ἀπὸ τῆς ΒΓ πλευρᾶς τετράγωνον ἴσον ἐστὶ τοῖς ἀπὸ τῶν ΒΑ, ΑΓ πλευρῶν τετραγώνοις.

Ἐν ἄρα τοῖς ὀρθογωνίοις τριγώνοις τὸ ἀπὸ τῆς

PYTHAGOREAN GEOMETRY

the angles $B\Delta\Gamma$, BAH is right, it follows that with a straight line BA and at the point A on it, two straight lines $A\Gamma$, AH , not lying on the same side, make the adjacent angles equal to two right angles ; therefore ΓA is in a straight line with AH [Eucl. i. 14]. For the same reasons BA is also in a straight line with $A\Theta$. And since the angle $\Delta B\Gamma$ is equal to the angle ZBA , for each is right, let the angle $AB\Gamma$ be added to each ; the whole angle ΔBA is therefore equal to the whole angle $ZB\Gamma$. And since ΔB is equal to $B\Gamma$, and ZB to BA , the two [sides] ΔB , BA are equal to the two [sides] $B\Gamma$, ZB respectively ; and the angle ΔBA is equal to the angle $ZB\Gamma$. The base $A\Delta$ is therefore equal to the base $Z\Gamma$, and the triangle $AB\Delta$ is equal to the triangle $ZB\Gamma$ [Eucl. i. 4]. Now the parallelogram $B\Lambda$ is double the triangle $AB\Delta$, for they have the same base $B\Delta$ and are in the same parallels $B\Delta$, $A\Lambda$ [Eucl. i. 41]. And the square HB is double the triangle $ZB\Gamma$, for they have the same base ZB and are in the same parallels ZB , HF . Therefore the parallelogram $B\Lambda$ is equal to the square HB . Similarly, if AE , BK are joined, it can also be proved that the parallelogram $\Gamma\Lambda$ is equal to the square $\Theta\Gamma$. Therefore the whole square $B\Delta E\Gamma$ is equal to the two squares HB , $\Theta\Gamma$. And the square $B\Delta E\Gamma$ is described on $B\Gamma$, while the squares HB , $\Theta\Gamma$ are described on BA , $A\Gamma$. Therefore the square on the side $B\Gamma$ is equal to the squares on the sides BA , $A\Gamma$.

Therefore in right-angled triangles the square on

¹ om. Heiberg. The words are equivalent to Common Notion 5, which must also be an interpolation as it is covered by Common Notion 2, *καὶ ἐὰν ἴσοις ἴσα προστεθῆ, τὰ ὅλα ἐστὶν ἴσα*, "if equals are added to equals the wholes are equal."

τὴν ὀρθὴν γωνίαν ὑποτεινούσης πλευρᾶς τετράγωνον ἴσον ἐστὶ τοῖς ἀπὸ τῶν τὴν ὀρθὴν [γωνίαν] περιεχουσῶν πλευρῶν τετραγώνοις· ὅπερ ἔδει δεῖξαι.

Procl. in Eucl. i., ed. Friedlein 426. 6-14

Τῶν μὲν ἱστορεῖν τὰ ἀρχαῖα βουλομένων ἀκούοντας τὸ θεώρημα τοῦτο εἰς Πυθαγόραν ἀναπεμπόντων ἐστὶν εὐρεῖν καὶ βουθύτην λεγόντων αὐτὸν ἐπὶ τῇ εὐρέσει. ἐγὼ δὲ θαυμάζω μὲν καὶ τοὺς πρώτους ἐπιστάνας τῇ τοῦδε τοῦ θεωρήματος ἀληθείᾳ, μειζόνως δὲ ἄγαμαι τὸν Στοιχειωτὴν, οὐ μόνον ὅτι δι' ἀποδείξεως ἐναργεστάτης τοῦτο κατέδησατο, ἀλλ' ὅτι καὶ τὸ καθολικώτερον αὐτοῦ τοῖς ἀνελέγκτοις λόγοις τῆς ἐπιστήμης ἐπίεσεν ἐν τῷ ἕκτῳ βιβλίῳ.

Ibid. 429. 9-15

Τῆς δὲ τοῦ Στοιχειωτοῦ ἀποδείξεως οὔσης φανερᾶς οὐδὲν ἠγοῦμαι δεῖν προσθεῖναι περιττόν, ἀλλὰ ἀρκεῖσθαι τοῖς γεγραμμένοις, ἐπεὶ καὶ ὅσοι προσέθεσαν τι πλεόν, ὡς οἱ περὶ Ἡρώνα καὶ Πάππον, ἠναγκάσθησαν προσλαβεῖν τι τῶν ἐν τῷ ἕκτῳ δεδειγμένων, οὐδενὸς ἔνεκα πραγματειώδους.

^a Eucl. vi. 31. *In right-angled triangles the figure on the side subtending the right angle is equal to the similar and similarly described figures on the sides containing the right angle.*

^b By οἱ περὶ Ἡρώνα καὶ Πάππον Proclus doubtless means, in accordance with his practice elsewhere, Heron and Pappus themselves. Pappus, in *Coll.* iv. 1, ed. Hultsch 176-178,



THIS PAGE IS LOCKED TO FREE MEMBERS

Purchase full membership to immediately unlock this page

SAVE \$3,999,994

Did you know we sell
paperback books too?

To buy our entire catalog
in paperback would cost
over \$4,000,000

Access it all now for
\$8.99/month

*Fair usage policy applies

Continue

GREEK MATHEMATICS

(d) THE APPLICATION OF AREAS

One of the greatest of Pythagorean discoveries was the method known as the application of areas, which became a powerful engine in the hands of successive Greek geometers. The geometer is said *to apply* (παραβάλλειν) an area to a given straight line when a rectangle or parallelogram equal to the area is constructed on that straight line exactly ; the area is said *to fall short* or *be deficient* (ἐλλείπειν) when the rectangle or parallelogram is constructed on a portion of the straight line ; and *to exceed* (ὑπερβάλλειν) when the rectangle or parallelogram is constructed on the straight line produced. The method is developed in the following propositions of Euclid's *Elements* : i. 44, 45 ; ii. 5, 6, 11 ; vi. 27, 28, 29. These proposi-

Procl. *in Eucl.* i., ed. Friedlein 419. 15-420. 12

Ἔστι μὲν ἀρχαῖα, φασὶν οἱ περὶ τὸν Εὐδῆμον, καὶ τῆς τῶν Πυθαγορείων μούσης εὐρήματα ταῦτα, ἣ τε παραβολὴ τῶν χωρίων καὶ ἡ ὑπερβολὴ καὶ ἡ ἔλλειψις. ἀπὸ δὲ τούτων καὶ οἱ νεώτεροι τὰ ὀνόματα λαβόντες μετήγαγον αὐτὰ καὶ ἐπὶ τὰς κωνικὰς λεγομένας γραμμάς, καὶ τούτων τὴν μὲν παραβολήν, τὴν δὲ ὑπερβολὴν καλέσαντες, τὴν δὲ

PYTHAGOREAN GEOMETRY

tions are equivalent to the solution of quadratic equations, not only in particular cases but in the most general form. The application of areas (*παραβολή τῶν χωρίων*) is therefore a vital part of the "geometrical algebra" of the Greeks, who dealt in figures as familiarly as we do in symbols. This method is the foundation of Euclid's theory of irrationals and Apollonius's treatment of the conic sections. The subject will be introduced by Proclus's comment on Eucl. i. 44, and then the relevant propositions of Euclid will be given, with their equivalents in modern algebraical notation. Though the precise form of the later propositions cannot be due to Pythagoras, depending as they do on a theory of proportion invented by Eudoxus, there can be no doubt, as Eudemus said, that the method goes back to the Pythagorean school, and most probably to the master himself.

Proclus, *on Euclid* i., ed. Friedlein 419. 15–420. 12

These things are ancient, says Eudemus, being discoveries of the Muse of the Pythagoreans, I mean the application of areas, their exceeding and their falling short. From these men the more recent geometers took the names that they gave to the so-called conic lines, calling one of these the *parabola*, one the *hyperbola* and one

GREEK MATHEMATICS

ἔλλειψιν, ἐκείνων τῶν παλαιῶν καὶ θείων ἀνδρῶν ἐν ἐπιπέδῳ καταγραφῇ χωρίων πρὸς εὐθείαν ὠρισμένην τὰ ὑπὸ τούτων σημαινόμενα τῶν ὀνομάτων ὀρώντων. ὅταν γὰρ εὐθείας ἐκκειμένης τὸ δοθὲν χωρίον πάσῃ τῇ εὐθείᾳ συμπαρατείνης, τότε παραβάλλειν ἐκεῖνο τὸ χωρίον φασίν, ὅταν μείζον δὲ ποιήσης τοῦ χωρίου τὸ μῆκος αὐτῆς τῆς εὐθείας, τότε ὑπερβάλλειν, ὅταν δὲ ἔλασσον, ὡς τοῦ χωρίου γραφέντος εἶναί τι τῆς εὐθείας ἐκτός, τότε ἐλλείπειν. καὶ οὕτως ἐν τῷ ἔκτῳ βιβλίῳ καὶ τῆς ὑπερβολῆς ὁ Εὐκλείδης μνημονεύει καὶ τῆς ἐλλείψεως, ἐνταῦθα δὲ τῆς παραβολῆς ἐδεήθη τῷ δοθέντι τριγώνῳ παρὰ τὴν δοθείσαν εὐθείαν ἴσον ἐθέλων παραβαλεῖν [παραλληλόγραμμον], ἵνα μὴ μόνον σύστασιν ἔχωμεν παραλληλογράμμου τῷ δοθέντι τριγώνῳ ἴσον, ἀλλὰ καὶ παρ' εὐθείαν ὠρισμένην παραβολήν.

Eucl. *Elem.* i. 44

Παρὰ τὴν δοθείσαν εὐθείαν τῷ δοθέντι τριγώνῳ ἴσον παραλληλόγραμμον παραβαλεῖν ἐν τῇ δοθείσῃ γωνίᾳ εὐθυγράμμῳ.

Ἔστω ἡ μὲν δοθείσα εὐθεία ἡ AB , τὸ δὲ δοθὲν τρίγωνον τὸ Γ , ἡ δὲ δοθείσα γωνία εὐθύγραμμος ἡ Δ . δεῖ δὴ παρὰ τὴν δοθείσαν εὐθείαν τὴν AB τῷ δοθέντι τριγώνῳ τῷ Γ ἴσον παραλληλόγραμμον παραβαλεῖν ἐν ἴσῃ τῇ Δ γωνίᾳ.



THIS PAGE IS LOCKED TO FREE MEMBERS

Purchase full membership to immediately unlock this page

FORGOTTEN BOOKS

FULL

MEMBERSHIP

797,885 Books!

All you can read

for only

\$8.99/month

Continue

*Fair usage policy applies



Συνεστάτω τῷ Γ τριγώνῳ ἴσον παραλληλό-
 γραμμον τὸ $ΒΕΖΗ$ ἐν γωνίᾳ τῇ ὑπὸ $ΕΒΗ$, ἣ ἐστὶν
 ἴση τῇ Δ · καὶ κείσθω ὥστε ἐπ' εὐθείας εἶναι τὴν
 $ΒΕ$ τῇ $ΑΒ$, καὶ διήχθω ἡ $ΖΗ$ ἐπὶ τὸ Θ , καὶ διὰ
 τοῦ A ὁποτέρᾳ τῶν $ΒΗ$, $ΕΖ$ παράλληλος ἤχθω ἡ
 $ΑΘ$, καὶ ἐπεζεύχθω ἡ $\ThetaΒ$. καὶ ἐπεὶ εἰς παραλλή-
 λους τὰς $ΑΘ$, $ΕΖ$ εὐθεῖα ἐνέπεσεν ἡ $\ThetaΖ$, αἱ ἄρα
 ὑπὸ $ΑΘΖ$, $\ThetaΖΕ$ γωνίαι δυσὶν ὀρθαῖς εἰσιν ἴσαι. αἱ
 ἄρα ὑπὸ $ΒΘΗ$, $ΗΖΕ$ δύο ὀρθῶν ἐλάσσονές εἰσιν·
 αἱ δὲ ἀπὸ ἐλασσόνων ἢ δύο ὀρθῶν εἰς ἄπειρον
 ἐκβαλλόμεναι συμπίπτουσιν· αἱ $\ThetaΒ$, $ΖΕ$ ἄρα
 ἐκβαλλόμεναι συμπεσοῦνται. ἐκβεβλήσθωσαν καὶ
 συμπιπτέτωσαν κατὰ τὸ K , καὶ διὰ τοῦ K σημείου
 ὁποτέρᾳ τῶν $ΕΑ$, $Ζ\Theta$ παράλληλος ἤχθω ἡ $K\Lambda$, καὶ
 ἐκβεβλήσθωσαν αἱ $\ThetaΑ$, $ΗΒ$ ἐπὶ τὰ Λ , M σημεία.
 παραλληλόγραμμον ἄρα ἐστὶ τὸ $\Theta\Lambda K Z$, διάμετρος
 δὲ αὐτοῦ ἡ ΘK , περὶ δὲ τὴν ΘK παραλληλόγραμμα
 μὲν τὰ $ΑΗ$, $MΕ$, τὰ δὲ λεγόμενα παραπληρώματα
 τὰ ΛB , BZ · ἴσον ἄρα ἐστὶ τὸ ΛB τῷ BZ . ἀλλὰ
 τὸ BZ τῷ Γ τριγώνῳ ἐστὶν ἴσον· καὶ τὸ ΛB ἄρα
 τῷ Γ ἐστὶν ἴσον. καὶ ἐπεὶ ἴση ἐστὶν ἡ ὑπὸ $ΗΒΕ$
 γωνία τῇ ὑπὸ $ΑΒΜ$, ἀλλὰ ἡ ὑπὸ $ΗΒΕ$ τῇ Δ ἐστὶν
 ἴση, καὶ ἡ ὑπὸ $ΑΒΜ$ ἄρα τῇ Δ γωνία ἐστὶν ἴση.

Παρὰ τὴν δοθεῖσαν ἄρα εὐθείαν τὴν $ΑΒ$ τῷ
 δοθέντι τριγώνῳ τῷ Γ ἴσον παραλληλόγραμμον
 παραβέβληται τὸ ΛB ἐν γωνίᾳ τῇ ὑπὸ $ΑΒΜ$, ἣ
 ἐστὶν ἴση τῇ Δ · ὅπερ ἔδει ποιῆσαι.

^a Since any rectilinear figure can be divided into triangles, this proposition can be used to solve Euclid's next problem (i. 45), which is: τῷ δοθέντι εὐθυγράμμῳ ἴσον παραλληλό-

PYTHAGOREAN GEOMETRY

Let the parallelogram BEZH be constructed, equal to the triangle Γ , in the angle EBH which is equal to Δ [i. 42]; and let it be placed so that BE is in a straight line with AB, and let ZH be produced to Θ , and through A let A Θ be drawn parallel to either BH or EZ [i. 31], and let ΘB be joined. Then, since the straight line ΘZ falls upon the parallels A Θ , EZ, the angles A ΘZ , ΘZE are equal to two right angles [i. 29]. Therefore the angles B ΘH , HZE are less than two right angles. Now the straight lines produced indefinitely from angles less than two right angles will meet. Therefore ΘB , ZE, if produced, will meet. Let them be produced and let them meet at K, and through the point K let K Λ be drawn parallel to either EA or Z Θ [i. 31], and let ΘA , HB be produced to the points Λ , M. Then $\Theta \Lambda K Z$ is a parallelogram, ΘK is its diameter, and AH, ME are parallelograms, ΛB , BZ the so-called complements, about ΘK . Therefore ΛB is equal to BZ [i. 43]. But BZ is equal to the triangle P, and therefore ΛB is equal to Γ [Common Notion 1]. And since the angle HBE is equal to the angle ABM [i. 15], while the angle HBE is equal to Δ , therefore the angle ABM is also equal to Δ .

Therefore the parallelogram ΛB , equal to the given triangle Γ , has been applied to the given straight line AB in the angle ABM which is equal to Δ ; which was to be done.^a

γραμμαν συστήσασθαι ἐν τῇ δοθείσῃ γωνίᾳ εὐθυγράμμῳ (to construct, in a given rectilineal angle, a parallelogram equal to a given rectilineal figure). The method is obvious and will not here be repeated. Proclus (*in Eucl. i.*, ed. Friedlein 422. 24–423. 5, cited *infra*, p. 316) observes that it was in consequence of this problem that ancient geometers were led to investigate the squaring of the circle.

Ἐὰν εὐθεία γραμμὴ τμηθῆ εἰς ἴσα καὶ ἄνισα, τὸ ὑπὸ τῶν ἀνίσων τῆς ὅλης τμημάτων περιεχόμενον ὀρθογώνιον μετὰ τοῦ ἀπὸ τῆς μεταξὺ τῶν τομῶν τετραγώνου ἴσον ἐστὶ τῷ ἀπὸ τῆς ἡμισείας τετραγώνῳ.

Εὐθεία γάρ τις ἢ AB τετμήσθω εἰς μὲν ἴσα κατὰ τὸ Γ , εἰς δὲ ἄνισα κατὰ τὸ Δ . λέγω, ὅτι τὸ ὑπὸ τῶν $A\Delta$, ΔB περιεχόμενον ὀρθογώνιον μετὰ τοῦ ἀπὸ τῆς $\Gamma\Delta$ τετραγώνου ἴσον ἐστὶ τῷ ἀπὸ τῆς ΓB τετραγώνῳ.

Ἀναγεγράφθω γὰρ ἀπὸ τῆς ΓB τετράγωνον τὸ ΓEZB , καὶ ἐπεζεύχθω ἢ BE , καὶ διὰ μὲν τοῦ Δ ὁποτέρᾳ τῶν ΓE , BZ παράλληλος ἤχθω ἢ ΔH , διὰ δὲ τοῦ Θ ὁποτέρᾳ τῶν AB , EZ παράλληλος πάλιν ἤχθω ἢ KM , καὶ πάλιν διὰ τοῦ A ὁποτέρᾳ τῶν $\Gamma\Lambda$, BM παράλληλος ἤχθω ἢ AK . καὶ ἐπεὶ ἴσον ἐστὶ τὸ $\Gamma\Theta$ παραπλήρωμα τῷ ΘZ παραπληρώματι, κοινὸν προσκείσθω τὸ ΔM . ὅλον ἄρα τὸ ΓM ὅλω τῷ ΔZ ἴσον ἐστίν. ἀλλὰ τὸ ΓM τῷ $A\Lambda$ ἴσον ἐστίν, ἐπεὶ καὶ ἢ $A\Gamma$ τῇ ΓB ἐστὶν ἴση· καὶ τὸ $A\Lambda$ ἄρα τῷ ΔZ ἴσον ἐστίν. κοινὸν προσκείσθω τὸ $\Gamma\Theta$. ὅλον ἄρα τὸ $A\Theta$ τῷ MNE γνώμονι ἴσον ἐστίν. ἀλλὰ τὸ $A\Theta$ τὸ ὑπὸ τῶν $A\Delta$, ΔB ἐστὶν· ἴση γὰρ ἢ

^a Lit. "between the sections."

^b The gnomon is indicated in the figure of the mss. by the three points M , N , Ξ and a dotted curve; there are thus in the figure two points M which should not be confused. In the next proposition a similar gnomon is described as NEO , and perhaps this is what Euclid here wrote.



THIS PAGE IS LOCKED TO FREE MEMBERS

Purchase full membership to immediately unlock this page

SAVE \$3,999,994

Did you know we sell
paperback books too?

To buy our entire catalog
in paperback would cost
over \$4,000,000

Access it all now for
\$8.99/month

*Fair usage policy applies

Continue

GREEK MATHEMATICS

$\Delta\Theta$ τῆ ΔB . καὶ ὁ $MN\Xi$ ἄρα γνῶμων ἴσος ἐστὶ τῷ
 ὑπὸ $A\Delta, \Delta B$. κοινὸν προσκείσθω τὸ ΛH , ὃ ἐστὶν
 ἴσον τῷ ἀπὸ τῆς $\Gamma\Delta$. ὁ ἄρα $MN\Xi$ γνῶμων καὶ
 τὸ ΛH ἴσα ἐστὶ τῷ ὑπὸ τῶν $A\Delta, \Delta B$ περιεχομένῳ
 ὀρθογωνίῳ καὶ τῷ ἀπὸ τῆς $\Gamma\Delta$ τετραγώνῳ. ἀλλὰ
 ὁ $MN\Xi$ γνῶμων καὶ τὸ ΛH ὅλον ἐστὶ τὸ $\Gamma E Z B$
 τετράγωνον, ὃ ἐστὶν ἀπὸ τῆς ΓB . τὸ ἄρα ὑπὸ τῶν
 $A\Delta, \Delta B$ περιεχόμενον ὀρθογώνιον μετὰ τοῦ ἀπὸ
 τῆς $\Gamma\Delta$ τετραγώνου ἴσον ἐστὶ τῷ ἀπὸ τῆς ΓB
 τετραγώνῳ.

Ἐὰν ἄρα κτλ.

^a If the unequal segments are p, q , then this theorem is equivalent to the algebraical proposition

$$pq + \left(\frac{p+q}{2} - q\right)^2 = \left(\frac{p+q}{2}\right)^2$$

or

$$\left(\frac{p+q}{2}\right)^2 - \left(\frac{p-q}{2}\right)^2 = pq.$$

This gives a ready means of obtaining the two rules, respectively attributed to the Pythagoreans and Plato (see *supra*, pp. 90-95) for finding integral square numbers which are the sum of two other integral square numbers. Putting $p = n^2$, $q = 1$, we have

$$\left(\frac{n^2+1}{2}\right)^2 - \left(\frac{n^2-1}{2}\right)^2 = n^2.$$

In order that the first two squares may be integers, n must be odd. This is the Pythagorean rule.

Putting $p = 2n^2, q = 2$,

we have $(n^2+1)^2 - (n^2-1)^2 = 4n^2.$

This is Plato's rule, starting from an even number $2n$.

The theorem can be made to yield a result of even greater interest, namely, the geometrical solution of the quadratic equation

$$ax - x^2 = b^2,$$

as is shown by Heath (*The Thirteen Books of Euclid's Ele-*

PYTHAGOREAN GEOMETRY

angle $A\Delta$, ΔB ; for $\Delta\Theta$ is equal to ΔB ; and therefore the gnomon $MN\Xi$ is equal to the rectangle $A\Delta$, ΔB . Let ΛH , which is equal to the square on $\Gamma\Delta$, be added to each ; therefore the gnomon $MN\Xi$ and ΛH are equal to the rectangle contained by $A\Delta$, ΔB and the square on $\Gamma\Delta$. But the gnomon $MN\Xi$ and ΛH are the whole square $PEZB$, which is described on PB ; therefore the rectangle contained by $A\Delta$, ΔB together with the square on $\Gamma\Delta$ is equal to the square on PB .

Therefore, etc.^a

ments, vol. i. p. 384, and *H.G.M.* i. 151, 152), following Simson ; see also Loria, *Le scienze esatte nell' antica Grecia*, pp. 42-45.

If $AB = a$, $\Delta B = x$,

then the theorem shows that

$$(a - x) \cdot x = \text{the rectangle } A\Theta = \text{the gnomon } MN\Xi.$$

If the area of the gnomon is given ($= b^2$), then we have

$$ax - x^2 = b^2.$$

To solve this equation geometrically is to find the point Δ , and in Pythagorean language this is to apply to a given straight line (a) a rectangle which shall be equal to a given square (b^2) and shall fall short by a square figure, that is, to construct the rectangle $A\Theta$ or the gnomon $MN\Xi$.

Draw ΓO perpendicular to AB and equal to b .

With centre O and radius equal to ΓB ($= \frac{1}{2}a$) describe a circle. Provided that b is greater than $\frac{1}{2}a$, this circle will cut AB in two points. One of these is the required point Δ , $\Delta B = x$, and the rectangle $A\Theta$ can be constructed.

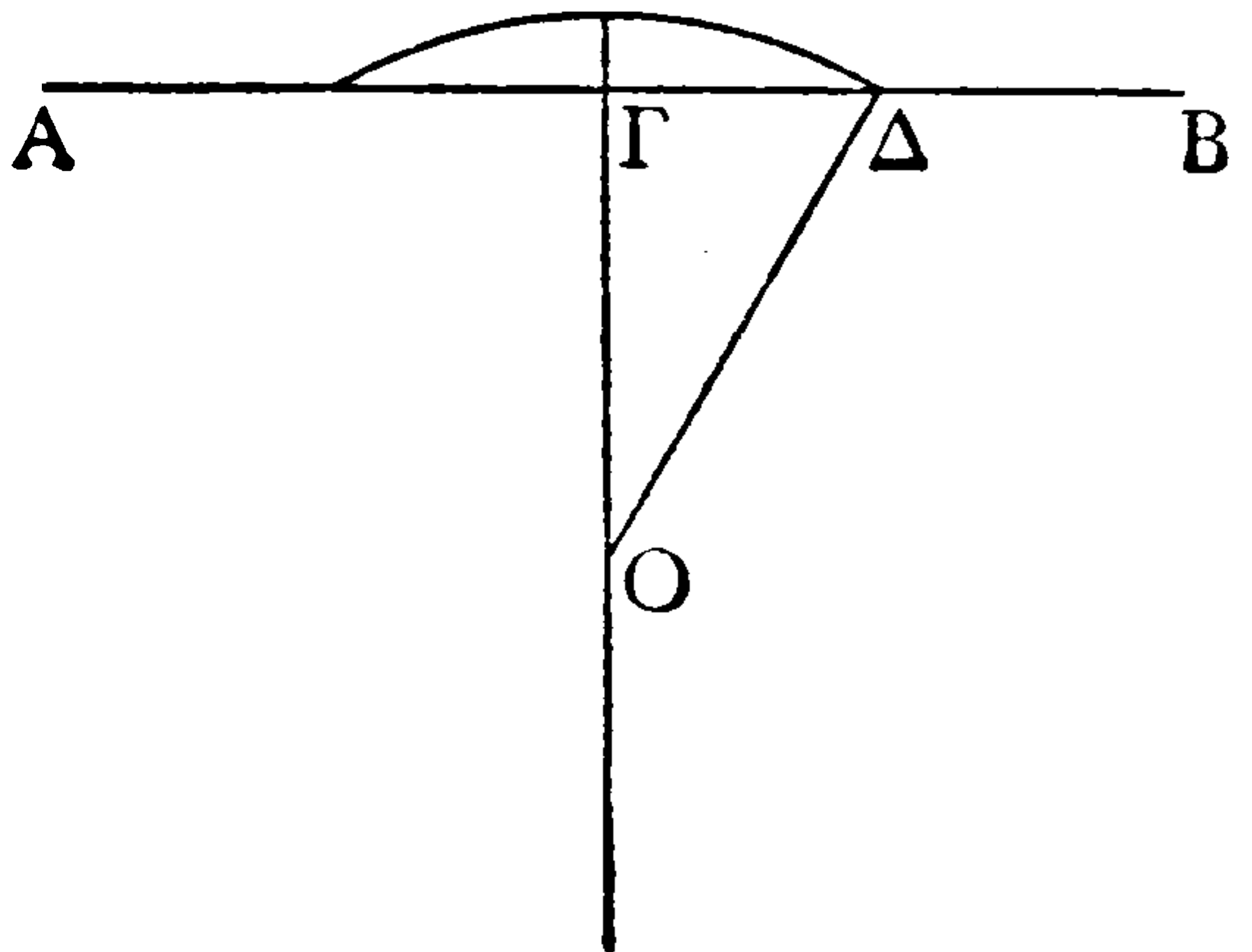

GREEK MATHEMATICS

Eucl. *Elem.* ii. 6

Ἐὰν εὐθεία γραμμὴ τμηθῆ διχα, προστεθῆ δέ τις αὐτῇ εὐθεία ἐπ' εὐθείας, τὸ ὑπὸ τῆς ὅλης σὺν τῇ προσκειμένῃ καὶ τῆς προσκειμένης περιεχόμενον ὀρθογώνιον μετὰ τοῦ ἀπὸ τῆς ἡμισείας τετραγώνου ἴσον ἐστὶ τῷ ἀπὸ τῆς συκκειμένης ἕκ τε τῆς ἡμισείας καὶ τῆς προσκειμένης τετραγώνω.

Εὐθεία γάρ τις ἡ AB τετμήσθω διχα κατὰ τὸ Γ σημείον, προσκείσθω δέ τις αὐτῇ εὐθεία ἐπ' εὐθείας ἡ $B\Delta$. λέγω, ὅτι τὸ ὑπὸ τῶν $A\Delta$, ΔB περιεχόμενον

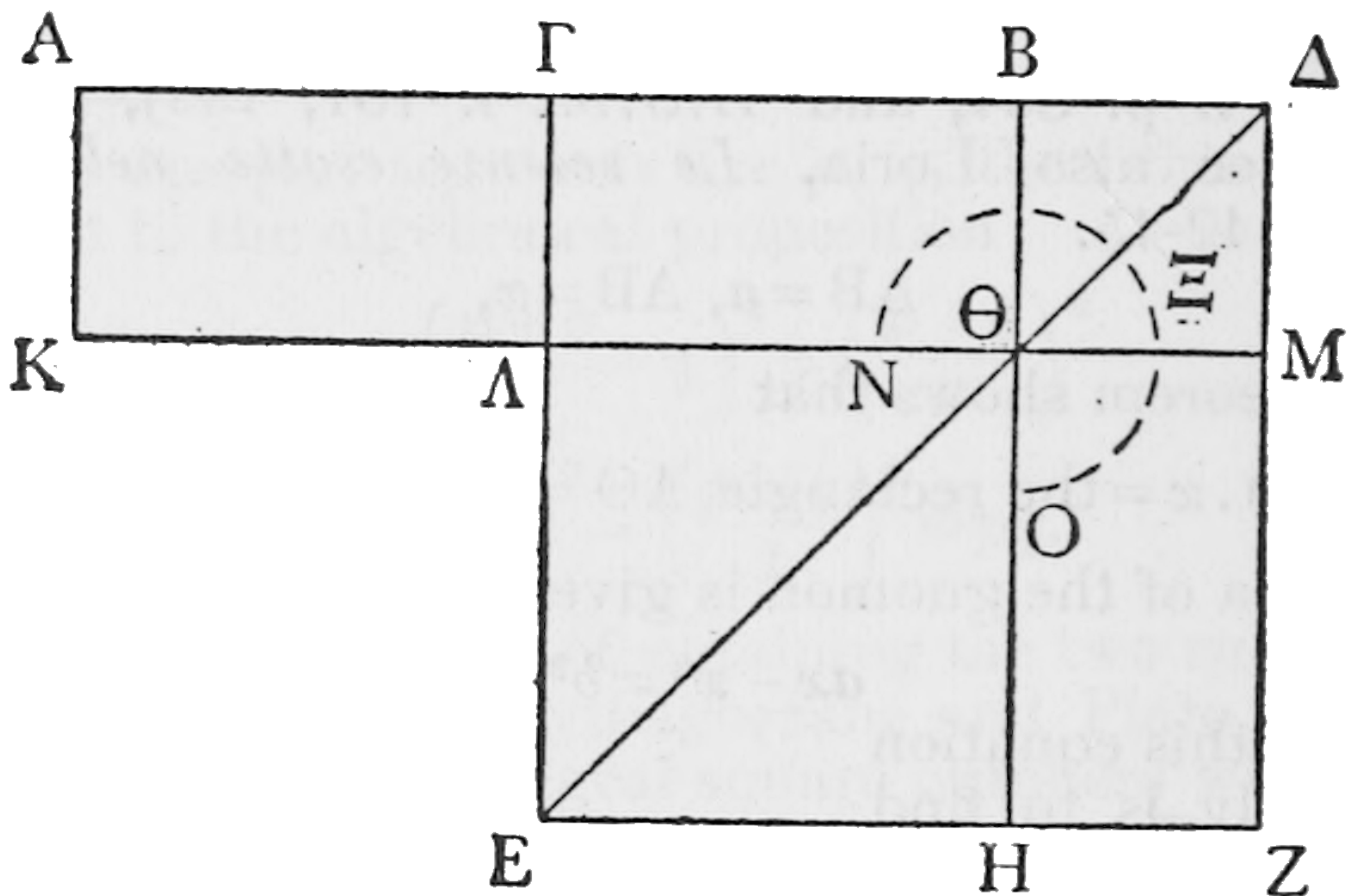

ὀρθογώνιον μετὰ τοῦ ἀπὸ τῆς ΓB τετραγώνου ἴσον ἐστὶ τῷ ἀπὸ τῆς $\Gamma\Delta$ τετραγώνω.

For by the proposition (ii. 5) just proved,

$$\begin{aligned} A\Delta \cdot \Delta B + \Gamma\Delta^2 &= \Gamma B^2 \\ &= O\Delta^2 \\ &= O\Gamma^2 + \Gamma\Delta^2 \quad (\text{i. 47}) \end{aligned}$$

$$\therefore A\Delta \cdot \Delta B = O\Gamma^2 = b^2.$$

or

$$(a-x)x$$

The two points in which the circle cuts AB give two real solutions of the equation, which are coincident when $b = \frac{1}{2}a$ and the circle touches AB .

There is no direct evidence that the Pythagoreans, or



THIS PAGE IS LOCKED TO FREE MEMBERS

Purchase full membership to immediately unlock this page

FORGOTTEN BOOKS

FULL

MEMBERSHIP

797,885 Books!

All you can read

for only

\$8.99/month

Continue

*Fair usage policy applies



Τὴν δοθεῖσαν εὐθείαν τεμεῖν ὥστε τὸ ὑπὸ τῆς ὅλης καὶ τοῦ ἑτέρου τῶν τμημάτων περιεχόμενον ὀρθογώνιον ἴσον εἶναι τῷ ἀπὸ τοῦ λοιποῦ τμήματος τετραγώνῳ.

Ἐστω ἡ δοθεῖσα εὐθεῖα ἡ AB . δεῖ δὴ τὴν AB τεμεῖν ὥστε τὸ ὑπὸ τῆς ὅλης καὶ τοῦ ἑτέρου τῶν

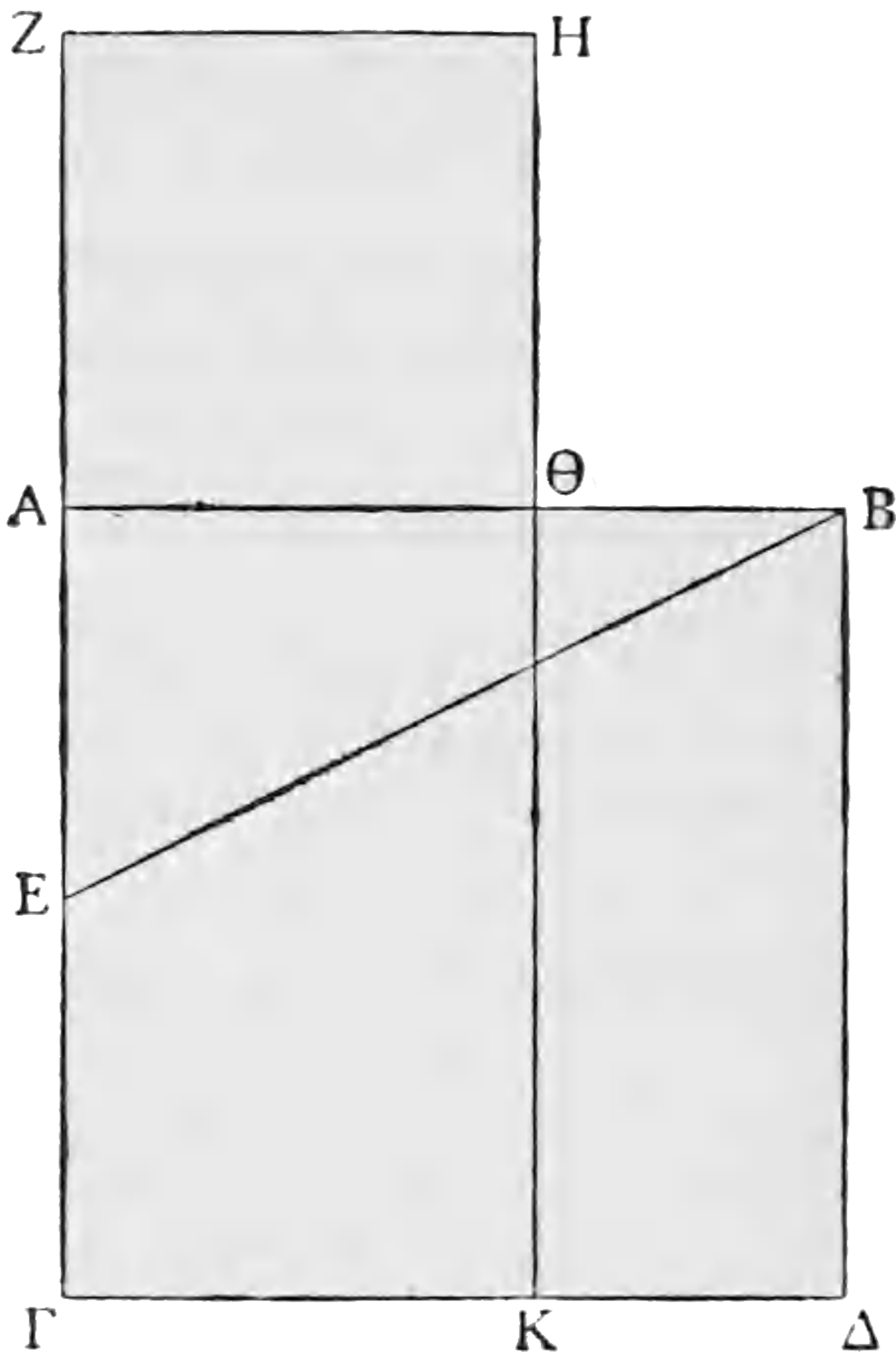

τμημάτων περιεχόμενον ὀρθογώνιον ἴσον εἶναι τῷ ἀπὸ τοῦ λοιποῦ τμήματος τετραγώνῳ.

Continued from p. 197.]

Simson first showed how to do this. Let BP be drawn perpendicular to AB and equal to b . With centre Γ and

PYTHAGOREAN GEOMETRY

Euclid, *Elements* ii. 11

To cut the given straight line so that the rectangle contained by the whole and one of the segments is equal to the square on the remaining segment.

Let AB be the given straight line; then it is required to cut AB so that the rectangle contained by the whole and one of the segments is equal to the square on the remaining segment.

radius ΓP let a circle be drawn cutting AB produced in Δ . Then Δ is the required point.

For by the proposition (ii. 6) just proved,

$$\begin{aligned} A\Delta \cdot \Delta B + \Gamma B^2 &= \Gamma \Delta^2 \\ &= \Gamma P^2 \\ &= \Gamma B^2 + BP^2 \\ \therefore A\Delta \cdot \Delta B &= BP^2 \\ \text{i.e. } ax + x^2 &= b^2. \end{aligned}$$

Because the circle cuts AB produced in two points there are two real solutions, and as the circle always cuts AB produced there is always a real solution. This bears out the algebraical proof that the equation

$$ax + x^2 = b^2$$

always has two real roots, which are equal when $b = \frac{1}{2}a$.

When we come to deal with Hippocrates' quadrature of lunes we shall come across the problem: To find x , when x is given by the equation

$$\sqrt{\frac{3}{2}}ax + x^2 = a^2.$$

This could have been solved theoretically by the above methods, and the solution was certainly not beyond the powers of Hippocrates. It seems more probable, however, from the wording of Eudemus's account, that he used an approximate mechanical solution for his purpose.

This same construction can be used to give a geometrical solution of the equation $x^2 - ax = b^2$. In the figure it has only to be supposed that $AB = a$ and $A\Delta$ (instead of $B\Delta$) = x . Then the theorem tells us that $x(x - a) = \text{the gnomon} = b^2$.

GREEK MATHEMATICS

Ἐναγεγράφθω γὰρ ἀπὸ τῆς AB τετράγωνον τὸ $AB\Delta\Gamma$, καὶ τετμήσθω ἡ $A\Gamma$ δίχα κατὰ τὸ E σημείον, καὶ ἐπεζεύχθω ἡ BE , καὶ διήχθω ἡ ΓA ἐπὶ τὸ Z , καὶ κείσθω τῇ BE ἴση ἡ EZ , καὶ ἀναγεγράφθω ἀπὸ τῆς AZ τετράγωνον τὸ $Z\Theta$, καὶ διήχθω ἡ $H\Theta$ ἐπὶ τὸ K . λέγω, ὅτι ἡ AB τέτμηται κατὰ τὸ Θ , ὥστε τὸ ὑπὸ τῶν $AB, B\Theta$ περιεχόμενον ὀρθογώνιον ἴσον ποιεῖν τῷ ἀπὸ τῆς $A\Theta$ τετραγώνῳ.

Ἐπεὶ γὰρ εὐθεῖα ἡ $A\Gamma$ τέτμηται δίχα κατὰ τὸ E , πρόσκειται δὲ αὐτῇ ἡ ZA , τὸ ἄρα ὑπὸ τῶν $\Gamma Z, ZA$ περιεχόμενον ὀρθογώνιον μετὰ τοῦ ἀπὸ τῆς AE τετραγώνου ἴσον ἐστὶ τῷ ἀπὸ τῆς EZ τετραγώνῳ. ἴση δὲ ἡ EZ τῇ EB . τὸ ἄρα ὑπὸ τῶν $\Gamma Z, ZA$ μετὰ τοῦ ἀπὸ τῆς AE ἴσον ἐστὶ τῷ ἀπὸ EB . ἀλλὰ τῷ ἀπὸ EB ἴσα ἐστὶ τὰ ἀπὸ τῶν BA, AE . ὀρθὴ γὰρ ἡ πρὸς τῷ A γωνία. τὸ ἄρα ὑπὸ τῶν $\Gamma Z, ZA$ μετὰ τοῦ ἀπὸ τῆς AE ἴσον ἐστὶ τοῖς ἀπὸ τῶν BA, AE . κοινὸν ἀφηρήσθω τὸ ἀπὸ τῆς AE . λοιπὸν ἄρα τὸ ὑπὸ τῶν $\Gamma Z, ZA$ περιεχόμενον ὀρθογώνιον ἴσον ἐστὶ τῷ ἀπὸ τῆς AB τετραγώνῳ. καί ἐστι τὸ μὲν ὑπὸ τῶν $\Gamma Z, ZA$ τὸ ZK . ἴση γὰρ ἡ AZ τῇ ZH . τὸ δὲ ἀπὸ τῆς AB τὸ $A\Delta$. τὸ ἄρα ZK ἴσον ἐστὶ τῷ $A\Delta$. κοινὸν ἀφηρήσθω τὸ AK . λοιπὸν ἄρα τὸ $Z\Theta$ τῷ $\Theta\Delta$ ἴσον ἐστίν. καί ἐστι τὸ μὲν $\Theta\Delta$ τὸ ὑπὸ τῶν $AB, B\Theta$. ἴση γὰρ ἡ AB τῇ $B\Delta$. τὸ δὲ $Z\Theta$ τὸ ἀπὸ τῆς $A\Theta$. τὸ ἄρα ὑπὸ τῶν $AB, B\Theta$ περιεχόμενον ὀρθογώνιον ἴσον ἐστὶ τῷ ἀπὸ ΘA τετραγώνῳ.

Ἡ ἄρα κτλ.

^a If $AB = a$, $A\Theta = x$, then AB has been so cut at Θ that

$$a(a - x) = x^2$$

or

$$x^2 + ax = a^2.$$



THIS PAGE IS LOCKED TO FREE MEMBERS

Purchase full membership to immediately unlock this page

SAVE \$3,999,994

Did you know we sell
paperback books too?

To buy our entire catalog
in paperback would cost
over \$4,000,000

Access it all now for
\$8.99/month

*Fair usage policy applies

Continue

GREEK MATHEMATICS

Eucl. *Elem.* vi. 27

Πάντων τῶν παρὰ τὴν αὐτὴν εὐθείαν παραβαλλομένων παραλληλογράμμων καὶ ἔλλειπόντων εἶδεσι παραλληλογράμμοις ὁμοίοις τε καὶ ὁμοίως κειμένοις τῷ ἀπὸ τῆς ἡμισείας ἀναγραφόμενῳ μέγιστόν ἐστι τὸ ἀπὸ τῆς ἡμισείας παραβαλλόμενον ὅμοιον ὃν τῷ ἔλλείματι.

*Ἐστω εὐθεῖα ἡ AB καὶ τετμήσθω δίχα κατὰ

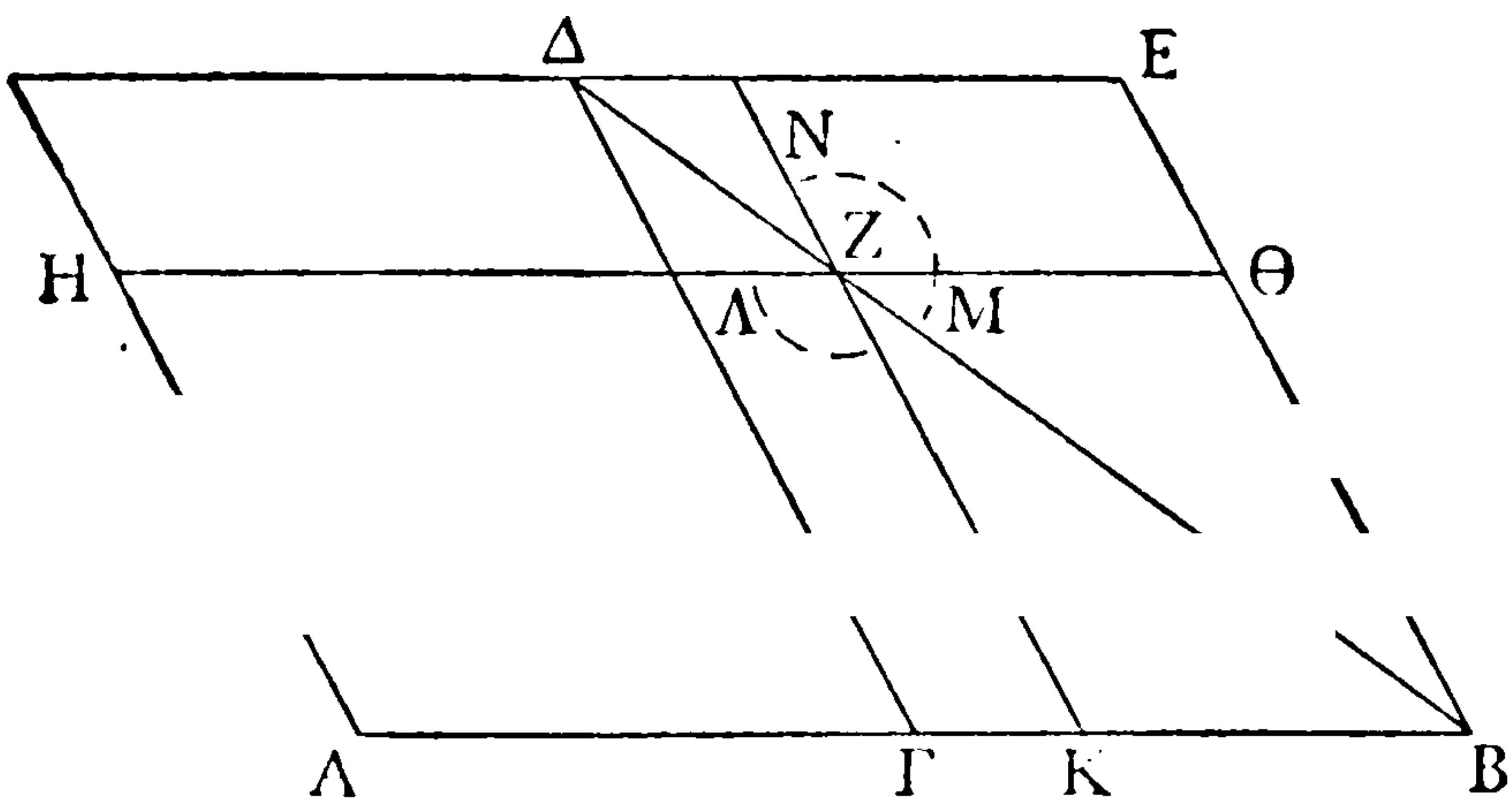

by a method based on ii. 6. There is good reason to believe, as will be shown below, pp. 222-225, that the Pythagoreans knew how to construct a regular pentagon $ABCDE$, and it is probable that this theorem was used in the construction, as can be shown if CE is allowed to cut AD in F .

For the Pythagoreans, knowing that the sum of the angles of any triangle is two right angles, would immediately have deduced that the sum of the internal angles of a regular pentagon is six right angles, and that each of the internal angles is therefore $\frac{6}{5}$ ths of a right angle. It easily follows that the angles CAD , ADC , DCA are respectively $\frac{2}{5}$ ths, $\frac{4}{5}$ ths and $\frac{4}{5}$ ths of a right angle, while the angles FCD , CDF , DFC are also respectively $\frac{2}{5}$ ths, $\frac{4}{5}$ ths and $\frac{4}{5}$ ths of a right angle. From this it follows that the triangles ACD , CDF are similar, while $AF = FC = CD$.

PYTHAGOREAN GEOMETRY

Euclid, *Elements* vi. 27

Of all the parallelograms applied to the same straight line and deficient by parallelogrammic figures similar and similarly situated to that described on the half of the straight line, that parallelogram is greatest which is applied to the half of the straight line and is similar to the defect.^a

Let AB be a straight line and let it be bisected

Therefore $AC : CD = CD : DF$
 or $AD : AF = AF : FD$
 or $AD \cdot FD = AF^2$.

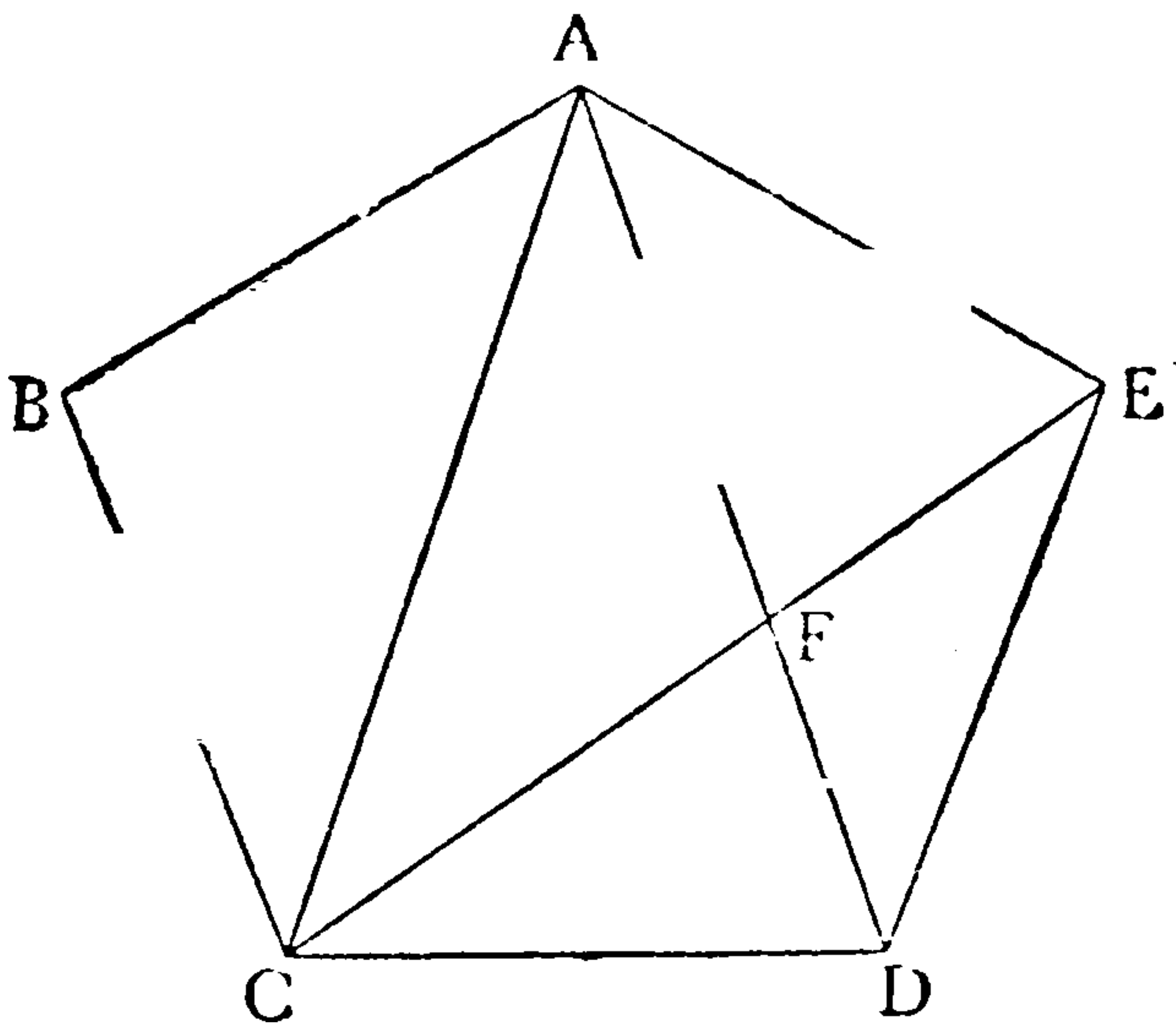

The point F can therefore be found according to the method of ii. 6, and the pentagon constructed, starting from AD.

^a This proposition gives the conditions under which it is possible to solve the next proposition, and so full consideration will be left to the note on p. 210. It is the first example we have met of a *διορισμός*. It will be remembered that according to Proclus Leon discovered *διορισμοί* (see *supra*, p. 150).

GREEK MATHEMATICS

τὸ Γ, καὶ παραβεβλήσθω παρὰ τὴν ΑΒ εὐθείαν τὸ ΑΔ παραλληλόγραμμον ἑλλείπον εἶδει παραλληλογράμμῳ τῷ ΔΒ ἀναγραφέντι ἀπὸ τῆς ἡμισείας τῆς ΑΒ, τουτέστι τῆς ΓΒ· λέγω, ὅτι πάντων τῶν παρὰ τὴν ΑΒ παραβαλλομένων παραλληλογράμμων καὶ ἑλλειπόντων εἶδεσι ὁμοίοις τε καὶ ὁμοίως κειμένοις τῷ ΔΒ μέγιστόν ἐστὶ τὸ ΑΔ. παραβεβλήσθω γὰρ παρὰ τὴν ΑΒ εὐθείαν τὸ ΑΖ παραλληλόγραμμον ἑλλείπον εἶδει παραλληλογράμμῳ τῷ ΖΒ ὁμοίῳ τε καὶ ὁμοίως κειμένῳ τῷ ΔΒ· λέγω, ὅτι μείζον ἐστὶ τὸ ΑΔ τοῦ ΑΖ.

Ἐπεὶ γὰρ ὁμοιόν ἐστὶ τὸ ΔΒ παραλληλόγραμμον τῷ ΖΒ παραλληλογράμμῳ, περὶ τὴν αὐτὴν εἰσι διάμετρον. ἤχθω αὐτῶν διάμετρος ἡ ΔΒ, καὶ καταγεγράφθω τὸ σχῆμα.

Ἐπεὶ οὖν ἴσον ἐστὶ τὸ ΓΖ τῷ ΖΕ, κοινὸν δὲ τὸ ΖΒ, ὅλον ἄρα τὸ ΓΘ ὅλῳ τῷ ΚΕ ἐστὶν ἴσον. ἀλλὰ τὸ ΓΘ τῷ ΓΗ ἐστὶν ἴσον, ἐπεὶ καὶ ἡ ΑΓ τῇ ΓΒ. καὶ τὸ ΗΓ ἄρα τῷ ΕΚ ἐστὶν ἴσον. κοινὸν προσκείσθω τὸ ΓΖ· ὅλον ἄρα τὸ ΑΖ τῷ ΛΜΝ γνώμονί ἐστὶν ἴσον· ὥστε τὸ ΔΒ παραλληλόγραμμον, τουτέστι τὸ ΑΔ, τοῦ ΑΖ παραλληλογράμμου μείζον ἐστὶν.

Πάντων ἄρα τῶν παρὰ τὴν αὐτὴν εὐθείαν παραβαλλομένων παραλληλογράμμων καὶ ἑλλειπόντων εἶδεσι παραλληλογράμμοις ὁμοίοις τε καὶ ὁμοίως κειμένοις τῷ ἀπὸ τῆς ἡμισείας ἀναγραφομένῳ μέγιστόν ἐστὶ τὸ ἀπὸ τῆς ἡμισείας παραβληθέν· ὅπερ ἔδει δεῖξαι.

Eucl. Elem. vi. 28

Παρὰ τὴν δοθείσαν εὐθείαν τῷ δοθέντι εὐθυ-



THIS PAGE IS LOCKED TO FREE MEMBERS

Purchase full membership to immediately unlock this page

FORGOTTEN BOOKS

FULL

MEMBERSHIP

797,885 Books!

All you can read

for only

\$8.99/month

Continue

*Fair usage policy applies



γράφῳ ἴσον παραλληλόγραμμον παραβαλεῖν ἔλλειπον εἶδει παραλληλογράμμῳ ὁμοίῳ τῷ δοθέντι· δεῖ δὲ τὸ διδόμενον εὐθύγραμμον [ὧ̄ δεῖ ἴσον παραβαλεῖν]¹ μὴ μείζον εἶναι τοῦ ἀπὸ τῆς ἡμισείας ἀναγραφομένου ὁμοίου τῷ ἐλλείματι [τοῦ τε ἀπὸ τῆς ἡμισείας καὶ ὧ̄ δεῖ ὅμοιον ἐλλείπειν].¹

Ἐστω ἡ μὲν δοθεῖσα εὐθεῖα ἡ ΑΒ, τὸ δὲ δοθὲν εὐθύγραμμον, ὧ̄ δεῖ ἴσον παρὰ τὴν ΑΒ παραβαλεῖν τὸ Γ μὴ μείζον [ὄν] τοῦ ἀπὸ τῆς ἡμισείας τῆς ΑΒ ἀναγραφομένου ὁμοίου τῷ ἐλλείματι, ὧ̄ δὲ δεῖ ὅμοιον ἐλλείπειν, τὸ Δ· δεῖ δὴ παρὰ τὴν δοθεῖσαν εὐθεῖαν τὴν ΑΒ τῷ δοθέντι εὐθυγράμμῳ τῷ Γ ἴσον παραλληλόγραμμον παραβαλεῖν ἔλλειπον εἶδει παραλληλογράμμῳ ὁμοίῳ ὄντι τῷ Δ.

Τετμήσθω ἡ ΑΒ δίχα κατὰ τὸ Ε σημεῖον, καὶ ἀναγεγράφθω ἀπὸ τῆς ΕΒ τῷ Δ ὅμοιον καὶ ὁμοίως κείμενον τὸ ΕΒΖΗ, καὶ συμπληρώσθω τὸ ΑΗ παραλληλόγραμμον.

Εἰ μὲν οὖν ἴσον ἐστὶ τὸ ΑΗ τῷ Γ, γεγονὸς ἂν εἴη τὸ ἐπιταχθέν· παραβέβληται γὰρ παρὰ τὴν δοθεῖσαν εὐθεῖαν τὴν ΑΒ τῷ δοθέντι εὐθυγράμμῳ τῷ Γ ἴσον παραλληλόγραμμον τὸ ΑΗ ἔλλειπον εἶδει παραλληλογράμμῳ τῷ ΗΒ ὁμοίῳ ὄντι τῷ Δ. εἰ δὲ οὐ,

¹ The bracketed words are interpolations by Theon in his recension of the *Elements* (Heiberg).

PYTHAGOREAN GEOMETRY

equal to the given rectilinear figure and deficient by a parallelogrammic figure similar to the given one; thus the given rectilinear figure must be not greater than the [parallelogram] described on the half [of the straight line] and similar to the defect.

Let AB be the given straight line, Γ the given rectilinear figure, to which the figure to be applied

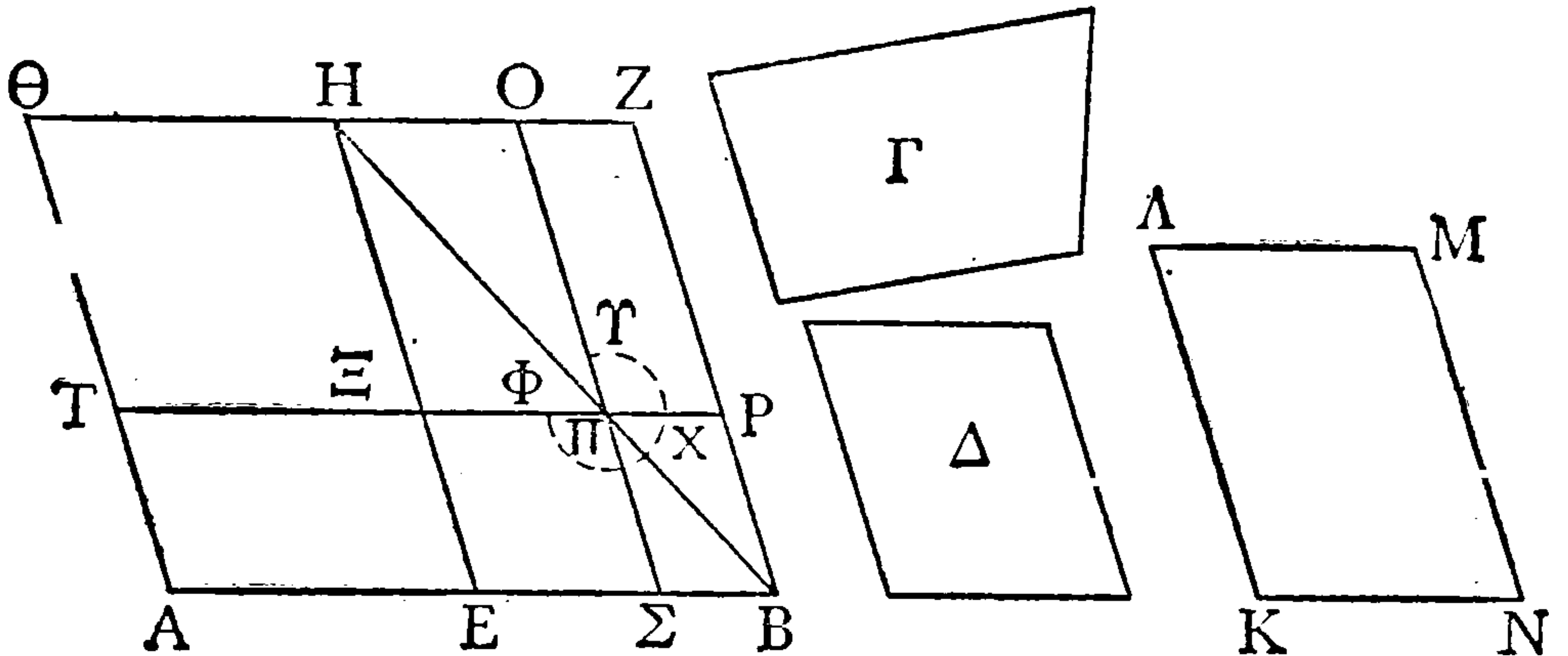

to AB is required to be equal, being not greater than the [parallelogram] described on the half [of the straight line] and similar to the defect, and Δ the [parallelogram] to which the defect is required to be similar; then it is required to apply to the given straight line AB a parallelogram equal to the given rectilinear figure Γ and deficient by a parallelogrammic form similar to Δ .

Let AB be bisected at the point E , and on E let $EBZH$ be described similar and similarly situated to Δ [vi. 18], and let the parallelogram AH be completed.

If then AH is equal to Γ , that which was enjoined will have been done; for there has been applied to the given straight line AB a parallelogram AH equal to the given rectilinear figure Γ and deficient by a parallelogrammic figure HB similar to Δ . But if not,

μείζον ἔστω τὸ ΘΕ τοῦ Γ. ἴσον δὲ τὸ ΘΕ τῷ ΗΒ·
 μείζον ἄρα καὶ τὸ ΗΒ τοῦ Γ. ὧ δὴ μείζον ἔστι
 τὸ ΗΒ τοῦ Γ, ταύτῃ τῇ ὑπεροχῇ ἴσον, τῷ δὲ Δ
 ὁμοιον καὶ ὁμοίως κείμενον τὸ αὐτὸ συνεστάτω τὸ
 ΚΛΜΝ. ἀλλὰ τὸ Δ τῷ ΗΒ [ἐστίν] ὁμοιον· καὶ τὸ
 ΚΜ ἄρα τῷ ΗΒ ἔστιν ὁμοιον. ἔστω οὖν ὁμόλογος
 ἢ μὲν ΚΛ τῇ ΗΕ, ἢ δὲ ΛΜ τῇ ΗΖ. καὶ ἐπεὶ ἴσον
 ἐστὶ τὸ ΗΒ τοῖς Γ, ΚΜ, μείζον ἄρα ἐστὶ τὸ ΗΒ
 τοῦ ΚΜ· μείζων ἄρα ἐστὶ καὶ ἢ μὲν ΗΕ τῆς ΚΛ,
 ἢ δὲ ΗΖ τῆς ΛΜ. κείσθω τῇ μὲν ΚΛ ἴση ἢ ΗΞ,
 τῇ δὲ ΛΜ ἴση ἢ ΗΟ, καὶ συμπληρώσθω τὸ
 ΞΗΟΠ παραλληλόγραμμον· ἴσον ἄρα καὶ ὁμοιόν
 ἐστὶ [τὸ ΗΠ] τῷ ΚΜ [ἀλλὰ τὸ ΚΜ τῷ ΗΒ ὁμοιόν
 ἐστίν]. καὶ τὸ ΗΠ ἄρα τῷ ΗΒ ὁμοιόν ἐστίν· περὶ
 τὴν αὐτὴν ἄρα διάμετρόν ἐστὶ τὸ ΗΠ τῷ ΗΒ.
 ἔστω αὐτῶν διάμετρος ἢ ΗΠΒ, καὶ καταγεγράφθω
 τὸ σχῆμα.

Ἐπεὶ οὖν ἴσον ἐστὶ τὸ ΒΗ τοῖς Γ, ΚΜ, ὧν τὸ
 ΗΠ τῷ ΚΜ ἔστιν ἴσον, λοιπὸς ἄρα ὁ ΥΧΦ γνώμων
 λοιπῷ τῷ Γ ἴσος ἐστίν. καὶ ἐπεὶ ἴσον ἐστὶ τὸ ΟΡ
 τῷ ΞΣ, κοινὸν προσκείσθω τὸ ΠΒ· ὅλον ἄρα τὸ
 ΟΒ ὅλω τῷ ΞΒ ἴσον ἐστίν. ἀλλὰ τὸ ΞΒ τῷ ΤΕ
 ἐστίν ἴσον, ἐπεὶ καὶ πλευρὰ ἢ ΑΕ πλευρὰ τῇ ΕΒ
 ἐστίν ἴση· καὶ τὸ ΤΕ ἄρα τῷ ΟΒ ἔστιν ἴσον. κοινὸν
 προσκείσθω τὸ ΞΣ· ὅλον ἄρα τὸ ΤΣ ὅλω τῷ
 ΦΧΥ γνώμονί ἐστίν ἴσον. ἀλλ' ὁ ΦΧΥ γνώμων
 τῷ Γ ἐδείχθη ἴσος· καὶ τὸ ΤΣ ἄρα τῷ Γ ἔστιν
 ἴσον.

Παρά τὴν δοθεῖσαν ἄρα εὐθείαν τὴν ΑΒ τῷ
 δοθέντι εὐθυγράμμω τῷ Γ ἴσον παραλληλόγραμ-
 μον παραβέβληται τὸ ΣΤ ἑλλείπον εἶδει παραλ-
 λογογράμμω τῷ ΠΒ ὁμοίω ὄντι τῷ Δ [ἐπειδή-



THIS PAGE IS LOCKED TO FREE MEMBERS

Purchase full membership to immediately unlock this page

SAVE \$3,999,994

Did you know we sell
paperback books too?

To buy our entire catalog
in paperback would cost
over \$4,000,000

Access it all now for
\$8.99/month

*Fair usage policy applies

Continue

GREEK MATHEMATICS

περ τὸ ΠΒ τῷ ΗΠ ὁμοίον ἐστίν]. ὅπερ ἔδει ποιῆσαι.

Eucl. *Elem.* vi. 29

Παρά τὴν δοθείσαν εὐθείαν τῷ δοθέντι εὐθύγραμμῳ ἴσον παραλληλόγραμμον παραβαλεῖν ὑπερβάλλον εἶδει παραλληλογράμμῳ ὁμοίῳ τῷ δοθέντι.

Ἐστω ἡ μὲν δοθείσα εὐθεία ἡ ΑΒ, τὸ δὲ δοθὲν εὐθύγραμμον, ᾧ δεῖ ἴσον παρά τὴν ΑΒ παραβαλεῖν,

^a If $AB = a$, $\Sigma\Pi = x$, while the sides of the given parallelogram Δ are in the ratio $b : c$, and the angle of Δ is α , then $\Sigma B = \frac{b}{c}x$, and

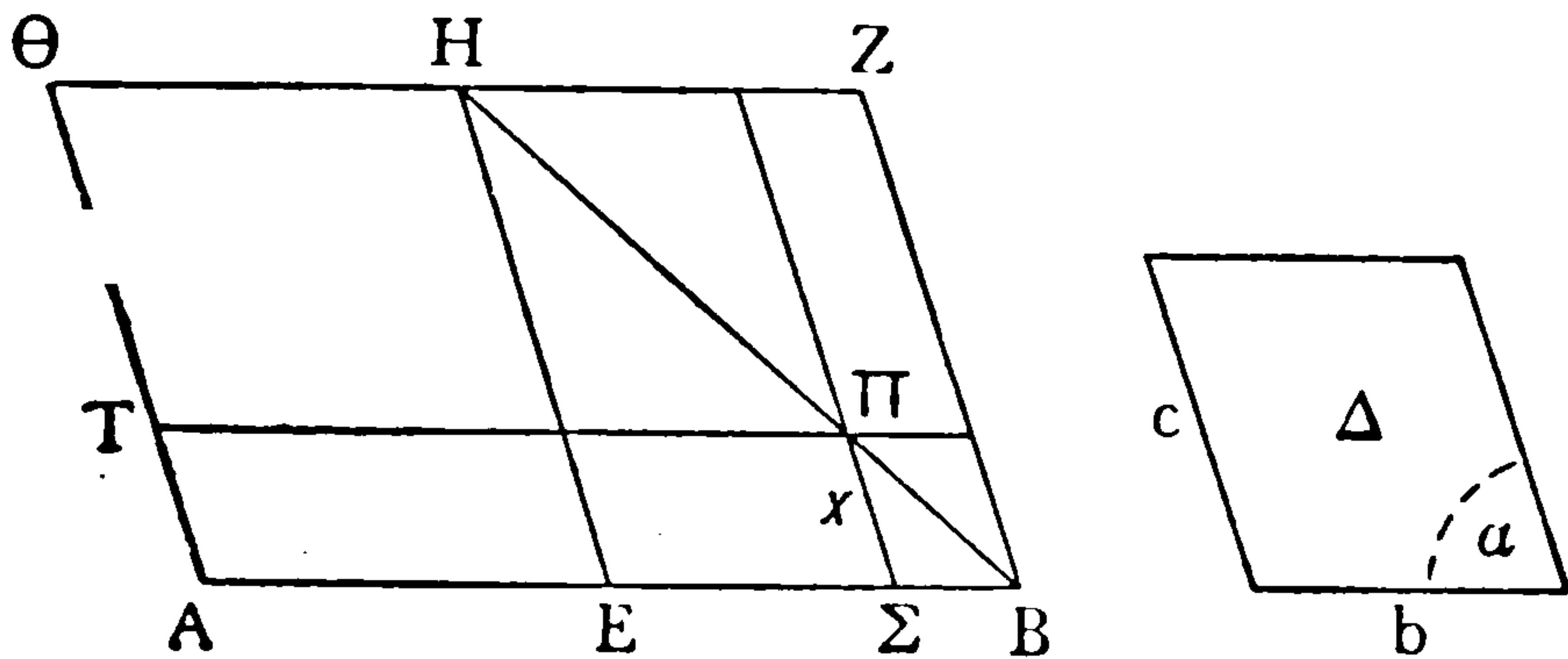

$$\begin{aligned} (\text{the parallelogram } T\Sigma) &= (\text{the parallelogram } TB) \\ &\quad - (\text{the parallelogram } \Pi B) \\ &= ax \sin \alpha - \frac{b}{c}x \cdot x \sin \alpha. \end{aligned}$$

If the area of the given rectilinear figure Γ is S , the proposition tells us that

$$ax \sin \alpha - \frac{b}{c}x^2 \sin \alpha = S.$$

To construct the parallelogram $T\Sigma$ is therefore equivalent to solving geometrically the equation

$$ax - \frac{b}{c}x^2 = \frac{S}{\sin \alpha}.$$

Heath (*The Thirteen Books of Euclid's Elements*, vol. ii

τὸ Γ, ὧ δὲ δεῖ ὅμοιον ὑπερβάλλειν, τὸ Δ· δεῖ δὴ παρὰ τὴν ΑΒ εὐθείαν τῷ Γ εὐθυγράμμῳ ἴσον παραλληλόγραμμον παραβαλεῖν ὑπερβάλλον εἶδει παραλληλογράμμῳ ὁμοίῳ τῷ Δ.

Τετμήσθω ἡ ΑΒ δίχα κατὰ τὸ Ε, καὶ ἀναγεγράφθω ἀπὸ τῆς ΕΒ τῷ Δ ὅμοιον καὶ ὁμοίως κείμενον παραλληλόγραμμον τὸ ΒΖ, καὶ συναμφοτέροις μὲν τοῖς ΒΖ, Γ ἴσον, τῷ δὲ Δ ὅμοιον καὶ ὁμοίως κείμενον τὸ αὐτὸ συνεστάτω τὸ ΗΘ. ὁμόλογος δὲ ἔστω ἡ μὲν ΚΘ τῇ ΖΛ, ἡ δὲ ΚΗ τῇ ΖΕ. καὶ ἐπεὶ μείζον ἐστὶ τὸ ΗΘ τοῦ ΖΒ, μείζων ἄρα ἐστὶ καὶ ἡ μὲν ΚΘ τῆς ΖΛ, ἡ δὲ ΚΗ τῆς ΖΕ. ἐκβεβλήσθωσαν αἱ ΖΛ, ΖΕ, καὶ τῇ μὲν ΚΘ ἴση ἔστω ἡ ΖΛΜ, τῇ δὲ ΚΗ ἴση ἡ ΖΕΝ, καὶ συμπληρώσθω τὸ ΜΝ· τὸ ΜΝ ἄρα τῷ ΗΘ ἴσον τέ ἐστὶ καὶ ὅμοιον. ἀλλὰ τὸ ΗΘ τῷ ΕΛ ἐστὶν ὅμοιον· καὶ τὸ ΜΝ ἄρα τῷ ΕΛ ὁμοίον ἐστὶν· περὶ τὴν αὐτὴν ἄρα διάμετρον ἐστὶ τὸ ΕΛ τῷ ΜΝ. ἤχθω αὐτῶν διάμετρος ἡ ΖΞ, καὶ καταγεγράφθω τὸ σχῆμα.

Ἐπεὶ ἴσον ἐστὶ τὸ ΗΘ τοῖς ΕΛ, Γ, ἀλλὰ τὸ ΗΘ τῷ ΜΝ ἴσον ἐστίν, καὶ τὸ ΜΝ ἄρα τοῖς ΕΛ, Γ ἴσον ἐστίν. κοινὸν ἀφηρήσθω τὸ ΕΛ· λοιπὸς ἄρα ὁ ΨΧΦ γνώμων τῷ Γ ἐστὶν ἴσος. καὶ ἐπεὶ ἴση ἐστὶν ἡ ΑΕ τῇ ΕΒ, ἴσον ἐστὶ καὶ τὸ ΑΝ τῷ ΝΒ, τουτέστι τῷ ΛΟ. κοινὸν προσκείσθω τὸ ΕΞ· ὅλον ἄρα τὸ ΑΞ ἴσον ἐστὶ τῷ ΦΧΨ γνώμονι. ἀλλὰ ὁ ΦΧΨ γνώμων τῷ Γ ἴσος ἐστίν· καὶ τὸ ΑΞ ἄρα τῷ Γ ἴσον ἐστίν.

Παρὰ τὴν δοθείσαν ἄρα εὐθείαν τὴν ΑΒ τῷ δοθέντι εὐθυγράμμῳ τῷ Γ ἴσον παραλληλόγραμμον παραβέβληται τὸ ΑΞ ὑπερβάλλον εἶδει παραλληλο-



THIS PAGE IS LOCKED TO FREE MEMBERS

Purchase full membership to immediately unlock this page

FORGOTTEN BOOKS

FULL

MEMBERSHIP

797,885 Books!

All you can read

for only

\$8.99/month

Continue

*Fair usage policy applies



γράμμω τῷ ΠΟ ὁμοίω ὄντι τῷ Δ, ἐπεὶ καὶ τῷ ΕΛ ἐστὶν ὁμοιον τὸ ΟΠ· ὅπερ ἔδει ποιῆσαι.

(e) THE IRRATIONAL

Schol. i. in Eucl. *Elem.* v., Eucl. ed. Heiberg
v. 415. 7-417. 14

Ἦλθον δὲ τὴν ἀρχὴν ἐπὶ τὴν τῆς συμμετρίας ζήτησιν οἱ Πυθαγόρειοι πρῶτοι αὐτὴν ἐξευρόντες ἐκ τῆς τῶν ἀριθμῶν κατανοήσεως. κοινῶ γὰρ ἀπάντων ὄντος μέτρου τῆς μονάδος καὶ ἐπὶ τῶν μεγεθῶν κοινὸν μέτρον εὔρειν οὐκ ἠδυνήθησαν. αἴτιον δὲ τὸ πάντα μὲν καὶ ὅποιοινοῦν ἀριθμὸν καθ' ὅποιασοῦν τομὰς διαιρούμενον μόνιον τι καταλιμπάνειν ἐλάχιστον καὶ τομῆς ἀνεπίδεκτον, πᾶν δὲ μέγεθος ἐπ' ἄπειρον διαιρούμενον μὴ καταλιμπάνειν μόνιον, ὃ διὰ τὸ εἶναι ἐλάχιστον τομὴν οὐκ ἐπιδέξεται, ἀλλὰ καὶ ἐκεῖνο ἐπ' ἄπειρον τεμνόμενον ποιεῖν ἄπειρα μόνια, ὧν ἕκαστον ἐπ' ἄπειρον τμηθήσεται, καὶ ἀπλῶς τὸ μὲν μέγεθος κατὰ μὲν τὸ μερίζεσθαι μετέχει τῆς τοῦ ἀπείρου ἀρχῆς, κατὰ δὲ τὴν ὁλότητα τῆς τοῦ πέρατος, τὸν δὲ ἀριθμὸν κατὰ μὲν τὸ μερίζεσθαι τῆς τοῦ πέρατος,

* If the angle of Δ is α and its sides are in the ratio $b : c$, while $AB = a$ and $O\Xi = x$, then

$$\begin{aligned} (\text{parallelogram } A\Xi) &= (\text{parallelogram } A\Pi) + (\text{parallelo-} \\ &\hspace{20em} \text{gram } B\Xi) \\ &= ax \sin \alpha + \frac{b}{c} x \cdot x \sin \alpha. \end{aligned}$$

PYTHAGOREAN GEOMETRY

grammic form ΠO similar to Δ , since $O\Pi$ is similar to $E\Lambda$; which was to be done.^a

(e) THE IRRATIONAL ^b

Euclid, *Elements* x., Scholium i., Eucl. ed. Heiberg
v. 415. 7-417. 14

The Pythagoreans were the first to make inquiry into commensurability, having first discovered it as a result of their observation of numbers; for though the unit is a common measure of all numbers they could not find a common measure of all magnitudes. The reason is that all numbers, of whatsoever kind, howsoever they be divided leave some least part which will not suffer further division; but all magnitudes are divisible *ad infinitum* and do not leave some part which, being the least possible, will not admit of further division, but that remainder can be divided *ad infinitum* so as to give an infinite number of parts, of which each can be divided *ad infinitum*; and, in sum, magnitude partakes in division of the principle of the infinite, but in its entirety of the principle of the finite, while number in division partakes of the

But by the proposition, if S is the area of Γ
(parallelogram $A\Xi$) = S ,

$$\therefore ax + \frac{b}{c}x^2 = \frac{S}{\sin a}.$$

To construct the parallelogram $A\Xi$ is therefore equivalent to solving geometrically this quadratic equation. There is always a real solution, and so no *διορισμός* is necessary as in the case of the preceding proposition. Heath (*The Thirteen Books of Euclid's Elements*, vol. ii. pp. 266-267) again shows how the procedure is equivalent to the algebraic method of completing the square. Euclid's solution corresponds to the root with the positive sign.

^b For further notices see *supra*, pp. 110-111, p. 149 n. c.

GREEK MATHEMATICS

κατὰ δὲ τὴν ὀλότητα τῆς τοῦ ἀπείρου . . . τῶν γὰρ Πυθαγορείων λόγος τὸν πρῶτον τὴν περὶ τούτων θεωρίαν εἰς τοῦμφανὲς ἐξαγαγόντα ναυαγίῳ περιπεσεῖν.

(f) THE FIVE REGULAR SOLIDS

Phil. ap. Stob. *Ecl.* 1, proem. 3, ed. Wachsmuth 18. 5 ;
Diels, *Vors.* i⁵. 412. 15–413. 2

Καὶ τὰ μὲν τᾶς σφαίρας σώματα πέντε ἐντί, τὰ ἐν τᾷ σφαίρα πῦρ (καὶ) ὕδωρ καὶ γᾶ καὶ ἀήρ, καὶ ὁ τᾶς σφαίρας ὀλκάς,¹ πέμπτον.

Aët. Plac. ii. 6. 5 ; Diels, *Vors.* i⁵. 403. 8–12

Πυθαγόρας πέντε σχημάτων ὄντων στερεῶν, ἅπερ καλεῖται καὶ μαθηματικά, ἐκ μὲν τοῦ κύβου φησὶ γεγονέναι τὴν γῆν, ἐκ δὲ τῆς πυραμίδος τὸ πῦρ, ἐκ δὲ τοῦ ὀκταέδρου τὸν ἀέρα, ἐκ δὲ τοῦ εἰκοσαέδρου τὸ ὕδωρ, ἐκ δὲ τοῦ δωδεκαέδρου τὴν τοῦ παντὸς σφαῖραν.

¹ ὀλκάς : ὀλκός coniecit Wilamowitz.

^o A regular solid is one having all its faces equal polygons and all its solid angles equal. The term is usually restricted to those regular solids in which the centre is singly enclosed. There are five, and only five, such figures—the pyramid, cube, octahedron, dodecahedron and icosahedron. They can all be inscribed in a sphere. Owing to the use made of them in Plato's *Timaeus* for the construction of the universe they were often called by the Greeks the *cosmic* or *Platonic* figures. As noted above (p. 148), Proclus attributes the construction of the cosmic figures to Pythagoras, but Suidas (*infra*, p. 378) says Theaetetus was the first to write on them. The theoretical construction of the regular solids and the calculation of their sides in terms of the radius of the circumscribed sphere occupies Book xiii. of Euclid's *Elements*. It



THIS PAGE IS LOCKED TO FREE MEMBERS

Purchase full membership to immediately unlock this page

SAVE \$3,999,994

Did you know we sell
paperback books too?

To buy our entire catalog
in paperback would cost
over \$4,000,000

Access it all now for
\$8.99/month

*Fair usage policy applies

Continue

GREEK MATHEMATICS

Plat. *Tim.* 53 c-55 c

Πρῶτον μὲν δὴ πῦρ καὶ γῆ καὶ ὕδωρ καὶ ἀήρ ὅτι σώματά ἐστι, δῆλόν που καὶ παντί. τὸ δὲ τοῦ σώματος εἶδος πᾶν καὶ βάθος ἔχει. τὸ δὲ βάθος αὐτῆς πᾶσα ἀνάγκη τὴν ἐπίπεδον περιειληφέναι φύσιν. ἡ δὲ ὀρθὴ τῆς ἐπιπέδου βάσεως ἐκ τριγώνων συνέστηκε. τὰ δὲ τρίγωνα πάντα ἐκ δυοῖν ἄρχεται τριγώνοις, μίαν μὲν ὀρθὴν ἔχοντος ἑκατέρου γωνίαν, τὰς δὲ ὀξείας· ὧν τὸ μὲν ἕτερον ἑκατέρωθεν ἔχει μέρος γωνίας ὀρθῆς πλευραῖς ἴσαις διηρημένης, τὸ δὲ ἕτερον ἀνίσοις ἀνισα μέρη νενεμημένης. . . .

Τοῖν δὴ δυοῖν τριγώνοις τὸ μὲν ἰσοσκελὲς μίαν εἴληχε φύσιν, τὸ δὲ πρόμηκες ἀπεράντους. προαιρετέον οὖν αὐτῶν τῶν ἀπείρων τὸ κάλλιστον, εἰ μέλλομεν ἄρξασθαι κατὰ τρόπον. ἂν οὖν τις ἔχη κάλλιον ἐκλεξάμενος εἰπεῖν εἰς τὴν τούτων σύστασιν, ἐκεῖνος οὐκ ἐχθρὸς ὧν ἀλλὰ φίλος κρατεῖ· τιθέμεθα δ' οὖν τῶν πολλῶν τριγώνων κάλλιστον εἶναι, ὑπερβάντες τὰλλα, ἐξ οὗ τὸ ἰσόπλευρον τρίγωνον ἐκ τρίτου συνέστηκεν. . . .

Οἷον δὲ ἕκαστον αὐτῶν γέγονεν εἶδος καὶ ἐξ ὧν συμπεσόντων ἀριθμῶν, λέγειν ἂν ἐπόμενον εἶη. ἄρξει δὴ τό τε πρῶτον εἶδος καὶ σμικρότατον συνιστάμενον· στοιχείον δ' αὐτοῦ τὸ τὴν ὑποτείνουσαν τῆς ἐλάττονος πλευρᾶς διπλασίαν ἔχον μήκει· σύνδυο δὲ τοιούτων κατὰ διάμετρον συντιθεμένων καὶ τρεῖς τούτου γενομένου, τὰς διαμέτρους

^a. This passage is put into the mouth of Timaeus of Locri, a Pythagorean leader, and in it Plato is generally held to be reproducing Pythagorean ideas.

^b i.e., the rectangular isosceles triangle and the rectangular scalene triangle.

PYTHAGOREAN GEOMETRY

Plato, *Timaeus* 53 c-55 c ^a

In the first place, then, it is clear to everyone, I think, that fire and earth and water and air are bodies. Now in every case the form of a body has depth. Further, it is absolutely necessary that depth should be bounded by a plane surface; and the rectilinear plane is composed of triangles. Now all triangles have their origin in two triangles, each having one right angle and the others acute; and one of these triangles has on each side half a right angle marked off by equal sides, while the other has the right angle divided into unequal parts by unequal sides.^b . . .

Of the two triangles, the isosceles has one nature only, but the scalene has an infinite number; and of these infinite natures the fairest must be chosen, if we would make a suitable beginning. If, then, anyone can claim that he has a fairer one for the construction of these bodies, he is no foe but shall prevail as a friend; but we shall pass over all the rest and lay down as the fairest of the many triangles that from which the equilateral triangle arises as a third when two are conjoined. . . .^c

In the next place we have to describe the form in which each kind has come into existence and from what numbers it is compounded. A beginning must be made with that kind which is primary and has the smallest components, and its element is the triangle whose hypotenuse is twice as long as the lesser side. When a pair of these triangles are joined diagonally and this is done three times, by drawing the hypo-

^c *i.e.*, the "fairest" of rectangular scalene triangles is half of an equilateral triangle, the sides being in the proportion 1, $\sqrt{3}$, 2.

GREEK MATHEMATICS

καὶ τὰς βραχείας πλευρὰς εἰς ταῦτόν ὡς κέντρον ἔρεισάντων, ἐν ἰσόπλευρον τρίγωνον ἕξ ἕξ τὸν ἀριθμὸν ὄντων γέγονεν.

Τρίγωνα δὲ ἰσόπλευρα συνιστάμενα τέτταρα κατὰ σύντρεις ἐπιπέδους γωνίας μίαν στερεὰν γωνίαν ποιεῖ, τῆς ἀμβλυτάτης τῶν ἐπιπέδων γωνιῶν ἐφεξῆς γεγονυῖαν· τοιούτων δὲ ἀποτελεσθειῶν τεττάρων πρῶτον εἶδος στερεόν, ὅλου περιφεροῦς διανεμητικὸν εἰς ἴσα μέρη καὶ ὅμοια, συνίσταται. δεύτερον δὲ ἐκ μὲν τῶν αὐτῶν τριγώνων, κατὰ δὲ ἰσόπλευρα τρίγωνα ὀκτῶ συστάντων, μίαν ἀπεργασαμένων στερεὰν γωνίαν ἐκ τεττάρων ἐπιπέδων· καὶ γενομένων ἕξ τοιούτων τὸ δεύτερον αὐτῶν σῶμα οὕτως ἔσχε τέλος. τὸ δὲ τρίτον ἐκ δις ἐξήκοντα τῶν στοιχείων συμπαγέντων, στερεῶν δὲ γωνιῶν δώδεκα, ὑπὸ πέντε ἐπιπέδων τριγώνων ἰσοπλεύρων περιεχομένης ἐκάστης, εἴκοσι βάσεις ἔχον ἰσοπλεύρους τριγώνους γέγονεν.

Καὶ τὸ μὲν ἕτερον ἀπήλλακτο τῶν στοιχείων

^a As in the accompanying diagram, the triangles AOF, COD, AOE, BOD, COE, BOF are joined together so as to form the equilateral triangle ABC. As Plato has already observed, an equilateral triangle can also be made out of two such triangles.

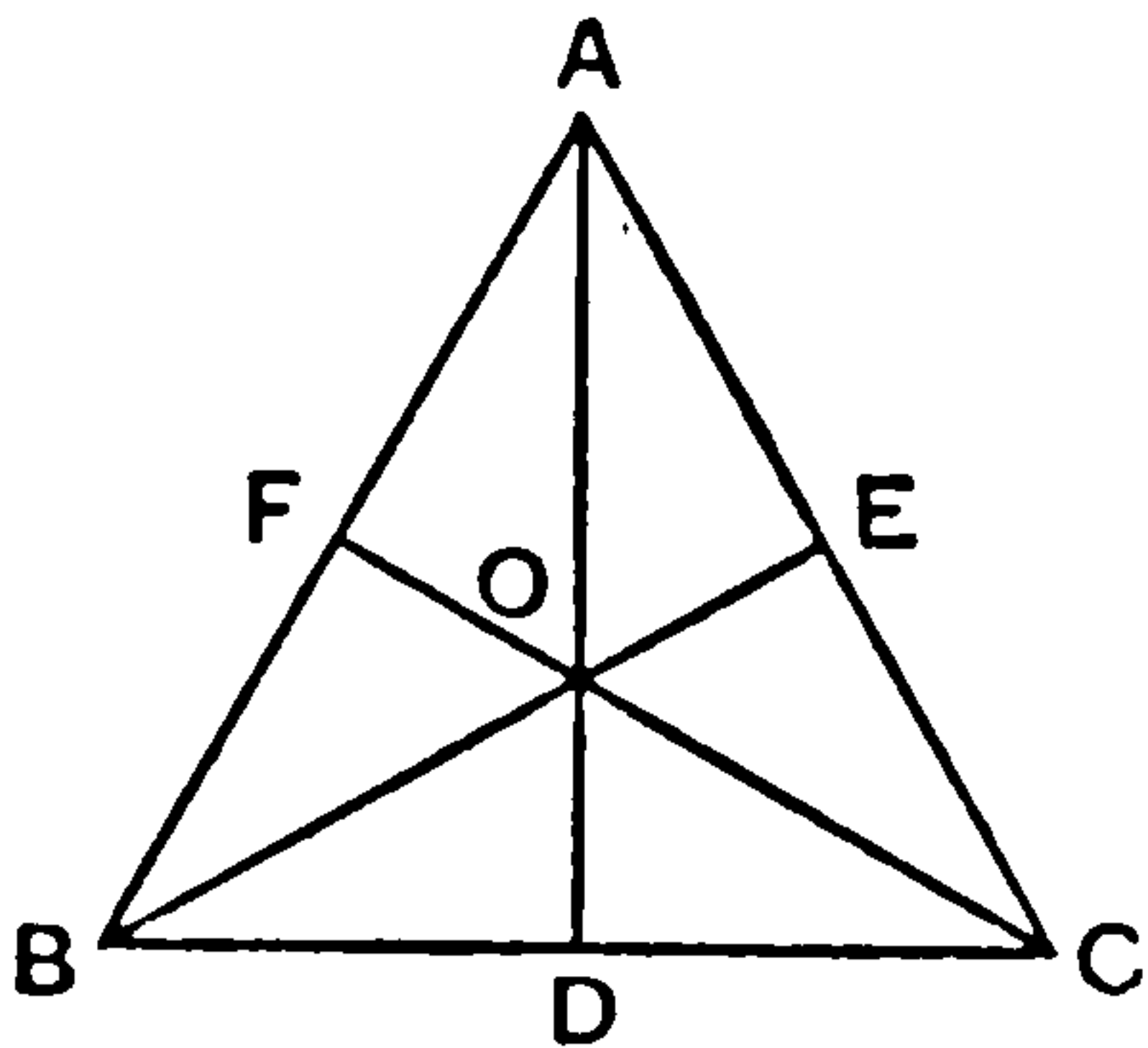

A. E. Taylor (*A Commentary on Plato's Timaeus*, pp. 374-375), first pointed out the correct meaning of κατὰ διάμετρον, "diagonally." Previously, following Boeckh, editors had supposed that

it meant "so that their hypotenuses coincide," e.g., triangle AOF is placed κατὰ διάμετρον with triangle AOE; Plato almost certainly meant that triangles AOF, COD are κατὰ διάμετρον.



THIS PAGE IS LOCKED TO FREE MEMBERS

Purchase full membership to immediately unlock this page

FORGOTTEN BOOKS

FULL

MEMBERSHIP

797,885 Books!

All you can read

for only

\$8.99/month

Continue

*Fair usage policy applies



GREEK MATHEMATICS

ταῦτα γεννήσαν, τὸ δὲ ἰσοσκελὲς τρίγωνον ἐγέννα τὴν τοῦ τετάρτου φύσιν, κατὰ τέτταρα συνιστάμενον, εἰς τὸ κέντρον τὰς ὀρθὰς γωνίας συνάγον, ἐν ἰσόπλευρον τετράγωνον ἀπεργασάμενον· ἐξ δὲ τοιαῦτα συμπαγέντα γωνίας ὀκτῶ στερεὰς ἀπέτελεσε, κατὰ τρεῖς ἐπιπέδους ὀρθὰς συναρμοθείσης ἑκάστης· τὸ δὲ σχῆμα τοῦ συστάντος σώματος γέγονε κυβικόν, ἐξ ἐπιπέδους τετραγώνους ἰσοπλεύρους βάσεις ἔχον· ἔτι δὲ οὔσης συστάσεως μιᾶς πέμπτης, ἐπὶ τὸ πᾶν ὁ θεὸς αὐτῇ κατεχρήσατο ἐκεῖνο διαζωγραφῶν.

Iambl. *De Vita Pythag.* 18. 88, ed. Deubner 52. 2-8

Περὶ δ' Ἰππάσου μάλιστα, ὡς ἦν μὲν τῶν Πυθαγορείων, διὰ δὲ τὸ ἐξενεγκεῖν καὶ γράψασθαι πρῶτως σφαῖραν τὴν ἐκ τῶν δώδεκα πενταγώνων ἀπώλετο κατὰ θάλατταν ὡς ἀσεβήσας, δόξαν δὲ λάβοι ὡς εὐρών, εἶναι δὲ πάντα ἐκείνου τοῦ ἀνδρός·

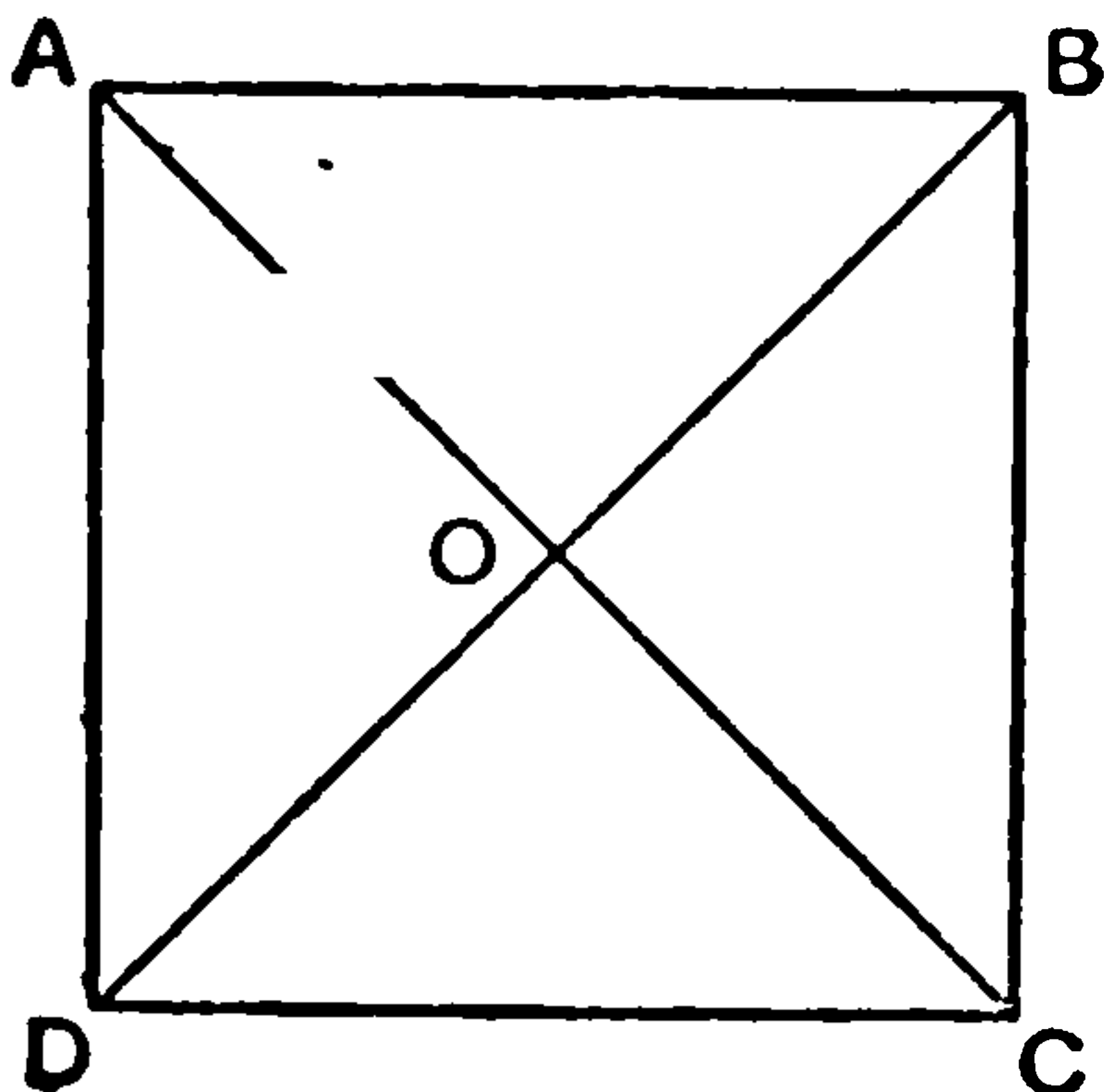

- As in the accompanying figure, the four isosceles scalene triangles AOB, DOC, BOC, DOA placed about the common vertex O form the square ABCD. The fourth figure is the cube, which has six faces, each a square (and is therefore made up of twenty-four of the elemental rectangular isosceles triangles), and eight solid angles, each formed by three of the squares; Plato later makes it the element of earth.

^b *i.e.*, the regular dodecahedron. This requires, however,

PYTHAGOREAN GEOMETRY

when it had produced these three solids, the nature of the fourth being produced by the isosceles triangle. When four such triangles are joined together, with their right angles drawn towards the centre, they form one equilateral quadrangle ^a; and six such quadrangles, put together, made eight solid angles, each composed of three plane right angles; and the shape of the body thus constructed was cubic, having six plane equilateral quadrangular bases. As there still remained one compound figure, the fifth,^b God used it for the whole, broidering it with designs.^c

Iamblichus, *On the Pythagorean Life* 18. 88,
ed. Deubner 52. 2-8

It is related of Hippasus that he was a Pythagorean, and that, owing to his being the first to publish and describe the sphere from the twelve pentagons, he perished at sea for his impiety, but he received credit for the discovery, though really it all belonged to a new element, the regular pentagon. It has twelve faces, each a regular pentagon, and twenty solid angles, each formed by three pentagons. The following passages give evidence that the Pythagoreans may have known the properties of the dodecahedron and pentagon. A number of objects of dodecahedral form have survived from pre-Pythagorean days.

^c This has often been held, following Plutarch, to refer to the twelve signs of the Zodiac, but A. E. Taylor (*A Commentary on Plato's Timaeus*, p. 377) rightly points out that the dodecagon, not the dodecahedron, would be the appropriate symbol for the Zodiac. He finds a clue to the meaning in *Timaeus Locrus* 98 ε, where it is pointed out that of the five regular solids inscribable in the same sphere the dodecahedron has the maximum volume and "comes nearest" to the sphere. Burnet finds the real allusion to the mapping of the apparently spherical heavens into twelve pentagonal regions.

προσαγορεύουσι γὰρ οὕτω τὸν Πυθαγόραν καὶ οὐ
καλοῦσιν ὀνόματι.

Luc. *Pro Lapsu inter Salut.* 5, ed. Jacobitz i. 330. 11-14

Καὶ τό γε τριπλοῦν αὐτοῖς τρίγωνον, τὸ δι'
ἀλλήλων, τὸ πεντάγραμμον, ᾧ συμβόλῳ πρὸς τοὺς
ὁμοδόξους ἐχρῶντο, ὑγίεια πρὸς αὐτῶν ὠνομάζετο.

• Iamblichus tells the same story, almost word for word, in *De communi Mathematica Scientia* c. 25 (ed. Festa 77. 18-24); the only substantial difference is the substitution of the word ἐξαγώνων for πενταγώνων, which is a slip. The story recalls the passage given above (p. 216) about the Pythagorean who perished at sea for revealing the irrational. He may very well have been the same person as Hippasus, for the irrational would quickly come to light in a study of the regular solids.



THIS PAGE IS LOCKED TO FREE MEMBERS

Purchase full membership to immediately unlock this page

SAVE \$3,999,994

Did you know we sell
paperback books too?

To buy our entire catalog
in paperback would cost
over \$4,000,000

Access it all now for
\$8.99/month

*Fair usage policy applies

Continue

VII. DEMOCRITUS

VII. DEMOCRITUS

Plut. *De Comm. Notit.* 39. 3, 1079 E

Ἔτι τοίνυν ὄρα τίνα τρόπον ἀπήντησε Δημοκρίτῳ, διαποροῦντι φυσικῶς καὶ ἐπιτυχῶς, εἰ κῶνος τέμνοιτο παρὰ τὴν βάσιν ἐπιπέδῳ, τί χρὴ διανοεῖσθαι τὰς τῶν τμημάτων ἐπιφανείας, ἴσας ἢ ἀνίσους γινομένας; ἀνίσοι μὲν γὰρ οὔσαι τὸν κῶνον ἀνώμαλον παρέξουσι, πολλὰς ἀποχαράξεις λαμβάνοντα βαθμοειδεῖς καὶ τραχύτητας· ἴσων δ' οὐσῶν, ἴσα τμήματα ἔσται, καὶ φανεῖται τὸ τοῦ κυλίνδρου πεπονθῶς ὁ κῶνος, ἐξ ἴσων συγκείμενος καὶ οὐκ ἀνίσων κύκλων, ὅπερ ἐστὶν ἀτοπώτατον.

Archim. *Meth.*, Archim. ed. Heiberg ii. 430. 1-9

Διόπερ καὶ τῶν θεωρημάτων τούτων, ὧν Εὐδόξος ἐξηύρηκεν πρῶτος τὴν ἀπόδειξιν, περὶ τοῦ κῶνου καὶ τῆς πυραμίδος, ὅτι τρίτον μέρος ὁ μὲν κῶνος

* Plutarch tells this on the authority of Chrysippus. Democritus came from Abdera. He was born about the same time as Socrates, and lived to a great age. Plato ignored him in his dialogues, and is said to have wished to burn all his works. The two passages here given contain all that is definitely known of his mathematics, but we are informed that he wrote a book *On the Contact of a Circle and a Sphere*; another on *Geometry*; a third entitled *Geometrica*; a fourth on *Numbers*; a fifth *On Irrational Lines and Solids*; and a sixth called Ἐκπετάσματα, which would deal with the



THIS PAGE IS LOCKED TO FREE MEMBERS

Purchase full membership to immediately unlock this page

FORGOTTEN BOOKS

FULL

MEMBERSHIP

797,885 Books!

All you can read

for only

\$8.99/month

Continue

*Fair usage policy applies



τοῦ κυλίνδρου, ἢ δὲ πυραμῖς τοῦ πρίσματος, τῶν
βάσιν ἐχόντων τὴν αὐτὴν καὶ ὕψος ἴσον, οὐ μικρὰν
ἀπονείμαι ἂν τις Δημοκρίτῳ μερίδα πρώτῳ τὴν
ἀπόφασιν τὴν περὶ τοῦ εἰρημένου σχήματος χωρὶς
ἀποδείξεως ἀποφηναμένῳ.

DEMOCRITUS

is a third part of the cylinder, and the pyramid of the prism, having the same base and equal height, no small share of the credit should be given to Democritus, who was the first to make the assertion with regard to the said figure,^o though without proof.

- So the Greek. Perhaps "type of figure."





THIS PAGE IS LOCKED TO FREE MEMBERS

Purchase full membership to immediately unlock this page

SAVE \$3,999,994

Did you know we sell
paperback books too?

To buy our entire catalog
in paperback would cost
over \$4,000,000

Access it all now for
\$8.99/month

*Fair usage policy applies

Continue

VIII. HIPPOCRATES OF CHIOS

(a) GENERAL

Philop. *in Phys.* A 2 (Aristot. 185 a 16), ed. Vitelli
31. 3-9

Ἴπποκράτης Χίος τις ὦν ἔμπορος, ληστρικῇ νηὶ περιπεσὼν καὶ πάντα ἀπολέσας, ἦλθεν Ἀθήναζε γραψόμενος τοὺς ληστάς, καὶ πολὺν παραμένων ἐν Ἀθήναις διὰ τὴν γραφὴν χρόνον, ἐφοίτησεν εἰς φιλοσόφους, καὶ εἰς τοσοῦτον ἕξως γεωμετρικῆς ἦλθεν, ὡς ἐπιχειρῆσαι εὐρεῖν τὸν κύκλου τετραγωνισμόν. καὶ αὐτὸν μὲν οὐχ εὔρε, τετραγωνίσας δὲ τὸν μηνίσκον ᾧήθη ψευδῶς ἐκ τούτου καὶ τὸν κύκλον τετραγωνίζειν· ἐκ γὰρ τοῦ τετραγωνισμοῦ τοῦ μηνίσκου καὶ τὸν τοῦ κύκλου τετραγωνισμόν ᾧήθη συλλογίζεσθαι.

(b) QUADRATURE OF LUNES

Simpl. *in Phys.* A 2 (Aristot. 185 a 14), ed. Diels
60. 22-68. 32

Ὁ μέντοι Εὐδήμος ἐν τῇ Γεωμετρικῇ ἱστορίᾳ οὐκ ἐπὶ τετραγωνικῆς πλευρᾶς δείξαι φησι τὸν Ἴπποκράτην τὸν τοῦ μηνίσκου τετραγωνισμόν,

VIII. HIPPOCRATES OF CHIOS

(a) GENERAL

Philoponus, *Commentary on Aristotle's Physics A 2*
(185 a 16), ed. Vitelli 31. 3-9

HIPPOCRATES of Chios was a merchant who fell in with a pirate ship and lost all his possessions. He came to Athens to prosecute the pirates and, staying a long time in Athens by reason of the indictment, consorted with philosophers, and reached such proficiency in geometry that he tried to effect the quadrature of the circle. He did not discover this, but having squared the lune he falsely thought from this that he could square the circle also. For he thought that from the quadrature of the lune the quadrature of the circle also could be calculated.^a

(b) QUADRATURE OF LUNES

Simplicius, *Commentary on Aristotle's Physics A 2*
(185 a 14), ed. Diels 60. 22-68. 32

Eudemus, however, in his *History of Geometry* says that Hippocrates did not demonstrate the quadrature

^a A lune (meniscus) is the figure included between two intersecting arcs of circles. It is unlikely that Hippocrates himself thought he had squared the circle, but for a discussion of this point see *infra*, p. 310 n. b.

ἀλλὰ καθόλου, ὡς ἂν τις εἴποι. εἰ γὰρ πᾶς μηνίσκος τὴν ἐκτὸς περιφέρειαν ἢ ἴσην ἔχει ἡμικυκλίου ἢ μείζονα ἢ ἐλάττονα, τετραγωνίζει δὲ ὁ Ἰπποκράτης καὶ τὸν ἴσην ἡμικυκλίου ἔχοντα καὶ τὸν μείζονα καὶ τὸν ἐλάττονα, καθόλου ἂν εἴη δεδειχῶς ὡς δοκεῖ. ἐκθήσομαι δὲ τὰ ὑπὸ τοῦ Εὐδήμου κατὰ λέξιν λεγόμενα ὀλίγα τινὰ προστιθεὶς (εἰς)¹ σαφήνειαν ἀπὸ τῆς τῶν Εὐκλείδου Στοιχείων ἀναμνήσεως διὰ τὸν ὑπομνηματικὸν τρόπον τοῦ Εὐδήμου κατὰ τὸ ἀρχαῖκὸν ἔθος συντόμους ἐκθεμένου τὰς ἀποδόσεις. λέγει δὲ ὧδε ἐν τῷ δευτέρῳ βιβλίῳ τῆς Γεωμετρικῆς ἱστορίας.

¹ εἰς add. Usener.

^a As Alexander asserted. Alexander, as quoted by Simplicius *in Phys.* (ed. Diels 56. 1-57. 24), attributes two quadratures to Hippocrates.

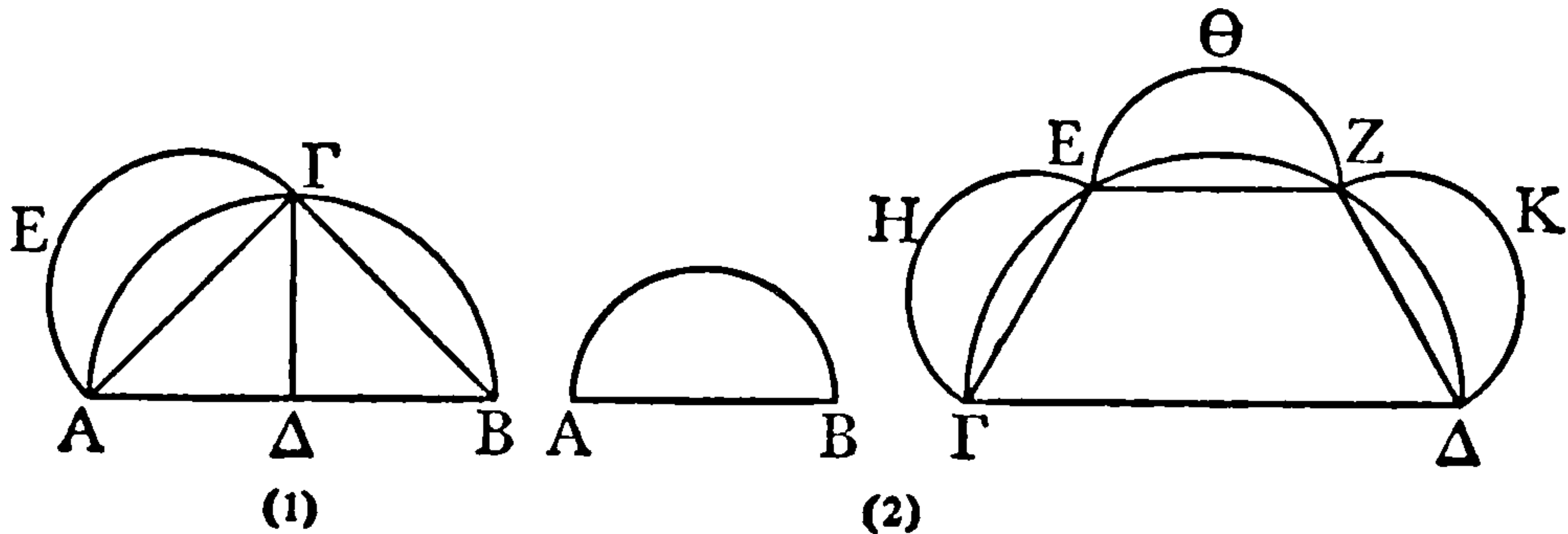

In the first, AB is the diameter of a circle, $A\Gamma$, ΓB are sides of a square inscribed in it, and $AΕΓ$ is a semicircle described on $A\Gamma$. Alexander shows that

$$\text{lune } AΕΓ = \text{triangle } A\Gamma\Delta.$$

In the second, AB is the diameter of semicircle and on $\Gamma\Delta$, equal to twice AB , a semicircle is described. $\GammaΕ$, $ΕΖ$, $Ζ\Delta$ are sides of a regular hexagon, and $\GammaΗΕ$, $ΕΘΖ$, $ΖΚ\Delta$ are semicircles described on $\GammaΕ$, $ΕΖ$, $Ζ\Delta$. Alexander shows that



THIS PAGE IS LOCKED TO FREE MEMBERS

Purchase full membership to immediately unlock this page

FORGOTTEN BOOKS

FULL

MEMBERSHIP

797,885 Books!

All you can read

for only

\$8.99/month

Continue

*Fair usage policy applies



GREEK MATHEMATICS

“ Καὶ οἱ τῶν μηνίσκων δὲ τετραγωνισμοὶ δόξαντες εἶναι τῶν οὐκ ἐπιπολαίων διαγραμμάτων διὰ τὴν οἰκειότητα τὴν πρὸς τὸν κύκλον ὑφ’ Ἰπποκράτους ἐγράφησάν τε πρῶτον καὶ κατὰ τρόπον ἔδοξαν ἀποδοθῆναι· διόπερ ἐπὶ πλέον ἀψώμεθά τε καὶ διέλθωμεν. ἀρχὴν μὲν οὖν ἐποιήσατο καὶ πρῶτον ἔθετο τῶν πρὸς αὐτοὺς χρησίμων, ὅτι τὸν αὐτὸν λόγον ἔχει τὰ τε ὅμοια τῶν κύκλων τμήματα πρὸς ἄλληλα καὶ αἱ βάσεις αὐτῶν δυνάμει. τοῦτο δὲ ἐδείκνυεν ἐκ τοῦ τὰς διαμέτρους δεῖξαι τὸν αὐτὸν λόγον ἐχούσας δυνάμει τοῖς κύκλοις.

“ Δειχθέντος δὲ αὐτῷ τούτου πρῶτον μὲν ἔγραφε μηνίσκου τὴν ἐκτὸς περιφέρεια ἔχοντος ἡμικυκλίου

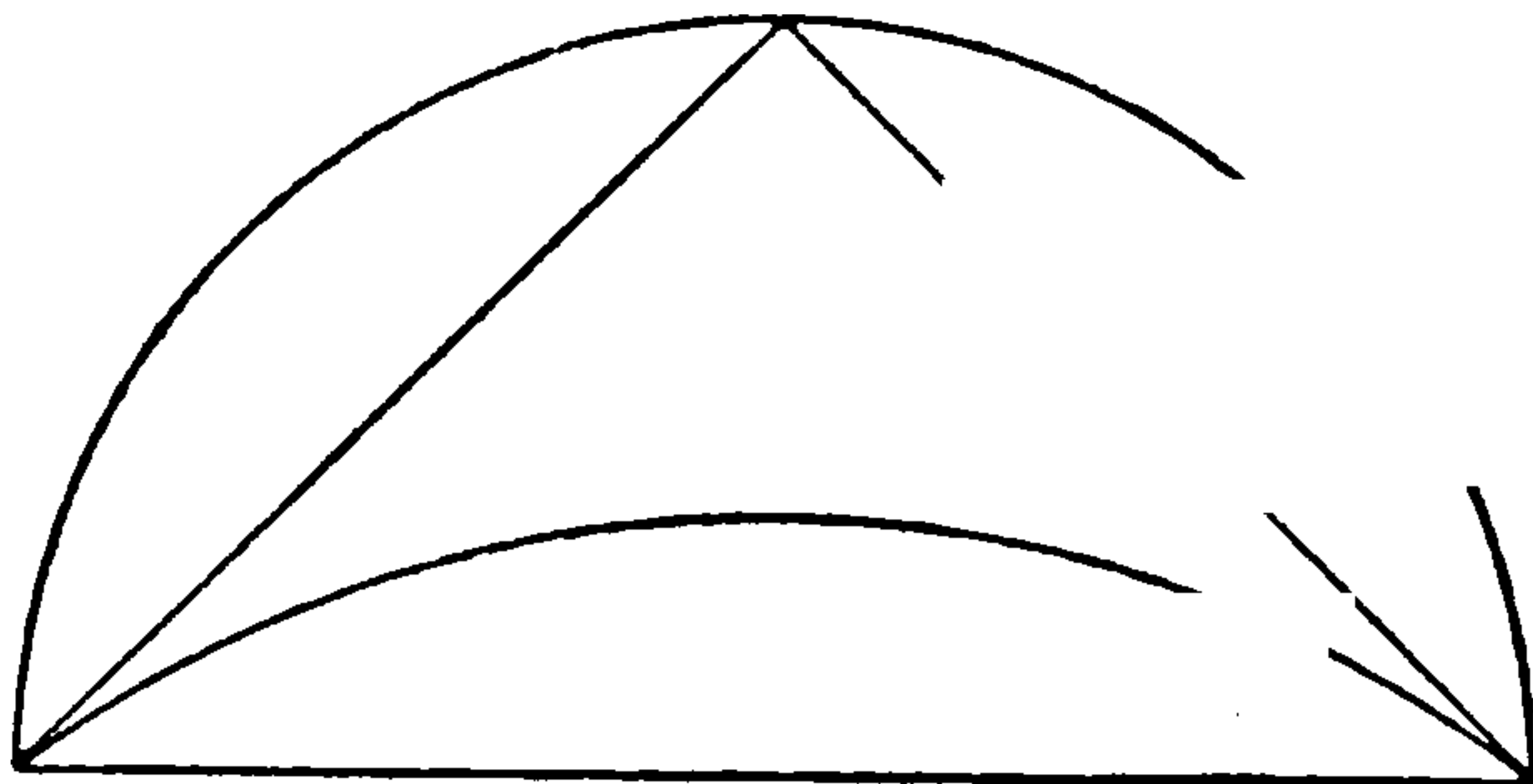

τίνα τρόπον γένοιτο ἂν τετραγωνισμός. ἀπεδίδου δὲ τοῦτο περὶ τρίγωνον ὀρθογώνιον τε καὶ ἰσοσκελὲς ἡμικύκλιον περιγράψας καὶ περὶ τὴν βάσιν τμήμα κύκλου τοῖς ὑπὸ τῶν ἐπιζευχθεισῶν ἀφαιρουμένοις ὅμοιον. ὄντος δὲ τοῦ περὶ τὴν βάσιν τμήματος ἴσου τοῖς περὶ τὰς ἑτέρας ἀμφοτέροις, καὶ κοινοῦ προστεθέντος τοῦ μέρους τοῦ τριγώνου τοῦ ὑπὲρ τὸ τμήμα τὸ περὶ τὴν βάσιν, ἴσος ἔσται ὁ μηνίσκος τῷ τριγώνῳ. ἴσος οὖν ὁ μηνίσκος τῷ τριγώνῳ δειχθεὶς τετραγωνίζοιτο ἂν. οὕτως μὲν

HIPPOCRATES OF CHIOS

“ The quadratures of lunes, which seemed to belong to an uncommon class of propositions by reason of the close relationship to the circle, were first investigated by Hippocrates, and seemed to be set out in correct form; therefore we shall deal with them at length and go through them. He made his starting-point, and set out as the first of the theorems useful to his purpose, that similar segments of circles have the same ratios as the squares on their bases.^a And this he proved by showing that the squares on the diameters have the same ratios as the circles.^b

“ Having first shown this he described in what way it was possible to square a lune whose outer circumference was a semicircle. He did this by circumscribing about a right-angled isosceles triangle a semicircle and about the base a segment of a circle similar to those cut off by the sides.^c Since the segment about the base is equal to the sum of those about the sides, it follows that when the part of the triangle above the segment about the base is added to both the lune will be equal to the triangle. Therefore the lune, having been proved equal to the triangle, can be squared. In this way, taking

^a Lit. “ as the bases in square.”

^b This is Eucl. xii. 2 (see *infra*, pp. 458-465). Euclid proves it by a method of exhaustion, based on a lemma or its equivalent which, on the evidence of Archimedes himself, can safely be attributed to Eudoxus. We are not told how Hippocrates effected the proof.

^c As Simplicius notes, this is the problem of Eucl. iii. 33 and involves the knowledge that similar segments contain equal angles.

GREEK MATHEMATICS:

οὖν ἡμικυκλίου τὴν ἔξω τοῦ μηνίσκου περιφέρειαν ὑποθέμενος ἐτετραγώνισεν ὁ Ἰπποκράτης τὸν μηνίσκον εὐκόλως.

“Εἶτα ἐφεξῆς μείζονα ἡμικυκλίου ὑποτίθεται συστησάμενος τραπέζιον τὰς μὲν τρεῖς ἔχον πλευρὰς

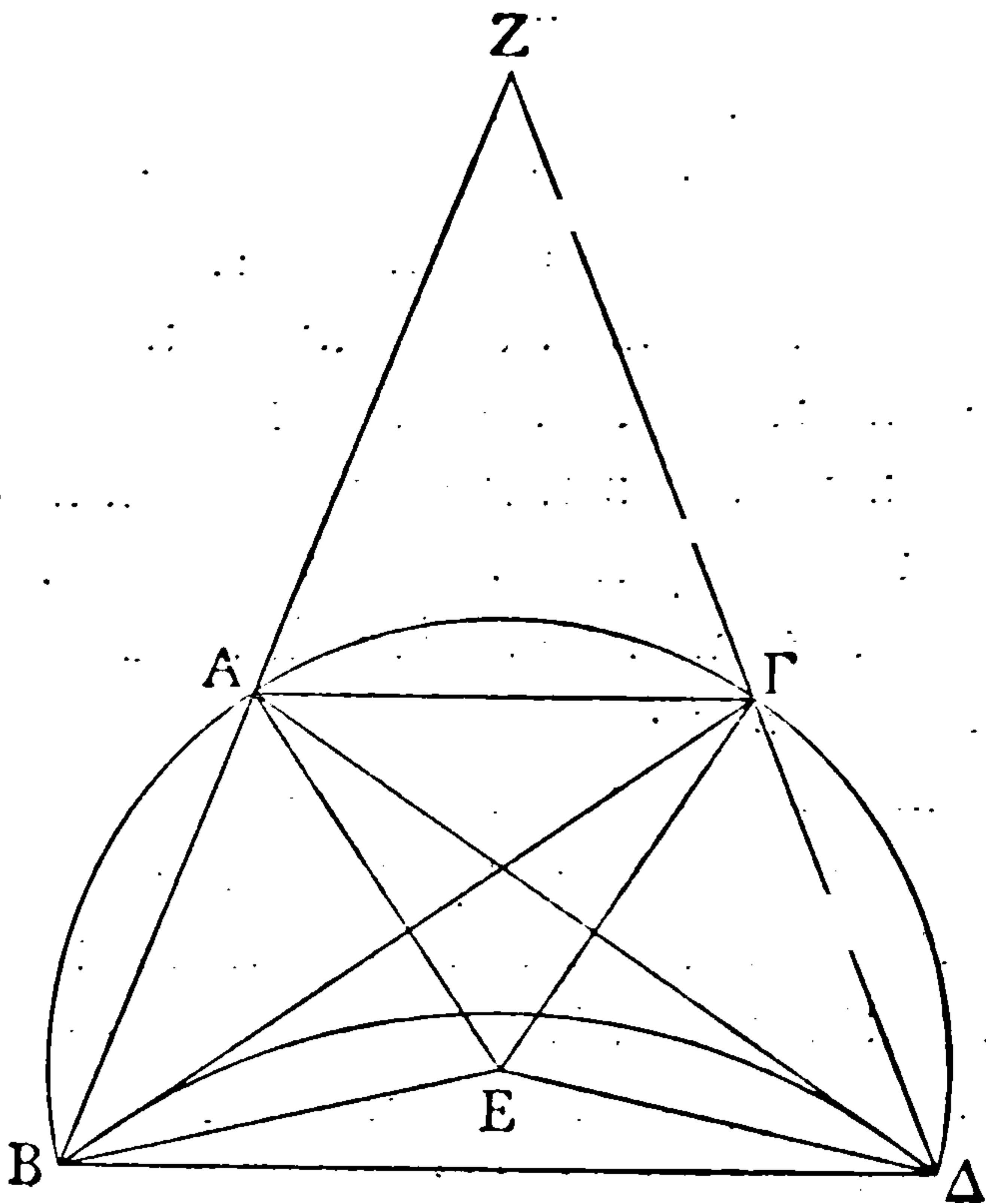

ἴσας ἀλλήλαις, τὴν δὲ μίαν τὴν μείζω τῶν παραλλήλων τριπλασίαν ἐκείνων ἐκάστης δυνάμει, καὶ τότε τραπέζιον περιλαβὼν κύκλῳ καὶ περὶ τὴν μεγίστην αὐτοῦ πλευρὰν ὁμοιον τμῆμα περιγράψας τοῖς ὑπὸ τῶν ἴσων τριῶν ἀποτεμνομένοις ἀπὸ τοῦ κύκλου. ὅτι δὲ μείζον ἐστὶν ἡμικυκλίου τὸ λεχθὲν τμῆμα, δῆλον ἀχθείσης ἐν τῷ τραπεζίῳ διαμέτρου. ἀνάγκη γὰρ ταύτην ὑπὸ δύο πλευρὰς ὑποτείνουσιν τοῦ τραπεζίου τῆς ὑπόλοιπου μιᾶς μείζονα ἢ δι-



THIS PAGE IS LOCKED TO FREE MEMBERS

Purchase full membership to immediately unlock this page

SAVE \$3,999,994

Did you know we sell
paperback books too?

To buy our entire catalog
in paperback would cost
over \$4,000,000

Access it all now for
\$8.99/month

*Fair usage policy applies

Continue

GREEK MATHEMATICS

πλασίαν εἶναι δυνάμει. ἡ ἄρα ΒΓ μείζον ἢ διπλάσιον δύναται ἑκατέρας τῶν ΒΑ, ΑΓ, ὥστε καὶ τῆς ΓΔ. καὶ τὴν μεγίστην ἄρα τῶν τοῦ τραπεζίου πλευρῶν τὴν ΒΔ ἀναγκαῖον ἔλαττον δύνασθαι τῆς τε διαμέτρου καὶ τῶν ἑτέρων πλευρῶν ἐκείνης, ὑφ' ἣν ὑποτείνει μετὰ τῆς διαμέτρου ἡ λεχθεῖσα. αἱ γὰρ ΒΓ, ΓΔ μείζον ἢ τριπλάσιον δύνανται τῆς ΓΔ, ἡ δὲ ΒΔ τριπλάσιον. ὁξεῖα ἄρα ἐστὶν ἡ ἐπὶ τῆς μείζονος τοῦ τραπεζίου πλευρᾶς βεβηκυῖα γωνία. μείζον ἄρα ἡμικυκλίου ἐστὶ τὸ τμήμα ἐν ᾧ ἐστὶν. ὅπερ ἐστὶν ἡ ἔξω περιφέρεια τοῦ μηνίσκου.

“Εἰ δὲ ἐλάττων ἡμικυκλίου εἴη, προγράψας τοιόνδε τι ὁ Ἰπποκράτης τοῦτο κατεσκεύασεν·

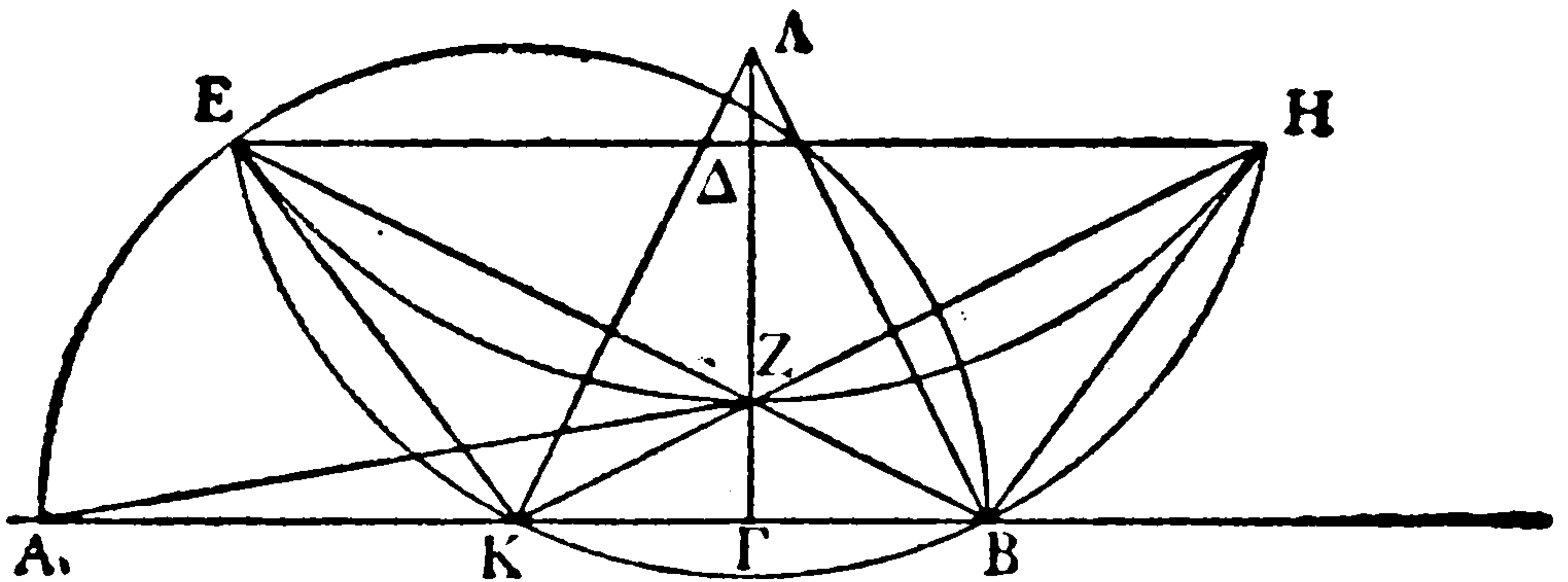

ἔστω κύκλος οὗ διάμετρος ἐφ' ἣ [ἡ]¹ ΑΒ, κέντρον δὲ αὐτοῦ ἐφ' ᾧ Κ· καὶ ἡ μὲν ἐφ' ἣ ΓΔ δίχα τε καὶ πρὸς ὀρθὰς τεμνέτω τὴν ἐφ' ἣ ΒΚ· ἡ δὲ ἐφ' ἣ ΕΖ κείσθω ταύτης μεταξὺ καὶ τῆς περιφέρειᾶς ἐπὶ τὸ Β νεύουσα τῶν ἐκ τοῦ κέντρου ἡμιολία οὖσα

¹ ἡ om. Diels.

• A proof is supplied in the text, probably by Simplicius though Diels attributes it to Eudemus. The proof is that, since ΒΔ is parallel to ΑΓ but greater than it, ΔΓ and ΒΑ produced will meet in Ζ. Then ΖΑΓ is an isosceles triangle,

HIPPOCRATES OF CHIOS

one of the remaining sides. Therefore the square on $B\Gamma$ is greater than double the square on either BA , $A\Gamma$, and therefore also on $\Gamma\Delta$.^a Therefore the square on $B\Delta$, the greatest of the sides of the trapezium, must be less than the sum of the squares on the diagonal and that one of the other sides which is subtended by the said [greatest] side together with the diagonal.^b For the squares on $B\Gamma$, $\Gamma\Delta$ are greater than three times, and the square on $B\Delta$ is equal to three times, the square on $\Gamma\Delta$. Therefore the angle standing on the greatest side of the trapezium ^c is acute. Therefore the segment in which it is is greater than a semicircle. And this segment is the outer circumference of the lune.^d

“ If [the outer circumference] were less than a semicircle, Hippocrates solved ^e this also, using the following preliminary construction. Let there be a circle with diameter AB and centre K . Let $\Gamma\Delta$ bisect BK at right angles ; and let the straight line EZ be placed between this and the circumference verging towards B so that the square on it is one-and-a-half so that the angle $ZA\Gamma$ is acute, and therefore **the angle $BA\Gamma$ is obtuse.**

^b *i.e.* $B\Delta^2 < B\Gamma^2 + \Gamma\Delta^2$.

^c *i.e.* the angle $B\Gamma\Delta$.

^d Simplicius notes that Eudemus has omitted the actual squaring of the lune, presumably as being obvious. Since

$$B\Delta^2 = 3BA^2$$

(segment on $B\Delta$) = 3 (segment on BA)

= sum of segments on BA , $A\Gamma$, $\Gamma\Delta$.

Adding to each side of the equation the portion of the trapezium included by the sides BA , $A\Gamma$ and $\Gamma\Delta$ and the circumference of the segment on $B\Delta$, we get

trapezium $AB\Delta\Gamma$ = lune bounded by the two circumferences
and so the lune is “squared.”

• Lit. “constructed.”

δυνάμει. ἡ δὲ ἐφ' ἧ ΕΗ ἤχθω παρὰ τὴν ἐφ' ἧ ΑΒ. καὶ ἀπὸ τοῦ Κ ἐπεζεύχθωσαν ἐπὶ τὰ Ε, Ζ. συμπίπτει δὲ ἐκβαλλομένη ἢ ἐπὶ τὸ Ζ ἐπιζευχθεῖσα τῇ ἐφ' ἧ ΕΗ κατὰ τὸ Η καὶ πάλιν ἀπὸ τοῦ Β ἐπὶ τὰ Ζ, Η ἐπεζεύχθωσαν. φανερόν δὲ ὅτι ἡ μὲν ἐφ' ἧ ΕΖ ἐκβαλλομένη ἐπὶ τὸ Β πεσεῖται (ὑπόκειται γὰρ ἡ ΕΖ ἐπὶ τὸ Β νεύουσα), ἡ δὲ ἐφ' ἧ ΒΗ ἴση ἔσται τῇ ἐφ' ἧ ΕΚ.

“ Τούτων οὖν οὕτως ἐχόντων τὸ τραπέζιον φημι ἐφ' οὗ ΕΚΒΗ περιλήψεται κύκλος.

“ Περιγεγράφθω¹ δὴ περὶ τὸ ΕΖΗ τρίγωνον τμήμα κύκλου, δῆλον ὅτι ἐκάτερον τῶν ΕΖ, ΖΗ ὁμοιον ἐκάστῳ τῶν ΕΚ, ΚΒ, ΒΗ τμημάτων.

“ Τούτων οὕτως ἐχόντων ὁ γενόμενος μηνίσκος οὗ ἐκτὸς περιφέρεια ἡ ΕΚΒΗ ἴσος ἔσται τῷ εὐθυγράμμῳ τῷ συγκειμένῳ ἐκ τῶν τριῶν τριγώνων τῶν ΒΖΗ, ΒΖΚ, ΕΚΖ. τὰ γὰρ ἀπὸ τῶν εὐθειῶν ἐφ' αἷς ΕΖ, ΖΗ ἀφαιρούμενα ἐντὸς τοῦ μηνίσκου ἀπὸ τοῦ εὐθυγράμμου τμήματα ἴσα ἐστὶ τοῖς ἐκτὸς

¹ Περιγεγράφθω . . . τμημάτων. In the text of Simplicius this sentence precedes the one above and Simplicius's comments thereon. It is here restored to the place which it must have occupied in Eudemus's *History*.

* This is the first example we have had to record of the type of construction known to the Greeks as νεύσεις, *inclinations* or *vergings*. The general problem is to place a straight line so as to *verge towards* (pass through) a given point and so that a given length is intercepted on it by other lines. In this case the problem amounts to finding a length x such that, if Z be taken on $\Gamma\Delta$ so that $BZ = x$ and BZ be produced to



THIS PAGE IS LOCKED TO FREE MEMBERS

Purchase full membership to immediately unlock this page

FORGOTTEN BOOKS

FULL

MEMBERSHIP

797,885 Books!

All you can read

for only

\$8.99/month

Continue

*Fair usage policy applies



τοῦ εὐθυγράμμου τμήμασιν ἀφαιρουμένοις ὑπὸ τῶν ΕΚ, ΚΒ, ΒΗ. ἑκάτερον γὰρ τῶν ἐντὸς ἡμιόλιόν ἐστιν ἑκάστου τῶν ἐκτός. ἡμιολία γὰρ¹ ὑπόκειται ἢ ΕΖ τῆς ἐκ τοῦ κέντρου, τουτέστι τῆς ΕΚ καὶ ΚΒ καὶ ΒΗ. εἰ οὖν ὁ μὲν μηνίσκος τὰ τρία τμήματά ἐστι καὶ τοῦ εὐθυγράμμου τὸ παρὰ τὰ δύο τμήματα, τὸ δὲ εὐθύγραμμον μετὰ τῶν δύο τμημάτων ἐστὶ χωρὶς τῶν τριῶν, ἔστι δὲ τὰ δύο τμήματα τοῖς τρισὶν ἴσα, ἴσος ἂν εἴη ὁ μηνίσκος τῷ εὐθυγράμμῳ.

“ Ὅτι δὲ οὗτος ὁ μηνίσκος ἐλάττονα ἡμικυκλίου τὴν ἐκτὸς ἔχει περιφέρειαν, δείκνυσι διὰ τοῦ τὴν ΕΚΗ γωνίαν ἐν τῷ ἐκτὸς οὔσαν τμήματι ἀμβλείαν εἶναι. ὅτι δε ἀμβλεία ἐστὶν ἢ ὑπὸ ΕΚΗ γωνία, δείκνυσιν οὕτως· ἐπεὶ² ἢ μὲν ἐφ’ ἢ ΕΖ ἡμιολία ἐστὶ τῶν ἐκ τοῦ κέντρου δυνάμει, ἢ δὲ ἐφ’ ἢ ΚΒ μείζων τῆς ἐφ’ ἢ ΒΖ ἢ διπλασία δυνάμει, φανερόν ὅτι καὶ ἢ ἐφ’ ἢ ΚΕ ἔσται τῆς ἐφ’ ἢ ΚΖ ἄρα μείζων ἢ διπλασία δυνάμει. ἢ δὲ ἐφ’ ἢ ΕΖ μείζων ἐστὶ δυνάμει τῶν ἐφ’ αἷς ΕΚ, ΚΖ. ἀμβλεία ἄρα ἐστὶν ἢ πρὸς τῷ Κ γωνία, ἔλαττον ἄρα ἡμικυκλίου τὸ τμήμα ἐν ᾧ ἐστὶν.

“ Οὕτως μὲν οὖν ὁ Ἰπποκράτης πάντα μηνίσκον ἐτετραγώνισεν, εἶπερ καὶ τὸν ἡμικυκλίου καὶ τὸν

¹ δυνάμει must be understood after ἡμιολία γὰρ, as Bretschneider first pointed out, but Diels and Rudio think that Simplicius probably omitted it as obvious, here and in his own comments.

² ἐπεὶ . . . ἐστὶν. Eudemus purports to give the proof in Hippocrates’ own words. Unfortunately Simplicius’s version is too confused to be worth reproducing. The proof is here given as reconstructed by Rudio. That it is substantially the proof given by Hippocrates is clear.

HIPPOCRATES OF CHIOS

the rectilinear figure cut off by EK, KB, BH. For each of the inner segments is one-and-a-half times each of the outer, because, by hypothesis, the square on EZ is one-and-a-half times the square on the radius, that is, the square on EK or KB or BH. Inasmuch then as the lune is made up of the three segments and the rectilinear figure *less* the two segments—the rectilinear figure including the two segments but not the three—while the sum of the two segments is equal to the sum of the three, it follows that the lune is equal to the rectilinear figure.

“That this lune has its outer circumference less than a semicircle, he proves by means of the angle EKH in the outer segment being obtuse. And that the angle EKH is obtuse, he proves thus.

Since $EZ^2 = \frac{3}{2} EK^2$

and $KB^2 > 2BZ^2$,

it is manifest that $EK^2 > 2KZ^2$.

Therefore $EZ^2 > EK^2 + KZ^2$.

The angle at K is therefore obtuse, so that the segment in which it is is less than a semicircle.

“Thus Hippocrates squared every lune, seeing that [he squared] not only the lune which has for its outer circumference a semicircle, but also the lune in which

* This is assumed. Heath (*H.G.M.* i. 195) supplies the following proof:

By hypothesis, $EZ^2 = \frac{3}{2}KB^2$.

Also, since A, E, Z, Γ are concyclic,

$$EB \cdot BZ = AB \cdot B\Gamma = KB^2$$

or $EZ \cdot ZB + BZ^2 = KB^2 = \frac{2}{3}EZ^2$.

It follows that $EZ > ZB$ and that $KB^2 > 2BZ^2$.

μείζονα ἡμικυκλίου καὶ τὸν ἐλάττονα ἔχοντα τὴν
ἐκτὸς περιφέρειαν.

“ Ἄλλὰ μηνίσκον ἅμα καὶ κύκλον ἐτετραγώνισεν
οὕτως· ἔστωσαν περὶ κέντρον ἐφ’ οὗ Κ δύο κύκλοι,
ἡ δὲ τοῦ ἐκτὸς διάμετρος ἑξαπλασία δυνάμει τῆς
τοῦ ἐντὸς καὶ ἑξαγώνου ἐγγραφέντος εἰς τὸν ἐντὸς
κύκλον τοῦ ἐφ’ οὗ ΑΒΓΔΕΖ αἱ τε ἐφ’ ὧν ΚΑ, ΚΒ,
ΚΓ ἐκ τοῦ κέντρου ἐπιζευχθεῖσαι ἐκβεβλήσθωσαν
ἕως τῆς τοῦ ἐκτὸς κύκλου περιφέρειας καὶ αἱ ἐφ’ ὧν
ΗΘ, ΘΙ, (ΗΙ)¹ ἐπεζεύχθωσαν καὶ δῆλον ὅτι καὶ αἱ
ΗΘ, ΘΙ ἑξαγώνου εἰσὶ πλευραὶ τοῦ εἰς τὸν μείζονα
κύκλον ἐγγραφομένου. καὶ περὶ τὴν ἐφ’ ἧ ΗΙ
τμήμα ὅμοιον τῷ ἀφαιρουμένῳ ὑπὸ τῆς ἐφ’ ἧ ΗΘ
περιγεγράφθω. ἐπεὶ οὖν τὴν μὲν ἐφ’ ἧ ΗΙ τρι-
πλασίαν ἀνάγκη εἶναι δυνάμει τῆς ἐφ’ ἧ ΘΗ τοῦ
ἑξαγώνου πλευρᾶς (ἡ γὰρ ὑπὸ δύο τοῦ ἑξαγώνου
πλευρᾶς ὑποτείνουσα μετὰ ἄλλης μιᾶς ὀρθὴν περι-

¹ ΗΙ add. Usener.



THIS PAGE IS LOCKED TO FREE MEMBERS

Purchase full membership to immediately unlock this page

SAVE \$3,999,994

Did you know we sell
paperback books too?

To buy our entire catalog
in paperback would cost
over \$4,000,000

Access it all now for
\$8.99/month

*Fair usage policy applies

Continue

GREEK MATHEMATICS

έχουσα γωνίαν τὴν ἐν ἡμικυκλίῳ ἴσον δύναται τῇ διαμέτρῳ, ἢ δὲ διάμετρος τετραπλάσιον δύναται τῆς τοῦ ἐξαγώνου ἴσης οὔσης τῇ ἐκ τοῦ κέντρου διὰ τὸ τὰ μήκει διπλάσια εἶναι δυνάμει τετραπλάσια), ἢ δὲ ΘΗ ἐξαπλασία τῆς ἐφ' ἧ AB, δῆλον ὅτι τὸ τμήμα τὸ περὶ τὴν ἐφ' ἧ ΗΙ περιγραφὲν ἴσον εἶναι συμβαίνει τοῖς τε ἀπὸ τοῦ ἐκτὸς κύκλου ὑπὸ τῶν ἐφ' αἷς ΗΘ, ΘΙ ἀφαιρουμένοις καὶ τοῖς ἀπὸ τοῦ ἐντὸς ὑπὸ τῶν τοῦ ἐξαγώνου πλευρῶν ἀπασῶν. ἢ γὰρ ΗΙ τῆς ΗΘ τριπλάσιον δύναται, ἴσον δὲ τῇ ΗΘ δύναται ἢ ΘΙ, δύναται δὲ ἑκάτερα τούτων ἴσον καὶ αἱ ἐξ πλευραὶ τοῦ ἐντὸς ἐξαγώνου, διότι καὶ ἡ διάμετρος τοῦ ἐκτὸς κύκλου ἐξαπλασίον ὑπόκειται δύνασθαι τῆς τοῦ ἐντὸς, ὥστε ὁ μὲν μηνίσκος ἐφ' οὗ ΗΘΙ τοῦ τριγώνου ἐλάττων ἂν εἴη ἐφ' οὗ τὰ αὐτὰ γράμματα τοῖς ὑπὸ τῶν τοῦ ἐξαγώνου πλευρῶν ἀφαιρουμένοις τμήμασιν ἀπὸ τοῦ ἐντὸς κύκλου. τὸ γὰρ ἐπὶ τῆς ΗΙ τμήμα ἴσον ἦν τοῖς τε ΗΘ, ΘΙ τμήμασι καὶ τοῖς ὑπὸ τοῦ ἐξαγώνου ἀφαιρουμένοις. τὰ οὖν ΗΘ, ΘΙ τμήματα ἐλάττω ἐστὶ τοῦ περὶ τὴν ΗΙ (τμήματος τοῖς)¹ τμήμασι [καὶ]² τοῖς ὑπὸ τοῦ ἐξαγώνου ἀφαιρουμένοις. κοινού οὖν προστεθέντος τοῦ ὑπὲρ τὸ τμήμα τὸ περὶ τὴν ΗΙ μέρους τοῦ τριγώνου, ἐκ μὲν τούτου καὶ τοῦ περὶ τὴν ΗΙ τμήματος τὸ τρίγωνον ἔσται, ἐκ δὲ τοῦ αὐτοῦ καὶ τῶν ΗΘ, ΘΙ τμημάτων ὁ μηνίσκος. ἔσται οὖν ἐλάττων ὁ μηνίσκος τοῦ τριγώνου τοῖς ὑπὸ τοῦ ἐξαγώνου ἀφαιρουμένοις τμήμασιν. ὁ ἄρα

¹ τμήματος τοῖς add. Bretschneider.

² καὶ om. Bretschneider.

• If ΗΛ be a side of the hexagon, then ΙΛ is a diameter and the angle ΗΛΙ is right. Therefore $ΗΙ^2 + ΗΛ^2 = ΙΛ^2$.

HIPPOCRATES OF CHIOS

side, is equal, since they form a right angle in the semicircle, to the square on the diameter, and the square on the diameter is four times the side of the hexagon, the diameter being twice the side in length and so four times as great in square^a), and $\Theta H^2 = 6 AB^2$, it is manifest that the segment circumscribed about HI is equal to the segments cut off from the outer circle by H Θ , ΘI , together with the segments cut off from the inner circle by all the sides of the hexagon.^b For $HI^2 = 3 H\Theta^2$, and $\Theta I^2 = H\Theta^2$, while ΘI^2 and $H\Theta^2$ are each equal to the sum of the squares on the six sides of the inner hexagonal, since, by hypothesis, the diameter of the outer circle is six times that of the inner. Therefore the lune H ΘI is smaller than the triangle H ΘI by the segments taken away from the inner circle by the sides of the hexagon. For the segment on HI is equal to the sum of the segments on H Θ , ΘI and those taken away by the hexagon. Therefore the segments [on] H Θ , ΘI are less than the segment about HI by the segments taken away by the hexagon. If to both sides there is added the part of the triangle which is above the segment about HI,^c out of this and the segment about HI will be formed the triangle, while out of the latter and the segments [on] H Θ , ΘI will be formed the lune. Therefore the lune will be less than the triangle by the segments taken away by the hexagon. For the lune and the

and so $HI^2 + \Theta H^2 = IA^2 = 4\Theta H^2$ (since $IA = 2\Theta H$). Consequently $HI^2 = 3\Theta H^2$.

$$\begin{aligned} \text{• For (segment on HI)} &= 3 \text{ (segment on H}\Theta) \\ &= 2 \text{ (segment on H}\Theta) + 6 \text{ (segment} \\ &\quad \text{on AB)} \\ &= \text{(segments on H}\Theta, \Theta I) + \text{(all seg-} \\ &\quad \text{ments of inner circle).} \end{aligned}$$

• i.e., the figure bounded by H Θ , ΘI and the arc IH.

μηνίσκος καὶ τὰ ὑπὸ τοῦ ἑξαγώνου ἀφαιρούμενα
 τμήματα ἴσα ἐστὶν τῷ τριγώνῳ. καὶ κοινοῦ προσ-
 τεθέντος τοῦ ἑξαγώνου τὸ τρίγωνον τοῦτο καὶ τὸ
 ἑξάγωνον ἴσα ἐστὶ τῷ τε μηνίσκῳ τῷ λεχθέντι καὶ
 τῷ κύκλῳ τῷ ἐντός. εἰ οὖν τὰ εἰρημένα εὐθύ-
 γραμμα δυνατόν τετραγωνισθῆναι, καὶ τὸν κύκλον
 ἄρα μετὰ τοῦ μηνίσκου.”

(c) TWO MEAN PROPORTIONALS

Procl. in Eucl. i., ed. Friedlein 212. 24-213. 11

Ἡ δὲ ἀπαγωγή μετάβασίς ἐστὶν ἀπ’ ἄλλου
 προβλήματος ἢ θεωρήματος ἐπ’ ἄλλο, οὗ γνω-
 σθέντος ἢ πορισθέντος καὶ τὸ προκείμενον ἔσται
 καταφανές, οἷον ὥσπερ καὶ τοῦ διπλασιασμοῦ τοῦ
 κύβου ζητηθέντος μετέθεσαν τὴν ζήτησιν εἰς ἄλλο,
 ᾧ τοῦτο ἔπεται, τὴν εὔρεσιν τῶν δύο μέσων, καὶ
 τὸ λοιπὸν ἐζήτουν, πῶς ἂν δύο δοθεισῶν εὐθειῶν
 δύο μέσαι ἀνάλογον εὔρεθειεν. πρῶτον δέ φασι
 τῶν ἀπορουμένων διαγραμμάτων τὴν ἀπαγωγήν
 ποιήσασθαι Ἰπποκράτην τὸν Χίον, ὃς καὶ μηνίσκον
 ἐτετραγώνισε καὶ ἄλλα πολλὰ κατὰ γεωμετρίαν
 εὔρεν εὐφυῆς περὶ τὰ διαγράμματα εἶπερ τις ἄλλος
 γενόμενος.

• What Hippocrates showed was that if $\frac{a}{x} = \frac{x}{y} = \frac{y}{b}$, then



THIS PAGE IS LOCKED TO FREE MEMBERS

Purchase full membership to immediately unlock this page

FORGOTTEN BOOKS

FULL

MEMBERSHIP

797,885 Books!

All you can read

for only

\$8.99/month

Continue

*Fair usage policy applies



IX. SPECIAL PROBLEMS

IX. SPECIAL PROBLEMS

1. DUPLICATION OF THE CUBE

(a) GENERAL

Theon Smyr., ed. Hiller 2. 3-12

Ἐρατοσθένης μὲν γὰρ ἐν τῷ ἐπιγραφομένῳ Πλατωνικῷ φησιν ὅτι, Δηλίοις τοῦ θεοῦ χρήσαντος ἐπὶ ἀπαλλαγῇ λοιμοῦ βωμὸν τοῦ ὄντος διπλασίονα κατασκευάσαι, πολλὴν ἀρχιτέκτοσιν ἐμπεσεῖν ἀπορίαν ζητοῦσιν ὅπως χρῆ στερεὸν στερεοῦ γενέσθαι διπλάσιον, ἀφικέσθαι τε πευσομένους περὶ τούτου Πλάτωνος. τὸν δὲ φάναι αὐτοῖς, ὡς ἄρα οὐ διπλασίου βωμοῦ ὁ θεὸς δεόμενος τοῦτο Δηλίοις ἐμαντεύσατο, προφέρων δὲ καὶ ὄνειδίζων τοῖς Ἑλλησιν ἀμελοῦσι μαθημάτων καὶ γεωμετρίας ὠλιγωρηκόσιν.

Eutoc. *Comm. in Archim. de Sphaera et Cyl.* ii., Archim. ed. Heiberg iii. 88. 4-90. 13

Βασιλεῖ Πτολεμαίῳ Ἐρατοσθένης χαίρειν.

Τῶν ἀρχαίων τινὰ τραγωδοποιῶν φασιν εἰσαγαγεῖν τὸν Μίνω τῷ Γλαύκῳ κατασκευάζοντα τάφον,

^a Wilamowitz (*Gött. Nachr.*, 1894) shows that the letter is a forgery, but there is no reason to doubt the story it relates, which is indeed amply confirmed; and the author must be thanked for having included in his letter a proof and an



THIS PAGE IS LOCKED TO FREE MEMBERS

Purchase full membership to immediately unlock this page

SAVE \$3,999,994

Did you know we sell
paperback books too?

To buy our entire catalog
in paperback would cost
over \$4,000,000

Access it all now for
\$8.99/month

*Fair usage policy applies

Continue

GREEK MATHEMATICS

πυθόμενον δέ, ὅτι πανταχοῦ ἑκατόμπεδος εἶη, εἶπεῖν·

μικρόν γ' ἔλεξας βασιλικοῦ σηκὸν τάφου·
διπλάσιος ἔστω, τοῦ καλοῦ δὲ μὴ σφαλεῖς
δίπλαζ' ἕκαστον κῶλον ἐν τάχει τάφου.

ἔδόκει δὲ διημαρτηκέναι· τῶν γὰρ πλευρῶν διπλασιασθεισῶν τὸ μὲν ἐπίπεδον γίνεται τετραπλάσιον, τὸ δὲ στερεὸν ὀκταπλάσιον. ἐζητεῖτο δὲ καὶ παρὰ τοῖς γεωμέτραις, τίνα ἂν τις τρόπον τὸ δοθὲν στερεὸν διαμένον ἐν τῷ αὐτῷ σχήματι διπλασιάσειεν, καὶ ἔκαλεῖτο τὸ τοιοῦτον πρόβλημα κύβου διπλασιασμός· ὑποθέμενοι γὰρ κύβον ἐζήτουν τοῦτον διπλασιάσαι. πάντων δὲ διαπορούντων ἐπὶ πολὺν χρόνον πρῶτος Ἰπποκράτης ὁ Χῖος ἐπενόησεν, ὅτι, ἔὰν εὐρεθῇ δύο εὐθειῶν γραμμῶν, ὧν ἡ μείζων τῆς ἐλάσσονός ἐστι διπλασία, δύο μέσας ἀνάλογον λαβεῖν ἐν συνεχείᾳ ἀναλογία, διπλασιασθήσεται ὁ κύβος, ὥστε τὸ ἀπόρημα αὐτῷ εἰς ἕτερον οὐκ ἔλασσον ἀπόρημα κατέστρεφεν. μετὰ χρόνον δὲ τινὰς φασιν Δηλίους ἐπιβαλλομένους κατὰ χρησμόν διπλασιάσαι τινὰ τῶν βωμῶν ἐμπεσεῖν εἰς τὸ αὐτὸ ἀπόρημα, διαπεμφαμένους δὲ τοὺς παρὰ τῷ Πλάτωνι ἐν Ἀκαδημίᾳ γεωμέτρας ἀξιοῦν αὐτοῖς εὐρεῖν τὸ ζητούμενον. τῶν δὲ φιλοπόνως ἐπιδιδόντων ἑαυτοὺς καὶ ζητούντων δύο τῶν δοθεισῶν δύο μέσας

^a Valckenaer attributed these lines to Euripides, but Wilamowitz has shown that they cannot be from any play by Aeschylus, Sophocles or Euripides and must be the work of some minor poet.

^b For if x, y are mean proportionals between a, b ,

then
$$\frac{a}{x} = \frac{x}{y} = \frac{y}{b}.$$

SPECIAL PROBLEMS

and as declaring, when he learnt it was a hundred feet each way : “ Small indeed is the tomb thou hast chosen for a royal burial. Let it be double, and thou shalt not miss that fair form if thou quickly doublest each side of the tomb.”^a He seems to have made a mistake. For when the sides are doubled, the surface becomes four times as great and the solid eight times. It became a subject of inquiry among geometers in what manner one might double the given solid, while it remained the same shape, and this problem was called the duplication of the cube ; for, given a cube, they sought to double it. When all were for a long time at a loss, Hippocrates of Chios first conceived that, if two mean proportionals could be found in continued proportion between two straight lines, of which the greater was double the lesser, the cube would be doubled,^b so that the puzzle was by him turned into no less a puzzle. After a time, it is related, certain Delians, when attempting to double a certain altar in accordance with an oracle, fell into the same quandary, and sent over to ask the geometers who were with Plato in the Academy to find what they sought. When these men applied themselves diligently and sought to find two mean proportionals between two given straight lines,

Therefore $y = \frac{x^2}{a} = \frac{ab}{x}$

and, eliminating y , $x^3 = a^2b$

so that $\frac{a^3}{x^3} = \frac{a}{b}$.

This property is stated in Eucl. *Elem.* v. Def. 10.

If $b = 2a$, then x is the side of a cube double a cube of side a . Once this was discovered by Hippocrates, the problem was always so treated.

λαβεῖν Ἀρχύτας μὲν ὁ Ταραντῖνος λέγεται διὰ τῶν ἡμικυλίνδρων εὐρηκεῖναι, Εὐδοξος δὲ διὰ τῶν καλουμένων καμπύλων γραμμῶν· συμβέβηκε δὲ πᾶσιν αὐτοῖς ἀποδεικτικῶς γεγραφεῖναι, χειρουργῆσαι δὲ καὶ εἰς χρεῖαν πεσεῖν μὴ δύνασθαι πλὴν ἐπὶ βραχύ τι τὸν Μέναιχμον καὶ ταῦτα δυσχερῶς. ἐπινενόηται δέ τις ὑφ' ἡμῶν ὀργανικὴ λήψις ῥαδία, δι' ἧς εὐρήσομεν δύο τῶν δοθεισῶν οὐ μόνον δύο μέσας, ἀλλ' ὅσας ἂν τις ἐπιτάξῃ.

(b) SOLUTIONS GIVEN BY EUTOCIUS

Eutoc. *Comm. in Archim. de Sphaera et Cyl.* ii., Archim. ed. Heiberg iii. 54. 26-56. 12

Εἰς τὴν σύνθεσιν τοῦ α'

Τούτου ληφθέντος ἐπεὶ δι' ἀναλύσεως αὐτῷ προέβη τὰ τοῦ προβλήματος, ληξάσης τῆς ἀναλύσεως εἰς τὸ δεῖν δύο δοθεισῶν δύο μέσας ἀνάλογον προσευρεῖν ἐν συνεχείᾳ ἀναλογία φησὶν ἐν τῇ συνθέσει· “εὐρήσθωσαν.” τὴν δὲ εὕρεσιν τούτων ὑπ' αὐτοῦ μὲν γεγραμμένην οὐδὲ ὅλως εὐρίσκομεν, πολλῶν δὲ κλεινῶν ἀνδρῶν γραφαῖς ἐντετυχήκαμεν τὸ πρόβλημα τοῦτο ἐπαγγελλομέναις, ὧν τὴν Εὐδόξου τοῦ Κνιδίου παρητησάμεθα γραφήν, ἐπειδὴ φησιν μὲν ἐν προοιμίῳ διὰ καμπύλων γραμμῶν αὐτὴν ἡύρηκεῖναι, ἐν δὲ τῇ ἀποδείξει πρὸς τῷ μὴ κεχρηῆσθαι καμπύλαις γραμμαῖς ἀλλὰ καὶ

^a “ Given a cone or cylinder, to find a sphere equal to the cone or cylinder ” (Archim. ed. Heiberg i. 170-174).

^b This is a great misfortune, as we may be sure Eudoxus would have treated the subject in his usual brilliant fashion.



THIS PAGE IS LOCKED TO FREE MEMBERS

Purchase full membership to immediately unlock this page

FORGOTTEN BOOKS

FULL

MEMBERSHIP

797,885 Books!

All you can read

for only

\$8.99/month

Continue

*Fair usage policy applies



GREEK MATHEMATICS

διηρημένην ἀναλογίαν εὐρών ὡς συνεχεῖ χρῆται· ὅπερ ἦν ἄτοπον ὑπονοῆσαι, τί λέγω περὶ Εὐδόξου, ἀλλὰ περὶ τῶν καὶ μετρίως περὶ γεωμετρίαν ἀνεστραμμένων. ἵνα δὴ ἢ τῶν εἰς ἡμᾶς ἐληλυθότων ἀνδρῶν ἔννοια ἐμφανῆς γένηται, ὃ ἐκάστου τῆς εὐρέσεως τρόπος καὶ ἐνταῦθα γραφήσεται.

Ibid. 56. 13–58. 14

Ὡς Πλάτων

Δύο δοθεισῶν εὐθειῶν δύο μέσας ἀνάλογον εὐρεῖν ἐν συνεχεῖ ἀναλογία.

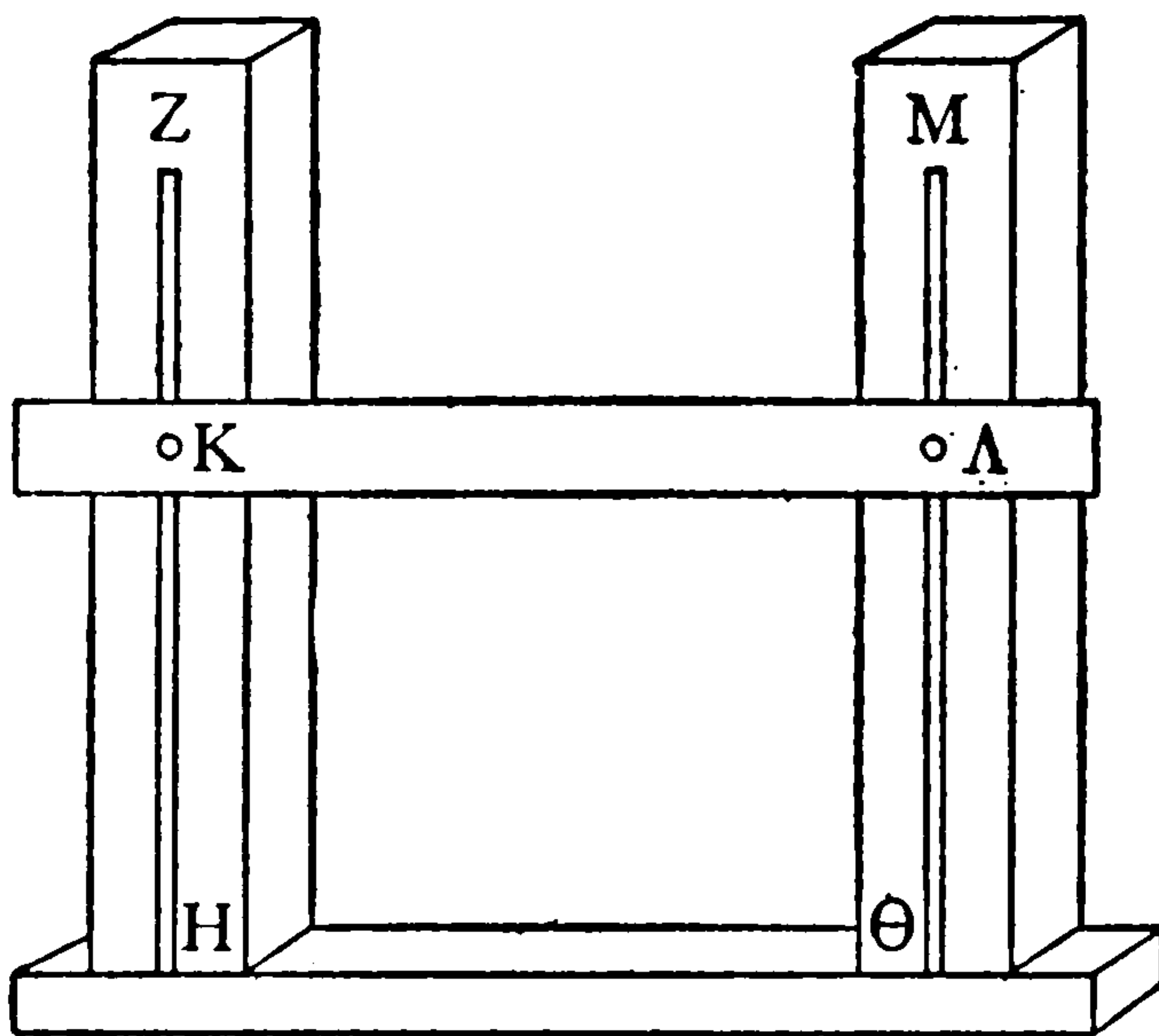

Ἐστῶσαν αἱ δοθεῖσαι δύο εὐθεῖαι αἱ ΑΒΓ πρὸς

^a The complete list of solutions given by Eutocius is: Plato, Heron, Philon, Apollonius, Diocles, Pappus, Sporus, Menaechmus (two solutions), Archytas, Eratosthenes, Nicomedes.

^b It is virtually certain that this solution is wrongly attributed to Plato. Eutocius alone mentions it, and if it had been known to Eratosthenes he could hardly have failed to

SPECIAL PROBLEMS

lines but he used as continuous a discrete proportion which he found. That would be a foolish thing to imagine, not only of Eudoxus, but of any one moderately versed in geometry. In order that the ideas of those men who have come down to us may be made manifest, the manner in which each made his discovery will be described here also.^a

Ibid. 56. 13–58. 14

(i.) *The Solution of Plato*^b

Given two straight lines, to find two mean proportionals in continuous proportion.

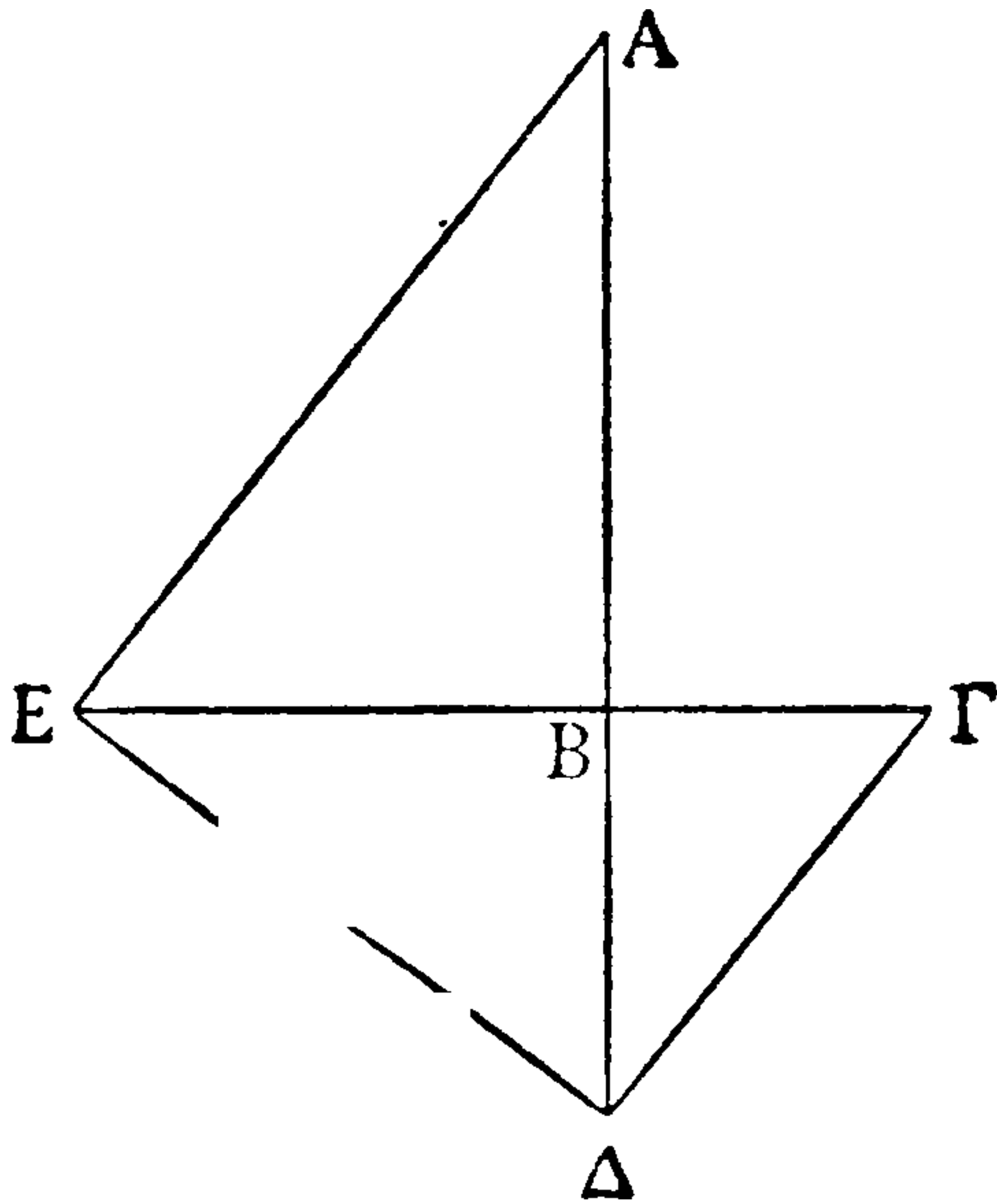

Let the two given straight lines be AB , $B\Gamma$, per-
cite it along with those of Archytas, Menaechmus and
Eudoxus. Furthermore, Plato told the Delians, according to
Plutarch's account, that Eudoxus or Helicon of Cyzicus
would solve the problem for them: he did not apparently
propose to tackle it himself. And Plutarch twice says that
Plato objected to mechanical solutions as destroying the
good of geometry, a statement which is consistent with his
known attitude towards mathematics.

GREEK MATHEMATICS

ὀρθὰς ἀλλήλαις, ὧν δεῖ δύο μέσας ἀνάλογον εὐρεῖν.
 ἐκβεβλήσθωσαν ἐπ' εὐθείας ἐπὶ τὰ Δ, Ε, καὶ
 κατεσκευάσθω ὀρθὴ γωνία ἢ ὑπὸ ΖΗΘ, καὶ ἐν ἐνὶ
 σκέλει, οἷον τῷ ΖΗ, κινείσθω κανὼν ὁ ΚΛ ἐν
 σωλῆνί τινι ὄντι ἐν τῷ ΖΗ οὕτως, ὥστε παράλ-
 ληλον αὐτὸν διαμένειν τῷ ΗΘ. ἔσται δὲ τοῦτο,
 εἰ καὶ ἕτερον κανόνιον νοηθῆ συμφυῆς τῷ ΘΗ,
 παράλληλον δὲ τῷ ΖΗ, ὡς τὸ ΘΜ. σωληνισθεισῶν
 γὰρ τῶν ἄνωθεν ἐπιφανειῶν τῶν ΖΗ, ΘΜ σωλῆσιν
 πελεκινοειδέσιν καὶ τύλων συμφυῶν γενομένων τῷ
 ΚΛ εἰς τοὺς εἰρημένους σωλῆνας ἔσται ἢ κίνησις
 τοῦ ΚΛ παράλληλος ἀεὶ τῷ ΗΘ. τούτων οὖν
 κατεσκευασμένων κείσθω τὸ ἐν σκέλος τῆς γωνίας
 τυχὸν τὸ ΗΘ ψαῦον τοῦ Γ, καὶ μεταφερέσθω ἢ τε
 γωνία καὶ ὁ ΚΛ κανὼν ἐπὶ τοσοῦτον, ἄχρις ἂν τὸ
 μὲν Η σημεῖον ἐπὶ τῆς ΒΔ εὐθείας ἢ τοῦ ΗΘ
 σκέλους ψαύοντος τοῦ Γ, ὁ δὲ ΚΛ κανὼν κατὰ μὲν
 τὸ Κ ψαύῃ τῆς ΒΕ εὐθείας, κατὰ δὲ τὸ λοιπὸν μέρος
 τοῦ Α, ὥστε εἶναι, ὡς ἔχει ἐπὶ τῆς καταγραφῆς,
 τὴν μὲν ὀρθὴν γωνίαν θέσιν ἔχουσαν ὡς τὴν ὑπὸ



THIS PAGE IS LOCKED TO FREE MEMBERS

Purchase full membership to immediately unlock this page

SAVE \$3,999,994

Did you know we sell
paperback books too?

To buy our entire catalog
in paperback would cost
over \$4,000,000

Access it all now for
\$8.99/month

*Fair usage policy applies

Continue

ΓΔΕ, τὸν δὲ ΚΛ κανόνα θέσιν ἔχειν, οἷαν ἔχει ἡ ΕΑ· τούτων γὰρ γεναμένων ἔσται τὸ προκείμενον. ὀρθῶν γὰρ οὐσῶν τῶν πρὸς τοῖς Δ, Ε ἔστιν, ὡς ἡ ΓΒ πρὸς ΒΔ, ἡ ΔΒ πρὸς ΒΕ καὶ ἡ ΕΒ πρὸς ΒΑ.

Ibid. 58. 15-16

Ὡς Ἡρων ἐν Μηχανικαῖς εἰσαγωγαῖς καὶ ἐν τοῖς Βελοποικοῖς

Papp. *Coll.* iii. 9. 26, ed. Hultsch 62. 26-64. 18 ; Heron, *Mech.* i. 11, ed. Schmidt 268. 3-270. 15

Ἐστωσαν γὰρ αἱ δοθεῖσαι εὐθεῖαι αἱ ΑΒ, ΒΓ πρὸς ὀρθὰς ἀλλήλαις κείμεναι, ὧν δεῖ δύο μέσας ἀνάλογον εὐρεῖν.

° The account may become clearer from the accompanying diagram in which the instrument is indicated in its final

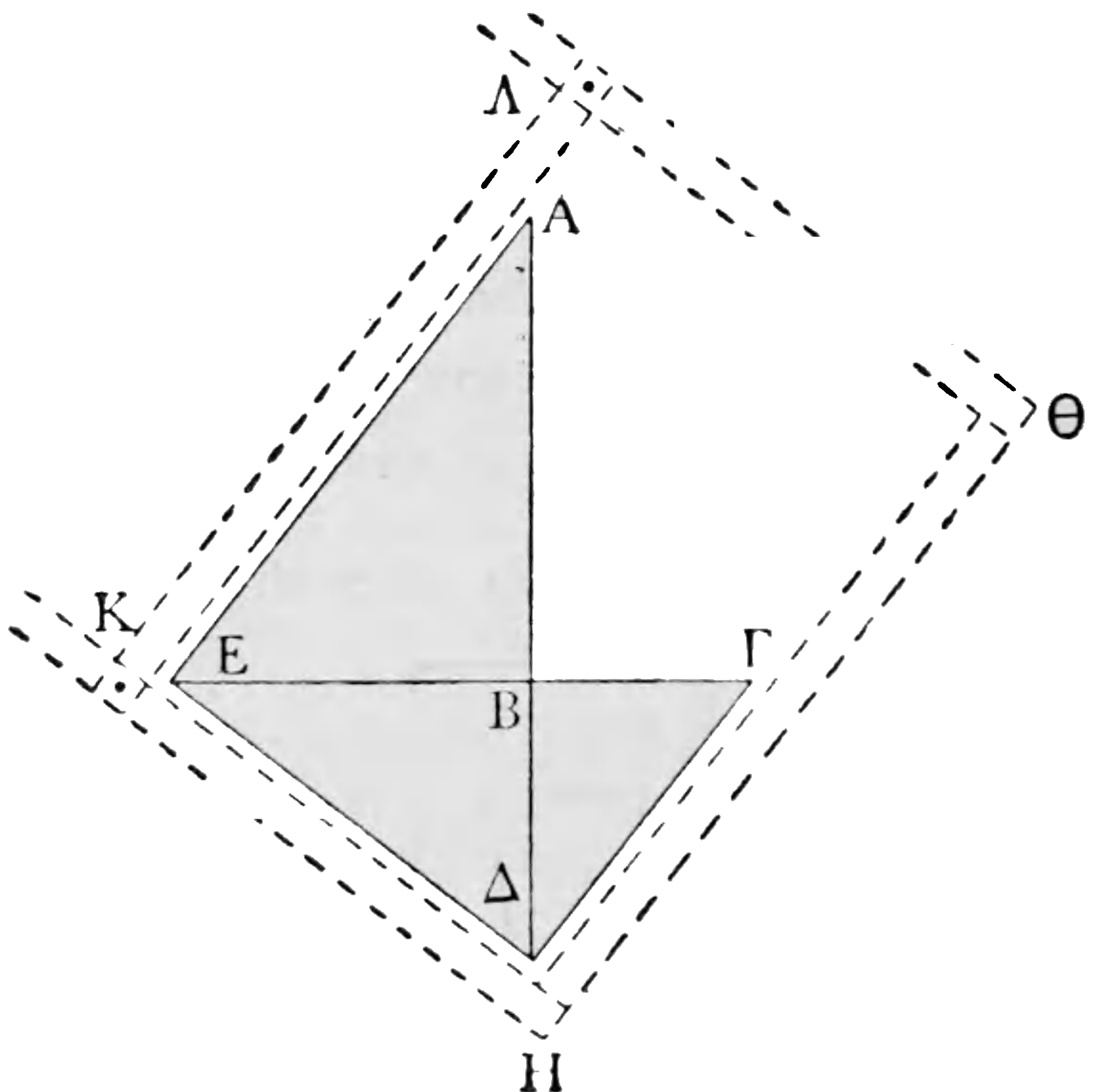

SPECIAL PROBLEMS

the ruler $K\Lambda$ takes up the position EA .^a When this is done, what was enjoined will be brought about. For since the angles at Δ , E are right, $\Gamma B : B\Delta = \Delta B : BE = EB : BA$. [Eucl. vi. 8, coroll.]

Ibid. 58. 15-16

(ii.) *The Solution of Heron in his "Mechanics" and "Construction of Engines of War"*^b

Pappus, *Collection* iii. 9. 26, ed. Hultsch 62. 26-64. 18 ;
Heron, *Mechanics* i. 11, ed. Schmidt 268. 3-270. 15

Let the two given straight lines between which it is required to find two mean proportionals be AB , $B\Gamma$ lying at right angles one to another.

position by dotted lines. $H\Theta$ is made to pass through Γ and the instrument is turned until the point H lies on AB produced. The ruler is then moved until its edge $K\Lambda$ passes through A . If K does not then lie on ΓB produced, the instrument has to be manipulated again until all conditions are fulfilled: (1) $H\Theta$ passes through Γ ; (2) H lies on AB produced; (3) $K\Lambda$ passes through A ; (4) K lies on ΓB produced. It may not be easy to do this, but it is possible.

^b Heron's own words have been most closely preserved by Pappus, whose version is here given in preference to Eutocius's, which includes some additions by the commentator. Schmidt also prefers Pappus's version in his edition of the Greek fragments of Heron's *Mechanics* in the Teubner edition of Heron's works (vol. ii., fasc. 1). The proof in the *Belopoeica* (edited by Wescher, *Poliorcétique des Grecs*, pp. 116-119) is extant. Philon of Byzantium and Apollonius gave substantially identical proofs.

GREEK MATHEMATICS

Συμπεπληρώσθω τὸ ΑΒΓΔ παραλληλόγραμμον, καὶ ἐκβεβλήσθωσαν αἱ ΔΓ, ΔΑ, καὶ ἐπεζεύχθωσαν αἱ ΔΒ, ΓΑ, καὶ παρακείσθω κανόνιον πρὸς τῷ Β σημείῳ καὶ κινείσθω τέμνον τὰς ΓΕ, ΑΖ, ἄχρις οὗ ἢ ἀπὸ τοῦ Η (ἀχθείσα)¹ ἐπὶ τὴν τῆς ΓΕ τομὴν ἴση γένηται τῇ ἀπὸ τοῦ Η ἐπὶ τὴν τῆς ΑΖ τομὴν. γεγονέτω, καὶ ἔστω ἡ μὲν τοῦ κανονίου θέσις ἡ ΕΒΖ, ἴσαι δὲ αἱ ΕΗ, ΗΖ. λέγω οὖν ὅτι αἱ ΑΖ, ΓΕ μέσαι ἀνάλογόν εἰσιν τῶν ΑΒ, ΒΓ.

Ἐπεὶ γὰρ ὀρθογώνιον ἐστὶν τὸ ΑΒΓΔ παραλληλόγραμμον, αἱ τέσσαρες εὐθείαι αἱ ΔΗ, ΗΑ, ΗΒ, ΗΓ ἴσαι ἀλλήλαις εἰσίν. ἐπεὶ οὖν ἴση ἡ ΔΗ τῇ ΑΗ καὶ διηῆκται ἡ ΗΖ, τὸ ἄρα ὑπὸ ΔΖΑ μετὰ τοῦ ἀπὸ ΑΗ ἴσον ἐστὶν τῷ ἀπὸ ΗΖ. διὰ τὰ αὐτὰ δὴ καὶ τὸ ὑπὸ ΔΕΓ μετὰ τοῦ ἀπὸ ΓΗ ἴσον ἐστὶν τῷ ἀπὸ ΗΕ. καὶ εἰσὶν ἴσαι αἱ ΗΕ,

¹ ἀχθείσα add. Hultsch.

^a The full proof requires ΗΘ to be drawn perpendicular to ΔΖ so that Θ bisects ΔΑ.

Then $\Delta Z \cdot ZA + A\Theta^2 = Z\Theta^2.$ [Eucl. ii. 6]

Add ΗΘ² to each side.

Then $\Delta Z \cdot ZA + AH^2 = HZ^2.$ [Eucl. i. 47]



THIS PAGE IS LOCKED TO FREE MEMBERS

Purchase full membership to immediately unlock this page

FORGOTTEN BOOKS

FULL

MEMBERSHIP

797,885 Books!

All you can read

for only

\$8.99/month

Continue

*Fair usage policy applies



ΗΖ. ἴσον ἄρα καὶ τὸ ὑπὸ ΔΖΑ μετὰ τοῦ ἀπὸ ΑΗ τῷ ὑπὸ ΔΕΓ μετὰ τοῦ ἀπὸ ΓΗ. ὦν τὸ ἀπὸ ΓΗ ἴσον ἐστὶν τῷ ἀπὸ ΗΑ. λοιπὸν ἄρα τὸ ὑπὸ ΔΕΓ ἴσον ἐστὶν τῷ ὑπὸ ΔΖΑ. ὡς ἄρα ἡ ΕΔ πρὸς ΔΖ, ἡ ΖΑ πρὸς ΓΕ. ὡς δε ἡ ΕΔ πρὸς ΔΖ, ἡ τε ΒΑ πρὸς ΑΖ καὶ ἡ ΕΓ πρὸς ΓΒ, ὥστε ἔσται καὶ ὡς ἡ ΑΒ πρὸς ΑΖ, ἡ τε ΖΑ πρὸς ΓΕ καὶ ἡ ΓΕ πρὸς ΓΒ. τῶν ἄρα ΑΒ, ΒΓ μέσαι ἀνάλογόν εἰσιν αἱ ΑΖ, ΓΕ.]

Eutoc. *Comm. in Archim. De Sphaera et Cyl.* ii., Archim. ed. Heiberg iii. 66. 8-70. 5

Ὡς Διοκλῆς ἐν τῷ Περὶ πυρίων

Ἐν κύκλῳ ἤχθωσαν δύο διάμετροι πρὸς ὀρθὰς αἱ ΑΒ, ΓΔ, καὶ δύο περιφέρειαι ἴσαι ἀπειλήφθωσαν ἐφ' ἑκάτερα τοῦ Β αἱ ΕΒ, ΒΖ, καὶ διὰ τοῦ Ζ παράλληλος τῇ ΑΒ ἤχθω ἡ ΖΗ, καὶ ἐπεζεύχθω ἡ ΔΕ. λέγω, ὅτι τῶν ΓΗ, ΗΘ δύο μέσαι ἀνάλογόν εἰσιν αἱ ΖΗ, ΗΔ.

Ἦχθω γὰρ διὰ τοῦ Ε τῇ ΑΒ παράλληλος ἡ

* Another fragment from the *Περὶ πυρίων* of Diocles is preserved by Eutocius (pp. 160 *et seq.*). It contains a solution by means of conics of the problem of dividing a sphere by a plane in such a way that the volumes of the resulting segments shall be in a given ratio, and refers both to Archi-

SPECIAL PROBLEMS

Therefore $\Delta Z \cdot ZA + AH^2 = \Delta E \cdot E\Gamma + \Gamma H^2.$

And $AH^2 = \Gamma H^2.$

Therefore $\Delta Z \cdot ZA = \Delta E \cdot E\Gamma.$

Therefore $E\Delta : \Delta Z = ZA : \Gamma E.$

But (by similar triangles)

$$E\Delta : \Delta Z = BA : AZ = E\Gamma : \Gamma B,$$

so that $AB : AZ = ZA : \Gamma E = \Gamma E : \Gamma B.$

Therefore $AZ, \Gamma E$ are mean proportionals between $A \cdot B, B\Gamma.$]

Eutocius, *Commentary on Archimedes' Sphere and Cylinder*
ii., Archim. ed. Heiberg iii. 66. 8-70. 5

(iii.) *The Solution of Diocles in his Book* *"On Burning Mirrors"* ^a

In a circle let there be drawn two diameters $AB, \Gamma\Delta$ at right angles, and on either side of B let there be cut off two equal arcs EB, BZ , and through Z let ZH be drawn parallel to AB , and let ΔE be joined. I say that $ZH, H\Delta$ are two mean proportionals between $\Gamma H, H\Theta$.

For let EK be drawn through E parallel to AB ;

medes and to Apollonius. Diocles must therefore have flourished later than these geometers. It appears also, from allusions in Proclus's commentary on Eucl. i., that the curve known to Geminus as the cissoid was none other than the curve here described and used by Diocles for finding two mean proportionals, though the identification is not certain (see Loria, *Le scienze esatte nell' antica Grecia*, pp. 410-415, Heath, *H.G.M.* i. 264). In that case, Diocles preceded Geminus, who flourished about 70 B.C. It is probable therefore that Diocles lived towards the end of the second century or the beginning of the first century B.C.

ΕΚ· ἴση ἄρα ἐστὶν ἢ μὲν ΕΚ τῇ ΖΗ, ἢ δὲ ΚΓ τῇ
 ΗΔ. ἔσται γὰρ τοῦτο δῆλον ἀπὸ τοῦ Λ ἐπὶ τὰ
 Ε, Ζ ἐπιζευχθεισῶν εὐθειῶν· ἴσαι γὰρ γίνονται
 αἱ ὑπὸ ΓΛΕ, ΖΛΔ, καὶ ὀρθαὶ αἱ πρὸς τοῖς Κ, Η·
 καὶ πάντα ἄρα πᾶσιν διὰ τὸ τὴν ΛΕ τῇ ΛΖ ἴσην
 εἶναι· καὶ λοιπὴ ἄρα ἢ ΓΚ τῇ ΗΔ ἴση ἐστίν.
 ἐπεὶ οὖν ἐστίν, ὡς ἢ ΔΚ πρὸς ΚΕ, ἢ ΔΗ πρὸς
 ΗΘ, ἀλλ' ὡς ἢ ΔΚ πρὸς ΚΕ, ἢ ΕΚ πρὸς ΚΓ·
 μέση γὰρ ἀνάλογον ἢ ΕΚ τῶν ΔΚ, ΚΓ· ὡς ἄρα
 ἢ ΔΚ πρὸς ΚΕ καὶ ἢ ΕΚ πρὸς ΚΓ, οὕτως ἢ ΔΗ



THIS PAGE IS LOCKED TO FREE MEMBERS

Purchase full membership to immediately unlock this page

SAVE \$3,999,994

Did you know we sell
paperback books too?

To buy our entire catalog
in paperback would cost
over \$4,000,000

Access it all now for
\$8.99/month

*Fair usage policy applies

Continue

πρὸς $H\Theta$. καὶ ἐστὶν ἴση ἢ μὲν ΔK τῇ ΓH , ἢ δὲ KE τῇ ZH , ἢ δὲ $K\Gamma$ τῇ $H\Delta$. ὡς ἄρα ἢ ΓH πρὸς HZ , ἢ ZH πρὸς $H\Delta$ καὶ ἢ ΔH πρὸς $H\Theta$. ἐὰν δὴ παρ' ἐκάτερα τοῦ B ληφθῶσιν περιφέρειαι ἴσαι αἱ MB , BN , καὶ διὰ μὲν τοῦ N παράλληλος ἀχθῆ τῇ AB ἢ NE , ἐπιζευχθῆ δὲ ἢ ΔM , ἔσονται πάλιν τῶν ΓE , ΞO μέσαι ἀνάλογον αἱ NE , $\Xi\Delta$. πλειόνων οὖν οὕτως καὶ συνεχῶν παραλλήλων ἐκβληθεισῶν μεταξὺ τῶν B , Δ καὶ ταῖς ἀπολαμβανομέναις ὑπ' αὐτῶν περιφερίαις πρὸς τῷ B ἴσων τεθεισῶν ἀπὸ τοῦ B ὡς ἐπὶ τὸ Γ καὶ ἐπὶ τὰ γενάμενα σημεία ἐπιζευχθεισῶν εὐθειῶν ἀπὸ τοῦ Δ , ὡς τῶν ὁμοίων ταῖς ΔE , ΔM , τμηθήσονται αἱ παράλληλοι αἱ μεταξὺ τῶν B , Δ κατὰ τινα σημεία, ἐπὶ τῆς προκειμένης καταγραφῆς τὰ O , Θ , ἐφ' ᾧ κανόνος παραθέσει ἐπιζεύξαντες εὐθείας ἕξομεν καταγε-

SPECIAL PROBLEMS

And $\Delta K = \Gamma H, KE = ZH, K\Gamma = H\Delta;$

therefore $\Gamma H : HZ = ZH : H\Delta = \Delta H : H\theta.$

If then on either side of B there be cut off equal arcs MB, BN, and NΞ be drawn through N parallel to AB, and ΔM be joined, NΞ, ΞΔ, will again be mean proportionals between ΓΞ, ΞO. If in this way more parallels are drawn continually between B, Δ, and arcs equal to the arcs cut off between them and B are marked off from B in the direction of Γ, and straight lines are drawn from Δ to the points so obtained, such as ΔE, ΔM, the parallels between B and Δ will be cut in certain points, such as O, θ in the accompanying figure. Joining these points with straight lines by applying a ruler we shall describe in the

GREEK MATHEMATICS

γραμμένην ἐν τῷ κύκλῳ τινὰ γραμμὴν, ἐφ' ἧς εἰάν ληφθῆ τυχὸν σημεῖον καὶ δι' αὐτοῦ παράλληλος ἀχθῆ τῇ ΛB , ἔσται ἡ ἀχθεῖσα καὶ ἡ ἀπολαμβανομένη ὑπ' αὐτῆς ἀπὸ τῆς διαμέτρου πρὸς τῷ Δ μέσαι ἀνάλογον τῆς τε ἀπολαμβανομένης ὑπ' αὐτῆς ἀπὸ τῆς διαμέτρου πρὸς τῷ Γ σημείῳ καὶ τοῦ μέρους αὐτῆς τοῦ ἀπὸ τοῦ ἐν τῇ γραμμῇ σημείου ἐπὶ τὴν $\Gamma\Delta$ διάμετρον.

Τούτων προκατεσκευασμένων ἔστωσαν αἱ δο-

^a Lit. "line." It is noteworthy that Diocles, or Eutocius, conceived the curve as made up of an indefinite number of

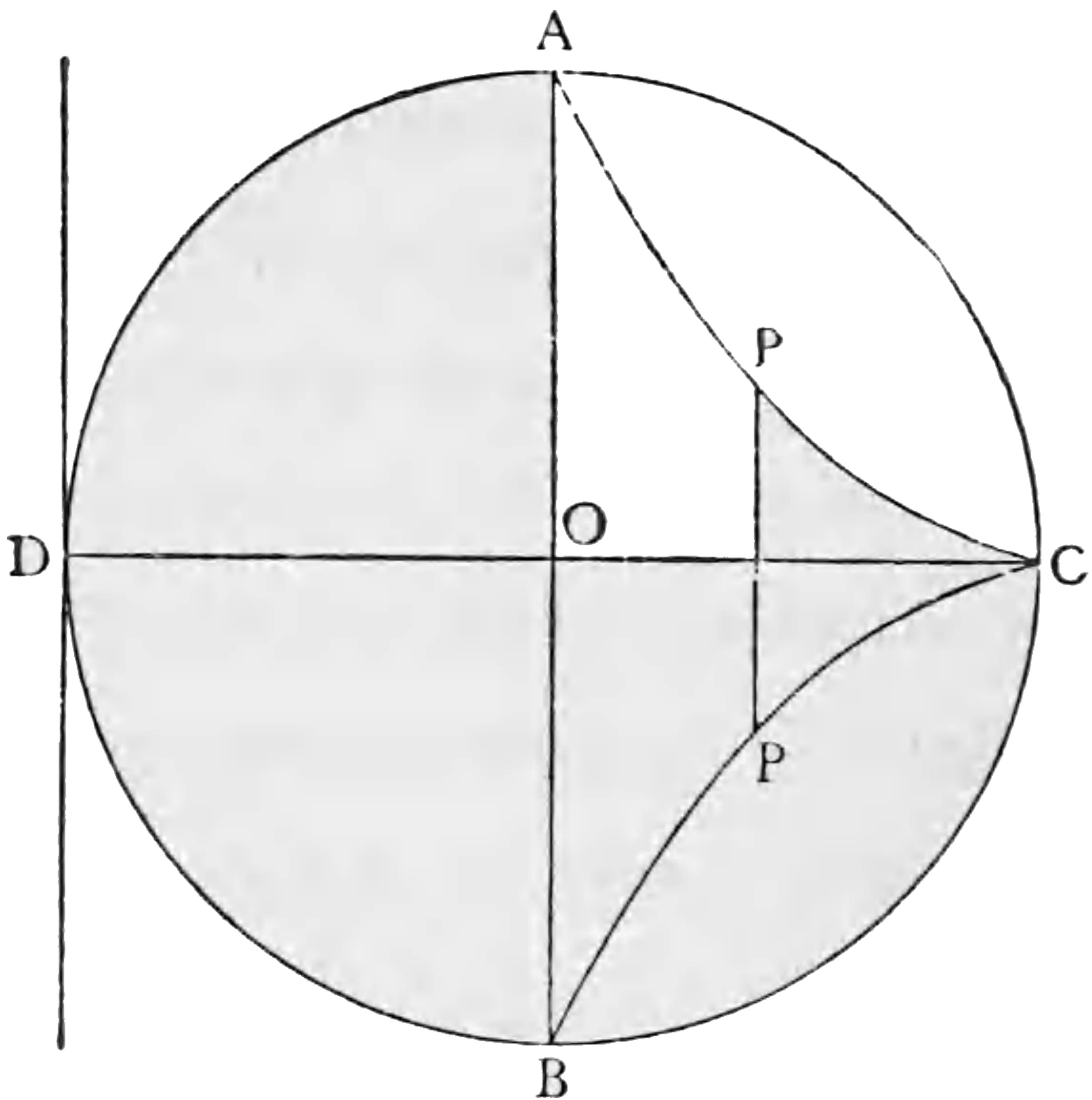

small straight lines, a typical Greek conception which has all the power of a theory of infinitesimals while avoiding its logical fallacies. The Greeks were never so modern as in this conception.

The curve described by Diocles has two branches, sym-



THIS PAGE IS LOCKED TO FREE MEMBERS

Purchase full membership to immediately unlock this page

FORGOTTEN BOOKS

FULL

MEMBERSHIP

797,885 Books!

All you can read

for only

\$8.99/month

Continue

*Fair usage policy applies



θεισαι δύο εὐθείαι, ὧν δεῖ δύο μέσας ἀνάλογον εὐρεῖν, αἱ A, B , καὶ ἔστω κύκλος, ἐν ᾧ δύο διάμετροι πρὸς ὀρθὰς ἀλλήλαις αἱ $\Gamma\Delta, EZ$, καὶ γεγράφθω ἐν αὐτῷ ἢ διὰ τῶν συνεχῶν σημείων γραμμὴ, ὡς προεῖρηται, ἢ $\Delta\Theta Z$, καὶ γεγονέτω, ὡς ἢ A πρὸς τὴν B , ἢ ΓH πρὸς HK , καὶ ἐπιζευχθεῖσα ἢ ΓK καὶ ἐκβληθεῖσα τεμνέτω τὴν γραμμὴν κατὰ τὸ Θ , καὶ διὰ τοῦ Θ τῇ EZ παράλληλος ἤχθω ἢ ΛM . διὰ ἄρα τὰ προγεγραμμένα τῶν $\Gamma\Lambda, \Lambda\Theta$ μέσαι ἀνάλογόν εἰσιν αἱ $M\Lambda, \Lambda\Delta$. καὶ ἐπεὶ ἔστιν, ὡς ἢ $\Gamma\Lambda$ πρὸς $\Lambda\Theta$, οὕτως ἢ ΓH πρὸς HK , ὡς δὲ ἢ ΓH πρὸς HK , οὕτως ἢ A πρὸς τὴν B , εἰ ἐν τῷ αὐτῷ λόγῳ ταῖς $\Gamma\Lambda, \Lambda M, \Lambda\Delta, \Lambda\Theta$ παρεμβάλωμεν μέσας τῶν A, B , ὡς τὰς N, Ξ , ἔσονται εἰλημμένα τῶν A, B μέσαι ἀνάλογον αἱ N, Ξ . ὅπερ ἔδει εὐρεῖν.

Ibid. 78. 13–80. 24

Ὡς Μέναιχμος

Ἔστωσαν αἱ δοθεῖσαι δύο εὐθείαι αἱ A, E . δεῖ δὴ τῶν A, E δύο μέσας ἀνάλογον εὐρεῖν.

Γεγονέτω, καὶ ἔστωσαν αἱ B, Γ , καὶ ἐκκείσθω θέσει εὐθεῖα ἢ ΔH πεπερασμένη κατὰ τὸ Δ , καὶ πρὸς τῷ Δ τῇ Γ ἴση κείσθω ἢ ΔZ , καὶ ἤχθω πρὸς ὀρθὰς ἢ $Z\Theta$, καὶ τῇ B ἴση κείσθω ἢ $Z\Theta$. ἐπεὶ οὖν τρεῖς εὐθείαι ἀνάλογον αἱ A, B, Γ , τὸ ὑπὸ τῶν A, Γ ἴσον ἐστὶ τῷ ἀπὸ τῆς B . τὸ ἄρα ὑπὸ

metrical about the diameter CD in the accompanying figure, and proceeding to infinity. There is a cusp at C and the tangent to the circle at D is an asymptote. If OC is the axis of x , and OA the axis of y , while the radius of the circle is a , then by definition the Cartesian equation of the curve is

SPECIAL PROBLEMS

given straight lines, between which it is required to find two mean proportionals, be A, B , and let there be a circle in which $\Gamma\Delta, EZ$ are two diameters at right angles to each other, and let there be drawn in it through the successive points a curve $\Delta\Theta Z$, in the aforesaid manner, and let $A : B = \Gamma H : HK$, and let Γ, K be joined, and let the straight line joining them be produced so as to cut the line in Θ , and through Θ let ΛM be drawn parallel to EZ ; therefore by what has been written previously $M\Lambda, \Lambda\Delta$ are mean proportionals between $\Gamma\Lambda, \Lambda\Theta$. And since $\Gamma\Lambda : \Lambda\Theta = \Gamma H : HK$ and $\Gamma H : HK = A : B$, if between A, B we place means N, Ξ in the same ratio as $\Gamma\Lambda, \Lambda M, \Lambda\Delta, \Lambda\Theta$,^a then N, Ξ will be mean proportionals between A, B ; which was to be found.

Ibid. 78. 13–80. 24

(iv.) *The Solutions of Menaechmus*

Let the two given straight lines be A, E ; it is required to find two mean proportionals between A, E .

Assume it done, and let the means be B, Γ , and let there be placed in position a straight line ΔH , with an end point Δ , and at Δ let ΔZ be placed equal to Γ , and let $Z\Theta$ be drawn at right angles and let $Z\Theta$ be equal to B . Since the three straight lines A, B, Γ are in proportion, $A.\Gamma = B^2$; therefore the rectangle com-

$$\frac{a+x}{\sqrt{a^2-x^2}} = \frac{a-x}{y} \text{ or } y^2(a+x) = (a-x)^3.$$

The curve was called by the Greeks the *cissoïd* (κισσοειδής γραμμή) because the portion within the circle reminded them of a leaf of ivy (κισσός).

^a *i.e.*, if we take $\Gamma\Lambda : \Lambda M = A : N$, $\Lambda M : \Lambda\Delta = N : \Xi$ and $\Lambda\Delta : \Lambda\Theta = \Xi : B$.

δοθείσης τῆς A καὶ τῆς Γ , τουτέστι τῆς ΔZ , ἴσον ἐστὶ τῷ ἀπὸ τῆς B , τουτέστι τῷ ἀπὸ τῆς $Z\Theta$. ἐπὶ παραβολῆς ἄρα τὸ Θ διὰ τοῦ Δ γεγραμμένης. ἤχθωσαν παράλληλοι αἱ ΘK , ΔK . καὶ ἐπεὶ δοθὲν τὸ ὑπὸ B , Γ —ἴσον γάρ ἐστι τῷ ὑπὸ A , E —δοθὲν ἄρα καὶ τὸ ὑπὸ $K\Theta Z$. ἐπὶ ὑπερβολῆς ἄρα τὸ Θ ἐν ἀσυμπτώτοις ταῖς $K\Delta$, ΔZ . δοθὲν ἄρα τὸ Θ . ὥστε καὶ τὸ Z .

Συντεθήσεται δὴ οὕτως. ἔστωσαν αἱ μὲν δοθεῖσαι εὐθεῖαι αἱ A , E , ἡ δὲ τῇ θέσει ἡ ΔH πεπερασμένη κατὰ τὸ Δ , καὶ γεγράφθω διὰ τοῦ Δ



THIS PAGE IS LOCKED TO FREE MEMBERS

Purchase full membership to immediately unlock this page

SAVE \$3,999,994

Did you know we sell
paperback books too?

To buy our entire catalog
in paperback would cost
over \$4,000,000

Access it all now for
\$8.99/month

*Fair usage policy applies

Continue

GREEK MATHEMATICS

παραβολή, ἧς ἄξων μὲν ἡ ΔΗ, ὀρθία δὲ τοῦ εἵδους
 πλευρὰ ἡ Α, αἱ δὲ καταγόμεναι ἐπὶ τὴν ΔΗ ἐν
 ὀρθῇ γωνίᾳ δυνάσθωσαν τὰ παρὰ τὴν Α παρα-
 κείμενα χωρία πλάτη ἔχοντα τὰς ἀπολαμβανο-
 μένας ὑπ' αὐτῶν πρὸς τῷ Δ σημείῳ. γεγράφθω
 καὶ ἔστω ἡ ΔΘ, καὶ ὀρθῇ ἡ ΔΚ, καὶ ἐν ἀσυμπτώτοις
 ταῖς ΚΔ, ΔΖ γεγράφθω ὑπερβολή, ἀφ' ἧς αἱ παρὰ
 τὰς ΚΔ, ΔΖ ἀχθεῖσαι ποιήσουσιν τὸ χωρίον ἴσον
 τῷ ὑπὸ Α, Ε· τεμείδῃ τὴν παραβολήν. τεμνέτω
 κατὰ τὸ Θ, καὶ κάθετοι ἤχθωσαν αἱ ΘΚ, ΘΖ.
 ἐπεὶ οὖν τὸ ἀπὸ ΖΘ ἴσον ἐστὶ τῷ ὑπὸ Α, ΔΖ,
 ἔστιν, ὡς ἡ Α πρὸς τὴν ΖΘ, ἡ ΘΖ πρὸς ΖΔ.
 πάλιν, ἐπεὶ τὸ ὑπὸ Α, Ε ἴσον ἐστὶ τῷ ὑπὸ ΘΖΔ,
 ἔστιν, ὡς ἡ Α πρὸς τὴν ΖΘ, ἡ ΖΔ πρὸς τὴν Ε.
 ἀλλ' ὡς ἡ Α πρὸς τὴν ΖΘ, ἡ ΖΘ πρὸς ΖΔ· καὶ
 ὡς ἄρα ἡ Α πρὸς τὴν ΖΘ, ἡ ΖΘ πρὸς ΖΔ καὶ ἡ
 ΖΔ πρὸς Ε. κείσθω τῇ μὲν ΘΖ ἴση ἡ Β, τῇ δὲ
 ΔΖ ἴση ἡ Γ. ἔστιν ἄρα, ὡς ἡ Α πρὸς τὴν Β, ἡ
 Β πρὸς τὴν Γ καὶ ἡ Γ πρὸς Ε. αἱ Α, Β, Γ, Ε
 ἄρα ἐξῆς ἀνάλογόν εἰσιν· ὅπερ ἔδει εὐρεῖν.

SPECIAL PROBLEMS

there be drawn through Δ a parabola whose axis is ΔH , and *latus rectum* A , and let the squares of the ordinates drawn at right angles to ΔH be equal to the areas applied to A having as their sides the straight lines cut off by them towards Δ . Let it be drawn, and let it be $\Delta\theta$, and let ΔK be perpendicular [to ΔH], and in the asymptotes $K\Delta$, ΔZ let there be drawn a hyperbola, such that the straight lines drawn parallel to $K\Delta$, ΔZ will make an area equal to the rectangle comprehended by A , E . It will then cut the parabola. Let it cut at θ , and let θK , θZ be drawn perpendicular. Since then

$$Z\theta^2 = A \cdot \Delta Z,$$

it follows that

$$A : Z\theta = \theta Z : Z\Delta.$$

Again, since $A \cdot E = \theta Z \cdot Z\Delta,$

it follows that

$$A : Z\theta = Z\Delta : E.$$

But $A : Z\theta = Z\theta : Z\Delta.$

Therefore $A : Z\theta = Z\theta : Z\Delta = Z\Delta : E.$

Let B be placed equal to θZ , and Γ equal to ΔZ . It follows that

$$A : B = B : \Gamma = \Gamma : E.$$

A , B , Γ , E are therefore in continuous proportion : which was to be found.^a

^a If a , x , y , b are in continuous proportion,

$$\frac{a}{x} = \frac{x}{y} = \frac{y}{b}, \text{ and } x^2 = ay, y^2 = bx, xy = ab.$$

Therefore x , y may be determined as the intersection of the parabola $y^2 = bx$ and the hyperbola $xy = ab$. This is the

GREEK MATHEMATICS

Ibid. 84. 12-88. 2

Ἡ Ἀρχύτου εὕρησις, ὡς Εὐδημος ἱστορεῖ

Ἐστῶσαν αἱ δοθεῖσαι δύο εὐθεῖαι αἱ ΑΔ, Γ·
δει δὴ τῶν ΑΔ, Γ δύο μέσας ἀνάλογον εὐρεῖν.

Γεγράφθω περὶ τὴν μείζονα τὴν ΑΔ κύκλος
ὁ ΑΒΔΖ, καὶ τῇ Γ ἴση ἐνηρμόσθω ἡ ΑΒ καὶ ἐκβλη-
θεῖσα συμπίπτέτω τῇ ἀπὸ τοῦ Δ ἐφαπτομένη τοῦ
κύκλου κατὰ τὸ Π, παρὰ δὲ τὴν ΠΔΟ ἤχθω ἡ

analytical expression of the solution given above, where $E=a$ and $A=b$. Menaechmus gave a second solution, reproduced by Eutocius, determining x, y as the intersection of the parabolas $x^2 = ay, y^2 = bx$.

This is the earliest known use of conic sections in the history of Greek mathematics, and Menaechmus is accordingly credited with their discovery. But the names parabola and hyperbola were not used by him; they are due to Apollonius; Menaechmus would have called them, with Archimedes, sections of a right-angled and obtuse-angled cone.

From the equations given above it follows that

$$x^2 + y^2 - bx - ay = 0$$

is a circle passing through the points common to the parabolas

$$x^2 = ay, y^2 = bx.$$

It follows that x, y may be determined by the intersection of this circle with the hyperbola $xy = ab$.

This is, in effect, the proof given by Heron, Philon and Apollonius. For, in the figure on p. 269, if ΔΖ, ΔΕ are the co-ordinate axes, ΑΒ = a , ΒΓ = b , then $x^2 + y^2 - bx - ay = 0$ is the circle passing through Α, Β, Γ, and $xy = ab$ is the hyperbola having ΔΖ, ΔΕ as asymptotes and passing through Β.



THIS PAGE IS LOCKED TO FREE MEMBERS

Purchase full membership to immediately unlock this page

FORGOTTEN BOOKS

FULL

MEMBERSHIP

797,885 Books!

All you can read

for only

\$8.99/month

Continue

*Fair usage policy applies



BEZ , καὶ νενοήσθω ἡμικυλίνδριον ὀρθὸν ἐπὶ τοῦ $AB\Delta$ ἡμικυκλίου, ἐπὶ δὲ τῆς $A\Delta$ ἡμικύκλιον ὀρθὸν ἐν τῷ τοῦ ἡμικυλινδρίου παραλληλογράμμῳ κείμενον· τοῦτο δὴ τὸ ἡμικύκλιον περιεγόμενον ὡς ἀπὸ τοῦ Δ ἐπὶ τὸ B μένοντος τοῦ A πέρατος τῆς διαμέτρου τεμεί τὴν κυλινδρικήν ἐπιφάνειαν ἐν τῇ περιαγωγῇ καὶ γράψει ἐν αὐτῇ γραμμὴν τινα· πάλιν δέ, ἐὰν τῆς $A\Delta$ μενούσης τὸ $A\Pi\Delta$ τρίγωνον περιενεχθῇ τὴν ἐναντίαν τῷ ἡμικυκλίῳ κίνησιν, κωνικήν ποιήσει ἐπιφάνειαν τῇ $A\Pi$ εὐθείᾳ, ἣ δὴ περιεγόμενῃ συμβαλεῖ τῇ κυλινδρικῇ γραμμῇ κατὰ τι σημεῖον· ἄμα δὲ καὶ τὸ B περιγράφει ἡμικύκλιον ἐν τῇ τοῦ κώνου ἐπιφανείᾳ. ἐχέτω δὴ θέσιν κατὰ τὸν τόπον τῆς συμπτώσεως τῶν γραμμῶν τὸ μὲν κινούμενον ἡμικύκλιον ὡς τὴν τοῦ ΔKA , τὸ δὲ ἀντιπεριεγόμενον τρίγωνον τὴν τοῦ ΔLA , τὸ δὲ τῆς εἰρημένης συμπτώσεως σημεῖον ἔστω τὸ K , ἔστω δὲ καὶ διὰ τοῦ B γραφόμενον ἡμικύκλιον τὸ BMZ , κοινὴ δὲ αὐτοῦ τομὴ καὶ τοῦ $B\Delta ZA$ κύκλου ἔστω ἡ BZ , καὶ ἀπὸ τοῦ K ἐπὶ τὸ τοῦ $B\Delta A$ ἡμικυκλίου ἐπίπεδον κάθετος ἤχθω· πεσεῖται δὴ ἐπὶ τὴν τοῦ κύκλου περιφέρειαν διὰ τὸ ὀρθὸν ἐστάναι τὸν κύλινδρον· πιπτέτω καὶ ἔστω ἡ KI , καὶ ἡ ἀπὸ τοῦ I ἐπὶ τὸ A ἐπιζευχθεῖσα συμβαλέτω τῇ BZ κατὰ τὸ Θ , ἡ δὲ AL τῷ BMZ ἡμικυκλίῳ κατὰ τὸ M , ἐπεζεύχθωσαν δὲ καὶ αἱ $K\Delta$, MI , $M\Theta$. ἐπεὶ οὖν ἐκάτερον τῶν ΔKA , BMZ ἡμικυκλίων ὀρθὸν ἐστὶ πρὸς τὸ ὑποκείμενον ἐπίπεδον, καὶ ἡ κοινὴ ἄρα αὐτῶν τομὴ ἡ $M\Theta$ πρὸς ὀρθάς ἐστὶ τῷ τοῦ κύκλου ἐπιπέδῳ· ὥστε καὶ πρὸς τὴν BZ ὀρθὴ ἐστὶν ἡ $M\Theta$. τὸ ἄρα ὑπὸ τῶν $B\Theta Z$, του-

SPECIAL PROBLEMS

and let a right half-cylinder be conceived upon the semicircle $AB\Delta$, and on $A\Delta$ a right semicircle lying in the parallelogram of the half-cylinder. When this semicircle is moved about from Δ to B , the end point A of the diameter remaining fixed, it will cut the cylindrical surface in its motion and will describe in it a certain curve. Again, if $A\Delta$ be kept stationary and the triangle $A\Pi\Delta$ be moved about with an opposite motion to that of the semicircle, it will make a conic surface by means of the straight line $A\Pi$, which in its motion will meet the curve on the cylinder in a certain point; at the same time B will describe a semicircle on the surface of the cone. Corresponding to the point in which the curves meet let the moving semicircle take up a position $\Delta'KA$,^a and the triangle moved in the opposite direction a position $\Delta\Lambda$; let the point of the aforesaid meeting be K , and let BMZ be the semicircle described through B , and let BZ be the section common to it and the circle $B\Delta ZA$, and let there be drawn from K a perpendicular upon the plane of the semicircle $B\Delta A$; it will fall upon the circumference of the circle because the cylinder is right. Let it fall, and let it be KI , and let the straight line joining I to A meet BZ in Θ ; let $A\Lambda$ meet the semicircle BMZ in M , and let $K\Delta$, MI , $M\Theta$ be joined. Therefore since each of the semicircles $\Delta'KA$, BMZ is at right angles to the underlying plane, their common section $M\Theta$ is also at right angles to the plane of the circle; so that $M\Theta$ is also at right angles to BZ . Therefore the rectangle contained by

^a In the text and figure of the mss. the same letter is used to indicate the initial and final positions of Δ ; for convenience they are distinguished in the figure and translation as Δ , Δ' . It would make the figure easier to grasp if Λ could be written Π' (for Λ is the final position of Π).

GREEK MATHEMATICS

τέστι τὸ ὑπὸ ΑΘΙ, ἴσον ἐστὶ τῷ ἀπὸ ΜΘ· ὁμοιον ἄρα ἐστὶ τὸ ΑΜΙ τρίγωνον ἑκατέρω τῶν ΜΙΘ, ΜΑΘ, καὶ ὀρθὴ ἢ ὑπὸ ΙΜΑ. ἔστιν δὲ καὶ ἢ ὑπὸ ΔΚΑ ὀρθή. παράλληλοι ἄρα εἰσὶν αἱ ΚΔ, ΜΙ, καὶ ἔσται ἀνάλογον, ὡς ἢ ΔΑ πρὸς ΑΚ, τουτέστιν ἢ ΚΑ πρὸς ΑΙ, οὕτως ἢ ΙΑ πρὸς ΑΜ, διὰ τὴν ὁμοιότητα τῶν τριγώνων. τέσσαρες ἄρα αἱ ΔΑ, ΑΚ, ΑΙ, ΑΜ ἐξῆς ἀνάλογόν εἰσιν. καὶ ἐστὶν ἢ ΑΜ ἴση τῇ Γ, ἐπεὶ καὶ τῇ ΑΒ· δύο ἄρα δοθεισῶν τῶν ΑΔ, Γ δύο μέσαι ἀνάλογον ηὔρηνται αἱ ΑΚ, ΑΙ.

•
 a The above solution is a remarkable achievement when it is remembered that Archytas flourished in the first half of the fourth century B.C., at which time Greek geometry was still in its infancy. It is quite easy, however, for us to represent the solution analytically. If ΑΔ is taken as the axis of x , the perpendicular to ΑΔ at Α in the plane of the paper as the axis of y , and the perpendicular to these lines as the axis of z , and if ΑΔ = a , Γ = b , then the point K is determined as the intersection of the following three curves :

(1) The cylinder $x^2 + y^2 = ax$,

(2) the curve formed by the motion of the half-circle about Α (a tore of inner diameter nil)

$$x^2 + y^2 + z^2 = a\sqrt{x^2 + y^2},$$

(3) the cone $x^2 + y^2 + z^2 = \frac{a^2}{b^2}x^2$.



THIS PAGE IS LOCKED TO FREE MEMBERS

Purchase full membership to immediately unlock this page

SAVE \$3,999,994

Did you know we sell
paperback books too?

To buy our entire catalog
in paperback would cost
over \$4,000,000

Access it all now for
\$8.99/month

*Fair usage policy applies

Continue

GREEK MATHEMATICS

Ibid. 88. 3-96. 27

Ὡς Ἐρατοσθένης . . .

Δεδόσθωσαν δύο ἄνισοι εὐθείαι, ὧν δεῖ δύο μέσας ἀνύλογον εὐρεῖν ἐν συνεχεῖ ἀναλογίᾳ, αἱ AE , $\Delta\Theta$, καὶ κείσθω ἐπὶ τινος εὐθείας τῆς $E\Theta$

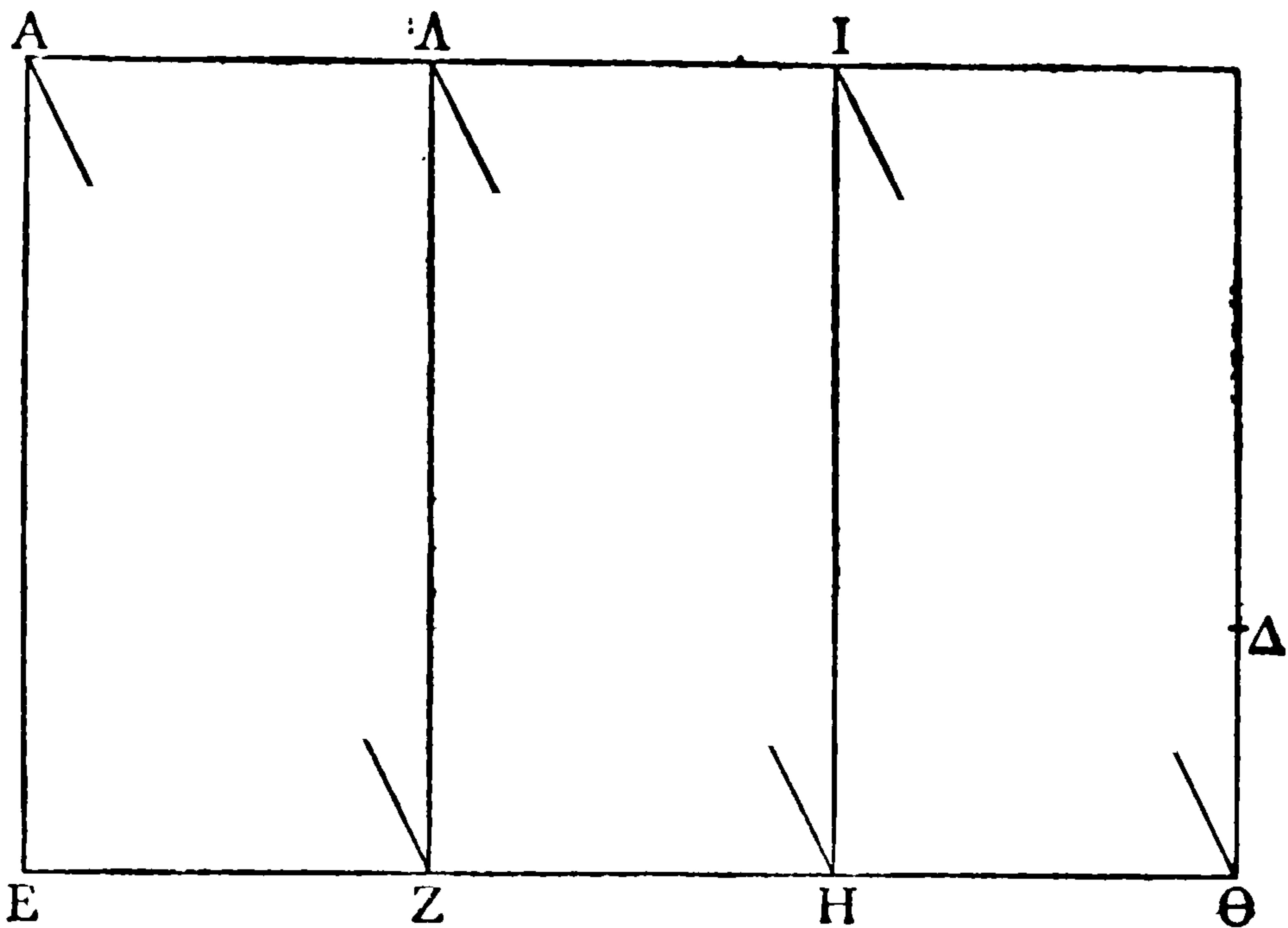

πρὸς ὀρθὰς ἢ AE , καὶ ἐπὶ τῆς $E\Theta$ τρία συνεστάτω παραλληλόγραμμα ἐφεξῆς τὰ AZ , ZI , $I\Theta$, καὶ ἤχθωσαν διάμετροι ἐν αὐτοῖς αἱ AZ , ΛH , $I\Theta$. ἔσονται δὴ αὐταὶ παράλληλοι. μένοντος δὴ τοῦ μέσου παραλληλογράμμου τοῦ ZI συνωσθήτω τὸ μὲν AZ ἐπάνω τοῦ μέσου, τὸ δὲ $I\Theta$ ὑποκάτω, καθάπερ ἐπὶ τοῦ δευτέρου σχήματος, ἕως οὐ γένηται τὰ A , B , Γ , Δ κατ' εὐθείαν, καὶ διήχθω διὰ τῶν A , B , Γ , Δ σημείων εὐθεῖα καὶ συμπίπτέτω τῇ $E\Theta$ ἐκβληθείσῃ κατὰ τὸ K . ἔσται δὴ, ὡς ἢ AK πρὸς KB , ἐν μὲν ταῖς AE , ZB παραλ-

SPECIAL PROBLEMS

Ibid. 88. 3-96. 27 •

(vi.) *The Solution of Eratosthenes . . .*

Let there be given two unequal straight lines AE , $\Delta\Theta$ between which it is required to find two mean proportionals in continued proportion, and let AE be placed at right angles to the straight line $E\Theta$, and upon $E\Theta$ let there be erected three successive parallelograms ^b AZ , ZI , $I\Theta$, and let the diagonals AZ , ΛH , $I\Theta$ be drawn therein ; these will be parallel. While the middle parallelogram ZI remains stationary, let the other two approach each other, AZ above the middle one, $I\Theta$ below it, as in the second figure,^c until A , B , Γ , Δ lie along a straight line, and let a straight line be drawn through the points A , B , Γ , Δ , and let it meet $E\Theta$ produced in K ; it will follow that in the parallels AE , ZB

$$AK : KB = EK : KZ$$

^a This is the letter falsely purporting to be by Eratosthenes of which the beginning has already been cited, *supra*, pp. 256-261. The extract here given ($\delta\epsilon\delta\acute{o}\sigma\theta\omega\sigma\alpha\nu . . .$) starts in Heiberg's text at 90. 30. Eratosthenes' solution is given, with variations, by Pappus, *Collection* iii. 7, ed. Hultsch 56. 18-58. 22.

^b Pappus says triangles in his account ; it makes no difference.

^c See p. 294.

GREEK MATHEMATICS

λήλοις ἢ ΕΚ πρὸς ΚΖ, ἐν δὲ ταῖς ΑΖ, ΒΗ παραλλήλοις ἢ ΖΚ πρὸς ΚΗ. ὡς ἄρα ἢ ΑΚ πρὸς ΚΒ, ἢ ΕΚ πρὸς ΚΖ καὶ ἢ ΚΖ πρὸς ΚΗ. πάλιν, ἐπεὶ ἐστίν, ὡς ἢ ΒΚ πρὸς ΚΓ, ἐν μὲν ταῖς ΒΖ, ΓΗ παραλλήλοις ἢ ΖΚ πρὸς ΚΗ, ἐν δὲ ταῖς ΒΗ, ΓΘ παραλλήλοις ἢ ΗΚ πρὸς ΚΘ, ὡς ἄρα ἢ ΒΚ πρὸς ΚΓ, ἢ ΖΚ πρὸς ΚΗ καὶ ἢ ΗΚ πρὸς ΚΘ. ἀλλ' ὡς ἢ ΖΚ πρὸς ΚΗ, ἢ ΕΚ πρὸς ΚΖ· καὶ ὡς ἄρα ἢ ΕΚ πρὸς ΚΖ, ἢ ΖΚ πρὸς ΚΗ καὶ ἢ ΗΚ πρὸς ΚΘ. ἀλλ' ὡς ἢ ΕΚ πρὸς ΚΖ, ἢ ΑΕ πρὸς ΒΖ, ὡς δὲ ἢ ΖΚ πρὸς ΚΗ, ἢ ΒΖ πρὸς ΓΗ, ὡς δὲ ἢ ΗΚ πρὸς ΚΘ, ἢ ΓΗ πρὸς ΔΘ· καὶ ὡς ἄρα ἢ ΑΕ πρὸς ΒΖ, ἢ ΒΖ πρὸς ΓΗ καὶ ἢ ΓΗ πρὸς ΔΘ. ηὔρηνται ἄρα τῶν ΑΕ, ΔΘ δύο μέσαι ἢ τε ΒΖ καὶ ἢ ΓΗ.

Ταῦτα οὖν ἐπὶ τῶν γεωμετρούμενων ἐπιφανειῶν ἀποδέδεικται· ἵνα δὲ καὶ ὀργανικῶς δυνώμεθα τὰς δύο μέσας λαμβάνειν, διαπήγνυται πλινθίον ξύλινον ἢ ἐλεφάντινον ἢ χαλκοῦν ἔχον τρεῖς πινακίσκους ἴσους ὡς λεπτοτάτους, ὧν ὁ μὲν μέσος ἐνήρμοσται, οἱ δὲ δύο ἐπωστοί εἰσιν ἐν χολέδραις, τοῖς δὲ μεγέθεσιν καὶ ταῖς συμμετρίαις ὡς ἕκαστοι ἑαυτοὺς πείθουσιν· τὰ μὲν γὰρ τῆς ἀποδείξεως ὡσαύτως συντελεῖται· πρὸς δὲ τὸ ἀκριβέστερον λαμβάνεσθαι τὰς γραμμὰς φιλοτεχνητέον, ἵνα ἐν τῷ συνάγεσθαι τοὺς πινακίσκους παράλληλα διαμένη πάντα καὶ ἄσχαστα καὶ ὀμαλῶς συναπτόμενα ἀλλήλοις.

Ἐν δὲ τῷ ἀναθήματι τὸ μὲν ὀργανικὸν χαλκοῦν ἐστίν καὶ καθήρμοσται ὑπ' αὐτὴν τὴν στεφάνην τῆς στήλης προσμεμολυβδοχοημένον, ὑπ' αὐτοῦ δὲ ἢ ἀπόδειξις συντομώτερον φραζομένη καὶ τὸ σχῆμα,



THIS PAGE IS LOCKED TO FREE MEMBERS

Purchase full membership to immediately unlock this page

FORGOTTEN BOOKS

FULL

MEMBERSHIP

797,885 Books!

All you can read

for only

\$8.99/month

Continue

*Fair usage policy applies



GREEK MATHEMATICS

μετ' αὐτὸ δὲ ἐπίγραμμα. ὑπογεγράφθω οὖν σοι καὶ ταῦτα, ἵνα ἔχῃς καὶ ὡς ἐν τῷ ἀναθήματι. τῶν δὲ δύο σχημάτων τὸ δεύτερον γέγραπται ἐν τῇ στήλῃ.

“ Δύο τῶν δοθεισῶν εὐθειῶν δύο μέσας ἀνάλογον εὐρεῖν ἐν συνεχείᾳ ἀναλογία. δεδόσθωσαν αἱ AE , $\Delta\Theta$. συνάγω δὴ τοὺς ἐν τῷ ὀργάνῳ πίνακας, ἕως ἂν κατ' εὐθείαν γένηται τὰ A , B , Γ , Δ σημεία. νοείσθω δὴ, ὡς ἔχει ἐπὶ τοῦ δευτέρου σχήματος. ἔστιν ἄρα, ὡς ἡ AK πρὸς KB , ἐν μὲν ταῖς AE , BZ παραλλήλοις ἢ EK πρὸς KZ , ἐν δὲ ταῖς AZ , BH ἢ ZK πρὸς KH . ὡς ἄρα ἡ EK πρὸς KZ , ἢ

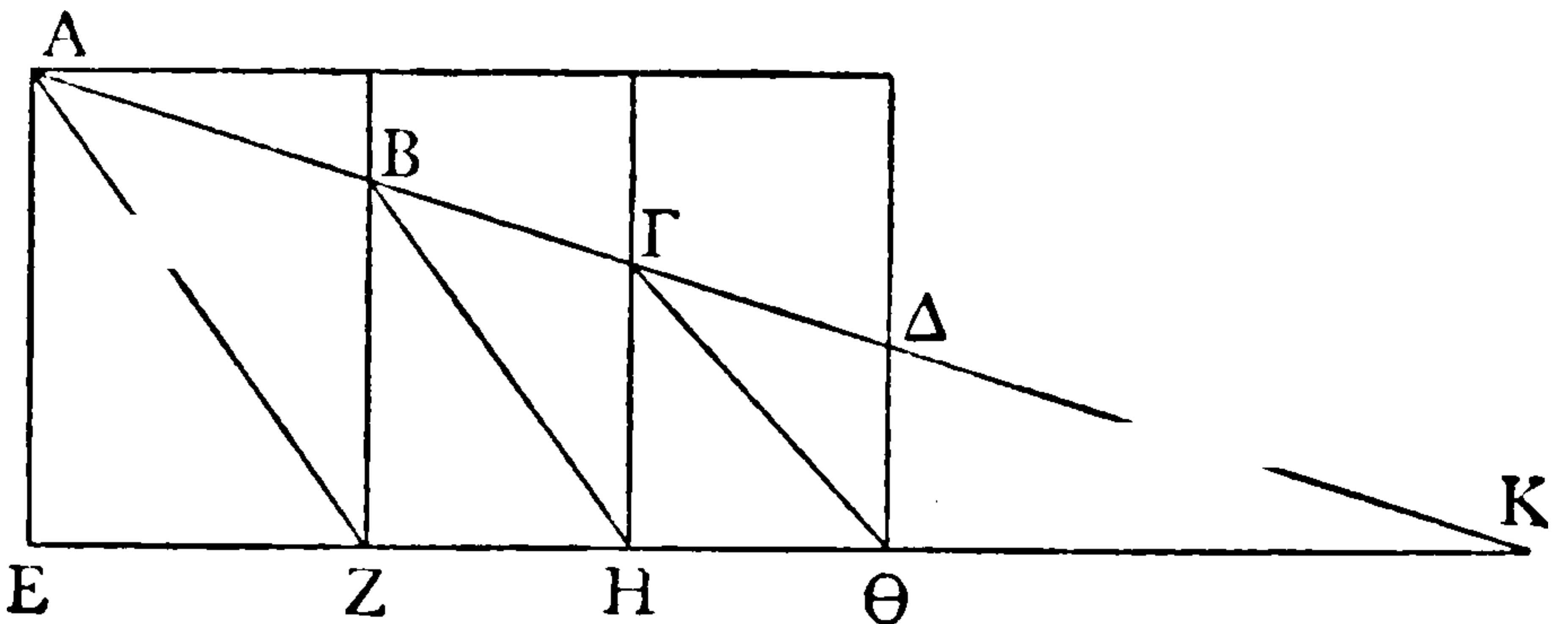

KZ πρὸς KH . ὡς δὲ αὐταὶ πρὸς ἀλλήλας, ἢ τε AE πρὸς BZ καὶ ἢ BZ πρὸς ΓH . ὡσαύτως δὲ δείξομεν, ὅτι καί, ὡς ἡ ZB πρὸς ΓH , ἢ ΓH πρὸς $\Delta\Theta$. ἀνάλογον ἄρα αἱ AE , BZ , ΓH , $\Delta\Theta$. ηὔρηται ἄρα δύο τῶν δοθεισῶν δύο μέσαι.

“ Ἐὰν δὲ αἱ δοθεῖσαι μὴ ἴσαι ᾦσιν ταῖς AE , $\Delta\Theta$, ποιήσαντες αὐταῖς ἀνάλογον τὰς AE , $\Delta\Theta$ τούτων ληψόμεθα τὰς μέσας καὶ ἐπανοίσομεν ἐπ' ἐκείνας, καὶ ἐσόμεθα πεποιηκότες τὸ ἐπιταχθέν. ἐὰν δὲ πλείους μέσας ἐπιταχθῆ εὐρεῖν, αἰεὶ ἐνὶ πλείους πινακίσκους καταστησόμεθα ἐν τῷ ὀργανίῳ τῶν ληφθησομένων μέσων. ἢ δὲ ἀπόδειξις ἢ αὐτή.

SPECIAL PROBLEMS

and the figure, and along with this is an epigram. These also shall be written below for you, in order that you may have what is on the votive gift. Of the two figures, the second is that which is inscribed on the pillar.^a

“Between two given straight lines to find two means in continuous proportion. Let $AE, \Delta\theta$ be the given straight lines. Then I move the tables in the instrument until the points A, B, Γ, Δ are in the same straight line. Let this be pictured as in the second figure. Then $AK : KB$ is equal, in the parallels AE, BZ , to $EK : KZ$, and in the parallels AZ, BH to $ZK : KH$; therefore $EK : KZ = KZ : KH$. Now this is also the ratio $AE : BZ$ and $BZ : \Gamma H$. Similarly we shall show that $ZB : \Gamma H = \Gamma H : \Delta\theta$; $AE, BZ, \Gamma H, \Delta\theta$ are therefore proportional. Between the two given straight lines two means have therefore been found.

“If the given straight lines are not equal to $AE, \Delta\theta$, by making $AE, \Delta\theta$ proportional to them and taking the means between these and then going back to the original lines, we shall do what was enjoined. If it is required to find more means, we shall continually insert more tables in the instrument according to the number of means to be taken; and the proof is the same.

^a The short proof and epigram which follow are presumably the genuine work of Eratosthenes, being taken from the votive gift. The reference to the *second* figure cannot, however, be genuine as there was only one figure on the votive offering; perhaps *δεύτερον* should be omitted.

“ Εἰ κύβον ἐξ ὀλίγου διπλήσιον, ὦγαθε, τεύχειν
 φράζειαι ἢ στερεὴν πᾶσαν ἐς ἄλλο φύσιν
 εὖ μεταμορφῶσαι, τόδε τοι πάρα, κἂν σὺ γε
 μάνδρην
 ἢ σιρὸν ἢ κοίλου φρεΐατος εὐρὺ κύτος
 τῆδ’ ἀναμετρήσαιο, μέσας ὅτε τέρμασιν ἄκροις
 συνδρομάδας δισσωῶν ἐντὸς ἔλης κανόνων.
 μηδὲ σὺ γ’ Ἀρχύτεω δυσμήχανα ἔργα κυλίνδρων
 μηδὲ Μεναιχμείους κωνοτομεῖν τριάδας
 διζήση, μηδ’ εἴ τι θεουδέος Εὐδόξιο
 καμπύλον ἐγ γραμμαῖς εἶδος ἀναγράφεται.
 τοῖσδε γὰρ ἐν πινάκεσσι μεσόγραφα μυρία τεύχοις
 ρεῖᾶ κεν ἐκ παύρου πυθμένος ἀρχόμενος.
 εὐαίων, Πτολεμαῖε, πατήρ ὅτι παιδὶ συνηβῶν
 πάνθ’, ὅσα καὶ Μούσαις καὶ βασιλεῦσι φίλα,
 αὐτὸς ἔδωρήσω· τὸ δ’ ἐς ὕστερον, οὐράνιε Ζεῦ,
 καὶ σκήπτρων ἐκ σῆς ἀντιάσειε χερός.
 καὶ τὰ μὲν ὡς τελείοιτο, λέγοι δέ τις ἄνθεμα λεύσ-
 σων
 τοῦ Κυρηναίου τοῦτ’ Ἐρατοσθένεος.”

Ibid. 98. 1-7

Ὡς Νικομήδης ἐν τῷ Περὶ κογχοειδῶν γραμμῶν
 Γράφει δὲ καὶ Νικομήδης ἐν τῷ ἐπιγεγραμμένῳ
 πρὸς αὐτοῦ Περὶ κογχοειδῶν συγγράμματι ὄργάνου
 κατασκευὴν τὴν αὐτὴν ἀποπληροῦντος χρεῖαν, ἐφ’
 ᾧ καὶ μεγάλα μὲν σεμνυνόμενος φαίνεται ὁ ἀνὴρ,
 πολλὰ δὲ τοῖς Ἐρατοσθένους ἐπεγγελῶν εὐρήμασιν

• Or “with a small effort,” Heiberg.

• Perhaps so called because there are three conic sections—of an acute-angled, right-angled and obtuse-angled cone



THIS PAGE IS LOCKED TO FREE MEMBERS

Purchase full membership to immediately unlock this page

SAVE \$3,999,994

Did you know we sell
paperback books too?

To buy our entire catalog
in paperback would cost
over \$4,000,000

Access it all now for
\$8.99/month

*Fair usage policy applies

Continue

ὡς ἀμηχάνοις τε ἅμα καὶ γεωμετρικῆς ἕξεως ἔστερημένοις.

Papp. Coll. iv. 26. 39-28. 43, ed. Hultsch 242. 13-250. 25

κς'. Εἰς τὸν διπλασιασμὸν τοῦ κύβου παράγεται τις ὑπὸ Νικομήδους γραμμὴ καὶ γένεσιν ἔχει τοιαύτην.

Ἐκκείσθω εὐθεία ἡ AB , καὶ αὐτῇ πρὸς ὀρθὰς ἡ $\Gamma\Delta Z$, καὶ εἰλήφθω τι σημεῖον ἐπὶ τῆς $\Gamma\Delta Z$ δοθὲν τὸ E , καὶ μένοντος τοῦ E σημείου ἐν ᾧ ἔστιν τόπων $\Gamma\Delta EZ$ εὐθεία φερέσθω κατὰ τῆς AB ευθειας^η ἔλκομένη διὰ τοῦ E σημείου οὕτως ὥστε διὰ παντὸς φέρεσθαι τὸ A ἐπὶ τῆς AB εὐθείας καὶ μὴ ἐκπίπτειν ἔλκομένης τῆς $\Gamma\Delta EZ$ διὰ τοῦ E . τοιαύτης δὲ κινήσεως γενομένης ἐφ' ἑκάτερα φανερόν ὅτι τὸ Γ σημεῖον γράψει γραμμὴν οἷα ἔστιν ἡ $\Lambda\Gamma M$, καὶ ἔστιν αὐτῆς τὸ σύμπτωμα τοιοῦτον. ὡς ἂν εὐθεία προσπίπτῃ τις ἀπὸ τοῦ E σημείου πρὸς τὴν γραμμὴν, τὴν ἀπολαμβανομένην μεταξύ τῆς τε AB εὐθείας καὶ τῆς $\Lambda\Gamma M$ γραμμῆς ἴσην εἶναι τῇ ΓA εὐθείᾳ· μενούσης γὰρ τῆς AB καὶ μένοντος τοῦ E σημείου, ὅταν γένηται τὸ A ἐπὶ τὸ H , ἡ $\Gamma\Delta$ εὐθεία τῇ $H\Theta$ ἐφαρμόσει καὶ τὸ Γ σημεῖον ἐπὶ τὸ Θ (πεσεῖται)¹. ἴση ἄρα ἔστιν ἡ $\Gamma\Delta$ τῇ $H\Theta$. ὁμοίως καὶ ἐὰν ἕτερα τις

¹ πεσεῖται add. Hultsch.

^a Eutocius proceeds to describe Nicomedes' solution; we shall give an alternative account by Pappus.

SPECIAL PROBLEMS

discoveries of Eratosthenes as impracticable and lacking in geometrical sense.^a

Pappus, *Collection* iv. 26. 39–28. 43, ed. Hultsch
242. 13–250. 25

26. For the duplication of the cube a certain line is drawn by Nicomedes and generated in this way.

Let there be a straight line AB , with $\Gamma\Delta Z$ at right angles to it, and on $\Gamma\Delta Z$ let there be taken a certain

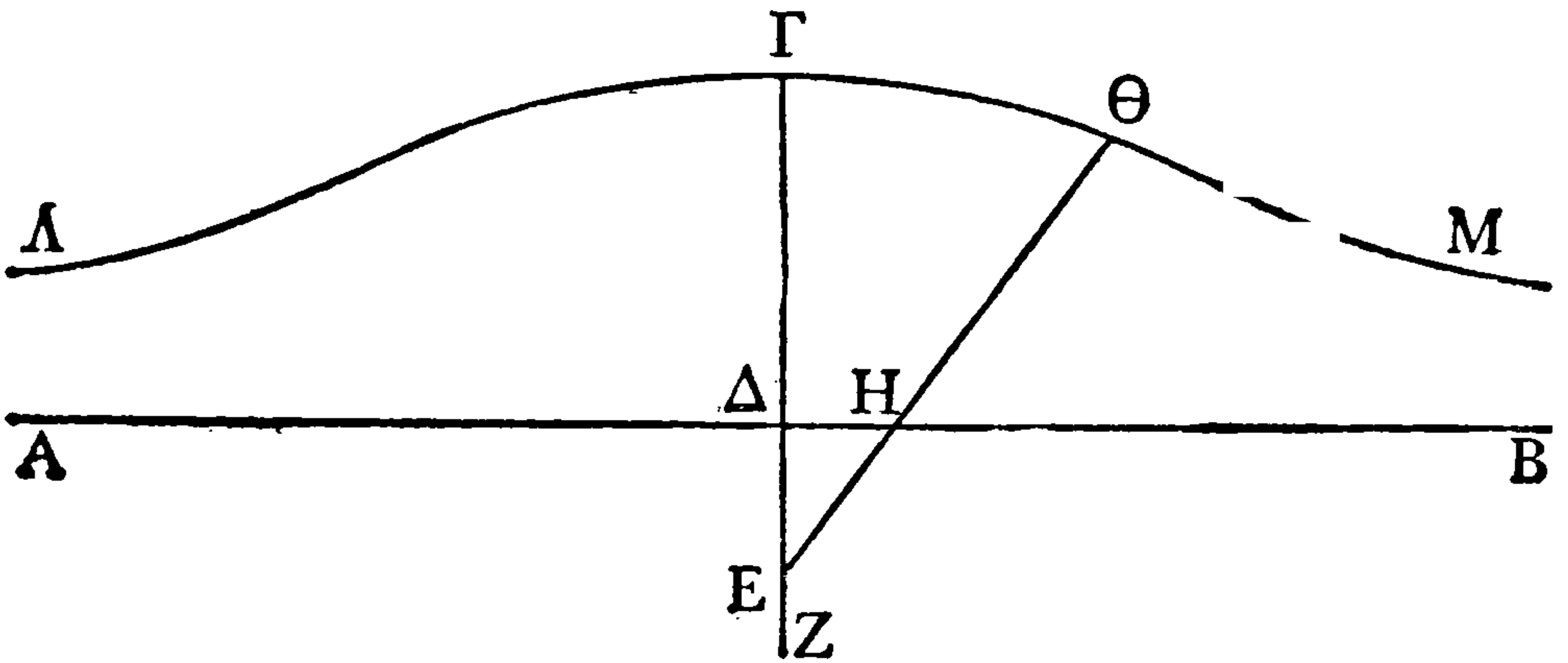

given point E , and while the point E remains in the same position let the straight line $\Gamma\Delta EZ$ be drawn through the point E and moved about the straight line $A\Delta B$ in such a way that Δ always moves along the straight line AB and does not fall beyond it while $\Gamma\Delta EZ$ is drawn through E . The motion being after this fashion on either side, it is clear that the point Γ will describe a curve such as $\Lambda\Gamma M$, and its property is of this nature: when any straight line drawn from the point E falls upon the curve, the portion cut off between the straight line AB and the curve $\Lambda\Gamma M$ is equal to the straight line $\Gamma\Delta$; for AB is stationary and the point E fixed, and when Δ goes to H , the straight line $\Gamma\Delta$ will coincide with $H\Theta$ and the point Γ will fall upon Θ ; therefore $\Gamma\Delta$ is equal to $H\Theta$.

ἀπὸ τοῦ Ε σημείου πρὸς τὴν γραμμὴν προσπέση, τὴν ἀποτεμνομένην ὑπὸ τῆς γραμμῆς καὶ τῆς ΑΒ εὐθείας ἴσην ποιήσει τῇ ΓΔ [ἐπειδὴ ταύτη ἴσαι εἰσὶν αἱ προσπίπτουσαι].¹ καλείσθω δέ, φησὶν, ἡ μὲν ΑΒ εὐθεῖα κανὼν, τὸ δὲ σημεῖον πόλος, διάστημα δὲ ἡ ΓΔ, ἐπειδὴ ταύτη ἴσαι εἰσὶν αἱ προσπίπτουσαι πρὸς τὴν ΛΓΜ γραμμὴν, αὕτη δὲ ἡ ΛΓΜ γραμμὴ κοχλοειδῆς πρώτη (ἐπειδὴ καὶ ἡ δευτέρα καὶ ἡ τρίτη καὶ ἡ τετάρτη ἐκτίθεται εἰς ἄλλα θεωρήματα χρησιμεύουσαι).

κζ'. Ὅτι δὲ ὀργανικῶς δύναται γράφεσθαι ἡ γραμμὴ καὶ ἐπ' ἔλαττον αἰεὶ συμπορεύεται τῷ κανόνι, τουτέστιν ὅτι πασῶν τῶν ἀπὸ τινῶν σημείων τῆς ΛΓΘ γραμμῆς ἐπὶ τὴν ΑΒ εὐθεῖαν καθέτων μεγίστη ἐστὶν ἡ ΓΔ κάθετος, αἰεὶ δὲ ἡ ἔγγιον τῆς ΓΔ ἀγομένη κάθετος τῆς ἀπώτερον μείζων ἐστίν, καὶ ὅτι, εἰς τὸν μεταξὺ τόπον τοῦ κανόνος καὶ τῆς κοχλοειδοῦς εἴαν τις ἡ εὐθεῖα, ἐκβαλλομένη τμηθήσεται ὑπὸ τῆς κοχλοειδοῦς, αὐτὸς ἀπέδειξεν ὁ Νικομήδης, καὶ ἡμεῖς ἐν τῷ εἰς τὸ Ἀνάλημμα Διοδώρου, τρίχα τεμείν τὴν γωνίαν βουλόμενοι, κεχρήμεθα τῇ προειρημένῃ γραμμῇ.

¹ ἐπειδὴ . . . προσπίπτουσαι " ex proximis inepte huc translata " del. Hultsch.

^a Let a be the interval or constant intercept between the curve and the base, and b the distance from the pole to the base (ΕΔ). If Θ is any point on the curve, and $E\Theta = \tau$, $\angle GE\Theta = \phi$, then the fundamental equation of the curve is

$$\tau = b \sec \phi + a.$$

If a is measured *backwards* from the base towards the pole, then another conchoidal figure is obtained on the same side of the base as the pole, having for its fundamental equation

$$\tau = b \sec \phi - a.$$

This takes three forms according as a is greater than,



THIS PAGE IS LOCKED TO FREE MEMBERS

Purchase full membership to immediately unlock this page

FORGOTTEN BOOKS

FULL

MEMBERSHIP

797,885 Books!

All you can read

for only

\$8.99/month

Continue

*Fair usage policy applies



GREEK MATHEMATICS

Διὰ δὴ τῶν εἰρημένων φανερόν ὡς δυνατόν ἐστὶν γωνίας δοθείσης ὡς τῆς ὑπὸ HAB καὶ σημείου ἐκτὸς αὐτῆς τοῦ Γ διάγειν τὴν ΓH καὶ ποιεῖν τὴν KH μεταξύ τῆς γραμμῆς καὶ τῆς AB ἴσην τῇ δοθείση.

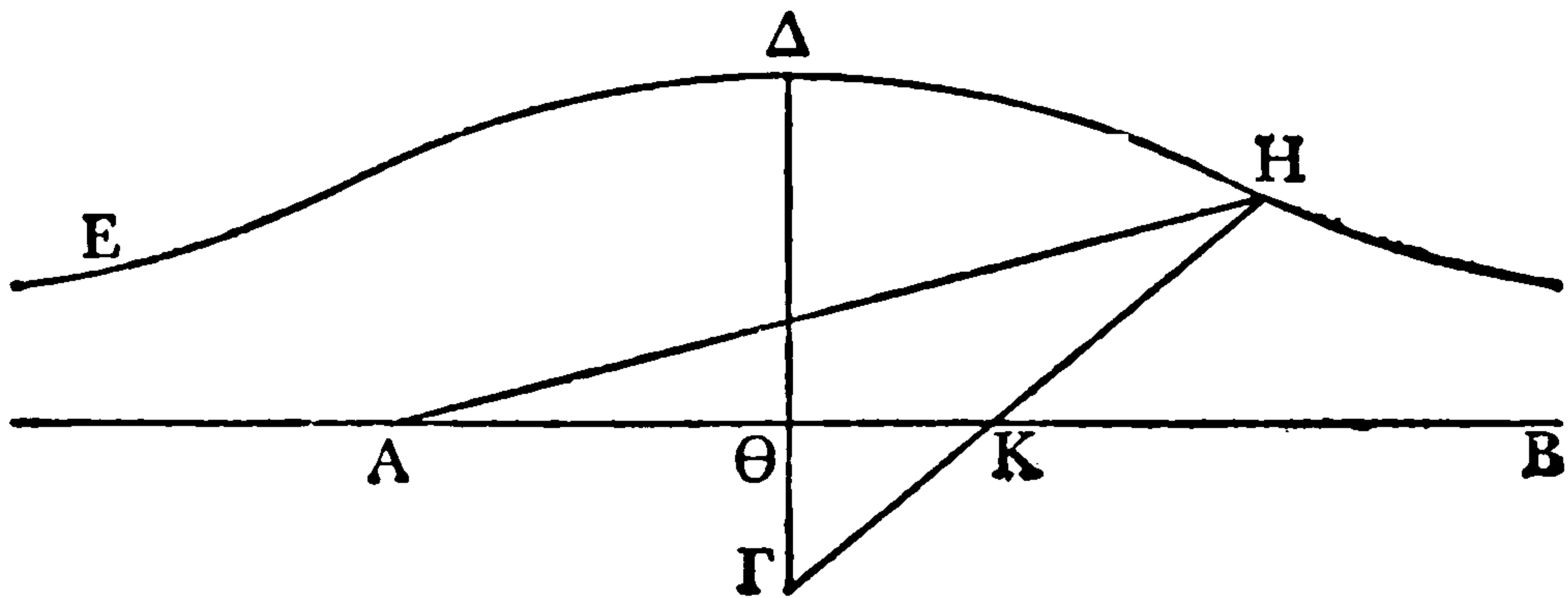

Ἦχθω κάθετος ἀπὸ τοῦ Γ σημείου ἐπὶ τὴν AB ἢ $\Gamma\Theta$ καὶ ἐκβεβλήσθω, καὶ τῇ δοθείση ἴση ἔστω ἢ $\Delta\Theta$, καὶ πόλῳ μὲν τῷ Γ , διαστήματι δὲ τῷ δοθέντι, τουτέστιν τῇ $\Delta\Theta$, κανόνι δὲ τῷ AB γεγράφθω κοχλοειδῆς γραμμὴ πρώτη ἢ $E\Delta H$. συμβάλλει ἄρα τῇ AH διὰ τὸ προλεχθέν. συμβαλλέτω κατὰ τὸ H , καὶ ἐπεζεύχθω ἢ ΓH . ἴση ἄρα καὶ ἢ KH τῇ δοθείση.

κη'. Τινὲς δὲ τῆς χρήσεως ἔνεκα παρατιθέντες κανόνα τῷ Γ κινουῦσιν αὐτόν, ἕως ἂν ἐκ τῆς πείρας ἢ μεταξύ ἀπολαμβανομένη τῆς AB εὐθείας καὶ τῆς $E\Delta H$ γραμμῆς ἴση γένηται τῇ δοθείση· τούτου γὰρ ὄντος τὸ προκείμενον ἐξ ἀρχῆς δείκνυται (λέγω δὲ κύβος κύβου διπλάσιος εὐρίσκεται). πρότερον δὲ δύο δοθεισῶν εὐθειῶν δύο μέσαι κατὰ τὸ συνεχὲς ἀνάλογον λαμβάνονται, ὧν ὁ μὲν Νικομήδης τὴν κατασκευὴν ἐξέθετο μόνον, ἡμεῖς

SPECIAL PROBLEMS

Now by what has been said it is clear that if there is an angle, such as HAB , and a point Γ outside the angle, it is possible so to draw ΓH as to make KH between the line and AB equal to a given straight line.

Let $\Gamma\Theta$ be drawn from the point Γ perpendicular to AB and produced to Δ so that $\Delta\Theta$ is equal to the given straight line, and with Γ for pole, the given straight line, that is $\Delta\Theta$, for interval, and AB for ruler let the first cochloid $E\Delta H$ be drawn ; then by what has been said above it will meet AH ; let it meet it in H , and let ΓH be joined ; KH will therefore be equal to the given straight line.

28. Some people, following [a more convenient] usage, apply a ruler to Γ and move it until by trial the portion between the straight line AB and the line $E\Delta H$ becomes equal to the given straight line ; and when this is done the problem which was posed at the outset is solved (I mean a cube which is double of a cube is found). But first two means in continuous proportion are taken between two given straight lines ; Nicomedes explained only the construction necessary

δὲ καὶ τὴν ἀπόδειξιν ἐφηρμόσαμεν τῇ κατασκευῇ
τὸν τρόπον τοῦτον.

Δεδόσθωσαν γὰρ δύο εὐθείαι αἱ ΓΛ, ΛΑ πρὸς
ὀρθὰς ἀλλήλαις, ὧν δεῖ δύο μέσας ἀνάλογον κατὰ
τὸ συνεχὲς εὐρεῖν, καὶ συμπεπληρώσθω τὸ ΑΒΓΛ
παραλληλόγραμμον, καὶ τετμήσθω δίχα ἑκατέρα
τῶν ΑΒ, ΒΓ τοῖς Δ, Ε σημείοις, καὶ ἐπιζευχθεῖσα

^a The proof is given by Eutocius with very few variations (pp. 104-106) and also in another place by Pappus himself (iii. 8, ed. Hultsch 58. 23-62. 13, with several differences). In iii. 8 the straight lines are called ΔΓ, ΔΑ, whereas here and in the passage from Eutocius the mss. have ΓΛ, ΛΑ. Wherever we have Λ here, it is reasonably certain that Pappus wrote Δ, and *vice versa*.



THIS PAGE IS LOCKED TO FREE MEMBERS

Purchase full membership to immediately unlock this page

SAVE \$3,999,994

Did you know we sell
paperback books too?

To buy our entire catalog
in paperback would cost
over \$4,000,000

Access it all now for
\$8.99/month

*Fair usage policy applies

Continue

μὲν ἡ ΑΑ ἐκβεβλήσθω καὶ συμπιπέτω τῇ ΒΒ ἐκβληθείσῃ κατὰ τὸ Η, τῇ δὲ ΒΒ πρὸς ὀρθὰς ἡ ΕΖ, καὶ προσβεβλήσθω ἡ ΓΖ ἴση οὔσα τῇ ΑΑ, καὶ ἐπεζεύχθω ἡ ΖΗ καὶ αὐτῇ παράλληλος ἡ ΓΘ, καὶ γωνίας οὔσης τῆς ὑπὸ τῶν ΚΓΘ ἀπὸ δοθέντος τοῦ Ζ διήχθω ἡ ΖΘΚ ποιοῦσα ἴσην τὴν ΘΚ τῇ ΑΑ ἢ τῇ ΓΖ (τοῦτο γὰρ ὡς δυνατὸν ἐδείχθη διὰ τῆς κοχλοειδοῦς γραμμῆς), καὶ ἐπεζευχθεῖσα ἡ ΚΛ ἐκβεβλήσθω καὶ συμπιπέτω τῇ ΑΒ ἐκβληθείσῃ κατὰ τὸ Μ· λέγω ὅτι ἐστὶν ὡς ἡ ΑΓ πρὸς ΚΓ, ἢ ΚΓ πρὸς ΜΑ, καὶ ἡ ΜΑ πρὸς τὴν ΑΑ.

Ἐπεὶ ἡ ΒΒ τέτμηται δίχα τῷ Ε καὶ πρόσκειται αὐτῇ ἡ ΚΓ, τὸ ἄρα ὑπὸ ΒΚΓ μετὰ τοῦ ἀπὸ ΓΕ ἴσον ἐστὶν τῷ ἀπὸ ΕΚ. κοινὸν προσκείσθω τὸ ἀπὸ ΕΖ· τὸ ἄρα ὑπὸ ΒΚΓ μετὰ τῶν ἀπὸ ΓΕΖ, τουτέστιν τοῦ ἀπὸ ΓΖ, ἴσον ἐστὶν τοῖς ἀπὸ ΚΕΖ, τουτέστιν τῷ ἀπὸ ΚΖ. καὶ ἐπεὶ ὡς ἡ ΜΑ πρὸς ΑΒ, ἢ ΜΑ πρὸς ΑΚ, ὡς δὲ ἡ ΜΑ πρὸς ΑΚ, οὕτως ἡ ΒΒ πρὸς ΓΚ, καὶ ὡς ἄρα ἡ ΜΑ πρὸς ΑΒ, οὕτως ἡ ΒΒ πρὸς ΓΚ. καὶ ἔστι τῆς μὲν ΑΒ ἡμίσεια ἡ ΑΑ, τῆς δὲ ΒΒ διπλῆ ἡ ΓΗ· ἔσται ἄρα καὶ ὡς ἡ ΜΑ πρὸς ΑΑ, οὕτως ἡ ΗΓ πρὸς ΚΓ. ἀλλ' ὡς ἡ ΗΓ πρὸς ΓΚ, οὕτως ἡ ΖΘ πρὸς ΘΚ διὰ τὰς παραλλήλους τὰς ΗΖ, ΓΘ· καὶ συνθέντι ἄρα ὡς ἡ ΜΑ πρὸς ΑΑ, ἢ ΖΚ πρὸς ΚΘ. ἴση δὲ ὑπόκειται καὶ ἡ ΑΑ τῇ ΘΚ, ἐπεὶ¹ καὶ τῇ ΓΖ ἴση ἐστὶν ἡ ΑΔ¹. ἴση ἄρα καὶ ἡ ΜΑ τῇ ΖΚ· ἴσον ἄρα καὶ τὸ ἀπὸ ΜΑ τῷ ἀπὸ ΖΚ. καὶ ἔστι τῷ μὲν ἀπὸ ΜΑ ἴσον τὸ ὑπὸ ΒΜΑ μετὰ τοῦ ἀπὸ ΑΑ, τῷ δὲ

¹ ἐπεὶ . . . ΑΔ. Hultsch thinks these words are interpolated; they appear in both other versions.

SPECIAL PROBLEMS

Δ , E respectively, and let $\Delta\Lambda$ be joined and produced, and let it meet ΓB produced in H , and let EZ be drawn at right angles to $B\Gamma$ in such a way that ΓZ is equal to $A\Delta$, and let ZH be joined and parallel to it let $\Gamma\Theta$ be drawn, and, since the angle $K\Gamma\Theta$ is given, from the given point Z let $Z\Theta K$ be so drawn as to make ΘK equal to $A\Delta$ or to ΓZ (that this is possible is proved by the cochloidal line), and let $K\Lambda$ be joined and produced, and let it meet AB produced in M ; I say that $\Lambda\Gamma : K\Gamma = K\Gamma : MA = MA : A\Lambda$.

Since $B\Gamma$ is bisected at E and $K\Gamma$ lies in $B\Gamma$ produced, therefore

$$BK \cdot K\Gamma + \Gamma E^2 = EK^2. \quad [\text{Eucl. ii. 6}]$$

Let EZ^2 be added to both sides.

$$\text{Therefore } BK \cdot K\Gamma + \Gamma E^2 + EZ^2 = EK^2 + EZ^2,$$

$$\text{that is } BK \cdot K\Gamma + \Gamma Z^2 = KZ^2. \quad [\text{Eucl. i. 47}]$$

$$\text{And since } MA : AB = M\Lambda : \Lambda K$$

$$\text{and } M\Lambda : \Lambda K = B\Gamma : \Gamma K,$$

$$\text{therefore } MA : AB = B\Gamma : \Gamma K.$$

$$\text{And } A\Delta = \frac{1}{2}AB, \Gamma H = 2B\Gamma.$$

$$\text{Therefore } MA : A\Delta = H\Gamma : K\Gamma.$$

But on account of HZ , $\Gamma\Theta$ being parallels,

$$H\Gamma : \Gamma K = Z\Theta : \Theta K.$$

Therefore, compounding,

$$M\Delta : \Delta A = ZK : K\Theta.$$

But by hypothesis $A\Delta = \Theta K$, since $\Gamma Z = A\Delta$;

$$\text{therefore } M\Delta = ZK;$$

$$\text{therefore } M\Delta^2 = ZK^2.$$

$$\text{And } M\Delta^2 = BM \cdot MA + \Delta A^2 \quad [\text{Eucl. ii. 6}]$$

GREEK MATHEMATICS

ἀπὸ ΖΚ ἴσον ἐδείχθη τὸ ὑπὸ ΒΚΓ μετὰ τοῦ ἀπὸ ΖΓ, ὧν τὸ ἀπὸ ΑΑ ἴσον τῷ ἀπὸ ΓΖ (ἴση γὰρ ὑπόκειται ἢ ΑΔ τῇ ΓΖ). ἴσον ἄρα καὶ τὸ ὑπὸ ΒΜΑ τῷ ὑπὸ ΒΚΓ. ὡς ἄρα ἢ ΜΒ πρὸς ΒΚ, ἢ ΓΚ πρὸς ΜΑ. ἀλλ' ὡς ἢ ΒΜ πρὸς ΒΚ, ἢ ΑΓ πρὸς ΓΚ. ὡς ἄρα ἢ ΑΓ πρὸς ΓΚ, ἢ ΓΚ πρὸς ΑΜ. ἔστι δὲ καὶ ὡς ἢ ΜΒ πρὸς ΒΚ, ἢ ΜΑ πρὸς ΑΑ. καὶ ὡς ἄρα ἢ ΑΓ πρὸς ΓΚ, ἢ ΓΚ πρὸς ΑΜ, καὶ ἢ ΑΜ πρὸς ΑΑ.

2. SQUARING OF THE CIRCLE

(a) GENERAL

Plut. *De Exil.* 17, 607E, F

Ἀνθρώπου δ' οὐδεὶς ἀφαιρεῖται τόπος εὐδαιμονίαν, ὥσπερ οὐδ' ἀρετὴν οὐδὲ φρόνησιν. ἀλλ' Ἀναξαγόρας μὲν ἐν τῷ δεσμωτηρίῳ τὸν τοῦ κύκλου τετραγωνισμόν ἔγραφε.

Aristoph. *Aves* 1001-1005

ΜΕΤΩΝ. Προσθεὶς οὖν ἐγὼ τὸν κανόν' ἄνωθεν τουτονὶ τὸν καμπύλον, ἐνθεὶς διαβήτην—μανθάνεις; ΠΕΙΣΘΕΤΑΙΡΟΣ. οὐ μανθάνω.

ΜΕΤΩΝ. Ὅρθῳ μετρήσω κανόνι προστιθείς, ἵνα ὁ κύκλος γένηταί σοι τετράγωνος.

^a This reference shows the popularity of the problem of squaring the circle in 414 B.C., when the *Birds* was first produced. Meton, who is here burlesqued, is the great astronomer who about eighteen years earlier had found that after any period of 6940 days (a little over nineteen solar 308



THIS PAGE IS LOCKED TO FREE MEMBERS

Purchase full membership to immediately unlock this page

FORGOTTEN BOOKS

FULL

MEMBERSHIP

797,885 Books!

All you can read

for only

\$8.99/month

Continue

*Fair usage policy applies



GREEK MATHEMATICS

(b) APPROXIMATION BY POLYGONS

(i.) *Antiphon*

Aristot. *Phys.* A 2, 185 a 14-17

Ἄμα δ' οὐδὲ λύειν ἅπαντα προσήκει, ἀλλ' ἢ ὅσα ἐκ τῶν ἀρχῶν τις ἐπιδεικνὺς ψεύδεται, ὅσα δὲ μή, οὗ, οἷον τὸν τετραγωνισμὸν τὸν μὲν διὰ τῶν τμημάτων γεωμετρικοῦ διαλύσαι, τὸν δὲ Ἄντιφῶντος οὐ γεωμετρικοῦ.

Them. in *Phys.* A 2 (Aristot. 185 a 14), ed. Schenkl
3. 30-4. 7

Ἐπεὶ καὶ τὰ ψευδογραφήματα ὅσα μὲν σῶζει τὰς γεωμετρικὰς ὑποθέσεις λυτέον τῷ γεωμέτρῃ, ὅσα δὲ μάχεται πρὸς ἐκείνας, παραιτητέον, οἷον

^a Antiphon was an Athenian sophist contemporary with Socrates.

^b The comments of Themistius, Philoponus and Simplicius on this passage are of great importance in the history of Greek geometry. All three agree (Simplicius with a reservation) that "the quadrature by means of segments" is to be ascribed to Hippocrates of Chios. Simplicius's reproduction of the passage in Eudemus's *History of Geometry* which tells us of certain areas squared by Hippocrates has already been given (*supra*, pp. 234-253). The four quadratures there given contain no fallacy. What then is the fallacy with which Aristotle and the commentators charge Hippocrates? It is most probably an alleged assumption by Hippocrates that because he had squared a particular lune in each of three kinds, he had squared all types of lunes; and, as he had also squared a figure consisting of a lune and a circle, that he had squared the circle. In fact, the last-mentioned lune was not of a kind which he had previously squared, and so he had not really squared the circle. But did Hippocrates think that he had squared the circle? There is no reason to suppose that he so thought, and it is extremely unlikely that a mathematician of his calibre

SPECIAL PROBLEMS

(b) APPROXIMATION BY POLYGONS

(i.) *Antiphon*^a

Aristotle, *Physics* A 2, 185 a 14-17

At the same time it is not convenient to refute everything, but only false demonstrations starting from the fundamental principles, and otherwise not; thus it is the business of the geometer to refute the quadrature by means of segments, but it is not the business of the geometer to refute that of Antiphon.^b

Themistius, *Commentary on Aristotle's Physics* A 2
(185 a 14), ed. Schenkl 3. 30-4. 7

For such false arguments as preserve the geometrical hypotheses are to be refuted by geometry, but such as conflict with them are to be left alone.

could be so deluded. Heiberg (*Philol.* xliii. 336-344) thinks that in the then state of logic he may have thought he had squared the circle. Björnbo (in Pauly-Wissowa, *Real-Encyclopädie*, xvi. 1787-1799) thinks he knew perfectly well what he had done, but used language calculated to give the impression that he had squared the circle. Both suggestions are highly improbable. Heath (*H.G.M.* i. 197) prefers to think that Hippocrates was trying to put what he had discovered in the most favourable light. Ross (*Aristotle's Physics*, p. 466) is of opinion that Hippocrates simply proved his quadratures of lunes and the sum of a lune and circle, no doubt in the hope of ultimately squaring the circle, but without any claim to have done so. This appears the best view. Aristotle has misunderstood what Hippocrates claimed to have done.

τμήματα means "segments," and is not properly used of "lunes," but mathematical terminology was fluid in Aristotle's time, and *τμήμα* may have been used to denote any portion cut out of a circle. In *De Caelo* ii. 8, 290 a 4, Aristotle uses it to denote a "sector."

δύο τινές κύκλον ἐπιχειρήσαντες τετραγωνίζειν Ἰπποκράτης τε ὁ Χίος καὶ ὁ Ἀντιφῶν. τὸν μὲν οὖν Ἰπποκράτους λυτέον. τὰς γὰρ ἀρχὰς φυλάττων παραλογίζεται τῷ μόνον μὲν ἐκεῖνον τὸν μηνίσκον τετραγωνίσει ὅς γράφεται περὶ τὴν τοῦ τετραγώνου πλευρὰν τοῦ εἰς τὸν κύκλον ἐγγραφομένου, πάντα¹ δὲ μηνίσκον οἷόν τε τετραγωνίζειν λαβεῖν εἰς¹ ἀπόδειξιν, πρὸς Ἀντιφῶντα δὲ οὐκέτ' ἂν ἔχοι λέγειν ὁ γεωμέτρης, ὅς ἐγγράφων τρίγωνον ἰσόπλευρον εἰς τὸν κύκλον καὶ ἐφ' ἐκάστης τῶν πλευρῶν ἕτερον ἰσοσκελὲς συνιστὰς πρὸς τῇ περιφερείᾳ τοῦ κύκλου καὶ τοῦτο ἐφεξῆς ποιῶν ὥστε ποτε ἐφαρμόσειν τοῦ τελευταίου τριγώνου τὴν πλευρὰν εὐθείαν οὔσαν τῇ περιφερείᾳ.

Simpl. in *Phys.* A 2 (Aristot. 185 a 14), ed. Diels
54. 20–55. 24

Ὁ δὲ Ἀντιφῶν γράψας κύκλον ἐνέγραφέ τι χωρίον εἰς αὐτὸν πολύγωνον τῶν ἐγγράφεσθαι δυναμένων. ἔστω δὲ εἰ τύχοι τετράγωνον τὸ ἐγγεγραμμένον. . . . καὶ δῆλον ὅτι ἡ συναγωγή παρὰ τὰς γεωμετρικὰς ἀρχὰς γέγονεν οὐχ ὡς ὁ Ἀλέξανδρός φησιν, “ὅτι ὑποτίθεται μὲν ὁ γεωμέτρης τὸ τὸν κύκλον τῆς εὐθείας κατὰ σημεῖον ἄπτεσθαι ὡς ἀρχήν, ὁ δὲ Ἀντιφῶν ἀναιρεῖ τοῦτο.” οὐ γὰρ ὑποτίθεται ὁ γεωμέτρης τοῦτο, ἀλλ' ἀποδείκνυσιν αὐτὸ ἐν τῷ τρίτῳ βιβλίῳ. ἄμεινον οὖν

¹ πάντα . . . εἰς: a lacuna in the text is satisfactorily filled, as Schenkl notes, if these words are supplied from Simplicius.

* Accounts differ about Antiphon's procedure, but it makes no difference to the result, which is to get a regular polygon approaching the circle as its limit. Themistius was
312



THIS PAGE IS LOCKED TO FREE MEMBERS

Purchase full membership to immediately unlock this page

SAVE \$3,999,994

Did you know we sell
paperback books too?

To buy our entire catalog
in paperback would cost
over \$4,000,000

Access it all now for
\$8.99/month

*Fair usage policy applies

Continue

λέγειν ἀρχὴν εἶναι τὸ ἀδύνατον εἶναι εὐθείαν ἐφαρμόσαι περιφερεία, ἀλλ' ἢ μὲν ἐκτὸς κατὰ ἓν σημεῖον ἐφάψεται τοῦ κύκλου, ἢ δὲ ἐντὸς κατὰ δύο μόνον καὶ οὐ πλείω, καὶ ἢ ἐπαφῆ κατὰ σημεῖον γίνεται. καὶ μέντοι τέμνων αἰεὶ τὸ μεταξύ τῆς εὐθείας καὶ τῆς τοῦ κύκλου περιφερείας ἐπίπεδον οὐ δαπανήσει αὐτὸ οὐδὲ καταλήψεταιί ποτε τὴν τοῦ κύκλου περιφέρειαν, εἴπερ ἐπ' ἄπειρόν ἐστι διαιρετὸν τὸ ἐπίπεδον. εἰ δὲ καταλαμβάνει, ἀνήρηται τις ἀρχὴ γεωμετρικὴ ἢ λέγουσα ἐπ' ἄπειρον εἶναι τὰ μεγέθη διαιρετά. καὶ ταύτην καὶ ὁ Εὐδῆμος τὴν ἀρχὴν ἀναιρεῖσθαι φησιν ὑπὸ τοῦ Ἀντιφῶντος.

(ii.) *Bryson*

Alex. Aphr. in *Soph. El.* 11 (Aristot. 171 b 7), ed. Wallies 90. 10-21

Ἄλλ' ὁ τοῦ Βρύσωνος τετραγωνισμὸς τοῦ κύκλου ἐριστικός ἐστι καὶ σοφιστικός, ὅτι οὐκ ἐκ τῶν οἰκείων ἀρχῶν τῆς γεωμετρίας ἀλλ' ἐκ τινων κοινοτέρων. τὸ γὰρ περιγράφειν ἐκτὸς τοῦ κύκλου

* Heath (*H.G.M.* i. 222-223) comments: "The objection to Antiphon's statement is really no more than verbal; Euclid uses exactly the same construction in xii. 2, only he expresses the conclusion in a different way, saying that, if the process be continued far enough, the small segments left over will be together less than any assigned area. Antiphon in effect said the same thing, which again we express by saying that the circle is the *limit* of such an inscribed polygon when the number of its sides is indefinitely increased. Antiphon therefore deserves an honourable place in the history of geometry as having originated the idea of *exhausting* an area by means of inscribed regular polygons

SPECIAL PROBLEMS

would be better therefore to say that the principle is that a straight line cannot coincide with the circumference, a straight line drawn from outside the circle touching it in one point only, a straight line drawn from inside cutting it in two points and not more, and tangential contact being in one point only. Now continual division of the space between the straight line and the circumference of the circle will never exhaust it nor ever reach the circumference of the circle, if the space is really divisible without limit. For if the circumference could be reached, the geometrical principle that magnitudes are divisible without limit would be violated. This was the principle which Eudemus says was violated by Antiphon.^a

(ii.) Bryson^b

Alexander, *Commentary on Aristotle's Sophistic Refutations* 11 (171 b 7), ed. Wallies 90. 10-21

But Bryson's quadrature of the circle is eristic and sophistical, because he proceeds not from principles peculiar to geometry but from wider principles. For to circumscribe a square about the circle and to

with an ever-increasing number of sides, an idea upon which Eudoxus founded his epoch-making *method of exhaustion*. The practical value of Antiphon's construction is illustrated by Archimedes' treatise on the *Measurement of a Circle* [reproduced below] . . . The same construction starting from a square was likewise the basis of Vieta's expression

for $\frac{2}{\pi}$, namely,

$$\frac{2}{\pi} = \cos \frac{\pi}{4} \cdot \cos \frac{\pi}{8} \cdot \cos \frac{\pi}{16} \cdot \dots$$

$$= \sqrt{\frac{1}{2}} \cdot \sqrt{\frac{1}{2} (1 + \sqrt{\frac{1}{2}})} \cdot \sqrt{\frac{1}{2} (1 + \sqrt{\frac{1}{2} (1 + \sqrt{\frac{1}{2}})})} \dots$$

^b Bryson was a pupil either of Socrates or of Euclid of Megara.

GREEK MATHEMATICS

τετράγωνον καὶ ἐντὸς ἐγγράφειν ἕτερον καὶ μεταξύ τῶν δύο τετραγώνων ἕτερον τετράγωνον, εἶτα λέγειν ὅτι ὁ μεταξύ τῶν δύο τετραγώνων κύκλος, ὁμοίως δὲ καὶ τὸ μεταξύ τῶν δύο τετραγώνων τετράγωνον τοῦ μὲν ἐκτὸς τετραγώνου ἐλάττονα εἶσι τοῦ δὲ ἐντὸς μείζονα, τὰ δὲ τῶν αὐτῶν μείζονα καὶ ἐλάττονα ἴσα ἐστίν, ἴσος ἄρα ὁ κύκλος καὶ τὸ τετράγωνον, ἕκ τινων κοινῶν ἀλλὰ καὶ ψευδῶν ἐστι, κοινῶν μὲν, ὅτι καὶ ἐπ' ἀριθμῶν καὶ χρόνων καὶ τόπων καὶ ἄλλων κοινῶν ἀρμόσοι ἄν, ψευδῶν δέ, ὅτι ὀκτὼ καὶ ἐννέα τῶν δέκα καὶ ἑπτὰ ἐλάττονες καὶ μείζονές εἰσι καὶ ὅμως οὐκ εἰσὶν ἴσοι.

(iii.) *Archimedes*

Procl. *in Eucl. i.*, ed. Kroll 422. 24-423. 5

Ἐκ τούτου δὲ οἶμαι τοῦ προβλήματος ἐπαχθέντες οἱ παλαιοὶ καὶ τὸν τοῦ κύκλου τετραγωνισμόν ἐζήτησαν. εἰ γὰρ παραλληλόγραμμον ἴσον εὐρίσκεται παντὶ εὐθυγράμμῳ, ζητήσεως ἄξιον, μὴ καὶ τὰ εὐθύγραμμα τοῖς περιφερογράμμοις ἴσα δεικνύναι δυνατόν. καὶ ὁ Ἀρχιμήδης ἔδειξεν, ὅτι πᾶς κύκλος ἴσος ἐστὶ τριγώνῳ ὀρθογωνίῳ, οὗ ἡ μὲν ἐκ κέντρου ἴση ἐστὶν μιᾷ τῶν περὶ τὴν ὀρθήν, ἡ δὲ περίμετρος τῇ βάσει.

Archim. *Dim. Circ.*, Archim. ed. Heiberg i. 232-242

α'

Πᾶς κύκλος ἴσος ἐστὶ τριγώνῳ ὀρθογωνίῳ, οὗ

^a Bryson marks a step beyond Antiphon because he conceived the circle as intermediate in area between an inscribed and an escribed polygon, an idea which was powerfully developed by Archimedes. The manner in which he took a square intermediate between the inscribed and escribed



THIS PAGE IS LOCKED TO FREE MEMBERS

Purchase full membership to immediately unlock this page

FORGOTTEN BOOKS

FULL

MEMBERSHIP

797,885 Books!

All you can read

for only

\$8.99/month

Continue

*Fair usage policy applies



GREEK MATHEMATICS

ἢ μὲν ἐκ τοῦ κέντρου ἴση μιᾷ τῶν περὶ τὴν ὀρθήν,
ἢ δὲ περίμετρος τῆ βάσει.

Ἐχέτω ὁ $ΑΒΓΔ$ κύκλος τριγώνῳ τῷ $Ε$, ὡς
ὑπόκειται· λέγω, ὅτι ἴσος ἐστίν.

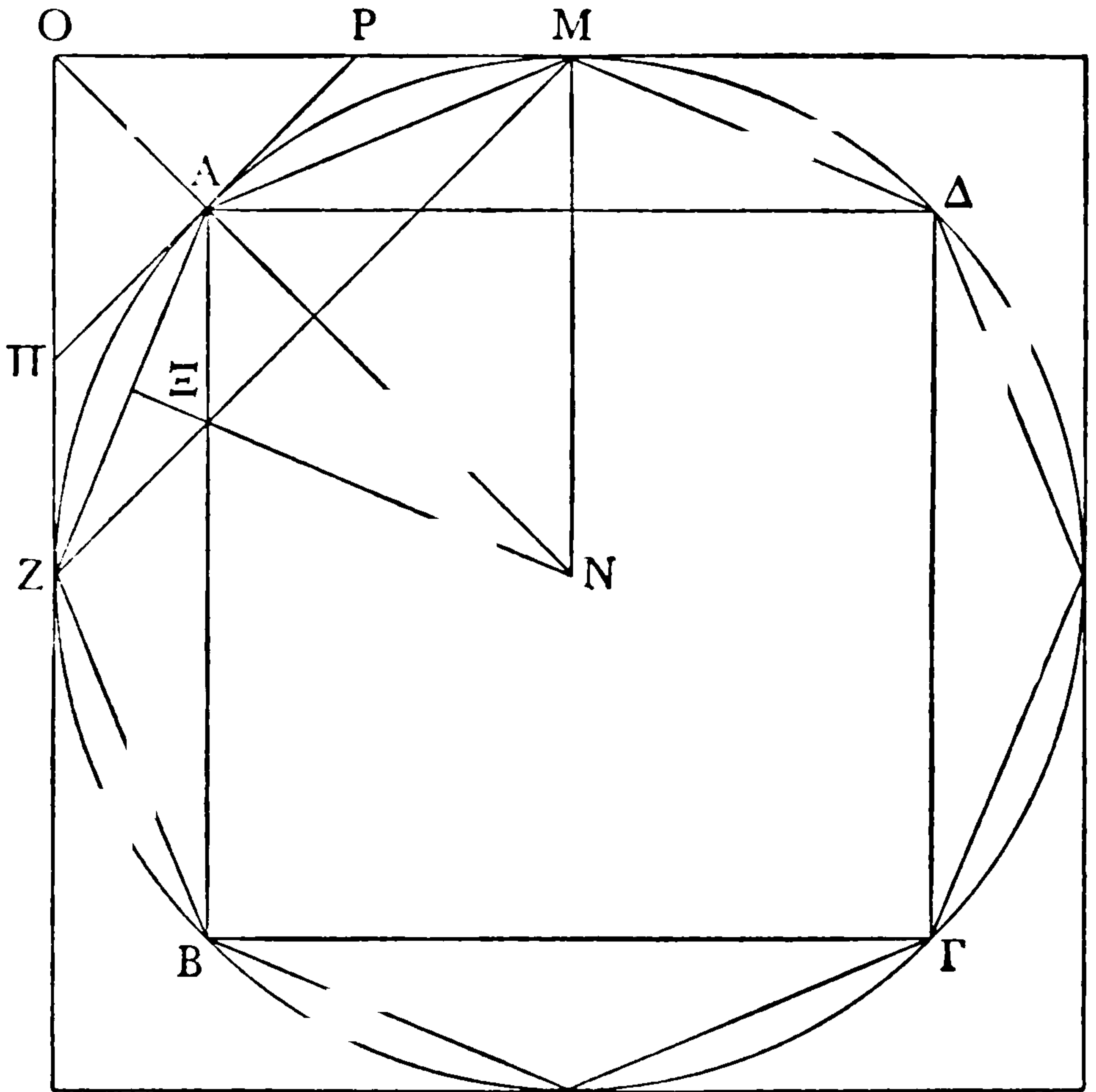

Εἰ γὰρ δυνατόν, ἔστω μείζων ὁ κύκλος, καὶ
ἐγγεγράφθω τὸ $ΑΓ$ τετράγωνον, καὶ τετμήσθωσαν
αἱ περιφέρειαι δίχα, καὶ ἔστω τὰ τμήματα ἤδη
ἐλάσσονα τῆς ὑπεροχῆς, ἣ ὑπερέχει ὁ κύκλος τοῦ
τριγώνου· τὸ εὐθύγραμμον ἄρα ἔτι τοῦ τριγώνου
ἐστὶ μείζον. εἰλήφθω κέντρον τὸ $Ν$ καὶ κάθετος

SPECIAL PROBLEMS

one of the sides about the right angle is equal to the radius, and the base is equal to the circumference.

Let the circle $AB\Gamma\Delta$ have to the triangle E the stated relation ; I say that it is equal.

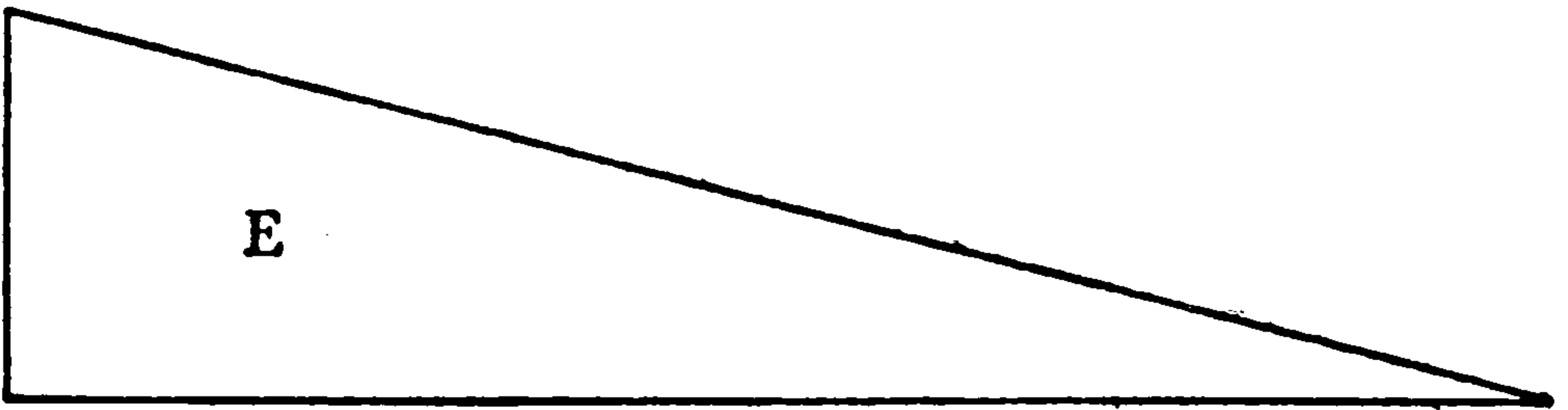

For, if possible, let the circle be greater, and let the square $A\Gamma$ be inscribed, and let the arcs be divided into equal parts [and let BZ , ZA , AM , $M\Delta$, etc., be drawn],^a and let the segments be less than the excess by which the circle exceeds the triangle.^b The rectilinear figure is therefore greater than the triangle.

^a Heiberg's note is: "Tale aliquid Archimedes sine dubio addiderat: Omnino in toto hoc opusculo genus dicendi et exponendi brevitatem tam negligentem laborat, ut manum excerptoris potius quam Archimedis agnoscas."

^b That this can be done is shown in Eucl. *Elem.* xii. 2, depending on x. 1. The latter theorem was probably discovered by Eudoxus, but is commonly known as the "Axiom of Archimedes" from his repeated use of it.

ἡ ΝΞ· ἐλάσσων ἄρα ἡ ΝΞ τῆς τοῦ τριγώνου πλευρᾶς. ἔστιν δὲ καὶ ἡ περίμετρος τοῦ εὐθύγραμμου τῆς λοιπῆς ἐλάττων, ἐπεὶ καὶ τῆς τοῦ κύκλου περιμέτρου· ἔλαττον ἄρα τὸ εὐθύγραμμον τοῦ Ε τριγώνου· ὅπερ ἄτοπον.

Ἐστω δὲ ὁ κύκλος, εἰ δυνατόν, ἐλάσσων τοῦ Ε τριγώνου, καὶ περιγεγράφθω τὸ τετράγωνον, καὶ τετμήσθωσαν αἱ περιφέρειαι δίχα, καὶ ἤχθωσαν ἐφαπτόμεναι διὰ τῶν σημείων· ὀρθὴ ἄρα ἡ ὑπὸ ΟΑΡ. ἡ ΟΡ ἄρα τῆς ΜΡ ἐστὶν μείζων· ἡ γὰρ ΡΜ τῇ ΡΑ ἴση ἐστὶ· καὶ τὸ ΡΟΠ τρίγωνον ἄρα τοῦ ΟΖΑΜ σχήματος μείζον ἐστὶν ἢ τὸ ἥμισυ. λελείφθωσαν οἱ τῷ ΠΖΑ τομει ὅμοιοι ἐλάσσους τῆς ὑπεροχῆς, ἢ ὑπερέχει τὸ Ε τοῦ ΑΒΓΔ κύκλου· ἔτι ἄρα τὸ περιγεγραμμένον εὐθύγραμμον τοῦ Ε ἐστὶν ἔλασσον· ὅπερ ἄτοπον· ἔστιν γὰρ μείζον, ὅτι ἡ μὲν ΝΑ ἴση ἐστὶ τῇ καθέτῳ τοῦ τριγώνου, ἡ δὲ περίμετρος μείζων ἐστὶ τῆς βάσεως τοῦ τριγώνου. ἴσος ἄρα ὁ κύκλος τῷ Ε τριγώνῳ.

γ'

Παντὸς κύκλου ἡ περίμετρος τῆς διαμέτρου τριπλασίων ἐστὶ καὶ ἔτι ὑπερέχει ἐλάσσονι μὲν ἢ ἐβδόμῳ μέρει τῆς διαμέτρου, μείζονι δὲ ἢ δέκα ἐβδομηκοστομόνοις.

^a i.e., the space between the arc ΖΑ of the circle and the sides ΖΠ, ΠΑ of the escribed polygon. The name given to this figure, τομεύς, is more properly used of a sector of a circle, and Heiberg notes: "τομει Archimedes non scripsit pro ἀποτμήματι." The process, it is not quite clearly stated



THIS PAGE IS LOCKED TO FREE MEMBERS

Purchase full membership to immediately unlock this page

SAVE \$3,999,994

Did you know we sell
paperback books too?

To buy our entire catalog
in paperback would cost
over \$4,000,000

Access it all now for
\$8.99/month

*Fair usage policy applies

Continue

GREEK MATHEMATICS

Ἐστω κύκλος καὶ διάμετρος ἡ $ΑΓ$ καὶ κέντρον τὸ $Ε$ καὶ ἡ $ΓΛΖ$ ἐφαπτομένη καὶ ἡ ὑπὸ $ΖΕΓ$ τρίτου ὀρθῆς· ἡ $ΕΖ$ ἄρα πρὸς $ΖΓ$ λόγον ἔχει, ὃν

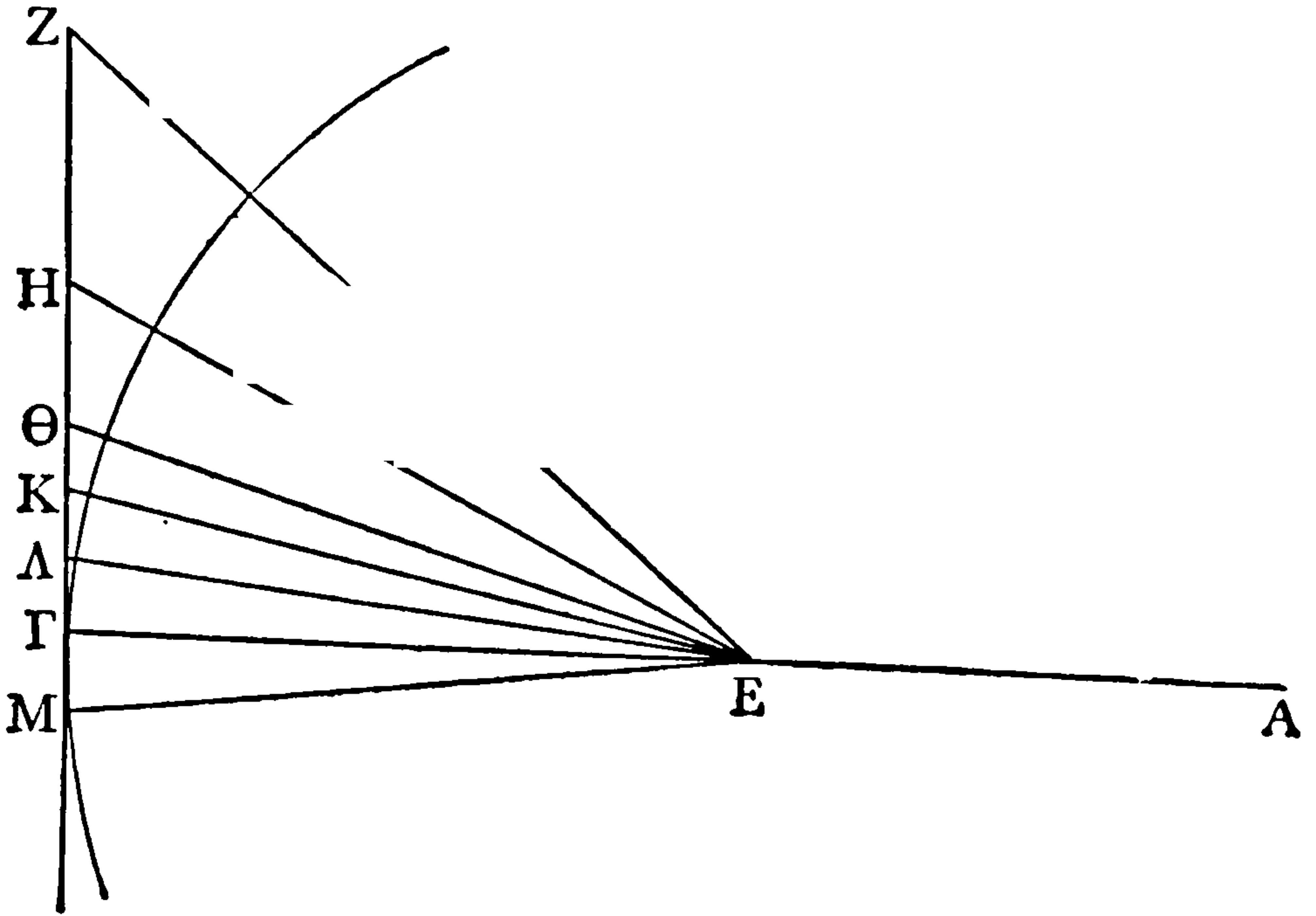

$\overline{τς}$ πρὸς $\overline{ρνγ}$, ἡ δὲ $ΕΓ$ πρὸς [τὴν] $ΓΖ$ λόγον ἔχει, ὃν $\overline{σξε}$ πρὸς $\overline{ρνγ}$. τετμήσθω οὖν ἡ ὑπὸ $ΖΕΓ$ δίχα τῇ $ΕΗ$. ἔστιν ἄρα, ὡς ἡ $ΖΕ$ πρὸς $ΕΓ$, ἡ $ΖΗ$ πρὸς $ΗΓ$ [καὶ ἐναλλάξ καὶ συνθέντι]. ὡς ἄρα συναμφότερος ἡ $ΖΕ$, $ΕΓ$ πρὸς $ΖΓ$, ἡ $ΕΓ$ πρὸς $ΓΗ$. ὥστε ἡ $\overline{ΓΕ}$ πρὸς $\overline{ΓΗ}$ μείζονα λόγον ἔχει ἢ περ $\overline{φοα}$ πρὸς $\overline{ρνγ}$. ἡ $ΕΗ$ ἄρα πρὸς $ΗΓ$ δυνάμει λόγον ἔχει, ὃν $\overset{\lambda\delta}{\overline{Μ}} \overline{,θυν}$ πρὸς $\overset{\beta}{\overline{Μ}} \overline{,γυθ}$. μήκει ἄρα, ὃν

^a As Eutocius explains in his commentary on this passage (Archim. ed. Heiberg iii. 234), if EZ is represented by 306 and $ΓΖ$ by 153, then by Pythagoras's theorem $ΕΓ^2 = 306^2 - 153^2 = 70227$. Since $265^2 = 70225$, $ΕΓ$ is therefore 265

SPECIAL PROBLEMS

Let there be a circle with diameter $A\Gamma$ and centre E , and let $\Gamma\Lambda Z$ be a tangent and the angle $Z\epsilon\Gamma$ one-third of a right angle. Then

$$E\Gamma : \Gamma Z [= \sqrt{3} : 1] > 265 : 153^a \quad . \quad . \quad (1)$$

and $EZ : Z\Gamma [= 2 : 1] = 306 : 153 \quad . \quad . \quad (2)$

Now let $\angle Z\epsilon\Gamma$ be bisected by EH . It follows that

$$ZE : E\Gamma = ZH : H\Gamma \text{ [Eucl. vi. 3]}$$

so that $[ZE + E\Gamma : E\Gamma = ZH + H\Gamma : H\Gamma$

$$= Z\Gamma : H\Gamma, \text{ or}]$$

$$ZE + E\Gamma : Z\Gamma = E\Gamma : H\Gamma.$$

Therefore $\Gamma E : \Gamma H [= E\Gamma + ZE : Z\Gamma$

$$> 265 + 306 : 153,$$

$$\text{by (1) and (2)]}$$

$$> 571 : 153 \quad . \quad . \quad (3)$$

Hence $EH^2 : H\Gamma^2 [= E\Gamma^2 + \Gamma H^2 : H\Gamma^2$

$$> 571^2 + 153^2 : 153^2]$$

$$> 349450 : 23409,$$

and a "minute and imperceptible fraction" ($\mu\acute{o}\rho\iota\omicron\nu \acute{\epsilon}\lambda\acute{\alpha}\chi\iota\sigma\tau\omicron\nu \kappa\alpha\iota \acute{\alpha}\nu\epsilon\pi\alpha\iota\sigma\theta\eta\tau\omicron\nu$). As the sides of the triangle are in the ratio $1, \sqrt{3}, 2$, this is equivalent to saying that $\sqrt{3} > \frac{265}{153}$. In the second part of the proof Archimedes assumes that $\sqrt{3} < \frac{1351}{780}$. The way in which he makes these assumptions, without explanation of any kind, shows that they were common in his day, and much ingenuity has been spent in devising processes by which they may have been reached. *v. Heath, The Works of Archimedes, lxxx-lxxxiv, xc-xcix.*

Eutocius fully explains the arithmetical working, where Archimedes merely sets down the results. In the translation the necessary working, where not given by Archimedes, is shown in square brackets. In the Greek text as we have it a few equalities are given where the argument requires inequalities. The translation reproduces what Archimedes must have written.

$\overline{\phi\zeta\alpha}$ ἢ πρὸς $\overline{\rho\nu\gamma}$. πάλιν δίχα ἢ ὑπὸ ΗΕΓ τῆ ΕΘ· διὰ
 τὰ αὐτὰ ἄρα ἢ ΕΓ πρὸς ΓΘ μείζονα λόγον ἔχει
 ἢ ὄν $\overline{\alpha\rho\xi\beta}$ ἢ πρὸς $\overline{\rho\nu\gamma}$. ἢ ΘΕ ἄρα πρὸς ΘΓ μείζονα
 λόγον ἔχει ἢ ὄν $\overline{\alpha\rho\sigma\beta}$ ἢ πρὸς $\overline{\rho\nu\gamma}$. ἔτι δίχα ἢ
 ὑπὸ ΘΕΓ τῆ ΕΚ· ἢ ΕΓ ἄρα πρὸς ΓΚ μείζονα
 λόγον ἔχει ἢ ὄν $\overline{\beta\tau\lambda\delta}$ δ' πρὸς $\overline{\rho\nu\gamma}$. ἢ ΕΚ ἄρα πρὸς



THIS PAGE IS LOCKED TO FREE MEMBERS

Purchase full membership to immediately unlock this page

FORGOTTEN BOOKS

FULL

MEMBERSHIP

797,885 Books!

All you can read

for only

\$8.99/month

Continue

*Fair usage policy applies



$\Gamma\text{Κ}$ μείζονα ἢ ὄν $\overline{\beta\tau\lambda\theta}$ δ' πρὸς $\overline{\rho\nu\gamma}$. ἔτι δίχα ἢ ὑπὸ ΚΕΓ τῆ $\Lambda\text{Ε}$. ἢ ΕΓ ἄρα πρὸς $\Lambda\Gamma$ μείζονα [μήκει] λόγον ἔχει ἢπερ τὰ $\overline{\delta\chi\omicron\gamma}$ \angle' πρὸς $\overline{\rho\nu\gamma}$. ἐπεὶ οὖν ἢ ὑπὸ ΖΕΓ τρίτου οὔσα ὀρθῆς τέτμηται τετράκις δίχα, ἢ ὑπὸ $\Lambda\text{ΕΓ}$ ὀρθῆς ἐστὶ μῆ'. κείσθω οὖν αὐτῇ ἴση πρὸς τῷ Ε ἢ ὑπὸ $\Gamma\text{ΕΜ}$. ἢ ἄρα ὑπὸ $\Lambda\text{ΕΜ}$ ὀρθῆς ἐστὶ κδ'. καὶ ἢ $\Lambda\text{Μ}$ ἄρα εὐθεία τοῦ περιτὸν κύκλον ἐστὶ πολυγώνου πλευρὰ πλευρὰς ἔχοντος $\overline{\zeta\varsigma}$. ἐπεὶ οὖν ἢ ΕΓ πρὸς τὴν $\Gamma\Lambda$ ἐδείχθη μείζονα λόγον ἔχουσα ἢπερ $\overline{\delta\chi\omicron\gamma}$ \angle' πρὸς $\overline{\rho\nu\gamma}$, ἀλλὰ τῆς μὲν ΕΓ διπλῆ ἢ $\Lambda\Gamma$, τῆς δὲ $\Gamma\Lambda$ διπλασίων ἢ $\Lambda\text{Μ}$, καὶ ἢ $\Lambda\Gamma$ ἄρα πρὸς τὴν τοῦ $\overline{\zeta\varsigma}$ -γώνου περίμετρον μείζονα λόγον ἔχει ἢπερ $\overline{\delta\chi\omicron\gamma}$ \angle' πρὸς $\overset{\alpha}{\text{Μ}}$ $\overline{\delta\chi\pi\eta}$. καὶ ἐστὶν τριπλάσια, καὶ ὑπερέχουσι $\overline{\chi\zeta\zeta}$ \angle' , ἄπερ τῶν $\overline{\delta\chi\omicron\gamma}$ \angle' ἐλάττονα ἐστὶν ἢ τὸ ἔβδομον· ὥστε τὸ πολύγωνον τὸ περιτὸν κύκλον τῆς διαμέτρου ἐστὶ τριπλάσιον καὶ ἐλάττονον ἢ τῷ ἔβδόμῳ μέρει μείζον· ἢ τοῦ κύκλου ἄρα περίμετρος πολὺ μᾶλλον ἐλάσσων ἐστὶν ἢ τριπλασίων καὶ ἔβδόμῳ μέρει μείζων.

Ἔστω κύκλος καὶ διάμετρος ἢ $\Lambda\Gamma$, ἢ δὲ ὑπὸ ΒΑΓ τρίτου ὀρθῆς· ἢ $\Lambda\text{Β}$ ἄρα πρὸς ΒΓ ἐλάσσονα λόγον ἔχει ἢ ὄν $\overline{\alpha\tau\nu\alpha}$ πρὸς $\overline{\psi\pi}$ [ἢ δὲ $\Lambda\Gamma$ πρὸς $\Gamma\text{Β}$, ὄν $\overline{\alpha\phi\zeta}$ πρὸς $\overline{\psi\pi}$]. δίχα ἢ ὑπὸ ΒΑΓ τῆ $\Lambda\text{Η}$. ἐπεὶ οὖν ἴση ἐστὶν ἢ ὑπὸ ΒΑΗ τῆ ὑπὸ ΗΓΒ , ἀλλὰ

SPECIAL PROBLEMS

so that $EK : \Gamma K > 2339\frac{1}{4} : 153 \quad \cdot \cdot \quad (8)$

Again, let $\angle KE\Gamma$ be bisected by ΛE .

Then $[KE : E\Gamma = K\Lambda : \Lambda\Gamma \quad [\text{Eucl. vi. 3}$

so that $KE + E\Gamma : E\Gamma = K\Lambda + \Lambda\Gamma : \Lambda\Gamma$

$= K\Gamma : \Lambda\Gamma, \text{ or}]$

$E\Gamma : \Lambda\Gamma [= E\Gamma + KE : K\Gamma$

$> 2334\frac{1}{4} + 2339\frac{1}{4} : 153,$

by (7) and (8),]

$> 4673\frac{1}{2} : 153.$

Now since $\angle ZE\Gamma$, which is the third part of a right angle, has been bisected four times, $\angle \Lambda E\Gamma$ is one forty-eighth of a right angle. Let $\angle FEM$ be placed at E equal to it. $\angle \Lambda EM$ is therefore one twenty-fourth of a right angle. And ΛM is therefore the side of a polygon escribed to the circle and having ninety-six sides. Since $E\Gamma : \Gamma\Lambda$ was proved to be greater than $4673\frac{1}{2} : 153$ and $\Lambda\Gamma = 2E\Gamma$, $\Lambda M = 2F\Lambda$, the ratio of $\Lambda\Gamma$ to the perimeter of the 96-sided polygon is greater than $[4673\frac{1}{2} : 96 \cdot 153, \text{ or}] 4673\frac{1}{2} : 14688$. And the ratio $[14688 : 4673\frac{1}{2}]$ is greater than 3, being in excess by $667\frac{1}{2}$, which is less than the seventh part of $4673\frac{1}{2}$; so that the [perimeter of the] escribed polygon is greater than three times the diameter by less than the seventh part; *a fortiori* therefore the circumference of the circle is less than $3\frac{1}{7}$ times the diameter.

Let there be a circle with diameter $A\Gamma$ and $\angle BA\Gamma$ one-third of a right angle. Then $AB : B\Gamma [= \sqrt{3} : 1] < 1351 : 780$.^a Let $BA\Gamma$ be bisected by AH . Now since $\angle BAH = \angle H\Gamma B$ and $\angle BAH = \angle H\Lambda\Gamma$, there-

^a See *supra*, p. 322 n. a.

GREEK MATHEMATICS

καὶ τῇ ὑπὸ ΗΑΓ, καὶ ἡ ὑπὸ ΗΓΒ τῇ ὑπὸ ΗΑΓ ἔστιν ἴση. καὶ κοινὴ ἡ ὑπὸ ΑΗΓ ὀρθή· καὶ τρίτη

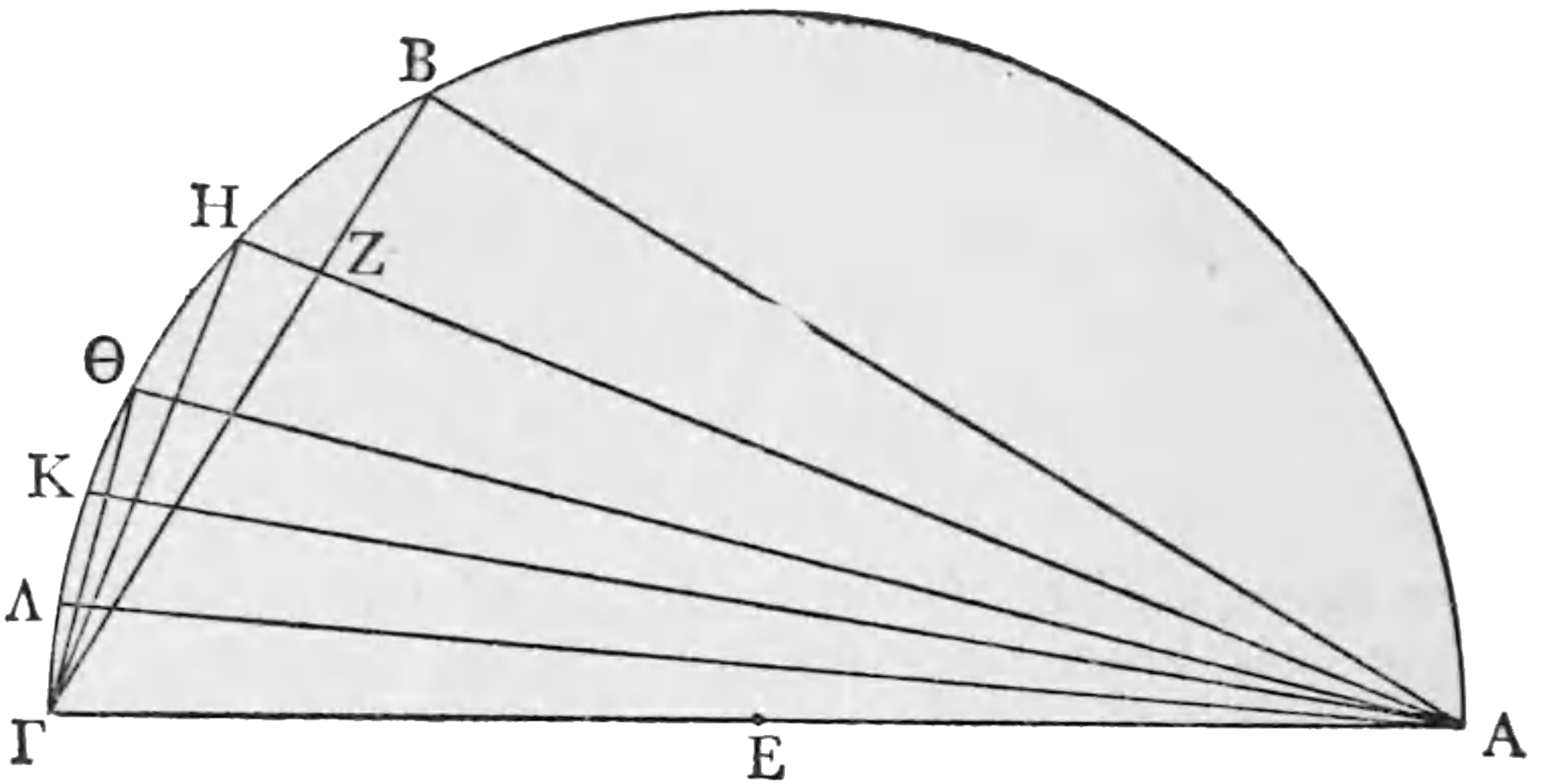

ἄρα ἡ ὑπὸ ΗΖΓ τρίτη τῇ ὑπὸ ΑΓΗ ἴση. ἰσογώνιον ἄρα τὸ ΑΗΓ τῷ ΓΗΖ τριγώνῳ· ἔστιν ἄρα, ὡς ἡ ΑΗ πρὸς ΗΓ, ἡ ΓΗ πρὸς ΗΖ καὶ ἡ ΑΓ πρὸς ΓΖ. ἀλλ' ὡς ἡ ΑΓ πρὸς ΓΖ, [καὶ] συναμφοτέρος ἡ ΓΑΒ πρὸς ΒΓ· καὶ ὡς συναμφοτέρος ἄρα ἡ ΒΑΓ πρὸς ΒΓ, ἡ ΑΗ πρὸς ΗΓ. διὰ τοῦτο οὖν ἡ ΑΗ πρὸς [τὴν] ΗΓ ἐλάσσονα λόγον ἔχει ἢ περ $\overline{\beta\lambda\iota\alpha}$ πρὸς $\overline{\psi\pi}$, ἡ δὲ ΑΓ πρὸς τὴν ΓΗ ἐλάσσονα ἢ ὄν $\overline{\gamma\iota\gamma}$ \angle' δ' πρὸς $\overline{\psi\pi}$. δίχα ἡ ὑπὸ ΓΑΗ τῇ ΑΘ· ἡ ΑΘ ἄρα διὰ τὰ αὐτὰ πρὸς τὴν ΘΓ ἐλάσσονα λόγον ἔχει ἢ ὄν $\overline{\epsilon\lambda\kappa\delta}$ \angle' δ' πρὸς $\overline{\psi\pi}$ ἢ ὄν $\overline{\alpha\omega\kappa\gamma}$ πρὸς $\overline{\sigma\mu}$ · ἑκατέρα γὰρ ἑκατέρας δ $\iota\gamma'$ · ὥστε ἡ ΑΓ πρὸς τὴν ΓΘ ἢ ὄν $\overline{\alpha\omega\lambda\eta}$ θ $\iota\alpha'$ πρὸς



THIS PAGE IS LOCKED TO FREE MEMBERS

Purchase full membership to immediately unlock this page

SAVE \$3,999,994

Did you know we sell
paperback books too?

To buy our entire catalog
in paperback would cost
over \$4,000,000

Access it all now for
\$8.99/month

*Fair usage policy applies

Continue

$\overline{\sigma\mu}$. ἔτι δίχα ἢ ὑπὸ $\Theta\Lambda\Gamma$ τῆ $\overline{ΚΑ}$ · καὶ ἢ $\overline{ΑΚ}$ πρὸς
 τὴν $\overline{ΚΓ}$ ἐλάσσονα [ἄρα] λόγον ἔχει ἢ ὄν $\overline{,αζ}$ πρὸς
 $\overline{\xi\varsigma}$ · ἐκατέρα γὰρ ἐκατέρας $\overline{ια}$ μ' · ἢ $\overline{ΑΓ}$ ἄρα πρὸς
 [τὴν] $\overline{ΚΓ}$ ἢ ὄν $\overline{,αθ}$ ς' πρὸς $\overline{\xi\varsigma}$. ἔτι δίχα ἢ ὑπὸ
 $\overline{ΚΑΓ}$ τῆ $\overline{ΛΑ}$ · ἢ $\overline{ΑΛ}$ ἄρα πρὸς [τὴν] $\overline{ΛΓ}$ ἐλάσσονα
 λόγον ἔχει ἢ ὄν τὰ $\overline{,βις}$ ς' πρὸς $\overline{\xi\varsigma}$, ἢ δὲ $\overline{ΑΓ}$ πρὸς
 $\overline{ΓΛ}$ ἐλάσσονα ἢ τὰ $\overline{,βιζ}$ δ' πρὸς $\overline{\xi\varsigma}$. ἀνάπαλιν
 ἄρα ἢ περίμετρος τοῦ πολυγώνου πρὸς τὴν διά-
 μετρον μείζονα λόγον ἔχει ἢπερ $\overline{,στλς}$ πρὸς $\overline{,βιζ}$
 δ' , ἄπερ τῶν $\overline{,βιζ}$ δ' μείζονά ἐστιν ἢ τριπλασίονα
 καὶ δέκα οα'. καὶ ἢ περίμετρος ἄρα τοῦ $\overline{\zeta\varsigma}$ -γώνου
 τοῦ ἐν τῷ κύκλῳ τῆς διαμέτρου τριπλασίων ἐστὶ
 καὶ μείζων ἢ $\overline{ι}$ οα'. ὥστε καὶ ὁ κύκλος ἔτι μᾶλλον
 τριπλασίων ἐστὶ καὶ μείζων ἢ $\overline{ι}$ οα'.

Ἐ ἄρα τοῦ κύκλου περίμετρος τῆς διαμέτρου

SPECIAL PROBLEMS

Further, let $\angle \theta A \Gamma$ be bisected by KA .

$$\begin{aligned} \text{Then} \quad AK : K\Gamma & \left[= A\Gamma + A\theta : \Gamma\theta \right. \\ & < 1838\frac{9}{11} + 1823 : 24, \\ & \qquad \qquad \qquad \text{by (3a) and (4a),} \\ & < 3661\frac{9}{11} : 240 \\ & < \frac{1}{4}\frac{1}{0} \cdot 3661\frac{9}{11} : \frac{1}{4}\frac{1}{0} \cdot 240 \\ & < 1007 : 66 \quad . \quad . \quad . \quad . \quad (5a) \end{aligned}$$

$$\begin{aligned} \text{[Hence} \quad A\Gamma^2 : K\Gamma^2 & = AK^2 + K\Gamma^2 : K\Gamma^2 \\ & < 1007^2 + 66^2 : 66^2 \\ & < 1018405 : 4356.] \end{aligned}$$

$$\text{Therefore} \quad A\Gamma : K\Gamma < 1009\frac{1}{8} : 66 \quad . \quad . \quad . \quad . \quad (6a)$$

Further, let $\angle KA\Gamma$ be bisected by ΛA .

$$\begin{aligned} \text{Then} \quad A\Lambda : \Lambda\Gamma & \left[= \Gamma A + AK : \Gamma K \right. \\ & < 1009\frac{1}{8} + 1007 : 66, \text{ by (5a)} \\ & \qquad \qquad \qquad \text{and (6a),]} \\ & < 2016\frac{1}{6} : 66. \end{aligned}$$

$$\begin{aligned} \text{[Hence} \quad A\Gamma^2 : \Gamma\Lambda^2 & = A\Lambda^2 + \Lambda\Gamma^2 : \Gamma\Lambda^2 \\ & < 2016\frac{1}{6}^2 + 66^2 : 66^2 \\ & < 4069284\frac{1}{3}\frac{1}{6} : 4356.] \end{aligned}$$

$$\text{Therefore} \quad A\Gamma : \Gamma\Lambda < 2017\frac{1}{4} : 66,$$

and *invertendo* $[\Gamma\Lambda : A\Gamma > 66 : 2017\frac{1}{4}]$.

But $\Gamma\Lambda$ is the side of a polygon of 96 sides; and accordingly] the perimeter of the polygon bears to the diameter a ratio greater than $[96 \cdot 66 : 2017\frac{1}{4}]$, or $6336 : 2017\frac{1}{4}$, which is greater than $3\frac{1}{7}\frac{0}{1}$. Therefore the perimeter of the 96-sided polygon is greater than $3\frac{1}{7}\frac{0}{1}$ times the diameter, so that *a fortiori* the circle is greater than $3\frac{1}{7}\frac{0}{1}$ times the diameter.

The perimeter of the circle is therefore more than

τριπλασίων ἐστὶ καὶ ἐλάσσονι μὲν ἢ ἐβδόμῳ μέρει, μείζονι δὲ ἢ ἰοα' μείζων.

β'

Ὁ κύκλος πρὸς τὸ ἀπὸ τῆς διαμέτρου τετράγωνον λόγον ἔχει, ὃν $\overline{ια}$ πρὸς $\overline{ιδ}$.

Ἐστω κύκλος, οὗ διάμετρος ἡ $ΑΒ$, καὶ περιγεγράφθω τετράγωνον τὸ $ΓΗ$, καὶ τῆς $ΓΔ$ διπλῆ ἡ $ΔΕ$, ἑβδομον δὲ ἡ $ΕΖ$ τῆς $ΓΔ$. ἐπεὶ οὖν τὸ

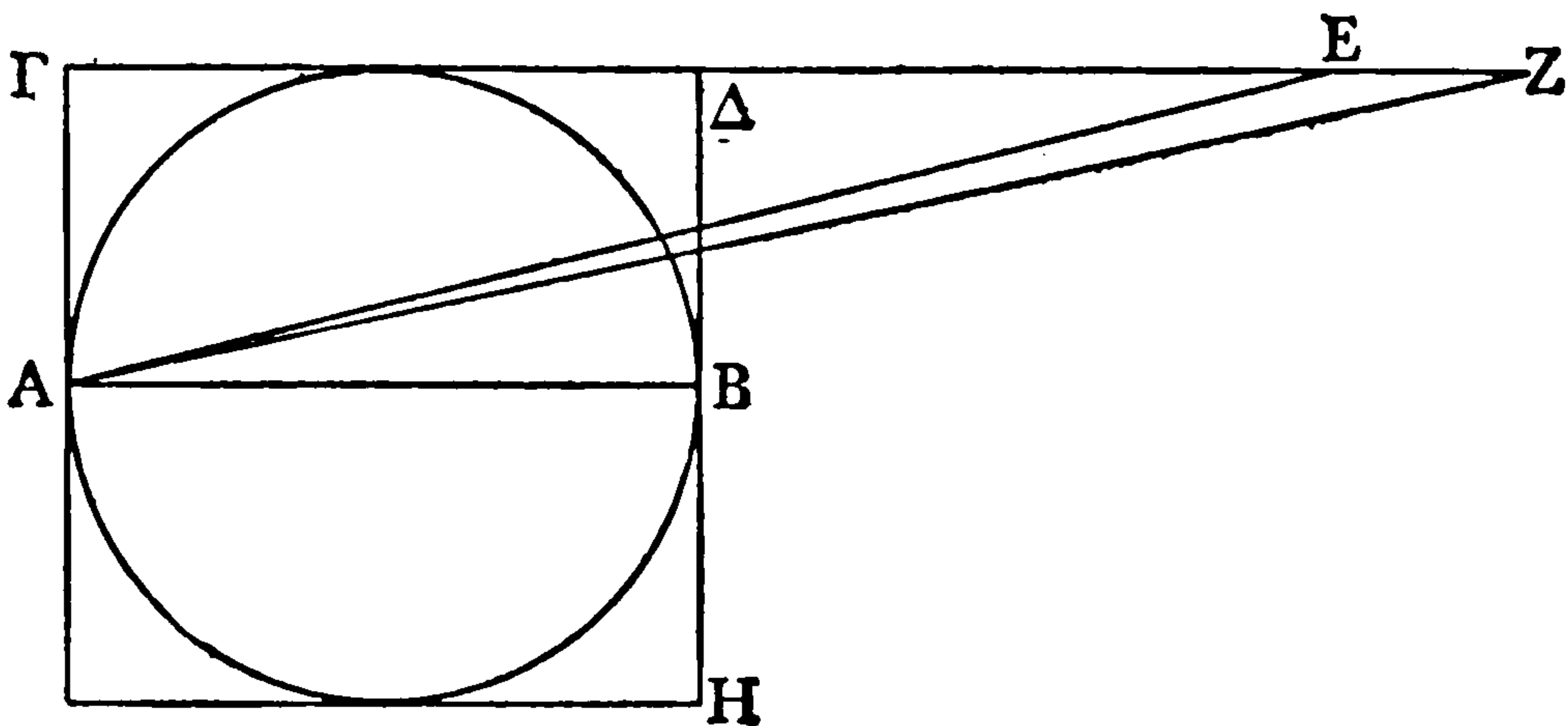

$ΑΓΕ$ πρὸς τὸ $ΑΓΔ$ λόγον ἔχει, ὃν $\overline{κα}$ πρὸς ζ , πρὸς δὲ τὸ $ΑΕΖ$ τὸ $ΑΓΔ$ λόγον ἔχει, ὃν ἑπτὰ πρὸς ἓν, τὸ $ΑΓΖ$ πρὸς τὸ $ΑΓΔ$ ἐστίν, ὡς $\overline{κβ}$ πρὸς ζ . ἀλλὰ τοῦ $ΑΓΔ$ τετραπλάσιόν ἐστὶ τὸ $ΓΗ$ τετράγωνον, τὸ δὲ $ΑΓΔΖ$ τρίγωνον τῷ $ΑΒ$ κύκλῳ ἴσον ἐστὶν [ἐπεὶ ἡ μὲν $ΑΓ$ κάθετος ἴση ἐστὶ τῇ ἐκ τοῦ κέντρου, ἡ δὲ βᾶσις τῆς διαμέτρου τριπλασίον καὶ τῷ ζ' ἔγγιστα ὑπερέχουσα δειχθήσεται]¹. ὁ κύκλος οὖν πρὸς τὸ $ΓΗ$ τετράγωνον λόγον ἔχει, ὃ $\overline{ια}$ πρὸς $\overline{ιδ}$.



THIS PAGE IS LOCKED TO FREE MEMBERS

Purchase full membership to immediately unlock this page

FORGOTTEN BOOKS

FULL

MEMBERSHIP

797,885 Books!

All you can read

for only

\$8.99/month

Continue

*Fair usage policy applies



GREEK MATHEMATICS

(c) SOLUTIONS BY HIGHER CURVES

(i.) *General*

Simpl. in *Cat.* 7, ed. Kalbfleisch 192. 15-25

Ἔστιν δὲ τετραγωνισμὸς κύκλου, ὅταν τῷ δοθέντι κύκλῳ ἴσον τετράγωνον συστησώμεθα. τοῦτο δὲ Ἄριστοτέλης μὲν, ὡς ἔοικεν, οὕτω ἐγνώκει, παρὰ δὲ τοῖς Πυθαγορείοις ηὔρησθαί φησιν Ἰάμβλιχος, “ὡς δῆλόν ἐστιν ἀπὸ τῶν Σέξτου τοῦ Πυθαγορείου ἀποδείξεων, ὅς ἄνωθεν κατὰ διαδοχὴν παρέλαβεν τὴν μέθοδον τῆς ἀποδείξεως. καὶ ὕστερον δέ, φησὶν, Ἀρχιμήδης διὰ τῆς Λυκομήδους¹ γραμμῆς καὶ Νικομήδης διὰ τῆς ἰδίως τετραγωνιζούσης καλουμένης καὶ Ἀπολλώνιος διὰ τινος γραμμῆς, ἣν αὐτὸς μὲν κοχλιοειδοῦς ἀδελφὴν προσγορεύει, ἣ αὐτὴ δὲ ἐστὶν τῇ Νικομήδους, καὶ Κάρπος δὲ διὰ τινος γραμμῆς, ἣ ἀπλῶς ἐκ διπλῆς κινήσεως καλεῖ, ἄλλοι τε πολλοὶ ποικίλως τὸ πρόβλημα κατεσκεύασαν,” ὡς Ἰάμβλιχος ἱστορεῖ.

¹ No meaning can be extracted from Λυκομήδους, which is an otherwise unknown word. The correct reading is probably ἐλικοειδοῦς, “spiral-shaped.”

SPECIAL PROBLEMS

(c) SOLUTIONS BY HIGHER CURVES

(i.) *General*

Simplicius, *Commentary on Aristotle's Categories* 7,
ed. Kalbfleisch 192. 15-25

The circle is squared when we construct a square equal to the given circle. Aristotle, it would appear, did not know how to do this, but Iamblichus says it was discovered by the Pythagoreans, "as is plain from the proofs of Sextus the Pythagorean,^a who received the method of the proof from early tradition. And later (he says), Archimedes effected it by means of the spiral-shaped curve,^b Nicomedes by means of the curve known by the special name *quadratrix*, Apollonius by means of a certain curve which he himself calls *sister of the cochloid*, but which is the same as Nicomedes' curve,^c Carpus by means of a certain curve which he simply calls that *arising from a double motion*,^d and many others constructed a solution of this problem in divers ways," as Iamblichus relates.

^a Sextus (more properly Sextius) lived in the reign of Augustus (or Tiberius) and there is no valid reason for believing the early Pythagoreans solved the problem.

^b Archimedes himself in his book *On Spirals*, which will be noticed when we come to him, merely uses the spiral to rectify the circle (Prop. 19). But the quadrature follows from *Measurement of a Circle*, Prop. 1.

^c Nothing further is known of Apollonius's "sister of the *cochloid*," but Heath (*H.G.M.* i. 232) points out that Apollonius wrote a treatise on the *cochlias*, or cylindrical helix, that the subtangent to this curve can be used to square the circular section of the cylinder, and that the name is sufficiently akin to justify Apollonius in speaking of it as the "sister of the *cochloid*."

^d Tannery thought this was the cycloid, but there is no evidence.

(ii.) *The Quadratrix*

Papp. *Coll.* iv. 30. 45–32. 50, ed. Hultsch 250. 33–258. 19

Construction of the Curve

λ'. Εἰς τὸν τετραγωνισμὸν τοῦ κύκλου παρελήφθη τις ὑπὸ Δεινοστράτου καὶ Νικομήδους γραμμὴ καὶ τινῶν ἄλλων νεωτέρων ἀπὸ τοῦ περὶ αὐτὴν συμπτώματος λαβοῦσα τοῦνομα· καλεῖται γὰρ ὑπ' αὐτῶν τετραγωνίζουσα καὶ γένεσιν ἔχει τοιαύτην.

Ἐκκείσθω τετράγωνον τὸ ΑΒΓΔ καὶ περὶ κέντρον τὸ Α περιφέρεια γεγράφθω ἡ ΒΕΔ, καὶ

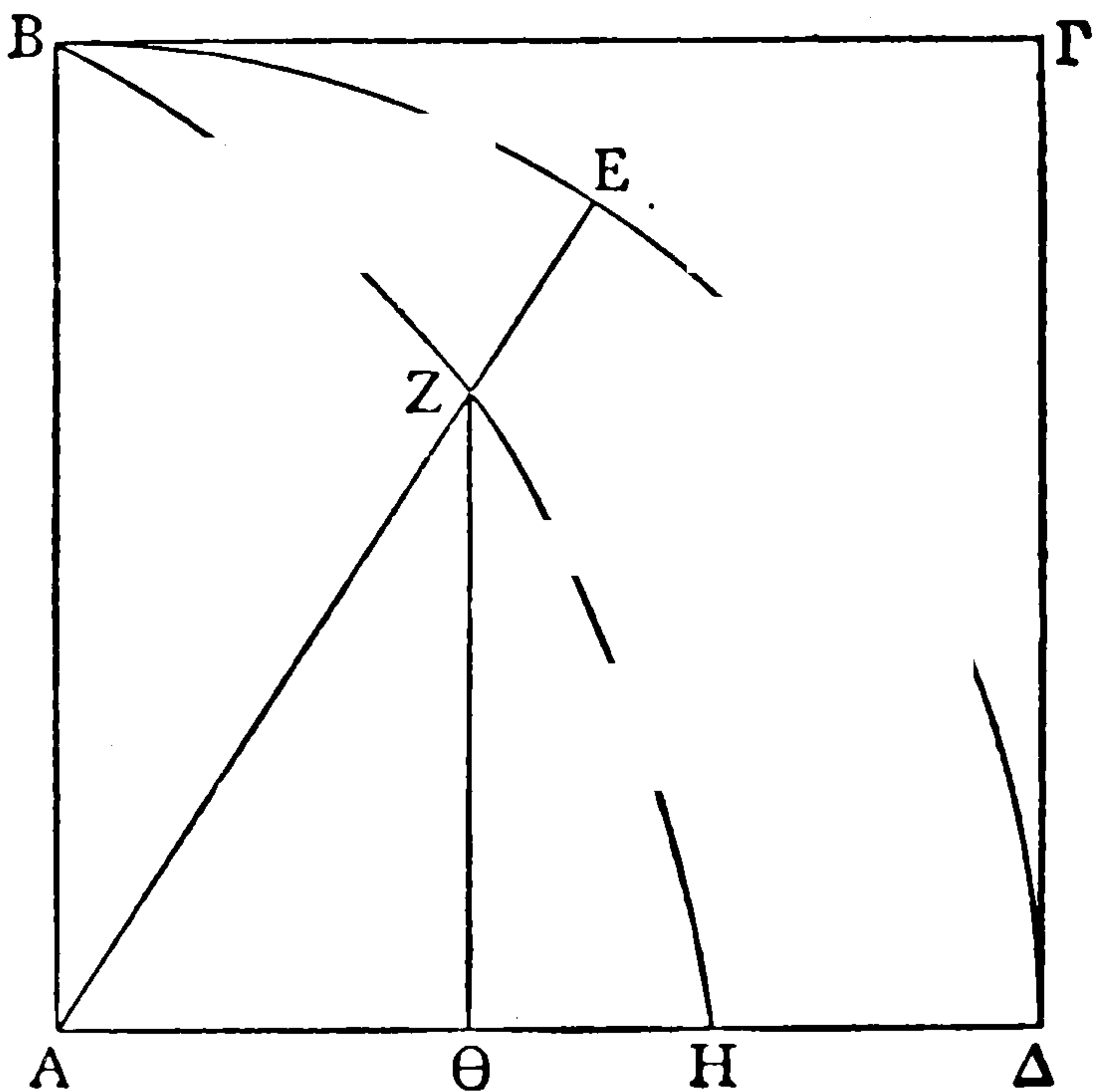

κινείσθω ἡ μὲν ΑΒ οὕτως ὥστε τὸ μὲν Α σημεῖον μένειν τὸ δὲ Β φέρεσθαι κατὰ τὴν ΒΕΔ περιφέρειαν, ἡ δὲ ΒΓ παράλληλος αἰεὶ διαμένουσα τῇ ΑΔ τῷ Β σημείῳ φερομένῳ¹ κατὰ τῆς ΒΑ συνακολουθείτω, καὶ ἐν ἴσῳ χρόνῳ ἡ τε ΑΒ κινουμένη



THIS PAGE IS LOCKED TO FREE MEMBERS

Purchase full membership to immediately unlock this page

SAVE \$3,999,994

Did you know we sell
paperback books too?

To buy our entire catalog
in paperback would cost
over \$4,000,000

Access it all now for
\$8.99/month

*Fair usage policy applies

Continue

ὁμαλῶς τὴν ὑπὸ ΒΑΔ γωνίαν, τουτέστιν τὸ Β σημείον τὴν ΒΕΔ περιφέρειαν, διανυέτω, καὶ ἡ ΒΓ τὴν ΒΑ εὐθείαν παροδευέτω, τουτέστιν τὸ Β σημείον κατὰ τῆς ΒΑ φερέσθω. συμβήσεται δῆλον τῇ ΑΔ εὐθείᾳ ἅμα ἐφαρμόζειν ἑκατέραν τὴν τε ΑΒ καὶ τὴν ΒΓ. τοιαύτης δὲ γινομένης κινήσεως τεμοῦσιν ἀλλήλας ἐν τῇ φορᾷ αἱ ΒΓ, ΒΑ εὐθεῖαι κατὰ τι σημείον αἰεὶ συμμεθιστάμενον αὐταῖς, ὑφ' οὗ σημείου γράφεται τις ἐν τῷ μεταξύ τόπῳ τῶν τε ΒΑΔ εὐθειῶν καὶ τῆς ΒΕΔ περιφέρειας γραμμὴ ἐπὶ τὰ αὐτὰ κοίλη, οἷα ἐστὶν ἡ ΒΖΗ, ἣ καὶ χρειώδης εἶναι δοκεῖ πρὸς τὸ τῷ δοθέντι κύκλῳ τετράγωνον ἴσον εὐρεῖν. τὸ δὲ ἀρχικὸν αὐτῆς σύμπτωμα τοιοῦτόν ἐστιν. ἥτις γὰρ ἂν διαχθῆ τυχούσα (πρὸς τὴν περιφέρειαν, ὡς ἡ ΑΖΕ, ἔσται ὡς ὅλη ἡ)¹ περιφέρεια πρὸς τὴν ΕΔ, ἡ ΒΑ εὐθεῖα πρὸς τὴν ΖΘ· τοῦτο γὰρ ἐκ τῆς γενέσεως τῆς γραμμῆς φανερόν ἐστιν.

Sporus's Criticisms

λα'. Δυσανεστῆται δὲ αὐτῇ ὁ Σπόρος εὐλόγως διὰ ταῦτα. πρῶτον μὲν γὰρ πρὸς ὃ δοκεῖ χρειώδης εἶναι πρᾶγμα, τοῦτ' ἐν ὑποθέσει λαμβάνει. πῶς γὰρ δυνατόν, δύο σημείων ἀρξαμένων ἀπὸ τοῦ Β

¹ πρὸς τὴν . . . ὅλη ἡ add. Hultsch.

SPECIAL PROBLEMS

formly, pass through the angle $BA\Delta$ (that is, the point B pass along the arc $B\Delta$), and $B\Gamma$ pass by the straight line BA (that is, let the point B traverse the length of BA). Plainly then both AB and $B\Gamma$ will coincide simultaneously with the straight line $A\Delta$. While the motion is in progress the straight lines $B\Gamma$, BA will cut one another in their movement at a certain point which continually changes place with them, and by this point there is described in the space between the straight lines BA , $A\Delta$ and the arc $BE\Delta$ a concave curve, such as BZH , which appears to be serviceable for the discovery of a square equal to the given circle. Its principal property is this. If any straight line, such as AZE , be drawn to the circumference, the ratio of the whole arc to $E\Delta$ will be the same as the ratio of the straight line BA to $Z\Theta$; for this is clear from the manner in which the line was generated.^a

Sporus's Criticisms^b

31. With this Sporus is rightly displeased for these reasons. In the first place, the end for which the construction seems to be useful is assumed in the hypothesis. For how is it possible, with two points

^a If $AZ = \rho$, $\angle ZAA\Delta = \phi$, $AB = a$, then the equation of the curve is

$$\frac{\frac{1}{2}\pi}{\phi} = \frac{a}{\rho \sin \phi}$$

or $\pi\rho \sin \phi = 2a\phi$.

^b These acute criticisms of the quadratrix as a practical method of squaring the circle appear to be well founded. Sporus, who was not much older than Pappus himself, lived towards the end of the third century A.D. He compiled a work called *Κηρία* giving extracts on the quadrature of the circle and duplication of the cube.

κινεῖσθαι, τὸ μὲν κατ' εὐθείας ἐπὶ τὸ Α, τὸ δὲ κατὰ περιφέρειας ἐπὶ τὸ Δ ἐν ἴσῳ χρόνῳ συναποκαταστήσαι¹ μὴ πρότερον τὸν λόγον τῆς ΑΒ εὐθείας πρὸς τὴν ΒΕΔ περιφέρειαν ἐπιστάμενον; ἐν γὰρ τούτῳ τῷ λόγῳ καὶ τὰ τάχη τῶν κινήσεων ἀνάγκη εἶναι. ἐπεὶ πῶς οἶόν τε συναποκαταστήναι τάχεσιν ἀκρίτοις χρώμενα, πλὴν εἰ μὴ ἂν κατὰ τύχην ποτὲ συμβῆ; τοῦτο δὲ πῶς οὐκ ἄλογον; ἔπειτα δὲ τὸ πέρασ αὐτῆς ὧ χρῶνται πρὸς τὸν τετραγωνισμόν τοῦ κύκλου, τουτέστιν καθ' ὃ τέμνει σημεῖον τὴν ΑΔ εὐθεῖαν, οὐχ εὐρίσκεται. νοείσθω δὲ ἐπὶ τῆς προκειμένης τὰ λεγόμενα καταγραφῆς· ὅποταν γὰρ αἱ ΓΒ, ΒΑ φερόμεναι συναποκατασταθῶσιν, ἐφαρμόσουσιν τῇ ΑΔ καὶ τομὴν οὐκέτι ποιήσουσιν ἐν ἀλλήλαις· παύεται γὰρ ἢ τομὴ πρὸ τῆς ἐπὶ τὴν ΑΔ ἐφαρμογῆς ἢ περ τομὴ πέρασ αὐτῆς ἐγένετο τῆς γραμμῆς, καθ' ὃ τῇ ΑΔ εὐθεία συνέπιπτεν. πλὴν εἰ μὴ λέγοι τις ἐπινοεῖσθαι προσεκβαλλομένην τὴν γραμμὴν, ὡς ὑποτιθέμεθα τὰς εὐθείας, ἕως τῆς ΑΔ. τοῦτο δ' οὐχ ἔπεται ταῖς ὑποκειμέναις ἀρχαῖς, ἀλλ' ὡς ἂν ληφθεῖη τὸ Η σημεῖον προειλημμένου τοῦ τῆς περιφέρειας πρὸς τὴν εὐθεῖαν λόγου. χωρὶς δὲ τοῦ δοθῆναι τὸν λόγον τοῦτον οὐ χρὴ τῇ τῶν εὐρόντων ἀνδρῶν δόξῃ πιστεύοντας παραδέχεσθαι τὴν γραμμὴν μηχανικωτέραν πῶς οὔσαν [καὶ εἰς πολλὰ προβλήματα χρησιμεύουσιν τοῖς μηχανικοῖς].² ἀλλὰ πρότερον παραδεκτέον ἐστὶ τὸ δι' αὐτῆς δεικνύμενον πρόβλημα.

¹ συναποκαταστήναι coniecit Hultsch.

² καὶ . . . μηχανικοῖς interpolatori tribuit Hultsch.



THIS PAGE IS LOCKED TO FREE MEMBERS

Purchase full membership to immediately unlock this page

FORGOTTEN BOOKS

FULL

MEMBERSHIP

797,885 Books!

All you can read

for only

\$8.99/month

Continue

*Fair usage policy applies



GREEK MATHEMATICS

Application of Quadratrix to Squaring of Circle

Τετραγώνου γὰρ ὄντος τοῦ ΑΒΓΔ καὶ τῆς μὲν περὶ τὸ κέντρον τὸ Γ περιφερείας τῆς ΒΕΔ, τῆς

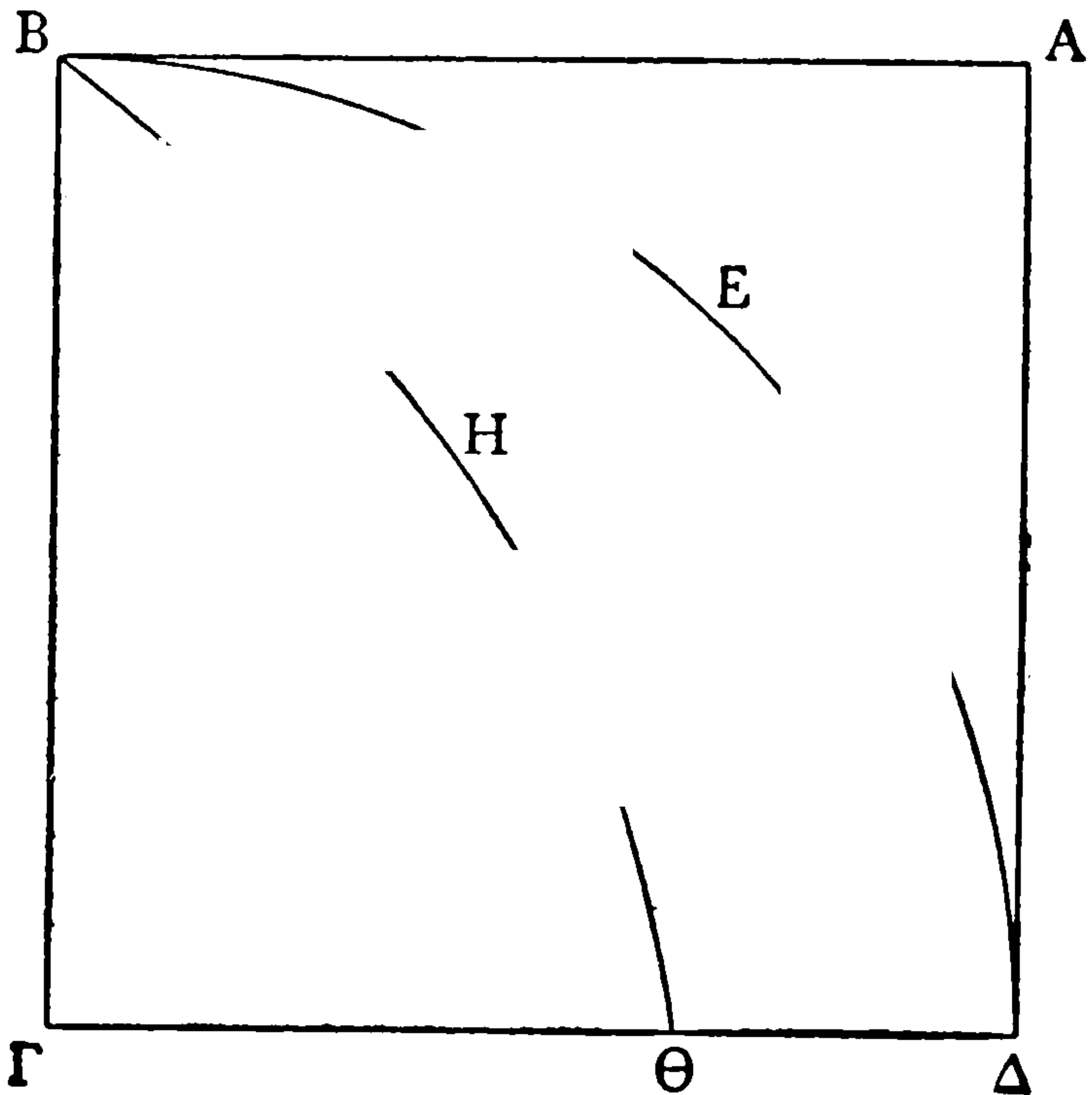

δὲ ΒΗΘ τετραγωνιζούσης γινομένης, ὡς προείρηται, δείκνυται, ὡς ἡ ΔΕΒ περιφέρεια πρὸς τὴν ΒΓ εὐθείαν, οὕτως ἡ ΒΓ πρὸς τὴν ΓΘ εὐθείαν. εἰ γὰρ μὴ ἔστιν, ἤτοι πρὸς μείζονα ἔσται τῆς ΓΘ ἢ πρὸς ἐλάσσονα.

Ἔστω πρότερον, εἰ δυνατόν, πρὸς μείζονα τὴν ΓΚ, καὶ περὶ κέντρον τὸ Γ περιφέρεια ἡ ΖΗΚ γεγράφθω τέμνουσα τὴν γραμμὴν κατὰ τὸ Η, καὶ κάθετος ἡ ΗΛ, καὶ ἐπιζευχθεῖσα ἡ ΓΗ ἐκβεβλήσθω ἐπὶ τὸ Ε. ἐπεὶ οὖν ἔστιν ὡς ἡ ΔΕΒ περιφέρεια πρὸς τὴν ΒΓ εὐθείαν, οὕτως ἡ ΒΓ,

SPECIAL PROBLEMS

Application of Quadratrix to Squaring of Circle

If $AB\Gamma\Delta$ is a square and $BE\Delta$ the arc of a circle with centre Γ , while $BH\Theta$ is a quadratrix generated in the aforesaid manner, it is proved that the ratio of the arc ΔEB towards the straight line $B\Gamma$ is the same as that of $B\Gamma$ towards the straight line $\Gamma\Theta$. For if it is not, the ratio of the arc ΔEB towards the straight line $B\Gamma$ will be the same as that of $B\Gamma$ towards either a straight line greater than $\Gamma\Theta$ or a straight line less than $\Gamma\Theta$.

Let it be the former, if possible, towards a greater straight line ΓK , and with centre Γ let the arc ZHK be drawn cutting the curve at H , and let the perpendicular $H\Lambda$ be drawn, and let ΓH be joined and pro-

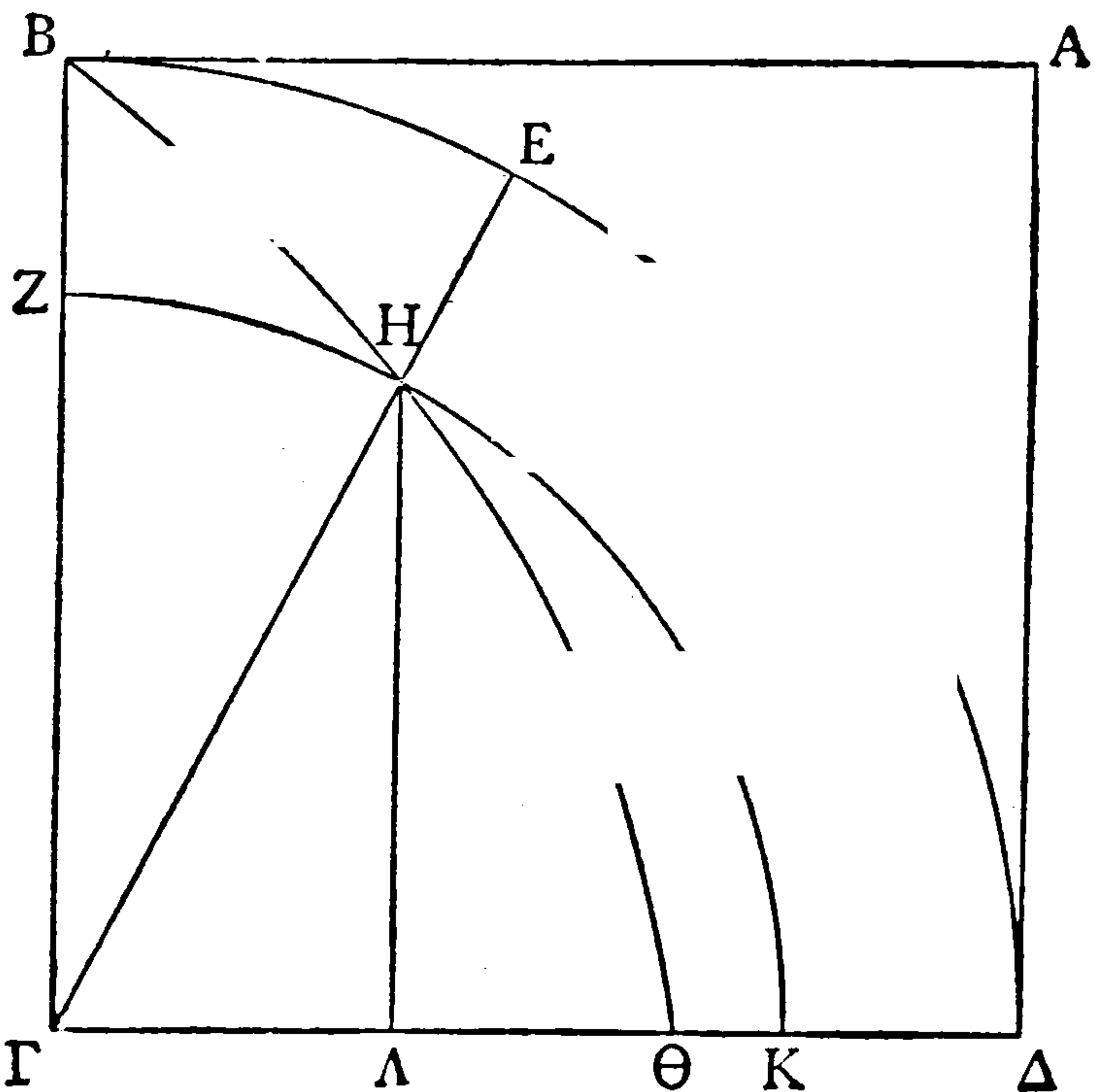

duced to E . Since therefore the ratio of the arc ΔEB towards the straight line $B\Gamma$ is the same as the

GREEK MATHEMATICS

τουτέστιν ἡ $\Gamma\Delta$, πρὸς τὴν $\Gamma\text{Κ}$, ὡς δὲ ἡ $\Gamma\Delta$ πρὸς τὴν $\Gamma\text{Κ}$, ἡ $\text{ΒΕ}\Delta$ περιφέρεια πρὸς τὴν $\text{ΖΗ}\text{Κ}$ περιφέρεια (ὡς γὰρ ἡ διάμετρος τοῦ κύκλου πρὸς τὴν διάμετρον, ἡ περιφέρεια τοῦ κύκλου πρὸς τὴν περιφέρεια), φανερόν ὅτι ἴση ἐστὶν ἡ $\text{ΖΗ}\text{Κ}$ περιφέρεια τῇ $\text{Β}\Gamma$ εὐθείᾳ. καὶ ἐπειδὴ διὰ τὸ σύμπτωμα τῆς γραμμῆς ἐστὶν ὡς ἡ $\text{ΒΕ}\Delta$ περιφέρεια πρὸς τὴν $\text{Ε}\Delta$, οὕτως ἡ $\text{Β}\Gamma$ πρὸς τὴν $\text{Η}\Lambda$, καὶ ὡς ἄρα ἡ $\text{ΖΗ}\text{Κ}$ πρὸς τὴν $\text{Η}\text{Κ}$ περιφέρεια, οὕτως ἡ $\text{Β}\Gamma$ εὐθεῖα πρὸς τὴν $\text{Η}\Lambda$. καὶ ἐδείχθη ἴση ἡ $\text{ΖΗ}\text{Κ}$ περιφέρεια τῇ $\text{Β}\Gamma$ εὐθείᾳ· ἴση ἄρα καὶ ἡ $\text{Η}\text{Κ}$ περιφέρεια τῇ $\text{Η}\Lambda$ εὐθείᾳ, ὅπερ ἄτοπον. οὐκ ἄρα ἐστὶν ὡς ἡ $\text{ΒΕ}\Delta$ περιφέρεια πρὸς τὴν $\text{Β}\Gamma$ εὐθεῖαν, οὕτως ἡ $\text{Β}\Gamma$ πρὸς μείζονα τῆς $\Gamma\Theta$.

λβ'. Λέγω δὲ ὅτι οὐδὲ πρὸς ἐλάσσονα. εἰ γὰρ

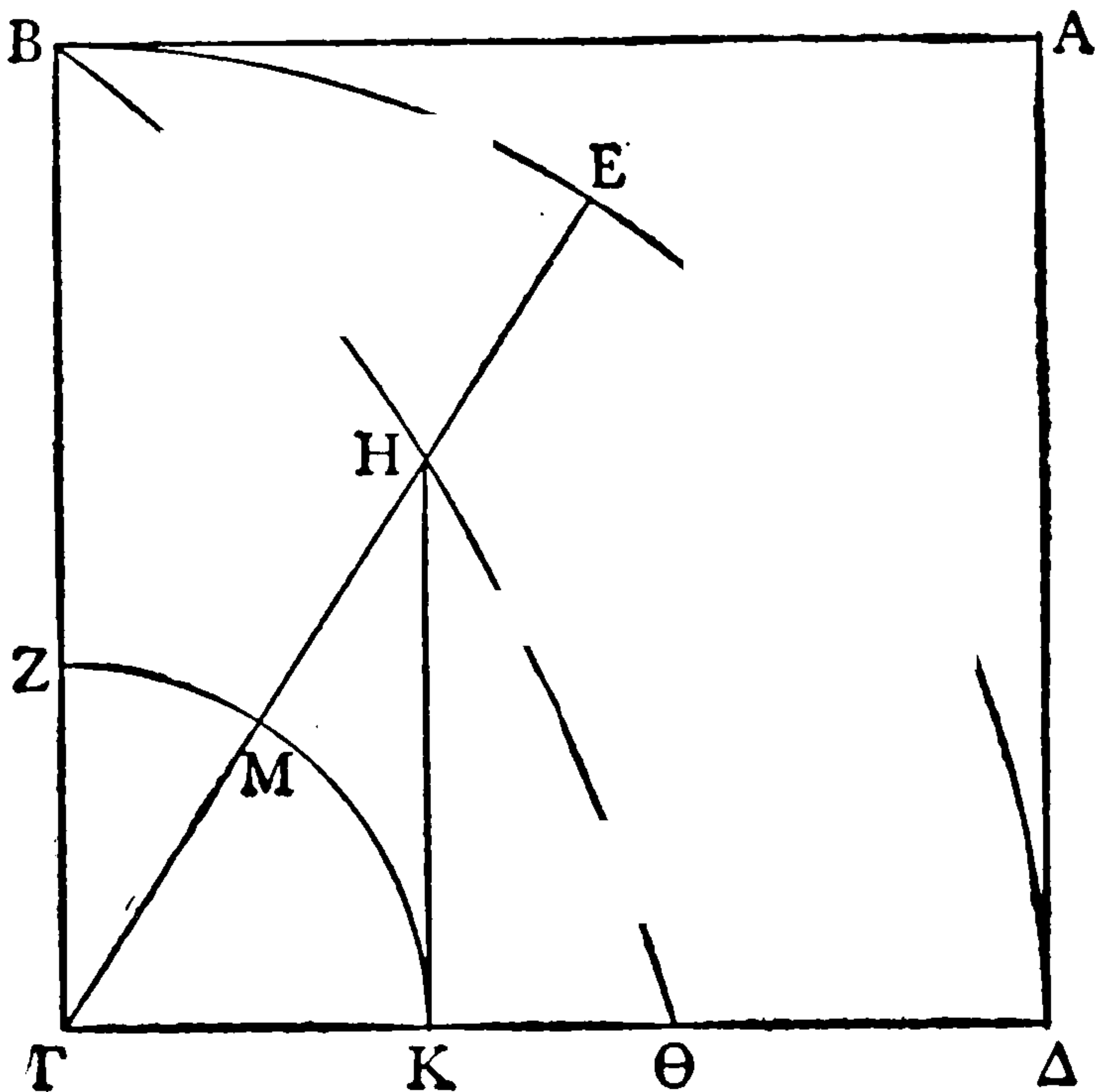

δυνατόν, ἔστω πρὸς τὴν $\text{Κ}\Gamma$, καὶ περὶ κέντρον τὸ



THIS PAGE IS LOCKED TO FREE MEMBERS

Purchase full membership to immediately unlock this page

SAVE \$3,999,994

Did you know we sell
paperback books too?

To buy our entire catalog
in paperback would cost
over \$4,000,000

Access it all now for
\$8.99/month

*Fair usage policy applies

Continue

GREEK MATHEMATICS

Γ περιφέρεια γεγράφθω ἢ ΖΜΚ, καὶ πρὸς ὀρθὰς τῇ ΓΔ ἢ ΚΗ τέμνουσα τὴν τετραγωνίζουσαν κατὰ τὸ Η, καὶ ἐπιζευχθεῖσα ἢ ΓΗ ἐκβεβλήσθω ἐπὶ τὸ Ε. ὁμοίως δὲ τοῖς προγεγραμμένοις δείξομεν καὶ τὴν ΖΜΚ περιφέρειαν τῇ ΒΓ εὐθείᾳ ἴσην, καὶ ὡς τὴν ΒΕΔ περιφέρειαν πρὸς τὴν ΕΔ, τουτέστιν ὡς τὴν ΖΜΚ πρὸς τὴν ΜΚ, οὕτως τὴν ΒΓ εὐθεῖαν πρὸς τὴν ΗΚ. ἐξ ὧν φανερόν ὅτι ἴση ἔσται ἢ ΜΚ περιφέρεια τῇ ΚΗ εὐθείᾳ, ὅπερ ἄτοπον. οὐκ ἄρα ἔσται ὡς ἢ ΒΕΔ περιφέρεια πρὸς τὴν ΒΓ εὐθεῖαν, οὕτως ἢ ΒΓ πρὸς ἐλάσσονα τῆς ΓΘ. ἐδείχθη δὲ ὅτι οὐδὲ πρὸς μείζονα· πρὸς αὐτὴν ἄρα τὴν ΓΘ.

Ἔστι δὲ καὶ τοῦτο φανερόν ὅτι ἢ τῶν ΘΓ, ΓΒ εὐθειῶν τρίτη ἀνάλογον λαμβανομένη εὐθεῖα ἴση ἔσται τῇ ΒΕΔ περιφερείᾳ, καὶ ἢ τετραπλασίων αὐτῆς τῇ τοῦ ὅλου κύκλου περιφερείᾳ. εὐρημένης δὲ τῇ τοῦ κύκλου περιφερείᾳ ἴσης εὐθείας πρόδηλον ὡς δὴ καὶ αὐτῶ τῶ κύκλῳ ῥᾶδιον ἴσον τετράγωνον συστήσασθαι· τὸ γὰρ ὑπὸ τῆς περιμέτρου τοῦ κύκλου καὶ τῆς ἐκ τοῦ κέντρου διπλάσιόν ἐστι τοῦ κύκλου, ὡς Ἀρχιμήδης ἀπέδειξεν.

3. TRISECTION OF AN ANGLE

(a) TYPES OF GEOMETRICAL PROBLEMS

Γapp. Coll. iv. 36. 57-59, ed. Hultsch 270. 1-272. 14

λς'. Τὴν δοθεῖσαν γωνίαν εὐθύγραμμον εἰς τρία ἴσα τεμεῖν οἱ παλαιοὶ γεωμέτραι θελήσαντες ἠπόρησαν δι' αἰτίαν τοιαύτην. τρία γένη φασὲν εἶναι

SPECIAL PROBLEMS

Γ let the arc ZMK be described, and let KH at right angles to $\Gamma\Delta$ cut the quadratrix at H, and let ΓH be joined and produced to E. In similar manner to what has been written above, we shall prove also that the arc ZMK is equal to the straight line $B\Gamma$, and that the ratio of the arc $BE\Delta$ towards $E\Delta$, that is, the ratio of ZMK towards MK, is the same as that of the straight line $B\Gamma$ towards HK. From this it is clear that the arc MK is equal to the straight line KH, which is absurd. The ratio of the arc $BE\Delta$ towards the straight line $B\Gamma$ is therefore not the same as the ratio of $B\Gamma$ towards a straight line less than $\Gamma\Theta$. Moreover it was proved not the same as the ratio of $B\Gamma$ towards a straight line greater than $\Gamma\Theta$; therefore it is the same as the ratio of $B\Gamma$ towards $\Gamma\Theta$ itself.

This also is clear, that if a straight line is taken as a third proportional to the straight lines $\Theta\Gamma$, ΓB it will be equal to the arc $BE\Delta$, and four times this straight line will be equal to the circumference of the whole circle. A straight line equal to the circumference of the circle having been found, a square can easily be constructed equal to the circle itself. For the rectangle contained by the perimeter of the circle and the radius is double of the circle, as Archimedes demonstrated.^a

3. TRISECTION OF AN ANGLE

(a) TYPES OF GEOMETRICAL PROBLEMS

Pappus, *Collection* iv. 36. 57-59, ed. Hultsch 270. 1-272. 14

36. When the ancient geometers sought to divide a given rectilinear angle into three equal parts they were at a loss for this reason. We say that there

^a See *supra*, pp. 316-321.

GREEK MATHEMATICS

τῶν ἐν γεωμετρίᾳ προβλημάτων, καὶ τὰ μὲν αὐτῶν ἐπίπεδα καλεῖσθαι, τὰ δὲ στερεά, τὰ δὲ γραμμικά. τὰ μὲν οὖν δι' εὐθείας καὶ κύκλου περιφερείας δυνάμενα λύεσθαι λέγοιτ' ἂν εἰκότως ἐπίπεδα· καὶ γὰρ αἱ γραμμαὶ δι' ὧν εὐρίσκεται τὰ τοιαῦτα προβλήματα τὴν γένεσιν ἔχουσιν ἐν ἐπιπέδῳ. ὅσα δὲ λύεται προβλήματα παραλαμβανομένης εἰς τὴν εὐρεσιν μιᾶς τῶν τοῦ κώνου τομῶν ἢ καὶ πλειόνων, στερεὰ ταῦτα κέκληται· πρὸς γὰρ τὴν κατασκευὴν χρήσασθαι στερεῶν σχημάτων ἐπιφανείαις, λέγω δὲ ταῖς κωνικαῖς, ἀναγκαῖον. τρίτον δέ τι προβλημάτων ὑπολείπεται γένος τὸ καλούμενον γραμμικόν· γραμμαὶ γὰρ ἕτεραι παρὰ τὰς εἰρημένας εἰς τὴν κατασκευὴν λαμβάνονται ποικιλώτεραν ἔχουσαι τὴν γένεσιν καὶ βεβιασμένην μᾶλλον, ἐξ ἀτακτοτέρων ἐπιφανειῶν καὶ κινήσεων ἐπιπεπλεγμένων γεννώμεναι. τοιαῦται δὲ εἰσιν αἱ τε ἐν τοῖς πρὸς ἐπιφανείαις καλουμένοις τόποις εὐρισκόμεναι γραμμαὶ ἕτεραί τε τούτων ποικιλώτεραι καὶ πολλαὶ τὸ πλῆθος ὑπὸ Δημητρίου τοῦ Ἀλεξανδρέως ἐν ταῖς Γραμμικαῖς ἐπιστάσεσι καὶ Φίλωνος τοῦ Τυανέως ἐξ ἐπιπλοκῆς πλεκτοειδῶν τε καὶ ἑτέρων παντοίων ἐπιφανειῶν εὐρισκόμεναι πολλὰ καὶ θαυμαστὰ συμπτώματα περὶ αὐτὰς ἔχουσαι. καὶ τινες αὐτῶν ὑπὸ τῶν νεωτέρων ἠξιώθησαν λόγου πλείονος, μία δὲ τις ἐξ αὐτῶν ἐστὶν ἢ καὶ παράδοξος ὑπὸ τοῦ Μενελάου κληθεῖσα γραμμὴ. τοῦ δὲ αὐτοῦ γένους ἕτεραι ἑλικές εἰσιν

• Whether τοποὶ πρὸς ἐπιφανείαις are "loci which are surfaces" or "loci which lie on surfaces" (e.g., the cylindrical helix) is a moot point. Euclid wrote two books under the title.



THIS PAGE IS LOCKED TO FREE MEMBERS

Purchase full membership to immediately unlock this page

FORGOTTEN BOOKS

FULL

MEMBERSHIP

797,885 Books!

All you can read

for only

\$8.99/month

Continue

*Fair usage policy applies



GREEK MATHEMATICS

τετραγωνίζουσαί τε καὶ κοχλοειδεῖς καὶ κισσοειδεῖς. δοκεῖ δέ πως ἀμάρτημα τὸ τοιοῦτον οὐ μικρὸν εἶναι τοῖς γεωμέτραις, ὅταν ἐπίπεδον πρόβλημα διὰ τῶν κωνικῶν ἢ τῶν γραμμικῶν ὑπὸ τινος εὔρισκῆται, καὶ τὸ σύνολον ὅταν ἐξ ἀνοικείου λύηται γένους, οἷόν ἐστιν τὸ ἐν τῷ πέμπτῳ τῶν Ἀπολλωνίου Κωνικῶν ἐπὶ τῆς παραβολῆς πρόβλημα καὶ ἡ ἐν τῷ περὶ τῆς ἑλικος ὑπὸ Ἀρχιμήδους λαμβανομένη στερεοῦ νεῦσις ἐπὶ κύκλον· μηδενὶ

the curve of the surface of the hemisphere on which it lies is equal to the square on the diameter of the sphere; the fact that this area can be squared is thought to justify the name *paradoxical*. An Arabian tradition that Menelaus reproduced in his *Elements of Geometry* Archytas's solution of the problem of duplicating the cube (involving the intersection of a torus, cylinder and cone) lends a certain plausibility to the suggestion (v. Heath, *H.G.M.* ii. 261, Loria, *Le scienze esatte*, pp. 518-520).

^a Heath identifies this (*Apollonius of Perga* cxxvii-cxxix) as *Conics* v. 58, where Apollonius finds the feet of the normals to a parabola passing through a given point by constructing a rectangular hyperbola whose intersections with the parabola give the required points. The feet of the normals could be found in the case of the parabola (though not of the ellipse or hyperbola) by the intersection of the parabola with a certain *circle*.

^b The assumption made by Archimedes (*Περὶ ἑλίκων* 8, 9) is to the following effect, the relevant portion of his figure being detached:

If $\Xi\Lambda$, KM are two chords of a circle, meeting at right angles at Γ , so that $\Xi\Gamma > \Gamma\Lambda$, then it is possible to draw another chord KN meeting $\Xi\Lambda$ in I such that $IN = M\Gamma$ (or, as Archimedes expresses the matter, *it is possible to place the straight line IN equal to $M\Gamma$ and verging towards K*).

SPECIAL PROBLEMS

this kind are spirals and quadratics and cochloids and cissoids. It appears to be no small error for geometers when a plane problem is solved by conics or other curved lines, and in general when any problem is solved by an inappropriate kind, as in the problem concerning the parabola in the fifth book of the *Conics* of Apollonius ^a and the verging of a solid character with respect to a circle assumed by Archimedes in his book on the spiral ^b; for it is possible

In general, the line KN is determined by the intersection of a hyperbola and a parabola, as Pappus himself shows in

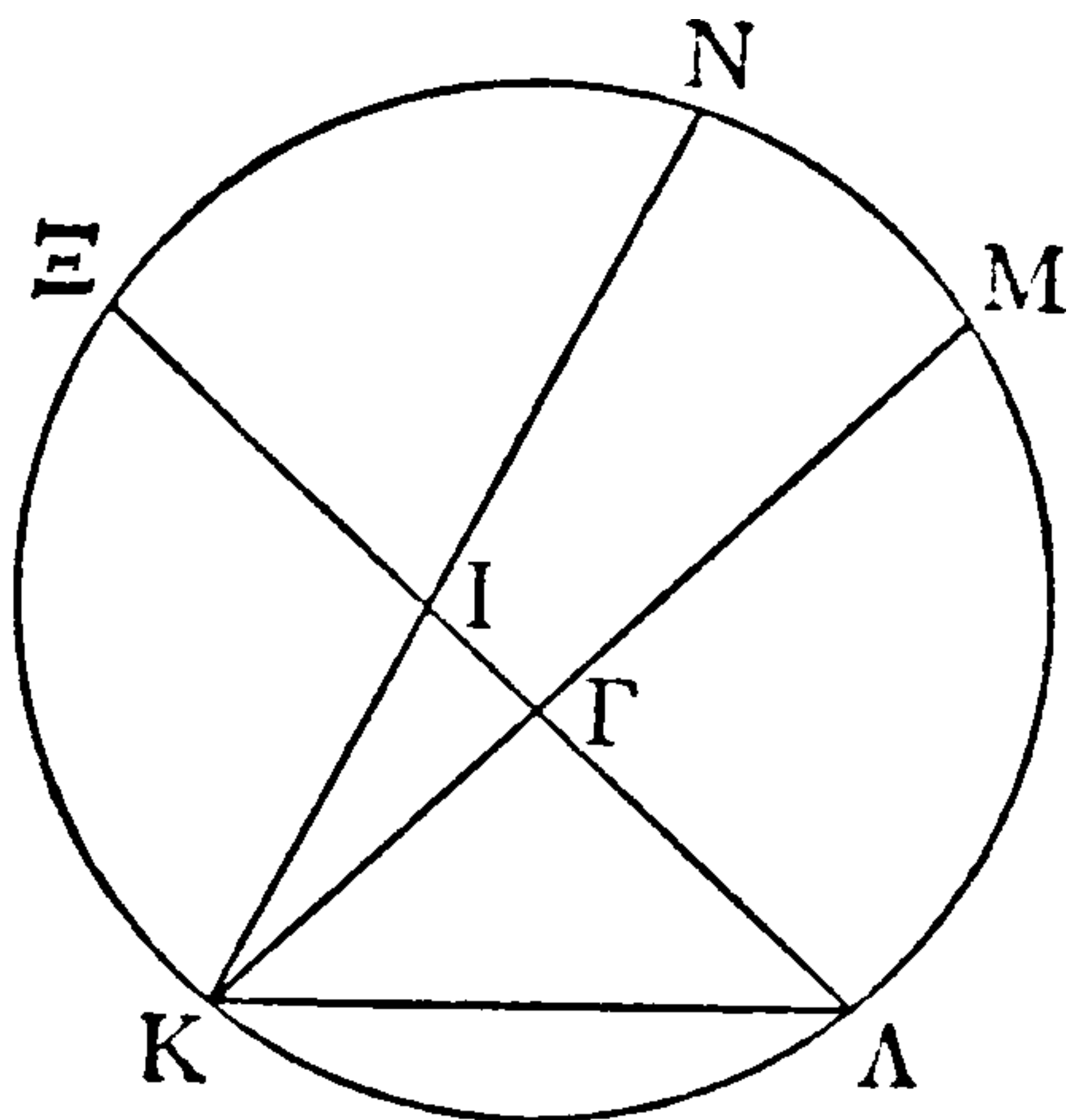

another place (iv. 52-53, ed. Hultsch 298-302). The particular case where $\Xi\Lambda$ is a diameter bisecting the chord KM in Γ can be solved by plane methods, namely, by the “application of areas”; the solution for the case where IN is to be made equal to $\sqrt{\frac{3}{2}}$ (radius of the circle) is assumed by Hippocrates in the fragment from Eudemus preserved by Simplicius (see *supra*, p. 244 n. a).

Archimedes gives no indication of the solution he had in mind, but all he requires for his purpose is its *possibility*; and its possibility can be demonstrated without any use of conics. For this reason Heath (*The Works of Archimedes* civ) thinks that Archimedes is to be excused from Pappus’s censure that he had solved a plane problem by solid methods.

GREEK MATHEMATICS

γὰρ προσχρώμενον στερεῶ δυνατὸν εὔρειν τὸ ὑπ' αὐτοῦ γραφόμενον θεώρημα, λέγω δὴ τὸ τὴν περιφέρειαν τοῦ ἐν τῇ πρώτῃ περιφορᾷ κύκλου ἴσην ἀποδείξαι τῇ πρὸς ὀρθὰς ἀγομένη εὐθείᾳ τῇ ἐκ τῆς γενέσεως ἕως τῆς ἐφαπτομένης τῆς ἔλικος. τοιαύτης δὴ τῆς διαφορᾶς τῶν προβλημάτων ὑπαρχούσης οἱ πρότεροι γεωμέτραι τὸ προειρημένον ἐπὶ τῆς γωνίας πρόβλημα τῇ φύσει στερεὸν ὑπάρχον διὰ τῶν ἐπιπέδων ζητοῦντες οὐχ οἰοί τ' ἦσαν εὔρισκειν· οὐδέπω γὰρ αἱ τοῦ κώνου τομαὶ συνήθεις ἦσαν αὐτοῖς, καὶ διὰ τοῦτο ἠπόρησαν· ὕστερον μέντοι διὰ τῶν κωνικῶν ἐτριχοτόμησαν τὴν γωνίαν εἰς τὴν εὔρεσιν χρησάμενοι τῇ ὑπογεγραμμένη νεύσει.

(b) SOLUTION BY MEANS OF A VERGING

Ibid. iv. 36. 60, ed. Hultsch 272. 15-274. 2

Παραλληλογράμμου δοθέντος ὀρθογωνίου τοῦ ΑΒΓΔ καὶ ἐκβληθείσης τῆς ΒΓ, δεόν ἔστω διαγαγόντα τὴν ΑΕ ποιεῖν τὴν ΕΖ εὐθείαν ἴσην τῇ δοθείσῃ.

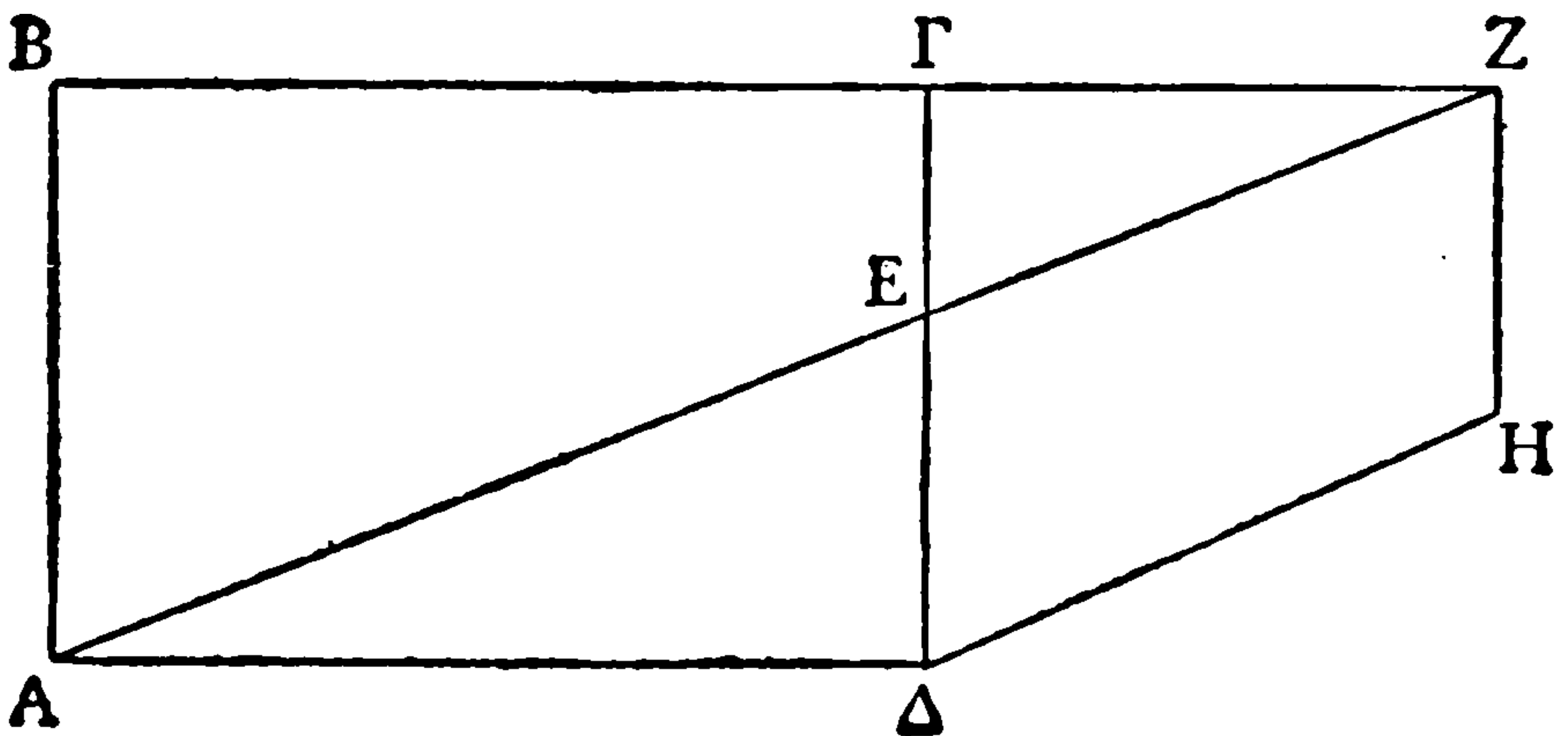

Γεγονέτω, καὶ ταῖς ΕΖ, ΕΔ παράλληλοι ἦχθωσαν



THIS PAGE IS LOCKED TO FREE MEMBERS

Purchase full membership to immediately unlock this page

SAVE \$3,999,994

Did you know we sell
paperback books too?

To buy our entire catalog
in paperback would cost
over \$4,000,000

Access it all now for
\$8.99/month

*Fair usage policy applies

Continue

αἱ ΔΗ, ΗΖ. ἐπεὶ οὖν δοθεῖσά ἐστιν ἡ ΖΕ καὶ ἔστιν ἴση τῇ ΔΗ, δοθεῖσα ἄρα καὶ ἡ ΔΗ. καὶ δοθὲν τὸ Δ· τὸ Η ἄρα πρὸς θέσει κύκλου περιφερείᾳ. καὶ ἐπεὶ τὸ ὑπὸ ΒΓΔ δοθὲν καὶ ἔστιν ἴσον τῷ ὑπὸ ΒΖ, ΕΔ, δοθὲν ἄρα καὶ τὸ ὑπὸ ΒΖ ΕΔ, τουτέστιν τὸ ὑπὸ ΒΖΗ· τὸ Η ἄρα πρὸς ὑπερβολῇ. ἀλλὰ καὶ πρὸς θέσει κύκλου περιφερείᾳ· δοθὲν ἄρα τὸ Η.

Ibid. iv. 38. 62, ed. Hultsch 274. 18–276. 14

λη'. Δεδειγμένου δὴ τούτου τρίχα τέμνεται ἡ δοθεῖσα γωνία εὐθύγραμμος οὕτως.

Ἐστω γὰρ ὀξεῖα πρότερον ἡ ὑπὸ ΑΒΓ, καὶ ἀποτινος σημείου κάθετος ἡ ΑΓ, καὶ συμπληρωθέντος τοῦ ΓΖ παραλληλογράμμου ἡ ΖΑ ἐκβεβλήσθω ἐπὶ

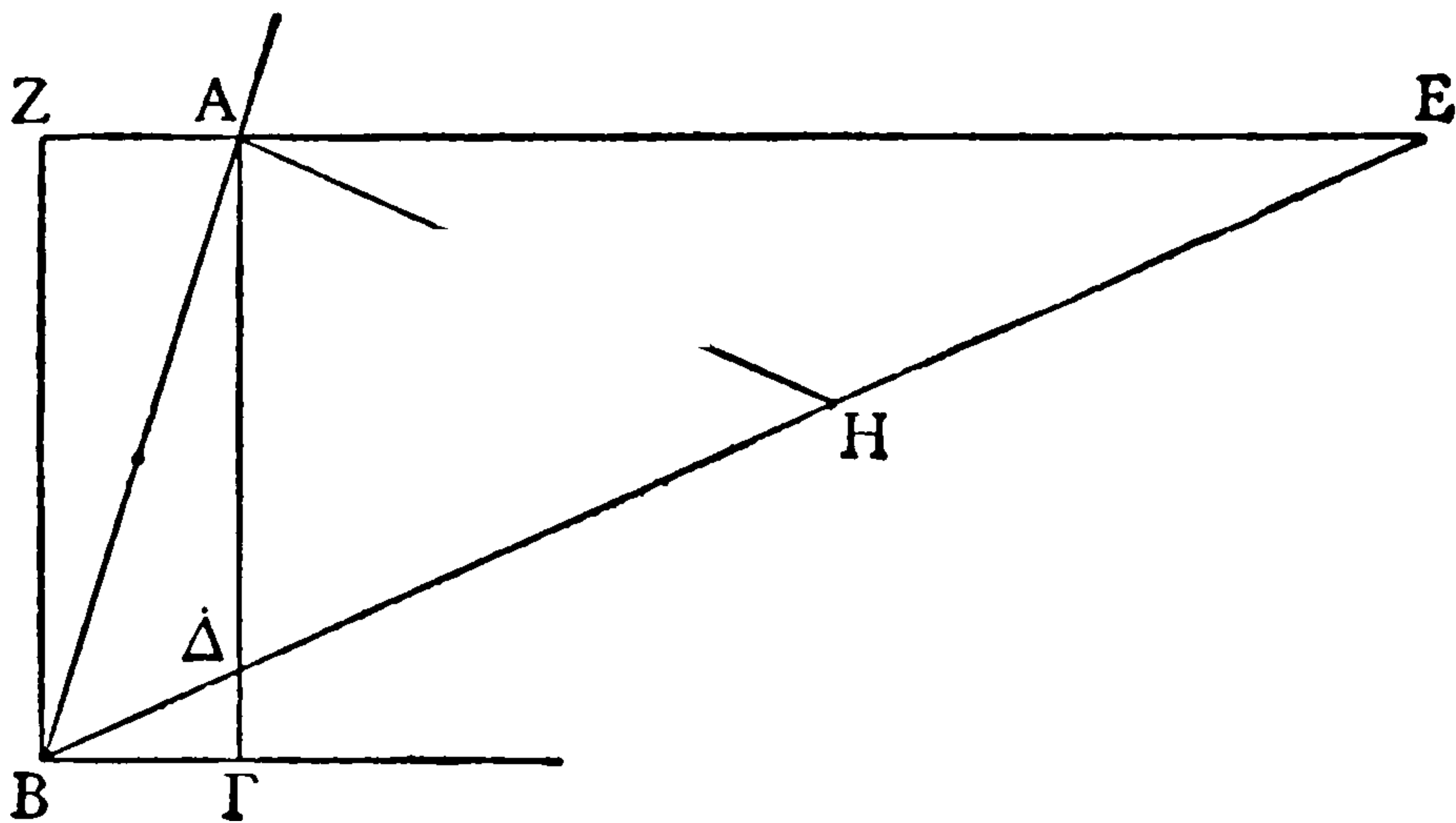

τὸ Ε, καὶ παραλληλογράμμου ὄντος ὀρθογωνίου τοῦ ΓΖ κείσθω μεταξύ τῶν ΕΑΓ εὐθεῖα ἡ ΕΔ νεύουσα ἐπὶ τὸ Β ἴση τῇ διπλασίᾳ τῆς ΑΒ (τοῦτο γὰρ ὡς δυνατόν γενέσθαι προγέγραπται). λέγω δὴ ὅτι τῆς δοθείσης γωνίας τῆς ὑπὸ ΑΒΓ τρίτον μέρος ἐστὶν ἡ ὑπὸ ΕΒΓ.

SPECIAL PROBLEMS

to EZ , $E\Delta$. Since ZE is given and is equal to ΔH , therefore ΔH is also given. And Δ is given; therefore H is on the circumference of a circle given in position. And since the rectangle contained by $B\Gamma$, $\Gamma\Delta$ is given and is equal to the rectangle contained by BZ , $E\Delta$ [Eucl. i. 43], therefore the rectangle contained by BZ , $E\Delta$ is given, that is, the rectangle contained by BZ , ZH is given; therefore H lies on a hyperbola. But it is also on the circumference of a circle given in position; therefore H is given.^a

Ibid. iv. 38. 62, ed. Hultsch. 274. 18–276. 14

38. With this proved, the given rectilineal angle is trisected in the following manner.

First let $AB\Gamma$ be an acute angle, and from any point [of the straight line AB] let the perpendicular $A\Gamma$ be drawn, and let the parallelogram ΓZ be completed, and let ZA be produced to E , and inasmuch as ΓZ is a right-angled parallelogram let the straight line $E\Delta$ be placed between EA , $A\Gamma$ so as to verge towards B and be equal to twice AB —that this is possible has been proved above; I say that $EB\Gamma$ is a third part of the given angle $AB\Gamma$.

^a The formal synthesis then follows as Pappus iv. 37.

GREEK MATHEMATICS

Τετμήσθω γὰρ ἡ ΕΔ δίχα τῷ Η, καὶ ἐπεζεύχθω ἡ ΑΗ· αἱ τρεῖς ἄρα αἱ ΔΗ, ΗΑ, ΗΕ ἴσαι εἰσίν· διπλῆ ἄρα ἡ ΔΕ τῆς ΑΗ. ἀλλὰ καὶ τῆς ΑΒ διπλῆ· ἴση ἄρα ἐστὶν ἡ ΒΑ τῇ ΑΗ, καὶ ἡ ὑπὸ ΑΒΔ γωνία τῇ ὑπὸ ΑΗΔ. ἡ δὲ ὑπὸ ΑΗΔ διπλασία τῆς ὑπὸ ΑΕΔ, τουτέστιν τῆς ὑπὸ ΔΒΓ· καὶ ἡ ὑπὸ ΑΒΔ ἄρα διπλῆ ἐστὶν τῆς ὑπὸ ΔΒΓ. καὶ ἐὰν τὴν ὑπὸ ΑΒΔ δίχα τέμωμεν, ἔσται ἡ ὑπὸ ΑΒΓ γωνία τρίχα τετμημένη.

(c) DIRECT SOLUTIONS BY MEANS OF CONICS

Ibid. iv. 43. 67-44. 68, ed. Hultsch 280. 20-284. 20

μγ'. Καὶ ἄλλως τῆς δοθείσης περιφερείας τὸ

^a We may easily show with Heath (*H.G.M.* i. 237-238) how the solution of the *νεῦσις* is equivalent to the solution of a cubic equation. If in the accompanying figure ZE, ZB are the axes of x, y respectively, and $ZA = a, ZB = b$, the point Θ giving E is determined as the intersection of the circle

$$(x - a)^2 + (y - b)^2 = 4(a^2 + b^2)$$

and the hyperbola $xy = ab$.

By eliminating x from these equations we may obtain

$$(y + b)(y^3 - 3by^2 - 3a^2y + a^2b) = 0.$$

One of the points of intersection of the circle and hyperbola is therefore given by $y = -b, x = -a$.

The other three are determined by the equation

$$y^3 - 3by^2 - 3a^2y + a^2b = 0.$$



THIS PAGE IS LOCKED TO FREE MEMBERS

Purchase full membership to immediately unlock this page

FORGOTTEN BOOKS

FULL

MEMBERSHIP

797,885 Books!

All you can read

for only

\$8.99/month

Continue

*Fair usage policy applies



GREEK MATHEMATICS

τρίτον ἀφαιρείται μέρος, χωρὶς τῆς νεύσεως, διὰ στερεοῦ τόπου τοιούτου.

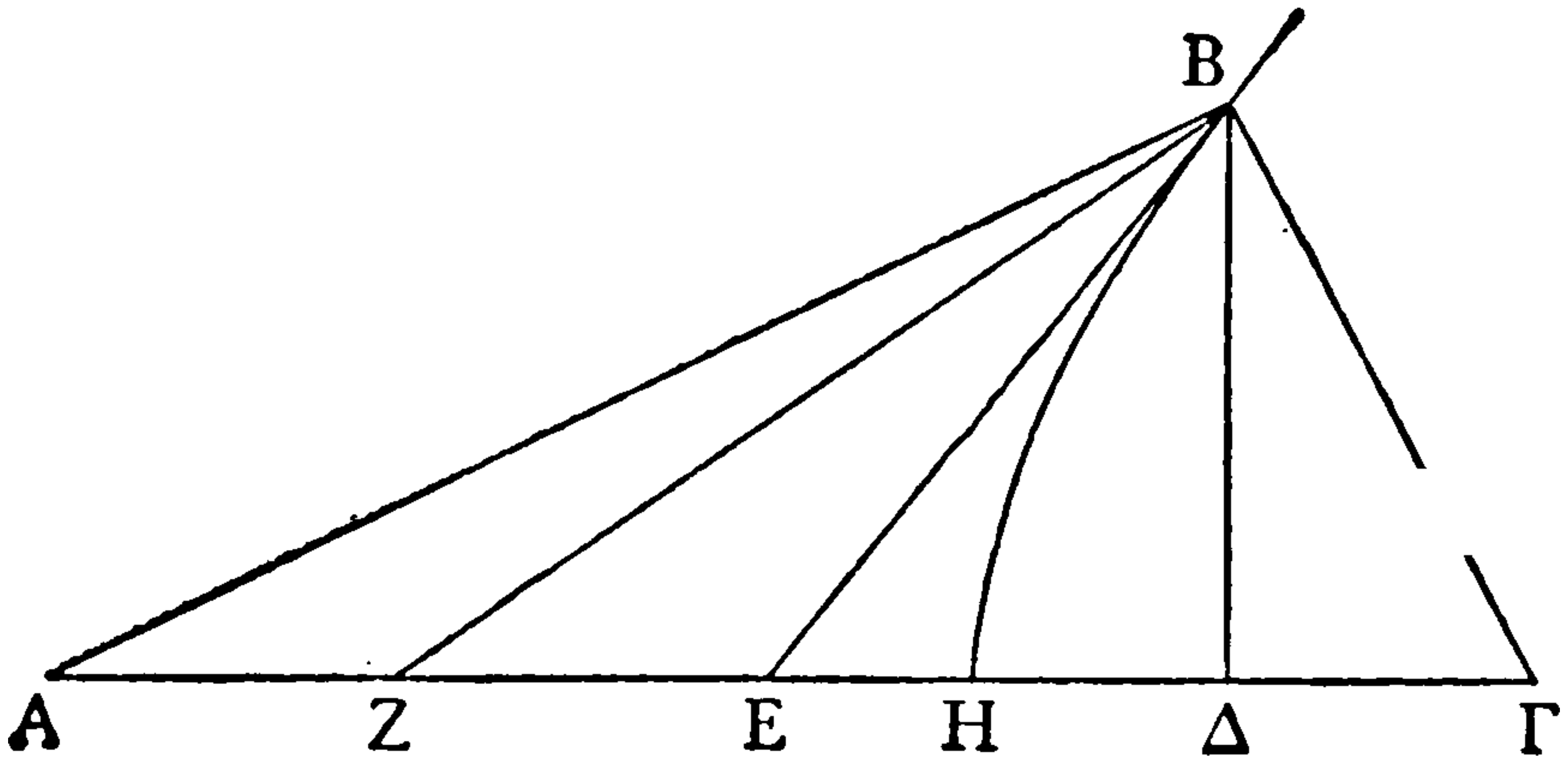

Θέσει ἡ διὰ τῶν Α, Γ, καὶ ἀπὸ δοθέντων ἐπ' αὐτῆς τῶν Α, Γ κεκλάσθω ἡ ΑΒΓ διπλασίαν ποιοῦσα τὴν ὑπὸ ΑΓΒ γωνίαν τῆς ὑπὸ ΓΑΒ· ὅτι τὸ Β πρὸς ὑπερβολῇ.

Ἦχθω καθέτος ἡ ΒΔ, καὶ τῇ ΓΔ ἴση ἀπειλήφθω ἡ ΔΕ· ἐπιζευχθεῖσα ἄρα ἡ ΒΕ ἴση ἔσται τῇ ΑΕ. κείσθω καὶ τῇ ΔΕ ἴση ἡ ΕΖ· τριπλασία ἀρα ἡ ΓΖ τῆς ΓΔ. ἔστω καὶ ἡ ΑΓ τῆς ΓΗ τριπλασία· ἔσται δὴ δοθὲν τὸ Η, καὶ λοιπὴ ἡ ΑΖ τῆς ΗΔ τριπλασία. καὶ ἐπεὶ τῶν ἀπὸ ΒΕ, ΕΖ ὑπεροχὴ ἔστιν τὸ ἀπὸ ΒΔ, ἔστιν δὲ καὶ τὸ ὑπὸ ΔΑ, ΑΖ τῶν αὐτῶν ὑπεροχὴ, ἔσται ἄρα τὸ ὑπὸ ΔΑΖ, τουτέστιν τὸ τρὶς ὑπὸ ΑΔΗ, ἴσον τῷ ἀπὸ ΒΔ· πρὸς ὑπερβολῇ ἄρα τὸ Β, ἧς πλαγία μὲν τοῦ πρὸς ἄξονι εἶδους ἡ

^a For by the equality of the triangles ΒΕΔ, ΒΓΔ, we have $\angle BE\Gamma = \angle B\Gamma E = 2\angle \Gamma AB$ (*ex hypothesi*). But $\angle BE\Gamma = \angle \Gamma AB + \angle ABE$.

Therefore $\angle \Gamma AB = \angle ABE$, and so $BE = AE$.

^b *i.e.* since $\Gamma H = \frac{1}{3}A\Gamma$ and $\Gamma\Delta = \frac{1}{3}\Gamma Z$, by subtraction,

$$\Gamma H - \Gamma\Delta = \frac{1}{3}(A\Gamma - \Gamma Z), \text{ or } H\Delta = \frac{1}{3}AZ.$$

SPECIAL PROBLEMS

given arc is furnished, without the use of a verging, by this solid locus.

Let the straight line through A, Γ be given in position, and from the given points A, Γ upon it let $AB\Gamma$ be inflected, making the angle $A\Gamma B$ double of ΓAB ; I say that B lies on a hyperbola.

For let $B\Delta$ be drawn perpendicular [to $A\Gamma$] and let ΔE be cut off equal to $\Gamma\Delta$; when BE is joined it will therefore be equal to AE.^a And let EZ be placed equal to ΔE ; therefore $\Gamma Z = 3\Gamma\Delta$. Now let ΓH be placed equal to $\frac{1}{3}A\Gamma$; therefore the point H will be given, and the remainder^b AZ will equal $3H\Delta$.

Now since ^c $BE^2 - EZ^2 = B\Delta^2,$

and $BE^2 - EZ^2 = \Delta A \cdot AZ,$

therefore $\Delta A \cdot AZ = B\Delta^2,$

that is $3A\Delta \cdot \Delta H = B\Delta^2;$

therefore B lies on a hyperbola with transverse axis

^d The reasoning here is much abbreviated, and in full may be written as follows:

$$\begin{aligned} BE^2 - EZ^2 &= BE^2 - E\Delta^2 \text{ (since } EZ = E\Delta \text{ ex hypothesi)} \\ &= B\Delta^2 \text{ (Eucl. i. 47)} \end{aligned}$$

$$\begin{aligned} \text{Now } BE^2 - EZ^2 &= AE^2 - EZ^2 \text{ (since BE was proved equal} \\ &\text{to AE)} \\ &= \Delta A \cdot AZ \text{ (Eucl. ii. 6)} \end{aligned}$$

$$\Delta A \cdot AZ = B\Delta^2$$

$$\therefore 3A\Delta \cdot \Delta H = B\Delta^2 \text{ (since } AZ \text{ was proved equal to } 3H\Delta)$$

$$\begin{aligned} \therefore B\Delta^2 : A\Delta \cdot \Delta H &= 3 : 1 \\ &= \frac{3AH^2}{AH^2}; \end{aligned}$$

\therefore B lies on a hyperbola with transverse axis AH and conjugate axis $\sqrt{3}AH$.

GREEK MATHEMATICS

ΑΗ, ἣ δὲ ὀρθία τριπλασία τῆς ΑΗ. καὶ φανερόν ὅτι τὸ Γ σημεῖον ἀπολαμβάνει πρὸς τῇ Η κορυφῇ τῆς τομῆς τὴν ΓΗ ἡμίσειαν τῆς πλαγίας τοῦ εἴδους πλευρᾶς τῆς ΑΗ.

Καὶ ἡ σύνθεσις φανερά· δεήσει γὰρ τὴν ΑΓ τεμεῖν ὥστε διπλασίαν εἶναι τὴν ΑΗ τῆς ΗΓ, καὶ περὶ ἄξονα τὸν ΑΗ γράψαι διὰ τοῦ Η ὑπερβολήν, ἣς ὀρθία τοῦ εἴδους πλευρὰ τριπλασία τῆς ΑΗ, καὶ δεικνύναι ποιούσαν αὐτὴν τὸν εἰρημένον διπλάσιον λόγον τῶν γωνιῶν. καὶ ὅτι τῆς δοθείσης κύκλου περιφερείας τὸ γ' ἀποτέμνει μέρος ἢ τοῦτον γραφομένη τὸν τρόπον ὑπερβολῇ συνιδεῖν ῥάδιον τῶν Α, Γ σημείων περάτων τῆς περιφερείας ὑποκειμένων.

μδ'. Ἐτέρως δὲ τὴν ἀνάλυσιν τοῦ τρίχα τεμεῖν τὴν γωνίαν ἢ περιφέρειαν ἐξέθεντό τινες ἄνευ τῆς νεύσεως. ἔστω δὲ ἐπὶ περιφερείας ὁ λόγος· οὐδὲν γὰρ διαφέρει γωνίαν ἢ περιφέρειαν τεμεῖν.

Γεγονέτω δὴ, καὶ τῆς ΑΒΓ περιφερείας τρίτον

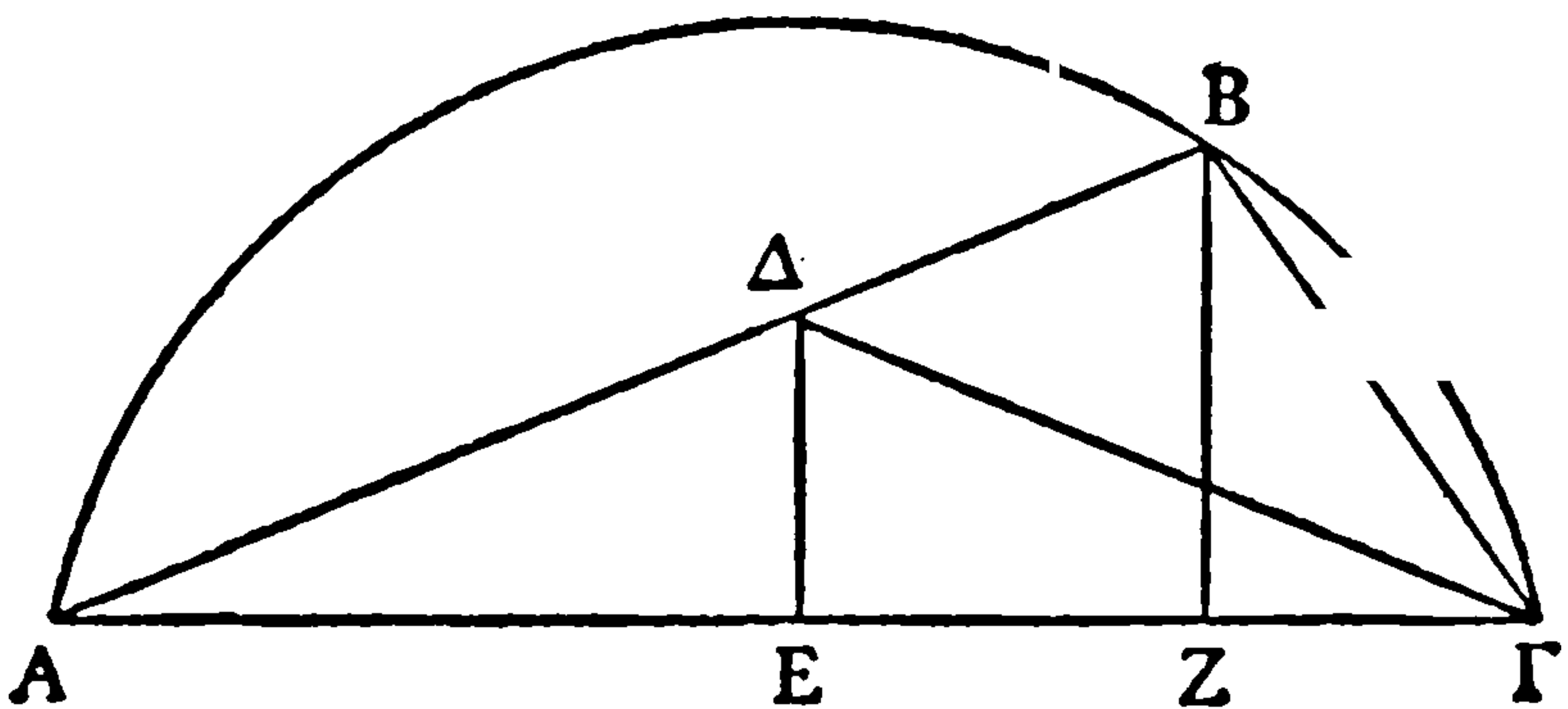

ἀπειλήφθω μέρος ἢ ΒΓ, καὶ ἐπεζεύχθωσαν αἱ ΑΒ, ΒΓ, ΓΑ· διπλασίων ἄρα ἢ ὑπὸ ΑΓΒ τῆς ὑπὸ



THIS PAGE IS LOCKED TO FREE MEMBERS

Purchase full membership to immediately unlock this page

SAVE \$3,999,994

Did you know we sell
paperback books too?

To buy our entire catalog
in paperback would cost
over \$4,000,000

Access it all now for
\$8.99/month

*Fair usage policy applies

Continue

ΒΑΓ. τετμήσθω δίχα ἡ ὑπὸ ΑΓΒ τῆ ΓΔ, καὶ κάθετοι αἱ ΔΕ, ΖΒ· ἴση ἄρα ἡ ΑΔ τῆ ΔΓ, ὥστε καὶ ἡ ΑΕ τῆ ΕΓ· δοθὲν ἄρα τὸ Ε. ἐπεὶ οὖν ἐστὶν ὡς ἡ ΑΓ πρὸς ΓΒ, οὕτως ἡ ΑΔ πρὸς ΔΒ, τουτέστιν ἡ ΑΕ πρὸς ΕΖ, καὶ ἐναλλάξ ἄρα ἐστὶν ὡς ἡ ΓΑ πρὸς ΑΕ, ἡ ΒΓ πρὸς ΕΖ. διπλῆ δὲ ἡ ΓΑ τῆ ΑΕ· διπλῆ ἄρα καὶ ἡ ΒΓ τῆς ΕΖ· τετραπλάσιον ἄρα τὸ ἀπὸ ΒΓ, τουτέστιν τὰ ἀπὸ τῶν ΒΖΓ, τοῦ ἀπὸ τῆς ΕΖ. ἐπεὶ οὖν δύο δοθέντα ἐστὶν τὰ Ε, Γ, καὶ ὀρθὴ ἡ ΒΖ, καὶ λόγος ἐστὶν τοῦ ἀπὸ ΕΖ πρὸς τὰ ἀπὸ τῶν ΒΖΓ, τὸ Β ἄρα πρὸς ὑπερβολῆ. ἀλλὰ καὶ πρὸς θέσει περιφερείᾳ· δοθὲν ἄρα τὸ Β. καὶ ἡ σύνθεσις φανερά·

^a The relation $BΓ = 2ΕΖ$ tells us that B lies on a hyperbola with foci A, Γ, directrix ΒΖ and eccentricity 2. Pappus proceeds to turn this into the axial form $ΕΖ^2 : ΒΖ^2 + ΖΓ^2 = 1 : 4$ which was more commonly used by the Greeks. In fact, there are only two other extant passages in which the focus-directrix property is used. One of them is also given by Pappus (vii., ed. Hultsch 1004-1014), who there proved

SPECIAL PROBLEMS

$\angle A\Gamma B = 2\angle BA\Gamma$. Let $\angle A\Gamma B$ be bisected by $\Gamma\Delta$, and let ΔE , ZB be drawn perpendicular; therefore $A\Delta$ is equal to $\Delta\Gamma$, so that AE is also equal to $E\Gamma$; therefore E is given.

Now because $A\Gamma : \Gamma B = A\Delta : \Delta B$ [Eucl. vi. 5
 $= AE : EZ$,

therefore alternately $\Gamma A : AE = B\Gamma : EZ$.

But $\Gamma A = 2AE$; and therefore $B\Gamma = 2EZ$; therefore $B\Gamma^2 = 4EZ^2$, that is, $BZ^2 + Z\Gamma^2 = 4EZ^2$. Now, since the two points E , Γ are given, and BZ is drawn at right angles, and the ratio $EZ^2 : BZ^2 + Z\Gamma^2$ is given, B lies on a hyperbola. But it also lies on an arc given in position; therefore B is given. And the synthesis is clear.^a

generally that "if the distance of a point from a fixed point is in a given ratio to its distance from a fixed line, the locus of the point is a conic section which is an ellipse, a parabola or a hyperbola according as the given ratio is less than, equal to, or greater than, unity." The proof is among a number of lemmas to the *Surface Loci* of Euclid, so presumably the focus-directrix property was already well known when Euclid wrote.



THIS PAGE IS LOCKED TO FREE MEMBERS

Purchase full membership to immediately unlock this page

FORGOTTEN BOOKS

FULL

MEMBERSHIP

797,885 Books!

All you can read

for only

\$8.99/month

Continue

*Fair usage policy applies



X. ZENO OF ELEA

Aristot. *Phys.* Z 9, 239 b 5–240 a 18

Ζήνων δὲ παραλογίζεται· εἰ γὰρ αἰεὶ, φησὶν, ἡρεμεῖ πᾶν ἢ κινεῖται¹ ὅταν ἢ κατὰ τὸ ἴσον, ἐστὶν δ' αἰεὶ τὸ φερόμενον ἐν τῷ νῦν, ἀκίνητον τὴν φερόμενην εἶναι ὀιστόν. τοῦτο δ' ἐστὶ ψεῦδος· οὐ γὰρ σύγκειται ὁ χρόνος ἐκ τῶν νῦν τῶν ἀδιαιρέτων, ὥσπερ οὐδ' ἄλλο μέγεθος οὐδέν.

Τέτταρες δ' εἰσὶν οἱ λόγοι περὶ κινήσεως Ζήνωνος οἱ παρέχοντες τὰς δυσκολίας τοῖς λύουσιν, πρῶτος μὲν ὁ περὶ τοῦ μὴ κινεῖσθαι διὰ τὸ πρότερον εἰς τὸ ἡμισυ δεῖν ἀφικέσθαι τὸ φερόμενον ἢ πρὸς τὸ τέλος, περὶ οὗ διείλομεν ἐν τοῖς πρότερον λόγοις.

¹ Zeller would bracket ἢ κινεῖται, and he is followed by Ross, but not, it seems to me, with sufficient reason. Diels, followed by Lee, has the unnecessary addition of οὐδὲν δὲ κινεῖται after these words. The passage as it stands is satisfactorily explained by Brochard (*Études de philosophie ancienne et de philosophie moderne*, p. 6) and by Heath (*H.G.M.* i. 276).

^a Zeno of Elea, who is represented by Plato (*Parm.* 127 B) as “about forty” when Socrates was a “very young man” (say in 450 B.C.), was a disciple of Parmenides. The object of his four arguments on motion, here reproduced from Aristotle, was to show that the rejection of Parmenides' doctrine of the unity of being led to self-contradictory results.

X. ZENO OF ELEA^a

Aristotle, *Physics* Z 9, 239 b 5–240 a 18

ZENO's argument is fallacious; for, he says, if everything is either at rest or in motion when it occupies a space equal to itself, while the object moved is always in the instant, the moving arrow is unmoved. But this is false; for time is not made up of indivisible instants, any more than is any other magnitude.

Zeno has four arguments about motion which present difficulties to those who try to resolve them. The first is that which says there is no motion because the object moved must arrive at the middle before it arrives at the end,^b concerning which we have already treated.

A vast literature has grown round these arguments, but the student will find most help in W. D. Ross, *Aristotle's Physics*, pp. 655-666, H. D. P. Lee, *Zeno of Elea*, and Heath, *H.G.M.* i. 271-283.

^b Not only has it to pass through the half-way point, but through half of the remaining half, and so on to infinity. If a is the length of the course measured from the goal, then the moving object before it reaches its goal has to pass through the points $\frac{a}{2}$, $\frac{a}{2^2}$, $\frac{a}{2^3}$. . . and so on through an infinite series which cannot be enumerated. Aristotle's answer is that the moving object has indeed to pass through an infinite number of positions, but in a finite time it has an infinite number of instants in which to do so.

* Διὸ καὶ ὁ Ζήνωνος λόγος ψεῦδος λαμβάνει τὸ μὴ ἐνδέχεσθαι τὰ ἄπειρα διελθεῖν ἢ ἄψασθαι τῶν ἀπείρων καθ' ἕκαστον ἐν πεπερασμένῳ χρόνῳ. διχῶς γὰρ λέγεται καὶ τὸ μῆκος καὶ ὁ χρόνος ἄπειρον, καὶ ὅλως πᾶν τὸ συνεχές, ἥτοι κατὰ διαίρεσιν ἢ τοῖς ἐσχάτοις. τῶν μὲν οὖν κατὰ τὸ ποσὸν ἀπείρων οὐκ ἐνδέχεται ἄψασθαι ἐν πεπερασμένῳ χρόνῳ, τῶν δὲ κατὰ διαίρεσιν ἐνδέχεται καὶ γὰρ αὐτὸς ὁ χρόνος οὕτως ἄπειρος. ὥστε ἐν τῷ ἀπείρῳ καὶ οὐκ ἐν τῷ πεπερασμένῳ συμβαίνει διέναι τὸ ἄπειρον, καὶ ἄπτεσθαι τῶν ἀπείρων τοῖς ἀπείροις, οὐ τοῖς πεπερασμένοις.*

Δεύτερος δ' ὁ καλούμενος Ἀχιλλεύς· ἔστι δ' οὗτος, ὅτι τὸ βραδύτατον οὐδέποτε καταληφθήσεται θεὸν ὑπὸ τοῦ ταχίστου· ἔμπροσθεν γὰρ ἀναγκαῖον ἐλθεῖν τὸ διώκον, ὅθεν ὤρμησε τὸ φεῦγον, ὥστ' αἰεὶ τι προέχειν ἀναγκαῖον τὸ βραδύτερον. ἔστι δὲ καὶ οὗτος ὁ αὐτὸς λόγος τῷ διχοτομεῖν, διαφέρει δ' ἐν τῷ διαιρεῖν μὴ δίχα τὸ προσλαμβανόμενον μέγεθος. τὸ μὲν οὖν μὴ καταλαμβάνεσθαι τὸ βραδύτερον συμβέβηκεν ἐκ τοῦ λόγου, γίγνεται δὲ παρὰ ταῦτό τῇ διχοτομίᾳ (ἐν ἀμφοτέροις γὰρ συμβαίνει μὴ ἀφικνεῖσθαι πρὸς τὸ πέρας διαιρου-

* The passage between the asterisks, to which Aristotle refers the reader, is *Phys. Z 2*, 233 a 21-31 and is reproduced here for convenience.

† Aristotle's argument is correct. The *Achilles* is a more general form of the *Dichotomy*. If the speed of Achilles is n times that of the tortoise (we learn from Themistius and Simplicius that the tortoise was the object pursued), and the tortoise starts a unit ahead, then when Achilles has reached the point where the tortoise started the



THIS PAGE IS LOCKED TO FREE MEMBERS

Purchase full membership to immediately unlock this page

SAVE \$3,999,994

Did you know we sell
paperback books too?

To buy our entire catalog
in paperback would cost
over \$4,000,000

Access it all now for
\$8.99/month

*Fair usage policy applies

Continue

μένου πως τοῦ μεγέθους· ἀλλὰ πρόσκειται ἐν τούτῳ ὅτι οὐδὲ τὸ τάχιστον τετραγωνημένον ἐν τῷ διώκειν τὸ βραδύτατον), ὥστ' ἀνάγκη καὶ τὴν λύσιν εἶναι τὴν αὐτήν. τὸ δ' ἀξιοῦν ὅτι τὸ προέχον οὐ καταλαμβάνεται, ψεῦδος· ὅτε γὰρ προέχει, οὐ καταλαμβάνεται· ἀλλ' ὅμως καταλαμβάνεται, εἴπερ δώσει διεξιέναι τὴν πεπερασμένην.

Οὗτοι μὲν οὖν οἱ δύο λόγοι, τρίτος δ' ὁ νῦν ῥηθείς, ὅτι ἡ οἰστοὺς φερομένη ἔστηκεν. συμβαίνει δὲ παρὰ τὸ λαμβάνειν τὸν χρόνον συγκεῖσθαι ἐκ τῶν νῦν· μὴ δεδομένου γὰρ τούτου οὐκ ἔσται ὁ συλλογισμός.

Τέταρτος δ' ὁ περὶ τῶν ἐν τῷ σταδίῳ κινουμένων ἐξ ἐναντίας ἴσων ὄγκων παρ' ἴσους, τῶν μὲν ἀπὸ τέλους τοῦ σταδίου τῶν δ' ἀπὸ μέσου, ἴσῳ τάχει, ἐν ᾧ συμβαίνει οἶεται ἴσον εἶναι χρόνον τῷ διπλασίῳ τὸν ἥμισυν. ἔστι δ' ὁ παραλογισμὸς

^a Achilles overtakes the tortoise when he has travelled a distance $1 + \frac{1}{n} + \frac{1}{n^2} + \dots ad\ inf.$

This is a convergent series whose sum is $\frac{n}{n-1}$. The ancients did not know how to sum an infinite series, but they knew that Achilles would catch the tortoise and that the problem *solvitur ambulando*.

^b Lachelier (*Revue de métaphysique et de morale*, xviii., pp. 346-347) and Ross explain that ἀπὸ τοῦ μέσου means from the turning point in the double course or δίαυλος. The race was from the τέλος to the μέσον and back again to the τέλος. On this interpretation it is possible to translate easily and naturally. Gaye, the Oxford translators and Lee, who do not accept this interpretation, but believe τὸ μέσον to refer

ZENO OF ELEA

concluded that the goal will not be reached ; but in this a dramatic effect is produced by saying that not even the swiftest will be successful in its pursuit of the slowest) and so the solution must necessarily be the same. The claim that the one in front is not overtaken is false ; for when in front he is not indeed overtaken, but he will nevertheless be overtaken if he give his pursuer a finite distance to go through.^a

These are two of the arguments, and the third is the one just mentioned, that the flying arrow is at rest. This conclusion follows from the assumption that time is composed of instants ; for if this is not granted the reasoning does not follow.

The fourth is that about the two rows of equal bodies moving past each other in the stadium with equal velocities in opposite directions, the one row starting from the end of the stadium, the other from the middle.^b This, he thinks, leads to the conclusion that half a given time is equal to its double. The

to the middle of the A s, are forced to paraphrase : “ The

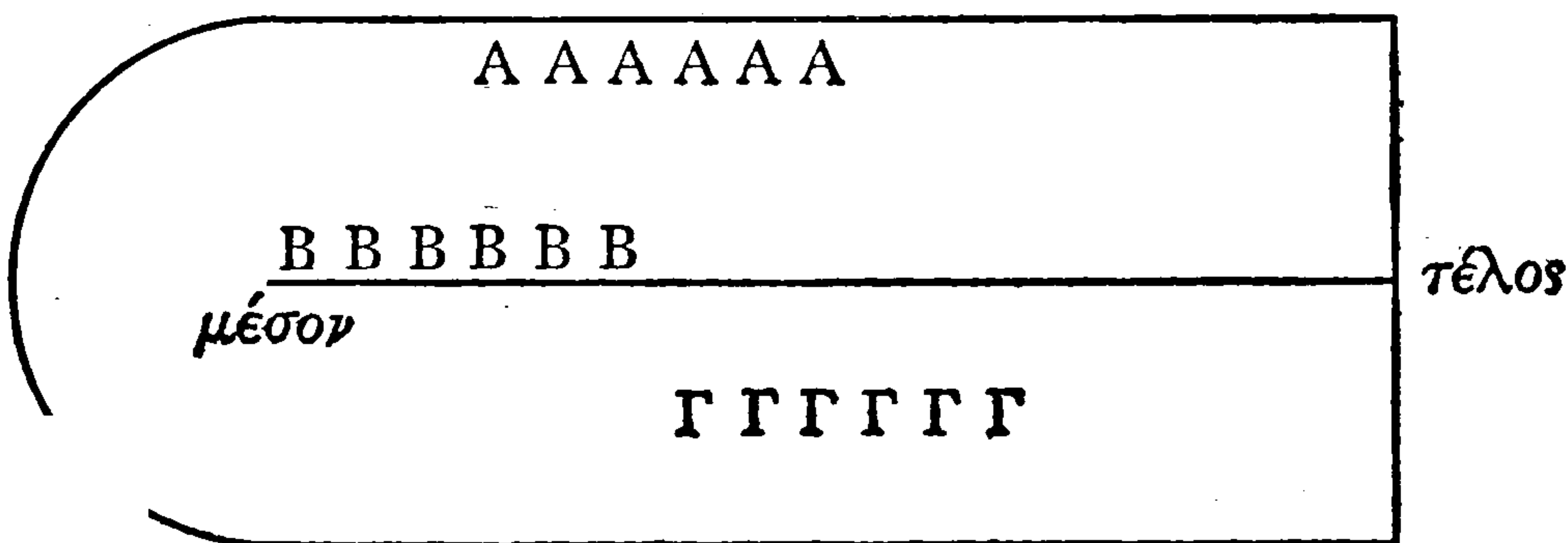

one row originally stretching from the goal to the middle-point of the stadium, the other from the middle-point to the starting-post.” Ross has to admit that τὸ μέσον is apparently not used elsewhere of the middle-point of the δίαυλος, but he rightly emphasizes the unnaturalness of any other interpretation.

GREEK MATHEMATICS

ἐν τῷ τὸ μὲν παρὰ κινούμενον τὸ δὲ παρ' ἡρεμοῦν τὸ ἴσον μέγεθος ἀξιοῦν τῷ ἴσῳ τάχει τὸν ἴσον φέρεσθαι χρόνον· τοῦτο δ' ἐστὶ ψεῦδος. οἷον ἔστωσαν οἱ ἐστῶτες ἴσοι ὄγκοι ἐφ' ὧν τὰ ΑΑ, οἱ δ' ἐφ' ὧν τὰ ΒΒ ἀρχόμενοι ἀπὸ τοῦ μέσου, ἴσοι τὸν ἀριθμὸν τούτοις ὄντες καὶ τὸ μέγεθος, οἱ δ' ἐφ' ὧν τὰ ΓΓ ἀπὸ τοῦ ἐσχάτου, ἴσοι τὸν ἀριθμὸν ὄντες τούτοις καὶ τὸ μέγεθος, καὶ ἰσοταχεῖς τοῖς Β. συμβαίνει δὴ τὸ πρῶτον Β ἅμα ἐπὶ τῷ ἐσχάτῳ εἶναι καὶ τὸ πρῶτον Γ, παρ' ἄλληλα κινουμένων. συμβαίνει δὲ τὸ Γ παρὰ πάντα [τὰ Β]¹ διεξεληλυθέναι, τὸ δὲ Β παρὰ τὰ ἡμίση· ὥστε ἡμισὺν εἶναι τὸν χρόνον· ἴσον γὰρ ἐκάτερόν ἐστι παρ'

¹ τὰ Β del. Ross.

• There seems little doubt that initially the rows of bodies were symmetrically arranged in the following way (we will assume half a dozen of each for convenience):

As



Bs



Γs





THIS PAGE IS LOCKED TO FREE MEMBERS

Purchase full membership to immediately unlock this page

FORGOTTEN BOOKS

FULL

MEMBERSHIP

797,885 Books!

All you can read

for only

\$8.99/month

Continue

*Fair usage policy applies



ἕκαστον. ἅμα δὲ συμβαίνει τὸ πρῶτον Β' παρά πάντα τὰ Γ παρεληλυθέναι· ἅμα γὰρ ἔσται τὸ πρῶτον Γ καὶ τὸ πρῶτον Β ἐπὶ τοῖς ἐναντίοις ἐσχάτοις, [ἴσον χρόνον παρ' ἕκαστον γιγνόμενον τῶν Β ὅσον περ τῶν Α, ὡς φησιν],³ διὰ τὸ ἀμφοτέρωθεν ἴσον χρόνον παρά τὰ Α γίνεσθαι. ὁ μὲν οὖν λόγος οὗτός ἐστιν, συμβαίνει δὲ παρά τὸ εἰρημένον ψεῦδος.

both cases, he gets his paradox, that half a given time is equal to the whole. He neglects the fact that the relative motion of Γ to Β is twice as great as the relative motion of Β to Α. If this is borne in mind, the paradox disappears. In order to support his interpretation Ross omits τὰ Β from the text: there is a rival reading τὰ Α and Ross suggests, with reason, that they are both glosses.

ZENO OF ELEA

each takes an equal time in passing each body. And it follows that at the same moment the first B has passed all the F s: for the first Γ and the first B will be simultaneously at opposite ends [of the A s], since both take an equal time in passing the A s. Such is his argument, and it comes about from the aforementioned fallacy.

¹ The vulgate has $\tau\grave{\alpha}$ B, but it would be incorrect to say all the B s have passed all the Γ s. One manuscript has $\tau\grave{o}$ α β , which would be a correct way of writing $\tau\grave{o}$ $\pi\rho\acute{\omega}\tau\omicron\nu$ B, and Ross accordingly adopts this.

² $\acute{\iota}\sigma\omicron\nu \dots \phi\eta\sigma\iota\nu$. These words will not stand interpretation and Ross omits them as a gloss in the margin on $\acute{\iota}\sigma\omicron\nu$ $\gamma\grave{\alpha}\rho$ $\acute{\epsilon}\kappa\acute{\alpha}\tau\epsilon\rho\acute{\omicron}\nu$ $\acute{\epsilon}\sigma\tau\iota\nu$ $\pi\alpha\rho'$ $\acute{\epsilon}\kappa\alpha\sigma\tau\omicron\nu$ which found its way into the text at the wrong place.



THIS PAGE IS LOCKED TO FREE MEMBERS

Purchase full membership to immediately unlock this page

SAVE \$3,999,994

Did you know we sell
paperback books too?

To buy our entire catalog
in paperback would cost
over \$4,000,000

Access it all now for
\$8.99/month

*Fair usage policy applies

Continue

XI. THEAETETUS

(a) GENERAL

Suidas, s.v. Θεαίτητος

Θεαίτητος, Ἀθηναῖος, ἀστρολόγος, φιλόσοφος, μαθητῆς Σωκράτους, ἐδίδαξεν ἐν Ἡρακλείᾳ. πρῶτος δὲ τὰ πέντε καλούμενα στερεὰ ἔγραψε. γέγονε δὲ μετὰ τὰ Πελοποννησιακά.

(b) THE FIVE REGULAR SOLIDS

Schol. i. in Eucl. *Elem.* xiii., Eucl. ed. Heiberg v. 654

Ἐν τούτῳ τῷ βιβλίῳ, τουτέστι τῷ ιγ', γράφεται τὰ λεγόμενα Πλάτωνος εἰσὶ σχήματα, ἃ αὐτοῦ μὲν οὐκ ἔστιν, τρία δὲ τῶν προειρημένων εἰσὶ σχημάτων τῶν Πυθαγορείων ἐστίν, ὃ τε κύβος καὶ ἡ πυραμὶς καὶ τὸ δωδεκάεδρον, Θεαιτήτου δὲ τό τε ὀκτάεδρον καὶ τὸ εἰκοσάεδρον. τὴν δὲ προσωυμίαν ἔλαβεν Πλάτωνος διὰ τὸ μεμνησθαι αὐτὸν ἐν τῷ Τιμαίῳ περὶ αὐτῶν.

* Theaetetus lived about 415–369 B.C. He is the subject of a dissertation *De Theaeteto Atheniensi* by Eva Sachs (Berlin, 1914).

XI. THEAETETUS •

(a) GENERAL

Suidas, *s.v. Theaetetus*

THEAETETUS, an Athenian, astronomer, philosopher, a pupil of Socrates, taught in Heraclea. He was the first to describe ^b the five solids so-called. He lived after the Peloponnesian wars.

(b) THE FIVE REGULAR SOLIDS

Euclid, *Elements* xiii., Scholium i., Eucl.
ed. Heiberg v. 654

In this book, that is, the thirteenth, are described the five Platonic figures, which are however not his, three of the aforesaid five figures being due to the Pythagoreans,^c namely, the cube, the pyramid and the dodecahedron, while the octahedron and icosahedron are due to Theaetetus. They received the name Platonic because he discourses in the *Timaeus* about them.

^b Possibly "construct."

^c For the relation of the Pythagoreans to the five regular solids, see *supra*, pp. 216-225. Theaetetus was probably the first to construct all five theoretically; the Pythagoreans could not have done that. For a full discussion, see Eva Sachs, *Die fünf Platonischen Körper*.

GREEK MATHEMATICS

(c) THE IRRATIONAL

Schol. lxii. in Eucl. *Elem.* x., Eucl. ed. Heiberg
v. 450. 16-18

Τὸ θεώρημα τοῦτο Θεαιτήτειόν ἐστιν εὖρημα,
καὶ μέμνηται αὐτοῦ ὁ Πλάτων ἐν Θεαιτήτῳ, ἀλλ'
ἐκεῖ μὲν μερικώτερον ἔγκειται, ἐνταῦθα δὲ καθόλου.

Plat. *Theaet.* 147 D-148 B

ΘΕΑΙΤΗΤΟΣ. Περὶ δυνάμεών τι ἡμῖν Θεόδωρος
ὁδε ἔγραφε, τῆς τε τρίποδος πέρι καὶ πεντέ-
ποδος [ἀποφαίνων]¹ ὅτι μήκει οὐ σύμμετροι τῆ
ποδιαία, καὶ οὕτω κατὰ μίαν ἐκάστην προαιρού-
μενος μέχρι τῆς ἑπτακαιδεκάποδος· ἐν δὲ ταύτῃ
πως ἐνέσχετο. ἡμῖν οὖν εἰσῆλθέ τι τοιοῦτον,
ἐπειδὴ ἄπειροι τὸ πλῆθος αἱ δυνάμεις ἐφαίνοντο,
πειραθῆναι συλλαβεῖν εἰς ἓν, ὅτῳ πάσας ταύτας
προσαγορεύσομεν τὰς δυνάμεις.

¹ ἀποφαίνων secl. Burnet.

• The enunciation is: *The squares on straight lines commensurable in length have to one another the ratio which a square number has to a square number; and squares which have to one another the ratio which a square number has to a square number will also have their sides commensurable in length. But the squares on straight lines incommensurable in length have not to one another the ratio which a square number has to a square number; and squares which have not to one another the ratio which a square number has to a square number will not have their sides commensurable in length either.*

^b Theodorus of Cyrene, claimed by Iamblichus (*Vit. Pythag.* 36) as a Pythagorean and said to have been Plato's teacher in mathematics (*Diog. Laert.* ii. 103).

^c Several conjectures have been put forward to explain



THIS PAGE IS LOCKED TO FREE MEMBERS

Purchase full membership to immediately unlock this page

FORGOTTEN BOOKS

FULL

MEMBERSHIP

797,885 Books!

All you can read

for only

\$8.99/month

Continue

*Fair usage policy applies



ΣΩΚΡΑΤΗΣ. Ἦ καὶ ἡϋρετέ τι τοιοῦτον;

ΘΕΑΙ. Ἐμοιγε δοκοῦμεν· σκόπει δὲ καὶ σύ.

ΣΩ. Λέγε.

ΘΕΑΙ. Τὸν ἀριθμὸν πάντα δίχα διελάβομεν τὸν μὲν δυνάμενον ἴσον ἰσάκεις γίνεσθαι τῷ τετραγώνῳ τὸ σχῆμα ἀπεικάσαντες τετράγωνόν τε καὶ ἰσόπλευρον προσείπομεν.

ΣΩ. Καὶ εὔ γε.

ΘΕΑΙ. Τὸν τοίνυν μεταξὺ τούτου, ὧν καὶ τὰ τρία καὶ τὰ πέντε καὶ πᾶς ὃς ἀδύνατος ἴσος ἰσάκεις γενέσθαι, ἀλλ' ἢ πλείων ἐλαττονάκεις ἢ ἐλάττων πλεονάκεις γίνεται, μείζων δὲ καὶ ἐλάττων αἰὲ πλευρὰ αὐτὸν περιλαμβάνει, τῷ προμήκει αὐτοῦ σχήματι ἀπεικάσαντες προμήκη ἀριθμὸν ἐκαλέσαμεν.

ΣΩ. Κάλιστα. ἀλλὰ τί τὸ μετὰ τοῦτο;

ΘΕΑΙ. Ὅσαι μὲν γραμμαὶ τὸν ἰσόπλευρον καὶ ἐπίπεδον ἀριθμὸν τετραγωνίζουσι, μῆκος ὠρισάμεθα, ὅσαι δὲ τὸν ἑτερομήκη, δυνάμεις, ὡς μήκει μὲν οὐ συμμέτρους ἐκείναις, τοῖς δ' ἐπιπέδοις ἀδύνανται. καὶ περὶ τὰ στερεὰ ἄλλο τοιοῦτον.

^a It is not possible to give the full force of the Greek as *δυνάμεις*, which literally means "powers," has to be trans-

THEAETETUS

SOCRATES. And did you find such a class ?

THEAET. I think we did ; but see if you agree.

Soc. Speak on.

THEAET. We divided all numbers into two classes. The one, consisting of numbers which can be represented as the product of equal factors, we likened in shape to the square and called them square and equilateral numbers.

Soc. And properly so.

THEAET. The numbers between these, among which are three and five and all that cannot be represented as the product of equal factors, but only as the product of a greater by a less or a less by a greater, and are therefore contained by greater and less sides, we likened to oblong shape and called oblong numbers.

Soc. Excellent. And what after this ?

THEAET. Such lines as form the sides of equilateral plane numbers we called lengths, and such as form the oblong numbers we called roots, because they are not commensurable with the others in length, but only with the plane areas which they have the power to form.^a And similarly in the case of solids.

lated "roots" to conform with mathematical usage. *δυνάμεις*, it will be noticed, are here limited to the square roots of oblong numbers, and are therefore always incommensurable.



THIS PAGE IS LOCKED TO FREE MEMBERS

Purchase full membership to immediately unlock this page

SAVE \$3,999,994

Did you know we sell
paperback books too?

To buy our entire catalog
in paperback would cost
over \$4,000,000

Access it all now for
\$8.99/month

*Fair usage policy applies

Continue

XII. PLATO

(a) GENERAL

Tzetzes, *Chil.* viii. 972-973

Πρὸ τῶν προθύρων τῶν αὐτοῦ γράψας ὑπῆρχε Πλάτων.

“Μηδεὶς ἀγεωμέτρητος εἰσίτω μου τὴν στέγην.”

Plut. *Quaes. Conv.* viii. 2. 1

Ἐκ δὲ τούτου γενομένης σιωπῆς, πάλιν ὁ Διογενιανὸς ἀρξάμενος “βούλεσθ’,” εἶπεν, “ἐπεὶ λόγοι περὶ θεῶν γεγόνασιν, ἐν τοῖς Πλάτωνος γενεθλίοις αὐτὸν Πλάτωνα κοινωνὸν παραλάβωμεν, ἐπισκεψάμενοι τίνα λαβὼν γνώμην ἀπεφήνατ’ αἰετι γεωμετρεῖν τὸν θεόν; εἴ γε δὴ θετέον εἶναι τὴν ἀπόφασιν ταύτην Πλάτωνος.” ἐμοῦ δὲ ταῦτ’ εἰπόντος ὡς γέγραπται μὲν ἐν οὐδενὶ σαφῶς τῶν ἐκείνου βιβλίων, ἔχει δὲ πίστιν ἰκανὴν καὶ τοῦ Πλατωνικοῦ χαρακτήρως ἐστίν.

Εὐθὺς ὑπολαβὼν ὁ Τυνδάρης “οἶει γάρ,” εἶπεν, “ὦ Διογενιανέ, τῶν περιπτῶν τι καὶ δυσθεωρήτων αἰνίττεσθαι τὸν λόγον, οὐχ ὅπερ αὐτὸς εἶρηκε καὶ γέγραφε πολλάκις, ὑμνῶν γεωμετρίαν, ὡς ἀπο-

• For Proclus’s notice of Plato, see *supra*, p. 150, and for 386

XII. PLATO ^a

(a) GENERAL

Tzetzes, *Book of Histories* viii. 972-973

OVER his front doors Plato wrote: "Let no one unversed in geometry come under my roof." ^b

Plutarch, *Convivial Questions* viii. 2. 1

Diogenianus broke the silence which followed this discussion by saying: "Since our discourse is about the gods, shall we make Plato share in it, especially as it is his birthday, and inquire what he meant when he said that God is for ever playing the geometer—if this saying is really Plato's?" I said that this saying is not plainly written in any of his works, but it is a credible saying and is of a Platonic character.

Thereupon Tyndares took up the discussion and said: "Do you think, Diogenianus, that this saying implies some subtle and recondite speculations, and not what he has so often mentioned, when he praises

the pseudo-Platonic instrument for finding two mean proportionals, *supra*, pp. 262-267. The mathematics in Plato is the subject of dissertations by C. Blass (*De Platone mathematico*, Bonn, 1861) and Seth Demel (*Platons Verhaltnis zur Mathematik*, Leipzig, 1929).

^b Johannes Tzetzes, the Byzantine pedant who lived in the twelfth century A.D., is not the best of authorities, so this charming story must be accepted with caution. The doors are presumably those of the Academy.

GREEK MATHEMATICS

σπῶσαν ἡμᾶς προσισχομένους τῇ αἰσθήσει καὶ ἀποστρέφουσαν ἐπὶ τὴν νοητὴν καὶ αἰδίον φύσιν, ἧς θεὰ τέλος ἐστὶ φιλοσοφίας οἷον ἐποπτεία τελετῆς; . . . διὸ καὶ Πλάτων αὐτὸς ἐμέμψατο τοὺς περὶ Εὐδοξον καὶ Ἀρχύταν καὶ Μέναιχμον εἰς ὀργανικὰς καὶ μηχανικὰς κατασκευὰς τὸν τοῦ στερεοῦ διπλασιασμὸν ἀπάγειν ἐπιχειροῦντας, ὥσπερ πειρωμένους δι' ἀλόγου δύο μέσας ἀνάλογον, ἧ παρείκοι, λαβεῖν· ἀπόλλυσθαι γὰρ οὕτω καὶ διαφθείρεσθαι τὸ γεωμετρίας ἀγαθὸν αὐθις ἐπὶ τὰ αἰσθητὰ παλινδρομούσης καὶ μὴ φερομένης ἄνω μηδ' ἀντιλαμβανομένης τῶν αἰδίων καὶ ἀσωμάτων εἰκόνων, πρὸς αἴσπερ ὧν ὁ θεὸς αἰεὶ θεὸς ἐστι.”

Aristox. *Harm.* ii. *ad. init.*, ed. Macran 122. 3-16

Βέλτιον ἴσως ἐστὶ τὸ προδιελθεῖν τὸν τρόπον τῆς πραγματείας τίς ποτ' ἐστίν, ἵνα προγιγνώσκοντες ὥσπερ ὁδὸν ἢ βαδιστέον ῥάδιον πορευώμεθα εἰδότες τε κατὰ τί μέρος ἐσμέν αὐτῆς καὶ μὴ λάθωμεν ἡμᾶς αὐτοὺς παρυπολαμβάνοντες τὸ πρᾶγμα. καθάπερ Ἀριστοτέλης αἰεὶ διηγείτο τοὺς πλείστους τῶν ἀκουσάντων παρὰ Πλάτωνος τὴν περὶ τὰγαθοῦ ἀκρόασιν παθεῖν· προσιέναι μὲν γὰρ ἕκαστον ὑπολαμβάνοντα λήψεσθαι τι τῶν νομιζομένων τούτων ἀνθρωπίνων ἀγαθῶν οἷον πλοῦτον ὑγίειαν ἰσχὺν τὸ ὅλον εὐδαιμονίαν τινὰ θαυμαστήν· ὅτε δὲ φανείησαν οἱ λόγοι περὶ μαθημάτων καὶ ἀριθμῶν καὶ γεωμετρίας καὶ ἀστρολογίας καὶ τὸ πέρασ ὅτι ἀγαθόν ἐστὶν ἓν, παντελῶς οἶμαι παράδοξόν τι

^a The play on the words ἀλόγου, ἀνάλογον cannot be reproduced in English, but we may compensate ourselves by playing on the words “means,” “mean proportionals.”



THIS PAGE IS LOCKED TO FREE MEMBERS

Purchase full membership to immediately unlock this page

FORGOTTEN BOOKS

FULL

MEMBERSHIP

797,885 Books!

All you can read

for only

\$8.99/month

Continue

*Fair usage policy applies



GREEK MATHEMATICS

ἐφαίνετο αὐτοῖς· εἶθ' οἱ μὲν ὑποκατεφρόνου τοῦ πράγματος οἱ δὲ κατεμέμφοντο.

(b) PHILOSOPHY OF MATHEMATICS

Plat. *Rep.* vi. 510 c–e

Οἶμαι γάρ σε εἰδέναί ὅτι οἱ περὶ τὰς γεωμετρίας τε καὶ λογισμοὺς καὶ τὰ τοιαῦτα πραγματευόμενοι, ὑποθέμενοι τό τε περιττὸν καὶ τὸ ἄρτιον καὶ τὰ σχήματα καὶ γωνιῶν τριττὰ εἶδη καὶ ἄλλα τούτων ἀδελφὰ καθ' ἑκάστην μέθοδον, ταῦτα μὲν ὡς εἰδότες, ποιησάμενοι ὑποθέσεις αὐτά, οὐδένα λόγον οὔτε αὐτοῖς οὔτε ἄλλοις ἔτι ἀξιοῦσι περὶ αὐτῶν διδόναι ὡς παντὶ φανερῶν, ἐκ τούτων δ' ἀρχόμενοι τὰ λοιπὰ ἤδη διεξιόντες τελευτῶσιν ὁμολογούμενως ἐπὶ τοῦτο οὐ ἂν ἐπὶ σκέψιν ὀρμήσωσι.

Πάνυ μὲν οὖν, ἔφη, τοῦτό γε οἶδα.

Οὐκοῦν καὶ ὅτι τοῖς ὀρωμένοις εἶδεσι προσχρῶνται καὶ τοὺς λόγους περὶ αὐτῶν ποιοῦνται, οὐ περὶ τούτων διανοούμενοι, ἀλλ' ἐκείνων περὶ οἷς ταῦτα ἔοικε, τοῦ τετραγώνου αὐτοῦ ἔνεκα τοὺς λόγους ποιοῦμενοι καὶ διαμέτρου αὐτῆς, ἀλλ' οὐ ταύτης ἣν γράφουσιν, καὶ τἄλλα οὕτως, αὐτὰ μὲν ταῦτα ἂν πλάττουσιν τε καὶ γράφουσιν, ὧν καὶ σκιαὶ καὶ ἐν ὕδασι εἰκόνες εἰσὶν, τούτοις μὲν ὡς εἰκόσιν αὐτῶν χρώμενοι, ζητοῦντες δὲ αὐτὰ ἐκείνα ἰδεῖν ἂν οὐκ ἂν ἄλλως ἴδοι τις ἢ τῇ διανοίᾳ.

Plat. *Ep.* vii. 342 a–343 b

Ἔστιν τῶν ὄντων ἑκάστῳ, δι' ὧν τὴν ἐπιστήμην ἀνάγκη παραγίγνεσθαι, τρία, τέταρτον δ' αὐτή—

PLATO

surprise. The result was that some of them scoffed at the thing, while others found great fault with it.

(b) PHILOSOPHY OF MATHEMATICS

Plato, *Republic* vi. 510 c-e

I think you know that those who deal with geometrics and calculations and such matters take for granted the odd and the even, figures, three kinds of angles and other things cognate to these in each field of inquiry ; assuming these things to be known, they make them hypotheses, and henceforth regard it as unnecessary to give any explanation of them either to themselves or to others, treating them as if they were manifest to all ; setting out from these hypotheses, they go at once through the remainder of the argument until they arrive with perfect consistency at the goal to which their inquiry was directed.

Yes, he said, I am aware of that.

Therefore I think you also know that although they use visible figures and argue about them, they are not thinking about these figures but of those things which the figures represent ; thus it is the square in itself and the diameter in itself which are the matter of their arguments, not that which they draw ; similarly, when they model or draw objects, which may themselves have images in shadows or in water, they use them in turn as images, endeavouring to see those absolute objects which cannot be seen otherwise than by thought.

Plato, *Epistle* vii. 342 a-343 b

For everything that exists there are three things through which knowledge about it must come ; the

πέμπτον δ' αὐτὸ τιθέναι δεῖ ὃ δὴ γνωστόν τε καὶ ἀληθῶς ἐστὶν ὄν—ἐν μὲν ὄνομα, δεύτερον δὲ λόγος, τὸ δὲ τρίτον εἶδωλον, τέταρτον δὲ ἐπιστήμη. περὶ ἐν οὖν λαβὲ βουλόμενος μαθεῖν τὸ νῦν λεγόμενον, καὶ πάντων οὕτω περὶ νόησον. κύκλος ἐστὶν τι λεγόμενον, ὧ τούτ' αὐτό ἐστὶν ὄνομα ὃ νῦν ἐφθέγγεθα. λόγος δ' αὐτοῦ τὸ δεύτερον, ἐξ ὀνομάτων καὶ ῥημάτων συγκείμενος· τὸ γὰρ ἐκ τῶν ἐσχάτων ἐπὶ τὸ μέσον ἴσον ἀπέχον πάντη, λόγος ἂν εἴη ἐκείνου ὡς περὶ στρογγύλον καὶ περιφερὲς ὄνομα καὶ κύκλος. τρίτον δὲ τὸ ζωγραφούμενόν τε καὶ ἐξαλειφόμενον καὶ τορνευόμενον καὶ ἀπολλύμενον· ὧν αὐτὸς ὁ κύκλος, ὃν περὶ πάντ' ἐστὶν ταῦτα, οὐδὲν πάσχει, τούτων ὡς ἕτερον ὄν. τέταρτον δὲ ἐπιστήμη καὶ νοῦς ἀληθῆς τε δόξα περὶ ταῦτ' ἐστὶν· ὡς δὲ ἐν τούτῳ αὐτὸ πᾶν θετέον, οὐκ ἐν φωναῖς οὐδ' ἐν σωμάτων σχήμασιν ἀλλ' ἐν ψυχαῖς ἐνόν, ὧ δῆλον ἕτερόν τε ὄν αὐτοῦ τοῦ κύκλου τῆς φύσεως τῶν τε ἔμπροσθεν λεχθέντων τριῶν. τούτων δὲ ἐγγύτατα μὲν συγγενείᾳ καὶ ὁμοιότητι τοῦ πέμπτου νοῦς πεπλησίακεν, τᾶλλα δὲ πλέον ἀπέχει. . . . κύκλος ἕκαστος τῶν ἐν ταῖς πράξεσι γραφομένων ἢ καὶ τορνευθέντων μεστὸς τοῦ ἐναντίου ἐστὶν τῷ πέμπτῳ—τοῦ γὰρ εὐθέος ἐφάπτεται πάντη—αὐτὸς δέ, φαμέν, ὁ κύκλος οὔτε τι μικρότερον οὔτε μείζον τῆς ἐναντίας ἔχει ἐν αὐτῷ φύσεως. ὄνομα τε αὐτῶν φαμεν οὐδὲν οὐδενὶ βέβαιον εἶναι, κωλύειν δ' οὐδὲν τὰ νῦν στρογγύλα καλούμενα εὐθέα κεκλήσθαι τὰ τε εὐθέα δὴ στρογγύλα, καὶ



THIS PAGE IS LOCKED TO FREE MEMBERS

Purchase full membership to immediately unlock this page

SAVE \$3,999,994

Did you know we sell
paperback books too?

To buy our entire catalog
in paperback would cost
over \$4,000,000

Access it all now for
\$8.99/month

*Fair usage policy applies

Continue

GREEK MATHEMATICS

οὐδὲν ἤττον βεβαίως ἔξειν τοῖς μεταθεμένοις καὶ ἐναντίως καλοῦσιν.

Aristot. *Met.* A 5, 987 b 14-18

Ἔτι δὲ παρὰ τὰ αἰσθητὰ καὶ τὰ εἶδη τὰ μαθηματικὰ τῶν πραγμάτων εἶναί φησι μεταξύ, διαφέροντα τῶν μὲν αἰσθητῶν τῷ αἶδια καὶ ἀκίνητα εἶναι, τῶν δ' εἰδῶν τῷ τὰ μὲν πόλλ' ἄττα ὅμοια εἶναι τὸ δ' εἶδος αὐτὸ ἐν ἑκάστον μόνον.

(c) THE "DIORISMOS" IN THE "MENO"

Plat. *Meno* 86 e-87 b

Λέγω δὲ τὸ ἐξ ὑποθέσεως ὧδε, ὥσπερ οἱ γεωμέτραι πολλάκις σκοποῦνται, ἐπειδάν τις ἔρηται αὐτοῦς, οἷον περὶ χωρίου, εἰ οἷόν τε ἐς τόνδε τὸν κύκλον τόδε τὸ χωρίον τρίγωνον ἐνταθῆναι, εἴποι ἄν τις ὅτι "οὐπω οἶδα εἰ ἔστι τοῦτο τοιοῦτον, ἀλλ' ὥσπερ μὲν τινα ὑπόθεσιν προὔργου οἶμαι ἔχειν πρὸς τὸ πρᾶγμα τοιάνδε. εἰ μὲν ἔστι τοῦτο τὸ χωρίον τοιοῦτον, οἷον παρὰ τὴν δοθείσαν αὐτοῦ γραμμὴν παρατείναντα ἐλλείπειν τοιούτῳ χωρίῳ, οἷον ἂν αὐτὸ τὸ παρατεταμένον ἦ, ἄλλο τι συμβαίνειν μοι δοκεῖ, καὶ ἄλλο αὖ, εἰ ἀδύνατόν ἐστι ταῦτα παθεῖν· ὑποθέμενος οὖν ἐθέλω εἰπεῖν σοι

PLATO

who transpose them and use them in the opposite way will find them no less stable than they are now.

Aristotle, *Metaphysics* A 5, 987 b 14-18

Again, he [Plato] said that besides perceptible objects and forms there are the objects of mathematics, which occupy an intermediate position; they differ from perceptible objects in being eternal and unchangeable, and from forms in that there are many alike, while the form itself is in each case unique.

(c) THE "DIORISMOS" IN THE "MENO"

Plato, *Meno* 86 E-87 B

I mean "by way of hypothesis" what the geometers often envisage when they are asked, for example, as regards a given area, whether this area can be inscribed in the form of a triangle in a given circle. The answer might be, "I do not know whether this is so, but I think I have, if I may so put it, a useful hypothesis. If this area is such that when applied [as a rectangle] to the given straight line ^a in the circle it is deficient by a figure [rectangle] similar to that which is applied, then one result seems to me to follow, while another result follows if what I have described is not possible. Accordingly, by laying down a hypothesis I am willing to tell you

* "The given straight line" can only be the diameter. The "application" of areas so as to be "deficient" in a given way is explained above, pp. 186-187.

GREEK MATHEMATICS

τὸ συμβαῖνον περὶ τῆς ἐντάσεως αὐτοῦ εἰς τὸν κύκλον, εἴτε ἀδύνατον εἴτε μή.”

• If AB is the diameter of a circle of centre O , and E is a point on the circumference, and the rectangles $ACEF$,

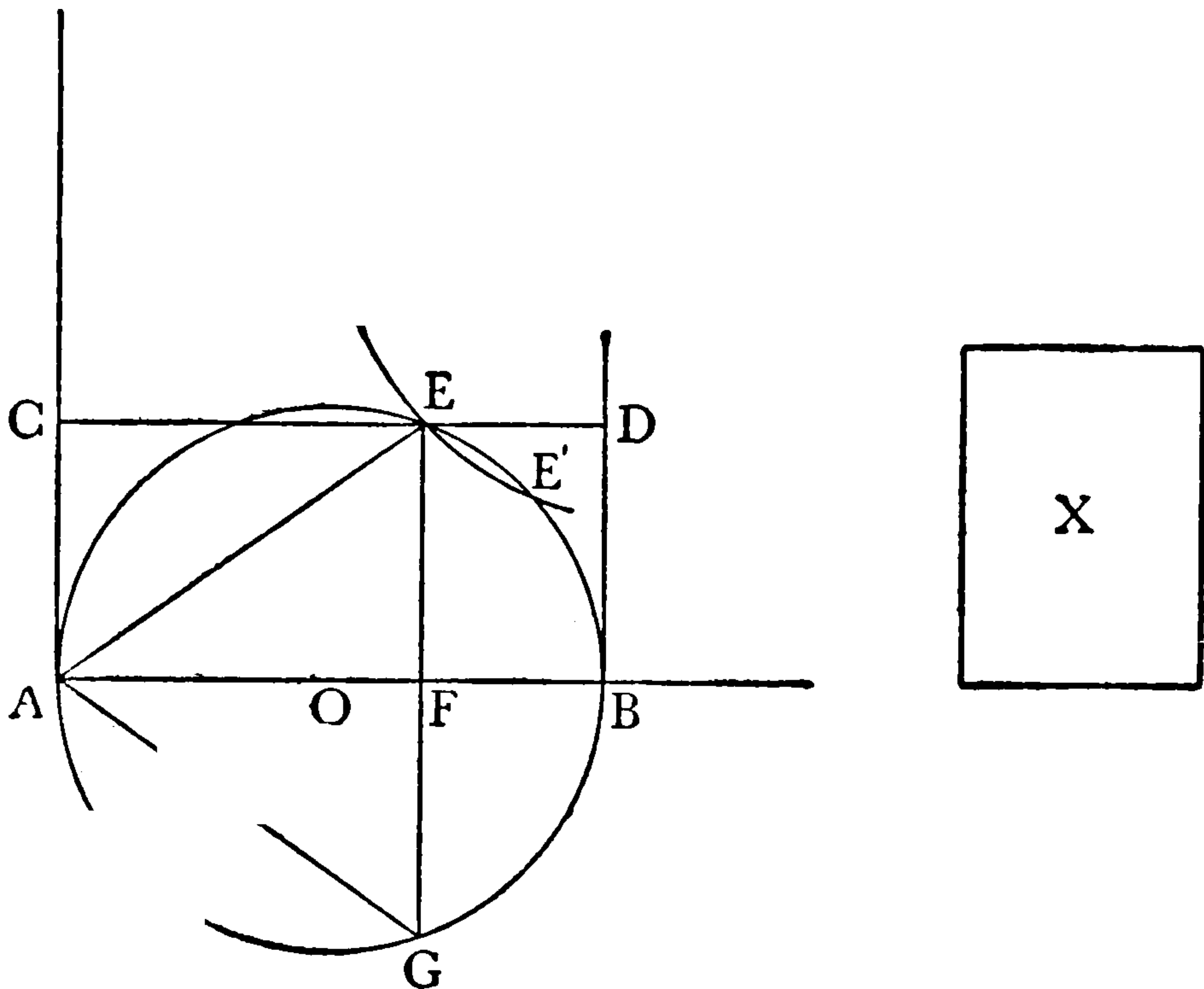

$FBDE$ are completed, and the chords EFG , AG are drawn, then the rectangle $ACEF$ is “applied” to the straight line AB and “falls short” by the rectangle $FBDE$ which is similar to the “applied” rectangle, for $AF : FE = EF : FB$. Moreover $ΔAEG$ is an isosceles triangle equal in area to the rectangle $ACEF$.

In order, therefore, to inscribe in the circle an isosceles



THIS PAGE IS LOCKED TO FREE MEMBERS

Purchase full membership to immediately unlock this page

FORGOTTEN BOOKS

FULL

MEMBERSHIP

797,885 Books!

All you can read

for only

\$8.99/month

Continue

*Fair usage policy applies



GREEK MATHEMATICS

(d) THE NUPTIAL NUMBER

Plat. *Rep.* viii. 546 B-D.

Ἔστι δὲ θείῳ μὲν γεννητῷ περίοδος ἣν ἀριθμὸς περιλαμβάνει τέλειος, ἀνθρωπείῳ δὲ ἐν ᾧ πρώτῳ αὐξήσεις δυνάμεναί τε καὶ δυναστεύομεναι, τρεῖς ἀποστάσεις, τέτταρας δὲ ὄρους λαβοῦσαι ὁμοιούντων τε καὶ ἀνομοιούντων καὶ αὐξόντων καὶ φθινόντων, πάντα προσήγορα καὶ ῥητὰ πρὸς ἄλληλα ἀπέφηναν· ὧν ἐπίτριτος πυθμὴν πεμπάδι συζυγεῖς δύο ἀρμονίας παρέχεται τρεῖς αὐξηθεῖς, τὴν μὲν ἴσην ἰσάκεις, ἑκατὸν τοσαυτάκεις, τὴν δὲ ἰσομήκη μὲν τῇ, προμήκη δέ, ἑκατὸν μὲν ἀριθμῶν ἀπὸ διαμέτρων ῥητῶν πεμπάδος, δεομένων ἑνὸς ἑκάστων, ἀρρήτων δὲ δυοῖν, ἑκατὸν δὲ κύβων τριάδος.

^a The passage is included here because of several interesting points for the history of Greek mathematics. Plato's language is so fancifully phrased that a completely satisfactory solution is difficult to get. The literature which has grown round this "nuptial number" is vast, but the most satisfying discussions are those by Adam, *The Republic of Plato* ii., pp. 204-208, 264-312, and A. G. Laird, *Plato's Geometrical Number and the Comment of Proclus*.

^b δυναστεύομεναι is a ἀπαξ λεγόμενον, and its meaning is uncertain. A straight line is said δύνασθαι ("to be capable of") an area when the square on it is equal to the area. Hence δυναμένη should mean the side of a square, as it does in Eucl. x. Def. 4. δυναστευομένη is a kind of passive of δυναμένη, meaning presumably that of which the δυναμένη is capable, and so could mean the square itself. It is

PLATO

(d) THE NUPTIAL NUMBER

Plato, *Republic* viii. 546 B-D •

The divine race has a cycle comprehended by a perfect number, but the number of the human race's cycle is the first in which root and square increases,^b forming three intervals and four terms of elements that make like and unlike and wax and wane, show all things agreeable and rational towards one another. The base of these things, the four-three joined with five, when thrice increased furnishes two harmonies, the one a square, so many times a hundred, the other a rectangle, one of its sides being a hundred of the numbers from the rational diameters of five, each diminished by one (or a hundred of the numbers from the irrational diameters of five, each diminished by two), the other side being a hundred of the cubes of three.^c

temerarious to try and get a precise meaning out of *αὐξήσεις δυνάμεναί τε καὶ δυναστευόμεναί*, and perhaps we should not inquire too closely into what is more mystical than mathematical. Laird thinks it means "if a square is equal to a rectangle."

^c The chief mathematical interest of the passage lies in the part most easy to decipher, that about the two "harmonies." The "irrational diameter of five" is the diagonal of a side of square 5, *i.e.* $\sqrt{50}$. The "rational diameter" of five is the nearest integer to the "irrational diameter," *i.e.* $\sqrt{50} - 1$. The "number" from the "rational" or "irrational" diameter is the square. A "hundred of the numbers from the rational diameter of five, each diminished by one" is therefore $100 \times (49 - 1) = 4800$; and the same number is expressed as "a hundred of the numbers from the irrational diameter of five, each diminished by two," for this is $100 \times (50 - 2) = 4800$. This number gives one side of the oblong and the other is "a hundred of the cubes of three," or $100 \times 27 = 2700$. The rectangle of which these

GREEK MATHEMATICS

(e) GENERATION OF NUMBERS

Plat. *Epin.* 990 c-991 b

Διὸ μαθημάτων δέον ἄν εἶη· τὸ δὲ μέγιστόν τε καὶ πρῶτον καὶ ἀριθμῶν αὐτῶν, ἀλλ' οὐ σώματα ἔχόντων, ἀλλὰ ὅλης τῆς τοῦ περιττοῦ τε καὶ ἀρτίου γενέσεώς τε καὶ δυνάμεως, ὅσῃν παρέχεται πρὸς τὴν τῶν ὄντων φύσιν. ταῦτα δὲ μαθόντι τούτοις ἐφεξῆς ἐστὶν ὃ καλοῦσι μὲν σφόδρα γελοῖον ὄνομα γεωμετρίαν, τῶν οὐκ ὄντων δὲ ὁμοίων ἀλλήλοις φύσει ἀριθμῶν ὁμοίωσις πρὸς τὴν τῶν ἐπιπέδων μοῖραν γεγονυῖά ἐστι διαφανῆς· ὃ δὲ θαῦμα οὐκ ἀνθρώπινον ἀλλὰ γεγονὸς θεῖον φανερόν ἄν γίγνοιτο τῷ δυναμένῳ συννοεῖν. μετὰ δὲ ταύτην τοὺς τρεῖς

are sides is therefore $4800 \times 2700 = 12,960,000$, and this is 3600^2 , which is the other "harmony."

These "rational" and "irrational" diameters are a clear reference to the "side-" and "diameter-numbers" of the Pythagoreans, for which see *supra*, pp. 132-139.

There is fairly widespread agreement that the geometrical number is $12,960,000 = 3600^2 = 4800 \times 2700$, but on the method by which this number is reached the widest divergence exists. Hultsch and Adam suppose that two numbers are obtained, one in the first sentence down to ἀπέφηναν, the other (12,960,000) in the remainder of the passage. Both agree that the first number is 216, but Hultsch obtains it as $2^3 \times 3^3$ and Adam as $3^3 + 4^3 + 5^3$. Hultsch then takes "the four-three joined with a five" to mean $4 + 3 + 5 = 12$, which is then multiplied by three (τρὶς αὐξηθεῖς), giving 36, and as this has to be taken "so many times a hundred" we get 3600 as the side of the square which is one of the "harmonies," and therefore the final number is 3600^2 . Adam takes "the four-three joined with a five" to be $3 \times 4 \times 5 = 60$, and τρὶς αὐξηθεῖς to mean multiplied by itself three times (*i.e.* raised to the fourth power, which gives us immediately $60^4 = 3600^2$). Laird, on the other hand, believes there is only one number



THIS PAGE IS LOCKED TO FREE MEMBERS

Purchase full membership to immediately unlock this page

SAVE \$3,999,994

Did you know we sell
paperback books too?

To buy our entire catalog
in paperback would cost
over \$4,000,000

Access it all now for
\$8.99/month

*Fair usage policy applies

Continue

ἠϋξημένους καὶ τῇ στερεᾷ φύσει ὁμοίους, τοὺς δὲ ἀνομοίους αὐτῶν γεγονότας ἑτέρα τέχνη ὁμοιοῖ, ταύτην δὲ στερεομετρίαν ἐκάλεσαν οἱ προστυχεῖς αὐτῆς γεγονότες· ὁ δὲ θεῖόν τ' ἐστὶ καὶ θαυμαστόν τοῖς ἐγκαθορώσι τε καὶ διανοουμένοις, ὡς περὶ τὸ διπλασίον ἀεὶ στρεφομένης τῆς δυνάμεως καὶ τῆς ἐξ ἐναντίας ταύτης καθ' ἑκάστην ἀναλογίαν εἶδος καὶ γένος ἀποτυποῦται πᾶσα ἡ φύσις. ἡ μὲν δὲ πρώτη τοῦ διπλασίου κατ' ἀριθμὸν ἐν πρὸς δύο κατὰ λόγον φερομένη, διπλασίον δὲ ἡ κατὰ δύναμιν οὖσα· ἡ δ' εἰς τὸ στερεόν τε καὶ ἀπτόν πάλιν αὐτῶν διπλασίον, ἀφ' ἑνὸς εἰς ὀκτὼ διαπορευθεῖσα· ἡ δὲ διπλασίου μὲν εἰς μέσον, ἴσως δὲ τοῦ ἐλάττονος πλέον ἑλάττόν τε τοῦ μείζονος, τὸ δ' ἕτερον τῶν αὐτῶν μέρει τῶν ἄκρων αὐτῶν ὑπερέχον τε καὶ ὑπερεχόμενον· ἐν μέσῳ δὲ τοῦ ἐξ πρὸς τὰ δώδεκα συνέβη τό τε ἡμιόλιον καὶ ἐπίτριτον· τούτων αὐτῶν

-
- These are probably cubes of integers.
 - These will be numbers with irrational cube roots.
 - What has been said about lines in the plane applies also to lines in three dimensions. Numbers incommensurable with each other, such as 1 and $\sqrt[3]{2}$, are made like when one is represented as the side of a unit cube and the other as the side of a cube twice as great. We know that this problem of doubling the cube was brought to Plato's notice (*supra*, pp. 258-259). The past tense suggests that Plato had in mind certain definite προστυχεῖς who coined the word στερεομετρία; the Pythagoreans, Theaetetus, Democritus and Eudoxus had all advanced the science.

^d What follows cannot be translated literally, and it is more than likely that the text is corrupt, or that it has reached us unrevised from Plato's first draft. But the general sense is clear. Successive multiplication of 1 by 2

PLATO

thrice increased and like to the solid nature,^a and those again which have been made unlike,^b he likens by another art, namely, that which its adepts called stereometry ^c; and a divine and marvellous thing it is to those who contemplate it and reflect how the whole of nature is impressed with species and kind according to each proportion as power and its converse continually turn about the double.^d First the double operates on the number 1 by simple multiplication so as to give 2, and a second double yields the square; by further doubling we reach the solid and tangible, the process having gone from 1 to 8. Then comes the application of the double to give the mean which is as much greater than the less as it is less than the greater, and the other mean is that which exceeds and is exceeded by the same part of the extremes; between 6 and 12 come both the *sesquialter* [9] and the *sesquitercius* [8]; turning between these two, to

gives the series 1, 2, 4, 8, which represent a point, a line, a square and a cube. This is a series in geometric progression, 2 being a geometrical mean between 1 and 4, and 4 a geometrical mean between 2 and 8. Two other means were known to the Pythagoreans (*supra*, pp. 110-115)—and the whole passage is thoroughly Pythagorean—the arithmetic and the harmonic. The arithmetic mean is equidistant between the two terms; the harmonic exceeds one term, and is exceeded by the other, by the same fraction of each term. Thus the arithmetic mean between 1 and 2 is $\frac{3}{2}$ and

the harmonic mean is $\frac{4}{3}$; clearing of fractions, the arithmetic mean between 6 and 12 is 9 and the harmonic mean 8.

“Power and its converse”—*ἡ δύναμις καὶ ἡ ἐξ ἐναντίας ταύτης*—I take to mean “number and its reciprocal”; we have to multiply by 2 to get the series 1, 2, 4, 8 and then take $\frac{1}{2}$ of 6 + 12 to get the arithmetic mean.

ἐν τῷ μέσῳ ἐπ' ἀμφοτέρα στρεφομένη τοῖς ἀνθρώποις σύμφωνον χρεῖαν καὶ σύμμετρον ἀπενείματο παιδιᾶς ῥυθμοῦ τε καὶ ἁρμονίας χάριν, εὐδαίμονι χορείᾳ Μουσῶν δεδομένη.

^a The reference to the choir of the Muses makes it clear, in my opinion, that the number 9 is referred to, though the construction of the sentence does not necessarily involve it. So W. R. M. Lamb in the Loeb version of the *Epinomis*, p. 482.

^b The whole passage should be compared with *Timaeus*, 35 B—36 B (see R. G. Bury's notes in the Loeb version, pp. 66-71, or A. E. Taylor, *A Commentary on Plato's Timaeus*, pp. 136-137). There Plato writes down the series 1, 2, 4, 8 and 1, 3, 9, 27, and then fills up the intervals between these



THIS PAGE IS LOCKED TO FREE MEMBERS

Purchase full membership to immediately unlock this page

FORGOTTEN BOOKS

FULL

MEMBERSHIP

797,885 Books!

All you can read

for only

\$8.99/month

Continue

*Fair usage policy applies



XIII. EUDOXUS OF CNIDOS

XIII. EUDOXUS OF CNIDOS

(a) THEORY OF PROPORTION

Schol. i. in Eucl. *Elem.* v., Eucl. ed. Heiberg v. 280. 1-9

Σκοπὸς τῷ πέμπτῳ βιβλίῳ περὶ ἀναλογιῶν διαλαβεῖν. . . . τὸ δὲ βιβλίον Εὐδόξου τινὲς εὗρεσιν εἶναι λέγουσι τοῦ Πλάτωνος διδασκάλου.

(b) VOLUME OF CONE AND PYRAMID

Archim. *De Sphaera et Cyl.* i., Pref., Archim. ed. Heiberg i. 4. 2-13

Διόπερ οὐκ ἂν ὀκνήσαιμι ἀντιπαραβαλεῖν αὐτὰ πρὸς τε τὰ τοῖς ἄλλοις γεωμέτραις τεθεωρημένα καὶ πρὸς τὰ δόξαντα πολὺ ὑπερέχειν τῶν ὑπὸ Εὐδόξου περὶ τὰ στερεὰ θεωρηθέντων, ὅτι πᾶσα πυραμὶς τρίτον ἐστὶ μέρος πρίσματος τοῦ βάσιν ἔχοντος τὴν αὐτὴν τῇ πυραμίδι καὶ ὕψος ἴσον, καὶ ὅτι πᾶς κῶνος τρίτον μέρος ἐστὶν τοῦ κυλίνδρου τοῦ βάσιν ἔχοντος τὴν αὐτὴν τῷ κώνῳ καὶ ὕψος ἴσον· καὶ γὰρ τούτων προυπαρχόντων φυσικῶς περὶ ταῦτα τὰ σχήματα, πολλῶν πρὸ Εὐδόξου



THIS PAGE IS LOCKED TO FREE MEMBERS

Purchase full membership to immediately unlock this page

SAVE \$3,999,994

Did you know we sell
paperback books too?

To buy our entire catalog
in paperback would cost
over \$4,000,000

Access it all now for
\$8.99/month

*Fair usage policy applies

Continue

GREEK MATHEMATICS

γεγενημένων ἀξίων λόγου γεωμετρῶν συνέβαινε
ὑπὸ πάντων ἀγνοεῖσθαι μηδ' ὑφ' ἑνὸς κατανοηθῆναι

(c) THEORY OF CONCENTRIC SPHERES

Aristot. *Met.* Λ 8, 1073 b 17-32

Εὐδοξος μὲν οὖν ἡλίου καὶ σελήνης ἑκατέρου
τὴν φορὰν ἐν τρισὶν ἐτίθετ' εἶναι σφαίραις, ὧν
τὴν μὲν πρώτην τὴν τῶν ἀπλανῶν ἄστρον εἶ-
ναι, τὴν δὲ δευτέραν κατὰ τὸν διὰ μέσων τῶν ζώ-
δίων, τὴν δὲ τρίτην κατὰ τὸν λελοξωμένον ἐν τῷ

• In his preface to the *Method* (see *supra*, p. 230) Archimedes says that Democritus enunciated these theorems, but without proof. It may safely be inferred from Archimedes' preface to the *Quadrature of the Parabola* (Archim. ed. Heiberg ii. 264. 9-22) that Eudoxus used for the proof a lemma equivalent to Euclid x. 1 (*infra*, pp. 452-455), and that the credit belongs to him for having made the *exhaustion* of an area by means of inscribed polygons a regular method in Greek geometry; to some extent he had been preceded by Antiphon and Hippocrates.

• We are told by Simplicius, on the authority of Eudemus, that Plato set astronomers the problem of finding what are the uniform and ordered movements which will "save the phenomena" of the planetary motions, and that Eudoxus was the first of the Greeks to concern himself with hypotheses of this sort. Eudoxus believed that the motion of the sun, moon and planets could be accounted for by a combination of circular movements, a view which remained unchallenged till Kepler. To account for the motion of the sun and moon he needed to use only three concentric spheres, but the motion of the planets required in each case four concentric spheres, the common centre being the centre of the earth. The spheres were of different sizes, one enclosing the other. Each planet was attached to a point on the equator of the innermost sphere, so that by the motion of this sphere alone the planet would describe a circle. But the poles of this

EUDOXUS OF CNIDOS

they were in fact unknown to the many competent geometers who lived before Eudoxus and had not been noticed by anyone.^a

(c) THEORY OF CONCENTRIC SPHERES

Aristotle, *Metaphysics* Λ 8, 1073 b 17-32

Eudoxus assumed that the motion both of the sun and of the moon takes place on three spheres,^b of which the first is that of the fixed stars, the second moves about the circle which passes through the middle of the signs of the zodiac, and the third moves about

sphere were not fixed, themselves moving on a larger sphere rotating about two different poles. The poles of this second sphere similarly lay on a third larger sphere moving about a different set of poles, and the poles of the third sphere on yet a fourth, moving about another set of poles. Each sphere rotated uniformly, but its speed was peculiar to itself. For the sun and moon only three spheres were needed, the two largest being the same as for the planets. The outermost circle (which comes first in the description by Aristotle and Simplicius), moving from east to west in twenty-four hours, reproduces the daily motion of the fixed stars. The second moves from west to east about an axis perpendicular to the plane of the zodiac circle (ecliptic), its equator accordingly revolving in the plane of the zodiac.

The subject belongs as much to Greek astronomy as to Greek mathematics, and for fuller information the reader is referred to the classic paper of Schiaparelli, *Le sfere omocentriche di Eudosso, di Callippo e di Aristotele* (Milan, 1875), to the works of Sir Thomas Heath (*Aristarchus of Samos*, pp. 193-224, *Greek Astronomy*, pp. 65-70, *H.G.M.* i. 329-335), and to W. D. Ross, *Aristotle's Metaphysics*, vol. ii., pp. 384-394. But Eudoxus's system of concentric rotating spheres is a geometrical *tour de force* of the highest order, and must find some notice here. In all the history of science there are few hypotheses that bear so unmistakably the stamp of genius.

πλάτει τῶν ζωδίων (ἐν μείζονι δὲ πλάτει λελοξῶσθαι καθ' ὃν ἡ σελήνη φέρεται ἢ καθ' ὃν ὁ ἥλιος). τῶν δὲ πλανωμένων ἄστρων ἐν τέτταρσιν ἐκάστου σφαίραις, καὶ τούτων δὲ τὴν μὲν πρώτην καὶ δευτέραν τὴν αὐτὴν εἶναι ἐκείναις (τὴν τε γὰρ τῶν ἀπλανῶν τὴν ἀπάσας φέρουσιν εἶναι, καὶ τὴν ὑπὸ ταύτῃ τεταγμένην καὶ κατὰ τὸν διὰ μέσων τῶν ζωδίων τὴν φορὰν ἔχουσιν κοινὴν ἀπασῶν εἶναι), τῆς δὲ τρίτης ἀπάντων τοὺς πόλους ἐν τῷ διὰ μέσων τῶν ζωδίων εἶναι, τῆς δὲ τετάρτης τὴν φορὰν κατὰ τὸν λελοξωμένον πρὸς τὸν μέσον ταύτης· εἶναι δὲ τῆς τρίτης σφαίρας τοὺς πόλους τῶν μὲν ἄλλων ἰδίου, τοὺς δὲ τῆς Ἀφροδίτης καὶ τοῦ Ἑρμοῦ τοὺς αὐτοὺς.

Simpl. in *De caelo* ii. 12 (Aristot. 293 a 4), ed. Heiberg
496. 23–497. 5

Ἡ δὲ τρίτη σφαῖρα τοὺς πόλους ἔχουσα ἐπὶ τοῦ ἐν τῇ δευτέρᾳ διὰ μέσων τῶν ζωδίων ἀπὸ μεσημβρίας τε πρὸς ἄρκτον στρεφομένη καὶ ἀπ' ἄρκτου πρὸς μεσημβρίαν συνεπιστρέψει τὴν τετάρτην καὶ ἐν αὐτῇ τὸν ἀστέρα ἔχουσιν καὶ δὴ τῆς κατὰ πλάτος κινήσεως ἔξει τὴν αἰτίαν· οὐ μὲν αὐτὴ μόνη· ὅσον γὰρ ἐπὶ ταύτῃ καὶ πρὸς τοὺς πόλους τοῦ διὰ μέσων τῶν ζωδίων ἦκεν ἂν ὁ ἀστήρ καὶ πλησίον τῶν τοῦ κόσμου πόλων ἐγίνετο· νυνὶ δὲ ἡ τετάρτη σφαῖρα περὶ τοὺς τοῦ <τοῦ>¹ ἀστέρος λοξοῦ κύκλου στρεφομένη πόλους ἐπὶ τὰναντία τῇ τρίτῃ ἀπ' ἀνατολῶν ἐπὶ δυσμὰς καὶ ἐν ἴσῳ χρόνῳ

¹ τοῦ τοῦ Heiberg.

• i.e. the equator of the third sphere.

^b i.e. Venus and Mercury.



THIS PAGE IS LOCKED TO FREE MEMBERS

Purchase full membership to immediately unlock this page

FORGOTTEN BOOKS

FULL

MEMBERSHIP

797,885 Books!

All you can read

for only

\$8.99/month

Continue

*Fair usage policy applies



GREEK MATHEMATICS

τὴν στροφὴν αὐτῶν ποιουμένη τό τε ἐπὶ πλέον ὑπερβάλλειν τὸν διὰ μέσων τῶν ζωδίων παραιτήσεται καὶ τὴν λεγομένην ὑπὸ Εὐδόξου ἵπποπέδην περὶ τὸν αὐτὸν τουτονὶ κύκλον τῷ ἀστέρι γράφειν παρέξεται, ὥστε, ὅποσον τὸ τῆς γραμμῆς ταύτης πλάτος, τοσοῦτον καὶ ὁ ἀστὴρ εἰς πλάτος δόξει παραχωρεῖν, ὅπερ ἐγκαλοῦσι τῷ Εὐδόξῳ.

- *i.e.* by the planet.
- *i.e.* "horse-fetter."
- Schiaparelli works out in detail the motion of a planet subject only to the rotations of the third and fourth spheres. The problem in its simplest expression, he says, is this:

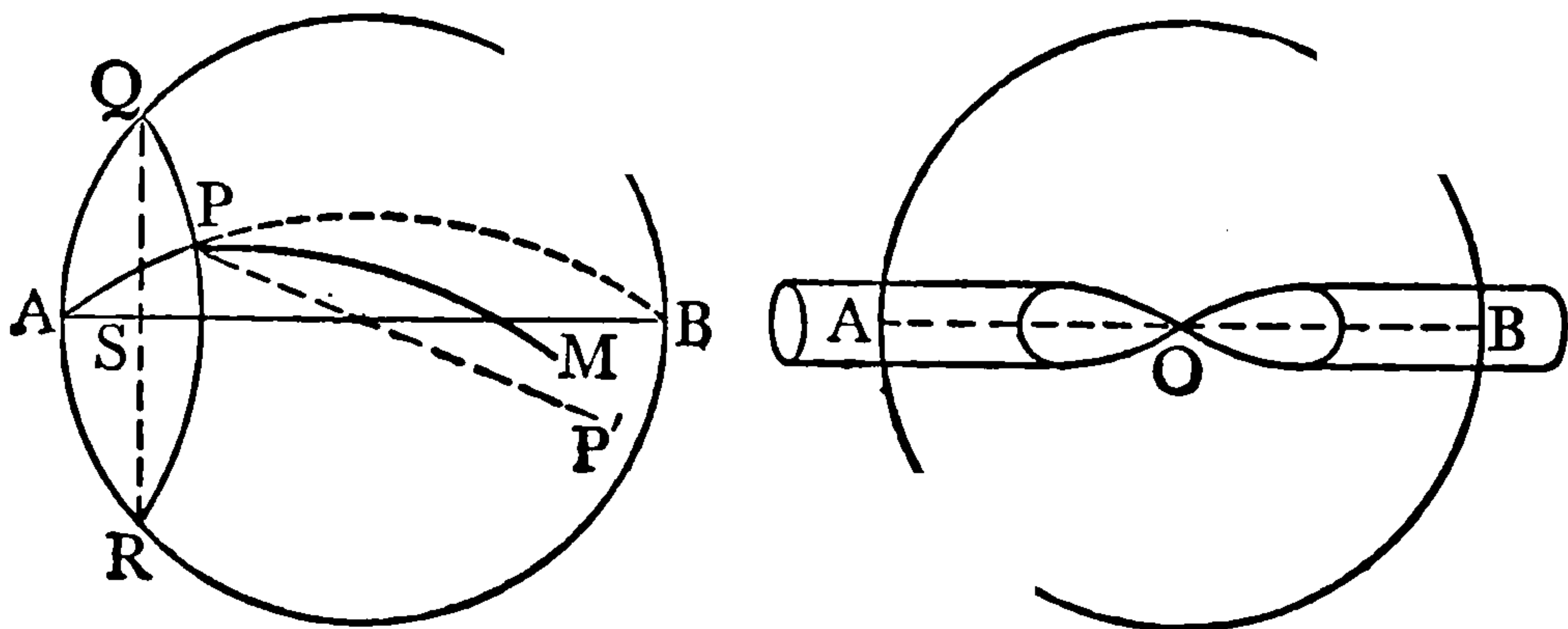

'A sphere rotates uniformly about the fixed diameter AB. P, P' are opposite poles on this sphere, and a second sphere concentric with the first rotates uniformly about PP' in the same time as the former sphere takes to turn about AB, but in the opposite direction. M is a point on the second sphere equidistant from the poles P, P' (that is to say, M is a point on the equator of the second sphere). It is required to find the path of M.' Schiaparelli found a solution by means of seven geometrical propositions which Eudoxus could have known, and he proved that the path described by M was like a figure-of-eight on the surface of the sphere (see second figure). This curve, which Schiaparelli called a

EUDOXUS OF CNIDOS

period, will prevent any excessive deviation ^a from the circle through the middle of the signs of the zodiac, and will constrain the planet to describe about the same zodiac circle the curve called by Eudoxus the *hippopede*,^b so that the breadth of this curve measures the apparent latitudinal motion of the planet, a view for which Eudoxus has been attacked.^c

“spherical lemniscate,” agrees with Eudoxus’s description of it as a *hippopede* (horse-fetter). It is the intersection of the sphere with a certain cylinder touching it internally at the double point O, namely, a cylinder with diameter equal to AS, the *sagitta* of the diameter of the small circle of the sphere on which P revolves.

For the proof of these statements the reader must be referred to Schiaparelli’s paper. An analytical expression is given by Norbert Herz in *Geschichte der Bahnbestimmung von Planeten und Kometen*, Part i., pp. 20, 21, and reproduced by Heath, *Aristarchus of Samos*, pp. 204-205, with further details.

Summing up, Heath says (*Aristarchus of Samos*, p. 211): “For the sun and moon the hypothesis of Eudoxus sufficed to explain adequately enough the principal phenomena, except the irregularities due to the eccentricities, which were either unknown to Eudoxus or neglected by him. For Jupiter and Saturn, and to some extent for Mercury also, the system was capable of giving on the whole a satisfactory explanation of their motion in longitude, their stationary points and their retrograde motions; for Venus it was unsatisfactory, and it failed altogether in the case of Mars. The limits of motion in latitude represented by the various *hippopedes* were in tolerable agreement with observed facts, although the periods of their deviations and their places in the cycle were quite wrong. But, notwithstanding the imperfections of the system of homocentric spheres, we cannot but recognize in it a speculative achievement which was worthy of the great reputation of Eudoxus and all the more deserving of admiration because it was the first attempt at a scientific explanation of the apparent irregularities of the motions of the planets.”



THIS PAGE IS LOCKED TO FREE MEMBERS

Purchase full membership to immediately unlock this page

SAVE \$3,999,994

Did you know we sell
paperback books too?

To buy our entire catalog
in paperback would cost
over \$4,000,000

Access it all now for
\$8.99/month

*Fair usage policy applies

Continue

XIV. ARISTOTLE

(a) FIRST PRINCIPLES

Aristot. *Anal. Post.* i. 10, 76 a 30–77 a 2

Λέγω δ' ἀρχὰς ἐν ἐκάστω γένει ταύτας, ὡς ὅτι ἔστι μὴ ἐνδέχεται δεῖξαι. τί μὲν οὖν σημαίνει καὶ τὰ πρῶτα καὶ τὰ ἐκ τούτων, λαμβάνεται· ὅτι δ' ἔστι, τὰς μὲν ἀρχὰς ἀνάγκη λαμβάνειν, τὰ δ' ἄλλα δεικνύναι, οἷον τί μονὰς ἢ τί τὸ εὐθύ καὶ τρίγωνον· εἶναι δὲ τὴν μονάδα λαβεῖν καὶ μέγεθος, τὰ δ' ἕτερα δεικνύναι.

Ἔστι δ' ὧν χρῶνται ἐν ταῖς ἀποδεικτικαῖς ἐπιστήμασι τὰ μὲν ἴδια ἐκάστης ἐπιστήμης τὰ δὲ κοινά, κοινὰ δὲ κατ' ἀναλογίαν, ἐπεὶ χρήσιμόν γε ὅσον ἐν τῷ ὑπὸ τὴν ἐπιστήμην γένει.

Ἴδια μὲν οἷον γραμμὴν εἶναι τοιανδί, καὶ τὸ εὐθύ, κοινὰ δὲ οἷον τὸ ἴσα ἀπὸ ἴσων ἂν ἀφέλη, ὅτι ἴσα τὰ λοιπά. ἰκανὸν δ' ἕκαστον τούτων ὅσον ἐν τῷ γένει· ταῦτό γὰρ ποιήσει, κἂν μὴ κατὰ πάντων

* Aristotle interspersed his writings with illustrations from mathematics, and as he lived just before Euclid he throws valuable light on the transformation which Euclid effected. A large number of the mathematical passages in Aristotle's works are translated, with valuable notes, in Sir Thomas Heath's posthumous book *Mathematics in Aristotle*.

XIV. ARISTOTLE ^a

(a) FIRST PRINCIPLES

Aristotle, *Posterior Analytics* i. 10, 76 a 30–77 a 2

I MEAN by the first principles in every genus those elements whose existence cannot be proved. The meaning both of these primary elements and of those deduced from them is assumed; in the case of first principles, their existence is also assumed, but in the case of the others deduced from them it has to be proved. Examples are given by the unit, the straight and triangular; for we must assume the existence of the unit and magnitude, but in the case of the others it has to be proved.

Of the first principles used in the demonstrative sciences some are peculiar to each science, and some are common, but common only by analogy, inasmuch as they are useful only in so far as they fall within the genus coming under the science in question.

Examples of peculiar first principles are given by the definitions of the line and the straight; common first principles are such as that, when equals are taken from equals, the remainders are equal. Only so much of these common first principles is needed as falls within the genus in question; for such a first principle will have the same force even though not

λάβη ἀλλ' ἐπὶ μεγεθῶν μόνον, τῷ δ' ἀριθμητικῷ ἐπ' ἀριθμῶν.

Ἔστι δ' ἴδια μὲν καὶ ἃ λαμβάνεται εἶναι, περὶ ἃ ἡ ἐπιστήμη θεωρεῖ τὰ ὑπάρχοντα καθ' αὐτά, οἷον μονάδας ἢ ἀριθμητικὴ, ἢ δὲ γεωμετρία σημεῖα καὶ γραμμάς. ταῦτα γὰρ λαμβάνουσι τὸ εἶναι καὶ τοδὶ εἶναι. τὰ δὲ τούτων πάθη καθ' αὐτά, τί μὲν σημαίνει ἕκαστον, λαμβάνουσιν, οἷον ἡ μὲν ἀριθμητικὴ τί περιπτὸν ἢ ἄρτιον ἢ τετράγωνον ἢ κύβος, ἢ δὲ γεωμετρία τί τὸ ἄλογον ἢ τὸ κεκλάσθαι ἢ νεύειν, ὅτι δ' ἔστι, δεικνύουσι διὰ τε τῶν κοινῶν καὶ ἐκ τῶν ἀποδεδειγμένων. καὶ ἡ ἀστρολογία ὡσαύτως. πᾶσα γὰρ ἀποδεικτικὴ ἐπιστήμη περὶ τρία ἐστίν, ὅσα τε εἶναι τίθεται (ταῦτα δ' ἐστὶ τὸ γένος, οὗ τῶν καθ' αὐτὰ παθημάτων ἐστὶ θεωρητικὴ), καὶ τὰ κοινὰ λεγόμενα ἀξιώματα, ἐξ ὧν πρώτων ἀποδείκνυσι, καὶ τρίτον τὰ πάθη, ὧν τί σημαίνει ἕκαστον λαμβάνει. ἐνίας μέντοι ἐπιστήμας οὐδὲν κωλύει ἕνια τούτων παρορᾶν, οἷον τὸ γένος μὴ ὑποτίθεσθαι εἶναι, ἂν ἢ φανερόν ὅτι ἔστιν (οὐ γὰρ ὁμοίως δῆλον ὅτι ἀριθμὸς ἐστὶ καὶ ὅτι ψυχρὸν καὶ θερμόν), καὶ τὰ πάθη μὴ λαμβάνειν τί σημαίνει, ἂν ἢ δῆλα· ὡσπερ οὐδὲ τὰ κοινὰ οὐ λαμβάνει τί σημαίνει τὸ ἴσα ἀπὸ ἴσων ἀφελεῖν, ὅτι γνώριμον. ἀλλ' οὐδὲν ἤττον τῇ γε φύσει τρία ταῦτά ἐστι, περὶ ὅ τε δείκνυσι καὶ ἃ δείκνυσι καὶ ἐξ ὧν.

Οὐκ ἔστι δ' ὑπόθεσις οὐδ' αἴτημα, ὃ ἀνάγκη

^a Euclid does not define κεκλάσθαι "to be inflected," or νεύειν, "to verge." For an example of "inflection," see *supra*, pp. 358-359, and of "verging," *supra* pp. 242-245.



THIS PAGE IS LOCKED TO FREE MEMBERS

Purchase full membership to immediately unlock this page

FORGOTTEN BOOKS

FULL

MEMBERSHIP

797,885 Books!

All you can read

for only

\$8.99/month

Continue

*Fair usage policy applies



εἶναι δι' αὐτὸ καὶ δοκεῖν ἀνάγκη. οὐ γὰρ πρὸς τὸν ἔξω λόγον ἢ ἀπόδειξις, ἀλλὰ πρὸς τὸν ἐν τῇ ψυχῇ, ἐπεὶ οὐδὲ συλλογισμός. αἰεὶ γὰρ ἔστιν ἐνστήναι πρὸς τὸν ἔξω λόγον, ἀλλὰ πρὸς τὸν ἔσω λόγον οὐκ αἰεὶ. ὅσα μὲν οὖν δεικτὰ ὄντα λαμβάνει αὐτὸς μὴ δείξας, ταῦτ', ἐὰν μὲν δοκοῦντα λαμβάνῃ τῷ μαθάνοντι, ὑποτίθεται, καὶ ἔστιν οὐχ ἀπλῶς ὑπόθεσις ἀλλὰ πρὸς ἐκεῖνον μόνον· ἂν δὲ ἢ μηδεμιᾶς ἐνούσης δόξης ἢ καὶ ἐναντίας ἐνούσης λαμβάνῃ τὸ αὐτὸ αἰτεῖται. καὶ τούτῳ διαφέρει ὑπόθεσις καὶ αἴτημα· ἔστι γὰρ αἴτημα τὸ ὑπεναντίον τοῦ μαθάνοντος τῇ δόξῃ, [ἢ] ὃ ἂν τις ἀποδεικτὸν ὄν λαμβάνῃ καὶ χρῆται μὴ δείξας.

Οἱ μὲν οὖν ὅροι οὐκ εἰσιν ὑποθέσεις (οὐδὲ γὰρ εἶναι ἢ μὴ λέγονται), ἀλλ' ἐν ταῖς προτάσεσιν αἱ ὑποθέσεις. τοὺς δ' ὅρους μόνον ξυνίεσθαι δεῖ· τοῦτο δ' οὐχ ὑπόθεσις, εἰ μὴ καὶ τὸ ἀκούειν ὑπόθεσιν τις εἶναι φήσῃ. ἀλλ' ὅσων ὄντων τῷ ἐκεῖνα εἶναι γίνεται τὸ συμπέρασμα. οὐδ' ὁ γεωμέτρης ψευδῇ ὑποτίθεται, ὥσπερ τινὲς ἔφασαν, λέγοντες ὡς οὐ δεῖ τῷ ψεύδει χρῆσθαι, τὸν δὲ γεωμέτρην ψεύδεσθαι λέγοντα ποδιαίαν τὴν οὐ ποδιαίαν ἢ εὐθείαν τὴν γεγραμμένην οὐκ εὐθείαν οὔσαν. ὁ δὲ γεωμέτρης οὐδὲν συμπεραίνεται τῷ τήνδε εἶναι γραμμὴν, ἣν αὐτὸς ἔφθεγκται, ἀλλὰ τὰ διὰ τούτων δηλούμενα. ἔτι τὸ αἴτημα καὶ ὑπόθεσις πᾶσα ἢ ὡς ὅλον ἢ ὡς ἐν μέρει, οἱ δ' ὅροι οὐδέτερον τούτων.

ARISTOTLE

hypothesis nor postulate. For demonstration is a matter not of external discourse but of meditation within the soul, since syllogism is such a matter. And objection can always be raised to external discourse but not to inward meditation. That which is capable of proof but assumed by the teacher without proof is, if the pupil believes and accepts it, *hypothesis*, though it is not hypothesis absolutely but only in relation to the pupil; if the pupil has no opinion on it or holds a contrary opinion, the same assumption is a *postulate*. In this lies the distinction between hypothesis and postulate; for a postulate is contrary to the pupil's opinion, demonstrable, but assumed and used without demonstration.

The *definitions* are not hypotheses (for they do not assert either existence or non-existence), but it is in the premisses of a science that hypotheses lie. Definitions need only to be understood; and this is not hypothesis, unless it be contended that the pupil's hearing is also a hypothesis. But hypotheses lay down facts on whose existence depends the existence of the fact inferred. Nor are the geometer's hypotheses false, as some have maintained, urging that falsehood must not be used, and that the geometer is speaking falsely in saying that the line which he draws is a foot long or straight when it is neither a foot long nor straight. The geometer draws no conclusion from the existence of the particular line of which he speaks, but from what his diagrams represent. Furthermore, all hypotheses and postulates are either universal or particular, but a definition is neither.

GREEK MATHEMATICS

(b) THE INFINITE

Aristot. *Phys.* Γ 6, 206 a 9-18

“Ὅτι δ’ εἰ μὴ ἔστιν ἄπειρον ἀπλῶς, πολλὰ ἀδύνατα συμβαίνει, δῆλον. τοῦ τε γὰρ χρόνου ἔσται τις ἀρχὴ καὶ τελευτή, καὶ τὰ μεγέθη οὐ διαιρετὰ εἰς μεγέθη, καὶ ἀριθμὸς οὐκ ἔσται ἄπειρος. ὅταν δὲ διωρισμένων οὕτως μηδετέρως φαίνηται ἐνδέχασθαι, διαιρητοῦ δεῖ, καὶ δῆλον ὅτι πῶς μὲν ἔστιν πῶς δ’ οὐ. λέγεται δὴ τὸ εἶναι τὸ μὲν δυνάμει τὸ δὲ ἐντελεχείᾳ, καὶ τὸ ἄπειρον ἔστι μὲν προσθέσει ἔστι δὲ καὶ διαιρέσει. τὸ δὲ μέγεθος ὅτι μὲν κατ’ ἐνέργειαν οὐκ ἔστιν ἄπειρον, εἴρηται, διαιρέσει δ’ ἐστίν· οὐ γὰρ χαλεπὸν ἀνελεῖν τὰς ἀτόμους γραμμάς· λείπεται οὖν δυνάμει εἶναι τὸ ἄπειρον.

Ibid. Γ 6, 206 b 3-12

Τὸ δὲ κατὰ πρόσθεσιν τὸ αὐτὸ ἐστὶ πῶς καὶ τὸ κατὰ διαίρεσιν· ἐν γὰρ τῷ πεπερασμένῳ κατὰ πρόσθεσιν γίνεταί ἀντεστραμμένως· ἢ γὰρ διαιρούμενον ὁράται εἰς ἄπειρον, ταύτῃ προστιθέμενον φανεῖται πρὸς τὸ ὠρισμένον. ἐν γὰρ τῷ πεπερασμένῳ μεγέθει ἂν λαβὼν τις ὠρισμένον προσλαμβάνῃ τῷ αὐτῷ λόγῳ, μὴ τὸ αὐτὸ τι τοῦ ὅλου μέγεθος περιλαμβάνων, οὐ διέξεισι τὸ πεπερασμένον· εἰ δ’ οὕτως αὔξη τὸν λόγον ὥστε αἰεὶ τι

^a After criticizing the beliefs of the Pythagoreans and Plato’s school, Aristotle has just shown that there cannot be an infinite sensible body.

^b The doctrine of “indivisible lines” is attributed to Plato by Aristot. *Met.* 992 a 20-22 and to Xenocrates, who succeeded Speusippus as head of the Academy, by Proclus



THIS PAGE IS LOCKED TO FREE MEMBERS

Purchase full membership to immediately unlock this page

SAVE \$3,999,994

Did you know we sell
paperback books too?

To buy our entire catalog
in paperback would cost
over \$4,000,000

Access it all now for
\$8.99/month

*Fair usage policy applies

Continue

GREEK MATHEMATICS

τὸ αὐτὸ περιλαμβάνειν μέγεθος, διέξεισι, διὰ τὸ πᾶν πεπερασμένον ἀναιρεῖσθαι ὄτῳ οὖν ὠρισμένῳ.

Ibid. Γ 6, 206 b 27–207 a 7

Πλάτων διὰ τοῦτο δύο τὰ ἄπειρα ἐποίησεν, ὅτι καὶ ἐπὶ τὴν αὐξὴν δοκεῖ ὑπερβάλλειν καὶ εἰς ἄπειρον ἵέναι καὶ ἐπὶ τὴν καθαίρεσιν. ποιήσας μέντοι δύο οὐ χρῆται· οὔτε γὰρ ἐν τοῖς ἀριθμοῖς τὸ ἐπὶ τὴν καθαίρεσιν ἄπειρον ὑπάρχει (ἢ γὰρ μονὰς ἐλάχιστον), οὔτε τὸ ἐπὶ τὴν αὐξὴν (μέχρι γὰρ δεκάδος ποιεῖ τὸν ἀριθμόν).

Συμβαίνει δὲ τούναντίον εἶναι ἄπειρον ἢ ὡς λέγουσιν. οὐ γὰρ οὐ μὴδὲν ἔξω, ἀλλ' οὐ αἰεί τι ἔξω ἐστί, τοῦτο ἄπειρόν ἐστιν. σημείον δέ· καὶ γὰρ τοὺς δακτυλίους ἀπείρους λέγουσι τοὺς μὴ ἔχοντας σφενδόνην, ὅτι αἰεί τι ἔξω ἐστί λαμβάνειν,

* From a finite magnitude AA' a "determinate part" (ὠρισμένον) AB is cut off. BA' is then divided at C , CA' at

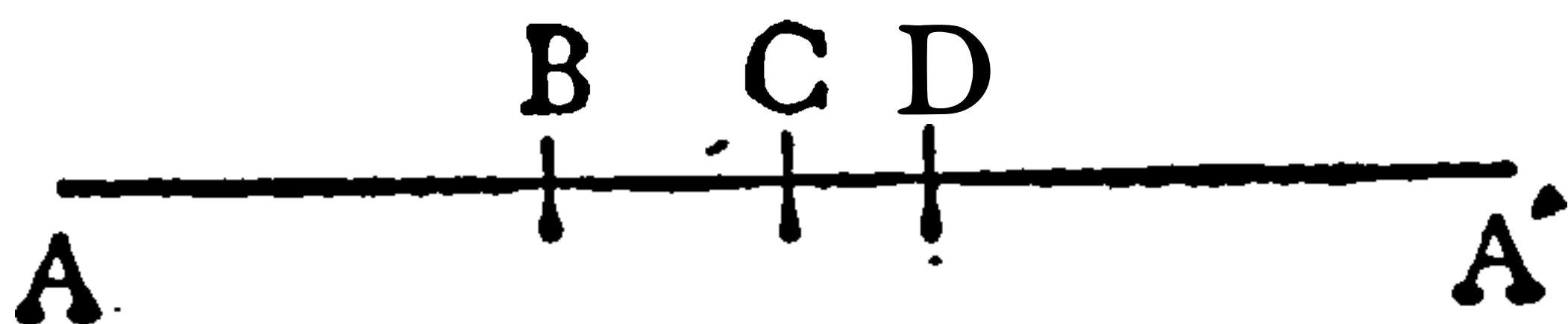

D and so on, in such a manner that the fractions diminish in the same ratio, *i.e.*, $AB, BC, CD \dots$ form a geometrical progression. If the fractions diminish in this way, then AA' will never be exhausted by this process, which will proceed *ad infinitum*. We may then look on AA' as divided into an infinite number of parts, giving an *infinite by division*, or we may look on AB as having added to it an infinite number of parts, giving an *infinite by addition*. But if the successive added fractions are equal to each other, *i.e.* $AB = BC = CD = \dots$, then AA' will be exhausted in a finite number of steps. This statement is equivalent to the

ARISTOTLE

magnitude, you will come to the end, since any finite magnitude is exhausted by continually subtracting from it any definite fraction whatsoever.^a

Ibid. Γ 6, 206 b 27-207 a 7

Plato posited two infinities^b for this reason, that it is possible to proceed without limit both by way of increase and by way of diminution. But although he posits two infinities he does not use them; for in numbers there is for him no infinite by way of diminution (for the unit is a minimum), nor by way of increase (for he makes number go up to ten).^c

So it comes about that the infinite is the opposite of what it is usually said to be. Not that beyond which there is nothing, but that of which there is always something beyond, is infinite. An illustration is given by the rings not having a bezel which are called endless, because there is always something beyond any Axiom of Archimedes, already used by Eudoxus (see *supra*, p. 319 n. b).

^b The reference is evidently to the famous "undetermined dyad of the great and small." A. E. Taylor (*Mind*, xxxv., pp. 419-440, 1926, and xxxvi., pp. 12-33, 1927) puts forward an ingenious theory of the nature of the "undetermined dyad." He sees a reference to the process of approximating more and more closely to a number by approximations alternately greater and less; D'Arcy Wentworth Thompson (*Mind*, xxxviii., pp. 43-55, 1929) adds the further refinement that the method is approximation by continued fractions. Though such conceptions were doubtless not beyond the mathematical capacity of Plato's Academy, they must remain guesses; and there is nothing to force us to believe that there is anything more profound in the concept of the undetermined dyad than Aristotle here indicates, viz., it is possible to proceed in an infinite series either by way of increase or by way of diminution.

Aristotle has probably misunderstood some *obiter dictum* of Plato's.

GREEK MATHEMATICS

καθ' ὁμοιότητα μὲν τινα λέγοντες, οὐ μέντοι κυρίως· δεῖ γὰρ τοῦτό τε ὑπάρχειν καὶ μηδέ ποτε τὸ αὐτὸ λαμβάνεσθαι· ἐν δὲ τῷ κύκλῳ οὐ γίγνεται οὕτως, ἀλλ' αἰεὶ τὸ ἐφεξῆς μόνον ἕτερον.

Ibid. Γ 7, 207 b 27-34

Οὐκ ἀφαιρεῖται δ' ὁ λόγος οὐδὲ τοὺς μαθηματικούς τὴν θεωρίαν, ἀναιρῶν οὕτως εἶναι ἄπειρον ὥστε ἐνεργεῖα εἶναι ἐπὶ τὴν αὐξήσιν ἀδιεξίτητον· οὐδὲ γὰρ νῦν δέονται τοῦ ἀπείρου (οὐ γὰρ χρῶνται), ἀλλὰ μόνον εἶναι ὅσῃν ἂν βούλωνται πεπερασμένην· τῷ δὲ μεγίστῳ μεγέθει τὸν αὐτὸν ἔστι τετμηῆσθαι λόγον ὀπηλικονοῦν μέγεθος ἕτερον· ὥστε πρὸς μὲν τὸ δεῖξαι ἐκείνοις οὐδὲν διοίσει τὸ εἶναι ἐν τοῖς οὕσιν μεγέθεσιν.

(c) PROOF DIFFERING FROM EUCLID'S

Aristot. Anal. Pr. i. 24, 41 b 5-22

Μᾶλλον δὲ γίνεται φανερόν ἐν τοῖς διαγράμμασιν, οἷον ὅτι τοῦ ἰσοσκελοῦς ἴσαι αἰ πρὸς τῇ βάσει. ἔστωσαν εἰς τὸ κέντρον ἠγμέναι αἰ ΑΒ. εἰ οὖν ἴσην λαμβάνοι τὴν ΑΓ γωνίαν τῇ ΒΔ μὴ ὅλως

^a Aristotle had been arguing that in any syllogism one of the propositions must be affirmative and universal.

^b Lit. "drawn."

^c For this method of expressing the sum of two angles by the juxtaposition of the letters representing them, see Archytas's method of representing the sum of two numbers



THIS PAGE IS LOCKED TO FREE MEMBERS

Purchase full membership to immediately unlock this page

FORGOTTEN BOOKS

FULL

MEMBERSHIP

797,885 Books!

All you can read

for only

\$8.99/month

Continue

*Fair usage policy applies



GREEK MATHEMATICS

ἀξιώσας ἴσας τὰς τῶν ἡμικυκλίων, καὶ πάλιν τὴν Γ τῇ Δ μὴ πᾶσαν προσλαβὼν τὴν τοῦ τμήματος, ἔτι δ' ἀπ' ἴσων οὐσῶν τῶν ὅλων γωνιῶν καὶ ἴσων ἀφηρημένων ἴσας εἶναι τὰς λοιπὰς τὰς EZ , τὸ ἐξ ἀρχῆς αἰτήσεται, εἰ μὴ λάβῃ ἀπὸ τῶν ἴσων ἴσων ἀφαιρουμένων ἴσα λείπεσθαι.

(d) MECHANICS

(i.) *Principle of the Lever*

[Aristot.] *Mech.* 3, 850 a-b

Ἐπεὶ δὲ θᾶπτον ὑπὸ τοῦ ἴσου βάρους κινεῖται ἢ μείζων τῶν ἐκ τοῦ κέντρου, ἔστι δὲ τρία τὰ περὶ τὸν μοχλόν, τὸ μὲν ὑπομόχλιον, σπάρτον καὶ κέντρον, δύο δὲ βάρη, ὃ τε κινῶν καὶ τὸ κινούμενον· ὃ οὖν τὸ κινούμενον βάρος πρὸς τὸ κινῶν, τὸ μῆκος πρὸς τὸ μῆκος ἀντιπέπονθεν. αἰεὶ δὲ ὅσω ἂν μείζον ἀφεστήκη τοῦ ὑπομοχλίου, ῥᾶον κινήσει. αἰτία δὲ ἐστὶν ἢ προλεχθεῖσα, ὅτι ἢ πλείον ἀπ-

^a Euclid proves this theorem by producing the equal sides AB , AC of an isosceles triangle to F , G where AF is

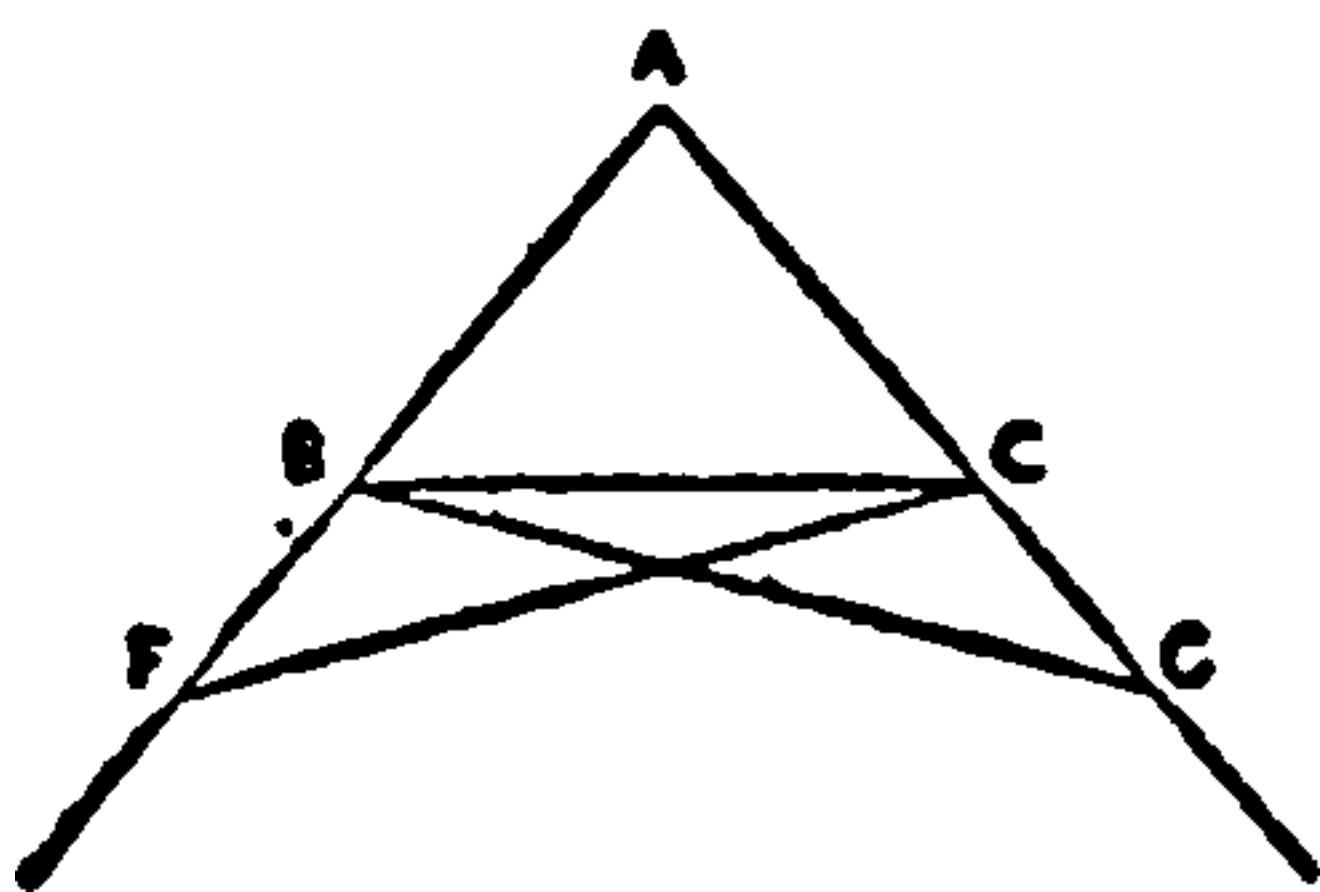

equal to AG . He shows that the triangle AFC is congruent with the triangle AGB , hence that the triangle BFC is congruent with the triangle CGB , and so finally that the angle ABC is equal to the angle ACB .

^b The *Mechanics* is not by Aristotle, but must have been

ARISTOTLE

without asserting generally that the angles of semi-circles are equal, and again that the angle Γ is equal to the angle Δ without assuming generally that the two angles of all segments are equal, and if we further inferred that, since the whole angles are equal, and equal angles have been subtracted from them, the remaining angles E, Z are equal, we should commit a *petitio principii* unless we assumed generally that if equals are subtracted from equals the remainders are equal.^a

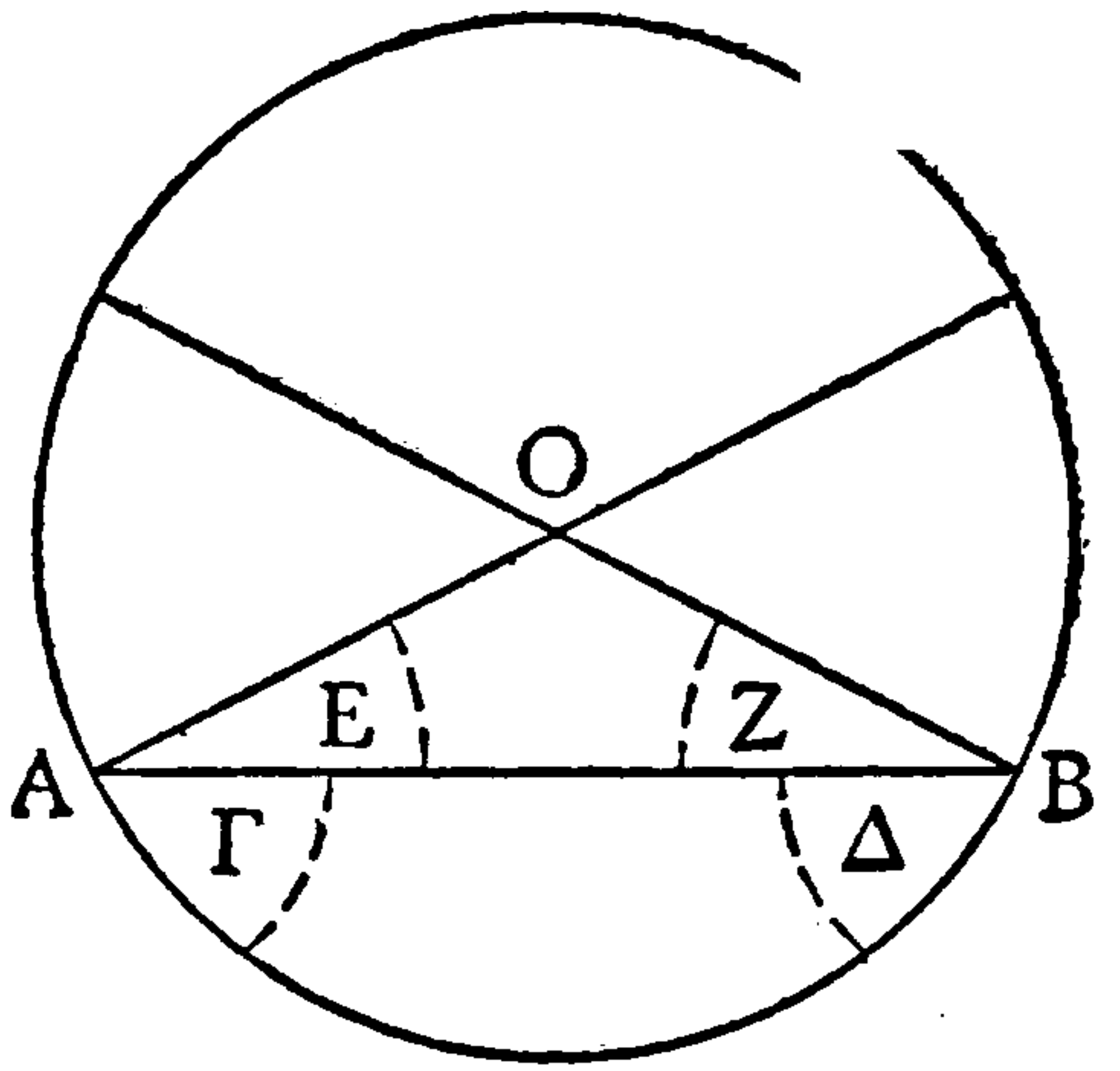

(d) MECHANICS

(i.) *Principle of the Lever*

[Aristotle], *Mechanics* 3, 850 a-b^b

Since the greater radius is moved more quickly than the less by an equal weight, and there are three elements in the lever, the fulcrum, that is the cord^c or centre, and two weights, that which moves and that which is moved, therefore the ratio of the weight moved to the moving weight is the inverse ratio of their distances from the fulcrum. It is always true that the farther the moving weight is away from the fulcrum, the more easily will it move. The reason is written by someone under his influence at a not much later date; it may be taken as reflecting Aristotle's own ideas.

^c The author has compared the fulcrum supporting a lever to the cord by which the beam of a balance is suspended.

έχουσα ἐκ τοῦ κέντρου μείζονα κύκλον γράφει.
ὥστε ἀπὸ τῆς αὐτῆς ἰσχύος πλέον μεταστήσεται
τὸ κινουὺν τὸ πλείον τοῦ ὑπομοχλίου ἄπεχον.

(ii.) *Parallelogram of Velocities*

[Aristot.] *Mech.* 1, 848 b

Ὄταν μὲν οὖν ἐν λόγῳ τινὶ φέρηται, ἐπ' εὐθείας
ἀνάγκη φέρεσθαι τὸ φερόμενον, καὶ γίνεται διά-
μετρος αὐτῆ τοῦ σχήματος ὃ ποιοῦσιν αἱ ἐν τούτῳ
τῷ λόγῳ συντεθεῖσαι γραμμαί.

Ἐστω γὰρ ὁ λόγος ὃν φέρεται τὸ φερόμενον,
ὃν ἔχει ἡ ΑΒ πρὸς τὴν ΑΓ· καὶ τὸ μὲν ΑΓ φερέσθω
πρὸς τὸ Β, ἡ δὲ ΑΒ ὑποφερέσθω πρὸς τὴν ΗΓ·
ἐνηνέχθω δὲ τὸ μὲν Α πρὸς τὸ Δ, ἡ δὲ ἐφ' ἡ ΑΒ
πρὸς τὸ Ε. εἰ οὖν ἐπὶ τῆς φορᾶς ὁ λόγος ἦν ὃν
ἡ ΑΒ ἔχει πρὸς τὴν ΑΓ, ἀνάγκη καὶ τὴν ΑΔ πρὸς
τὴν ΑΕ τοῦτον ἔχειν τὸν λόγον. ὁμοιον ἄρα ἐστὶ
τῷ λόγῳ τὸ μικρὸν τετράπλευρον τῷ μείζονι, ὥστε
καὶ ἡ αὐτῆ διάμετρος αὐτῶν, καὶ τὸ Α ἔσται πρὸς
Ζ. τὸν αὐτὸν δὴ τρόπον δειχθήσεται καὶ ὅπου-
οὖν διαληφθῆ ἡ φορά· αἰεὶ γὰρ ἔσται ἐπὶ τῆς δια-
μέτρου. φανερόν οὖν ὅτι τὸ κατὰ τὴν διάμετρον
φερόμενον ἐν δύο φοραῖς ἀνάγκη τὸν τῶν πλευρῶν
φέρεσθαι λόγον.

^a i.e. has two linear movements in a constant ratio to each other.

^b i.e. parallelogram.



THIS PAGE IS LOCKED TO FREE MEMBERS

Purchase full membership to immediately unlock this page

SAVE \$3,999,994

Did you know we sell
paperback books too?

To buy our entire catalog
in paperback would cost
over \$4,000,000

Access it all now for
\$8.99/month

*Fair usage policy applies

Continue

XV. EUCLID

XV. EUCLID

(a) GENERAL

Stob. *Ecl.* ii. 31. 114, ed. Wachsmuth ii. 228. 25-29

Παρ' Εὐκλείδῃ τις ἀρξάμενος γεωμετρῆιν, ὡς τὸ πρῶτον θεώρημα ἔμαθεν, ἤρετο τὸν Εὐκλείδην· “τί δέ μοι πλέον ἔσται ταῦτα μαθόντι;” καὶ ὁ Εὐκλείδης τὸν παῖδα καλέσας “δός,” ἔφη, “αὐτῷ τριώβολον, ἐπειδὴ δεῖ αὐτῷ ἐξ ὧν μαθάνει κερδαίνειν.”

(b) THE ELEMENTS

(i.) Foundations

Eucl. *Elem.* i.

Ὅροι

- α'. Σημεῖόν ἐστιν, οὐ μέρος οὐθέν.
- β'. Γραμμὴ δὲ μῆκος ἀπλατές.
- γ'. Γραμμῆς δὲ πέρατα σημεία.

* Hardly anything is known of the life of Euclid beyond what has already been stated in the passage quoted from Proclus (*supra*, p. 154). From Pappus vii. 35, ed. Hultsch ii. 678. 10-12, *infra*, p. 489, we infer the additional detail that he taught at Alexandria and founded a school there. Arabian references are summarized by Heath, *The Thirteen Books of Euclid's Elements*, 2nd edn., 1926, vol. i. pp. 4-6. Euclid must have flourished c. 300 B.C.



THIS PAGE IS LOCKED TO FREE MEMBERS

Purchase full membership to immediately unlock this page

FORGOTTEN BOOKS

FULL

MEMBERSHIP

797,885 Books!

All you can read

for only

\$8.99/month

Continue

*Fair usage policy applies



GREEK MATHEMATICS

δ'. Εὐθεία γραμμὴ ἐστίν, ἣτις ἐξ ἴσου τοῖς ἐφ' ἑαυτῆς σημείοις κεῖται.

ε'. Ἐπιφάνεια δὲ ἐστίν, ὃ μῆκος καὶ πλάτος μόνον ἔχει.

ς'. Ἐπιφανείας δὲ πέρατα γραμμαί.

ζ'. Ἐπίπεδος ἐπιφάνειά ἐστίν, ἣτις ἐξ ἴσου ταῖς ἐφ' ἑαυτῆς εὐθείαις κεῖται.

η'. Ἐπίπεδος δὲ γωνία ἐστίν ἢ ἐν ἐπιπέδῳ δύο γραμμῶν ἀπτομένων ἀλλήλων καὶ μὴ ἐπ' εὐθείας κειμένων πρὸς ἀλλήλας τῶν γραμμῶν κλίσις.

θ'. Ὄταν δὲ αἱ περιέχουσαι τὴν γωνίαν γραμμαὶ εὐθεῖαι ᾧσιν, εὐθύγραμμος καλεῖται ἢ γωνία.

ι'. Ὄταν δὲ εὐθεῖα ἐπ' εὐθείαν σταθεῖσα τὰς ἐφεξῆς γωνίας ἴσας ἀλλήλαις ποιῆ, ὀρθὴ ἑκατέρα τῶν ἴσων γωνιῶν ἐστίν, καὶ ἡ ἐφεστηκυῖα εὐθεῖα κάθετος καλεῖται, ἐφ' ἣν ἐφέστηκεν.

ια'. Ἀμβλεία γωνία ἐστίν ἢ μείζων ὀρθῆς.

ιβ'. Ὄξεια δὲ ἢ ἐλάσσων ὀρθῆς.

ιγ'. Ὄρος ἐστίν, ὃ τινός ἐστίν πέρασ.

ιδ'. Σχήμα ἐστίν τὸ ὑπὸ τινος ἢ τινῶν ὄρων περιεχόμενων.

ιε'. Κύκλος ἐστίν σχῆμα ἐπίπεδον ὑπὸ μιᾶς γραμμῆς περιεχόμενον [ἢ καλεῖται περιφέρεια], πρὸς ἣν ἀφ' ἑνὸς σημείου τῶν ἐντὸς τοῦ σχήματος κειμένων πᾶσαι αἱ προσπίπτουσαι εὐθεῖαι [πρὸς τὴν τοῦ κύκλου περιφέρειαν] ἴσαι ἀλλήλαις εἰσίν.

ισ'. Κέντρον δὲ τοῦ κύκλου τὸ σημεῖον καλεῖται.

ιζ'. Διάμετρος δὲ τοῦ κύκλου ἐστίν εὐθεῖά τις διὰ τοῦ κέντρου ἠγμένη καὶ περατουμένη ἐφ'

* Plato (*Parmenides* 137 E) defines a straight line as "that of which the middle covers the ends." Euclid appears to be trying to say the same kind of thing in more geometrical

EUCLID

4. A *straight line* is a line which lies evenly with the points on itself.^a

5. A *surface* is that which has length and breadth only.

6. The extremities of a surface are lines.

7. A *plane surface* is a surface which lies evenly with the straight lines on itself.

8. A *plane angle* is the inclination towards one another of two lines in a plane which meet one another and do not lie in a straight line.

9. And when the lines containing the angle are straight, the angle is called *rectilineal*.

10. When a straight line set up on a straight line makes the adjacent angles equal one to another, each of the equal angles is *right*, and the straight line standing on the other is called a *perpendicular* to that on which it stands.

11. An *obtuse angle* is an angle greater than a right angle.

12. An *acute angle* is an angle less than a right angle.

13. A *boundary* is that which is the extremity of anything.

14. A *figure* is that which is contained by any boundary or boundaries.

15. A *circle* is a plane figure contained by one line such that all the straight lines falling on it from one point among those lying within the figure are equal one to another.

16. And the point is called the *centre* of the circle.

17. A *diameter* of the circle is any straight line drawn through the centre and terminated in both

language. Neither statement is satisfactory as a definition (cf. Def. 7).

ἐκάτερα τὰ μέρη ὑπὸ τῆς τοῦ κύκλου περιφερείας, ἧτις καὶ δίχα τέμνει τὸν κύκλον.

ιη'. Ἡμικύκλιον δέ ἐστι τὸ περιεχόμενον σχῆμα ὑπὸ τε τῆς διαμέτρου καὶ τῆς ἀπολαμβανομένης ὑπ' αὐτῆς περιφερείας. κέντρον δὲ τοῦ ἡμικυκλίου τὸ αὐτό, ὃ καὶ τοῦ κύκλου ἐστίν.

ιβ'. Σχήματα εὐθύγραμμά ἐστι τὰ ὑπὸ εὐθειῶν περιεχόμενα, τρίπλευρα μὲν τὰ ὑπὸ τριῶν, τετράπλευρα δὲ τὰ ὑπὸ τεσσάρων, πολύπλευρα δὲ τὰ ὑπὸ πλειόνων ἢ τεσσάρων εὐθειῶν περιεχόμενα.

κ'. Τῶν δὲ τριπλεύρων σχημάτων ἰσόπλευρον μὲν τρίγωνόν ἐστι τὸ τὰς τρεῖς ἴσας ἔχον πλευράς, ἰσοσκελὲς δὲ τὸ τὰς δύο μόνας ἴσας ἔχον πλευράς, σκαληνὸν δὲ τὸ τὰς τρεῖς ἀνίσους ἔχον πλευράς.

κα'. Ἐτι δὲ τῶν τριπλεύρων σχημάτων ὀρθογώνιον μὲν τρίγωνόν ἐστι τὸ ἔχον ὀρθὴν γωνίαν, ἀμβλυγώνιον δὲ τὸ ἔχον ἀμβλείαν γωνίαν, ὀξυγώνιον δὲ τὸ τὰς τρεῖς ὀξείας ἔχον γωνίας.

κβ'. Τῶν δὲ τετραπλεύρων σχημάτων τετράγωνον μὲν ἐστίν, ὃ ἰσόπλευρόν τέ ἐστι καὶ ὀρθογώνιον, ἑτερόμηκες δέ, ὃ ὀρθογώνιον μὲν, οὐκ ἰσόπλευρον δέ, ῥόμβος δέ, ὃ ἰσόπλευρον μὲν, οὐκ ὀρθογώνιον δέ, ῥομβοειδὲς δὲ τὸ τὰς ἀπεναντίον πλευράς τε καὶ γωνίας ἴσας ἀλλήλαις ἔχον, ὃ οὔτε ἰσόπλευρόν ἐστίν οὔτε ὀρθογώνιον· τὰ δὲ παρὰ ταῦτα τετράπλευρα τραπέζια καλεῖσθω.

κγ'. Παράλληλοί εἰσιν εὐθεῖαι, αἵτινες ἐν τῷ αὐτῷ ἐπιπέδῳ οὔσαι καὶ ἐκβαλλόμεναι εἰς ἄπειρον ἐφ' ἐκάτερα τὰ μέρη ἐπὶ μηδέτερα συμπίπτουσιν ἀλλήλαις.

^a Heath classifies modern definitions of parallel straight
440



THIS PAGE IS LOCKED TO FREE MEMBERS

Purchase full membership to immediately unlock this page

SAVE \$3,999,994

Did you know we sell
paperback books too?

To buy our entire catalog
in paperback would cost
over \$4,000,000

Access it all now for
\$8.99/month

*Fair usage policy applies

Continue

Αἰτήματα

α'. Ἡιτήσθω ἀπὸ παντὸς σημείου ἐπὶ πᾶν σημεῖον εὐθεῖαν γραμμὴν ἀγαγεῖν.

β'. Καὶ πεπερασμένην εὐθεῖαν κατὰ τὸ συνεχές ἐπ' εὐθείας ἐκβαλεῖν.

γ'. Καὶ παντὶ κέντρῳ καὶ διαστήματι κύκλον γράφεισθαι.

δ'. Καὶ πάσας τὰς ὀρθὰς γωνίας ἴσας ἀλλήλαις εἶναι.

ε'. Καὶ ἐὰν εἰς δύο εὐθείας εὐθεῖα ἐμπίπτουσα τὰς ἐντὸς καὶ ἐπὶ τὰ αὐτὰ μέρη γωνίας δύο ὀρθῶν ἐλάσσονας ποιῆ, ἐκβαλλομένας τὰς δύο εὐθείας ἐπ' ἄπειρον συμπίπτειν, ἐφ' ἃ μέρη εἰσὶν αἱ τῶν δύο ὀρθῶν ἐλάσσονες.

not cut one another, (b) they meet at infinity, (c) they have a common point at infinity; (2) parallel straight lines have the same, or like, direction or directions; (3) parallel straight lines have the distance between them constant. Euclid's definition belongs to 1(a), and he avoids many fallacies latent in the other definitions, showing himself superior not only to many ancient, but to many modern, geometers.

^a The chief purpose of these first three postulates is perhaps not to lay down that straight lines and circles can be drawn, but to delineate the nature of Euclidean space. They imply that space is continuous (not discrete) and infinite (not limited).

^b This gives a determinate magnitude by which angles

EUCLID

POSTULATES

1. Let the following be postulated: to draw a straight line from any point to any point.

2. To produce a finite straight line continuously in a straight line.

3. To describe a circle with any centre and diameter.^a

4. All right angles are equal one to another.^b

5. If a straight line falling on two straight lines make the interior angles on the same side less than two right angles, the two straight lines, if produced indefinitely, meet on that side on which are the angles less than two right angles.^c

can be measured, but it does far more. To prove this statement it would be necessary to assume the *invariability of figures*. Euclid preferred to postulate the equality of right angles, which amounts to an assumption of the *invariability of figures* or the *homogeneity of space*.

^c Heath says that this postulate "must ever be regarded as among the most epoch-making achievements in the domain of geometry," and observes: "When we consider the countless successive attempts made through more than twenty centuries to prove the postulate, many of them by geometers of ability, we cannot but admire the genius of the man who concluded that such a hypothesis, which he found necessary to the validity of his whole system of geometry, was really indemonstrable."

The postulate was frequently attacked in antiquity and many attempts have been made to prove it—by Ptolemy and Proclus in ancient days, by Wallis, Saccheri, Lambert and Legendre in modern times. All have failed. By omitting this postulate, Lobachewsky, Bolyai and Riemann developed "non-Euclidean" systems of geometry. Saccheri, in his book *Euclides ab omni naevo vindicatus* (1733), saw the possibility of alternative hypotheses, and worked out the consequences of several; but his faith in Euclidean geometry as the sole possible geometry was so strong that he failed to realize the full implications of his work.

Κοιναὶ ἔννοιαι

- α'. Τὰ τῷ αὐτῷ ἴσα καὶ ἀλλήλοις ἐστὶν ἴσα.
 β'. Καὶ ἐὰν ἴσοις ἴσα προστεθῆ, τὰ ὅλα ἐστὶν ἴσα.
 γ'. Καὶ ἐὰν ἀπὸ ἴσων ἴσα ἀφαιρεθῆ, τὰ καταλειπόμενά ἐστὶν ἴσα.
 [δ'. Καὶ ἐὰν ἀνίσοις ἴσα προστεθῆ, τὰ ὅλα ἐστὶν ἄνισα.
 ε'. Καὶ τὰ τοῦ αὐτοῦ διπλάσια ἴσα ἀλλήλοις ἐστὶν.
 ς'. Καὶ τὰ τοῦ αὐτοῦ ἡμίση ἴσα ἀλλήλοις ἐστὶν.]
 ζ'. Καὶ τὰ ἐφαρμόζοντα ἐπ' ἀλλήλα ἴσα ἀλλήλοις ἐστὶν.
 η'. Καὶ τὸ ὅλον τοῦ μέρους μεῖζόν [ἐστὶν].
 [θ'. Καὶ δύο εὐθεῖαι χωρίον οὐ περιέχουσιν.]

(ii.) *Theory of Proportion*

Eucl. *Elem.* v.

Ὅροι

- α'. Μέρος ἐστὶ μέγεθος μεγέθους τὸ ἔλασσον τοῦ μεῖζονος, ὅταν καταμετρῆ τὸ μεῖζον.
 β'. Πολλαπλάσιον δὲ τὸ μεῖζον τοῦ ἐλάττονος, ὅταν καταμετρῆται ὑπὸ τοῦ ἐλάττονος.
 γ'. Λόγος ἐστὶ δύο μεγεθῶν ὁμογενῶν ἢ κατὰ πηλικότητά ποια σχέσις.
 δ'. Λόγον ἔχειν πρὸς ἀλλήλα μεγέθη λέγεται, ἂ δύναται πολλαπλασιαζόμενα ἀλλήλων ὑπερέχειν.
 ε'. Ἐν τῷ αὐτῷ λόγῳ μεγέθη λέγεται εἶναι πρῶτον πρὸς δεύτερον καὶ τρίτον πρὸς τέταρτον,



THIS PAGE IS LOCKED TO FREE MEMBERS

Purchase full membership to immediately unlock this page

FORGOTTEN BOOKS

FULL

MEMBERSHIP

797,885 Books!

All you can read

for only

\$8.99/month

Continue

*Fair usage policy applies



GREEK MATHEMATICS

ὅταν τὰ τοῦ πρώτου καὶ τρίτου ἰσάκεις πολλαπλάσια τῶν τοῦ δευτέρου καὶ τετάρτου ἰσάκεις πολλαπλασίων καθ' ὅποιονοῦν πολλαπλασιασμόν ἑκάτερον ἑκατέρου ἢ ἅμα ὑπερέχη ἢ ἅμα ἴσα ἢ ἢ ἅμα ἐλλείπη ληφθέντα κατάλληλα.

ς'. Τὰ δὲ τὸν αὐτὸν ἔχοντα λόγον μεγέθη ἀνάλογον καλείσθω.

ζ'. "Ὅταν δὲ τῶν ἰσάκεις πολλαπλασίων τὸ μὲν τοῦ πρώτου πολλαπλάσιον ὑπερέχη τοῦ τοῦ δευτέρου πολλαπλασίου, τὸ δὲ τοῦ τρίτου πολλαπλάσιον μὴ ὑπερέχη τοῦ τοῦ τετάρτου πολλαπλασίου, τότε τὸ πρῶτον πρὸς τὸ δεύτερον μείζονα λόγον ἔχειν λέγεται, ἢ πρὸς τὸ τρίτον πρὸς τὸ τέταρτον.

η'. Ἀναλογία δὲ ἐν τρισὶν ὅροις ἐλαχίστη ἐστίν.

θ'. "Ὅταν δὲ τρία μεγέθη ἀνάλογον ἢ, τὸ πρῶτον πρὸς τὸ τρίτον διπλασίονα λόγον ἔχειν λέγεται ἢ πρὸς τὸ δεύτερον.

^a In the translation of this remarkable definition I cannot improve on Heath. Literal translation is difficult because the words καθ' ὅποιονοῦν πολλαπλασιασμόν come only once in the Greek but refer both to τὰ . . . ἰσάκεις πολλαπλάσια in the nominative and τῶν . . . ἰσάκεις πολλαπλασίων in the genitive.

The definition, which avoids all mention of a part of a magnitude (unlike *Elements* vii. Def. 21), is applicable to all magnitudes, commensurable and incommensurable. It must be due, in substance at least, to Eudoxus (see *supra*, p. 408). The definition has often been assailed through misunderstanding, but has been brilliantly defended by such great mathematicians as Barrow and De Morgan, and was adopted by Weierstrass for his definition of equal numbers.

EUCLID

if any equimultiples whatever be taken of the first and third, and any equimultiples whatever of the second and fourth, the former equimultiples alike exceed, are alike equal to, or alike fall short of, the latter equimultiples respectively taken in corresponding order.^a

6. Let magnitudes which have the same ratio be called *proportional*.

7. When, of the equimultiples, the multiple of the first magnitude exceeds the multiple of the second, but the multiple of the third does not exceed the multiple of the fourth, then the first is said *to have a greater ratio* to the second than the third has to the fourth.

8. A proportion in three terms is the least possible.

9. When three magnitudes are proportional, the first is said to have to the third the *duplicate ratio* of that which it has to the second.^b

Max Simon (*Euclid und die sechs planimetrischen Bücher*, p. 110) thinks it is clear from this definition that the Greeks possessed a notion of number as general as modern mathematicians. Heath (*The Thirteen Books of Euclid's Elements*, ii., pp. 124-126) shows how Euclid's definition divides all rational numbers into two *coextensive* classes, and so defines equal ratios in a manner exactly corresponding to Dedekind's theory of the irrational.

De Morgan gives the following modern equivalent of the definition. "Four magnitudes, A and B of one kind, and C and D of the same or another kind, are proportional when all the multiples of A can be distributed among the multiples of B in the same intervals as the corresponding multiples of C among those of D." That is to say, m , n being any numbers whatsoever, if m A lies between n B and $(n+1)B$, m C lies between n D and $(n+1)D$.

^b If $\frac{a}{x} = \frac{x}{b}$, then $\frac{a}{b} = \frac{a^2}{x^2}$, and a has to b the *duplicate ratio* of a to x .

ι'. Όταν δὲ τέσσαρα μεγέθη ἀνάλογον ἦ, τὸ πρῶτον πρὸς τὸ τέταρτον τριπλασίονα λόγον ἔχειν λέγεται ἤπερ πρὸς τὸ δεύτερον, καὶ αἰεὶ ἐξῆς ὁμοίως, ὡς ἂν ἡ ἀναλογία ὑπάρχη.

ια'. Ὁμόλογα μεγέθη λέγεται τὰ μὲν ἡγούμενα τοῖς ἡγουμένοις τὰ δὲ ἐπόμενα τοῖς ἐπομένοις.

ιβ'. Ἐναλλάξ λόγος ἐστὶ λήψις τοῦ ἡγουμένου πρὸς τὸ ἡγούμενον καὶ τοῦ ἐπομένου πρὸς τὸ ἐπόμενον.

ιγ'. Ἀνάπαλιν λόγος ἐστὶ λήψις τοῦ ἐπομένου ὡς ἡγουμένου πρὸς τὸ ἡγούμενον ὡς ἐπόμενον.

ιδ'. Σύνθεσις λόγου ἐστὶ λήψις τοῦ ἡγουμένου μετὰ τοῦ ἐπομένου ὡς ἑνὸς πρὸς αὐτὸ τὸ ἐπόμενον.

ιε'. Διαίρεσις λόγου ἐστὶ λήψις τῆς ὑπεροχῆς, ἣ ὑπερέχει τὸ ἡγούμενον τοῦ ἐπομένου, πρὸς αὐτὸ τὸ ἐπόμενον.

ισ'. Ἀναστροφή λόγου ἐστὶ λήψις τοῦ ἡγουμένου πρὸς τὴν ὑπεροχήν, ἣ ὑπερέχει τὸ ἡγούμενον τοῦ ἐπομένου.

ιζ'. Δι' ἴσου λόγος ἐστὶ πλειόνων ὄντων μεγεθῶν καὶ ἄλλων αὐτοῖς ἴσων τὸ πλῆθος σύνδυο λαμβανομένων καὶ ἐν τῷ αὐτῷ λόγῳ, ὅταν ἦ ὡς ἐν τοῖς πρώτοις μεγέθεσι τὸ πρῶτον πρὸς τὸ ἔσχατον, οὕτως ἐν τοῖς δευτέροις μεγέθεσι τὸ

^a The magnitudes must be in continuous proportion. If $\frac{a}{x} = \frac{x}{y} = \frac{y}{b}$, then $\frac{a}{b} = \frac{a^3}{x^3}$, and a has to b the *triplicate* ratio of a to x . Alternatively, a cube with side a has the same ratio to a cube with side x as a to b (see *supra*, p. 258 n. b).



THIS PAGE IS LOCKED TO FREE MEMBERS

Purchase full membership to immediately unlock this page

SAVE \$3,999,994

Did you know we sell
paperback books too?

To buy our entire catalog
in paperback would cost
over \$4,000,000

Access it all now for
\$8.99/month

*Fair usage policy applies

Continue

πρῶτον πρὸς τὸ ἔσχατον· ἢ ἄλλως· λήψις τῶν ἄκρων καθ' ὑπεξαίρεσιν τῶν μέσων.

ιη'. Τεταραγμένη δὲ ἀναλογία ἐστίν, ὅταν τριῶν ὄντων μεγεθῶν καὶ ἄλλων αὐτοῖς ἴσων τὸ πλήθος γίνηται ὡς μὲν ἐν τοῖς πρώτοις μεγέθεσιν ἡγούμενον πρὸς ἐπόμενον, οὕτως ἐν τοῖς δευτέροις μεγέθεσιν ἡγούμενον πρὸς ἐπόμενον, ὡς δὲ ἐν τοῖς πρώτοις μεγέθεσιν ἐπόμενον πρὸς ἄλλο τι, οὕτως ἐν τοῖς δευτέροις ἄλλο τι πρὸς ἡγούμενον.

(iii.) *Theory of Incommensurables*

Eucl. *Elem.* x.

Ὅροι

α'. Σύμμετρα μεγέθη λέγεται τὰ τῷ αὐτῷ μέτρῳ μετρούμενα, ἀσύμμετρα δέ, ὧν μηδὲν ἐνδέχεται κοινὸν μέτρον γενέσθαι.

β'. Εὐθεῖαι δυνάμει σύμμετροί εἰσιν, ὅταν τὰ ἀπ' αὐτῶν τετράγωνα τῷ αὐτῷ χωρίῳ μετρῆται, ἀσύμμετροι δέ, ὅταν τοῖς ἀπ' αὐτῶν τετραγώνοις μηδὲν ἐνδέχεται χωρίον κοινὸν μέτρον γενέσθαι.

γ'. Τούτων ὑποκειμένων δείκνυται, ὅτι τῇ προτεθείσῃ εὐθείᾳ ὑπάρχουσιν εὐθεῖαι πλήθει ἄπειροι σύμμετροί τε καὶ ἀσύμμετροι αἱ μὲν μήκει μόνον, αἱ δὲ καὶ δυνάμει. καλείσθω οὖν ἡ μὲν προτεθείσα εὐθεῖα ῥητή, καὶ αἱ ταύτη σύμμετροι εἴτε μήκει

* δι' ἴσου must mean "at an equal distance," i.e., after an equal number of terms. If $a, b, c \dots m, n$ is one set of magnitudes and $A, B, C \dots M, N$ the other, and $a : b = A : B$, and so on, up to $m : n = M : N$, then $a : n = A : N$. This is proved in v. 22. The definition merely serves to gave a name to the inference.

EUCLID

set of magnitudes ; in other words, a taking of the extremes by removal of the intermediate terms.^a

18. A *perturbed proportion* arises when, there being three magnitudes and another set equal to them in multitude, as antecedent is to consequent in the first magnitudes, so is antecedent to consequent in the second magnitudes, while as the consequent is to the other term in the first magnitudes, so is the other term to the antecedent in the second magnitudes.^b

(iii.) *Theory of Incommensurables*

Euclid, *Elements* x.

DEFINITIONS

1. Those magnitudes are said to be *commensurable* which are measured by the same common measure, and those *incommensurable* which cannot have any common measure.

2. Straight lines are *commensurable in square*, when the squares on them are measured by the same area, and *incommensurable in square* when the squares on them cannot have any area as a common measure.

3. With these hypotheses, it is proved that there exist straight lines infinite in multitude which are commensurable and incommensurable respectively, some in length only, and others in square also, with an assigned straight line. Let then the assigned straight line be called *rational*, and those straight lines which are commensurable with it, whether in length

^a If a, b, c and A, B, C are the two sets of magnitudes, and $a : b = B : C, b : c = A : B$ the proportion is said to be *perturbed*. It follows that $a : c = A : C$. This is a particular case of the inference $\delta\iota' \text{ } \dot{\iota}\sigma\upsilon\upsilon$ and is proved in v. 23.

GREEK MATHEMATICS

καὶ δυνάμει εἴτε δυνάμει μόνον ῥηταί, αἱ δὲ ταύτη ἀσύμμετροι ἄλογοι καλεῖσθωσαν.

δ'. Καὶ τὸ μὲν ἀπὸ τῆς προτεθείσης εὐθείας τετράγωνον ῥητόν, καὶ τὰ τούτῳ σύμμετρα ῥητά, τὰ δὲ τούτῳ ἀσύμμετρα ἄλογα καλεῖσθω, καὶ αἱ δυνάμεναι αὐτὰ ἄλογοι, εἰ μὲν τετράγωνα εἴη, αὐταὶ αἱ πλευραί, εἰ δὲ ἕτερα ἄτινα εὐθύγραμμα, αἱ ἴσα αὐτοῖς τετράγωνα ἀναγράφουσαι.

α'

Δύο μεγεθῶν ἀνίσων ἐκκειμένων, ἐὰν ἀπὸ τοῦ μείζονος ἀφαιρεθῆ μείζον ἢ τὸ ἥμισυ καὶ τοῦ καταλειπομένου μείζον ἢ τὸ ἥμισυ, καὶ τοῦτο ἀεὶ γίγνηται, λειφθήσεται τι μέγεθος, ὃ ἔσται ἔλασσον τοῦ ἐκκειμένου ἐλάσσονος μεγέθους.

*Ἐστω δύο μεγέθη ἄνισα τὰ ΑΒ, Γ, ὧν μείζον τὸ ΑΒ· λέγω, ὅτι ἐὰν ἀπὸ τοῦ ΑΒ ἀφαιρεθῆ μείζον ἢ τὸ ἥμισυ καὶ τοῦ καταλειπομένου μείζον ἢ τὸ ἥμισυ, καὶ τοῦτο ἀεὶ γίγνηται, λειφθήσεται τι μέγεθος, ὃ ἔσται ἔλασσον τοῦ Γ μεγέθους.

Ἐὰν τὸ Γ γὰρ πολλαπλασιαζόμενον ἔσται ποτὲ τοῦ



THIS PAGE IS LOCKED TO FREE MEMBERS

Purchase full membership to immediately unlock this page

FORGOTTEN BOOKS

FULL

MEMBERSHIP

797,885 Books!

All you can read

for only

\$8.99/month

Continue

*Fair usage policy applies



ΑΒ μείζον. πεπολλαπλασιάσθω, καὶ ἔστω τὸ ΔΕ τοῦ μὲν Γ πολλαπλάσιον, τοῦ δὲ ΑΒ μείζον, καὶ διηρήσθω τὸ ΔΕ εἰς τὰ τῷ Γ ἴσα τὰ ΔΖ, ΖΗ, ΗΕ, καὶ ἀφηρήσθω ἀπὸ μὲν τοῦ ΑΒ μείζον ἢ τὸ ἥμισυ τὸ ΒΘ, ἀπὸ δὲ τοῦ ΑΘ μείζον ἢ τὸ ἥμισυ τὸ ΘΚ, καὶ τοῦτο αἰ γινέσθω, ἕως ἂν αἰ ἐν τῷ ΑΒ διαιρέσεις ἰσοπληθεῖς γένωνται ταῖς ἐν τῷ ΔΕ διαιρέσεσιν.

Ἐστῶσαν οὖν αἰ ΑΚ, ΚΘ, ΘΒ διαιρέσεις ἰσοπληθεῖς οὔσαι ταῖς ΔΖ, ΖΗ, ΗΕ· καὶ ἐπεὶ μείζον ἐστὶ τὸ ΔΕ τοῦ ΑΒ, καὶ ἀφήρηται ἀπὸ μὲν τοῦ ΔΕ ἔλασσον τοῦ ἡμίσεως τὸ ΕΗ, ἀπὸ δὲ τοῦ ΑΒ μείζον ἢ τὸ ἥμισυ τὸ ΒΘ, λοιπὸν ἄρα τὸ ΗΔ λοιποῦ τοῦ ΘΑ μείζον ἐστίν. καὶ ἐπεὶ μείζον ἐστὶ τὸ ΗΔ τοῦ ΘΑ, καὶ ἀφήρηται τοῦ μὲν ΗΔ ἥμισυ τὸ ΗΖ, τοῦ δὲ ΘΑ μείζον ἢ τὸ ἥμισυ τὸ ΘΚ, λοιπὸν ἄρα τὸ ΔΖ λοιποῦ τοῦ ΑΚ μείζον ἐστίν. ἴσον δὲ τὸ ΔΖ τῷ Γ· καὶ τὸ Γ ἄρα τοῦ ΑΚ μείζον ἐστίν. ἔλασσον ἄρα τὸ ΑΚ τοῦ Γ.

Καταλείπεται ἄρα ἀπὸ τοῦ ΑΒ μεγέθους τὸ ΑΚ μέγεθος ἔλασσον ὃν τοῦ ἐκκειμένου ἐλάσσονος μεγέθους τοῦ Γ· ὅπερ ἔδει δεῖξαι—ὁμοίως δὲ δειχθήσεται, κἂν ἡμίση ἢ τὰ ἀφαιρούμενα.

EUCLID

than AB [see v. Def. 4]. Let it be multiplied, and let ΔE be a multiple of Γ , greater than AB , and let ΔE be divided into the parts ΔZ , ZH , HE equal to Γ , and from AB let there be subtracted $B\Theta$ greater than its half, and from $A\Theta$ let there be subtracted ΘK greater than its half, and so on continually, until the divisions in AB are equal in multitude to the divisions in ΔE .

Let, then, AK , $K\Theta$, ΘB be divisions equal in multitude with ΔZ , ZH , HE ; now since ΔE is greater than AB , and from ΔE there has been subtracted EH less than its half, and from AB there has been subtracted $B\Theta$ greater than its half, therefore the remainder $H\Delta$ is greater than the remainder ΘA . And since $H\Delta$ is greater than ΘA , and from $H\Delta$ there has been subtracted the half, HZ , and from ΘA there has been subtracted ΘK greater than its half, therefore the remainder ΔZ is greater than the remainder AK . Now ΔZ is equal to Γ ; and therefore Γ is greater than AK . Therefore AK is less than Γ .

There is therefore left of the magnitude AB the magnitude AK which is less than the lesser magnitude set out, namely, Γ ; which was to be proved—and this can be similarly proved even if the parts to be subtracted be halves.^a

^a This important theorem is often known as the Axiom of Archimedes because of the use to which he puts it, or a similar lemma: "The excess by which the greater of two unequal areas exceeds the lesser can, by being continually added to itself, be made to exceed any given finite area." Archimedes makes no claim to have discovered this lemma, which is doubtless due to Eudoxus. The chief use of the "axiom" by Euclid is to prove *Elements* xii. 2, that circles are to one another as the squares on their diameters.

GREEK MATHEMATICS

Prop. 111, coroll.

Ἡ ἀποτομὴ καὶ αἱ μετ' αὐτὴν ἄλογοι οὔτε τῆ μέσῃ οὔτε ἀλλήλαις εἰσὶν αἱ αὐταί. . . .

Καὶ ἐπεὶ δέδεικται ἡ ἀποτομὴ οὐκ οὔσα ἡ αὐτὴ τῆ ἐκ δύο ὀνομάτων, ποιούσι δὲ πλάτη παρὰ ῥητὴν

* Much of Eucl. *Elem.* x. is devoted to an elaborate classification of irrational straight lines. Zeuthen (*Geschichte der Mathematik im Altertum und Mittelalter*, p. 56) suggests that, inasmuch as one straight line looks very much like another, the Greeks could not perceive by simple inspection that difference among irrational quantities which our system of algebraic symbols enables us to see; consequently they were led to classify irrational straight lines in the manner of Eucl. *Elem.* x., and we know from an Arabic commentary on this book discovered by Woepcke (*Mémoires présentés à l'Académie des Sciences*, xiv., 1856, pp. 658-720) that Theaetetus had to some extent preceded Euclid. In this system irrational straight lines are classified according to the areas they produce when "applied" (*v. supra*, pp. 186-187) to other straight lines. For full details the reader must be referred to Loria, *Le scienze esatte nell' antica Grecia*, pp. 225-231, Heath's notes in *The Thirteen Books of Euclid's Elements*, vol. iii., and *H.G.M.* i. 404-411, but it may be useful to give here, in Heath's notation, the modern algebraic equivalents of Euclid's irrational straight lines. A medial line is of the form $k^{\frac{1}{2}}\rho$, *i.e.*, the positive solution of the equation $x^2 - \rho\sqrt{k}\cdot\rho = 0$. The other twelve irrational lines are compound, and may best be arranged in pairs as follows:

$$\left. \begin{array}{l} 1. \text{ Binomial} \\ \text{Apotome} \end{array} \right\} \rho \pm \sqrt{k} \cdot \rho,$$

being the positive roots of the equation

$$x^4 - 2(1+k)\rho^2 \cdot x^2 + (1-k)^2\rho^4 = 0.$$

$$\left. \begin{array}{l} 2. \text{ First bimedial} \\ \text{First apotome of a medial} \end{array} \right\} k^{\frac{1}{2}}\rho \pm k^{\frac{1}{2}}\rho,$$

being the positive roots of the equation

$$x^4 - 2\sqrt{k}(1+k)\rho^2 \cdot x^2 + k(1-k)^2\rho^4 = 0.$$



THIS PAGE IS LOCKED TO FREE MEMBERS

Purchase full membership to immediately unlock this page

SAVE \$3,999,994

Did you know we sell
paperback books too?

To buy our entire catalog
in paperback would cost
over \$4,000,000

Access it all now for
\$8.99/month

*Fair usage policy applies

Continue

παραβαλλόμενοι αἱ μετὰ τὴν ἀποτομὴν ἀποτομὰς ἀκολουθῶς ἐκάστη τῇ τάξει τῇ καθ' αὐτήν, αἱ δὲ μετὰ τὴν ἐκ δύο ὀνομάτων τὰς ἐκ δύο ὀνομάτων καὶ αὐταὶ τῇ τάξει ἀκολουθῶς, ἕτεραι ἄρα εἰσὶν αἱ μετὰ τὴν ἀποτομὴν καὶ ἕτεροι αἱ μετὰ τὴν ἐκ δύο ὀνομάτων, ὡς εἶναι τῇ τάξει πάσας ἀλόγους ἰγ,

Μέσην,

Ἐκ δύο ὀνομάτων,

Ἐκ δύο μέσων πρώτην,

Ἐκ δύο μέσων δευτέραν,

Μείζονα,

Ῥητὸν καὶ μέσον δυναμένην,

Δύο μέσα δυναμένην,

Ἀποτομὴν,

Μέσης ἀποτομὴν πρώτην,

Μέσης ἀποτομὴν δευτέραν,

Ἐλάσσονα,

Μετὰ ῤητοῦ μέσον τὸ ὅλον ποιούσαν,

Μετὰ μέσου μέσον τὸ ὅλον ποιούσαν.

(iv.) *Method of Exhaustion*

Eucl. *Elem.* xii. 2

Οἱ κύκλοι πρὸς ἀλλήλους εἰσὶν ὡς τὰ ἀπὸ τῶν διαμέτρων τετράγωνα.

Ἐστῶσαν κύκλοι οἱ ΑΒΓΔ, ΕΖΗΘ, διάμετροι δὲ αὐτῶν αἱ ΒΔ, ΖΘ· λέγω, ὅτι ἐστὶν ὡς ὁ ΑΒΓΔ κύκλος πρὸς τὸν ΕΖΗΘ κύκλον, οὕτως τὸ ἀπὸ τῆς ΒΔ τετράγωνον πρὸς τὸ ἀπὸ τῆς ΖΘ τετράγωνον.

• Eudemus attributed the discovery of this important theorem to Hippocrates (see *supra*, p. 238). Unfortunately we do not know how Hippocrates proved it.

EUCLID

applied to a rational straight line, the straight lines following the apotome produce, as breadths, apotomes according to their order, and those following the binomial straight line produce, as breadths, binomials according to their order, therefore the straight lines following the apotome are different, and the straight lines following the binomial straight line are different, so that in all there are, in order, thirteen straight lines,

Medial,

Binomial,

First bimedial,

Second bimedial,

Major,

Side of a rational plus a medial area,

Side of the sum of two medial areas,

Apotome,

First apotome of a medial straight line,

Second apotome of a medial straight line,

Minor,

Producing with a rational area a medial whole,

Producing with a medial area a medial whole.

(iv.) *Method of Exhaustion*

Euclid, *Elements* xii. 2^a

Circles are to one another as the squares on the diameters.

Let $AB\Gamma\Delta$, $EZH\Theta$ be circles, and $B\Delta$, $Z\Theta$ their diameters; I say that, as the circle $AB\Gamma\Delta$ is to the circle $EZH\Theta$, so is the square on $B\Delta$ to the square on $Z\Theta$.

GREEK MATHEMATICS

Εἰ γὰρ μή ἐστιν ὡς ὁ $ΑΒΓΔ$ κύκλος πρὸς τὸν $ΕΖΗΘ$, οὕτως τὸ ἀπὸ τῆς $ΒΔ$ τετράγωνον πρὸς τὸ ἀπὸ τῆς $ΖΘ$, ἔσται ὡς τὸ ἀπὸ τῆς $ΒΔ$ πρὸς τὸ ἀπὸ τῆς $ΖΘ$, οὕτως ὁ $ΑΒΓΔ$ κύκλος ἤτοι πρὸς ἕλασσόν τι τοῦ $ΕΖΗΘ$ κύκλου χωρίον ἢ πρὸς μείζον. ἔστω πρότερον πρὸς ἕλασσον τὸ $Σ$. καὶ ἐγγεγράφθω εἰς τὸν $ΕΖΗΘ$ κύκλον τετράγωνον τὸ $ΕΖΗΘ$. τὸ δὴ ἐγγεγραμμένον τετράγωνον μείζον ἐστιν ἢ τὸ ἥμισυ τοῦ $ΕΖΗΘ$ κύκλου, ἐπειδήπερ ἐὰν διὰ τῶν $Ε, Ζ, Η, Θ$ σημείων ἐφαπτομένας τοῦ κύκλου ἀγάγωμεν, τοῦ περιγραφομένου περὶ τὸν κύκλον τετραγώνου ἡμισὺ ἐστὶ τὸ $ΕΖΗΘ$ τετράγωνον, τοῦ δὲ περιγραφέντος τετραγώνου ἐλάττων ἐστὶν ὁ κύκλος· ὥστε τὸ $ΕΖΗΘ$ ἐγγεγραμμένον τετράγωνον μείζον ἐστὶ τοῦ ἡμίσεως τοῦ $ΕΖΗΘ$ κύκλου. τετμήσθωσαν δίχα αἱ $ΕΖ, ΖΗ, ΗΘ, ΘΕ$ περιφέρειαι κατὰ τὰ $Κ, Λ, Μ, Ν$ σημεία, καὶ ἐπεζεύχθωσαν αἱ $ΕΚ, ΚΖ, ΖΛ, ΛΗ, ΗΜ, ΜΘ, ΘΝ, ΝΕ$. καὶ ἕκαστον ἄρα τῶν $ΕΚΖ, ΖΛΗ, ΗΜΘ, ΘΝΕ$ τριγώνων μείζον ἐστὶν ἢ τὸ ἥμισυ τοῦ καθ' ἑαυτὸ τμήματος τοῦ κύκλου, ἐπειδήπερ ἐὰν διὰ τῶν $Κ, Λ, Μ, Ν$ σημείων ἐφαπτομένας τοῦ κύκλου ἀγάγωμεν καὶ ἀναπληρώσωμεν τὰ ἐπὶ τῶν $ΕΖ, ΖΗ, ΗΘ, ΘΕ$ εὐθειῶν παραλληλόγραμμα, ἕκαστον τῶν $ΕΚΖ, ΖΛΗ, ΗΜΘ, ΘΝΕ$ τριγώνων ἡμισυ ἔσται τοῦ καθ' ἑαυτὸ παραλληλογράμμου, ἀλλὰ τὸ καθ'



THIS PAGE IS LOCKED TO FREE MEMBERS

Purchase full membership to immediately unlock this page

FORGOTTEN BOOKS

FULL

MEMBERSHIP

797,885 Books!

All you can read

for only

\$8.99/month

Continue

*Fair usage policy applies



ἑαυτὸ τμήμα ἔλαττόν ἐστι τοῦ παραλληλογράμμου· ὥστε ἕκαστον τῶν ΕΚΖ, ΖΛΗ, ΗΜΘ, ΘΝΕ τριγώνων μείζον ἐστι τοῦ ἡμίσεως τοῦ καθ' ἑαυτὸ τμήματος τοῦ κύκλου. τέμνοντες δὴ τὰς ὑπολειπομένας περιφερείας δίχα καὶ ἐπιζευγνύντες εὐθείας καὶ τοῦτο ἀεὶ ποιοῦντες καταλείψομέν τινα ἀποτμήματα τοῦ κύκλου, ἃ ἔσται ἐλάσσονα τῆς ὑπεροχῆς, ἣ ὑπερέχει ὁ ΕΖΗΘ κύκλος τοῦ Σ χωρίου. ἐδείχθη γὰρ ἐν τῷ πρώτῳ θεωρήματι τοῦ δεκάτου βιβλίου, ὅτι δύο μεγεθῶν ἀνίσων ἐκκειμένων, εἴαν ἀπὸ τοῦ μείζονος ἀφαιρεθῆ μείζον ἢ τὸ ἡμισυ καὶ τοῦ καταλειπομένου μείζον ἢ τὸ ἡμισυ, καὶ τοῦτο ἀεὶ γίγνηται, λειφθήσεται τι μέγεθος, ὃ ἔσται ἐλάσσον τοῦ ἐκκειμένου ἐλάσσονος μεγέθους. λελείφθω οὖν, καὶ ἔστω τὰ ἐπὶ τῶν ΕΚ, ΚΖ, ΖΛ, ΛΗ, ΗΜ, ΜΘ, ΘΝ, ΝΕ τμήματα τοῦ ΕΖΗΘ κύκλου ἐλάττονα τῆς ὑπεροχῆς, ἣ ὑπερέχει ὁ ΕΖΗΘ κύκλος τοῦ Σ χωρίου. λοιπὸν ἄρα τὸ ΕΚΖΛΗΜΘΝ πολύγωνον μείζον ἐστι τοῦ Σ χωρίου. ἐγγεγράφθω καὶ εἰς τὸν ΑΒΓΔ κύκλον τῷ ΕΚΖΛΗΜΘΝ πολυγώνῳ ὅμοιον πολύγωνον τὸ ΑΞΒΟΓΠΔΡ· ἔστιν ἄρα ὡς τὸ ἀπὸ τῆς ΒΔ τετράγωνον πρὸς τὸ ἀπὸ τῆς ΖΘ τετράγωνον, οὕτως τὸ ΑΞΒΟΓΠΔΡ πολύγωνον πρὸς τὸ ΕΚΖΛΗΜΘΝ πολύγωνον. ἀλλὰ καὶ ὡς τὸ ἀπὸ τῆς ΒΔ τετράγωνον πρὸς τὸ ἀπὸ τῆς ΖΘ, οὕτως ὁ ΑΒΓΔ κύκλος πρὸς τὸ Σ χωρίον· καὶ ὡς ἄρα ὁ ΑΒΓΔ κύκλος πρὸς τὸ Σ χωρίον, οὕτως τὸ ΑΞΒΟΓΠΔΡ πολύγωνον πρὸς τὸ ΕΚΖΛΗΜΘΝ πολύγωνον· ἐναλλάξ ἄρα ὡς ὁ ΑΒΓΔ κύκλος πρὸς τὸ ἐν αὐτῷ πολύγωνον, οὕτως τὸ Σ χωρίον πρὸς τὸ ΕΚΖΛΗΜΘΝ πολύγωνον. μείζων δὲ ὁ ΑΒΓΔ

EUCLID

about it is less than the parallelogram ; so that each of the triangles EKZ , $Z\Lambda H$, $HM\Theta$, ΘNE is greater than the half of the segment of the circle about it. Thus, by bisecting the remaining circumferences and joining straight lines, and doing this continually, we shall leave some segments of the circle which will be less than the excess by which the circle $EZH\Theta$ exceeds the area Σ . For it was proved in the first theorem of the tenth book that, if two unequal magnitudes be set out, and if from the greater there be subtracted a magnitude greater than its half, and from the remainder a magnitude greater than its half, and so on continually, there will be left some magnitude which is less than the lesser magnitude set out. Let such segments be then left, and let the segments of the circle $EZH\Theta$ on EK , KZ , $Z\Lambda$, ΛH , HM , $M\Theta$, ΘN , NE be less than the excess by which the circle $EZH\Theta$ exceeds the area Σ . Therefore the remainder, the polygon $EKZ\Lambda HM\Theta N$, is greater than the area Σ . Let there be inscribed, also, in the circle $AB\Gamma\Delta$ the polygon $A\Xi BO\Gamma\Pi\Delta P$ similar to the polygon $EKZ\Lambda HM\Theta N$; therefore as the square on $B\Delta$ is to the square on $Z\Theta$, so is the polygon $A\Xi BO\Gamma\Pi\Delta P$ to the polygon $EKZ\Lambda HM\Theta N$ [xii. 1]. But as the square on $B\Delta$ is to the square on $Z\Theta$, so is the circle $AB\Gamma\Delta$ to the area Σ ; therefore also as the circle $AB\Gamma\Delta$ is to the area Σ , so is the polygon $A\Xi BO\Gamma\Pi\Delta P$ to the polygon $EKZ\Lambda HM\Theta N$ [v. 11] ; therefore, alternately, as the circle $AB\Gamma\Delta$ is to the polygon in it, so is the area Σ to the polygon $EKZ\Lambda HM\Theta N$. Now the circle

κύκλος τοῦ ἐν αὐτῷ πολυγώνου· μείζον ἄρα καὶ τὸ Σ χωρίον τοῦ ΕΚΖΛΗΜΘΝ πολυγώνου. ἀλλὰ καὶ ἔλαττον· ὅπερ ἐστὶν ἀδύνατον. οὐκ ἄρα ἐστὶν ὡς τὸ ἀπὸ τῆς ΒΔ τετράγωνον πρὸς τὸ ἀπὸ τῆς ΖΘ, οὕτως ὁ ΑΒΓΔ κύκλος πρὸς ἔλασσόν τι τοῦ ΕΖΗΘ κύκλου χωρίον. ὁμοίως δὴ δείξομεν, ὅτι οὐδὲ ὡς τὸ ἀπὸ ΖΘ πρὸς τὸ ἀπὸ ΒΔ, οὕτως ὁ ΕΖΗΘ κύκλος πρὸς ἔλασσόν τι τοῦ ΑΒΓΔ κύκλου χωρίον.

Λέγω δὴ, ὅτι οὐδὲ ὡς τὸ ἀπὸ τῆς ΒΔ πρὸς τὸ ἀπὸ τῆς ΖΘ, οὕτως ὁ ΑΒΓΔ κύκλος πρὸς μείζόν τι τοῦ ΕΖΗΘ κύκλου χωρίον.

Εἰ γὰρ δυνατόν, ἔστω πρὸς μείζον τὸ Σ . ἀνάπαλιν ἄρα ὡς τὸ ἀπὸ τῆς ΖΘ τετράγωνον πρὸς τὸ ἀπὸ τῆς ΔΒ, οὕτως τὸ Σ χωρίον πρὸς τὸν ΑΒΓΔ κύκλον. ἀλλ' ὡς τὸ Σ χωρίον πρὸς τὸν ΑΒΓΔ κύκλον, οὕτως ὁ ΕΖΗΘ κύκλος πρὸς ἔλαττόν τι τοῦ ΑΒΓΔ κύκλου χωρίον· καὶ ὡς ἄρα τὸ ἀπὸ τῆς ΖΘ πρὸς τὸ ἀπὸ τῆς ΒΔ, οὕτως ὁ ΕΖΗΘ κύκλος πρὸς ἔλασσόν τι τοῦ ΑΒΓΔ κύκλου χωρίον· ὅπερ ἀδύνατον ἐδείχθη. οὐκ ἄρα ἐστὶν ὡς τὸ ἀπὸ ΒΔ τετράγωνον πρὸς τὸ ἀπὸ τῆς ΖΘ, οὕτως ὁ ΑΒΓΔ κύκλος πρὸς μείζόν τι τοῦ ΕΖΗΘ κύκλου χωρίον. ἐδείχθη δέ, ὅτι οὐδὲ πρὸς ἔλασσον· ἔστιν ἄρα ὡς τὸ ἀπὸ τῆς ΒΔ τετράγωνον πρὸς τὸ ἀπὸ τῆς ΖΘ, οὕτως ὁ ΑΒΓΔ κύκλος πρὸς τὸν ΕΖΗΘ κύκλον.

Οἱ ἄρα κύκλοι πρὸς ἀλλήλους εἰσὶν ὡς τὰ ἀπὸ τῶν διαμέτρων τετράγωνα· ὅπερ ἔδει δείξαι.



THIS PAGE IS LOCKED TO FREE MEMBERS

Purchase full membership to immediately unlock this page

SAVE \$3,999,994

Did you know we sell
paperback books too?

To buy our entire catalog
in paperback would cost
over \$4,000,000

Access it all now for
\$8.99/month

*Fair usage policy applies

Continue

(v.) *Regular Solids*Eucl. *Elem.* xiii. 18

Τὰς πλευρὰς τῶν πέντε σχημάτων ἐκθέσθαι καὶ συγκρίναι πρὸς ἀλλήλας.

Ἐκκείσθω ἡ τῆς δοθείσης σφαίρας διάμετρος ἡ AB , καὶ τετμήσθω κατὰ τὸ Γ ὥστε ἴσην εἶναι τὴν AG τῇ GB , κατὰ δὲ τὸ Δ ὥστε διπλασίονα εἶναι τὴν $A\Delta$ τῆς ΔB , καὶ γεγράφθω ἐπὶ τῆς AB ἡμικύκλιον τὸ AEB , καὶ ἀπὸ τῶν Γ , Δ τῇ AB πρὸς ὀρθὰς ἤχθωσαν αἱ GE , ΔZ , καὶ ἐπεζεύχθωσαν αἱ AZ , ZB , EB . καὶ ἐπεὶ διπλῆ ἐστὶν ἡ $A\Delta$ τῆς ΔB , τριπλῆ ἄρα ἐστὶν ἡ AB τῆς $B\Delta$. ἀναστρέψαντι ἡμιολία ἄρα ἐστὶν ἡ BA τῆς $A\Delta$. ὡς δὲ ἡ BA πρὸς τὴν $A\Delta$, οὕτως τὸ ἀπὸ τῆς BA πρὸς τὸ ἀπὸ τῆς AZ . ἰσογώνιον γάρ ἐστι τὸ AZB τρίγωνον τῷ $AZ\Delta$ τριγώνῳ. ἡμιόλιον ἄρα ἐστὶ τὸ ἀπὸ τῆς BA τοῦ ἀπὸ τῆς AZ . ἔστι δὲ καὶ ἡ τῆς σφαίρας διάμετρος δυνάμει ἡμιολία

^a For the earlier history of the regular, cosmic or Platonic figures, v. *supra*, pp. 216-225, 378-379.

^b This proposition cannot be fully understood without the previous propositions in the book which it assumes, but it will give an insight into the thoroughness and comprehensiveness of Euclid's methods.

EUCLID

(v.) *Regular Solids* ^a

Euclid, *Elements* xiii. 18 ^b

To set out the sides of the five figures and to compare them one with another.

Let AB , the diameter of the given sphere, be set out, and let it be cut at Γ so that $A\Gamma$ is equal to ΓB , and at Δ so that $A\Delta$ is double of ΔB ; and on AB let the semicircle AEB be drawn, and from F, Δ let $\Gamma E, \Delta Z$ be drawn at right angles to AB , and let AZ, ZB, EB be joined. Then since $A\Delta = 2\Delta B$, therefore $AB = 3B\Delta$. *Convertendo*, therefore $BA = \frac{3}{2}A\Delta$. But $BA : A\Delta = BA^2 : AZ^2$ [v. Def. 9], for the triangle AZB is equiangular with the triangle $AZ\Delta$ [vi. 8];

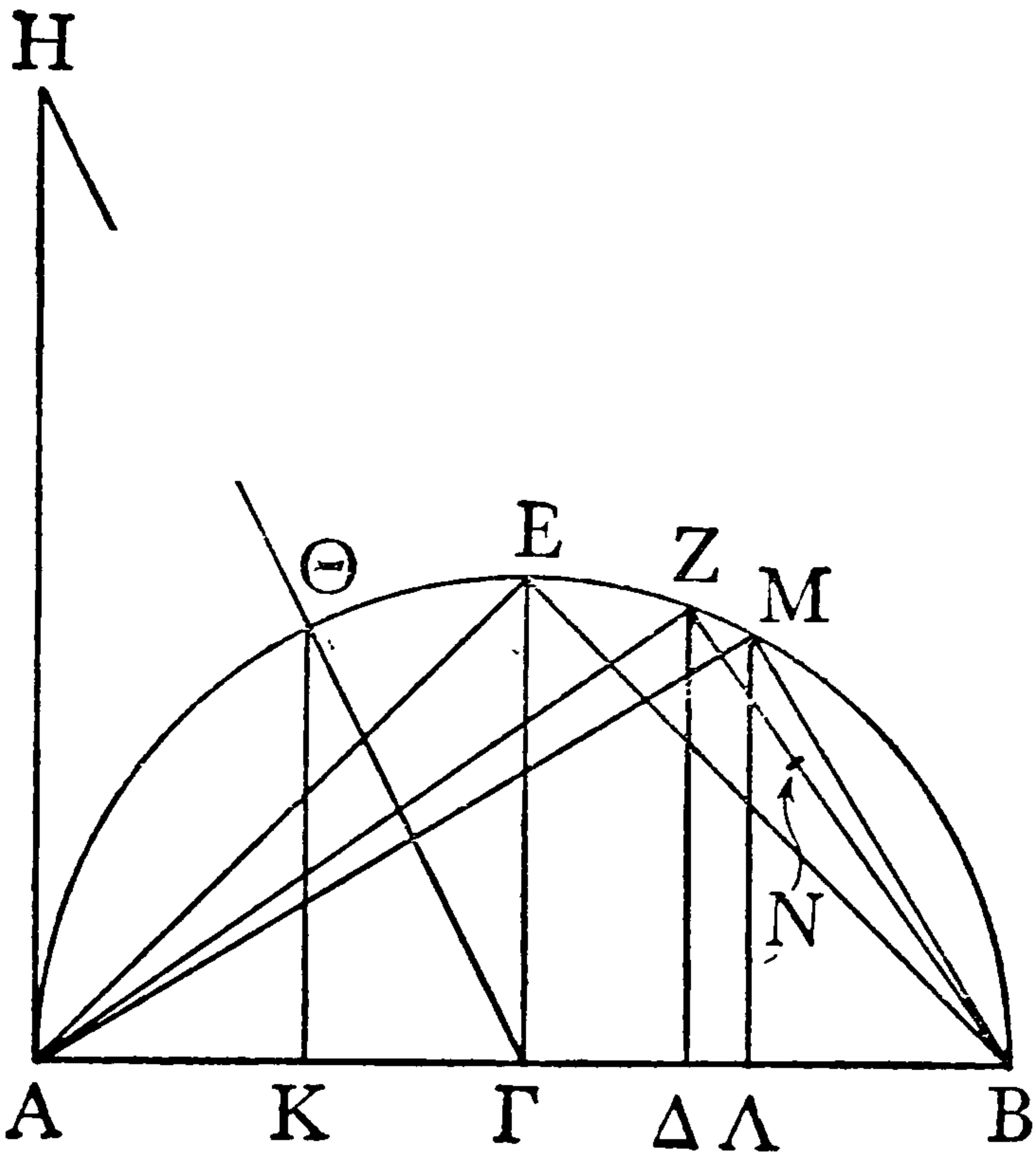

therefore $BA^2 = \frac{3}{2}AZ^2$. But the square on the diameter of the sphere is also one-and-a-half times the

τῆς πλευρᾶς τῆς πυραμίδος. καί ἐστιν ἡ AB ἡ τῆς σφαίρας διάμετρος· ἡ AZ ἄρα ἴση ἐστὶ τῇ πλευρᾷ τῆς πυραμίδος.

Πάλιν, ἐπεὶ διπλασίων ἐστὶν ἡ AD τῆς DB , τριπλῆ ἄρα ἐστὶν ἡ AB τῆς BD . ὡς δὲ ἡ AB πρὸς τὴν BD , οὕτως τὸ ἀπὸ τῆς AB πρὸς τὸ ἀπὸ τῆς BZ · τριπλάσιον ἄρα ἐστὶ τὸ ἀπὸ τῆς AB τοῦ ἀπὸ τῆς BZ . ἔστι δὲ καὶ ἡ τῆς σφαίρας διάμετρος δυνάμει τριπλασίων τῆς τοῦ κύβου πλευρᾶς. καί ἐστιν ἡ AB ἡ τῆς σφαίρας διάμετρος· ἡ BZ ἄρα τοῦ κύβου ἐστὶ πλευρά.

Καὶ ἐπεὶ ἴση ἐστὶν ἡ AG τῇ GB , διπλῆ ἄρα ἐστὶν ἡ AB τῆς BG . ὡς δὲ ἡ AB πρὸς τὴν BG , οὕτως τὸ ἀπὸ τῆς AB πρὸς τὸ ἀπὸ τῆς BE · διπλάσιον ἄρα ἐστὶ τὸ ἀπὸ τῆς AB τοῦ ἀπὸ τῆς BE . ἔστι δὲ καὶ ἡ τῆς σφαίρας διάμετρος δυνάμει διπλασίων τῆς τοῦ ὀκταέδρου πλευρᾶς. καί ἐστιν ἡ AB ἡ τῆς δοθείσης σφαίρας διάμετρος· ἡ BE ἄρα τοῦ ὀκταέδρου ἐστὶ πλευρά.

Ἦχθω δὲ ἀπὸ τοῦ A σημείου τῇ AB εὐθείᾳ πρὸς ὀρθὰς ἡ AH , καὶ κείσθω ἡ AH ἴση τῇ AB , καὶ ἐπεζεύχθω ἡ HG , καὶ ἀπὸ τοῦ Θ ἐπὶ τὴν AB κάθετος ἤχθω ἡ ΘK . καὶ ἐπεὶ διπλῆ ἐστὶν ἡ HA τῆς AG · ἴση γὰρ ἡ HA τῇ AB · ὡς δὲ ἡ HA πρὸς τὴν AG , οὕτως ἡ ΘK πρὸς τὴν KG , διπλῆ ἄρα καὶ ἡ ΘK τῆς KG . τετραπλάσιον ἄρα ἐστὶ τὸ ἀπὸ τῆς ΘK τοῦ ἀπὸ τῆς KG · τὰ ἄρα ἀπὸ τῶν ΘK , KG , ὅπερ ἐστὶ τὸ ἀπὸ τῆς ΘG , πενταπλάσιόν ἐστι τοῦ ἀπὸ τῆς KG . ἴση δὲ ἡ ΘG τῇ GB · πενταπλάσιον ἄρα ἐστὶ τὸ ἀπὸ τῆς BG τοῦ ἀπὸ τῆς GK · καὶ ἐπεὶ διπλῆ ἐστὶν ἡ AB τῆς GB , ὡν ἡ AD τῆς DB ἐστὶ διπλῆ, λοιπὴ ἄρα ἡ BD λοιπῆς



THIS PAGE IS LOCKED TO FREE MEMBERS

Purchase full membership to immediately unlock this page

FORGOTTEN BOOKS

FULL

MEMBERSHIP

797,885 Books!

All you can read

for only

\$8.99/month

Continue

*Fair usage policy applies



τῆς ΔΓ ἔστι διπλῆ. τριπλῆ ἄρα ἢ ΒΓ τῆς ΓΔ·
 ἑνναπλάσιον ἄρα τὸ ἀπὸ τῆς ΒΓ τοῦ ἀπὸ τῆς ΓΔ.
 πενταπλάσιον δὲ τὸ ἀπὸ τῆς ΒΓ τοῦ ἀπὸ τῆς ΓΚ·
 μεῖζον ἄρα τὸ ἀπὸ τῆς ΓΚ τοῦ ἀπὸ τῆς ΓΔ.
 μείζων ἄρα ἔστιν ἢ ΓΚ τῆς ΓΔ. κείσθω τῇ ΓΚ
 ἴση ἢ ΓΛ, καὶ ἀπὸ τοῦ Λ τῇ ΑΒ πρὸς ὀρθὰς
 ἤχθω ἢ ΛΜ, καὶ ἐπεζεύχθω ἢ ΜΒ. καὶ ἐπεὶ
 πενταπλάσιόν ἔστι τὸ ἀπὸ τῆς ΒΓ τοῦ ἀπὸ τῆς
 ΓΚ, καὶ ἔστι τῆς μὲν ΒΓ διπλῆ ἢ ΑΒ, τῆς δὲ ΓΚ
 διπλῆ ἢ ΚΛ, πενταπλάσιον ἄρα ἔστι τὸ ἀπὸ τῆς
 ΑΒ τοῦ ἀπὸ τῆς ΚΛ. ἔστι δὲ καὶ ἢ τῆς σφαι-
 ρας διάμετρος δυνάμει πενταπλασίων τῆς ἐκ τοῦ
 κέντρου τοῦ κύκλου, ἀφ' οὗ τὸ εἰκοσάεδρον ἀνα-
 γέγραπται. καὶ ἔστιν ἢ ΑΒ ἢ τῆς σφαίρας διά-
 μετρος· ἢ ΚΛ ἄρα ἐκ τοῦ κέντρου ἔστι τοῦ
 κύκλου, ἀφ' οὗ τὸ εἰκοσάεδρον ἀναγέγραπται· ἢ
 ΚΛ ἄρα ἑξαγώνου ἔστι πλευρὰ τοῦ εἰρημένου
 κύκλου. καὶ ἐπεὶ ἢ τῆς σφαίρας διάμετρος σύγ-
 κείται ἔκ τε τῆς τοῦ ἑξαγώνου καὶ δύο τῶν τοῦ
 δεκαγώνου τῶν εἰς τὸν εἰρημένον κύκλον ἐγγρα-
 φομένων, καὶ ἔστιν ἢ μὲν ΑΒ ἢ τῆς σφαίρας
 διάμετρος, ἢ δὲ ΚΛ ἑξαγώνου πλευρά, καὶ ἴση ἢ
 ΑΚ τῇ ΛΒ, ἑκατέρα ἄρα τῶν ΑΚ, ΛΒ δεκαγώνου
 ἔστι πλευρὰ τοῦ ἐγγραφομένου εἰς τὸν κύκλον, ἀφ'
 οὗ τὸ εἰκοσάεδρον ἀναγέγραπται. καὶ ἐπεὶ δεκα-
 γώνου μὲν ἢ ΛΒ, ἑξαγώνου δὲ ἢ ΜΛ· ἴση γάρ
 ἔστι τῇ ΚΛ, ἐπεὶ καὶ τῇ ΘΚ· ἴσον γὰρ ἀπέχουσιν

^a Euclid's procedure, in constructing the icosahedron inscribable in a given sphere, is first to construct a circle with radius r such that $r^2 = \frac{1}{5}d^2$, where d is the diameter of the sphere. In this he inscribes a regular decagon, and from its

EUCLID

$B\Delta$ is double of the remainder $\Delta\Gamma$. Therefore $B\Gamma = 3\Gamma\Delta$; therefore $B\Gamma^2 = 9\Gamma\Delta^2$. But $B\Gamma^2 = 5\Gamma K^2$; therefore $\Gamma K^2 > \Gamma\Delta^2$. Therefore $\Gamma K > \Gamma\Delta$. Let $\Gamma\Lambda$ be made equal to ΓK , and from Λ let ΛM be drawn at right angles to AB , and let MB be joined. Then since $B\Gamma^2 = 5\Gamma K^2$, and $AB = 2B\Gamma$, $K\Lambda = 2\Gamma K$, therefore $AB^2 = 5K\Lambda^2$. But the square on the diameter of the sphere is also five times the square on the radius of the circle from which the icosahedron has been described [xiii. 16, coroll.].^a And AB is the diameter of the sphere; therefore $K\Lambda$ is the radius of the circle from which the icosahedron has been described; therefore $K\Lambda$ is a side of the hexagon in the said circle [iv. 15, coroll.]. And since the diameter of the sphere is made up of the side of the hexagon and two of the sides of the decagon inscribed in the same circle [xiii. 16, coroll.], and AB is the diameter of the sphere, while $K\Lambda$ is the side of the hexagon, and $AK = \Lambda B$, therefore each of the straight lines AK , ΛB is a side of the decagon inscribed in the circle from which the icosahedron has been described. And since ΛB belongs to a decagon and $M\Lambda$ to a hexagon (for $M\Lambda$ is equal to $K\Lambda$ since it is also equal to ΘK ,

angular points draws straight lines perpendicular to the plane of the circle and equal in length to r ; this determines the angular points of another decagon inscribed in an equal parallel circle. By joining alternate angular points of one decagon, he obtains a pentagon, and then does the same with the other decagon, but in such a manner that the angular points are not opposite one another. Joining the angular points of one pentagon to the nearest angular points of the other, he obtains ten equilateral triangles, which are faces of the icosahedron. He completes the procedure by finding the common vertices of the five equilateral triangles standing on each of the pentagons, which form the remaining faces of the icosahedron.

GREEK MATHEMATICS

ἀπὸ τοῦ κέντρου· καὶ ἔστιν ἑκατέρα τῶν ΘΚ, ΚΛ διπλασίων τῆς ΚΓ· πενταγώνου ἄρα ἔστιν ἡ ΜΒ. ἡ δὲ τοῦ πενταγώνου ἔστιν ἡ τοῦ εἰκοσαέδρου· εἰκοσαέδρου ἄρα ἔστιν ἡ ΜΒ.

Καὶ ἐπεὶ ἡ ΖΒ κύβου ἐστὶ πλευρά, τετμήσθω ἄκρον καὶ μέσον λόγον κατὰ τὸ Ν, καὶ ἔστω μείζον τμήμα τὸ ΝΒ· ἡ ΝΒ ἄρα δωδεκαέδρου ἐστὶ πλευρά.

Καὶ ἐπεὶ ἡ τῆς σφαίρας διάμετρος ἐδείχθη τῆς μὲν ΑΖ πλευρᾶς τῆς πυραμίδος δυνάμει ἡμιολία, τῆς δὲ τοῦ ὀκταέδρου τῆς ΒΕ δυνάμει διπλασίων, τῆς δὲ τοῦ κύβου τῆς ΖΒ δυνάμει τριπλασίων, οἷων ἄρα ἡ τῆς σφαίρας διάμετρος δυνάμει ἕξ, τοιούτων ἡ μὲν τῆς πυραμίδος τεσσάρων, ἡ δὲ τοῦ ὀκταέδρου τριῶν, ἡ δὲ τοῦ κύβου δύο. ἡ μὲν ἄρα τῆς πυραμίδος πλευρὰ τῆς μὲν τοῦ ὀκταέδρου πλευρᾶς δυνάμει ἐστὶν ἐπίτριτος, τῆς δὲ τοῦ κύβου δυνάμει διπλῆ, ἡ δὲ τοῦ ὀκταέδρου τῆς τοῦ κύβου δυνάμει ἡμιολία. αἱ μὲν οὖν εἰρημέναι τῶν τριῶν σχημάτων πλευραί, λέγω δὴ πυραμίδος καὶ ὀκταέδρου καὶ κύβου, πρὸς ἀλλήλας εἰσὶν ἐν λόγοις ῥητοῖς. αἱ δὲ λοιπαὶ δύο, λέγω δὴ ἡ τε τοῦ εἰκοσαέδρου καὶ ἡ τοῦ δωδεκαέδρου, οὔτε πρὸς ἀλλήλας οὔτε πρὸς τὰς προειρημένας εἰσὶν ἐν



THIS PAGE IS LOCKED TO FREE MEMBERS

Purchase full membership to immediately unlock this page

SAVE \$3,999,994

Did you know we sell
paperback books too?

To buy our entire catalog
in paperback would cost
over \$4,000,000

Access it all now for
\$8.99/month

*Fair usage policy applies

Continue

λόγοις ῥητοῖς· ἄλογοι γάρ εἰσιν, ἢ μὲν ἐλάττων, ἢ δὲ ἀποτομή.

Ὅτι μείζων ἐστὶν ἢ τοῦ εἰκοσαέδρου πλευρὰ ἢ MB τῆς τοῦ δωδεκαέδρου τῆς NB , δείξομεν οὕτως.

Ἐπεὶ γὰρ ἰσογώνιον ἐστὶ τὸ $Z\Delta B$ τρίγωνον τῷ ZAB τριγώνῳ, ἀνάλογόν ἐστὶν ὡς ἡ ΔB πρὸς τὴν BZ , οὕτως ἡ BZ πρὸς τὴν BA . καὶ¹ ἐπεὶ τρεῖς εὐθεῖαι ἀνάλογόν εἰσιν, ἔστιν ὡς ἡ πρώτη πρὸς τὴν τρίτην, οὕτως τὸ ἀπὸ τῆς πρώτης πρὸς τὸ ἀπὸ τῆς δευτέρας¹. ἔστιν ἄρα ὡς ἡ ΔB πρὸς τὴν BA , οὕτως τὸ ἀπὸ τῆς ΔB πρὸς τὸ ἀπὸ τῆς BZ . ἀνάπαλιν ἄρα ὡς ἡ AB πρὸς τὴν BD , οὕτως τὸ ἀπὸ τῆς ZB πρὸς τὸ ἀπὸ τῆς BD . τριπλῆ δὲ ἡ AB τῆς BD . τριπλάσιον ἄρα τὸ ἀπὸ τῆς ZB τοῦ ἀπὸ τῆς BD . ἔστι δὲ καὶ τὸ ἀπὸ τῆς AD τοῦ ἀπὸ τῆς ΔB τετραπλάσιον. διπλῆ γὰρ ἡ AD τῆς ΔB . μείζον ἄρα τὸ ἀπὸ τῆς AD τοῦ ἀπὸ τῆς ZB . μείζων ἄρα ἡ AD τῆς ZB . πολλῶ ἄρα ἡ AD τῆς ZB μείζων ἐστίν. καὶ τῆς μὲν AD ἄκρον καὶ μέσον λόγον τεμνομένης τὸ μείζον τμῆμά ἐστὶν ἡ KL , ἐπειδήπερ ἡ μὲν LK ἑξαγώνου ἐστίν, ἡ δὲ KA δεκαγώνου. τῆς δὲ ZB ἄκρον καὶ μέσον λόγον τεμνομένης τὸ μείζον τμῆμά ἐστὶν ἡ NB . μείζων ἄρα ἡ KL τῆς NB . ἴση δὲ ἡ KL τῇ LM . μείζων ἄρα ἡ LM τῆς NB [τῆς δὲ LM μείζων ἐστὶν ἡ

¹ καὶ ἐπεὶ . . . δευτέρας. "Miramur, cur haec definitio hoc loco omnibus verbis citetur, praesertim forma parum Euclidea, cum tamen antea in hac ipsa propositione toties tacite sit usurpata. itaque puto, verba καὶ ἐπεὶ . . . δευτέρας subditiva esse."—Heiberg.

• If r be the radius of the sphere circumscribing the five regular solids,

EUCLID

said sides ; for they are irrational, the one being *minor* [xiii. 16], the other an *apotome* [xiii. 17].^a

That the side MB of the icosahedron is greater than the side NB of the dodecahedron we shall prove thus.

For since the triangle ZΔB is equiangular with the triangle ZAB [vi. 8], the proportion arises, ΔB : BZ = BZ : BA [vi. 4]. And since the three straight lines are in proportion, as the first is to the third, so is the square on the first to the square on the second [v. Def. 9] ; therefore ΔB : BA = ΔB² : BZ² ; therefore, inversely, AB : BΔ = ZB² : BΔ². But AB = 3BΔ ; therefore ZB² = 3BΔ². But AΔ² = 4ΔB², for AΔ = 2ΔB ; therefore AΔ² > ZB² ; therefore AΔ > ZB ; therefore AΛ is by far greater than ZB. And, when AΛ is cut in extreme and mean ratio, KΛ is the greater segment, since ΛK belongs to a hexagon, and KA to a decagon [xiii. 9] ; and when ZB is cut in extreme and mean ratio, NB is the greater segment ; therefore KΛ is greater than NB. But KΛ = ΛM ; therefore ΛM > NB. Therefore MB,

$$\text{side of pyramid} = \frac{2}{3}\sqrt{6} \cdot r$$

$$\text{side of octahedron} = \sqrt{2} \cdot r$$

$$\text{side of cube} = \frac{2}{3}\sqrt{3} \cdot r$$

$$\text{side of icosahedron} = \frac{r}{5}\sqrt{10(5 - \sqrt{5})}$$

$$\text{side of dodecahedron} = \frac{r}{3}(\sqrt{15} - \sqrt{3}).$$

In the sense of the term irrational as used by Euclid's predecessors and by modern mathematicians, all these expressions are irrational ; but in the special sense of Eucl. *Elem.* x. Def. 3, the first three are rational, because their squares are commensurable one with another. The fourth and fifth expressions are irrational even in Euclid's sense, belonging to two species of irrational lines investigated in Book x.

MB].¹ πολλῶ ἄρα ἢ MB πλευρὰ οὔσα τοῦ εἰκοσαέδρου μείζων ἐστὶ τῆς NB πλευρᾶς οὔσης τοῦ δωδεκαέδρου· ὅπερ ἔδει δεῖξαι.

Λέγω δὴ, ὅτι παρὰ τὰ εἰρημένα πέντε σχήματα οὐ συσταθήσεται ἕτερον σχῆμα περιεχόμενον ὑπὸ ἰσοπλεύρων τε καὶ ἰσογωνίων ἴσων ἀλλήλοις.

Ἐπὶ μὲν γὰρ δύο τριγώνων ἢ ὅλως ἐπιπέδων στερεὰ γωνία οὐ συνίσταται. ὑπὸ δὲ τριῶν τριγώνων ἢ τῆς πυραμίδος, ὑπὸ δὲ τεσσάρων ἢ τοῦ ὀκταέδρου, ὑπὸ δὲ πέντε ἢ τοῦ εἰκοσαέδρου· ὑπὸ δὲ ἕξ τριγώνων ἰσοπλεύρων τε καὶ ἰσογωνίων πρὸς ἐνὶ σημείῳ συνισταμένων οὐκ ἔσται στερεὰ γωνία· οὔσης γὰρ τῆς τοῦ ἰσοπλεύρου τριγώνου γωνίας διμοίρου ὀρθῆς ἔσονται αἱ ἕξ τέσσαρσιν ὀρθαῖς ἴσαι· ὅπερ ἀδύνατον· ἅπαντα γὰρ στερεὰ γωνία ὑπὸ ἔλασσόνων ἢ τεσσάρων ὀρθῶν περιέχεται. διὰ τὰ αὐτὰ δὴ οὐδὲ ὑπὸ πλειόνων ἢ ἕξ γωνιῶν ἐπιπέδων στερεὰ γωνία συνίσταται.

Ἐπὶ δὲ τετραγώνων τριῶν ἢ τοῦ κύβου γωνία περιέχεται· ὑπὸ δὲ τεσσάρων ἀδύνατον· ἔσονται γὰρ πάλιν τέσσαρες ὀρθαί.

Ἐπὶ δὲ πενταγώνων ἰσοπλεύρων καὶ ἰσογωνίων, ὑπὸ μὲν τριῶν ἢ τοῦ δωδεκαέδρου· ὑπὸ δὲ τεσσάρων ἀδύνατον· οὔσης γὰρ τῆς τοῦ πενταγώνου ἰσοπλεύρου γωνίας ὀρθῆς καὶ πέμπτου, ἔσονται αἱ τέσσαρες γωνίαι τεσσάρων ὀρθῶν μείζους· ὅπερ ἀδύνατον.

Οὐδὲ μὲν ὑπὸ πολυγώνων ἑτέρων σχημάτων περισχεθήσεται στερεὰ γωνία διὰ τὸ αὐτὸ ἄτοπον.

Οὐκ ἄρα παρὰ τὰ εἰρημένα πέντε σχήματα

¹ τῆς . . . MB del Heiberg.



THIS PAGE IS LOCKED TO FREE MEMBERS

Purchase full membership to immediately unlock this page

FORGOTTEN BOOKS

FULL

MEMBERSHIP

797,885 Books!

All you can read

for only

\$8.99/month

Continue

*Fair usage policy applies



GREEK MATHEMATICS

ἕτερον σχῆμα στερεὸν συνταθήσεται ὑπὸ ἰσοπλεύρων τε καὶ ἰσογωνίων περιεχόμενον· ὅπερ ἔδει δεῖξαι.

(c) THE DATA

Eucl., ed. Heiberg-Menge vi. 2. 1-15

Ὅροι

α'. Δεδομένα τῷ μεγέθει λέγεται χωρία τε καὶ γραμμαὶ καὶ γωνίαι, οἷς δυνάμεθα ἴσα πορίσασθαι.

β'. Λόγος δεδόσθαι λέγεται, ὧν δυνάμεθα τὸν αὐτὸν πορίσασθαι.

γ'. Εὐθύγραμμα σχήματα τῷ εἶδει δεδόσθαι λέγεται, ὧν αἱ τε γωνίαι δεδομένοι εἰσὶ κατὰ μίαν καὶ οἱ λόγοι τῶν πλευρῶν πρὸς ἀλλήλας δεδομένοι.

δ'. Τῇ θέσει δεδόσθαι λέγονται σημεία τε καὶ γραμμαὶ καὶ γωνίαι, ἃ τὸν αὐτὸν αἰεὶ τόπον ἐπέχει.

ε'. Κύκλος τῷ μεγέθει δεδόσθαι λέγεται, οὗ δέδοται ἢ ἐκ τοῦ κέντρου τῷ μεγέθει.

ς'. Τῇ θέσει δὲ καὶ τῷ μεγέθει κύκλος δεδόσθαι λέγεται, οὗ δέδοται τὸ μὲν κέντρον τῇ θέσει, ἢ δὲ ἐκ τοῦ κέντρου τῷ μεγέθει.

(d) THE PORISMS

Procl. in Eucl. i., ed. Friedlein 301. 21-302. 13 ; Eucl., ed. Heiberg-Menge viii. 237. 9-27

Ἐν τι τῶν γεωμετρικῶν ἐστὶν ὀνομάτων τὸ πόρισμα. τοῦτο δὲ σημαίνει διττόν· καλοῦσι γὰρ

^a Euclid's *Data* (Δεδομένα) is his only work in pure geometry to have survived in Greek apart from the *Elements*. (His book *On Divisions of Figures* has survived in Arabic, v. supra, p. 156 n. c.) It is closely connected with Books i.-vi. of the *Elements*, and its general character will be suffi-

EUCLID

figures, can be constructed so as to be contained by equilateral and equiangular figures ; which was to be proved.

(c) THE DATA ^a

Eucl., ed. Heiberg-Menge vi. 2. 1-15

Definitions

1. Areas, lines and angles are said to be given in magnitude when we can make others equal to them.

2. A ratio is said to be given when we can make another equal to it.

3. Rectilinear figures are said to be given in species when their angles are severally given and the ratios of the sides one towards another are also given.

4. Points, lines and angles are said to be given in position when they always occupy the same place.

5. A circle is said to be given in magnitude when the radius is given in magnitude.

6. A circle is said to be given in position and in magnitude when the centre is given in position and the radius in magnitude.

(d) THE PORISMS

Proclus, *On Euclid i.*, ed. Friedlein 301. 21-302. 13 ;

Eucl., ed. Heiberg-Menge viii. 237. 9-27

Porism is one of the terms used in geometry. It has a twofold meaning. For porisms are in the first

ciently indicated by these first few definitions. The object of a proposition called a *datum* is to prove that, if in a figure certain properties are given, other properties are also given, in one or other of the senses defined in the definitions. Pappus included the book in his *Τόπος ἀναλυόμενος* (*Treasury of Analysis*).

πορίσματα, καὶ ὅσα θεωρήματα συγκατασκευάζεται ταῖς ἄλλων ἀποδείξεσιν οἷον ἔρμια καὶ κέρδη τῶν ζητούντων ὑπάρχοντα, καὶ ὅσα ζητεῖται μὲν, εὐρέσεως δὲ χρήζει καὶ οὔτε γενέσεως μόνης οὔτε θεωρίας ἀπλῆς. ὅτι μὲν γὰρ τῶν ἰσοσκελῶν αἱ πρὸς τῇ βάσει ἴσαι θεωρηῖσαι δεῖ, καὶ ὄντων δὴ τινων¹ πραγμάτων ἐστὶν ἢ τοιαύτη γνῶσις. τὴν δὲ γωνίαν δίχα τεμεῖν ἢ τρίγωνον συστήσασθαι ἢ ἀφελεῖν ἢ προσθέσθαι,² ταῦτα πάντα ποιήσιν τινος ἀπαιτεῖ· τοῦ δὲ δοθέντος κύκλου τὸ κέντρον εὐρεῖν, ἢ δύο δοθέντων συμμετρῶν μεγεθῶν τὸ μέγιστον καὶ κοινὸν μέτρον εὐρεῖν, ἢ ὅσα τοιάδε, μεταξύ πῶς ἐστὶ προβλημάτων καὶ θεωρημάτων. οὔτε γὰρ γενέσεις εἰσὶν ἐν τούτοις τῶν ζητουμένων, ἀλλ' εὐρέσεις, οὔτε θεωρία ψιλή. δεῖ γὰρ ὑπ' ὄψιν ἀγαγεῖν καὶ πρὸ ὀμμάτων ποιήσασθαι τὸ ζητούμενον. τοιαῦτα ἄρα ἐστὶν καὶ ὅσα Εὐκλείδης πορίσματα γέγραφε, γ' βιβλία Πορισμάτων συντάξας.

Papp. Coll. vii., ed. Hultsch 648. 18–660. 16 ; Eucl., ed. Heiberg-Menge viii. 238. 10–243. 5

Μετὰ δὲ τὰς Ἐπαφὰς ἐν τρισὶ βιβλίοις Πορίσματά ἐστὶν Εὐκλείδου, πολλοῖς ἄθροισμα φιλοτεχνότατον εἰς τὴν ἀνάλυσιν τῶν ἐμβριθεστέρων προβλημάτων . . .

¹ τινων Heiberg, τῶν codd.

² προσθέσθαι Heiberg, θέσθαι codd.

^a A porism in this sense is commonly called a *corollary*.
^b Euclid's *Porisms* has unfortunately not survived, which is a great misfortune as it appears to have been the most original and advanced of all his works. Our knowledge of its contents comes solely from Pappus.

^c Pappus is describing the books comprised in his *Τόπος ἀναλυόμενος* (*Treasury of Analysis*). He proceeds to give an



THIS PAGE IS LOCKED TO FREE MEMBERS

Purchase full membership to immediately unlock this page

SAVE \$3,999,994

Did you know we sell
paperback books too?

To buy our entire catalog
in paperback would cost
over \$4,000,000

Access it all now for
\$8.99/month

*Fair usage policy applies

Continue

GREEK MATHEMATICS

Περιλαβεῖν δὲ πολλὰ μιᾷ προτάσει ἤκιστα δυνα-
 τὸν ἐν τούτοις διὰ τὸ καὶ αὐτὸν Εὐκλείδην οὐ πολλὰ
 ἐξ ἑκάστου εἴδους τεθεικέναι, ἀλλὰ δείγματος
 ἕνεκα ἐκ τῆς πολυπληθείας ἐν ἧ¹ ὀλίγα. πρὸς
 ἀρχῇ δὲ ὅμως² τοῦ πρώτου βιβλίου τέθεικεν ὁμο-
 ειδῆ τινὰ³ ἐκείνου τοῦ δαψιλεστέρου εἴδους τῶν
 τόπων, ὡς ἰ τὸ πλῆθος. διὸ καὶ περιλαβεῖν ταύτας
 μιᾷ προτάσει ἐνδεχόμενον εὐρόντες οὕτως ἐγρά-
 ψαμεν· ἐὰν ὑπτίου ἢ παρυπτίου τρία τὰ ἐπὶ μιᾶς
 σημεία [ἢ παραλλήλου τῆς ἐτέρας τὰ δύο]⁴ δε-
 δομένα ἢ, τὰ δὲ λοιπὰ πλὴν ἑνὸς ἄπτηται θέσει
 δεδομένης εὐθείας, καὶ τοῦθ' ἄψεται θέσει δεδο-
 μένης εὐθείας. τοῦτ' ἐπὶ τεσσάρων μὲν εὐθειῶν
 εἴρηται μόνων, ὧν οὐ πλείονες ἢ δύο διὰ τοῦ αὐτοῦ
 σημείου εἰσίν, ἀγνοεῖται δὲ ἐπὶ παντὸς τοῦ προ-

¹ ἐν ἧ Littré, ἕνια Hultsch.

² δὲ ὅμως Heiberg, δεδομένον cod. (sequente lacuna) del. Hultsch.

³ τινὰ Heiberg, πᾶν cod., πάντ' Hultsch.

⁴ ἢ . . . δύο interpolatori trib. Hultsch.

* The four straight lines are described in the Greek as (the sides) ὑπτίου ἢ παρυπτίου, i.e., as the sides of *supine* and *hyper-supine* quadrilaterals. Robert Simson (*Opera quaedam reliqua*, p. 348) explains a ὑπτιον σχῆμα as being of the
 482

Now to comprehend many propositions in one enunciation is far from easy in these porisms, because Euclid himself has not given many of each species, but out of a great number he has selected one or a few by way of example. But at the beginning of the first book he has given certain allied propositions, ten in number, from that more abundant species consisting of loci. Finding that these can be comprehended in one enunciation, we have therefore written it out in this manner: *If, in a system of four straight lines which cut one another two and two, the three points [of intersection] on one straight line be given, while the rest except one lie on different straight lines given in position, the remaining point also will be on a straight line given in position.*^a This has been enunciated in the case of four straight lines only, of which not more than two pass through the same point, and it is not nature of (1) in the accompanying diagrams, while (2) and (3) are *παρύπτια σχήματα*. He also explained the correct

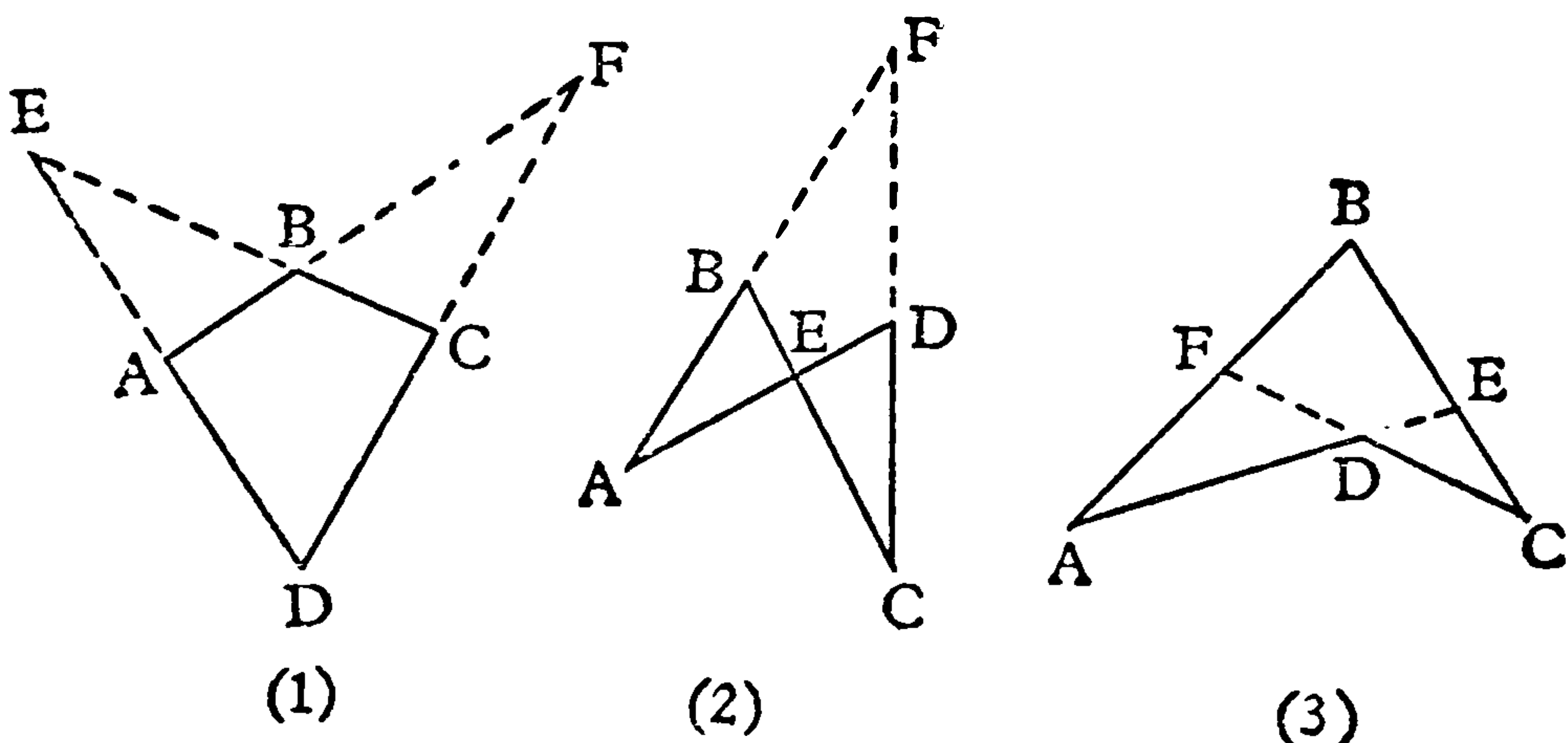

meaning of the rather loose proviso, *τὰ δὲ λοιπὰ πλὴν ἑνὸς ἄπτηται θέσει δεδομένης εὐθείας*. Applied to these figures, the enunciation states that if A, B, F are given, while the loci of C and D are straight lines, then the locus of E is also a straight line.

τεινομένου πλήθους ἀληθῆς ὑπάρχον οὕτως λεγόμενον· εἰάν ὅποσαιοῦν εὐθεῖαι τέμνωσιν ἀλλήλας, μὴ πλείονες ἢ δύο διὰ τοῦ αὐτοῦ σημείου, πάντα δὲ ἐπὶ μιᾶς αὐτῶν δεδομένα ἦ, καὶ τῶν ἐπὶ ἑτέρας ἕκαστον ἀπτηται θέσει δεδομένης εὐθείας, ἢ καθολικωτέραν οὕτως· εἰάν ὅποσαιοῦν εὐθεῖαι τέμνωσιν ἀλλήλας, μὴ πλείονες ἢ δύο διὰ τοῦ αὐτοῦ σημείου, πάντα δὲ τὰ ἐπὶ μιᾶς αὐτῶν σημεία δεδομένα ἦ, τῶν δὲ λοιπῶν τὸ πλήθος ἐχόντων τρίγωνον ἀριθμὸν ἢ πλευρὰ τούτου ἕκαστον ἔχη σημεῖον ἀπτόμενον εὐθείας θέσει δεδομένης, τῶν τριῶν μὴ πρὸς γωνίαις ὑπαρχόντων τριγώνου χωρίου, ἕκαστον λοιπὸν σημεῖον ἀψεται θέσει δεδομένης εὐθείας. τὸν δὲ Στοιχειωτὴν οὐκ εἰκὸς ἀγνοῆσαι τοῦτο, τὴν δ' ἀρχὴν μόνην τάξαι. . . .

Ἔχει δὲ τὰ τρία βιβλία τῶν Πορισμάτων λήματα $\lambda\eta$, αὐτὰ δὲ θεωρημάτων ἐστὶν $\overline{\rho\sigma\alpha}$.

^a Sc. a triangle having as its sides three of the given straight lines.

^b The meaning of this enunciation was discovered by Simson, and is given by Loria (*Le scienze esatte nell' antica Grecia*, p. 256 n. 3) as follows: "If a complete n -lateral be deformed so that its sides respectively turn about n points on a straight line, and $(n - 1)$ of its $\frac{1}{2}n(n - 1)$ vertices move each on a straight line, the remaining $\frac{1}{2}(n - 1)(n - 2)$ of its vertices likewise move on straight lines; provided that it is not possible to form with the $(n - 1)$ vertices any triangle having for sides the sides of the polygon." We may sympathize with the frank confession of Edmond Halley (*Apollonii Pergaei De sectione rationis*, p. xxxvii) that he could make no sense out of this passage.



THIS PAGE IS LOCKED TO FREE MEMBERS

Purchase full membership to immediately unlock this page

FORGOTTEN BOOKS

FULL

MEMBERSHIP

797,885 Books!

All you can read

for only

\$8.99/month

Continue

*Fair usage policy applies



GREEK MATHEMATICS

(e) THE CONICS

Papp. Coll. vii. 30-36, ed. Hultsch 672. 18-678. 24

Τὰ Εὐκλείδου βιβλία δὲ Κωνικῶν Ἀπολλώνιος ἀναπληρώσας καὶ προσθεῖς ἕτερα δὲ παρέδωκεν ἡ Κωνικῶν τεύχη. Ἀρισταῖος δέ, ὃς γέγραφε τὰ μέχρι τοῦ νῦν ἀναδιδόμενα στερεῶν τόπων τεύχη ἔστιν συνεχῆ τοῖς κωνικοῖς, ἐκάλει [καὶ οἱ πρὸ Ἀπολλωνίου]¹ τῶν τριῶν κωνικῶν γραμμῶν τὴν μὲν ὀξυγωνίου, τὴν δὲ ὀρθογωνίου, τὴν δὲ ἀμβλυγωνίου κώνου τομήν. . . . ὃν δὲ φησιν [sc. Ἀπολλώνιος] ἐν τῷ τρίτῳ τόπον ἐπὶ $\bar{\gamma}$ καὶ δὲ γραμμὰς μὴ τελειωθῆναι ὑπὸ Εὐκλείδου, οὐδ' ἂν αὐτὸς ἠδυνήθη οὐδ' ἄλλος οὐδεὶς ἄλλ' οὐδὲ μικρόν τι προσθεῖναι τοῖς ὑπὸ Εὐκλείδου γραφεῖσιν² διὰ γε μόνων τῶν προδεδειγμένων ἤδη κωνικῶν ἄχρι τῶν κατ' Εὐκλείδην, ὡς καὶ αὐτὸς μαρτυρεῖ λέγων ἀδύνατον εἶναι τελειωθῆναι, χωρὶς ὧν αὐτὸς προγράφει ἠναγκάσθη. ὁ δὲ Εὐκλείδης ἀποδεχόμενος τὸν Ἀρισταῖον ἄξιον ὄντα ἐφ' οἷς ἤδη παραδεδώκει κωνικοῖς, καὶ μὴ φθάσας ἢ μὴ θελήσας ἐπικαταβάλλεσθαι τούτων τὴν αὐτὴν πραγματείαν, ἐπιεικέστατος ὧν καὶ πρὸς ἅπαντας εὐμενῆς τοὺς καὶ κατὰ ποσὸν συναύξειν δυναμένους τὰ μαθήματα, ὡς δεῖ, καὶ μηδαμῶς προσκρουστικὸς ὑπάρχων, καὶ ἀκριβῆς μὲν οὐκ ἀλαζονικὸς δὲ καθάπερ οὗτος, ὅσον δυνατόν ἦν δεῖξαι τοῦ τόπου διὰ τῶν ἐκείνου

¹ καὶ οἱ πρὸ Ἀπολλωνίου del. Hultsch.

² ἄλλ' . . . γραφεῖσιν del. Hultsch.

• Euclid's *Conics* has not survived, but an idea of its contents can be obtained from Archimedes' references to propositions proved in the *Elements of Conics* (ἐν τοῖς κωνικοῖς 486

EUCLID

(e) THE CONICS ^a

Pappus, *Collection* vii. 30-36, ed. Hultsch 672. 18-678. 24

Apollonius, who completed the four books of Euclid's *Conics* and added another four, gave us eight books of *Conics*. Aristaeus, who wrote the still extant ^b five books of *Solid Loci* supplementary to the *Conics*, called the three conics sections of an acute-angled, right-angled and obtuse-angled cone respectively. . . . Apollonius says in his third book that the "locus with respect to three or four lines" had not been fully worked out by Euclid, and in fact neither Apollonius himself nor anyone else could have added anything to what Euclid wrote, using only those properties of conics which had been proved up to Euclid's time; as Apollonius himself bears witness when he says that the locus could not be fully investigated without the propositions that he had been compelled to work out for himself. Now Euclid regarded Aristaeus as deserving credit for his contributions to conics, and did not try to anticipate him or to overthrow his system; for he showed scrupulous fairness and exemplary kindness towards all who were able in any degree to advance mathematics, and was never offensive, but aimed at accuracy, and did not boast like the other. Accordingly he wrote so much about the locus as was possible by means of *στοιχείοις*), a term which would cover the treatises both of Aristaeus and of Euclid. The *Surface-Loci* and the *Porisms* of Euclid appear to have contained further developments in the theory of conics.

^b This has been taken to imply that Euclid's *Conics* was already lost when Pappus wrote. Nothing more is known of this Aristaeus, unless he is identical with the Aristaeus said by Hypsicles (Eucl. ed. Heiberg-Menge v. 6. 22-23) to have written a book called *Comparison of the Five Regular Solids*.

GREEK MATHEMATICS

Κωνικῶν ἔγραφεν, οὐκ εἰπὼν τέλος ἔχειν τὸ δεικνύμενον. τότε γὰρ ἦν ἀναγκαῖον ἐξελέγκειν, νῦν δ' οὐδαμῶς, ἐπεῖτοι καὶ αὐτὸς ἐν τοῖς Κωνικοῖς ἀτελῆ τὰ πλείστα καταλιπὼν οὐκ εὐθύνεται. προσθεῖναι δὲ τῷ τόπῳ τὰ λειπόμενα δεδύνηται προφαντασιωθεῖς τοῖς ὑπὸ Εὐκλείδου γεγραμμένοις ἤδη περὶ τοῦ τόπου καὶ συσχολάσας τοῖς ὑπὸ Εὐκλείδου μαθηταῖς ἐν Ἀλεξανδρείᾳ πλείστον χρόνον, ὅθεν ἔσχε καὶ τὴν τοιαύτην ἔξιν οὐκ ἀμαθῆ.

Οὗτος δὲ ὁ ἐπὶ γ καὶ δ γραμμᾶς τόπος, ἐφ' ᾧ μέγα φρονεῖ προσθεῖς χάριν ὀφείλειν εἰδέναί τῳ πρώτῳ γράψαντι, τοιοῦτός ἐστιν.¹ ἔαν γάρ, θέσει δεδομένων τριῶν εὐθειῶν, ἀπὸ τινος τοῦ αὐτοῦ² σημείου καταχθῶσιν ἐπὶ τὰς τρεῖς ἐν δεδομέναις γωνίαις εὐθείαι, καὶ λόγος ἦ δοθεῖς τοῦ ὑπὸ δύο κατηγμένων περιεχομένου ὀρθογωνίου πρὸς τὸ ἀπὸ τῆς λοιπῆς τετράγωνον, τὸ σημεῖον ἄψεται θέσει δεδομένου στερεοῦ τόπου, τουτέστιν μιᾶς τῶν τριῶν κωνικῶν γραμμῶν. καὶ ἔαν ἐπὶ δ εὐθείας θέσει δεδομένας καταχθῶσιν εὐθείαι ἐν δεδομέναις γωνίαις, καὶ λόγος ἦ δοθεῖς τοῦ ὑπὸ δύο κατηγμένων πρὸς τὸ ὑπὸ τῶν λοιπῶν δύο κατηγμένων, ὁμοίως τὸ σημεῖον ἄψεται θέσει δεδομένης κώνου τομῆς.

¹ ὁ δὲ Εὐκλείδης . . . τοιοῦτός ἐστιν “ scholiastae cuidam historiae quidem veterum mathematicorum non imperito, sed qui dicendi genere languido et inconcinno usus sit ” tribuit Hultsch.

² τοῦ αὐτοῦ del. Hultsch.

• The three-line locus is, of course, a particular example of the four-line locus. It seems clear that Apollonius himself did not have a complete solution of the four-line locus, but



THIS PAGE IS LOCKED TO FREE MEMBERS

Purchase full membership to immediately unlock this page

SAVE \$3,999,994

Did you know we sell
paperback books too?

To buy our entire catalog
in paperback would cost
over \$4,000,000

Access it all now for
\$8.99/month

*Fair usage policy applies

Continue

GREEK MATHEMATICS

Eucl. *Phaen.* Praef., Eucl. ed. Heiberg-Menge viii. 6. 5-7

Ἐὰν γὰρ κῶνος ἢ κύλινδρος ἐπιπέδῳ τμηθῆ μὴ παρὰ τὴν βάσιν, ἢ τομὴ γίγνεται ὀξυγωνίου κώνου τομῆ, ἣτις ἐστὶν ὁμοία θυρεῶ.

(f) THE SURFACE-LOCI

Papp. *Coll.* vii., ed. Hultsch 636. 23-24

Εὐκλείδου Τόπων τῶν πρὸς ἐπιφανείᾳ β̄.

Procl. *in Eucl.* i., ed. Friedlein 394. 16-395. 2

Καλῶ δὲ τοπικὰ μὲν, ὅσοις ταῦτὸν σύμπτωμα πρὸς ὄλῳ τινὶ τόπῳ συμβέβηκεν, τόπον δὲ γραμμῆς ἢ ἐπιφανείας θέσιν ποιούσαν ἐν καὶ ταῦτὸν σύμπτωμα. τῶν γὰρ τοπικῶν τὰ μὲν ἐστὶ πρὸς γραμμαῖς συνιστάμενα, τὰ δὲ πρὸς ἐπιφανείαις. καὶ ἐπειδὴ τῶν γραμμῶν αἱ μὲν εἰσὶν ἐπίπεδοι, αἱ δὲ στερεαί—ἐπίπεδοι μὲν, ὧν ἐν ἐπιπέδῳ ἀπλή ἢ νόησις, ὡς τῆς εὐθείας, στερεαὶ δέ, ὧν ἢ γένεσις ἔκ τινος τομῆς ἀναφαίνεται στερεοῦ σχήματος, ὡς τῆς κυλινδρικής ἔλικος καὶ τῶν κωνικῶν γραμμῶν

by the first two lines so drawn to the square on the third line is constant. For a solution and full discussion of the four-line locus, reference should be made to Zeuthen, *Die Lehre von den Kegelschnitten im Altertum*, pp. 126 ff., or Heath, *Apollonius of Perga*, pp. cxxxviii-cl.

* Euclid's *Phenomena* is an astronomical work largely based on two treatises by Autolycus of Pitane (c. 315-240 B.C.) which are also extant.

† Menaechmus is believed to have discovered the conic sections as sections of a right-angled, acute-angled and obtuse-angled cone respectively by a plane perpendicular

EUCLID

Euclid, Preface to *Phenomena*,^a Eucl. ed. Heiberg-Menge
viii. 6. 5-7

If a cone or cylinder be cut by a plane not parallel to the base, the resulting section is a section of an acute-angled cone which is similar to a shield.^b

(f) THE SURFACE-LOCI

Pappus, *Collection* vii., ed. Hultsch 636. 23-24

Euclid's two books of *Surface-Loci*.^c

Proclus, *On Euclid* i., ed. Friedlein 394. 16-395. 2

I call locus-theorems those which deal with the same property throughout the whole of a locus, and a locus I call a position of a line or surface which has throughout one and the same property. Some locus-theorems are constructed on lines and others on surfaces. Furthermore, since lines may be plane or solid—plane being those which are simply generated in a plane, like the straight line, and solid those which are generated from some section of a solid figure, like the cylindrical helix or the conic sections

to a generating line. This passage shows that Euclid, at least, was also aware that an ellipse could be obtained as a section of a right cylinder by a plane not parallel to the base, and the fact may well have been known before his time; Heiberg (*Literär-geschichtliche Studien über Euklid*, p. 88) thinks that Menaechmus probably used *θυρεός* as the name for the ellipse.

^c This entry is taken from the list of books in Pappus's *Τόπος ἀναλυόμενος* (*Treasury of Analysis*). The work is lost, but we can conjecture what surface-loci were from remarks by Proclus and Pappus himself, and we can get some idea of the contents of Euclid's treatise from two lemmas given to it by Pappus.

GREEK MATHEMATICS

—φαίην ἂν καὶ τῶν πρὸς γραμμαῖς τοπικῶν τὰ μὲν ἐπίπεδον ἔχειν τόπον, τὰ δὲ στερεόν.

Papp. *Coll.* vii. 312-316, ed. Hultsch 1004. 16-1010. 15;
Eucl. ed. Heiberg-Menge viii. 274. 18-278. 15

Εἰς τοὺς πρὸς ἐπιφανείᾳ

α'. Ἐὰν ᾖ εὐθεία ἡ AB καὶ παρὰ θέσει ἡ $\Gamma\Delta$, καὶ ᾖ λόγος τοῦ ὑπὸ $A\Delta B$ πρὸς τὸ ἀπὸ $\Delta\Gamma$, τὸ Γ

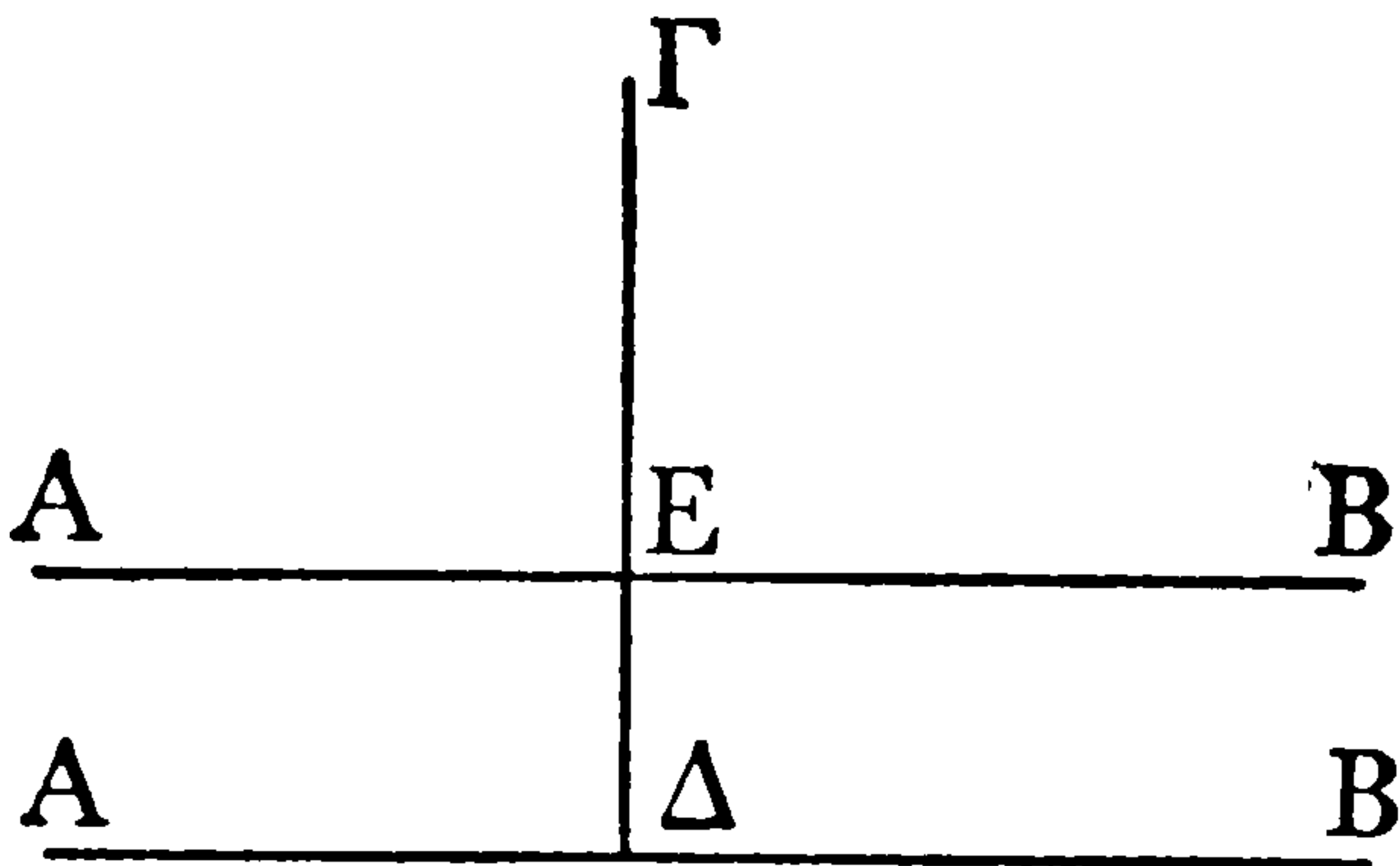

ἄπτεται κωνικῆς γραμμῆς. ἐὰν οὖν ᾖ μὲν AB στερηθῆ τῆς θέσεως, καὶ τὰ A, B στερηθῆ τοῦ δοθέντα¹ εἶναι, γένηται δὲ πρὸς θέσει εὐθείαις² ταῖς AE, EB , τὸ Γ μετεωρισθὲν γίνεται πρὸς θέσει ἐπιφανείᾳ. τοῦτο δὲ ἐδείχθη.

β'. Ἐὰν ᾖ θέσει εὐθεία ἡ AB καὶ δοθὲν τὸ Γ

¹ δοθέντα Heiberg, δοθέντος cod., Hultsch.

² εὐθείαις Tannery, εὐθεία cod.

* From this passage, confirmed by Eutocius, line-loci would appear to be loci which *are* lines, and surface-loci would seem to be loci which *are* surfaces. Pappus, in *Coll.* iv. 33, ed. Hultsch 258. 20-25, implies, however, that surface-loci are loci *traced on* surfaces, and he gives the cylindrical helix as an example of such a locus. Cf. *supra*, p. 348 n. a.



THIS PAGE IS LOCKED TO FREE MEMBERS

Purchase full membership to immediately unlock this page

FORGOTTEN BOOKS

FULL

MEMBERSHIP

797,885 Books!

All you can read

for only

\$8.99/month

Continue

*Fair usage policy applies



ἐν τῷ αὐτῷ ἐπιπέδῳ, καὶ διαχθῆ ἡ $\Delta\Gamma$, καὶ πρὸς ὀρθὰς¹ ἀχθῆ ἡ $\Delta\epsilon$, λόγος δὲ ἡ τῆς $\Gamma\Delta$ πρὸς $\Delta\epsilon$,

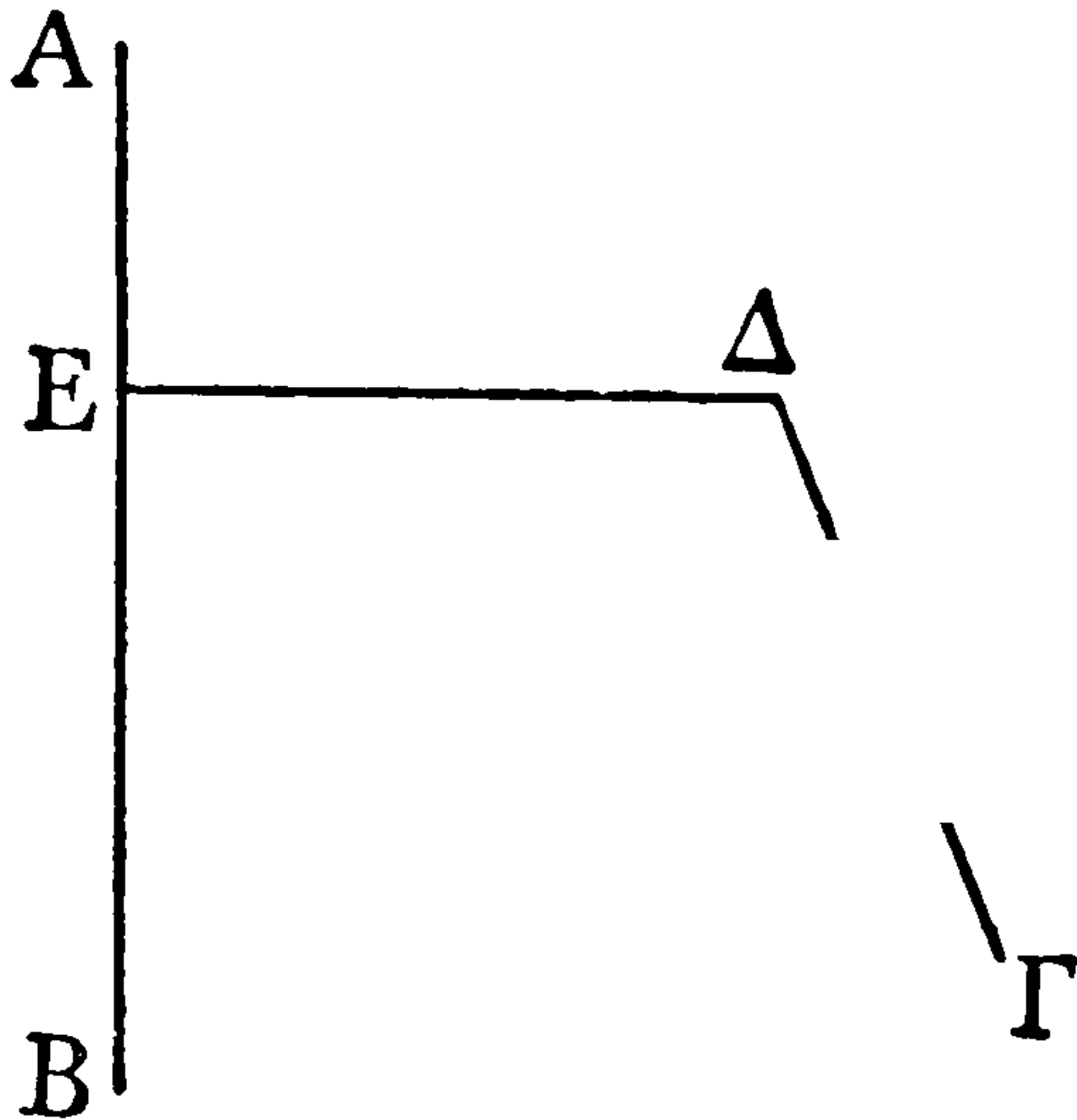

τὸ Δ ἄπτεται θέσει κωνικῆς τομῆς· δεικτέον² δέ, ὅτι γραμμῆς (μέρος ποιεῖ τὸν τόπον).³ δειχθήσεται δὲ οὕτως προγραφέντος τόπου⁴ τοῦδε.

γ'. Δύο δοθέντων τῶν A, B καὶ ὀρθῆς τῆς $\Gamma\Delta$ λόγος ἔστω τοῦ ἀπὸ $A\Delta$ πρὸς τὰ ἀπὸ $\Gamma\Delta, \Delta B$. λέγω, ὅτι τὸ Γ ἄπτεται κώνου τομῆς, εἴαν τε ἡ ὁ λόγος ἴσος πρὸς ἴσον ἢ μείζων πρὸς ἐλάσσονα ἢ ἐλάσσων πρὸς μείζονα.

Ἔστω γὰρ πρότερον ὁ λόγος ἴσος πρὸς ἴσον. καὶ ἐπεὶ ἴσον ἐστὶν τὸ ἀπὸ $A\Delta$ τοῖς ἀπὸ $\Gamma\Delta, \Delta B$, κείσθω τῇ $B\Delta$ ἴση ἡ $\Delta\epsilon$. ἴσον ἄρα ἐστὶ τὸ ὑπὸ $BA\epsilon$ τῷ ἀπὸ $\Delta\Gamma$. τετμήσθω δίχα ἡ AB τῷ Z .

¹ πρὸς ὀρθὰς Hultsch, παρὰ θέσει cod.

² δεικτέον Hultsch in adn., δείκνυται cod.

³ μέρος ποιεῖ τὸν τόπον add. Gerhardt, Hultsch.

⁴ τόπου "immo τοῦ λήμματος" Hultsch.

of being given . . ." The text leaves it uncertain whether, when AB is no longer given in position, it remains constant

the point Γ be given in the same plane, and $\Delta\Gamma$ be drawn, and ΔE be drawn perpendicular [to the given straight line AB], and if the ratio $\Gamma\Delta : \Delta E$ be given, the point Δ will lie on a conic section.^a But it must be shown that part of the curve forms the locus. This will be proved as follows by means of this lemma.

3. Given ^b the two points A, B and the perpendicular $\Gamma\Delta$, let the ratio $A\Delta^2 : \Gamma\Delta^2 + \Delta B^2$ be given. I say that the point Γ lies on a conic section, whether the ratio be of equal to equal, or greater to less, or less to greater.

For in the first place let the ratio be of equal to equal. Since $A\Delta^2 = \Gamma\Delta^2 + \Delta B^2$, let ΔE be made equal to $B\Delta$.

Then	$[BA \cdot AE + E\Delta^2 = A\Delta^2$	[Eucl. ii. 6
	$= \Gamma\Delta^2 + \Delta B^2$	[<i>ex. hyp.</i> ,
and so]	$BA \cdot AE$	$= \Gamma\Delta^2.$

in length or varies. Zeuthen conjectures that two cases were considered by Euclid: (1) AB remains of constant length, while AE, EB are parallel instead of meeting in a point; and (2) AE, EB meet in a point and AB always moves parallel to itself, so varying in length. In the former case Γ lies on the surface described by a conic section moving bodily, in the latter case the surface is a cone.

^a This is the definition of a conic in terms of its focus and directrix, AB being the directrix, Γ the focus, Δ any point on the curve, and the ratio $\Gamma\Delta : \Delta E$ the eccentricity of the conic. Since Pappus proves this property for all three conics by transforming it to the more familiar axial form, it must have been assumed by Euclid without proof, and was presumably first demonstrated by Aristaeus. This is all the more remarkable as the focus-directrix property is nowhere mentioned by Apollonius, and, indeed, is found in only two other places in the whole of the Greek mathematical writings, *v. supra*, p. 362 n. a.

^b Diagram on p. 496.

δοθέν ἄρα τὸ Z . καὶ ἔσται διπλῆ ἡ AE τῆς $Z\Delta$
 ὥστε τὸ ὑπὸ BAE τὸ δῖς ἔστιν ἑπτάων $AB, Z\Delta$.

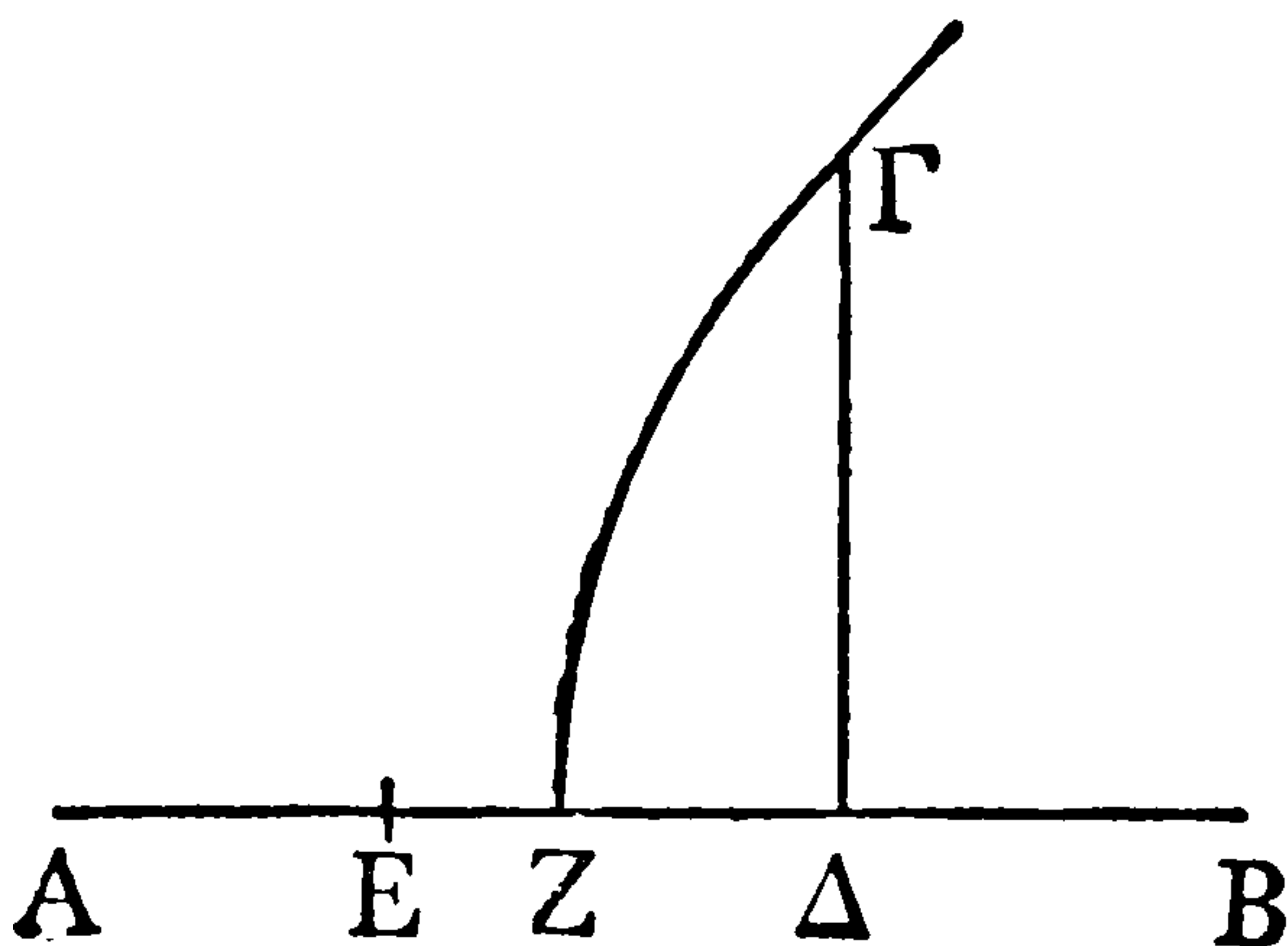

καὶ ἔστιν ἡ διπλῆ τῆς AB δουθεῖσα· τὸ ἄρα ὑπὸ
 δοθείσης καὶ τῆς $Z\Delta$ ἴσον ἔστιν τῷ ἀπὸ τῆς $\Delta\Gamma$.
 τὸ Γ ἄρα ἄπτεται θέσει παραβολῆς ἐρχομένης
 διὰ τοῦ Z .

δ'. Συντεθήσεται δὴ ὁ τόπος οὕτως·

Ἐστω τὰ δοθέντα A, B , ὁ δὲ λόγος ἔστω ἴσος
 πρὸς ἴσον, καὶ τετμήσθω ἡ AB δίχα τῷ Z , τῆς
 δὲ AB διπλῆ ἔστω ἡ Γ , καὶ θέσει οὔσης εὐθείας
 τῆς ZB πεπερασμένης κατὰ τὸ Z , τῆς δὲ P δεδο-
 μένης τῷ μεγέθει, γεγράφθω περιᾶξονα τὸν ZB
 παραβολὴ ἡ HZ , ὥστε, οἷον εἰς ἐπ' αὐτῆς
 σημεῖον ληφθῆ ὡς τὸ Γ , κάθετος δὲ ἀχθῆ ἡ $\Gamma\Delta$,
 ἴσον εἶναι τὸ ὑπὸ $P, Z\Delta$, τῷ ἀπὸ $\Delta\Gamma$. καὶ
 ἤχθω ὀρθὴ ἡ BH . λέγω, ὅτι τὸ ΓH μέρος τῆς
 παραβολῆς ἔστιν.¹

ἤχθω γὰρ κάθετος ἡ $\Gamma\Delta$, καὶ τῇ $B\Delta$ ἴση κείσθω
 ἡ ΔE . ἐπεὶ οὖν διπλῆ ἔστιν ἡ μὲν AB τῆς BZ ,
 ἡ δὲ EB τῆς $B\Delta$, διπλῆ ἄρα καὶ ἡ AE τῆς $Z\Delta$. τὸ
 ἄρα ὑπὸ BAE ἴσον ἔστιν τῷ δῖς ὑπὸ τῶν AB ,



THIS PAGE IS LOCKED TO FREE MEMBERS

Purchase full membership to immediately unlock this page

SAVE \$3,999,994

Did you know we sell
paperback books too?

To buy our entire catalog
in paperback would cost
over \$4,000,000

Access it all now for
\$8.99/month

*Fair usage policy applies

Continue

GREEK MATHEMATICS

$Z\Delta$, τουτέστιν τῷ ἀπὸ $\Delta\Gamma$. κοινὸν προσκείσθω τὸ ἀπὸ $E\Delta$ ἴσον ὄν τῷ ἀπὸ ΔB . ὅλον ἄρα τὸ ἀπὸ

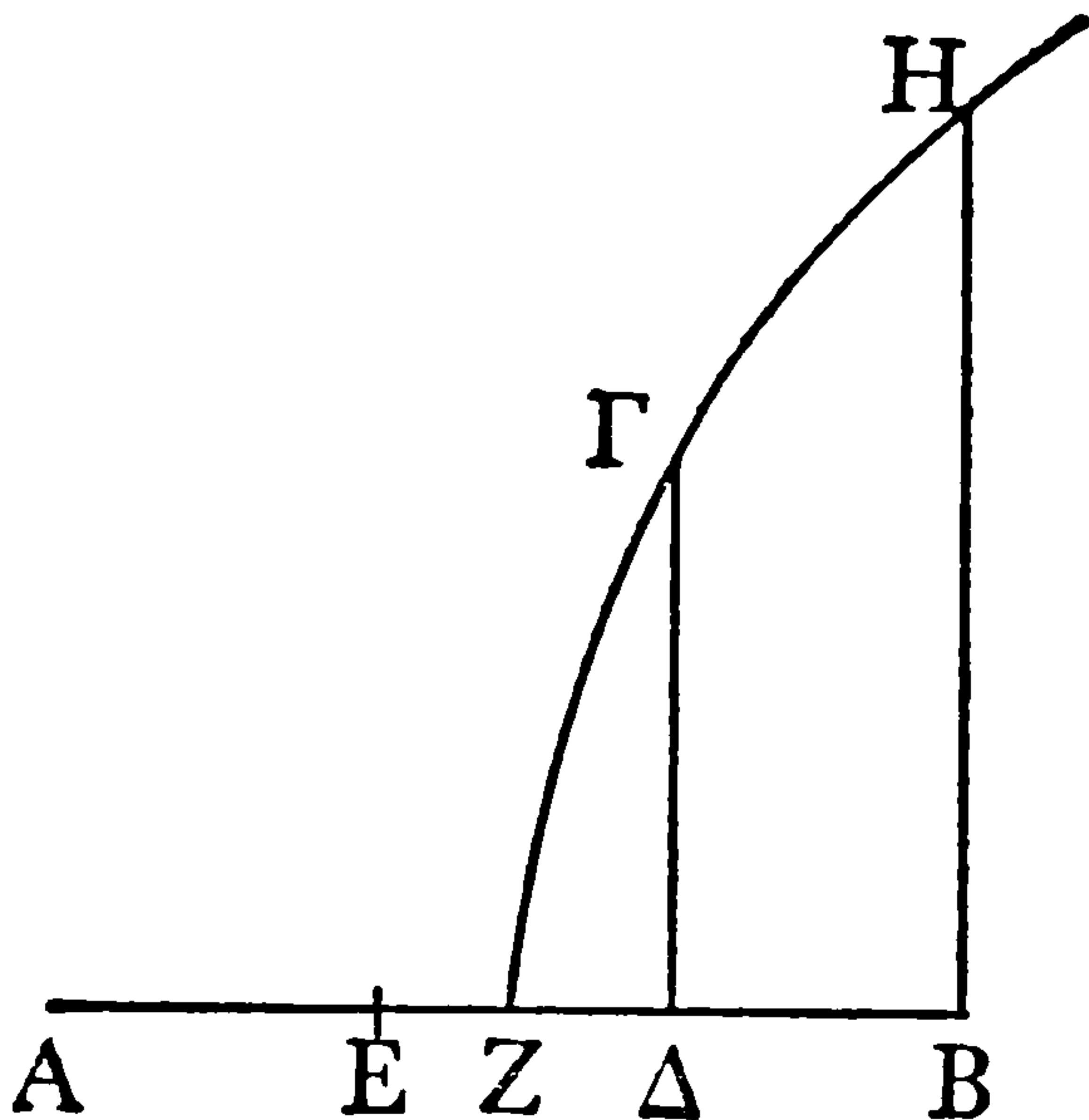

P

$A\Delta$ ἴσον ἐστὶν τοῖς ἀπὸ τῶν $\Gamma\Delta$, ΔB . ἡ $Z\Gamma H$ ἄρα γραμμὴ ποιεῖ τὸν τόπον.

ε'. Ἐστω δὴ πάλιν τὰ δύο δοθέντα σημεία τὰ A , B , καὶ εὐθειᾶ τε ἡ $\Delta\Gamma$ καὶ ὀρθή,¹ λόγος δὲ ἔστω τοῦ ἀπὸ $A\Delta$ πρὸς τὰ ἀπὸ $B\Delta$, $\Delta\Gamma$ ἐπὶ μὲν τῆς πρώτης πτώσεως μείζων πρὸς ἐλάσσονα,² ἐπὶ δὲ τῆς δευτέρας ἐλάσσων πρὸς μείζονα³. λέγω, ὅτι τὸ Γ ἄπτεται κώνου τομῆς, ἐπὶ μὲν τῆς πρώτης πτώσεως ἐλλείψεως, ἐπὶ δὲ τῆς δευτέρας ὑπερβολῆς.

Ἐπεὶ γὰρ λόγος ἐστὶν τοῦ ἀπὸ $A\Delta$ πρὸς τὰ ἀπὸ $B\Delta$, $\Delta\Gamma$, ὁ αὐτὸς αὐτῷ γεγονέτω ὁ τοῦ ἀπὸ $E\Delta$

EUCLID

Let the equals $E\Delta^2$, ΔB^2 be added to either side ;

then $\quad [BA \cdot AE + E\Delta^2 = \Gamma\Delta^2 + \Delta B^2$

and so] $\quad A\Delta^2 = \Gamma\Delta^2 + \Delta B^2. \quad [\text{Eucl. ii. 6}$

Therefore the curve $Z\Gamma H$ forms the locus.

5. Again, let the two given points be A , B , and let $\Delta\Gamma$ be a perpendicular straight line, and let the ratio $A\Delta^2 : B\Delta^2 + \Delta\Gamma^2$ be in the first case the ratio of a greater to a less, and in the second case of a less to a greater. I say, that the point Γ lies on a conic section, which is in the first case an ellipse and in the second case a hyperbola.^a

Since the given ratio is $A\Delta^2 : B\Delta^2 + \Gamma\Delta^2$, let $[E$ be taken on AB so that] $E\Delta^2 : \Delta B^2$ be in the same

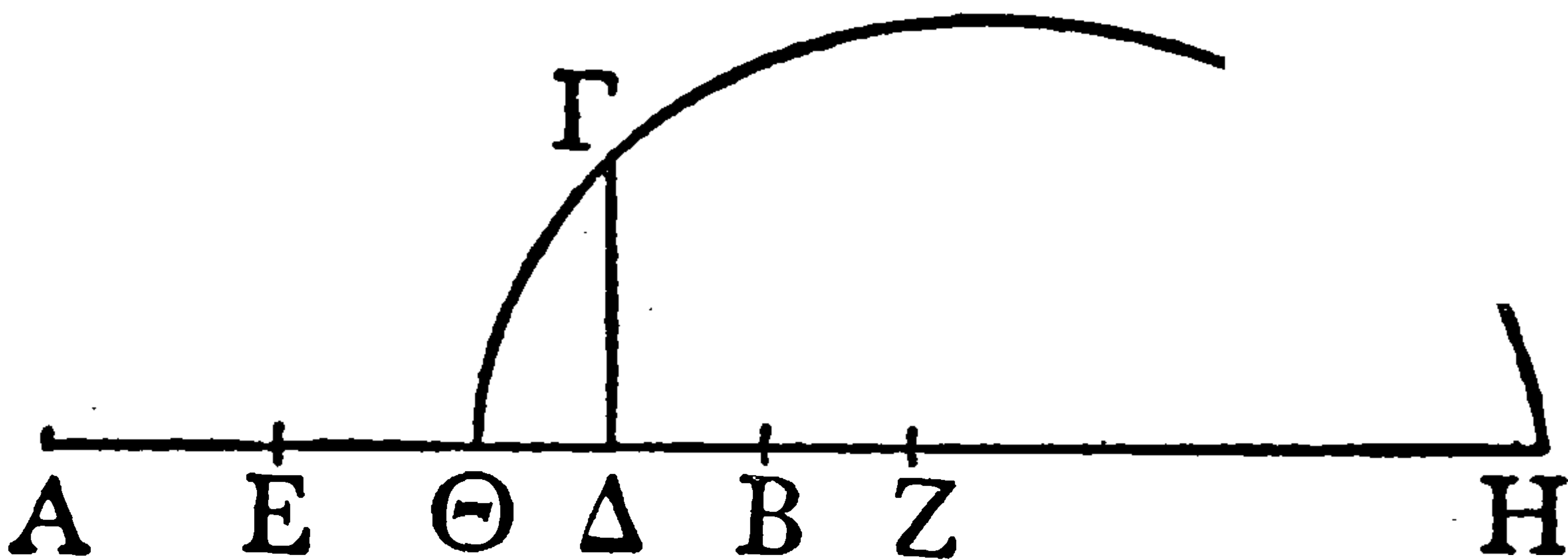

^a The Greek text from this point onwards is unsatisfactory, and contains mathematical errors which Commandinus and Hultsch corrected. The demonstration also leaves many gaps which I have filled, again following those commentators.

¹ εὐθείᾳ τε ἢ $\Delta\Gamma$ καὶ ὀρθῇ Heiberg ; κατήχθω ὀρθῇ ἢ $\Delta\Gamma$, Commandinus, Hultsch ; ἐφάπτεται ἢ $\Delta\Gamma$ καὶ ὀρθῇ cod.

² μείζων πρὸς ἐλάσσονα Hultsch, ἐλάσσων πρὸς μείζονα cod.

³ ἐλάσσων πρὸς μείζονα Hultsch, μείζων πρὸς ἐλάσσονα cod.

⁴ $E\Delta$ Hultsch, $B\Delta$ cod.

πρὸς τὸ ἀπὸ ΔΒ.¹ ἐπὶ μὲν οὖν τῆς πρώτης πτώσεως ἐλάσσων ἐστὶν ἡ ΒΔ τῆς ΔΕ, ἐπὶ δὲ τῆς

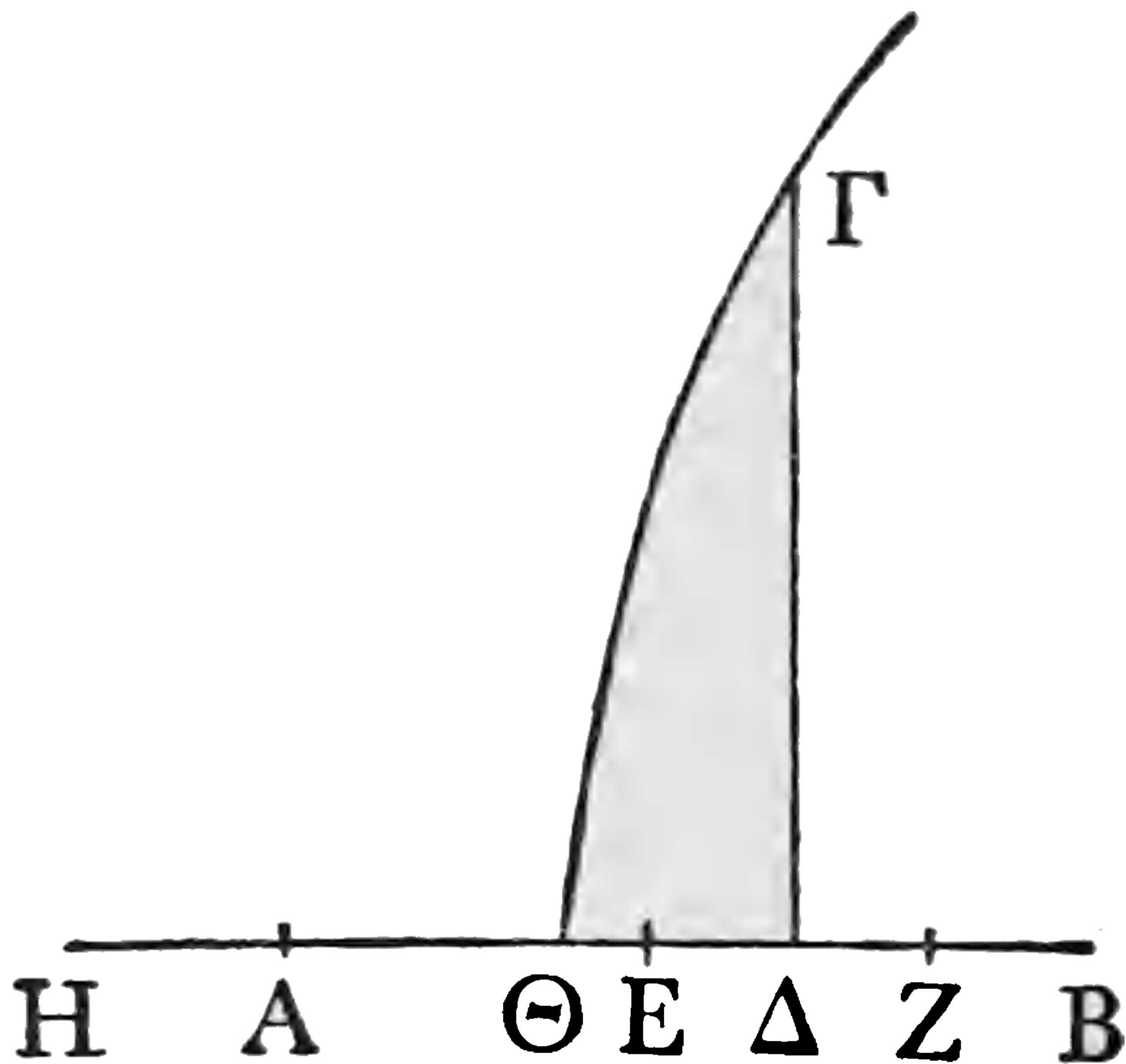

δευτέρας μείζων ἐστὶν ἡ ΒΔ τῆς ΔΕ. κείσθω οὖν τῇ ΕΔ ἴση ἡ ΔΖ. ἐπεὶ λόγος ἐστὶν τοῦ ἀπὸ ΑΔ πρὸς τὰ ἀπὸ ΓΔ, ΔΒ, καὶ ἐστὶν αὐτῶ ὁ αὐτὸς ὁ τοῦ ἀπὸ ΕΔ πρὸς τὸ ἀπὸ ΔΒ, καὶ λοιπὸς ἄρα τοῦ ὑπὸ ΖΑΕ πρὸς τὸ ἀπὸ ΔΓ λόγος ἐστὶν δοθείς. ἐπεὶ δὲ λόγος ἐστὶν τῆς ΕΔ πρὸς ΔΒ [καὶ τῆς ΖΔ πρὸς ΔΒ]² καὶ τῆς ΖΒ πρὸς ΒΔ, ὁ αὐτὸς αὐτῶ γεγονέτω ὁ τῆς ΑΒ πρὸς ΒΗ. καὶ ὅλης ἄρα τῆς ΑΖ πρὸς ΔΗ λόγος ἐστὶν δοθείς. πάλιν, ἐπεὶ λόγος ἐστὶν τῆς ΕΔ πρὸς ΔΒ δοθείς, [καὶ τῆς ΕΒ ἄρα πρὸς ΒΔ λόγος ἐστὶν δοθείς].³ ὁ αὐτὸς αὐτῶ γεγονέτω ὁ τῆς ΑΘ⁴ πρὸς ΒΘ. λόγος ἄρα καὶ τῆς ΑΒ πρὸς ΒΘ ἐστὶν δοθείς. [δοθὲν ἄρα τὸ Θ].⁵ καὶ λοιπὸς τῆς ΑΕ πρὸς ΘΔ λόγος ἐστὶν δοθείς. καὶ τοῦ ὑπὸ ΖΑΕ ἄρα πρὸς τὸ ὑπὸ ΘΔΗ λόγος ἐστὶν δοθείς. τοῦ δὲ ὑπὸ ΖΑΕ πρὸς τὸ ἀπὸ ΓΔ λόγος ἐστὶν δοθείς. καὶ τοῦ ὑπὸ ΗΔΘ ἄρα πρὸς τὸ ἀπὸ

¹ ΔΒ Hultsch, ΔΕ cod.

² καὶ . . . πρὸς ΔΒ del. Hultsch.



THIS PAGE IS LOCKED TO FREE MEMBERS

Purchase full membership to immediately unlock this page

FORGOTTEN BOOKS

FULL

MEMBERSHIP

797,885 Books!

All you can read

for only

\$8.99/month

Continue

*Fair usage policy applies



GREEK MATHEMATICS

$\Delta\Gamma$ λόγος ἐστὶν δοθείς. καὶ ἐστὶν δύο δοθέντα τὰ Θ , H . ἐπὶ μὲν ἄρα τῆς πρώτης πτώσεως τὸ Γ ἄπτεται ἐλλείψεως, ἐπὶ δὲ τῆς δευτέρας ὑπερβολῆς.

(g) THE OPTICS

Eucl. *Optic.* 8, Eucl. ed. Heiberg-Menge vii. 14. 1-16. 5

Τὰ ἴση μεγέθη καὶ παράλληλα ἄνισον διεστηκότα ἀπὸ τοῦ ὀφθαλμοῦ οὐκ ἀναλόγως τοῖς διαστήμασιν ὁράται.

Ἔστω δύο μεγέθη τὰ AB , $\Gamma\Delta$ ἄνισον διεστηκότα ἀπὸ τοῦ ὀφθαλμοῦ τοῦ E . λέγω, ὅτι οὐκ ἐστὶν, ὡς

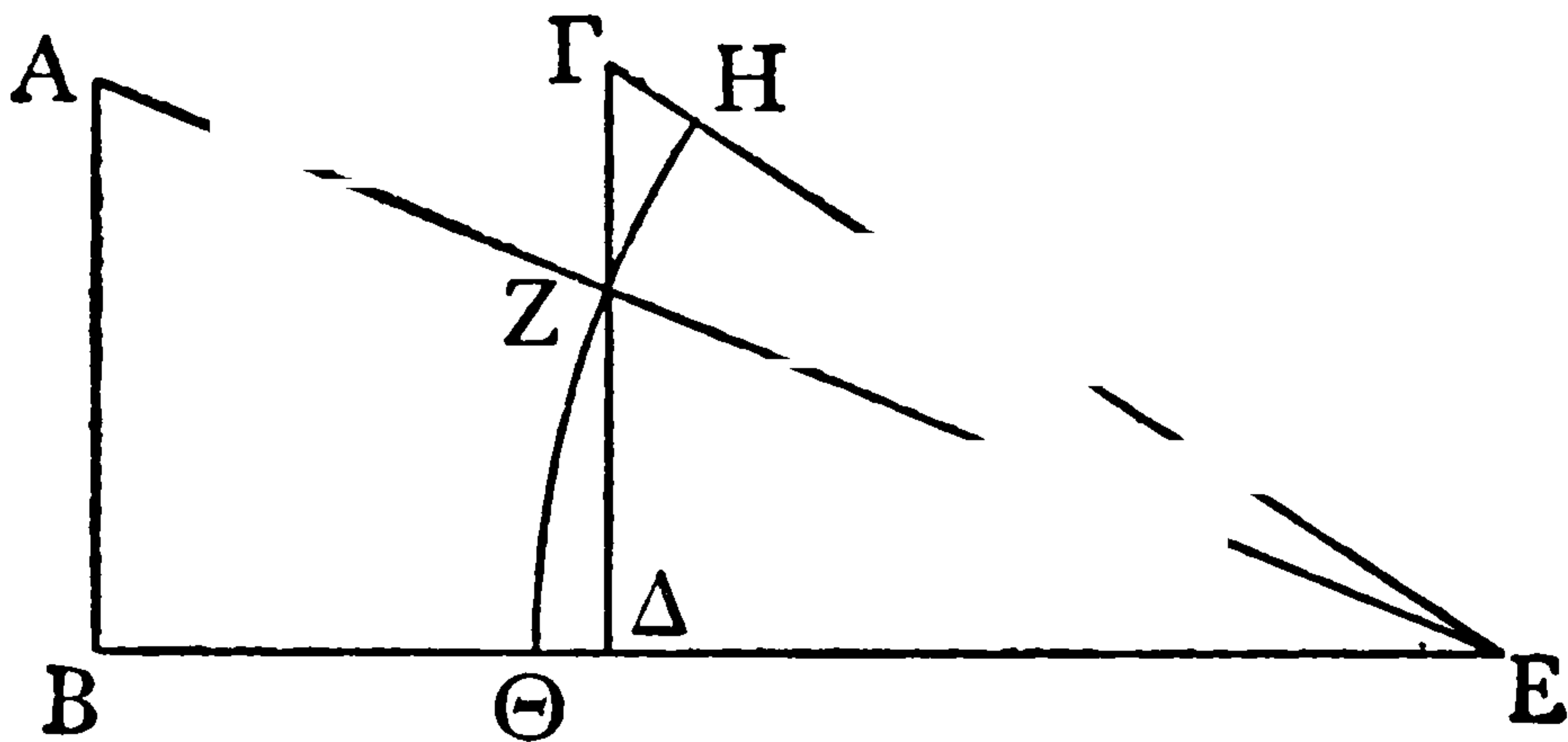

φαίνεται ἔχον, ὡς τὸ $\Gamma\Delta$ πρὸς τὸ AB , οὕτως τὸ BE πρὸς τὸ $E\Delta$. προσπιπτέτωσαν γὰρ ἀκτῖνες αἱ AE , $E\Gamma$, καὶ κέντρῳ μὲν τῷ E διαστήματι δὲ τῷ EZ κύκλου γεγράφθω περιφέρεια ἡ $HZ\Theta$. ἐπεὶ οὖν τὸ $EZ\Gamma$ τρίγωνον τοῦ EZH τομέως μείζον ἐστὶν, τὸ δὲ $EZ\Delta$ τρίγωνον τοῦ $EZ\Theta$ τομέως ἔλαττόν ἐστιν, τὸ $EZ\Gamma$ ἄρα τρίγωνον πρὸς τὸν

^a Pappus proceeds to make the formal synthesis, as in the case of the parabola, and then formally proves his original

EUCLID

$A\theta : B\theta = E\Delta : \Delta B$, therefore] the points H, θ are also given. [Therefore in the first case $H\theta$ is the diameter of an ellipse, in the second it is the diameter of a hyperbola; and] therefore the point Γ lies in the first case on an ellipse, in the second on a hyperbola.^a

(g) THE OPTICS ^b

Euclid, *Optics* 8, Eucl. ed. Heiberg-Menge vii. 14. 1–16. 5

The apparent sizes of equal and parallel magnitudes at unequal distances from the eye are not proportional to those distances.

Let $AB, \Gamma\Delta$ be the two magnitudes at unequal distances from the eye, E . I say that the ratio of the apparent size of $\Gamma\Delta$ to the apparent size of AB is not equal to the ratio of BE to $E\Delta$. For let the rays $AE, E\Gamma$ fall,^c and with centre E and radius EZ let the arc of a circle, $HZ\theta$, be drawn. Then since the triangle $EZ\Gamma$ is greater than the sector EZH , while the triangle $EZ\Delta$ is less than the sector $EZ\theta$, therefore

proposition in the case where the locus is a parabola; the proof where the locus is an ellipse or hyperbola has been lost, but can easily be supplied.

^b Euclid's *Optics* exists in two recensions, both contained in vol. vii. of the Heiberg-Menge edition of Euclid's works. One is the recension of Theon, but Heiberg discovered in Viennese and Florentine mss. an earlier and markedly different recension, and there is every reason to believe it is Euclid's own work; it is from this earlier text that the proposition here quoted is given. The *Optics* is an elementary treatise on perspective. It is based on some false physical hypotheses, but has some interesting mathematical theorems.

^c Euclid, like Plato, believed [*Optics*, Def. 1] that rays of light proceed from the eye to the object, and not from the object to the eye.

ΕΖΗ τομέα μείζονα λόγον ἔχει ἤπερ τὸ ΕΖΔ τρίγωνον πρὸς τὸν ΕΖΘ τομέα. καὶ ἐναλλάξ τὸ ΕΖΓ τρίγωνον πρὸς τὸ ΕΖΔ τρίγωνον μείζονα λόγον ἔχει ἤπερ ὁ ΕΖΗ τομεὺς πρὸς τὸν ΕΖΘ τομέα, καὶ συνθέντι τὸ ΕΓΔ τρίγωνον πρὸς τὸ ΕΖΔ τρίγωνον μείζονα λόγον ἔχει ἤπερ ὁ ΕΗΘ τομεὺς πρὸς τὸν ΕΖΘ τομέα. ἀλλ' ὡς τὸ ΕΔΓ πρὸς τὸ ΕΖΔ τρίγωνον, οὕτως ἡ ΓΔ πρὸς τὴν ΔΖ. ἡ δὲ ΓΔ τῇ ΑΒ ἐστὶν ἴση, καὶ ὡς ἡ ΑΒ πρὸς τὴν ΔΖ, ἡ ΒΕ πρὸς τὴν ΕΔ. ἡ ΒΕ ἄρα πρὸς τὴν ΕΔ μείζονα λόγον ἔχει ἤπερ ὁ ΕΗΘ τομεὺς πρὸς τὸν ΕΖΘ τομέα. ὡς δὲ ὁ τομεὺς πρὸς τὸν τομέα, οὕτως ἡ ὑπὸ ΗΕΘ γωνία πρὸς τὴν ὑπὸ ΖΕΘ γωνίαν. ἡ ΒΕ ἄρα πρὸς τὴν ΕΔ μείζονα λόγον ἔχει ἤπερ ἡ ὑπὸ ΗΕΘ γωνία πρὸς τὴν ὑπὸ ΖΕΘ. • καὶ ἐκ μὲν τῆς ὑπὸ ΗΕΘ γωνίας βλέπεται τὸ ΓΔ, ἐκ δὲ τῆς ὑπὸ ΖΕΘ τὸ ΑΒ. οὐκ ἀνάλογον ἄρα τοῖς ἀποστήμασιν ὁράται τὰ ἴσα μεγέθη.

• This is equivalent, of course, to saying that

$$\frac{\tan \text{HE}\Theta}{\tan \text{ZE}\Theta} > \frac{\text{angle ZE}\Theta}{\text{angle HE}\Theta},$$

a well-known theorem in trigonometry; the full expression



THIS PAGE IS LOCKED TO FREE MEMBERS

Purchase full membership to immediately unlock this page

SAVE \$3,999,994

Did you know we sell
paperback books too?

To buy our entire catalog
in paperback would cost
over \$4,000,000

Access it all now for
\$8.99/month

*Fair usage policy applies

Continue

**PRINTED IN GREAT BRITAIN
BY ROBERT MACLEHOSE AND CO. LTD
THE UNIVERSITY PRESS, GLASGOW**

THE LOEB CLASSICAL LIBRARY

VOLUMES ALREADY PUBLISHED

Latin Authors

- AMMIANUS MARCELLINUS. Translated by J. C. Rolfe. 3 Vols.
(2nd Imp. revised.)
- APULEIUS: THE GOLDEN ASS (METAMORPHOSES). W. Adlington
(1566). Revised by S. Gaselee. (7th Imp.)
- ST. AUGUSTINE: CITY OF GOD. 7 vols. Vol. I, G. H. McCracken.
ST. AUGUSTINE, CONFESSIONS OF. W. Watts (1631). 2 Vols. (Vol. I.
7th Imp., Vol. II. 6th Imp.)
- ST. AUGUSTINE, SELECT LETTERS. J. H. Baxter. (2nd Imp.)
- AUSONIUS. H. G. Evelyn White. 2 Vols. (2nd Imp.)
- BEDE. J. E. King. 2 Vols. (2nd Imp.)
- BOETHIUS: TRACTS and DE CONSOLATIONE PHILOSOPHIAE. Rev.
H. F. Stewart and E. K. Rand. (6th Imp.)
- CAESAR: ALEXANDRIAN, AFRICAN and SPANISH WARS. A. G. Way.
- CAESAR: CIVIL WARS. A. G. Peskett. (5th Imp.)
- CAESAR: GALLIC WAR. H. J. Edwards. (10th Imp.)
- CATO: DE RE RUSTICA; VARRO: DE RE RUSTICA. H. B. Ash and
W. D. Hooper. (3rd Imp.)
- CATULLUS. F. W. Cornish; TIBULLUS. J. B. Postgate; PER-
VIGILIUM VENERIS. J. W. Mackail. (12th Imp.)
- CELSUS: DE MEDICINA. W. G. Spencer. 3 Vols. (Vol. I. 3rd Imp.
revised, Vols. II. and III. 2nd Imp.)
- CICERO: BRUTUS, and ORATOR. G. L. Hendrickson and H. M.
Hubbell. (3rd Imp.)
- [CICERO]: AD HERENNIUM. H. Caplan.
- CICERO: DE FATO; PARADOXA STOICORUM; DE PARTITIONE
ORATORIA. H. Rackham (With De Oratore, Vol. II.) (2nd Imp.)
- CICERO: DE FINIBUS. H. Rackham. (4th Imp. revised.)
- CICERO: DE INVENTIONE, etc. H. M. Hubbell.
- CICERO: DE NATURA DEORUM and ACADEMICA. H. Rackham.
(2nd Imp.)
- CICERO: DE OFFICIIS. Walter Miller. (6th Imp.)
- CICERO: DE ORATORE. 2 Vols. E. W. Sutton and H. Rackham.
(2nd Imp.)
- CICERO: DE REPUBLICA and DE LEGIBUS. Clinton W. Keyes.
(4th Imp.)
- CICERO: DE SENECTUTE, DE AMICITIA, DE DIVINATIONE. W. A.
Falconer. (6th Imp.)
- CICERO: IN CATALINAM, PRO FLACCO, PRO MURENA, PRO SULLA.
Louis E. Lord. (3rd Imp. revised.)
- CICERO: LETTERS TO ATTICUS. E. O. Winstedt. 3 Vols. (Vol. I.
6th Imp., Vols. II and III. 4th Imp.)

- CICERO : LETTERS TO HIS FRIENDS. W. Glynn Williams. 3 Vols.
(Vols. I. and II. 3rd Imp., Vol. III. 2nd Imp. revised.)
- CICERO : PHILIPPICS. W. C. A. Ker. (3rd Imp. revised.)
- CICERO : PRO ARCHIA, POST REDITUM, DE DOMO, DE HARUSPICUM
RESPONSIS, PRO PLANCIO. N. H. Watts. (4th Imp.)
- CICERO : PRO CAECINA, PRO LEGE MANILIA, PRO CLUENTIO, PRO
RABIRIO. H. Grose Hodge. (3rd Imp.)
- CICERO : PRO MILONE, IN PISONEM, PRO SCAURO, PRO FONTEIO,
PRO RABIRIO POSTUMO, PRO MARCELLO, PRO LIGARIO, PRO REGE
DEIOTARO. N. H. Watts. (2nd Imp.)
- CICERO : PRO QUINCTIO, PRO ROSCIO AMERINO, PRO ROSCIO
COMOEDO, CONTRA RULLUM. J. H. Freese. (3rd Imp.)
- CICERO : TUSCULAN DISPUTATIONS. J. E. King. (4th Imp.)
- CICERO : VERRINE ORATIONS. L. H. G. GREENWOOD. 2 Vols.
(Vol. I. 3rd Imp., Vol. II. 2nd Imp.)
- CLAUDIAN. M. Platnauer. 2 Vols. (2nd Imp.)
- COLUMELLA : DE RE RUSTICA, DE ARBORIBUS. H. B. Ash, E. S.
Forster and E. Heffner. 3 Vols. (Vol. I. 2nd Imp.)
- CURTIUS, Q. : HISTORY OF ALEXANDER. J. C. Rolfe. 2 Vols. (2nd
Imp.)
- FLOBUS. E. S. Forster and CORNELIUS NEPOS. J. C. Rolfe. (2nd
Imp.)
- FRONTINUS : STRATAGEMS and AQUEDUCTS. C. E. Bennett and
M. B. McElwain. (Vol. I. 3rd Imp., Vol. II. 2nd Imp.)
- FRONTO : CORRESPONDENCE. C. R. Haines. 2 Vols. (Vol. I. 3rd
Imp., Vol. II. 2nd Imp.)
- GELLIUS. J. C. Rolfe. 3 Vols. (Vol. I. 3rd Imp., Vols. II. and
III. 2nd Imp.)
- HORACE : ODES and EPODES. C. E. Bennett. (14th Imp. revised.)
- HORACE : SATIRES, EPISTLES, ARS POETICA. H. R. Fairclough.
(9th Imp. revised.)
- JEROME : SELECTED LETTERS. F. A. Wright. (2nd Imp.)
- JUVENAL and PERSIUS. G. G. Ramsay. (7th Imp.)
- LIVY. B. O. Foster, F. G. Moore, Evan T. Sage, and A. C. Schlesinger.
14 Vols. Vols. I.-XIII. (Vol. I. 4th Imp., Vols. II., III., V., and
IX. 3rd Imp. ; Vols. IV., VI.-VIII., X.-XII. 2nd Imp. revised.)
- LUCAN. J. D. Duff. (3rd Imp.)
- LUCRETIUS. W. H. D. Rouse. (7th Imp. revised.)
- MARTIAL. W. C. A. Ker. 2 Vols. (Vol. I. 5th Imp., Vol. II. 4th
Imp. revised.)
- MINOR LATIN POETS : from PUBLILIUS SYRUS to RUTILIUS
NAMATIANUS, including GRATTIUS, CALPURNIUS SICULUS, NEMESI-
ANUS, AVLANUS, and others with "Aetna" and the "Phoenix."
J. Wight Duff and Arnold M. Duff. (3rd Imp.)
- OVID : THE ART OF LOVE AND OTHER POEMS. J. H. Mozley. (3rd
Imp.)
- OVID : FASTI. Sir James G. Frazer. (2nd Imp.)
- OVID : HEROIDES and AMORES. Grant Showerman. (5th Imp.)
- OVID : METAMORPHOSES. F. J. Miller. 2 Vols. (Vol. I. 10th Imp.,
Vol. II. 8th Imp.)
- OVID : TRISTIA and EX PONTO. A. L. Wheeler. (3rd Imp.)



THIS PAGE IS LOCKED TO FREE MEMBERS

Purchase full membership to immediately unlock this page

FORGOTTEN BOOKS

FULL

MEMBERSHIP

797,885 Books!

All you can read

for only

\$8.99/month

Continue

*Fair usage policy applies



Greek Authors

- ACHILLES TATIUS.** S. Gaselee. (*2nd Imp.*)
- AENEAS TACTICUS, ASCLEPIODOTUS and ONASANDER.** The Illinois Greek Club. (*2nd Imp.*)
- AESCHINES.** C. D. Adams. (*2nd Imp.*)
- AESCHYLUS.** H. Weir Smyth. 2 Vols. (Vol. I. *6th Imp.*, Vol. II. *5th Imp.*)
- ALCIPHON, AELIAN, PHILOSTRATUS LETTERS.** A. B. Benner and F. H. Fobes.
- ANDOCIDES, ANTIPHON.** Cf. MINOR ATTIC ORATORS.
- APOLLODORUS.** Sir James G. Frazer. 2 Vols. (Vol. I. *3rd Imp.*, Vol. II. *2nd Imp.*)
- APOLLONIUS RHODIUS.** R. C. Seaton. (*5th Imp.*)
- THE APOSTOLIC FATHERS.** Kirsopp Lake. 2 Vols. (Vol. I. *8th Imp.*, Vol. II. *6th Imp.*)
- APPIAN : ROMAN HISTORY.** Horace White. 4 Vols. (Vol. I. *4th Imp.*, Vols. II. and IV. *3rd Imp.*, Vol. III. *2nd Imp.*)
- ARATUS.** Cf. CALLIMACHUS.
- ARISTOPHANES.** Benjamin Bickley Rogers. 3 Vols. Verse trans. (*5th Imp.*)
- ARISTOTLE : ART OF RHETORIC.** J. H. Freese. (*3rd Imp.*)
- ARISTOTLE : ATHENIAN CONSTITUTION, EUDEMIAN ETHICS, VICES AND VIRTUES.** H. Rackham. (*3rd Imp.*)
- ARISTOTLE : GENERATION OF ANIMALS.** A. L. Peck. (*2nd Imp.*)
- ARISTOTLE : METAPHYSICS.** H. Tredennick. 2 Vols. (*3rd Imp.*)
- ARISTOTLE : METEOROLOGICA.** H. D. F. Lee.
- ARISTOTLE : MINOR WORKS.** W. S. Hett. On Colours, On Things Heard, On Physiognomies, On Plants, On Marvellous Things Heard, Mechanical Problems, On Indivisible Lines, On Situations and Names of Winds, On Melissus, Xenophanes, and Gorgias. (*2nd Imp.*)
- ARISTOTLE : NICOMACHEAN ETHICS.** H. Rackham. (*6th Imp. revised.*)
- ARISTOTLE : OECONOMICA and MAGNA MORALIA.** G. C. Armstrong ; (with Metaphysics, Vol. II.). (*3rd Imp.*)
- ARISTOTLE : ON THE HEAVENS.** W. K. C. Guthrie. (*3rd Imp. revised.*)
- ARISTOTLE : On Sophistical Refutations, On Coming to be and Passing Away, On the Cosmos.** E. S. Forster and D. J. Furley.
- ARISTOTLE : ON THE SOUL, PARVA NATURALIA, ON BREATH.** W. S. Hett. (*2nd Imp. revised.*)
- ARISTOTLE : ORGANON, CATEGORIES : On Interpretation, Prior Analytics.** H. P. Cooke and H. Tredennick. (*3rd Imp.*)
- ARISTOTLE : PARTS OF ANIMALS. A. L. Peck ; MOTION AND PROGRESSION OF ANIMALS.** E. S. Forster. (*3rd Imp. revised.*)
- ARISTOTLE : PHYSICS.** Rev. P. Wicksteed and F. M. Cornford. 2 Vols. (Vol. I. *2nd Imp.*, Vol. II. *3rd Imp.*)
- ARISTOTLE : POETICS and LONGINUS.** W. Hamilton Fyfe ; **DEMETRIUS ON STYLE.** W. Rhys Roberts. (*5th Imp. revised.*)
- ARISTOTLE : POLITICS.** H. Rackham. (*4th Imp. revised.*)
- ARISTOTLE : PROBLEMS.** W. S. Hett. 2 Vols. (*2nd Imp. revised.*)
- ARISTOTLE : RHETORICA AD ALEXANDRUM (with PROBLEMS. Vol. II.).** H. Rackham.

- ARRIAN : HISTORY OF ALEXANDER and INDICA. Rev. E. Iliffe Robson. 2 Vols. (Vol. I. *3rd Imp.*, Vol. II. *2nd Imp.*)
- ATHENAEUS : DEIPNOSOPHISTAE. C. B. Gulick. 7 Vols. (Vols. I., IV.-VII. *2nd Imp.*)
- ST. BASIL : LETTERS. R. J. Deferrari. 4 Vols. (*2nd Imp.*)
- CALLIMACHUS, Hymns and Epigrams, and LYCOPHRON. A. W. Mair ; ARATUS. G. R. Mair. (*2nd Imp.*)
- CLEMENT OF ALEXANDRIA. Rev. G. W. Butterworth. (*3rd Imp.*)
- COLLUTHUS. Cf. OPPIAN.
- DAPHNIS AND CHLOE. Thornley's Translation revised by J. M. Edmonds : and PARTHENIUS. S. Gaselee. (*4th Imp.*)
- DEMOSTHENES I : OLYNTHIACS, PHILIPPICS and MINOR ORATIONS. I.-XVII. and XX. J. H. Vince. (*2nd Imp.*)
- DEMOSTHENES II : DE CORONA and DE FALSA LEGATIONE. C. A. Vince and J. H. Vince. (*3rd Imp. revised.*)
- DEMOSTHENES III : MEIDIAS, ANDROTION, ARISTOCRATES, TIMOCRATES and ARISTOGEITON, I. and II. J. H. Vince. (*2nd Imp.*)
- DEMOSTHENES IV-VI : PRIVATE ORATIONS and IN NEAERAM. A. T. Murray. (Vol. IV. *2nd Imp.*)
- DEMOSTHENES VII : FUNERAL SPEECH, EROTIC ESSAY, EXORDIA and LETTERS. N. W. and N. J. DeWitt.
- DIO CASSIUS : ROMAN HISTORY. E. Cary. 9 Vols. (Vols. I. and II. *3rd Imp.*, Vols. III.-IX. *2nd Imp.*)
- DIO CHRYSOSTOM. J. W. Cohoon and H. Lamar Crosby. 5 Vols. Vols. I.-IV. *2nd Imp.*)
- DIODORUS SICULUS. 12 Vols. Vols. I.-VI. C. H. Oldfather. Vol. VII. C. L. Sherman. Vols. IX and X. R. M. Geer. (Vols. I.-IV. *2nd Imp.*)
- DIOGENES LAERTIUS. R. D. Hicks. 2 Vols. (Vol. I. *4th Imp.*, Vol. II. *3rd Imp.*)
- DIONYSIUS OF HALICARNASSUS : ROMAN ANTIQUITIES. Spelman's translation revised by E. Cary. 7 Vols. (Vols. I.-V. *2nd Imp.*)
- EPICETUS. W. A. Oldfather. 2 Vols. (*2nd Imp.*)
- EURIPIDES. A. S. Way. 4 Vols. (Vols. I. and II. *7th Imp.*, Vols. III. and IV. *6th Imp.*) Verse trans.
- EUSEBIUS : ECCLESIASTICAL HISTORY. Kirsopp Lake and J. E. L. Oulton. 2 Vols. (Vol. I. *3rd Imp.*, Vol. II. *4th Imp.*)
- GALEN : ON THE NATURAL FACULTIES. A. J. Brock. (*4th Imp.*)
- THE GREEK ANTHOLOGY. W. R. Paton. 5 Vols. (Vols. I. and II. *5th Imp.*, Vol. III. *4th Imp.*, Vols. IV and V. *3rd Imp.*)
- GREEK ELEGY AND IAMBUS with the ANACREONTEA. J. M. Edmonds. 2 Vols. (Vol. I. *3rd Imp.*, Vol. II. *2nd Imp.*)
- THE GREEK BUCOLIC POETS (THEOCRITUS, BION, MOSCHUS). J. M. Edmonds. (*7th Imp. revised.*)
- GREEK MATHEMATICAL WORKS. Ivor Thomas. 2 Vols. (*2nd Imp.*)
- HERODES. Cf. THEOPHRASTUS : CHARACTERS.
- HERODOTUS. A. D. Godley. 4 Vols. (Vols. I.-III. *4th Imp.*, Vol. IV. *3rd Imp.*)
- HESIOD AND THE HOMERIC HYMNS. H. G. Evelyn White. (*7th Imp. revised and enlarged.*)

- HIPPOCRATES and the FRAGMENTS OF HERACLEITUS. W. H. S. Jones and E. T. Withington. 4 Vols. (3rd Imp.)
- HOMER: ILLAD. A. T. Murray. 2 Vols. (Vol. I. 7th Imp., Vol. II. 6th Imp.)
- HOMER: ODYSSEY. A. T. Murray. 2 Vols. (8th Imp.)
- ISAEUS. E. W. Forster. (3rd Imp.)
- ISOCRATES. George Norlin and LaRue Van Hook. 3 Vols. (2nd Imp.)
- ST. JOHN DAMASCENE: BARLAAM AND IOASAPH. Rev. G. R. Woodward and Harold Mattingly. (3rd Imp. revised.)
- JOSEPHUS. H. St. J. Thackeray and Ralph Marcus. 9 Vols. Vols. I.-VII. (Vol. V. 3rd Imp., Vols. I.-IV., VI. and VII. 2nd Imp.)
- JULIAN. Wilmer Cave Wright. 3 Vols. (Vols. I. and II. 3rd Imp., Vol. III. 2nd Imp.)
- LUCIAN. A. M. Harmon. 8 Vols. Vols. I.-V. (Vols. I. and II. 4th Imp., Vol. III. 3rd Imp., Vols. IV and V. 2nd Imp.)
- LYCOPHRON. Cf. CALLIMACHUS.
- LYRA GRAECA. J. M. Edmonds. 3 Vols. (Vol. I. 4th Imp., Vol. II. revised and enlarged, and III. 3rd Imp.)
- LYSIAS. W. R. M. Lamb. (2nd Imp.)
- MANETHO. W. G. Waddell: PTOLEMY: TETRABIBLOS. F. E. Robbins. (2nd Imp.)
- MARCUS AURELIUS. C. R. Haines. (4th Imp revised.)
- MENANDER. F. G. Allinson. (3rd Imp. revised)
- MINOR ATTIC ORATORS (ANTIPHON, ANDOCIDES, LYCURGUS, DEMADES, DINARCHUS, HYPEREIDES). K. J. Maidment and J. O. Burrt. 2 Vols. (Vol. I. 2nd Imp.)
- NONNOS: DIONYSIACA. W. H. D. Rouse. 3 Vols. (2nd Imp.)
- OPPLAN, COLLUTHUS, TRYPHIODORUS. A. W. Mair. (2nd Imp.)
- PAPYRI. NON-LITERARY SELECTIONS. A. S. Hunt and C. C. Edgar. 2 Vols. (Vol. I. 2nd Imp.) LITERARY SELECTIONS. Vol. I. (Poetry). D. L. Page. (3rd Imp.)
- PARTHENIUS. Cf. DAPHNIS AND CHLOE.
- PAUSANIAS: DESCRIPTION OF GREECE. W. H. S. Jones. 5 Vols. and Companion Vol. arranged by R. E. Wycherley. (Vols. I. and III. 3rd Imp., Vols. II., IV. and V. 2nd Imp.)
- PHILO. 10 Vols. Vols. I.-V.; F. H. Colson and Rev. G. H. Whitaker. Vols. VI.-IX.; F. H. Colson. (Vols. II.-III., V.-IX. 2nd Imp., Vols. I. and IV., 3rd Imp.)
- PHILO: two supplementary Vols. (*Translation only.*) Ralph Marcus.
- PHILOSTRATUS: THE LIFE OF APPOLLONIUS OF TYANA. F. C. Conybeare. 2 Vols. (Vol. I. 4th Imp., Vol. II. 3rd Imp.)
- PHILOSTRATUS: IMAGINES; CALLISTRATUS: DESCRIPTIONS. A. Fairbanks.
- PHILOSTRATUS and EUNAPIUS: LIVES OF THE SOPHISTS. Wilmer Cave Wright. (2nd Imp.)
- PINDAR. Sir J. E. Sandys. (7th Imp. revised.)
- PLATO: CHARMIDES, ALCIBIADES, HIPPARCHUS, THE LOVERS, THEAGES, MINOS and EPINOMIS. W. R. M. Lamb. (2nd Imp.)
- PLATO: CRATYLUS, PARMENIDES, GREATER HIPPIAS, LESSER HIPPIAS. H. N. Fowler. (4th Imp.)



THIS PAGE IS LOCKED TO FREE MEMBERS

Purchase full membership to immediately unlock this page

SAVE \$3,999,994

Did you know we sell
paperback books too?

To buy our entire catalog
in paperback would cost
over \$4,000,000

Access it all now for
\$8.99/month

*Fair usage policy applies

Continue

IN PREPARATION

Greek Authors

ARISTOTLE : HISTORY OF ANIMALS. A. L. Peck.
CALLIMACHUS : FRAGMENTS. C. A. Trypanis.
PLOTINUS : A. H. Armstrong.

Latin Authors

ST. AUGUSTINE : CITY OF GOD.
CICERO : PRO SESTIO, IN VATINIUM.
CICERO : PRO CAELIO, DE PROVINCIIS CONSULARIBUS, PRO BALBO.
J. H. Freese and R. Gardner.
PHAEDRUS : Ben E. Perry.

DESCRIPTIVE PROSPECTUS ON APPLICATION

London
Cambridge, Mass.

WILLIAM HEINEMANN LTD
HARVARD UNIVERSITY PRESS