

Forgotten Books

— www.forgottenbooks.com —

Copyright © 2016 FB &c Ltd.

All rights reserved. No part of this publication may be reproduced, distributed, or transmitted in any form or by any means, including photocopying, recording, or other electronic or mechanical methods, without the prior written permission of the publisher, except in the case of brief quotations embodied in critical reviews and certain other noncommercial uses permitted by copyright law.

A DICTIONARY
OF
ELECTRICAL WORDS,
TERMS AND PHRASES.

BY
EDWIN J. HOUSTON, A.M.,
PROFESSOR OF NATURAL PHILOSOPHY AND PHYSICAL GEOGRAPHY IN THE CENTRAL HIGH SCHOOL
OF PHILADELPHIA; PROFESSOR OF PHYSICS IN THE FRANKLIN INSTITUTE OF
PENNSYLVANIA; ELECTRICIAN OF THE INTERNATIONAL
ELECTRICAL EXHIBITION,
ETC., ETC.

SECOND EDITION. REWRITTEN AND GREATLY ENLARGED.

NEW YORK:
THE W. J. JOHNSTON COMPANY, LIMITED,
167-176 TIMES BUILDING.

1892.

COPYRIGHT, 1889 AND 1892,
BY THE W. J. JOHNSTON COMPANY, LIMITED.

PREFACE TO THE FIRST EDITION.

THE rapid growth of electrical science, and the almost daily addition to it of new words, terms and phrases, coined, as they too frequently are, in ignorance of those already existing, have led to the production of an electrical vocabulary that is already bewildering in its extent. This multiplicity of words is extremely discouraging to the student, and acts as a serious obstacle to a general dissemination of electrical knowledge, for the following reasons :

1. Because, in general, these new terms are not to be found even in the unabridged editions of dictionaries.

2. The books or magazines, in which they were first proposed, are either inaccessible to the ordinary reader, or, if accessible, are often written in phraseology unintelligible except to the expert.

3. The same terms are used by different writers in conflicting senses.

4. The same terms are used with entirely different meanings.

5. Nearly all the explanations in the technical dictionaries are extremely brief as regards the words, terms and phrases of the rapidly growing and comparatively new science of electricity.

In this era of extended newspaper and periodical publication, new words are often coined, although others, already in existence, are far better suited to express the same ideas. The new terms are used for a while and then abandoned ; or, if retained, having been imperfectly defined, their exact meaning is capable of no little ambiguity; and, subsequently, they are often unfortunately adopted by different writers with such varying shades of meaning, that it is difficult to understand their true and exact significance.

Then again, old terms buried away many decades ago and long since forgotten, are dug up and presented in such new garb that their creators would most certainly fail to recognize them.

It has been with a hope of removing these difficulties to some extent that the author has ventured to present this Dictionary of Electrical Words, Terms and Phrases to his brother electricians and the public generally.

He trusts that this dictionary will be of use to electricians, not only by showing the wonderful extent and richness of the vocabulary of the science, but also by giving the general consensus of opinion as to the significance of its different words, terms or phrases. It is, however, to the general public, to whom it is not only a matter of interest but also one of necessity to fully understand the exact meaning of electrical literature, that the author believes the book will be of the greatest value.

In order to leave no doubt concerning the precise meaning of the words, terms and phrases thus defined, the following plan has been adopted of giving :

- (1.) A concise definition of the word, term or phrase.

- (2.) A brief statement of the principles of the science involved in the definition.

(3.) Where possible and advisable, a cut of the apparatus described or employed in connection with the word, term or phrase defined.

It will be noticed that the second item of the plan makes the Dictionary approach to some extent the nature of an Encyclopedia. It differs, however, from an Encyclopedia in its scope, as well as in the fact that its definitions in all cases are concise.

Considerable labor has been expended in the collection of the vocabulary, for which purpose electrical literature generally has been explored. In the alphabetical arrangement of the terms and phrases defined, much perplexity has arisen as to the proper catch-word under which to place them. It is believed that part of the difficulty in this respect has been avoided by the free use of cross references.

In elucidating the exact meaning of terms by a brief statement of the principles of the science involved therein, the author has freely referred to standard textbooks on electricity, and to periodical literature generally. He is especially indebted to works or treatises by the following authors, viz. : S. P. Thompson, Larden, Cumming, Hering, Prescott, Ayrton, Ayrton and Perry, Pope, Lockwood, Sir William Thomson, Fleming, Martin and Wetzler, Preece, Preece and Sivewright, Forbes, Maxwell, De Watteville, J. T. Sprague, Culley, Mascart and Joubert, Schwendler, Fontaine, Noad, Smee, Depretz, De la Rive, Harris, Franklin, Cavallo, Grove, Hare, Daniell, Faraday and very many others.

The author offers his Dictionary to his fellow electricians as a starting point only. He does not doubt that his book will be found to contain many inaccuracies, ambiguous statements, and possibly doubtful definitions. Pioneer work of this character must, almost of necessity, be marked by incompleteness. He, therefore, invites the friendly criticisms of electricians generally, as to errors of omission and commission, hoping in this way to be able finally to crystallize a complete vocabulary of electrical words, terms and phrases.

The author desires in conclusion to acknowledge his indebtedness to his friends, Mr. Carl Hering, Mr. Joseph Wetzler and Mr. T. C. Martin, for critical examination of the proof sheets; to Dr. G. G. Faught for examination of the proofs of the parts relating to the medical applications of electricity, and to Mr. C. E. Stump for valuable aid in the illustration of the book; also to Mr. George D. Fowle, Engineer of Signals of the Pennsylvania Railroad Company, for information concerning their System of Block Signaling, and to many others.

EDWIN J. HOUSTON.

CENTRAL HIGH SCHOOL, PHILADELPHIA, PA.,
SEPTEMBER, 1889.

PREFACE TO THE SECOND EDITION.

THE first edition of the "Dictionary of Electrical Words, Terms and Phrases" met with so favorable a reception that the entire issue was soon exhausted. Although but a comparatively short time has elapsed since its publication, electrical progress has been so marked, and so many new words, terms and phrases have been introduced into the electrical nomenclature, that the preparation of a new edition has been determined on rather than a mere reprint from the old plates.

The wonderful growth of electrical science may be judged from the fact that the present work contains more than double the matter and about twice the number of definitions that appeared in the earlier work. Although some of this increase has been due to words which should have been in the first edition, yet in greater part it has resulted from an actual multiplication of the words used in electrical literature.

To a certain extent this increase has been warranted either by new applications of electricity or by the discovery of new principles of the science. In some cases, however, new words, terms or phrases have been introduced notwithstanding the fact that other words, terms or phrases were already in general use to express the same ideas.

The character of the work is necessarily encyclopedic. The definitions are given in the most concise language. In order, however, to render these definitions intelligible, considerable explanatory matter has been added.

The Dictionary has been practically rewritten, and is now, in reality, a new book based on the general lines of the old book, but considerably changed as to order of arrangement and, to some extent, as to method of treatment.

As expressed in its preface, the author appreciates the fact that the earlier book was tentative and incomplete. Though the wide scope of the second edition, the vast number of details included therein, and the continued growth of the electrical vocabulary must also necessarily make this edition incomplete, yet the author ventures to hope that it is less incomplete than the first edition. He again asks kindly criticisms to aid him in making any subsequent edition more nearly what a dictionary of so important a science should be.

The order of arrangement in the first edition has been considerably changed. The initial letter under which the term or phrase is defined is in all cases that of the noun. For example, "Electric Light" is defined under the term "Light, Electric — —"; "Diameter of Commutation" under "Commutation, Diameter of — —," "Alternating Current Dynamo-Electric Machine" under "Machine, Dynamo-Electric, Alternating Current — —." As before, the book has numerous cross references.

Although the arrangement of the words, terms and phrases under the initial letter of the first word, term or phrase, as, for example, "Electric Light" under the letter E, might possess some advantages, yet, in the opinion of the author, the educational value

of the work would be thereby considerably decreased, since to a great extent such an arrangement would bring together incongruous portions of the science.

Frequent cross references render it possible to use the Dictionary as a text-book in connection with lectures in colleges and universities. With such a book the student need make notes only of the words, terms or phrases used, and afterwards, by the use of the definitions and explanatory matter connected therewith, work up the general subject matter of the lecture. The author has successfully used this method in his teaching.

In order to separate the definitions from the descriptive matter, two sizes of type have been used, the definitions being placed in the larger sized type.

In the descriptive matter the author has not hesitated to quote freely from standard electrical works, electrical magazines, and periodical literature generally. Among the numerous works consulted, besides those to which reference has already been made in the preface to the first edition, he desires to acknowledge his indebtedness especially to "The Alternating Current Transformer," by J. A. Fleming; to various works of John W. Urquhart; to "Modern Views of Electricity," by Prof. O. J. Lodge; to "A Text-book of Human Physiology," by Landois & Sterling; and to "Practical Application of Electricity in Medicine and Surgery," by Liebig & Rohe.

The cuts or diagrams used in the book have either been drawn especially for the work or have been taken from standard electrical publications.

The chart of standard electrical symbols and diagrams has been taken from Prof. F. B. Crocker's paper on that subject.

The definition of terms used in systems of electric railways have been taken mainly from a paper on "Standards in Electric Railway Practice," by O. T. Crosby.

The author desires especially to express his obligations to Prof. F. B. Crocker of the Electrical Engineering Department, Columbia College, New York, and to Carl Hering, of Philadelphia, for critical examination of the entire manuscript and for many valuable suggestions; also to *The Electrical World* and the *Electrical Engineer* of New York, and to Prof. Elihu Thomson, Edward Caldwell, T. C. Martin, Dr. Louis Bell, Joseph Wetzler, Nikola Tesla, Wm. H. Wahl, Prof. Wm. D. Marks, Prof. A. E. Dolbear, C. W. Pike, John Hoskin, and numerous others, for aid in connection with new words or phrases. So far as they relate to the medical applications of electricity, the proof sheets were revised by Dr. G. G. Faught, of Philadelphia.

The author desires to thank critics of the first edition and the electrical fraternity in general for valuable suggestions. He presents this second edition of his Dictionary in the hope that it may to some extent properly represent the vocabulary of electrical science.

CENTRAL HIGH SCHOOL,
PHILADELPHIA, May, 1892.

EDWIN J. HOUSTON.

A DICTIONARY

OF

ELECTRICAL

WORDS, TERMS AND PHRASES.

A

A. or An.—An abbreviation sometimes used in medical electricity for anode. (See *Anode*.)

A. C. C.—An abbreviation used in medical electricity for Anodic Closure Contraction. (See *Contraction, Anodic Closure*.)

A. D. C.—An abbreviation used in medical electricity for Anodic Duration Contraction. (See *Contraction, Anodic Duration*.)

A. O. C.—An abbreviation used in medical electricity for Anodic Opening Contraction. (See *Contraction, Anodic Opening*.)

Abscissa of Rectilinear Co-ordinates.—A line or distance cut off along axis of abscissas.

The abscissa of the point D, Fig. 1, on the curve O D R, is the distance D 1, or its equal A 2, measured or cut off on the line A C, the axis of abscissas; or, briefly, A 2, is the abscissa of the point D.

Abscissas, Axis of — — — — — One of the axes of co-ordinates used for determining the position of points on a curved line.

Thus the position of the point D, Fig. 1, on the curved line O D R, is determined by the perpendicular distances, D 1 and D 2, of such point from two straight lines, A B and A C, called the *axes of co-ordinates*. A C, is called the *axis of ab-*

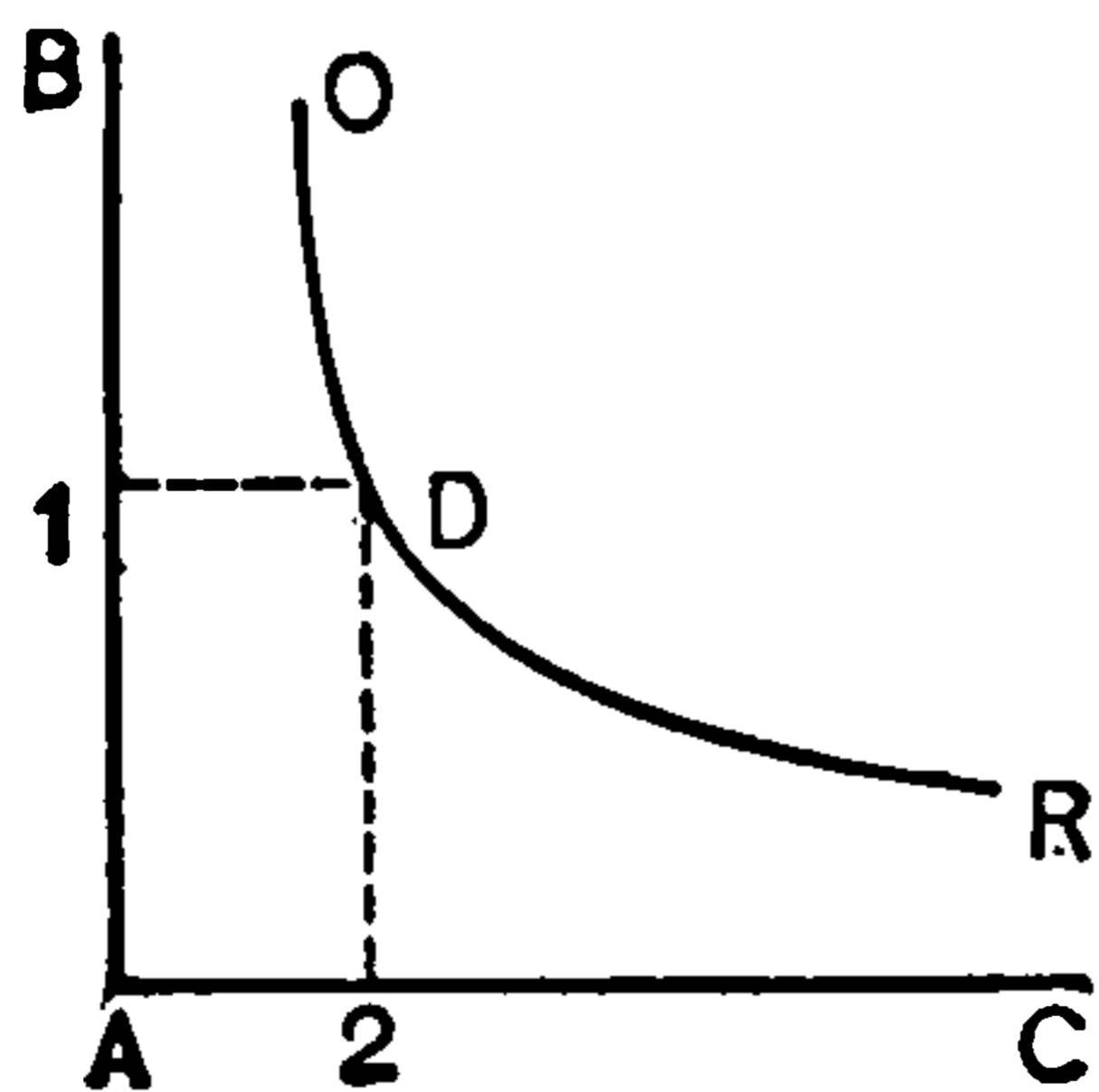

Fig. 1. Axes of Co-ordinates.

scissas, and A B, the *axis of ordinates*. The point

A, where the lines are considered as starting or originating, is called the *point of origin*, or, generally, the *origin*.

The use of co-ordinates was first introduced by the famous mathematician, Des Cartes.

Absolute.—Complete in itself.

The terms absolute and relative are used in electricity in the same sense as ordinarily.

Thus, a galvanometer is said to be calibrated *absolutely* when the exact current strengths required to produce given deflections are known; or, in other words, when the *absolute* current strengths are known; it is said to be calibrated *relatively* when only the *relative* current strengths required to produce given deflections are known.

The word absolute, as applied to the units employed in electrical measurements, was introduced by Gauss to indicate the fact that the values of such units are independent both of the size of the instrument employed and of the value of gravity at the particular place where the instrument is used.

The word absolute is also used with reference to the fact that the values of the units could readily be redetermined from well known constants, in case of the loss of the standards.

The *absolute units of length, mass, and time* are more properly called the C. G. S. units, or the *centimetre-gramme-second units*. (See *Units, Absolute*.)

An absolute system of units based on the *milligramme, millimetre, and second*, was proposed by Weber, and was called the *millimetre milligramme-second units*. It has been replaced by

the C. G. S. units. (See *Units, Centimetre-Gramme-Second. Units, Fundamental.*)

Absolute Block System for Railroads.—(See *Block System for Railroads, Absolute.*)

Absolute Calibration.—(See *Calibration, Absolute.*)

Absolute Electrometer.—(See *Electrometer, Absolute.*)

Absolute Galvanometer.—(See *Galvanometer, Absolute.*)

Absolute Unit of Current.—(See *Current, Absolute Unit of.*)

Absolute Unit of Electromotive Force.—(See *Force, Electromotive, Absolute Unit of.*)

Absolute Unit of Inductance.—(See *Inductance, Absolute Unit of.*)

Absolute Unit of Resistance.—(See *Resistance, Absolute Unit of.*)

Absolute Unit of Self-Induction.—(See *Induction, Self, Absolute Unit of.*)

Absolute Units.—(See *Units, Absolute.*)

Absolute Vacuum.—(See *Vacuum, Absolute.*)

Absorption.—The taking, or, literally, drinking in, of one form of matter by another, such as a gas, vapor or liquid by a solid; or of the energy of sound, light, heat, or electricity by ordinary matter.

Absorption, Acoustic — —The taking in of the energy of sound waves produced by one sounding or vibrating body by another vibrating body.

Acoustic absorption may result in the dissipation of the absorbed energy, as heat, or in sympathetic vibrations. (See *Vibrations, Sympathetic.*)

Absorption, Electric — —The apparent soaking of an electric charge into the glass or other solid dielectric of a Leyden jar or condenser. (See *Condenser.*)

The capacity of a condenser varies with the time the condenser remains charged and with the time taken in charging. Some of the charge acts as if it *soaked into* the solid dielectric, and this is the cause of the *residual charge*. (See *Charge, Residual.*) Therefore, when the con-

denser is discharged, less electricity appears than was passed in; hence the term *electric absorption*.

Absorption, Luminous — —The absorption of the energy of light in its passage through bodies.

When sunlight falls on an opaque colored body, such for example as a red body, all the colors but the reds are absorbed. The reds are then thrown off and thus cause the color. In the same manner, when sunlight falls on a transparent colored body, such for example as red, all colors but the reds are absorbed, and the reds are transmitted.

When sunlight falls on a phosphorescent body, a part of the light is absorbed as heat; another part is absorbed by the molecules being set into motion sufficiently rapid to cause them to emit light or to become luminous.

A mass of glowing gas or vapor absorbs waves of light of the same length as those it itself emits. This is the cause of the dark lines of the solar spectrum, called the Fraunhofer lines.

The amount of light absorbed by the glass globe of an incandescent lamp, according to Urquhart, is as follows, viz.:

Clear glass	10 per cent.
Ground glass.....	35 “
Opalescent glass.....	50 “

Absorption, Selective — —The absorption of a particular or selected character of waves of sound, light, heat, or electricity.

Absorption, Thermal — —The absorption of heat energy in its passage through a body.

The phenomena of thermal absorption are similar to those of luminous absorption. A substance that is transparent to heat, or which allows heat waves to pass through without absorption, is called *diathermanous*, or *diathermanic*, or is said to be *transparent to heat*.

Absorptive Power.—(See *Power, Absorptive.*)

Acceleration.—The rate of change of velocity.

Acceleration is thus distinguished from velocity: velocity expresses in time the rate-of-change of position, as a velocity of three metres per second; acceleration expresses in time the rate-of-change of velocity, as an acceleration of one centimetre per second.

Since all matter is inert, and cannot change its

condition of rest or motion without the application of some force, acceleration is necessarily due to some force outside the matter itself. A force may therefore be measured by the acceleration it imparts to a given mass of matter.

Acceleration is *positive* when the velocity is *increasing*, and *negative* when it is *decreasing*.

Acceleration, Dimensions of — — The value of the acceleration expressed in terms of the length or of distance by the time. (See *Acceleration, Unit of*.)

Acceleration, Unit of — — That acceleration which will give to a body unit-velocity in unit-time; as, for example, one centimetre-per-second in one second.

Bodies falling freely in a vacuum, and approximately so in air, acquire an acceleration which in Paris or London, at the end of a second, amounts to about 981 centimetres per second, or nearly 32.2 ft. per second.

$$A = \frac{V}{T}, \text{ or, in other words,}$$

The acceleration equals the velocity divided by the time.

But, since velocity equals the Distance, or the Length traversed in a Unit of Time, $V = \frac{L}{T}$.

$$\text{Therefore, } A = \frac{V}{T} = \frac{\frac{L}{T}}{T} = \frac{L}{T^2}, \text{ or}$$

The acceleration equals the length, or the distance passed through, divided by the square of the time in seconds.

These formulæ represent the *Dimensions of Acceleration*.

Accumulated Electricity.—(See *Electricity, Accumulated*.)

Accumulating Electricity.—(See *Electricity, Accumulating*.)

Accumulation of Electricity.—(See *Electricity, Accumulation of*.)

Accumulator.—A word sometimes applied to any apparatus in which the strength of a current is increased by the motion past it of a conductor, the currents produced in which tend to strengthen and increase the current which causes the induction.

The word accumulator is sometimes applied to Sir Wm. Thomson's *Electric Current Accumulator*.

Current accumulators operate on the reaction principle of dynamo-electric machines. In this sense, therefore, a dynamo-electric machine is an accumulator. (See *Machine, Dynamo-Electric, Reaction Principle of*.)

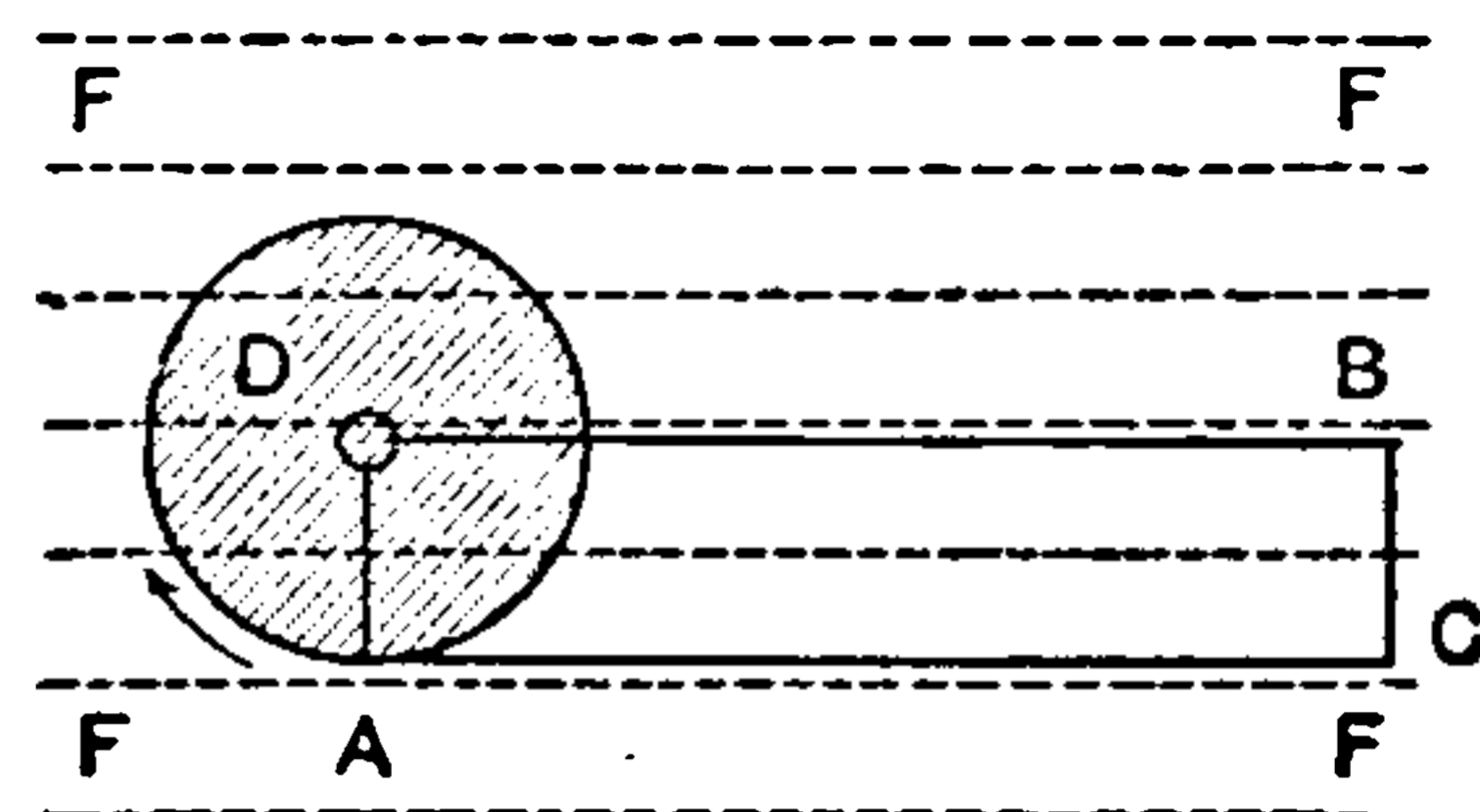

Fig. 2. Barlow's Wheel.

The copper disc D, Fig. 2, has freedom of rotation, on a horizontal axis at O, in a magnetic field, the lines of force of which, represented by the dotted lines in the drawing, pass downward perpendicularly into the plane of the paper.

If, now, a current from any source be passed in the direction A, O, B, C, A, through the circuit A, O, B, C, A, which is provided with spring contacts at O, and A, the disc will rotate in the direction of the curved arrow. This motion is due to the current acting on that part of the disc which lies between the two contacts—A and O. This apparatus is known as *Barlow's Wheel*.

If, when no current is passing through the circuit, the disc be turned in the direction of the arrow, a current is set up in such a direction as would oppose the rotation of the disc. (See *Law, Lenz's*.)

If, however, the disc be turned in the opposite direction to that of the arrow, induction currents will as before be produced in the circuit. As this rotation of the disc tends to move the circuit O A, towards the parallel but oppositely directed circuit B C, these two circuits being parallel and in opposite directions tend to repel one another, and there will thus be set up induced currents that tend to oppose the motion of rotation, and the current of the circuit will therefore increase in strength. (See *Dynamics, Electro*.) Should then a current be started in the circuit, and the original field be removed, the induction will be continued, and a current which, up to a certain extent, increases or accumulates, is maintained in the circuit during rotation of the disc. (*Larden*.)

Barlow's Wheel, when used in this manner, is known as *Thomson's Electric Current Accumulator*.

Accumulator.—A word often applied to a Leyden jar or condenser, which permits the gradual collection from an electric source of a greater charge than it would otherwise be capable of containing.

A condenser. (See *Condenser*.)

The ability of a source to accumulate an increased charge when connected to a condenser is due to the increased capacity which a plate or other conductor acquires when placed near another plate or conductor. (See *Condenser. Jar, Leyden*.)

Accumulator, Capacity of — —The capacity of a condenser, expressed in microfarads. (See *Condenser, Capacity of*.)

Accumulator or Condenser; Laws of Accumulation of Electricity.—Sir W. Snow Harris, by the use of his Unit-Jar and Electric Thermometer, deduced the following laws for the accumulation of electricity, which we quote from Noad's "Student's Text-Book of Electricity," revised by Preece:

(1.) "Equal quantities of electricity are given off at each revolution of the plate of an electrical machine to an *uncharged surface*, or to a surface *charged* to any degree of saturation."

(2.) "A coated surface receives equal quantities of electricity in equal times; and the number of revolutions of the plate is a fair measure of the relative quantities of electricity, all other things remaining the same."

(3.) "The free action of an electrical accumulation is estimated by the interval it can break through, and is directly proportional to the quantity of electricity."

(4.) "The free action is inversely proportional to the surface."

(5.) "When the electricity and the surface are increased in the same ratio, the discharging interval remains the same; but if, as the electricity is increased, the surface is diminished, the discharging interval is directly as the square of the quantity of electricity."

(6.) "The resistance of air to discharge is as the square of the density directly."

According to some later investigations, the quantity a plane surface can receive under a given density depends on the linear boundary of the surface as well as on the area of the surface.

"The amount of electrical charge depends on

surface and linear extension conjointly. There exists in every plane surface what may be termed an *electrical boundary*, having an important relation to the grouping or disposition of the electric particles in regard to each other and to surrounding matter. This boundary in circles or globes is represented by their circumferences. In plane rectangular surfaces, it is by their linear extension or perimeter. If this *boundary* be constant, their electrical charge varies with the *square root of the surface*. If the *surface* be constant the charge varies with the *square root of the boundary*. If the surface and boundary both vary, the charge varies with the *square root of the surface multiplied into the square root of the boundary*."

These laws apply especially to continuous surfaces taken as a whole, and not to surfaces divided into separate parts.

By electrical charge Harris meant the quantity sustained on a given surface under a given electrometer indication; by electrical intensity, he meant the indication of the electrometer corresponding to a given quantity on a given surface.

(See *Condenser, Capacity of. Capacity, Electrostatic. Capacity, Specific Inductive*.)

Accumulators of this character are now generally called Condensers. (For more modern principles concerning their construction and capacity see *Condenser. Condenser, Capacity of*.)

Accumulator, Secondary or Storage Cell — —Two inert plates partially surrounded by a fluid incapable of acting chemically on either of them until after the passage of an electric current, when they become capable of furnishing an independent electric current.

This use of the term accumulator is the one most commonly employed. A better term for such a cell is a secondary or storage cell. (See *Cell, Secondary or Storage*.)

Commercially, an accumulator consists of a single jar and its electrolyte, in which a single set of positive and negative plates is properly placed.

Accumulator, Water-Dropping — —An apparatus devised by Sir W. Thomson for increasing the difference of potential between two electric charges.

The tube X Y, Fig. 3, connects with a reservoir of water which is maintained at the zero potential of the earth. The water escapes from

the openings at C and D, in small drops and falls on funnels provided, as shown, to receive the separate drops and again discharge them.

The vessels A, A', and B, B', which are electrically connected as shown, are maintained at a certain small difference of potential, as indicated by the respective + and - signs.

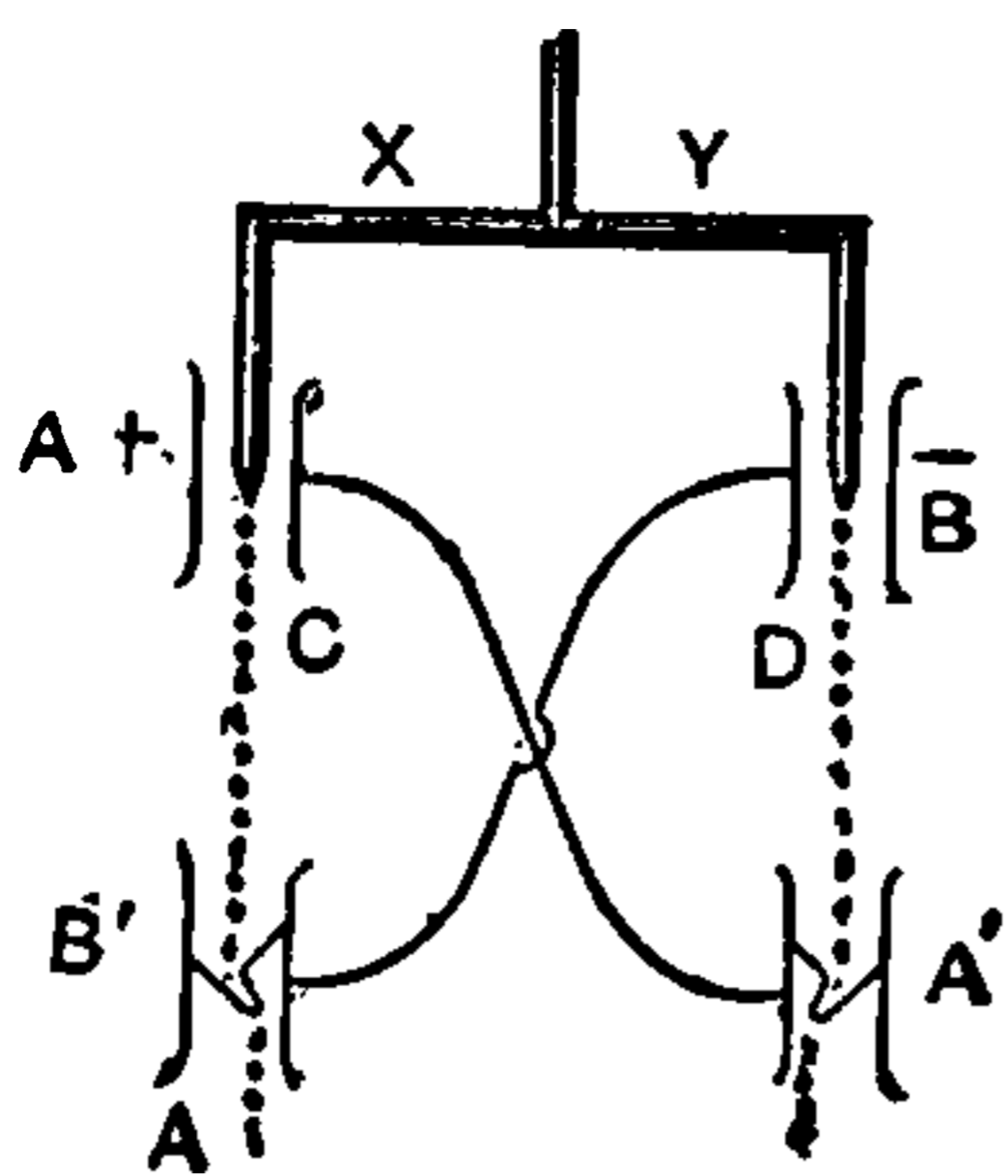

Fig. 3. Water-Dropping Accumulator.

Under these circumstances, therefore, C and D, will be charged inductively with charges opposite to those of A and B, or with - and + electricities respectively. As the drops of water fall on the funnels, the charges which the funnels thus constantly receive are given up to B' and A', before the water escapes. Since, therefore, B, B', and A, A', are receiving constant charges, the difference of potential between them must continually increase. This apparatus operates on the same principle as the replenisher. The drops of water act as the carriers, and A, A', and B, B', as the hollow vessels. (See *Replenisher*.)

Achromatic.—Free from false coloration.

Images formed by ordinary lenses do not possess the true colors of the object, unless the edges of the lenses are cut off by the use of a diaphragm; *i. e.*, an opaque plate with a central circular opening. The edges of the lenses disperse the light like an ordinary prism, and so produce rainbow colored (prismatic) fringes in the image. The use of an achromatic lens is to obviate this false coloration.

Achromatizable.—Capable of being freed from false coloration.

Achromatize.—To free from false coloration.

Achromatizing.—Freeing from false coloration.

Acid, Spent — — A battery acid, or other acid, that has become too weak for efficient action.

In a voltaic cell the acid of the electrolyte becomes spent by combining with the metal of the positive plate.

Acidometer.—A special form of hydrometer used in determining the specific gravity of the acid liquid in a secondary or storage

cell. (See *Areometer or Hydrometer. Cell, Storage*.)

The scale on the acidometer tube is made to indicate the density according to the distance the floating instrument sinks in the liquid.

Aclinic Line.—(See *Line, Aclinic*.)

Acoustic Absorption.—(See *Absorption, Acoustic*.)

Acoustic Engraving.—(See *Engraving, Acoustic*.)

Acoustic Telegraphy.—(See *Telegraphy, Acoustic*.)

Acoustic Tetanus.—(See *Tetanus, Acoustic*.)

Acoutemeter, Electric — — An apparatus for electrically testing the delicacy of hearing.

The Acoutemeter is one of the many applications of Hughes' sonometer. It consists of three flat coils placed parallel to one another on a graduated rod, passing through their axes. The central coil, which is used as the primary of an induction coil, is fixed. The other two, which are employed as secondary coils, are movable. (See *Sonometer, Hughes'. Coil, Induction. Microphone*.) A microphone, electrical tuning fork, switches, plugs, and other accessories, are suitably placed and connected. The subject whose hearing is to be tested is placed with his back to the apparatus, and with two telephone receivers tightly fixed to his ears. As various sounds are produced, the outer or movable coils are moved gradually away from the central coil, until no sound is heard in the telephone receivers. This distance is in the inverse ratio of the delicacy of hearing of the individual.

Actinic Photometer.—(See *Photometer, Actinic*.)

Actinic Ray.—(See *Ray, Actinic*.)

Actinism.—The chemical effects of light, as manifested by the decomposition of various substances.

Under the influence of the sun's light, the carbonic acid absorbed by the leaves of plants is decomposed in the living leaves into carbon, which is retained by the plant for the formation of its woody fibre or ligneous tissue, and oxygen, which is thrown off.

The bleaching of curtains, carpets, and other fabrics exposed to sunlight is caused by the actinic power of the light. The photographic picture is impressed by the actinic power of light on a plate covered with some sensitive metallic salt.

Actinograph.—An apparatus for measuring and recording the intensity of the chemical effects of light.

Actinography.—The method of measuring and recording the intensity of the chemical effects of light.

Actinometer.—A word sometimes applied to a pyrhelimeter. (See *Pyrhelimeter*.)

Actinometer, Electric — —An apparatus for electrically measuring the intensity of the chemically active rays present in any luminous radiation.

The rays from the luminous source are permitted to fall on a selenium resistance, and their intensity determined by the change observed in the resistance as indicated by the deflections of a galvanometer placed in circuit with the selenium resistance. Or, a thermo-electric pile is employed, and the amount of heat present determined by the indications of a galvanometer placed in its circuit.

Action, Cataphoric — —The action of electric osmose or cataphoresis. (See *Cataphoresis*.)

Action Currents.—(See *Currents, Action*.)

Action, Inductive, Lines of — — Lines within the space, separating a charge and a neighboring body, along which electrostatic inductive action takes place.

Lines of electrostatic force.

Lines of inductive action pass through the dielectric, separating the two bodies, and terminate on the surfaces of the conductor. According to the now generally received notions, the electrostatic charge exists in the mass of the dielectric, and not in that of the conductor. The lines of inductive action terminate against the surfaces, one at the positive, and the other at the negative surface. A true E. M. F. exists in the space traversed by lines of inductive action. A conductor brought into this space becomes electrified, or is strained in such a manner that a momentary current is produced by the rearrange-

ment of the electrification brought about by electrostatic induction.

Action, Local, of Dynamo-Electric Machine — —The loss of energy in a dynamo-electric machine by the setting up of eddy currents in its pole pieces, cores, or other conducting masses. (See *Currents, Eddy*.)

In a dynamo-electric machine local action is obviated by a *lamination of the pole pieces, armature core, etc.* (See *Core, Lamination of*.)

Action, Local, of Voltaic Cell — — An irregular dissolving or consumption of the zinc or positive element of a voltaic battery, by the fluid or electrolyte, when the circuit is open or broken, as well as when closed, or in regular action.

Local action is due to small particles of such impurities as carbon, iron, arsenic, or other negative elements, in the positive plate. These impurities form with the positive element minute voltaic couples, and thus direct the corrosive action of the liquid to portions of the plate near them. Local action causes a waste of energy. It may be avoided by the amalgamation of the zinc. (See *Zinc, Amalgamation of*.)

Action, Magne-Crystalline — —A term proposed by Faraday to express differences in the action of magnetism on crystalline bodies in different directions.

A needle of tourmaline, if hung with its axis horizontal, is no longer paramagnetic, as usual, but diamagnetic. The same is true of a crystal of bismuth. Faraday concluded from these experiments that a force existed distinct from either the paramagnetic or the diamagnetic force. He called this the *magne-crystalline force*.

Plücker infers from these phenomena that a definite relation exists between the *ultimate form of the particles of matter and their magnetic behavior*. The subject may be regarded as yet somewhat obscure. (See *Polarity, Diamagnetic*.)

Action of a Current on a Magnetic Pole. —(See *Current, Action of, on a Magnetic Pole*.)

Action, Refreshing, of Current — — The restoration, after fatigue, of muscular and nervous excitability obtained by the action of

voltaic alternatives. (See *Alternatives, Voltaic*.)

Activity.—The work done per second by any agent. (This term is but seldom used.)

Work-per-second, or, as generally termed in the United States, Power, or Rate of Doing Work. (See *Power*.)

Activity, Unit of — —A rate of working that will perform one unit of work per second.

In C. G. S. units, the activity of one erg per second.

The C. G. S. unit of activity is very small. One *Watt*, the practical unit of activity or power, is equal to ten million ergs per second. (See *Watt*.)

The unit of activity generally used for mechanical power is the horse-power, or 746 watts. (See *Horse-Power*.)

Actual Caутery.—(See *Caутery, Actual*.)

Acute Angle.—(See *Angle, Acute*.)

Adapter.—A screw nozzle fitted to an electric lamp, provided with a screw thread to enable it to be readily placed on a gas bracket or chandelier in place of an ordinary gas burner.

Adherence.—The quality or property of adhering. (See *Adhesion*.)

Adherence, Magnetic — —Adhesion between surfaces due to magnetic attraction.

Magnetic adhesion has been applied, among other things, to a brake action on car wheels, either by causing them to adhere directly to the track or to a brake-block.

Adhesion.—The mutual attraction which exists between unlike molecules. (See *Attraction, Molecular*.)

The phenomena of adhesion are due to the mutual attraction of dissimilar molecules.

Adhesion, Electric — —Adhesion between surfaces due to the attraction of unlike electrostatic charges.

Molecular adhesion must be distinguished from the attraction which causes a piece of dry and warmed writing paper, that has been rubbed by a piece of india-rubber, to stick to a papered wall. In this latter case the attraction between the wall

and the paper is due to the mutual attraction of two dissimilar electrostatic charges. Molecular adhesion must also be distinguished from the attraction of opposite magnetic poles.

Adhesion, Galvanoplastic — —The adhesion of a galvanoplastic deposit or coating to surfaces subjected to electroplating. (See *Plating, Electro*.)

Adiathermancy.—Opacity to heat.

A substance is said to be *diathermanous* when it is transparent to heat. Clear, colorless crystals of rock salt are very transparent both to light and to heat. Rock salt, covered with a layer or deposit of lampblack or soot, is quite transparent to heat. An adiathermanous body is one which is opaque to heat.

Heat transparency varies not only with different substances, but also with the nature of the source from which the heat is derived. Thus, a substance may be opaque to heat from a non-luminous source, such as a vessel filled with boiling water, while it is comparatively transparent to heat from a luminous source, such as an incandescent solid or a voltaic arc.

A similar difference exists as regards transparency to light. A colorless glass will allow light of any color to pass through it. A blue glass will allow blue light to pass freely through it, but will completely prevent the passage of any red light; and so with other colors.

Adiathermanic.—Possessing the quality of adiathermancy. (See *Adiathermancy*.)

Adjustable Condenser.—(See *Condenser, Adjustable*.)

Adjuster, Cord — —A device for adjusting the length of a pendant cord.

Adjustment.—Such a regulation of any apparatus as will enable it to properly perform its functions.

Æpinus' Condenser.—(See *Condenser, Æpinus'*.)

Aerial Cable.—(See *Cable, Aerial*.)

Aerial Cable, Suspending Wire of — — (See *Wire, Suspending, of Aerial Cable*.)

Aerial Line.—(See *Line, Aerial*.)

Aerolites.—A name sometimes given to meteorites.

Meteorites are masses of solids which pass

through the upper portions only of the earth's atmosphere on their approach to the orbit of the earth, or which fall through the air on the earth's surface from the sky. They are luminous at night and are followed by a train of fire. The luminosity is due to heat produced by friction through the air. Meteors frequently burst from the sudden expansion of their outer portions.

Some meteorites are composed of nearly pure iron alloyed with nickel. The majority of them, however, are merely stones or oxidized substances. Their average velocity is about 26 miles a second.

Affinity, Chemical — —Atomic attraction.

The force which causes atoms to unite and form chemical molecules.

Atomic or chemical attraction generally results in a loss of the characteristic qualities or properties which distinguish one kind of matter from another. In this respect chemical affinity differs from *adhesion*, or the force which holds unlike molecules together. (See *Adhesion. Attraction, Molecular.*) If, for example, sulphur is mixed with lampblack, no matter how intimate the mixture, the separate particles, when examined by a magnifying glass, exhibit their peculiar color, lustre, etc. If, however, the sulphur is chemically united with the carbon, a colorless, transparent, mobile liquid, called carbon bisulphide, results, that possesses a disagreeable, penetrating odor.

Chemical affinity, or atomic combination, is influenced by a variety of causes, viz.:

(1.) *Cohesion.* Cohesion, by binding the molecules more firmly together, opposes their mutual atomic attraction.

A solid rod of iron will not readily burn in the flame of an ordinary lamp; but, if the cohesion be overcome by reducing the iron rod to filings, it burns with brilliant scintillations when dropped into the same flame. In this case the increase of surface and the increased temperature, of the smaller particles also contribute to the result.

(2.) *Solution.* Solution, by giving the molecules greater freedom of motion, favors their chemical combination.

(3.) *Heat.* Heat sometimes favors atomic combination possibly by decreasing the cohesion, and, possibly, by altering the electrical relations of the atoms. If too great, heat may produce decomposition. There is for most substances a critical

temperature below which chemical combination will not take place. (See *Thermolysis.*)

(4.) *Light.* Decomposition, or the lessening of chemical affinity, through the agency of light, is called *Actinism*. Light also causes the direct combination of substances. A mixture of equal volumes of hydrogen and chlorine unites explosively when exposed to the action of full sunlight. (See *Actinism.*)

(5.) *Electricity.* An electric spark will cause an explosive combination of a mixture of oxygen and hydrogen. Electricity also produces chemical decomposition. (See *Electrolysis.*)

Helmholtz accounts for the electro-chemical attraction of oxygen for zinc by supposing that all substances possess a definite amount of attraction for electricity, and that the attraction of zinc in this respect exceeds that of copper and the other metals. He thus regards the zinc as attracting its electric charge rather than as attracting the oxygen. Since both zinc and copper are dyad metals, this view, as will be seen, is at variance with later views.

Chemical affinity may be caused by the opposite attractions of electrical charges naturally possessed by the atoms of matter. This would appear to be rendered probable by the law of electro-chemical equivalence. (See *Equivalence, Electro-Chemical, Law of. Electricity, Atom of.*)

After Currents.—(See *Currents, After.*)

Aging of Alcohol, Electric — —(See *Alcohol, Electric Aging of.*)

Agonal.—Pertaining to the agone. (See *Agone.*)

Agone.—A line connecting places on the earth's surface where the magnetic needle points to the true geographical north.

The line of no declination or variation of a magnetic needle. (See *Needle, Magnetic, Declination of.*)

As all the places on the earth where the magnetic needle points to the true north may be arranged on a few lines, it will be understood that the pointing of the magnetic needle to the true geographical north is the exception and not the rule. In many places, however, the deviation from the true geographical north is so small that the direction of the needle may be regarded as approximately due north.

Agonic.—Pertaining to the agone.

Air-Blast for Commutators.—An invention of Prof. Elihu Thomson to prevent the injurious action of destructive flashing at the commutator of a dynamo-electric machine.

A thin, forcible blast of air is delivered through suitable tubes at points on the three-part commutator cylinder of the Thomson-Houston dynamo, where the collecting brushes bear on its surface. The effect is to blow out the arc or prevent its formation and thus avoid its destructive action on the commutator segments. The use of the air-blast also permits the free application of oil, thus further avoiding wear.

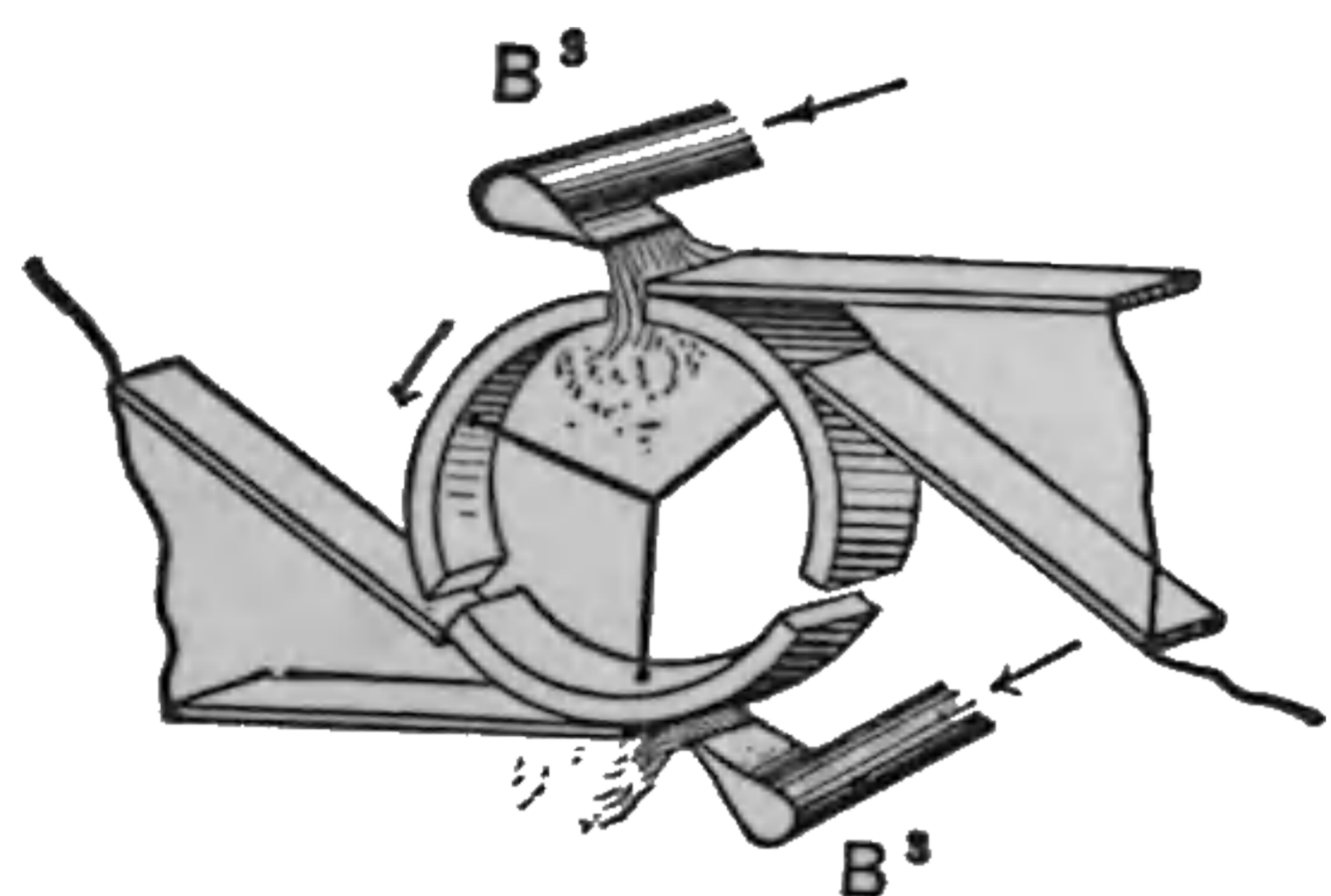

Fig. 4. Air-Blast on Commutator

The blast-nozzles are shown at B³, B³, Fig. 4, near the collecting brushes.

The air-supply is obtained from a blower attached directly to the shaft of the machine. Its construction and operation will be readily understood from an inspection of Fig. 5, in which the

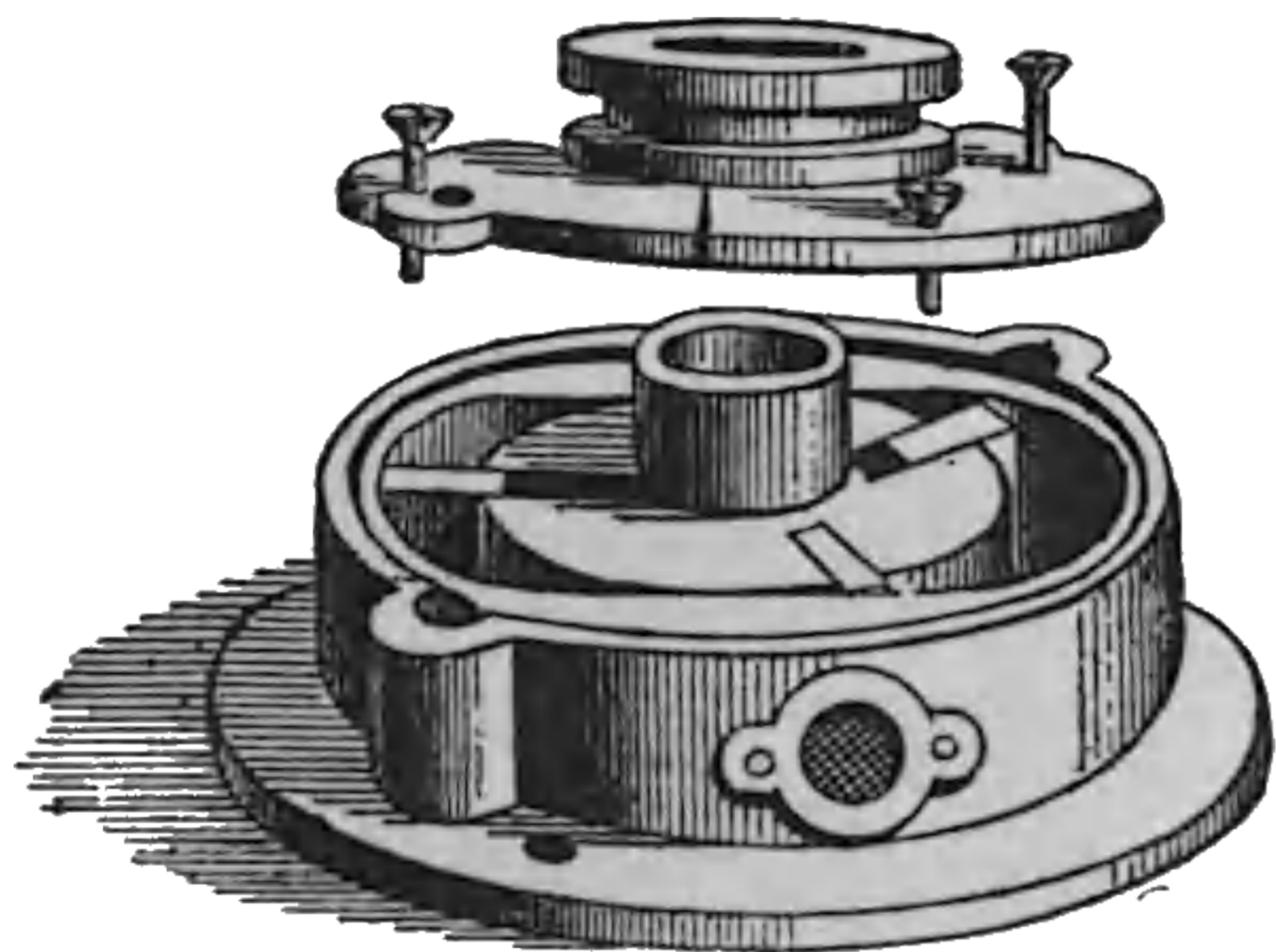

Fig. 5. The Thomson Blower.

top is removed for ready examination of the interior parts.

Air Churning.—(See *Churning, Air.*)

Air Condenser.—(See *Condenser, Air.*)

Air Field.—(See *Field, Air.*)

Air-Gap.—(See *Gap, Air.*)

Air-Line Wire.—(See *Wire, Air-Line.*)

Air Magnetic Circuit.—(See *Circuit, Air Magnetic.*)

Air-Pump.—(See *Pump, Air.*)

Air-Pump, Geissler's Mercurial — — (See *Pump, Air, Geissler's Mercurial.*)

Air-Pump, Mechanical — — (See *Pump, Air, Mechanical.*)

Air-Pump, Mercurial — — (See *Pump, Air, Mercurial.*)

Air-Pump, Sprengel's Mercurial — — (See *Pump, Air, Sprengel's Mercurial.*)

Air-Space Cut-Out.—(See *Cut-Out, Air-Space.*)

Alarm, Burglar — — A device, generally electric, for automatically announcing the opening of a door, window, closet, drawer, or safe, or the passage of a person through a hallway, or on a stairway.

Electric burglar-alarm devices generally consist of mechanism for the operation of an automatic make-and-break bell on the opening or closing of an electric circuit. The bell may either continue ringing only while the contact remains closed, or, may, by the throwing on of a local circuit or battery, continue ringing until stopped by some non-automatic device, such as a hand-switch.

The alarm-bell is stationed either in the house when occupied, or on the outside when the house is temporarily vacated, or may connect directly with the nearest police station.

Burglar-alarm apparatus is of a variety of forms. Generally, devices are provided by means of which, in case of house protection, an *annunciator* shows the exact part where an entrance has been attempted. (See *Annunciator, Burglar-Alarm.*) Switches are provided for disconnecting all or parts of the house from the alarm when so desired, as well as to permit windows to be partly raised for purposes of ventilation without sounding the alarm. A clock is frequently connected with the alarm for the purpose of automatically disconnecting any portion of the house at or for certain intervals of time.



Fig. 6 shows a burglar-alarm with annunciator, switches, switch-key, cut-off, and clock.

Alarm, Burglar, Central-Station — — A burglar-alarm, the contact points of which are placed in the places to be protected, and

connected by suitable circuits with alarms placed in a centrally located station.

In a system of central-station burglar-alarms, a number of houses, factories, banks, etc., are all connected telegraphically with the nearest police station, or other central station, constantly provided with police officers. A series of contacts are placed on doors, windows, safes and money drawers, and connected with alarms and annunciators placed in the central station. An unauthorized entrance, therefore, is automatically telegraphed to the central station and its exact location indicated on the annunciator. Systems of central-station fire-alarms are constructed on a similar plan.

Alarm, Electric — — An automatic device by which attention is called to the occurrence of certain events, such as the opening of a door or window; the stepping of a person on a mat or staircase; the rise or fall of temperature beyond a given predetermined point; or, a device intended to call a person to a telegraphic or telephonic instrument.

Electric-alarms are operated by means of the ringing of an electro-magnetic or mechanical bell,

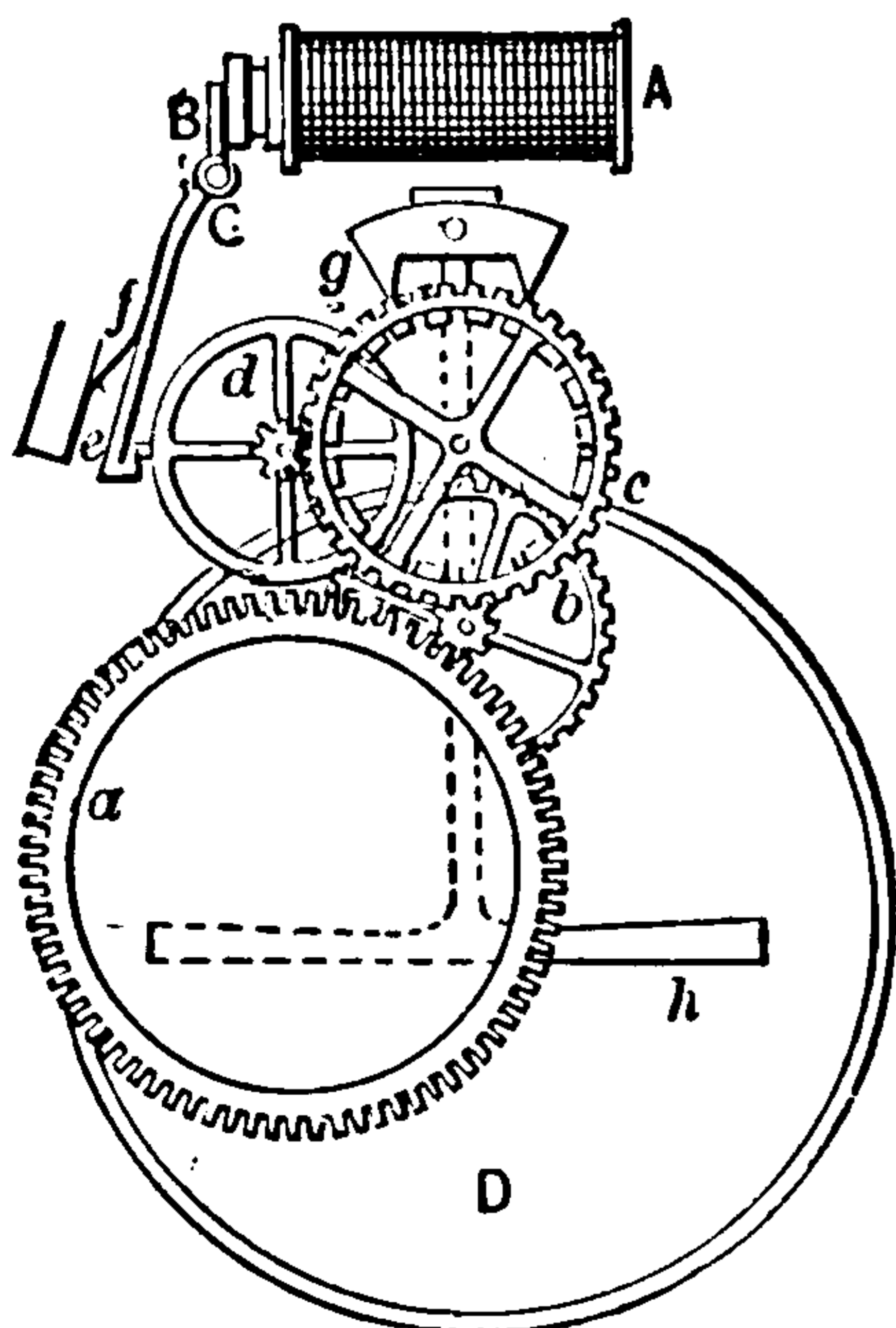

Fig. 7. Electrically Started Mechanical Alarm.

which is electrically called into action by either closing or opening an electric circuit, generally the former.

Electric-alarms may be divided into two classes, viz.:

(1.) Mechanically operated alarms, or those in

which the alarm is given by clock-work, started by means of an electric current.

(2.) Those in which the alarm is both set in action and operated by an electric current.

In Fig. 7 is shown the general construction of an electrically started mechanical alarm. The attraction of the armature B, by the electro-magnet A, moves the armature lever pivoted at C, and thus releases the catch e, and permits the spring or weight connected with the clock movement to set it in motion and strike the bell.

Electrically actuated alarm-bells are generally of the automatic make-and-break form. The striking lever is operated by the attraction of the armature of an electro-magnet, and is provided with a contact-point, so placed that when the hammer is drawn away from the bell, by the action of a spring, on the electro-magnet losing its magnetism, a contact is made, but when the hammer is drawn towards the bell the contact is opened. When, therefore, the hammer strikes the bell, the circuit is opened, and the electro-magnet releases its armature, permitting a spring to again close the contact by moving the striking lever away from the bell. Once set into action, these movements are repeated while there is battery power sufficient to energize the magnet.

In Fig. 8, in which is shown an electrically actuated alarm-bell, the battery terminals are con-

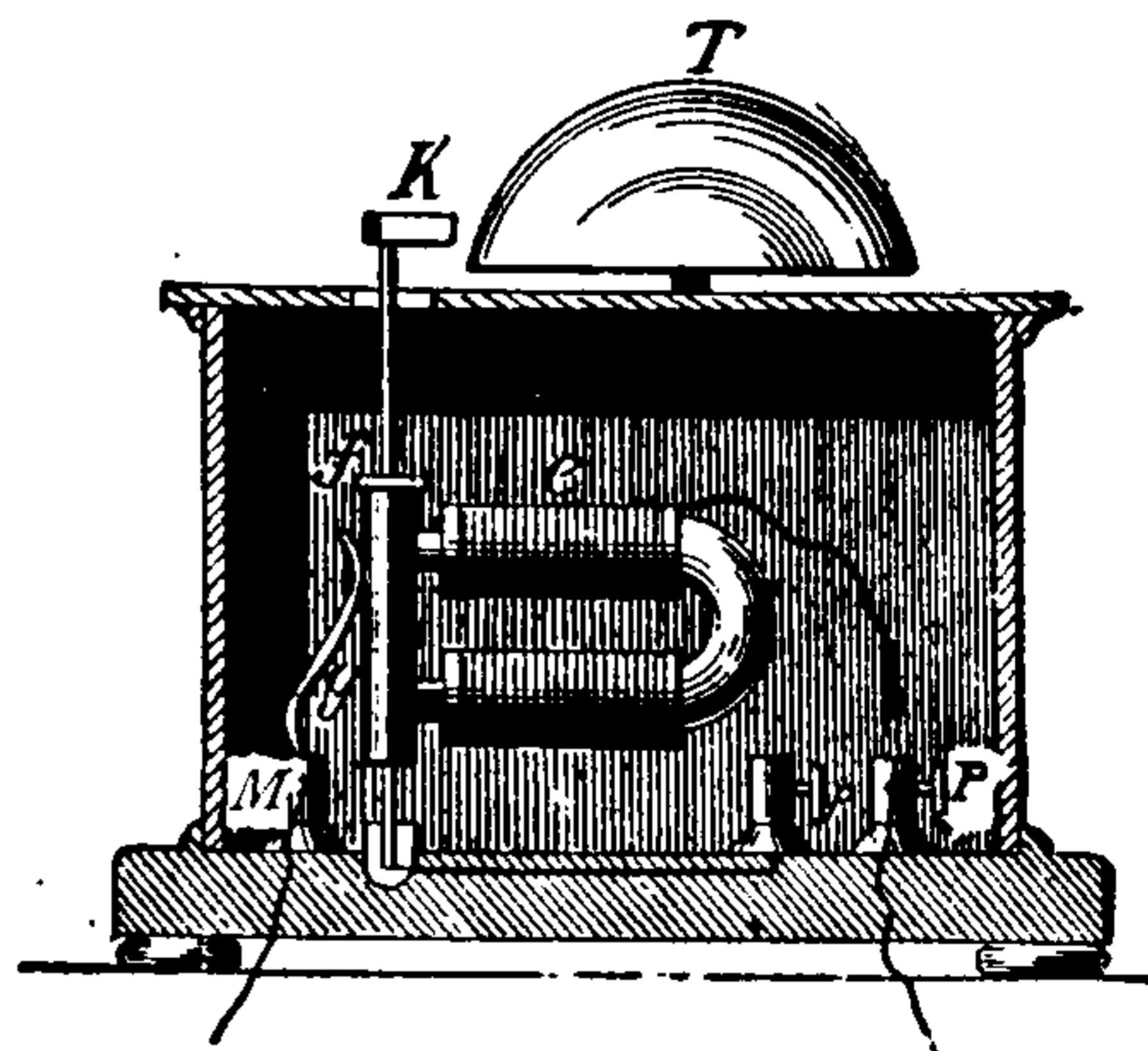

Fig. 8. Automatic Make-and-Break.

ected with the right and left hand binding-posts, P and M. The hammer, K, is connected with a striking lever, which forms part of the circuit, and which is attached to the armature of the electro-magnet e. A metallic spring, g, bears against the armature when the latter is away from the magnet, but does not touch the armature when it is moved towards the magnet. A small spring draws the lever away from the magnet when no current is passing. The movements of the arma-

THIS PAGE IS LOCKED TO FREE MEMBERS

Purchase full membership to immediately unlock this page



HISTORY

Tens of thousands of important historical sources, many previously unobtainable, are now available for the first time with a Forgotten Books Full Membership.

Unlimited Access
\$8.99/month

Continue

*Fair usage policy applies

posing it to the action of electrically produced ozone.

Instead of the ordinary process of aging alcohol, by exposing it in partially closed vessels to the action of air, it is exposed to the action of ozone, electrically produced.

The ozone employed is obtained in substantially the usual way by the passage of a rapid succession of electric sparks through air.

Alcohol, Electric Rectification of — — A process whereby the bad taste and odor of alcohol, due to the presence of aldehydes, are removed by the electrical conversion of the aldehydes into true alcohols through the addition of hydrogen atoms.

An electric current sent through the liquid between zinc electrodes liberates oxygen and hydrogen from the decomposition of the water. The nascent or atomic hydrogen converts the aldehydes into alcohol and deprives the products of their fusel oil, while the oxygen forms insoluble zinc oxide.

Algebraic Co-efficient.—(See *Co-efficient, Algebraic*.)

Algebraic Notation.—(See *Notation, Algebraic*.)

All-Night Arc Lamp.—(See *Lamp, All-Night Arc*.)

All-Night Electric Lamp.—(See *Lamp, All-Night Arc*.)

Allotropic.—Pertaining to allotropy. (See *Allotropy*.)

Allotropic State.—(See *State, Allotropic*.)

Allotropy.—A variation of the physical properties of an elementary substance without change of composition of its molecules.—(See *State, Allotropic*.)

Alloy.—A combination, or mixture, of two or more metallic substances.

Alloys in most cases appear to be true chemical compounds. In a few instances, however, they may form simple mixtures.

The composition of a few important alloys is here given:

Solder, plumber's; Tin 66 parts, Lead 34 parts.

Pewter, hard; Tin 92 parts, Lead 8 parts.

Britannia metal; Tin 100 parts, Antimony 8 parts, Copper 4 parts, Bismuth, 1 part.

Type metal; Lead 80, Antimony 20 parts.

Brass, white; Copper 65, Zinc 35 parts.

Brass, red; Copper 90, Zinc 10 parts.

Speculum metal; Copper 67, Tin 33 parts.

Bell metal; Copper 78, Tin 22 parts.

Aluminium bronze; Copper 90, Aluminium 10 parts.

Alloy.—To form a combination or mixture of two or more metallic substances.

Alloy, German Silver — — An alloy employed for the wires of resistance coils, consisting of 50 parts of copper, 25 of zinc, and 25 of nickel.

German silver wire is suitable for resistance coils, because its resistance varies but slightly with changes of temperature. It is cheaper than *platinum-silver alloy*, and is therefore employed extensively. Platinum silver alloy, however, has more resistance for a given size of wire, and its resistance varies somewhat less than German silver with changes of temperature, and is therefore used where greater accuracy is desired.

Alloy, Palladium — — An alloy of palladium with other metals.

Palladium forms a number of useful alloys with various metals. Some of the palladium alloys are as elastic as steel, are unaffected by moisture or ordinary corrosive agencies, and are entirely devoid of paramagnetic properties; that is to say, they cannot be magnetized after the manner of iron.

These properties have been utilized by their discoverer, Paillard, in their employment for the hair-springs, escapements and balance wheels of watches, in order to permit the watches to be carried into strong magnetic fields without any appreciable effects on the rate of the watch. A number of careful tests made by the author, by long continued exposure of watches, thus protected by the Paillard alloys, in extraordinary fields, show that the protection thus given the watches enables them to be carried into the strongest possible magnetic fields without appreciably affecting their rate.

The Paillard palladium alloys have the following composition, viz.:

Alloy No. 1.

Palladium.....60 to 75 parts.

Copper15 to 25 “

Iron 1 to 5 “

Alloy No. 2.

Palladium.....	50 to 75	parts.
Copper.....	20 to 30	"
Iron.....	5 to 20	"

Alloy No. 3.

Palladium.....	65 to 75	..
Copper.....	15 to 25	..
Nickel.....	1 to 5	"
Gold.....	1 to 2½	"
Platinum.....	¼ to 2	"
Silver.....	3 to 10	..
Steel.....	1 to 5	..

Alloy No. 4.

Palladium.....	45 to 50	..
Silver.....	20 to 25	..
Copper.....	15 to 25	..
Gold.....	2 to 5	..
Platinum.....	2 to 5	..
Nickel.....	2 to 5	..
Steel.....	2 to 5	..

The great value of the palladium alloys, when employed for the hair-springs of watches, arises not only from their non-magnetizable properties, and their inoxidizability, but particularly from the fact that their elasticity is approximately the same for comparatively wide ranges of temperature.

Alloy, Platinum-Silver — — An alloy consisting of one part of platinum, and two parts of silver.

Platinum-silver alloy is now extensively employed for resistance coils from the fact that changes in temperature of the alloy produce but comparatively small changes in its electrical resistance. (See *Alloy, German Silver.*)

Alphabet, Telegraphic — — An arbitrary code consisting of dots and dashes, sounds, deflections of a magnetic needle, flashes of light, or movements of levers, following one another in a given predetermined order, to represent the letters of the alphabet and the numerals.

Alphabet, Telegraphic: International Code — — The code of signals for letters, etc., employed in England and on the European continent generally.

Similar symbols are employed for the numerals and the punctuation marks.

It will be observed that it is mainly in the

characters of the American Morse, in which spaces are used, that the Continental characters differ from the American. This is due to the use of the needle instrument with which a space cannot well be represented. A movement or deflection of the

	Printing	Single Needle		Printing	Single Needle
a	—	↘	n	—	↘
b	—...	↘	o	—	↘
c	—	↘	p	—	↘
d	—	↘	q	—	↘
e	.	↘	r	—	↘
f	—	↘	s	...	↘
g	—	↘	t	—	↘
h	↘	u	—	↘
i	..	↘	v	—	↘
j	—	↘	w	—	↘
k	—	↘	x	—	↘
l	—	↘	y	—	↘
m	—	↘	z	—	↘

International Telegraphic Code.

needle to the left signifies a dot; a movement to the right, a dash.

Alphabet, Telegraphic: Morse's — — Various groupings of dots and dashes, or deflections of a magnetic needle to the right and left, which represent the letters of the alphabet or other signs.

In the Morse alphabet dots and dashes are employed in recording systems, and sounds of varying intervals, corresponding to the dots and dashes, in the sounder system.

A dash is equal in length of time to three dots. The space between the separate characters of a single letter is equal to one dot, except in the American Morse, in which the following letters contain longer spaces: C, O, R, Y, and Z. The lengthened spaces are equal to two dots. L is one and a half times the length of T.

The sound produced by the down stroke of the sounding lever in the Morse sounder is readily distinguishable from the up stroke. When these differences are taken in connection with the intervals between successive sounds there is no difficulty in reading by sound.

(For methods of receiving the alphabet, see *Sounder, Morse Telegraphic Recorder, Morse Recorder, Bain's Chemical Recorder, Siphon Relay, Magnet, Receiving.*) In the *needle telegraph*, the code is similar to that used in the Morse Alphabet. (See *Telegraphy, Single-Needle.*)

AMERICAN MORSE CODE.
ALPHABET.

a ---	n ---
b ---	o - -
c - - -	p - - - -
d - - - -	q - - - - -
e .	r - - -
f - - -	s - - -
g - - - -	t -
h - - - -	u - - -
i - -	v - - - -
j - - - - -	w - - - -
k - - - -	x - - - -
l - - - -	y - - - -
m - - - -	z - -

& - - - -

NUMERALS.

1 - - - - -	6 - - - - -
2 - - - - -	7 - - - - -
3 - - - - -	8 - - - - -
4 - - - - -	9 - - - - -
5 - - - - -	0 - - - - -

PUNCTUATION MARKS.

Period - - - - -	Interrogation - - - - -
Comma - - - - -	Exclamation - - - - -

	Printing	Single Needle
1	- - - - -	\\ / / / /
2	- - - - -	\\ / / / /
3	- - - - -	\\ / / / /
4	- - - - -	\\ / / / /
5	- - - - -	\\ / / / /
6	- - - - -	\\ / / / /
7	- - - - -	\\ / / / /
8	- - - - -	\\ / / / /
9	- - - - -	\\ / / / /
10	- - - - -	\\ / / / /
Period	- - - - -	\\ / / / /
Comma	- - - - -	\\ / / / /
Interrogation	- - - - -	\\ / / / /
Exclamation	- - - - -	\\ / / / /
Colon	- - - - -	\\ / / / /
Semicolon	- - - - -	\\ / / / /

Alteration Theory of Muscle or Nerve Current.—(See *Theory, Alteration, of Muscle or Nerve Current.*)

Alternating Arc.—(See *Arc, Alternating.*)

Alternating Current Circuit.—(See *Circuit, Alternating Current.*)

Alternating Current Condenser.—(See *Condenser, Alternating Current.*)

Alternating Current Dynamo-Electric Machine.—(See *Machine, Dynamo-Electric, Alternating Current.*)

Alternating Current Electric Motor.—(See *Motor, Electric, Alternating Current.*)

Alternating Currents.—(See *Currents, Alternating.*)

Alternating Currents, Distribution of Electricity by — — (See *Electricity, Distribution of, by Alternating Currents.*)

Alternating Discharge.—(See *Discharge, Alternating.*)

Alternating Dynamo-Electric Machine.—(See *Machine, Dynamo-Electric, Alternating Current.*)

Alternating Electrostatic Field.—(See *Field, Alternating Electrostatic.*)

Alternating Electrostatic Potential.—(See *Potential, Alternating Electrostatic.*)

Alternating Field.—(See *Field, Alternating.*)

Alternating Influence Machine, Wimshurst's — — (See *Machine, Wimshurst's Alternating Influence.*)

Alternating Magnetic Field.—(See *Field, Alternating Magnetic.*)

Alternating Magnetic Potential.—(See *Potential, Alternating Magnetic.*)

Alternating Potential.—(See *Potential, Alternating.*)

Alternating Primary Currents.—(See *Currents, Alternating Primary.*)

Alternating Secondary Currents.—(See *Currents, Alternating Secondary.*)

Alternation.—A change in direction or phase.

Alternations.—Changes in the direction of a current in a circuit.

A current that changes its direction 300 times per second is said to possess 300 alternations per second.

Alternations, Complete — — A change in the direction of a current in a circuit from its

former direction and back again to that direction. A complete to-and-fro change.

Complete alternations are sometimes indicated by the symbol \sim .

Alternations, Frequency of — — — A phrase employed to denote the number of alternations per second.

Alternative Path.—(See *Path, Alternative*.)

Alternatives, Voltaic — — — A term used in medical electricity to indicate sudden reversals in the polarity of the electrodes of a voltaic battery.

An alternating current from a voltaic battery, obtained by the use of a suitable commutator.

Sudden reversals of polarity produce more energetic effects of muscular contraction than do simple closures or completions of the circuit.

The muscular contraction produced by a voltaic current is much stronger when the direction of the current is rapidly reversed by means of a commutator than when the current is more slowly broken and the poles then reversed.

The effect of voltaic alternatives is to produce quick contractions that are in strong contrast to the prolonged contractions that result from the faradic current. In the faradic machine, the reversals are so rapid that the muscle fails to return to rest before it is again contracted.

Voltaic alternatives are sometimes indicated by the contraction V. A.

Alternator.—A name commonly given to an alternate current dynamo. (See *Machine, Dynamo-Electric, Alternating Current*.)

Alternator, Compensated Excitation of — — — An excitation of an alternating current dynamo-electric machine, in which the field is but partially excited by separate excitement, the remainder of its exciting current being derived from the commuted currents of a small transformer placed in the main circuit of the machine.

The object of compensated excitation of an alternator is to render the machine self-governing.

Amalgam.—A combination or mixture of a metal with mercury.

Amalgam, Electric — — — A substance

with which the rubbers of the ordinary frictional electric machines are covered.

Electric amalgams are of various compositions. The following formula produces an excellent amalgam :

Melt together five parts of zinc and three of tin, and gradually pour the molten metal into nine parts of mercury. Shake the mixture until cold, and reduce to a powder in a warm mortar. Apply to the cushion by means of a thin layer of stiff grease.

Mosaic gold, or bisulphide of tin, and powdered graphite, both act as good electric amalgams.

An electric amalgam not only acts as a conductor to carry off the negative electricity, but, being highly negative to the glass, produces a far higher electrification than would mere leather or chamois.

Amalgamate.—To form into an amalgam.

Amalgamating.—Forming into an amalgam.

Amalgamation.—The act of forming into an amalgam, or effecting the combination of a metal with mercury.

Amalgamation of Zinc Plates of Voltaic Cell.—(See *Plates, Zinc, of Voltaic Cell, Amalgamation of*.)

Amber.—A resinous substance, generally of a transparent, yellow color.

Amber is interesting electrically as being believed to be the substance in which the properties of electric attractions and repulsions, imparted by friction or rubbing, were first noticed. It was called by the Greeks *ἤλεκτρον*, from which the word electricity is derived. This property was mentioned by the Greek, Thales of Miletus, 600 B. C., as well as by Theophrastus.

American System of Telegraphy.—(See *Telegraphy, American System of*.)

American Twist-Joint.—(See *Joint, American Twist*.)

American Wire Gauge.—(See *Gauge, Wire, American*.)

Ammeter.—A form of galvanometer in which the value of the current is measured directly in ampères. (See *Galvanometer*.)

An ampère-meter or ammeter is a commercial form of galvanometer in which the deflections of

a magnetic needle are calibrated or valued in ampères. As a rule the coils of wire in an ammeter are of lower resistance than in a voltmeter. The magnetic needle is deflected from its zero position by the field produced by the current whose strength in ampères is to be measured. This needle is held in the zero position by the action of a magnetic field, either of a permanent or an electro-magnet, by the action of a spring, or by a weight under the influence of gravity. There thus exist a variety of ammeters, viz.: *permanent-magnet* ammeters, *electro-magnetic* ammeters, *spring* ammeters and *gravity* ammeters.

In the form originally devised by Ayrton and Perry, the needle came to rest almost immediately, or was *dead-beat* in action. (See *Damping*.) It moved through the field of a permanent magnet. The instrument was furnished with a number of coils of insulated wire, which could be connected either in *series* or in *multiple-arc* by means of a *commutator*, thus permitting the scale reading to be verified or calibrated by the use of a single voltaic cell. (See *Circuits, Varieties of. Commutator. Calibration, Absolute. Calibration, Relative.*) In this case the coils were turned to series, and a plug pulled out, thus introducing a resistance of one ohm.

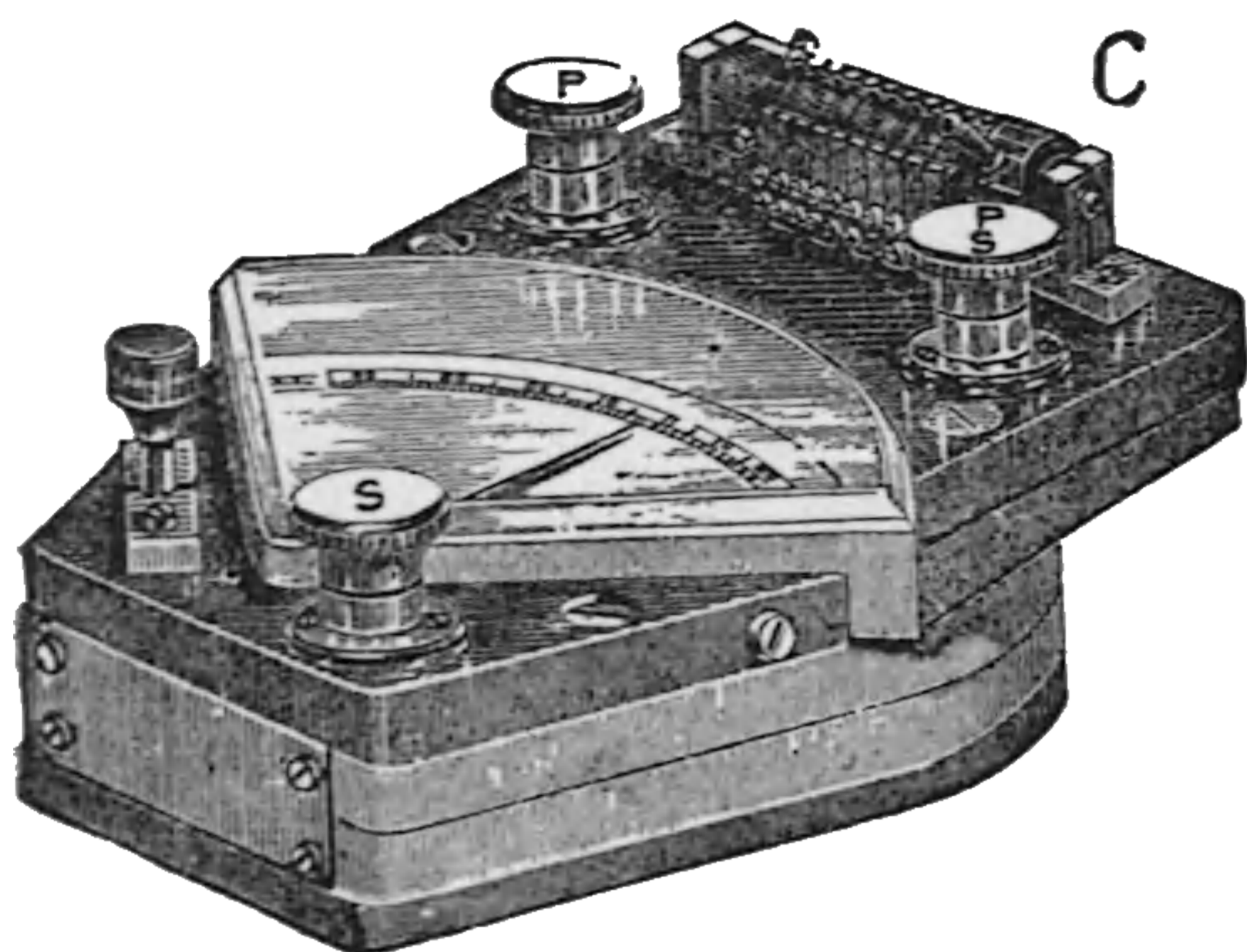

Fig. 12. Ayrton and Perry Ammeter.

Fig. 12 represents an ampère-meter devised by Ayrton and Perry. A device called a *commutator* for connecting the coils either in series or parallel is shown at C. Binding posts are provided at P, PS, and S. The dynamo terminals are connected at the posts P, PS, and the current will pass only when the coils are in multiple, thus avoiding accidental burning of the coils. In this case the entire current to be measured passes through the coils so coupled. The posts S and PS, are for connecting the single battery cell current.

A great variety of ampère-meters, or ammeters, have been devised. They are nearly all, how-

ever, constructed on essentially the same general principles.

Commercial ammeters are made in a great variety of forms. When the currents to be measured are large, as is generally the case in electric light or power stations, they consist of a coil of insulated wire, often of a single turn, or even of but a part of a turn, having a balanced core of iron or steel capable of moving freely within it.

Ammeter, Electro-Magnetic — — A form of ammeter in which a magnetic needle is moved against the field of an electro-magnet by the field of the current it is measuring. (See *Ammeter*.)

Ammeter, Gravity — — A form of ammeter in which a magnetic needle is moved against the force of gravity by the field of the current it is measuring. (See *Ammeter*.)

Ammeter, Magnetic-Vane — — An ammeter in which the strength of a magnetic field produced by the current that is to be measured is determined by the repulsion exerted between a fixed and a movable iron vane, placed in said field and magnetized thereby. (See *Voltmeter, Magnetic-Vane*.)

Ammeter, Permanent-Magnet — — A form of ammeter in which a magnetic needle is moved against the field of a permanent magnet by the field of the current it is measuring. (See *Ammeter*.)

Ammeter, Reducteur for — — (See *Reducteur, or Shunt for Ammeter*.)

Ammeter, Spring — — A form of ammeter in which a magnetic needle is moved against the action of a spring by the field of the current it is measuring. (See *Ammeter*.)

Amorphous.—Having no definite crystalline form.

Mineral substances have certain crystalline forms, that are as characteristic of them as are the forms of animals or plants. Under certain circumstances, however, they occur without definite crystalline form, and are then said to be amorphous solids.

Ampèrage.—The number of ampères passing in a given circuit.

The current strength in any circuit as indicated by an ampère-meter placed in the circuit.

Ampère.—The practical unit of electric current.

Such a rate-of-flow of electricity as transmits one coulomb per second.

Such a current (or rate-of-flow or transmission of electricity) as would pass with an electromotive force of one volt through a circuit whose resistance is equal to one ohm.

A current of such a strength as would deposit .005084 grain of copper per second.

A current of one ampère is a current of such definite strength that it would flow through a circuit of a certain resistance and with a certain electromotive force. (See *Force, Electromotive. Volt. Resistance. Ohm.*)

Since the ohm is the practical unit of resistance, and the volt the practical unit of electromotive force, the ampère, or the practical unit of current, is the current that would flow through unit resistance, under unit pressure or electromotive force.

To make this clearer, take the analogy of water flowing through a pipe under the pressure of a column of water. That which causes the flow is the *pressure* or *head*; that which resists the flow is the *friction* of the water against the pipe, which will vary with a number of circumstances. The *rate-of-flow* may be represented by *so many cubic inches of water per second*.

As the pressure or head increases, the flow increases proportionally; as the resistance increases, the flow diminishes.

Electrically, electromotive force corresponds to the pressure or head of the water, and resistance to the friction of the water and the pipe. The ampère, which is the *unit rate-of-flow per second*, may therefore be represented as follows,

viz.: $C = \frac{E}{R}$, as was announced by Ohm in his law. (See *Law of Ohm.*)

This expression signifies that C, the *current* in *ampères*, is equal to E, the *electromotive force* in *volts*, divided by R, the *resistance* in *ohms*.

We measure the rate-of-flow of liquids as so many *cubic inches* or *cubic feet per second*—that is, in units of quantity. We measure the rate-of-flow of electricity as so much electricity per second. The electrical unit of quantity is called the *Coulomb*. (See *Coulomb.*) The coulomb is such a quantity as would pass in one second through a circuit in which the rate-of-flow is one ampère.

An *ampère* is therefore equal to *one coulomb per second*.

The electro-magnetic unit of current is such a current that, passed through a conducting wire bent into a circle of the radius of one centimetre, would tend to move perpendicular to its plane a *unit magnetic pole* held at its centre, and sufficiently long to practically remove the other pole from its influence, with unit force, *i. e.*, the force of one *dyne*. (See *Dyne.*) The ampère, or practical electro-magnetic unit, is *one-tenth* of *such a current*; or, in other words, the *absolute unit of current* is ten ampères.

An ampère may also be defined by the chemical decomposition the current can effect as measured by the quantity of hydrogen liberated, or metal deposited.

Defined in this way, an ampère is such a current as will deposit .00111815 gramme, or .017253 grain, of silver per second on one of the plates of a silver *voltmeter*, from a solution of silver nitrate containing from 15 to 30 per cent. of the salt (See *Voltmeter*), or which will decompose .00009326 gramme, or .001439 grain of dilute sulphuric acid per second, or pure sulphuric acid at 59 degrees F. diluted with about 15 per cent. of water, that is, dilute sulphuric acid of Sp. Gr. of about 1.1. The present scientific and commercial practice is to take the ampère to be such a current as will deposit 4.024 grammes of silver in one hour.

Ampère Arc.—(See *Arc, Ampère.*)

Ampère-Feet.—(See *Feet, Ampère.*)

Ampère-Hour.—(See *Hour, Ampère.*)

Ampère-Meter.—An ammeter. (See *Ammeter.*)

Ampère-Meter, Balance or Neutral Wire — — An ampère-meter placed in the circuit of the neutral wire, in the three-wire system of electric distribution, for the purpose of showing the excess of current passing over one side of the system as compared with the other side, when the central wire is no longer neutral.

Ampère-Minute.—(See *Minute, Ampère.*)

Ampère Ring.—(See *Ring, Ampère.*)

Ampère-Second.—(See *Second, Ampère.*)

Ampère Tap.—(See *Tap, Ampère.*)

Ampère-Turn.—(See *Turn, Ampère.*)

Ampère-Turn, Primary — — (See *Turn, Ampère, Primary.*)

Ampère-Turn, Secondary — — (See *Turn, Ampère, Secondary.*)

Ampère-Volt.—A watt, or the $\frac{1}{748}$ of a horse-power.

This term is generally written *volt-ampère.* (See *Volt-Ampère.*)

Ampère-Winding.—(See *Winding, Ampère.*)

Ampère's Rule for Effect of Current on Needle.—(See *Rule, Ampère's, for Effect of Current on Needle.*)

Ampère's Theory of Magnetism.—(See *Magnetism, Ampère's Theory of.*)

Ampèrian Currents.—(See *Currents, Ampèrian.*)

Amplitude of Vibration or Wave.—(See *Vibration or Wave, Amplitude of.*)

Ammunition-Hoist, Electric — — An electrically operated hoist for raising ammunition to the deck of a ship.

In the electric ammunition-hoist the electric motor which moves the hoist is made to follow the motions of the operator's hand, both as regards direction and speed. The motion of a crank, or wheel, causes a switch to start an electric motor in a certain direction, which tends to close the switch, thus necessitating a race between the operator and the motor. Should the operator begin to close the switch more slowly, the motor will overtake him, will partially close the switch, and thus lower the speed of the motor.

Analogous Pole.—(See *Pole, Analogous.*)

Analysis.—The determination of the composition of a compound substance by separating it into the simple or elementary substances of which it is composed.

Analysis, Electric — — The determination of the composition of a substance by electrical means.

Various processes have been proposed for electric analysis; they consist essentially in decomposing the substance by means of electric currents, and are either qualitative or quantitative. (See *Electrolysis.*)

Analysis, Electrolytic — — A term sometimes used instead of electric analysis, (See *Analysis, Electric.*)

Analysis, Qualitative — — A chemical

analysis which merely ascertains the kinds of elementary substances present.

Analysis, Quantitative — — A chemical analysis which ascertains the relative proportions in which the different components enter into a compound.

Analyzable.—Separable into component parts.

Analyze.—To separate into component parts.

Analyze, Electrically — — To separate electrically into component parts.

Analyzer, Electric — — A gridiron of metallic wires which is transparent to electromagnetic waves, when its length is perpendicular to them, but opaque to them—*i. e.*, possessing the ability to reflect them—when rotated 90 degrees from its former position.

The electric analyzer, it will be observed, is analogous to an analyzer for polarized light. A reflecting surface, for example, being able to reflect polarized light in a given position, and unable to reflect it when rotated 90 degrees from such position, is capable of acting as an analyzer for polarized light.

Analyzer, Gray's, Harmonic Telegraphic — — An electro-magnet, the armature of which consists of a steel ribbon stretched in a metallic frame and capable through regulation, as to tension, by means of a screw, of being tuned to a certain note.

The steel ribbon is thrown into vibration whenever pulsations from the transmitting instruments are sent over the line corresponding to the rate of motion of the ribbon, but is not set into vibration by any others. If, therefore, a number of different analyzers, tuned to different notes, are placed on the same line, each will be operated only by the pulsations sent into the line corresponding to its rate of motion, and thus multiple transmission in the same direction is possible. In order to strengthen the tones of the analyzers, each is provided with a resonant air column. (See *Resonator. Telegraphy, Multiplex.*)

Analyzing.—Separating into component parts.

Anelectric.—A word formerly applied to bodies (conductors) which it was believed could not be electrified by friction.

THIS PAGE IS LOCKED TO FREE MEMBERS

Purchase full membership to immediately unlock this page

Know Your Bible

Forgotten Books' Full Membership provides unlimited access to more than 28,000 volumes of Christian literature for \$8.99/month

HOLY BIBLE

Continue

*Fair use policy applies

molecule which appears at the *anode*. (See *Electrolysis. Anode.*)

As the anode is connected with the electro-positive terminal of a source, the *anion is the electro-negative radical or group of atoms, and therefore appears at the electro-positive terminal.*

A kation, or electro-positive radical, appears at the kathode, which is connected with the electro-negative terminal of the battery. Oxygen and chlorine are anions. Hydrogen and the metals are kations.

Anisotropic Conductor.—(See *Conductor, Anisotropic.*)

Anisotropic Medium.—(See *Medium, Anisotropic.*)

Annealing, Electric — — A process for annealing metals in which electric heating is substituted for ordinary heating.

Annual Inequality of Earth's Magnetism.—(See *Inequality, Annual, of Earth's Magnetism.*)

Annual Variation of Magnetic Needle.—(See *Needle, Magnetic, Annual Variation of.*)

Annunciator, Burglar-Alarm — — An annunciator used in connection with a system of burglar-alarms. (See *Alarm, Burglar.*)

Annunciator Clock, Electric — — (See *Clock, Electric Annunciator.*)

Annunciator Drop.—(See *Drop, Annunciator.*)

Annunciator Drop, Automatic — — (See *Drop, Automatic Annunciator.*)

Annunciator, Electro-Magnetic — — An electric device for automatically indicating the points or places at which one or more electric contacts have been closed.

The character of the annunciator depends, of course, on the character of the places at which these points, places or stations are situated.

Annunciators are employed for a variety of purposes. In hotels they are used for indicating the number of a room the occupant of which desires some service, which he signifies by pushing a button, thus closing an electric circuit. This is indicated or announced on the annunciator by the falling of a *drop*, on which is printed a number corresponding with the room, and by the

ringing of a bell to notify the attendant. The number is released by the movement of the armature of an electro-magnet. The drops are replaced in their former position by some mechanical device operated by the hand. In the place of a drop a

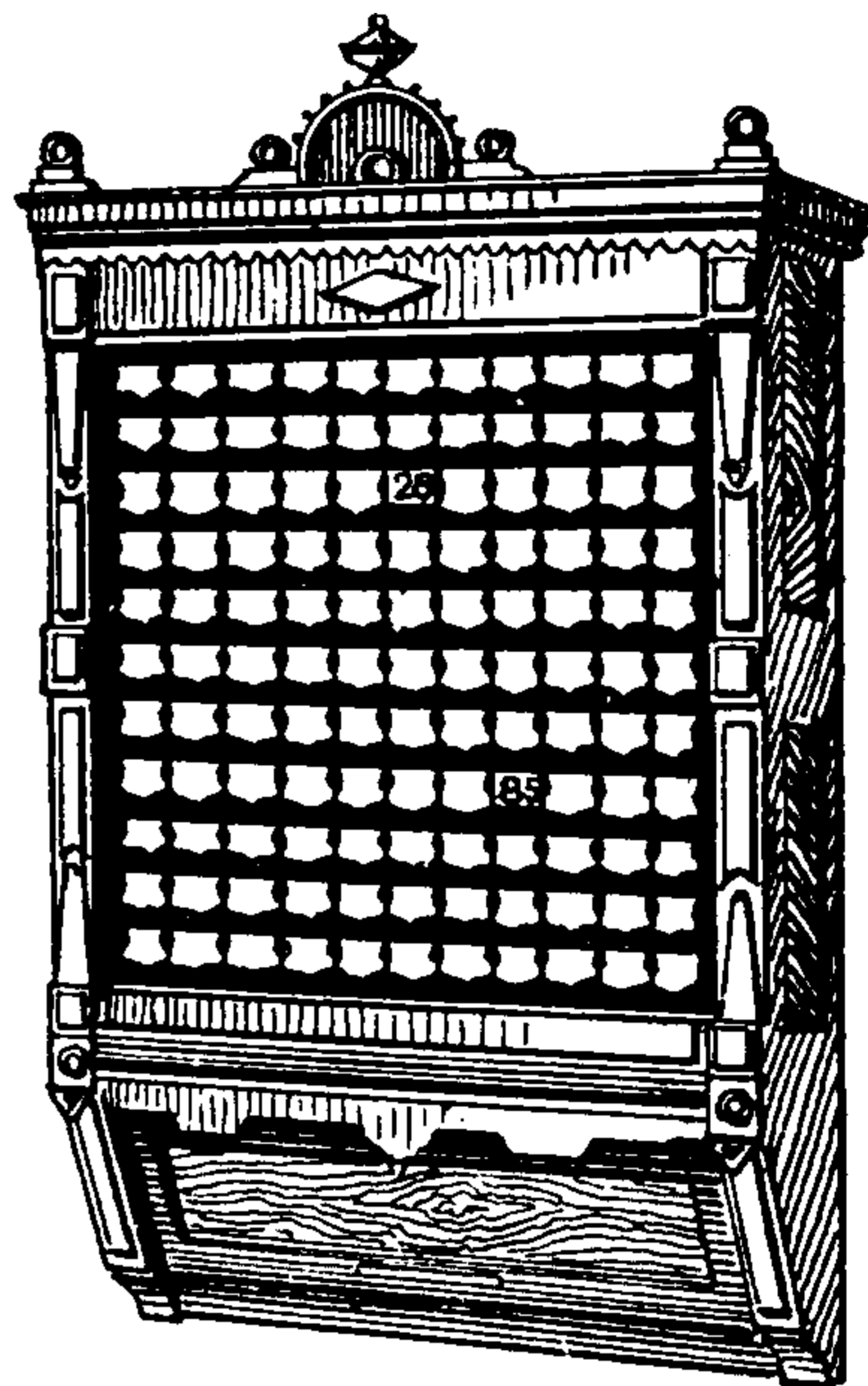

Fig. 14. *Electro-Magnetic Annunciator.*

needle is sometimes used, which, by the attraction of the armature of an electro-magnet, points to the number signaling.

Annunciators for houses, burglar-alarms, fire-alarms, elevators, etc., are of the same general construction.

Annunciators are generally operated by electro-magnetic attraction or repulsion, and are therefore sometimes called *electro-magnetic annunciators.*

Fig. 14 shows an annunciator suitable for use in hotels.

The numbers 28 and 85 are represented as having been dropped by the closing of the circuit connected with them.

Annunciator, Elevator — — An annunciator connected with an elevator to indicate the floor signaling.

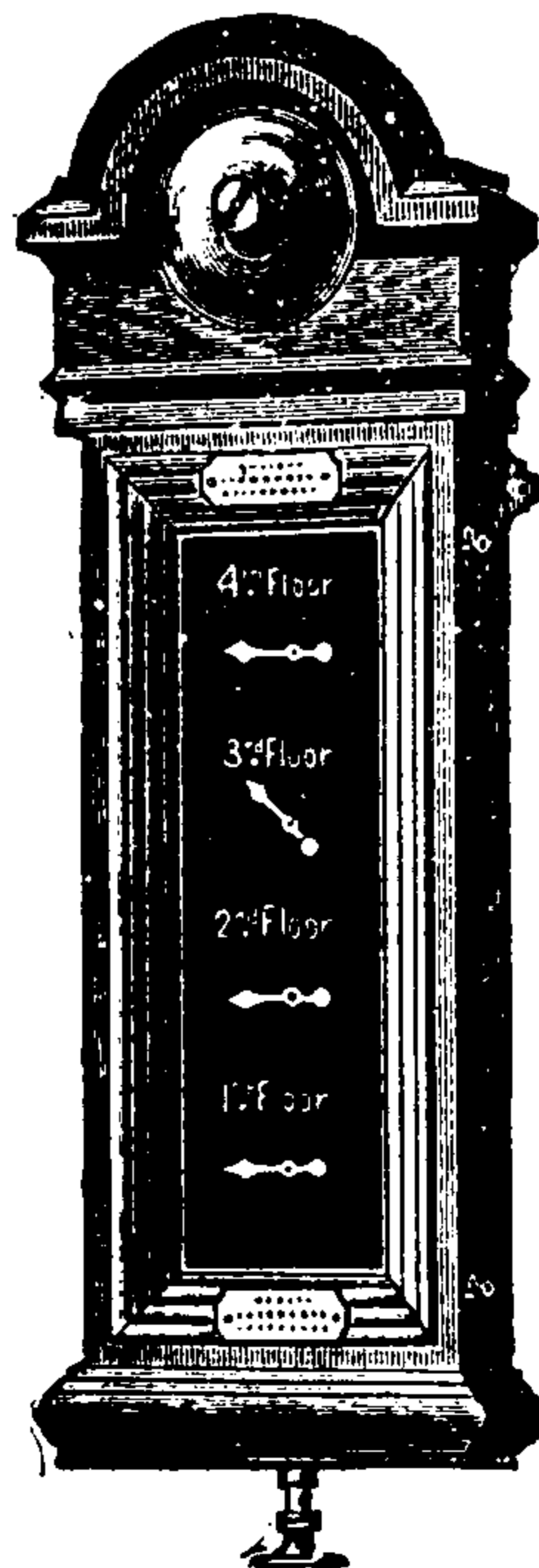

Fig. 15. *Elevator Annunciator.*

One form of elevator annunciator is shown in Fig. 15.

Annunciator, Fire-Alarm — —An annunciator used in connection with a system of fire-alarms.

Annunciator, Gravity-Drop — —An annunciator whose signals are operated by the fall of a drop.

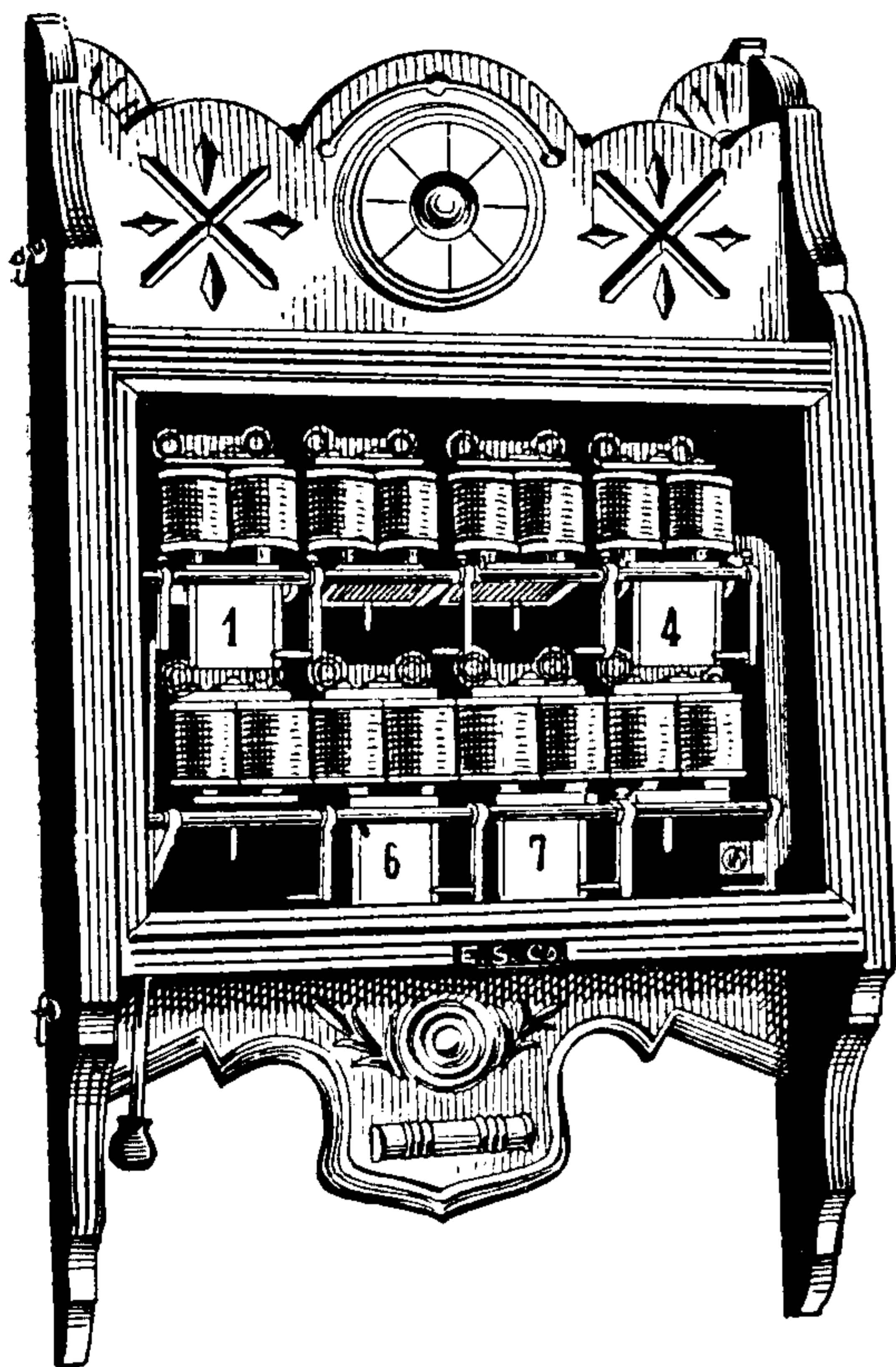

Fig. 16. Gravity-Drop Annunciator.

A form of gravity-drop annunciator is shown in Fig. 16. The armature mechanism for the release of the drop will be understood by an inspection of the drawing.

Annunciator, Hotel — —An annunciator connected with the different rooms of a hotel.

A hotel-annunciator is generally provided with a return bell and guest-call.

Annunciator, House — —An annunciator connected with the rooms of a house.

Annunciator, Needle — —An annunciator, the indications of which are given by the movements of a needle instead of the fall of a drop.

A form of needle-annunciator is shown in Fig. 17.

Annunciator, Oral or Speaking Tube — —An annunciator electrically operated

by means of a puff of breath transmitted through an ordinary speaking tube.

The oral-annunciator is a contrivance whereby a central office is placed in communication with a number of speaking tubes coming from different points in a hotel or other place. A person in any room, who wishes to communicate with the central office, blows through the speaking tube in his room, and thus, by effecting an electric contact, rings a bell and operates a drop at the annunciator, thus indicating the exact tube at which the attendant is to receive the message. The attendant can thus be placed in easy communication with each of the rooms whose speaking tubes connect with the annunciator.

Annunciator, Pendulum or Swinging — —An annunciator, the indicating arm of which consists of a pendulous, or swinging arm,

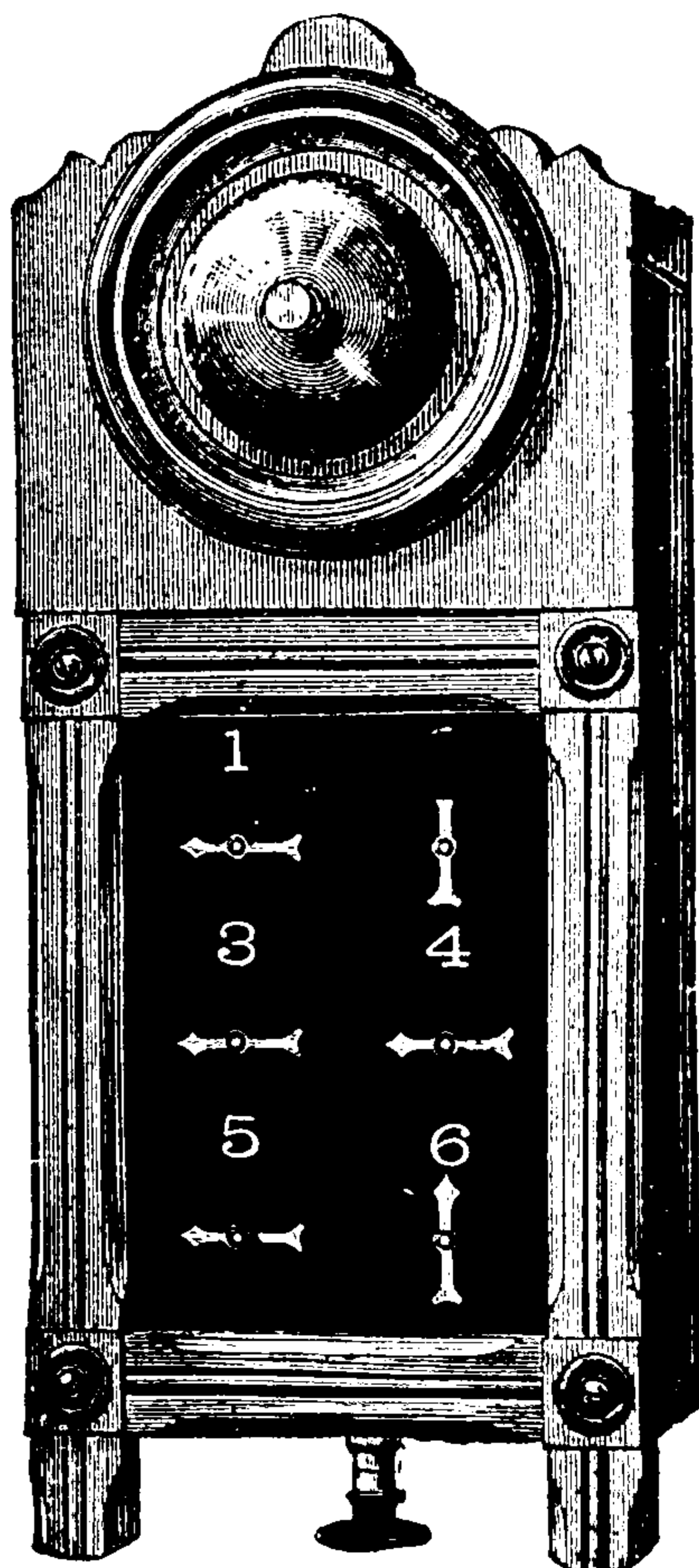

Fig. 17. Needle-Annunciator.

which, when at rest, points vertically downward, and which is moved to the right or left by the action of the current.

Pendulous, or swinging-annunciators are generally so arranged as to need no replacement.

On the cessation of the current the indicator arm drops vertically downward.

A relay is preferably used with pendulum-annunciators, since the rapid makes and breaks of the current by the bell alarm interfere with their satisfactory action.

Anodal.—Pertaining to the anode. (See *Anode*.)

Anodal Diffusion.—(See *Diffusion, Anodal*.)

Anode.—The conductor or plate of a decomposition cell connected with the positive terminal of a battery, or other electric source.

That terminal of an electric source out of which the current flows into the liquid of a decomposition cell or voltameter is called the anode.

That terminal of an electric source into which the current flows from a decomposition cell or voltameter is called the kathode.

The anode is connected with the carbon or positive terminal of a voltaic battery, and the kathode with the zinc, or negative terminal. Therefore the word anode has been used to signify the positive terminal of an electric source, and kathode, the negative terminal, and in this sense is employed generally in electro-therapeutics. It is preferable, however, to restrict the use of the words anode and kathode to those terminals of a source at which electrolysis is taking place.

The terms anode and kathode in reality refer to the electro-receptive devices through which the current flows. Since it is assumed that the current flows out of a source from its positive pole or terminal, and back through the source at its negative pole or terminal, the pole of any device which is connected with the positive pole of a source is the part or place at which the current enters and flows through it, and that connected with the negative pole, the part at which it leaves. Hence, probably, the change in the use of the words already referred to.

Since the *anion*, or the *electro negative* radical, appears at the *anode*, it is the anode of an *electro-plating bath*, or the plate connected with the positive terminal of the source, that is dissolved.

When the term *anode* was first proposed by Faraday, voltaic batteries were the only available electric source, and *the term referred only to the*

positive terminal of a voltaic battery when placed in an electrolyte.

Anodic.—Pertaining to the anode. (See *Anode*.)

Anodic Electro-Diagnostic Reactions.—(See *Reactions, Kathodic and Anodic Electro-Diagnostic*.)

Anodic Opening Contraction.—(See *Contraction, Anodic Opening*.)

Anomalous Magnet.—(See *Magnet, Anomalous*.)

Anomalous Magnetization.—(See *Magnetization, Anomalous*.)

Anti-Induction Cable — — (See *Cable, Anti-Induction*.)

Anti-Induction Conductor.—(See *Conductor, Anti-Induction*.)

Antilogous Pole.—(See *Pole, Antilogous*.)

Anvil.—The front contact of a telegraphic key that limits its motion in one direction. (See *Key, Telegraphic*.)

Aperiodic Galvanometer.—(See *Galvanometer, Aperiodic*.)

Apparatus, Faradic-Induction — —
An induction coil apparatus for producing faradic currents.

A voltaic battery is connected with the primary of an induction coil, and its current rapidly broken by an *automatic break*, or by a hand break. The alternating or faradic currents thus produced in the secondary coils are used for electro-therapeutic purposes. (See *Coil, Induction*.)

Faradic induction apparatus is made in a great variety of forms. They all operate, however, on essentially the same principles.

Apparatus, Faradic, Magneto-Electric — —
— — A small magneto-electric machine employed in electro-therapeutics for producing faradic currents.

Magneto-electric faradic machines consist essentially of a coil of wire wrapped on an armature core that is rotated before the poles of permanent magnets. No commutator is employed, since it is desired to obtain rapidly alternating currents.

Apparatus, Interlocking — —
— — Devices for mechanically operating from a distant signal

tower, railroad switches and semaphore signals for indicating the position of such switches, by means of a system of interlocking levers, so constructed that the signals and the switches are so interlocked as to render it impossible, after a route has once been set up and a signal given, to clear a signal for a route that would conflict with the one previously set up. (See *Block System for Railroads.*)

Apparatus, Magneto-Electric Medical — —A term applied to small magneto-electric machines employed in medical electricity for the production of uncommuted or faradic currents. (See *Apparatus, Faradic, Magneto-Electric.*)

Apparatus, Registering, Electric — — Devices for obtaining permanent records by electrical means.

Apparatus, Registering, Telegraphic — —A name sometimes given to a telegraphic recorder. (See *Recorder, Chemical, Bain's. Recorder, Morse. Recorder, Siphon.*)

Apparent Co-efficient of Induction. — (See *Induction; Apparent Co-efficient of.*)

Arago's Disc. — (See *Disc, Arago's.*)

Arc. — A voltaic arc. (See *Arc, Voltaic.*)

Arc. — To form a voltaic arc.

A dynamo-electric machine is said to arc at the commutator, when the current passes as visible sparks across the spaces between adjacent segments.

This action at the commutator is more generally called *sparking* or *burning*.

Arc, Alternating — —A voltaic arc formed by means of an alternating current.

In order to avoid the extinction of the arc a certain number of alternations per second is necessary. The alternating arc produces a loud singing noise. At very high frequencies, however, the noise disappears.

The alternating arc, not possessing a fixed positive crater, requires to be covered by a good reflector to throw the light downward.

Arc, Ampère — —A single conductor bent in an arc of a circle, and used in electric balances for measuring the electric current.

Arc Blow-Pipe. — (See *Blow-Pipe, Electric Arc.*)

Arc, Compound — —An arc formed between more than two separate electrodes.

Arc, Counter Electromotive Force of — —An electromotive force generally believed to be set up on the formation of a voltaic arc, opposed in direction to the electromotive force maintaining the arc. (See *Force, Electromotive, Counter.*)

This counter electromotive force is believed to have its origin partly in the energy absorbed at the crater of the positive carbon, where the carbon is volatilized, and given out at the nipple on the negative carbon, where it is deposited or solidified. It is to be noted in this connection that the apparent resistance of the carbon voltaic arc is not directly proportional to the length of the arc.

Arc, Electric — —A term sometimes used for the voltaic arc. (See *Arc, Voltaic.*)

Arc, Frying of — —A frying sound attending the formation of a voltaic arc when the carbons are too near together.

The cause of the frying sound is probably the same as that of hissing. (See *Arc, Hissing of.*)

Arc, Hissing of — —A hissing sound attending the formation of voltaic arcs when the carbons are too near together.

The cause of the hissing is not entirely understood. Prof. Elihu Thomson suggests that it is due to a too rapid volatilization of the carbons.

Arc Lamp. — (See *Lamp, Arc.*)

Arc Lamp, Electric — — (See *Lamp, Electric Arc.*)

Arc Lamp, Triple Carbon Electric — — (See *Lamp, Arc, Triple Carbon Electric.*)

Arc Lighting. — (See *Lighting, Arc.*)

Arc, Metallic — —A voltaic arc formed between metallic electrodes.

When the voltaic arc is formed between metallic electrodes instead of carbon electrodes, a flaming arc is obtained, the color of which is characteristic of the burning metal; thus copper forms a brilliant green arc. The metallic arc, as a rule is much longer than an arc with the same current taken between carbon electrodes.

Arc Micrometer. — (See *Micrometer, Arc.*)

Arc, Noisy — —A voltaic arc, the maintenance of which is attended by frying, hissing, or spluttering sounds.

Arc, Quiet — —A voltaic arc which is maintained without sensible sounds.

Arc, Roaring of — —A roaring sound attending the formation of a voltaic arc when the carbons are too near together and a very powerful current is used.

Arc, Simple — —An arc formed between two electrodes.

Arc, Spluttering of — —A spluttering sound attending the formation of a voltaic arc.

Prof. Elihu Thomson suggests that the cause of spluttering is due to the presence of impurities in the carbons, or from the sudden evolution of gas from insufficiently baked carbons.

Arc, Voltaic — —The brilliant arc or bow of light which appears between the electrodes or terminals, generally of carbon, of a sufficiently powerful source of electricity, when separated a short distance from each other.

The source of light of the electric arc lamp.

It is called the voltaic arc because it was first obtained by the use of the battery invented by Volta. The term arc was given to it from the shape of the luminous *bow* or *arc* formed between the carbons.

To form the voltaic arc the carbon electrodes are first placed in contact and then gradually separated. A brilliant arc of flame is formed between them, which consists mainly of volatilized carbon. The electrodes are consumed, first, by actual combination with the oxygen of the air; and, second, by volatilization under the combined influence of the electric current and the intense heat.

As a result of the formation of the arc, a crater is formed at the end of the positive carbon, and appears to mark the point out of which the greater part of the current flows.

The crater is due to the greater volatilization of the electrode at this point than elsewhere. It marks the position of highest temperature of the electrodes, and is the main source of the light of the arc. When, therefore, the voltaic arc is employed for the purposes of illumination with vertically opposed carbons, the positive carbon should be made the upper carbon, so that the

focus of greatest intensity of the light may be favorably situated for illumination of the space below the lamp. When, however, it is desired to illumine the side of a building *above* an arc lamp, the lower carbon should be made positive.

The positive carbon is consumed about twice as rapidly as the negative, both because the negative oxygen attacks the points of the positive carbon, and because the positive carbon suffers the most rapid volatilization.

The electric current passes through the space occupied by the voltaic arc because—

(1.) The heated arc is a partial conductor of electricity.

(2.) Because small charges of electricity are carried bodily forward from the positive to the negative carbon through the space of the voltaic arc, by means of the minute particles which are volatilized at the positive electrode.

S. P. Thompson has shown that the temperature of the light-emitting surface of the carbon is the temperature of the volatilization of carbon, and is therefore constant.

Dr. Fleming found that “A rise of potential along the arc takes place very suddenly, just in the neighborhood of the crater.”

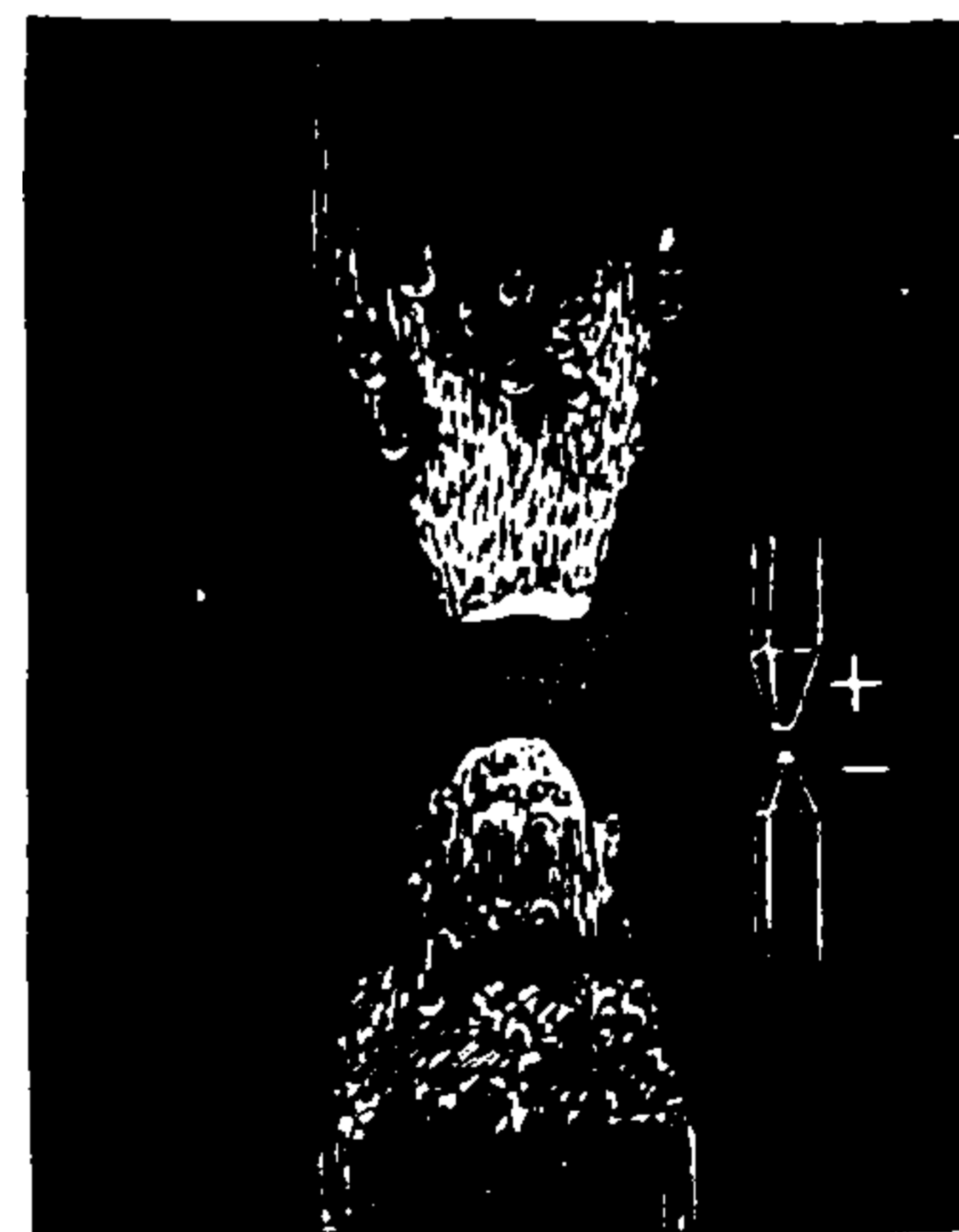

Fig. 18. Voltaic Arc.

The rounded masses or globules that appear on the surface of the electrodes are due to deposits of molten foreign matters in the carbon.

The carbon, both of the crater and its opposed nipple, is converted into pure, soft graphite.

Arc, Voltaic, Resistance of — —The resistance offered by the voltaic arc to the passage of the current.

As in all other conductors, the ohmic resistance of the arc increases with its length, and decreases with its area of cross-section. The apparent resistance, however, is not directly proportional to the length. An increase of temperature decreases the resistance of the voltaic arc.

The total apparent resistance of the voltaic arc is composed of two parts, viz.:

(1.) The true ohmic resistance. (See *Resistance, Ohmic.*)

(2.) The counter electromotive force, or spurious resistance. (See *Resistance, Spurious.*)

Arc, Watt — —A voltaic arc, the electric power of which is equal to a given number of watts.

The ordinary long-arc, as employed in arc lighting, has a difference of potential of about 45 volts and a current strength of about 10 ampères. It is, therefore, a 450-watt arc.

Arch, Auroral — —The archlike form sometimes assumed by the auroral light. (See *Aurora Borealis.*)

Arcing.—Discharging by means of voltaic arcs. (See *Arc, Voltaic.*)

Arcing at the commutator of a dynamo-electric machine not only prevents the proper operation of the machine, but eventually leads to the destruction of the brushes and the commutator.

Areometer, Bead — —A form of areometer suitable for rapidly testing the density of the liquid in a storage cell.

The bead areometer consists of a glass tube, open at both top and bottom, containing a few glass beads, so weighted as to float at liquid densities such as 1.105, 1.170, 1.190 and 1.200. To use the instrument, it is immersed in the liquid of the storage cell, and then withdrawn. The finger being kept in the upper opening, the liquid does not escape through the small opening at the bottom. The density is then ascertained by noting the beads that float.

Areometer or Hydrometer. —An instrument for determining the specific gravity of a liquid.

A common form of hydrometer consists, as shown in Fig. 19, of a closed glass tube, provided with a bulb, and filled at the lower end with mercury or shot, so as to insure its vertical position when floating in a liquid. When placed in different liquids, it floats with part of the tube out of the liquid. The lighter the liquid, the

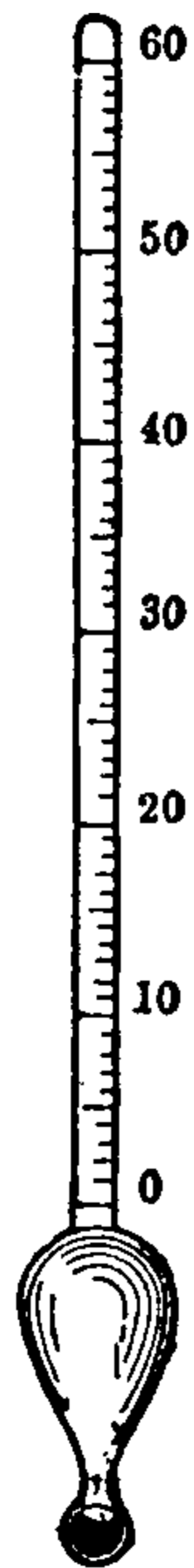

Fig. 19. Hydrometer.

smaller is the portion that remains out of the liquid when the instrument floats. The specific gravity is determined by observing the depth to which the instrument sinks when placed in different liquids, as compared with the depth it sinks when placed in water.

Areometry.—The measurement of specific gravity by means of an areometer.

Argand Burner, Electric Hand-Lighter — —(See *Burner, Argand, Electric Hand-Lighter.*)

Argand Burner, Electric Plain-Pendant — —(See *Burner, Plain Pendant, Argand, Electric.*)

Argand Burner, Electric Ratchet-Pendant — —(See *Burner, Ratchet-Pendant, Argand, Electric.*)

Argyrometry.—The art of determining the weight of electrolytically deposited silver. (See *Balance, Plating.*)

Arm, Balance — —One of the resistances of an electric balance. (See *Arms, Bridge or Balance. Bridge, Electric.*)

Arm, Bridge — —A bridge arm. (See *Arms, Bridge or Balance.*)

Arm, Cross — —A horizontal beam attached to a pole for the support of the insulators for telegraph, electric light or other electric wires.

A telegraphic arm. (See *Arm, Telegraphic.*)

Arm, Rocker — —An arm on which the brushes of a dynamo or motor are mounted for the purpose of shifting their position on the commutator.

Arm, Semaphore — —The movable arm of the signal apparatus employed in block systems for railroads, for the purpose of informing engineers of trains of the condition of the road as regards other trains.

In the absolute block system, as used on some roads, there are two positions for the semaphore arm, viz.:

(1.) For Danger—when in a horizontal position, or at 90 degrees with the vertical supporting pole.

(2.) Clear—when dropped below the horizontal position through an angle of 75 degrees.

In the Permissive Block System, a third position

intermediate between the 1st and the 2d, or at an angle of 37 degrees 30 minutes with the horizontal position, is used for caution. (See *Block System for Railroads.*)

Arm, Signal — — A semaphore arm. (See *Arm, Semaphore.*)

Arm, Telegraphic — — A cross-arm placed on a telegraphic pole for the support of the insulators.

These arms are generally called cross-arms.

Armature.—A mass of iron or other magnetizable material placed on or near the pole or poles of a magnet.

In the case of a *permanent magnet*, the armature, when used as a *keeper*, is of soft iron and is placed directly on the magnet poles. In this case it preserves or keeps the magnetism by closing the *lines of magnetic force* of the magnet through the soft iron of the armature, and is then called a *keeper*. (See *Force, Magnetic, Lines of.*)

In the case of an electro-magnet, the armature is placed near the poles, and is moved toward them whenever the magnet is energized by the passage of the current through the magnetizing coils. This movement is made against the action of a spring or weights, so that on the loss of magnetism by the magnet, the armature moves from the magnet poles. (See *Magnet, Permanent. Magnet, Keeper of.*)

When the armature is of soft iron it moves toward the magnet on the completion of the circuit through its coils, no matter in what direction the current flows, and is then called a *non-polarized armature*. (See *Armature, Non-Polarized.*)

When made of *steel*, or of another electro-mag-

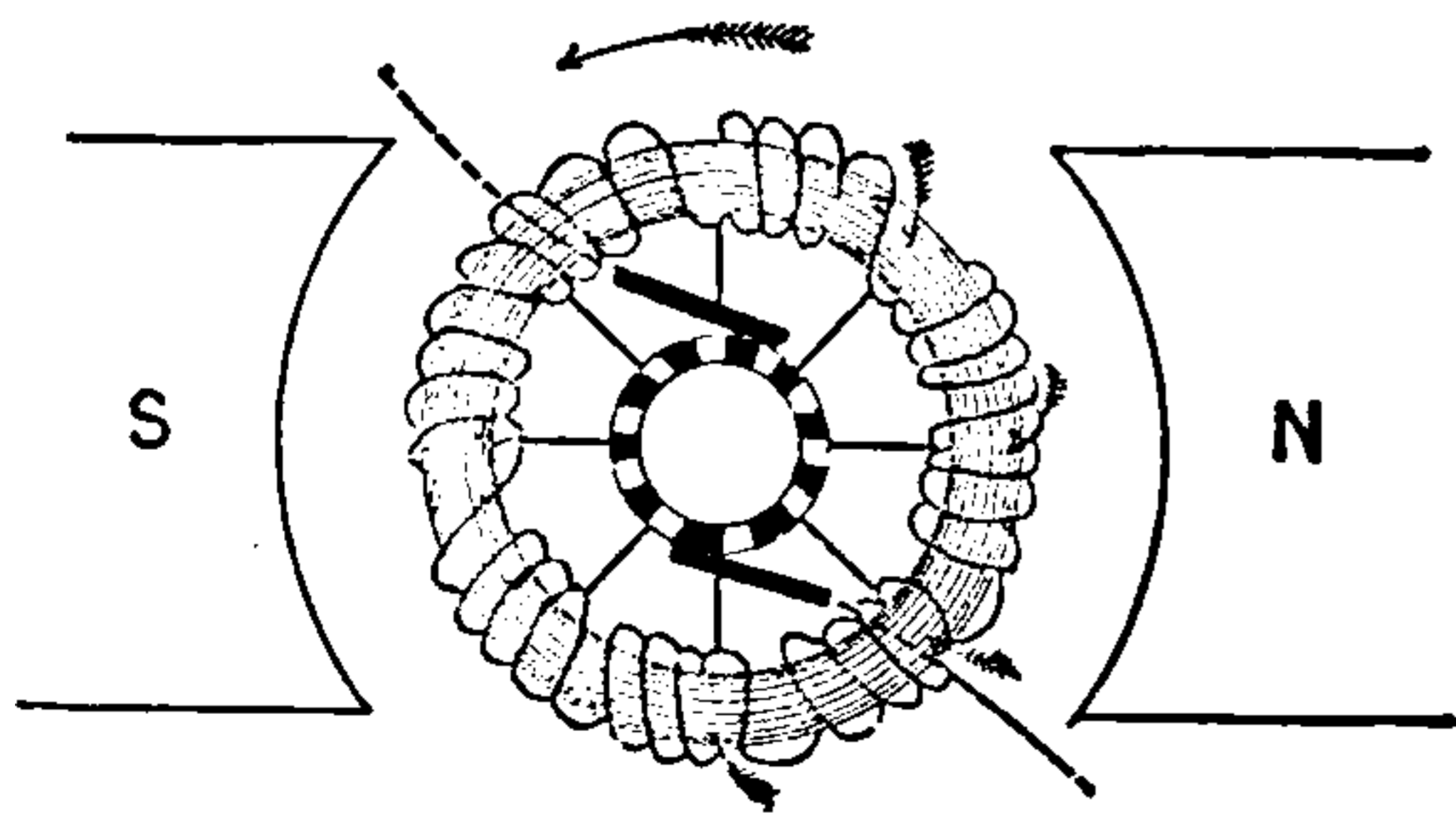

Fig. 20. Bi-polar Armature.

net, it moves from or toward the poles, according to whether the poles of the armature are of the same or of a different polarity from those of the magnet. Such an armature is called a *polarized armature*. (See *Armature, Polarized.*)

Armature, Bi-polar — — An armature of a dynamo-electric machine the polarity of which is reversed twice in every revolution through the field of the machine.

A form of bi-polar armature is shown in Fig. 20. The word bi-polar armature is not generally employed. The term applies rather to the field-magnet poles than to the armature.

Armature Bore.—(See *Bore, Armature.*)

Armature Bore, Elliptical — — (See *Bore, Elliptical Armature.*)

Armature Chamber.—(See *Chamber, Armature.*)

Armature Coils, Dynamo — — (See *Coils, Armature, of Dynamo-Electric Machine.*)

Armature Core, Dynamo — — (See *Core, Armature, of Dynamo-Electric Machine.*)

Armature, Cylindrical — — A term sometimes applied to a drum armature. (See *Armature, Drum. Armature, Dynamo-Electric Machine.*)

Armature, Cylindrical Ring.—A ring armature with a core in the shape of a comparatively long cylinder.

Armature, Disc — — An armature of a dynamo-electric machine, in which the armature coils consist of flat coils, supported on the surface of a disc. (See *Armature, Dynamo-Electric Machine.*)

Armature, Dissymmetrical Induction of — — Any induction produced in the armature of a dynamo-electric machine that is unequal in amount on opposite halves, or in symmetrically disposed portions of the armature.

Dissymmetrical induction in the armature may cause annoying or injurious sparking at the commutator. It may arise—

- (1.) From a lack of symmetry in the amount of the armature windings.
- (2.) From a lack of symmetry in the arrangement of the armature windings on the armature core.
- (3.) From a lack of symmetry of the pole pieces of the machine.
- (4.) From an improper position of the brushes

THIS PAGE IS LOCKED TO FREE MEMBERS

Purchase full membership to immediately unlock this page



HISTORY

Tens of thousands of important historical sources, many previously unobtainable, are now available for the first time with a Forgotten Books Full Membership.

Unlimited Access
\$8.99/month

Continue

*Fair usage policy applies

tion of the circuit, no matter in what direction the current passes through the coils.

The term non-polarized is used in contradistinction to polarized armature. (See *Armature, Polarized.*)

The non-polarized armature of a relay magnet is generally called the *neutral-relay armature*.

Armature of a Cable, or Cable-Armature.

—A term sometimes employed for the sheathing or protecting coat of a cable.

The term armor sheathing or coating is preferable:

Armature of a Condenser, or Condenser Armature.—A term sometimes applied to the metallic plates of a condenser or Leyden jar.

The use of this term is unnecessary and ill-advised. The term coating or plate would appear to be preferable.

Armature of Holtz Machine, or Holtz-Machine Armature.—The pieces of paper that are placed on the stationary plate of the Holtz and other similar electrostatic induction machines.

Armature Pockets.—(See *Pockets, Armature.*)

Armature, Polarized — —An armature which possesses a polarity independent of that imparted by the magnet pole near which it is placed.

In permanent magnets the armatures are made of soft iron, and therefore, by *induction*, become of a polarity opposite to that of the magnet poles that lie nearest them. They have, therefore, only a motion of attraction toward such poles. (See *Induction, Magnetic.*)

In electro-magnets the armatures may either be made of soft iron, in which case they are attracted only on the passage of the current; or they may be formed of permanent steel magnets, or may be electro-magnets themselves, in which case the passage of the current through the coils of the electro-magnet, or electro-magnets, may cause either attraction or repulsion, according as the adjacent poles are of opposite polarity or are of the same polarity.

Armature, Pole — —An armature the coils of which are wound on separate poles

that project radially from the periphery of a disc, drum or ring.

A pole-armature showing the arrangement of

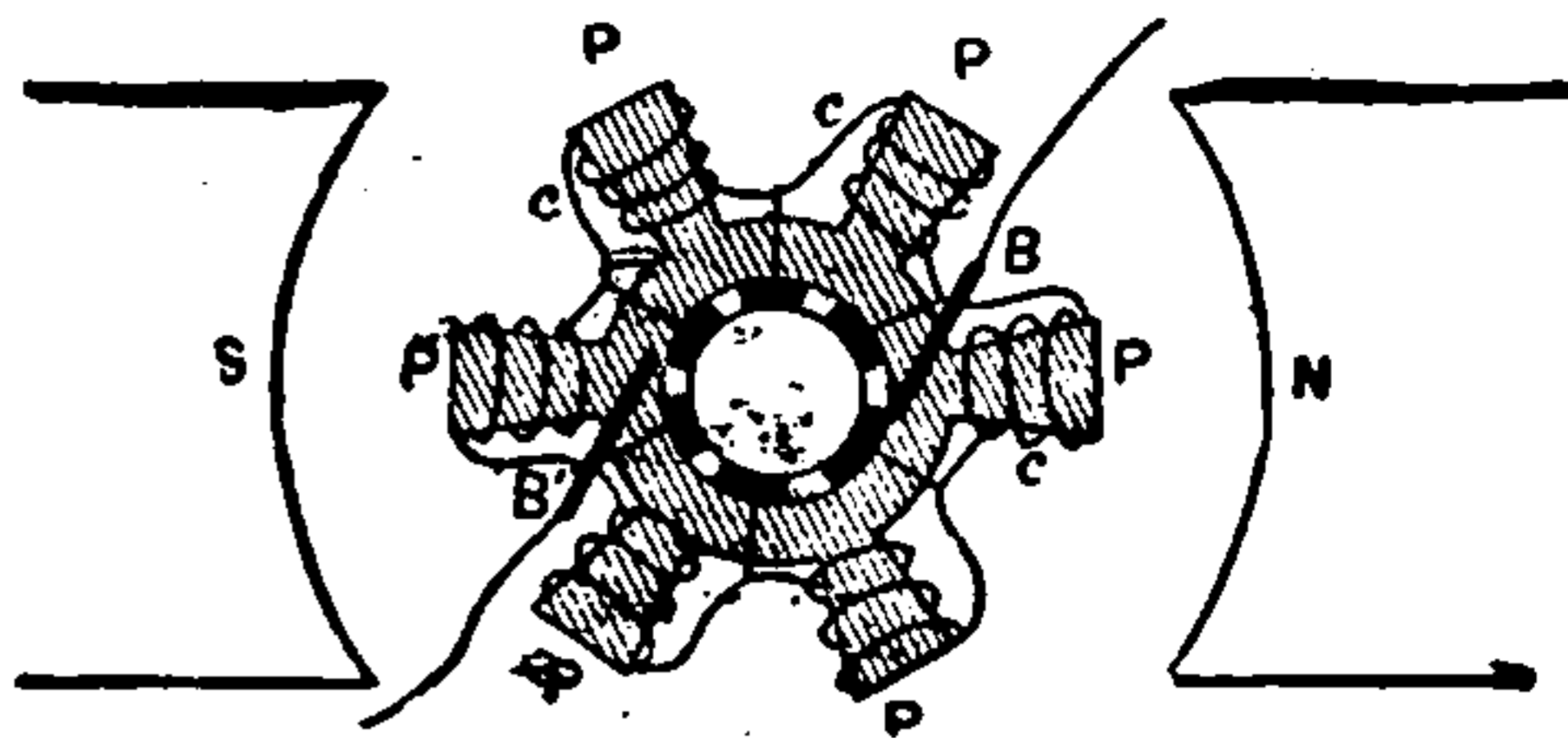

Fig. 22. Pole-Armature.

the coils and their connection to the commutator segments is seen in Fig. 22.

Armature, Quantity — —An old term for an armature wound with but a few coils of comparatively low resistance.

Armature, Radial — —A term sometimes used instead of pole-armature. (See *Armature, Pole.*)

Armature, Ring — —A dynamo-electric machine armature, the coils of which are wound on a ring-shaped core.

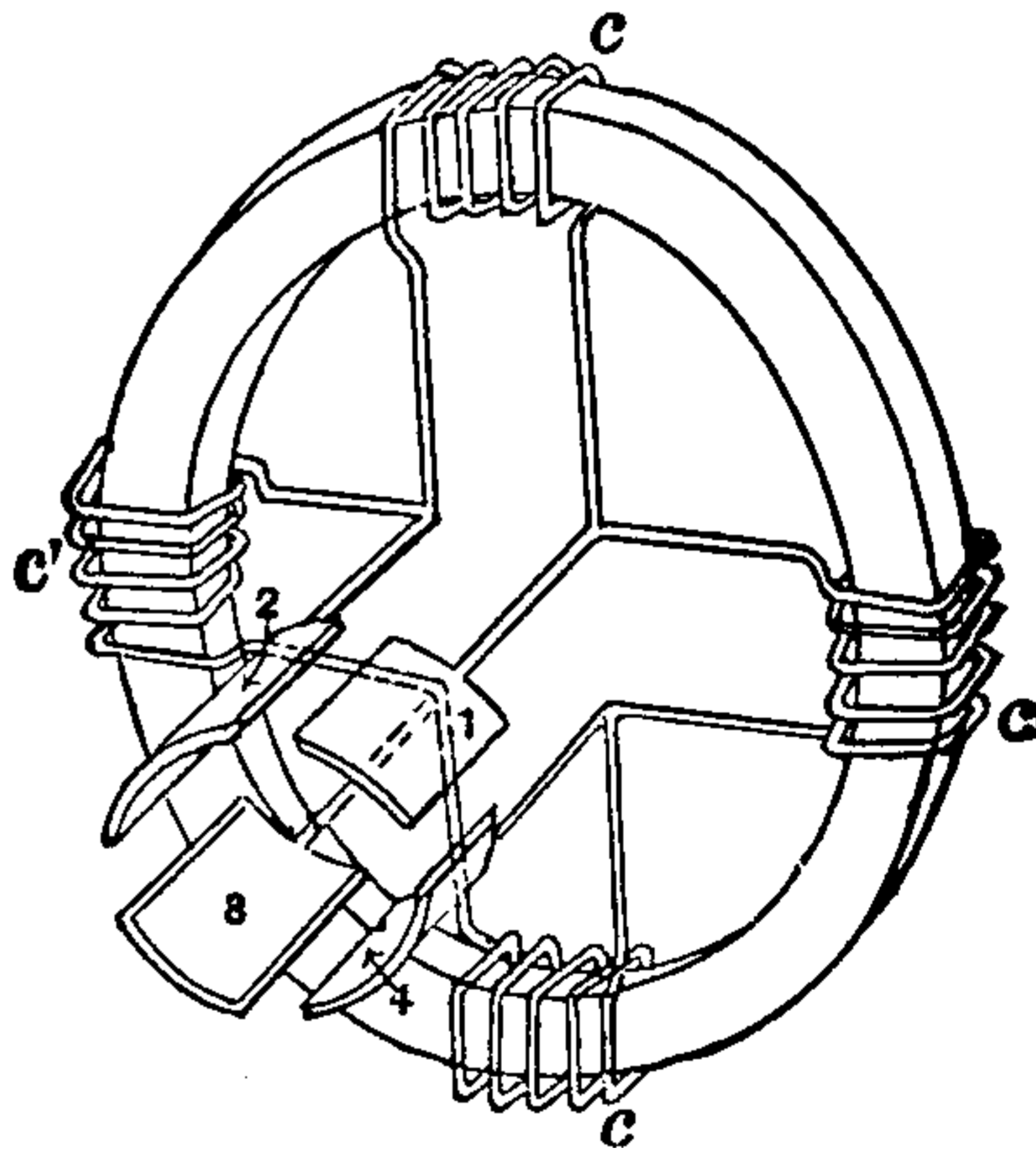

Fig. 23. Ring-Armature.

A ring-armature is shown in Fig. 23, together with the disposition of the coils and their connection to the segments of the commutator.

Armature, Shuttle — —A variety of drum armature in which a single coil of wire is wound in an H-shaped groove formed in a bobbin shaped core.

The old form of Siemens-armature.

Armature, Single-Loop — —A closed conducting circuit consisting of a single loop, capable of revolving in a magnetic field so as to cut its lines of force.

Armature, Spider.—(See *Spider, Armature.*)

Armature, Spherical — —A dynamo-electric machine armature, the coils of which are wound on a spherical iron core.

The Thomson-Houston dynamo, which is the only machine employing an armature of this type, has its armature formed by wrapping three coils of insulated wire on a core of iron so shaped as to insure an approximately spherical armature when wrapped.

Armature, Toothed-Ring — —An armature, the core of which is in the shape of a ring, provided with a number of teeth in the spaces between which the armature coils are placed.

Armature, Unipolar — —A dynamo-electric machine armature whose polarity is not reversed during its rotation in the field of the machine.

Armature, Ventilation of — —A process for insuring the free passage of air through the armature of a dynamo-electric machine in order to prevent overheating.

Armor of Cable.—(See *Cable, Armor of.*)

Armored Cable.—(See *Cable, Armored.*)

Armored Conductor.—(See *Conductor, Armored.*)

Arms, Bridge or Balance — —The electric resistances, in the electric balance or bridge. (See *Bridge, Electric.*)

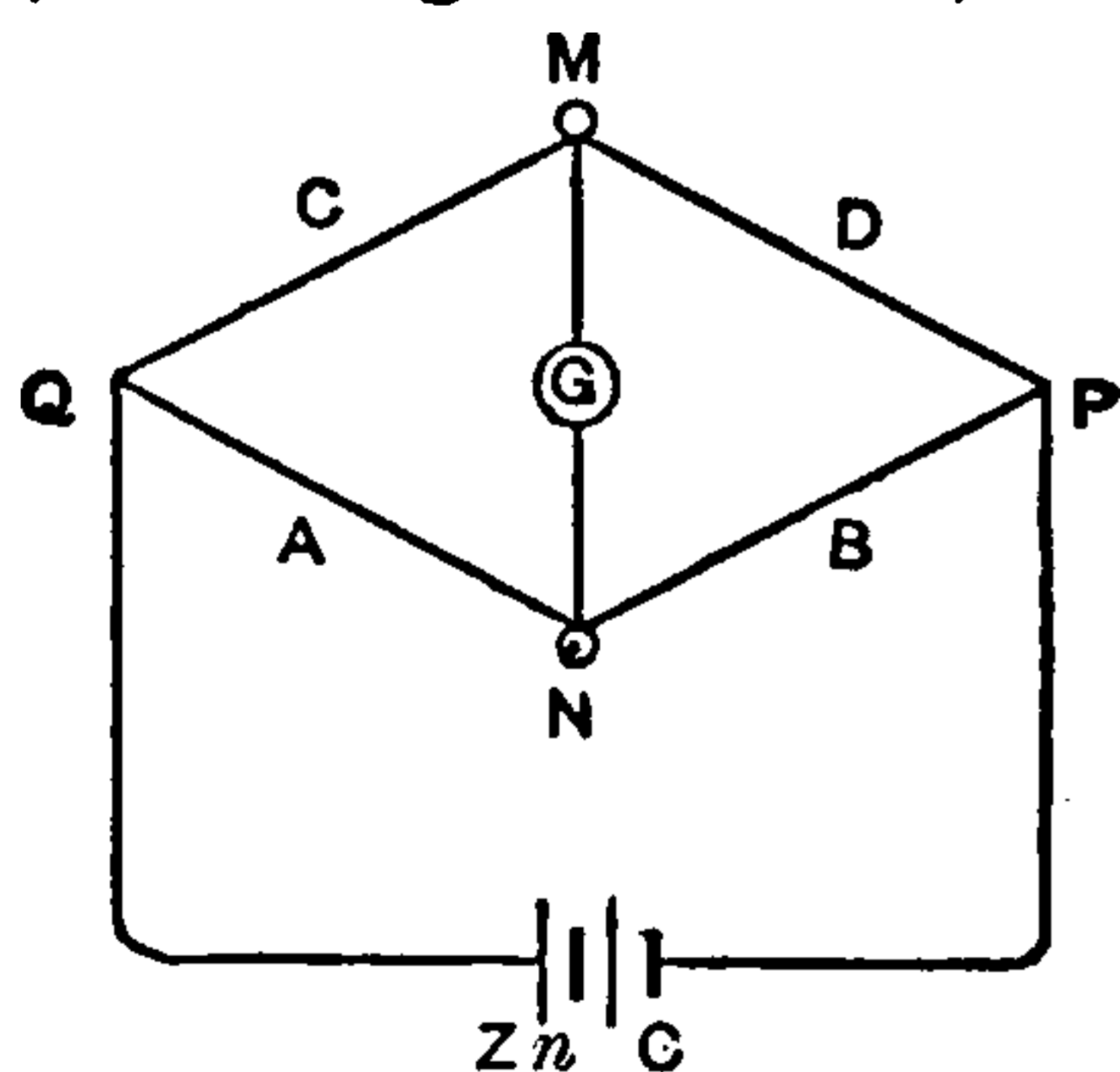

Fig. 24. Arms of Balance.

An unknown resistance, such, for example, as D, Fig. 24, is measured by proportioning the known resistances, A, C and B, so that no current flows through the galvanometer G, across the circuit or bridge M G N.

Arms, Proportionate — —The two resistances or arms of an electric bridge whose relative or proportionate resistances only are required to be known in order to determine,

in connection with a known resistance, the value of an unknown resistance placed in the remaining arm of the bridge.

Thus is Fig. 24, A and B, are the proportionate arms.

Arrangement or Device, Electromotive — —A term sometimes employed to represent a dynamo-electric machine, voltaic cell or other electric source, by means of which electromotive force can be produced.

Electric sources do not produce electric currents, but differences of potential or electromotive force. Electric sources are therefore very properly termed electromotive devices.

Arrester, Lightning — —A device by means of which the apparatus placed in any electric circuit is protected from the destructive effects of a flash or bolt of lightning.

In the phenomena of *lateral induction* and *alternative path*, we have seen the tendency of a *disruptive* discharge to take a short-cut across an intervening air space, rather than through a longer though better conducting path. Most lightning arresters are dependent for their operation on this tendency to lateral discharge. (See *Induction, Lateral. Path, Alternative.*)

A form of lightning arrester is shown in Fig. 25.

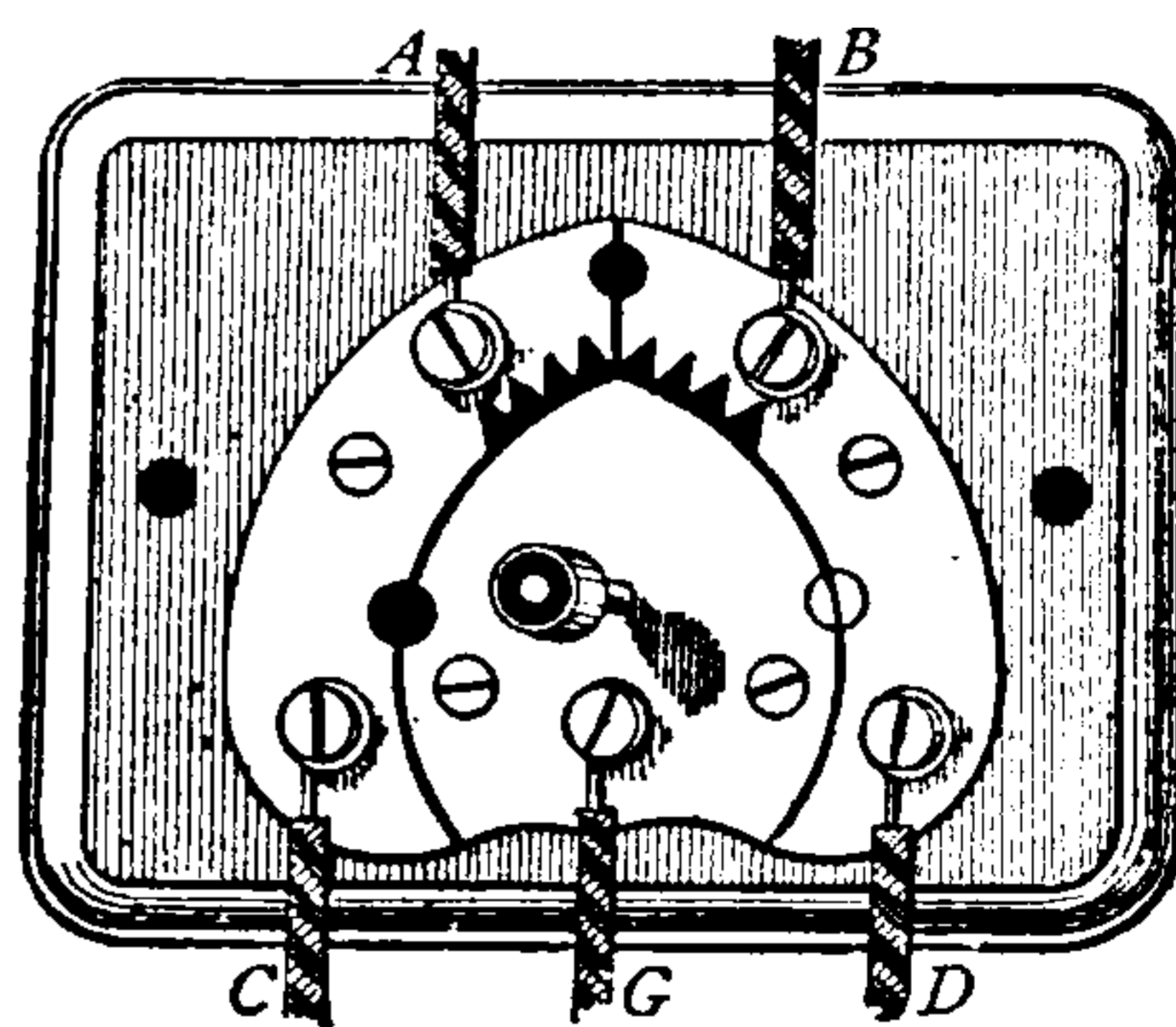

Fig. 25. Comb Lightning-Arrester.

The line wires, A and B, are connected by two metallic plates to C and D, respectively.

These plates are provided with points, as shown, and placed near a third plate, connected to the ground by the wire G. Should a bolt strike the line, it is discharged to the earth through the wire G.

Various forms are given to lightning arresters of this type. The projections are sometimes placed on the ground-connected plate as well as on the plates connected to line wires. This form is sometimes called a *comb arrester*, or *protector*.

Arrester, Lightning, Comb — — A term sometimes applied to a lightning arrester in which both the line and ground plates are furnished with a series of teeth, like those on a comb. (See *Arrester, Lightning*.)

Arrester, Lightning, Counter-Electromotive Force — — A lightning arrester, in which the passage of the discharge through the instruments to be protected is opposed by a counter-electromotive force, generated by induction on the passage of the discharge of the bolt to earth.

The counter-electromotive force lightning arrester is an invention of Professor Elihu Thomson.

It assumes a variety of forms. In the shape shown in Fig. 26, the line circuit of the dynamo,

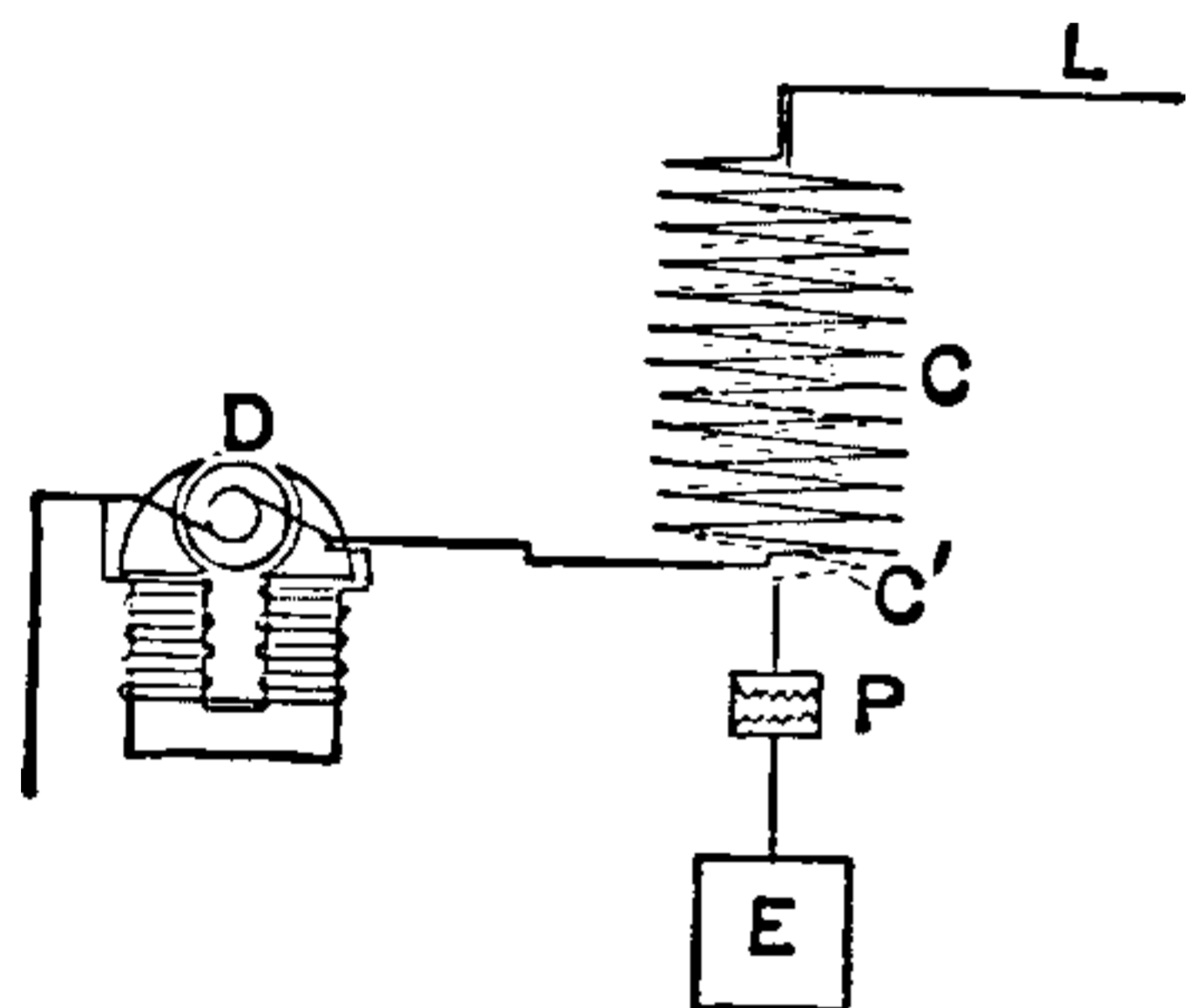

Fig. 26. Counter-Electromotive Force Lightning Arrester.

D, has one end connected to ground, and the other end has two conducting paths to ground. One of these paths is through the ordinary comb-protector at P, by the ground plate E; this circuit includes a few turns

of wire C'. The other path is through a corresponding coil C, either interior or exterior to C', so as to be within its inductive field. As will be seen from the figure, C, is connected through the machine to the ground.

The induction coils C and C', are thoroughly insulated from each other.

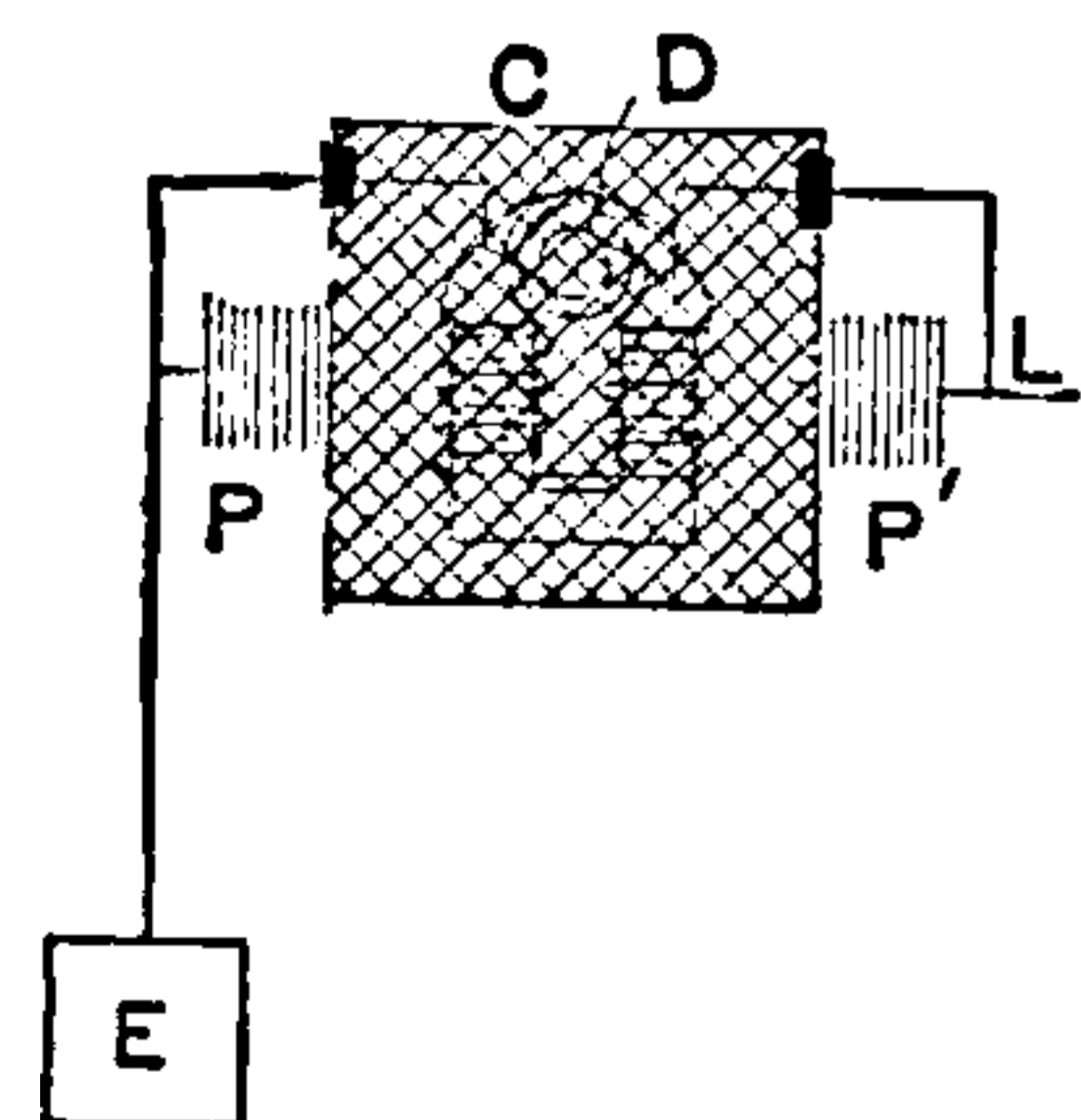

Fig. 27. Counter-Electromotive Force Lightning Arrester.

Should a lightning flash or other static discharge pass through the circuit C', which is of comparatively low self-induction, a counter-electromotive force is produced in the other coil C, which protects the line circuit.

In the form of lightning arrester shown in Fig. 27, the coil in the path of the direct lightning discharge is formed into an exterior mesh or net work surrounding the dynamo to be protected. In this case, the coils of the dynamo act as the secondary coils in which the counter electromotive force is set up.

Arrester, Lightning, Transformer — — A form of lightning arrester designed for the protection of transformers.

The Thomson arrester for transformers operates on the same principle as his arc-line protector. In the latter the arc, when formed, is blown out by the action of the field of an electro-magnet. This arc is formed on curved metallic bows, one of which is connected to line and the other to earth. The arc is formed at the smallest interval between the bows, and is extinguished by being driven by action of a magnetic field toward greatest interval.

Arrester Plate of Lightning Protector.— (See *Plate, Arrester, of Lightning Protector*.)

Arrester Plates.—(See *Plates, Arrester*.)

Articulate Speech.—(See *Speech, Articulate*.)

Artificial Carbons.—(See *Carbons, Artificial*.)

Artificial Illumination.—(See *Illumination, Artificial*.)

Artificial Line.—(See *Line, Artificial*.)

Artificial Magnet.—(See *Magnet, Artificial*.)

Asphyxia.—Suspended respiration, resulting eventually in death, from non-aeration of the blood.

In cases of insensibility by an electric shock a species of asphyxia is sometimes brought about. This is due, probably, to the failure of the nerves and muscles that carry on respiration. The exact manner in which death by electrical shock results is not known. (See *Death, Electric*.)

Assymmetrical Resistance.—(See *Resistance, Assymmetrical*.)

Astatic.—Possessing no directive power.

Usually applied to a magnetic or electro-magnetic device which is free from any tendency to take a definite position on account of the earth's magnetism.

Astatic Circuit.—(See *Circuit, Astatic.*)

Astatic Couple.—See *Couple, Astatic.*)

Astatic Galvanometer.—(See *Galvanometer, Astatic.*)

Astatic Needle.—(See *Needle, Astatic.*)

Astatic Pair.—(See *Pair, Astatic.*)

Astatic System.—(See *System, Astatic.*)

Astronomical Meridian.—(See *Meridian, Astronomical.*)

Asymptote of Curve.—(See *Curve, Asymptote of.*)

Atmosphere, An — — A unit of gas or fluid pressure equal to about 15 pounds to the square inch.

At the level of the sea the atmosphere exerts a pressure of about 15 pounds avoirdupois, or, more accurately, 14.73 pounds, on every square inch of the earth's surface. This value has therefore been taken as a unit of fluid pressure.

For more accurate measurements pounds to the square inch are employed.

In the metric system of weights and measures an atmosphere is considered equal to 1,033 grammes per square centimetre.

Atmospheric pressures are measured by instruments called *Manometers*. (See *Manometer.*)

Atmosphere, Residual — — The traces of air or other gas remaining in a space which has been exhausted of its gaseous contents by a pump or other means.

It is next to impossible to remove all traces of air from a vessel by any known form of pump or other appliance. (See *Vacuum, Absolute.*)

Atmosphere, The — — The ocean of air which surrounds the earth.

The atmosphere is, approximately, composed, by weight, of oxygen 23 parts, and nitrogen 77 parts. Besides these there are from 4 to 6 parts in 10,000 of carbonic acid gas (or about a cubic inch of carbonic acid to a cubic foot of air), and varying proportions of the vapor of water.

The oxygen, nitrogen and carbonic acid form the constant ingredients of the atmosphere, the vapor of water the variable ingredient. There are in most localities a number of other variable ingredients present as impurities.

Atmospheric Electricity.—(See *Electricity, Atmospheric.*)

Atmospheric Electricity, Origin of — — (See *Electricity, Atmospheric, Origin of.*)

Atom.—The smallest quantity of elementary or simple matter that can exist.

An ultimate particle of matter.

Atom means that which cannot be cut. It is generally believed that material atoms are absolutely unalterable in size, shape, weight and density; that they can neither be cut, scratched, flattened, nor distorted; and that they are unaffected in size, density, or shape, by heat or cold, or by any known physical force.

Although almost inconceivably small, atoms nevertheless possess a definite size and mass. According to Sir William Thomson, the smallest visible organic particle, 1/4000 of a millimetre in diameter, will contain about 30,000,000 atoms.

Atom, Closed-Magnetic Circuit of — — (See *Circuit, Closed-Magnetic, of Atom.*)

Atom, Gramme — — Such a number of grammes of any elementary substance as is numerically equal to the atomic weight of the substance.

The gramme-atom of a substance represents the number of *calories* required to raise the temperature of one gramme of that substance through 1 degree C. (See *Heat, Atomic. Calorie.*) Thus, in the case of chlorine, whose atomic weight is 35.5, its gramme-atom is 35.5; consequently 35.5 small calories of heat would be required to raise one gramme-atom of chlorine through 1 degree C.

Atom of Electricity.—(See *Electricity, Atom of.*)

Atom, Vortex — — A number of particles of the universal ether moving in the manner of a vortex ring.

The theory of vortex atoms, so formed from vortex rings, was propounded by Sir William Thomson in order to explain how a readily movable substance, like the universal ether, could be made to possess the properties of a rigid solid. If it be granted that a vortex motion has once been imparted to the universal ether, Thomson shows that such rings would be indestructible. (See *Matter, Thomson's Hypothesis of.*)

Atomic Attraction. — (See *Attraction, Atomic.*)

Atomic Capacity.—(See *Capacity, Atomic.*)

Atomic Currents.—(See *Currents, Atomic.*)

Atomic Energy.—(See *Energy, Atomic.*)

Atomic Heat.—(See *Heat, Atomic.*)

Atomic or Molecular Induced Currents.—(See *Currents, Induced, Molecular or Atomic.*)

Atomic Weight.—(See *Weight, Atomic.*)

Atomicity.—The combining capacity of the atoms.

The relative equivalence of the atoms or their atomic capacity.

The elementary atoms do not always combine atom for atom. Some single atoms of certain elements will combine with two, three, four, or even more atoms of another element.

The value of the atomic capacity of an atom is also called its *quantivalence* or *valency*.

Elements whose atomic capacity is—

One,	are called	Monads,	or	Univalent.
Two,	“	Dyads,	“	Bivalent.
Three,	“	Triads,	“	Trivalent.
Four,	“	Tetrads,	“	Quadrivalent.
Five,	“	Pentads,	“	Quinivalent
Six,	“	Hexads,	“	Sexivalent.
Seven,	“	Heptads,	“	Septivalent.

Atomization.—The act of obtaining liquids in a spray of finely divided particles.

In most cases the term is not literally correct, as each of the smallest particles so obtained usually consist of many thousands of atoms.

Atomize.—To separate into a fine spray by means of an atomizer. (See *Atomizer.*)

Atomizer.—An apparatus for readily obtaining a finely divided jet or spray of liquid.

A jet of steam, or a blast of air, is driven across the open end of a tube that dips below the surface of the liquid to be atomized. The partial vacuum so formed draws up the liquid, which is then blown by the current into a fine spray.

Attract.—To draw together.

Attracted-Disc Electrometer.—(See *Electrometer, Attracted-Disc.*)

Attracting.—Drawing together.

Attraction.—Literally the act of drawing together.

In science the name attraction is given to a series of unknown causes which effect, or are assumed to effect, the drawing together of atoms, molecules or masses.

Attraction and repulsion underlie nearly all natural phenomena. While their effects are well known, it is doubtful if anything is definitely known of their true causes.

Since attraction, pure and simple, necessitates the belief in action at a distance, an action which is now generally discredited, we must, strictly speaking, regard the term attraction as being but a convenient substitution of the effect for the cause.

It would appear much more reasonable to regard the effects of attraction as produced by a true push exerted from the outside of the bodies. According to this notion, two masses of matter undergoing attraction are pushed together rather than drawn or attracted together.

It has been suggested that gravitation may perhaps be an effect of a longitudinal motion or vibratory thrust in the universal ether. If this is the case, and the ether is sensibly incompressible, the velocity of gravitation, it would appear, should be almost infinite.

Attraction, Atomic — — The attraction which causes the atoms to combine. (See *Affinity, Chemical.*)

In the opinion of Lodge, atomic attraction is the result of the attraction of dissimilar charges of electricity possessed by all atoms, which are capable of uniting or entering into chemical combination. (See *Electricity, Atom of.*)

Attraction, Capillary — — The molecular attractions that are concerned in capillary phenomena. (See *Capillarity.*)

Attraction, Electro-Dynamic — — The mutual attraction of electric currents, or of conductors through which electric currents are passing. (See *Dynamics, Electro.*)

Attraction, Electro-Magnetic — — The mutual attraction of the unlike poles of electro-magnets. (See *Magnet, Electro.*)

Attraction, Electrostatic — — The mutual attraction exerted between unlike electric charges, or bodies possessing unlike electric charges.

For example, the pith ball supported on an insulated string is attracted, as shown at A, Fig. 28,

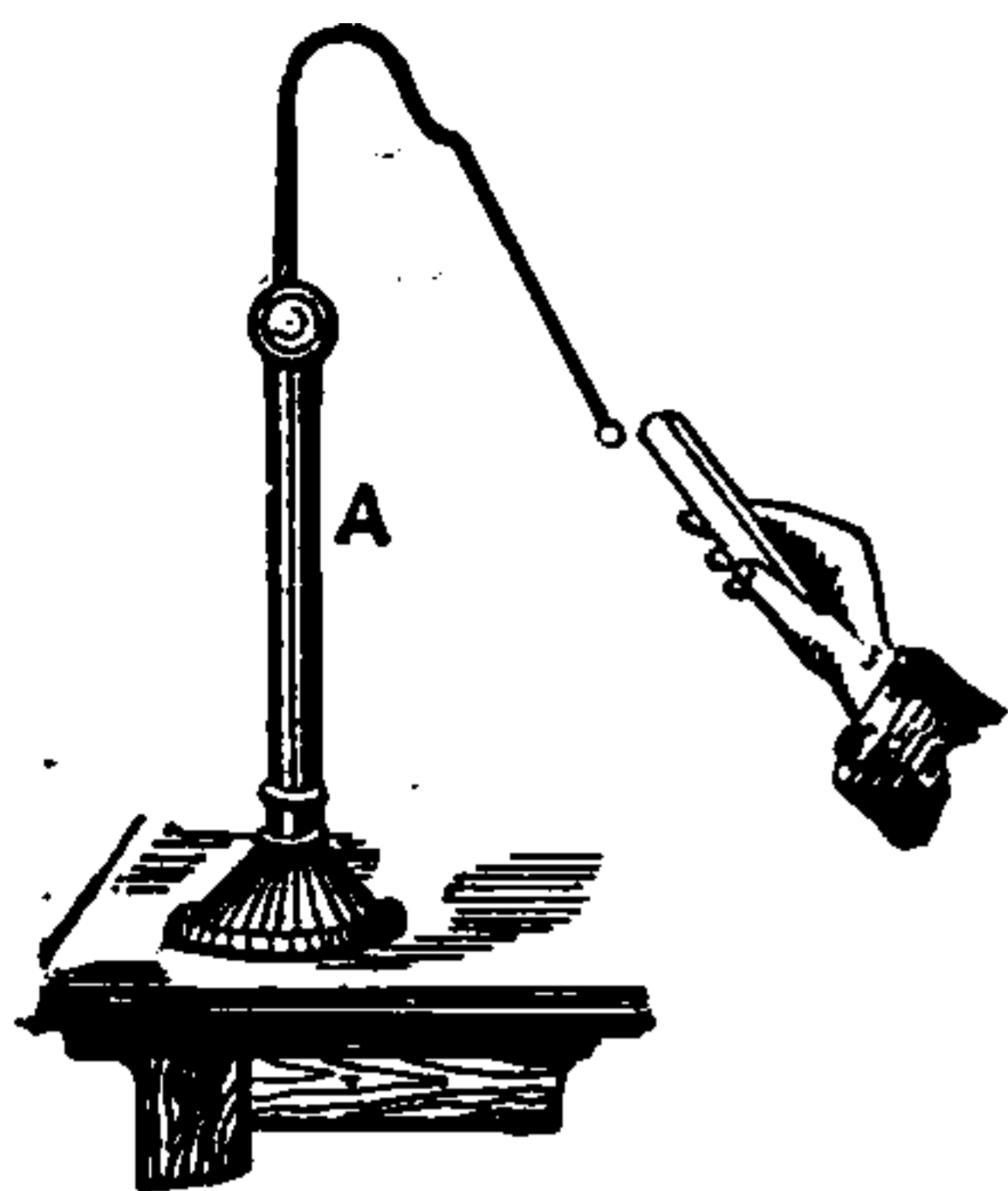

Fig. 28. *Electrostatic Attraction.*

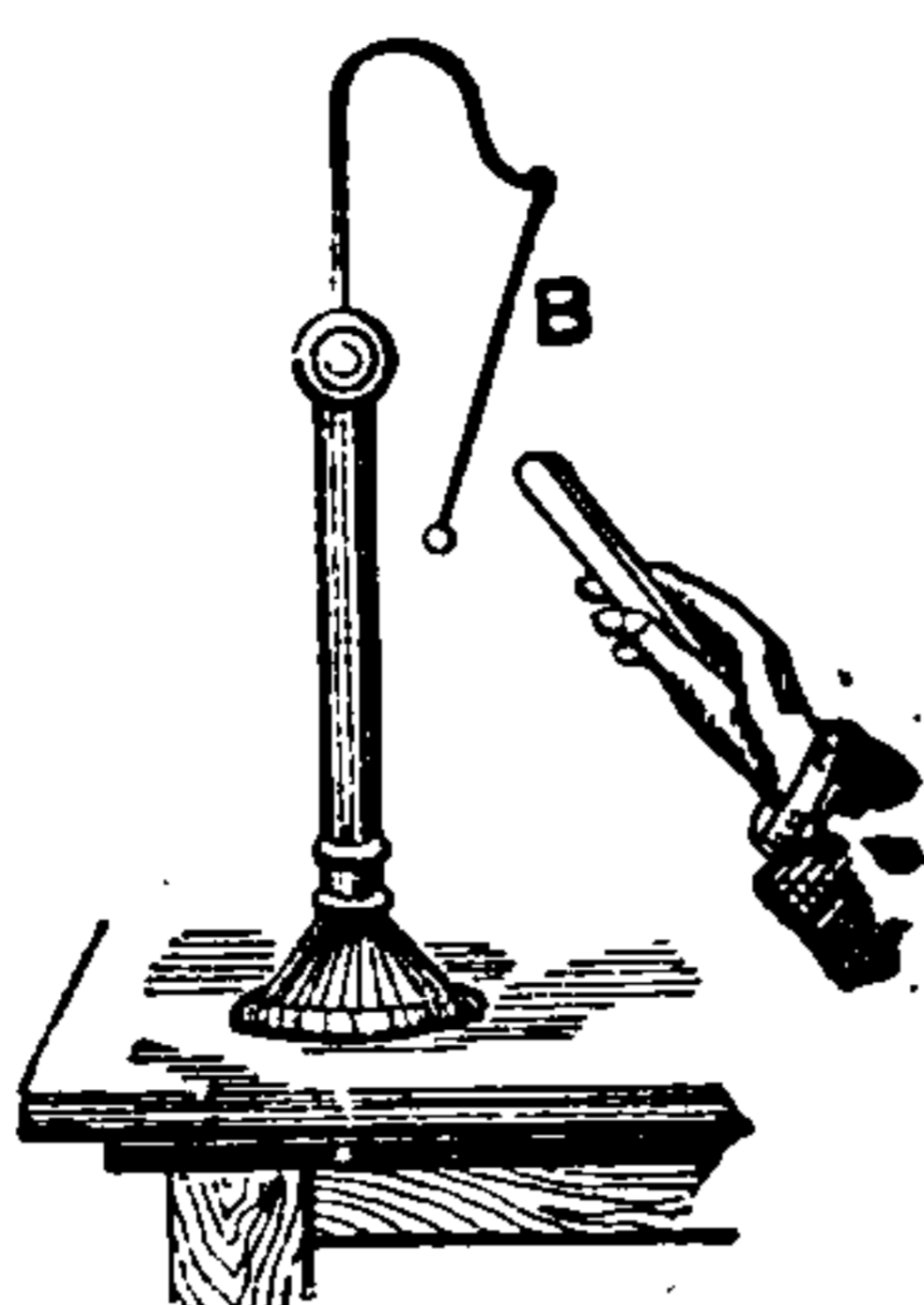

Fig. 29. *Electrostatic Repulsion.*

by a bit of sulphur which has been briskly rubbed by a piece of silk. As soon, however, as the ball touches the sulphur and receives a charge, it is repelled, as shown at B, Fig. 29.

These attractions and repulsions are due to the effects of *electrostatic induction*. (See *Induction, Electrostatic*.)

Attraction, Magnetic — — The mutual attraction exerted between unlike magnet poles.

Magnetic attractions and repulsions are best shown by means of the *magnetic needle* N S, Fig. 30. The N. pole of an approached magnet

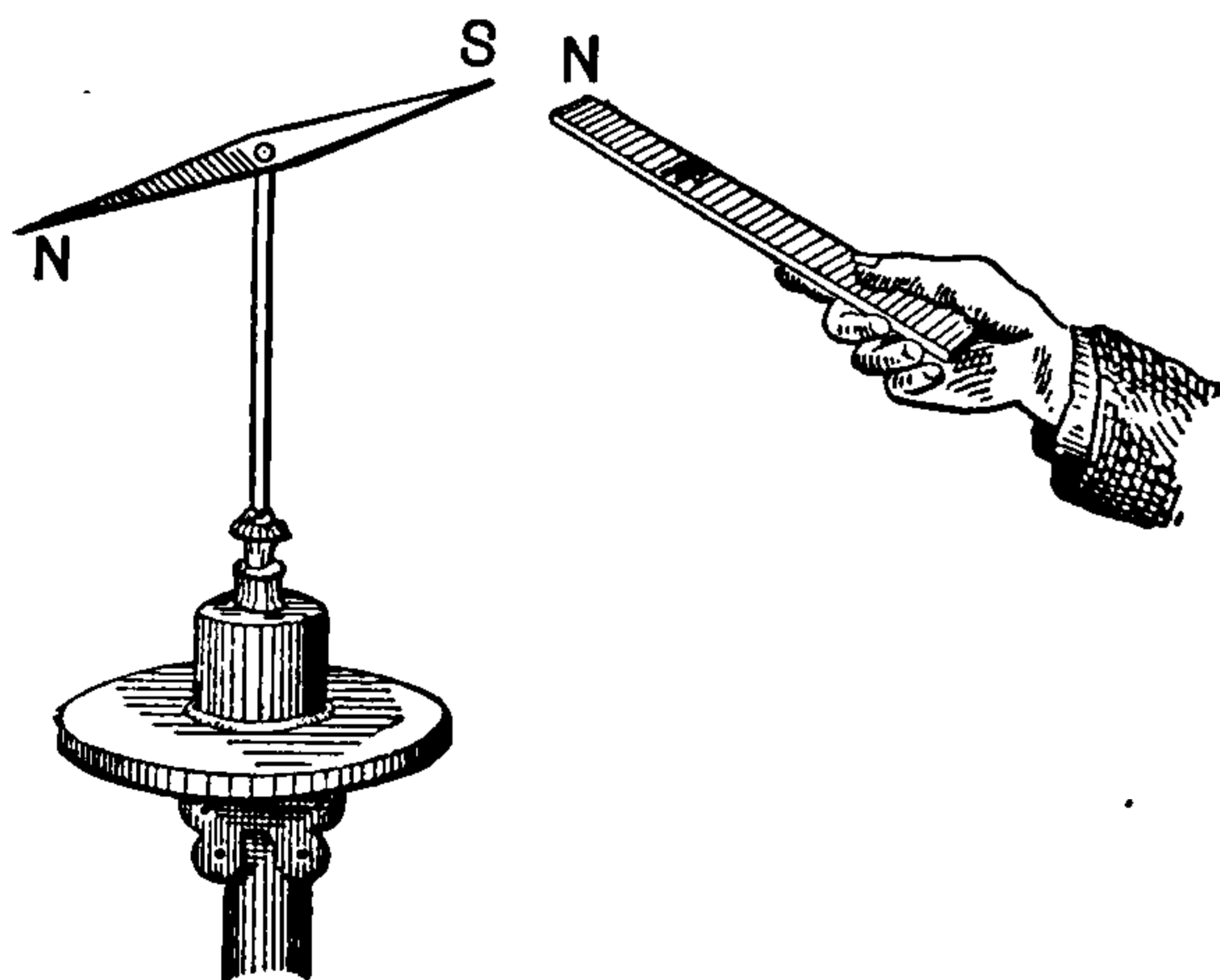

Fig. 30. *Magnetic Attraction.*

attracts the S. pole of the needle but repels the N. pole.

The laws of magnetic attraction and repulsion may be stated as follows, viz.:

(1.) Magnet poles of the same name repel each other; thus, a north pole repels another north pole, a south pole repels another south pole.

(2.) Magnet poles of unlike names attract each other; thus a north pole attracts a south pole, or a south pole attracts a north pole.



Fig. 31. *Floating Magnet.*

A small bar magnet, N S, Fig. 31, laid on the top of a light vessel floating on the surface of a liquid, may be readily employed to illustrate the laws of magnetic attraction and repulsion.

Attraction, Mass — — The mutual attraction exerted between masses of matter. (See *Gravitation*.)

Attraction, Molar — — A term sometimes employed for mass attraction.

Gravitation is an example of mass attraction, where the mass of the earth attracts the mass of some body placed near it. (See *Gravitation*.)

Attraction, Molecular — — The mutual attraction exerted between neighboring molecules.

The attraction of like molecules, or those of the same kind of matter, is called *Cohesion*; that of unlike molecules, *Adhesion*.

The tensile strength of iron or steel is due to the cohesion of its molecules. Paint adheres to wood, or ink to paper, by cohesion or the attraction between the unlike molecules.

Attraction of Gravitation.—A term generally applied to the mutual attraction between masses. (See *Gravitation*.)

Attractions and Repulsions of Currents.—(See *Currents, Attractions and Repulsions of*.)

Audiphone.—A thin plate of hard rubber held in contact with the teeth, and maintained at a certain tension by strings attached to one of its edges, for the purpose of aiding the hearing.

The plate is so held that the sound-waves from a speaker's voice impinge directly against its flat surface. It operates by means of some of the waves being transmitted to the ear directly through the bones of the head.

The audiphone is sometimes called a *denti-phones*.

Aural Electrode.—(See *Electrode, Aural*.)

Aurora Australis.—The Southern Light. A name given to an appearance in the south-

ern heavens similar to that of the Aurora Borealis. (See *Aurora Borealis*.)

Aurora Borealis.—The Northern Light. Luminous sheets, columns, arches, or pillars of pale, flashing light, generally of a red color, seen in the northern heavens.

The auroral light assumes a great variety of appearances, to which the terms *auroral arch, bands, coronæ, curtains* and *streamers* are applied.

The exact cause of the aurora is not as yet known. It would appear, however, beyond any reasonable doubt, that the auroral flashes are due to the passage of electrical discharges through the upper, and therefore rarer, regions of the atmosphere. The intermittent flashes of light are probably due to the discharges being influenced by the earth's magnetism.

Auroras are frequently accompanied by *magnetic storms*. (See *Storm, Magnetic*.)

The occurrence of auroras is nearly always simultaneous with that of an unusual number of *sun spots*. Auroras are therefore probably connected with outbursts of the solar energy. (See *Spots, Sun*.)

The auroral light examined by the spectroscope gives a *spectrum* characteristic of luminous gaseous matter, *i. e.*, contains a few bright lines; but, according to S. P. Thompson, this spectrum is produced by matter that is not referable with certainty to that of any known substance.

Whatever may be the exact cause of auroras, their appearance is almost exactly reproduced by the passage of electric discharges through vacua.

Aurora Polaris.—A general term sometimes applied to aurora in the neighborhood of either pole, or in either the northern or the southern hemisphere.

Auroral Arch.—(See *Arch, Auroral*.)

Auroral Bands.—(See *Bands, Auroral*.)

Auroral Coronæ.—(See *Coronæ, Auroral*.)

Auroral Curtain.—(See *Curtain, Auroral*.)

Auroral Flashes.—(See *Flashes, Auroral*.)

Auroral Light.—(See *Light, Auroral*.)

Auroral Storm.—(See *Storm, Auroral*.)

Auroral Streamer.—(See *Streamer, Auroral*.)

Auroras and Magnetic Storms, Peri-

odicity of — — Observed coincidences between the occurrence of auroras, magnetic storms, and sun-spots.

The occurrence of auroras, or magnetic storms, at periods of about eleven years apart, corresponds to the well-known *eleven-year sun-spot period*.

The period also agrees with a variation in the magnetic declination of any place, which, according to Sabine, occurs once in every eleven years.

Austral Magnetic Pole.—(See *Pole, Magnetic, Austral*.)

Autographic Telegraphy.—(See *Telegraphy, Autographic*.)

Automatic Annunciator Drop.—(See *Drop, Annunciator, Automatic*.)

Automatic Bell.—(See *Bell, Automatic Electric*.)

Automatic Contact Breaker.—(See *Contact Breaker, Automatic*.)

Automatic Cut-Out.—(See *Cut-Out, Automatic*.)

Automatic Cut-Out for Multiple-Connected Electro-Receptive Devices.—(See *Cut-Out, Automatic, for Multiple-Connected Electro-Receptive Devices*.)

Automatic Cut-Out for Series-Connected Electro-Receptive Devices.—(See *Cut-Out, Automatic, for Series-Connected Electro-Receptive Devices*.)

Automatic Drop.—(See *Drop, Automatic*.)

Automatic Electric Burner.—(See *Burner, Automatic Electric*.)

Automatic Electric Safety System for Railroads.—(See *Railroads, Automatic Electric Safety System for*.)

Automatic Fire-Alarm.—(See *Alarm, Fire, Automatic*.)

Automatic Gas Cut-Off.—(See *Cut-Off, Automatic Gas*.)

Automatic Indicator.—(See *Indicator, Automatic*.)

Automatic Make-and-Break.—(See *Make-and-Break, Automatic*.)

Automatic Oiler.—(See *Oiler, Automatic*.)

THIS PAGE IS LOCKED TO FREE MEMBERS

Purchase full membership to immediately unlock this page

Know Your Bible

Forgotten Books'
Full Membership
provides unlimited
access to more than
28,000 volumes of
Christian literature for
\$8.99/month

**HOLY
BIBLE**

Continue

*Fair use policy applies

B. W. G.—A contraction for Birmingham wire gauge. (See *Gauge, Birmingham Wire*.)

A contraction sometimes used for the new British wire gauge.

Back Electromotive Force.—(See *Force, Electromotive, Back*.)

Back-Stroke of Lightning.—(See *Lightning, Back-Stroke of*.)

Bain's Chemical Recorder.—(See *Recorder, Chemical, Bain's*.)

Bain's Printing Solution.—(See *Solution, Bain's Printing*.)

Balance Arms.—(See *Arms, Bridge or Balance*.)

Balance, Bi-filar Suspension — — An instrument similar in construction to Coulomb's torsion balance, but in which the needle is hung by two separate fibres instead of by a single one. (See *Balance, Coulomb's Torsion. Suspension, Bi-filar*.)

Balance, Centi-Ampère — — An ammeter in the form of a balance, whose scale is graduated to give direct readings in centi-ampères.

Ampère balances giving readings in various decimals or multiples of ampères have been devised by Sir William Thomson. The strength of current passing is determined by the action on a movable ring or coil, placed between two fixed rings or coils.

The movable ring is in a horizontal plane nearly midway between the two fixed rings. The fixed rings are traversed by the current in opposite directions, so that one attracts and the other repels the movable ring. The movable ring is attached to one end of a horizontal balance arm, and a similar movable ring, also provided with attracting and repelling fixed rings, is attached to the opposite end of the balance arm. In order to avoid disturbance of horizontal components of terrestrial, or of local magnetic force, the current is sent in the same direction through the two movable rings. The balancing is effected by means of a weight, sliding on a nearly horizontal arm attached to the balance. A counterpoise weight is used in connection with the sliding weight.

A standard Thomson centi-ampère balance is shown in Fig. 33. In measuring a current,

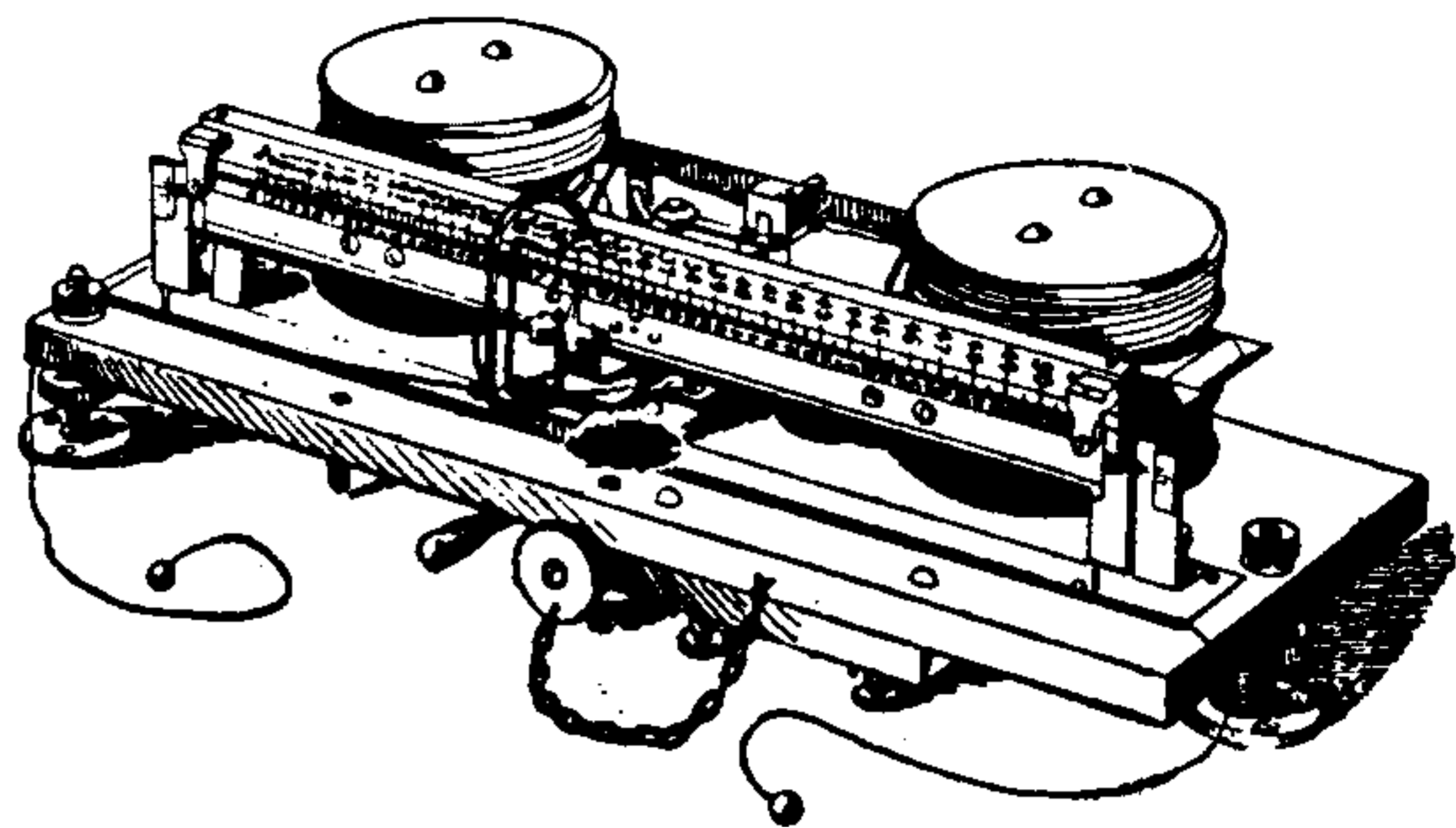

Fig. 33. Centi-Ampère Balance.

the weight is moved along the scale until the balance comes to rest.

Balance, Composite — — A balance form of ammeter devised by Sir William Thomson, which can be used for an ampère-meter, a watt-meter, or a volt-meter, according to the manner in which its sets of fine and coarse wire coils are connected. (See *Balance, Centi-Ampère*.)

Balance, Coulomb's Torsion — — An apparatus to measure the force of electric or magnetic repulsion between two similarly charged bodies, or between two similar magnet poles, by opposing to such force the torsion of a thin wire.

The two forces *balance* each other; hence the origin of the name.

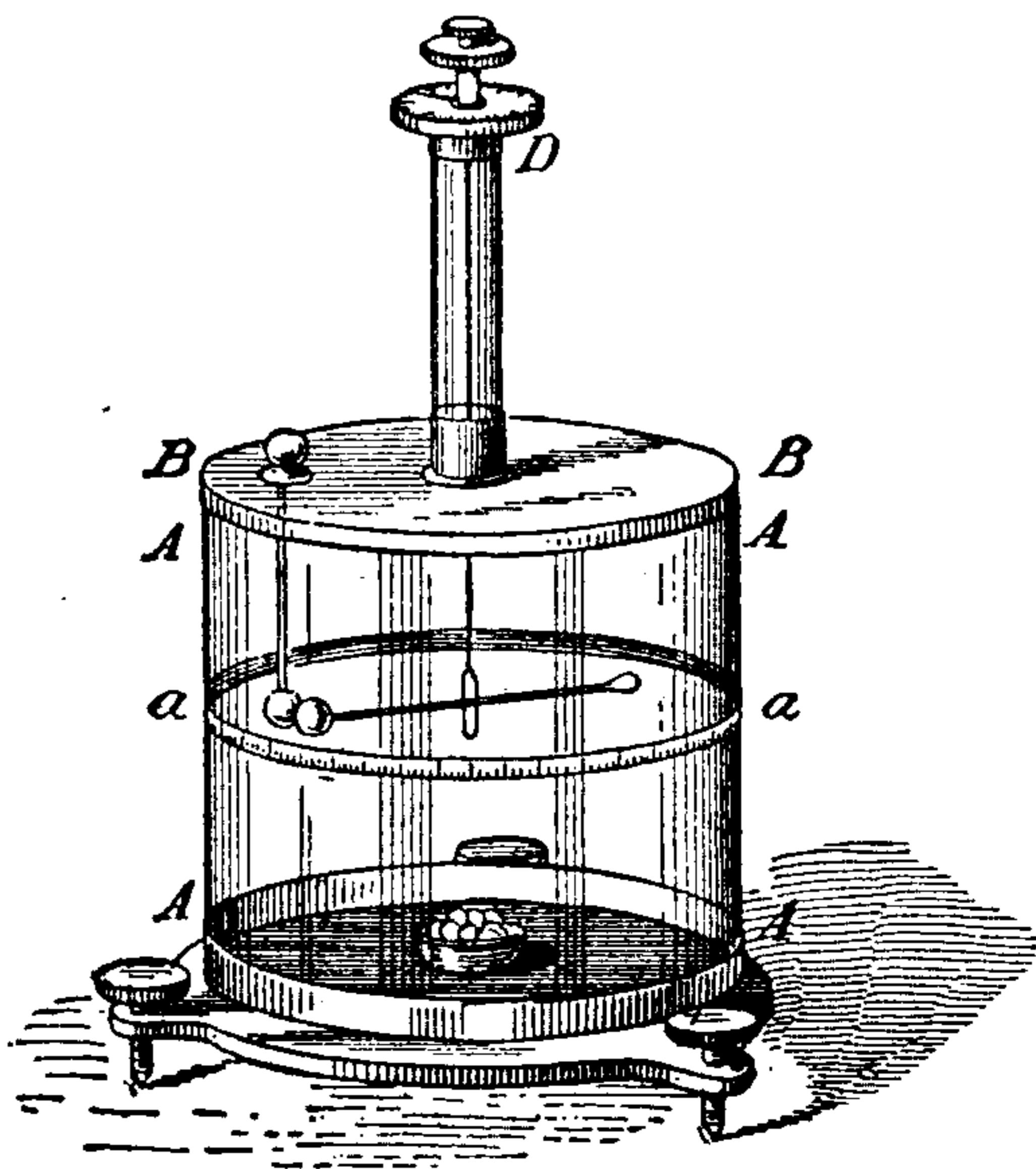

Fig. 34. Coulomb's Torsion Balance.

Fig. 34 represents a Coulomb torsion balance, adapted to the measurement of the force

of electrostatic repulsion. A delicate needle of shellac, having a small gilded pith ball at one of its ends, is suspended by a fine metallic wire. A *proof-plane*, B, is touched to the electrified surface whose charge is to be measured, and is then placed as shown in the figure. (See *Plane, Proof*.) There is a momentary attraction of the needle, and then a repulsion, which causes the needle to be moved a certain distance from the ball on the proof-plane. This distance is measured in degrees on a graduated circle a a, marked on the instrument. The force of the repulsion is calculated by determining the amount of torsion required to move the needle a certain distance toward the ball of the electrified proof-plane.

This torsion is obtained by the movement of the *torsion head* D, the amount of which motion is measured on a graduated circle at D. The measurement is based on the fact that the force required to twist a wire is proportional to the angle of torsion.

Balance, Deci-Ampère — — An ammeter in the form of a balance, whose scale is graduated to give direct readings in deci-ampères. (See *Balance, Centi-Ampère*.)

Balance, Deka-Ampère — — An ammeter in the form of a balance, whose scale is graduated to give direct readings in deka-ampères. (See *Balance, Centi-Ampère*.)

Balance, Electric — — A term frequently used for Wheatstone's electric bridge. (See *Bridge, Electric*.)

The electric bridge is sometimes called a balance because, when in use in measuring resistances, one resistance or set of resistances balances another resistance or set of resistances.

Balance, Hekto-Ampère — — An ammeter in the form of a balance, whose scale is graduated to give direct readings in hekto-ampères. (See *Balance, Centi-Ampère*.)

Balance Indicator.—(See *Indicator, Balance*.)

Balance, Induction, Hughes' — — An apparatus for the detection of the presence of a metallic or conducting substance by the aid of induced electric currents.

Hughes' induction balance is shown in Fig. 35. A, B, C and D are bobbins, wound with about 300 feet of No. 32 copper wire. The coils are

connected as shown, A and B, in the circuit of a battery, and C and D, in the circuit of a telephone. The coils, A and B, and C and D, are placed at

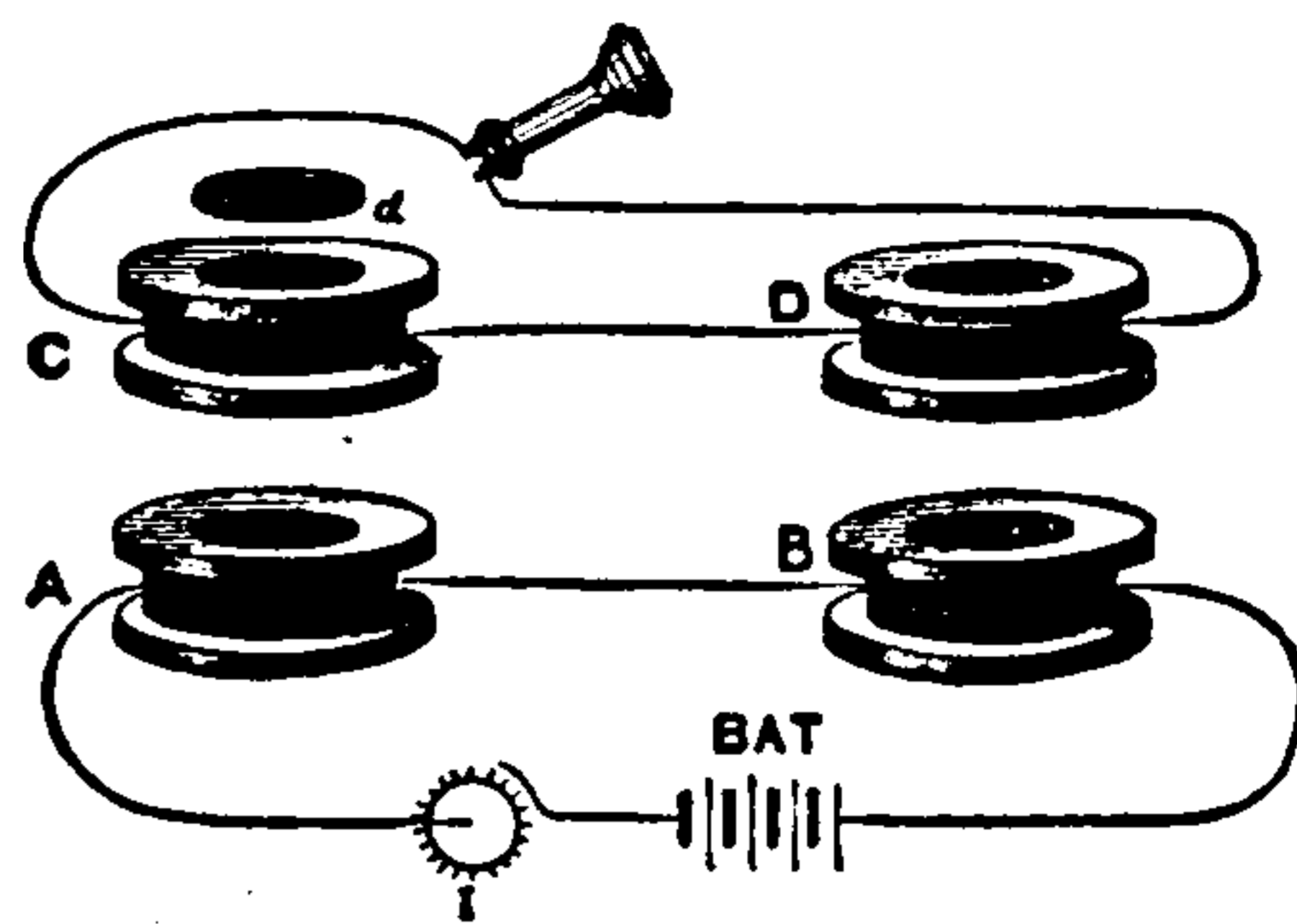

Fig. 35. Hughes' Induction Balance.

such a distance apart as to prevent any mutual induction occurring between them. The coils are so joined that the direction of the induction of A, on C, is opposite to that of B, on D.

The coils, A and B, then act as primaries, and C and D, as secondaries. In the battery circuit is an interrupter I, which is caused to continually make and break the circuit.

The coils are so adjusted that the opposing secondary coils produce but little noise to one listening at the telephone. This can readily be done by the adjusting of a single pair of coils.

If a single coin or mass of metal be introduced between either A and C, or B and D, or even above one of the coils, as at d, the balance will be disturbed, since some of the induction is now expended in producing electric currents in the interposed metal, and a sound will therefore be heard in the telephone. But if precisely similar metals are placed in similar positions, between A and C, and B and D, no sound is heard in the telephone, since the inductive effects due to the two metals are the same.

The slightest difference, however, either in composition, size or position, destroys the balance, and causes a sound to be heard in the telephone.

A spurious coin is thus readily detected when compared with a genuine coin.

A somewhat similar instrument has been employed to detect and locate a bullet or other foreign metallic substance in the human body.

In order to determine the amount of the disturbance, an instrument called a sonometer is used (See *Sonometer, Hughes'*), in which a single secondary coil, placed in the circuit of a telephone, slides on a graduated bar between two fixed primary coils, so wound as to exert equal and opposite inductions on the secondary. When, therefore, the secondary is exactly in the middle of the

graduated bar, and consequently exactly midway between the two fixed primary coils, no sounds are heard in the telephone, but when moved to one side or the other the sounds are heard. Switches are so arranged that the telephone can be readily switched from the induction balance to the telephone, or *vice versa*. When, therefore, a metallic disc is placed in one of the coils of the induction balance, and a noise is heard in the telephone, the coil of the sonometer is shifted so that the noise heard in this telephone is judged by the ear to be equal, and the comparison can then be made by means of simple calculations.

The following table gives, in arbitrary values, the results of various experiments as to the sensitiveness in this respect of discs of different metals, of various sizes and shapes :

Silver, chemically pure.....	125
Gold.....	117
Silver, commercial.....	115
Aluminium.....	112
Copper.....	100
Zinc.....	80
Bronze.....	75
Tin.....	74
Iron, ordinary.....	53
German silver.....	50
Iron, pure.....	40
Copper, alloyed.....	40
Lead.....	58
Antimony.....	35
Bismuth.....	10
Zinc, alloyed.....	6
Carbon.....	2

—(*Fleming*.)

An inspection of this table shows that the values found for different metals do not correspond with their electric conducting power, although, roughly speaking, the best conductors stand at the top of the table, and the worst at the bottom. The effects appear to be dependent for their action on the phenomena of magnetic screening, for—

(1.) If slots are cut in the middle of the plate its disturbing action is either removed or very much decreased.

(2.) If a flat coil of copper wire replaces a disc of metal no effect is produced on the induction balance when its ends are open, but when closed the coil acts just like a disc, or continuous plate of metal.

(3.) The difference between various metals in-

serted as discs in the induction balance is less at high speeds of reversal than at low speeds.

Balance, Kilo-Ampère — — — An ammeter in the form of a balance, whose scale is graduated to give direct readings in kilo-amperes. (See *Balance, Centi-Ampère*.)

Balance of Induction in Cable.—(See *Induction, Balance of, in Cable*.)

Balance, Plating — — — An automatic device for disconnecting the current from the article to be plated, as soon as a certain increase in weight has been obtained.

The objects to be plated are suspended at one end of a balance, and when a certain increase in weight has been gained, the balance tips and breaks the circuit. Edison's electric meter is based on this principle.

Balance, Thermic, or Bolometer.—An apparatus constructed on the principle of the differential galvanometer, devised by Professor Langley for determining small differences of temperature. (See *Galvanometer, Differential*.)

A coil composed of two separately insulated wires, wound together, is suspended in a magnetic field, and has a current sent through it. Under normal conditions, this current separates into two equal parts, and runs through the wires in opposite directions. It therefore produces no sensible field, and suffers no deflection by the field in which it is suspended.

Any local application of heat producing a difference in temperature in these coils, causing a difference in resistance, prevents this equality. A field is therefore produced in the suspended coil, which, though extremely small, is rendered measurable by means of the powerful field produced in the coil, within which the double coil is suspended.

Differences of temperature as small as one-fourteen thousandth of a degree Fahrenheit are detected by the instrument.

Balance, Wheatstone's Electric — — — A name often given to the electric bridge or balance. (See *Bridge, Electric*.)

Balanced-Metallic Circuit.—(See *Circuit, Balanced-Metallic*.)

Balanced Resistances.—(See *Resistances, Balanced*.)

Balata.—An insulating material.

Balata, when prepared for use as an insulating material, is somewhat like gutta-percha.

Ball, Electric Time — —A ball, supported in a prominent position on a tall pole, and caused to fall at the exact hour of noon, or at any other predetermined time, for the purpose of thus giving correct time to an entire neighborhood.

The release of the ball is effected by the closing of an electric circuit, either automatically, or through the agency of an observer.

Ball, Fire — —A term sometimes applied to globular lightning. (See *Lightning, Globular.*)

Ball Lightning.—(See *Lightning, Ball.*)

Ballistic Curve.—(See *Curve, Ballistic.*)

Ballistic Galvanometer.—(See *Galvanometer, Ballistic.*)

Balloon, Electric — —A balloon, or air ship, provided with electric power so as to be able to be steered or moved against the direction of the wind.

Electric balloons have been moved against the wind and steered with a certain amount of success, by the use of electric motors driven by storage batteries. All that is needed to make aerial navigation a commercial success is the ability to obtain great power with a small weight. The storage battery does this to a limited extent.

Bearing in mind the high efficiency of the electric motor, it would appear that the problem of successful aerial navigation will be solved when the discovery is made of means for directly converting the chemical potential energy of coal into electrical energy.

Balloon Signaling for Military Purposes.—(See *Signaling, Balloon, for Military Purposes.*)

Balls, Pith — —Two balls of pith, suspended by conducting threads of cotton to insulated conductors, employed to show the electrification of the same by their mutual repulsion.

The pith balls connected with the insulated cylinder A B, Fig. 36, not only show the electrification of the cylinder, but serve also to roughly

indicate the peculiarities of distribution of the charge thereon.

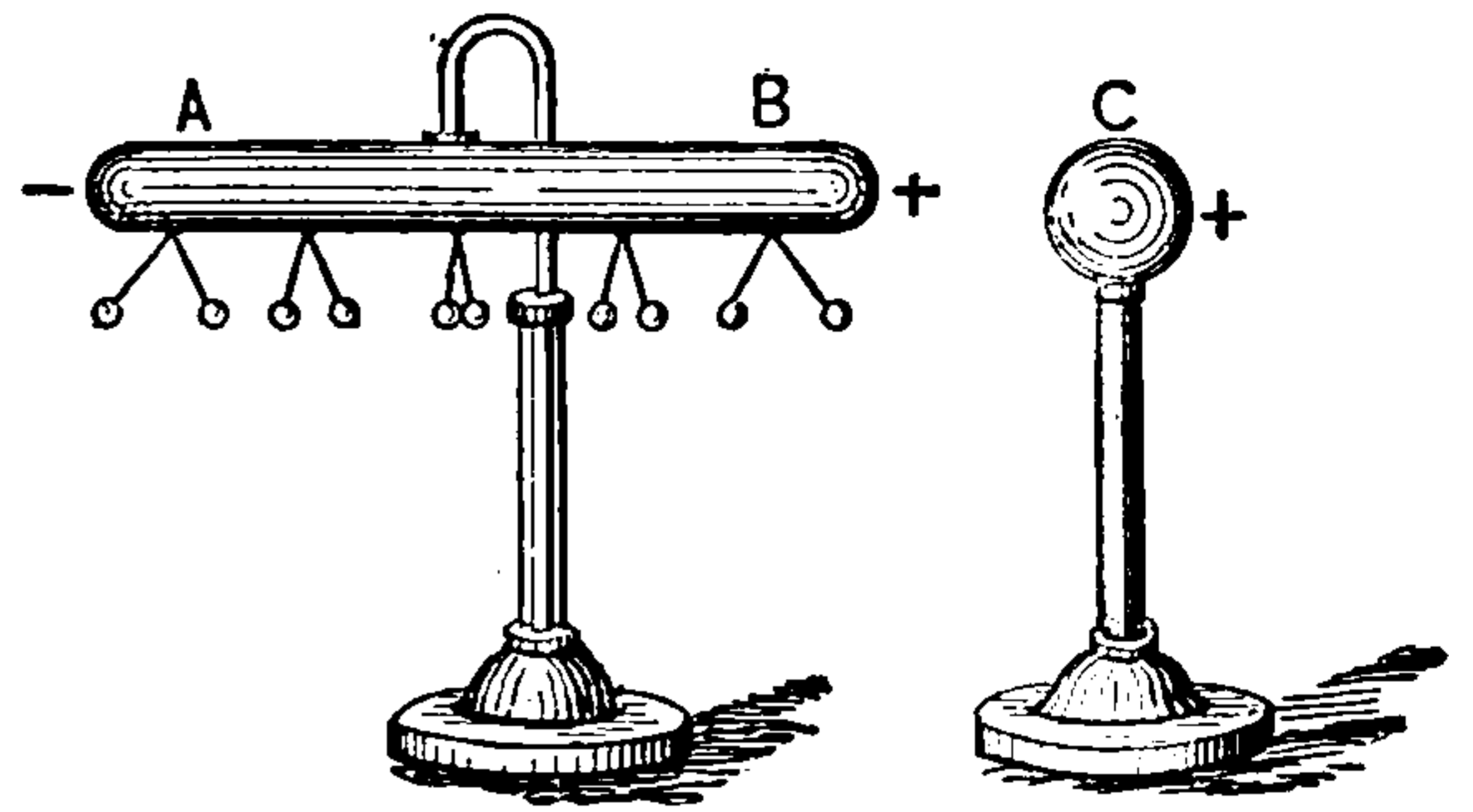

Fig. 36. Pith Ball Cylinder.

Bands, Auroral — —Approximately parallel streaks of light sometimes seen during the prevalence of the aurora. (See *Aurora Borealis.*)

Bank of Lamps.—(See *Lamps, Bank of.*)

Banked Battery.—(See *Battery, Banked.*)

Bar, Detorsion — —A bar placed in a magnetic instrument called a declinometer for the purpose of removing the torsion of the suspending thread of the magnet.

The detorsion bar of the declinometer is generally made of gun metal of the same weight as that of the suspended magnet. A small magnet is placed in a rectangular aperture in the middle of the bar.

Bar Electro-Magnet.—(See *Magnet, Electro, Bar.*)

Barad.—A unit of pressure proposed by the British Association.

One barad equals one dyne per square centimetre.

Barometer.—An apparatus for measuring the pressure or weight of the atmosphere.

Barometric Column.—(See *Column, Barometric.*)

Bars, Bus — —Omnibus bars. (See *Bars, Omnibus.*)

Bars, Krizik's — —Cores of various shapes, provided for solenoids, in which the distribution of the metal in the bar is so proportioned as to insure as nearly as possible a uniform attraction or pull while in different positions in the solenoid.

Krizik's bars of various shapes are shown in Fig. 37. It will be observed that in all cases the

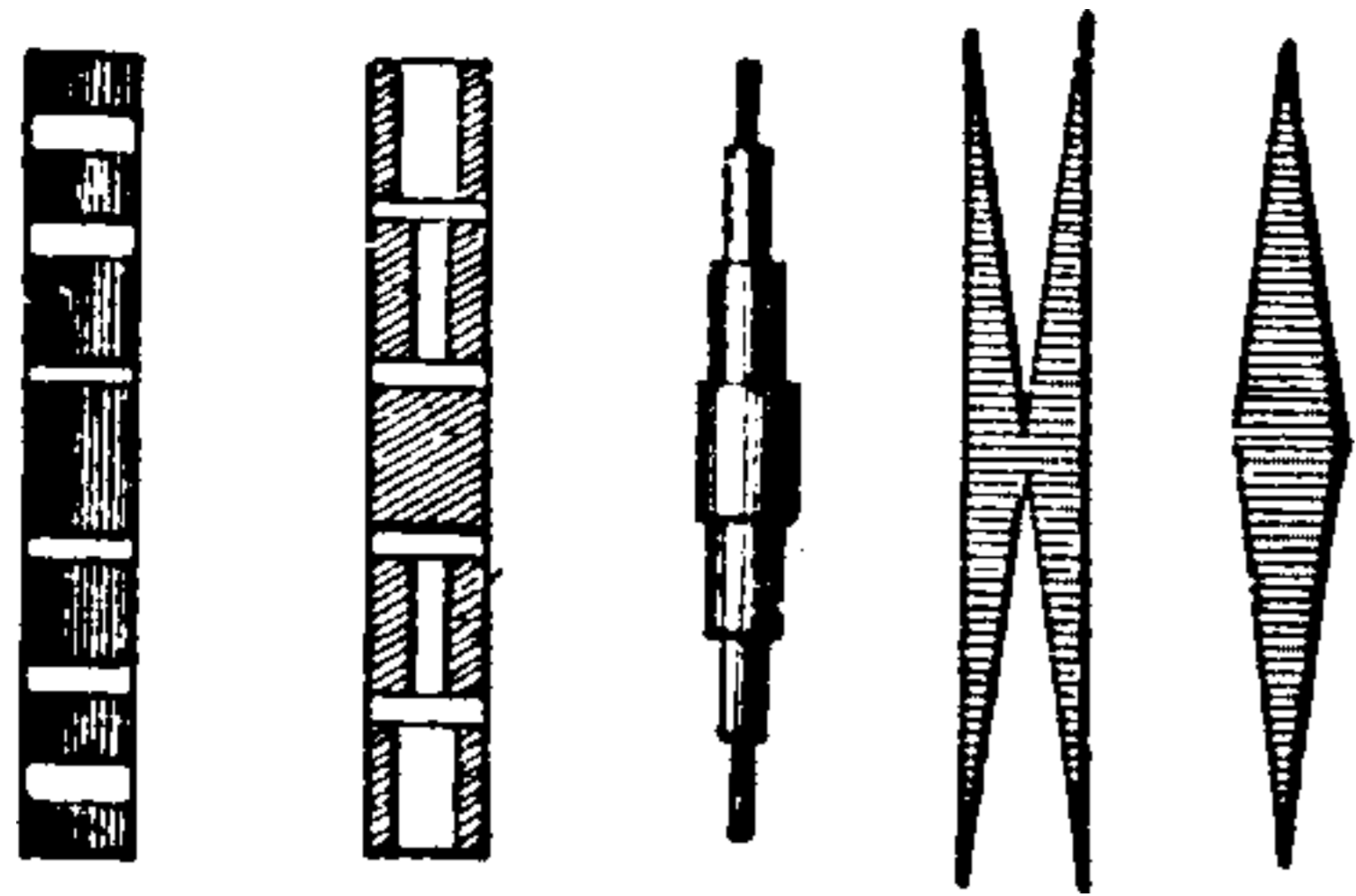

Fig. 37. Krizik's Bars.

mass of metal is greater toward the middle of the core than near the ends.

When a core of uniform diameter is drawn into a solenoid, the attraction or pull is not uniform in strength for different positions of the bar. When the bar is just entering the solenoid, the pull is strongest; as soon as the end passes the middle of the core the attraction decreases, until, when the centres of the bar and core coincide, the motion ceases, since both ends of the solenoid attract equally in opposite directions. By proportioning the bars, as shown in the figure, a fairly uniform pull for a considerable length may be obtained.

Bars, Negative-Omnibus — —The bus-bars that are connected with the negative terminal of the dynamos. (See *Bars, Omnibus*.)

Bars, Neutral-Omnibus — —The bus-bars that are connected with the neutral dynamo terminal in a three-wire system of distribution.

Bars, Omnibus — —Heavy bars of conducting material connected directly to the poles of dynamo-electric machines, in electric incandescent light or electric railway installations, and therefore receiving the entire current produced by the machine.

Main conductors common to two or more dynamos in an electrical generating plant.

The terms bus and omnibus bars refer to the fact that the entire or whole current is carried by them.

Bars, Positive-Omnibus — —The bus-bars that are connected with the positive terminal of the dynamos.

Bath, Bi-polar — —An electro-therapeutic bath, the current applied to which enters at one part of the tub, and leaves at another part.

The electrodes for the bi-polar bath consist of suitably shaped copper plates, generally called *shovel electrodes*.

Bath, Copper — —An electrolytic bath containing a readily electrolyzable solution of a copper salt, and a copper plate acting as the anode, and placed in the liquid near the object to be electro-plated, which forms the kathode. (See *Plating, Electro*.)

The sulphate, the cyanide and the acetate of copper are used for copper baths. The use of the sulphate is objectionable. The cyanide is expensive. The acetate is therefore very generally employed. Wahl gives the following formula for a copper bath, viz.:

Water.....	1,000 parts.
Acetate of copper, crystallized.....	20 "
Carbonate of soda.....	20 "
Bisulphite of soda.....	20 "
Cyanide of potassium (pure)	20 "

Bath, Electro-Plating — —Tanks containing metallic solutions in which articles are placed so as to be electro-plated. (See *Plating, Electro*.)

Strictly speaking a plating bath includes not only the vessel and its metallic solution, but also the metallic plate acting as the anode and the article to be plated forming the kathode.

Bath, Electro-Therapeutic — —A bath furnished with suitable electrodes and used in the application of electricity to curative purposes.

Such baths should be used only under the advice of a regular physician.

Bath, Gold — —An electrolytic bath containing a readily electrolyzable solution of a gold salt and a gold plate acting as the anode, and placed in the liquid opposite the object to be plated, which forms the kathode. (See *Plating, Electro*.)

Electro gilding may be accomplished either with or without the aid of heat. Hot gilding appears to give a smoother and cleaner deposit.

The following is a fairly good solution for a gold bath:

Water.....	1,000 parts.
Cyanide of potassium, pure..	20 "
Gold	10 "

—(Wahl.)

The gold is first converted into neutral chloride by dissolving it in 25 parts of pure hydrochloric acid to which 12.5 parts of pure nitric acid has been added. When the gold is completely dissolved, the liquid is heated until of a dark red color, in order to expel any excess of acid.

Bath, Head, Electric — —A variety of electric breeze, applied therapeutically to the head of the patient.

The patient is placed on an insulating stool and connected with one pole of an electrostatic induction machine, the other pole of which is connected to a circle of insulated points suspended over the head.

Bath, Hydro-Electric — —A bath in which electro-therapeutic treatment is given by applying one electrode to the metallic lining of the tub, and the other electrode to the body of the bather.

Bath, Multipolar-Electric — —An electro-therapeutic bath, in which more than two electrodes are employed.

It is not clear that the multipolar-electric bath possesses any decided advantages over the bi-polar bath.

Bath, Nickel — —An electrolytic bath containing a readily electrolyzable salt of nickel, a plate of nickel acting as the anode of a battery and placed in the liquid near the object to be coated, which forms the kathode. (See *Plating, Electro.*)

The double sulphate of nickel and ammonium (from 5 to 8 parts dissolved in 100 parts of water) is used for the bath. Some prefer to add sulphate of ammonium and citric acid to the above solution.

Bath, Shower, Electric — —A shower bath in which the falling drops carry electric charges to the patient subjected thereto.

The water is rendered slightly alkaline. One pole is immersed in the alkaline water and the other connected to a metallic stool on which the patient is placed.

Bath, Silver — —An electrolytic bath containing a readily electrolyzable salt of silver and a plate of silver acting as the anode of an electric source and placed in the liquid near the object to be coated, which forms the kathode. (See *Plating, Electro.*)

The double cyanide of silver and potassium is the salt usually employed in the silver bath.

The following bath is recommended by Roseleur:

Water	1,000 parts.
Cyanide of potassium (pure)	50 “
Pure silver.....	25 “

The silver (granulated) is treated with pure nitric acid (43 degrees Beaumé) and converted into nitrate of silver. The solution is then heated to dryness and subsequently fused. The fused nitrate so obtained is dissolved in fifteen times its weight of distilled water and treated with a solution of cyanide of potassium (10 per cent. of the cyanide), by means of which silver cyanide is thrown down as a precipitate. This precipitate is then separated and washed. It is added to the 1,000 parts of water, dissolved, and the cyanide of potassium afterward added, thus forming the double cyanide required for the bath.

Bath, Stripping — —A bath for removing an electro-plating of gold, silver, or other metal, either by simple dipping or by electric action.

Bath, Ungilding — —A stripping bath suitable for the removal of a coating of gold. (See *Bath, Stripping.*)

Bath, Unipolar-Electric — —An electro-therapeutic bath, the water of which forms one of the electrodes of the source, and the other electrode is attached to a metallic rod fixed at a convenient height above the tub.

The bath tub is formed of non-conducting substances. The terminals of the electrode connected with the water terminate in metal plates located at suitable points in the tub. The current is applied by the patient making and breaking contact at the vertical metal rod with his hands.

The unipolar-electric bath is employed instead of local galvanization where it is desired to limit the application to especial organs or particular parts of the body. In general galvanization the patient is placed on an electrode of large surface, formed of a large sponge-covered metallic plate, on which he sits or rests. This electrode is connected with the kathode of the battery. The anode is connected with a large sponge electrode, which is moved regularly over the body of the patient; sometimes the moistened hand of the operator is used in place of the sponge electrode.

Bath, Unsilvering — —A stripping bath suitable for the removal of a coating of silver. (See *Bath, Stripping*.)

Bathometer.—An instrument invented by Siemens for obtaining deep-sea soundings without the use of a sounding line.

The bathometer depends for its operation on the varied attraction of the earth for a suspended weight in parts of the ocean differing in depth. As the vessel passes over deep portions of the ocean, the solid land of the bottom, being further from the ship, exerts a smaller attraction than it would in shallow parts, where it is nearer; for, although in the deep parts of the ocean the water lies between the ship and the bottom, the smaller density of the water as compared with the land causes it to exert a smaller attraction than in the shallower parts, where the bottom is nearer the ship. The varying attraction of the earth is caused to act on a mercury column, the reading of which is effected by means of an electric contact.

Battery, Banked — —A term sometimes applied to a battery from which a number of separate circuits are supplied with currents.

The term banked-battery is sometimes applied to a multiple-arc connected battery.

Battery, Cautery — —A term sometimes employed in electro-therapeutics, for a multiple connected voltaic battery adapted for producing electric incandescence for cautery effects.

Battery, Closed-Circuit — —A voltaic battery which may be kept constantly on closed-circuit without serious polarization.

The gravity battery is a closed-circuit battery. As employed for use on most telegraph lines, it is maintained on a closed circuit. When an operator wishes to use the line he opens his switch, thus breaking the circuit and calling his correspondent. Such batteries should not polarize. (See *Cell, Voltaic, Polarization of*.)

Battery, Connection of, for Quantity — —A term, now generally in disuse, formerly employed to indicate the grouping of voltaic cells, now known as parallel or multiple.

The arrangement or coupling of a number of voltaic cells in multiple reduces the internal resist-

ance of the battery, and thus permits a greater current, or quantity, of electricity to pass; hence the origin of the term.

Battery, Dynamo — —The combination or coupling together of several separate dynamo-electric machines so as to act as a single electric source.

The dynamos may be connected to the leads either in series, in multiple, in multiple-series or in series-multiple.

Battery, Dynamo, Electric Machine — —A dynamo battery. (See *Battery, Dynamo*.)

Battery, Electric — —A general term applied to the combination, as a single source, of a number of separate electric sources.

The separate sources may be coupled either in *series*, in *multiple*, in *multiple-series*, or in *series-multiple*. (See *Circuits, Varieties of*.)

The term battery is sometimes incorrectly applied to a single voltaic couple or cell.

Battery, Floating, De la Rive's — —A floating voltaic cell, the terminals of which are connected with a coil of insulated wire, employed to show the attractions and repulsions between magnets and movable electric circuits.

The cell, shown in Fig. 38, consists of a vol-

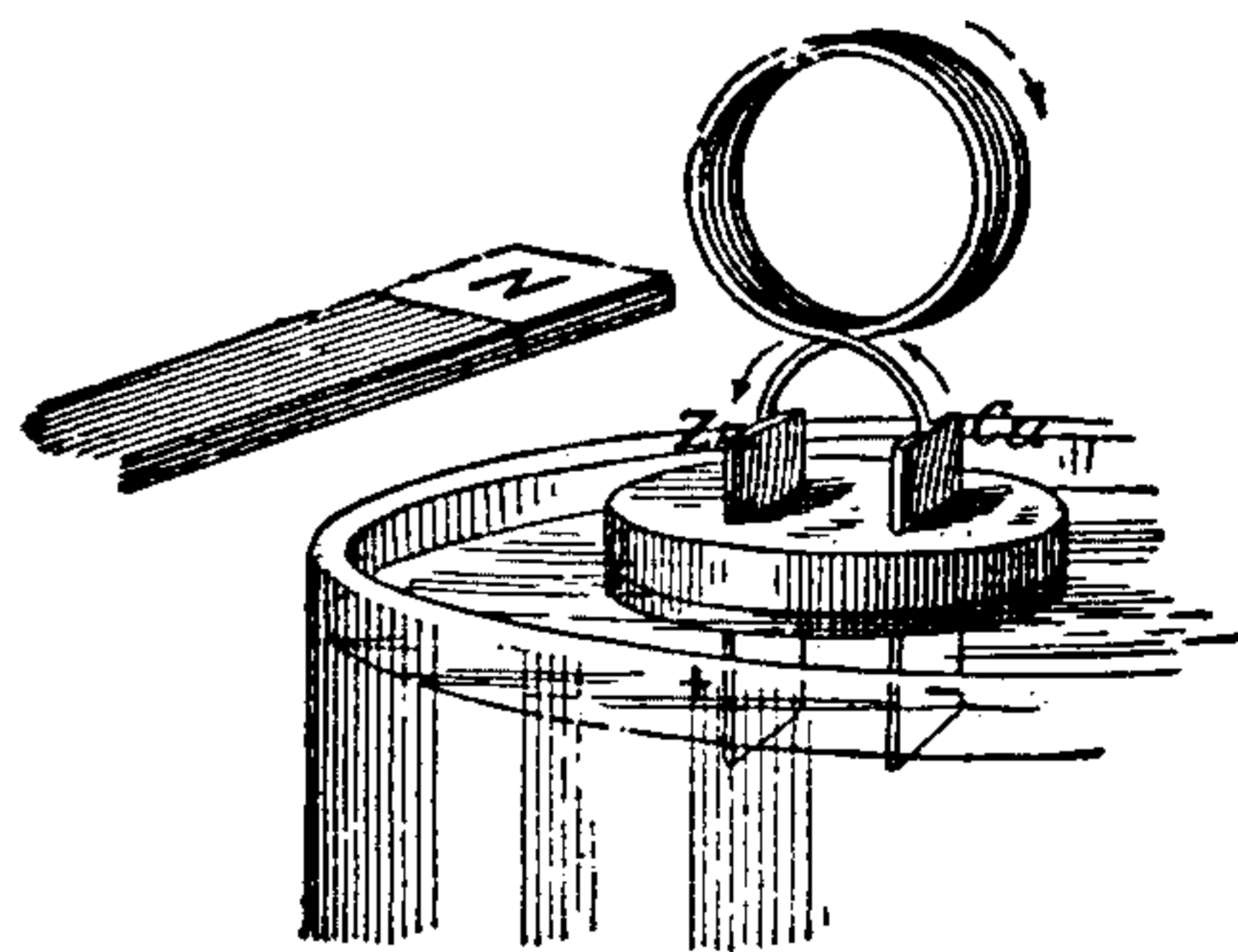

Fig. 38. Floating Cell.

taic couple of zinc and copper, the terminals of which are connected to the circular coil of insulated wire, as shown, and the whole floated by means of a cork, in a vessel containing dilute sulphuric acid.

When the current flows through the coil in the direction shown by the arrows, the approach of the N-seeking pole of a magnet will cause the cell to be attracted or to move towards the magnet pole, since the *south face* or end of the coil is nearer the *north pole* of the magnet. If the other

THIS PAGE IS LOCKED TO FREE MEMBERS

Purchase full membership to immediately unlock this page



HISTORY

Tens of thousands of important historical sources, many previously unobtainable, are now available for the first time with a Forgotten Books Full Membership.

Unlimited Access
\$8.99/month

Continue

*Fair usage policy applies

shown in Fig. 41. It consists of straight bars of steel, p, p, p, with their similar poles placed near together and inserted in masses of soft iron, N and S, as shown.

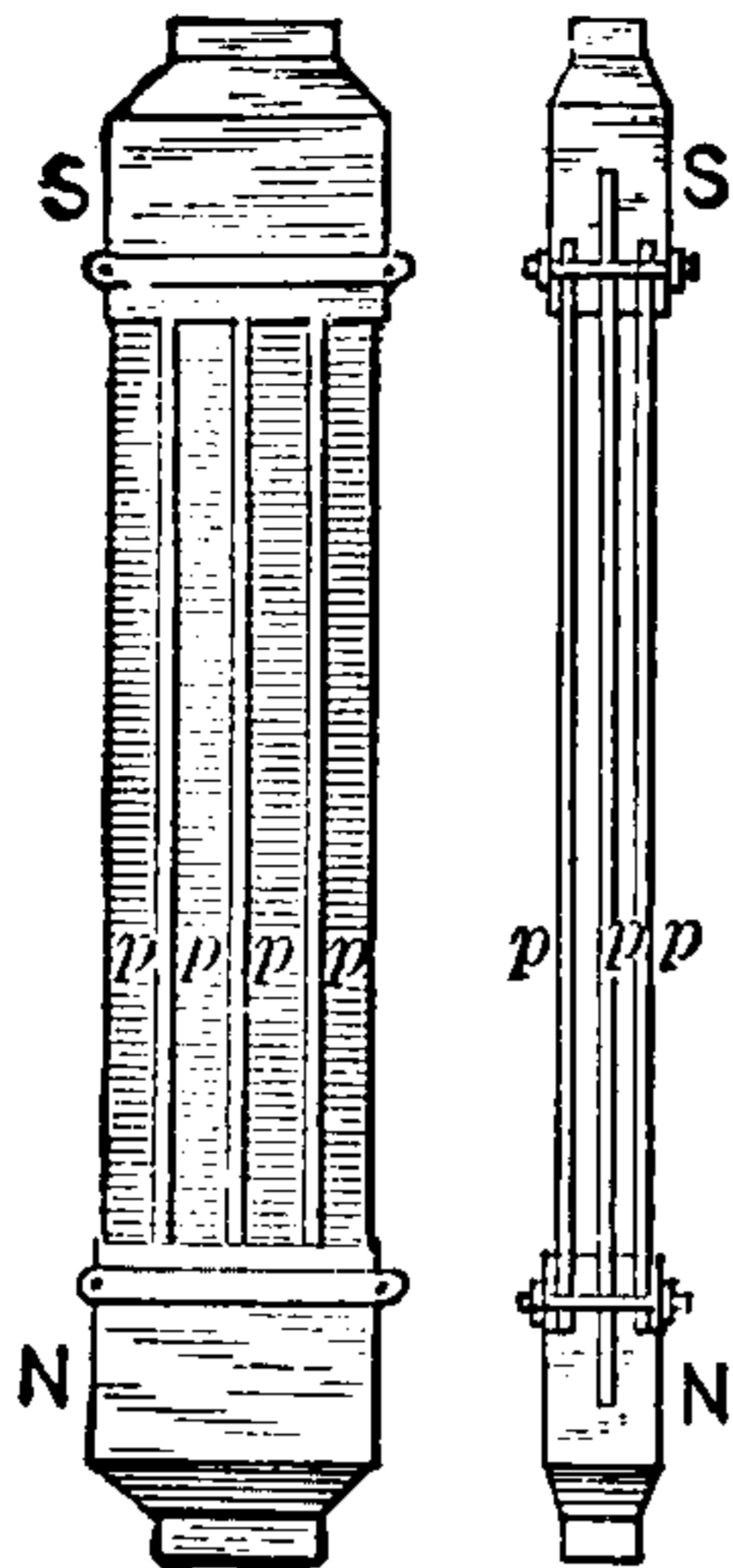

Fig. 41. Magnetic Battery, or Compound Magnet.

Battery, Main — — The battery, in a system of telegraphic communication, that is employed for sending the signals over the main line, as distinguished from any battery employed for any other particular work, such, for example, as that of the local battery. (See *Battery, Local*.)

Battery, Multiple-Connected — — A battery the single cells of which are connected to one another and to the mains or conductors in multiple. (See *Circuit, Multiple*.)

Battery, Open-Circuit — — A voltaic battery which is normally on open-circuit, and which is used continuously only for comparatively small durations of time on closed-circuit.

Leclanché-cells form an excellent open-circuited battery. They have a comparatively high electromotive force, but rapidly polarize. They cannot therefore be economically used for furnishing currents continuously for long durations of time. When left on open-circuit, however, they readily depolarize. They therefore form an excellent battery for such work as annunciator bells, burglar alarms, etc., where the current is only required for short periods of time, separated by comparatively long intervals of rest. (See *Cell, Voltaic, Leclanché*.)

Battery Plates of Secondary or Storage Cell, Forming of — — (See *Plates of Secondary or Storage Cell, Forming of*.)

Battery, Plunge — — A number of separate voltaic cells connected so as to form a single cell or electric source, the plates of which are so supported on a horizontal bar as to be capable of being simultaneously placed in, or removed from, the exciting liquid.

The plunge battery shown in Fig. 42, consists

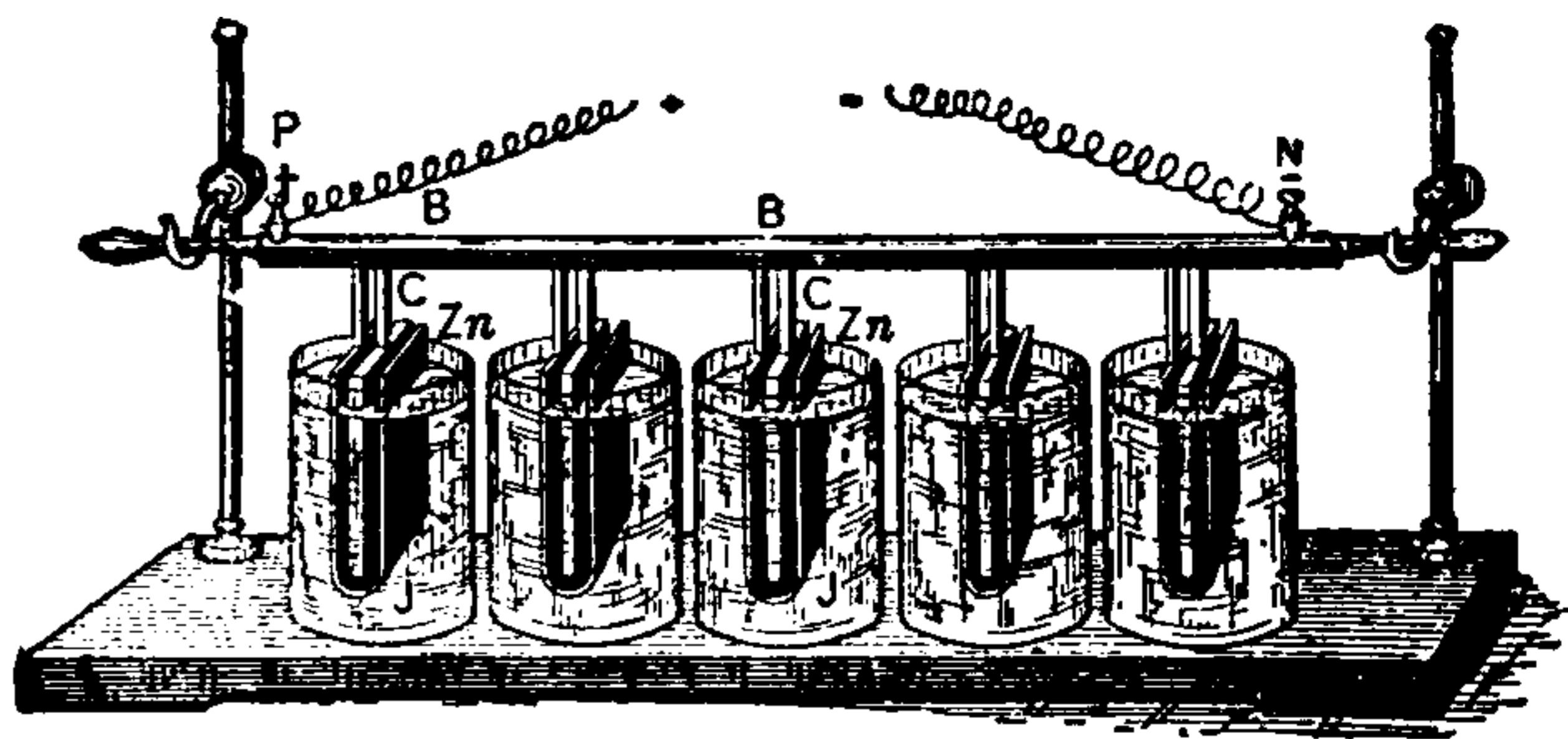

Fig. 42. Plunge Battery.

of a number of zinc-carbon elements immersed in an electrolyte of dilute sulphuric acid, or in *electropon liquid*, contained in separate jars, J, J. (See *Liquid, Electropon*.)

The mode of support to the horizontal bar will be understood from an inspection of the drawing.

Battery, Primary — — The combination of a number of separate primary cells so as to form a single source.

The term *primary battery* is used in order to distinguish it from secondary or storage battery. (See *Cell, Secondary, Cell, Storage*.)

Battery, Secondary — — The combination of a number of separate secondary or storage cells, so as to form a single electric source. (See *Electricity, Storage of*.)

Battery, Selenium — — The combination of a number of separate selenium cells so as to form an electric source. (See *Cell, Selenium*.)

Battery, Series-Connected — — A battery, the separate cells of which are connected to one another and to the line or conductor in series. (See *Circuit, Series*.)

Battery Solution.—(See *Solution, Battery*.)

Battery, Split — — A voltaic battery connected in series, but having one of its middle plates connected with the ground.

By the employment of the device of a split-battery, the poles of the battery are maintained at potentials differing in opposite directions from the potential of the earth.

Battery, Storage — — A number of separate storage cells connected so as to form a single electric source.

A cell of a storage battery is shown in Fig. 43.

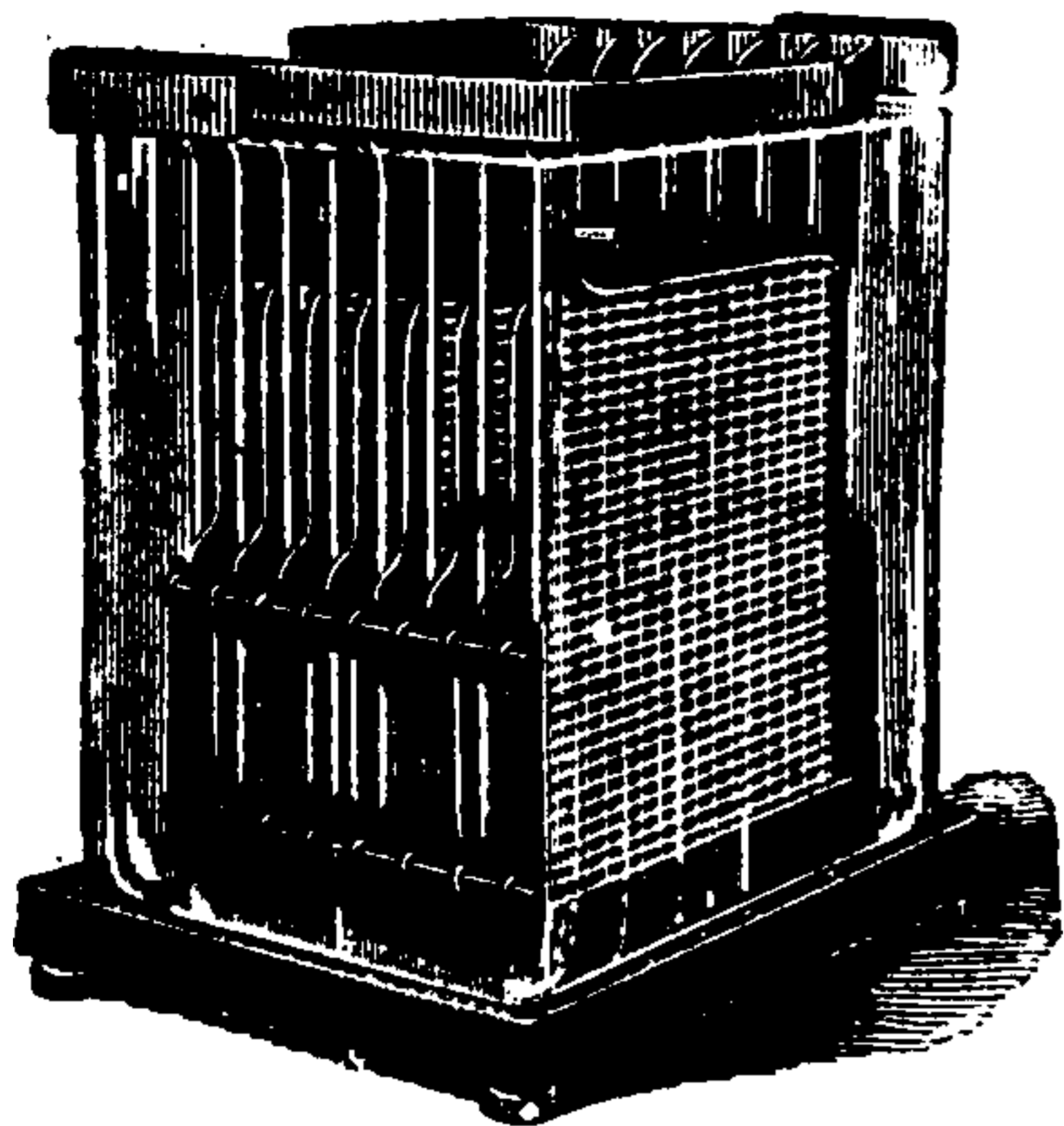

Fig. 43. Storage Battery.

Battery, Storage, Element of — —A single set of positive and negative plates of a storage cell connected so as to be ready for placing in the acid liquid of the jar or cell.

A term sometimes applied to one of the storage cells in a storage battery.

This latter use of the term element is unfortunate, since from the analogous case of a primary cell, an element would consist of a single plate, either positive or negative, and not of both. That is, every voltaic couple consists of two elements, the positive and the negative.

Battery, Thermo — —A term often applied to a thermo-electric battery. (See *Battery, Thermo-Electric*.)

Battery, Thermo-Electric — —The combination, as a single thermo-electric cell, of a number of separate thermo-electric cells or couples. (See *Couple, Thermo-Electric*.)

Battery, Voltaic — —The combination, as a single source, of a number of separate voltaic cells.

Battery, Water — —A battery formed of zinc and copper couples immersed in an electrolyte of ordinary water.

Any voltaic couple can be used, the positive element of which is slightly acted on by water. When numerous couples are employed considerable difference of potential can be obtained.

Water batteries are employed for charging electrometers. They are not capable of giving any considerable current, owing to their great internal resistance.

Bead Areometer or Hydrometer.—(See *Areometer, Bead*.)

Bec-Carcel.—The Carcel, or French unit of light. (See *Carcel*.)

Bell, Automatic-Electric — —An electric bell furnished with an automatic contact-breaker. (See *Contact-Breaker, Automatic*.)

A form of automatic-electric bell is shown in Fig. 44. The relation of the electro-magnet, its armature and the bell lever, will be readily understood from an inspection of the drawing.

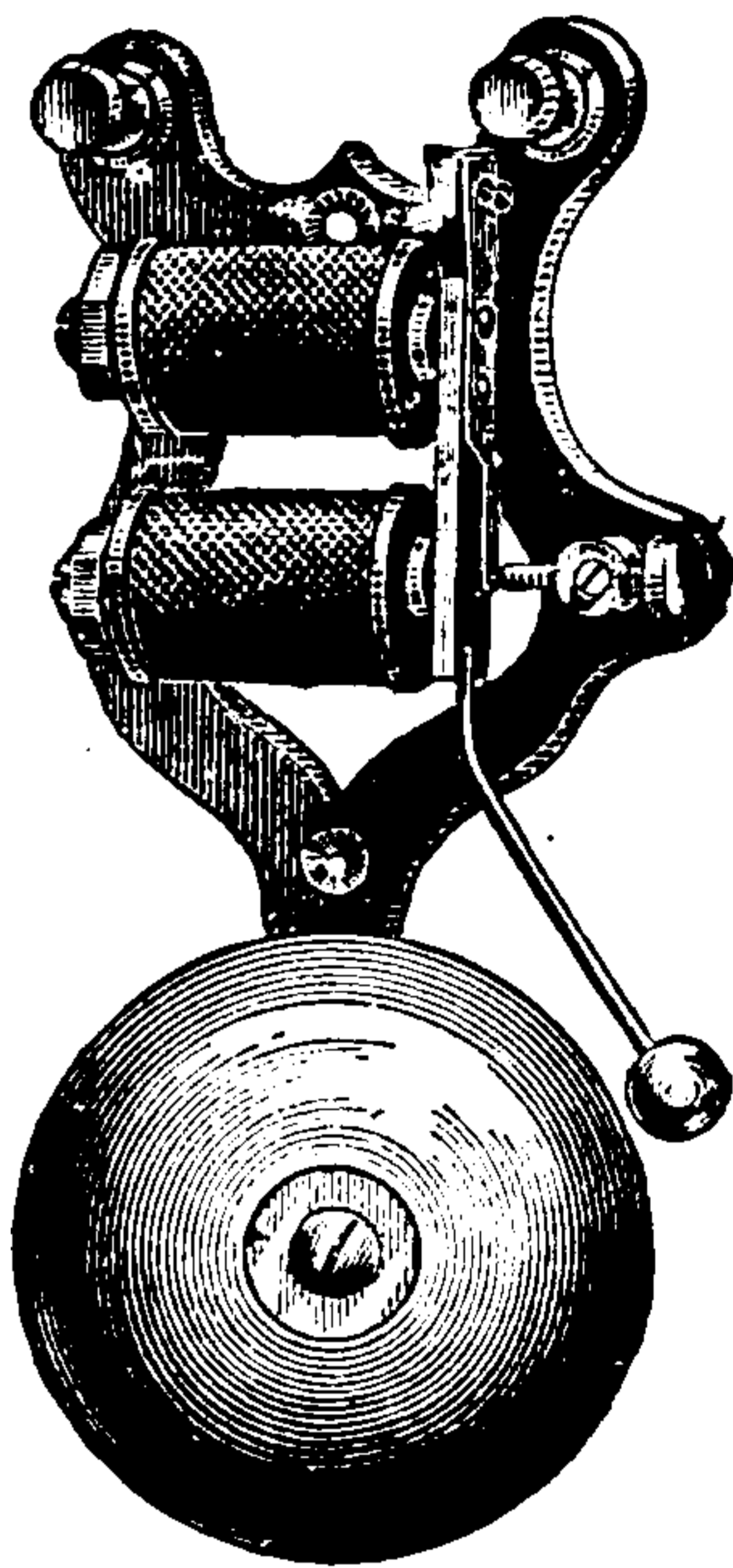

Bell, Call — —An electric bell used to call the attention of an operator to the fact that his correspondent wishes to communicate with him.

Bell, Circular — —A bell so constructed that all its moving parts are contained in the gong. (See Fig. 44. *Automatic Electric Bell*.)

Bell, Continuous-Sounding Electric — —An electric bell, which, on the completion of the circuit, continues striking until stopped either by hand or automatically.

On the completion of the circuit, the attraction of an armature throws a catch off from a lever, and thus permits the lever to fall and complete a contact and allows the current to ring the bell; or the bell is rung by clockwork, which is thrown into action by the passage of a current through an electro-magnet. (See *Bell, Electro-Mechanical*.)

Bell, Differential Electric — —An electric bell, the magnetizing coils of which are differentially wound.

Differential winding is of advantage where a very strong current is required, as this winding decreases the sparking at the contacts, on the opening of the circuit.

Bell, Electro-Magnetic, Siemens-Armature Form — —A form of electro-mag-

netic bell in which the movements of the bell armature are obtained by the reversal of polarity that takes place when alternating currents are passed through the coils of a simple, single coil, Siemens-armature.

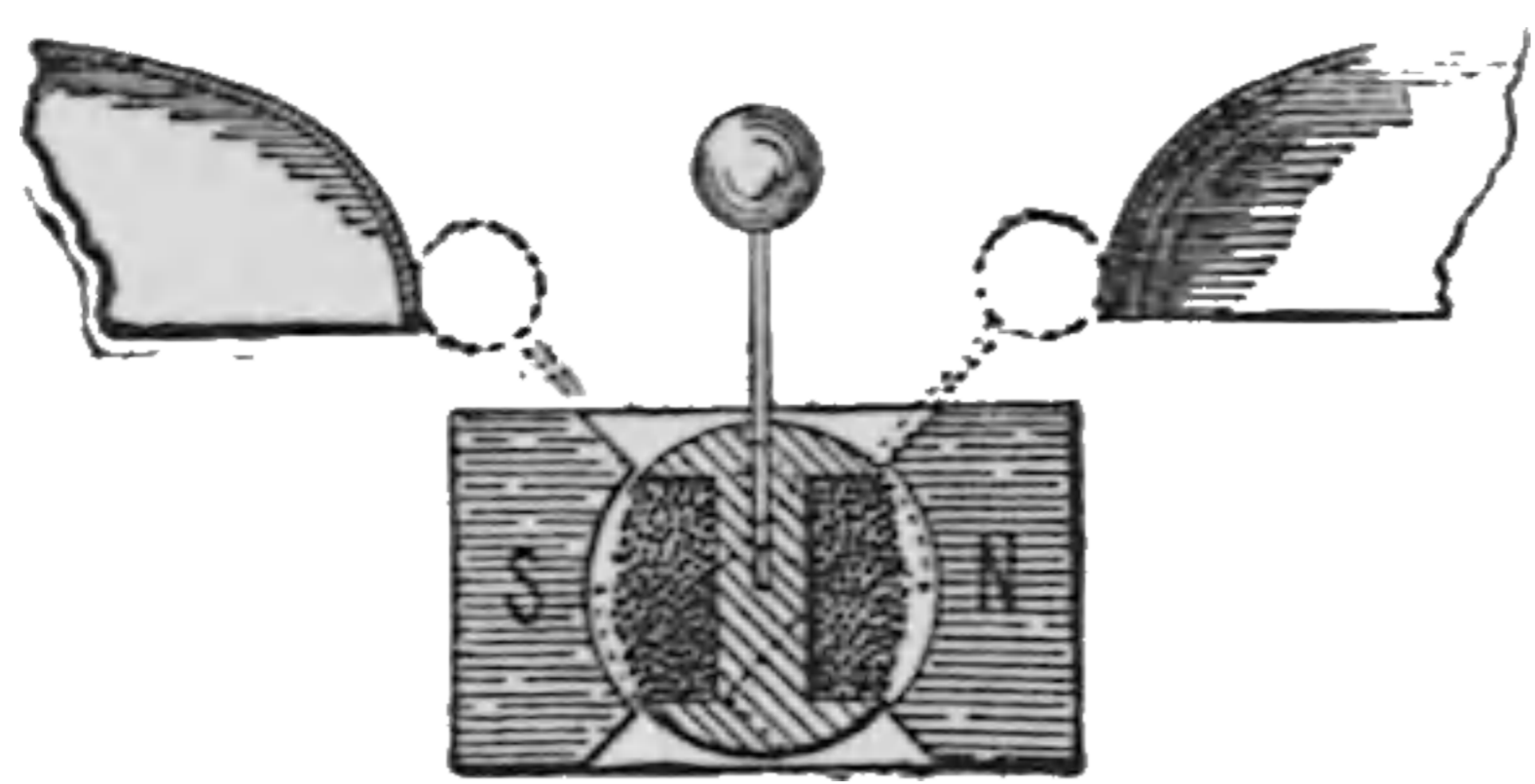

Fig. 45. Siemens-Armature Form of Electro-Magnetic Bell.

The details will be readily understood from an examination of Fig. 45.

Bell, Electro-Mechanical — —A bell, the striking apparatus of which is driven by a weight or spring, called into action by the movement of the armature of an electro-magnet. (See *Alarm, Electric*.)

Bell, Extension-Call — —A device for prolonging the sound of a magneto call.

An alarm bell is automatically connected with

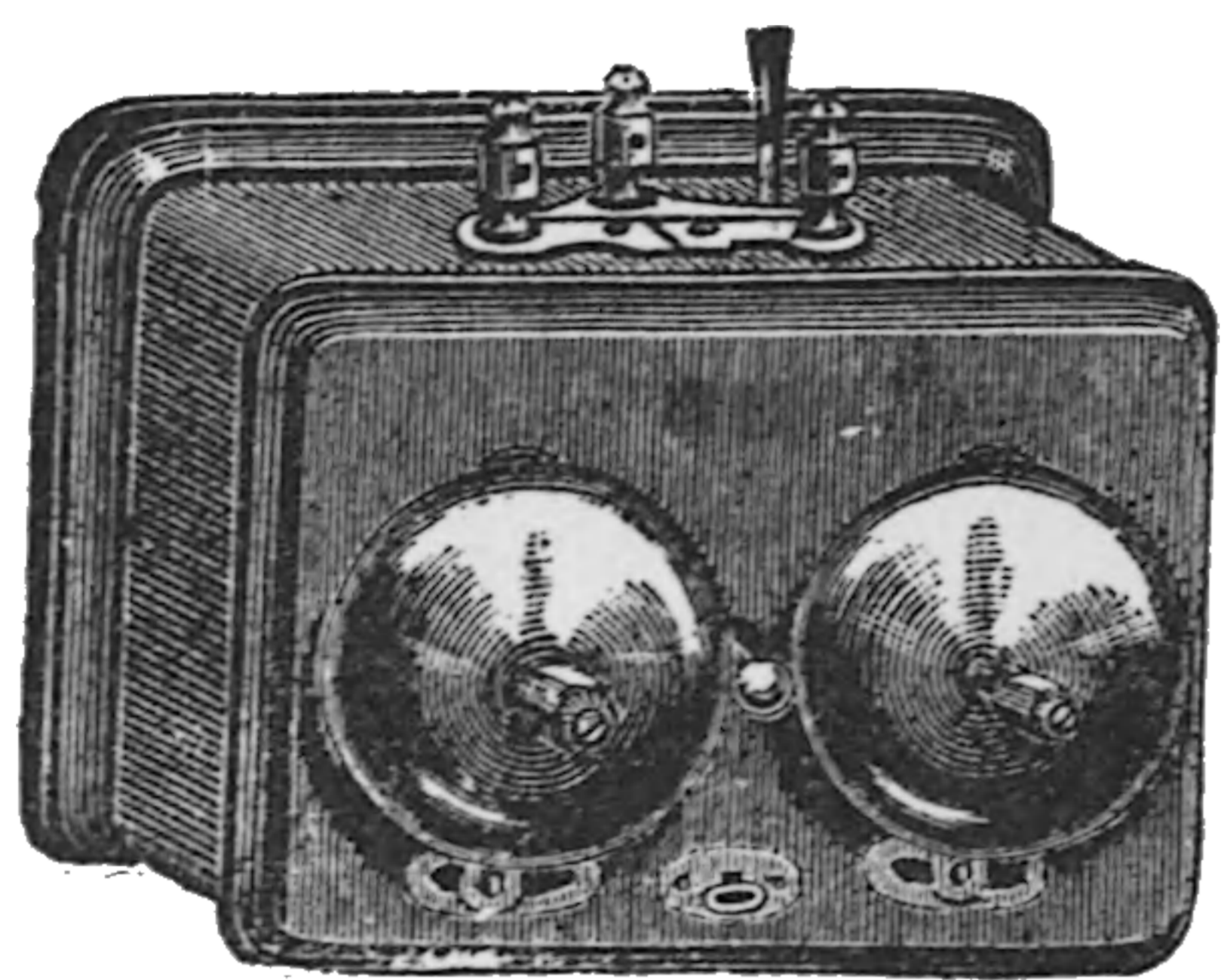

Fig. 46. Extension-Call Bell.

the circuit of a local battery by means of the current generated by the magneto-call, and continues sounding after the current of the magneto call has ceased.

A form of extension-call bell is shown in Fig. 46.

Bell, Indicating — —An electric bell in which, in order to distinguish between different bells in the same office, a number is displayed by each bell when it rings.

Bell, Magneto-Electric — —An electric bell, the current employed to operate or strike which is obtained by the motion of a magneto-electric machine.

Bell, Night — —In a telephone exchange, a bell, switched into connection with the shunted circuit of an annunciator case, and intended, by its constant ringing, to call the attention of the night operator to the falling of a drop.

Bell, Relay, Electric — —An electric bell in which a relay magnet is employed to switch a local battery into the circuit of the sounding apparatus of the bell.

The relay bell is suitable for use when the bell to be sounded is situated at a great distance. As the current from the line, when this is long, is too weak to ring the bell, it throws into action a local battery by the action of a relay.

Relay bells were used in the early forms of acoustic telegraphs as employed in England with relay sounders.

The dots and dashes of the Morse alphabet were indicated by the sounds of two bells, a tap on one bell indicating a dot, and a tap on the other a dash. This system is now practically abandoned.

Bell-Shaped Magnet.—(See *Magnet, Bell-Shaped*.)

Bell, Shunt, Electric — —An electric bell, the magnetizing coils of which are placed on the line in shunt.

In the case of shunt-connected electric bells, one of the bells must make and break the circuit for all the rest. The series-connected electric bell is used where the distance between the separate bells is great, in order to save the expense of multiple connections.

In most cases, where a number of electric bells are to be simultaneously sounded, connection in multiple is adopted.

Bell, Single-Stroke Electric — —An electric bell that gives a single stroke only for each make of the circuit.

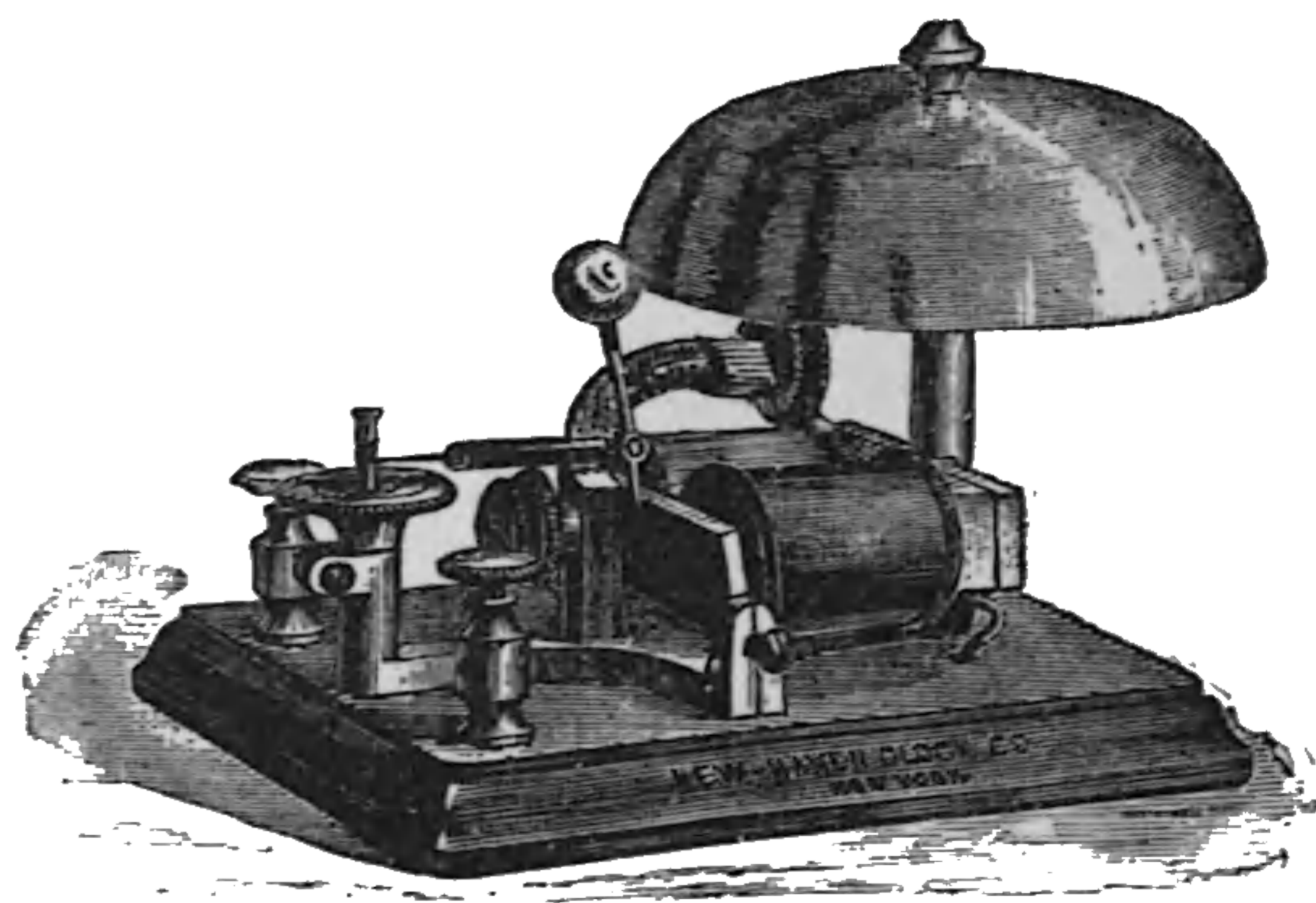

Fig. 47. Single-Stroke Bell.

Since the bell gives a single stroke for each completion of the circuit, its use permits of ready communication between any two places by any

system of prearranged signals. A buzzer may be used for the same purpose. A form of single-stroke bell is shown in Fig. 47. On completing the circuit, the current, through its coils, attracts the armature and causes a single stroke of the bell.

Bell, Telephone-Call — —A call bell used to call a correspondent to the telephone.

The telephone-call bell is generally a magneto-electric bell.

Bell, Trembling — —A name sometimes given to a vibrating or an automatic make-and-break bell. (See *Make-and-Break, Automatic.*)

Bell, Vibrating — —A trembling bell. (See *Bell, Trembling.*)

Bias of Relay Tongue.—(See *Tongue, Relay, Bias of.*)

Bichromate Voltaic Cell.—(See *Cell, Voltaic, Bichromate.*)

Bi-filar Suspension.—(See *Suspension, Bi-filar.*)

Bi-filar Suspension Balance.—(See *Balance, Bi-filar Suspension.*)

Bi-filar Winding.—(See *Winding, Bi-filar.*)

Binary Compound.—(See *Compound, Binary.*)

Binding Coils.—(See *Coils, Binding.*)

Binding-Post.—(See *Post, Binding.*)

Binding-Screw.—(See *Screw, Binding.*)

Binding Wire for Telegraph Lines.—(See *Wire, Binding, for Telegraph Lines.*)

Biology, Electro — —That branch of electric science which treats of the electric conditions of living animals and plants, and the effects of electricity upon them.

Electro-Biology includes :

(1.) Electro-Physiology.

(2.) Electro-Therapy, or Electro-Therapeutics.

Bioplasm.—Any form of living matter possessing the power of reproduction.

Bioscopy, Electric — —The determination of the presence of life or death by the passage of electricity through the nerves and muscles.

Bi-polar.—Having two poles.

Bi-polar Armature.—(See *Armature, Bi-polar.*)

Bi-polar Bath.—(See *Bath, Bi-polar.*)

Birmingham Wire Gauge.—(See *Gauge, Wire, Birmingham.*)

Bi-Telephone.—(See *Telephone, Bi.*)

Bitite.—A variety of insulating material.

Black Electro-Metallurgical Deposit.—(See *Deposit, Black Electro-Metallurgical.*)

Black Lead.—A variety of carbon employed in various electrical processes.

Black lead is also termed *plumbago* or *graphite*. (See *Plumbago. Graphite.*)

The term black lead is a misnomer, since the substance is carbon and not lead. The term is an old one, and is still very generally used.

Blasting, Electric — —The electric ignition of powder or other explosive material in a blast. (See *Fuse, Electric.*)

The current required for the ignition of the fuse is generally obtained by means of a magneto-electric machine. In the form of magneto-blasting machine, shown in Fig. 48, the movement

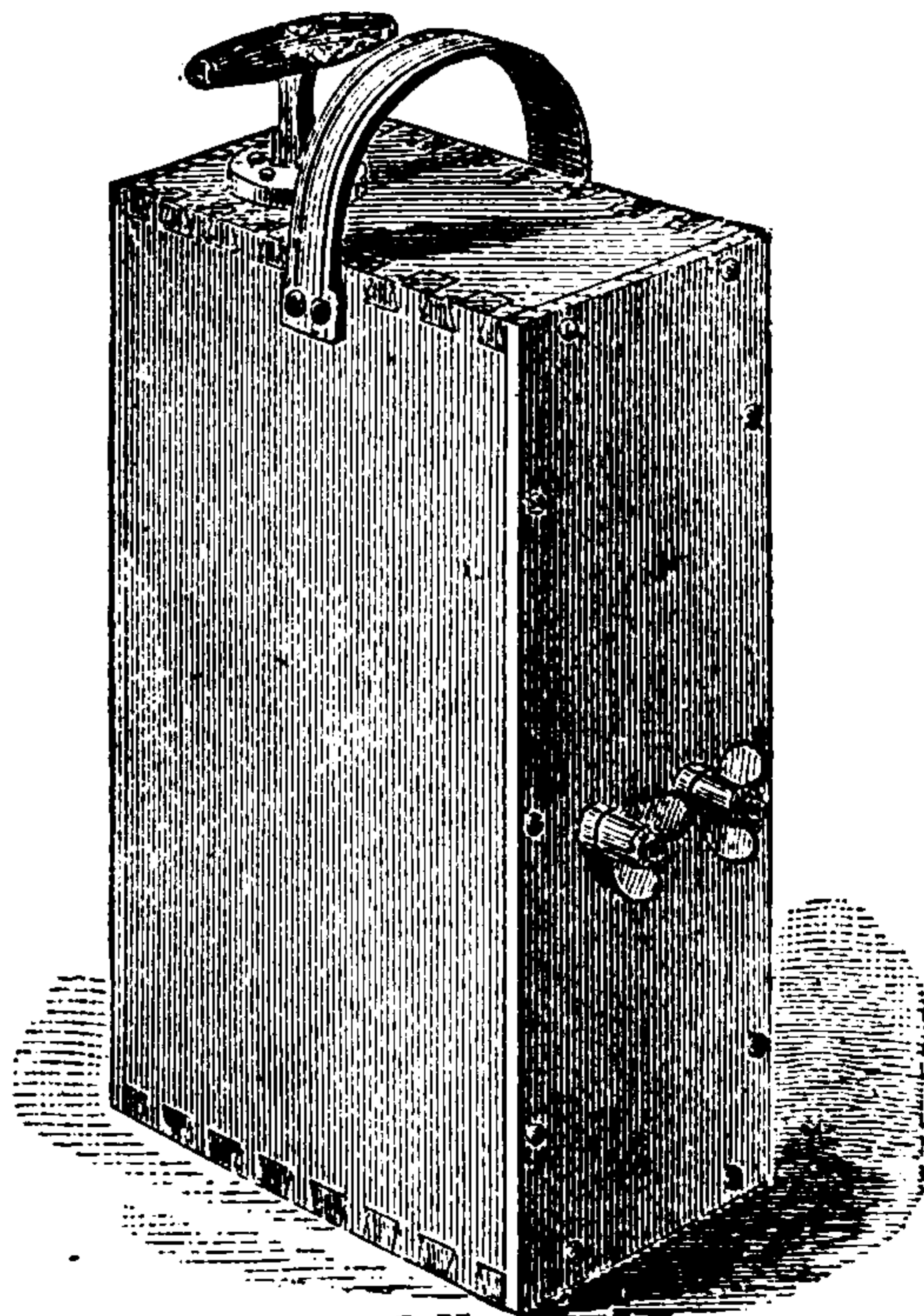

Fig. 48. Magneto-Blasting Machine.

of the handle shown at the top of the figure causes the rapid rotation of a cylindrical armature constructed on the Wheatstone and Siemens principle. The magnets are of iron, and are furnished

with coils of insulated wire. On the rotation of the armature the current developed therein increases the field of the field magnet, and, when of the proper degree of intensity, is thrown into the outer circuit, and ignites the fuse.

Bleaching, Electric — — Bleaching processes in which the bleaching agents are liberated, as required, by the agency of electrolytic decomposition.

In the process of Naudin and Bidet, the current from a dynamo-electric machine is passed through a solution of common salt between two closely approached electrodes. The chlorine and sodium thus liberated react on each other and form sodium hypochloride, which is drawn off by means of a pump and used for bleaching. (See *Electrolysis*.)

Block, Branch — — A device employed in electric wiring for taking off a branch from a main circuit. (See *Wiring*.)

A form of branch-block, with its fuses attached, is shown in Fig. 49.

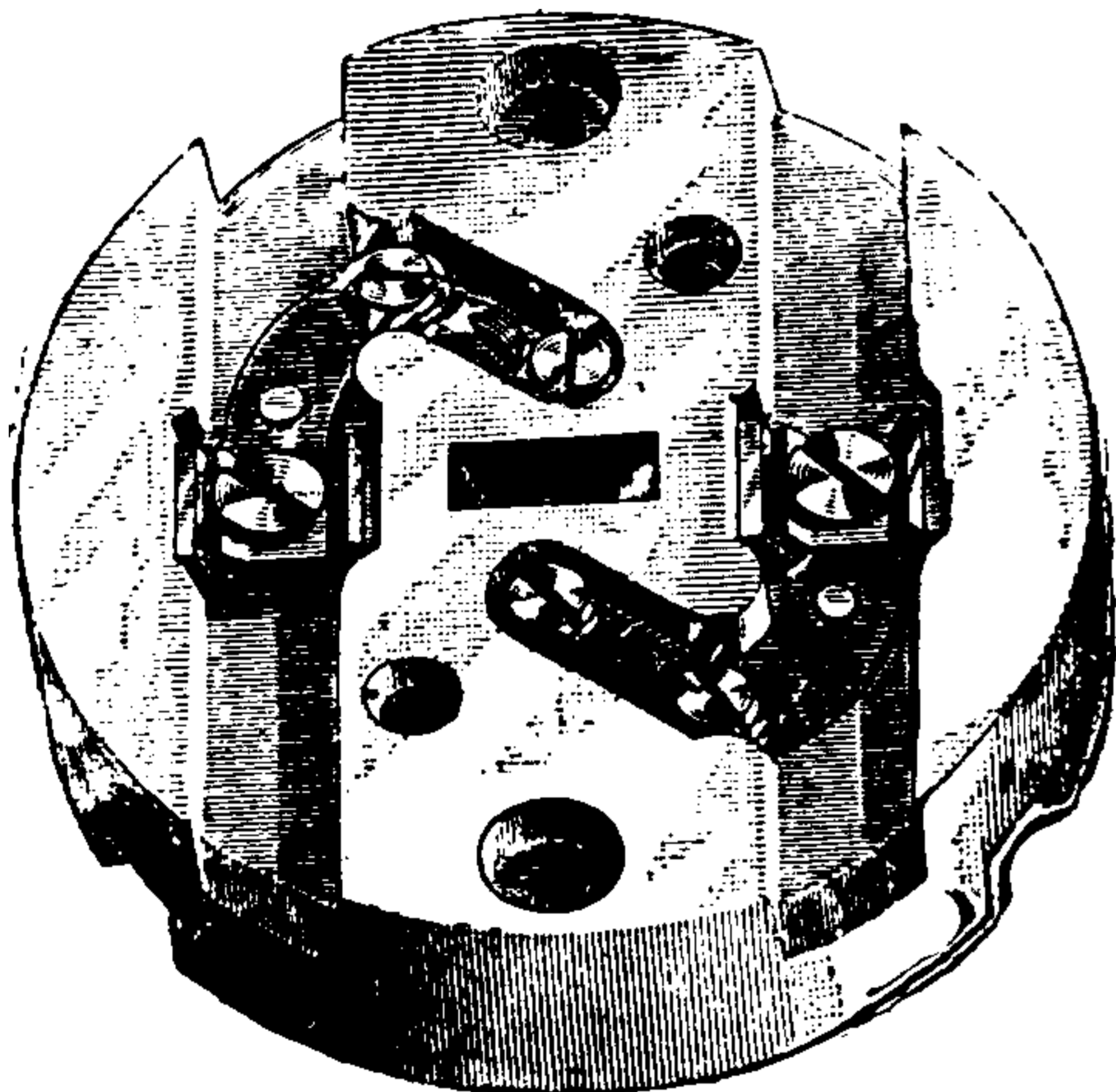

Fig. 49. Branch-Block.

Block, Cross-Over — — A device to permit the safe crossing of one wire over another in molding or cleat wiring.

Block, Fuse — — A block containing a safety fuse or fuses for incandescent light circuits. (See *Fuse, Safety*.)

Block System for Railroads.—(See *Railroads, Block System for*.)

Block Wire.—(See *Wire, Block*.)

Blow-Pipe, Electric — — A blow-pipe in which the air-blast is obtained by a stream of air particles produced at the point of a

charged conductor by a convection discharge.

The candle flame, Fig. 50, is blown in the di-

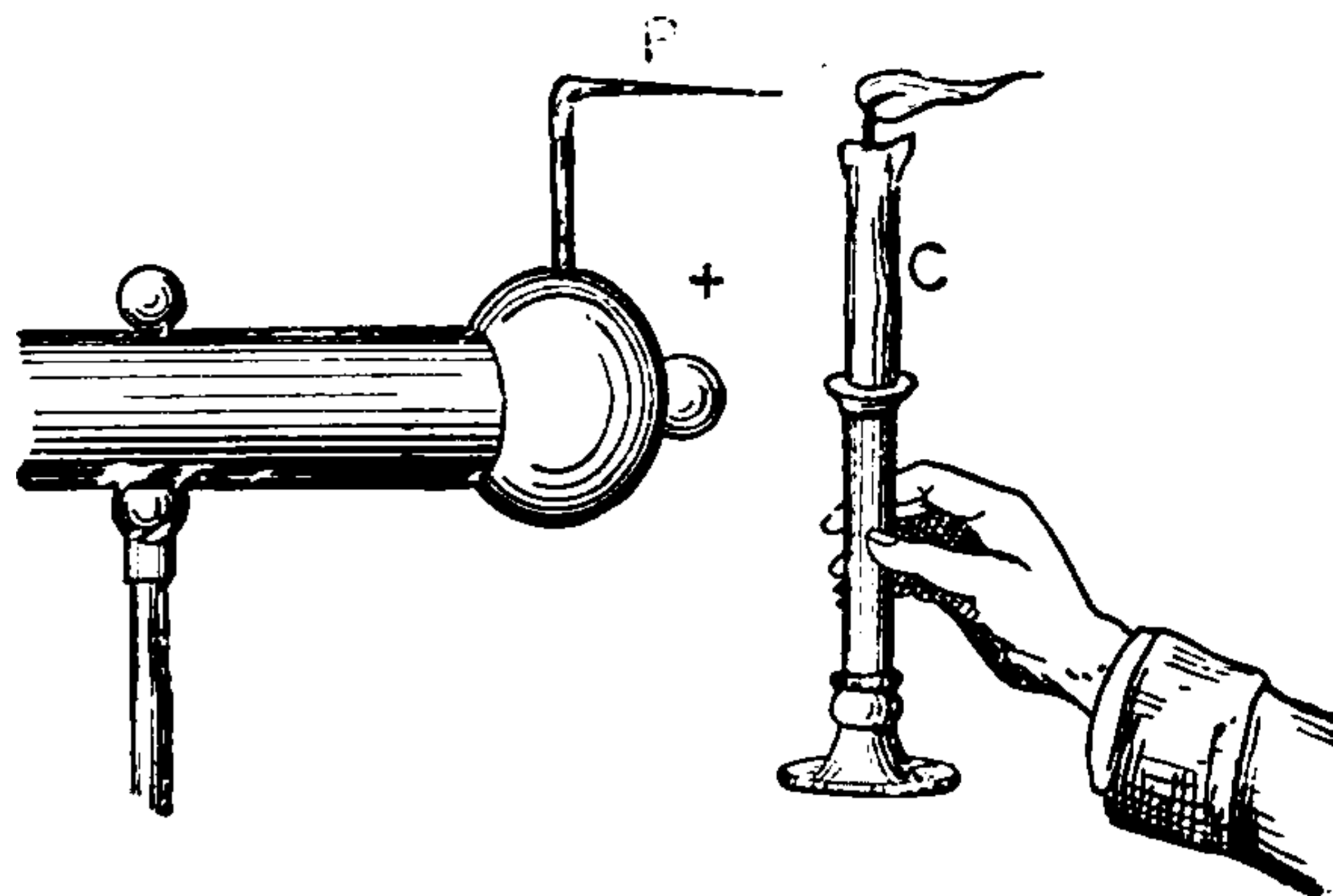

Fig. 50. Convection Blow-Pipe.

rection of the stream of air particles passing off from the point P. (See *Convection, Electric*.)

Blow-Pipe, Electric-Arc — — A device of Werdermann for cutting rocks, or other refractory substances, in which the heat of the voltaic arc is directed, by means of a magnet, or a blast of air, against the substance to be cut.

The carbons are placed parallel, so as to readily enter the cavity thus cut or fused. This invention has never been introduced into extensive practice.

In the welding process of Benardos and Olzewski, the welding temperature is obtained by means of an electric arc taken between two suitably shaped electrodes.

In the electric-arc blow-pipe, shown in Fig. 51, the voltaic arc, taken between two vertical carbon electrodes, is deflected into a horizontal position under the influence of the inclined poles of a powerful electro-magnet.

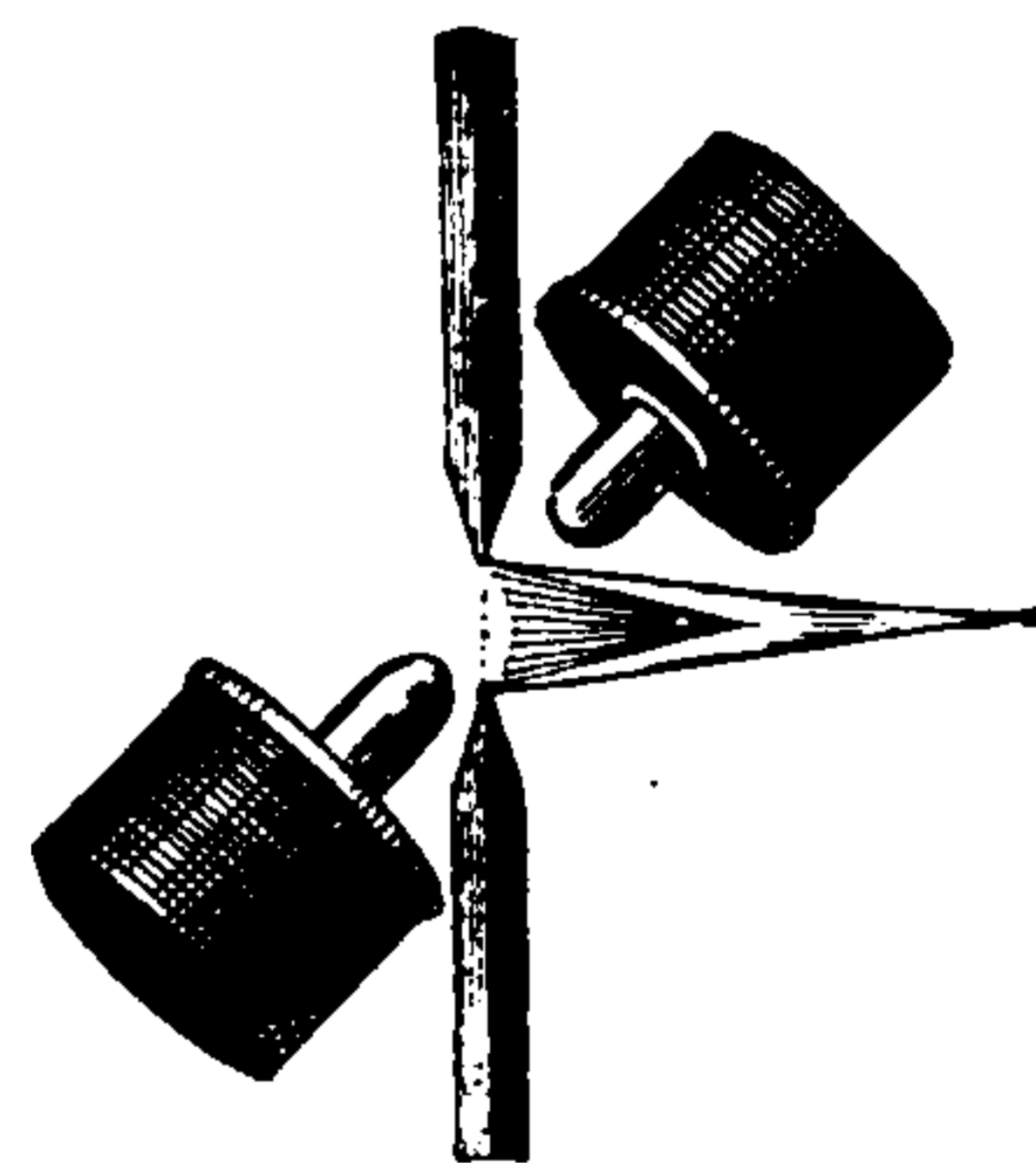

Fig. 51. Electric-Arc Blow-Pipe.

The highly heated carbon vapor which constitutes the voltaic arc is deflected by the magnet in the same direction as would be any other movable circuit or current.

Board, Cross-Connecting — — In a system of telegraphic or telephonic communication, a board to which the line terminals are run before entering the switchboard, so as to

readily place any subscriber in connection with any desired section of the switchboard.

Board, Fuse — —A board of slate or other incombustible material on which all the safety fuses in an installation are assembled.

The fuse board is used for avoiding accidents from the firing of the fuses.

Board, Hanger — —A form of board provided for the ready placing or removal of an arc lamp from a circuit.

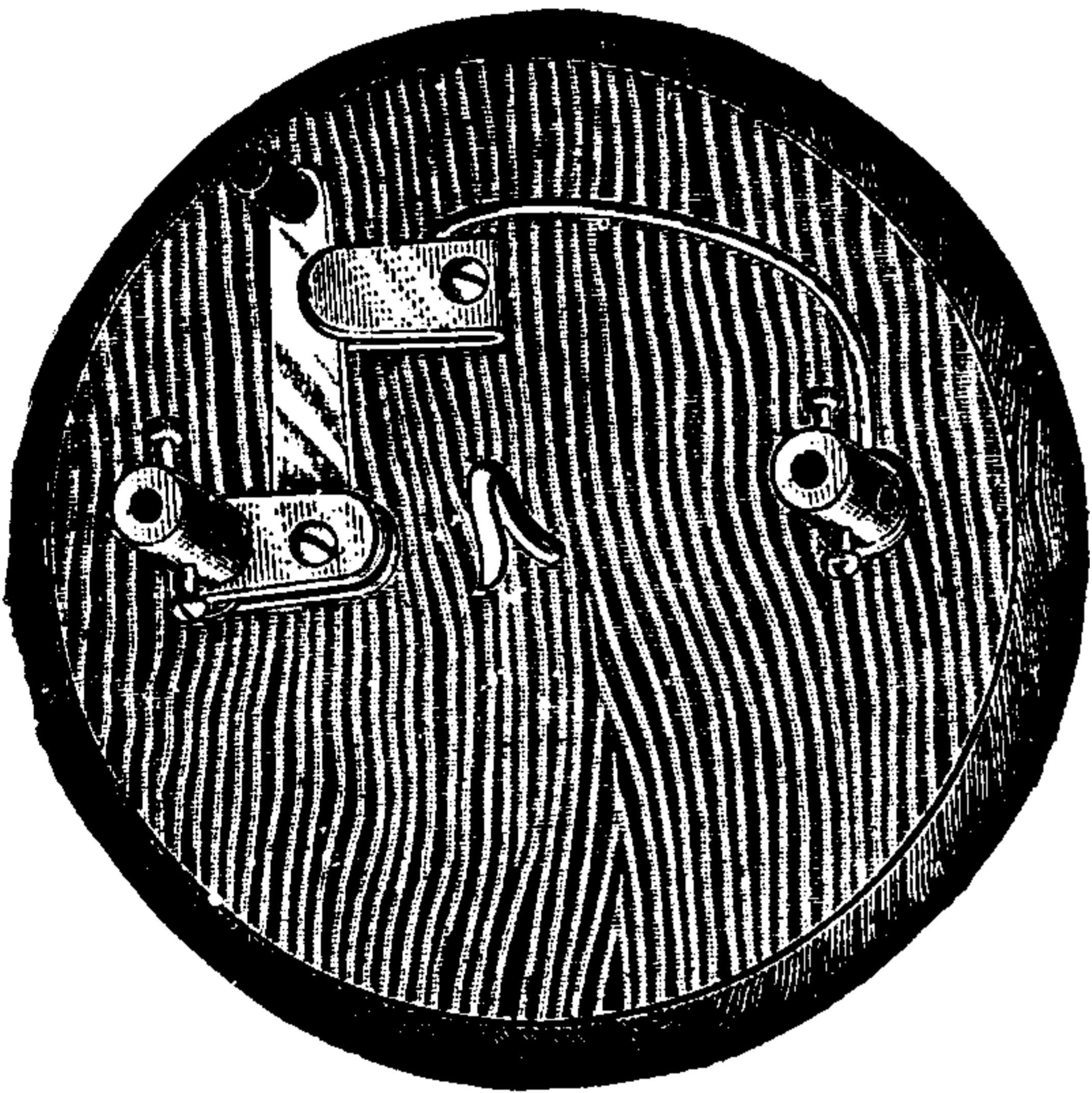

Fig. 52. Hanger-Board.

A hanger-board contains a switch or cut-out for the ready opening or closing of the circuit. A form of hanger-board is shown in Fig. 52.

Board, Key — —Any board to which are connected electric keys or switches.

Board, Legging-Key — —A key board employed for the purpose of legging an operator into a circuit connecting two or more subscribers. (See *Leg.*)

Board, Multiple Switch — —A board to which the numerous circuits employed in systems of telegraphy, telephony, annunciator or electric light and power circuits are connected.

Various devices are employed for closing these circuits, or for connecting or cross-connecting them with one another, or with neighboring circuits.

A multiple switchboard, for example, for a telephone exchange, will enable the operator to connect any subscriber on the line with any other subscriber on that line, or on another neighbor-

ing line provided with a multiple switchboard. To this end the following parts are necessary:

(1.) Devices whereby each line entering the exchange can readily have inserted in its circuit a loop connecting it with another line. This is accomplished by placing on the switchboard a separate *spring-jack* connection for each separate line. This connection consists essentially of one or two springs made of any conducting metal, which are maintained in metallic contact when the plug key is not inserted, but which are readily separated from one another by the introduction of the *plug-key*, Fig. 53, the terminals, a and b, of which are insulated from each other, and are connected to the ends of a loop coming from another line. As the key is inserted, the metallic spring or springs of the spring-jack are separated and the metallic pieces, a and b, are brought into good sliding contact therewith, thus introducing the loop into the circuit. (See *Spring-Jack.*)

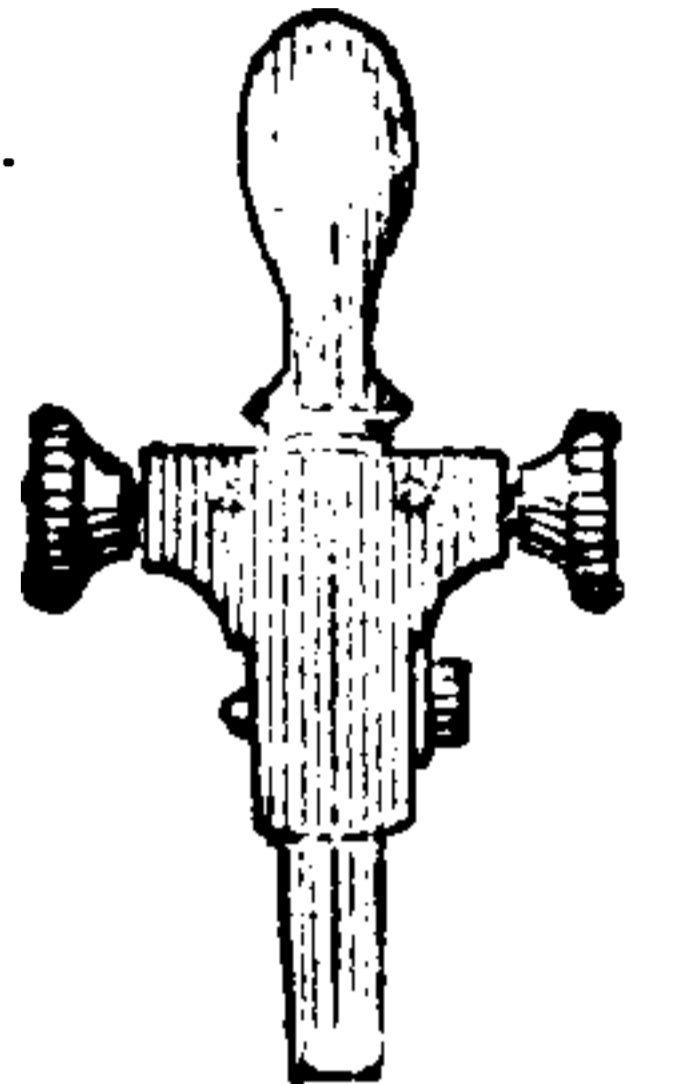

Fig. 53. Plug-Key.

(2.) As many separate annunciator-drops as there are separate subscribers. These are provided so as to notify the Central Office of the particular subscriber who desires a connection. Alarm-bells to call the operator's attention to the calling subscriber, or to the falling of a drop, are generally added. (See *Bell, Call.*)

(3.) Connecting cords and keys for connecting the operator's telephone, and means for ringing subscribers' bells, and clearing out drops.

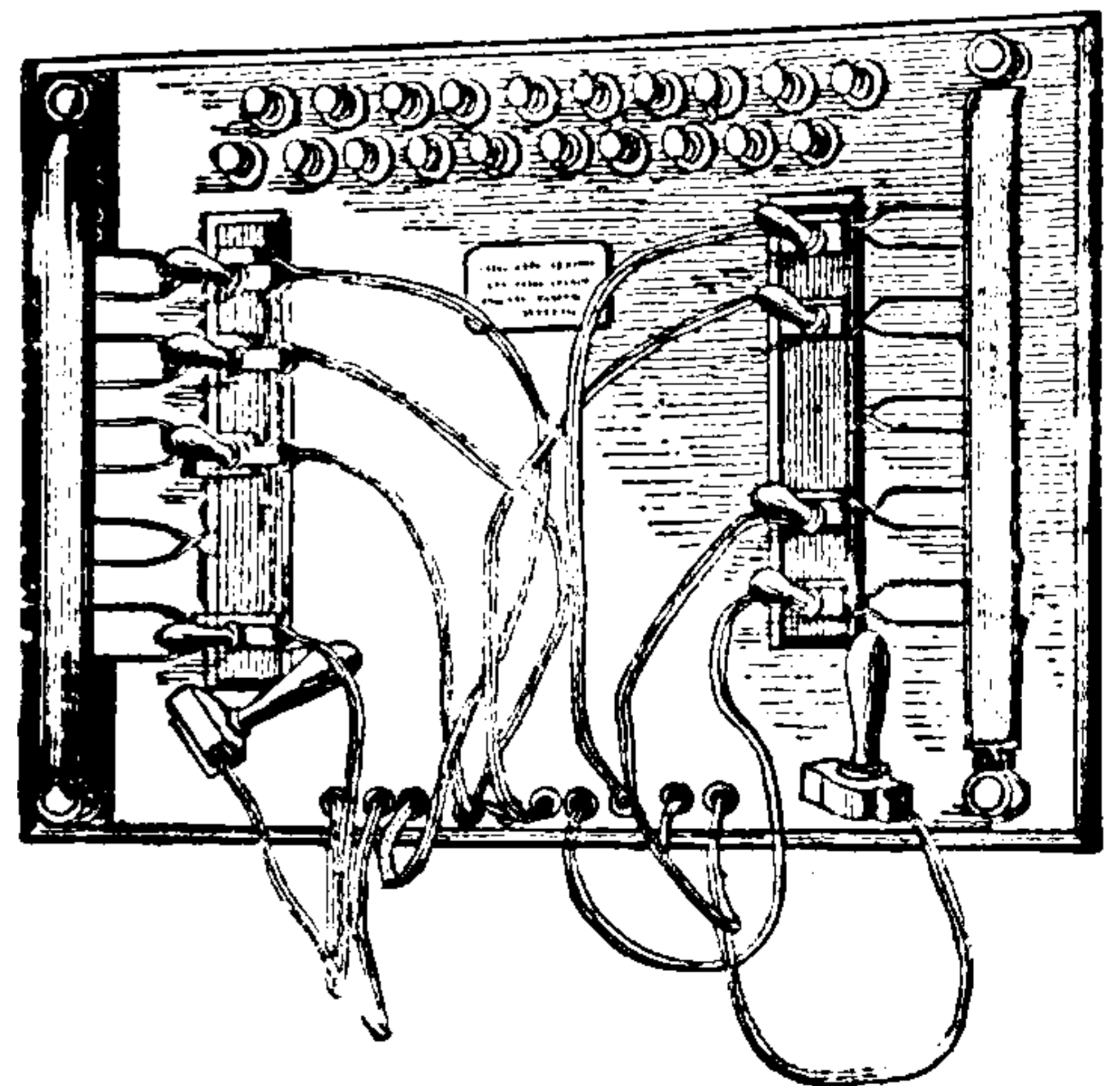

Fig. 54. Multiple Switchboard for Electric Light.

In *Multiple Switchboards* for the *Electric Light* or *Distributing Switches*, spring-jack contacts are connected with the terminals of different circuits,

and plug switches with the dynamo terminals. By these means, any dynamo can be connected with any circuit, or a number of circuits can be connected with the same dynamo, or a number of separate dynamos can be placed in the same circuit without interference with the lights.

Board, Switch — —A board provided with a switch or switches, by means of which electric circuits connected therewith may be opened, closed, or interchanged.

Board, Switch, Telegraphic — —A device employed at a telegraph station by means of which any one of a number of telegraph instruments, in use at that station, may be placed in or removed from any line connected with the station, or by means of which one wire may be connected to another.

The ability to readily connect one wire with another is of use in case of interruption to telegraph lines, in which case a through circuit may be made up of sections of different circuits.

In the switchboard shown in Fig. 55, the upper left-hand binding-post is connected to earth; the four remaining binding-posts are connected to two separate instruments—the sec-

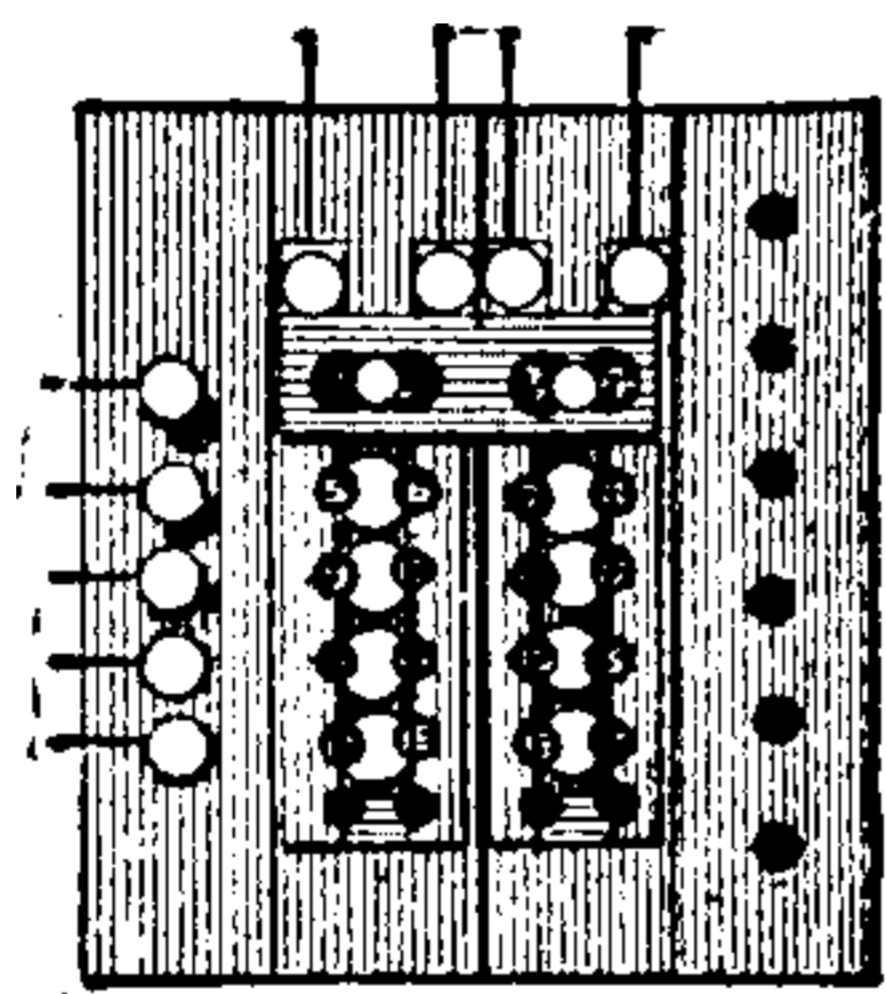

Fig. 55. Telegraphic Switchboard.

ond and third from the top to one instrument, and the fourth and fifth to another instrument. The four posts at the top of the figure are connected to two lines running east and west.

Various connections are made by the insertion of plug keys in the various openings.

Board, Switch, Trunking — —A switchboard in which a few subscribers only are connected with the operator, thus enabling him to obtain any other subscriber by means of trunk wires extending to the other sections. (See *Wire, Trunk*.)

Boat, Electric — —A boat provided with electric motive power.

Electric power has been applied both to ordinary vessels and to submarine torpedo boats.

Boat, Submarine Electric — —A boat capable of being propelled and steered while entirely under water.

The motive power of such boats is generally

electricity. The requisite buoyancy is obtained by means of an air chamber. Artificial ventilation is maintained, the fresh air requisite for breathing being derived from a compressed air cylinder.

Boat, Torpedo — —A boat used for carrying and discharging torpedoes. (See *Torpedo*.)

Bobbin, Electric — —An insulated coil of wire for an electro-magnet.

Body, Charged — —A body containing an electric charge.

Charges are bound or free. (See *Charge, Bound. Charge, Free*.)

Body, Electrified — —A body containing an electric charge.

Body, Human, Resistance of — —The resistance which the human body offers to the passage of an electric current.

The resistance of the human body to the passage of a current varies with the time. The resistance rapidly decreases after a short time.

“The resistance diminishes because of the conduction of water in the epidermis under the action of the constant current and the congestion of the cutaneous blood vessels in consequence of the stimulation.” (*Landois and Stirling*.)

The resistance also varies markedly with the condition of the surface, the condition of the skin, and with the shape, area, position and material of the electrodes by which the current is led into and carried out of the parts. It very seldom is less than 1,000 ohms under the most favorable conditions, and with ordinary contacts is many times that amount.

The muscles offer nearly nine times the resistance in a direction transverse to the fibres than longitudinally to them. (*Hermann*.)

The resistance of the epidermis is greater than that of any other tissue of the body.

The human body probably possesses a true asymmetrical resistance; that is to say, when taken after the current has been passing for some time, its resistance is different in different directions. This variation in the apparent resistance is believed by some to be due to polarization effects.

Body, Insulated — —A body supported on an insulator, or non-conductor of electricity.

THIS PAGE IS LOCKED TO FREE MEMBERS

Purchase full membership to immediately unlock this page

Know Your Bible

Forgotten Books' Full Membership provides unlimited access to more than 28,000 volumes of Christian literature for \$8.99/month

HOLY BIBLE

Continue

*Fair use policy applies

circuits as will provide a current of the requisite strength for each of the devices. For example, if the normal current on the line is seven ampères, then each of the seven multiple-connected electro-

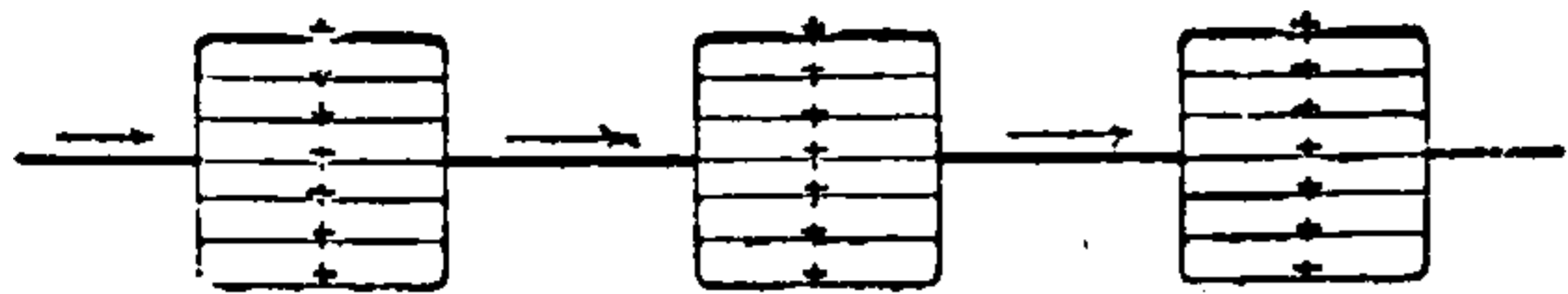

Fig. 57. Series-Multiple Circuit.

receptive devices shown in Fig. 57 will have a current of one ampère passing through it, provided the resistance of each branch is the same.

In order to protect the remaining devices from variations in the current on the extinguishment of any of the devices, automatic cut-outs are provided, which divert the current thus cut off through a resistance equivalent to that of the device.

A variety of distribution boxes are in use. (See *Circuits, Varieties of.*)

Box, District-Call — —A box by means of which an electric signal is automatically sent over a telegraphic line and received by an electro-magnetic device at the other end of the line.

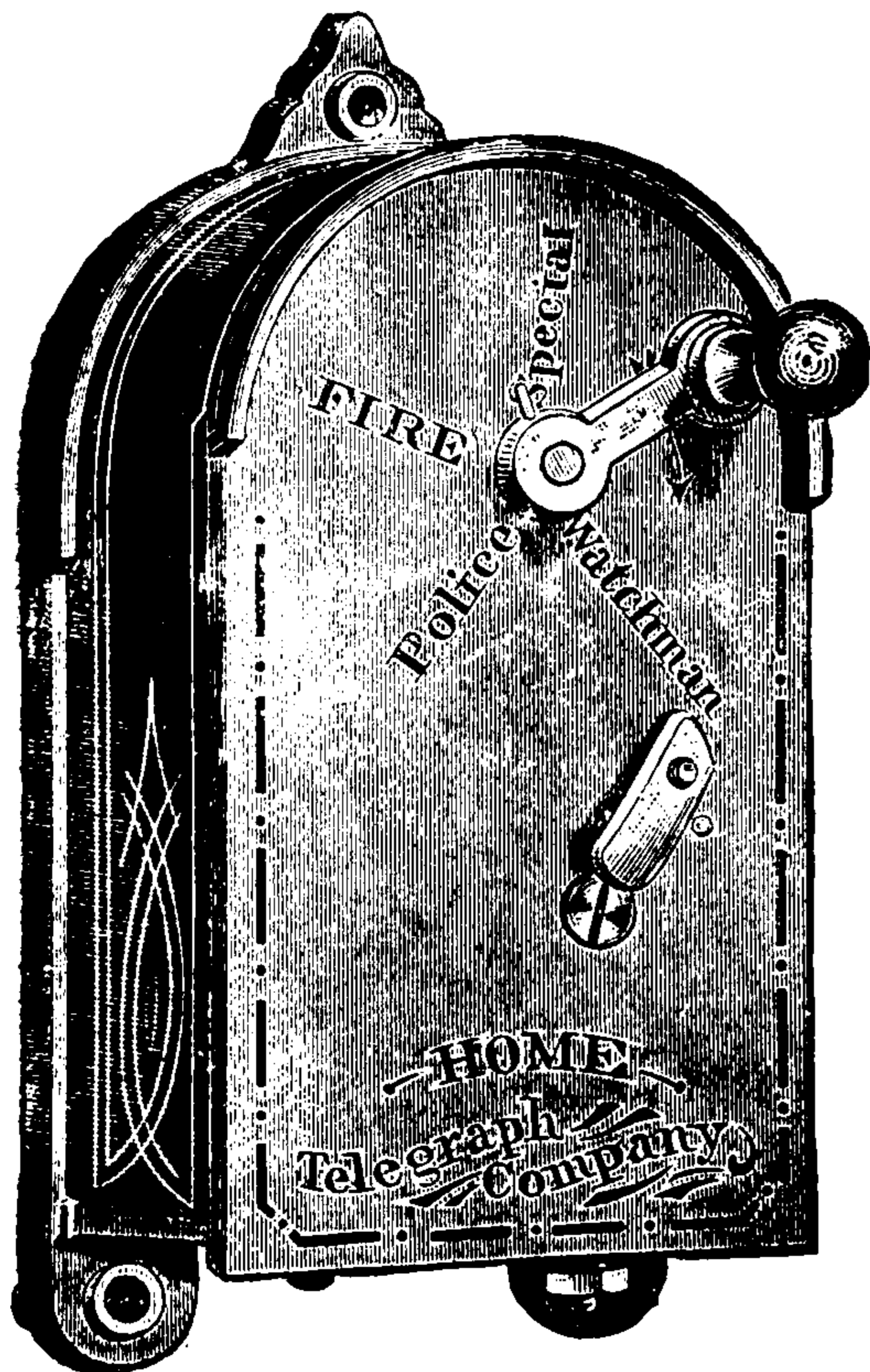

Fig. 58. District Call Box.

A system of district calls includes a number of call boxes connected by telegraphic lines with a central station. A wheel, or its equivalent, set in

motion by the pulling of a lever, makes and breaks an electric circuit and sends over the line a succession of electric impulses of varying length, separated from one another by varying intervals of time. These impulses may be received at the central station as a series of dots and dashes, or may, by means of a Morse sounder, produce successive sounds. By pulling the lever or handle through different distances, different signals may be sent to the central station and serve as calls for various services, such as messenger boys, fire alarm, police, special, etc.

The general appearance of a four-call district box is shown in Fig. 58. In order to transmit a call for any particular one of these four services the handle is pulled until it comes opposite to the letters indicating the required service, and is then released. The service required is then indicated at the receiving, or central station, through the varying signals sent over the line by the movement of the break-wheel, on the release of the handle.

Box, Fire-Alarm Signal — —A signal box provided for the purpose of automatically sending an alarm of fire.

The fire-alarm box shown in Fig. 59, operates

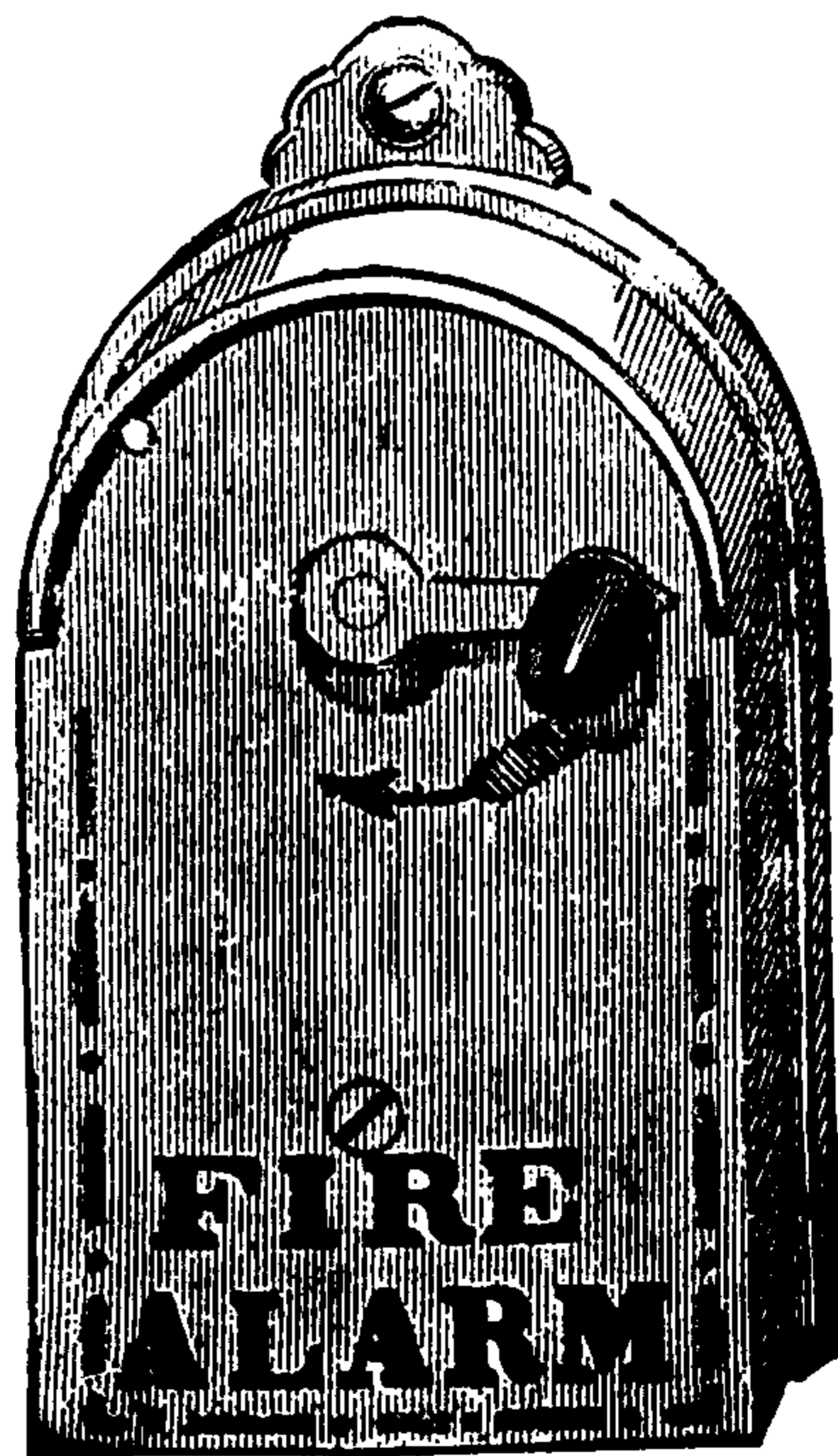

Fig. 59. Fire-Alarm Signal-Box.

on the same principle as the district call box. The movement of the handle in the direction of the arrow drives a wheel that makes and breaks a circuit at certain intervals.

The fire-alarm signal boxes are connected

either with a central station, or with the engine houses of the district in which the alarm is sounded, or with both.

Box, Fire-Alarm Telegraph — — — An automatic-call signal-box employed for sending an alarm of fire to a central station.

A form of fire-alarm telegraph box is shown in Fig. 60. It consists essentially of a circuit-breaker

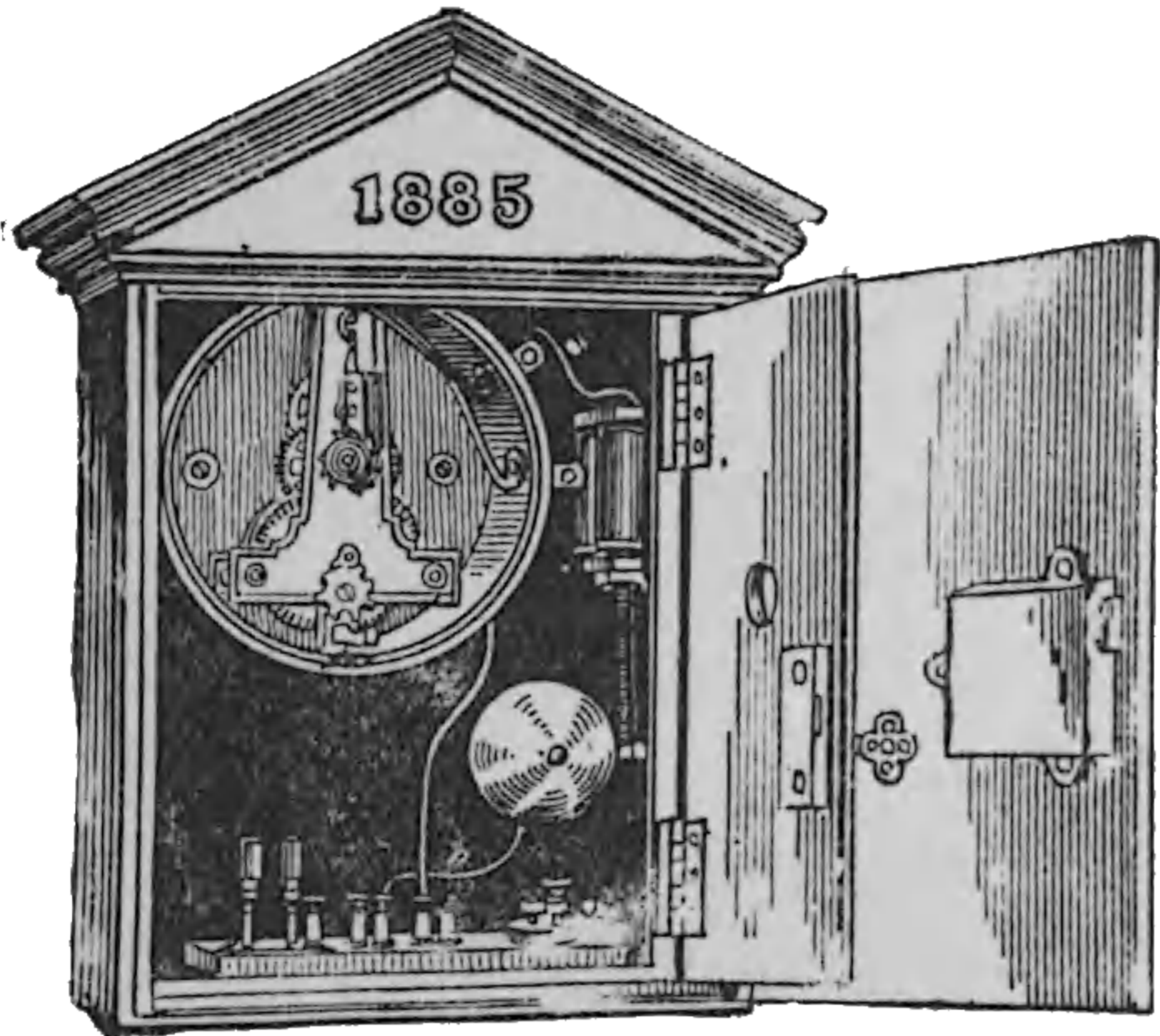

Fig. 60. Fire-Alarm Telegraph Box.

that is moved by pulling down a lever. The release of the lever repeats the signal to the fire department at the central station a certain number of times. The box also contains a relay bell, lightning arrester and signal-bell key.

Box, Fishing — — — A term sometimes used instead of junction box. (See *Box, Junction*.)

Box, Flush — — — A box or space, flush with the surface of a road-bed, provided in a system of underground wires or conduits, to facilitate the introduction of the conductors into the conduit, or for the examination of the conductors.

Box, Fuse — — — The box in which the fuse-wire of a safety-fuse is placed.

The fuse-box should be formed of moisture-proof, incombustible, insulating materials.

Box, Junction — — — A moisture-proof box provided in a system of underground con-

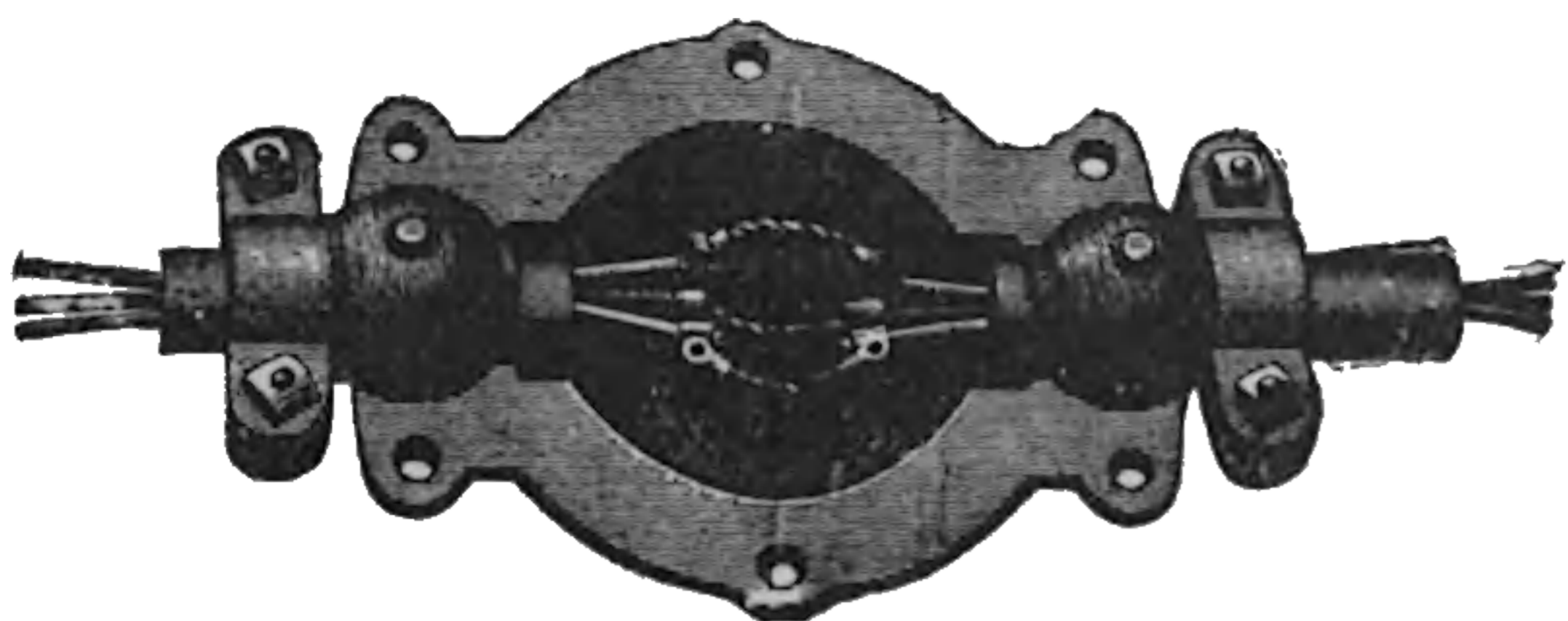

Fig. 61. Junction Box.

ductors to receive the terminals of the feeders, in which connection is made between

the feeders and the mains, and from which the current is distributed to the individual consumer. (See *Feeder, Main, Electric*.)

A form of junction box for coupling lengths of conductors is shown in Fig. 61.

Box, Patrol Alarm — — — An automatic-signal call-box provided for use on the outside of buildings.

The call-box is placed inside a box, the outer door of which is furnished with a Yale lock.

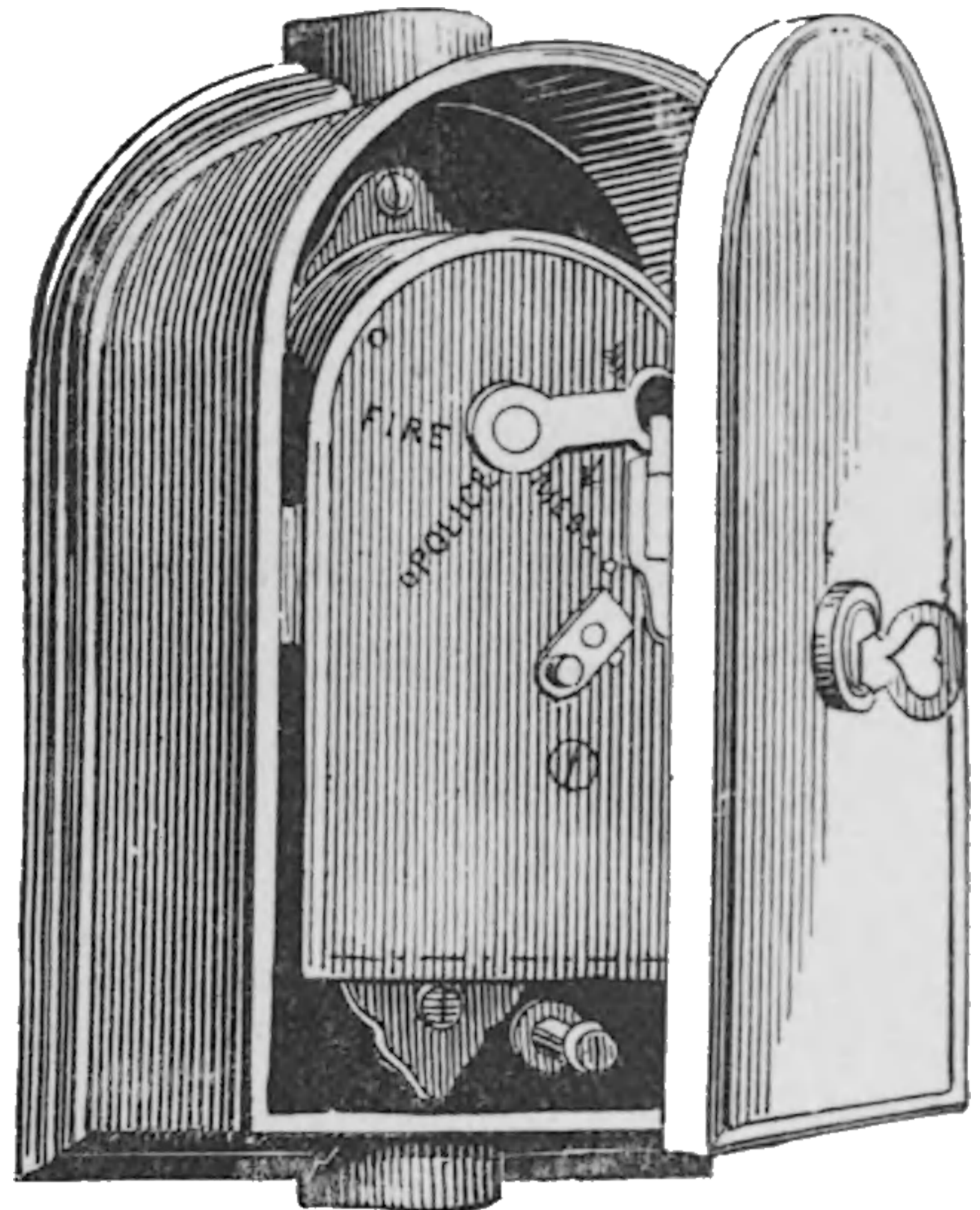

Fig. 62. Patrol Box.

A form of patrol box is shown in Fig. 62.

Box, Resistance — — — A box containing a number of separate coils of known resistances employed for determining the value of an unknown resistance, and for other purposes. (See *Bridge, Electric, Box Form of*.)

Box-Sounding Relay.—(See *Relay, Box-Sounding*.)

Box-Sounding Telegraphic Relay.—(See *Relay, Box-Sounding Telegraphic*.)

Box, Splice — — — A box provided for holding splice joints and loops, and so arranged as to be readily accessible for examination, re-arranging, cross-connecting, etc.

Splice-boxes vary in shape and construction according to the purposes for which they are designed.

Box, Splice, Four-way — — — A splice-box provided with four ways or tubular conduits.

Box, Splice, Two Way — — — A splice-

box provided with but two tubular conduits or ways.

Box, Tumbling — —A rotating box in which metallic articles that are to be electroplated are placed so as to be polished by attrition against one another.

Boxing the Compass.—(See *Compass, Boxing the.*)

Bracket, Lamp, Electric — —A device similar to a bracket for a gas burner for holding or supporting an electric lamp.

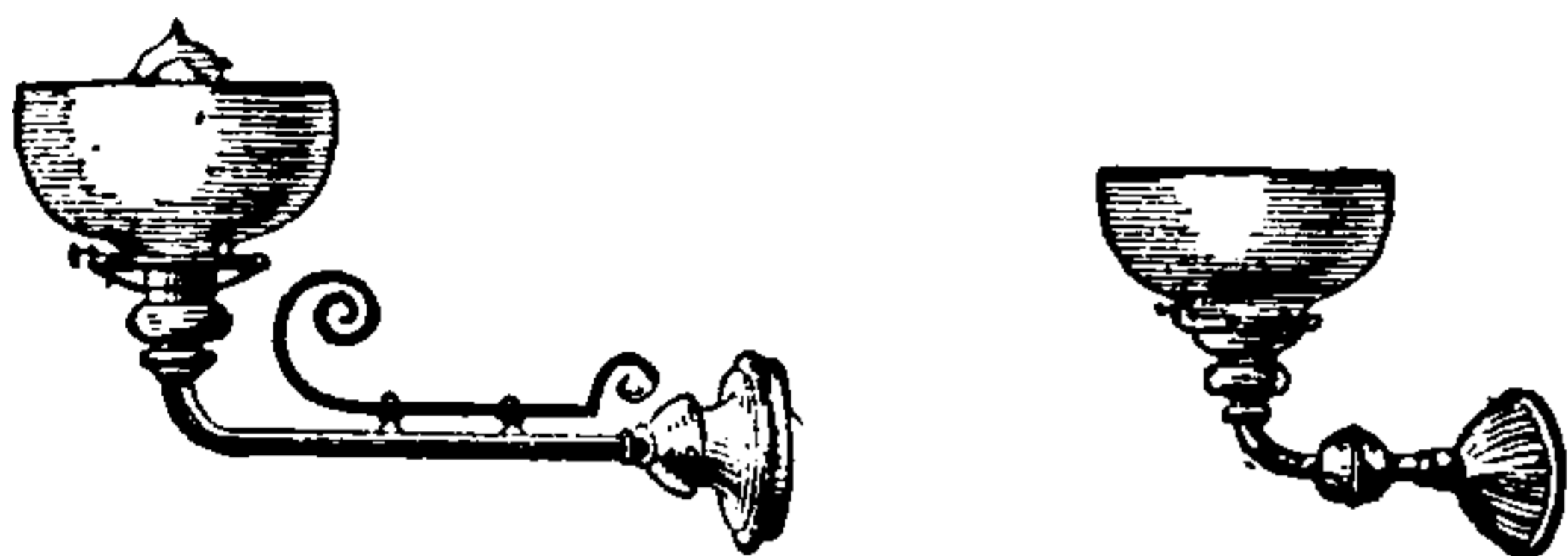

Fig. 63. Lamp Bracket. Fig. 64. Lamp Bracket.

Lamp brackets are either fixed or movable.

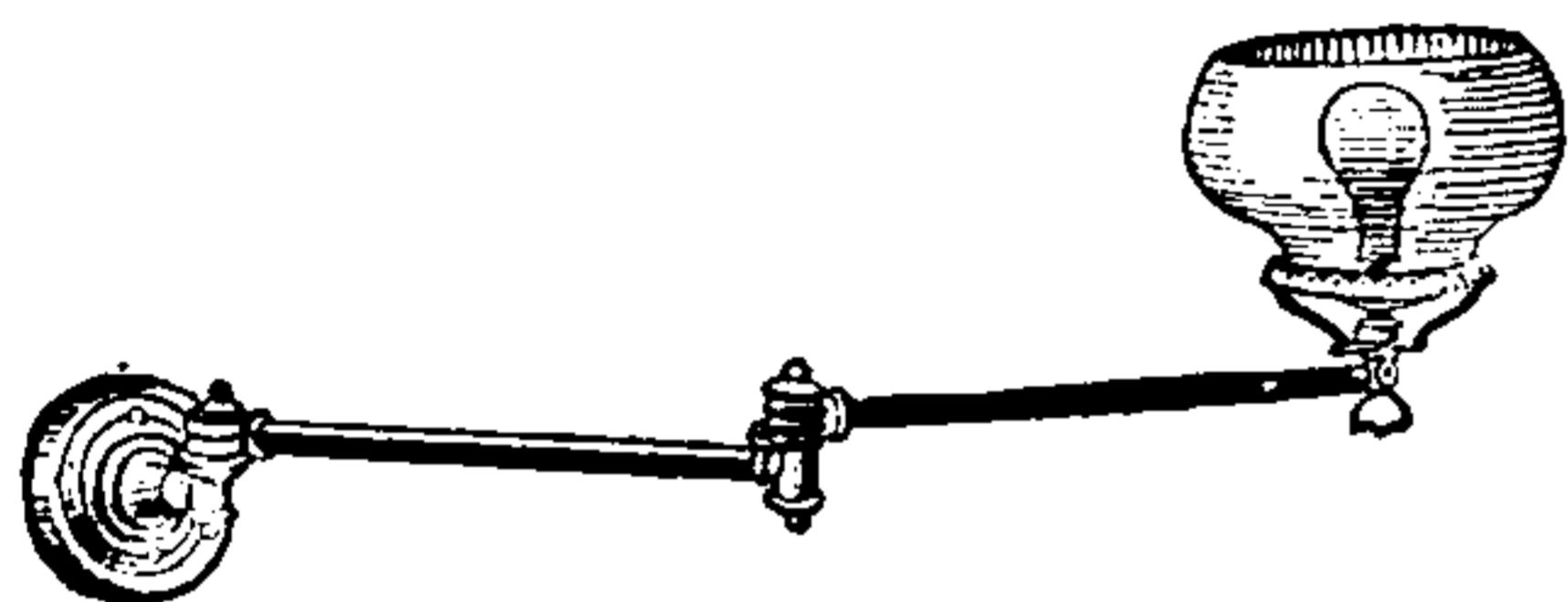

Fig. 65. Lamp Bracket, Movable Arms.

Those shown in Figs. 63 and 64 are fixed. That shown in Fig. 65 is movable.

Bracket, Telegraphic — —A support or cross piece placed on a telegraph pole for the support of the insulators of telegraphic lines.

Telegraphic insulators are supported either on wooden *arms*, or on iron or metal *brackets*.

Fig. 66 shows a form of iron bracket. Fig. 67 shows a form of wooden arm.

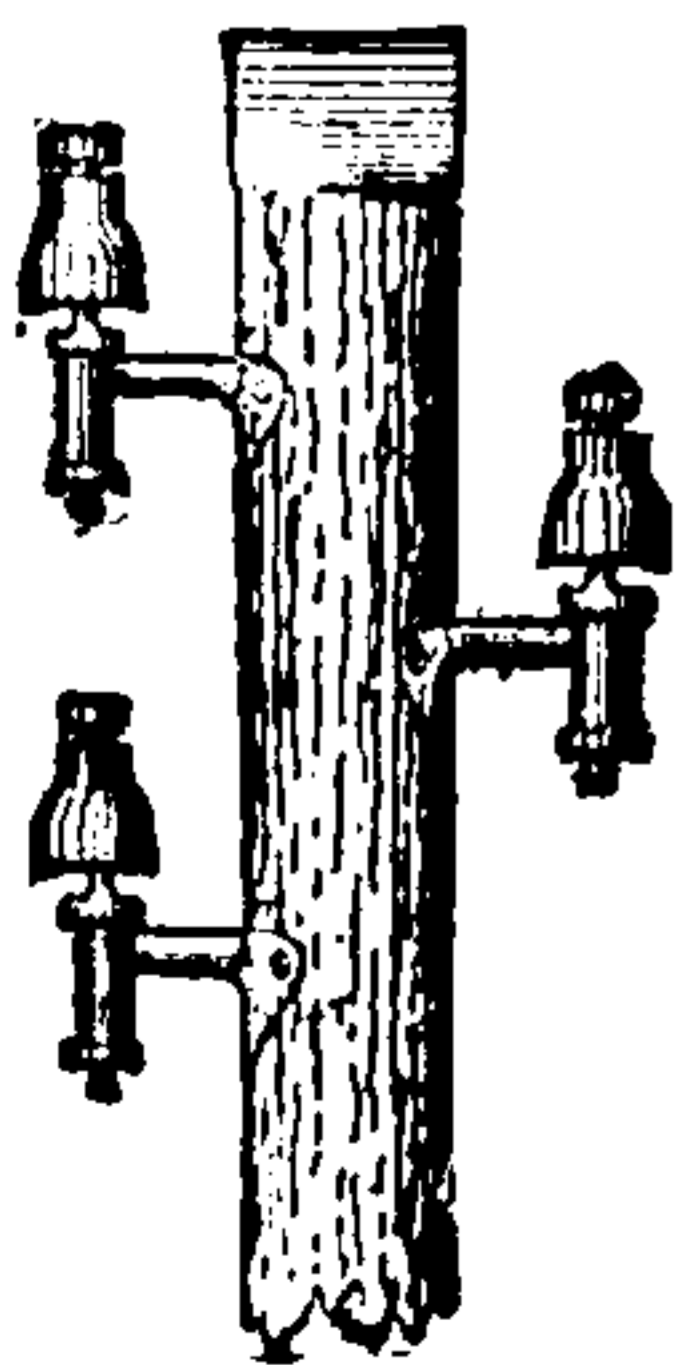

Fig. 66. Telegraphic Bracket.

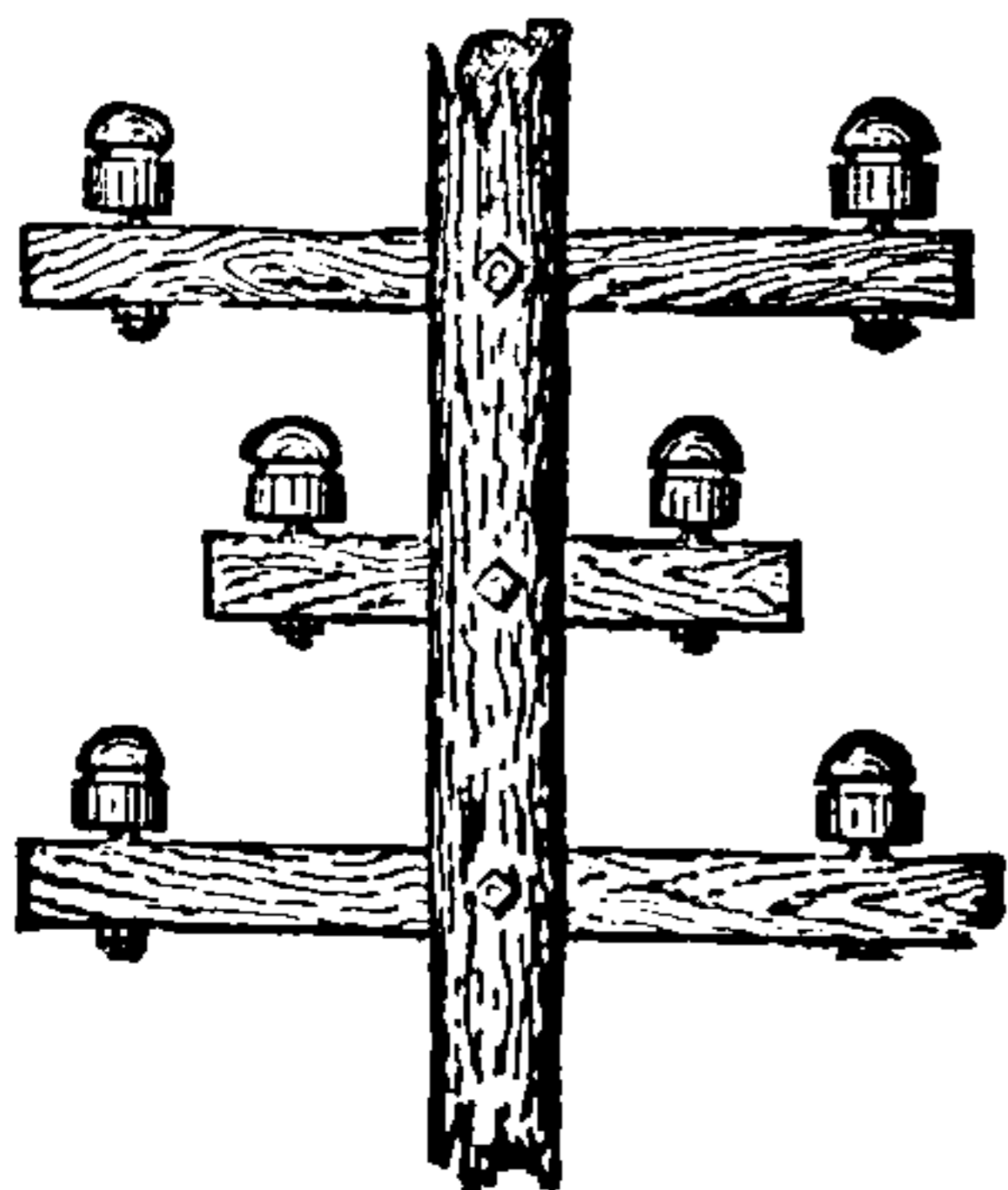

Fig. 67. Telegraphic Cross-Arm.

Various well known modifications of these shapes are in common use. (For details, see *Pole, Telegraphic.*)

Braid, Tubular — —A braid of fibrous insulating material, woven in the form of a tube, and provided for drawing over a splice after two wires have been connected.

Braided Wire.—(See *Wire, Braided.*)

Brake, Electro-Magnetic — —A brake for car wheels, the braking power for which is either derived entirely from electro-magnetism, or is thrown into action by electro-magnetic devices.

Electro-magnetic car brakes are of a great variety of forms. They may, however, be arranged in two classes, viz.:

(1.) Those in which magnetic adhesion, or the magnetic attraction of the brake to the wheels, is employed.

(2.) Ordinary brake mechanism in which the force operating the brake is thrown into action by an electro-magnet.

Brake, Friction — —A name sometimes given to a Prony brake. (See *Brake, Prony.*)

Brake, Magneto-Electric — —A device for checking the swing of a galvanometer, in which a slight inverse current is sent through the coils of the galvanometer.

The Frey magneto-electric brake, as shown in Fig. 68, consists of a small coil, connected by a

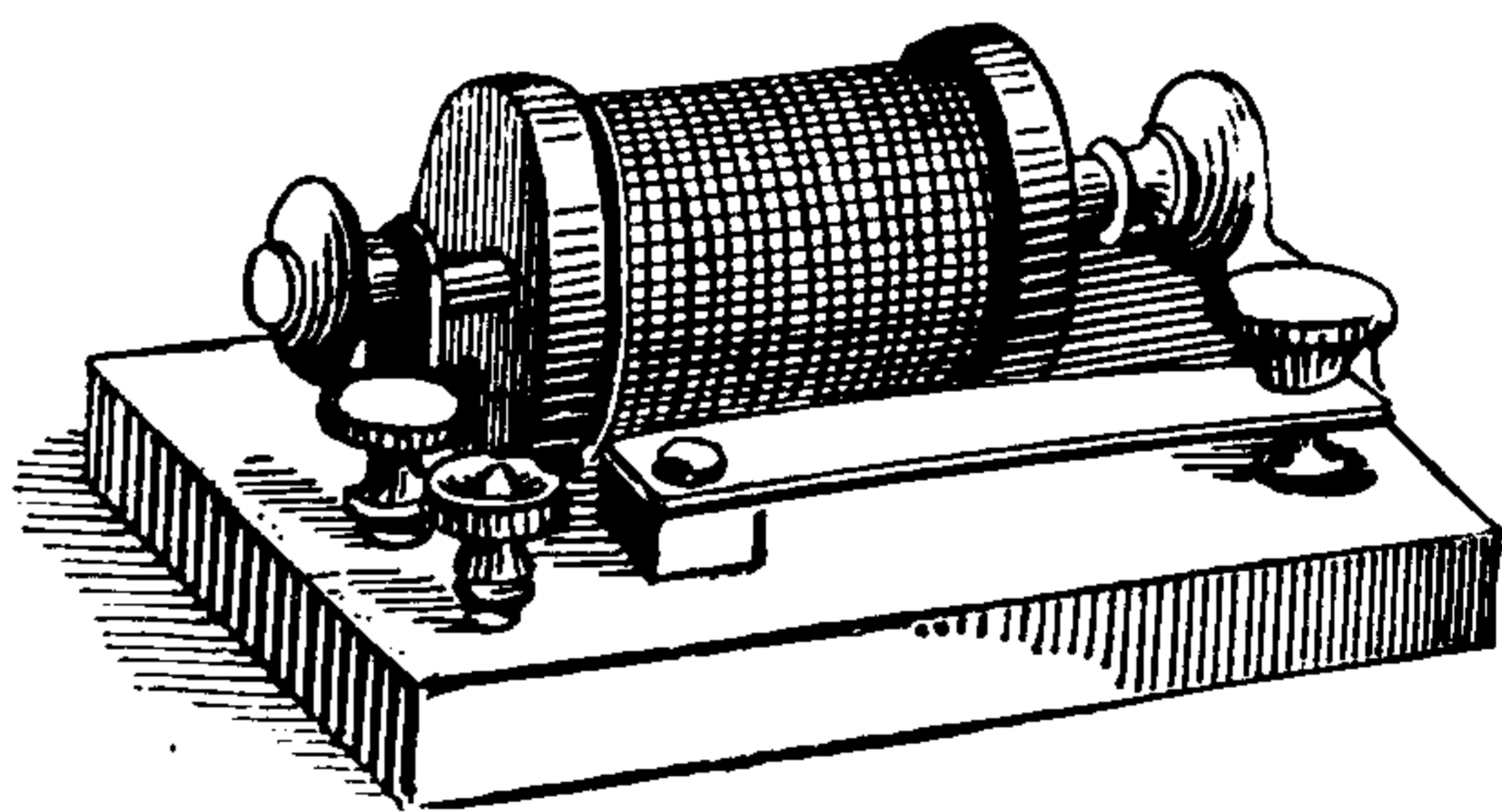

Fig. 68. Electric Brake.

contact-key with the galvanometer terminals. A small adjustable magnet coil is provided for regulating the action of the inverse current. To avoid disturbance, the brake is placed at least 4 or 5 feet from the galvanometer. Manipulation of the ordinary galvanometer key attains the same end in a much simpler manner.

Brake, Prony — —A mechanical device for measuring the power of a driving shaft.

An inflexible beam, Fig. 69, is provided at one end with a clamping device for clamping the driving shaft or pulley, and at the other end A, with a pan for holding weights.

If the brake be arranged as shown in Fig. 69, and the shaft rotate in the direction of the arrow, the tendency will be to carry the beam around with the shaft, placing it at some given moment

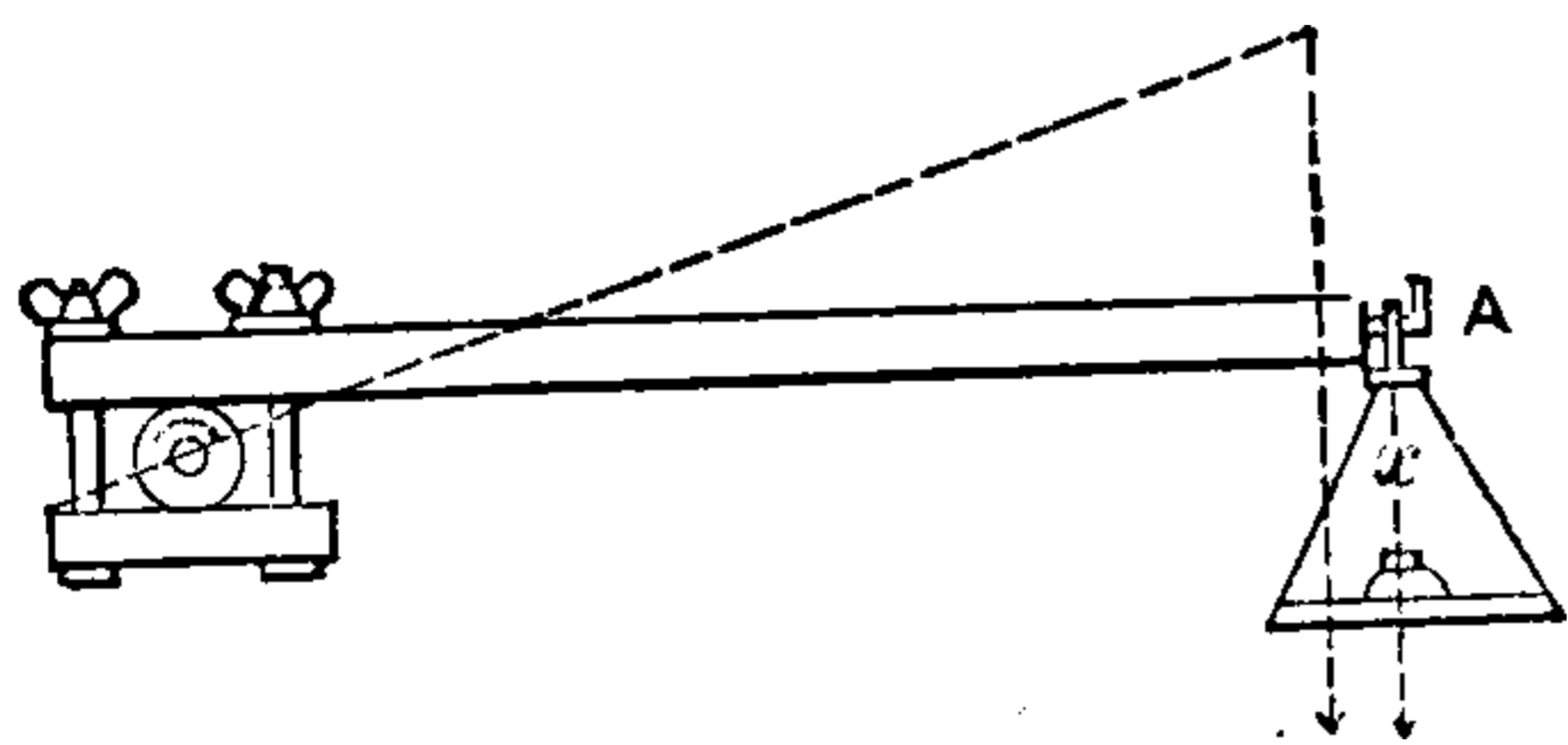

Fig. 69. Prony Brake.

in the position shown by the dotted line. If a sufficiently heavy weight be placed at x, in a pan hung at A, the beam will assume a position vertically downwards. If, however, the torque, or

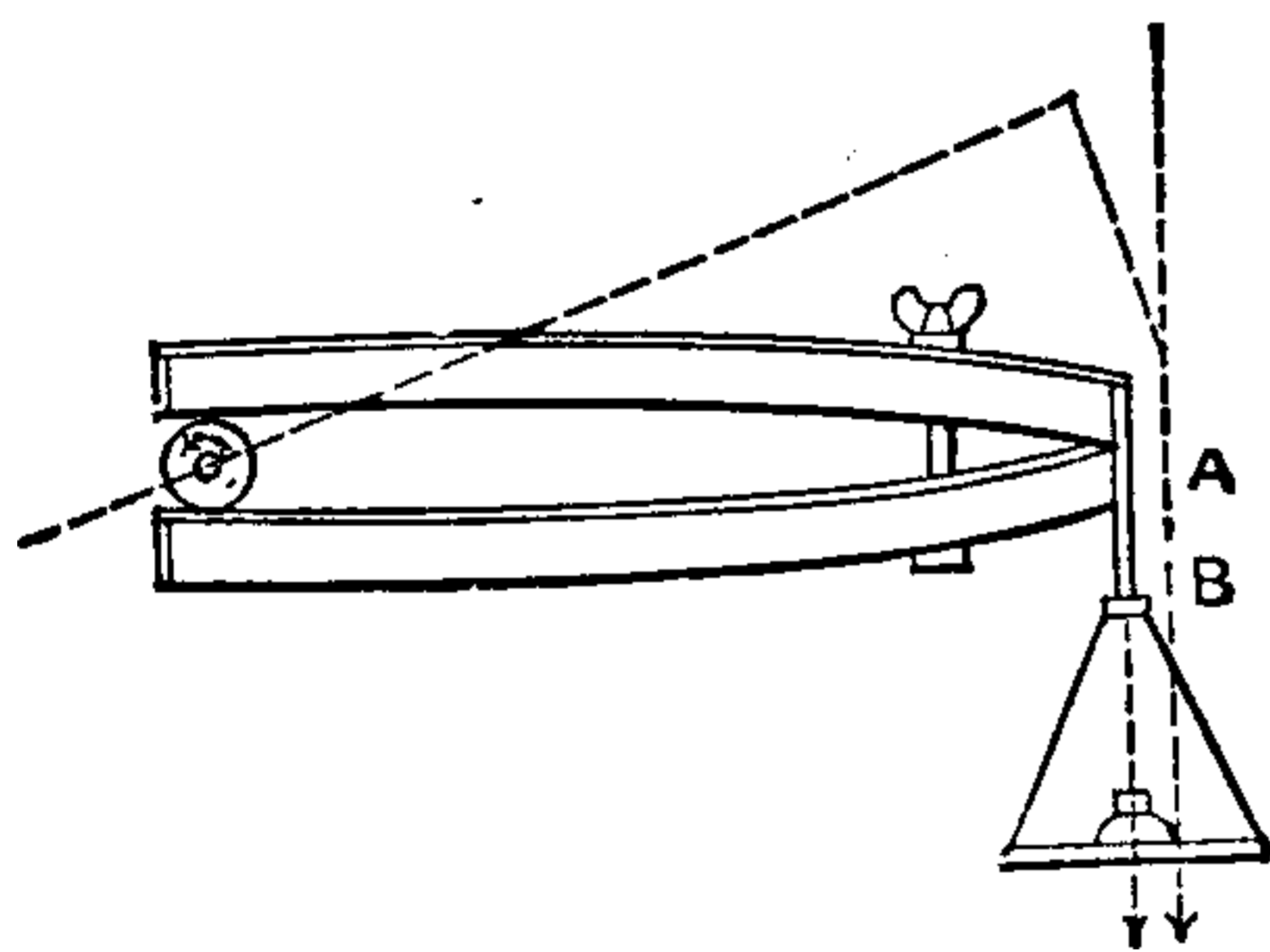

Fig. 70. Prony Brake.

twisting force of the driving shaft, be balanced by the weight, the bar will remain horizontal. The power can then be calculated by multiplying the weight in pounds by the circumference in feet of the circle of which the bar is a radius, and this product by the number of turns of the driving shaft per minute. The product will be the num-

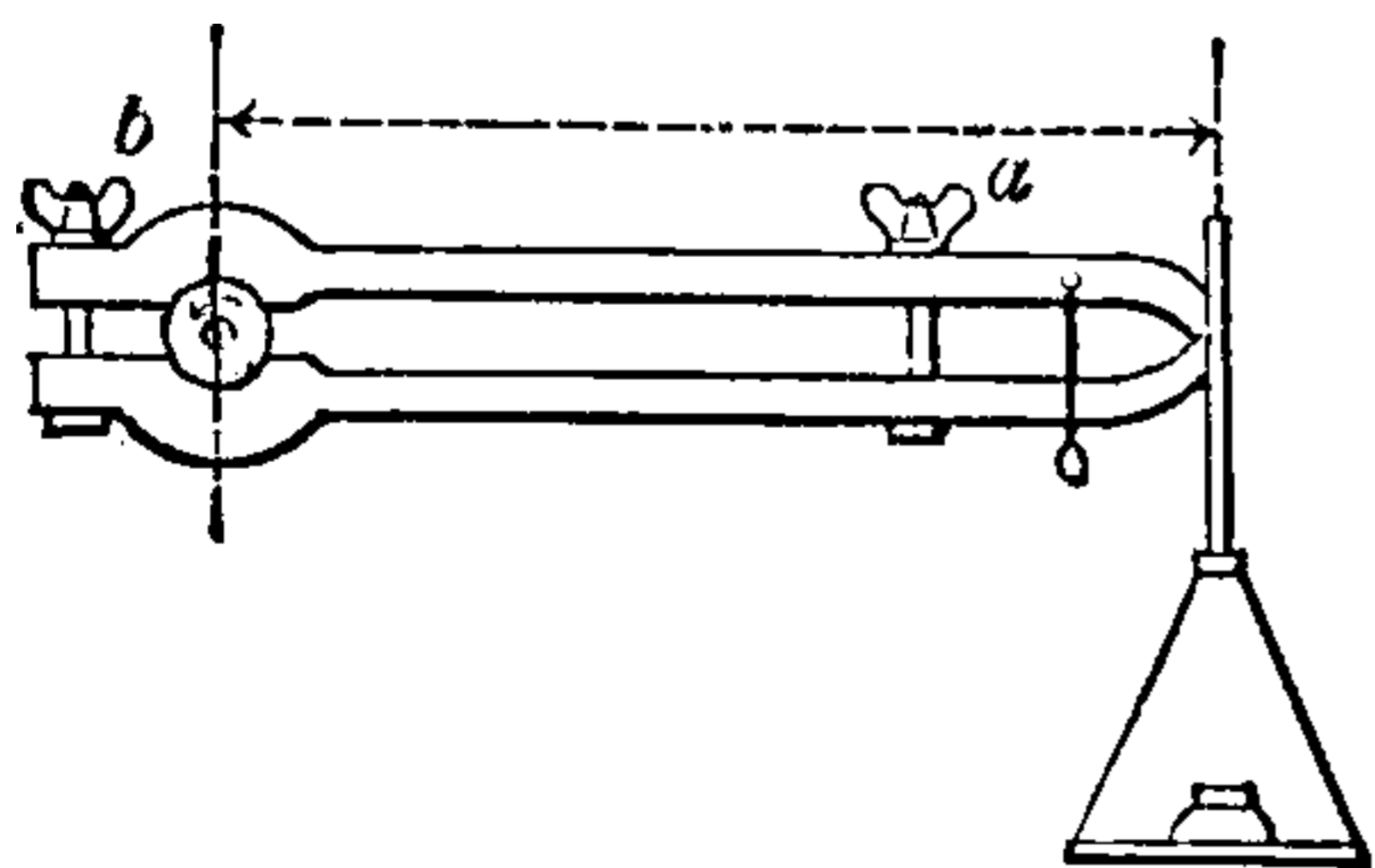

Fig. 71. Prony Brake.

ber of foot-pounds per minute, and, when divided by 33,000, will give the *horse-power*.

Some modified forms of the Prony brake are shown in Figs. 70 and 71.

A simple form of brake consists of a cord passed over the pulley, of the machine to be tested. A weight is hung at one end of the cord. The other

end of the cord is attached to the top of a spring balance, the other end of which is fastened to the floor. A reading of the spring balance is taken while the pulley is at rest and when it is in motion, and the result calculated.

Branch.—A term applied to any principal distributing conductor from which outlets are taken or taps made.

Branch-Block.—(See *Block, Branch*.)

Branch Conductors.—(See *Conductor, Branch*.)

Branch Fuse.—(See *Fuse, Branch*.)

Branch, Sub — —A distributing conductor taken from a branch.

Branding, Electric — —A process whereby the branding tool is heated by electrical incandescence instead of by ordinary heat.

The branding tool consists essentially of a small transformer with devices for regulating the current strength by switches and choking coils.

Brassing, Electro — —Coating a surface with a layer of brass by electro-plating. (See *Plating, Electro*.)

The plating bath contains a solution of copper and zinc; a brass plate is used as an anode.

Break.—A want of continuity in a circuit.

Break, Circuit Loop — —A device for introducing a loop in any part of a line circuit.

A form of circuit loop-break is shown in Fig. 72.

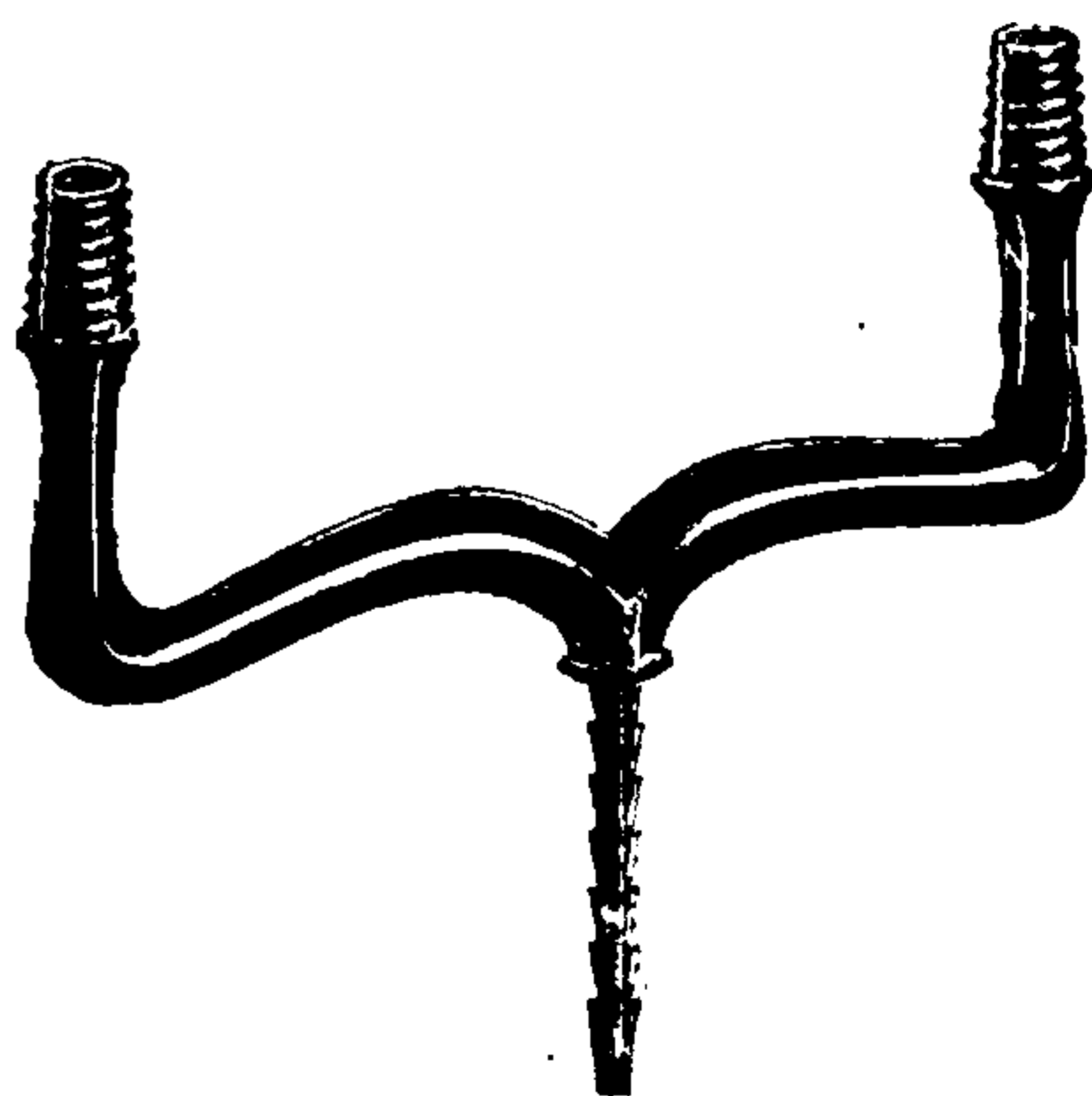

Fig. 72. Circuit Loop Break.

It consists essentially of a rigid frame with two porcelain or other suitable insulators for the support of the loop wires.

Break-Down Switch.—(See *Switch, Break-Down*.)

Break-Induced Current.—(See *Current, Break-Induced*.)

Break, Mercury — — — A form of circuit breaker operated by the removal of a conductor from a mercury surface.

Mercury breaks assume a variety of forms. One end of the circuit is connected with the mercury, and the other with the conductor.

Break Shock.—(See *Shock, Break*.)

Breaker, Circuit — — — Any device for breaking a circuit.

Breaking the Primary.—(See *Primary, Breaking the*.)

Breaking Weight of Telegraph Wires.—(See *Wires, Telegraph, Breaking Weight of*.)

Breath Figures.—(See *Figures, Breath*.)

Breeze, Electric — — — A term sometimes employed in electro-therapeutics for a brush discharge.

One of the electrodes, consisting of a single point or a number of points, is held near the parts to be treated so that the convective discharge is received thereon. The other electrode is connected to the body of the patient.

Breeze, Electro-Therapeutic — — — An electric breeze. (See *Breeze, Electric*.)

Breeze, Head, Electro-Therapeutic — — — A form of electric convective discharge, or electric breeze, applied to the head. (See *Breeze, Electric*.)

Breeze, Static — — — An electric breeze obtained by the convective discharge of an electrostatic charge.

Bridge-Arms.—(See *Arms, Bridge or Balance*.)

Bridge, Box — — — A box of resistance coils so arranged as to be capable of being used directly as a Wheatstone electric balance. (See *Bridge, Electric, Box Form of*.)

The commercial form of Wheatstone's balance.

Bridge, Electric — — — A device for measuring the value of electric resistances.

The electric bridge is also called the Electric Balance.

This is called a bridge because the wire M, G, N, bridges or joins points of equal potential.

A, B, C and D, Fig. 73, are four electric resistances, any one of which can be determined in *ohms*, provided the absolute value of one of the others, and the relative values of any two of the remaining three are known in ohms.

A voltaic battery, Zn C, is connected at Q and P, so as to branch at P, and again unite at

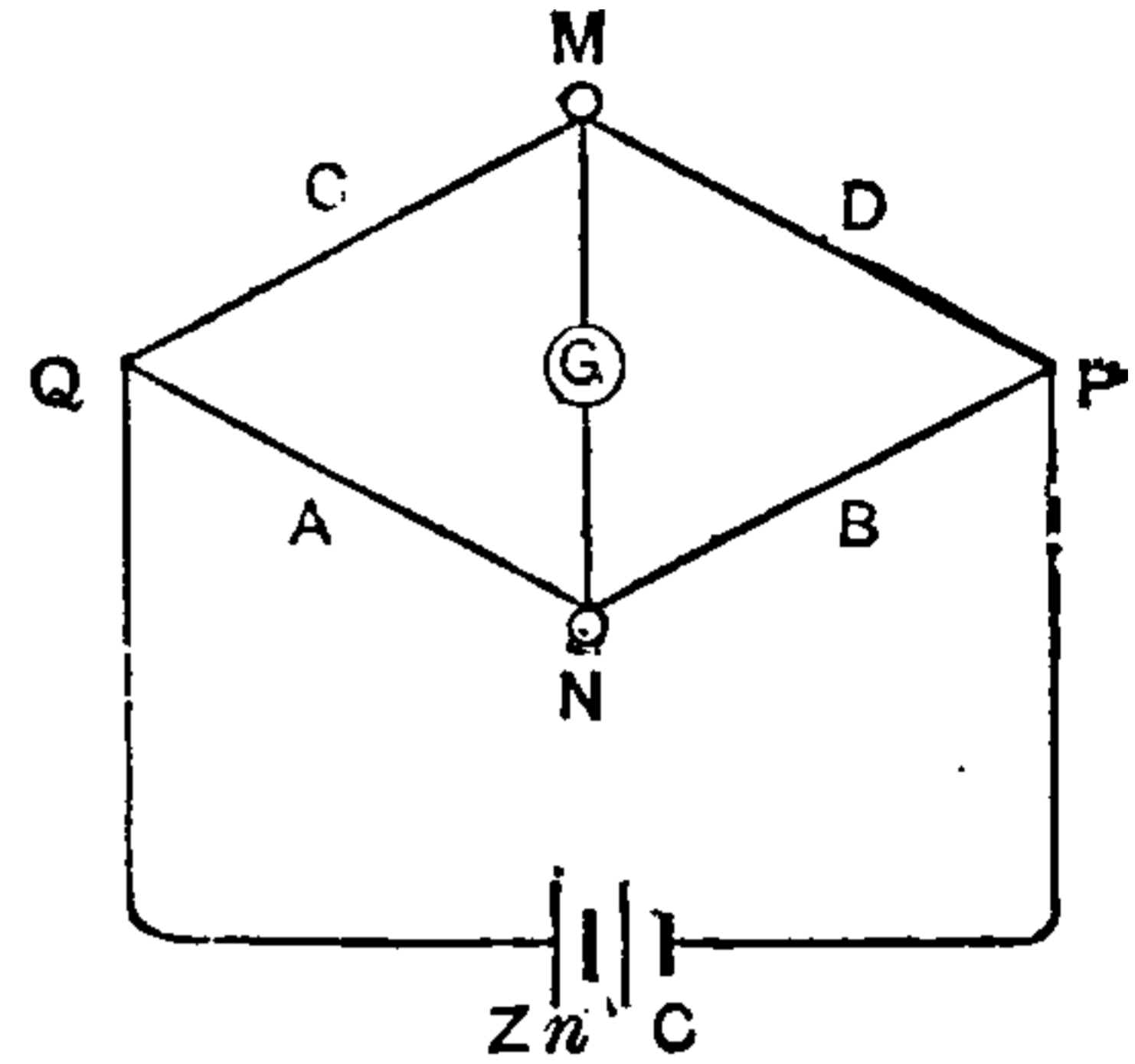

Fig. 73. Electric Balance.

Q, after passing through the conductor D C, and B A.

A sensitive galvanometer, G, is connected at M N, as shown.

The passage of a current through any resistance is attended by a fall of potential proportional to the resistance. (See *Potential, Electric*.) If, then, the resistances A, C and B, are so proportioned to the value of the unknown resistance D, that no current passes through the galvanometer G, the two points, M and N, in the two circuits, Q M P and Q N P, are at the same potential. That is to say, the fall of potential along Q M P and Q N P, at the points M and N, is equal. Since the fall of potential is proportional to the resistance, it follows that

$$\begin{aligned} A : B &:: C : D, \\ \text{or } A \times D &= B \times C, \\ \text{or } D &= \left(\frac{B}{A}\right) C. \end{aligned}$$

If then we know the values of A, B and C, the value of D, can be readily calculated.

By making the value $\frac{B}{A}$, some simple ratio, the value of D, is easily obtained in terms of C.

The resistances A, B and C, may consist of coils of wire whose resistance is known. To avoid their magnetism affecting the galvanometer needle during the passage of the current through them, they should be made of wire bent into two

parallel wires and wrapped in coils called *resistance coils*; or a *resistance box* may be used. (See *Coil, Resistance. Box, Resistance.*)

There are two general forms of Wheatstone's Bridge, the box form, and the sliding form.

Bridge, Electric, Arms of — — The resistances of an electric bridge or balance. (See *Bridge, Electric.*)

Bridge, Electric, Box Form of — — A commercial form of bridge or balance in which all the known arms or branches of the bridge, except the unknown arm, consist of standardized resistance coils, whose values are given in ohms. (See *Coil, Resistance.*)

The box form of bridge or balance is shown in

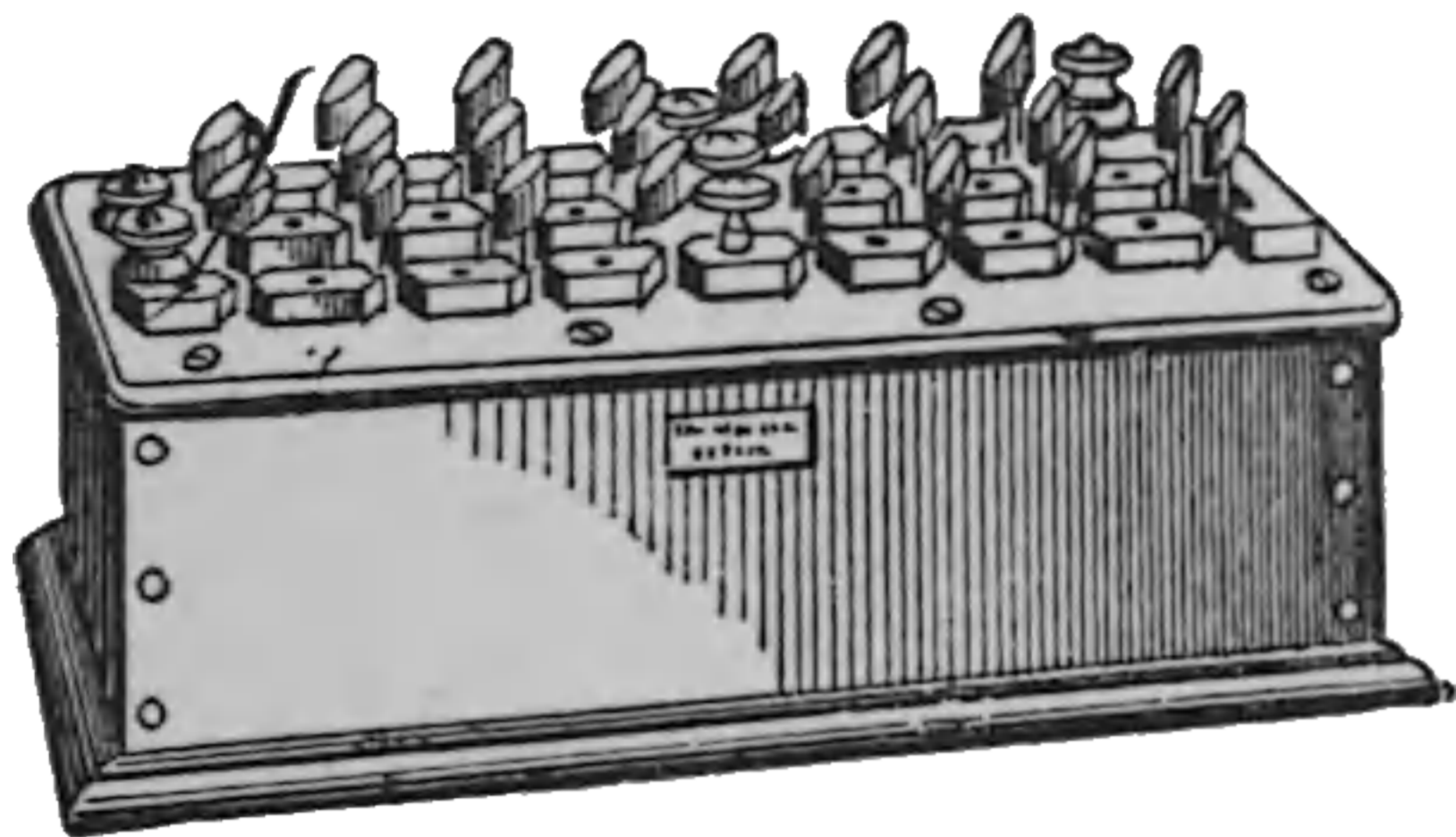

Fig. 74. Box Balance.

perspective in Fig. 74, and in plan in Fig. 75. The bridge arms, corresponding to the resistances

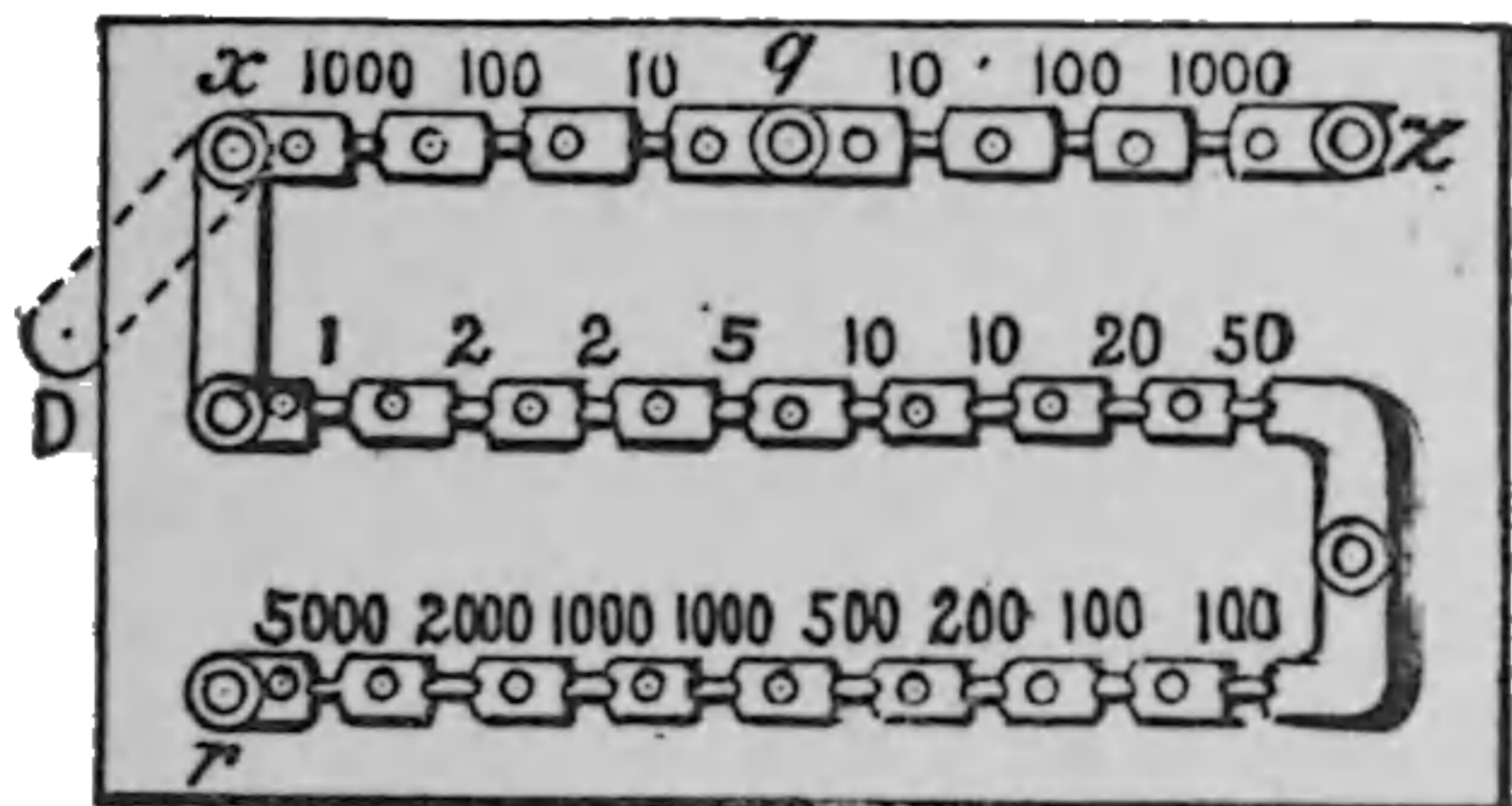

Fig. 75. Box Balance.

A and B, of Fig. 73, consist of resistance coils of 10, 100 and 1,000 ohms each, inserted in the arms qz , and qx , of Fig. 75. These are called the *proportional coils*. The arm corresponding to resistance C, of Fig. 73, is composed of separate resistances of 1, 2, 2, 5, 10, 10, 20, 50, 100, 100, 200, 500, 1,000, 1,000, 2,000 and 5,000 ohms. In some forms of box bridges additional decimal resistances are added.

The resistance coils are wound, as shown in Fig. 76, after the wire has been bent on itself in the middle. This is done in order to avoid the effects of induction, among which are a disturbing action on a galvanometer used near them, and the introduction of a spurious resistance in the coils themselves. (See *Resistance, Spurious.*)

To avoid the effects of changes of resistance occasioned by changes of temperature, the coils are made of German silver, or, preferably, of alloys called *Platinoid* or *Platinum silver*. Even when these alloys are used, care should be taken not to allow the currents to pass continuously through the resistance coils longer than a few moments.

The coils, C, C', are connected with one another in series by soldering their ends to the short-

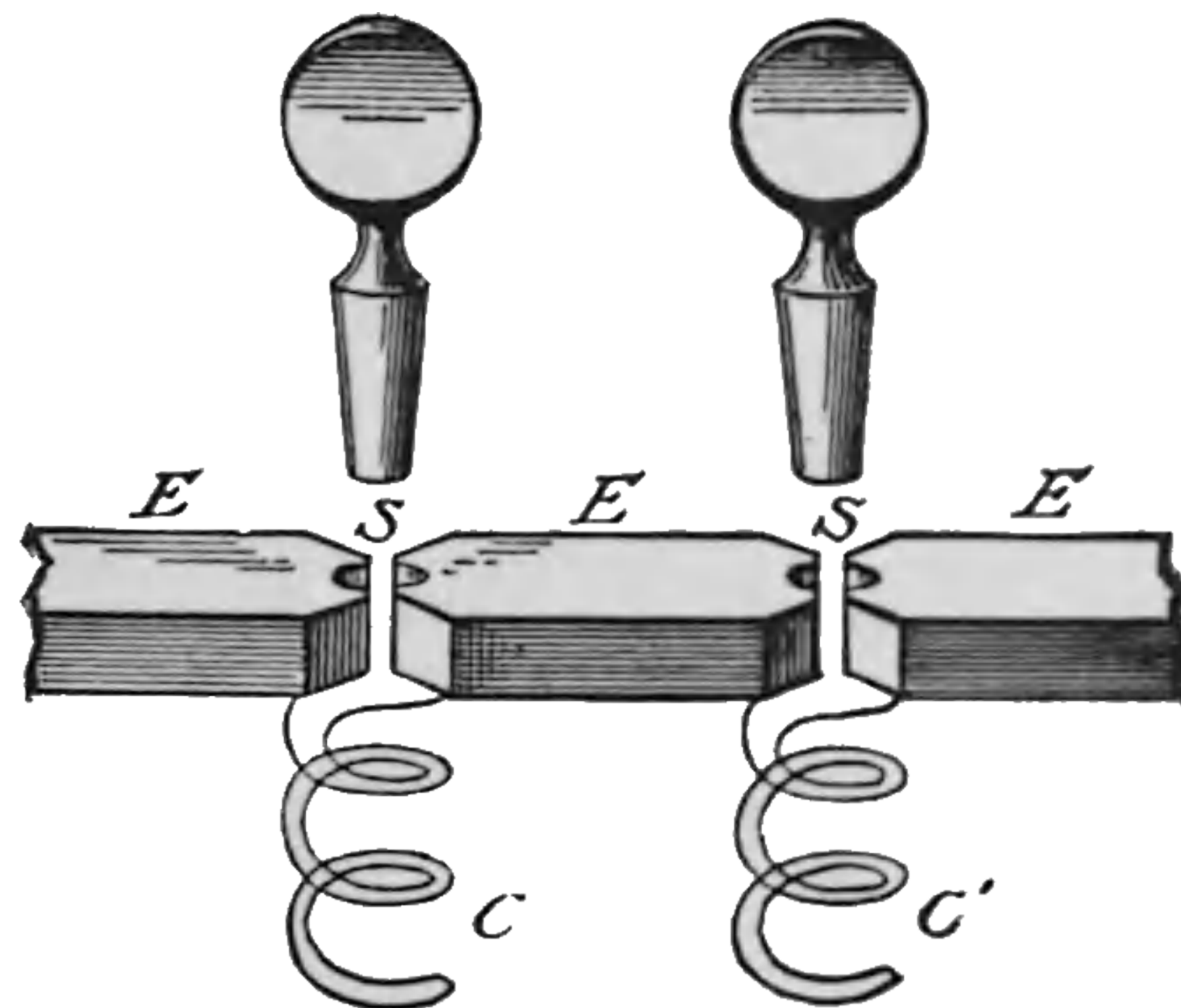

Fig. 76. Resistance Coils.

thick pieces of brass, E, E, E, Fig. 76. On the insertion of the plug-keys, at S, S, the coils are cut out by short-circuiting. Care should be taken to see that the plug-keys are firmly inserted and free from grease or dirt, as otherwise the coil will not be completely cut out. As each plug-key is inserted it should be turned slightly in the opening, so as to insure good contact.

The following are the connections, viz.: The galvanometer is inserted between q and r , Fig. 77,

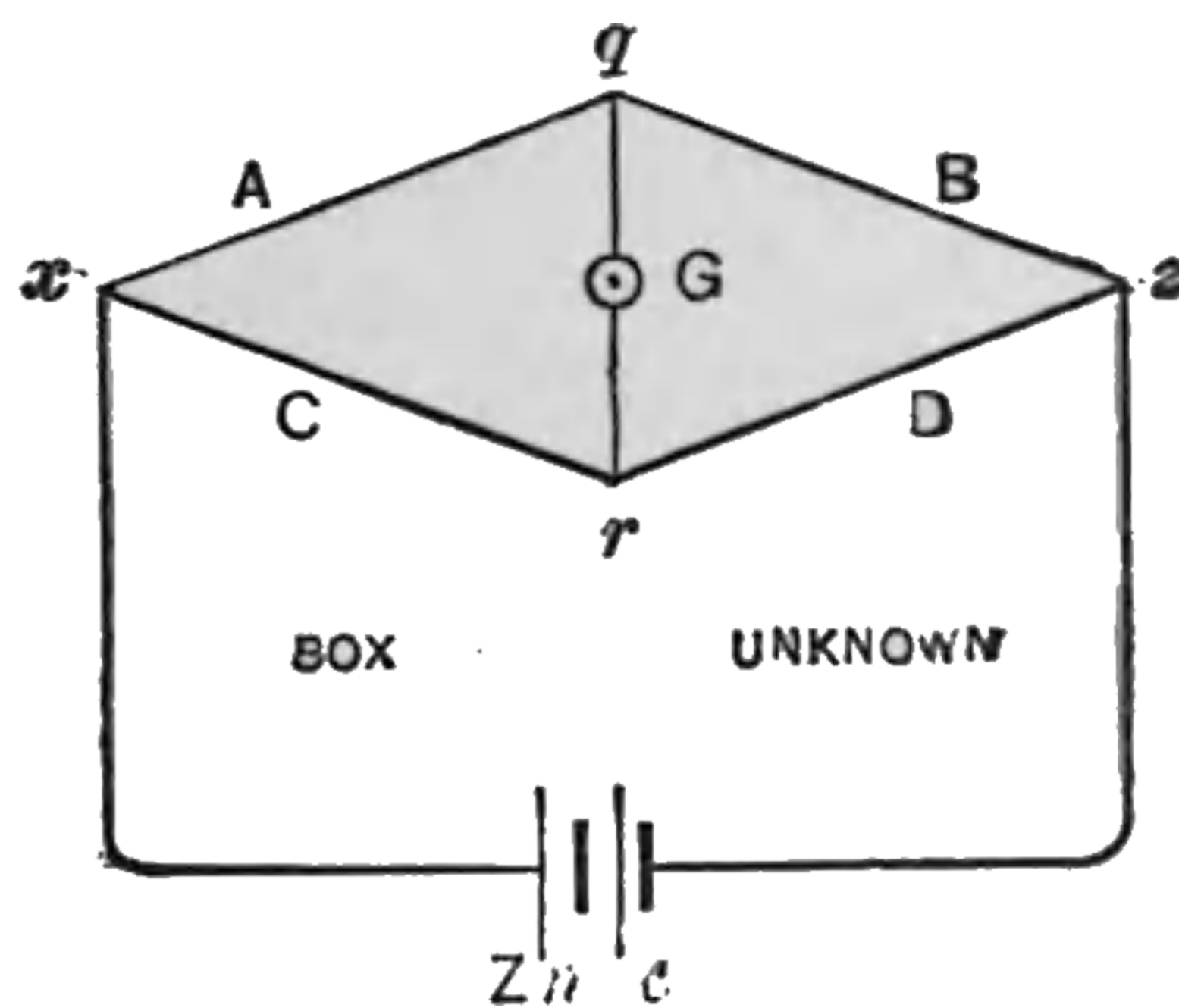

Fig. 77. Electric Balance.

the unknown resistance between z and r ; the battery is connected to x and z . A convenient proportion being taken for the value of the proportional coils, resistances are inserted in the arm C, until no deflection is shown by the galvanometer G. The similarity between these connections and those shown in Fig. 75 will be seen from an inspection of Fig. 77. The arms, A and B, correspond to qx and qz , of Fig. 75; C, to the arm

x r, Fig. 75; and D, to the unknown resistance. We then have as before:

$$A:B::C:D, \text{ or } A \times D = B \times C. \therefore D = \left(\frac{B}{A}\right) C.$$

The advantage of the simplicity of the ratios, A and B, or 10, 100 and 1,000 of the bridge box, will therefore be manifest. The battery terminals may also be connected to q and r, and the galvanometer terminals to x and z, without disturbing the proportions.

Bridge, Electric, Commercial Form of — — A name sometimes given to the box form of Wheatstone's electric balance. (See *Bridge, Electric, Box Form of*.)

Bridge, Electric Duplex — — An arrangement of telegraphic circuits in the form of a Wheatstone electric bridge for the purposes of duplex telegraphy. (See *Telegraphy, Duplex, Bridge Method of*.)

Bridge, Electric, Proportionate Arms of — — (See *Arms, Proportionate*.)

Bridge, Electric, Slide-Form of — — A balance in which the proportionate arms of the bridge are formed of a single thin wire, of uniform diameter, generally of German silver, of comparatively high resistance. The length of this wire is usually one metre; hence this apparatus is often called the metre bridge.

A *Sliding Contact Key* slides over the wire; one terminal of the key is connected with the galvanometer and the other with the wire when the key is depressed. As the wire is of uniform diameter the resistances of the arms, A and B, Fig. 78, will

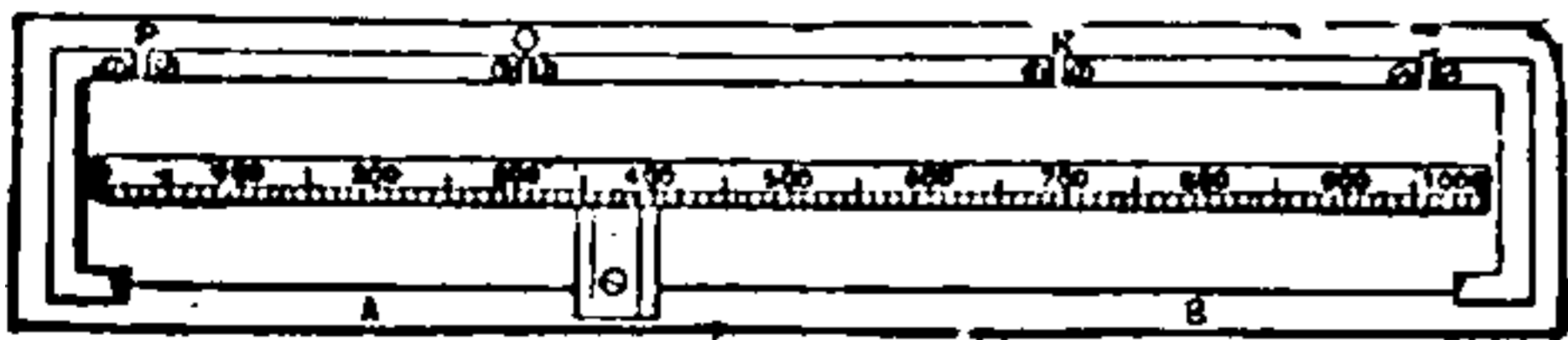

Fig. 78. Slide Bridge.

be directly proportional to the lengths. A scale placed near the wire serves to measure these lengths. A thick metal strip connected with the slide wire has four gaps at P, Q, R and S.

When in ordinary use, the gaps at P and S, are either connected by stout strips of conducting material or by known resistances, in which latter case they act simply as ungraduated extensions of the slide wire, and, like lengthening the slide wire, increase the sensibility of the instrument.

The unknown resistance is then inserted in the gap at Q, and a known resistance, generally the *resistance box*, in that at R. The galvanometer has one of its terminals connected to the metal strip between Q and R, and its other terminal to the sliding key. The battery terminals are connected to the metal strips between P and Q, and R and S, respectively.

These connections are more clearly seen in the form of bridge shown in Fig. 79. The slide wire, w w, consists of three separate wires each a metre



Fig. 79. Slide Form of Bridge.

in length, so arranged that only one wire, or two in series, or all three in series, can be used. Matters being now arranged as shown, the sliding key is moved until no current passes through the galvanometer when the key is depressed.

The slide form of bridge is not entirely satisfactory, since the uncertainty of the spring-contact causes a lack of correspondence between the point of contact and the point of the scale on which the index rests.

The loss of uniformity in the diameter of the wire, due to constant use, causes a lack of correspondence between the resistance of the wire and its length. With care, however, very accurate results can be obtained by the slide form.

Bridge, Inductance — — An apparatus for measuring the inductance of a circuit similar to a Wheatstone bridge. (See *Inductance*.)

Professor Hughes employed an inductance bridge of the following description:

Four resistances, Q, S, R and P, arranged as shown in Fig. 80, form the bridge. The resistances, Q, S and R, consist of sections of German silver wire, one metre in length, each of the resistance of 4 ohms. P, is a coil of wire possessing sensible inductance. The object of the

THIS PAGE IS LOCKED TO FREE MEMBERS

Purchase full membership to immediately unlock this page



HISTORY

Tens of thousands of important historical sources, many previously unobtainable, are now available for the first time with a Forgotten Books Full Membership.

Unlimited Access
\$8.99/month

Continue

*Fair usage policy applies

arch within about a half inch. A space is hollowed out between these ends, for the reception of a short needle of well-magnetized hardened steel, suspended by a wire from a torsion head.

The movements of the needle are measured on a scale by a spot of light reflected from a mirror.

The electro-magnet maintains a constant difference of magnetic potential at the two shorter ends of the rectangle. If, therefore, the four bars, or arms of the bridge, are magnetically identical, there will be no deflection, since no difference of potential will exist at the ends of the bars between which the needle is suspended. If, however, one of the bars or arms be moved even a trifle, the needle is at once deflected, the motion becoming a maximum when the bar is entirely removed. If replaced by another bar, differing in cross-section, constitution, or molecular structure, the balance is likewise disturbed.

The magnetic bridge is very sensitive. It was designed by its inventor for testing the magnetic qualities of the iron used in the construction of dynamo-electric machines.

Bridge Method of Duplex Telegraphy.—(See *Telegraphy, Duplex, Bridge Method of.*)

Bridge Method of Quadruplex Telegraphy.—(See *Telegraphy, Quadruplex, Bridge Method of.*)

Bridge, Metre — —A slide form of Wheatstone's electric bridge, in which the slide wire is one metre in length. (See *Bridge, Electric, Slide Form of.*)

Bridge, Resistance — —A term sometimes applied to an electric bridge or balance. (See *Bridge, Electric.*)

Bridge, Reversible — —A bridge or balance so arranged that the proportionate coils can be readily interchanged, thus permitting the bridge coils to be readily tested by reversing.

Bridge, Wheatstone's Electric — —A name given to the electric bridge or balance. (See *Bridge, Electric.*)

Bridges.—Heavy copper wires suitably shaped for connecting the dynamo-electric machines in an incandescent light station to the bus-rods or wires.

Bright Dipping.—(See *Dipping, Bright.*)

Bright Dipping Liquid.—(See *Liquid, Bright Dipping.*)

Britannia Joint.—(See *Joint, Britannia.*)

Broken Circuit.—(See *Circuit, Broken.*)

Bronzing, Electro — —Coating a surface with a layer of bronze by electro-plating. (See *Plating, Electro.*)

The plating bath contains a solution of tin and copper.

Brush-and-Spray Discharge.—(See *Discharge, Brush-and-Spray.*)

Brush Discharge. — (See *Discharge, Brush.*)

Brush Electrode.—(See *Electrode, Brush.*)

Brush, Faradic — —An electrode in the form of a brush employed in the medical application of electricity.

The bristles are generally made of nickelized copper wire.

Brush-Holders for Dynamo-Electric Machines.—Devices for supporting the collecting brushes of dynamo-electric machines.

As the brushes require to be set or placed on the commutator in a position which often varies with the speed of the machine, and with changes in the resistance of the external circuit, all brush-holders are provided with some device for moving them concentrically with the commutator cylinder.

Brush Rocker.—(See *Rocker, Brush.*)

Brush, Scratch — —A brush made of wire or stiff bristles, etc., suitable for cleaning the surfaces of metallic objects before placing them in the plating bath.

Scratch brushes are made of various shapes and are provided with wires or bristles of varying coarseness.

Some forms of scratch and finishing brushes are shown in Fig. 83. They are circular in outline

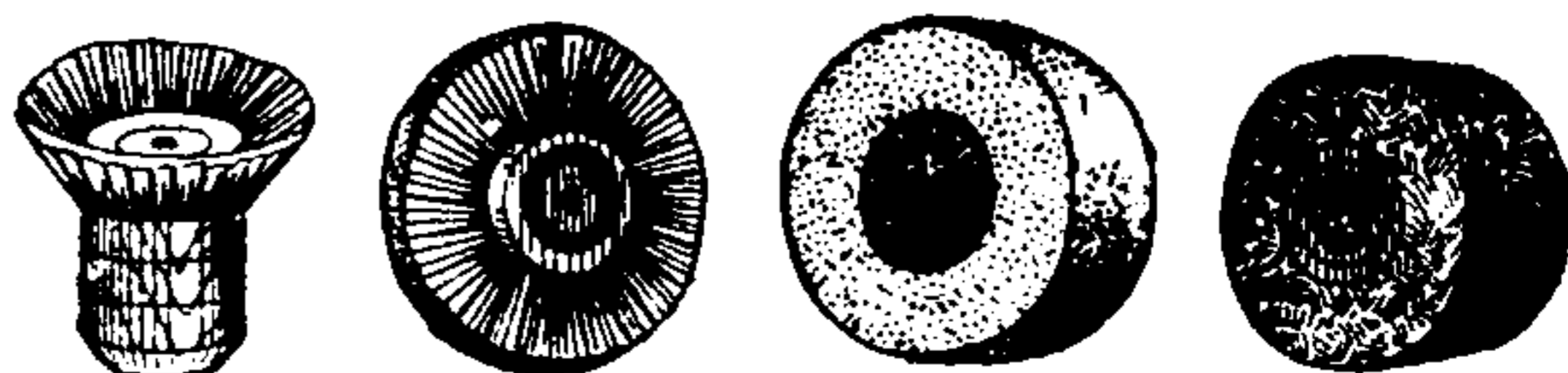

Fig. 83. Scratch Brushes.

and are adapted for use in connection with a lathe.

Brush, Scratch, Circular — —A scratch brush of a circular shape, so fitted as to be capable of being placed in a lathe and set in rapid rotation.

Brush, Scratch, Hand — —A scratch brush operated by hand, as distinguished from a circular scratch brush operated by a lathe.

Brushes, Adjustment of Dynamo-Electric Machines — —Shifting the brushes into the required position on the commutator cylinder, either non-automatically by hand, or automatically by the current itself. (See *Regulation, Automatic, of Dynamo-Electric Machines.*)

Brushes, Carbon, for Electric Motors — —Plates of carbon for leading current to electric motors. (See *Brushes of Dynamo-Electric Machine.*)

These are generally known simply as brushes.

Brushes, Collecting, of Dynamo-Electric Machine — —Conducting brushes which bear on the commutator cylinder, and take off the current generated by the difference of potential in the armature coils. (See *Brushes of Dynamo-Electric Machine.*)

Brushes, Lead of — —The angle through which the brushes of a dynamo-electric machine must be moved forward, or in the direction of rotation, in order to diminish sparking and to get the best output from the dynamo.

The necessity for the lead arises from the counter magnetism or magnetic reaction of the armature, and the magnetic lag of its iron core. (See *Lead, Angle of.*)

The position of the brushes on the commutator to insure the best output is practically the same in a series dynamo for any current strength. In shunt and compound dynamos it varies with the lead.

Brushes of Dynamo-Electric Machine. — Strips of metal, bundles of wire, slit plates of metal, or plates of carbon, that bear on the commutator cylinder of a dynamo-electric machine, and carry off the current generated.

Rotary brushes consisting of metal discs are sometimes employed. Copper is almost univer-

sally used for the brushes of dynamo-electric machines. Carbon brushes are often used for dynamo-electric motors.

The brush shown at B, Fig. 84, is formed of copper wires, soldered together at the non-bearing end. A copper plate, slit at the bearing end, is shown at C, and bundles of copper plates, soldered together at the non-bearing end, are shown at D.

The brushes should bear against the commutator cylinder with sufficient force to prevent jumping, and consequent burning, and yet not so hard as to cause excessive wear.

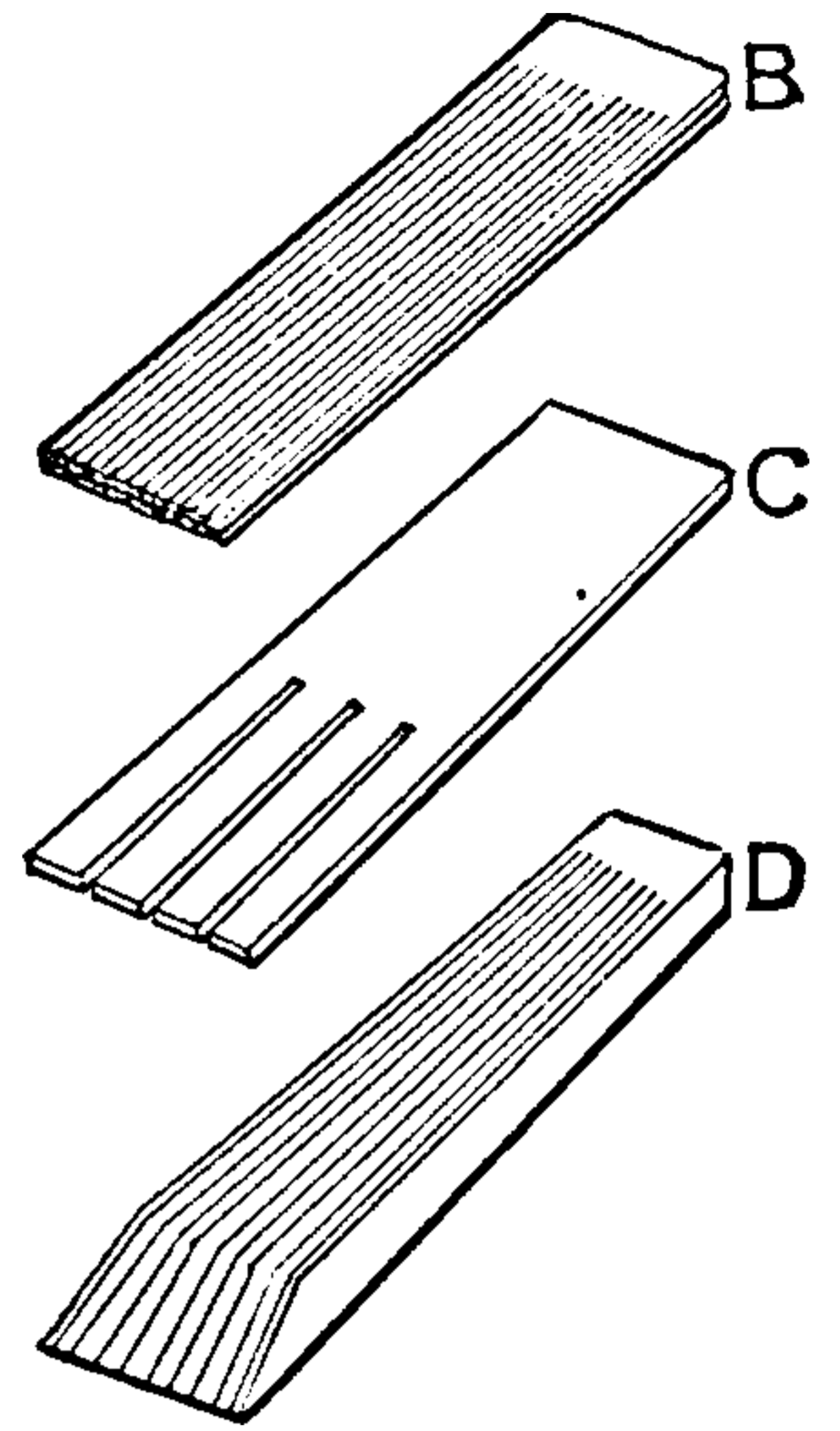

Fig. 84. Brushes.

Brushes, Rotating, of Dynamo-Electric Machines — —Discs of metal, employed in place of the ordinary brushes for carrying off the current from the armatures of dynamo-electric machines.

Brushing, Scratch — —Cleansing the surface of an article to be electroplated, by friction with a scratch brush.

Scratch brushing is generally done with the brushes wet by various solutions.

Buckling.—Irregularities in the shape of the surfaces of the plates of storage cells, following a too rapid discharge.

Bug.—A term originally employed in quadruplex telegraphy to designate any fault in the operation of the apparatus.

This term is now employed, to a limited extent, for faults in the operation of any electric apparatus.

Bug-Trap.—A device employed to overcome the "bug" in quadruplex telegraphy.

Bulb, Lamp — —The chamber or globe in which the filament of an incandescent electric lamp is placed.

The chamber or globe of a lamp must be of such construction as to enable the high vacuum necessary to the operation of the lamp to be maintained.

Bunched Cable.—(See *Cable, Bunched.*)

Bunched Cable, Straightaway — —
(See *Cable, Bunched, Straightaway.*)

Bunched Cable, Twisted — —(See
Cable, Bunched, Twisted.)

Bunsen Voltaic Cell.—(See *Cell, Voltaic, Bunsen's.*)

Buoy, Electric — —A buoy on which luminous electric signals are displayed.

Burglar Alarm.—(See *Alarm, Burglar.*)

Burglar Alarm Annunciator.—(See *Annunciator, Burglar Alarm.*)

Burglar Alarm Contacts.—(See *Contacts, Burglar Alarm.*)

Burglar Alarm, Yale Lock Switch for —
(See *Alarm, Yale-Lock-Switch Burglar.*)

Burner, Argand Electric — —An argand gas-burner that is lighted by means of an electric spark.

The argand electric burner assumes a variety of forms, such as the *plain-pendant*, the *ratchet-pendant* and the *automatic*. They are also used in systems of multiple gas lighting.

Burner, Argand Electric, Automatic — —An argand burner arranged for automatic electric lighting. (See *Burner, Automatic-Electric.*)

Burner, Argand Electric, Hand-Lighter — —A plain-pendant electric burner adapted for lighting an argand gas-burner. (See *Burner, Plain-Pendant Electric.*)

Burner, Argand-Electric, Plain-Pendant — —A plain-pendant electric burner adapted for lighting an argand gas burner. (See *Burner, Plain-Pendant Electric.*)

Burner, Argand-Electric, Ratchet-Pendant — —A ratchet-pendant electric burner adapted for lighting an argand gas-burner. (See *Burner, Ratchet-Pendant Electric.*)

Burner, Automatic-Electric — —An electric device for both turning on the gas and lighting it, and turning it off, by alternately touching different buttons.

The gas-cock is opened or closed by the motion of an armature, the movements of which are controlled by two separate electro-magnets. One push-button, usually a white one, turns the gas on

by energizing one of the electro-magnets and, at the same time, lights it by means of a succession of sparks from a spark coil. Another push-button, usually a black one, turns the gas off by energizing the other electro-magnet. The turning on or off of the gas is accomplished by positive motions. Automatic burners are also made with a single button.

An Argand Electric Burner is shown in Fig. 85.

Burner, Electric Candle — —A device for electrically lighting a gas jet in a burner surrounded by a porcelain tube in imitation of a candle.

Electric candle burners are either simple or ratchet candle burners.

Burner, Hand-Lighting Electric — —A name sometimes applied to a plain-pendant electric burner. (See *Burner, Plain-Pendant Electric.*)

Burner, Jump-Spark — —A term sometimes applied to a gas burner in which the issuing gas is ignited by a spark that jumps between the metallic points placed on it.

Jump-spark burners are used in systems of multiple gas lighting. (See *Lighting, Electric Gas.*)

Burner, Plain-Pendant Electric — —A gas-burner provided with a pendant for the purpose of lighting the gas by means of a spark, Fig. 86. Plain-Pendant Burner.

The gas is first turned on by hand at the ordi-

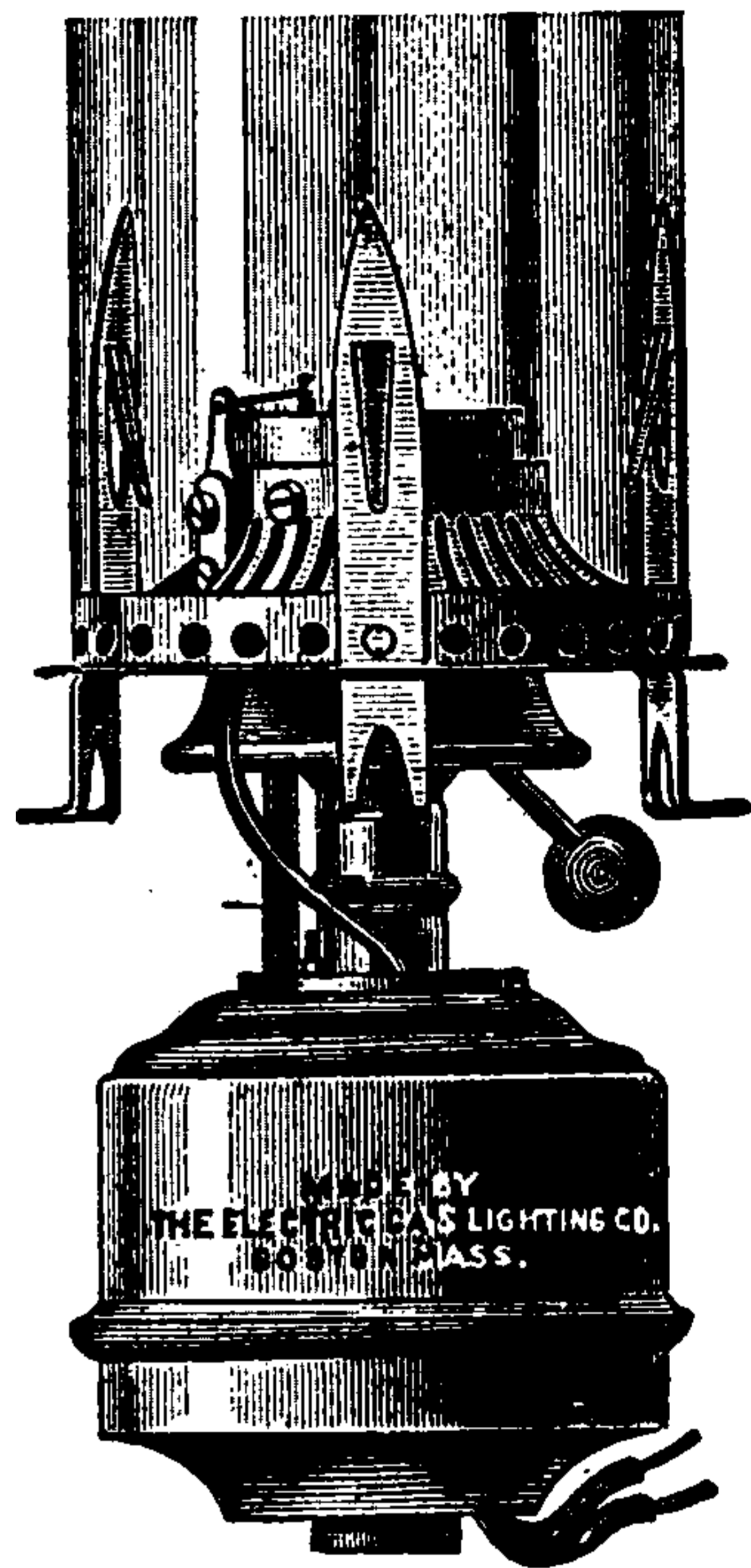

Fig. 85. Argand Electric Burner.

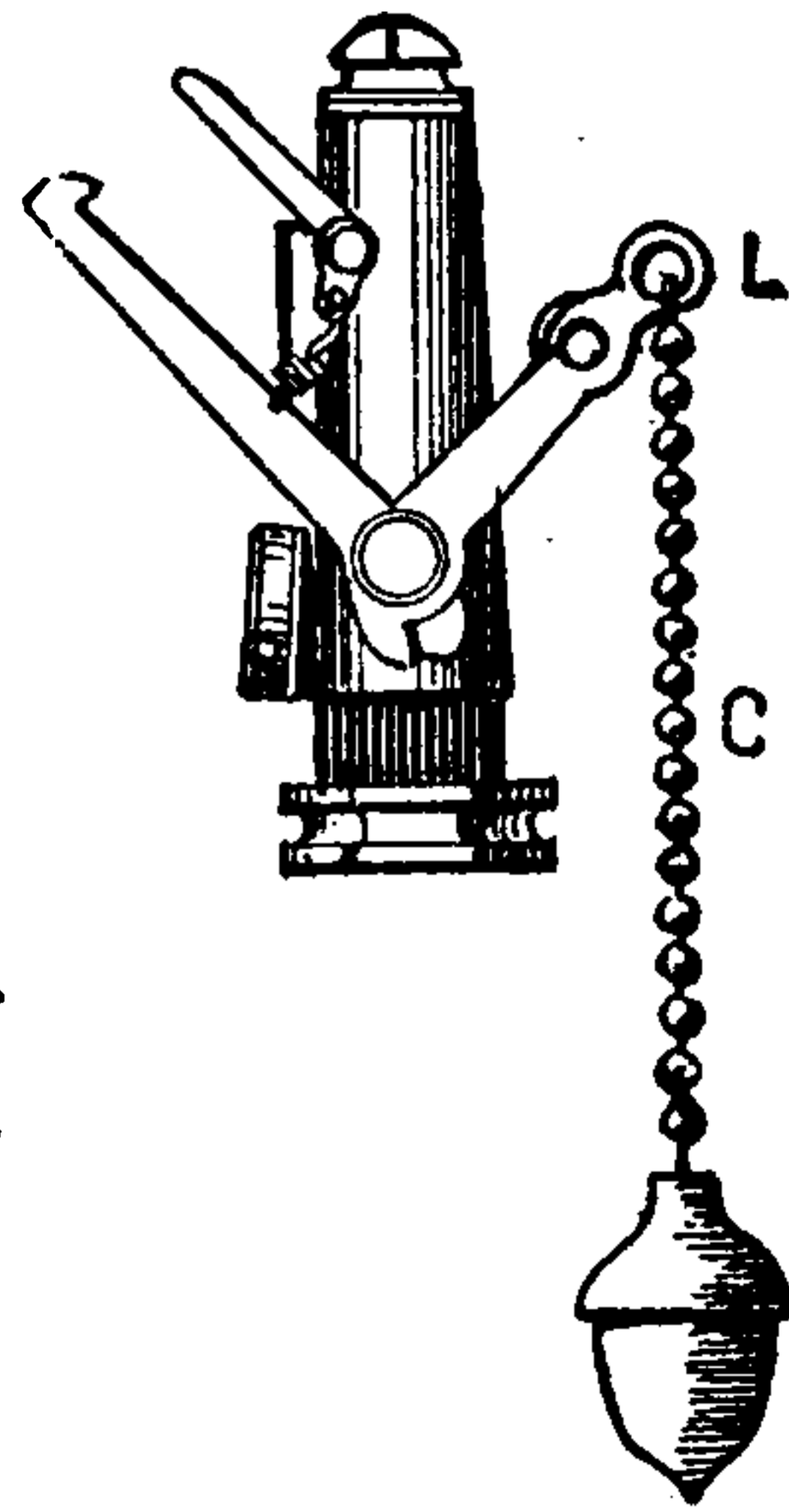

Fig. 86. Plain-Pendant Burner.

nary key, and is then lighted by pulling the pendant C, Fig. 86. A spark from a spark coil ignites the gas.

This is sometimes called an *electric hand-lighting burner*.

Burner, Ratchet-Pendant Candle Electric — —A burner for both lighting and extinguishing a candle gas jet.

Burner, Ratchet-Pendant Electric — —A gas-burner in which one pulling of a pendant turns on the gas and ignites it by means of an electric spark from a spark coil, and the next pulling of the pendant turns off the gas.

A ratchet-wheel and pawl are operated by the motion of the pendant. The first pull of the pendant chain moves the ratchet so as to open a four-way gas cock, and at the same time light the gas at the burner tip by a *wipe-spark* from a spark coil. On the next pull of the pendant, the four-way cock is turned so as to turn off the gas. Alternate pulls, therefore, light and extinguish the gas.

Burner, Simple Candle Electric — —A plain-pendant electric burner. (See *Burner, Plain Pendant Electric*.)

Burner, Thumb-Cock Electric — —An electric gas-burner, in which the turning of an ordinary thumb-cock turns on the gas, and ignites it by a spark produced by a wiping contact actuated by the motions of the thumb-cock.

A form of thumb-cock burner is shown in Fig. 87.

Burner, Vibrating - Electric — —An electric gas-burner in which the gas is lighted after it is turned on by hand, by means of the spark from a spark coil produced on the rapid

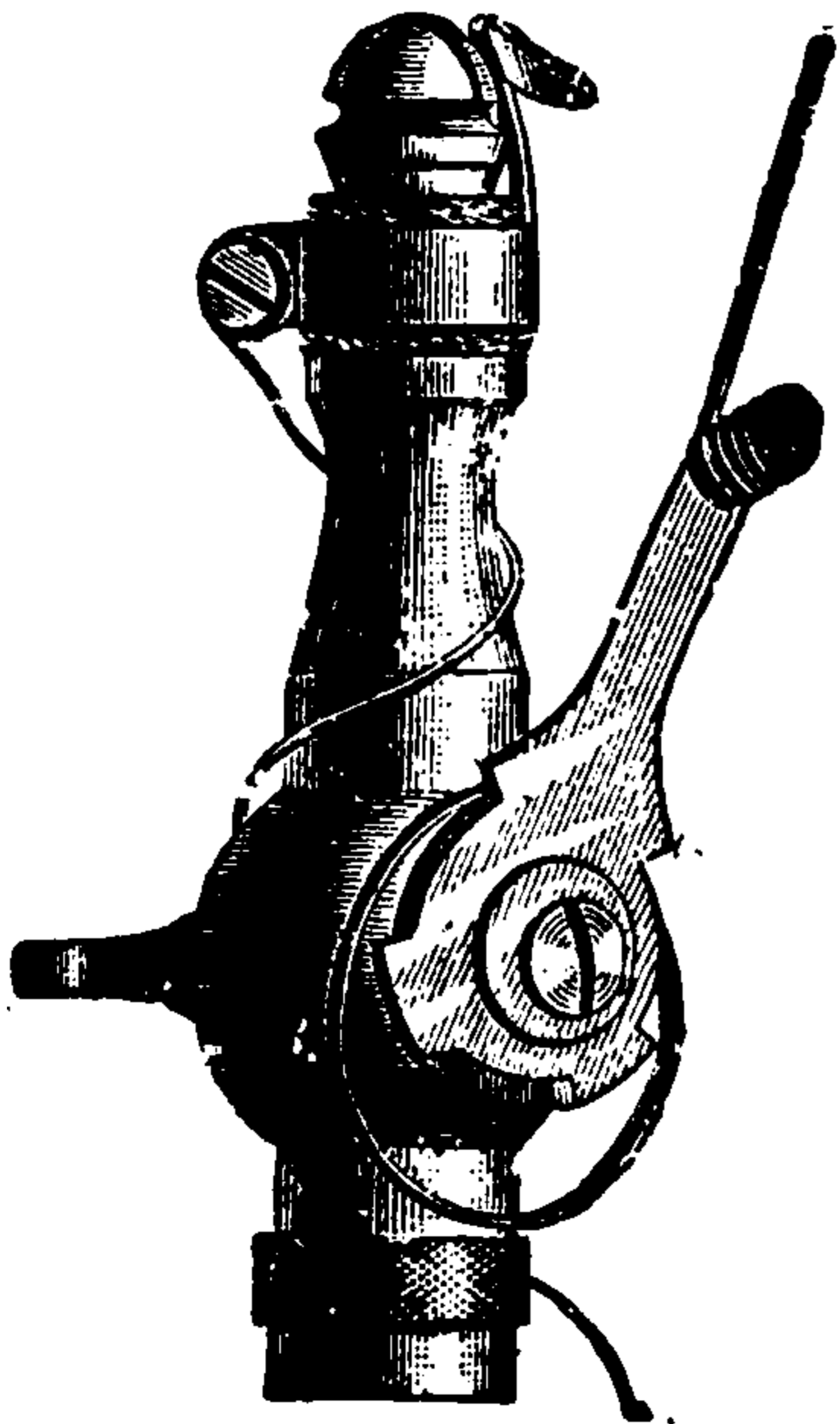

Fig. 87. *Thumb-Cock Burner.*

making and breaking of the circuit by a vibrating contact.

The vibrating-electric burner has a single electro-magnet. It is operated by means of a button or switch, and may be used on single lights or on groups of lights. It bears the same relation to the automatic burner that the plain-pendant burner does to the ratchet burner.

Burnetize.—To subject to the Burnetizing process. (See *Burnetizing*.)

Burnetizing.—A method adopted for the preservation of wooden telegraph poles by injecting a solution of zinc chloride into the pores of the wood. (See *Pole, Telegraphic*.)

Burning at Commutator of Dynamo.—An arcing at the brushes of a dynamo-electric machine, due to their imperfect contact, or improper position, which results in loss of energy and destruction of the commutator segments.

Bus.—A word generally used instead of omnibus. (See *Omnibus*.)

Bus-Bars.—(See *Bars, Bus*.)

Bus-Rod Wires.—(See *Wires Bus-Rod*.)

Bus-Wire.—(See *Wire, Bus*.)

Butt Joint.—(See *Joint, Butt*.)

Button, Carbon — —A resistance of carbon in the form of a button.

A button of carbon is used as an electric resistance in a variety of apparatus; its principal use, however, is in the transmitting instrument of the electric telephone. In the telephone transmitter, the button is so placed between contact-plates that when the plates are pressed together by the sound-waves, the electrical resistance is decreased by a decrease in the thickness of the carbon button, an increase in its density, and an increase in the number of points where the carbon touches the plates. Rheostats, or resistances, have been made by the use of a number of carbon buttons or discs piled one on another and placed in a glass tube. Discs of carbonized cloth form excellent resistances for such purposes.

Button, Press — —A push button. (See *Button, Push*.)

Button, Push — —A device for closing

in electric circuit by the movement of a button.

A button, when pushed by the hand, closes the

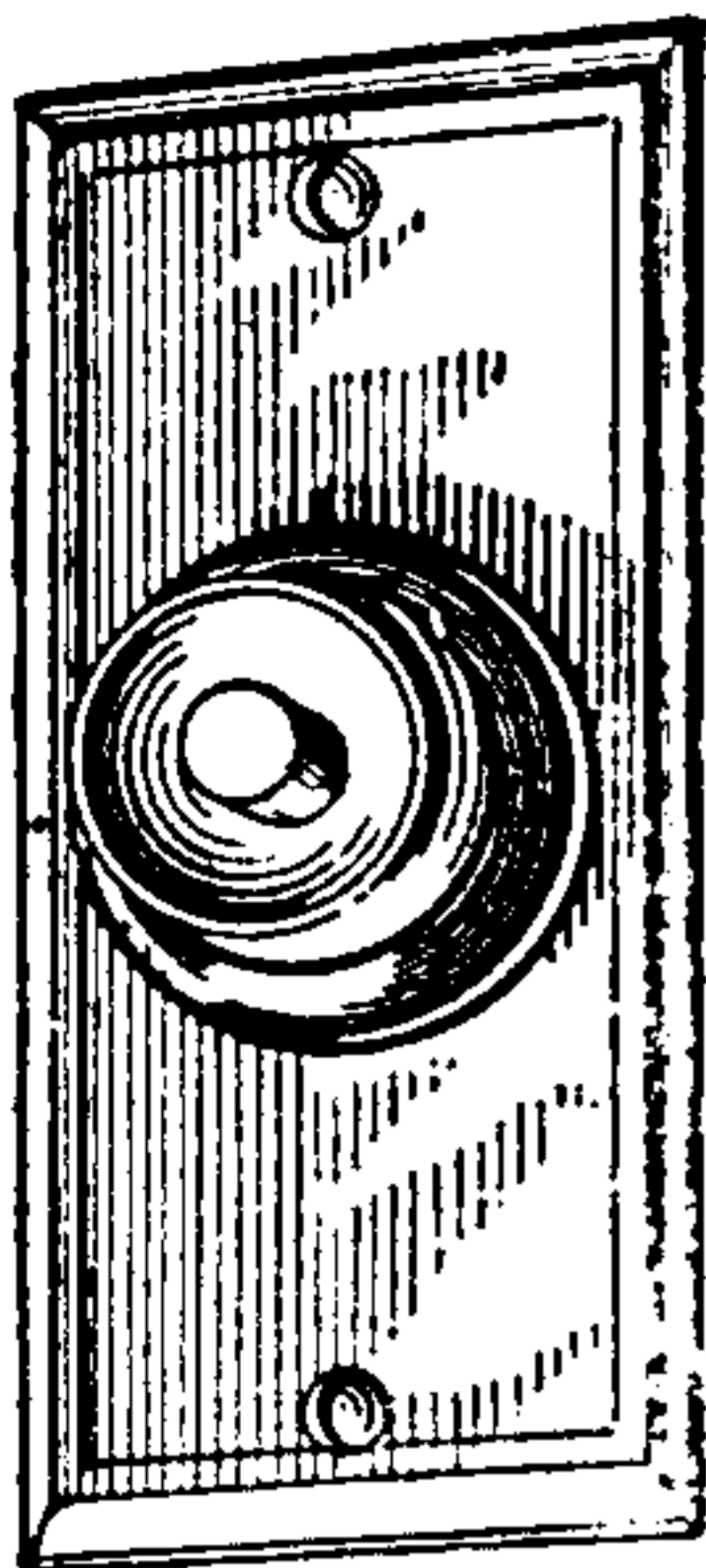

Fig. 88. Push Button.

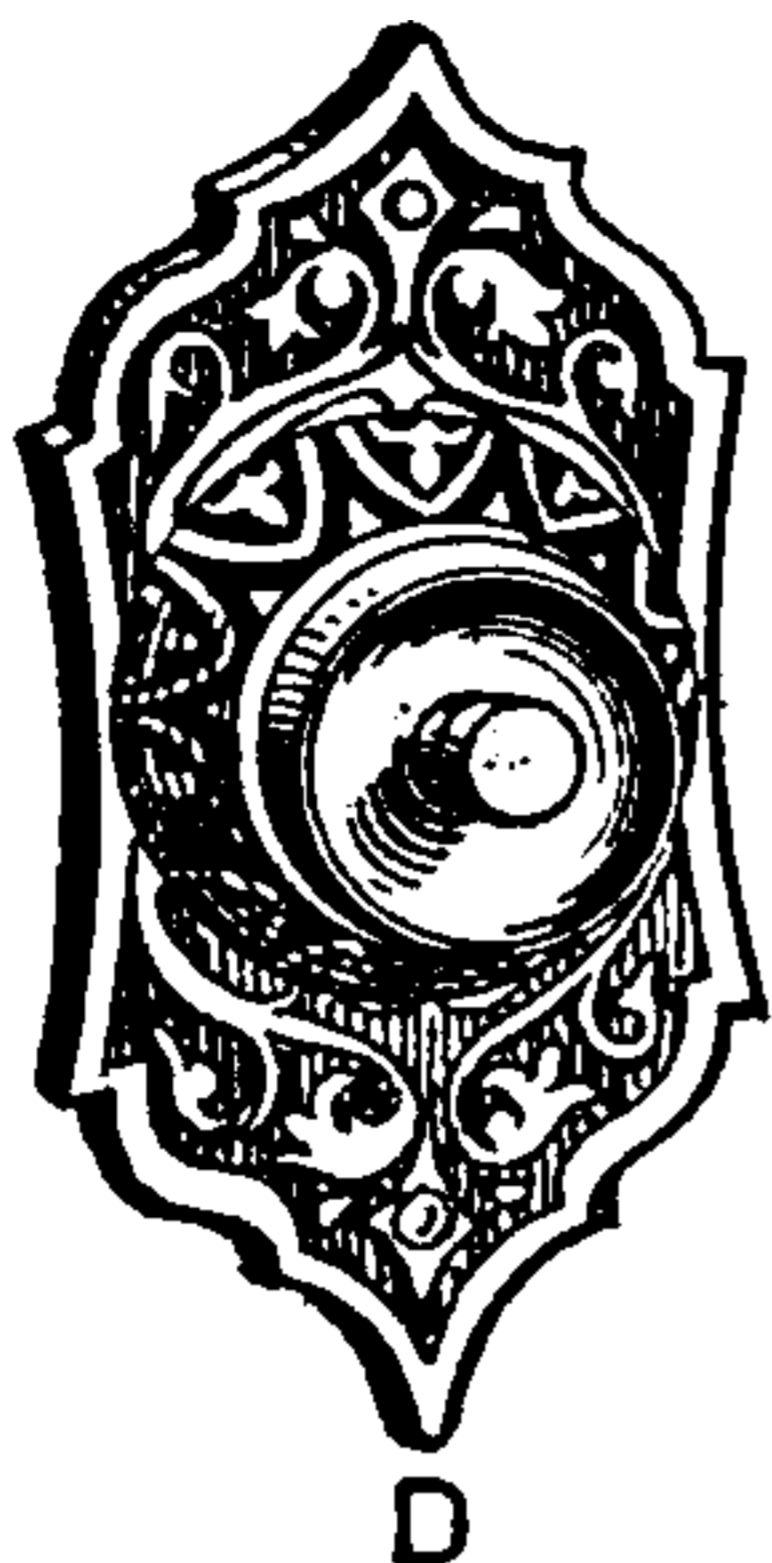

Fig. 89. Push Button.

contact, and thus completes a circuit in which some electro-receptive device is placed. This circuit is opened by a spring, on the removal of the pressure. Some forms of push-buttons are shown in Figs. 88, 89 and 90.

A floor-push for dining-rooms and offices is shown in Fig. 90.

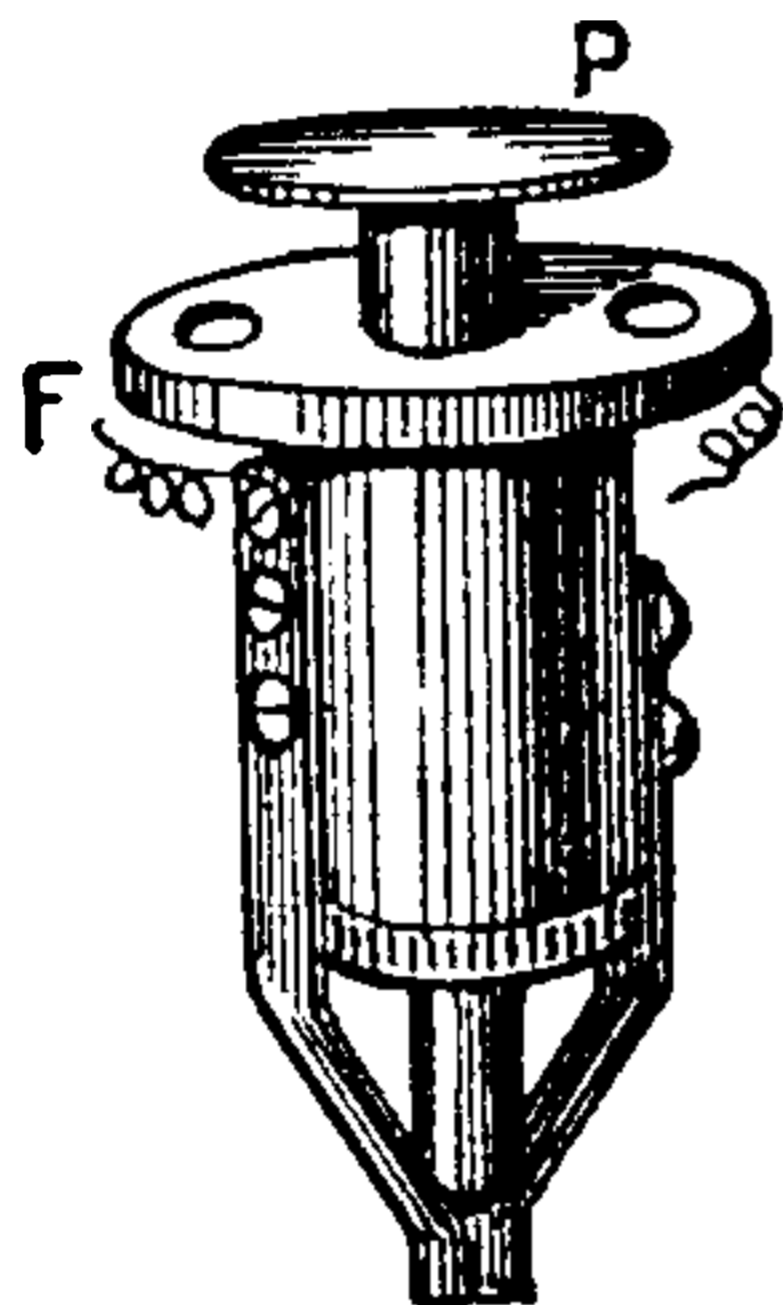

Fig. 90. Floor Push.

Fig. 88 shows the general appearance of an ordinary bell-push. The arrangement of the interior spring contacts will be understood by an inspection of Fig. 91.

Buzzer, Electric — — A call, not as loud as that of a bell, produced by a rapid

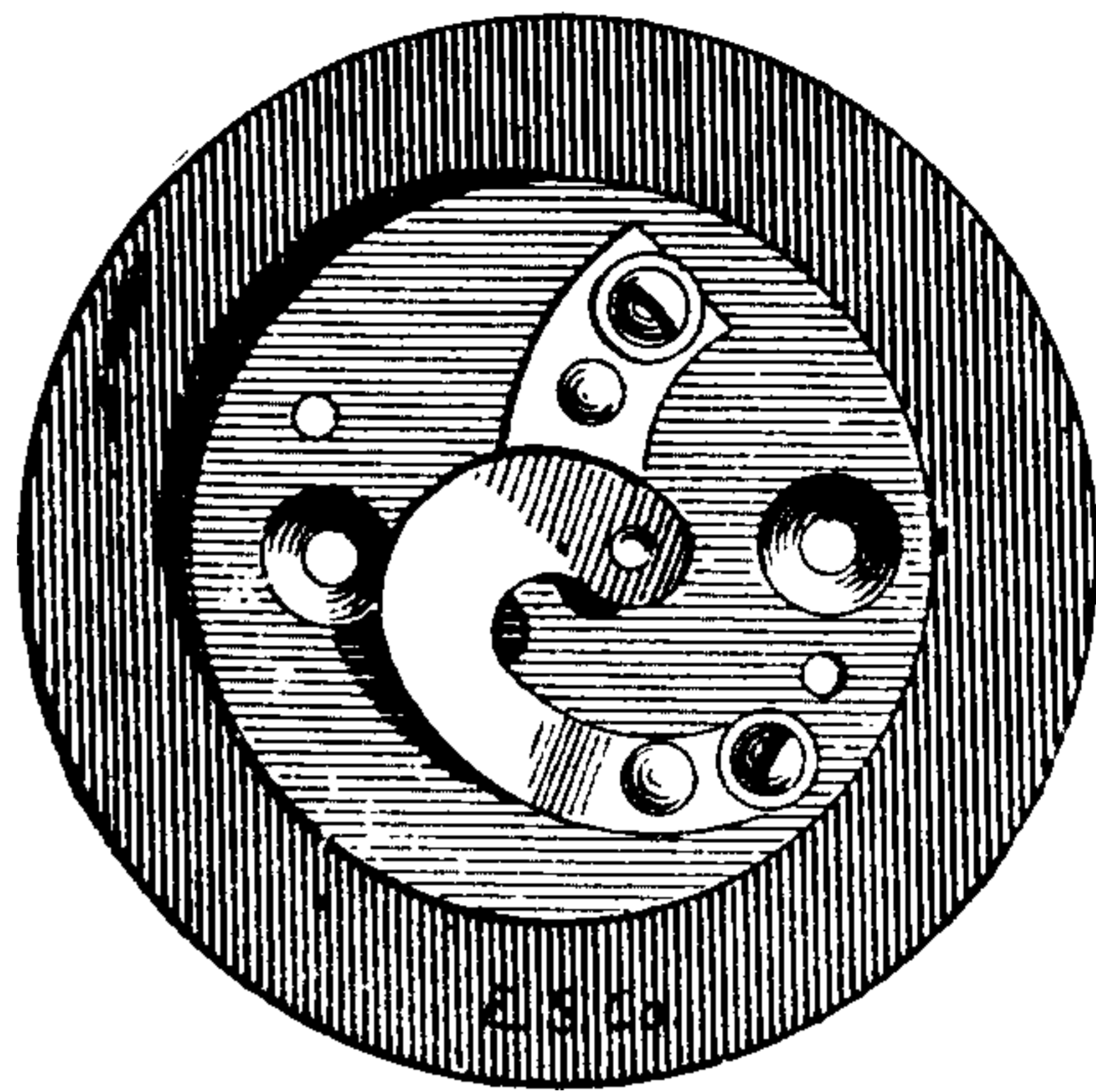

Fig. 91. Spring Contact of Bell Push.

automatic make-and-break. (See *Make-and-Break, Automatic*.)

The buzzer is generally placed inside a resonant

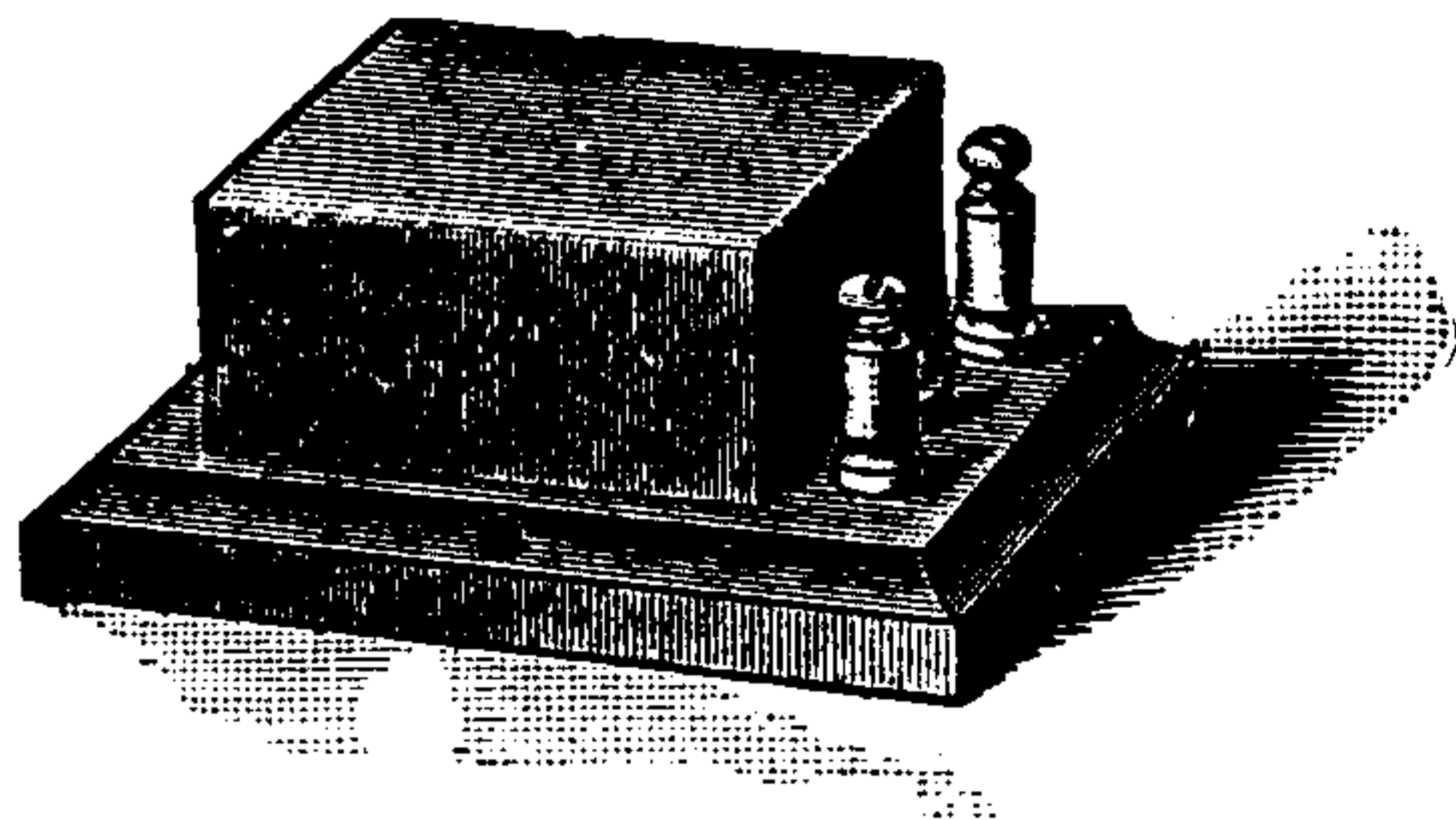

Fig. 92. Buzzer.

case of wood in order to strengthen the sound by resonance. A form of buzzer is shown in Fig. 92.

C

C.—An abbreviation for centigrade.

Thus, 20 degrees C. means 20 degrees of the centigrade thermometric scale. (See *Scale, Centigrade Thermometer*.)

C.—A contraction for current.

Generally a contraction for the current in ampères, as $C = \frac{E}{R}$.

C. C.—A contraction for cubic centimetre. (See *Weights and Measures, Metric System of*.)

C. G. S. Units.—A contraction for centimetre-gramme-second units. (See *Units, Centimetre-Gramme-Second*.)

C. P.—A contraction for candle power. (See *Candle, Standard*.)

Cable.—An electric cable. (See *Cable, Electric*.)

Cable.—To send a telegraphic dispatch, by means of a cable.

Cable, Aerial — — A cable suspended in the air from suitable poles.

Cable, Anti-Induction, Waring — — A form of anti-induction cable.

In the Waring anti-induction cable the separate conductors are covered with a fibrous insulator, from which all air and moisture is expelled, and the fibre then saturated with an insulating ma-

terial called ozite. The conductors are then protected from the inductive effects of neighboring conductors by a continuous sheath of lead alloyed with tin.

Where the cables are bunched, the bunches are sometimes again surrounded by insulating material, and the whole then covered by a continuous lead sheathing; generally, however, the separately insulated conductors are bunched, and then covered by a single sheathing of lead alloyed with tin.

Cable, Armature of — — The armor of a cable. (See *Armature of a Cable*.)

Cable, Armor of — — The protecting sheathing or metallic covering on the outside of a submarine or other electric cable.

Cable, Armored — — An electric cable provided, in addition to its insulating coating, with a protective coating or sheathing, generally of metal tubing or wire.

Cable-Box.—(See *Box, Cable*.)

Cable, Bunched — — A cable containing more than a single wire or conductor.

Some forms of bunched, lead-covered cables, are shown in Fig. 93.

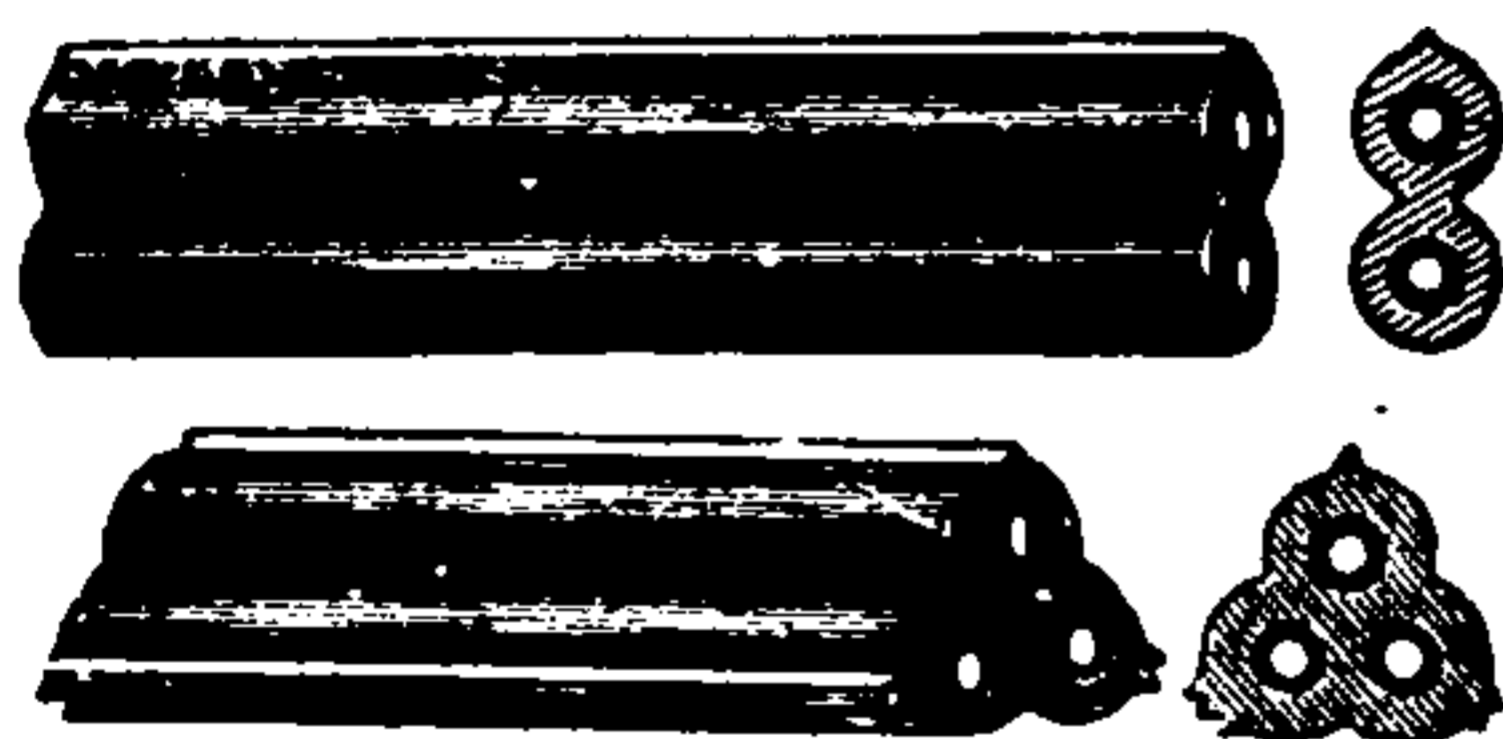

Fig. 93. *Bunched Cables.*

Cable, Bunched, Straightaway — — A bunched cable the separate conductors of which extend in the direction of the length of the cable without any twisting, being placed in successive layers.

In arranging the separate conductors in successive layers an advantage is gained in testing for a given wire in order to make a loop, splice, or branch with the next adjoining section. This is rendered still easier by giving the conductors of the successive layers some distinctive form of braiding in the fibrous insulating material, or some distinctive color.

Cable, Bunched, Twisted — — A bunched cable, the separate conductors of which are twisted-pairs placed in successive layers.

Each twisted-pair of a bunched cable acts as a metallic circuit, and, moreover, possesses the advantage of avoiding the ill effects of induction, so disadvantageous in telephone circuits.

In laying up the twisted-pairs in successive layers in a bunched cable, the direction of twisting is reversed in each successive layer. This form is especially desirable on all long cable lines.

In the case of twisted cables for telephone lines, the twists are sometimes made as frequent as one in every three or four inches. In such cases the cross-talk of induction is inappreciable.

Cable, Capacity of — — The quantity of electricity required to raise a given length of a cable to a given potential, divided by the potential.

The amount of charge for a given potential that any single conductor will take up with the rest of the conductors grounded. (See *Capacity, Electrostatic*.)

The ability of a wire or cable to permit a certain quantity of electricity to be passed into it before acquiring a given difference of potential.

Before a telegraph line or cable can transmit a signal to its further end, its difference of potential must be raised to a definite amount dependent on the character of the instruments and the nature of the system.

The first effect of electricity being passed into a line is to produce an accumulation of electricity on the line, similar to the charge in a condenser. Cables especially act as condensers, and from the high specific inductive capacity of the insulating materials employed, permit considerable induction to take place between the core and the metallic armor or sheathing, or the ground.

The capacity of a cable depends on the capacity of the wire; *i. e.*, on its length and surface, on the specific inductive capacity of its insulation, and its neighborhood to the earth, or to other conducting wires, casings, armors, or metallic coatings. Submarine or underground cables therefore have a greater capacity than air lines.

This accumulation of electricity produces a retardation in the speed of signaling, because the wire must be charged before the signal is received at the distant end, and discharged or neutralized before a current can be sent in the reverse direction. This latter may be done by connecting each end to earth, or by the action of the reverse current itself.

The smaller the electrostatic capacity of a cable, therefore, the greater the speed of signaling. (See *Retardation*.)

The capacity of a cable is measured in *microfarads*. (See *Farad, Micro*.)

Cable Clip.—(See *Clip, Cable*.)

Cable-Core.—(See *Core of Cable*.)

Cable, Core-Ratio of — — The ratio between the diameter of the insulation of a cable and the mean diameter of the strand.

The core-ratio is represented by $\frac{D}{d}$; where D , is the diameter of the insulation, and d , the mean diameter of the strand. Should the extreme diameter of the strand of a cable be used in calculations for insulation resistance, inductive capacity, etc., erroneous values would be obtained. The measured diameter of the copper conductor is consequently decreased some five per cent., and, in this way, correct values are approximately obtained.—(Clark & Sabine.)

Cable, Duplex — — A conductor consisting of two separate cables placed parallel to each other.

The duplex cable is used especially in the alternating current system.

Cable, Electric — — The combination of an extended length of a single insulated conductor, or two or more separately insulated electric conductors, covered externally with a metallic sheathing or armor.

Strictly speaking, the word cable should be limited to the case of more than a single conductor. Usage, however, sanctions the employment of the word to indicate a single insulated conductor.

The conducting wire may consist of a single wire, of a number of separate wires electrically connected, or of a number of separate wires insulated from one another.

An electric cable consists of the following parts, viz.:

- (1.) The conducting wire or *core*.
- (2.) The insulating material for separating the several wires; and
- (3.) The *armor* or protecting covering, consisting of strands of iron wire, or of a metallic coating or covering of lead.

As to their position, cables are *aerial*, *submarine*, or *underground*. As to their purpose,

they are *telegraphic*, *telephonic*, or *electric light and power cables*. As to the number of their conductors they are *single-wire* or *bunched cables*. Bunched cables are *straightaway* or *twisted*.

Fig. 94 shows a form of submarine cable the

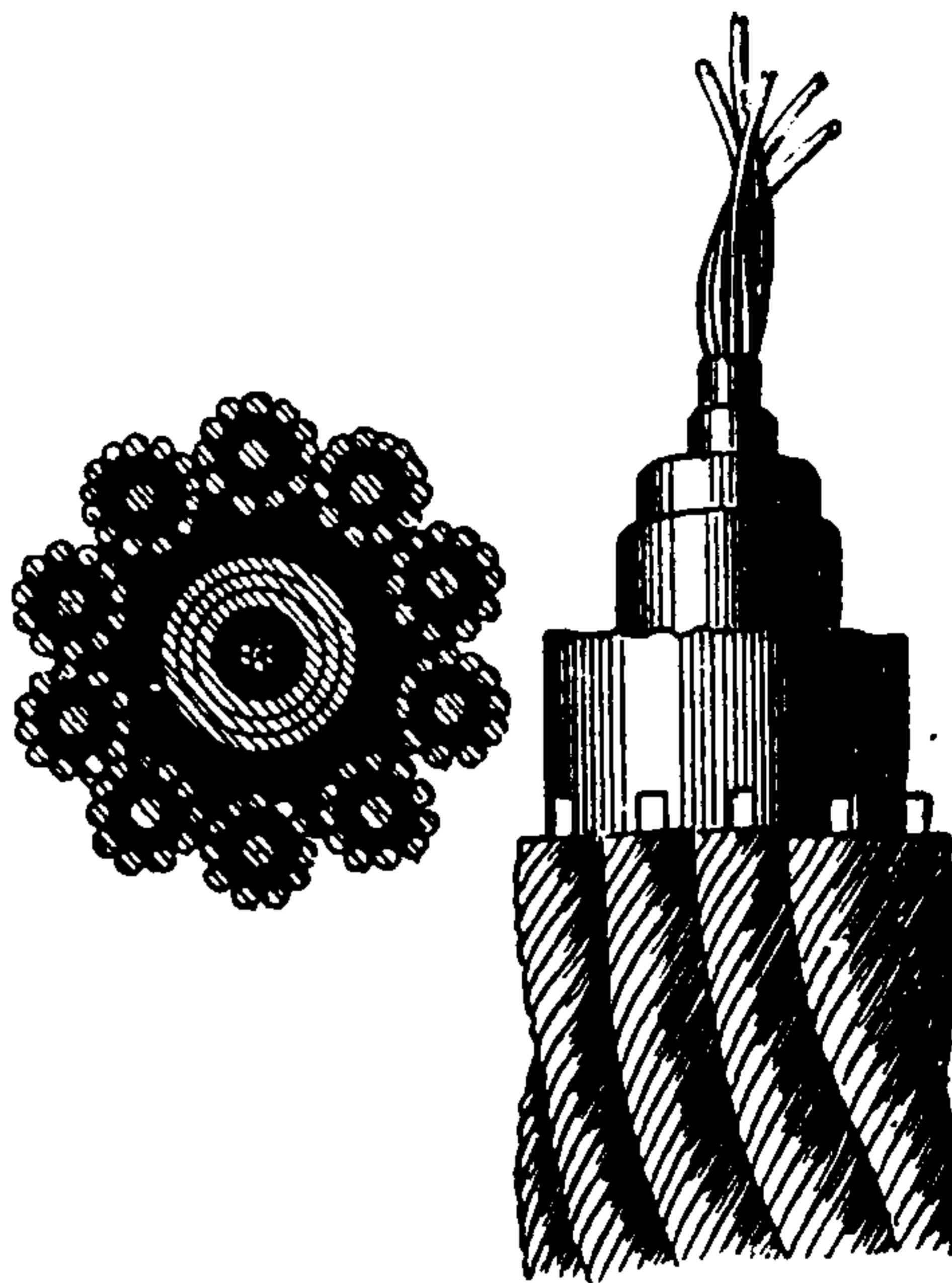

Fig. 94. *Electric Cable*.

armor of which is formed of strands of iron wire.

Cable, Electric Light or Power — — A cable designed to distribute the electric current employed in electric light or power systems.

Electric light cables are generally *underground*. They may be *submarine*. (See *Cable, Electric*.)

Cable, Flat — — A cable, the separate conductors of which are laid-up side by side so as to form a flat conductor.

A flat cable is suitable for house work as being less objectionable in appearance when placed on the outside of ceilings or walls.

Cable, Flat Duplex — — A flat, laid-up cable containing two wires.

Cable-Grip.—(See *Grip, Cable*.)

Cable-Hanger.—(See *Hanger, Cable*.)

Cable-Hanger Tongs.—(See *Tongs, Cable-Hanger*.)

Cable Laid-Up in Layers.—A term applied to a cable, all the conducting wires of which are in layers.

THIS PAGE IS LOCKED TO FREE MEMBERS

Purchase full membership to immediately unlock this page

Know Your Bible

Forgotten Books' Full Membership provides unlimited access to more than 28,000 volumes of Christian literature for \$8.99/month

HOLY BIBLE

Continue

*Fair use policy applies

Calahan's Stock Printer.—(See *Printer, Stock, Calahan's.*)

Calamine, Electric — —A crystalline variety of silicate of zinc that possesses pyroelectric properties. (See *Electricity, Pyro.*)

Cal-Electricity.—(See *Electricity, Cal.*)

Calibrate.—To determine the absolute or relative value of the scale divisions, or of the indications of any electrical instrument, such as a galvanometer, electrometer, voltmeter, wattmeter, etc.

Calibrating.—The act of determining the absolute or relative value of the deflections, or indications of an electric instrument.

Calibration, Absolute — —The determination of the absolute values of the reading of an electrometer, galvanometer, voltmeter, ampèremeter, or other similar instrument.

The calibration of a galvanometer, for example, consists in the determination of the law which governs its different deflections, and by which is obtained in ampères, either the absolute or the relative currents required to produce such deflections.

For various methods of calibration, see standard works on electrical testing, or on electricity.

Calibration, Invariable, of Galvanometer — —In galvanometers with absolute calibration, a method for preventing the occurrence of variations in the intensity of the field of the galvanometer, due to the neighborhood of masses of iron, etc.

Calibration, Relative — —The determination of the relative values of the reading of an electrometer, voltmeter, ampèremeter, or other similar instrument.

Caliper, Micrometer — —A name sometimes given to a vernier wire gauge. (See *Gauge, Vernier Wire.*)

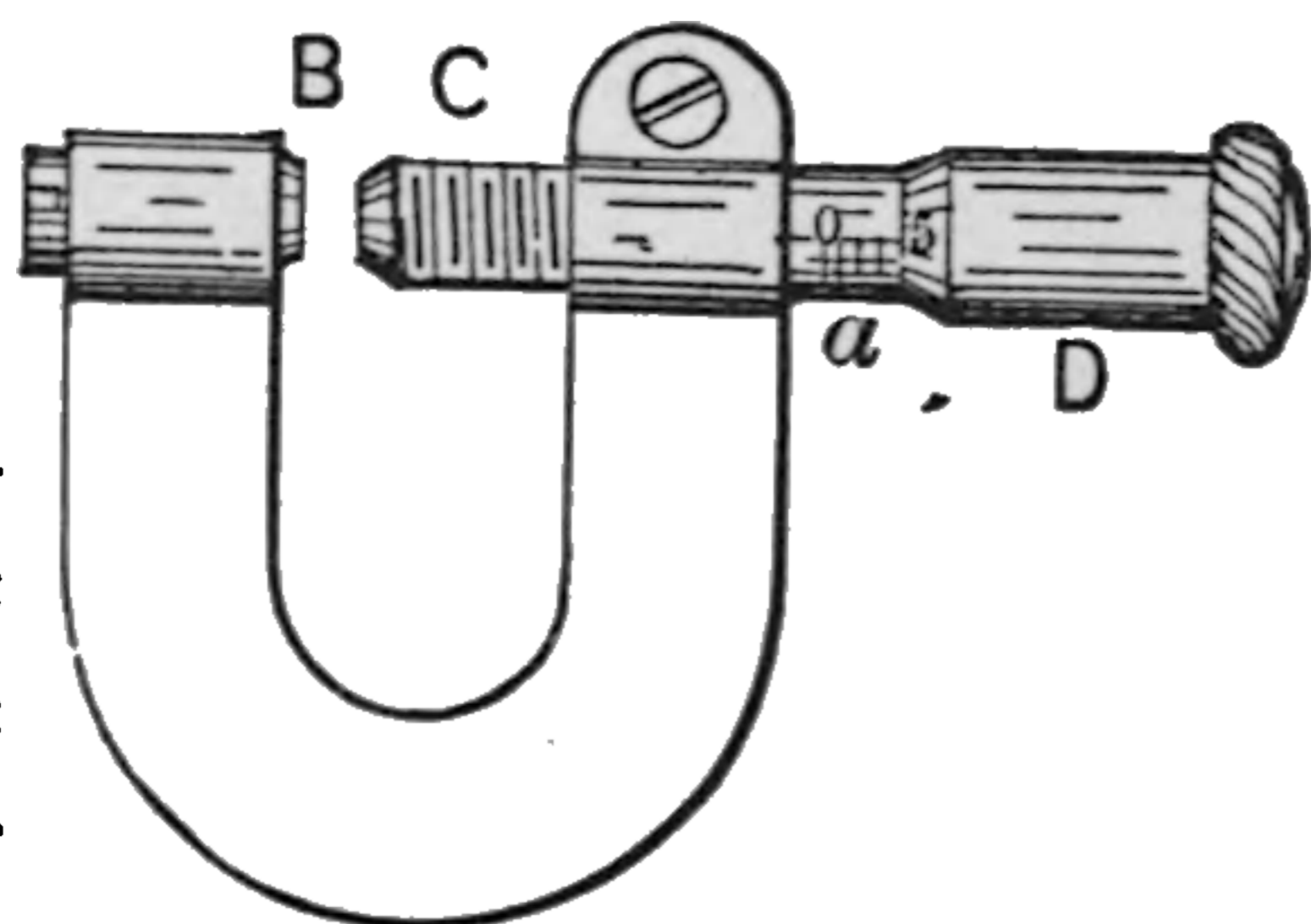

Fig. 95. Micrometer Caliper.

A form of micrometer caliper is shown in Fig. 95.

Call-Bell, Extension — —(See *Bell, Extension Call.*)

Call-Bell, Magneto-Electric — —An electric call-bell operated by currents produced by the motion of a coil of wire before the poles of a permanent magnet.

A well known form of magneto call-bell is shown

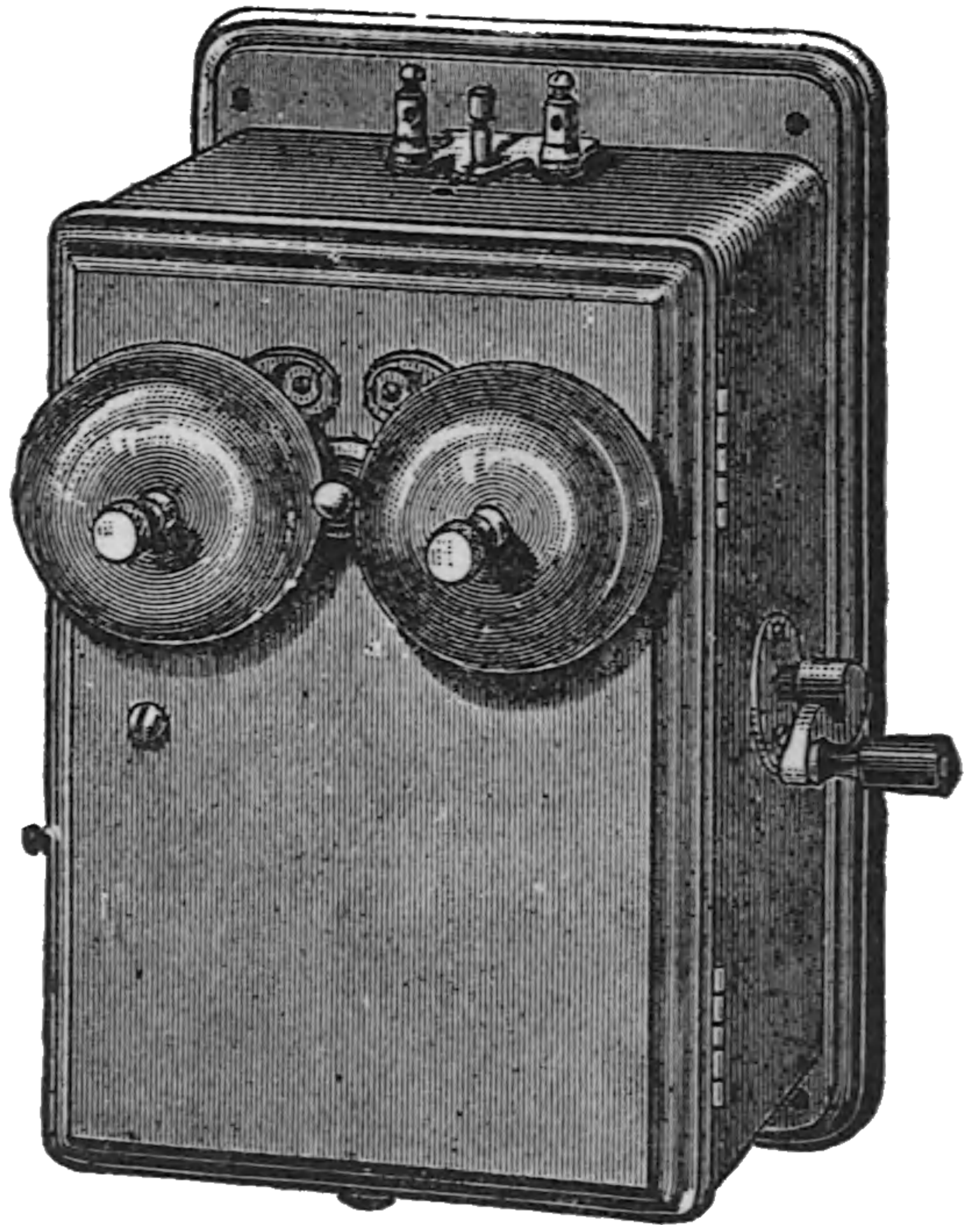

Fig. 96. Magneto Call Bell.

in Fig. 96. The armature is driven by the rotation of the handle.

Call-Bell, Telephone — —An electric bell, the ringing of which is used to call a person to a telephone.

Call, Electric Bell — —An electric bell sometimes used to call the attention of an operator to the fact that his correspondent wishes to communicate with him, or to notify an attendant that some service is desired.

Call, Messenger — —A district call-box. (See *Box, District Call.*)

Call, Thermo-Electric — —An instrument for sounding an alarm when the temperature rises above, or falls below, a fixed point.

In one form of thermo-electric call a needle is moved over a dial by a simple thermic device and rings a bell when the temperature for which it has been set is attained. The thermo-call is applicable to the regulation of the temperature of

dwellings, incubators, hot houses, breweries, drying rooms, etc.

Callaud Voltaic Cell.—(See *Cell, Voltaic, Callaud's*.)

Calling-Drop.—(See *Drop, Calling*.)

Calorescence.—The transformation of invisible heat-rays into luminous rays, when received by certain solid substances.

The term was proposed by Tyndall. The light from a voltaic arc is passed through a hollow glass lens filled with a solution of iodine in bisulphide of carbon.

This solution is opaque to light but quite transparent to heat.

If a piece of charred paper, or thin platinum foil, is placed in the *focus* of these invisible rays, it will be heated to brilliant incandescence. (See *Focus*.)

Caloric.—A term formerly applied to the fluid which was believed to be the cause or essence of heat.

The use of the word caloric at the present time is very unscientific, since heat is now known to be an effect of a wave motion and not a material thing. (See *Heat*.)

Calorie.—A heat unit.

There are two calories, the small and the large calorie.

The amount of heat required to raise the temperature of one gramme of water from 0 degree C. to 1 degree C. is called the *small calorie*.

The amount of heat required to raise 1,000 grammes, or a kilogramme, of water from 0 degree C. to 1 degree C. is called the *great calorie*. The first usage of the word is the commoner.

This word is sometimes spelled *calory*.

Calorie, Great — —The amount of heat required to raise the temperature of one kilogramme of water from 0 degree C. to 1 degree C.

Calorie, Small — —The amount of heat required to raise the temperature of one gramme of water from 0 degree C. to 1 degree C.

Calorimeter.—An instrument for measuring the amount of heat or thermal energy contained or developed in a given body.

Thermometers measure temperature only. A

thermometer plunged in a cup full of boiling water shows the same temperature that it would in a tub full of boiling water. The quantity of heat energy present in the two cases is of course greatly different, and can be measured by a calorimeter only.

Various forms of calorimeters are employed.

In order to determine the quantity of heat in a given weight of any body, this weight may be heated to a definite temperature, such as the boiling point of water, and placed in a vessel containing ice. The quantity of ice melted by the body in cooling to the temperature of the ice, is determined by measuring the amount of water derived from the melting of the ice. Care must be observed to avoid the melting of the ice by external heat.

In this way the amount of heat required to raise the temperature of a given weight of a body a certain number of degrees, or the capacity of the body for heat, may be compared with the capacity of an equal weight of water. This ratio is called the specific heat. (See *Heat, Specific*.)

The heat energy, present in a given weight of any substance at a given temperature, can be determined by means of a calorimeter; for, since a pound of water heated 1° F. absorbs an amount of energy equal to 772 foot-pounds, the energy can be readily calculated if the number of pounds of water and the number of degrees of temperature are known. (See *Heat, Mechanical Equivalent of*.)

Calorimeter, Electric — —An instrument for measuring the heat developed in a conductor or any piece of electrical apparatus, in a given time, by an electric current.

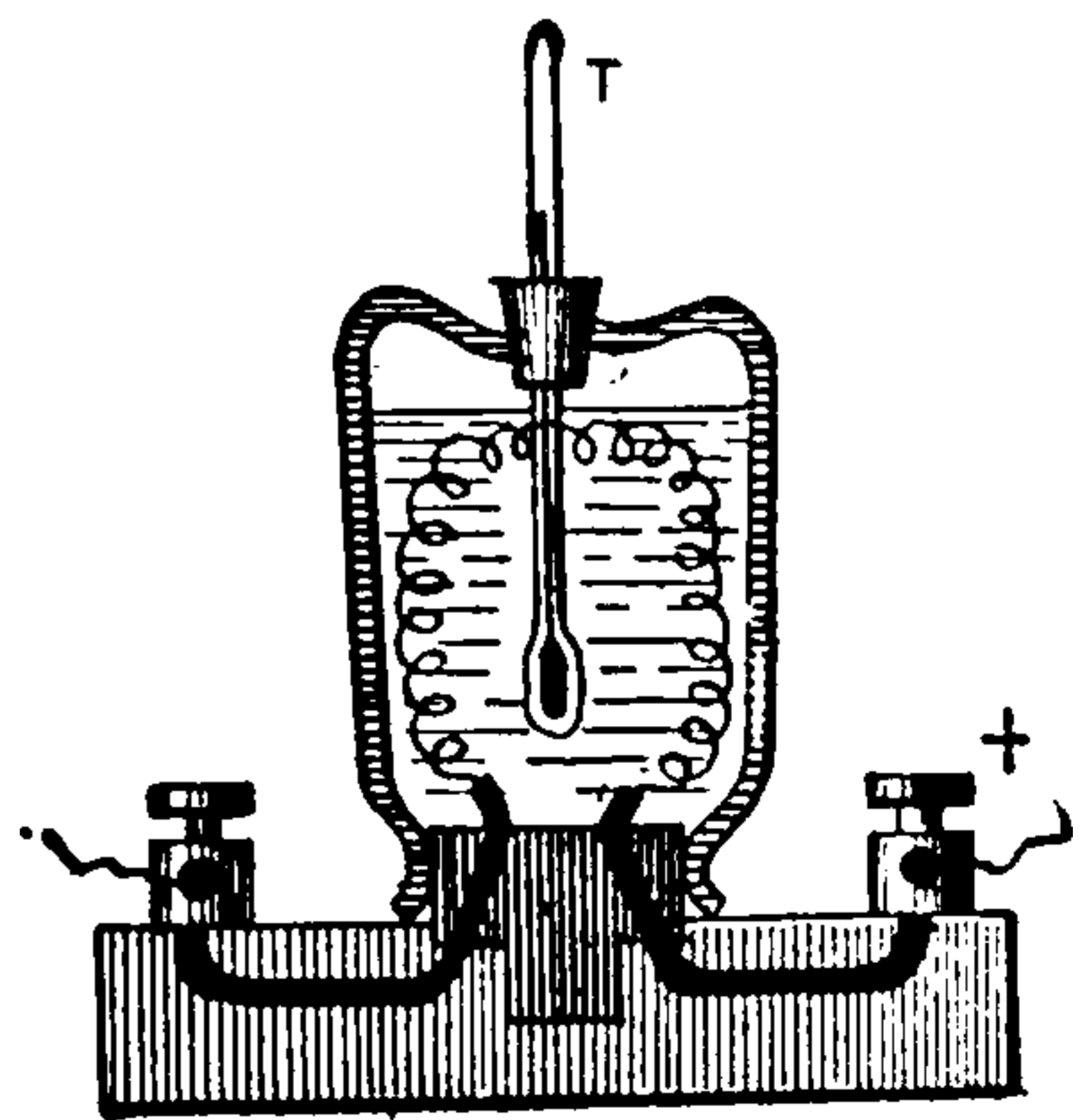

Fig. 97. *Electric Calorimeter.*

A vessel containing water is provided with a thermometer T, Fig. 97. The electric current

passes for a measured time through a wire immersed in the liquid.

The quantity of heat is determined from the increase of temperature, and the weight of the water heated.

According to Joule, the number of *heat units* developed in a conductor by an electric current is proportional:

- (1.) To the resistance of the conductor.
- (2.) To the square of the current passing.
- (3.) To the time the current is passing.

(See *Heat Unit, English.*)

The heating power of a current is as the square of the current only when the resistance remains the same. (See *Heat, Electric.*)

Calorimetric.—Pertaining to or by means of the calorimeter.

Calorimetric measurement is the measurement of heat energy made by means of the calorimeter. (See *Calorimeter.*)

Calorimetrically.—In a calorimetric manner.

Calorimetric Photometer.—(See *Photometer, Calorimetric.*)

Calorimotor.—A name applied to a deflagrator. (See *Deflagrator.*)

Calory.—A term used for *calorie*.

Calorie is the preferable orthography. (See *Calorie.*)

Cam, Electro-Magnetic — —A form of magnetic equalizer, which depends for its operation on the lateral approach of a suitably shaped polar surface. (See *Equalizer, Magnetic.*)

Cam, Listening — —In a telephone exchange system, a metallic cam by means of which an operator is placed in circuit with a subscriber.

Candle.—The unit of photometric intensity.

Such a light as would be produced by the consumption of two grains of a standard candle per minute.

An electric lamp of 16 candle-power, or one of 2,000 candle-power, is a light that gives respectively 16 or 2,000 times as much light as one standard candle.

Candle Burner, Electric — —(See *Burner, Electric Candle.*)

Candle, Electric — —A term applied to the Jablochhoff candle, and other similar devices. (See *Candle, Jablochhoff.*)

Candle, Foot — —A unit of illumination equal to the illumination produced by a standard candle at the distance of 1 foot.

According to this unit, the illumination produced by a standard candle at the distance of 2 feet would be but the one-fourth of a foot-candle; at 3 feet, the one-ninth of a foot-candle, etc.

The advantage of the proposed standard lies in the fact that knowing the illumination in foot-candles required for the particular work to be done, it is easy to calculate the position and intensity of the lights required to produce the illumination.

Candle, Jablochhoff — —An electric arc light in which the two carbon electrodes are placed parallel to each other and maintained a constant distance apart by means of a sheet of insulating material placed between them.

The Jablochhoff electric candle consists of two parallel carbons, separated by a layer of kaolin or other heat-resisting insulating material, as shown in Fig. 98. The current is passed into and out of the carbons at one end of the candle, and forms a voltaic arc at the other end. In order to start the arc, a thin strip called the *igniter*, consisting of a mixture of some readily ignitable substance, connects the upper ends of the carbons.

An alternating current is employed with these candles, thus avoiding the difficulty which would otherwise occur from the more rapid consumption of the positive than the negative carbon. (See *Current, Alternating.*)

Candle, Metre — —The illumination produced by a standard candle at the distance of one metre. (See *Candle, Foot.*)

Candle-Power.—(See *Power, Candle.*)

Candle-Power, Rated — —(See *Power, Candle, Rated.*)

Candle-Power, Spherical — —(See *Power, Candle, Spherical.*)

Candle, Standard — —A candle of

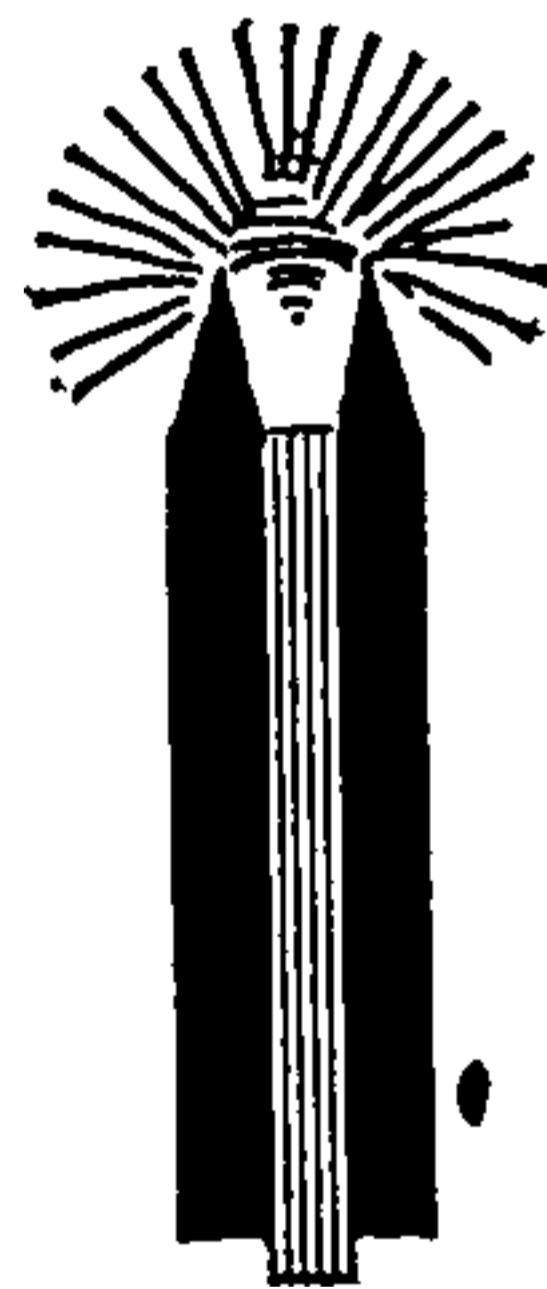

Fig. 98. Jablochhoff Candle.

definite composition which, with a given consumption in a given time, will produce a light of a fixed and definite brightness.

A candle which burns 120 grains of spermaceti wax per hour, or 2 grains per minute, will give an illumination equal to *one standard candle*.

Unless considerable care is taken, erroneous results will be obtained from the use of the standard candle. According to Slingo and Brooker the following are among the most important causes of these errors :

(1.) Defective forms of candle which cause a varying consumption of the material per second, and consequently a varying light for the standard candle.

(2.) Variations in the composition of the spermaceti of which the candle is composed. Spermaceti is not a definite chemical compound, but consists of a mixture of various substances; therefore, even if the consumption is maintained constant, the light-giving power is not necessarily constant.

(3.) Variations in the composition and character of the wick, such as the number and size of the threads of which it is formed and the closeness of the strands, all of which circumstances influence the amount of light given off by the candle.

(4.) The light emitted in certain directions varies in a marked degree with the shape of the wick. The mere bending of a wick may, therefore, cause the amount of light to vary considerably.

(5.) The light varies with the thickness of the wick. Thick wicks give less light than thin wicks.

(6.) The light given by the standard candle varies with the temperature of the testing-room. As the temperature rises the light given by the standard candle increases.

(7.) Currents of air, by producing variations in the amount of melting wax in the cup of the candle, vary the amount of light emitted.

These difficulties in obtaining a fixed amount of light from a standard candle, together with the difficulty of comparing the feeble light of a single candle with the light of a much more powerful source, such as an arc lamp, coupled with the additional difficulty arising from the difference in the colors of the lights, have led to the use of other standards of light than those furnished by the standard candle.

Caoutchouc. or India-Rubber.—A resin-

ous substance obtained from the milky juices of certain tropical trees.

Caoutchouc possesses high powers of electric insulation, and is used either pure or combined with sulphur.

Cap, Insulator — — A covering or cap placed some distance above an insulator, but separated from it by an air space.

Insulator caps are intended for protection of the insulators from injury by the throwing of stones or other malicious acts. Insulator caps are generally made of iron. They are highly objectionable, owing to the facility they offer for the accumulation of dust and dirt.

Capacity, Atomic — — The quantivalence or valency of an atom. (See *Atomcity*.)

Capacity, Dielectric — — A term employed in the same sense as specific inductive capacity. (See *Capacity, Specific Inductive*.)

Capacity, Electro-Dynamic — — A term formerly employed by Sir William Thomson for self-induction. (See *Induction, Self*.)

Capacity, Electrostatic — — The quantity of electricity which must be imparted to a given body or conductor as a charge, in order to raise its potential a certain amount. (See *Potential, Electric*.)

The electrostatic capacity of a conductor is not unlike the capacity of a vessel filled with a liquid or gas. A certain quantity of liquid will fill a given vessel to a level dependent on the size or capacity of the vessel. In the same manner a given quantity of electricity will produce, in a conductor or condenser, a certain difference of electric level, or difference of potential, dependent on the electrical capacity of the conductor or condenser.

Or, taking the analogous case of a gas-tight vessel, the quantity of gas that can be forced into such a vessel depends on the size of the vessel and the pressure with which it is forced in. A tension or pressure is thus produced by the gas on the walls of the vessel, which is greater the smaller the size of the vessel and the greater the quantity of gas forced in.

In the same manner, the smaller the capacity of a conductor, the smaller is the charge required

to raise it to a given potential, or the higher the potential a given charge will raise it.

The capacity K , of a conductor or condenser, is therefore directly proportional to the charge Q , and inversely proportional to the potential V ; or,

$$K = \frac{Q}{V}.$$

From which we obtain $Q = KV$; or,

The quantity of electricity required to charge a conductor or condenser to a given potential is equal to the capacity of the conductor or condenser multiplied by the potential through which it is raised.

Capacity, Electrostatic, Unit of — —

Such a capacity of a conductor or condenser that an electromotive force of one volt will charge it with a quantity of electricity equal to one coulomb.

The farad. (See *Farad*.)

Capacity of Cable.—(See *Cable, Capacity of*.)

Capacity of Condenser.—(See *Condenser, Capacity of*.)

Capacity of Leyden Jar.—(See *Jar, Leyden, Capacity of*.)

Capacity of Line.—(See *Line, Capacity of*.)

Capacity of Polarization of a Voltaic Cell.—(See *Cell, Voltaic, Capacity of Polarization of*.)

Capacity, Safe Carrying, of a Conductor — —
—The maximum electric current the conductor will carry without becoming unduly heated.

Capacity, Specific Inductive — —
The ability of a dielectric to permit induction to take place through its mass, as compared with the ability possessed by a mass of air of the same dimensions and thickness, under precisely similar conditions.

The relative power of bodies for transmitting electrostatic stresses and strains analogous to permeability in metals.

The ratio of the capacity of a condenser whose coatings are separated by a dielectric of a given substance to the capacity of a similar condenser whose plates are separated by a plate or layer of air.

The inductive capacity of a dielectric is compared with that of air.

According to Gordon and others, the specific inductive capacities of a few substances, compared with air, are as follows:

Air.....	1.00
Glass.....	3.013 to 3.258
Shellac.....	2.740
Sulphur.....	2.580
Gutta-percha.....	2.462
Ebonite.....	2.284
India-rubber.....	2.220 to 2.497
Turpentine.....	2.160
Petroleum.....	2.030 to 2.070
Paraffin (solid).....	1.994
Carbon bisulphide.....	1.810
Carbonic acid.....	1.00036
Hydrogen.....	0.99967
Vacuum.....	0.99941

Faraday, who proposed the term *specific inductive capacity*, employed in his experiments a condenser consisting of a metallic sphere A, Fig. 99, placed inside a large hollow sphere B.

The concentric space between A and B was filled with the substance whose specific inductive capacity was to be determined.

Capacity, Specific Magnetic — —
A term sometimes employed in the sense of magnetic permeability.

Conductibility for lines of magnetic force in the same sense that specific inductive capacity is conductibility for lines of electrostatic force.

This term has received the name of specific mag-

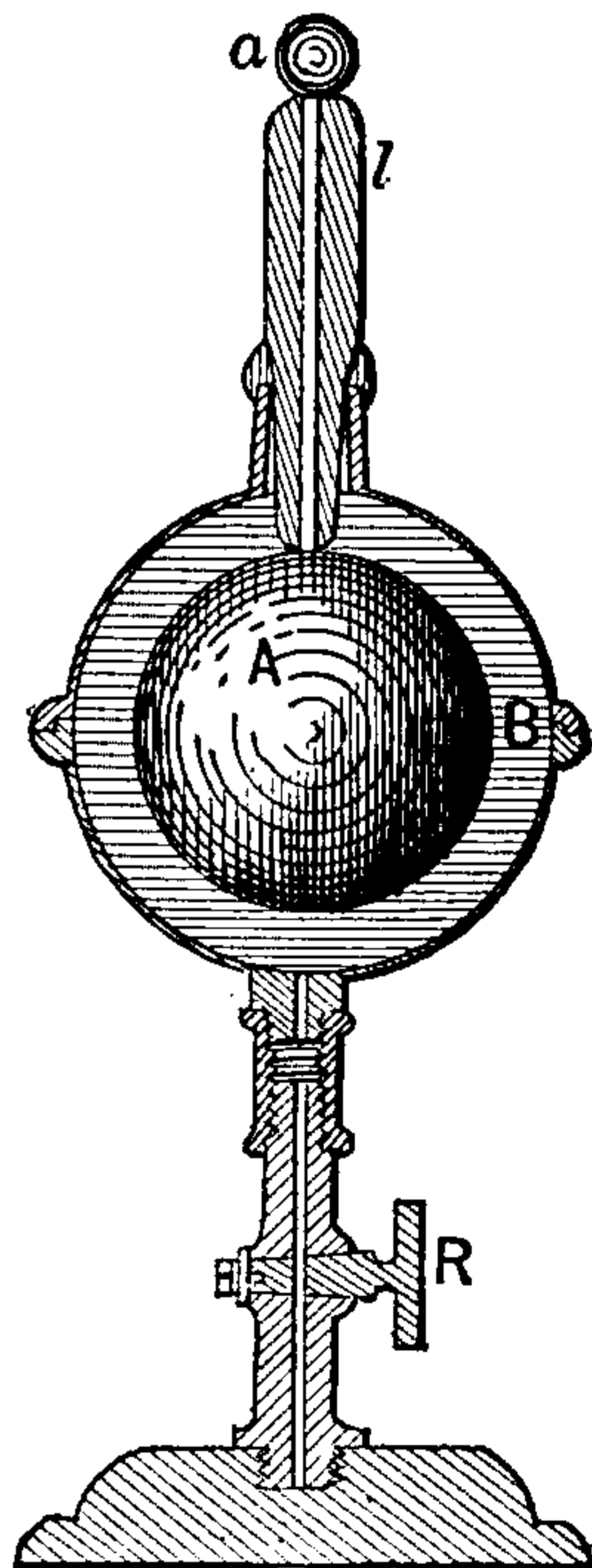

Fig 99. Condenser.

netic capacity in order to distinguish it from specific inductive capacity. The velocity of propagation of waves in any elastic medium is proportional to the quotient obtained by extracting the square root of the elasticity of the medium divided by the square root of its density; or,

$$V = \sqrt{\frac{E}{D}}$$

Similarly, the speed with which inductive waves travel depends on the relation between the elasticity and the density of the medium. Calling $\frac{1}{K}$, the electric elasticity, then its reciprocal, K , corresponds with the dielectric capacity. The electrical density, μ , corresponds with the magnetic permeability. The velocity of wave transmission is therefore,

$$V = \sqrt{\frac{\frac{1}{K}}{\frac{\mu}{1}}} = \sqrt{\frac{1}{K \times \mu}}$$

Capacity, Storage, of Secondary Cell —
—(See *Cell, Secondary or Storage, Capacity of.*)

Capillarity.—The elevation or depression of liquids in tubes of small internal diameter.

The liquid is elevated when it wets the walls, and depressed when it does not wet the walls of the tube.

The phenomena of capillarity are due to the mutual attractions existing between the molecules of the liquid for one another, and the mutual attraction between the molecules of the liquid and those of the walls of the tube.

In capillarity, therefore, the approximately level surface caused by the equal attraction of all the molecules towards the earth's centre is disturbed by the unequal attraction exerted on each molecule by the walls of the tube and by the remaining molecules.

Capillarity, Effects of, on Voltaic Cell —
—Effects caused by capillary action which disturb the proper action of a voltaic cell.

These effects are as follows:

(1.) Creeping, or efflorescence of salts. (See *Creeping, Electric. Efflorescence.*)

(2.) Oxidation of contacts and consequent introduction of increased resistance into the battery circuit. The liquid enters the capillary spaces between the contact surfaces and oxidizes them.

Capillary.—Of a small or hair-like diameter or size.

A capillary tube is a tube of small hair-like diameter. (See *Capillarity.*)

Capillary Attraction.—(See *Attraction, Capillary.*)

Capillary Contact-Key.—(See *Key, Capillary Contact.*)

Capillary Electrometer.—(See *Electrometer, Capillary.*)

Carbon.—An elementary substance which occurs naturally in three distinct allotropic forms, viz.: charcoal, graphite and the diamond. (See *Allotropy.*)

Carbon-Brushes for Electric Motors.—
(See *Brushes, Carbon, for Electric Motors.*)

Carbon Button.—(See *Button, Carbon.*)

Carbon-Clutch or Clamp of Arc Lamp.
—(See *Clutch, Carbon, of Arc Lamp.*)

Carbon-Electrodes for Arc Lamps.—(See *Electrodes, Carbon, for Arc Lamps.*)

Carbon-Holders for Arc Lamps.—(See *HOLDERS, Carbon, for Arc Lamps.*)

Carbon Points.—(See *Points, Carbon.*)

Carbon Transmitter for Telephones.—
(See *Transmitter, Carbon, for Telephones.*)

Carbonic Acid Gas.—(See *Gas, Carbonic Acid.*)

Carboning Lamps.—(See *Lamps, Carboning.*)

Carbonizable.—Capable of being carbonized. (See *Carbonization, Processes of.*)

Carbonization.—The act of carbonizing. (See *Carbonization, Processes of.*)

Carbonization, Processes of — —
Means for carbonizing material.

The carbonizable material is placed in suitably shaped boxes, covered with powdered plumbago or lamp-black, and subjected to the prolonged action of intense heat while out of contact with air.

The electrical conducting power of the carbon which results from this process is increased by the action of the heat, and, probably, also, by the deposit in the mass, of carbon resulting from the subsequent decomposition of the hydro-carbon gases produced during carbonization.

When the carbonization is for the purpose of producing conductors for incandescent lamps, in order to obtain the uniformity of conducting power, electrical homogeneity, purity and high refractory power requisite, selected fibrous material, cut or shaped in at least one dimension

prior to carbonization, must be taken, and subjected to as nearly uniform carbonization as possible.

Carbonize.—To reduce a carbonizable material to carbon. (See *Carbonization, Processes of*.)

Carbonized Cloth Discs for High Resistances.—(See *Cloth Discs Carbonized, for High Resistances*.)

Carbonizer.—Any apparatus suitable for reducing carbonizable material to carbon.

Carbonizing.—Subjecting a carbonizable substance to the process of carbonization. (See *Carbonization, Processes of*.)

Carbons, Artificial — —Carbons obtained by the carbonization of a mixture of pulverized carbon with different carbonizable liquids.

Powdered coke, or gas-retort carbon, sometimes mixed with lamp-black or charcoal, is made into a stiff dough with molasses, tar, or any other hydro-carbon liquid. The mixture is molded into rods, pencils, plates, bars or other desired shapes by the pressure of a powerful hydraulic press. After drying, the carbons are placed in crucibles and covered with lamp-black or powdered plumbago, and raised to an intense heat at which they are maintained for several hours. By the carbonization of the hydro-carbon liquids, the carbon paste becomes strongly coherent, and by the action of the heat its conducting power increases.

To give increased density after baking, the carbons are sometimes soaked in a hydro-carbon liquid, and subjected to a re-baking. This may be repeated a number of times.

Carbons, Concentric-Cylindrical — — A cylindrical rod of carbon placed inside a hollow cylinder of carbon but separated from it by an air space, or by some other insulating, refractory material.

Jablochkoff candles sometimes are made with a solid cylindrical electrode, concentrically placed in a hollow cylindrical carbon.

Carbons, Cored — — A cylindrical carbon electrode for an arc lamp that is molded around a central core of charcoal, or other softer carbon.

Much of the unsteadiness of the arc light is due to changes in the position of the arc. Cored carbons, it is claimed, render the arc light steadier, by maintaining the arc always at the softer carbon and hence at the central point of the electrode.

A core of harder carbon, or other refractory material, is sometimes provided for the negative carbon.

Carbons, Flashed — — Carbons which have been subjected to the flashing process. (See *Carbons, Flashing Process for*.)

Carbons, Flashing Process for — — A process for improving the electrical uniformity of the carbon conductors employed in incandescent lighting, by the deposition of carbon in their pores, and over their surfaces at those places where the electric resistance is relatively great.

The carbon conductor or filament is placed in a vessel filled with the vapor of a hydrocarbon liquid called rhigolene, or any other readily decomposable hydrocarbon liquid, and gradually raised to electric incandescence by the passage through it of an electric current. A decomposition of the hydrocarbon vapor occurs, the carbon resulting therefrom being deposited in and on the conductor.

As the current is gradually increased, the parts of the conductor first rendered incandescent are the places where the electric resistance is the highest, these parts, therefore, and practically these parts only, receive the deposit of carbon. As the current increases, other portions become successively incandescent and receive a deposit of carbon, until at last the filament glows with a uniform brilliancy, indicative of its electric homogeneity.

A carbon whose resistance varies considerably at different parts could not be successfully employed in an incandescent lamp, since if heated by a current sufficiently great to render the points of comparatively small resistance satisfactorily incandescent, the temperature of the points of high resistance would be such as to lower the life of the lamp, while if only those portions were safely heated, the lamp would not be economical. The flashing process is therefore of very great value in the manufacture of an incandescent lamp.

The name "flashing" was applied to the process by reason of the flashing light emitted by the

THIS PAGE IS LOCKED TO FREE MEMBERS

Purchase full membership to immediately unlock this page



HISTORY

Tens of thousands of important historical sources, many previously unobtainable, are now available for the first time with a Forgotten Books Full Membership.

Unlimited Access
\$8.99/month

Continue

*Fair usage policy applies

In electric case-hardening, the superficial layers of a piece of iron are converted into steel by electrically heating the same, while surrounded by a layer of case-hardening flux and carbonaceous substances such as animal charcoal, shavings of horn, leather cuttings or other similar substances.

In the case of a readily oxidizable metal like iron, oxidation is prevented by surrounding the metal by a hydrocarbon gas, which, when sufficiently heated, deposits on the surfaces a protective coating of carbon. This layer of carbon gradually carbonizes the iron.

Case Wiring.—(See *Wiring, Case.*)

Cataphoresis.—A term sometimes employed in place of electric osmose. (See *Osmose, Electric.*)

The word cataphoresis applies to the cases where medicinal substances, such as iodine, cocaine, quinine, etc., are caused to pass through organic tissues in the direction of flow of an electric current, or from the anode to the kathode. This action is probably due to an electrolytic action.

Cataphoric Action.—(See *Action, Cataphoric.*)

Catch, Safety — —A wire, plate, strip, or box of readily fusible metal, capable of conducting, without fusing, the current ordinarily employed on the circuit, but which fuses and thus breaks the circuit on the passage of an abnormally large current.

Safety-catches are generally placed on multiple-arc and multiple-series circuits. (See *Fuse, Safety.*)

Catelectrotonus.—An orthography sometimes applied to Kathelectrotonus. (See *Kathelectrotonus.*)

Cathetometer.—An instrument for the accurate measurement of vertical height.

The cathetometer consists essentially of an accurately divided vertical rod which carries a sliding support for a telescope. The telescope is provided with two spider lines at right angles to one another, so placed as to be seen in front of the object whose height is to be measured. From observations taken in different positions, the measurement of the true vertical height is readily obtained.

Cathion.—A term sometimes used instead of Kathion.

More correctly written Kathion. (See *Kathion.*)

Cathode.—A term sometimes used instead of Kathode.

Catoptrics.—That branch of optics which treats of the reflection of light.

Causty, Galvano — —A term sometimes used for galvano-cautery. (See *Cautery, Galvano.*)

Cauterization.—The act of cauterizing, or burning with a heated solid or caustic substance.

Cauterization, Electric — —Subjecting to cauterization by means of a wire electrically heated. (See *Cautery, Electric.*)

Cauterize.—To subject to cauterization, or burning with a heated solid or caustic substance.

Cauterizer, Electric — —A term sometimes applied to an electric cautery. (See *Cautery, Electric.*)

Cautery, Actual — —A burning or searing with a white-hot metal.

Cautery Battery.—(See *Battery, Cautery.*)

Cautery, Electric — —An instrument used for electric cauterization.

In electro-therapeutics, the application of variously shaped platinum wires heated to incandescence by the electric current in place of a knife, for removing diseased growths, or for stopping hemorrhages.

The operation, though painful during application, is afterward less painful than that with a knife, since secondary hemorrhage seldom occurs, and the wound rapidly heals.

Electric cautery is applicable in cases where the knife would be inadmissible owing to the situation of the parts or their surroundings.

Cautery, Galvano — —A term frequently employed in place of electric cautery. (See *Cautery, Electric.*)

Cautery, Galvano Electric — —An electric cautery. (See *Cautery, Electric.*)

Cautery, Galvano Thermal — —A term sometimes used for an electric cautery. (See *Cautery, Electric.*)

Cautery-Knife Electrode.—(See *Electrode. Cautery-Knife.*)

Cautery, Thermal — —A cautery heated by heat other than that of electric origin, as distinguished from an electric cautery. (See *Cautery, Electric.*)

Ceiling Rose.—(See *Rose, Ceiling.*)

Cell, Depositing — —An electrolytic cell in which an electro-metallurgical deposit is made. (See *Metallurgy. Electro.*)

Cell, Electrolytic — —A cell or vessel containing an electrolyte, in which electrolysis is carried on.

An electrolytic cell is called a *voltmeter* when the value of the current passing is deduced from the weight of the metal deposited.

Cell, Impulsion — —A photo-electric cell whose sensitiveness to light may be restored or destroyed by slight impulses given to the plates, such as by blows or taps, or electro-magnetic impulses.

An impulsion cell may be prepared by pasting pieces of tin-foil, the opposite faces of which are respectively polished and dull, on the opposite faces of a plate of glass, so as to expose dissimilar sides to the light, when the cells are dipped in alcohol.

Cell, Photo-Electric — —A cell capable of producing differences of potential when its opposite faces are unequally exposed to radiant energy.

Photo-voltaic cells are made in a variety of forms, both with selenium and with different metallic substances. (See *Cell, Selenium.*)

Cell, Porous — —A jar of unglazed earthenware, employed in double-fluid voltaic cells, to keep the two liquids separated.

The use of a porous cell necessarily increases the internal resistance of the cell, from the decrease it produces in the area of cross section of liquid between the two elements. When the battery is dismantled, the porous cells should be kept under water, otherwise the crystallization of the zinc sulphate or other salt is apt to produce serious exfoliation, or scaling off, or even to crumble the porous cell.

A porous cell is sometimes called a *diaphragm*, but only properly so when the cell is reduced to a single separating plate. (See *Cell, Voltaic.*)

Cell, Secondary — —A term sometimes used instead of storage cell.

The term secondary cell is used in contradistinction to primary or voltaic cell.

Cell, Secondary or Storage. Boiling of — —A term sometimes applied to the gassing of a storage cell. (See *Cell, Storage, Gassing of.*)

Cell, Secondary or Storage, Capacity of — —The product of the current in amperes, by the number of hours the battery is capable of furnishing said current, when fully charged, until exhausted.

The capacity of storage cells is given in ampere-hours. A storage battery with a capacity of 1,000 ampere-hours can furnish, say a current of fifty amperes for twenty hours, or a current of one hundred amperes for ten hours; or a current of twenty-five amperes for forty hours.

Cell, Secondary or Storage, Gassing of — —An escape of gas due to the decomposition of water on passage of too strong a charging current.

Cell, Secondary or Storage, Renovation of — —The revivifying or recharging of a run-down, or discharged storage cell.

Cell, Secondary or Storage, Time-Fall of Electromotive Force of — —(See *Force. Electromotive of Secondary or Storage Cell, Time-Fall, of.*)

Cell, Secondary or Storage, Time-Rise of Electromotive Force of — —(See *Force, Electromotive of, Secondary or Storage Cell, Time-Rise, of.*)

Cell, Selenium — —A cell consisting of a mass of selenium fused in between two conducting wires or electrodes of platinized silver or other suitable metal.

A convenient manner of forming a selenium cell is to wind two separate spirals of platinized silver wire around a cylinder of hard wood, taking care to maintain them a constant distance apart, so as to avoid contact between them. The space between these wires is filled with fused selenium, which is allowed to cool gradually.

Exposure to sunlight reduces the resistance of a selenium cell to about one-half its resistance in

the dark, but neither the resistance nor the reduction ratio long remains constant.

A selenium cell produces a difference of potential, or electromotive force, when one of its electrode faces is exposed to light, while the other is kept in darkness.

According to Von Uljanin, who experimented with selenium melted in between two parallel platinized plates, cooled under pressure, and then reduced from the amorphous to the sensitive crystalline variety by gradual cooling after two or three heatings in a paraffine bath up to 195 degrees, the following peculiarities were observed:

(1.) Exposure of one of the electrodes to sunlight produced an electromotive force which causes a current to flow from the dark to the illumined electrode.

(2.) The maximum electromotive force was 0.12 volt.

(3.) The electromotive force disappeared instantaneously and completely on the darkening of the electrodes.

(4.) A slight difference in the electromotive force was observed when the positive and negative electrodes were alternately exposed to the light, the maximum electromotive force being attained by the exposure of the negative electrode.

(5.) If both electrodes are similarly illumined the resulting current strength is decreased and may reach zero.

(6.) The action of light is instantaneous.

(7.) Most of the selenium cells experimented with exhibited an electromotive force of polarization.

(8.) The electromotive force of polarization is diminished by exposure to light.

(9.) The electrical resistance and sensitiveness to light as regards the production of an electromotive force decrease with time. This is probably due to a gradual change in the allotropic state of the selenium. (See *State, Allotropic.*)

(10.) The electromotive force produced is proportional to the intensity of the illumination only when the obscure rays or heat rays are absent.

(11.) Of different wave lengths the orange-yellow rays in the diffraction spectrum, and the greenish-yellow in the prismatic spectrum produced the greatest effect.

Among some of the more recent applications of selenium cells are the following:

(I.) A selenium cell is so placed in a circuit containing an electro-magnet and switch, that on

one of its electrodes being exposed to the decreased illumination of coming night it automatically turns on an electric lamp, and, conversely, on the approach of daylight, and the consequent illumination of the electrode, turns it off.

(2.) A device whereby the presence of light, as for example that carried by a burglar, automatically rings an alarm and thus calls the attention of the watchman of the building.

Cell, Standard — — (See *Cell, Voltaic, Standard.*)

Cell, Storage — — Two relatively inert plates of metal, or of metallic compounds, immersed in an electrolyte incapable of acting considerably on them until after an electric current has been passed through the liquid from one plate to the other and has changed their chemical relations.

A single one of the cells required to form a secondary battery.

Sometimes, the jar containing a single cell is called a storage cell.

This latter use of the word is objectionable.

A storage cell is also called an accumulator.

On the passage of an electric current through the electrolyte, its decomposition is effected and the electro-positive and electro-negative radicals are deposited on the plates, or unite with them, so that on the cessation of the charging current, there remains a voltaic cell capable of generating an electric current.

A storage cell is *charged* by the passage through the liquid from one plate to the other of an electric current, derived from any external source. The *charging current* produces an electrolytic decomposition of the inert liquid between the plates, depositing the *electro-positive radicals, or kathions*, on the plate connected with the negative terminal of the source, and the electro-negative radicals, or *anions*, on the plate connected with the positive terminal.

On the cessation of the charging current, and the connection of the charged plates by a conductor outside the liquid, a current is produced, which flows through the liquid from the plate covered with the electro-positive radicals, to that covered with the electro-negative radicals, or in the *opposite direction to that of the charging current.*

The simplest storage cell is Planté's cell, which, as originally constructed, consists of two plates of

lead immersed in dilute sulphuric acid, H_2SO_4 . On the passage of the charging current, the plates A and B, Fig. 101, dipped in H_2SO_4 , are covered respectively with lead peroxide, PbO_2 , and finely divided, spongy lead. The peroxide is formed on the positive plate, and the metallic lead on the negative plate. The acid and water should have a specific gravity of about 1.170. When the cell is fully charged the acid solution loses its clearness and becomes milky in appearance, and the

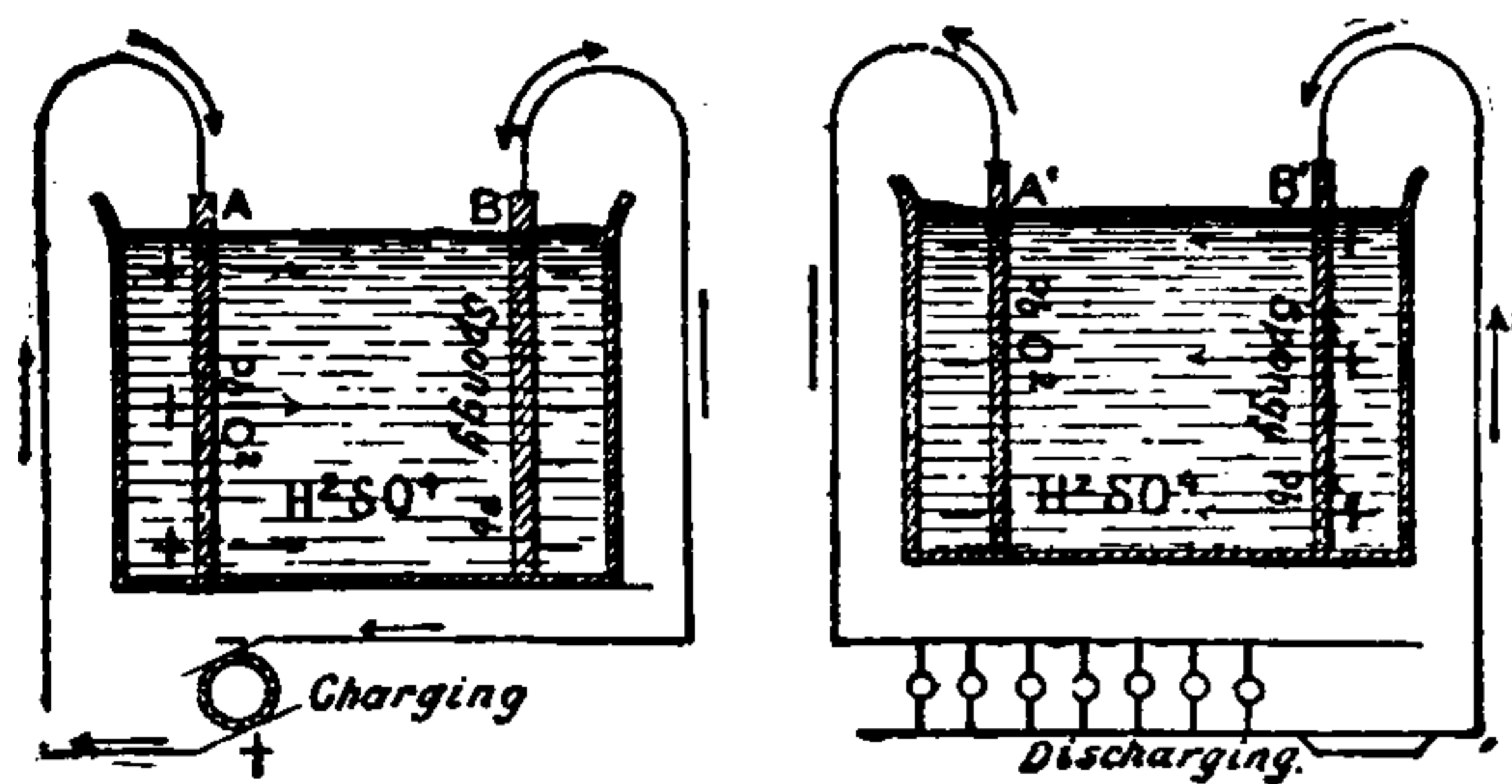

Figs. 101 and 102. Storage Cell.

specific gravity increases to 1.195. This increase is a good sign of a full charge.

When the charging current ceases to pass, the cell discharges in the opposite direction, viz., from B' to A', that is, from the spongy lead plate to the peroxide plate through the electrolyte, as shown in Fig. 102.

As a result of this discharging current the peroxide, PbO_2 , on A', gives up one of its atoms of oxygen to the spongy lead on B', thus leaving both plates coated with a layer of PbO , lead monoxide, or litharge. When this change is thoroughly effected, the cell becomes inert, and will furnish no further current until again charged by the passage of a current from some external source.

In order to increase the capacity of the storage cells, and thus prolong the time of their discharge, the coating of lead monoxide thus left on each of the plates, when neutral, is made as great as possible. To effect this, a process called "forming the plates" is employed, which consists in first charging the plates as already described, and then reversing the direction of the charging current, the currents being sent through the cell in alternately opposite directions, until a considerable depth of the lead plates has been acted on.

It will be noticed that during the action of the charging current, the oxygen is transferred from the PbO , on one plate, to the PbO , on the other plate, thus leaving one Pb , and the other PbO_2 ; and that on discharging, one atom of oxygen is

transferred from the PbO_2 , to the Pb , thus leaving both plates covered with PbO . In reality this is but the final result of the action, hydrated sulphate of lead, PbO, H_2SO_4 , being formed and subsequently decomposed. Other compounds are formed that are but imperfectly understood.

In order to decrease the time required for forming, accumulators, or secondary cells, have been constructed, in which metallic plates covered with red lead Pb_3O_4 replace the lead plates in the original Planté cell. On charging, the Pb_3O_4 is peroxidized at the anode, i. e., converted into PbO_2 , and deoxidized, and subsequently converted into metallic lead at the cathode. Or, in place of the above Pb_3O_4 , red lead is placed on the anode and PbO , or litharge, on the cathode.

Plates of compressed litharge have also been recently used for this purpose. Storage cells so formed have a greater storage capacity per unit weight than those in which a grid is employed, but a higher resistance.

In all cases where a metal plate is employed various irregularities of surface are given to the plates, in order to increase their extent of surface and to afford a means for preventing the separation of the coatings. The metallic form thus provided is known technically as a *grid*.

Unless care is exercised, the plates will buckle from the difference in the expansion of the lead and its filling of oxide. This buckling is attended with an increase in the resistance of the cell and the gradual separation of the oxides that cover or fill it.

Cell, Thermo-Electric — — A name applied to a thermo-electric couple. (See *Couple, Thermo-Electric*.)

Cell, Voltaic — — The combination of two metals, or of a metal and a metalloid, which, when dipped into a liquid or liquids called electrolytes, and connected outside the liquid or liquids by a conductor, will produce a current of electricity.

Different liquids or gases may take the place of the two metals, or of the metal and metalloid. (See *Battery, Gas*.)

Plates of zinc and copper dipped into a solution of sulphuric acid and water, and connected outside the liquid by a conductor, form a simple voltaic cell.

If the zinc be of ordinary commercial purity,

and is not connected outside the liquid by a conductor, the following phenomena occur:

(1.) The sulphuric acid or hydrogen sulphate, H_2SO_4 , is decomposed, zinc sulphate, $ZnSO_4$, being formed, and hydrogen, H_2 , liberated.

(2.) The hydrogen is liberated mainly at the surface of the zinc plate.

(3.) The entire mass of the liquid becomes heated.

If, however, the plates are connected outside the liquid by a conductor of electricity, then the phenomena change and are as follows, viz.:

(1.) The sulphuric acid is decomposed as before; but,

(2.) The hydrogen is liberated at the surface of the copper plate only.

(3.) The heat no longer appears in the liquid only, but in all parts of the circuit.

(4.) An electric current now flows through the entire circuit, and will continue so to flow as long as there is any sulphuric acid to be decomposed, and zinc with which to form zinc sulphate.

The energy which previously appeared as heat only, now appears in part as electric energy.

Therefore, although the mere contact of the two metals with the liquid will produce a difference of potential, it is the *chemical potential energy* which became *kinetic* during chemical combination that supplies the energy required to maintain the electric current. (See *Energy, Kinetic. Energy, Potential.*)

A voltaic cell consists of two plates of different metals, or of a metal and a metalloid (or of two gases, or two liquids, or of a liquid and a gas), each of which is called a *voltaic element*, and which, taken together, form what is called a *voltaic couple*.

The *voltaic couple* dips into a liquid called an *electrolyte*, which, as it transmits the electric current, is decomposed by it. The elements are connected outside the electrolyte by any conducting material.

Direction of the Current.—In any voltaic cell the current is assumed to flow *through the liquid*, from the metal most acted on to the metal least acted on, and *outside the liquid*, through the outside circuit, from the metal least acted on to the metal most acted on.

In Fig. 103 a *zinc-copper* voltaic couple is shown, immersed in dilute sulphuric acid. Here, since the zinc is dissolved by the sulphuric acid, the zinc is positive, and the copper negative in the liquid. The zinc and copper are of opposite polarities out of the liquid.

There is still a considerable difference of opinion as to the exact cause of the potential difference of the voltaic cell. There can be no doubt that a true contact force exists, but the chemical potential energy of the positive plate is the source of energy which maintains the potential difference.

The difference in the polarity of the zinc and copper in and out of the liquid is generally denied by most of the later writers on electricity, since tests by a sufficiently delicate electrometer show that the entire zinc plate is negative and the entire copper plate positive. Remembering, however, the convention as to the direction of the flow of the current, since the current flows from the zinc to the copper through the liquid, we may still fairly regard the zinc as positive and the copper as negative in the liquid. It will be remembered, that in every source the polarity within the source is necessarily opposite to the polarity outside it. The copper plate is therefore called the *negative plate*, and the wire connected to its end out of the liquid, the *positive electrode*. Similarly, the zinc plate is called the *positive plate*, and the wire connected to it the *negative electrode*.

It will of course be understood that in the above sketch the current flows only on the completion of the circuit outside the cell; that is, when the conductors attached to the zinc and copper plates are electrically connected.

Amalgamation of the Zinc Plate.—When zinc is used for the positive element, it will, unless chemically pure, be dissolved by the electrolyte when the circuit is open, or will be irregularly dissolved when the circuit is closed, producing currents in little closed circuits from minute voltaic couples formed by the zinc and such impurities as *carbon, lead, or iron*, etc., always found in commercial zinc. (See *Action, Local, of Voltaic Cell.*) As it is practically impossible to obtain chemically pure zinc, it is necessary to *amalgamate* the zinc plate; that is, to cover it with a thin layer of zinc amalgam.

Polarization of the Negative Plate.—Since the evolved hydrogen appears at the surface of the negative plate, the surface of this plate, unless

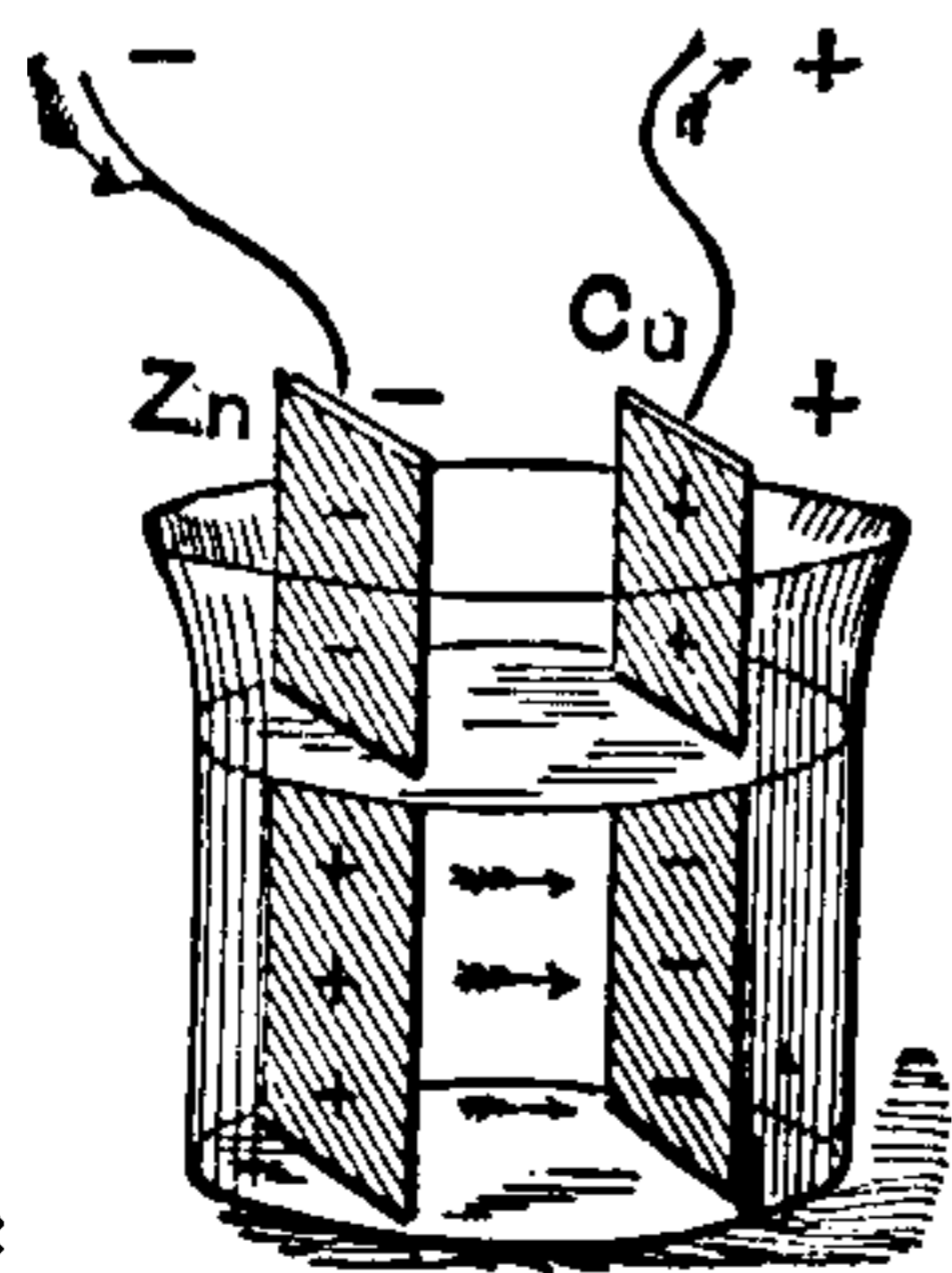

Fig. 103. Voltaic Couple.

means are adopted to avoid it, will, after a while, become coated with a film of hydrogen gas, or as it is technically called, will become polarized. (See *Cell, Voltaic, Polarization of.*)

The effect of this polarization is to cause a falling off or weakening of the current produced by the battery, due to the formation of a *counter-electromotive force* produced by the hydrogen-covered plate; that is to say, the negative plate, now being covered with hydrogen, a very highly electro-positive element, tends to produce a current in a direction opposed to that of the cell proper. (See *Force, Electromotive, Counter.*)

This decrease in current strength is rendered still greater by the increased resistance in the cell, due to the bubbles of hydrogen, and to the decreased electromotive force, due to the increase in the density of the zinc sulphate, in the case of zinc in hydrogen sulphate.

In the case of *storage cells*, the counter-electromotive force of polarization is employed as the source of *secondary currents*. (See *Electricity, Storage of. Cell, Secondary. Cell, Storage.*)

In order to avoid the effects of polarization in voltaic cells, and thus insure constancy of current, the bubbles of gas at the negative plate are mechanically carried off either by roughening its surface, by forcing the electrolyte against the plate as by shaking, or by a stream of air; or else the negative plate is surrounded by some liquid or solid substance which will remove the hydrogen, by entering into combination with it. (See *Cell, Voltaic, Polarization of.*)

Voltaic cells are therefore divided into cells with one or with two fluids, or electrolytes, or into:

- (1.) Single-fluid cells; and
- (2.) Double-fluid cells.

Very many forms of voltaic cells have been devised. The following are among the more important, viz.: Of the Single-Fluid Cells, the *Grenet*, *Foggenдорff*, or *Bichromate*, the *Zinc-Copper*, the *Zinc-Carbon* and the *Smee*. Of the Double-Fluid Cells, *Grove's*, *Bunsen's*, *Callaud* or *Gravity*, *Daniell's*, *Leclanché*, *Siemens-Halske* and the *Meidinger*.

Of all the voltaic cells that have been devised two only, viz., the *Gravity*, a modified *Daniell*, and the *Leclanché*, have continued until now in very general use, the gravity cell being used on *closed-circuited lines*, and the *Leclanché* on *open-circuited lines*; the former being the best suited

of all cells to furnish the *continuous constant currents* employed in most systems of telegraphy, and the latter for furnishing the intermittent currents required for ringing bells, operating annunciators, or for similar work.

Cell, Voltaic, Absorption and Generation of Heat in — — (See *Heat, Absorption and Generation of, in Voltaic Cell.*)

Cell, Voltaic, Bichromate — — A zinc-carbon couple used with an electrolyte known as *electropoion*, a solution of bichromate of potash and sulphuric acid in water. (See *Liquid, Electropoion.*)

Bichromate of sodium or chromic acid are sometimes used instead of the bichromate of potassium.

The zinc, Fig. 104, is amalgamated and placed between two carbon plates. The terminals connected with the zinc and carbon are respectively *negative* and *positive*. In the form shown in the figure, the zinc plate can be lifted out of the liquid when the cell is not in action.

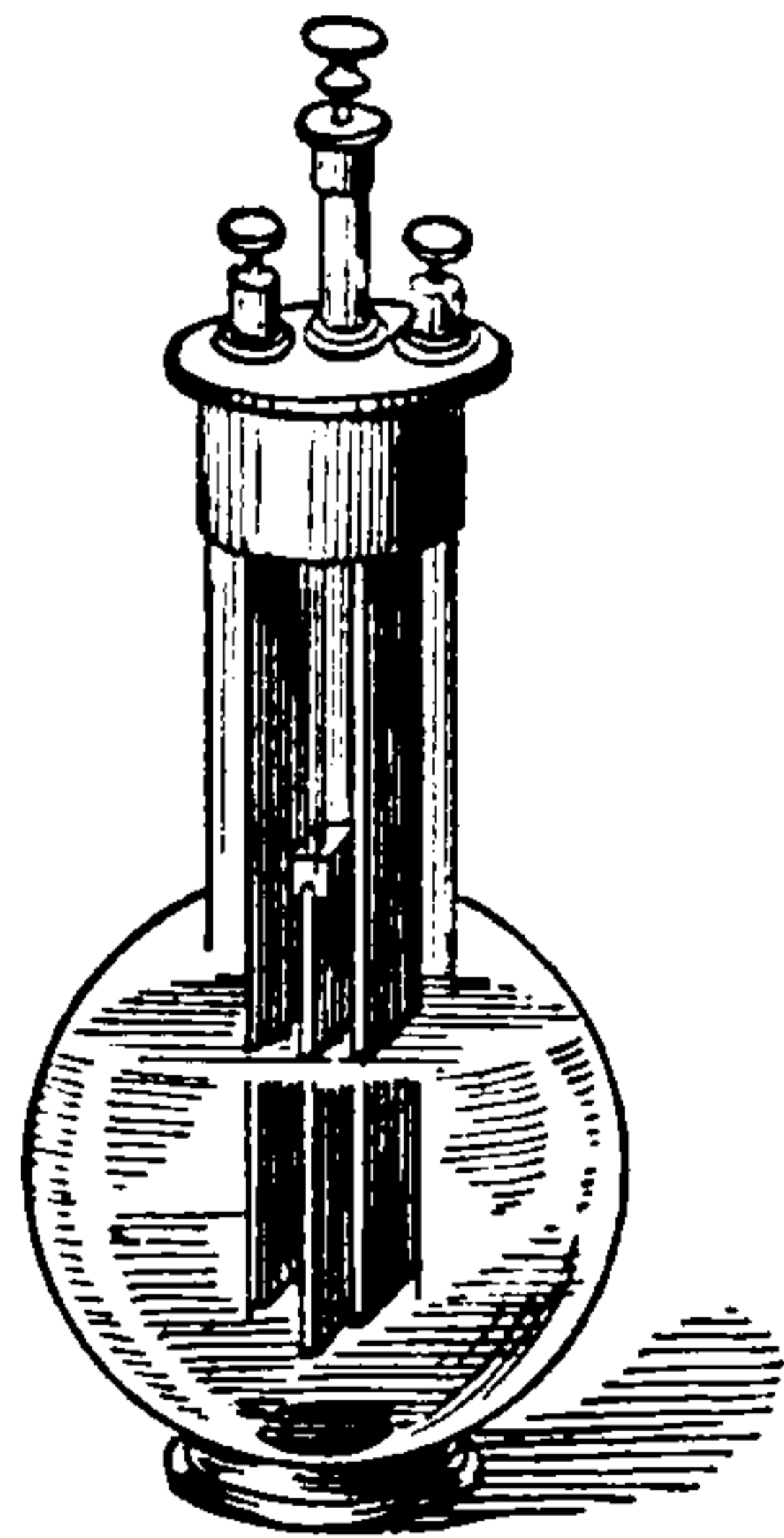
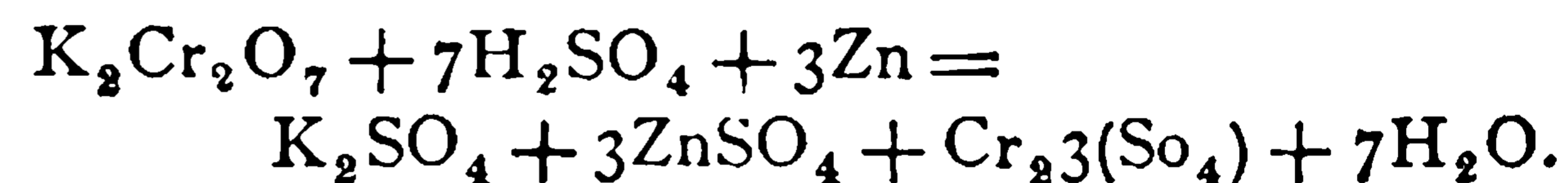

Fig. 104. Bichromate Cell.

The bichromate cell is excellent for purposes requiring strong currents where long action is not necessary. As this cell readily polarizes it cannot be advantageously employed continuously for any considerable period of time. It becomes depolarized, however, when left for some time on open circuit.

The following chemical reaction probably takes place when the cell is furnishing current, viz.:



This cell gives an electromotive force of about 1.9 volts.

Cell, Voltaic, Bunsen's — — A zinc-carbon couple, the elements of which are immersed respectively in electrolytes of dilute sulphuric and strong nitric acids.

Bunsen's cell is the same as *Grove's*, except that the platinum is replaced by carbon. The zinc surrounds the porous cell containing the car-

bon. The polarity is as indicated in Fig. 105. (See *Cell, Voltaic, Grove.*)

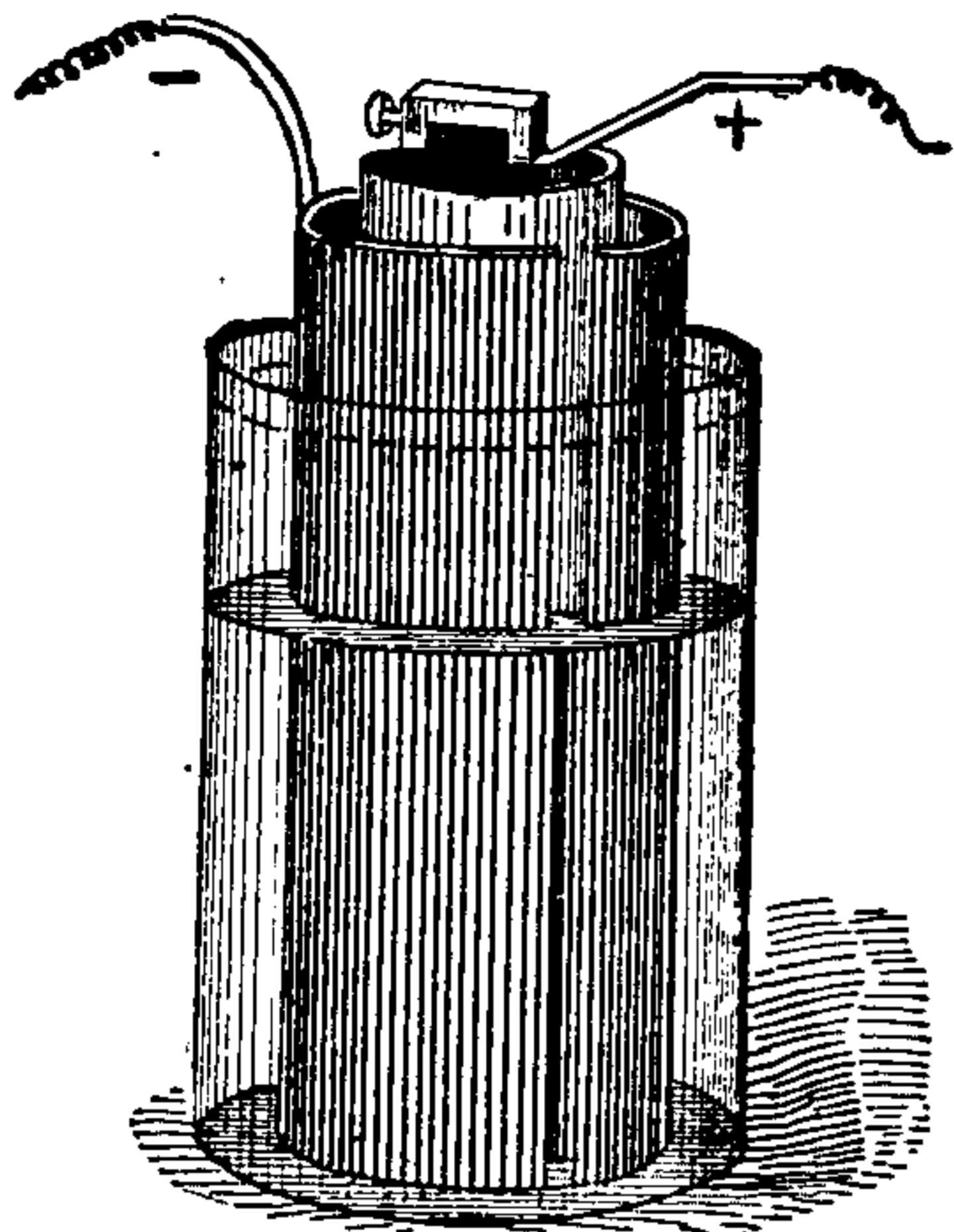

Fig. 105. *Bunsen Cell.*

The Bunsen cell gives an electromotive force of about 1.96 volts.

Cell, Voltaic, Callaud's — — A name sometimes given to the gravity cell. (See *Cell, Voltaic, Gravity.*)

Cell, Voltaic, Capacity of Polarization of — — The quantity of electricity required to be discharged by a voltaic cell in order to produce a given polarization. (See *Cell, Voltaic, Polarization of.*)

During the discharge of a voltaic cell an electromotive force is gradually set up that is opposed to that of the cell. The quantity of electricity required to produce a given polarization depends, of course, on the condition and size of the plates. Such a quantity is called the capacity of polarization.

Cell, Voltaic, Closed-Circuit — — A voltaic cell that can be left for a considerable time on a closed circuit of comparatively small resistance without serious polarization.

The term closed-circuit voltaic cell is used in contradistinction to open-circuit cell, and applies to a cell that can only be kept on closed circuit for a comparatively short time.

Daniell's cell and the gravity cell are closed-circuit cells. Leclanché's is an open-circuit cell.

Cell, Voltaic, Contact Theory of — — A theory which accounts for the production of difference of potential or electromotive force in the voltaic cell by the contact of the elements of the voltaic couple with one another by means of the electrolyte.

The mere contact of two dissimilar substances through the electrolyte will produce a difference of potential, but the cause of the current which a voltaic cell is able to maintain is the chemical potential energy which becomes kinetic during combination. (See *Cell, Voltaic, Series, Contact.*)

Most authorities explain the difference of potential produced by the contact of different metals by the fact that the metals are surrounded by air. They point out the fact that the order of the metals in the contact-series is almost identical with the order of their electrochemical power as deduced from their chemical equivalents, and their heat of combination with oxygen. It would appear, therefore, that the difference of potential between a metal and the air which surrounds it, is a measure of the tendency of the metal to become oxidized.

The origin of the electromotive force of a zinc-copper couple, in an electrolyte of hydrogen sulphate, is the superior affinity of the zinc for the oxygen, over that of the copper for the oxygen.

Cell, Voltaic, Creeping in — — The formation, by efflorescence, of salts on the sides of the porous cup of a voltaic cell, or on the walls of the vessel containing the electrolyte.

Paraffining the portions of the walls out of the liquid, or covering the surface of the liquid with a neutral oil, obviates much of this difficulty. (See *Efflorescence.*)

Cell, Voltaic, Daniell's — — A zinc-copper couple, the elements of which are immersed respectively in electrolytes of dilute sulphuric acid, and a saturated solution of copper sulphate.

In the form of Daniell's cell, shown in Fig. 106, the copper element is made in the form of a cylinder c, and is placed in a porous cell. The copper cylinder is provided with a wire basket near the top, filled with crystals of blue vitriol, or copper sulphate, so as to maintain the strength of the solution while the cell is in use. The zinc is in the shape of a cylinder and is placed so as to surround the porous cell. This cell gives a nearly constant electromotive force.

The constancy of action of Daniell's cell depends on the fact that for every molecule of sulphuric acid decomposed in the outer cell, an additional molecule of sulphuric acid is supplied by the decomposition of a molecule of copper sulphate in the inner cell. This will be better un-

THIS PAGE IS LOCKED TO FREE MEMBERS

Purchase full membership to immediately unlock this page

Know Your Bible

Forgotten Books' Full Membership provides unlimited access to more than 28,000 volumes of Christian literature for \$8.99/month

HOLY BIBLE

Continue

*Fair use policy applies

Cell, Voltaic, Gravity — —A zinc-copper couple, the elements of which are employed with electrolytes of dilute sulphuric acid or dilute zinc sulphate, and a concentrated solution of copper sulphate respectively.

The use of a porous cell is open to the objection of increased internal resistance. Moreover, the porous cell is apt to receive a coating of copper which often deposits on the cell instead of on the copper plate. The gravity cell was devised in order to avoid the use of a porous cell. As its name indicates, the two fluids are separated from each other by gravity.

The copper plate is the lower plate, and is surrounded by crystals of copper sulphate. The zinc, generally in the form of an open wheel, or crow-foot, is suspended near the top of the liquid, as shown in Fig. 109.

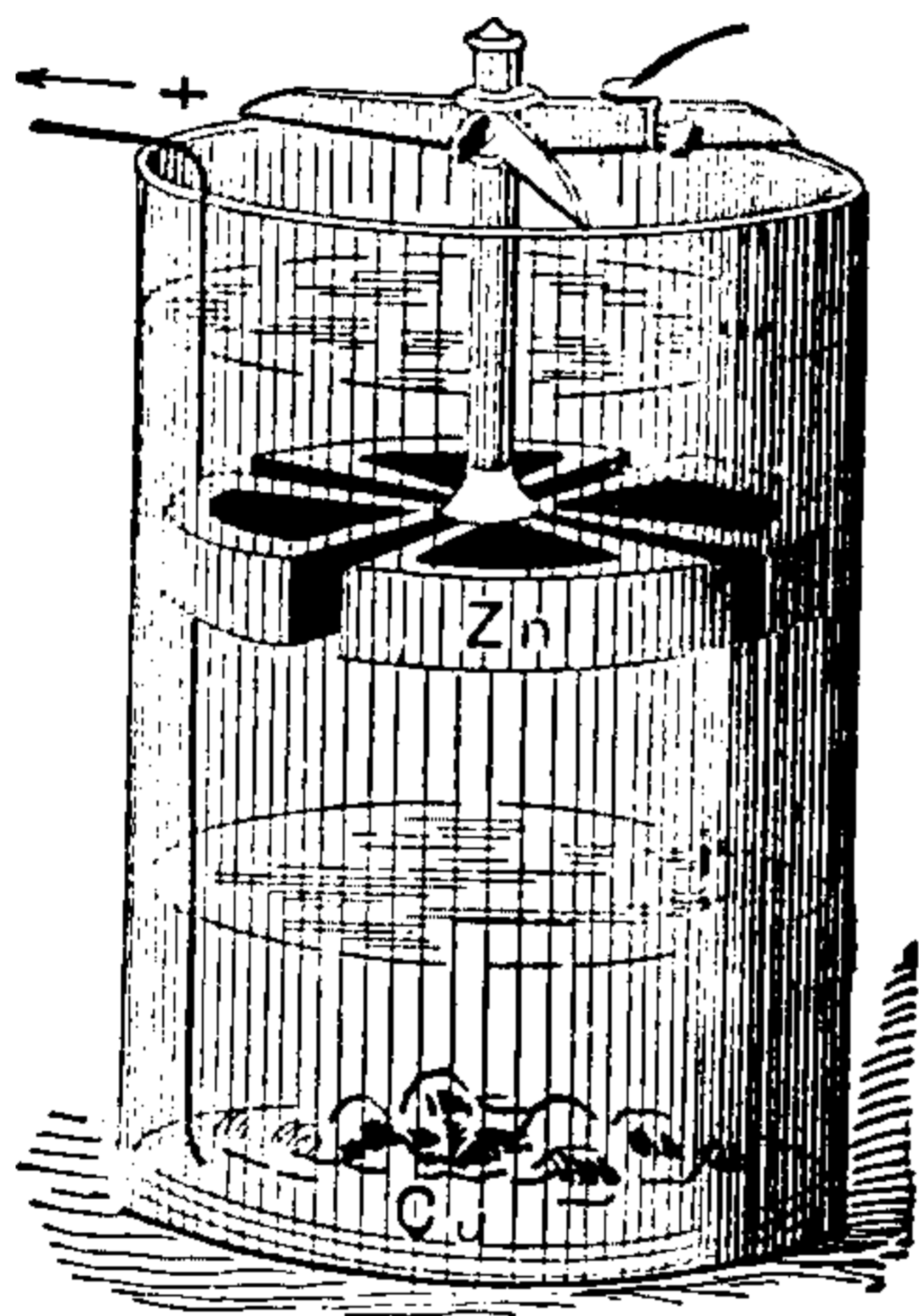

Fig. 109. The Gravity Cell.

When the cell is set up with sulphuric acid, the reactions are the same as in the Daniell cell. When copper sulphate and zinc sulphate alone are used, zinc replaces the copper in the copper sulphate. The action is then merely a substitution process. (See *Cell, Voltaic, Daniell's.*)

A dilute solution of zinc sulphate is generally used to replace the dilute sulphuric acid. It gives a somewhat lower electromotive force, but ensures a greater constancy for the cell.

Cell, Voltaic, Grenet — —A name sometimes given to the bichromate cell. (See *Cell, Voltaic, Bichromate.*)

Cell, Voltaic, Grove — —A zinc-platinum couple, the elements of which are used with electrolytes of sulphuric and nitric acids respectively.

The zinc, Z, Fig. 110, is amalgamated and placed in dilute sulphuric acid, and the platinum, P, in strong nitric acid (HNO₃) in a porous cell to separate it from the sulphuric acid. (See *Cell, Porous.*) In the Grove cell the current is moderately constant, since the polarization of the plati-

num plate is prevented by the nitric acid, which oxidizes and thus removes the hydrogen that tends to be liberated at its surface. The constancy of the current is not maintained for any considerable time, since the two liquids are rapidly decomposed, or consumed, zinc sulphate forming in the sulphuric acid, and water in the nitric acid.

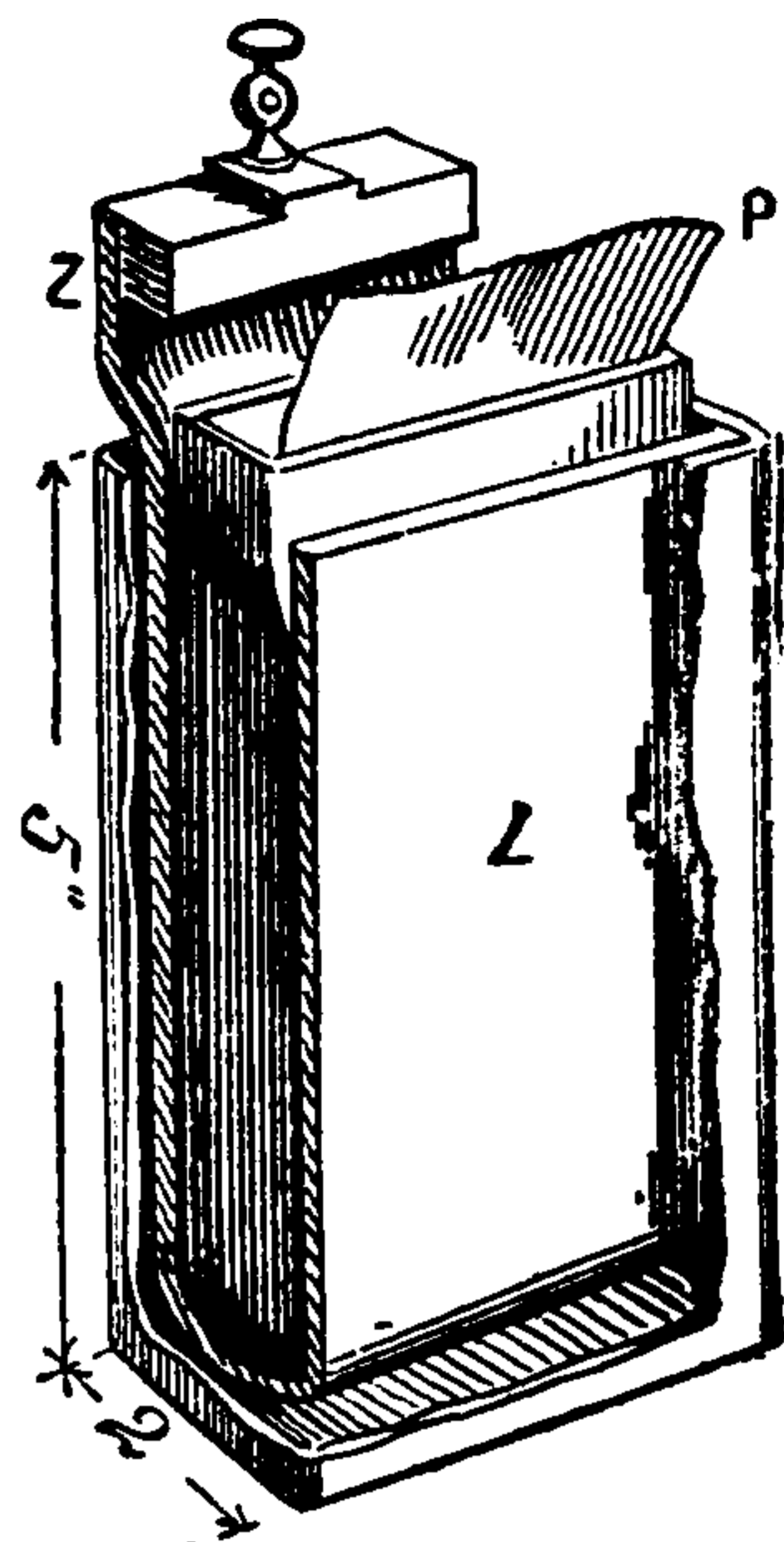
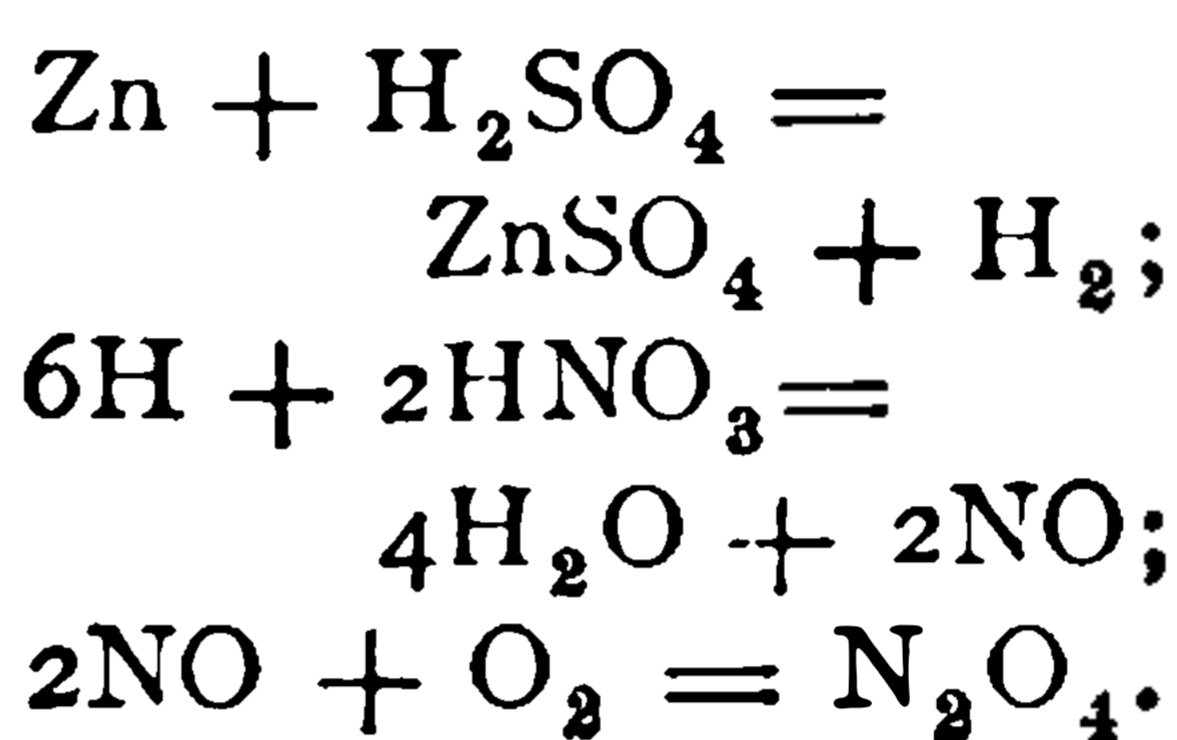
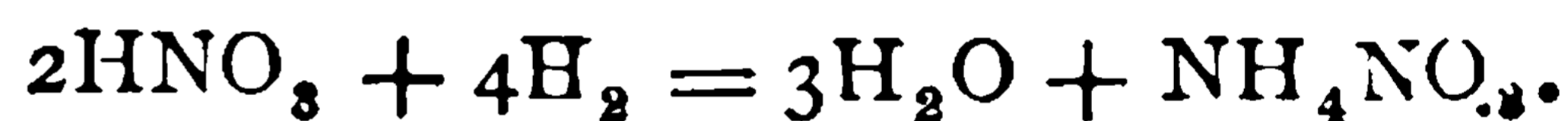

Fig. 110. Grove's Cell.

The chemical reactions are as follows, viz.:



Nitrate of ammonium is sometime; formed when the nitric acid becomes dilute by decomposition. The reaction is as follows:



The cell gives an electromotive force of 1.93 volts.

When the porous cell is good, the resistance of the Grove cell may be calculated according to the following formula of Ayrton:

$$R = \frac{3.6 \times d}{A} \text{ ohms,}$$

where d, is the distance in inches between the platinum and zinc plates, and A, the square inches of the immersed portion of the platinum plate.

Cell, Voltaic, Leclanché — —A zinc-carbon couple, the elements of which are used in a solution of sal-ammoniac and a finely divided layer of black oxide of manganese respectively.

The zinc is in the form of a slender rod and dips into a saturated solution of *sal-ammoniac*, NH₄Cl.

The negative element consists of a plate of carbon, C, Fig. 111, placed in a porous cell, in which is a mixture of black oxide of manganese and broken gas-retort carbon, tightly packed around the carbon plate. By this means a greatly extended surface of carbon surrounded by black

oxide of manganese, MnO_2 , is secured. The entire outer jar, and the spaces inside the porous cell are filled with the solution of sal-ammoniac.

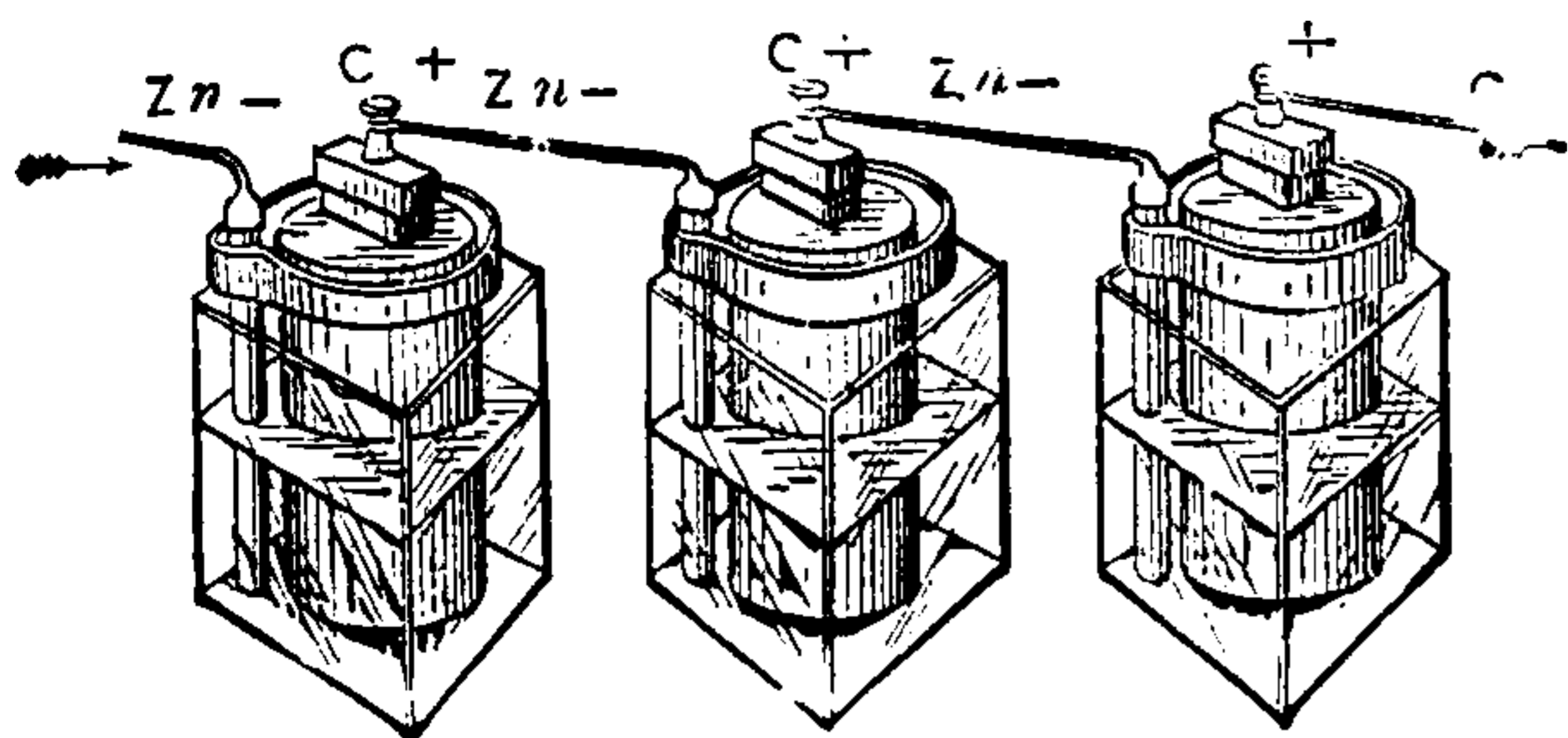
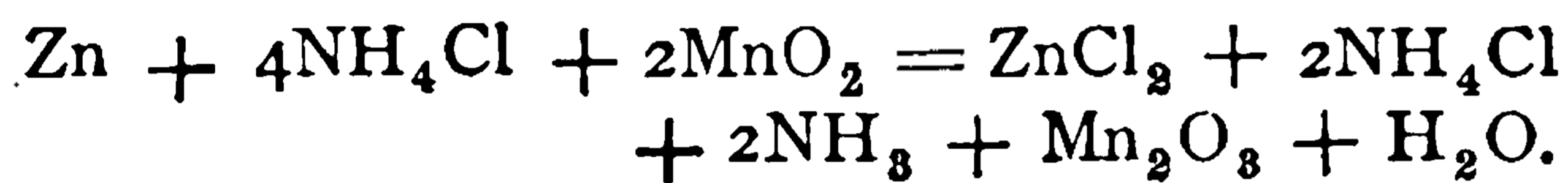

Fig. 111. The Leclanché Cell.

This cell, though containing but a single fluid, belongs, in reality, to the class or type of *double-fluid cells*, being one in which the negative element is surrounded by an oxidizing substance, the black oxide of manganese, which replaces the nitric acid or copper sulphate in the other double-fluid cells.

This reaction is generally given :



This reaction is denied by some, who believe the following to take place :



The $ZnCl_2$ and NH_3 react as follows :

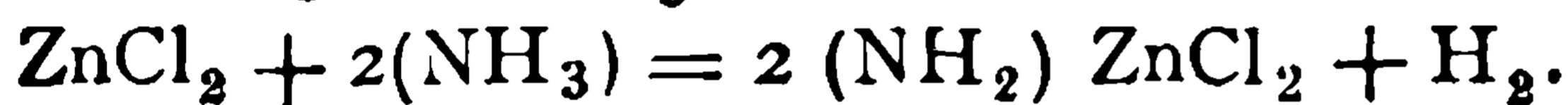

or, possibly, $4H + 3MnO_2 = Mn_2O + 2H_2O.$

The Leclanché cell gives an electromotive force of about 1.47 volts. It rapidly polarizes, and cannot, therefore, give a steady current for any prolonged time. When left on open circuit, however, it quickly depolarizes.

Cell, Voltaic, Local Action of — — (See *Action, Local, of Voltaic Cell.*)

Cell, Voltaic, Meidinger — — A zinc-copper couple, the elements of which are employed with dilute sulphuric acid, or solution of sulphate of magnesia, and strong nitric acid, respectively.

The Meidinger cell is a modification of the Daniell cell. The *zinc-copper* couple is thus arranged: Z Z, Fig. 112, is an amalgamated zinc ring placed near the walls of the vessel, A A, constricted at b b. The copper element, c, is similarly placed with respect to the walls of the vessel d d. The glass cylinder h, filled with

crystals of copper sulphate, has a small hole in its bottom, and keeps the vessel, d d, supplied with saturated solution of copper sulphate. The cell is charged with dilute sulphuric acid, or a dilute solution of Epsom salts, or magnesium sulphate.

Cell, Voltaic, Open-Circuit

— — A voltaic cell that cannot be kept on closed circuit, with a comparatively small resistance, for any considerable time without serious polarization.

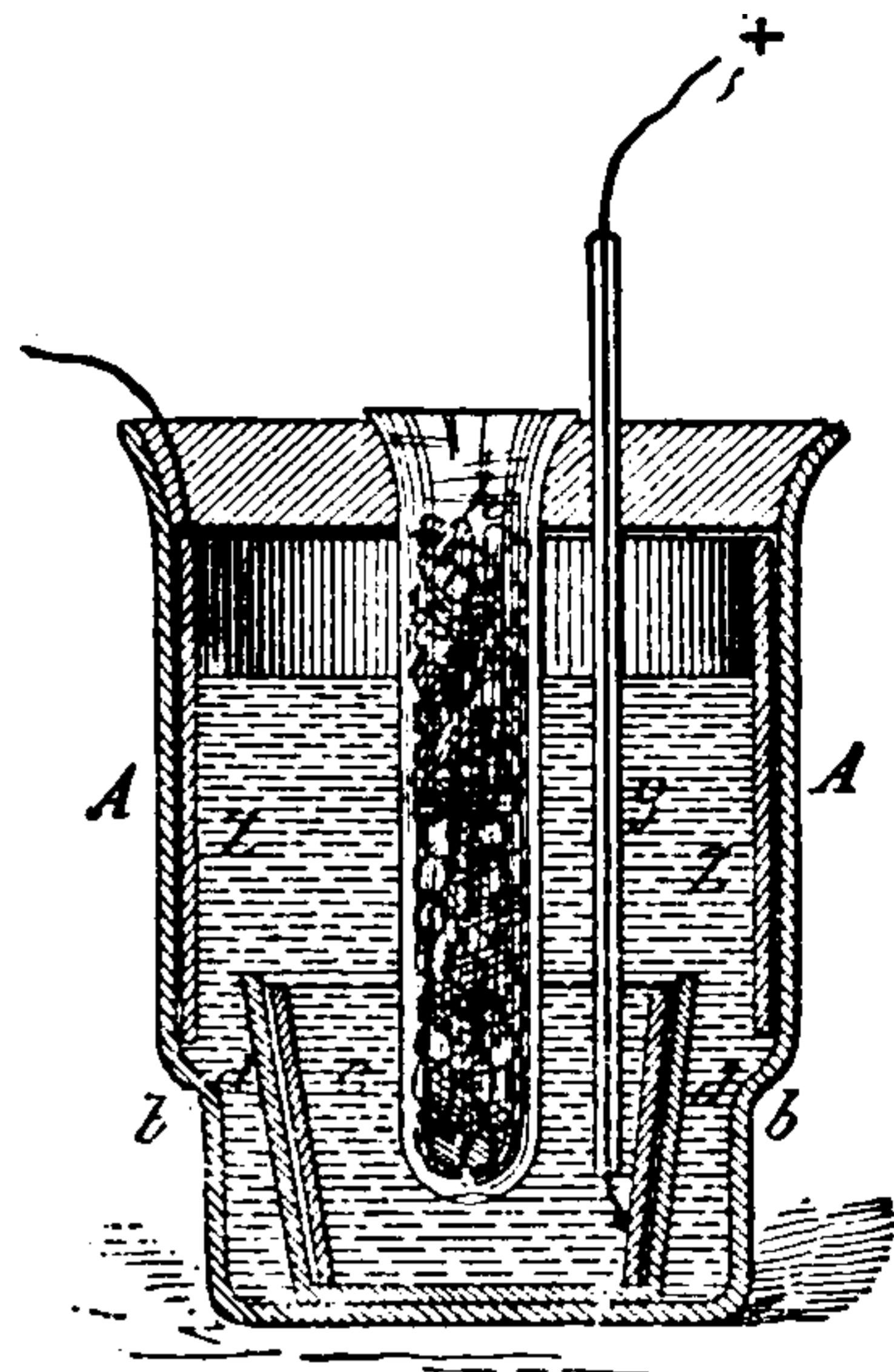

Fig. 112. The Meidinger Cell.

A Leclanché cell is an open-circuit cell. The term open-circuit cell is used in contradistinction to closed-circuit cell, such as the Daniell. (See *Cell, Voltaic, Closed-Circuit.*)

Cell, Voltaic, Poggendorff — — A name sometimes given to the Grenet cell. (See *Cell, Voltaic, Grenet.*)

Cell, Voltaic, Polarization of — — The collection of a gas, generally hydrogen, on the surface of the negative element of a voltaic cell.

The collection of a positive substance like hydrogen on the negative element or plate of a voltaic cell sets up a *counter-electromotive force*, which tends to produce a current in the opposite direction to that produced by the cell. (See *Force, Electromotive, Counter.*)

Polarization causes a decrease in the normal current of a voltaic cell:

(1.) On account of the *increased resistance* of the cell from the bubbles of gas which form part of its circuit.

(2.) On account of the *counter-electromotive force*, produced by polarization.

There are three ways in which the ill effects of the polarization of a voltaic cell can be avoided. These are :

(1.) *Mechanical.* — The negative plate is furnished with a roughened surface which enables the

bubbles of gas to escape from the points on such surface; or, a stream of gas, or air, is blown through the liquid against the plate and thus mechanically brushes the bubbles off.

(2.) *Chemical*.—The surface of the negative plate is surrounded by some powerful oxidizing substance, such as chromic or nitric acid, which is capable of oxidizing the hydrogen, and thus thoroughly removing it from the plate.

The oxidizing substance may form the entire electrolyte, as is the case of the bichromate solution employed in the zinc-carbon couple. Generally, however, it has been found preferable to employ a separate liquid, like nitric acid, to completely surround the negative plate, and another liquid for the positive plate, the two liquids being generally kept from mixing by a porous cell, or diaphragm. Such cells are called *double-fluid cells*. (See *Cell, Voltaic, Double-Fluid*.)

(3.) *Electro-Chemical*.—This also necessitates a double-fluid cell. The negative element is immersed in a solution of a salt of the same metal as that forming the negative plate. Thus, a copper plate, immersed in a solution of copper sulphate, cannot be polarized, since metallic copper is deposited on its surface by the action of the hydrogen which tends to be liberated there.

The constancy of action of a Daniell cell depends on a deposition of metallic copper on its copper plate as well as on the formation of hydrogen sulphate, and the solution of additional copper sulphate from the crystallized salt placed in the cell. (See *Cell, Voltaic, Daniell's*.)

Cell, Voltaic, Primary, Exhaustion of — — The inability of a primary voltaic cell to furnish any further current, unless fresh electrolyte, or fresh positive element, or both, are supplied to it.

In the case of exhaustion of a primary voltaic cell the stock of fresh energy is supplied to the cell from the chemical potential energy of the positive element, or of the electrolyte or electrolytes. (See *Energy, Chemical Potential*.)

In most voltaic cells a marked decrease in the current strength is observed soon after the circuit is closed, and, therefore, long before the cell is exhausted. This decrease is due—

(1.) To the increased internal resistance due to the bubbles of hydrogen on the negative plate.

(2.) To the counter-electromotive force of polarization, where zinc is employed with an electrolyte of sulphuric acid.

(3.) To the decrease in the electromotive force due to an increase in the density of the zinc sulphate.

Cell, Voltaic, Secondary, Exhaustion of — — The inability of a secondary cell to furnish any further current, unless fresh electro-positive and electro-negative materials are formed in it by the passage of the charging current.

In the case of the exhaustion of a secondary voltaic cell, the stock of fresh energy supplied to the cell is derived from the electric energy of the charging current. (See *Energy, Electric*.)

Cell, Voltaic, Siemens-Halske — — A zinc-copper couple, the elements of which are employed with dilute sulphuric acid and saturated solution of copper sulphate respectively.

The Siemens-Halske cell is a modification of Daniell's. A ring of zinc, Z Z, Fig. 113, sur-

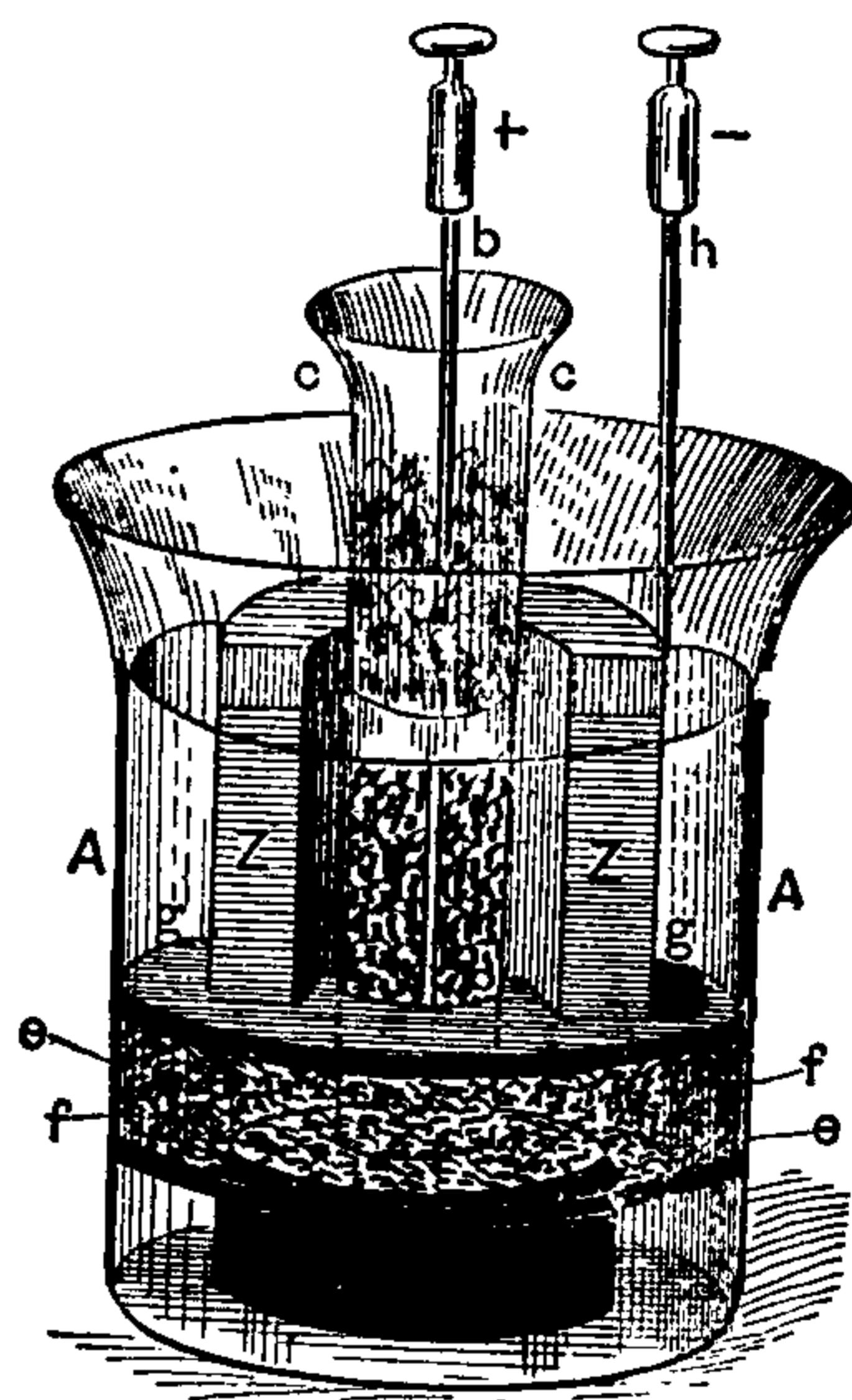

Fig. 113. Siemens-Halske Cell.

rounds the glass cylinder, c c. The porous cell is replaced by a diaphragm, f f, of porous paper, formed by the action of sulphuric acid on a mass of paper pulp. Crystals of copper sulphate are placed in the glass jar, c c, and rest on the copper plate, k, formed of a close copper spiral. Terminals are attached at b and h. The entire cell is charged with dilute sulphuric acid. The resistance of the cell is high.

Cell, Voltaic, Silver Chloride — — A zinc and silver couple immersed in electrolytes of sal-ammoniac or common salt and silver chloride.

The zinc acts as the positive element, and a silver wire, around which a cylinder of fused silver chloride is cast, as the negative element. The zinc, and the silver wire and silver chloride, are placed in a small glass test-tube and covered with the sal-ammoniac or common salt, and the tube closed by a cork of paraffin, to prevent the evaporation of the electrolyte. When sal-ammoniac is used, the strength of the solution is that obtained by dissolving 23 grammes of pure sal-ammoniac in 1 litre of water. The silver chloride acts as a depolarizer.

This cell is used as a standard cell, known as De la Rue's standard cell, from its inventor, Warren De la Rue. Its electromotive force is 1.068 volts.

Cell, Voltaic, Simple — — Any voltaic cell formed of a single couple immersed in a single exciting liquid.

Cell, Voltaic, Single-Fluid — — A voltaic cell in which but a single fluid or electrolyte is used.

Single-fluid voltaic cells possess the disadvantage of polarizing during action. This polarization is due to the electro-positive element of the electrolyte collecting on the surface of the negative plate, or within its mass. For example, where dilute sulphuric acid is the electrolyte, hydrogen gas collects on the negative plate and lowers the *electromotive force* produced by the cell, by a *counter-electromotive force* thereby generated. (See *Force, Electromotive. Force, Electromotive, Counter.*)

Cell, Voltaic, Smee — — A zinc-silver couple used with an electrolyte of dilute sulphuric acid, H_2SO_4 .

A form of Smee cell is shown in Fig. 114. Here the plate of silver is placed between two zinc plates.

The silver plate is roughened and covered with a coating of metallic platinum, in the condition known as *platinum black*. (See *Platinum Black.*) This cell was formerly extensively employed in *electro-metallurgy* but is now replaced by *dynamo-electric-machines*. (See *Metallurgy, Electro. Machine, Dynamo-Electric.*)

A zinc carbon couple is sometimes used to replace the zinc-silver couple. A couple of zinc-lead is also used, though not very advantageously.

The Smee cell was one of the earliest forms of voltaic cells.

In the zinc-silver couple the chemical reaction that takes place when the cell is furnishing current is as follows, viz.:

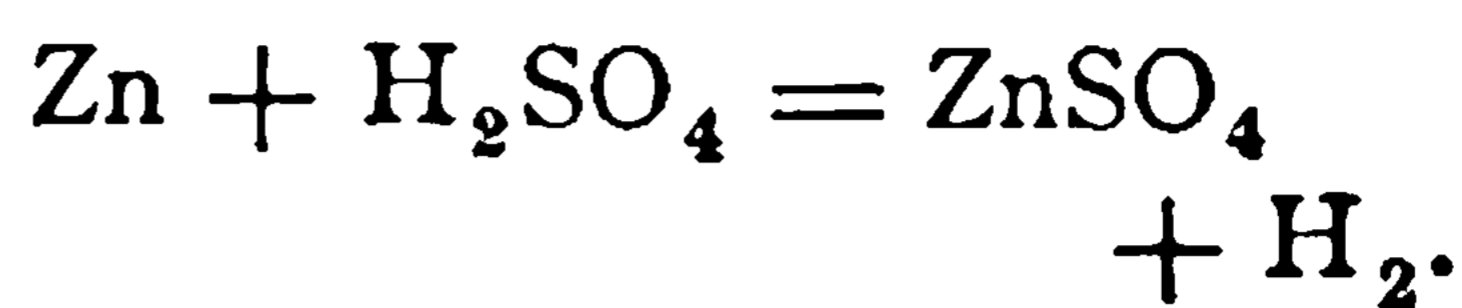

The Smee cell gives an electromotive force of about .65 volt.

Cell, Voltaic, Standard — — A voltaic cell the electromotive force of which is constant, and which, therefore, may be used in the measurement of an unknown electromotive force.

Absolute constancy of electromotive force is impossible to attain, but if the current of the standard cell is closed but for a short time the electromotive force may be regarded as practically invariable.

Cell, Voltaic, Standard, Clark's — — The form of standard cell shown in Fig. 115.

Latimer Clark's standard cell assumes a variety of forms. The H-form is arranged as shown in Fig. 115. The vessel to the left contains, at A, an amalgam of pure zinc. The other vessel contains, at M, mercury covered with pure mercurous sulphate, Hg_2SO_4 . Both vessels are then filled, above the level of the cross tube, with a saturated solution of zinc sulphate Z, Z, to which a few crystals of the same are added. Tightly fitting corks C, C, prevent loss by evaporation.

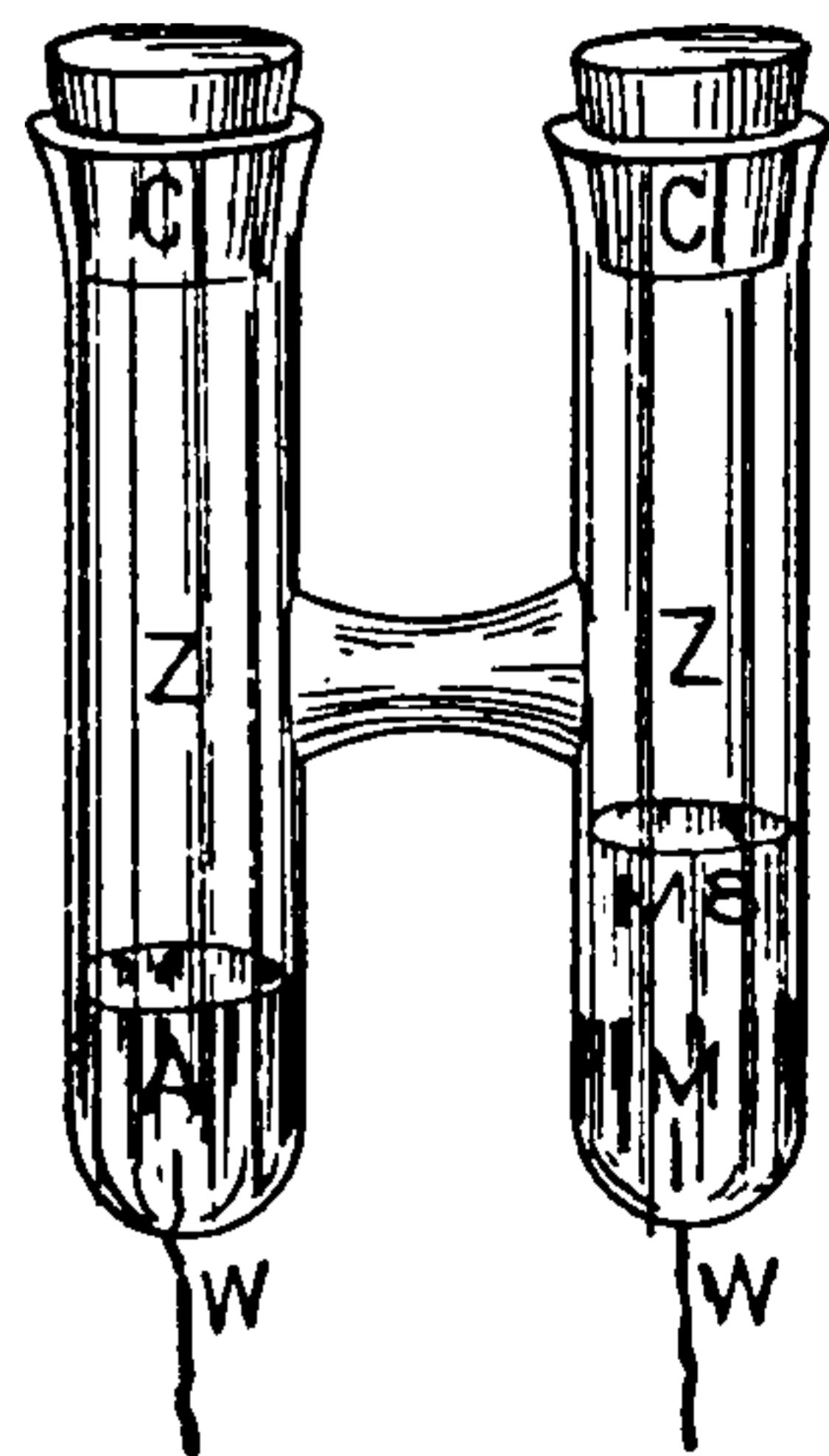

Fig. 115. Clark's Standard Cell.

The voltage of this cell in legal volts is 1.438 [1 — 0.00077 (t — 15 degrees C.)]—(Ayrton.)

The value t, is the temperature in degrees of the centigrade scale.

Cell, Voltaic, Standard, Rayleigh's Form of Clark's — — A modified form of Clark's cell.

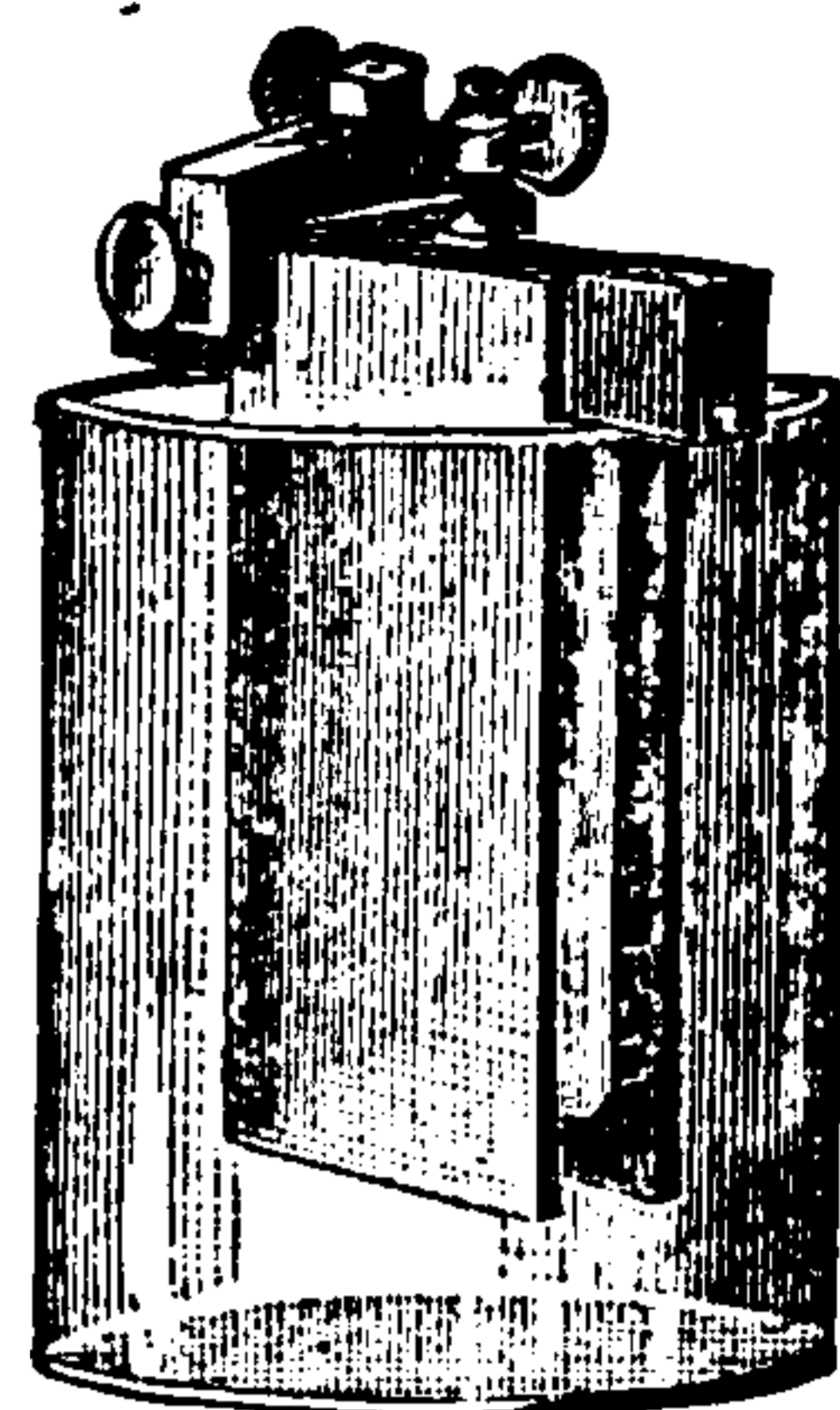

Fig. 114. Smee Cell.

Lord Rayleigh's form of Clark's standard cell is shown in Fig. 116. The electrodes pass respectively through the bottom and top of the test tube of glass. On the lower electrode a layer of mercury, Hg, is placed. On this rests a layer of mercurous sulphate paste made sufficiently semi-fluid with a solution of zinc sulphate to form an approximately level surface. The zinc, Zn, is attached to the upper electrode and is immersed in this semi-fluid paste.

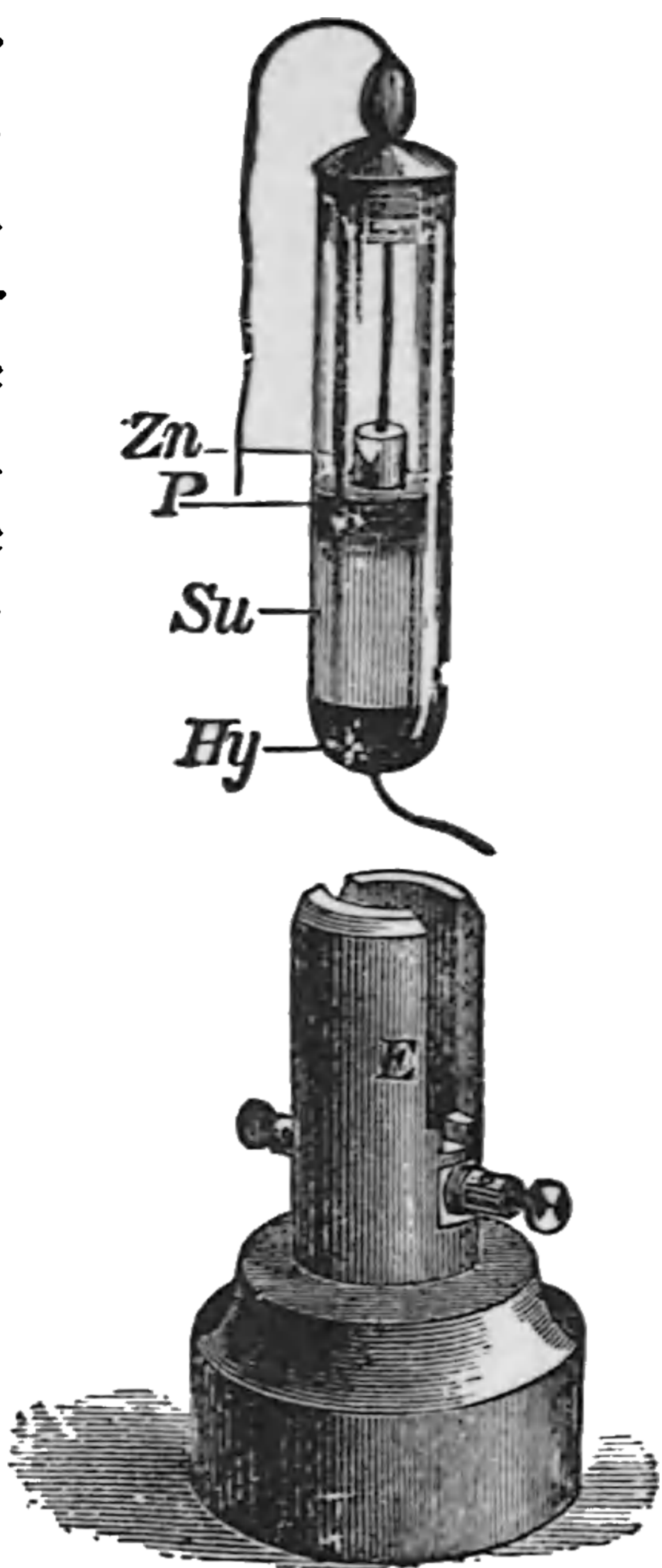

Fig. 116. Rayleigh's Form of Clark's Standard Cell.

The mercurous sulphate appears to act to keep the mercury free from impurities.

The electromotive force of this cell has been carefully determined by Rayleigh. Its value in true volts is :

$$E = 1.435 [1 - .00077 (t - 15)]$$

when t, is the temperature in degrees Centigrade.

This cell is often called Clark's normal element.

Cell, Voltaic, Standard, De la Rue's — —
—A form of silver-chloride cell. (See *Cell, Voltaic, Silver-Chloride.*)

Cell, Voltaic, Standard, Fleming's — —

The form of standard cell shown in Fig. 117.

The U-tube, Fig. 117, is connected, as shown, by means of taps, with two vessels filled with chemically pure solutions of copper sulphate of sp. gr. 1.1 at 15 degrees C., and zinc sulphate of sp. gr. 1.4 at 15 degrees C. respectively. To use the cell the zinc rod Zn, connected with a wire passing through a rubber stopper, is placed in the

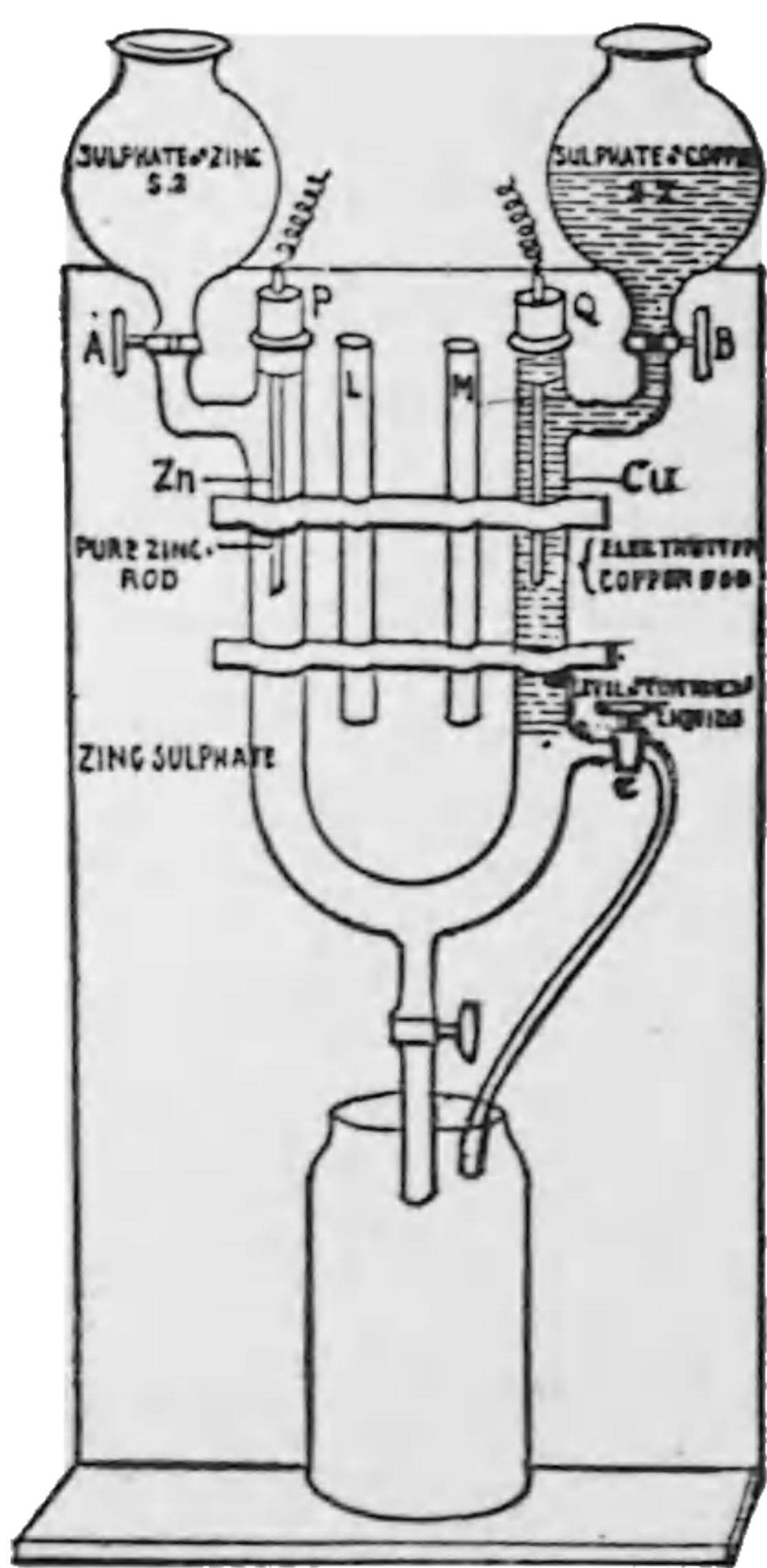

Fig. 117. Fleming's Standard Cell.

left-hand branch. The tap A, is opened and the entire U-tube is filled with the denser zinc sulphate solution. The tap at C, is then

opened, and the liquid in the right-hand branch above the tap is discharged into the lower vessel, but, from this part only. The tap C, is then closed, and the tap B, opened, and the lighter copper sulphate allowed to fill the right-hand branch above the tap C. The copper rod Cu, fitted to a rubber stopper and connected with a conducting wire, is then placed in the copper solution.

Tubes are provided at L and M, for the reception of the zinc and copper rods when not in use. The copper rod is prepared for use by freshly electro-plating it with copper. The electromotive force of this cell is 1.074 volts. If the line of demarkation between the two liquids is not sharp, the arms of the vessels are emptied, and fresh liquid is run in.

Cell, Voltaic, Standard, Lodge's — —
A form of standard Daniell cell.

Lodge's standard cell is shown in Fig. 118. Through the tube T, in a wide mouthed bottle, is passed the glass tube, in the mouth of which is placed a zinc rod. To the bottom of the tube T, a small test-tube t, containing crystals of copper sulphate, is fastened by means of a string or rubber band. The uncovered end of a gutta-percha insulated copper wire projects at the bottom of t, through a tube in a tightly fitting cork, and forms the copper electrode. The bottle is partly filled as shown with a solution of zinc sulphate.

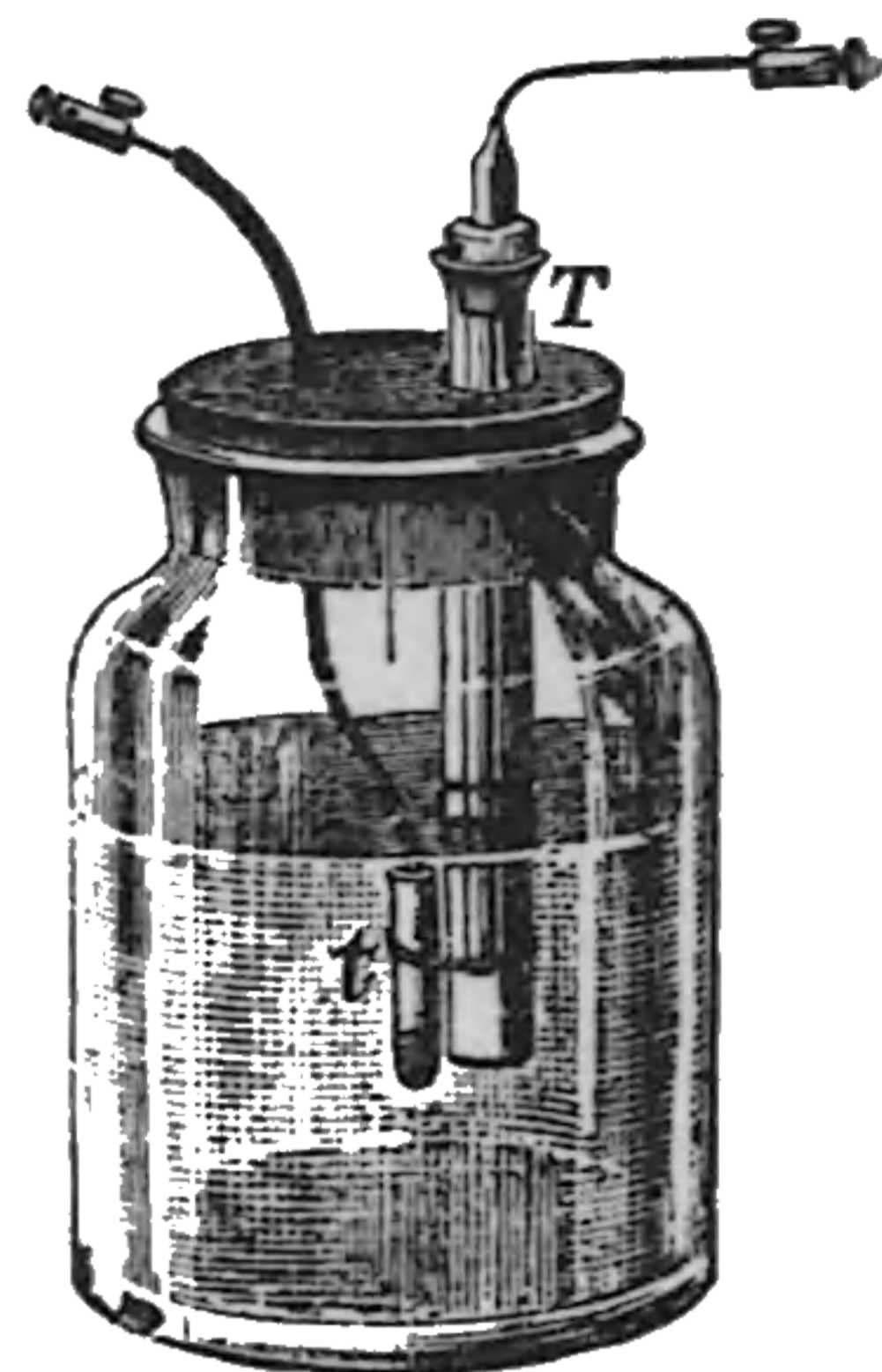

Fig. 118. Lodge's Form of Daniell's Cell.

The internal resistance of this cell is so high that it is only employed in the use of zero methods with a condenser.

Cell, Voltaic, Standard, Sir William Thomson's — —
—A form of standard Daniell cell.

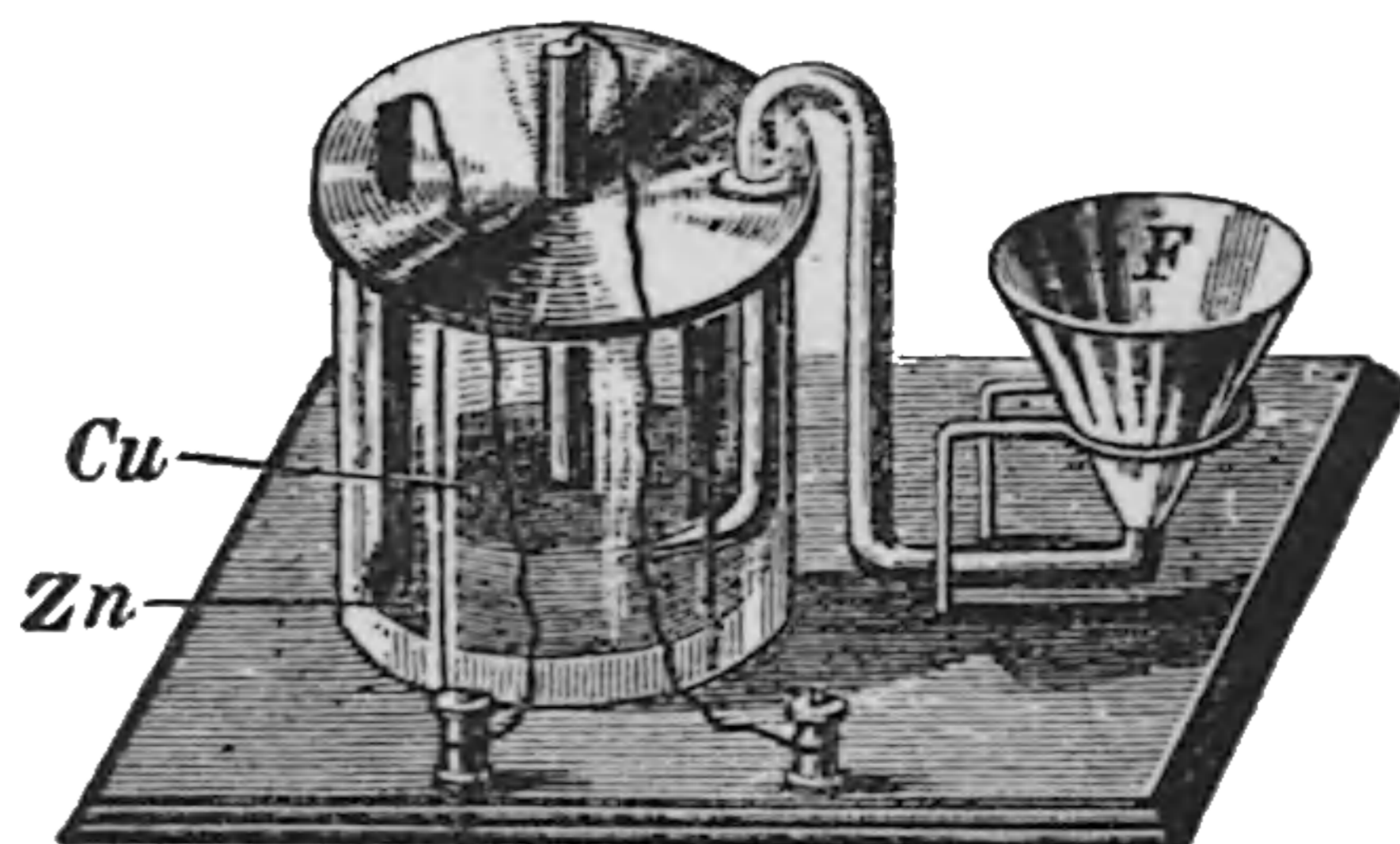

Fig. 119. Thomson's Form of Daniell's Cell.

Sir Wm. Thomson's standard cell is shown in Fig. 119. A zinc disc is placed at the bottom of the

cylindrical vessel and a solution of zinc sulphate of sp. gr. 1.2 poured over it. By means of the funnel F, a half-saturated solution of copper sulphate is carefully poured over this and floats on it owing to its smaller density. The electromotive force of this cell is 1.072 *true volts* at 15 degrees C.

Cell, Voltaic, Standardizing a — — — — — Determining the exact value of the electromotive force of a voltaic cell, in order to enable it to be used as a standard in determining the electromotive force of any other electric source.

Cell, Voltaic, Two-Fluid — — — — — A term sometimes employed in place of double-fluid cell. (See *Cell, Voltaic, Double-Fluid*.)

Cell, Voltaic, Water — — — — — A voltaic cell in which the exciting liquid is merely water.

Any voltaic couple can be used, the positive element of which is acted on by water. (See *Battery, Voltaic*.)

Cell, Voltaic, Zinc-Carbon — — — — — A cell in which zinc and carbon form the positive and negative elements respectively.

A name sometimes given to the bichromate cell.

Cell, Voltaic, Zinc-Copper — — — — — A cell in which zinc and copper form the positive and negative elements respectively.

Cell, Voltaic, Zinc-Lead — — — — — A zinc-lead couple sometimes used, though not very advantageously, to replace the zinc-silver couple in a Smee cell. (See *Cell, Voltaic, Smee*.)

Cells, Coupled — — — — — A number of separate cells connected in any way so as to form a single source.

Cells, Voltaic, Series-Connected — — — — — A number of separate voltaic cells connected in series so as to form a single source. (See *Circuit, Series*.)

Cement-Lined Conduit. — (See *Conduit, Cement-Lined*.)

Cements, Insulating — — — — — Various mixtures of gums, resins and other substances, possessing the ability to bind two or more

substances together and yet to electrically insulate one from the other.

Centi.—(As a prefix)—The one-hundredth part of.

Centi-Ampère.—One-hundredth of an ampère.

Centi-Ampère Balance.—(See *Balance, Centi-Ampère*.)

Centigrade Thermometer Scale. — (See *Scale, Centigrade Thermometer*.)

Centigramme.—The hundredth of a gramme

One centigramme equals 0.1544 grains avoirdupoise. (See *Weights and Measures, Metric System of*.)

Centilitre.—The hundredth of a litre.

One centilitre equals 0.6102 of a cubic inch. (See *Weights and Measures, Metric System of*.)

Centimetre.—The hundredth of a metre.

One centimetre equals 0.3937 inch. (See *Weights and Measures, Metric System of*.)

Centimetre-Gramme-Second Units.—(See *Units, Centimetre-Gramme-Second*.)

Central Galvanization.—(See *Galvanization, Central*.)

Central Station.—(See *Station, Central*.)

Central Station Burglar Alarm.—(See *Alarm, Burglar, Central Station*.)

Central Station Lighting.—(See *Lighting, Electric Central Station*.)

Centre of Gravity.—(See *Gravity, Centre of*.)

Centre of Oscillation.—(See *Oscillation, Centre of*.)

Centre of Percussion.—(See *Percussion, Centre of*.)

Centrifugal Force.—(See *Force, Centrifugal*.)

Centrifugal Governor.—(See *Governor, Centrifugal*.)

Chain Lightning. — (See *Lightning, Chain*.)

Chain, Linked Magnetic and Electric — — — — — A chain of three links, the separate links of which consist of the primary circuit,

the magnetic circuit, and the secondary circuit respectively, of an induction coil.

The conception of a linked magnetic and electric chain, in studying the action of an induction coil, was first developed by Kapp. A linked magnetic and electric chain is shown in Fig. 120.

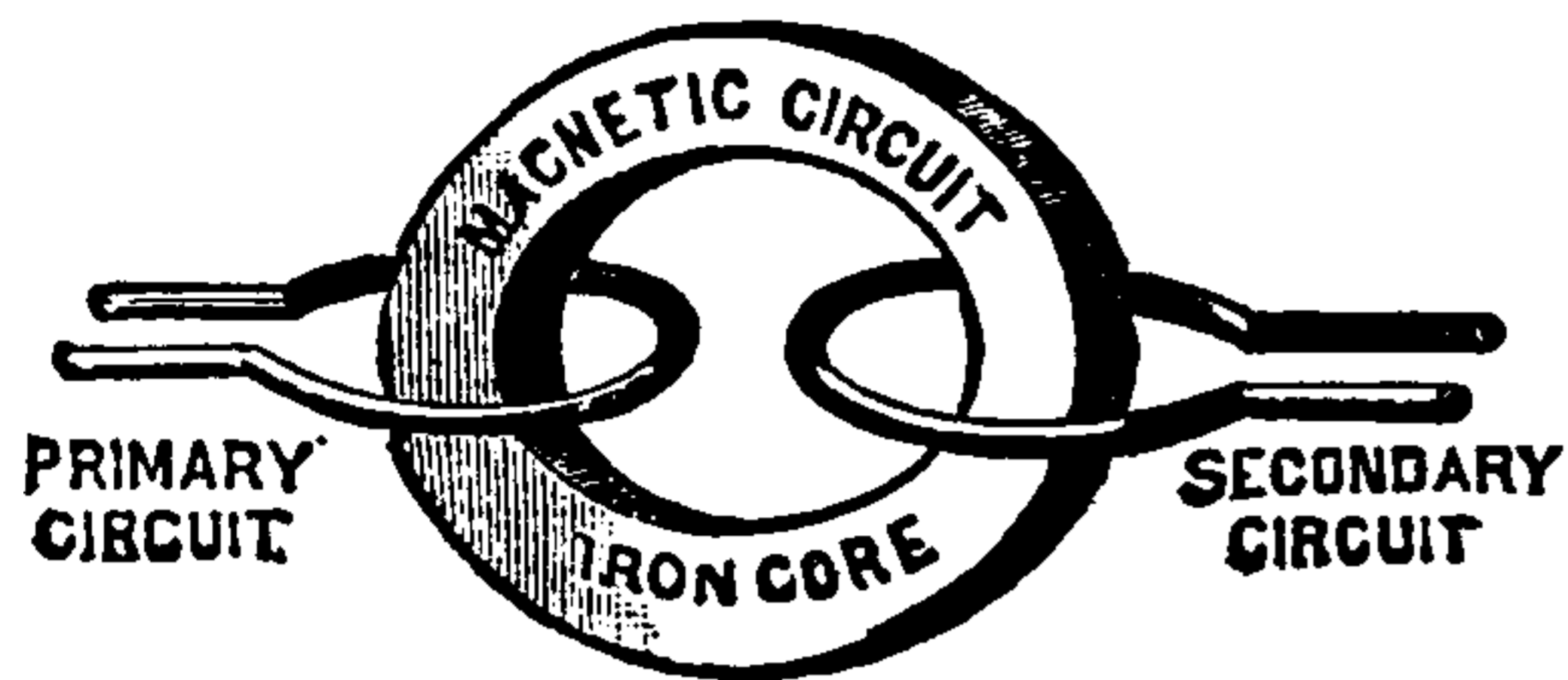

Fig. 120. *Linked Magnetic and Electric Chain.*

If, in such a case, the magnetic core or circuit is of varying magnetization, when one of the electric circuits has a periodic current passed through it, the various phenomena of the induction coil are produced. (See *Coil, Induction.*)

Chain, Molecular — — — A polarized chain of molecules that is supposed to exist in an electrolyte during its electrolytic decomposition, or in a voltaic cell on closing its circuit. (See *Hypothesis, Grotthus.*)

Chain Pull.—(See *Pull, Chain.*)

Chamber, Armature — — — The armature bore. (See *Bore, Armature.*)

Chamber of Lamp.—(See *Lamp, Chamber of.*)

Change, Chemical — — — Any change in matter resulting from atomic combination and the consequent formation of new molecules.

Some chemical changes are caused by atomic combinations and the formation of new molecules. They are necessarily attended by a loss of the specific identity of the substances involved in the change. Thus carbon, a black solid, combined with sulphur, a yellow solid, produces carbon disulphide, a colorless, odorous liquid. (See *Atom.*)

Change, Physical — — — Any change in matter resulting from a change in the relative position of its molecules, without the formation of new molecules.

Ice, when heated, is turned into water; steel, when stroked by a magnet, is rendered permanently magnetic; a piece of vulcanite or hard

rubber stroked by a piece of cat skin becomes electrified. In all these cases, which are instances of physical changes, the substances retain their specific identity. This is true in all cases of physical changes. (See *Molecule.*)

Changing-over Switch.—(See *Switch, Changing-over.*)

Changing Switch.—(See *Switch, Changing.*)

Characteristic Curve.—(See *Curve, Characteristic.*)

Characteristic Curve of Parallel Transformer.—(See *Curve, Characteristic, of Parallel Transformer.*)

Characteristic Curve of Series Transformer.—(See *Curve, Characteristic, of Series Transformer.*)

Characteristics of Sound.—(See *Sound, Characteristic of.*)

Charge, Bound — — — The condition of an electric charge on a conductor placed near another conductor, but separated from it by a medium through which electrostatic induction can take place. (See *Induction, Electrostatic.*)

When a charged conductor is placed near another conductor, but separated from it by a dielectric or medium through which induction can take place, a charge of the opposite name is induced in the neighboring conductor. This charge is so held or bound on the conductor by the mutual attraction of the opposite charge that it is not discharged on connection with the earth unless both conductors are simultaneously touched by any good conductor. The bound charge was formerly called *dissimulated* or *latent electricity*. (See *Electricity, Dissimulated or Latent.*)

Charge, Density of — — — The quantity of electricity per unit of area at any point on a charged surface.

Coulomb used the phrase *surface density* to mean the quantity of electricity per unit of area at any point on a surface.

Charge, Dissipation of — — — The gradual but final loss of any charge by leakage, which occurs even in a well insulated conductor.

This loss is more rapid with negatively charged conductors, than with those positively charged.

THIS PAGE IS LOCKED TO FREE MEMBERS

Purchase full membership to immediately unlock this page



HISTORY

Tens of thousands of important historical sources, many previously unobtainable, are now available for the first time with a Forgotten Books Full Membership.

Unlimited Access
\$8.99/month

Continue

*Fair usage policy applies

Chart, Isodynamic — —A map or chart on which the isodynamic lines are marked. (See *Map or Chart, Isodynamic. Lines, Isodynamic.*)

Chart, Isogonal — —An isogonic chart. (See *Map or Chart, Isogonal.*)

Chart, Isogonic — —A map or chart on which the isogonic lines are marked. (See *Map or Chart, Isogonic. Lines, Isogonic.*)

Chatterton's Compound. — (See *Compound, Chatterton's.*)

Chemical Change.—(See *Change, Chemical.*)

Chemical Effect.—(See *Effect, Chemical.*)

Chemical Equivalent.—(See *Equivalent, Chemical.*)

Chemical Galvano-Cautery.—(See *Cautery, Galvano-Chemical.*)

Chemical Phosphorescence.—(See *Phosphorescence, Chemical.*)

Chemical Photometer.—(See *Photometer, Chemical.*)

Chemical Potential Energy.—(See *Energy, Chemical Potential.*)

Chemical Recorder, Bain's — —(See *Recorder, Chemical, Bain's.*)

Chemistry, Electro — —That branch of electric science which treats of chemical compositions and decompositions effected by the electric current. (See *Electrolysis. Decomposition, Electrolytic.*)

That branch of chemistry which treats of combinations and decompositions by means of electricity.

Electro-chemistry treats of the formation of new molecules, by the combination of atoms under the electric force, as well as the decomposition of molecules by electricity.

The action of a series of sparks passed through air, in forming nitric acid, is an instance of the former, and electrolytic decompositions in general afford instances of the latter.

Chimes, Electric — —Bells rung by the attractions and repulsions of electrostatic charges.

The bells B and B, Fig. 121, are conductively connected to the *prime* or *positive* conductor +,

of a frictional machine. The bell C, is insulated from this conductor by means of a silk thread, but is connected with the ground by the metallic chain. Under these circumstances the clappers, l, l, insulated by silk threads, t, t, are attracted to B, B, by an induced charge and repelled to C, where they lose their charge only to be again attracted to B, B. In this way the bells will continue ringing as long as the electric machine is in operation.

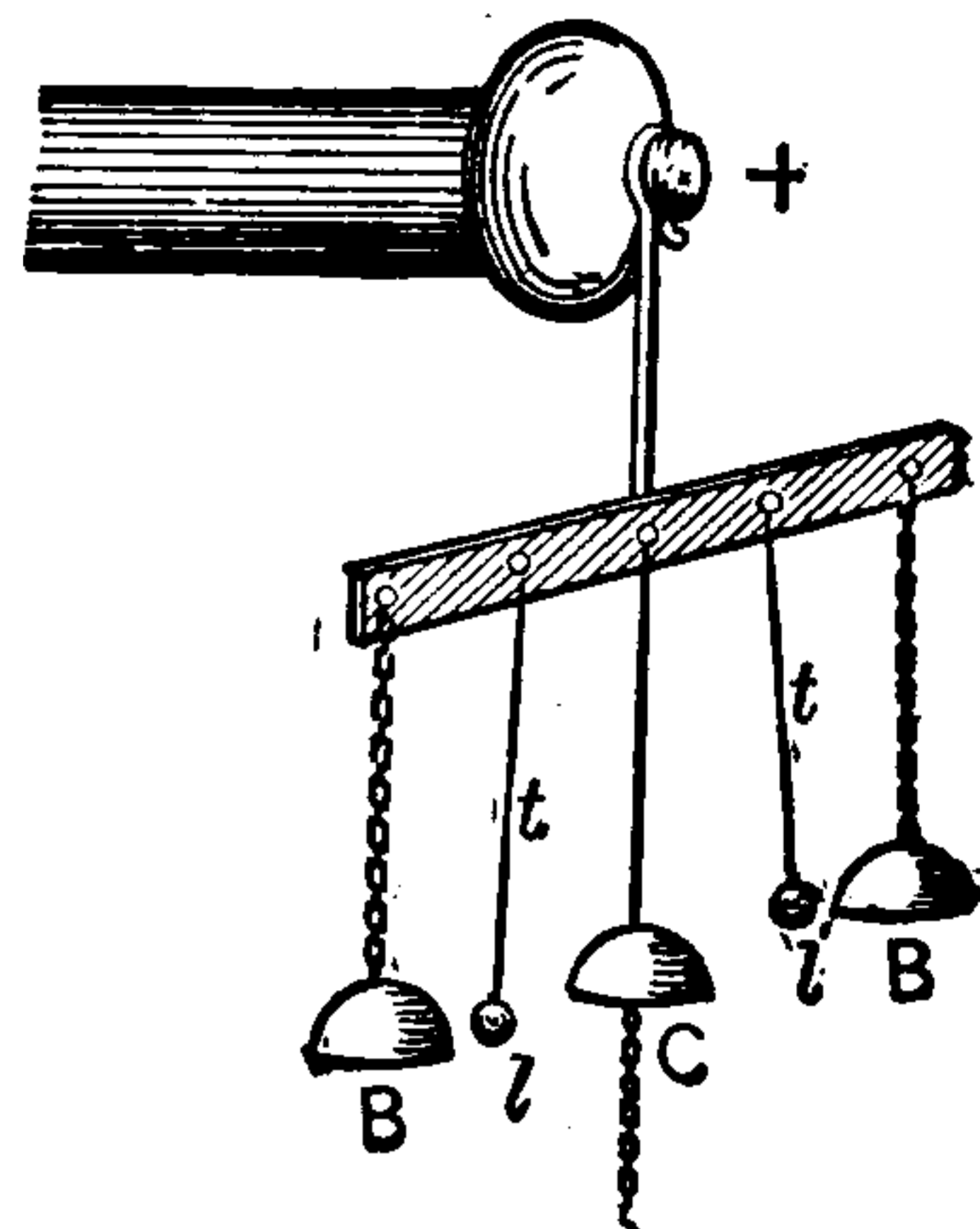

Fig. 121. Electric Chimes.

Choking Coil.—(See *Coil, Choking.*)

Chronograph, Electric — —An electric apparatus for automatically measuring and registering small intervals of time.

Chronographs, though of a variety of forms, generally register small intervals of time by causing a tuning fork or vibrating bar of steel, whose rate of motion is accurately known, to trace a sinuous line on a smoke-blackened sheet of paper, placed on a cylinder driven at a uniform rate of motion by clockwork. If the fork is known to produce, say, 256 vibrations per second be used, each sinuous line will represent $\frac{1}{256}$ part of a second.

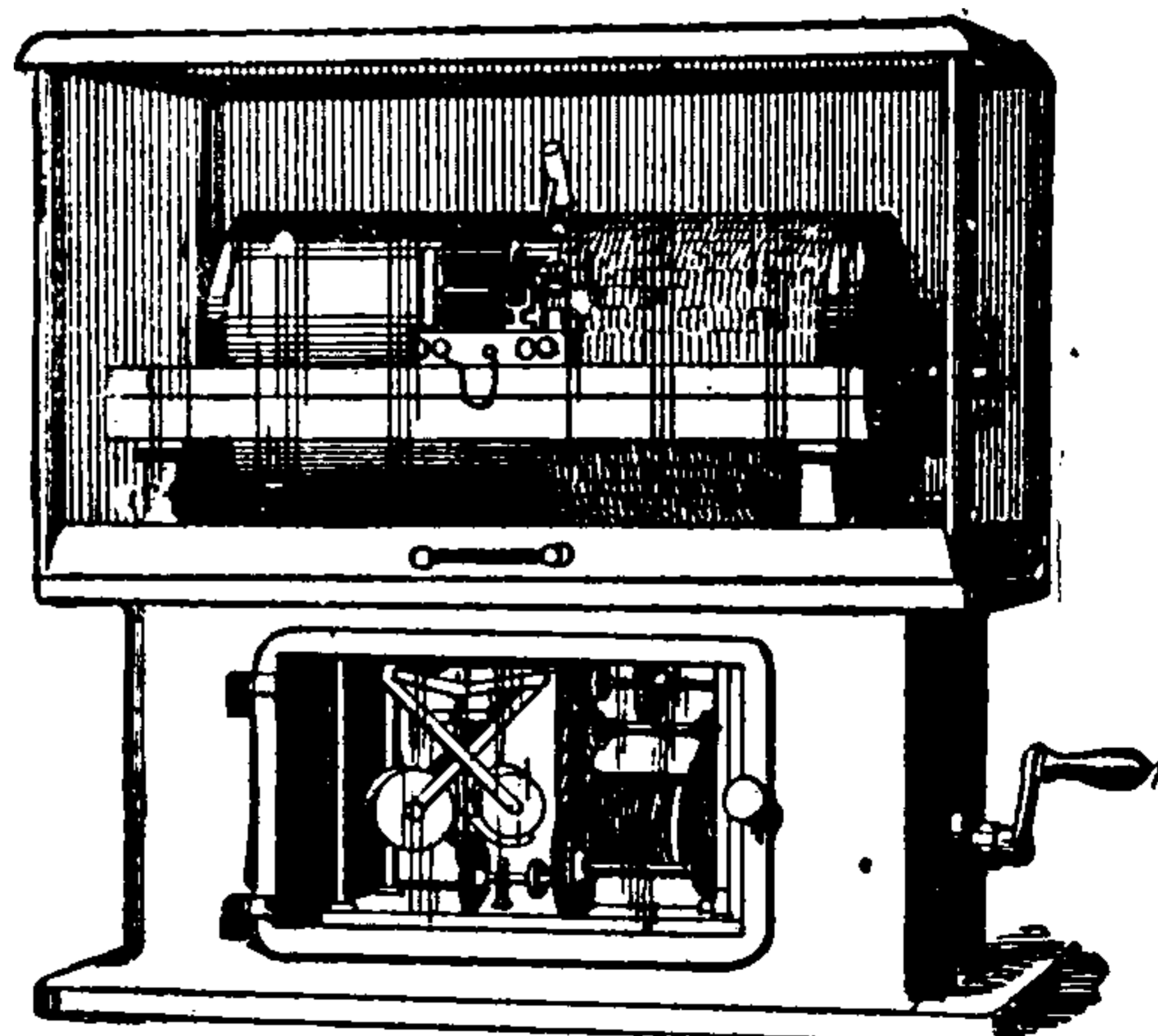

Fig. 122. Electric Chronograph.

An electro-magnet is used to make marks on the line at the beginning and the end of the observation, and thus permit its duration to be measured.

In the form of electric chronograph shown

in Fig. 122, an electro-magnet, the armature of which carries a pen, is supported on a carriage moved by clockwork over a sheet of paper wrapped on a rotating cylinder. A clock is so connected with the circuit of the electro-magnet that it makes or breaks the circuit at the end of every second second, and so moves, or displaces, the armature, as to cause an elevation or depression in the otherwise continuous sinuous line, that would be drawn on the paper by the double motion of its rotation and the movement of the pen-carriage.

When it is desired to know with great precision the exact time of occurrence of any event, such, for example, as the transit of a star over the meridian, the observer, who carries in his hand a push button, or other form of electric key, closes or opens the circuit at the exact moment and so superposes an additional mark on the sinuous line. Since the exact time of starting the clock is known, and the intervals between the regular successive marks are two seconds each, it is easy to estimate from its position between any two such marks the exact value of the additional mark interposed. Fig. 122, taken from Young, shows a form of chronograph by Warner & Swasey. The details of this apparatus will be understood from an inspection of the drawing.

Chronograph Record.—(See *Record, Chronograph.*)

Chronoscope, Electric — —An apparatus for electrically indicating, but not necessarily recording, small intervals of time.

This term is often used for chronograph.

The interval of time required for a rifle ball to pass between two points may be determined by causing the ball to pierce two wire screens placed a known distance apart. As the screens are successively pierced, an electric circuit is thus made or broken, and marks are registered electrically on any apparatus moving with a known velocity.

Cigar-Lighter, Electric — —(See *Lighter, Cigar, Electric.*)

Cipher Code.—(See *Code, Cipher.*)

Circle, Azimuth — —The arc of a great circle passing through the point of the heavens directly overhead, called the Zenith, and the point directly beneath, called the Nadir.

Circle, Dipping — —A term sometimes applied to an inclination compass. (See *Compass, Inclination.*)

Circle, Galvanic — —A term sometimes used for galvanic circuit. (See *Circuit, Galvanic.*)

Circle of Reference.—The circle, by reference to which simple harmonic motion may be studied, by comparison with uniform motion around such circuit. (See *Motion, Simple Harmonic.*)

Circle, Voltaic — —A name formerly employed for voltaic cell or circuit. (See *Cell, Voltaic. Circuit, Voltaic.*)

Circuit, Air-Magnetic — —That part of the path of a line of magnetic induction which takes place wholly through air.

Circuit, Alternating Current — —A circuit in which an alternating current of electricity is flowing. (See *Current, Alternating.*)

Circuit, Astatic — —A circuit consisting of two closed curves enclosing equal surfaces.

Such a circuit is not deflected by the action of the earth's field. The circuit disposed, as shown in Fig. 123, is astatic and produces two equal and opposite fields at S and S'.

(See *Mag. Fig. 123. Astatic Circuit. netism, Ampère's Theory of.*)

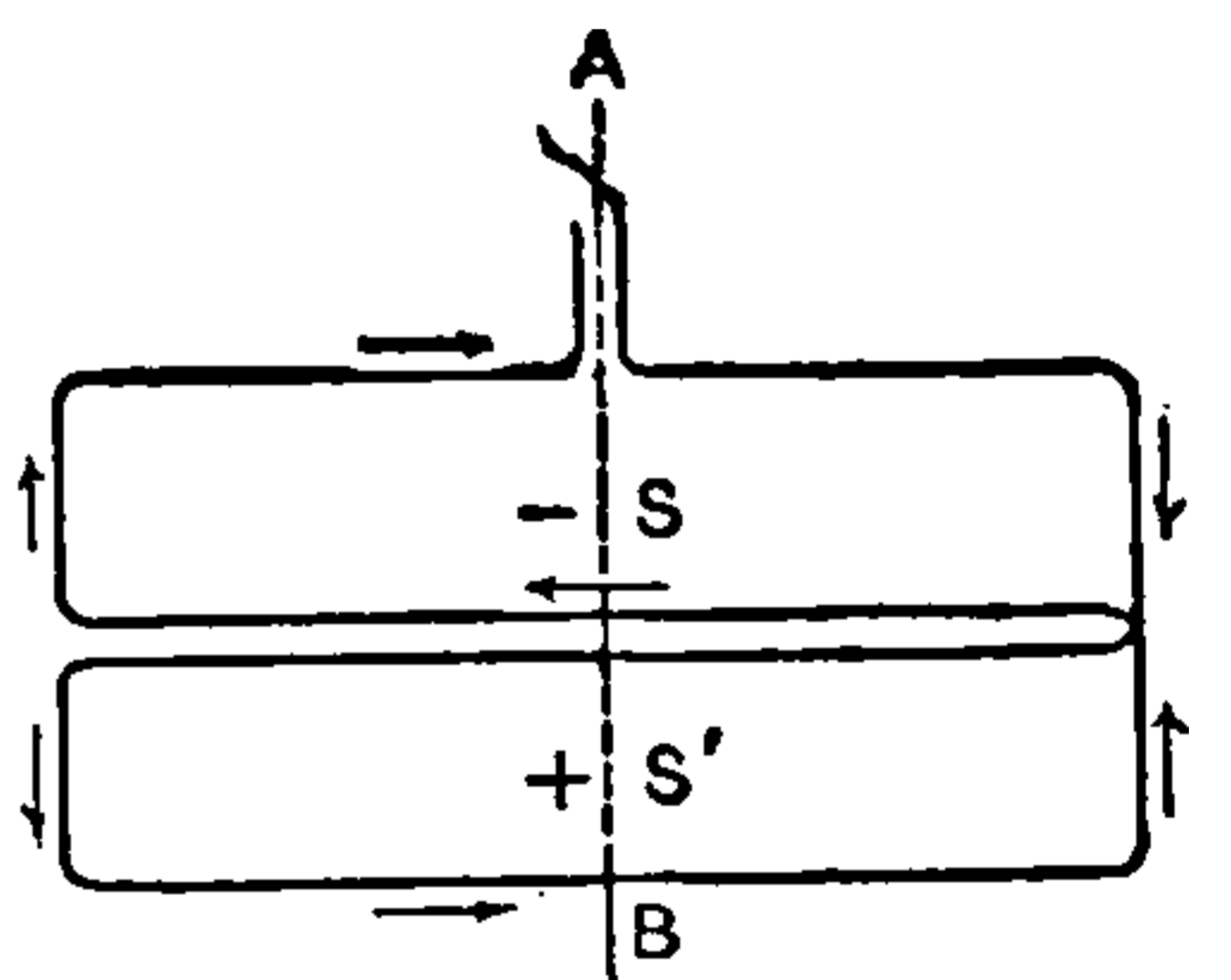

Circuit, Balanced-Metallic — —A metallic circuit, the two sides of which have similar electrical properties.

Circuit Breaker.—(See *Breaker, Circuit.*)

Circuit, Broken — —An open circuit. A circuit, the electrical continuity of which has been disturbed, and through which the current has therefore ceased to pass.

Circuit, Closed — —A circuit is closed, completed, or made when its conducting continuity is such that the current can pass.

Circuit, Closed Iron-Magnetic — —The name applied to the path of any line

of magnetic force, which takes place entirely through iron, steel, or other paramagnetic substance.

Circuit, Closed-Loop Parallel — —A variety of parallel circuit in which the lead and the return circuit are arranged in the form of concentric circuits, with the receptive devices placed radially between them.

Circuit, Closed-Magnetic — —A magnetic circuit which lies wholly in iron or other substance of high magnetic permeability.

All lines of magnetic force form closed circuits. The term closed-magnetic circuit is used in contradistinction to a divided circuit, or one in which an air gap exists in the substance of high mag-

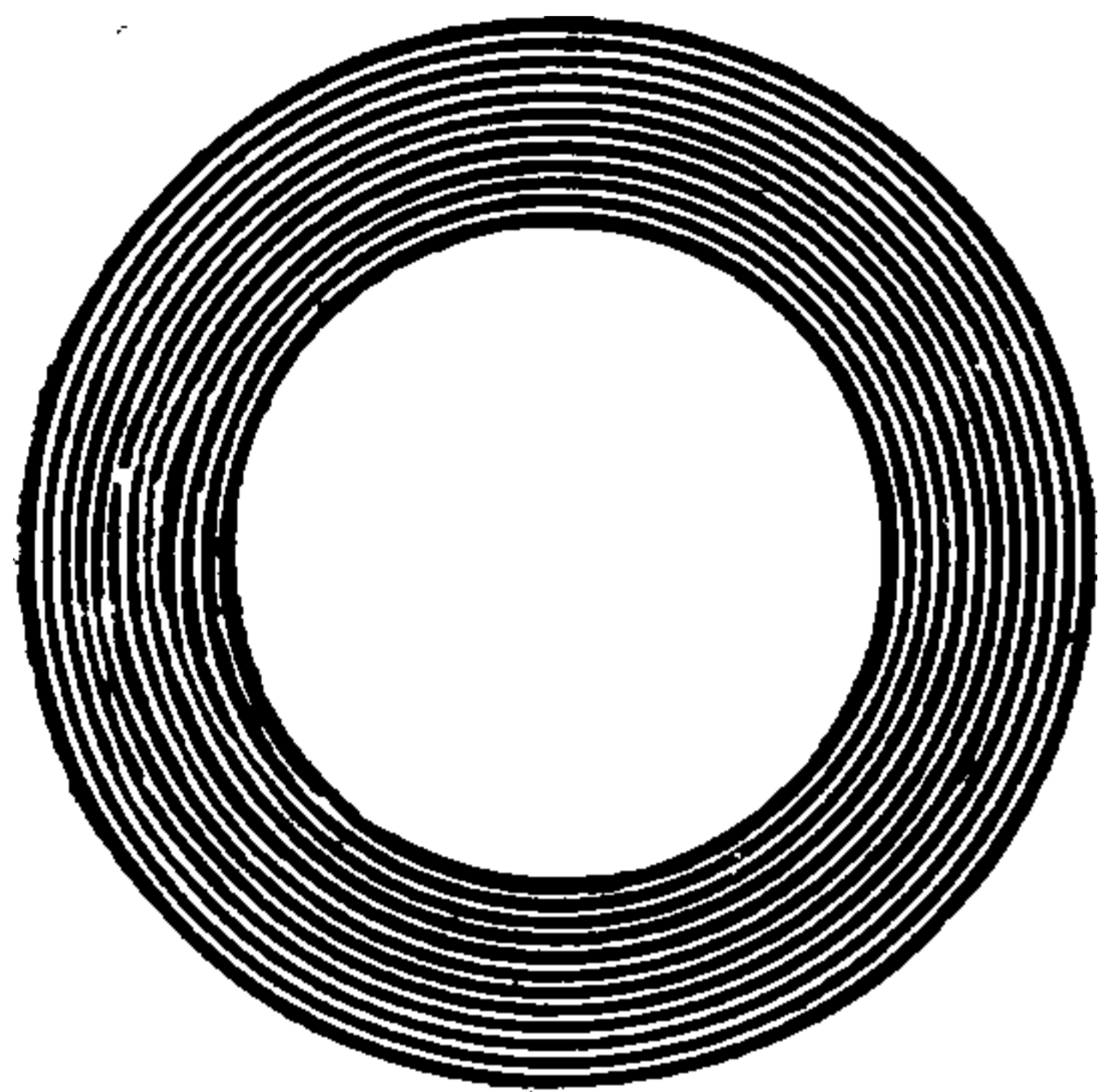

Fig. 124. Closed-Magnetic Circuit.

netic permeability forming the remainder of the circuit. This introduces so high a resistance that such a circuit is sometimes called an open-magnetic circuit. An iron ring, such as shown in Fig. 124, forms a closed-magnetic circuit.

Circuit, Closed-Magnetic, of Atom — —A closed-magnetic circuit, or closed lines of magnetic force supposed to lie entirely in the atom itself.

The assumption of closed lines of magnetic force in atoms or molecules was made in order to explain the original polarity of the same, and to account for some of the other phenomena of magnetism.

When the atom is subjected to a magnetizing force, such, for example, as the field of an electric current, these closed lines of force are assumed to open out and produce lines of polarized atoms. According to Lodge, for every single line of force produced by the current passing through a coil of wire surrounding an iron core, some 3,000 lines of magnetic force are added to it from the iron. Therefore an iron core greatly increases the magnetic strength of a hollow coil of wire.

Circuit, Closed-Magnetic, of Molecule — —A closed-magnetic circuit assumed to lie wholly within the molecule.

As it is not known whether the assumed magnetic circuit lies within the atom or the molecule, it is called indifferently the closed-atomic or closed-molecular circuit. (See *Circuit, Closed-Magnetic, of Atom.*)

Circuit, Completed — —A closed circuit.

A circuit, the conducting continuity of which is unbroken.

A completed circuit is also called a made or closed circuit.

Circuit, Compound — —A circuit containing more than a single source, or more than a single electro-receptive device, or both, connected by conducting wires.

The term compound circuit is sometimes applied to a *series circuit*. (See *Circuit, Series.*) The term, however, is a bad one, and is not generally adopted.

Circuit, Constant-Current — —A circuit in which the current or number of amperes is maintained constant notwithstanding changes occurring in its resistance.

The series-circuit, as maintained for arc-lamps, is a constant-current circuit. (See *Regulation, Automatic.*)

Circuit, Constant-Potential — —A circuit, the potential or number of volts of which is maintained approximately constant.

The multiple-arc or parallel circuit is an approximately constant-potential circuit.

Circuit, Derivative — —A derived or shunt circuit. (See *Circuit, Shunt.*)

Circuit, Derived — —A term applied to a shunt circuit.

If, in addition to the galvanometer G, the conductor S, Fig. 125, be connected with the circuit of the battery B, a derived circuit will thus be established, and a current will flow through S, diminishing the current in the galvanometer. (See *Circuit, Shunt.*)

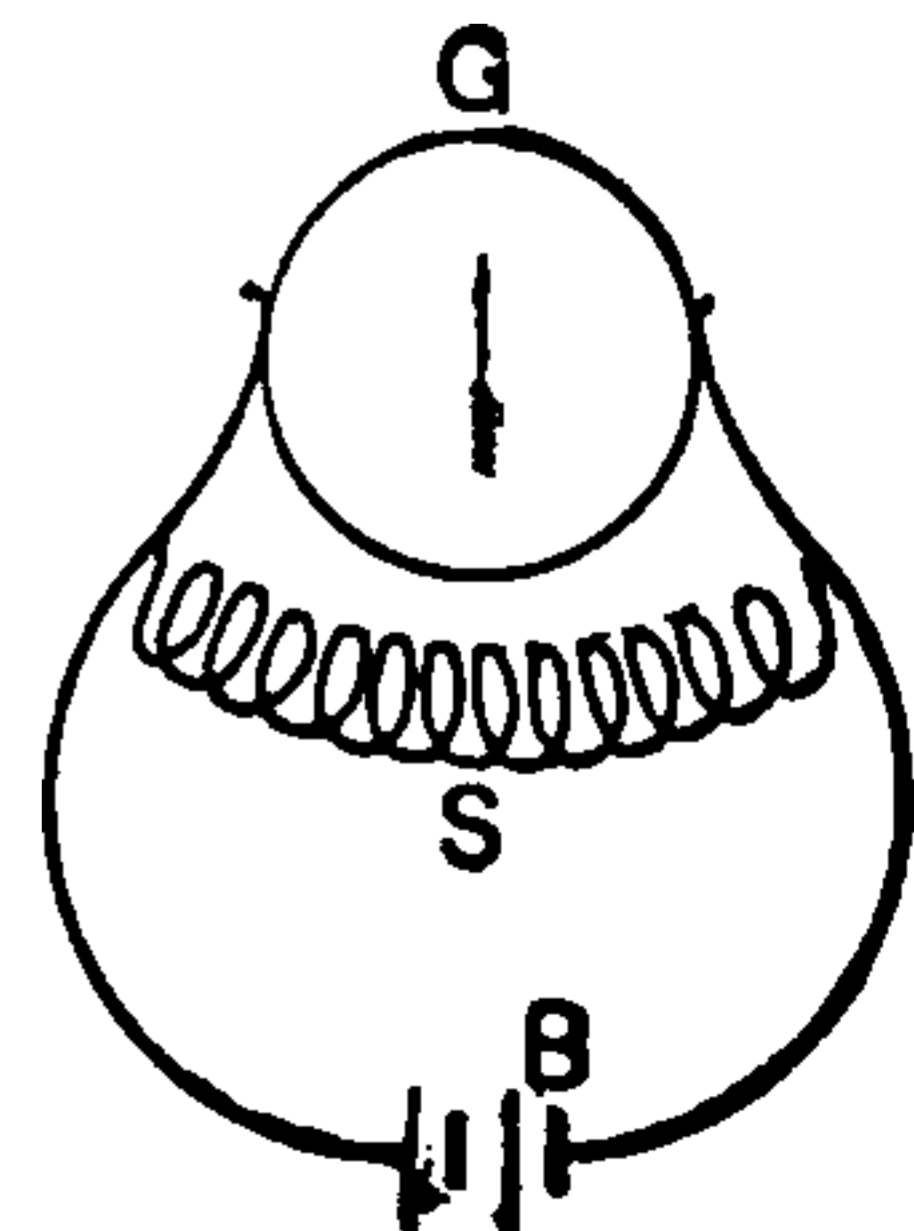

Fig. 125. Derived Circuit.

THIS PAGE IS LOCKED TO FREE MEMBERS

Purchase full membership to immediately unlock this page

Know Your Bible

Forgotten Books' Full Membership provides unlimited access to more than 28,000 volumes of Christian literature for \$8.99/month

HOLY BIBLE

Continue

*Fair use policy applies

A circuit whose conducting continuity is incomplete.

Circuit, Inductive — — Any circuit in which induction takes place.

Circuit, Internal — — That part of a circuit which is included within the electric source.

The electric current passing through the internal circuit does no useful work.

Circuit, Leg of — — One part of a twisted or metallic circuit.

Circuit, Line — — The wire or other conductors in the main line of any telegraphic or other electric circuit.

Circuit, Line, Telegraphic — — The conductor or line connecting different telegraphic stations.

Circuit, Local-Battery — — The circuit, in a telegraphic system, in which is placed a local battery as distinguished from a main battery. (See *Telegraphy, American or Morse System of.*)

Circuit, Loop — — A term sometimes applied to a circuit in parallel or multiple-arc. (See *Circuit, Multiple.*)

Circuit Loop Break. — (See *Break, Circuit Loop.*)

Circuit, Made — — A completed circuit. A circuit, whose conducting continuity is unbroken.

A made circuit is often called a completed or closed circuit. (See *Circuit, Closed.*)

Circuit, Magnetic — — The path through which the lines of magnetic force pass.

All lines of magnetic force form closed circuits.

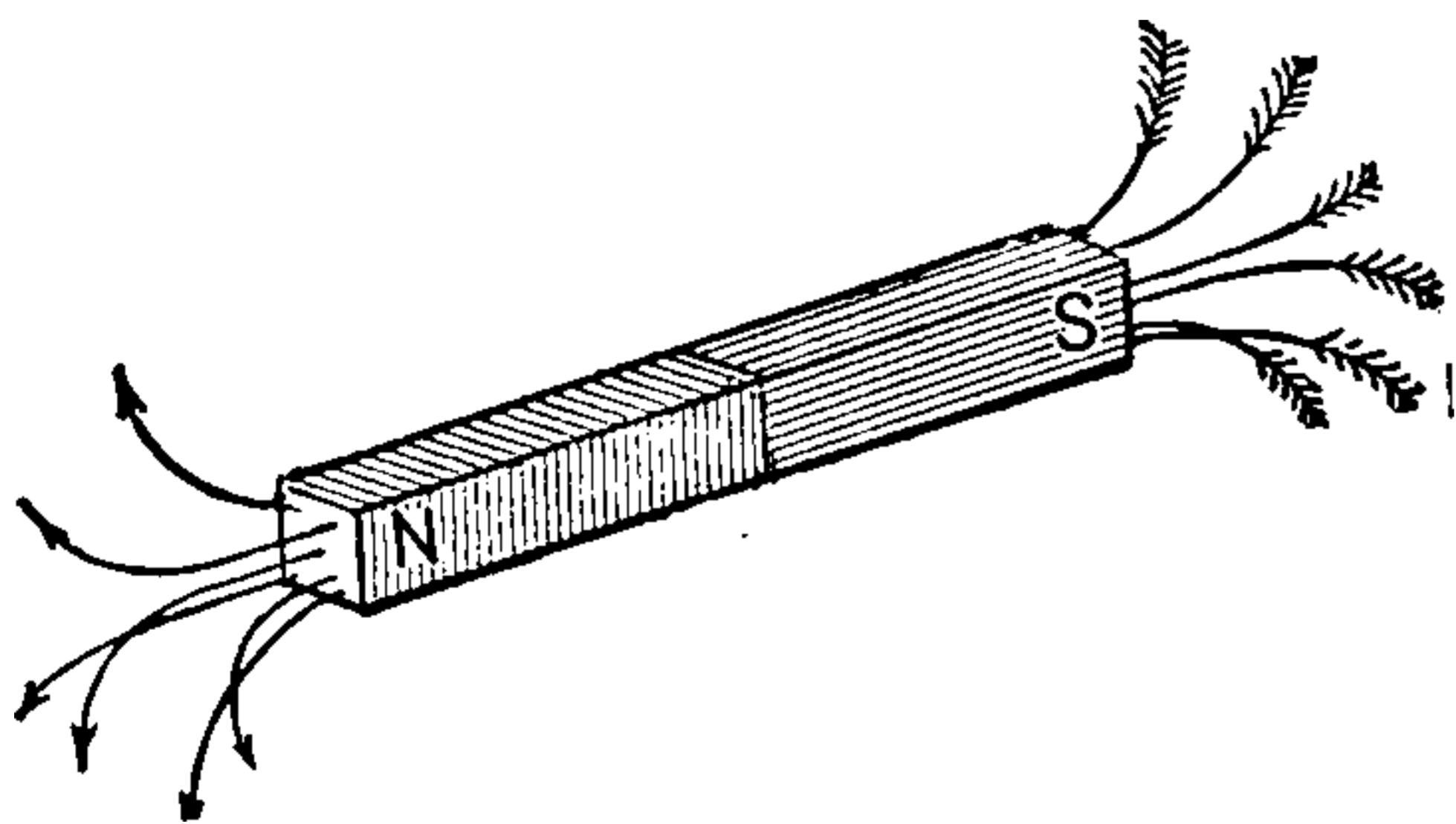

Fig. 127. Magnetic Circuit.

In the bar magnet, shown in Fig. 127, part of this path is through the air. In order to reduce or lower the *resistance* of a magnetic circuit, iron

is often placed around the magnet. The magnet is then said to be *iron-clad*.

The armature of a magnet lowers the magnetic resistance by affording a better path for the lines of magnetic force than the air between the poles.

The magnetic circuit always tries to shorten its path, or to render itself as compact as possible. This is seen in the action of an armature drawn towards a magnet pole.

Circuit, Main-Battery — — A term sometimes used for line circuit. (See *Circuit, Line.*)

Circuit, Metallic — — A circuit in which the ground is not employed as any part of the path of the current, metallic conductors being employed throughout the entire circuit.

Circuit, Multiple — — A compound circuit, in which a number of separate sources or separate electro-receptive devices, or both, have all their positive poles connected to a single positive lead or conductor, and all their negative poles to a single negative lead or conductor.

The connection of three Bunsen cells, in multiple, is shown in Fig. 128, where the three car-

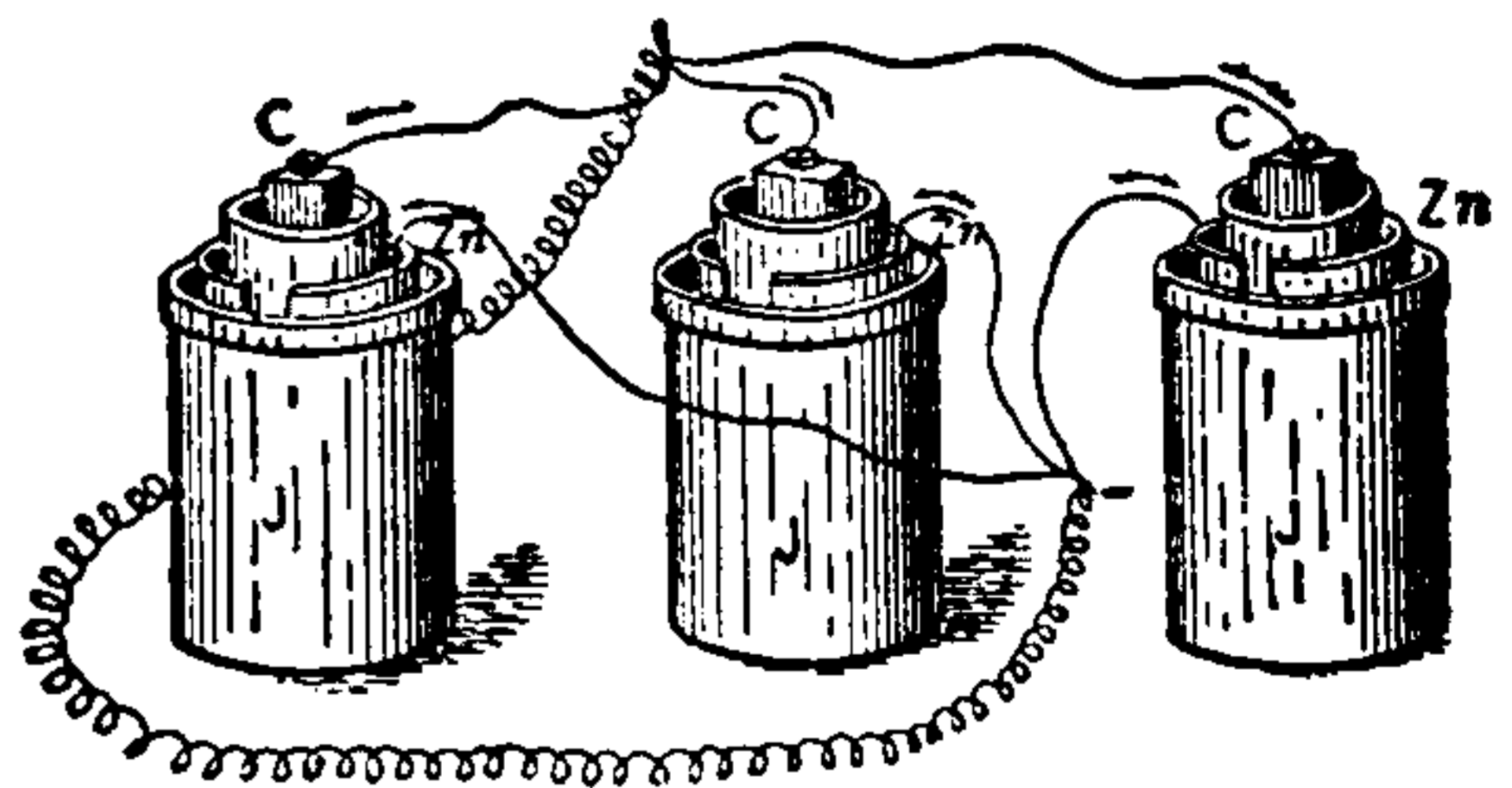

Fig. 128. Batteries connected in a Multiple Circuit.

bons, C, C, C, are connected together so as to form the positive, or + terminal of the battery, and the three zincs, Zn, Zn, Zn, are similarly connected together so as to form the negative, or — terminal.

The electromotive force is the same as that of a single cell, or source. The internal resistance of the source is as much less than the resistance of any single source as the area of the combined negative or positive plates is greater than that of any single negative or positive plate; or, in other words, is less in proportion to the number of cells, or other separate sources so coupled.

The connection of six cells in multiple or parallel circuit, is shown in Fig. 129.

In the case of the six cells, the current would be,

$$C = \frac{E}{\frac{r}{6} + r'}$$

where E , is the electromotive force, r , the internal, and r' , the external resistance.

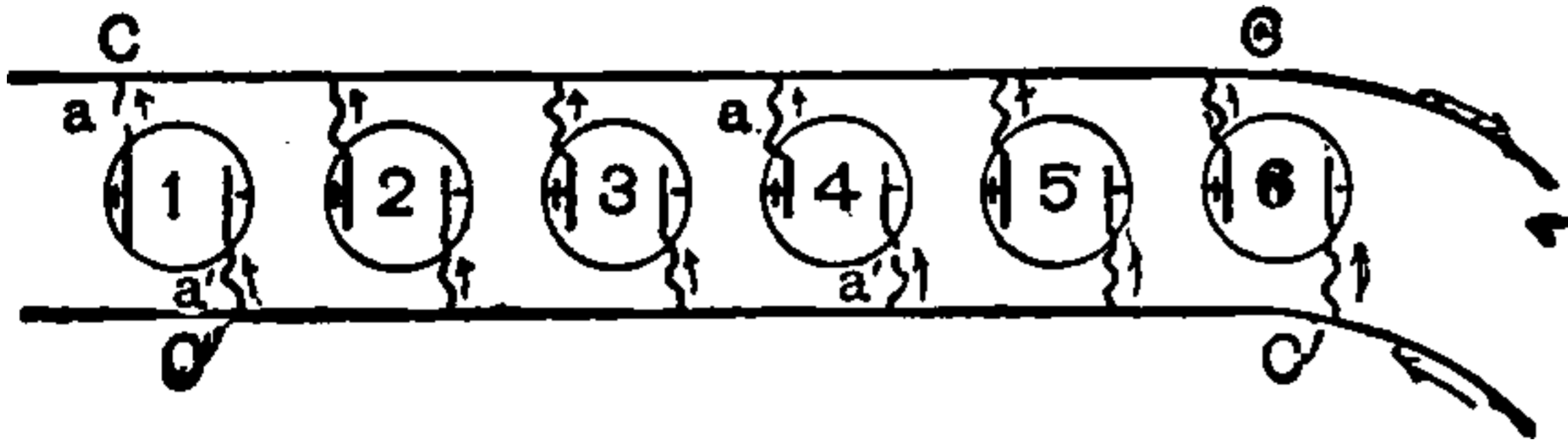

Fig. 129. Six Cells Connected in Multiple.

In the case of voltaic cells the effect of multiple connection on the internal resistance of the source is to increase the area of cross-section of the liquid in the direct proportion of the number of cells added, and consequently to decrease the resistance in the same proportion.

When strong or large currents of low electromotive force are required, connections in multiple-arc are generally employed.

The multiple-arc connection was formerly called *connection-for-quantity*. This term is now abandoned.

The total resistance for the parallel circuit is obtained as follows: calling the separate resistances of the separate electro-receptive devices, R' , R'' , R''' , etc., etc., etc., total resistance,

$$R = \frac{R' \times R'' \times R'''}{R' R'' + R'' R''' + R' R'''}$$

or, what is the same thing, the conductivity is the sum of the reciprocal of the separate resistances, *i. e.:*

$$\text{Conductivity} = \frac{1}{R'} + \frac{1}{R''} + \frac{1}{R'''}$$

The joint resistance of only two separate resistances joined in a multiple-circuit is equal to the product of the separate resistances divided by their sum.

When the separate resistances joined in multiple arc are all of the same value, the joint resistance is equal to the resistance of one of them divided by their number.

Circuit, Multiple-Arc — — — A term often used for multiple circuit. (See *Circuit, Multiple*.)

Circuit, Multiple-Series — — — A compound circuit in which a number of separate

sources, or separate electro-receptive devices, or both, are connected in a number of separate groups in series, and these separate groups subsequently connected in multiple.

In Fig. 130, a multiple-series circuit of six

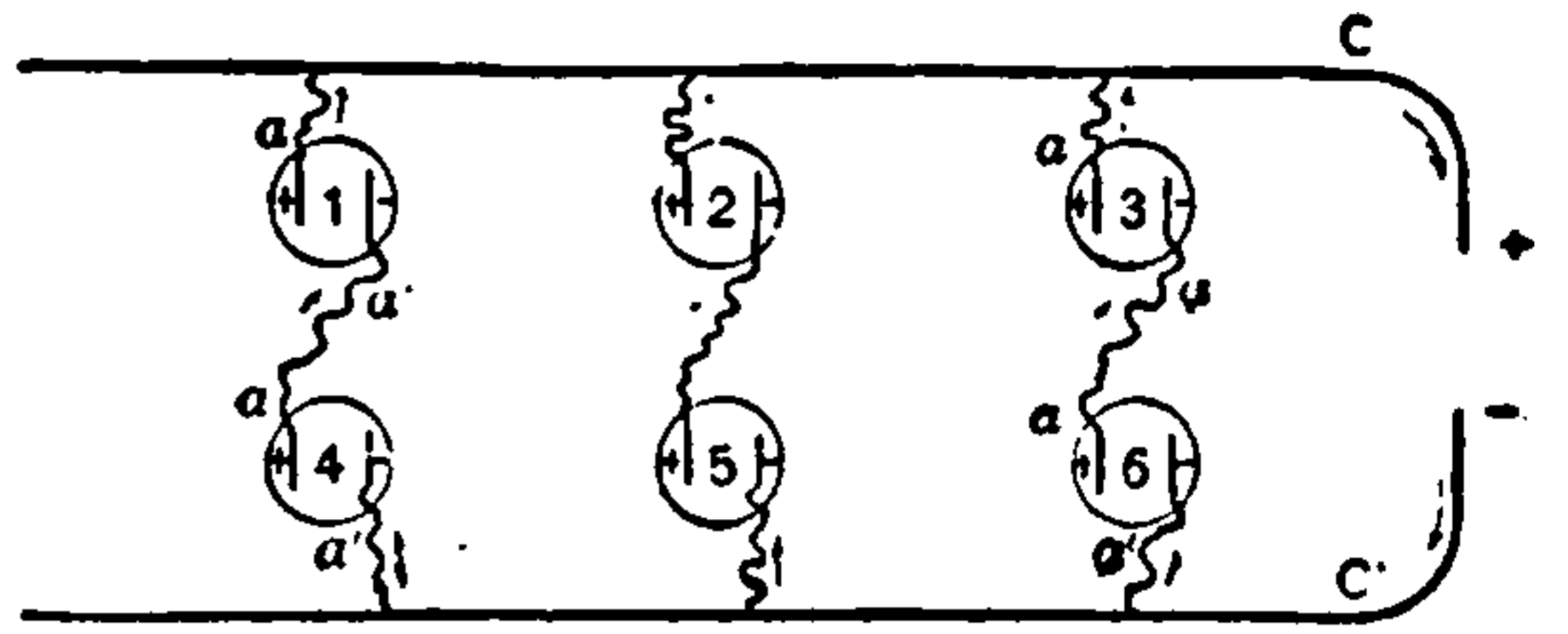

Fig. 130. Multiple-Series-Connected Cells.

sources is shown, in which three separate groups of two series-connected cells are coupled in multiple. The current takes the paths indicated by the arrows. The electromotive force of the source will be increased in proportion to the number of cells in series, and the internal resistance decreased in proportion to the number in parallel.

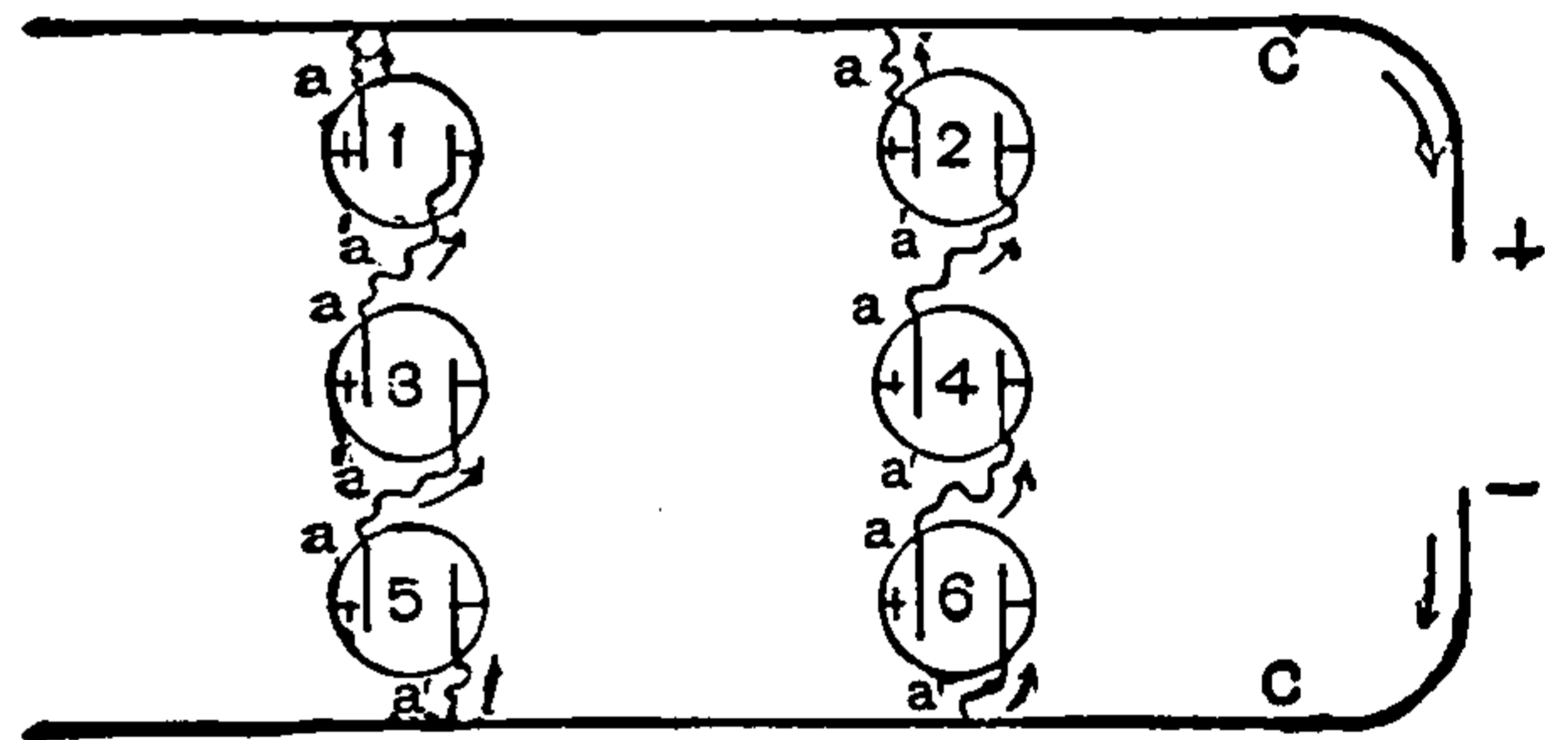

Fig. 131. Cells Connected in Multiple-Series.

$$C = \frac{3E}{\frac{3r}{2} + r'}$$

In Fig. 131, six cells are arranged in two groups of three series-connected cells, and these three groups connected in parallel.

Calling r , the resistance of each separate cell, the total resistance for the multiple-series circuit for a circuit containing three cells in parallel and two in series is,

$$R = \frac{2r}{3}$$

for three in series and two in parallel,

$$R = \frac{3r}{2}$$

If, therefore, the circuit of this battery be closed by a resistance equal to r , the current would be in the case of Fig. 130,

$$C = \frac{2E}{\frac{2r}{3} + r'}$$

Circuit, Negative Side of — — The side of a circuit opposite to the positive side. (See *Circuit, Positive Side of*.)

That side or half of a circuit connected to or leading from the positive terminal of the source of current.

Circuit, Open — — A broken circuit.

A circuit, the conducting continuity of which is broken.

Circuit, Open-Iron Magnetic — —

The path of a line of magnetic induction, which passes partly through iron, and partly through an air space.

The magnetic circuit is always closed, that is the lines of magnetic force always form closed paths. The term "open" is used in contradistinction only to "closed" iron magnetic circuit, in which the entire path of a line of force passes through iron. (See *Circuit, Magnetic*.)

Circuit, Parallel — — A name sometimes applied to circuits connected in multiple. (See *Circuit, Multiple*.)

Circuit, Parallel-Tree — — A form of parallel circuit in which the receptive devices are placed in parallel between the leads and returns, and the branches and sub-branches arranged in a tree-like form.

Circuit, Positive Side of — — That side of a circuit, bent in the form of a circle, in which, if an observer stood with his head in the positive region, he would see the current pass round him from his right hand towards his left.—(*Daniell*.)

Circuit, Recoil — — A term sometimes applied to the circuit that lies in the alternative path of a discharge. (See *Path, Alternative*.)

Circuit, Return — — That part of a circuit by which the electric current returns to the source.

In a multiple-circuit the lead that is connected to the negative terminals of the separate sources.

Circuit, Series — — A compound circuit in which the separate sources, or the separate electro-receptive devices, or both, are so placed that the current produced in each, or passed through each, passes successively

through the entire circuit from the first to the last.

The six cells, shown in Fig. 132, are connected in series by joining the positive pole of each cell with the negative pole of the succeeding cell, the negative and positive poles at the extreme ends

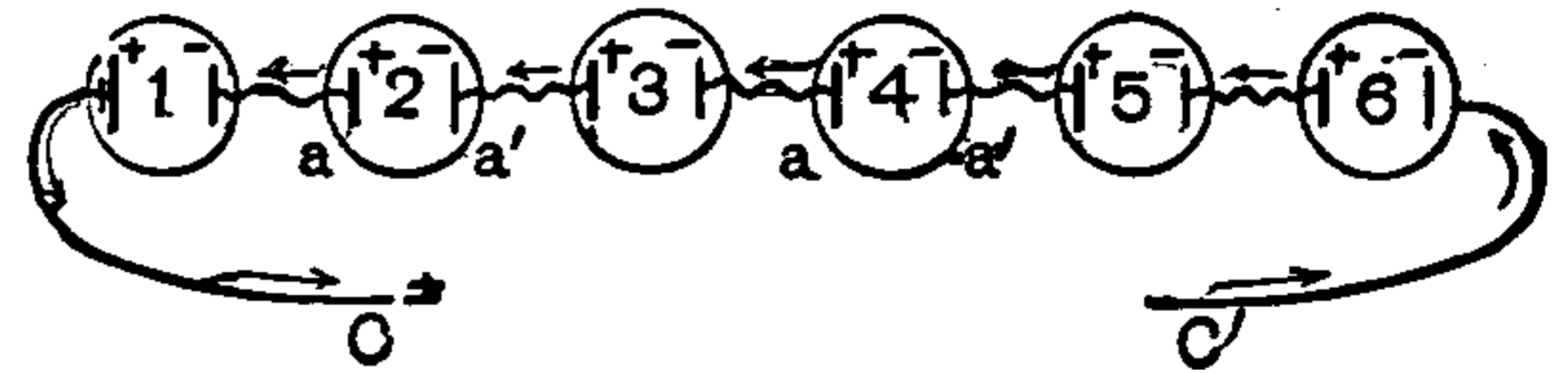

Fig. 132. Series Circuit.

being connected by conductors with the external circuit.

The connection of three Leclanché cells in series is clearly shown in Fig. 133. The carbons,

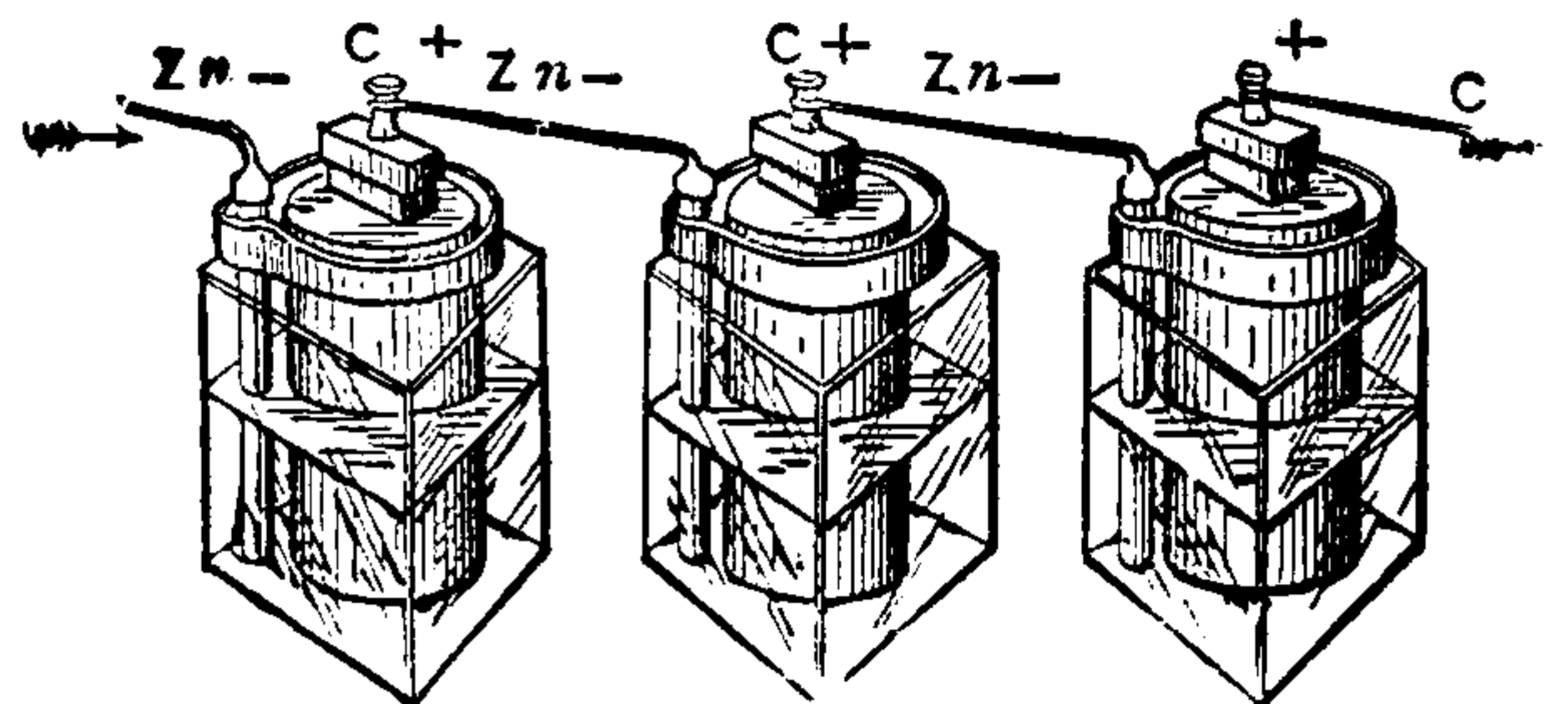

Fig. 133. Voltaic Cells Connected in Series.

C, C, of the first and second cells are connected to the zincs, Zn, Zn, of the second and third cells, thus leaving the zinc, Zn, of the first cell, and the carbon, C, of the third cell, as the terminals of the battery. The direction of the current is shown by the arrows.

The resistance of such a connection is equal to the sum of the resistances of all of the separate sources.

The electromotive force is equal to the sum of the separate electromotive forces.

If the electromotive force of a single cell is equal to E , its internal resistance to r , and the resistance of the leads and electro-receptive devices to r' , then the current in the circuit,

$$C = \frac{E}{r + r'}$$

If six of such cells are coupled in series, the current becomes

$$C = \frac{6E}{6r + r'}$$

If, however, the internal resistance of each cell be so small as to be neglected, the formula becomes

$$C = \frac{6E}{r'}$$

THIS PAGE IS LOCKED TO FREE MEMBERS

Purchase full membership to immediately unlock this page



HISTORY

Tens of thousands of important historical sources, many previously unobtainable, are now available for the first time with a Forgotten Books Full Membership.

Unlimited Access
\$8.99/month

Continue

*Fair usage policy applies

The time required from the moment of closing the circuit, for a current to rise to a value equal to $\frac{e-I}{e}$ of the full value, or .632 of the maximum value.

In the above, e , equals 2.71828, or the base of the Napierian system of logarithms.

The time-constant is proportional to the conductivity of the circuit and its formal resistance.

Approximately the time constant of a circuit is the time from closing the circuit, in which the current rises to two-thirds of its maximum value, this maximum value being determined by the formula, $C = \frac{E}{R}$.

The time-constant of a circuit may be reduced—

(1.) By decreasing the self-induction of the circuit.

(2.) By increasing the resistance.

In the case of a magnetic conductor the time-constant is proportional to a quantity (the permeability) which is determined by the capacity of the conductor to utilize part of the energy in producing magnetization of its substance.—(*Fleming.*)

Circuit, Voltaic — —The path through which the current flows out from a voltaic cell or battery, through the translating devices and back again to the cell or battery.

Circuits, Forked — —A term employed in telegraphy to indicate circuits that radiate from any single point.

Forked circuits are employed in simultaneously transmitting messages to several stations.

Circuits, Varieties of — —Conducting paths provided for the passage of an electric current.

Electric circuits may be divided, according to their complexity, into—

- (1.) Simple.
- (2.) Compound.

According to the peculiarities of their connections, into—

- (1.) Shunt or derived.
- (2.) Series.
- (3.) Multiple, multiple-arc or parallel.
- (4.) Multiple-series.
- (5.) Series-multiple.

Either the circuits, the sources, or the electro-

receptive devices may be connected in series, in multiple, in multiple-series or in series-multiple.

According to their resistance, circuits are divided into—

- (1.) High-resistance.
- (2.) Low-resistance.

According to their relation to the electric source, into—

- (1.) Internal circuits.
- (2.) External circuits.

According to their position, or the work done, circuits are divided into very numerous classes; thus, in telegraphy, we have the following, viz.:

- (1.) The line-circuit.
- (2.) The earth or ground circuit.
- (3.) The local-battery circuit.
- (4.) The main-battery circuit, etc.

Circular Bell.—(See *Bell, Circular.*)

Circular Units.—(See *Units, Circular.*)

Circular Units (Cross-Sections), Table of — —(See *Units, Circular (Cross-Sections), Table of.*)

Clamp, Carbon — —A carbon clutch. (See *Clutch, Carbon, of Arc Lamp.*)

Clamp for Arc Lamps.—A clamp for gripping the lamp-rod, *i. e.*, the rod that supports the carbon electrodes of arc lamps. (See *Lamp, Electric, Arc.*)

Clamp, Rod — —A carbon clutch. (See *Clamp for Arc Lamps.*)

Clark's Compound.—(See *Compound, Clark's.*)

Clark's Standard Voltaic Cell.—(See *Cell, Voltaic, Standard, Clark's.*)

Clark's Standard Voltaic Cell, Rayleigh's Form of — —(See *Cell, Voltaic, Standard, Rayleigh's Form of Clark's.*)

Clay Electrode.—(See *Electrode, Clay.*)

Cleansing, Fire — —The removal of grease from metallic articles, that are to be electro-plated, by subjecting them to the action of heat.

This cleansing is for the purpose of obtaining a uniform, adherent coating.

Clearance-Space.—(See *Space, Clearance.*)

Clearing-Out Drops.—(See *Drops, Clearing-Out.*)

Cleat, Crossing — — A cleat so arranged as to permit the crossing of one pair of wires under or over another pair without contact with each other.

Cleat-Wiring.—(See *Wiring, Cleat.*)

Cleats, Electric — — Suitably shaped pieces of wood, porcelain, hard rubber or other non-conducting material used for fastening and supporting electric conductors to ceilings, walls, etc.

A simple form of wooden cleat is shown in Fig. 135.



Fig. 135. Wooden Cleat.

Clepsydra, Electric — — An instrument for measuring time by the escape of water or other liquid under electrical control.

Climbers, Pole — — Devices employed by linemen for climbing wooden telegraph poles.

A climber with straps for attachment to the leg and foot is shown in Fig. 136.

Clip, Cable — — A term sometimes used for cable hanger. (See *Hanger, Cable.*)

Clock, Electric — — A clock, the works of which are moved, controlled, regulated or wound, either entirely or partially, by the electric current.

Electric clocks may be divided into three classes, viz.:

(1.) Those in which the works are moved entirely or partially by the electric current.

(2.) Those which are controlled or regulated by the electric current.

(3.) Those which are merely wound by the current.

A clock moving independently of electric power is prevented from gaining or losing time, by means of a slight retardation or acceleration electrically imparted. The entire motion of the balance wheel is, sometimes imparted by electricity.

An example of one of many forms of controlling electric clocks is shown in Fig. 137, where the split battery (See *Battery, Split*), P N, is connected, as shown, to the spring contacts S and S'. In this way currents are sent into the circuit in alternately opposite directions.

The pendulum bob, Fig. 138, of the controlled clock is formed of a hollow coil of insulated wire, which encircles one or both of two permanent magnets, A and A', placed with their opposite poles facing each other.

When the pendulum of the controlling clock is in the position shown in Fig. 137, the current passes in the direction E P S n W, etc., and through the coil C, Fig. 138. When the pendulum of the controlling clock is in contact with S', the current flows through W n S' N E, etc., and through the coil C in the opposite direction. In this manner a slight motion forwards or backwards is imparted to the pendulum, which is thus kept in time with the controlling clock.

Mercury contacts are sometimes employed in place of the springs S and S'. Induction currents may also be employed.

Clocks of non-electric action may be electrically controlled, or correctly set at certain intervals, either automatically by a central clock, or by the depression of a key operated by hand from an astronomical observatory.

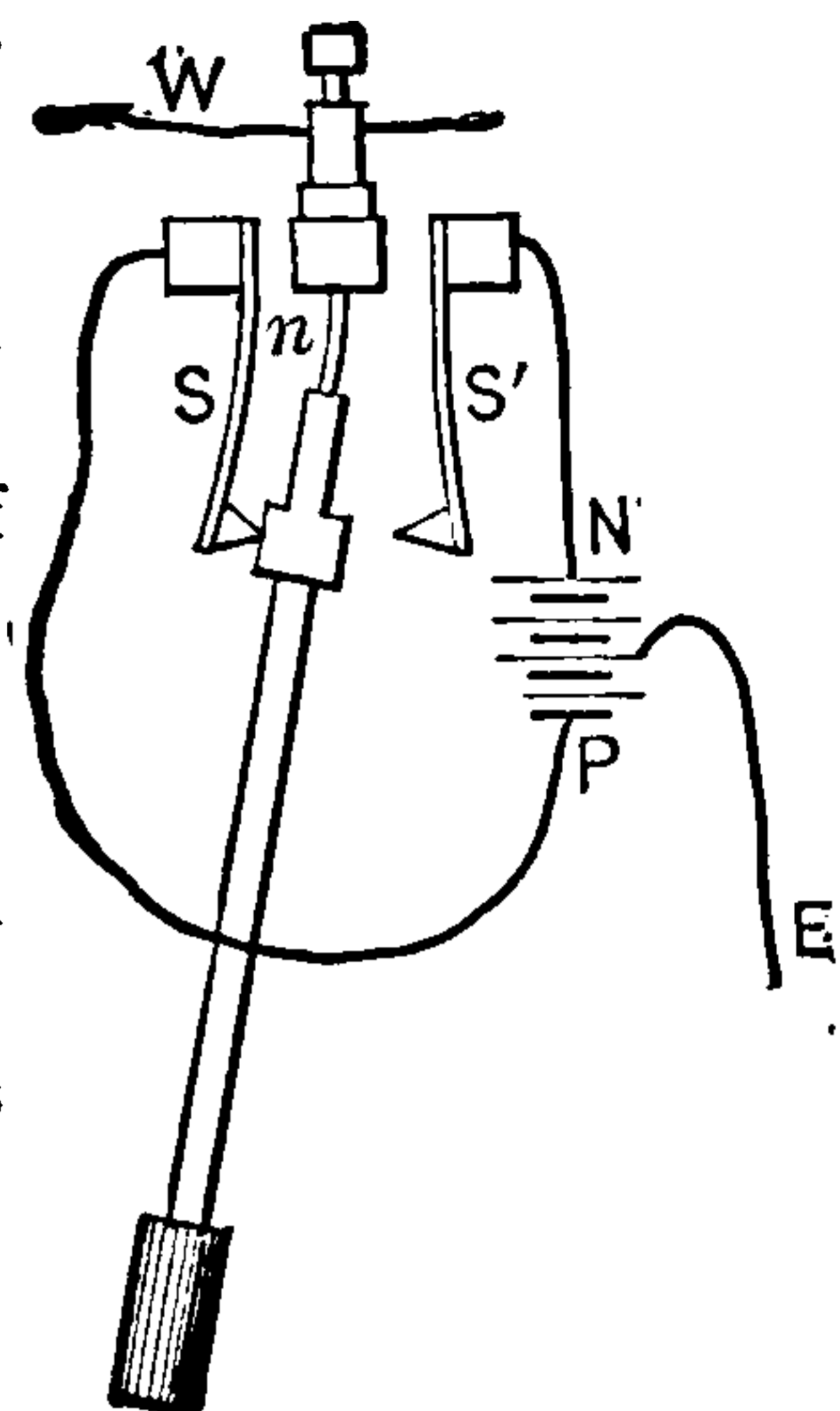

Fig. 137. Controlling Clock.

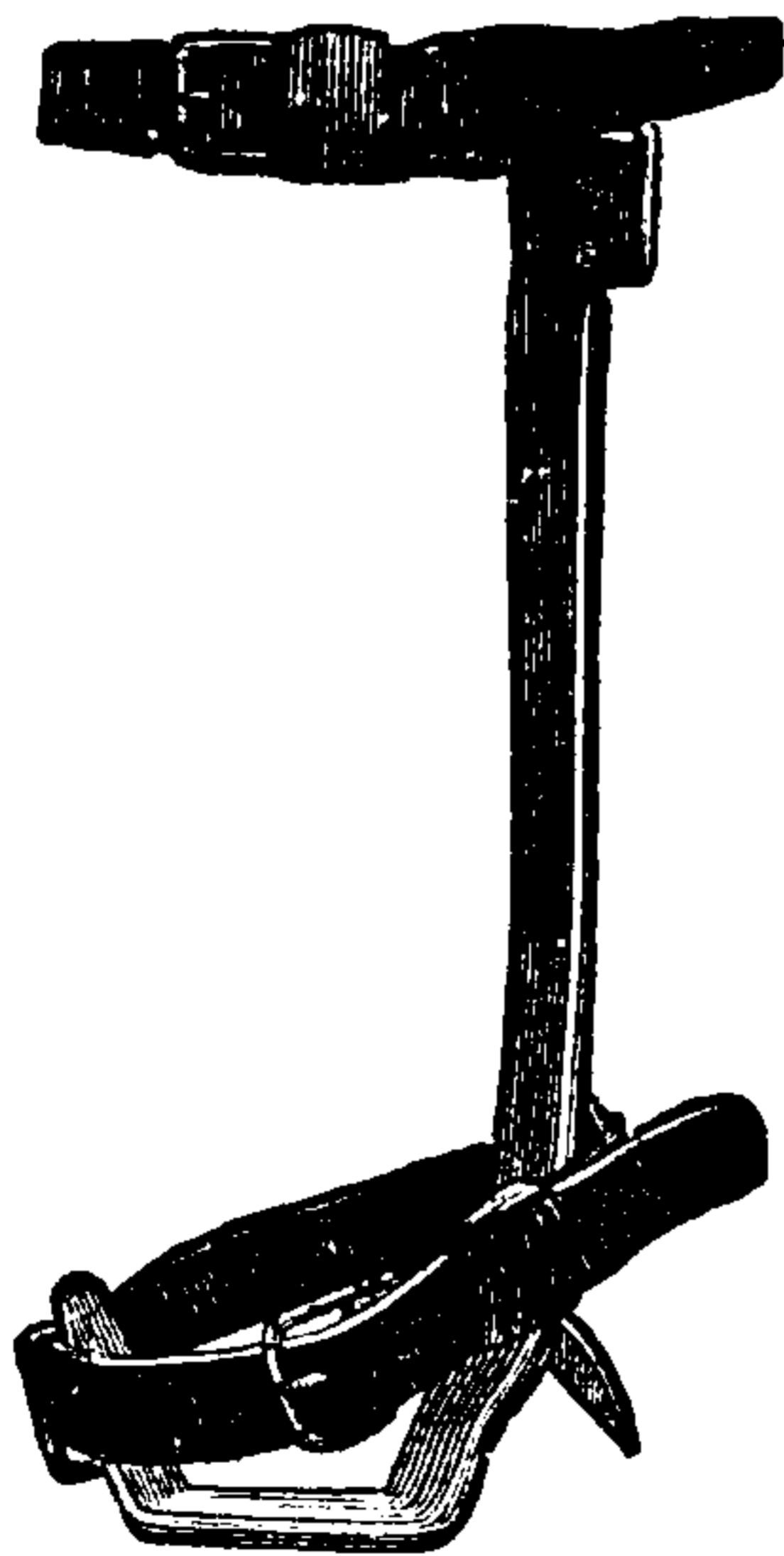

Fig. 136. Climber and Straps.

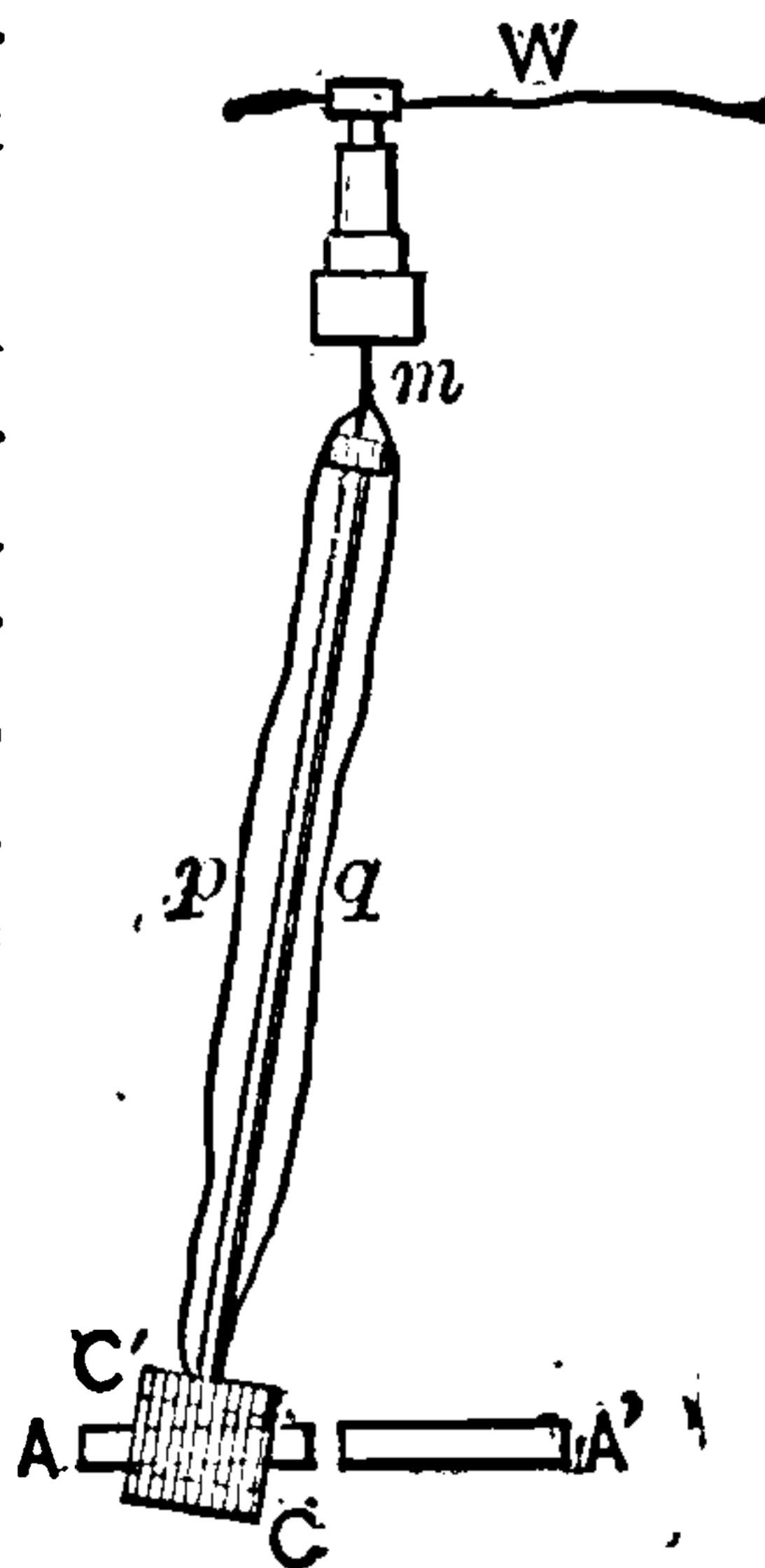

Fig. 138. Controlled Clock.

In a system of *time-telegraphy*, the controlling clock is called the *master clock*, and the controlled clocks, the *secondary clocks*.

Secondary clocks are generally mere dials, con-

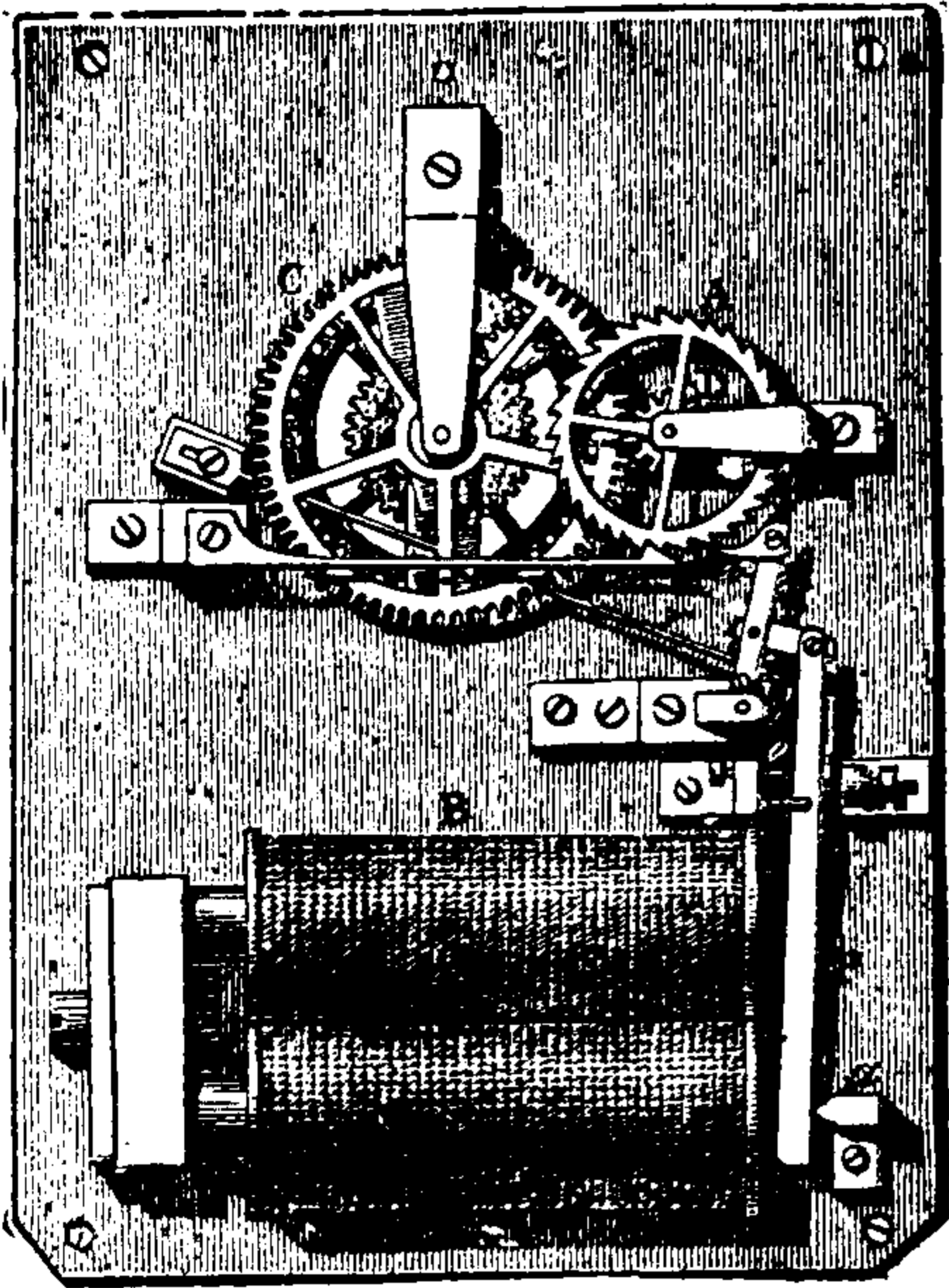

Fig. 139. Mechanism of Secondary Clock.

taining *step-by-step movements*, for moving the hour, minute and second hands, as shown in Fig. 139.

In Spellier's clock, a series of armatures H, Fig. 140, mounted on the circumference of a

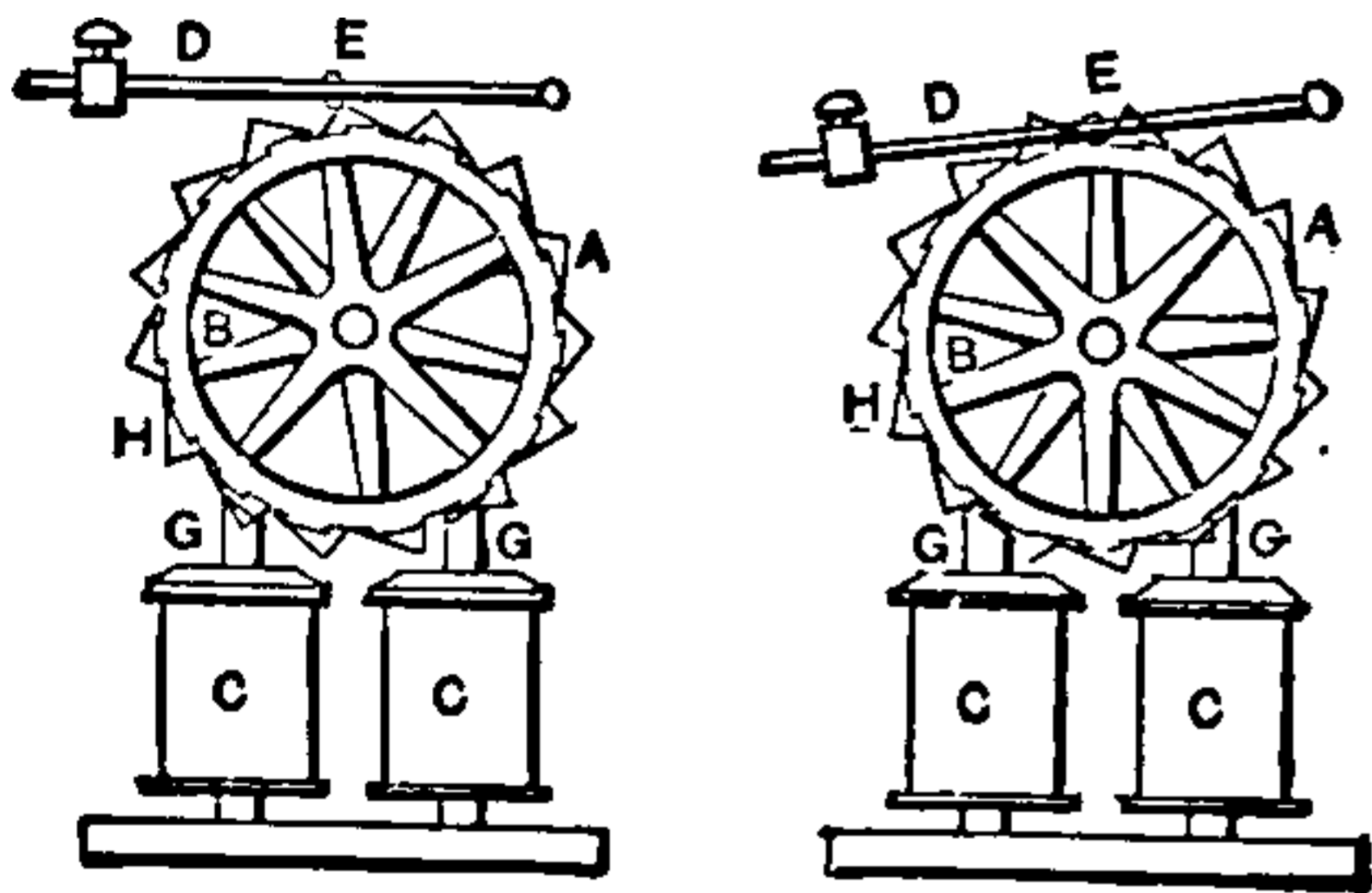

Fig. 140. Spellier's Electric Clock.

wheel, connected with the escapement wheel, pass successively, with a step-by-step movement, over the poles of electro-magnets. On the completion of the circuit, they are attracted towards the magnet, and on the breaking of the circuit they are drawn away by the fall of the weight F, placed on the lever D, pivoted at E. A pulley at E, runs over the surface of a peculiarly shaped cog on the escapement wheel.

Clock, Electric Annunciator — —A clock, the hands or works of which, at certain predetermined times, make electric contacts and thus ring bells, release drops, trace records, etc.

Clock, Electrical-Controlling — —In a system of time telegraphy, the master clock, whose impulses move or regulate the secondary clocks. (See *Clock, Electric*.)

Clock, Electrically-Controlled — —In a system of time telegraphy, a secondary clock, that is either driven or controlled by the master clock. (See *Clock, Electric*.)

Clock, Electrolytic, Tesla's — —A time piece in which the rotation of the wheel work is obtained by the difference in weight of the two halves of a delicately pivoted and well-balanced wheel placed in an electrolytic bath.

In the electrolytic clock of Nikola Tesla, a delicately formed and balanced disc of copper is supported on a horizontal axis at right angles to the shortest distance between the two electrodes, and placed in a bath of copper sulphate. Its two halves become respectively electro-positive and electro-negative when a current is passed through the bath, and consequently metal is deposited on one half and dissolved from the other half. The rotation of the disc under the influence of gravity is caused to mark time.

An electrolytic clock could therefore be made to answer roughly as an electric meter.

Clock, Master — —The central or controlling clock in a system of electric time-distribution, from which the time is transmitted to the secondary clocks in the circuit. (See *Clock, Electric*.)

Clock, Secondary — —Any clock in a system of time telegraphy that is controlled by the master clock. (See *Clock, Electric*.)

Clock, Self-Winding — —A clock that at regular intervals is automatically wound by the action of a small electro-magnetic motor contained within it.

This motor is usually run by one or more voltaic cells, concealed in the case of the clock.

Closed-Circuit.—(See *Circuit, Closed*.)

Closed-Circuit Battery.—(See *Battery, Closed-Circuit*.)

Closed-Circuit, Single-Current, Signaling — —(See *Signaling, Single-Current, Closed-Circuit*.)

THIS PAGE IS LOCKED TO FREE MEMBERS

Purchase full membership to immediately unlock this page

Know Your Bible

Forgotten Books' Full Membership provides unlimited access to more than 28,000 volumes of Christian literature for \$8.99/month

HOLY BIBLE

Continue

*Fair use policy applies

The *efficiency* may be the *commercial efficiency*, which is the useful or available energy in the external circuit divided by the total mechanical energy; or it may be the *electrical efficiency*, which is the available electrical energy divided by the total electrical energy.

The *efficiency of conversion* is the total electrical energy developed, divided by the total mechanical energy applied.

If M , equals the mechanical energy,

W , the useful or available electrical energy,
and

w , the electrical energy absorbed by the machine, and

m , the *stray power*, or the power lost in friction, eddy currents, air friction, etc.

Then, since

$$M = W + w + m,$$

The Commercial Efficiency

$$= \frac{W}{M} = \frac{W}{W + w + m}.$$

The Electrical Efficiency

$$= \frac{W}{W + w}.$$

The Efficiency of Conversion

$$= \frac{W + w}{M} = \frac{W + w}{W + w + m}.$$

Co-efficient of Electro-Magnetic Inertia.

—(See *Inertia, Electro-Magnetic, Co-efficient of*.)

Co-efficient of Expansion.—(See *Expansion, Co-efficient of*.)

Co-efficient of Expansion, Linear — —
(See *Expansion, Linear, Co-efficient of*.)

Co-efficient of Magnetic Induction.—(See *Induction, Magnetic, Co-efficient of*.)

Co-efficient of Magnetization.—(See *Magnetization, Co-efficient of*.)

Co-efficient of Mutual-Inductance.—(See *Inductance, Mutual, Co-efficient of*.)

Co-efficient of Mutual-Induction.—(See *Induction, Mutual, Co-efficient of*.)

Co-efficient of Self-Induction.—(See *Induction, Self, Co-efficient of*.)

Coercitive Force.—(See *Force, Coercitive*.)

Coercive Force.—(See *Force, Coercive*.)

Coil, Choking — — — A coil of wire so

wound on a core of iron as to possess high self-induction.

Choking-coils are used to obstruct or cut off an alternating current with a loss of power less than with the use of a mere ohmic resistance.

Fig. 141 shows a choking-coil. It consists of a circular solenoid of insulated wire, wound on a core of soft iron wire. A thorough division of the core is obtained by forming it of coils of insulated iron wire. In this way, no eddy currents are produced in the coil. When a simple periodic electromotive force is applied to the terminals of such a coil, if the magnetic permeability of the coil is constant, a simple periodic current is produced, which lags behind the phase of the impressed electromotive force by a constant angle. If the impressed electromotive force is sufficiently great to more than saturate the core, the choking coil ceases to choke the current. The higher the periodicity the greater is the choking effect of a given coil, or the smaller the coil may be made to produce a given effect.

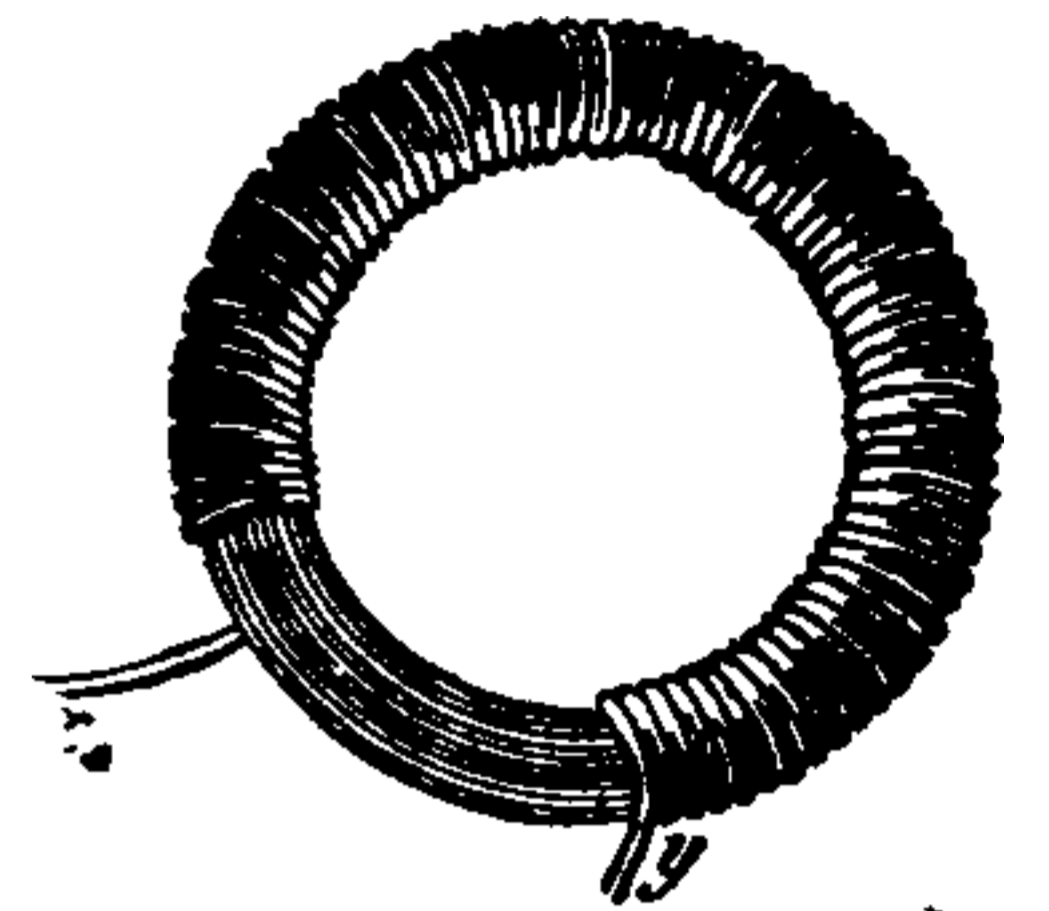

Fig. 141. Choking-Coil.

Since an open-magnetic circuit requires a greater current to saturate it than a closed-magnetic circuit, the complete throttling or choking power of such a coil is increased by forming its core of a closed magnetic circuit, *i. e.*, of a circuit in which there is no air space or gap. (See *Circuit, Divided-Magnetic. Circuit, Closed-Magnetic*.)

Coil, Electric — — — A convolution of insulated wire through which an electric current may be passed. (See *Magnet, Electro*.)

Coil, Electric — — — A convolution of insulated wire through which an electric current may be passed. (See *Magnet, Electro*.)

The term coil is usually applied to a number of turns or to a spool of wire.

Coil, Impedance — — — A term sometimes applied to a choking-coil. (See *Coil, Choking*.)

Such a coil has a high self-induction. Its impedance is therefore high. (See *Induction, Self-Impedance*.)

Coil, Induction — — — An apparatus consisting of two parallel coils of insulated wire employed for the production of currents by mutual induction. (See *Induction, Mutual. Induction, Electro-Dynamic*.)

A rapidly interrupted battery current, sent through a coil of wire called the *primary coil*, induces alternating currents in a coil of wire called the *secondary coil*.

As heretofore made, the primary coil consists of a few turns of a thick wire, and the secondary coil of many turns, often thousands, of fine wire. Such coils are generally called *Ruhmkorff coils*, from the name of a celebrated manufacturer of them.

In the form of Ruhmkorff coil, shown in Fig. 142, the primary wire, wound on a core formed

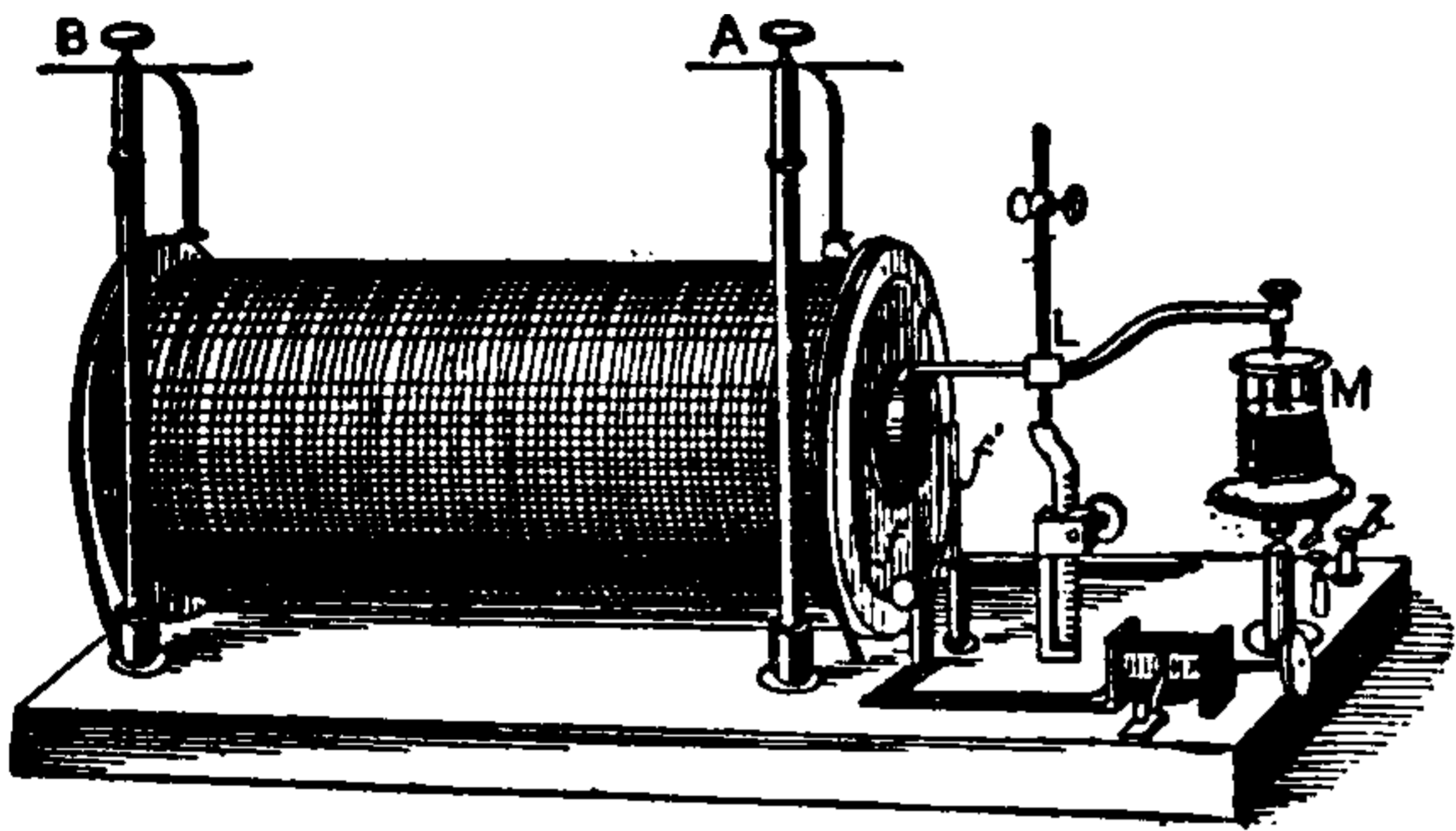

Fig. 142. Ruhmkorff Coil.

of a bundle of soft iron wires, has its ends brought out as shown at *f, f'*. The fine wire, forming the secondary coil, is wrapped around an insulated cylinder of vulcanite, or glass, surrounding the primary coil. This wire is very thin, and in some coils is over one hundred miles in length.

If the core of an induction coil were made solid it would heat considerably and therefore cause a loss of energy. The core is therefore laminated, usually by forming it of a bundle of soft iron wire.

Too great a division of the core, however, is inadvisable, since, although the eddy currents therein are thereby avoided, yet, too great a division of the core acts practically so to decrease the magnetic permeability that the greatest efficiency cannot be obtained.

The ends of the secondary coil are connected to the insulated pillars A and B.

The primary current is rapidly broken by means of a mercury break, shown at L and M.

The *commutator*, shown to the right and front of the base, is provided for the purpose of cutting off the current through the primary, or for changing its direction. When a battery which produces a comparatively large current of but a few volts electromotive force is connected with the primary, and its current rapidly interrupted, a torrent of sparks will pass between A and B, having an electromotive force of many thousands of times the number of volts of the primary cur-

rent, but of a correspondingly smaller current strength.

In such cases, excepting losses during conversion, the energy in the primary current, or *C E*, is equal to the energy in the secondary current, or *C' E'*. As much therefore as *E'*, the electromotive force of the secondary current, exceeds *E*, the electromotive force of the primary current, the current strength *C'*, of the secondary, will be less than the current strength *C*, of the primary. This is approximately true only, and only in induction coils possessing a closed magnetic circuit. (See *Transformer*.)

Fig. 143 shows diagrammatically the arrange-

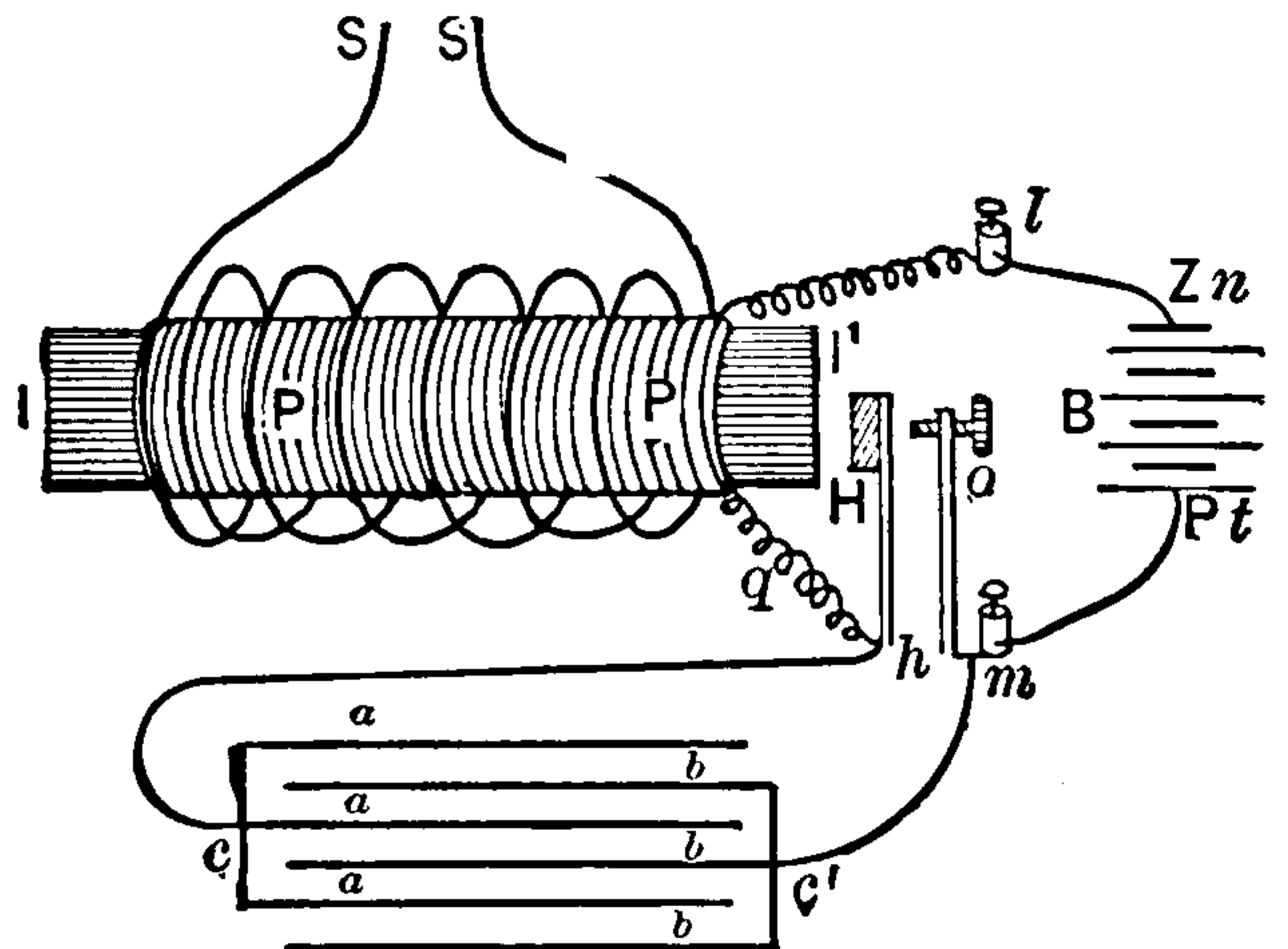

Fig. 143. Circuit Connections of Induction Coil.

ment and connection of the different parts of an induction coil.

The core *II'*, consists of a bundle of soft iron wires, each of which is covered with a thin insulating layer of varnish or oxide. A primary wire *PP*, consisting of a few turns of comparatively thick wire, is wound around the core, and a greater length of thin wire *SS*, is wound upon the primary. This is called the secondary. So as not to confuse the details of the figure it is represented as a few turns.

The terminals of the battery *B*, are connected to the primary wire, through the automatic interrupter, in the manner shown. It will be seen that the attraction of the core *II'*, for the vibrating armature *H*, will break contact at the point *o*, and cause a continued interruption of the battery current.

The condenser *cc'*, is connected as shown. It acts to diminish the sparking at the contact points on breaking contact, and thus, by making the battery current more sudden, to make its inductive action greater.

The reactions which take place when a simple

periodic electromotive force is impressed on the primary of an induction coil are substantially thus stated by J. A. Fleming:

(1.) The application of a simple periodic impressed electromotive force produces a simple periodic current, moving under an effective electromotive force of self-induction, and brings into existence a counter-electromotive force of self-induction, which causes the primary current to lag behind, by an angle called the angle of lag.

(2.) The field around the primary, and, therefore, the induction through the secondary, is *in consonance* with the primary current, and the impressed electromotive force in the secondary is *in quadrature* with the primary current. (See *Consonance. Quadrature, In.*)

(3.) The secondary-impressed electromotive force gives rise to a secondary current moving under an effective electromotive force and creating a counter electromotive force of self-induction.

(4.) This secondary current reacts in its turn on the primary, and creates what is called the back-electromotive force, or the reacting-inductive-electromotive force of the primary circuit.

(5.) There is then a phase-difference between the primary and secondary currents, and also between the primary-impressed electromotive force and the primary current.

If, as in Fig. 144, two electric circuits are

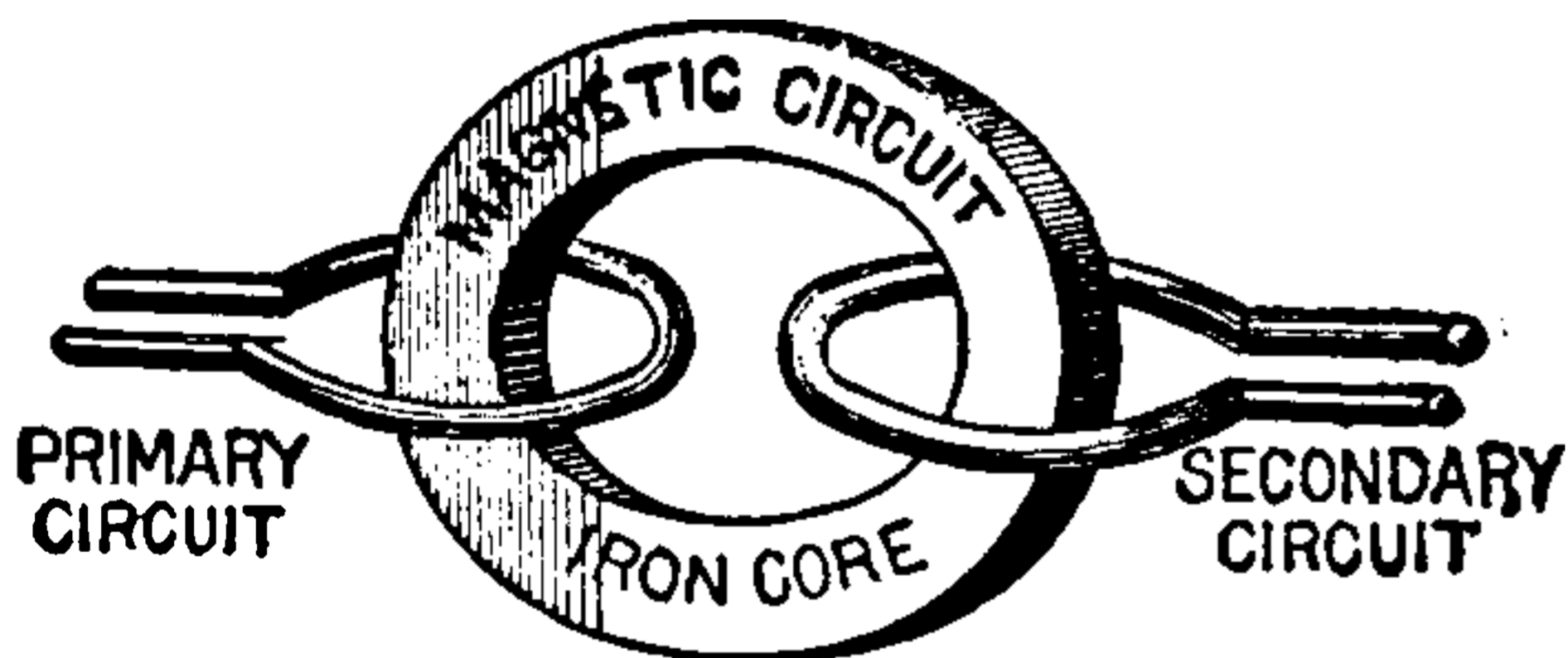

Fig. 144. *Electric and Magnetic Link.*

linked with a magnetic circuit, and a small periodic electromotive force be impressed on the primary, the following phenomena occur:

(1.) A periodic primary current is set up in the primary circuit, which, though of the same periodic time as the impressed electromotive force, differs from it in phase.

(2.) A wave of counter electromotive force is produced in the primary circuit by the inductive action, which does not coincide either with the impressed electromotive force, nor with the primary current.

(3.) A wave of magnetization is produced in the iron core, which lags behind the primary

current by somewhat less than 90 degrees of phase.

(4.) A wave of impressed electromotive force is produced in the secondary circuit, due to and measured by the rate of change of magnetic induction in the core, and lagging 90 degrees, or more, behind the magnetization wave.

(5.) A wave of secondary current, lagging behind the secondary electromotive force in phase, except where the circuit consists of a few turns of conductor, or is connected with an external circuit of practically no inductance.—(*Fleming.*)

Coil, Induction, Inverted — — An induction coil in which the primary coil is made of a long, thin wire, and the secondary coil of a short, thick wire.

By the use of an inverted coil, a current of high electromotive force and comparatively small current strength, *i. e.*, but of few *ampères*, is *converted* or *transformed* into a current of comparatively small electromotive force and large current strength. For advantages of this conversion see *Electricity, Distribution of, by Alternating Currents.*

Inverted induction coils are called *converters* or *transformers*. (See *Transformer.*)

Coil, Induction, Medical — — An induction coil used for medical purposes.

A form of induction coil used for medical purposes is shown in Fig. 145.

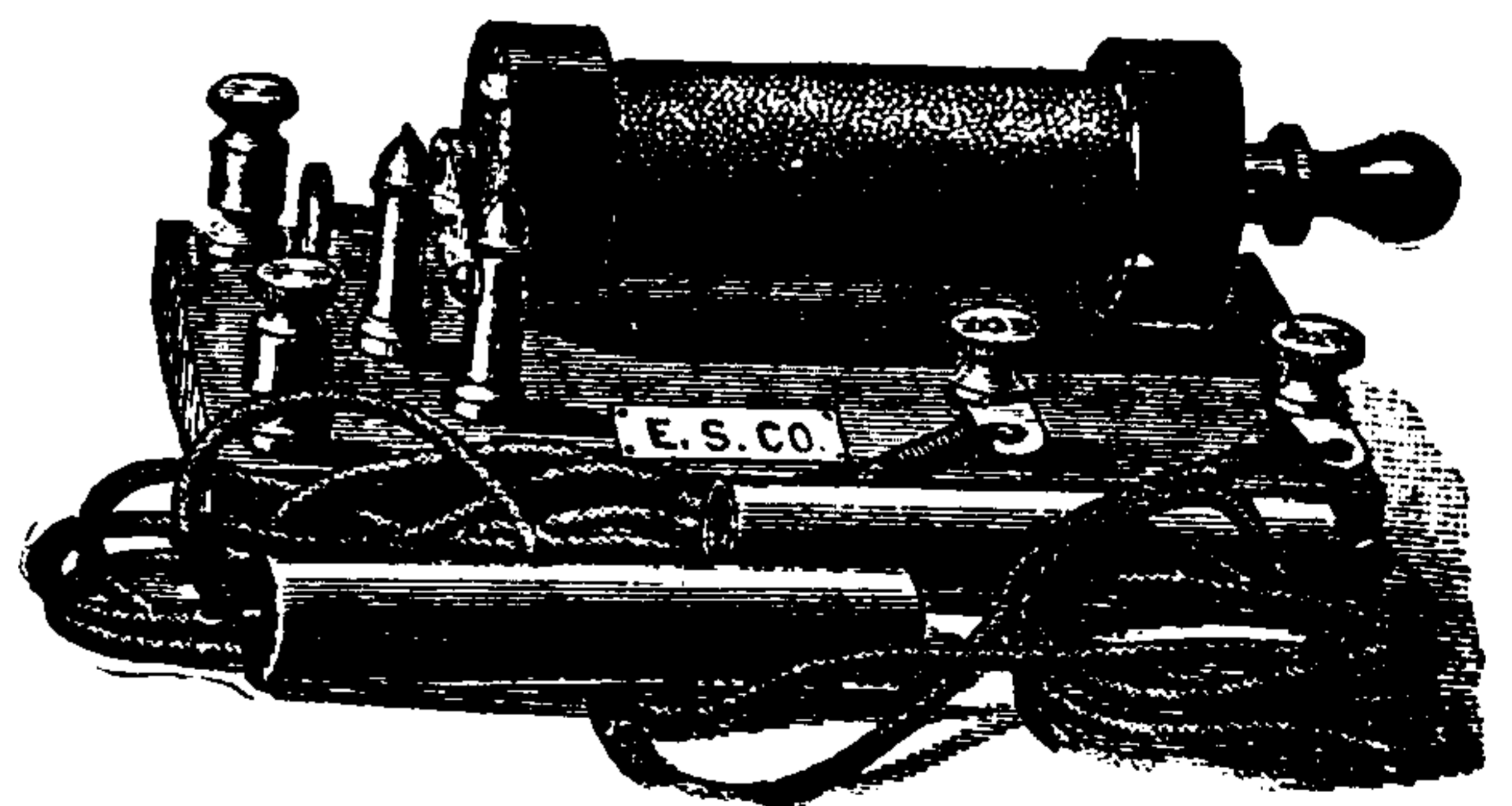

Fig. 145. *Medical Induction Coil.*

Coil, Induction, Microphone — — An induction coil, in which the variations in the circuit of the primary are obtained by means of microphone contacts. (See *Microphone.*)

The carbon-button telephone transmitter is a microphone in its action, its electric resistance varying with the varying pressure caused by the sound waves. The carbon-button is in the primary circuit of an induction coil, variations in

THIS PAGE IS LOCKED TO FREE MEMBERS

Purchase full membership to immediately unlock this page



HISTORY

Tens of thousands of important historical sources, many previously unobtainable, are now available for the first time with a Forgotten Books Full Membership.

Unlimited Access
\$8.99/month

Continue

*Fair usage policy applies

insertion of a thermometer. The lower part of the coil, B, is immersed in water up to the shoulder of A, and the water stirred from time to

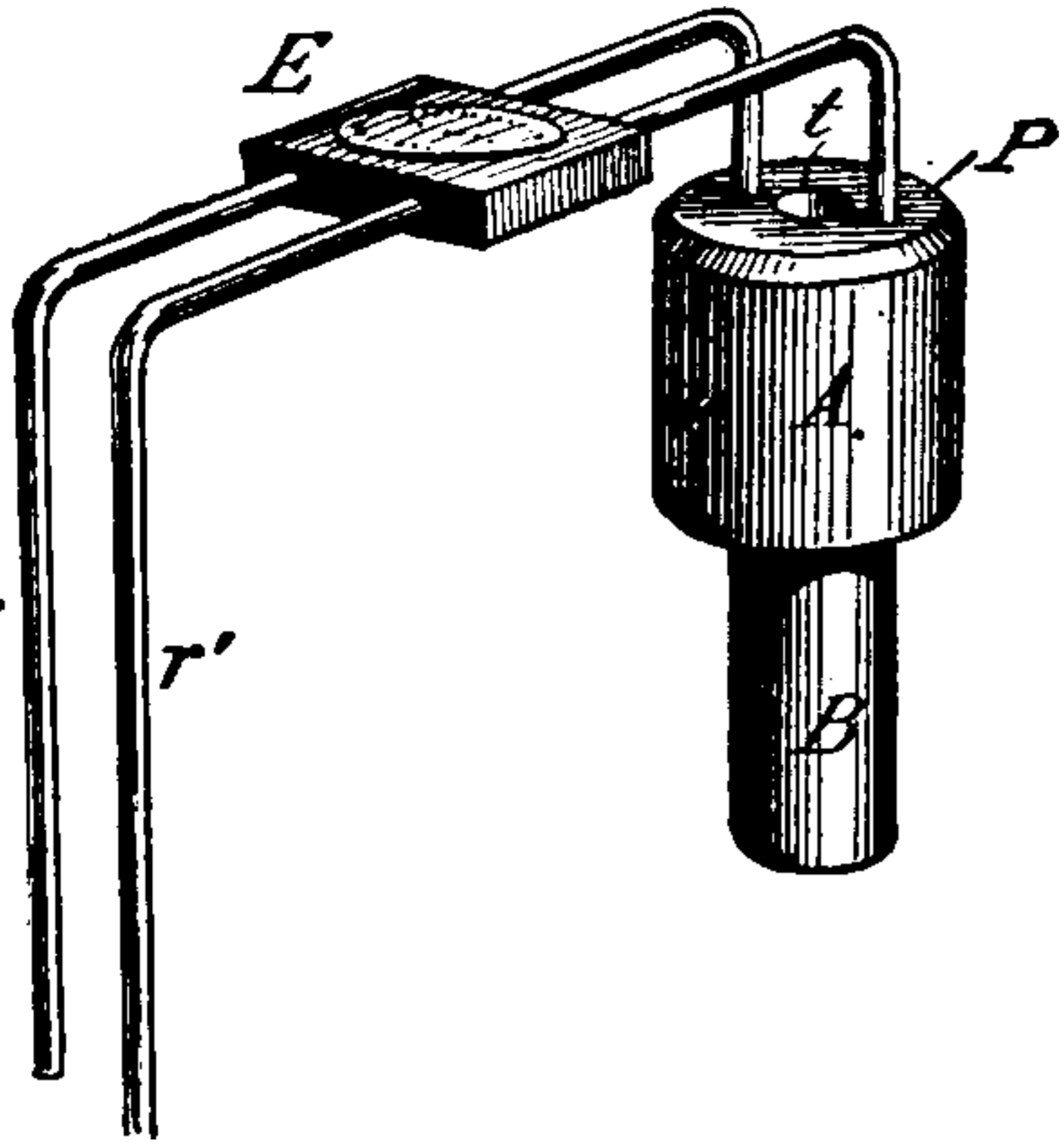

Fig. 148. Standard Ohm.

time. Since the coil is heated by the current, successive observations should be at least ten minutes apart. Only mild currents should be passed through the coils.

Coil, Resistance, Standardized — —

Resistance coils whose resistances have been carefully determined by comparison with a standard ohm or other standard coils.

Coil, Ruhmkorff — — A term sometimes applied to any induction coil, the secondary of which gives currents of higher electromotive force than the primary. (See *Coil, Induction*.)

Coil, Secondary — — That coil or conductor of an induction coil or transformer, in which alternating currents are induced by the rapidly interrupted or alternating currents in the primary coil. (See *Coil, Induction Transformer*.)

Coil, Shunt — — A coil placed in a derived or shunt circuit. (See *Circuit, Shunt*.)

Coil, Spark — — A coil of insulated wire connected with the main circuit in a system of electric gas-lighting, the extra spark pro-



Fig. 149. Spark Coil.

duced on breaking the circuit of which is employed for electrically igniting gas jets.

Spark coils are employed where the number of

gas jets to be simultaneously lighted is not too great. When this number exceeds certain limits, the spark from an induction coil is more advantageously used.

A spark coil is shown in Fig. 149.

Coils, Armature, of Dynamo-Electric Machine — — The coils, strips or bars that are wound or placed on the armature core.

To avoid needless resistance the wire, or other conductor, of the armature coils, should be as short and thick as will enable the desired electromotive force to be obtained without excessive speed of rotation.

The armature coils should enclose as many lines of force as possible (*i. e.*, they should have as nearly a circular outline as possible). In drum-armatures, the breadth of the armature is frequently made nearly equal to its length, unless other considerations prevent.

When the armature wire consists of rods or bars, it should be laminated or slit in planes parallel to the lines of force so as to avoid eddy currents. Other things being equal, the

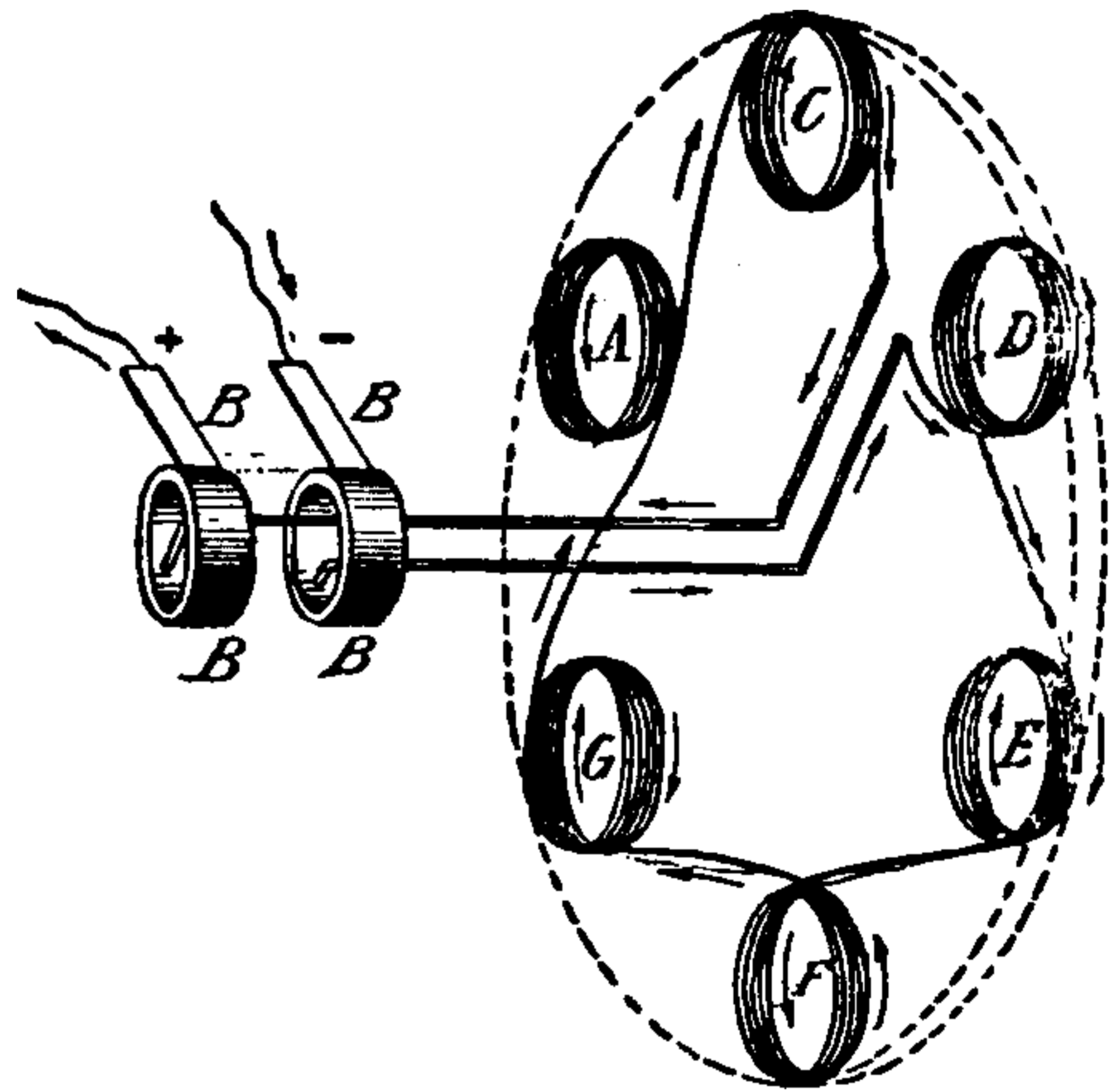

Fig. 150. Series Connection of Armature Coils.

greater the number of coils, the more uniform the current generated. The separate coils should be symmetrically disposed; otherwise irregular induction, and consequent *sparking* at the commutator results.

The coils of pole-armatures should be wound near the poles rather than on the middle of the cores. In order to avoid undue heating, spaces for air ventilation are not inadvisable. Various connections of the armature coils are used.

In some machines all the coils are connected in a closed circuit. In some, the coils are independent of one another, and, either for the entire revolution, or for part of a revolution, are on an open-circuit.

In alternating current dynamos in order to obtain the rapid reversals or alternations of current, which in some machines are as high as 12,000 per minute, a number of poles of alternate polarity are employed. The separate coils that are used on the armature may be coupled either in series or in multiple-arc.

Where a comparatively low electromotive force is sufficient, such as for incandescent lamps in multiple-arc, the separate coils are united in parallel; but for purposes where a considerable electromotive force is necessary, as for example, in systems of alternate current distribution, with converters at considerable distances from the generating dynamo, they are often connected in series, as shown in Fig. 150.

Coils, Binding — — Coils of wire wound on the outside of the armature coils, and at right angles thereto, to prevent the loosening of the armature wires by the action of centrifugal force.

The binding coils are generally made of hard brass wire.

Coils, Compensating — — — A term sometimes applied to the series coils placed on a shunt-wound dynamo.

Coils, Conjugate — — — Two coils so placed, as regards each other, that an interruption of the current in one produces no induced current in the other.

When two coils are conjugate to each other, the lines of force of one do not pass through the other. Consequently such coils can produce no induction in one another.

Coils, Henry's — — — A number of separate induction coils so connected that the currents induced in the secondary wire of the first coil, are caused to induce currents in the secondary wire of the second coil, with whose primary it is connected in series, and so on throughout all the coils.

A series of three of Henry's coils is shown in Fig. 151. An intermittent battery current is sent

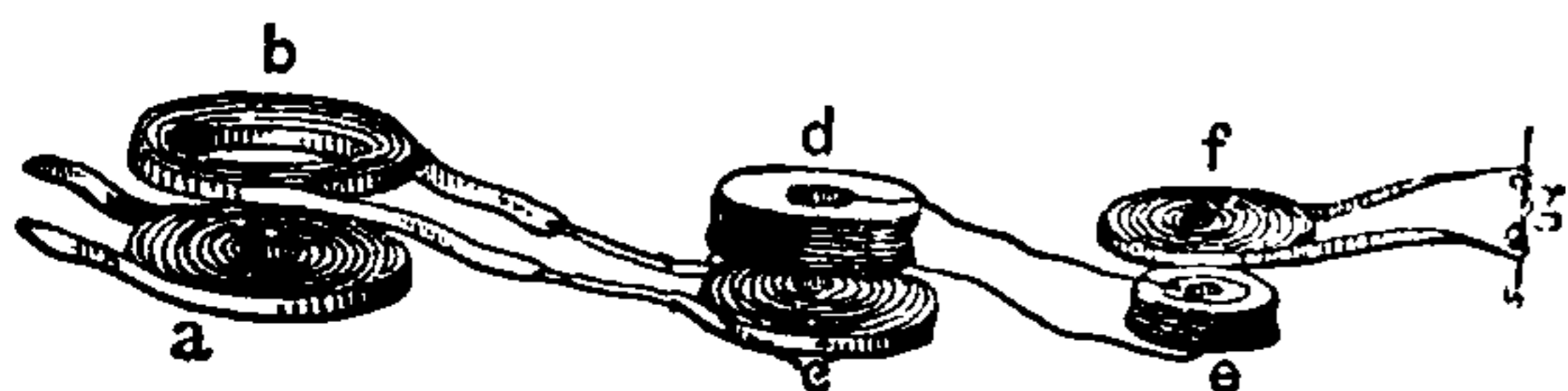

Fig. 151. Henry's Coils.

into a, the secondary, b, of which is connected with the primary, c, of the second coil. The

secondary, d, of the second coil, is connected with the primary, e, of the third coil, and the currents finally induced in f, are employed for any useful purpose, such as the magnetization of a bar of iron at g.

The current in b, is sometimes called a *Secondary Current*, or a *Current of the Second Order*; that induced by this secondary current in d, is called a *Tertiary Current*, or a *Current of the Third Order*; that in f, a *Current of the Fourth Order*. Henry carried these successive inductions up to currents of the *Seventh Order*.

Henry's coils in reality consist of separate induction coils, connected, as above explained, in series.

In Fig. 152, the tertiary current induced in

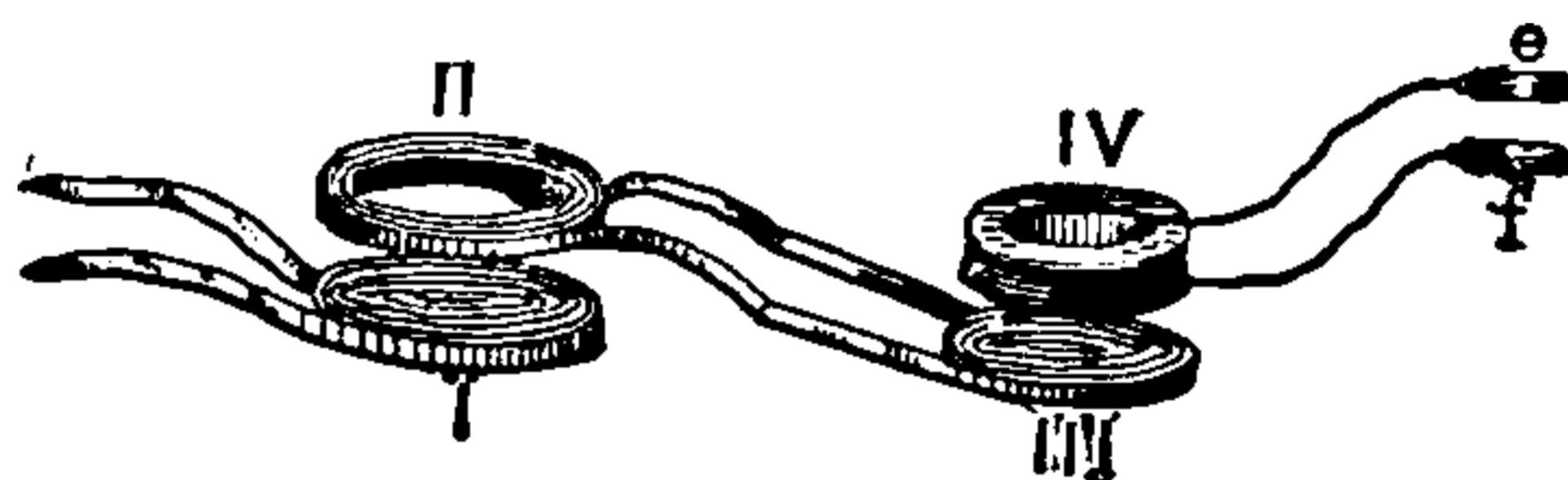

Fig. 152. Tertiary Currents of Coils.

IV, may be employed to give shocks to a person grasping the handles, e and f.

Coils, Proportional — — — Pairs of resistance coils, generally of 10, 100 and 1,000 ohms each, forming the proportional arms of the balance or bridge, and employed in the box, or commercial form of Wheatstone's bridge. (See *Bridge, Electric, Commercial Form of.*)

Cold, Production of, by Electricity — — — An absorption of energy and consequent reduction of temperature at a thermo-electric junction by the passage of an electric current across such junction in a certain direction.

When an electric current passes across a thermo-electric junction, the junction is either heated or cooled. In the case of an antimony-bismuth couple, if the current passes from the antimony

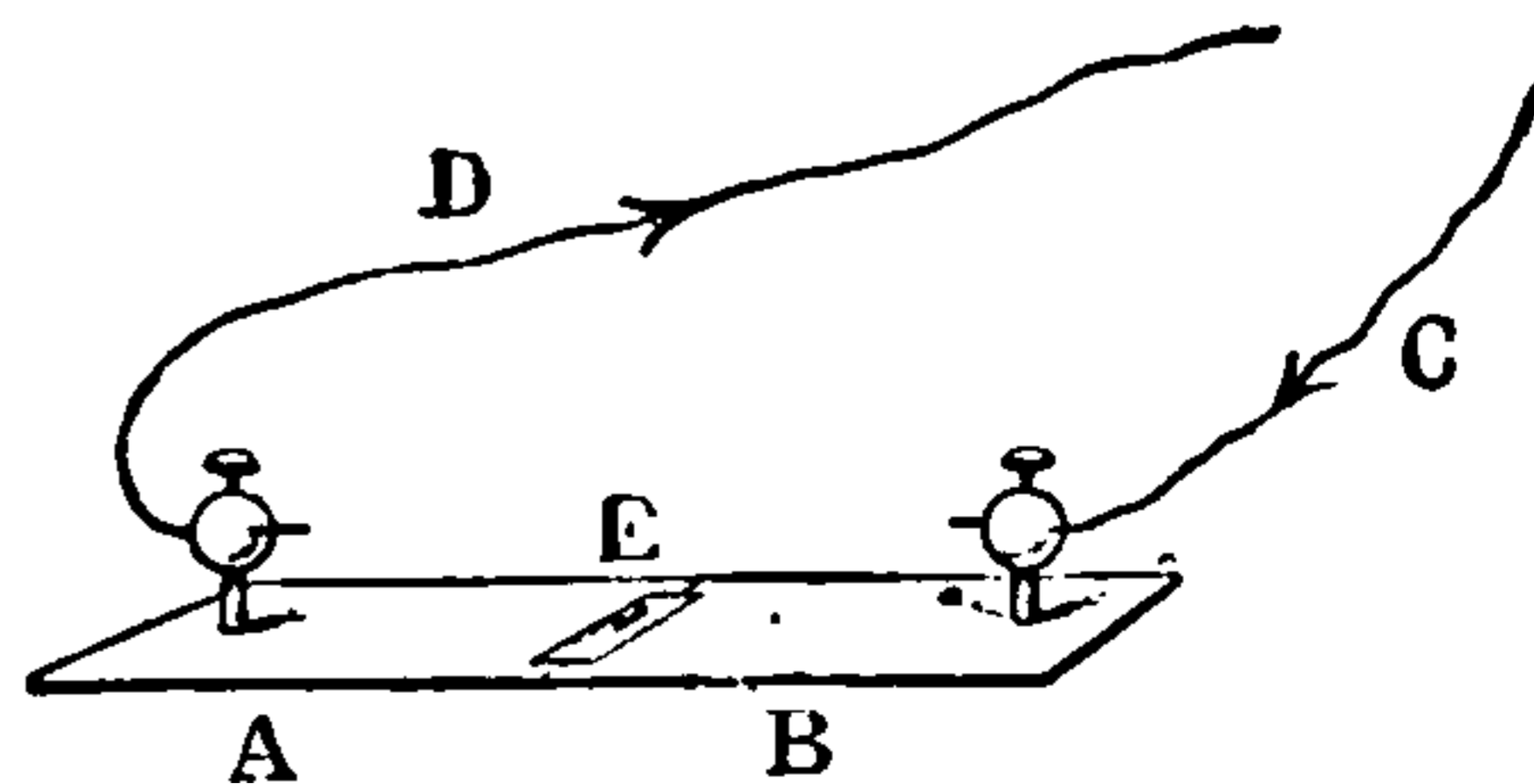

Fig. 153. Freezing of Water by Electricity.

to the bismuth the junction is heated; if it passes from the bismuth to the antimony it is cooled. In the apparatus shown in Fig. 153, the antimony-bismuth couple is arranged as shown for the

freezing of water by means of the electric current. A and B, represent plates of antimony and bismuth respectively. A small cavity, at E, serves to hold a drop of water. When a current has passed in the direction shown by the arrows, a drop of water, previously cooled to the temperature of melting ice, is solidified by the lowering of the temperature at the junction.

Collecting Brushes of Dynamo-Electric Machine.—(See *Brushes, Collecting, of Dynamo-Electric Machine.*)

Collectors, Electric — —Devices employed for collecting or taking off electricity from a moving electric source.

Collectors of Electric Frictional Machines.—The metallic points that collect the charge from the glass plate or cylinder of a frictional electric machine.

Collectors of Dynamo Electric Machines.—The brushes that rest on the commutator cylinder, and carry off the current generated on the rotation of the armature.

Collectors are properly called commutators when they are employed to cause an alternate current to become continuous, or to flow in one and the same direction.

Colloids.—One of the two classes into which substances are separated by dialysis.

By dialysis bodies are separated into crystalloids, or bodies capable of crystallizing, and colloids or jelly-like bodies, incapable of crystallizing. Colloids possess great cohesion and but slight diffusibility. (See *Dialysis.*)

Colombin.—An insulating substance, consisting of a mixture of sulphate of barium and sulphate of calcium, placed between the parallel carbons of the Jablochhoff candle.

Column, Barometric — —A column, usually of mercury, approximately 30 inches in vertical height, sustained in a barometer, or other tube, by the pressure of the atmosphere.

The space above the barometric column contains a vacuum known as the *Torricellian vacuum*. (See *Vacuum, Torricellian.*)

Column, Electric — —A term formerly applied to a voltaic pile. (See *Pile, Voltaic.*)

Colza Oil.—(See *Oil, Colza.*)

Combination Gas Fixtures.—(See *Fixtures, Gas, Combination.*)

Combined Tangent and Sine Galvanometer.—(See *Galvanometer, Combined Tangent and Sine.*)

Comb Lightning Arrester.—(See *Arrester, Lightning, Comb.*)

Comb Protector.—(See *Protector, Comb.*)

Commercial Efficiency.—(See *Efficiency, Commercial.*)

Commercial Efficiency of Dynamo.—(See *Efficiency, Commercial, of Dynamo.*)

Commercial Form of Electric Bridge.—(See *Bridge, Electric, Commercial Form of.*)

Communicator, Electric — —A term formerly employed for a telegraphic key. (See *Key, Telegraphic.*)

Commutating Transformers, Distribution of Electricity by — —(See *Electricity, Distribution of, by Commutating Transformers.*)

Commutation.—The act of commuting, as of currents.

Commutation, Diameter of — —In a dynamo-electric machine a diameter on the commutator cylinder on one side of which the differences of potential, produced by the movement of the coils through the magnetic field, tend to produce a current in a direction opposite to those on the other side.

That diameter on the commutator cylinder of an open-circuited armature that joins the points of contact of the collecting brushes.

Thus in Fig. 154, the directions of the induced electromotive forces are indicated by the arrows. The *diameter of commutation* is therefore the line $n n'$. The term *neutral line* is also sometimes given to this line. It lies at right angles to the line of maximum magnetization $m m$.

In a *closed-circuited* armature, that is, in an armature the coils of which are connected in a closed circuit, the collecting brushes rest on the commutator cylinder at the *neutral line*, or on the *diameter of commutation*.

In an open-circuited armature, however, where the coils are independent of each other, the collecting brushes must be set at $m m$, at right angles to the neutral line $n n$. The term *diameter*

THIS PAGE IS LOCKED TO FREE MEMBERS

Purchase full membership to immediately unlock this page

Know Your Bible

Forgotten Books' Full Membership provides unlimited access to more than 28,000 volumes of Christian literature for \$8.99/month

HOLY BIBLE

Continue

*Fair use policy applies

and supported on a commutator cylinder usually placed on the shaft of the armature.

The ends of the armature coils are connected to commutator strips or segments.

The number of metallic pieces or segments, A. and A', on the *commutator cylinder* depends on the number, arrangement and connection of the armature coils, and on the disposition of the *magnetic field* of the machine.

Figs. 156, 157 and 158 show the connections of an armature coil to the plates of a *two-part commutator*.

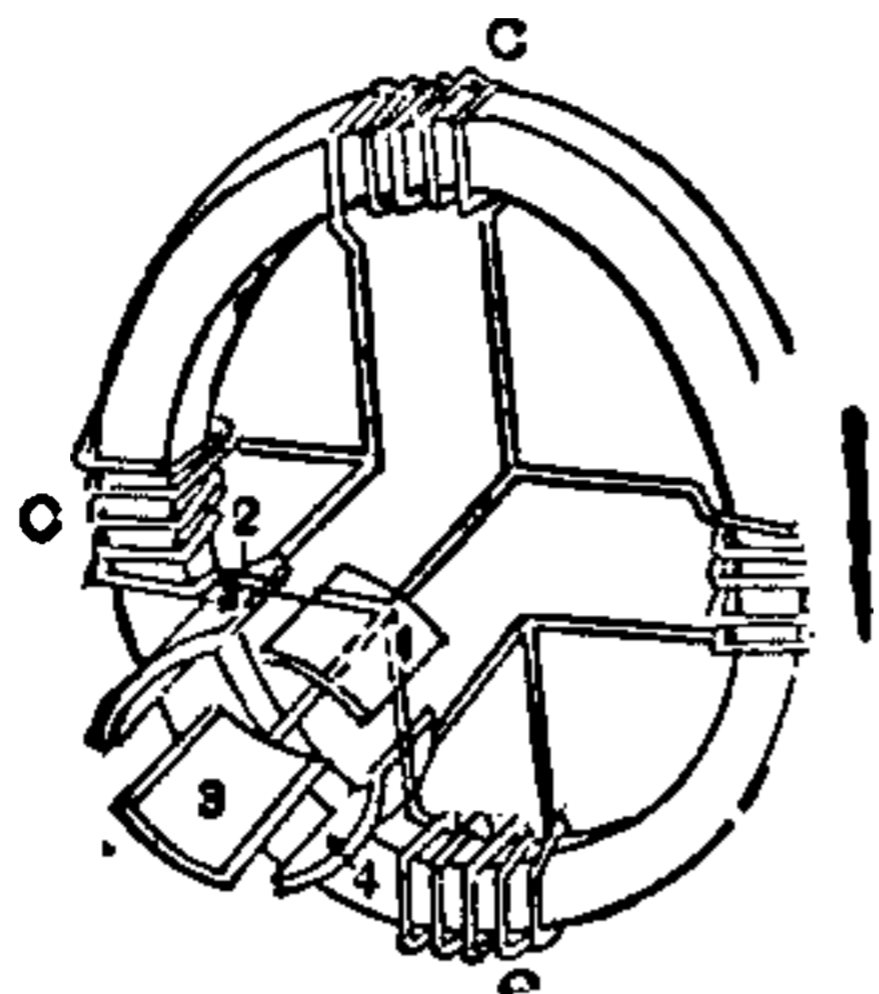

Fig. 159. Four-part Commutator.

A four-part commutator for a ring armature, and the connections of the coils thereto, are shown in Fig. 159.

The commutator strips may either connect the separate coils in a closed-circuited armature, in which the coils are all connected with one another, or, in an open-circuited armature, in which the separate coils are independent of one another.

Commutator, Ruhmkorff's — — A name given by Ruhmkorff to a device placed on his induction coil for the purpose of changing or reversing the direction of the battery current through the primary.

This *reverser* is shown in Fig. 160. (See *Coil, Ruhmkorff's*.)

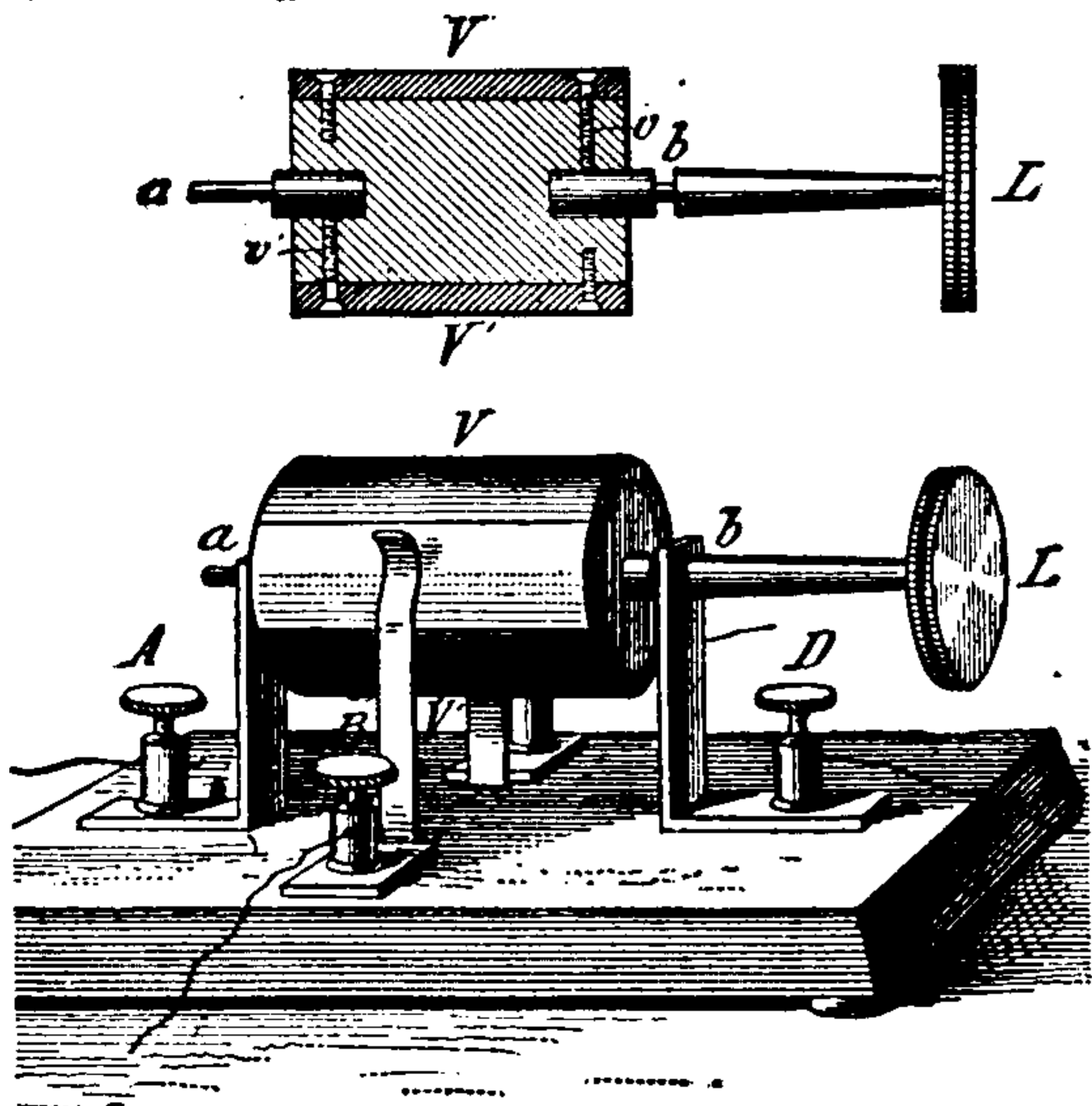

Fig. 160. Ruhmkorff's Commutator.

Two metallic strips, V, V, supported on a cylinder of insulating material, are in contact with the battery terminals A, and D, through two vertical springs that bear on them. On a half rotation of the cylinder by the thumb screw L,

the strips V, V, change places as regards the vertical springs, and thus reverse the direction of the battery current.

Commutated Currents. — (See *Currents, Commuted*.)

Commuter, Current — — Any apparatus by means of which electrical currents, flowing alternately in different directions, may be caused to flow in one and the same direction.

A Commutator.

Commuting. — Causing to flow in one and the same direction.

Commuting Currents. — (See *Currents, Commuting*.)

Compartment Manhole of Conduit. — (See *Manhole, Compartment, of Conduit*.)

Compass, Azimuth — — A compass used by mariners for measuring the horizontal distance of the sun or stars from the magnetic meridian. (See *Azimuth, Magnetic*.)

A mariner's Compass.

A single magnetic needle, or several magnetic needles, are placed parallel to one another on the lower surface of a card, called the *compass card*. This card is divided into the four *cardinal points*, N, S, E and W, and these again subdivided into thirty-two points called *Rhumbs*.

In the azimuth compass these divisions are supplemented by a further division into degrees.

A form of azimuth compass is shown in Fig. 161. In order to maintain the compass box in a

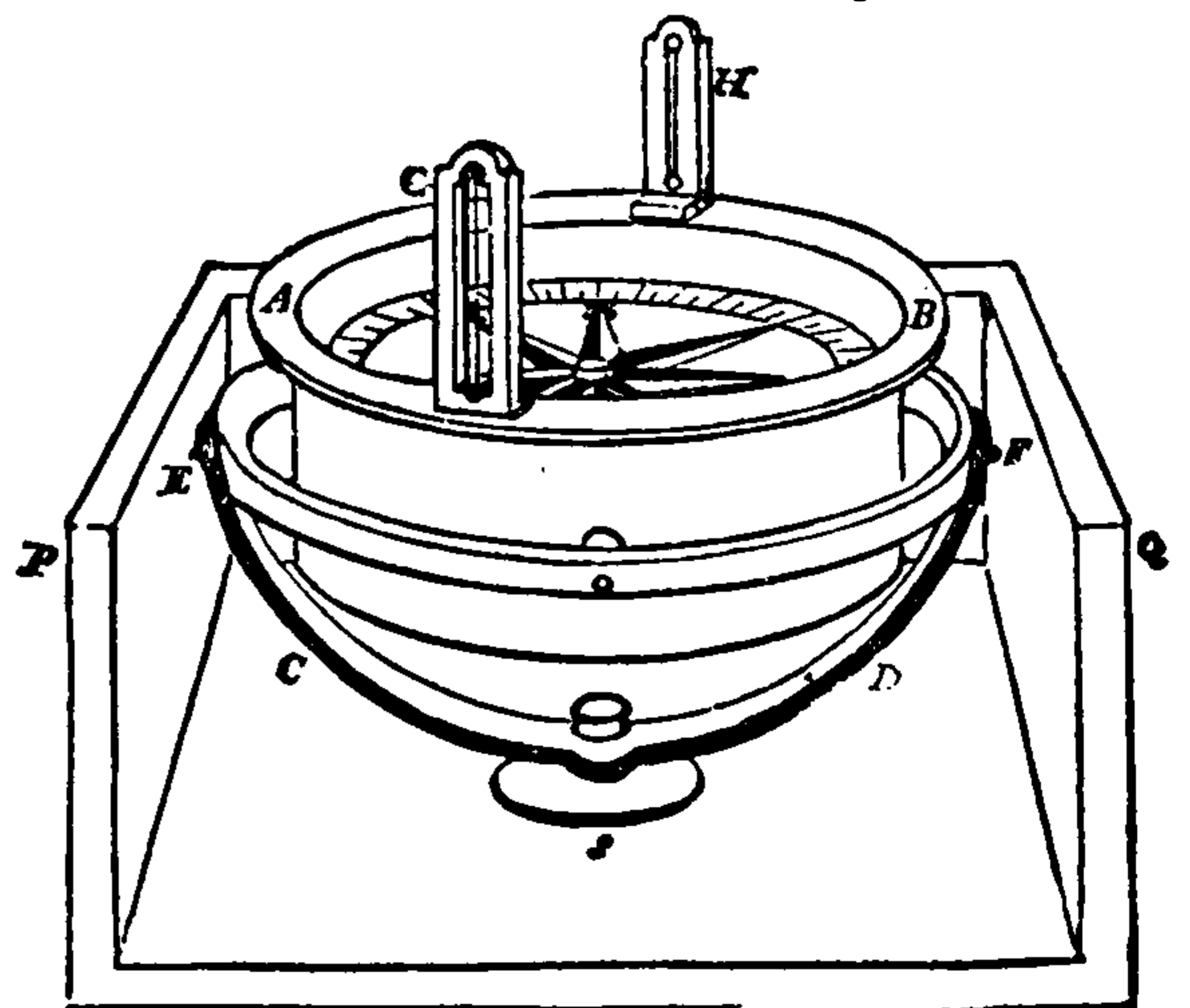

Fig. 161. Azimuth Compass.

horizontal position, despite the rolling of the ship, the box, A B, is suspended in the larger box, P Q, on two concentric metallic circles, C D, and

EF, pivoted on two horizontal axes at right angles to each other. This kind of support is technically termed *Gimbals*. Sights **G, H**, are provided for measuring the magnetic azimuth of any object.

Compass, Boxing the — — Naming, consecutively, all the different points or rhumbs of the compass from any one of them. (See *Compass, Points of*.)

Compass-Card.—(See *Card, Compass*.)

Compass, Inclination — — A magnetic needle moving freely in a single vertical plane, and employed for determining the angle of dip at any place.

An *Inclinometer*. (See *Inclinometer*.)

A dipping circle. (See *Circle, Dipping*.)

The needle **M**, Fig. 162, is supported on knife

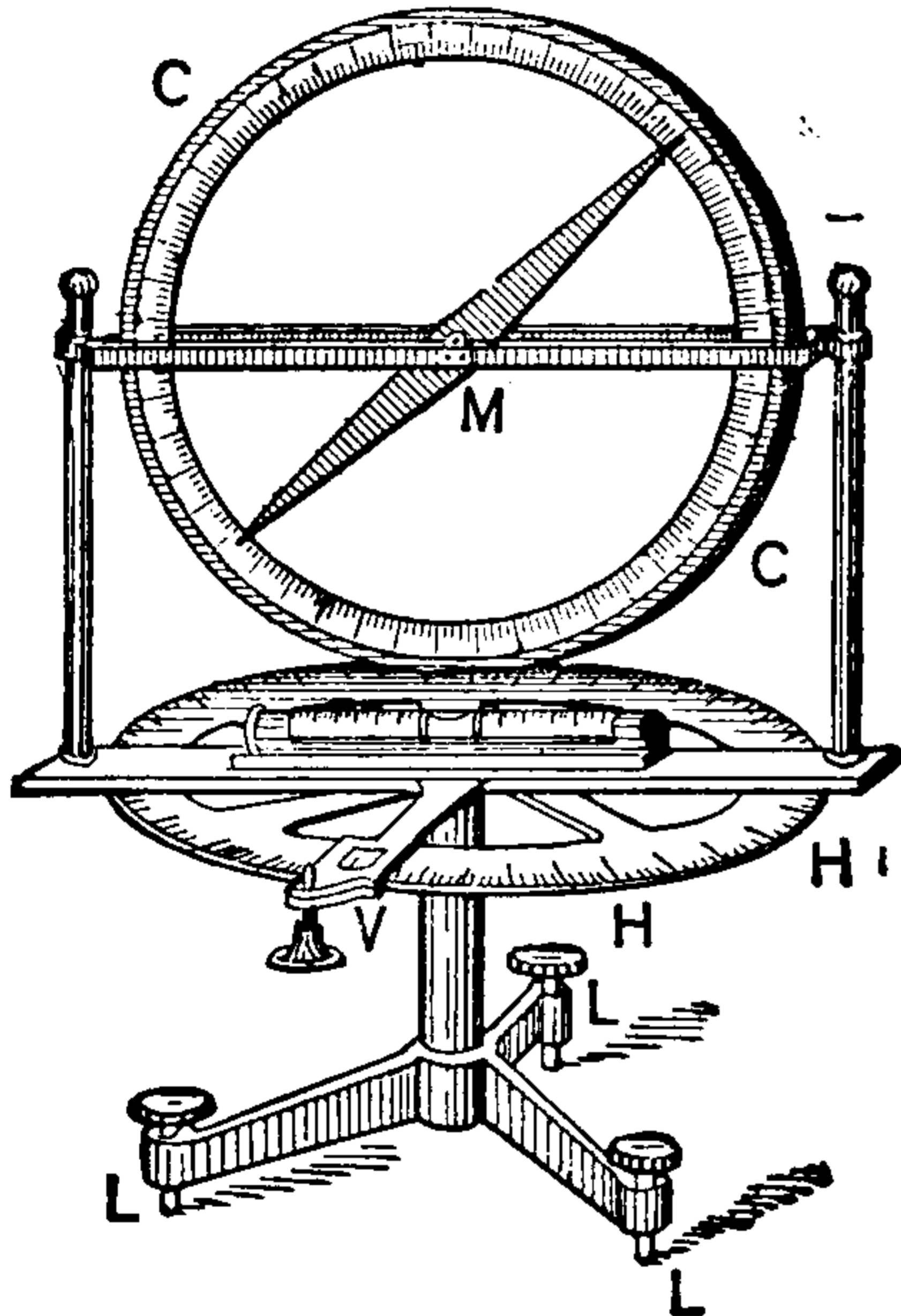

Fig. 162 *Inclination Compass.*

edges so as to be free to move only in the vertical plane of the graduated vertical circle **C C**. This circle is movable over the horizontal graduated circle **H H**. In order to determine the true angle of dip, the vertical plane in which the needle is free to move must be placed exactly in the plane of the magnetic meridian.

To ascertain this plane the vertical circle is moved until the needle points vertically downwards. It is then in a plane 90 degrees from the magnetic meridian. The vertical circle is then moved over the horizontal circle 90 degrees, in which position it is in the plane of the magnetic meridian, when the true angle of the dip is read off.

For an explanation of the reason of this see

Component, Horizontal and Vertical, of the Earth's Magnetism.

Compass, Mariner's — — A name often applied to an azimuth compass. (See *Compass, Azimuth*.)

Compass, Points of — — The thirty-two points into which a compass card is divided.

Sixteen of these points are shown in Fig. 163.

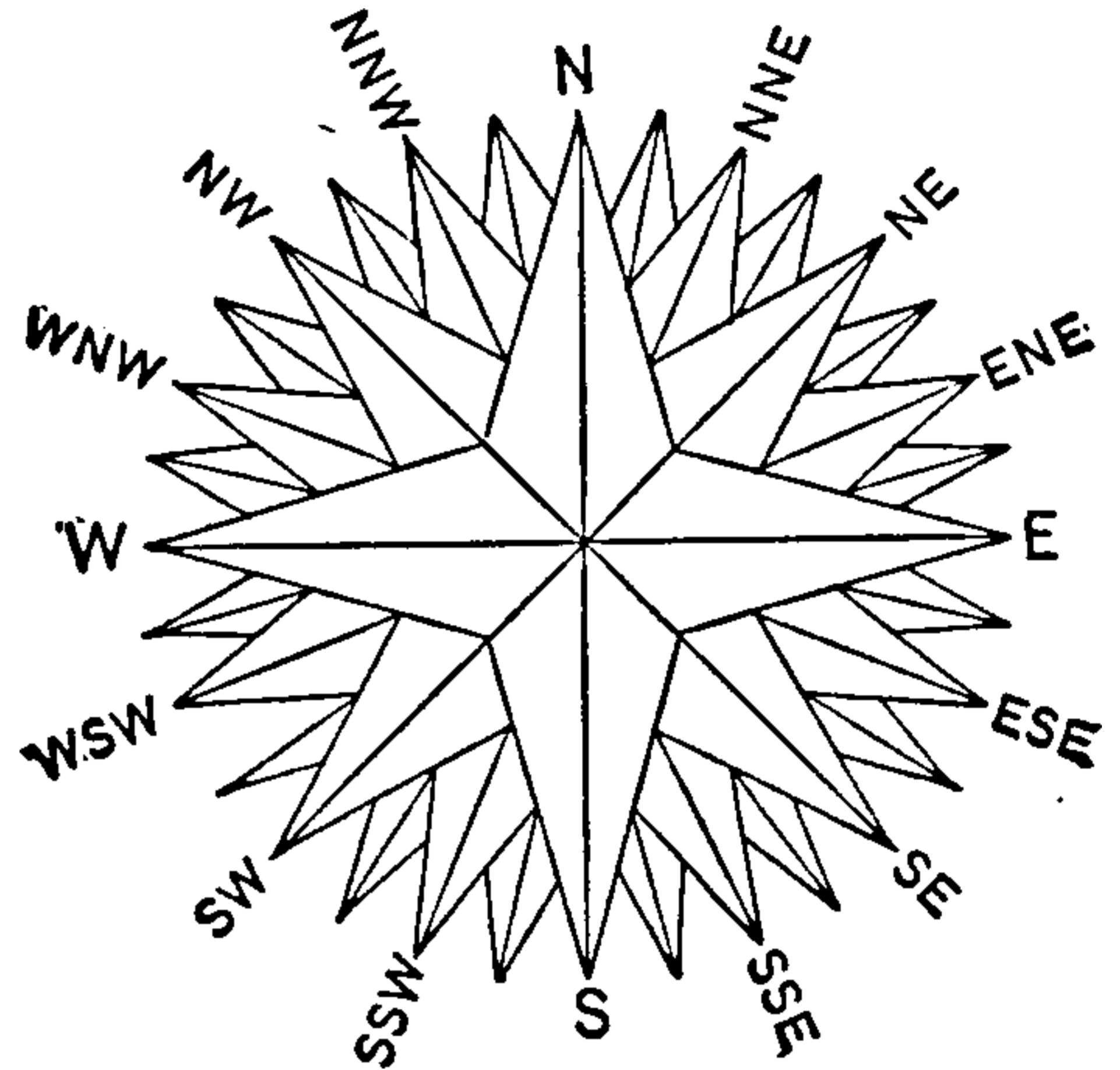

Fig. 163. *Points of Compass.*

The position of the remaining points will be readily seen by an inspection of the figures.

These points are as follows:

- | | |
|-----------------|-----------------|
| 1. North. | 17. South. |
| 2. N. by E. | 18. S. by W. |
| 3. N. N. E. | 19. S. S. W. |
| 4. N. E. by N. | 20. S. W. by S. |
| 5. N. E. | 21. S. W. |
| 6. N. E. by E. | 22. S. W. by W. |
| 7. E. N. E. | 23. W. S. W. |
| 8. E. by N. | 24. W. by S. |
| 9. East. | 25. West. |
| 10. E. by S. | 26. W. by N. |
| 11. E. S. E. | 27. W. N. W. |
| 12. S. E. by E. | 28. N. W. by W. |
| 13. S. E. | 29. N. W. |
| 14. S. E. by S. | 30. N. W. by N. |
| 15. S. S. E. | 31. N. N. W. |
| 16. S. by E. | 32. N. by W. |

Boxing the Compass consists in naming all these points consecutively from any one of them.

The direction in which the ship is sailing is determined by means of a point fixed on the inside of the compass box, directly in the line of the vessel's bow.

Compass, Rhumbs of — — The points of a mariner's compass. (See *Compass, Points of*.)

Compensated Alternator.—(See *Alternator, Compensated.*)

Compensated Excitation of Alternator.—(See *Alternator, Compensated Excitation of.*)

Compensating Coils.—(See *Coils, Compensating.*)

Compensating Magnet.—(See *Magnet, Compensating.*)

Complement of Angle.—(See *Angle, Complement of.*)

Completed-Circuit.—(See *Circuit, Completed.*)

Component.—One of the two or more separate forces into which any single force may be resolved; or, conversely, the separate forces which together produce any single resulting force.

When two or more forces act simultaneously to produce motion in a body, the body will move

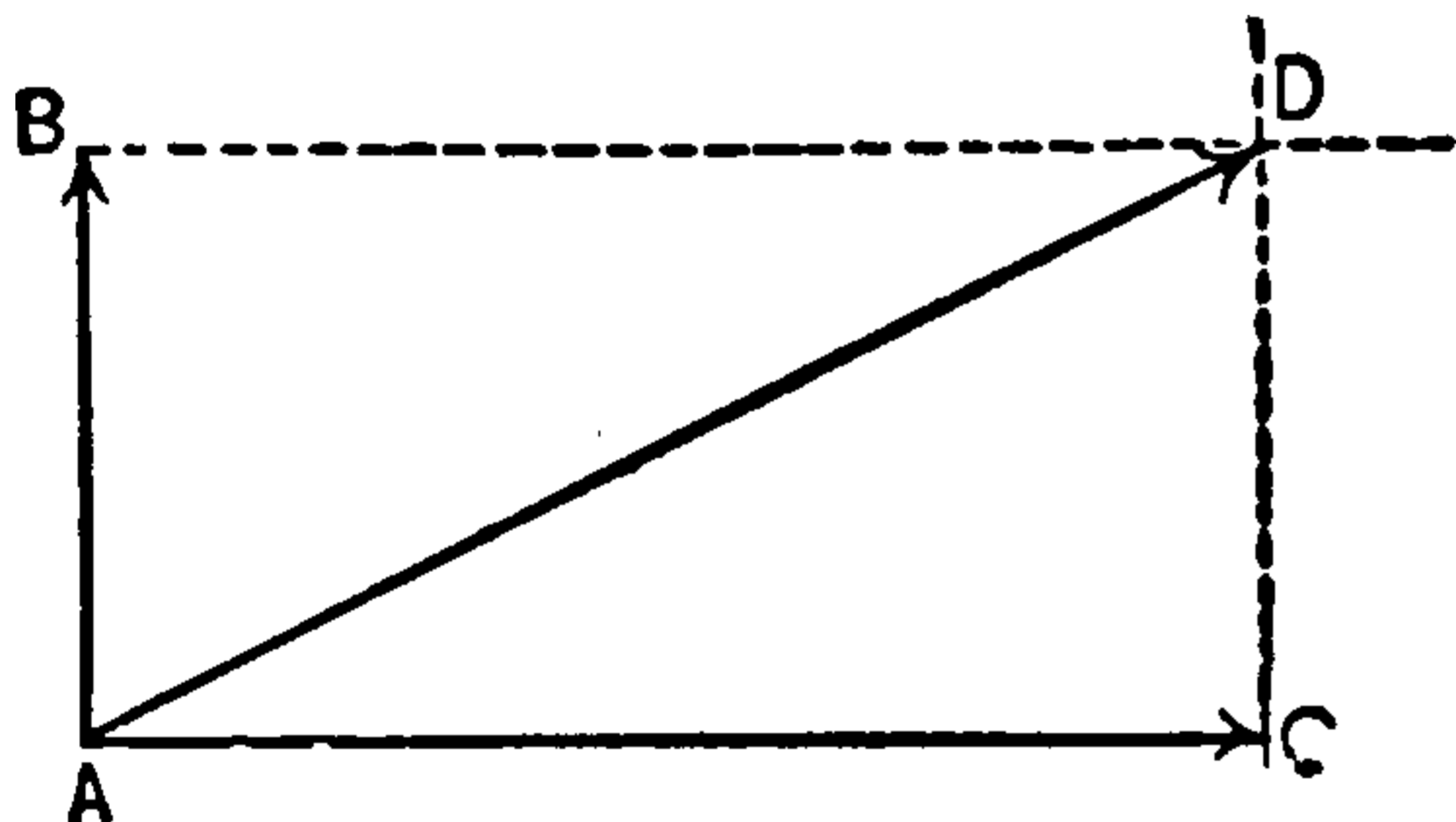

Fig. 164. Composition of Forces.

with a given force in a single direction called the *resultant*. The separate forces, or directions of motion, are called the *components*.

Two forces acting simultaneously on a body at A, Fig. 164, tending to move it in the direction

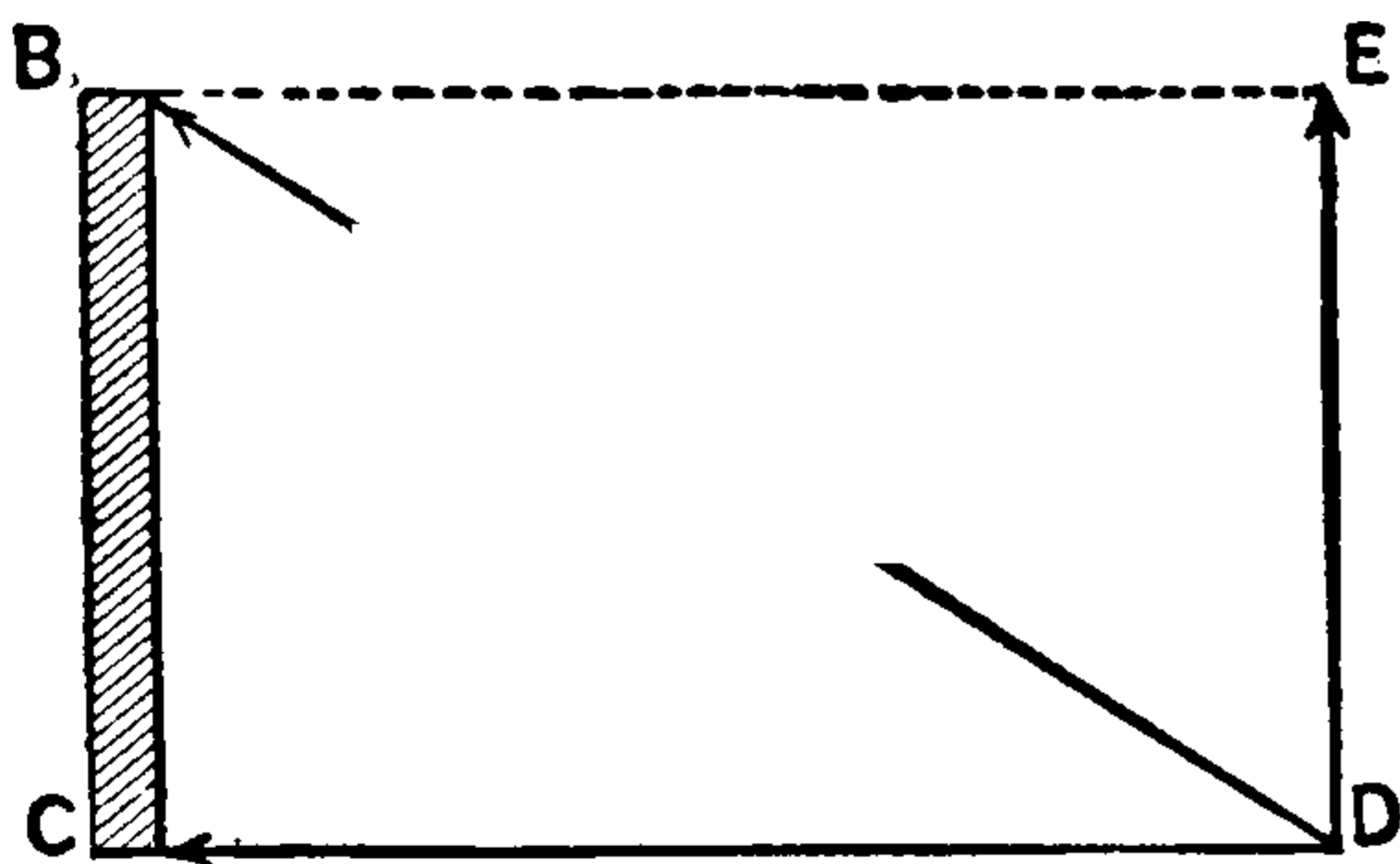

Fig. 165. Resolution of Forces.

of the arrows, along A B, and A C, with intensities proportioned to the lengths of the lines A B, and A C, respectively, will move it in the direction A D, obtained by drawing B D, and D C,

parallel to A C, and A B, respectively, and then drawing A D, through the point of intersection, D. This is called the *Composition of Forces*. A D, is the resultant force, and A B and A C, are its components.

Conversely, a single force, acting in the direction of D B, Fig. 165, against a surface, B C, may be regarded as the resultant of the two separate forces, D E, and D C, one parallel to C B, and one perpendicular to it. D E, being parallel to C B, produces no pressure, and the absolute effect of the force will, therefore, be represented by C D.

This separation of a single force into two or more separate forces is called the *resolution of forces*, the force, D B, being resolved into the components, D E and D C.

Component Currents.—(See *Currents, Component.*)

Component, Horizontal, of Earth's Magnetism — — That portion of the earth's directive force which acts in a horizontal direction.

That portion of the earth's magnetic force which acts to produce motion in a compass needle free to move in a horizontal plane only.

Let A B, Fig. 166, represent the *direction* and *magnitude* of the earth's magnetic field on a magnetic needle. The magnetic force will lie in the plane of the magnetic meridian, which will be assumed to be the plane of the paper C A D. The earth's field, A B, can be resolved into two components, A D, the *horizontal* component, and A C, the *vertical* component.

In the case of a magnetic needle, like the ordinary compass needle, which is free to move in a horizontal plane only, the horizontal component alone directs the needle. A weight is applied to balance the vertical component.

When the needle is free to move in a vertical plane, and this plane corresponds with that of the magnetic meridian, the entire magnetic force, A B, acts to place the needle, supposed to be properly balanced, in the direction of the lines of force of the earth's magnetic field at that point.

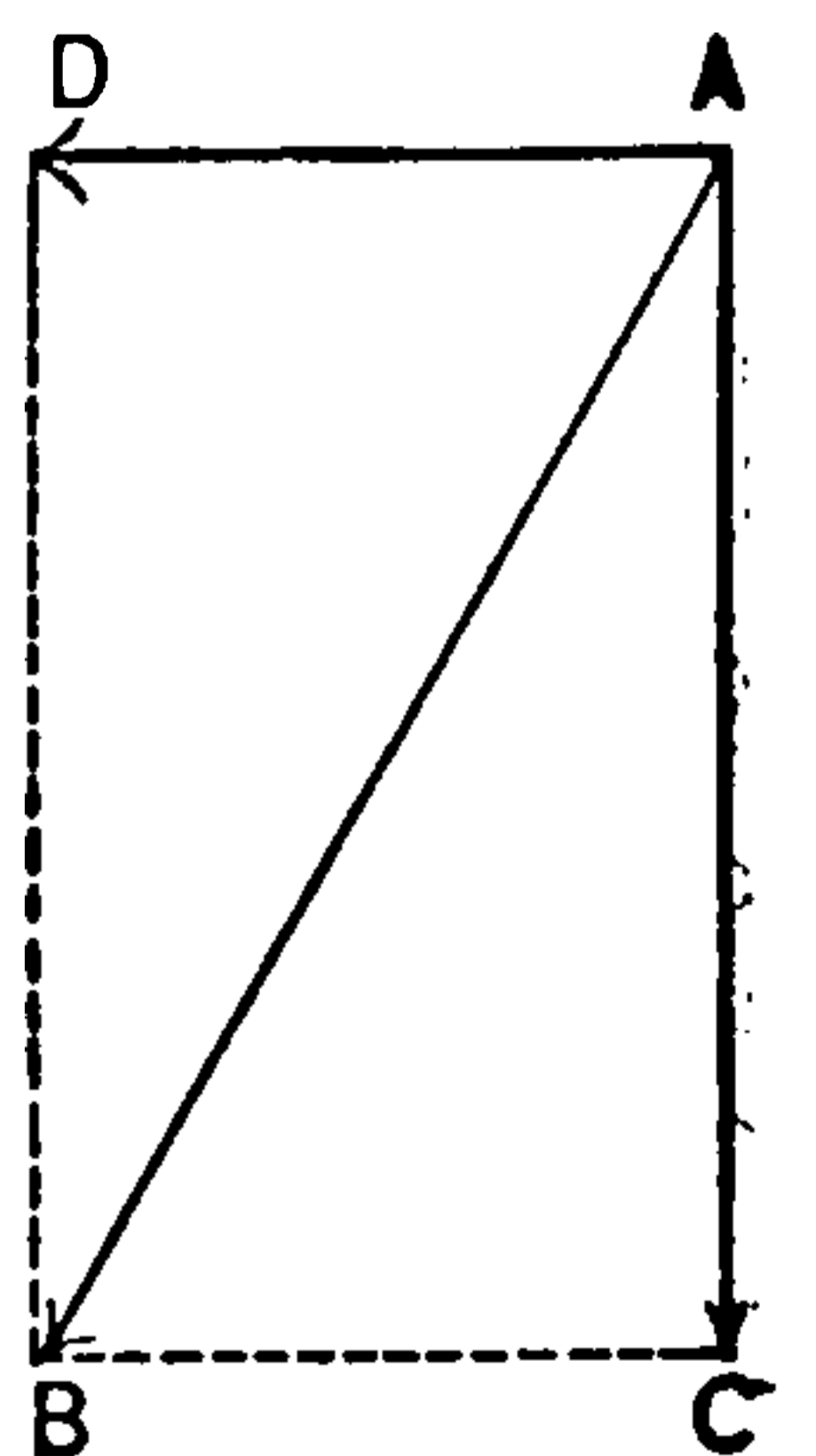

Fig. 166. Components of Earth's Magnetism.

THIS PAGE IS LOCKED TO FREE MEMBERS

Purchase full membership to immediately unlock this page



HISTORY

Tens of thousands of important historical sources, many previously unobtainable, are now available for the first time with a Forgotten Books Full Membership.

Unlimited Access
\$8.99/month

Continue

*Fair usage policy applies

If, however, it be placed near C, but separated from it by a *dielectric*, such as a plate of glass B, and C, be connected with the ground, A, will receive a much greater charge. (See *Dielectric*.)

Suppose, for example, that A, be connected with the positive conductor of a frictional electric machine, it will by *induction* establish a negative charge on the surface C, nearest it, and repel a positive charge to the earth. The presence of these two opposite charges on the opposed surfaces of A and C, permits A, to receive a fresh charge from the machine. (See *Induction, Electrostatic*.)

The charge in a condenser in reality resides on the opposite surfaces of the glass, or other dielectric separating the metallic coatings, as can be shown by removing the coatings after charging.

The condenser resulted from the discovery of the Leyden jar. (See *Far, Leyden*.)

The capacity of a condenser is measured in *microfarads*. (See *Farad*.)

In practice condensers are made of sheets of tin foil, connected to A and B, respectively, and separated from one another by sheets of oiled silk, paraffined paper, or thin plates of mica, as shown in Fig. 168.

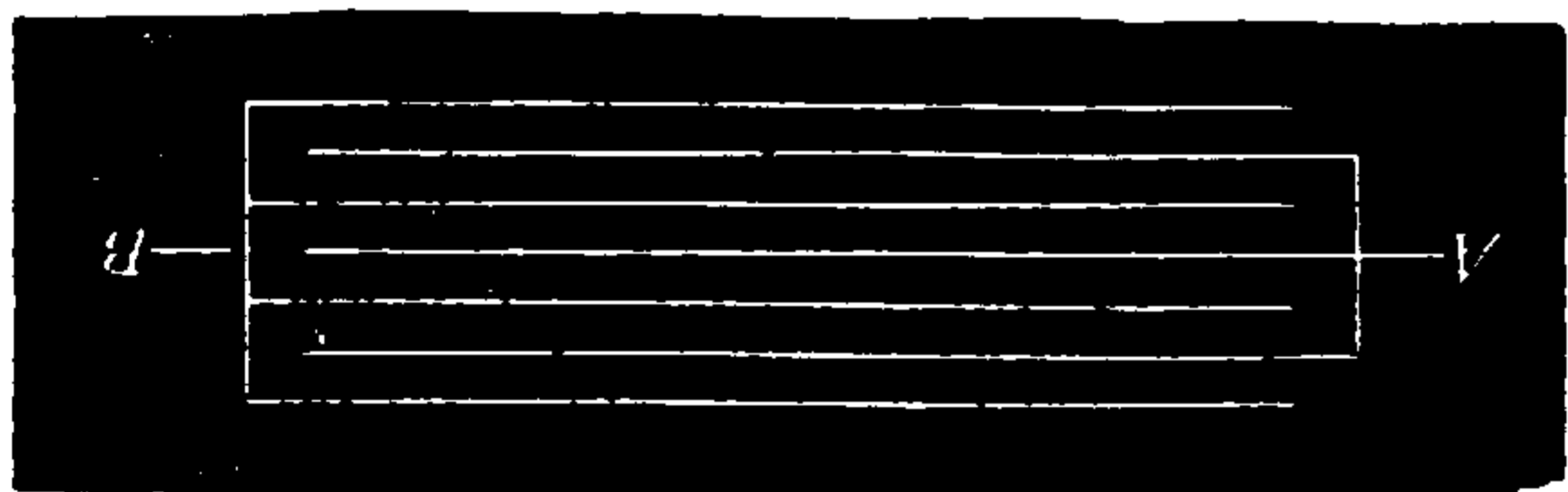

Fig. 168. Condenser.

A Leyden jar or condenser does not store electricity any more than a storage battery does. The same quantity of electricity passes out of the opposite coating of the jar that is passed into the other coating. The jar, therefore, possesses no store of electricity. What it really possesses is a store of electrical energy.

According to Ayrton, if the capacity of a condenser, in farads, be F , and the difference of potentials, with which it is charged, be V , volts, the store of electric energy it possesses, or the work it can do when discharged, is,

$$\text{Work} = \frac{F \times V^2}{2.712} \text{ foot-pounds.}$$

Condenser, Adjustable — — A condenser, the plates of which can be readily adjusted so as to obtain the same capacity as that of the conductor to be measured.

In order to obtain a comparatively wide range of adjustability, a condenser is composed of say four separate sections: consisting of one of 2 microfarads, one of 1 microfarad and two of $\frac{1}{2}$ microfarad, thus making in all 4 microfarads.

Condenser, Epstein — — A name given to an early form of condenser. (See *Condenser*.)

Condenser, Air — — A condenser in which layers of air act as the dielectric.

A form of air condenser is shown in Fig. 169.

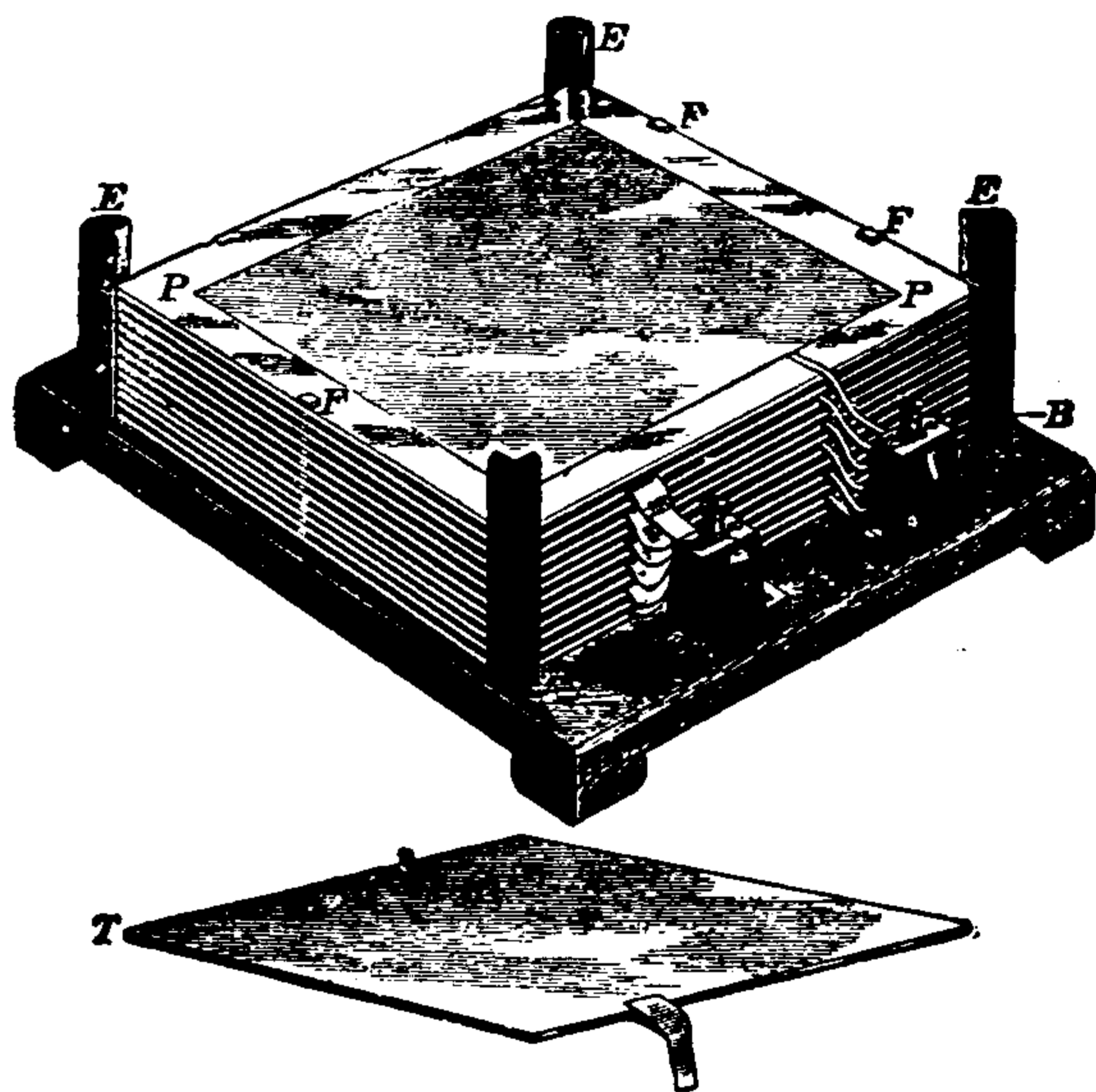

Fig. 169. Air Condenser.

It consists essentially of one set of thin plates of glass partially coated on both sides with sheets of tin foil, so as to leave uncoated a space of about one inch around the edge of the glass. The glass plates do not act as dielectrics, but merely as supports for the tin foil, hence the foil on both sides of the plates is connected electrically.

Another set of plates alternating with the above have the tin foil placed over the whole surface of the glass.

These plates are placed, alternately, over one another on a stand between guide rods of vulcanite E, E, E, E, in the manner shown, and are separated from one another by fragments of glass of the same thickness. The plates with the foil over their entire surface are all connected together and to the terminal B, to form the outer coating, and the plates with the foil over nearly all their surfaces are all connected together and to the terminal A, to form the inner coating of the condenser.

There is thus formed a condenser in which practically two extended conducting surfaces are

separated from each other by a thin layer of air, which acts as the dielectric.

Condenser, Alternating-Current — —
A condenser suitable for use in connection with a system for the distribution of electric energy by means of alternating currents.

Alternating-current condensers must have a very thin dielectric in order to avoid too great bulk. This, of course, introduces a difficulty as regards liability of failure of insulation, which must be carefully avoided.

Condenser, Armature of — — (See *Armature of a Condenser*.)

Condenser, Capacity of — — —The quantity of electricity in coulombs a condenser is capable of holding before its potential in volts is raised a given amount.

The ratio between the quantity of electricity in coulombs on one coating and the potential difference in volts between the two coatings.—(*Ayrton*.)

The capacity is directly proportional to the charge Q , and inversely proportional to the potential V , or,

$$K = \frac{Q}{V},$$

or, since $Q = K V$, the quantity of electricity required to charge a condenser to a given potential is equal to the capacity of the condenser multiplied by the potential through which it is carried.

The capacity of a condenser increases in direct proportion to the increase in the area of its coatings.

When the coatings are plane and parallel to each other, the capacity of the condenser is in the inverse ratio to the distance between the coatings.

Condenser, Coating of — — (See *Coating of Condenser*.)

Condenser, Plate — — —A condenser, the metallic coatings of which are placed on suitably supported plates.

Condenser, Poles of — — (See *Poles of Condenser*.)

Condenser, Time-Constant of — — —The time in which the charge of a condenser falls to the 1-2.71828 part of its original value.

Condensers, Distribution of Electricity by Means of — — (See *Electricity, Distri-*

bution of. by Alternating Currents, by means of Condensers. Electricity, Distribution of, by Continuous Currents, by means of Condensers.)

Conduct.—To pass electricity through conducting substances.

To determine the general direction in which electricity shall pass through the ether or dielectric surrounding the so-called conducting substance. (See *Conduction, Electric*.)

Conductance.—A word sometimes used in place of conducting power.

Conductivity.

Conductance, Magnetic — — —A word sometimes used instead of magnetic permeability. (See *Permeability Magnetic*.)

The magnetic conductance is equal to the total induction through the circuit divided by the magnetizing force.

Conducting Cord.—(See *Cord, Conducting*.)

Conducting, Electrical — — —Possessing the power of passing electricity through any conducting substance.

Possessing the power of determining the direction in which electricity shall pass through the ether surrounding a substance. (See *Conductor*.)

Conducting Power.—(See *Power Conducting*.)

Conducting Power for Electricity.—(See *Power, Conducting, for Electricity*.)

Conducting Power for Lines of Magnetic Force.—(See *Force, Magnetic, Lines of, Conducting Power of*.)

Conducting Power, Tables of — — — (See *Power, Conducting, Tables of*.)

Conduction Current.—(See *Current, Conduction*.)

Conduction, Disruptive — — —A species of conduction in which the resistance of the conductor is suddenly overcome.

Disruptive conduction is seen in the disruptive discharge of a condenser, or Leyden jar.

Conduction, Electric — — —The so-

called flow or passage of electricity through a metallic or other similarly acting substance.

The ability of a substance to determine the direction in which electric energy shall be transmitted through the ether surrounding it.

The ability of a substance to determine the direction in which a current of electricity passes from one point to another.

When a conducting wire has its ends connected with an electric source, a current of electricity is, in common language, said to flow through the wire, and this was formerly believed to be a correct statement. According to modern views, however, the electric energy is believed to pass through the ether or other dielectric surrounding the conductor, the so-called conductor forming merely a sink, where the electrical energy dissipates itself. The conductor simply acts to direct the current.

Since, however, the energy practically passes by means of, and in the general direction of the conductor, there is no objection in speaking of the electricity as flowing through the conductor.

Conduction, Electric, Disruptive — — A conduction of electric energy which accompanies a disruptive discharge. (See *Discharge, Disruptive*.)

Conduction, Electric, Metallic — — A conducting of electric energy of the same character as that which occurs in metallic substances.

Conduction, Electrolytic — — A term sometimes employed to indicate the passage of electricity through an electrolyte.

There is no passage of electricity through an electrolyte in the same sense as through an ordinary conductor.

When, through electrolysis, an electromotive force is brought to bear on a molecule of say HCl, it is assumed by some that the liberated hydrogen atoms travel on the whole in one direction, and the liberated chlorine atoms in the opposite direction. The atoms thus moving through the liquid may by their electric charges be assumed to convey electricity, and this fact has given rise to the term electrolytic conduction.

In electrolytic conduction the charges are necessarily equal, but the speeds of their motion are unequal. In a given liquid, each atom has

its own rate of motion, no matter with what it has been combined. Hydrogen travels faster than any other kind of atom. The conductivity of a liquid depends on the sum of the speeds with which the two opposed atoms travel.

This assumed double stream of oppositely moving atoms is denied by most physicists. (See *Hypothesis, Grotthus*.)

Conductive-Discharge.—(See *Discharge, Conductive*.)

Conductivity, Electric — — The reciprocal of electric resistance.

Since the conductivity is greater the less the resistance, the conductivity will be equal to the reciprocal of the resistance, and may be so defined. The conductivity is therefore equal to $\frac{1}{R}$.

Conductivity, Equivalent — — A conductivity equal to the sum of several conductivities.

Conductivity per Unit of Mass.—The reciprocal of the resistance of a substance per unit of mass.

Conductivity per Unit of Volume.—The reciprocal of the resistance of a substance per cubic centimetre or per cubic inch.

The resistance is measured from one face of the cube to the opposite face.

Conductivity Resistance.—(See *Resistance, Conductivity*.)

Conductivity, Specific — — The particular conductivity of a substance for electricity.

The specific or particular resistance of a given length and unit of cross-section of a substance as compared with the same length and area of cross-section of some standard substance.

Conductivity, Specific Magnetic — — The specific or particular permeability of a substance to lines of magnetic force.

The specific magnetic conductivity is measured by the ratio of the magnetization produced to the magnetizing force which produces it.

The specific magnetic conductivity is the analogue of specific inductive capacity, or conductivity for lines of electrostatic force. It is also the analogue for specific conducting power for heat.

THIS PAGE IS LOCKED TO FREE MEMBERS

Purchase full membership to immediately unlock this page

Know Your Bible

Forgotten Books'
Full Membership
provides unlimited
access to more than
28,000 volumes of
Christian literature for
\$8.99/month

**HOLY
BIBLE**

Continue

*Fair use policy applies

Conductor, Conjugate — — In a system of linear conductors, any pair of conductors that are so placed as regards each other that a variation of the resistance or the electromotive force in the one causes no variation in the current of the other.

Conductor, Earth-Circuited — — A conductor connected to the ground, or to an earth-connected circuit.

Conductor, House-Service — — A term employed in a system of multiple incandescent lamp distribution for that portion of the circuit which is included between the service cut-out and the centre or centres of distribution, or between this cut-out and one or more points on house mains.

Conductor, Isotropic — — A conductor which possesses the same powers of electric conduction in all directions.

An electrically homogeneous conducting medium.

Conductor, Leakage — — A conductor placed on a telegraph circuit for the purpose of preventing the disturbing effects of leakage into a neighboring line by providing a direct path for such leakage to the earth.

The leakage conductor, as devised by Varley consists of a thick wire attached to the telegraph pole. The lower end of the conductor is grounded, and its upper end projects above the top of the pole.

There exists some doubt in the minds of experienced telegraph engineers whether it is well to apply leakage conductors to telegraphic or telephonic lines of over 12 or 15 miles in length, since such conductors greatly increase the electrostatic capacity of the line, and thus cause serious retardation.

Conductor, Lightning — — A term sometimes used for a lightning rod. (See *Rod, Lightning*.)

Conductor, Open-Circuited — — A conductor arranged as an open or broken circuit.

Conductor, Potential of — — The relation existing between the quantity of electricity in a conductor and its capacity.

A given quantity of electricity will raise the

potential of a conductor higher in proportion as the capacity of the conductor becomes less.

Conductor, Potential of, Methods of Varying — — The potential of a conductor may be varied in the following ways:

(1.) By varying its electric charge.

(2.) By varying its size or shape without altering its charge.

(3.) By varying its position as regards neighboring bodies.

This resembles the case of a gas whose tension or pressure may be varied as follows, viz.:

(1.) By varying the quantity of gas.

(2.) By varying the size of the gas holder in which it is kept, and

(3.) By varying the temperature.

Difference of potential, therefore, corresponds—

(1.) With difference of level in liquids.

(2.) With difference of pressure in gases.

(3.) With difference of temperature in heat.

—(*Ayrton*.)

Conductor, Prime — — The positive conductor of a frictional electric or electrostatic machine. (See *Machine, Frictional Electric*.)

Conductor, To Short-Circuit a — — To shunt a conductor with a circuit of comparatively small resistance.

Conductor, Underground — — An electric conductor placed underground by actual burial or by passing it through underground conduits or subways.

Underground conductors, though less unsightly than the ordinary aerial conductors, require to be laid with unusual care to render them equally safe, since, when contacts do occur, all the wires in the same conduit are apt to be simultaneously affected, thus spreading the danger in many different directions. They are, however, less liable to dangers arising from occasional accidental crosses or contacts.

Conductors, Service — — Conductors employed in systems of incandescent lighting connected to the street mains and to the electric apparatus placed in the separate buildings or areas to be lighted.

Conduit, Cement-Lined — — A cable conduit, the separate ducts of which are surrounded by any suitable cement.

Conduit, Handhole of — — (See *Handhole of Conduit*.)

Conduit, Manhole of — — (See *Manhole of Conduit*.)

Conduit, Multiple — — A conduit formed of concrete or other insulating material, and furnished with a number of separate ducts.

Conduit, Open-Box — — A conduit consisting of an open box of wood placed in a trench and closed with a wooden cover after the introduction of the cable.

Cables or wires may be drawn through such conduits in the usual manner.

Conduit, Rodding a — — Introducing a wire or rope into the duct of a closed conduit preparatory to drawing the cable through.

Various methods are in use for rodding a conduit. One much followed consists in using sections of gas pipe, the ends of which are furnished with screw threads.

The sections are about four feet in length. One section is pushed into the duct at one manhole and the successive sections are introduced into the duct and screwed onto the section in the duct and pushed through until a sufficient length is obtained to reach the next manhole, a rope or cable is then pulled through from one manhole to the next.

Conduit, Underground Electric — — An underground passageway or space for the reception of electric wires or cables. (See *Subway, Electric*.)

Congelation.—The act of freezing, or the change of a liquid into a solid on loss of heat, or change of pressure.

Conjugate Coils.—(See *Coils, Conjugate*.)

Connect.—To place or bring into electric contact.

Connecting.—Placing or bringing into electric contact.

Connection for Intensity.—Connection in series. (See *Connection, Series*.)

This term is now nearly obsolete.

Connection for Quantity.—Connection in multiple. (See *Connection, Multiple*.)

This term is now nearly obsolete.

Connection, Mercurial — — A form of readily adjustable connection obtained by providing the poles of one piece of electric apparatus with cups or cavities filled with mercury, into which the terminals of another piece of apparatus are dipped in order to place the two in circuit with each other.

This form of connection is used particularly when a very perfect contact or one free from friction is desired.

Connection, Multiple — — Such a connection of a number of separate electric sources, or electro-receptive devices, or circuits, that all the positive terminals are connected to one main or positive conductor, and all the negative terminals are connected to one main or negative conductor.

In the multiple connection of a number of electro-receptive devices, when the devices are connected as above described to positive and negative leads that are maintained at a constant difference of potential, the current passes through the devices from one lead to the other by branching and flowing through as many separate circuits as there are separate receptive devices, and the opening or closing of one of these circuits does not affect the others. (See *Circuits, Varieties of*.)

Connection, Multiple-Series — — Such a connection of a number of separate electric sources, or separate electro-receptive devices, or circuits, that the sources or devices are connected in a number of separate groups in series, and each of these groups connected to main positive and negative conductors or leads in multiple arc. (See *Circuits, Varieties of*.)

Connection of Battery for Quantity.—(See *Battery, Connection of, for Quantity*.)

Connection of Electric Sources in Cascade.—(See *Cascade, Connection of Electric Sources in*.)

Connection of Voltaic Cells for Intensity.—(See *Intensity, Connection of Voltaic Cells for*.)

Connection, Series — — The connection of a number of separate electric sources, or electro-receptive devices, or cir-

cuits, so that the current passes successively from the first to the last in the circuit. (See *Circuits, Varieties of.*)

Connection, Series-Multiple — — Such a connection of a number of separate electro-receptive devices, that the devices are placed in multiple groups or circuits, and these separate groups connected with one another in series.

Connection, Telephonic Cross — — A device employed in systems of telephonic communication for the purpose of lessening the bad effects of induction, in which equal lengths of adjacent parallel wires are alternately crossed so as to alternately occupy the opposite sides of the circuit.

Connector.—A device for readily connecting or joining the ends of two or more wires. (See *Post, Binding.*)

Connector, Double — — A form of binding screw suitable for readily connecting two wires together.

A form of double connector is shown in Fig. 170.

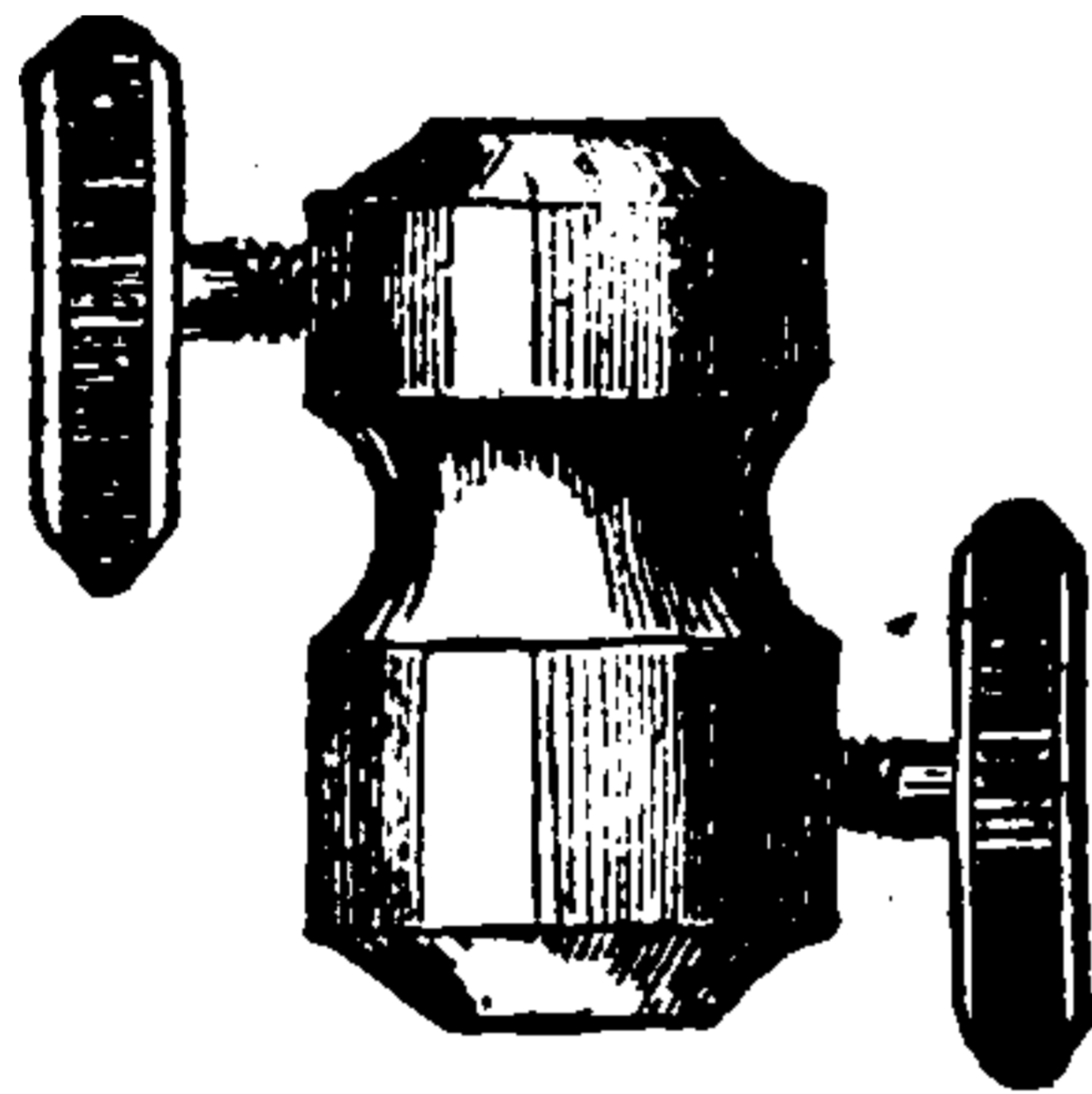

Fig. 170. Double Connector.

Conning Tower. — (See *Tower, Conning.*)

Consequent Points.—(See *Points, Consequent.*)

Consequent Poles.—(See *Poles, Consequent.*)

Conservation of Energy.—(See *Energy, Conservation of.*)

Consonance, "In Consonance."—A term employed to express the fact that one simple periodic quantity, *i. e.*, a wave or vibration, agrees in phase with another.

Constant.—That which remains invariable.

Constant-Current.—(See *Current, Constant.*)

Constant-Current Circuit.—(See *Circuit, Constant Current.*)

Constant-Current, Distribution of Electricity by — — (See *Electricity, Distribution of, by Constant Currents.*)

Constant, Dielectric — — A term sometimes employed in place of specific inductive capacity. (See *Capacity, Specific Inductive.*)

Constant, Galvanometer — — The numerical factor connecting the current passing through a galvanometer with the deflection produced by such current.

Sometimes a distinction is made between the galvanometer constant and the reduction factor, the former being used to indicate the relation between the current and the geometrical constant of the galvanometer, while the latter is used in the sense just defined of galvanometer constant.

Constant Inductance.—(See *Inductance, Constant.*)

Constant Potential.—(See *Potential, Constant.*)

Constant-Potential Circuit.—(See *Circuit, Constant-Potential.*)

Constant, Time, of Electro-Magnet — — The time required for the magnetizing current to rise to the $\frac{e-I}{e}$ of its final value.

Contact-Breaker, Automatic — — A device for causing an electric current to rapidly make and break its own circuit.

The spring *c*, Fig. 171, carries an armature of soft iron, *B*, and is placed in a circuit in such a manner that the circuit is closed when platinum contacts placed on the ends of *D* and *B*, touch each other. In this case the armature, *B*, is attracted to the core *A*, of the electro-magnet, thus breaking the circuit and causing the magnet to lose its magnetism. The elasticity of the spring *C*, causes it to fly back and again close the contacts, thus again energizing the electro-magnet and again attracting *B*, and breaking the circuit. The makes and breaks usually follow each other so rapidly as to produce a musical note. (See *Alarm, Electric.*)

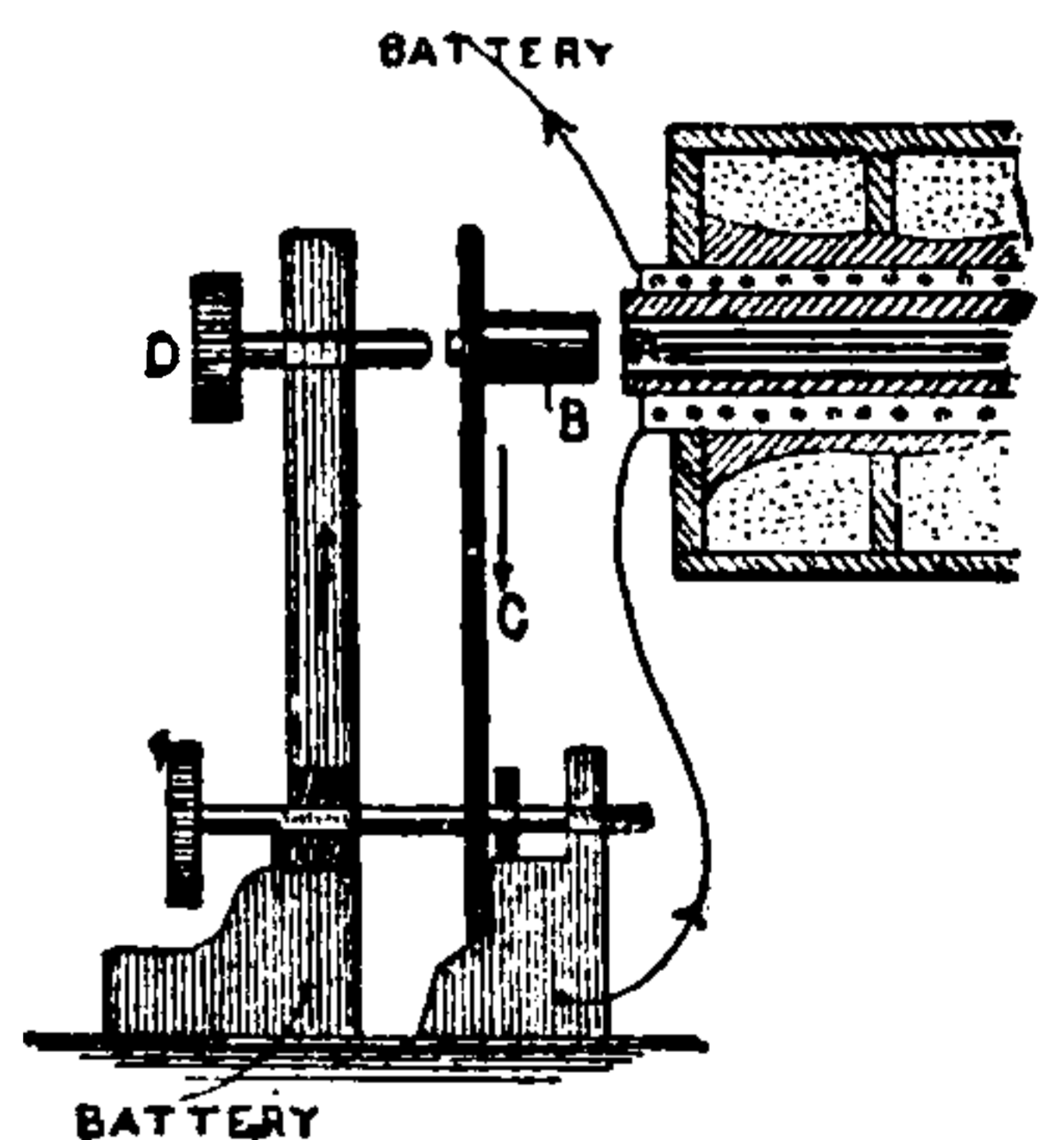

Fig. 171. Automatic Contact Breaker.

Contact, Dotting — — An electric con-

THIS PAGE IS LOCKED TO FREE MEMBERS

Purchase full membership to immediately unlock this page



HISTORY

Tens of thousands of important historical sources, many previously unobtainable, are now available for the first time with a Forgotten Books Full Membership.

Unlimited Access
\$8.99/month

Continue

*Fair usage policy applies

accidentally placed in firm connection with another metallic circuit.

(2.) *Partial*, as by imperfect conductors being placed across wires, or bad earths, or defective insulation.

(3.) *Intermittent*, as by occasional contacts of swinging wires, etc.

Contacts, Burglar Alarm — —Contacts fitted to windows, doors, tills, steps, floors, etc., so that a movement of the parts from their natural position gives an alarm by sounding a conveniently located bell.

Contacts, Lamp — —Metallic plates or rings connected with the terminals of an incandescent lamp for ready connection with the line.

Contacts, Mercurial — —Electric contacts that are opened or closed by the expansion or contraction of a mercury column.

In the commonest forms of mercurial contacts, on the expansion of the mercury by heat it reaches a contact point placed in the tube, and thus completes the circuit through its own mass.

Or, on contraction it breaks a contact, and thus disturbing an electric balance, sounds an alarm.

Continental Code Telegraphic Alphabet. —(See *Alphabet, Telegraphic, International Code*.)

Continuity of Current.—(See *Current, Continuous*.)

Continuous Current.—(See *Current, Continuous*.)

Continuous Current, Distribution of Electricity by — —(See *Electricity, Distribution of, by Constant Currents*.)

Continuous Current, Dynamo-Electric Machine — —(See *Machine, Dynamo-Electric, Continuous Current*.)

Continuous-Sounding Electric Bell.—(See *Bell, Continuous-Sounding Electric*.)

Continuous Wires or Conductors.—(See *Wires or Conductors, Continuous*.)

Contraction, Anodic Closure — —The muscular contraction observed on the closing of a voltaic circuit, the anode of which is placed over a nerve, and the kathode at some other part of the body.

This term is generally written A. C. C.

Contraction, Anodic Duration — —The length of time the muscle continues in contraction on the opening or closing of a circuit, the anode of which is placed over the part contracted.

This term is generally written A. D. C.

Contraction, Anodic Opening — —The muscular contraction observed on the opening of a voltaic circuit, the anode of which is placed over a nerve, and the kathode at some other part of the body.

This term is generally written A. O. C.

When the anode is placed over a nerve and a weak current is employed, if the circuit be kept closed for a few minutes, it will be noticed that, on opening the circuit the contraction will be much greater than if it had been opened after being closed for only a few seconds. The effect of the A. O. C. therefore depends not only on the current strength, but also on the time during which the current has passed through the nerve.

Contraction of Lines of Magnetic Force.—(See *Force, Magnetic, Contraction of Lines of*.)

Contractures.—In electro-therapeutics, prolonged muscular spasms, or tetanus, caused by the passage of electric currents.

Contraplex Telegraphy.—(See *Telegraphy, Contraplex*.)

Controlled Clock.—(See *Clock, Electric*.)

Controller.—A magnet, in the Thomson-Houston system of automatic regulation, whose coils are traversed by the main current, and by means of which the regulator magnet is automatically thrown into or out of the main circuit on changes in the strength of the current passing. (See *Regulation, Automatic*.)

Controlling Clock.—(See *Clock, Electric*.)

Controlling Magnet.—(See *Magnet, Controlling*.)

Convection Currents.—(See *Currents, Convection*.)

Convection, Electric — —The air particles, or air streams, which are thrown off from the pointed ends of a charged, insulated conductor.

Convection streams, like currents flowing through conductors, act magnetically, and are themselves acted on by magnets. The same thing is true of the brush discharge, of the voltaic arc, and of convective discharges in vacuum tubes.

Convection, Electrolytic — —A term proposed by Helmholtz to explain the apparent conduction of electricity by an electrolyte, without consequent decomposition.

Helmholtz assumes that the atoms of oxygen or hydrogen, adhering to the electrodes during electrolysis, are mechanically dislodged and diffused through the liquid, thus carrying off the electricity by the charges received while in contact with the electrodes.

Convection of Heat, Electric — —(See *Heat, Electric Convection of*.)

Convection Streams.—(See *Streams, Convection*.)

Convective Discharge.—(See *Discharge, Convective*.)

Conversion, Efficiency of, of Dynamo — —The total electric energy developed by a dynamo, divided by the total mechanical energy required to drive the dynamo. (See *Co-efficient, Economic, of a Dynamo-Electric Machine*.)

The efficiency of conversion

$$= \frac{W + w}{M} = \frac{W + w}{W + w + m},$$

where W , equals the useful or available electrical energy, M , the total mechanical energy, w , the electrical energy absorbed by the machine, and m , the stray power, or the power lost in friction, eddy currents, air friction, etc.

Converted Currents.—(See *Currents, Converted*.)

Converter.—The inverted induction coil employed in systems of distribution by means of alternating currents.

A term sometimes used instead of transformer. (See *Transformer*.)

Converter, Closed-Iron Circuit — —A closed-iron circuit transformer. (See *Transformer, Closed-Iron Circuit*.)

Converter, Constant-Current — —A constant-current transformer. (See *Transformer, Constant-Current*.)

Converter, Efficiency of — —The efficiency of a transformer. (See *Transformer, Efficiency of*.)

Converter Fuse.—(See *Fuse, Converter*.)

Converter, Hedgehog — —A form of transformer. (See *Transformer, Hedgehog*.)

Converter, Multiple — —A multiple transformer. (See *Transformer, Multiple*.)

Converter, Open-Iron-Circuit — —An open-iron-circuit transformer. (See *Transformer, Open-Iron-Circuit*.)

Converter, Series — —A series transformer. (See *Transformer, Series*.)

Converter, Step-down — —A step-down transformer. (See *Transformer, Step-down*.)

Converter, Step-up — —A step-up transformer. (See *Transformer, Step-up*.)

Converter, Welding — —A welding transformer. (See *Transformer, Welding*.)

Converting Currents.—(See *Currents, Converting*.)

Cooling Box of Hydro-Electric Machine.—(See *Box, Cooling, of Hydro-Electric Machine*.)

Co-ordinates, Axes of — —The axes of abscissas and ordinates.

The two straight lines, usually perpendicular to each other, to which distances representing values are referred for the graphic representation of such values. (See *Abscissas, Axes of*.)

Copper Bath.—(See *Bath, Copper*.)

Copper Plating.—(See *Plating, Copper*.)

Copper Ribbon.—A variety of strap copper. (See *Copper, Strap*.)

Copper, Strap — —Copper conductors in the form of straps or flat bars.

Strap copper is used on the armatures of some dynamos. Heavy copper conductors for such purposes are divided into strap copper so as to avoid eddy currents. The straps are placed alongside one another and insulated by a coating of varnish.

Copper Wire, Hard-Drawn — —(See *Wire, Copper, Hard-Drawn*.)

Copper Wire, Soft-Drawn — —(See *Wire, Copper, Soft-Drawn*.)

Copper Voltmeter.—(See *Voltmeter, Copper.*)

Coppered Plumbago.—(See *Plumbago, Coppered.*)

Coppering, Electro — — Electro-plating with copper. (See *Plating, Electro.*)

Cord-Adjuster.—(See *Adjuster, Cord.*)

Cord, Conducting — — A small flexible cable, usually containing several conductors separated from one another by insulating material.

Cord, Electric — — A flexible, insulated electric conductor, generally containing at least two parallel wires.

Electric cords are named from the purposes for which they are employed, *battery cords, dental cords, lamp cords, motor cords, switch cords, etc.*



Fig. 172. Flexible Cord.

A two-conductor flexible cord, in which each cord is composed of a number of bare copper wires placed parallel to and in contact with one another, is shown in Fig. 172. The several separate wires give flexibility to the cord.

Cord, Pendant — — A flexible conductor provided for conveying the current to a hanging electric lamp supported by it.

Cords, Telephone — — Flexible conductors for use in connection with a telephone.

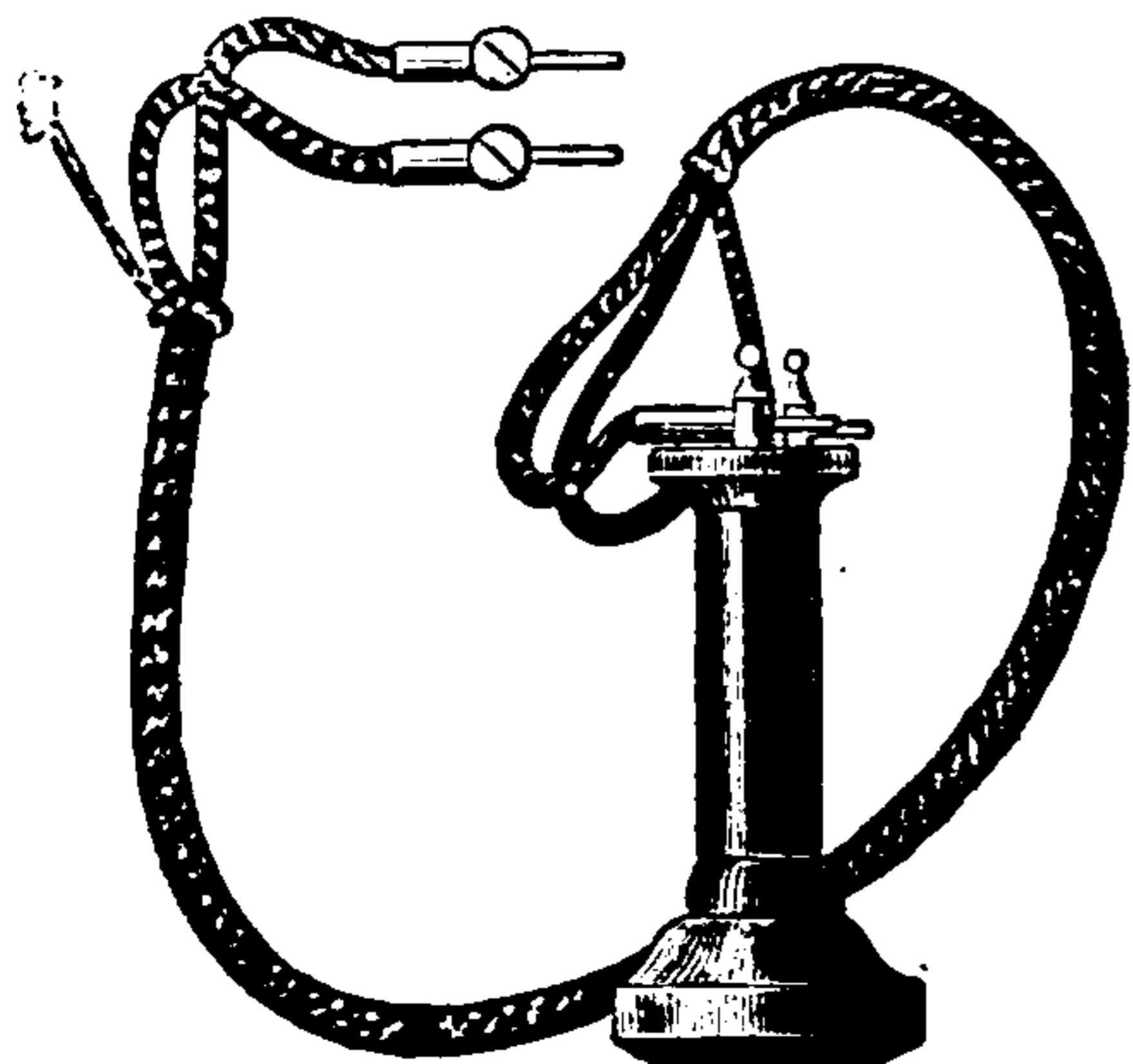

Fig. 173. Telephone Cords.

Telephone cords, attached to an articulating telephone, are shown in Fig. 173.

Core, Armature, Filamentous — — An armature core, the iron of which consists of wire.

Core, Armature, H — — An armature core in the shape of the letter H, generally known as the shuttle armature, and sometimes as the girder armature.

This form is also called an I armature.

The H armature core was the form originally given to the Siemens armature. In this form a single coil of wire was secured on the cross-bar of the H armature core, so as to fill up the entire space inside the letter, and the ends of the wire connected to a two-part commutator.

Core, Armature, Lamination of — — The subdivision of the core of the armature of a dynamo-electric machine into separate insulated plates or strips for the purpose of avoiding eddy or Foucault currents.

This lamination must always be perpendicular to the direction of the eddy currents that would otherwise be produced. (See *Currents, Eddy.*)

Core, Armature, of Dynamo-Electric Machine — — The iron core, on, or around which, the armature coils of a dynamo-electric machine are wound or placed.

The armature core is laminated for the purpose of avoiding the formation of *eddy* or Foucault *currents*.

In *drum*, and in *ring-armatures*, the laminæ should be in the form of thin insulated discs or plates of soft iron; in *pole-armatures* they should be in the form of bundles of insulated wires.

The iron in the cores should be of such an area of cross-section, as not to be readily oversaturated.

Core, Armature, Radially-Laminated — — An armature core, the iron of which consists of thin iron washers.

Core, Armature, Ribbed — — A cylindrical armature core provided with longitudinal projections or ribs that serve as spaced channels or grooves for the reception of the armature coils.

Core, Armature, Tangentially-Laminated — — An armature core, the iron of which consists of a coiled ribbon.

Core, Armature, Ventilation of — — Means for passing air through the armature

THIS PAGE IS LOCKED TO FREE MEMBERS

Purchase full membership to immediately unlock this page

Know Your Bible

Forgotten Books' Full Membership provides unlimited access to more than 28,000 volumes of Christian literature for \$8.99/month

HOLY BIBLE

Continue

*Fair use policy applies

conveying an ampère.—(Ayrton.) (See *Ampère. Farad. Volt.*)

Coulomb's Torsion Balance.—(See *Balance, Coulomb's Torsion.*)

Coulomb-Volt.—A Joule, or .7373 foot-pound.

The term is generally written *volt-coulomb*. (See *Volt-Coulomb.*)

Counter, Electric — —A device for counting and registering such quantities as the number of fares collected, gallons of water pumped, sheets of paper printed, revolutions of an engine per second, votes polled, etc.

Various electric devices are employed for this purpose. They are generally electro-magnetic in character.

Counter-Electromotive Force. — (See *Force, Electromotive, Counter.*)

Counter Electromotive Force Lightning Arrester.—(See *Arrester, Lightning, Counter-Electromotive Force.*)

Counter-Electromotive Force of Convective Discharge.—(See *Force, Electromotive, Counter, of Convective Discharge.*)

Counter-Electromotive Force of Mutual Induction.—(See *Force, Electromotive, Counter, of Mutual Induction.*)

Counter-Electromotive Force of Self-Induction.—(See *Force, Electromotive, Counter, of Self-Induction.*)

Counter-Electromotive Force of Self-Induction of the Primary.—(See *Force, Electromotive, Counter, of Self-Induction of the Primary.*)

Counter-Electromotive Force of Self-Induction of the Secondary.—(See *Force, Electromotive, Counter, of Self-Induction of the Secondary.*)

Counter-Electromotive Force of the Primary.—(See *Force, Electromotive, Counter, of the Primary.*)

Counter Inductive Effect.—(See *Effect, Counter Inductive.*)

Couple.—In mechanics, two equal parallel forces acting in opposite directions but not in the same line, and tending to cause rotation.

The *moment*, or *effective power of a couple*, is

equal to the intensity of one of the forces multiplied by the perpendicular distance between the directions of the two forces.

Couple, Astatic — —Two magnets of exactly equal strength so placed one over the other in the same vertical plane as to completely neutralize each other.

An astatic couple has no directive tendency. A pair of magnets combined as an astatic couple is called an astatic needle. (See *Needle, Astatic.*)

Couple, Magnetic — —The couple which tends to turn a magnetic needle, placed in the earth's field, into the plane of the magnetic meridian.

If a magnetic needle is in any other position than in the magnetic meridian, there will be two parallel and equal forces acting at A and B, Fig. 174, in the directions shown by the arrows. Their effect will be to rotate the needle until it comes to rest in the magnetic meridian N S.

The total force acting on either pole of a needle free to move in any direction, is equal to the strength of that pole multiplied by the total intensity of the earth's field at that place ; or, if free to move in a horizontal direction only, is equal to the intensity of the earth's horizontal component of magnetism at that place, multiplied by the strength of that pole.

The effective power or moment of a magnetic couple is equal to the force exerted on one of the poles multiplied by the perpendicular distance, P Q, between their directions.

The effective power or moment of a magnetic couple is equal to the force exerted on one of the poles multiplied by the perpendicular distance, P Q, between their directions.

Couple, Moment of — —The effective power or force of a couple.

The moment of a couple is equal to the intensity of one of the forces multiplied by the perpendicular distance between the direction of the forces.

Couple, Thermo-Electric — —Two dissimilar metals which, when connected at their ends only, so as to form a completed electric circuit, will produce a difference of potential, and hence an electric current, when one of the ends is heated more than the other.

Thus if a bar of bismuth be soldered to a bar

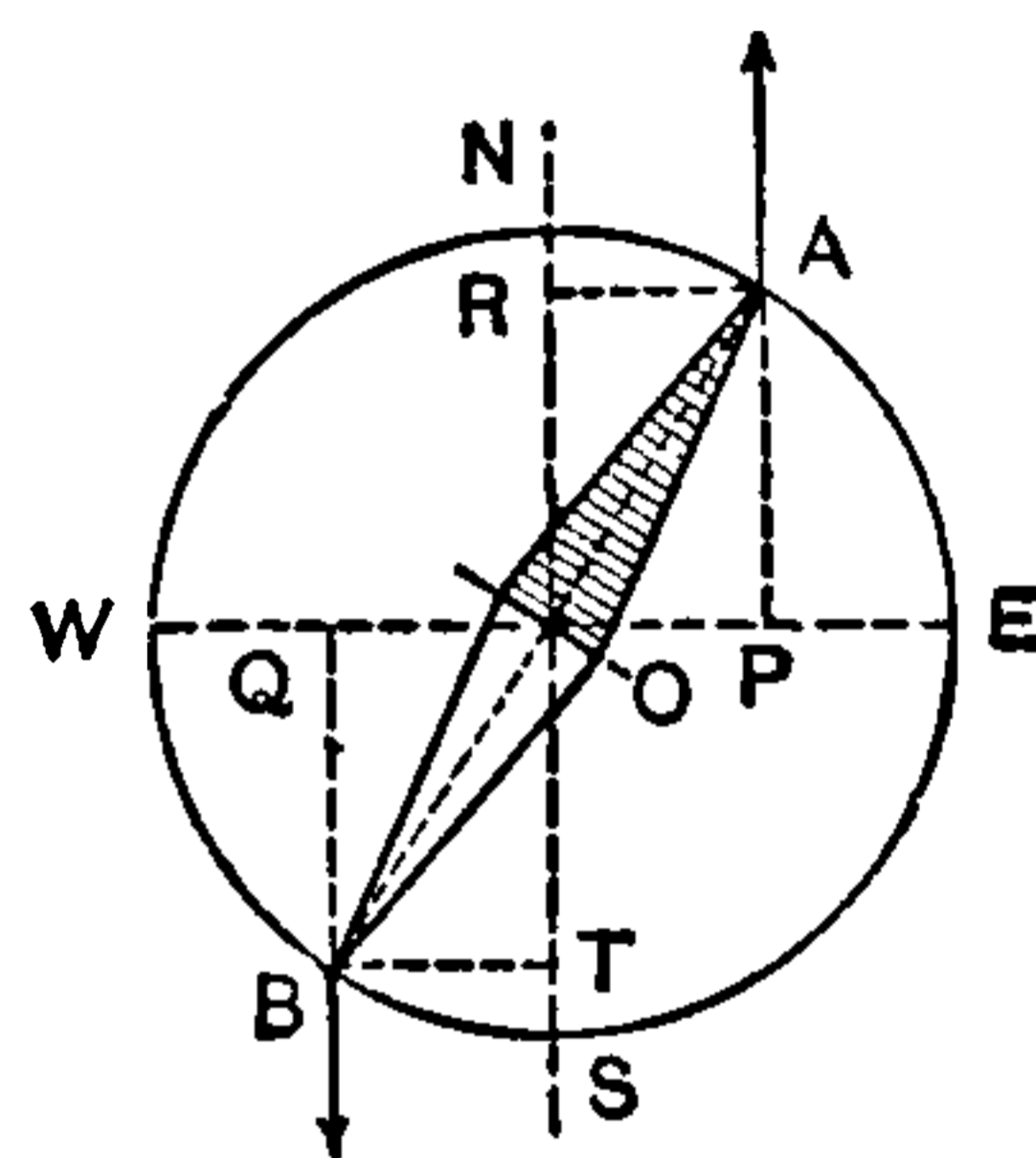

Fig. 174. Magnetic Couple.

of antimony the combination will form a thermo-electric couple, and the circuit so formed will have a current passing through it when one junction is hotter or colder than the other.

There is, according to Lodge, a true contact force, at a thermo-electric junction, as is shown by the reversible heat effects produced when an electric current is passed across such junction; for, in one direction more heat is produced, and in the opposite direction less heat. This, as is well known, differs from the irreversible heat produced by a current through a homogeneous metallic conductor. The reversible heat effects, or as they are called the *Peltier effects*, may overpower and conceal the heating effects. But, in addition to these effects, since a difference of potential, called a *Thomson effect*, exists in a substance unequally heated, currents are so produced, and these are also influential in causing the difference of potential of a thermo-electric couple.

“There are then,” says Lodge, “in a simple circuit of two metals with their junctions at different temperatures, altogether four E. M. Fs., one in each metal, from hot to cold, or *vice versa*, and one at each junction, and the current which flows around such a circuit is propelled by the resultant of these four.” * * * “These four forces, two Thomson forces in the metals, and two Peltier forces at their junctions, may some of them help and some hinder the current.” * * * “Whenever they help, the locality is to that extent cooled; whenever they hinder, it is to that extent warmed.”

The action of a thermo-electric couple in producing a difference of potential is therefore a complicated one, and depends on Peltier and Thomson effects, as well as on the thermo-electric effect. (See *Effect, Peltier. Effect, Thomson. Effect, Thermo-Electric.*)

Couple, Voltaic— — Two materials, usually two dissimilar metals, capable of acting as an electric source when dipped in an electrolyte, or capable of producing a difference of electric potential by mere contact.

Liquids and gases are capable of acting as voltaic couples.

All voltaic cells have two metals, or a metal and a metalloid, or two gaseous or liquid substances which are of such a character that, when dipped into the exciting fluid one only is chemically acted on.

Each one of these two substances is called an *element* of the cell, and the two taken collectively form a *voltaic couple*.

The elements of a voltaic couple may consist of two gases or two liquids. (See *Battery, Gas.*)

Coupled Cells.—(See *Cells, Coupled.*)

Coupler, Voltaic — — Any device by means of which voltaic cells may be readily coupled or connected in different forms of circuits. (See *Circuits, Varieties of.*)

Coupling of Voltaic Cells or Other Electric Sources.—A term indicating the manner in which a number of separate electric sources may be connected so as to form a single source. (See *Circuits, Varieties of.*)

Cramp, Telegrapher's — — An affection of the hand of a telegrapher due to immoderate and excessive use of the same muscles, somewhat similar to the disease known as writer's cramp.

Telegrapher's cramp, like writer's cramp, may be defined as a professional neurosis of co-ordination. It appears not only in certain groups of muscles, but is limited to such groups, only when they are performing certain complicated operations. For example, telegrapher's cramp is practically a paralysis of certain muscles of the hand and wrist of the operator. These muscles, when called on to perform the somewhat delicate movements required in sending a telegraphic dispatch, are incapable of performing their proper functions, but when called on to perform in part other similar actions, provided *all* these actions are not required to be used, appear to be unaffected.

The ability of the operator to send with either hand would lessen the liability to this disease.

Crater in Positive Carbon.—A depression at the end of the positive carbon of an arc lamp which appears when a voltaic arc is formed. (See *Arc, Voltaic.*)

Creep, Diffusion — — The flow of an electric current in portions of a conducting substance, outside the parts that lie in the direct lines between the points where the terminals of the same are applied to the conducting substance.

Creeping, Electric — —A term sometimes applied to the creeping of a current. (See *Current, Creeping of*.)

Creeping in Voltaic Cell.—(See *Cell, Voltaic, Creeping in*.)

Creeping of Current.—(See *Current, Creeping of, Electric*.)

Creeping, Saline — —The formation of salts by efflorescence on the walls of a solid immersed in a solution of a salt.

Creosoting.—A process employed for the preservation of wood, as, for example, telegraph poles, by injecting creosote into the pores of the wood. (See *Pole, Telegraphic*.)

Crith.—A term proposed by A. W. Hoffman, as a unit of weight, or the weight of one litre, or cubic decimetre, of hydrogen at 0° C. and 760 mm. barometric pressure.

Critical Current. — (See *Current, Critical*.)

Critical Current of a Dynamo.—(See *Current, Critical, of a Dynamo*.)

Critical Distance of Lateral Discharge through Alternative Path.—(See *Distance, Critical, of Lateral Discharge through an Alternative Path*.)

Critical Speed of Compound-Wound Dynamo.—(See *Speed, Critical, of Compound-Wound Dynamo*.)

Crookes' Dark Space.—(See *Space, Dark, Crookes'*.)

Crookes' Electric Radiometer.—(See *Radiometer, Electric, Crookes'*.)

Cross Arm.—(See *Arm, Cross*.)

Cross-Connecting Board.—(See *Board, Cross-Connecting*.)

Cross, Electric — —A connection, generally metallic, accidentally established between two conducting lines.

A defect in a telegraph, telephone or other circuit caused by two wires coming into contact by crossing each other.

A *swinging or intermittent cross* is caused by wires, which are too slack, being occasionally blown into contact by the wind.

A *weather cross* arises from defective action of the insulators in wet weather.

Cross, Swinging or Intermittent — — An accidental contact, generally metallic, caused by wires being brought into occasional contact with one another, or with some other conductor, by the intermittent action of the wind.

Cross, Weather — —A contact or leak occurring in a telegraphic or other line during wet weather, from the defective action of the insulators.

Crossing Cleat.—(See *Cleat, Crossing*.)

Crossing, Live-Trolley — —A device whereby a trolley moving over a line that crosses a second line at an angle is enabled to maintain its electrical connection with the line while crossing.

A live-trolley crossing is necessitated where one line of electric railway crosses another. The upper line must, of course, provide a space or opening for crossing the lower line at the points of intersection. This is effected in the Bagnall live-trolley crossing, shown in Fig. 175, by attach-



Fig. 175. Live-Trolley Crossing.

ing to the upper trolley wire a bridge piece of light lathe casting, provided at its centre with a gap through which the trolley wire passes. This bridge piece is insulated from the trolley wire by means of a disc of insulating material at the centre of the bridge, which is provided with a hinged curved lever, that in its normal position rests under the influence of gravity in the position shown in the figure. The passage of the trolley wheel along the wire carries the line under it and thus bridges the gap, as shown by the position of the dotted lines.

Crossing Wires.—(See *Wires, Crossing*.)

Cross-Over Block.—(See *Block, Cross-Over*.)

Cross-Over, Trolley — —A device by means of which a trolley is enabled to pass over the points where different lines cross one another without serious interruption.

THIS PAGE IS LOCKED TO FREE MEMBERS

Purchase full membership to immediately unlock this page



HISTORY

Tens of thousands of important historical sources, many previously unobtainable, are now available for the first time with a Forgotten Books Full Membership.

Unlimited Access
\$8.99/month

Continue

*Fair usage policy applies

then finally another in the same direction before connecting with the ground.

The effect of the third charge is to reduce the potential of the line more nearly to zero at the end of the signal.

Curb, Single — —A device for increasing the speed of signaling telegraphically by ridding the line of its previous charge by sending a reversed current through it before connecting with the ground.

In single-curb signaling the operator in discharging the line before sending another signal through it, before putting the line to earth, reverses the battery, and then connects to earth.

Current, Absolute Unit of — —A current of 10 ampères. (See *Ampère. Units, Practical.*)

A current of such a strength that when passed through a circuit of a centimetre in length bent in the form of an arc of a circle one centimetre in radius, will act with the force of a dyne on a magnetic pole of unit strength, placed at the centre of the arc.

The ampère, the practical unit of current, is but $\frac{1}{10}$ the value of the absolute unit of current.

Current, Action of, on a Magnetic Pole — —An attraction or repulsion dependent on the name of the pole and the direction of the current.

Two currents of electricity attract or repel each other according to the direction in which they are flowing, and the mutual positions of their circuits. A current and a magnetic pole exert an action on each other which, strictly speaking, is neither attraction nor repulsion, but which is rotation, that may, however, be regarded as being produced by the combined action of attraction and repulsion.

Current, Alternating — —A current which flows alternately in opposite directions.

A current whose direction is rapidly reversed.

The non-commuted currents generated by the differences of potential in the armature of a dynamo-electric machine are alternating or simple-periodic-currents.

In a characteristic curve of the electromotive forces of alternating currents, positive electromotive forces, or those that would produce cur-

rents in a certain direction, are indicated by values *above* a horizontal line, and negative electromotive forces, by values *below* the line.

The curves A B C, and C D E, Fig. 177, are

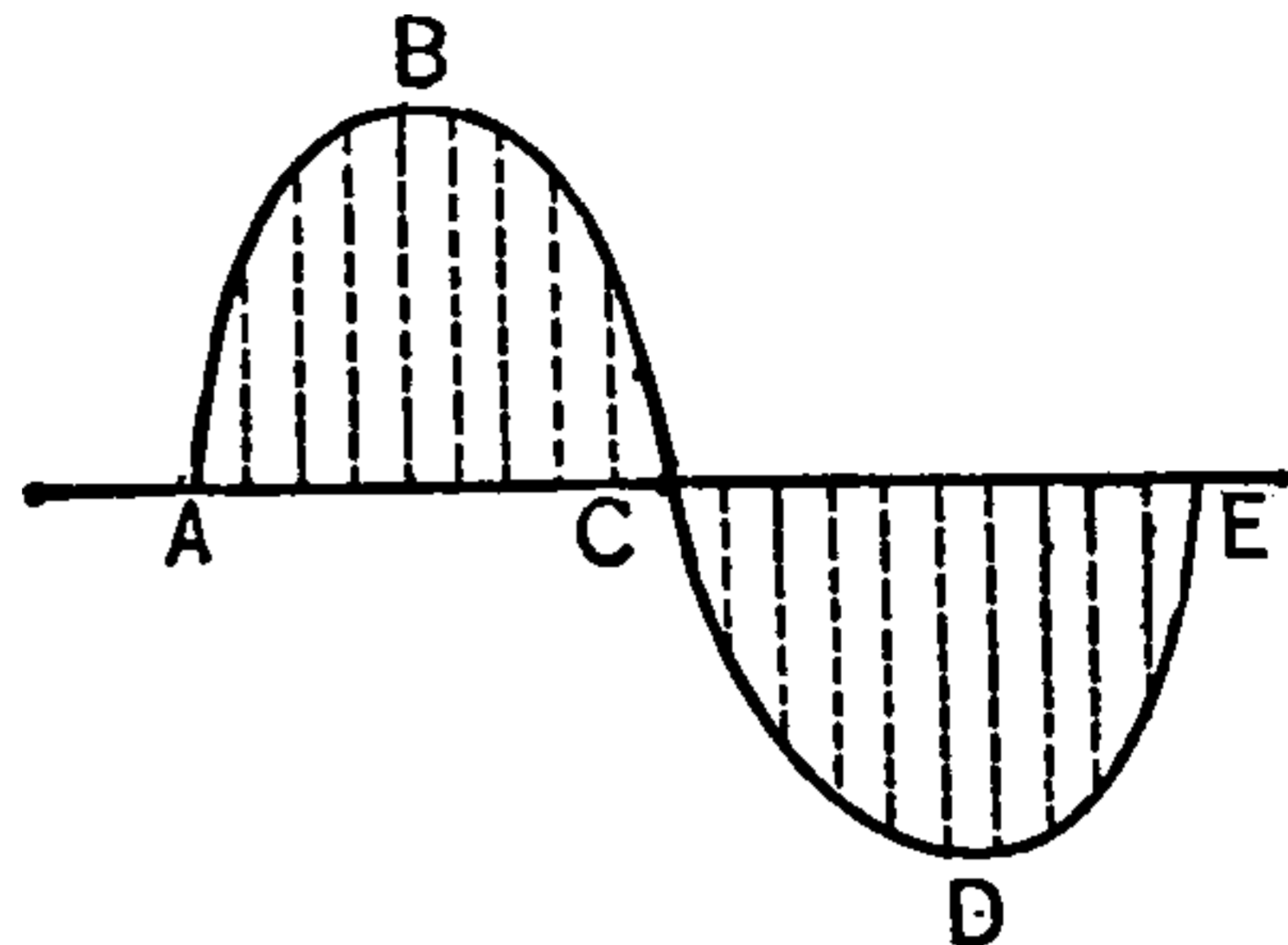

Fig. 177. Curve of Electromotive Forces of Alternating Currents.

often called *phases*, and represent the alternate phases of the current.

Current, Alternative — —A voltaic alternative. (See *Alternatives, Voltaic.*)

Current, Assumed Direction of Flow of — —The direction the current is assumed to take, *i. e.*, from the positive pole of the source through the circuit to the negative pole of the source.

The electricity is assumed to come out of the source at its positive pole, and to return or flow back into the source at its negative pole. This convention as to the direction of the electric current is in accordance with the assumption of the direction of flow of lines of magnetic forces.

The old idea of a dual or double current flowing in opposite directions is still maintained by some. (See *Force, Lines of, Direction of.*)

Current, Axial — —In electro-therapeutics a current flowing in a nerve in the opposite direction to the normal impulse in the nerve.

Current, Break-Induced — —The current induced by a current in its own, or in another circuit, on breaking or opening the same.

The current induced in the secondary on the breaking of the primary circuit.

The break-induced current set up by a current in its own circuit is sometimes called the *direct-induced* current.

Lord Rayleigh has shown that within certain limits the break-induced current has a greater effect in magnetizing steel needles, the smaller the number of turns of wire in the secondary. In

the case of a galvanometer, it is well known that the opposite is true. The deflection of the galvanometer needle depends on the strength of the whole current. The magnetizing power depends, for the greater part, on the strength of the current at the beginning of its formation.

Current, Closed-Circular — — A current flowing in a circular circuit.

A small closed-circular current may be replaced magnetically by a thin disc of steel, magnetized in a direction perpendicular to its face, and the edge of which corresponds to the edge of the circular conductor.

Current-Commuter. — (See *Commuter, Current.*)

Current, Conduction — — The current that passes through a metallic or other conducting substance, as contradistinguished from a current produced in a non-conductor or dielectric. (See *Current, Displacement.*)

Current, Constant — — A current that continues to flow in the same direction for some time without varying in strength.

This term is sometimes used to mean a continuous or direct current in contradistinction to an alternating current, but it ought to be applied only to unvarying currents. such, for example as a constant current of 10 ampères.

Current, Continuous — — An electric current which flows in one and the same direction

Although the term continuous current is used as synonymous with constant current, it is not entirely so; a continuous current flows constantly in the same direction. A constant current not only flows continuously in the same direction, but maintains an approximately constant current strength.

This term continuous current is used in the opposite sense to alternating current, and in the same sense as a direct current.

Current, Creeping of Electric — — A change in the direction of path of a current from the direct line between the points of connection with the source.

When the terminals of any electric source are placed in contact with any two points of a metallic sheet of conducting material, the flow of the current is not confined to the direct line between the

points of contact, but creeps or diffuses into portions of the conducting plate surrounding this direct line. (See *Current, Diffusion of.*)

In a somewhat similar manner, the current is said to creep, or to establish a partial short-circuit around the poles of a poorly insulated voltaic battery, or other electric source.

Current, Critical — — The current at which a certain result is reached.

Current, Critical, of a Dynamo — — That value of the current at which the characteristic curve begins to depart from a nearly straight line. — (*Silvanus P. Thompson.*)

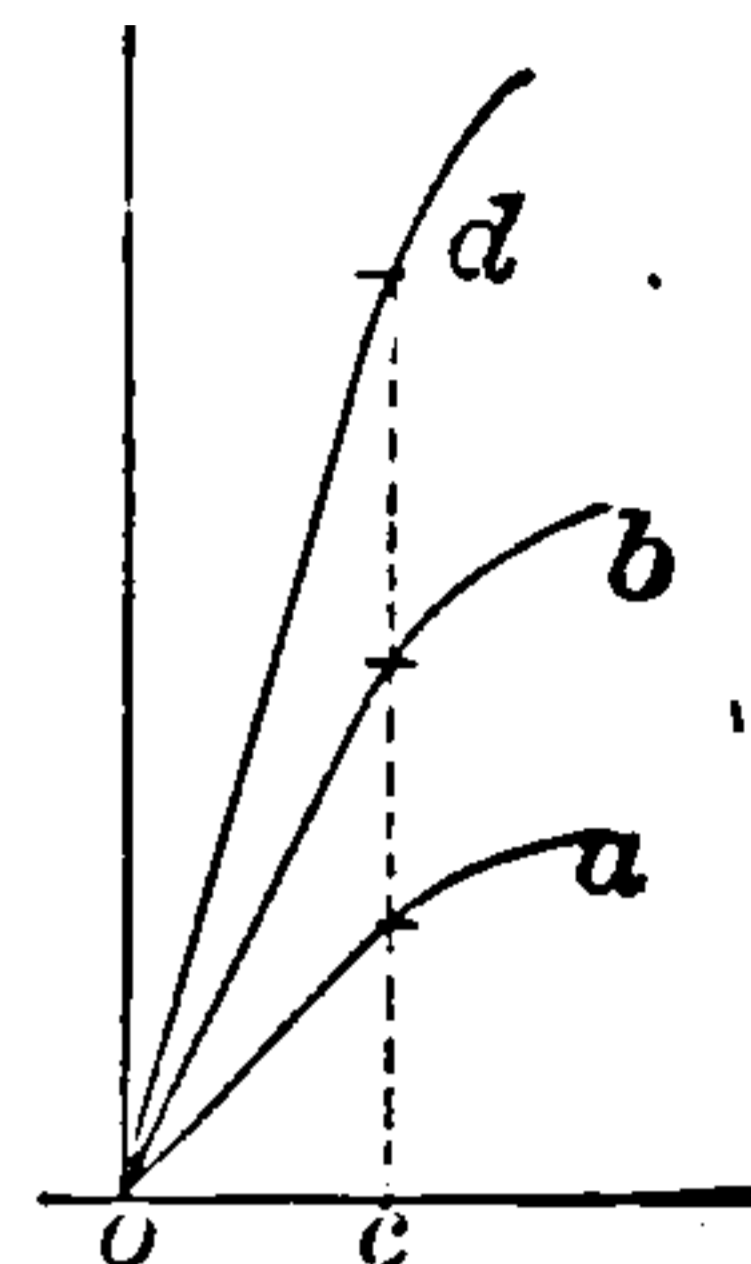

Fig 178. Critical Curve of Dynamo Current

In Fig. 178 the critical current is shown in three different cases, as occurring where the dotted vertical line cuts the characteristic curves.

The speed at which a series dynamo excites itself is often called the *critical speed*.

Current, Demarcation — — A term sometimes applied to an electric current obtained from an injured muscle.

“Every injury of a muscle or nerve causes at the point of injury a dying surface, which behaves negatively to the positive intact substance.”— (*Landois & Stirling.*)

Current Density.—The current of electricity which passes in any part of a circuit as compared with the area of cross-section of that part of the circuit.

In a dynamo-electric machine the current density in the armature wire should not, according to Silvanus P. Thompson, exceed 2,500 ampères per square inch of area of transverse section of conductor.

The current density in a dynamo wire, of necessity depends on the sectional area of the coils. If, for example, a current of 50 ampères be safe in an armature section of eight turns it may be safely increased to 100 ampères if the conductors are cross-sectioned so as to make but four turns.—(*Urquhart.*)

In electro-plating, for every definite current strength that passes through the bath, or in other words, for a definite number of coulombs, a definite weight of metal is deposited, the charac-

ter of which depends on the current density. The character of an electrolytic deposit will therefore depend on the *current density* at that part of the circuit where the deposit occurs.

The following table from Urquhart gives the practical working value for the current density for electro-metallurgical deposits :

CURRENT DENSITY (OR AMPÈRES ON CATHODE).	
Solution of	Ampères per square foot.
Copper, acid bath.....	5.0 to 10.0
Copper, cyanide bath.....	3.0 " 5.0
Silver, double cyanide.....	2.0 " 5.0
Gold, chloride in cyanide.....	1.0 " 2.0
Nickel, double sulphate.....	6.0 " 8.0
Brass, cyanide.....	2.0 " 3.0
Tin.....

Current, Diacritical — —Such a strength of the magnetizing current as produces a magnetization of an iron core equal to half-saturation.

The diacritical current is the current which, flowing through the diacritical number of ampère-turns, will bring up the magnetism produced to half-saturation.

The diacritical number of ampère-turns is such a number of ampère-turns as would reduce the magnetic permeability to half its full value.

Current, Diffusion of — —A term employed to designate the difference in the density of current in different portions of a conductor. (See *Current, Creeping of, Electric.*)

Current, Diffusion of Electro-Therapeutic — —The difference in the density of current in different portions of the human body between the electro-therapeutic electrodes.

When the electrodes are placed at any two given points of the human body, the current branches through various paths, extending in a general direction from one electrode to the other, according to the law of branched or derived circuits, and flowing in greater amount, or with greater density of current, through the relatively better conducting paths. (See *Current Density.*)

This is sometimes called the creeping of the current. (See *Current, Creeping of.*)

Current, Direct — —A current con-

stant in direction, as distinguished from an alternating current.

A continuous current.

Current, Direct-Induced — —The current induced in a circuit by induction on itself, or self-induction, on breaking or opening the circuit. (See *Currents, Extra.*)

This is called the direct-induced current because its direction is in the same direction as the inducing current.

Current, Direction of — —The direction an electric current is assumed to take out from one pole of any source through the circuit and its translating devices back to the source through its other pole.

Conventionally, the current is assumed to come out from the positive pole of the source and to go back to the source at the negative pole.

Current, Displacement — —The rate of change of electric displacement.

A brief conduction current produced in a dielectric by an electric displacement. (See *Displacement, Electric.*)

This is called a displacement current in order to distinguish it from a conduction current in any conductor.

The displacement current continues while the displacement of electricity is going on. Displacement currents have all the properties of conduction currents, and, like the latter, produce a magnetic field; in fact, they resemble extremely brief conduction currents.

The difference between conducting substances and dielectrics, lies in the fact that the conducting substances do not possess an elastic force, enabling them to resist electric displacement. In other words, conducting substances possess no *electric elasticity*, and can have no true displacement current established in them. (See *Elasticity, Electric.*)

A displacement current, like a conduction current, possesses a magnetic field, or is encircled by lines of magnetic force. (See *Field, Magnetic, of an Electric Current.*)

Current, Electric — —The quantity of electricity which passes per second through any conductor or circuit.

The rate at which a definite quantity of electricity passes or flows through a conductor or circuit.

THIS PAGE IS LOCKED TO FREE MEMBERS

Purchase full membership to immediately unlock this page

Know Your Bible

Forgotten Books'
Full Membership
provides unlimited
access to more than
28,000 volumes of
Christian literature for
\$8.99/month

**HOLY
BIBLE**

Continue

*Fair use policy applies

and according to what laws? Briefly stated, the tendency of recent views is that this energy is conveyed through the electro-magnetic medium or ether, and that the function of the wire is to localize the direction or to concentrate the flow in a particular path, and thus provide a *sink* or place in which the energy can be dissipated. * * *

Taking again, for instance, the case of the discharge of a condenser by a conductor. He says: "Before the discharge we know that the energy resides in the dielectric, between the conducting plates. If these plates are connected by a wire, according to these views, the energy is transferred outwards along the electrostatic, equipotential surfaces, and moves *on* to the wire and is there converted into heat. According to this view we must suppose the lines of electrostatic induction, running from plate to plate, to move outwards, as the dielectric strain lessens, and while still keeping their ends on the plates, to finally converge in on the wire and be there broken up and their energy dissipated as heat."

In other words, some of the energy of the expanding lines of induction is changed into magnetic energy; this energy is contained in ring-shaped tubes of force, which expand outwards from between the plates and then contract on some other part of the conductor.

The time of the discharge, then, consists of the following steps, viz.:

(1.) The time during which the energy of the charge is nearly all electrostatic and is represented by the energy contained in the lines or tubes of electrostatic induction, running from plate to plate of the condenser.

(2.) The time during which the discharge is at its maximum and the energy consists of two parts, viz.: energy associated with the outward expanding lines of electrostatic induction, and energy associated with the closed lines or tubes of magnetic force, which at first are expanding and afterwards contracting.

(3.) The time when the energy has been absorbed, or the period in which the energy in the wire or the conductor has either been dissipated in the form of non-luminous radiation or obscure heat.

(4.) The time during which this non-luminous heat gives up its energy again to the surrounding medium in the shape of heat waves.

Current, Electro-Therapeutic Polarizing
— — The current which produces the

phenomena of electrotonus. (See *Electrotonus*.)

Current, Element of — — A term employed in mathematical discussions to indicate a very small part of a current for ease in considering its action on a magnetic needle or other similar body.

Current, Faradic — — In electro-therapeutics, the current produced by an induction coil, or by a magneto-electric machine.

A rapidly alternating current, as distinguished from a uniform voltaic current.

A voltaic current that is rapidly alternated by means of any suitable key or switch is sometimes called a *voltaic alternative*. The discharge from a Holtz machine is sometimes called a *Franklinic Current*. (See *Alternatives, Voltaic Current, Franklinic*.)

Current-Filaments. — (See *Filament, Current*.)

Current, Franklinic — — A term sometimes used in electro-therapeutics for a current produced by the action of a frictional electric machine.

The term, Franklinic current, is used in contradistinction to Faradic current, or that produced by induction coils, or, in contradistinction to a galvanic or voltaic current, or that produced by a voltaic battery.

Current, Generation of, by Dynamo-Electric Machine — — The difference of potential developed in the armature coils by the cutting of the lines of magnetic force of the field by the coils, during the rotation of the armature.

If a loop of wire whose ends are connected to the two-part commutator, shown in Fig. 179, be

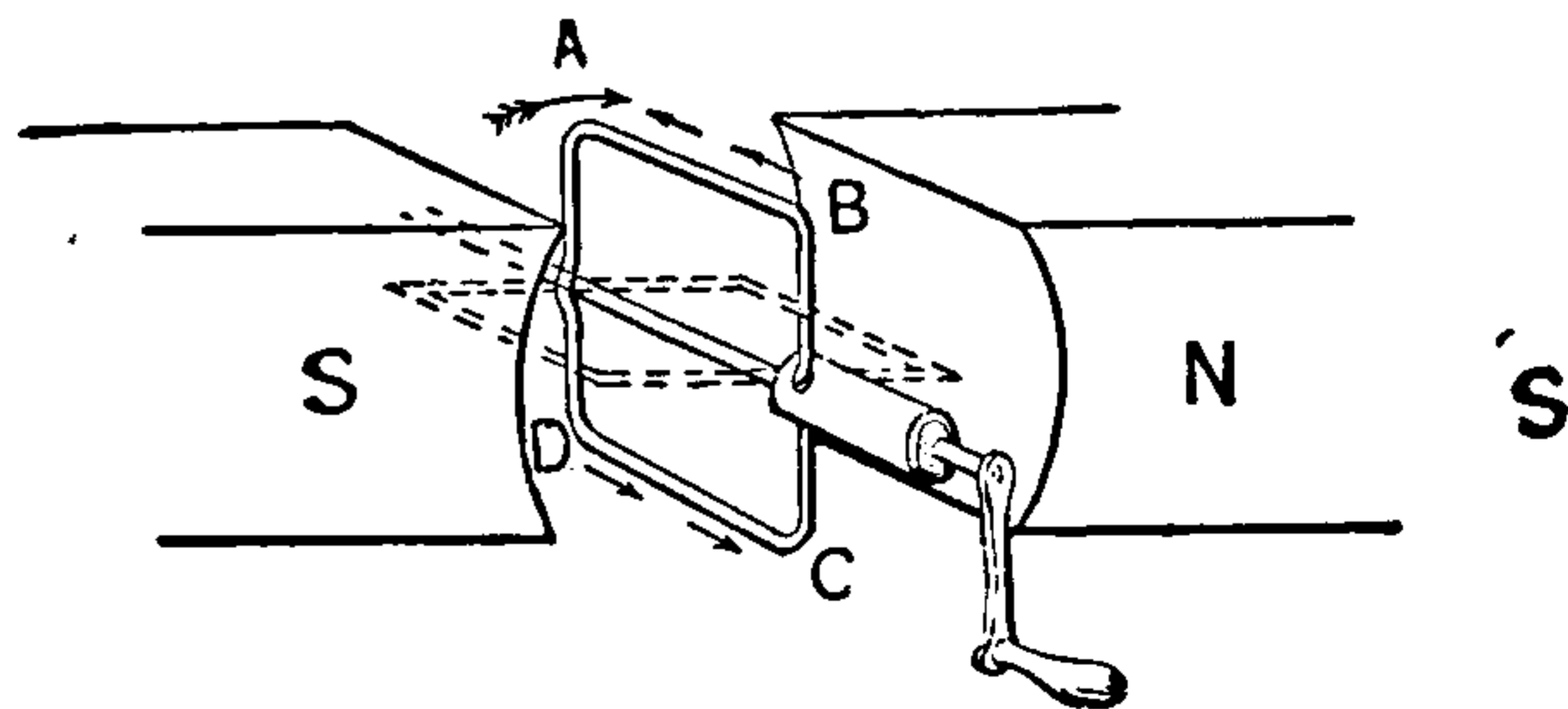

Fig. 179. Induction in Armature Loop.

rotated in the magnetic field between the magnet poles N and S, in the direction of the large arrow, differences of potential will be generated which

will cause currents to flow in the direction indicated by the small arrows during its motion past the north pole from the top to the bottom, but in the opposite direction during its motion past the south pole—from the bottom to the top. If, now, collecting brushes rest on the commutator in the positions shown in the Fig. 180. the vertical line

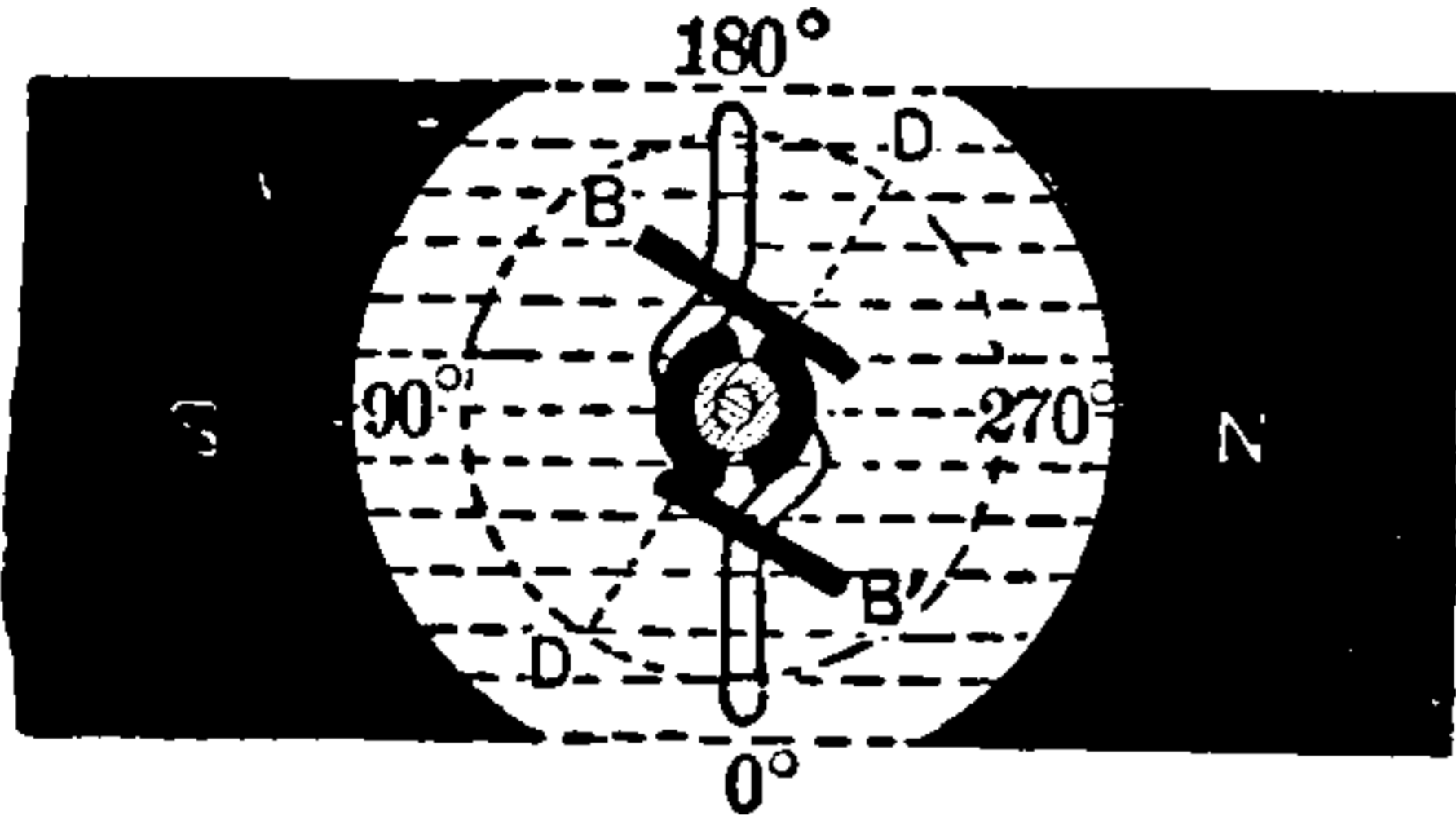

Fig. 180. Action of Commutator.

of the gap between the poles corresponding with the vertical gap between the commutator segments, the currents generated in the loop will be caused to flow in one and the same direction, and B', will become the positive brush, since the end of the loop is connected with it only so long as it is positive. As soon as it becomes negative, from the current in the loop flowing in the opposite direction, the other end, which is then positive, is connected with the positive brush.

A similar series of changes occur at the negative brush B.

Theoretically, the neutral points, where the brushes rest, would be in the vertical line coinciding with that of the gap between the poles. An inspection of the figure shows that the *neutral line*, or the *diameter of commutation*, is displaced in the direction of rotation. (See *Commutation, Diameter of.*) The displacement of the brushes, so necessitated, is called the *lead*.

The cause of the lead is the reaction that occurs between the magnetic poles of the field magnets

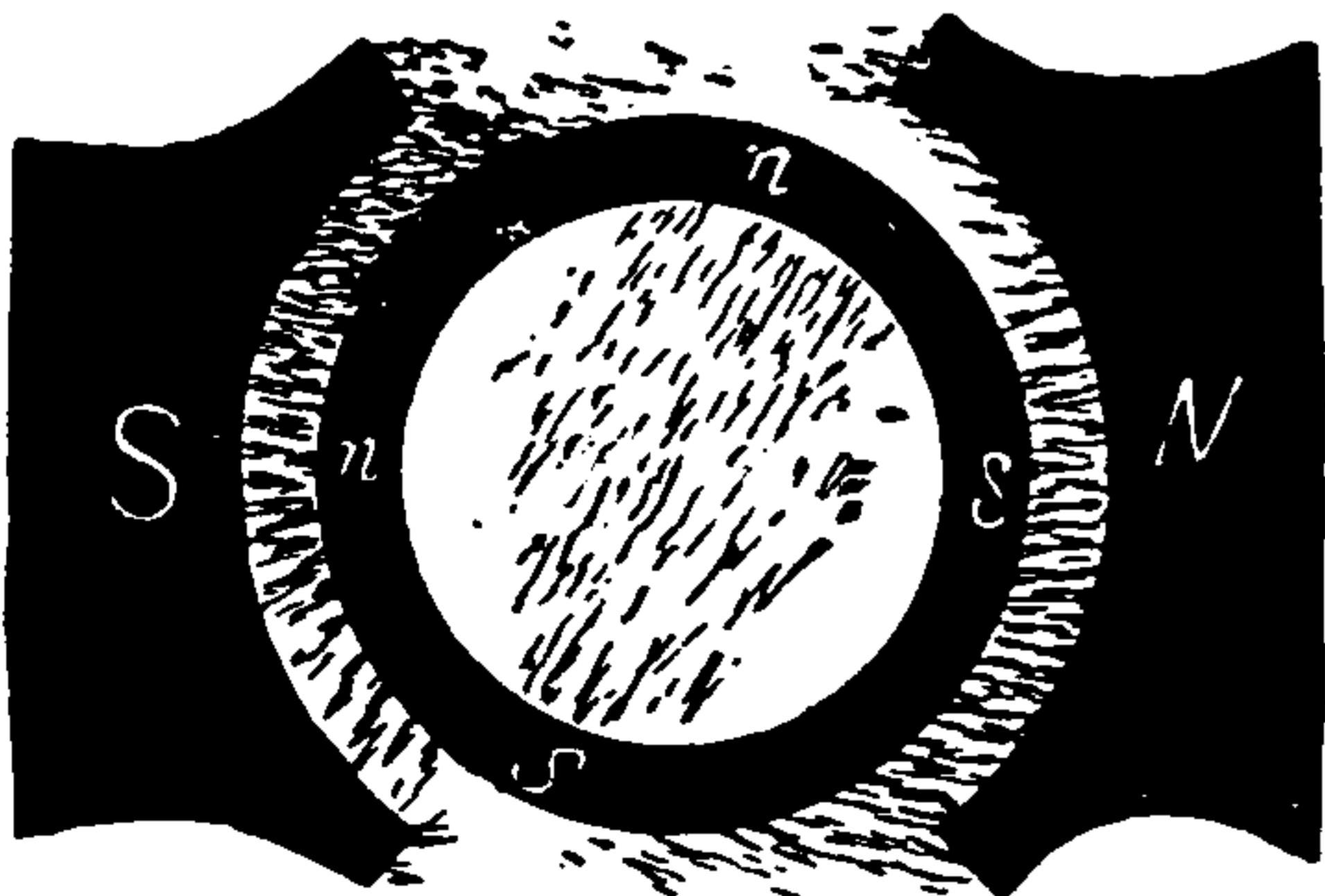

Fig 181 Cause of Lead of Brushes.

and those of the armature, the result of which is to displace the field magnet poles, and to cause a change in the density in the field. This is shown in Fig. 181, where the density of the lines of force indicates the position of the diameter of commu-

tation as being near, or at right angles to the diameter of greatest average magnetic density. (See *Lead, Angle of. Lag, Angle of.*)

Current-Governor.—(See *Governor, Current.*)

Current, Homogeneous Distribution of — —Such a distribution of a current through any conductor in which there is an equal density of current at all portions of any cross-section of the conductor.

When the flow of a constant current is established in a solid conducting wire, there is a homogeneous distribution of current in that conductor.

Current, Induced — —The current produced in a conductor by cutting lines of force.

The induced current results from differences of potential produced by electro-dynamic induction. (See *Induction, Electro-Dynamic.*)

Current-Induction. — (See *Induction, Current.*)

Current, Intensity of — —An old term sometimes employed to indicate the current which resulted from a considerable difference of potential, or a great electromotive force.

This term was also formerly used as synonymous with strength of current.

This use of the term is now abandoned.

Voltaic batteries, connected in series so as to give a considerable difference of potential, were spoken of as being connected for *intensity*.

This term has also been used for the quantity of electricity conveyed per second across a unit area of cross-section.

Intensity of current is more properly called density of current. (See *Current Density.*)

Current, Intermittent — —A current that does not flow continually, but which flows and ceases to flow at intervals, so that electricity is practically alternately present and absent from the circuit.

Current, Inverse-Secondary — —The make-induced current. (See *Current, Make-Induced.*)

Current, Jacobi's Unit of — —Such a current that when passed through a voltmeter will liberate a cubic centimetre of

oxygen and hydrogen at 0 degrees C. and 760 mm. barometric pressure.

One Jacobi's unit of current equals $\frac{1}{10.32}$ ampère. (Obsolete.)

Current, Make-Induced — —The current induced by a current in its own circuit on making or closing the same.

The current produced in the secondary of an induction coil on the making or completion of the circuit of the primary.

The make-induced current is also called the inverse-secondary current, because its direction is opposite to that of the inducing current.

Current, Make or Break Induced, Duration of — —The time during which the induced inverse or direct-secondary currents continue.

Blaserna made a number of experiments, which he claims shows :

(1.) The greater the distance apart of the primary and the secondary, that is, the less their mutual-induction, the less the maximum value of the secondary current, and the greater the delay in establishing that maximum.

(2.) The delay in establishing the maximum of the break or direct-secondary current is not as great as in the case of the make, or inverse-secondary current.

(3.) When the coils are near together, the induced currents at starting are established by a series of electric oscillations.

(4.) The primary current establishes itself by a series of electrical oscillations.

(5.) That the interposition of dielectric substances, such as glass between the coils, reduces the time between the making or breaking of the primary current and the beginning of the secondary current. This last conclusion was negatived by some experiments of Bernstein.

Blaserna determined in the case of certain experiments the following value for the durations of the secondary currents :

Inverse-secondary current lasts .000485 second.

Direct-secondary current lasts .000275 second.

Helmholtz contradicts the results of Blaserna, and asserts :

(1.) That no perceptible difference in the zero points of the currents is produced by varying the distance between the primary and secondary.

(2) That the sparks produced by the breaking

of the primary last for an appreciable time, something like $\frac{1}{15000}$ to $\frac{1}{40000}$ of a second.

(3.) The duration of the break-spark is never constant, but depends in great part on the amount of platinum given off from the contacts at each spark.

Current-Meter.—A form of galvanometer. (See *Galvanometer*.)

Current, Momentary — —A current that continues to flow but for a short time.

Current, Multi-Phase — —A rotating current. (See *Current, Rotating*.)

Current, Muscle — —In electro-therapeutics, the current flowing through a muscle. Muscle currents are produced either by stimulation, or during activity of a muscle. According to L. Hermann, uninjured muscles, or perfectly dead muscles, yield no currents, but such currents result only from an injury. (See *Current, Demarcation*.)

Current, Non-Homogeneous Distribution of — —Such a distribution of current passing through a conductor in which there is an unequal density of current at all portions of any cross-section of the conductor.

When a rapidly alternating current is passed through any solid conductor, the current density is greater at the surface and less towards the centre. The current distribution in such a conductor is non-homogeneous, and the want of uniformity of current density is greater as the rapidity of alternation or periodicity is greater.

Current, Outgoing — —The current sent out over the line from a station provided with a duplex or quadruplex transmission, as distinguished from the received current. (See *Current, Received*.)

Current, Periodic — —A simple periodic current. (See *Currents, Simple Periodic*.)

Current, Periodic, Power of — —An amount of work, per second, equal to the product of the electromotive force taken at successive moments of time during a complete cycle, multiplied by the current strength taken at the corresponding moments during the cycle.

Since the electromotive force and current in

THIS PAGE IS LOCKED TO FREE MEMBERS

Purchase full membership to immediately unlock this page



HISTORY

Tens of thousands of important historical sources, many previously unobtainable, are now available for the first time with a Forgotten Books Full Membership.

Unlimited Access
\$8.99/month

Continue

*Fair usage policy applies

izes the effects of the current B'; or, it is equal to it in effect.

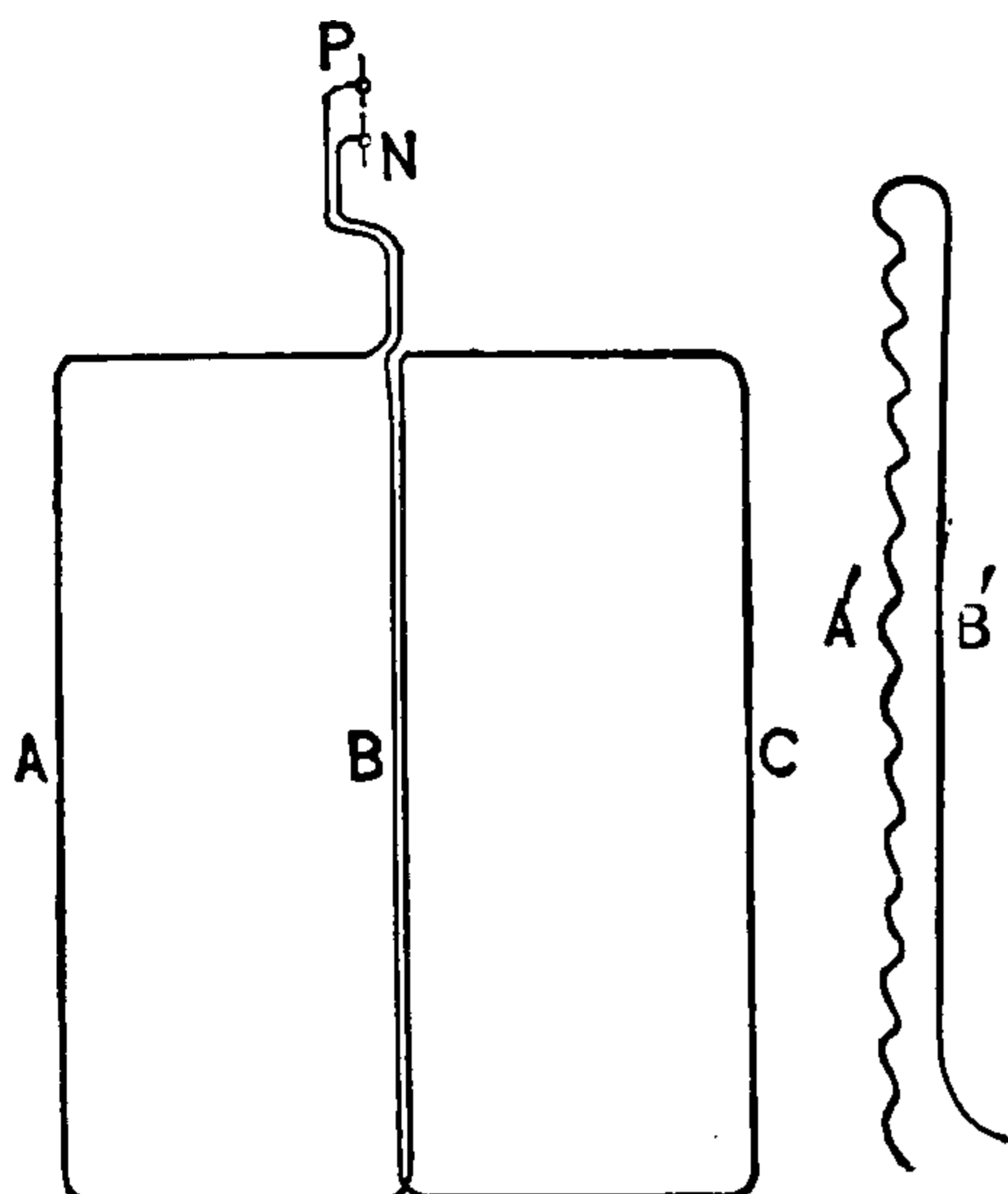

Fig. 182. Rectilinear Equivalent of Sinuous Current.

In calculating the effects of sinuous currents it is convenient to consider them as consisting of a

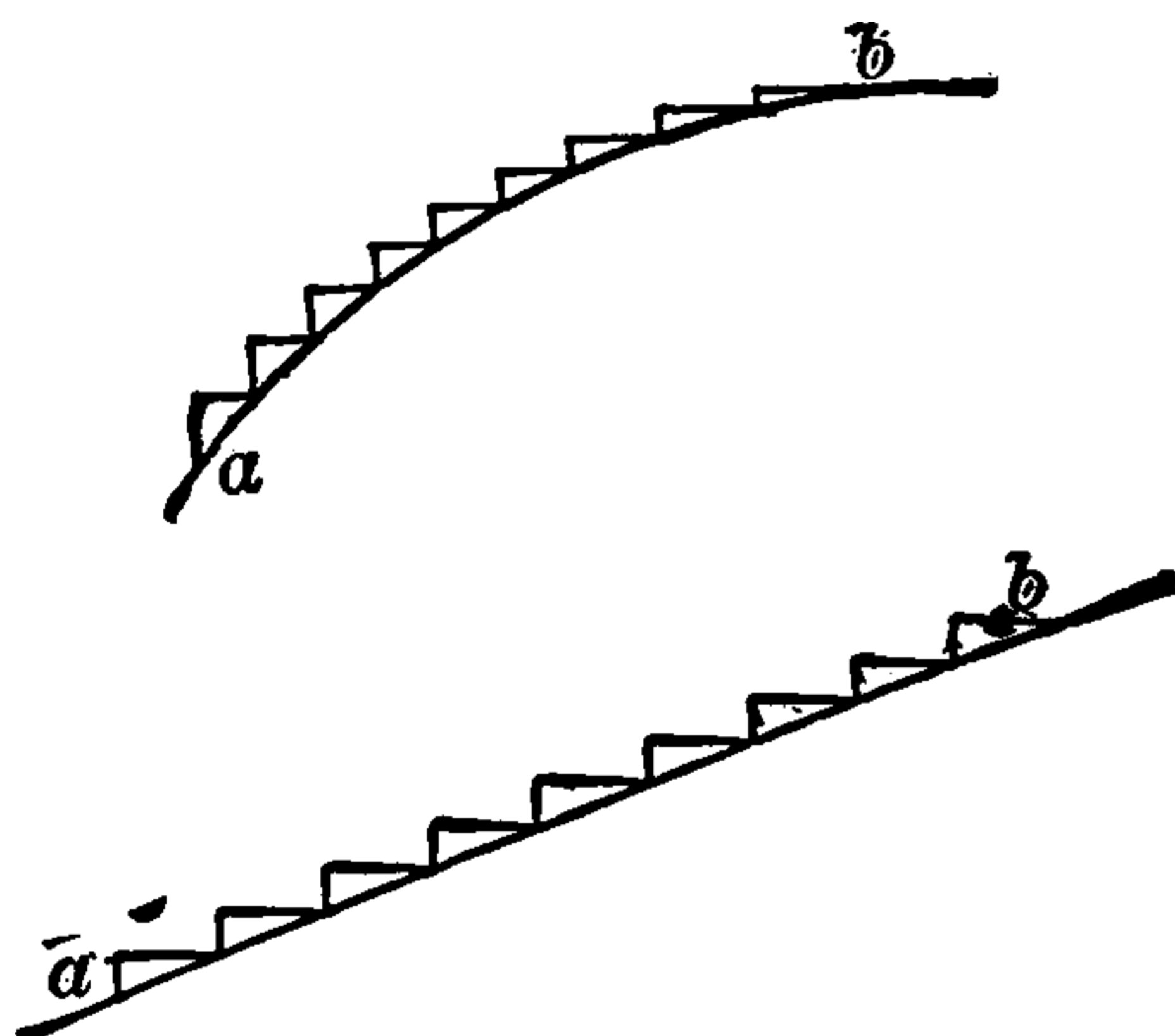

Fig. 183. Sinuous Currents.

succession of short, straight portions at right angles to one another, as shown in Fig. 183.

Current, Steady — — A current whose strength does not vary from time to time.

In a steady current the quantity of electricity flowing through each unit of area of the equipotential surface of the conductor is the same for each succeeding interval of time. Such a current is sometimes called a *uniformly distributed current*.

Current Streamlets.—(See *Streamlets, Current*.)

Current Strength.—The product obtained by dividing the electromotive force by the resistance.

The current strength for a constant current according to Ohm's law is—

$$C = \frac{E}{R}.$$

Current strength is proportional to the amount of the magnetic or chemical (electrolytic) effects it is capable of producing.

For a simple-periodic current, the current strength necessarily varies from time to time.

The average current strength of a simple-periodic current is equal to the average impressed electromotive force divided by the impedance. (See *Impedance*.)

The maximum current strength is equal to the maximum impressed electromotive force divided by the impedance.

Current, to Transform a — — To change the electromotive force of a current by its passage through a converter or transformer.

To convert a current.

Current, Transforming a — — Changing the electromotive force of a current by its passage through a converter or transformer.

Current, Undulating — — An undulatory current. (See *Currents, Undulatory*.)

Current, Uniformly-Distributed — — A term sometimes employed in the same sense as steady current. (See *Current, Steady*.)

Current, Unit Strength of — — Such a strength of current that when passed through a circuit one centimetre in length, arranged in an arc one centimetre in radius, will exert a force of one dyne on a unit magnet pole placed at the centre.

This absolute unit is equal to ten ampères or practical units of current. (See *Ampère*.)

Current, Variable Period of — — The period which exists while an electric current is being increased or decreased in strength, or while it is being reversed.

Currents, Action — — Physiological currents obtained during the activity of a muscle or nerve.

Currents, After — — In electro-therapeutics, currents produced in nervous or muscular tissue when a constant current, which has been flowing through the same, has been stopped.

After currents are due to internal polarization.

Currents, Alternating-Primary — — The currents employed in the primary of a

transformer to induce alternating currents in the secondary. (See *Transformer*.)

Currents, Alternating-Secondary — — The currents induced in the secondary of a transformer by the alternating currents in the primary. (See *Transformer*.)

Currents, Alternating, Shifting of Phase of — — (See *Phase, Shifting of, of Alternating Currents*.)

Currents, Ampèrian — — The electric currents that are assumed in the ampèrian theory of magnetism to flow around the molecules of a magnet. (See *Magnetism, Ampère's Theory of*.)

The ampèrian currents are to be distinguished from the *eddy, Foucault, or parasitical currents*, since, unlike them, they are directed so as to produce useful effects. (See *Currents, Eddy*.)

It is not believed that the ampèrian currents are produced in magnetizable substances by the act of magnetization. The atoms or molecules were magnetic originally. All the magnetizing force does is to arrange the molecules or atoms, or to set them in one and the same direction.

Currents, Angular — — Currents flowing through circuits that cross or are inclined to one another at any angle. (See *Dynamics, Electro*.)

Currents, Atomic — — A term sometimes used instead of molecular or ampèrian currents. (See *Currents Ampèrian*.)

Currents, Attractions and Repulsions of — — The mutual attractions or repulsions exerted by currents on one another through the interaction of their magnetic fields. (See *Dynamics, Electro*.)

Currents, Commuted — — Electric currents that have been caused to flow in one and the same direction. (See *Commutator*.)

Currents, Commuting — — Causing several currents to flow in one and the same direction.

Currents, Component — — The two or more currents into which it may be conceived that a single current can be divided, so as to produce the same effects of attraction or repulsion that the single current would do.

The idea of component currents is based on the similar idea of the components of any single force.

Currents, Continuity of — — The freedom from variation in current strength or current direction.

Currents, Convection — — Currents produced by the bodily carrying forward of static charges in convection streams. (See *Streams, Convection*.)

In a convection current, the static charge is bodily carried forward.

Rowland has shown experimentally that a moving electric charge is the equivalent of an electric current. He rotated a gilded ebonite disc between two gilt glass discs, near which were placed a number of delicate magnetic needles. When certain rapidity of rotation was obtained, the discs were found to affect the magnetic needles the same as would a current of electricity flowing in a circular conductor, whose form coincided with the periphery of the disc.

Currents, Converted — — Electric currents changed either in their electromotive force or in their strength, by passage through a converter or transformer. (See *Transformer*.)

Currents, Converting — — Changing the electromotive force of currents by their passage through a converter or transformer. (See *Transformer*.)

Currents, Diaphragm — — Electric currents produced by forcing a liquid through the capillary pores of a diaphragm. (See *Osmose, Electric*.)

Currents, Earth — — Electric currents flowing through the earth, caused by a difference of potential at different parts.

The causes of these differences of potential are various and are not well understood.

Currents, Eddy — — Useless currents produced in the pole pieces, armatures, field-magnet cores of dynamo-electric machines or motors, or other metallic masses, either by their motion through magnetic fields, or by variations in the strength of electric currents flowing near them.

Sensible eddy currents are produced in the mass

of the conducting wire on the armature of a dynamo-electric machine when the wire is comparatively heavy.

Such currents are called *eddy currents*, *local currents*, *Foucault currents*, or *parasitical* currents. They form closed-circuits of comparatively low resistance, and tend to cause undue heating of armatures or pole pieces. They not only cause a

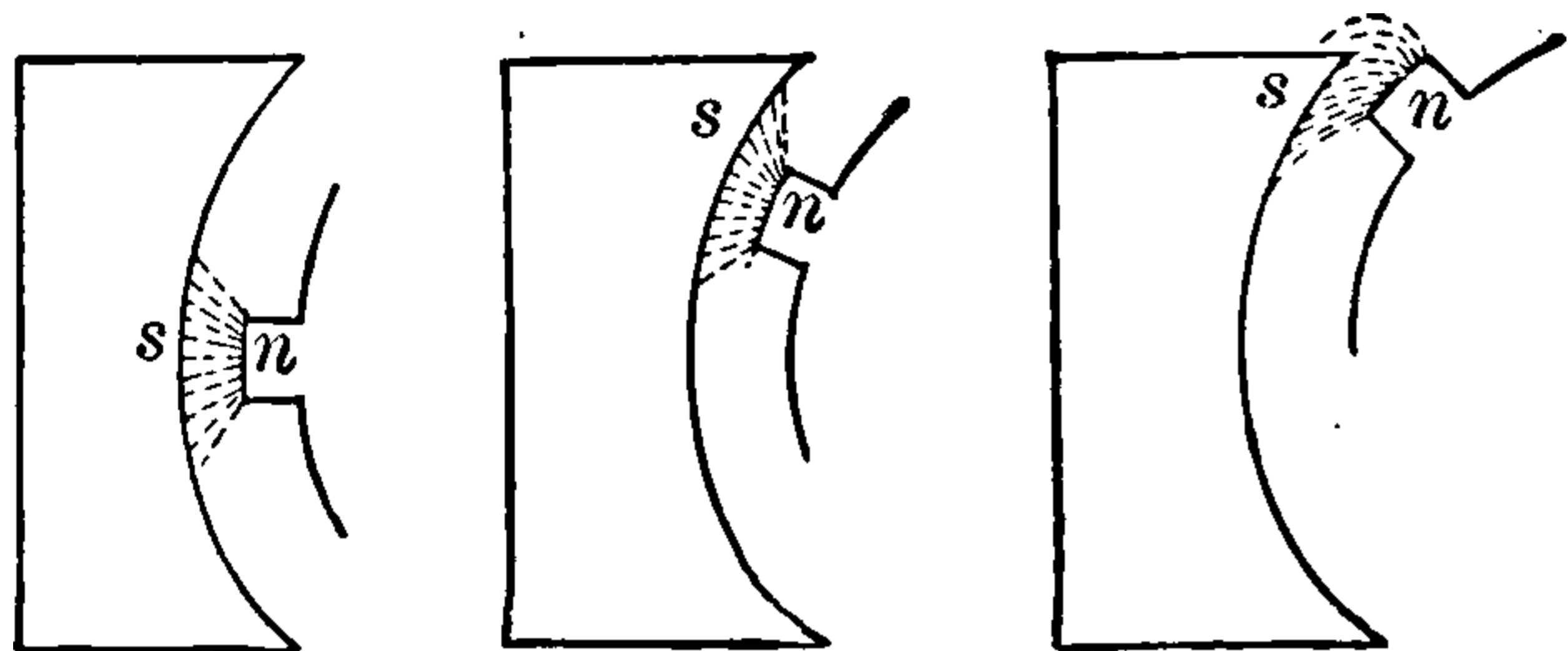

Fig. 184. Foucault Currents in Pole Pieces.

useless expenditure of energy, but interfere with the proper operation of the device.

To reduce them as far as practicable, the pole pieces, armature cores or armature wires, are laminated. (See *Core, Lamination of*.)

These local currents are perhaps preferably called Foucault currents when they take place in magnetic cores, pole pieces or armature cores, and eddy currents when they occur in the armature wire or conductor. When the armature conductor is made up of copper bars, for example, the eddy currents in the latter are usually considerable.

Since Foucault currents in dynamo-electric machine cores are due to variations in the magnetic

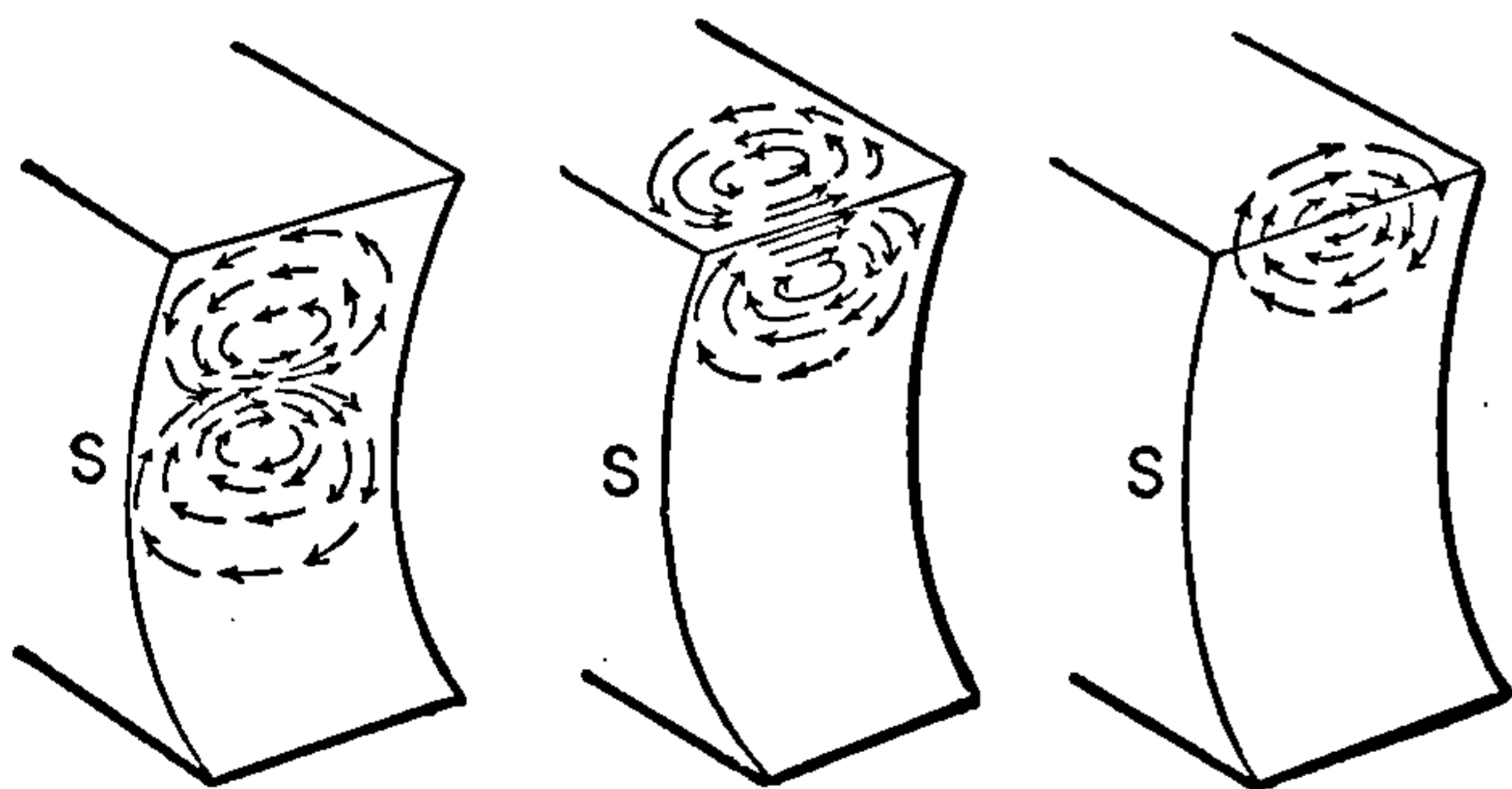

Fig. 185. Foucault Currents in Pole Pieces.

strength of the field magnets, or of the armature, they will be of greatest intensity when the changes in the magnetic strength are the greatest and most sudden.

These changes are most marked, and consequently the Foucault currents are strongest at those corners of the pole pieces of a dynamo from which the armature is moved in its rotation, as will be seen from an inspection of Fig. 184.

Fig. 185, shows Foucault currents generated in pole pieces.

Currents, Eddy-Conduction — — A term employed for ordinary eddy currents in conductors, in order to distinguish them from eddy-displacement currents. (See *Currents, Eddy-Displacement*.)

Currents, Eddy Deep Seated — — Eddy currents set up in the mass of a conductor subjected to electro-dynamic induction in contradistinction to superficially seated eddy currents. (See *Currents, Eddy, Superficial*.)

Currents, Eddy-Displacement — — Eddy currents produced in the mass of a dielectric or insulator, when lines of magnetic or electrostatic force pass through the dielectric or insulator.

Eddy-displacement currents are produced in a dielectric or non-conductor, when it is moved across a magnetic field, so as to cut the lines of magnetic force.

Eddy displacement currents would also occur if a dielectric is subjected to varying electrostatic induction.

Currents, Eddy, Superficial — — Eddy currents produced in conducting substances that are limited to the outer layers thereof.

The eddy currents produced by alternating currents are superficial if the alternating currents are sufficiently rapid. The oscillatory currents produced during the discharge of a Leyden jar are more superficial in proportion as the discharge takes place rapidly. When currents are produced in a magnetizable body by the discharge of a Leyden jar, they are more and more superficial, as the discharge of the jar is more and more rapid. The reason a slow discharge of a jar or condenser produces a greater magnetizing effect is, because of the checking or screening action the superficial eddy currents exert on the interior of the mass of the magnetizable substance when the discharge is very rapid.

Currents, Electrotonic — — In electrotherapeutics, currents due to internal polarization in the nerve fibre between the conducting core of the nerves and the enclosing sheaths.

Currents, Extra — — Currents produced in a circuit by the induction of the current on itself on the opening or closing of

THIS PAGE IS LOCKED TO FREE MEMBERS

Purchase full membership to immediately unlock this page

Know Your Bible

Forgotten Books' Full Membership provides unlimited access to more than 28,000 volumes of Christian literature for \$8.99/month

HOLY BIBLE

Continue

*Fair use policy applies

tinguished by the term, currents of the second, third, fourth, etc., order. (See *Coils, Henry's.*)

Currents, Parasitical — —A name sometimes applied to eddy currents. (See *Currents, Eddy.*)

Currents, Positive — —A term employed in single-needle telegraphy for currents sent over the line in a positive direction by depressing a key that connects the line with the positive pole of a battery and so deflects the needle to the right. (See *Telegraphy, Single-Needle.*)

Currents, Reversed — —A name sometimes applied to alternating currents. (See *Current, Alternating.*)

Currents, Secondary — —The currents produced by secondary batteries in contradistinction to the currents produced by primary batteries.

The currents produced by the secondary conductor of an induction coil, as distinguished from the currents sent into the primaries.

This second use of the term secondary current is more usual.

Currents, Self-Induced — —A current produced by self-induction.

An extra current. (See *Induction, Self-Currents, Extra.*)

Currents, Simple Periodic — —Currents, the flow of which is variable, both in strength and duration, and in which the flow of electricity, passing any section of the conductor, may be represented by a simple periodic curve.

A current of such a nature that the continuous variation of the flow of electricity past any area of cross-section of the conductor, or the variations in the electromotive force of which can be expressed by a simple-periodic or harmonic curve. (See *Curve, Simple-Harmonic.*)

Alternate currents are simple-periodic currents.

The average current strength of simple-periodic currents is equal to the average impressed electromotive force divided by the impedance.

The transmission of rapidly varying or simple-periodic currents through conductors differs very greatly from the transmission of steady cur-

rents. With a steady current, the current density is the same for all areas of cross-section of the conductor. For a rapidly intermittent current, the current density is greater near the surface, and when the rate of intermission is sufficiently great, the current is entirely absent at the centre of the conductor.

Lord Rayleigh has shown that when the rate of intermission is 1,050 per second, the effective resistance of a wire 160 mm. in length, and 30 mm. in diameter, is 1.84 times its resistance to steady currents. He found that the increase of resistance is greater in the case of conductors of great diameter than in those of small diameter.

As regards the character of conductor best suited for transmitting rapidly alternating currents, it can be shown :

(1.) That for transmitting alternate currents of moderate frequency, say of about 1,000 per second, copper conductors should be used in preference to rods of iron.

(2.) That the conductor should be in the form of thin strips, or if tubular, of thin walls.

(3.) That the mere stranding of the conductor, *i. e.*, forming it of separate insulated conductors connected in parallel, will be of no effect in preventing the current from acting on the outside of the conductor, unless the conductor be arranged in the form of a cable, in which one part forms a lead, and another part the return.

Stephan draws the following analogy between the flow of alternating currents in a conductor and the flow of heat in a hot wire :

“Suppose a wire or conductor, uniformly heated from centre to circumference, be suddenly taken into a space where the temperature is high, the outer portions of the wire first rise in temperature, and afterwards the inner portions. In the case of a conductor of circular cross-section, the heat penetrates successive concentric layers. The same phenomena occur when an electromotive force is suddenly set up between the ends of a cylindrical conductor. The current gradually penetrates the conductor from the outside to the centre.

“Now suppose the heated wire is carried into a cooler space, the heat waves pass out radially from the centre towards the circumference. The cooling wire corresponds to the case of a conductor in which the external electromotive force is suddenly removed.”

According to this conception, the heat conducting power of any substance corresponds to its electrical conducting power.

According to Stephan, in the case of a conductor of iron of 4 mm. in diameter, traversed by an alternating current of 250 alternations per second, the current density on the surface is about twenty-five times as great as that at its axis.

Where the conductor is of non-magnetic material, the difference in the current density is not so marked.

Rapidly intermittent currents produce a real increase in the resistance of the conductor, which must not be confused with the fact that the impedance is greater than the ohmic resistance, but rather as an actual increase in the rate at which energy is dissipated per unit of current.

Since current density is greatest at the outside portions of a conductor, and the central portions are nearly, if not entirely, deserted by the current, we may regard the conductor as having the ohmic resistance of a hollow cylinder of the same diameter as the conductor, with a correspondingly smaller area of cross-section, and therefore, of greater ohmic resistance per unit of length.

The condition of affairs in the case of a conductor in which a current of electricity is beginning to flow, is now very generally regarded somewhat as follows, viz.:

The current begins at the surface of the conductor, and more or less slowly soaks through towards the centre. If the current is constant, the current soon reaches the deepest layers; but, if it is rapidly intermittent, before it can soak very far into the conductor towards its axis, it is turned back towards the surface, and so becomes confined to layers which will be more and more superficial, as the rapidity of reversal increases.

Therefore, for convenience, we may regard a solid conductor, through which a rapidly intermittent current of electricity is flowing, as being practically converted into a hollow cylinder of the same diameter as the solid conductor, the area of cross-section of which hollow cylinder becomes smaller and smaller, as the rapidity of alternation is increased.

Another, and perhaps the more correct conception of the condition of affairs in a solid conductor traversed by a rapidly alternating current of electricity, has been pointed out by Maxwell, and afterwards by Heavyside, Rayleigh and Hughes. This conception is to regard the central portions of the conductor as possessing a counter electromotive force greater than the outer portions. The entire current flowing across any section of a conductor

may be regarded as made up of little *current streamlets*, parallel to one another.

The central streamlets, or filaments, from their mutual induction on one another, experience a greater resistance in reaching their full strength than the surface filaments do. Taken in this sense, we may state generally that the transmission of rapidly alternating currents through conductors depends on the inductance, rather than on the resistance; but for steady currents, it depends more on the resistance than on the inductance.

In periodic or oscillatory currents, as those produced by the discharge of a Leyden jar, or condenser, the surface streamlets have a current density far greater than the central streamlets.

The true or ohmic resistance of the circuit is a minimum when the current is uniformly distributed through all parts of the cross-section of the conductor, and the dissipation of energy through the generation of heat is less than for any other distribution.

The conception of a periodic current flowing through a conductor, starting from the surface and gradually soaking in towards the centre, regards the energy of an electric current—not as being pushed through the conductor, as water through a pipe, but as actually being absorbed at its surface, from the surrounding dielectric, or as being, so to speak, rained down on the conductor from the space outside of it.

Currents, Swelling — — In electro-therapeutics, currents that begin weak and are gradually made stronger and then weaker.

Currents, Swelling-Faradic — — A term employed in electro-therapeutics for faradic currents that are caused to gradually increase in strength and then to gradually decrease to zero strength.

Currents, Transient — — Currents that are but of momentary duration.

Currents, Undulatory — — Currents the strength and direction of whose flow gradually change.

The term undulatory currents is used in contradistinction to pulsatory currents, in which the strength changes suddenly. In actual practice, such currents differ from undulatory currents more in degree than in kind, since, when sent into a line, the effects of *retardation* tend to obliterate, to a greater or less extent, the sudden

differences in intensity on which their pulsatory character depends.

The currents produced in the coils of the Siemens magneto-electric key, in which the mechanical to-and-fro motion of the key sends electrical impulses into the line, are, in point of fact, undulatory in character, when they follow one another rapidly.

The currents in most dynamo-electric machines, the number of whose armature coils is comparatively great, are, so far as the variations in their intensity or strength are concerned, undulatory in character even when non-commuted.

The currents on all telephone lines that transmit articulate speech are undulatory. This is true, whether the transmitter employed merely varies the resistance by variations of pressure, or actually employs makes-and-breaks that rapidly follow one another.—(See *Current, Pulsatory. Current, Intermittent.*)

Curtain, Auroral — —A sheet of auroral light having the shape of a curtain. (See *Aurora Borealis.*)

Curve, Asymptote of — —A straight line which continually approaches a curved line, but meets or becomes tangent to such curved line only at an infinite distance.

In Fig. 186, the curve C D, continually approaches the asymptote yz , but never meets it.

It is at first difficult to understand how one line can continually approach another and yet never meet it. But it will be readily understood if it is remembered that in all cases of asymptotic approach each advance becomes smaller and smaller.

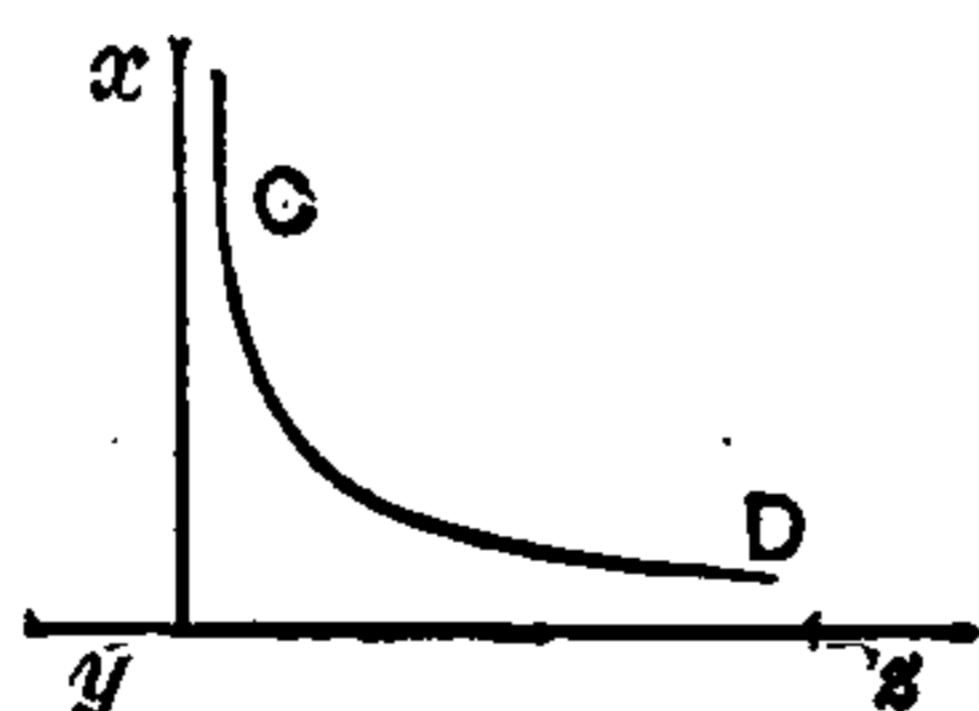

Fig. 186. Asymptote of Curve.

This mathematical conception is like a value which, although constantly reduced to one-half of its former value, is nevertheless never reduced to zero or no value.

Curve, Ballistic — —The curve actually described by a projectile thrown in any other than a vertical direction through the air.

The path of a projectile in a vacuum is a parabola—that is, the path A E B, Fig. 187. In air, the effects of fluid resistances cause the projectile to take the path A C D, called a *ballistic curve*.

The ballistic curve has a smaller vertical height than the parabola. The projectile also has a

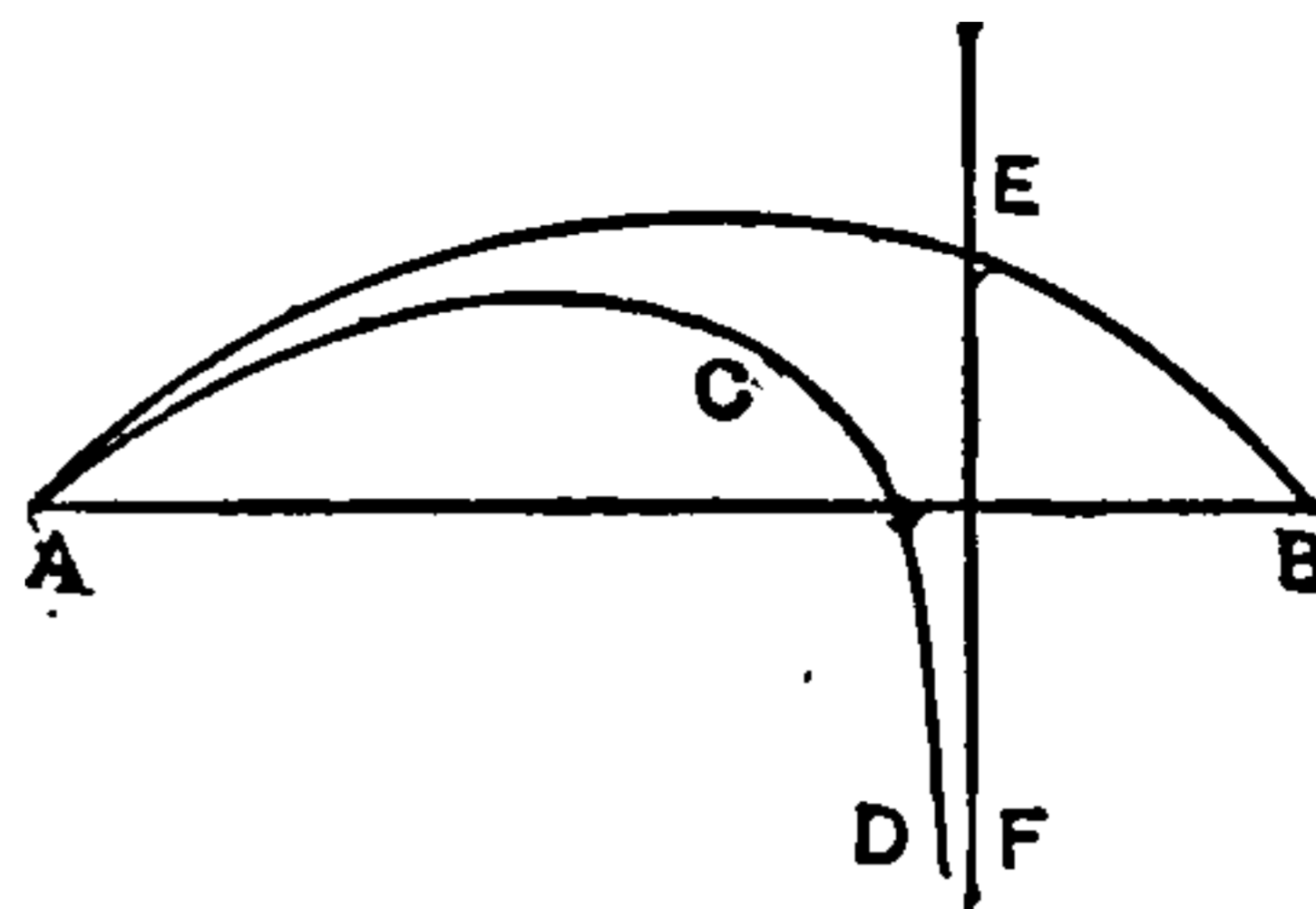

Fig. 187. Ballistic Curve.

smaller vertical range. Instead of reaching the point B, it continually approaches the perpendicular E F.

Curve, Characteristic — —A diagram in which a curve is employed to represent the ratio of certain varying values.

The electromotive force generated in the armature coils of a dynamo-electric machine, when the magnetic field is of a constant intensity, is theoretically proportional to the speed of rotation. In practice this is modified by a number of circumstances.

The relation existing between the speed and electromotive force may be graphically represented by referring the values to two straight lines, one horizontal and the other vertical, called respectively the *axes of abscissas and ordinates*. (See *Abscissas, Axis of.*) If, in a given case, the

number of revolutions is marked off along the horizontal line from the point o, Fig. 188, in distances from o, proportional to the number of revolutions, and the corresponding electromotive forces are marked

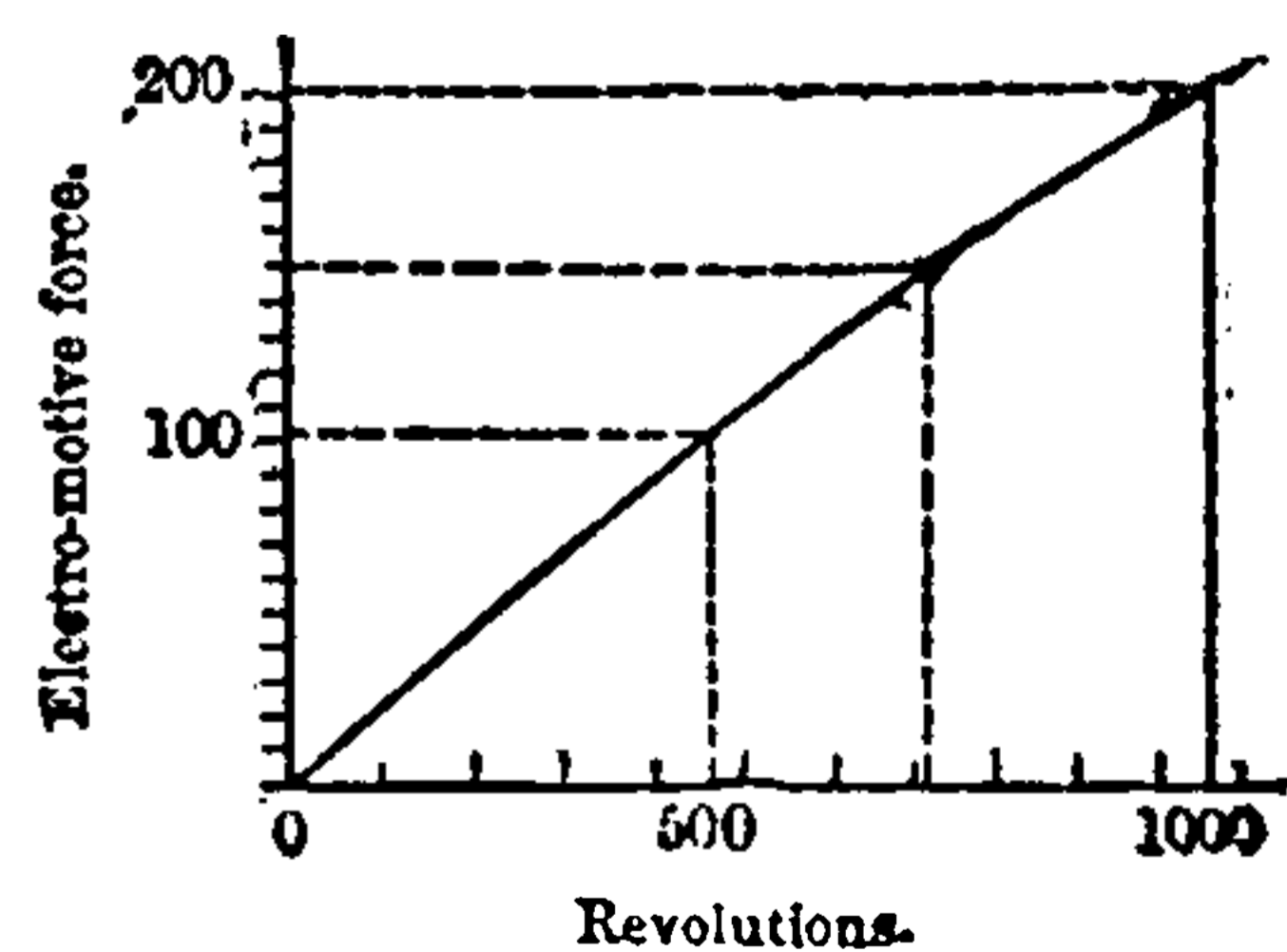

Fig. 188. Characteristic Curve.

off along the vertical line in distances from o, proportional to the electromotive forces, the points where these lines intersect will form the characteristic curve as shown in Fig. 188.

Curve, Characteristic, of Parallel Transformer — —A curve so drawn that its ordinate and abscissa at any point represent the secondary electromotive force and the secondary current of a multiple connected transformer, when the resistance of the secondary circuit has a certain definite value.

With a constant electromotive force in the pri-

THIS PAGE IS LOCKED TO FREE MEMBERS

Purchase full membership to immediately unlock this page



HISTORY

Tens of thousands of important historical sources, many previously unobtainable, are now available for the first time with a Forgotten Books Full Membership.

Unlimited Access
\$8.99/month

Continue

*Fair usage policy applies

Curves, Isochasmen — — Curves drawn on the earth's surface between zones having equal frequency of auroral discharges.

The isochasmen curves are nearly at right angles to the magnetic meridian.

Curves, Magnetic — — Curved lines showing the direction of the lines of magnetic force in any field, formed by sprinkling iron filings on a sheet of paper or glass held in the field of a magnet, and gently tapping the support so as to permit the filings to properly arrange themselves. (See *Figures, Magnetic.*)

Cut-In, To — — To introduce an electro-receptive device into the circuit of an electric source by completing or making the circuit through it.

Cut-Off, Automatic Gas — — A device for automatically cutting out the battery from an electric gas-lighting circuit on the accidental grounding of the circuit.

Unless the battery is disconnected from the circuit on the establishing of a ground, the battery will polarize and soon become useless.

Cut-Out, A — — A device by means of which an electro-receptive device or loop may be thrown out of the circuit of an electric source.

In any system of light or power distribution, a cut out is generally placed outside a building into which a loop or branch of the main circuit runs, so as to permit that loop or branch to be readily disconnected therefrom. In the same way cut-out keys or switches are generally placed in the circuit of the loop and each electro-receptive device.

Cut-Out, Air-Space — — A modified form of paper cut-out, in which the disc of paper or mica is replaced by the resistance of an air-space.

Although the resistance of an air-space is so high as to be practically immeasurable, yet it is overcome or broken by a much lower difference of potential than an equal thickness of paper or mica. (See *Path, Alternative. Cut-Out, Film.*)

Cut-Out, Automatic — — Any device that will automatically cut-out, or remove, a translating device, or an electric source, from an electric circuit, whenever any predetermined effect is produced.

Cut-Out, Automatic, for Multiple-Connected Electro-Receptive Devices — — A device for automatically cutting an electro-receptive device, such as a lamp, out of the circuit of the leads.

Automatic cut-outs for incandescent lamps, when connected to the leads in multiple-arc, consist of strips of readily melted metal called *safety fuses*, which on the passage of an excessive current fuse, and thus automatically break the cir-

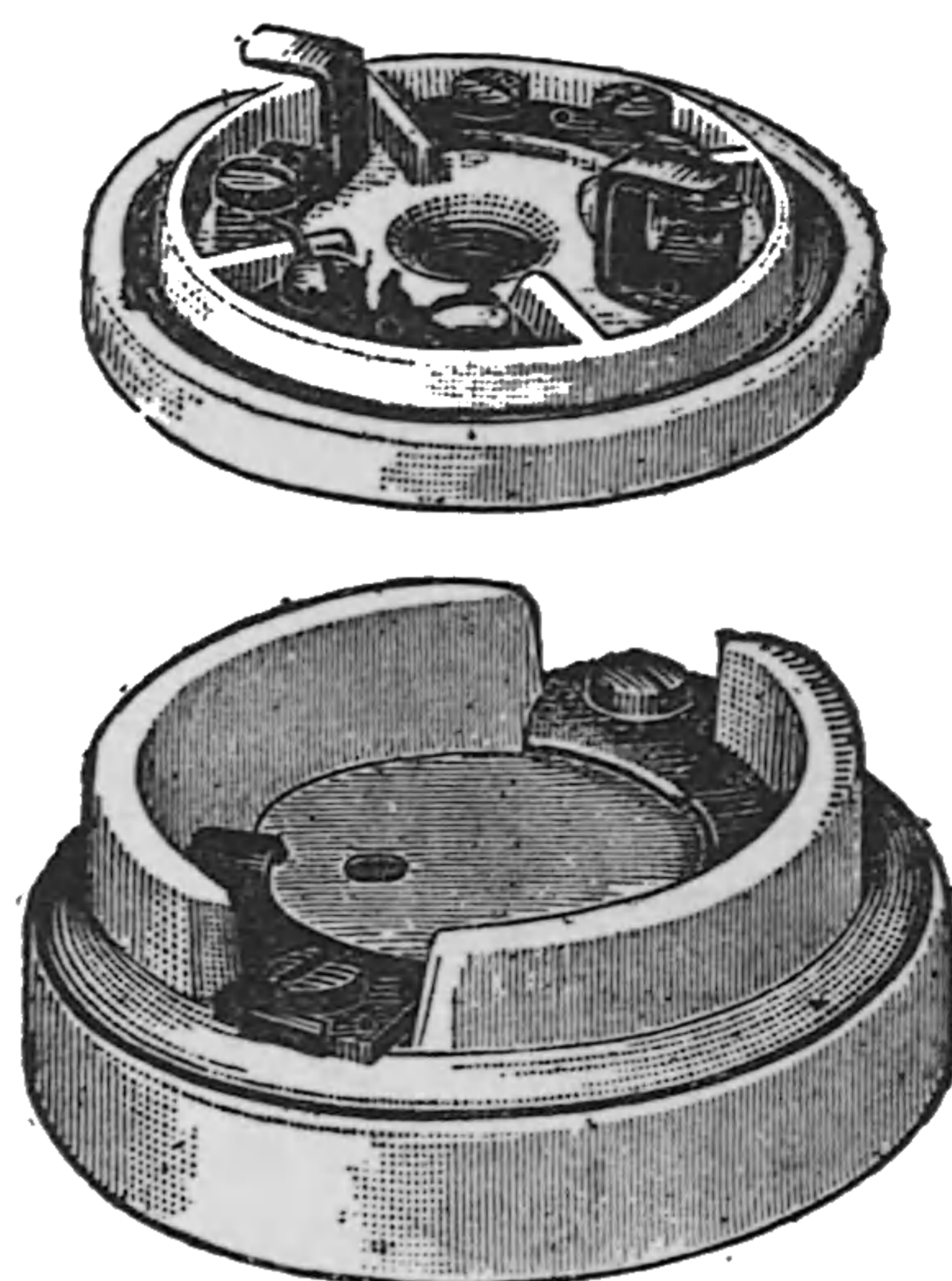

Fig. 192. Ceiling Cut-Out.

cuit in that particular branch. (See *Catch, Safety.*)

A form of ceiling cut-out, made of porcelain, is shown in Fig. 192, with the two halves separated

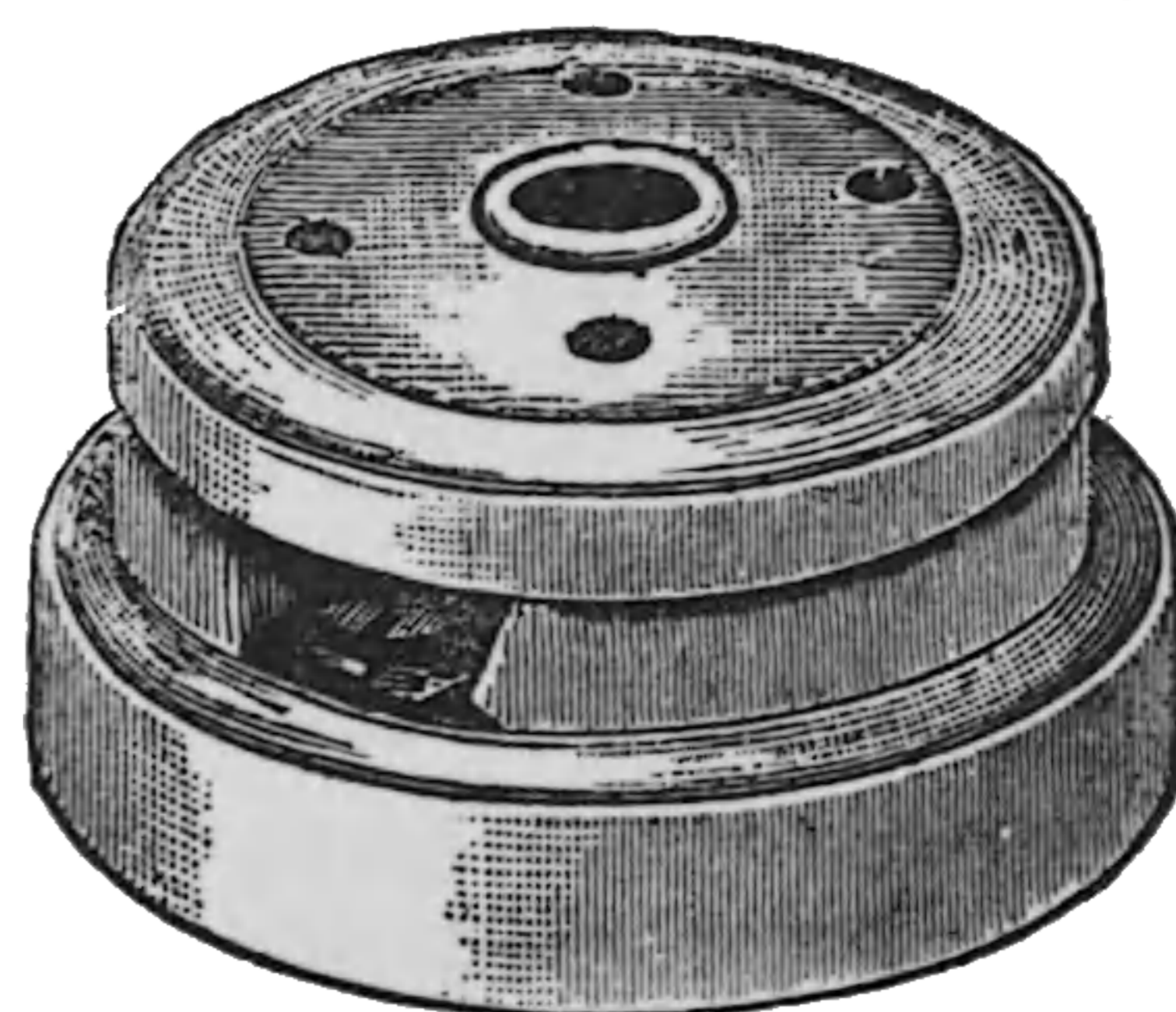

Fig. 193. Ceiling Cut-Out.

to show interior details, and in Fig. 193, with the two halves placed together.

Cut-Out, Automatic, for Series-Connected Electro-Receptive Devices — —A device whereby an electro-receptive device, such as an electric arc lamp, is, to all intents and purposes, automatically cut out, or removed from the circuit, by means of a shunt of low resistance, which permits the greater part of the current to flow past the lamp.

It will be observed that the lamp, though still in the circuit, is to all practical intents cut out from the same, since the proportion of the current that now passes through it is too small to operate it.

In most series arc lamps, cut-outs are operated by means of an electro-magnet placed in a shunt circuit of high resistance around the carbons. If the carbons fail to properly feed, the arc increases in length and consequently in resistance. More current passes through the shunt magnet, until finally, when a certain predetermined limit is reached, the armature of the electro-magnet is attracted to the magnet pole and mechanically completes the short circuit past the lamp.

In some automatic cut-outs the fusion of a readily fused wire, placed in a shunt circuit around the carbons, permits a spring to complete the short circuit.

The automatic cut-out prevents the accidental extinguishing of any single lamp in a series circuit from extinguishing the remaining lamps on that circuit.

Cut-Out, Automatic Time — —A device arranged so as to automatically cut out a translating device, or an electric source, from a circuit, at the end of a certain predetermined time.

Cut-Out, Duplex — —A cut-out so arranged that when one bar or strip is fused or melted by an abnormal current another can be immediately substituted for it.

Cut-Out, Film — —A cut-out in which a film, or sheet of paper or mica, is interposed between a line plate and an earth plate, which, when punctured by a spark, short circuits the instruments on the line.

Cut-Out, Main-Line — —An automatic cut-out placed on the main line. (See *Cut-Out, Automatic*.)

A form of main-line cut-out is shown in Fig.

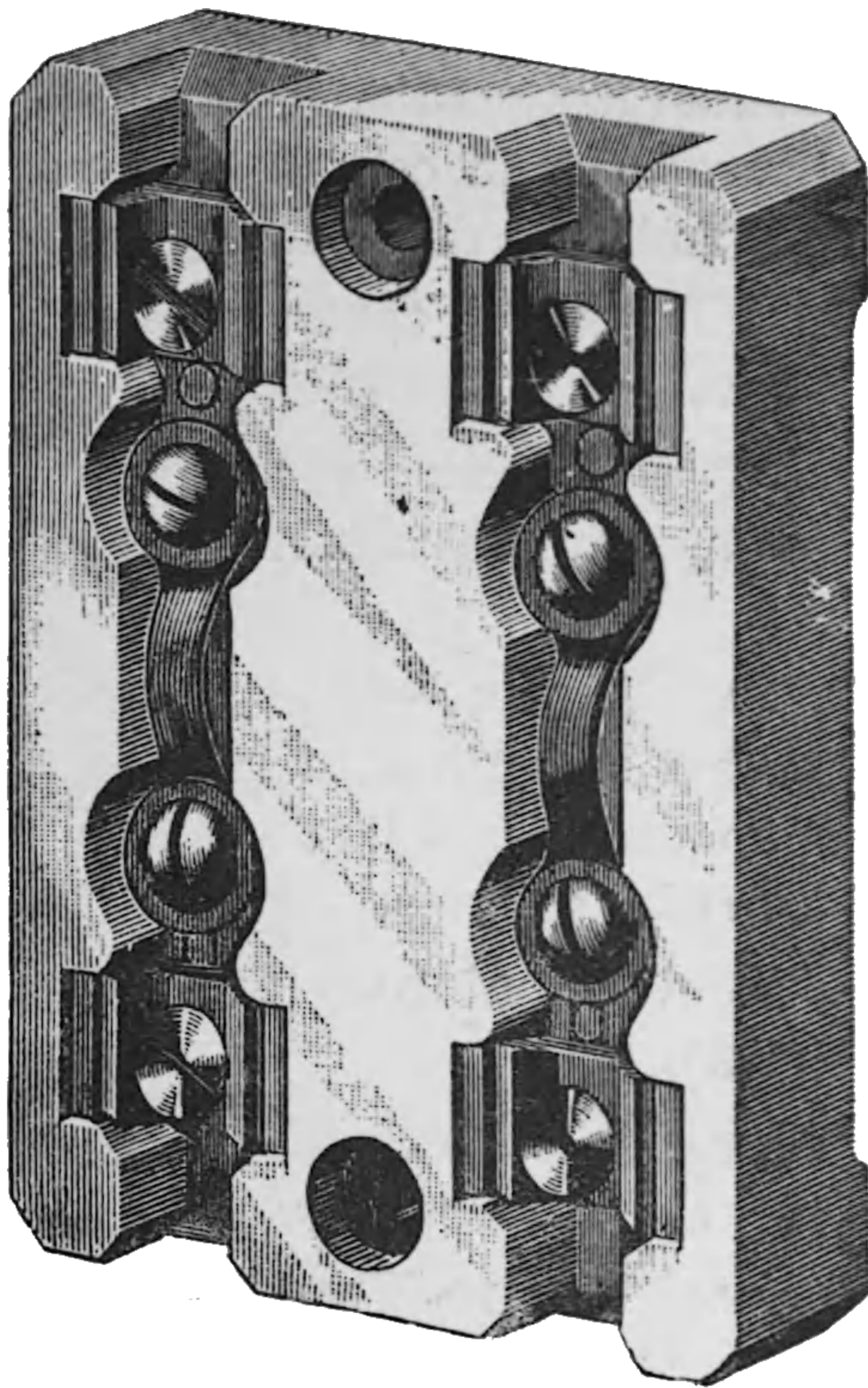

Fig. 194. Main-Line Cut-Out.

194. The fuses are shown as attached to the fuse-block.

Cut-Out, Paper — —A term sometimes employed instead of film cut-out. (See *Cut-Out, Film*.)

Cut-Out, Rosette — —A rosette for an electrolier, containing a cut-out. (See *Rosette*.)

Cut-Out, Spring-Jack — —A device similar in general construction to a spring-jack, but employed to cut out a circuit.

An insulated plug is thrust between spring contacts, thus breaking the circuit by forcing them apart.

Cut Out, To — —To remove an electro-receptive device from the circuit of an electric source by disconnecting or diverting the circuit from it.

Cutting Lines of Force.—(See *Force, Lines of Cutting*.)

Cycle.—A period of time within which a certain series of phenomena regularly recur, in the same order.

Cycle, Magnetic — —A single round of magnetic changes to which a magnetizable

substance, such as a piece of iron, is subjected when it is magnetized from zero to a certain maximum magnetization, then decreased to zero, reversed and carried to a negative maximum, and then decreased again to zero.

Cyclical Magnetic Variation.—(See *Variation, Cyclical Magnetic.*)

Cyclotrope.—A name proposed in place of transformer or converter. (See *Transformer.*)

Cylinder, Vortex — —A number of vortex stream-lines grouped parallel to one another about a straight line which forms the axis or core of the vortex.

Cylindrical Armature.—(See *Armature, Cylindrical.*)

Cylindrical Carbon Electrodes.—(See *Electrodes, Cylindrical Carbon.*)

Cylindrical Electro-Magnet.—(See *Magnet, Electro, Cylindrical.*)

Damped Magnetic Needle.—(See *Needle, Magnetic, Damped.*)

Damper.—A metallic cylinder provided in an induction coil so as to partially or completely surround the iron core, for the purpose of varying the intensity of the currents induced in the secondary.

The metallic cylinder acts as a screen or shield for the rapidly alternating currents traversing the field of the primary. (See *Screening, Magnetic.*) As the damper is pulled out, a greater length of the core is exposed to the induction.

Damper.—A term sometimes applied to a dash-pot or other similar apparatus provided for the purpose of preventing the too sudden movement of a lever or other part of a device. (See *Dash-Pot.*)

Some form of damper or dash-pot is used on most electric arc lamps, the upper carbon of which is fed by a direct fall.

The double use of this word is unfortunate.

Damping.—The act of stopping vibratory motion such as bringing a swinging mag-

Cylindrical Magnet.—(See *Magnet, Cylindrical.*)

Cylindrical Ring Armature.—(See *Armature, Cylindrical Ring.*)

Cymogene.—An extremely volatile liquid which is given off from crude coal oil during the early parts of its distillation.

The two liquids which are obtained from the condensation of the vapors given off during the first parts of the distillation of coal oil are called *cymogene*, and *rhigolene*. These liquids are employed on account of their extreme volatility for the artificial production of cold.

Rhigolene is employed by some for the *treatment* or *flashing* of the carbons used in incandescent lamps. (See *Carbons, Flashing Process for.*)

Cystoscopy, Electric — —A name given to Hitze's method of ocular examination of the human bladder by electric illumination.

D

netic needle quickly to rest, so as to determine the amount of its deflection, without waiting until it comes to rest after repeated swingings to and fro.

Damping devices are such as offer resistance to quick motion, or high velocities. Those generally employed in electrical apparatus are either *air* or *fluid friction*, obtained by placing vanes on the axis of rotation, or by checking the movements of the needle by means of the currents it sets up, during its motion, in the mass of any conducting metal placed near it. These currents, as Lenz has shown, always tend to produce motion in a direction opposed to that of the motion causing them. *Bell-shaped magnets* are especially suitable for this kind of damping. (See *Magnet, Bell Shaped.*)

The needle of a galvanometer is *dead-beat* when its *moment of inertia* is so small that its oscillations in an intense field are very quick, and the mirror, acting as a vane, causes the movements to die out very rapidly, and the needle therefore moves sharply over the scale from point to point and comes quickly to a *dead stop*. When the needle or swinging coil is heavy and moves in an intense

THIS PAGE IS LOCKED TO FREE MEMBERS

Purchase full membership to immediately unlock this page

Know Your Bible

Forgotten Books' Full Membership provides unlimited access to more than 28,000 volumes of Christian literature for \$8.99/month

HOLY BIBLE

Continue

*Fair use policy applies

increases. This was conclusively shown by the independent investigations of Tatum and Tesla.

Decalescence.—A term proposed by Prof. Elihu Thomson for an absorption of sensible heat, which occurs at a certain time during the heating of a bar of steel.

Decalescence will thus be observed to be the reverse of recalescence, which is the phenomenon of the emission of sensible heat at a certain time during the cooling of a heated bar of steel. (See *Recalescence*.)

Deci (as a prefix).—The one-tenth.

Deci-Ampère.—One-tenth of an ampère.

Deci-Ampère Balance.—(See *Balance, Deci-Ampère*.)

Deci-Lux.—The one-tenth of a lux. (See *Lux*.)

Declination.—The variation of a magnetic needle from the true geographical north.

The magnetic declination is east or west. (See *Needle, Magnetic, Declination of*.)

Declination, Angle of — —The angle which measures the deviation of the magnetic needle to the east or west of the true geographical north.

The angle of variation of a magnetic needle.

In Fig. 195, if N S, represents the true north and south line, the angle of declination is N O A, and the sign of the variation is east, because the deviation of the needle is toward the east. (See *Needle, Magnetic, Declination of*.)

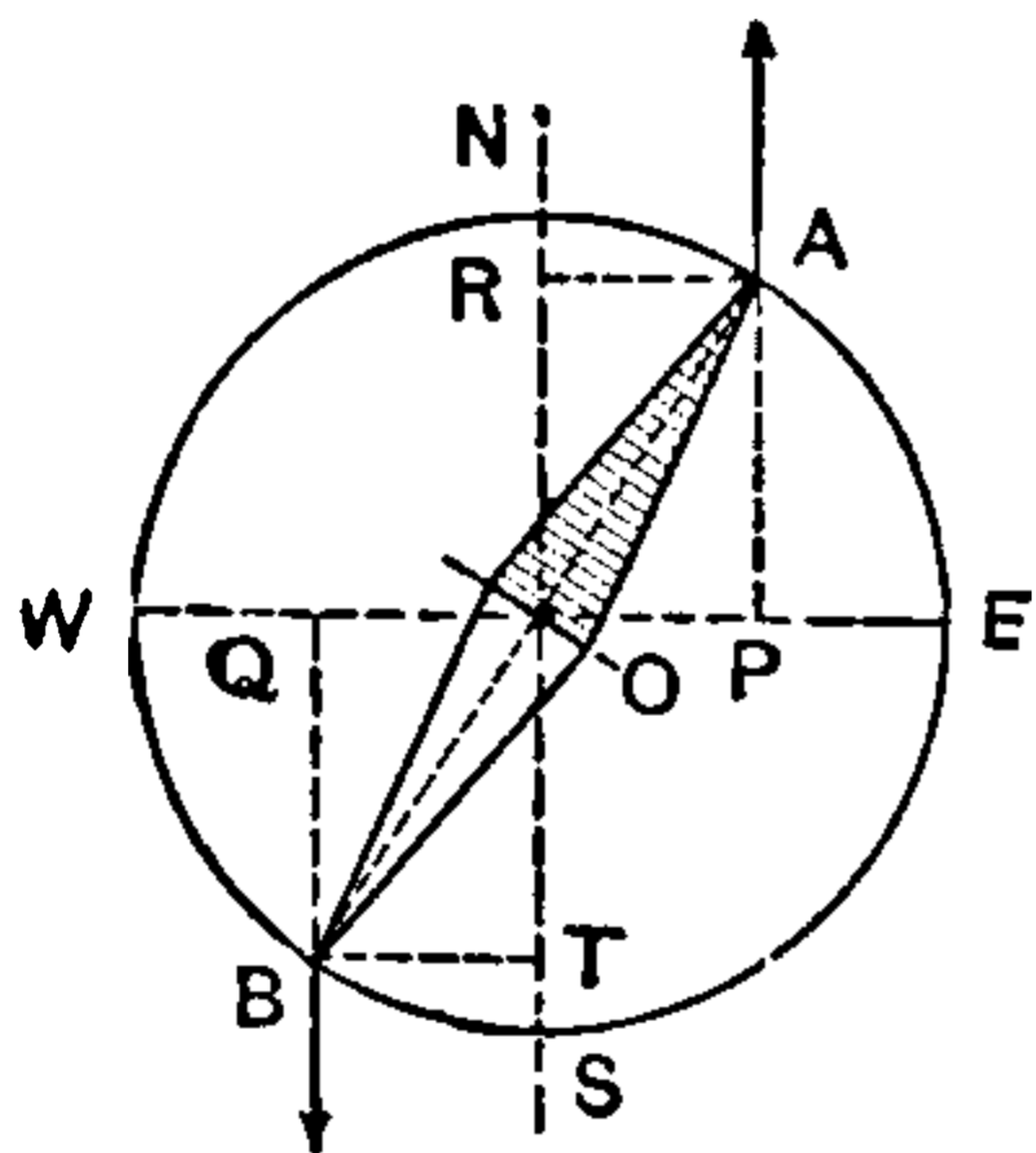

Fig. 195. Declination of Needle.

Declinometer.—A magnetic needle suitably arranged for the measurement of the value of the magnetic declination or variation at any place.

Decomposition.—In chemistry the separation of a molecule into its constituent atoms or groups of atoms. (See *Molecule, Atom*.)

Decomposition, Electric — —Chemical decomposition by means of an electric discharge or current.

This decomposition may result from an increase

of temperature produced by the electric discharge, or from the passage of the current. In the latter case it is more properly called *electrolytic decomposition*.

Decomposition, Electric, Crystallization by — —(See *Crystallization by Electrolytical Decomposition*.)

Decomposition, Electrolytic — —The separation of a molecule into its constituent atoms or groups of atoms by the action of the electric current.

These atoms or groups of atoms are either electro-positive or electro-negative in character. (See *Electrolysis, Anion, Kathion*.)

De-energize.—To deprive an electro-receptive device of its operating current.

De-energizing.—Depriving an electro-receptive device of its operating current.

Deep-Seated Eddy Currents.—(See *Currents, Eddy, Deep-Seated*.)

Deep-Water Submarine Cable.—(See *Cable, Submarine, Deep-Sea*.)

Deflagration, Electrical — —The fusion and volatilization of metallic substances by the electric current.

Deflagrator.—The name given to a voltaic battery, of small internal resistance, employed by Hare in the electric deflagration of metallic substances.

Deflection Method.—(See *Method, Deflection*.)

Deflection of Magnetic Needle.—(See *Needle, Magnetic, Deflection of*.)

Degeneration.—Such a degeneration of the muscular or cellular structure of any cell or organ that incapacitates it from performing its functions.

Degeneration of Energy.—(See *Energy, Degeneration of*.)

Degeneration, Partial, Reaction of — —That form of alteration to electric stimulation, in which the nerves show no abnormal reaction to electric stimulation, while the muscles, when directly stimulated by the constant current, exhibit the reaction of degeneration. (See *Degeneration, Reaction of*.)

Degeneration, Reaction of — —A qualitative and quantitative alteration of nerves and muscles to electric stimulation.

According to Landois and Stirling the following conditions characterize essentially the reaction of degeneration: "The excitability of the *muscles* is diminished or abolished for the faradic current, while it is increased for the galvanic current from the third to the fifty-eighth day; it again diminishes, however, with variations, from the seventy-second to eightieth day; the anodic closing contraction is stronger than the cathodic closing contraction." * * * "The diminution of the excitability of the *nerves* is similar for the galvanic and faradic currents."

Deka (as a prefix).—Ten times.

Deka-Ampère.—Ten ampères.

Deka-Ampère Balance.—(See *Balance, Deka-Ampère*.)

De la Rue's Standard Voltaic Cell.—(See *Cell, Voltaic, Standard, De la Rue's*.)

Deliquescence.—The solution of a crystalline solid arising from its absorption of vapor of water from the atmosphere.

Demagnetizable.—Capable of being deprived of magnetism.

Demagnetization.—A process, generally directly opposite to that for producing a magnet, by means of which the magnet may be deprived of its magnetism.

A magnet may be deprived of its magnetism, or be demagnetized—

(1.) By heating it to redness.

(2.) By touching to its poles magnet poles of the same name as its own.

(3.) By reversing the directions of the motions by which its magnetism was originally imparted, if magnetized by touch, by stroking it with a magnet in the opposite direction from that which would have to be given in order to produce the magnetization which is to be removed from it.

(4.) By exposing it in a helix to the influence of currents which will impart magnetism opposite to that which it originally possessed.

Avria claims that a smaller magnetizing force is required to demagnetize a needle than is required to magnetize it.

Demagnetization of Watches.—(See *Watches, Demagnetization of*.)

Demagnetize.—To deprive of magnetism.

Demagnetizing.—Depriving of magnetization.

Demarcation Current.—(See *Current, Demarcation*.)

Demarcation Surface.—(See *Surface, Demarcation*.)

Density, Electric — —The quantity of free electricity on any unit of area of surface.

The density is said to be positive or negative according as to whether the charge is positive or negative. (See *Charge, Density of, Plane, Magnetic Proof*.)

Density, Magnetic — —The strength of magnetism as measured by the number of lines of magnetic force that pass through a unit area of cross-section of the magnet, *i. e.*, a section taken at right angles to the lines of force. (See *Field, Magnetic*.)

Density of Charge.—(See *Charge, Density of*.)

Density of Current. — (See *Current Density*.)

Density of Field.—(See *Field, Density of*.)

Density, Surface — —A phrase used by Coulomb to mean the quantity of electricity per unit of area at any point on a surface. (See *Charge Density, Density, Electric*.)

Dental-Mallet, Electro-Magnetic — — A mallet for filling teeth, the blows of which are struck by means of electrically-driven mechanism.

Electro-magnetism was first employed for this purpose by Bonwill, of Philadelphia.

Dentiphone.—An audiphone. (See *Audiphone*.)

Depolarization.—The act of reducing or removing the polarization of a voltaic cell or battery. (See *Cell, Voltaic, Polarization of*.)

Depolarize.—To deprive of polarization.

Depolarizing.—Depriving of polarization.

Depolarizing Fluid.—(See *Fluid, Depolarizing*.)

Deposit, Black, Electro-Metallurgical — —A crystalline variety of electro-metallurgical deposit. (See *Deposit, Electro-Metallurgical*.)

Deposit, Crystalline, Electro-Metallurgical — —A non-adherent, non-coherent film of electrolytically deposited metal. (See *Deposit, Electro-Metallurgical*.)

Deposit, Electro-Metallurgical — — The deposit of metal obtained by any electro-metallurgical process.

To obtain a good metallic deposit the density of the current must be regulated according to the strength of the metallic solution employed.

Electro-metallurgical deposits are either—

(1.) *Reguline*, or flexible, adherent and strongly coherent metallic films, deposited when neither the current nor the solution is too strong; or,

(2.) *Crystalline*; or non-adherent and non-coherent deposits.

The crystalline deposit may either be of a *loose, sandy character*, which is thrown down when too feeble a current is used with too strong a metallic solution, or it may consist of a *black deposit*, which is thrown down when the current is too strong as compared with the strength of the solution. This latter character of deposit is sometimes technically called *burning*, and takes place most frequently at sharp corners and edges, where the current density is greatest. (See *Current Density*.)

Deposit, Electro-Metallurgical Nodular — —A coherent, irregular electro-metallurgical deposit which occurs whenever the current density falls below its normal value.

Deposit, Electro-Metallurgical, Reguline — —A flexible, adherent and strongly coherent film of metal electrolytically deposited. (See *Deposit, Electro-Metallurgical*.)

Deposit, Electro-Metallurgical, Sandy — —A non-coherent electro-metallurgical deposit which occurs whenever the current density exceeds its normal value.

Depositing Cell.—(See *Cell, Depositing*.)

Depositing Vat.—(See *Vat, Depositing*.)

Deposition, Electric — —The depositing of a substance, generally a metal, by the action of electrolysis. (See *Electrolysis*.)

The electric deposition of a metal on any conducting surface is sometimes called an electro-metallurgical deposition. (See *Metallurgy, Electro*.)

Deprez-d'Arsonval Galvanometer.—(See *Galvanometer, Deprez-d'Arsonval*.)

Derivative Circuit.—(See *Circuit, Derivative*.)

Derived Circuit.—(See *Circuit, Derived*.)

Derived Units.—(See *Units, Derived*.)

Destructive Distillation.—(See *Distillation, Destructive*.)

Detector Galvanometer.—(See *Galvanometer, Detector*.)

Detector, Ground — —In a system of incandescent lamp distribution, a device placed in the central station, for showing by the candle-power of a lamp the approximate location of a ground on the system.

Fig. 196, shows a form of ground-detector, in

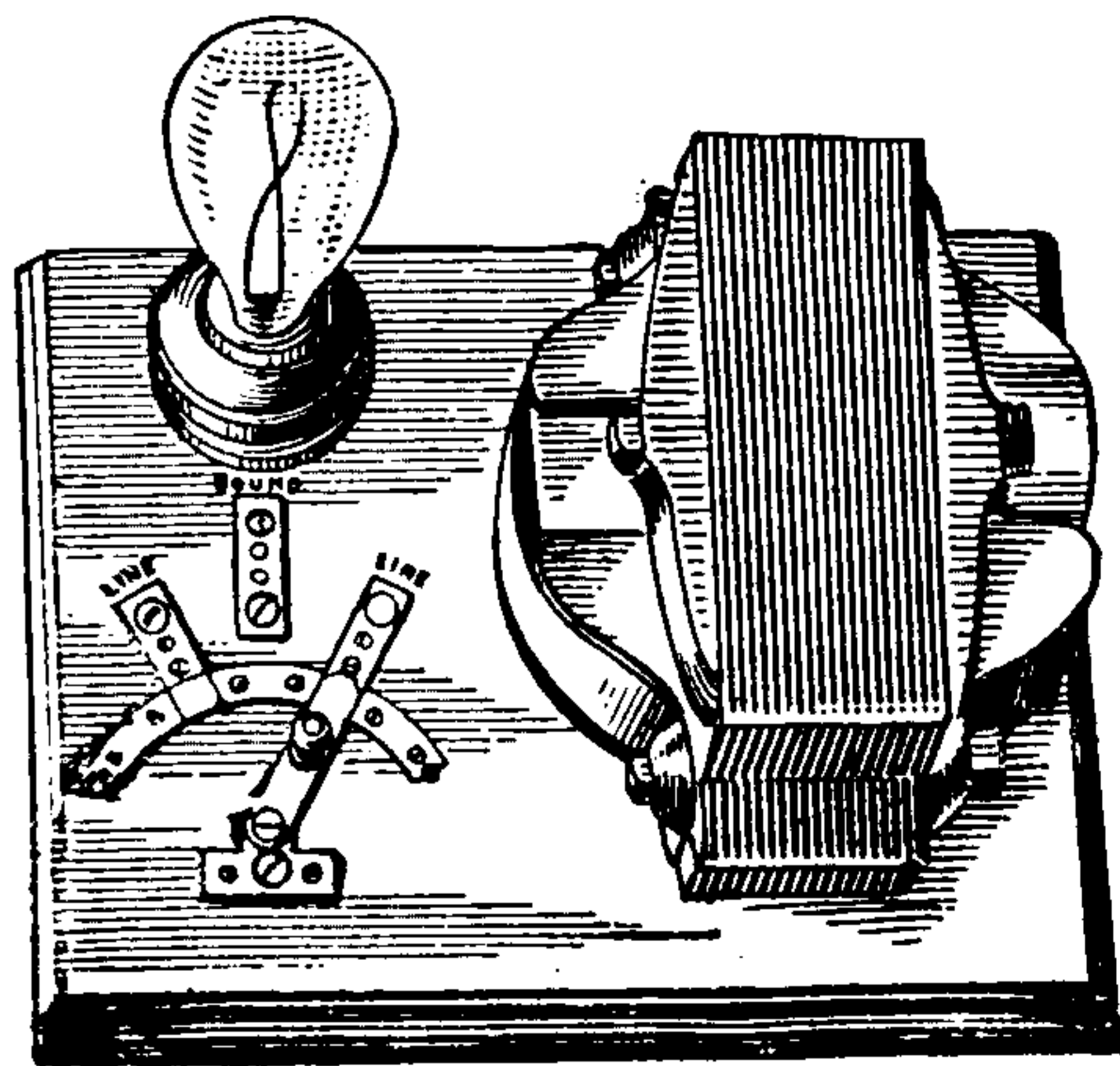

Fig. 196. *Ground-Detector*.

which a small transformer is placed on a board in connection with a lamp and a two-way switch. One terminal of the primary of the transformer is put to ground, while the other can be connected by means of the switch to one or the other of the two primary mains of the distribution circuit. Should an earth exist on either main, then when the testing transformer has its pole connected to the other main, the lamp in its secondary circuit will light up, providing the leak is of sufficient magnitude to permit a sufficiently great current to pass through the primary circuit.

Detorsion Bar.—(See *Bar, Detorsion*.)

Device, Electro-Receptive — —Various

THIS PAGE IS LOCKED TO FREE MEMBERS

Purchase full membership to immediately unlock this page



HISTORY

Tens of thousands of important historical sources, many previously unobtainable, are now available for the first time with a Forgotten Books Full Membership.

Unlimited Access
\$8.99/month

Continue

*Fair usage policy applies

Devices, Electro-Receptive, Multiple-Arc-Connected — —A term used in place of multiple-connected electro-receptive devices. (See *Devices, Electro-Receptive, Multiple-Connected.*)

Devices, Electro-Receptive, Multiple-Series-Connected — —A connection of electro-receptive devices in which a number of separate electro-receptive devices are connected in groups in series, and each of these separate groups afterwards connected in multiple-arc.

The multiple-series connection permits electro-receptive devices to be placed on mains whose electromotive force would be too high to permit a single service to be connected directly to them. It is of great value in the distribution of incandescent lamps by constant currents, since by permitting a higher electromotive force to be employed on the main conductors, it reduces the dimensions of the conductors required for the economical distribution of the current. (See *Circuits, Varieties of.*)

Devices, Electro-Receptive, Series-Connected — —The connection of electro-receptive devices in which the devices are placed consecutively in the circuit, so that the current passes successively through all of them from the first to the last.

The series-connection of electro-receptive devices is suited to *constant-current circuits*. The work done in the device is developed by the fall of potential in each device. This kind of connection is used in most systems of arc light and telegraphic lines. (See *Circuits, Varieties of.*)

Devices, Electro-Receptive, Series-Multiple-Connected — —A connection of electro-receptive devices in which a number of separate electro-receptive devices are joined in separate multiple groups, and each of these groups subsequently connected with one another in series.

The effect of series-multiple connections is to split up the current into a number of separate currents of smaller strength, but of the same electromotive force. It is applicable to such cases as the combination of arc and incandescent lamps in the same circuit. (See *Circuits, Varieties of.*)

Devices, Translating, Multiple-Con-

nected — —A term sometimes used for multiple-connected electro-receptive devices. (See *Devices, Electro-Receptive, Multiple-Connected.*)

Devices, Translating, Multiple-Arc-Connected — —A term used in place of multiple-connected electro-receptive devices. (See *Devices, Electro-Receptive, Multiple-Connected.*)

Devices, Translating, Multiple-Series-Connected — —A term sometimes used instead of multiple-series-connected electro-receptive devices. (See *Devices, Electro-Receptive, Multiple-Series-Connected.*)

Devices, Translating, Series-Connected — —A term sometimes used for series-connected electro-receptive devices. (See *Devices, Electro-Receptive, Series-Connected.*)

Devices, Translating, Series-Multiple-Connected — —A term sometimes used for series-multiple-connected electro-receptive devices. (See *Devices, Electro-Receptive, Series-Multiple-Connected.*)

Dextrorsal Helix.—(See *Helix, Dextrorsal.*)

Dextrorsal Solenoid.—(See *Solenoid, Dextrorsal.*)

Diacritical Current.—(See *Current, Diacritical.*)

Diacritical Number.—(See *Number, Diacritical.*)

Diacritical Point of Magnetic Saturation.—(See *Saturation, Magnetic, Diacritical Point of.*)

Diagnosis, Electro.—Diagnosis by means of the exaggeration or diminution of the reaction of the excitable tissues of the body when subjected to the varying influences of electric currents.

The electric current has also been applied in order to distinguish between forms of paralysis, and as a final test of death.

Diagnostic, Electro — —Pertaining to electro-diagnosis. (See *Diagnosis, Electro.*)

Diagometer, Rousseau's — —An apparatus in which an attempt is made to

determine the chemical composition and consequent purity of certain substances by their electrical conducting powers.

The arrangement of the apparatus is shown in Fig. 197. A dry pile, A, has its negative, or —

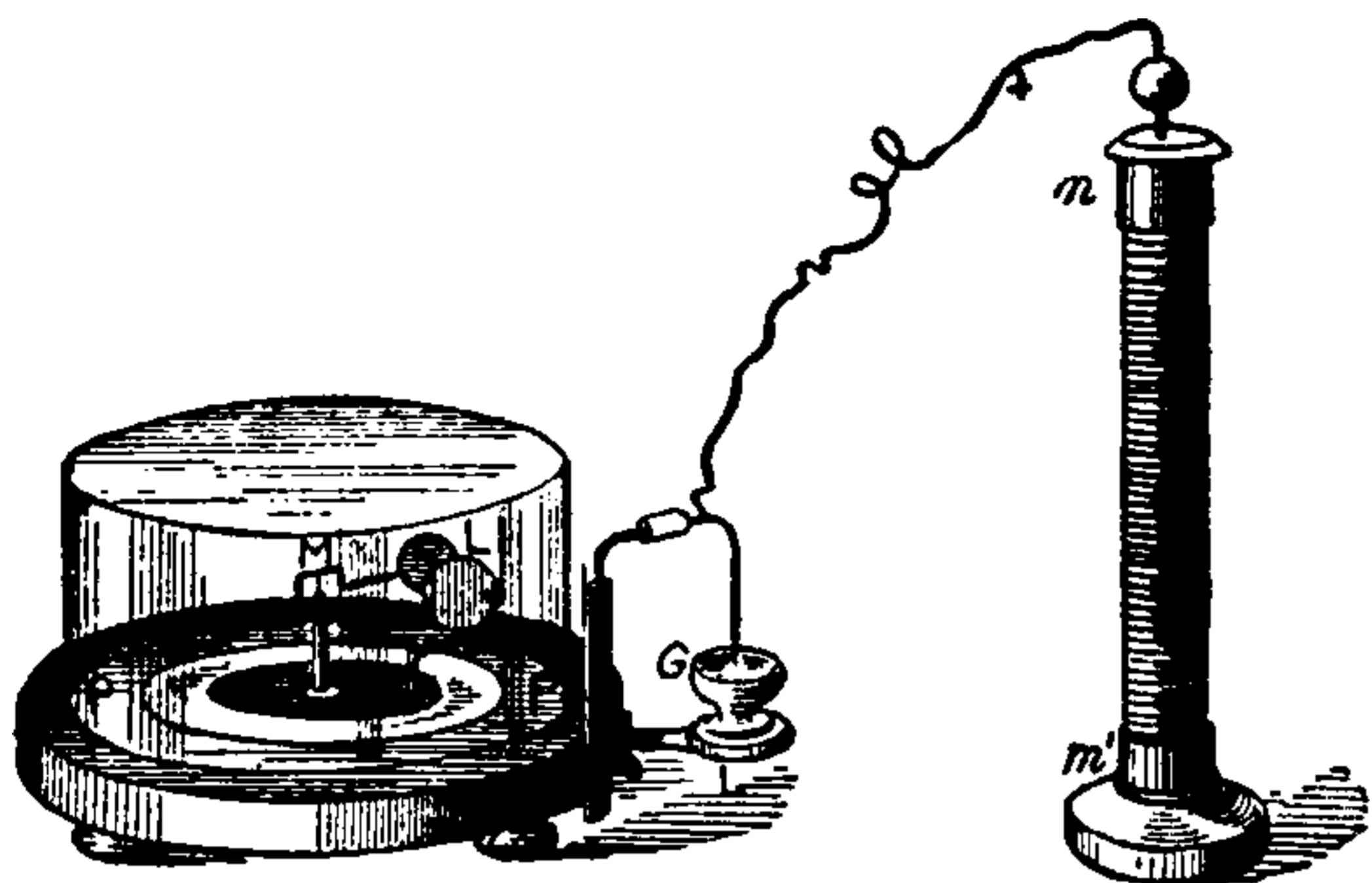

Fig. 197. Rousseau's Diagonometer.

terminal, m' , grounded. Its positive, or $+$ terminal is connected to a delicately supported, and slightly magnetized needle, M, terminated by a conducting plate, L. Opposite L, and at the same height, is a fixed plate of slightly larger size. The needle M, when at rest in the plane of the magnetic meridian, is in contact at L, with the fixed plate. If, therefore, the upper plate of the pile is connected with the needle M, both plates are similarly charged and repulsion takes place, the needle coming to rest at a certain distance from the fixed plate.

The substance whose purity is to be determined is placed in the cup G, which is connected, through L, with the fixed plate. A branch wire from the $+$ terminal of the pile is then dipped into the substance in G, and its purity determined from the length of time required for the two plates at L, to be discharged through the material in G.

It is claimed that the instrument will detect the difference between pure coffee and chicory. Its practical application, however, is very doubtful.

Diagram, Thermo-Electric — — A diagram in which the thermo-electric power between different metals is designated for different temperatures.

The differences of potential, produced by the mere contact of two metals, varies, not only with the kind of metals, and the physical state of each metal, but also with their temperature. This difference of potential, maintained in consequence of the difference of temperature between the junctions of a *thermo-electric couple*, is approximately proportional to the differences of temperature of these junctions, if these differences are not great, and is equal to the product of such

differences of temperature and a number dependent on the metals in the couple. This number is called the *thermo-electric power*. (See *Couple, Thermo-Electric. Thermo-Electric Power*.)

In Fig. 198 (after Tait), the thermo-electric

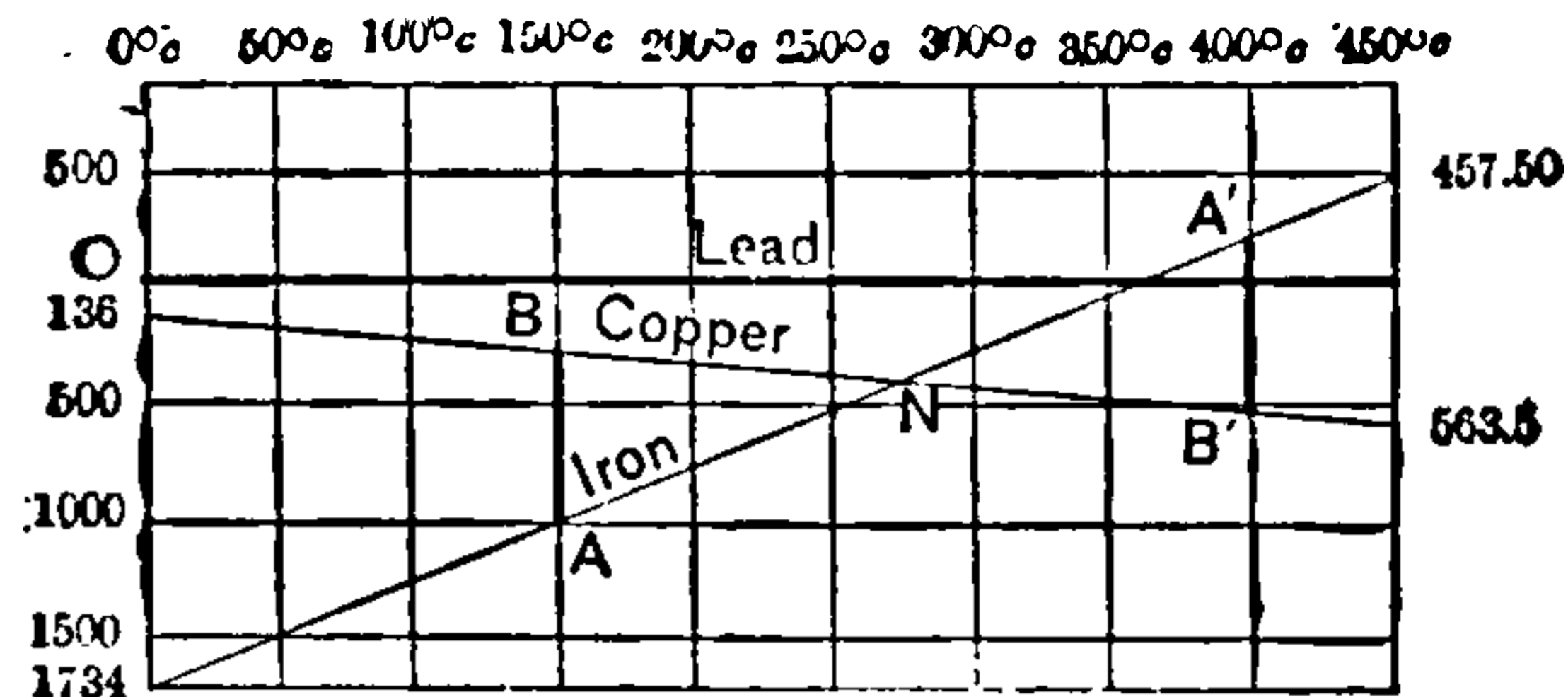

Fig. 198. Thermo-Electric Diagram.

power is shown between lead and iron, and lead and copper. The numbers at the top of the table represent degrees of the centigrade thermometer. Those at the sides represent the differences of potential in *micro-volts*.

The thermo-electric power of the copper-iron couple decreases from the freezing point of water, 0 degrees C., to a temperature of 274.5 degrees C., when it becomes zero. Beyond that temperature the thermo-electric power increases, but in the opposite direction. The point at which this occurs is called the *neutral point*.

Dial Telegraph.—(See *Telegraphy, Dial*.)

Dialysis.—The act of separating a mixture of crystalloids and colloids by diffusion through a membrane.

If, for example, the contents of a stomach, in a case of suspected poisoning, be placed in a vessel, the bottom of which is formed of a sheet of parchment paper and floated in water, the crystalloid or substances capable of crystallizing, will pass into the water and the colloid, an uncrystallized jelly-like substance, will remain in the vessel. This process has been used to detect the presence of poison in the stomach in post-mortem cases.

Diamagnetic.—The property possessed by substances like bismuth, phosphorus, antimony, zinc and numerous others, of being apparently repelled when placed between the poles of powerful magnets.

When diamagnetic substances in the form of rods or bars are placed, as in Fig. 199, between the poles of a powerful electro-magnet, they place themselves at right angles to the poles, or are apparently repelled.

Paramagnetic substances like iron or steel, on the contrary, come to rest under similar circum-

stances in a straight line joining the poles, at right angles to the position shown in Fig. 199.

Paramagnetic substances are sometimes called *ferro-magnetic*, or substances magnetic after the manner of iron. This word is unnecessary and ill-advised. The term *sidero-magnetic*, which has also been proposed in place of paramagnetic, is also unnecessary.

Paramagnetic substances appear to concentrate the lines of magnetic force on them; that is, their magnetic resistance is smaller than that of the air or other medium in which the magnet is placed. They, therefore, come to rest with their greatest dimensions in the direction of the lines of magnetic force.

Diamagnetic substances appear to have a greater magnetic resistance than that of the air around them. They, therefore, come to rest with their least dimensions in the direction of the lines of magnetic force.

The difference between paramagnetic and diamagnetic substances is generally believed to be due to the varying resistance these substances thus offer to lines of magnetic force as compared with that offered by air or by a vacuum.

Tyndall comes to the conclusion as the result of extended experimentation: "That the diamagnetic force is a polar force, the polarity of diamagnetic bodies being opposed to that of paramagnetic ones under the same conditions of excitement."

This view, however, is not generally accepted by scientists.

Diamagnetism is also possessed by certain liquid and gaseous substances.

Diamagnetic Polarity.—(See *Polarity. Diamagnetic.*)

Diamagnetically.—In a diamagnetic manner.

Diamagnetism.—A term applied to the magnetism of diamagnetic bodies. (See *Diamagnetic.*)

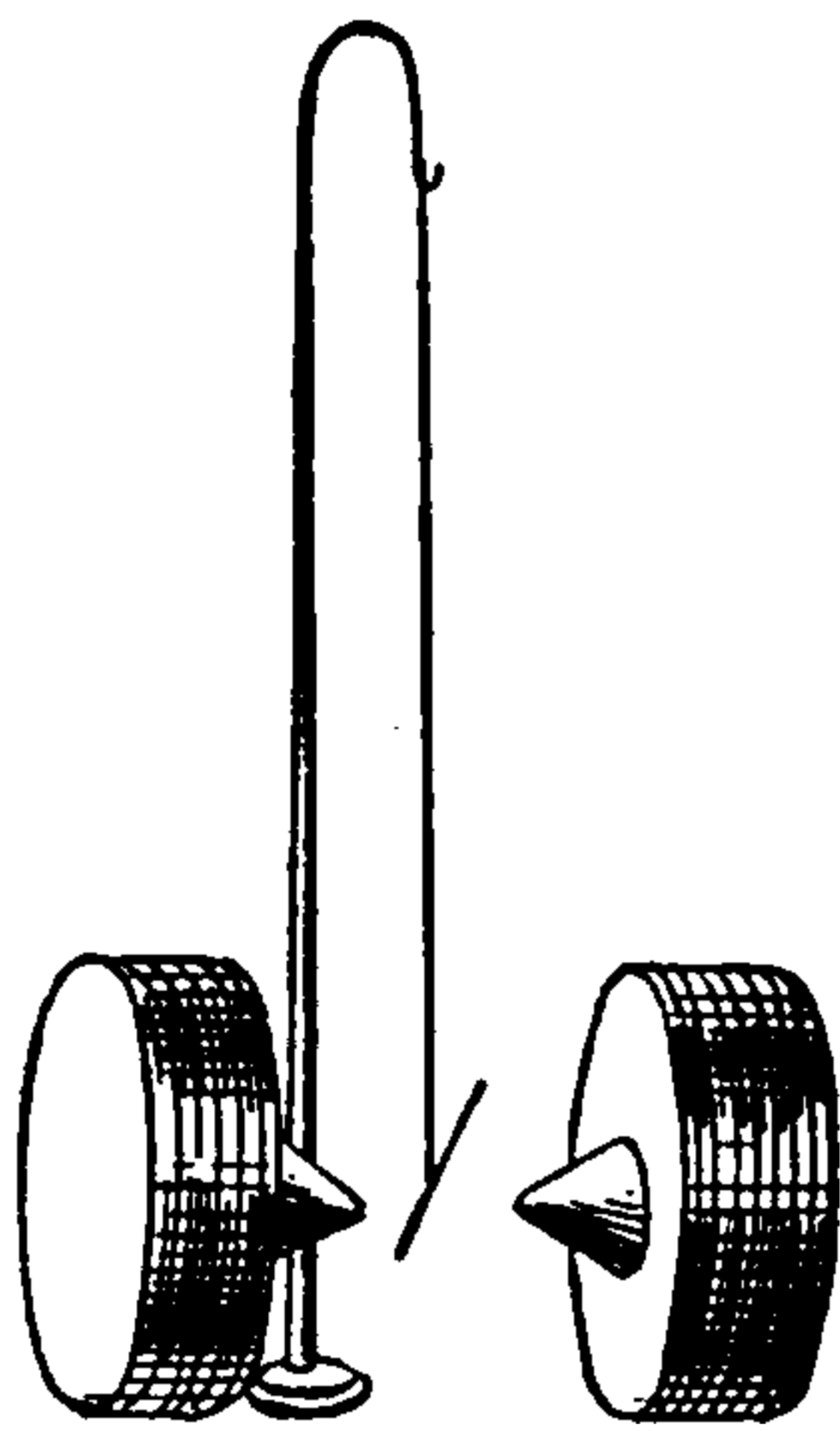

Fig. 199 Effect of Paramagnetism.

Diamagnetism, Weber's Theory of —
—A theory to account for the phenomena of diamagnetism.

Weber's theory of diamagnetism, like Ampère's theory of magnetism, supposes that magnetic substances consist of originally magnetized molecules or atoms, and that the act of magnetization consists of polarizing these atoms or molecules, or turning them in one and the same direction. That the original condition of the molecules or atoms is probably due to the passage of electricity, which continually circulates through their mass, the atoms being supposed to possess perfect conductivity.

Suppose the substance through whose molecules or atoms these currents are flowing be immersed in a magnetic field. All of the molecules or atoms which can turn so as to look along lines of force in the right direction will have the current flowing in them thereby weakened so long as they remain in the field. When drawn out of it, however, these currents will regain their normal strength.

Suppose now the case of a substance, in which the currents are normal but weak, immersed in a strong magnetic field. There may thereby be effected a complete reversal of the direction of these currents, and others may be produced which flow in the opposite direction, and which will continue so to flow as long as the substance remains in the field. Such currents would then be sufficient to explain the phenomena of diamagnetic action.

An electric current produced in a circuit near which a momentary current of electricity is suddenly brought has now the opposite direction to that which produces it, and this momentary current would tend to produce repulsion. When,

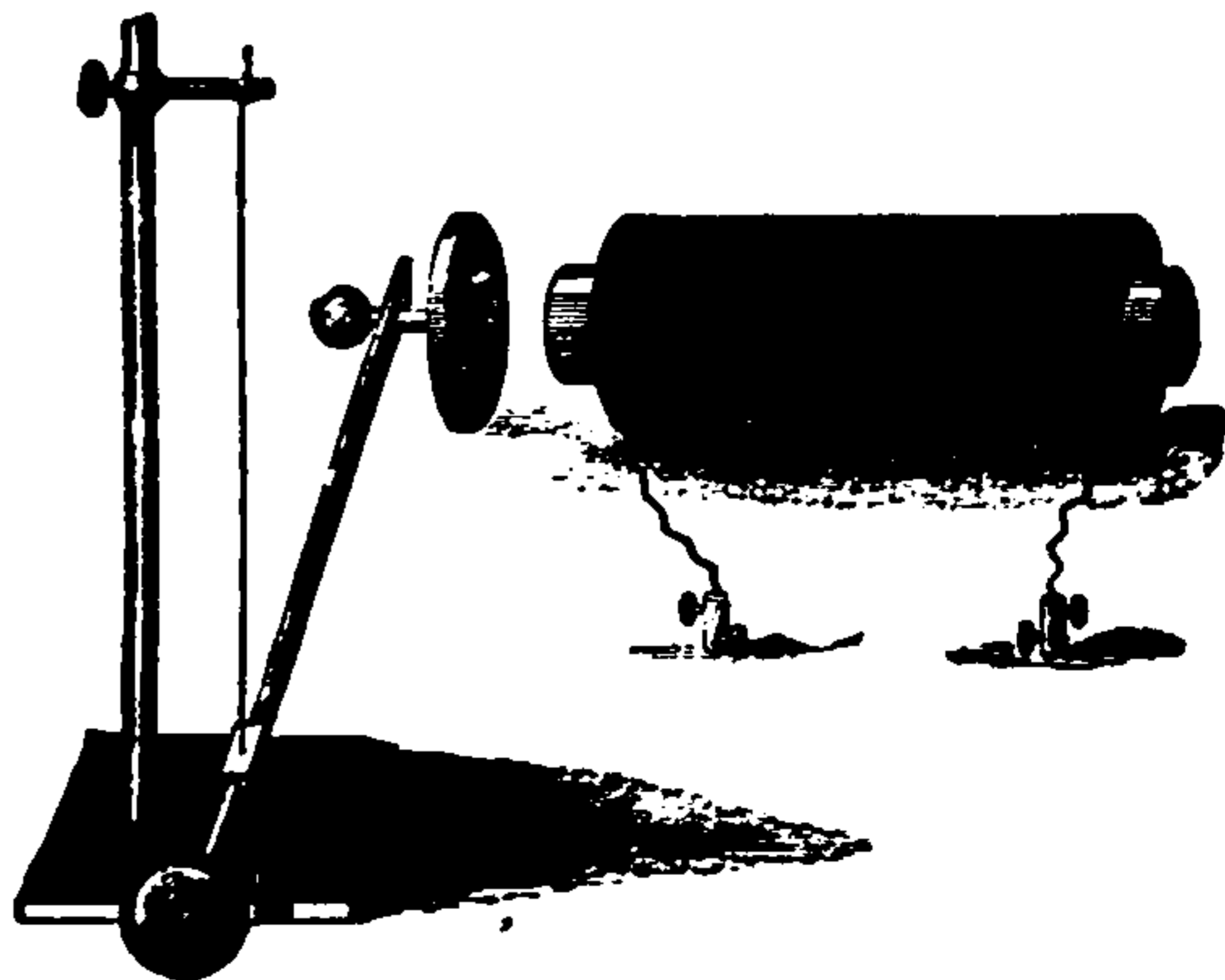

Fig. 200. Weber's Theory of Diamagnetism.

too, the circuit is drawn out of the neighborhood in which another current is flowing, another mo-

THIS PAGE IS LOCKED TO FREE MEMBERS

Purchase full membership to immediately unlock this page

Know Your Bible

Forgotten Books' Full Membership provides unlimited access to more than 28,000 volumes of Christian literature for \$8.99/month

HOLY BIBLE

Continue

*Fair use policy applies

Dielectric Constant.—(See *Constant, Dielectric.*)

Dielectric Density of a Gas.—(See *Gas, Dielectric Density of.*)

Dielectric, Polarization of — —A molecular strain produced in the dielectric of a Leyden jar or other condenser, by the attraction of the electric charges on its opposite faces, or by the electrostatic stress. (See *Strain, Dielectric.*)

A term formerly employed in place of electric displacement.

Faraday, in his study of the action of induction, in denying the possibility of action at a distance, thought that the dielectric through which induction takes place was polarized, and that in this way the induction was transmitted across the intervening space between the inducing and the induced body, by the action of the contiguous particles of the dielectric.

The polarization of the glass of a Leyden jar, and the accompanying strain, are seen by the frequent piercing of the glass, and by the *residual charge* of the jar. (See *Charge, Residual.*)

Dielectric Resistance.—(See *Resistance, Dielectric.*)

Dielectric Strain.—(See *Strain, Dielectric.*)

Dielectric Strength of a Gas.—(See *Gas, Dielectric Strength of.*)

Dielectric Stress.—(See *Stress, Dielectric.*)

Difference of Potential.—(See *Potential, Difference of.*)

Differential Electric Bell.—(See *Bell, Differential Electric.*)

Differential Galvanometer.—(See *Galvanometer, Differential.*)

Differential Inductometer.—(See *Inductometer, Differential.*)

Differential Method of Duplex Telegraphy.—(See *Telegraphy, Duplex, Differential Method of.*)

Differential Relay.—(See *Relay, Differential.*)

Differential Thermo-Pile.—(See *Pile, Thermo, Differential.*)

Differential Voltmeter.—(See *Voltmeter, Siemens' Differential.*)

Differentially Wound Motor.—(See *Motor, Differentially Wound.*)

Diffusion, Anodal — —A term applied to the introduction of any drug into the human body by electricity.

The cataphoretic introduction of drugs into the body. (See *Cataphoresis.*)

A sponge or other similar electrode, saturated with a solution of the drug, is connected with the anode of a source and placed over the part to be treated and its kathode connected to another part of the body in a nearly direct line with the anode and the current passed.

Diffusion Creep.—(See *Creep, Diffusion.*)

Diffusion of Electric Current.—(See *Current, Diffusion of.*)

Diffusion of Lines of Force.—(See *Force, Lines of, Diffusion of.*)

Dimensions of Acceleration.—(See *Acceleration, Dimensions of.*)

Dimensions of Units—(See *Units, Dimensions of.*)

Diminished Electric Irritability.—(See *Irritability, Electric, Diminished.*)

Dimmer — —A choking coil, employed in a system of distribution by converters or transformers, for regulating the potential of the feeders.

The dimmer consists essentially of a choking coil wound around a laminated ring of soft iron,

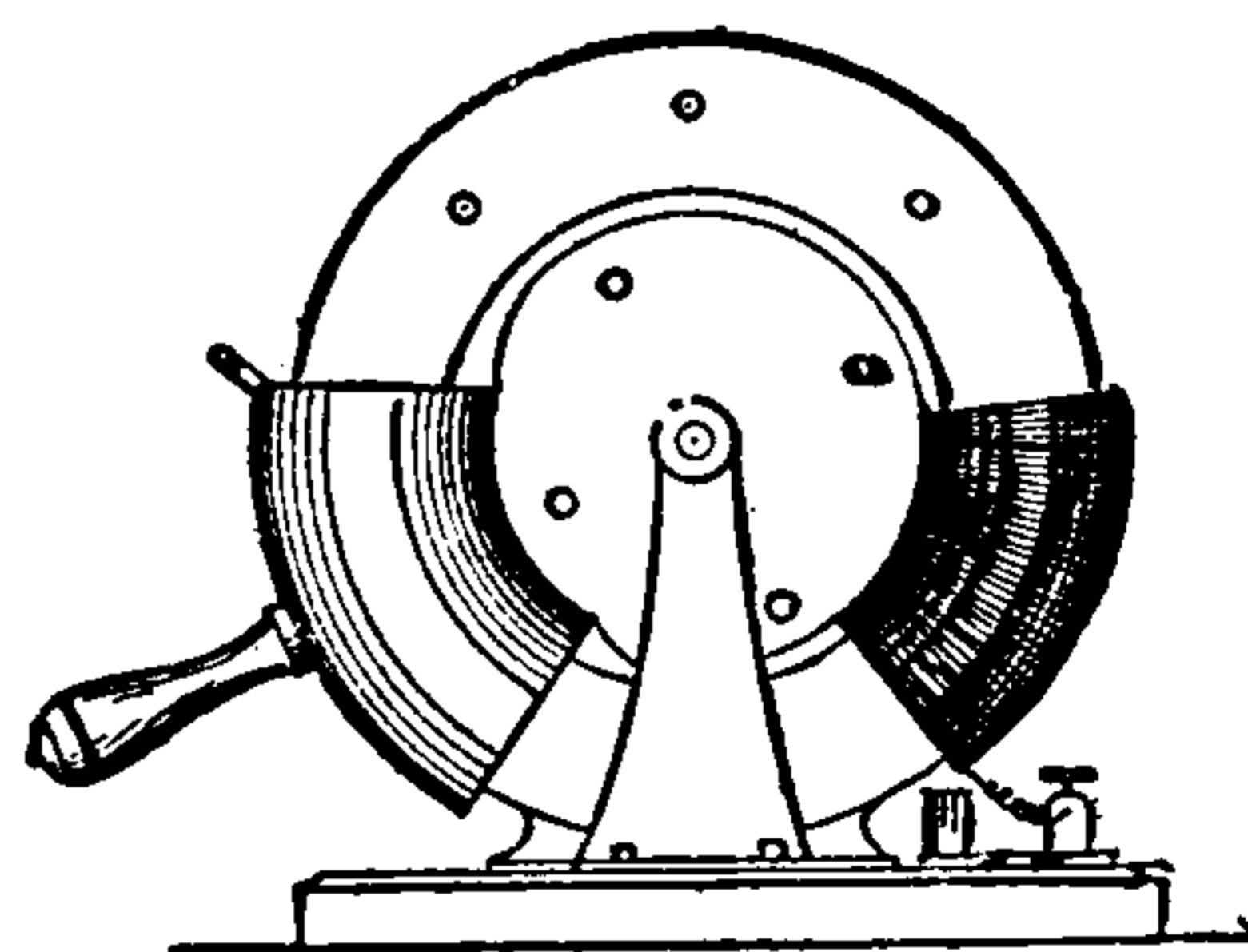

Fig. 201. Reaction Coil Dimmer.

and provided with an envelope of heavy copper. The copper ring, by its position as regards the choking coil, adjusts or regulates the self-induction of the coil, and consequently regulates the potential of the feeders. The dimmer is used in theatres or similar situations to turn the lights up or down.

The reaction coil or dimmer is shown in Fig. 201. The choking coil is wound on a ring of iron. The copper sheath is furnished with a handle to permit its position to be readily changed with respect to the coil of insulated wire. A laminated iron drum is supported on bearings inside the ring. When the sheath is over the coil, the coil offers but a small resistance to the passage of the current. When away from it the self-induction of the coil is increased.

Dioptre.—A unit of refracting power.

A lens of one dioptre has a focal length of one metre. One of two dioptres has a focal length of 50 centimetres; one of four dioptres 25 centimetres. This is also spelled *dioptry*.

Dioptric.—Relating to dioptrics.

Dioptrics.—The science which treats of the refraction of light.

Dioptry.—A word sometimes used for *dioptre*. (See *Dioptre*.)

Dip, Magnetic — —The deviation of a magnetic needle from a true horizontal position.

The inclination of the magnetic needle towards the earth.

The magnetic needle shown in Fig. 202, though

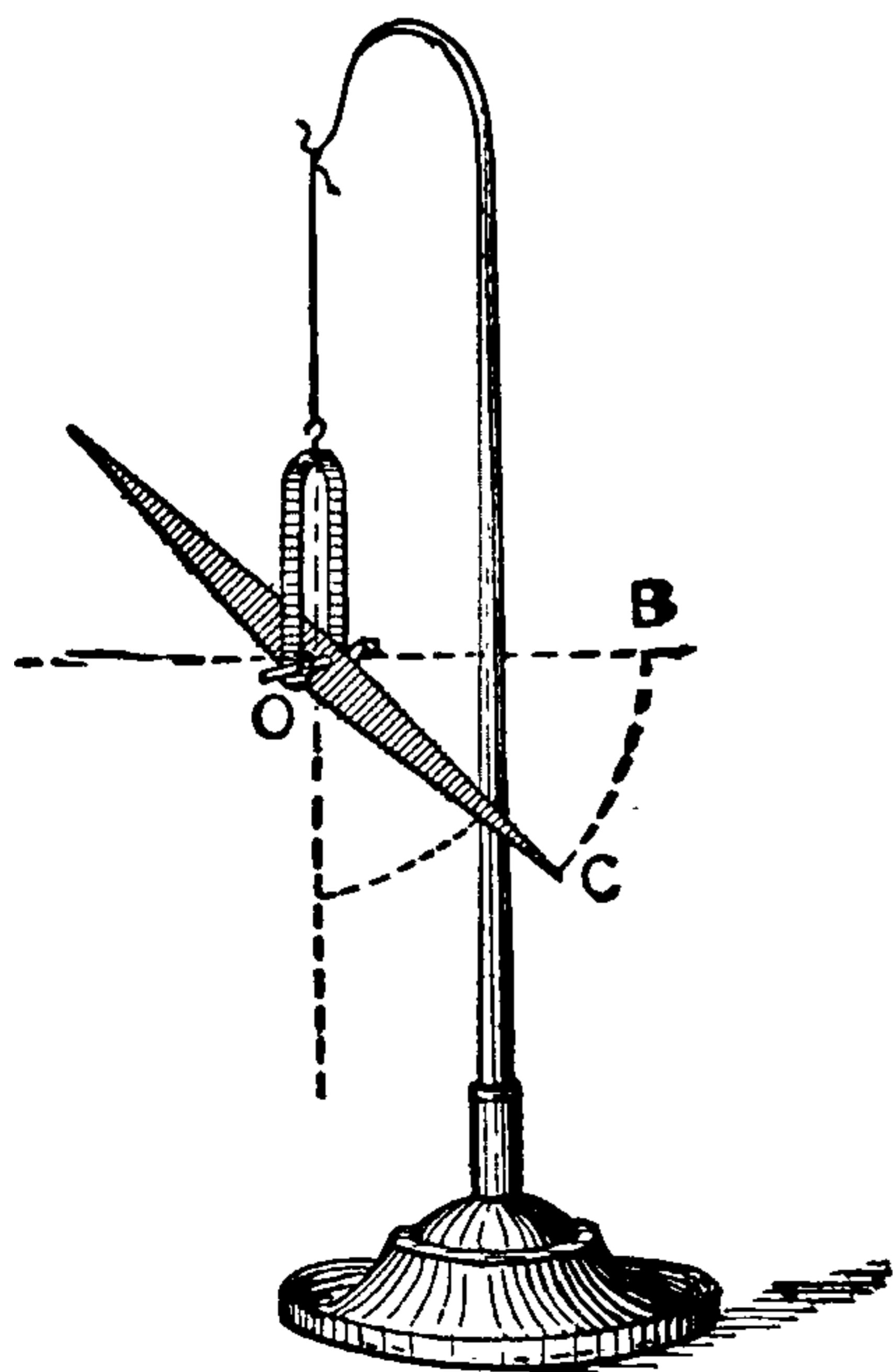

Fig. 202. Angle of Dip.

supported at its centre of gravity, will not retain a horizontal position in all places on the earth's surface.

In the northern hemisphere its *north-seeking* end will dip or incline at an angle B O C, called the *angle of dip*. In the southern hemisphere its south seeking end will dip.

The cause of the dip is the unequal distance of the magnetic poles of the earth from the poles of the needle.

The *magnetic equator* is a circle passing around the earth midway (in intensity) between the earth's magnetic poles. There is no dip at the magnetic equator. At either magnetic pole the angle of dip is 90 degrees.

Dip, or Inclination, Angle of — — The angle which a magnetic needle, free to move in both a vertical and a horizontal plane, makes with a horizontal line passing through its point of support.

The angle of dip of a magnetic needle. (See *Inclination, Angle of*.)

Diplex Telegraphy.—(See *Telegraphy, Diplex*.)

Dipping.—An electro-metallurgical process whereby a deposit or thin coating of metal is obtained on the surface of another metal by dipping it in a readily decomposable metallic salt.

Cleansing surfaces for electro-plating processes by immersing them in various acid liquors.

Dipping, Bright — —Dipping in acid liquors for the purpose of obtaining a bright electro-metallurgical coating.

Dipping Circle.—(See *Circle, Dipping*.)

Dipping, Dead — —Dipping in acid liquors for the purpose of obtaining a dead or unpolished surface on an electro-metallurgical coating.

Dipping, Electro-Metallurgical — — A process for obtaining an electro-metallurgical deposit on a metallic surface by dipping it in a solution of a readily decomposable metallic salt.

A bright, polished iron surface, when simply dipped into a solution of copper-sulphate, receives a coating of metallic copper from the electrolytic action thus set up.

This process is known technically as *dipping*. The term dipping is also used in electro-metallurgy to indicate the process of cleaning the

articles, that are to be electro-plated, by dipping them in various acid or alkaline baths.

Direct Current.—(See *Current, Direct.*)

Direct-Current Electric Motor.—(See *Motor, Electric, Direct-Current.*)

Direct Electromotive Force.—(See *Force, Electromotive, Direct.*)

Direct Excitation.—(See *Excitation, Direct.*)

Direct-Induced Current.—(See *Current, Direct-Induced.*)

Direct, or Break-Induced Current — —(See *Current, Direct. Current, Break-Induced.*)

Direct Working.—(See *Working, Direct.*)

Direction, Negative, of Electrical Convection of Heat — —A direction in which heat is transmitted through an unequally heated conductor by electric convection, during the passage of electricity through the conductor, opposite that of the current. (See *Heat, Electric Convection of.*)

Direction of Lines of Force.—(See *Force, Lines of, Direction of.*)

Direction, Positive, of Electrical Convection of Heat — —A direction in which heat is transmitted through an unequally heated conductor by electric convection, during the passage of electricity through the conductor, the same as that of the current. (See *Heat, Electric Convection of.*)

Direction, Positive, Round a Circuit — —In a plane circuit looked at from one side, a direction opposite to that of the hands of a clock.

This is a convention which has been made in order to conveniently connect the direction of the electromotive force produced by induction, with the direction of the induction.

Direction, Positive, Through a Circuit — —In a plane circuit, looked at from one side, a direction through the circuit away from the observer.

Directive Tendency of Magnetic Needle.—(See *Needle, Magnetic, Directive Tendency of.*)

Disc, Arago's — —A disc of copper

or other non-magnetic metallic substance, which, when rapidly rotated under a magnetic needle, supported independently of the disc, causes the needle to be deflected in the direction of rotation, and, when the velocity of the disc is sufficiently great, to rotate with it.

Such disc is shown in Fig. 203 at b. The move-

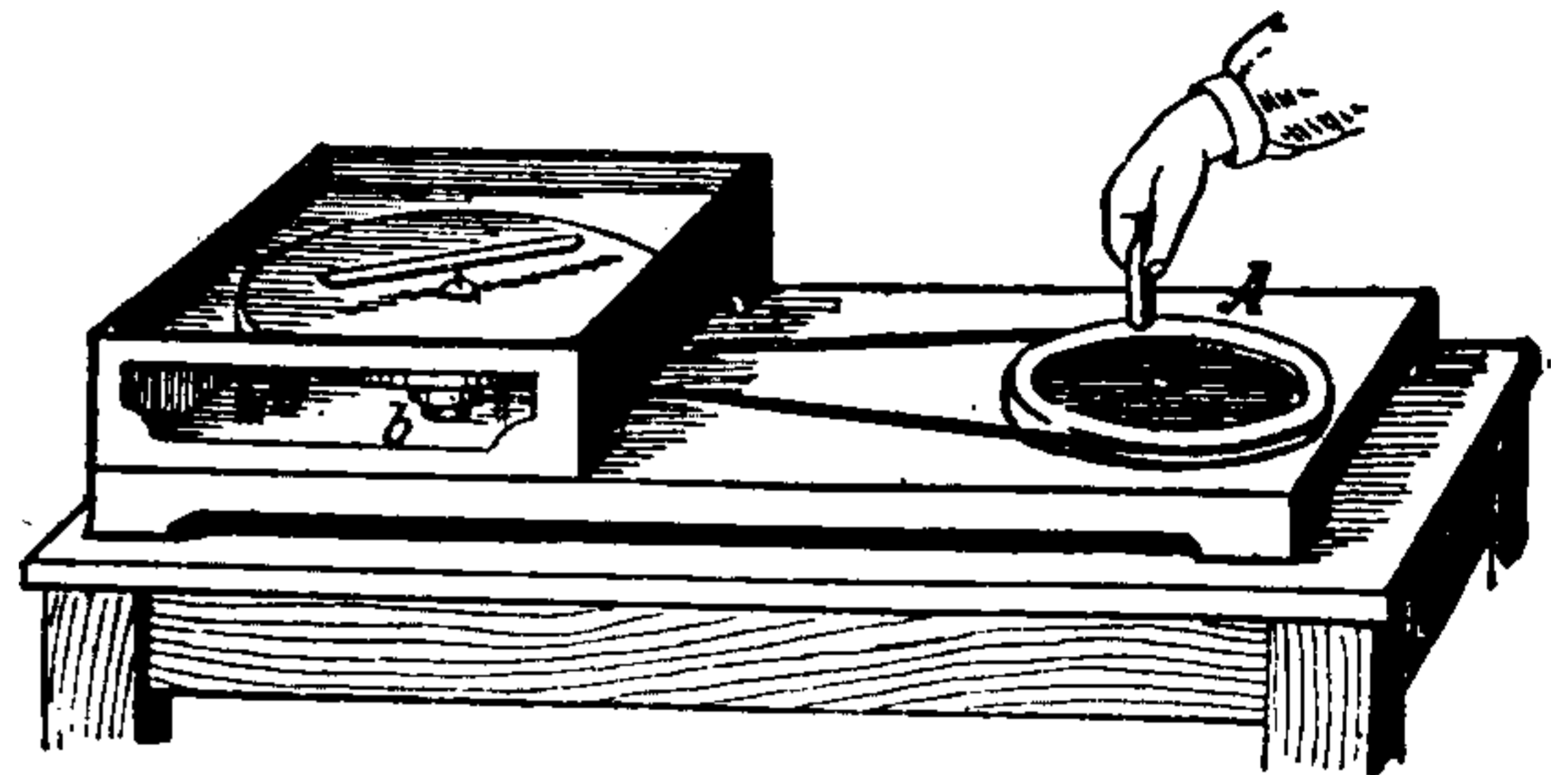

Fig. 203. Arago's Disc.

ment of the needle is due to electric currents, induced by the disc moving through the field of the needle so as to cut its lines of magnetic force. To obtain the best results the disc must move very rapidly, and should be near the needle. Moreover, the needle should be powerful.

This effect was discovered by Arago, in 1824. Since a magnetic needle moving over a metallic plate produces electric currents in a direction which tends to stop the motion of the needle, a damping of the motion of a magnetic needle is sometimes effected by causing it to move near a metal plate. The induced currents, which the needle produces in the plate by its motion over it, tend to retard the motion of the needle. (See *Damping. Law, Lenz's.*)

Disc Armature.—(See *Armature, Disc.*)

Disc, Faraday's — —A metallic disc movable in a magnetic field on an axis parallel to the direction of the field.

Such a disc is shown in Fig. 204, and moves,

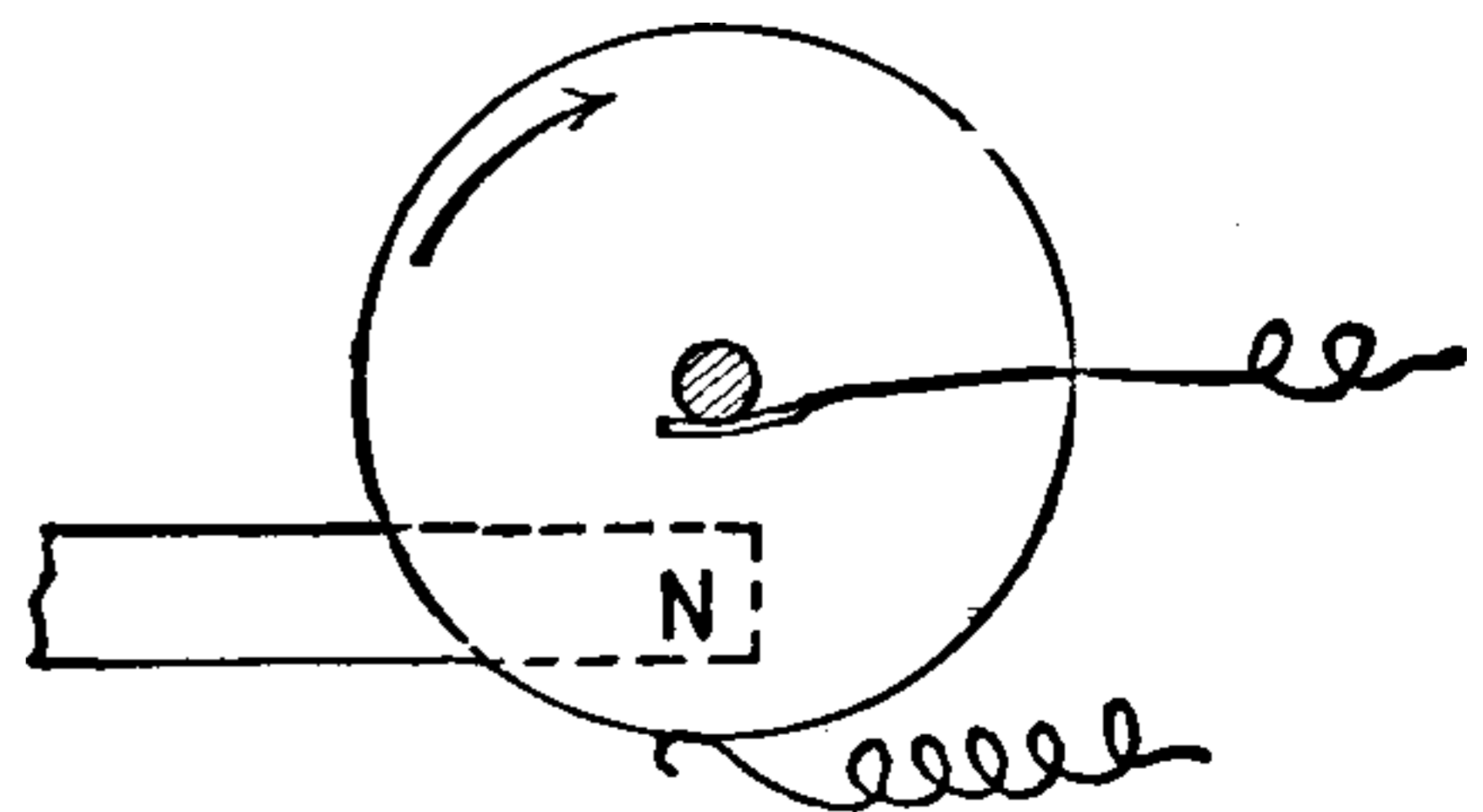

Fig. 204. Faraday's Disc.

as will be seen, so as to cut the lines of magnetic force at right angles.

The difference of potential generated by the motion of such a disc may be caused to produce a current, by providing a circuit which is completed through the portion of the disc that at any

THIS PAGE IS LOCKED TO FREE MEMBERS

Purchase full membership to immediately unlock this page



HISTORY

Tens of thousands of important historical sources, many previously unobtainable, are now available for the first time with a Forgotten Books Full Membership.

Unlimited Access
\$8.99/month

Continue

*Fair usage policy applies

singular, the luminous stream is not at all easily deflected by the approach of a conducting body.

“At this stage the streams seemingly pass with the greatest freedom through considerable thicknesses of insulators, and it is particularly interesting to study their behavior. For this purpose it is convenient to connect to the terminals of the coil two metallic spheres, which may be placed at any desired distance (Fig. 208). Spheres are pref-

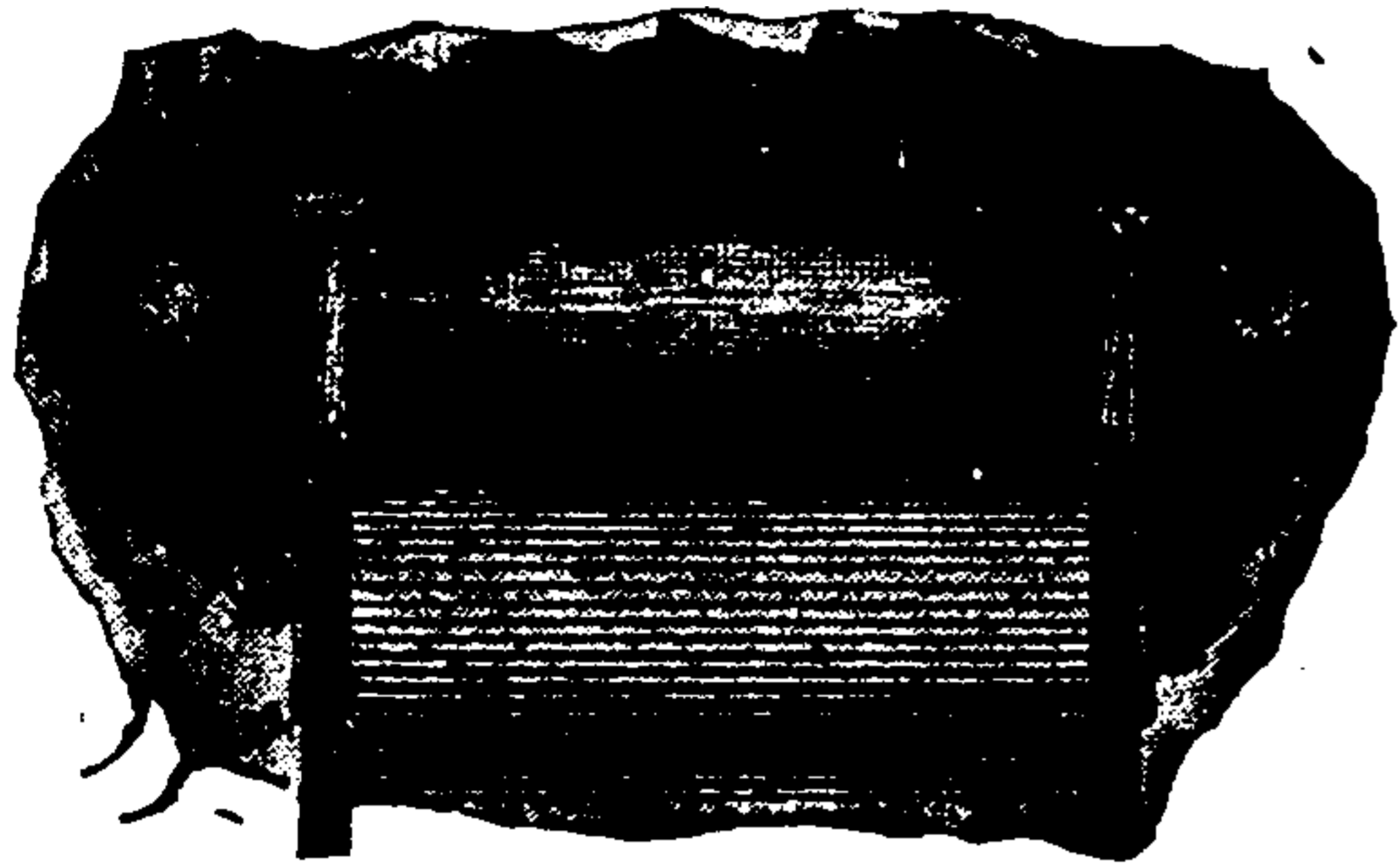

Fig. 207. *Fifth Typical Form of Discharge (Tesla).*

erable to plates, as the discharge can be better observed. By inserting dielectric bodies between the spheres, beautiful discharge phenomena may be observed. If the spheres be quite close and a spark be playing between them, by interposing a thin plate of ebonite between the spheres the spark instantly ceases and the discharge spreads into an intensely luminous circle several inches in diameter, provided the spheres are sufficiently large. The passage of the stream heats, and, after a while, softens the rubber so much that two

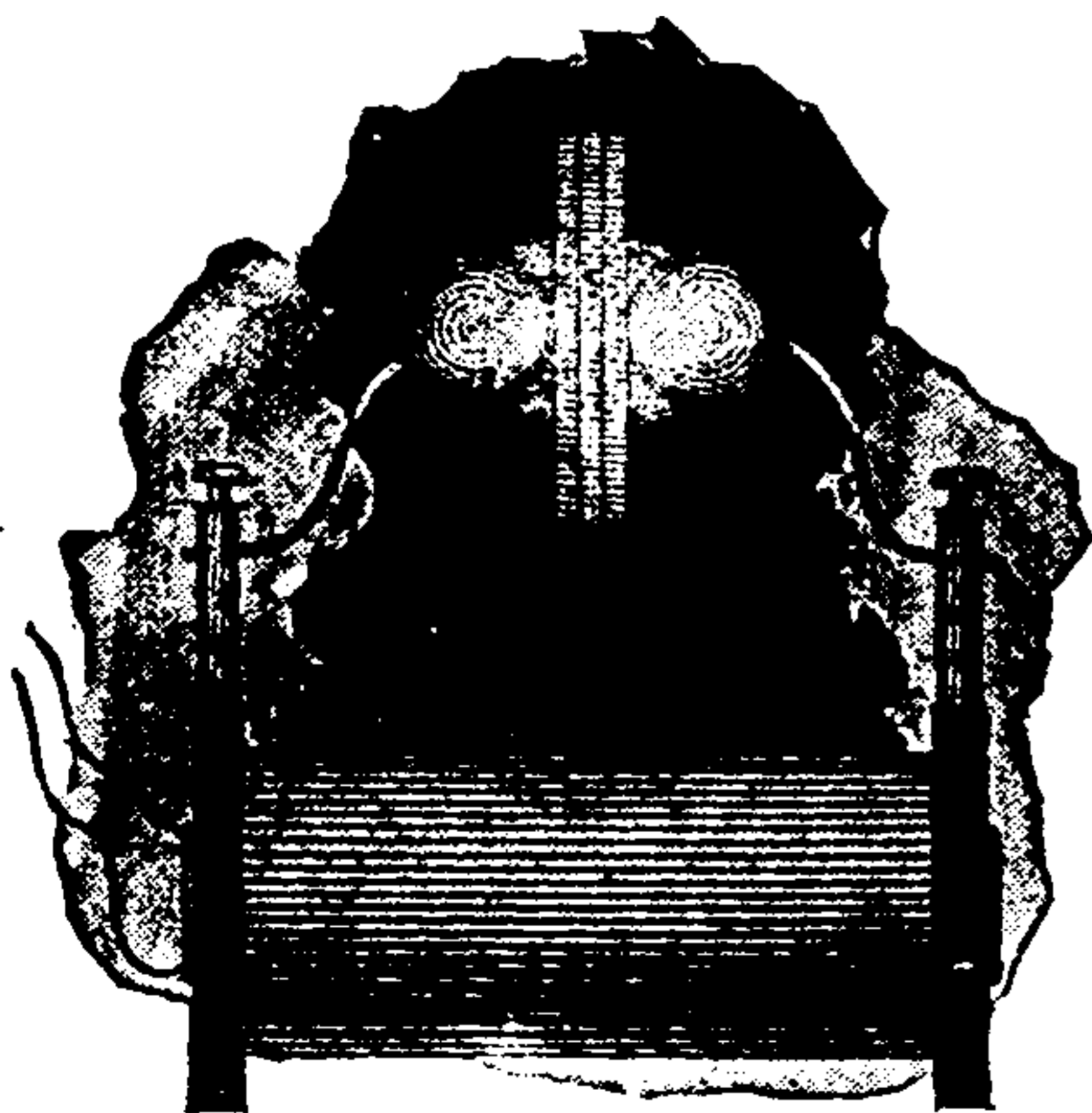

Fig. 208. *Luminous Discharge with Interposed Insulators.*

plates may be made to stick together in this manner. If the spheres are so far apart that no spark occurs, even if they are far beyond the striking distance, by inserting a thick plate of glass the discharge is instantly induced to pass from the spheres to the glass in the form of luminous streams. It appears almost as though these

streams pass *through* the dielectric. In reality this is not the case, as the streams are due to the molecules of the air which are violently agitated in the space between the oppositely charged surfaces of the spheres.

“When no dielectric other than air is present, the bombardment goes on, but is too weak to be visible; by inserting a dielectric the inductive effect is much increased, and besides, the projected air molecules find an obstacle and the bombardment becomes so intense that the streams become luminous. If by any mechanical means we could effect such a violent agitation of the molecules we could produce the same phenomenon. A jet of air escaping through a small hole under enormous pressure and striking against an insulating substance, such as glass, may be luminous in the dark, and it might be possible to produce phosphorescence of the glass or other insulators in this manner.

“The greater the specific inductive capacity of the interposed dielectric, the more powerful the effect produced. Owing to this the streams show themselves with excessively high potentials even if the glass be as much as one and one-half to two inches thick. But besides the heating due to bombardment, some heating goes on undoubtedly in the dielectric, being apparently greater in glass than in ebonite. I attribute this to the greater specific inductive capacity of the glass in consequence of which, with the same potential difference, a greater amount of energy is taken up in it than in rubber. It is like connecting to a battery a copper and a brass wire of the same dimensions. The copper wire, though a more perfect conductor, would heat more by reason of its taking more current. Thus what is otherwise considered a virtue of the glass is here a defect. Glass usually gives way much quicker than ebonite; when it is heated to a certain degree the discharge suddenly breaks through at one point, assuming then the ordinary form of an arc.”

Discharge, Conductive — — A discharge effected by leading the charge off through a conductor placed in contact with the charged body.

Discharge, Convective — — A discharge which occurs from the points on the surface of a highly charged conductor, through the repulsion by the conductor of air particles that in this manner carry off minute charges.

A convective discharge, though often attended by a feeble sound, is sometimes called a *silent discharge*, in order to distinguish it from the *noisy, disruptive discharge*, which is attended by a sharp snap, or when considerable, by a loud report.

A convective discharge is also called a *glow* or *brush discharge*. The latter is best seen at the small button at the end of the *prime* or *positive conductor* of a frictional electric machine.

The *positive discharge* from a point or small rounded conductor is always *brush-shaped*; the *negative* discharge is always *star-shaped*.

In rarefied gases, the discharge is convective in character and produces various luminous effects of great beauty, the color of which depends on the kind of gas, and the size, shape and material of the electrodes, and on the degree of the vacuum.

Thus in the rarefied space of the vessel shown in Fig. 209, the discharge becomes an ovoidal mass of light, sometimes called the *Philosopher's Egg*.

When the discharges in rarefied gases follow one another very rapidly, alternations of light and darkness, or *stratifications*, or *striæ* are produced.

The breadth of the dark bands increases as the vacuum becomes higher. The light portions start at the positive electrode, and are hotter than the dark portions.

The effects of luminous convective discharges are best seen in exhausted glass tubes, called *Geissler tubes*, containing residual atmospheres of various gases. (See *Tubes, Geissler*.)

Discharge, Dead-Beat — — A non-oscillatory discharge. (See *Discharge, Oscillatory*.)

Discharge, Disruptive — — A sudden, and more or less complete, discharge that takes place across an intervening non-conductor or dielectric.

A mechanical strain of the dielectric occurs, which *suddenly* breaks down as it were and per-

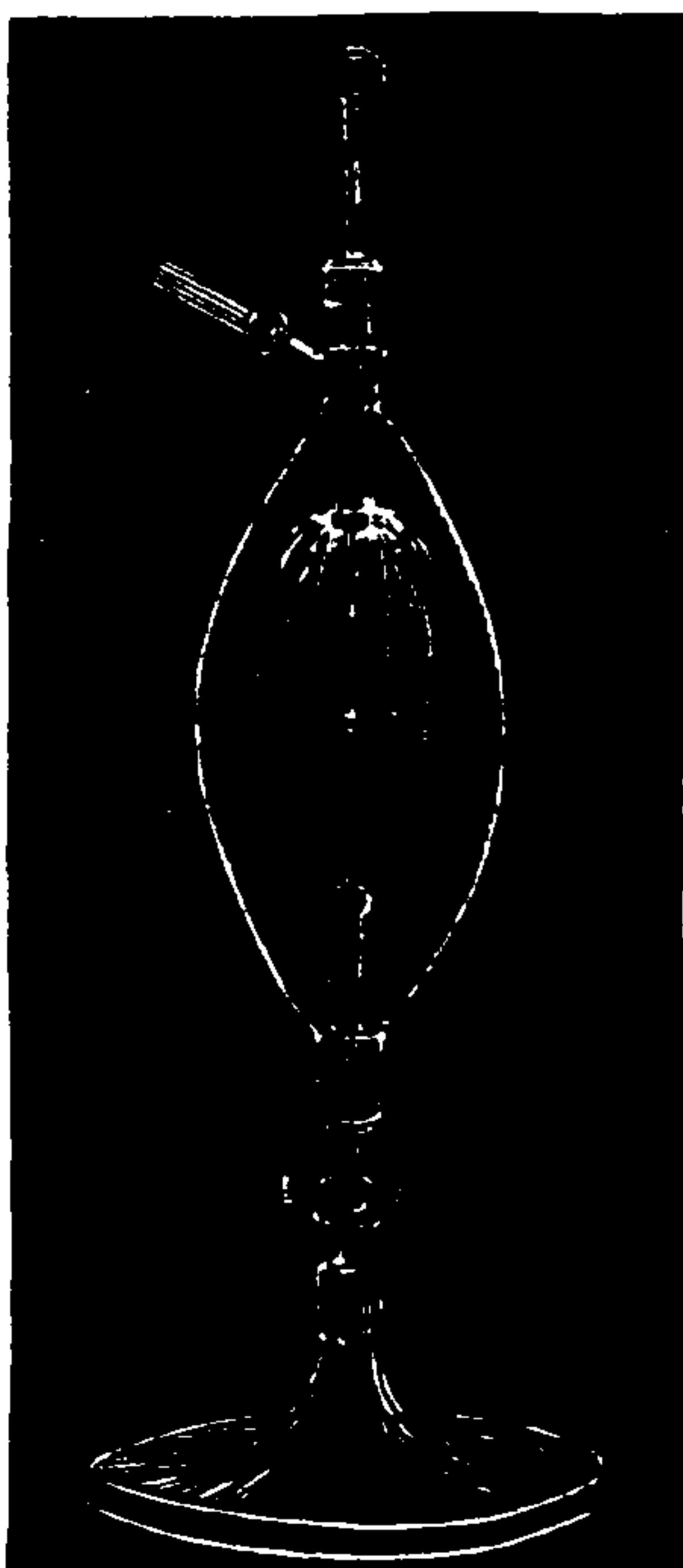

Fig. 209. Discharge in Rarefied Air.

mits the discharge to pass as a spark, or rapid succession of sparks.

In air, the spark, when long, generally takes the zigzag path, as shown in Fig. 210.

The sparks produced by disruptive discharges consist of heated gases, together with portions of the conductor that are volatilized by the heat.

The discharge of a Leyden jar or condenser may be disruptive, as when the discharging rod is held with one knob connected with one coating, and the other near the other coating. It may be gradual, as when the two coatings are alternately connected with the ground. The discharge of a Leyden jar as, indeed, the disruptive discharge in general, is *oscillatory*.

The *stress* is often sufficient to pierce the glass.

Discharge, Duration of — — The time required to effect a complete disruptive discharge.

The disruptive discharge is not instantaneous; some time is required to effect it. Estimates of the duration of a flash of lightning based on the duration of a Leyden jar discharge, are misleading from the enormous difference in the quantity and the potential in the two cases. The fact that the disruptive discharge is oscillatory and consists of a number of discharges taking place in alternately opposite directions shows that the discharge is not instantaneous.

Leyden jar discharges, are, however, accomplished in very small periods of time.

Discharge, Flaming — — The white and flaming arc-like discharge that occurs between the terminals of the secondary of an induction coil, when, with a great number of alternations per second, the current through the primary is increased beyond that required for the sensitive-thread discharge. (See *Discharge, Sensitive-Thread*.)



Fig. 210. Disruptive Discharge.

According to Tesla the flaming discharge is best produced when the number of alternations is not too great and certain relations between capacity, self-induction and frequency are observed. These relations must be such as will permit the flow through the circuit of the maximum current, and thus may be obtained with wide variations in the frequency. The flaming discharge develops considerable heat, and is characterized by the absence of the shrill note accompanying less powerful discharges. This is probably due to the enormous frequency.

Some idea of the flaming discharge may be had

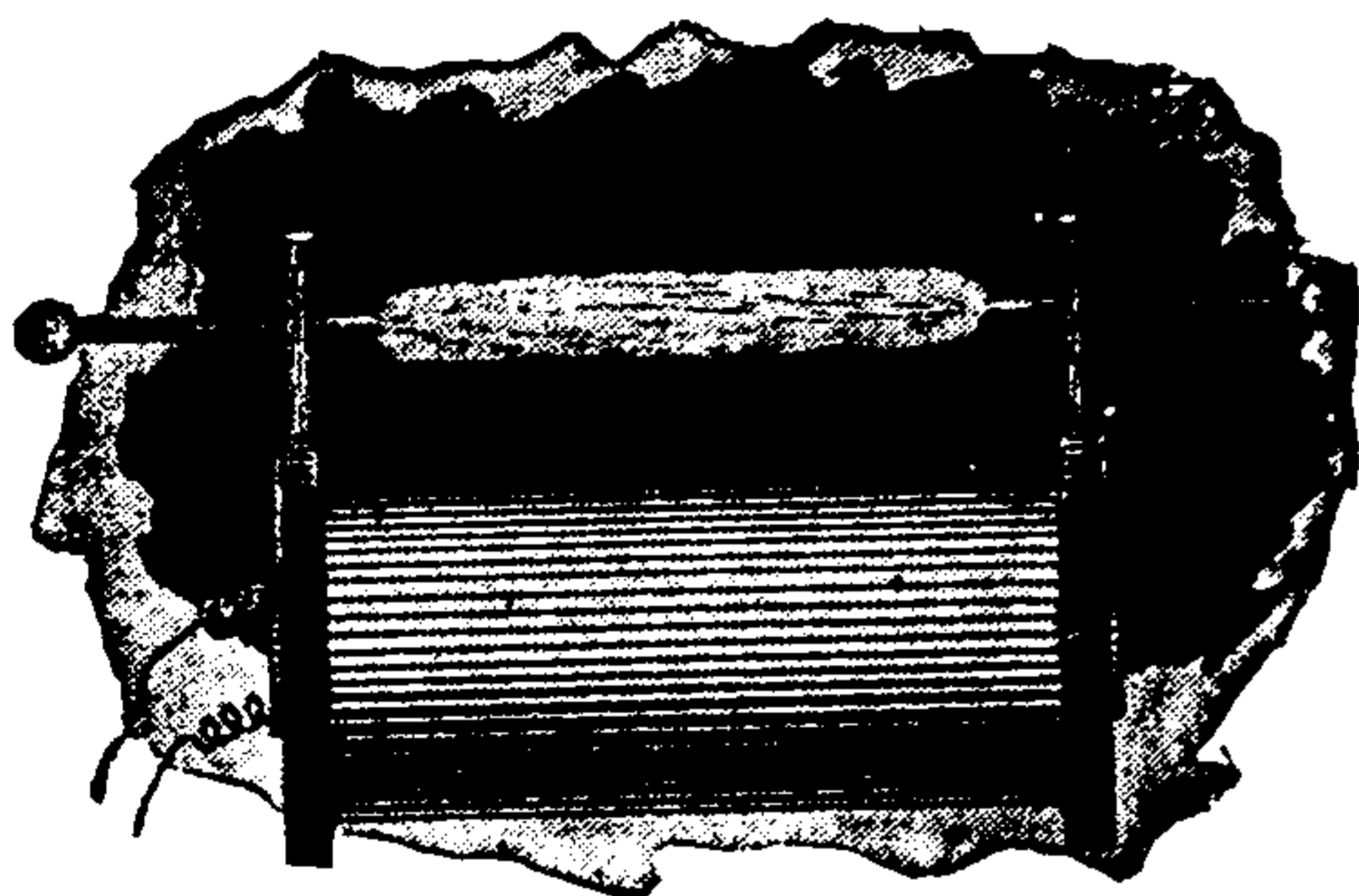

Fig. 211. Flaming Discharge (Tesla).

from an inspection of Fig. 211, taken from Tesla.

Discharge, Glow — —A form of convective discharge. (See *Discharge, Convective*.)

Discharge, Impulsive — —A discharge produced in conductors by suddenly created differences of potential.

Impulsive discharges are influenced more by the inductance of a conductor than by its true ohmic resistance. (See *Inductance, Resistance, Ohmic*.)

A mass of gun-cotton simply ignited in the open air, produces but little effect on any resisting object placed below it. If, however, it be rapidly ignited by means of a detonator, and is thus fired with much greater rapidity, it may shatter anything placed beneath it.

In a similar manner, a rapidly discharged current, or impulsive discharge, produces, through the inductance of the conductor, a series of effects somewhat similar to the above, in which a great impedance is produced by a sudden change of direction.

Discharge, Induced Currents, Effects Produced by — —Varying classes of effects produced by the discharges of induced currents.

The effects produced by discharges of induced currents are classified by Fleming as follows:

(1.) Effects depending on the entire quantity of the discharge.

a. Galvanometric effects.

If the needle of the galvanometer has a period or time of oscillation that is long, as compared with the time of duration of the discharge, the sine of one-half the angle of deflection is proportional to the whole quantity of the discharge.

b. Electro-chemical effects.

The quantity of an electrolyte broken up is proportional to the quantity of electricity which passes through it.

(2.) Effects depending on the average of the square of the current strength at any instant during the discharge.

a. Heating effects.

The rate of dissipation as heat, according to Joule's law, is proportional to the square of the current strength passing.

b. Electro-dynamic effects.

When a discharge passes through a circuit, part of which is fixed and part movable, the forces of attraction and repulsion which take place between them at any instant are proportional to the square of the current strength.

(3.) Effects depending on rate of change of the current.

a. Physiological effects.

The effect of the discharge in producing physiological shock increases with the suddenness of the discharge. Of two discharges which reached the same maxima that which reached it first would produce the greatest physiological effect. Recent investigations by Tesla and others would appear to partly disprove the above statement.

b. Telephonic effects.

The telephone, like the body of an animal, is affected more by the rate of change than by the current strength at any instant.

c. Magnetic effects.

Rayleigh has shown that the magnetic effects of the discharge depend upon the maximum current strength during the discharge, or upon the initial current strength, in cases where the current dies away gradually. Since the time required for the permanent magnetizing of a steel wire is small compared with the duration of the induced current, the amount of magnetism acquired depends essentially on the initial or maximum current strength during the discharge, irrespective of the time during which said discharge lasts.

THIS PAGE IS LOCKED TO FREE MEMBERS

Purchase full membership to immediately unlock this page

Know Your Bible

Forgotten Books' Full Membership provides unlimited access to more than 28,000 volumes of Christian literature for \$8.99/month

HOLY BIBLE

Continue

*Fair use policy applies

The disruptive discharge of a Leyden jar, or condenser, is not effected by a single rush of electricity. When discharged through a comparatively small resistance, a number of alternate partial discharges and recharges occur, which produce true *oscillations* or *undulatory discharges*.

These oscillations are caused by the *induction of the discharge* on itself, and are similar to the self-induction of a current.

The existence of the oscillating discharge in the case of a Leyden jar or condenser, proves, in the opinion of some, that electricity, taken along with matter, possesses a property similar to inertia.

Discharge, Oscillatory — —A term sometimes used for an oscillating discharge. (See *Discharge, Oscillating*.)

Discharge, Periodic — —An electric discharge which changes its direction at regular intervals or periods.

An alternating discharge.

Discharge, Periodically-Decreasing — —An oscillating discharge whose decrease is periodic. (See *Discharge, Oscillating*.)

Discharge, Sensitive-Thread — —The thin, thread-like discharge that occurs between the terminals of the secondary of an induction coil of high frequency.

The sensitive-thread discharge occurs, according to Tesla, when the number of alternations per

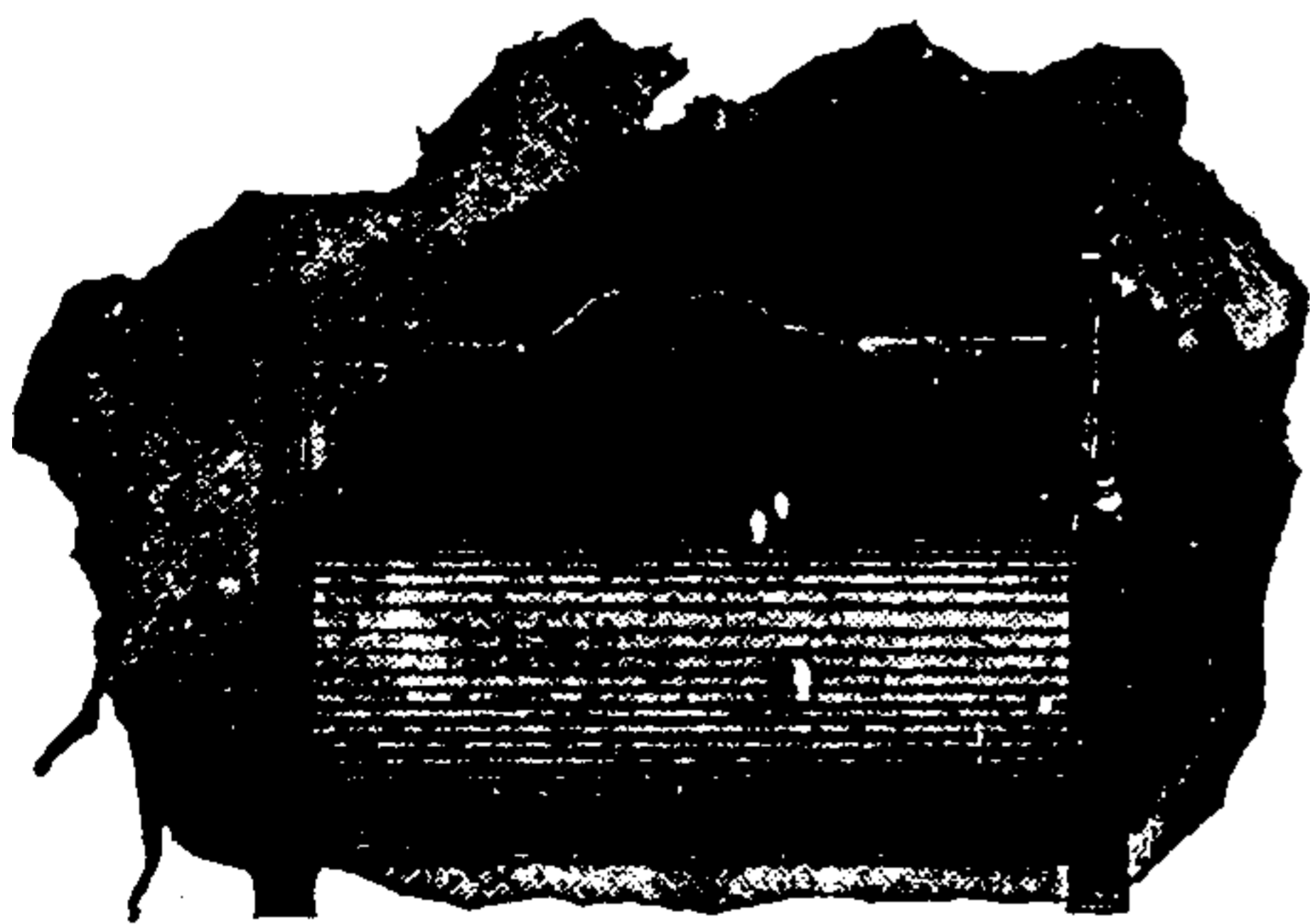

Fig. 213. Sensitive-Thread Discharge (Tesla).

second is high and the current through the primary small. This discharge has the form of a thin, feebly-colored thread. Though very sensitive, being deflected by a mere breath, it is nevertheless quite persistent, if the terminals be at one-third of the striking distance apart. Tesla ascribes its extreme sensitiveness, when long, to the motion of suspended dust particles in the air.

The general appearance of the sensitive-thread discharge is shown in Fig. 213, taken from Tesla.

Discharge, Silent — —A name given to a convective discharge in order to distinguish it from the more noisy disruptive discharge.

The convective discharge in reality is attended by a feeble sound, which, however, is quiet when compared with the more pronounced sound of the disruptive discharge. (See *Discharge, Convective*.)

Discharge, Stratified — —The form of alternate light and dark spaces assumed by the discharges of an induction coil through a partially exhausted gas. (See *Tube, Stratification*.)

The striæ are explained by Curtis as follows: "Under the influence of the electric rhythm of the rapidly following discharges the molecules of the residual gas collect in alternately dense and rarefied spaces. The light bands correspond to the spaces where the molecules are comparatively crowded together, and their concomitant friction produces the luminous disturbance. The dark spaces are where the molecules are further apart, and where their collisions are consequently less frequent."

Discharge, Streaming — —A form assumed by the flaming discharge between the terminals of the secondary of an induction coil when the frequency of the alternations increases beyond a certain limit, and the potential has consequently increased.

The streaming discharge partakes of the general characteristics of the flaming discharge. Luminous streams pass in abundance, not only between the terminals of the secondary, but, according to Tesla, who has carefully studied these phenomena, between the primary and the secondary, through the insulating dielectric separating

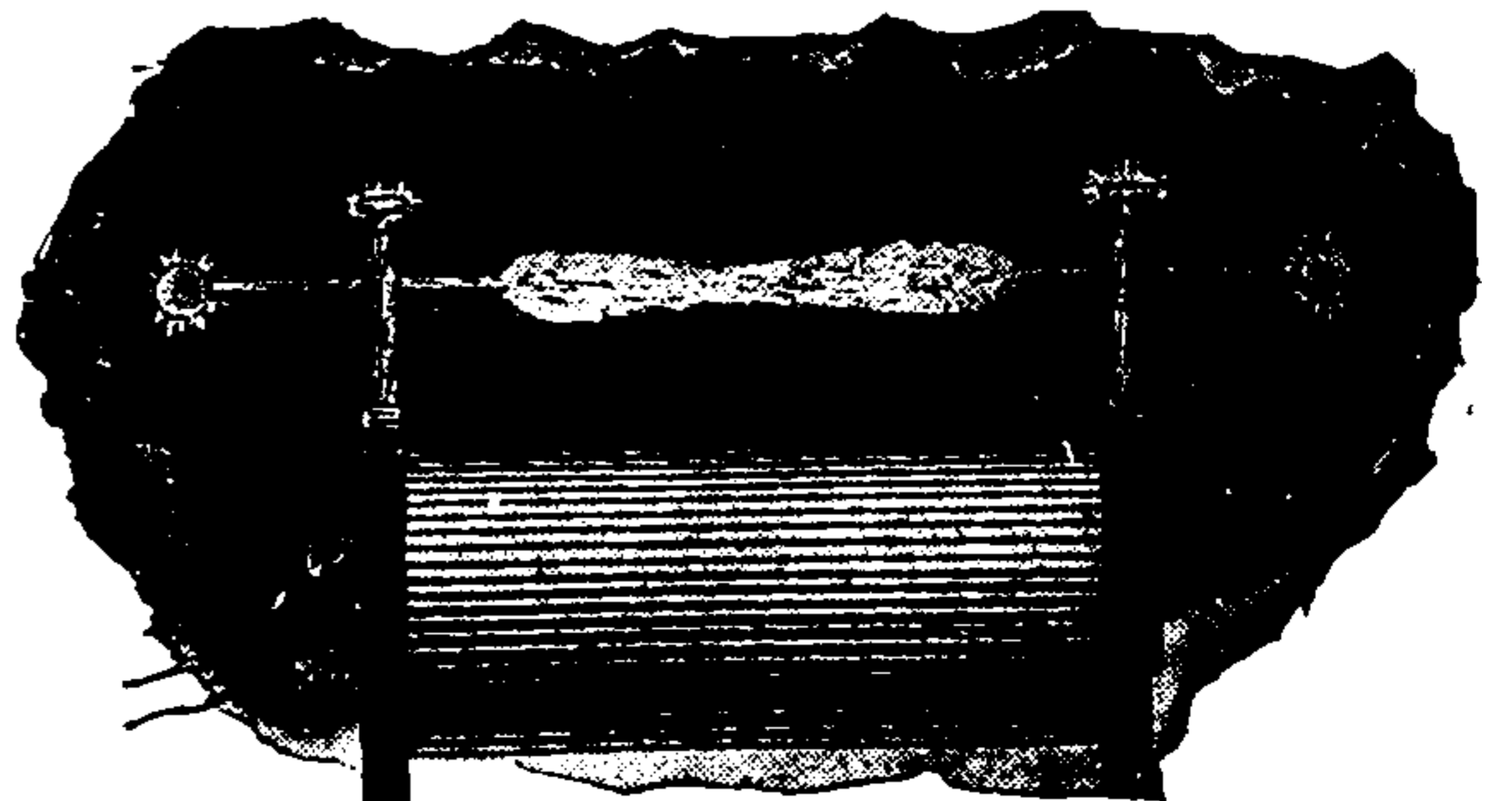

Fig. 214. Streaming Discharge (Tesla).

them. The streams not only pass between the terminals, but also issue from all points and pro-

jections, as will be seen from Fig. 214, taken from Tesla.

When the streaming discharge reaches a certain higher limit it becomes a *brush-and-spray discharge*. (See *Discharge, Brush-and-Spray*.)

The streaming discharge obtained from an induction coil with high frequencies differs from that of an electrostatic machine in that it neither possesses the violet color of the positive static discharge nor the brightness of the negative, but is intermediate in color.

Discharge, Surging — — A term sometimes applied to an oscillatory discharge. (See *Discharge, Oscillatory*.)

Discharge, to Electrically — — To equalize differences of potential by connecting them by means of a conductor.

Discharge, Undulatory — — A discharge, the strength and direction of which gradually change. (See *Currents, Undulatory*.)

Discharge, Unidirectional — — An electric discharge which takes place from the beginning to the end, in one and the same direction.

Discharge, Velocity of — — The time required for the passage of a discharge through a given length of conductor.

According to modern views it is the ether surrounding the wire or conductor which conveys the electric pulses. All the energy which gets into the conductor is dissipated as heat.

The velocity of propagation of discharge of the pulses produced by the oscillating discharge of a Leyden jar through the inter-atomic or inter-molecular ether, *i.e.*, through the fixed ether within different substances, varies with the substance. Through free ether the velocity is that of light, or 185,000 miles a second.

The velocity of discharge through long conductors or cables is much lessened by the *capacity* of the cable, and the effects of *induction*, and will therefore vary in different cases. (See *Retardation*.)

Discharger, Universal — — An apparatus for sending the discharge of a powerful Leyden battery or condenser in any desired direction.

The universal discharger consists essentially of

metallic rods, supported on insulated pillars and capable of ready motion, both towards and from one another, as well as in vertical and horizontal planes. The object which is to receive the discharge is placed on an insulated table between the rods, and the latter connected with the opposite coatings of the battery or condenser, when the discharge passes through it.

The term universal discharger is sometimes applied to the discharging tongs.

Discharging, Electrically — — The act of equalizing differences of potential by connection with a conductor.

Discharging Rod.—(See *Rod, Discharging*.)

Discharging Tongs.—(See *Tongs, Discharging*.)

Disconnect.—To break or open an electric circuit.

Disconnecter.—A key or other device for opening or breaking a circuit.

Disconnecting.—The act of opening or breaking an electric circuit.

Disconnection.—A term employed to designate one of the varieties of faults caused by the accidental breaking or disconnection of a circuit.

Disconnections of this kind may be :

(1.) *Total*; as by a switch inadvertently left open; or by the accidental breaking of a part of the circuit.

(2.) *Partial*; as by a dirty contact; a loose, or badly soldered joint; a poorly clamped binding screw; a loose terminal, or a bad earth.

(3.) *Intermittent*; as by swinging joints, alternate expansions or contractions on changes of temperature; the collection of dust and dirt in dry weather, and their washing out in wet weather.

Disconnection, Intermittent — — Any fault in a line which occurs at intervals or intermittently.

Disconnection, Partial — — A partial fault in a line caused by any imperfect contact.

Disconnection, Total — — A fault in a line occasioned by a complete break in the circuit.

Disguised Electricity.—(See *Electricity, Disguised*.)

Disjuncter.—A device employed in a system for the distribution of electric energy by means of continuous currents by condensers, for the purpose of periodically reversing the constant current sent over the line. (See *Electricity, Distribution of, by Continuous Current by Means of Condensers.*)

Dispersion Photometer.—(See *Photometer, Dispersion.*)

Displacement Current.—(See *Current, Displacement.*)

Displacement, Electric—— —A displacement of electricity in a uniform and non-crystalline dielectric when lines of electrostatic or magnetic force pass through it.

The quantity of electricity displaced in any homogeneous, non-crystallizable dielectric, by the action of an electric force through the unit area of cross-section, taken perpendicular to the direction of the electric force.

Electric displacement is produced under an elastic strain, which continues only while the electric force is acting.

Displacement, Electric, Lines of—— — Lines of electric induction along which electric displacement takes place.

Displacement, Electric, Oscillatory —— —A displacement of electricity in a dielectric or non-conductor of an oscillatory character.

Displacement, Electric, Theory of —— —A theory which regards the electricity produced on an insulated conductor, by induction through a dielectric, as displaced out of the dielectric on to the conductor, or into the dielectric from the conductor, by the influence of the electric force.

This conception was introduced into science by Maxwell, after a careful study of Faraday's denial of action at a distance.

Suppose a small insulated sphere to receive a charge of electricity $+Q$. It will, by induction, produce an equal and opposite charge $-Q$, on the inner surface, and a similar charge on the outer surface of the small hollow sphere, placed near it, but separated by the dielectric. There has, therefore, been a displacement of electricity through the dielectric. The medium of the

dielectric has connected the two bodies, and the phenomena have appeared by the action of the electric force on the substance of the dielectric; or, in other words, there has been no action at a distance.

According to this conception, an electric current, called a displacement current, exists in the dielectric, while displacement is taking place.

Displacement Waves.—(See *Waves, Displacement.*)

Disruptive Electric Conduction.—(See *Conduction, Electric, Disruptive.*)

Dissimulated or Latent Electricity.—(See *Electricity, Dissimulated or Latent.*)

Dissipation of Charge.—(See *Charge, Dissipation of.*)

Dissipation of Energy.—(See *Energy, Dissipation of.*)

Dissipation of Energy, Hysterical —— —(See *Energy, Hysterical, Dissipation of. Hysteresis.*)

Dissipation, Specific Hysterical —— — The specific loss of energy by hysteresis in the case of a particular substance. (See *Hysteresis.*)

Dissociate.—To separate a compound substance into its constituents.

Dissociation.—The separation of a chemical compound into its constituent parts.

Dissymmetrical Induction of Armature.—(See *Armature, Dissymmetrical Induction of.*)

Dissymmetrical Magnetic Field.—(See *Field, Magnetic, Dissymmetrical.*)

Dissymmetry of Commutation.—(See *Commutation, Dissymmetry of.*)

Distance, Critical, of Lateral Discharge Through an Alternative Path —— —The distance at which a discharge will take place through an air space of given dimensions, in preference to passing through a metallic circuit of comparatively small resistance.

Distance, Explosive —— —A term sometimes employed for sparking distance. (See *Distance, Sparking.*)

Distance, Sparking —— —The distance

THIS PAGE IS LOCKED TO FREE MEMBERS

Purchase full membership to immediately unlock this page



HISTORY

Tens of thousands of important historical sources, many previously unobtainable, are now available for the first time with a Forgotten Books Full Membership.

Unlimited Access
\$8.99/month

Continue

*Fair usage policy applies

Double-Break Knife Switch.—(See *Switch, Double-Break Knife*.)

Double-Carbon Arc Lamp.—(See *Lamp, Electric Arc, Double-Carbon*.)

Double-Cone Insulator.—(See *Insulator, Double-Cone*.)

Double-Connector.—(See *Connector, Double*.)

Double-Contact Key.—(See *Key, Double-Contact*.)

Double-Cup Insulator.—(See *Insulator, Double-Cup*.)

Double-Curb.—(See *Curb, Double*.)

Double-Curb Signaling.—(See *Signaling, Curb, Double*.)

Double-Current Signaling.—(See *Signaling, Double-Current*.)

Double-Current Translator.—(See *Translator, Double-Current*.)

Double-Current Transmitter.—(See *Transmitter, Double-Current*.)

Double-Current Working — —The employment, in systems of telegraphy, by means of suitable keys, of currents from voltaic batteries, in alternately opposite directions, thus increasing the speed of signaling. (See *Working, Reverse-Current*.)

Double-Fluid Electrical Hypothesis.—(See *Electricity, Double-Fluid Hypothesis of*.)

Double-Fluid Voltaic Cell.—(See *Cell, Voltaic, Double-Fluid*.)

Double-Magnet Dynamo-Electric Machine.—(See *Machine, Dynamo-Electric, Double-Magnet*.)

Double-Pen Telegraphic Register.—(See *Register, Double-Pen, Telegraphic*.)

Double-Refraction.—(See *Refraction, Double*.)

Double-Refraction, Electric.—(See *Refraction, Double, Electric*.)

Double-Shackle Insulator.—(See *Insulator, Double-Shackle*.)

Double-Shed Insulator.—(See *Insulator, Double-Shed*.)

Double-Tapper Key.—(See *Key, Double-Tapper*.)

Double-Touch, Magnetization by — — A method for producing magnetization by the simultaneous touch of two magnet poles. (See *Magnetization, Methods of*.)

Double-Transmission.—(See *Transmission, Double*.)

Double-Trolley.—(See *Trolley, Double*.)

Doubler of Electricity.—An early form of continuous electrophorus. (See *Electrophorus*.)

Drifting Torpedo.—(See *Torpedo, Drifting*.)

Drill, Electro-Magnetic — —A drill applied especially to blasting or mining operations, operated by means of electricity.

Drip Loop.—(See *Loop, Drip*.)

Driven Pulley.—(See *Pulley, Driven*.)

Driven Shaft.—(See *Shaft, Driven*.)

Driving Pulley.—(See *Pulley, Driving*.)

Driving Shaft.—(See *Shaft, Driving*.)

Driving Spider.—(See *Spider, Driving*.)

Drop, Annunciator — —A movable signal operated by an electro-magnet, and placed on an annunciator, the dropping of which indicates the closing or opening of the circuit with which the electro-magnet is connected.

The falling of the drop may be attended by the sounding of a bell or other alarm, or, it may give a silent indication.

Drop, Annunciator, Automatic — —A drop for an annunciator, which on the closing of a circuit, falls and holds the circuit closed until the drop is raised.

Drop, Annunciator, Gravity — —A drop for an annunciator, acted on by gravity when released by the movement of the armature of an electro-magnet.

Drop, Automatic — —A device for automatically closing the circuit of a bell and holding it closed until stopped by resetting a drop.

The automatic drop is especially applicable to burglar alarms. On the opening of a door or shutter, the closing of the circuit moves the armature of an electro-magnet, and, by the falling of a drop, closes the circuit and holds it closed until mechanically opened by the replacing of the drop. The general appearance of the automatic drop is shown in Fig. 215.

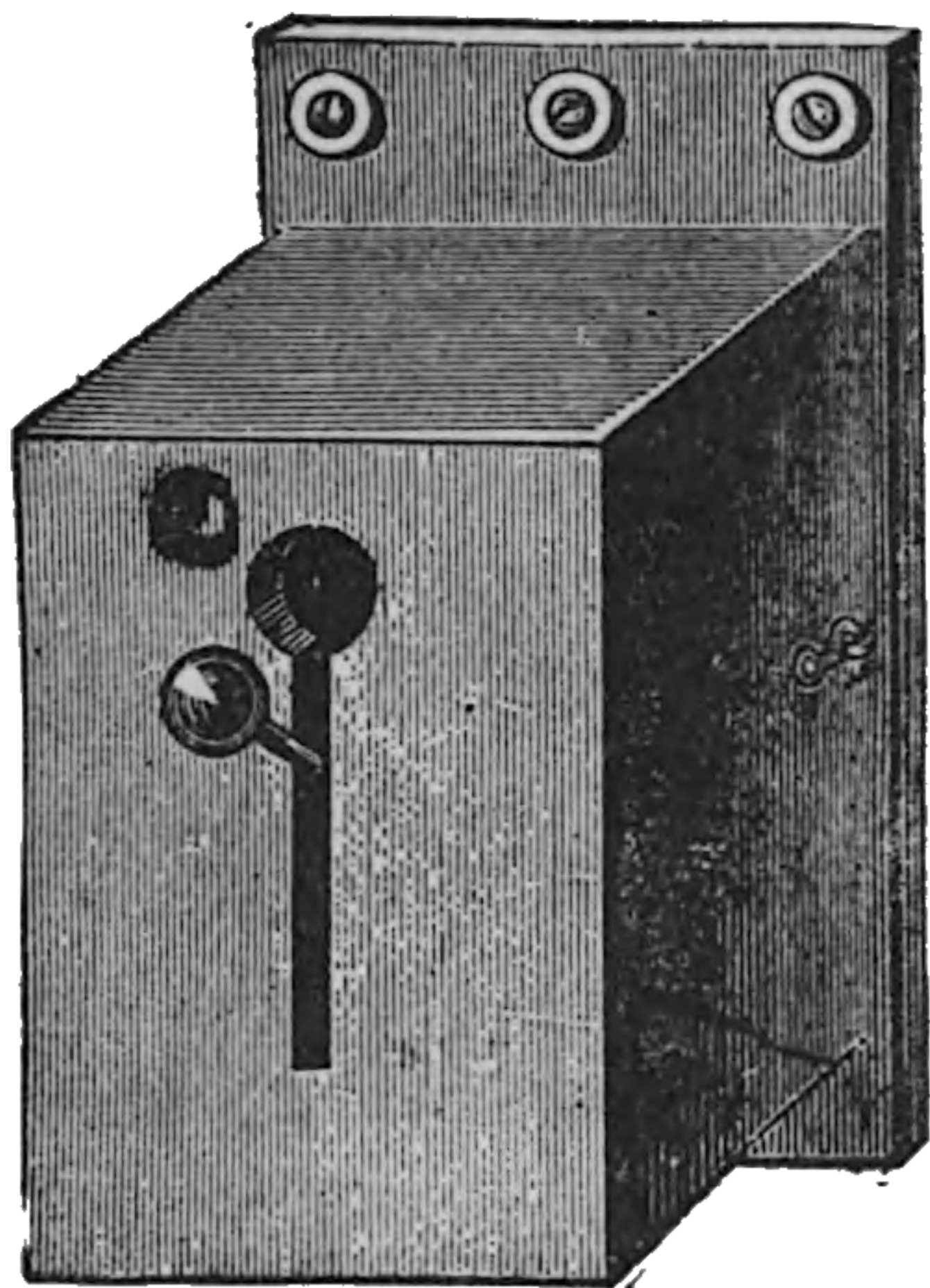

Fig. 215. Automatic Drop.

Drop, Calling

— — An annunciator drop employed to indicate to the operator in a telegraphic or telephonic system that one subscriber wishes to be connected with another.

Drop of Potential.—(See *Potential, Drop of.*)

Drops, Clearing Out — — Restoring the drops of annunciators to their normal position after they have been thrown out of the same by the closing of the circuits of their magnets.

These clearing-out devices as placed on most forms of annunciators are generally mechanical in operation.

Drum Armature.—(See *Armature, Drum.*)

Drum, Electro-Magnetic — — A drum, used in feats of legerdemain, operated by an automatic electro-magnetic make and break apparatus.

Dry Distillation.—(See *Distillation, Dry.*)

Dry Electrode.—(See *Electrode, Dry.*)

Dry Pile.—(See *Pile, Dry.*)

Dry Voltaic Cell.—(See *Cell, Voltaic, Dry.*)

Dub's Laws.—(See *Laws, Dub's.*)

Duplex Cable.—(See *Cable, Duplex.*)

Duplex Cut-Out.—(See *Cut-out, Duplex.*)

Duplex Flat Cable.—(See *Cable, Flat Duplex.*)

Duplex Telegraphy.—(See *Telegraphy, Duplex.*)

Duplex Wire.—(See *Wire, Duplex.*)

Duration of Electric Discharge.—(See *Discharge, Duration of.*)

Duration of Make-Induced Current.—(See *Current, Make or Break Induced, Duration of.*)

Dust Figures, Lichtenberg's — — (See *Figures, Lichtenberg's Dust.*)

Dyad.—A chemical element which has two bonds by which it can unite or combine with another element.

An element whose atomicity is bivalent.

Dyeing, Electric — — The application of electricity either to the reduction or the oxidation of the salts used in dyeing.

Goppelsröder, in his processes of *electric dyeing*, forms and fixes aniline black on cloth as follows, viz.: the cloth, saturated with an aniline salt, is placed on an insulated metallic plate, inert to the aniline salt, and connected with one pole of a battery or other electric source. The other pole is connected with a metallic plate on which the required design is drawn. On the passage of the current, the design is traced in aniline black on the cloth. A minute or two suffices for the operation.

A species of electrolytic writing is obtained on cloths arranged as above by substituting a carbon pencil for the metallic plate. On writing with this pencil, as with an ordinary pencil, the passage of the current so directed is followed by the deposition of aniline black.

By means of a somewhat similar process writing in white on a colored ground is obtained.

Dynamic Electricity.—(See *Electricity, Dynamic.*)

Dynamics, Electro — — That branch of electric science which treats of the action of electric currents on one another and on themselves or on magnets.

The principles of electro-dynamics were discovered by Ampère in 1821.

A convenient form of apparatus, for showing experimentally the action of one current on another, consists of two upright metallic columns

or pillars, which support horizontal metallic arms containing mercury cups, y, and c, Fig. 216,

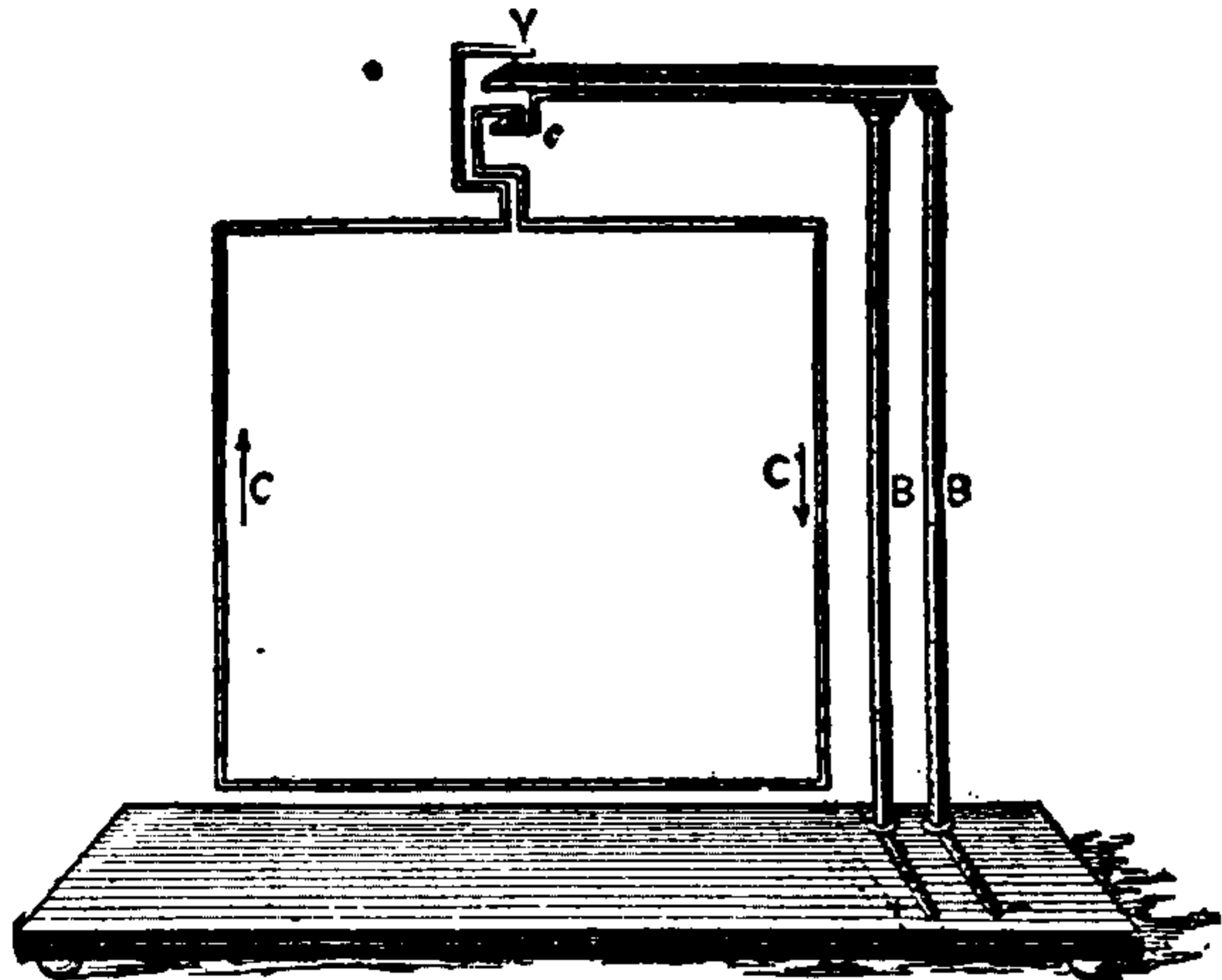

Fig. 216. Deflection of a Circuit by a Current.

The circuit is bent in the form of a rectangle, circle or solenoid, and terminates in points that dip in the mercury cups. The current is led into and out of the apparatus at the points + and - at the base of the upright supports.

When a magnet, or another circuit, is approached to the movable circuit thus provided, attractions or repulsions are produced according to the position of the magnet, or the direction of the currents in the two circuits.

If a magnet A B, Fig. 217, be placed, as shown,

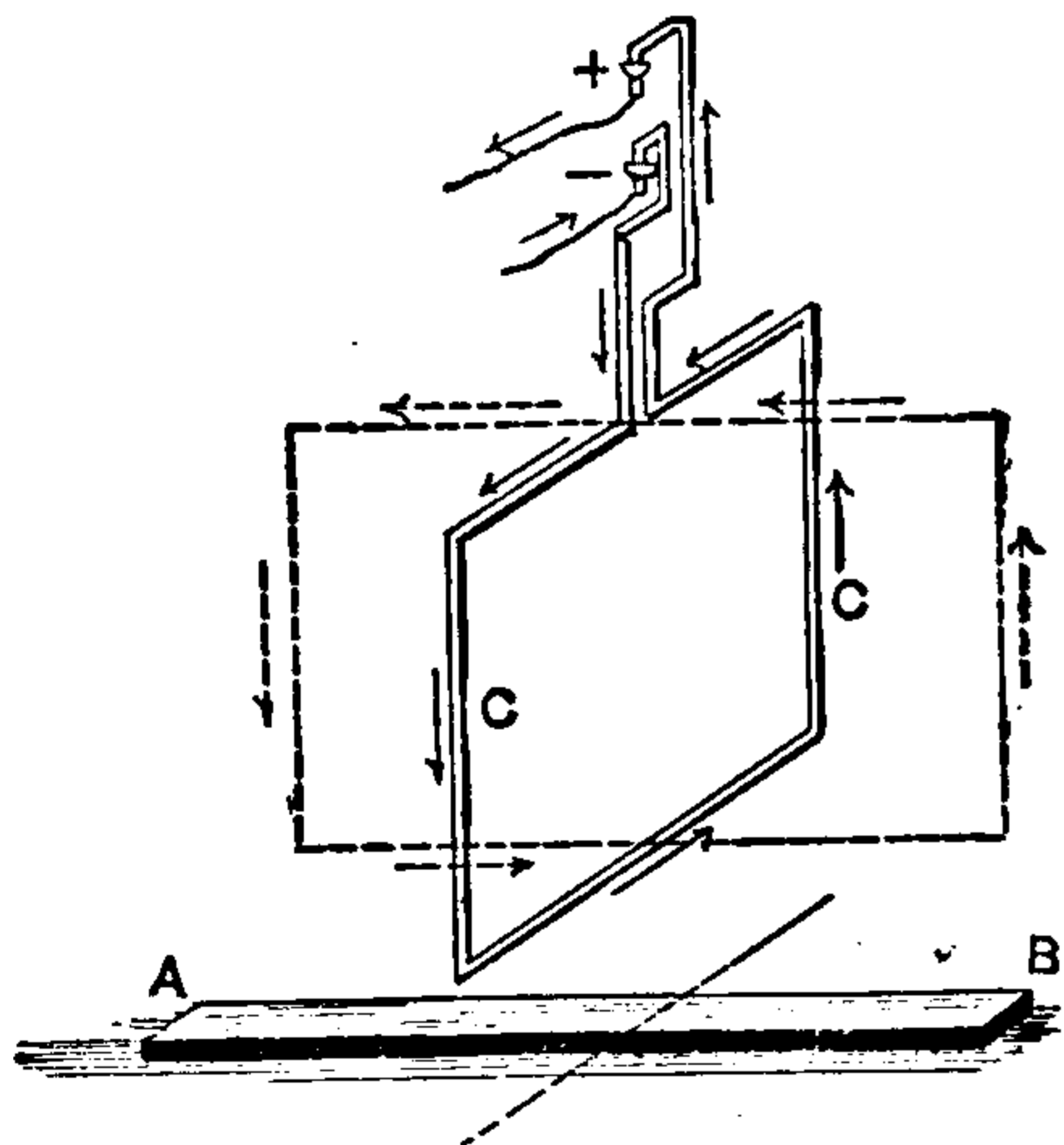

Fig. 217. Deflection of Circuit by a Magnet.

below the movable circuit C C, the circuit will tend to place itself at right angles to the axis of the magnet. This movement is the same as would occur if electric currents were circulating around the magnet in the direction of the assumed *Ampèrian currents*. It also illustrates the principle of the electric motor. (See *Magnetism, Ampère's Theory of.*)

Ampère has given the results of his investigations as to the mutual attractions and repulsions of cur-

rents in the following statements, which are known as *Ampère's Laws*:

(I.) Parallel portions of a circuit attract one another if the currents in them are flowing in the same direction, and repel one another if the currents are flowing in opposite directions.

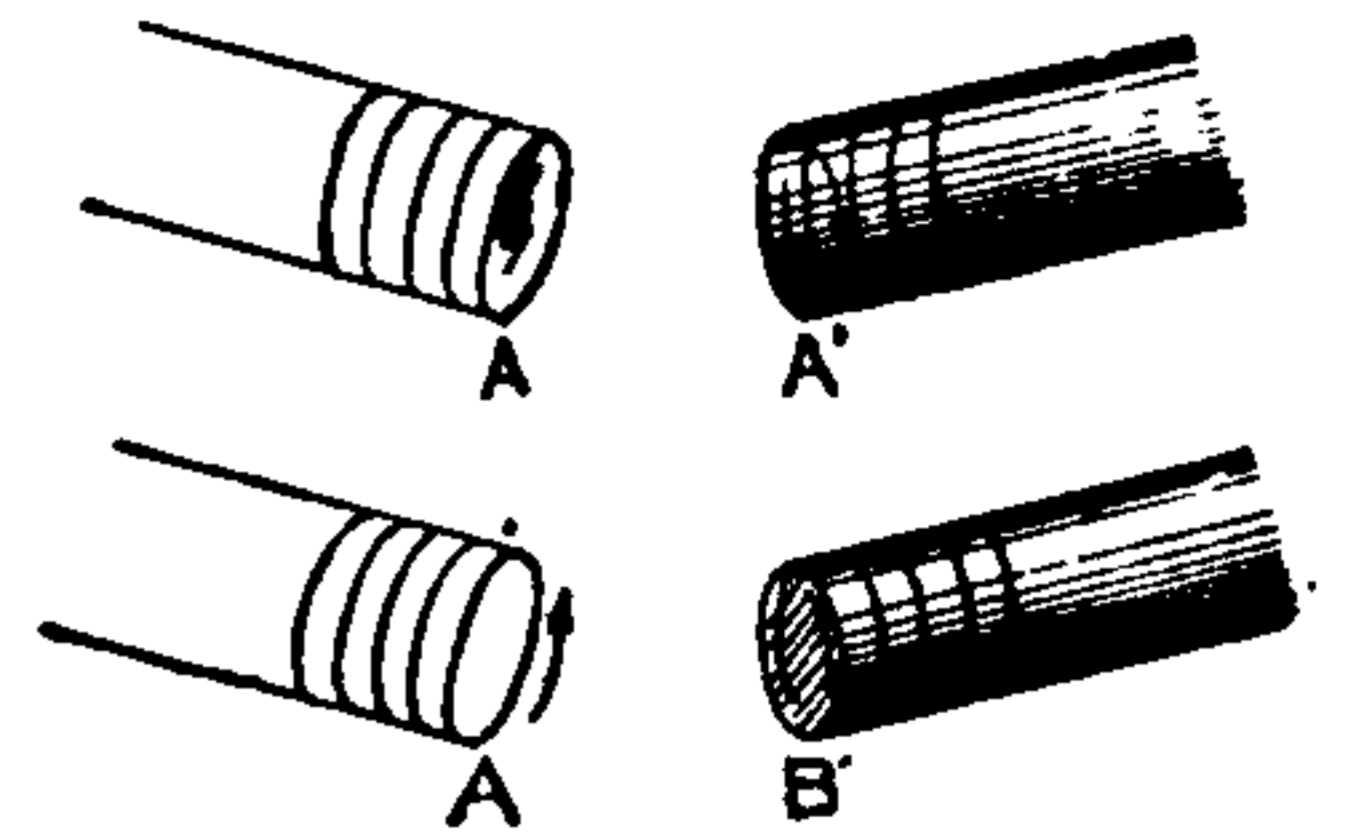

Fig. 218. Action of Solenoid Poles.

A current flowing through a spiral tends to shorten the spiral from the attraction of the parallel currents in contiguous turns.

Similar poles of two solenoids repel each other, as at A, A', Fig. 218, because, when opposed to each other, the currents that produce these poles

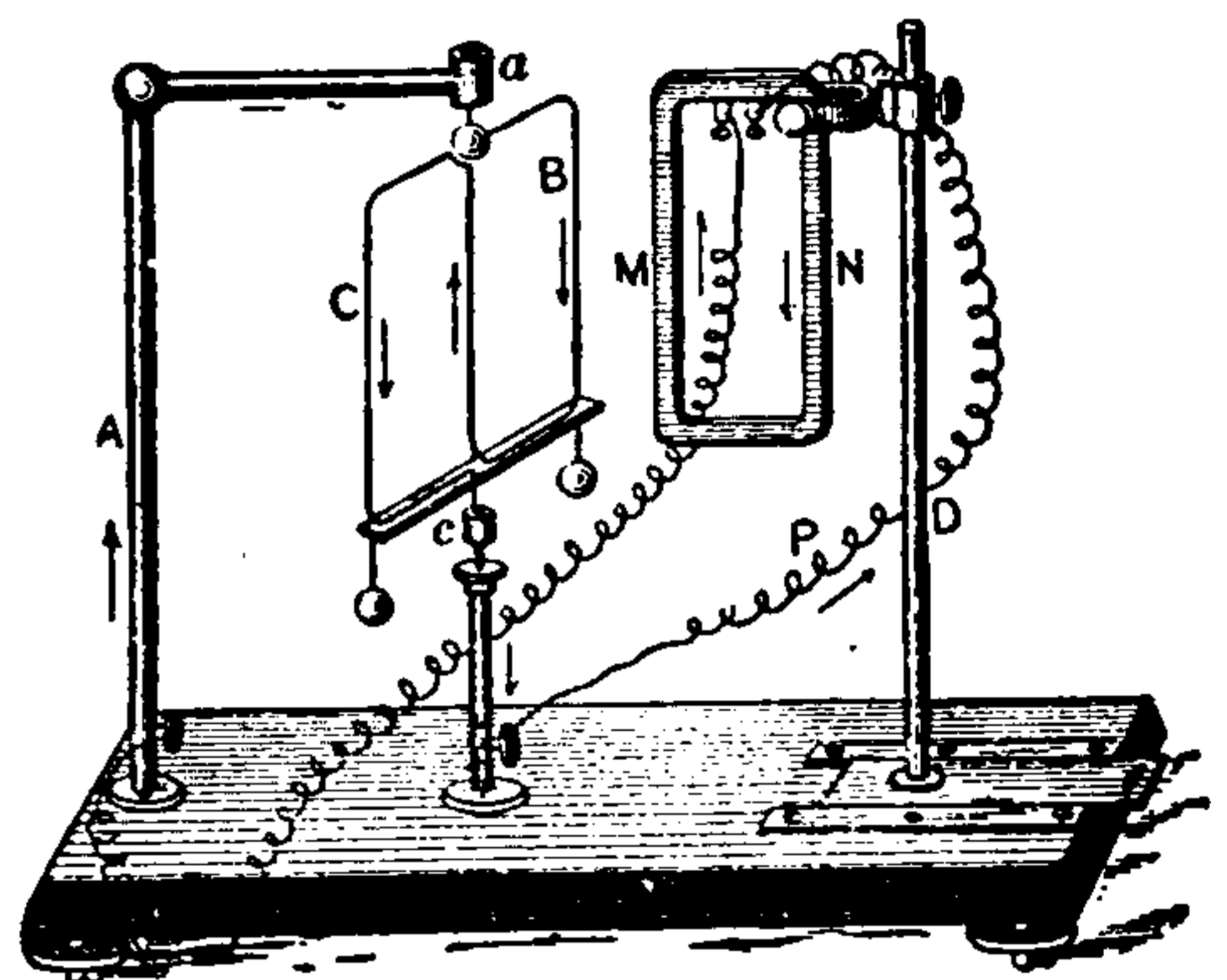

Fig. 219. Ampère's Stand.

are flowing in opposite directions, as may be seen from an inspection of the drawing.

Dissimilar solenoid poles, on the contrary, attract each other as at A, B, in Fig. 218, since

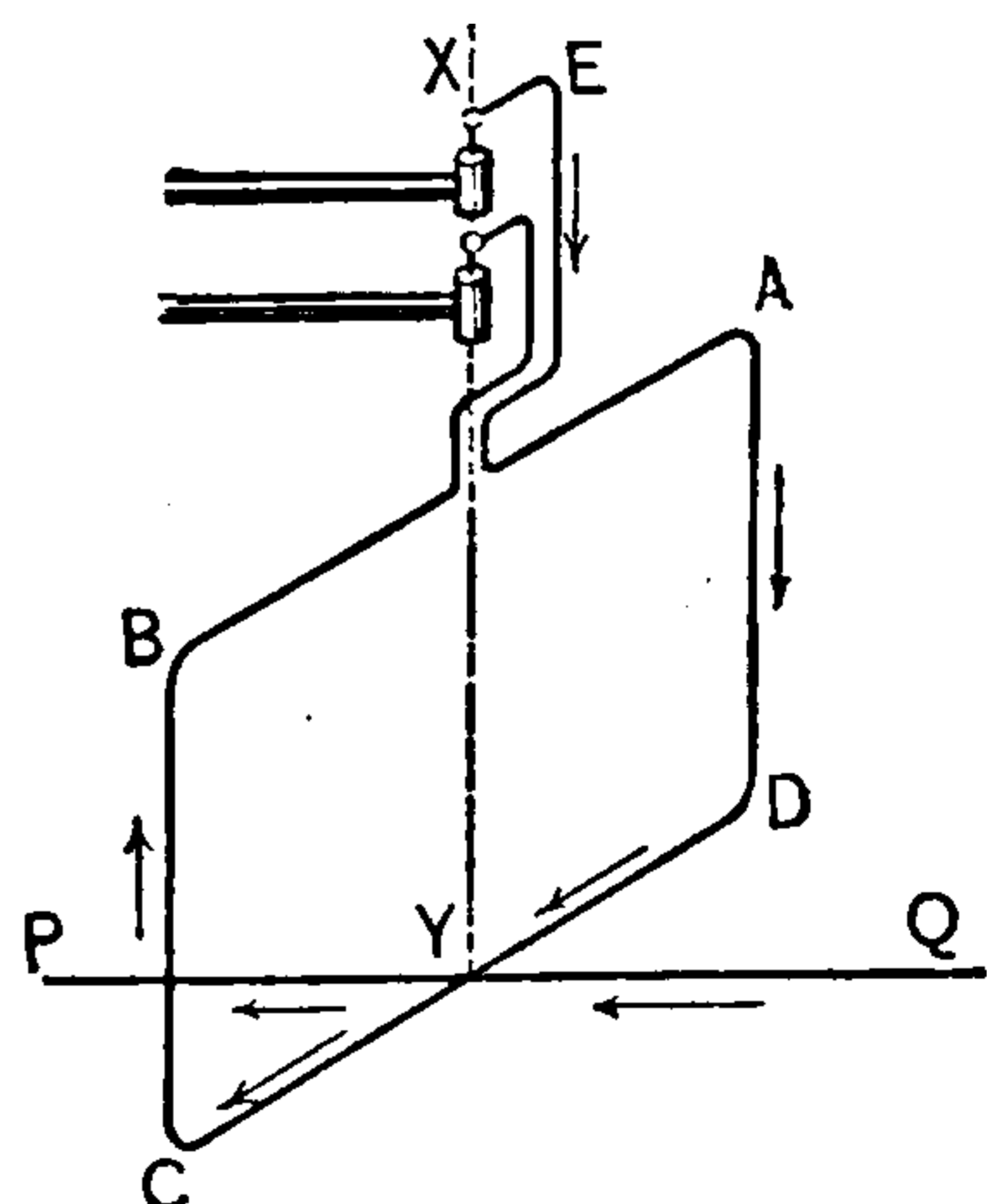

Fig. 220. Electro-Dynamic Attraction.

the currents which produce them flow in the same direction.

In Fig. 219, a form of Ampère's stand is shown, in which one of the circuits is in the form of the

THIS PAGE IS LOCKED TO FREE MEMBERS

Purchase full membership to immediately unlock this page

Know Your Bible

Forgotten Books' Full Membership provides unlimited access to more than 28,000 volumes of Christian literature for \$8.99/month

HOLY BIBLE

Continue

*Fair use policy applies

magnet. As soon as the current passes, the thread will wrap itself around the bar magnet, one half of it twisting itself round the north pole, the other half round the south pole.

(2.) The experiment suggested by Professor S. P. Thompson: An electric current is sent through a stream of mercury while it is flowing between two poles of a powerful electro-magnet; when the current is sent through the magnet, the stream is twisted in spiral directions which vary, either with the direction of the current, or with the direction of the magnetic polarity.

(3.) Somewhat similar effects can be shown by the rotation of a stream of gas round a magnetic pole placed in an exhausted glass receiver.

Dynamo.—The name frequently applied to a dynamo-electric machine used as a generator. (See *Machine, Dynamo-Electric.*)

Dynamo Balancing Rheostat.—(See *Rheostat, Dynamo Balancing.*)

Dynamo-Battery.—(See *Battery, Dynamo.*)

Dynamo Brush Trimmer.—(See *Trimmer, Dynamo Brush.*)

Dynamo, Composite-Field — —A dynamo whose field coils are series and separately excited.

Additional separately excited coils placed on the field of a series wound dynamo render it self-regulating.

A composite dynamo is a form of compounded dynamo.

Dynamo, Compound-Wound.—A compound-wound dynamo-electric machine. (See *Machine, Dynamo-Electric, Compound-Wound.*)

Dynamo, Contact — —A form of dynamo in which the space between the armature and field magnet poles is so reduced that they actually touch one another.

In contact dynamos both field and armature revolve. This form of dynamo has not been very successful in practice.

Dynamo-Electric Machine.—(See *Machine, Dynamo-Electric.*)

Dynamo-Electric Machine, Alternating Current — —(See *Machine, Dynamo-Electric, Alternating Current.*)

Dynamo-Electric Machine Armature.—(See *Armature, Dynamo-Electric Machine.*)

Dynamo-Electric Machine Armature Coils.—(See *Coils, Armature, of Dynamo-Electric Machine.*)

Dynamo-Electric Machine Armature Core.—(See *Core, Armature, of Dynamo-Electric Machine.*)

Dynamo-Electric Machine Battery.—(See *Battery, Dynamo-Electric Machine.*)

Dynamo-Electric Machine, Bi-Polar — —(See *Machine, Dynamo-Electric, Bi-Polar.*)

Dynamo-Electric Machine, Collecting Brushes of — —(See *Brushes, Collecting, of Dynamo-Electric Machine.*)

Dynamo-Electric Machine Commutator — —(See *Commutator, Dynamo-Electric Machine.*)

Dynamo-Electric Machine, Compound-Wound — —(See *Machine, Dynamo-Electric, Compound-Wound.*)

Dynamo-Electric Machine, Generation of Current by — —(See *Current, Generation of, by Dynamo-Electric Machine.*)

Dynamo-Electric Machine, Field Magnets — —(See *Magnets, Field, of Dynamo-Electric Machine.*)

Dynamo-Electric Machine, Methods of Increasing the Electromotive Force Generated by — —(See *Force, Electromotive, Generated by Dynamo-Electric Machine, Method of Increasing.*)

Dynamo-Electric Machine, Mouse-Mill, Sir William Thomson's — —(See *Machine, Dynamo-Electric, Mouse-Mill, Sir William Thomson's.*)

Dynamo-Electric Machine, Multipolar — —(See *Machine, Dynamo-Electric, Multipolar.*)

Dynamo-Electric Machine, Pole-Pieces of — —(See *Pole-Pieces of Dynamo-Electric Machine.*)

Dynamo-Electric Machine, Reversibility of — —(See *Machine, Dynamo-Electric, Reversibility of.*)

Dynamo-Electric Machine, Varieties of — — (See *Machine, Dynamo-Electric, Varieties of.*)

Dynamo, Inductor — — A dynamo-electric machine for alternating currents in which the differences of potential causing the currents are obtained by magnetic changes in the cores of the armature and field coils by the movement past them of laminated masses of iron inductors.

The coils corresponding to the armature and field magnets of the ordinary dynamo are stationary. The laminated masses of iron, employed to cause magnetic changes in the cores of the field and armature coils, are fixed on an inductor wheel which is rapidly revolved in front of them. The magnets corresponding to the field magnets are called the primary poles, and are magnetized by an exciter. The magnets corresponding to the armature are called the secondary poles and are placed so as to alternate with the primary poles. The inductors are so shaped that they carry the magnetism of one pole of the primary magnet to the secondary poles when the inductor is in one position, and of the opposite pole when in a slightly different position. The inductor wheel therefore acts as a magnetic commutator and changes the position of the secondary magnet as it rotates, thus producing electromotive force. The number of alternations per revolution is equal to twice the number of inductors placed on the inductor wheel.

Dynamo, Inverted — — A dynamo-electric machine in which the armature bore or chamber is placed below the field magnet coils.

The term inverted is used in contradistinction to the overtyping dynamo. (See *Dynamo, Overtyping.*)

Dynamo, Mouse Mill — — A form of dynamo-electric machine designed by Sir William Thomson to act as the replenisher of one of his electrometers. (See *Replenisher.*)

Dynamo, Multiphase — — A polyphase dynamo. (See *Dynamo, Polyphase. Dynamo, Rotating Current.*)

Dynamo, Overtyping — — A dynamo-electric machine, the armature bore or chamber of which is placed above the field magnet coils instead of below them as in many forms.

The overtyping form of dynamo possesses the advantage of better avoiding magnetic leakage.

Dynamo, Polyphase — — A name sometimes applied to a rotating current dynamo. (See *Dynamo, Rotating Current.*)

Dynamo, Pyromagnetic — — A name sometimes applied to a pyromagnetic generator. (See *Generator, Pyromagnetic.*)

Dynamo, Rotary-Phase — — A term sometimes employed for a rotating current dynamo. (See *Dynamo, Rotating Current.*)

Dynamo, Separately-Excited — — A separately-excited dynamo-electric machine. (See *Machine, Dynamo-Electric, Separately-Excited.*)

Dynamo, Series — — A series-wound dynamo-electric machine. (See *Machine, Dynamo-Electric, Series-Wound.*)

Dynamo, Shunt — — A shunt-wound dynamo-electric machine. (See *Machine, Dynamo-Electric, Shunt-Wound.*)

Dynamograph. — A term sometimes applied to a type-writing telegraph that records the message in type-written characters, both at the sending and the receiving ends.

Dynamometer. — A name given to a variety of apparatus for measuring the power of an engine or motor.

In all dynamometers the strain on the belt or other moving part is measured, say in pounds, and the speed of the moving part is also measured in feet per second. The product of the strain in

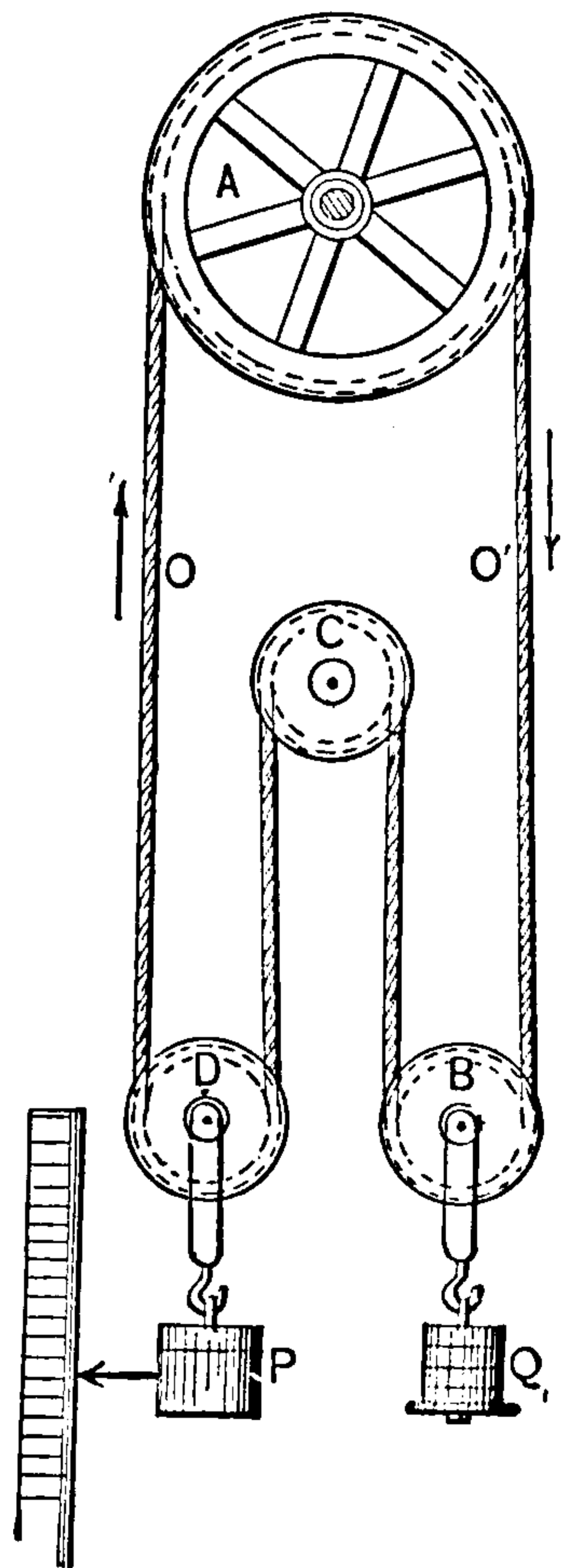

Fig. 223. Parsons' Dynamometer.

pounds by the velocity in feet per second, divided by 550, will give the horse power.

One of the many forms of dynamometers is shown in Fig. 223. It is known as Parsons' Dynamometer.

The driving pulley is shown at A, and the driven pulley at C. Weights hung at Q_1 , are varied so as to maintain the axes of the suspended pulleys, D and B, as nearly as possible at the same height. Then the tension T_1 and T_2 , on the sides O and O', of the belts, will be represented by the following equation :

$$T_2 - T_1 = \frac{P - Q}{2},$$

from which, knowing the belt speed, the horse power may be deduced.

There are several other forms of dynamometer, such as the cradle dynamometer, in which the machine is supported on knife edges and the torque or pull exerted on or by the machine is balanced by weights sliding on a lever. In these dynamometers the power is transmitted through them and they are therefore called transmission dynamometers.

Dynamometer, Electro — — — A form of galvanometer for the measurement of electric currents.

In Siemens' Electro-Dynamometer, shown in Fig. 224, there are two coils; a fixed coil, C, secured to an upright support, and a movable coil, L, consisting often of but a single turn of wire. The movable coil is suspended by means of a thread and a delicate spring, S, capable of being twisted by turning a milled screw-head through an angle of torsion measured on a scale by means of an index connected to the screw-head. The two ends of the movable coil dip into mercury cups so connected that the current to be measured passes through the fixed and movable coils in series.

When ready for use the movable coil is at right angles to the fixed coil. The current to be measured is then sent into the coils, and their mutual action tends to place the movable coil parallel to the fixed coil against the torsion of the spring, S. The amount of this force can be ascertained by determining the amount of torsion required to bring the movable coil back to its zero position.

Since the same current passes through both the fixed and movable coils, and they both act on each other, the deflecting force here is evidently proportional to the square of the strength of the

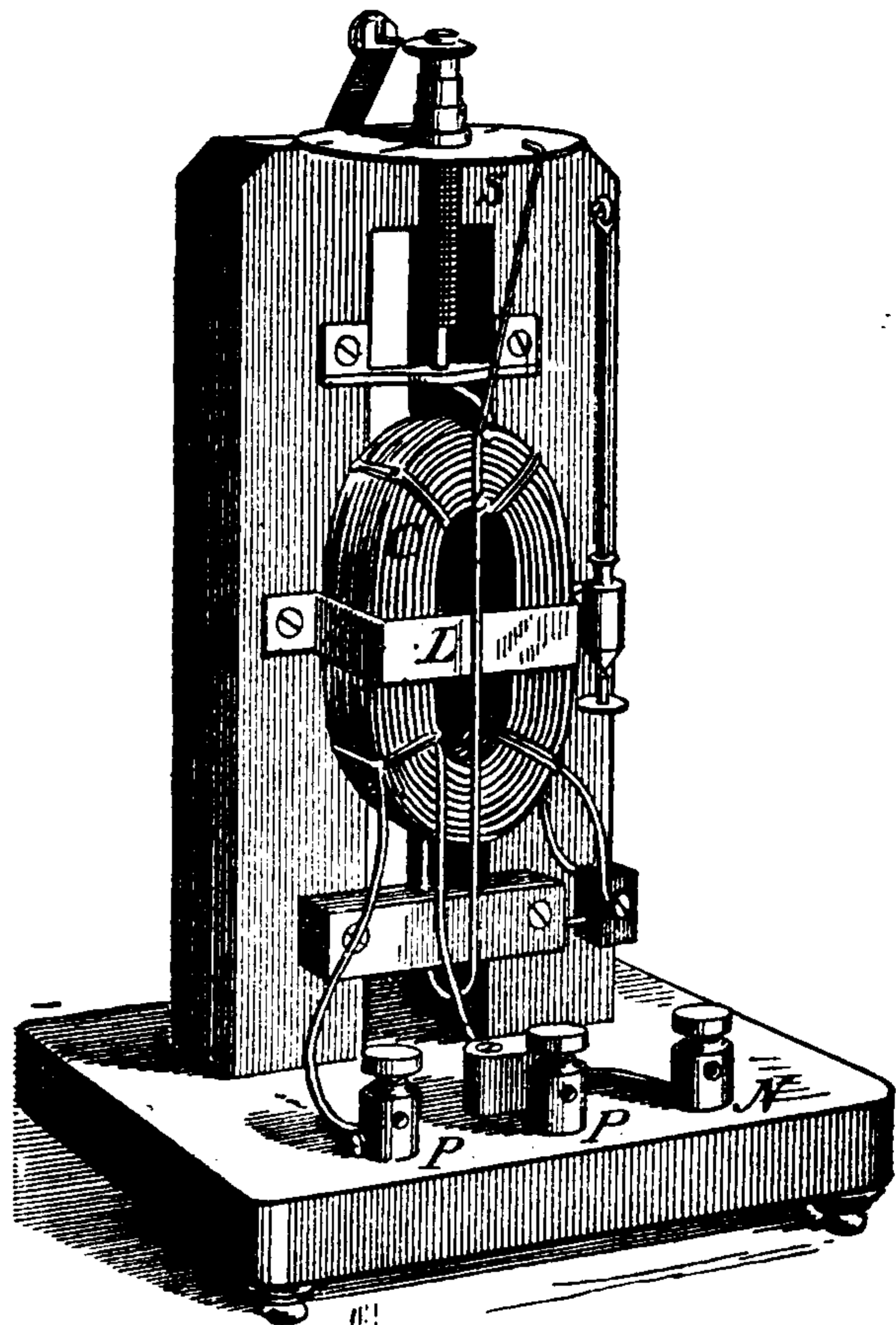

Fig. 224. Siemens' Electro-Dynamometer.

current to be measured. The deflecting force, and consequently the current strength, is therefore proportional to the square root of the angle of torsion, and not directly to the angle of torsion.

Dyne.—The unit of force.

The force which in one second can impart a velocity of 1 centimetre per second to a mass of 1 gramme.

The dyne is the unit of force, or a force capable, after acting for one second on a mass of 1 gramme, of giving it a velocity of 1 centimetre per second. The *weight* of a body in *dynes*, or the force with which it gravitates, is equal to its mass in grammes, multiplied by the acceleration imparted to it in centimetres per second. For this latitude the acceleration is about 981 centimetres per second.

THIS PAGE IS LOCKED TO FREE MEMBERS

Purchase full membership to immediately unlock this page



HISTORY

Tens of thousands of important historical sources, many previously unobtainable, are now available for the first time with a Forgotten Books Full Membership.

Unlimited Access
\$8.99/month

Continue

*Fair usage policy applies

Eddy-Displacement Currents.—(See *Currents, Eddy-Displacement*.)

Eel, Electric — —An eel possessing the power of giving powerful electric shocks. The *gymnotus electricus*.

The electricity is produced by an organ extending the entire length of the body.

According to Faraday, the shock given by a specimen of the animal examined by him was equal to that of 15 Leyden jars, having a total surface of 25 square feet. Fig. 225 shows the general appearance of the animal.

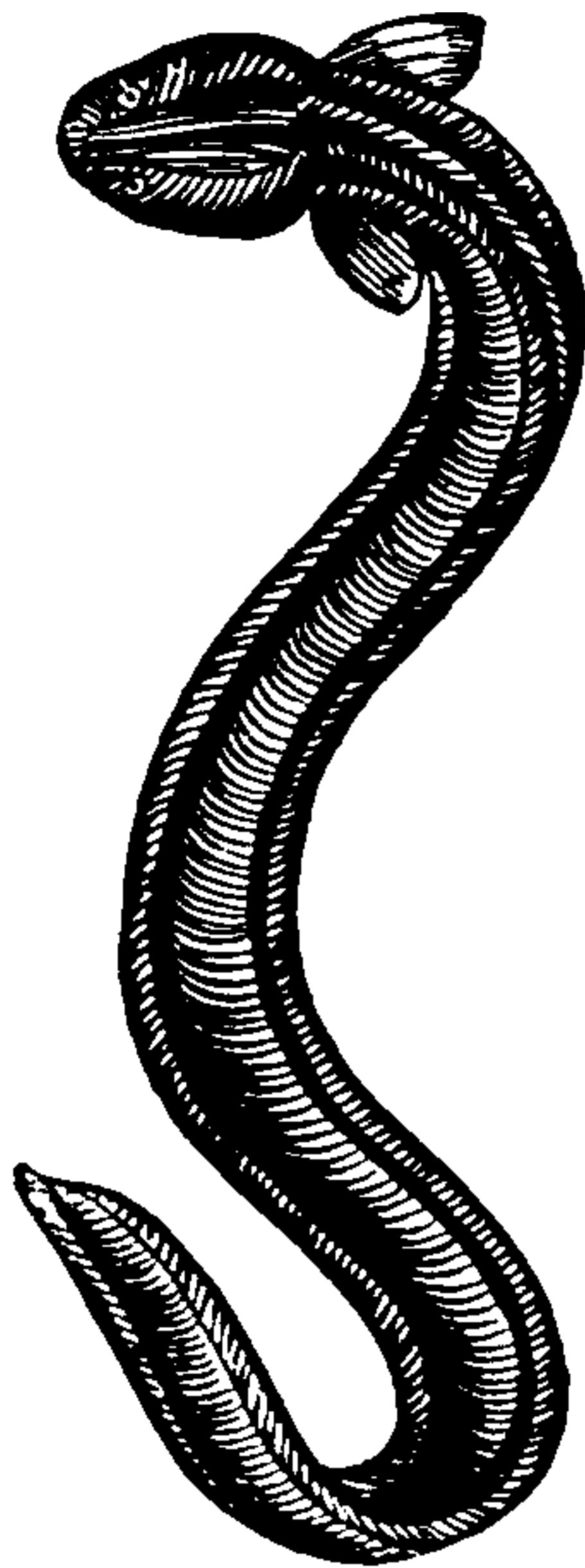

Fig. 225. *Electric Eel.*

Effect, Acheson — — The increase in the electromotive force of the secondary of a transformer by the action of the changes in temperature of its core. (See *Electricity, Cal.*)

Effect, Chemical — —The effect occasioned by atomic combination, which results in a loss of those properties or peculiarities by which the substances entering into combination are ordinarily recognized.

Atomic combination, resulting in the formation of new molecules.

The formation of new molecules necessitates the possession by the new substance of properties distinct and separate from those of its constituents.

Black carbon, and yellow sulphur, for example, both solids, unite chemically to form a transparent colorless liquid.

Chemical changes differ from physical changes, which latter can occur in a substance without the formation of new molecules, and consequently without the loss by it of the properties it ordinarily possesses.

Thus a sheet of vulcanite, electrified by friction, still retains its characteristic density, shape, color, etc.

Effect, Counter-Inductive — —The opposal of current or charge by means of a counter-electromotive force produced by induction.

In the Thomson counter-electromotive force lightning arrester, a counter-electromotive force, produced by the inductive effects of the passage of the bolt to earth, protects the instrument by opposing the passage of the bolt. (See *Arrester, Lightning, Counter-Electromotive Force*.)

Effect, Edison — —An electric discharge which occurs between one of the terminals of the incandescent filament of an electric lamp, and a metallic plate placed near the filament but disconnected therefrom, as soon as a certain difference of potential is reached between the lamp terminals.

The effect of the discharge is to produce a current in a circuit connected to one pole of the lamp terminals and the metallic plate, as may be shown by means of a galvanometer.

Effect, Electrotonic — —An altered condition of excitability of a nerve produced when in the electrotonic state. (See *Electrotonus*.)

Effect, Faraday — —The rotation of the plane of polarization of a beam of plane polarized light by its passage through a magnetic field.

Lodge suggests the following explanation for the Faraday effect: As is well known, a strongly magnetized medium possesses a different magnetic susceptibility to additional magnetizing forces in the same direction than it does in the opposite direction. It therefore follows that the vibrations are resolved into two opposed circular components, which travel through the medium with different rates of velocity, since one tends to magnetize it and the other to demagnetize it. The plane of rotation will therefore be rotated.

He also suggests the following explanation for the Faraday effect, viz.: He assumes that the Ampèrian molecular currents in such substances as exhibit rotation in a magnetic field, do not consist of two equal and opposite electrical currents, but that one of the currents is slightly stronger than the other. Suppose, for example, that in iron the positive Ampèrian current is weaker than the negative, and that the ether as a whole is rotating with the negative current. Any ethereal vibration entering such a medium will begin to screw itself in the direction opposed to that of the magnetizing current. In copper, or other similar substances, the rotation should take place in the opposite direction.

Effect, Ferranti — — An increase in the electromotive force, or difference of potential, of mains or conductors towards the end of the same farthest from the terminals that are connected with a source of constant potential.

The Ferranti effect refers to the increase of the electromotive force on the mains employed in systems for the transmission of electrical energy by means of alternating currents. It was found, for example, in the currents used on the mains connected with one of Mr. Ferranti's alternating dynamos and leading to the town of Deptford, that instead of finding a drop of potential at the ends of the mains farthest from the dynamo, as was expected, a notable increase in the potential occurred. These effects were observed during the laying of the mains. Testing the potential by placing an incandescent lamp in the circuit across the mains, the increase of the potential with the increase of the length of the main was shown by the increased brilliancy of the light of the incandescent lamp.

Various explanations have been given as the cause of the Ferranti effect.

Effect, Hall — — A transverse electromotive force, produced by a magnetic field in substances undergoing electric displacement.

This transverse electromotive force is probably

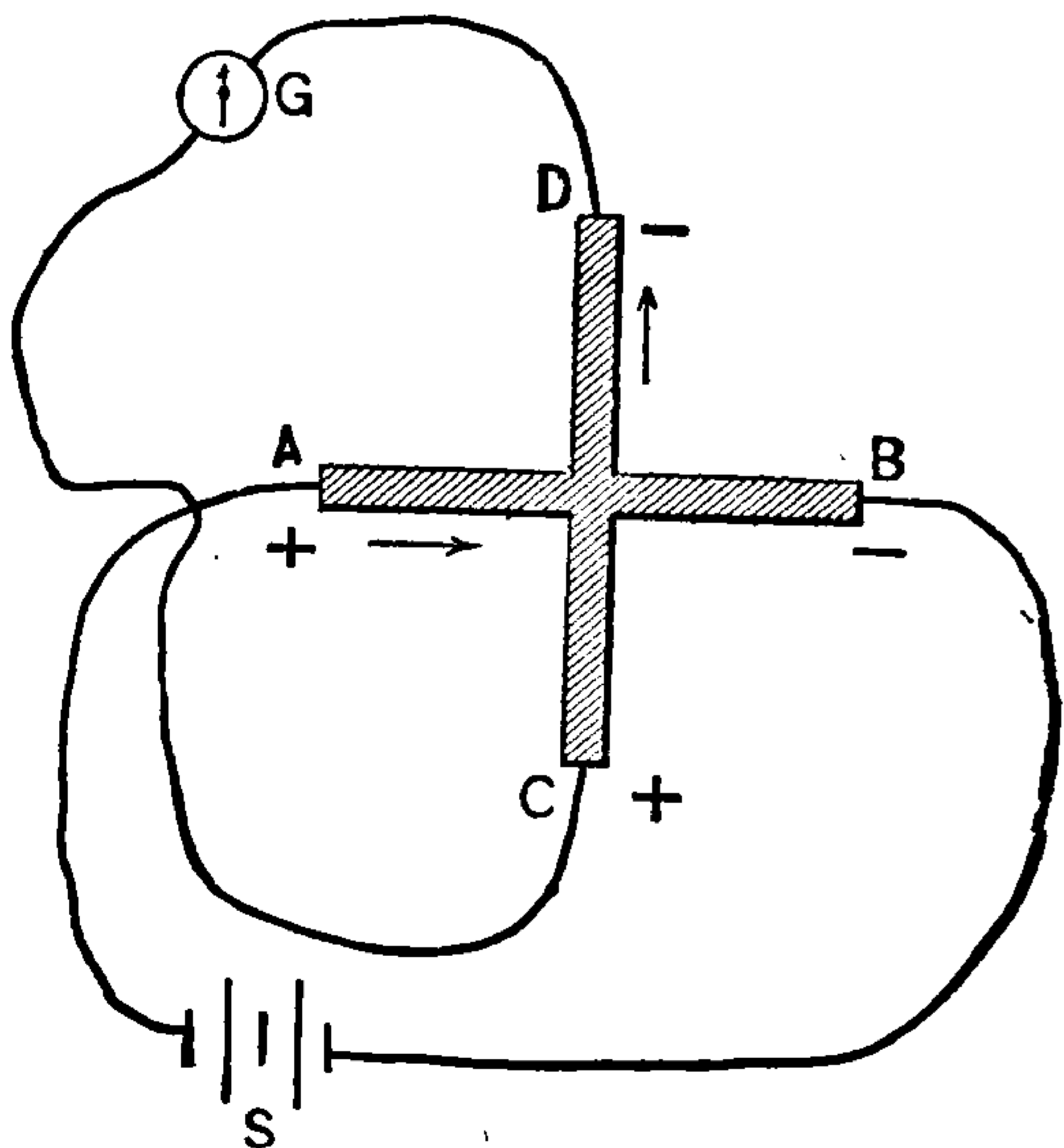

Fig. 226. Hall Effect.

due to magnetic whirls, in a manner similar to the Faraday effect.

The Hall effect is produced by placing a very thin metallic strip, conveying an electric current, in a strong magnetic field.

The cross A B C D, Fig. 226, is cut out of a

gold leaf or other very thin metallic sheet. The ends A and B, are connected with the terminals of a battery S, and the ends C and D, with the galvanometer G.

None of the battery current can therefore flow through the galvanometer.

If, now, the metallic cross be placed in a powerful magnetic field, the lines of force of which are perpendicular to the plane of the cross, the deflection of the galvanometer needle will show the existence of a current, which, if the battery current flows in the direction of the arrow, or from A, to B, and the lines of magnetic force pass through the paper from the *front to the back of the sheet*, when the cross is formed of gold, silver, platinum or tin-foil, will flow through C D, from C to D, but in the opposite direction if formed of iron. These effects cease if the conductor is increased in thickness beyond a certain extent.

As regards the production of the Hall effect by the influence of a magnetic field on conductors, Mr. Shelford Bidwell suggests that since magnetism affects the conductivity of metals in a complicated manner, it is possible that metallic substances conveying an electric current in a magnetic field are more or less strained by the mechanical forces, and that, therefore, heat may be unequally developed, and that the resistance thus being modified in places, there may be produced disturbances of the flow which may rapidly produce in part a transverse electromotive force.

Effect, Hall, Real — — A transverse electromotive force produced in conductors conveying electric currents, by magnetic whirls, in a manner similar to that in which the Faraday effect is produced. (See *Effect, Faraday*.)

Effect, Hall, Spurious — — An apparent transverse electromotive force produced in conductors conveying electric currents in magnetic fields, by changes, produced by magnetism, in the conductivity of the metals, and the consequent production of local disturbances in the electrical flow, thus resulting in an apparent transverse electromotive force.

Effect, Impulsion — — The restoration or loss of sensitiveness of a photo-voltaic cell to the action of light, produced by means of an impulse such as that of a tap or blow, or electro-magnetic impulse.

Effect, Joule — —The heating effect produced by the passage of an electric current through a conductor, arising merely from the resistance of the conductor.

The rate at which this occurs is proportional to the *resistance of the conductor* through which the current is passing multiplied by the *square of the current*. (See *Heat, Electric*.)

Effect, Kerr — —A term applied to the electrostatic optical effect discovered by Dr. Kerr, viz., that a beam of plane polarized light is elliptically polarized when transmitted across an electrostatic field.

The Kerr effect does not take place in free space, but occurs in different senses or directions in different media.

Like the Faraday effect, the Kerr effect depends on the presence of a dense medium, and the direction of the effect depends on the character of the medium.

Effect, Mordey — —A term sometimes applied to a decrease in the value of hysteresis in the iron of a dynamo armature at full load.

Effect, Peltier — —The heating effect produced by the passage of an electric current across a thermo-electric junction or surface of contact between two different metals. (See *Junction, Thermo-Electric*.)

The passage of the current across a thermo-electric junction produces either heat or cold. If *heat* is produced by its passage in *one direction*, *cold* is produced by its passage in the *opposite direction*. The Peltier effect may, therefore, mask the Joule effect.

The *Peltier effect* is the converse of the *thermo-electric effect*, where the unequal heating of metallic junctions results in an electric current. (See *Effect, Joule. Effect, Thomson*.)

The quantity of heat absorbed or emitted by the Peltier effect is proportional to the current strength, and not, as in the Joule effect, to the square of the current.

Effect, Photo-Voltaic — —The change in the resistance of selenium or other substances effected by their exposure to light. The photo-voltaic effect is seen in the case of the selenium cell. (See *Cell, Selenium*.)

Effect, Seebeck — —A term sometimes used instead of thermo-electric effect. (See *Effect, Thermo-Electric*.)

This term has nearly passed out of use.

Effect, Skin — —The tendency of alternating currents to avoid the central portions of solid conductors and to flow or pass mostly through the superficial portions.

The so-called skin effect is more pronounced the more frequent the alternations.

Effect, Thermo-Electric — —The production of an electromotive force at a thermo-electric junction by a difference of temperature between that junction and the other junction of the thermo-electric couple. (See *Couple, Thermo-Electric. Junction, Thermo-Electric*.)

Effect, Thomson — —The production of an electromotive force in unequally heated homogeneous conducting substances.

A term also applied to the increase or decrease in the differences of temperature in an unequally heated conductor, produced by the passage of an electrical current through the conductor.

The Thomson effects vary according to whether the current passes from a colder to a hotter part of the conductor, or the reverse.

The Thomson effects differ in direction in different metals, and are absent in lead. Thomson has pointed out the similarity between this species of thermo-electric phenomena, and *convection by heat*, or the phenomena of a liquid circulating in a closed rectangular tube, under the influence of differences of temperature, *in which the heated fluid gives out heat in the cooler parts of the circuit, and takes in heat in the warmer parts*. This would presuppose that positive electricity carries heat in copper like a real fluid, but that in iron it acts as though its specific heat were a negative quantity, in which respect it is unlike a true fluid.

“We may express,” says Maxwell, “both the Peltier and the Thomson effects by stating that when an electric current is flowing from places of smaller to places of greater thermo-electric power, heat is absorbed, and when it is flowing in the reverse direction heat is generated, and this whether the difference of thermo-electric power in the two places arises from a difference in the

THIS PAGE IS LOCKED TO FREE MEMBERS

Purchase full membership to immediately unlock this page

Know Your Bible

Forgotten Books' Full Membership provides unlimited access to more than 28,000 volumes of Christian literature for \$8.99/month

HOLY BIBLE

Continue

*Fair use policy applies

Electric Absorption.—(See *Absorption, Electric.*)

Electric Acoutemeter.—(See *Acoutemeter, Electric.*)

Electric Actinometer.—(See *Actinometer, Electric.*)

Electric Adhesion.—(See *Adhesion, Electric.*)

Electric Aging of Alcohol.—(See *Alcohol, Electric Aging of.*)

Electric Alarm.—(See *Alarm, Electric.*)

Electric Alarm Speaking-Tube Mouth-Piece.—(See *Speaking-Tube Mouth-Piece, Electric Alarm.*)

Electric Amalgam.—(See *Amalgam, Electric.*)

Electric Ammunition Hoist.—(See *Hoist, Ammunition, Electric.*)

Electric Analysis.—(See *Analysis, Electric.*)

Electric Analyzer.—(See *Analyzer, Electric.*)

Electric Anemometer.—(See *Anemometer, Electric.*)

Electric Annealing.—(See *Annealing, Electric.*)

Electric Annunciator Clock.—(See *Clock, Electric Annunciator.*)

Electric Arc.—(See *Arc, Electric.*)

Electric Arc Blow-Pipe.—(See *Blow-Pipe, Electric Arc.*)

Electric Argand Burner, Hand-Lighter — — (See *Burner, Argand Electric, Hand-Lighter.*)

Electric Argand Burner, Plain-Pendant — — (See *Burner, Argand Electric, Plain-Pendant.*)

Electric Argand Burner, Ratchet-Pendant — — (See *Burner, Argand Electric, Ratchet-Pendant.*)

Electric Balance.—(See *Balance, Electric.*)

Electric Balloon.—(See *Balloon, Electric.*)

Electric Battery.—(See *Battery, Electric.*)

Electric Bell, Continuous-Sounding — — (See *Bell, Continuous-Sounding Electric.*)

Electric Bell, Differential.—(See *Bell, Differential Electric.*)

Electric Bell, Mechanical.—(See *Bell, Electro-Mechanical.*)

Electric Bell Pull.—(See *Pull, Bell, Electric.*)

Electric Bioscopy.—(See *Bioscopy, Electric.*)

Electric Bi-Polar Bath.—(See *Bath, Bi-Polar.*)

Electric Blasting.—(See *Blasting, Electric.*)

Electric Bleaching.—(See *Bleaching, Electric.*)

Electric Blow-Pipe.—(See *Blow-Pipe, Electric.*)

Electric Boat.—(See *Boat, Electric.*)

Electric Bobbin.—(See *Bobbin, Electric.*)

Electric Body-Protector.—(See *Body-Protector, Electric.*)

Electric Boiler-Feed.—(See *Boiler-Feed, Electric.*)

Electric Branding.—(See *Branding, Electric.*)

Electric Breeze.—(See *Breeze, Electric.*)

Electric Bridge.—(See *Bridge, Electric.*)

Electric Buoy.—(See *Buoy, Electric.*)

Electric Burner.—(See *Burner, Automatic Electric.*)

Electric Buzzer.—(See *Buzzer, Electric.*)

Electric Cable.—(See *Cable, Electric.*)

Electric Calamine.—(See *Calamine, Electric.*)

Electric Call-Bell.—(See *Bell, Call.*)

Electric Calorimeter.—(See *Calorimeter, Electric.*)

Electric Candle.—(See *Candle, Electric.*)

Electric Case-Hardening.—(See *Case-Hardening, Electric.*)

Electric Cauterization.—(See *Cauterization, Electric.*)

Electric Cauterizer.—(See *Cauterizer, Electric.*)

Electric Cautey.—(See *Cautey, Electric.*)

Electric Charge.—(See *Charge, Electric.*)

Electric Chimes.—(See *Chimes, Electric.*)

Electric Chronograph.—(See *Chronograph, Electric.*)

Electric Chronoscope.—(See *Chronoscope, Electric.*)

Electric Cigar-Lighter.—(See *Lighter, Cigar, Electric.*)

Electric Circuit.—(See *Circuit, Electric.*)

Electric Cleats.—(See *Cleats, Electric.*)

Electric Clepsydra.—(See *Clepsydra, Electric.*)

Electric Clock.—(See *Clock, Electric.*)

Electric Coil.—(See *Coil, Electric.*)

Electric Column.—(See *Column, Electric.*)

Electric Communicator.—(See *Communicator, Electric.*)

Electric Conducting.—(See *Conducting, Electrical.*)

Electric Conduction.—(See *Conduction, Electric.*)

Electric Convection of Heat.—(See *Heat, Electric Convection of.*)

Electric Cord.—(See *Cord, Electric.*)

Electric Counter.—(See *Counter, Electric.*)

Electric Creeping.—(See *Creeping, Electric.*)

Electric Cross.—(See *Cross, Electric.*)

Electric Crucible.—(See *Crucible, Electric.*)

Electric Current.—(See *Current, Electric.*)

Electric Cystoscopy.—(See *Cystoscopy, Electric.*)

Electric Damping.—(See *Damping, Electric.*)

Electric Death.—(See *Death, Electric.*)

Electric Decomposition.—(See *Decomposition, Electric.*)

Electric Density.—(See *Density, Electric.*)

Electric Deposition.—(See *Deposition, Electric.*)

Electric Determination of Longitude.—(See *Longitude, Electric Determination of.*)

Electric Displacement.—(See *Displacement, Electric.*)

Electric Distillation.—(See *Distillation, Electric.*)

Electric Door-Bell Pull.—(See *Pull, Electric Door-Bell.*)

Electric Double-Refraction.—(See *Double-Refraction, Electric.*)

Electric Dyeing.—(See *Dyeing, Electric.*)

Electric Dynamometer, Siemens'.—(See *Dynamometer, Electro.*)

Electric Eel.—(See *Eel, Electric.*)

Electric Efficiency.—(See *Efficiency, Electric.*)

Electric Elasticity.—(See *Elasticity, Electric.*)

Electric Elevator.—(See *Elevator, Electric.*)

Electric Endosmose.—(See *Endosmose, Electric.*)

Electric Energy.—(See *Energy, Electric.*)

Electric Entropy.—(See *Entropy, Electric.*)

Electric Escape.—(See *Escape, Electric.*)

Electric Etching.—(See *Etching, Electro.*)

Electric Evaporation.—(See *Evaporation, Electric.*)

Electric Excitability of Nerve or Muscular Fibre.—(See *Excitability, Electric, of Nerve or Muscular Fibre.*)

Electric Exhaustion.—(See *Exhaustion, Electric.*)

Electric Expansion.—(See *Expansion, Electric.*)

Electric Exploder.—(See *Exploder, Electric Mine.*)

Electric Explorer.—(See *Explorer, Electric*.)

Electric Field.—(See *Field, Electric*.)

Electric Figures, Breath — —(See *Figures, Electric, Breath*.)

Electric Figures, Lichtenberg's — —(See *Figures, Electric, Lichtenberg's*.)

Electric Fishes.—(See *Fishes, Electric*.)

Electric Fly.—(See *Fly, Electric*.)

Electric Flyer.—(See *Flyer, Electric*.)

Electric Fog.—(See *Fog, Electric*.)

Electric Force.—(See *Force, Electric*.)

Electric Furnace.—(See *Furnace, Electric*.)

Electric Fuse.—(See *Fuse, Electric*.)

Electric Gas-Lighting.—(See *Gas-Lighting, Electric*.)

Electric Gas-Lighting, Multiple — —(See *Gas-Lighting, Multiple Electric*.)

Electric Gas-Lighting Torch.—(See *Torch, Electric Gas-Lighting*.)

Electric Gastroscope.—(See *Gastroscope, Electric*.)

Electric Gilding.—(See *Gilding, Electric*.)

Electric Governor.—(See *Governor, Electric*.)

Electric Hand-Lighter for Argand Burner.—(See *Burner, Argand Electric Hand-Lighter*.)

Electric Head-Bath.—(See *Bath, Head, Electric*.)

Electric Head-Light.—(See *Head-Light, Locomotive, Electric*.)

Electric Heat.—(See *Heat, Electric*.)

Electric Heater.—(See *Heater, Electric*.)

Electric Horse Power.—(See *Power, Horse, Electric*.)

Electric Hydrotasimeter.—(See *Hydrotasimeter, Electric*.)

Electric Ignition.—(See *Ignition, Electric*.)

Electric Images.—(See *Images, Electric*.)

Electric Incandescence.—(See *Incandescence, Electric*.)

Electric Indicator for Steamships.—(See *Indicator, Electric, for Steamships*.)

Electric Indicators.—(See *Indicators, Electric*.)

Electric Inertia.—(See *Inertia, Electric*.)

Electric Insolation.—(See *Insolation, Electric*.)

Electric Installation.—(See *Installation, Electric*.)

Electric Insulation.—(See *Insulation, Electric*.)

Electric Irritability.—(See *Irritability, Electric*.)

Electric Jar.—(See *Jar, Electric*.)

Electric Jewelry.—(See *Jewelry, Electric*.)

Electric Lamp, Arc — —(See *Lamp, Electric, Arc*.)

Electric Lamp-Bracket.—(See *Bracket, Lamp, Electric*.)

Electric Lamp, Incandescent — —(See *Lamp, Electric, Incandescent*.)

Electric Lamp, Semi-Incandescent — —(See *Lamp, Electric, Semi-Incandescent*.)

Electric Lamp, Socket for.—(See *Socket, Electric Lamp*.)

Electric Launch.—(See *Launch, Electric*.)

Electric Letter-Box.—(See *Letter-Box, Electric*.)

Electric Light.—(See *Light, Electric*.)

Electric Lighting, Central Station — —(See *Station, Central*.)

Electric Lighting, Isolated — —(See *Lighting, Electric, Isolated*.)

Electric Light or Power Cable.—(See *Cable, Electric Light or Power*.)

Electric Lock.—(See *Lock, Electric*.)

Electric Locomotive.—(See *Locomotive, Electric*.)

Electric Log.—(See *Log, Electric*.)

Electric Loom.—(See *Loom, Electric*.)

Electric Loop.—(See *Loop, Electric*.)

Electric Machine, Frictional — —(See *Machine, Frictional Electric*.)

THIS PAGE IS LOCKED TO FREE MEMBERS

Purchase full membership to immediately unlock this page



HISTORY

Tens of thousands of important historical sources, many previously unobtainable, are now available for the first time with a Forgotten Books Full Membership.

Unlimited Access
\$8.99/month

Continue

*Fair usage policy applies

Electric Seismograph.—(See *Seismograph, Electric.*)

Electric Shadow.—(See *Shadow, Electric.*)

Electric Shock.—(See *Shock, Electric.*)

Electric Shower Bath.—(See *Bath, Shower Electric.*)

Electric Shunt Bell.—(See *Bell, Shunt, Electric.*)

Electric Single-Stroke Bell.—(See *Bell, Single-Stroke Electric.*)

Electric Siphon.—(See *Siphon, Electric.*)

Electric Soldering.—(See *Soldering, Electric.*)

Electric Sphygmograph.—(See *Sphygmograph, Electrical.*)

Electric Sterilization.—(See *Sterilization, Electric.*)

Electric Storm.—(See *Storm, Electric.*)

Electric Striæ.—(See *Striæ, Electric.*)

Electric Submarine Boat.—(See *Boat, Submarine, Electric.*)

Electric Sunstroke.—(See *Sunstroke, Electric.*)

Electric Surgings.—(See *Surgings, Electric.*)

Electric Swaging.—(See *Swaging, Electric.*)

Electric Tanning.—(See *Tanning, Electric.*)

Electric Target.—(See *Target, Electric.*)

Electric Teazer.—(See *Teazer, Electric Current.*)

Electric Telehydrobarometer.—(See *Telehydrobarometer, Electric.*)

Electric Tell-Tale Signal.—(See *Signal, Electric Tell-Tale.*)

Electric Tempering.—(See *Tempering, Electric.*)

Electric Tension.—(See *Tension, Electric.*)

Electric Thermo-Call.—(See *Thermo-Call, Electric.*)

Electric Thermometer.—(See *Thermometer, Electric.*)

Electric Throwback-Indicator.—(See *Indicator, Electrical Throwback.*)

Electric Time-Ball.—(See *Ball, Electric Time.*)

Electric Time-Meter.—(See *Meter, Electric Time.*)

Electric Torpedo.—(See *Torpedo, Electric.*)

Electric Tower.—(See *Tower, Electric.*)

Electric Tramway.—(See *Tramway, Electric.*)

Electric Transmitters.—(See *Transmitter, Electric.*)

Electric Trumpet.—(See *Trumpet, Electric.*)

Electric Turn-Table.—(See *Turn-Table, Electric.*)

Electric Typewriter.—(See *Typewriter, Electric.*)

Electric Valve.—(See *Valve, Electric.*)

Electric Valve Burner, Argand — — (See *Valve Burner, Argand Electric.*)

Electric Varnish.—(See *Varnish, Electric.*)

Electric Vibrating Burner.—(See *Burner, Vibrating, Electric.*)

Electric Volatilization.—(See *Volatilization, Electric.*)

Electric Water or Liquid Level Alarm.— (See *Alarm, Water or Liquid Level.*)

Electric Welding.—(See *Welding, Electric.*)

Electric Whirl.—(See *Whirl, Electric.*)

Electric Whistle, Automatic Steam — — (See *Whistle, Steam, Automatic Electric.*)

Electric Wood Mouldings.—(See *Mouldings, Electric Wood.*)

Electric Work.—(See *Work, Electric.*)

Electrical Controlling Clock.—(See *Clock, Electrical Controlling.*)

Electrically.—In an electrical manner.

Electrically Controlled Clock.—(See *Clock, Electrically Controlled.*)

Electrically Discharge, To — — (See *Discharge, To Electrically.*)

Electrically Discharging.—(See *Discharging, Electrically.*)

Electrically Energizing.—(See *Energizing, Electrically.*)

Electrically Operated Alarm.—(See *Alarm, Electrically Operated.*)

Electrically Retarding.—(See *Retarding, Electrically.*)

Electrician.—One versed in the principles and applications of electrical science.

Electrician, Electro-Therapeutical — —
—A medical electrician.

Electrician, Medical — — One skilled in the application of electricity to the human body for diagnosis or curative purposes.

A medical electrician should possess a full knowledge, not only of the principles and applications of electric science, but also of physics and chemistry and of the medical sciences.

Electricity.—The name given to the unknown thing, matter or force, or both, which is the cause of electric phenomena.

Electricity, no matter how produced, is believed to be one and the same thing.

The terms *frictional-electricity*, *pyro-electricity*, *magneto-electricity*, *voltaic or galvanic electricity*, *thermo-electricity*, *contact-electricity*, *animal or vegetable-electricity*, etc., etc., though convenient for distinguishing their origin, have no longer the significance formerly attributed to them as representing different kinds of the electric force. (See *Electricity, Single-Fluid Hypothesis of.*)

Electricity, Accumulated — — Electricity collected in or by means of accumulators.

Electricity, Accumulating — — Obtaining successively increasing electrical charges. (See *Electricity, Accumulation of.*)

Electricity, Accumulation of — — A general term applied indifferently to—

(1.) The gradual collecting of electric energy in a Leyden jar or condenser.

(2.) The increase of an electric charge by the action of various devices called accumulators.

(3.) The production of a charge by the use of machines called influence machines.

(4.) The collection of electric energy in the so-called storage batteries or accumulators.

Electricity, Animal — — Electricity produced during life in the bodies of animals.

All animals produce electricity during life. In some, such as the electric eel or torpedo, the amount is comparatively large. In others, it is small.

Some of these animals, when of full size, are able to give very severe shocks, and use this curious power as a means of defense against their enemies.

If the spinal cord of a recently killed frog be brought into contact with the muscles of the thigh, a contraction will ensue.—(*Matteucci.*)

The nerve and muscle of a frog, connected by a water contact with a sufficiently delicate galvanometer, show the presence of a current that may last several hours. Du Bois-Reymond showed that the *ends* of a section of muscular fibres are negative, and their *sides* positive, and has obtained a current by suitably connecting them.

In the opinion of some electro-therapeutists no electric current exists in passive, normal nerve or muscular tissue. In an injured tissue a current, called a *demarkation current*, is produced. (See *Current, Demarcation.*)

All muscular contractions, however, apparently produce electric currents.

In electro-therapeutics, it is probable that greater success would accrue in practice if the human body were regarded as an electric source as well as an electro-receptive device.

Electricity, Atmospheric — — The free electricity almost always present in the atmosphere.

The following facts have been discovered concerning atmospheric electricity, viz.:

(1.) The free electricity of the atmosphere is generally positive, but often changes to negative on the approach of fogs and clouds.

(2.) It exists in greater quantity in the higher regions of the air than near the earth's surface.

(3.) It is stronger when the air is still than when the wind is blowing.

(4.) It is subject to yearly and daily changes in its intensity, being stronger in winter than in summer, and at the middle of the day than either at the beginning or the close.

Electricity, Atmospheric, Origin of —

—The exact cause of the free electricity of the atmosphere is unknown.

Peltier ascribes the cause of the free electricity of the atmosphere to a negatively excited earth, which charges the atmosphere by *induction*. (See *Induction, Electrostatic*.) Free atmospheric electricity has also been ascribed to the evaporation of water; to the condensation of vapor; to the friction of the wind; to the motion of terrestrial objects through the earth's magnetic field; to induction from the sun and other heavenly bodies; to differences of temperature; to combustion, and to gradual oxidation of plant and animal life. It is possible that all these causes may have some effect in producing the free electricity of the atmosphere.

Whatever is the cause of the free electricity of the atmosphere, there can be but little doubt that it is to the condensation of aqueous vapor that the high *difference of potential* of the lightning flash is due. (See *Potential, Difference of*.) As the clouds move through the air they collect the free electricity on the surfaces of the minute drops of water of which they are composed, and when many thousands of these subsequently collect in larger drops the difference of potential is enormously increased in consequence of the equally enormous decrease in the surface of any single drop over the sum of the surfaces of the drops that have coalesced to form it.

Electricity, Atom of — —A quantity of electricity equal in amount to that possessed by any chemical monad atom.

Professor Lodge points out the fact that the charge of a monad atom of any element is the smallest charge a body can possess, and is possibly as indivisible as the atom itself. He points out the fact that chemical affinity or atomic attraction may be due to the electrical attraction of atoms containing unlike charges; that although the difference of potential between the atoms is small, probably somewhere between 1 and 3 volts, the distances separating them are so very small that their mutual attractive force must be almost infinitely great.

As D'Auria has pointed out, if the centres of attraction of the atoms be the centres of the atoms themselves, then the atoms, if approached to actual contact, would be separated from one another by a distance equal to half the sum of their diameters. If, however, the centre of at-

traction be situated at any point on the surface of the atoms the distance of separation would become equal to zero, calling d , the distance between them, m and m' , their respective masses, and S , a co-efficient varying with the substance, and f , the force of mutual attraction, then :

$$f = S \left(\frac{m m'}{d^2} \right)$$

from which we see that the value of f , becomes infinite when the atoms are in contact.

Electricity, Cal — —Electricity produced by changes of temperature in the core of a transformer.

The changes of temperature in the transformer core can produce a difference of potential in the secondary circuit which increases the electromotive force induced in the secondary by the variations in the primary. This is sometimes called the Acheson effect. (See *Effect, Acheson*.)

Electricity, Conservation of — —A term proposed by Lippman to express the fact that when a body receives an electric charge in the open air, the earth and heavenly bodies receive an equal and opposite charge, thus preserving the sum of the total positive and negative electricities in the universe.

Electricity, Contact — —Electricity produced by the mere contact of dissimilar metals.

The mere contact of two dissimilar metals results in the production of opposite electrical charges on their opposed surfaces, or in a difference of electric potential between these surfaces. The cause of this difference of potential is now very generally ascribed to the voltaic couple being surrounded by the atmosphere, the oxygen of which acts more energetically on the positive element than it does on the negative element.

The mere contact of dissimilar metals cannot produce a constant electric current. An electric current possesses kinetic energy. To produce a constant electric current, therefore, energy must be expended.

The voltaic pile through the contact of dissimilar metals produces a difference of potential, yet the cause of the current is to be found in chemical action. (See *Cell, Voltaic*.)

Electricity, Disguised — —Dissimulated electricity. (See *Electricity, Dissimulated or Latent*.)

THIS PAGE IS LOCKED TO FREE MEMBERS

Purchase full membership to immediately unlock this page

Know Your Bible

Forgotten Books' Full Membership provides unlimited access to more than 28,000 volumes of Christian literature for \$8.99/month

HOLY BIBLE

Continue

*Fair use policy applies

out. If the number of electro-receptive devices be great, such a circuit is necessarily characterized by a comparatively high electromotive force.

Since the current passes successively through all the electro-receptive devices, an automatic safety device is necessary in order to automatically provide a short circuit of comparatively low resistance past a faulty device, and thus prevent a single faulty device from invalidating the action of all other devices in the circuit.

Arc lamps are usually connected to the line circuit in series.

In a system of *multiple-distribution*, the electro-receptive devices are connected to the main line or leads in *multiple-arc*, or *parallel*, so that each device added *decreases the resistance of the circuit*. In order, therefore, to maintain a proper current through the electro-receptive devices, the mains must be kept at a nearly constant difference of potential. The electro-receptive devices employed in such a system of distribution are generally of high electric resistance, so that the introduction or removal of a few of the electro-receptive devices will not materially alter the resistance of the whole circuit, and will not, therefore, materially affect the remaining lights.

In this system automatic safety devices, operating by the fusion of a readily melted alloy or metal, are provided for the purpose of preventing too powerful currents from passing through any branch connected with the *main conductors or leads*. (See *Plug, Fusible*.)

Incandescent lamps are generally connected with the main conductors or leads in *parallel* or *multiple-arc*.

Distribution of incandescent lamps by series connections is sometimes employed. Such lamps are usually of comparatively low resistance, and are provided each with an automatic cut-out, which establishes a short circuit past the lamp on its failure to properly operate.

During the passage of an electric current through any series-distribution circuit, energy is expended in different portions of the circuit, in proportion to the resistance of these parts. In any system, economy of distribution necessitates that the energy expended in the electro-receptive devices must bear as large a proportion as practicable to the energy expended in the source and leads. In series-distribution, this can readily be accomplished even if the resistance of the leads is comparatively high, since the total resistance of the circuit increases with every electro-receptive

device added. Comparatively thin wires can therefore be employed for a very considerable extent of territory covered, without very great loss.

In systems of multiple-distribution, however, this is impossible; for, since every electro-receptive device added decreases the total resistance of the circuit, unless the resistance of the leads is correspondingly decreased the economy becomes smaller, unless the resistance of the leads was originally so low as to be inappreciable when compared with the change of resistance.

In systems of distribution by alternating currents this is avoided by passing a current of but small strength and considerable difference of potential over a line connecting distant points, and converting this current into a current of large strength and small difference of potential at the places where it is required for use.

Electricity, Distribution of, by Continuous Current, by Means of Condensers — — A system of distribution devised by Doubrava, in which a continuous current is conducted to certain points in the line where a device called a "disjuncter" is employed, to reverse it periodically, and the reversed currents so obtained directly used to charge condensers in the circuit of which induction coils are used.

This method of distribution is a variety of distribution by means of constant currents.

The condensers are used to feed incandescent lamps or other electro-receptive devices.

Electricity, Distribution of, by Continuous Current, by Means of Transformers — — A system for the transmission of electric energy by means of continuous or direct currents that are sent over the line to suitably located stations where motor-dynamos are used for transformers.

The dynamo armature is used with two separate circuits, one of a short and coarse wire, and one of a long fine wire. This construction will permit the conversion of a high to a low potential or *vice versa*; or two separate dynamos can be placed on the same shaft and one used as the motor.

It is evident that a motor generator can be constructed to convert continuous currents into alternate, or alternate currents into continuous cur-

rents. In this last case the armature and fixed circuits must be kept separate.

Another form of continuous current conversion is effected by means of the motion of a commutator which effects a rotation of magnetic polarity in a double-wound armature of fine and coarse wire.

Electricity, Distribution of, by Motor Generators — —A system of electric distribution in which a continuous current of high potential, distributed over a main line, is employed at the points where its electric energy is to be utilized for driving a motor, which in turn drives a dynamo, the current of which is used to energize the electro-receptive devices.

This method of distribution is a variety of distribution by means of continuous or direct currents.

In another system of distribution by means of motor generators, the motor and dynamo are combined in one with a double-wound armature, the fine wire coils in which receive the high potential driving current and the coarse wire coils furnish the low potential current used in the distribution circuits.

Electricity, Double Fluid Hypothesis of — —A hypothesis which endeavors to explain the causes of electric phenomena by the assumption of the existence of two different electric fluids.

The double fluid hypothesis assumes:

(1.) That the phenomena of electricity are due to two tenuous and imponderable fluids, the positive and the negative.

(2.) That the particles of the positive fluid repel one another, as do also the particles of the negative fluid; but that the particles of positive fluid attract the particles of the negative and *vice versa*.

(3.) That the two fluids are strongly attracted by matter, and when present in it produce electrification.

(4.) That the two fluids attract one another and unite, thus masking the properties of each.

(5.) That the act of friction separates these fluids, one going to the rubber and the other to the thing rubbed.

Professor Lodge is disposed to favor the double rather than the single fluid hypothesis. He states in support of this belief the following facts, viz.:

(1.) An electric wind or breeze is produced both at the positive and negative terminals of an

electrical machine, and this whether the point be attached directly to these terminals, or whether it be held in the hand of a person near them.

(2.) The well known peculiarities connected with the spark discharge, seen in Wheatstone's experiments on the velocity of electricity.

(3.) An electrostatic strain scarcely affects the volume of the dielectric, thus suggesting or showing a distorting stress, which alters the shape of the substance of the dielectric, but not its size.

(4.) The effects of electrolysis in what he assumes the double procession of the atoms past each other in opposite directions.

(5.) The phenomena of self-induction, or the behavior of a thick wire on an alternating current.

(6.) The apparent absence of momentum in the electric current, or moment of inertia in an electro-magnet so far as tested.

Electricity, Dynamic — —A term sometimes employed for current electricity in contradistinction to static electricity.

Electricity, Franklinic — —A term sometimes employed in electro-therapeutics, for the electricity produced by a frictional or an electrostatic-induction machine. (See *Current, Franklinic*.)

Electricity, Frictional — —Electricity produced by friction.

This term as formerly employed to indicate static charges as distinguished from currents, is gradually falling into disuse, and the frictional electric machines are being generally replaced by continuous-induction machines, like those of Holtz, Töpler-Holtz, or Wimshurst.

The character of the charge produced by friction depends on the nature of the rubber as well as on that of the thing rubbed.

In the following table the substances are so arranged that any one in the list becomes positively electrified when rubbed by any which follows it:

Positive.

Cat's fur.

Polished glass.

Wool.

Cork at ordinary temperatures.

Coarse brown paper.

Cork heated.

White silk.

Black silk.

Shellac.

Rough glass.—(*Forbes*.)

Negative.

It will be seen that the character of the charge produced by friction depends on the character of the surfaces rubbed. This is seen from the foregoing table, where—

(1.) The roughness of the surface, as in the case of glass, produces a difference in the nature of the charge; thus, rough glass is at the bottom of the table, and smooth, polished glass near the top.

(2.) The state of the surface as shown by the color. Black silk rubbed with white silk is negative to it.

(3.) The state of the surface, as varied by the temperature. Hot cork receives a negative charge when rubbed against a piece of cold cork.

Forbes has pointed out that these differences are probably due to the change produced in the ability of the surface to radiate heat or light. A substance or body which radiates the most light or heat is negative. Thus, a hot body radiates more heat than a cold body, and is negative to it. A rough surface is negative to a smooth surface because it radiates more heat than a smooth surface. For the same reason a black surface is negative to a white surface. In this latter case, however, the black surface is the worse radiator of light.

The contact of dissimilar substances has long been considered by some as one of the requisites for the ready production of electricity by friction. In fact, the production of electricity by friction has been ascribed as an effect due to a true contact force at the points of junction of the rubber and the thing rubbed. Others, however, deny the existence of a true contact force of this nature. (See *Force, Contact.*)

Electricity, Galvanic — —A term used by some in place of voltaic electricity. (See *Electricity, Voltaic.*)

The use of the term galvanic electricity would appear to be less logical than the word voltaic, since Volta, and not Galvani, was the first to find out the true origin of the difference of potential produced in the voltaic pile.

Electricity, Hertz's Theory of Electro-Magnetic Radiations or Waves — —A theory, now generally accepted, which regards light as one of the effects of electro-magnetic pulsations or waves.

The recent brilliant researches of Dr. Hertz, of Karlsruhe, show that when an impulsive discharge

is passing through a conductor, ether waves are radiated or propagated in all directions in the space surrounding the conductor, and that these waves are in all respects similar to those of light, except that they are much longer.

The electro-magnetic waves are set up in the luminiferous ether, and move through it with the same velocity as that of light. Moreover, electro-magnetic waves possess the same powers of reflection, refraction, interference, resonance, etc., etc., as are possessed by waves of light. (See *Resonator, Electric.*)

When an alternating or simple faradic current or pulse of electricity is transmitted from one end to the other of a long metallic conductor, the pulses are believed to travel through the universal ether surrounding the conductor rather than through the conductor itself. The velocity of this propagation in free ether is the same as that of light, and, indeed, is identical with that of light itself. In the inter-atomic or inter-molecular ether, whether of conductors, or of dielectrics, the velocity of propagation varies with the nature of the medium.

The waves produced by electric pulses are of much greater length than those of light.

According to Lodge a condenser of the capacity of a micro-farad, if discharged through a coil having the self-induction of 1 ohm, will give rise to waves in the ether 1,200 miles in length, and will possess a rate of oscillation equal to about 157 complete wave-lengths per second.

A common pint Leyden jar discharged through an ordinary discharging rod, will produce a series of waves about 15 to 20 metres in length, and will possess a rate of oscillation equal to about ten million per second.

Lodge calculates that in order to obtain the short waves requisite to influence the retina of the eye, and thus produce light, the circuit in which the electrical oscillations take place must have at least atomic dimensions, and that the phenomena of light may therefore be due to local oscillations or surging in circuits of atomic dimensions. (See *Light, Maxwell's Electro-Magnetic Theory of.*)

Electricity, Latent — —A term formerly applied to bound electricity.

Electricity, Magneto — —Electricity produced by the motion of magnets past conductors, or of conductors past magnets.

Electricity produced by magneto-electric

THIS PAGE IS LOCKED TO FREE MEMBERS

Purchase full membership to immediately unlock this page



HISTORY

Tens of thousands of important historical sources, many previously unobtainable, are now available for the first time with a Forgotten Books Full Membership.

Unlimited Access
\$8.99/month

Continue

*Fair usage policy applies

Electricity, Single-Fluid Hypothesis of — —A hypothesis which endeavors to explain the cause of electrical phenomena by the assumption of the existence of a single electric fluid.

The single-fluid hypothesis assumes:

(1.) That the phenomena of electricity are due to the presence of a single, tenuous, imponderable fluid.

(2) That the particles of this fluid mutually repel one another, but are attracted by all matter.

(3.) That every substance possesses a definite capacity for holding the assumed electric fluid, and, that when this capacity is just satisfied no effects of electrification are manifest.

(4.) That when the body has less than this quantity present, it becomes *negatively excited*, and when it has more, *positively excited*.

(5.) That the act of friction causes a redistribution of the fluid, part of it going to one of the bodies, giving it a surplus, thus positively electrifying it, and leaving the other with a deficit, thus negatively electrifying it.

The single-fluid hypothesis has been provisionally accepted by some with this modification, that a negatively excited body is thought to be the one which contains the *excess* of the assumed fluid, and a positively excited body the one which contains the *deficit*.

They make this change on account of the phenomena observed in Crookes' tube, where the molecules of the residual gas are observed to be thrown off from the *negative* and not from the positive terminal. (See *Tube, Crookes'*.)

Another view considers electricity to be due to differences of ether pressure, electricity being the ether itself, and electromotive force, the differences of ether pressures. Positive electrification is assumed to result from a surplusage of energy, and negative electrification from a deficit of energy.

At the present time the views of Hertz are generally accepted. (See *Electricity, Hertz's Theory of Electro-Magnetic Radiations or Waves.*)

Electricity, Specific Heat of — —A term proposed by Sir William Thomson to indicate the analogies existing between the absorption and emission of heat in purely thermal phenomena, and the absorption and emission of heat in thermo-electric phenomena. (See *Heat, Specific.*)

As we have already seen heat is either given

out or absorbed, when an electric current passes from one metal to another across a junction between them. (See *Effect, Peltier.*)

So, too, when electricity passes through an unequally heated wire, the current tends to increase or decrease the differences of temperature, according to the direction in which it flows, and according to the character of the metal. (See *Effect, Thomson.*)

“If electricity were a fluid,” says Maxwell, “running through the conductor as water does through a tube, and always giving out or absorbing heat till its temperature is that of the conductor, then in passing from hot to cold it would give out heat, and in passing from cold to hot it would absorb heat, and the amount of this heat would depend on the specific heat of the fluid.”

Electricity, Static — —A term applied to electricity produced by friction.

The term static electricity is properly employed in the sense of a *static charge* but not as *static electricity*, since that would indicate a particular kind of electricity, and, as is now generally recognized, electricity, from no matter what source it is derived, is one and the same thing.

Electricity, Storage of — —A term improperly employed to indicate such a storage of energy as will enable it to directly reproduce electric energy.

A so-called storage battery does not store electricity, any more than the spring of a clock can be said to store time or sound. The spring stores muscular energy, *i. e.*, renders the muscular kinetic energy potential, which, again becoming kinetic, causes the works of the clock to move or strike.

In the same way in a so-called storage battery, the energy of an electric current is caused to produce electrolytic decompositions of such a nature as independently to produce a current on the removal of the electrolyzing current. (See *Cell, Secondary. Cell, Storage.*)

Electricity, Thermo — —Electricity produced by differences of temperature at the junctions of dissimilar metals.

If a bar of antimony is soldered to a bar of bismuth, and the free ends of the two metals are connected by means of a galvanometer, an application of heat to the junction, so as to raise its

temperature above the rest of the circuit, will produce a difference of potential, which, if neutralized, will cause a current to flow *across* the *junction* from the bismuth to the antimony (against the alphabet, or from B to A). If the junction be cooled below the rest of the circuit, a current is produced across the junction from the antimony to the bismuth (with the alphabet, or from A to B). These currents are called *thermo-electric currents*, and are proportional to the differences of temperature.

Even the same metal, in different physical states or conditions, such as a wire, part of which is straight and the remainder bent into a spiral as at H C, Fig. 228, if heated at F by the flame of

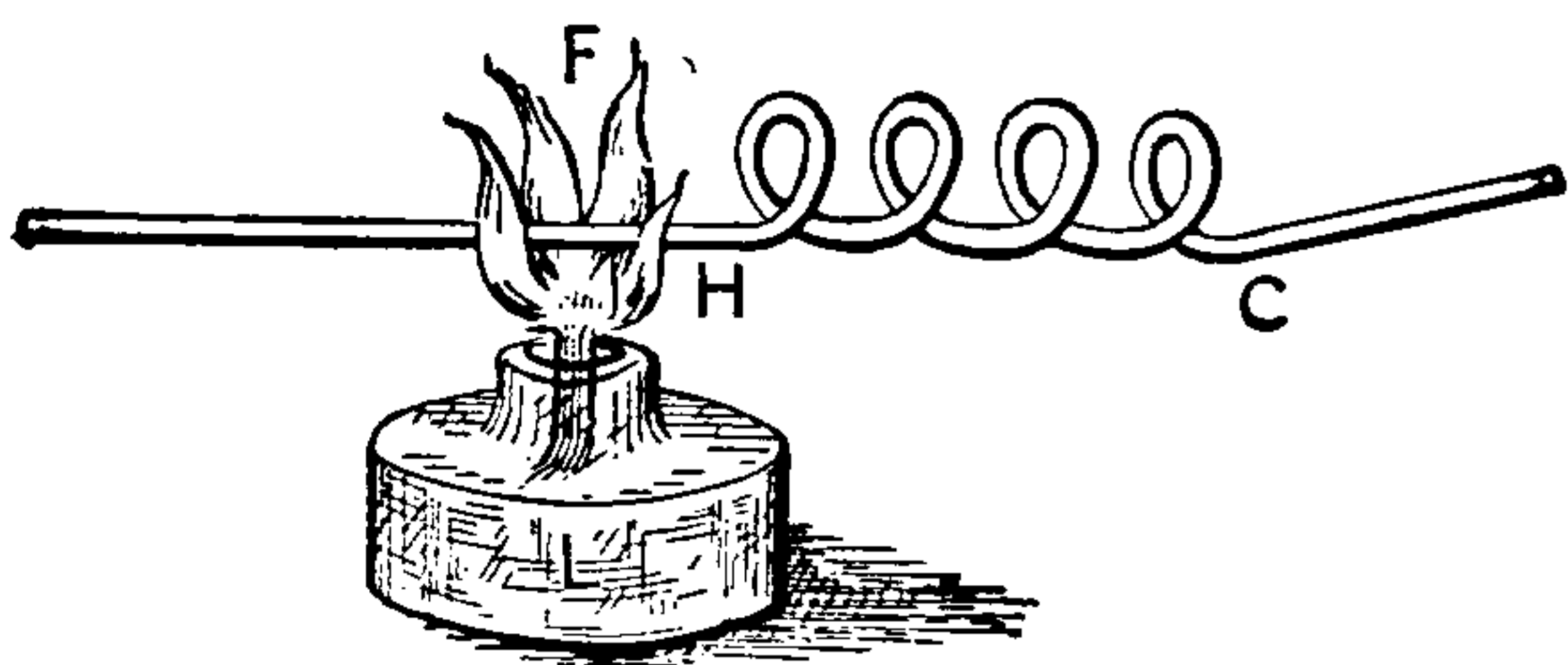

Fig. 228. Thermo-Electricity.

a lamp will have a difference of potential developed in it.

The same thing may also be shown by placing a cylinder of bismuth J, Fig. 229, in a gap in a

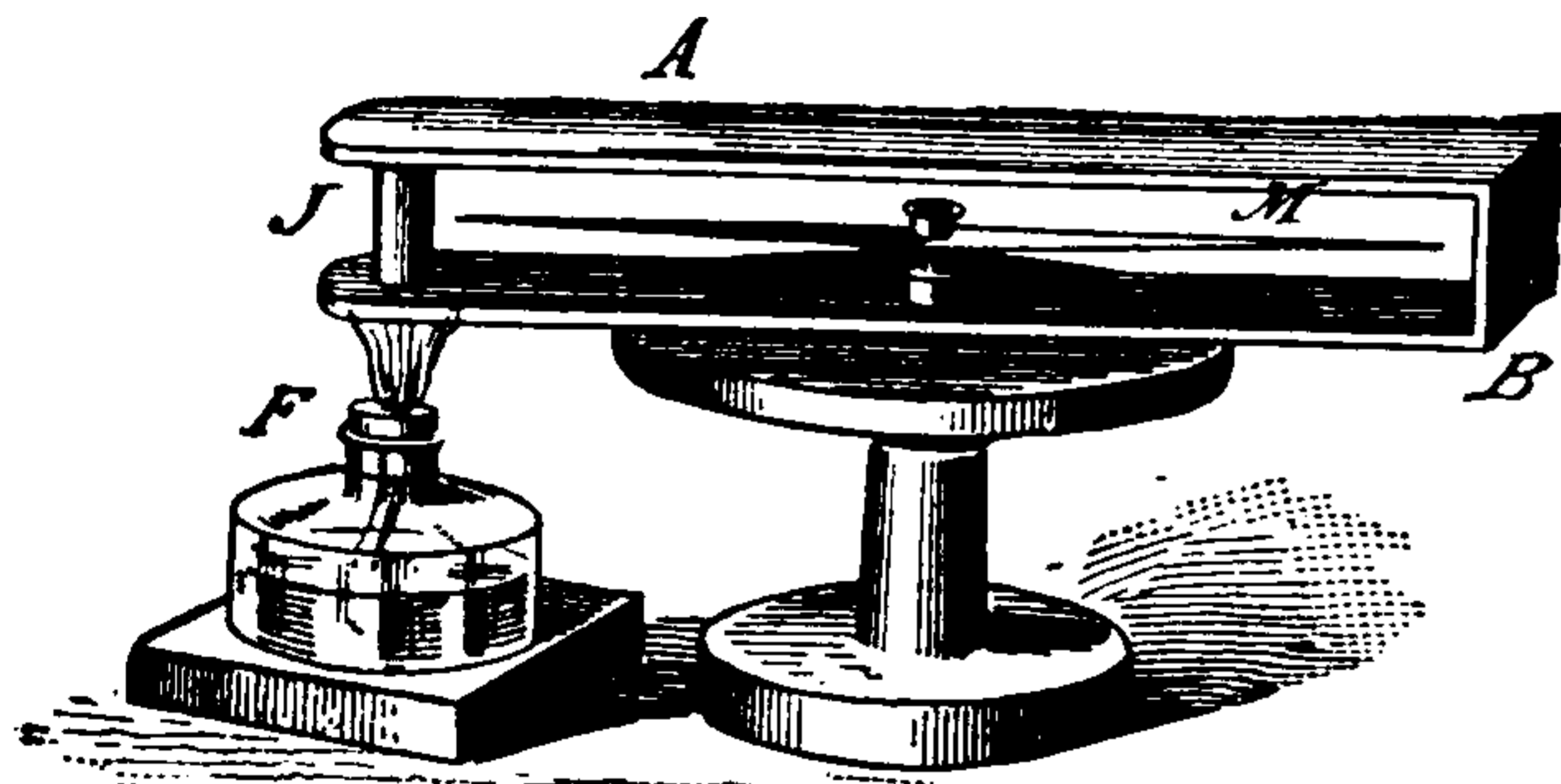

Fig. 229. Thermo-Electric Circuit.

hollow rectangle of copper A B, inside of which a magnetic needle, M, is supported.

The rectangle of copper being placed in the magnetic meridian, on heating the junction by the flame of a lamp F, the needle will be deflected by a current produced by the difference of temperature.

Thermo-electricity is generally obtained by means of the combination of a *thermo-electric couple*, in a *thermo-electric cell*. (See *Couple, Thermo-Electric. Cell, Thermo-Electric.*)

Since the difference of potential produced by a single thermo-electric couple is small, a number of such couples or cells are generally connected in

series to produce a *thermo-electric battery*. (See *Battery, Thermo-Electric.*)

Electricity, Unit Quantity of — — The quantity of electricity conveyed by unit current per second.

The practical unit quantity of electricity is the *coulomb*, which is the quantity conveyed by a current of one ampère in one second.

Electricity, Unit Quantity of, Natural — — The quantity of electricity possessed as a charge by any elementary monad atom. (See *Electricity, Atom of.*)

Electricity, Varieties of — — A classification of electricity according to its state of rest or motion, or to the peculiarities of its motion.

Lodge classifies the different varieties of electricity as follows, viz.:

(1.) Electricity at Rest, or Static Electricity.

This branch of electric science treats of phenomena belonging to stresses and strains in insulated media, when brought into the neighborhood of electric charges, together with the modes of exciting such electric charges, and the laws of their interactions.

(2.) Electricity in Locomotion, or Current Electricity.

This branch of electric science treats of the phenomena produced in metallic conductors, chemical compounds and dielectric media, by the passage of electricity through them, and the modes of exciting electricity into motion, together with the laws of its flow.

(3.) Electricity in Rotation, or Magnetism.

This branch of electric science treats of the phenomena produced in electricity in whirling or vortex motion, the manner in which such whirls may be produced, the strains and stresses which they produce, and the laws of their interactions.

(4.) Electricity in Vibration, or Radiation.

This branch of electric science treats of the study of the propagation of periodic or undulatory disturbances through various kinds of media, the laws regulating wave velocity, wave length, reflection, interference, dispersion, polarization and other similar phenomena generally studied under light.

A misleading classification of electricity is sometimes made according to the sources which produce it. This is misleading, since electricity, no matter how produced, is one and the same.

The so-called varieties of electricity may be divided into different classes according to the nature of the source. The principles of these are as follows:

(1.) Frictional-Electricity, or that produced by the friction of one substance against another.

(2.) Voltaic-Electricity, or that produced by the contact of dissimilar substances under the influence of chemical action.

(3.) Thermo-Electricity, or that produced by differences of temperature in a thermo couple.

(4.) Pyro-Electricity, or that produced by differences of temperature in certain crystalline solids.

(5.) Magneto-Electricity, or that produced by the motion of a conductor through the field of permanent magnets. This is a variety of—

(6.) Dynamo-Electricity, or that produced by moving conductors so as to cut lines of magnetic force.

(7.) Vital-Electricity, or that produced under the influence of life or accompanying life.

Electricity, Vitreous — —A term formerly employed to indicate positive electricity.

It was formerly believed that the friction of glass with other bodies always produces the same kind of electricity. This, however, is now known not to be the case.

The term is now replaced by *positive electricity*. (See *Electricity, Resinous*.)

Electricity, Voltaic — —Differences of potential produced by the agency of a voltaic cell or battery.

Electricity is the same thing or phase of energy by whatever source it is produced.

Electrics.—Substances capable of becoming electrified by friction.

Substances like the metals, which, when held in the hand could not be electrified by friction were formerly called *non-electrics*.

These terms were used by Gilbert in the early history of the science.

This distinction is not now generally employed since conducting substances if insulated, may be electrified by friction.

Electrifiable.—Capable of being endowed with electric properties.

Electrification.—The act of becoming electrified.

The production of an electric charge.

Electrified Body.—(See *Body, Electrified*.)

Electrify.—To endow with electrical properties.

Electrine.—Relating to electrum, or amber.

Electrization, Therapeutical — —Subjecting different parts of the human body to the action of electric currents for the cure of diseased conditions.

Electro-Biology.—(See *Biology, Electro*.)

Electro-Brassing.—(See *Brassing, Electro*.)

Electro-Bronzing.—(See *Bronzing, Electro*.)

Electro-Capillary Phenomena.—(See *Phenomena, Electro-Capillary*.)

Electrocesis.—A word proposed for curing by electricity.

Electro-Chemical Equivalent. — (See *Equivalent, Electro-Chemical*.)

Electro-Chemical Meter.—(See *Meter, Electro-Chemical*.)

Electro-Chemical Telephone.—(See *Telephone, Electro-Chemical*.)

Electro-Chemistry. — (See *Chemistry, Electro*.)

Electro-Chromic Rings.—(See *Rings, Electro-Chromic*.)

Electro-Contact Mine.—(See *Mine, Electro-Contact*.)

Electro-Coppering. — (See *Coppering, Electro*.)

Electro-Crystallization.—(See *Crystallization, Electro*.)

Electrocution.—Capital punishment by means of electricity.

Electrode.—Either of the terminals of an electric source.

The term was applied by Faraday to either of the conductors placed in an electrolytic bath and conveying the current into it, and this is its strict meaning. The terms pole or terminal apply to the ends of a break in any electric circuit.

Electrode, Aural — —A therapeutic electrode, shaped for the treatment of the

THIS PAGE IS LOCKED TO FREE MEMBERS

Purchase full membership to immediately unlock this page

Know Your Bible

Forgotten Books' Full Membership provides unlimited access to more than 28,000 volumes of Christian literature for \$8.99/month

HOLY BIBLE

Continue

*Fair use policy applies

Anode, and the negative electrode the *Kathode*. No matter for what purposes employed, they are generally in electro-therapeutics termed electrodes. In precise use these terms should be restricted to the electrodes when used for electrolytic decomposition.

The electrodes are made of different shapes and of different materials according to the character of the work the current is to perform.

Electrodes, Carbon, for Arc-Lamps — — —
Rods of artificial carbon employed in arc lamps.

These are more properly called simply arc-lamp carbons.

Arc-lamp carbons are moulded into the shape of rods, from plastic mixtures of carbonaceous materials and carbonizable liquids. On the subsequent carbonization of these rods the ingredients are caused to cohere in one solid mass by the deposit of carbon derived from the carbonizable materials. (See *Carbons, Artificial.*)

Carbons for arc-lamps are generally copper-coated, so as to somewhat decrease their resistance, and insure a more uniform consumption. Arc-lamp carbons are sometimes provided with a central *core* of softer carbon, which fixes the position of the arc and thus insures a steadier light. (See *Carbons, Cored.*)

Electrodes, Cored — — — Carbon electrodes of a cylindrical shape provided with a central cylinder of softer carbon.

The use of cored electrodes for arc lamps is for the purpose of steadying the light by maintaining the arc in a central position. This is effected by the greater vaporization of the softer carbon of the core.

Electrodes, Cylindrical Carbon — — — Carbon cylinders used for electrodes of arc-lamps, or for battery plates.

Electrodes, Electro-Therapeutic — — — Electrodes of various shapes employed in electro-therapeutics.

The electro-therapeutic electrode, as distinguished from the indifferent electrode, is especially shaped for the particular purpose for which it is designed.

When the electricity is intended to affect the skin or superficial portions of the body only, it is applied dry, and is then generally metallic. To reach the deeper structures, such as the muscle or nerve trunks, moistened sponge electrodes are

employed. Before their use the skin should be thoroughly moistened. Sponge-electrodes are generally made conducting by a solution of some saline substance, such as common salt.

Electrodes, Erb's Standard Size of — — — Standard sizes of electrodes generally adopted in electro-therapeutics.

The following standard sizes have been proposed by Erb, viz.:

- | | | | |
|------|--------------------|---------------|----------------------|
| (1.) | Fine electrode.... | $\frac{1}{2}$ | centimetre diameter. |
| (2.) | Small " | 2 | " " |
| (3.) | Medium " | 7.5 | " " |
| (4.) | Large " | 6 x 2 | " " |
| (5.) | Very large do.... | 8 x 16 | " " |

Electrodes, Non-Polarizable — — — Electrodes employed in electro-therapeutics, that are so constructed as to avoid the effects of polarization.

Non-polarizable electrodes are obtained by employing two amalgamated zinc wires, dipped into saturated solution of zinc chloride placed in glass tubes, and closing the lower ends of the tubes by a piece of potter's clay. The contact of an electrode so prepared with the tissues of the body does not produce a polarization.

Electro-Diagnosis.—(See *Diagnosis, Electro.*)

Electro-Diagnostic.—(See *Diagnostic, Electro.*)

Electro-Dynamic Attraction.—(See *Attraction, Electro-Dynamic.*)

Electro-Dynamic Capacity.—(See *Capacity, Electro-Dynamic.*)

Electro-Dynamic Induction.—(See *Induction, Electro-Dynamic.*)

Electro-Dynamic Repulsion.—(See *Repulsion, Electro-Dynamic.*)

Electro-Dynamics.—(See *Dynamics, Electro.*)

Electro-Dynamometer.—(See *Dynamometer, Electro.*)

Electro-Etching.—Electric etching. (See *Etching, Electro.*)

Electrogenesis.—Results following the application of electricity to the spinal cord or nerve after the withdrawal of the electrodes.

Electro-Gilding.—(See *Gilding, Electro.*)

Electro-Kinetics.—(See *Kinetics, Electro.*)

Electrolier.—A chandelier for holding electric lamps, as distinguished from a chandelier for holding gas-lights.

Electrology.—That branch of science which treats of electricity. (Obsolete.)

Electrolysis.—Chemical decomposition effected by means of an electric current.

When an electric current is sent through an *electrolyte, i. e.*, a liquid which permits the current to pass only by means of the decomposition of the liquid, the decomposition that ensues is called *electrolytic decomposition*.

The electrolyte is decomposed or broken up into atoms or groups of atoms or *radicals*, called *ions*.

The *ions* are of two distinct kinds, viz.: The *electro-positive ions*, or *kathions*, and the *electro-negative ions*, or *anions*.

Since the *anode* of the source is connected with the electro-positive terminal, it is clear that the *anions*, or the *electro-negative ions*, must appear at the *anode*, and the *kathions*, or *electro-positive ions*, must appear at the *kathode*.

Hydrogen, and the metals generally, are *kathions*. Oxygen, chlorine, iodine, etc., are *anions*.

The vessel containing the electrolyte, in which these decompositions take place, is sometimes called an *electrolytic cell*.

An electrolytic cell is called a *voltameter* when it is arranged for measuring the current passing by means of the amount of decomposition it effects. (See *Voltameter*.)

Electrolysis by Means of Alternating Currents.—Electrolytic decomposition effected by means of alternating currents.

When an alternating current is passed through dilute sulphuric acid, in a voltameter provided with large platinum electrodes, no visible decomposition occurs. If, however, the size of the electrodes be decreased below a certain point, then visible decomposition occurs.

Verdet showed that when no other break exists in the circuit of the alternating current within the voltameter, no indications of electrolysis are obtained, unless the alternating current is very powerful. If, however, a break is made in the secondary circuit, so that the dis-

charge has to pass as a spark, then visible signs of electrolysis are produced by comparatively feeble alternating currents.

When electrolysis occurs by means of alternating currents—

(1.) The gases collected at both electrodes have the same composition.

(2.) Where the quantities of electricity that alternately pass in opposite directions are unequal, the electrodes show manifest polarization, and, when connected by a conductor, yield a current like a secondary battery.

(3.) The electrodes manifest no sensible polarization where the quantities of electricity that alternately pass in opposite directions are equal.

Electrolysis, Faraday's Laws of — —
The principal facts of electrolysis are given in the following laws:

(1.) The amount of chemical action in any given time is equal in all parts of the circuit.

(2.) The number of *ions* liberated in a given time is proportional to the strength of the current passing. Twice as great a current will liberate twice as many *ions*. The current may be regarded as being carried through the electrolyte by the ions: since an ion is capable of carrying a fixed charge only of $+$ or $-$ electricity, any increase in the current strength necessitates an increase in the number of ions.

(3.) When the same current passes successively through several cells containing different electrolytes, the weights of the *ions* liberated at the different electrodes will be equal to the strength of the current multiplied by the electro-chemical equivalent of the *ion*. (See *Equivalence, Electro-Chemical, Law of*.)

The *chemical equivalent* is proportional to the *atomic weight* divided by the *valency*. (See *Equivalent, Chemical*.)

The electro-chemical equivalent of any element is equal to the weight in grammes of that element set free by one coulomb of electricity, and is found by multiplying the electro-chemical of hydrogen by the chemical equivalent of that element. (See *Equivalent, Electro-Chemical*.)

Electrolyte, Polarization of — ——The formation of molecular groups or chains, in which the poles of all the molecules of any chain are turned in the same direction, viz.: with their positive poles facing the negative plate, and their negative poles facing the

positive plate. (See *Cell, Voltaic. Hypothesis, Grotthus'*.)

Electrolytic or Electrolytical.—Pertaining to electrolysis.

Electrolytic Analysis.—(See *Analysis, Electrolytic*.)

Electrolytic Cell.—(See *Cell, Electrolytic, Tesla's*.)

Electrolytic Clock.—(See *Clock, Electrolytic*.)

Electrolytic Conduction.—(See *Conduction, Electrolytic*.)

Electrolytic Convection.—(See *Convection, Electrolytic*.)

Electrolytic Decomposition.—(See *Decomposition, Electrolytic*.)

Electrolytic Hydrogen.—(See *Hydrogen, Electrolytic*.)

Electrolytic Writing.—(See *Writing, Electrolytic*.)

Electrolytically.—In an electrolytic manner.

Electrolyzable.—Capable of being electrolyzed, or decomposed by means of electricity.

Electrolyzed.—Separated or decomposed by means of electricity.

Electrolyzing.—Causing or producing electrolysis.

Electro-Magnet.—(See *Magnet, Electro*.)

Electro-Magnetic Ammeter.—(See *Ammeter, Electro-Magnetic*.)

Electro-Magnetic Annunciator.—(See *Annunciator, Electro-Magnetic*.)

Electro-Magnetic Attraction.—(See *Attraction, Electro-Magnetic*.)

Electro-Magnetic Bell-Call.—(See *Call, Bell, Magneto-Electric*.)

Electro-Magnetic Bell, Siemens' Armature — — (See *Bell, Electro-Magnetic, Siemens' Armature Form*.)

Electro-Magnetic Brake.—(See *Brake, Electro-Magnetic*.)

Electro-Magnetic Cam.—(See *Cam, Electro-Magnetic*.)

Electro-Magnetic Dental-Mallet.—(See *Dental-Mallet, Electro-Magnetic*.)

Electro-Magnetic Drill.—(See *Drill, Electro-Magnetic*.)

Electro-Magnetic Engine.—(See *Engine, Electro-Magnetic*.)

Electro-Magnetic Exploder.—(See *Exploder, Electro-Magnetic*.)

Electro-Magnetic Eye.—(See *Eye, Electro-Magnetic*.)

Electro-Magnetic Impulse.—(See *Impulse, Electro-Magnetic*.)

Electro-Magnetic Induction.—(See *Induction, Electro-Magnetic*.)

Electro-Magnetic Medium.—(See *Medium, Electro-Magnetic*.)

Electro-Magnetic Meter.—(See *Meter, Electro-Magnetic*.)

Electro-Magnetic Momentum of Secondary Circuit.—(See *Momentum, Electro-Magnetic, of Secondary Circuit*.)

Electro-Magnetic Pop-Gun.—(See *Pop-Gun, Electro-Magnetic*.)

Electro-Magnetic Radiation.—(See *Radiation, Electro-Magnetic*.)

Electro-Magnetic Repulsion.—(See *Repulsion, Electro-Magnetic*.)

Electro-Magnetic Resonator.—(See *Resonator, Electro-Magnetic*.)

Electro-Magnetic Shunt.—(See *Shunt, Electro-Magnetic*.)

Electro-Magnetic Solenoid.—(See *Solenoid, Electro-Magnetic*.)

Electro-Magnetic Strain.—(See *Strain, Electro-Magnetic*.)

Electro-Magnetic Stress.—(See *Stress, Electro-Magnetic*.)

Electro-Magnetic Theory of Light, Maxwell's — — (See *Light, Maxwell's Electro-Magnetic Theory of*.)

Electro-Magnetic Vibrator.—(See *Vibrator, Electro-Magnetic*.)

Electro-Magnetic Voltmeter.—(See *Voltmeter, Electro-Magnetic*.)

THIS PAGE IS LOCKED TO FREE MEMBERS

Purchase full membership to immediately unlock this page



HISTORY

Tens of thousands of important historical sources, many previously unobtainable, are now available for the first time with a Forgotten Books Full Membership.

Unlimited Access
\$8.99/month

Continue

*Fair usage policy applies

A form of capillary electrometer is shown in Fig. 231, in which a horizontal glass tube with a drop of acid at B, has its ends connected with two vessels M and N, filled with mercury. If a current be passed through the tube, a movement of the drop *towards the negative pole* will be observed. Where the electromotive force does not exceed one volt, the amount of the movement is proportional to the electromotive force.

Electrometer, Quadrant — — An electrometer in which an electrostatic charge is measured by the attractive and repulsive force of four plates or quadrants, on a light needle of aluminium suspended within them.

The sectors or quadrants are of brass, and are so shaped as to form a hollow cylindrical box when placed together. The four sectors, or quadrants, are insulated from one another, but the opposite ones are connected by a conducting wire, as shown in Fig.

232. A light needle of aluminium, *u*, maintained at some constant potential, by connection with the inner coating of a Leyden jar, is suspended, generally by two parallel silk threads,

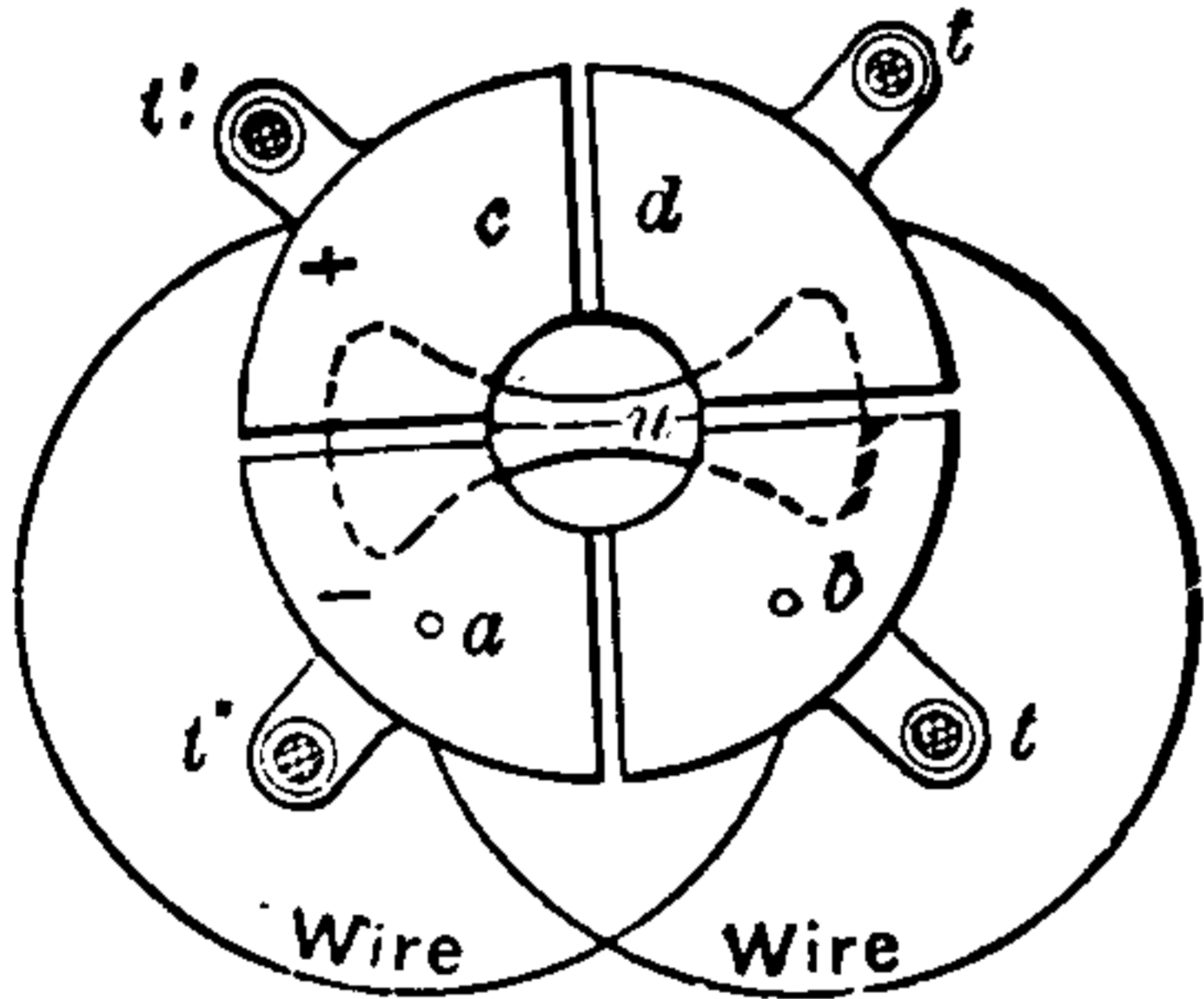

Fig. 232. Quadrant Electrometer.

so as to freely swing inside the hollow box. This needle, when at rest, is in the position shown by the dotted lines, with its axis of symmetry exactly under one of the slots or spaces between two opposite sectors. (See *Suspension, Bi-Filar.*)

The quadrant electrometer, shown in Fig. 233, has one of its quadrants removed so as to show the suspended aluminium needle.

A similar form of instrument is shown in Fig. 234, with all the quadrants in place, and the whole instrument covered by a glass shade.

To use the quadrant electrometer the pairs of sectors are connected with the two bodies whose difference of potential is to be measured, and the deflection of the needle observed, generally through a *telescope*, by means of a spot of light reflected from a mirror attached to the upper part of the needle.

Sometimes the segments are made in the shape of a cylinder, and the needle in the shape of a suspended rectangle.

Electrometer, Registering — — An electrometer, the deviations of the needle of which are automatically registered.

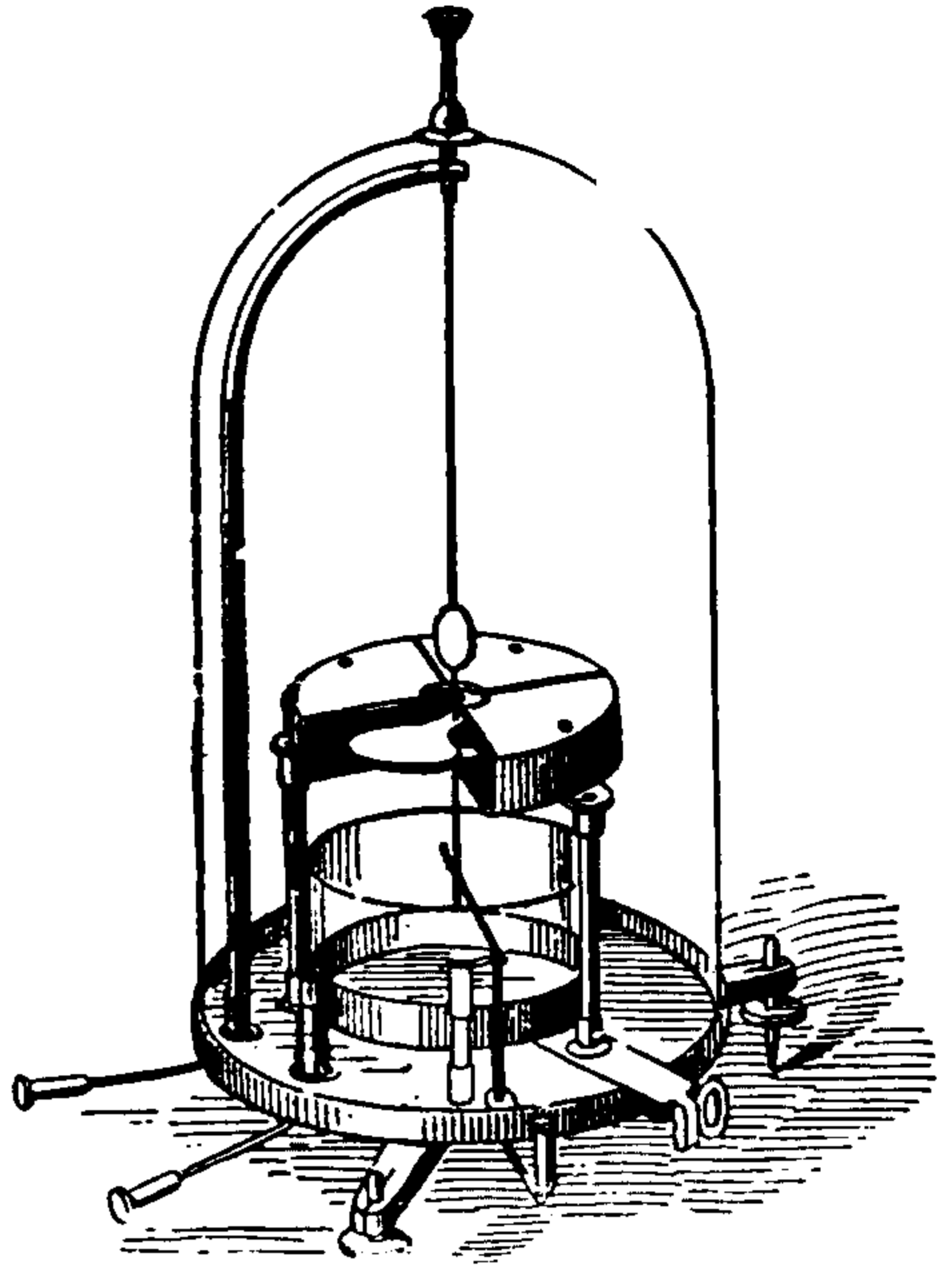

Fig. 233. Quadrant Electrometer, Showing Suspended Needle.

The registration of this class of electrometer is obtained by means of photography. The spot of

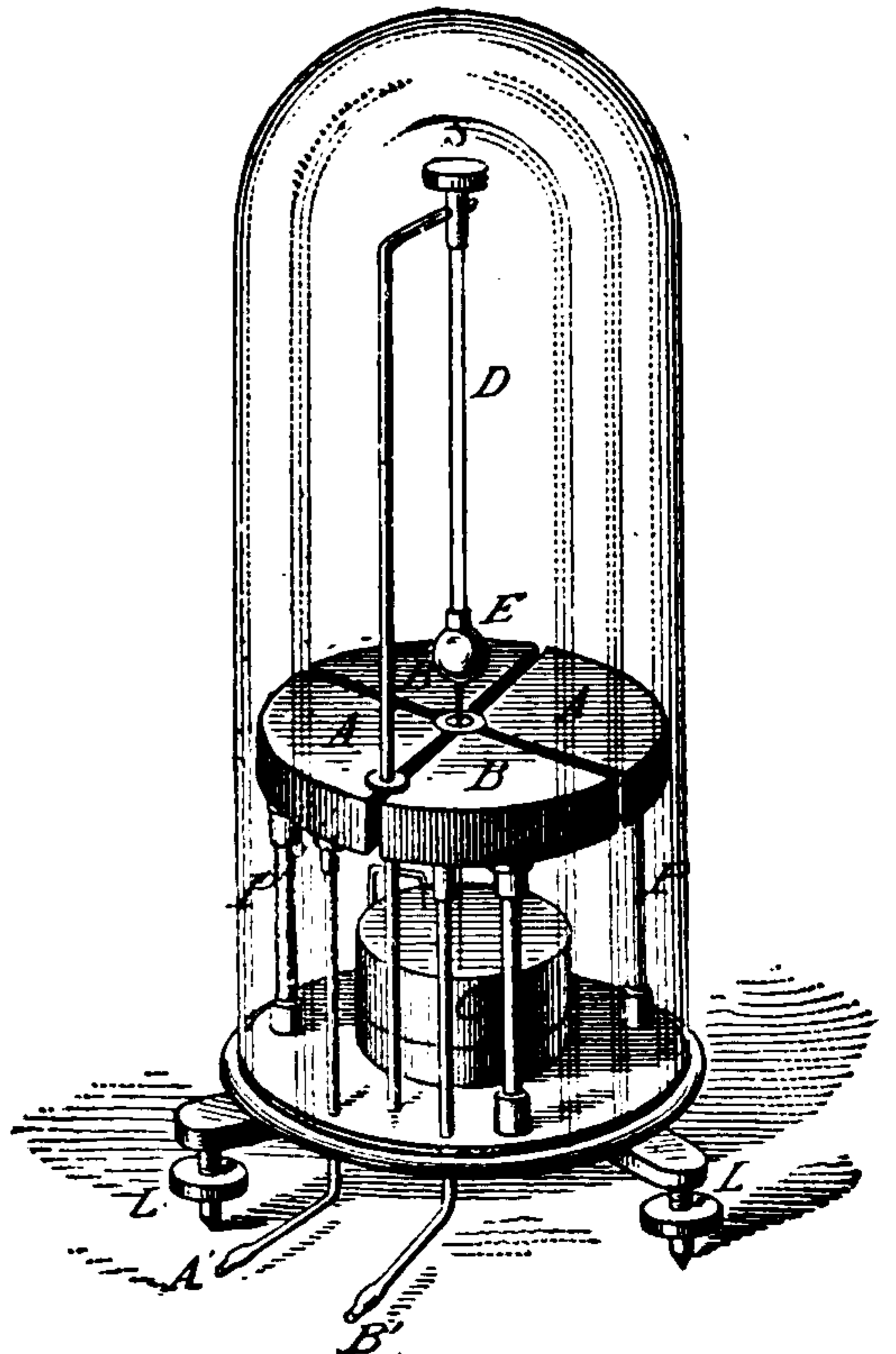

Fig. 234. Quadrant Electrometer.

light, reflected from the mirror of the electrometer, falls on a fillet of sensitized paper, moved by clockwork.

Electromotive Arrangement or Device.—(See *Arrangement or Device, Electromotive.*)

Electromotive Difference of Potential.—(See *Potential, Difference of Electromotive.*)

Electromotive Force.—(See *Force, Electromotive.*)

Electromotive Force, Average — — (See *Force, Electromotive, Average or Mean.*)

Electromotive Force, Back or Counter — — (See *Force, Electromotive, Back.*)

Electromotive Force, Direct — — (See *Force, Electromotive, Direct.*)

Electromotive Force, Inductive — — (See *Force, Electromotive, Inductive.*)

Electromotive Force, Secondary-Im-pressed — — (See *Force, Electromotive, Secondary-Im-pressed.*)

Electromotive Force, Simple-Periodic — — (See *Force, Electromotive, Simple-Periodic.*)

Electromotive Force, Transverse — — (See *Force, Electromotive, Transverse.*)

Electromotive Impulse.—(See *Impulse, Electromotive.*)

Electro-Motograph.—(See *Motograph, Electro.*)

Electro-Muscular.—(See *Muscular, Electro.*)

Electro-Muscular Excitation.—(See *Excitation, Electro-Muscular.*)

Electronecrosic.—Pertaining to capital punishment by means of electricity.

Electronecrosis.—A word proposed for capital punishment by means of electricity.

Electro-Negative Ions.—(See *Ions, Electro-Negative.*)

Electronegatives.—The atoms or radicals that appear at the anode or positive terminal during electrolysis.

The anions. (See *Electrolysis, Anion.*)

Electro-Nervous Excitability.—(See *Excitability, Electro-Nervous.*)

Electro-Nickeling.—(See *Nickeling, Electro.*)

Electro-Optics.—(See *Optics, Electro.*)

Electrophanic.—Pertaining to capital punishment by means of electricity.

Electrophanical.—Pertaining to capital punishment by means of electricity.

Electrophanize.—To inflict capital punishment by means of electricity.

Electrophanity.—Capital punishment by means of electricity.

The word electrophanity would appear to be far preferable to the word electrocution, since it is in accordance with etymological usage, while electrocution is not.

Electrophila.—A devotee of electricity.

Electrophobia.—A word proposed for fear of electricity.

Electrophoric.—Pertaining to an electrophorus. (See *Electrophorus.*)

Electrophorus.—An apparatus for the production of electricity by electrostatic induction. (See *Induction, Electrostatic.*)

A disc of vulcanite, or hard rubber B, contained in a metallic form, is rubbed briskly by a piece of cat's skin and the insulated metallic disc, A, is placed on the centre of the vulcanite disc, as shown in Fig. 235.

The negative charge produced in B, by friction, produces by induction a positive charge on the part of A, nearest it, and a negative charge on the part furthest from it.

In this condition, if the disc be raised from the plate by means of its insulating handle, as shown in Fig. 236, no electrical effects will be noticed, since the two opposite and equal charges unite and neutralize each other. If, however, the disc A, be first touched by the finger, and then raised from the disc B, it will be found to be positively charged.

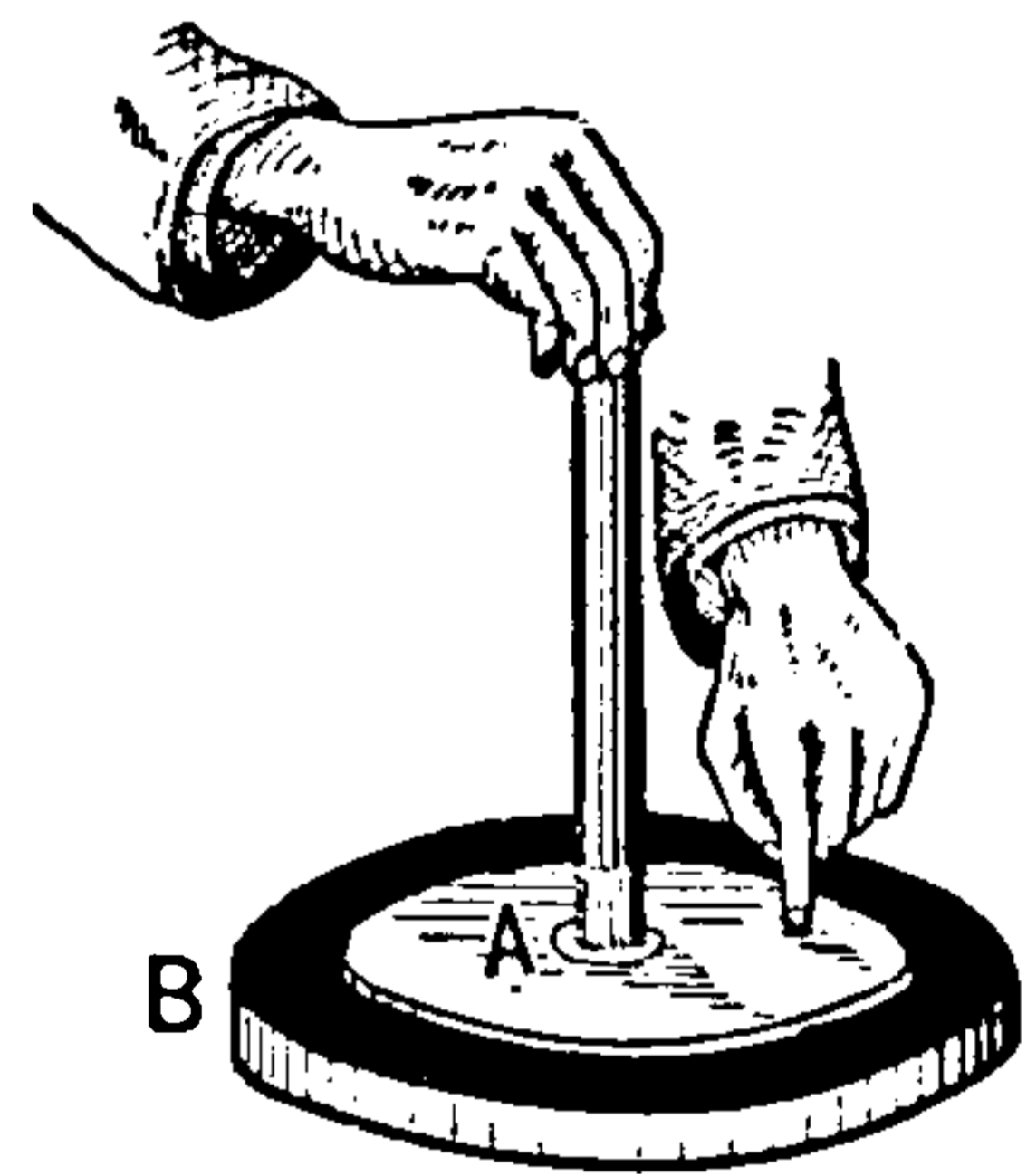

Fig. 235. Electrophorus, Charging.

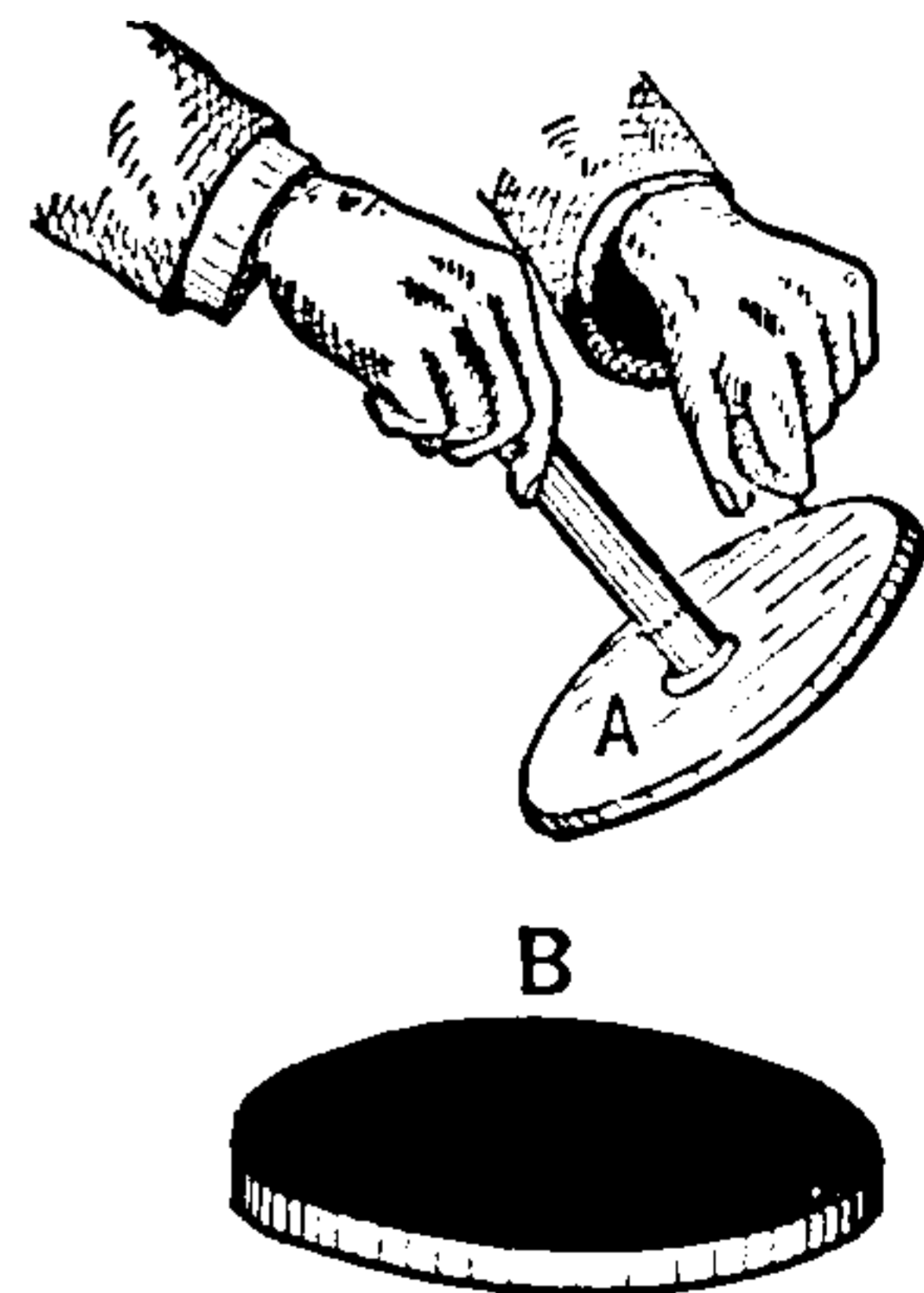

Fig. 236. Electrophorus, Discharging.

Electro-Physiology.—(See *Physiology, Electro.*)

Electropic Medium.—(See *Medium, Electropic.*)

Electro-Plating.—(See *Plating, Electro.*)

Electro-Plating Bath.—(See *Bath, Electro-Plating.*)

Electro-Pneumatic Signals.—(See *Signals, Electro-Pneumatic.*)

Electro-Pneumatic Thermostat.—(See *Thermostat, Electro-Pneumatic.*)

Electropoion Liquid.—(See *Liquid, Electropoion.*)

Electro-Positive Ions.—(See *Ions, Electro-Positive.*)

Electropositives.—The atoms or radicals that appear at the kathode or negative terminal of any source during electrolysis.

The kathions. (See *Electrolysis, Kathion.*)

Electro-Prognosis.—(See *Prognosis, Electric.*)

Electro-Puncture.—(See *Puncture, Electro.*)

Electro-Receptive Devices.—(See *Device, Electro-Receptive.*)

Electro-Receptive Devices, Multiple-Arc-Connected — — (See *Devices, Electro-Receptive, Multiple-Arc-Connected.*)

Electro-Receptive Devices, Multiple-Series-Connected — — (See *Devices, Electro-Receptive, Multiple-Series-Connected.*)

Electro-Receptive Devices, Series-Connected — — (See *Devices, Electro-Receptive, Series-Connected.*)

Electro-Receptive Devices, Series-Multiple-Connected — — (See *Devices, Electro-Receptive, Series-Multiple-Connected.*)

Electroscope.—An apparatus for showing the presence of an electric charge, or for determining its sign, whether positive or negative, but not for measuring its amount or value.

In the gold-leaf electroscope, two gold leaves, n, n, Fig. 239, suspended near each other, show by their repulsion the presence of an electric charge. Two pith balls may be used for the same purpose.

The pith balls B, B, shown in Fig. 237, form a simple electroscope. If repelled by a charge, when approached by a similar charge in S, they will at once be still further repelled, as shown by the dotted lines.

To use an electroscope for determining the *sign* of

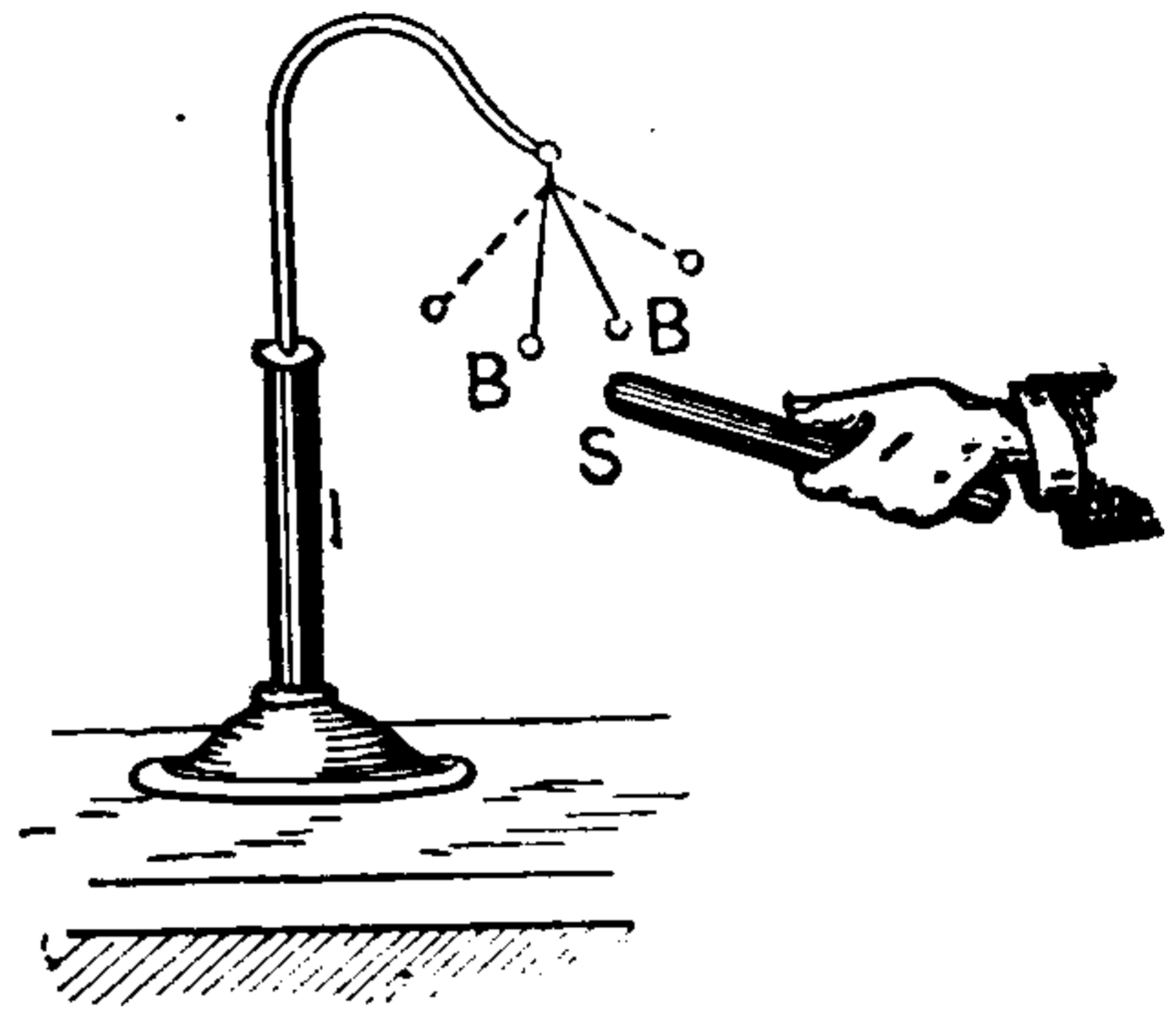

Fig. 237. Pith Ball Electroscope.

an unknown charge, the gold leaves or pith balls are first slightly repelled by a charge of known name, as, for example, positive, applied to the knob C, Fig. 239. They are then charged by the electrified body whose charge is to be determined. If they are further repelled, its charge is positive. If they are first attracted and afterwards repelled, its charge is negative.

Two posts B, Fig. 239, connected with the earth, increase the amount of divergence by induction.

Electroscope, Condensing, Volta's — —

An electroscope employed for the detection of feeble charges, the leaves of which are charged by means of a condenser.

The condensing electroscope, Fig. 238, is formed of two metallic plates, placed at the top of the instrument, and separated by a suitable dielectric. The upper plate, P, is removable by means of the insulated handle, G.

To employ the electroscope, as for example, to detect the free charge in an unequally heated crystal of tourmaline, the crystal is touched to the lower plate, while the upper plate is connected to the ground by the finger. On the subsequent removal of the upper plate an enormous decrease

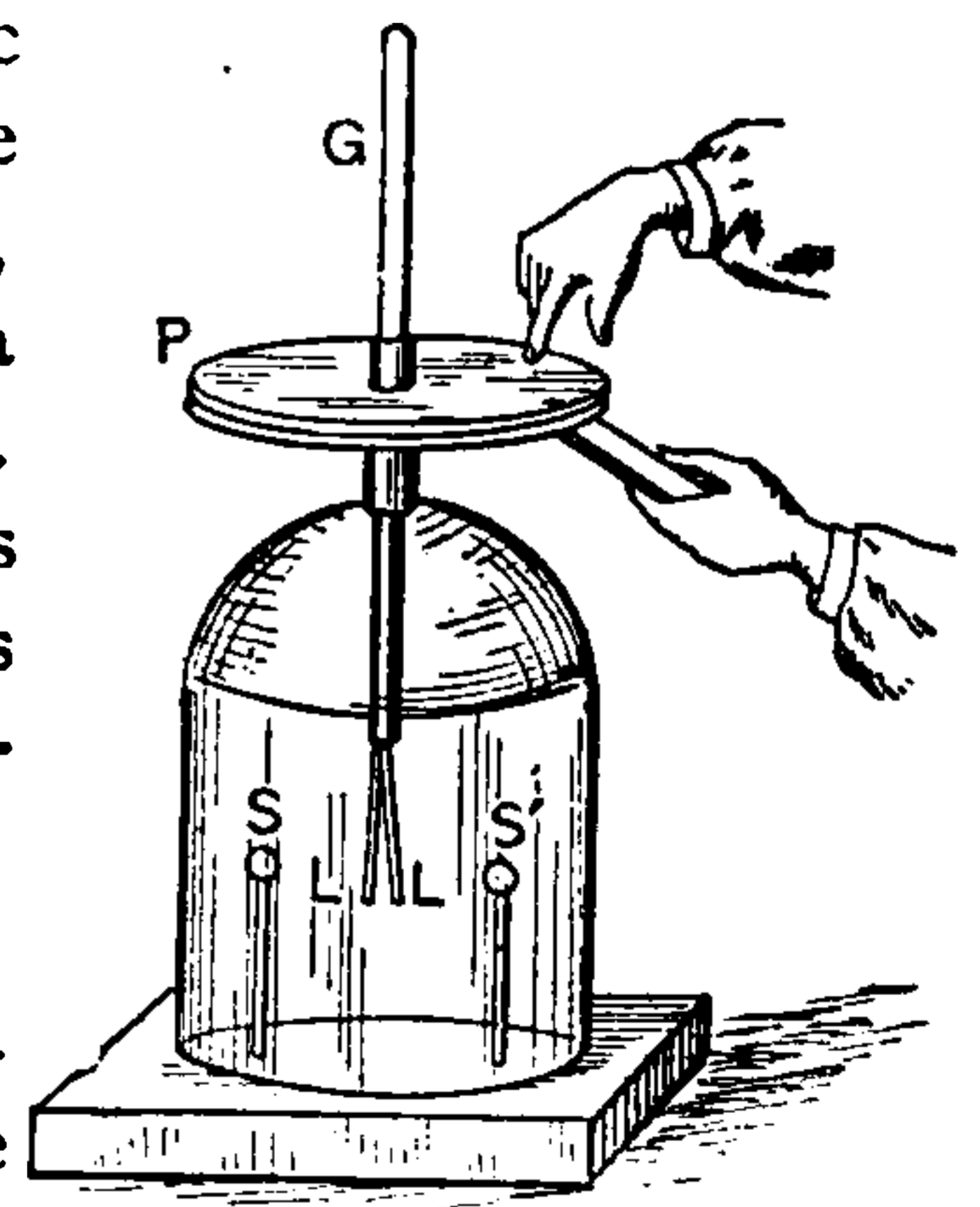

Fig. 238. Condensing Electroscope.

THIS PAGE IS LOCKED TO FREE MEMBERS

Purchase full membership to immediately unlock this page

Know Your Bible

Forgotten Books' Full Membership provides unlimited access to more than 28,000 volumes of Christian literature for \$8.99/month

HOLY BIBLE

Continue

*Fair use policy applies

The principles of electrostatics are embraced in the following laws, viz.:

(1.) Charges of like name, *i. e.*, either positive or negative, repel each other. Charges of unlike name attract each other.

(2.) The forces of attraction or repulsion between two charged bodies are directly proportional to the product of the quantities of electricity possessed by the bodies and inversely proportional to the square of the distance between them.

These laws can be demonstrated by the use of Coulomb's torsion balance. (See *Balance, Torsion.*)

Calling q , and q^1 , the quantities of electricity possessed by the two bodies, and r , the distance between them, then, if f , is the force exerted by their mutual action,

$$f = \frac{q q^1}{r^2}.$$

Electro-Technics.—(See *Technics, Electro.*)

Electrothanasing.—Producing death by electricity.

Electrothanasia.—A word proposed for death by electricity.

The death referred to here is death other than that caused by capital punishment.

Electrothanasise.—To produce death by electricity.

The death here referred to is other than that caused by capital punishment.

Electrothanasose.—To cause death by electricity.

Electrothanasotic.—Pertaining to capital punishment by means of electricity.

Electrothanasosing.—Causing death by electricity.

Electrothanasosis.—A word proposed for death by electricity.

The death here referred to is death other than that caused by capital punishment.

Electro-Therapeutic Bath.—(See *Bath, Electro-Therapeutic.*)

Electro-Therapeutic Breeze.—(See *Breeze, Electro-Therapeutic.*)

Electro-Therapeutic Diffusion of Current.—(See *Current, Diffusion of, Electro-Therapeutic.*)

Electro-Therapeutic Dosage.—(See *Dosage, Electro-Therapeutical.*)

Electro-Therapeutic Electrode.—(See *Electrode, Electro-Therapeutic.*)

Electro-Therapeutic Electrodes.—(See *Electrode, Electro-Therapeutic.*)

Electro-Therapeutic Galvanization.—(See *Galvanization, Electro-Therapeutical.*)

Electro-Therapeutic Head-Breeze.—(See *Breeze, Head, Electro-Therapeutic.*)

Electro-Therapeutics.—(See *Therapeutics, Electro.*)

Electro-Therapeutist.—(See *Therapeutist, Electro.*)

Electro-Therapy.—(See *Therapy, Electro.*)

Electro-Thermal Meter.—(See *Meter, Electro-Thermal.*)

Electro-Tinning.—(See *Tinning, Electro.*)

Electrotisic.—Pertaining to capital punishment by means of electricity.

Electrotising.—Producing capital punishment by means of electricity.

Electrotisis.—A word proposed for capital punishment by means of electricity.

Electrotonic Current.—(See *Current, Electrotonic.*)

Electrotonic Effect.—(See *Effect, Electrotonic.*)

Electrotonic Excitability.—(See *Excitability, Electrotonic.*)

Electrotonic State.—(See *State, Electrotonic.*)

Electrotonus.—A condition of altered functional activity which occurs in a nerve when subjected to the action of an electric current.

The electrotonic state is produced by the passage through a nerve of a constant current called the polarizing current.

Electrotonus is attended by the modification of the nerve in the following respects, viz.:

(1.) In its electromotive force.

(2.) In its excitability.

The passage of the constant current produces a change in the electromotive force of that part of the nerve traversed by the current.

This alteration in muscular excitability may consist in either an increased or a decreased functional activity. The *decreased* functional activity occurs in the neighborhood of the anode, or the positive terminal, and is called the *anelectrotonic state*. The *increased* functional activity occurs in the neighborhood of the kathode, or the negative terminal, and is called the *kathoelectrotonic state*. (See *Anelectrotonus*. *Kathoelectrotonus*.)

This altered functional activity affects not only the *intra polar* parts of the nerve, or that part between the electrodes, but also the *extra-polar portions*, or, in other words, the remainder of the nerve.

The electrotonic state is characterized by two varieties, viz.: those in which the electromotive force of the nerve is decreased, and those in which the electromotive force of the nerve is increased. These varieties of electrotonus are called respectively the negative and positive phase of electrotonus. (See *Electrotonus, Negative Phase of*. *Electrotonus, Positive Phase of*.)

Electrotonus, Negative Phase of — —

A decrease in the electromotive force of a nerve effected by sending a current through the nerve in the opposite direction to the nerve current. (See *Current, Nerve*.)

Electrotonus, Positive Phase of — —

An increase in the electromotive force of a nerve effected by sending a current through the nerve in the same direction as the nerve current.

The increase in the electromotive force not only affects the portions of the nerve in the *intra-polar* regions, but in the *extra polar* regions as well.

Electrotype.—A type, cast, or impression of an object obtained by means of electro-metallurgy. (See *Metallurgy, Electro. Electrotyping*.)

Electrotyping, or the Electrotype Pro-

cess — — — Obtaining casts or copies of objects by depositing metals in molds by the agency of electric currents.

The molds are made of wax, or other plastic substance, rendered conducting by coating it with powdered plumbago.

The mold is connected with the negative battery terminal, and placed in a metallic solution, generally of copper sulphate, opposite a plate of metallic copper, connected with the positive battery terminal. As the current passes, the metal is deposited on the mold at the kathode, and dissolved from the metallic plate at the anode, thus producing an exact copy or cast and at the same time maintaining constant the strength of the bath.

Electrozemia.—A word proposed for capital punishment by means of electricity.

Electrum.—A name given by the ancients to various substances that could be readily electrified by friction.

The term electrum included a number of substances, but was applied mainly either to amber or to an alloy of gold and silver.

Element.—Any kind of matter which cannot be decomposed into simpler matter.

Matter that is formed or composed of but one kind of atoms.

Oxygen and hydrogen are *elements* or varieties of elementary matter. They cannot be decomposed into anything but oxygen or hydrogen. Water, on the contrary, is *compound matter*, since it can be decomposed into its constituent parts, oxygen and hydrogen.

There are about seventy well-known elements, some of which are very rare, occurring in extremely small quantities.

The evidence of the true elementary condition of many of the elements is based, to a great extent, on the fact that so far they have resisted all efforts made to decompose them into simpler substances. We should bear in mind, however, that until Davy's use of the voltaic battery, potash, soda, and many other similar compounds were regarded as true elements. It is not improbable that many of the now so-called elements, may hereafter be decomposed into simpler constituents.

The following table gives the names, chemical

symbols, approximate atomic weights and equivalents of the principal elements :

Names of Elements.	Symbol.	Approximate Atomic Weight.	Chemical Equivalent.*
Aluminium	Al.	27.	9 [compounds
Antimony	Sb.	120.	40 in <i>ous</i> , 24 in <i>ic</i>
Arsenic	As.	74.9	24.9 in <i>ous</i> , 15 in <i>ic</i>
Barium	Ba.	136.8	68.4
Beryllium	Be	9.1	4.6
Bismuth	Bi.	207.5	69.2
Boron	B.	10.9	3.6
Bromine	Br.	79.8	79.8
Cadmium	Cd.	111.8	55.9
Caesium	Cs.	132.6	66.3
Calcium	Ca.	40.	20
Carbon	C.	12.	6
Cerium	Ce.	140.4	
Chlorine	Cl.	35.4	35.4
Chromium	Cr.	52.	26 in <i>ous</i> , 17.3 in <i>ic</i>
Cobalt	Co	58.9	29.5
Copper	Cu.	63.2	31.6
Didymium	D.	144.6	
Erbium	E.	165.9	
Fluorine	F.	19.	19.
Gallium	Ga.	68.9	
Germanium	Ge.	72.3	
Glucinum	G.		
Gold	Au.	196.2	196.2 in <i>ous</i> , 65.4 in <i>ic</i>
Hydrogen	H.	1.	1
Indium	In.	113.4	37.8
Iodine	I.	126.6	126.6
Iridium	Ir	192.7	95.4, 64.2, 48.2
Iron	Fe.	55.9	28 in <i>ous</i> , 18.6 in <i>ic</i>
Lanthanum	L.	138.5	
Lead	Pb.	206.5	103.3
Lithium	L.	7.	7
Magnesium	Mg.	24.	12
Manganese	Mn.	53.9	27
Mercury	Hg.	199.7	199.7 in <i>ous</i> , 99.9 in <i>ic</i>
Molybdenum	Mo.	95.5	
Nickel	Ni.	57.9	28
Niobium	Nb.	93.8	
Nitrogen	N.	14.	14
Osmium	Os.	198.5	
Oxygen	O.	16.	8
Palladium	Pd.	105.7	52.9 in <i>ous</i> , 26.4 in <i>ic</i>
Phosphorus	P.	31.	6.2 in phosphates
Platinum	Pt.	194.4	97.2 in <i>ous</i> , 48.6 in <i>ic</i>
Potassium	K.	39.1	39.
Rhodium	R.	104.1	52 in <i>ous</i> , 34.7 in <i>ic</i>
Rubidium	Rb.	85.3	85.3
Ruthenium	Ru.	104.2	52.1 in <i>ous</i> , 34.7 in <i>ic</i>
Samarium	Sm.	150.02	
Scandium	Sc.	44.	
Selenium	Se.	78.8	
Silicon	Si.	28.2	7.
Silver	Ag.	107.7	107.7
Sodium	Na.	23.	23
Strontium	Sr.	87.4	43.7
Sulphur	S.	32.	
Tantalum	Ta.	182.1	
Tellurium	Te	128.	
Thallium	Tl.	203.7	203.7 in <i>ous</i> , 67.9 in <i>ic</i>
Thorium	Th.	233.4	
Tin	Sn.	117.7	58.9 in <i>ous</i> , 29.4 in <i>ic</i>
Titanium	Ti.	48.	24 in <i>ous</i> , 12 in <i>ic</i>
Tungsten	W.	183.6	91.8 in <i>ous</i>
Uranium	U.	238.5	119.2 in <i>ous</i>
Vanadium	Va.	51.3	17.1 in <i>ous</i>
Ytterbium	Yb.	172.8	
Yttrium	Y.	89.8	
Zinc	Zn.	64.9	32.5
Zirconium	Zr.	89.4	

* Atomic weight divided by the valency.

Element, Negative — — One of the substances forming a voltaic couple. (See *Couple, Voltaic.*)

Element, Negative, of a Voltaic Cell — — That element or plate of a voltaic cell into which the current passes from the exciting fluid of the cell.

The plate that is not acted on by the electrolyte during the generation of current by the cell.

The copper or carbon plate, respectively, in a zinc-copper or zinc-carbon couple.

It must be carefully borne in mind that the conductor attached to the *negative element of a voltaic pile is the positive conductor or electrode of the pile*, since the current that flows into the plate from the liquid or electrolyte must flow out of the plate where it projects beyond the liquid.

Element of Current.—(See *Current, Element of.*)

Element of Storage Battery.—(See *Battery, Storage, Element of.*)

Element, Positive — — That element or plate of a voltaic cell from which the current passes into the exciting fluid of the cell.

The element of a voltaic couple which is acted on by the exciting fluid of the cell. (See *Couple, Voltaic.*)

Element, Thermo-Electric — — One of the two metals or substances which form a thermo-electric couple. (See *Couple, Thermo-Electric.*)

Element, Voltaic — — One of the two metals or substances which form a voltaic couple. (See *Couple, Voltaic.*)

Elements, Electrical Classification of — — A classification of the chemical elements into two groups or classes according to whether they appear at the anode or kathode when electrolyzed.

The chemical elements may be arranged into electro-positive and electro-negative according to whether, during electrolysis, they appear at the negative or positive terminal of the source respectively.

The electro-positive elements or radicals are called *kathions*, and appear at the kathode or electro-negative terminal. The electro-negative

THIS PAGE IS LOCKED TO FREE MEMBERS

Purchase full membership to immediately unlock this page



HISTORY

Tens of thousands of important historical sources, many previously unobtainable, are now available for the first time with a Forgotten Books Full Membership.

Unlimited Access
\$8.99/month

Continue

*Fair usage policy applies

against the earth's attraction, through a distance of say ten feet, and placed on a suitable support, an amount of energy, equal to the ten foot-pounds of work done on the weight, becomes potential.

In the same manner if the elementary atoms of carbon and oxygen, when combined so as to form carbonic acid, are raised or separated from one another sufficiently to decompose the carbonic acid and separate the carbon from the oxygen, the amount of potential energy the carbon and oxygen possess, as a result of having been separated, is equal precisely to that originally required to separate them. In this manner each chemical element possesses a store of chemical-potential energy peculiar to it, and any element with which it may subsequently enter into combination. When elements combine chemically this potential energy is expended in producing heat.

Energy, Conservation of — — The indestructibility of energy.

The total quantity of energy in the universe is unalterable.

The total energy of the universe is not, however, available for the production of work useful for man.

When energy disappears in one form it reappears in some other form. This is called the *conservation* or *indestructibility* of energy. The commonest form in which energy reappears is as *heat*, and in this case some of the heat is lost to the earth by radiation. This *degradation* or *dissipation of energy* causes some of the energy of the earth to become *non-available* to man.

Energy is therefore *available* and *non-available*. (See *Entropy*.)

Energy, Correlation of — — A term sometimes applied to the different phases under which energy may appear.

Since energy is indestructible, when it disappears in one form or phase, it must reappear in another form or phase. The correlation of the different phases of energy, therefore, necessarily follows from the fact that all energy is indestructible.

Energy, Degradation of — — Such a dissipation of energy as to render it non-available to man. (See *Energy, Conservation of. Entropy*.)

Energy, Dissipation of — — The expenditure or loss of available energy.

Energy, Electric — — The power which electricity possesses of doing work.

In the case of a liquid mass at different levels, the liquid at the higher level possesses a certain amount of *potential energy* measured by the *quantity* of the liquid at the higher level, and the *excess of its height over that of the lower level*; or, by the difference between the two levels. Any difference of level will produce a flow of the liquid *from the higher to the lower level*, and during the flow of this current of liquid, potential energy will be lost, and a certain amount of work will be done.

In the case of electricity, the *difference of electric level*, or *potential*, between any two points of a conductor, causes an electric current to flow between these points toward the lower electric level, during which *electric potential energy* is lost, and *work* is accomplished by the electric current. (See *Potential, Electric*.)

The amount of this electric work is measured by the *quantity of electricity* that flows, multiplied by the *difference of potential* under which it flows. (See *Joule. Volt-Coulomb*.)

Electric energy, however, is generally measured in *electric power*, or *rate of doing electric work*.

Since an *ampère* is one *coulomb-per-second*, if we measure the difference of potential in *volts*, the product of the ampères by the volts will give the electrical power in *volt-ampères*, or *watts*, or *units of electric power*. $C E = \text{Watts}$. (See *Ampère. Volt. Watt*.)

One *horse power* equals 550 foot-pounds per second. One watt or volt-ampère = $\frac{1}{746}$ of a horse-power, or one *horse-power* equals 746 *volt ampères* or *watts*, therefore:

The current in ampères, multiplied by the difference of potential in volts, divided by 746, equals the rate of doing work in horse-powers.

Thus, if .7 ampère is required to operate a 16 candle, 110 volt, incandescent lamp, it requires 4.8 *watts* per candle.

One Watt = 44.2394 foot-pounds per minute.

One Watt = .737324 foot-pound per second.

The *Heat Activity*, or the heat-per-second produced by an electric current, is also proportional to the product $C E$, or the watts, for the heat is proportional to the *square* of the current in *ampères* multiplied by the *resistance* in ohms, or $C^2 R = \text{the watts}$. (See *Calorimeter, Electric*.)

By *Ohm's Law* (See *Ohm's Law*)

$$C = \frac{E}{R} \text{ (1), or } C R = E \text{ (2),}$$

But the electric power, or the watts, = $C E$ (3).

If, now, we substitute the value of E , taken from equation (2) in equation (3) we have

$$C E = C \times C R = C^2 R;$$

therefore $C^2 R = \text{Watts}$.

To determine the heating power of a current in *small calories*, calling H , the amount of heat required to raise 1 *gramme* of water through 1° Cent., and C , the current in ampères—

$$H = C^2 R \times .24.$$

Or, for any number of seconds, t ,

$$H = C^2 R t \times .24.$$

(See *Calorie*.)

But from *Ohm's Law*,

$$C = \frac{E}{R} \text{ (1),}$$

and the formula for electric power or the watts = $C E$. (2) By substituting in equation (2) and the value of C , in equation (1),

$$C E = E \times \frac{E}{R} = \frac{E^2}{R} = \text{Watts.}$$

That is to say, the electric power in any part of a circuit varies directly as the *square* of the *electromotive force*.

We, therefore, have three expressions for the value of the watt, or *the unit of electric power*, viz.:

$$C E = \text{Watts.} \quad (1)$$

$$C^2 R = \text{Watts.} \quad (2)$$

$$\frac{E^2}{R} = \text{Watts.} \quad (3)$$

(1.) $C E = \text{Watts}$; or the electric power is proportional to the product of the *quantity of electricity per-second*, that passes, in *ampères*, and the *difference of electric potential or level*, through which it passes, in *volts*.

(2.) $C^2 R = \text{Watts}$; or the electric power varies *directly* as the *resistance* R , when the *current is constant*, or as the *square of the current*, if the *resistance* is constant. That is to say, if with a given resistance the power of a given current has a certain value, and the current flowing through this same resistance be *doubled*, the power is *four times as great*, or is as the *square of the current*.

(3.) $\frac{E^2}{R} = \text{Watts}$, or the electric power is *in-*

versely as the *resistance* R , when the *electromotive force* is constant, and is *directly proportional to the square of the electromotive force* if the *resistance* is constant.

A circuit of *one ohm* resistance will have a power of *one watt*, when under an *electromotive force* of *one volt*, since it would then have a current of *one ampère* flowing through it, and $C E = 1$. If, however, the resistance be halved or becomes .5 ohm, then two ampères pass, or the power equals 2 watts.

The power varies as the *square of the electromotive force* in any part of a circuit, when the *resistance is constant* in that part. Thus 2 ampères, and 2 volts, in a circuit of one ohm resistance, give a power, $C E = 2 \times 2 = 4$ watts. If now, R , remaining the same, the *electromotive force* be raised to 4 volts, then since E , is doubled, C , or the ampères, is doubled, and $C \times E = 4 \times 4 = 16$ watts, or $\frac{E^2}{R} = \frac{16}{1} = 16$.

Energy, Electric, Transmission of —
—The transmission of mechanical energy between two distant points connected by an electric conductor, by converting the mechanical energy into electrical energy at one point, sending the current so produced through the conductor, and reconvertng the electrical into mechanical energy at the other point.

A system for the electric transmission of energy embraces:

(1.) *A conducting circuit* between the two stations.

(2.) *An electric source* or battery of electric sources or machines at one of the stations, generally in the form of a dynamo-electric machine or machines, for converting mechanical energy into electric energy.

(3.) *Electro-receptive devices*, generally *electric motors*, at the other station for reconvertng the electric into mechanical energy. (See *Motor, Electric*.)

Energy, Flow of — —The flow or transmission of energy from the medium or dielectric surrounding a conductor which is directing a current of electricity on to the conductor. (See *Law, Poynting's*.)

Energy, Hysterisial, Dissipation of —
—The dissipation of energy by means of

hysteresis. (See *Energy, Dissipation of. Hysteresis.*)

Energy, Kinetic — —Energy which is due to motion as distinguished from potential energy. (See *Energy, Potential.*)

Energy-Meter.—(See *Meter, Energy.*)

Energy of Position.—(See *Position, Energy of.*)

Energy of Stress.—(See *Stress, Energy of.*)

Energy, Potential — —Stored energy. Potency, or capability of doing work.

Energy possessing the power or potency of doing work, but not actually performing such work.

The capacity for doing work possessed by a body at rest, arising from its position as regards the earth, or from the position of its atoms as regards other atoms, with which it is capable of combining.

A pound of coal, if raised vertically one foot, possesses, as a mere weight, an amount of energy capable of doing an amount of work equal to one foot-pound. The atoms of carbon, however, of which it is composed, have been *raised* or *separated from those of oxygen*, or some other elementary substance, and when the coal is burned, or the carbon atoms fall towards the oxygen atoms (*i. e.*, unite with them), the coal gives up the potential energy of its atoms in the form of heat.

All elementary substances possess in the same way *atomic* or *chemical-potential energy*, or the energy with which they tend to fall together, or enter into combination. This energy varies in amount in different elements and becomes kinetic, as heat, on combination with other elements. (See *Energy, Chemical-Potential.*)

Energy, Radiant — —Energy transferred to or charged on the universal ether.

Radiant energy is of three forms, *viz.*:

- (1.) Obscure radiation, or heat.
- (2.) Luminous radiation, or light.
- (3.) Electro-magnetic radiation.

Energy, Static — —A term used to express the energy possessed by a body at rest, resulting from its position as regards other bodies, in contradistinction to kinetic energy or the energy possessed by a body whose

atoms, molecules or masses are in actual motion.

Potential energy.

The general term for static energy is *potential energy*. (See *Energy, Potential.*)

Energy, Storage of— —The change from any form of kinetic energy, to any form of potential energy. (See *Energy, Kinetic, Energy, Potential.*)

Engine, Electro-Magnetic — —A motor whose driving power is electricity. (See *Motor, Electric.*)

Engraving, Acoustic — —Engraving by the human voice.

In the *Phonograph, Graphophone* and *Gramophone*, a diaphragm, set in vibration by the speaker's voice, cuts or engraves a record of its to-and-fro movements on a sheet of tin foil, a cylinder of hardened wax, or a specially coated plate of metal or glass. This record is employed in order to *reproduce the speech*. (See *Phonograph.*)

Engraving, Electric — —A method for electrically etching or engraving a metallic plate by covering it with wax, tracing the design on the wax so as to expose the metal, connecting the metal with the positive terminal of a battery, and placing it in a bath opposite another plate of metal.

By the action of electrolysis the metal is *dissolved* from the exposed portions and *deposited* on the plate connected with the other terminal of the battery. (See *Electrolysis.*)

In this manner the design is obtained in the form of an etching or cutting of the plate.

By connecting the waxed plate to the negative terminal of the electric source, the metal will be *deposited* on the exposed portions of the plate, thus producing the design in relief. Unless great care is taken, this latter method is not, however, apt to produce a sufficiently uniform deposit to enable the plate so formed to be used for printing from.

Electric engraving is sometimes called *electro-etching*.

Entropy.—In thermo-dynamics the non-available energy in any system.—(*Clausius and Mayer.*)

In thermo-dynamics, the available energy in any system.—(*Tait, Thomson and Maxwell.*)

THIS PAGE IS LOCKED TO FREE MEMBERS

Purchase full membership to immediately unlock this page

Know Your Bible

Forgotten Books'
Full Membership
provides unlimited
access to more than
28,000 volumes of
Christian literature for
\$8.99/month

**HOLY
BIBLE**

Continue

*Fair use policy applies

that is, to its atomic weight, divided by its valency. (See *Valency*.)

Thus, the atomic weight of oxygen is sixteen times greater than the atomic weight of hydrogen. Oxygen is a diad; that is, has twice the combining power of hydrogen. The passage of a given quantity of electricity will liberate eight times, by weight, as much oxygen as hydrogen; or, to put it in another way, the passage of a given quantity of electricity will liberate two atoms of hydrogen for every atom of oxygen.

The atomic weight of chlorine is 35.4. The passage of a given amount of electricity will liberate a weight of chlorine 35.4 greater than the weight of hydrogen; or, for every atom of chlorine it will liberate one atom of hydrogen. Here the passage of a given amount of electricity liberates one atom of the monad element hydrogen for every atom of the monad element chlorine.

The atomic weight of gold is 196.2, and its atomicity or valency is 3. The passage of a given amount of electricity will liberate $\frac{196.2}{3} = 65.4$ in *ic* compounds as great a weight of the triad element gold as of hydrogen; or, will liberate them in the proportion of one atom of gold for every three atoms of hydrogen.

Generalizing, it appears, therefore, that the passage of the same quantity of electricity through an electrolyte liberates the same number of atoms of a monad element, no matter what their nature may be. It liberates one-half as many of the diad atoms as it does of the monads, and one-third as many of the triad atoms as of the monads.

Professor Lodge points out, that assuming the truth of the theory that a current of electricity flows in an electrolyte by means of a true electric convection, each atom carrying an electric charge, then it would seem that every monad atom carries an equal charge of electricity, whether it be an atom of hydrogen, chlorine, potassium, silver, or mercury. That each diad element carries twice as much, and that each triad element carries three times as much.

In general, the number of atoms liberated by a given current of electricity is equal to the number of atoms of hydrogen, divided by the valency of the atom. "The electric charge," says Lodge, "belonging to each atom of matter, is a simple multiple of a definite quantity of electricity, which quantity is an absolute constant, quite independent of the nature of the particular substance to which the atom belongs."

The specific charge thus hypothetically given to each atom of matter is believed never to be lost.

Atoms capable of entering into combination are supposed to be oppositely charged, and chemical affinity is, according to this supposition, believed to be the result of the mutual attractions of opposite electric charges naturally and originally possessed by the atoms of matter.

Lodge points out the following results which naturally flow from the hypothesis that the atoms of matter possess definite positive and negative charges of electricity, viz.:

(1.) That the amount of electricity possessed by each monad atom is exceedingly small, being about the hundred thousand millionth part of the ordinary electrostatic unit, or less than the hundred trillionth of a coulomb.

(2.) The charge being small, the potential is necessarily low.

Probably something between one and three volts is a high difference of potential between two oppositely charged atoms.

(3.) The nearness of the attracting atoms, however, can cause a very strong electrostatic attraction between them.

(4.) That chemical affinity, or atomic attraction, is caused by the presence of these electric charges.

(5.) That the electrical force between two atoms at any distance is ten thousand million billion times greater than their gravitation attraction at the same distance, or, the force has an intensity per unit of mass capable of producing an acceleration, nearly one trillion times greater than that of gravity at the earth's surface.

Equivalent, Chemical — — The quotient obtained by dividing the atomic weight of any elementary substance by its atomicity. (See *Weight, Atomic. Atomicity*.)

The ratio between the quantity of an element and the quantity of hydrogen it is capable of replacing.

That quantity of an elementary substance that is capable of combining with or replacing one atom of hydrogen.

The chemical equivalent has a different value from the atomic weight whenever the valency is greater than unity. Thus the atomic weight of gold is 196.2, but since in *ic* compounds one atom of gold is capable of combining with three atoms of hydrogen, the weight of the gold equivalent to that of one atom of hydrogen is one-third of 196.2, or 65.4.

Equivalent Conductivity.—(See *Conductivity, Equivalent*.)

Equivalent, Electro-Chemical — —A number representing the weight in grammes of an elementary substance liberated during electrolysis by the passage of one coulomb of electricity. (See *Electrolysis, Coulomb*.)

The chemical equivalent of a substance multiplied by the electro-chemical equivalent of hydrogen.

The electro-chemical equivalent is, therefore, found by multiplying the electro-chemical equivalent of hydrogen by the chemical equivalent of the element.

It may be determined experimentally that one coulomb of electricity, expended electrolytically, will liberate .0000105 gramme of hydrogen. Therefore a current of one *ampère*, or one *coulomb-per-second*, will liberate .0000105 gramme of hydrogen per second. The number .0000105 is the electro-chemical equivalent of hydrogen.

In the same manner the electro-chemical equivalents of the other elements are obtained by multiplying the electro-chemical equivalent of hydrogen by the chemical equivalent of the substance.

Thus, the chemical equivalent of potassium is 39.1, therefore its electro-chemical equivalent is $39.1 \times .0000105 = .00041055$. By multiplying the strength of the current that passes by the electro-chemical equivalent of any substance we obtain the weight of that substance liberated by electrolysis. (See *Equivalence, Electro-Chemical, Law of*.)

To determine the electro-chemical equivalent of the other elements see table of chemical equivalents on page 212.

Equivalent, Joule's — —The mechanical equivalent of heat. (See *Heat, Mechanical Equivalent of*.)

Equivalent of Heat, Mechanical — — (See *Heat, Mechanical Equivalent of*.)

Equivalent Resistance.—(See *Resistance, Equivalent*.)

Equivolt.—A term proposed by J. T. Sprague for the unit of electrical energy, applied especially to chemical decomposition.

Sprague defines an equivolt as follows: "The mechanical energy of one volt electromotive force exerted under unit conditions through one equivalent of chemical action in grains."

This term has not been generally accepted. (See *Volt-Coulomb, Joule*.)

Erb's Standard Size of Electrodes.—(See *Electrodes, Erb's Standard Size of*.)

Erg.—The unit of work, or the work done when unit force is overcome through unit distance.

The work accomplished when a body is moved through a distance of one centimetre with the force of one dyne. (See *Dyne*.)

A dyne centimetre.

The work done when a weight of one gramme is raised against gravity through a vertical height of one centimetre is equal to 981 ergs, because the weight of one gramme is 1×981 dynes, or 981 ergs.

The following values for the erg, the unit of work, and the dyne, the unit of force, are taken from Hering:

$$1 \text{ erg} = 1 \text{ dyne centimetre.}$$

$$1 \text{ erg} = 0.0000001 \text{ joule.}$$

$$981 \text{ ergs} = 1 \text{ gramme centimetre.}$$

$$1,937.5 \text{ ergs} = 1 \text{ foot grain.}$$

$$13,562,600 \text{ ergs} = 1 \text{ foot-pound.}$$

$$1 \text{ dyne} = 1.0194 \text{ milligrammes.}$$

$$1 \text{ dyne} = 0.015731 \text{ grain.}$$

$$1 \text{ dyne} = 0.0010194 \text{ grammes.}$$

$$1 \text{ dyne} = 0.00003596 \text{ ounce avoirdupois.}$$

$$63.568 \text{ dynes} = 1 \text{ grain.}$$

$$981 \text{ dynes} = 1 \text{ gramme.}$$

Ergmeter.—An apparatus for measuring the work of an electric current in ergs.

Erg-ten.—A term proposed for ten million ergs or $1 \times 10^{10} = 10,000,000,000$.

In representing large numbers containing many ciphers the following plan is generally adopted for representing the number of ciphers that are to be added to a given number. Thus, suppose it is desired to represent the number 3,800,000,000. When written 38×10^8 it indicates that 38 is to be multiplied by 10^8 or 100,000,000, or, in other words, that 38 is to be followed by 8 ciphers, thus 3,800,000,000.

A negative exponent, as 3×10^{-8} represents the corresponding decimal thus, .00000003.

$1 \text{ erg} \times 10^{10}$, or 10,000,000,000 is called an *erg ten*. $1 \times 10^6 =$ an *erg six*. These terms are not in general use. Ten meg-ergs is a preferable phrase to an erg-ten. (See *Meg-erg*.)

Escape, Electric — —A term some-

times employed to indicate the loss of charge on an insulated conductor. (See *Leakage, Electric.*)

Escaping Fluid, Flow-Lines of — —
(See *Flow-Lines of Escaping Fluid.*)

Escaping Fluid, Stream-Lines of — —
(See *Stream-Lines of Escaping Fluid.*)

Essential Resistance.—(See *Resistance, Essential.*)

Etching, Electro — — — A term sometimes employed instead of electro-engraving. (See *Engraving, Electric.*)

Etching, Galvanic — — — Electro-Engraving. (See *Engraving, Electric.*)

Ether.—The tenuous, highly elastic fluid that is assumed to fill all space, and by vibrations or waves in which light and heat are transmitted.

Although the existence of the ether is assumed in order to explain certain phenomena, its actual existence is very generally credited by scientific men, and, in reality, proofs are not wanting to fairly establish such existence.

Light and heat are believed to be due to transverse vibrations in the ether. Magnetism appears to be due to whirls or whirlpools, and an electric current is believed by some to be due to pulses of waves of ether set in motion by differences in the ether pressures.

It is not correct to regard the luminiferous ether as possessing no weight, or as being imponderable. Maxwell estimates its density as

$\frac{936}{1,000,000,000,000,000,000,000}$ that of water. It is very readily moved or set into vibration, its rigidity being estimated at about $\frac{1}{1,000,000,000}$ that of steel.

According to the speculations of some physicists the ether is not discontinuous or granular, but it is similar to what might be regarded as an almost impalpable jelly.

Ethereal.—Pertaining to the universal ether.

Eudiometer.—A voltameter in which separate graduated vessels are provided for the reception and measurement of the gaseous products evolved during electrolysis. (See *Voltameter.*)

In all cases electrodes for eudiometers must be used which do not enter into combination with the evolved gaseous products. In the case of oxygen and hydrogen, platinum is generally used.

A form of eudiometer is shown in Fig. 241.

Two separate glass vessels, provided at the top with stop cocks, and open at their lower ends, rest in a vessel of water A, over platinum electrodes, connected electrically with binding posts K, K. Both vessels are filled with water slightly acidulated with sulphuric acid, and, when connected with a battery of sufficient electromotive force (not less than 1.45 volts), electrolysis takes place,

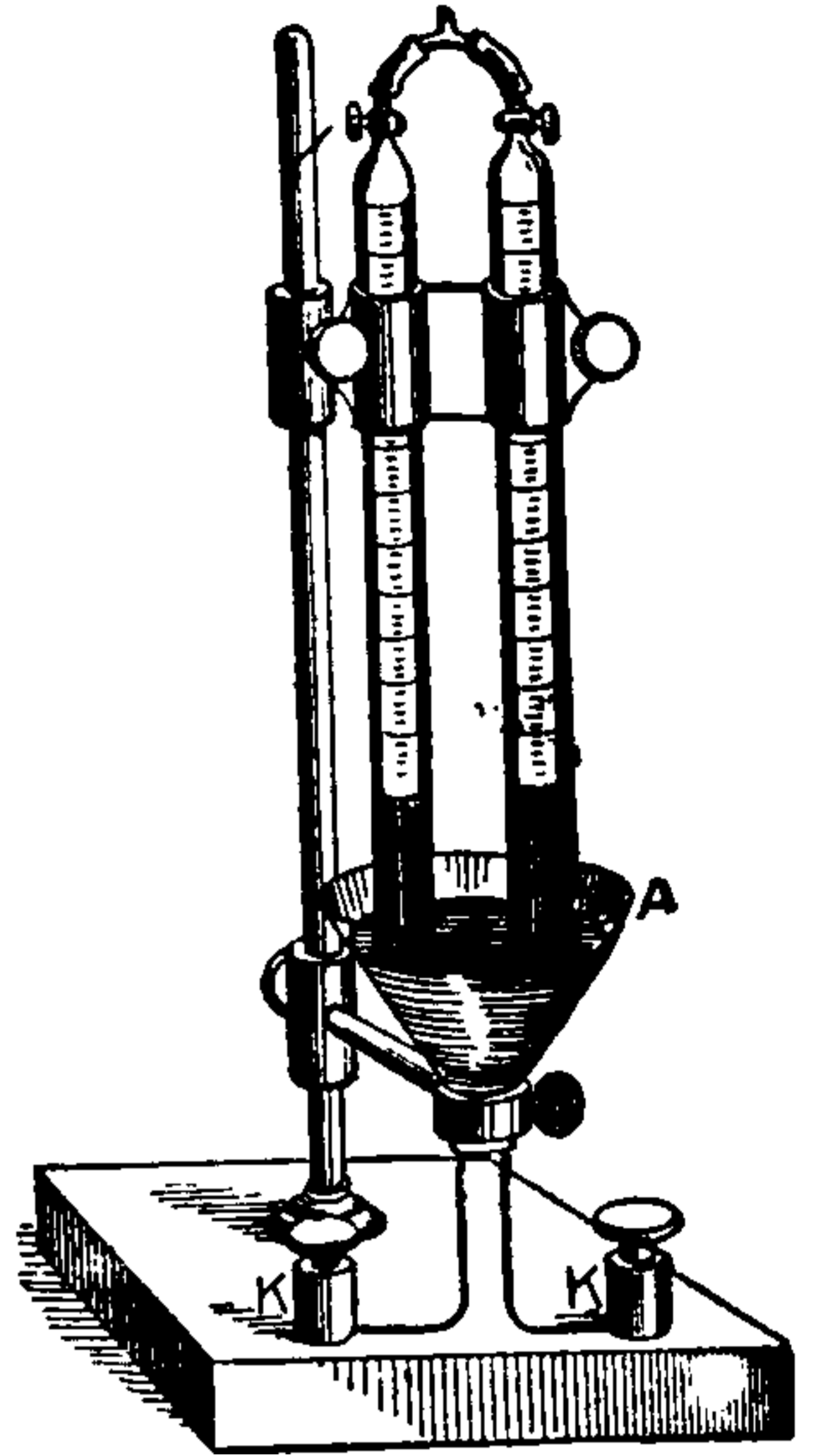

Fig. 241. Eudiometer.

and hydrogen gas collects in the vessel over the platinum electrode connected with the negative battery terminal, and oxygen in the vessel over the electrode connected with the positive battery terminal. The volume of the hydrogen is approximately twice as great as that of the oxygen. (See *Water, Electrolysis of.*)

The proportion is not exactly 2 to 1, because,
(1.) Some of the hydrogen is occluded or absorbed by the platinum electrode.

(2.) Some of the oxygen is given off as triatomic oxygen, or ozone, which is denser and occupies less space than free atomic oxygen.

Eudiometric.—Pertaining to the eudiometer. (See *Eudiometer.*)

Eudiometrically.—By means of the eudiometer.

Evaporation.—The change from the liquid to the vaporous state.

Wet clothes exposed to the air are dried by the evaporation of the water.

Evaporation is greater:

- (1.) The more extended the surfaces exposed.
- (2.) The higher the temperature of the air.
- (3.) The dryer the air, or the smaller the quantity of vapor it contains already.
- (4.) The stronger the wind.
- (5.) The smaller the barometric pressure.

Evaporation, Electric — — — The forma-

THIS PAGE IS LOCKED TO FREE MEMBERS

Purchase full membership to immediately unlock this page



HISTORY

Tens of thousands of important historical sources, many previously unobtainable, are now available for the first time with a Forgotten Books Full Membership.

Unlimited Access
\$8.99/month

Continue

*Fair usage policy applies

living animal, or in producing an involuntary contraction of a muscle.

Du Bois-Reymond has shown that these effects depend :

(1.) On the strength of the current employed. The excitability occurs only when the current begins to flow, and when it ceases flowing; or, when the electrodes first touch the nerves, and when they are separated from it. Subsequent investigations have shown that this is true only for the frog's nerves, and is true for the human nerves only in the case of moderate currents, strong currents producing tetanus.

(2.) On the rapidity with which the current used reaches its maximum value, that is, on the rapidity of change of *current density*. (See *Current Density*.)

Excitability, Electro-Nervous — — In electro-therapeutics the electric excitation of a nerve.

Excitability, Electrotonic — — The actual excitability of a nerve when in the electrotonic condition. (See *Electrotonus*. *Anelectrotonus*. *Kathelectrotonus*.)

Excitability, Faradic — — Muscular or nervous excitability following the employment of the rapidly intermittent currents produced by induction coils. (See *Coil, Induction*.)

Faradic excitability is different from *galvanic excitability*, or that produced by means of a continuous voltaic current. (See *Excitability, Galvanic*.)

Excitability, Galvanic — — A term sometimes employed for electric excitability of nerve or muscular fibre. (See *Excitability, Electric, of Nerve or Muscular Fibre*.)

Excitation, Compensated, of Alternator. — (See *Alternator, Compensated Excitation of*.)

Excitation, Direct — — The excitement of a muscle by placing an electrode on the muscle itself.

Excitation, Electro-Muscular — — In electro-therapeutics the galvanic or faradic excitation of the muscle, or its excitation by the continuous currents of a voltaic battery, or the alternating currents of an induction coil.

Excitation, Faradic — — Excitation of muscle or nerve fibre by means of rapidly

alternating currents of electricity. (See *Excitability, Faradic*.)

Excitation, Indirect — — The excitement of a muscle from its nerve.

Exciter of Field. — (See *Field, Exciter of*.)

Exciting Liquid of Voltaic Cell. — (See *Cell, Voltaic, Primary, Exciting Liquid of*.)

Execution, Electric — — Causing the death of a criminal, in cases of capital punishment, by means of the electric current.

Electric execution has been adopted by the State of New York, in accordance with the following law :

“The Court shall sentence the prisoner to death within a certain week, naming no day or hour, and not more than eight nor less than five weeks from the day of sentence. The execution must take place in the State prison to which convicted felons are sent by the Court, and the executioner must be the agent and warden of the prison.

“No newspaper may print any details of the execution, which is to be inflicted by electricity. A current of electricity is to be caused to pass through the body of the condemned of sufficient intensity to kill him, and the application is to be continued until he is dead.”

Exhaustion, Electric — — Physiological effects resembling those produced by sun-stroke, resulting from prolonged exposure to the radiation of unusually large voltaic arcs. (See *Sun-Stroke, Electric*.)

Exhaustion of Primary Voltaic Cell. — (See *Cell, Voltaic, Primary, Exhaustion of*.)

Exhaustion of Secondary Voltaic Cell. — (See *Cell, Voltaic, Secondary, Exhaustion of*.)

Exhaustion of Voltaic Cell. — (See *Cell, Voltaic, Exhaustion of*.)

Exhaustion, Reaction of — — A condition of nervous and muscular irritability to electric excitation when a certain reaction, produced by a given current strength, cannot be reproduced without an increase of current strength.

The reaction of exhaustion may be regarded as a special variety of the reaction of degeneration. (See *Degeneration, Reaction of*.)

The reaction of degeneration embraces the following modifications of irritability, viz.:

(1.) Disappearance or diminution of nervous irritability to both galvanic and faradic currents.

(2.) Disappearance of faradic and increase of galvanic irritability of muscles, generally associated with an increase of mechanical irritability.

(3) Disappearance of faradic and increase of galvanic muscular irritability associated generally with increased mechanical irritability.

(4.) Tardy, delayed contraction of muscles instead of quick reaction of normal muscle.

(5.) Marked modifications of normal sequence of contraction.—*Liebig & Rohé.*

Expanding Magnetic Whirl.—(See *Whirl, Expanding Magnetic.*)

Expansion, Co-efficient of — —The fractional increase in the dimensions of a bar or rod when heated from 32 degrees to 33 degrees F. or from 0 degree to 1 degree C.

The fractional increase in the length of the bar is called the *Co-efficient of Linear Expansion.*

The fractional increase in the surface is called the *Co-efficient of Surface Expansion.*

The fractional increase in the volume is called the *Co-efficient of Cubic Expansion.*

Expansion, Electric — —The increase in volume produced in a body on giving such body an electric charge.

A Leyden jar increases in volume when a charge is imparted to it. This result is due to an expansion of the glass due to the electric charge. According to Quincke, some substances, such as resinous or oily bodies, manifest a *contraction of volume* on the reception of an electric charge.

Expansion Joint. — (See *Joint, Expansion.*)

Expansion, Linear, Co-efficient of — — A number expressing the fractional increase in length of a bar for a given increment of heat.

The co-efficients of expansion of a few substances are given in the following table:

	Temp.	
Aluminium.....	16 to 100 degrees C.	0.0000235
Brass	0 " 100 " "	0.0000188
Copper	0 " 100 " "	0.0000167
German silver..	0 " 100 " "	0.0000184
Glass	0 " 100 " "	0.0000071
Iron	13 " 100 " "	0.0000123
Lead	0 " 100 " "	0.0000280
Platinum	0 " 100 " "	0.0000089
Silver	0 " 100 " "	0.0000194
Zinc.....	0 " 100 " "	0.0000230

—(*Anthony & Brackett.*)

Exploder, Electric Mine — —A small magneto-electric machine used to produce the currents of high electromotive force employed in the direct firing of blasts.

Exploder, Electro-Magnetic — —A small magneto-electric machine used to produce the currents of high electromotive force employed in the direct firing of blasts.

Explorer, Electric — —An apparatus operated by means of induced currents, and employed for the purpose of locating bullets or other foreign metallic substances in the human body. (See *Balance, Induction, Hughes'.*)

Explorer, Magnetic — —A small, flat coil of insulated wire, used, in connection with the circuit of a telephone, to determine the position and extent of the magnetic leakage of a dynamo-electric machine or other similar apparatus. (See *Magnetophone.*)

Explosive Distance.—(See *Distance, Explosive.*)

Extension Call-Bell.—(See *Bell, Extension Call.*)

External Circuit.—(See *Circuit, External.*)

External Secondary Resistance. — (See *Resistance, External Secondary*)

Extra Currents.—(See *Currents, Extra.*)

Extraordinary Resistance.—(See *Resistance, Extraordinary.*)

Extra-Polar Region.—(See *Region, Extra-Polar.*)

Eye, Electro-Magnetic—A term proposed for a certain form of spark-micrometer employed by Hertz in his experiment on electro-magnetic radiation.

This apparatus has received the above name because it enables the observer to see or localize an electromagnetic disturbance.

The particular spark-micrometer that has received the name of the electro-magnetic eye had the form of a circle 35 centimetres in radius, and was formed of a copper wire 2 millimetres in diameter. Like all spark-micrometer circuits, it had its terminals separated by a small air-space.

Eye, Selenium — —An artificial eye in

which a selenium resistance takes the place of the retina and two slides the place of the eyelids.

The selenium resistance is placed in the circuit of a battery and a galvanometer. When the slides L, L, Fig. 244, are shut, the galvanometer deflection is less than when they are open.

The opening of the aperture between the slides L, L, may be automatically accomplished by the action of the light itself, by moving them by an electro-magnet placed in the circuit of a local battery, and a selenium resistance may be so arranged that when light falls on it the slides L, L, are moved together, and when the amount of such light is small they are moved apart, by the action

of a spring. In this way there is obtained a device roughly resembling the dilatation or con-

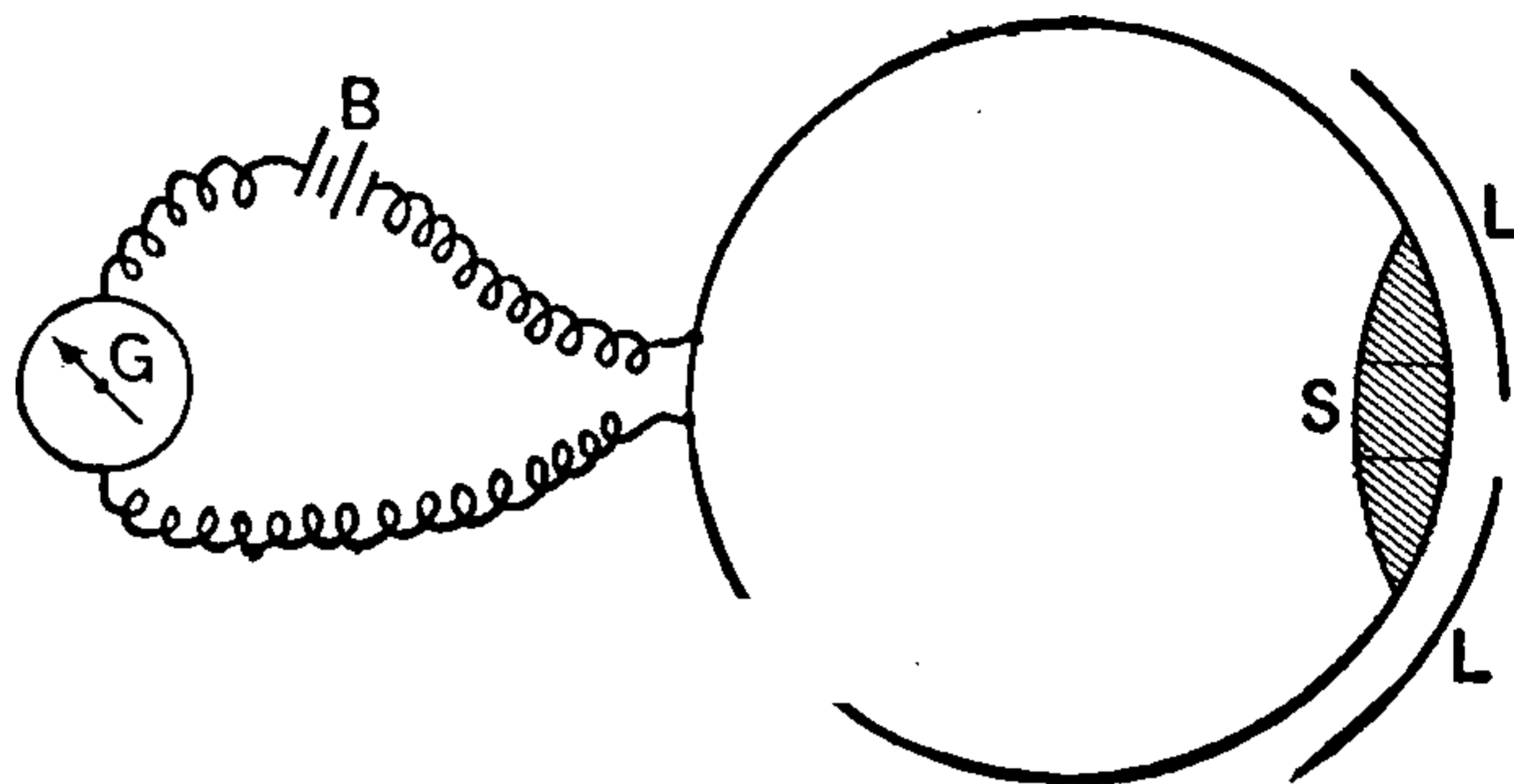

Fig 244. Selenium Eye.

traction of the pupil of the eye from the action of light on the iris. (See *Photometer, Selenium.*)

F

Fac-Simile Telegraphy, or Pantelegraphy.—(See *Telegraphy, Fac-Simile.*)

Fahrenheit's Thermometer Scale.—(See *Scale, Thermometer, Fahrenheit's.*)

Fall of Potential.—(See *Potential, Fall of.*)

False Magnetic Pole — —(See *Pole, Magnetic, False.*)

False Resistance.—(See *Resistance, False.*)

False Zero.—(See *Zero, False.*)

Fan Guard.—(See *Guard, Fan.*)

Farad.—The practical unit of electric capacity.

Such a capacity of a conductor or condenser that one coulomb of electricity is required to produce in the conductor or condenser a difference of potential of one volt.

As in gases, a quart vessel will hold a quart of gas under unit pressure of one atmosphere, so, in electricity, a conductor or *condenser*, whose capacity is one farad, will hold a quantity of electricity equal to one *coulomb* when under an electromotive force of one volt.

It may cause some perplexity to the student to understand why there should be in electricity one *unit of capacity* to represent the *size* of the vessel or conductor, and another to represent the *amount* or quantity of electricity required to fill

such vessel. But, like a gas, electricity acts, in effect, as if it were very compressible, so that the quantity required to fill any condenser will de-

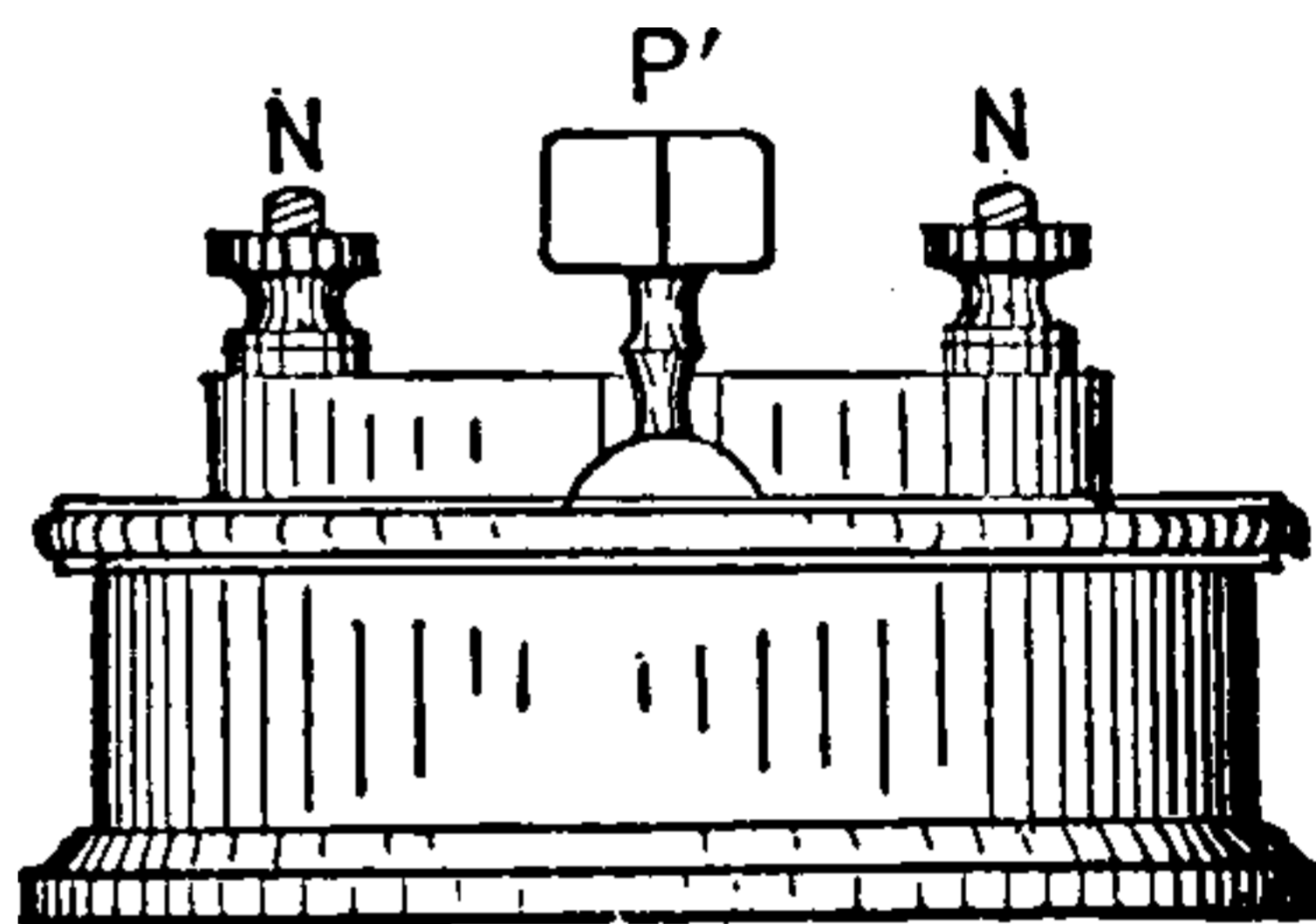

Fig 245. Elevation of Standardized Condenser.

pend on the electromotive force under which it is put into the conductor or condenser.

For purposes of measurement, capacities of conductors are compared with those of condensers

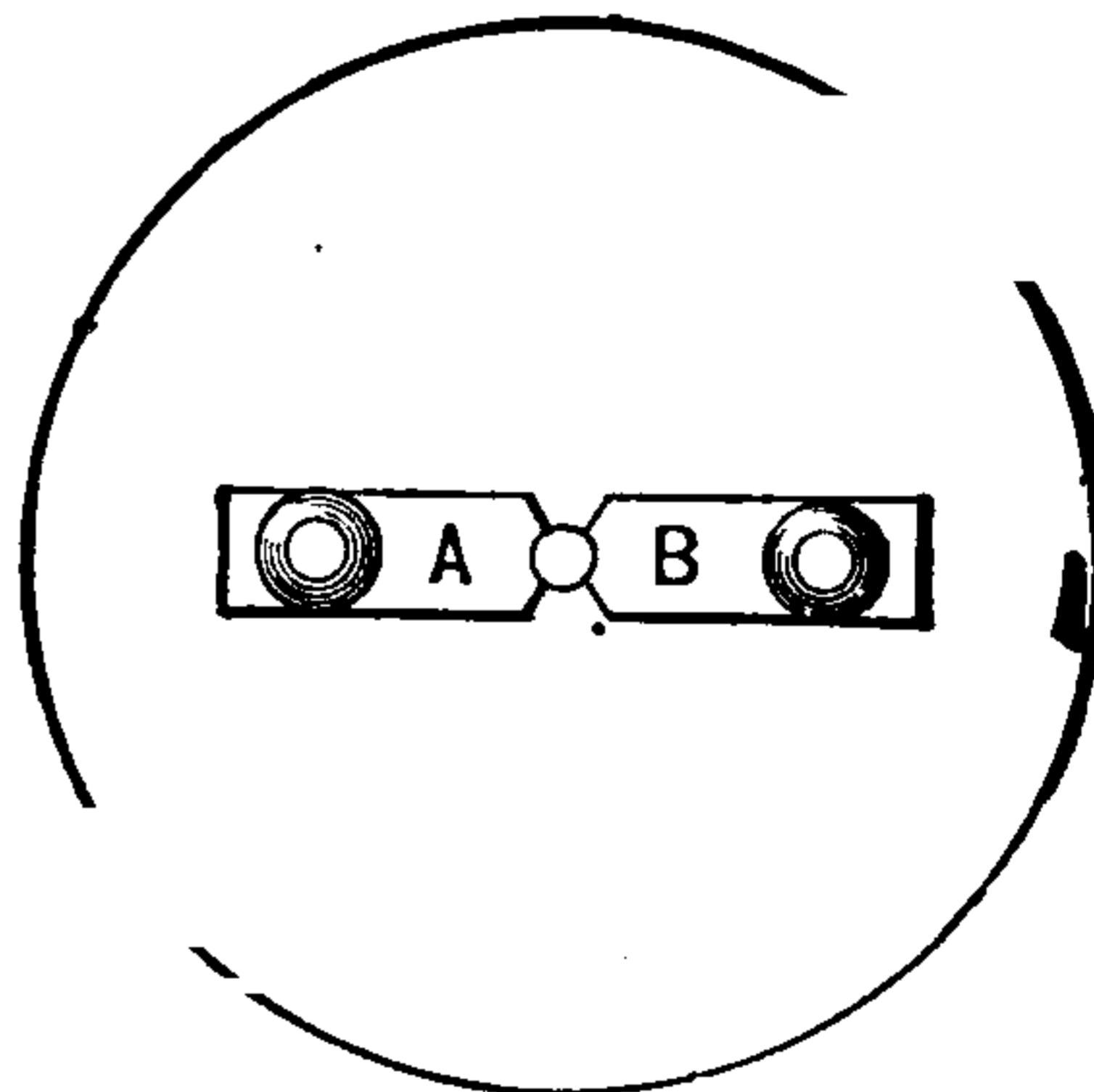

Fig. 246. Plan of Standardized Condenser.

whose capacities are known in microfarads, or fractions thereof. The microfarad, or the $\frac{1}{1,000,000}$ of a farad, is used because of the very great size of a farad.

THIS PAGE IS LOCKED TO FREE MEMBERS

Purchase full membership to immediately unlock this page

Know Your Bible

Forgotten Books' Full Membership provides unlimited access to more than 28,000 volumes of Christian literature for \$8.99/month

HOLY BIBLE

Continue

*Fair use policy applies

If the dynamo is in good connection with the ground, as is frequently the case in marine plants, this fault is the same as a ground.

Faults, Localization of — —Determining the position of a fault on a telegraph line or cable by calculations based on the fall in the potential of the line measured at different points, or by loss of charge, etc.

For details, see standard works on electrical measurements.

Feed, Clockwork, for Arc Lamps — — An arrangement of clockwork for obtaining a uniform feed motion of one or both electrodes of an arc lamp.

The clockwork is automatically thrown into or out of action by an electro-magnet, usually placed in a shunt circuit around the carbons.

Feed, To — —To supply with an electric current, as by a dynamo or other source.

Feeder.—One of the conducting wires or channels through which the current is distributed to the main conductors.

Feeder, Standard or Main — —The main feeder to which the standard pressure indicator is connected, and whose pressure controls the pressure at the ends of all the other feeders.

The term pressure in the above definition is used in the sense of electromotive force or difference of potential.

Feeder-Wires.—(See *Wires, Feeder.*)

Feeders.—In a system of distribution by constant potential, as in incandescent electric lighting, the conducting wires extending between the bus-wires or bars, and the junction boxes.

A feeder differs from a main in that a main consists of a conductor that may be tapped at any point to supply a customer, while a feeder leads direct from the dynamo or other source to a main and is not tapped at any point.

Feeders, Negative — —The feeders that are connected with the negative terminal of the dynamo. (See *Feeders.*)

Feeders, Positive — —The feeders that are connected with the positive terminal of the dynamo. (See *Feeders.*)

Feeding Device of Electric Arc Lamp.— (See *Device, Feeding, of an Arc Lamp. Feed, Clockwork, for Arc-Lamps.*)

Feeding-Wire.—(See *Wire, Feeding.*)

Feet, Ampère — —The product of the current in ampères by the distance in feet through which that current passes.

It has been suggested that the term ampère-feet should be employed in expressing the strength of electro-magnetism in the field magnets of dynamo-electro machines or other similar apparatus.

Ferranti Effect.—(See *Effect, Ferranti.*)

Ferro-Magnetic Substance.—(See *Substance, Ferro-Magnetic.*)

Fibre, Quartz — —A fibre suitable for suspending galvanometer needles, etc., made of quartz.

The quartz fibre is obtained by fusing quartz and drawing out the fused material as a fine thread, in a manner similar to the production of glass fibres. Quartz fibres possess marked advantage over silk fibres, in that they are 5.4 times stronger for equal diameters, and especially, in that they return to the zero point, after very considerable deflections.

Quartz fibres are readily obtained by fusing quartz pebbles together in the voltaic arc, and drawing them apart with a rapid, but steady, uniform motion.

Fibre Suspension.—(See *Suspension, Fibre.*)

Fibre, Vulcanized — —A variety of insulating material suitable for purposes not requiring the highest insulation.

Vulcanized fibre is, however, seriously affected by long exposure to moisture.

Fibrone.—An insulating substance.

Field, Air — —That portion of a magnetic field in which the lines of force pass through air only.

Field, Alternating — —An electrostatic or magnetic field the positive direction of the lines of force in which is alternately reversed or changed in direction.

Field, Alternating Electrostatic — — An electrostatic field, the potential of which is rapidly alternating.

An alternating electrostatic field is, according to Tesla's experiments, produced in the neighborhood of the terminals of the secondary of an induction coil, through whose primary, alternations of high frequency are passing.

Field, Alternating Magnetic.—A magnetic field the direction of whose lines of force is alternately reversed.

Field, Density of — —The number of lines of force that pass through any field, per unit of area of cross-section.

Field, Electric — —A term sometimes used in place of an electrostatic field. (See *Field, Electrostatic*.)

Field, Electro-Magnetic — —The space traversed by the lines of magnetic force produced by an electro-magnet. (See *Field, Magnetic*.)

Field, Electrostatic — —The region of electrostatic influence surrounding a charged body.

Electrostatic attractions or repulsions take place along certain lines called lines of electrostatic force. These lines of force produce a field called an *electrostatic* field. *Electric level* or *potential* is measured along these lines, just as gravitation levels are measured with a plumb line along the lines of gravitation force. (See *Potential, Electric*.)

Work is done when a body is moved along the lines of electrostatic force in a direction *from* an oppositely charged body, or *towards* a similarly charged body, just as work is done against gravity when a body is moved along the lines of gravitation force, away from the earth's centre, or vertically upwards.

Field, Exciter of — —In a separately excited dynamo-electric machine, the dynamo-electric machine, voltaic battery, or other electric source employed to produce the field of the field magnets. (See *Machine, Dynamo-Electric*.)

Field, Intensity of — —The strength of a field as measured by the number of lines of force that pass through it per unit of area of cross-section. (See *Field, Electrostatic*, *Field, Magnetic*.)

Field, Magnetic — —The region of

magnetic influence surrounding the poles of a magnet.

A space or region traversed by lines of magnetic force.

A place where a magnetic needle, if free to move, will take up a definite position, under the influence of the lines of magnetic force.

Unit strength of magnetic field is the field which would be produced by a magnetic pole of unit strength at unit distance.

Magnetic attractions and repulsions are assumed to take place along certain lines called *lines of magnetic force*. The directions of these lines in any plane of a magnetic field may be shown by sprinkling iron filings over a sheet of paper held in a horizontal position to a magnet pole inclined

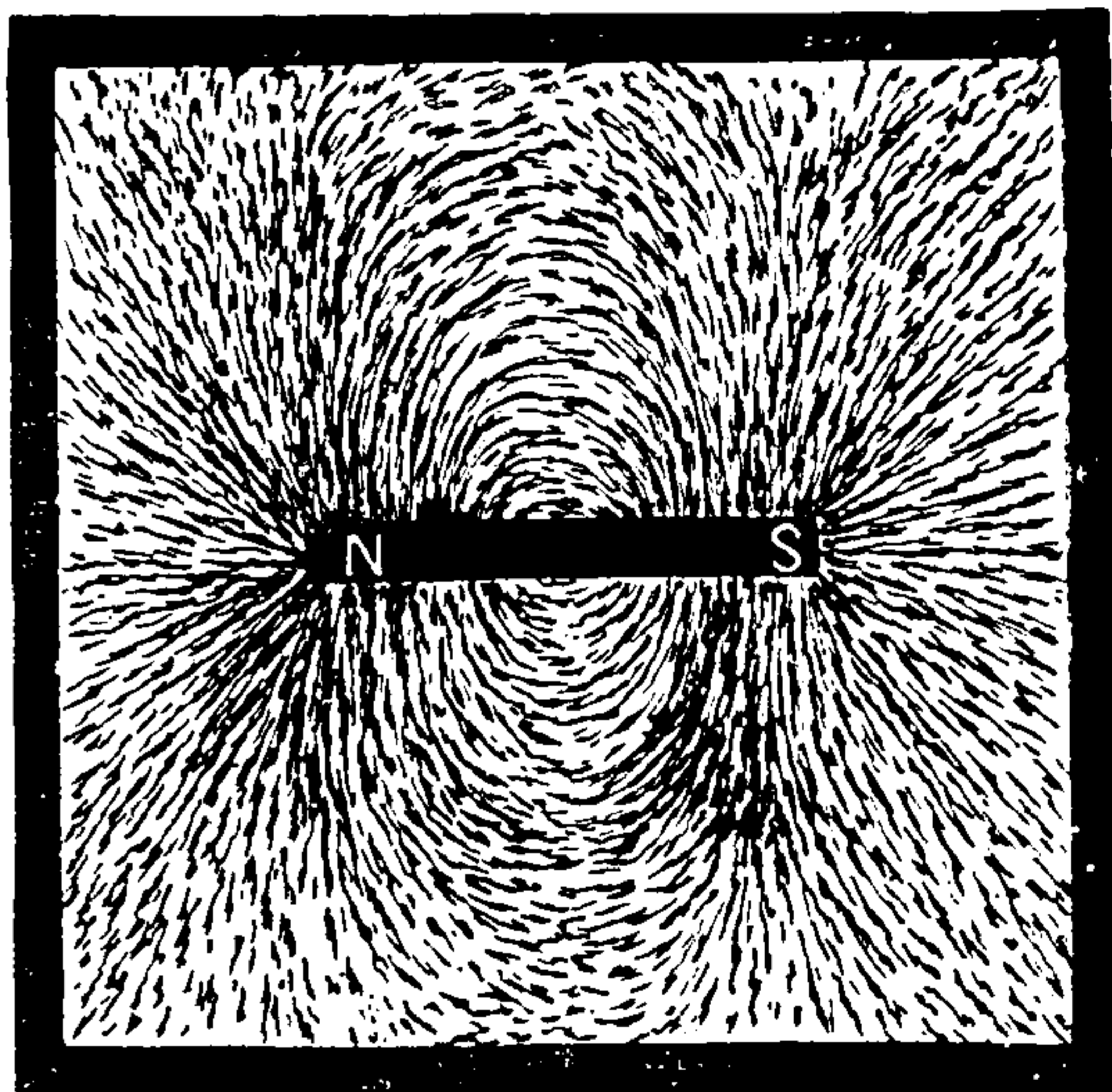

Fig. 249. Magnetic Field.

to the paper in the desired plane and then gently tapping the paper.

The groupings of iron filings so obtained are sometimes called *magnetic figures*.

The directions of the lines of force thus shown will appear from an inspection of Fig. 249, taken in a plane joining the two poles of a straight bar magnet, and Fig. 250, taken in a plane at right angles to the north pole of a straight bar magnet.

In Fig. 249, the repulsion of the lines of force at either pole is shown by the radiation of the chains of magnetized iron particles. The mutual attraction of unlike polarities is shown by the curved lines.

In Fig. 250, the repulsion of the similarly magnetized chains is clearly shown.

Lines of magnetic force are assumed to pass out from the north pole and back again into the magnet at its south pole. This assumed direction

is called the *direction of the lines of magnetic force*.

Faraday expressed his conception of lines of magnetic force as follows:

“Every line of force must therefore be considered as a closed circuit, passing, in some part of its course, through a magnet and having an equal amount of force in every part of its course. There

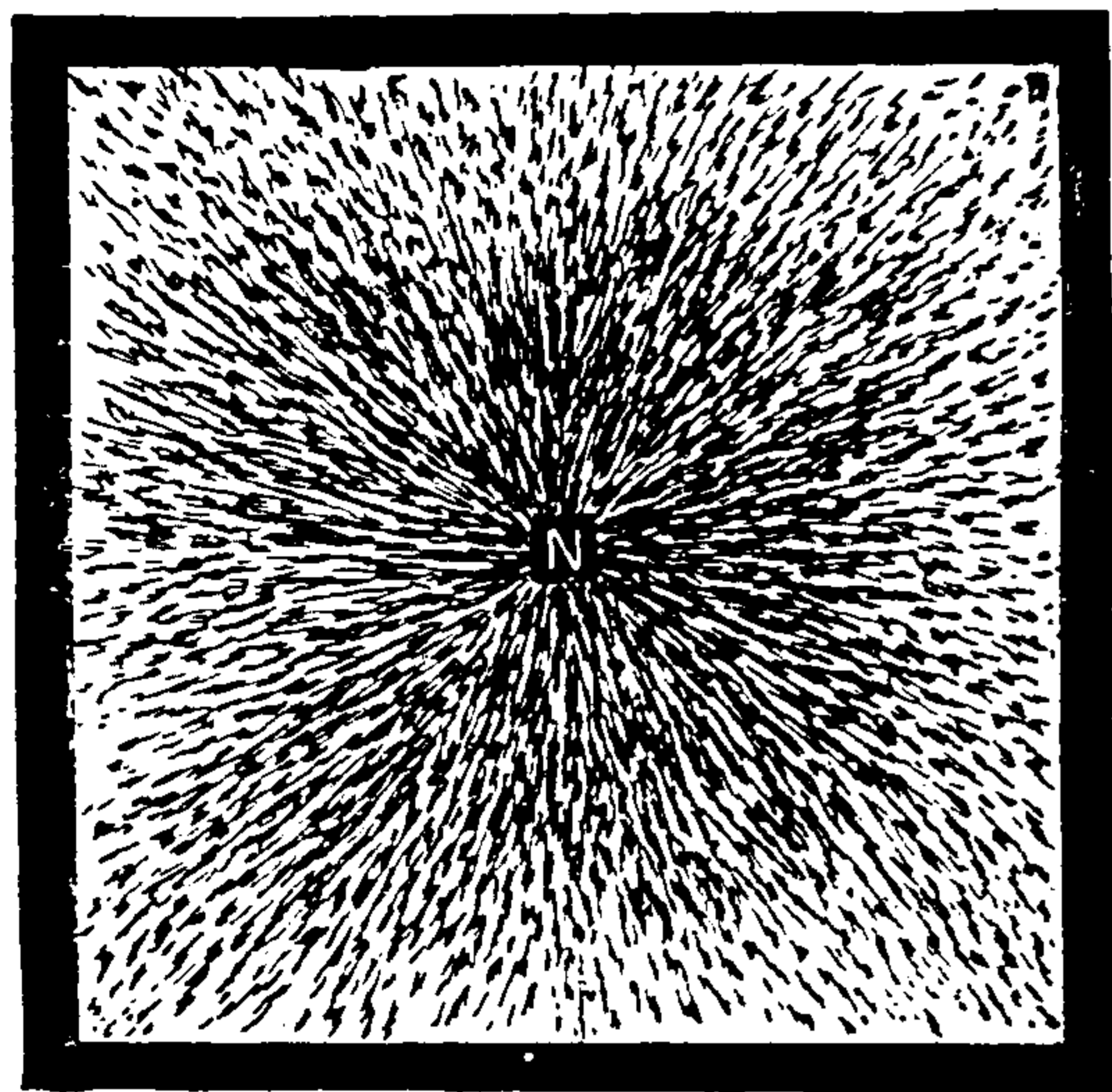

Fig. 250. Magnetic Field.

exist lines of force within the magnet of the same nature as those without. What is more, they are exactly equal in *amount* to those without. They have a relation in direction to those without and are, in fact, continuations of them.”

When a conductor, such as a wire through which a powerful current of electricity is flowing, is dipped in a mass of iron filings, a chain of iron filings is formed, the north end of which is urged around the conductor in one direction and the south end in the opposite direction, so that the movable chain of filings surrounds or grips the conductor in concentric rings or circles.

The *density of a magnetic field* is directly proportional to the number of lines of force per unit of area of cross-section.

A *single line of force*, or a *unit line of force*, is such an intensity of field as exists in each square centimetre of cross-section of a unit magnetic field.

A magnetic field is *uniform*, or possesses *uniform intensity*, when it possesses the same number of lines of force per square centimetre of area of cross-section.

Field, Magnetic, Alternating — — The magnetic field produced by means of an alternating current.

Field, Magnetic, Dissymmetrical — — A field whose lines of force are not symmetrically distributed in adjacent halves.

Field, Magnetic, Expanding of — — An increase in the length of the lines of magnetic force in any field, or an increase in the length of their magnetic circuit.

Field, Magnetic, of an Electric Current — — The magnetic field surrounding a cir-

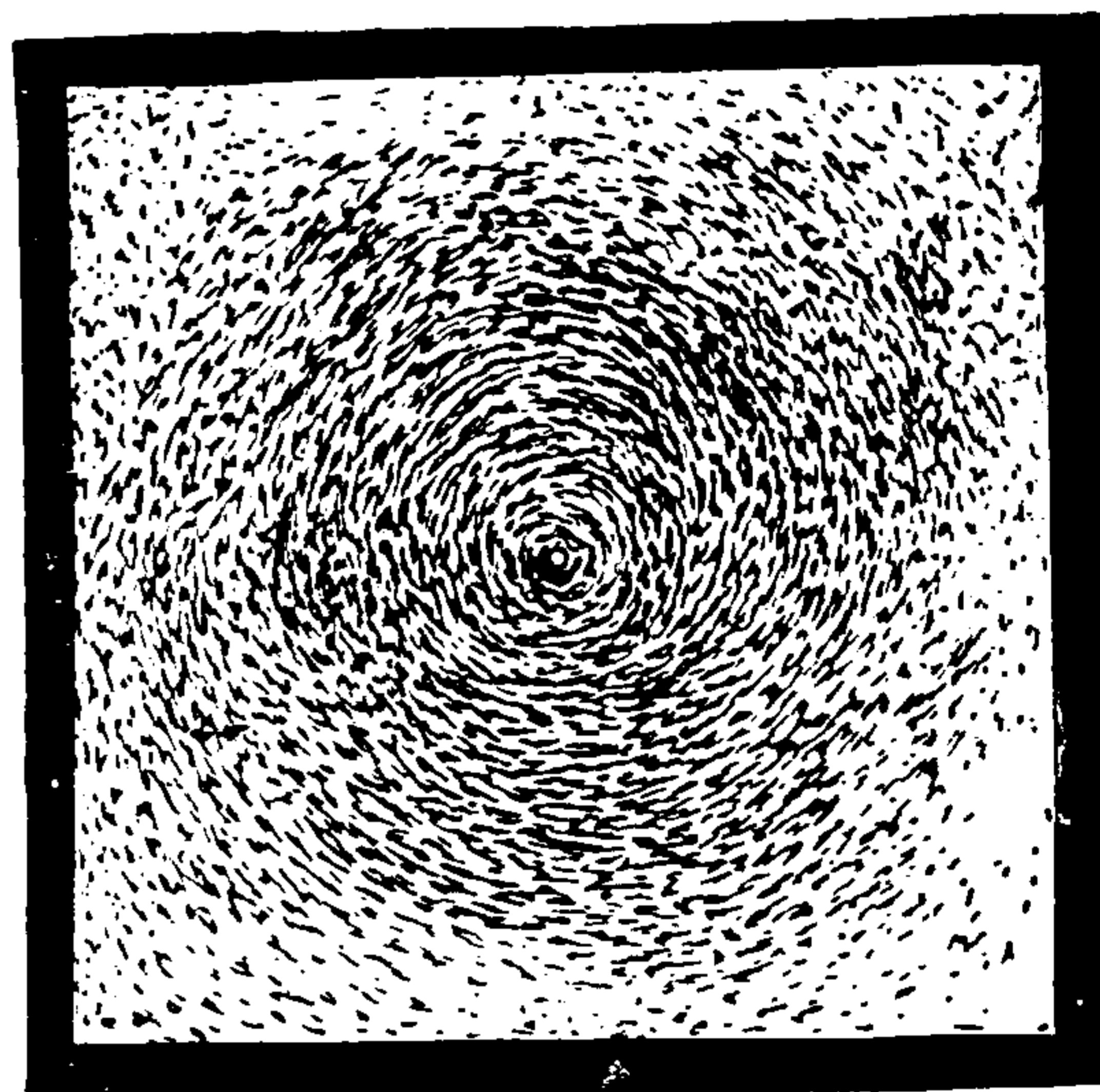
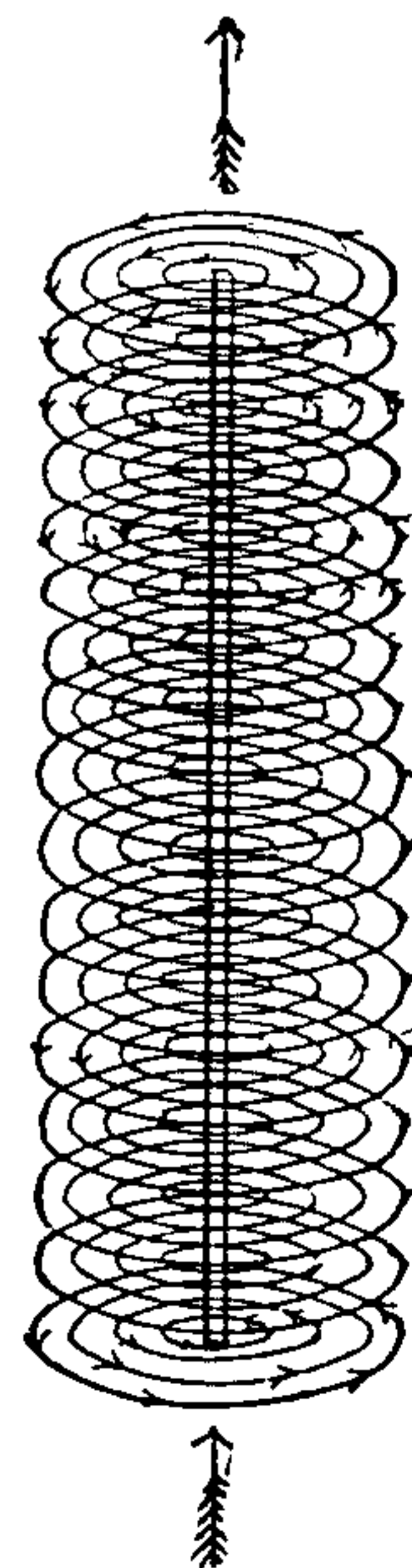

Fig. 251. Field of Current.

cuit through which an electric current is flowing.

An electric current produces a magnetic field. This was discovered by Oersted in 1819, and may be shown by sprinkling iron filings on a sheet of paper, placed on the wire conductor conveying the current, at right angles to the direction in which the current is passing. Here the lines of force appear as concentric circles, extending around the conductor, as shown in Fig. 251. Their direction, as regards the length of the conductor, is shown in Fig. 252. The electric current sets up these *magnetic whirls* around the conductor on its passage through it.



The *direction of the lines of magnetic force* produced by an electric current, and hence its *magnetic polarity*, depends on the direction in which the electric current flows. This direction

Fig. 252. Direction of Lines of Force.

THIS PAGE IS LOCKED TO FREE MEMBERS

Purchase full membership to immediately unlock this page



HISTORY

Tens of thousands of important historical sources, many previously unobtainable, are now available for the first time with a Forgotten Books Full Membership.

Unlimited Access
\$8.99/month

Continue

*Fair usage policy applies

Field, Magnetic, Uniform — —A field traversed by the same number of lines of magnetic force in all unit portions of area of cross-section. (See *Field, Magnetic*.)

Field, Magnetic, Waste — —A term sometimes employed for stray field. (See *Field, Magnetic, Stray*.)

Field, Rotating-Current — —A magnetic field produced by means of a rotating current. (See *Current, Rotating*.)

Field, Uniform Density of — —A uniform density in all equal areas of cross-section of field.

Field, Vortex-Ring — —The field of influence possessed by a vortex-ring.

Professor Dolbear points out the fact that the direction of the rotation of a fluid constituting a vortex-ring resembles the magnet flux in a magnetic field, and shows, from the action of such rings on one another, that they possess a true field, or atmosphere of influence outside their actual bodies. He infers that such rings possess true polarity, since the motions producing them have different directions on opposite sides or ends.

Figure of Merit of Galvanometer.—(See *Galvanometer, Figure of Merit of*.)

Figures, Breath — —Faint figures of condensed vapor produced by electrifying a coin, placing it momentarily on the surface of a sheet of clean, dry glass, and then breathing gently on the spot where the coin was placed.

The moisture collects on the electrified portions of the plate and forms a fairly distinct image of the coin.

Figures, Electric — —Figures of various shapes produced on electrified surfaces by the arrangement of dust particles or vapor vesicles under the influence of electric charges.

Electric figures are of two varieties, viz.:

- (1.) Dust figures.
- (2.) Breath figures.

Figures, Lichtenberg's Dust — — Figures produced by writing on a sheet of shellac with the knob of a charged Leyden jar, and then sprinkling over the sheet dried and powdered sulphur and red lead, which have

been previously mixed together, and are so rendered, respectively negative and positive.

The red lead collects on the negative parts of the shellac surface, and the sulphur on the positive parts, in curious figures, known as *Lichtenberg's Dust Figures*, one of which is shown in Fig. 254.

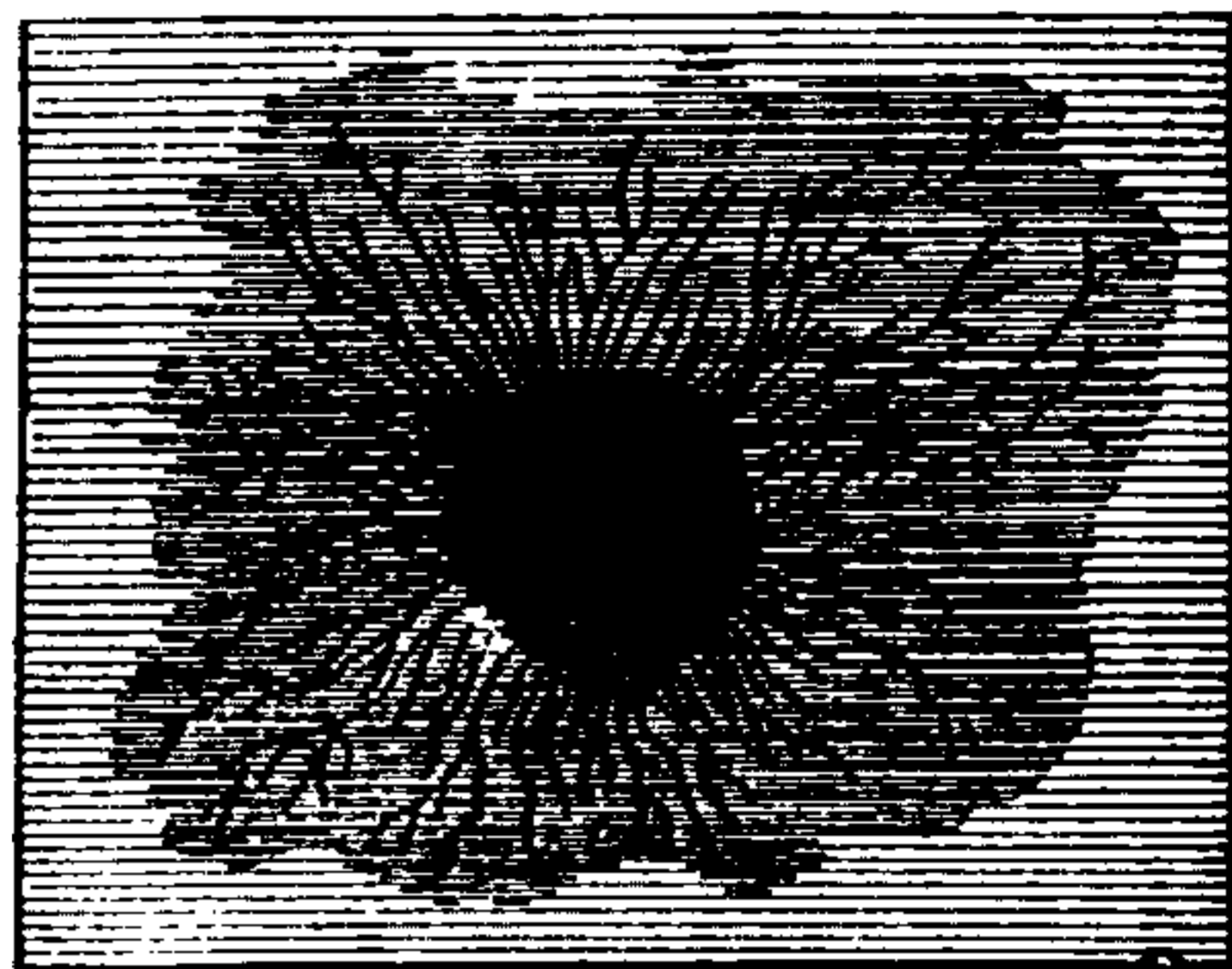

Fig. 254. *Lichtenberg's Dust Figures*.

These figures show very clearly that an electric charge tends to creep irregularly over the surface of an insulating substance.

Figures, Magnetic — —A name sometimes applied to the groupings of iron filings on a sheet of paper so held in a magnetic field as to be grouped or arranged under the influence of the lines of force of the same. (See *Field, Magnetic*.)

Filament.—A slender thread or fibre.

The term is applied generally to threads or fibres varying considerably in diameter.

Filament, Current — —A term sometimes employed in place of current streamlet. (See *Streamlets, Current*.)

Filament, Magnetic — —A polarized line or chain of ultimate magnetic particles.

This is sometimes called a *uniform magnetic filament*.

A bar-magnet possesses but two free poles. When broken at its neutral point or equator, the bar will develop free poles at the broken ends. This is explained by considering the magnet to be composed of a number of separate particles, separately magnetized. A single chain or filament of such particles is called a magnetic filament. (See *Magnet, Neutral Point of. Magnetism, Hughes' Theory of. Magnetism, Ewing's Theory of*.)

Filament of Incandescent Electric Lamp.

—(See *Lamp, Incandescent Electric, Filament of.*)

Filament, Uniform Magnetic — —A term sometimes applied to a magnetic filament. (See *Filament, Magnetic.*)

Filaments, Flashed — —Filaments for an incandescent lamp, that have been subjected to the flashing process. (See *Carbons, Flashing Process for.*)

Filamentous Armature Core.—(See *Core, Armature, Filamentous.*)

Film Cut-Out.—(See *Cut-Out, Film.*)

Finder, Induction — —A term sometimes employed for a magnetic explorer.

Finder, Position, Electric — —A device by means of which the exact position of an object can be obtained.

By means of a position-finder a gunner can be telephoned or otherwise ordered to fire at objects he cannot see, and yet obtain a fair degree of accuracy.

Finder, Range, Electric — —A device by means of which the exact distance of an enemy's ship or other target can be readily determined.

The operation of an electric range-finder is based on a method somewhat similar to the solving of a triangle for the purpose of determining distances. If the base line of a triangle and the two angles at the base are known, the other two sides and the included angle can be determined.

In the range-finder, the resistance of a German silver wire corresponds to the graduated arc of the theodolite used to measure the angles, and a rheostat, as a receiving instrument, measures the values of the angles. The base line is a constant, so that the receiving instrument is marked in yards instead of angles. To use the range-finder, two observers watch the target object continuously through a telescope. They do this and nothing else, while a third observer watches a galvanometer and so alters a resistance, by moving a contact or slide key along a resistance wire, as to keep the needle of the galvanometer constantly at zero. The exact distance being thus ascertained, the gunner can make the proper allowance in firing.

Finder, Wire — —Any form of galvanometer used to locate or find the corre-

sponding ends of different wires in a bunched cable.

The different wires in a cable are usually tagged and numbered at the end of the cable and at the joints. The telephone has been successfully employed as a wire finder.

Fire Alarm Annunciator.—(See *Annunciator, Fire Alarm.*)

Fire Alarm, Automatic — —(See *Alarm, Fire Automatic.*)

Fire Alarm Contact.—(See *Contact, Fire Alarm.*)

Fire Alarm Signal Box.—(See *Box, Fire Alarm Signal.*)

Fire Alarm Telegraph Box.—(See *Box, Fire Alarm Telegraph.*)

Fire Ball.—(See *Ball, Fire.*)

Fire Cleansing.—(See *Cleansing, Fire.*)

Fire Extinguisher, Electric — —A thermostat or mercury contact, which automatically completes a circuit and turns on a water supply for extinguishing a fire, on a certain predetermined increase of temperature.

Fire, Hot, St. Elmo's — —A term proposed by Tesla for a form of powerful brush discharge between the secondary terminals of a high frequency induction coil. (See *Discharge, Brush-and-Spray.*)

This form of St. Elmo's fire differs from the ordinary form in being hot. Its general appearance is shown in Fig. 255, taken from Tesla.

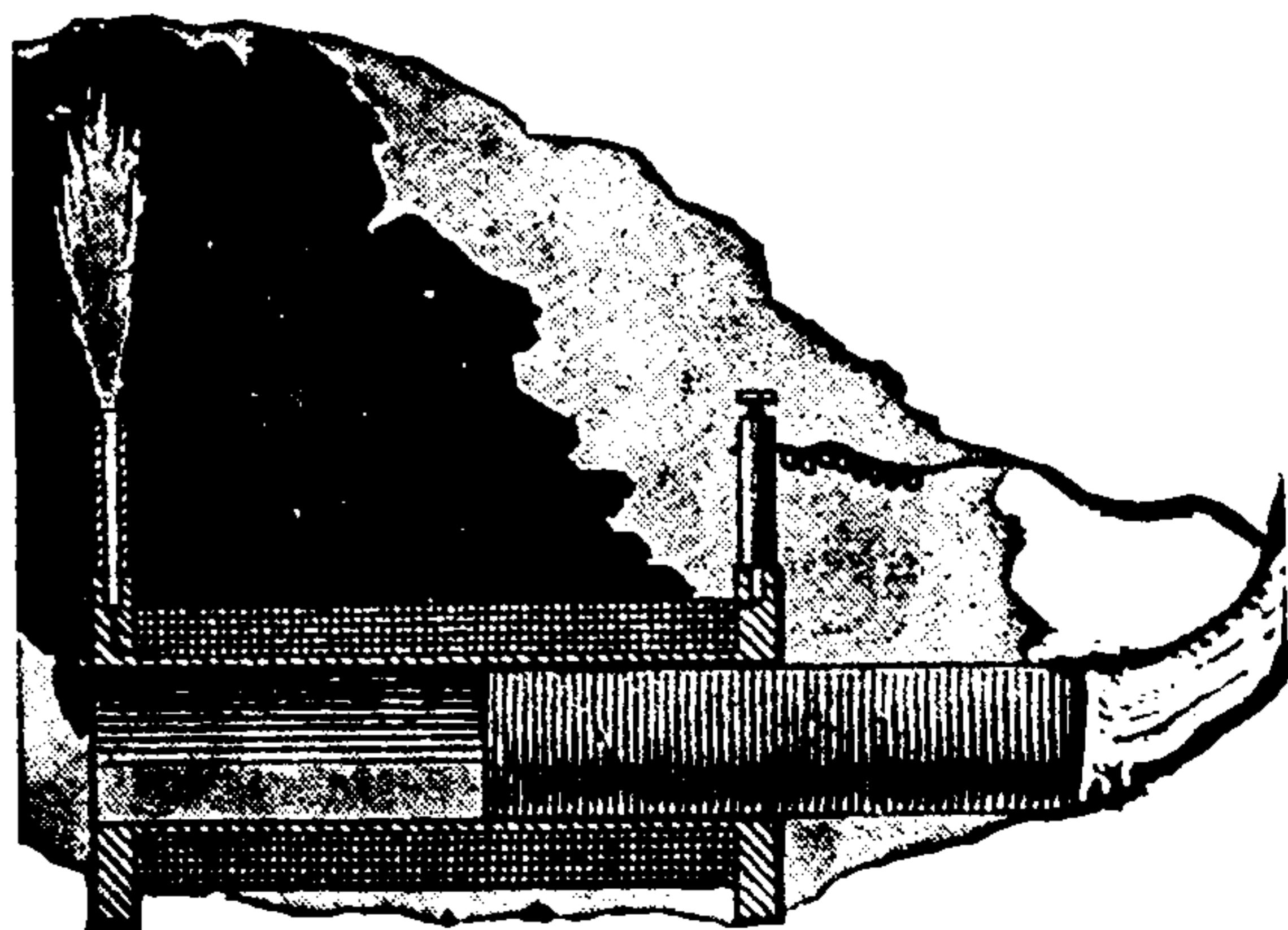

Fig. 255. St. Elmo's Hot Fire.

Describing its production he says: "In many of these experiments, when powerful effects are wanted for a short time, it is advantageous to use

iron cores with the primaries. In such case a very large primary coil may be wound and placed side by side with the secondary, and, the nearest terminal of the latter being connected to the primary, a laminated iron core is introduced through the primary into the secondary as far as the streams will permit. Under these conditions an excessively powerful brush, several inches long, which may be appropriately called 'St. Elmo's hot fire,' may be caused to appear at the other terminal of the secondary, producing striking effects. It is a most powerful ozonizer; so powerful indeed, that only a few minutes are sufficient to fill the whole room with the smell of ozone, and it undoubtedly possesses the quality of exciting chemical affinities."

Fire, St. Elmo's — — Tongues of faintly luminous fire which sometimes appear on the pointed ends of bodies in connection with the earth, such as the tops of church steeples or the masts of ships.

The appearance of the St. Elmo's fire is due to brush discharges of electricity.

Fishes, Electric — — A term applied to various fishes, such as the eel and the ray, which possess the ability of protecting themselves by giving electric shocks to objects touching them. (See *Eel, Electric*.)

Fishing Box.—(See *Box, Fishing*.)

Fittings or Fixtures, Electric Light — — The sockets, holders, arms, etc., required for holding or supporting incandescent electric lamps.

Fixed Secondary. — (See *Secondary, Fixed*.)

Fixtures, Telegraphic — — A term generally limited to the variously shaped supports provided for the attachment of telegraphic wires.

Fixtures, Telegraphic House-Top — — Telegraphic fixtures placed on the roofs of buildings for the support of the lines.

Flaming Discharge. — (See *Discharge, Flaming*.)

Flash, Side — — A sparking or lateral discharge taking place from the sides of a conductor, when an impulsive rush of electricity passes through it.

The phenomenon of side flashing is due to a lateral discharge which takes the alternative path, instead of a path of much smaller ohmic resistance. The tendency to side flash results from the fact that the metallic circuit possesses inductance. (See *Path, Alternative. Discharge, Lateral. Inductance*.)

Flashed Carbons. — (See *Carbons, Flashed*.)

Flashed Filaments. — (See *Filaments, Flashed*.)

Flashes, Auroral — — Sudden variations in the intensity of the auroral light.

Intermittent flashes of auroral light that occur during the prevalence of an aurora. (See *Aurora Borealis*.)

Flashing of Carbons, Process for the — — (See *Carbons, Flashing Process for*.)

Flashing of Dynamo-Electric Machine. — (See *Machine, Dynamo-Electric, Flashing of*.)

Flat Cable.—(See *Cable, Flat*.)

Flat Duplex Cable.—(See *Cable, Flat Duplex*.)

Flat Ring Armature.—(See *Armature, Flat Ring*.)

Flats.—A name sometimes applied to those parts of commutator segments the surface of which, through wear, has become lower than the other portions. (See *Commutator*.)

Fleming's Gauss.—(See *Gauss, Fleming's*.)

Fleming's Standard Voltaic Cell.—(See *Cell, Voltaic, Standard, Fleming's*.)

Flexible Electric Light Pendant.—(See *Pendant, Flexible Electric Light*.)

Flexible Lead.—(See *Lead, Flexible*.)

Floating Battery, De la Rive's.—(See *Battery, Floating, De la Rive's*.)

Flow.—In hydraulics, the quantity of water or other fluid which escapes from an orifice in a containing vessel, or through a pipe, in a given time.

Flow-Lines of Escaping Fluid.—Lines within the mass of a fluid in motion, drawn at

THIS PAGE IS LOCKED TO FREE MEMBERS

Purchase full membership to immediately unlock this page

Know Your Bible

Forgotten Books' Full Membership provides unlimited access to more than 28,000 volumes of Christian literature for \$8.99/month

**HOLY
BIBLE**

Continue

*Fair use policy applies

Flyer, Electric — — A wheel arranged so as to be set into rotation by the escape of convection streams from its points when connected with a charged conductor.

A wheel formed of light radial arms P, P, P, etc., shaped as shown in Fig. 256, and capable of rotation on the vertical axis A, is set into rapid rotation when connected with the prime conductor of a frictional or influence machine, through the *convection streams* of air particles, which are shot off from the points or extremities of the radial arms. The wheel is driven by the reaction of these streams in a direction opposite to that of their escape. (See *Discharge, Convective.*)

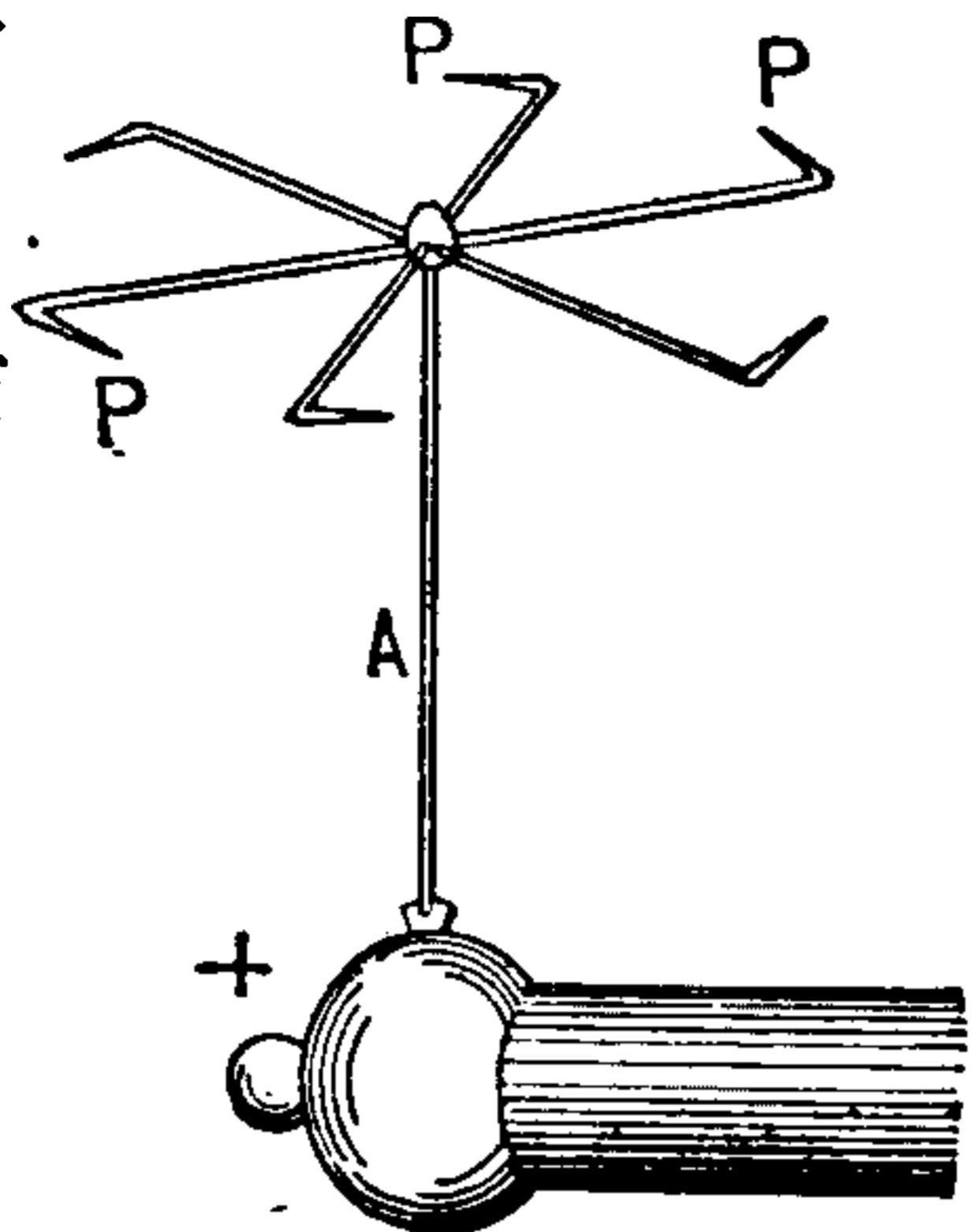

Fig. 256. Electric Flyer.

Focus.—A point in front or back of a lens or mirror, where all the rays of light meet or seem to meet. (See *Lens, Achromatic.*)

Fog, Electric — — A dense fog which occurs on rare occasions when there is an unusual quantity of free electricity in the atmosphere.

During these electric fogs the free electricity of the atmosphere changes its polarity at frequent intervals.

Following Horn of Pole Pieces of Dynamo-Electric Machine.—(See *Horns, Following, of Pole Pieces of a Dynamo-Electric Machine.*)

Foot-Candle.—(See *Candle, Foot.*)

Foot-Pound.—A unit of work. (See *Work.*)

The amount of work required to raise 1 pound vertically through a distance of 1 foot.

The same amount of work, viz., 3 foot-pounds, is done by raising 1 pound through a vertical distance of 3 feet, or 3 pounds through a vertical distance of 1 foot.

Apart from air friction, the amount of work done in raising 1 pound through 1 foot, viz., 1 foot-pound, is the same whether this work be done in one second or in one day. The *power*, or the *rate of doing work*, is, however, very different in the two cases. (See *Power.*)

Force.—Any cause which changes or tends

to change the condition of rest or motion of a body.

Force, Centrifugal — — The force that is supposed to urge a rotating body directly away from the centre of rotation.

If a stone be tied to a string and whirled around, and the string break, the stone will not fly off directly away from the centre, but will move along the tangent to the point where it was when the string broke.

The centrifugal force in reality is the force which is represented by the tension to which the string is subjected during this rotation.

Force, Coercitive — — A name sometimes applied to coercive force. (See *Force, Coercive.*)

Force, Coercive — — The power of resisting magnetization or demagnetization.

Coercive force, in the sense of resisting demagnetization, is sometimes called *magnetic retentivity*.

Hardened steel possesses great coercive force; that is, it is magnetized or demagnetized with difficulty.

Soft iron possesses very feeble coercive force.

It is on account of the feeble coercive force of the soft iron core of an electro-magnet that its main value depends, since it is thereby enabled to rapidly acquire its magnetization, on the completion of a circuit through its coils, and to rapidly lose its magnetization on the opening of such circuit.

Force, Contact — — A difference of electrostatic potential, produced by the contact of dissimilar metals.

That a difference of potential is produced by the mere contact of dissimilar metals is now generally recognized. Such a force is generally called the true contact force. (See *Force, True Contact.*)

According to Lodge, a true contact force has no existence. There is no evidence, he thinks, of a peculiar electromotive force at the point of contact, but that the phenomena are due simply to the fact that the metals are immersed in air or oxygen, which is capable of combining with one of them, and that, therefore, the cause of the phenomena is the greater action, for instance, of the oxygen of the air on the zinc than on the copper.

According to this view, the voltaic effect is due not to the difference of potential between the zinc and copper, but to the difference of the action of the air or moisture.

Force de Cheval or Cheval Vapeur.—The French term for horse-power.

The force de cheval is equal to 75 kilogramme-metres per second, or 32,549 foot-pounds per minute.

The English horse-power is equal to 33,000 foot-pounds per minute. 1 force de cheval equals .98634 horse-power; 1 horse-power equals 1.01385 force de cheval.—(*Hering.*)

Force, Electric — — The force developed by electricity.

This term is generally limited to the force of attraction or repulsion produced by an electrostatic charge.

Force, Electromotive — — The force starting electricity in motion, or tending to start electricity in motion.

The force which moves or tends to move electricity.

The term is an unfortunate one. Strictly speaking, electromotive force is not a force at all: at least, it is not a force in the Newtonian sense, where force is only that which acts on *matter*.

The term electromotive force is generally written thus: E. M. F.

The unit of electromotive force is the volt.

When electric induction takes place, there results a change in the distribution of the thing called electricity, whereby a movement occurs that results in a positive and a negative charge. The cause which produces this movement is called the electromotive force.

There is an unfortunate want of uniformity at present in the use of the term "electromotive force." By some, the electromotive force is regarded as something which causes the difference of potential; by others the electromotive force is regarded as being produced by the difference of potential; and, by still others, electromotive force is regarded as the entire electric moving cause produced by any source; while anything less than this is called by them potential difference.

Those who regard the electromotive force as the cause which produces the potential difference look on the electromotive force as acting within

the source and maintaining a potential difference at its terminals.

Silvanus P. Thompson uses the term electromotive force in his "Elementary Lessons in Electricity and Magnetism" as follows: "The term 'electromotive force' is employed to denote that which moves or tends to move electricity from one place to another. For brevity we sometimes write it E. M. F. In this particular case it is obviously the result of difference of potential and proportional to it; just as in water pipes, a difference in level produces a pressure, and the pressure produces a flow as soon as the tap is turned on, so difference of potential produces electromotive force, and electromotive force sets up a current as soon as a circuit is completed for the electricity to flow through."

Mascart and Joubert, in their work on "Electricity and Magnetism," Vol. I., say: "In all cases the difference of potential $V_1 - V_2$, may be considered as producing the motion of electrical masses; it is often called the electromotive force."

Maxwell, in his "Elementary Treatise on Electricity," speaking of the potential differences which may be shown to exist at the terminals of a Daniell voltaic cell when on open circuit, says: "This difference of potential is called the electromotive force of a Daniell cell."

Balfour Stewart, in his "Electricity and Magnetism," says: "This difference of electric level we shall call E, and, indeed, it is merely a manner of expressing the cause of electromotive force."

Prof. Fleming, in his "Short Lectures to Electrical Artisans," says: "The difference of electrical level or potential must be caused by some electromotive force acting in the conductor."

Prof. Anthony, in "A Review of Modern Electrical Theories," regards the potential difference as due to electromotive force. He says: "Difference of potential results from a changed electrical distribution, an electrical strain, and represents the tendency to return to the state of equilibrium. Electromotive force is the something from without that produced the electric strain."

Hering, in his "Principles of Dynamo-Electric Machines," says: "Difference of potential is, as the name implies, the difference of electrical potential between any two points of a circuit, and may, therefore, be applied to that at the poles of a machine, battery or lamp, or at the ends of leads, or, in general, to any two points in a circuit. The term 'electromotive force,' however,

applies only to the maximum difference of potential which exists in the circuit, or, in other words, the total generated difference of potential."

This last paragraph expresses the distinction between the two terms as ordinarily used in connection with dynamos and batteries.

Force, Electromotive, Absolute Unit of — — A unit of electromotive force expressed in absolute or C. G. S. units.

The one-hundred millionth part of a volt, since 1 volt equals 10^8 C. G. S. units of electromotive force. (See *Units, Practical.*)

Force, Electromotive, Average or Mean — — The sum of the values of a number of separate electromotive forces divided by their number.

The square root of the mean square of the electromotive force of an alternating or variable current.

When a wire in the armature of a dynamo-electric machine cuts the lines of magnetic force in the field of the machine, the electromotive force produced depends on the number of lines of force cut per second. This will vary for different positions of the coil. The mean value of the varying electromotive forces between the brushes, is the average electromotive force.

Force, Electromotive, Back — — A term sometimes used for counter electromotive force.

Counter electromotive force is the preferable term. (See *Force, Electromotive, Counter.*)

Force, Electromotive, Counter — — An opposed or reverse electromotive force, which tends to cause a current in the opposite direction to that actually produced by the source.

In an electric motor, an electromotive force contrary to that produced by the current which drives the motor, and which is proportional to the velocity attained by the motor.

Counter electromotive force acts to diminish the current in the same manner as a resistance would, and is therefore sometimes called *spurious resistance* in order to distinguish it from an *ohmic* or *true resistance*.

Counter electromotive force is sometimes expressed in ohms, though it is not a *true ohmic resistance*. (See *Resistance, Spurious.*)

The counter electromotive force of a voltaic battery is due to the *polarization* of the cells. Since this force is due to the current in the cell, it can never exceed such current or reverse its direction. It may, however, equal it and thus stop its flow. (See *Cell, Voltaic, Polarization of.*)

In a *storage cell*, the charging current produces an electromotive force counter to itself, which, as in a motor, is a true measure of the energy stored in the cell. Economy requires that the electromotive force of the charging current should be as little as possible greater than that of the counter electromotive force of the cell it is charging.

In a voltaic arc a counter electromotive force is believed to be set up by polarization.

Force, Electromotive, Counter, of Convective Discharge — — Resistance to the passage of an electric discharge through a high vacuum, somewhat of the nature of a counter electromotive force.

The resistance to the passage of convective discharges, therefore, is due to the following causes:

- (1.) True ohmic resistance.
- (2.) Counter electromotive force.

Force, Electromotive, Counter, of Mutual Induction — — The counter electromotive force produced by the mutual induction of the primary and secondary circuits on each other.

Force, Electromotive, Counter, of Self-Induction — — That part of the impressed electromotive force which is producing, or which tends to produce, at any instant a change in the current strength.

Force, Electromotive, Counter, of Self-Induction of the Primary — — A counter electromotive force produced in the primary circuit of an induction coil by the action thereon of a simple periodic electromotive force.

The counter electromotive force produced in the primary circuit of an induction coil by the application of a simple periodic impressed electromotive force to the primary circuit.

Force, Electromotive, Counter, of Self-Induction of the Secondary — — A counter electromotive force produced in the secondary by the periodic variations in the effective electromotive force in the secondary.

THIS PAGE IS LOCKED TO FREE MEMBERS

Purchase full membership to immediately unlock this page



HISTORY

Tens of thousands of important historical sources, many previously unobtainable, are now available for the first time with a Forgotten Books Full Membership.

Unlimited Access
\$8.99/month

Continue

*Fair usage policy applies

Force, Electromotive, Photo — — An electromotive force produced by the action of light on selenium. (See *Cell, Selenium*.)

Force, Electromotive, Reacting Inductive, of the Primary Circuit — — The back or counter electromotive force produced in the primary circuit by the current set up by induction in the secondary.

Force, Electromotive, Secondary Impressed — — An electromotive force produced in the secondary coil or circuit by a periodic electromotive force impressed on the primary.

Force, Electromotive, Simple-Periodic — — An electromotive force which varies in such manner as to produce a simple periodic current, or an electromotive force the variations of which can be correctly represented by a simple-periodic curve.

Force, Electromotive, Thermo — — An electromotive force, or difference of potential, produced by differences of temperature acting at thermo-electric junctions.

Force, Electromotive, Transverse — — An electromotive force excited by a magnetic field in a substance in which electric displacement is occurring.

It is to a transverse electromotive force that the Hall effect is due. (See *Effect, Hall*.)

Force, Electromotive, Zigzag — — An electromotive force, the curve of which would have the general form of a zigzag.

Force, Electrostatic — — The force producing the attractions or repulsions of charged bodies.

Force, Electrostatic, Lines of — — Lines of force produced in the neighborhood of a charged body by the presence of the charge.

Lines extending in the direction in which the force of electrostatic attraction or repulsion acts.

An insulated charged conductor produces around it an electrostatic field, in a manner somewhat similar to the magnetic field produced by a magnet or an electric current. (See *Field, Electrostatic*.)

Lines of electrostatic force pass through dielectrics. Whether the force acts to produce electrostatic induction, by means of a polarization of the dielectric, or by means of a tension set up in the substance of the dielectric, is not known.

Force, Electrostatic, Lines of, Assumed Flow of — — A mathematical conception in which the phenomena of electricity are compared with the similar phenomena of heat.

In heat no flow of heat occurs over isothermal surfaces, or surfaces at the same temperature. Between different isothermal surfaces, the flow will vary with the power of heat conduction. In electricity, no flow occurs over equipotential surfaces. Specific inductive capacity corresponds to heat conductivity, and the lines of force to the lines of heat conduction. (See *Capacity, Specific Inductive*.)

Force, Lines of, Contraction of — — A decrease that occurs in the length of the circular lines of force that surround a circuit through which an electric current is passing, while the current is decreasing in intensity or strength.

The contraction or decrease in the average diameter of the circular lines of force of an electric circuit is similar to the expansion or growth of lines of force, excepting that the movement is one of decrease in diameter, and takes place in the opposite direction, *i. e.*, towards the circuit, instead of away from it. (See *Force, Lines of, Growth or Expansion of*.)

Force, Lines of, Cutting — — Passing a conductor through lines of magnetic force, so as to cut or intersect them.

The cutting of lines of magnetic force produces differences of potential. This is true whether the conductor moves through a stationary field or whether the field itself moves through the stationary conductor, so that the lines of force and the conductor cut one another. This cutting is mutual. Each line of force cuts and is cut by the circuit. Since all lines of force form closed-circuits or paths, the cutting of the circuit by the lines of force, or the reverse, forms a link or chain, and the cutting takes place at the moment of linking or unlinking, *i. e.*, of cutting.

Force, Lines of, Diffusion of — — The deflection of the lines of magnetic force from

their ordinary position, between the poles that produce them.

Force, Lines of, Direction of — —The direction in which it is assumed that the lines of magnetic force pass.

It is generally agreed to consider the lines of magnetic force as coming out of the north pole of a magnet and passing into its south pole, as shown in Fig. 257.

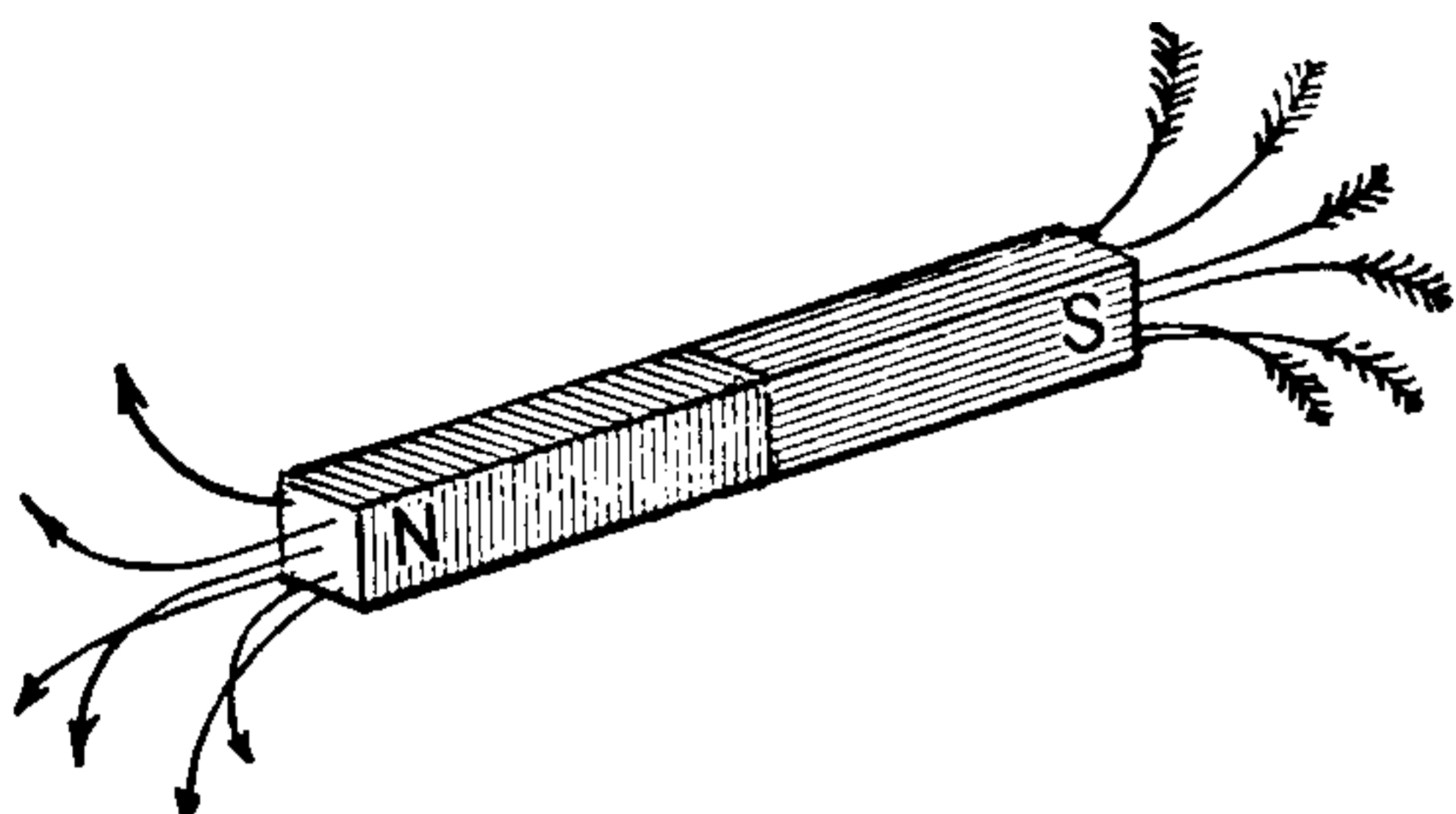

Fig. 257. *Direction of Lines of Force.*

This is sometimes called the positive direction of the lines of force and agrees in general with the direction in which the electric current is assumed to flow, which is from the positive to the negative. That is to say, the lines of magnetic force are assumed to flow or pass out of the north pole and into the south pole of a magnet. Of course there is no direct evidence of any flow, or of any particular direction characterizing the lines of force. (See *Field, Magnetic.*)

The lines of electrostatic force are assumed to pass out of a positively charged surface and into a negatively charged surface.

Force, Lines of, Growth or Expansion of — —The increase in the length of path through which lines of force pass, consequent on an increase in the strength of the magnetization of a magnet, or on an increase in the strength of the magnetizing current.

The circular lines of force which surround a conductor through which a current is flowing, may be regarded as starting from the surface of the conductor and growing in size as they spread outwards, at the same time new lines of force being formed in their places. This action continues while the strength of the current is increasing, somewhat like the series of concentric waves which are formed on the surface of water, when a stone is dropped into it.

In their growth or expansion outwards from the conductor, if the lines of force cut or pass through neighboring conductors, they produce

therein differences of electric potential, capable, on being connected by a conductor, of producing electric currents.

Force, Lines of, Radiation of — —The passing of lines of force out of the north pole of a magnet or solenoid.

In gross matter all lines of magnetic induction either pass through magnetized iron, or other paramagnetic substance which surrounds an electric circuit. Since lines of force pass through a vacuum, the ether which occupies such a space must also be regarded as permitting the passage of lines of force.

Force, Loops of — —A term sometimes employed in the sense of lines of force. (See *Force, Magnetic, Lines of.*)

The term "Lines of Force" is generally adopted in place of Faraday's term "Loops of Force."

Force, Magnetic — —The force which causes the attractions or repulsions of magnetic poles.

Force, Magnetic, Line of — —Arbitrarily a single line of magnetic force.

Practically the lines of magnetic force which pass through a unit area of cross-section of a magnetic field of unit strength.

Force, Magnetic, Lines of — —Lines extending in the direction in which the magnetic force acts.

Lines extending in the direction in which the force of magnetic attraction or repulsion acts. (See *Field, Magnetic.*)

Faraday regarded the lines of magnetic force as possessing tension along one direction. Lines of force act as if they were stretched elastic threads, possessed of the property of lengthening or shortening, and of repelling one another.

Force, Magnetic, Lines of, Conducting Power for — —A term employed by Faraday for magnetic permeability. (See *Permeability, Magnetic.*)

Force, Magnetic, Lines of, Positive Direction of — —The direction in which a free north-seeking pole would move along the lines of force when placed in a magnetic field.

Force, Magnetic, Telluric — —The earth's magnetic force.

Force, Magneto-Motive — —The force that moves or drives the lines of magnetic force through a magnetic circuit against the magnetic resistance.

A Committee of the American Institute of Electrical Engineers on "Units and Standards" proposed the following definition.

The magneto-motive force in a magnetic circuit is 4π multiplied by the flow of the current linked with that circuit. The magneto-motive force between two points connected by a line is the line integral of the magnetic force along that line. Difference of magnetic potential constitutes magneto-motive force."

The same committee gave the electro-magnetic dimensional formula $L^{\frac{1}{2}} M^{\frac{1}{2}} T^{-1}$.

The flow or flux of lines of magnetic force in any magnetic circuit is proportional to the magneto-motive force divided by the magnetic resistance; or, expressing the law in the form of Ohm's law for current:

$$\text{Magnetic Flux} = \frac{\text{Magneto-Motive Force}}{\text{Reluctance.}}$$

In this formula the word reluctance is used in place of magnetic resistance. In the case of an electro-magnet, the magneto-motive force is proportional to the strength of the current which flows and the number of times it circulates; or, more simply, is proportional to the number of ampère turns. (See *Turns, Ampère.*)

Force, Magneto-Motive, Absolute Unit of — — 4π multiplied by unit current of one turn.

Force, Magneto-Motive, Practical Unit of — —A value of the magneto-motive force equal to 4π multiplied by the ampères of one turn, or to $\frac{1}{10}$ of the absolute unit.

Force, Motor Electromotive — —A term proposed by F. J. Sprague for the counter electromotive force of a motor.

During the rotation of the armature of an electric motor in its field, a counter electromotive force is produced in its coils, which acts as a spurious resistance and opposes the flow or passage of the driving current through its coils. As the speed of the motor increases, this counter electromotive force increases and the strength of the driving current decreases until a certain

maximum speed is reached, when, theoretically, no current passes.

When a load is placed on the electric motor, the speed, and consequently the counter electromotive force, is decreased and more driving current is permitted to pass. It was this consideration, viz.: that the load automatically regulates the current required to drive the motor, that led to the name motor-electromotive force. (See *Force, Electromotive, Counter.*)

Force, Resolution of — —The separation of a single force, acting with a given intensity in a given direction, into a number of separate forces acting in some other direction.

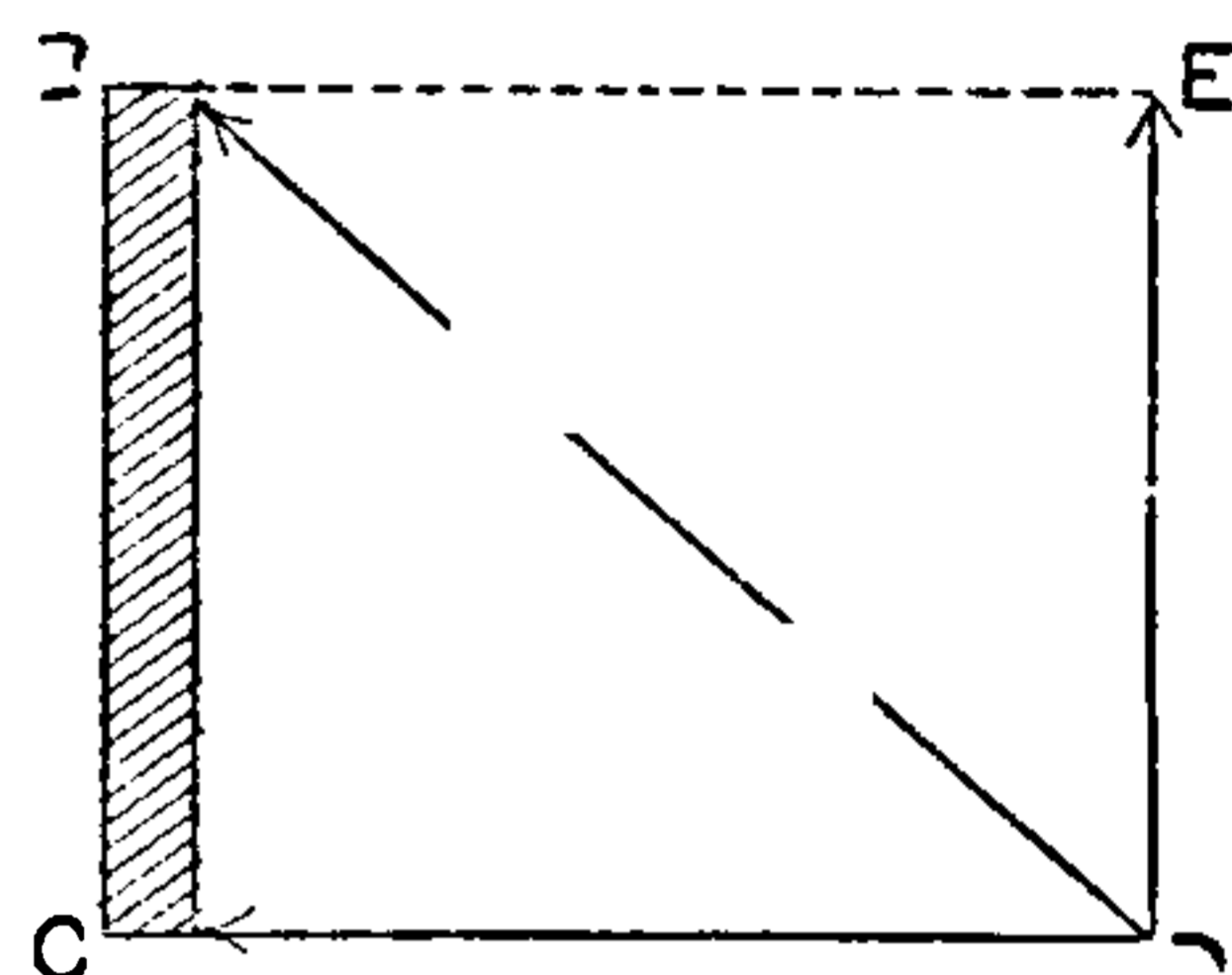

Fig. 258. Resolution of Force.

Thus the force D B, Fig. 258, acting with the intensity and in the direction shown, may be resolved into two component forces, D

E and D C, acting in the directions and having the intensities shown. The single force D B, has been resolved into two separate forces D E and C D.

Force, True Contact — —A force or effect entirely distinct from the voltaic effect, which exists at the points of contact between two dissimilar metals.

The truth of the existence of a true contact force at the junction of dissimilar metals is seen by the reversible heat effects observed, when a current of electricity is passed across a junction of two dissimilar metals. When the current is passed in one direction, an increase of temperature is produced, but when passed in the opposite direction, a decrease of temperature. (See *Effect, Peltier.*)

Hence there would appear to be a force existing at the junction, helping the electricity along in one direction, but opposing it in the opposite direction. In one direction the electricity does work and consumes its own energy in so doing. In the other direction it opposes the passage of the current, and there results a generation of heat.

Force, Tubes of — —Tubes bounded by lines of electrostatic or magnetic force.

Lines of force never intersect one another. Hence a tube of force may be regarded as con-

THIS PAGE IS LOCKED TO FREE MEMBERS

Purchase full membership to immediately unlock this page

Know Your Bible

Forgotten Books'
Full Membership
provides unlimited
access to more than
28,000 volumes of
Christian literature for
\$8.99/month

**HOLY
BIBLE**

Continue

*Fair use policy applies

Friction Brake.—(See *Brake, Friction.*)

Frictional Electrical Machine.—(See *Machine, Frictional Electric.*)

Frictional Electricity.—(See *Electricity, Frictional.*)

Frog, Galvanoscopic — — The hind legs of a recently killed frog employed as an electroscope or galvanoscope, by sending an electric current from the nerves to the muscles. (See *Electroscope.*)

In 1786, Luigi Galvani made the observation that when the legs of a recently killed frog were touched by a metallic conductor connecting the nerves with the muscles, the legs were convulsed as though alive. He repeated this experiment and found the movements were more pronounced when two dissimilar metals, such as iron and copper, were employed in the manner shown in Fig. 260.

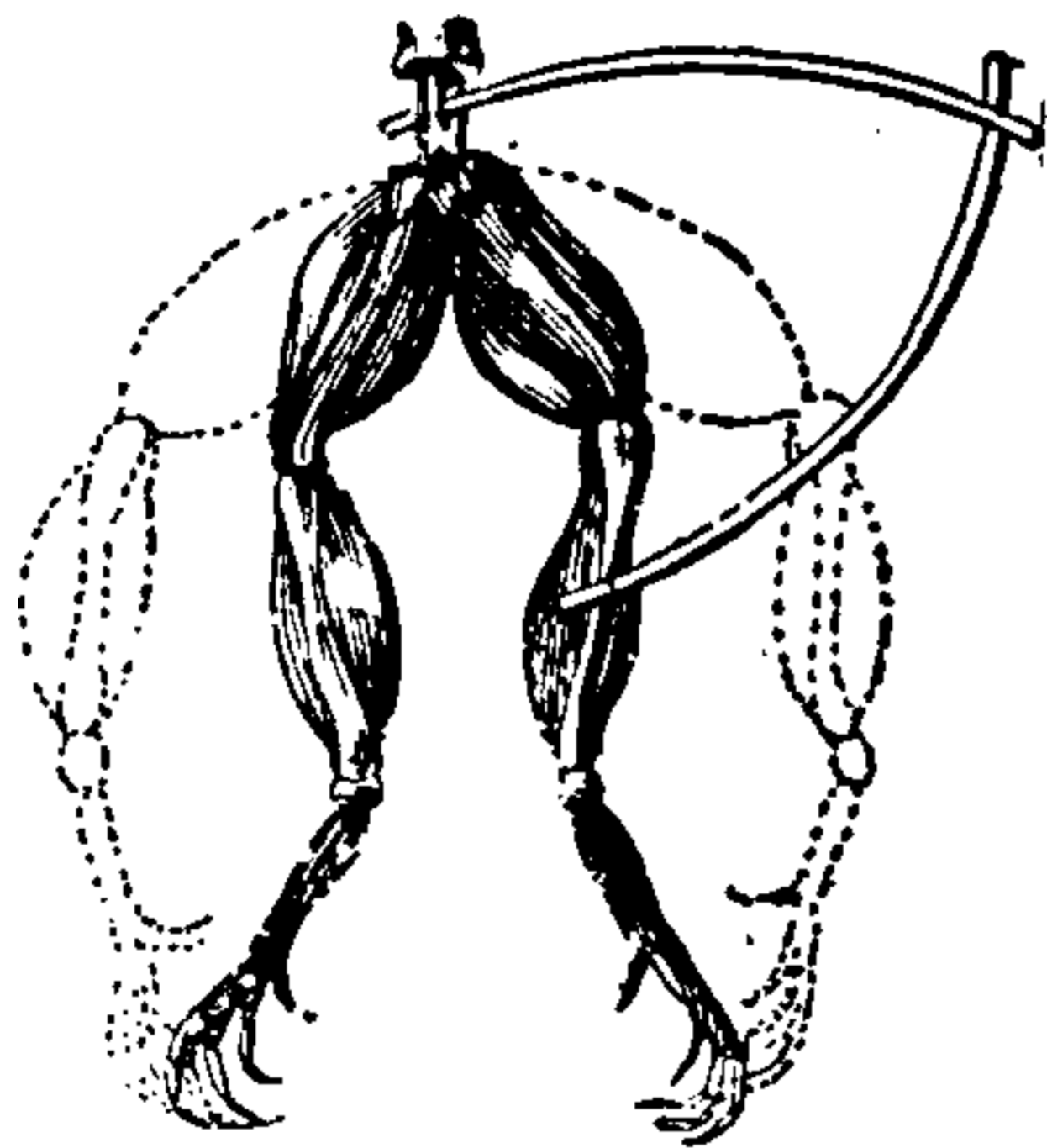

Fig. 260. Galvanoscopic Frog.

The classic experiment created intense excitement in the scientific world, and Galvani at first believed that he had discovered the true vital fluid of the animal, but afterwards recognized it as electricity, which he believed to be obtained from the body of the animal. Volta claimed that the movements were due to electricity caused by the contact of dissimilar metals, and thus produced his famous voltaic pile. (See *Pile, Voltaic.*)

Frog, Trolley — — The name given to the device employed in fastening or holding together the trolley wires at any point where the trolley wire branches, and properly guiding the trolley wheel along the trolley wire on the movement of the car over the track.

Frog, Trolley, Right-Hand — — A trolley frog used at the point where the branch trolley wire leaves the main line on the right of the direction in which the car is moving.

Frog, Trolley, Standard — — The trolley frog used at the point where two branch lines make equally converging angles to the main line.

Frog, Trolley, Three-Way — — A trol-

ley frog used where the line branches in three directions.

Frying of Arc.—(See *Arc, Frying of.*)

Fulgurite.—A tube of vitrified sand, believed to be formed by a bolt of lightning.

The fulgurite consists of an irregular shaped tube of glass formed of sand which has been melted by the electric discharge.

Full Contact.—(See *Contact, Metallic.*)

Fuller's Mercury Bichromate Voltaic Cell.—(See *Cell, Voltaic, Fuller's Mercury Bichromate.*)

Fulminate.—The name of a class of highly explosive compounds.

Fulminating gold, silver and mercury are highly explosive substances. Fulminates are employed in percussion caps.

Function, Trigonometrical — — Certain quantities, the values of which are dependent on the length of the arcs subtended by angles, which are taken for the measures of the arcs or angles instead of the arcs themselves.

The trigonometrical functions are the sine, the co-sine, the tangent, the co-tangent, the secant and the co-secant.

These are generally abbreviated thus, viz.: sin., cos., tan., cot., sec. and co-sec.

The sine of an angle or arc is the perpendicular distance from one extremity of the arc to the diameter passing through the other extremity.

Thus in Fig. 261 B D, is the sine of the angle B O A, or of the arc, B A.

The co-sine of an angle or arc is that part of the diameter which lies

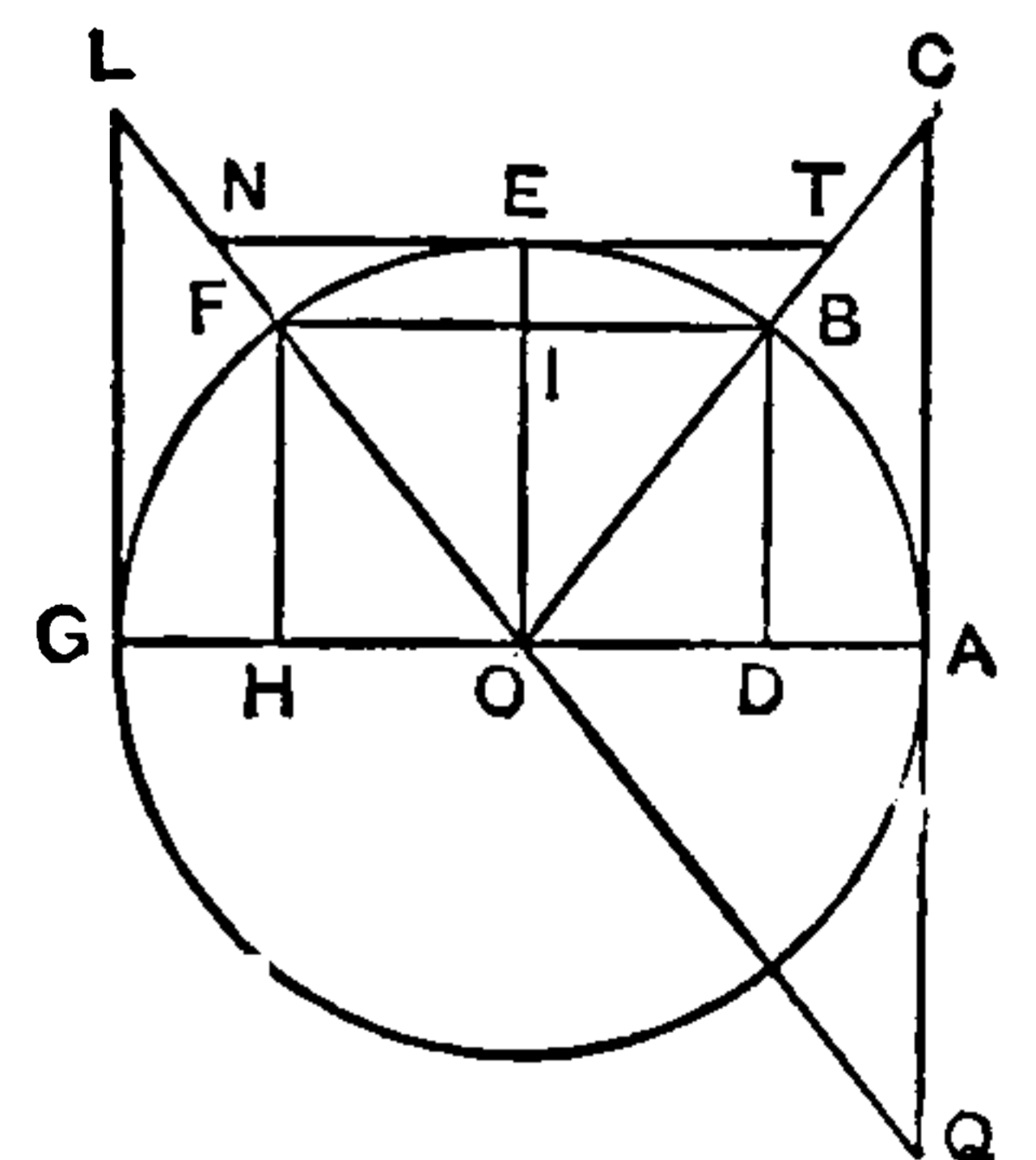

Fig. 261. Trigonometrical Functions.

between the foot of the sine and the centre. Thus, D O, is the co-sine of the angle B O A, or of the arc B A.

The co-sine of an arc is equal to the sine of its complement. Thus E O B, or B E, the complement of B A, has for its sine I B, which is equal to O D. (See *Angle, Complement of.*)

If the arc is greater than a right angle, or 90

degrees, such, for instance, as the angle $T O G$, or the arc $B E F G$, $B D$, is its sine. This is also the sine of $B O A$, or $B A$, which is the supplement of $T O G$, or $B E F G$. Hence the sine of an arc is equal to the sine of its supplement.

The same is true of the co-sine.

The tangent of an angle or arc is a straight line touching the arc at one extremity, drawn perpendicular to the diameter at that end of the arc, and limited by a straight line connecting the centre of the circle and the other end of the arc. Thus $C A$, is the tangent of the angle $B O A$, or the arc $B A$.

The co-tangent of an angle or arc is equal to the tangent of its complement. Thus $E T$, is the co-tangent of the angle $B O A$, or the arc $B A$.

The tangent of an angle or arc is equal to the tangent of its supplement. Thus $A C$, is the tangent of the angle $B O A$, or the arc $B A$. It is also equal to the tangent of the angle $B O G$, or the arc $B E F G$, the corresponding supplement of the angle $B O A$, or the arc $B A$.

The secant of an angle or arc is the straight line drawn from the centre of the circle through one extremity of the arc and limited by the tangent passing through the other extremity. Thus $O C$, is the secant of the angle $B O A$, or of the arc $B A$.

The secant of an angle or arc is equal to the secant of its supplement.

The co-secant of an angle or arc is equal to the secant of its complement.

Thus $O T$, is the co-secant of the angle $B O A$, or of the arc $B A$.

It will be observed that the co-sine, the co-tangent and the co-secant are respectively the sine, tangent and secant of the complement of the arc, or in other words, the complement-sine, the complement-tangent and the complement-secant.

Fundamental Units.—(See *Units, Fundamental*.)

Furnace, Electric — —A furnace in which heat generated electrically is employed for the purpose of effecting difficult fusions for the extraction of metals from their ores, or for other metallurgical operations.

In electric furnaces, the heat is derived either from electric incandescence or from the voltaic arc. The latter form is frequently adopted.

The substance to be treated is exposed directly

to the voltaic arc. In some forms of furnace the crushed ore is permitted to fall through the arc, and the melted matter received in a suitable vessel in which the separation of the substances so formed is afterwards completed. In other forms of furnace, the ore is placed between two electrodes of carbon or other refractory substance, between which a powerful current is passed. In the Cowles furnace, when aluminium is reduced, molten copper forms an alloy with the aluminium as soon as separated.

Very numerous applications of electricity to furnace operations have been made.

Fuse Block.—(See *Block, Fuse*.)

Fuse Board.—(See *Board, Fuse*.)

Fuse Box.—(See *Box, Fuse*.)

Fuse, Branch — —A safety fuse or strip placed in a branch circuit. (See *Fuse, Safety*.)

Fuse, Converter — —A safety fuse connected with the circuit of a converter or transformer.

Fuse, Electric — —A device for electrically igniting a charge of powder.

Electric fuses are employed both in blasting operations and for firing cannon.

Electric fuses are operated either by means of the direct spark, or by the incandescence of a thin wire placed in the circuit. They are therefore either *high tension*, or *low tension fuses*.

The advantages of an electric fuse consist in the fact that its use permits the simultaneous firing of a number of charges in a mining operation, thus obtaining a greater effect from the explosion. A fulminate of mercury is frequently employed in connection with some forms of electric fuses.

Fuse, Electric, High-Tension — —A fuse that is ignited by the heating power of an electric spark.

High-tension fuses, therefore, require a high electromotive force. This is obtained either by means of induction coils or by some form of electrostatic induction machine.

Fuse, Electric, Low-Tension — —A fuse that is ignited by heating a wire to incandescence by the passage through it of an electric current.

Fuse, Electric, Stratham's — —A form

of fuse, in which the ignition is effected by the electric spark, is shown in Fig. 262.

The spark passes through a break A B, in the insulated leads D. Since gunpowder is not readily ignited by an electric spark, a peculiar priming material is employed at A B, in the place of ordinary powder.

Fuse Links. — (See *Links, Fuse.*)

Fuse, Magazine — —A safety fuse so arranged as to readily permit the replacement of the fuse when burned out.

A spool contains a coil of fuse wire. In order to release the burned-out fuse, a wedge-shaped device is provided to open the clamps that hold the fuse strip to release the portions of burned-out fuse left, and connection with the fuse strip is severed while the attachment of the new strip is being made.

Fuse, Main — —A safety fuse or strip placed in a main circuit. (See *Fuse, Safety.*)

Fuse, Platinum — —A thin platinum wire rendered incandescent by the passage of an electric current and employed for the ignition of a charge of powder. (See *Fuse, Electric.*)

Fuse, Safety — —A strip, plate or bar of lead, or some readily fusible alloy, that automatically breaks the circuit in which it is placed on the passage of a current of suf-



Fig. 262.
Stratham's
Fuse.

ficient power to fuse such strip, plate or bar, when such current would endanger the safety of other parts of the circuit.

Safety fuses are often called safety strips or safety plugs.

Safety fuses are made of alloys of lead, and are placed in boxes lined with non-combustible material in order to prevent fires from the molten metal.

Fig. 263 shows a fusible strip F, connected with leads L, L. Safety fuses are placed on all branch circuits, and are made of sizes proportionate to the number of lamps they guard.

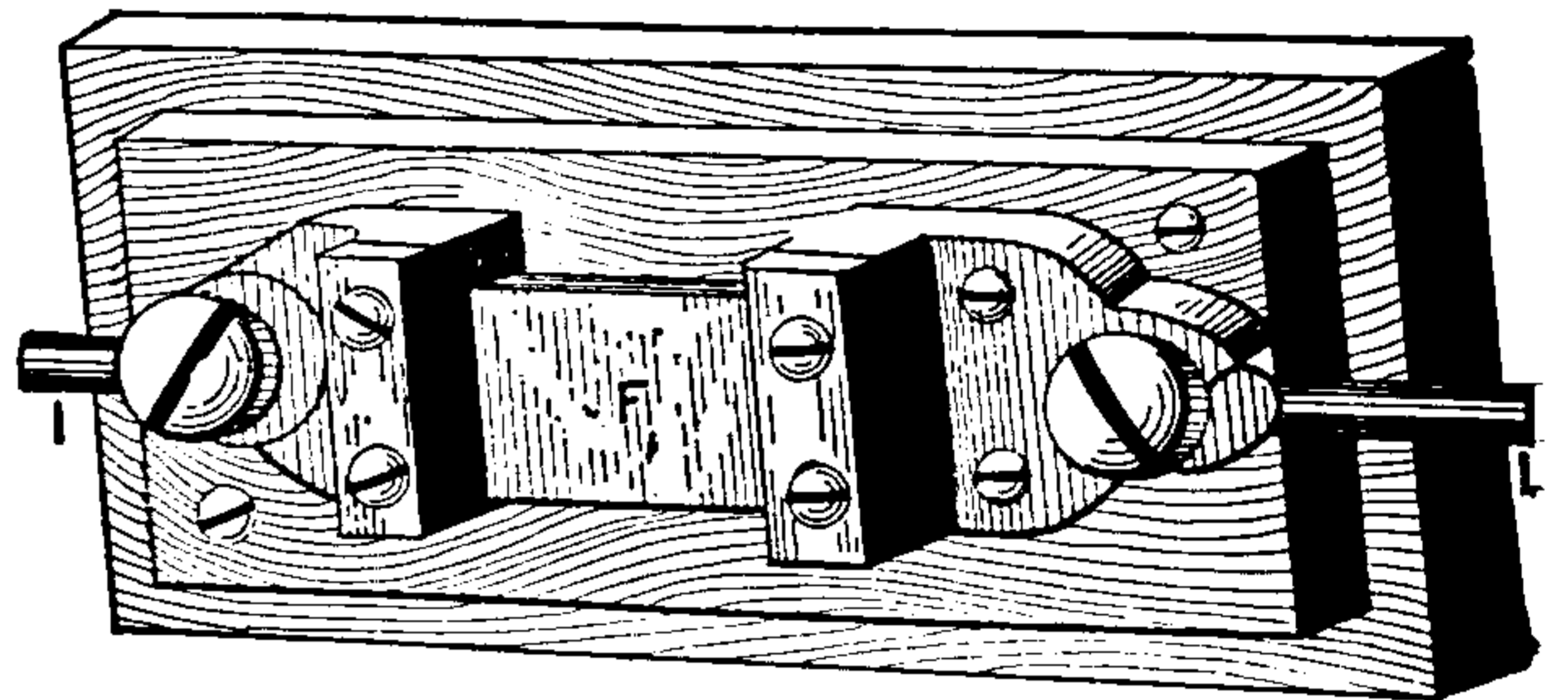

Fig. 263. Safety Fuse.

Since incandescent lamps are generally placed in the circuit in multiple-arc, or in multiple-series, one or more of the circuits can be opened by the fusion of the plug without interfering with the continuity of the rest of the circuits. In series circuits, however, such as arc-light circuits, when a lamp is cut out, a short circuit or path around it must be provided in order to avoid the extinguishing of the rest of the lights.

Fuse Wire.—(See *Wire, Fuse.*)

Fusible Plug.—A term commonly applied to a safety plug. (See *Fuse, Safety*

G

Gains.—The spaces cut in the faces of telegraph poles for the support or placing of the cross arms.

Galvanic Battery.—(See *Battery, Galvanic.*)

Galvanic Cell.—(See *Cell, Voltaic.*)

Galvanic Circle.—(See *Circle, Galvanic.*)

Galvanic Circuit.—(See *Circuit, Galvanic.*)

Galvanic Dosage.—(See *Dosage, Galvanic.*)

Galvanic Electricity.—(See *Electricity, Galvanic.*)

Galvanic Excitability of Nerve or Muscular Fibre.—(See *Excitability, Electric, of Nerve or Muscular Fibre.*)

Galvanic Irritability.—(See *Irritability, Galvanic.*)

THIS PAGE IS LOCKED TO FREE MEMBERS

Purchase full membership to immediately unlock this page



HISTORY

Tens of thousands of important historical sources, many previously unobtainable, are now available for the first time with a Forgotten Books Full Membership.

Unlimited Access
\$8.99/month

Continue

*Fair usage policy applies

direction shown by the straight arrow, Fig. 264, or from + to —, will deflect a magnetic needle in the direction shown by the curved arrows.

The following rules show the direction of the

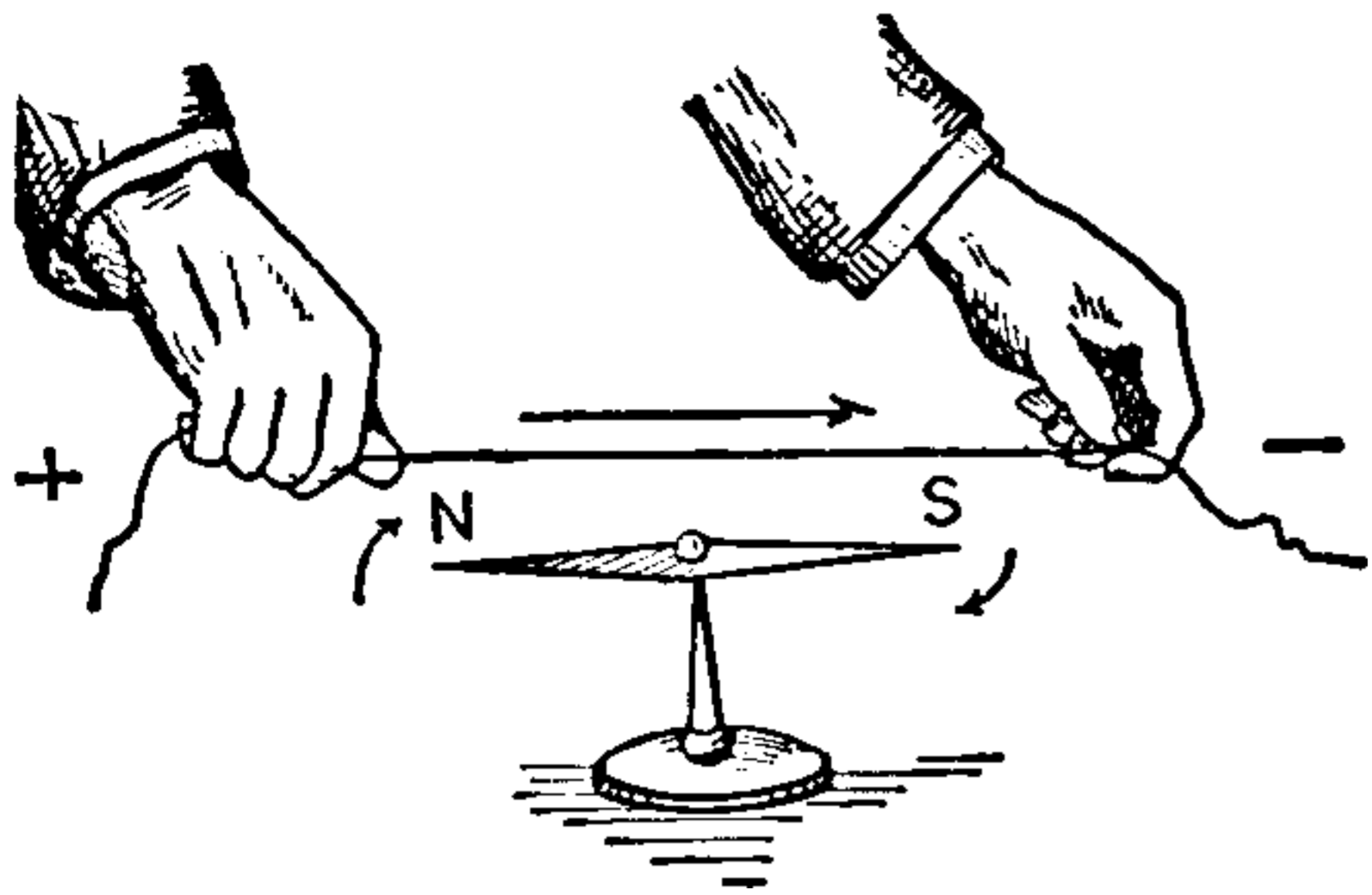

Fig. 264. Oersted's Experiment.

deflection of a magnetic pole by an electrical current:

(1.) Place the right hand on the conductor through which the current is flowing, with the palm facing the north pole, and with the fingers pointing in the direction of the current. The thumb will indicate the direction in which the north pole tends to move.

(2.) Suppose an ordinary corkscrew so placed along the conductor, through which a current of electricity is passing, that when twisted, it will move in the direction of the current. The handle will then turn in the direction in which the north pole of the magnet tends to move.

(3.) Imagine one swimming along the conductor in the direction of the current and facing the magnet. The north pole will tend to move towards the left hand of the swimmer.

Prof. Forbes has shown that the direction of the deflection of a magnet by a current is such

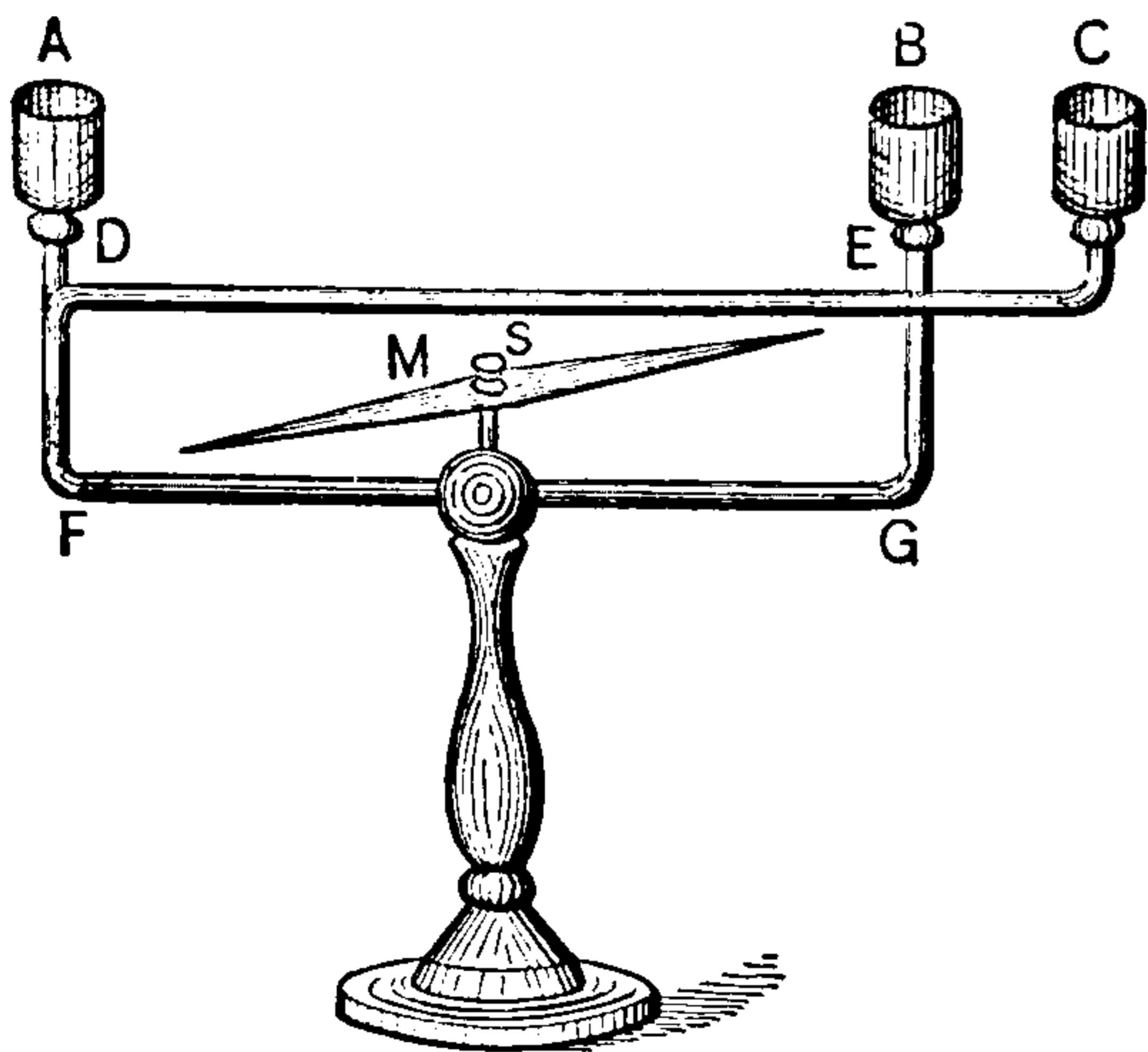

Fig. 265. Ampère's Apparatus.

that if the magnet were flexible, it would wrap itself round the current.

If the wire be bent in the form of a hollow rectangle F, D, E, G, Fig. 265, and the needle, M,

be placed inside the circuit, the upper and lower branches of the current will deflect the needle in the same direction, and the effect of the current will thus be multiplied. Mercury cups are provided at A, B and C, for a ready change in the direction of the current. (See *Needle, Astatic.*)

This principle of the multiplication of the deflecting power of a current was first applied to galvanometers by Schweigger, who used a number of turns of insulated wire for the purpose of obtaining a greater deflection of the needle. He called such a device a multiplier. In extremely sensitive galvanometers, very many turns of wire are employed, in some cases amounting to many thousands. Such galvanometers are of high resistance. Others, of low resistance, often consist of a single turn of wire and are used in the direct measurement of large currents.

A Schweigger's multiplier or coil C, C, of many turns of insulated wire, is shown in Fig. 266. The action of such a coil on the needle M, is comparatively great, even when the current is small.

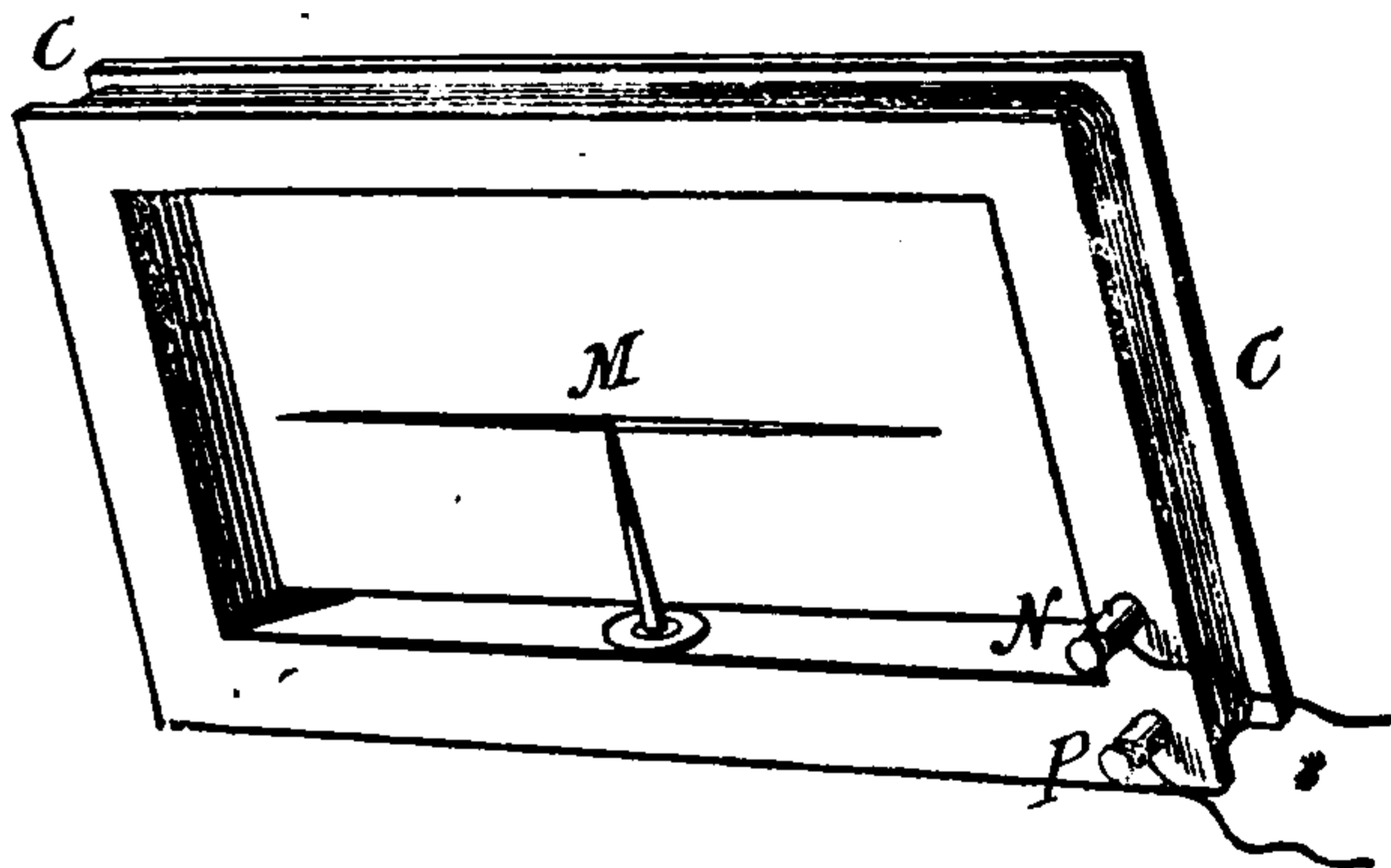

Fig. 266. Schweigger's Multiplier.

In the case of any galvanometer, when no current is passing, the needle, when at rest, should in general occupy a position parallel to the plane of the coil. On the passage of the current, the needle tends to place itself in a position at right angles to the direction of the current, or to the length of the conducting wire in the coil. The strength of the current passing is determined by observing the amount of this deflection as measured in degrees on a graduated circle over which the needle moves.

The needle is deflected by the current from a position of rest, either in the earth's magnetic field or in a field obtained from a permanent or an electro magnet. In the first case, when in use to measure a current, the plane of the galvanometer coils must coincide with the planes of the magnetic meridian. In the other case, the instru-

ment may be used in any position in which the needle is free to move.

Galvanometers assume a variety of forms according either to the purposes for which they are employed, or to the manner in which their deflections are valued.

Galvanometer, Absolute — — A galvanometer whose constant can be calculated with an absolute calibration. (See *Calibration, Absolute*.)

Such a galvanometer is called absolute because if the dimensions of its coil and needle are known, the current can be determined directly from the observed deflection of the needle.

Galvanometer, Aperiodic — — A galvanometer the needle of which comes to its position without any oscillation.

A dead-beat galvanometer. (See *Galvanometer, Dead-Beat*.)

Galvanometer, Astatic — — A galvanometer, the needle of which is astatic. (See *Needle, Astatic*.)

Nobili's astatic galvanometer is shown in Fig. 267. The astatic needle, suspended by a fibre b, has its lower needle placed inside a coil, a, consisting of many turns of insulated wire, its upper needle moving over the graduated dial. The current to be measured is led into and from the coil at the binding posts, x and y.

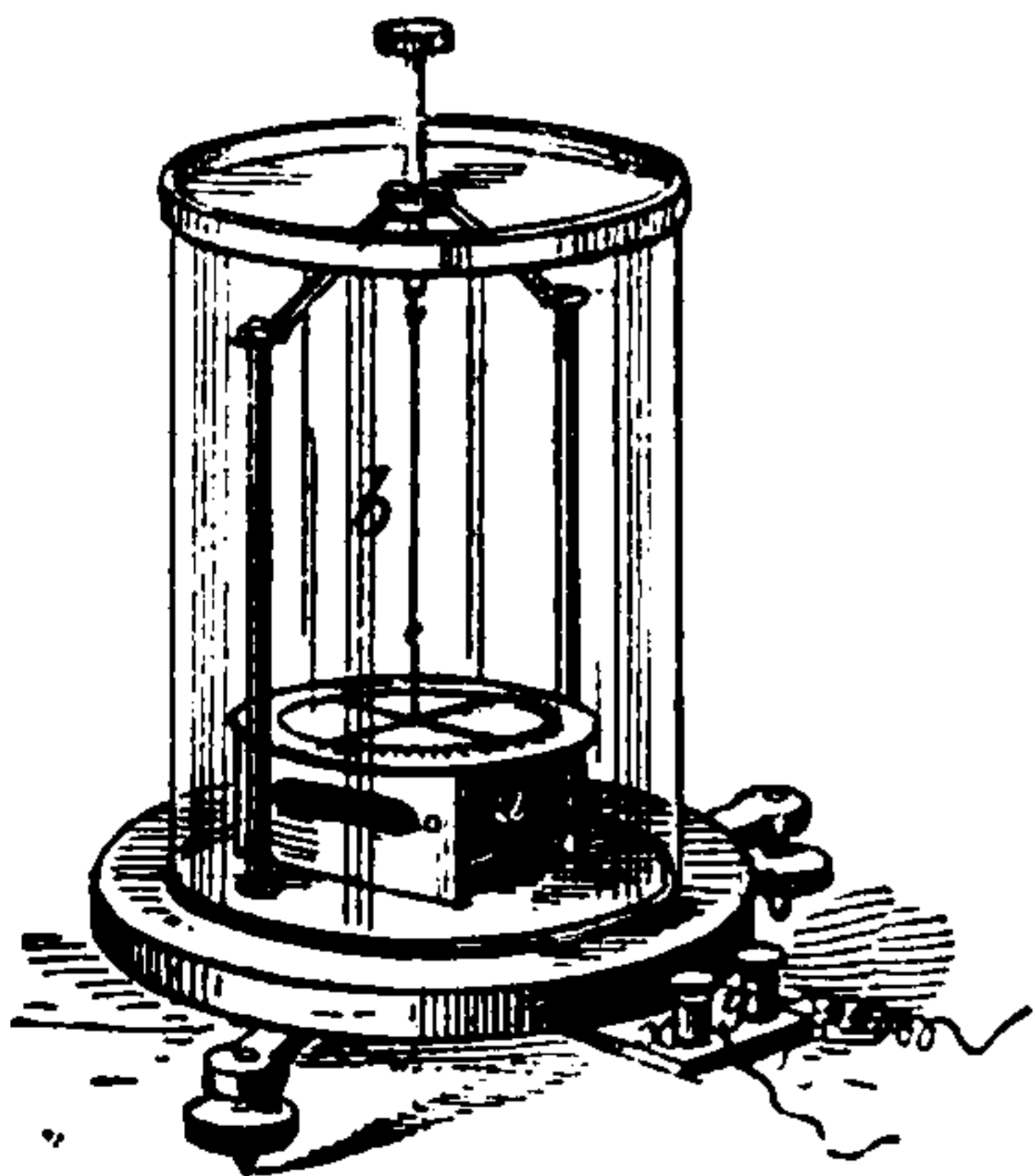

Fig. 267. Astatic Galvanometer.

In this instrument, if small deflections only are employed, the deflections are sensibly proportional to the strength of the deflecting currents.

Galvanometer, Ballistic — — A galvanometer designed to measure the strength of currents that last but for a moment, such, for example, as the current caused by the discharge of a condenser.

The quantity of electricity passing in any circuit is equal to the current multiplied by the time. Since the current caused by the discharge of a condenser lasts but for a small time, during which it passes from zero to a maximum and back again to zero, the magnetic needle in a ballistic galvanometer takes the form of a ballistic pendulum, *i. e.*, it is given such a mass, and acquires such a slow motion, that its change of position does not

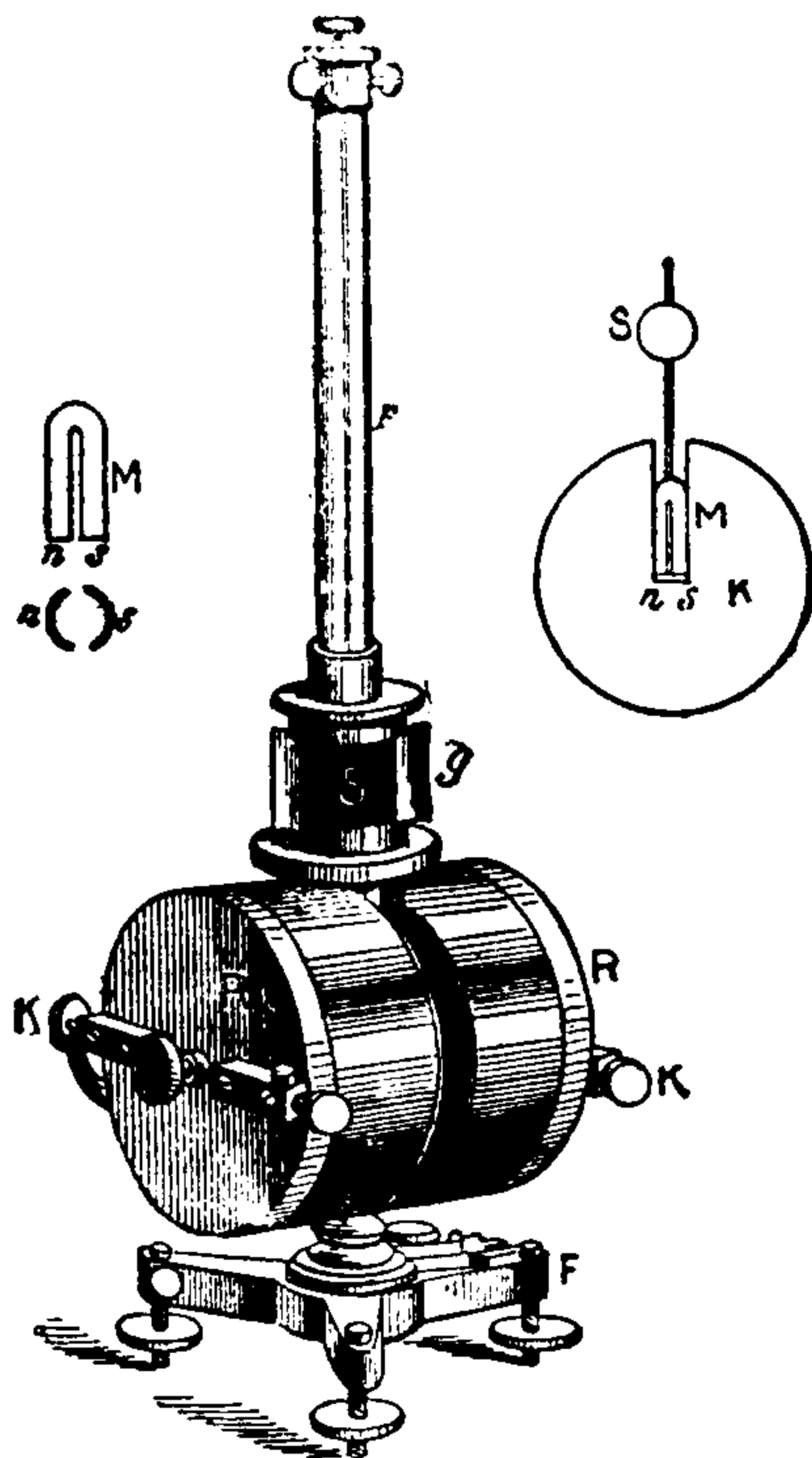

Fig. 268. Ballistic Galvanometer.

practically begin until the impulses have ceased to act.

In the ballistic galvanometer of Siemens and Halske, the coils R, R, Fig. 268, have a bell-shaped magnet, M, suspended inside them by means of an aluminium wire. The magnet is provided with a mirror S, for measuring the deflections. The bell-shaped magnet is shown in elevation at M, and in plane at n, s.

In using the ballistic galvanometer, it is necessary to see that the needle is absolutely at rest before the charge is sent through the coils.

A form of ballistic galvanometer by Nalder is shown in Fig. 269.

The ordinary form of compensating magnet is, in this galvanometer, replaced by the small magnet A, capable of rotation in a horizontal plane, but incapable of being raised or lowered, as is usual in such magnets. This form of compensating magnet possesses the advantage of being able to alter the direction of the field on the needle system,

without considerably altering its intensity. When the galvanometer is for ready use the magnet A, is turned until the needle is brought to zero. The

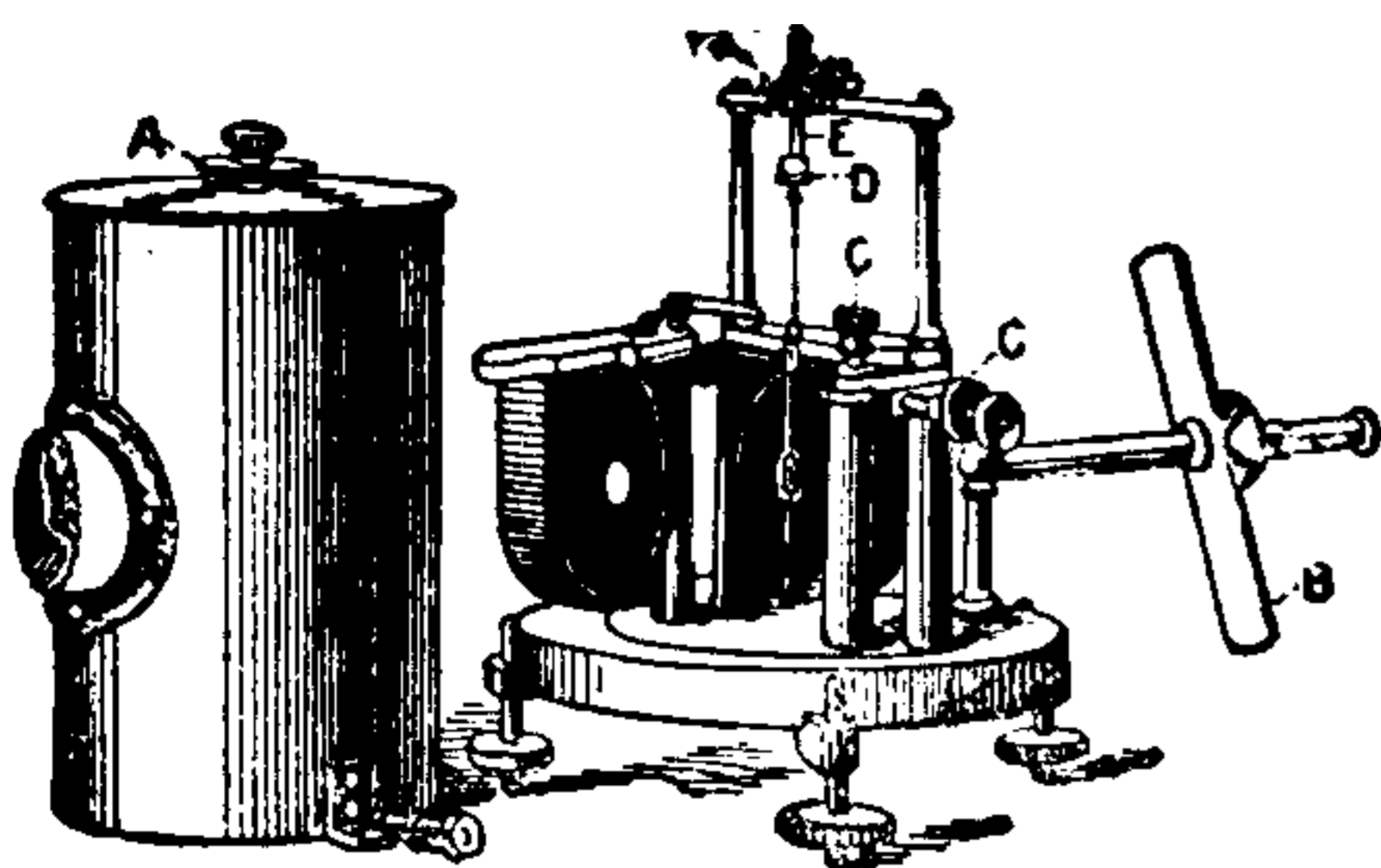

Fig. 269. Nalder's Galvanometer.

combined field of earth and magnet A, are then brought to the degree of sensitiveness required

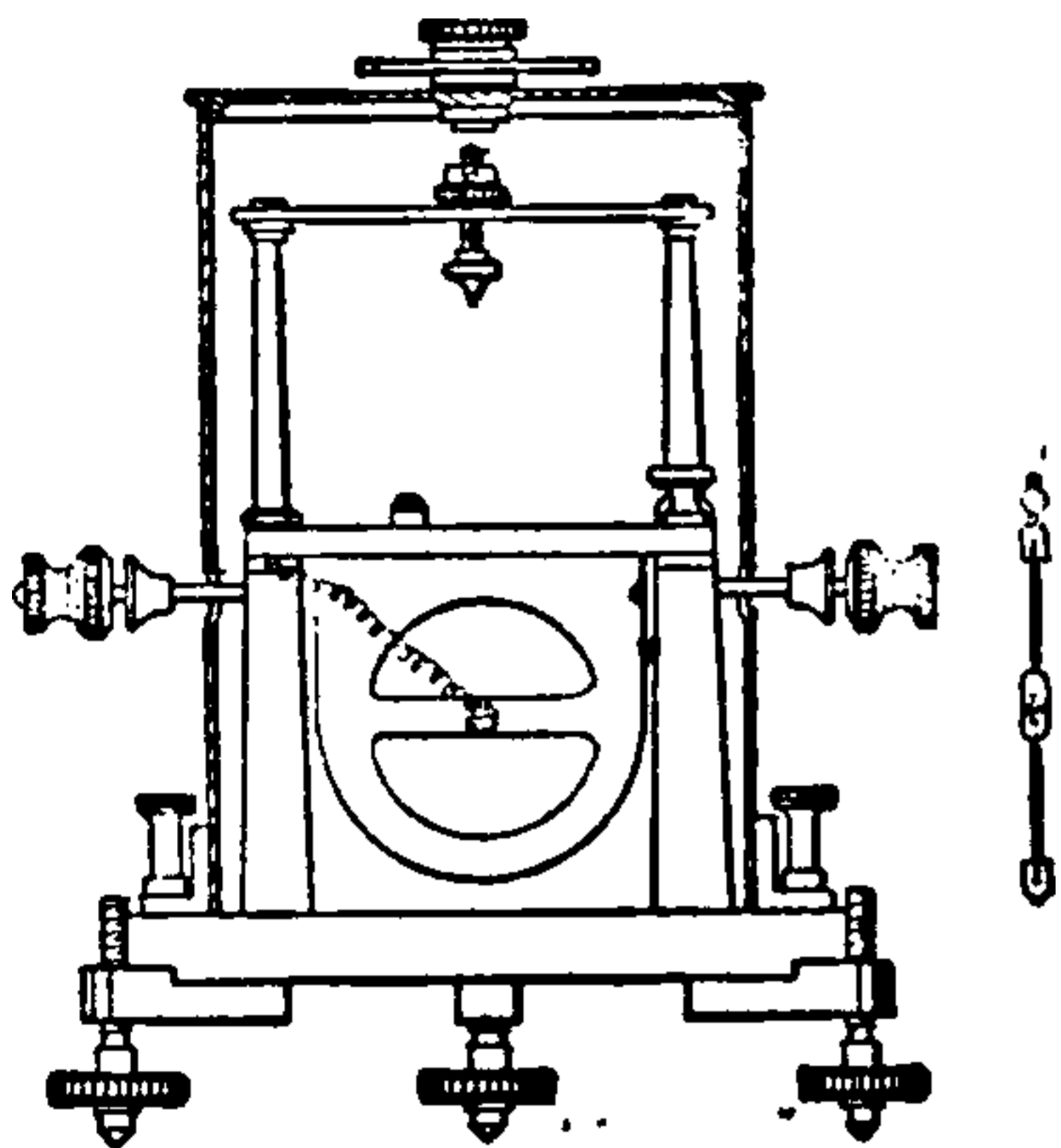

Fig. 270. Nalder's Galvanometer.

by rotating magnet B, on its shaft, or altering its distance from the needle. In order to insure ease in replacing the fibre, the front coil is hinged as shown. The fibre D, is supported on E, one end of which it is free to turn, so as to permit of the removal of torsion; D, being twisted can be raised or lowered at E. The needle system with heavy bell-shaped magnet is shown in Fig. 270.

Galvanometer, Combined Tangent and Sine — — A galvanometer furnished with two magnetic needles of different lengths. The small needle is used for tangent measurements, and the long needle for sine measurements.

Galvanometer Constant.—(See *Constant, Galvanometer.*)

Galvanometer, Dead-Beat — — A galvanometer, the needle of which comes quickly to rest, instead of swinging repeatedly to-and-fro. (See *Damping.*)

Galvanometer, Deprez-D'Arsonval — — A form of dead-beat galvanometer.

The movable part of the Deprez-D'Arsonval galvanometer consists of a light rectangular coil

C, Fig. 271, of many turns of wire, supported by two silver wires H J and D E, between the poles of a strong permanent horseshoe magnet A A'. The position of the coil may be altered as to height by screws at H and E. The supporting wires, prevent by their torsion the swinging of the coil, as does also the cylinder of soft iron B, placed inside the coil, and supported independently of it. The movements of the coil are observed by means of a spot of light reflected from a mirror J, attached to the wire H J.

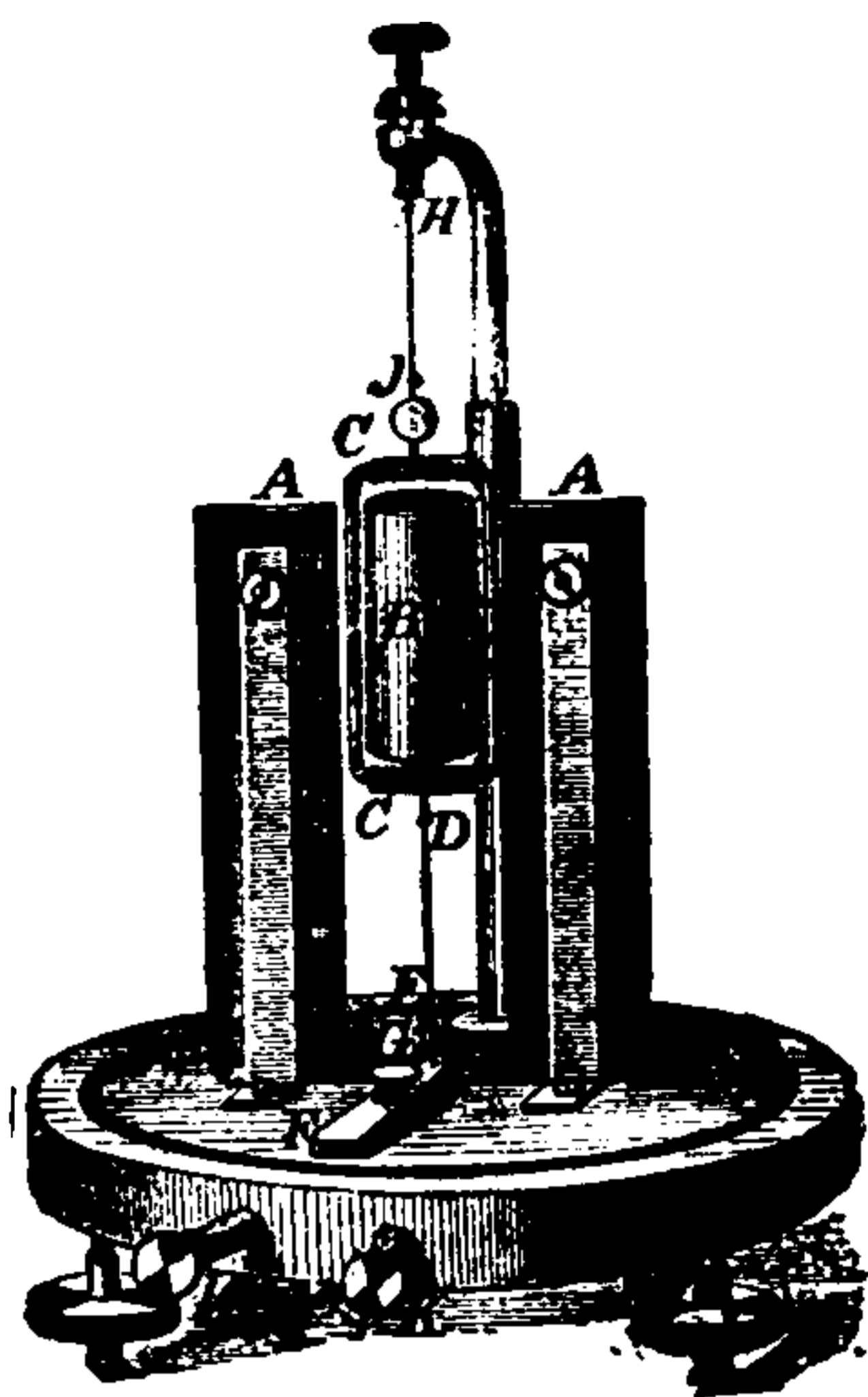

Fig. 271. Deprez-D'Arsonval Galvanometer.

Galvanometer, Detector — — A form of galvanometer employed for rough testing work.

A form of detector galvanometer is shown in Fig. 272.

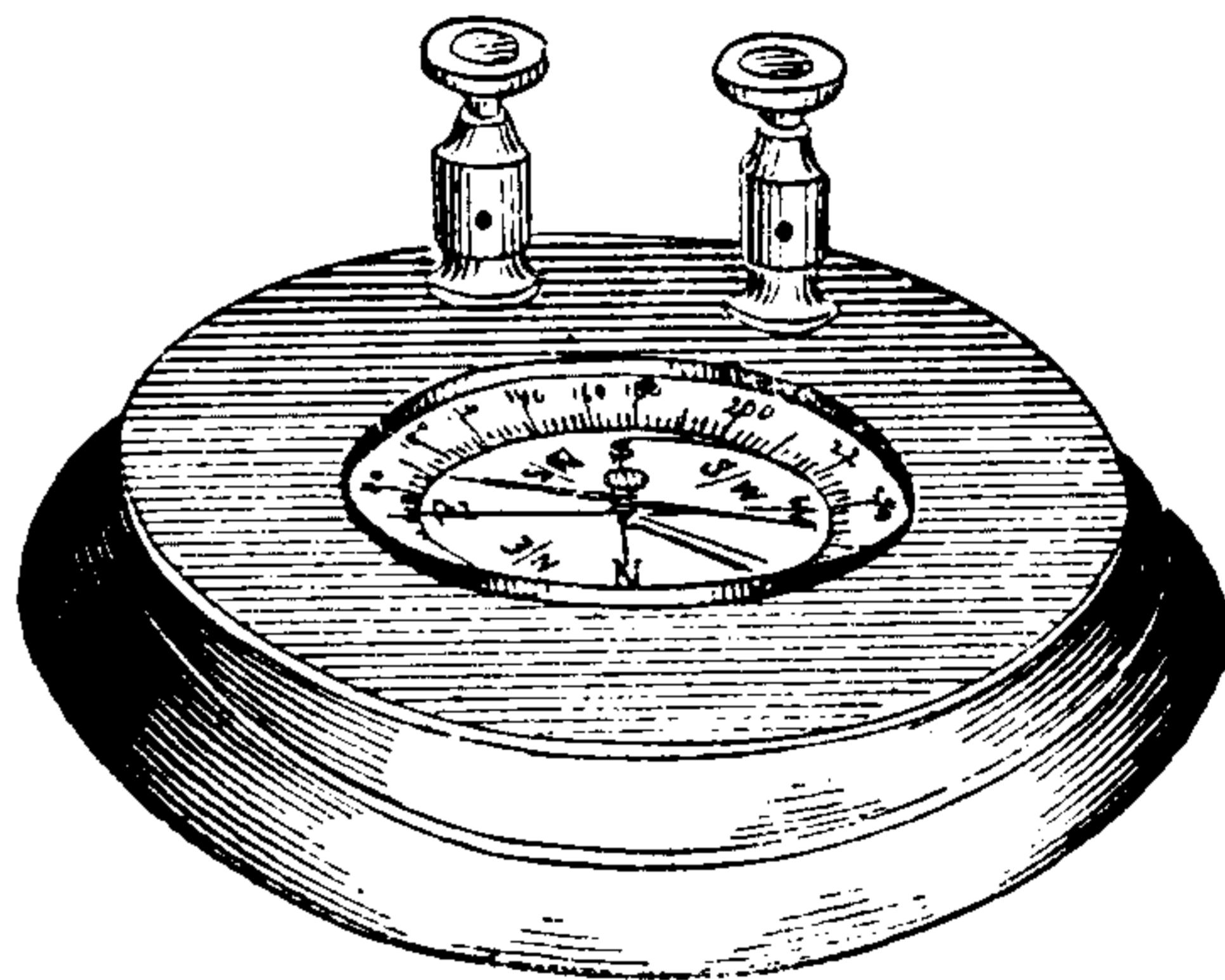

Fig. 272. Detector Galvanometer.

Galvanometer, Differential — — A galvanometer containing two coils so wound as to tend to deflect the needle in opposite directions.

The needle of a differential galvanometer shows no deflection when two equal currents are sent through the coils in opposite directions, since, under these conditions, each coil neutralizes the other's effects. Such instruments may be used in comparing resistances. The Wheatstone Bridge, however, in most cases, affords a preferable method for such purposes. (See *Bridge, Electric.*)

THIS PAGE IS LOCKED TO FREE MEMBERS

Purchase full membership to immediately unlock this page

Know Your Bible

Forgotten Books' Full Membership provides unlimited access to more than 28,000 volumes of Christian literature for \$8.99/month

HOLY BIBLE

Continue

*Fair use policy applies

Galvanometer, Sensibility of — — The readiness and extent to which the needle of a galvanometer responds to the passage of an electric current through its coils. (See *Galvanometer*.)

Galvanometer-Shunt.—(See *Shunt, Galvanometer*.)

Galvanometer, Sine — — A galvanometer in which a vertical coil is movable around a vertical axis, so that it can be made to follow the magnetic needle in its deflections.

In the sine galvanometer, the coil is moved so as to follow the needle until it is parallel with the coil. Under these circumstances, the strength of the deflecting currents in any two different cases is proportional to the sines of the angles of deflection.

A form of sine galvanometer is shown in Fig. 276. The vertical wire coil is seen at M. A needle of any length less than the diameter of the coil M, moves over the graduated circle N. The coil M, is movable over the graduated horizontal circle H, by which the amount of the movement

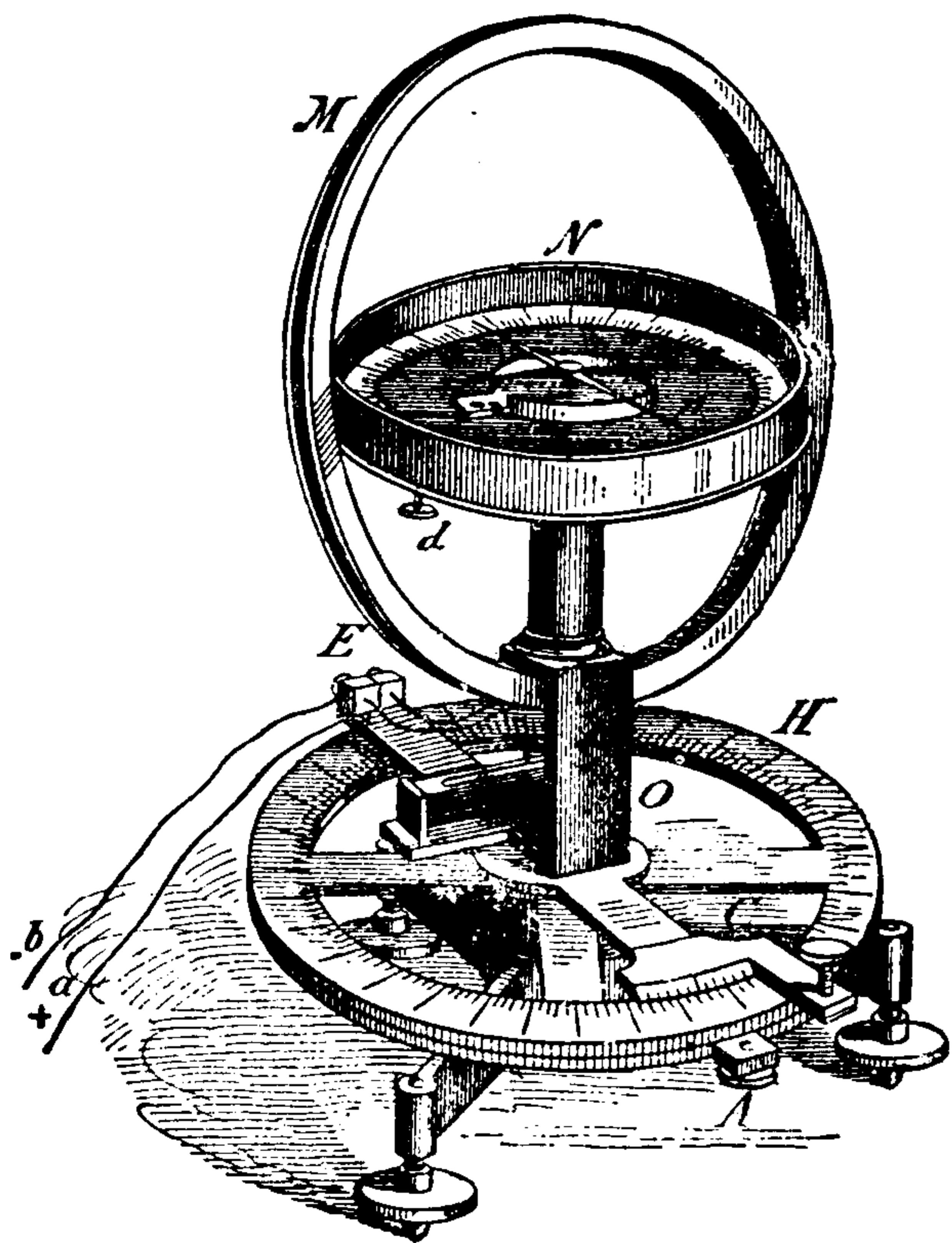

Fig. 276. Sine Galvanometer.

necessary to bring the needle to zero is measured. The current strength is proportional to the sine of the angle measured on this circle, through which it is necessary to move the coil M, from its

position when the needle is at rest in the plane of the earth's magnetic meridian, until the needle is not further deflected by the current, although parallel to the coil M.

Galvanometer, Tangent — — An instrument in which the deflecting coil consists of a coil of wire within which is placed a needle very short in proportion to the diameter of the coil, and supported at the centre of the coil.

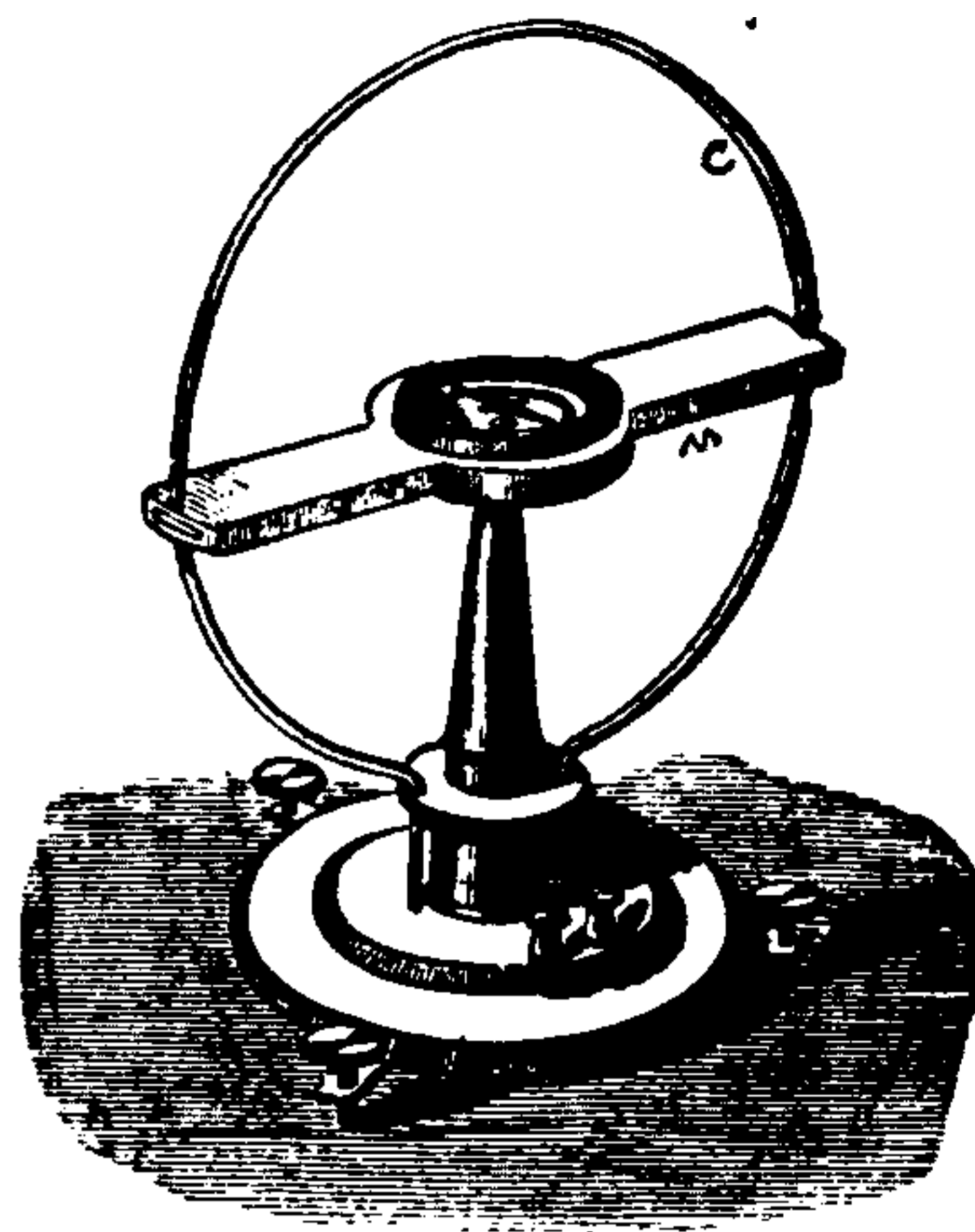

Fig. 277. Tangent Galvanometer.

A galvanometer acts as a tangent galvanometer only when the needle is very small as compared with the diameter of the coil. The length of the needle should be less than one-twelfth the diameter of the coil.

A form of tangent galvanometer is shown in Fig. 277. The needle is supported at the exact centre of the coil C.

Under these circumstances, the strengths of two different deflecting currents are proportional to the tangents of the angles of deflection. Tangent galvanometers are sometimes made with coils of wire containing many separate turns.

Galvanometer, Tangent, Obach's — — A form of galvanometer in which the deflecting coil, instead of being in a fixed vertical position, is movable about a horizontal axis, so as to decrease the delicacy of the instrument, and thus increase its range of work.

Galvanometer, Torsion — — A galvanometer in which the strength of the deflecting current is measured by the torsion exerted on the suspension system.

A ball-shaped magnet, shown at the right of Fig. 278, is suspended by a thread and spiral

spring between two coils of high resistance, placed parallel to each other in the positions shown. On the deflection of the magnet, by the current to be measured, the strength of the current is determined by the amount of the torsion required to bring the magnet back to its zero point.

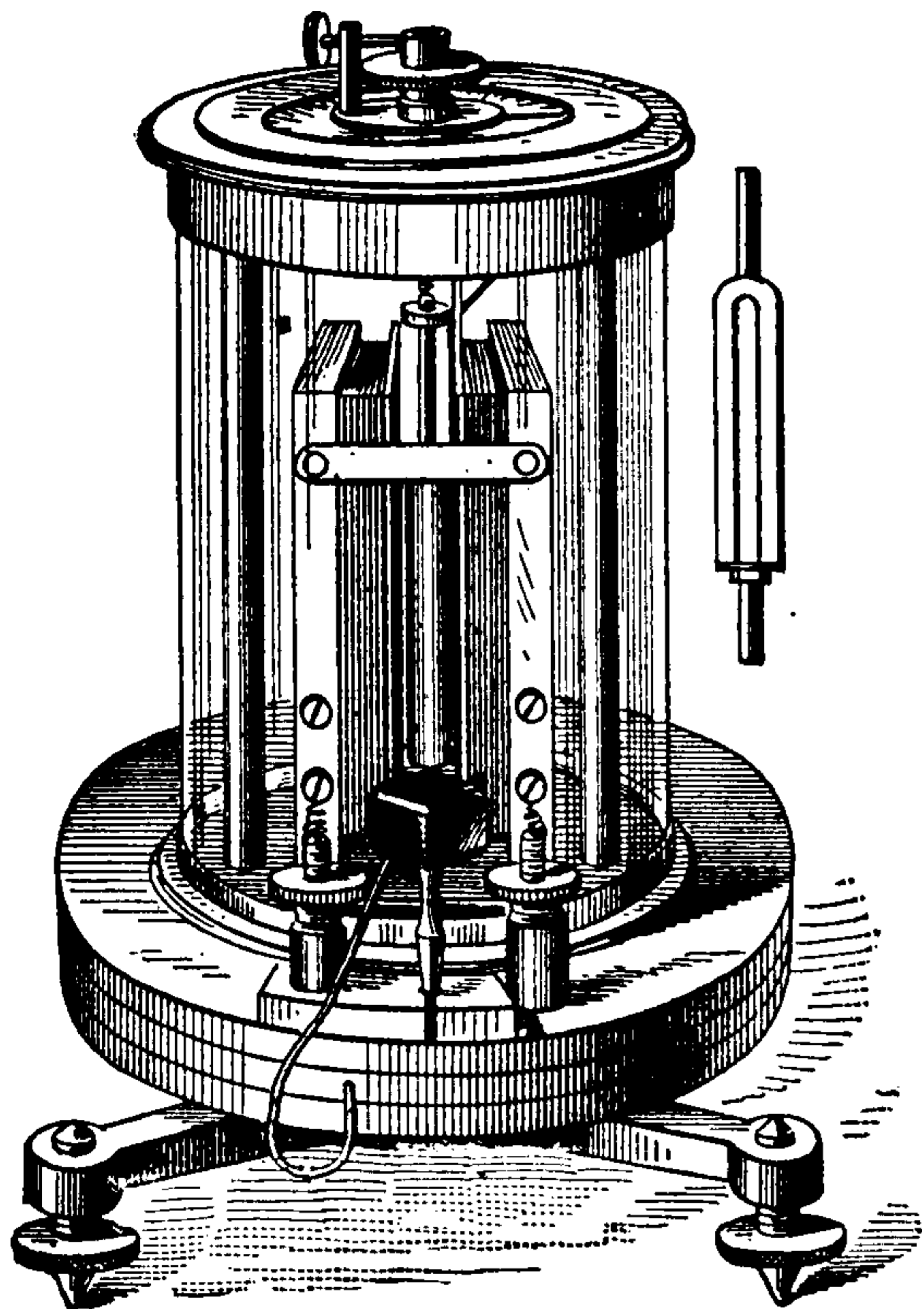

Fig. 278. Torsion Galvanometer.

The angle of torsion is measured on the horizontal scale at the top of the instrument.

In the torsion galvanometer, unlike the electro-dynamometer, the action between the coils and the movable magnet is as the current strength causing the deflection. In the electro-dynamometer, since an increase of current in the deflecting coils also takes place in the deflected coil, the mutual action of the two is as the square of the current strength causing the deflection.

Galvanometer, Upright — —A galvanometer, the needle of which moves in a vertical plane. (See *Galvanometer, Vertical*.)

Galvanometer, Vertical — —A galvanometer the needle of which is capable of motion in a vertical plane only.

In the vertical galvanometer, the north pole of the needle is weighted so that the needle assumes a vertical position when no current is passing. In the form shown in Fig. 279, two needles

are sometimes employed, one of which is placed inside the coils C, C.

The vertical galvanometer is not as sensitive as the ordinary forms. It is employed, however, in various forms for an electric current indicator, or even for a rough current measurer.

Galvanometer Voltmeter.—An instrument devised by Sir William Thomson, for the measurement of differences of electric potential.

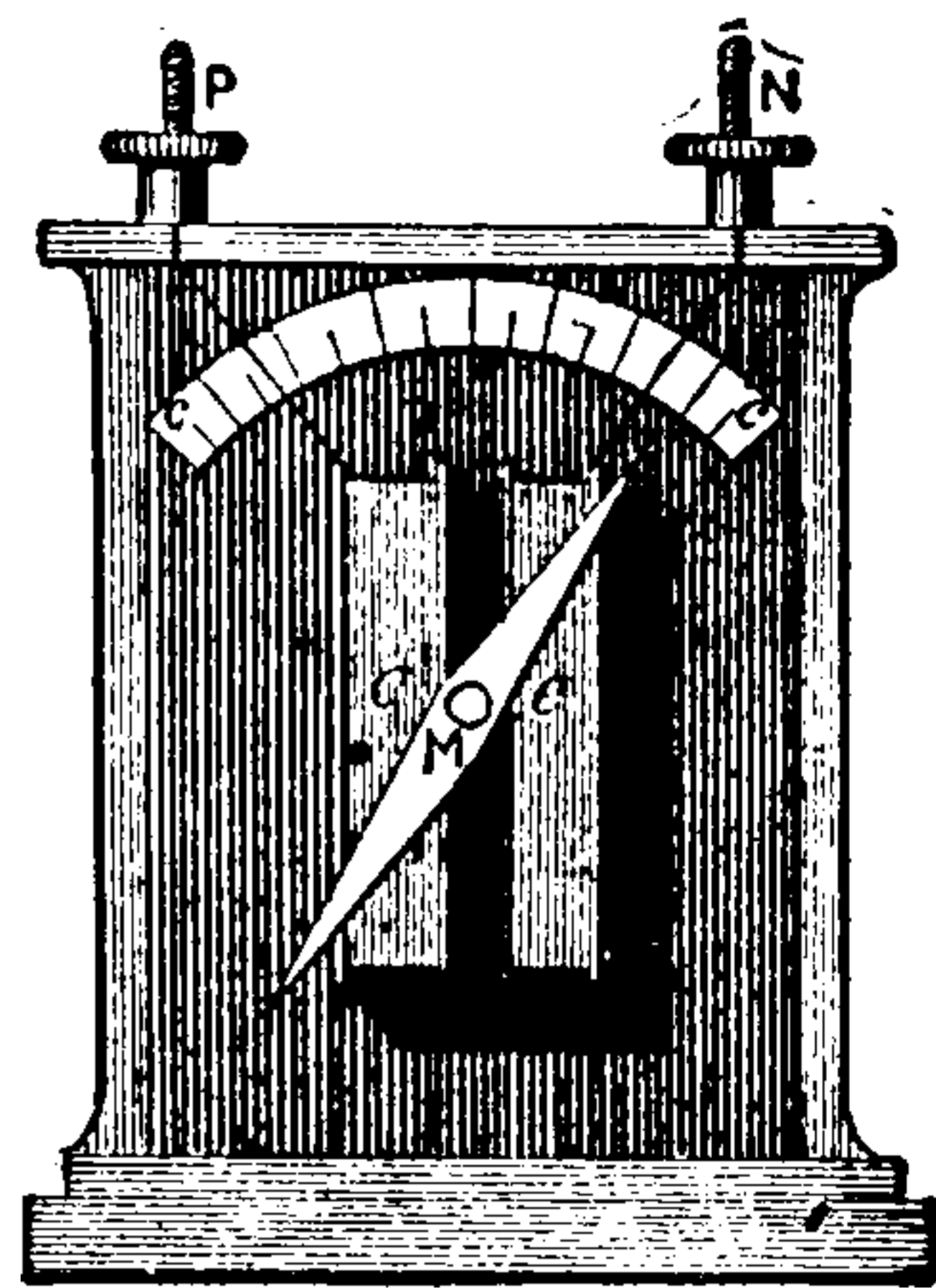

Fig. 279. Vertical Galvanometer.

This instrument is so arranged that by a single correction for the varying strength of the earth's field in any place, the results are read at once in volts.

A coil of insulated wire shown at A, Fig. 280, has a resistance of over 5,000 ohms. A magnetic needle, formed of short parallel needles placed above one another, and called a magnetometer needle, is attached to a long but light aluminium index, moving over a graduated scale. A movable, semi-circular magnet B, called the restoring magnet, is placed over the needle, and is used for varying the effect of the earth's field at any point. The sensitiveness of the instrument may be varied either by the restoring magnet or by sliding the magnetometer box nearer to or further away from the coil.

The voltmeter galvanometer depends for its operation on the fact that when a galvanometer of sufficiently high resistance is introduced be-

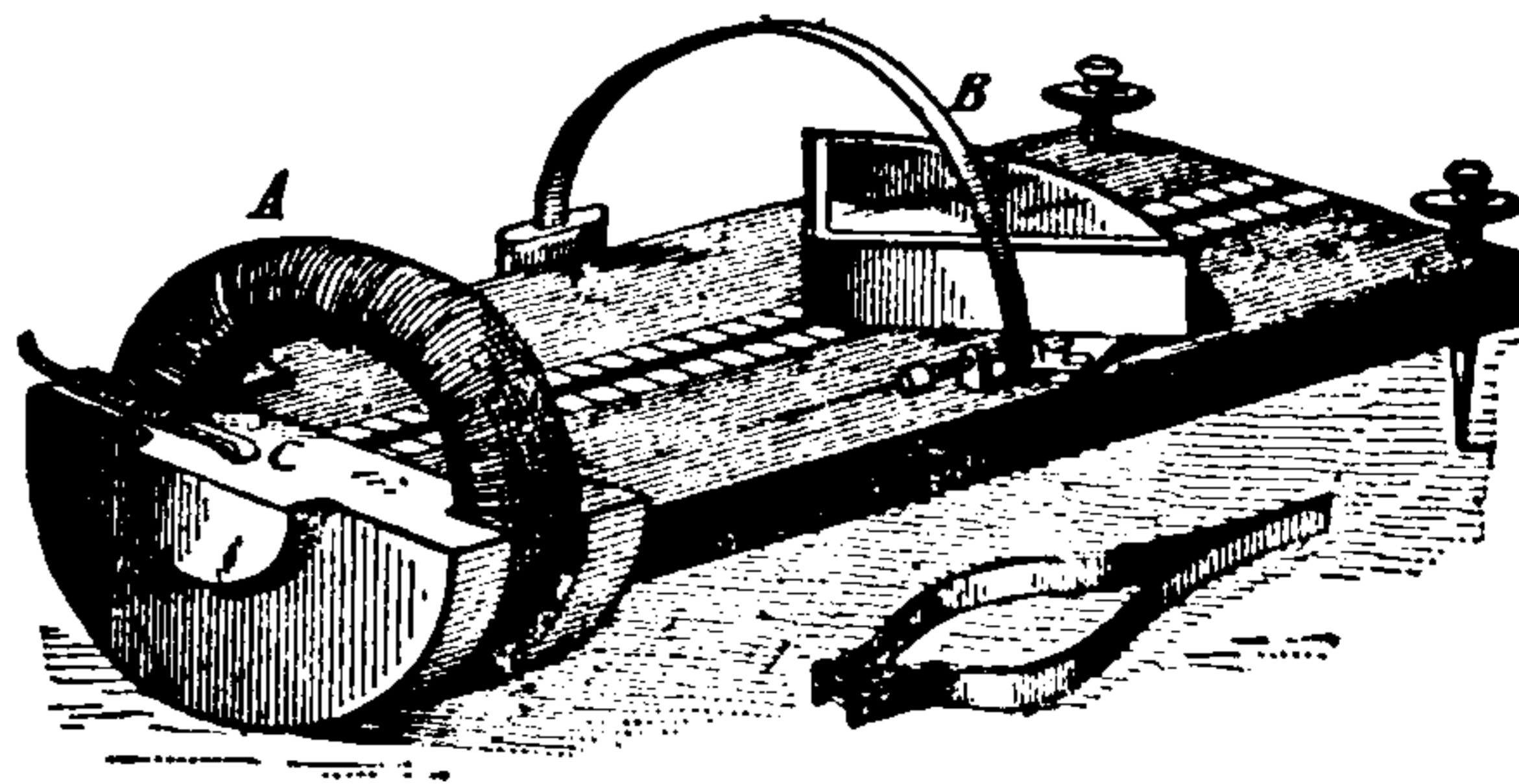

Fig. 280. Galvanometer Voltmeter.

tween any two points in a circuit, the current that passes through it, and hence the deflection of its needle, is directly proportional to the difference of potential between such two points.

Galvanometers for the commercial measurements of currents assume a variety of forms. They are generally so constructed as to read off the ampères, volts, ohms, watts, etc., directly. They are called ampèremeters or ammeters, voltmeters, ohmmeters, wattmeters, etc. For their fuller description reference should be had to standard works on electrical measurement.

Galvanometric.—Of or pertaining to the galvanometer. (See *Galvanometer*.)

Galvanometrical.—Of or pertaining to the galvanometer. (See *Galvanometer*.)

Galvanometrically.—In a galvanometric manner.

Galvano-Plastics.—(See *Plastics, Galvano*.)

Galvanoplasty.—The art of galvanoplastics. (See *Plastics, Galvano*.)

Galvano-Puncture.—(See *Puncture, Galvano*.)

Galvanoscope.—A term sometimes improperly employed in place of galvanometer.

A galvanoscope, strictly speaking, is an instrument intended rather to show the existence of an electric current than to measure it in degrees. It may, however, be roughly calibrated, and then it differs from a galvanometer only in delicacy and accuracy.

Galvano-Therapeutics.—A term sometimes used for electro-therapeutics.

Electro-therapeutics is by far the preferable term and is almost universally employed in the United States.

Gap, Air — —A gap, or opening in a magnetic circuit containing air only. (See *Gap, Air, Magnetic*.)

The air gap between two magnetic poles may be regarded as the space in which an armature acting as a magneto receptive device is placed, which by the action upon it of the lines of magnetic force passing through the gap has differences of potential generated in its coils of insulated wire.

Gap, Air, Magnetic — —A gap filled with air which exists in the opening at any part of a core of iron or other medium of high permeability.

The space between the pole pieces and arma-

ture core is called the air gap in dynamos or motors even though partly filled with copper conductors. It is also called the interference space.

The gap or air space of an electro-magnet decreases the strength of its magnetization because—

The increased reluctance of the air gap causes a decrease in the number of lines of magnetic force which pass through the magnetic circuit.

Gap, Spark — —A gap forming part of a circuit between two opposing conductors, separated by air, or other similar dielectric which is closed by the formation of a spark only when a certain difference of potential is attained.

Gap, Wire-Gauge — —(See *Gauge, Wire, Gap*.)

Gas-Battery.—(See *Battery, Gas*.)

Gas Burner, Argand, Plain-Pendant, Electric — —(See *Burner, Argand Electric, Plain-Pendant*.)

Gas Burner, Argand, Ratchet-Pendant, Electric — —(See *Burner, Argand Electric, Ratchet-Pendant*.)

Gas Burner, Automatic Electric — —(See *Burner, Automatic Electric*.)

Gas Burner, Plain-Pendant, Electric — —(See *Burner, Plain-Pendant Electric*.)

Gas Burner, Ratchet-Pendant, Electric — —(See *Burner, Ratchet-Pendant Electric*.)

Gas, Carbonic Acid — —A gaseous substance formed by the union of one atom of carbon with two atoms of oxygen.

Carbonic acid gas is formed during the combustion of carbon by a sufficient supply of air.

Gas, Dielectric Density of — —A term sometimes employed instead of dielectric strength of gas. (See *Gas, Dielectric Strength of*.)

Gas, Dielectric Strength of — —The strain a gas is capable of bearing without suffering disruption, or without permitting a disruptive discharge to pass through it.

The dielectric strength of a gas depends—

(1.) On the nature of the gas.

(2.) On its pressure.

THIS PAGE IS LOCKED TO FREE MEMBERS

Purchase full membership to immediately unlock this page



HISTORY

Tens of thousands of important historical sources, many previously unobtainable, are now available for the first time with a Forgotten Books Full Membership.

Unlimited Access
\$8.99/month

Continue

*Fair usage policy applies

Gauge, Wire, Micrometer — — A gauge employed for accurately measuring the diameter of a wire in thousandths of an inch, based on the principle of the vernier or micrometer. (See Fig. 283.)

The wire to be measured is placed between a fixed support B, and the end C, of a long movable screw, which accurately fits a threaded tube a. A thimble D, provided with a milled head, fits over the screw C, and is attached to the upper part. The lower circumference of D, is divided into a scale of twenty equal parts. The tube A, is graduated into divisions equal to the pitch of the screw. Every fifth of these divisions is marked as a larger division.

The principle of the operation of the gauge is as follows: Suppose the screw has fifty threads to the inch, the pitch of the screw, or the distance between two contiguous threads, is therefore $\frac{1}{50}$ or .02 of an inch.

One complete turn of the screw will, therefore, advance the sleeve D, over the scale a, the .02 of an inch. If the screw is only moved through one of the twenty parts marked on the end of the thimble or sleeve parts, or the $\frac{1}{20}$ of a com-

plete turn, the end C, advances towards B, the $\frac{1}{50}$ of $\frac{1}{50}$, i. e., $\frac{1}{1000}$ or .001 inch.

Suppose now a wire is placed between B and C, and the screw advanced until it fairly fills the

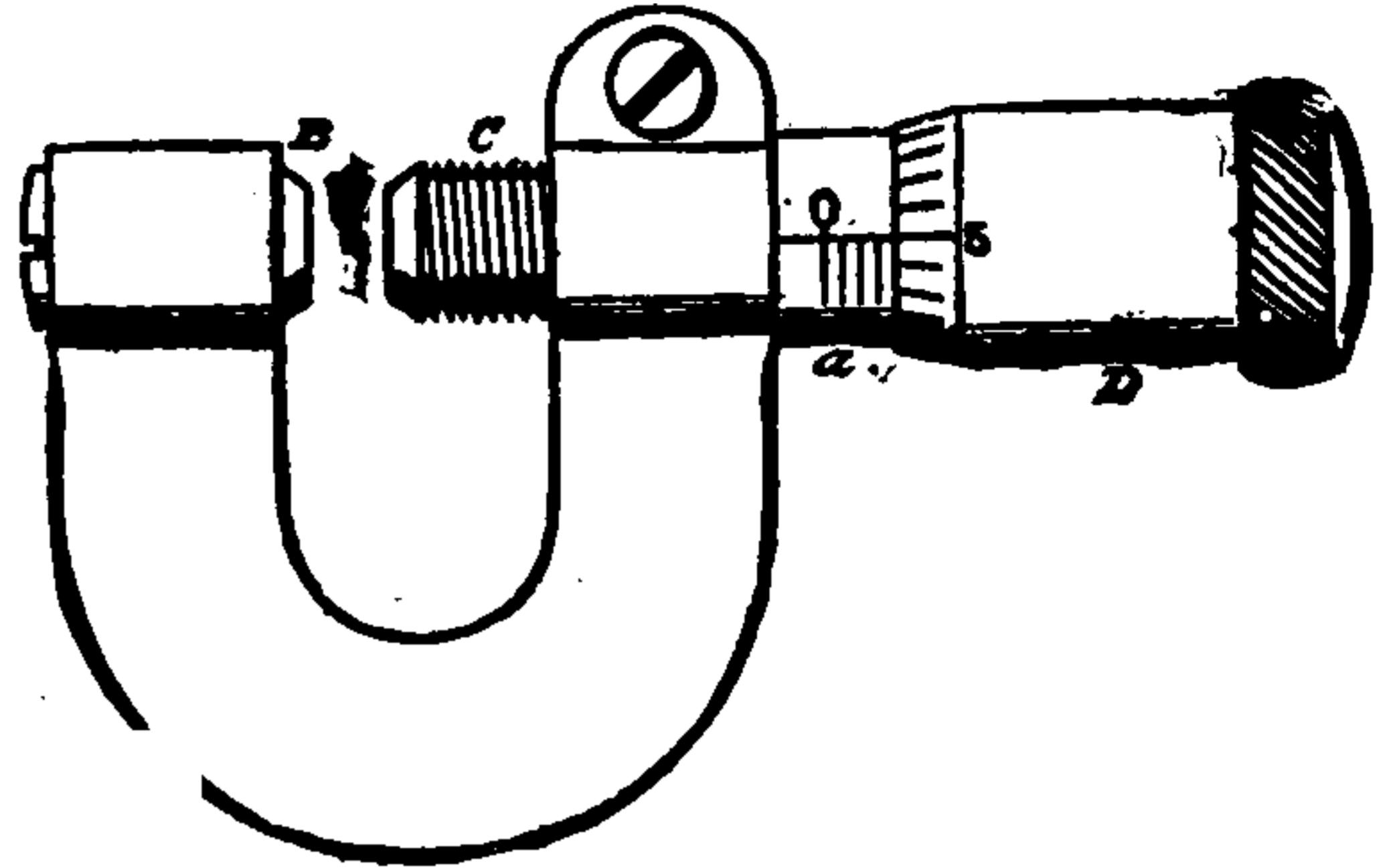

Fig. 283. Vernier Wire Gauge.

space between them, and the reading shows two of the larger divisions on the scale a, three of the smaller ones and three on the end of the sleeve D, then

Two large divisions of scale a.....	=	.2	inch
Three smaller divisions of scale a..	=	.06	"
Three divisions on circular scale			
on D.....	=	.003	"
<hr/>			
Diameter of wire.....		.263	

Serious inconvenience has arisen in practice

NEW LEGAL STANDARD WIRE GAUGE (ENGLISH).

Tables of Sizes, Weights, Lengths and Breaking Strains of Iron Wire.

Size on Wire Gauge.	Diameter.		Sectional area in sq. inches.	Weight of		Length of Cwt.	Breaking Strains.		Size on Wire Gauge.
	Inch.	Millimetres.		100 yards.	Mile.		Annealed.	Bright.	
				Lbs.	Lbs.	Yards.	Lbs.	Lbs.	
7/0.....	.500	12.7	.1963	193.4	3404	58	10470	15700	7/0
6/0.....	.464	11.8	.1691	166.5	2930	67	9017	13525	6/0
5/0.....	.432	11.	.1466	144.4	2541	78	7814	11725	5/0
4/0.....	.400	10.2	.1257	123.8	2179	91	6702	10052	4/0
3/0.....	.372	9.4	.1087	107.1	1885	105	5796	8694	3/0
2/0.....	.348	8.8	.0951	93.7	1649	120	5072	7608	2/0
1/0.....	.324	8.2	.0824	81.2	1429	138	4397	6595	1/0
1.....	.300	7.6	.0707	69.9	1225	161	3770	5655	1
2.....	.276	7.	.0598	58.9	1037	190	3190	4785	2
3.....	.252	6.4	.0499	49.1	864	228	2660	3990	3
4.....	.232	5.9	.0423	41.6	732	269	2254	3381	4
5.....	.212	5.4	.0353	34.8	612	322	1883	2824	5
6.....	.192	4.9	.0290	28.0	502	393	1544	2316	6
7.....	.176	4.5	.0243	24.	422	467	1298	1946	7
8.....	.160	4.1	.0201	19.8	348	566	1072	1608	8
9.....	.144	3.7	.0163	16.	282	700	869	1303	9
10.....	.128	3.3	.0129	12.7	223	882	687	1030	10
11.....	.116	3.	.0106	10.4	183	1077	564	845	11
12.....	.104	2.6	.0085	8.4	148	1333	454	680	12
13.....	.092	2.3	.0066	6.5	114	1723	355	532	13
14.....	.080	2.	.0050	5.	88	2240	268	402	14
15.....	.072	1.8	.0041	4.	70	2800	218	326	15
16.....	.064	1.6	.0032	3.2	56	3500	172	257	16
17.....	.056	1.4	.0025	2.4	42	4667	131	197	17
18.....	.048	1.2	.0018	1.8	32	6222	97	145	18
19.....	.040	1.	.0013	1.2	21	9333	67	100	19
20.....	.036	.9	.0010	1.	18	11200	55	82	20

(Issued by the Iron and Steel Wire Manufacturers' Association.)

from the numerous arbitrary numbers of sizes of wires employed by different manufacturers. These differences are gradually leading to the abandonment of arbitrary sizes for wires and employing in place thereof the diameters directly in inches or thousandths of an inch.

Gauge, Wire, Round — —A device for accurately measuring the diameter of a wire.

The round wire gauge shown in Fig. 284 is very generally used for telegraph lines. Notches

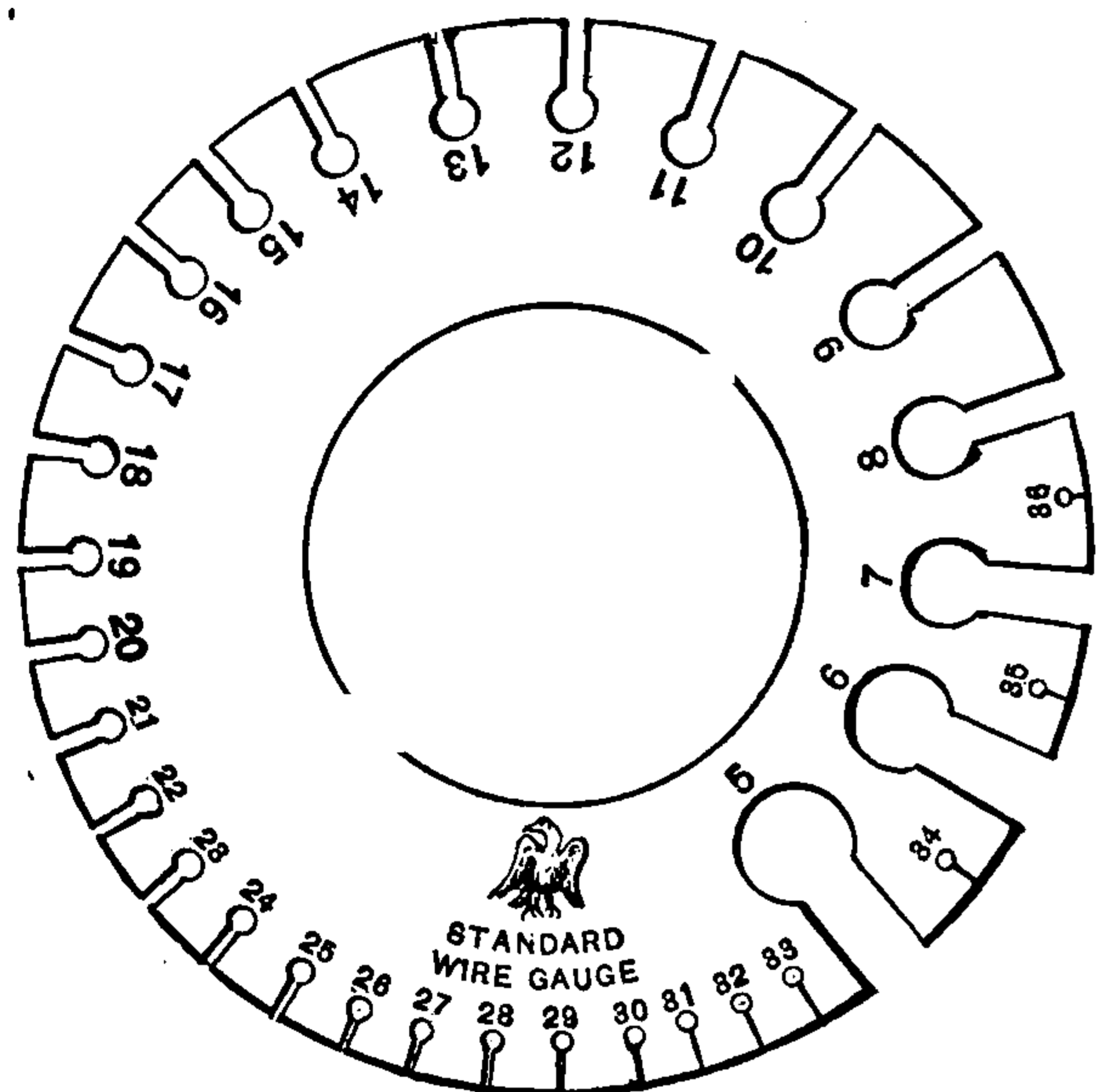

Fig. 284. Round Wire Gauge.

for varying widths, cut in the edges of a circular plate of tempered steel, serve to approximately measure the diameter of a wire, the sides of the wire being passed through the slots. Numbers, indicating the different sizes of the wire, are affixed to each of the openings.

Gauge, Wire, Self-Registering — —A wire gauge arranged to give the exact diameter of the wire to be measured directly without calculation.

A form of self-registering wire gauge is shown in Fig. 285. The wire or plate is inserted in the gap between a fixed and a movable plate. The numbers corresponding to the diameter of the wire or plate are shown on one side of the gauge and the gauge numbers on the other side.

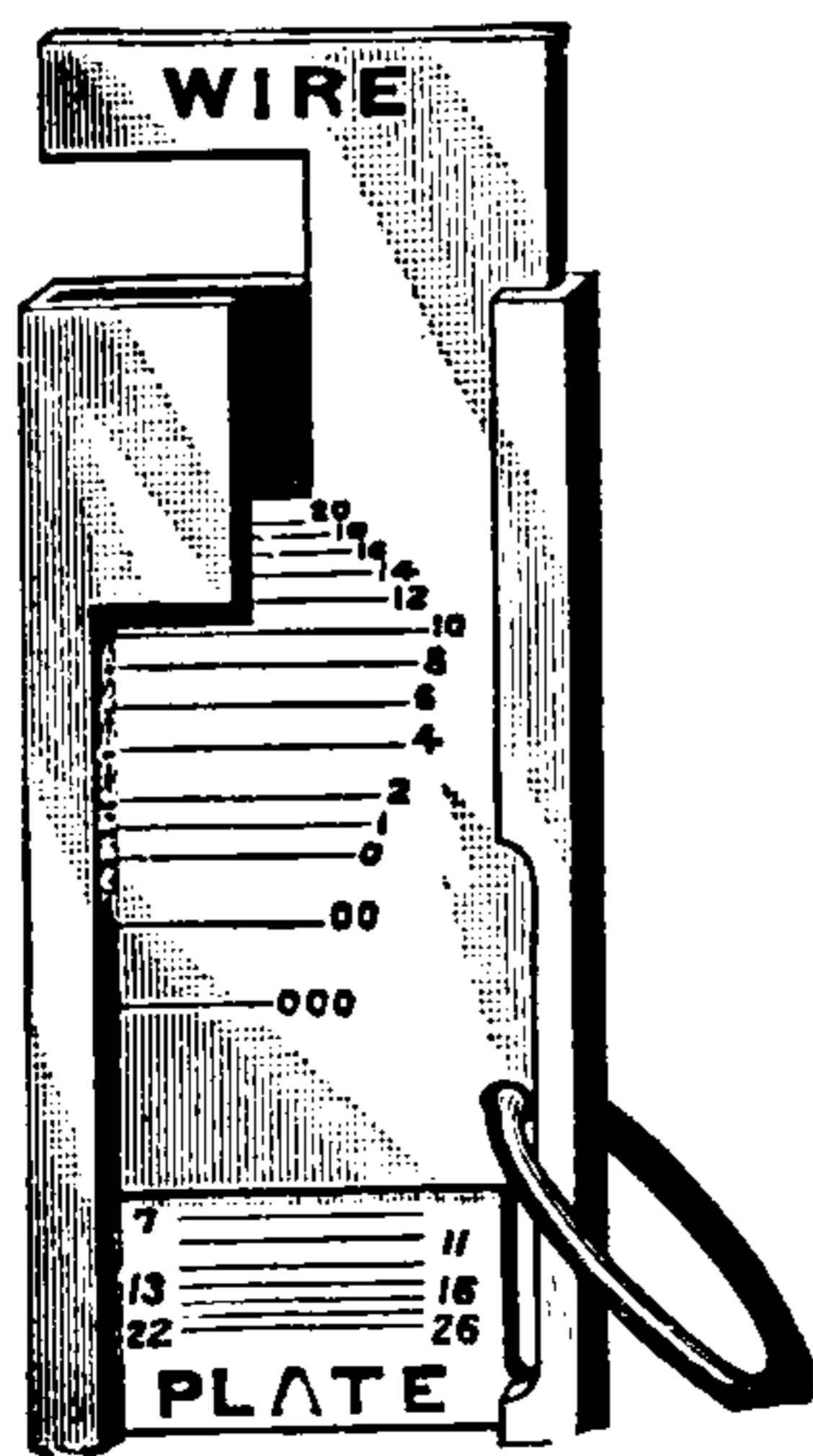

Fig 285. Wire and Plate Gauge.

Gauge, Wire, Standard — —A wire gauge adopted by the National Telephone Exchange Association at Providence, R. I., and by the National Electric Light Association, at Baltimore, Md., in February, 1886.

The value of the standard as compared with the other gauges will be seen from an inspection of the table in this column:

Gauges, Wire, Varieties of — —The following table gives a comparison of the principal wire gauges in use.

COMPARISON OF THE DIFFERENT WIRE GAUGES.

Number of Wire Gauge.	American or Brown & Sharpe.	Birmingham, or Stubs.	Washburn & Moen Mfg. Co., Worcester, Mass.	Trenton Iron Co., Trenton, N. J.	Standard Wire Gauge.	Old English from Brass Mfrs.' List.
00000046			
0000043	.45		
0000	.46	.454	.393	.4	.400	
000	.40964	.425	.362	.36	.372	
00	.3648	.38	.331	.33	.348	
0	.32495	.34	.307	.305	.324	
1	.2893	.3	.283	.285	.300	
2	.25763	.284	.263	.265	.276	
3	.22942	.259	.244	.245	.252	
4	.20431	.238	.225	.225	.232	
5	.18194	.22	.207	.205	.212	
6	.16202	.203	.192	.19	.192	
7	.14428	.18	.177	.175	.176	
8	.12849	.165	.162	.16	.160	
9	.11443	.148	.148	.145	.144	
10	.10189	.134	.135	.13	.128	
11	.090742	.12	.12	.1175	.116	
12	.080808	.109	.105	.105	.104	
13	.071961	.095	.092	.0925	.092	
14	.064084	.083	.08	.08	.080	.083
15	.057068	.072	.072	.07	.072	.072
16	.05082	.065	.063	.061	.064	.065
17	.04525	.058	.052	.0525	.056	.058
18	.040303	.049	.047	.045	.048	.049
19	.035390	.042	.041	.039	.040	.04
20	.031961	.035	.035	.034	.036	.035
21	.028462	.032	.032	.03	.032	.0315
22	.025347	.028	.028	.27	.028	.0295
23	.022571	.025	.025	.024	.024	.027
24	.0201	.022	.023	.0215	.022	.025
25	.0179	.02	.02	.019	.020	.023
26	.01594	.018	.018	.018	.018	.0205
27	.014195	.016	.017	.017	.0164	.01875
28	.012641	.014	.016	.016	.0148	.0165
29	.011257	.013	.015	.015	.0136	.0155
30	.010025	.012	.014	.014	.0124	.01375
31	.008928	.01	.0135	.013	.0116	.01225
32	.00795	.009	.013	.012	.0108	.01125
33	.00708	.008	.011	.011	.0100	.01025
34	.006304	.007	.01	.01	.0092	.0095
35	.005614	.005	.0095	.009	.0084	.009
36	.005	.004	.009	.008	.0076	.0075
37	.0044530085	.00725	.0068	.0065
38	.003965008	.0065	.006	.00575
39	.0035310075	.00575	.0057	.005
40	.003144007	.005	.0048	.0045

NUMBER, DIAMETER, WEIGHT, LENGTH AND RESISTANCE OF PURE COPPER WIRE.

American Gauge.

No.	Diameter. Inches.	Weight, sp. gr. = 8.889.		Length. Ft. per lb.	Resistance of Pure Copper at 70° Fahrenheit.		
		Grs. per ft.	Lbs. per 1,000 feet.		Ohms per 1,000 ft.	Feet per ohm.	Ohms per lb.
0000...	.46000	4475.33	640.40	1.56	.051	19605.69	.0000798
000...	.40964	3549.07	507.01	1.97	.064	15547.87	.000127
00...	.36480	2814.62	420.09	2.49	.081	12330.36	.000202
0...	.32486	2233.28	319.04	3.13	.102	9783.63	.000320
1...	.28930	1770.13	252.88	3.95	.129	7754.66	.00051
2...	.25763	1403.79	200.54	4.99	.163	6149.78	.000811
3...	.22942	1113.20	159.03	6.29	.205	4876.73	.001289
4...	.20431	882.85	126.12	7.93	.259	3867.62	.00205
5...	.18194	700.10	100.01	10.00	.326	3067.06	.00326
6...	.16202	555.0	79.32	12.61	.411	2432.22	.00518
7...	.14429	440.27	62.90	15.90	.519	1928.75	.00824
8...	.12849	349.18	49.88	20.05	.654	1529.69	.01311
9...	.11443	276.94	39.56	25.28	.824	1213.22	.02083
10...	.10190	219.57	31.37	31.88	1.040	961.91	.03314
11...	.09074	174.15	24.88	40.20	1.311	762.93	.05269
12...	.08081	138.11	19.73	50.69	1.653	605.03	.08377
13...	.07196	109.52	15.65	63.91	2.084	479.80	.13321
14...	.06408	86.86	12.41	80.59	2.628	380.51	.2118
15...	.05707	68.88	9.84	101.63	3.314	301.75	.3368
16...	.05082	54.63	7.81	128.14	4.179	239.32	.5355
17...	.04525	43.32	6.19	161.59	5.269	189.78	.8515
18...	.04030	34.35	4.91	203.76	6.645	150.50	1.3539
19...	.03589	26.49	3.78	264.26	8.617	116.05	2.2772
20...	.03196	21.61	3.09	324.00	10.566	94.65	3.423
21...	.02846	17.13	2.45	408.56	13.323	75.06	5.443
22...	.025347	13.59	1.94	515.15	16.799	59.53	8.654
23...	.022572	10.77	1.54	649.66	21.185	47.20	13.763
24...	.0201	8.54	1.22	819.21	26.713	37.43	21.885
25...	.0179	6.78	.97	1032.96	33.684	29.69	34.795
26...	.01594	5.37	.77	1326.61	42.477	23.54	55.331
27...	.014195	4.26	.61	1642.55	53.563	18.68	87.979
28...	.012641	3.38	.48	2071.22	67.542	14.81	139.893
29...	.011258	2.68	.38	2611.82	85.170	11.74	222.449
30...	.010025	2.13	.30	3293.97	107.391	9.31	353.742
31...	.008928	1.69	.24	4152.22	135.402	7.39	562.221
32...	.00795	1.34	.19	5236.66	170.765	5.86	894.242
33...	.00703	1.06	.15	660.271	215.312	4.64	1421.646
34...	.0063	.84	.12	8328.30	271.583	3.68	2261.82
35...	.00551	.67	.10	10501.35	342.413	2.92	3596.104
36...	.005	.53	.08	13238.83	431.712	2.32	5715.36
37...	.00445	.42	.06	16691.06	544.287	1.84	9084.71
38...	.003965	.34	.05	20854.65	686.511	1.46	14320.26
39...	.003531	.27	.04	26302.23	865.046	1.16	22752.6
40...	.003144	.21	.03	33175.94	1091.865	.92	36223.59

Gauss.—The unit of intensity of magnetic field.

The term gauss for unit of intensity of magnetic field was proposed by S. P. Thompson as being that of a field whose intensity is equal to 10^8 C. G. S. units, that is, 10^8 lines of force per square centimetre.

J. A. Fleming proposes, for the value of the gauss, such strength of field as would develop an electromotive force of one volt in a wire one million centimetres in length, moving through such a field with unit velocity.

Fleming's value for the gauss was assumed on account of the small value of the gauss proposed

by S. P. Thompson. It is one hundred times greater in value than Thompson's gauss.

Sir William Thomson proposes, for the value of the gauss, such an intensity of magnetic field as is produced by a current of one weber (ampère) at the distance of one centimetre.

Gauss, Fleming's — — Such a strength of magnetic field as is able to develop an electromotive force of one volt in a wire one million centimetres in length moved through the field with unit velocity. (See *Gauss*.)

Gauss, S. P. Thompson's — — Such a strength of magnetic field that its intensity is equal to 10^8 C. G. S. units. (See *Gauss*.)

THIS PAGE IS LOCKED TO FREE MEMBERS

Purchase full membership to immediately unlock this page

Know Your Bible

Forgotten Books' Full Membership provides unlimited access to more than 28,000 volumes of Christian literature for \$8.99/month

HOLY BIBLE

Continue

*Fair use policy applies

The operation of the pyro-magnetic generator is dependent upon the fact that any variation in the number of lines of magnetic force that pass through a conductor will develop differences of electric potential therein. Such variations may be effected either by varying the position of the conductor as regards the magnetic field, or by varying the magnetic field itself. The latter method of generating differences of potential is utilized in the pyro-magnetic generator, and is effected in it by varying the magnetization of rolls of thin iron or nickel by the action of heat.

A form of pyro-magnetic generator devised by Edison is shown in Figs. 286 and 287.

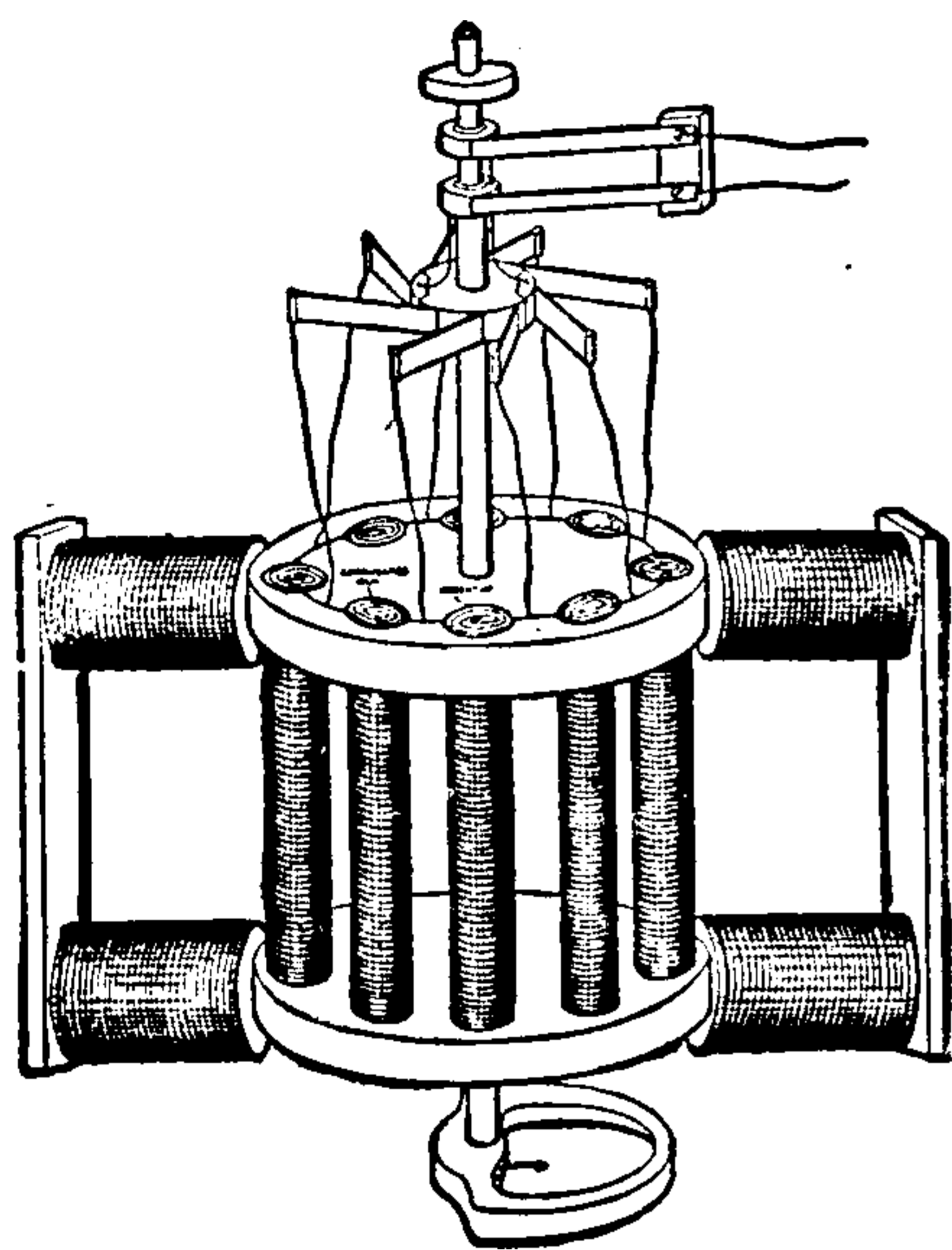

Fig 287. Edison's Pyro-Magnetic Generator.

This apparatus is sometimes called a pyro-magnetic dynamo.

Eight electro-magnets are provided, each with an armature consisting of a roll of corrugated iron. Each of these armatures is provided with a coil of insulated wire wound on it and protected by asbestos paper. The armatures pass through two iron discs as shown. The armature coils are connected in series in a closed-circuit, the wires from the coils being connected with metallic brushes that rest on a commutator supported on a vertical axis. A pair of metallic rings is provided above the commutator to carry off the current generated.

The vertical axis is provided below with a semi-circular screen called a guard plate which rotates with the axis and cuts off or screens one-half the iron armatures from the heated air.

When the axis is rotated, the difference in the

magnetization of the armatures, when hot and cold, develops electromotive forces which result in the production of an electric current.

Generator, Secondary — — A term frequently employed for a converter or transformer.

The word transformer is now almost universally employed. (See *Transformer*.)

Generator, Watt — — A term sometimes employed for stating the power in watts that any electric source is capable of producing.

Estimating the power of a dynamo-electric machine by the number of watts it is capable of producing is very convenient in practice, and is now very generally adopted. A dynamo capable of furnishing a difference of potential of 1,000 volts, and a current of 10 ampères, would be said to be a 10,000 watt-generator.

The term watt-generator, though applicable to the case of any electric source, is in practice generally limited to the case of dynamo-electric machines or secondary batteries.

Generators, Motor, Distribution of Electricity by — — (See *Electricity, Distribution of, by Motor Generators*.)

Geographical Distribution of Thunder Storms.—(See *Storms, Thunder, Geographical Distribution of*.)

Geographical Equator.—(See *Equator, Geographical*.)

Geographical Meridian.—(See *Meridian, Geographical*.)

German Silver Alloy.—(See *Alloy, German Silver*.)

Gilding, Electric — — The electrolytic deposition of gold on any object.

Electro-plating with gold. (See *Plating, Electro*.)

The surfaces of the object to be gilded are made electrically conducting, if not already so, and are then connected to the negative terminal of a voltaic cell or other source, and immersed in a plating bath containing a solution of a salt of gold, directly opposite a plate of gold, connected with the positive terminal of the source. The objects to be plated thus become the cathode, and the plate of gold the anode of the plating bath. On the passage of a suitable current, the gold is dissolved from the plate at the anode and deposited

on the object at the kathode. (See *Bath, Gold. Kathode. Anode.*)

Gilt Plumbago.—(See *Plumbago, Gilt.*)

Gimbals.—Concentric rings of brass, suspended on pivots in a compass box, and on which the compass card is supported so as to enable it to remain horizontal notwithstanding the movements of the ship. (See *Compass, Azimuth.*)

Each ring is suspended on two pivots placed directly opposite each other, that is, at the ends of a diameter, which in one ring is at right angles to that in the other.

Girder Armature.—(See *Armature, Girder.*)

Globe, Vapor, of Incandescent Lamp — —A glass globe surrounding the chamber of an incandescent electric lamp, for the purpose of enabling the lamp to be safely used in an explosive atmosphere, or to permit the lamp to be exposed in places where water is liable to fall on it.

Such a vapor globe is shown in Fig. 288. In the event of accidental breakage of the outside globe, the lamp chamber proper prevents the ignition of the explosive gases. In such cases, however, the outer protecting chamber should be promptly replaced.

In some forms of vapor globes, a valve is provided, opening outwards, in order to permit the expanded air to escape when a given pressure is reached, and yet, at the same time, to prevent the entrance of gas or vapor from without.

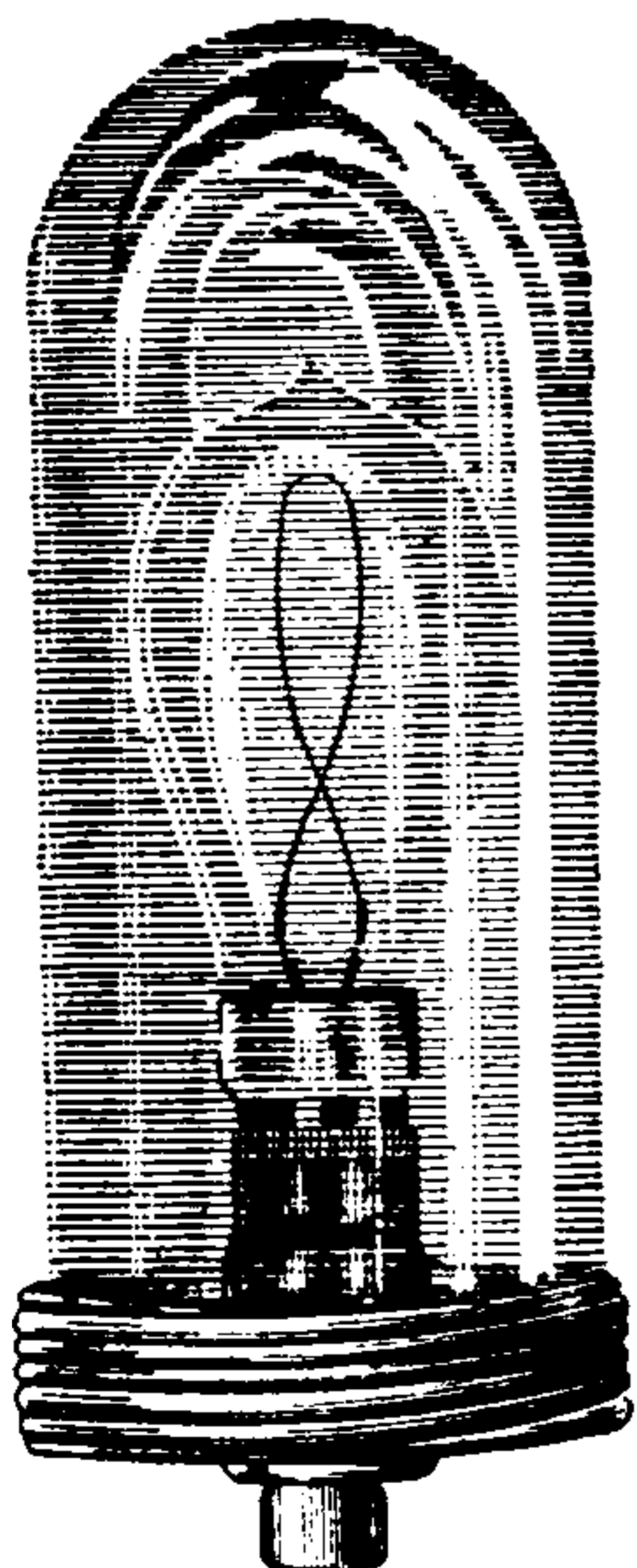

Fig. 288 Vapor Globe.

Glow Discharge.— (See *Discharge, Glow.*)

Glow Lamp.—(See *Lamp, Electric Glow.*)

Gold Bath.—(See *Bath, Gold.*)

Gold-Leaf Electroscope.—(See *Electroscope, Gold-Leaf.*)

Gold-Plating.—(See *Plating, Gold.*)

Gong, Electro-Mechanical — —A gong

struck or operated by mechanical force at times which are dependent on the passage of an electric current.

The motive power is the mechanical force developed by a bent spring, the fall of a weight, etc., and, by suitable mechanism, is permitted to act only on the passage of an electric current.

Governor, Centrifugal — —A device for maintaining constant the speed of a steam engine or other prime mover, despite sudden changes in the load or work.

In a ball governor, any increase in speed causes the balls to fly out from the centre of rotation by centrifugal force. This motion is utilized to control a valve or other regulating device. If the speed of the engine falls, the balls move towards the centre, shifting the valve or regulating device in the opposite direction.

Governor, Current — —A current regulator.

A device for maintaining constant the current strength in any circuit.

Current governors are either automatic or non-automatic. (See *Regulation, Automatic.*)

Governor, Electric — —A device for electrically controlling the speed of a steam engine, the direction of current in a plating bath, the speed of an electric motor, the resistance of an electric circuit, the flow of water or gas into or from a containing vessel, or for other similar purposes.

The particular form assumed by the apparatus varies with the character of the work it is intended to accomplish. In some cases an ordinary ball or centrifugal governor is employed to open or close a circuit; or, a mass of mercury in a rotating vessel is caused, at a certain speed, to open or close a circuit; or, the resistance of a bundle of carbon discs is caused to vary, either by pressure produced by centrifugal force, or by the movement of an armature.

Governor, Periodic — —A name applied by Ayrton & Perry to a form of governor for an electric motor, in which the current is automatically cut out for a certain portion of each revolution.

Governor, Spasmodic — —A name given by Ayrton & Perry to a form of governor for an electric motor, in which the cur-

rent is automatically cut off in proportion as the work is cut off.

The spasmodic governor consists essentially of a cone dipping into the surface of mercury in a rotating vessel. As the speed of the governor increases on a lightening of the load, the surface of the mercury is curved by the increased centrifugal force, until finally the mercury leaves the contact point and thus cuts off the current.

Governor, Steam, Electric — —A device used in connection with a valve to so electrically regulate the supply of steam to an engine, that the engine shall be driven at such a speed as will maintain either a constant current or a constant potential.

In the electric governor, the steam valve is operated by an electro-magnet, whose coils, in the case of a constant current machine, are of thick wire placed in the main circuit, and, in that of a constant potential machine, are of thin wire placed in a shunt around the mains.

Graduators.—Devices, generally electro-magnetic, employed in systems of simultaneous telegraphic and telephonic transmission over the same wire, so inserted in the line circuit as to obtain the makes and breaks required in a system of telegraphic communication so gradually that they fail to sensibly influence the diaphragm of a telephone placed in the same circuit.

Gramme.—A unit of weight equal to 15.43235 grains.

The gramme is equal to the weight of one cubic centimetre of pure water at the temperature of its maximum density. It has various multiples and decimal divisions—of the former, the kilogramme or one thousand grammes is the most frequently used; of the latter, the centigramme or the one-hundredth of a gramme, and the milligramme or the one-thousandth of a gramme. (See *Weights and Measures, Metric System of.*)

Gramme Atom.—(See *Atom, Gramme.*)

Gramme Molecule.—(See *Molecule, Gramme.*)

Gramophone.—An apparatus for recording and reproducing articulate speech. (See *Phonograph.*)

Gramophone Record.—(See *Record, Gramophone.*)

Graphite.—A soft variety of carbon suitable for writing on paper or similar surfaces.

Graphite is the material that is employed for the so-called black lead of lead pencils. It is sometimes called plumbago. Strictly speaking, the term graphite is only applicable to the variety of plumbago suitable for use in lead pencils.

Graphite is used for rendering surfaces to be electro-plated, electrically conducting, and also for the brushes of dynamos and motors. For the latter purpose it possesses the additional advantage of decreasing the friction by means of its marked lubricating properties.

Graphophone, Micro — —A modification of the phonograph in which, instead of a single diaphragm, a number of separate non-metallic diaphragms are caused to act on a single diaphragm to record the speech, so that the separate diaphragms can be thrown into strong vibration when reproducing the speech.

Graphophone, Phonograph — —A term sometimes applied to the graphophone. (See *Graphophone, Micro. Phonograph.*)

Graphophone Record.—(See *Record, Graphophone.*)

Gray's Harmonic Telegraphic Analyzer.—(See *Analyzer, Gray's Harmonic Telegraphic.*)

Gray's Harmonic Telegraphy.—(See *Telegraphy, Gray's Harmonic Multiple.*)

Gravitation.—A name applied to the force which causes masses of matter to tend to move towards one another.

This motion is assumed to be that of attraction, that is, the bodies are assumed to be drawn together. It is not impossible, however, that they may be pushed together.

Gravitation, like electricity, is well known, so far as its effects are concerned; but, as to the true cause of either, particularly the former, we are in comparative ignorance.

The general facts of gravitation may be succinctly stated by the following law, generally known as Newton's law.

Every particle of matter in the universe is attracted by every other particle of matter, and itself attracts every other particle of matter, with a force which is directly proportional to the product of the masses of the two quantities of matter

THIS PAGE IS LOCKED TO FREE MEMBERS

Purchase full membership to immediately unlock this page



HISTORY

Tens of thousands of important historical sources, many previously unobtainable, are now available for the first time with a Forgotten Books Full Membership.

Unlimited Access
\$8.99/month

Continue

*Fair usage policy applies

Guard, Wire Shade — —A guard of wire netting provided for the protection of a shade.

A form of wire shade is shown in Fig. 289.

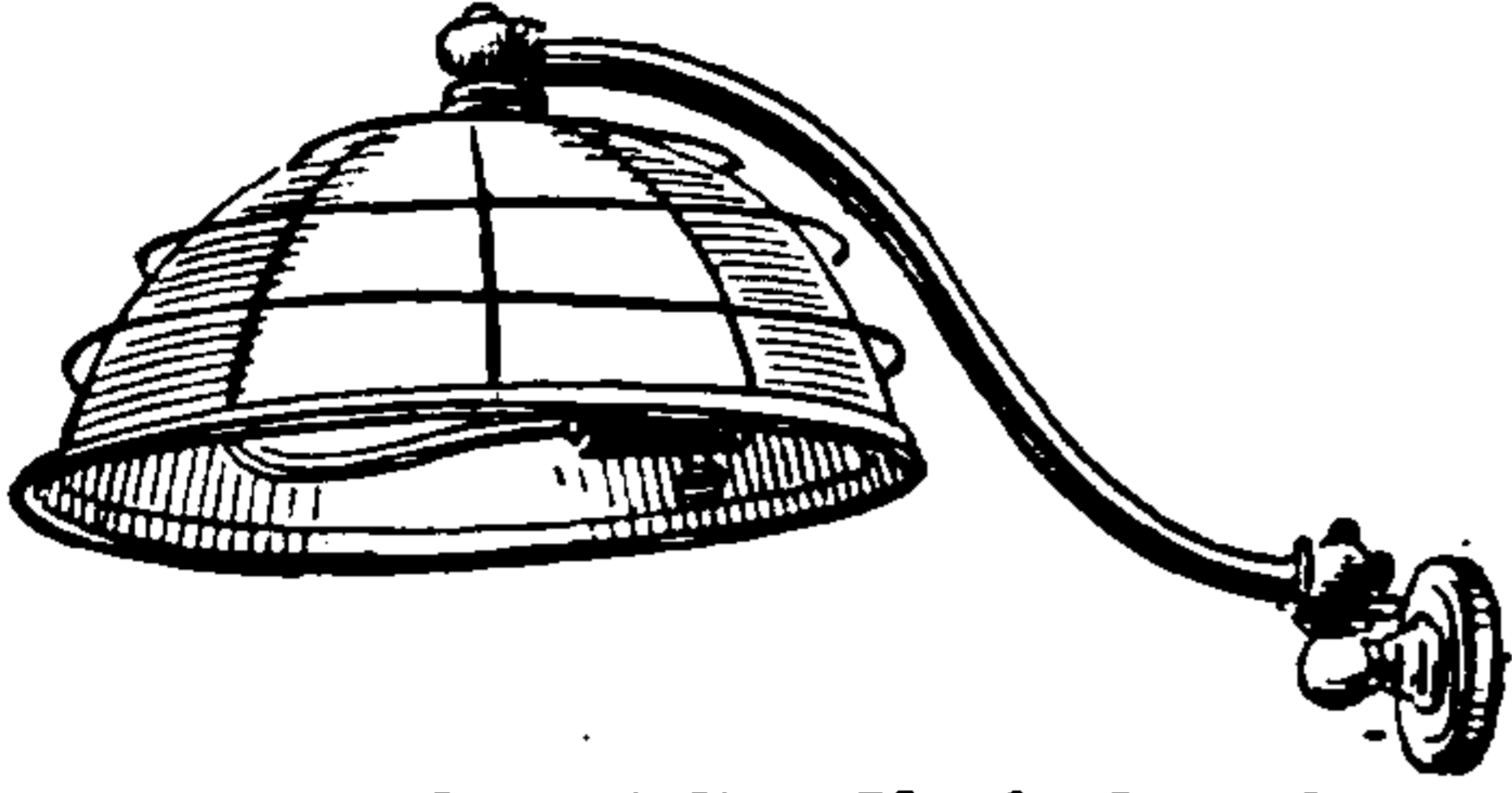

Fig. 289. Wire Shade Guard.

Gutta-Percha.—A resinous gum obtained from a tropical tree, and valuable electrically for its high insulating powers.

Gutta-percha readily softens by heat, but on

cooling becomes hard and tough. Unlike India-rubber, it possesses but little elasticity. Its specific inductive capacity is 4.2, that of air being 1, and of vulcanized rubber, 2.94. (See *Capacity, Specific Inductive.*)

Gutta-percha is obtained largely from the East Indies, from a tree which yields a brownish gum. It is a fibrous and tenacious substance with but little flexibility, and is unaffected by acids. Oils produce less effect upon it than on India-rubber.

Gutta-percha is one of the best insulating materials known for sub-aqueous cables.

Gymnotus Electricus.—The electric eel. (See *Eel, Electric.*)

Gyrometer.—A speed indicator. (See *Indicator, Speed.*)

H

H.—A contraction for the horizontal intensity of the earth's magnetism.

H.—A contraction proposed for one unit of self-induction.

H.—A contraction used in mathematical writings for the magnetizing force that exists at any point, or, generally, for the intensity of the magnetic force.

The letter H, when used in mathematical writings or formulæ for the intensity of the magnetic force, is always represented in bold or heavy faced type, thus : **H**.

H-Armature Core.—(See *Core, Armature, H.*)

Hail, Assumed Electric Origin of — — A hypothesis, now generally rejected, framed to explain the origin of the alternate coatings of ice and snow in a hail stone, by the alternate electric attractions and repulsions of the stones between neighboring, oppositely charged, snow and rain clouds.

It is now generally recognized that the electric manifestations attending hail storms are the *effects* and not the *causes* of the hail. (See *Para-grêles.*)

Hair, Electrolytic Removal of — — The permanent removal of hair from any part

of the body, by the electrolytic destruction of the hair follicles.

A platinum negative electrode is inserted in the hair follicle and the positive electrode, covered with moist sponge or cotton, is held in the hand of the patient. A current of from two to four *milli-amperes* from a battery of from eight to ten Leclanché elements is then passed for from ten to thirty seconds. A few bubbles of gas appear, and the hairs are then removed from the follicles by a pair of forceps. (See *Milli-Ampère.*)

When the work is properly done there is no destruction of the skin and therefore no marks or scars.

In the removal of hair from the face, it is preferable that the current should slowly reach its maximum strength.

Half-Shades for Incandescent Lamps.—Shades for incandescent electric lamps, in which one-half of the lamp chamber proper is covered with a coating of silver, or other reflecting surface for reflecting the light, or is ground for the purpose of diffusing the light.

The half-shade is applicable to cases where it is desired to throw out the light, not in all directions, but on one side only of any plane. Sometimes the dividing plane is taken parallel to the length of the incandescing filament and sometimes at right angles to it. When the lamp is placed

within a surrounding globe the reflecting surface may be placed on this globe instead of on the lamp chamber.

Hall Effect.—(See *Effect, Hall.*)

Halleyan Lines.—(See *Lines, Halleyan.*)

Halpine-Savage Torpedo.—(See *Torpedo, Halpine-Savage.*)

Handhole of Conduit.—A box or opening communicating with an underground cable, provided for readily tapping the cable, and of sufficient size to permit of the introduction of the hand.

Hand-Lighting Argand Electric Burner.—(See *Burner, Argand Electric, Hand-Lighter.*)

Hand-Lighting Electric Burner.—(See *Burner, Hand-Lighting Electric.*)

Hand-Regulation.—(See *Regulation, Hand.*)

Hand-Regulator.—(See *Regulator, Hand.*)

Hanger-Board.—(See *Board, Hanger.*)

Hanger, Cable — —A hanger or hook suitably secured to the cable and designed to sustain the weight of the cable by intermediately supporting it on iron or steel wires strung above the cable.

A cable hanger or cable clip is shown in Fig. 290. The mode of supporting the cable C, by the hanger hook H, will be readily understood from an inspection of the figure.

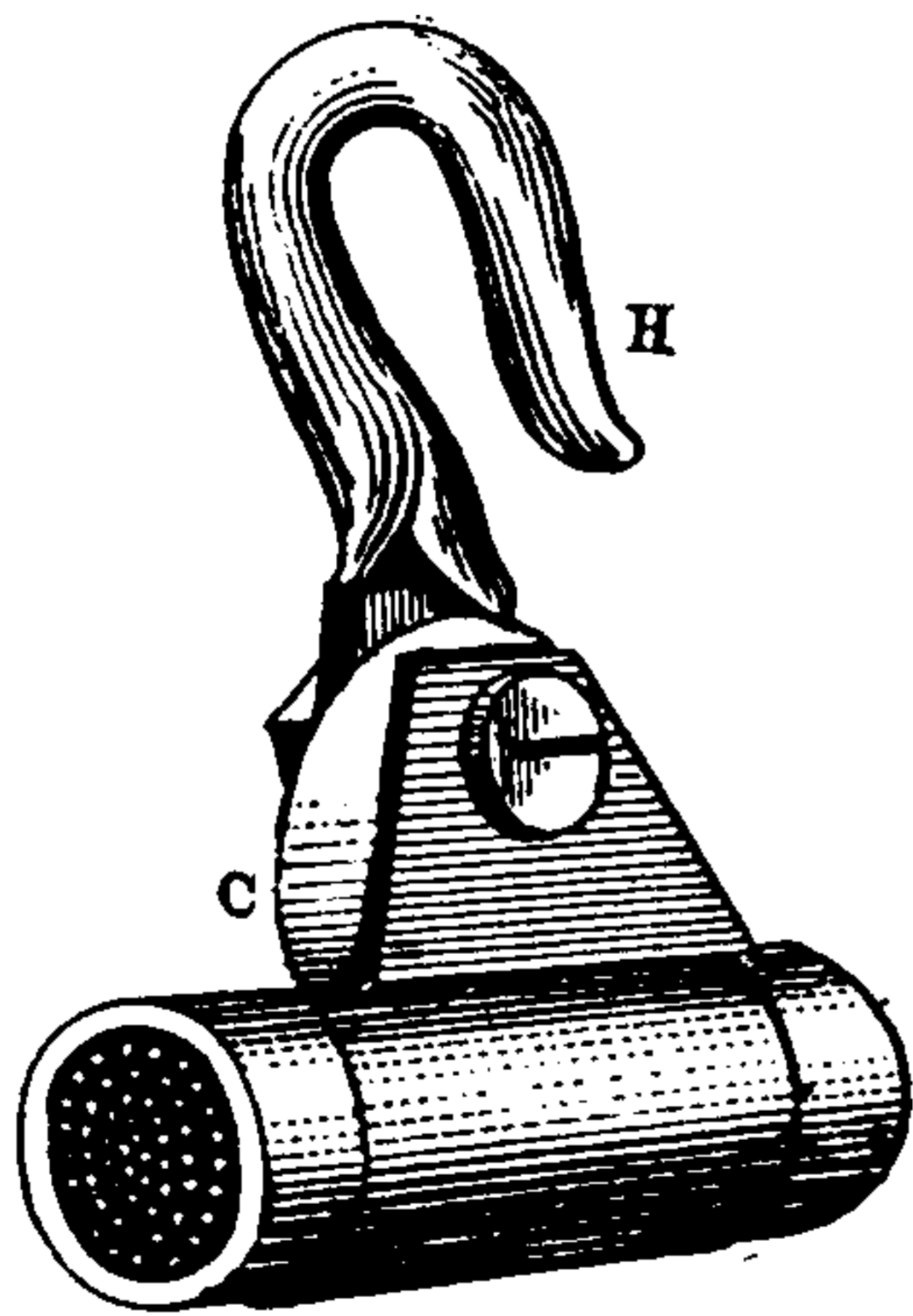

Fig. 290. Cable Hanger.

The weight per foot of an aerial cable is generally so great that the poles or supports would require to be very near together, unless the device of intermediate supports, by means of cable clips or hangers, were adopted.

Hanger, Double-Curve Trolley — —A trolley hanger generally employed at the ends of single and double curves, and on intermediate points on double track curves, supported by lateral strain in opposite directions.

Hanger, Single-Curve Trolley — —A trolley hanger supported on a single track curve, except at the ends and on the inside curve of a double track line, by lateral strain in one direction.

Hanger, Straight-Line Trolley — —A trolley hanger on a straight trolley line suitably supported by a span wire so as to have a vertical strain only.

Hanger, Trolley — —A device for supporting and properly insulating trolley wires.

Hard-Drawn Copper Wire.—(See *Wire, Copper, Hard-Drawn.*)

Harmonic Receiver.—(See *Receiver, Harmonic.*)

Harmonic Telegraphy.—(See *Telegraphy, Gray's Harmonic Multiple.*)

Head Bath, Electric — —(See *Bath, Head, Electric.*)

Head Breeze, Electro-Therapeutic — —(See *Breeze, Head, Electro-Therapeutic.*)

Head Light, Locomotive, Electric — —An electric light placed in the focus of a parabolic reflector in front of a locomotive engine.

The lamp is so placed that its voltaic arc is a little out of the focus of the reflector, so that, by giving a slight divergence to the reflected light, the illumination extends a short distance on either side of the tracks.

Heat.—A form of energy.

The phenomena of heat are due to a vibratory motion impressed on the molecules of matter by the action of some form of energy.

Heat in a body is due to the vibrations or oscillations of its molecules. Heat is transmitted through space by means of a wave motion in the universal ether. This wave motion is the same as that causing light.

A hot body loses its heat by producing a wave motion in the surrounding ether. This process is called *radiation*. (See *Radiation.*)

The energy given off by a heated body cooling is called radiant energy.

Radiant energy is transmitted by means of ether waves; it is of two kinds, viz.:

(1.) *Obscure Heat*, or heat which does not affect the eye, although it can impress a photographic image on a sufficiently sensitive photographic plate.

(2.) *Luminous Heat*, or heat which accompanies light. (See *Energy, Radiant.*)

Heat is conducted, or transmitted through bodies, with different degrees of readiness.

Some bodies are good conductors of heat, others are poor conductors.

Heat is transmitted through liquids by means of currents occasioned by differences in density caused by differences of temperature. These currents are called *convection currents*.

Heat is measured as to its *relative degree of intensity* by the *thermometer*. It is measured as to its *amount* or *quantity* by the *calorimeter*. (See *Thermometer, Electric. Calorimeter.*)

The heat unit most commonly employed is, perhaps, the *calorie*, or the amount of heat required to raise one gramme of water one degree centigrade.

Another *heat unit*, very generally employed in the United States and England, is the quantity of heat required to raise one pound of water one degree Fahrenheit. This is called the English heat unit. (See *Calorie. Units, Heat. Joule. Volt-Coulomb.*)

Heat, Absorption and Generation of, in Voltaic Cell — — The heat effects which attend the action of a voltaic cell.

The chemical action of the exciting liquid or electrolyte on the positive plate or element of a voltaic cell, like all cases of chemical combination, is attended by a development of heat.

When, however, the circuit of the cell is closed, the energy liberated during the chemical combination appears as electricity, which develops heat in all parts of the circuit. (See *Heat, Electric. Cell, Voltaic.*)

Heat, Atomic — — A constant product obtained by multiplying the specific heat of an elementary substance by its *atomic weight*. (See *Weight, Atomic.*)

Dulong and Petit have discovered the remarkable fact that the product of the specific heat of all elementary substances by their atomic weights is nearly the same. The product is called the *atomic heat*, and is about equal to 6.4.

Dulong and Petit's law may be stated as follows, viz.: *All elementary atoms require the same quantity of heat to heat them to the same number of degrees.*

The atomic heat of any body divided by its specific heat gives its atomic weight.

The heat imparted to any body performs three kinds of work, viz.:

(1.) That expended in external work, such, for example, as in overcoming the atmospheric pressure.

(2.) That expended in internal work, or in overcoming the attractions of the atoms and driving them apart.

(3.) That expended in overcoming the temperature, or the true specific heat, or heat expended in increasing the molecular vis-viva.

The expenditure of energy is greatest in the third head. The exact value of the three factors is as yet unknown, and in the opinion of Weber and others the correctness of Dulong and Petit's law cannot be regarded as being satisfactorily established.

Regnault has proved that Dulong and Petit's law is true for compound bodies, *i. e.*, in all compounds of similar composition the product of the specific heat by the total chemical equivalent is constant.

The following table from Anthony and Bracket illustrates the law of Dulong and Petit:

Elements.	Specific Heat of Equal Weight.	Atomic Weight.	Product of Specific Heat into Atomic Weight.
Iron	0.114	55.9	6.372
Copper.....	0.095	63.17	6.001
Mercury.....	0.0314 (Solid)	199.71	6.128
Silver	0.057	107.67	6.137
Gold	0.0329	196.15	6.453
Tin.....	0.056	117.7	6.591
Lead	0.0314	206.47	6.483
Zinc.....	0.0955	64.9	6.198

“This product—the atomic heat of elements, the molecular heat of compounds—has the following physical meaning: Of any substance whose atomic or molecular weight we know, we may take a number of grammes numerically equal to the atomic or molecular weight; for example, 35.5 grammes of chlorine, 16 grammes of marsh gas; we may call such quantity the gramme atom or the gramme molecule of the substance. The atomic heat or the molecular heat of a substance is the number of calories of heat necessary to raise the temperature of a gramme atom or a gramme molecule of the substance through 1 degree C.”—(Daniell.)

Heat, Electric — — The heat developed by the passage of an electric current through a conductor.

THIS PAGE IS LOCKED TO FREE MEMBERS

Purchase full membership to immediately unlock this page

Know Your Bible

Forgotten Books' Full Membership provides unlimited access to more than 28,000 volumes of Christian literature for \$8.99/month

HOLY BIBLE

Continue

*Fair use policy applies

current of electricity is sent through a metallic wire, the middle of which is maintained at a constant temperature, and the ends at the temperature of melting ice.

The distribution of heat during the passage of a current through an unequally heated conductor.

If the central portions of a metallic bar are heated the curve of heat distribution is symmetrical. On sending an electric current through the wire it is heated according to Joule's law, and the curve of heat distribution is still symmetrical. But the current in passing from the colder to the hotter parts of the wire produces an additional heating effect at this point, and in passing from the warmer to the colder parts of the wire produces a cooling effect. (See *Effect, Peltier. Effect, Thomson.*) The curve of heat distribution is then no longer symmetrical. The term *Electrical Convection of Heat*, has been given to the dissymmetrical distribution of heat so effected.

Sir William Thomson, who studied these effects, found that the electrical convection of heat in copper takes place in the opposite direction to that in iron; that is to say, the electrical convection of heat is negative in iron, (*i. e.*, the direction is opposite to that of the current), and positive in copper.

Heat, Irreversible — —Heat produced in a homogeneous conductor by the passage of electricity through it.

This heat, according to Joule's law, is proportional to the square of the current, and is produced no matter in what direction the current is passing. In this respect it is unlike the heat produced by the passage of electricity through a heterogeneous conductor, in which case heat is developed or liberated only by the passage of the current in a given direction: on the passage of the current in the opposite direction, heat being absorbed and the temperature lowered. (See *Heat, Reversible.*)

Heat Lightning.—(See *Lightning, Heat.*)

Heat, Luminous — —A variety of radiant energy which affects the eye, as light.

Radiant heat and light are, in reality, different effects produced by one and the same cause, viz., by vibrations or waves in the universal ether. In general the waves producing heat are of

greater length and smaller frequency than are those producing light.

Heat, Mechanical Equivalent of — — The amount of mechanical energy, converted into heat, that would be required to raise the temperature of 1 pound of water 1 degree Fahr.

The mechanical equivalence between the amount of energy expended and the amount of heat produced, as measured in heat units.

Joule's experiments, the results of which are generally accepted, gave 772 foot-pounds as the energy equivalent to that expended in raising the temperature of 1 pound of water 1 degree Fahr.

Heat, Molecular — —The number of calories of heat required to raise the temperature of one gramme-molecule of any substance 1 degree C. (See *Molecule, Gramme. Heat, Atomic.*)

Heat, Obscure — —A variety of radiant energy which does not effect the eye.

Radiant heat is sometimes divided into luminous heat and obscure heat. (See *Heat, Luminous.*)

Heat, Red — —The temperature at which a body, whose temperature is gradually increasing, begins to glow or to emit red rays of light.

When a refractory solid body is gradually heated to incandescence, the red waves of light are first emitted, then the orange, and successively afterwards the yellow, green, blue, indigo and violet, when the body emits white light or is white hot.

Heat, Reversible — —The heat produced in a heterogeneous conductor by the passage through it of an electric current in a certain direction.

Reversible heat is produced at the junction of two metals, where a difference of potential exists between them, or where their heterogeneity is greatest. It is called reversible because it depends upon the direction in which the current is passing. If the current be passed in a certain direction across the junction, heat is liberated; while, if it be passed in the opposite direction, heat is absorbed, or cold results.

Reversible heat effects are seen in the Peltier effect. (See *Effect, Peltier.*)

Heat, Specific — —The capacity of a substance for heat as compared with the capacity of an equal quantity of some other substance taken as unity.

Water is generally taken as the standard for comparison, because its capacity for heat is greater than that of any other common substance.

Different quantities of heat are required to raise the temperature of a given weight of different substances through 1 degree. The specific heats of substances are generally compared with water or with hydrogen, the capacity of these substances for heat being very great.

According to Dulong and Pettit, the specific heat of all elementary atoms is the same. For example, the heat energy of an atom of hydrogen is equal to that of an atom of oxygen, but since a given mass of hydrogen, under similar conditions of temperature and pressure, contains sixteen times as many atoms as an equal mass of oxygen, therefore, when compared weight for weight, hydrogen has a specific heat sixteen times greater than that of oxygen.

Or, in general, comparing equal weights, the specific heat of an elementary substance is inversely proportional to its atomic weight. (See *Heat, Atomic.*)

Heat, Specific, of Electricity — —(See *Electricity, Specific Heat of.*)

Heat Unit.—The quantity of heat required to raise a given weight of water through a single degree.

There are a number of different heat units. The most important are:

(1.) The British Heat Unit, or Thermal Unit, or the amount of heat required to raise 1 pound of water 1 degree Fahr. This unit represents an amount of work equal to 772 foot-pounds.

(2.) The Greater Calorie, or the amount of heat required to raise the temperature of 1,000 grammes of water 1 degree C. (See *Caloriè.*)

(3.) The Smaller Calorie, or the amount of heat required to raise the temperature of one gramme of water 1 degree C.

(4.) The Joule, or the quantity of heat developed in one second by the passage of a current of one ampère through a resistance of one ohm.

1 joule equals .0002407 large calories.

1 joule equals .2407 small calories.

1 foot-pound equals 1.356 joules.

1 pound-Centigrade equals 1884.66 joules.

1 " " " 1389.6 foot-pounds.

1 " Fahrenheit " 1047.03 joules.

Heat Unit, English — —(See *Units, Heat.*)

Heat Unit or Calorie.—(See *Calorie.*)

Heat Unit or Joule.—(See *Joule.*)

Heat, White — —The temperature at which light of all wave lengths from the red to the violet is emitted from a heated body, and the body, therefore, glows with a white light.

A solid substance heated to white incandescence emits a continuous spectrum, *i. e.*, a spectrum in which all the wave lengths of light from the red to the violet are present.

Heater, Electric — —A device for the conversion of electricity into heat for purposes of artificial heating.

Electric heaters consist essentially of coils or circuits of some refractory metal through which the current is passed. These coils or circuits are surrounded by air or finely divided solids, and are placed inside metallic boxes or radiators, which throw off or radiate the heat produced.

When employed for the heating of liquids the coils are placed directly in the liquid to be heated, or are surrounded by radiating boxes placed in the liquid.

Heating Effects of Currents.—(See *Currents, Heating Effects of.*)

Hedgehog Transformer.—(See *Transformer, Hedgehog.*)

Hecto-Ampère — —One hundred ampères.

Heliograph.—An instrument for telegraphic communication that operates by employing flashes of light to represent the dots and dashes of the Morse alphabet, or the movements of the needles of a needle telegraph to the right or the left. (See *Alphabet, Telegraphic.*)

The flashes of light are thrown from the surface of a plane mirror. Motions to the right or left may be employed in order to distinguish between the dots and dashes, or the same may be effected by the relative durations of the flashes of

light, or by the intervals between successive flashes.

Telegraphic communication has been carried on between steamers during foggy weather by means of their fog horns; or between locomotives by their steam whistles.

Helix, Dextrorsal — — A name sometimes applied to a dextrorsal solenoid. (See *Solenoid, Dextrorsal*.)

The magnetic polarity of a helix or solenoid depends not only on the direction in which the current is passed, but also on the direction in which the wire is coiled or wound. (See *Magnet, Electro*.)

Helix, Sinistrorsal — — A name sometimes applied to a sinistrorsal solenoid. (See *Solenoid, Sinistrorsal*.)

Hemihedral Crystal.—(See *Crystal, Hemihedral*.)

Henry, A — — The practical unit of self-induction.

It has been generally agreed in the United States to call the practical unit of self-induction a henry, in place of a secohm or quadrant. The name henry should be adopted, not only by American electricians, but also by those of other countries, since the terms secohm or quadrant are contrary to the generally adopted usage of employing for such the names of distinguished electricians, who have passed from their labors.

The fact that of all discoverers in the field of self-induction, none possesses so great a claim as that of Prof. Henry, must be generally acknowledged. As early as 1832 he published in *Silliman's Journal* a paper in which he described experiments, showing clearly that the spark obtained by breaking the current of a battery, in which a long wire was interposed, was greater than when a short wire was employed, and that this increased length of spark was further increased by coiling the wire, and that the phenomena were ascribed to the action of the current on itself.

A committee of the American Institute of Electrical Engineers, after careful consideration, recommended to the Institute that the value of the practical unit of inductance should be equal to 10^9 C. G. S. units of inductance, usually expressed by a length equal to one earth quadrant or 1 000,000,000 centimetres.

The value of the practical unit of inductance, or the "henry," may in some cases be too high for

convenience; in such cases it may be expressed by some fractional dimension, such, for example, as milli-henry.

Hercules Stone.—(See *Stone, Hercules*.)

Hermetical Seal.—(See *Seal, Hermetical*.)

Hertz's Theory of Electricity.—(See *Electricity, Hertz's Theory of*.)

Heterostatic.—A term applied by Sir William Thomson to distinguish a form of electrometer in which the electrification is measured by determining the mutual influence of the attraction exerted by the charge to be measured and the attraction of an opposite charge imparted to the instrument by a source independent of the charge to be measured.

The term heterostatic distinguishes this form of electrometer from an idiostatic instrument, or one in which the measurement is effected by determining the repulsion between the charge to be measured and the repulsion of a charge of the same name, *i. e.*, positive or negative, imparted to the instrument from an independent source. (See *Electrometer*)

Hick's Automatic Button Repeater.—(See *Repeaters, Telegraphic*.)

High-Bars.—A term applied to those commutator segments, or parts of commutator segments, which, through less wear, faulty construction or looseness, are higher than adjoining portions. (See *Commutator*.)

High-Frequency Currents, Electric Lighting by — — (See *Lighting, Electric, by High-Frequency Currents*.)

High Resistance Magnet.—(See *Magnet, High Resistance*.)

High Speed Electric Motor.—(See *Motor, Electric, High Speed*.)

High Tension Electric Fuse.—(See *Fuse, Electric High Tension*.)

Hissing of Arc.—(See *Arc, Hissing of*.)

Holder for Safety Fuse.—A box or other receptacle of refractory material for holding a safety fuse, and catching the molten metal when fused.

The holder or fuse box is provided to prevent the

THIS PAGE IS LOCKED TO FREE MEMBERS

Purchase full membership to immediately unlock this page



HISTORY

Tens of thousands of important historical sources, many previously unobtainable, are now available for the first time with a Forgotten Books Full Membership.

Unlimited Access
\$8.99/month

Continue

*Fair usage policy applies

A rate of doing work equal to 33,000 pounds raised 1 foot per minute, or 550 pounds raised 1 foot per second.

A rate of doing work equal to 4,562.33 kilogrammes raised 1 metre per minute.

A careful distinction must be drawn between work and power. The same amount of work is done in raising 1 pound through 10 feet whether it be done in one minute or in one hour. The power expended or the rate of doing work is, however, quite different, being in the former case sixty times greater than in the latter.

1 horse-power = 550 foot-pounds per second.

“ = 33,000 foot-pounds per minute.

“ = 4,562.33 kilogramme-metres per minute.

“ = 745,941 watts.

“ = 1.01385 metric horse-power.

Horse-Power, Electric — — (See *Power, Horse, Electric*.)

Horse-Power Hour.—(See *Hour, Horse-Power*.)

Horse-Power, Metric — — A unit of power in which rate of doing work is equal to 75 kilogramme-metres. (See *Horse-Power*.)

Horseshoe Electro-Magnet.—(See *Magnet, Electro, Horseshoe*.)

Horseshoe Magnet.—(See *Magnet, Horseshoe*.)

Hot, Red — — Sufficiently heated to emit red light only. (See *Heat, Red*.)

Hot St. Elmo's Fire.—(See *Fire, Hot, St. Elmo's*.)

Hot, White — — Sufficiently heated to emit all the colored lights of the spectrum. (See *Heat, White*.)

Hotel Annunciator.—(See *Annunciator, Hotel*.)

Hour, Ampère — — A unit of electrical quantity equal to one ampère flowing for one hour.

The ampère-hour is in reality a unit of quantity like the coulomb. It is used in the service of electric currents, and is equal to the product of the current delivered by the time in hours. The ampère-hour is not a measure of energy, but when

combined with the volt, and expressed in watt hours, it is a measure of energy.

The capacity of any service for maintaining a flow of current is measured in ampère-hours. Thus, if any service, such as a primary or secondary battery, has a capacity of 80 ampère-hours, it will supply 8 ampères for ten hours, or it may give 10 ampères for eight hours.

The storing capacity of accumulators is generally given in ampère-hours. The same is true of primary batteries.

One coulomb equals .0002778 ampère-hours.

One ampère-hour equals 3,600 coulombs.

Hour, Horse-Power — — A unit of work. An amount of work equal to one horse-power for an hour.

One horse power is equal to 1,980,000 foot-pounds, or 745.941 watt hours.

Hour, Kilo-Watt — — A unit of electrical power equal to a kilo-watt maintained for one hour.

Hour, Lamp — — Such a service of electric current as will maintain one electric lamp during one hour.

The number of lamp-hours is obtained by multiplying the number of lamps by the average number of hours during which the lamps are burning.

The use of lamp-hours is for the purpose of estimating the current supplied to a consumer by counting the number of hours each lamp is in service.

To convert lamp-hours to watt-hours, multiply the number of lamp-hours by the number of watts per lamp. The watt hours, divided by 746, will then give the electrical horse-power hours. (See *Hour, Watt*.)

Hour, Watt — — A unit of electrical work.

An expenditure of an electrical work of one watt for one hour.

Lamp-hours are converted to watt-hours by multiplying the number of lamp-hours by the number of watts per lamp. (See *Hour, Lamp*.)

House Annunciator.—(See *Annunciator, House*.)

House Main.—(See *Main, House*.)

House-Service Conductor.—(See *Conductor, House-Service*.)

House-Top Fixtures, Telegraphic — —
(See *Fixtures, Telegraphic House-Top.*)

House Wire.—(See *Wire, House.*)

Hughes' Electro-Magnet.—(See *Magnet, Electro, Hughes'.*)

Human Body, Electric Resistance of — —
(See *Body, Human, Resistance of.*)

Hydro-Electric Bath.—(See *Bath, Hydro-Electric.*)

Hydro-Electric Machine, Armstrong's
— —(See *Machine, Armstrong's Hydro-Electric.*)

Hydrogen, Electrolytic — —Hydrogen produced by electrolytic decomposition.

It is the electrolytic hydrogen liberated in a voltaic cell at the surface of the negative plate, which causes polarization and consequent decrease in the resulting current strength, by reason both of the counter-electromotive force it produces and the increased resistance it produces in the cell.

Electrolytic hydrogen is atomic hydrogen; *i. e.*, hydrogen with its bonds open or free. It therefore possesses much stronger chemical affinities than does molecular hydrogen. Electrolytic oxygen which is evolved at the same time as the electrolytic hydrogen has been successfully employed in electric bleaching. Hydrogen peroxide is also formed and acts as a bleaching agent.

Hydrometer or Areometer.—An apparatus for determining the specific gravity of liquids. (See *Areometer or Hydrometer.*)

Hydro-Plastics.—(See *Plastics, Hydro.*)

Hydro-Plasty.—The art of hydro-plastics. (See *Plastics, Hydro.*)

Hydrotasimeter, Electric — —An electrically operated apparatus designed to show at a distance the exact position of any water level.

In most forms of the electric hydrotasimeter a float placed in the liquid and connected with an electric circuit breaks this circuit, and, at intervals, sends positive impulses into the line when rising and negative impulses when falling. These are registered by means of an index moved by a step-by-step motion, positive currents moving it in one direction and negative currents moving it in the opposite direction.

Hygrometer.—An apparatus for determining the amount of moisture in the air.

Hygrometrical.—Of or pertaining to the hygrometer.

Hygrometrically.—In the manner of the hygrometer.

Hypothesis.—A provisional assumption of facts or causes the real nature of which is unknown, made for the purpose of studying the effects of such causes.

When the facts assumed by a hypothesis can be shown to be presumably true the hypothesis becomes a theory. A theory, therefore, gives a more correct expression of the relations between the causes and effects of natural phenomena than does a hypothesis.

Hypothesis, Double-Fluid Electric — —
(See *Electricity, Double-Fluid Hypothesis of.*)

Hypothesis, Grothüss' — —A hypothesis proposed by Grothüss to account for the electrolytic phenomena that occur on closing the circuit of a voltaic cell.

Grothüss' hypothesis assumes:

(1.) That before the electric circuit is closed the molecules of the electrolyte are arranged in an irregular or unpolarized condition, as repre-

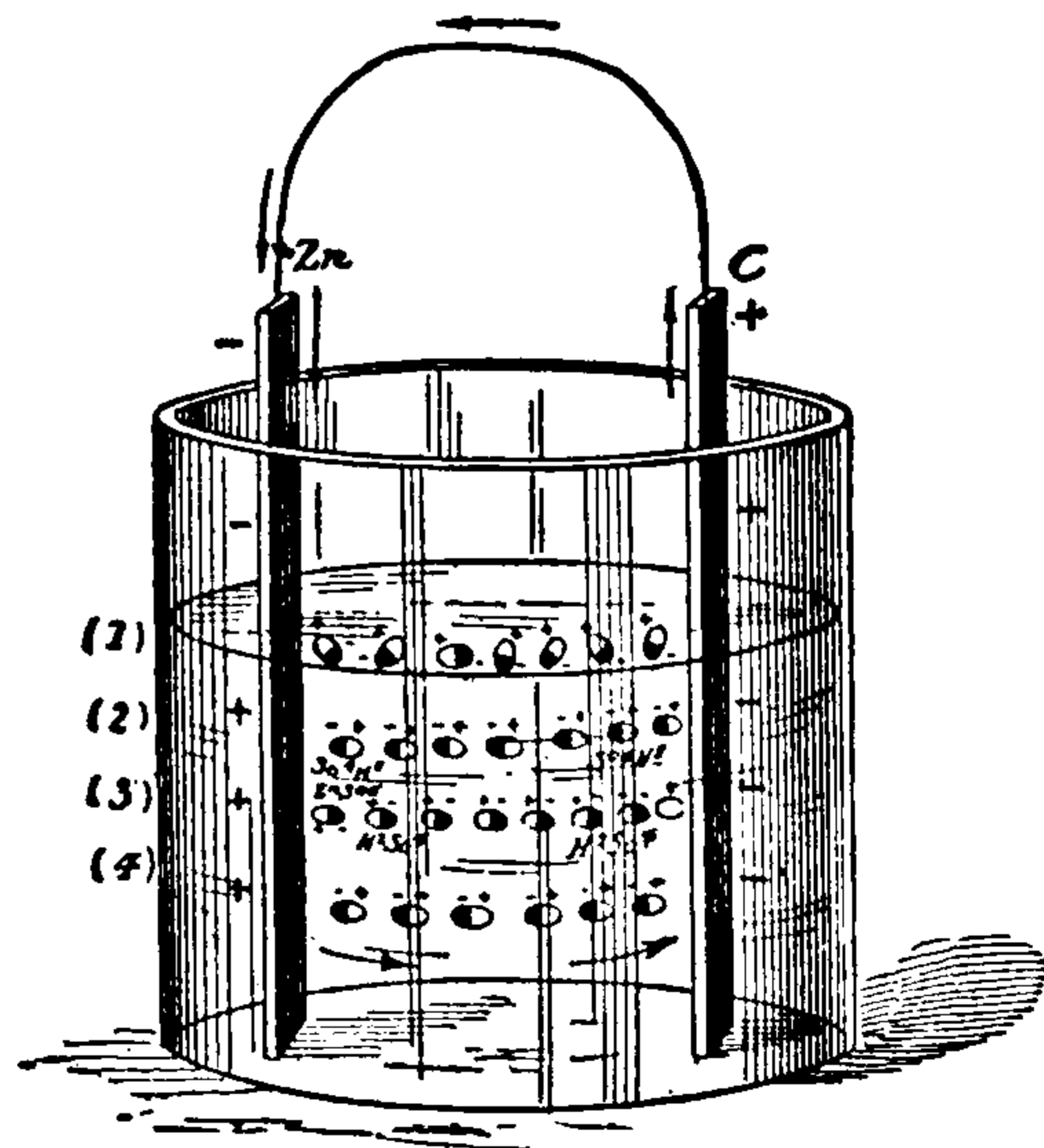

Fig. 293. Grothüss' Hypothesis of Electrolytic Polarization.

sented at (1), Fig. 293. These molecules are shaded as shown in Fig. 294, to indicate their composition and polarity.

(2.) When the circuit is closed and a current

begins to pass, a polarization of the electrolyte, as shown at (2), ensues, whereby all the negative ends of the molecules of hydrogen sulphate, or sulphuric acid, are turned towards the positive or zinc plate, and all the positive ends towards the negative or copper plate. This, as will be seen, will turn the SO_4 ends towards the zinc, and the H_2 ends towards the copper.

(3.) A decomposition of the polarized chain, whereby the SO_4 unites with the zinc and the H_2 liberated reunites with the SO_4 of the molecule next to it in the chain, and its liberated H_2 with the one next to it, and so on until the last liberated H_2 in the chain is given off at the surface of the copper or negative plate. This leaves the chain of molecules as shown at (3).

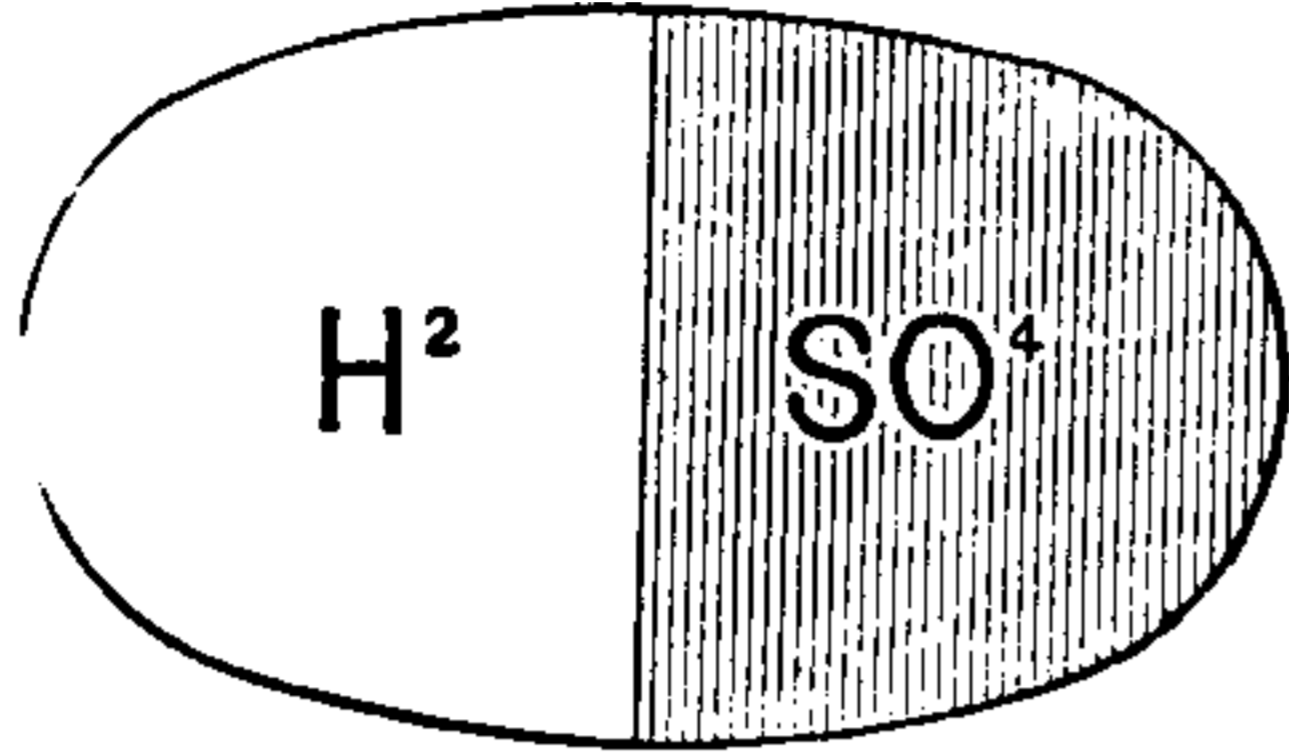

Fig. 294. Conventionalized Molecule.

(4.) A semi-rotation of the molecules of the chain, as at (3), until they assume the position shown at (4). This rotation is required, since all the molecules in (3) are turned with their similar poles towards similarly charged battery plates.

Hypothesis, Single-Fluid Electric —
—(See *Electricity, Single-Fluid Hypothesis of*.)

Hypothetical.—Of or pertaining to a hypothesis.

Hypsometer.—An apparatus for determining the height of a mountain or other elevation by ascertaining the exact temperature at which water boils at such elevation.

The use of a thermometer to measure the height of a mountain or other elevation is based on the fact that a given decrease in the temperature of the boiling point of water invariably attends a given decrease in the atmospheric pressure. Therefore, as the observer goes further above the level of the sea, the boiling point of water becomes lower, and from this decrease the height of the mountain or other elevation may be calculated.

Hypsometrical.—Of or pertaining to the hypsometer.

Hypsometrically.—In the manner of the hypsometer.

Hysteresial Dissipation of Energy.—(See *Energy, Hysteresial Dissipation of*.)

Hysteresis.—Molecular friction to magnetic change of stress.

A retardation of the magnetizing or demagnetizing effects as regards the causes which produce them.

The quality of a paramagnetic substance by virtue of which energy is dissipated on the reversal of its magnetization.

The ratio of magnetic induction to the magnetizing force producing it, or, in other words, the magnetic permeability, is greater when the magnetizing force is decreasing, than when it is increasing. This phenomenon is seen in the well known retention of magnetism in iron after the withdrawal of the force causing the magnetization, and was called by Ewing *hysteresis*, from *ὑστέρησις*, to lag behind.

If a curve is constructed in which the horizontal abscissas represent the magnetizing force, or the magnetizing current to which they are proportional, and the vertical ordinates the number of lines of induction passing through the body that is being magnetized, both in the case of gradually increasing and gradually decreasing currents, the curve will be found to have greater values for the decreasing than for the increasing current. Constructing a curve in this manner for the case of a ring of iron, which has been first suddenly magnetized and then demagnetized, taking the magnetizing force along the line F H, Fig. 295, and the resulting magnetization along the line M N, a loop is formed in the curve, as shown in the figure. The arrows show the direction of the magnetizing force; the shaded area the work done due to hysteresis.

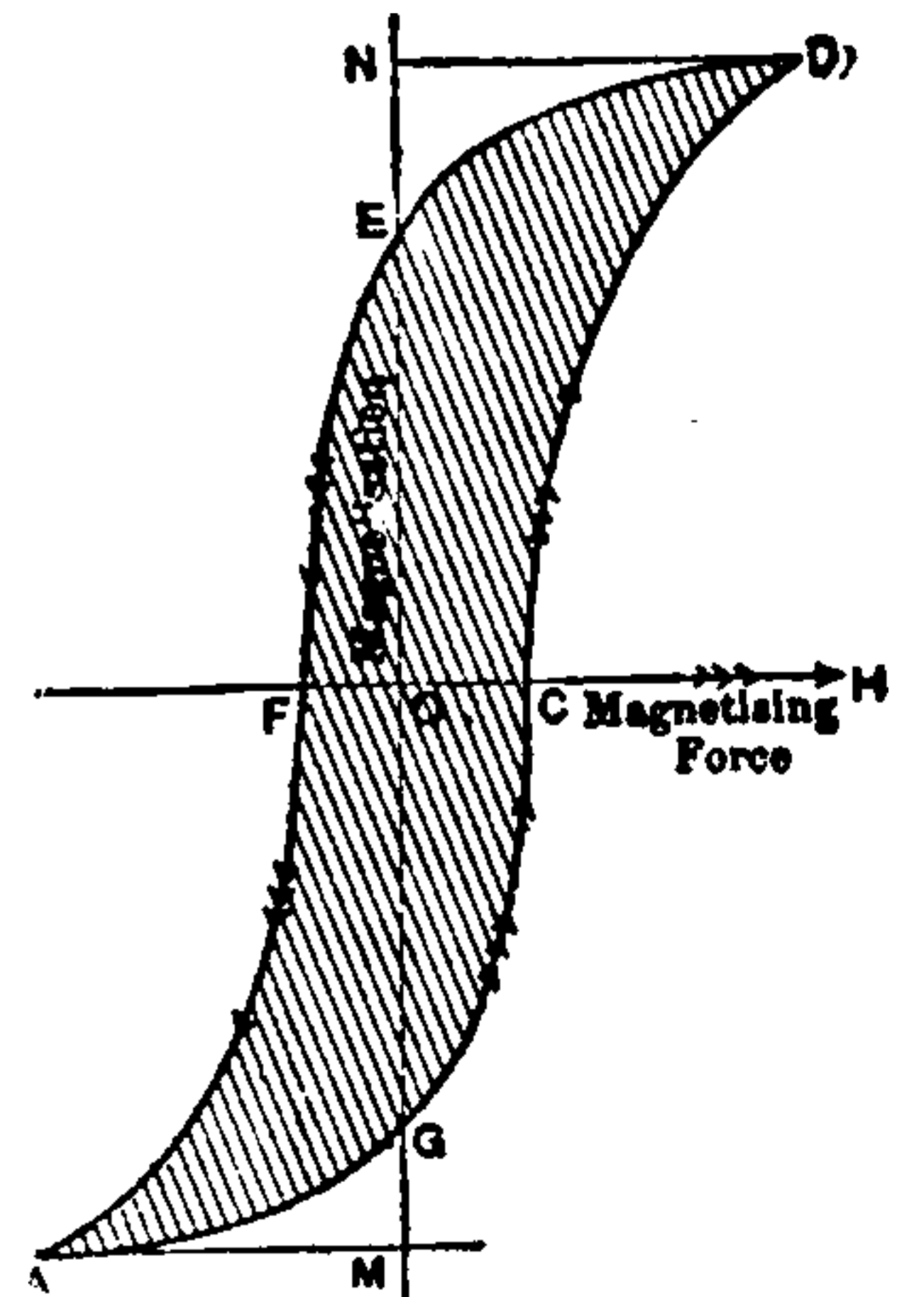

Fig. 295. Curves of Hysteresis (Ewing).

The area of this loop represents the amount of energy per unit of volume expended in performing a magnetic cycle, *i. e.*, in carrying the iron ring through a magnetization and subsequent demagnetization.

The physical meaning of the loop is that a lag-

THIS PAGE IS LOCKED TO FREE MEMBERS

Purchase full membership to immediately unlock this page

Know Your Bible

Forgotten Books' Full Membership provides unlimited access to more than 28,000 volumes of Christian literature for \$8.99/month

HOLY BIBLE

Continue

*Fair use policy applies

I

I. H. P.—A contraction for indicated horse-power, or the horse-power of an engine as obtained by the means of an indicator card.

I. W. G.—A contraction for Indian wire gauge.

Idio-Electrics.—A name formerly applied to such bodies as amber, resin or glass, which are readily electrified by friction, and which were then supposed to be electric in themselves.

This distinction was based on an erroneous conception, and the word is now obsolete.

Idiostatic.—A term employed by Sir William Thomson to designate an electrometer in which the measurement is effected by determining the repulsion between the charge to be measured and that of a charge of the same sign imparted to the instrument from an independent source. (See *Heterostatic*.)

Idle Poles.—(See *Poles, Idle*.)

Igniter, Jablochhoff — — A small strip of carbon, or some carbonaceous material that is readily rendered incandescent by the current, placed between the free ends of the parallel carbons of a Jablochhoff candle, for the establishment of the arc on the passage of the current.

The igniter is necessary in the Jablochhoff electric candle, since the parallel carbons are rigidly kept at a constant distance apart by the insulating material placed between them, and cannot therefore be moved together as in the case of the ordinary lamp. (See *Candle, Jablochhoff*.)

Ignition, Electric — — The ignition of a combustible material by heat of electric origin.

The electric ignition of wires is generally accomplished by electric incandescence. Ignition may be accomplished by the heat of the voltaic arc. (See *Heat, Electric. Furnace, Electric*.)

The ignition of combustible gases is accomplished by the heat of the electric spark. (See *Burner, Automatic, Electric*.)

Illumination, Artificial — — The employment of artificial sources of light.

A good artificial illuminant should possess the following properties, viz.:

(1.) It should give a general or uniform illumination as distinguished from sharply marked regions of light and shadow.

To this end a number of small lights well distributed are preferable to a few large lights.

(2.) It should give a steady light, uniform in brilliancy, as distinguished from a flickering, unsteady light. Sudden changes in the intensity of a light injure the eyes and prevent distinct vision.

(3.) It should be economical, or not cost too much to produce.

(4.) It should be safe, or not likely to cause loss of life or property. To this intent it should, if possible, be inclosed in or surrounded by a lantern or chamber of some incombustible material, and should preferably be lighted at a distance.

(5.) It should not give off noxious fumes or vapors when in use, nor should it unduly heat the air of the space it illumines.

(6.) It should be reliable, or not apt to be unexpectedly extinguished when once lighted.

The electric incandescent lamp is an excellent artificial illuminant.

(1.) It is capable of great subdivision, and can, therefore, produce a uniform illumination.

(2.) It is steady and free from sudden changes in its intensity.

(3.) It compares favorably in point of economy with coal oil or gas, provided its extent of use is sufficiently great.

(4.) It is safer than any known illuminant, since it can be entirely inclosed and can be lighted from a distance or at the burner without the dangerous friction match.

The leads, however, must be carefully insulated and protected by safety fuses. (See *Fuse, Safety*.)

(5.) It gives off no gases, and produces far less heat than a gas-burner of the same candle power.

It perplexes many people to understand why the incandescent electric light should not heat the air of a room as much as a gas light, since it is quite as hot as the gas light. It must be remembered, however, that a gas-burner, when lighted, not only permits the same quantity of

gas to enter the room which would enter it if the gas were simply turned on and not lighted, but that this bulk of gas is still given off, and is, indeed, considerably increased by the combination of the illuminating gas with the oxygen of the atmosphere; and, moreover, this great bulk of gas escapes as highly heated gases. Such gases are entirely absent in the incandescent electric light, and consequently its power of heating the surrounding air is much less than that of gas lights.

(6.) It is quite reliable, and will continue to burn as long as the current is supplied to it.

Illumination, Lighthouse, Electric — —The application of the electric arc light to lighthouses.

A powerful arc light is placed in the focus of the dioptric lens now commonly employed in lighthouses. Since the consumption of the carbon electrodes would alter the position of the focus of the light, electric lamps for such purposes are constructed to feed both of their carbons, instead of the upper carbon only, as in the case of the ordinary arc lamp. Such lamps are called focusing lamps.

Illumination, Unit of — —A standard of illumination proposed by Preece, equal to the illumination given by a standard candle at the distance of 12.7 inches.

According to Preece, the illumination of the average streets of London, where gas is employed, is equal to about one-tenth of this standard in the neighborhood of a gas lamp, and about one-fiftieth in the middle space between two lamps.

The term unit of illumination, in place of intensity of light, was proposed by Preece in order to avoid the very great difficulty in determining the intensity of a light in a street or space where there were a number of luminous sources, and where the directions of incidence of the different lights vary so greatly.

A carcel standard at the distance of a metre will illumine a surface to the same intensity of illumination as a standard candle at the distance of 12.7 inches. (See *Candle, Foot.*)

Illumined Electrode.—(See *Electrode, Illumined.*)

Imbibition Currents.—(See *Currents, Imbibition.*)

Images, Electric — —A term some-

times applied to the charge produced on a neighboring surface by induction from a known charge.

A positive charge produces, by induction, on a flat metallic surface near it, a negative charge which is distributed with varying density over the surface, but acts electrically as would an equal quantity of negative electricity placed back of the plate at the same distance the positive charge is in front of it. The correspondence of this charge with the image of an object seen in a plane mirror, has led to the term electric image.

Maxwell defines electric image as follows: "An electric image is an electrified point, or system of points, on one side of a surface, which would produce, on the other side of that surface, the same electrical action which the actual electrification of the surface really does produce."

Impedance.—Generally any opposition to current flow.

The sum of the ohmic resistance and the spurious resistance of a circuit measured in ohms.

A quantity which is related to the strength of the impressed electromotive force of a simple periodic or alternating current, in the same manner that resistance is related to the steady electromotive force of a continuous current.

In the case of steady currents, the current strength is equal to the electromotive force divided by the resistance; or,

$$\text{Current strength} = \frac{\text{Electromotive force}}{\text{Resistance.}}$$

In the case of a simple periodic or alternating current, the average current strength is equal to the average impressed electromotive force divided by the impedance; or,

$$\text{Average current strength} = \frac{\text{Average impressed electromotive force}}{\text{Impedance.}}$$

Since impedance, like true resistance of the circuit, can be measured in ohms, it is sometimes called the virtual resistance.

Impedance is a quantity equal to the square root of the sum of the squares of the inductive resistance of the circuit and the ohmic resistance.

In the case of simple periodic or alternating currents, the average current strength is equal to the average impressed electromotive force, divided by the impedance; the maximum current strength

is equal to the maximum impressed electromotive force, divided by the impedance.

The impedance of a circuit can be represented geometrically as follows: Draw a right angled triangle (Fig. 296), the base of which represents the ohmic resistance of the circuit, and the perpendicular, the inductive resistance; then the hypotenuse will represent the impedance.

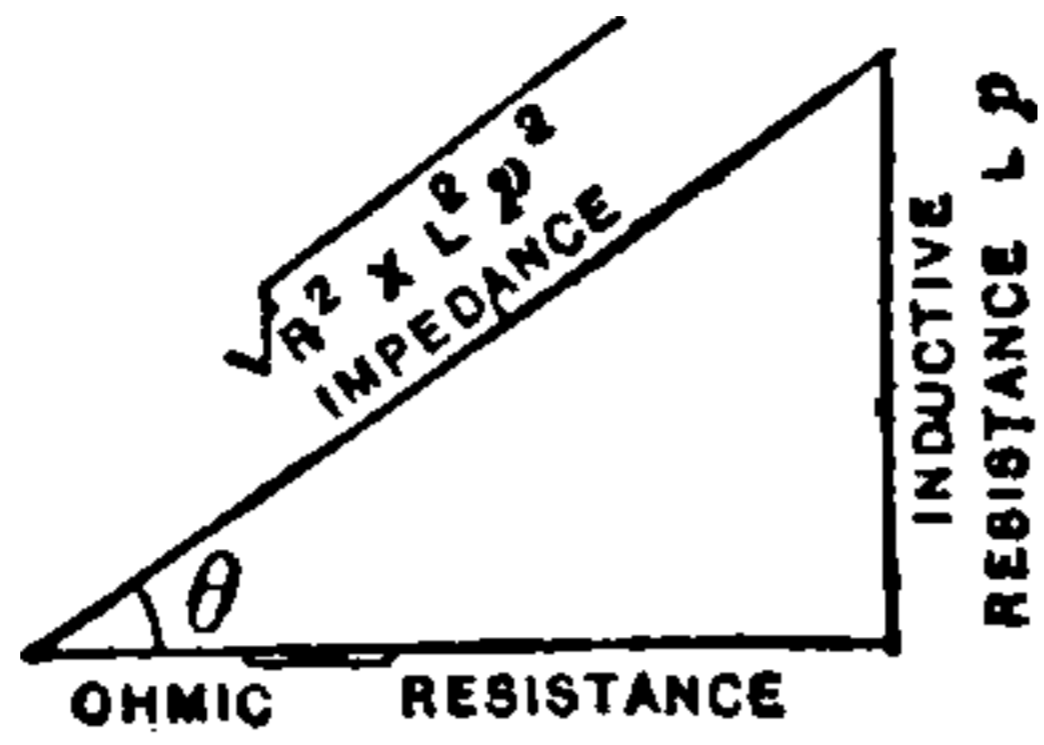

Fig. 296. Geometrical Representation of Impedance.

Since the ohmic resistance equals R , and the inductive resistance equals the inductance L , multiplied by $2\pi n$, in which n , is the frequency, the value of the impedance is equal to

$$\sqrt{R^2 + 4\pi^2 n^2 L^2}.$$

Impedance Coil.—(See *Coil, Impedance*.)

Impedance, Impulsive or Oscillatory

—The impedance which a conductor offers to an impulsive or oscillatory discharge.

The impulsive impedance varies in simple proportion to the frequency of the periodic current. It depends on the form and size of the circuit, but it is independent of its resistance or permeability.

Imponderable.—That which possesses no weight.

A term formerly applied to the luminiferous or universal ether, but now generally abandoned.

It is very questionable whether it is possible for any form of matter to be actually imponderable or to possess no attraction for other matter.

An imponderable fluid, as, for example, the universal ether, as the term is now generally employed, is a fluid whose weight is comparatively small and insignificant, and not a fluid an infinite quantity of which would be entirely devoid of weight.

Impressed Electromotive Force.—(See *Force, Electromotive, Impressed*.)

Impulse, Electro-Magnetic — —An impulse produced in the ether surrounding a conductor by the action of an impulsive discharge, or by a pulsating field.

Impulse, Electromotive — —An impulse producing an impulsive rush of electricity.

The term is employed to distinguish between the ordinary electromotive force which produces a steady current of electricity and an electromotive impulse which produces an impulsive rush of electricity or impulsive discharge.

Impulsion Cell.—(See *Cell, Impulsion*.)

Impulsion Effect.—(See *Effect, Impulsion*.)

Impulsive Impedance.—(See *Impedance, Impulsive or Oscillatory*.)

Incandescence.—To shine or glow by means of heat.

Incandescence.—The shining or glowing of a substance, generally a solid, by reason of a sufficiently high temperature.

Incandescence, Electric — —The shining or glowing of a substance, generally a solid, by means of heat of electric origin.

Electric incandescence of solid substances differs from ordinary incandescence, in the fact that unless the substance is electrically homogeneous throughout, the temperature is not uniform in all parts, but is highest in those portions where the resistance is highest and the radiation smallest.

The deposition of carbon in and on a carbon conductor by the *flashing process* is quite different as performed by electrical incandescence, than it would be if the carbons were heated by ordinary furnace or other heat. (See *Carbons, Flashing Process for*.)

Incandescence, Thermal — —The shining or glowing of a substance, generally a solid, by means of heat other than that of electric origin.

Incandescent.—Shining or glowing with heat.

Incandescent Ball Electric Lamp.—(See *Lamp, Electric, Incandescent Ball*.)

Incandescent Electric Lamp, Life Curve of — —(See *Curve, Life, of Incandescent Lamp*.)

Incandescent Electric Lamp, Life of — —(See *Lamp, Electric, Incandescent, Life of*.)

Incandescent Straight Filament Lamp.—(See *Lamp, Incandescent, Straight Filament*.)

THIS PAGE IS LOCKED TO FREE MEMBERS

Purchase full membership to immediately unlock this page



HISTORY

Tens of thousands of important historical sources, many previously unobtainable, are now available for the first time with a Forgotten Books Full Membership.

Unlimited Access
\$8.99/month

Continue

*Fair usage policy applies

manner, the opening of the throttle sets the indicator needle to "ahead," etc.

Indicator, Electric Throwback — — An annunciator with a drop that is electrically replaced. (See *Annunciator, Electro-Magnetic.*)

Indicator, Lamp — — An apparatus used in the central station of a system of incandescent lamp distribution to indicate the presence of the proper voltage or potential difference on the mains.

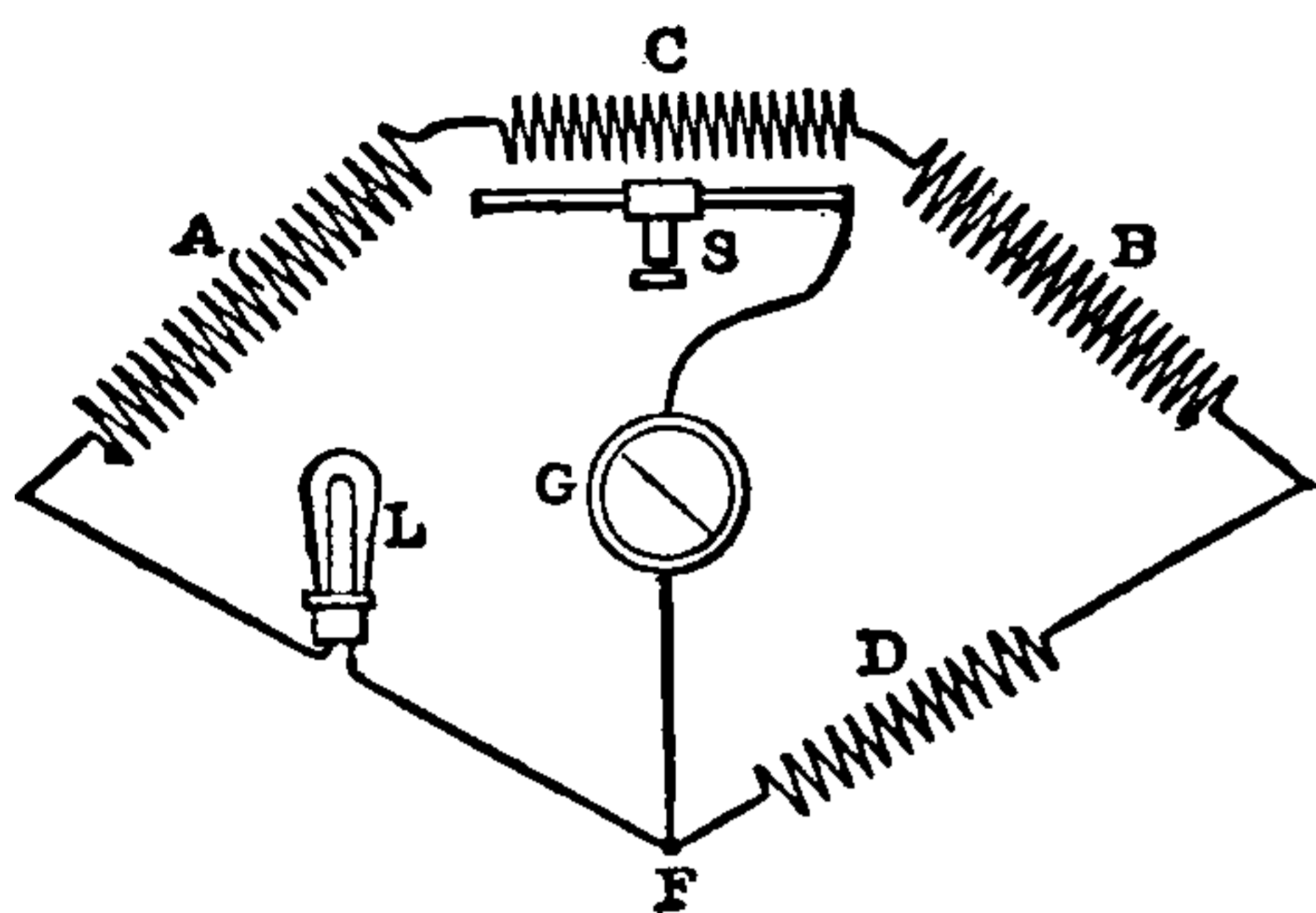

Fig. 297. Edison-Howell Lamp Indicator.

The lamp indicator of Edison and Howell is shown in Fig. 297. It consists essentially of a Wheatstone bridge with the resistances arranged as shown. A galvanometer at G, serves, by the movements of its magnetic needle, to act as an indicator. This needle remains at zero, when the potential difference is the exact voltage required on the circuit with which the indicator is connected. The incandescent lamp at L, being one of the resistances, and being constantly traversed by the current, will have a fixed resistance for the temperature at which it is designed to run. The other resistances are so proportioned as to insure the needle at G, remaining at zero. If, however, the potential varies, the temperature of the lamp L, varies, and, being carbon, its resistance also varies, a rise of temperature corresponding to a fall of lamp resistance, which destroys the balance of the bridge and deflects the galvanometer needle. The attendant then regulates the potential to bring the needle back to zero.

Indicator, Mechanical Throwback — — An annunciator with a mechanical drop. (See *Annunciator, Electro-Magnetic. Annunciator, Drop. Annunciator, Gravity.*)

Indicator, Pendulum — — An annunciator, the indicating arm of which is operated

by means of a pendulum. (See *Annunciator, Pendulum.*)

Indicator, Potential — — An apparatus for indicating the potential difference between any points of a circuit.

A voltmeter is a potential indicator. It is, however, more than an indicator, since it gives the value of the potential difference in volts. (See *Voltmeter.*) A lamp indicator is a potential indicator. (See *Indicator, Lamp.*)

Indicator, Semaphore — — An annunciator in which a gravity drop or shutter is caused to fall by the action of the electric current, thus exposing a number of other signals back of the drop or shutter.

Indicator, Speed — — A name sometimes applied to a tachometer. (See *Tachometer.*)

A form of speed indicator is shown in Fig. 298. The endless screw drives the wheel when the triangular point is held firmly against the centre of the revolving shaft or pulley.

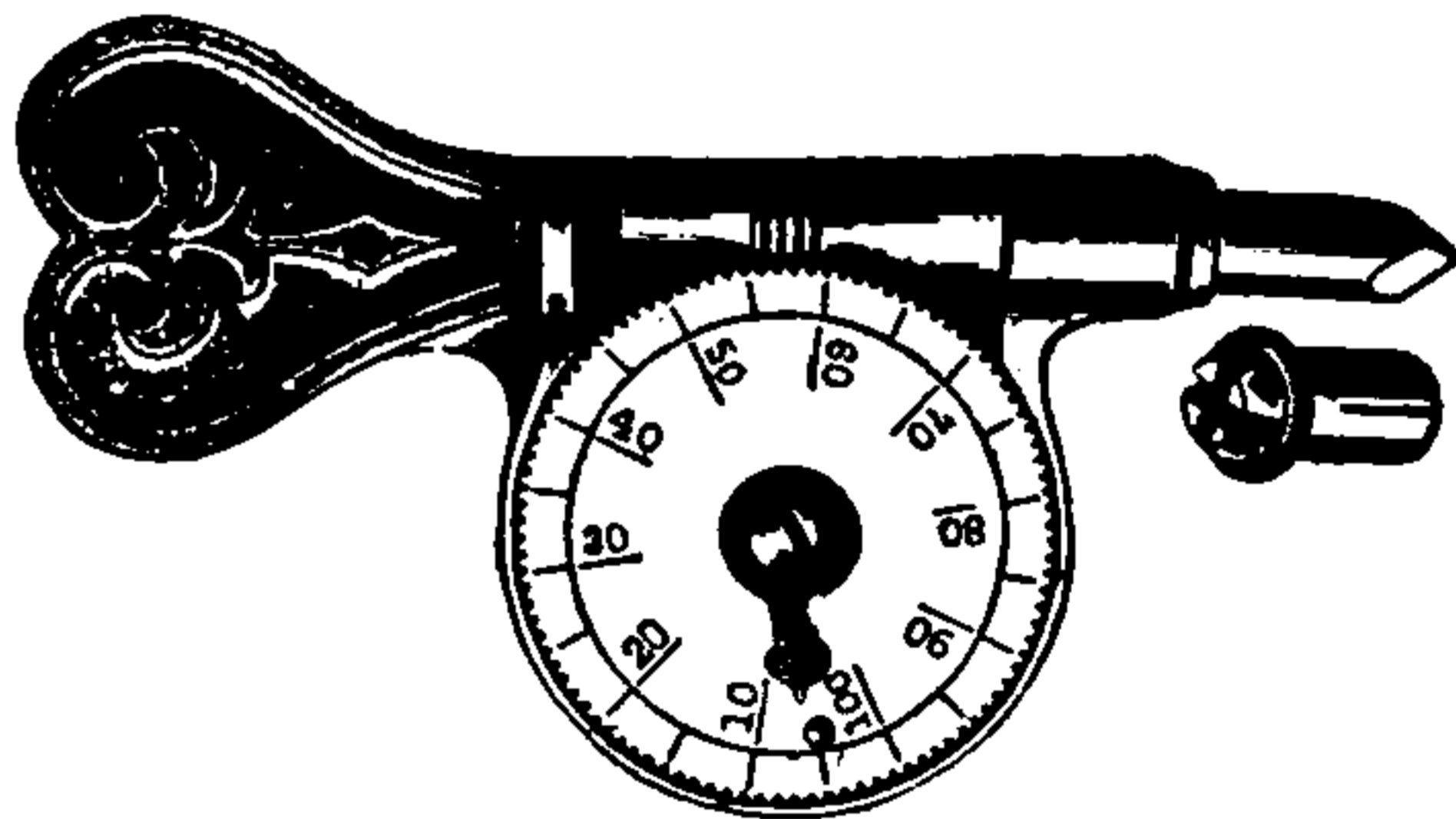

Fig. 298. Speed Indicator.

Indicator, Voltaic Battery — — A device for indicating the condition of a voltaic battery.

Indifferent Point.—(See *Point, Indifferent.*)

Indirect Excitation.—(See *Excitation, Indirect.*)

Induced Atomic Currents.—(See *Currents, Induced, Atomic or Molecular.*)

Induced Current.—(See *Current, Induced.*)

Induced Direct Current.—(See *Current, Direct, Induced.*)

Induced Electrostatic Charge.—(See *Charge, Induced Electrostatic.*)

Induced Molecular Currents.—(See *Currents, Induced Molecular.*)

Induced Reverse Currents.—(See *Current, Reverse, Induced.*)

Inductance — — —The induction of a circuit on itself, or on other circuits.

Self-induction.

A term now generally employed instead of self-induction.

That property in virtue of which a finite electromotive force, acting on a circuit, does not immediately generate the full current due to its resistance, and when the electromotive force is withdrawn, time is required for the current strength to fall to zero.—(*Fleming.*)

A quality by virtue of which the passage of an electric current is necessarily accompanied by the absorption of electric energy in the formation of a magnetic field.

The inductance of a circuit depends:

(1.) On the form or shape of the circuit.

(2.) On the magnetic permeability of the space surrounding the circuit.

(3.) On the magnetic permeability of the circuit itself.

For the variations of current strength in electric circuits, inductance is not unlike mass, or moment of inertia, as regards variations of velocity. Time is required to produce velocity in a heavy body by the action of any force; so also time is required to produce a current by the action of an electromotive force.

The electro-magnetic energy present in any given current is equal to the square of the current multiplied by the inductance. Since one of these factors (the current strength) represents the force, the other, the inductance, must have the dimension of a distance or length. Inductance, therefore, is measurable in units of length. If the circuits are formed of magnetizable materials, the inductance of a circuit is the ratio between the total inductance taking place through the circuit to the current producing it.

If the circuit is formed entirely of non-magnetic material, surrounded entirely by materials of constant magnetic permeability (such as air, insulators and diamagnetic materials generally), the inductance is a constant quantity and depends only on the form or shape of the circuit. In this case, the total inductance through the circuit is proportional to the magnetizing force, and the magnetic resistance, or the magnetic conductance of the magnetic circuit, is equal to the total induc-

tion through the circuit, divided by the magnetizing force.

In cases where the magnetic circuit is partly or wholly of paramagnetic substances, where the induction bears no constant ratio to the magnetizing force, and where the induction takes place partly or wholly in media of variable permeability, the co-efficient of self-induction, or the inductance, must be defined in three ways:

(1.) As the ratio between the counter electromotive force in any circuit and the time rate of variation of the current producing it.

(2.) As the ratio between the total induction through the circuit and the current producing it.

(3.) As the energy associated with the circuit in the form of magnetic field, due to unit current in that circuit, or as the co-efficient by which half the square of the current must be multiplied to obtain the electro-kinetic energy of the circuit at that instant.—(*Fleming.*)

A flat sheet or strip of metal possesses less inductance than a round conductor of equal cross-section.

This may be explained by conceiving that a flat conductor presents a greater absorption surface to the dielectric.

Therefore, the perfect form for a conductor transmitting rapidly alternating currents is that of a flat sheet or strip of copper, or preferably a copper tube.

The experiments of Hughes show that the inductance of a conductor may be regarded as an effect due to the time required for the rapidly periodic current to penetrate the conductor, and that the decrease in the inductance, produced by forming the conductor of a strip or bar, is due to the decreased distance the current has to pass to the inner parts.

Inductance, Absolute Unit of — — —A unit of length equal to one centimetre.

A length equal to an earth quadrant or 10^9 centimetres is called the practical unit of inductance. The practical unit of inductance was formerly called a secohm or quadrant. It is now generally called a henry. (See *Henry, A.*)

Inductance Bridge.—(See *Bridge, Inductance.*)

Inductance, Co-efficient of — — —A constant quantity, such that when multiplied by the current strength passing in any coil or circuit, will represent numerically the induction through the coil or circuit due to that current.

A term sometimes used for co-efficient of self-induction. (See *Induction, Co-efficient of*.)

Inductance, Constant — —The inductance which occurs in circuits formed wholly of non-magnetic materials, immersed in or surrounded by media of constant magnetic permeability or magnetic conductance for lines of magnetic force. (See *Permeability, Magnetic*.)

When the lines of magnetic force pass through such materials as ordinary insulators, or diamagnetic materials, such as copper, the inductance is constant, provided the geometric form of the circuit remains the same.

Inductance, Formal, of Circuit — — That part of the counter electromotive force of a circuit which depends on the form of the circuit.

Inductance, or Self-Induction, Practical Unit of — —A length equal to the earth quadrant or 10^9 centimetres.

The absolute unit of inductance is equal to 1 centimetre.

Inductance, Oscillatory, Electric — — Inductance produced by electric oscillations.

Inductance, Unit of — —A term now generally used for unit of self-induction.

The value of the inductance may be given either in absolute or in practical units of inductance. The absolute unit of inductance is equal to a length of one centimetre. The practical unit of inductance is equal to 1,000,000,000 centimetres or 10^9 centimetres.

The practical unit of inductance was formerly called a seohm. The term henry is generally used for this unit. (See *Henry, A.*)

Inductance, Variable — —The inductance which occurs in circuits formed partly or wholly of substances like iron or other paramagnetic substances, the magnetic permeability of which varies with the intensity of the magnetic induction, and where the lines of force have their circuit partly or wholly in such material of variable magnetic permeability.

Induction.—An influence exerted by a

charged body or by a magnetic field on neighboring bodies without apparent communication.

A medium is necessary to connect the body producing the induction and that in which the induction is produced. (See *Induction, Electrostatic. Induction, Magnetic. Induction, Electro-Dynamic*.)

Induction, Apparent Co-efficient of — —A term sometimes used for co-efficient of apparent magnetic induction. (See *Induction, Magnetic, Apparent Co-efficient of*.)

It is called the apparent co-efficient of induction because its value is different from what it would be if the eddy currents were entirely suppressed. The eddy currents increase the resistance of the primary and decrease its inductance.

Induction-Balance, Hughes' — —(See *Balance, Induction, Hughes'*.)

Induction, Balance of, in Cable — — The removal of induction in a cable by neutralization by the presence of equal and opposite effects.

A balance is obtained of the inductive effects of the neighboring conductors, whether in the bunched cable or outside of it.

Induction-Bridge.—(See *Bridge, Inductance*.)

Induction, Co-efficient of — —A term sometimes used for co-efficient of magnetic induction. (See *Induction, Magnetic, Co-efficient of*.)

Induction Coil.—(See *Coil, Induction*.)

Induction Coil, Inverted — —(See *Coil, Induction, Inverted. Transformer*.)

Induction, Current — —A term sometimes used for voltaic induction. (See *Induction, Voltaic. Induction, Electro-Dynamic*.)

Induction, Dissymmetrical, of Armature — —An induction produced by the passage of a different number of lines of magnetic force through adjoining halves of the armature.

Induction, Electro-Dynamic — —Electromotive forces set up by induction in conductors which are either actually or practically moved so as to cut the lines of magnetic force.

THIS PAGE IS LOCKED TO FREE MEMBERS

Purchase full membership to immediately unlock this page

Know Your Bible

Forgotten Books' Full Membership provides unlimited access to more than 28,000 volumes of Christian literature for \$8.99/month

HOLY BIBLE

Continue

*Fair use policy applies

decreasing the intensity of the current in the primary, an induced current will be set up in the secondary circuit in the same direction as the primary current.

From all of these phenomena, we see that any *increase* of current in a conductor produces in a neighboring conductor an *induced inverse* current; or one in the *opposite direction to the inducing current*, while a *decrease* of such current produces a *direct induced current*, or one in the *same direction as the inducing current*.

If the induction coil be made, as in Fig. 301, with its primary coil movable into and out of the secondary coil, then the following phenomena will occur:

(1.) When the primary coil is moved toward the secondary coil an *inverse* current is induced in the secondary; and,

(2) When the primary coil is moved away from the secondary coil a *direct* current is induced in the secondary.

The movements of permanent magnets towards or from a coil will also produce an induced current.

If, for example, the apparatus be arranged as in Fig. 302, then:

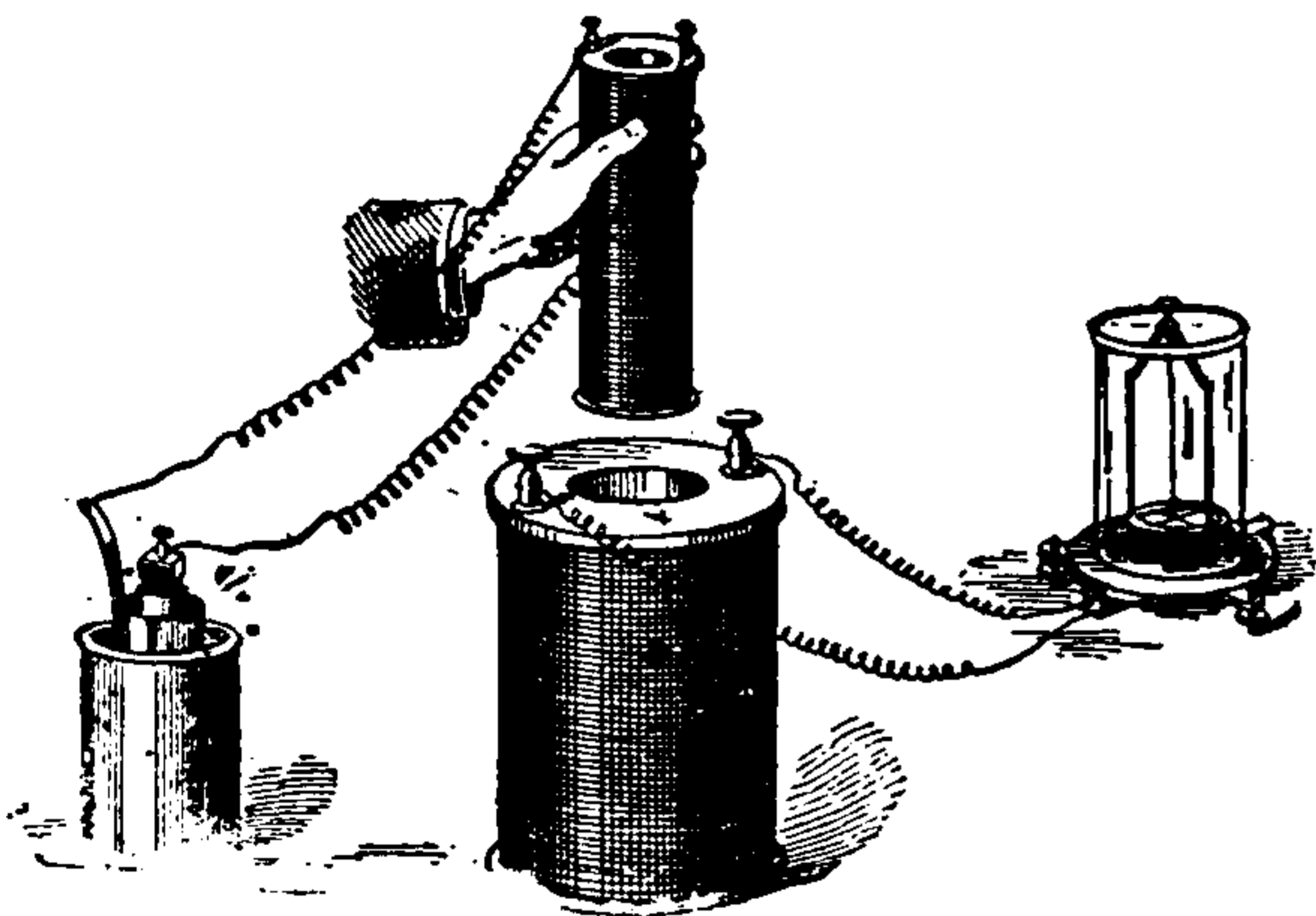

Fig. 301. Electro-Dynamic Induction.

(1.) A motion of the magnet towards the coil produces an induced current in the coil in one direction, and

(2.) Its motion away from the magnet produces an induced current in the coil in the opposite direction.

The directions of these induced currents are respectively *inverse* and *direct* as compared with the direction of the ampèrian currents which are assumed to produce the magnetic poles of permanent magnets, or of the currents that actually produce electro-magnets. (See *Magnetism, Ampère's Theory of.*)

These facts may be expressed by the following laws :

(1.) Any *increase* in the number of lines of force

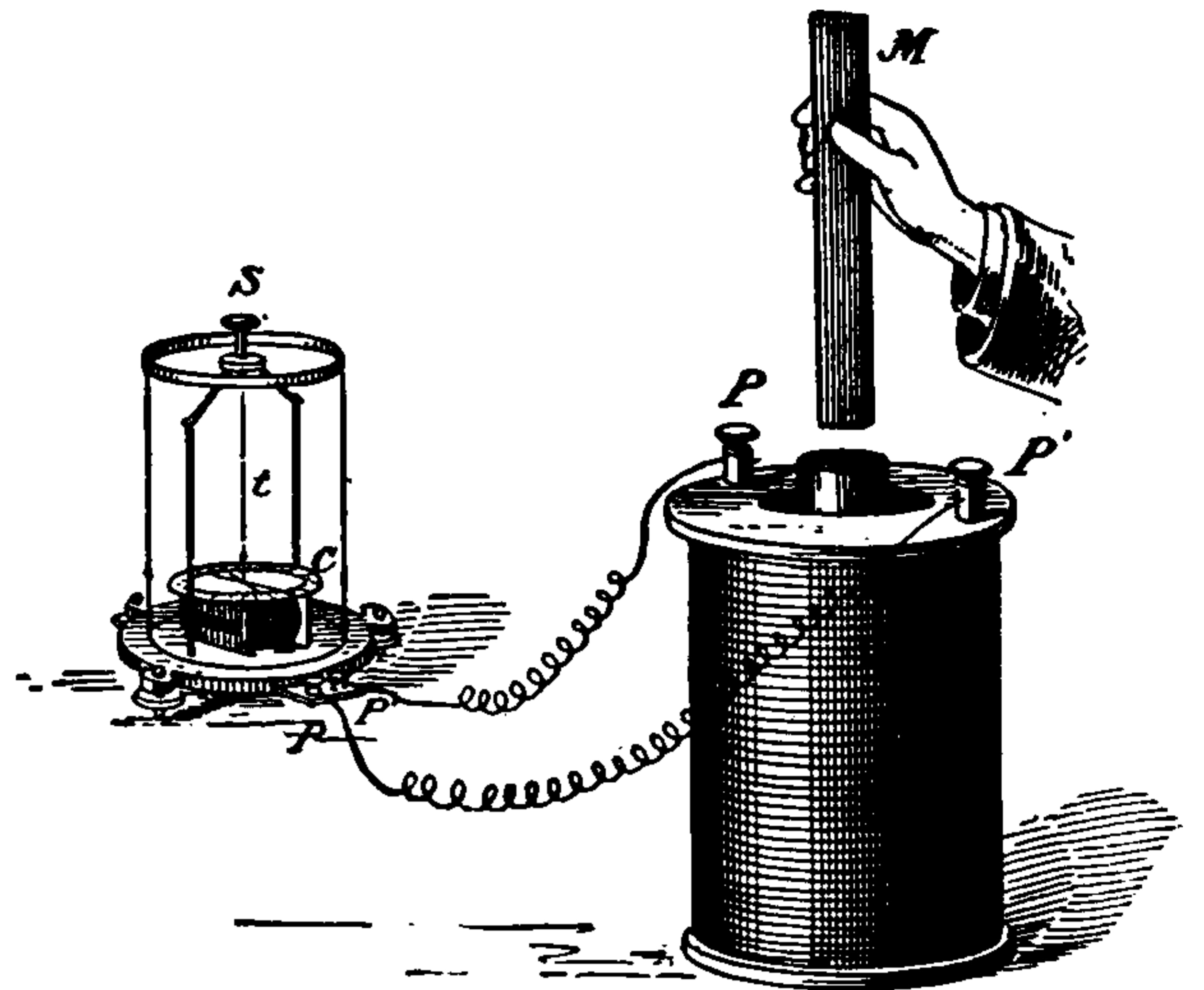

Fig. 302. Magneto-Electric Induction.

which pass through a circuit produces an *inverse* current in that circuit, while any *decrease* in the number of such lines of force which pass through any circuit produces a *direct* current in that circuit.

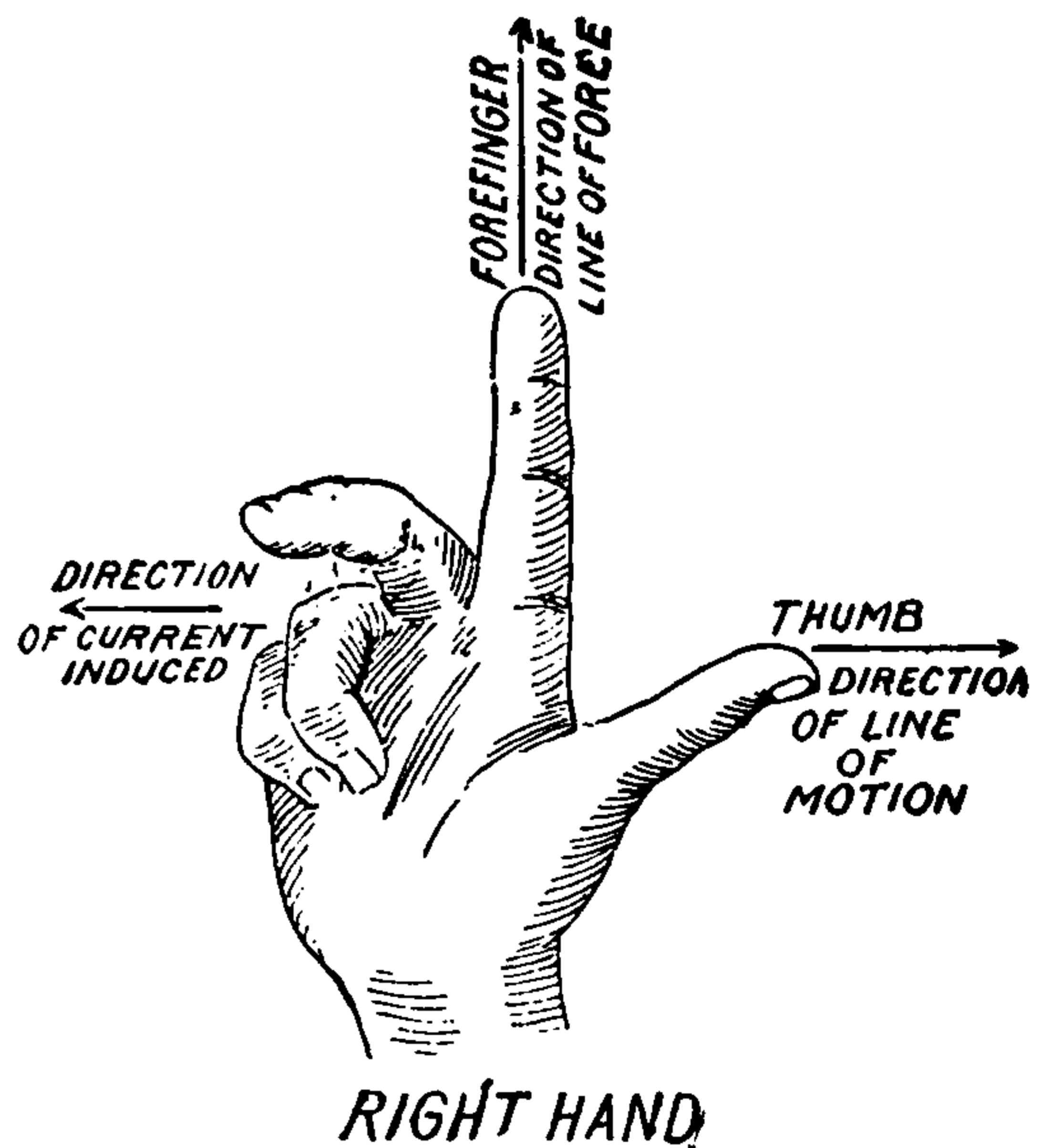

Fig. 303. Fleming's Rule.

(2.) The intensity of the induced current, or, more correctly, the *difference of potential* produced, is proportional to the rate of *increase* or *decrease* of the lines of force passing through the circuit.

A conductor, therefore, when moved through

a magnetic field so as to cut the lines of magnetic force, will have a difference of potential generated, and if its circuit is closed so that the difference of potential can neutralize itself, it will have a current produced in it by induction.

A simple but effective manner of remembering the direction of such currents is that proposed by Fleming.

If the hand be held with the fingers extended, as in Fig. 303, and the direction of the *forefinger* represent the positive direction of the lines of force, *i. e.*, those coming out of the N. pole of a magnet, then, if a wire or other conductor be moved in the direction in which the *thumb* points, so as to cut these lines of force at right angles, that is, if the conductor have its length moved directly across these lines, it will have an induced current developed in it in the direction in which the *middle finger* points. (See *Force, Lines of, Direction of.*)

Or, the same thing can, perhaps, be even more readily remembered by cutting a piece of paper in the shape shown in Fig. 304, marking it as shown, and then bending the arm P, upward at the dotted line, so as to form three axes at right angles to one another.

As has been already remarked, a *difference of potential*, and not a current, is produced by moving a conductor through a magnetic field so as to cut its lines of force.

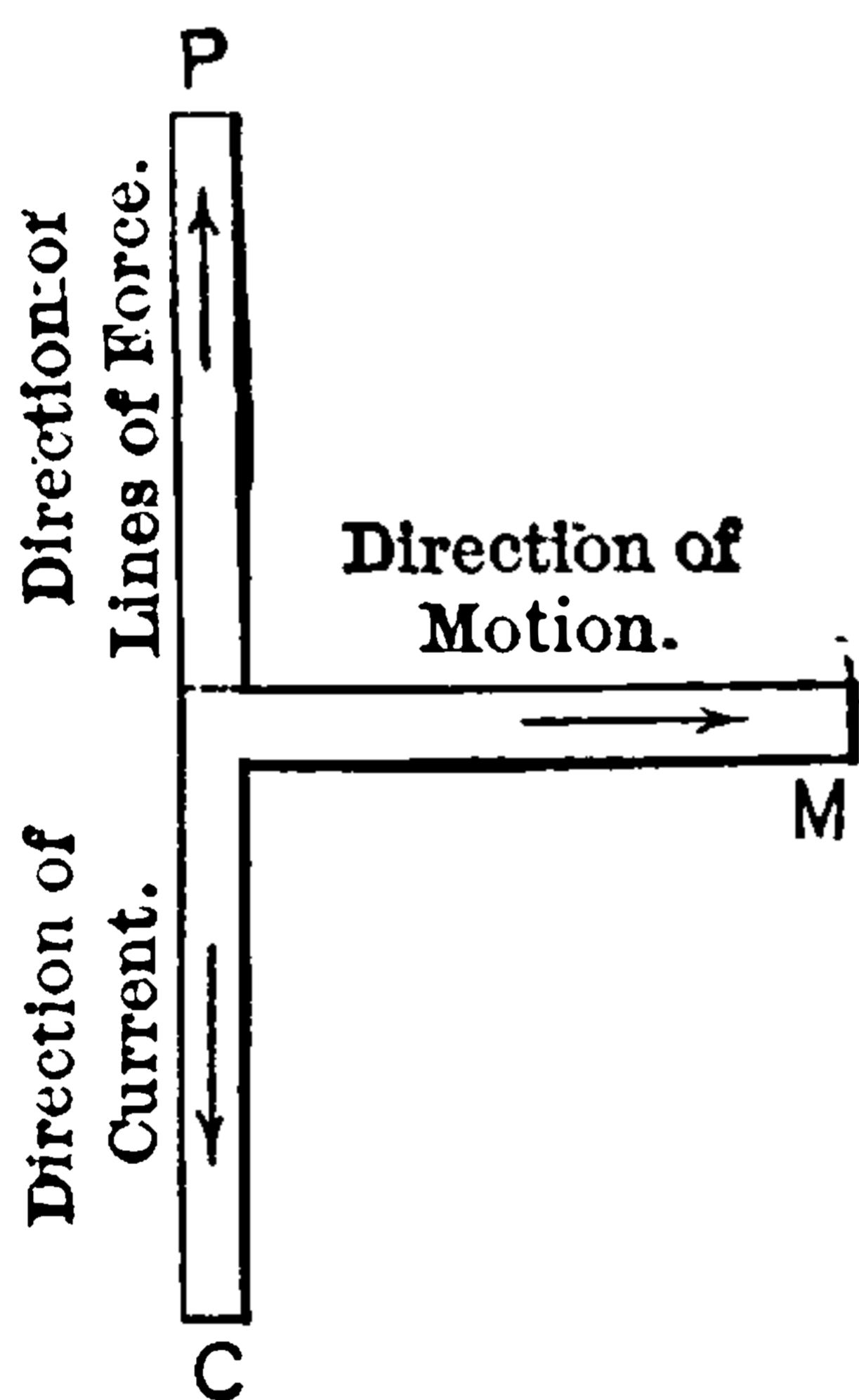

Fig. 304. Fleming's Rule.

It can be shown that in order to generate a difference of potential of *one volt*, 100,000,000 C. G. S. lines of force must be cut per second.

In electro-dynamic induction, the induced current is produced by the energy absorbed in moving the conductor through the magnetic field. Lenz has shown that in all cases of electro-dynamic induction, produced by the movement either of the circuit or of the magnet, the current induced in the circuit is in such a direction as to produce a magnet pole which would tend to oppose the motion.

Induction, Electro-Magnetic — — A variety of electro-dynamic induction in which electric currents are produced by the motion

of electro-magnets or electro-magnetic solenoids. (See *Induction, Electro-Dynamic.*)

Induction, Electrostatic — — The production of an electric charge in a conductor brought into an electrostatic field.

If the insulated conductor A B, Fig. 305, be brought into the positive electrostatic field of the insulated conductor C, then,

(1.) A charge will be produced on A and B, as will be indicated by the divergence of the pith balls.

(2.) This charge is negative at the end A, nearest C, and positive at the end B, furthest from C, as can be shown by an *electroscope*. (See *Electroscope.*)

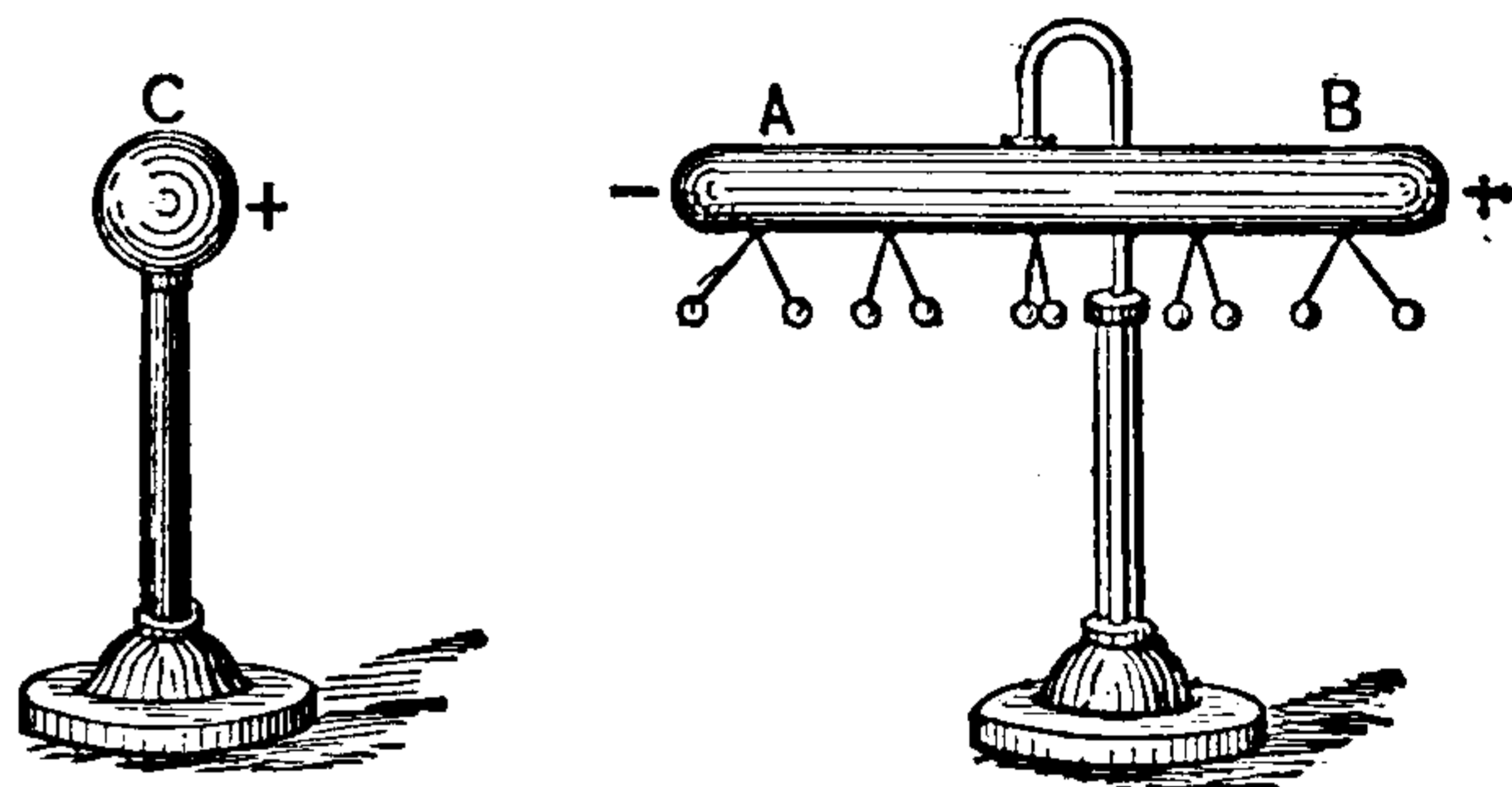

Fig. 305. Electrostatic Induction.

(3.) The charges at A and B, are equal to each other; for, if the conductor A B, be removed from the field of C, without touching it, the opposite charges completely neutralize each other.

(4.) If, however, the conductor A B, be touched at any place by a conductor connected with the earth, it will lose its positive charge, and will remain negatively charged when removed from the field of C. It is in this manner that an *electrophorus* is charged. (See *Electrophorus.*)

(5.) The amount of the charges produced in the conductor, A B, can never be greater than that in the inducing body C. That is to say, the

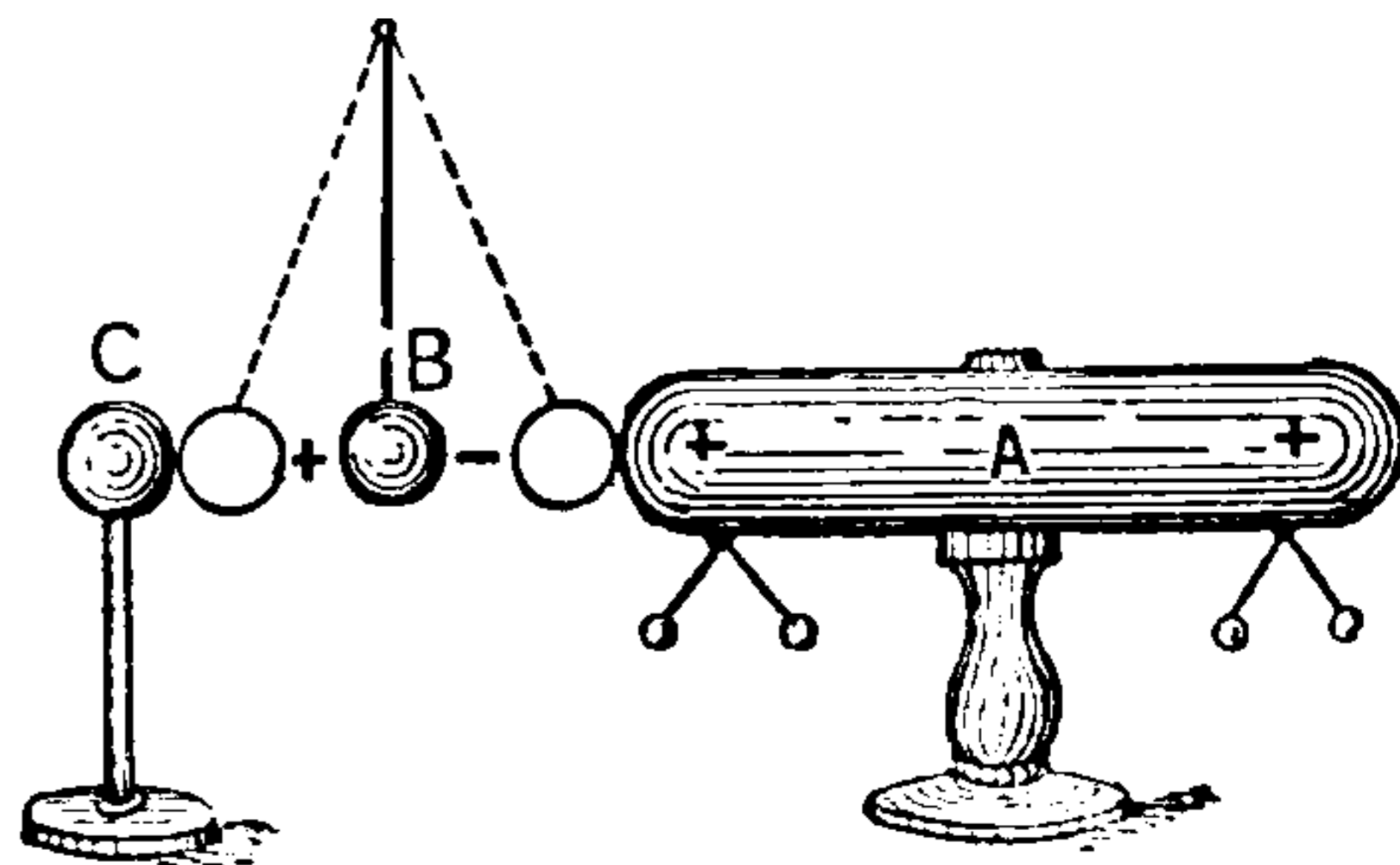

Fig. 306. Induction Precedes Attraction.

negative electricity at A, may be sufficient in amount to neutralize the positive charge on C, if allowed to do so. In point of fact the charge in-

duced is less in amount than the inducing charge, according to the distance between C and A, and the nature and condition of the medium which separates them.

The attractions of light bodies by charged surfaces are due to the opposite charge produced on those parts of the light bodies that are nearest the charged body.

The pith ball B, Fig. 306, suspended by a silk thread between an insulated positively charged conductor A, and the uninsulated conductor C, will receive by induction a negative charge on the side nearest A, and a positive charge on the side nearest C. It is therefore attracted to A, where, receiving a positive charge, it is repelled to C, where it is discharged and again assumes a vertical position. Induction again occurs, and consequent attraction and repulsion. These movements follow one another so long as a sufficient charge remains in A.

Induction, Faradic, Apparatus — —
(See *Apparatus, Faradic Induction.*)

Induction-Finder.—(See *Finder, Induction.*)

Induction, Lateral — — An induction observed between closely approached portions of a circuit through which an impulsive discharge, such as the disruptive discharge of a Leyden jar, is passed as a long spark, thereby making the resistance of the circuit high.

A long copper wire, bent in the form of a rectangle, has its free ends near their extremities bent so as to approach within half an inch of each other. One of the ends of the wire is provided with a metallic ball and the other end connected with the earth. If, now, a Leyden jar charge is passed through the wire by connecting the outer coating with the end of the earth-connected wire and holding the inside coating near the knob, a spark will pass through the half inch of space between the approached portions of the circuit.

This discharge is due to what was formerly called lateral induction. The discharge of a Leyden jar is an oscillatory discharge, and it passes through the intervening air space instead of through the conductor because the resistance of the latter to the rapid alternations produces a counter electromotive force which acts as a resistance whose value is greater than that of the air space itself. (See *Path, Alternative.*)

Induction, Magnetic — — The production of magnetism in a magnetizable substance by bringing it into a magnetic field.

Suppose a small portion of a magnetizable body is placed in a magnetic field produced in a gap separating two closely approximated poles. To simplify matters, suppose this small portion to be a free unit pole. It will be acted on by two forces:

(1.) The force due to the magnetic field.

(2.) The force due to the free magnetism, which appears at the surface of the gap or cut.

The force on the unit pole is compounded of these two separate forces, and is called the *magnetic induction* of the space. Magnetic induction is, therefore, strictly speaking, a quantity.

The direction of magnetic force and the magnetic induction are the same in an air space outside a magnet. Within a bar of iron or other paramagnetic material, under induction in a magnetic field, the magnetic force at any point is due not only to the external or original field, but also to the field produced by the polarity induced, which acts opposed to the magnetic force at points. Magnetic force and magnetic induction are identical only where there is no magnetism.—(*Fleming.*)

When a magnetizable body is brought into a magnetic field the following phenomena occur, viz.:

(1.) The lines of magnetic force pass through the body and are condensed upon it. (See *Field, Magnetic. Paramagnetic.*)

(2.) If the body is free to move around an axis, but is not free to move bodily towards the magnet pole, it will come to rest with its greatest extent or length in the direction of the lines of force; *i. e.*, in the direction in which it will offer the least resistance to the lines of force that thread through it.

(3.) The body will therefore become a magnet, its south pole being situated where the lines of force enter it and its north pole where they pass out from it. Since the lines of magnetic force are assumed to come out of the north pole of a magnet and to enter its south pole, if a magnetizable substance is brought near a north pole, the lines of force from that north pole will enter it at those parts nearest such north pole, thereby rendering such points south, and will pass out of its further end, which will thereby become north.

(4.) The intensity of the induced magnetism

THIS PAGE IS LOCKED TO FREE MEMBERS

Purchase full membership to immediately unlock this page



HISTORY

Tens of thousands of important historical sources, many previously unobtainable, are now available for the first time with a Forgotten Books Full Membership.

Unlimited Access
\$8.99/month

Continue

*Fair usage policy applies

induction which takes place in the field of a magnet whose field is stationary as regards the body in which induction is occurring.

The term static magnetic induction is used in contradistinction to dynamic magnetic induction which occurs in a moving field. (See *Induction, Electro-Dynamic.*)

Induction, Magnetic, Surface-Integral of — — A term employed in the same sense as the magnetic induction which takes place over a given area.

Induction, Magneto-Electric — — A variety of electro-dynamic induction in which electric currents are produced by the motion of permanent magnets, or of conductors past permanent magnets. (See *Induction, Electro-Dynamic.*)

Induction, Mutual — — Induction produced by two neighboring circuits on each other by the mutual interaction of their magnetic fields. (See *Induction, Electro-Dynamic. Currents, Extra.*)

Induction produced in neighboring charged conductors by the mutual interaction of their electrostatic fields. (See *Field, Electrostatic.*)

The mutual induction of two conductors or circuits, is equal to the ratio of the induction which takes place through one of the circuits, to the strength of current in the other circuit, which is producing the induction

Induction, Mutual, Co-efficient of — — The quantity which represents the number of lines of force which are common to or linked in with two circuits, which are producing mutual induction on each other.

The maximum value the co-efficient of mutual induction can have, is equal to the square root of the product of the inductance of the two circuits, or $\sqrt{L \times N}$, in which L and N, are the constant co-efficients of self-induction of the two circuits.

Induction, Mutual, Loops of — — Loops or lines of induction produced in any circuit by variations in the intensity of the current flowing in a neighboring circuit.

The lines of induction produced by a circuit, in which a current of electricity is flowing, are closed loops or circles surrounding the circuit once or more. The wire or circuit is formed by

coiling a conductor a number of times in a circular coil, and this circular coil is placed near another coil in which a varying current is flowing.

As the lines of induction grow or increase, they cut the circular coil, forming lines of induction in the shape of loops, a number of which pass around it. They are called loops of mutual induction.

Induction, Open-Circuit — — The induction produced in an open circuit by means of electric pulses in neighboring circuits.

The researches of Hertz have shown that when an impulsive discharge, or an oscillatory discharge, occurs, an induction occurs even in open-circuited conductors. He shows that these inductive effects are due to electro-magnetic waves or oscillations set up in the surrounding ether, which are propagated through free ether with the velocity of light. When these electro-magnetic waves or radiations impinge on any circuit, if its dimensions be such that sympathetic vibrations can be excited therein, such vibrations are set up and cause similar phenomena to those of the exciting cause, viz., oscillatory discharges or electro-magnetic vibrations. Hertz calls these sympathetic circuits, resonators, from their resemblance to acoustic resonators. (See *Resonators, Electric.*)

Induction, Oscillatory — — A name sometimes applied to open-circuit induction. (See *Induction, Open-Circuit.*)

Induction, Reflection of — — A term proposed by Fleming to express an action which resembles a reflection of inductive power.

The coils A and B, Fig. 308, are arranged as

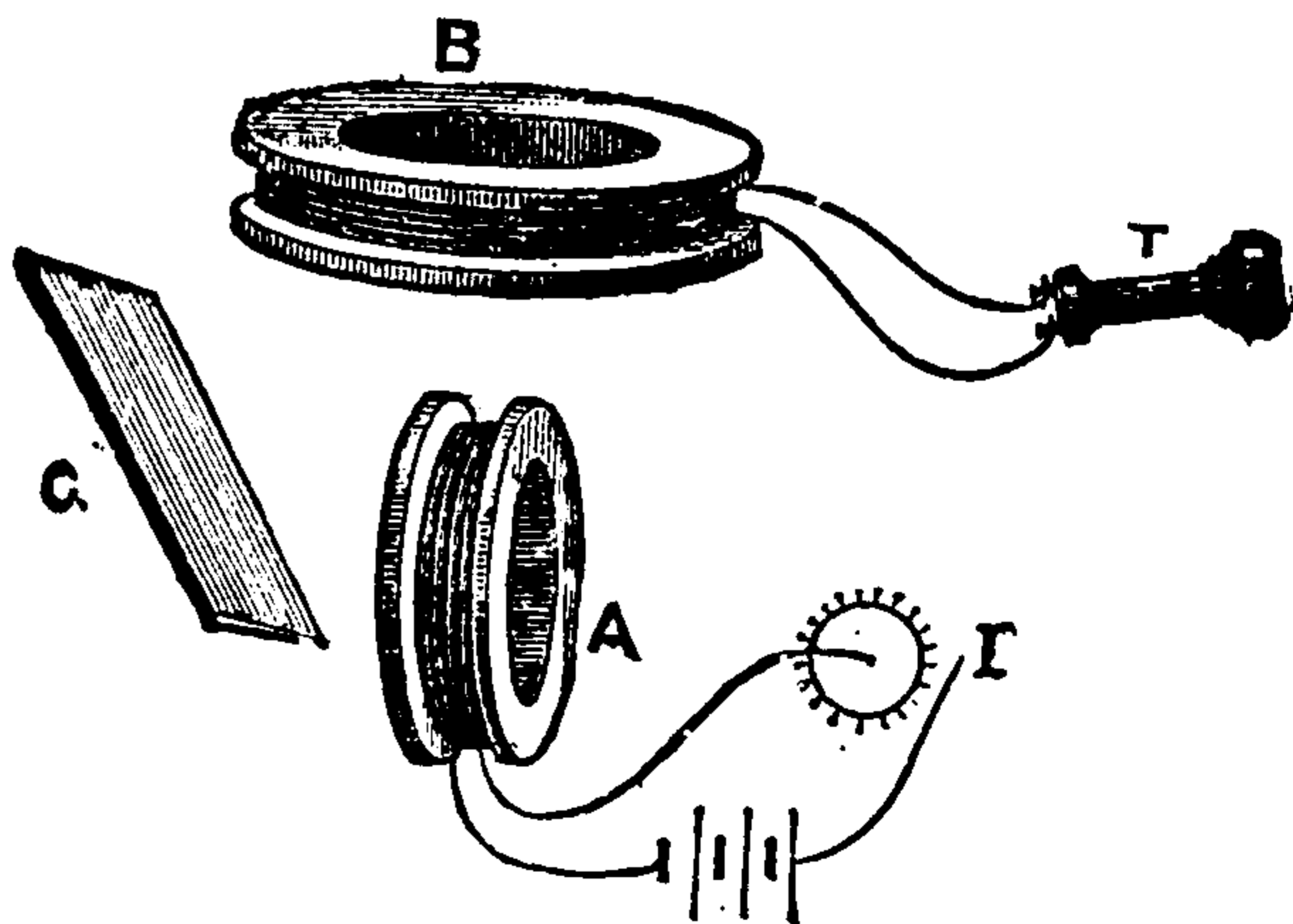

Fig. 308. Reflection of Induction.

shown, so as to act as the primary and secondary respectively of an induction coil, and are placed

conjugate or perpendicular to each other. (See *Coils, Conjugate*.) Therefore, no sounds are heard in the telephone T, when the current is rapidly reversed. If, however, a plate of copper, C, is placed in the position shown, then sounds are heard in the telephone. The action here resembles a reflection of the inductive action from A to B, by means of the plate C. The explanation is, of course, simple. Though A, can exert no action on B, because the two coils are conjugate to each other, yet A, can produce secondary currents in C; and these reacting on B, produce tertiary currents in C, and, therefore, sounds in the telephone.

Induction, Self — — Induction produced in a circuit at the moment of starting or stopping the currents therein by the induction of the current on itself. (See *Currents, Extra*.)

A coil having unit self-induction, is sometimes said to have one tube of induction, or line of force added to its field for each increase of one unit of current.

Induction, Self, Absolute Unit of — — A term sometimes employed for absolute unit of inductance. (See *Inductance, Absolute Unit of*.)

Induction, Self, Ayrton & Perry's Standard of — — A standard for the comparison of values of self-induction.

The standard of self-induction of Ayrton & Perry consists of three bobbins of wire, two fixed and one movable. The movable bobbin is so arranged as to be capable of motion through 180 degrees within the fixed bobbins. The coils are wound on the surface of the zone of a sphere.

This apparatus permits of the ready comparison of the self-induction in different circuits, or in the same circuit under different conditions.

Induction, Self, Co-efficient of — — The number of lines of force the current would induce or enclose in itself when the current flowing through it is equal to one absolute unit.

A term sometimes employed in the sense of inductance of a circuit.

The co-efficient of self-induction is defined by Fleming as follows: "In the case of circuits conveying electric currents, which are wholly made of non-magnetic material, and wholly immersed

in a medium of constant magnetic permeability, the total induction through the circuit per unit of current flowing in that circuit, when removed from the neighborhood of all other magnets and circuits, is called the co-efficient of self-induction; otherwise the ratio of the numerical values of the electro-magnetic momentum of such circuit, and the current flowing in it, when totally removed from all other currents and magnets, is the numerical value of the inductance of the circuit."

Since the magnetic lines due to a current in a circuit thread through the convolutions of the circuit itself, any variation in the current induces a difference of potential in the circuit itself, since the lines of force produced by the current in the circuit pass through or cut the circuit.

The ratio between this self-induced electromotive force, and the rate of change in the current which causes it, is called the co-efficient of self-induction.—(*S. P. Thompson*.)

For a given coil the co-efficient of self-induction is, according to S. P. Thompson:

(1.) Proportional to the square of the number of convolutions.

(2.) Is increased by the use of an iron core.

(3.) If the magnetic permeability is assumed as constant, the co-efficient of self-induction is numerically equal to the product of the number of lines of magnetic force due to the current, and the number of times they are enclosed by the circuit.

Induction, Self, Magnetic — — A retardation in the appearance of magnetization, after the application of the magnetizing force, due to the influence of the magnetic lag.

Magnetic retardation.

This retardation in the magnetization has received the name of magnetic self-induction or retardation because it corresponds to the retardation in the starting or stopping of a current, in a conducting circuit, due to the self-induction of the current.

Induction, Self, Unit of — — The unit of inductance. (See *Inductance, Unit of*.)

The unit of self-induction is now generally called the unit of inductance.

Induction, Symmetrical, of Armature — — An induction produced by the simultaneous passage of the same number of lines of magnetic force through adjoining halves of the armature.

Induction Telegraphy, Current Induction System of — — (See *Telegraphy, Induction, Current Induction System of.*)

Induction Telegraphy, Static Induction System of — — (See *Telegraphy, Induction, Static Induction System of.*)

Induction Top.—(See *Top, Induction.*)

Induction, Total Magnetic — — The total magnetic induction of any space is the number of lines of magnetic induction which pass through that space, where the magnetizable material is placed, together with the lines added by the magnetization of the magnetic material.

Induction, Tubes of — — A portion of a magnetic field containing a number of closely contiguous lines of induction terminated by equipotential surfaces, or surfaces perpendicular to the lines of induction.

Tubes of induction possess the following characteristics:

(1.) The product of a normal cross-section of a tube and the mean magnetic induction which takes place over that section is the same for all cross-sections of the tube. In other words, the flux or flow of induction is constant throughout the entire length of the tube.

(2.) The normal cross-section of any equipotential surface at any point of a tube of induction is inversely proportional to the magnetic induction at that point.

(3.) All tubes of induction form endless tubes. This is necessary, since all lines of induction form closed circuits.

(4.) All tubes of induction may be expressed by a single line of induction, which, in the case of a uniform field, occupies the centre of the tube. (See *Force, Tubes of.*)

Induction, Voltaic — — A variety of electro-dynamic induction produced by circuits on themselves or on neighboring circuits.

Mutual induction. (See *Induction, Electro-Dynamic.*)

This kind of induction is usually called current induction.

Induction, Unipolar — — A term sometimes applied to the induction that occurs when a conductor is so moved through a

magnetic field as to continuously cut its lines of force.

If the conducting wire, A B C, Fig. 309, be ro-

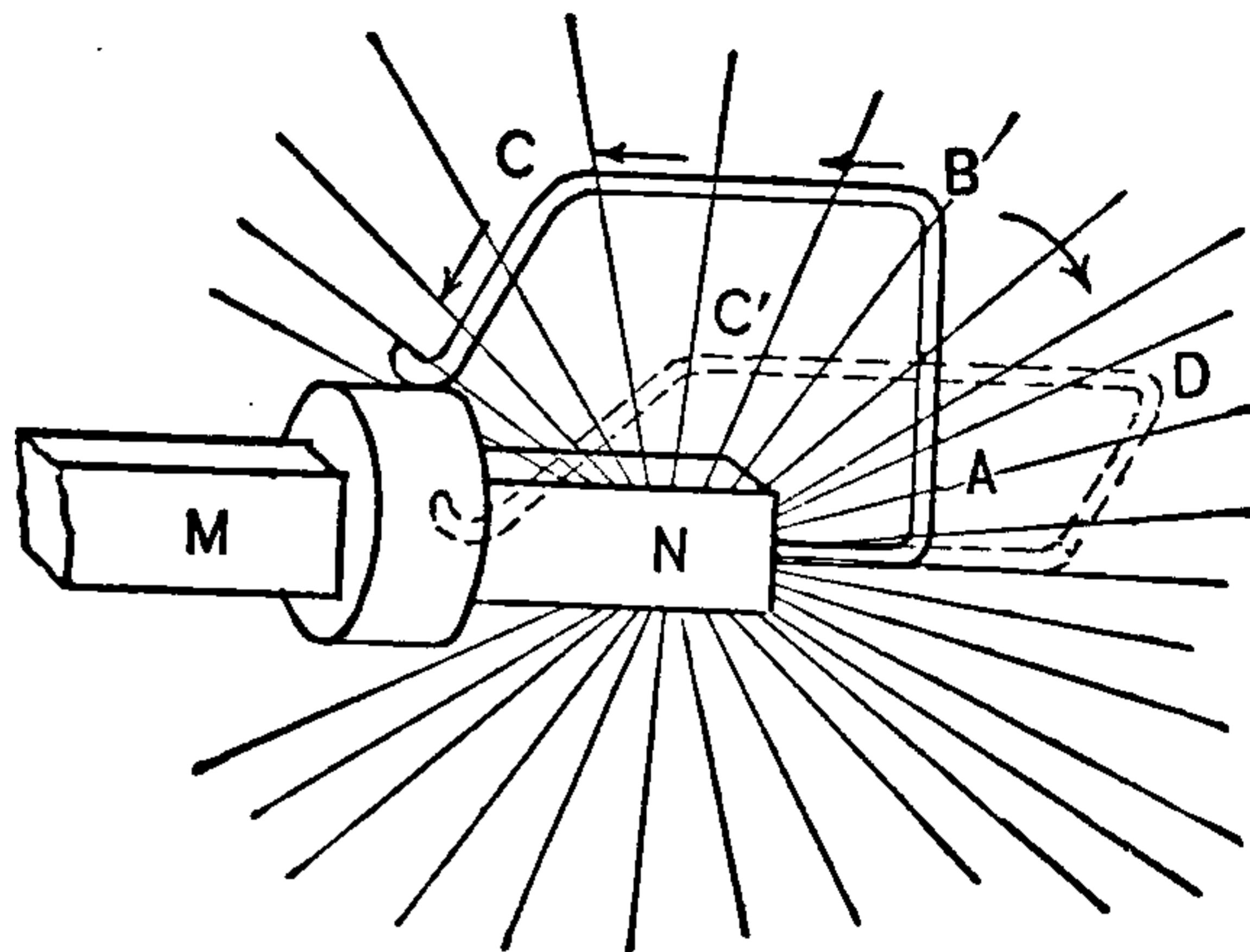

Fig. 309. Unipolar Induction.

tated (in a direction toward the observer) around the pole N, of a magnet, it will continuously cut its lines of magnetic force in practically the same direction, and will therefore produce a difference of potential that will result in a continuous current in the direction of the arrows. The end A, is supported in a recess in N, while the end near C, slides on a projection on the middle of the magnet.

Unipolar induction occurs in the case of Sturgeon's wheel, in which a metallic disc mounted on an axis is rotated between the poles of a magnet so as to cut the lines of magnetic force. In this case a difference of potential is generated which will produce a current that flows from the axis to the periphery, provided contact points are placed on the axis of rotation and the periphery of the disc connecting these parts of the disc in a closed circuit.

Unipolar dynamos operate by the continuous cutting of lines of magnetic force.

Strictly speaking, there is no such thing as a unipolar dynamo or unipolar induction, since a single magnetic pole cannot exist by itself. Continuous cutting of lines of magnetic force, however, can exist, and produces, unlike the ordinary bipolar induction, a continuous current without the use of a commutator.

Inductionless Resistance. — (See *Resistance, Inductionless.*)

Inductive Capacity, Specific — — (See *Capacity, Specific Inductive.*)

Inductive Circuit.—(See *Circuit, Inductive.*)

THIS PAGE IS LOCKED TO FREE MEMBERS

Purchase full membership to immediately unlock this page

Know Your Bible

Forgotten Books' Full Membership provides unlimited access to more than 28,000 volumes of Christian literature for \$8.99/month

HOLY BIBLE

Continue

*Fair use policy applies

A term employed to indicate the tendency of a current to resist its stopping or starting.

By self-induction an electromotive force is produced in a wire or other conductor at the moment of starting the current in it that tends to oppose the starting of such current, and also an electromotive force at the moment of stopping the current, in such a direction as to prolong or continue the current. In other words, self-induction tends to retard the rise or fall of the current.

Fleming traces the following comparison between the moment of inertia of a rotating wheel and the energy of its rotation on the one side, and the inductance of a circuit and the electro-magnetic energy of the circuit on the other.

(1.) The angular momentum of a fly-wheel is equal to the numerical product of its moment of inertia and the angular velocity of the wheel. Similarly the electro-magnetic momentum is equal to the product of the inductance of the circuit by the current flowing through it at any instant.

(2.) The rate of change of the angular momentum of the wheel, at any instant, is a measure of the rotational force of the couple acting at that instant.

Similarly the rate of change of the electro-magnetic momentum of the circuit is the measure of the electromotive force acting on it so far as mere change of current is concerned, and irrespective of that part of the electromotive force required to overcome the ohmic resistance.

An electric current does not start or stop instantaneously. It requires time to do either, just as a stream of water or other fluid does, and it is this property which is referred to by the term electric inertia. Inertia does not appear to be possessed by electricity apart from matter. "It is doubtful," says Lodge, "whether electricity of itself, and disconnected from matter, has any inertia."

Inertia, Electro-Magnetic — — A term sometimes employed instead of inductance, or the self-induction of a current. (See *Inductance. Inertia, Electric.*)

Inertia, Electro-Magnetic, Co-efficient of — — A term sometimes employed in place of the co-efficient of inductance or self-inductance of a circuit.

Inertia, Magnetic — — The inability of a magnetic core to instantly lose or acquire magnetism.

A magnet core tends to continue in the magnetic state in which it was placed.

The magnetic inertia is sometimes called the magnetic lag.

To decrease the magnetic inertia, the strength of the magnetizing current is increased and the length of the iron core decreased. The iron should also be quite soft. (See *Lag, Magnetic. Force, Coercive.*)

Inferred Zero.—(See *Zero, Inferred.*)

Infinity Plug.—(See *Plug, Infinity.*)

Influence.—A term sometimes used instead of electrostatic induction. (See *Induction, Electrostatic.*)

The word influence is used by some to apply to the case of electrostatic induction, as distinguished from electro-magnetic or magnetic induction.

Influence Charge.—(See *Charge, Influence.*)

Influence Machine.—(See *Machine, Influence.*)

Inker, Morse — — A form of telegraphic ink-writer. (See *Ink-Writer, Telegraphic.*)

Ink-Writer, Telegraphic — — A device employed for recording the dots and dashes of a telegraphic message in ink on a fillet or strip of paper.

A telegraphic ink-writer is a form of telegraphic recorder. (See *Recorder, Morse.*)

Inside Wiring.—(See *Wiring, Inside.*)

Insolation, Electric — — A term sometimes employed for electric sunstroke, or electric prostration. (See *Sunstroke, Electric. Prostration, Electric.*)

Installation.—A term embracing the entire plant and its accessories required to perform any specified work.

The act of placing, arranging or erecting a plant or apparatus.

Installation, Electric — — The establishment of any electric plant.

An electric light installation, for example, includes the steam engine and boilers, or other prime movers, the dynamo-electric machines, the line wires or leads, and the lamps.

Insulated Body.—(See *Body, Insulated.*)

Insulating Cements.—(See *Cements, Insulating*.)

Insulating Sleeve.—(See *Sleeve, Insulating*.)

Insulating Stool.—(See *Stool, Insulating*.)

Insulating Tape.—(See *Tape, Insulating*.)

Insulating Tube.—(See *Tube, Insulating*.)

Insulating Varnish.—(See *Varnish, Electric*.)

Insulation, Electric — — Non-conducting material so placed with respect to a conductor as to prevent the loss of a charge, or the leakage of a current.

In the case of coils the character of the insulation of the coil of wires through which the current is to pass must be considered from the standpoint of the cooling of the coil by radiation.

In considering the safest and most economical current density to employ in any dynamo or motor, the depth of the coil, *i. e.*, the thickness of its coils, must be considered, as well as the character of the materials employed for the insulation. Such substances as silk or wool, which are characterized by low heat conduction, retain the heat longer than cotton. Hence the depth of a silk covered coil should necessarily be less than that of one covered with cotton.

Insulation Joint.—(See *Joint, Insulation*.)

Insulation, Porous — — An insulating material containing air or gas placed between the conductor and the insulating covering.

A strip of perforated paper is used for covering the bare conductor, and the insulating material is placed on the outside of this; or, a cord is wrapped separately around the conductor, and the insulating material is placed on the outside of this. By these means, as will be seen, a layer of air exists between the conductor and its insulating covering.

Insulation Resistance.—(See *Resistance, Insulation*.)

Insulation, Static — — A term employed in electro-therapeutics for a method of treatment by convection streams or dis-

charges, in which the patient is seated on an insulated stool connected to one pole or electrode of an influence machine, while the other pole or electrode is connected to the ground.

Insulator Cap.—(See *Cap, Insulator*.)

Insulator, Dice-Box — — A name sometimes applied to a double-cone insulator. (See *Insulator, Double-Cone*.)

Insulator, Double-Cone — — An insulator in which the line wire passes through and is supported by means of a tube consisting of two inverted cones joined at their smaller bases.

Insulator, Double-Cup — — An insulator consisting of two funnel-shaped cups, placed in an inverted position on the supporting pin and insulated from one another by a free air space, except near the ends, which are cemented.

The wire is wrapped in a groove on the outside of the outer cup. This possesses the advantage of exposing it to the rain, which thus cleanses the insulator and improves its power of insulation. The inner cup is supported on a pin and the outer cup cemented to it. Any leakage must, therefore, pass over the entire surface of both cups.

Insulator, Double-Shackle — — A form of insulator used in shackling a wire, consisting of two single-shackle insulators.

Insulator, Double-Shed — — A double-cup insulator. (See *Insulator, Double-Cup*.)

Insulator, Fluid — — An insulator provided with a small, internally placed, annular, cup-shaped space, filled with an insulating oil, thus increasing the insulating power of the support.

The line wire is wrapped in a groove on the outside of the insulator. Any surface leakage between the wire and ground in wet weather must occur between the outer surface of the insulator, which is kept cleansed by the rain, and the inner surface, where it is supported by the pin. But to do this, the current must cross the oil in the cup, which, from its high power of insulation, effectually prevents leakage.

Insulator, Invert — — An insulator

placed on the top of the wire instead of underneath it, as was formerly done.

Insulator, Oil — —A fluid insulator filled with oil. (See *Insulator, Fluid*.)

Insulator Pins.—(See *Pins, Insulator*.)

Insulator, Single-Shackle — —A form of insulator used for shackling a wire. (See *Shackling a Wire*.)

Insulator, Single-Shed — —An insulator with a single inverted cup.

The wire is wrapped around a groove on the outside of the cup, where it is exposed to the cleansing action of the rain. The cup is inverted and supported on a pin, to which it is screwed and cemented.

Insulator, Telegraphic or Telephonic — —A non-conducting support of telegraphic, telephonic, electric light or other wires.

Insulators are generally made of glass, earthen-

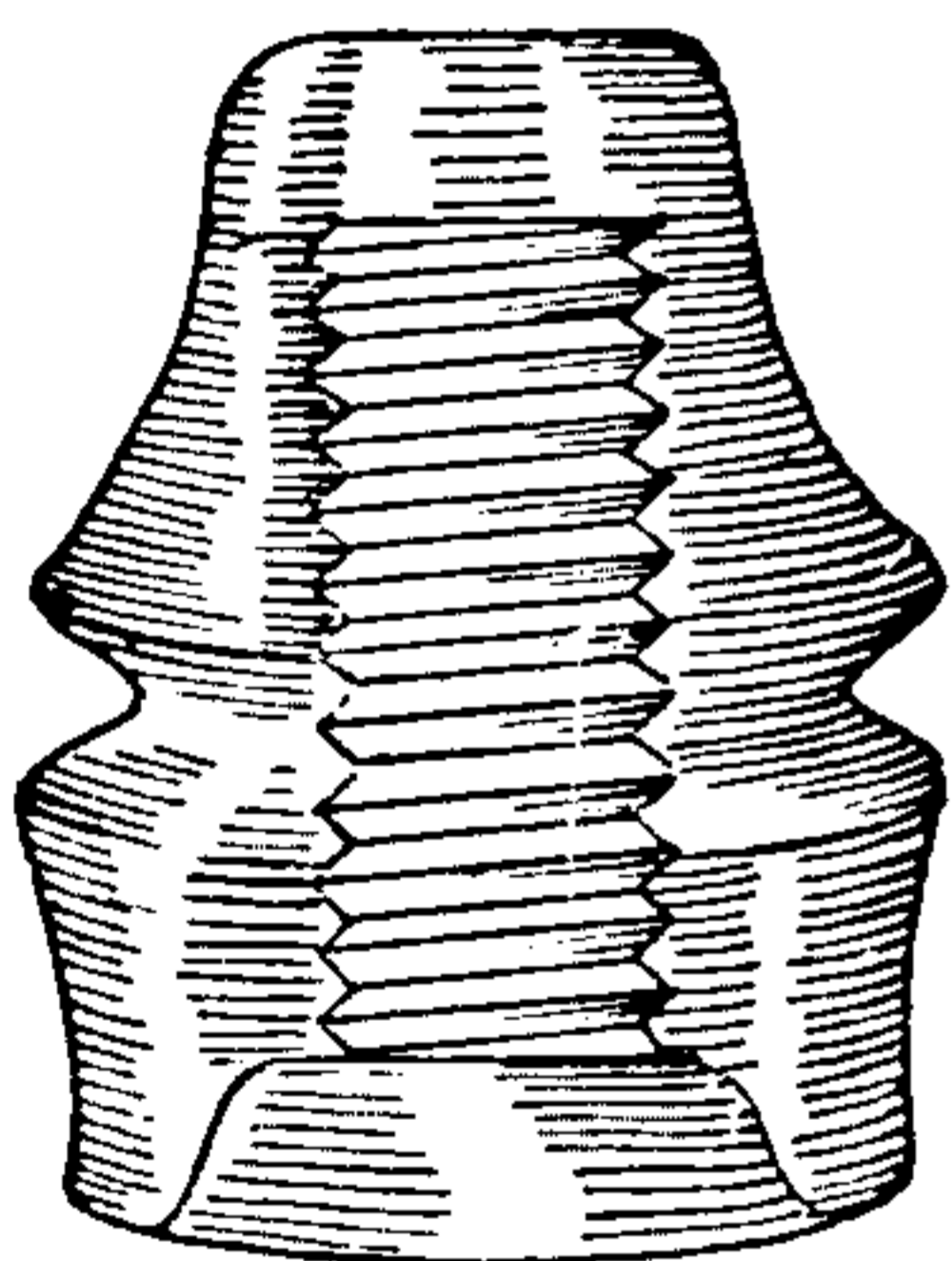

Fig. 310. Glass Insulator.

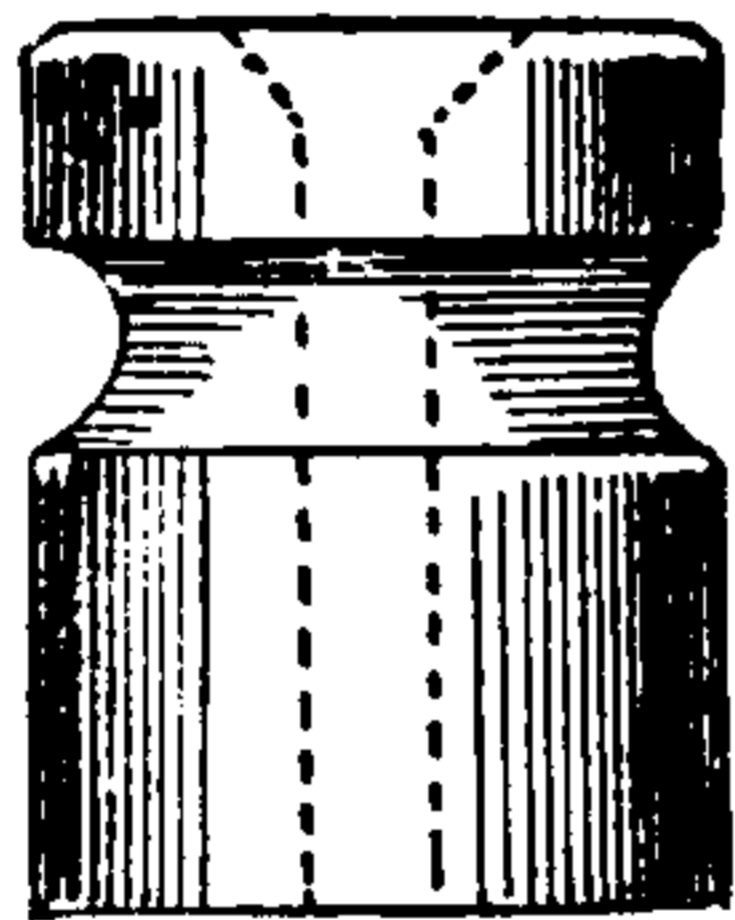

Fig. 311. Porcelain Insulator.

ware, porcelain or hard rubber, and assume a variety of forms, some of which are shown in Figs. 310, 311 and 312. Of whatever material they are made, it is necessary that the surface on which the wire rests, or around which it is wrapped, should be smooth, so as to avoid abrasion, either of its insulating covering or of the wire itself.

Two things are to be considered in the selection of an insulator, viz :

(1.) The insulating power of the material of which the insulator is composed, so as to reduce the leakage as much as possible. (See *Leakage, Electric*.)

(2.) The tensile strength of the material. so

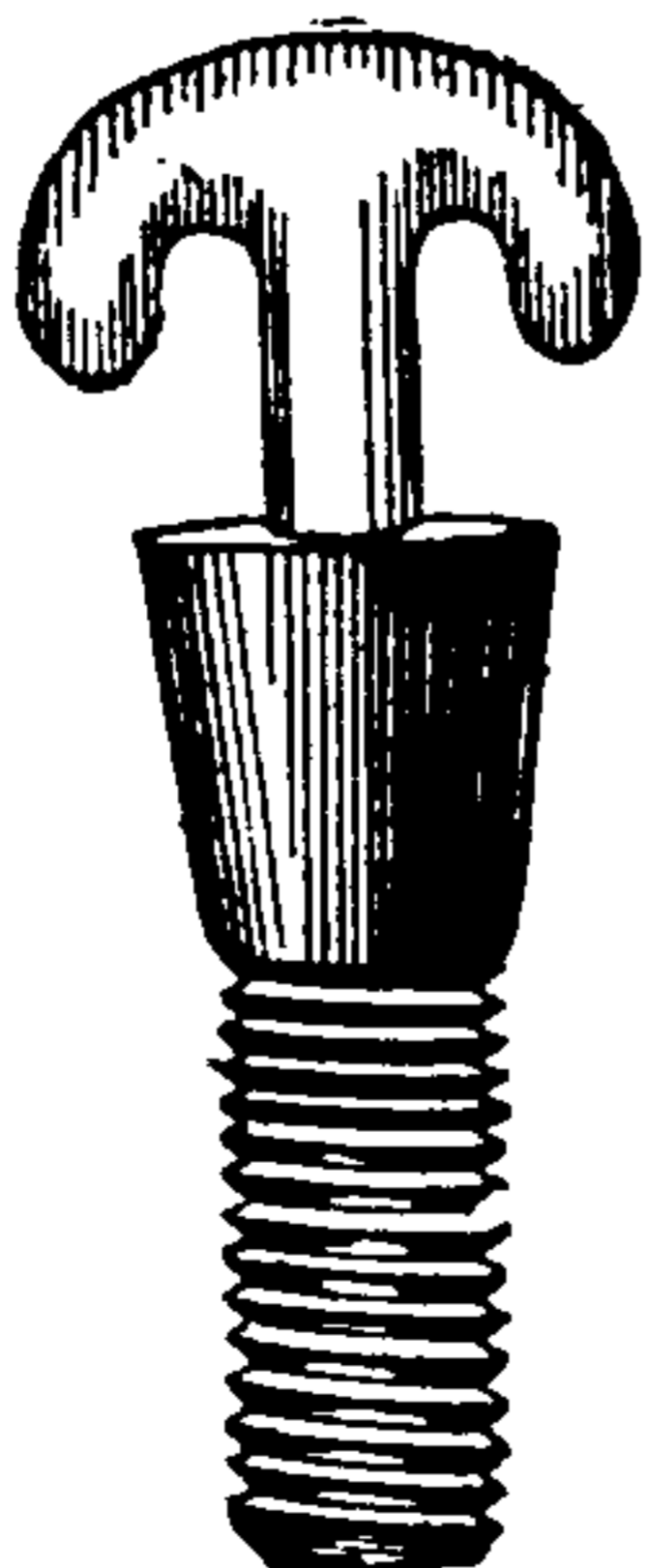

Fig. 312. Hard Rubber Insulator.

that in case of heavy wires no breaks may result from the fracture of the insulator.

Some forms of insulators are shown in Figs. 310, 311 and 312. They are screwed to the pins by the threads shown. The insulating materials of which they are formed are of glass, porcelain and hard rubber respectively.

Insulator, Window-Tube — —A tube of vulcanite or other insulating material provided for the insulation of a wire entering a room.

The wire conductor passes through the middle of the tube, which is firmly fixed in an opening passing through the window frame.

Insulator, Z — —A form of double-cup insulator in which the insulating material, earthenware or porcelain, is made in a single piece, instead of in two separate pieces.

The body of the insulator is conical in form, and the interior air space presents a shape approximately that of the letter Z.

The double form is used in order to diminish the leakage.

Intensity Armature.—(See *Armature, Intensity*.)

Intensity, Connection of Voltaic Cells for — —A term formerly employed for series-connected voltaic battery cells. (Obsolete.)

Intensity, Magnetic — —Density of magnetic induction.

Magnetic flux per square centimetre.

A committee of the American Institute of Electrical Engineers on "Units and Standards," proposes the following definition for magnetic intensity:

The induction density at a point within an element of surface is the surface differential at that point.

The practical unit of magnetic intensity is 10^9 or 100,000,000 C. G. S. lines per square centimetre.

In practice, excluding the earth's field, intensities range from 100 to 20,000 C. G. S. lines per square centimetre, and the working unit should, perhaps, have the prefix milli or micro.

Intensity, Magnetic, Pole of — —The earth's magnetic poles as determined by means of the oscillations of a magnetic needle.

THIS PAGE IS LOCKED TO FREE MEMBERS

Purchase full membership to immediately unlock this page



HISTORY

Tens of thousands of important historical sources, many previously unobtainable, are now available for the first time with a Forgotten Books Full Membership.

Unlimited Access
\$8.99/month

Continue

*Fair usage policy applies

lyte are decomposed by electrolysis. (See *Electrolysis*.)

The electro-negative ions are called the anions, because they appear at the anode of a decomposition cell. (See *Anions. Anode*.)

Ions, Electro-Positive — —The positive atoms, or groups of atoms, called radicals, into which the molecules of an electrolyte are decomposed by electrolysis. (See *Electrolysis*.)

The electro-positive ions are called the kathions, because they appear at the kathode of a decomposition cell. (See *Kathion. Kathode*.)

Iron-Clad Electro-Magnet.—(See *Magnet, Electro, Iron-Clad*.)

Iron-Clad Magnet.—(See *Magnet, Iron-Clad*.)

Iron Core, Effect of, on the Magnetic Strength of a Hollow Coil of Wire — — An increase in the number of lines of magnetic force, beyond those produced by the current itself, due to the opening out of the closed magnetic circuits in the atoms or molecules of the iron.

The atoms or molecules of the iron possess naturally closed magnetic circuits, or closed lines of magnetic force, lying entirely within the mass of the iron. When the iron is placed in a magnetic field, these minute closed circuits open out and are added to the lines of force produced by the circuit itself. The opening out of these closed atomic or molecular lines of magnetic force is attended by the formation of lines of polarized molecules or atoms.

Roughly speaking, according to Lodge, for each single line of magnetic force produced by the electric current, there are some 3,000 lines of magnetic force added to it from the iron, the exact number varying with the kind of iron, the physical condition of the iron and the degree of magnetization.

Iron, Galvanized — —Iron covered by a layer of zinc by dipping it in a bath of molten zinc.

The process of galvanizing iron is designed to prevent the corrosion or rusting of the iron on exposure to the air. (See *Metals, Electrical Protection of*.)

The word galvanized probably had its origin in

an assumed galvanic or voltaic action, in causing the zinc to adhere to the iron. The true galvanic or voltaic action, viz., the galvanic protection, comes after the galvanizing process is completed.

Iron-Work Fault of Dynamo.—(See *Fault, Iron-Work, of Dynamo*.)

Irreversible Heat.—(See *Heat, Irreversible*.)

Irritability, Electric — —Irritability of nervous or muscular tissue by an electric discharge.

Irritability, Electric, Diminished — — A decreased irritability of nervous or muscular tissue, produced by an electric current of given strength.

Diminished electric irritability is often present in certain diseases of the motor apparatus.

Irritability, Electric, Increased — — An irritability of nervous or muscular tissue produced by a much weaker electric current than that required to produce it in normal tissue.

Irritability, Faradic — —Muscular contractions produced by the action of a faradic current on a nerve.

The action of the faradic current is to cause a prolonged tonic contraction, which continues while the current continues. Though the natural action is to produce a contraction, followed by a relaxation on each make and break, yet the makes and breaks follow one another so rapidly that the relaxation has not time to occur before the next contraction follows.

Irritability, Galvanic — —Muscular contractions produced by the action of a galvanic current.

The action of a galvanic current is to cause a single, quick, momentary contraction of a muscle on each starting or completion of the circuit.

The contractions are stronger in the case of galvanic currents when the direction of the current is reversed with a commutator instead of by an actual break at the poles. Such a break is called a voltaic alternative, and the currents so produced *voltaic alternatives*. (See *Alternatives, Voltaic*.)

Isobaric Lines.—(See *Lines, Isobaric*.)

Isobars.—Lines connecting places on the

earth's surface which have the same barometric pressure.

The isobaric lines are generally corrected for differences of elevation of the surface.

Isobars are often called isobaric lines.

A study of the isobaric lines, or isobars, is of great assistance in making forecasts or predictions of coming changes in the weather.

Isochasmens Curves.—(See *Curves, Isochasmens.*)

Isochronism.—Equality of time of vibration or motion.

Isochronize.—To produce equality of time of vibration or motion.—(See *Isochronism.*)

Isochronizing.—Producing equality of time of vibration or motion. (See *Isochronism.*)

Isochronous Vibrations or Oscillations.—(See *Vibrations or Oscillations, Isochronous.*)

Isoclinic Chart.—(See *Chart, Inclination.*)

Isoclinic Lines.—(See *Lines, Isoclinic.*)

Isodynamic Chart.—(See *Chart, Isodynamic.*)

Isodynamic Lines.—(See *Lines, Isodynamic.*)

Isodynamic Map.—(See *Chart, Isodynamic.*)

Iso-Electric Points.—(See *Points, Iso-Electric.*)

Isogonal.—Pertaining to the isogonic lines.

Isogonal Lines.—(See *Lines, Isogonal.*)

Isogonal Map or Chart.—(See *Map or Chart, Isogonal.*)

Isogonic.—Pertaining to the isogonal lines.

Isogonic Chart.—(See *Chart, Isogonic.*)

Isogonic Lines.—(See *Lines, Isogonic.*)

Isogonic Map.—(See *Map, Isogonic.*)

Isolated Electric Lighting.—(See *Lighting, Electric, Isolated.*)

Isolatine.—A kind of insulating material.

Isothermal Surfaces.—(See *Surfaces, Isothermal.*)

Isotropic Conductor.—(See *Conductor, Isotropic.*)

Isotropic Medium.—(See *Medium, Isotropic.*)

J

J.—A contraction proposed for Joule.

Jablochkoff Candle.—(See *Candle, Jablochkoff.*)

Jacketed Magnet.—(See *Magnet, Jacketed.*)

Jacobi's Law.—(See *Law, Jacobi's.*)

Jar, Electric — —A name formerly given to the Leyden jar.

Jar, Leyden — —A condenser in the form of a jar, in which the metallic coatings are placed opposite each other on the outside and the inside of the jar respectively.

The metal coatings should not extend to more than two-thirds of the height of the jar, the rest of the glass being varnished to avoid the creeping of the charges over the glass in damp weather. The inside coating is connected by means of a

metallic chain to a knob on the top of the jar, as shown in Fig. 313. The conductor supporting the knob passes through a dry cork or plug of some insulating material.

To charge the jar, the outside coating is connected with the earth, as by holding it in the hand, and the outside coating is connected with the conductor of a machine. (See *Condenser. Accumulator.*)

The inner coating of the jar is usually connected with the knob by means of a chain or wire as shown above. This necessitates a support for the ball and stem, which is generally obtained by a cork or wooden plug inserted in the mouth of

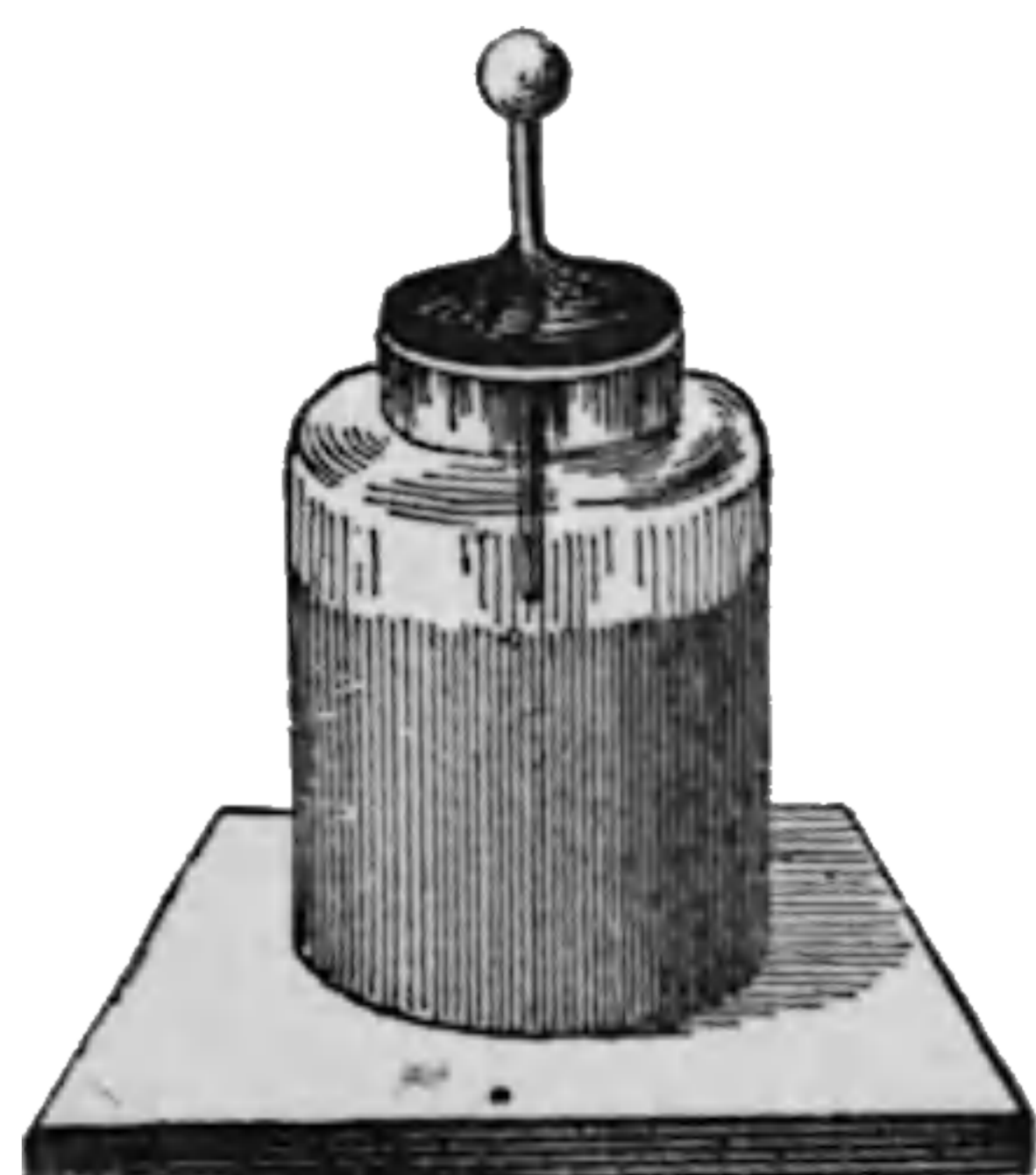

Fig. 313. Leyden Jar.

the jar. Such a form, however, is extremely objectionable, since, although the top of the jar be covered with shellac varnish to avoid leakage, it affords but a poor insulation in damp weather, because both the metallic rod supporting the ball and

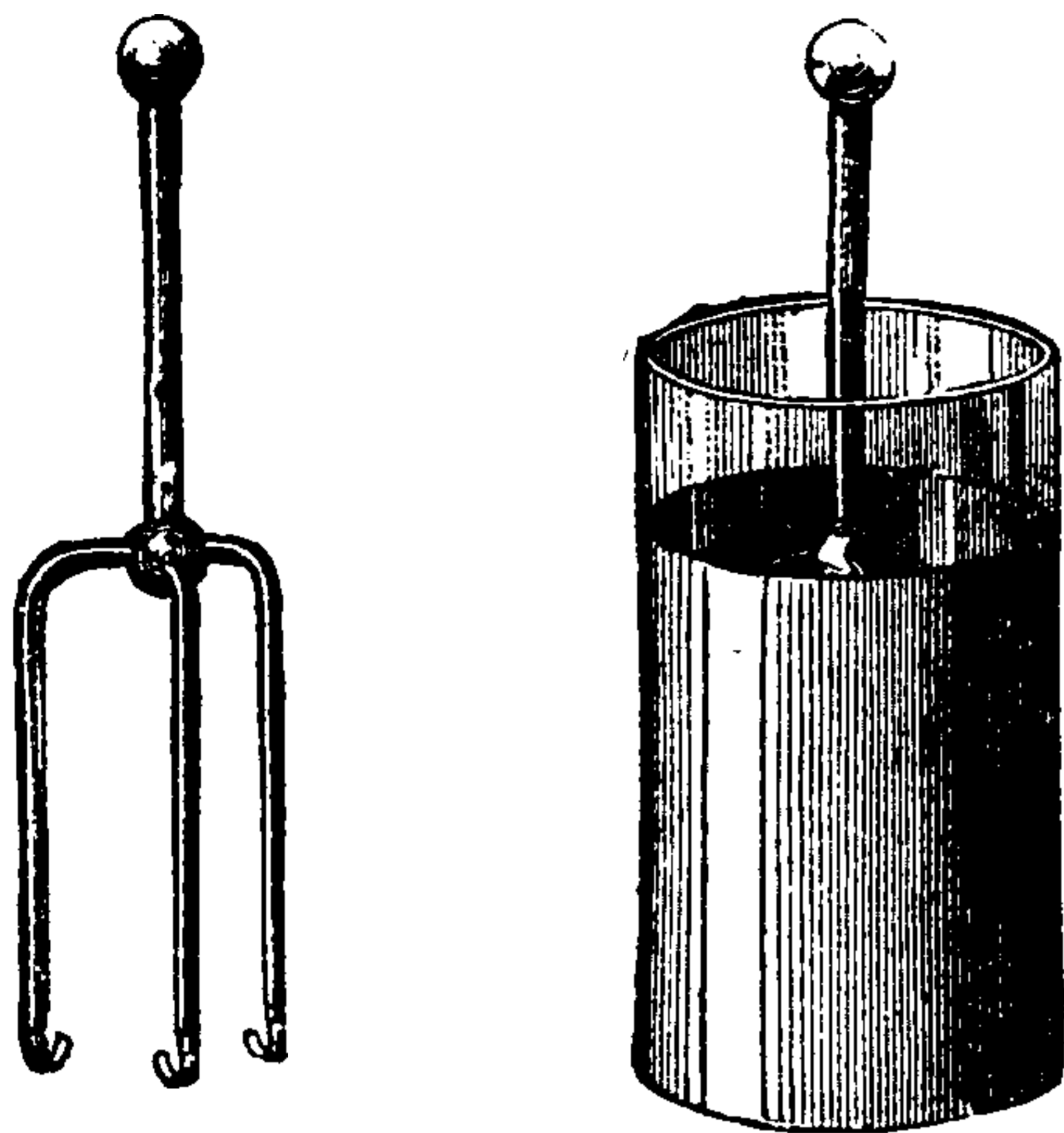

Fig. 314. Sir William Thomson's Leyden Jar.

the damp wood or cork are in connection with the glass and thus facilitate leakage.

To overcome these objections a form of jar has been devised by Sir William Thomson, in which the knob is supported on three feet, which rest on the inner coating. In this form the uncoated glass can be readily kept dry and clean. This form is shown in Fig. 314.

A layer of sulphuric acid is sometimes employed for the inner coating of the Leyden jar. This serves the double purpose of acting as a coating and an absorber of moisture during damp weather.

Jar, Leyden, Capacity of — —The quantity of electricity a Leyden jar will hold at a given difference of potential.

The capacity of a jar is equal to the quantity of electricity divided by the difference of potential such quantity produces in the jar; or the capacity $= \frac{Q}{V}$, where Q = the quantity, and V , the difference of potential.

Jar, Leyden, Coatings of — —(See *Coatings of Leyden Jar.*)

Jar, Lightning — —A Leyden jar, the coatings of which consist of metallic filings.

As the discharge passes, an irregular series of sparks appear, which somewhat resemble in their shape a lightning flash. Hence the origin of the term.

Jar of Secondary Cell.—The containing

vessel in which the plates of a single secondary cell are placed.

Jar, Porous — —A porous cell. (See *Cell, Porous.*)

Jar, Scintillating — —A Leyden jar, the coatings of which, instead of being formed of continuous sheets of tin-foil or other conducting substances, are formed of small pieces of such substances, placed at regular intervals on the glass or dielectric so as to leave a small space between them.

Such a jar has received the name of scintillating jar, because when discharged by connecting its two opposite coatings the discharge appears as minute sparks, which jump across the space between the metallic pieces.

Jar, Unit — —A small Leyden jar sometimes employed to measure approximately the quantity of electricity passed into a Leyden battery or condenser.

As shown in Fig. 315, the unit jar consists of a small Leyden jar j , whose outer coating is connected with a sliding metallic rod b , provided at each end with a rounded knob, and the inner coating of which is connected with a metallic knob c , placed as shown, inside a glass jar d , opposite a ball on the lower end of b .

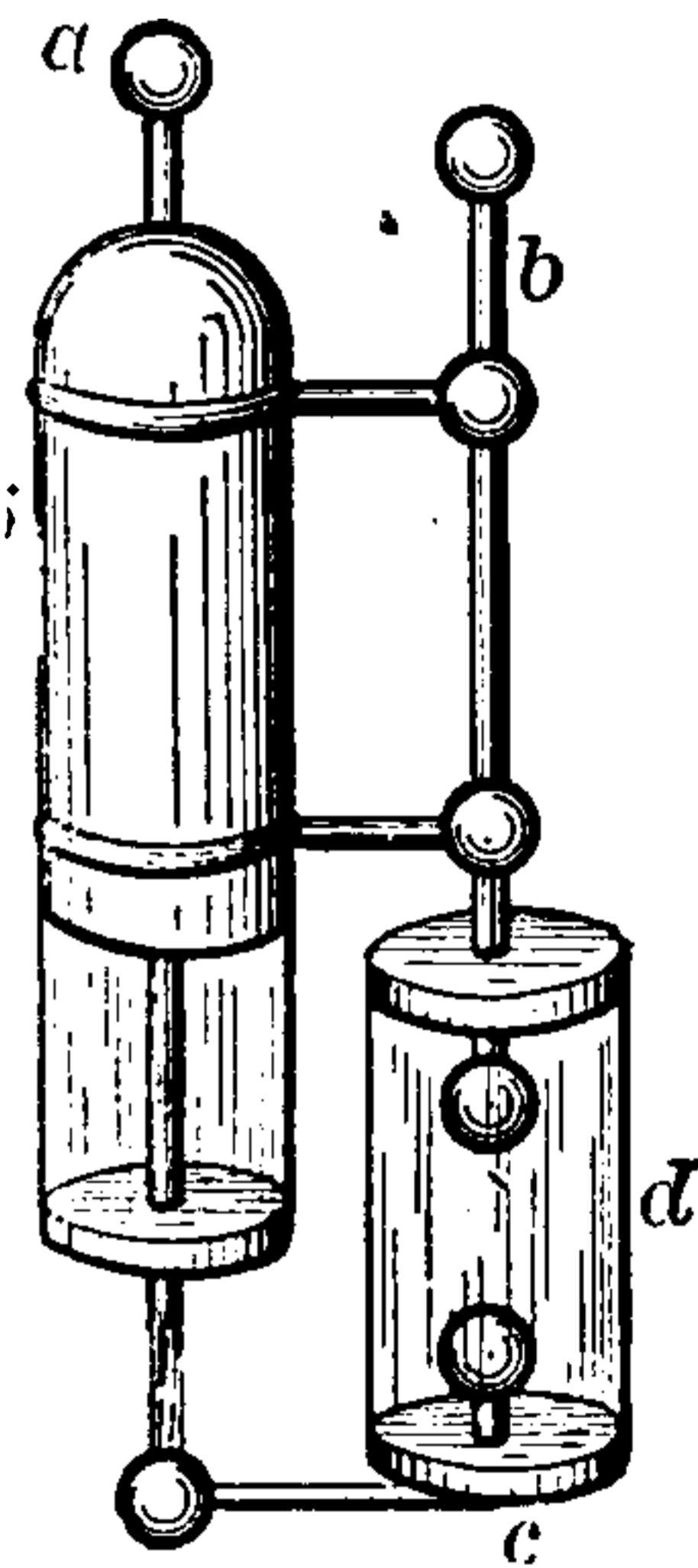

Fig. 315. Unit Jar.

When, now, the inside of the unit jar, or the end connected with c , is connected with the charging source, such as a machine, and the outside at a , is connected with the jar or jars to be charged, for every spark that passes between d and c , a definite quantity has passed a .

The value of this unit charge may be varied by varying the distance between d and c .

The smaller the unit jar is in proportion to the jar to be charged, and the shorter the distance between c and d , the more reliable are the comparative results obtained.

Jars, Leyden, Charging, by Cascade — —(See *Cascade, Charging Leyden Jars by.*)

Jet, Gas, Carcel Standard — —A lighted gas jet employed for determining the candle-power of gas by measuring the height

THIS PAGE IS LOCKED TO FREE MEMBERS

Purchase full membership to immediately unlock this page

Know Your Bible

Forgotten Books' Full Membership provides unlimited access to more than 28,000 volumes of Christian literature for \$8.99/month

HOLY BIBLE

Continue

*Fair use policy applies

elevation at the joint is no greater than elsewhere, the lap joint is preferable to the butt joint.

Joint, Expansion — — A joint for underground conductors, tubes or pipes, exposed to considerable changes of temperature, in which a sliding joint is provided to safely permit a change of length on expansion or contraction.

Joint, Insulation — — A joint in an insulating material or covering in which a continuity is insured in the conducting as well as the insulating substance.

Joint, Lap — — A joint effected by overlapping short portions near the ends of the things to be joined, and securing them while in such position.

Joint, Lap, for Wires — — A joint effected between two wires by overlapping their ends and subsequently soldering.

Joint, Magnetic — — The line of junction between two separate parts of magnetizable material.

Magnetic joints should be of such a nature as to permit the passage of the lines of magnetic force with the least increase in the resistance of the magnetic circuit.

Magnetic joints in the field magnets of a dynamo-electric machine should be as few as possible, since the resistance of the best magnetic joint to the passage of the lines of force is necessarily greater than that of the same material without such joints.

Joint, Metallic Conducting — — A joint in a conductor in which a continuity of conducting power is secured.

Joint Resistance of Parallel Circuits. — (See *Resistance, Joint, of Parallel Circuits.*)

Joint, Sleeve — — A junction of the ends of conducting wires obtained by passing them through tubes and then twisting and soldering.

All joints should be soldered, but in so doing care must be taken that the soldering liquid or solid employed is free from acids or other corrosive materials, and that all traces of the soldering liquid or solid are removed from the wire before the joint is covered with insulating material.

Kerite, okonite or other insulating tape, should

preferably be wrapped around the joint after it is soldered.

In making a joint in a gutta-percha covered wire, such as a submarine cable, the following method may be employed: The bared and cleansed wires are twisted together and soldered. The soldered joint is then covered with a layer of plastic insulating material made of a mixture of gutta-percha, tar and rosin. (See *Chatterton's Compound.*) In order to insure a good junction between this and the gutta-percha covering on the rest of the wire, the outer surface of the gutta-percha is removed for about two inches from each side of the joint, so as to remove its oxidized surface. After the coating is put on, it is warmed gently by a warm joining tool, not by the flame of a lamp. A sheet of warmed gutta-percha is then wrapped around the joint, and while it and the joint are still hot, another coating of the plastic insulating material is applied. Successive layers of gutta-percha and some other insulating material are generally applied in the case of submarine cables.—(*Culley.*)

Joint, Telegraphic, McIntire's Parallel Sleeve — — A joint for telegraphic or other wires, in which the ends to be joined are slipped into parallel sleeves or tubes, which are afterward twisted around each other.

A general view of the parallel sleeve joint, both before and after twisting, is shown in Fig. 320.

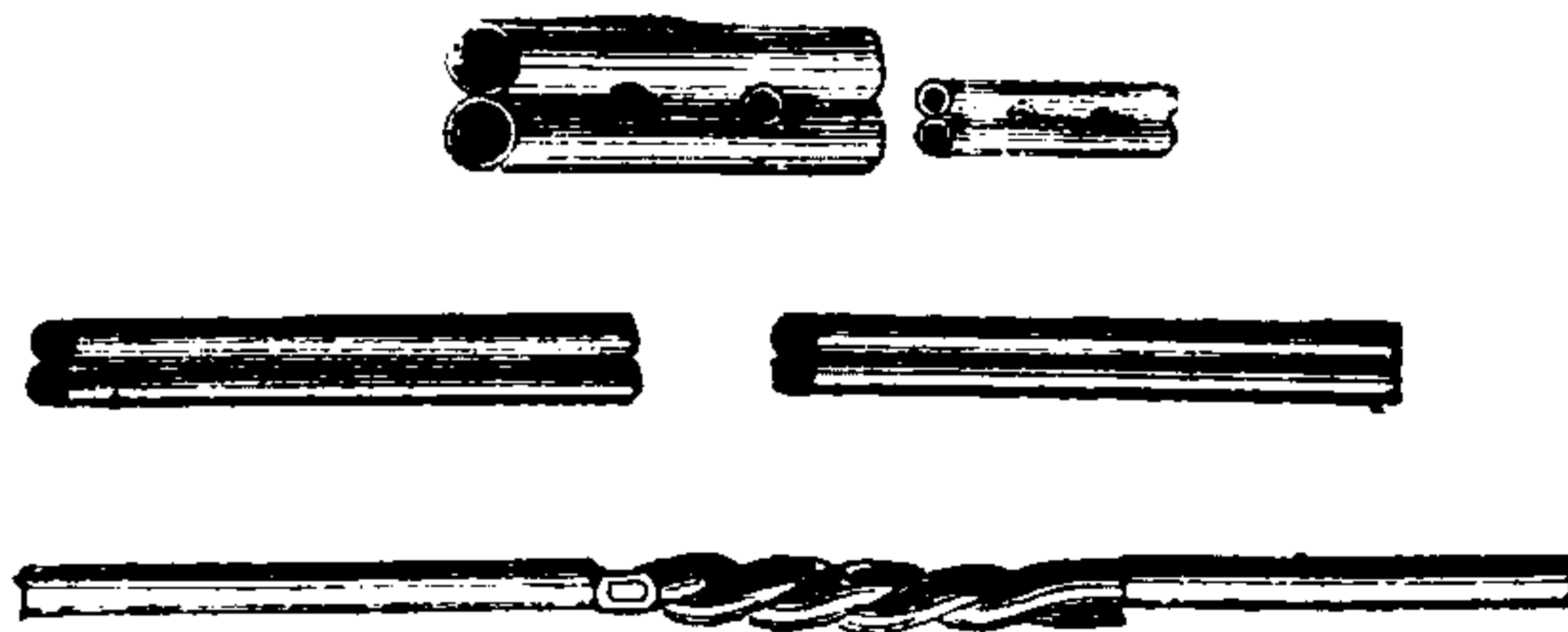

Fig. 320. McIntire's Parallel Sleeve Joint.

The twisting is done by means of the specially devised twisting clamp shown in Fig. 321.



Fig. 321. Twisting Clamp for McIntire's Parallel Joint.

Joint, Telegraphic or Telephonic — — A juncture of the ends of two electric conductors so as to insure a permanent junction whose resistance shall not be appreciably greater per unit of length than that of the rest of the wire.

In making a joint, care should always be taken to scrape the insulating material from the wires and clean their surfaces before twisting them together.

Telegraph wires were formerly joined by the ordinary bell-hangers' joint; that is, the wires were simply looped together. The constant vibrations to which the wires are subjected caused such a joint to be abandoned and an improvement introduced by bolting the ends together, as shown in Fig. 322.



Fig. 322. Telegraphic Joint.

Joint, Testing of—Ascertaining the resistance of the insulating material around a joint in a cable.

The resistance of the insulating material of a cable at a joint is necessarily high, since the joint forms but a small part of length of the cable. It should not, however, be large as compared with an equal length of another part of the cable with a perfect core.

Two methods for testing cable joints are generally employed, viz.:

(1.) A conductor is charged through the joints for a given time, and the deflection obtained by its discharge compared with the discharge of the same condenser charged for an equal length of time through a few feet of perfect cable.

(2.) A charged conductor is permitted to discharge itself through the joint, and the amount lost in a given time noted.

For description of different methods, see Kempe's "Handbook of Electrical Testing."

Joulad.—A term proposed for the Joule.

This term is not generally adopted. (See *Joule*.)

Joule.—The unit of electric energy or work.

The volt-coulomb.

The amount of electric work required to raise the potential of one coulomb of electricity one volt.

The joule may be regarded as a unit of energy or work in general, apart from electrical work or energy.

1 joule..... = 10,000,000 ergs.

1 joule..... = .73732 foot-pounds.

1 joule..... = 1 volt-coulomb.

1 joule..... = .24 calorie.

4.2 joules..... = 1 small calorie.

1 joule per second = 1 watt.

The British Association proposed to call one joule the work done by one watt in one second.

Joule, as a Heat Unit.—The quantity of heat developed by the passage of a current of one ampère through a resistance of one ohm. (See *Joule*.)

Joule Effect.—(See *Effect, Joule*.)

Joule's Cylindrical Electro-Magnet.—(See *Magnet, Electro, Joule's Cylindrical*.)

Joule's Law.—(See *Laws of Joule*.)

Junction Box.—(See *Box, Junction*.)

Jump-Spark Burner.—(See *Burner, Jump-Spark*.)

Junction, Thermo-Electric.—A junction between any thermo-electric couple. (See *Cell, Thermo-Electric*.)

K

K.—A contraction for electrostatic capacity. (See *Capacity, Electrostatic*.)

K. C. C.—In electro-therapeutics, a brief method of writing cathodic closure contraction, or the effects of muscular contraction observed at the kathode on the closure of a circuit.

K. D. C.—In electro-therapeutics, a brief method of writing cathodic duration con-

traction, or the effects of muscular contraction observed at the kathode after the current has been passing for some time.

K. W.—A contraction for kilo-watt. (See *Watt, Kilo*.)

Kaolin.—A variety of white clay sometimes employed for insulating purposes.

Jablochkoff sometimes employed kaolin between the parallel carbons of his electric candle

for the purpose of insulating them from each other. He also devised an electric lamp in which a spark of considerable difference of potential, obtained from an ordinary induction coil, was caused to raise a surface of kaolin to incandescence by passage over it.

Kapp Lines.—(See *Lines, Kapp*.)

Kartavert.—A kind of insulating material.

Katelectrotonus.—A word sometimes used instead of kathelectrotonus. (See *Kathelectrotonus*.)

Kathelectrotonic State.—(See *State, Kathelectrotonic*.)

Kathelectrotonic Zone.—(See *Zone, Kathelectrotonic*.)

Kathelectrotonus.—In electro-therapeutics, the condition of increased functional activity that occurs in a nerve in the neighborhood of the kathode or negative electrode. (See *Electrotonus*.)

Kathion.—The electro-positive ion, atom or radical into which the molecule of an electrolyte is decomposed by electrolysis. (See *Electrolysis. Ions*.)

Kathion is sometimes written *cathion*.

In electrolysis the *kathion*, or the electro-positive ion or radical, appears at the kathode or electro-negative electrode. Similarly, the *anion*, or the electro-negative ion or radical, appears at the anode or the electro-positive electrode.

Kathodal.—Pertaining to the kathode. (See *Kathode*.)

Kathode.—The conductor or plate of an electro-decomposition cell connected with the negative terminal or electrode of a battery or other source.

The word kathode is sometimes applied to the negative terminal of a battery or source, whether connected with a decomposition cell or not. It is preferable, however, to restrict its use to decomposition cells. (See *Anode*.)

The word kathode is sometimes written *cathode*.

Kathodic.—Pertaining to the kathode. (See *Kathode*.)

Kathodic Electro-Diagnostic Reactions.—(See *Reactions, Electro-Diagnostic*.)

Keeper of Magnet.—(See *Magnet, Keeper of*.)

Kerite.—An insulating material.

Kerr Effect.—(See *Effect, Kerr*.)

Key Board.—(See *Board, Key*.)

Key, Capillary Contact — — A form of fluid contact in which the circuit is closed or broken by means of a wire which is dipped into or removed from the surface of a mass of mercury.

In order to avoid an increase in the resistance of the circuit, due to the formation of oxide of mercury, the contact surface of the mercury is kept covered with a layer of dilute alcohol.

Key, Discharge — — A key employed to enable the discharge from a condenser or cable to be readily passed through a galvanometer for purposes of measurement.

Key, Discharge, Kempe's — — A discharge key constructed as shown in Fig. 323.

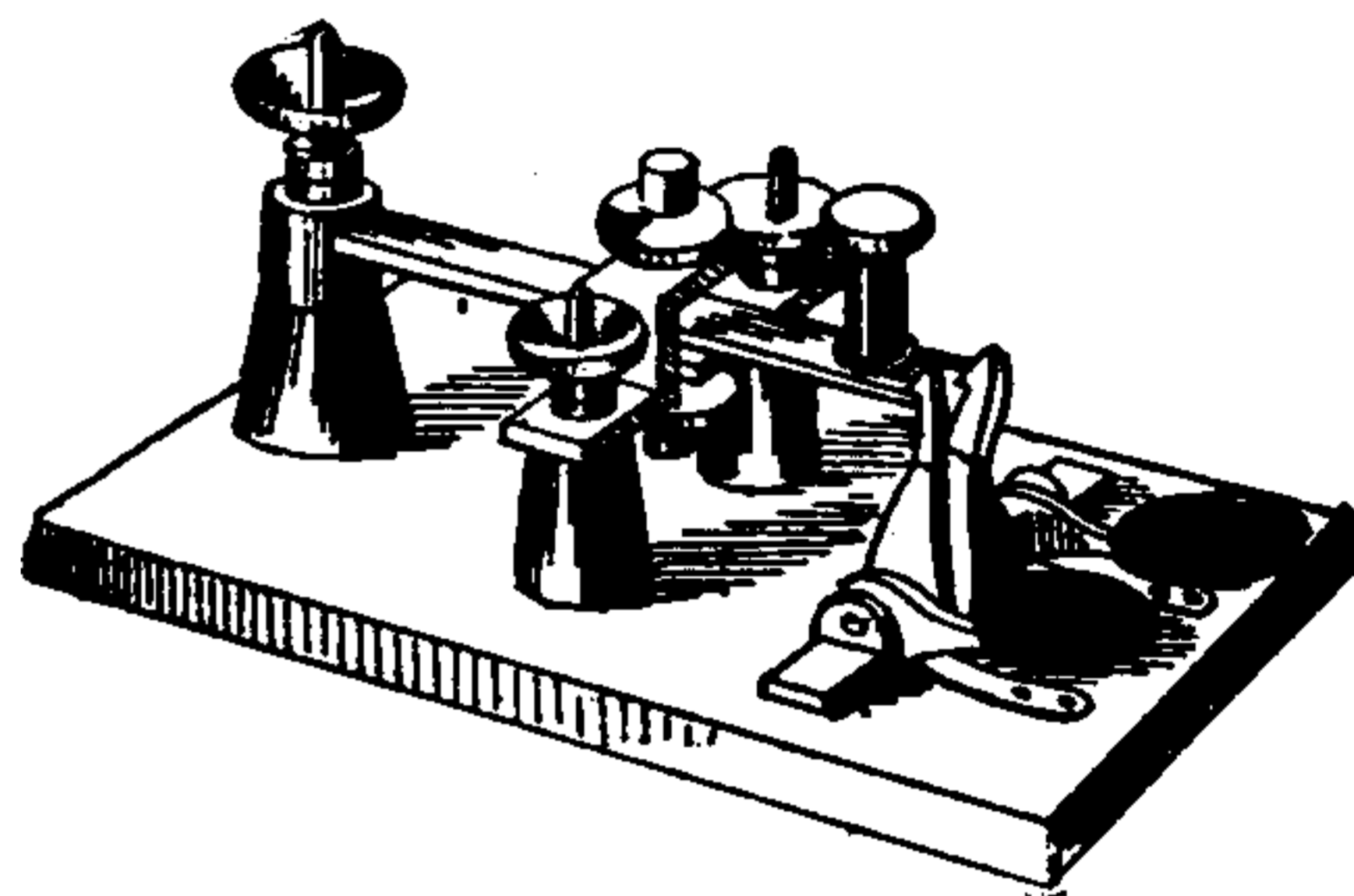

Fig. 323. Kempe's Discharge Key.

The solid lever, hinged at one extremity, plays between two contacts connected to two terminals, and has two finger triggers at its free end marked "Discharge" and "Insulate," connected respectively to two ebonite hooks. The hook attached to that marked "Discharge" is a little higher than the other, so that when the lever is caught against it, the key rests in an intermediate position between the contacts, and, when caught against the lower trigger, it rests against the bottom contact. When in the last position, a depression of the "Insulate" trigger causes the lever to spring up against the second hook, thus insulating it from either contact, and on the depression of the "Discharge" trigger, the lever springs up against the top contact.

Key, Discharge, Webb's — — A discharge key constructed as shown in Fig. 324.

A horizontal lever L, Fig. 324, passing between two contacts and hinged at J, is pressed upward by a spring. The free end of this lever terminates in two steps, 1 and 2. A vertical lever, pro-

THIS PAGE IS LOCKED TO FREE MEMBERS

Purchase full membership to immediately unlock this page



HISTORY

Tens of thousands of important historical sources, many previously unobtainable, are now available for the first time with a Forgotten Books Full Membership.

Unlimited Access
\$8.99/month

Continue

*Fair usage policy applies

quadruplex system by an increase in the strength of the current. (See *Telegraphy, Quadruplex.*)

Key, Magneto-Electric — —A telegraph key for sending an electric impulse into a line, so arranged that a coil of wire on an armature connected with the key lever is, by the movements of the key, moved toward or from the poles of a permanent magnet, the movements of the key thus producing the currents sent into the line.

Key, Plug — —A simple form of key in which a connection is readily made or broken by the insertion of a plug of metal between two metallic plates that are thus introduced into a circuit.

A form of plug key is shown in Fig. 327.

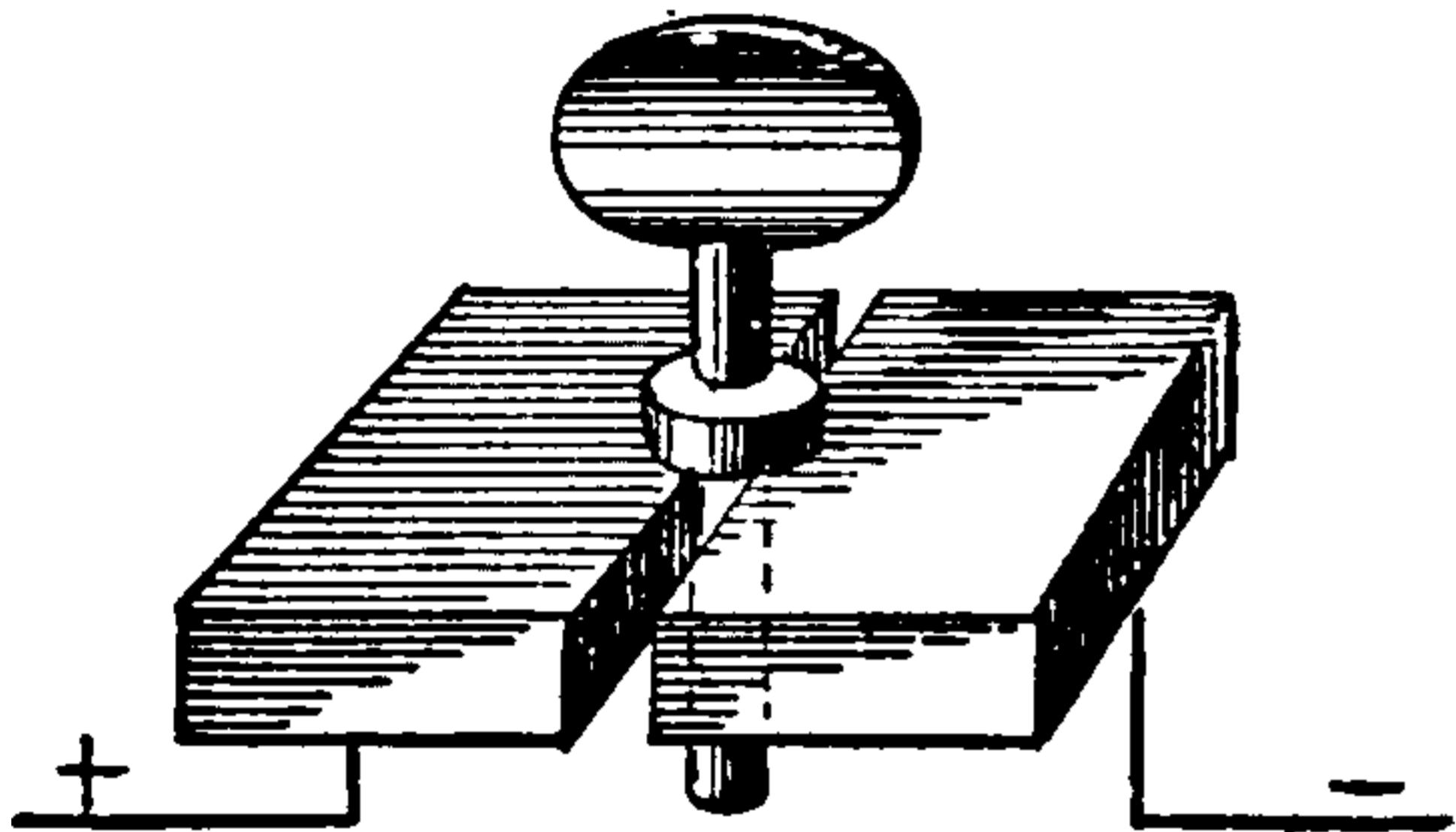

Fig. 327. Plug Key.

Key, Reversing — —A key inserted in the circuit of a galvanometer for obtaining deflections of the needle on either side of the galvanometer scale.

A form of reversing key is shown in Fig. 328. The galvanometer terminals are connected to the binding posts 2 and 3, and the circuit terminals to the other two posts. On depressing K, the

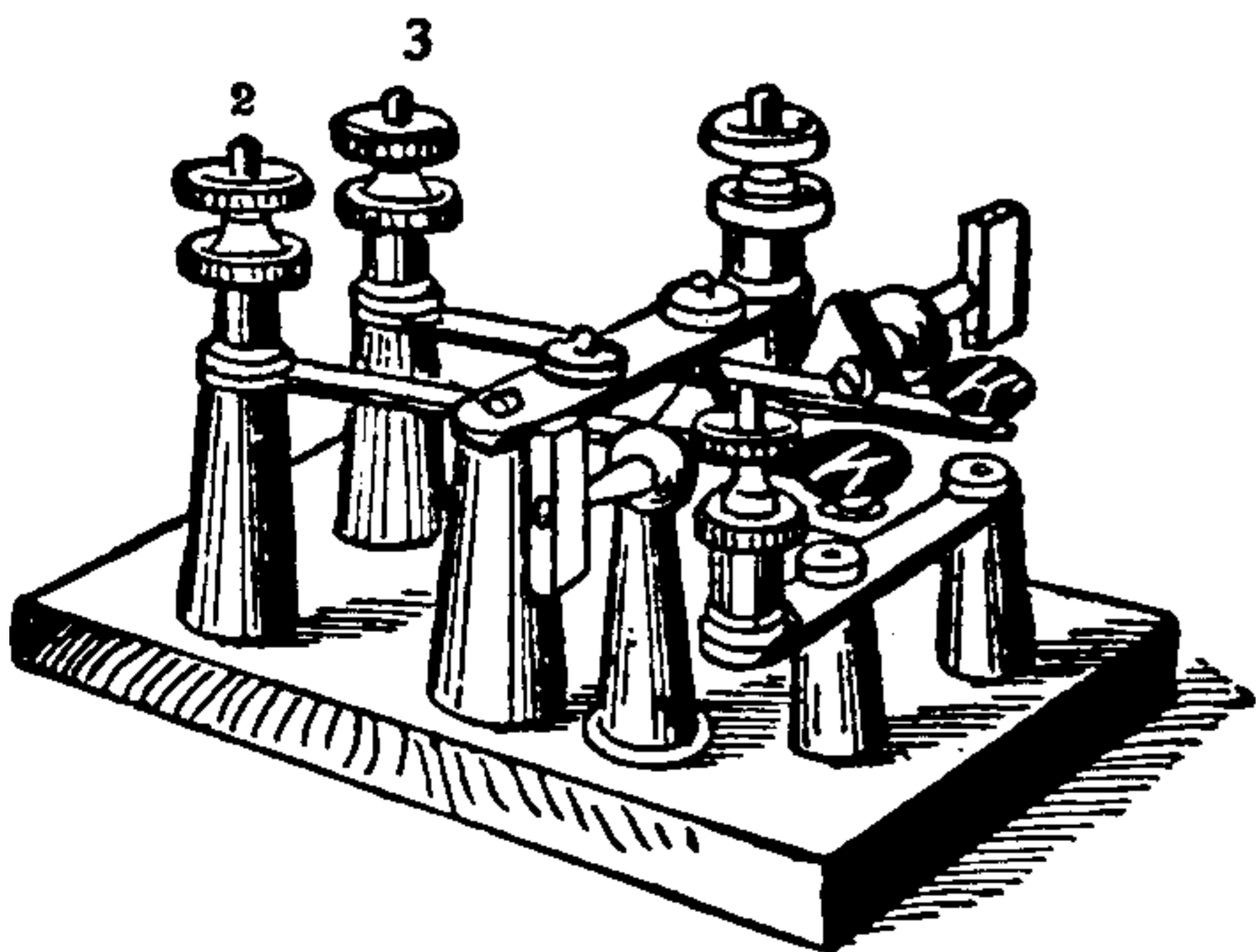

Fig. 328. Reversing Key.

current flows in one direction and on depressing K', it flows in the opposite direction. Clamps, operated by handles, are provided so as to close either of the keys permanently, if so desired.

Key, Reversing, of Quadruplex Telegraphic System — —A key employed to reverse the direction of the current and so operate one of the distant instruments, in a quadruplex system, by a change in the direction of the current. (See *Telegraphy, Quadruplex.*)

Key, Short-Circuit — —A key which in its normal condition short circuits the galvanometer.

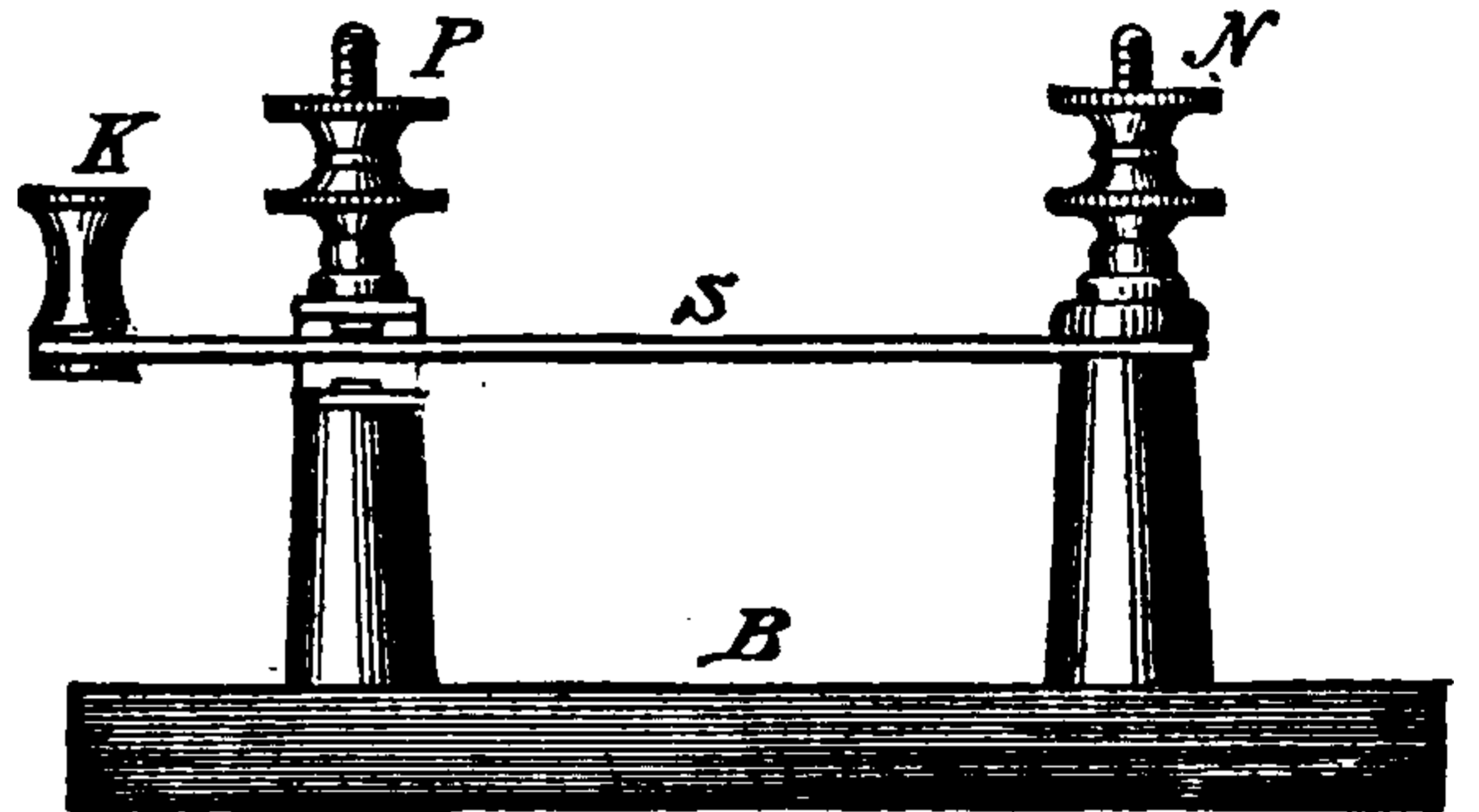

Fig. 329. Short-Circuit Key.

Such a short-circuit key is provided for the purpose of protecting the galvanometer from injury by large currents being accidentally passed through its coils. In the form shown in Fig. 329, the spring S, rests against a platinum contact; but when depressed by the insulated head at K, it rests against an ebonite contact, and throws the galvanometer into the desired circuit.

The key is provided with double binding posts at P and N, for convenience of attachment to resistance coils, batteries, etc.

In the form of a short-circuit key shown in Fig. 330, a catch is provided for the purpose of keeping the key down when once depressed. Its arrangement will be readily understood from an inspection of the figure.

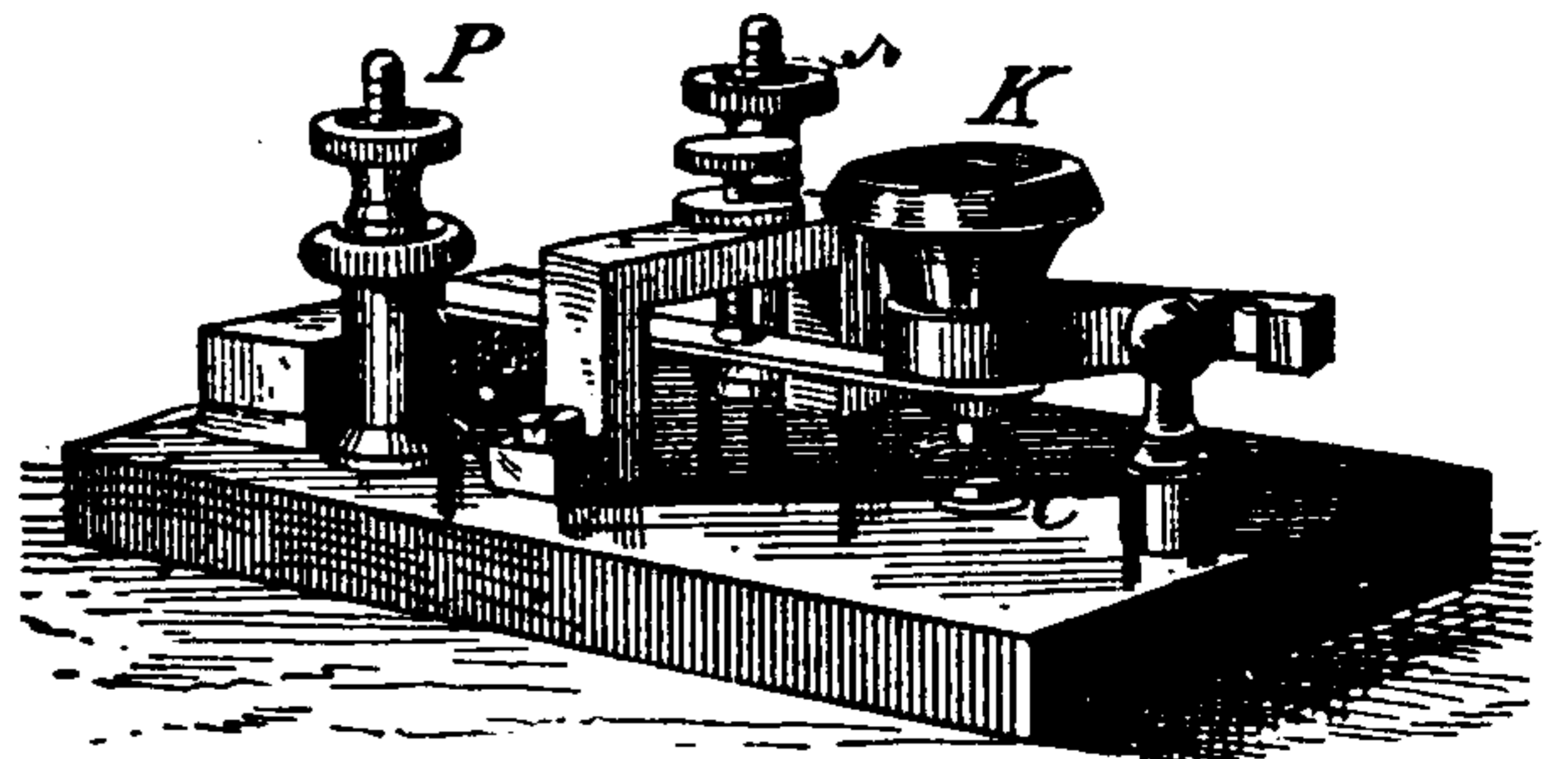

Fig. 330. Short-Circuit Key.

Key, Sliding-Contact — —The key employed in the slide form of Wheatstone bridge, to make contact with the wire over which the sliding contact passes. (See *Bridge, Electric, Slide Form of.*)

Key, Stationary Floor — —An electric key or push button placed on the floor so as to be readily closed by the foot.

This form of key is especially suitable for use in connection with an electric bell and annunciator for readily calling an attendant. (See *Annunciator, Electro-Magnetic.*)

Key, Telegraphic — —The key employed for sending over the line the successive makes and breaks that produce the dots and dashes of the Morse alphabet, or the deflections of the needle of the needle telegraph. (See *Telegraphy, American System of.*)

Kick.—A recoil.

Kicking Coil.—(See *Coil, Kicking.*)

Kilo (*as a prefix*).—One thousand times.

Kiloampère.—One thousand ampères.

Kiloampère Balance.—(See *Balance, Kiloampère.*)

Kilodyne.—One thousand dynes. (See *Dyne.*)

Kilogramme.—One thousand grammes, or 2.2046 pounds avoirdupois. (See *Weights, French System of.*)

Kilojoule.—One thousand joules.

Kilometre.—One thousand metres.

Kilowatt.—One thousand watts.

Kilowatt Hour.—(See *Hour, Kilowatt.*)

Kine.—A unit of velocity proposed by the British Association.

A kine equals 1 centimetre per second.

Kinetic Energy.—(See *Energy, Kinetic.*)

Kinetic Theory of Matter.—(See *Matter, Kinetic Theory of.*)

Kinetics, Electro — —A term sometimes applied to the phenomena of electric currents, or electricity in motion, as distinguished from electrostatics, or the phenomena of electric charges, or electricity at rest.

Kinetograph.—A device for the simultaneous reproduction of a distant stage and its actors under circumstances such that the actors can be heard at any distance from the theatre.

The sounds heard by the distant audience are actual reproductions of those uttered during the

performance, though not at the time of their utterance. The appearance of the stage and its actors represents the appearance of a previous reproduction of the play or opera or other performance, as taken by means of a Kodak camera with a film cylinder and drop shutter, operated by an electric motor, exposing, say, forty plates a second. By means of a projecting lantern these photographic pictures are thrown on a curtain on a stage at the distant theatre in regular order of sequence, while a loud-speaking phonograph puts song and speech into the mouths of the mimic actors and thus gives the phantom stage the semblance of life and reality.

Kite, Franklin's — —A kite raised in Philadelphia, Pa., in June, 1752, by means of which Franklin experimentally demonstrated the identity between lightning and electricity, and which, therefore, led to the invention of the lightning rod.

It is true that Dalibard, on the 10th of May, 1752, prior to Franklin's experiment, succeeded in drawing sparks from a tall iron pole he had erected in France. This experiment was, however, tried at the suggestion of Franklin, to whom it must properly be ascribed.

A description of this kite is given by Franklin in the following letter:

Letter XI, from BENJ. FRANKLIN, Esq., of Philadelphia, to PETER COLLINSON, Esq.,
F. R. S., London.

“OCT. 19, 1752.

“As frequent mention is made in public papers, from Europe, of the success of the Philadelphia experiment for drawing the electric fire from clouds by means of pointed rods of iron erected on high buildings, etc., it may be agreeable to the curious to be informed that the same experiment has succeeded in Philadelphia, though made in a different and more easy manner, which is as follows:

“Make a small cross of two light strips of cedar, the arms so long as to reach to the four corners of a large thin handkerchief when extended; tie the corners of the handkerchief to the extremities of the cross, so you have the body of a kite, which, being properly accommodated with a tail, loop and string, will rise in the air like those made of paper, but this, being of silk, is fitter to bear the wet and wind of a thunder gust without tearing. To the top of the upright stick of the cross is to

be fixed a very sharp pointed wire rising a foot or more above the wood. To the end of the twine, next the hand, is to be tied a silk ribbon, and where the silk and twine join, a key may be fastened. This kite is to be raised when a thunder gust appears to be coming on, and the person who holds the string must stand within a door or window, or under some cover, so that the silk ribbon may not be wet, and care must be taken that the twine does not touch the frame of the door or window. As soon as any of the thunder clouds come over the kite the pointed wire will draw the electric fire from them, and the kite, with all the twine, will be electrified, and the loose filaments of the twine will stand out every way, and be attracted by an approaching finger. And when the rain has wet the kite and twine so that it can conduct the electric fire freely, you will find it stream out plentifully from the key on the approach of your knuckle. At this key the phial may be charged, and from electric fire thus obtained spirits may be kindled, and all the other electric experiments be performed, which are usually done by the help of a

rubbed glass globe or tube, and thereby the sameness of the electric matter with that of lightning completely demonstrated.

“B. FRANKLIN.”

Knife Break Switch.—(See *Switch, Knife Break.*)

Knot or Nautical Mile.—A length equal to 6,087 feet.

The English statute mile is equal to 5,280 feet. The value of the nautical mile is therefore in excess of that of the statute mile.

Kohlrausch's Law.—(See *Law of Kohlrausch.*)

Krizik's Bars.—(See *Bars, Krizik's.*)

Kyanized.—Subjected to the kyanizing process. (See *Kyanizing.*)

Kyanizing.—A process employed for the preservation of wooden telegraphic poles by injecting a solution of corrosive sublimate into the pores of the wood. (See *Pole, Telegraphic.*)

L

L.—A contraction for co-efficient of inductance. (See *Inductance, Co-efficient of.*)

L.—A contraction for length.

Labile Galvanization.—(See *Galvanization, Labile.*)

Lag, Angle of — — The angle through which the axis of magnetism of the armature of a dynamo-electric machine is shifted by reason of the resistance its core offers to sudden reversals of magnetization.

An armature of a bi-polar dynamo-electric machine has its magnetism reversed twice in every rotation. The iron of the core resists these magnetic reversals. The result of this resistance is to shift the axis of magnetism in the direction of rotation. The angle through which the axis has thereby been shifted is called the *angle of lag*.

The term, angle of lag, is sometimes incorrectly applied so as to include a similar result produced by the magnetization due to the armature current itself. It is this latter action which, in armatures with soft iron cores, is the main cause of the angle

of lead. (See *Brushes, Lead of. Lead, Angle of.*)

Lag, Angle of, of Current — — An angle whose tangent is equal to the ratio of the inductive to the ohmic resistance.

An angle, the tangent of which is equal to the inductive resistance of the circuit, divided by the ohmic resistance of the circuit.

An angle, the co-sine of which is equal to the ohmic resistance of the circuit, divided by the impedance of the circuit.

Lag, Magnetic — — A magnetic viscosity as manifested by the sluggishness with which a magnetizing force produces its magnetizing effects in iron.

The tendency of the iron core of a magnet, or of the armature of a dynamo-electric machine, to resist, and, therefore, retard magnetization.

This retardation, or lag, is called the *magnetic lag*.

The lead necessary to give the brushes of a dynamo-electric machine to insure quiet action has by

THIS PAGE IS LOCKED TO FREE MEMBERS

Purchase full membership to immediately unlock this page

Know Your Bible

Forgotten Books' Full Membership provides unlimited access to more than 28,000 volumes of Christian literature for \$8.99/month

HOLY BIBLE

Continue

*Fair use policy applies

so gradually as to produce no perceptible effect on the steadiness of the light.

Arc lamps are generally placed in *series circuits*, that is, in circuits in which the current passes successively through all the lamps in the circuit, and returns to the source. In order to avoid the breaking of the entire circuit through the extinguishing of a single arc, on the breaking of its circuit, an *automatic safety device* is provided for each lamp. This safety device consists essentially of an electro-magnet so placed in a shunt circuit, that, as the resistance of the arc becomes too great, the increased current, which will then flow through the coils of the electro-magnet, at last produces a movement of its armature which closes a short circuit around the lamp, and thus cuts it out of the circuit.

Arc lamps assume a great variety of forms. A well known form is shown in Fig. 332.

Lamp, Arc, Triple Carbon — — An arc lamp in which three carbon electrodes are used.

The positive carbons consist of two ordinary cylindrical carbons, placed parallel to each other. The negative carbon is shaped like the figure 8. The arc is established between one of the positive carbons and the corresponding side of the negative carbon. The feeding of the lamp is attended by a shifting back and forth of the arc between the positive carbons and from side to side of the negative carbons.

The design of the triple carbon arc lamp is to produce a lamp of long life.

Lamp Bracket, Electric — — (See *Bracket, Lamp, Electric*.)

Lamp Bulb.—(See *Bulb, Lamp*.)

Lamp, Carcel — — An oil lamp employed in France as a photometric standard.

Fig. 333 shows a form of carcel lamp. Like the standard candle, the carcel is a standard only when it consumes a given weight of the light-producing substance in a given time.

Lamp, Chamber of — —

The glass bulb or chamber of an incandescing electric lamp in which the incandescing conductor is

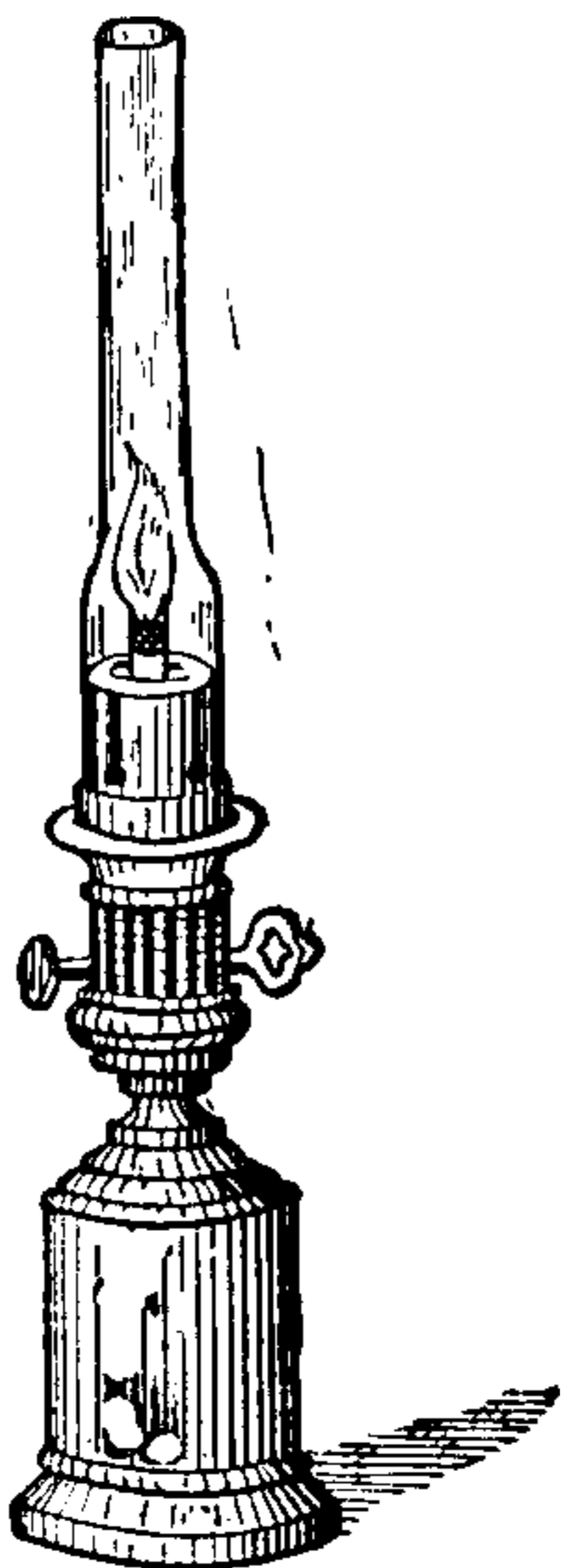

Fig. 333.
Carcel Lamp.

placed, and in which is maintained a high vacuum.

The transparency of the lamp chamber and consequently the efficiency of the lamp may decrease—

(1.) From the settling of dust or dirt on its outer walls.

(2.) From the deposit of carbon or metal on its inner walls.

To obviate the first cause of diminished transparency the outside of the lamp chamber should be frequently cleansed. The diminished transparency, due to the second cause, cannot be removed. When it has reached a certain point, it is more economical to replace the old lamp by a new lamp.

In a properly made lamp the dimming of the lamp chamber is not apt to occur unless a stronger current than the normal current is passed through the lamp.

Lamp Clamp.—(See *Clamp for Arc Lamps*.)

Lamp, Contact — — A form of semi-incandescing electric lamp in which a carbon pencil is pressed against a slab of carbon or other refractory material.

The source of light in an electric contact lamp is twofold, viz.:

(1.) A minute arc formed at the points of imperfect contact.

(2.) The incandescence of the carbon pencil, and the points of the slab of carbon against which it is pressed.

Lamp Contacts.—(See *Contacts, Lamp*.)

Lamp, Electric, Arc, Carbon Electrodes for — — (See *Electrodes, Carbon, for Arc Lamps*.)

Lamp, Electric, Arc, Differential — — An arc lamp in which the movements of the carbons are controlled by the differential action of two magnets opposed to each other, one of whose coils is in the direct and the other in a shunt circuit around the carbons.

Sometimes the differential coils are placed on the same magnet core.

Lamp, Electric, Arc, Double Carbon — — An electric arc lamp provided with two pairs of carbon electrodes, so arranged that when one pair is consumed, the circuit is automatically completed through the other pair.

Lamp, Electric Glow — —A term employed mainly in Europe for an incandescent electric lamp. (See *Lamp, Electric, Incandescent*.)

Lamp, Electric, Incandescent — —An electric lamp in which the light is produced by the electric incandescence of a strip or filament of some refractory substance, generally carbon.

The carbon strip or filament is usually bent into the form of a horseshoe or loop, and placed inside a glass vessel called the lamp chamber. The lamp chamber is exhausted by means of a mercury pump, generally to a fairly high vacuum.

In order to insure the complete removal from the lamp chamber of all the air it originally contained, the carbon strips that are placed within it are maintained at a high temperature during the process of exhaustion. This temperature, in practice, is obtained by sending the current through the carbon strip as soon as nearly all the air is removed. Towards the end of the pumping operation the current is increased so as to raise the carbons to their full brilliancy.

The lamp chamber is also maintained at a fairly high temperature.

To insure this heating of the walls of the lamp chamber by the incandescent carbons during pumping, for the purpose of driving off all the air adhering to the walls of the chamber, they are sometimes covered with some readily removable preparation of lamp black.

The operation of driving off the gases absorbed by the carbons is termed the *occluded gas process*, and is essential to the successful sealing of an incandescent lamp. By its means, a considerable quantity of air or other gaseous substances shut up or occluded by the carbon is driven out of the carbon, which it would be impossible to get rid of by the mere operation of pumping. In order to insure the success of the operation, it is necessary that the heating must take place while the lamp is being exhausted, since otherwise the expelled gases would be re-absorbed. (See *Gas, Occlusion of*.)

Both the exhaustion and the incandescence continue up to the moment the lamp chamber is hermetically sealed; otherwise, some of the air might remain in the lamp chamber.

The lamp chamber is hermetically sealed, usually by the fusion of the glass in the manner

adopted in the sealing of Geissler tubes or Crookes' radiometers.

For the preparation of the carbon strip, its carbonization and the flashing of the strip, see *Carbonization, Processes of. Carbons, Flashing Process for*.

The ends of the carbon strip, or filament, are attached to *leading-in wires* of platinum that pass through the glass walls of the lamp chamber, and are fused therein by melting the glass around them in the same manner as are the leading-in wires of the Geissler tubes and other similar apparatus.

Incandescent lamps are generally connected to the leads or circuits in multiple-arc or in multiple-series. They are, however, sometimes connected to the line in series. (See *Circuits, Varieties of*.)

In the case of multiple-arc or multiple-series connection, the resistance of the filament is comparatively high. In the case of series-connection the resistance is comparatively low.

Incandescent electric lamps assume a variety of different forms. In all cases, however, the shape of the filament is such that the leading-in wires that carry the current to and from the filament shall enter and leave the lamp chamber at points that are comparatively near together. This is for the purpose of avoiding the unnecessary production of shadows.

Commercial incandescent electric lamps are generally marked with the potential difference in volts that must be applied at the terminals in order to furnish the current necessary to properly operate them. If this potential difference is made greater, the can-



Fig. 334. Incandescent Electric Lamp.

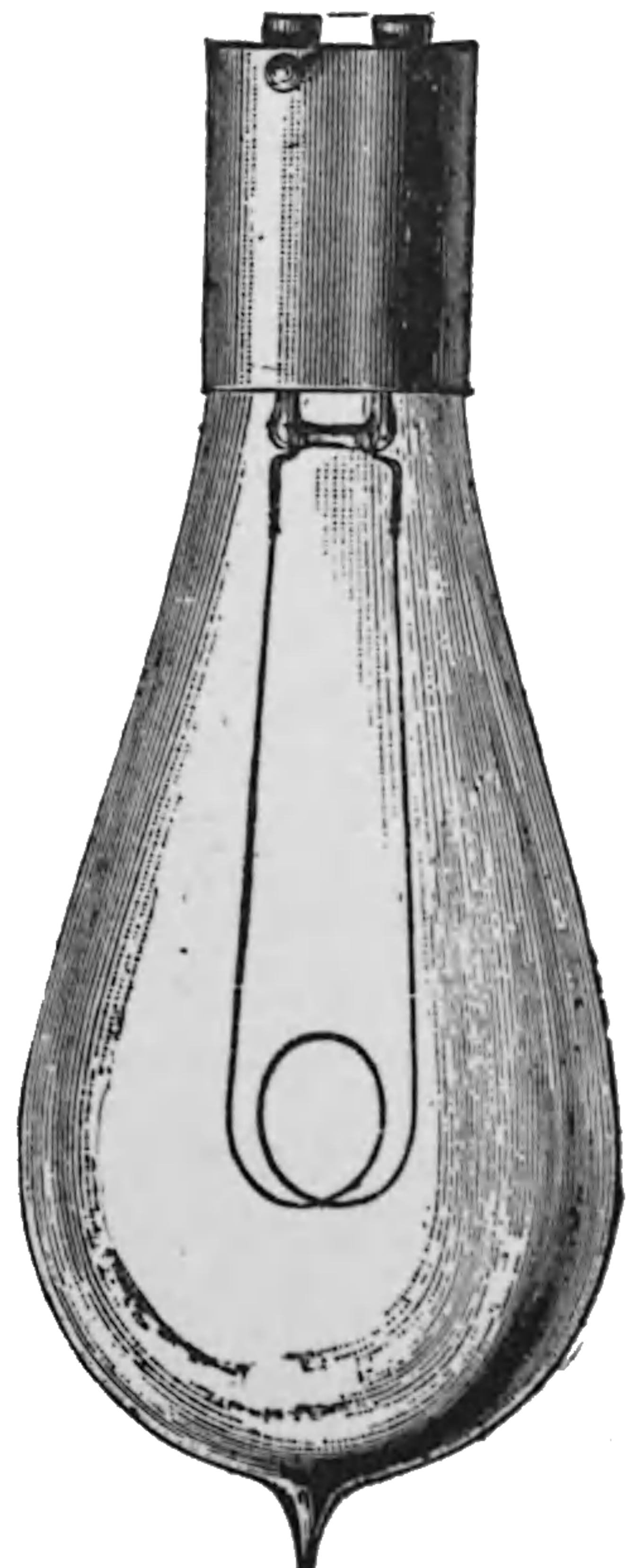

Fig. 335. Swan Incandescent Lamp.

The power of the lamp is greatly increased, but its life greatly decreased.

The lamp chamber is more liable in such cases to become less transparent from the deposit of a thin layer of carbon or metal on its inner surfaces.

In the Swan lamp the filament is made of cotton thread. These threads are immersed in a mixture of two parts of sulphuric acid and one of water, which converts the cellulose of the thread into artificial parchment. The filaments are rapidly washed as soon as they are removed from the sulphuric acid until all traces of the acid are removed. They are then passed through discs so as to insure a uniform area of cross-section, and are then wrapped on rods of carbon or earthenware of the required outline, packed in a crucible filled with powdered charcoal, and carbonized.

The form generally given to the Swan filament is that shown in Fig. 335.

Lamp, Electric, Incandescent Ball —
—An incandescent electric lamp in which the light is produced by a sphere or ball of carbon placed in an exhausted receiver of glass.

When subjected to the effects of electrostatic waves of high frequency of alternation, such a lamp becomes luminous from the incandescence of the carbon ball or sphere. Tesla's incandescent ball electric lamp is a modification of his straight filament lamp. (See *Lamp, Incandescent, Straight Filament.*)

The construction of Tesla's ball incandescent electric lamp will be readily understood from an inspection of Fig. 336.

Lamp, Electric, Incandescent, Half-Shades for — — (See *Half-Shades for Incandescent Lamps.*)

Lamp, Electric, Incandescent, Life of — — The number of hours that an incandescent electric lamp, when traversed by the normal current, will continue to afford a good commercial light.

The failure of an electric incandescent lamp results either from the volatilization or rupture of the carbon conductor, or from the failure of the

vacuum of the lamp chamber. Since the employment of the flashing process, and the process for removing the occluded gases, it is not unusual for incandescent lamps to have a life of several thousand hours. (See *Carbons, Flashing Process for.*)

The life of an incandescent electric lamp should not be considered as continuing until the filament actually breaks. As soon as the lamp chamber has become covered with such a deposit of carbon or coating of metal as to considerably decrease the amount of light which passes through the chamber, the lamp should be considered as useless.

Lamp, Electric, Incandescent, Three-Filament, for Multi-Phase Circuits — — An incandescent lamp for use on multi-phase circuits, provided with three leading-in-wires, connected to the free ends of three filaments, the other ends of which are connected in a common joint.

When properly acting, the current passing through each filament should, at any instant, equal the sum of the currents in the other two filaments, which, as is well known, is the property of any three-phase circuit.

Lamp, Electric, Outrigger for — — (See *Outrigger for Electric Lamp.*)

Lamp, Electric, Pendant — — An incandescent electric lamp suspended by flexible twin-wire.

Lamp, Electric, Safety — — An incandescent electric lamp, with thoroughly insulated leads, employed in mines, or other similar places, where the explosive effects of readily ignitable substances are to be feared.

Such lamps are often directly attached to a portable battery, in which case they can be readily carried about from place to place.

Lamp, Electric, Semi-Incandescent — — An electric lamp in which the light is due to the combined effects of a voltaic arc and electric incandescence.

In the Reynier semi-incandescent lamp, shown in Fig. 337, a thin pencil of carbon C, is gently pressed against a block of graphite B. A lateral contact is provided at L, through a block of graphite I, by means of which the current is con-

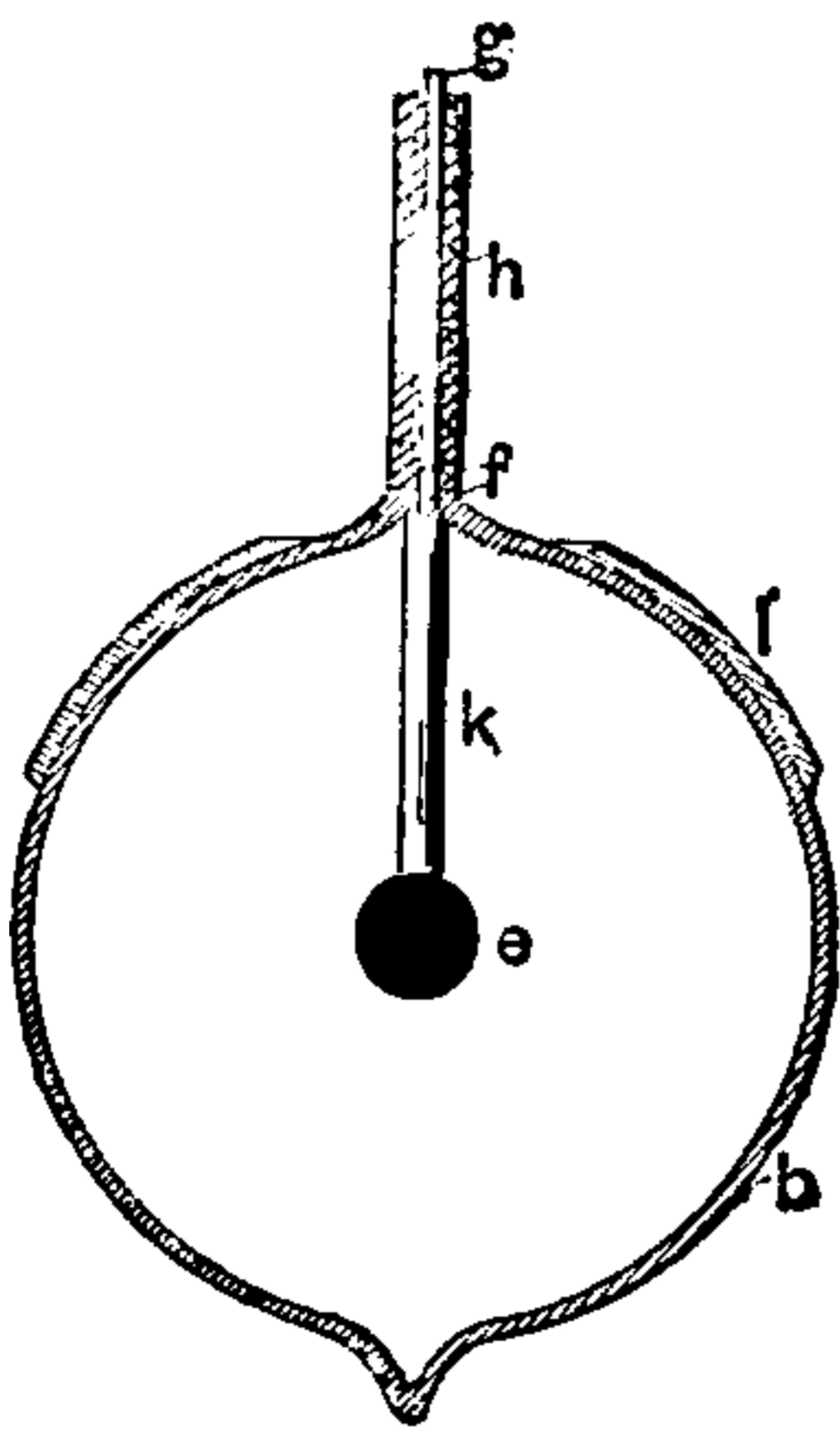

Fig. 336. Tesla's Incandescent Ball Electric Lamp.

THIS PAGE IS LOCKED TO FREE MEMBERS

Purchase full membership to immediately unlock this page



HISTORY

Tens of thousands of important historical sources, many previously unobtainable, are now available for the first time with a Forgotten Books Full Membership.

Unlimited Access
\$8.99/month

Continue

*Fair usage policy applies

ings *s* and *m*, form the plates of a condenser. The other terminal of the machine may be connected to the metal coated walls of the room, or to metallic plates suspended from the ceiling.

Lamp Indicator.—(See *Indicator, Lamp*.)

Lamp, Pilot — —In systems for the operation of electric lamps, an incandescent lamp employed in a station to indicate the difference of potential at the dynamo terminals, by means of the intensity of its emitted light.

Lamp Rod.—(See *Rod, Lamp*.)

Lamp Socket Switch.—(See *Switch, Lamp Socket*.)

Lamps, Bank of — —A term applied to a number of lamps, equal to about half the load, that were formerly placed in view of the attendant in circuit with a dynamo that is to be placed in a parallel circuit with another dynamo, one of the lamps of which is also in view.

When the lamps “in bank” were judged to be of the same brilliancy as the one fed by the other dynamo, the attendant switched the dynamo parallel with the other, and at the same time cut off the bank of lamps from the switched in dynamo.

The method is, however, wrong. The proper way is to make the voltage of the dynamo equal to that of the circuit. Then connect it and finally raise its electromotive force until it takes its share of the load.

Lamps, Carboning — —Placing carbons in electric arc lamps.

When the carbons are consumed, the lamp requires recarboning. The old carbon ends are replaced by new carbons, and the lamp rods cleansed.

Large Calorie.—(See *Calorie, Great*.)

Latent Electricity.—(See *Electricity, Latent*.)

Lateral Discharge.—(See *Discharge, Lateral*.)

Lateral Induction.—(See *Induction, Lateral*.)

Lateral Leakage of Lines of Magnetic Force.—(See *Leakage, Lateral, of Lines of Magnetic Force*.)

Lateral Magnetic Leakage.—(See *Leakage, Lateral, of Lines of Magnetic Force*.)

Latitude, Magnetic — —The distance a place is situated north or south of the magnetic equator.

All places that have the same magnetic latitude have the same value for the magnetic inclination and magnetic intensity, or are on the same isoclinical and isodynamic lines. The magnetic latitude is the same at all points of a magnetic parallel.

Launch, Electric — —A boat, the motive power for which is electricity, suitable for launching from a ship.

Up to the present time electric launches have been propelled by means of electric motors, driven by means of powerful storage batteries.

A form of electric launch constructed for the English Government is shown in Fig. 340. It is

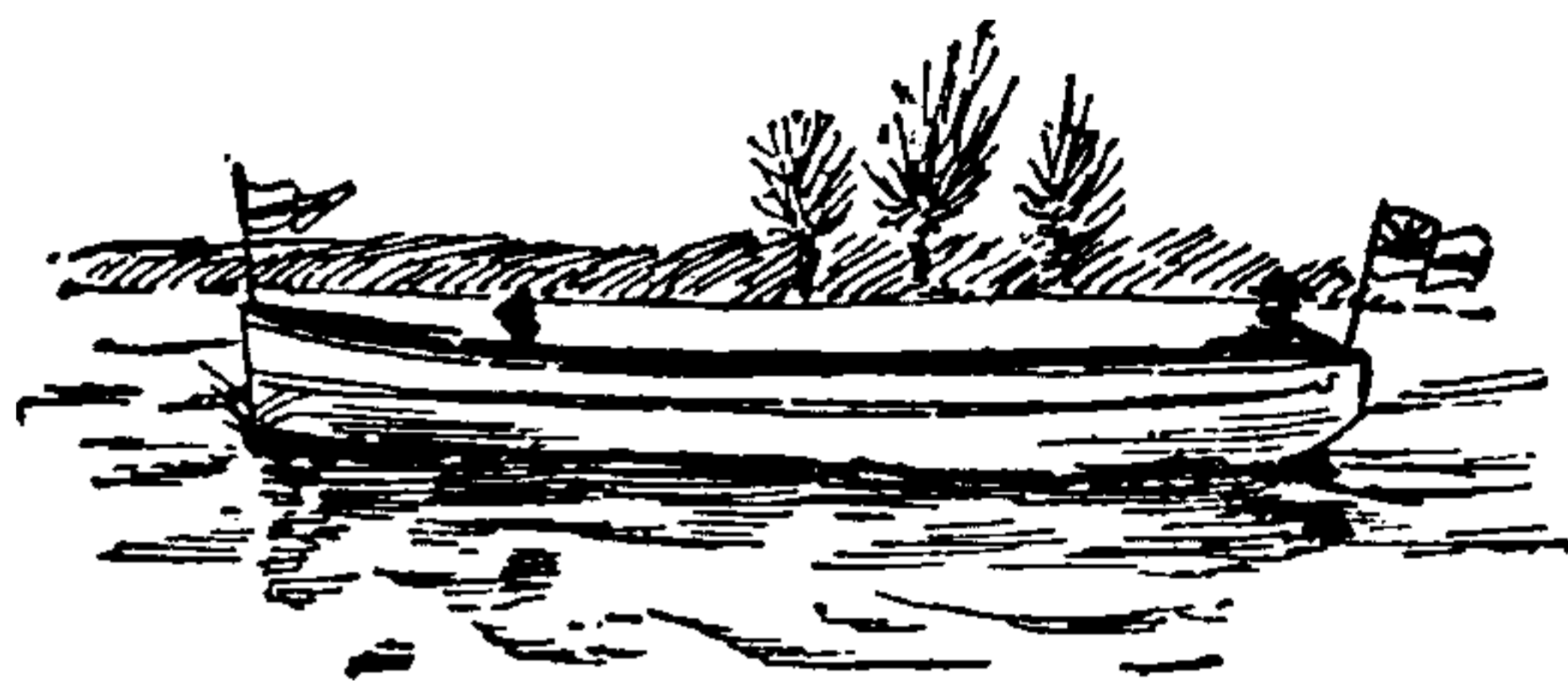

Fig. 340. *Electric Launch.*

48½ feet in length over all, by 8 feet 9 inches beam, with an average draft of 2 feet 3 inches. Its speed is 8 knots per hour. It will carry forty fully equipped soldiers.

Law, Jacobi's — —The maximum work done by a motor is reached when the counter-electromotive force is equal to one-half of the impressed electromotive force, or,

$$E = \frac{e}{2}$$

Law, Joule's — —The heating power of a current is proportional to the product of the resistance and the square of the current strength. (See *Heat, Electric*.)

Law, Natural — —A correct expression of the order in which the causes and effects of natural phenomena follow one another.

The law of gravitation, for example, correctly expresses the order of sequence of the phenomena which result when unsupported bodies fall to the earth. It should be carefully borne in mind, however, that natural laws cannot be regarded as explaining the *ultimate causes of natural pheno-*

mena, but merely express their order of occurrence or sequence.

We are ignorant, for example, of the true cause of gravitation and are only acquainted with its effects. This is true of all ultimate physical causes, save for our belief in their origin in a Divine will.

Law of Electro-Chemical Equivalence.—(See *Equivalence, Electro-Chemical, Law of.*)

Law of Kohlrausch.—In electrolytic conduction, each atom has a rate of motion for a given liquid, which is independent of the element with which it may have been combined.

In the following table, the rate of motion of various kinds of atoms through nearly pure water for a difference of potential of one volt per linear centimetre, is given:

H.....	1.08	centimetres	per hour.
K.....	0.205	centimetre	"
Na.....	0.126	"	"
Li.....	0.094	"	"
Ag.....	0.166	"	"
C.....	0.213	"	"
I.....	0.216	"	"
NO ₃	0.174	"	"

Law of Ohm, or Law of Current Strength.—The strength of a continuous current is directly proportional to the difference of potential or electromotive force in the circuit, and inversely proportional to the resistance of the circuit, *i. e.*, is equal to the quotient arising from dividing the electromotive force by the resistance.

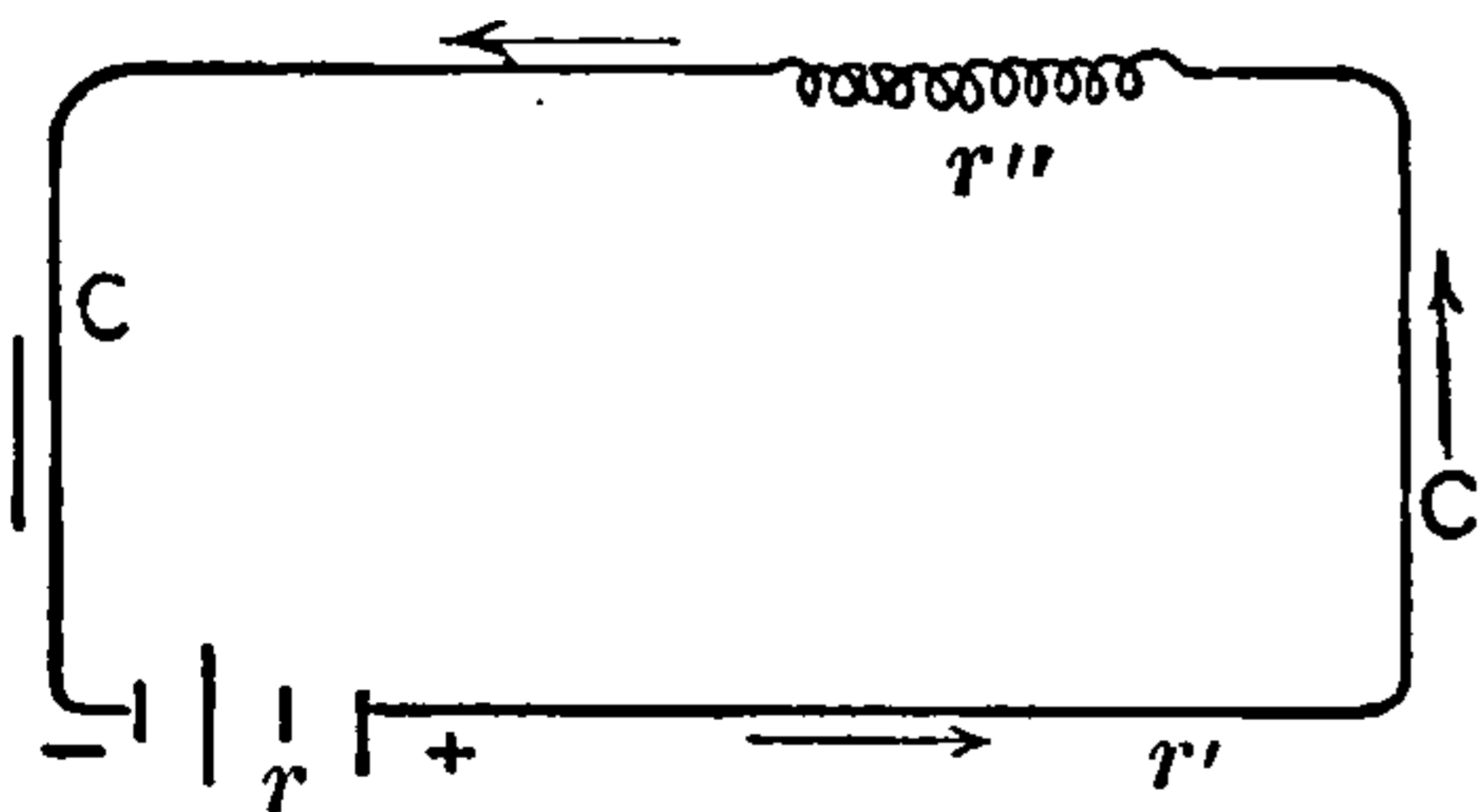

Fig. 341. Current Strength in Circuit.

Ohm's law is expressed algebraically thus:

$$C = \frac{E}{R}; \text{ or, } E = C R.$$

If the electromotive force is given in volts, and the resistance in ohms, the formula will give the current strength directly in ampères.

The resistance of any electric circuit, as, for example, that shown in Fig. 341, consists of three parts, viz.:

- (1.) The internal resistance of the source, r .
- (2.) That of the conducting wires or leads, r' ; and
- (3.) That of the electro-receptive, r'' , energized by the current. Ohm's law applied to this case would be:

$$C = \frac{E}{r + r' + r''}.$$

That is, the resistance of the entire circuit is equal to the sum of the separate resistances of its different parts.

$$\text{Since } C = \frac{E}{R}, (1); \text{ then } E = C R, (2);$$

$$\text{and } R = \frac{E}{C}, (3).$$

But, since a current of one ampère is equal to one *coulomb per second*, then, in order to determine in coulombs the quantity of electricity passing in a given number of seconds, it is only necessary to multiply the current by the time in seconds, or $Q = C T$ (4).

Hence, referring to the above equations (1), (2), (3) and (4); according to Ohm's law:

(1.) The current in ampères is equal to the electromotive force in *volts* divided by the resistance in *ohms*.

(2.) The electromotive force in *volts* is equal to the product of the current in *ampères* and the resistance in *ohms*.

(3.) The resistance in *ohms* is equal to the electromotive force in *volts* divided by the current in *ampères*.

(4.) The *quantity* of electricity in *coulombs* is equal to the current in *ampères* multiplied by the time in seconds.

Law of Volta, or Law for Contact-Series.—A law for the differences of electric potential produced by the contact of dissimilar metals or other substances.

“The difference of potential between any two metals is equal to the sum of the differences of potential between the intervening substances in the contact series.” (See *Electricity, Contact. Series, Contact.*)

Law, Pflüger's — — A given tract of nerve is stimulated by the appearance of kathelectrotonus and the disappearance of anelectrotonus; not, however, by the disap-

pearance of kathelectrotonus nor by the appearance of anelectrotonus.—(*Landois and Stirling.*)

Law, Poynting's — — At any point in a magnetic field, or a conductor conveying current, the energy moves perpendicularly to the plane containing the lines of electric force or the lines of magnetic force, and the amount of energy crossing the unit of area of this plane per second is equal to the product of the intensities of the two forces multiplied by the sine of the angle between them, divided by 4π .

If E , represents the electric force of a small body charged with positive electricity, and H , the magnetic force or forces of a smaller free unit north pole, and, if these forces at any point in the magnetic field are inclined at an angle, θ , then e , the flow of energy per second at this point, in a direction perpendicular to the planes of E and H is,

$$e = \frac{E H \sin. \theta}{4 \pi}.$$

There is, therefore, a difference in the direction of the flow of electricity and the flow of electric energy. Electricity may be conceived as passing through the conductor something like water through a pipe, but electrical energy does not travel in this way. Electrical energy travels through the surrounding dielectric, which is thereby strained, and it propagates this strain from point to point until it reaches the conductor and is there dissipated.

Law, Voltametric — — The chemical action produced by electrolysis in any electrolyte is proportional to the amount of electricity which passes through the electrolyte.

This is called the Voltametric law, because any vessel containing an electrolyte, and furnished with electrodes, so that electrolysis may take place on the passage of the current, and is provided with means for measuring the amount of the electrolysis which occurs, is called a Voltmeter. (See *Voltmeter. Electrolysis.*)

Laws, Ampère's, or Laws of Electro-Dynamic Attraction and Repulsion — — Laws expressing the attractions and repulsions of electric circuits on one another or on magnets.

Laws, Dub's — — The magnetism excited at any transverse section of a magnet is proportional to the square root of the distance between the given section and the near end of the magnet."

"The free magnetism at any given transverse section of a magnet is proportional to the difference between the square root of half the length of the magnet and the square root of the distance between the given section and the nearest end."

Laws, Kirchoff's — — The laws for branched or shunted circuits.

These laws may be expressed as follows:

(1.) In any number of conductors meeting at a point, if currents flowing to the point be considered as $+$, and those flowing away from it as $-$, the algebraic sum of the meeting currents will be zero.

This is the same thing as saying as much electricity must flow away from the point as flows toward it.

(2.) In any system of closed circuits the algebraic sum of the products of the currents into the resistances is equal to the electromotive force in the circuit.

In this case all currents flowing in a certain direction are taken as positive, and those flowing in the opposite direction as negative. All electromotive forces tending to produce currents in the direction of the positive current are taken as positive, and those tending to produce currents in the opposite direction, as negative.

This follows from Ohm's law; for, since $C = \frac{E}{R}$, the electromotive force $E = CR$, and this is true, no matter how often the circuit is branched.

Laws, Lenz's — — Laws for determining the directions of currents produced by electrodynamic induction.

The direction of the currents set up by electrodynamic induction is always such as to oppose the notions by which such currents were produced.

Laws of Becquerel, or Laws of Magneto-Optic Rotation.—Laws for the magneto-optic rotation of the plane of polarization of light. (See *Rotation, Magneto-Optic.*)

Laws of Coulomb, or Laws of Electro-

THIS PAGE IS LOCKED TO FREE MEMBERS

Purchase full membership to immediately unlock this page

Know Your Bible

Forgotten Books' Full Membership provides unlimited access to more than 28,000 volumes of Christian literature for \$8.99/month

HOLY BIBLE

Continue

*Fair use policy applies

Lead, Cable — —A lead containing a conductor formed of several stranded conductors, as distinguished from a wire lead or a lead containing a single conductor.

Lead, Flexible — —A conductor formed of a number of small stranded conductors for the purpose of obtaining flexibility.

Lead, Flexible Twin — —A flexible conductor in which two parallel and separately insulated wires are placed.

Lead of Brushes of Dynamo-Electric Machine.—The angular deviation from the normal position, which it is necessary to give the brushes on the commutator of a dynamo-electric machine, in order to obtain efficient action. (See *Lead, Angle of.*)

Lead Scoring Tool.—(See *Tool, Scoring, Lead.*)

Lead Sleeve.—(See *Sleeve, Lead.*)

Lead, Tee.—(See *Tee, Lead.*)

Lead, Wire — —A lead consisting of a single conductor, as distinguished from a cable lead, or a lead containing a number of stranded conductors.

Lead Wire.—(See *Wire, Lead.*)

Leading Horn of Pole Pieces of Dynamo-Electric Machine.—(See *Horns, Leading, of Pole Pieces of a Dynamo-Electric Machine.*)

Leading-In Wires.—(See *Wires, Leading-In.*)

Leading-Up Wires.—(See *Wires, Leading-Up.*)

Leads.—The conductors in any system of electric distribution.

In distribution by parallel, the conductors through which the current flows from the source are sometimes called the leads in contradistinction to those through which it returns to the source.

The leads, or main conductors, in a multiple system of electric lighting, must maintain a constant potential at the lamp terminals. The dimensions of the leads are, therefore, so proportioned as to absorb as small an amount of potential as possible. Since, in incandescent lighting, where the lamps are connected to the leads in multiple-arc, the total resistance of the lamps is comparatively

small, the resistance of the leads must be quite small in order to avoid a marked drop of potential. Comparatively large conductors must, therefore, be used.

The main conductor for series circuits, such as for arc-lights, has in all parts the same current strength. Since the sum of the resistances of the lamps in such a circuit is quite high, a comparatively high resistance in the conductor may be employed without a proportionally large absorption of potential. Comparatively small conductors can therefore be used. (See *Electricity, Distribution of, by Constant Currents. Electricity, Distribution of, by Alternating Currents.*)

Leads, Armature, Twist in — —A displacement of the ends of the wires connected to the commutator segment, with respect to the position of the coils on the armature, for the purpose of obtaining a more convenient position for the diameter of commutation, that is, for the collecting brushes.

Leak, Oscillatory — —A leak or gradual loss of electricity which takes place in alternately opposite directions.

Leak, Unidirectional — —A gradual loss or leakage of electricity which takes place in one and the same direction.

The term has been employed to distinguish such a leak from an oscillatory leak.

Leakage Conductor.—(See *Conductor, Leakage.*)

Leakage, Electric — —The gradual dissipation of a current due to insufficient insulation.

Some leakage occurs under nearly all circumstances. On telegraphic lines, during wet weather, the leakage is often so great as to interfere with the proper working of the lines.

Leakage, Electrostatic — —The gradual dissipation of a charge due to insufficient insulation.

The leakage of a well insulated conductor, placed in a high vacuum, is almost inappreciable. Crookes has maintained electric charges in high vacua for years without appreciable loss.

Leakage, Lateral, of Lines of Magnetic Force — —The failure of lines of magnetic

force to pass approximately parallel to one another through a bar of iron or other magnetizable material, when it has come to rest in a magnetic field in which it is free to move.

The escape of the lines of magnetic force from the sides of a bar or other similar magnet, instead of from the poles at the end.

When a bar of magnetizable material, suspended so as to be free to move, comes to rest in a magnetic field in which it is undergoing magnetization, it has its greatest length parallel to the direction of the lines of force. If the bar is a long, thin, straight bar, the lines of force do not all pass in or come out at its ends. On the contrary, many of these lines of force or induction pass in or come out at other points. The magnetic induction is, therefore, unequal at different sections of the bar. In other words, the magnetic flux or intensity is not constant per unit of all cross-sections of such bar.

Leakage, Magnetic — — A useless dissipation of the lines of magnetic force of a dynamo-electric machine, or other similar device, by their failure to pass through the armature where they are needed.

Useless dissipation of lines of magnetic force outside that portion of the field of a dynamo-electric machine through which the armature moves.

Such a leakage can be detected by an instrument called a *magnetophone*. (See *Magnetophone*.)

Magnetic leakage results in lowering the efficiency of the dynamo. (See *Co-efficient, Economic, of a Dynamo-Electric Machine*.)

Leclanché's Voltaic Cell.—(See *Cell, Voltaic, Leclanché*.)

Leg.—In a system of telephonic exchange, where a ground return is used, a single wire, or, where a metallic circuit is employed, two wires, for connecting a subscriber with the main switchboard, by means of which any subscriber may be legged or placed directly in circuit with two or more other parties.

Leg of Circuit.—(See *Circuit, Leg of*.)

Legal Earth Quadrant.—(See *Quadrant, Legal Earth*.)

Legal Ohm.—(See *Ohm, Legal*.)

Legging-Key Board.—(See *Board, Legging-Key*.)

Length of Spark.—(See *Spark, Length of*.)

Lens, Achromatic — — A lens the images formed by which are free from the false coloration produced in other lenses by dispersion.

An ordinary lens can be rendered approximately achromatic by the use of a diaphragm. Achromatic lenses generally consist of the com-

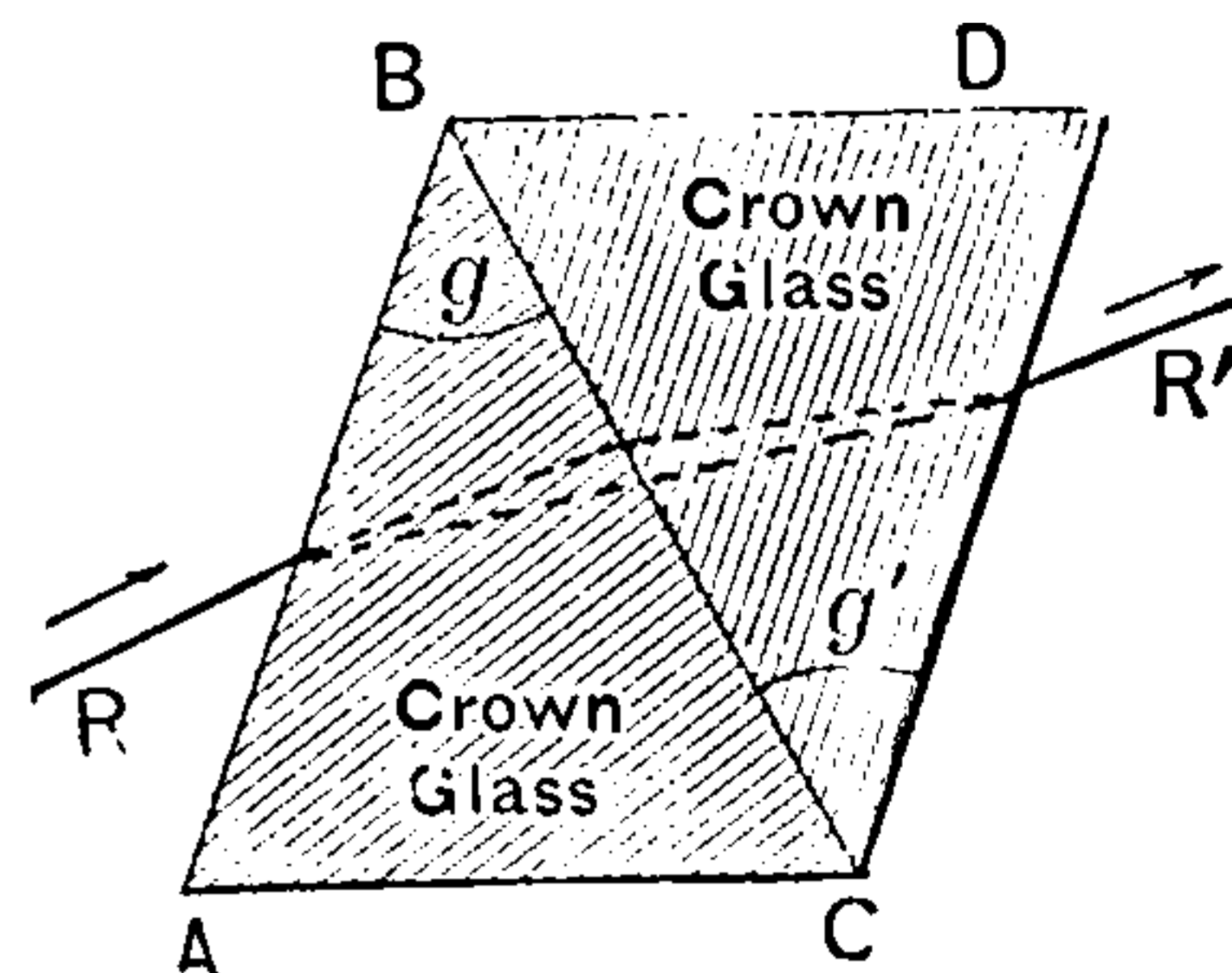

Fig. 342. Equal and Opposite Refracting Angles.

ination of a double convex lens of flint glass and a concave lens of crown glass.

The ray of light entering the prism A B C, Fig. 342, suffers dispersion (separation into prismatic colors). This dispersion in the same

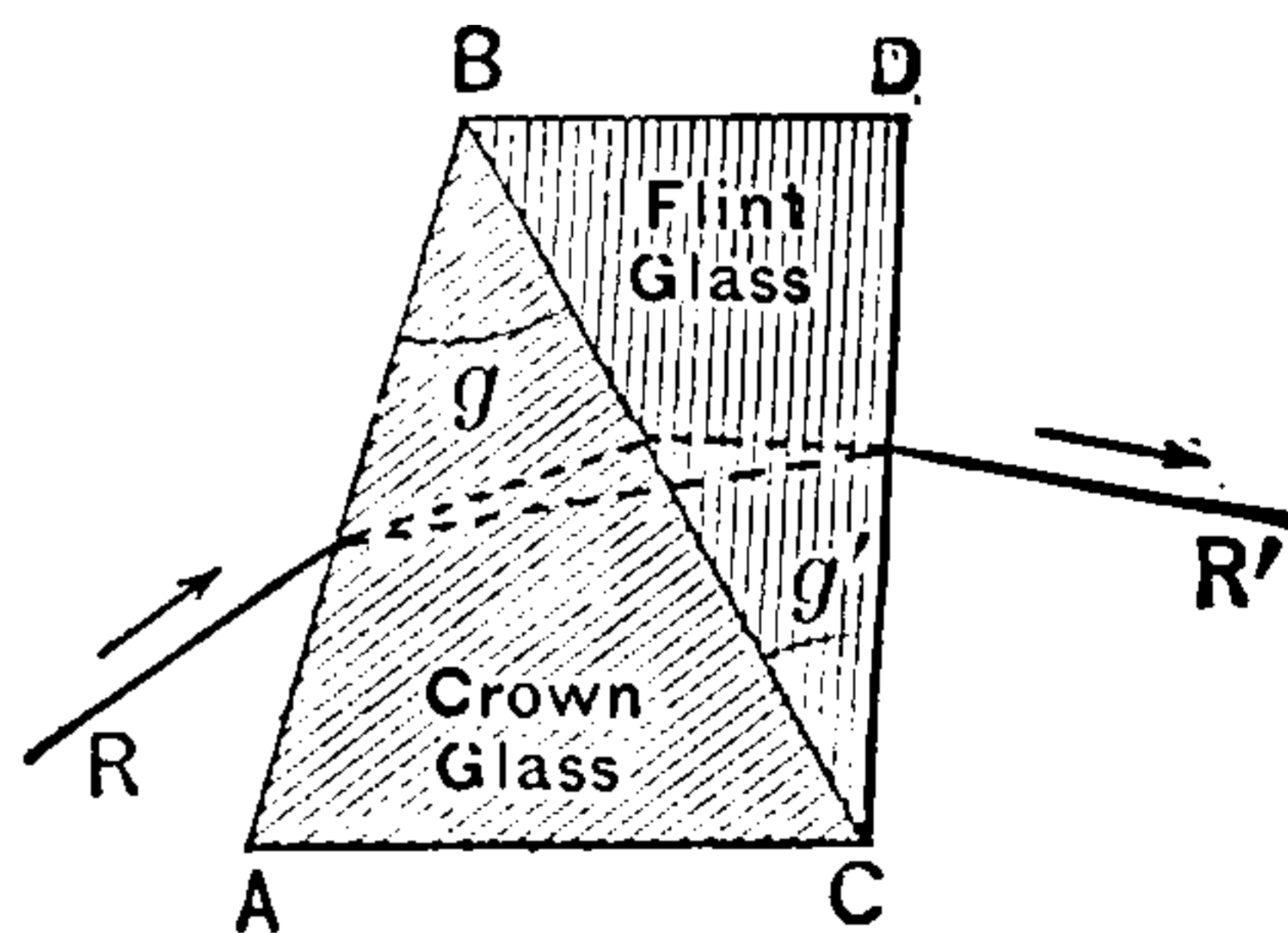

Fig. 343. Principle of Achromatism.

medium is proportional to the angle g , between the incident and emergent faces, called the *refracting angle*.

If, now, another prism B C D, of the same material, with a refracting angle g' , equal to g , is combined with the first prism in the manner shown in Fig. 342, it will produce an equal but opposite dispersion, so that the ray of light will emerge at R', free from rainbow tints, but parallel to its original direction.

The variety of glass called *crown glass* produces only half as great dispersion of light as the variety called *flint glass*, under the same refract-

ing angle g . If the prism $A B C$, of crown glass, Fig. 343, whose angle g , is twice as great as the refracting angle g' , of the prism $B C D$, of flint glass, be placed together in the manner shown, then the ray R , will be transmitted at R' , free from color, *but will not emerge parallel to its original direction*; in other words, it suffers refraction or bending. Consequently such a combination can be used to free a pencil of light from false coloration and yet permit it to undergo refraction, and thus act as a lens. (See *Refraction*.)

The construction of achromatic lenses is based on this principle.

The crown glass is generally made with two

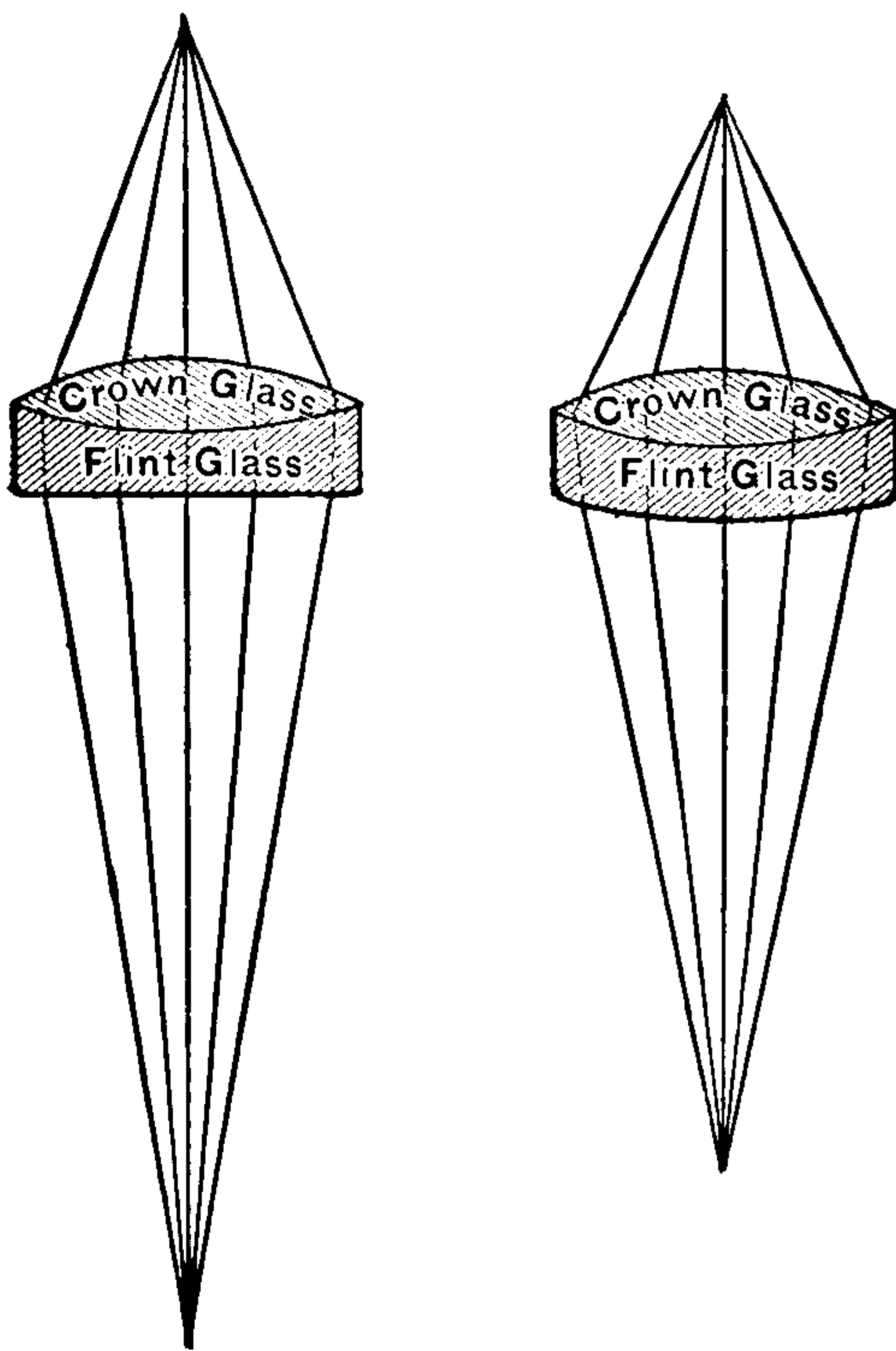

Fig. 344. *Plano-Convex Achromatic Lens.* Fig. 345. *Achromatic Lens.*

convex surfaces; the flint glass, with one concave and one plane surface, as shown in Fig. 344.

Sometimes both surfaces of the flint glass are made curved, as in Fig. 345.

Lenz's Law.—(See *Law, Lenz's*.)

Letter Box, Electric — —A device that announces the deposit of a letter in a box by the ringing of a bell, or by the movement of a needle or index.

These devices generally act by the closing or opening of an electric circuit on the fall of the letter into the box.

Leyden Jar.—(See *Jar, Leyden*.)

Leyden Jar Pattery.—(See *Battery, Leyden Jar*.)

Lichtenberg's Dust Figures.—(See *Figures, Lichtenberg's Dust*.)

Life Curve of Incandescent Electric Lamp.—(See *Curve, Life, of Incandescent Electric Lamp*.)

Life of Electric Incandescent Lamp.—(See *Lamp, Incandescent, Life of*.)

Light, Auroral — —The light given off during the prevalence of an aurora. (See *Aurora Borealis*.)

Light, Electric — —Light produced by the action of electric energy.

Electric light is produced by electric energy in various ways, the most important of which are as follows, viz.:

(1.) By the passage of an electric discharge through a gas or vapor, either in a rarefied condition, at ordinary atmospheric pressure, or at pressures higher than that of the ordinary pressure. In any of these cases the gas or vapor is heated to incandescence by the passage of the discharge.

(2.) By the incandescence of a solid by the heating power of the current, as in the incandescent lamp.

(3.) By the incandescence of a solid by the action of a rapidly alternating electrostatic field, as in Tesla's incandescent lamp.

(4.) By the volatilization of a solid and the formation thereby of a voltaic arc.

(5.) By the combination of the effects of incandescence and the voltaic arc.

The amount of light produced in proportion to the amount of energy expended to produce it is probably least in the case of light produced by the sparks of a Wimshurst or Holtz machine, or as in (1), than in any other case in which electric energy acts to produce luminous energy.

Light, Electric, Pumping of — —(See *Pumping of Electric Light*.)

Light, Intensity of — —The brilliancy or illuminating power of a light as measured by a photometer in standard candles or other standard units. (See *Photometer, Candle, Standard*.)

Light, Maxwell's Electro - Magnetic Theory of — —A hypothesis for the

THIS PAGE IS LOCKED TO FREE MEMBERS

Purchase full membership to immediately unlock this page



HISTORY

Tens of thousands of important historical sources, many previously unobtainable, are now available for the first time with a Forgotten Books Full Membership.

Unlimited Access
\$8.99/month

Continue

*Fair usage policy applies

for lighting the surrounding space for purposes of exploration.

Light, Southern — — (See *Aurora Australis*.)

Light, Tail — — A light displayed at the rear end of trains in order to avoid rear collisions. (See *Railroads, Block System for*.)

Lighter, Cigar, Electric — — An apparatus for electrically lighting a cigar.

A cigar lighter consists essentially of a wire or rod of refractory substance, rendered incandescent by the passage of a current obtained from a voltaic battery, secondary generator, or other electric source.

Lighter, Electric, Argand — — A name sometimes given to an argand electric plain-pendant burner. (See *Burner, Argand-Electric, Plain-Pendant*.)

Lighter, Electric, Argand Valve — — A name sometimes given to an argand electric ratchet-pendant burner. (See *Burner, Argand-Electric, Ratchet-Pendant*.)

Lighthouse Illumination, Electric — — (See *Illumination, Lighthouse, Electric*.)

Lighting, Arc — — Artificial illumination obtained by means of an arc light.

The term arc lighting is used in contradistinction to incandescent lighting. In the United States, and, indeed, generally, a number of arc lights are placed in series on the line circuit, connected generally with a series dynamo. Each of the lamps is provided with a safety cut-out, which cuts out or removes a defective lamp from the circuit by automatically turning or switching the current through a shunt of low resistance.

Lighting, Electric, by High Frequency Currents — — A system of electric lighting, in which rods, bars or filaments of carbon or other refractory substances are raised to incandescence when placed in a rapidly alternating electrostatic field.

This system of electric lighting was invented by Nikola Tesla. Its general principles will be understood from an inspection of Fig. 346.

G, is a dynamo producing alternating currents of comparatively low potential. A portion of its current P, acting as the primary of an induction coil, induces alternating currents of high

potential in the secondary circuit S, which, charging the condenser C, is disruptively discharged into the circuit A, provided with an air gap at A' through P'. The inductive action of P', on S', produces oscillatory currents of

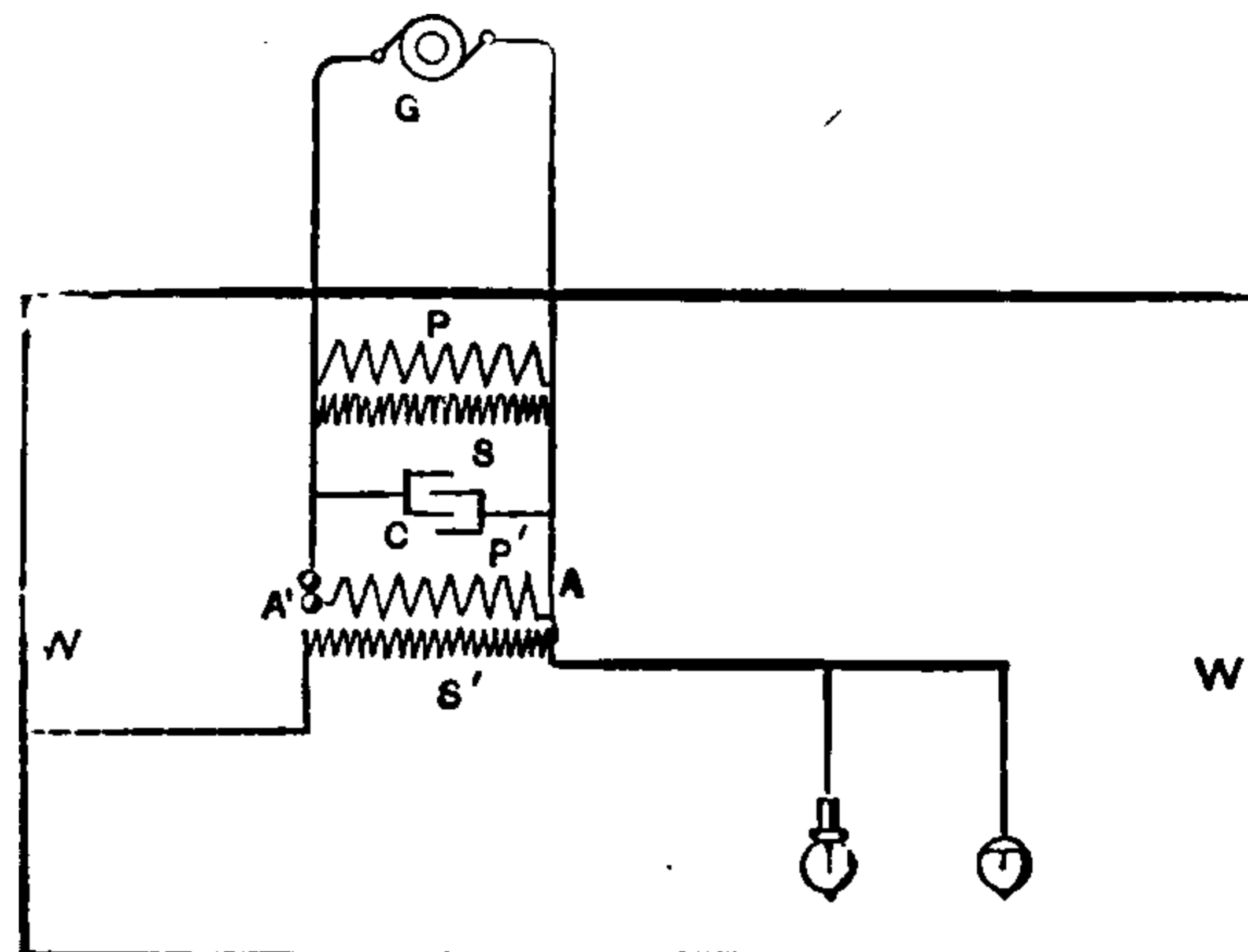

Fig. 346. Tesla's High Frequency Currents System of Lighting.

enormous frequency and potential in the secondary circuits connected therewith. In the apparatus shown in Fig. 346, two incandescent electric lamps are connected with the secondary circuit, one with a single straight filament, and the other with a ball conductor. The other terminal of S', is connected to the walls of the room to be lighted. (See *Lamp, Incandescent, Straight Filament. Lamp, Electric, Incandescent Ball*.)

Lighting, Electric, Central Station — — The lighting of a number of houses or other buildings from a single station, centrally located.

Central station lighting is distinguished from isolated lighting by the fact that a number of separate buildings, houses or areas, are lighted by the current produced at a single station, centrally located, instead of from a number of separate electric sources located in each of the houses, etc., to be lighted. (See *Electricity, Distribution of*.)

Lighting, Electric Gas — — Igniting gas jets by means of electric discharges.

Electric sparks are caused to pass through a jet of escaping gas, and thus to light it. These sparks are obtained from a spark-coil, *i. e.*, a coil of insulated wire connected in series with the circuit so as to produce an extra current on the sudden breaking of the circuit, the discharge of which produces a spark capable of igniting the gas. In cases where a number of burners are to be simultaneously lighted the sparks required for

lighting the gas are obtained from the secondary of an induction coil. (See *Burner, Automatic Electric.*)

Lighting, Electric, Isolated — —A system of electric lighting where a separate electric source is placed in each house or area to be lighted, as distinguished from the central station lighting, where electric sources are provided for the production of the current required for an entire neighborhood.

Lighting, Electric, Long-Arc System of — —A system of electric lighting in which long arcs are maintained between the carbon electrodes.

Lighting, Electric, Short-Arc System — —A system of electric lighting in which short voltaic arcs are maintained between the carbon electrodes.

Systems of short arcs require an electromotive force of about 25 volts, which is about one-half that employed in long arcs. To develop an equal amount of heat energy in a short arc as in a long arc, therefore, requires that the current be of double strength.

The greater part of the light of a voltaic arc is given off from a tiny crater, which is formed in the end of the positive carbon. In the short arc system the crater lies so near the negative carbon that much of its light is necessarily obscured, and troublesome shadows are sometimes produced. The long-arc system avoids these difficulties.

Lightning.—The spark or bolt that results from the disruptive discharge of a cloud to the earth, or to a neighboring cloud. (See *Electricity, Atmospheric. Kite, Franklin's.*)

Lightning Arrester.—(See *Arrester, Lightning.*)

Lightning, Back-Stroke of — —An electric discharge, caused by an induced charge, which occurs after the direct discharge of a lightning flash.

The shock is not caused by the lightning flash itself, but most probably by a charge which is induced in neighboring conductors by the discharge. A similar effect may be noticed by standing near the conductor of a powerful electric machine, when shocks are felt at every discharge.

The back-stroke has been ascribed by many to

the oscillations by which a disruptive discharge is effected. (See *Discharge, Oscillating.*)

The effects of the return shock are sometimes quite severe. They are often experienced by sensitive people, on the occurrence of a lightning discharge, at a considerable distance from the place where the discharge occurred.

In some instances, the return stroke has been sufficiently intense to cause death. In general, however, its effects are much less severe than those of the direct lightning discharge.

Lightning, Ball — —A name sometimes given to globular lightning. (See *Lightning, Globular.*)

Lightning, Chain — —A variety of lightning flash in which the discharge takes a rippling path, somewhat resembling a chain.

Lightning Conductor.—(See *Rod, Lightning.*)

Lightning, Forked — —A variety of lightning flash, in which the discharge, on nearing the earth or other object, divides into two or more branches.

Lightning, Globular — —A rare form of lightning, in which a globe of fire appears, which quietly floats for a while in the air and then explodes with great violence.

The exact cause of globular lightning is unknown. Phenomena allied to it, however, have been observed by Planté during the series discharge of his rheostatic machine. Similar phenomena are sometimes, though rarely, observed during the discharge of a powerful Leyden battery. Sir Wm. Thomson ascribes the effect to an optical illusion due to the persistence of the visual impression of a bright flash. This, however, would not account for the explosion which almost invariably attends globular lightning.

Lightning Guard.—(See *Guard, Lightning.*)

Lightning, Heat — —A variety of lightning flash in which the discharge lights up the surfaces of the neighboring clouds.

Sheet lightning is unaccompanied by thunder. It may be regarded as a brush discharge from one cloud to another.

Heat lightning is a variety of sheet lightning. (See *Lightning, Sheet.*)

Lightning Jar.—(See *Jar, Lightning*.)

Lightning, Return-Stroke of — —A term sometimes applied to the back-stroke of lightning. (See *Lightning, Back-Stroke of*.)

Lightning Rod.—(See *Rod, Lightning*.)

Lightning Rod for Ships.—(See *Rod, Lightning, for Ships*.)

Lightning, Sheet — —A variety of lightning flash unaccompanied by any thunder audible to the observer, in which the entire surfaces of the clouds are illumined.

The cause of sheet lightning has been ascribed to reflection from clouds of lightning flashes that occur too far below the horizon either to permit them to be directly seen, or the thunder to be heard.

If a Geissler tube, which contains several concentric tubes, be charged by a Holtz machine, and then touched at different parts by the hands, a succession of luminous discharges will be seen in the dark, that bear a remarkable resemblance to the flashes of heat or sheet lightning.

Lightning Stroke.—(See *Stroke, Lightning*.)

Lightning Stroke, Back or Return — —(See *Stroke, Lightning, Back or Return*.)

Lightning, Summer — —A name sometimes given to heat lightning. (See *Lightning, Heat*.)

Lightning, Volcanic — —The lightning discharges that attend most volcanic eruptions.

Volcanic lightning is possibly sometimes due to the friction of volcanic dust particles against one another, or against the air, but is more probably caused by the sudden condensation of the water vapor that is generally disengaged during volcanic eruptions.

Lightning, Zigzag — —The commonest variety of lightning flashes, in which the discharge apparently assumes a forked zigzag, or even a chain-shaped path.

This form is seen in the discharge of a Holtz machine, or of a *Ruhmkorff Induction Coil*.

Photographic pictures of such lightning discharges appear to show that these discharges are in reality zigzag curves, rather than sharp angular zigzags.

Limiting Stop.—(See *Stop, Limiting*.)

Limb, Rheoscopic — —A term sometimes applied to a sensitive nerve muscle preparation, employed to detect the presence of an electric current. (See *Frog, Galvanoscope*.)

Line.—A wire or other conductor connecting any two points or stations.

Line, Aclinic — —A line connecting places on the earth's surface which have no magnetic inclination.

The magnetic equator of the earth. (See *Equator, Magnetic*.)

Line Adjuster.—An instrument invented by Delany for overcoming the effects of leakage on the adjustment of the relays in a way line.

When any key is opened, the line circuit is simultaneously broken at both ends so that there is a moment of no current, which causes all the relays to respond.

Line, Aerial — —An air line as distinguished from an underground conductor.

Line, Agonic — —A line connecting places on the earth's surface where the magnetic needle has no declination, or where it points to the true geographical north. (See *Agonic*.)

Line, Artificial — —A line so made up by condensers and resistance coils as to have the same inductive effects on charging or discharging as an actual telegraph line.

In duplex telegraphy by the differential method, the artificial line used must have its capacity balanced against that of the line, so as to avoid the effects of self-induction, and other effects produced by charging and discharging.

Line, Capacity of — —The ability of a line or cable to act like a condenser, and therefore like it to possess a capacity. (See *Cable, Capacity of*.)

Line Circuit.—(See *Circuit, Line*.)

Line Circuit, Telegraphic — —(See *Circuit, Line, Telegraphic*.)

Line, Neutral, of a Magnet — —A line joining the neutral points of a magnet or

THIS PAGE IS LOCKED TO FREE MEMBERS

Purchase full membership to immediately unlock this page

Know Your Bible

Forgotten Books' Full Membership provides unlimited access to more than 28,000 volumes of Christian literature for \$8.99/month

HOLY BIBLE

Continue

*Fair use policy applies

The total number of Kapp lines passing through a magnet and air space is equal to the ampère turns divided by the total magnetic reluctance in the magnetic circuit.—(*Urquhart.*)

Lines of Electric Displacement.—(See *Displacement, Electric, Lines of.*)

Lines of Electrostatic Force.—(See *Force, Electrostatic, Lines of.*)

Lines of Force, Cutting — — (See *Force, Lines of, Cutting.*)

Lines of Force, Direction of — — (See *Force, Lines of, Direction of.*)

Lines of Inductive Action.—(See *Action, Inductive, Lines of.*)

Lines of Magnetic Force.—(See *Force, Magnetic, Lines of.*)

Lines of Magnetic Force, Conducting Power for — — (See *Force, Magnetic, Lines of, Conducting Power for.*)

Lines of Magnetic Induction.—(See *Induction, Magnetic, Lines of.*)

Lines, Overhead — — A term applied to telegraph, telephone and electric light or power lines that run overhead, in contradistinction to similar lines placed underground.

Lines, Vortex-Stream — — Lines extending in the direction in which the particles of a fluid are moving.

A vortex stream is supposed to be composed of a number of vortex-stream lines.

Linked Magnetic and Electric Chain.—(See *Chain, Linked Magnetic and Electric.*)

Links, Fuse — — Strips or plates of fusible metal in the form of links, employed for safety fuses for incandescent or other circuits.

Liquid, Bright Dipping — — A liquid used in electro-plating for dipping articles preparatory to electro-plating, so as to insure a bright plating deposit on them when afterwards subjected to the plating process.

A bright dipping liquid is prepared by the addition of 1 volume of common table salt to a mixture of 100 volumes each of sulphuric and nitric acids. For small objects or articles of copper, or other readily corroded metals, the

above solution is diluted by the addition of one-eighth its volume of water.

Liquid, Electropoion — — A battery liquid consisting of 1 pound of bichromate of potash dissolved in 10 pounds of water, to which 2½ pounds of commercial sulphuric acid has been gradually added.

This liquid is employed with the carbon-zinc cell or the bichromate of potash cell.

Liquid, Exciting, of Voltaic Cell — — The electrolyte or liquid in a voltaic cell, which acts on the positive plate.

Liquid Level Alarm.—(See *Alarm, Water or Liquid Level.*)

Liquid Resistance Load.—(See *Load, Liquid Resistance.*)

Liquid, Stripping — — A liquid employed to remove a coating of one metal from the surface of another, without affecting the other metal.

The character of the stripping liquid used will depend on the kind of metal to be removed, and whether the stripping is to be accomplished by solution effected by chemical action, or by electrolytic action.

Liquid, Specific Resistance of — — (See *Resistance, Specific, of Liquid.*)

Liquor, Spent — — Any liquor, such as that in the acid or other baths used in electroplating, that has become weakened by use.

Listening Cam.—(See *Cam, Listening.*)

Load, Liquid Resistance — — An artificial load for a dynamo-electric machine, consisting of a mass of liquid interposed between electrodes.

A liquid is generally rendered better conducting by the addition of a small quantity of soluble salt, such, for example, as sulphate of soda.

Local Action of Dynamo-Electric Machine.—(See *Action, Local, of Dynamo-Electric Machine.*)

Local Action of Voltaic Cell.—(See *Action, Local, of Voltaic Cell.*)

Local Battery.—(See *Battery, Local.*)

Local Battery Circuit.—(See *Circuit, Local-Battery.*)

Local Currents.—(See *Currents, Local.*)

Local Faradization.—(See *Faradization, Local.*)

Local Galvanization.—(See *Galvanization, Local.*)

Localization of Faults.—(See *Faults, Localization of.*)

Lock, Electric — —A lock that is automatically unlocked by the aid of electricity.

The electric lock is so arranged that the action of a push button at a distance unlocks the door. A speaking tube communicates with the house, and the pressing of a push button on any floor of the house unlocks the door. The mere shutting of the door locks it.

A form of electric lock is shown in Fig. 347.

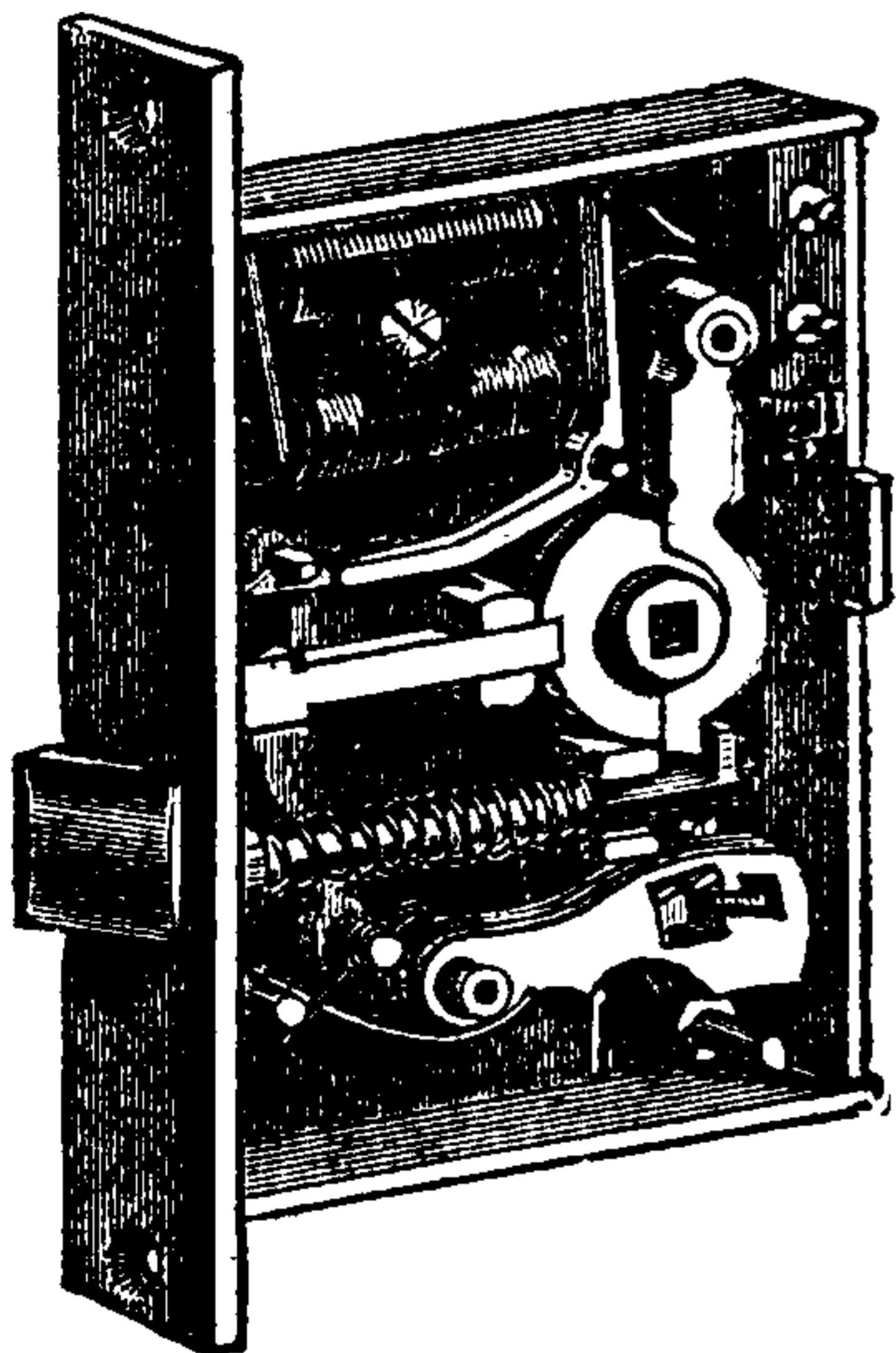

Fig. 347. *Electric Lock.*

Locomotive, Electric — —A railway engine whose motive power is electricity. (See *Railroads, Electric.*)

Locomotive Head Light, Electric — — (See *Head Light, Locomotive.*)

Lodestone.—A name formerly applied to an ore of iron (magnetic iron ore), that naturally possesses the power of attracting pieces of iron to it.

Lodestone, or magnetic iron ore, must be regarded as a magnetizable substance that has become permanently magnetic from its situation in the earth's magnetic field. Such beds of ore concentrate the lines of the earth's magnetic field on them, and thus become magnetic.

Lodge's Standard Voltaic Cell. —(See *Cell, Voltaic, Standard, Lodge's.*)

Log, Electric — —An electric device for measuring the speed of a vessel.

A log, operated by the rotation of a wheel, is caused to register the number of its rotations by a step-by-step recording apparatus operated by breaks in the circuit, made during the rotation of the wheel, at any given number of turns, say 100, or some other convenient multiple. Such a log may be kept constantly in the water, and observed when required, or it can be caused to make a permanent record of its actual speed at any time during the entire run.

Logarithm.—The exponent of the power to which it is necessary to raise a fixed number, in order to produce a given number.

A table of logarithms enables the operations of multiplication, division, the raising of powers, and the extraction of roots, to be readily performed by simple addition, subtraction, multiplication or division, respectively. When thoroughly understood, logarithms greatly reduce the labor of mathematical calculations. For the manner in which they are used, the student is referred to any standard work on mathematics.

Logarithmic Curve.—(See *Curve, Logarithmic.*)

Long-Coil Magnet.—(See *Magnet, Long-Coil.*)

Long-Core Electro-Magnet.—(See *Magnet, Electro, Long-Core.*)

Long-Shunt Compound-Wound Dynamo-Electric Machine.—(See *Machine, Dynamo-Electric, Compound-Wound, Long-Shunt.*)

Longitude, Electric Determination of — —The determination of the longitude of a place, by differences in time between it and a place on the prime meridian, as simultaneously determined telegraphically.

In determinations of this character allowance must be made for the retarding effects of long telegraphic lines, or cables.

Loom, Electric — —A device by means of which Jacquard cards in the ordinary loom are replaced by a simple perforated metal plate, the perforations in which correspond to those in the Jacquard card.

The necessary movements are effected by means of electro-magnets.

Loop Break.—A device for introducing a loop in a break made at any part of a circuit.

The rigidity of the line wire, between the points of attachment of the loop introduced, is maintained by means of some inflexible non-conducting material inserted in the break.

Loop Circuit.—(See *Circuit, Loop*.)

Loop, Drip — — An inclined loop placed where the outside conductors enter a building.

The inclination is upwards towards the point of entrance to the building. This device of a drip loop is adopted for the purpose of preventing the rain water from flowing along the inclined wire into the building. This is effected by making the wire incline from the building, thus throwing the drainage from the building.

Loop, Electric — — A portion of a main circuit consisting of a wire going out from one side of a break in the main circuit and returning to the other side of the break.

Loops are employed for the purpose of connecting a branch telegraph office with the main line; for placing one or more electric arc lamps on the main line circuit; for connecting a *messenger call* or *telephone circuit* with a main line; and for numerous similar purposes.

Loops of Force.—(See *Force, Loops of*.)

Loops of Mutual Induction.—(See *Induction, Mutual, Loops of*.)

Low-Resistance Magnet.—(See *Magnet, Low-Resistance*.)

Low-Tension Electric Fuse.—(See *Fuse, Electric, Low-Tension*.)

Loxodrograph.—An apparatus for electrically recording on paper the actual course of a ship by the combined action of magnetism and photography.

Luces.—Plural of lux. (See *Lux*.)

Luminescence.—A limited power of emitting light, possessed by certain bodies which have previously acquired potential energy by exposure to light or radiant energy.

The term luminescence was proposed by E. Wiedemann to cover the case of the emission of

light under circumstances differing from the emission or radiation of light by incandescence. Luminescence applies to the case of a radiation, generally selective in character, that is apparently due to effects allied to, or the same as, those of fluorescence and phosphorescence. For example, magnesium oxide or zinc oxide, when heated above a certain critical temperature, radiates far more light than equally hot carbon.

The spectrum of such luminescent light is especially rich in certain wave lengths. The ability of the substance to continue to furnish this extra light is, however, limited. After a comparatively short time, the additional light, or selective radiation, disappears. The luminescent light is apparently due to molecular potential energy stored in the substance during its exposure to light. Luminescence may be developed in bodies in the following manner, viz.:

- (1.) By heat.
- (2.) By chemical action.
- (3.) By friction.
- (4.) By exposure to the sun, or by actual impact of light waves.
- (5.) By electricity.
- (6.) By vital forces, as in the fire fly, or the glow worm.

Luminescence, Rejuvenation of — — Reimparting by exposure to light, or any other suitable means, the power of luminescence to a substance after it has lost this power.

Luminous Absorption.—(See *Absorption, Luminous*.)

Lunar Inequality of Earth's Magnetic Variation or Inclination.—(See *Inequality, Lunar, of Earth's Magnetic Variation or Inclination*.)

Lunar Inequality of Earth's Magnetism.—(See *Inequality, Lunar, of Earth's Magnetism*.)

Lux.—A name proposed by Preece for the unit of intensity of illumination.

The illumination given by a standard candle at the distance of 12.7 inches.

The illumination given by 1 carcel at the distance of 1 metre.

The illumination given by a lamp of 10,000 candles at 105.8 feet. (See *Illumination, Unit of*.)

THIS PAGE IS LOCKED TO FREE MEMBERS

Purchase full membership to immediately unlock this page



HISTORY

Tens of thousands of important historical sources, many previously unobtainable, are now available for the first time with a Forgotten Books Full Membership.

Unlimited Access
\$8.99/month

Continue

*Fair usage policy applies

tric machine proper, consists of the following parts, viz.:

(1.) The revolving portion, usually the *armature*, in which the electromotive force is developed, which produces the current.

It must be borne in mind that it is not current, but *difference of electric potential*, or *electromotive force*, that is developed by any electric source from which a current is obtained. For ease of reference, however, we will speak of an electric current as being generated by the armature, or by the source. No ambiguity will be introduced if the student bears the above in mind.

(2.) The *field magnets*, which produce the field in which the armature revolves.

(3.) The *pole pieces*, or free terminals of the field magnets.

(4.) The *commutator*, by which the currents developed in the armature are caused to flow in one and the same direction. In alternating machines, and in some continuous current dynamos this part is called the *collector*, and does not rectify the currents.

(5.) The *collecting brushes*, that rest on the *commutator cylinder* and take off the current generated in the armature.

Machine, Dynamo-Electric, Alternating-Current — —A dynamo-electric machine in which alternating currents are produced.

The field magnets may be either permanent magnets or electro-magnets. When electro-magnets are used, their coils may be separately excited by another machine whose current is continuous; or, they may be excited by the commuted current of a separate coil on the armature; or, they may be partly excited by commuted currents and partly by commuted currents from a transformer, placed in the main circuit of the dynamo.

Machine, Dynamo-Electric, Armature of — —(See *Armature, Dynamo-Electric Machine*.)

Machine, Dynamo-Electric, Bed-Piece of — —The frame or base on which a dynamo is supported.

The bed-piece is sometimes called the dynamo frame or base.

Machine, Dynamo-Electric, Bi-Polar — —A dynamo-electric machine, the armature of which rotates in a field formed by two magnet poles, as distinguished from a ma-

chine the armature of which rotates in a field formed by more than two magnet poles.

A dynamo-electric machine whose armature rotates in the field formed by more than two poles is called a multi-polar machine. (See *Machine, Dynamo-Electric, Multi-Polar*.)

Machine, Dynamo-Electric, Carcass of — —A term sometimes used in place of the field magnet frame of a dynamo-electric machine. (See *Machine, Dynamo-Electric, Frame of*.)

The term, field magnet frame, would appear to be the preferable term. The term, however, is used in France, and is derived from the French word for skeleton.

Machine, Dynamo-Electric, Closed-Coil — —A dynamo-electric machine, the armature coils of which are grouped in sections, communicating with successive bars of a collector, so as to be connected continuously together in a closed circuit.

The Gramme dynamo and most continuous-current dynamos are closed-coil dynamos.

Machine, Dynamo-Electric, Closed-Coil Disc — —A closed-coil dynamo-electric machine, the armature core of which is disc-shaped.

Machine, Dynamo-Electric, Closed-Coil Drum — —A closed-coil dynamo-electric machine, the armature core of which is drum-shaped.

Machine, Dynamo-Electric, Closed-Coil Ring — —A closed-coil dynamo-electric machine, the armature core of which is ring-shaped.

Machine, Dynamo-Electric, Collectors — —(See *Collectors of Dynamo-Electric Machines*.)

Machine, Dynamo-Electric, Compound Winding of — —(See *Winding, Compound, of Dynamo-Electric Machine*.)

Machine, Dynamo-Electric, Compound-Wound — —Machines whose field magnets are excited by more than one circuit of coils, or by more than a single electric source.

The object of compound winding is to make

the dynamo self-regulating under changes in its working load. A shunt-wound dynamo renders both series and multiple circuits approximately constant as regards their working. Multiple circuits, however, require great constancy of potential, and for this purpose the compounding of the dynamos is necessary.

In the compound dynamo, the shunt coils are superposed on the series coils, or are used in connection with them. The shunt coils consist of a much greater number of convolutions of fine wire than the series coils, which are of coarse wire.

Separate excitation is sometimes compounded either with series or with shunt field magnet coils.

Compound dynamos are of two classes, viz.:

(1.) Those designed to produce a constant potential, and

(2.) Those designed to produce a constant current.

For Constant Potential :

In the long-shunt compound-wound dynamo, the terminals of the shunt coil are connected with the binding posts of the machine. As the current leaves the armature it has two paths to take: one, the thick series coils, to the external circuit, and the other the finer and longer shunt coils. The resistance of the shunt coils is greater than that of the armature. Current variations in the armature will, therefore, produce no appreciable effect on the magnetizing power of the shunt, which acts as a nearly uniform exciter of the field.

In a shunt-wound dynamo connected to a multiple circuit, the introduction of an additional number of receptive devices into the circuit requires more current, and this would tend to cause a slight drop in the potential. The object of the series coils is to prevent this drop. The series coils, therefore, act as compensators. If the coils are too powerful the compensation will have the effect of increasing the potential.

The combination of a series and separately excited machine is shown in Fig. 351. The field is in series with the armature, but has also an additional and separate excitation.

The combination of a series and shunt machine insures the excitation of the field both by the main and by the shunted current. Such a combination is shown in Fig. 353.

For Constant Current :

The combination of shunt and separately excited machines is shown in Fig. 356. In this machine the field is excited by means of a shunt

to the external circuit, and by a current produced by a separate source.

The combination of a series and magneto machine is shown in Fig. 352. This, also, is designed to give a constant current.

Machine, Dynamo-Electric, Compound-Wound, Long-Shunt — — A compound-wound dynamo-electric machine, in which the shunt-field magnet coils form a shunt to the binding posts of the machine.

In the short-shunt compound-wound dynamo-electric machine, the ends of the shunt coil are connected to the brushes of the machine.

Machine, Dynamo-Electric, Compound-Wound, Short-Shunt — — A compound-wound dynamo-electric machine in which the shunt-field magnet coils form a shunt to the armature only, as distinguished from the armature and series coils combined.

In the short-shunt dynamo-electric machine, the ends of the shunt coil are connected to the brushes of the machine, and not to the binding posts of the machine, or to the external circuit, as in the long-shunt machine.

Machine, Dynamo-Electric, Continuous-Current — — A dynamo-electric machine, the current of which is commuted so as to flow in one and the same direction, as distinguished from an alternating dynamo.

Machine, Dynamo-Electric, Double-Magnet — — A term sometimes applied to a dynamo-electric machine, the field magnets of which have two consequent poles.

Machine, Dynamo-Electric, Economic Co-efficient of — — A name formerly applied to the efficiency of a dynamo-electric machine. (See *Machine, Dynamo-Electric, Efficiency of*.)

Machine, Dynamo-Electric, Efficiency of — — The ratio between the electric energy or the electrical horse-power produced by a dynamo, and the mechanical energy or horse-power expended in driving the dynamo.

The *Efficiency* may be the *Commercial Efficiency*, which is the useful or available energy in the external circuit divided by the total mechanical energy; or it may be the *Electrical Efficiency*, which is the available electric energy divided by the total electric energy.

The *Efficiency of Conversion* is the total electrical energy developed, divided by the total mechanical energy applied.

If M , equals the mechanical energy,

W , the useful or available electrical energy,
and

w , the electrical energy absorbed by the machine, and

m , the *Stray Power*, or the power lost in friction, eddy currents, air friction, etc.

Then, since

$$M = W + w + m,$$

$$\text{Commercial Efficiency} \dots = \frac{W}{M} = \frac{W}{W + w + m}.$$

$$\text{Electrical Efficiency} \dots = \frac{W}{W + w}.$$

$$\text{Efficiency of Conversion} = \frac{W + w}{M} = \frac{W + w}{W + w + m}.$$

Machine, Dynamo-Electric, Flashing of

— —A name given to long flashing sparks at the commutator, due to the short circuiting of the external circuit at the commutator, by arcing over the successive commutator insulating strips.

Machine, Dynamo-Electric, Frame of

— —The bed-piece that supports a dynamo-electric machine.

The frame is sometimes called the dynamo bed-piece.

The word frame is sometimes applied to the field magnet cores and yokes.

Machine, Dynamo-Electric, Local Action of — —(See *Action, Local, of Dynamo-Electric Machine*.)

Machine, Dynamo-Electric, Mouse-Mill, Sir Wm. Thomson's — —A dynamo-electric machine designed by Sir Wm. Thomson, named from the resemblance of its armature to a mouse mill.

The armature conductor of this dynamo consists of parallel bars of copper, arranged on a hollow cylinder, like the bars on a mouse mill.

Machine, Dynamo-Electric, Multipolar — —A dynamo-electric machine, the armature of which revolves in a field formed by more than a single pair of poles.

This form is usually adopted for large machines as being more economical.

Fig. 349 shows a multipolar dynamo with four poles.

Machine, Dynamo-Electric, Open-Coil — —A dynamo-electric machine, the armature coils of which, though connected to

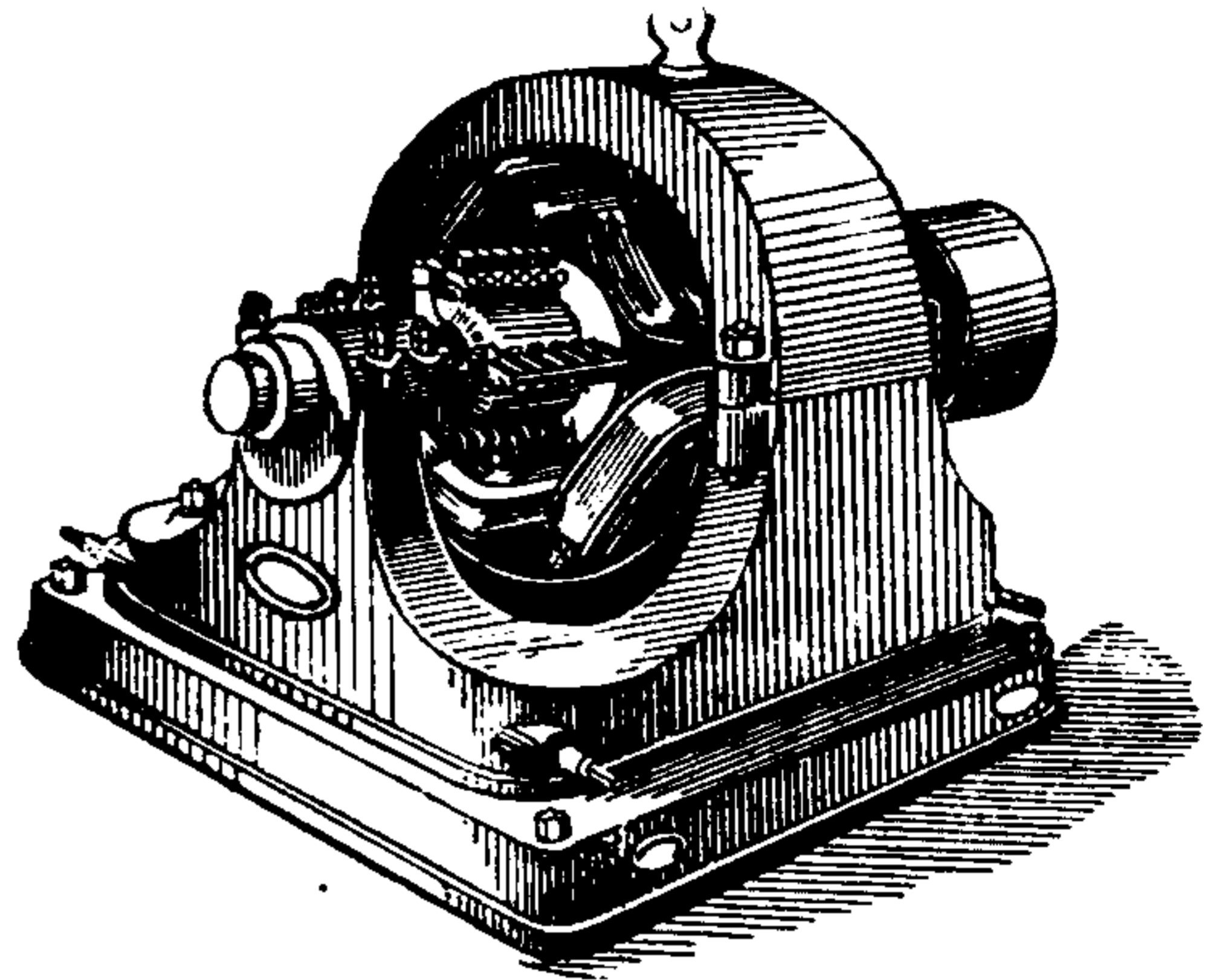

Fig. 349. Multipolar Dynamo with Four Poles.

the successive bars of the commutator, are not connected continuously in a closed circuit.

The Brush and the Thomson-Houston arc dynamos are open-coil machines.

Machine, Dynamo-Electric, Open-Coil Disc — —An open-coil dynamo-electric machine, the armature of which is disc-shaped.

Machine, Dynamo-Electric, Open-Coil Drum — —An open-coil dynamo-electric machine, the armature core of which is drum-shaped.

Machine, Dynamo-Electric, Open-Coil Ring — —An open-coil dynamo-electric machine, the armature core of which is ring-shaped.

Machine, Dynamo-Electric, Output of — —The electric power of the current generated by a dynamo-electric machine expressed in volt-ampères, watts or kilo-watts.

S. P. Thompson suggests that dynamo-electric machines be rated as to their practical safe capacity in *units of output of 1,000 watts, or one kilo-watt*. According to this, an 8-unit machine might give, say, 100 ampères at a difference of potential of 80 volts, or 2,000 ampères at a difference of potential of 4 volts. Such a unit would be far more expressive than the usual method of rating a machine as having a capacity of such and such a number of lights.

Machine, Dynamo-Electric, Reaction Principle of — —The mutual interaction

THIS PAGE IS LOCKED TO FREE MEMBERS

Purchase full membership to immediately unlock this page

Know Your Bible

Forgotten Books' Full Membership provides unlimited access to more than 28,000 volumes of Christian literature for \$8.99/month

HOLY BIBLE

Continue

*Fair use policy applies

A series and separately excited compound-wound dynamo-electric machine is shown in Fig. 352.

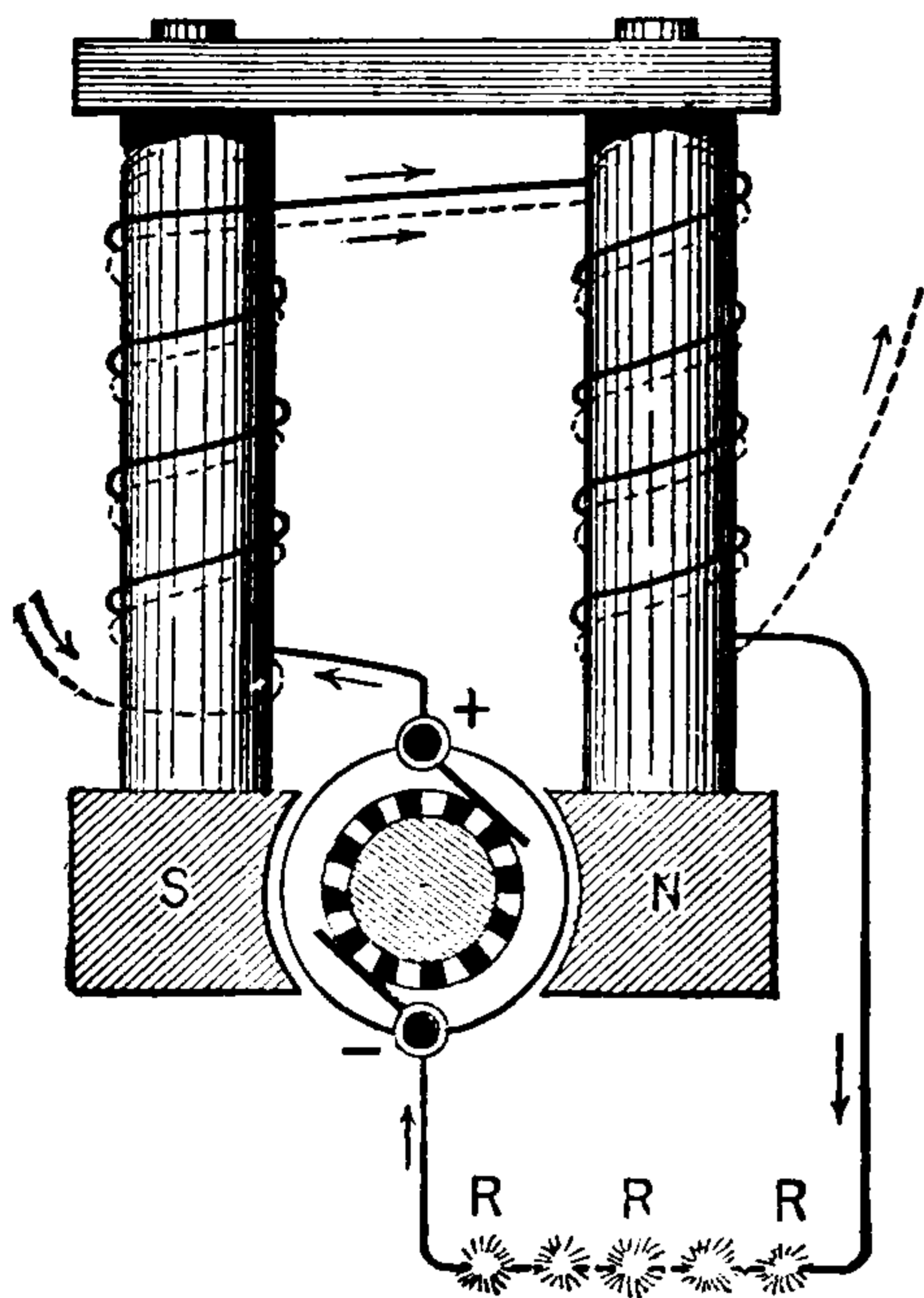

Fig. 352. Series and Separately Excited Dynamo.

This machine is employed for maintaining a constant potential at its terminals.

Machine, Dynamo-Electric, Series and Shunt Wound — — A compound-wound

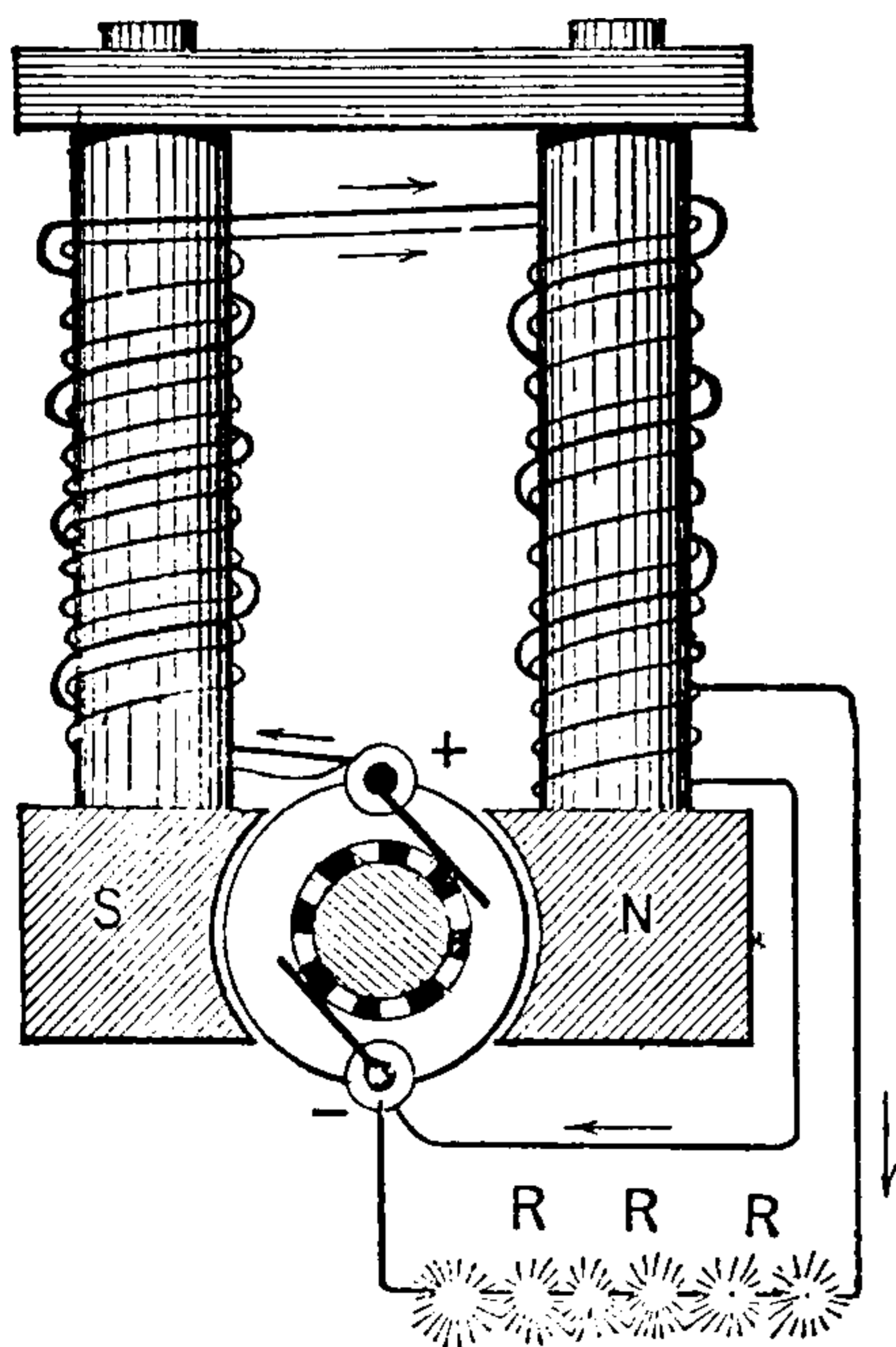

Fig. 353. Series and Shunt-Wound Dynamo.

dynamo-electric machine in which the field magnets are wound with two separate coils, one of which is in series with the armature and the external circuit, and the other in shunt with the armature.

This is usually called a compound-wound machine. (See *Machine, Dynamo-Electric, Compound-Wound*.)

A compound-wound series and shunt dynamo-electric machine is shown in Fig. 353. This machine is designed to maintain constant potential at its terminals.

There are two varieties of series and shunt-wound dynamos, viz.:

(1.) Long-shunt compound-wound dynamo.

(2.) Short-shunt compound-wound dynamo.

(See *Machine, Dynamo-Electric, Compound-Wound, Long-Shunt. Machine, Dynamo-Electric, Compound-Wound, Short-Shunt*.)

Machine, Dynamo-Electric, Series-Wound

— — A dynamo-electric machine, in which the field circuit and the external circuit are

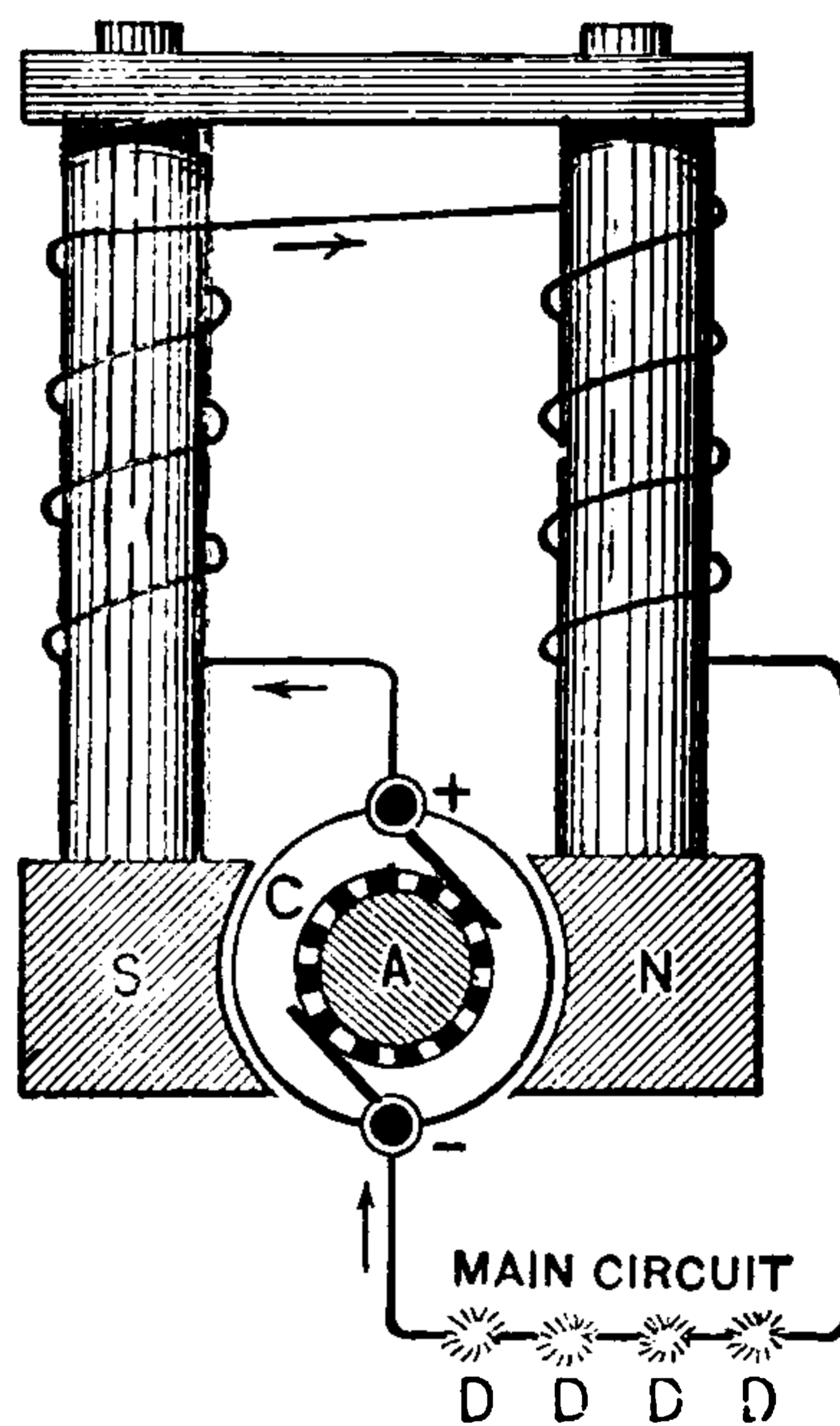

Fig. 354. Series Dynamo.

connected in series with the armature circuit, so that the entire armature current must pass through the field coils.

A series dynamo-electric machine is shown in Fig. 354. Here the armature circuit, the field circuit and the external circuit are all connected in series.

Since in a series-wound dynamo the armature coils, the field and the external series circuit are in series, any increase in the resistance of the external circuit will decrease the electromotive force from the decrease in the magnetizing currents. A decrease in the resistance of the external circuit will, in a like manner, increase the electromotive force from the increase in the magnetizing current.

The use of a regulator avoids these changes in the electromotive force.

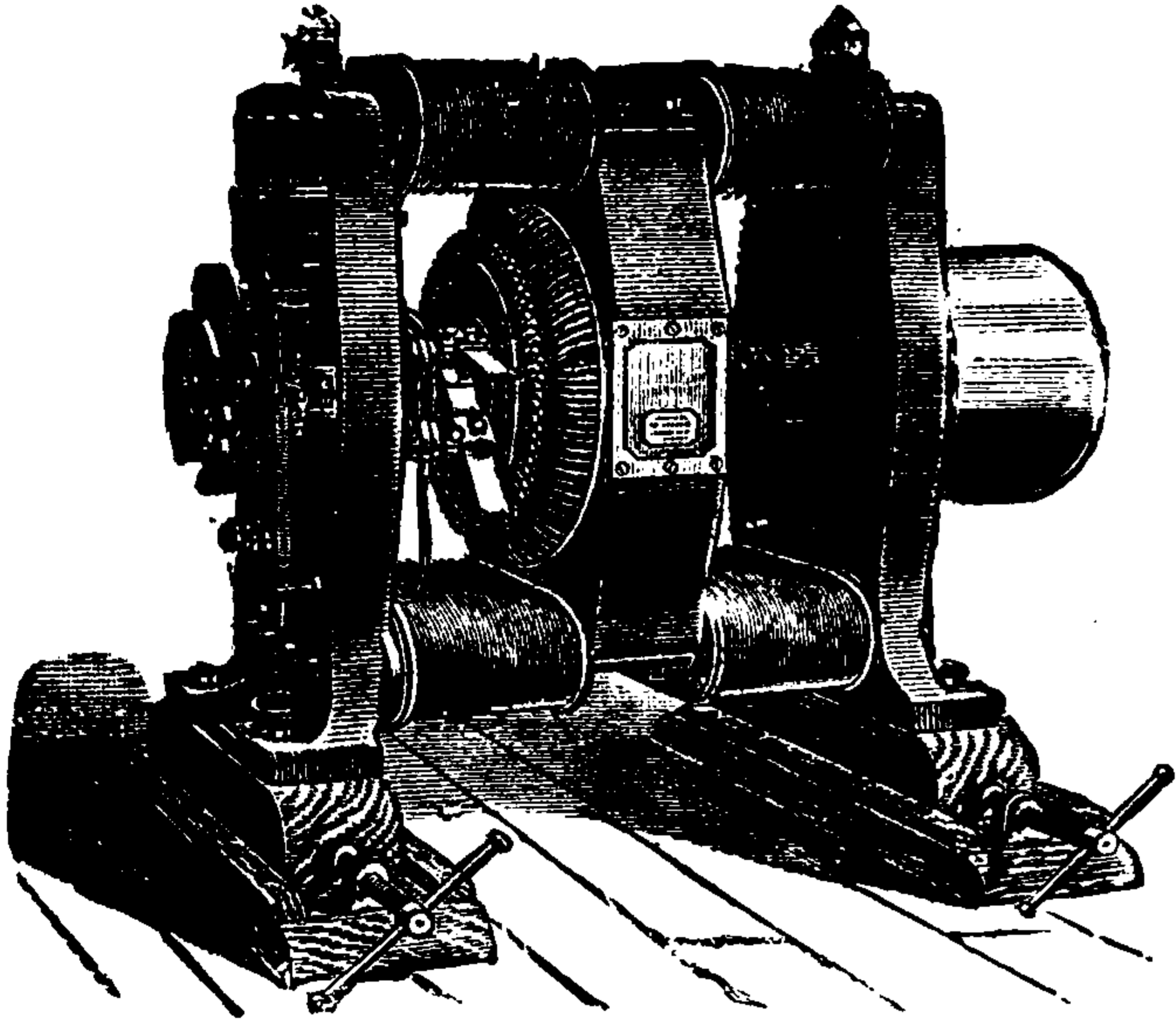

Fig. 355. Series Dynamo.

The dynamo shown in Fig. 355 is series connected. The armature is ring-shaped. The armature core consists of a ring made of soft iron wire. The field is bi-polar, and is obtained by the use of four magnet coils and two consequent poles.

Machine, Dynamo-Electric, Shunt and Separately Excited — — A compound-wound dynamo-electric machine, in which

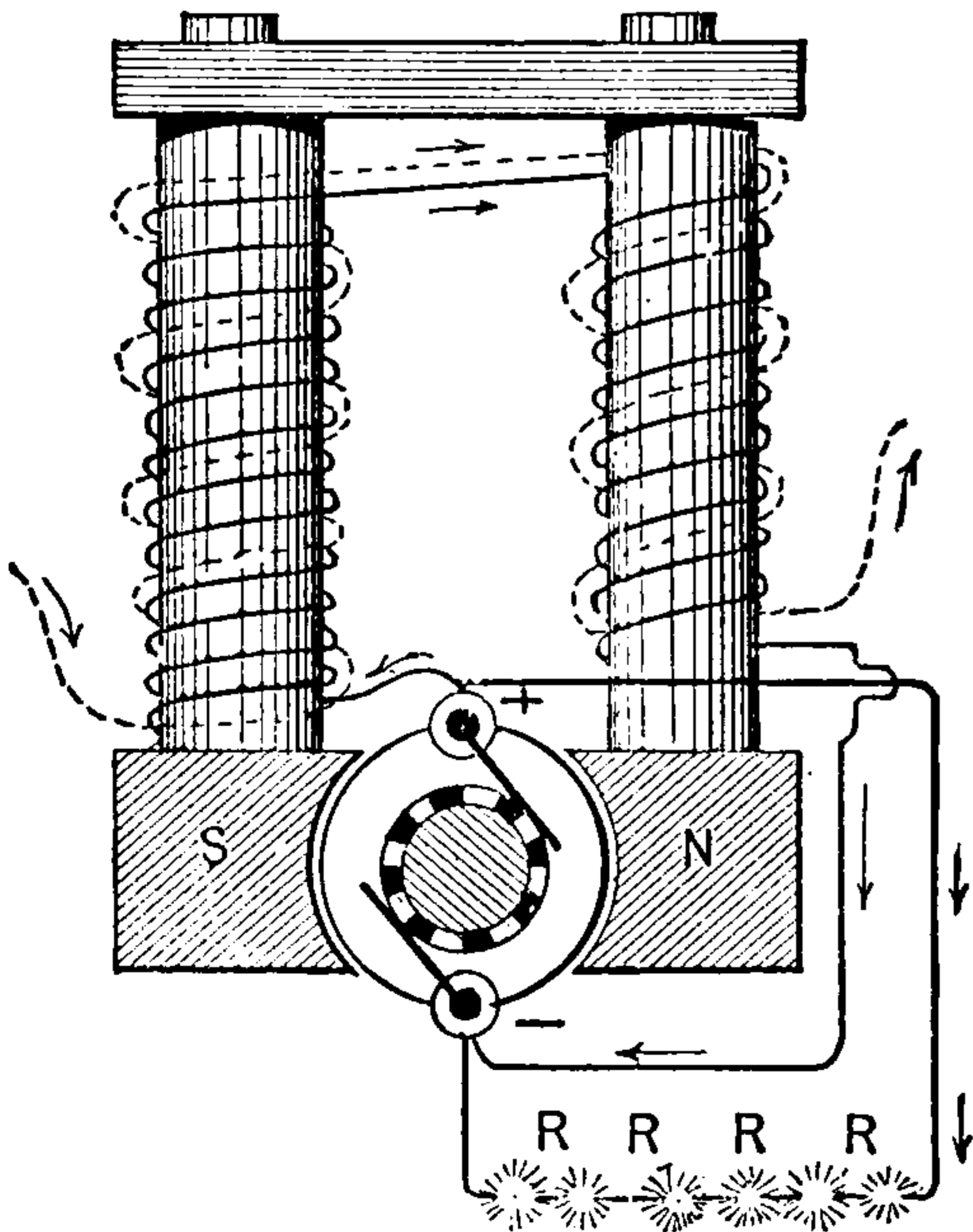

Fig. 356. Shunt and Separately Excited Dynamo.

the field is excited both by means of a shunt to the armature circuit, and by a current produced by a separate source.

A shunt and separately excited compound-

wound dynamo-electric machine is shown in Fig. 356. This machine maintains a constant current in its circuit, notwithstanding changes in its external circuit.

Machine, Dynamo-Electric, Shunt-Wound — — A dynamo-electric machine in which the field magnet coils are placed in a shunt to the armature circuit, so that only a portion of the current generated passes through the field magnet coils, but all the difference of potential of the armature acts at the terminals of the field circuit.

A shunt dynamo-electric machine is shown in Fig. 357.

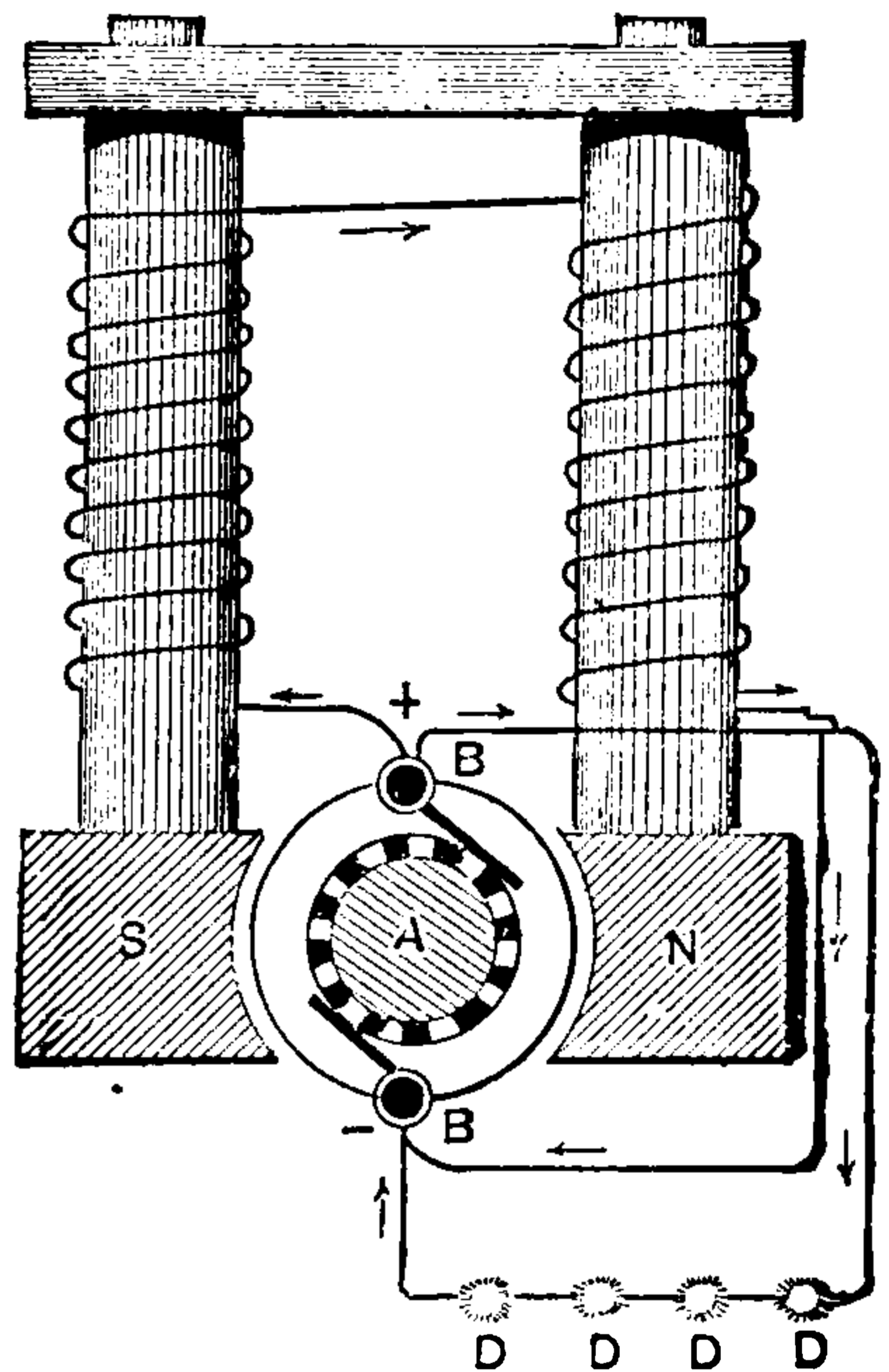

Fig. 357. Shunt Dynamo.

In a shunt dynamo-electric machine, an increase in the resistance of the external circuit increases the electromotive force, and a decrease in the resistance of the external circuit decreases the electromotive force. This is just the reverse of the series-wound dynamo.

In a shunt-wound dynamo a continuous balancing of the current occurs. The current dividing at the brushes between the field and the external circuit in the inverse proportion to the resistance of these circuits, if the resistance of the external circuit becomes greater, a proportionately greater current passes through the field magnets, and so causes the electromotive force to become greater. If, on the contrary, the resistance of the external circuit decreases, less current passes through the field, and the electromotive force is proportionately decreased.

In a shunt-wound dynamo the resistance of the shunt should be at least four hundred times that of the armature. It is sometimes as much as one thousand times as great.—(*Urquhart.*)

To obtain complete regulation of the machine some form of compounding is necessary. (See *Machine, Dynamo-Electric, Compound-Wound.*)

Machine, Dynamo-Electric, Single-Magnet — —A dynamo-electric machine, in which the field magnet poles are obtained by means of a single coil of insulated wire, instead of by more than a single coil.

Machine, Dynamo-Electric, Sparking of — —An irregular and injurious operation of a dynamo-electric machine, attended with sparks at the collecting brushes.

Sparking consists in the formation of small arcs under the collecting brushes. One cause of sparking is to be found in the brushes leaving one commutator strip before making connection with the next strip.

Sparking from this cause may be avoided by so placing the brushes as to cause them to bridge over the space between two consecutive bars, thus permitting them to touch one bar before leaving the other. Two brushes, electrically connected, are sometimes employed for this purpose, or the slots between contiguous bars are slightly inclined to the axis of rotation.

Sparking causes a burning of the commutator strips, and an irregular consumption of the brushes, both of which produce further irregularities by the wear of the brushes against the commutator bars.

At the moment the brush touches two contiguous commutator bars, it short circuits the coil terminating at those bars. On the breaking of this closed circuit, a spark appears under the brushes. This spark is often considerable, since from the comparatively small resistance of the coil, it is apt, when short circuited, to produce a heavy current if not exactly at the neutral point.

Another cause of sparking is to be found in the self-induction of the armature coils. The extra current on breaking forms an injurious spark under the brushes. This spark may be considerable, since the current produced in the coil on momentarily short circuiting it by the brushes simultaneously touching the adjoining commutator segments may be large.

Sparking occurs when the brushes are not set

close to the neutral line. Since the principal cause for the change in the lead of the brushes is the magnetizing effect of the armature coils, it is preferable to make the number of windings of these as few as possible, and to obtain the necessary differences of potential by increasing the speed of rotation and the strength of the magnetic field of the machine. Short armature coils also lessen the sparking due to *self-induction*.

Sparking at the brushes is also caused by the jumping of improperly supported or constructed brushes.

When the brushes are not set close to the neutral point, long *flashing sparks* are apt to occur.

A lack of symmetry of winding of the armature coils will necessarily be attended by injurious flashing, from the impossibility of properly adjusting the brushes.

Machine, Dynamo-Electric, Synchronizing — —Adjusting the phases of two alternating current dynamos so as to permit their being coupled or joined in parallel.

Machine, Dynamo-Electric, to Short Circuit a — —To put a dynamo-electric machine on a circuit of comparatively small electric resistance.

Machine, Dynamo-Electric, Unit of Output of — —A unit for the electric power furnished by the current of a dynamo-electric machine.

A unit of output equal to 1,000 watts or 1 kilowatt.

A machine furnishing a current of 100 ampères at a difference of potential of 80 volts, would have an output of 8,000 watts, and would, therefore, be rated as an 8-unit machine.

Machine, Electric, Rubber of — —A cushion of leather covered with an electric amalgam, and employed to produce electricity by its friction against the plate or cylinder of a frictional electric machine. (See *Machine, Frictional Electric.*)

Machine, Electrostatic Induction — —A machine in which a small initial charge produces a greatly increased charge by its inductive action on a rapidly rotated disc of glass or other dielectric.

An excellent type and example of such a machine is found in the Holtz machine, which con-

THIS PAGE IS LOCKED TO FREE MEMBERS

Purchase full membership to immediately unlock this page



HISTORY

Tens of thousands of important historical sources, many previously unobtainable, are now available for the first time with a Forgotten Books Full Membership.

Unlimited Access
\$8.99/month

Continue

*Fair usage policy applies

from the points of the paper armatures, as well as the character of the charge, will be understood. There thus results, as is shown, a positive charge on both the front and back of the upper half of

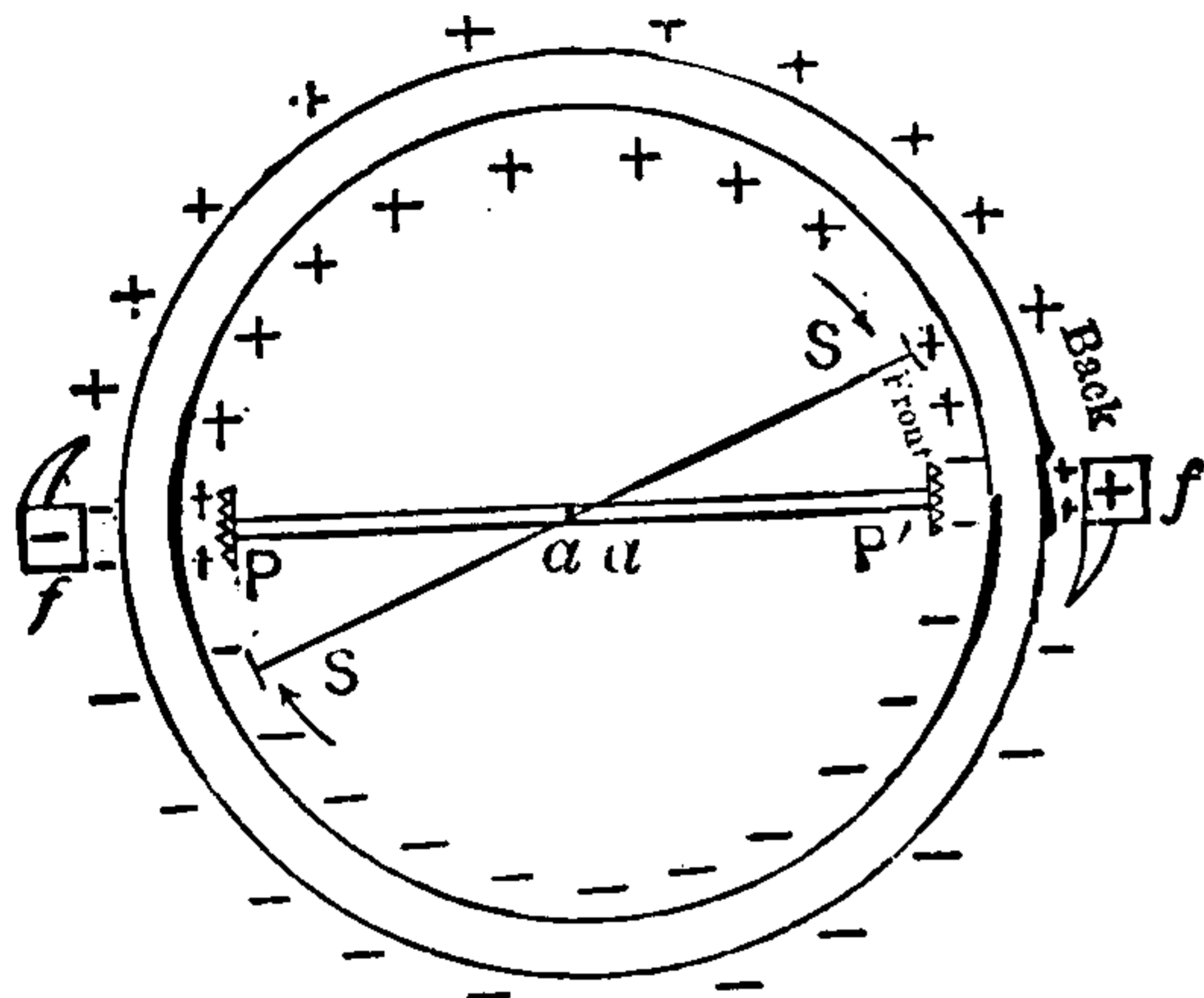

Fig. 359. Plate of Holtz Machine.

the rotating plate, and a negative charge on both sides of its lower half. A reversal of polarity of the plate occurs at the line P a a P'. Sometimes the reversal does not occur, and the machine either loses its charge entirely, or in part. A conductor S S, furnished with points, is sometimes provided to lessen the chances of lack of reversal.

Machine, Faradic — — A machine for producing faradic currents.

There are two varieties of faradic machines, viz.: magneto-faradic apparatus and simple induction apparatus.

Machine, Frictional Electric — — A machine for the development of electricity by friction.

A frictional electric machine consists of a plate or cylinder of glass A, Fig. 360, capable of rotation on a horizontal axis.

A rubber formed of a chamois skin, covered with an amalgam of tin and mercury, is placed at B. By the rotation of the plate the

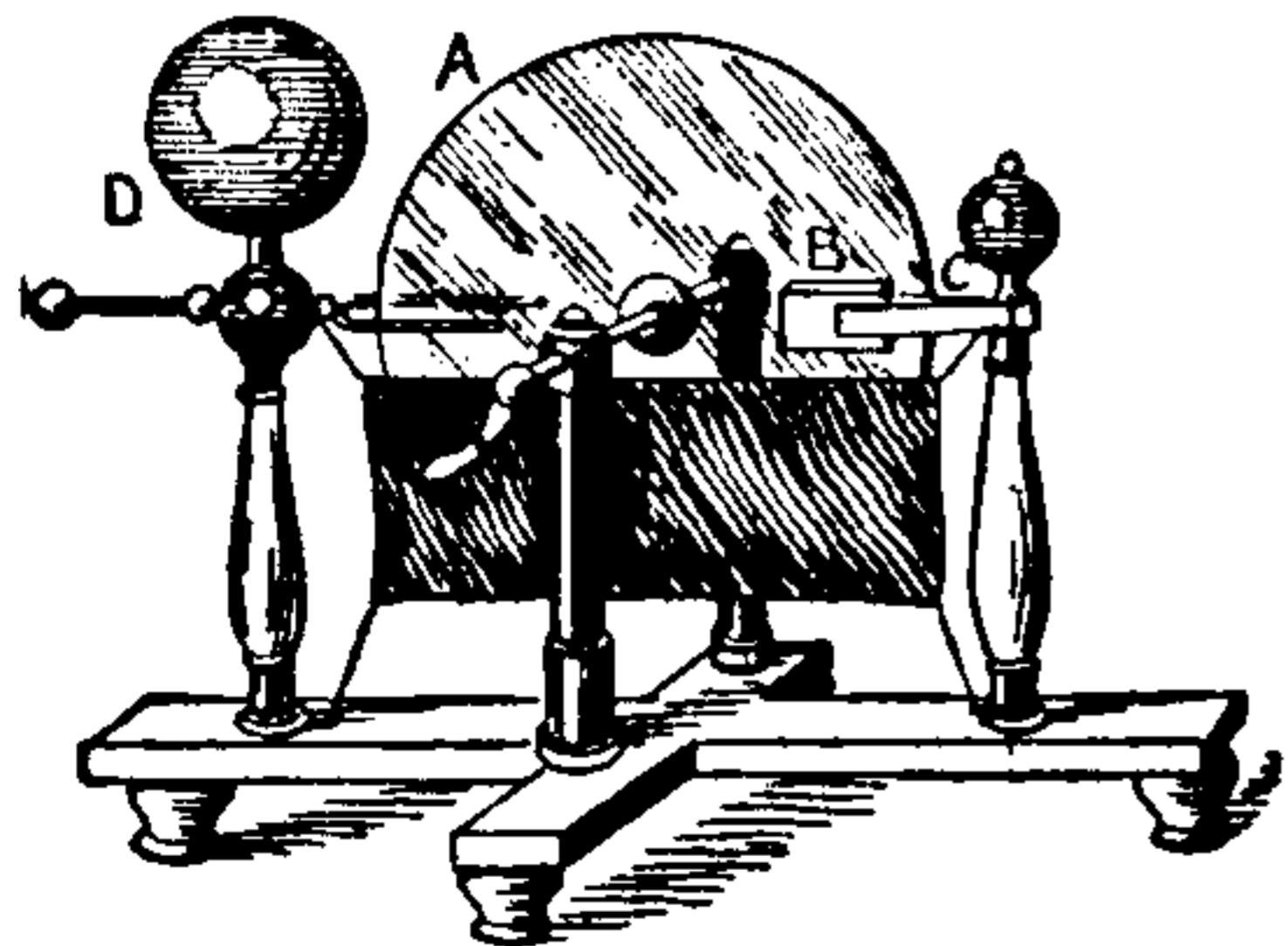

Fig. 360. Frictional Electric Machine.

rubber becomes negatively and the glass positively excited. An insulated conductor D, called the *prime* or *positive conductor*, provided with a

comb of points, becomes positively charged by induction. The machine will develop electricity best if a conductor attached to the rubber is connected with the ground, as by a chain.

Machine, Holtz — — A particular form of electrostatic induction machine. (See *Machine, Electrostatic Induction*.)

Machine, Influence — — An electrical machine depending for its action on electrostatic induction.

The Wimshurst and Holtz machines are influence machines. (See *Machine, Electrostatic Induction. Machine, Wimshurst Electrical. Machine, Holtz*.)

Machine, Influence, Wimshurst's Alternating — — An electrostatic induction machine by means of which a series of rapidly alternating charges are produced.

Although such a machine furnishes a torrent of sparks between its terminals, yet it is unable to furnish a permanent charge to a Leyden jar or condenser, since its oscillatory discharges, continually undo at any small interval of time, what was done at the preceding interval, and thus leave the jar uncharged.

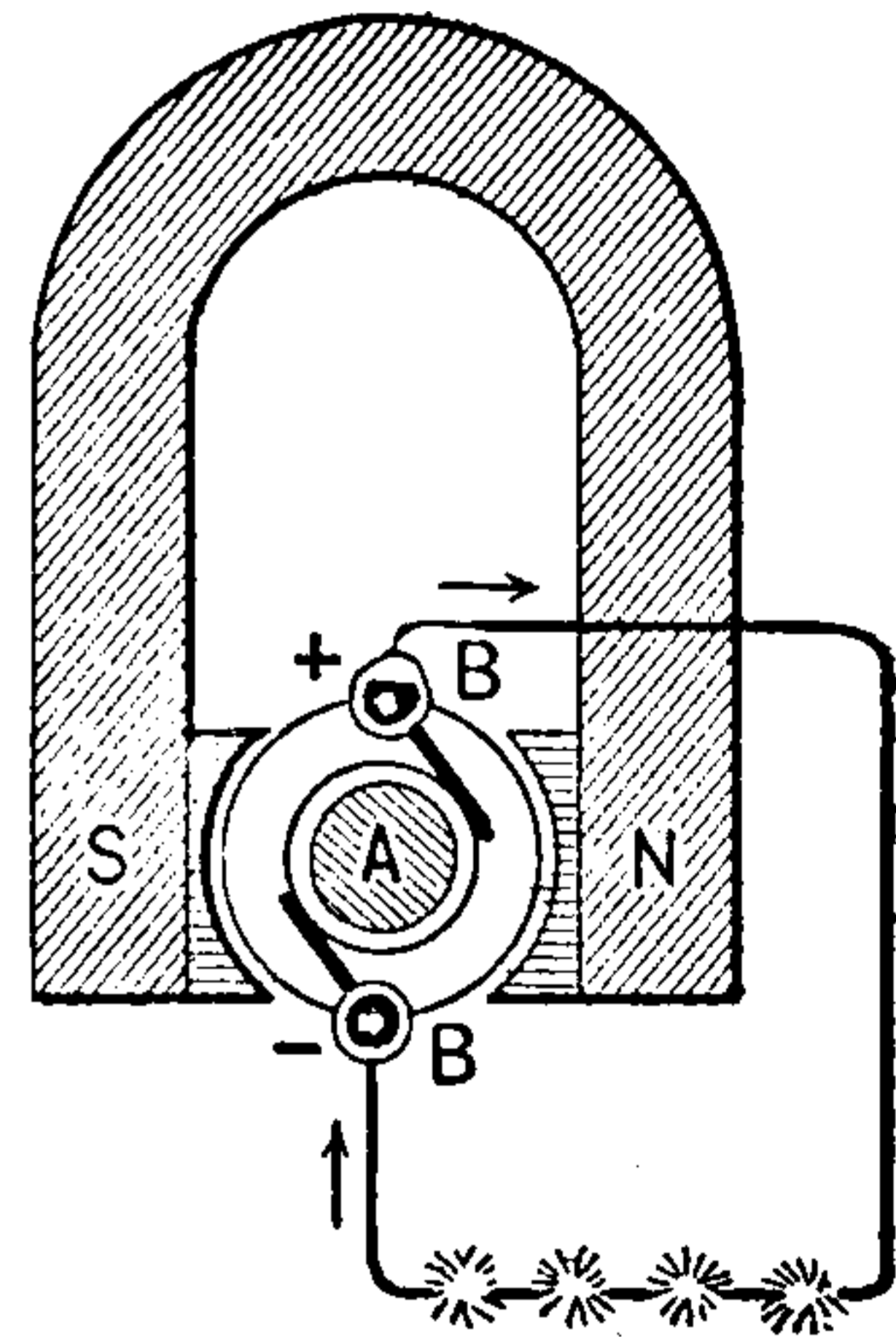

Machine, Magneto Blasting — — A magneto-electric machine employed for generating the current used in electric blasting.

Fig. 361. Magneto-Electric Machine.

Machine, Magneto-Electric — — A machine in which there are no field magnet coils, the magnetic field of the machine being due to the action of permanent steel magnets.

A dynamo in which currents are produced by the motion of armature coils past permanent magnets. (See *Machine, Dynamo-Electric*.)

A magneto-electric machine is shown in Fig. 361.

Another form of magneto-electric machine is shown in Fig. 362.

This latter form of machine is known as a hand generator, in contradistinction to one driven by power and called a power generator.

The field is obtained by means of a number of separate permanent magnets so combined as to

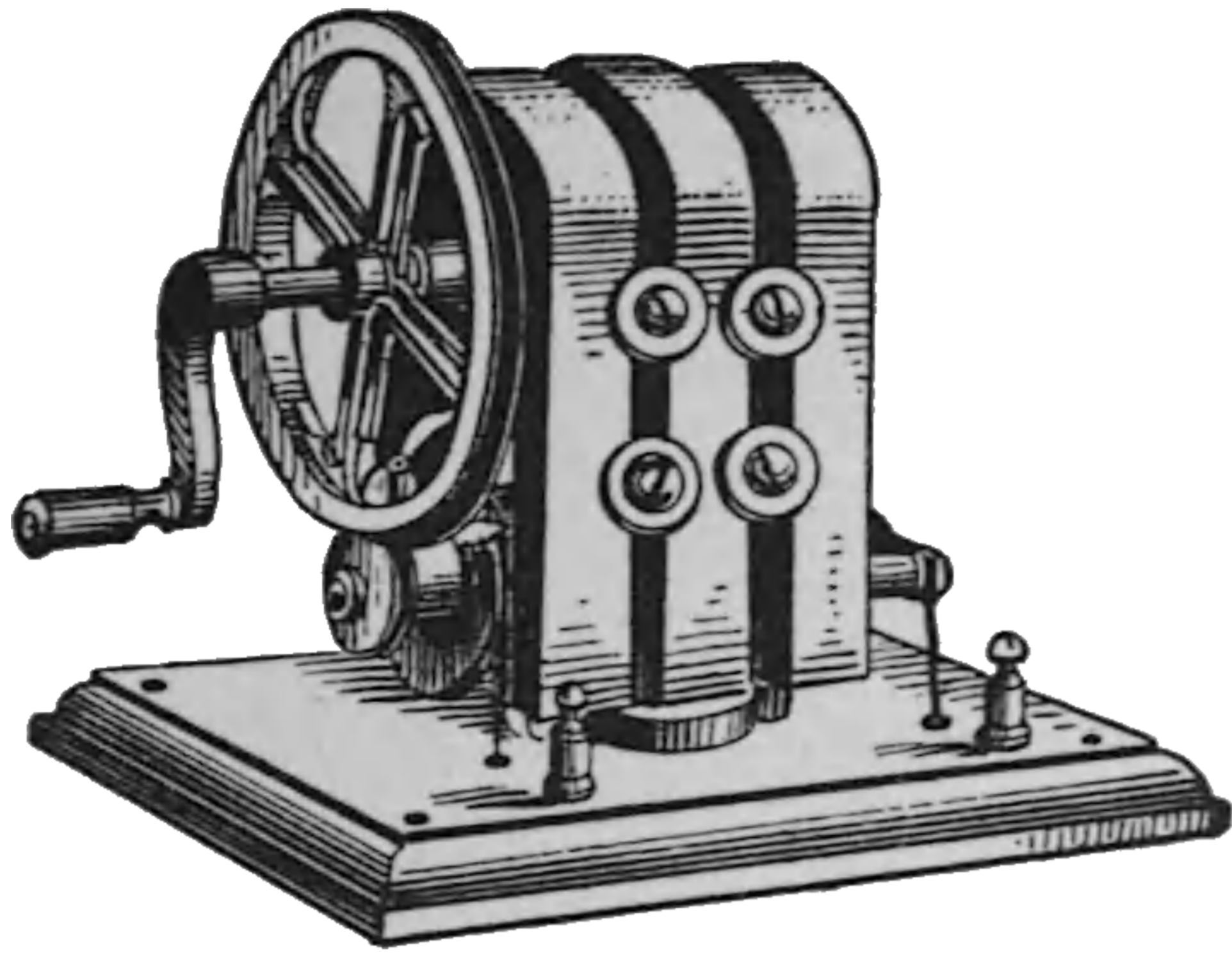

Fig. 362. Magneto-Electric Machine.

act as a single magnet. The armature is rotated by hand.

Machine, Mouse-Mill — — A form of convection induction machine, invented by Sir William Thomson to act as the replenisher of his electrometer. (See *Machine, Electrostatic Induction*.)

Machine, Rheostatic — — A machine devised by Planté in which continuous static effects of considerable intensity are obtained by charging a number of condensers in multiple-arc and discharging them in series.

The condensers are charged by connecting them with a number of secondary or storage batteries.

Machine Telegraphy.—(See *Telegraphy, Machine*.)

Machine, Töppler-Holtz — — A modified form of Holtz machine in which the initial charge of the armatures is obtained by the friction of metallic brushes against the armatures.

Machine, Wimshurst Electrical — — A form of convection electric machine invented by Wimshurst.

Like the Holtz machine, the Wimshurst machine is a convection induction machine. It is, however, more efficient in action, and will probably soon supersede the former machine. The Wimshurst machine consists of two shellac-varnished glass plates that are rapidly rotated in opposite directions. Thin metallic strips are placed on the outside of each of the plates, in the radial positions shown in Fig 363. These strips act

both as *inductors* and *carriers*; the carriers of one plate acting as inductors to the other plate.

Two curved brass rods, terminating in fine wire brushes that touch the plates, are placed as shown, one at the front of the plate, and one at the back, at right angles to each other. Pairs of conduct.

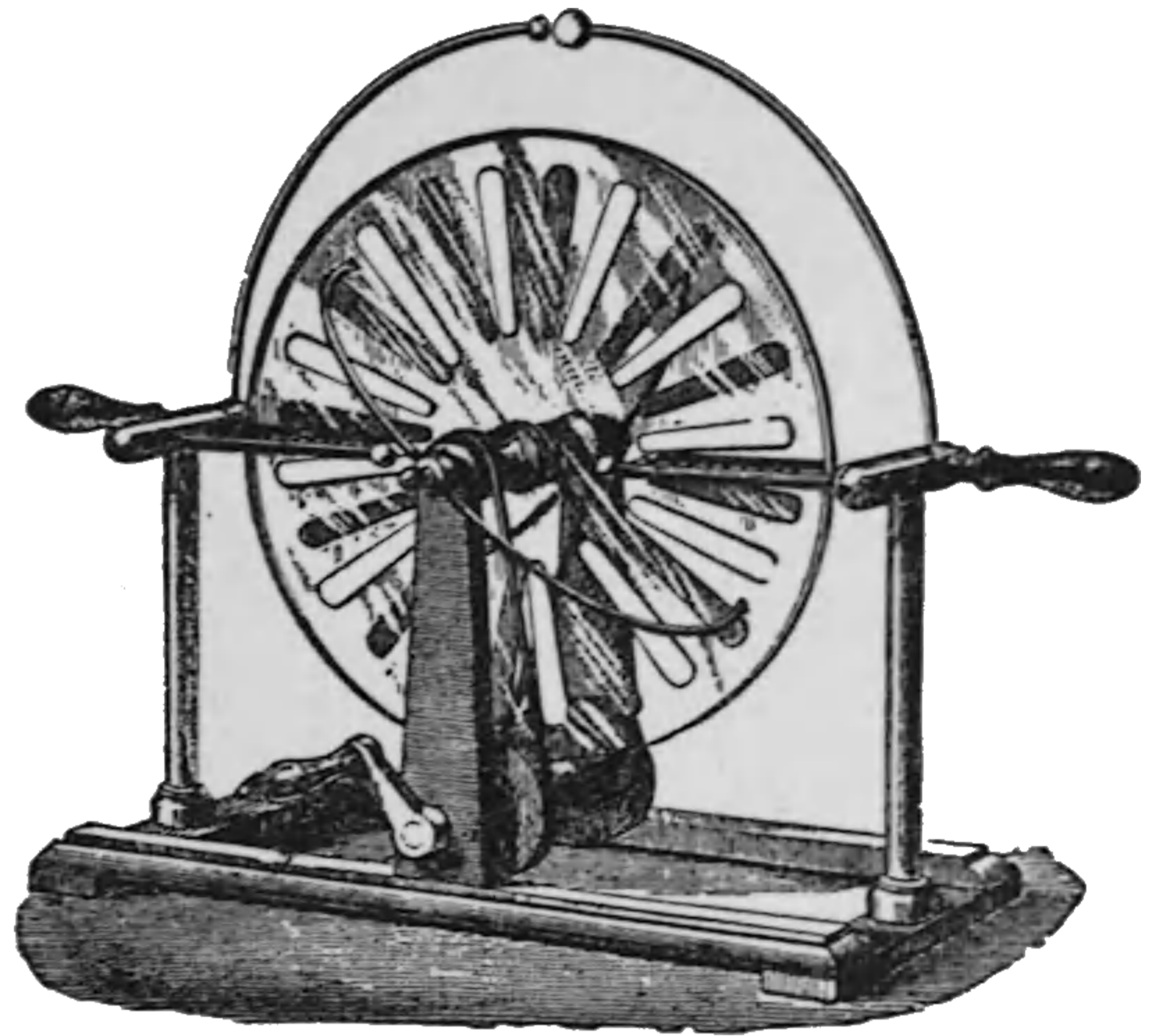

Fig. 363. The Wimshurst Electrical Machine.

ors, connected together, provided with collecting points, are placed diametrically opposite each other, as shown. Sliding conductors, terminated with metallic balls, are provided for discharging the conductors. Leyden jars, the inner coatings of which are connected with two discharging rods, and the outer coatings together, may be employed in this as in the Holtz machine.

The exact action of this machine is not thoroughly understood.

Machines, Dynamo-Electric, Varieties of — — Dynamo-electric machines may be divided into classes according to—

- (1.) The manner in which the magnetism of the field magnets is obtained.
- (2.) The character of their armatures.
- (3.) The nature of the current obtained, whether continuous or alternating.
- (4.) The form of their field magnets.
- (5.) The nature of their magnetic fields.
- (6.) The manner in which the current of the field magnets, the armature and the external circuits are connected.

Mack — — A term proposed by Mr. Oliver Heaviside for a unit of self-induction.

The term Mack is derived from Maxwell. The unit of self-induction has also been a secohm and a quadrant.

The term Max would seem to be indicated. In the United States the unit of self-induction is called a Henry, after Prof. Joseph Henry. (See *Henry, A.*)

Made Circuit.—(See *Circuit, Made.*)

Magazine Fuse.—(See *Fuse, Magazine.*)

Magne-Crystallic Action.—(See *Action, Magne-Crystallic.*)

Magnet.—A body possessing the power of attracting the unlike pole of another magnet or of repelling the like pole; or of attracting readily magnetizable bodies like iron filings to either pole.

A body possessing a magnetic field. (See *Field, Magnetic.*)

The lines of force are assumed in passing through the magnetic field to come out at the north pole of the magnet and to go in at the south pole. All lines of force form closed magnetic circuits. If a magnetizable body is brought into a magnetic field, the lines of magnetic force are concentrated on it and pass through it. The body therefore becomes magnetic. The intensity of the resulting magnetism depends on the number of lines of force that pass through the body, and the polarity on the direction in which they pass through it.

A magnetized bar cannot be regarded as a source of energy in itself. Energy must be expended to magnetize the iron, and must also be expended to demagnetize it.

Magnet, Anomalous — — A magnet possessing more than two free poles.

There is no such thing as a unipolar magnet.



Fig. 364. Anomalous Magnet.

All magnets have two poles. Sometimes, however, several magnets are so grouped that there appear to be more than two poles in the same magnet.



Fig. 365. Anomalous Magnet.

Thus, in Fig. 364, the magnet A B C, appears to possess three poles, two positive poles at A and C, and a central negative pole at B.

It is clear, however, that the central pole is in reality formed of two juxtaposed negative poles, and that A B C, actually consists of two magnets with two poles to each.

The magnet A B C D, Fig. 365, which in like manner appears to possess four separate poles, in reality is formed of three magnets with two poles to each.

Since unlike magnetic poles neutralize each other, it is clear that only similar poles can thus be placed together in order to produce additional magnet poles.

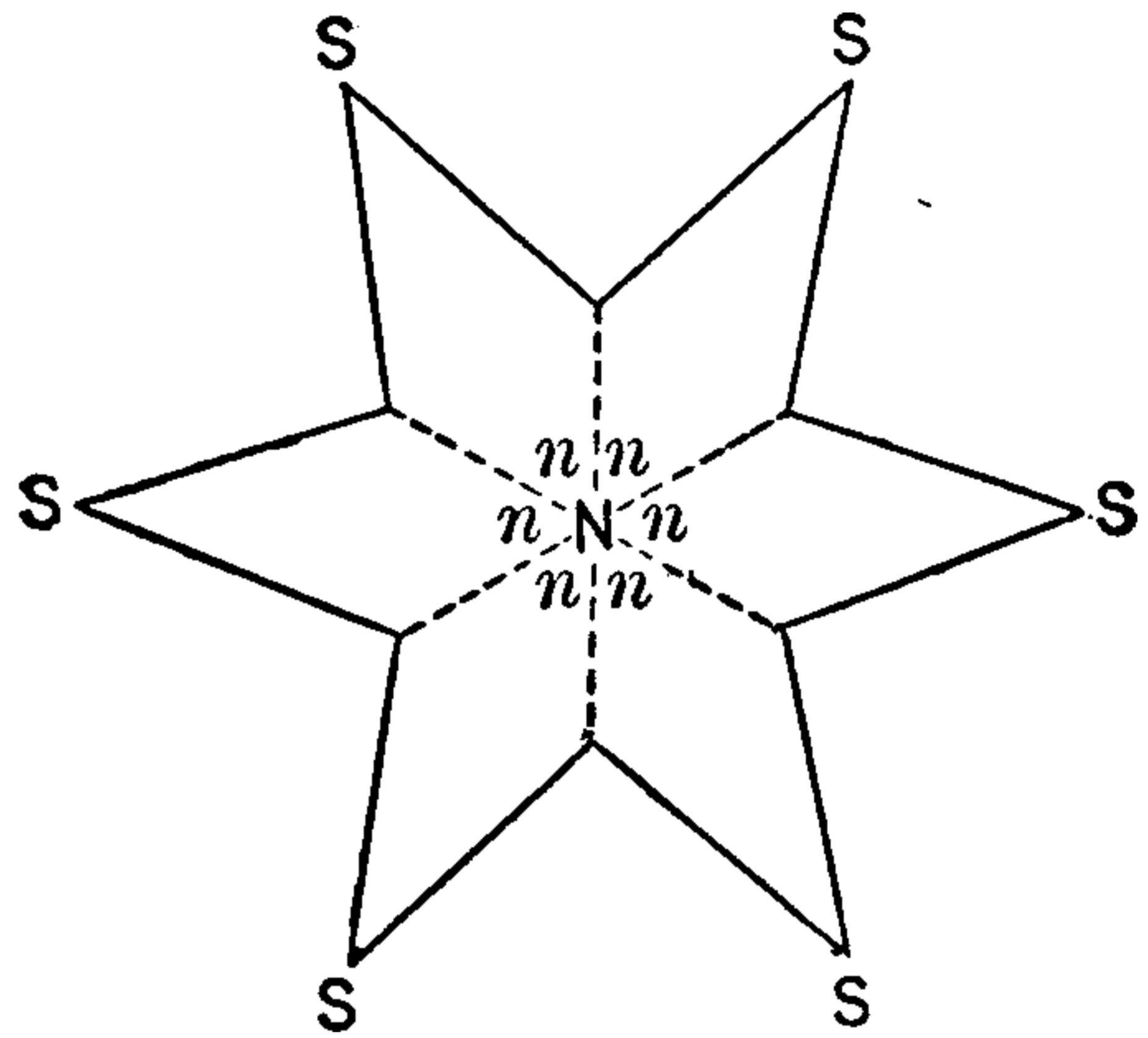

Fig. 366. Anomalous Magnet.

The six-pointed star shown in Fig. 366, is an anomalous magnet with apparently seven poles. The formation of the central N-pole, as is evident from an inspection of the drawing, is due to the six separate north poles, n, n, n, n, n, n, of the six separate magnets Sn, Sn, etc. Such a magnet would be formed by touching the star at the point N, with the S-pole of a sufficiently powerful magnet.

The extra poles are sometimes called *consequent poles*. Their presence may be shown by means of a compass needle, or by rolling the magnet in iron filings, which collect on the poles.

Magnet, Artificial — — A magnet produced by induction from another magnet, or from an electric current.

Any magnet not found in nature is called an artificial magnet.

Magnet, Axial — — A name sometimes given to a solenoid with an axial or straight core.

Magnet, Bell-Shaped — — A modification of a horseshoe magnet in which the approached poles are semi-annular in shape, and form a split tube.

Bell-shaped magnets are used in many galva-

THIS PAGE IS LOCKED TO FREE MEMBERS

Purchase full membership to immediately unlock this page

Know Your Bible

Forgotten Books' Full Membership provides unlimited access to more than 28,000 volumes of Christian literature for \$8.99/month

HOLY BIBLE

Continue

*Fair use policy applies

of lines of magnetic force in the field produced by an electric current.

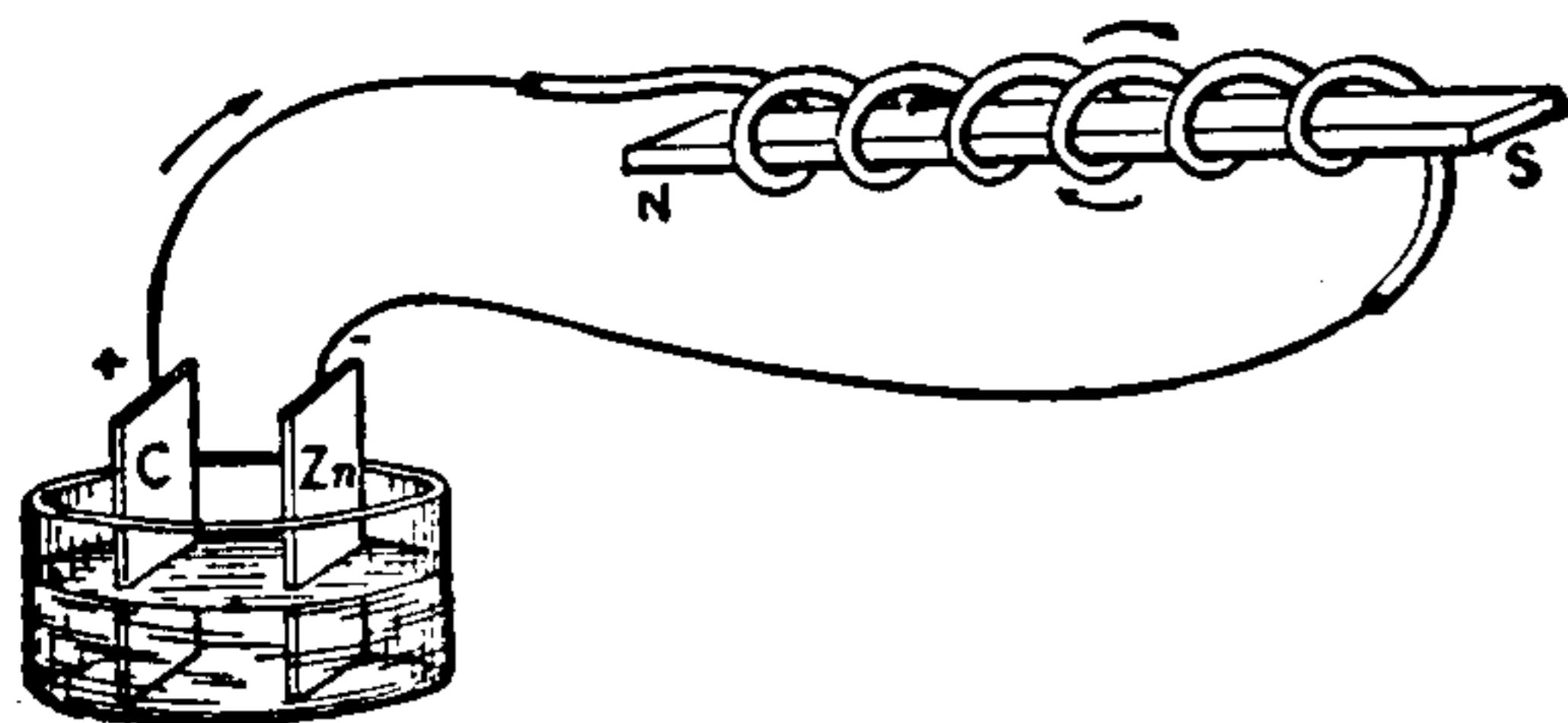

Fig. 369. Polarity of Current.

The direction of this polarity may be predicted by the following modification of a rule by Ampère:

Imagine yourself swimming in the wire in the direction of the current; if, then, your face is

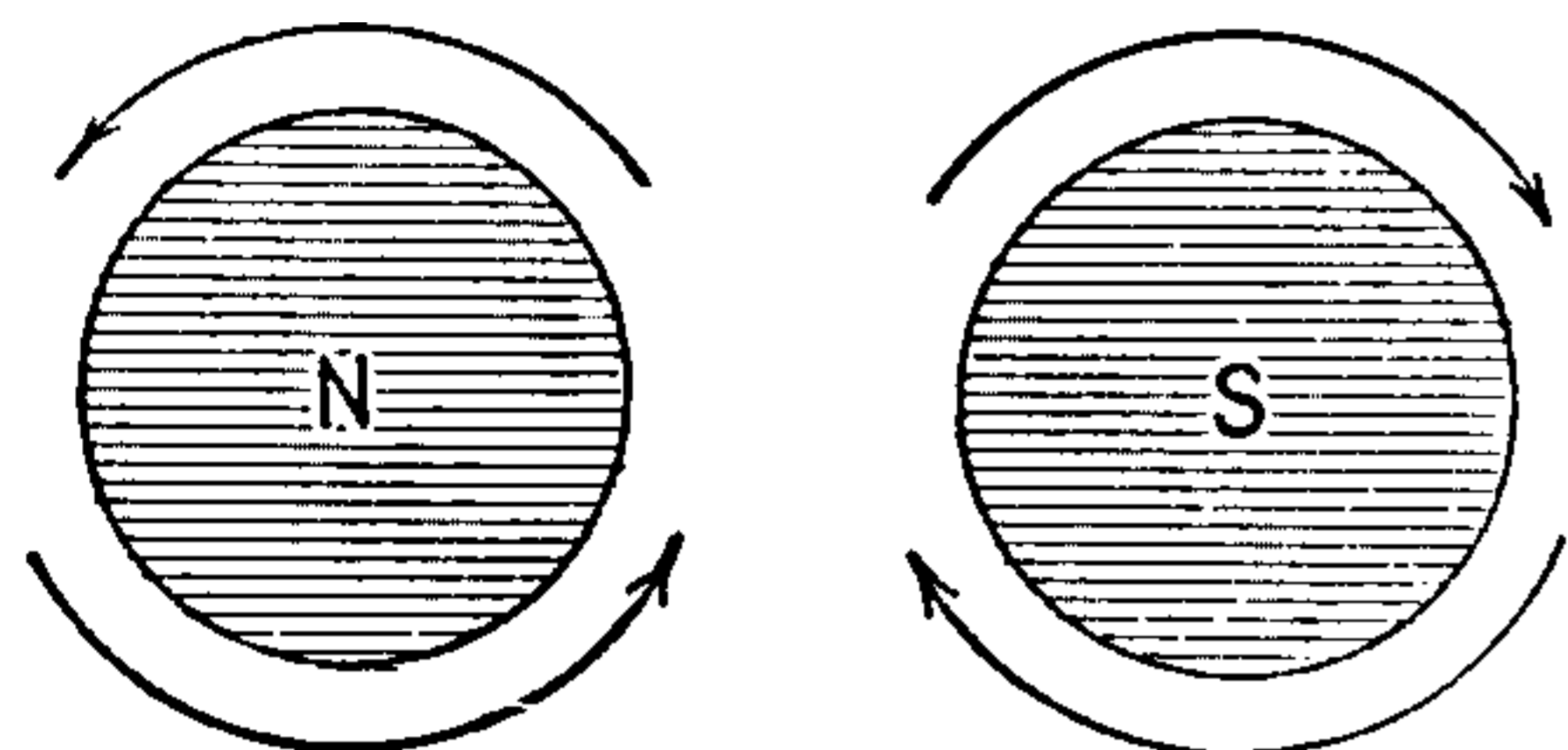

Fig. 370. North and South Magnet Poles.

turned toward the bar that is being magnetized, its North seeking pole will be on your left.

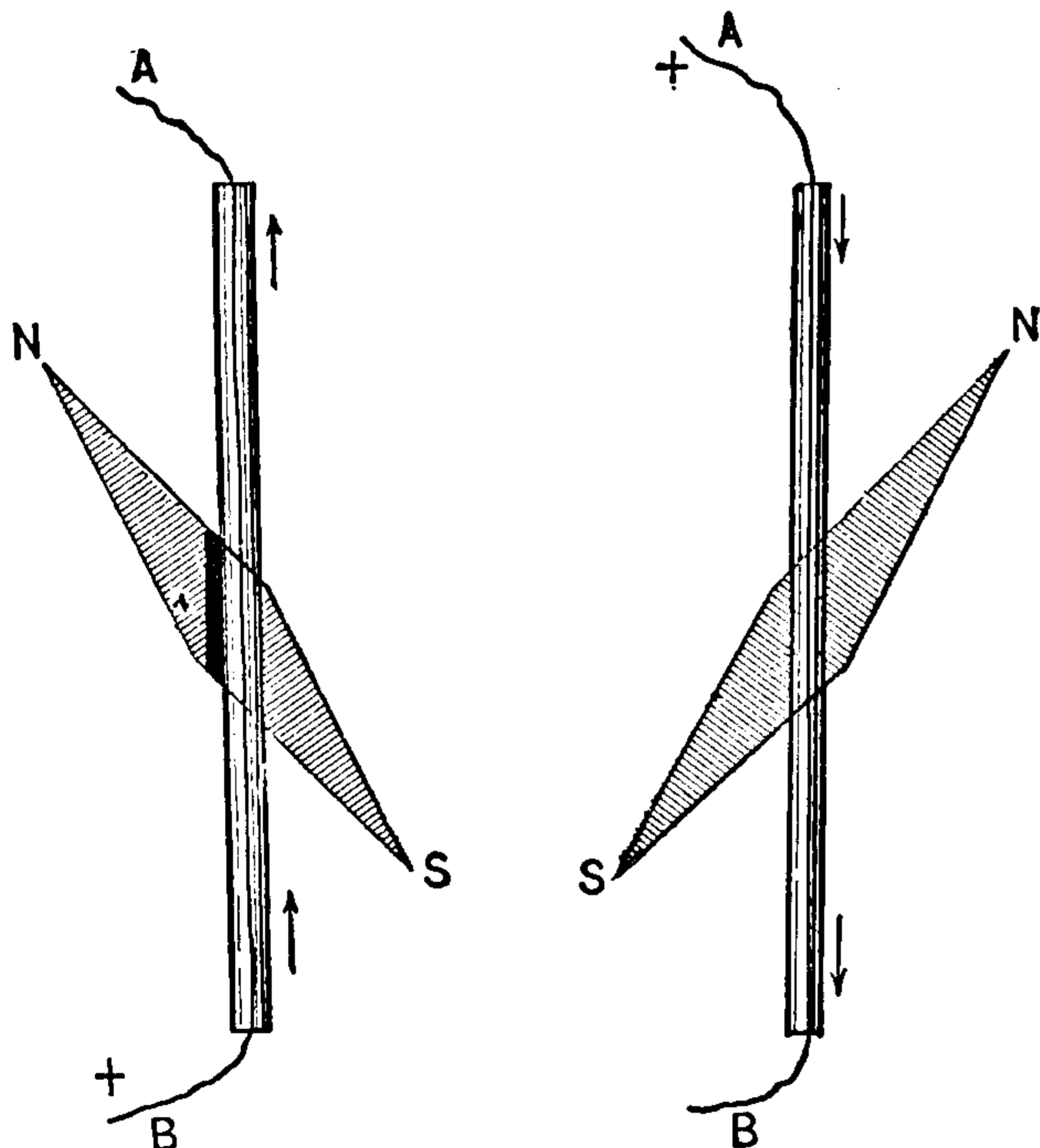

Fig. 371. Deflection of Magnetic Needle.

Fig. 372. Deflection of Magnetic Needle.

If, for example, the conductor A B, be traversed by a current in the direction from B, to A, as shown in Fig. 371, the north pole N, of the needle N S, placed under the conductor, is deflected, as shown, to the left of the observer, who is supposed to be swimming in the current, facing the needle. If the current flow in the opposite

direction, as from A, to B, as shown in Fig. 372, the N, pole of the needle is deflected as shown, but still to the left of the observer supposed to be swimming as before.

In any electric circuit, the lines of magnetic force, produced by the passage of the current, form circles around the circuit in planes at right angles to the direction of the current, as shown in Fig. 373. The direction of these lines of force is the same as that of the hands of a watch, if the current be supposed to flow away from the observer. (See *Field, Magnetic, of an Electric Current.*)

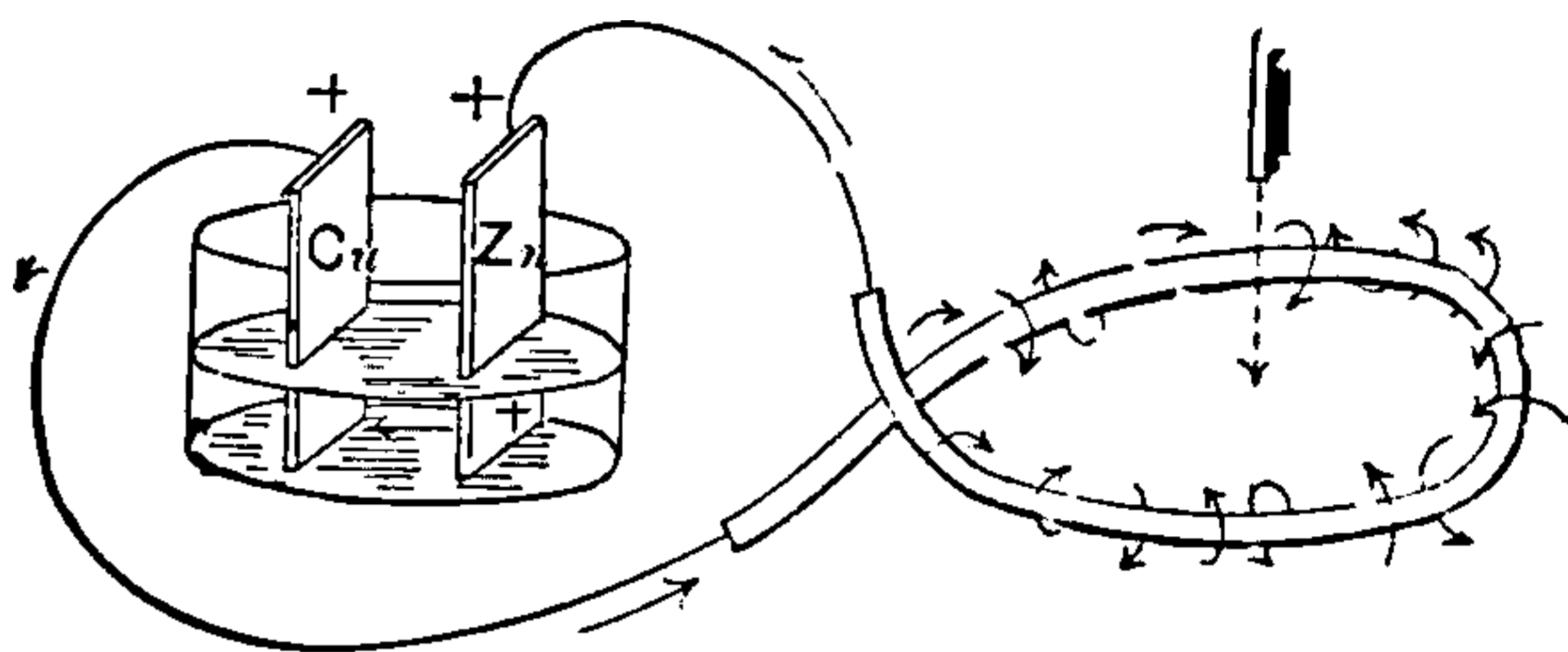

Fig. 373. Direction of Lines of Force.

Remembering now that the lines of force are supposed to come out at the north pole of a magnet, and to pass in at the south pole, it is evident that if the current flows in the direction shown in Fig.

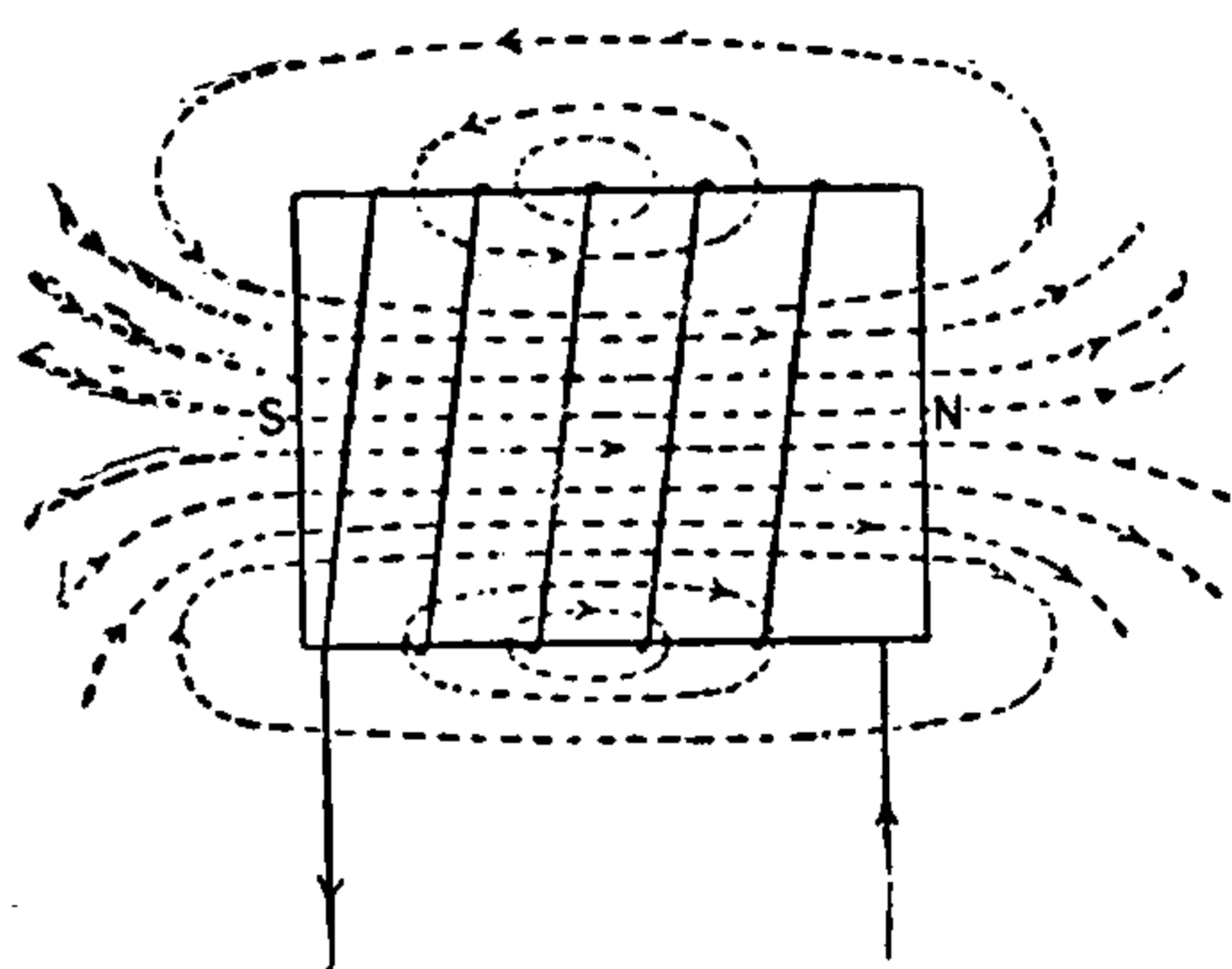

Fig. 374. Direction of Lines of Force.

374, the lines of force will come out at the north pole and pass in at the south pole.

Since in a right-handed helix the wire passes around the axis in the opposite direction to that in which it passes in a left-handed helix, it is evident that the helices shown in Fig. 375 at 1, and 2, will produce opposite polarities at the points of entrance and exit by a current flowing in the direction of the arrows.

If the current be sent through the right-handed helix, shown at 1, from b, to a, that is, from the left to the right in the figure, a south pole will be produced at b, and a north pole at a. If, however, it be sent from a, to b, the polarity will be reversed.

If the current be sent through the left-handed

helix, shown at 2, from a, to b, that is, from the left to the right in the figure, a north pole will be produced at a, and a south pole at b. If, however, it be sent in the opposite direction, the polarity will be reversed.

Therefore, in an electro-magnet, on the core of which several layers or thicknesses of wire are wound, in which the current flows through one layer, in, say a direction from right to left, the current must return through the next layer in the opposite direction, or from left to right. The polarities of the same extremities of the helices are, however, the same in all cases, *since the layers are successively right and left handed to the current.* The winding shown at 3, produces consequent poles.

The following laws express the more important principles concerning electro-magnets:

(1.) The magnetic intensity (strength) of an electro-magnet is nearly proportional to the strength of the magnetizing current, provided the core is not saturated.

(2.) The magnetic strength is proportional to the number of turns of wire in the magnetizing coil; that is, to the number of ampère turns. (See *Turns, Ampère.*)

(3.) The magnetic strength is independent of the thickness or material of the conducting wires.

These laws may be embraced in the more general statement that the strength of an electro-

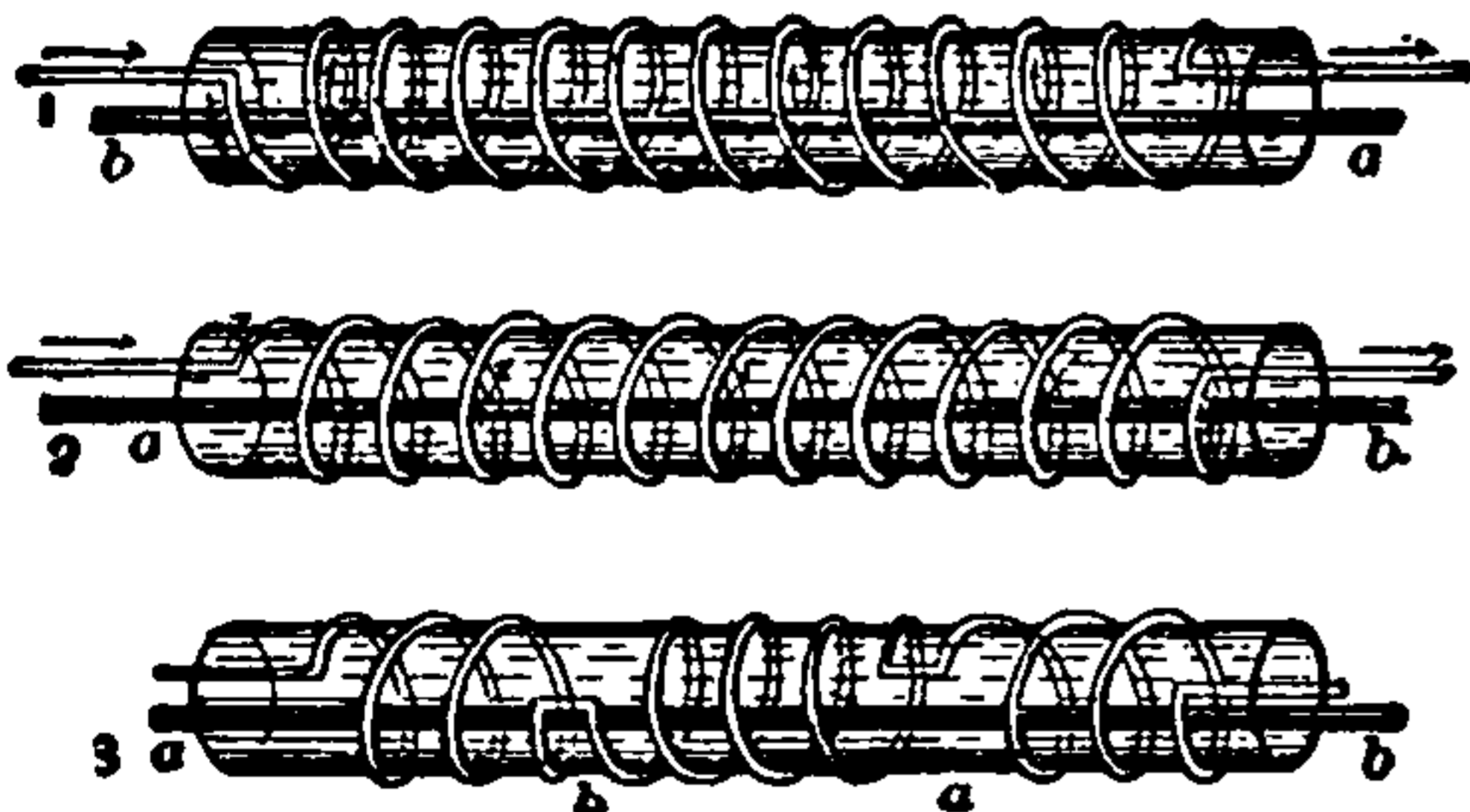

Fig. 375. *Right-Handed, Left-Handed and Anomalous Helices.*

magnet, the size of the magnet being the same, is proportional to the number of its ampère turns. (See *Turns, Ampère.*)

A short interval of time is required for a current to thoroughly magnetize a powerful electro-magnet.

A few moments are also required for a powerful magnet to thoroughly lose its magnetism. At the same time electro magnets are capable of acquiring or losing their magnetism with very great rapidity. It is, in fact, on this ability possessed to so remarkable a degree by soft iron, that

the value of an electro-magnet for many purposes depends. (See *Lag, Magnetic.*)

A difference exists between the action of a magnetized disc and a hollow coil of wire through which a current of electricity is passing. So far as the space outside either is concerned, the action is the same, but the coil is penetrable on the inside and the disc is not, and for the inside of the space, therefore, there is a difference in the action.

Magnet, Electro, Bar — — An electro-magnet, the core of which is in the form of a straight bar or rod.

Magnet, Electro, Cylindrical — — An electro-magnet, the core of which consists of a hollow cylinder provided with a slot extending parallel to its axis.

The gap in the cylinder suffices for the placing of the magnetizing coils, and forms the poles. This form of electro-magnet was devised by Joule. Its construction will be understood from an inspection of Fig. 376.

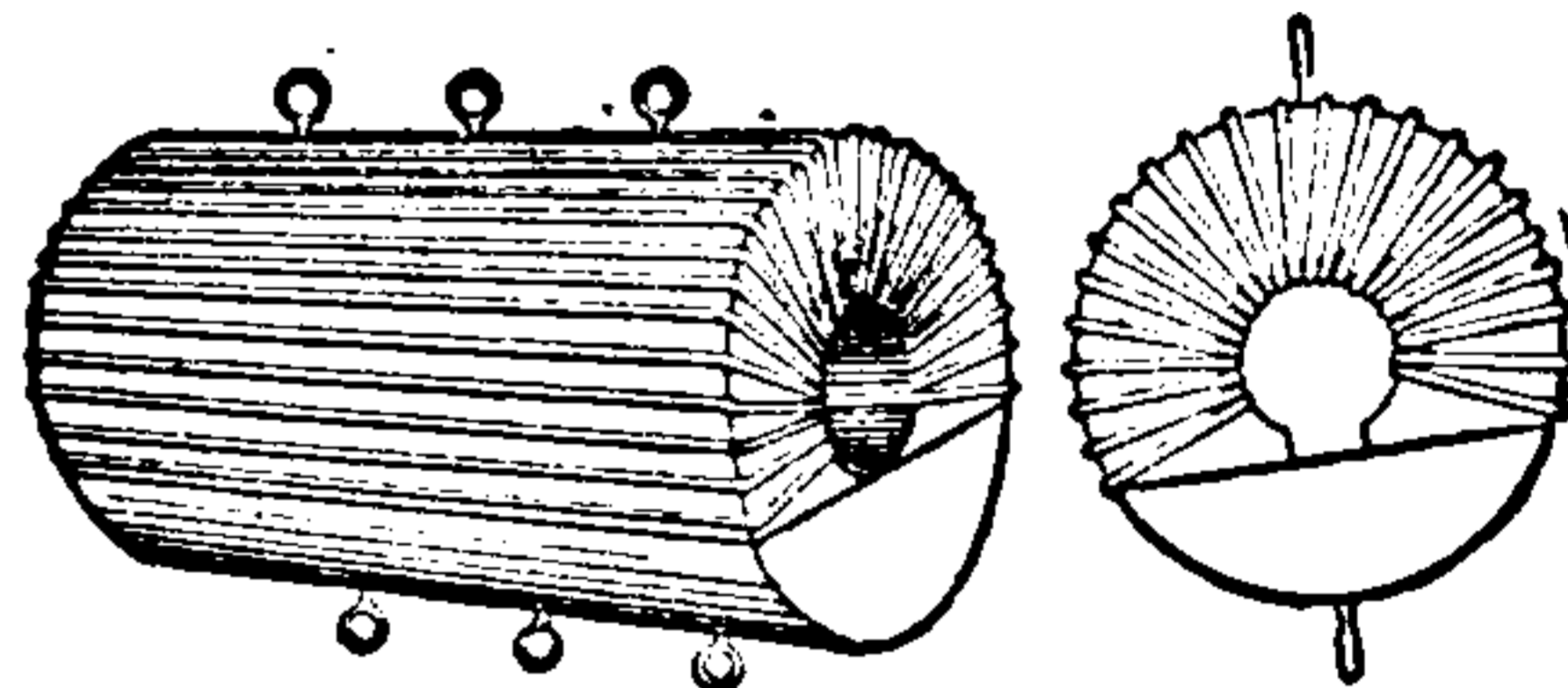

Fig. 376. *Cylindrical Electro-Magnet.*

Magnet, Electro, Horseshoe — — An electro-magnet, the core of which is in the shape of a horseshoe or U.

Magnet, Electro, Hughes' — — An electro-magnet in which a U-shaped permanent magnet is provided with pole pieces of soft iron, on which only are placed the magnetizing coils.

A quick acting electro-magnet, in which the magnetizing coils are placed on soft iron pole pieces that are connected with and form the prolongations of the poles of a permanent horseshoe magnet.

Hughes devised this form of electro-magnet in order to obtain the best effects from currents of but short duration.

He thus obtained a quick acting magnet, necessary to insure the success of his system of printing telegraph, where the magnetizing currents at times have a duration of but the .20 of a second.

Magnet, Electro, Joule's Cylindrical — —An electro-magnet provided with a hollow cylindrical core. (See *Magnet, Electro, Cylindrical*.)

Magnet, Electro, Iron-Clad — —An electro-magnet whose magnetizing coil is almost entirely surrounded by iron.

The effect of the iron casing is to greatly reduce the magnetic resistance of the circuit. A form of iron-clad electro-magnet is shown in Fig. 377. Here one of the poles is connected with a casing of iron, external to the coils, and is thus brought nearer to the other pole.

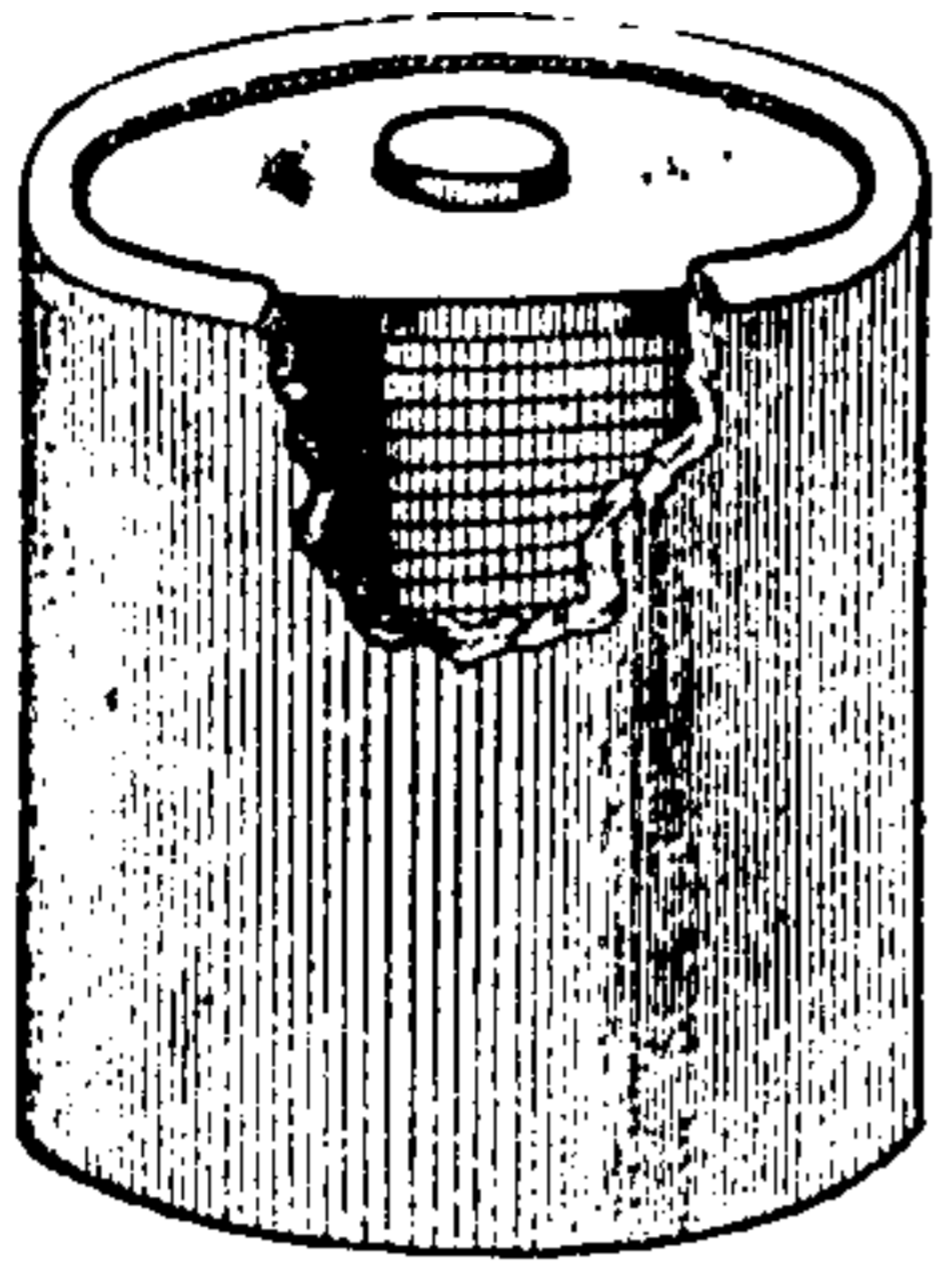

Fig. 377. *Iron-Clad Electro-Magnet.*

Magnet, Electro, Long-Core — —An electro-magnet with a long core of iron.

A long-core electro-magnet magnetizes and demagnetizes much more slowly than a short-core electro-magnet.

Magnet, Electro, Short-Core — —An electro-magnet with a short core of iron.

A short-core electro-magnet possesses the power of being magnetized and demagnetized much more rapidly than a long-core magnet.

Magnet, Electro, Yoked-Horseshoe — —A horseshoe electro-magnet, in which the two straight limbs are formed of two straight rods or bars, yoked together at one pair of ends by a yoke or bar of iron.

In some cases the magnetizing coils are placed on each of the limbs. Sometimes, however, a single coil is placed at the middle of the yoke and the limbs are left bare.

Even with the closest possible fitting the resistance of the magnetic circuit is much greater in this form of electro-magnet, owing to the smaller permeability of the air gap at the joints, than it would be if the entire core were made of a single piece of iron. A yoked electro magnet is, however, more convenient to make and use.

Magnet, Electro, Zigzag — —A multipolar electro-magnet, the magnetizing coils of which are separately wound in grooves cut in the face of straight or curved bars.

A form of zigzag electro-magnet devised by Joule is shown in Fig. 378. The spiral character of the winding produces the alternate North and South polarities shown in the figure.

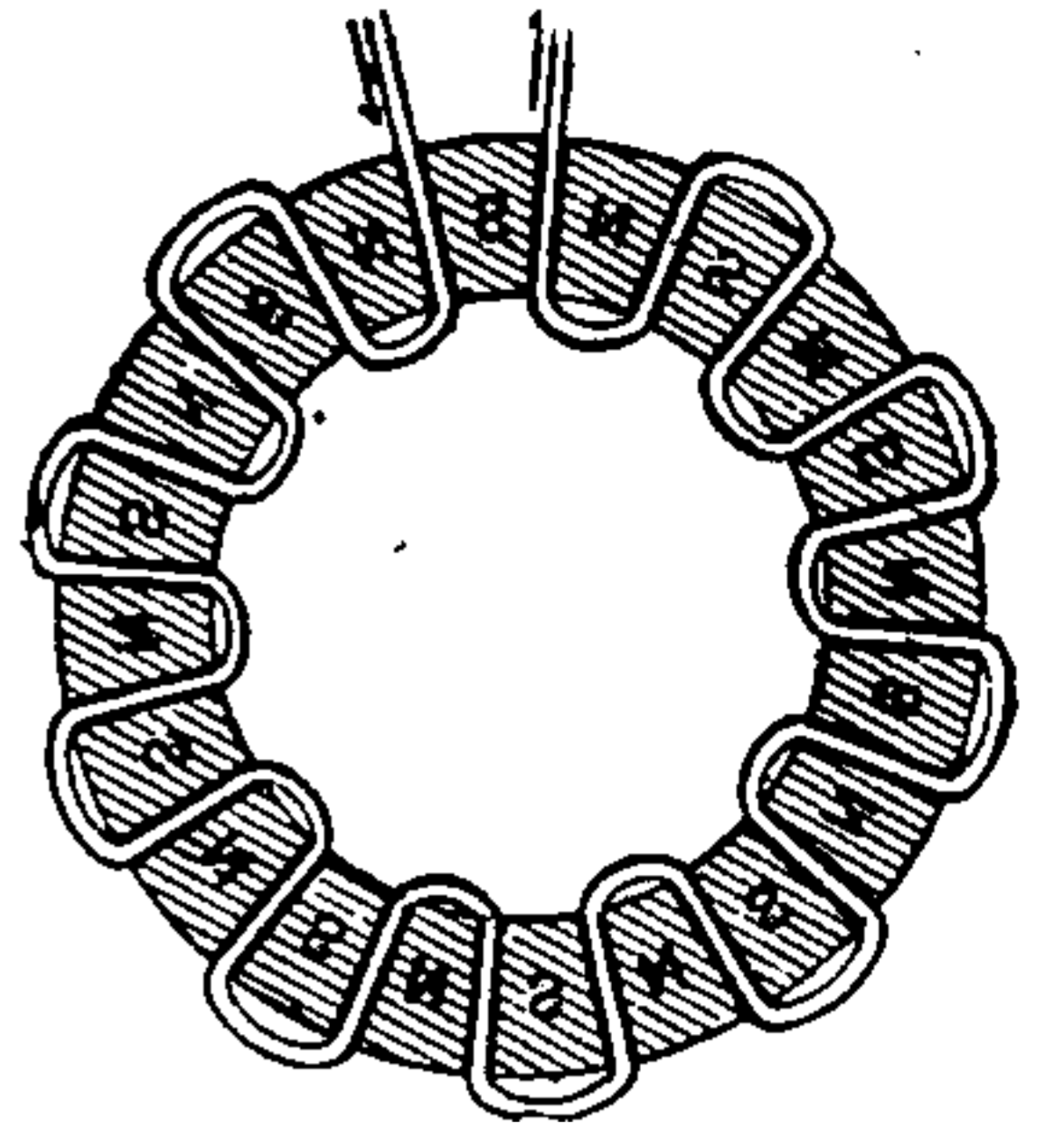

Fig 378 *Zigzag Electro-Magnet.*

Magnet, Equator of — —A point approximately midway between the poles of a straight bar magnet, or nearly midway from the poles of a horseshoe magnet if measured along the bar from each pole.

This term was proposed by Dr. Gilbert. It is now almost entirely displaced by the term *neutral point*.

Magnet, High-Resistance — —A term sometimes used in place of long-coil magnet whose coils have a high electric resistance. (See *Magnet, Long-Coil*.)

The term long-coil magnet is, perhaps, the preferable one, because the resistance of a coil, *per se*, has nothing to do with its magnetizing power, which is determined by its ampère turns. (See *Turns, Ampère. Magnet, Long Coil*.)

Magnet, Horseshoe — —A magnetized bar of steel or iron bent in the form of a horseshoe or letter U.

Magnet, Iron-Clad — —A magnet whose magnetic resistance is lowered by a casing of iron connected with the core and provided for the passage of the lines of magnetic force. (See *Magnet, Tubular*.)

Magnet, Jacketed — —A term sometimes applied to a form of iron-clad magnet. (See *Magnet, Iron-Clad*.)

Magnet, Keeper of — —A mass of soft iron applied to the poles of a magnet through which its lines of magnetic force pass. (See *Field, Magnetic*.)

The keeper of a magnet differs from its *armature* in that the keeper while acting as such is always kept on the poles to prevent loss of magnetization, while the armature, besides acting as a keeper, may be attracted towards, or, if an electro-magnet, be repelled from the magnet poles. While performing its functions the keeper is always fixed; the armature generally, though

THIS PAGE IS LOCKED TO FREE MEMBERS

Purchase full membership to immediately unlock this page



HISTORY

Tens of thousands of important historical sources, many previously unobtainable, are now available for the first time with a Forgotten Books Full Membership.

Unlimited Access
\$8.99/month

Continue

*Fair usage policy applies

whose armature is employed to bring a local battery into action at the receiving station, the current of which operates the register or sounder.

Magnet, Short-Coil — — An electro-magnet whose magnetizing coil consists of a few turns of short, thick wire.

Magnet, Simple — — A simple magnetized bar.

The term simple magnet is used in contradistinction to compound magnet. (See *Magnet, Compound*.)

Magnet, Sluggish — — A magnet that magnetizes or demagnetizes sluggishly.

An electro-magnet becomes sluggish when surrounded by a sheathing of copper, on account of the currents induced in the sheathing in a direction opposite to those passing through the magnetizing coil.

Magnet, Solenoidal — — A thin, uniformly magnetized straight bar of steel, of such a length that its poles, situated at extremities or ends of its longer axis, act on external objects as if equal and opposite quantities of magnetism were concentrated at such extremities.

It derives its name solenoidal from the similarity between its action and that of a solenoid. Unless very carefully magnetized, a magnet will not act as a solenoidal magnet. (See *Magnet, Electro. Magnetism, Solenoidal Distribution of*.)

Magnet, Tubular — — A form of horseshoe magnet, in which one pole is brought near the opposite pole by a hollow cylinder or tube of iron, which is placed in contact with one of the magnetic poles, so as to completely surround the other, except in the plane of cross-section of that pole.

A form of iron-clad magnet. (See *Magnet, Iron-Clad*.)

There is thus obtained a magnet, with two concentric poles, one solid and the other annular, the portative power of which is much greater than that of a horseshoe magnet of equal dimensions.

Magnet, Field, of Dynamo-Electric Machine — — One of the electro-magnets employed to produce the magnetic field of a dynamo-electric machine.

The field magnets consist of a suitable *frame*, or *core*, on which the *field magnet coils* are wound.

The *field magnet cores* are made of thick and solid iron, as soft as possible. They should contain plenty of iron in order to avoid too ready *magnetic saturation*.

All edges and corners are to be avoided, since they tend to cause an irregular distribution of the field.

The field magnets should in general have sufficient magnetic strength to prevent the magnetizing effect of the armature from unduly influencing the field, and thus, by causing too great a *lead*, produce injurious *sparking*.

Magnetic or Magnetical.—Pertaining to magnetism.

Magnetic Adherence.—(See *Adherence, Magnetic*.)

Magnetic Air Circuit.—(See *Circuit, Air, Magnetic*.)

Magnetic Air Gap.—(See *Gap, Air, Magnetic*.)

Magnetic Attraction.—(See *Attraction, Magnetic*.)

Magnetic Axis.—(See *Axis, Magnetic*.)

Magnetic Axis of a Straight Needle.—(See *Axis, Magnetic, of a Straight Needle*.)

Magnetic Azimuth.—(See *Azimuth, Magnetic*.)

Magnetic Battery.—(See *Battery, Magnetic*.)

Magnetic Bridge.—(See *Bridge, Magnetic*.)

Magnetic Circuit.—(See *Circuit, Magnetic*.)

Magnetic Closed-Circuit.—(See *Circuit, Closed Magnetic*.)

Magnetic Conductance.—(See *Conductance, Magnetic*.)

Magnetic Core, Closed — — (See *Core, Closed-Magnetic*.)

Magnetic Core, Open — — (See *Core, Open-Magnetic*.)

Magnetic Couple.—(See *Couple, Magnetic*.)

Magnetic Curves.—(See *Curves, Magnetic.*)

Magnetic Day of Disturbance.—(See *Day of Disturbance, Magnetic.*)

Magnetic Declination.—(See *Declination.*)

Magnetic Density.—(See *Density, Magnetic.*)

Magnetic Dip.—(See *Dip, Magnetic.*)

Magnetic Elements of a Place.—(See *Elements, Magnetic, of a Place.*)

Magnetic Equalizer.—(See *Equalizer, Magnetic.*)

Magnetic Explorer.—(See *Explorer, Magnetic.*)

Magnetic, Ferro — —Magnetic after the manner of iron or other paramagnetic body. (See *Paramagnetic.*)

Magnetic Field.—(See *Field, Magnetic.*)

Magnetic Field, Reversing — —(See *Field, Magnetic, Reversing.*)

Magnetic Field, Shifting — —(See *Field, Magnetic, Shifting.*)

Magnetic Figures.—(See *Figures, Magnetic. Field. Magnetic.*)

Magnetic Filament. — (See *Filament, Magnetic.*)

Magnetic Flow.—(See *Flow, Magnetic.*)

Magnetic Flux.—(See *Flux, Magnetic.*)

Magnetic Force.—(See *Force, Magnetic.*)

Magnetic Inclination.—(See *Inclination, Magnetic.*)

Magnetic Induction.—(See *Induction, Magnetic.*)

Magnetic Induction, Dynamic — — (See *Induction, Magnetic, Dynamic.*)

Magnetic Induction, Static — —(See *Induction, Magnetic, Static.*)

Magnetic Inertia.—(See *Inertia, Magnetic.*)

Magnetic Intensity. — (See *Intensity, Magnetic.*)

Magnetic Joint.—(See *Joint, Magnetic.*)

Magnetic Lag.—(See *Lag, Magnetic.*)

Magnetic Latitude.—(See *Latitude, Magnetic.*)

Magnetic Leakage.—(See *Leakage, Magnetic.*)

Magnetic Lines of Force.—(See *Force, Magnetic, Lines of.*)

Magnetic Mass.—(See *Mass, Magnetic.*)

Magnetic Memory.—(See *Memory, Magnetic.*)

Magnetic Meridian.—(See *Meridian, Magnetic.*)

Magnetic Moment.—(See *Moment, Magnetic.*)

Magnetic Normal Day.—(See *Day, Normal, Magnetic.*)

Magnetic Observatory.—(See *Observatory, Magnetic.*)

Magnetic Output.—(See *Output, Magnetic.*)

Magnetic Parallel.—(See *Parallels, Magnetic.*)

Magnetic Permeability.—(See *Permeability, Magnetic.*)

Magnetic Permeance.—(See *Permeance, Magnetic.*)

Magnetic Permeation.—(See *Permeation, Magnetic.*)

Magnetic Poles.—(See *Poles, Magnetic.*)

Magnetic Poles, False — —(See *Pole, Magnetic, False.*)

Magnetic Proof Piece.—(See *Piece, Magnetic Proof.*)

Magnetic Proof Plane.—(See *Plane, Proof, Magnetic.*)

Magnetic Reluctance.—(See *Reluctance, Magnetic.*)

Magnetic Repulsion.—(See *Repulsion, Magnetic.*)

Magnetic Resistance.—(See *Resistance, Magnetic.*)

Magnetic Retardation.—(See *Retardation, Magnetic.*)

Magnetic Retentivity.—(See *Retentivity, Magnetic.*)

Magnetic Saturation.—(See *Saturation, Magnetic.*)

Magnetic Screen or Shield.—(See *Screen or Shield, Magnetic.*)

Magnetic Screening.—(See *Screening, Magnetic.*)

Magnetic Self-Induction.—(See *Induction, Self, Magnetic.*)

Magnetic Shells.—(See *Shells, Magnetic.*)

Magnetic Shunt.—(See *Shunt, Magnetic.*)

Magnetic, Sidero — — A term proposed by S. P. Thompson to replace the term ferromagnetic. (See *Magnetic, Ferro.*)

Magnetic Solenoid.—(See *Solenoid, Magnetic.*)

Magnetic Sounds.—(See *Sounds, Magnetic.*)

Magnetic Spin.—(See *Spin, Magnetic.*)

Magnetic Storm.—(See *Storm, Magnetic.*)

Magnetic Strain.—(See *Strain, Magnetic.*)

Magnetic Stress.—(See *Stress, Magnetic.*)

Magnetic Susceptibility.—(See *Susceptibility, Magnetic.*)

Magnetic Theodolite.—(See *Theodolite, Magnetic.*)

Magnetic Unit Pole.—(See *Pole, Unit, Magnetic.*)

Magnetic Units.—(See *Units, Magnetic.*)

Magnetic-Vane Ammeter.—(See *Ammeter, Magnetic-Vane.*)

Magnetic-Vane Voltmeter.—(See *Voltmeter, Magnetic-Vane.*)

Magnetic Variations.—(See *Variation, Magnetic.*)

Magnetic Variation Transit.—(See *Transit, Magnetic Variation.*)

Magnetic Variometer.—(See *Variometer, Magnetic.*)

Magnetic Viscosity.—(See *Viscosity, Magnetic.*)

Magnetic Whirl.—(See *Whirls, Magnetic.*)

Magnetic Whirl, Expanding — — (See *Whirl, Magnetic, Expanding.*)

Magnetics, Electro — — That branch of electric science which treats of the relations that exist between electric circuits and magnets.

Magnetism.—That branch of science which treats of the nature and properties of magnets and the magnetic field. (See *Field, Magnetic.*)

A property or condition of matter attended by the existence of a magnetic field.

Magnetism, Ampère's Theory of — — A theory or hypothesis proposed by Ampère, to account for the cause of magnetism, by the presence of electric currents in the ultimate particles of matter.

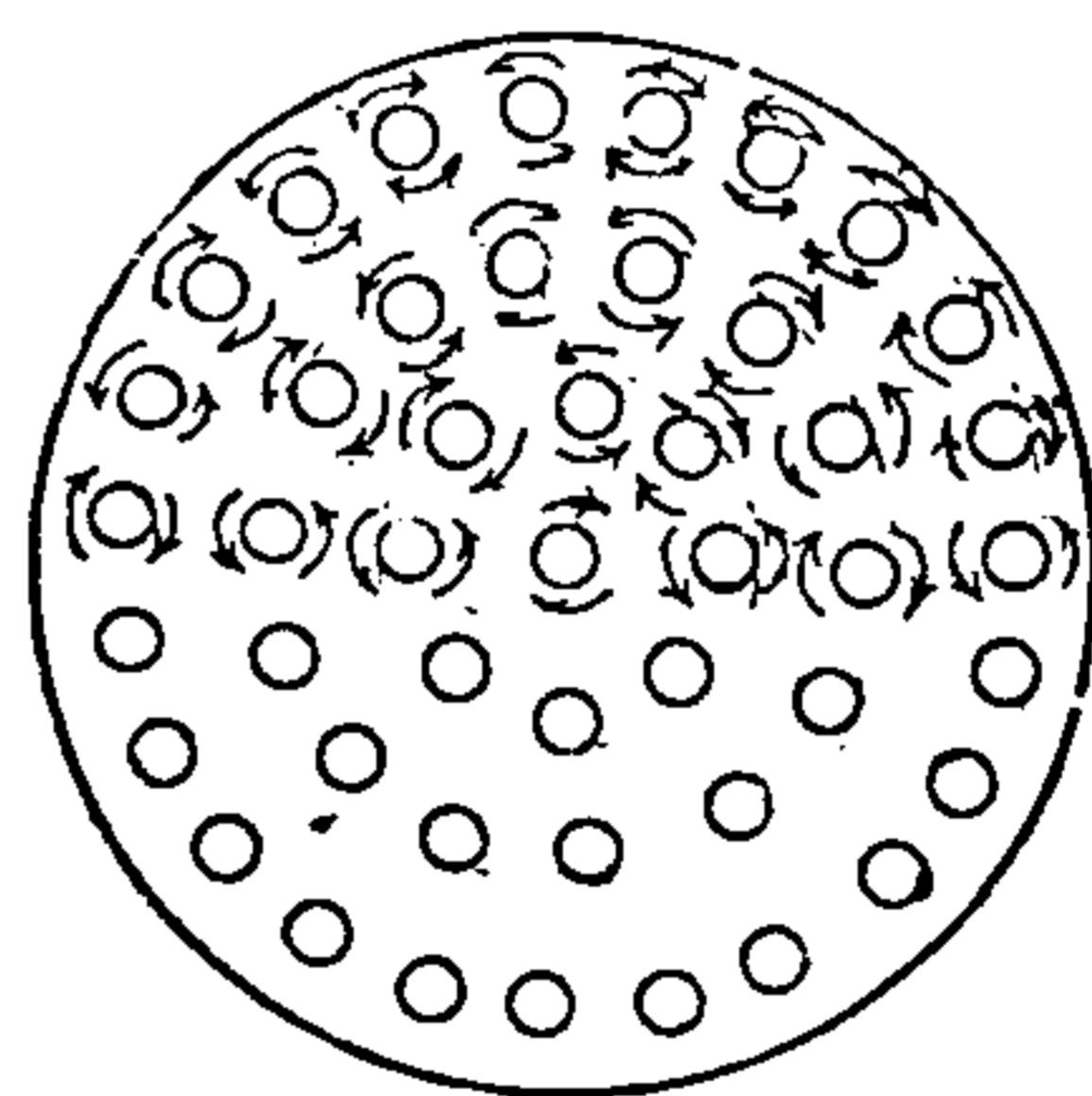

Fig. 379. Unmagnetized Bar (after Ampère).

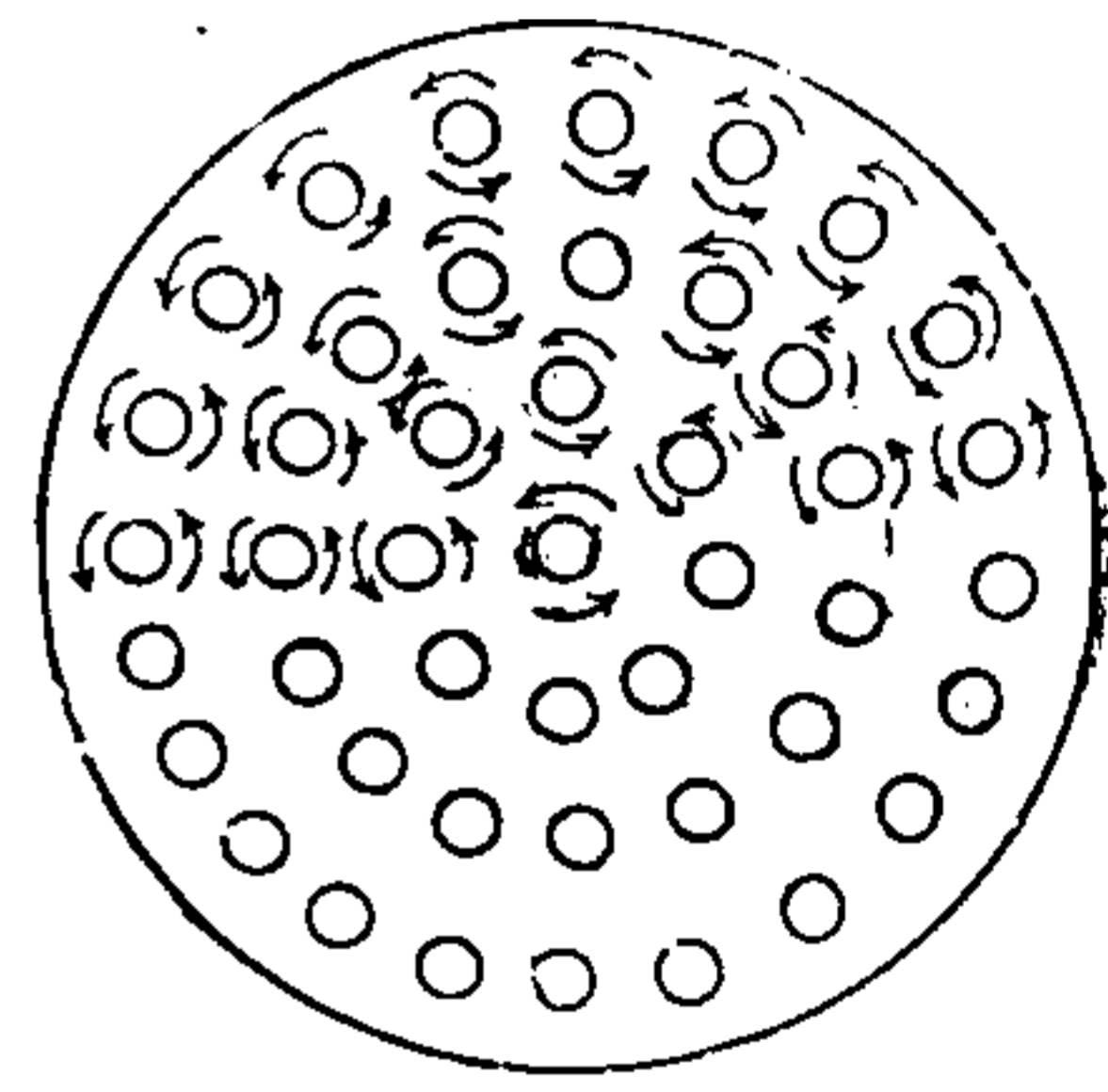

Fig. 380. Magnetized Bar (after Ampère).

This theory assumes:

(1.) That the ultimate particles of all magnetizable bodies have closed electric circuits in which electric currents are continually flowing.

(2.) That in an unmagnetized body these circuits neutralize one another because they have different directions.

(3.) That the act of magnetization consists in such a polarization of the particles as will cause these currents to flow in one and the same direction, *magnetic saturation* being reached when all the separate circuits are parallel to one another.

(4.) That *coercive force* is due to the resistance these circuits offer to a change in the direction of their planes.

Figs. 379 and 380 show the circular paths of some of these circuits. Fig. 379 shows the as-

THIS PAGE IS LOCKED TO FREE MEMBERS

Purchase full membership to immediately unlock this page

Know Your Bible

Forgotten Books' Full Membership provides unlimited access to more than 28,000 volumes of Christian literature for \$8.99/month

HOLY BIBLE

Continue

*Fair use policy applies

this illumined area, produces, in Prof. Biglow's opinion, those differences in the direction and intensity of the magnetic lines of the earth's field that correspond to differences in the earth's magnetic intensity, declination and inclination.

It will be observed that in all these theories the sun is the prime factor in the production of the earth's magnetism.

The evident connection between the earth's magnetism and the solar radiation is established from the well known connection between the so-called magnetic storms and variations in the intensity of the earth's magnetism.

Magnetic storms are always attended by outbursts of solar energy, known technically as sun-spots. A series of observations on the numbers and frequency of sun-spots, plotted in the form of a curve, the ordinates of which represent the times of occurrence of the spots and the abscissas, the number of such spots, prove that such curve agrees, in a remarkable manner, with a similar curve representing the variations of the earth's magnetic field.

An evident connection, too, exists between the earth's magnetism and the prevalence of the aurora borealis.

Magnetism, Electro — — Magnetism produced by means of electric currents.

The discovery by Oersted, in 1820, of the action of an electric current on a magnetic needle, was almost immediately followed by the simultaneous and independent discoveries by Arago and Davy, of the method of magnetizing iron by the passage of an electric current around it.

These observations were first reduced to a theory by Ampère. (See *Magnetism, Ampère's Theory of. Magnet, Electro.*)

Magnetism, Ewing's Theory of — — A theory of magnetism proposed by Prof. Ewing, based on the assumption of originally magnetized particles.

Ewing's theory of magnetism assumes that the ultimate particles of matter are naturally magnetic and possess polarity. In this respect Ewing's theory agrees with the theories of Hughes and Weber. Ewing does not believe, however, in the necessity for the assumption of any arbitrary restraining or constraining force to the movements of these ultimate magnetic particles other than those due to their own mutual magnetic attractions and repulsions. He assumes that in a magnet,

the centres about which the molecular magnets rotate are maintained at constant distances from one another, save only as they are affected by the action of strain.

He has experimentally demonstrated the principles of his theory by means of a model in which a number of small magnetic needles are so supported as to be capable of free motion in a horizontal plane, when under varying magnetic forces.

According to Ewing, "magnetic hysteresis" is not the result of any quasi-frictional resistance to molecular rotation, but arises from a molecule moving from one position of stable equilibrium to another position of stable equilibrium through a position of unstable equilibrium. "This process," says Ewing, "considered mechanically, is not reversible. The forces are different for the same displacement, going and coming, and there is dissipation of energy. In the model, the energy thus expended sets the little bars swinging, and their swings take some time to subside. In the actual solid, the energy which the molecular magnet loses as it swings through unstable positions, generates eddy currents in surrounding matter. Let the magnets of the model be furnished with air vanes to damp their swings and the correspondence is complete."

In Hughes' modification of Weber's theory of magnetism, it was held, that when magnetized iron was suddenly demagnetized by torsion or flexure, it lost its magnetization because the molecular magnets came to rest in closed chains, which produced no external effects. Experimentation with Ewing's model of a magnet shows that when the separate magnets after having been placed in any particular grouping are permitted to come to rest free from any external magnetic force, they do not arrange themselves in closed chains, but in general the tendency appears to be the formation of lines consisting of two, three or more magnets each member of a line being strongly controlled by its next member in that line, but influenced by the neighbors which lie off the line on either side.

The fact that a given force, suddenly applied, produces more magnetic induction than when gradually applied, and leaves less residual magnetism when suddenly than when gradually removed is presumably due to the inertia of the molecules.

The influence of mechanical vibration in increasing the magnetic susceptibility and decreas-

ing the magnetic retentiveness, is ascribed by Ewing to the fact that the vibrations cause periodic variations in the distances between the centres of rotation of the magnetic molecules; thus making the molecular magnets respond more readily to changes of magnetic force during the time they are moving away from one another, when their magnetic stability is less, but also increasing the ease with which they respond to changes of magnetic force, by causing them to swing.

Ewing discusses the theoretical effects of temperature on magnetism as follows, viz.: Suppose a moderate magnetizing force to be applied so that nothing like saturation is obtained, if now the temperature be raised; then

(1.) The magnetic permeability increases until the temperature reaches a certain (high) critical value.

(2.) At this temperature there is suddenly an almost complete disappearance of magnetic quality.

He explains these facts as follows, viz.: An increase of temperature by increasing the distance between the molecular centres causes a decrease in their stability.

The loss of magnetic qualities, when a certain temperature is reached, is, he believes, due to the fact that at such temperatures the magnetic molecules are set into actual rotation, when, naturally, all traces of polarity would disappear.

Ewing's theory of magnetism also accounts to a considerable extent for the effects of stress and consequent elastic strain on the magnetic qualities of iron, nickel and cobalt.

The following general summary of his theory is taken mainly from Prof. Ewing's original articles as published in the *Journal of the Society of Arts*:

(1.) That in considering the magnetization of iron and other magnetic metals to be caused by the turning of permanent molecular magnets, we may look simply to the magnetic forces which the molecular magnets exert upon one another as the cause of their directional stability. There is no need to suppose the existence of any quasi-elastic directing force, or any quasi-frictional resistance to rotation.

(2.) That the intermolecular magnetic forces are sufficient to account for all the general characteristics of the process of magnetization, including the variations of susceptibility which occur as the magnetizing force is increased.

(3.) That the intermolecular magnetic forces are equally competent to account for the known facts of retentiveness and coercive force, and the characteristics of cyclic magnetic processes.

(4.) The magnetic hysteresis and the dissipation of energy which hysteresis involves are due to molecular instability, resulting from intermolecular magnetic actions, and are not due to anything in the nature of frictional resistance to the rotation of the molecular magnets.

(5.) That this theory is wide enough to admit an explanation of the differences in magnetic quality which are shown by different substances, or by the same substance in different states.

(6.) That it accounts in a general way for the known effects of vibration, of temperature, and of stress, upon magnetic quality.

(7.) That, in particular, it accounts for the known fact that there is hysteresis in the relation of magnetism to stress.

(8.) That it further explains why there is in magnetic metals hysteresis in physical quality generally with respect to stress.

(9.) That, in consequence, any (not very small) cycle of stress occurring in a magnetic metal involves dissipation of energy.

It can be demonstrated by means of experiments with a model constructed according to Ewing's hypothesis, that this hypothesis comes nearer than any which had been proposed before in explaining the following effects:

(1.) The behavior of a piece of iron when placed in a magnetic field whose strength is made to pass through a cycle of changes.

(2.) That nearly all reversals of sign on the change of the magnetizing force are accompanied by small changes in the magnetization.

(3.) That a piece of iron submitted to vibrations or mechanical shocks, is magnetized and demagnetized more readily and with a smaller hysteretic area than if it had remained undisturbed by vibrations.

(4.) The phenomenon of "time lag" in magnetization.

(5.) The phenomena of stress, both those which occur when a body has first been placed in a magnetic field and the stress made to vary, and those which occur when a body is first placed in a constant stress and the magnetizing force is made to vary.

(6.) The effects of heat on magnetization, both as regards the effect of comparatively low heating on increase of magnetic susceptibility, and the

THIS PAGE IS LOCKED TO FREE MEMBERS

Purchase full membership to immediately unlock this page



HISTORY

Tens of thousands of important historical sources, many previously unobtainable, are now available for the first time with a Forgotten Books Full Membership.

Unlimited Access
\$8.99/month

Continue

*Fair usage policy applies

Magnetism, Terrestrial — —A name applied to the magnetism of the earth.

Terrestrial magnetism has been ascribed to a variety of causes. (See *Magnetism, Earth's, Theories as to Cause of.*)

Magnetism, Vertical Component of Earth's — —(See *Component, Vertical, of Earth's Magnetism.*)

Magnetite.—Magnetic oxide of iron, or Fe_3O_4 , found in nature, as an ore or mineral.

Lode-stone consists of pieces of magnetized magnetite.

Magnetizable.—Capable of being magnetized after the manner of a paramagnetic substance like iron.

The most magnetizable metals are iron, nickel, cobalt and manganese. (See *Paramagnetism.*)

Magnetization.—The act of calling out or of endowing with magnetic properties.

Magnetizable substances are magnetized by being placed in magnetic fields. (See *Field, Magnetic. Magnetization, Methods of.*)

The act of initial magnetization is not exactly the same as the act of subsequent magnetization.

A piece of steel, which has once been magnetized and subsequently demagnetized, is a thing entirely distinct, as regards its magnetization, from a piece of steel which has never before been magnetized, and such a piece can never be placed exactly in the same position as regards a magnetizing force, unless it is actually melted and recast, or, perhaps, maintained for a comparatively long time at a white heat.

Magnetization, Anomalous — —The magnetization obtained from an oscillatory discharge, such as that of a Leyden jar.

In 1842, Henry described the 'real character of anomalous magnetization, and showed that there was nothing anomalous in such magnetization, but rather in the fact that the magnetizing currents possessed no simple direction. He remarks on this subject as follows:

“This anomaly, which has remained so long unexplained, and which, at first sight, appears at variance with all our theoretical ideas of the connection of electricity and magnetism, was, after considerable study, satisfactorily referred to an action of the discharge of a Leyden jar which had never before been recognized. The discharge,

whatever may be its nature, is not correctly represented (employing the simplicity of Franklin) by the single transfer of an imponderable fluid from one side of the jar to the other; the phenomena require us to admit the existence of a principal discharge in one direction and then several reflex actions backward and forward, each more feeble than the preceding, until the equilibrium is obtained. All the facts are shown to be in accordance with the hypothesis, and a ready explanation is afforded by it of a number of phenomena which are to be found in the older works on electricity, but which have until this time remained unexplained.”

Magnetization by Touch.—The production of magnetism in a magnetizable substance by touching it with a magnet.

There are three methods of magnetization by touch, viz.:

- (1.) Single touch.
- (2.) Separate touch.
- (3.) Double touch.

In single touch, the magnetization of a bar of iron or other magnetizable material is effected by the touch of a single magnet.

In Single Touch, the magnetizing magnet is drawn over the bar to be magnetized from end to end and returned through air, the stroke being repeated a number of times. The end of the bar the magnet leaves is magnetized oppositely to the magnetizing pole.

By some writers the method of single touch is described as that effected

by placing the magnetizing magnet N S (Fig. 384) on the middle of the bar to be magnetized, and drawing it to the end and returning through the air as before, and then reversing the pole, placing it on the middle of the bar and drawing it towards the other end. The

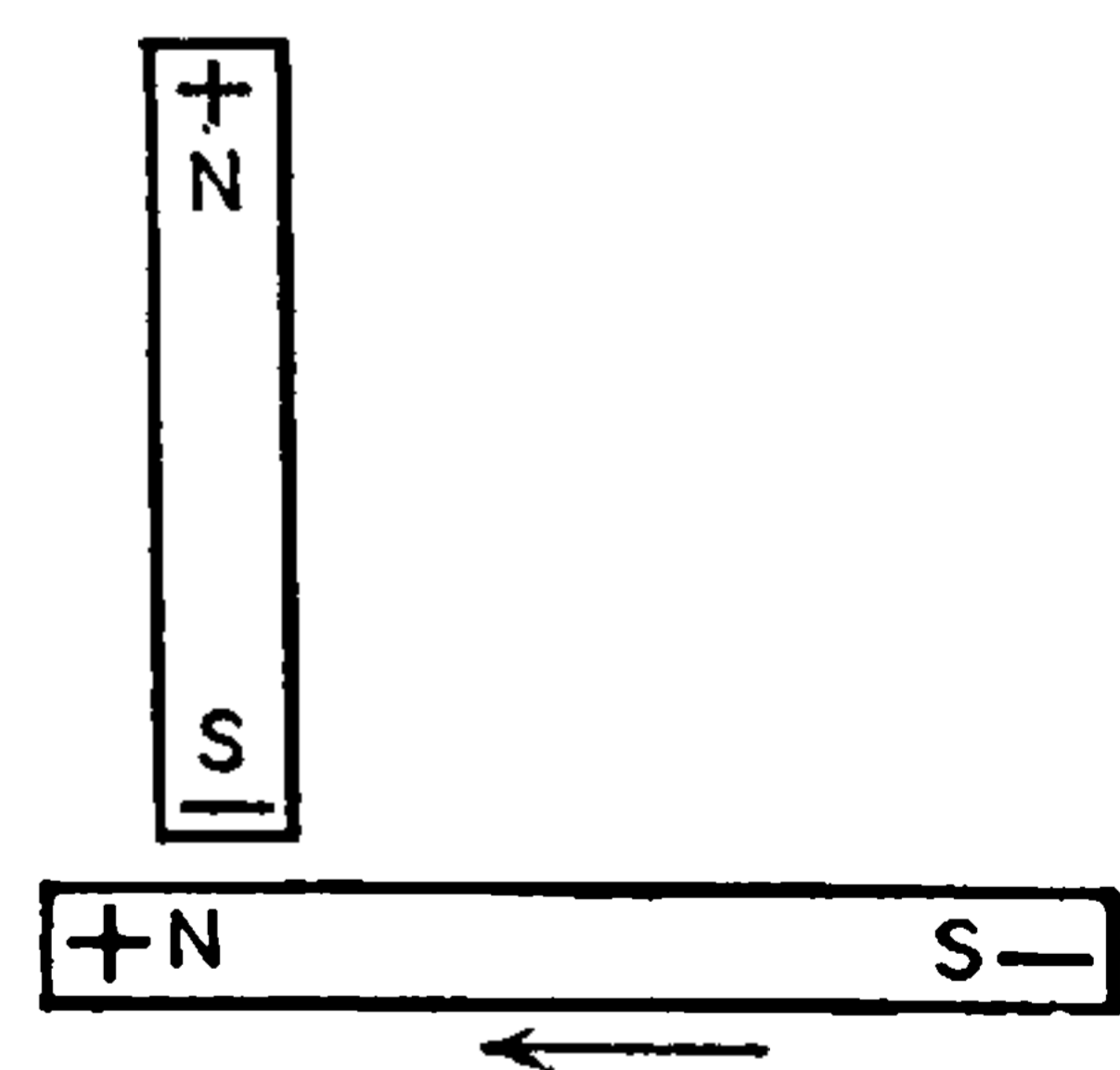

Fig. 384. Magnetization by Single Touch.

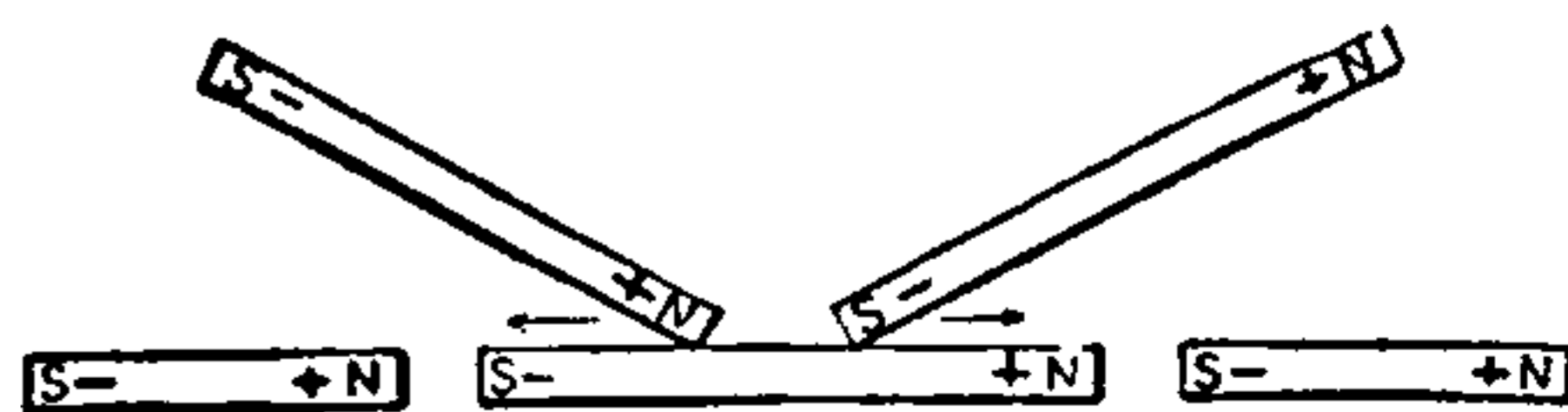

Fig. 385. Magnetization by Separate Touch.

former would, however, appear to be the better use of the term single touch.

In Separate Touch, two magnetizing bars are placed with their opposite poles at the middle

of the bar to be magnetized and drawn away from each other towards its ends, as shown in Fig. 385. This motion is repeated a number of times, the poles being each time returned through the air.

In the above, as in all cases of magnetization by touch, better effects are produced, if the bar

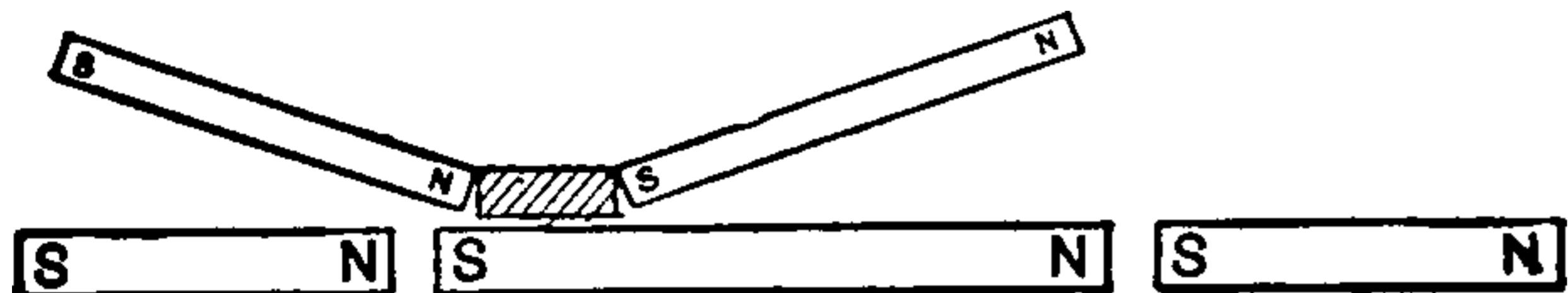

Fig. 386. Magnetization by Double Touch.

to be magnetized is rested on the opposite poles of another magnet, or, as shown in Fig. 386, placed near them.

In Double Touch the two magnets are placed with their opposite poles together on the middle of the bar to be magnetized, as shown in Fig. 386. They are then moved to one end of the bar, when, instead of removing them and passing them back through the air to the other end, they are moved over the surface of the bar to be magnetized to the other end, and these to and-fro motions are repeated a number of times. The motion is stopped at the middle of the bar, when the magnetizing magnets are moving in the opposite direction to that at which they began to move. This insures an equal number of strokes to the two halves of the bar. The method of double touch produces stronger magnetization than either of the other methods, but does not effect such an even distribution of the magnetism, and therefore is not applicable to the magnetization of needles.

A variety of double touch is shown in Fig. 387, where four bars, to be magnetized, are placed in the form of a hollow rectangle, with only their ends touching at their edges, the angular spaces

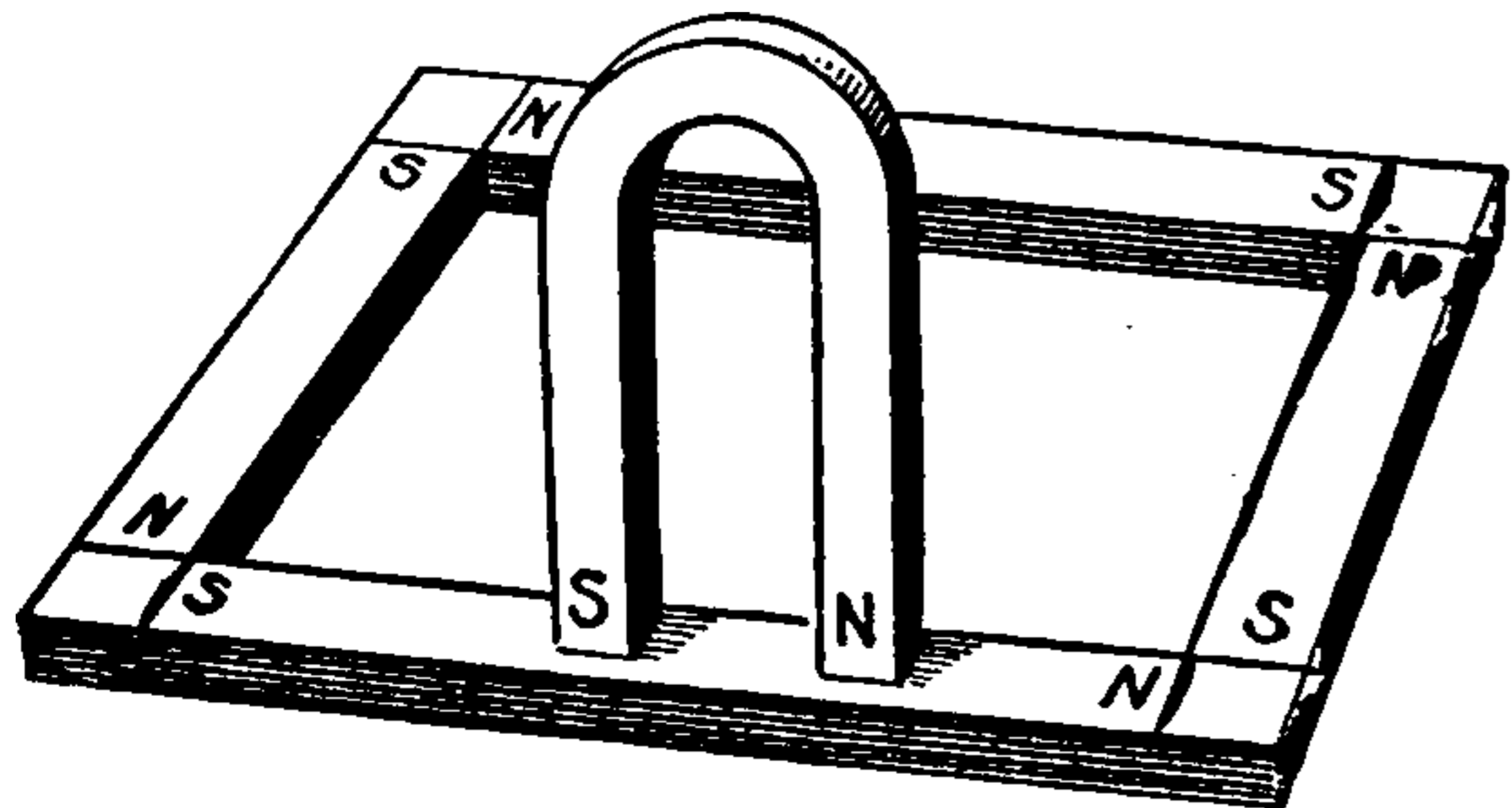

Fig. 387. Magnetization by Double Touch.

at the corners being filled with pieces of soft iron. The horseshoe magnet NS, is then moved around the circuit several times in the same direction. This is believed to produce a more uniform mag-

netization than the ordinary method of double touch.

Magnetization, Co-efficient of — — A number representing the intensity of magnetization produced in a magnetizable body, divided by the magnetizing force H.

Calling k , the co-efficient of magnetization; I , the intensity of the resulting magnetization, and H , the magnetizing force producing it, then

$$k = \frac{I}{H}.$$

The co-efficient of magnetization is sometimes called the magnetic susceptibility.

A paramagnetic body when placed in a magnetic field concentrates the lines of magnetic force on it, or causes them to pass through it. The intensity of the magnetization so produced depends, therefore,

(1.) On the intensity of the magnetizing field.

(2.) On the ability of the metal to concentrate the lines of force on it; that is, on the nature of the metal, or on its magnetic permeability. (See *Permeability, Magnetic. Paramagnetism. Diamagnetism.*)

The intensity of magnetization will, therefore, be equal to the product of the co-efficient of magnetization and the intensity of the magnetizing field. It will, also, of course, depend on the area of cross-section of the magnetized body.

The co-efficient of magnetization of paramagnetic bodies is said to be positive, and that of diamagnetic bodies to be negative, because paramagnetic bodies concentrate the lines of magnetic force on them, while diamagnetic bodies appear to repel the lines of force. (See *Paramagnetic. Diamagnetic.*)

Magnetization, Critical Current of — — The current at which any certain or definite effect of magnetization is produced.

Magnetization, Intensity of — — A quantity showing the intensity of the magnetization produced in a substance.

A quantity showing the intensity with which a magnetizable substance is magnetized.

The intensity of magnetization depends:

(1.) On the intensity of the magnetizing field.

(2.) On the magnetic permeability, or on the conducting power of the substance for lines of magnetic force.

The greater the strength of the magnetizing field, and the greater the magnetic permeability, the greater is the intensity of the magnetization produced.

When, therefore, a magnetizable substance is placed in a magnetizing field, the intensity of the magnetization will depend on the magnetic susceptibility of the substance; that is, on the ratio of the induced magnetization to the magnetizing force producing it.

Soft iron has a high co-efficient of magnetization, or its magnetic susceptibility is high. (See *Susceptibility, Magnetic. Magnetization, Co-efficient of.*)

The intensity of magnetization through a substance is measured by dividing the magnetic moment by the magnetic volume.

If a bar of soft iron is placed with its greatest length extending in the direction of the lines of force in a magnetic field, it will have induced in it a certain intensity of magnetization which may be expressed as follows:

$$\text{Intensity of Magnetization} = \frac{m \cdot l}{\text{Volume}} = k H,$$

where m , equals the strength of the magnet; l , its length; k , the co-efficient of magnetization, and H , the intensity of the magnetizing field.—(*S. P. Thompson.*)

“The moment of a magnet, or of any element of a magnet, may be considered numerically to be made up of two factors, one, its volume, and the other *its intensity of magnetization*, or simply its *magnetization*, and hence, for a uniformly magnetized small linear needle, we may define the intensity of its magnetization by saying that it has magnetic moment of unit volume.”—(*Fleming.*)

Magnetization, Maximum — —A term sometimes used for magnetic saturation.

Urquhart states, as the result of numerous experiments, that the number of lines of magnetic force that usually pass through a bar of soft iron 1 square centimetre in area of cross-section, when magnetized to a maximum, is equal to 32,000. Ewing gives the number in the particular case of a very extraordinary magnetization as being equal to 45,350 per square centimetre area of cross-section.

Magnetization, Methods of — —Magnetization effected either by induction from another magnet, or by means of induction by an electric current.

The substance to be magnetized is brought into a magnetic field, so that the lines of magnetic force pass through it. All methods of magnetization may be divided into methods of *magnetization by touch* and *magnetization by the electric current*. (See *Magnetization by Touch.*)

Magnetization, Permanent, Intensity of — —A term employed for the intensity of a permanent magnetization produced in hard steel, as distinguished from the magnetization temporarily produced in soft iron. (See *Magnetization, Intensity of.*)

Magnetization, Temporary, Intensity of — —The intensity of the magnetization temporarily induced in a bar of soft iron, as distinguished from permanent magnetization induced in hard steel. (See *Magnetization, Intensity of.*)

Magnetization, Time-Lag of — —A lag which appears to exist between the time of action of the magnetizing force and the appearance of the magnetism.

The time which must elapse in the case of a given paramagnetic substance before a magnetizing force can produce magnetization.

In the opinion of some physicists there is no such thing as a true magnetic time-lag, the apparent time-lag being due entirely either to hysteresis or to eddy currents. According to them, while the magnetizing force is increasing, it produces, in the iron, reversely-directed surface-eddy-currents, which produce a reversed or opposed magnetizing force in the more deeply seated layers of the iron, the time-lag being due to the interval which is required for these eddy currents to die away and thus permit the magnetizing force to produce its full magnetization.

According to others, however, a true time-lag does exist entirely apart from the existence of surface-eddy-currents.

Magnetize.—To endow with magnetic properties.

Magnetized.—Endowed or impressed with magnetic properties.

Magnetizing.—Causing or producing magnetism.

Magneto-Blasting Machine.—(See *Machine, Magneto-Blasting.*)

THIS PAGE IS LOCKED TO FREE MEMBERS

Purchase full membership to immediately unlock this page

Know Your Bible

Forgotten Books' Full Membership provides unlimited access to more than 28,000 volumes of Christian literature for \$8.99/month

HOLY BIBLE

Continue

*Fair use policy applies

as shown at F_1 and F_2 , Fig. 390. A magnetic coil C , surrounds the middle portion of each circuit as shown. The operation as described by Mr. Chas. Steinmetz, from whom the above description is mainly taken, is as follows, viz.: "The front part s_1 of the left iron piece becomes south, and the back part n_1 north polarity; the front part of the right iron piece n_2 becomes north, and the back part south; and the lines of magnetic force travel in the front from the right to the left, from n_2 to s_1 ; in the back the opposite way, from the left to the right, or from n_1 to s_2 , either through the air, or, when n_2 and s_1 , or n_1 and s_2 , are connected by a piece of magnetizable metal, through this and through the air.

In the middle of the coil C , stands a small soft iron needle with an aluminum indicator, which plays over a scale K , and is held in a vertical position by the lines of magnetic force of the coil C , itself, deflected to the left by the lines of magnetic force traversing the front part of the instrument from n_2 to s_1 , deflected to the right by the lines traversing the back from n_1 to s_2 . This needle shows by its zero position that the magnetic flow through the air in front from n_2 to s_1 has the same strength as the magnetic flow in the back from n_1 to s_2 through the air.

Now we put a piece of soft iron x on the front of the instrument. A large number of lines go through x , less through the air from n_2 to s_1 ; but all these lines go from n_1 to s_2 through the air at the back part of the magnetometer, the front part and back part of the instrument being connected in series in the magnetic circuit. Therefore the needle is deflected to the right by the magnetic flow in the back of the instrument.

Now, we put another piece of iron, y , on the back part of the instrument, then equilibrium would be restored as soon as the same number of lines of magnetic force go through x , as through y , because then also the same number of lines go through air in the front as in the back. As will be noted, the air here takes the place of the resistances a and b , influencing the galvanometer needle G , as in the diagram Fig. 389.

The operation of the instrument is exceedingly simple and is as follows: Into the coil C , an electric current is sent which is measured by the ammeter A , and regulated by the resistance-switch R . Then the needle, which before had no fixed position, points to zero.

Now, we lay the piece of iron, the magnetic properties of which we want to determine, on the

back part of the instrument. The needle is deflected to the left. On the front of the instrument we put Norway iron rods of known cross-section and known conductivity, until equilibrium is again restored. Then the iron in the front has the same magnetic resistance as the iron in the back, and the ratio of the cross-sections gives directly the ratio of the conductivities; so that by a single reading the magnetic conductivity of any piece of iron can be compared with that of the Norway iron standard.

For absolute determinations, the iron is turned off into pieces of exactly 4 square centimetres cross-section and 20 centimetres in length, both ends fitting into holes in large blocks of Norway iron, which are laid against the pole pieces of the magnetometer, so that the transient resistance from pole face to iron is eliminated.

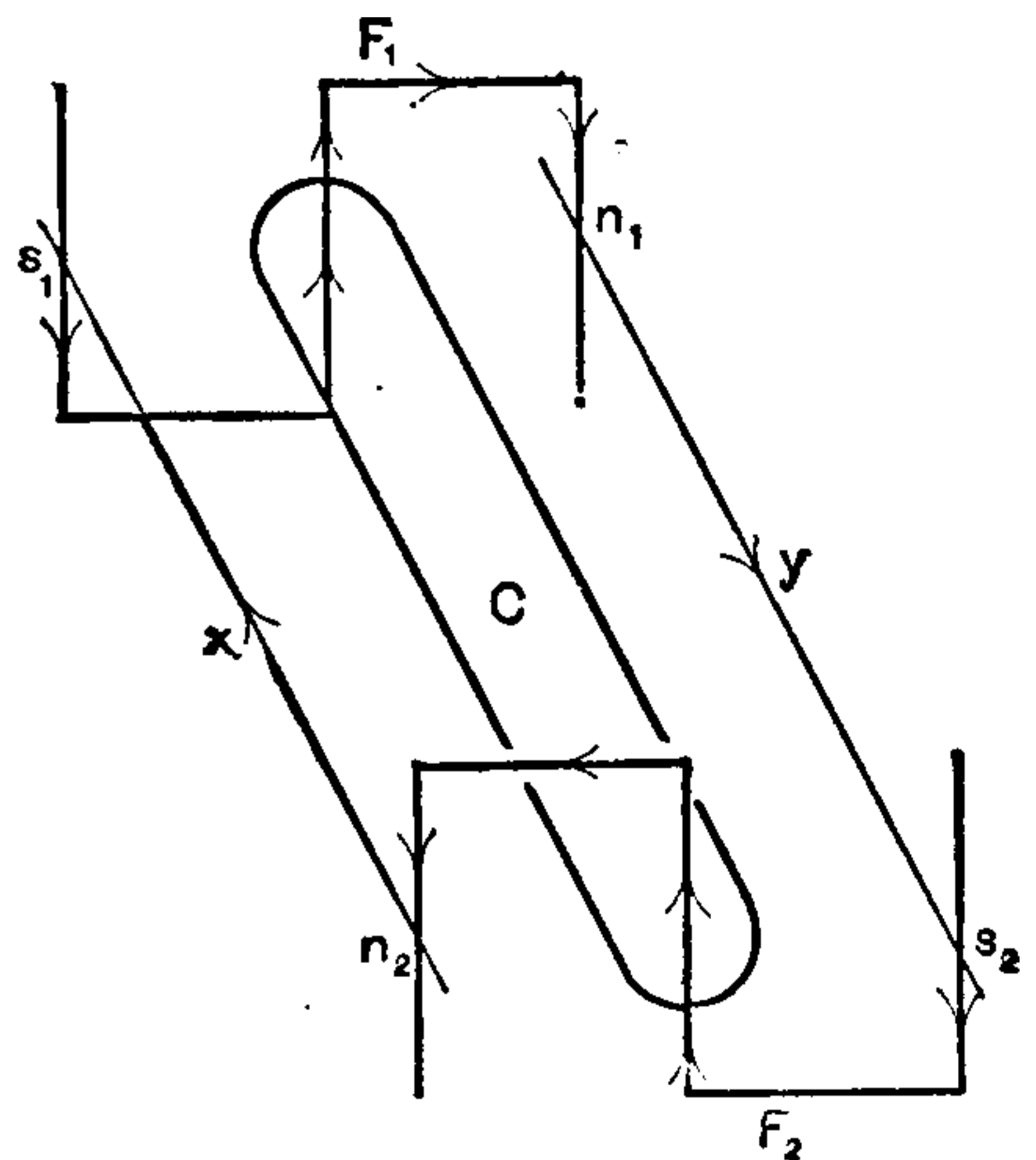

Fig. 390. Eickemeyer's Differential Magnetometer.

Magnetometer, Self-Recording — A self-recording apparatus, by means of which the daily and hourly variations of magnetic needles in the earth's field, at any locality, are continuously registered.

The self-recording magnetometer employed in the observatory at Kew, consists essentially of means of obtaining a photographic record of a spot of light reflected from a mirror, attached to the needle whose variations are to be recorded. The photographic record is received on a strip of sensitized paper, maintained in uniform and continuous motion by means of suitable clock-work. The record so obtained is called a magnetograph.

Magneto-Motive Force. — (See *Force, Magneto-Motive.*)

Magneto-Motive Force, Absolute Unit of — — (See *Force, Magneto-Motive, Absolute Unit of*.)

Magneto-Motive Force, Practical Unit of — — (See *Force, Magneto-Motive, Practical Unit of*.)

Magneto-Optic Rotation.—(See *Rotation, Magneto-Optic*.)

Magnetophone.—A species of magnetic siren in which sounds are produced in an electro-magnetic telephone by the periodic currents produced in its coils by the rotation of a perforated metallic disc in a magnetic field.

As the speed of the disc increases, the pitch of the note increases. The apparatus was invented by Prof. Carhart, in 1883. A similar apparatus is useful in studying the distribution of the magnetic field of a dynamo-electric machine. In this case, a small, thin coil of insulated wire is held in the different regions around the machine, while the telephone is held to the ear of the observer. Magnetic leakage, or useless dissipation of lines of magnetic force outside the field proper of the machine, is at once rendered manifest by the musical note caused by variations in the intensity of the field.

Since the intensity of the note heard will vary according to the intensity of the field, and also according to the position in which the coil is held, such a coil becomes a *magnetic explorer*, and by its use the distribution and varying intensity of an irregular field can be ascertained. Its use is especially advantageous in proportioning dynamo-electric machines and electric motors. (See *Explorer, Magnetic*.)

Magneto-Receptive Device.—(See *Device, Magneto-Receptive*.)

Magneto-Static Current Meter. — (See *Meter, Current, Magneto-Static*.)

Magneto-Static Screening.—(See *Screening, Magneto-Static*.)

Magneto-Statics.—(See *Statics, Magneto*.)

Magneto-Therapy.—(See *Therapy, Magneto*.)

Main Battery.—(See *Battery, Main*.)

Main-Battery Circuit. — (See *Circuit, Main-Battery*.)

Main, Electric — — The principal conductor in any system of electric distribution.

Main Feeder.—(See *Feeder, Standard or Main*.)

Main Fuse.—(See *Fuse, Main*.)

Main, House — — A term employed in a system of multiple incandescent lamp distribution for the conductor connecting the house service conductors with a centre of distribution, or with a street main.

Main-Line Cut-Out.—(See *Cut-Out, Main-Line*.)

Main, Street — — In a system of incandescent lamp distribution the conductors extending in a system of networks through the streets from junction box to junction box, through which the current is distributed from the feeder ends, through cut-outs, to the district to be lighted, and from which service wires are taken.

Main, Sub — — A name sometimes given to the distributing conductor that is connected directly to a main.

The branch nearest the main. (See *Branch*.)

Main Wire.—(See *Wire, Main*.)

Mains of Electric Railroads.—The wires or conductors used for carrying the current from the feeders through the tap wires to the trolley wires.

Make.—A completion of a circuit.

Make-and-Break.—The periodic alternate completion and opening of a circuit.

Make-and-Break, Automatic — — A term sometimes employed for such a combination of contact points with the armature of any electro-magnet, that the circuit is automatically made and broken with great rapidity.

An automatic make-and-break is used in most forms of electric alarms in connection with some form of electric bell. (See *Alarm, Electric*.)

It is also used in the Ruhmkorff induction coil in order to produce the variations in the primary circuit. (See *Coil, Induction*.)

Make-Induced Current. — (See *Current, Make-Induced*.)

Making the Primary.—(See *Primary, Making the.*)

Mallet, Electro-Magnetic Dental —
—(See *Dental-Mallet, Electro-Magnetic.*)

Mangin Projector.—(See *Projector, Mangin.*)

Man-Hole, Compartment, of Conduit —
—A man-hole provided with suitably supported shelves or compartments, guarded by locked doors that protect different cable sections.

Man-Hole of Conduit.—An opening of sufficient size to admit a man, communicating from the surface of the roadbed with an underground conduit.

Manipulator, Breguet's — —The sending instrument employed by Breguet in his system of step-by-step or dial telegraphy. (See *Telegraphy, Step-by-Step.*)

Manometer.—An apparatus for measuring the tension or pressure of gases.

Manometers are either mercurial or metallic. Mercurial manometers are of two classes, viz., manometers with free air and manometers with compressed air.

Manometers measure the pressure of gases either in atmospheres, *i. e.*, in multiples or decimals of 15 pounds to the square inch, or in inches of mercury.

Map or Chart, Inclination — —A chart or map on which lines are drawn, showing the lines of equal dip or inclination, or the isoclinic lines.

An *inclination chart* is shown in Fig. 391.

It will be seen that the magnetic equator, or line of no dip, does not correspond with the geographical equator, being generally north of the equator in the Eastern Hemisphere, and south of it in the Western. The figures attached to the lines indicate the value of the angle of dip.

Map or Chart, Isodynamic — —A map of the earth on a mercator's projection, on which isodynamic lines are drawn.

An isodynamic chart is shown in Fig. 392. It will be observed that the *isodynamic lines* do not exactly coincide with the *isoclinic lines*, since the line of least magnetic intensity does not correspond with the line of the magnetic equator.

The point of *least magnetic intensity* is found at

about lat. 20 degrees S., and lon. 35 degrees W. The point of *greatest magnetic intensity* is found at about lat. 52 degrees N. and lon. 92 degrees W.

Another, though weaker point of magnetic intensity, is found in Siberia. These are distinguished from the true magnetic poles by the term *Poles of Intensity*.

The *Poles of Verticity*, as determined by the *dipping needle*, and the *Poles of Intensity*, as determined by the *needle of oscillation*, therefore do not coincide in the Northern Hemisphere.

Map or Chart, Isogonal — —A term sometimes used for an isogonic map or chart.

Map or Chart, Isogonic — —A chart on which the isogonal lines are marked.

An isogonic map or chart is sometimes called a declination map or chart.

In the declination or variation chart, shown in Fig. 393, the region of western declination is indicated by the shading. There is a remarkable oval patch in the northeastern part of Asia, in which the declination is west. A similar oval of decreased inclination is seen in the Southern Pacific.

The entire earth acts like a huge magnet with south magnetic polarity in the Northern Hemisphere.

It is not known whether the earth possesses but a single pair of magnetic poles or more than a single pair. The variations in the declination, and in the intensity of its magnetism, due to the position of the sun, as well as the marked magnetic disturbances that accompany the occurrence of sun-spots, would appear to connect the earth's magnetism in some manner with the solar radiation. (See *Magnetism, Earth's, Theories as to Cause of.*)

Marine Galvanometer.—(See *Galvanometer, Marine.*)

Mariner's Compass.—(See *Compass, Azimuth.*)

Marked Pole of Magnet.—(See *Magnet, Marked Pole of.*)

Markers.—Colored flags, or signal lights, generally green, displayed in systems of block railway signaling at the ends of trains, in order to avoid accidents from trains breaking in two. (See *Railroads, Block System for.*)

THIS PAGE IS LOCKED TO FREE MEMBERS

Purchase full membership to immediately unlock this page



HISTORY

Tens of thousands of important historical sources, many previously unobtainable, are now available for the first time with a Forgotten Books Full Membership.

Unlimited Access
\$8.99/month

Continue

*Fair usage policy applies

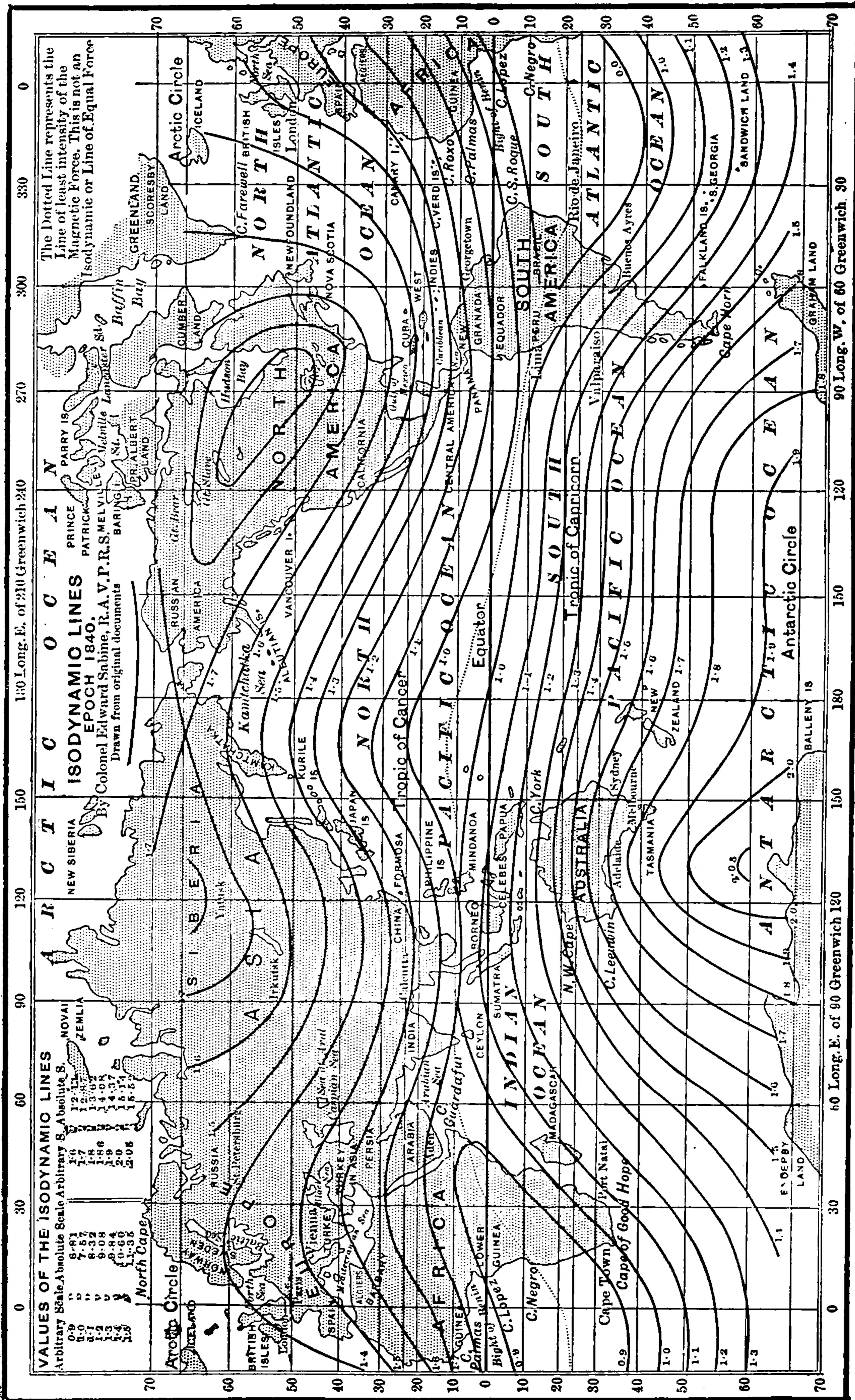

Fig. 392. Isodynamic Chart.

Mass.—The quantity of matter contained in a body.

Mass must be carefully distinguished from *weight*. The weight of a given quantity of matter depends on the attraction which the earth possesses for it, and this, on the earth's surface, varies with the latitude, being greatest at the poles and least at the equator. It also varies with different elevations above the level of the sea. The *mass*, however, is the same under all circumstances, whether for different latitudes or altitudes, on the earth's surface.

Mass Attraction.—(See *Attraction, Mass.*)

Mass, Magnetic — —A quantity of magnetism which at unit distance produces an action equal to unit force.

Mass, Unit of — —The quantity of matter which under certain conditions will balance the weight of a standard gramme or pound.

The gramme is equal to the one-thousandth part of a piece of platinum called the kilogramme, deposited as a standard in the archives of the French Government, and intended to be equal to the mass of 1 cubic centimetre of water at the temperature of its maximum density.

Massage.—A treatment for the purpose of effecting changes in general nutrition or action of particular parts of the body, by kneading, rubbing, friction, etc.

Massage, Electro — —The application of electricity to the body during its massage.

Connections are established between the patient and a battery by connecting one electrode of a source to the kneading instrument, and the other electrode to the body of the patient.

Masses, Electric — —A mathematical conception for such quantities of electricity as at unit distance will produce an attraction or repulsion equal to unit force.

Electrical masses are assumed to be equal when they produce on two identical bodies of small dimensions charges of the same electric force.

Master Clock.—(See *Clock, Master.*)

Materials, Insulating — —Non-conducting substances which are placed around a conductor, in order that it may either retain an electric charge, or permit the passage of

an electric current through the conductor without sensible leakage.

Various gases, liquids or solids may be employed as insulators. A very high vacuum affords the best known insulation.

Matter.—Anything which occupies space in three directions and prevents other matter from simultaneously occupying the same space.

Matter is composed of *atoms*, which unite to form *molecules*. (See *Atom. Molecule.*)

Matter, Elementary — —Matter which cannot be decomposed into simpler matter.

Varieties of elementary matter are called *elements*. (See *Element.*)

Matter, Kinetic Theory of — —A theory which assumes that the molecules of matter are in a constant state of motion or vibration towards or from one another in paths that lie within the spheres of their mutual attractions or repulsions.

The molecules of gases have great freedom of motion, and are so far removed from one another as to be but little, if any, influenced by their mutual attractions. They are therefore assumed to move in straight lines with very great velocity until they collide against one another, or against the sides of the containing vessel, when they are reflected and again move in straight lines in a new path.

Matter, Radiant, or Ultra-Gaseous — —A term proposed by Crookes for the peculiar condition of the gaseous matter which constitutes the residual atmospheres of high vacua.

This is now generally recognized as a fourth state of matter, these four states being:

- (1.) Solid.
- (2.) Liquid.
- (3.) Gaseous.
- (4.) Ultra-gaseous or radiant.

The peculiar properties of radiant matter are seen in the mechanical effects of the localized pressures produced when such residual atmospheres are locally heated or electrified.

In *Crookes' radiometer*, vanes of mica, silvered on one face and covered with lampblack on the opposite face, are supported on a vertical axis so as to be capable of rotation and placed in a glass vessel in which a *high vacuum* is maintained. On

THIS PAGE IS LOCKED TO FREE MEMBERS

Purchase full membership to immediately unlock this page

Know Your Bible

Forgotten Books' Full Membership provides unlimited access to more than 28,000 volumes of Christian literature for \$8.99/month

HOLY BIBLE

Continue

*Fair use policy applies

son imagines the ether to be set in motion in minute vortex rings, and shows that a readily movable fluid body, like ether, once set in such motion should possess the properties of a solid. In a perfect fluid, such as ether, these vortex rings once formed, would be practically imperishable or indestructible.

Thomson regards the atoms of matter as consisting of such vortex rings. Vortex rings can be formed in the air by cutting a circular aperture in the end of a pasteboard box, and tapping sharply against the end of the box. In order to render the rings visible, the box may be previously filled with smoke.

Vortex rings formed in smoky air differ from vortex rings in the ether, in the fact that air is not a perfect fluid, while ether is. Air vortex rings increase in size and decrease in energy. Vortex rings of the ether would not vary in size.

According to Thomson's vortex theory of matter, the atoms of matter are the same as the ether which surrounds them. They cannot be produced in ether by any known way; therefore, they cannot be manufactured, or, as it were, created. Nor, on the other hand, can they be destroyed; in other words, they are indestructible. They are elastic, capable of definite vibrations, possess all the properties of matter save, in the opinion of some, the very important property of gravitation. As Prof. Lodge points out, the fact that this property is not present should cause Sir William Thomson's theory of matter to be accepted with considerable hesitation.

Matthiessen's Metre-Gramme Standard.—(See *Metre-Gramme Standard, Matthiessen's.*)

Matthiessen's Mile Standard.—(See *Mile Standard, Matthiessen's.*)

Matting, Invisible Electric Floor — —A matting or other floor covering, provided with a series of electric contacts, which are closed by the passage of a person walking over them.

This matting is provided as an adjunct to a system of burglar alarms. The electric bell or annunciator, connected with the different contacts, is disconnected during the day-time, or while the rooms are occupied. (See *Alarm, Burglar.*)

Maximum Magnetization.—(See *Magnetization, Maximum.*)

McIntire's Parallel Sleeve Telegraphic Joint.—(See *Joint, Telegraphic, McIntire's Parallel Sleeve.*)

Measurements, Electric — —Determinations of the values of the electromotive force, resistance, current, capacity, energy, etc., in any electric circuit.

Electric measurements may be either qualitative or quantitative.

In qualitative electric measurements the relative values only are obtained; in quantitative measurements the actual values are obtained.

Mechanical Alarm, Electric — —(See *Alarm, Electro-Mechanical.*)

Mechanical Electric Bell.—(See *Bell, Electro-Mechanical.*)

Mechanical Equivalent of Heat.—(See *Heat, Mechanical Equivalent of.*)

Mechanical Mine.—(See *Mine, Mechanical.*)

Mechanical Throwback Indicator. — (See *Indicator, Mechanical Throwback.*)

Medical Induction Coil.—(See *Coil, Induction Medical.*)

Medical Magneto-Electric Apparatus.— (See *Apparatus, Magneto-Electric Medical.*)

Medium, Anisotropic — —A medium in which equal stresses do not produce equal strains when applied in different directions.

A medium, homogeneous in structure like crystalline bodies, but possessing different powers of specific inductive capacity in different directions.

An eolotropic medium. (See *Medium, Eolotropic.*)

The latter term is used to distinguish it from an isotropic medium. (See *Medium, Isotropic.*)

Medium, Eolotropic — —A medium in which equal stresses do not produce the same strains when applied in different directions. (See *Medium, Isotropic.*)

Medium, Electro-Magnetic — —Any medium in which electro-magnetic phenomena occur.

The medium through which electro-magnetic waves are propagated is now universally re-

garded as the luminiferous or universal ether. (See *Electricity, Hertz's Theory of Electro-Magnetic Radiations or Waves.*)

Medium, Isotropic — —A medium in which equal stresses applied in any direction produce equal strains.

A transparent medium which possesses the same optical or electric properties in all directions.

An optically homogeneous, transparent medium.

Such media are called isotropic to distinguish them from anisotropic or eolotropic, or those in which equal stresses produce unequal strains in different directions. (See *Medium, Anisotropic. Medium, Eolotropic.*)

Meg or Mega (as a prefix).—1,000,000 times; as, megohm, 1,000,000 ohms; megavolt, 1,000,000 volts.

Megaloscope, Electric — —An apparatus for the medical exploration of the cavities of the body.

The light necessary for exploration is obtained from a small incandescent lamp placed at the extremity of a tube, suitably shaped for introduction into the special organ for which it is devised. The organ so illumined throws its light on a prism, by means of which the light is caused to pass through a series of lenses by which it is viewed.

Megavolt.—1,000,000 volts.

Megohm.—1,000,000 ohms.

Meidinger Voltaic Cell.—(See *Cell, Voltaic, Meidinger.*)

Memory, Magnetic — —A term proposed by J. A. Fleming for coercive force.

Soft iron has but a feeble memory of its past magnetization.

Mercurial Connection.—(See *Connection, Mercurial.*)

Mercurial Contact. — (See *Connection, Mercurial.*)

Mercurial Temperature Alarm.—(See *Alarm, Mercurial Temperature.*)

Mercury Break.—(See *Break, Mercury.*)

Mercury Cup.—(See *Cup, Mercury.*)

Meridian, Astronomical — —A great circle passing through any point in the heavens, and the North and South poles of the heavens.

The astronomical meridian corresponds to the geographical meridian. The former is considered as passing around the dome of the heavens; the latter, around the surface of the earth. In order to locate any point in the heavens, a great circle of the heavens is caused to pass through that point and through the astronomical North and South poles.

Meridian, Geographical — —The geographical meridian of a place is a great circle passing through that place and the North and South geographical poles of the earth.

Meridian, Magnetic — —The magnetic meridian of any place is the meridian which passes through the poles of a magnetic needle at that place when in a position of rest under the free influence of the earth's magnetism.

The *plane of the magnetic meridian* at any place is a vertical plane passing through the poles of a magnetic needle in a position of rest under the free influence of the earth's magnetism at that place.

The magnetic meridian may be regarded as the vertical plane in which a freely suspended magnetic needle comes to rest in the earth's magnetic field.

Meridional.—Pertaining to the meridian.

Message Wire.—(See *Wire, Message.*)

Messenger Call.—(See *Call, Messenger.*)

Metallic Arc.—(See *Arc, Metallic.*)

Metallic Circuit.—(See *Circuit, Metallic.*)

Metallic Coating.—(See *Coating, Metallic.*)

Metallic Conducting Joint.—(See *Joint, Metallic Conducting.*)

Metallic Contact.—(See *Contact, Metallic.*)

Metallic Electric Conduction. — (See *Conduction, Electric, Metallic.*)

Metallization.—The rendering of a non-conducting surface electrically conducting by covering it with a metallic coating, so as to

enable it to readily receive a metallic coating by electro-plating. (See *Plating, Electro.*)

Metallochromes.—A name sometimes given to Nobili's rings. (See *Rings, Nobili's.*)

Metalloid.—A name formerly applied to a non-metallic body, or to a body having only some of the properties of a metal, as carbon, boron, oxygen, etc.

The term is now but little used.

Metallurgy, Electro — —That branch of applied science which relates to the electrical reduction or treatment of metals.

Metallurgical processes effected by the agency of electricity.

Electro-Metallurgy embraces :

(1.) The reduction of metals from their ores, either directly during fusion by the heat of the voltaic arc, or the heat of incandescence, or by the electrolysis of solutions of their ores, or ores in the fused state. (See *Electrolysis. Furnace, Electric.*)

(2.) Electroplating.

(3.) Electrotyping.

The application of electricity to the reduction of metals is carried on in the electric furnace for the reduction of the aluminium ores, for example.

Metals, Electric Deflagration of — — The volatilization of metals by electric incandescence.

Metals, Electric Refining of — — Purifying metals by means of electricity.

Different methods are employed for the electric refining of metals. They are generally electrolytic in character.

Metals, Electrical Protection of — — The protection of a metal from corrosion by placing it in connection with another metal, which, when exposed to the corroding liquid, vapor or gas, will form with the metal to be protected the positive element of a voltaic couple.

The negative element of a voltaic couple is protected by the presence of the positive element, which is alone corroded. This method has been adopted with considerable success to electrically protect metals from corrosion.

The following are examples of this protection :

(1.) Davy proposed to protect the copper

sheathing of ships from corrosion by attaching pieces of zinc to the copper sheathing. This succeeded too well, since the copper salts which were formerly produced, and acted as a poison to the marine plants and animals, being now absent, permitted these organisms to thrive to such an extent as to seriously foul the ship's bottom.

(2.) A ring of zinc attached to a lightning rod, near its points, has, it is claimed, the power of protecting the points from corrosion.

(3.) Iron bars of railings, if sunk or embedded in zinc, are preserved from corrosion near the junction of the two metals, but if sunk in lead are rapidly corroded, because iron is electro-positive to lead, but electro-negative to zinc.

(4.) Tinned iron rapidly corrodes or rusts when the iron is exposed to the atmosphere by a scratch or abrasion, because the iron is electro-positive to tin. Nickel-plated iron, for the same reason, rusts rapidly on the exposure of an abraded surface.

(5.) Zinced or galvanized iron, or iron covered with a deposit of zinc, is protected from corrosion because the zinc, being positive to iron, can alone be corroded, and the zinc is also protected in part by the coating of insoluble oxide that is formed.

Meteorites.—Aerolites. (See *Aerolites.*)

Meter, Ampère — —(See *Ampère-Meter. Ammeter.*)

Meter, Current — —A term now applied to an electric meter or galvanometer which measures the current in ampères, as distinguished from one which measures the energy in watts.

This term is sometimes loosely applied to a galvanometer.

The term galvanometer is preferable. (See *Galvanometer.*)

Meter, Current, Magneto-Static — —A current meter in which a small steel magnet, or system of magnets, is suspended at the centre of the uniform magnetic field produced by the combined influence of two coils and two systems of powerful permanent magnets.

Meter, Electric — —Any apparatus for measuring commercially the quantity of electricity that passes in a given time through any consumption circuit.

THIS PAGE IS LOCKED TO FREE MEMBERS

Purchase full membership to immediately unlock this page



HISTORY

Tens of thousands of important historical sources, many previously unobtainable, are now available for the first time with a Forgotten Books Full Membership.

Unlimited Access
\$8.99/month

Continue

*Fair usage policy applies

placed in a shunt around the circuit to be measured. These two coils, instead of acting on a needle, act on each other, and the amount of this deflection will, therefore, be proportional to the watts present.

A form of watt meter is shown in Fig. 396.

Method, Deflection — — A method employed in electrical measurements, as distinguished from the zero method, in which a deflection, produced on any instrument by a given current, or by a given charge, is utilized for determining the value of that current or charge.

The conditions remaining the same, the same current or charge will produce the same deflection at any time. Different deflections produced by currents or charges, the values of which are unknown, are determined by certain ratios existing between the deflections and the currents or charges. These ratios are determined experimentally by the *calibration* of the instrument. (See *Calibrate*.)

Deflection methods are opposed to *zero* or *null methods*, in which latter a balance of opposite electromotive forces, or a proportionally equal fall of electric potential, is ascertained by the failure of a delicately poised needle to be moved by a current or a charge.

Method, Null or Zero — — Any method employed in electrical measurements, in which the values of the electromotive force in volts, the resistance in ohms, or the current in amperes, or other similar units, are determined by balancing them against equal values of the same units, and ascertaining such equality, not by the deflections of the needle of a galvanometer, or of an electrometer, but by the absence of such deflections.

The advantage of zero methods is found in the fact that the galvanometer or electrometer may then be made as sensitive as possible, which is not otherwise the case, since great deflections are generally to be avoided, especially in tangent galvanometers. (See *Galvanometer*. *Electrometer*.)

Method of Magnetization by Touch.— (See *Magnetization by Touch*.)

Methven's Screen.—(See *Screen*, *Methven's*.)

Metre Bridge.—(See *Bridge*, *Metre*.)

Metre Candle.—(See *Candle*, *Metre*.)

Metre-Gramme Standard, Matthiessen's
— — A unit of resistance.

The resistance of a wire one metre in length, and of such a diameter as would cause the wire to weigh one gramme.

One metre-gramme of pure hard drawn copper has a resistance of .1469 B. A. units at zero degrees C. as determined by Matthiessen (*Phil. Mag.*, May, 1865).

Metre-Millimetre — — A resistance unit of length of a wire or other conductor of the length of one metre and of the area of cross-section of one square millimetre.

According to the report of the Committee of the American Institute of Electrical Engineers of 1890, on a Standard Wiring Table, a metre-millimetre of pure soft copper wire has a resistance of .02057 B. A. units at zero degrees C. From the corresponding term, milfoot, millimetre-metre would appear to be the preferable term.

Metric Horse-Power.—(See *Horse-Power*, *Metric*.)

Metric System of Weights and Measures.—(See *Weights and Measures*, *Metric System of*.)

Mho.—A term proposed by Sir Wm. Thomson for the practical unit of conductivity.

Such a unit of conductivity as is equal to the reciprocal of 1 ohm.

The conducting power is equal to $\frac{1}{R}$ or the reciprocal of the resistance.

The word *mho*, as is evident, is obtained by inverting the order of sequence of the letters in the word *ohm*.

Mica.—A mineral substance employed as an insulator.

Mica is a silicious mineral. It occurs of varying degrees of transparency, and splits or cleaves readily into transparent laminæ. It is a good non-conductor, is fairly fire proof, and is not hygroscopic.

Mica is used extensively in insulating the metallic segment of commutators of motors and dynamo-electric machines and in various other electric work.

Mica, Moulded ———An insulating substance consisting of finely divided mica made into a paste, with some fused insulating substance, and moulded into any desired shape.

Finely divided mica mixed with gum-shellac rendered plastic by means of heat, forms a good insulating substance.

Micro (as a prefix).—The one-millionth; as, a microfarad, the millionth of a farad; a microvolt, the one-millionth of a volt.

Micro-Farad.—(See *Farad, Micro*.)

Micro-Graphophone.—A modified form of phonograph in which several independent non-metallic diaphragms are used instead of the single diaphragm of the phonograph. (See *Graphophone, Micro*.)

Micrometer, Arc ———An apparatus for the accurate measurement of the length of a voltaic arc by means of a micrometer.

The distance between two carbon electrodes—one movable and the other fixed—placed inside a glass vessel, is accurately determined by means of a micrometer placed on the movable electrode. The operation is similar to that of the *vernier wire gauge*.

Micrometer, Spark ———A term sometimes applied to Hertz's electric resonator. (See *Resonator, Electric*.)

Micron.—A measure of length.

The one-millionth part of a metre.

The micron is equal to .00004 of an inch, very nearly.

Microphone.—An apparatus invented by Prof. Hughes for rendering faint or distant sounds distinctly audible.

The microphone depends for its operation on variations produced in the resistance of the circuit of a battery, or other electric source, by means of a loose contact. These variations in the resistance are caused to produce corresponding movements in the diaphragm of a receiving telephone.

The loose contact may take a variety of forms. Originally it was made in the form shown in Fig. 397, in which a small piece of carbon E, pointed at both ends, is inserted in holes near the ends of cross-pieces of carbon B and C. The thin upright board A, on which these are supported, acts as a

sounding board or diaphragm, and its movements by sound waves are at once audible to a person listening at the receiving telephone. The walking of a fly over the sounding board is heard as a loud sound.

The forms of transmitting telephones invented by Reis, Edison, Blake, Berliner and others, are in reality varieties of microphones.

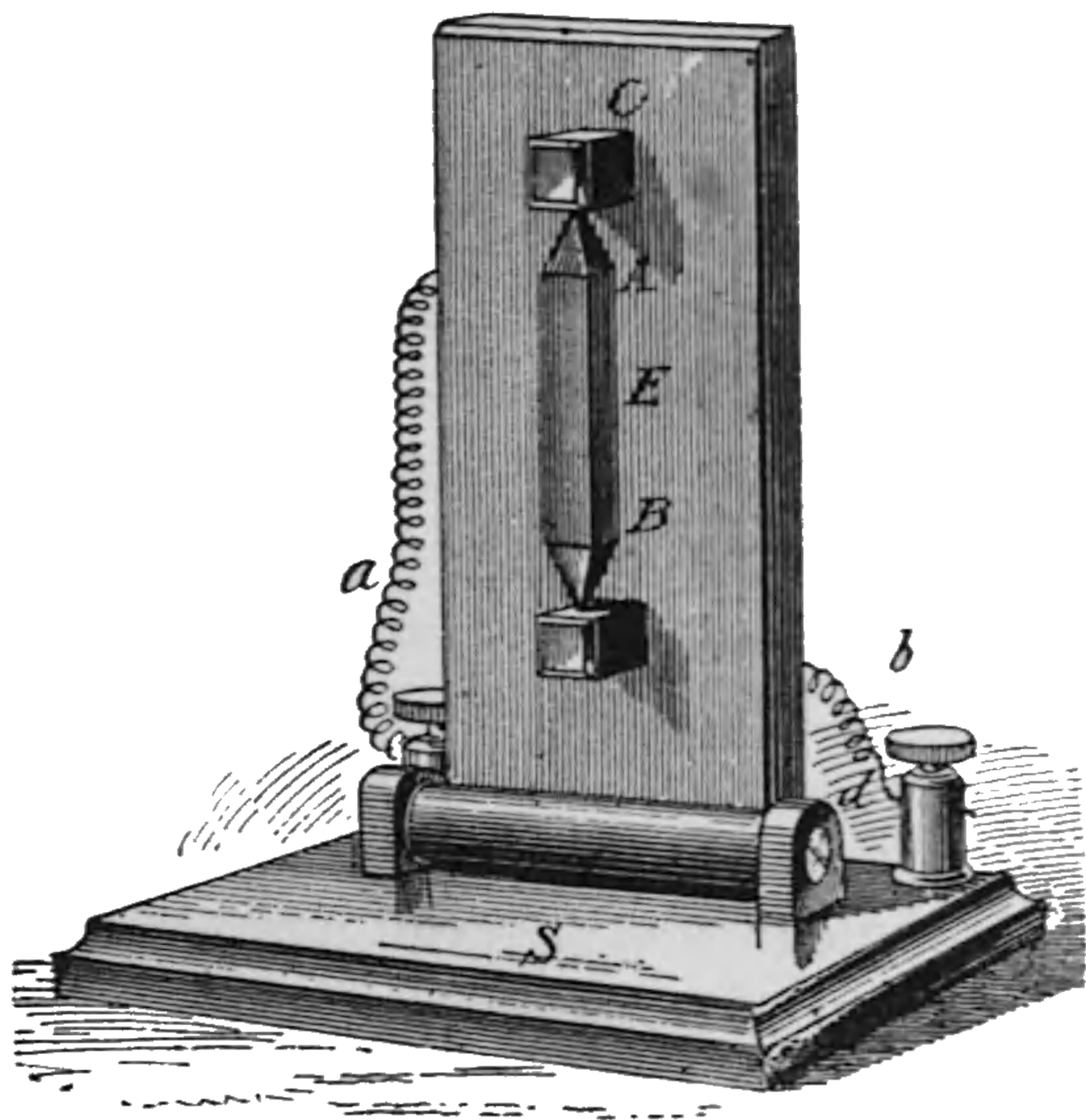

Fig. 397. Microphone.

Microphone Relay.—(See *Relay, Microphone*.)

Micro-Seismograph.—(See *Seismograph, Micro*.)

Microtasimeter.—An apparatus invented by Edison to measure minute differences of temperature, or of moisture, by the resulting differences of pressure.

A change of temperature, or moisture, is caused to produce variations in the resistance of a button of compressed lampblack, placed in the circuit of a delicate galvanometer. The apparatus, though of surprising delicacy, is scarcely capable of practical application, from the fact that the resistance of the carbon does not resume its normal value on the removal of the pressure.

Micro-Volt.—(See *Volt, Micro*.)

Mil.—A unit of length equal to the $\frac{1}{1000}$ of an inch, or .001 inch, used in measuring the diameter of wires.

Mil, Circular ———A unit of area employed in measuring the areas of cross-sections of wires, equal to .78540 square mil. The area of a circle one mil in diameter.

One circular mil equals .000000785 square inch.

The area of cross-section of a circular wire in circular mils is equal to the square of its diameter expressed in mils. (See *Units, Circular.*)

Mil-Foot.—A resistance unit of length of one foot of wire or other conductor of one mil diameter.

The resistance of a mil-foot of soft copper wire or wire 1 foot long and .001 of an inch in diameter is equal to 9.720 B. A. units at 0 degrees C.

Mil, Square — —A unit of area employed in measuring the areas of cross-sections of wires, equal to .000001 square inch.

One square mil equals 1.2732 circular mil.

Mile, Nautical — —A knot, or a distance of 6,087 feet, or very nearly 1.15 statute miles.

The $\frac{1}{214720}$ of the earth's equatorial circumference, or the $\frac{1}{60}$ of a degree of longitude at the equator, or about 2,029 yards.

A nautical or geographical mile being the $\frac{1}{214720}$ of 24,899 miles, has a value somewhat greater than that of the statute mile.

Mile Standard, Matthiessen's — —A standard of resistance equal to the resistance of one mile of pure copper wire $\frac{1}{16}$ inch in diameter at 15.5 degrees C.

Matthiessen's mile standard has a resistance of 13.59 B. A. units at 15.5 degrees C.

Mile, Statute — —The ordinary unit of distance on land, equal to 5,280 feet.

Milli (as a prefix).—The one-thousandth part.

Milli-Ampère.—The thousandth of an ampère.

Milli-Calorie.—The smaller calorie. (See *Calorie, Small.*)

Milli-Oerstedt.—The one-thousandth of an Oerstedt.

Mimosa Sensitiva.—A sensitive plant whose leaves fold or shut up when touched.

The fibres of all the sensitive plants, such, for example, as the above, the Venus' Fly-trap, etc., like all muscular fibre, and indeed all protoplasm, suffer contraction when traversed by electric currents.

Mine, Electro-Contact — —A submarine mine that is fired automatically on the completion of the current of a battery

placed on the shore through the closing of floating contact points by passing vessels. (See *Mine, Submarine.*)

Mine Exploder, Electro-Magnetic — —
A form of electro-magnetic exploder. (See *Exploder, Electro-Magnetic.*)

Mine, Mechanical — —A submarine mine that is fired when struck by a passing ship by the action of some contrivance contained within the torpedo itself, and having no connection whatever with the shore.

Mine, Observation — —A variety of submarine mine that is fired when the enemy's vessels are observed to be within the destructive area of the mine. (See *Mine, Submarine.*)

Various means are adopted for obtaining the current required for firing such mines. A sufficiently powerful battery is generally used. An electro-magnetic mine exploder may, under certain circumstances, be employed. (See *Mine Exploder, Electro-Magnetic.*)

Mine, Submarine — —A mass of gun-cotton or other explosive contained in a water-tight vessel and placed under water so as to be exploded on the passage over it of an enemy's vessel.

A submarine mine is a stationary torpedo arranged for the defense of a harbor. A harbor is protected by a number of mines which are so arranged as to be readily exploded by the passage of an enemy's ship, but safely crossed by other vessels.

Submarine mines consist essentially of gun-cotton or other explosives contained in water-tight vessels anchored in very carefully located positions, and connected with the shore by means of cables.

An operating-room at the shore end of the cable is furnished with batteries, measuring instruments, contact keys, etc., etc., by means of which the mines can be exploded by the transmission of an electric current through the cables; or, the mines are furnished with automatic circuit closers in which two central points are closed by the passage of the vessel. In ordinary times this current is too weak to ignite the fuse, and merely closes a relay in the operating room, which in turn directs a current through a bell or indicator, but, of course, too weak to fire the fuse.

THIS PAGE IS LOCKED TO FREE MEMBERS

Purchase full membership to immediately unlock this page

Know Your Bible

Forgotten Books' Full Membership provides unlimited access to more than 28,000 volumes of Christian literature for \$8.99/month

HOLY BIBLE

Continue

*Fair use policy applies

the co-efficient of mutual induction, multiplied by the current strength in the primary, when the primary current is fully established.

When the primary current is fully established, the number of lines of force which pass through the secondary circuit is equal to the co-efficient of mutual induction, multiplied by the strength of the primary current.

Monophotal Arc-Light Regulator.—(See *Regulator, Monophotal Arc-Light*.)

Mordey Effect.—(See *Effect, Mordey*.)

Morse Alphabet.—(See *Alphabet, Telegraphic: Morse's*.)

Morse Inker.—(See *Inker, Morse*.)

Morse Recorder.—(See *Recorder, Morse*.)

Morse Register.—(See *Register, Morse*.)

Morse System of Telegraphy.—(See *Telegraphy, Morse System of*.)

Morse's Telegraphic Alphabet.—(See *Alphabet, Telegraphic: Morse's*.)

Morse's Telegraphic Sounder.—(See *Sounder, Morse's Telegraphic*.)

Motion, Energy of — —A term sometimes applied to actual or kinetic energy in contradistinction to potential energy. (See *Energy, Actual*.)

Motion, Simple-Harmonic. — —Motion which repeats itself at regular intervals, taking place backwards or forwards, and which may be studied by comparison with uniform motion round a circle of reference.—(*Daniell*.)

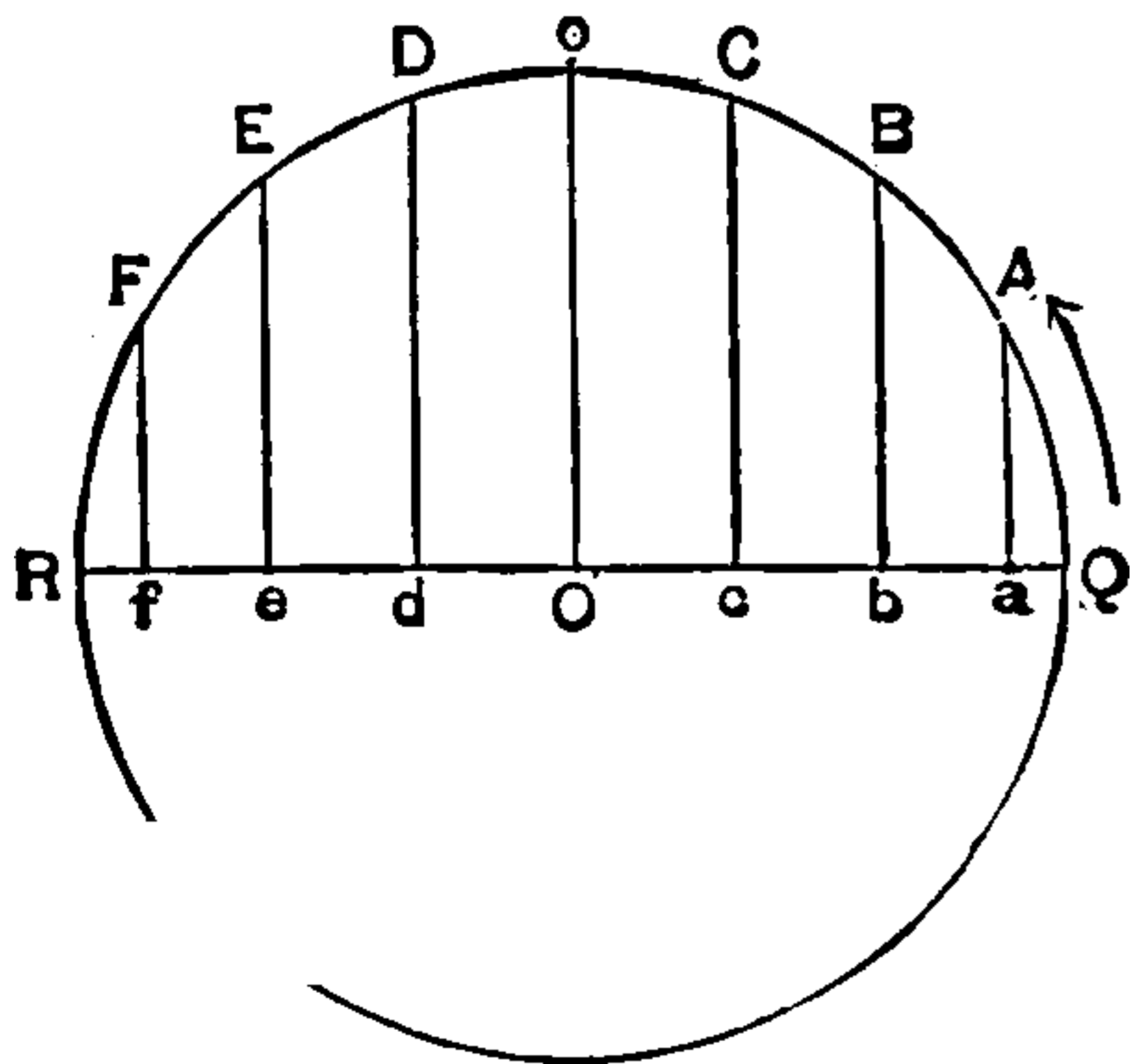

Fig. 398. *Simple-Harmonic Motion.*

Motion which is a simple periodic function of the time.

Suppose a pendulum be set swinging in a certain path. If the path of such a pendulum, or, as it is generally called, a conical pendulum, be

looked at from above or from below, it will appear to be circular; if observed from one side it will appear elliptical, and this elliptical path will appear longer and narrower as the eye of the observer approaches the level of the plane in which the bob moves, when the bob will appear to travel backwards and forwards in a straight line. The bob will appear to be moving faster, when it is moving right across the field of view.

Let the circle Q C R (Fig. 398) be the path in which the bob moves, and let Q A, A B, B C, C o, etc., be equal distances in such path. Let the lines A a, B b, C c, o O, etc., be drawn perpendicular to the line Q R. Then when looked at, with the eye on the level of the plane in which the bob travels, the line Q R, will be the path in which the bob appears to move backwards and forwards, and the lines, Q a, a b, b c, c O, etc., will represent the spaces apparently traversed in equal intervals of time.

The circle Q o R, is called the circle of reference.

Motion, Simple-Harmonic, Amplitude of — —The length of the swing from the median position to its extreme position, in either direction.

The line O Q, or O R, in the circle of reference Q O R (Fig. 398).

Motion, Simple-Harmonic, Negative Direction of — —The motion which a body, with a simple-harmonic motion, has when it appears to move from left to right.

Motion, Simple-Harmonic, Period of — —The interval of time which elapses between two successive passages of a moving particle, over the same point, in the same direction.

The period of simple-harmonic motion represents the time of one complete motion around a circle called the circle of reference. (See *Motion, Simple-Harmonic*.)

Motion, Simple-Harmonic, Phase of — —The position of a point executing a simple harmonic motion, expressed in terms of the interval of time which has elapsed since such point last passed through the middle of its path in the positive direction.—(*Anthony & Brackett*.)

The exact position of a particle executing a simple-harmonic motion for any instant of time can be readily expressed in terms of the phase.

Motion, Simple-Harmonic, Positive Direction of — — The motion which a body moving in simple-harmonic motion has, when it appears to move from right to left.

Motion, Simple-Periodic — — A term sometimes employed in the sense of simple-harmonic motion. (See *Motion, Simple-Harmonic.*)

Motion, Simple-Sine — — A term sometimes employed in the sense of simple-harmonic motion. (See *Motion, Simple-Harmonic.*)

Motograph, Electro — — An apparatus invented by Edison whereby the friction of a platinum point against a rotating cylinder of moist chalk, is reduced by the passage of an electric current.

This result is due to electrolytic action at the points of contact, varying the friction.

The electro-motograph, though less certain in its action than an electro-magnet, may replace it in certain electric apparatus.

The detailed construction of the electro motograph will be understood from an inspection of Fig. 399.

The lever A, pivoted with a universal joint at C, has a metallic point at its free extremity F, resting on a strip of moistened paper N, and held against it with some pressure by the action of the spring S. The paper N, rests on the metallic drum G, over which it is moved on the rotation of the drum by clockwork. A spring R, acts to move the lever A, in a direction opposite to that in which it tends to move by the rotation of the drum G.

The main battery L, is connected at its negative pole to the point F, and at its positive pole, through the key K, to the metallic drum G. The local battery L B, is connected through the sounder X, to the contacts D and X.

When the key K, is open, the friction of F, on the paper N, is sufficient to move the lever A, to the right so as to close the circuit of the local battery, but when the key K, is depressed, the current of L, passing through the paper, decomposes the chemicals with which it is moistened, lessens the friction of the point F, and permits the spring B, to draw the lever A, to the left, thus opening the circuit of the local battery L B.

The movements of the key are therefore reproduced by the armature of the electro-magnet X.

An excellent loud speaking telephone has been devised by Edison on the principle of the electro-motograph.

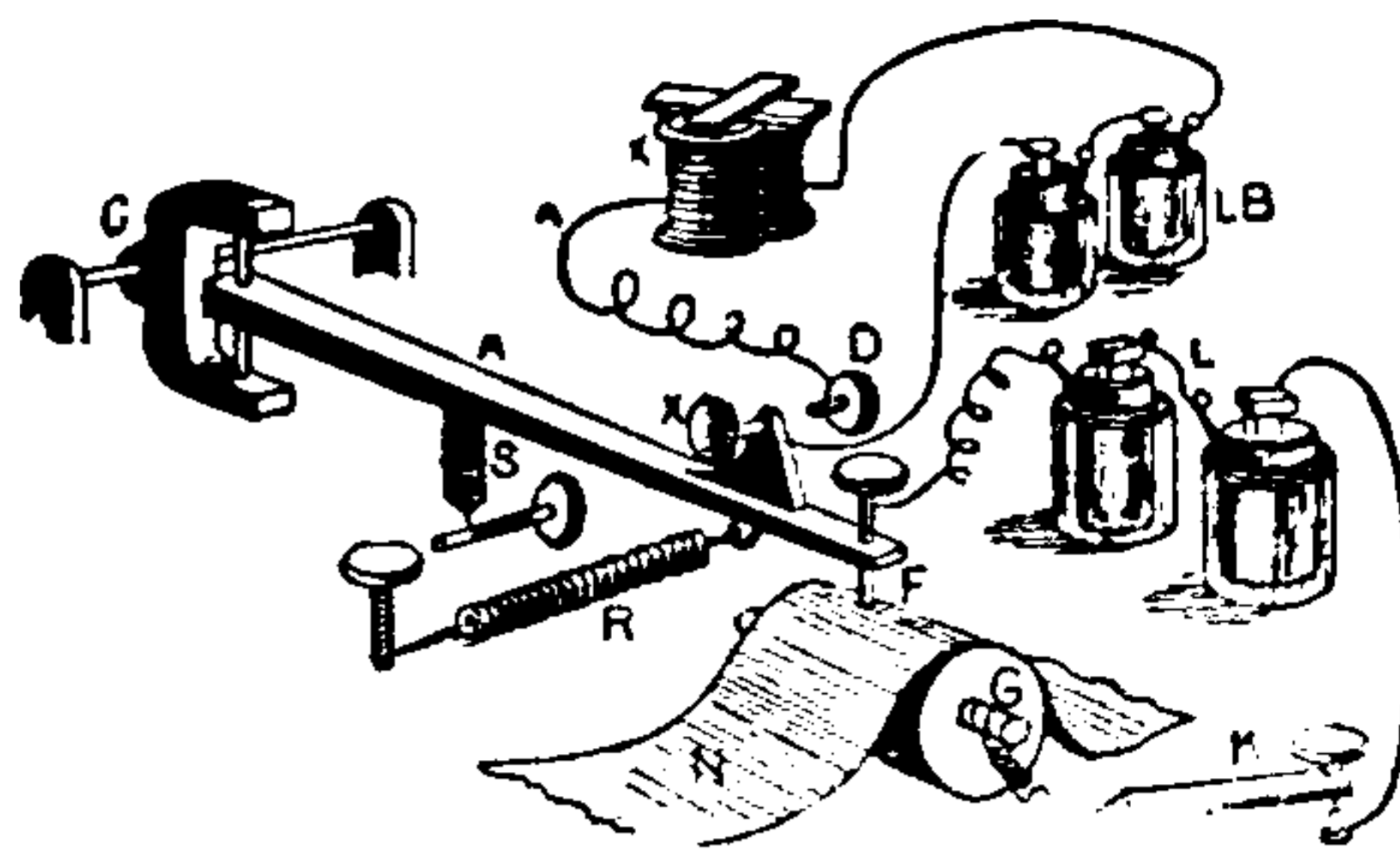

Fig. 399. *Electro-Motograph.*

Motor, Compound-Wound — — An electric motor whose field magnets are excited by a series and a shunt wire. (See *Machine, Dynamo-Electric, Compound-Wound.*)

Motor, Differentially Wound — — A compound-wound motor, in which the current in the shunt coils opposes in its magnetizing effects the current in a series coil, so that the efficient magnetizing effect produced is the difference in the magnetizing effect of the two coils.

Motor, Electric — — A device for transforming electric power into mechanical power.

All practical electric motors depend for their operation on the tendency to motion in a magnetic field of a conductor carrying a current or on magnetic attraction or repulsion. The entire magnetism may be produced by the current, or part may be obtained from permanent magnets, and the rest from electro-magnets.

A dynamo-electric machine will act as a motor if a current is sent through it. Such a motor is sometimes called an *electro motor*. The term electric motor would, however, appear to be the preferable one.

In all cases the rotation is in such a direction as to induce in the armature an electromotive force opposed to that of the driving current; this is therefore called the counter electromotive force.

A *magneto-dynamo*, or a dynamo the field of which is obtained from permanent magnets, or a *separately excited dynamo*, will operate as a motor when a current is sent through its armature, and will turn it in the *opposite direction* to that required to drive it in order to produce a current in the same direction.

A *series dynamo* will operate as a motor when

a current is sent through it. If the current is sent through it in the opposite direction to that which it produces when in operation as a *generator*, the polarity of the field is reversed and the dynamo will turn as a motor in the *opposite direction* to that required to produce the current. If the current is reversed, the polarity of both the field and the armature is again reversed, and the dynamo still rotates as a motor in the *opposite direction* to that in which it is rotated as a generator.

A series dynamo, therefore, always rotates as a motor in a direction opposite to that of its rotation as a generator.

When, however, the polarity of the field only is reversed by changing the connection between the armature and the field, the rotation is in the same direction.

A shunt dynamo operated as a motor will also turn in but one direction, but this direction is the same as that in which it turns when operating as a generator; for if the direction of the current in the armature is the same as in a generator, that in the shunt is reversed.

A compound wound dynamo will move in a direction opposite to that of its motion as a generator if the series part is more powerful than the shunt, and in the same direction if the shunt part is more powerful than the series. To use a compound-wound dynamo as a differential motor the connections need not be changed. For a cumulative motor it is necessary to reverse the connections of the series coils.

Alternating-Current Dynamo.—The current from an alternating-current dynamo, if sent through another similar alternating-current dynamo running at the same speed, will drive it as a motor. Such a machine possesses the disadvantage of requiring to be maintained at a speed depending on that of the driving dynamo, and also that it requires to be brought to nearly this speed before the driving current is supplied to it. As a result of this last requirement, variations in the load are apt to stop the motor. Considerable improvements, however, are being introduced into alternate-current motors, by which these difficulties are almost entirely removed.

An alternating current sent through any self-exciting dynamo-electric machine, such as a shunt or series machine, will drive it continuously as a motor. The sudden reversals in the magnetization of its cores will, however, unless the cores are thoroughly laminated, set up power-

ful eddy currents that will injuriously heat the machine, and there is also excessive sparking at the brushes.

The *reversibility of any dynamo-electric machine*, or its ability to operate as a motor if supplied with a current, leads to a fact of great importance in the efficiency of electric motors, viz.: that during rotation there is induced in the armature during its passage through the field of the machine, an electromotive force opposed to that produced in the armature by the driving current, or a *counter electromotive force*. (See *Resistance, Spurious. Force, Counter Electromotive*.) This counter electromotive force acts as a *spurious resistance*, and opposes the passage of the driving current, so that, as the speed of the electric motor increases, the strength of the driving current becomes less, until, when a certain maximum speed is reached, very little current passes. In actual practice, this maximum speed is not attained, or is only momentarily attained, and a small, nearly constant, current is expended in overcoming friction at the bearings, air friction, etc.

When, however, the load is placed on the motor, that is, when it is caused to do work, the speed is reduced and the counter electromotive force is decreased, thus permitting a greater current to pass. The fact that the load thus automatically regulates the current required to drive the motor, renders electric motors very economical in operation.

The relations between the power required to drive the generating dynamo, and that produced by the electric motor, are such that *the maximum work per second is done by the motor when it runs at such a rate that the counter electromotive force it produces is half that of the current supplied to it*. The maximum work or activity of an electric motor is therefore done when its theoretical efficiency is only 50 per cent. This, however, must be carefully distinguished from the maximum efficiency of an electric motor. A maximum efficiency of 100 per cent. can be attained theoretically; and, in actual practice, considerably over 90 per cent. is obtained. In such cases, however, the motor is doing work at less than its *maximum power*.

This is Jacobi's law of maximum effect, but does not apply to *actual* motors on account of the limitations of current carrying capacity. For example, a motor of 9 horse power and 90 per cent. efficiency loses 1 horse-power in heat within

THIS PAGE IS LOCKED TO FREE MEMBERS

Purchase full membership to immediately unlock this page



HISTORY

Tens of thousands of important historical sources, many previously unobtainable, are now available for the first time with a Forgotten Books Full Membership.

Unlimited Access
\$8.99/month

Continue

*Fair usage policy applies

the passage of air through the portion of the iron tubes so screened. The air is supplied to the furnace by passing down from above through the

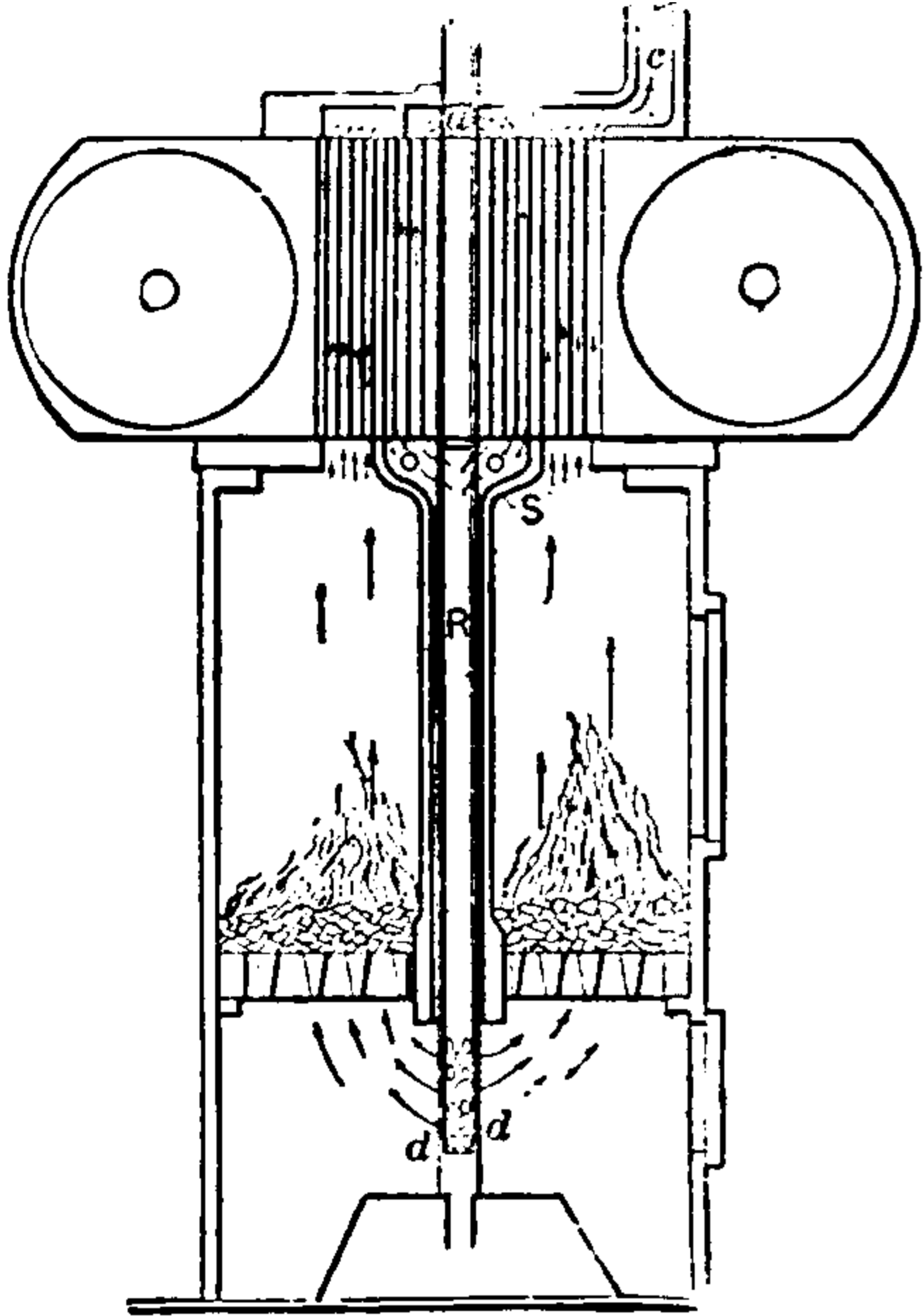

Fig. 400. Pyromagnetic Motor.

tubes so screened. This is shown in the drawings, the direction of the heating and the cooling air currents being indicated by the arrows. The

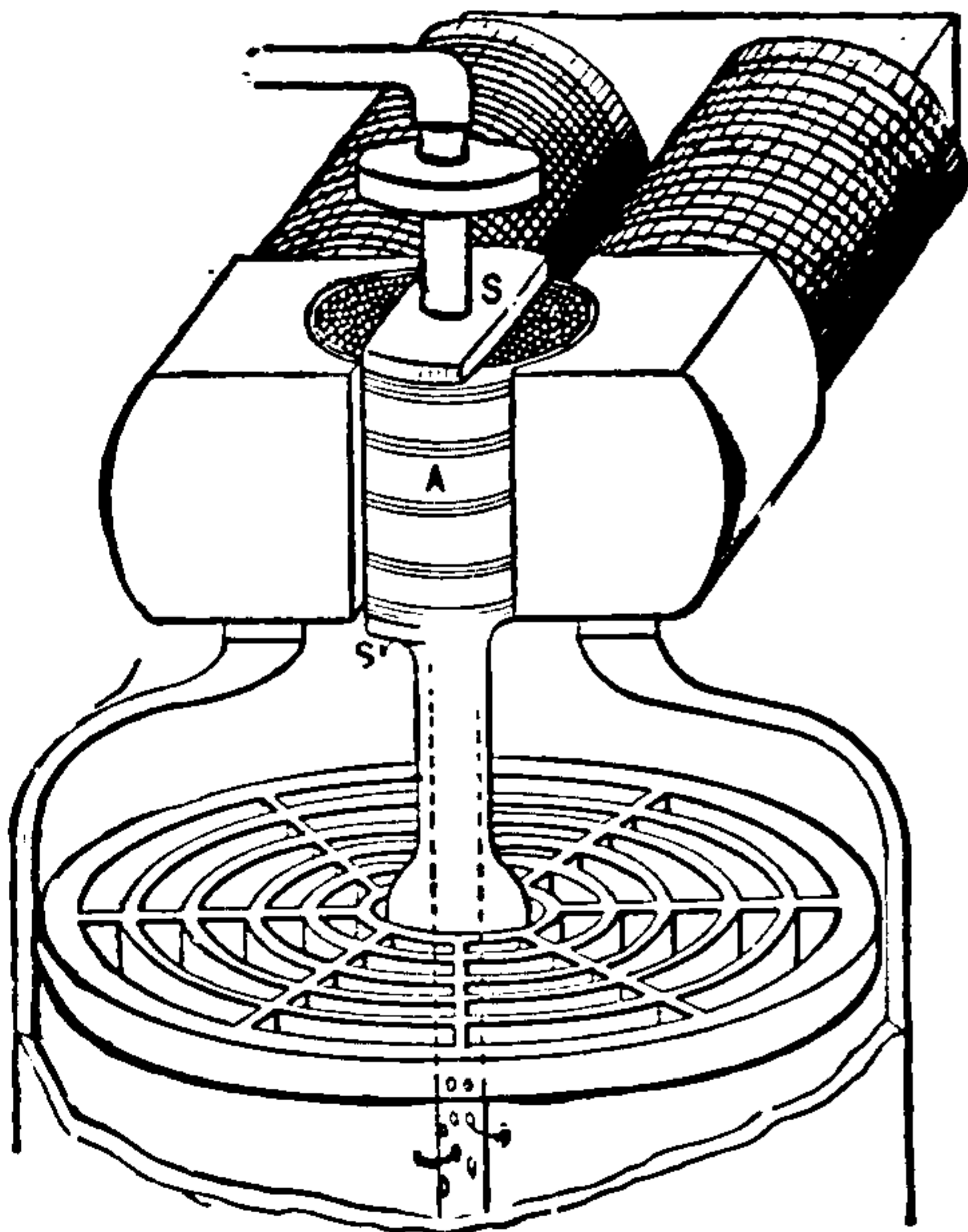

Fig. 401. Pyromagnetic Motor.

supply of air from above thus insures the more rapid cooling of the screened portion of the tubes.

Motor, Rotating-Current — — An electric motor designed for use with a rotating electric current.

Unlike alternating current motors, rotary-current motors will, like continuous-current motors, readily start with a load. (See *Current, Rotating*.)

Motor, Series-Wound — — An electric motor in which the field and armature are connected in series with the external circuit as in a series dynamo. (See *Machine, Dynamo-Electric, Series-Wound*.)

Motor, Shunt-Wound — — An electric motor in which the field magnet coils are placed in a shunt to the armature circuit. (See *Machine, Dynamo-Electric, Shunt-Wound*.)

Motor Standards. — (See *Standards, Motor*.)

Moulded Mica.—(See *Mica, Moulded*.)

Moulding, Electric Wood — — Moulding of dried, non-conducting wood, provided with longitudinal grooves for the reception and support of electric wires or conductors.

Wood mouldings are employed for the protection and concealment of electric conductors.

Moulding Wiring. — (See *Wiring, Moulding*.)

Mouse-Mill Dynamo. — (See *Dynamo, Mouse-Mill*.)

Mouse-Mill Machine. — (See *Machine, Mouse-Mill*.)

Mouth Pieces.—(See *Pieces, Mouth*.)

Movable Secondary. — (See *Secondary, Movable*.)

Mover, Prime — — In a system of distribution of power the motor by which secondary motors or movers are driven.

In a steam plant, the steam engine is the prime mover; the shafts or machines driven by the main shaft are sometimes called the secondary movers. The main shaft is called the driving shaft. Its motion is carried by means of belts to other shafts, called driven shafts. The pulleys on the driving or driven shafts are called respectively the driving and driven pulleys.

Movers, Secondary — — The shafts or machines driven by the main shafts in order to distinguish them from the steam engine or other mover which drives it. (See *Mover, Prime*.)

Multi-Cellular Electrostatic Voltmeter.—(See *Voltmeter, Multi-Cellular Electrostatic.*)

Multiphase Current.—(See *Current, Multiphase.*)

Multiphase Dynamo.—(See *Dynamo, Multiphase.*)

Multiphase System.—(See *System, Multiphase.*)

Multiple-Arc Circuit.—(See *Circuit, Multiple-Arc.*)

Multiple-Arc-Connected Electro-Receptive Devices.—(See *Devices, Electro-Receptive, Multiple-Arc-Connected.*)

Multiple-Arc-Connected Sources.—(See *Sources, Multiple-Arc-Connected.*)

Multiple-Arc-Connected Translating Devices.—(See *Devices, Translating, Multiple-Arc-Connected.*)

Multiple-Brush Rocker.—(See *Rocker, Multiple-Brush.*)

Multiple-Brush Yoke.—(See *Yoke, Multiple-Pair Brush.*)

Multiple Cable Core.—(See *Cable, Multiple-Core.*)

Multiple Circuit.—(See *Circuit, Multiple.*)

Multiple Conduit.—(See *Conduit, Multiple.*)

Multiple-Connected Battery.—(See *Battery, Multiple-Connected.*)

Multiple-Connected Electro-Receptive Devices.—(See *Devices, Electro-Receptive, Multiple-Connected.*)

Multiple-Connected Electro-Receptive Devices, Automatic Cut-Out for — — (See *Cut-Out, Automatic, for Multiple-Connected Electro-Receptive Devices.*)

Multiple-Connected Translating Devices.—(See *Devices, Translating, Multiple-Connected.*)

Multiple Connection.—(See *Connection, Multiple.*)

Multiple Distribution of Electricity by Constant Potential Circuits.—(See *Electricity, Multiple Distribution of, by Constant Potential Circuits.*)

Multiple Electric-Gaslighting.—(See *Gaslighting, Multiple Electric.*)

Multiple-Series.—A multiple connection of series groups. (See *Connection, Series Multiple.*)

Usage in regard to this term is divided. By some the term multiple-series is applied to a series connection of parallel groups. This is done on account of the order of the words, multiple-series indicating, it is claimed, a series connection of multiple groups.

Multiple-Series Circuit.—(See *Circuit, Multiple-Series.*)

Multiple-Series-Connected Electro-Receptive Devices.—(See *Devices, Electro-Receptive, Multiple-Series-Connected.*)

Multiple-Series-Connected Sources.—(See *Sources, Multiple-Series-Connected.*)

Multiple-Series-Connected Translating Devices.—(See *Devices, Translating, Multiple-Series-Connected.*)

Multiple-Series Connection.—(See *Connection, Multiple-Series.*)

Multiple-Switch Board.—(See *Board, Multiple-Switch.*)

Multiple Transformer.—(See *Transformer, Multiple.*)

Multiple Transmission.—(See *Transmission, Multiple.*)

Multiple Working of Dynamo-Electric Machines.—(See *Working, Multiple, of Dynamo-Electric Machines.*)

Multiplex Telegraphy.—(See *Telegraphy, Multiplex.*)

Multiplicator.—A word sometimes used for multiplier.

Multiplier, Galvanic — — A term formerly applied to a galvanometer. (See *Galvanometer.*)

Multiplier, Schweigger's — — The name first given to a coil consisting of a

number of turns of insulated wire, provided for the purpose of increasing the strength of the magnetic field produced by an electric current, and consequently the amount of its deflecting power on a magnetic needle.

Schweigger's multiplier was in fact an early form of galvanometer. (See *Galvanometer*.)

Multiplying Power of Shunt. — (See *Shunt, Multiplying Power of*.)

Multipolar Armature.—(See *Armature, Multipolar*.)

Multipolar Dynamo-Electric Machine.—(See *Machine, Dynamo-Electric, Multipolar*.)

Multipolar-Electric Bath.—(See *Bath, Multipolar Electric*.)

Muscle Current.—(See *Current, Muscle*.)

Muscles, Electrical Excitation of — — (See *Excitation, Electro-Muscular*.)

Muscular, Electro — — —Pertaining to the influence of electricity on the muscles.

Muscular or Nerve Fibre, Excitability of — — (See *Excitability, Electric, of Nerve or Muscular Fibre*.)

Muscular Pile, Matteucci's — — —(See *Pile, Muscular, Matteucci's*.)

Musket, Electric — — — A gun in which the charge is ignited by a platinum wire rendered incandescent by the action of a battery placed in the stock of the gun.

Mutual Inductance.—(See *Inductance*.)

Mutual Induction. — (See *Induction, Mutual*.)

Mutual Induction, Co-efficient of — — —(See *Induction, Mutual, Co-efficient of*.)

Myria (as a prefix).—A million times.

N

N.—A contraction employed in mathematical writings for the whole number of lines of magnetic force in any magnetic circuit.

N.—A contraction for North Pole.

This N, may be distinguished from the N, used for expressing the whole number of lines of magnetic force, by making the former light and the latter heavy.

N. H. P.—A contraction for Nominal Horse-Power.

Nominal horse-power is a somewhat indefinite term for a quantity dependent on the length of stroke and the dimensions of the cylinder. This quantity is a dependent one, because it varies necessarily with the type of engine.

Nascent State.—(See *State, Nascent*.)

Natural Currents.—(See *Currents, Natural*.)

Natural Law.—(See *Law, Natural*.)

Natural Magnet.—(See *Magnet, Natural*.)

Natural Unit of Electricity.—(See *Electricity, Natural Unit of*.)

Natural Unit of Quantity of Electricity, — — —(See *Electricity, Unit Quantity of, Natural*.)

Nautical Mile.—(See *Mile, Nautical*.)

Needle Annunciator.—(See *Annunciator, Needle*.)

Needle, Astatic — — —A compound magnetic needle of great sensibility, possessing little or no directive power.

An astatic needle consisting of two separate magnetic needles, rigidly connected together and placed parallel and directly over each other, with opposite poles opposed.

An astatic needle is shown in Fig. 402. The two magnets N S, and S' N', are directly opposed in their polarities, and are rigidly connected together by means of the axis a, a. So disposed, the two magnets act as a very weak single needle when placed in a magnetic field.

Were the two magnets N S, and S' N', of exactly equal strength, with their poles placed in exactly the same vertical plane, they would completely neutralize each other, and the needle

THIS PAGE IS LOCKED TO FREE MEMBERS

Purchase full membership to immediately unlock this page

Know Your Bible

Forgotten Books' Full Membership provides unlimited access to more than 28,000 volumes of Christian literature for \$8.99/month

HOLY BIBLE

Continue

*Fair use policy applies

netic declination that take place at regular periods of the year.

The annual variations of the magnetic field were discovered by Cassini in 1786.

Needle, Magnetic, Daily Variation of — — Variations in the value of the magnetic declination that take place at different periods of the day.

It was noticed, for example, in London that the north pole of the magnetic needle begins to move westward between 7 and 8 A. M. and continues this movement until 1 P. M., when it begins to move towards the east until near 10 P. M., when it again begins its westward course.

Needle, Magnetic, Damped — — A magnetic needle so placed as to quickly come to rest after it has been set in motion. (See *Damping*.)

Magnetic damping is readily effected by causing the needle to move near a metallic plate. On the motion of the needle the currents set up in the plate by dynamo-electric induction tend, according to Lenz's law, to oppose the motions producing them. (See *Induction, Electro-Dynamic Laws, Lenz's*.)

Needle, Magnetic, Declination of — — The angular deviation of the magnetic needle from the true geographical north.

The variation of the magnetic needle.

The declination of the magnetic needle is either E. or W. (See *Declination, Angle of*.)

Declination, or variation, is different at different parts of the earth's surface.

Lines connecting places which have the same value and direction for the declination are called isogonous lines. A chart on which the isogonous lines are marked is called a variation chart.

The value of the declination varies at different times. These variations of the declination are:

(1.) *Secular*, or those occurring during great intervals of time. Thus, in London, in 1580 the magnetic needle had a variation of about 11 degrees east. This eastern declination decreased in 1622 to 6 degrees E., and in 1680 the needle pointed to the true north. In 1692 the declination was 6 degrees W.; in 1730, 13 degrees W.; in 1765, 20 degrees W.; and in 1818 the needle reached its greatest western declination and is

now moving eastwards. The declination, however, is still west.

(2.) *Annual*, the needle varying slightly in its declination during different seasons of the year.

(3.) *Diurnal*, the needle varying slightly in its declination during different hours of the day.

(4.) *Irregular*, or those which occur during the prevalence of a magnetic storm.

It has been discovered that the occurrence of a magnetic storm is simultaneous with the occurrence of an unusual number of sun spots. (See *Spots, Sun*.)

Needle, Magnetic, Deflection of — — The movement of a needle out of a position of rest in the earth's magnetic field or in the field of another magnet, by the action of an electric current or another magnet.

The deflection of the needle is sometimes called its elongation. This latter term is, however, but little used, and is unnecessary.

Needle, Magnetic, Dipping — — A magnetic needle suspended so as to be free to move in a vertical plane, employed to determine the angle of dip or the magnetic inclination. (See *Dip, Magnetic. Inclination, Magnetic. Inclinator. Chart, Inclination*.)

A dipping needle is shown in Fig. 406. The

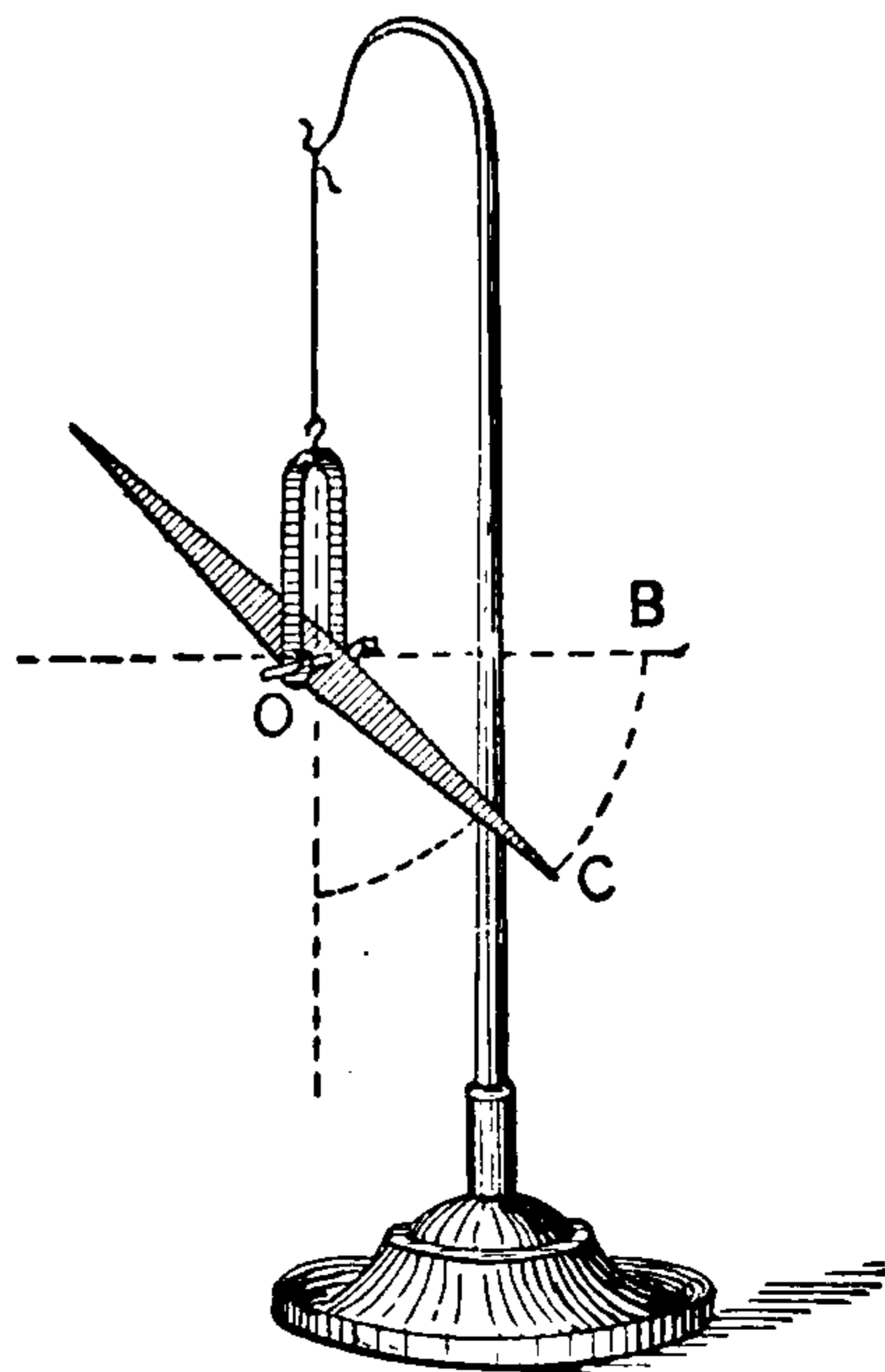

Fig. 406. Dipping Needle.

angle B O C, which marks the deviation of the needle from the horizontal position, is called the angle of dip.

Needle, Magnetic, Directive Tendency of — — The tendency of a magnetic needle to move so as to come to rest in the direction of the lines of the earth's magnetic field.

The directive power of the magnetic needle is due to the attraction of the earth's magnetic poles for the poles of the needle, or to the action of the earth's magnetic field. Since the force of the earth's magnetism forms a couple, there is no tendency for the needle to move bodily forward towards either of the earth's poles. Its tendency is merely to rotate until it comes to rest within the lines of the earth's magnetic field, entering at its south pole, passing through its mass and coming out at its north pole.

Of course this would be true in the case of a directing magnet only when it is at a great distance from the needle. Otherwise, there would be motion towards the poles as well as rotation.

Needle, Magnetic, Inclination or Dip of — — The deviation of a mechanically balanced magnetic needle from a horizontal position.

The direction of a magnetic needle in all parts of the earth, except at the magnetic equator, differs from a level or horizontal position. One of its ends inclines or dips towards the ground. (See *Dip, Magnetic. Needle, Magnetic, Dipping.*)

Needle, Magnetic, Orientation of — — The coming to rest of a magnetic needle in the earth's magnetic field.

Needle, Magnetic, Variation of — — The angular deviation of a magnetic needle from the true geographic north.

The declination of the magnetic needle. (See *Declination.*)

Needle of Oscillation.—A small magnetic needle employed for measuring the intensity of a magnetic field by counting the number of oscillations the needle makes in a given time, when disturbed from its position of rest in such field. (See *Magnetization, Intensity of. Lines, Isodynamic.*)

This use of a magnetic needle in determining the magnetic intensity of any place is analogous to the use of the pendulum in determining the intensity of gravity at any place.

Suppose, for example, that at a certain place the needle made 245 oscillations in ten minutes, and

that at another place it made 211 in the same time. Then the relative intensities at these two places would be as the square of these two numbers, or as 1 : 1.3482.

Needle, Telegraphic — — A needle employed in telegraphy to represent by its movements to the left or right respectively the dots and dashes of the Morse alphabet. (See *Telegraphy, Needle System of.*)

Needle, Throw of — — A phrase sometimes used for the angular deflection of a needle, particularly when the needle is swinging.

The displacement of the magnetic needle is called the deflection, the elongation, or the throw. The first will appear to be the preferable term when the needle comes to rest in a displaced position.

Negative Charge.—(See *Charge, Negative.*)

Negative Direction of Electrical Convection of Heat.—(See *Direction, Negative, of Electrical Convection of Heat.*)

Negative Direction of Simple-Harmonic Motion.—(See *Motion, Simple-Harmonic, Negative Direction of.*)

Negative Electricity.—(See *Electricity, Negative.*)

Negative Electrode.—(See *Electrode, Negative.*)

Negative Element of a Voltaic Cell.—(See *Element, Negative, of a Voltaic Cell.*)

Negative Feeders.—(See *Feeders, Negative.*)

Negative Omnibus Bars.—(See *Bars, Negative Omnibus.*)

Negative Phase of Electrotonus.—(See *Electrotonus, Negative Phase of.*)

Negative Plate of Storage Battery.—(See *Plate, Negative, of Storage Cell.*)

Negative Plate of Voltaic Cell.—(See *Plate, Negative, of Voltaic Cell.*)

Negative Pole.—(See *Pole, Negative.*)

Negative Potential.—(See *Potential, Negative.*)

Negative Side of Circuit.—(See *Circuit, Negative Side of.*)

Negative Wire.—(See *Wire, Negative.*)

Negatively.—In a negative manner.

Negatively Excited.—Charged with negative electricity. (See *Electricity, Negative.*)

Nerve or Muscular Fibre, Excitability of — —(See *Excitability, Electric, of Nerve or Muscular Fibre.*)

Nerves, Action of Electricity on — — Stimulating and other actions produced in nerves by the passage of electricity through them, dependent on the direction and character of the current. (See *Electrotonus. Galvanization. Faradization. Galvano-Faradization.*)

Net, Faraday's — —An insulated net of cotton gauze, or other similar material, capable of being turned inside out without being thereby discharged, employed for demonstrating that in a charged, insulated conductor the entire charge is accumulated on the outer surface of the conductor.

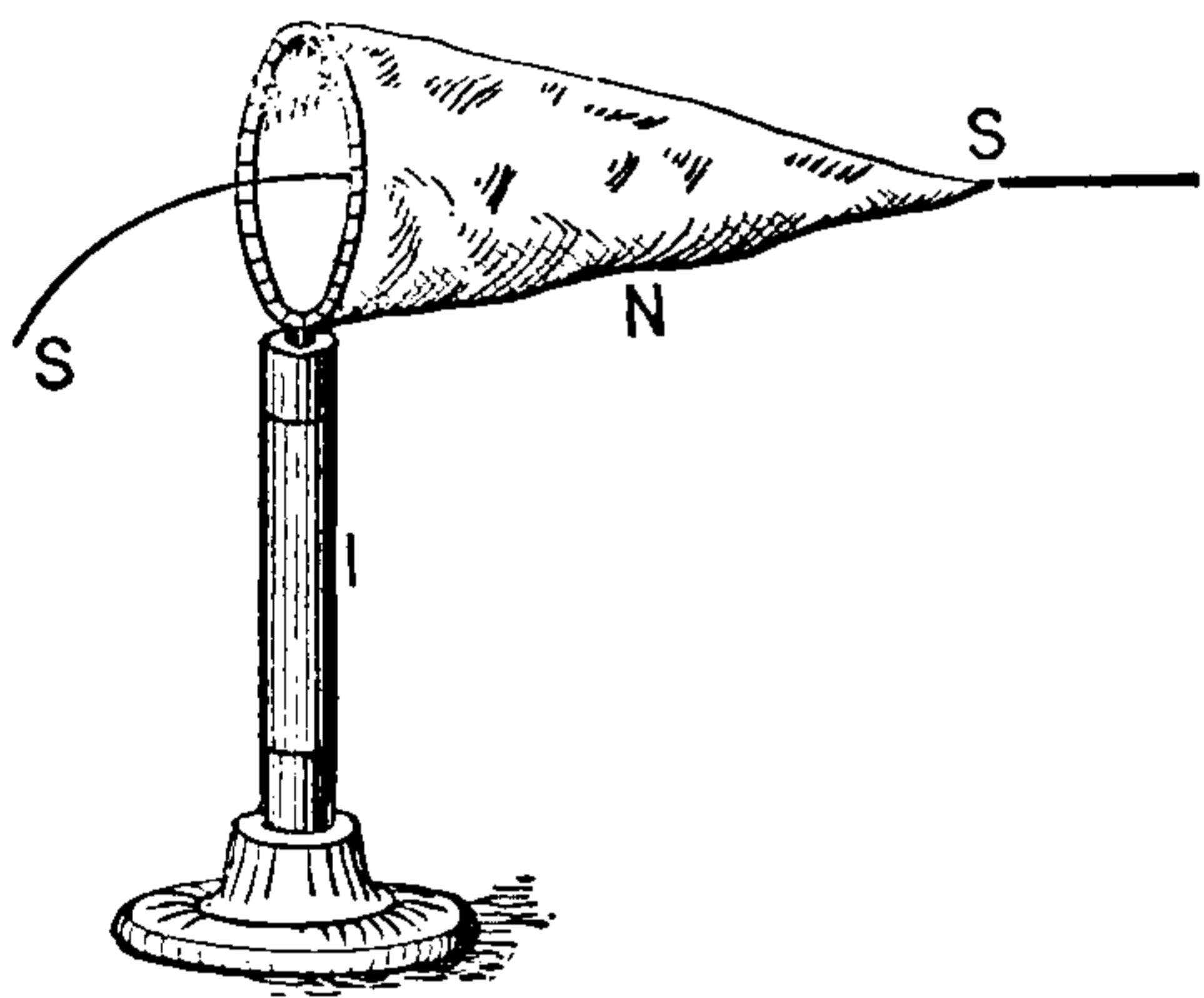

Fig. 407. Faraday's Net.

Faraday's net, as shown in Fig. 407, consists of a bag N, of cotton gauze, or mosquito netting, supported on an insulating stand I. When tested by a proof plane, no free electric charge is found on the inside, though such a charge is readily detected by the same means on the outside. By the aid of the silk strings S, S, the bag can be turned inside out, when the charge will then all be found on the then inside, or the now outside.

Faraday was in the habit of protecting his delicate electroscopes against outside electrification by covering them with gauze. To properly act as an electric screen, the gauze should be connected with the earth.

Faraday constructed a small insulated room,

twelve feet in height, breadth and depth, covered on the inside with tin-foil, and, on charging this room from the outside, he was unable to detect the presence of any charge on the inside, even by the aid of his most delicate instruments. This room is often referred to as Faraday's Cube.

Nets, Torpedo — —Steel wire netting suspended from or attached to a ship's side for the purpose of ensuring protection against moving torpedoes.

Network of Currents.—(See *Currents, Network of. Laws, Kirchhoff's.*)

Neutral Armature.—(See *Armature, Neutral.*)

Neutral Feeder. — The feeder that is connected with the neutral or intermediate terminal of the dynamos in a three-wire system of distribution. (See *Feeders.*)

Neutral Line of Commutator Cylinder. —(See *Line, Neutral, of Commutator Cylinder.*)

Neutral-Omnibus Bars. — (See *Bars, Neutral-Omnibus.*)

Neutral Point.—(See *Point, Neutral.*)

Neutral Points of a Dynamo-Electric Machine.—(See *Points, Neutral, of Dynamo-Electric Machine.*)

Neutral Points of Magnet.—(See *Points, Neutral, of Magnet.*)

Neutral Points of Thermo-Electric Diagram.—(See *Points, Neutral, of Thermo-Electric Diagram.*)

Neutral-Relay Armature.—(See *Armature, Neutral-Relay.*)

Neutral Section of Magnet.—(See *Section, Neutral, of Magnet.*)

Neutral Wire.—(See *Wire, Neutral.*)

Neutral Wire Ampère-Meter.—(See *Ampère-Meter, Balance or Neutral Wire.*)

New Ohm.—(See *Ohm, New.*)

Nickel Bath.—(See *Bath, Nickel.*)

Nickeling, Electro — —Electroplating with nickel. (See *Plating, Electro.*)

Nickel-Plating.—(See *Plating, Nickel.*)

Night Bell.—(See *Bell, Night.*)

THIS PAGE IS LOCKED TO FREE MEMBERS

Purchase full membership to immediately unlock this page



HISTORY

Tens of thousands of important historical sources, many previously unobtainable, are now available for the first time with a Forgotten Books Full Membership.

Unlimited Access
\$8.99/month

Continue

*Fair usage policy applies

Nominal Candle-Power.—(See *Power, Candle, Nominal.*)

Non-Automatic Variable Resistance.—(See *Resistance, Variable, Non-Automatic.*)

Non-Conductors.—Substances that offer so great resistance to the passage of an electric current through their mass as to practically exclude a discharge passing through them.

Non-conductors are called insulators, because they electrically insulate substances placed on or surrounded by them.

The terms non-conductors or insulators are ordinarily used in a relative sense to mean bodies which allow no practical or appreciable current to pass through them, since there are no substances known, apart, perhaps, from the universal ether, that absolutely prevent the flow of an electric current, the difference of potential of which is sufficiently great.

The entire absence of ordinary matter, as in the case of a high vacuum, appears to render a high vacuum very nearly, if not entirely, an absolute insulator.

Non-Electrics.—A term formerly applied to substances like metals or other conductors which appeared not to become electrified by friction.

The term non-electric, was used in contradistinction to electrics, or substances readily electrified by friction. The distinction no longer holds, since non-electrics, if insulated, are readily electrified by friction.

Non-Homogeneous Current-Distribution.—(See *Current, Non-Homogeneous, Distribution of.*)

Non-Illumined Electrode.—(See *Electrode, Non-Illumined.*)

Non-Inductive Resistance.—(See *Resistance, Non-Inductive.*)

Non-Oscillatory Discharge.—(See *Discharge, Non-Oscillatory.*)

Non-Polarized Armature.—(See *Armature, Non-Polarized.*)

Non-Polarizable Electrodes.—(See *Electrodes, Non-Polarizable.*)

Non-Wasting Electrode.—(See *Electrode, Non-Wasting.*)

Normal Day, Magnetic — —(See *Day, Normal Magnetic.*)

Northern Light.—The Aurora Borealis. (See *Aurora Borealis.*)

Notation, Algebraic — —A system of arbitrary symbols employed in algebra.

The following brief description of the notation employed in algebra is for the use of the non-mathematical reader.

Quantities are represented in algebra by letters, such as a, and b, x, and y, etc.

Addition is represented thus: $a + b$.

Subtraction is represented thus: $a - b$.

Multiplication is represented thus: $a \times b$, or simply by writing the letters next to each other ab .

Division is represented thus: $a \div b$, or $\frac{a}{b}$

An Exponent, or figure placed *to the right* of a letter, *above* it as a^3 , indicates that the *quantity* represented by a, is to be *multiplied* by itself three times, as $a \times a \times a$, or $a a a$.

A Co-efficient, or figure placed *to the left* of a quantity, indicates the number of times that quantity is to be taken; thus, $3 a$, indicates that a is to be *added* three times, thus: $a + a + a$, or $3 \times a$.

A Radical Sign or *Root*, thus \sqrt{a} , or $^2\sqrt{a}$, indicates that the square root of the quantity a is to be taken. In the same manner $^3\sqrt{a}$, indicates that the cube root of a is to be taken.

These expressions are sometimes written $a^{\frac{1}{2}}$, or $a^{\frac{1}{3}}$.

Equality is indicated thus: $a^3 = a \times a \times a$, or $a^{\frac{1}{2}} = \sqrt{a}$.

A negative exponent a^{-2} indicates $\frac{1}{a^2}$, or is the exponent of the reciprocal of the quantity indicated.

Null or Zero Method.—(See *Method, Null or Zero.*)

Null Point.—(See *Point, Null.*)

Number, Diacritical — —Such a number of ampère-turns at which a given core would receive a magnetization equal to half saturation.

O

Ω.—A contraction for megohm. (See *Ohm, Meg.*)

ω.—A contraction for ohm. (See *Ohm.*)

Obscure Heat.—(See *Heat, Obscure.*)

Observation Mine.—(See *Mine, Observation.*)

Observatory, Magnetic — — An observatory in which observations of the variations in the direction and intensity of the earth's magnetic field are made.

Magnetic observatories are generally furnished with self-registering magnetic apparatus, such as *magnetographs, magnetometers, inclinometers.* (See *Magnetometer. Magnetograph. Inclinometer.*)

Magnetic observatories are generally constructed entirely of non-magnetic materials; that is, of such materials as are destitute of *paramagnetic properties.*

Obtuse Angle.—(See *Angle, Obtuse.*)

Occlusion of Gas.—(See *Gas, Occlusion of.*)

Odorscope.—An apparatus in which the determination of an odor was attempted by the measurement of the effect the odorous vapor, or effluvia, produced on a variable contact resistance.

The *microtasimeter* was used in connection with the odorscope. (See *Diagometer, Rousseau's. Microtasimeter.*)

Oerstedt, An — — A proposed term for the unit of electric current, in place of an ampère.

The term has not been adopted.

Ohm.—The unit of electric resistance.

Such a resistance as would limit the flow of electricity under an electromotive force of one volt to a current of one ampère, or to one coulomb per second. (See *Unit, B.A. Ohm, Legal. Ohm, Standard.*)

A value equal to 10^9 absolute electro-magnetic units.

A value which is represented by a velocity of 10^9 , or 1,000,000,000 centimetres per second.

It may be difficult at first to see how resistance can be correctly represented by a velocity. The following consideration may render this clear: The formula for calculating the velocity is $V = \frac{D}{T}$, or the velocity equals the distance passed through in unit time. Now, by examining the formula for the value of the resistance, expressed in terms of the electro-magnetic units (see *Units, Electro-Magnetic, Dimensions of*), it may be seen to be that resistance =

$$\frac{\text{Electromotive force}}{\text{Current}} = \frac{L}{T}$$

But this value is of the nature of a velocity, being equal to the length, divided by the time. Resistance, therefore, has the dimensions of a velocity.

This is clearly expressed by Silvanus P. Thompson in his "Elementary Lessons in Electricity and Magnetism," as follows, viz.: "Suppose we have a circuit composed of two horizontal coils, C S, and D T (Fig. 410), 1 centimetre apart, joined at C D, and completed by means of a sliding piece, A B. Let this variable circuit be placed in a uniform magnetic field of unit intensity, the lines of force being directed vertically downwards through the circuit.

"If, now, the slider be moved along towards S T, with a velocity of n , centimetres per second, the number of additional lines of force embraced by the circuit will increase at the rate of n , per second; or, in other words, there will be an *in-*

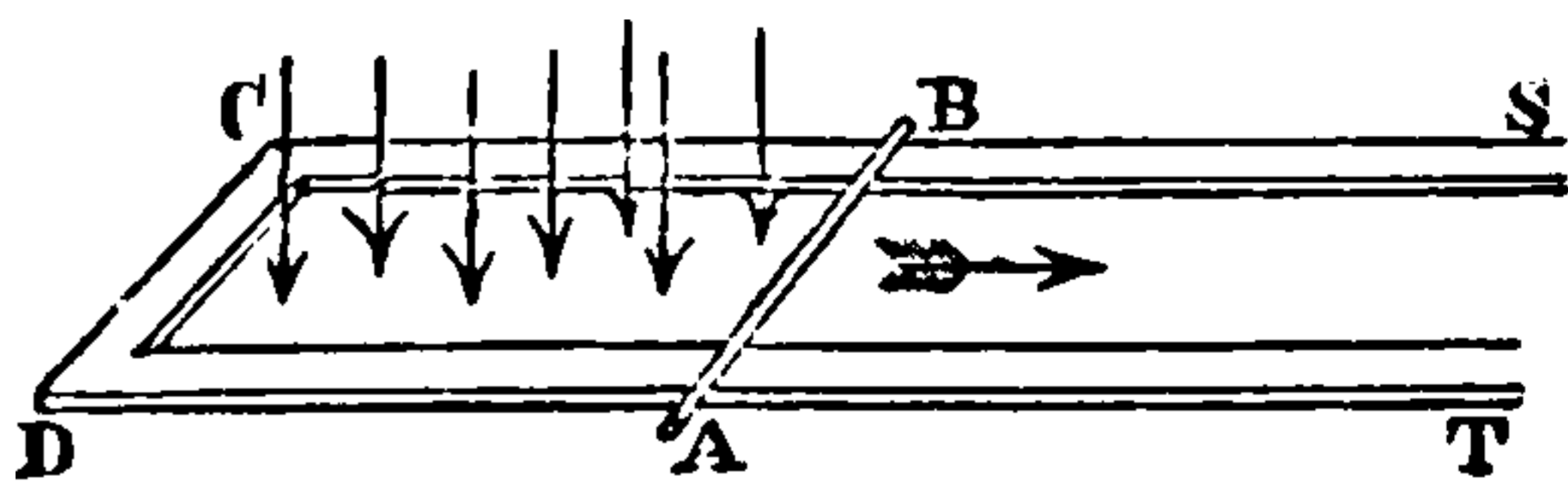

Fig. 410. Resistance as a Velocity.

duced electromotive force impressed upon the circuit, which will cause a current to flow through the slider from A to B. Let the rails have no resistance, then the strength of the current will depend on the resistance of A B. Now, let A B, move at such a rate that the current shall be of unit strength. If its resistance be one absolute (electro-magnetic) unit, it need only move at the rate of 1 centimetre per second. If its resistance be greater, it must move with a proportionately

greater velocity; the velocity at which it must move to keep up a current of unit strength being numerically equal to its resistance. *The resistance known as "1 ohm" is intended to be 10^9 absolute electro-magnetic units, and, therefore, is represented by a velocity of 10^9 centimetres, or 10,000,000 metres (1 earth-quadrant) per second.*"

Ohm, B. A. — — — A contraction for British Association ohm.

Ohm, Board of Trade — — — A unit of resistance as determined by a committee of the English Board of Trade.

A committee consisting of Sir W. Thomson, Lord Rayleigh, Dr. J. Hopkinson and other authorities appointed by the Board of Trade (England) has recently recommended that the ohm be taken as the resistance of a column of mercury 106.3 centimetres in length and one square millimetre area of cross-section at 0 degrees C. and since this value agrees with the best experimental results, it will probably be generally and finally adopted.

Ohm, British Association — — — The British Association unit of resistance, adopted prior to 1884.

The value of the unit of electric resistance, or the ohm, was determined by a Committee of the British Association as being equal to the resistance at 0 degree C. of a column of mercury 1 square millimetre in area of cross-section and 104.9 centimetres in length. This length was taken as coming nearest the value of the true ohm deduced experimentally from certain theoretical considerations. Subsequent re-determinations showed the value so obtained to be erroneous.

The value of the ohm is now taken internationally, as adopted by the International Electric Congress in 1884, as the resistance of a column of mercury 106 centimetres in length, and 1 square millimetre in area of cross-section. This last value is called the *legal ohm*, to distinguish it from the B. A. ohm, which, as above stated, is equal to a mercury column 104.9 centimetres in length. Usage now sanctions the use of the word *ohm* to mean the legal ohm.

This value of the legal ohm is provisional until the exact length of the mercury column can be finally determined. (See *Ohm, Board of Trade.*)

The following are the relative values of these units, viz.:

1 legal ohm.....	= 1.0112 B. A. ohm.
“ “	= 1.0600 Siemens unit.
1 B. A. ohm.....	= .9889 legal ohm.
1 “ “	= 1.0483 Siemens unit.
1 Siemens unit....	= .9540 B. A. ohm.
“ “	= .9434 legal ohm.

Ohm, Legal — — — The resistance of a column of mercury 1 square millimetre in area of cross-section, and 106 centimetres in length, at the temperature of 0 degree C. or 32 degrees F. (See *Unit, B. A.*)

1 ohm = 1.00112 B. A. units. This value of the ohm was adopted by the International Electric Congress, in 1884, as a value that should be accepted internationally as the true value of the ohm. This value, however, was provisional, and was never actually legalized. It will probably be replaced by the new (106.3 cm.) ohm. (See *Ohm, Board of Trade.*)

Ohm, Meg — — — One million ohms.

Ohm, New — — — A term sometimes used for the Board of Trade ohm. (See *Ohm, Board of Trade.*)

Ohm, Standard — — — A length of wire having a resistance of the value of the true or legal ohm, employed in standardizing resistance coils.

The standard ohm, as issued by the Electric Standards Committee of England, has the form

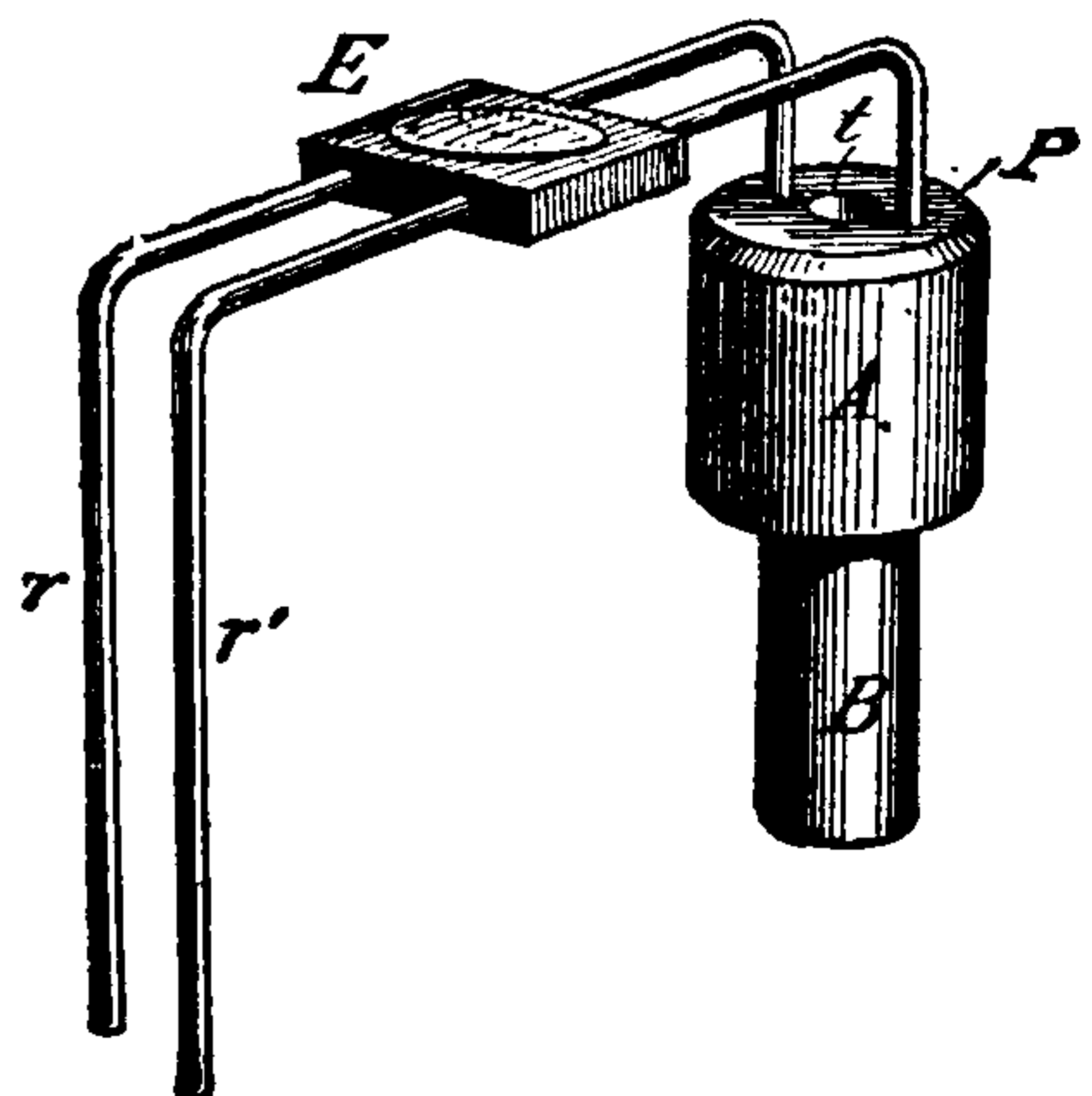

Fig. 411. Standard Ohm.

shown in Fig. 411. The coil of wire is formed of an alloy of platinum and silver, insulated by silk covering and melted paraffine. Its ends are soldered to thick copper rods *r, r'*, for ready connection with mercury cups. The coil is at *B*. The space above it at *A*, is filled with paraffine, except at the opening *t*, which is provided for the insertion of a thermometer.

THIS PAGE IS LOCKED TO FREE MEMBERS

Purchase full membership to immediately unlock this page

Know Your Bible

Forgotten Books' Full Membership provides unlimited access to more than 28,000 volumes of Christian literature for \$8.99/month

HOLY BIBLE

Continue

*Fair use policy applies

Open-Circuit Voltaic Cell.—(See *Cell, Voltaic, Open-Circuit.*)

Open-Circuit Voltmeter.—(See *Voltmeter, Open-Circuit.*)

Open-Circuited.—Put on an open circuit.

Open-Circuited Conductor.—(See *Conductor, Open-Circuited.*)

Open-Circuited Thermostat.—(See *Thermostat, Open-Circuit.*)

Open-Coil Drum Dynamo-Electric Machine.—(See *Machine, Dynamo-Electric, Open-Coil Drum.*)

Open-Coil Dynamo-Electric Machine.—(See *Machine, Dynamo-Electric, Open-Coil.*)

Open-Coil Ring Dynamo-Electric Machine.—(See *Machine, Dynamo-Electric, Open-Coil Ring.*)

Open-Iron-Circuit Transformer.—(See *Transformer, Open-Iron-Circuit.*)

Open-Iron Magnetic Circuit.—(See *Circuit, Open-Iron Magnetic.*)

Open Magnetic Core.—(See *Core, Open-Magnetic.*)

Opening Shock.—(See *Shock, Opening.*)

Operation, Magnet — — The use of a magnet for the purpose of removing particles of iron from the human eye.

Optical Strain.—(See *Strain, Optical.*)

Optical Strain, Electro-Magnetic — — (See *Strain, Optical Electro-Magnetic.*)

Optical Strain, Electrostatic — — (See *Strain, Electrostatic, Optical.*)

Optics, Electro — — That branch of electricity which treats of the general relations that exist between light and electricity.

The phenomena of electro-optics may be arranged under the following heads, viz.:

(1.) Electrostatic stress, produced by an electrostatic field causing an optical strain in a transparent medium, whereby such medium acquires the property of either rotating the plane of polarization of a beam of plane polarized light, or of doubly refracting light.

(2.) Electro magnetic stress produced by a

magnetic field causing an optical strain in a transparent medium, whereby such medium acquires the property of either rotating the plane of polarization, or of doubly refracting light. (See *Refraction, Double, Electric.*)

(3.) Changes in the electric resistance of bodies caused by the action of light. (See *Cell, Selenium.*)

(4.) The relation existing between the values of the index of refraction of a transparent medium and its specific inductive capacity. (See *Refraction. Capacity, Specific Inductive.*)

This relation has been shown to be as follows:

The specific inductive capacity is approximately equal to the square of the index of refraction.

(5.) The relation existing between the velocity of light and the value of the ratio of electrostatic and the electro-magnetic units, thus giving a basis for an electro-magnetic theory of light. (See *Light, Maxwell's Electro-Magnetic Theory of.*)

Polarized light reflected from the surface of a magnet, although it penetrates the substance to but a trifling extent, yet has its plane of polarization distinctly rotated by the magnetic whirls in the iron.

Oral or Speaking-Tube Annunciator.—(See *Annunciator, Oral or Speaking-Tube.*)

Ordinate.—A distance taken on a perpendicular line called the axis of ordinates, in contradistinction to the axis of abscissas. (See *Ordinates, Axis of.*)

Thus in Fig. 413, D I, is the ordinate of the point D, in the curve O D R.

Ordinates, Axis of — — One of the axes of co-ordinates used for determining the position of the points in a curved line.

Thus in Fig. 413 the line A B, is called the axis of ordinates because it is the line on which the ordinate 2 D, is measured.

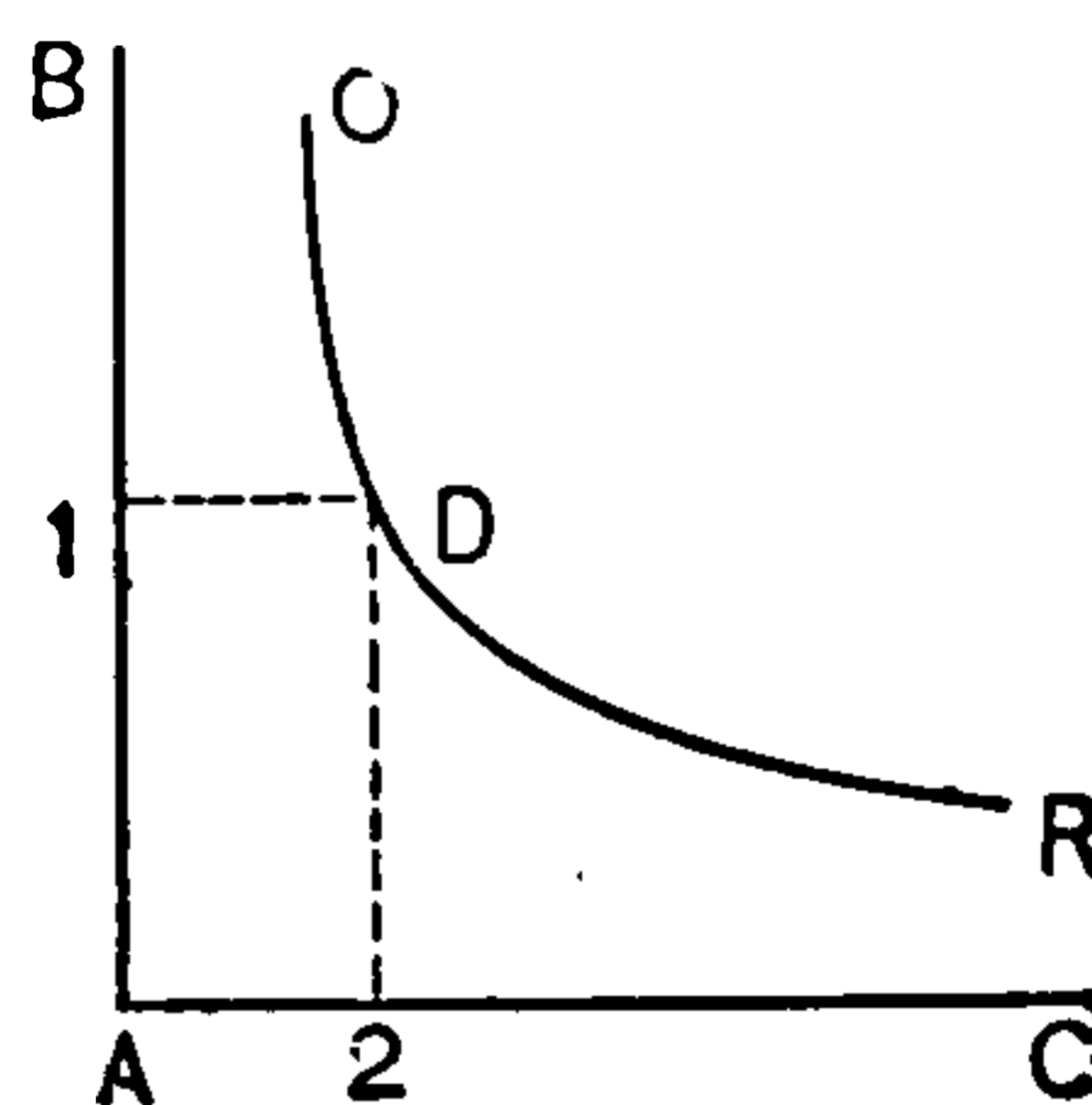

Fig. 413. Axis of Ordinates.

Ores, Electric Treatment of — — Processes for the extraction of metals from their ores.

These processes are referable to three distinct classes, viz.:

(1.) Those in which the reduction is effected by means of heat of electric origin.

(2.) Those in which the reduction is effected by the combined action of heat and electrolysis.

(3.) Those in which the reduction is effected by means of electrolysis only.

Organ, Electric — —A wind organ, in which the escape of air into the different pipes is electrically controlled.

In an electric organ, the keys, instead of operating levers, as usual, to admit the passage of air into the pipes, merely complete the circuit of a battery through a series of controlling electro-magnets. With such an arrangement, the keyboard can be placed at any desired distance.

Electric organs have been constructed, in which a chemical or mechanical record is made of the notes struck by the performer, as well as the musical value of such notes. By such a device the musical creations of a composer are permanently recorded in characters that are capable of interpretation by a compositor skilled in musical notation.

Orientation of Magnetic Needle.—(See *Needle, Magnetic, Orientation of*.)

Origin, Point of — —The point where the axes of co-ordinates start or originate. (See *Co-ordinates, Axes of*.)

Orthogonal.—Rectangular, or right-angled.

Oscillating Discharge.—(See *Discharge, Oscillating*.)

Oscillating Needle.—(See *Needle of Oscillation*.)

Oscillation, Centre of — —A point in a body swinging like a pendulum, which is neither accelerated nor retarded, during its oscillations, by the portions of the pendulum that are situated respectively above or below it.

If all the mass were concentrated at the centre of oscillation the time of oscillation would be the same.

The centre of oscillation is always below the centre of gravity. The vertical distance between the centre of oscillation and the point of support of a pendulum, determines the *virtual length* of the pendulum, and hence its number of vibrations per second. (See *Pendulum, Laws of*.)

Oscillations, Electric — —The series of partial, intermittent discharges of which the apparent instantaneous discharge of a Leyden jar through a small resistance actually consists.

These partial discharges produce a series of electric oscillations of the current in the circuit of the discharge, which consist of true to and-fro or backward-and-forward motions of the electricity. This phenomenon was discovered by Joseph Henry.

Oscillations, Open-Circuit, Electric — —Electric oscillations produced in open circuits by the presence of electric pulses in neighboring circuits.

Oscillatory Discharge.—(See *Discharge, Oscillatory*.)

Oscillatory Electric Displacement.—(See *Displacement, Electric, Oscillatory*.)

Oscillatory Electromotive Force.—An electromotive force which is rapidly periodic.

Oscillatory Inductance.—(See *Inductance, Oscillatory, Electric*.)

Oscillatory Induction.—(See *Induction, Oscillatory*.)

Osmose.—The unequal mixing of liquids of different densities through the pores of a separating medium.

If a solution of sugar and water be placed in a bladder, the neck of which is tied to a straight glass tube, and the bladder is then immersed in a vessel of pure water with the tube in a vertical position, the two liquids will begin to mix, the sugar and the water passing through the bladder into the pure water, and the pure water passing into the sugar and water in the bladder. This latter current is the stronger of the two, as will be shown by the water *rising* in the vertical glass tube.

The stronger of the two currents, that is, the one directed towards the higher level, or the one which produces the higher level, is called the *endosmotic current*, and the weaker current the *exosmotic current*.

Osmose, Electric — —A difference of liquid level between two liquids placed on opposite sides of a diaphragm produced by the passage of a strong electric current

through the liquids between two electrodes placed therein.

The higher level is on the side towards which the current flows through the diaphragm, thus apparently indicating an onward motion of the liquid with the current, or, in other words, the liquid is higher around the *kathode* than around the *anode*. The difference of level is most marked when poorly conducting liquids are employed.

As a converse of this, Quincke has shown that electric currents are set up when a liquid is forced by pressure through a porous diaphragm. The term *diaphragm currents* has been proposed for these currents. Their electromotive force depends on the nature of the liquid, on the material of the diaphragm, and on the pressure that forces the liquid through the diaphragm. (See *Phenomena, Electro-Capillary. Currents, Diaphragm.*)

Osmotic.—Of or pertaining to osmose. (See *Osmose.*)

Osteotome, Electric — —A revolving electrically propelled saw, employed in the surgical cutting of bones.

An electric osteotome consists essentially of a form of revolving engine known as a dental engine, furnished with a circular saw, or other rotary cutter, driven or propelled by electricity.

Outgoing Current.—(See *Current, Outgoing.*)

Outlet.—In a system of incandescent lamp distribution the places in a building where the fixtures or lamps are attached.

The outlets are left in a building by the wireman for the electric fixtureman to attach the device intended to be used on the circuits so provided.

Output, Magnetic — —The product of the magnetic flux by the magneto-motive force.

Output of Dynamo-Electric Machine.— (See *Machine, Dynamo-Electric, Output of.*)

Outrigger for Electric Lamp.—A device for suspending an electric arc lamp so as to cause it to stand out from the wall of a building.

An outrigger and hood with lamp attached are shown in Fig. 414.

Outrigger Torpedo.—(See *Torpedo, Outrigger.*)

Over-Compounded.—The compounding of a dynamo-electric machine so as to produce

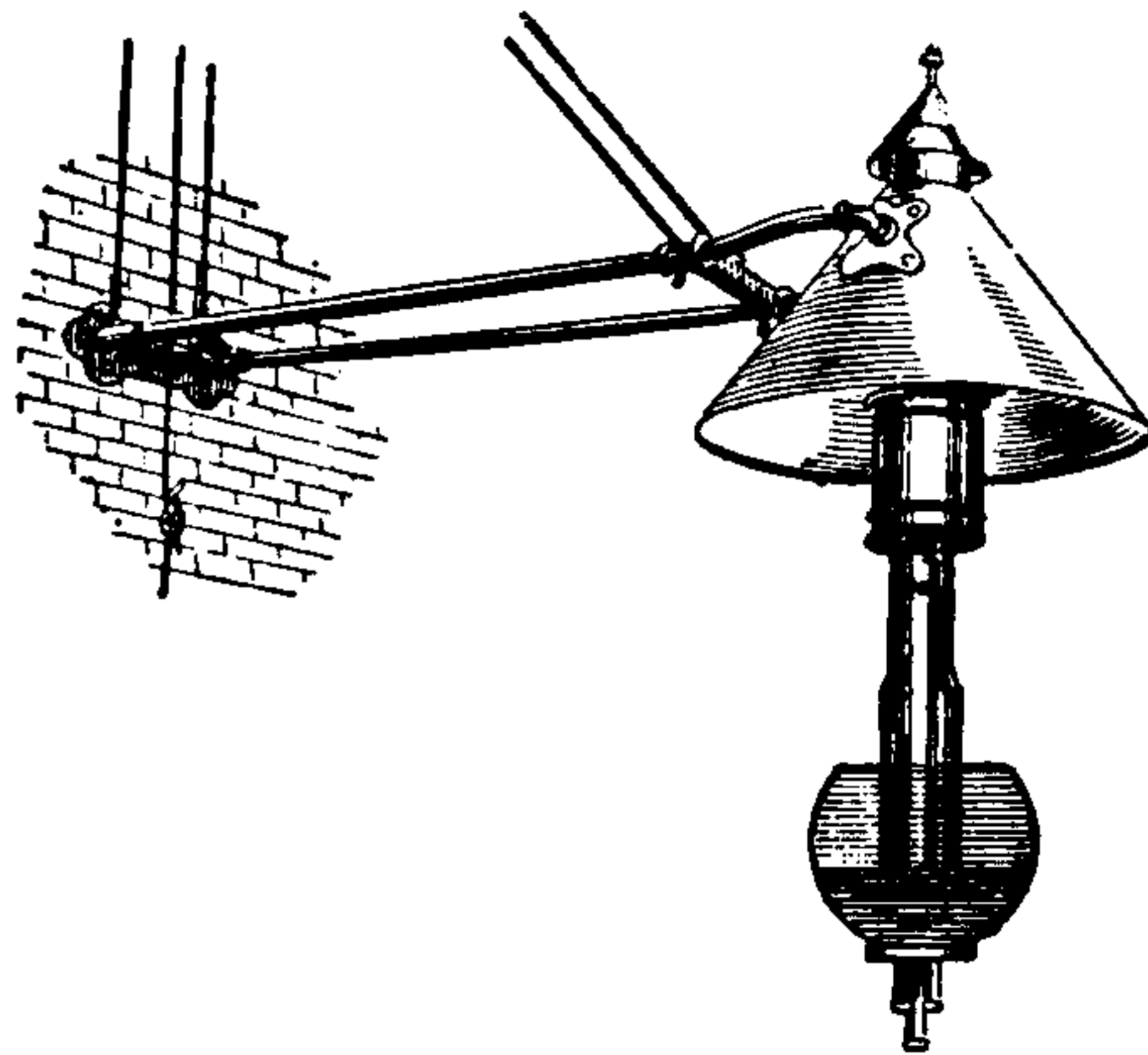

Fig 414. Outrigger and Hood.

an increase of voltage under increase of load.

Over-compounding is generally employed for compensating for drop or loss of potential in the line or conductor, and is adjusted to a definite percentage of increase from light to full load in accordance with the amount of drop, or loss, for which such compensation was designed.

Overhead Lines.—(See *Lines, Overhead.*)

Overhead System, Continuous, of Motive Power for Electric Railroads — —(See *Railroads, Electric, Continuous Overhead System of Motive Power for.*)

Overload of Electric Motor.—(See *Motor, Electric, Overload of.*)

Overtones.—Additional, faint tones, accompanying nearly every distinct musical tone, by the presence of which the peculiarity or quality of such tone is produced. (See *Sound, Characteristics of.*)

Overtones, Electric — —Electric vibrations produced in open-circuited conductors by electric resonance, of higher rates than the fundamental vibrations.

The existence of electrical overtones necessitates the existence of electric nodes. (See *Nodes, Electrical.*)

Overtime Dynamo.—(See *Dynamo, Overtime.*)

Ozite.—An insulating substance.

Ozokerite.—An insulating substance.

THIS PAGE IS LOCKED TO FREE MEMBERS

Purchase full membership to immediately unlock this page



HISTORY

Tens of thousands of important historical sources, many previously unobtainable, are now available for the first time with a Forgotten Books Full Membership.

Unlimited Access
\$8.99/month

Continue

*Fair usage policy applies

Care must be taken in paraffining wooden or other absorbent articles, to dry them before immersing in the melted paraffine, since, if water be present, steam is formed explosively, and the melted paraffine scattered in all directions.

Paragrêles.—Lightning rods, intended to protect fields against the destructive action of hail. (See *Hail, Assumed Electrical Origin of.*)

It was formerly believed that hail is caused by electricity. It is now generally believed that the electricity in hail storms is caused by the hail. It will, therefore, readily be understood that paragrêles can afford no real protection.

Parallax.—The apparent angular displacement of an object when seen from two different points of view.

In reading the exact division on a scale to which a needle points, care must be taken to look directly down on the needle, and not sideways, so as to avoid the error of displacement due to *parallax*.

Parallel Circuit.—(See *Circuit, Parallel.*)

Parallel Series.—(See *Series, Parallel.*)

Parallelogram of Forces.—(See *Forces, Parallelogram of.*)

Parallels, Magnetic — — Lines connecting places on the earth's surface at right angles to the isogonal lines, or lines of equal declination or variation.

The magnetic parallels are at right angles to the magnetic meridians. The magnetic parallels lie in planes parallel to the magnetic equator. (See *Needle, Magnetic, Declination of. Meridian, Magnetic.*)

Paramagnetic.—Possessing properties ordinarily recognized as magnetic.

Possessing the power of concentrating the lines of magnetic force.

Paramagnetic is a term employed in contradistinction to *diamagnetic*. (See *Diamagnetic.*) A paramagnetic substance, cut in the form of a bar whose length is much greater than its breadth and thickness, will, when suspended in a magnetic field in the manner shown in Fig. 415, take up a position of rest with its *greatest length* in the *direction of the lines of force, i. e.*, will point *axially*.

In other words, the lines of force will so pass through the paramagnetic substance as to reduce the *magnetic resistance* of the circuit as much as possible.

Paramagnetic substances, therefore, concentrate the lines of force on them. (See *Resistance, Magnetic.*)

Diamagnetic substances, on the contrary, when placed as shown in Fig. 415, assume a position of rest with their *least dimensions in the direction of the lines of force, i. e.*

they point *equatorially*.

This is the position in which they are placed by the lines of force, in order to insure the *least magnetic resistance* in the circuit of these lines.

The magnetic resistance of diamagnetic substances is great as compared with that of paramagnetic substances.

The term *ferro-magnetic* has been proposed for *paramagnetic*. If

another term be required, which is doubtful, *sidero-magnetic*, proposed by S. P. Thompson, would appear to be preferable. (See *Magnetic, Ferro. Magnetic, Sidero.*)

Tyndall believes that the magnetic polarity possessed by diamagnetic substances is the result of a distinct polar force, different in its nature from ordinary magnetism. His views, in this respect, are not generally accepted. (See *Polarity, Diamagnetic.*)

Paramagnetically.—In a paramagnetic manner. (See *Paramagnetism.*)

Paramagnetism.—The magnetism of a paramagnetic substance.

Parasitical Currents.—(See *Currents, Parasitical.*)

Paratonnère.—A French term for lightning rod, sometimes employed in English technical works.

Lightning rod would appear to be the preferable term.

Partial Contact.—(See *Contact, Partial.*)

Partial Disconnection.—(See *Disconnection, Partial.*)

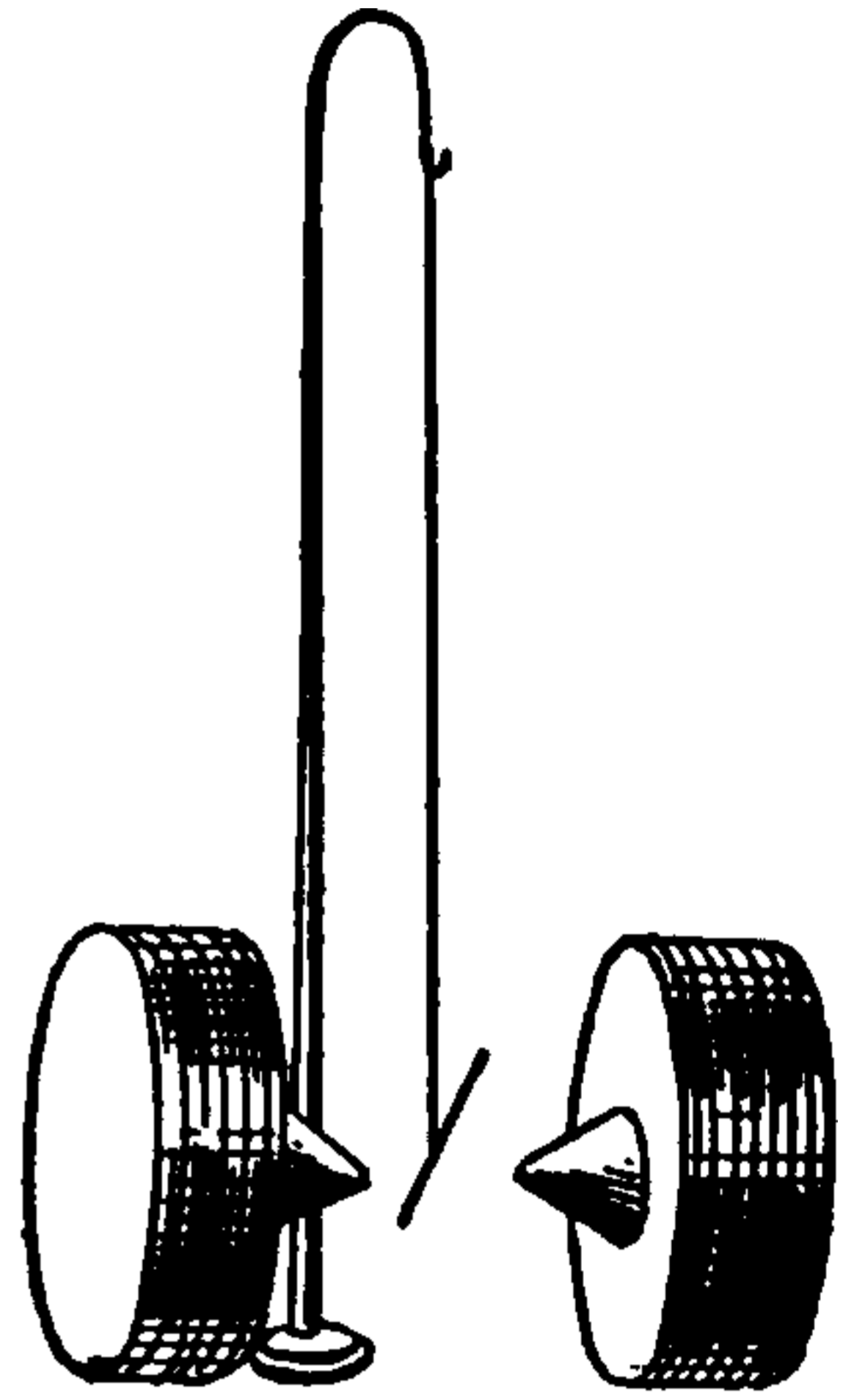

Fig. 415. Diamagnetic Polarity

Partial Earth.—(See *Earth, Partial*.)

Partial Reaction of Degeneration.—(See *Degeneration, Partial Reaction of*.)

Passive State.—(See *State, Passive*.)

Path, Alternative — —The path or circuit taken by an impulsive discharge, in preference to another path or circuit, open to the discharge, although of enormously smaller ohmic resistance.

The alternative path is the path taken by the discharge produced by what was formerly called lateral induction.

The explanation of the reason the discharge takes the alternative path is that the counter-electromotive force of self-induction of the circuit, produced by the impulsive discharge, is so great as to make the path of the circuit itself, although formed of conducting materials, practically non-conducting.

If a Leyden jar is provided with discharge wires or conductors, as shown in Fig. 416, a discharge

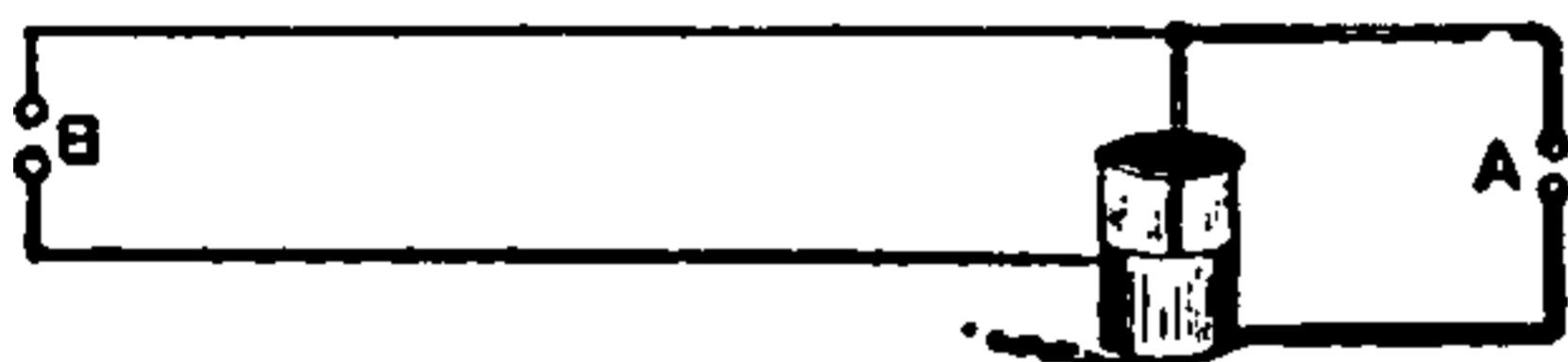

Fig. 416. *Phenomena of Alternative Path.*

taking place at A, is accompanied simultaneously by an even longer spark at B, between the ends of two long open-circuit leads.

To explain in a general manner the phenomena of the alternative path, we may say that the discharge at A, gives rise to electric oscillations in the leads connected with B, and that there are sent out into the surrounding medium radiations of precisely the same nature as those which produce light, only of a wave length so long as to be unable to produce on the eye the effects of light.

If the space between the balls at B, is too great for the discharge to take place, the wires glow and throw out minute sparks or brushes of light.

The action of the ordinary lightning arrester depends on the principle of the alternative path. The resistance of the metallic circuit, composed of the line and the instruments, is so great in the case of the impulsive discharge of a lightning flash, that the discharge takes place between a series of points connected with the line plate and another series of points connected with the ground plate. (See *Arrester, Lightning*)

Dr. Lodge, who has studied the principle of alternative path in the case of lightning rods, finds that the distance at which the discharge

would pass across an air space in preference to a metallic circuit, was greater for a thick copper

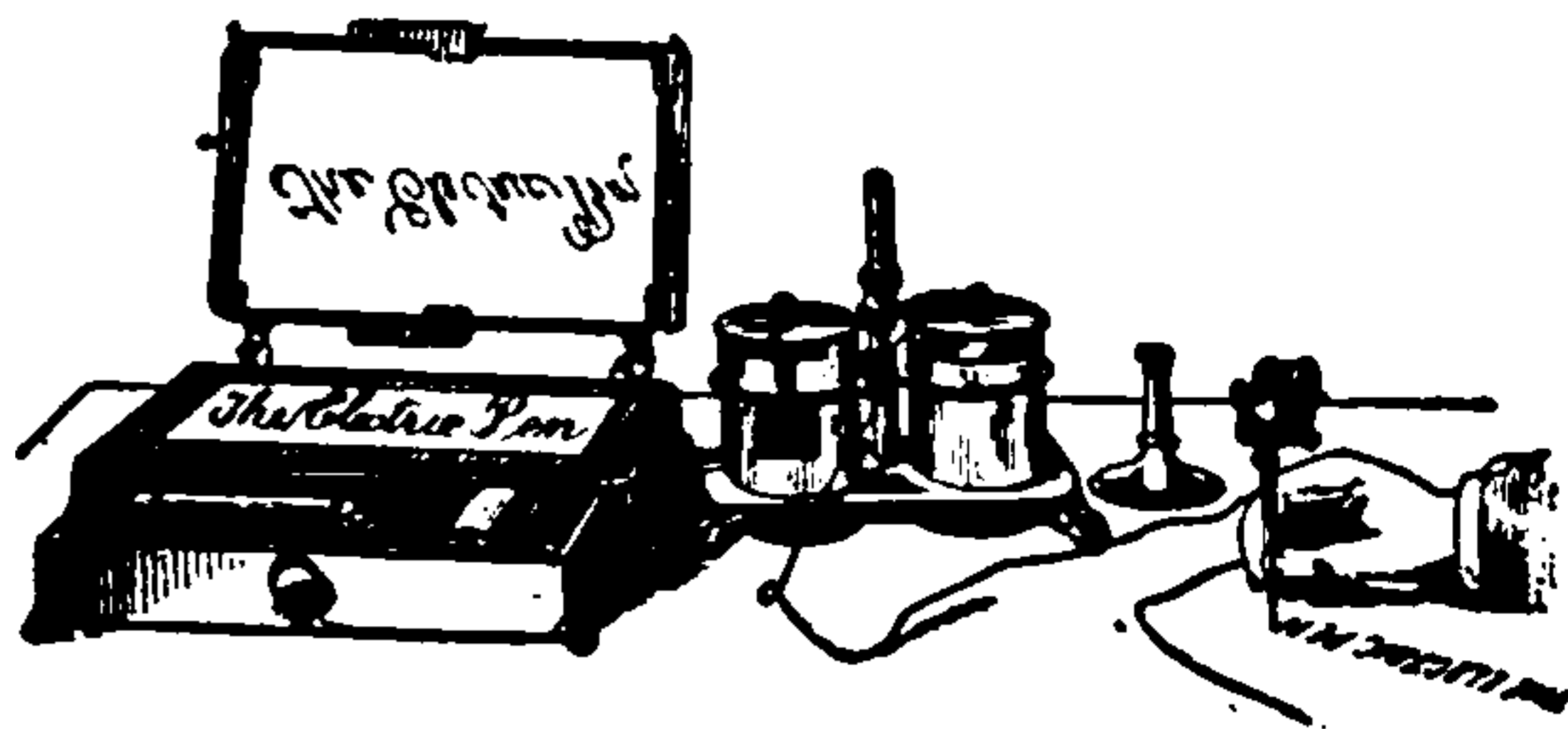

Fig. 417. *Edison Electric Pen.*

rod, 40 feet long, than for an iron rod of No. 27 B. W. G. of 33.03 ohmic resistance.

Patrol Alarm Box.
—(See *Box, Patrol Alarm*.)

Peltier Effect. —
(See *Effect, Peltier*.)

Pen Carriage. —
(See *Carriage, Pen*.)

Pen, Electric —
—A device for manifold copying, in which a sheet of paper is made into a stencil by minute perforations obtained by a needle driven by a small electric motor and the stencil afterwards employed in connection with an inked roller for the production of any required number of copies.

Mechanical pens are constructed on the same principle, the perforations being obtained by mechanical instead of by electric power.

In the Edison electric pen, Fig. 417, the perforations are made by an electric motor driven by a voltaic battery. The manifold press with its inked pad is shown to the left of the figure.

Pendant Cord.—(See *Cord, Pendant*.)

Pendant, Electric — —A hanging fix-

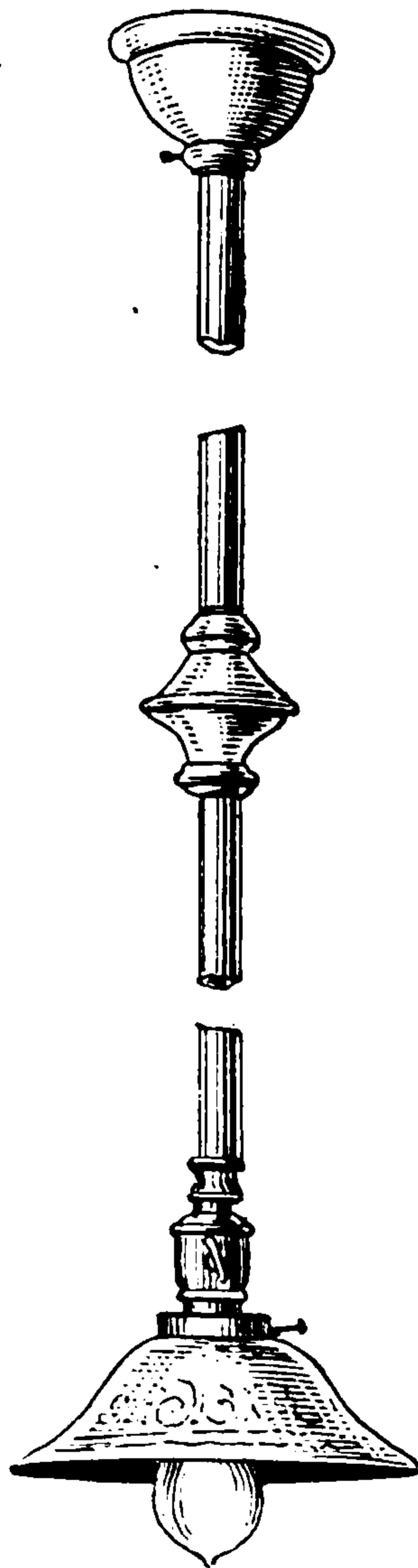

Fig. 418. *Electric Pendant.*

ture provided with a socket for the support of an incandescent lamp.

A form of electric pendant is shown in Fig. 418.

Pendant, Flexible Electric Light — —A pendant for an incandescent lamp formed by the flexible conductors which support the lamp.

The advantages procured by a flexible pendant are evident in that both the length of the flexible conductor from which the lamp is hanging and position of the lamp can be changed considerably.

Pendulum Annunciator.—(See *Annunciator, Pendulum or Swinging.*)

Pendulum, Electric — —A pendulum so arranged that its to-and-fro motions send electric impulses over a line, either by making or breaking contacts.

An electrical tuning fork whose to-and-fro movements are maintained by electric impulses.

Electric pendulums are employed in systems for the electrical distribution of time.

Sometimes instead of using true pendulums for such purposes, coils, mounted on tuning forks, or on the ends of flexible bars of steel, called reeds, are used for the purpose of establishing currents, or modifying the currents that are already passing in a circuit. The movement of a magnetic diaphragm, as in the case of a telephone diaphragm, towards and from a coil of wire, is another illustration of an electric pendulum.

Electric tuning-fork pendulums are employed in Delany's system of synchronous-multiplex telegraphy, and in Gray's harmonic-multiple telegraphy. (See *Telegraphy, Synchronous-Multiplex, Delany's System. Telegraphy, Gray's Harmonic-Multiple.*)

Pendulum, Laws of — —The laws which express the peculiarities of the motion of a simple pendulum.

A simple pendulum is one in which the entire weight is considered as concentrated at a single point, suspended at the end of a weightless, inflexible and inextensible line.

The following are the laws of the simple pendulum :

(1.) Oscillations of small *amplitude* are approximately *isochronous*; that is, are made in times that are sensibly equal. (See *Vibration or Wave, Amplitude of. Isochronism.*)

(2.) In pendulums of different lengths, the duration of the oscillations is proportional to the square root of the length of the pendulum.

(3.) In the same pendulum, the length being preserved invariable, the duration of the oscillation is inversely proportional to the square root of the intensity of gravity.

The *intensity of gravity*, at any latitude, may be determined by the number of oscillations of a pendulum of a given length. In the same manner the *intensity of a magnetic field*, or the *intensity of magnetization* of a magnet, may be determined by the *needle of oscillation*, by observing the number of oscillations a needle makes in a given time when disturbed from its position of rest. (See *Needle of Oscillation.*)

Since a simple physical pendulum is a physical impossibility, the *virtual length* of a pendulum, that is, the vertical distance between its point of support and the *centre of oscillation*, is taken as the true length of the pendulum.

If the irregularly shaped body, shown in Fig. 419, whose centre of gravity is at G, is made to swing like a pendulum, either on S, or O, its oscillations will be performed in equal times, and the body will act as a simple pendulum, whose virtual length is S O.

If, while suspended at S, it be struck at O, it will oscillate around S, without producing any pressure on the supporting axis at S, on which it turns. If floating entirely submerged in a liquid, a blow at O, would cause it to move in a straight line in the direction of the blow, without rotation.

The point O, is called the *centre of percussion*, or the *centre of oscillation*. The centre of oscillation is always below the *centre of gravity*.

Pentane Standard.—(See *Standard, Pentane.*)

Percussion, Centre of — —That point in a body suspended so as to move as a pendulum at which a blow would produce rotation, but no forward motion, or motion of translation.

Perforator, Paper — —An apparatus employed in systems of automatic telegraphy for punching in a fillet of paper the circular or elongated spaces that produce the dots and

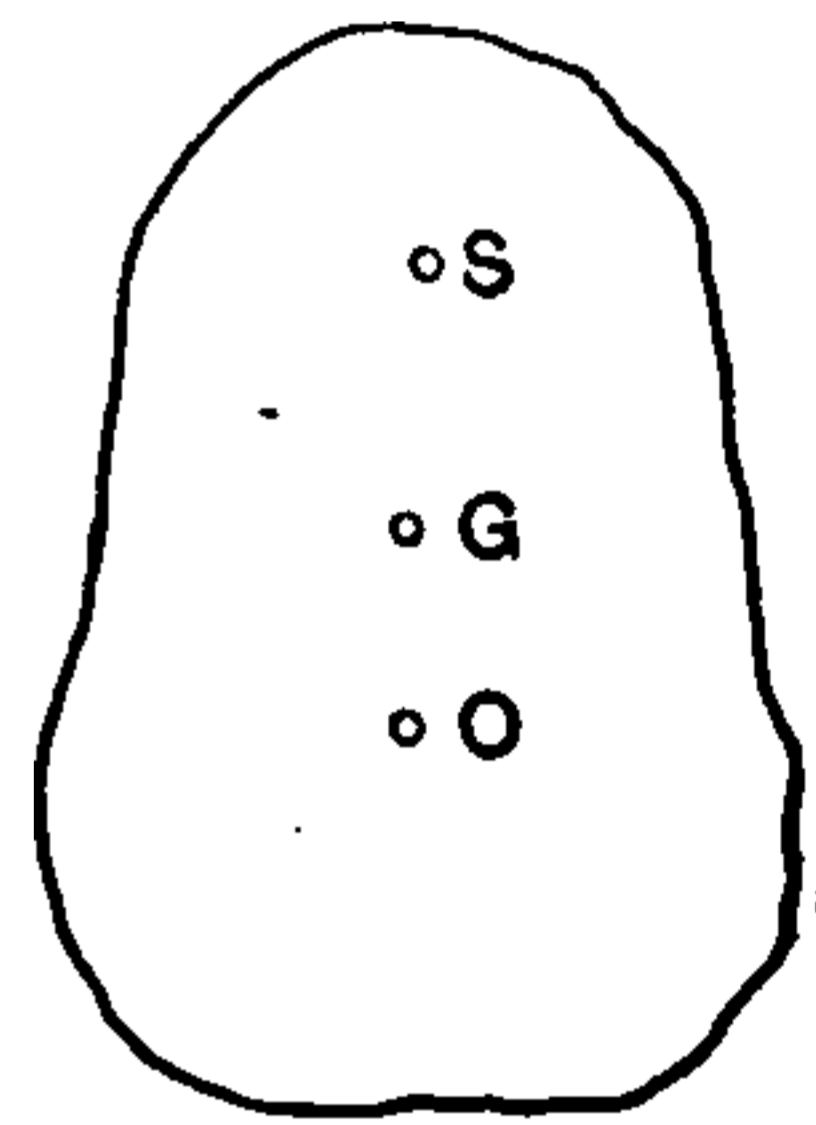

Fig 419. Centre of Oscillation.

THIS PAGE IS LOCKED TO FREE MEMBERS

Purchase full membership to immediately unlock this page

Know Your Bible

Forgotten Books' Full Membership provides unlimited access to more than 28,000 volumes of Christian literature for \$8.99/month

HOLY BIBLE

Continue

*Fair use policy applies

tion produced, or the intensity of magnetic induction, and H , the magnetizing force; then,

$$\mu = \frac{B}{H}$$

The permeability of non-magnetic materials, such as insulators, or non-magnetic metals, such as copper, etc., is assumed to be practically equal to that of air, or to unity.

The magnetic permeability decreases as the magnetization increases. When a piece of iron has been magnetized up to a certain intensity, its permeability becomes less for any further magnetization; or, the substance shows a tendency to reach magnetic saturation. In good iron, this limit is reached at about 125,000 lines of force to the square inch of area of cross section.

The magnetic permeability varies greatly, not only with different specimens of iron, but also with the previous history of the iron, as to whether or not it has before been subjected to magnetization or demagnetization, and also as to whether the value of the permeability is taken while the magnetization is increasing or decreasing.

Permeameter.—An apparatus devised by S. P. Thompson, for roughly measuring the magnetic permeability.

Thompson's permeameter consists essentially of a rectangular piece of soft iron, provided with a slot, for the reception of the magnetizing coil. A hole bored in one end of the block serves to receive the bar or rod of iron whose permeability is to be determined. On the magnetization of the bar to be tested, the square root of the force required to detach the rod from the lower surface of the iron block, is a measure of the permeation of the lines of magnetic forces through its end faces.

Permeance, Magnetic — —Magnetic permeability. (See *Permeability, Magnetic*.)

Permeating, as of Lines of Force.—The passing of lines of force through a magnetic substance. (See *Permeability, Magnetic*.)

Permeation, Magnetic — —The passage of lines of magnetic force through any permeable substance.

Permissive Block System for Railroads.—(See *Railroads, Permissive Block System for*.)

Pflüger's Law.—(See *Law, Pflüger's*.)

Phantom Wires.—(See *Wires, Phantom*.)

Phase, Angle of Difference of, between Alternating Currents of Same Period — — The angle which measures the shifting of phase of a simple periodic current with respect to another due to lag or other cause.

Phase, Shifting of, of Alternating Current — —A change in phase of current due to magnetic lag or other causes.

Phase of Vibration.—(See *Vibration, Phase of*.)

Phelps' Stock Printer.—(See *Printer, Stock, Phelps'*.)

Phenomena, Electro-Capillary — — Phenomena observed in capillary tubes at the contact surfaces of two liquids.

Where acidulated water is in contact with mercury, each liquid possesses a definite surface tension, and each a definite shape of surface. The two liquids, however, do not actually touch, there being a small interval or space between them. This space acts as a minute accumulator. But the liquid and water, being different substances in contact, possess different potentials. Any cause which alters the shape of these contact surfaces, and consequently the extent of the spaces between them, necessarily alters the capacity of the condenser, and consequently the difference of potential. Therefore the mere shaking of the tube, or heating it, will produce electric currents from the resulting differences of potential. Conversely, an electric current sent across the contact-surfaces will produce motion as a result of a change in the value of the surface tension. An electro-capillary telephone has been constructed on the former principle, and an electrometer on the latter. (See *Electrometer, Capillary*.)

Phenomena, Porret — —An increase in the diameter of a nerve fibre in the neighborhood of the positive pole when traversed by a voltaic current.

When a voltaic current passes through fresh living substance the contents of the muscular fibre exhibit a streaming movement in the direction the current is flowing, viz., from the positive to the

negative. This causes the fibre to swell up or increase in diameter at the negative electrode.

Pherope.—A name sometimes applied to a telephote. (See *Telephote*.)

Phial, Leyden — —A name sometimes applied to a Leyden jar. (See *Jar, Leyden*.)

Philosopher's Egg.—(See *Egg, Philosopher's*.)

Phonautograph.—An apparatus for the automatic production of a visible tracing of the vibrations produced by any sound.

Phonautographic apparatus consists essentially of devices by which the sound waves are caused to impart their to-and-fro movements to a diaphragm, at the centre of which a pencil or tracing point is attached. The record is received on a sheet of paper, or wax, or on a smoked glass or other suitable surface.

Leon Scott's Phonautograph, which is among the forms best known, consists of a hollow conical

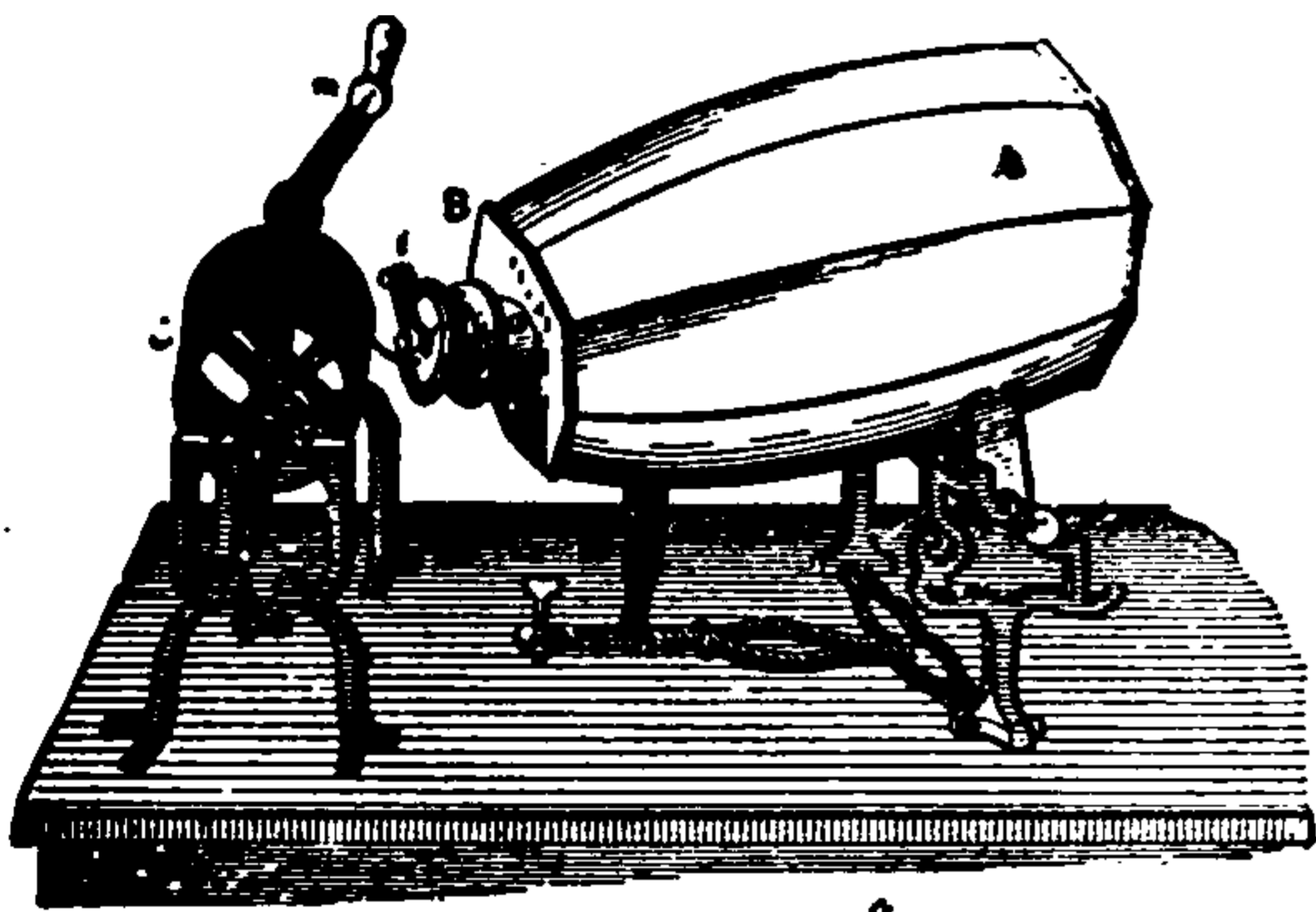

Fig 421. Scott's Phonautograph.

vessel A, Fig. 421, with a diaphragm of parchment stretched tightly like a drumhead over its smaller aperture B. A tracing point attached to the centre of the diaphragm, traces a sinuous line on the surface of a soot-covered cylinder C, that is uniformly rotated under the tracing point. As the cylinder is advanced a short distance with every rotation, a sinuous spiral line is traced on the surface.

Phone.—A term frequently used for telephone.

Phonic Wheel.—(See *Wheel, Phonic*.)

Phonogram.—A record produced by the phonograph. (See *Phonograph*.)

Phonograph.—An apparatus for the reproduction of articulate speech, or of sounds

of any character, at any indefinite time after their occurrence, and for any number of times.

In Edison's phonograph the voice of the speaker, received by an elastic diaphragm of thin sheet iron or other similar material, is caused to indent a sheet of tin-foil placed on the surface of a cylinder C, Fig. 422, that is maintained at a uniform rate of rotation by the crank at W. In

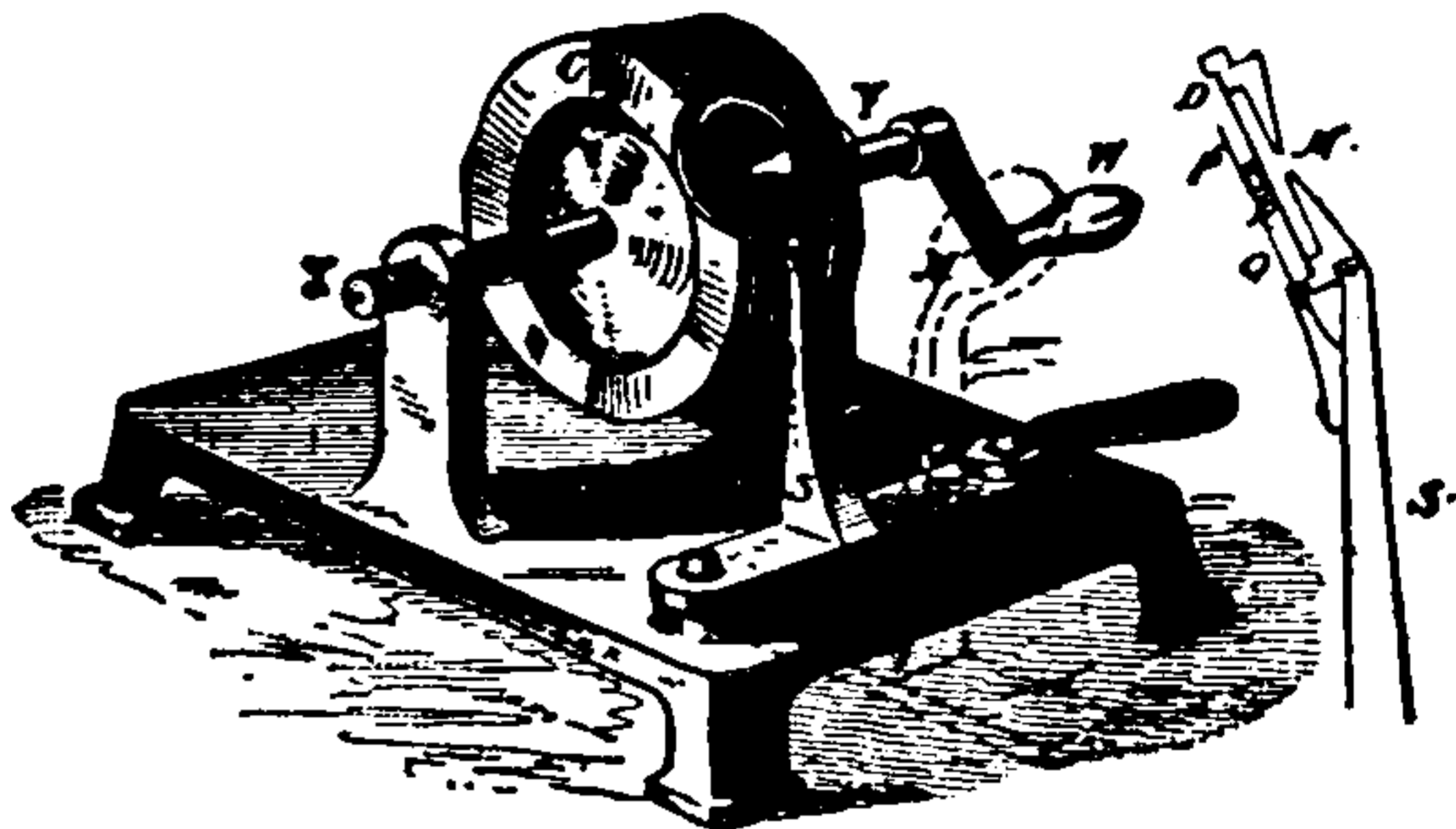

Fig. 422.

the form shown in Fig. 422, the motion is by hand. In a later improved form the cylinder is driven by means of an electric motor or by clockwork.

In order to reproduce the speech or other sounds the *phonogram record* is placed on the surface of a cylinder similar to that on which it was received (or is kept on the same surface), and the tracing point, placed at the beginning of the record and being maintained against it by gentle pressure, is caused, by the rotation of cylinder, to follow the indentations of the phonogram record. As the point is thus moved up and down the hills and hollows of the record surface,

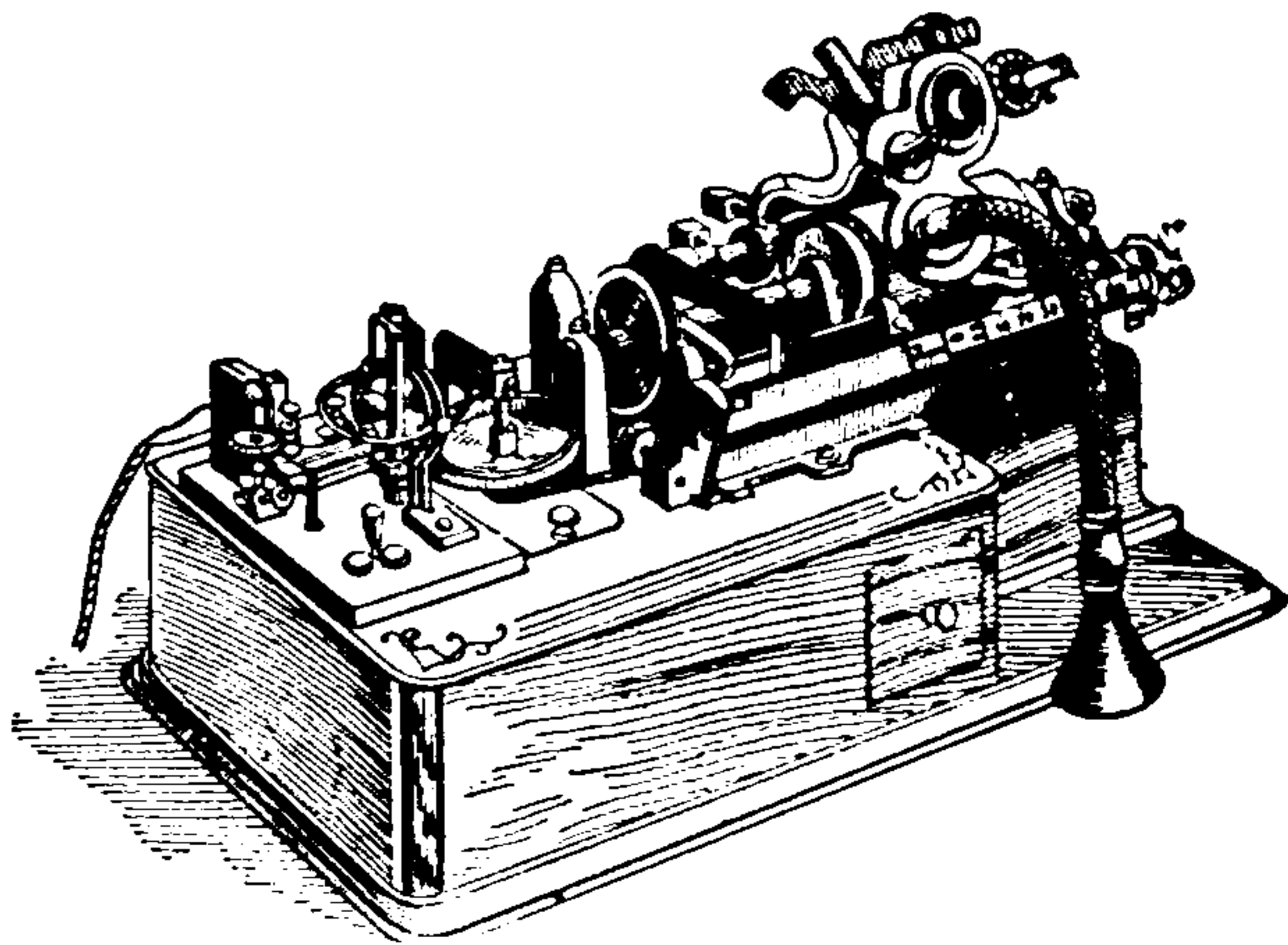

Fig. 423. Edison's Improved Phonograph.

the diaphragm, to which it is attached, is given to-and-fro motions that exactly correspond to the to-and-fro motions it had when impressed originally by the sounds it recorded on the phonogram record. A person listening at this dia-

phragm will therefore hear an exact reproduction of the sounds originally uttered.

In this manner the voices of relatives, distinguished singers or statesmen can be preserved for future generations.

In Edison's improved phonograph the record surface consists of a cylinder of hardened wax. The rotary motion of the cylinder is obtained by means of an electric motor. Two diaphragms are used, one for recording, and one for reproducing the sound waves. As shown in Fig. 423, the recording diaphragm is in position against the cylinder. The recording diaphragm is made of malleable glass. The reproducing diaphragm is formed of bolting silk covered with a thin layer of shellac.

In the *Graphophone* of Bell and Tainter the point attached to the diaphragm is caused to cut

or grease, receives the record in a sinuous, spiral line. This record is subsequently etched into the metal by any suitable means, or is photographically reproduced on another sheet of metal.

Glass covered with a deposit of soot is sometimes employed for the latter process. The apparatus is shown in Fig. 425, as arranged for the reproduction of speech.

In Mr. Berliner's apparatus, the record surface is impressed by a point attached to the transmitting diaphragm, *in a direction parallel to the record surface*, and not, as in the instrument of Mr. Edison, in a direction at right angles to the same. This method would appear to be the best calculated for a more exact reproduction of articulate speech, since it permits comparatively loud speaking or singing, without interfering

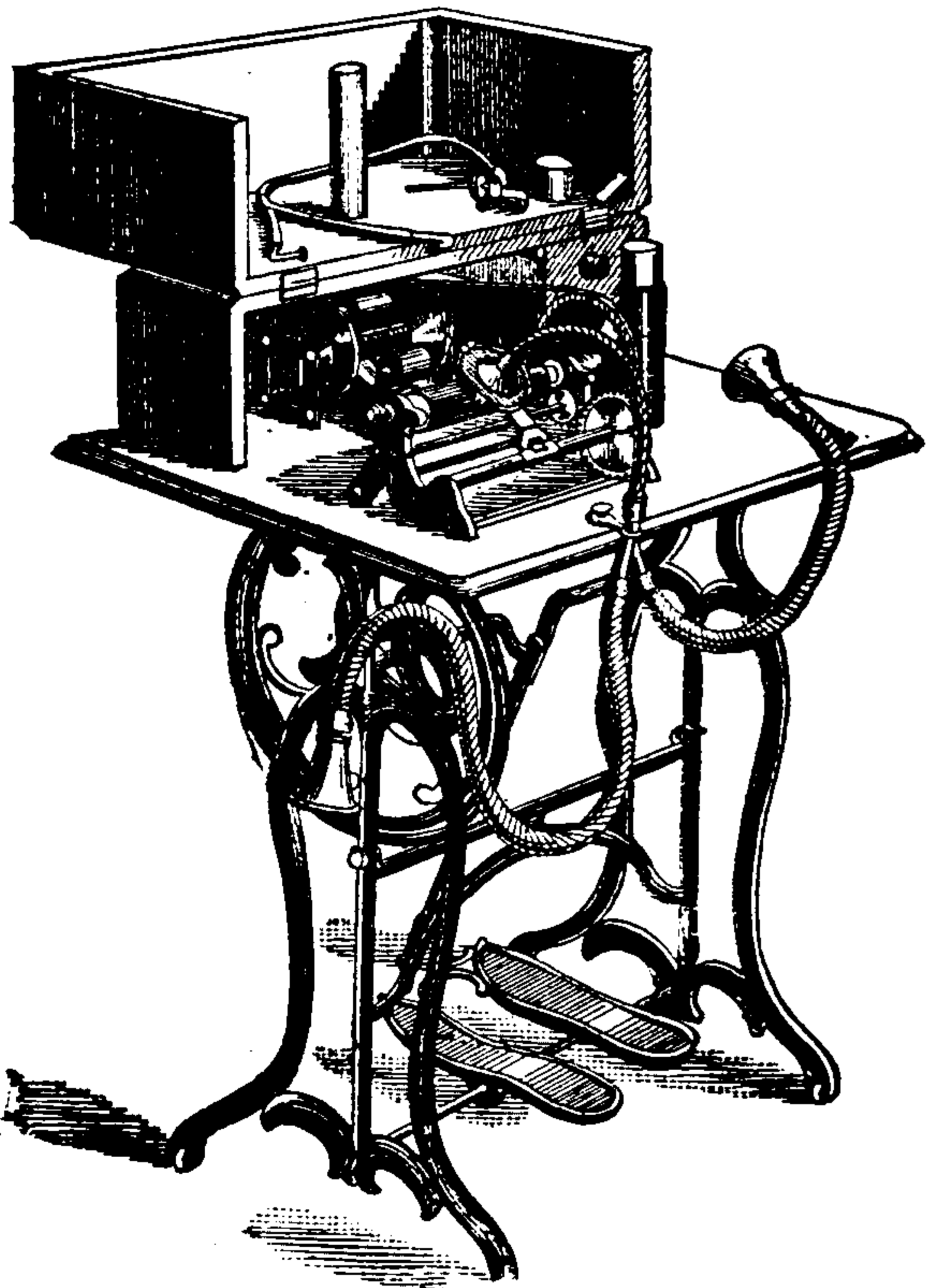

Fig. 424. Bell and Tainter's Graphophone.

or engrave a cylinder of hardened wax. Two separate diaphragms are employed, one for speaking, and the other for hearing.

The recording surface is made of a mixture of beeswax and paraffine. A uniformity of rotation of the cylinder is obtained by means of a motor provided with a suitable governor. An ordinary conversation of some five minutes, it is claimed, can be recorded on the surface of a cylinder 6 inches long and $1\frac{1}{4}$ inch in diameter.

In the *Gramophone* of Berliner, a circular plate of metal, covered with a film of finely divided oil

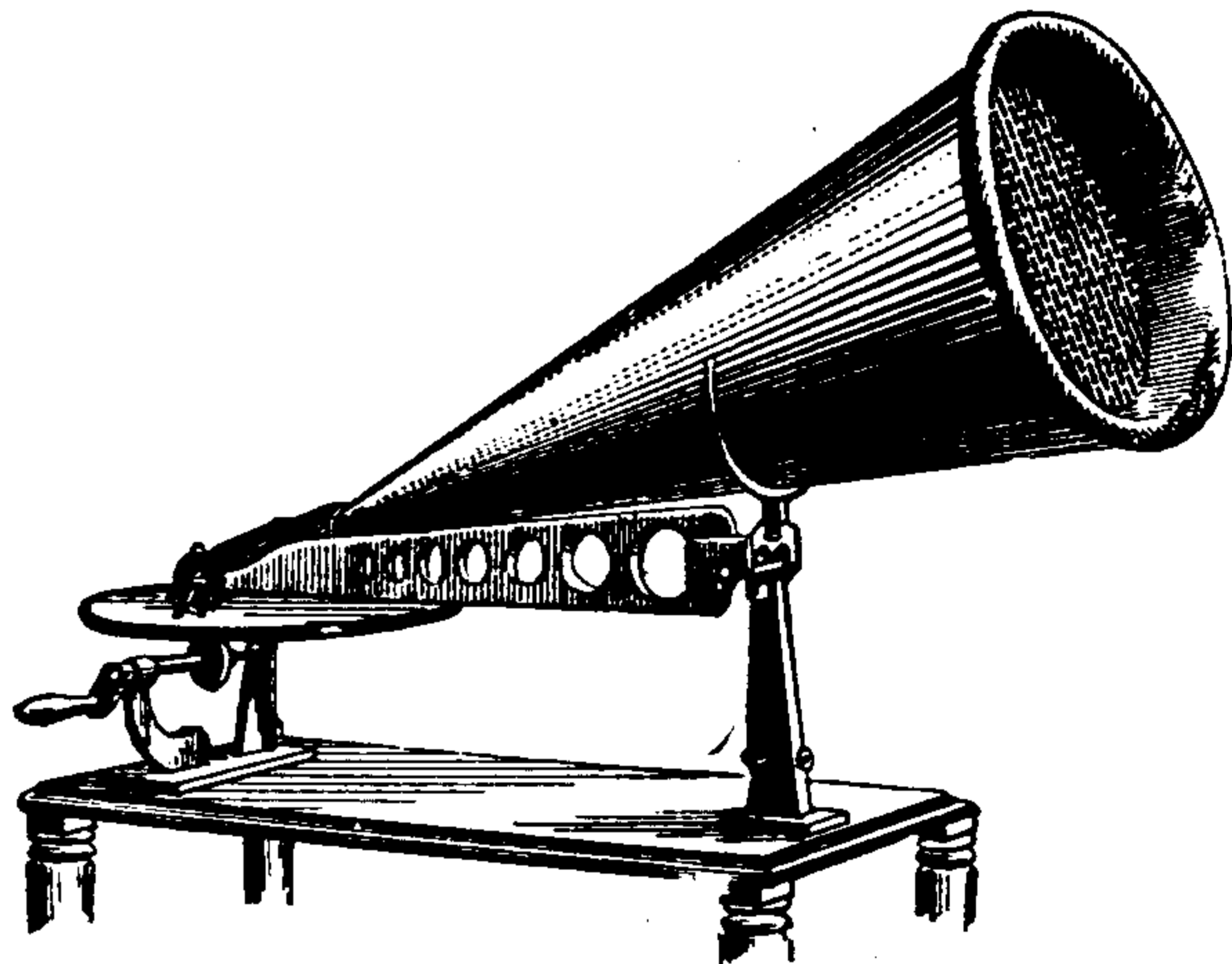

Fig. 425. Berliner's Gramophone.

with the quality of the reproduced sounds. Since the resistance to indentation, or vertical cutting, increases more rapidly than the increase in the *amplitude of vibration* of the cutting point, it follows that the louder the sounds recorded by the phonograph or graphophone, the less complete would be the quality of the reproduced sounds, or the less the probability of the peculiarities of the speaker's voice being recognized. In order to avoid this, the speaker in the phonograph and the graphophone speaks in an ordinary conversational tone only. (See *Vibration or Wave, Amplitude of*)

For purposes of dictation, and, indeed, most commercial purposes, this is rather an advantage than otherwise.

Phonograph Record. — (See *Record, Phonograph.*)

Phonoplex.—Literally sound folds.

A system of telegraphy. (See *Telegraphy, Phonoplex.*)

THIS PAGE IS LOCKED TO FREE MEMBERS

Purchase full membership to immediately unlock this page



HISTORY

Tens of thousands of important historical sources, many previously unobtainable, are now available for the first time with a Forgotten Books Full Membership.

Unlimited Access
\$8.99/month

Continue

*Fair usage policy applies

of a specific chemical substance by the oxygen of the air.

Chemical phosphorescence is seen in the fire-fly and the glow-worm. (See *Phosphorescence*.)

Phosphorescence, Electric — — Phosphorescence caused in a substance by the passage of an electric discharge.

The phosphorescent material is placed in an exhausted glass tube, as shown in Fig. 426, and submitted to the action of a series of discharges, as from a Ruhmkorff coil, or Holtz machine. The violet-blue light of such discharge is very efficient in producing phosphorescence. Phosphorescence is thus effected by subjecting the phosphorescent material to the molecular bombardment which is produced by such discharges in a high vacuum. (See *Bombardment, Molecular*.)

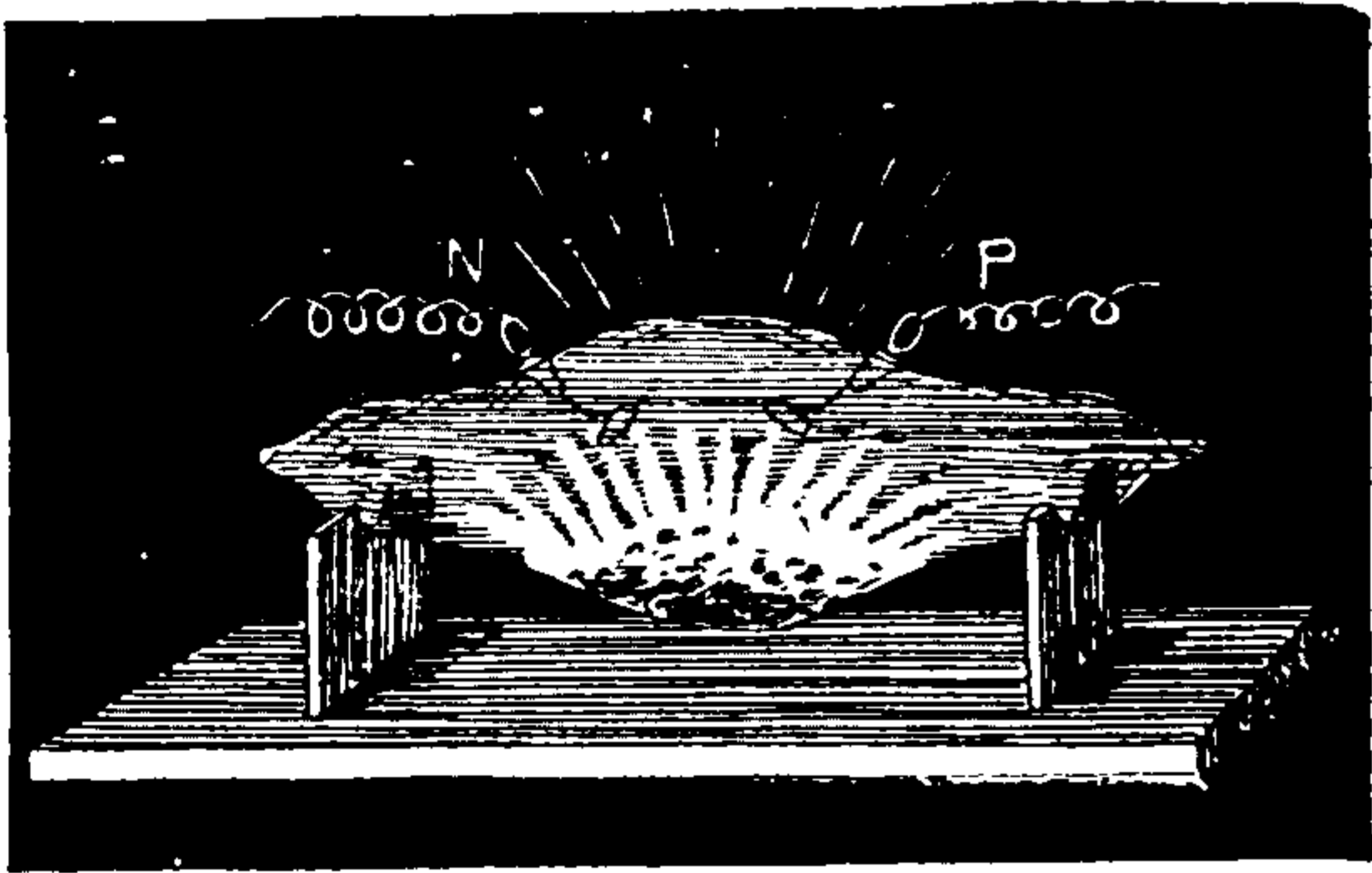

Fig. 426. *Electric Phosphorescence*.

Phosphorescence, Physical — — Phosphorescence produced in matter by the actual impact of light waves resulting in a vibratory motion of the molecules of sufficient rapidity to cause them to emit light.

Physical phosphorescence is distinguished from chemical phosphorescence in that in the former the energy required to produce molecular vibrations is imparted by the light to which the phosphorescent body is exposed, while in chemical phosphorescence the energy producing the light is derived from the chemical potential energy of the specific substance burned. (See *Phosphorescence*.)

Phosphorescent.—Possessing the properties or qualities of phosphorescence.

Phosphorescing.—Emitting phosphorescent light. (See *Phosphorescence*.)

Phosphorescope.—An apparatus for measuring the phosphorescent power of any substance. (See *Phosphorescence*.)

Phosphorus, Electric Smelting of — — An electric process for the direct production of phosphorus.

In the electric smelting of phosphorus, the crude material, consisting of a mixture of bones or animal phosphates and carbon, is fed into a space between two electrodes connected to the poles of a source of powerful alternating currents. The apparatus is similar in general to the Cowles furnace for the reduction of aluminium. The heat produced by the alternating currents decomposes the phosphates, and the volatilized phosphorus is condensed in suitable chambers.

Photochronograph.—An electric instrument for automatically recording the transit of a star across the meridian.

In a small camera connected with the eye-piece of the transit instrument is placed a sensitized plate.

A sidereal clock has an electric attachment to its pendulum, so made that a shutter alternately exposes and conceals the photographic plate, and thus permits the image of a star to be formed on the plate at intervals during its passage across the field of the telescope. An image of the spider lines is afterwards fixed on the plate by the light of a lamp, held for a few moments before the object glass of a telescope. A shutter is provided, by means of which this light is prevented from falling on the trail of the star across the field of the glass. In this manner the time of passage of the star across the meridian is automatically recorded on the photographic plate.

The photochronograph is also adapted for similarly automatically recording the transit or passage of any heavenly body across any imaginary line in the heavens.

Photo-Electric Cell.—(See *Cell, Photo-Electric*.)

Photo-Electricity.—(See *Electricity, Photo*.)

Photo-Electromotive Force.—(See *Force, Electromotive, Photo*.)

Photometer.—An apparatus for measuring the intensity of the light emitted by any luminous source.

There are various methods for measuring the intensity of a beam of light passing through any given space, or emitted from any luminous

source; these methods are embraced in the use of the following apparatus:

(1.) *Calorimetric Photometer*, in which the light to be measured is absorbed by the face of a thermo-electric pile, and the electric current thereby produced is carefully measured. Since *obscure radiation* or heat will also thus produce an electric current, it is necessary first to absorb all the heat by passing the beam of light through an alum cell.

(2.) *Actinic, or Chemical Photometers*, in which the intensity of the light is estimated by a comparison of the depth of coloration produced on a fillet of photographic paper under similar conditions of exposure to a standard light, and the light to be measured.

The combination of pure hydrogen and chlorine, or the decomposition of pure mercurous chloride, have been employed for the purpose of determining the intensities of two lights by measuring the amount of chemical action effected.

(3.) *Shadow Photometers*, in which a shadow produced by the light to be measured is compared with a shadow produced by a *standard candle*. (See *Candle, Standard*.)

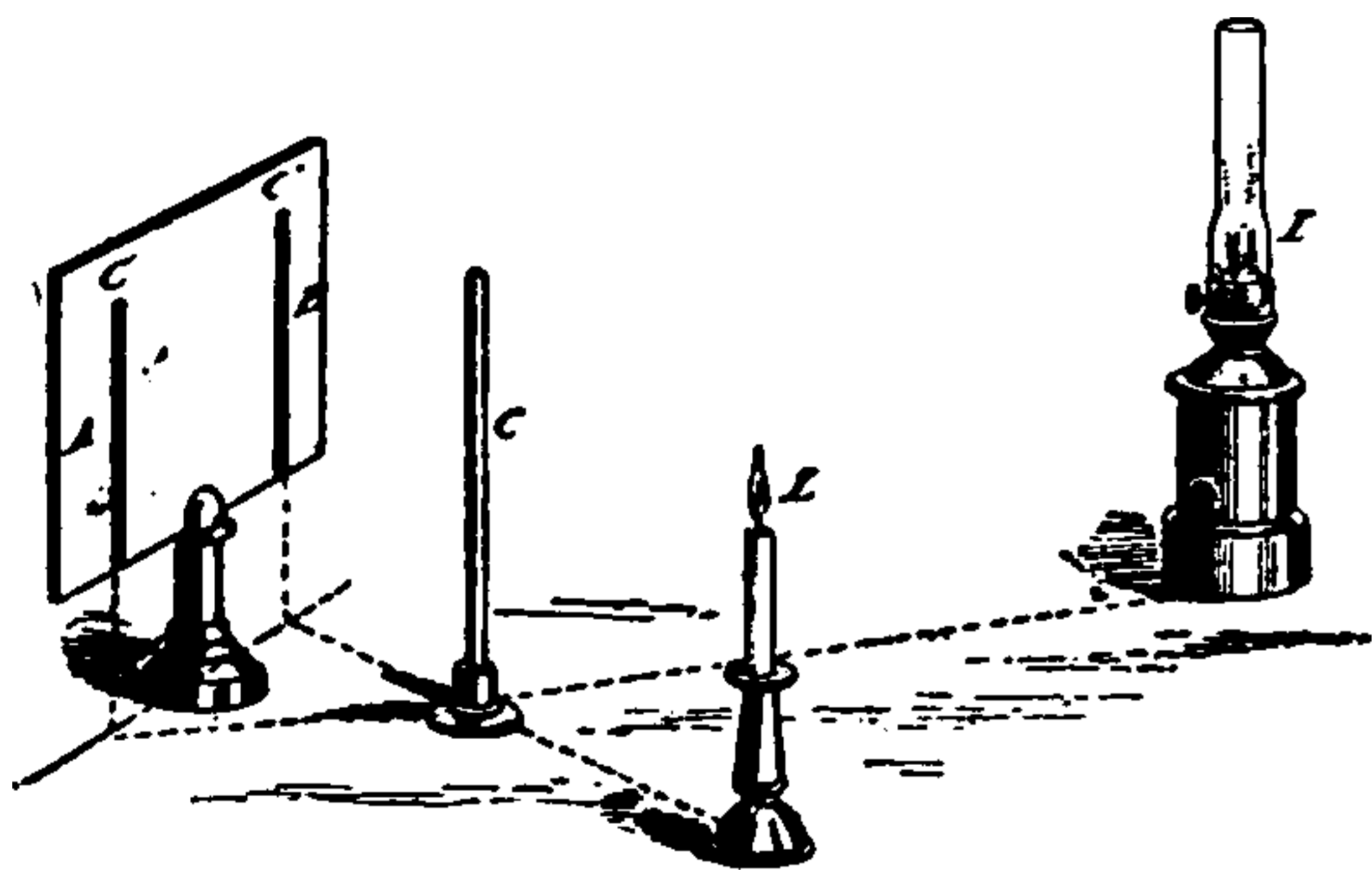

Fig. 427. *The Shadow Photometer.*

Rumford's photometer, shown in Fig. 427, is an example of this form of instrument. The standard candle, shown at L, casts a shadow C", of an opaque rod C, on the screen at B.

The light to be measured L', is moved away from the screen until its shadow C', on the screen at A, is judged by the eye to be of the same depth. The distance between the screen and the lights is then measured in straight lines. *The relative intensities of the two lights are then proportional to the squares of their distances.* If, for example, the candle be at 10 inches from the screen, and the lamp at 40 inches, then the intensities are as $10^2 : 40^2$ or as 100 : 1,600, or the lamp is a 16 candle-power lamp.

This photometer is based on the fact that the shadow of each source is illumined by the light of the other source.

These results are more accurate if the two shadows are adjoining or nearly adjoining.

(4.) *Translucent-Disc Photometers*.—The light to be measured and a standard candle are placed on opposite sides of a sheet of paper the centre of which contains a grease spot. The standard candle is kept at a fixed distance from the paper and both it and the paper are moved towards or from the light to be measured until both sides of the paper are adjudged to be equally illumined.

In Bunsen's photometer a vertical sheet of paper with a grease spot at its centre, is exposed to the illumination of a standard candle on one side, and the light to be measured on the other.

The sheet of paper is placed inside a dark box provided with two plane mirrors placed at such an angle to the paper that an observer can readily see both sides of the paper at the same time.

This box can be slid along a graduated, horizontal scale towards, or from, the light to be measured, and carries with it the standard candle mounted on it at a constant distance of 10 inches. If the box is too near the light to be measured, the grease spot appears brighter on the side of the sheet of paper nearest the candle. If too near the candle, it appears brighter on the side of the sheet of paper nearest the light to be measured. The position in which the spot appears equally bright on both sides, is the position in which both sides of the paper are equally illumined, and the relative intensities of the two lights are then directly as the squares of their distances from the sheet of paper.

Shadow, and translucent-disc photometers being dependent on equal illumination, are reliable only when the color of the lights compared is the same. For the determination of the photometric intensity of very bright lights, the standard candle is replaced by a carcel lamp, a standard gas jet, or by the light emitted by a given mass of platinum, heated to incandescence by a given current of electricity. (See *Lamp, Carcel. Gas-Jet, Carcel Standard. Light, Platinum Standard*.)

Preece's photometer belongs to the class of translucent disc photometers. A tiny incandescent lamp is placed in a box, the top of which has a white paper screen on which is a grease spot. The box is placed in the street where the intensity of illumination is to be measured, and the inten-

sity of the light of the incandescent lamp is varied until the grease spot disappears. The current of electricity then passing through the incandescent lamp acts as the measure of the illumination.

In the case of the shadow photometer, or of Bunsen's photometer, if the intensity of illumination is the same, the relative intensities of the two lights may be determined as follows:

Calling I , and i , respectively the relative intensities of the standard light, and the light to be measured, and D , and d , their respective distances from the screen, then

$$I : i :: D^2 : d^2, \text{ or } I \times d^2 = i \times D^2;$$

$$\text{that is, } i = I \left(\frac{d^2}{D^2} \right).$$

Or, the intensity of the light to be measured is $\left(\frac{d^2}{D^2} \right)$ times the intensity of the standard light.

If, for example, D and d , represent 10 and 100 inches, respectively, the intensity of i , is 100 times the intensity I , the standard light.

(5.) *Dispersion Photometers.*—A class of photometers in which, in order to more readily compare or measure a very bright or intense light, like that of an arc lamp, the intensity of the light is decreased by dispersion a readily measurable amount.

Ayrton & Perry's Dispersion Photometer.—A photometer in which, in order to bring an intensely bright light, like an electric arc light, to

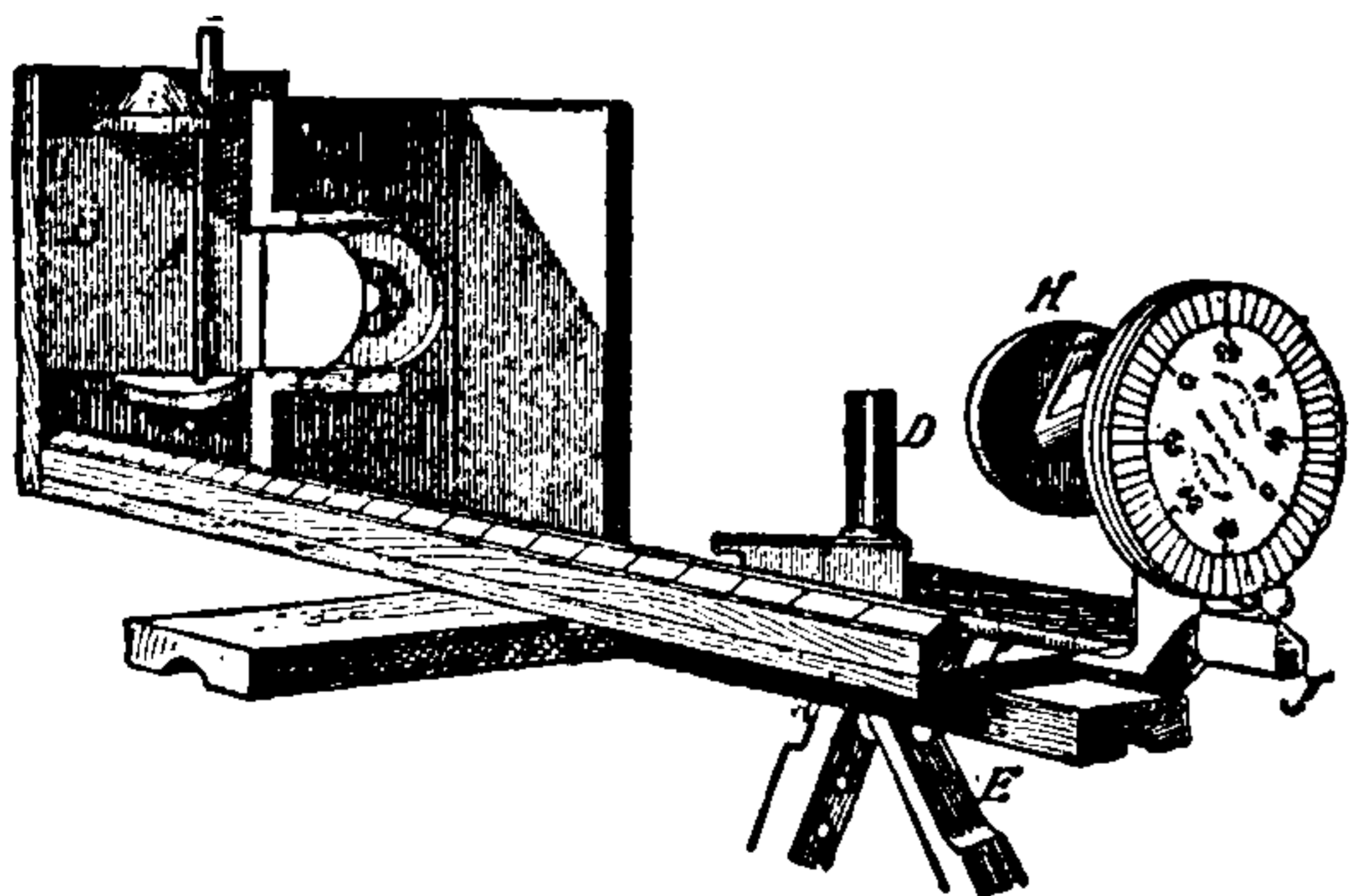

Fig. 428. Ayrton & Perry's Dispersion Photometer.

such an intensity as will permit it to be readily compared with a standard candle, its intensity is weakened by its passage through a diverging (concave) lens.

Ayrton & Perry's dispersion photometer is shown in two different positions, Figs. 428 and 429. The apparatus is supported on a tripod stand E , arranged so as to obtain exact leveling.

A plane mirror H , movable around a pin placed directly under its centre, can be rotated and thus reflect the light after its passage through the diverging lens, while still maintaining its distance from the electric light.

The horizontal axis of this mirror is inclined 45 degrees to its reflecting surface in order to avoid errors arising from varying absorption at different angles of reflection.

The inclination of the beam to the horizontal is indicated by means of an index attached to the mirror and moving over the graduated circle G .

A black rod A , casts its shadow on a screen of white blotting paper B . A standard candle, placed in the holder D , casts its shadow alongside the shadow cast by the electric light. The lens is now displaced until the shadow of the electric light is of the same intensity as that of the candle, when viewed successively through sheets of red and green glass.

A graduated scale serves to mark the distances of the candle and the lens, respectively, from the screen, from which data the intensity of the electric light may be calculated.

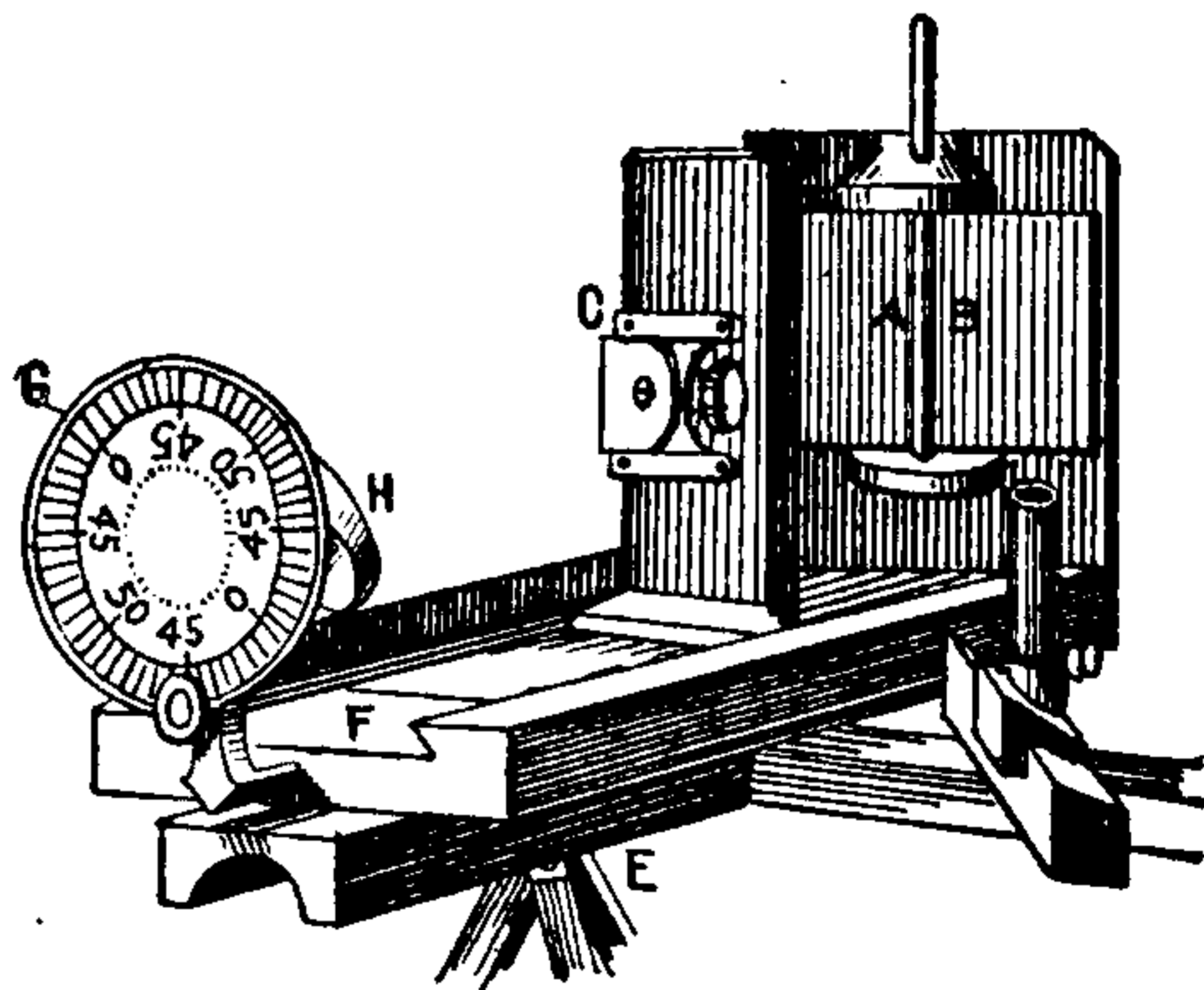

Fig. 429. Ayrton and Perry's Dispersion Photometer.

(6.) *Selenium Photometers.*—Instruments in which the relative intensities of two lights are determined by the variations produced in a selenium resistance.

In Siemens' Selenium photometer a selenium cell is employed in connection with an electric circuit for determining the intensity of light.

The tube $A B$, Fig. 430, is furnished at A , with a diaphragm, and at B , with a selenium plate, connected by wires $G G$, with the circuit of a battery and a galvanometer.

A graduated scale $L M$, bears the standard candle N . The tube $A B$, is capable of rotation on the vertical axis F . A reflecting mirror galvanometer is used in connection with the selenium photometer. The light to be measured is placed

THIS PAGE IS LOCKED TO FREE MEMBERS

Purchase full membership to immediately unlock this page

Know Your Bible

Forgotten Books' Full Membership provides unlimited access to more than 28,000 volumes of Christian literature for \$8.99/month

HOLY BIBLE

Continue

*Fair use policy applies

measured is estimated by a comparison of the distances at which it and a standard light produce a shadow of the same intensity. (See *Photometer*.)

Photometer, Translucent Disc — —A photometer in which the light to be measured is placed on one side of a partly translucent and partly opaque disc, and a standard candle is placed on the opposite side, and the intensity of the light estimated by the distances of the light from the disc when an equal illumination of all parts of the disc is obtained. (See *Photometer*.)

When the illumination of the opposite sides of such a disc is equal, the relative positions of the transparent and opaque portions of the disc are indistinguishable.

Photometer, Varley's — —A form of photometer in which the intensity of the light to be measured is determined from the relative openings of two concentric circular diaphragms placed in two rotating discs, and through which the standard light and the light to be measured respectively pass.

The general arrangement of Varley's photometer is shown in Fig. 431. The concentric cir-

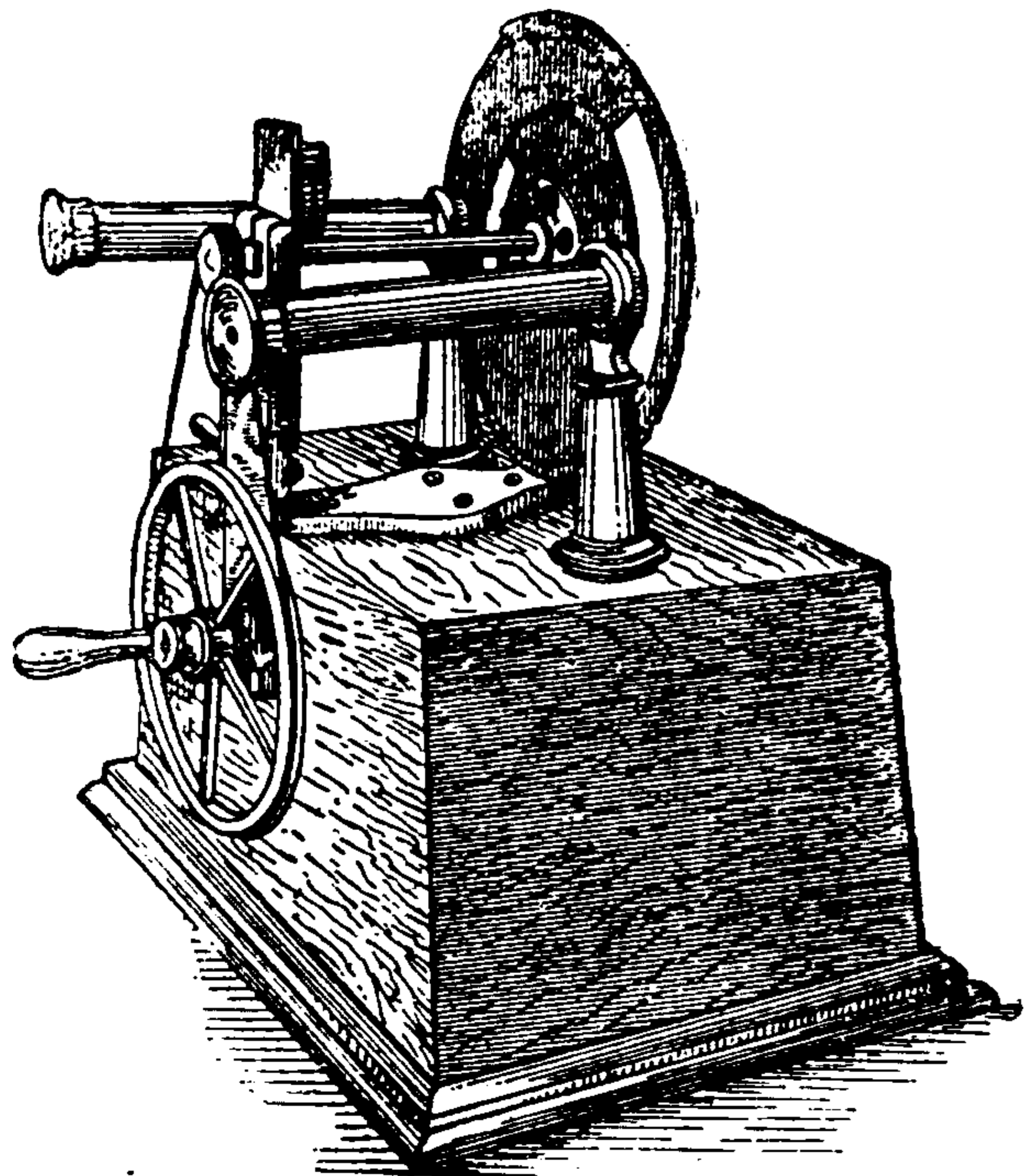

Fig. 431. Varley's Photometer.

cular apertures extend circumferentially 180 degrees, and are reversed so that when one half

ring is fully open, the other is completely closed; or, if one ring, say the outer, is opened 160 degrees, the inner is opened 20 degrees. The quantity of light then which passes through the outer ring from the light to be measured is eight times that passed through the inner ring. The circle is divided into 2,000 parts, instead of into 360 degrees, and, by means of a vernier, these parts are further divided into 10 parts, permitting a reading of the 20,000 divisions.

Two collimeters placed in front of the disc, project a disc with a black centre and a luminous spot respectively. The discs are regulated until the light projected on the screen produces a uniform disc. This is readily ascertained, since if one or the other predominate, a disc with gray spot, or a gray marginal ring with a bright spot, will appear.

The general appearance of the circular diaphragm, corresponding to different relative positions of the two discs, is shown in Fig. 432.



Fig. 432. Circular Diaphragm of Varley's Photometer.

Photometric.—Of or pertaining to the photometer. (See *Photometer*.)

Photometrically.—In a photometric manner.

Photophone.—An instrument invented by Bell for the telephonic transmission of articulate speech along a ray of light instead of along a conducting wire.

A beam of light, reflected from a diaphragm against which the speaker's voice is directed, is caused to fall on a selenium resistance inserted in the circuit of a voltaic battery, and a telephone. The changes thus effected in the resistance of the circuit by the varying amounts of light reflected on the selenium resistance from the diaphragm, while moving to-and-fro under the influence of the speaker's voice, produce in the receiving telephone a series of to-and-fro movements similar to those impressed on the transmitting diaphragm. One listening at the telephone can hear whatever has been spoken in the neighborhood of the transmitting diaphragm. Telephonic communication can, therefore, by such means be carried on along a

ray or beam of light, theoretically through any distance. (See *Resistance, Selenium.*)

A block of vulcanite or of certain other substances may be used as the receiver, since it has been discovered that a rapid succession of flashes of light produces an audible sound in small masses of these substances.

The term *sonorescence* has been proposed for the property possessed by such substances of emitting sounds when subjected to such intermittent flashes of light. (See *Sonorescence.*)

Photophore, Trouve's — — An apparatus in which the light of a small incandescent electric lamp is employed for purposes of medical exploration.

A small incandescent lamp is placed in a tube containing a concave mirror and a converging lens.

Photo-Telegraphy.—The electric production of pictures, writing, charts or diagrams at a distance.

Photo-Telegraphy is sometimes called telephotography; it is a species of fac-simile telegraphy. (See *Telegraphy, Fac-Simile, Telephotography.*)

Photo-Voltaic Effect.—(See *Effect, Photo-Voltaic.*)

Physical Change.—(See *Change, Physical.*)

Physical Phosphorescence.—(See *Phosphorescence, Physical.*)

Physiological.—Pertaining to physiology.

Physiological Rheoscope.—(See *Rheoscope, Physiological.*)

Physiologically.—In a physiological manner.

Physiology, Electro — — The study of electric phenomena of living animals and plants.

Living animals and plants present electric phenomena, due to the electricity naturally produced by them. It is the province of electrophysiology to ascertain the causes and effects of these phenomena.

Piano, Electric — — A piano in which the strings are struck by hammers actuated by means of electro-magnets, instead of by the usual mechanical action of levers.

An electric piano-action is mainly useful in permitting the instrument to be played at any distance from the key-board. It is also of value from the ease it affords in recording the pieces played.

It fails, however, to properly preserve the various modulations of force so requisite for brilliant instrumentation.

Pickle.—An acid solution in which metallic objects are dipped before being galvanized, or electroplated, in order to thoroughly cleanse their surfaces.

The pickle used for the preparation of iron for galvanization is a weak solution of sulphuric acid in water. Various acids, or acid liquids, are employed for insuring the thorough cleansing of metallic surfaces so necessary in order to ensure an even, uniform, adherent coating of metal by the process of electroplating. (See *Plating, Electro*)

Piece, Magnetic Proof — — A paramagnetic rod, ellipsoid or sphere employed for ascertaining the distribution of magnetism over a magnet by the force required to detach the same. (See *Paramagnetic.*)

Prof. S. P. Thompson points out the fact that the presence of the proof-piece so alters the distribution of magnetism on the magnet to be measured as to render this method unreliable. He also shows that the force required for detachment depends on the magnetic permeability of the proof-piece, as well as on its shape and its position in the magnetic circuit.

Pieces, Mouth — — Openings into air chambers, generally circular in shape, placed over the diaphragms of telephones, phonographs, gramophones or graphophones to permit the ready application of the mouth in speaking, so as to set the diaphragm into vibration.

The mouth-piece may be also utilized by the ear of an observer listening so as to be affected by its vibrations.

Pieces, Pole, of Dynamo-Electric Machine — — Masses of iron connected with the poles of the field magnet frames of dynamo-electric machines, and shaped to conform to the outline or contour of the armature.

The pole pieces are made in a variety of forms, but in all cases are so shaped as to conform to the outline of the space in which the armature rotates.

The pole pieces are brought as near as possible to the armature, so as to increase the intensity of the magnetic induction. The intervening air space should be as thin as possible, but of as large an area as convenient.

The opposite pole pieces should not have their extensions brought too near together, as this will permit of serious loss through *magnetic leakage*. The distance between them should be as many times the depth of the armature windings as possible. (See *Leakage, Magnetic*.)

Rounded edges are preferable to sharp edges for the same reason.

Pile, Dry — —A voltaic pile or battery consisting of numerous cells, the voltaic couple in each of which consists of sheets of paper covered with zinc-foil on one side and black oxide of manganese on the other.

Various modifications of the above form have been made.

The term dry-pile is a misnomer, since all such piles contain substances moistened by liquid electrolytes.

Pile, Muscular, Matteucci's — —A voltaic battery or pile, the elements of which are formed of longitudinal and transverse sections of muscle alternately connected.

Matteucci's experiments appear to show that the lower the animal is in the scale of creation, the stronger is the current produced, and the longer its duration. Du Bois-Reymond has shown that the muscular current is not due to contact, but to the differences of electric potential naturally possessed by the muscles themselves.

The nerves also possess the power of producing differences of electromotive force, and hence currents. (See *Electrotonus*.)

Pile, Thermo, Differential — —A thermopile in which the two opposite faces are exposed to the action of two nearly equal sources of heat in order to determine accurately the differences in the thermal intensities of such sources of heat.

Pile, Thermo-Electric — —A number of separate thermo-electric couples, united in

series, so as to form a single thermo-electric source. (See *Couple, Thermo-Electric*.)

A thermo-electric pile is sometimes called a thermo-electric battery.

Fig. 433 shows Nobili's thermopile, in which a number of bismuth-antimony thermo-electric couples connected in a continuous series, as shown partly in Fig. 434, are insulated from one another, except at their junctions, and packed in a metallic box, supported as shown in Fig. 433.

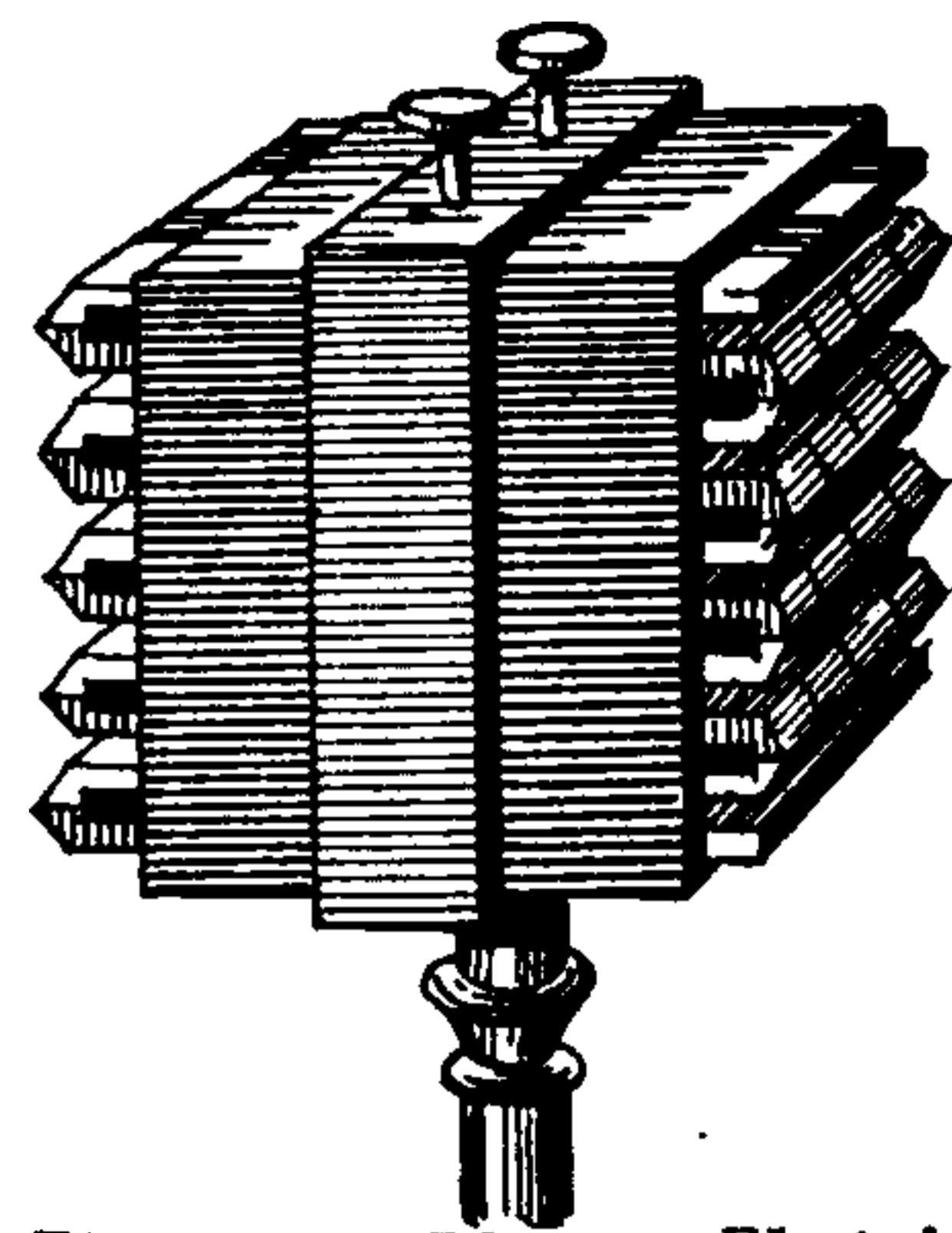

The free terminals of the series are connected to binding posts. Differences of temperature between the two faces of the pile, where the junctions are exposed, result in a difference of potential equal to the sum of the differences of potential of all the thermo-electric couples.

A careful inspection will show that the junctions are formed successively at *opposite* faces of the pile, so that if the junctions be numbered successively, the *even junctions* will come at one face, and the

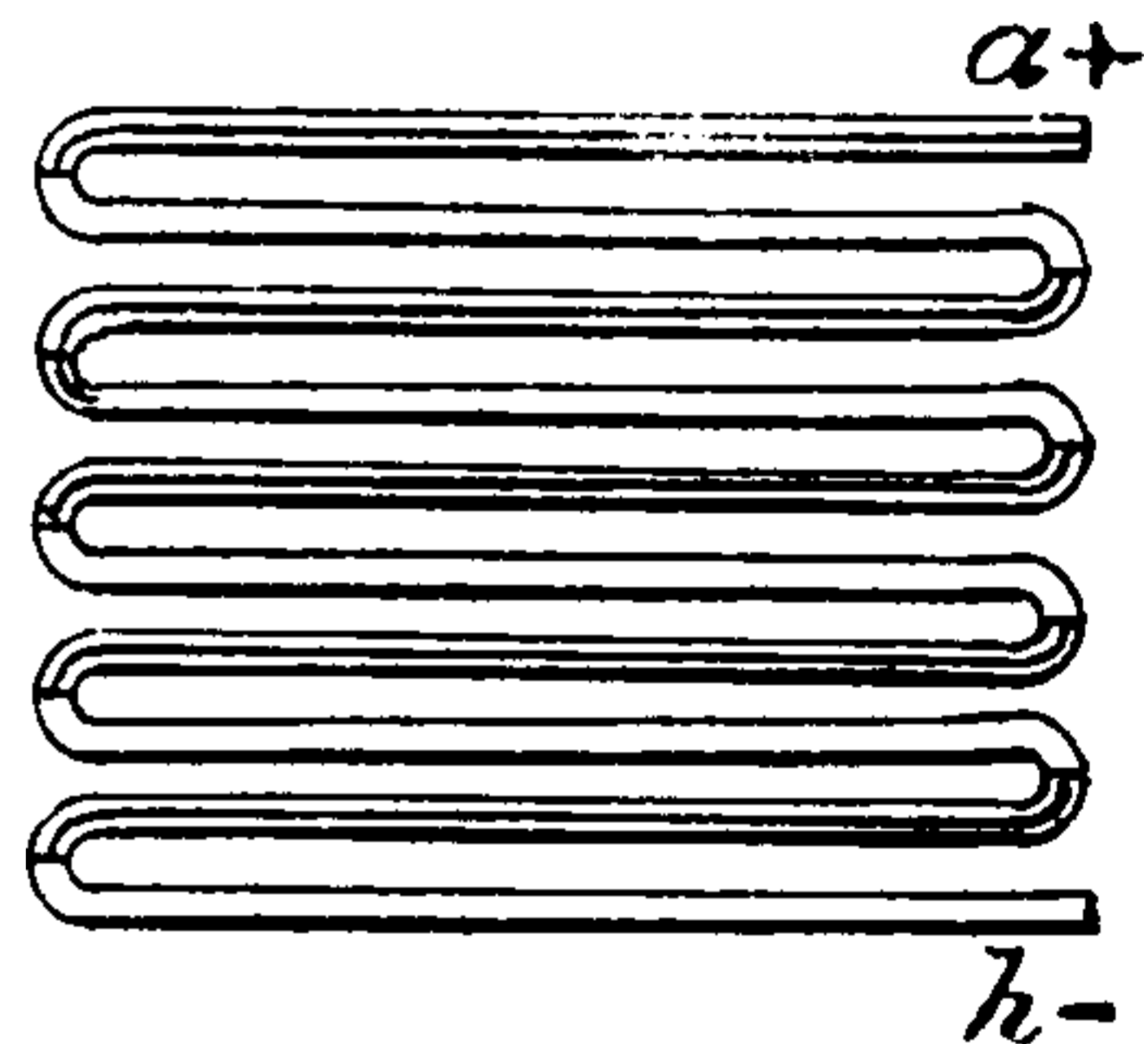

odd junctions at the other. This is necessary in order to permit all the thermo-electric couples to *add* their differences of potential; for, if, as in Fig. 435, a *thermo-electric chain* be formed,

Fig. 434. Series-Connected Thermo-Electric Couples.

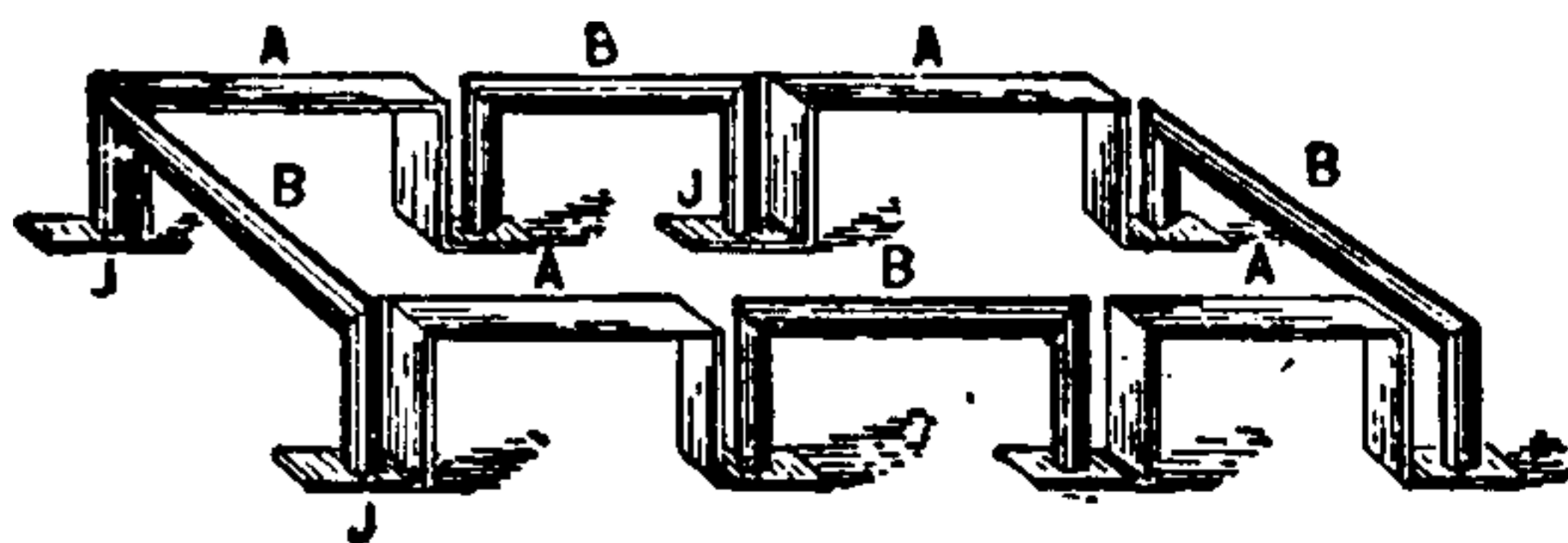

Fig. 435. Thermo-Electric Circuit.

no currents will result from equally heating any two consecutive junctions J, J, of the metals A and B, since the electromotive forces so produced oppose each other.

Thermopiles have been constructed by Clamond, of couples of iron and an alloy of zinc and antimony, of sufficient power to produce a voltaic arc whose illuminating power equaled 40

THIS PAGE IS LOCKED TO FREE MEMBERS

Purchase full membership to immediately unlock this page



HISTORY

Tens of thousands of important historical sources, many previously unobtainable, are now available for the first time with a Forgotten Books Full Membership.

Unlimited Access
\$8.99/month

Continue

*Fair usage policy applies

The proof-plane is used in connection with some form of electrometer. (See *Balance, Coulomb's Torsion.*)

Plane, Proof, Magnetic — —A small coil of wire placed in the circuit of a delicate galvanometer, and used for the purpose of exploring a magnetic field.

When the coil is suddenly inverted in a magnetic field, if a long-coil galvanometer provided with a heavy needle is used, the number of lines of force which pass through the area of cross-section of the coil will be proportional to the sine of half the angle of the first swing of the needle.

Plant.—A word sometimes used for installation, or for the apparatus required to carry on any manufacturing operation.

An electric plant includes the steam engines or other prime motors, the generating dynamo or dynamos, the lamps and other electro-receptive devices, and the circuits connected therewith.

Plant Electricity. — (See *Electricity, Plant. Plants, Electricity of.*)

Plants, Electricity of — —Electricity produced naturally by plants during their vigorous growth.

DuBois-Reymond and others have shown that plants while in a vigorous vital state are active sources of electricity.

If one of the terminals of a galvanometer be inserted into a fruit near its stem, and the other terminal into the opposite part of the fruit, the galvanometer at once shows the presence of an electric current.

Buff has shown that the roots and interior portions of plants are always negatively charged, while the flowers, fruits and green twigs are positively charged.

Plant tissue or fibre, like the muscular fibre of animals, exhibits in many cases a true contraction on the passage through it of an electric current. This is seen in the *Mimosa sensitiva*, or Sensitive Fern, in the Venus' Fly-Trap, and in several other species of plants.

Pouillet concludes from numerous observations that the free positive electricity of the atmosphere is partly due to the vapors disengaged by growing plants.

The peculiar geographical distribution of thunder storms, however, does not favor this assump-

tion. (See *Storm, Thunder, Geographical Distribution of.*)

Plastics, Galvano — —A term sometimes employed for electrotyping, that is where the deposits are sufficiently thick to permit of ready separation from the object which forms the mould.

Literally, the cold moulding or shaping of metals by electrotyping. (See *Plating, Electro. Metallurgy, Electro.*)

The word galvano-plastics is sometimes used as synonymous with electrotyping, electro-plating, or electro-metallurgy generally.

Plastics, Hydro — —The art of electrically shaping or depositing metals in the wet by electrotyping. (See *Plastics, Galvano.*)

Plate, Arrester, of Lightning Protector — —That plate of a lightning protector which is directly connected with the circuit to be protected, as distinguished from the plate that is connected with the ground. (See *Arrester, Lightning.*)

Plate Condenser.—(See *Condenser, Plate.*)

Plate, Ground, of Lightning Arrester — —That plate of a comb lightning arrester which is connected to the earth or ground. (See *Arrester, Lightning, Comb.*)

Plate, Negative, of Storage Cell — —That plate of a storage cell which, by the action of the charging current, is converted into or partly covered with a coating of spongy lead.

That plate of a storage battery which is connected with the negative terminal of the charging source, and which is therefore the negative pole of the battery on discharging.

The usage is the reverse of that in the case of the primary battery.

Plate, Negative, of Voltaic Cell — —The electro-negative element of a voltaic couple. (See *Couple, Voltaic.*)

That element of a voltaic couple which is negative in the electrolyte of the cell. (See *Electrolyte.*)

The negative plate of a voltaic cell is the plate not acted on by the electrolyte. In a zinc-carbon

couple in dilute sulphuric acid, the carbon plate is the negative plate. (See *Cell, Voltaic.*)

The negative plate is to be carefully distinguished from the negative pole, which is the terminal connected to the positive plate. The terminal connected to the negative plate is the positive pole. (See *Cell, Voltaic.*)

Plate, Positive, of Storage Battery — — That plate of a storage battery which is converted into, or covered by, a layer of lead peroxide, by the action of the charging current.

That plate of a storage battery which is connected with the positive terminal of the charging source and which is, therefore, the positive pole of the battery on discharging.

It will be noticed that the usage in this respect is the reverse of that in the case of primary batteries, in which the positive plate is positive in the liquid only; the end which projects from the liquid, or the terminal connected with it being negative.

In storage batteries, the positive plate is connected with the positive pole. (See *Battery, Storage. Cell, Voltaic.*)

Plate, Positive, of Voltaic Cell — — The electro-positive element of a voltaic couple. (See *Couple, Voltaic.*)

That element of a voltaic couple which is positive in the electrolyte of the cell. (See *Electrolysis.*)

The positive plate of a voltaic cell is the plate out from which the current flows through the electrolyte.

The zinc plate of a zinc-carbon couple is the positive plate. (See *Cell, Voltaic.*)

The current leaves the cell, however, to flow or pass through the external circuit at the wire or terminal connected with the negative plate. (See *Cell, Voltaic.*)

Plate, Primary, of Condenser — — That plate of a condensing transformer in which the inducing charge is placed in order to induce a charge of different potential in the secondary plate.

Plate, Secondary, of Condenser — — That plate of a condensing transformer in which the induced charge is produced by the induction of a charge on the primary plate.

Plate, Zinc, of Voltaic Cell. Amalgama-

tion of — — —Covering the surface of the zinc plate of a voltaic cell with a thin layer of amalgam in order to avoid local action. (See *Action, Local, of Voltaic Cell. Zinc, Amalgamation of.*)

Plates, Arrester — — —A term sometimes applied to the two plates of an ordinary comb lightning arrester. (See *Arrester, Lightning, Comb.*)

The plate that is connected to the line to be protected, is more correctly called the arrester plate, and that connected to the ground the ground plate.

Plates of Secondary or Storage Cell, Forming of — — —Obtaining a thick coating of lead peroxide on the lead plates of a storage battery, by repeatedly sending the charging current through the cell alternately in opposite directions.

The effect of sending a current between two lead plates immersed in dilute sulphuric acid, is to coat one of the plates with lead peroxide. On the sending of the current in the opposite direction, the other plate is coated with lead peroxide. If now the current is sent in the opposite direction, more peroxide is deposited on one of the plates, and the peroxide at the other plate is converted into spongy lead.

At the end of charging, the battery will form an independent source of current. (See *Cell, Storage.*)

Platform, Pole — — —A platform, capable of supporting several men, placed on a terminal pole provided with a cable box, for the purpose of affording a ready means of inspecting and arranging the conductors in the box.

Plating Balance. — (See *Balance, Plating.*)

Plating Bath, Electro — — — (See *Bath, Electro-Plating.*)

Plating, Copper — — —Electro-plating with copper. (See *Plating, Electro. Bath, Copper.*)

Plating, Electro — — —The process of covering any electrically conducting surface with a metal by the aid of the electric current.

By the aid of electro-plating, the baser metals are covered with silver, gold or platinum, or with any other metal, such as nickel or copper.

The process of electro-plating is carried on as follows:

The object to be plated is connected with the negative terminal of a battery and placed in a solution of the metal with which it is to be plated, opposite a plate of that metal connected to the positive terminal of the battery. If, for example, the object is to be plated with copper, it is placed in a solution of copper sulphate or blue vitriol, opposite a plate of copper. By this arrangement the object to be plated forms the kathode of the plating bath, and the plate of copper forms the anode.

On the passage of the current the copper sulphate (Cu SO_4) is decomposed, metallic copper being deposited in an adherent layer on the articles attached to the kathode, and the acid radical (SO_4) appearing at the anode, where it combines with one of the atoms of the copper plate. Since for every molecule of copper sulphate decomposed in the electrolyte, a new molecule of copper sulphate is thus formed, by the gradual solution of the copper anode, the strength of the solution in the bath is maintained as long as any of the copper plate remains at the anode, and the ordinary activity of the cell is not otherwise interfered with.

When any other metals, such as gold, silver or nickel, for example, are to be deposited, suitable solutions of their salts are placed in the bath, and plates of the same metal hung at the anode.

The character and coherence of the metallic coatings thus obtained depend on the nature and strength of the plating bath, and on the density of the current employed. The size and position of the anode, as compared with the size and position of the objects to be plated, must therefore be carefully attended to, as well as the strength of

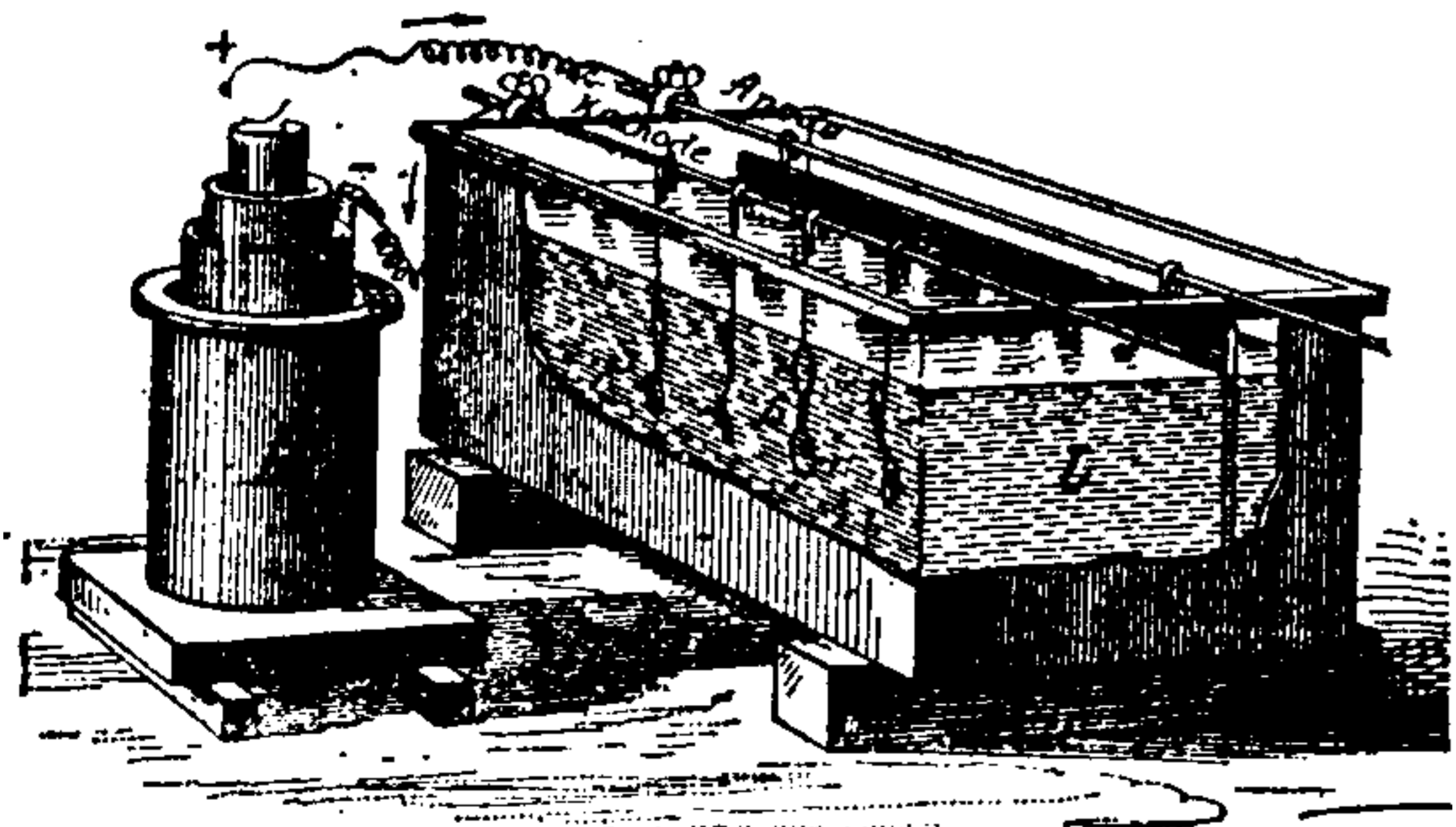

Fig. 439. *Electro-Plating*

the metallic solution and the current strength passing. (See *Current Density*.)

Fig. 439, shows a bath arranged for silver-plating.

The anode consists of a plate of silver. The

spoons, forks, etc., to be plated are immersed in a suitable silver solution and connected with the kathode.

The electro-plating process when employed for the production of electrotype plates is called electrotyping. Here the object is to obtain a reproduction in metal of any particular form, such as of type or of some natural object. It was called by Jacobi the *galvanoplastic* process. The term *electrotyping* is, however, more generally adopted. (See *Electrotyping, or the Electrotpe Process*.)

Plating, Gold — — Electro-plating with gold. (See *Plating, Electro. Bath, Gold*.)

Plating, Nickel — — Electro-plating with nickel. (See *Plating, Electro. Bath, Nickel*.)

Plating, Sectional — — Plating an article with a greater thickness of metal at certain points than at the rest of the surface.

Sectional plating is employed for such objects as spoons, etc., which are, by this method, given a greater thickness of deposit at the under portions of the bowl and handle, where the spoon usually rests, and is, therefore, exposed to the greatest wear.

Sectional plating is effected by means of sectional plating frames. (See *Plating, Electro. Frames, Sectional Plating*.)

Plating, Silver — — Electro-plating with silver. (See *Plating, Electro. Bath, Silver*.)

Platinoid.—An alloy consisting of German silver containing 1 or 2 per cent. of metallic tungsten.

Platinoid is suitable for use in resistance coils on account of the comparatively small influence produced on its electric resistance by changes of temperature.

Its resistance is 60 per cent. higher than that of German silver.

Platinum.—A refractory and not readily oxidizable metal, of a tin-white color.

The co-efficient of expansion of platinum by heat is very nearly that of ordinary glass. Platinum is, therefore, generally employed for the leading-in conductors of an incandescent lamp. These conductors are fused into the glass of the lamp chamber. On the heating of the wires by

THIS PAGE IS LOCKED TO FREE MEMBERS

Purchase full membership to immediately unlock this page

Know Your Bible

Forgotten Books' Full Membership provides unlimited access to more than 28,000 volumes of Christian literature for \$8.99/month

HOLY BIBLE

Continue

*Fair use policy applies

The active material forming the plugs is placed in the spaces in the grid while in the plastic condition. On the subsequent hardening of this material, these grid plugs cannot readily fall out, since the spaces are so shaped that their interior portions are of greater diameter than at the surface of the plates.

Plumbago.—An allotropic modification of carbon.

Plumbago, the material commonly known as *black lead*, is the same as graphite. Powdered plumbago is employed in *electrotyping processes* for rendering non-conducting surfaces electrically conducting. For this purpose powdered plumbago is dusted on the surfaces, which thus acquire the power of receiving a metallic lustre by friction. Stove polishes are formed of mixtures of plumbago and other cheap materials. (See *Graphite*.)

Strictly speaking, the term graphite is properly applied to such varieties of plumbago as are suitable for direct use for writing purposes, as in lead pencils.

Plumbago, Coppered — — Powdered plumbago coated with copper, for use in the metallization of objects to be electro-plated. (See *Metallization*.)

Plumbago, Gilt — — Powdered plumbago whose conducting power for electricity has been increased by coating it with metallic gold.

Gilt plumbago is used for rendering non-conducting surfaces electrically conducting and thus preparing them for electro-plating.

To prepare gilt plumbago, dissolve in 100 parts of sulphuric ether 1 part of chloride of gold, mix in this 60 parts of powdered plumbago, and expose to air and light until all ether has volatilized. Then dry in an oven.

Plumbago, Silvered — — Powdered plumbago coated with metallic silver for use in the metallization of objects to be electro-plated.

Plunge Battery.—(See *Battery, Plunge*.)

Pneumatic Perforator.—(See *Perforator, Pneumatic*.)

Pneumatic Signals, Electro — — (See *Signals, Electro-Pneumatic*.)

Pockets, Armature — — Spaces provided in an armature for the reception of the

armature coils. (See *Coils, Armature, of Dynamo-Electric Machine*.)

Poggendorff's Voltaic Cell.—(See *Cell, Voltaic, Poggendorff's*.)

Point, Carbon — — A term formerly applied to the carbon electrodes used in the production of the voltaic arc.

Point, Indifferent — — A point in the intra-polar regions of a nerve where the anelectrotonic and kathelectrotonic regions meet, and where the excitability is therefore unchanged.

This is sometimes called the neutral point.

Point of Lightning Rod.—(See *Rod, Lightning, Points on*.)

Point of Origin.—(See *Origin, Point of*.)

Point, Neutral — — In electro-therapeutics, a term sometimes used instead of indifferent point. (See *Point, Indifferent*.)

Point, Nodal — — The null point in a circuit traversed by electric oscillations. (See *Point, Null*.)

Point, Null — — Such a point on a micrometer circuit, that when joined or connected with the secondary circuit of an induction coil, the sparks in the micrometer circuit are either very greatly decreased or are entirely absent.

The null point on the micrometer circuit is situated symmetrically with respect to the micrometer knobs.

If the induction coil A, Fig. 440, has its secondary circuit connected as

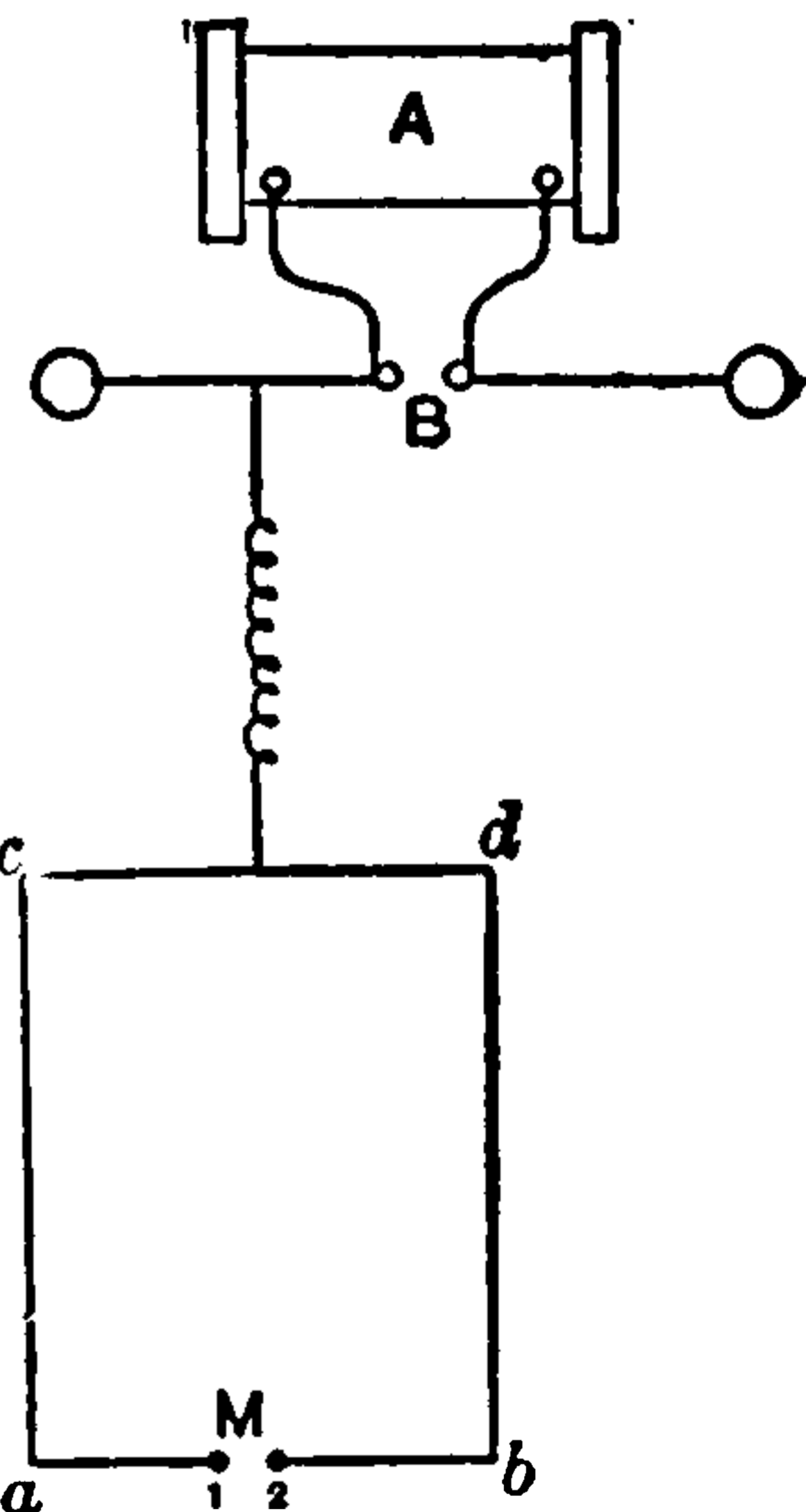

shown with the micrometer circuit at the point e, situated at the centre of the micrometer circuit, the point will be a null point, and the effects of sparks at the micrometer knobs, at M, will be greatly decreased. Under the conditions shown in the figure, the electrical oscillations in the micrometer circuit must be regarded as in the condition of stationary waves or vibrations. It would seem, therefore, that definite waves or vibrations are set up in the microm-

eter circuit, in the same way as are the vibrations produced in an elastic bar set in vibration by a violin bow, or by a blow from a hammer.

Points, Consequent — —The points or places in an anomalous magnet where the consequent poles are situated. (See *Magnet, Anomalous. Pole, Anomalous.*)

Points, Corresponding — —Points where the lines of electrostatic force surrounding an insulated charged conductor enter the surfaces of neighboring conductors.

Points on the surface of a body placed in an electrostatic field where the lines of electrostatic force enter its surface, and thus produce a charge equal and opposite to that of the surface of the body at the points from which they came.

Corresponding points receive, in accordance with the laws of electrostatic induction, charges equal and opposite to those of the surfaces from which the lines of electrostatic force originate.

Points, Electric Action of — —The effect of points placed on an insulated, charged conductor, in slowly discharging the conductor by electric convection. (See *Convection, Electric.*)

The cause of this action of points is to be attributed to the increased density of a charge on the surface of a conductor at the points and the consequent production of convection streams of air, which thus gradually carry off the charge. (See *Charge, Distribution of.*)

Points, Iso-Electric — —A term sometimes used in electro-therapeutics for points of equal potential.

Points, Neutral, of Dynamo-Electric Machine — —Two points of greatest difference of potential, situated on the commutator cylinder, at the opposite ends of a diameter thereof, at which the collecting brushes must rest in order to carry off the current quietly.

These are called the neutral points because the coils that are short-circuited by the brushes lie in the magnetically neutral points of the armature. (See *Line, Neutral, of Commutator Cylinder.*)

Points, Neutral, of Magnet — —Points approximately midway between the poles of

a magnet. (See *Line, Neutral, of a Magnet. Magnet, Equator of.*)

Points, Neutral, of Thermo-Electric Diagram — —The points on a thermo-electric diagram where the lines representing the thermo-electric powers of any two metals cross one another.

A mean temperature for any two metals in a thermo-electric series, at which, if their two junctions are slightly over and slightly under the mean temperature (the one as much above as the other is below), no effective electromotive force is developed. (See *Diagram, Thermo-Electric. Couple, Thermo-Electric.*)

Points or Rhumbs of Compass.—(See *Compass, Points of.*)

Polar Region.—(See *Region, Polar.*)

Polar Tips.—(See *Tips, Polar.*)

Polarity, Diamagnetic — —A polarity the reverse of ordinary magnetic polarity, the existence of which was assumed by Faraday to explain the phenomena of diamagnetism. (See *Diamagnetism.*)

Faraday assumed that diamagnetic substances, when brought into a magnetic field, acquired *north magnetism* in those parts that were nearest the north pole, instead of *south magnetism*, as with ordinary magnetic substances. The north pole thus obtained would, he thought, explain the apparent repulsion of a slender rod of any diamagnetic material delicately suspended in a strong magnetic field, and cause it to point equatorially, or with the lines of force passing through its least dimensions. This supposition was subsequently abandoned by Faraday. It has recently been revived by Tyndall. (See *Diamagnetism.*)

The action of a diamagnetic body, when placed in a magnetic field, is now generally ascribed to the fact that the atmosphere, by which such body is surrounded, is more powerfully paramagnetic than the diamagnetic substance. The diamagnetic substance comes to rest in an equatorial position, because in that position there is the greatest length of air in the path of the magnetic lines, which has a smaller magnetic resistance than the diamagnetic substance.

Polarity, Magnetic — —The polarity acquired by a magnetizable substance when brought into a magnetic field.

The direction of magnetic polarity, acquired by a substance when brought into a magnetic field, depends on the direction in which the lines of magnetic force pass through it. Where these lines enter the substance a south pole is produced, and where they pass out, a north pole is produced. The *axis of magnetization lies in the direction of the lines of force as they pass through the body*, and the *intensity of magnetization* depends on the number of these lines of force which pass through the body.

The cause of magnetic polarity is not definitely known. Hughes' hypothesis attributes it to a property inherent in all matter. Ampère attributes it to closed electric circuits in the ultimate particles. Whatever its cause, it is invariably manifested by a magnetic field, the lines of force of which are assumed to have the direction already mentioned. (See *Magnetism, Hughes' Theory of. Magnetism, Ampère's Theory of. Magnetism, Ewing's Theory of.*)

Polarization, Galvanic — —A term sometimes applied to the polarization of a voltaic cell. (See *Cell, Voltaic, Polarization of.*)

Polarization, Internal, of Moist Bodies — —A polarization exhibited by such moist bodies as the nerves, muscular fibres, the juicy parts of vegetables and animals, or in general by all bodies possessing a firm structure filled with a liquid, on the passage through them of a strong electric current.

Polarization, Magnetic Rotary — —The rotation of the plane of polarization of a beam of plane-polarized light consequent on its passage through a plate of glass subjected to the stress of a magnetic field. (See *Rotation, Magneto-Optic.*)

Polarization of Dielectric.—(See *Dielectric, Polarization of.*)

Polarization of Electrolyte.—(See *Electrolyte, Polarization of.*)

Polarization of Voltaic Cell.—(See *Cell, Voltaic, Polarization of.*)

Polarized Armature.—(See *Armature, Polarized.*)

Polarized Relay.—(See *Relay, Polarized.*)

Polarizing Current. — (See *Current, Polarization.*)

Polarizing Electro-Therapeutic Current. —(See *Current, Electro-Therapeutic Polarizing.*)

Pole, Analogous — —That pole of a pyro-electric substance, like tourmaline, which acquires a positive electrification while the temperature of the crystal is rising. (See *Electricity, Pyro.*)

Pole, Anomalous — —A name sometimes given to those parts or poles in an anomalous magnet which consist of two similar free poles placed together. (See *Magnet, Anomalous.*)

Pole, Antilogous — —That pole of a pyro-electric substance, like tourmaline, which acquires a negative electrification when the temperature of the crystal is rising, and a positive electrification when it is falling. (See *Electricity, Pyro.*)

Pole, Armature — —(See *Armature, Pole.*)

Pole Changer.—A switch or key for changing or reversing the direction of current produced by any electric source, such as a battery.

The *commutator of a Ruhmkorff coil* is a simple form of pole changer. It is, however, usually called a commutator. (See *Coil, Induction.*)

Pole-Changing and Interrupting Electrode Handle.—(See *Electrode-Handle, Pole-Changing and Interrupting.*)

Pole-Changing Switch.—(See *Switch, Pole-Changing.*)

Pole Climbers.—(See *Climbers, Pole.*)

Pole, Consequent — —A magnet pole formed by two free north or two free south poles placed together. (See *Magnet, Anomalous.*)

Pole, Magnetic, Austral — —A name formerly employed in France for the north-seeking pole of a magnet.

That pole of a magnet which points to the earth's geographical north.

It will be observed that the French regarded the magnetism of the earth's Northern Hemisphere

THIS PAGE IS LOCKED TO FREE MEMBERS

Purchase full membership to immediately unlock this page



HISTORY

Tens of thousands of important historical sources, many previously unobtainable, are now available for the first time with a Forgotten Books Full Membership.

Unlimited Access
\$8.99/month

Continue

*Fair usage policy applies

The *terminal pole*, or the last pole at each end of the line, or where the wires bend at an angle of nearly 90 degrees, is made larger than usual and is often cut square.

The holes for the poles must be dug in the true line of the wires, and not at an angle to such line. As little ground should be disturbed in the digging as possible. *Earth borers*, or modifications of the ordinary ship auger, are generally employed for this purpose. When the pole is placed in position the ground should be *rammed* or *punned* around the pole.

In *setting the pole*, it is generally buried at least 5 feet in the ground. In England the poles are planted to a depth of about one-fifth of their length. In embankments and loose ground, they are planted deeper than in more solid earth. On curves, the poles should be inclined a little so as to lean back against the lateral strain of the wire, since by the time the ground has completely set, the strain of the wire will have pulled them into an erect position.

Care must be taken to so plant the poles on that side of a road or railway that the prevailing winds will blow them off the roadbed, should it overturn them. As to location, the top of steep cuttings is preferable to the slope. In all exposed positions, it is preferable to strengthen the poles by *stays* attached to both sides.

Where the number of wires is unusually large, heavy timber, or in case of its absence, double

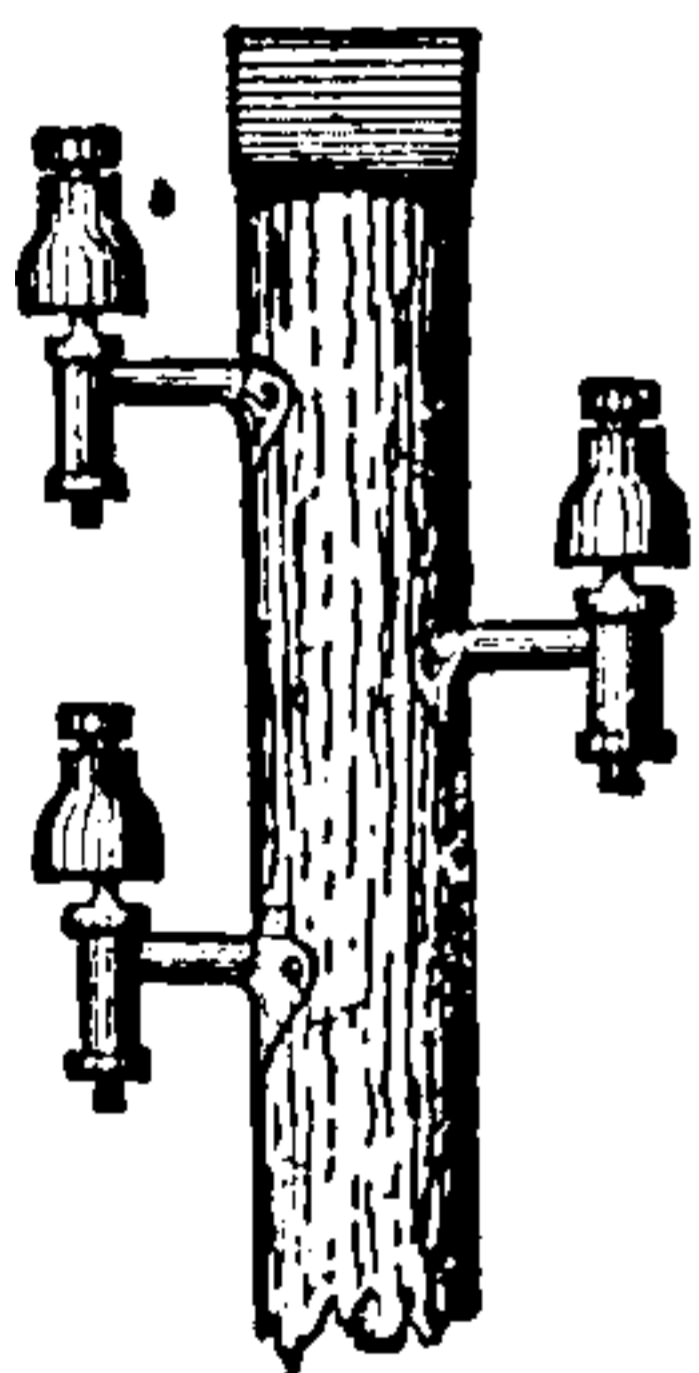

Fig. 441. Telegraphic Brackets.

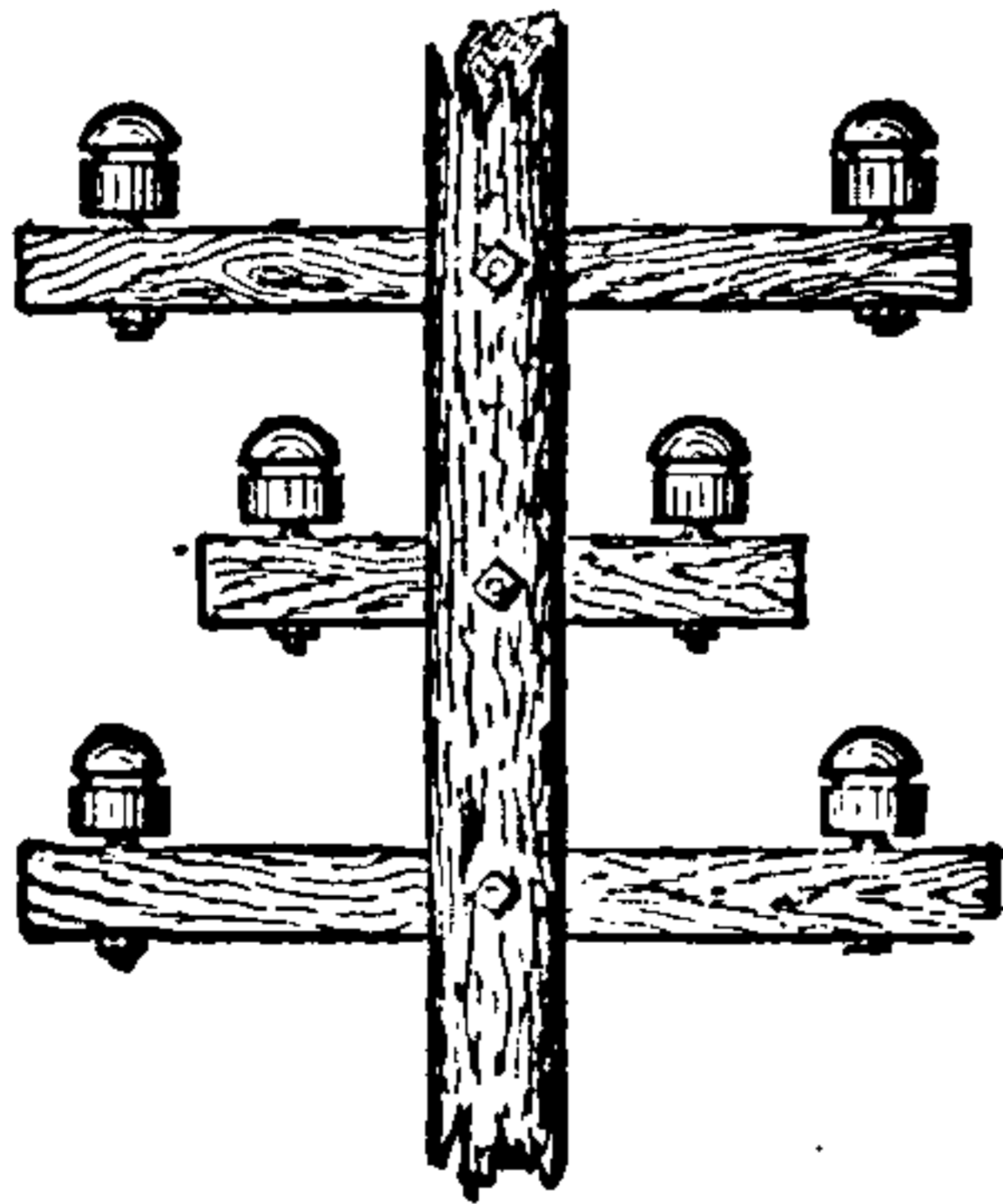

Fig. 442. Telegraphic Arms.

poles suitably braced together, must be employed. In long lines the poles should all be numbered in order to afford ease of reference in case of repair.

When, even with the best *punning*, and other precautions, the pole is judged to be unable to resist the strain on it, *stays* and *struts* are employed. A *stay* is used when it is desired to remove the *pull* or *tension* from the pole; a *strut*, when it is desired to remove the *thrust* or *pressure*.

The *arms* or *brackets*, or the cross-pieces that

support the *insulators*, should all be placed on the same side of the poles. Some common forms of brackets are shown in Fig. 441, and of telegraphic arms in Fig. 442.

Saddle brackets should be placed on alternate sides of the poles. When the strain on an insulator is too great, on account of the wire going off at a sharp angle, a *shackle* is used. This is a special form of insulator which confines the strain to one spot.

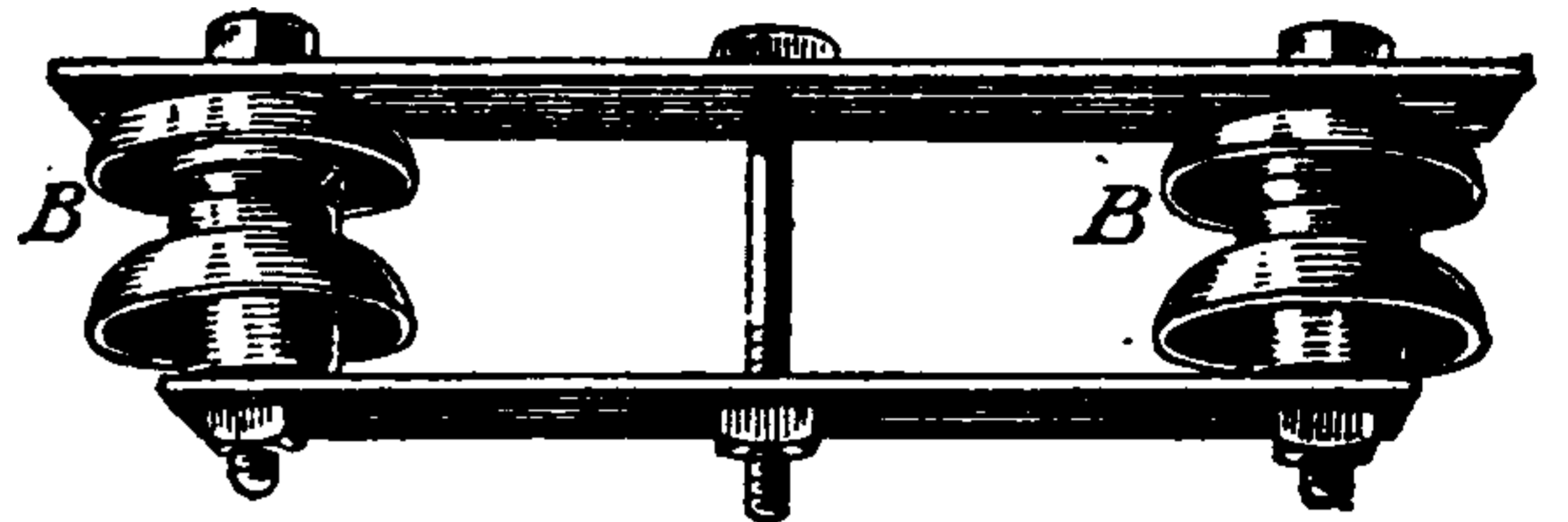

Fig. 443. Double Shackles.

A form of *double shackle* is shown in Fig. 443. The wire passes around the recess at B, between the two insulators.

On curves, or in any situation where there is a probability, in case of the breaking of an insula-

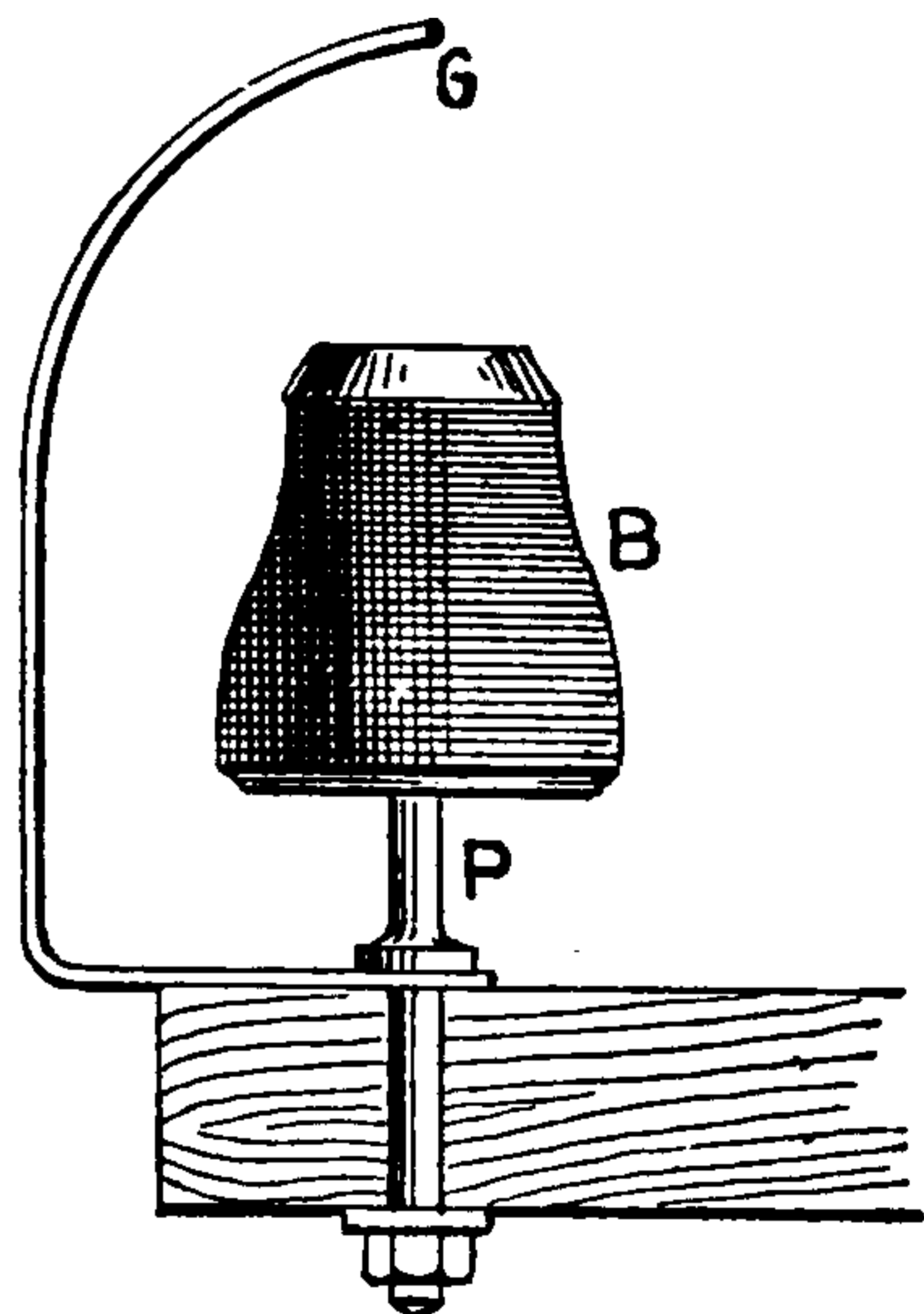

Fig. 444. Hook Guard.

tor, of a wire getting into a dangerous position, *guards* should be employed.

Guards are of two kinds, viz.: *hoop guards* and *hook guards*. A form of *hook guard* is shown in Fig. 444.

When wooden poles are employed various preservative methods are adopted to protect the wood from decay, which is very apt to occur, especially where the pole enters the ground. Some of these forms are as follows, viz. :

(1.) *Charring* and *tarring* the butt end of the pole where it enters the ground, so as to expel the sap and destroy injurious plant or animal germs.

The charred end is then cleansed and dipped in a mixture of tar and slaked lime.

(2.) *Burnetizing*, or the introduction of chloride of zinc into the pores of the wood, by placing the poles in an open tank filled with a solution of this salt.

(3.) *Kyanizing*, or the similar introduction of corrosive sublimate, or mercuric chloride.

(4.) *Boucherizing*, or the injection of a solution of copper sulphate into the pores of the wood.

(5.) *Creosoting*, or the application of creosote to well seasoned poles.

Pole, Telegraphic, Punning of — — Ramming or packing the earth around the base of a telegraph pole for the purpose of more securely fixing it in the ground.

Pole, Telegraphic, Terminal — — —The pole at either end of a telegraphic line.

As the first or last pole in a telegraphic line is not supported on opposite sides by the line wires, it is generally made stouter than the intermediate poles, and greater care is taken to fix it securely in the ground.

Pole, Testing — — —A term sometimes employed in electro-therapeutics for the indifferent pole or electrode. (See *Electrode, Indifferent.*)

Pole, Trolley — — —The pole which supports the trolley bearing and rests on the socket in the trolley base frame in an overhead wire electric railway system.

Pole, Unit, Magnetic — — —A magnetic pole of such a strength that it would act with a unit or dyne of force on another unit pole at a distance of one centimetre.

Poles, Consequent — — —The name given to single magnetic poles formed by two free N. poles or two free S. poles placed together. (See *Magnet, Anomalous.*)

Poles, Idle — — —Poles or electrodes in Crookes' tubes, between which discharges are not taking place.

The idle poles have no connection with the induction coils or other sources from which the electric discharges are obtained. These poles are provided for attaching galvanometer wires, etc., in the study of the Edison effect, or for the study of the

electrical condition of the dark space and other regions of the atmosphere of the tube.

Poles, Magnetic — — —The two points where the lines of magnetic force pass from the iron into the air, and from the air into the iron.

The two points in a magnet where the magnetic force appears to be concentrated.

In reality the magnetic force is most concentrated at the neutral points of a magnet, through which all the lines of force pass.

All magnets possess at least two poles, one positive or north, and the other negative or south.

The lines of magnetic force are assumed to come out of a magnet at its north pole, and to enter it at its south pole.

Poles, Magnetic, of Verticity — — —(See *Verticity, Poles of, Magnetic.*)

Poles of Condenser.—The terminals of a condenser. (See *Condenser.*)

Poles of Magnetic Intensity.—(See *Intensity, Magnetic, Pole of.*)

Polyphase Current.—(See *Current, Multi-Phase.*)

Polyphotal Arc Light Regulators.—(See *Regulator, Polyphotal Arc-Light.*)

Popgun, Electro-Magnetic — — —A magnetizing coil, provided with a tubular space for the insertion of a core, much shorter than the length of the coil, which, when the energizing current is passed through the coil, is thrown violently out from the coil.

The movement and consequent expulsion of the core is due to the action of the lines of magnetic force which complete their circuit through the core.

Porcelain.—A variety of insulating material.

A translucent variety of earthenware.

Porous Cell.—(See *Cell, Porous.*)

Porous Cup.—(See *Cup, Porous.*)

Porous Insulation.—(See *Insulation, Porous.*)

Porous Jar.—(See *Jar, Porous.*)

Porret's Phenomena.—(See *Phenomena, Porret.*)

Portative Power.—(See *Power, Portative*.)

Portelectric.—An electric carrier.

A system of electric transportation by means of the successive attractions of a number of hollow helices of insulated wire on a hollow solenoidal iron car.

The solenoidal car forms the movable core of the helical coils. As it moves through these coils it automatically closes the circuit of an electric current through the coils in advance of it and opens the circuit of the coils in its rear. In this way the solenoidal car advances in a line coincident with the axis of the helical coils, being virtually sucked through them by their magnetic attractions. This system of electric propulsion is unique in systems of electric traction. The motor becomes a mere mass of iron or other paramagnetic material. The system is suitable for the carriage of mail or other comparatively light articles at a high speed.

In an experimental plant at Dorchester, Mass., a track of 2,784 feet in length was laid in the approximate form of an oval. The track was formed by an upper and lower rail of steel, suitably supported by stringers.

The car, which forms the movable core of the solenoidal coils, was of wrought iron, and was cylindrical in shape, with conical ends. It was

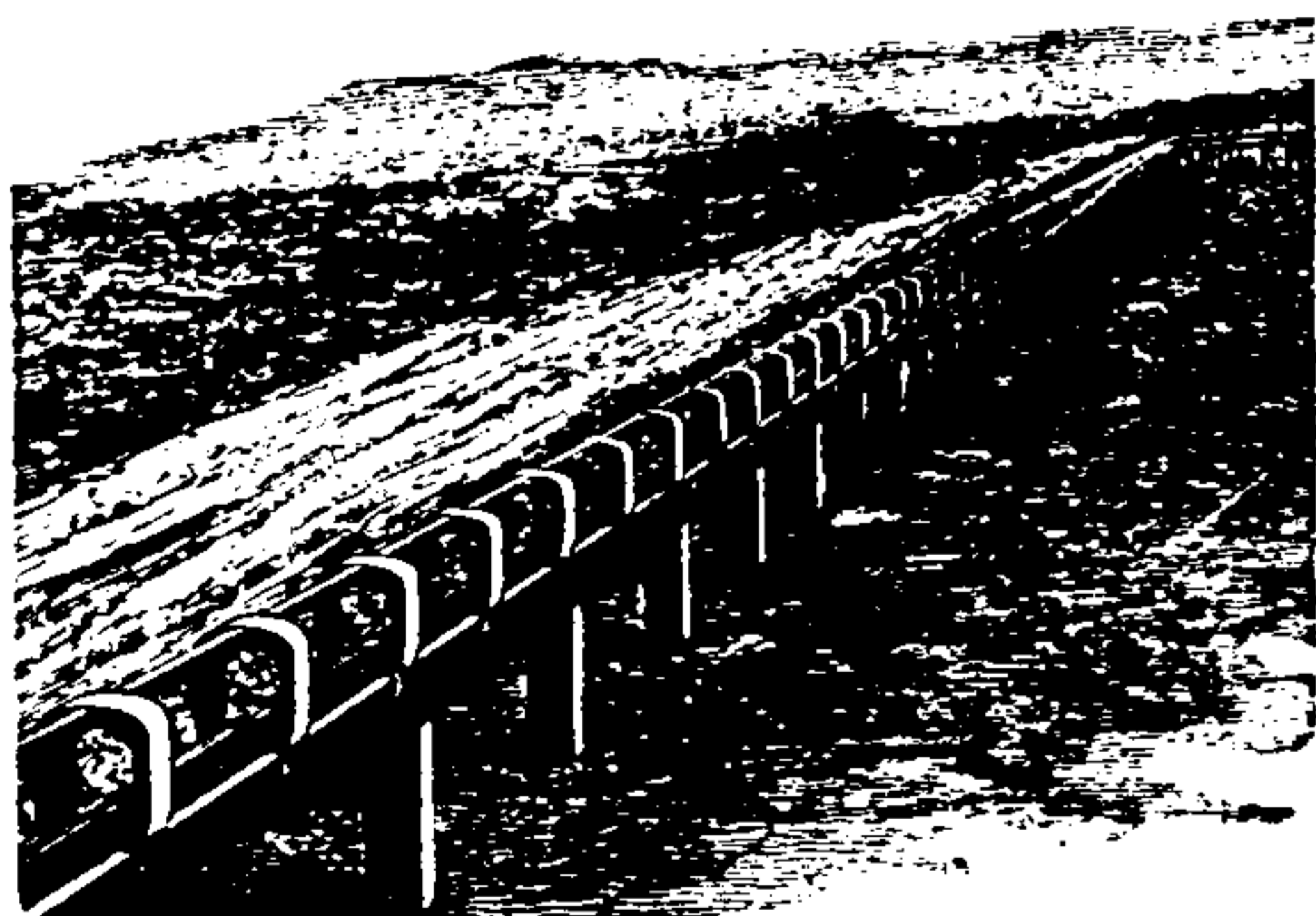

Fig. 445. *Portelectric Track.*

12 feet in length and 10 inches in diameter, and weighed about 500 pounds. It would carry about 10,000 letters. It had two flanged wheels above and two below.

The solenoidal coils, by the attractive power of which the core was moved, embraced the track and the movable core or carrier. They were fixed along the track at intervals of 6 feet from centre to centre. Each coil was formed of 630 turns of No. 14 copper wire. The upper track rail is divided into sections which form conductors for the driving current. A central wheel was

placed on the top of the carrier and connected the several helices successively with the electric

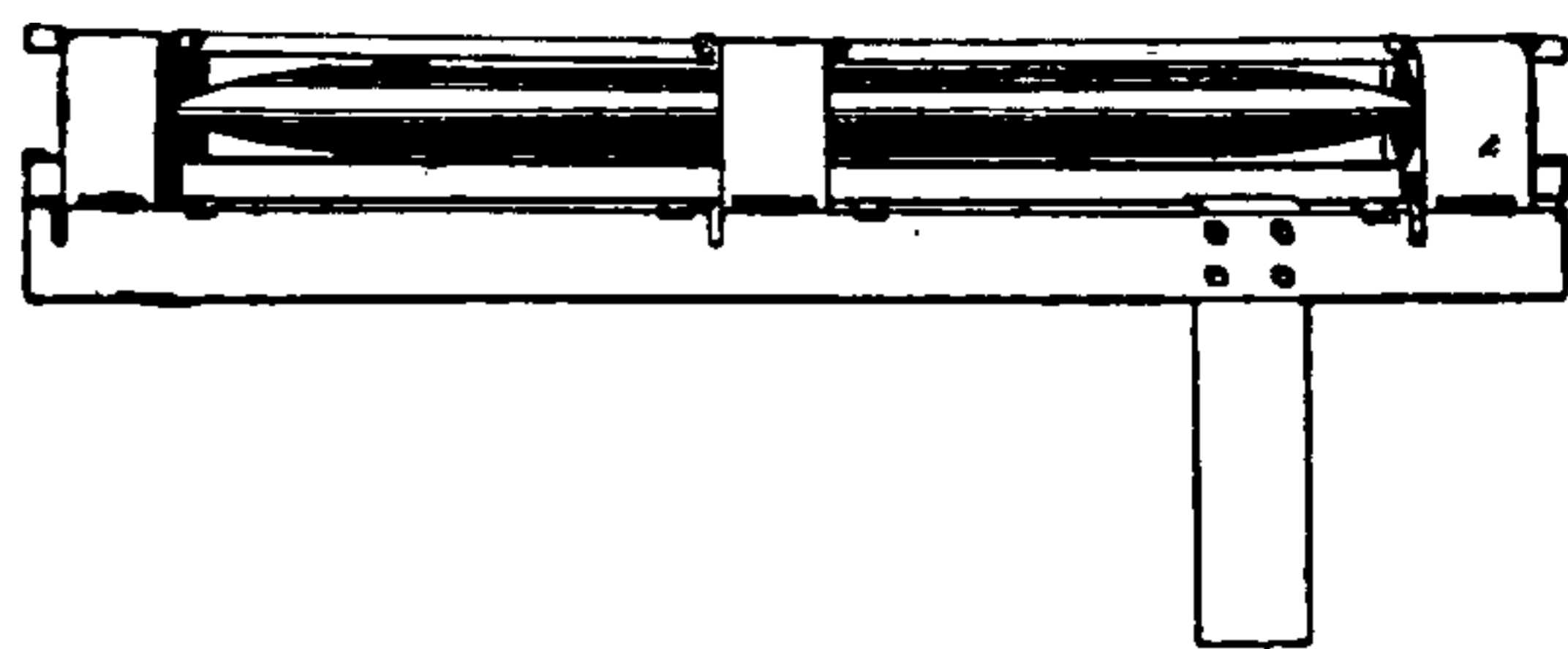

Fig. 446. *Portelectric Car.*

source as the carrier was drawn forward. A speed of about 34 miles an hour was reached.

A section of the track is shown in Fig. 445, and the shape and general structure of the carrier in Fig. 446.

Portrait, Electric — —A portrait formed on paper by the electric volatilization of gold or other metal.

An electric portrait is obtained by cutting on a thin card a portrait in the form of a stencil. A sheet of gold leaf is then placed on one side of the

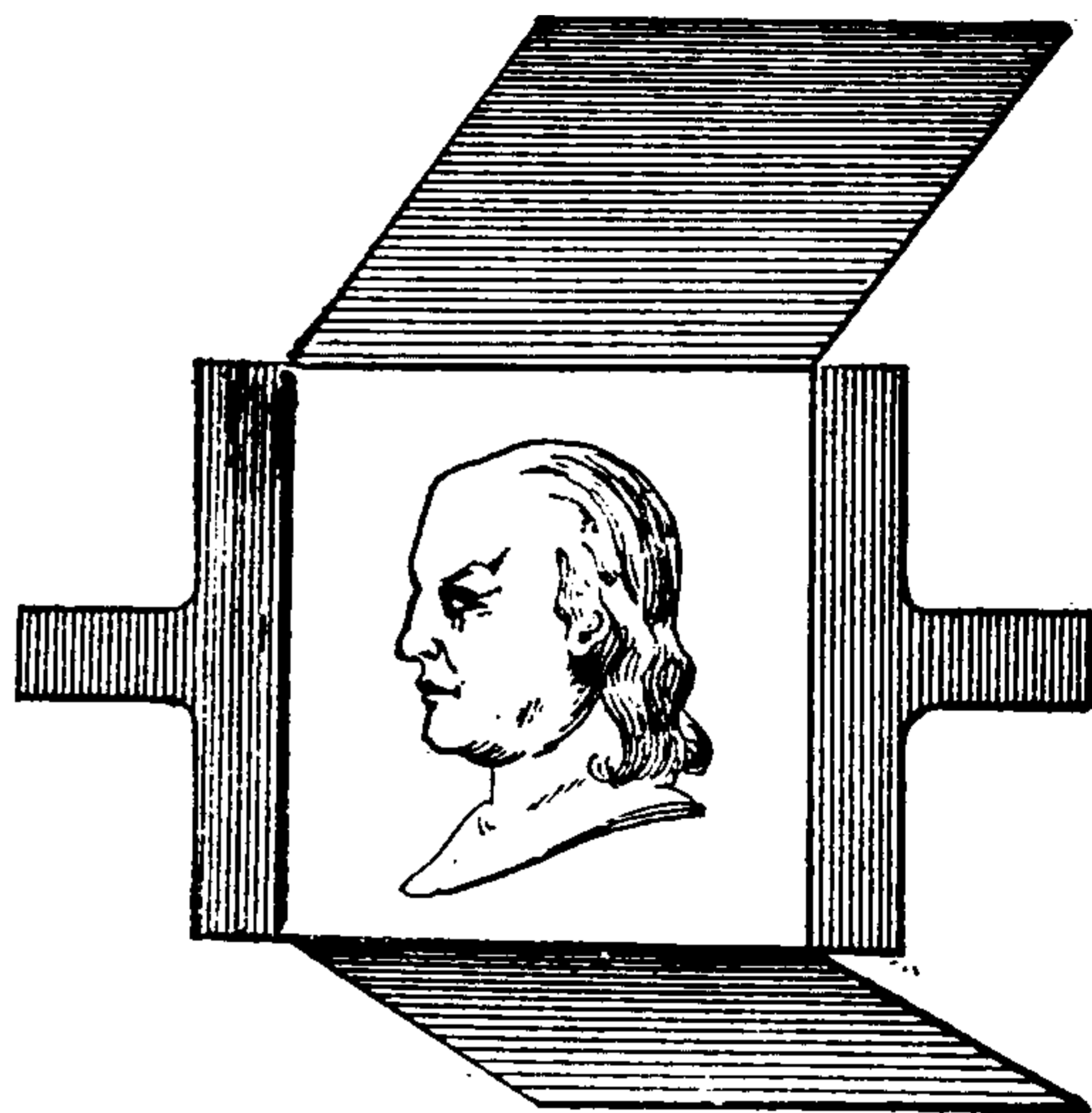

Fig. 447. *Electric Portrait.*

paper stencil, and a sheet of paper on the other side; sheets of tin-foil are then placed on the outside, as shown in Fig. 447, and the whole firmly pressed together. If, now, a disruptive discharge is passed through from one sheet of tin-foil to the other, the gold leaf is volatilized, and a purplish stain is left on the paper of the outlines of the stenciled card, thus forming an electric portrait.

Position, Energy of — —A term used for stored energy, or potential energy. (See *Energy, Potential*.)

Positive Direction of a Simple-Harmonic Motion.—(See *Motion, Simple-Harmonic, Positive Direction of*.)

THIS PAGE IS LOCKED TO FREE MEMBERS

Purchase full membership to immediately unlock this page

Know Your Bible

Forgotten Books' Full Membership provides unlimited access to more than 28,000 volumes of Christian literature for \$8.99/month

HOLY BIBLE

Continue

*Fair use policy applies

Potential, Difference of, Methods of Measuring — — Methods employed for determining differences of potential.

These methods are as follows:

(1.) *By the Method of Weighing*, that is, by obtaining the *weight* required to overcome the attraction between two oppositely charged plates, or oppositely energized coils; or by measuring the repulsion between similarly charged surfaces, or similarly energized coils.

(2.) *By the Use of Electrometers*, or apparatus designed for measuring differences of potential. (See *Electrometers*.)

(3.) *By the Use of Galvanometers*.

Differences of potential, in the case of currents, may be determined from the quantity of electricity which flows per second through a given circuit, that is, by the number of ampères, just as the pressure of water at any point in the side of a containing vessel can be determined by the quantity of water that flows per second. Difference of potential in the case of currents, therefore, may be measured by any galvanometer which measures the current directly in ampères, provided the resistance of the circuit is known.

Potential, Drop of — — A term sometimes used instead of fall of potential. (See *Potential, Fall of*.)

Potential, Electric — — The power of doing electric work.

Electric level.

Electric potential can be best understood by comparison with the case of a liquid such as water.

The ability of a water supply or source to do work depends:

(1.) On the quantity of water.

(2.) On the level of the water, as compared with some other level; or, in other words, on the *difference between the two levels*.

In a like manner the ability of electricity to do work depends:

(1.) On the quantity of electricity.

(2.) On the electric potential at the place where the electricity is produced, as compared with that at some other place; or, in other words, on the *difference of potential*.

In the case of water flowing through a pipe, when its flow has been fully established, the quantity which passes in a given time is the same at any cross-section of the pipe.

In the case of electricity, the quantity of electricity flowing through any conductor, or part of a circuit, is the same at any cross-section. A galvanometer introduced into a break in any part of the conductor would show the same strength of current.

But, though the quantity of water which passes is the same at any cross-section of a pipe, the *pressure per square inch* is not the same, even in the case of a horizontal pipe of the same diameter throughout, but becomes less, or suffers a *loss of head*, or *difference of pressure*, at any two points along the pipe. This difference of pressure causes the flow of water between these two points against the *resistance of the pipe*.

So, too, in the case of a conductor carrying an electric current, when the full current strength has been established, the quantity of electricity that passes is the same at all cross-sections.

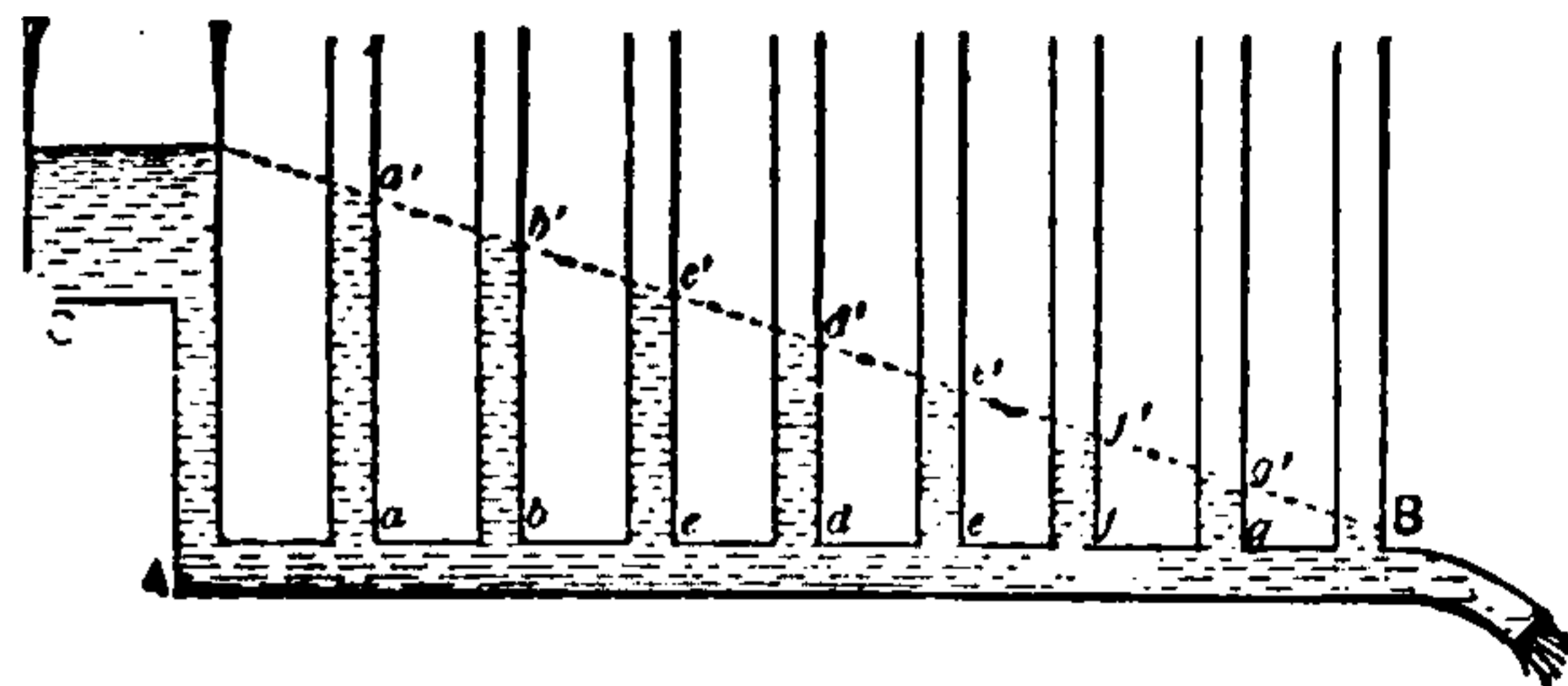

Fig. 449. Hydraulic Gradient.

The electric pressure or potential, however, is by no means the same at all points in the conductor, but suffers a loss of electric head or level, in the direction in which the electricity is flowing. It is this electric head or level, or difference of electric potential, that causes the electricity to flow against the resistance of the conductor.

These analogies can be best shown by the following illustration:

In Fig. 449, a reservoir, or source of water, at C, communicates with the horizontal pipe AB, furnished with open vertical tubes at a, b, c, d, e, f, g, and B. If the outlet at B, is closed, the level of the water in the communicating vessels is the same as at the source; but if the liquid escape freely from B, the level of the water in the branch pipes will be found on the inclined dotted line, or at a', b', c', d', e', f', g', which may be called the *hydraulic gradient*.

The pressure per square inch, at any cross section of the horizontal pipe, which is measured by the height of the liquid in the vertical pipe at that point, *decreases in the direction in which the liquid is flowing*. The force that urges the liquid

through the pipe between any two points, may be called the *liquid-motive force* (*Fleming*) and is measured by the *difference of pressure* between these points.

In Fig. 450, the dynamo-electric machine at D, has its negative pole grounded, and its positive pole connected to a long lead, A B, the positive pole of which is also grounded. A *fall of potential*, represented by the inclined dotted line, occurs between A and B, in the direction in which the electricity is flowing.

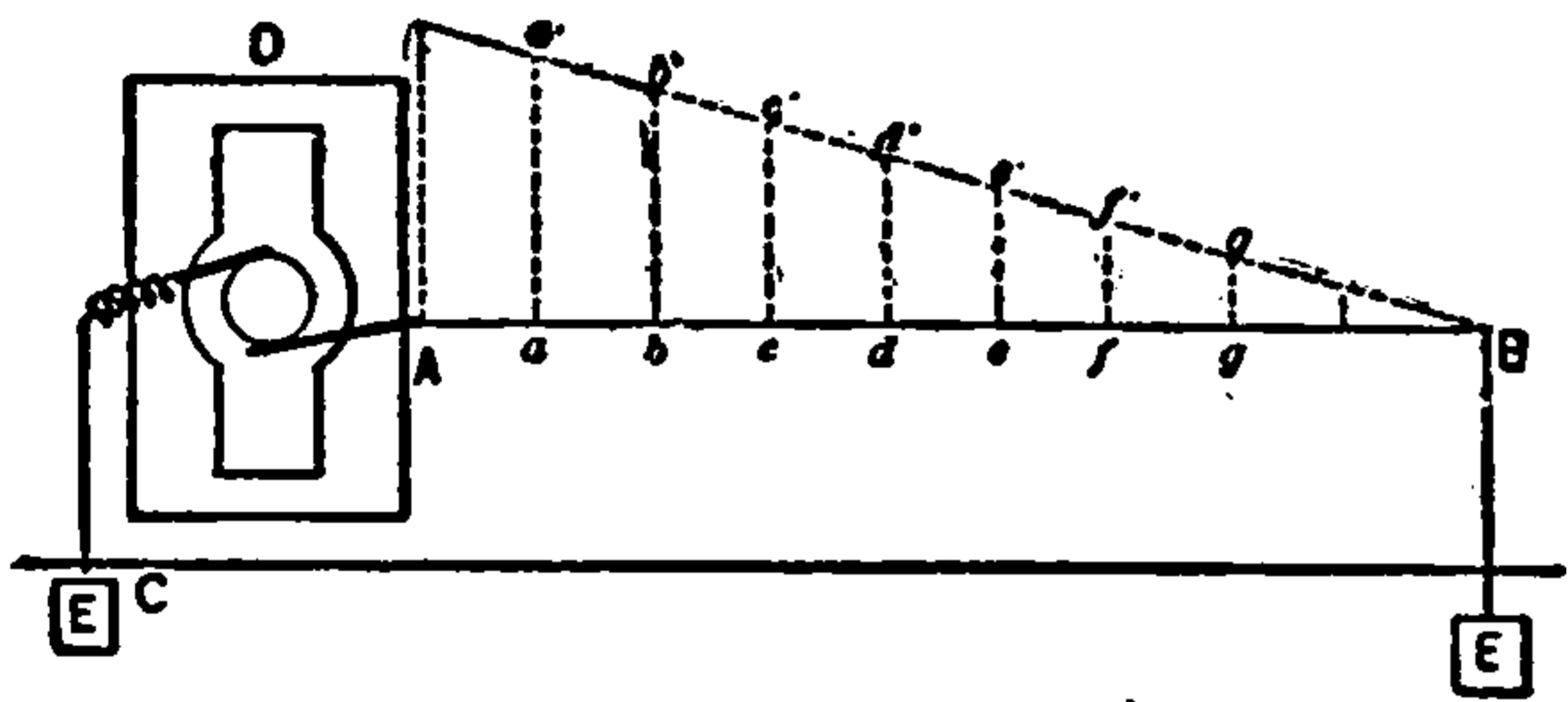

Fig. 450. Fall of Electric Potential.

The dynamo-electric machine may be regarded as a pump that is raising the electricity from a lower to a higher level, and passing it through the lead A B. The electric *pressure* or *potential* producing the flow is greatest near the dynamo and least at the further end, the differences at the points a, b, c, d, e, f, and g, being represented by the vertical lines a a', b b', c c', d d', e e', f f', and g g'.

The electricity flows between any two points as a and b, in the conductor A B, in virtue of the difference of electric pressure or potential between these two parts, or the difference between a a' and b b'.

Differences of potential must be distinguished from differences in electric charge, or *electrostatic density*. If two conductors at different potentials are connected by a conductor, a current will flow through this conductor. When their potential is the same, *no current flows*. The density of a charge is the quantity of electricity per unit of area.

The electric potential is the same at all points of an insulated charged conductor; the density is different at different points, except in the case of a sphere. The potential, however, is the same, since no current flows, or the charge does not redistribute itself. The density on an insulated, isolated sphere, is uniform over all parts of the surface, and its potential is the same at all points. If now the sphere be approached to another body, its density will vary at different parts of its sur-

face, and while the charge is redistributing itself so as to produce these differences in density the potential will vary. As soon, however, as this redistribution is effected and no further current exists, the potential is the same over all points, though the density differs at different points.

An electric source not only produces but also maintains a difference of potential. In the case of the flow of liquid in a pipe, if a continuous current of the liquid be maintained from the higher level in the reservoir to a lower level, as, for example, by means of a pump, it must flow through the pump to the reservoir, from the lower level towards the higher level. In case of an electric source, since the thing called electricity flows through a closed circuit, if its direction of flow in that part of the circuit external to the source—*i. e.*, in the external or useful current—be from a higher to a lower level, then its flow through the remainder of the circuit—*i. e.*, through the source—must be from the lower to the higher level. Since, however, the electrical potential of a body represents the work the electricity is capable of doing, the work done by the electricity may be regarded as being that done when it passes from the higher to the lower level.

Potential, Electrostatic — —The power of doing work possessed by a unit quantity of positive electricity charged or residing on an insulated body.

Potential, Electrostatic, Difference of — —Difference of potential of an electric charge. (See *Potential, Difference of, Electrostatics*.)

Potential Energy.—(See *Energy, Potential*.)

Potential, Fall of — —A decrease of potential in the direction in which an electric current is flowing, proportional to the resistance when the current is constant. (See *Potential, Electric*.)

Potential Galvanometer.—(See *Galvanometer, Potential*.)

Potential Indicator.—(See *Indicator, Potential*.)

Potential, Magnetic — —The amount of work required to bring up a unit north-seeking magnetic pole from an infinite distance to a given point in a magnetic field.

Potential of Conductor, Methods of Varying — — (See *Conductor, Potential of, Methods of Varying.*)

Potential of Conductors.—(See *Conductor, Potential of.*)

Potential, Negative — — That potential in the circuit external to the source towards which the electric current flows.

Generally the lower potential, or lower level.

Potential, Positive — — That potential in the circuit external to the source, from which the electric current flows.

The higher potential or higher level.

Potential, Uniform — — A potential that does not vary.

A constant potential. (See *Potential, Constant.*)

An electric source is said to generate a uniform potential when it maintains a constant difference of potential at its terminals.

Potential, Unit Difference of — — Such a difference of potential between two points that requires the expenditure of one erg of work to bring a unit of positive electricity from one of these points to the other, against the electric force. (See *Erg.*)

The practical unit of difference of potential is the volt. (See *Volt.*)

Potential, Zero — — An arbitrary level from which electric potentials are measured.

As we measure the heights of mountains from the arbitrary mean level of the sea, so we measure electric levels from the arbitrary level of the potential of the earth.

Potentiometer.—An apparatus for the galvanometric measurement of electromotive forces, or differences of potential, by a zero method. (See *Method, Null or Zero.*)

In the potentiometer the difference of potential to be measured is balanced or opposed by a known difference of potential, and the equality of the balance is determined by the failure of one or more galvanometers, placed in shunt circuits, to show any movement of their needles.

The principle of operation of the potentiometer will be understood from an inspection of Fig. 451. A secondary battery S, has its terminals con-

nected to the ends of a uniform wire A B, of high resistance called the *potentiometer wire*. There will, therefore, occur a regular drop or fall of potential along this wire, which, since the wire is uniform, will be equal per unit of length. This drop of potential can be shown by connecting the terminals of a delicate galvanometer, generally of high resistance, to different parts of the wire, when the deflection of the needle will be propor-

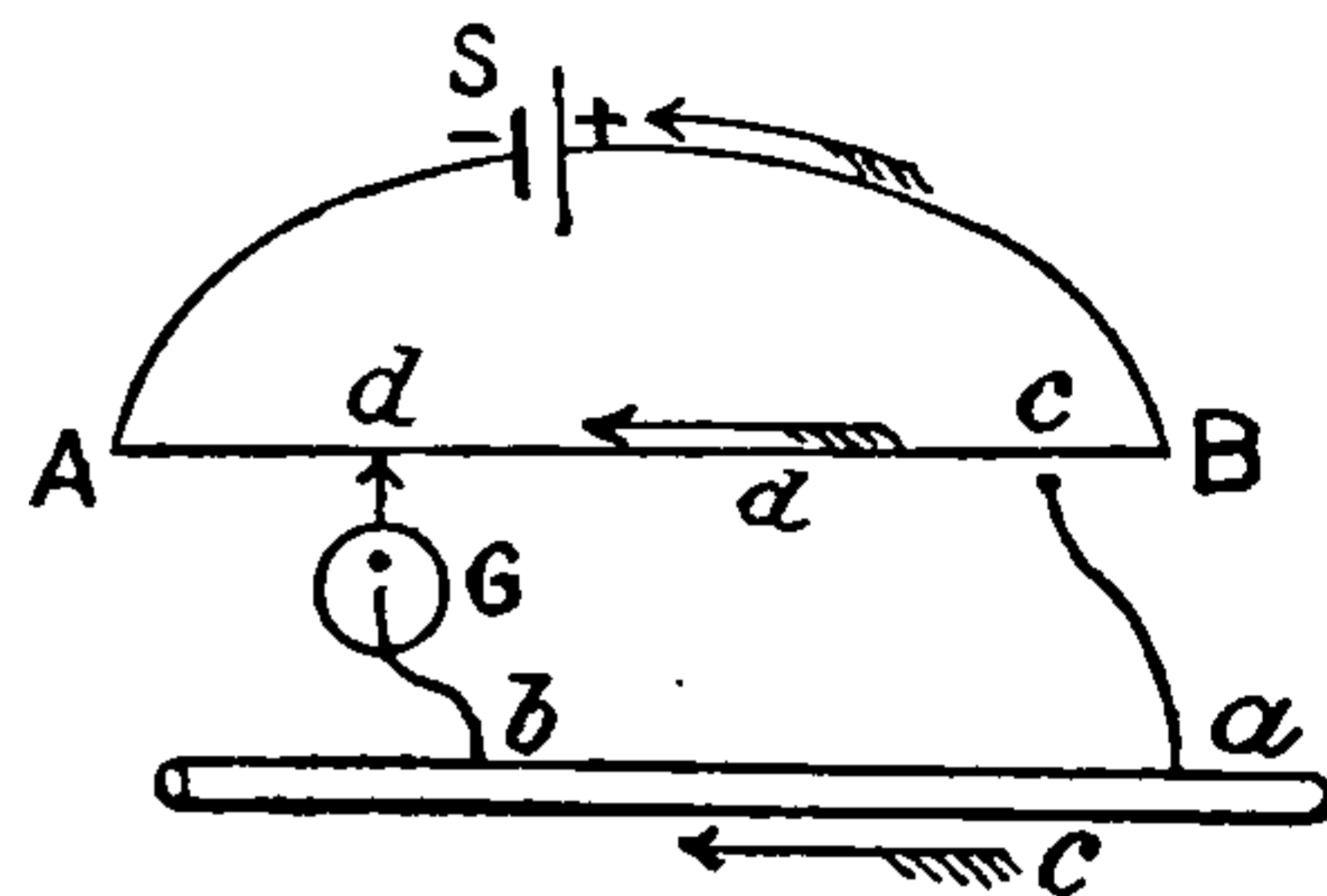

Fig. 451. Potentiometer.

tional to the drop of potential between the two points of the wire touched. If, now, the terminals of a *standard cell* be inserted in the circuit of the galvanometer, so as to oppose the current taken from the potentiometer wire, and the contacts of the potentiometer wire be slid along the wire until no deflection of the galvanometer needle is produced, the drop of potential between these two points on the wire will be equal to the difference of potential of the standard cell. (See *Cell, Voltaic, Standard.*)

Suppose, now, it be desired to measure the difference of potential between two points a and b, on the wire C, through which a current is flowing. Connect the points b and d, and a and c, as shown, with the delicate high resistance galvanometer G, in either of them. Now slide c, towards d, until the needle of G, shows no deflection. The potential between a and b, is then equal to that between c and d.

Potentiometer Wire.—(See *Wire, Potentiometer.*)

Power.—Rate of doing work.

Mechanical power is generally measured in horse power, which is equal to work done at the rate of 550 foot-pounds per second.

The C. G. S. unit of power is one erg per second.

The practical unit of power is the watt, or 10,000,000 ergs per second. The kilowatt is even more frequently used as the unit of power than the watt. (See *Power, Unit of.*)

Power, Absorptive — — The property

THIS PAGE IS LOCKED TO FREE MEMBERS

Purchase full membership to immediately unlock this page



HISTORY

Tens of thousands of important historical sources, many previously unobtainable, are now available for the first time with a Forgotten Books Full Membership.

Unlimited Access
\$8.99/month

Continue

*Fair usage policy applies

its conducting power for heat was greatly increased.

Kohlrausch estimates the conducting power of distilled water at .00000000025, that of mercury being taken as unity.

The best conductors of electricity are the best conductors of heat.

This fact is well illustrated by the following table from Ayrton :

RELATIVE CONDUCTIVITIES PER CUBIC UNIT.

Name of Metal.	Electricity.	Heat.
Silver, annealed.....	100	100
Copper, ".....	94.1	74.8
Gold, ".....	73	54.8
Platinum.....	16.6	9.4
Iron.....	15.5	10.1
Tin.....	11.4	15.4
Lead.....	7.6	7.9
Bismuth.....	1.1	1.8

The electric conductivity of porous conductors decreases much more rapidly than the heat conductivity.

Practically perfect insulators for electricity can be obtained, but are unknown for heat.

Edlund believes the universal ether to be almost a perfect conductor. He bases this belief on the phenomena of sun spots, the occurrence of which is almost immediately followed by the occurrence of magnetic disturbances on the earth.

Lodge regards the luminiferous ether as being almost a perfect non-conductor, because he thinks that conductors must be opaque. It may be suggested in this connection that Edlund's hypothesis as to the conductibility of magnetic effects through the ether is also capable of an explanation by the effects of magnetic induction.

The conducting power for alternating currents is not the same as for steady currents. When the alternations become very high, the difference between these conducting powers of the metals becomes almost inappreciable.

Iron is an enormously worse conductor of electricity than copper for rapidly alternating currents, at least when the alternations are not too great. When, however, the alternations are extremely high, such as those which are produced by the discharge of a Leyden jar or lightning flash, the iron is as good a conductor as the copper. The reason for this is evident. The discharge in such cases keeps to the extreme outer

layer of the conductor, so that the composition of the substance is practically of no effect.

Hughes has shown that the resistance of an iron telephone line of the usual diameter, to periodic currents of about 100 per second, is somewhat more than three times its resistance for steady currents.

There is no such thing as conduction of electricity in gases. Electricity makes its way through a gas by a sudden piercing of the dielectric, or, in other words, by a disruptive discharge. (See *Discharge, Disruptive.*) In such a disruptive discharge it may be assumed that the gas becomes a conductor of electricity while the discharge is passing. It would then partake of the nature of an electrolytic conductor, since the discharge takes place by means of a true locomotion of atoms. (See *Conduction, Electrolytic.*)

Power, Conducting, for Heat — — The ability of a substance to transmit heat through its mass.

The metals are good conductors of heat. They are also good conductors of electricity. The conducting powers for heat and electricity are nearly identical. As the temperature of a body increases, its conducting power for heat is decreased. Carbon forms an exception to this statement.

The flow of heat across a wall formed of a homogeneous material, the exposed faces of which are of equal extent and are maintained at a constant difference of temperature, takes place in accordance with the following laws:

(1.) The rate of flow across all perpendicular sections is the same.

(2.) A uniform drop of temperature occurs from one side of the wall to the other in the direction in which the flow is taking place.

(3.) The rate of flow is proportional to the difference in temperature.

The similarity between the laws of the flow of heat under the circumstances just named and the flow of electricity through a conductor is evident; the electrical current being the same in all parts of the circuit, a drop of potential occurring in the direction in which the current is moving, and the flow being proportional to the difference of potential.

Power, Conducting, Tables of — — Tables in which the relative conducting

powers of different substances are given. (See *Resistance, Tables of.*)

Power, Electric — — Power developed by means of electricity.

Power, Electric, Distribution of — — The distribution of electric power by means of any suitable system of generators, connecting circuits and electric motors.

Power, Electric Transmission of — — The transmission of mechanical energy by converting it into electric energy at one point or end of a line, and reconverting it into mechanical energy at some other point on the line. (See *Energy, Electric, Transmission of.*)

Power, Horse — — A rate of doing work equal to 550 foot-pounds per second, or 33,000 foot-pounds per minute.

1 horse-power = 745.94×10^7 ergs per second.
(See *Erg.*)

“ = 745.941 watts. (See *Watt.*)

“ = 42.746 lb. Fahr. heat units per min. (See *Units, Heat.*)

“ = 23.748 lb. Cent. heat units per min. (See *Units, Heat.*)

Power, Horse, Electric — — Such a rate of doing electric work as is equal to 746 watts or 746 volt-coulombs per second.

This rate is equivalent to 33,000 foot-pounds per minute, or 550 foot-pounds per second.

Just as 1 pound of water raised through the vertical distance of 1 foot requires the expenditure of a foot-pound of energy, so 1 coulomb of electricity acting through the difference of potential of 1 volt requires a certain amount of work to be done on it. (See *Coulomb, Volt, Potential, Electric.*)

This amount is called a volt-coulomb or joule, and measured in foot-pounds is equal to .737324 foot-pounds. The volt coulomb, or joule, is therefore the unit of electric work, just as the foot-pound is the unit of mechanical work.

The electric work of any circuit in joules is equal to the product of the volts by the coulombs.

If we determine the rate per second at which the coulomb; pass, and multiply this product by the volts, we have a quantity which represents the electrical power, or rate of doing electrical work.

But 1 ampère is equal to 1 coulomb per second; therefore, if we multiply the current in ampères by the difference of potential in volts, the product is equal to the electrical power or rate of doing electrical work.

The product of an ampère by a volt is called a volt-ampère, or a watt.

One watt = .0013406 horse-power, or

One horse-power = 745.941 watts.

Therefore the electrical horse-power = $\frac{C E}{746}$,
where C = the current in ampères and E = the difference of potential in volts.

Power, Multiplying, of Shunt — — (See *Shunt, Multiplying Power of.*)

Power of Periodic Current.—(See *Current, Periodic, Power of.*)

Power, Portative — — The carrying power of a magnet. (See *Magnet, Portative Power of.*)

Power, Projecting, of Magnet — — The power a magnet possesses of throwing or projecting its lines of magnetic force across an intervening air space or gap.

The greater the air space the greater the magnetic reluctance, and consequently the greater the magnetizing force required to overcome it. Magnets of great projecting power are generally of great length, to accommodate the long coils of wire required.

Power, Resuscitating, of Secondary Battery Cell — — The power possessed by an apparently completely discharged secondary or storage cell of furnishing additional current after a protracted rest.

This resuscitating power is probably due to depolarization. It is therefore present in primary as well as in secondary batteries.

Power, Stray — — That part of the power employed in driving a dynamo, which is lost through friction, air churning or air currents, eddy currents, hysteresis, etc.

Power, Thermo-Electric — — A number which, when multiplied by the difference of temperature of a thermo-electric couple, will give the difference of potential thereby generated in micro-volts. (See *Diagram, Thermo-Electric.*)

Power, Units of — — Various units employed in the measurement of power.

The following table of units of power is taken from Hering's work on dynamo-electric machines.

Unit of Power.

1 erg per second..	= .0000001 watt.
1 watt, or 1 volt-ampère, or 1 joule per second, or 1 volt-coulomb per second.....	= 10000000 ergs per second.
“	= 44.2394 foot-pounds per min.
“	= 6.11622 kilogram - metres per min.
“	= .0573048 lb.-Fah., heat unit per min.
“	= .318360 lb.-Cent., heat unit per min.
“	= .0144402 klgr.-Cent. heat unit per min.
“	= .0013592 metric horse-power.
“	= .0013406 horse-power.
1 foot-pound per min.....	= 226043 ergs per second.
“	= .0226043 watt.
“	= .13825 kilogram-metre per min.
“	= .00003072 metric horse-power.
“	= .000030303 horse-power.
1 kilogram - metre per min.....	= 1635000 ergs per second.
“	= .163500 watt.
“	= 7.23314 foot-pounds per min.
“	= .0002222 metric horse-power.
“	= .0002192 horse-power.
1 metric horse-power, or 1 French horse-power, or 1 cheval-vapeur, or 1 force de cheval, or 1 Pferdekraft.	= $735\ 75 \times 10^7$ ergs per second.
“	= 735.750 watts.
“	= 32549.0 foot-pounds per min.
“	= 4500 kilogram-metres per min.

1 metric h.-p., etc.	= 42.162 lb.-Fah., heat units per min.
“	= 23.423 lb.-Cent., heat units per min.
“	= 10.625 klg.-Cent., heat units per min.
“	= .98634 horse-power heat units per min.
1 horse-power....	= 745.94×10^7 ergs per second.
“ = 745.941 watts.
“ = 33000 foot-pounds per min.
“ = 4562.33 kilogram - metres per min.
“ = 42.746 lb.-Fah., heat units per min.
“ = 23.748 lb.-Cent., heat units per min.
“ = 10.772 klg. - Cent., heat units per min.
“ = 1.01385 metric horse-power.
1 lb.-Fah., heat unit per min....	= 17.45×10^7 ergs per sec.
“	= 17.4505 watts.
“	= .23718 metric horse-power.
“	= .023394 horse-power.
1 lb. Cent., heat unit per min....	= 31.41×10^7 ergs per sec.
“	= 31.4109 watts.
“	= .04269 metric horse-power.
“	= .042109 horse-power.
1 klgr.-Cent., heat unit per min....	= 69.25×10^7 ergs per sec.
“	= 69.249 watts.
“	= .09412 metric horse-power.
“	= .092835 horse-power.

Poynting's Law.—(See *Law, Poynting's.*)

Practical Unit of Inductance, or Self-Induction.—(See *Inductance, or Self-Induction, Practical Unit of.*)

Practical Unit of Magneto-Motive Force.—(See *Force, Magneto-Motive, Practical Unit of.*)

Practical Units.—(See *Units, Practical.*)

Pressel.—A press switch or push connected to the end of a flexible, pendant conductor.

Pressure Wires.—(See *Wires, Pressure.*)

Primary Battery.—(See *Battery, Primary.*)

THIS PAGE IS LOCKED TO FREE MEMBERS

Purchase full membership to immediately unlock this page

Know Your Bible

Forgotten Books' Full Membership provides unlimited access to more than 28,000 volumes of Christian literature for \$8.99/month

HOLY BIBLE

Continue

*Fair use policy applies

arc in order to stop the direct light from the arc which would have divergent rays. The door C, is formed of a number of cylindrical lenses, placed parallel to one another, which cause the rays to diverge horizontally, when so desired.

Prony Brake.—(See *Brake, Prony*.)

Proportional Coils.—(See *Coils, Proportional*.)

Proportionate Arms.—(See *Arms, Proportionate*.)

Proportionate Arms of Electric Bridge.—(See *Arms, Proportionate*.)

Prostration, Electric — — Physiological exhaustion or prostration, resembling that produced by sunstroke, resulting from prolonged exposure to the radiation of an unusually large voltaic arc. (See *Sunstroke, Electric*.)

Protection, Electric, of Houses, Ships and Buildings Generally — — Means for protection against the destructive effects of a lightning discharge, consisting essentially in the use of lightning rods. (See *Rod, Lightning*.)

Protection, Electric, of Metals — — (See *Metals, Electrical Protection of*.)

Protective Sheath.—(See *Sheath, Protective*.)

Protector, Cable — — A device for the safe discharge of the static charge produced on the metallic sheathing of a cable, or on conductors surrounding or adjacent to the cable, consequent on changes in the electromotive force applied to the conducting core of such cable.

The cable protector is provided for the purpose of preventing the discharge of the charge from piercing and thus injuring the insulation of the cable itself.

Protector, Comb — — A term sometimes applied to a lightning protector or arrester, in which both the line and ground plates are furnished with a series of teeth, like those on a comb. (See *Arrester, Lightning*.)

Protector, Voltaic Battery — — A device for automatically disconnecting a voltaic battery, whenever the circuit in which it is placed becomes grounded.

The battery protector is used in systems of electric gaslighting, where, unless great care is exercised in insulating the circuits, considerable annoyance is often experienced from the readiness with which grounds are established. This arises from the high electromotive force of the spark obtained from the spark coil, piercing the insulation and establishing a ground through the gas pipes.

Protoplasm, Effects of Electric Currents on — — Contractions observed in all protoplasm on the passage of an electric current through it.

Protoplasm, the basis of plant and animal life, or the jelly-like matter that fills all organic cells, whatever may be the origin of such cells, suffers contraction when traversed by an electric current.

An increased activity in the movements of a form of microscopic life called the *amæba* is occasioned by slight shocks from an induction coil; stronger discharges produce tetanic contractions, with, in some cases, expulsion of food or even of the nucleus. A uniform strength of current produces contraction and imperfect tetanus.

Pull.—A contact maker, similar in general construction to a push button, but operated by means of a pulling rather than a pushing force.

The pull is preferable to the push in exposed positions, such as outer doors, where moisture is apt to injure pushes.

Pull, Chain — — A chain pendant attached to a pendant burner for the movement of the wipe-spark spring and the ratchet in an electrically lighted gas burner.

Pull, Door Bell, Electric — — A circuit-closing device attached to a bell pull and operated by the ordinary motion of the pull.

Pull, Electric Bell — — A circuit-closing device operated by a pull.

Fig. 453 shows a form of electric bell pull. On pulling the bell handle, contact springs, that rest on a ring of insulating material when the

pull is in its normal position, are brought into contact with a metal ring, thus completing the cir-

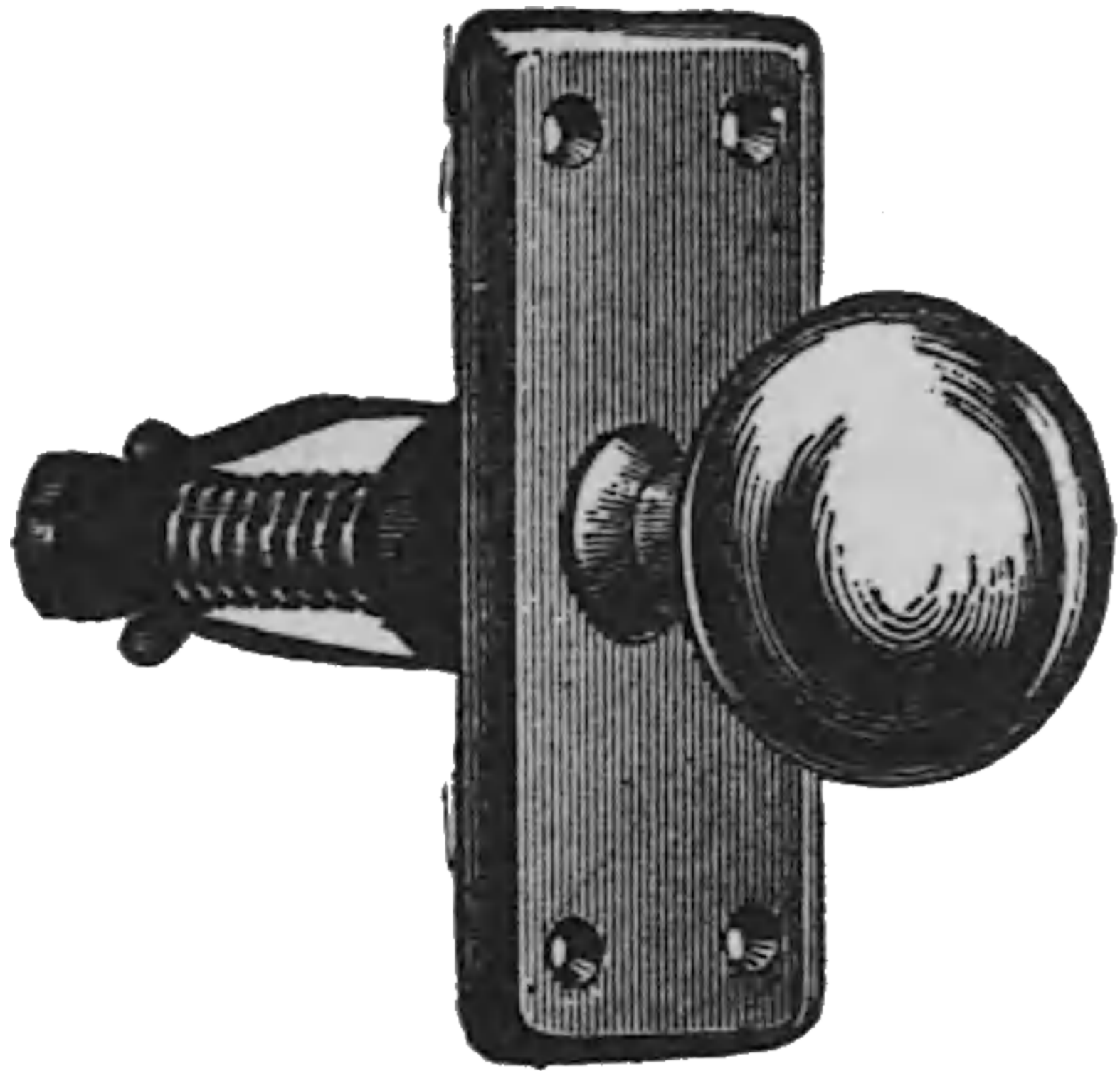

Fig. 453. Electric Bell Pull.

cuit. The bell pull is often used to replace the ordinary push button.

Pulley, Driven — — A pulley attached to the driven shaft. (See *Mover, Prime.*)

Pulley, Driving — — A pulley attached to the driving shaft. (See *Mover, Prime.*)

Pulsating Current.—(See *Current, Pulsating.*)

Pulsation.—A quantity of the nature of an angular velocity, equal to 2π multiplied by the frequency of the oscillation, or, equal to 2π divided by the duration of a single period.

Pulsatory Current.—(See *Current, Pulsatory.*)

Pulsatory Magnetic Field.—(See *Field, Magnetic, Pulsatory.*)

Pulse, Electrical — — An electric oscillation.

A momentary flow of electricity from a conductor, which gradually varies from the zero value to the maximum, and then to the zero value again, like a pulse or vibration in an elastic medium.

Electric pulses are set up in conductors connected with the coatings of a Leyden jar, on the discharge of the same. Such pulses produce a series of electrical oscillations, which move alternately backwards and forwards, until the discharge is gradually dissipated. (See *Oscillations, Electric.*)

The circumstances influencing the rate of propagation of an electric pulse through different parts of a closed circuit, according to Lodge, are—

(1.) The extra inertia, or the so-called magnetic susceptibility in the conducting substance, especially at its outer parts.

(2.) An undue constriction or throttling of the medium through which the disturbance is passing.

(3.) The nature of the insulating medium.

Pump, Air, Geissler Mercurial — — A mercurial air pump, in which the vacuum is attained by the aid of a Torricellian vacuum.

In the *Geissler Mercury Pump*, Fig. 454, a vacuum is obtained by means of the Torricellian vacuum produced in

a large glass bulb that forms the upper extremity of a *barometric column*. The lower end of this tube or column is connected with a reservoir of mercury by means of a flexible rubber tube. To fill the bulb with mercury the reservoir is raised above its level, *i. e.*, above thirty inches, the air it contains being allowed to escape through an opening governed by a stopcock. The vessel to be exhausted is connected with the bulb, and by means of a two-way exhaustion cock, communication can be made with the bulb, when it contains a Torricellian vacuum, and shut off from it while its air is being expelled.

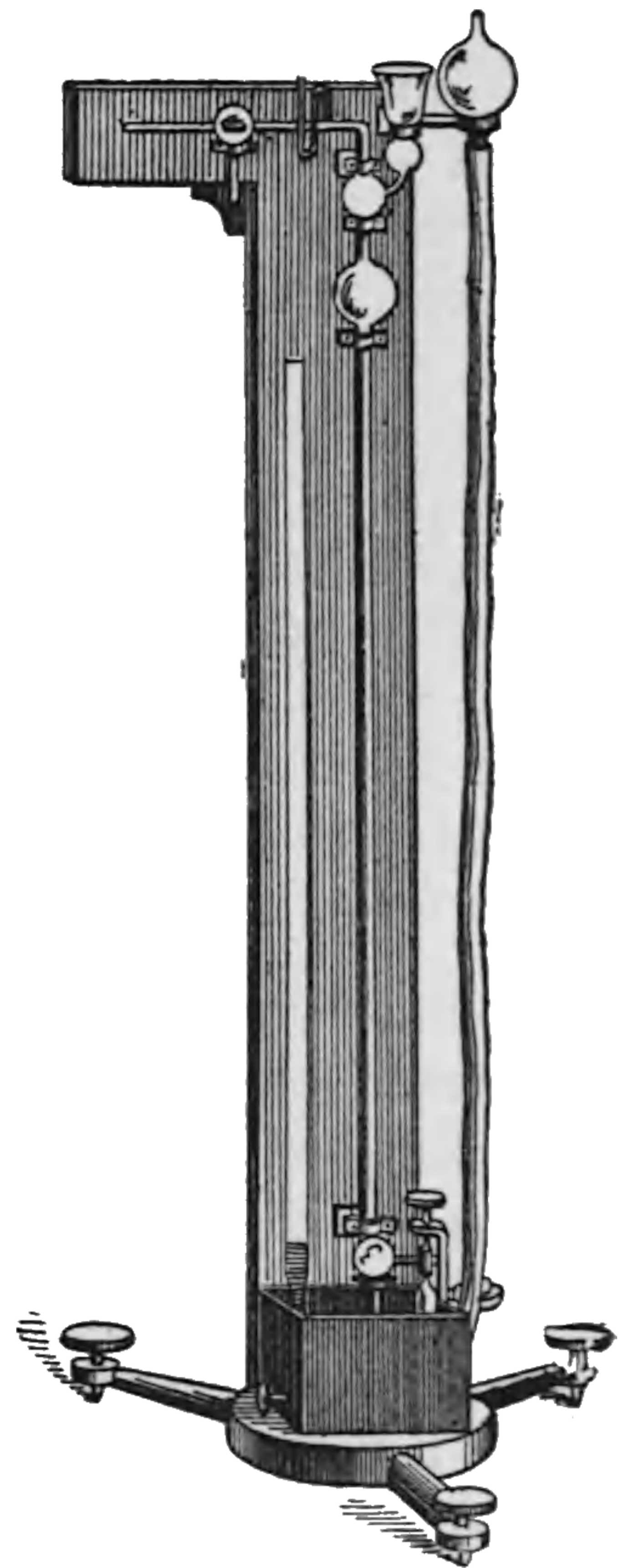

Fig. 454. Geissler's Mercurial Air Pump.

In actual practice the mercury is mechanically pumped into the barometric column, and the valves are opened either by hand, or automatically by electrical means.

Pump, Air, Mechanical — — A mechanical device for exhausting or removing the air from any vessel.

An excellent form of air pump is shown in Fig. 455, which is a drawing of Bianchi's pump.

Three valves, all opening upwards, are placed

at the top and bottom of the cylinder, and in the piston, respectively. These valves are mechanically opened and closed at the proper moment by the movements of the piston, *i. e.*, their action is *automatic*. This enables a much higher vacuum to be obtained than when the valves open and close by the tension of the air.

Mechanical pumps are unable to readily produce the high vacua employed in most electric lamps. Mercury pumps are employed for this purpose. (See *Pump, Air, Mercurial*.)

Pump, Air, Mercurial — — A device for obtaining a high vacuum by the use of mercury.

Mercury pumps are in general of two types of construction, viz. :

(1.) The Geissler pump.

(2.) The Sprengel pump. (See *Pump, Air, Geissler Mercurial*. *Pump, Air, Sprengel's Mercurial*.)

Pump, Air, Sprengel's Mercurial — — A mercurial air pump in which the vacuum is obtained by means of the fall of a stream of mercury.

In the Sprengel mercury pump, Fig. 456, the fall of a mercury stream causes the exhaustion of a reservoir connected with the vertical tube, by the mechanical action of the mercury in entangling bubbles of air. These bubbles are largest at the beginning of the exhaustion, but become smaller and smaller near the end, until, at last, the characteristic metallic click of mercury or other liquid falling in a good vacuum

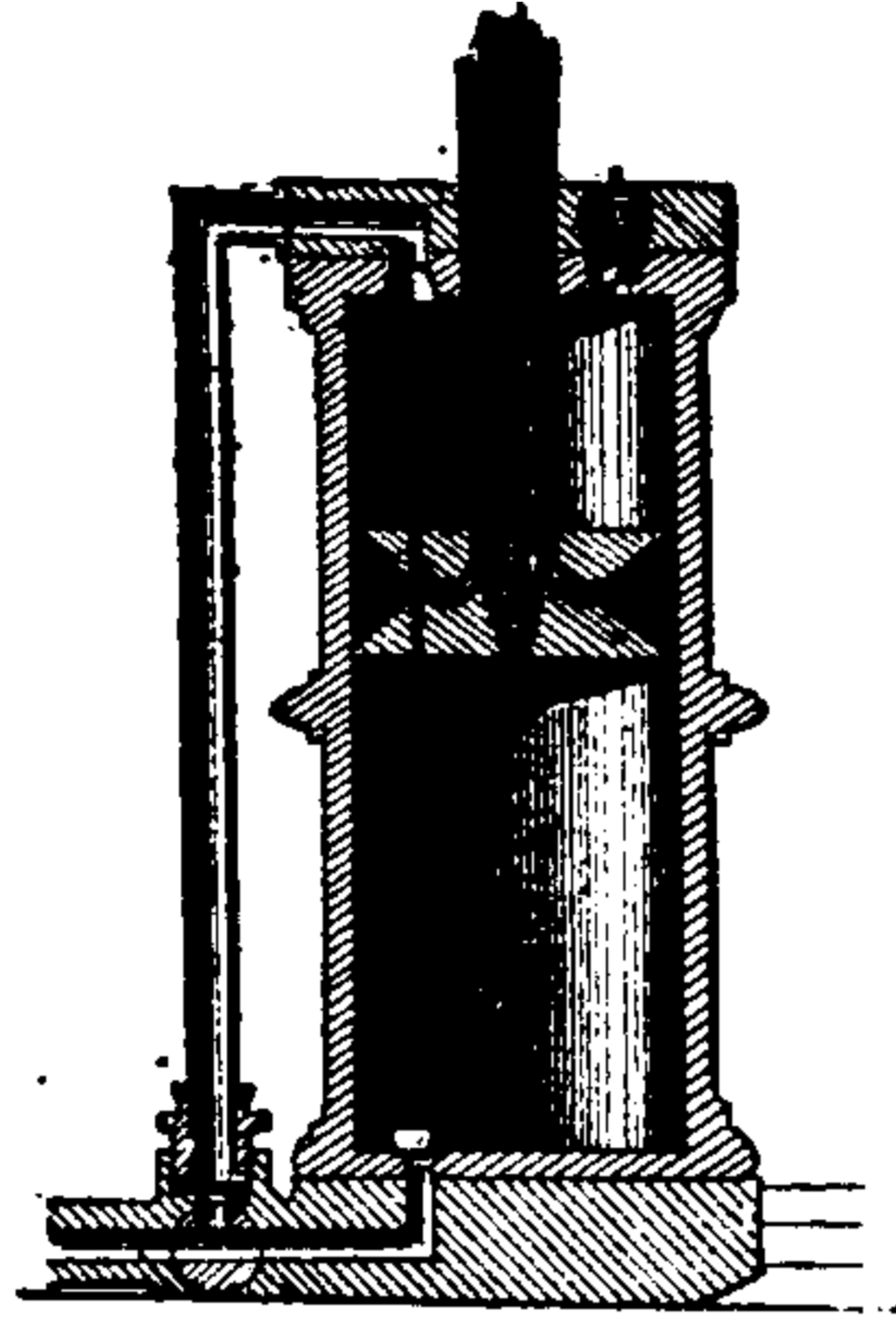

Fig. 455. Barrel of Bianchi's Air Pump.

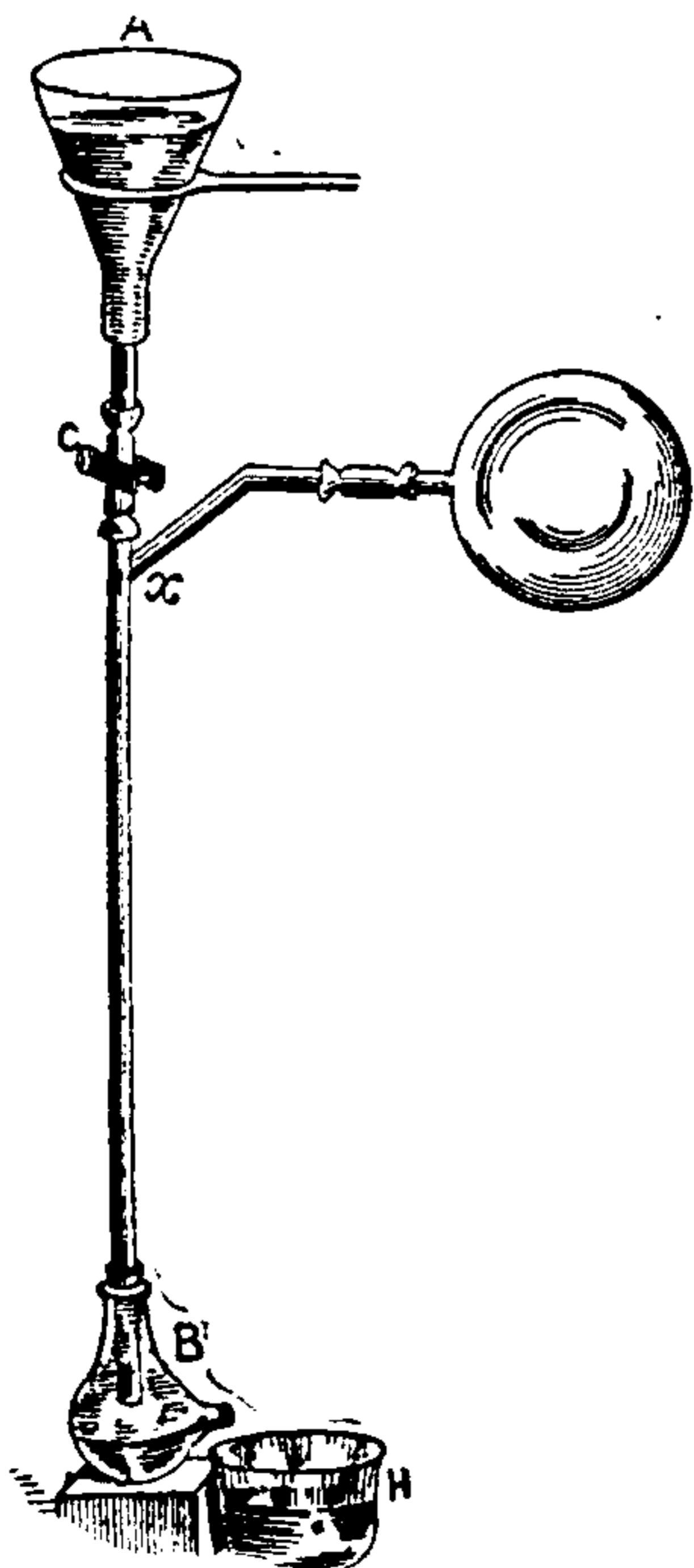

Fig. 456. Sprengel's Mercurial Air Pump.

is heard. The exhaustion may be considered as completed when the bubbles entirely disappear from the column.

The Sprengel pump produces a better vacuum than the Geissler pump, but is slower in its action.

In actual practice, the mercury that has fallen through the tube is again raised to the reservoir connected to the drop tube by the action of a mechanical pump.

Pumping of Electric Lights.—A term sometimes applied to a pulsating or periodical increase and decrease in the brilliancy of the light.

This action is generally due to the periodic slipping of the belt or other driving mechanism. In the case of arc lamps it may also be caused by the improper action of the feeding device of the lamp.

Puncture, Electro — — The application of electrolysis to the treatment of aneurisms or diseased growths.

The blood is decomposed by the introduction of a fine platinum needle connected with the anode of a battery, and insulated, except near its point, by a covering of vulcanite.

The kathode is a sponge-covered metallic plate.

Puncture, Galvano — — A term sometimes applied to electro-puncture. (See *Puncture, Electro*.)

Punning of Telegraph Pole.—(See *Pole, Telegraphic, Punning of*.)

Push.—A name sometimes applied to a push button, or to a floor push. (See *Push, Floor, Button, Push*.)

Push Button.—(See *Button, Push*.)

Push-Button Rattler.—(See *Rattler, Push-Button*.)

Push, Floor — — A push button placed on the floor of a room so as to be readily operated by means of the foot. (See *Button, Push*.)

Pyknometer.—A term sometimes used for the specific gravity bottle employed in determining the specific gravity of a liquid.

Pyrheliometer.—An apparatus for measuring the energy of the solar radiation.

THIS PAGE IS LOCKED TO FREE MEMBERS

Purchase full membership to immediately unlock this page



HISTORY

Tens of thousands of important historical sources, many previously unobtainable, are now available for the first time with a Forgotten Books Full Membership.

Unlimited Access
\$8.99/month

Continue

*Fair usage policy applies

Quantity Armature. — (See *Armature, Quantity.*)

Quantity, Connection of Battery for — — (See *Battery, Connection of, for Quantity.*)

Quantity Efficiency of Storage Battery. — (See *Efficiency, Quantity, of Storage Battery.*)

Quantity, Unit of Electric — — A definite amount or quantity of electricity called the coulomb. (See *Coulomb.*)

Although the exact nature of electricity is unknown, yet, like a fluid (a liquid or gas), electricity can be accurately measured as to quantity.

A current of 1 ampère, for example, is a current in which one coulomb of electricity passes in every second.

A condenser of the capacity of 1 farad, is large enough to hold 1 coulomb of electricity if forced into the condenser under an electromotive force of 1 volt. (See *Capacity, Electrostatic. Farad. Volt. Ampère.*)

Quiet Arc. — (See *Arc, Quiet.*)

Quiet Discharge. — (See *Discharge, Silent.*)

Quicking Solution. — (See *Solution, Quicking.*)

R

R. — A contraction used for ohmic resistance.

ρ . — A contraction used for specific resistance.

Radial Armature. — (See *Armature, Radial.*)

Radially Laminated Armature Core. — (See *Core, Armature, Radially-Laminated.*)

Radiant Energy. — (See *Energy, Radiant.*)

Radiant Matter. — (See *Matter, Radiant, or Ultra-Gaseous.*)

Radiate. — To transfer energy by means of waves.

Radiating. — Transferring energy by means of waves.

Radiation. — Transference of energy by means of waves.

When an elastic body is set into vibration, whether it be the vibrations that produce light, heat or electricity, energy is charged on the body, and the body will then continue to vibrate until it imparts to some medium surrounding it an amount of energy exactly equal to that originally imparted to itself.

In the case of a sonorous body the energy is transferred from the vibrating body to the air around it. For example, in the case of an elastic metallic wire set into vibration, the wire will continue to vibrate until it does as much work on the surrounding air as was originally done on it, in order to set it into vibration.

In the case of a heated body the energy is transferred from the body to the luminiferous ether around it. For example, in the case of the same wire heated above the temperature of the air, the energy imparted to the molecules of the metal by the source of heat causes them to move towards and from one another. These to and-fro motions of the molecules cause the surrounding ether to be set into waves, and as much energy is imparted to the ether, as was originally imparted to the wire in order to heat it.

In the case of a luminous body the energy is transferred from the body to the luminiferous ether. For example, if the wire is heated to luminosity by a certain amount of energy imparted to it, the surrounding ether is now set into waves of both light and heat, which differ from one another only in their wave length, and the luminous body will continue to radiate light and heat until it imparts to the surrounding ether an amount of energy exactly equal to that originally imparted to it.

So, too, in the case of a body charged with electricity. If disruptively discharged, the impulsive rush of electricity, so produced, causes the energy charged on it to be radiated as electromagnetic waves into the surrounding ether. The discharging body is, to all intents and purposes, in the same condition as the vibrating elastic wire, and dissipates or radiates its energy in much the same manner.

Radiation, Electro-Magnetic — — The sending out in all directions from a con-

ductor, through which an oscillating discharge is passing, of electro-magnetic waves in all respects similar to those of light except that they are of much greater length. (See *Electricity, Hertz's Theory of Electro-Magnetic Radiations or Waves.*)

Radiation of Electricity.—(See *Electricity, Radiation of.*)

Radiation of Lines of Force.—(See *Force, Lines of, Radiation of.*)

Radical, Compound — —A group of unsaturated atoms.

A group of elementary atoms, some of the bonds of which are open, or not connected or joined with the bonds of other atoms. (See *Atomicity.*)

For example, hydroxyl, HO, is a compound radical, with one of the two bonds of the diad oxygen atom, open or unsaturated.

Radical, Simple — —An unsaturated atom with its bond or bonds free.

A single unsaturated atom as distinguished from an unsaturated group of atoms.

Radicals.—Unsaturated atoms or groups of atoms, in which one or more of the bonds are left open or free.

Radicals are either *Simple* or *Compound*.

The radical may be regarded as the basis to which other elements may be added, or as the nucleus around which they may be grouped.

Thus H_2O , forms a complete chemical molecule, because the bonds of all its constituent atoms are saturated, thus $H-O-H$. But $H-O-$, or *hydroxyl*, is a radical, because its oxygen atom possesses one unsaturated or free bond. By combining with the radical (NO_2), it forms nitric acid, thus $H-O-(NO_2)$ or $II NO_3$.

During electrolysis, the molecules of the electrolyte are decomposed into two groups of simple or compound radicals, called *ions*. These *ions* are respectively electro-positive and electro-negative, and are called *kathions* and *anions*. (See *Ions, Electrolysis.*)

Radiometer, Crookes' — —An apparatus for showing the action of radiant matter in producing motion from the effects of the reaction of a stream of molecules escaping from a number of easily moved heated surfaces. (See *Matter, Radiant, or Ultra-Gaseous.*)

Radiometer, Electric, Crookes — — A radiometer in which the repulsion of the molecules of the residual atmosphere takes place from electrified instead of from heated surfaces. (See *Radiometer, Crookes'.*)

Radio-Micrometer, Boys' — —An electrical apparatus for measuring the intensity of radiant heat.

The action of the radio-micrometer depends on the deflection, by a magnetic field, of a suspended thermo-electric circuit composed of three metals, viz.: two bars of antimony and bismuth, or of their alloys, which are soldered side by side to the end of a minute disc or strip of copper foil, as shown in Fig. 457. This disc or foil of copper is

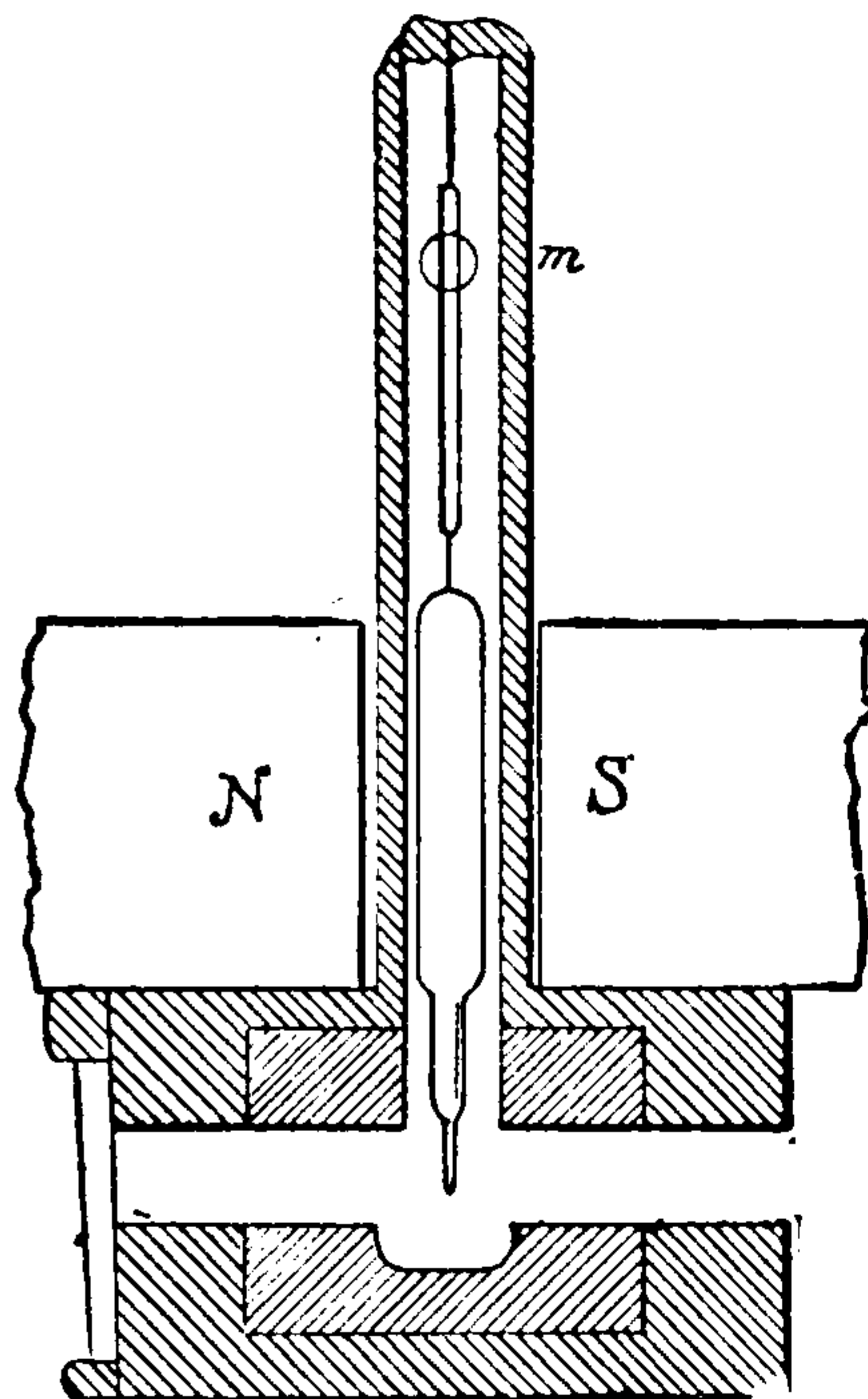

Fig. 457. Boys' Radio-Micrometer.

provided for the purpose of receiving the radiation that is to be measured. The upper ends of the thermo-couple are soldered to the ends of a long, narrow, inverted U-shaped piece of copper wire, which completes the thermo-electric circuit.

The absorption of radiant energy by the copper disc connected to the thermo-electric couple produces an electric current, and the circuit, being suspended in a magnetic field, is at once deflected to a degree dependent on the intensity of the radiation, or of the current generated at the thermo-electric junction.

The means adopted for the suspension of the system are shown in Figs. 457 and 458. A small piece of straight wire is soldered to the up-

per end of the copper stirrup, which completes the thermo-electric circuit. This wire is cemented to the lower end of a glass tube, the upper end of which is provided with a mirror, and the whole suspended, as shown, by a quartz fibre in the field of a powerful magnet.

In a radio-micrometer made by Prof. Boys, the minuteness of the suspended circuit may be judged from the following actual dimensions, viz.: Thermo-electric bars, $\frac{1}{8} \times \frac{1}{80} \times \frac{1}{200}$ inch; copper circuit of number 36 copper wire, 1 inch long and about $\frac{1}{10}$ inch wide; copper heat-receiving surface, blackened on the face exposed to the radiation, $\frac{1}{10}$ inch in diameter, or $\frac{1}{4} \times \frac{1}{80}$ inch; receiver, $\frac{1}{10}$ inch square, $\frac{1}{200}$ inch thick; quartz fibre 4 inches long, $\frac{1}{8000}$ inch in diameter.

This instrument, when properly adjusted for extreme sensitiveness, should give clear indications when the blackened surface is warmed but the $\frac{1}{800000}$ degree Centigrade. It will respond to the heat radiated on the surface of a half penny from a candle flame at a distance of 1,530 feet.

In order to avoid the disturbance due to the magnetic qualities of the antimony and bismuth bars, the central portions of the metallic block, inside which the system is suspended, is made of iron, as shown by the heavier shading in Fig. 457.

This mass of iron serves as a magnetic screen to the thermo-electric bars, but permits the action of the field on the circuit.

Radiophone.—A name sometimes given to the photophone. (See *Photophone*.)

Radiophony.—The production of sound by a body capable of absorbing radiant energy when an intermittent beam of light or heat falls on it.

The action of radiant energy, when absorbed by matter, is to cause its expansion by the consequent increase of temperature. This occurs even when the body is but momentarily exposed to a

flash of light, but the instantaneous expansion thus produced immediately dies away, and by itself is indistinguishable. If, however, a sufficiently rapid succession of such flashes fall on the body, the instantaneous expansions and contractions produce an appreciable musical note.

The sounds so produced have been utilized by Bell and Tainter in the construction of the *Photophone*. (See *Photophone*.)

Railroad, Electric.—A railroad, or railway, the cars on which are driven or propelled by means of electric motors connected with the cars.

The electric current that drives the motor is derived either from storage batteries placed on the cars, or from a dynamo-electric machine, or battery of dynamo-electric machines, conveniently situated at some point on the road. The current from the dynamo is led along the line by suitable electric conductors and is passed into the electric motor as the car runs along the tracks in various ways, viz.:

Systems for the electric propulsion of cars may, therefore, be divided into the dependent system, in which the driving current is obtained from conductors placed somewhere outside the cars, and the independent system, where the current is derived from primary or secondary batteries placed on the cars. (See *Railroads, Electric, Dependent System of Motive Power for. Railroads, Electric, Independent System of Motive Power for.*)

In the dependent system, the conductors which supply the car with current are placed either overhead, on the surface of the road-bed or underground. Thus arise three divisions of the dependent system:

- (1.) The Surface System.
- (2.) The Underground System.
- (3.) The Overhead System.

(1.) *The Surface System.*—By placing one or both rails in the circuit of the dynamo and taking the current from the tracks by means of sliding or rolling contacts connected with the motor.

(2.) *The Underground System.*—By placing the conducting wires parallel to each other in a longitudinally slotted underground conduit in the road-bed, and provided with two central plates, insulated from one another and connected respectively to the motor terminals, and taking the current by means of a traveling brush or roller, called a plow, sled or shoe. On the movement of the car over the track, these traveling contacts touch the

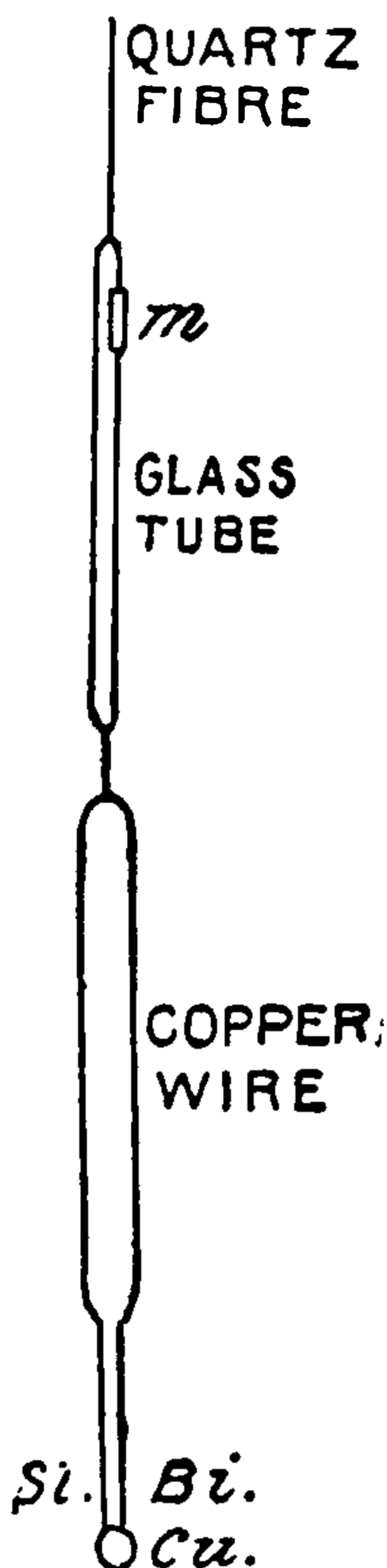

Fig. 458. Boys' Radio-Micrometer.

THIS PAGE IS LOCKED TO FREE MEMBERS

Purchase full membership to immediately unlock this page

Know Your Bible

Forgotten Books' Full Membership provides unlimited access to more than 28,000 volumes of Christian literature for \$8.99/month

HOLY BIBLE

Continue

*Fair use policy applies

by the display of suitable signals, more than one train or engine from being on the same block at the same time.

There are two kinds of railway block systems in common use, viz.:

(1.) The *Absolute Block System*.

(2.) The *Permissive Block System*.

In the absolute system, which is the safer, one train only is permitted on any particular block at a given time.

In the permissive block system more than one train is permitted, under certain circumstances and conditions, to occupy the same block simultaneously, each train then being notified of the fact that it is not alone on the block.

The absolute block system, though expensive to construct and maintain, is the only one that should be permitted by law to exist on roads whose traffic exceeds a certain amount.

An absolute block system is employed on the London Underground Railroad, and on the Pennsylvania Railroad Systems.

The system in use on the New York Division of the Pennsylvania Railroad is as follows:

The road between Philadelphia and Jersey City is divided into some seventy sections, the length of each section being dependent on the amount of

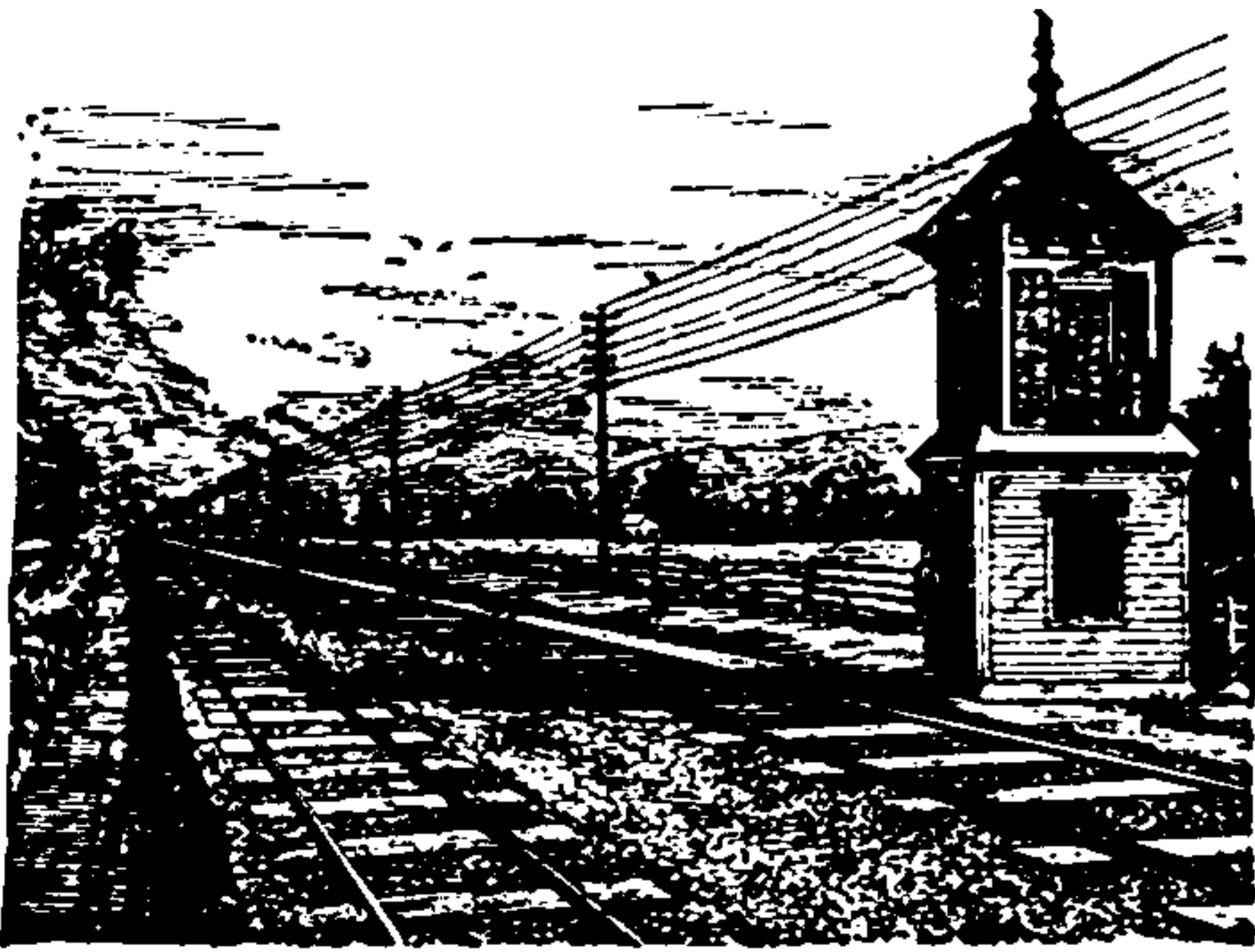

Fig. 462. Block Tower.

daily traffic, thus, between Jersey City and Newark, where the traffic is great, there are some fifteen sections, although the distance is only 7.9 miles.

In each block-tower there are connections with three separate and distinct telegraph lines or circuits, viz.:

(1.) A line or wire called the *train wire*, connecting the block-tower with the General Dispatcher's office at Jersey City. This line is used for sending train orders only.

(2.) A line or wire called the *block wire*, con-

necting each block-tower with the next tower on each side of it.

(3.) A line or wire called the *message wire*, and used for local traffic or business.

The general arrangement of the block-tower is shown in Fig. 462.

Each of the block-towers is sufficiently elevated above the road-bed to afford the operator an unobstructed view of the tracks.

The operator, having ascertained the actual condition of the track, either by observation or by telegraphic communication with the stations on either side of him, gives notice of this condition to all trains passing his station by the display of certain semaphore signals.

The semaphore signals as used on the Pennsylvania Railroad are shown in Figs. 463 and 464.

The form shown in Fig. 463 is used in the abso-

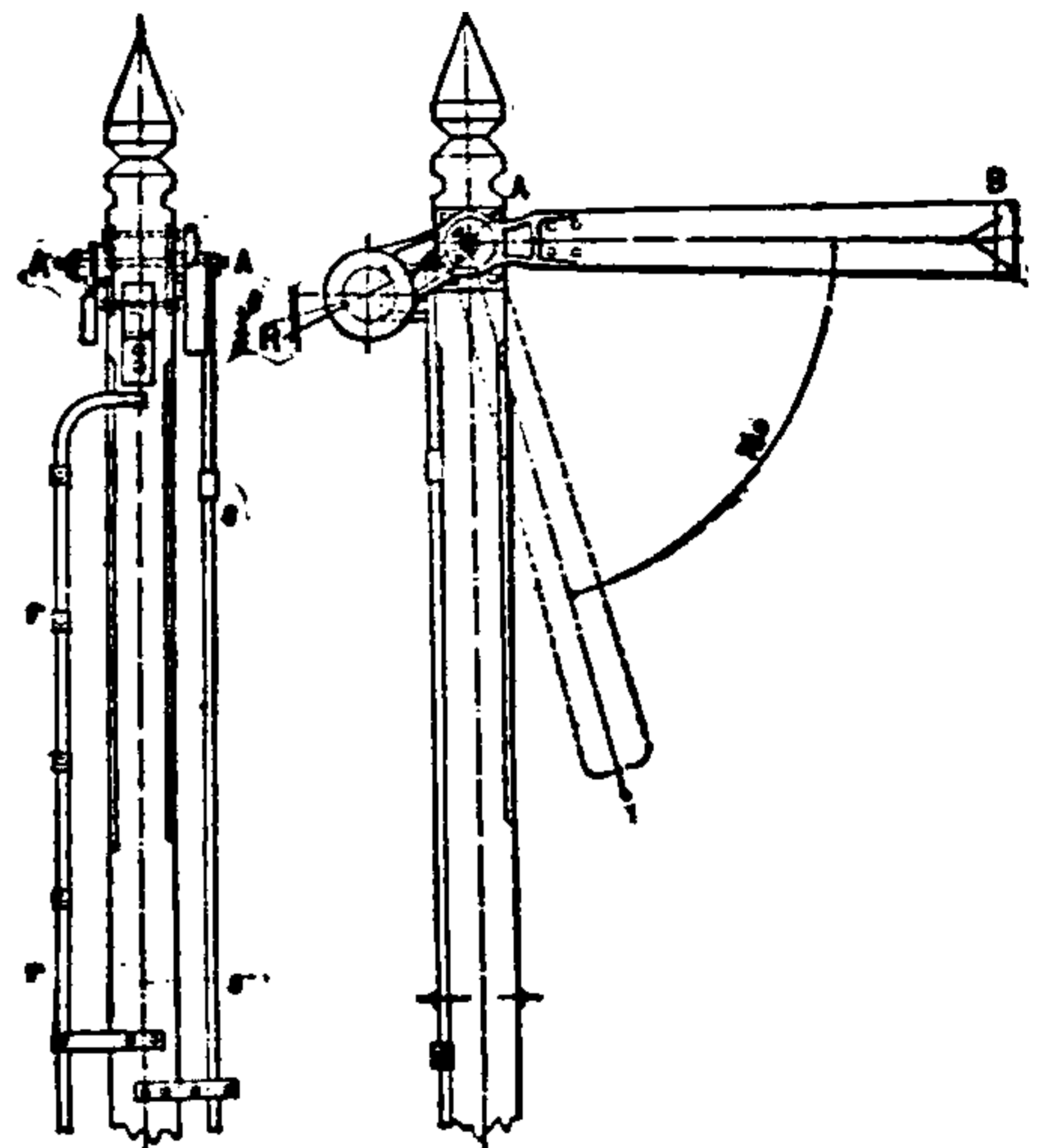

Fig. 463. Semaphore Signal—Absolute System.

lute system, and that shown in Fig. 464 in the permissive system. These signals consist essentially of an upright support provided with a movable arm A B, called the *semaphore arm*, capable of being set in any of two or three positions. The semaphore signal is placed outside the signal tower, often several hundred feet away, but is readily set from the tower in any of the desired positions by the operator, by the movement of rods connected with levers.

In the permissive system, the semaphore arm can be set in three positions, viz.:

(1.) In a horizontal position, or where the semaphore arm makes an angle of 90 degrees with the upright.

(2.) Or it may be dropped down from the horizontal position through an angle of 75 degrees, as shown in Fig. 463.

(3.) Or it may occupy a position exactly inter-

mediate between the first and second, or $37^{\circ} 30'$ below the horizontal, as shown in Fig. 464.

Position No. 1 is the danger signal, and when it is displayed the train may not enter the block it governs.

Position No. 2 shows that the track is clear, and that the train may safely enter the block it governs.

Position No. 3, which is used in the permissive block system, only signifies caution, and permits the train to cautiously enter the block and look out for further signals.

The semaphore arm consists of a light wooden arm, 11 inches wide by $5\frac{1}{2}$ feet in length, painted red or other suitable color that can be easily distinguished by daylight.

By night the positions of the semaphore arm are indicated by colored lights. These lights are

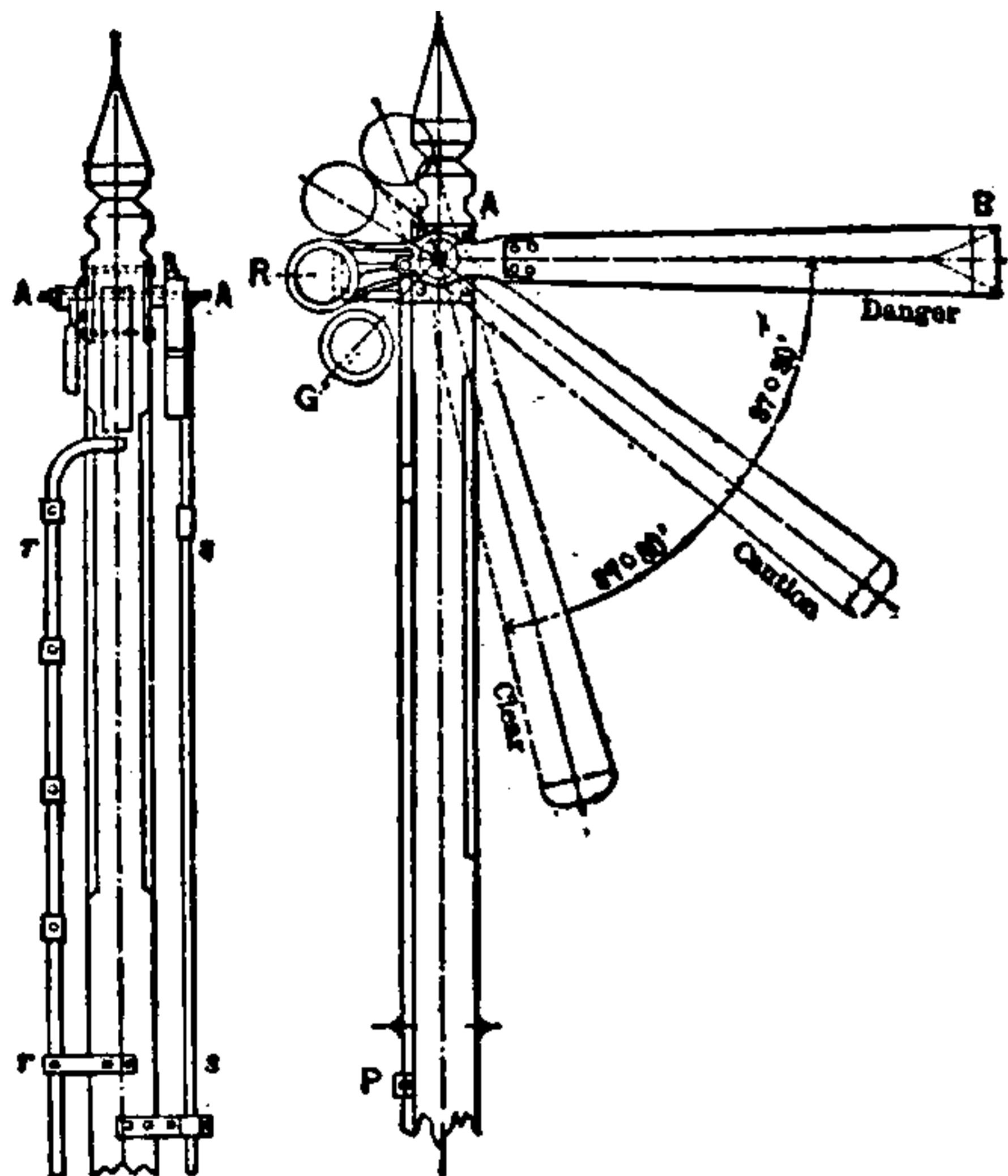

Fig. 464. Semaphore Signal—Permissive System.

operated as follows, viz.: in the absolute system, the semaphore arm A B, pivoted at A, bears at its shorter end a disc or lens of red glass R, and, in the permissive system, below this another disc or lens of green glass G. An oil lantern, provided with an uncolored glass lens, is so supported on a bracket fastened to the upright that when the semaphore arm points to danger the red glass is immediately in front of the lantern; when it points to caution, the green glass is in front of the lantern; but when it points to safety, the lantern is left uncovered save by its uncolored glass.

At night, therefore, when the semaphore arm is set to danger, a red light is displayed; when it points to caution, a green light is displayed; and when it points to safety, a white light is displayed.

In some systems the position of the semaphore

arm is shown at night by means of light reflected from a parabolic mirror, at the focus of which the signal lantern is placed. This method possesses the advantage over other systems of rendering it very improbable that the engineer would mistake an ordinary light for a signal light.

The green light is only used in the permissive block system. In the absolute block system, the semaphore arm has two positions only; viz., danger, or horizontal, and safety, or 75 degrees below the horizontal.

A single arm is used when it is intended to govern a single track only. Where the condition of a number of tracks is to be indicated, several arms are employed, one above the other.

When semaphore signals are placed on each side of a double-track road, the semaphore arm pointing to the right of the vertical support governs the line running to the right.

When the semaphore signals are placed at junctions or switch-crossings, the operator in the signal-tower opens or closes the switches from the tower by the movements of levers that set the switches, and then displays the proper semaphore signal for that crossing or route; red, or danger, if the route is blocked, and white, or safety, if it is clear. Here the interlocking apparatus is employed, which consists in devices by means of which, when a route has once been set up and a signal given for that route, the switches and signals are so interlocked that no signal can possibly be given for a conflicting route.

The signals or switches are operated by means of iron rods passing over rollers or pulleys. These rods are attached by suitable connections to the switch or semaphore signals, and are operated by means of levers from the signal-tower. Switches can be operated as far as 1,000 feet from the tower; signals as far as 2,500 feet.

Colored switch-signals are placed opposite the end of the switches to indicate the positions of the switch. These signals consist of red and white discs for day, and a lantern provided with red and white glasses for night. When the switch on any line is open, the switch-signal shows red; when shut, it shows white. These switch-signals are only used in the yards.

No passenger train is permitted on a block, after another train has passed the signal station, until a dispatch has been received from the station ahead that the train has passed and the block is thus cleared.

As an additional precaution against rear col-

lisions, *tail-lights* are displayed at the ends of the trains. These consist of lanterns placed on each side of the rear end of the last car. These lanterns are furnished with three glass slides. The side of the lantern towards the rear of the car shows a *red* light; that to the front and side of the car shows a green light. The engineer, looking out of the cab, can thus see a green light, which serves as a "*marker*" and indicates to him that his train is intact. By day a green flag, placed in the same position as the lantern, serves the same purpose as a *marker*. An observer on the track, or in the tower, sees the red lights on the rear of the train when it has passed.

Freight trains are now run on separate tracks, except in places where the extra tracks are not yet completed. Here they do not run on schedule time, but are permitted to follow one another at intervals that depend on the condition of the tracks as shown by the signals displayed.

Railroads, Electric, Continuous Overhead System of Motive Power for — —

A variety of the dependent system of motive power for electric railroads in which a continuous bare conductor is connected with the terminals of a generating dynamo, and supported overhead by suitable means, and a traveling wheel or trolley is moved over the same by the motion of the car, in order to carry off the current from the line to the car motor. (See *Railroads, Electric, Dependent System of Motive Power for.*)

Railroads, Electric, Continuous Surface System of Motive Power for — —

A variety of the dependent system of motive power for electric railroads, in which the terminals of the generating dynamo are connected to the continuous bare metallic conductor that extends along the entire track on the surface of the roadway or street, and from which the current is taken off by means of a traveling conductor connected with the moving car. (See *Railroads, Electric, Continuous Underground System of Motive Power for.*)

Railroads, Electric, Continuous Underground System of Motive Power for — —

A variety of the dependent system of motive power for electric railways, in which a continuous bare conductor is placed under-

ground in an open slotted conduit, and the current taken off from the same by means of sliding or rolling contacts carried on the moving car. (See *Railroads, Electric, Dependent System of Motive Power for.*)

Railroads, Electric, Dependent System of Motive Power for — — — A term now generally used for a system of motive power for the propulsion of electric railway cars, in which the electric current is taken from wires or conductors connected with electric sources external to the cars.

A dependent system of motive power for electric railways includes three distinct varieties, namely :

- (1.) The Underground System.
- (2.) The Surface System.
- (3.) The Overhead System.

In all of these systems the bare conductor connected with the terminals of a generating dynamo may form either one continuous wire or it can be divided into separate portions or sections.

The underground system embraces two distinct varieties :

1st. A continuous bare conductor placed in an open slotted conduit.

2d. A sectional bare conductor placed in an open slotted conduit.

In the first variety of the underground system, bare conductors are placed in an open slotted conduit, and connected with the terminals of a dynamo-electric machine which generates the current that is to be employed for the propulsion of the cars. Traveling contacts placed on the car and connected with an electric motor, carry off the current from the bare conductor by rolling or sliding over it.

In the second variety of the underground system, a section of a bare conductor, or bare metallic points that, on the passage of the car over them are automatically connected with the generating dynamo, replace the continuous metallic conductors of the first system.

In the surface system, the wires or conductors that are connected with the generating dynamo, instead of being placed in the underground open slotted conduit, are placed directly on the surface of the street or roadbed and the current carried off from the same by suitable contacts placed on the car.

In most cases, however, in which the surface system is adopted, the conductors that are con-

THIS PAGE IS LOCKED TO FREE MEMBERS

Purchase full membership to immediately unlock this page



HISTORY

Tens of thousands of important historical sources, many previously unobtainable, are now available for the first time with a Forgotten Books Full Membership.

Unlimited Access
\$8.99/month

Continue

*Fair usage policy applies

of the car over them, and to switch them out as the car leaves them. (See *Railroads, Electric, Dependent System of Motive Power for.*)

Railroads, Electric, Sectional Underground System of Motive Power for — —A variety of the dependent system of motive power for electric railroads in which a sectional conductor is placed underground in a slotted conduit, and the current taken from the same by means of sliding or rolling contacts connected with the moving car. (See *Railroads, Electric, Dependent System of Motive Power for.*)

Railroads, Electric, Section Line of — —Any part of the overhead electric conductors insulated from other parts so as to permit its supply of electric power to be separately controlled.

Railroads, Electric, Signal Service System for — —The system of electric signals used on railways for ascertaining the condition of the roads, sending instructions to engineers, and conveying intelligence generally from stations along the road to the running trains.

Railroads, Electric, Single-Trolley System — —A system of electric railroad propulsion in which a single trolley is employed to take the driving current from a single overhead trolley wire.

The earth, or a conductor placed along the track on the roadbed, acts as the return. (See *Railroads, Electric, Dependent System of Motive Power for.*)

Railroads, Permissive Block System for — —A block system in which more than one train is permitted under given conditions to occupy the same block simultaneously. (See *Railroads, Block System for.*)

Railway, Electric — —An electric railroad. (See *Railroad, Electric.*)

Range, Molecular — —The distance at which the molecules of matter exert a sensible attraction for one another.

This distance has been estimated in the case of zinc and oxygen as equal to about the ten-millionth of a millimetre.

Ratchet-Pendant Argand-Electric Burner. —(See *Burner, Argand-Electric, Ratchet-Pendant.*)

Ratchet-Pendant Electric Burner. —(See *Burner, Ratchet-Pendant, Electric.*)

Ratchet-Pendant Electric Candle Burner. —(See *Burner, Ratchet-Pendant Candle Electric.*)

Ratio, Velocity — —A ratio, in the nature of a velocity, that exists between the dimensions of the electrostatic and the electro-magnetic units.

This ratio will be understood from the comparison of the following units. In each case the numerator gives the dimensions in the electrostatic and the denominator the dimensions in the electro-magnetic system :

$$\text{Quantity, } \frac{M^{\frac{1}{2}} L^{\frac{3}{2}} T^{-1}}{M^{\frac{1}{2}} L^{\frac{1}{2}}} = \frac{L}{T} = V .$$

Here the value of the ratio, viz., the *length* divided by the *time*, is clearly in the nature of a velocity, for $V = \frac{L}{T}$.

$$\text{Potential, } \frac{M^{\frac{1}{2}} L^{\frac{1}{2}} T^{-1}}{M^{\frac{1}{2}} L^{\frac{3}{2}} T^{-2}} = \frac{T}{L} = \frac{1}{V} .$$

$$\text{Capacity, } \frac{L}{L^{-1} T^2} = \frac{L^2}{T^2} = V^2 .$$

$$\text{Resistance, } \frac{L^{-1} T}{L T^{-1}} = \frac{T^2}{L^2} = \frac{1}{V^2} .$$

A remarkable similarity exists between the value of the *velocity* expressed in C. G. S. units, and the velocity of light, which is of great significance in the *electro-magnetic theory of light*. (See *Light, Maxwell's Electro-Magnetic Theory of.*)

The velocity of light is 2.9992×10^{10} centimetres per second.

The velocity ratio, v , is 2.9800×10^{10} centimetres per second.

Rattler, Push-Button — —A device connected with a push button to show that the bell connected at a distant point, in the circuit of a push button, rings when the button is pressed.

Ray, Actinic — —A ray of light or other form of radiant energy that possesses the

power of effecting chemical action. (See *Decomposition*.)

All rays of light, and even some of those invisible to the human eye, are *actinic* to some particular chemical substance or another. Whether the ether waves produce the effects of heat, of light or of chemical decomposition depends on the *nature of the material on which they fall, as well as on the character of the waves themselves*.

Ray, Electric (*Raia torpedo*) — — A species of fish named the ray, which, like the electric eel, possesses the power of producing electricity.

The electric organ is situated at the back of the head, and consists of hundreds of polygonal, cellular laminae, supplied with numerous nerve fibres, as shown in Fig. 465. (See *Fishes. Electric*.)

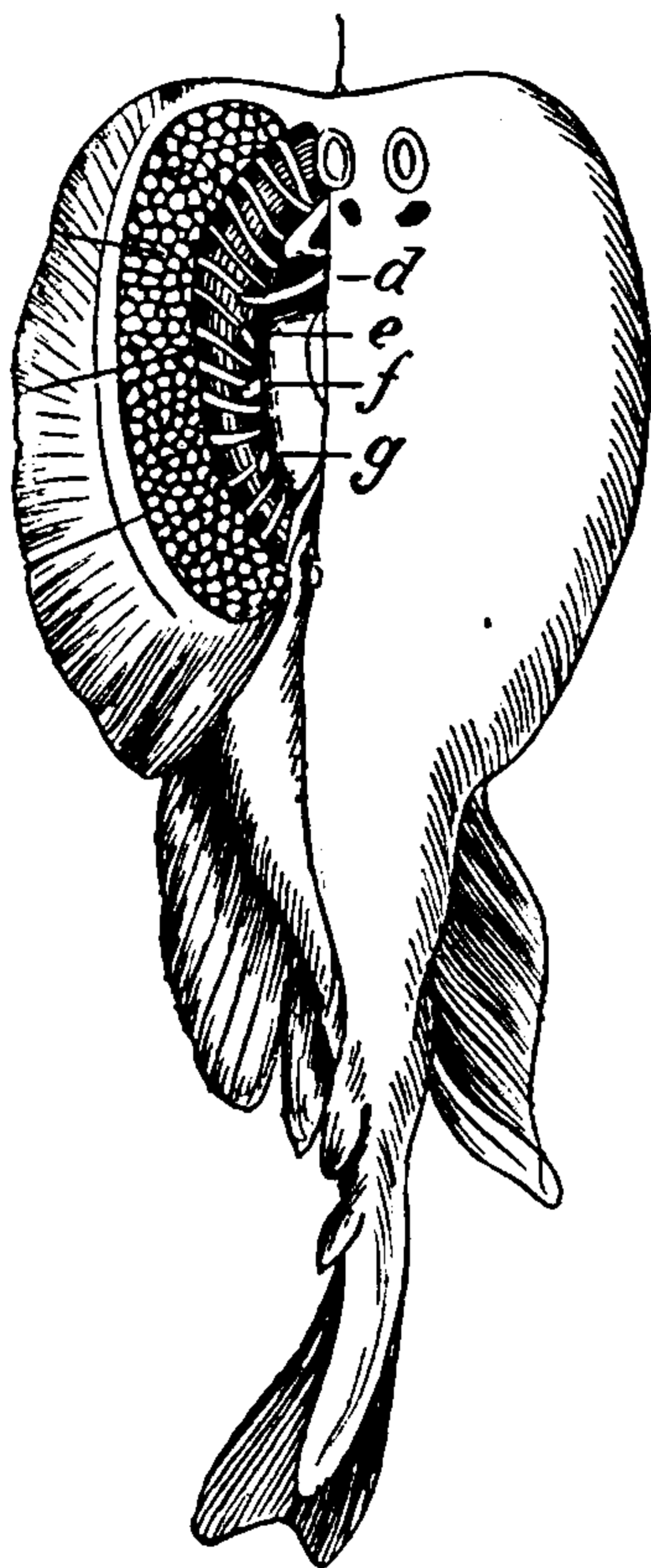

Rayleigh's Form of Clark's Standard Voltaic Cell. — (See *Cell, Voltaic, Standard, Rayleigh's Form of Clark's*.) Fig. 465. *The Raia Torpedo*.

Reaction.—In electro-therapeutics muscular contractions following the closing or opening of an electric circuit.

Reaction Coil.—(See *Coil, Reaction*.)

Reaction of Degeneration.—(See *Degeneration, Reaction of*.)

Reaction of Exhaustion.—(See *Exhaustion, Reaction of*.)

Reaction Principle of Dynamo-Electric Machines.—(See *Machine, Dynamo-Electric, Reaction Principle of*.)

Reaction Telephone.—(See *Telephone, Reaction*.)

Reaction Time.—(See *Time, Reaction*.)

Reaction Wheel, Electric — — (See *Wheel, Reaction, Electric*.)

Reactions, Kathodic and Anodic Electro-Diagnostic — — The reactions which occur at the kathode or anode of an electric source placed on or over any part of a living body.

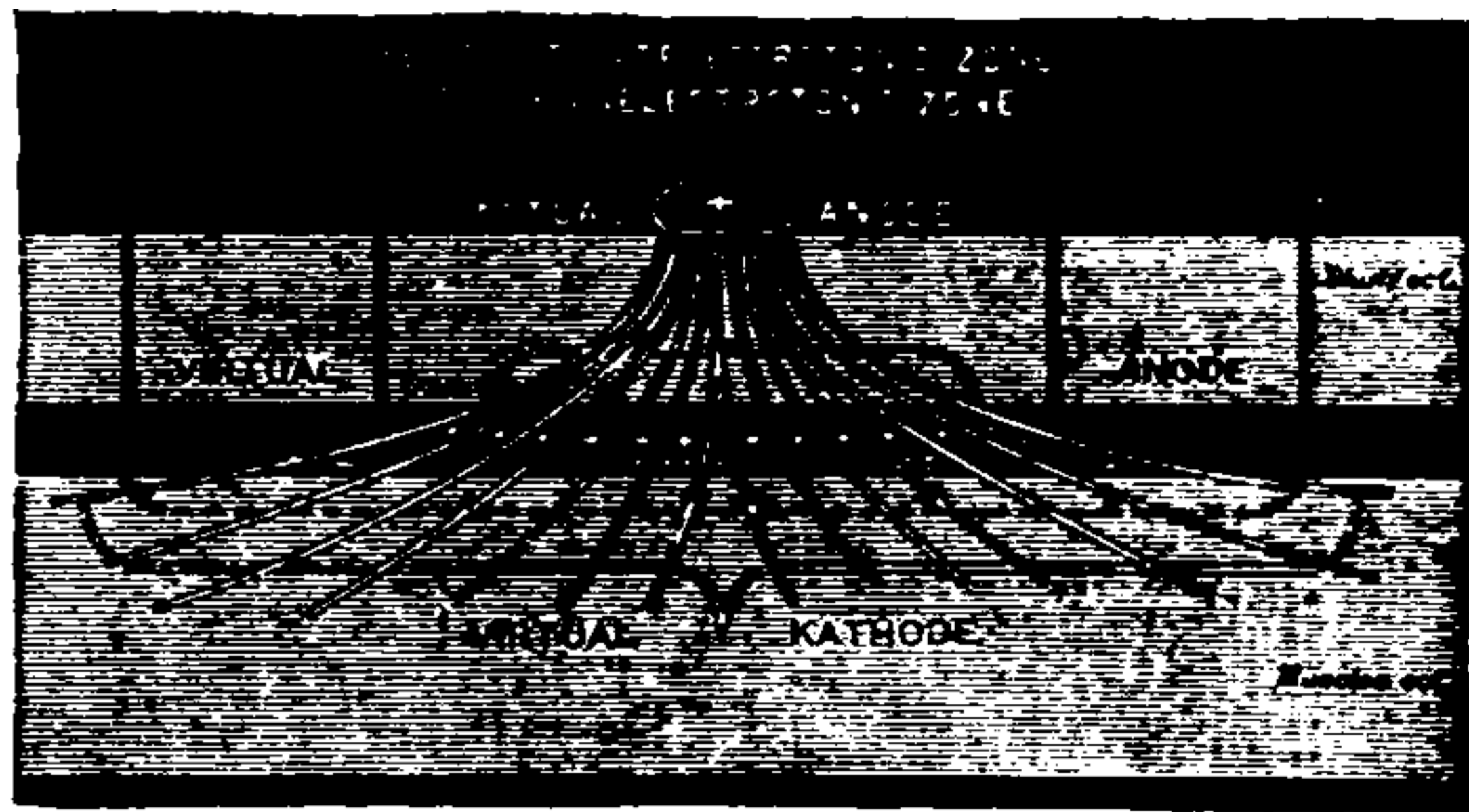

Fig. 466. *Kathodic and Anodic Reactions*.

Fig. 466, from De Wetteville's "Medical Electricity" represents what he assumes takes place at the points of entrance and exit of the current in a nerve submitted to the action of the anode of an electric source. Two zones are formed, an anodic and a kathodic zone; the virtual anode is formed by the portion of the skin nearer the nerve, and the virtual kathode by the adjoining muscles. There are thus formed two zones of influence—one immediately around the anode, called the polar or anodic electrotonic zone, and one surrounding this and including the virtual kathode, and called the peripolar, or kathelectrotonic zone.

Reading Telescope.—(See *Telescope, Reading*.)

Real Efficiency of Storage Battery.—(See *Efficiency, Real, of Storage Battery*.)

Real Hall Effect.—(See *Effect, Hall, Real*.)

Recalescence.—The property, possessed by incandescent steel when cooling, of again becoming incandescent after a certain degree of cooling has been reached.

The property of recalescence was first pointed out by Barrett.

A steel wire heated at the middle or near one end to a bright red, and allowed to cool in a dim light, will cool until a low red heat is reached, when it will be observed to reheat at some point in the originally heated portion. This reheating is manifested by a brighter red spot

which moves along the portion originally heated. This reheating is called *recalescence*, and is due to latent heat (potential energy), which, disappearing when the bar was heated, again becomes sensible (kinetic energy) on cooling.

The temperature at which recalescence takes place is sensibly the temperature at which heated steel regains its magnetizability.

Received Current.—(See *Current, Received*.)

Receiver, Gramophone — —The receiver employed in the gramophone. (See *Gramophone*.)

Receiver, Graphophone — —The receiver employed in the graphophone. (See *Phonograph*.)

Receiver, Harmonic — —A receiver, employed in systems of harmonic telegraphy, consisting of an electro-magnetic reed, tuned to vibrate to one note or rate only. (See *Telegraphy, Gray's Harmonic Multiple*.)

Receiver Magnet.—(See *Magnet, Receiving*.)

Receiver, Phonographic — —The apparatus employed in a telephone, phonograph, graphophone or gramophone for the reproduction of articulate speech. (See *Phonograph*.)

Receiver, Telephonic — —The receiver employed in the telephone. (See *Telephone*.)

Receptive Device, Electro — —(See *Device, Electro-Receptive*.)

Receptive Device, Magneto — —(See *Device, Magneto-Receptive*.)

Reciprocal — —The reciprocal of any number is the quotient arising from dividing unity by that number.

Thus, for example, the reciprocal of 4, is $\frac{1}{4}$ or .250.

The conducting power of any circuit is equal to the reciprocal of its resistance; or, in other words, the conducting power is inversely proportional to the resistance.

The following table contains the reciprocals of the numerals up to 100:

TABLE OF RECIPROCAL.

No.	Re- cipro- cal.	No.	Re- cipro- cal.	No.	Re- cipro- cal.	No.	Re- cipro- cal.	No.	Re- cipro- cal.
2	0.5000	22	0.0455	42	0.0338	62	0.0161	82	0.0122
3	0.3333	23	0.0435	43	0.0233	63	0.0159	83	0.0120
4	0.2500	24	0.0417	44	0.0227	64	0.0156	84	0.0119
5	0.2000	25	0.0400	45	0.0222	65	0.0154	85	0.0118
6	0.1667	26	0.0385	46	0.0217	66	0.0152	86	0.0116
7	0.1429	27	0.0370	47	0.0213	67	0.0149	87	0.0115
8	0.1250	28	0.0357	48	0.0208	68	0.0147	88	0.0114
9	0.1111	29	0.0345	49	0.0204	69	0.0145	89	0.0112
10	0.1000	30	0.0333	50	0.0200	70	0.0143	90	0.0111
11	0.0909	31	0.0323	51	0.0196	71	0.0141	91	0.0110
12	0.0833	32	0.0313	52	0.0192	72	0.0139	92	0.0109
13	0.0769	33	0.0303	53	0.0189	73	0.0137	93	0.0108
14	0.0714	34	0.0294	54	0.0185	74	0.0135	94	0.0106
15	0.0667	35	0.0286	55	0.0182	75	0.0133	95	0.0105
16	0.0625	36	0.0278	56	0.0179	76	0.0132	96	0.0104
17	0.0588	37	0.0270	57	0.0175	77	0.0130	97	0.0103
18	0.0556	38	0.0263	58	0.0172	78	0.0128	98	0.0102
19	0.0526	39	0.0256	59	0.0169	79	0.0127	99	0.0101
20	0.0500	40	0.0250	60	0.0167	80	0.0125	100	0.0100
21	0.0476	41	0.0244	61	0.0164	81	0.0123		

—(Clark & Sabine.)

Recoil Circuit.—(See *Circuit, Recoil*.)

Record, Chronograph — —A record made by means of a chronograph for the purpose of measuring and recording small intervals of time. (See *Chronograph, Electric*.)

Record, Gramophone — —The irregular indentations, cuttings or tracings made by a point attached to the diaphragm spoken against, and employed in connection with the receiving diaphragm for the reproduction of articulate speech.

Record, Graphophone — —The record made by the movement of the diaphragm of the graphophone. (See *Phonograph*.)

Record, Phonographic — —The record produced in a phonograph, for the subsequent reproduction of audible articulate speech.

Record, Telephonic — —The record produced by the diaphragm of a receiving telephone.

Various methods have been proposed for obtaining telephonic records, but none of them have yet been introduced into actual commercial use.

Recorder, Chemical, Bain's — —An apparatus for recording the dots and dashes of

THIS PAGE IS LOCKED TO FREE MEMBERS

Purchase full membership to immediately unlock this page

Know Your Bible

Forgotten Books' Full Membership provides unlimited access to more than 28,000 volumes of Christian literature for \$8.99/month

HOLY BIBLE

Continue

*Fair use policy applies

coil b b, through the suspending wire f f', and is moved by it to the right or the left, according to its direction, to an extent that depends on the current strength.

The fine glass siphon n, which dips into a reservoir of ink at m, is capable of movement on a vertical axis l, and is moved backwards or forwards, in one direction by a thread k, attached

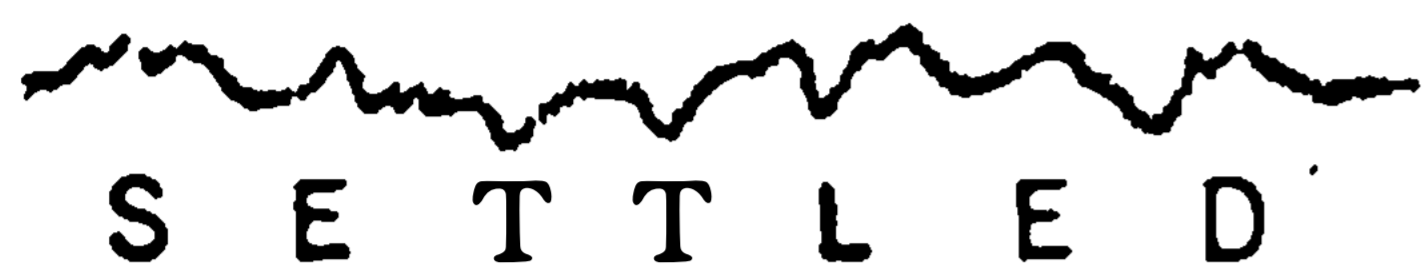

Fig. 471. Record of Siphon Recorder.

to b, and in the opposite direction by a retractile spring attached to an arm of the axis l.

As the paper is moved under the point of the siphon, an irregular curved line is marked thereon.

Two records as actually received by a siphon recorder are shown in the Figs. 470 and 471. Movements upwards correspond to the dots, and downwards to dashes.

Rectification of Alcohol, Electric —
—(See *Alcohol, Electric Rectification of*.)

Rectified.—Turned in one and the same direction.

The alternate currents in a dynamo-electric machine are rectified or caused to flow in one and the same direction by means of a commutator.

The word commuted, generally used in this connection, would appear to be preferable to the word rectified. (See *Commutator*.)

Rectilinear Co-ordinates, Abscissa of —
—(See *Abscissa of Rectilinear Co-ordinates*.)

Rectilinear Current.—(See *Current, Rectilinear*.)

Red Heat.—(See *Heat, Red*.)

Red Hot.—(See *Hot, Red*.)

Reducteur or Resistance for Voltmeter.
—A coil of known resistance as compared with the resistance of the coils of a voltmeter, and connected with them in series for the purpose of increasing the range of the instrument. (See *Voltmeter*.)

Reducteur or Shunt for Ammeter.—A shunt coil connected in multiple with the coils of an ammeter for the purpose of changing the value of the readings.

The ratio of the resistance of the reducteur and the ammeter coils is known. A reducteur increases the range of current measured by the ammeter.

Refining of Metals, Electric — —The refining of metals by the application of electrolysis.

When certain precautions are taken, metals thrown down from their solutions, are obtained in a chemically pure condition. This fact is utilized in the electrical refining of metals. If, for example, a plate of impure copper is to be refined electrolytically, it is used as the anode of a copper bath, and placed opposite a thin plate of pure copper forming the kathode. The passage of the current gradually dissolves the copper from the plate at the anode, and deposits it in a chemically pure condition on the plate at the kathode.

Somewhat similar principles are employed for electrically refining other metals.

Reflect.—To throw off from a surface, according to the laws of reflection, as of waves in an elastic medium. (See *Reflection, Laws of*.)

Reflecting.—Throwing off from a surface, according to the laws of reflection. (See *Reflection, Laws of*.)

Reflecting Galvanometer.—(See *Galvanometer, Reflecting*.)

Reflection.—The throwing back of a body or wave from a surface at an angle equal to that at which it strikes such surface. (See *Reflection, Laws of*.)

Reflection, Laws of — —The laws governing the reflection of light

(1.) The angle of reflection, or the angle included between the reflected ray and the perpendicular to the reflecting surface at the point of incidence, is equal to the angle of incidence, or the angle included between the striking ray and the perpendicular to the reflecting surface at the point of incidence.

(2.) The plane of the angle of incidence coincides with the plane of the angle of reflection.

Reflection of Electro-Magnetic Waves.
—(See *Waves, Electro-Magnetic, Reflection of*.)

Reflection of Induction.—(See *Induction, Reflection of*.)

Reflector.—A plane or curved surface, capable of regularly reflecting light.

Reflector, Parabolic — —A reflector,

or mirror, the reflecting surface of which is a paraboloid, or such a surface as would be obtained by the revolution of a parabola about its axis.

A parabolic curve, which may be regarded as a section of a parabola, is shown in Fig. 472. A parabola has the following properties: If lines $F P$, $F P$, etc., be drawn from the point F , called the focus, to any point, P , P , etc., in the curve, and the lines $P p$, $P p$, $P p$, etc., be then drawn severally parallel to the axis, $V M$, then all such angles, $F P p$, $F P p$, will be bisected by verticals to tangents at the point P , P , and P .

Therefore, if a light be placed at the focus of a parabolic reflector, all the light reflected from the surface of the parabola will pass off sensibly parallel to the axis $V M$.

In *Locomotive Head lights*, a lamp is placed at the focus of a parabolic reflector, and the parallel beam so obtained is utilized for the illumination of the track. In a *search light* an electric arc lamp is placed at the focus of a parabolic reflector, or at the focus of a lens.

A parabolic reflector is used for search lights, sometimes in connection with an arc lamp. A focusing arc lamp must be used for this purpose, so as to maintain the voltaic arc at the focus of the parabolic reflector, notwithstanding the unequal consumption of the positive and negative carbons. (See *Arc, Voltaic*.)

Refract.—To change the direction of waves in any elastic medium in accordance with the laws of refraction. (See *Refraction*.)

Refracting.—Changing the direction of waves in an elastic medium in accordance with the laws of refraction.

Refraction.—The bending of a ray of sound, light, heat, or electro-magnetism at the surface of any medium whose density differs from that through which such ray was previously passing.

Rays of sound, light, heat or electro-magnetism are transmitted or propagated in straight lines as long as the density of the homogeneous medium through which they are passing undergoes no change. That is, as long as the medium

is homogeneous or isotropic. (See *Medium, Isotropic*.) As the rays enter the surface of a medium which differs in density from that through which they have been passing, they are bent or refracted at the surface of such a medium.

This bending takes place towards a perpendicular to the refracting surface at the point of incidence, when the medium into which the rays are entering is of greater density than that they are leaving, and from the perpendicular when the medium they are entering is of less density than that they are leaving.

The refraction or bending of the ray is caused by the difference in the velocity with which the waves are propagated through the two media.

There is no refraction or deviation when the two rays enter the new medium at right angle; to its surface, or when there is no angle of incidence.

Refraction, Double — — The property possessed by certain substances of splitting up a ray of light passed through them into two separate rays, and thus doubly refracting the ray.

Certain specimens of calc spar possess the property of double refraction. Each of the two rays into which the original ray is separated is polarized. Such calc spar is called doubly refracting calc spar.

Refraction, Double, Electric — — The property of doubly refracting light acquired by some transparent substances while in an electrostatic or electro-magnetic field.

Transient or momentary powers of double refraction, acquired by a transparent substance while placed in an electric field.

The intensity of double refraction is proportioned to the square of the electric force.

The action of an electric field in endowing a substance with the power of double refraction while kept in such field, is due to the strain produced by the electrostatic stress of the field.

A similar transient power of double refraction is acquired by many bodies when subjected to the strain produced by a simple mechanical stress.

Refreshing Action of Current.—(See *Action, Refreshing, of Current*.)

Region, Extra-Polar — — A term applied in electro-therapeutics to the region

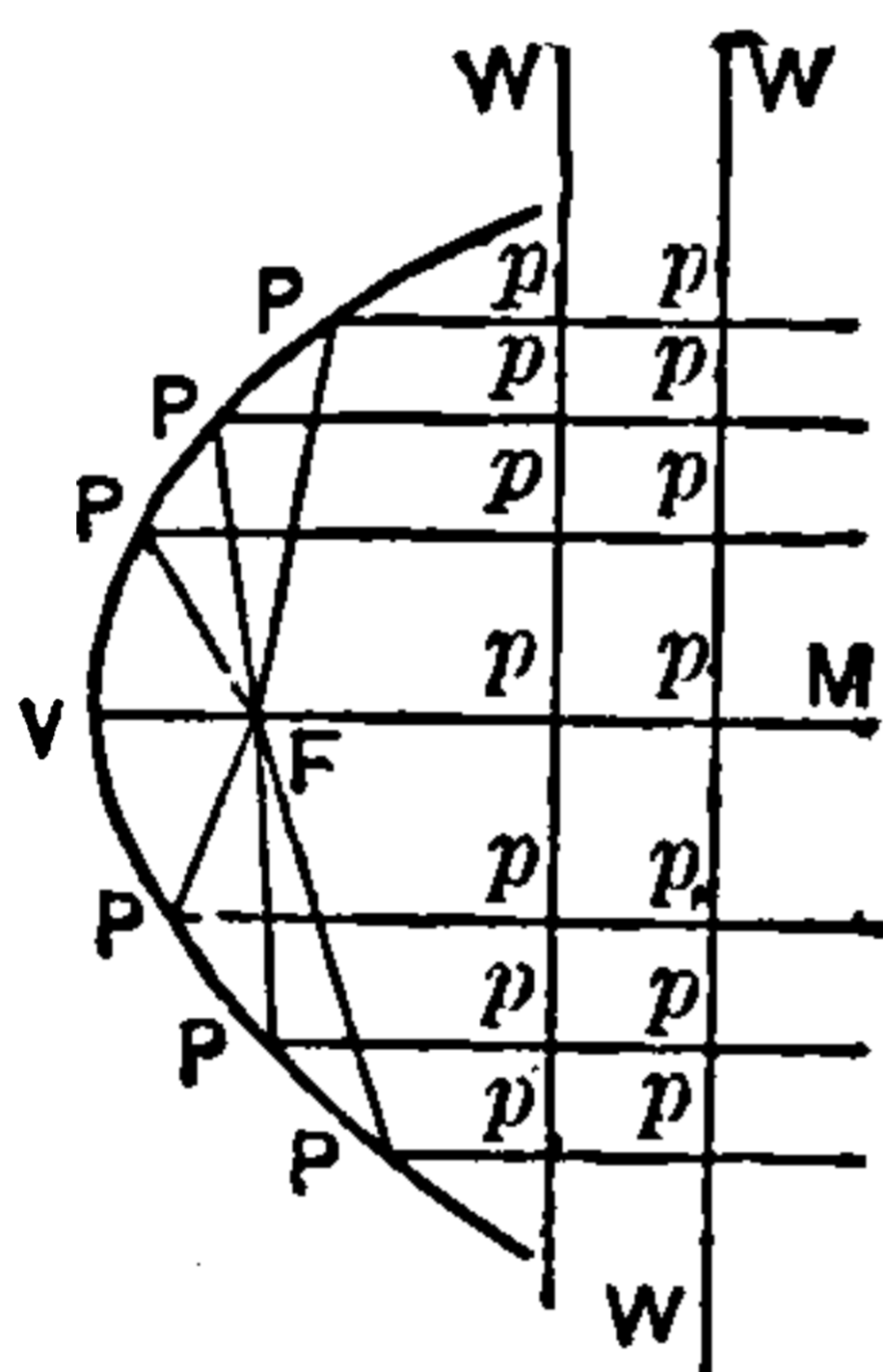

Fig. 472. Parabolic Reflector.

which lies outside or beyond the therapeutic electrode.

The term extra-polar region is used in contradistinction to polar region. (See *Region, Polar.*)

Region, Polar — —A term applied in electro-therapeutics to that region or part of the body which lies directly below the therapeutic electrode.

Register, Double-Pen Telegraphic — —A telegraphic register provided with two separate styluses or pens for recording the telegraphic message on a fillet of paper. (See *Register, Telegraphic.*)

Register, Morse — —A name sometimes given to a Morse recorder. (See *Recorder, Morse.*)

Register, Telegraphic — —An apparatus employed at the receiving end of a telegraphic line for the purpose of obtaining a permanent record of the telegraphic dispatch.

The telegraphic register consists essentially of means whereby a fillet or tape of paper is drawn mechanically under a pen or stylus attached to the armature of an electro-magnet and moving therewith.

The pen or stylus presses against the paper whenever the armature is attracted to the electro-magnet, and is held there while the cur-

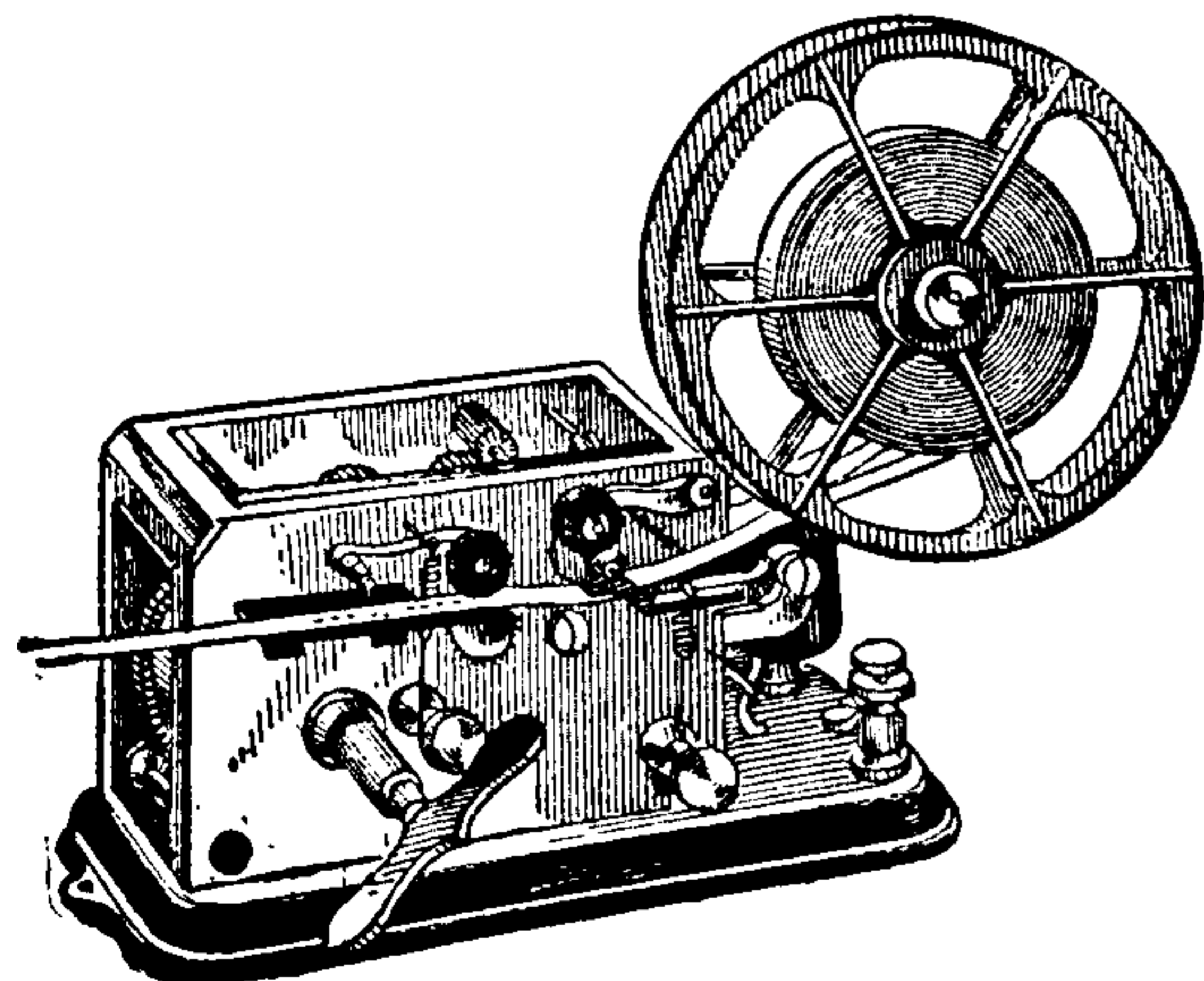

Fig. 473. Ink-Writing Register.

rent is passing through the coils of the electro-magnet. By these means the dots and dashes of the telegraphic alphabet are recorded on the paper fillet as embossed or printed dots and dashes. The Morse register is an apparatus of this description. (See *Recorder, Morse.*)

A form of ink-writing telegraphic register is shown in Fig. 473. It is self-starting.

Register, Time, for Railroads — —A telegraphic recording apparatus or register designed to record all telegraphic messages transmitted over a line.

The record is received on an endless band or fillet of paper. It is useful in case of disputes as to the time certain messages were sent over the line.

Register, Watchman's Electric — —A device for permanently recording the time of a watchman's visit to each of the different localities he is required to visit at stated intervals.

These registers are of a variety of forms. They consist, however, in general, of a drum or disc of paper driven by clockwork, on which a mark is made by a stylus or pencil, operated on the closing of a circuit by the pressing of a push button or the pressing of a key by the watchman at each station.

Registering Apparatus, Electric — — (See *Apparatus, Registering, Electric.*)

Registering Electrometer.—(See *Electrometer, Registering.*)

Regulable, Automatically — —Capable of being automatically regulated. (See *Regulation, Automatic.*)

Regulate, Automatically — —To regulate in an automatic manner. (See *Regulation, Automatic.*)

Regulation, Automatic — —Regulation automatically effected.

Regulation, Automatic, of Dynamo-Electric Machine — —Such a regulation of a dynamo-electric machine as will automatically preserve constant either the current or the potential difference.

The automatic regulation of dynamo-electric machines may be accomplished in the following ways, viz.:

(1.) *By a Compound Winding of the Machine.*

This method is particularly applicable to constant-potential machines. By this winding, the magnetizing effect of the shunt coils is maintained approximately constant, while that of the series coils varies proportionally to the load on the machine.

The series coils are sometimes wound close to

THIS PAGE IS LOCKED TO FREE MEMBERS

Purchase full membership to immediately unlock this page



HISTORY

Tens of thousands of important historical sources, many previously unobtainable, are now available for the first time with a Forgotten Books Full Membership.

Unlimited Access
\$8.99/month

Continue

*Fair usage policy applies

the usual centrifugal governor which maintains a constant speed.

(6.) *Electric Governing of the Driving Engine*, in which the governor is regulated by the current itself instead of by the speed of rotation, as usual.

Regulation, Hand — — Such a regulation of a dynamo-electric machine as will preserve constant, either the current or the potential, said regulation being effected by hand as distinguished from automatic regulation.

Regulator, Automatic — — A device for securing automatic regulation as distinguished from hand regulation. (See *Regulation, Hand. Regulation, Automatic.*)

Regulator, Hand — — A resistance box, the separate coils or resistances of which can be readily placed in or removed from a circuit by means of a hand-moved switch.

The term hand regulator is used as distinguished from automatic regulator. (See *Regulator, Automatic. Regulation, Automatic.*)

Regulator Magnet.—(See *Magnet, Regulator.*)

Regulator, Monophotal Arc-Light — — A term sometimes employed for an electric arc lamp in which the whole current passes through the arc-regulating mechanism, and which is usually operated singly in circuit with a dynamo.

Regulator, Polyphotal Arc-Lamp — — A regulator for an arc lamp suitable for maintaining a number of lamps in series circuit with the dynamo.

Polyphotal regulators differ from monophotal regulators in that their regulating electro-magnets are energized by a shunt circuit around the electrodes of the lamp, while in monophotal regulators such electro-magnets are placed in the direct circuit. The terms monophotal and polyphotal are not generally used in America.

Reguline Electro-Metallurgical Deposit.—(See *Deposit, Electro-Metallurgical, Reguline.*)

Rejuvenation of Luminescence.—(See *Luminescence, Rejuvenation of.*)

Relative Calibration.—(See *Calibration, Relative.*)

Relay.—An electro-magnet, employed in systems of telegraphy, provided with contact points placed on a delicately supported armature, the movements of which throw a battery, called the local battery, into or out of the circuit of the receiving apparatus.

A relay is sometimes called a receiving magnet.

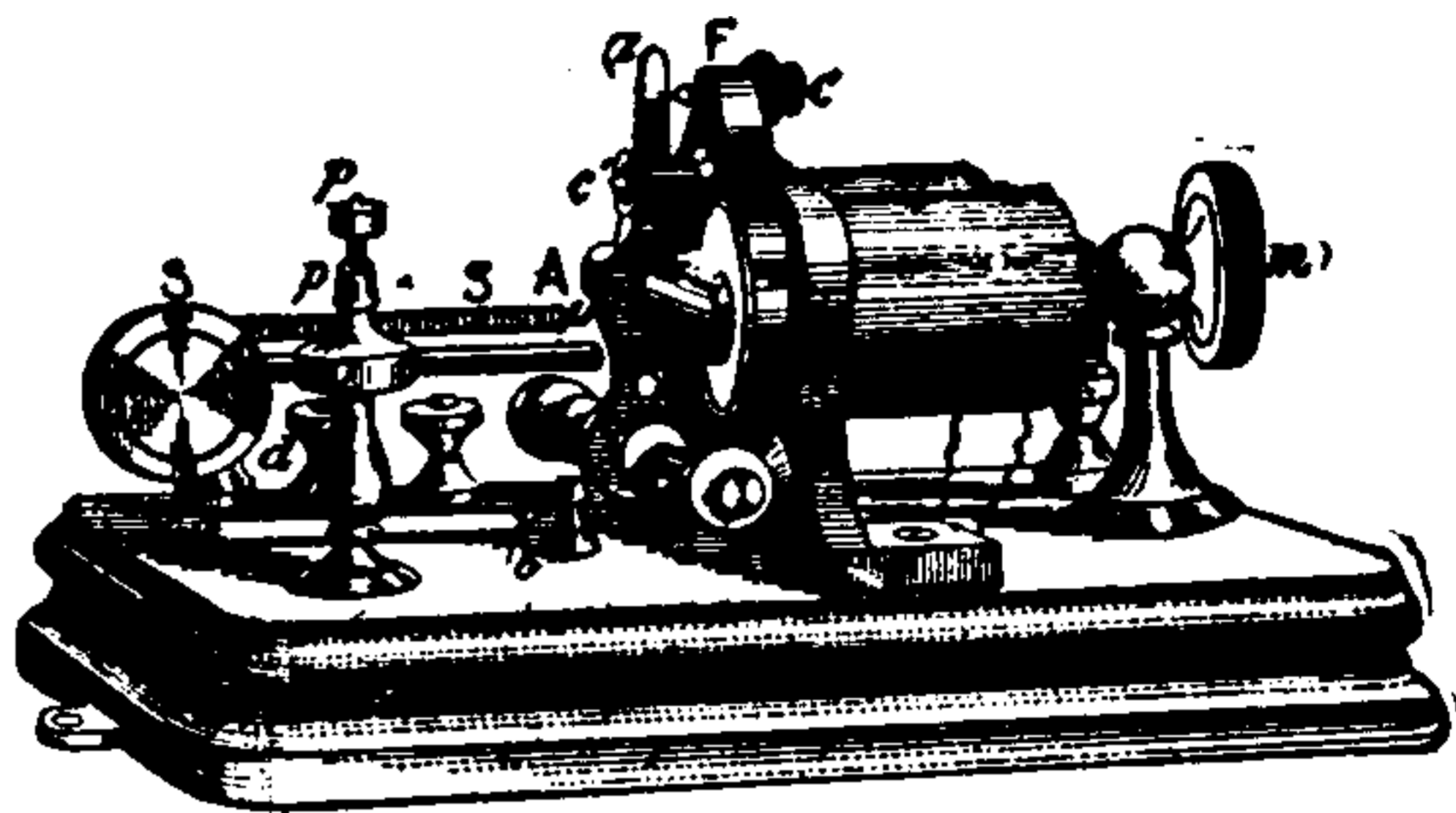

Fig. 477. *Telegraphic Relay.*

The use of a relay permits much smaller currents to be used than could otherwise be done, since the electric impulses, on reaching a distant station, are required to do no other work than attracting a delicately poised movable contact, and thus, by throwing a local battery into the circuit of the receiving apparatus, to cause such local battery to perform the work of registering. Its use is especially required in the Morse system of telegraphy in order to cause the sounder to be distinctly heard.

A form of relay that is much used is shown in Fig. 477.

The electro-magnet *M*, is wound with many turns of very fine wire. In the form used by the Western Union Telegraph Company, there are about 8,500 turns, having resistance of 150 ohms. A screw *m*, is provided for moving the electro-magnet *M*, a slight distance in or out, for the purposes of adjustment. A semi-cylindrical armature *A*, of soft iron, is attached to the insulated armature lever *a*, the lower end of which is supported by a steel arbor, which is pivoted between two set screws.

A retractile spring *S'*, regulable at *S*, is provided for moving the armature away from the electro-magnet. There are four binding posts, two of which are placed in the circuit of the electro-magnet, and two in that of the local battery. The ends of the line wire are connected with the former, and the receiving instrument placed in the circuit of the latter. A platinum

contact is placed on the end of a screw supported at F, opposite a similar contact, near the end a, of the armature lever. The contact is regulable by means of a screw c.

On the energizing of the electro-magnet, the attraction of its armature closes the platinum contact, and, by thus completing the circuit of the local battery, causes an attraction of the armature of the receiving apparatus. On the cessation of the current in the main line, the spring S', pulls the armature away from the magnet, breaks the circuit of the local battery, and thus permits a similar spring on the receiving instrument to pull its armature away. Thus all the movements of the armature of the relay are reproduced with increased intensity by the armature of the receiving instrument.

The connections of the relay to the local battery and the registering apparatus, will be better understood from an inspection of Fig. 478, which represents a form of relay much used in Germany.

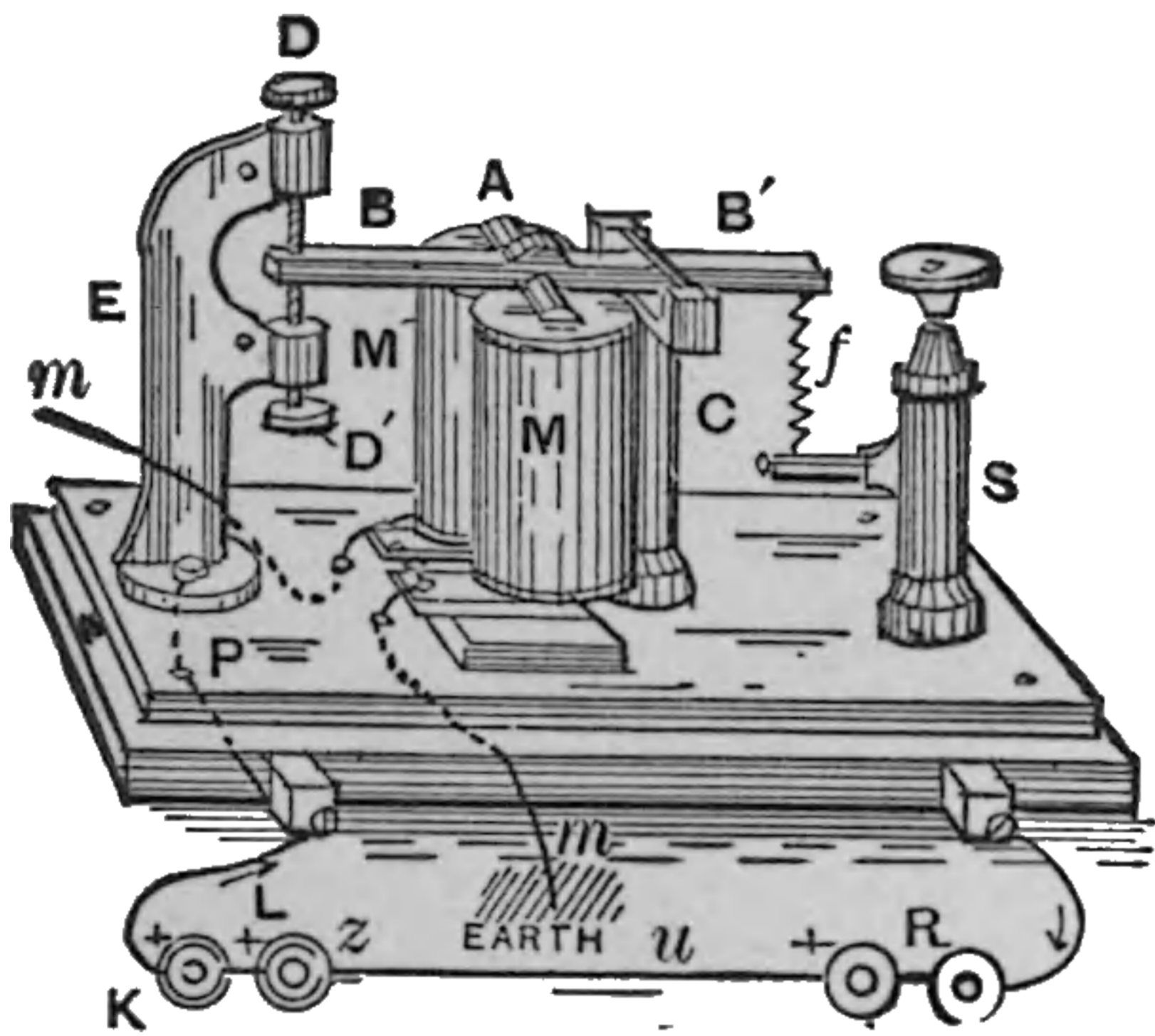

Fig. 478. Telegraphic Relay, German Pattern.

The retractile spring f, is regulated by the up-and-down movements of its lower support, which slides in the vertical pillar S. The line wire is shown at m m, connected at one end to earth by a ground wire.

The registering apparatus R, is connected in the circuit of the local battery L, as shown. The contacts are made by the end B, of the lever B B', attached to the armature A, of the electro-magnet M M.

Relay Bell.—(See *Bell, Relay, Electric.*)

Relay, Box-Sounding Telegraphic — —A relay the magnet of which is surrounded by a resonant case of wood for the purpose of increasing the intensity of the sound made by the armature of the magnet.

A form of box-sounding relay is shown in Fig. 479.

Relay, Differential — —A telegraphic

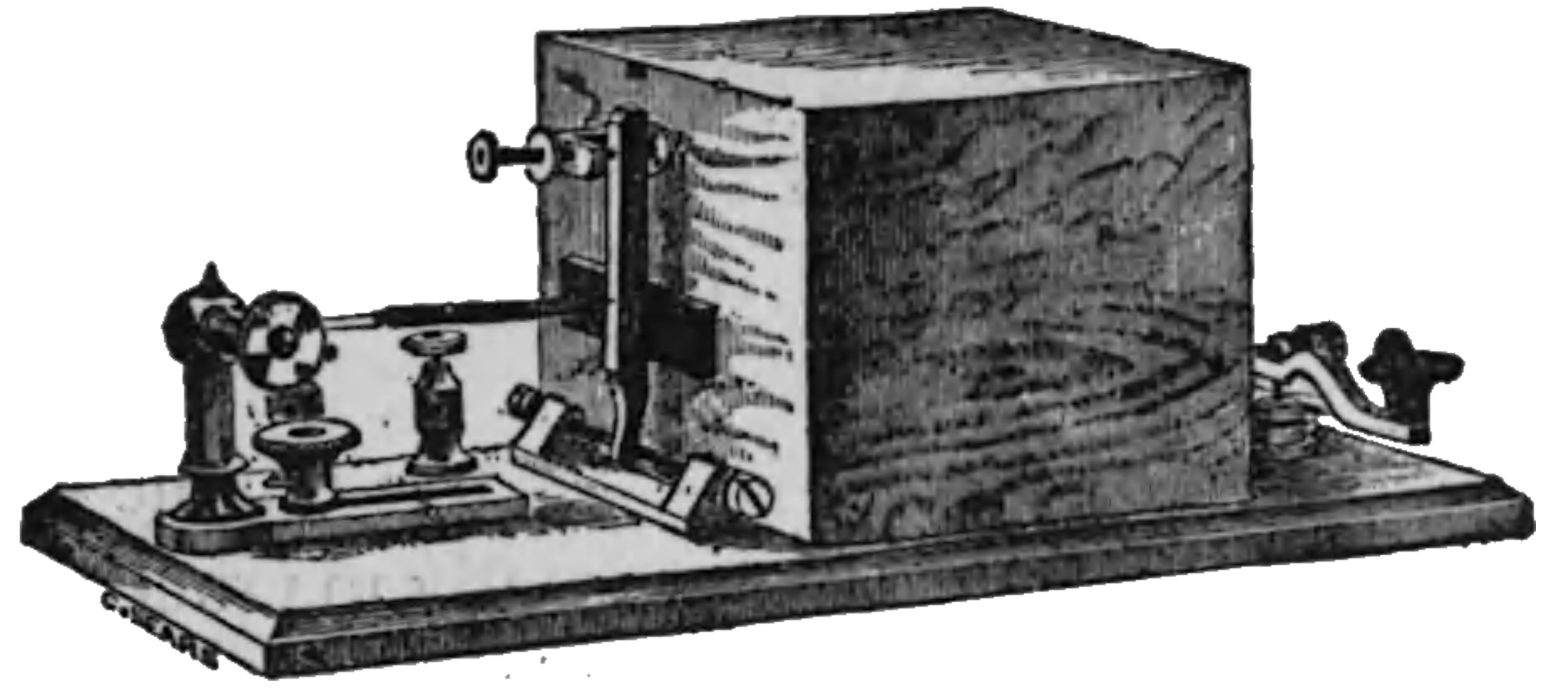

Fig. 479. Box-Sounding Relay

relay containing two differentially wound coils of wire on its magnet cores.

When the currents which pass through these two coils are of the same strength, there is no movement of the armature, since the fields of the two coils neutralize each other.

The differential relay is used in the differential method of duplex and quadruplex telegraphy. (See *Telegraphy, Duplex Differential Method of. Telegraphy, Quadruplex Differential Method of.*)

Relay Magnet.—A name sometimes given to a relay. (See *Relay.*)

Relay, Microphone — —A device for automatically repeating a telephonic message over another wire.

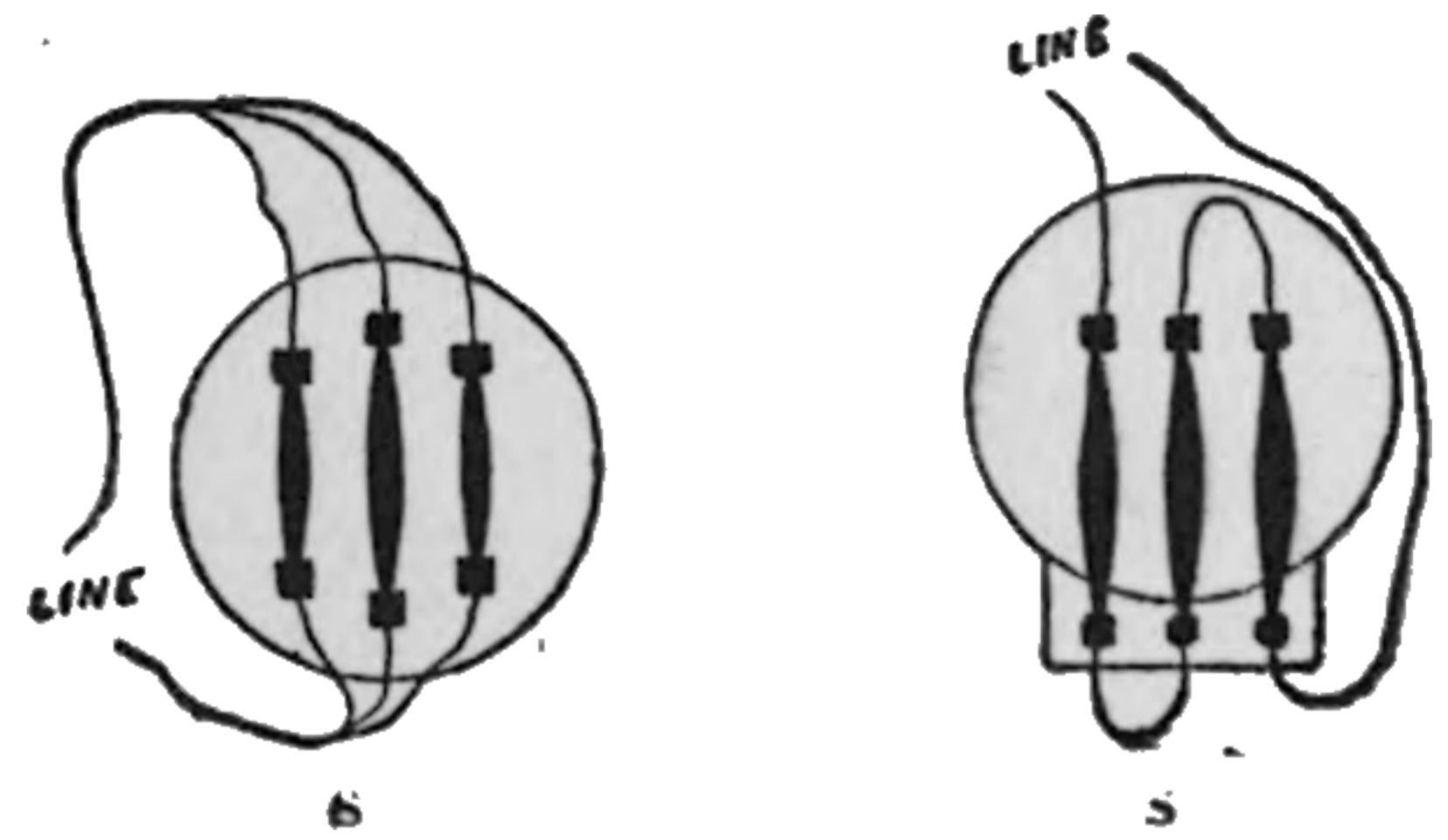

Fig. 480. Microphone Relay.

A form of microphone relay is shown in Figs. 480 and 481.

Several minute microphones mounted on the

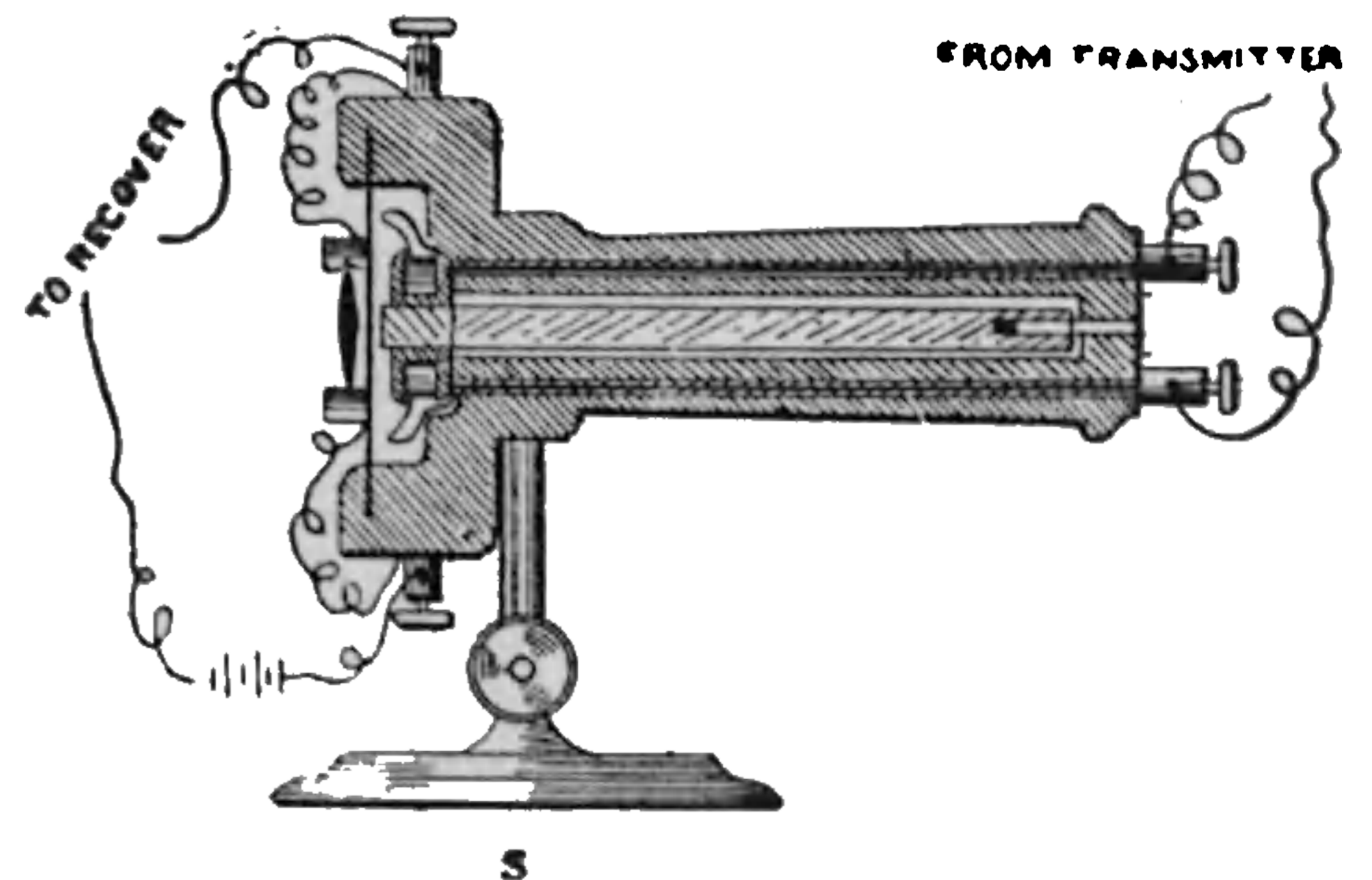

Fig. 481. Microphone Relay.

diaphragm of the telephone whose message is to be repeated, so vary the resistance of a local battery included in their circuit as to automatically repeat the articulate speech received.

The microphones may be connected either in

multiple arc or in series, as shown respectively to the left and right in Fig. 480.

Relay, Pocket Telegraphic — — A form of telegraphic relay of such small dimensions as to permit it to be readily carried in the pocket.

Relay, Polarized — — A telegraphic relay provided with a permanently magnetized armature in place of the soft iron armature of the ordinary instrument.

In the form of polarized relay shown in Fig. 482, N S, is a *steel magnet*, whose magnetism is consequently permanent, with its north and south poles at N, and S, respectively. The cores of the electro-magnet m, m', are of soft iron, and, since they rest on the north pole of the permanent steel magnet, the poles, brought very near together by the armatures at n, n', will be of the same polarity as N, *when no current is passing through the coils m, m'*; but when such current does pass, *one of these poles becomes of stronger north polarity, while the other changes its polarity to south.*

By these means to-and fro movements of the armature lever, with its contact point, are effected without the use of a retractile spring; movement in one direction occurring on the closing of the circuit due to the electro-magnetism developed

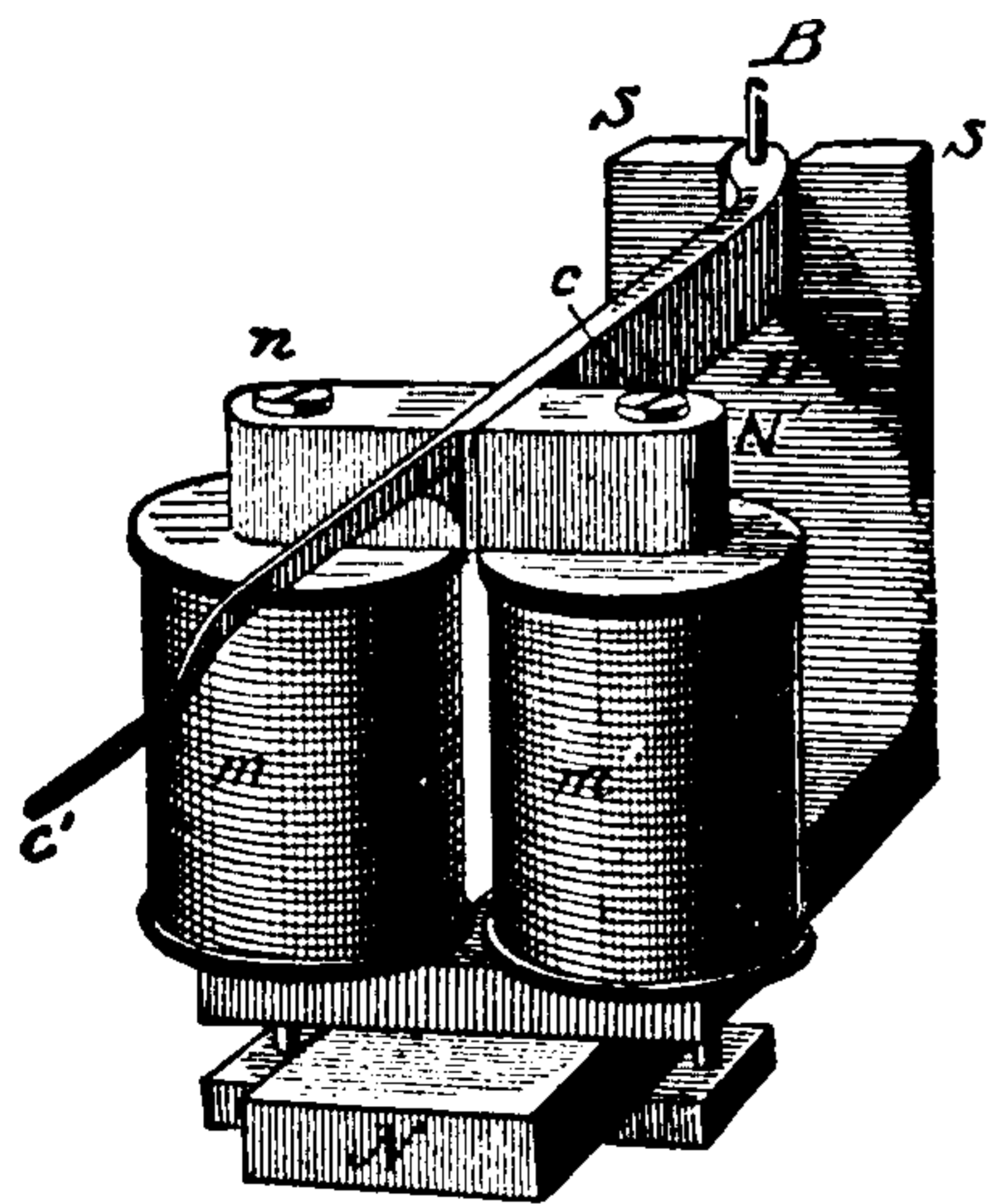

Fig. 482. Polarized Relay.

by the coils m, m', and movement in the opposite direction, on the losing of this magnetism on breaking the circuit, by the permanent magnetism of the steel magnet N S.

These movements are imparted to the soft iron lever c, c', pivoted at B, and passing between the closely approached soft iron poles at n, n'. This lever rests at the end c', against a contact point

when moved in one direction, and against an insulated point when moved in the opposite direction. It rests against the insulated point when no current is passing through the coils m, m'.

If the armature lever were placed in a position exactly midway between the poles n, and n', it would not move at all, being equally attracted by each; but if moved a little nearer one pole than the other, it would be attracted to, and rest against, the nearer pole.

When alternating currents are employed on the line, the lever c, c', must be adjusted as nearly as possible in the middle of the space between n and n', in which case it will remain on the side to which it was last attracted, until a current in the opposite direction moves it to the other side.

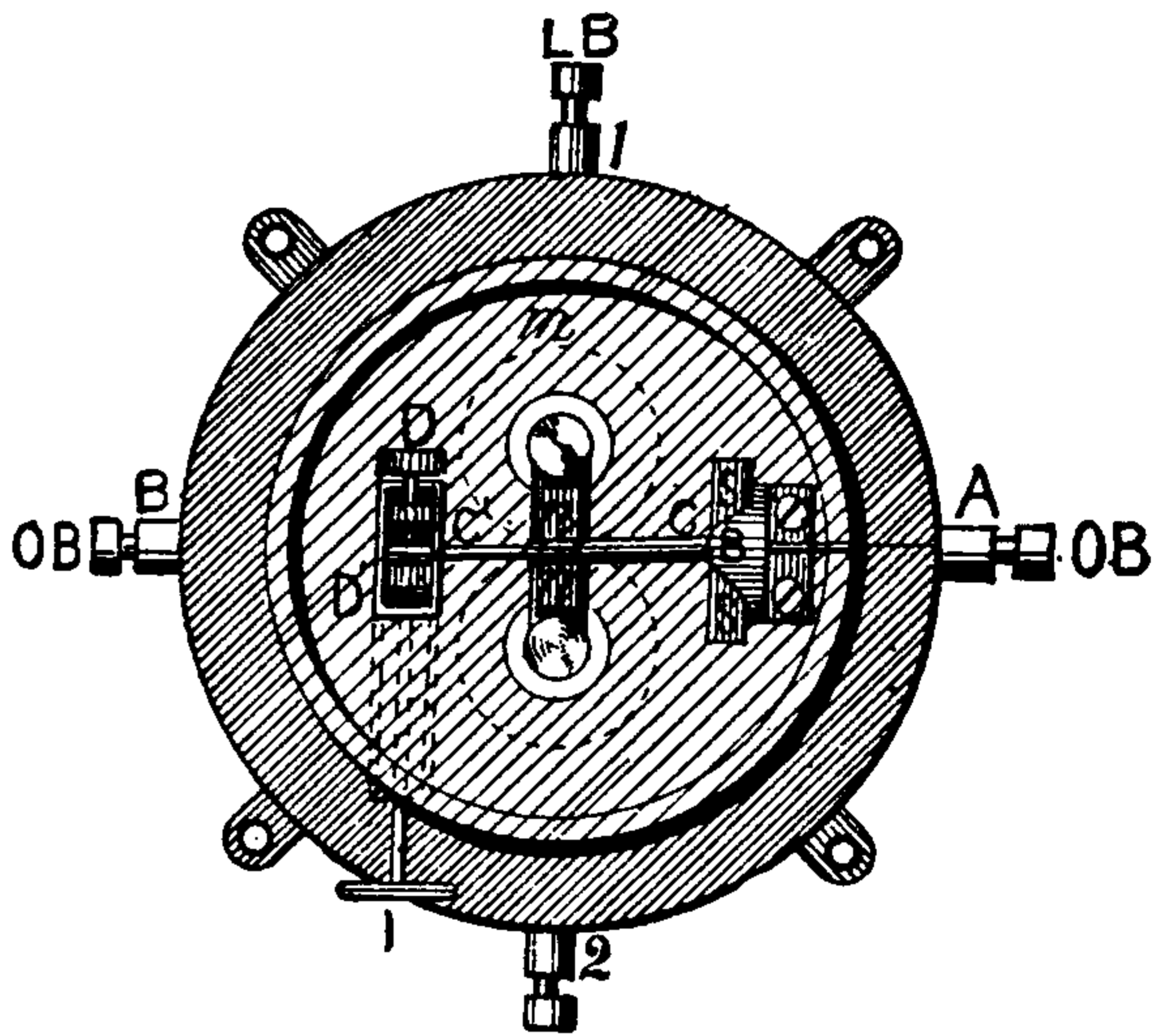

Fig. 483. A Detail of the Polarized Relay.

The space between the magnet poles n, n', and the contacts of the armature lever at D, and D', are shown in detail in Fig. 483, which is a plan of Fig. 482. The *binding posts* for the line battery are shown at L B, 1, and 2, and those for the local battery at A and B. The dotted lines show the connections.

Since the polarized relay dispenses with the retractile spring, it is far more sensitive than the ordinary instrument. Once adjusted, no further regulation is required, in which respect it differs very decidedly from non-polarized relays.

There are other forms of polarized relays, but the above will suffice to illustrate the general principle of their operation.

Relay Shunt, Stearn's — — (See *Shunt, Relay, Stearn's.*)

Reluctance, Magnetic — — A term recently proposed in place of magnetic resistance to express the resistance offered by a

THIS PAGE IS LOCKED TO FREE MEMBERS

Purchase full membership to immediately unlock this page

Know Your Bible

Forgotten Books' Full Membership provides unlimited access to more than 28,000 volumes of Christian literature for \$8.99/month

HOLY BIBLE

Continue

*Fair use policy applies

placed directly opposite the armatures of the relay magnets.

The extra local magnet L, is cut out of the circuit of B', the *extra local battery*, when the main circuit is broken, and the armature is in contact with c. As soon as this happens, however, the spring s, drawing away the armature, and thus opening the short-circuit of no resistance between c and a, establishes a circuit through L. On a, coming in contact with c, the circuit is again broken.

The tension of the spring s, is so regulated that a very rapid vibration of a, is maintained so constantly, that it is impossible to close the main circuit when L, is not cut out. The armature a, will therefore respond to very weak impulses of the relay magnet.

On breaking the *western main circuit* N, the lever a, vibrates very rapidly. The lever l, of the sounder R, first breaks the circuit of L, and afterwards that of the *eastern main circuit* E, which passes through M. Both L' and M', being broken, a slight tension of s', will hold a, in place, thus avoiding the breaking of the western main circuit through the closing of the local circuit through R. On the closing of the western circuit, the reverse of these operations occurs.

The author has taken the above explanation mainly from Pope's work on "Modern Practice of the Electric Telegraph."

Repeating Sounder.—(See *Sounder, Repeating.*)

Replenisher.—A static influence machine devised by Sir William Thomson for charging the quadrants of his quadrant electrometer.

Two brass carriers C and D, shown in Fig. 486, are electrically fixed to the end of the vulcanite rod E, which is capable of rotation by the thumb screw at M, in the direction shown by the arrow. Hollow metal half-cylinders, A and B, act as inductors, a strip of brass fixed around the edges of a piece of vulcanite P, connecting the metallic springs S, and S', as shown.

The action of the replenisher is readily under-

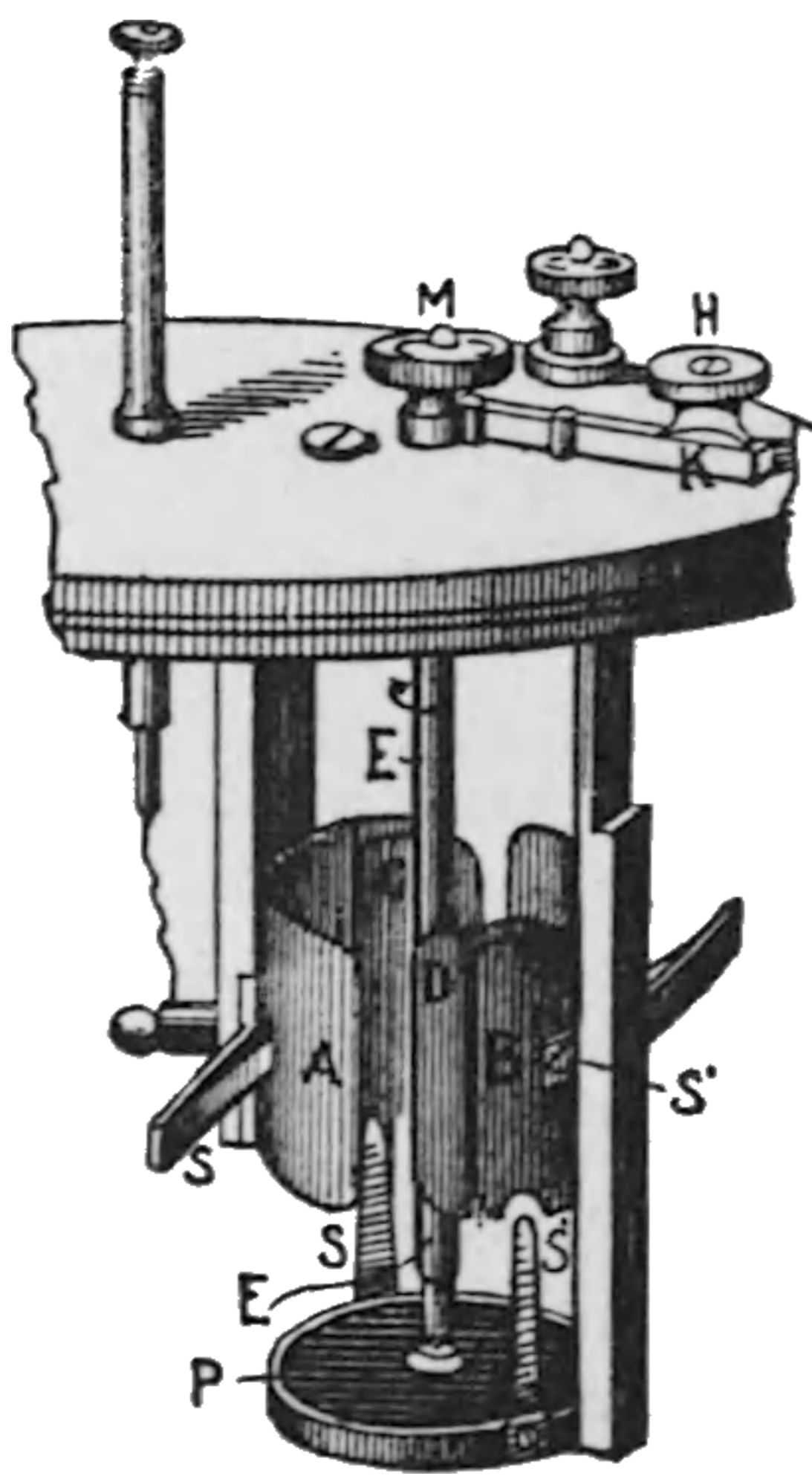

Fig. 486. The Replenisher.

stood from the following considerations, as suggested by Ayrton in his "Practical Electricity":

A and B, Fig. 487, are two insulated hollow metallic vessels having a small difference of potential between them, A, being the higher. C, and D, are two small uncharged conductors held by insulating strings. If C and D, be held near A and B, as shown, the potential of C, will, by induction, be raised somewhat above that of D, so that when connected by a conductor, such as the metallic wire W, a small quantity of positive electricity will flow from C, to D, thus leaving D, positively, and C, negatively charged.

If, now, C and D, are removed from W, and placed in the bottom of B and A, as shown in Fig. 488, the difference of potential between A, and B, will be thereby increased, and if they are then withdrawn, and totally discharged, and

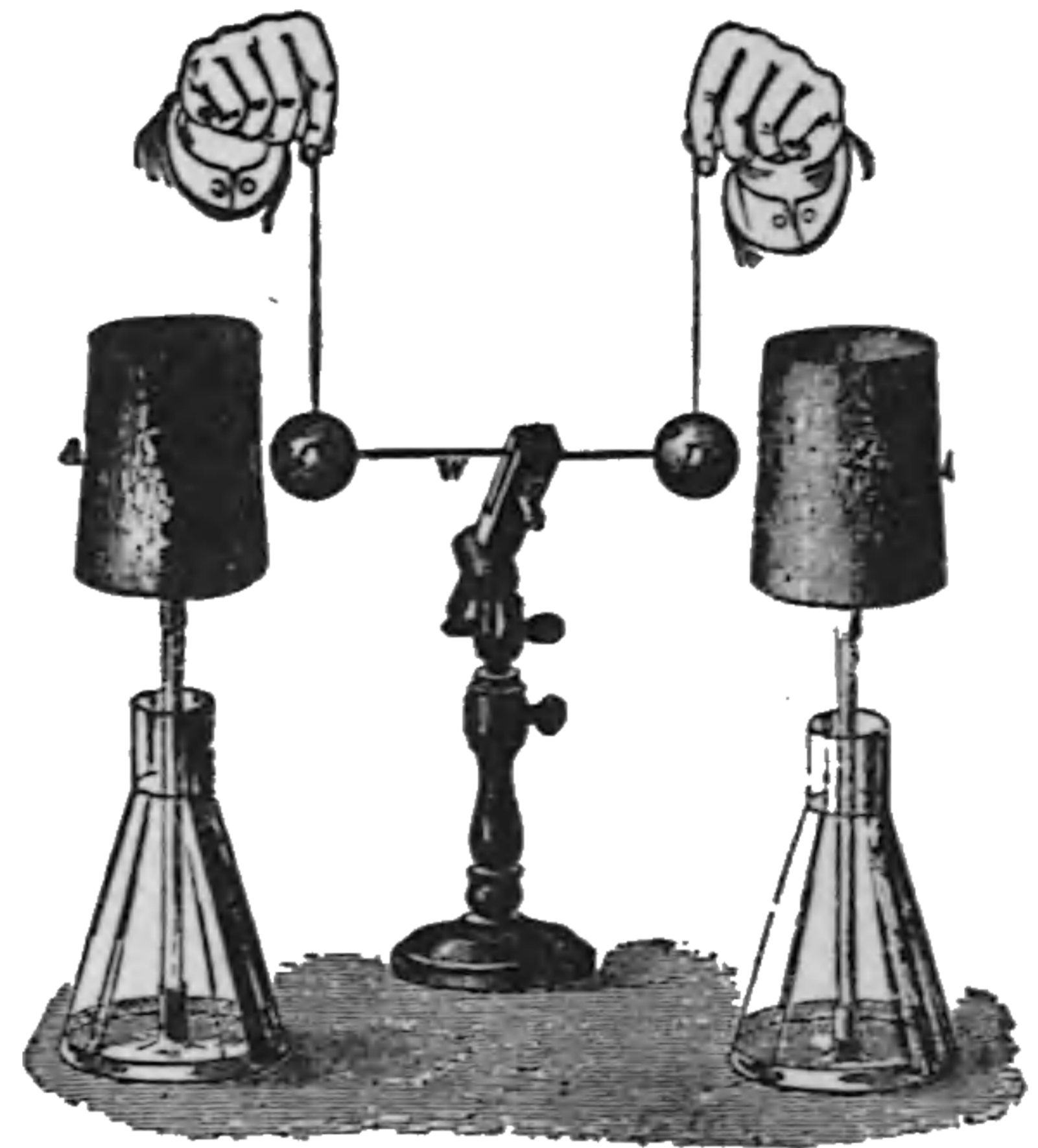

Fig. 487. Action of Replenisher.

again placed in the first position shown, an additional charge can be given to A and B, and this can be repeated as often as desired.

In the replenisher, A and B, correspond to the vessels A and B; the brass carriers C and D, to the balls C and D, and the spring S S, and M,

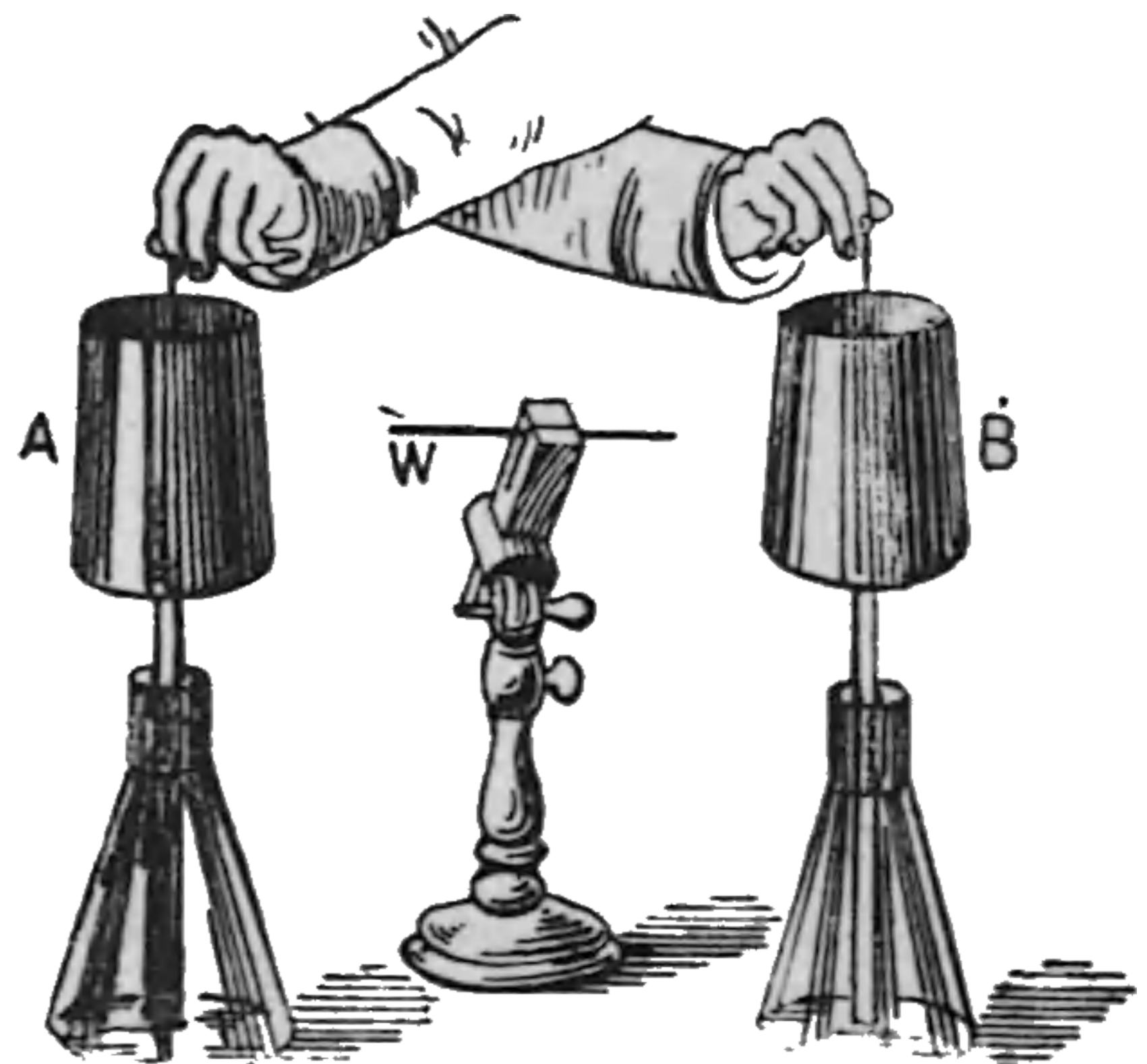

Fig. 488. Action of Replenisher.

to the wire W. No initial charge need be given to A and B, since they are invariably found to

be at a sufficient difference of potential to build up the charge.

Replenisher, Carriers of — —The moving conductors of a replenisher which carry the charges and thus permit of an accumulation of such charges. (See *Replenisher*.)

Repulsion, Electric — —The mutual driving apart or tendency to mutually drive apart existing between two similarly charged bodies, or the mutual driving apart of similar electric charges.

Repulsion, Electro-Dynamic — —The mutual repulsion between two electric circuits whose currents are flowing in opposite directions.

Parallel currents flowing in opposite directions repel one another, because their lines of magnetic force have the same direction in adjoining parts of the circuit. (See *Dynamics, Electro*.)

Repulsion, Electro-Magnetic — —The mutual repulsion produced by two similar electro-magnetic poles.

Repulsion, Electrostatic — —The mutual repulsion produced by two similar electric charges.

Repulsion, Magnetic — —The mutual repulsion exerted between two similar magnetic poles.

Repulsion, Molecular — —The mutual repulsion existing between molecules arising from their kinetic energy. (See *Matter, Kinetic Theory of*.)

Residual Atmosphere—(See *Atmosphere, Residual*.)

Residual Charge.—(See *Charge, Residual*.)

Residual Magnetism.—(See *Magnetism, Residual*.)

Resin.—A general term applied to a variety of dried juices of vegetable origin.

Resins are, in general, transparent, inflammable solids, soluble in alcohol, and, in general, excellent non-conductors of electricity. Rosin is one of the varieties of resin.

Resinous Electricity.—(See *Electricity, Resinous*.)

Resistance.—Something placed in a circuit for the purpose of opposing the passage or

flow of the current in the circuit or branches of the circuit in which it is placed.

The electrical resistance of a conductor is that quality of the conductor in virtue of which there is a fixed numerical ratio between the potential difference of the two opposing faces of a cubic unit of such conductor, and the quantity of electricity which traverses either face per second, assuming a steady flow to take place normal to these faces, and to be uniformly distributed over them, such flow taking place solely by an electromotive force outside the volume considered.

The term is used in the first definition in the concrete sense of something intended for or used as a resistance. For the physical definitions and facts see *Resistance, Electric*.

Gases offer very high resistance to the flow of an electric current. Their non-conducting power causes the increase of resistance which attends the polarization of a voltaic cell. (See *Cell, Voltaic, Polarization of*.)

Resistances consist of coils, strips, bars or spirals of metal, or plates of carbon, or metallic powders, powdered or granulated carbon, or liquids.

Resistance, Absolute Unit of — —The one thousand millionth of an ohm. (See *Ohm, Units, Practical*.)

Resistance, Assymmetrical — —Conductors or parts of conductors, which offer a greater resistance to the flow of an electric current in one direction than in another.

Assymmetrical conductors are unknown, so far as structural peculiarities are concerned, but can be obtained by the use of counter electromotive forces, acting as resistance. This term was proposed by Wilke in discussing the obtaining of continuous currents by commutatorless dynamo-electric machines.

The resistance of the human body is possibly an assymmetrical resistance.

An evident application of an assymmetrical resistance is to direct alternating currents so as to cause the current that passes to flow in and to the same direction.

Resistance, Balanced — —A resistance so placed in a circuit as to be balanced or made equal to another resistance connected therewith.

Resistance, Balanced, for Dynamos —

—A resistance that possesses a range sufficient to balance one dynamo against another with which it is desired to run in parallel.

—(*Urquhart.*)

Resistance Box.—(See *Box, Resistance.*)

Resistance Bridge.—(See *Bridge, Resistance.*)

Resistance Coil.—(See *Coil, Resistance.*)

Resistance Coil, Standard — —(See *Coil, Resistance, Standard.*)

Resistance, Conductivity — —The resistance offered by a substance to electric conduction, or to the passage of electricity through its mass.

Resistance, Dielectric — —A term sometimes employed for the resistance of a dielectric to mechanical strains produced by electrification.

The dielectric resistance of the glass, or other dielectric of a Leyden jar or condenser, is frequently overcome by the passage of the charges on the conducting surfaces, and the glass is thus pierced.

The term dielectric resistance would appear to be badly chosen; for, like all substances, dielectrics possess a true ohmic resistance, which increases with the increase of length, and decreases with the increase of area of cross-section.

The resistance of the dielectric, however, differs from the ordinary ohmic resistance of conductors, in that the resistance of the dielectric is suddenly overcome, and the discharge passes disruptively as a spark.

Resistance, Effect of Heat on Electric — —Nearly all metallic conductors have their electric resistance increased by an increase of temperature.

The carbon conductor of an incandescent electric lamp, on the contrary, has its resistance decreased when raised to electric incandescence. The decrease amounts to about three-eighths of its resistance when cold.

The effects of heat on electric resistance may be summarized as follows:

(1.) The electric resistance of metallic conductors increases as the temperature rises. In some alloys this increase is small.

(2.) The electric resistance of electrolytes decreases as the temperature rises.

(3.) The electric resistance of dielectrics and non-conductors decreases as the temperature rises.

RESISTANCE AND CONDUCTIVITY OF PURE COPPER AT DIFFERENT TEMPERATURES.

Centigrade Temperature.	Resistance.	Conductivity.	Centigrade Temperature.	Resistance.	Conductivity.
0°	1.00000	1.00000	16°	1.06168	.94190
1	1.00381	.99624	17	1.06563	.93841
2	1.00756	.99250	18	1.06959	.93494
3	1.01135	.98878	19	1.07356	.93148
4	1.01515	.98508	20	1.07742	.92814
5	1.01896	.98139	21	1.08164	.92452
6	1.02280	.97771	22	1.08553	.92121
7	1.02663	.97406	23	1.08954	.91782
8	1.03048	.97042	24	1.09365	.91445
9	1.03435	.96679	25	1.09763	.91110
10	1.03822	.96319	26	1.10161	.90776
11	1.04199	.95970	27	1.10567	.90443
12	1.04599	.95603	28	1.10972	.90113
13	1.04990	.95247	29	1.11382	.89784
14	1.05406	.94893	30	1.11782	.89457
15	1.05774	.94541			

—(*Latimer Clark.*)

Resistance, Electric — —The ratio between the electromotive force of a circuit and the current that passes therein.

The reciprocal of electrical conductivity.

Resistance can be defined as the reciprocal of electrical conductivity, because even the best electrical conductors possess appreciable resistance.

Ordinarily the resistance of a circuit may be conveniently regarded as that which *opposes* or *resists* the passage of the current. Strictly speaking, however, this is not true, since from *Ohm's law* (See *Law of Ohm, or Law of Current Strength*)

$$C = \frac{E}{R}, \text{ from which we obtain}$$

$$R = \frac{E}{C}, \text{ which shows that resistance is a}$$

ratio between the electromotive force that causes the current and the current so produced.

Resistance may be expressed as a velocity. The dimensions of resistance in terms of the electro-magnetic units are

$$\frac{L}{T}$$

(See *Units, Electro-Magnetic.*) But these are the dimensions of a velocity, which is the ratio of the distance passed over in unit time. Resistance may therefore be expressed as a velocity.

THIS PAGE IS LOCKED TO FREE MEMBERS

Purchase full membership to immediately unlock this page



HISTORY

Tens of thousands of important historical sources, many previously unobtainable, are now available for the first time with a Forgotten Books Full Membership.

Unlimited Access
\$8.99/month

Continue

*Fair usage policy applies

TABLE OF CONDUCTING POWERS AND RESISTANCES IN OHMS—B. A. UNITS.

NAMES OF METALS.	Conducting power at 0 degree C.	Resistance of a wire one foot long weighing one grain.	Resistance of a wire one metre long weighing one gramme.	Resistance of a wire one foot long, $\frac{1}{1000}$ inch in diameter.	Resistance of a wire one metre long, one millimetre in diameter.	Approximate percentage of variation in resistance for 1 degree of temperature at 20 deg.
Silver, annealed.....	0.2214	0.1544	9.936	0.01937	0.377
Silver, hard drawn.....	100.00	0.2421	0.1689	9.151	0.02103
Copper, annealed.....	0.2064	0.1440	9.718	0.02057	0.388
Copper, hard drawn.....	99.55	0.2106	0.1469	9.940	0.02104
Gold, annealed.....	0.5849	0.4080	12.52	0.02650	0.355
Gold, hard drawn.....	77.96	0.5950	0.4150	12.74	0.02697
Aluminium, annealed.....	0.06822	0.05759	17.72	0.03751
Zinc, pressed.....	29.02	0.5710	0.3983	32.22	0.07244	0.365
Platinum, annealed.....	3.536	2.464	55.09	0.1166
Iron, annealed.....	16.81	1.2425	0.7522	59.40	0.1251
Nickel, annealed.....	13.11	1.0785	0.8666	75.78	0.1604
Tin, pressed.....	12.36	1.317	0.9184	80.36	0.1701	0.365
Lead, pressed.....	8.32	3.236	2.257	119.39	0.2527	0.387
Antimony, pressed.....	4.62	3.324	2.3295	216.0	0.4571	0.389
Bismuth, pressed.....	1.24	5.054	3.525	798.0	1.689	0.354
Mercury, liquid.....	18.740	13.071	600.0	1.270	0.072
Platinum-silver, alloy, hard or annealed.....	4.243	2.959	143.35	0.3140	0.031
German silver, hard or annealed.....	2.652	1.850	127.32	0.2695	0.044
Gold, silver, alloy, hard or annealed.....	2.391	1.668	66.10	0.1399	0.065

—(Jenkin.)

which these distances are readily adjustable, as shown.

Resistance, Equivalent — —A single resistance which may replace a number of separate resistances in a circuit without altering the value of the current traversing it.

Resistance, Essential — —A term sometimes used instead of internal resistance.

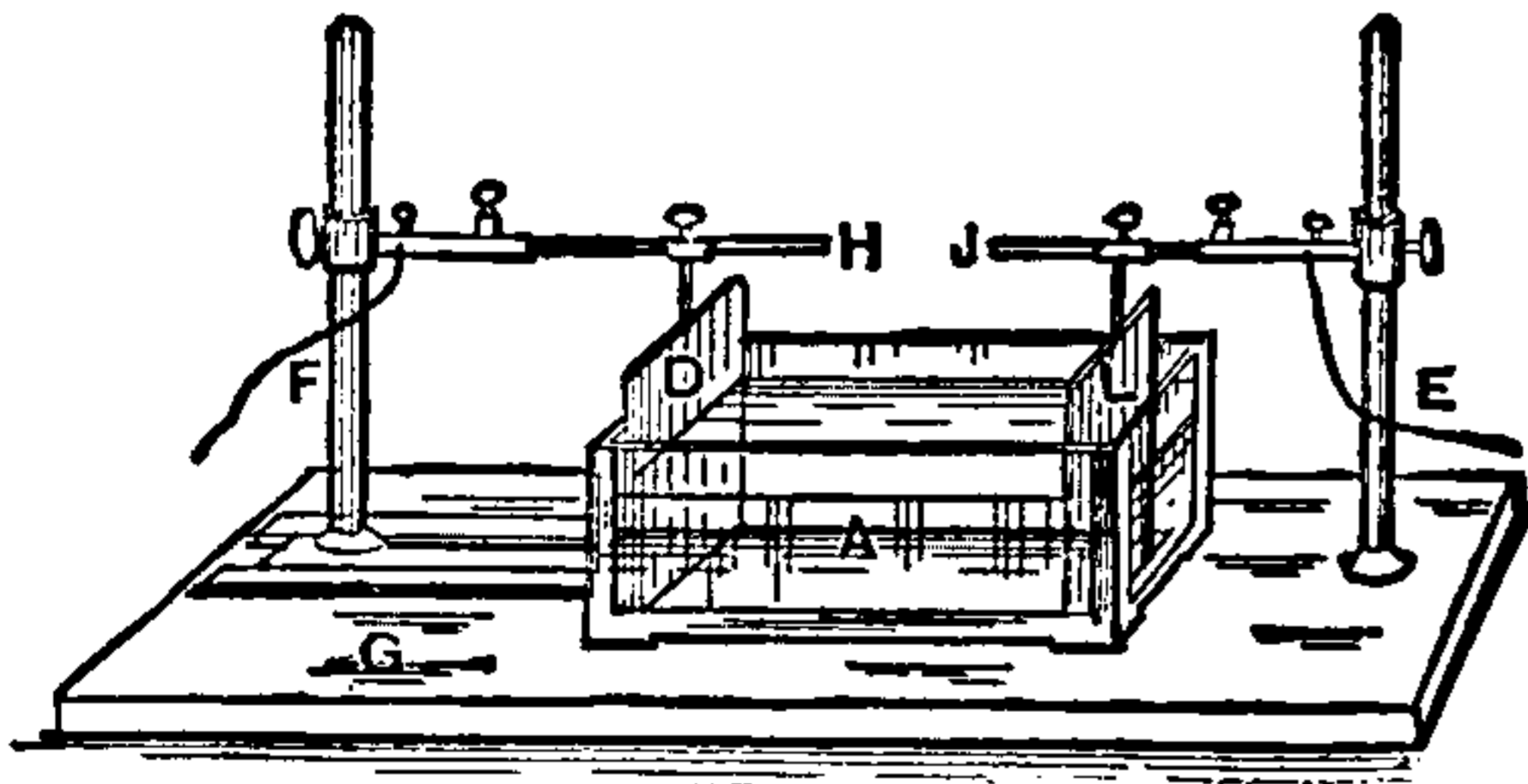

Fig. 490. Apparatus for Measuring Resistance of Liquid.

Resistance, External Secondary — —A term proposed by Du Bois Reymond for the change in the resistance of a circuit external to the electric source when cataphoric action takes place. (See *Action, Cataphoric*.)

“If the copper electrodes of a constant battery be placed in a vessel filled with a solution of cupric sulphate and from each electrode there projects a cushion saturated with this fluid, then,

on placing a piece of muscle, cartilage, vegetable tissue, or even a prismatic strip of coagulated albumen across these cushions, we observe, that very soon after the circuit is closed, there is a considerable variation of the current. * * * This phenomenon is called ‘external secondary resistance.’” —(Landois and Sterling.)

Resistance, Extraordinary — —A term sometimes employed instead of external resistance. (See *Resistance, External Secondary*.)

Resistance, False — —A resistance arising from a counter electromotive force and not directly from the dimensions of the circuit, or from its specific resistance.

The false resistance of any circuit is sometimes called its spurious resistance. (See *Force, Electromotive, Counter. Resistance, Spurious*.)

Resistance, Inductionless — —A term sometimes used instead of non-inductive resistance. (See *Resistance, Non-Inductive*.)

Resistance, Inductive — —A resistance which possesses self-induction.

Resistance, Insulation — —The resistance of a line or conductor existing between the line or conductor and the earth through the insulators, or between the two

wires of a cable through the insulating material separating them.

The insulation resistance of a telegraph line is the resistance that exists between the line and the earth, through its insulators. The insulation resistance will decrease as the length of line increases, since for any increase in the number of poles and insulators there is a proportional increase in the area of cross-section of the insulating supports.

If the insulation resistance is 1,000,000 ohms per mile, in a line 200 miles in length, the insulation resistance is only 5,000 ohms, that is, $\frac{1,000,000}{200} = 5,000$ ohms.

Resistance, Joint, of Parallel Circuits

— — The joint resistance of two parallel circuits is determined by means of the following formula :

$$R = \frac{r r'}{r + r'}$$

Where R = the joint resistance of any two circuits whose separate resistances are respectively r and r' .

When there are three resistances r , r' and r'' , in parallel, the joint resistance,

$$R = \frac{r r' r''}{r r' + r r'' + r' r''}$$

(See *Circuits, Varieties of.*)

Resistance, Magnetic — — The reciprocal of magnetic permeability or conductivity for lines of magnetic force.

Resistance offered by a medium to the passage of the lines of magnetic force through it.

The magnetic resistance of the circuit of the lines of force is reduced by forming the circuit of a medium having a high magnetic permeability, such as soft iron. This is accomplished by the armature or keeper of a magnet, or by the iron in an iron-clad magnet. (See *Magnet, Iron-Clad.*)

Resistance, Measurement of — —

Methods employed for determining the resistance of any circuit or part of a circuit.

Numerous methods are employed for this purpose. Among these are :

(1.) *The use of a resistance box with a Wheatstone bridge*, by opposing or balancing the unknown resistance against a known resistance. (See *Balance, Wheatstone's Electric.*)

(2.) *The differential galvanometer.* (See *Galvanometer, Differential.*)

(3.) *The method of substitution.*

(4.) *Comparison of the deflections of a galvanometer.*

Method of Substitution.—A resistance-box R , Fig. 491, galvanometer G , and the resistance x , that is to be measured, are placed in the direct circuit of the battery B , by means of conductors of such thick wire that their resistance can be neglected.

The deflection of the galvanometer is first measured with x , in circuit, and no resistance in the box R . The resistance x , is then cut out of the circuit by placing a thick copper wire across the terminals of the mercury cups at $m m'$, and resistances unplugged in R , until the same deflection is obtained. Then, *if the electromotive force of the battery has remained constant*, the resistances unplugged equal the unknown resistance.

For full description of the various methods of determining resistance the reader is referred to "*Ayrton's Practical Electricity*," "*Kempe's Handbook of Testing*," or other standard books on electrical measurements.

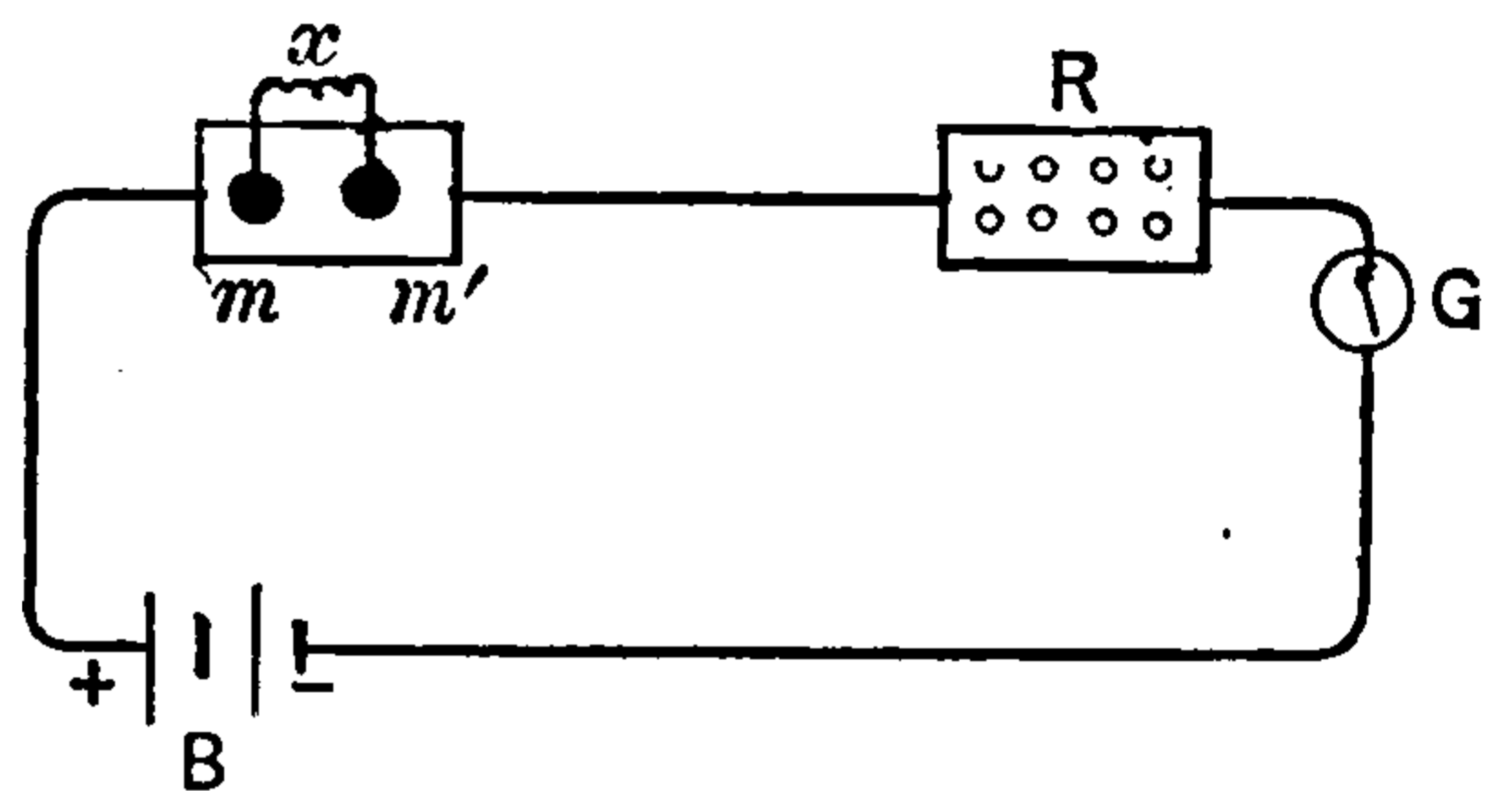

Fig. 491 Substitution Method.

When several resistances are placed in series in any circuit, by measuring the difference of potential at their terminals, their values can be determined by simple calculation, being directly proportional to these differences of potential.

This method is especially applicable to the measurement of such low resistances as the armatures of dynamo-electric machines.

Resistance, Non-Inductive — — A resistance in which self-induction is practically absent.

An incandescent lamp filament is practically a non-inductive resistance when compared with a coil on the helix of an electro-magnet.

Resistance of Human Body.—(See *Body, Human, Resistance of.*)

Resistance of Voltaic Arc.—(See *Arc, Voltaic, Resistance of.*)

Resistance, Ohmic — —The true resistance of a conductor due to its dimensions and specific conducting power, as distinguished from the spurious resistance produced by a counter electromotive force. (See *Force, Electromotive, Counter. Resistance, Spurious.*)

The term ohmic resistance must be regarded as a pleonasm. Its use can only be permitted in contradistinction to counter electromotive force resistance. True and spurious resistance would seem preferable.

Resistance or Cell, Selenium — —A mass of crystalline selenium, the resistance of which is reduced by placing it in the form of narrow strips between the edges of broad conducting plates of brass.

The selenium employed for this purpose is the vitreous variety which has been fused and maintained for several hours at about 220 degrees C., by means of which its resistance is reduced.

By exposure to sunlight, the resistance of a selenium cell is decreased fully one-half its resistance in the dark. The selenium cell is used in the photophone. (See *Photophone.*)

Resistance or Reducteur for Voltmeter. —(See *Reducteur or Resistance for Voltmeter.*)

Resistance, Secondary — —A term sometimes used in place of external secondary resistance. (See *Resistance, External Secondary.*)

Resistance Slide.—(See *Slide, Resistance.*)

Resistance, Specific — —The particular resistance which a substance offers to the passage of electricity through it.

In absolute measure, the resistance in absolute units between the opposite faces of a centimetre cube of the given substance.

In the practical system the resistance given in ohms.

Resistance, Specific Conduction — —A term sometimes used instead of specific resistance. (See *Resistance, Specific.*)

Resistance, Specific, of Liquids — —The resistance of a given length (one centimetre) and area of cross-section (one square centimetre) of any liquid as compared with the resistance of an equal length and cross-section of pure silver.

The resistance of a few common liquids and solutions is here given from Lupton:

Water, pure, at 75 degrees C.	1.188×10^8 ohms,	
<i>i. e.</i> ,	118,800,000.	
Water at 4 degrees C	9.100×10^6	“
Water at 11 degrees C	3.400×10^5	“
Dilute hydrogen sulphate (sulphuric acid) at 18 degrees C., 5 per cent. acid	4.88	
Dilute hydrogen sulphate at 18 degrees C., 3 per cent. acid	1.38 ohms.	
Nitric acid at 18 degrees C., density 1.32	1.61	“
Saturated solution of copper sulphate (blue vitriol) at 10 degrees C	29.30	“
Saturated solution of zinc sulphate at 14 degrees C	21.50	“
Hydrochloric acid, 20 per cent. acid, at 18 degrees C	1.34	“
Sal ammoniac, 25 per cent. salt	2.53	“
Common salt, saturated, at 13 degrees C	5.30	“

It will be observed that the resistance varies considerably with differences of temperature.

Resistance, Spurious — —A false resistance arising from the development of a counter electromotive force. (See *Resistance, False. Force, Electromotive, Counter.*)

The spurious resistance is also called the false resistance, in order to distinguish it from the true or ohmic resistance. (See *Resistance, Electric.*)

Resistance, Standard — —A resistance used for comparison with or the determination of unknown resistances.

A committee appointed by the American Institute of Electrical Engineers in 1890 reported the following values for the standard resistance of copper wire; at 0 degree C. in B. A. U. and legal ohms, viz.:

THIS PAGE IS LOCKED TO FREE MEMBERS

Purchase full membership to immediately unlock this page

Know Your Bible

Forgotten Books' Full Membership provides unlimited access to more than 28,000 volumes of Christian literature for \$8.99/month

HOLY BIBLE

Continue

*Fair use policy applies

pulse to travel backwards and forwards along the conducting wires, is exactly equal to the time of a complete oscillation in the circuit, or when the length of the open-circuit wires is equal to half a wave length, or some multiple of half a wave length.

The fact that the length of the spark is greatest when certain relations exist between the dimensions of the two circuits, shows that the time-rate of an electrical pulse in any circuit depends on the dimensions of that circuit.

In the case of acoustic resonance, in order that one tuning fork may be able to excite vibrations in another, the fork producing or exciting the vibration must be strictly in unison with the fork in which the vibrations are excited, and any variations produced in the rate of vibration of the sounding fork, by overloading it, or, in other words, by altering its dimensions, checks the effects of its resonance.

In a similar manner, any alterations in the dimensions of the circuit, checks or diminishes the effects of electric resonance in a neighboring circuit, which was previously in unison with it. This has been experimentally shown by Hertz as follows:

An induction coil A, Fig. 492, has the terminals of its secondary connected to an open rectangular circuit provided with sparking terminals, 1, and 2, called a spark micrometer. Under certain conditions, when the discharge occurs at the terminals B,

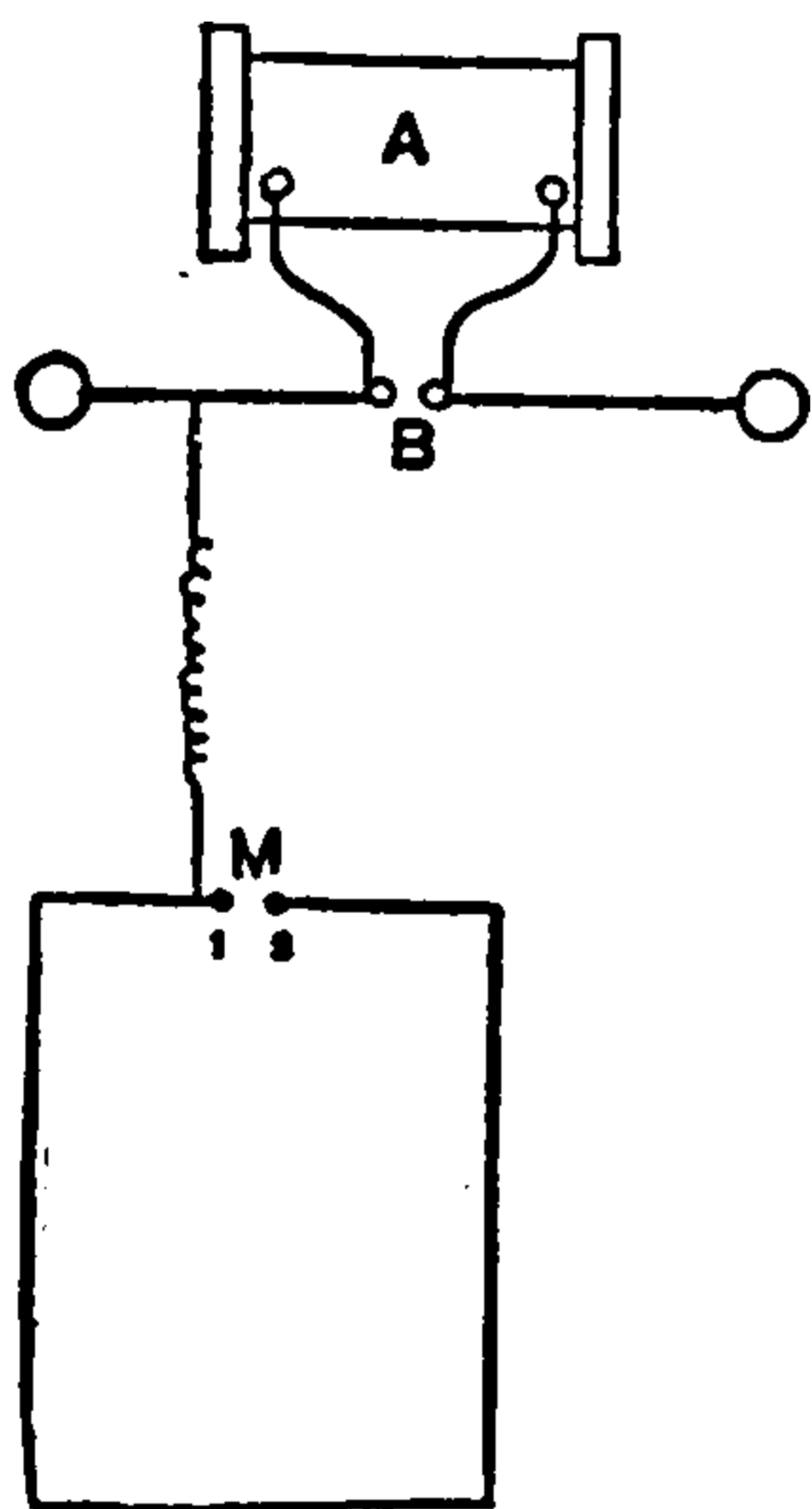

Fig. 492. *Electrical Resonance.*

of the ordinary discharger, sparks are produced by electric resonance in the electric resonator formed by the spark micrometer at M.

Supposing, now, that a certain character of spark is obtained at the terminals B, that is, a certain velocity of electrical pulsations is obtained which depends on the nature of the spark; suppose, moreover, that the dimensions of the spark micrometer or electric resonator are such that the greatest length of spark is obtained. Then, any alteration in the character of these sparks, between the terminals at B, varies the intensity of the sparks in the spark micrometer.

If, for example, the apparatus be arranged

as shown in Fig. 493, in which one of the secondary terminals of the induction coil has connected with it a copper wire *i g h*. The sparks at M, decrease considerably. When, however, the conductor C, is connected with the free end H, of this additional conductor, then this effect is not observed, as is shown by the fact that when the conductor C, is attached at the point G, it produces no effect on it.

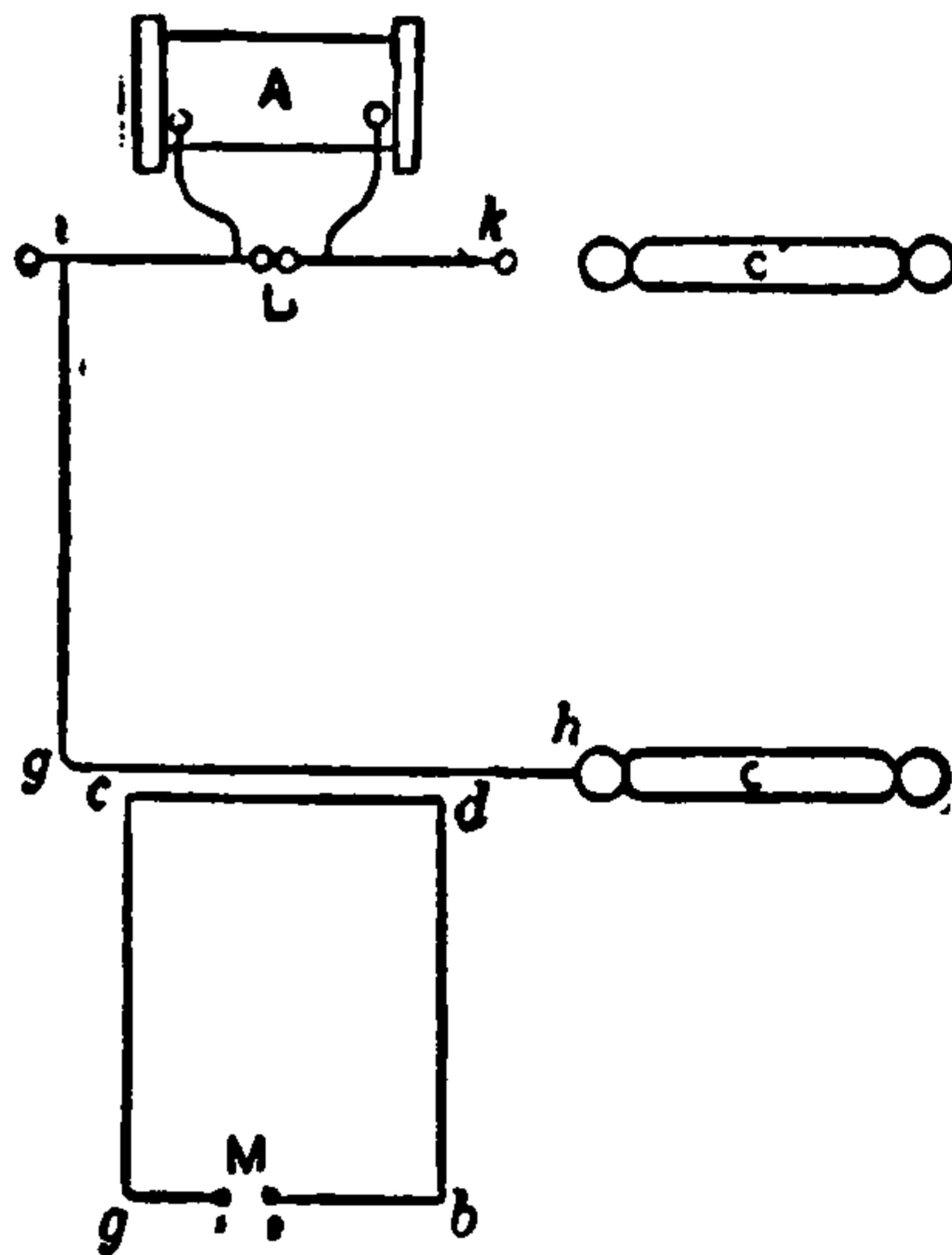

Fig. 493. *Electric Resonance.*

In another experiment with the same apparatus, matters may be arranged that the sparks in the micrometer circuit pass singly. When, now, another conductor C', is attached to K, a stream of sparks immediately passes.

It would appear, therefore, from the above experiments, that when two circuits are taken, having as nearly as possible the same vibration periods, any alteration in the dimensions of either will prevent one from producing electrical resonance in the other.

In the above experiments Hertz demonstrated the following facts, viz.,

(1.) The sparks in the micrometer circuit are smaller when the discharges take place between points, or a point and a plate, instead of between knobs.

(2.) The micrometer sparks are feebler in rarefied gas than in air at ordinary pressures.

(3.) Extremely slight differences in the nature of secondary sparks produce considerable difference in the length of the micrometer sparks.

Hertz found the above results were obtained when the secondary sparks were of a brilliant color, and were attended by a sharp crack.

(4.) The length of the spark in the micrometer

circuit varies with the length of the micrometer circuit.

This, of course, follows from the fact that any alteration of the length in the micrometer circuit, produces, by electrical retardation, a corresponding alteration in the time of the electrical pulses.

(5.) No effect is produced in the length of the micrometer spark by variations in the material, the resistance, or the diameter of the wire forming the micrometer circuit.

This is probably because the rate of propagation of electrical pulses along a conductor, depends mainly on the capacity of the conductor, and on its co-efficient of self-induction, and only to a slight extent on its resistance.

(6.) The length of wire connecting the micrometer circuit with the secondary circuit has but little effect, provided such length does not exceed a few metres.

Local disturbances, therefore, must traverse conductors without undergoing any appreciable change.

(7.) The position of the point on the micrometer circuit connected with the secondary circuit, is of the greatest importance.

When the point on the micrometer circuit is situated symmetrically with respect to the two micrometer knobs, variations of potential will reach the terminals in the same phase, and there will be but little effect, as seen by the sparks between the micrometer knobs. Such a point on the micrometer knobs is called the null point, or it is called as in a corresponding case in acoustics, a nodal point. (See *Point, Null. Point, Nodal.*)

(8.) When the conductors are of sufficient length, their approach produces disturbances in a previously adjusted and quiet spark micrometer, just as the approach of a conductor would.

Probably one of the most curious effects connected with the phenomena of electrical resonance is that pointed out by Lodge, viz.: that when the spark from a secondary circuit is so placed that the light is visible from a micrometer circuit, the effects of the discharge are greatly increased. Lodge also found that the light from burning magnesium wire, or, in general, light rich in the ultra-violet rays, produces the same effect.

Resonator, Electric — — An apparatus employed by Hertz in his investigations on electric resonance. (See *Resonance, Electric.*)

An electric resonator consists essentially of an

open-circuited conductor, or circuit of such dimensions that electro-magnetic waves or pulses are propagated through it at the same rate as those which are occurring in a neighboring circuit from which electro-magnetic radiation is taking place. Under these circumstances electro-magnetic pulses are set up sympathetically by resonance in the open circuit of the resonator, like the sympathetic vibrations in a tuning fork, when placed near another vibrating tuning fork, which is giving off sound waves of exactly the same period of vibration as its own.

Resonator, Electro-Magnetic — — A term applied to the Hertz spark micrometer, in which electro-magnetic waves are produced by electric resonance. (See *Resonance, Electric.*)

Resultant.—In mechanics, a single force that represents in direction and intensity the effects of two or more separate forces.

The separate forces are called the components. (See *Components.*)

Retardation.—A decrease in the speed of telegraphic signaling caused either by the induction of the line conductor on itself, or by mutual induction between it and neighboring conductors, or by condenser action, or by all.

The line must receive a certain charge before a current sent into it at one end can produce a signal at the other end. This charge will depend on the length and surface of the wire, on the neighborhood of the wire to the earth or other wires, and on the nature of the insulating material between the wire and neighboring conductors. This results in a charge given to the wire which is lost as a current for signaling. The greater the *electrostatic capacity* of the line wire, the greater will be the retardation in signaling. (See *Capacity, Specific Inductive. Dielectric. Capacity, Electrostatic. Induction, Electro-Dynamic.*)

Retardation in signaling is produced by the following causes :

(1.) *Self-Induction* which produces extra currents. (See *Induction, Self. Currents, Extra.*)

The extra current on making, retards the beginning of the signal ; the extra current on breaking, retards its stopping.

(2.) *Mutual Induction* between the line conductor and neighboring conductors.

(3.) The *Magnetic Inertia* or *Lag*, or the time required to magnetize or demagnetize the core of the electro-magnetic receptive devices used on the line.

(4.) By *Condenser Action*, the cable acting as a condenser.

Retardation, Electric — —A retardation in the starting or stopping of an electric current, arising from self-induction. (See *Induction, Self. Retardation.*)

Retardation, Inductive — —A retardation in the appearance of a signal at the distant end of a cable, produced by the action of induction. (See *Retardation.*)

Retardation, Magnetic — —A retardation in the magnetization or demagnetization of a substance due to magnetic lag. (See *Retardation. Lag, Magnetic.*)

Retarding, Electrically — —Decreasing the speed of telegraphic signaling, by means of induction. (See *Retardation.*)

Retentivity, Magnetic — —A term proposed by Lamont in place of coercive force, or the power possessed by a magnetizable substance of resisting magnetization or demagnetization. (See *Force, Coercive.*)

Return Circuit.—(See *Circuit, Return.*)

Return, Earth — —(See *Earth Return.*)

Return Ground.—(See *Ground-Return.*)

Return Wire or Conductor.—(See *Wire, Return.*)

Returns.—In a system of distribution, those conductors through which the current flows back from the electro-receptive devices to the source. (See *Leads.*)

The word returns is sometimes used in a system of distribution by parallel circuits, to distinguish between the conductor by which the current goes back or returns from the receptive devices to the dynamo, and the conductor that leads it to the receptive devices. The term leads is, however, often applied to both conductors.

Reverse-Induced Current.—(See *Current, Reverse-Induced.*)

Reversed Currents.—(See *Currents, Reversed.*)

Reverser, Current — —A switch, or other apparatus, designed to reverse the direction of a current.

Reversible Bridge.—(See *Bridge, Reversible.*)

Reversible Heat.—(See *Heat, Reversible.*)

Reversibility of Dynamo.—The ability of a dynamo to operate as a motor when traversed by an electric current. (See *Motor, Electric.*)

Reversing Gear of Electric Motor.—(See *Motor, Electric, Reversing Gear of.*)

Reversing Key.—(See *Key, Reversing.*)

Reversing Key of Quadruplex Telegraphic System.—(See *Key, Reversing, of Quadruplex Telegraphic System.*)

Reversing Magnetic Field.—(See *Field, Magnetic, Reversing.*)

Rheochord.—A word formerly employed instead of rheostat. (See *Rheostat.*)

Rheometer.—A word formerly employed for any device for measuring the strength of a current.

This word is now obsolete and is replaced by the word galvanometer. (See *Galvanometer.*)

Rheomotor.—A word formerly employed to designate any electric source.

This word is now obsolete, and replaced by the various names of the different electric sources. (See *Source, Electric.*)

Rheophore.—A word formerly employed to indicate a portion of a circuit conveying a current and capable of deflecting a magnetic needle placed near it. (Obsolete.)

Rheoscope.—A word formerly employed in place of the present word galvanoscope, for an instrument intended to show the presence of a current, or its direction, but not to measure its strength. (Obsolete.)

Rheoscope, Physiological — —A sensitive nerve-muscle preparation employed to determine the presence of an electric current. (See *Frog, Galvanoscope.*)

THIS PAGE IS LOCKED TO FREE MEMBERS

Purchase full membership to immediately unlock this page



HISTORY

Tens of thousands of important historical sources, many previously unobtainable, are now available for the first time with a Forgotten Books Full Membership.

Unlimited Access
\$8.99/month

Continue

*Fair usage policy applies

Rings, Electro-Chromic — —A term sometimes applied to metallochromes. (See *Metallochromes*.)

Rings, Nobili's — —A term sometimes used for metallochromes. (See *Metallochromes*.)

Roaring of Arc.—(See *Arc, Roaring of*.)

Rocker Arm.—(See *Arm, Rocker*.)

Rocker, Brush — —In a dynamo-electric machine or electric motor, any device for shifting the position of the brushes on the commutator cylinder.

Rocker, Multiple-Pair Brush — —A term sometimes used for multiple-pair brush yoke. (See *Yoke, Multiple-Pair Brush*.)

Rocker, Single-Brush — —A device by means of which a single pair of brushes are so supported on a dynamo-electric machine or electric motor, as to be capable of being readily shifted into the desired position on the commutator cylinder.

Rocker, Single-Pair Brush — —A term sometimes used for single-pair brush yoke. (See *Yoke, Single-Pair Brush*.)

Rod Clamp.—(See *Clamp, Rod*.)

Rod, Clutch — —A clutch or clamp provided in an arc lamp to seize the lamp rod and thus arrest its fall, during feeding, beyond a certain predetermined point.

The clutch or clamp is caused to release or hold the lamp rod by the action of an electro-magnet placed in a shunt circuit around the electrodes. (See *Lamp, Arc, Electric*.)

Rod, Discharging — —A jointed rod provided at both ends with balls and connected at the middle by a swinging joint which permits the balls to move towards or from one another, employed for the disruptive discharge of Leyden batteries or condensers. (See *Discharge, Disruptive. Jar, Leyden*.)

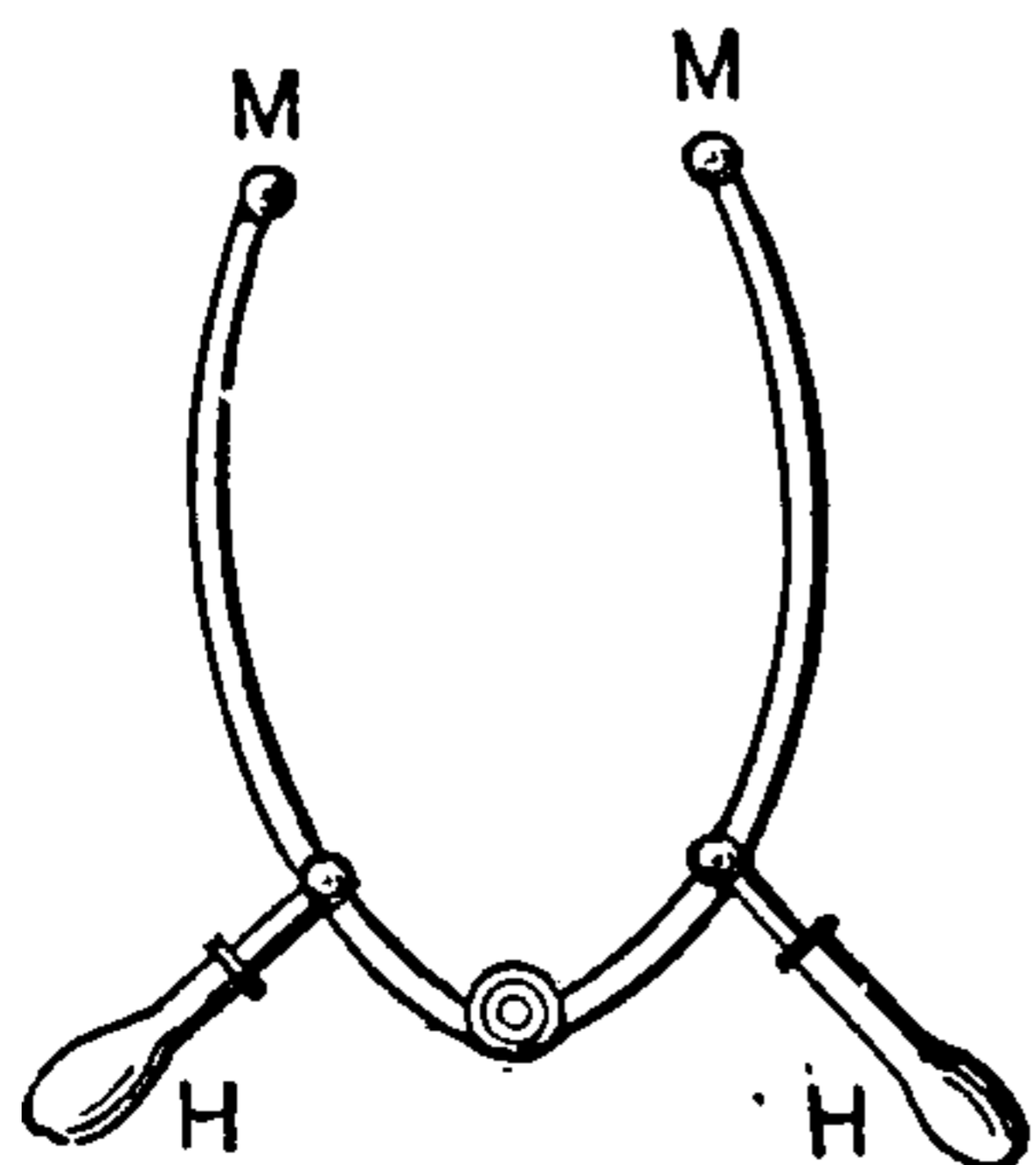

Fig. 495. Discharging Rod.

The insulated handles H, H, Fig. 495, permit

the balls at M, M, to be readily applied to the opposite coatings of the jar or condenser.

The name discharging tongs is sometimes applied to this apparatus.

Rod, Lamp — —A metallic rod provided in electric arc lamps for holding the carbon electrodes.

When the upper carbon only is fed, as is the case in most arc lamps, there is usually but one lamp rod provided. The clutch or clamp of the feeding device acts against this rod, which must of necessity be at least as long as the upper carbon. (See *Lamp, Arc, Electric*.)

Rod, Lightning — —A rod, or wire cable of good conducting material, placed on the outside of a house or other structure, in order to protect it from the effects of a lightning discharge.

Lightning rods were invented by Franklin. The results of a very extended inquiry on the subject, leave no room for doubt that a lightning rod, properly placed and constructed, affords an efficient protection to the buildings on which it is placed.

To insure this protection, however, the following conditions were, until very recently, generally insisted on in order to permit the rod to properly act, viz.:

(1.) The rod, generally of iron or copper, should have such an area of cross-section as to enable it to carry without fusion the heaviest bolt it is liable to receive in the latitude in which it is located.

When of iron, the area of cross-section should be about seven times greater than when of copper.

(2.) The rod should be continuous throughout, all joints being carefully avoided.

When joints are used, they should be made of as low resistance as possible, and should be protected against corrosion.

(3.) The upper extremity of the rod should terminate in one or more points formed of some metal that is not readily corroded, such as platinum or nickel.

(4.) The lower end of the rod should be carried down into the earth until it meets permanently damp or moist ground, where it should be attached to a fairly extended metallic surface buried in the ground.

Metallic plates will answer for grounding the

rod, but, if gas or water pipes are available, the rod should be placed in good electrical connection therewith, by wrapping it around and soldering it to such pipes.

This fourth requirement is of great importance to the proper action of a lightning rod, and unless thoroughly fulfilled, may render the rod worthless, no matter how carefully the other requirements are attended to. When a bolt strikes a lightning rod which is not properly grounded, the discharge is almost certain to destroy the building to which the rod is connected.

(5.) The rod should not be insulated from the building, unless to prevent stains from the oxidation of the metal. On the contrary, the rod should be directly connected with all masses of metal in its path, such as tin roofs, gutter spouts, metallic cornices, etc. In this way only can dangerous disruptive lateral discharges from the rod to such masses of metal be avoided.

(6.) The rod should project above the roof or highest part of the building, or, in other words, the height of the rod should bear a certain proportion to the size of the building to be protected.

A rod will protect a conical space around it, the radius of whose base is equal to the vertical height of the rod above the ground, but whose sides are curved inwards instead of being straight. Where the building is very high, a number of separate rods *all connected to one another* should be employed.

A lightning rod sometimes fails to protect a house or barn, from the fact that a heated, ascending current of air from a fire in the house, or from the gradual heating of green hay or grain in the barn, acting as a conductor, increases the virtual height of the house beyond the ability of its rods to protect it.

(7.) A stranded conductor is much better than an equal cross-section of a solid rod of the same metal.

A copper tape is better than a copper rod for lightning rods, because a rapidly periodic current, whose periodicity is sufficiently great, passes practically over the surface of the conductor only. Considering an electric current as taking its energy from the surrounding dielectric, a tape is better, because the surface which absorbs the energy is greater in the case of a tape than of a solid rod. (See *Law, Poynting's.*)

A lightning rod more frequently acts to quietly discharge an impending cloud by *convective dis-*

charge than by an actual *disruptive discharge* of the same. (See *Discharge, Convective. Discharge, Disruptive.*)

Lightning rods should be frequently tested to see that no breaks or oxidation of their joints have occurred.

Professor Lodge takes exception to some of the heretofore generally received notions concerning the action of lightning rods. He distinguishes between two distinct kinds of discharge that may occur between a charged cloud and the earth, viz.:

(1.) A steady strain or current.

(2.) An impulsive rush or oscillatory discharge.

A discharge by a steady strain or current occurs when the cloud gradually approaches a point on the earth; or, in the case of the cloud being stationary, when it receives its charge gradually by the approach of another cloud.

In steady discharge, the lightning rod, with its pointed end, either quietly discharges the cloud by a convective discharge, or by a harmless conductive discharge through the rod, after a spark has passed disruptively between the cloud and the rod. (See *Discharge, Convective. Discharge, Conductive. Discharge, Disruptive.*)

The impulsive discharge or rush occurs whenever the cloud that discharges to the earth receives its charge suddenly, as by the discharge into it of a neighboring cloud, or when a bound charge, produced by the presence of a neighboring charged cloud, is suddenly liberated by discharge, and, thus becoming free, impulsively discharges to the earth.

In all cases of an impulsive discharge or rush, a counter electromotive force is set up in the rod, which resists the discharge through the rod and causes the electricity to rush back and spit off in lateral discharges. In this case the conducting power of the rod has no effect in facilitating the discharge. Indeed, the smaller its resistance, and the longer the oscillations last, the greater the danger from lateral discharges. (See *Discharge, Lateral. Path, Alternative.*)

The following principles advanced by Lodge differ from the views heretofore generally received, viz.:

(1.) Iron is a better substance for a lightning rod than copper, because it is equally as good a conductor as copper for very rapidly alternating currents, and is more difficult to fuse.

(2.) All neighboring metallic conductors should be connected to earth. These connections should.

preferably be by separate conductors rather than by the rod itself.

(3.) The lightning conductors should have a good separate earth, but should be connected to water pipes, gas pipes, etc., if near them, by an underground connection.

(4.) The lightning conductor should be detached from the building and not close against it.

(5.) The rod should be of flat section, or a stranded conductor.

Rod, Lightning, for Ships — —A system of rods designed to afford electric protection for vessels at sea.

Since the lightning discharge takes place between the points of greatest difference of potential, and these points are generally the cloud and the nearest point of the earth, tall objects are especially liable to be struck.

Ships at sea should, therefore, be thoroughly protected from lightning.

In Harris' system of lightning protection for ships, the rods are connected with a series of copper plates and rods so placed on the masts as to readily yield to strains. These plates or rods are electrically connected with the copper sheathing of the vessel and *with all large masses of metal* in the vessel. This latter precaution is especially necessary in the case of men-of-war, in order to protect the powder magazine.

Harris' method for the lightning protection of ships was adopted only after very considerable opposition. It proved, however, so efficacious in practice that serious effects of lightning on vessels so protected are now almost unknown. In 1845, Harris received the honor of knighthood from the English Government for his services in this respect.

Rod, Lightning, Points on — —Points of inoxidizable material, placed on lightning rods, to effect the quiet discharge of a cloud by convection streams. (See *Rod, Lightning, Convection, Electric.*)

Rod, Thunder — —A term formerly used for lightning rod. (See *Rod, Lightning.*)

Rods, Bus — —Heavy copper rods employed in a central or distributing station, to which all the terminals of the generating dynamos are connected, and from which the current passes to the different points of the distribution system over the feeders.

Bus rods are often called bus bars or bus wires. (See *Wires, Bus.*)

Rodding a Conduit.—(See *Conduit, Rodding a.*)

Rolling Contact.—(See *Contact, Rolling.*)

Rose, Ceiling — —An ornamental ceiling plate through which an electric conductor passes.

Rosette.—An ornamental plate provided with contacts connected to the terminals of the service wires, and placed in a wall for the ready attachment of the incandescent lamp.

A word sometimes used in place of rose.

Rosette Cut-Out.—(See *Cut-Out, Rosette.*)

Rotary Magnetic Polarization.—(See *Polarization, Magnetic Rotary.*)

Rotary-Phase Current.—(See *Current, Rotating.*)

Rotary-Phase Dynamo.—(See *Dynamo, Rotary-Phase.*)

Rotary-Phase Motor.—(See *Motor, Rotating Current.*)

Rotary-Phase Transformer.—(See *Transformer, Rotary-Phase.*)

Rotating Brushes of Dynamo-Electric Machine.—(See *Brushes, Rotating, of Dynamo-Electric Machines.*)

Rotating Current.—(See *Current, Rotating.*)

Rotating Current Field.—(See *Field, Rotating Current.*)

Rotating Current Motor.—(See *Motor, Rotating Current.*)

Rotating Current Transformer.—(See *Transformer, Rotatory Current.*)

Rotation, Electro-Magnetic — —A rotation obtained by electro-magnetic attractions and repulsions. (See *Disc, Arago's. Disc, Faraday's. Motor, Electric.*)

Rotation, Magneto-Optic — —A rotation of the plane of polarization of a beam of polarized light on its passage through a transparent medium when placed in a strong magnetic field.

The medium only possesses such properties while in the field.

THIS PAGE IS LOCKED TO FREE MEMBERS

Purchase full membership to immediately unlock this page

Know Your Bible

Forgotten Books' Full Membership provides unlimited access to more than 28,000 volumes of Christian literature for \$8.99/month

HOLY BIBLE

Continue

*Fair use policy applies

Salient Magnetic Pole.—(See *Pole, Magnetic, Salient*.)

Saline Creeping.—(See *Creeping, Saline*.)

Salts, Electrolysis of — —The decomposition of a salt into its electro-positive and negative radicals or ions. (See *Electrolysis*.)

Sandy Deposit, Electro-Metallurgical — —(See *Deposit, Electro-Metallurgical, Sandy*.)

Saturated Solution.—(See *Solution, Saturated*.)

Saturation, Magnetic — —The maximum magnetization which can be imparted to a magnetic substance.

The condition of iron, or other paramagnetic substance, when its intensity of magnetization is so great that it fails to be further sensibly magnetized by any magnetic force, however great.

When the core of an electro-magnet is saturated by the passage of an electric current, the only further increase of its magnetization that is possible, is that due to the magnetic field of the increased current which may be sent through its coils. This is comparatively insignificant.

A permanent magnet is sometimes said to be super-saturated, that is, to have received more magnetism than it can retain for any considerable time after its magnetization.

In the saturated field magnets of a dynamo-electric machine the magnetic density is seldom taken at a larger value than 16,000 lines per square centimetre of area of cross-section. But this is only *practical* saturation, since Ewing has forced 45,300 lines per square centimetre by using an enormously high magnetizing force ($H = 24,500$).

Saturation, Magnetic, Diacritical Point of — —A term proposed by S. P. Thompson for such a value of the co-efficient of magnetic saturation, that the core is magnetized to exactly one-half its possible maximum of magnetization.

Saw, Electric — —A platinized steel wire, employed while incandescent for cutting hard substance.

Scale, Tangent — —A scale designed for use with a galvanometer, on which the values of the tangents are marked, instead of

equal degrees as ordinarily, thus avoiding the necessity of finding from tables the tangents corresponding to the degrees.

Such a scale may be constructed as follows: Draw the *tangent* B T, to the circle, Fig. 497, and lay off on it any number of equal divisions or parts, as, for example, the thirty shown in the annexed figure. Connect these parts with the centre C, of the circle. The arc of the circle will

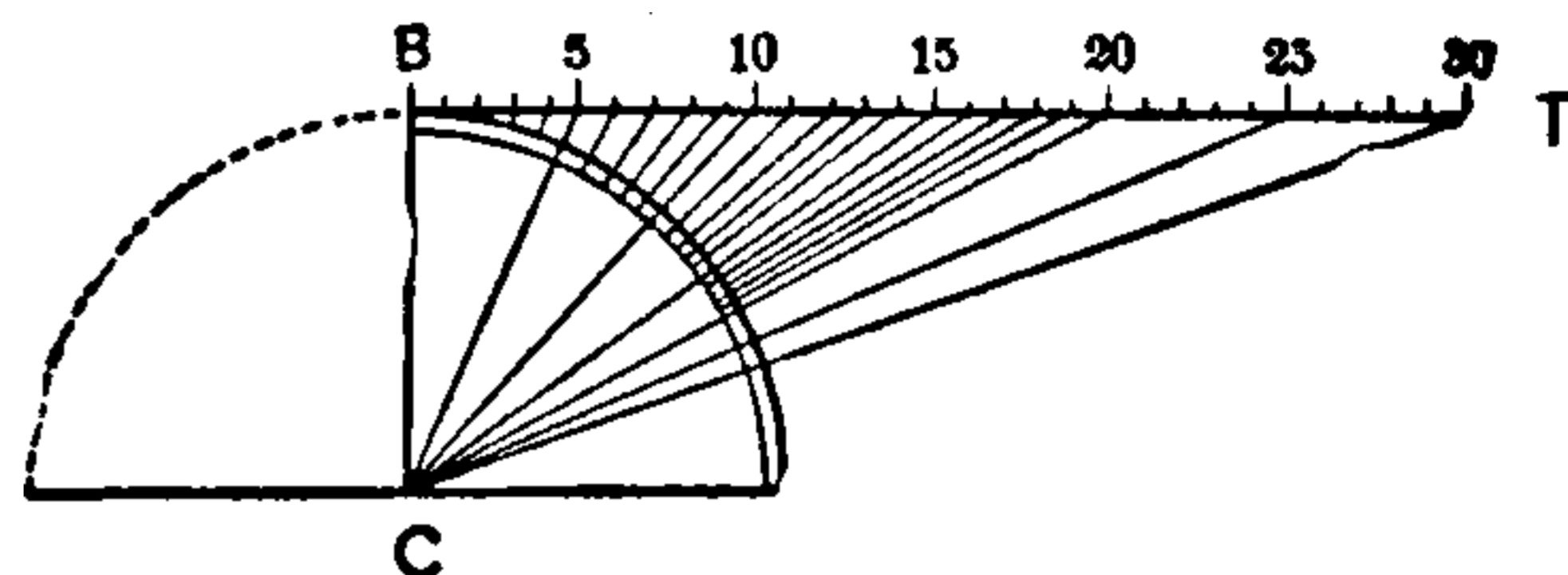

Fig. 497. Tangent Scale.

thus be divided into parts proportional to the value of the tangents of the angles.

These parts are more nearly equal the nearer they are to B, and grow smaller and smaller the further they are from B. In tangent galvanometers it is therefore very difficult to accurately determine the current strength when the deflections of the needle are very large.

Scale, Thermometer, Centigrade — —A thermometer scale, in which the length of the thermometric tube between the melting point of ice and the boiling point of water is divided into one hundred equal parts or degrees.

Centigrade degrees are indicated by a C., thus 0 degree C. or 100 degrees C., to distinguish them from Fahrenheit degrees that are marked F. In the Fahrenheit scale the freezing point of water is taken at 32 degrees, and the boiling point at 212 degrees.

Scale, Thermometer, Fahrenheit's — —A thermometer scale in which the length of the thermometer tube between the melting point of ice and the boiling point of water is divided into 180 equal parts called degrees.

Fahrenheit degrees are indicated by an F., thus, 32 degrees F.

The freezing point of water in Fahrenheit's scale is marked 32 degrees F., and the boiling point of water is marked 212 degrees F.

Schiseophone.—An electro-mechanical appliance for detecting flaws and internal defects in rails or other metallic masses.

The schiseophone consists essentially in the combination of a microphone and telephone with a mechanical hammer and induction balance.

Schweigger's Multiplier.—(See *Multiplier, Schweigger's*.)

Scintillating Jar.—(See *Jar, Scintillating*.)

Scratch Brush.—(See *Brush, Scratch*.)

Scratch Brush, Circular — — (See *Brush, Scratch, Circular*.)

Scratch Brush, Hand — — (See *Brush, Scratch, Hand*.)

Scratch Brushing.—(See *Brushing, Scratch*.)

Screen, Electric — — —A closed conductor placed over a body to screen or protect it from the effects of external electrostatic fields.

An electric screen is sometimes called an electric shield.

The ability of a closed, hollow conductor to act as a screen, arises from the fact that all points on its inner surface are at the same potential, and therefore are not affected by an increase or decrease in the potential of the outside of the conductor as compared with that of the earth. (See *Net, Faraday's*.)

No considerable thickness is required for the efficient operation of an electric screen.

Screen, Magnetic — — —A hollow box whose sides are made of thick iron, placed around a magnet or other body so as to cut it off or screen it from any magnetic field external to the box.

Magnetic screens are placed around delicate galvanometers to avoid any variations in their field due to extraneous masses of iron or neighboring magnets. They are also sometimes placed around watches to shield or screen the works from the effects of magnetism.

To act effectively, when the external fields are at all powerful, magnetic screens must be made of thick iron. They differ in this respect from electrostatic shields, which will afford protection against electrostatic charges although they may be but mere films.

Screen, Methven's — — —A vertical rectangular metallic screen used in connection with a standard argand burner, for furnishing a standard amount of light for photometric purposes.

In a rectangular screen a small vertical slot is made of such dimensions as to permit an amount

of light to pass just equal to two standard candles. The proper burning of the argand lamp is determined by supplying sufficient gas to produce a flame exactly 3 inches high. The glass chimney used in the burner is 6 inches high, and is provided with two horizontal wires placed on each side of the burner at the required height.

Methven's screen possesses the advantage of being easily used and of furnishing a reliable standard of light. Extended experiments made with it appear to show that the amount of light produced depends rather on the height of the gas flame than on the quality of the gas itself. In using Methven's screen care should be taken

(1.) To see that the gas flame is of exactly the required height.

(2.) That the chimney on the lamp is quite clean.

(3.) That the top of the flame is as regular as possible.

As this last point is almost impossible to obtain in actual practice, the flame is adjusted so that the highest point extends about one-eighth of an inch above the height of the horizontal wires.

(4.) That the lamp and apparatus be permitted to acquire its normal temperature before the readings are taken.

Fig. 498 shows the construction of the ordinary Methven standard screen. The vertical slot in the screen is placed as shown before the standard argand burner. Horizontal wires

for the adjustment of the height of the flame are placed one on each side of the gas chimney.

Screening, Electrostatic — — —Screening or shielding from the inductive effects of a charge.

A continuous metallic surface surrounding an air space to be shielded, completely protects any body placed within such air space from electrostatic influence. (See *Cube, Faraday's*.)

Screening, Magnetic — — —Preventing magnetic induction from taking place by interposing a metallic plate, or a closed circuit of insulated wire, between the body producing

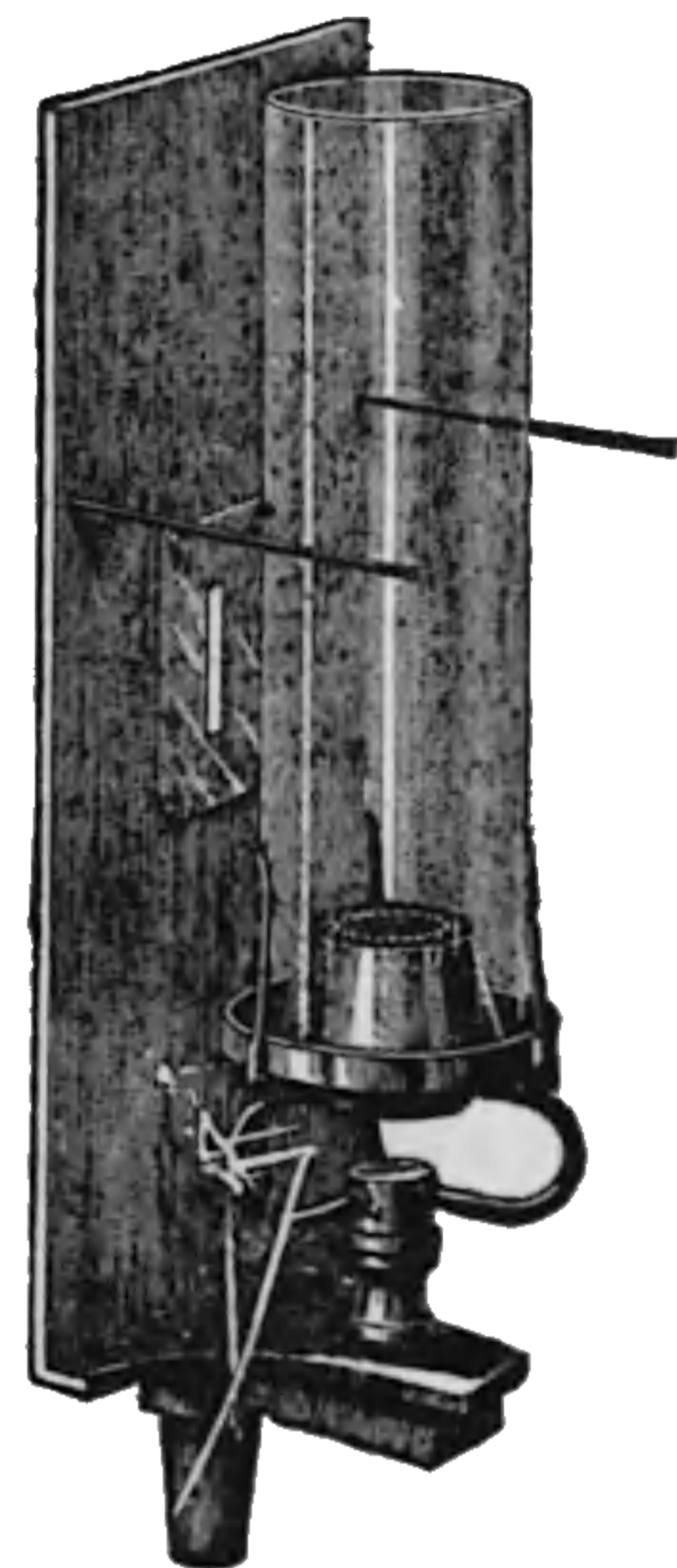

Fig. 498. Methven's Standard Screen.

the magnetic field and the body to be magnetically screened.

A magnetic needle is screened from the action of the earth's field by placing it inside a hollow iron box, which prevents the lines of force of the earth's field from passing through it by concentrating them on itself. This action is dependent on the fact that iron is paramagnetic and therefore offers the lines of force less resistance through its mass than elsewhere. A plate of copper would not effect any such magnetic shielding or screening.

In any magnetic field, however, in which the strength of the field is undergoing rapid, periodic variations, a plate of copper or other electric conductor may act as a screen to protect neighboring conductors from the effects of magnetic induction, and its ability to thoroughly effect such a screening will depend directly on its conducting power.

If, for example, the copper plate *c* (Fig. 499), be interposed between a coil of copper ribbon *a*, and the fine wire coil *b*, it will greatly reduce the intensity of the induced currents, produced when rapidly alternating currents are sent through *a*. If, however, the copper plate be slit, as shown to the right at *a*, the screening effect is lost, but is regained if the slit be connected by a conductor. Similarly a flat coil of insulated wire effects no screening action when open, but when closed acts as the uncut copper plate.

Here the screening action is due to the fact that the energy of the field is spent in producing eddy currents in the interposed metal screen or coils. If the metal screen is discontinuous in the direction in which the eddy currents tend to flow, the inability of the screen to absorb the energy as eddy currents prevents its action as a screen.

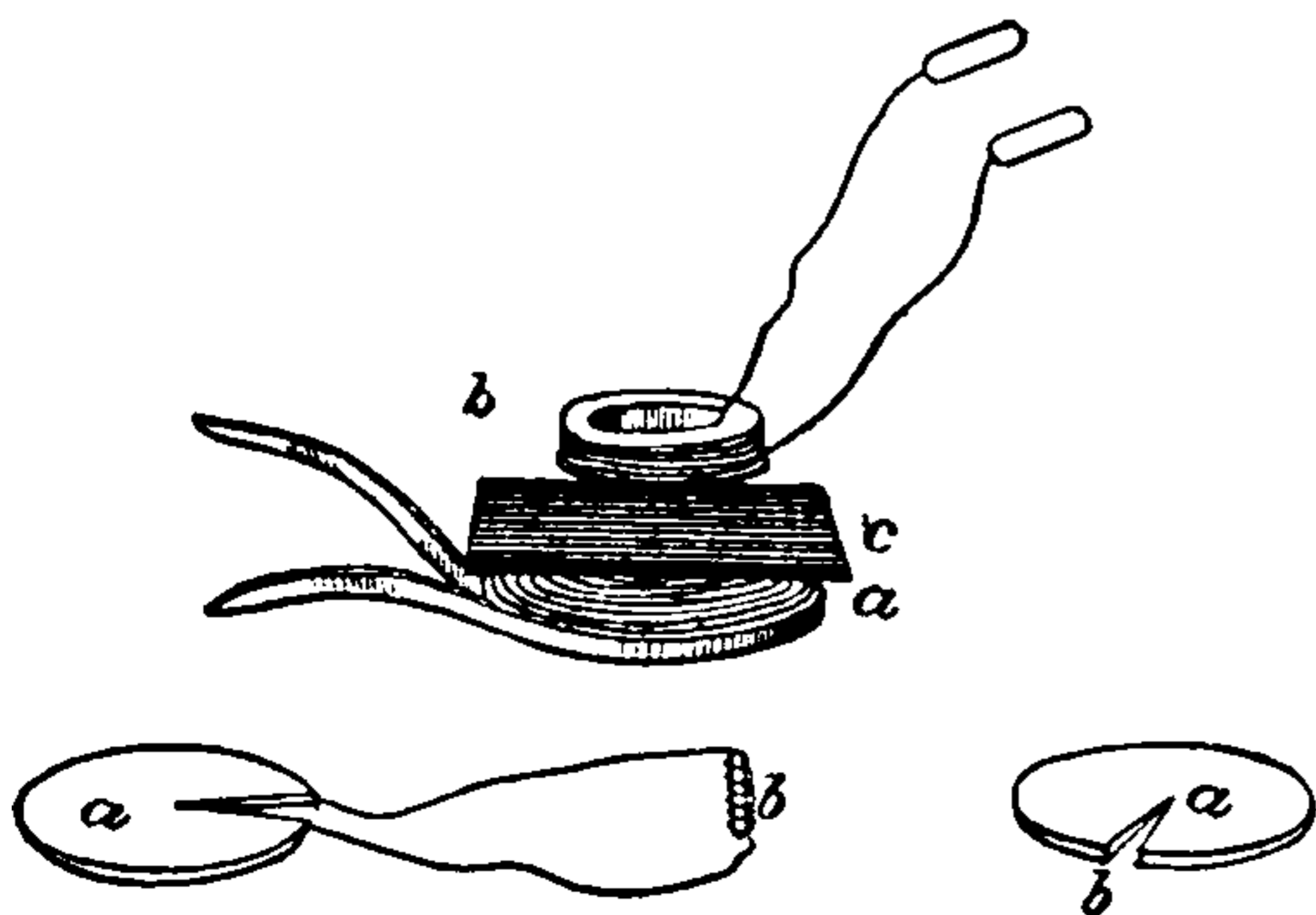

Fig. 499.

The word magnetic screening is generally employed in the latter sense of preventing magnetic

induction from occurring in a neighboring conductor, by interposing some conducting substance in which eddy currents can be freely established.

As to the efficiency of the screening action, if the makes-and-breaks do not follow one another very rapidly, the following principles can be proved:

(1.) If the screening material have absolutely no electrical resistance it will effect a perfect magnetic screening when placed between the primary and secondary, no matter what its thickness may be.

(2.) If the screen have a finite conductivity, the screening will be imperfect, unless the thickness of the material employed is considerable.

If, however, the makes-and-breaks follow one another very rapidly, then

The screening effect of even imperfect conductors will become manifest with comparatively thin screens of metal.

As to magnetic screening, therefore, it follows that the less the conductivity, the greater must be the speed of reversal, in order that the screening action may be effective.

Where a screen of iron is employed, an additional effect is produced by the fact that the small magnetic resistance of the metal, or its conductivity for lines of magnetic force, causes the lines of induction to pass through its mass, and thus effect a screening action for the space on the other side. This action is, by some, called magnetic screening.

In the case of iron screens, considerable thickness is required in the metal plate, in order to obtain efficient screening action of this latter character. On account of this action of iron, in conducting away lines of force, a much smaller speed of reversal is required, in order to obtain effective screening action, where plates of iron are used, than in the case of plates of other metal.

The apparatus shown in Fig. 500 was employed

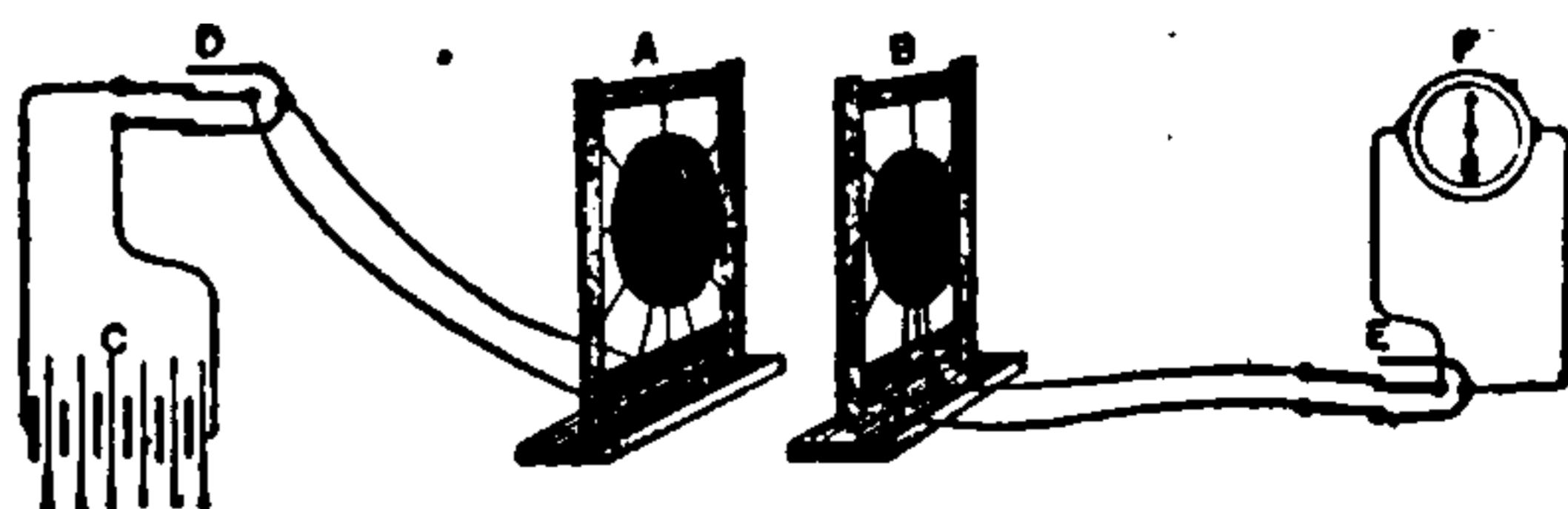

Fig. 500. Willoughby Smith's Apparatus.

by Mr. Willoughby Smith, in studying the effects of magnetic screening.

The flat coils A, and B, were employed for the primary and secondary coils respectively, and were connected to the battery C, and the galva-

THIS PAGE IS LOCKED TO FREE MEMBERS

Purchase full membership to immediately unlock this page



HISTORY

Tens of thousands of important historical sources, many previously unobtainable, are now available for the first time with a Forgotten Books Full Membership.

Unlimited Access
\$8.99/month

Continue

*Fair usage policy applies

Secondary Cell.—(See *Cell, Secondary*.)

Secondary Cell, Jar of — — (See *Jar of Secondary Cell*.)

Secondary Clock.—(See *Clock, Secondary*.)

Secondary Coil.—(See *Coil, Secondary*.)

Secondary Currents.—(See *Currents, Secondary*.)

Secondary, Fixed — — The secondary of an induction coil, that, as is common in such coils, is fixed, as contradistinguished from a movable secondary. (See *Secondary, Movable*.)

Secondary Generator.—(See *Generator, Secondary*.)

Secondary Impressed Electromotive Force.—(See *Force, Electromotive, Secondary Impressed*.)

Secondary, Movable — — The secondary conductor of an induction coil, which, instead of being fixed as in most coils, is movable.

The peculiar movements observed in the secondary of an induction coil when the secondary is free to move, have been carefully studied by Prof. Elihu Thomson. The secondaries employed for this purpose are in the shape of rings, discs, spheres, wedges, bars, wheels, etc., etc.

The primary is in the form of a straight cylindrical coil surrounding a straight core. The coils are traversed by rapidly alternating currents and possess considerable impedance.

Among the many phenomena concerning the behavior of movable secondaries in such a rapidly alternating field are the following, viz.:

(1.) A metallic ring, resting on lugs attached to the coils of the primary, is thrown violently off the magnet on the passage of alternating currents through the primary.

(2.) Two metallic rings of the same diameter brought into the field are mutually attracted to each other, with sufficient force to sustain the weight of one of the rings when the other ring is held in the field.

(3.) Metallic spheres are set into rotation when so held near the primary pole as to be shielded

from the action of part of the rapidly alternating field. When held on one side of the pole, this rotation occurs in the opposite direction to that when held on the opposite side.

(4.) Metallic discs similarly placed are similarly set into rotation.

(5.) The speed of rotation of spheres or discs varies in different positions.

(6.) Spheres or discs of diamagnetic substances attain their maximum rotation when held in position at right angles to those of paramagnetic substances.

(7.) Bars of steel or substances possessing high coercive power, placed dissymmetrically on the primary as regards their centres of gravity, exhibit the phenomena of a shifting magnetic field. (See *Field, Magnetic, Shifting*.)

(8.) A wedge-shaped piece of steel placed with a flat face on the primary, exhibits a shifting magnetic field, and acts on movable metallic masses near it, just as though a fluid substance was escaping with great velocity from its edges.

Secondary Movers.—(See *Movers, Secondary*.)

Secondary Plate of Condenser.—(See *Plate, Secondary, of Condenser*.)

Secondary Spiral.—(See *Spiral, Secondary*.)

Secretion Current.—(See *Current, Secretion*.)

Section Line of Electric Railway.—(See *Railroads, Electric, Section Line of*.)

Section, Neutral, of Magnet — — A section passing through the neutral line or equator of a magnet. (See *Line, Neutral, of a Magnet, Magnet, Equator of*.)

Section, Trolley — — A single continuous length of trolley wire, with or without its branches.

Sectional or Divided Overhead System of Motive Power for Electric Railroads.—(See *Railroads, Electric, Sectional Overhead System of Motive Power for*.)

Sectional or Divided Surface System of Motive Power for Electric Railroads.—(See *Railroads, Electric, Sectional Surface System of Motive Power for*.)

Sectional or Divided Underground System of Motive Power for Electric Railroads.—(See *Railroads, Electric, Sectional Underground System of Motive Power for.*)

Sectional Plating.—(See *Plating, Sectional.*)

Sectional Plating Frame.—(See *Frames, Sectional Plating.*)

Seebeck Effect.—(See *Effect, Seebeck.*)

Seismograph, Electric — —An apparatus for electrically recording the direction and intensity of earthquake shocks.

Seismograph, Micro — —An electric apparatus for photographically registering the vibrations of the earth produced by earthquakes or other causes.

The micro-seismograph consists essentially of a microphone placed on the ground and connected with a telephone. A small concave mirror movable about a horizontal axis is supported on a plate of aluminium supported on a platinum wire connected with the diaphragm of the telephone. The movements of the diaphragm of the telephone are permanently recorded on a strip of sensitized paper that is moved before the mirror.

Selective Absorption.—(See *Absorption, Selective.*)

Selenium.—A comparatively rare element generally found associated with sulphur.

Selenium Battery.—(See *Battery, Selenium.*)

Selenium Cell.—(See *Cell, Selenium.*)

Selenium Eye.—(See *Eye, Selenium.*)

Selenium Photometer.—(See *Photometer, Selenium.*)

Self-Induced Current.—(See *Currents, Self-Induced.*)

Self-Induction.—(See *Induction, Self.*)

Self-Induction, Co-efficient of — —(See *Induction, Self Co-efficient of.*)

Self-Recording Magnetometer.—(See *Magnetometer, Self-Recording.*)

Self-Registering Wire Gauge. — (See *Gauge, Wire, Self-Registering.*)

Self-Winding Clock.—(See *Clock, Self-Winding.*)

Semaphore.—A variety of signal apparatus employed in railroad block systems.

The semaphore used on the Pennsylvania Railroad consists of a wooden post, in the neighborhood of twenty feet in height, on which a wooden arm or blade, six feet in length and a foot in width, is displayed.

When the block is clear, during the day the arm is placed pointing downwards at an angle of 75 degrees with the horizontal; during night semaphore displays a white light. When the block is not clear, the arm or blade is placed in a horizontal position by day, or displays a red light at night. (See *Railroads, Block System for.*)

Semaphore Arm.—(See *Arm, Semaphore.*)

Semaphore Indicator.—(See *Indicator, Semaphore.*)

Sender, Zinc — —A device employed in telegraphic circuits, by means of which, in order to counteract the retardation produced by the charge given to the line, a momentary reverse current is sent into the line after each signal.

A zinc sender generally consists of a low resistance Siemens relay introduced between the line and the front contact of the signaling key.

Sensibility, Electro — —An effect produced on a sensory nerve by its electrization.

Sensibility of Galvanometer.—(See *Galvanometer, Sensibility of.*)

Sensitive Thread Discharge.—(See *Discharge, Sensitive Thread.*)

Separate Coil Dynamo-Electro Machine.—(See *Machine, Dynamo-Electric, Separate Coil.*)

Separate Touch, Magnetization by — —(See *Touch, Separate.*)

Separately Excited Dynamo.—(See *Dynamo, Separately Excited*)

Separately Excited Dynamo-Electric Machine.—(See *Machine, Dynamo-Electric, Separately Excited.*)

Separator.—An insulating sheet of ebonite, or other similar substance, corrugated and perforated so as to conform to the outline of the plates of a storage battery, and placed between them at suitable intervals, in such a

manner as to avoid short-circuiting, without impeding the free circulation of the liquid.

Series and Magneto Dynamo-Electric Machine.—(See *Machine, Dynamo-Electric, Series and Magneto.*)

Series and Separately Excited Dynamo-Electric Machine.—(See *Machine, Dynamo-Electric, Series and Separately Excited.*)

Series and Shunt-Wound Dynamo-Electric Machine.—(See *Machine, Dynamo-Electric, Series and Shunt-Wound.*)

Series Circuit.—(See *Circuit, Series.*)

Series-Connected Battery.—(See *Battery, Series-Connected.*)

Series-Connected Electro-Receptive Devices.—(See *Devices, Electro-Receptive, Series-Connected.*)

Series-Connected Electro-Receptive Devices, Automatic Cut-out for — — (See *Cut-out, Automatic, for Series-Connected Electro-Receptive Devices.*)

Series-Connected Sources.—(See *Sources, Series-Connected.*)

Series-Connected Translating Devices.—(See *Devices, Translating, Series-Connected.*)

Series-Connected Voltaic Cells.—(See *Cells, Voltaic, Series-Connected.*)

Series Connection.—(See *Connection, Series.*)

Series, Contact — — A series of metals arranged in such an order that each becomes positively electrified by contact with the one that follows it.

The contact values of some metals, according to Ayrton and Perry, are as follows:

CONTACT SERIES.

Difference of Potential in Volts.

Zinc.....	}210
Lead.....			
Lead.....	}069
Tin.....			
Tin.....	}313
Iron.....			
Iron.....	}146
Copper.....			
Copper.....	}238
Platinum.....			
Platinum.....	}113
Carbon.....			

The difference in potential between zinc and carbon is equal to 1.089, and is obtained by adding the successive differences of potential between the intermediate couples, thus:

$$.210 + .069 + .313 + .146 + .238 + .113 = 1.089.$$

This fact is known technically as *Volta's Law*, which may be formulated as follows:

The difference of potential, produced by the contact of any two metals, is equal to the sum of the differences of potentials between the intervening metals in the contact series.

Series Distribution of Electricity by Constant Currents.—(See *Electricity, Series Distribution of, by Constant Current Circuit.*)

Series-Multiple.—A series of multiple connections. (See *Circuit, Series-Multiple.*)

Series-Multiple Circuit.—(See *Circuit, Series-Multiple.*)

Series - Multiple-Connected Electro-Receptive Devices.—(See *Devices, Electro-Receptive, Series-Multiple-Connected.*)

Series-Multiple-Connected Sources. — (See *Sources, Series-Multiple-Connected.*)

Series-Multiple-Connected Translating Devices.—(See *Devices, Translating, Series-Multiple-Connected.*)

Series-Multiple Connection.—(See *Connection, Series-Multiple.*)

Series, Parallel — — A term sometimes applied to a multiple-series connection. (See *Connection, Multiple-Series.*)

Series, Thermo-Electric — — A list of metals so arranged according to their thermo-electric powers, that each metal in the series is electro-positive to any metal lower in the list.

Series-Transformer.—(See *Transformer, Series.*)

Series Turns of Dynamo-Electric Machine.—(See *Turns, Series, of Dynamo-Electric Machine.*)

Series Winding.—(See *Winding, Series.*)

Series-Wound Dynamo.—(See *Dynamo, Series.*)

Series-Wound Dynamo-Electric Machine.—(See *Machine, Dynamo-Electric, Series-Wound.*)

THIS PAGE IS LOCKED TO FREE MEMBERS

Purchase full membership to immediately unlock this page

Know Your Bible

Forgotten Books' Full Membership provides unlimited access to more than 28,000 volumes of Christian literature for \$8.99/month

HOLY BIBLE

Continue

*Fair use policy applies

Shell, Magnetic — —A sheet or layer consisting of magnetic particles, all of whose north poles are situated in one of the flat surfaces of the layer, and the south poles in the opposite surface. (See *Magnetism, Lamellar Distribution of.*)

Shell Transformer.—(See *Transformer, Shell.*)

Shield, Magnetic, for Watches — —A hollow case of iron, in which a watch is permanently kept, in order to shield it from the influence of external magnetic fields. (See *Screen, Magnetic.*)

Shifting Magnetic Field.—(See *Field, Magnetic, Shifting.*)

Shifting Zero.—(See *Zero, Shifting.*)

Ships, Lightning Rods for — —(See *Rod, Lightning, for Ships.*)

Ship's Sheathing, Electric Protection of — —Attaching pieces of zinc to the copper sheathing of a ship for the purpose of preventing the corrosion of the copper by the water. (See *Metals, Electrical Protection of.*)

Shock, Break — —A term sometimes employed in electro-therapeutics for the physiological shock produced on the opening or breaking of an electric circuit.

Shock, Electric — —The physiological shock produced in an animal by an electric discharge.

Shock, Opening — —The physiological shock produced on the opening or breaking of an electric circuit.

Shock, Static — —A term employed in electro-therapeutics for a mode of applying Franklinic currents or discharges, by placing the patient on an insulating stool and applying one pole of a static machine provided with small condensers or Leyden jars, to an insulated platform on which the patient is placed, while the other pole is applied to the body of the patient by the operator.

The electrode applied to the body of the patient is provided with a ball electrode. Shocks are given to the patient on the approach of this electrode by the discharge of the Leyden jars.

Short-Arc System of Electric Lighting.—(See *Lighting, Electric, Short-Arc System.*)

Short-Circuit.—To establish a short circuit. (See *Circuit, Short.*)

Short-Circuit Key.—(See *Key, Short-Circuit.*)

Short-Circuiting.—Establishing a short circuit. (See *Circuit, Short.*)

Short-Circuiting Plug.—(See *Plug, Short-Circuiting.*)

Short-Coil Magnet.—(See *Magnet, Short-Coil.*)

Short-Core Electro-Magnet.—(See *Magnet, Electro, Short-Core.*)

Short-Shunt Compound-Wound Dynamo-Electric Machine.—(See *Machine, Dynamo-Electric, Compound-Wound, Short-Shunt.*)

Shunt.—An additional path established for the passage of an electric current or discharge.

Shunt.—To establish an additional path for the passage of an electric current or discharge.

Shunt and Separately Excited Dynamo-Electric Machine.—(See *Machine, Dynamo-Electric, Shunt and Separately Excited.*)

Shunt Circuit.—(See *Circuit, Shunt.*)

Shunt Dynamo-Electric Machine.—(See *Machine, Dynamo-Electric, Shunt-Wound.*)

Shunt, Electric Bell — —(See *Bell, Shunt, Electric.*)

Shunt, Electro-Magnetic — —In a system of telegraphic communication an electro-magnet whose coils are placed in a shunt circuit around the terminals of the receiving relay.

The electro-magnetic shunt operates by its self-induction. Its poles are permanently closed by a soft iron armature so as to reduce the resistance of the magnetic circuit. (See *Induction, Self.*)

On making the circuit in the coils of a receiving relay, a current is produced in the coils of the electro-magnetic shunt in the *opposite direction* to the relay current; and, on breaking the circuit in the relay, a current is produced in the coils of the electro-magnetic shunt in the *same direction* as the current in the relay.

The connection of the coils of the electro-magnetic shunt with those of the receiving relay, however, is such that on making the circuit in the relay the current in the shunt coils flows through the relay in the same direction, and on breaking the circuit it flows in the opposite direction. Therefore this shunt produces the following effects:

(1.) At the commencement of each signal in the receiving relay, it produces an induced current in the same direction which strengthens the current in the relay.

(2.) At the ending of each signal in the receiving relay, it produces a current in the opposite direction, which hastens the motion of the tongue of the polarized relay. (See *Relay, Polarized.*)

Shunt, Galvanometer — — A shunt placed around a sensitive galvanometer for the purpose of protecting it from the effects of a strong current, or for altering its sensibility. (See *Shunt.*)

The current which will flow through the shunt wire depends on the relative resistance of the galvanometer and of the shunt. In order that only $\frac{1}{10}$, $\frac{1}{100}$, or $\frac{1}{1000}$, of the total current shall pass through the galvanometer, it is necessary that the resistances of the shunt shall be the $\frac{1}{9}$, $\frac{1}{99}$, or $\frac{1}{999}$, of the galvanometer resistance.

Fig. 502 shows a shunt, in which the resistances, as compared with that of the galvanometer, are those above referred to. The galvanometer terminals are connected at N, N. Plug keys are used to connect one or another of the shunts with the circuit. (See *Shunt, Multiplying Power of.*)

Shunt, Magnetic — — An additional path of magnetic material provided in a mag-

netic circuit for the passage of the lines of force.

Shunt, Multiplying Power of — — A quantity, by which the current flowing through a galvanometer provided with a shunt, must be multiplied, in order to give the total current.

The multiplying power of a shunt may be determined from the following formula, viz.:

$A = \left(\frac{s + g}{s} \right) \times C$, in which $\frac{s + g}{s}$ = the multiplying power of a shunt whose resistance is s ; g , is the galvanometer resistance; C , the current through the galvanometer, and A , the total current passing; s and g , are taken in *ohms*, and C and A , in ampères.

Suppose, for example, that but $\frac{1}{10}$ the entire current is to flow through the galvanometer; then the resistance of the shunt must evidently be $\frac{1}{9}g$, for,

$$\frac{s}{s + g} = \frac{1}{10} = \frac{1}{10};$$

or, $10s = s + g$. $10s - s = g$ $\therefore 9s = g$; or, $s = \left(\frac{1}{9}\right)g$.

Shunt or Reducteur for Ammeter.—(See *Reducteur or Shunt for Ammeter.*)

Shunt Ratio.—The ratio existing between the shunt and the circuit which it shunts (See *Shunt, Multiplying Power of.*)

Shunt, Relay, Stearns' — — A shunt employed in the differential method of duplex telegraphy to short-circuit the relay and then permit the line current to be cut off directly after it has completed its work in closing the local circuit.

The use of the relay shunt permits the slackening of the armature spring of the relay, because the decreased duration of the line current does not produce so strong a magnetization of the iron.

Shunt-Turns of Dynamo-Electric Machine.—(See *Turns, Shunt, of Dynamo-Electric Machine.*)

Shunt-Wound Dynamo-Electric Machine.—(See *Machine, Dynamo-Electric, Shunt-Wound.*)

Shunt-Wound Motor.—(See *Motor, Shunt-Wound.*)

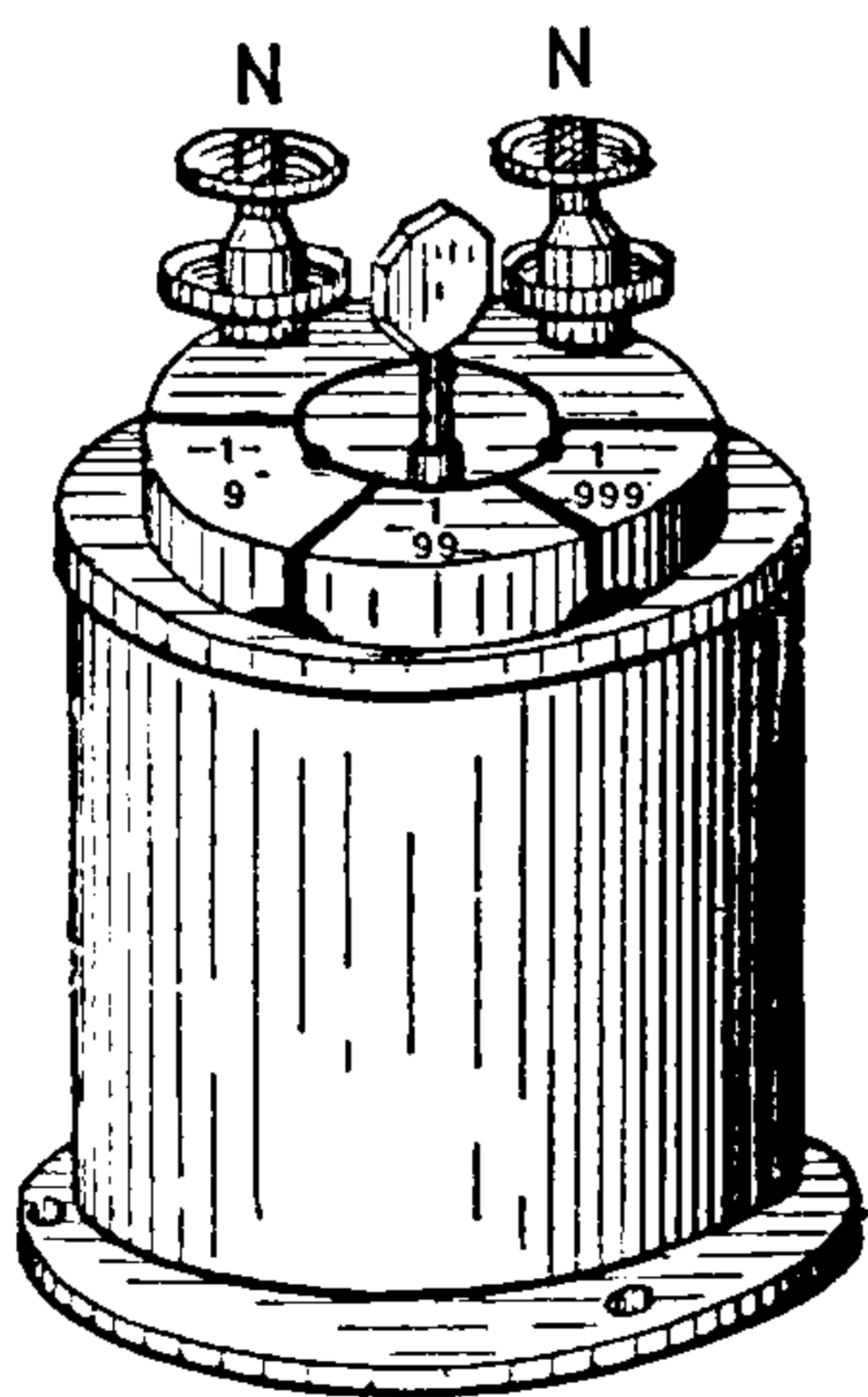

Fig. 502. Galvanometer Shunt.

Shunting.—Establishing a shunt circuit.

Shuttle Armature.—(See *Armature, Shuttle.*)

Side A, of Quadruplex Table.—(See *Table, Quadruplex, A, Side of.*)

Side B, of Quadruplex Table.—(See *Table, Quadruplex, B, Side of.*)

Side Flash.—(See *Flash, Side.*)

Sidero-Magnetic.—(See *Magnetic, Sidero.*)

Siemens' - Armature Electro-Magnetic Bell.—(See *Bell, Electro-Magnetic, Siemens' Armature Form.*)

Siemens' Differential Voltmeter.—(See *Voltmeter Siemens' Differential.*)

Siemens' Electric Pyrometer.—(See *Pyrometer, Siemens' Electric.*)

Siemens-Halske Voltaic Cell.—(See *Cell, Voltaic, Siemens-Halske.*)

Siemens' Water Pyrometer.—(See *Pyrometer, Siemens' Water.*)

Signal Arm.—(See *Arm, Signal.*)

Signal, Electric Tell-Tale — —An electrically operated signal, generally silent, whereby the appearance of a white or colored disc, on a black or otherwise uniformly colored surface, indicates the occurrence of a certain predetermined event.

Signal Service for Electric Railways.—(See *Railroads, Electric, Signal Service System for.*)

Signals, Electro-Pneumatic — —Signals operated by the movements of diaphragms or pistons moved by compressed air, the escape of which is controlled electrically.

Signaling, Balloon, for Military Purposes — —Transmitting intelligence of the movements of an enemy's army obtained from observations made in balloons by means of telephone circuits connected with the balloon.

Signaling, Curb — —In cable telegraphy a system for avoiding the effects of retardation by rapidly discharging the cable before another electric impulse is sent into

it, by reversing the battery, before connecting it to earth, and then connecting to earth before beginning the next signal.

Signaling, Double-Curb — —In curb signaling, a method by which the cable, after being connected with the battery for sending a signal, is subjected to a reverse battery, but instead of being put to earth after this connection, as in single-curb signaling, the battery is again reversed and connected to earth.

The time during which the cable is connected to the reversed battery before being put to earth, that is, the time during which it receives the positive and negative currents, may be made of any suitable duration.

Signaling, Double-Current — —Signaling by means of currents that alternately change their direction.

Double-current signaling was devised by Varley in order to avoid the effects of the induction of underground conductors on Morse telegraphic apparatus. The idea of reversing the direction of the current was to hasten the discharge of the wire, which was prolonged by induction. Double-current working, however, possesses other advantages, and is used in duplex and quadruplex transmission.

Signaling, Single-Curb — —In curb signaling, a method by which the cable, after connection with the battery for sending a signal, is subjected to a reverse battery current, and then put to earth before again being connected to the battery for sending the next signal.

Signaling, Single-Current — —Signaling by making or breaking the circuit of a single current.

Single-current signaling is of two kinds, viz.:

(1.) *Open-Circuit Signaling*, in which the batteries are fixed at each station, and are in circuit only when signaling.

(2.) *Closed-Circuit Signaling*, where the batteries are divided, one half generally being at each end of the line, and so connected that both sets flow in the same direction.

Signaling, Single-Current, Closed-Circuit — —A system of single-circuit signaling in which the sending batteries are placed at each end of the line and are so connected as

THIS PAGE IS LOCKED TO FREE MEMBERS

Purchase full membership to immediately unlock this page



HISTORY

Tens of thousands of important historical sources, many previously unobtainable, are now available for the first time with a Forgotten Books Full Membership.

Unlimited Access
\$8.99/month

Continue

*Fair usage policy applies

Single-Wire Circuit.—(See *Circuit, Single-Wire.*)

Sinistrorsal Solenoid or Helix.—(See *Solenoid, Sinistrorsal.*)

Sinuuous Currents.—(See *Current, Sinuuous.*)

Siphon, Electric — —A siphon in which the stoppage of flow, due to the gradual accumulation of air, is prevented by electrical means.

In the electric siphon, an opening is provided at the highest part of the bend of the siphon tube, and a chamber is attached thereto, provided with a float. Contact points are so connected with the float that when it falls, contact is made, and when it rises, contact is broken.

The closing of the circuit, on the fall of the float, operates an electric motor which drives an air pump which exhausts the air from the siphon. Or the float being raised in the siphon, the contact is broken and the operation of the pump is stopped.

Siphon Recorder.—(See *Recorder, Siphon.*)

Sir William Thomson's Standard Cell.—(See *Cell, Voltaic, Standard, Sir William Thomson's.*)

Skin Effect.—(See *Effect, Skin.*)

Skin, Faradization of — —The therapeutic treatment of the skin by a faradic current.

For efficient faradization the skin should be thoroughly dried and a metallic brush or electrode employed. For very sensitive parts, as, for example, the face, the hand of the operator, first thoroughly dried, is to be preferred as an electrode.

Skin, Human, Electric Resistance of — —The electric resistance offered by the skin of the human body.

The electric resistance of the skin is subject to marked differences in different parts of the body, where its thickness or continuity varies. It varies still more with variations in its condition of moisture. Even in the same individual the resistance varies materially under apparently similar conditions.

Sleeve, Insulating — —A tube of treated paper or other insulating material, provided

for covering a splice in an insulated conductor.

Sleeve Joint.—(See *Joint, Sleeve.*)

Sleeve, Lead — —A lead tube provided for making a joint in a lead-covered cable.

Sled.—The sliding contacts drawn after a moving electric railway car through the slotted underground conduit containing the wires or conductors from which the driving current is taken.

Slide Bridge.—(See *Bridge, Electric, Slide Form of.*)

Slide, Resistance — —A rheostat, in which the separate resistances or coils are placed in or removed from a circuit by means of a sliding contact or key.

Apparatus employed in telegraphy for charging a conductor to a given fraction of the maximum potential of the battery so as to adjust its charge in order to balance the varying charge of a cable.

The resistance slide consists essentially of a set of resistance coils of high insulation and of equal resistance. Suppose, for example, ten such equal coils to be connected in series, then if connected to the charging battery the potential will vary by one-tenth at the junction between each pair. A condenser, therefore, will be charged to any number of tenths of the potential of the charging battery by connecting it at suitable points.

A second set of coils of equal resistance is arranged so as to subdivide any of the lower coils, thus permitting an adjustment to within a hundredth of the potential of the battery.

Slide Wire.—(See *Wire, Slide.*)

Sliding Contact.—(See *Contact, Sliding.*)

Slow-Speed Electric Motor.—(See *Motor, Electric, Slow-Speed.*)

Sluggish Magnet.—(See *Magnet, Sluggish.*)

Small Calorie.—(See *Calorie, Small.*)

Smee Voltaic Cell.—(See *Cell, Voltaic, Smee.*)

Smelting, Electro — —The separation or reduction of metallic substances from their ores by means of electric currents.

Snap Switch.—(See *Switch, Snap*.)

Soaking-In.—A term sometimes employed by telegraphers to represent the gradual penetration of an electric charge by a neighboring dielectric.

An electric displacement occurs in the neighboring dielectric, and produces thereby what is generally called the residual charge.

Soaking-Out.—A term sometimes employed by telegraphers to represent a gradual discharge which occurs in the case of a charged conductor in a neighboring dielectric.

When a condenser, or other similar conductor, is discharged, the discharge is not instantaneous. The charge which soaked in, gradually recovers, or soaks-out.

Socket, Electric Lamp — —A support

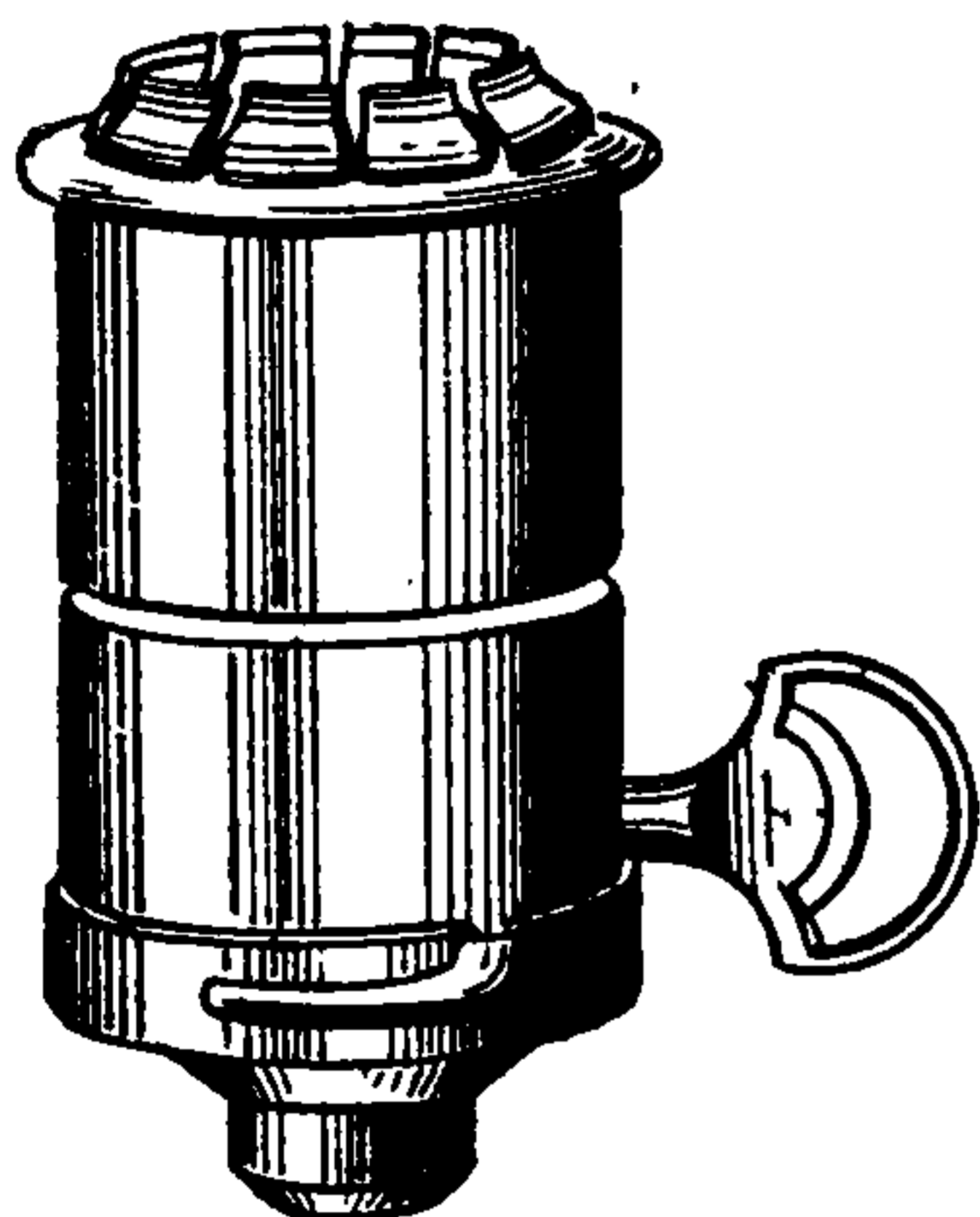

Fig. 503. Lamp Socket.

for the reception of an incandescent electric lamp.

Incandescent lamp sockets are generally made so that the mere insertion of the base of the lamp

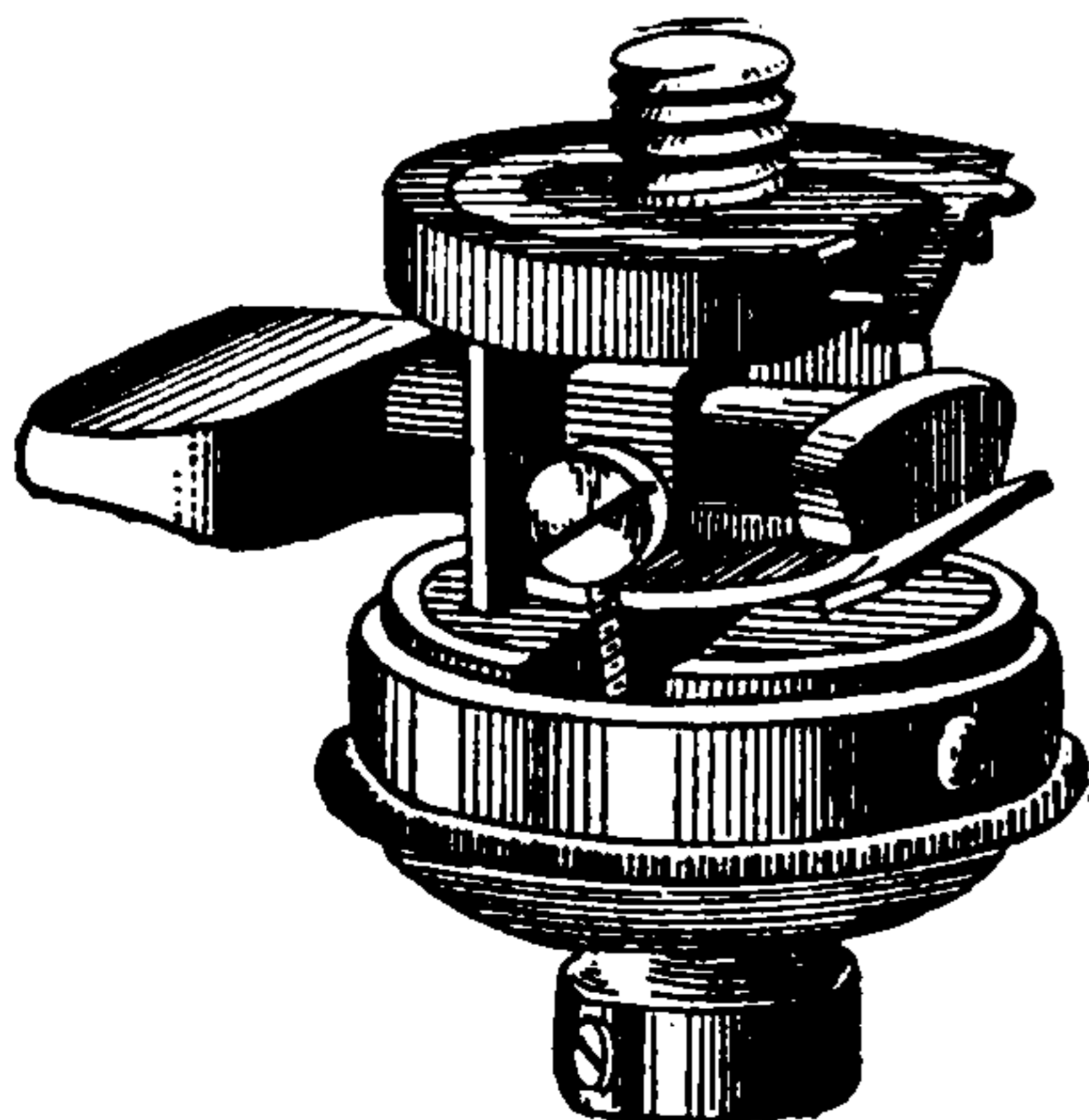

Fig. 504. Lamp Socket.

in the socket completes the connection of the lamp terminals with the terminals of the socket. The

socket terminals are connected with the leads that supply current to the lamp; the removal of the lamp from the socket automatically breaks its circuit. The socket is generally provided with a key for turning the lamp on or off without removing it from the socket.

Figs. 503 and 504 show forms of lamp sockets for incandescent lamps and the details of the key for connecting or disconnecting the lamp with the leads.

Socket, Wall — —A socket placed in a wall and provided with openings for the insertion of a wall plug with which the ends of a flexible twin-lead are connected.

A wall-socket permits the temporary connection of a portable electric lamp, a push button or other device with the conductor or lead.

Soft-Drawn Copper Wire.—(See *Wire, Copper, Soft-Drawn*.)

Soldering, Electric — —A process for obtaining metallic joints, in which heat generated by the electric current is used to melt the solder in the place of ordinary heat.

Solenoid.—A cylindrical coil of wire the convolutions of which are circular.

An electro-magnetic helix. (See *Solenoid, Electro-Magnetic, or Electro-Magnetic Helix*.)

A solenoid is termed dextrorsal or sinistrorsal according to the direction in which its wire is wound. (See *Solenoid, Dextrorsal. Solenoid, Sinistrorsal*.)

Solenoid Core.—The core, usually of soft iron, placed within a solenoid and magnetized by the magnetic field of the current passing through the solenoid.

The soft iron core of a solenoid differs from that of an electro-magnet in the fact that the core of the solenoid is *movable*, while that of the electro-magnet is fixed. (See *Magnet, Electro*.)

In order to obtain a nearly uniform pull in its various positions in the solenoid, the soft iron cores are made of a shape which insures a greater mass of metal towards the middle of the core. (See *Bars, Krizik's*.)

Solenoid, Dextrorsal — —A solenoid in which the winding is right-handed. (See *Solenoid, Practical*.)

Solenoid, Electro-Magnetic, or Electro-Magnetic Helix — —The name given to

a cylindrical coil of wire, each of the convolutions of which is circular.

A circuit bent in the form of a helix, supported at its two extremities, as shown in Fig. 505, and traversed by an electric current, will move into the magnetic meridian of the place, and, if free to move in a vertical plane, will come to rest in the line of the magnetic inclination or dip of the place.

A solenoid traversed by an electric current acquires thereby all the properties of a magnet, and is attracted and repelled by other magnets. Its poles are situated at the ends of the cylinder on which the solenoid may be supposed to be wound.

Solenoid, Ideal — — A solenoid consisting of a cylinder built up of a number of true circular currents, with all faces of like polarity turned in the same direction and entirely independent of one another.

The practical solenoid differs from the ideal solenoid in that the successive circular circuits or currents are all connected with one another in series.

The polarity of a solenoid depends on the direction of the current as regards the direction in which the solenoid is wound.

This solenoid is sometimes called an electro-magnetic solenoid or helix, in order to distinguish

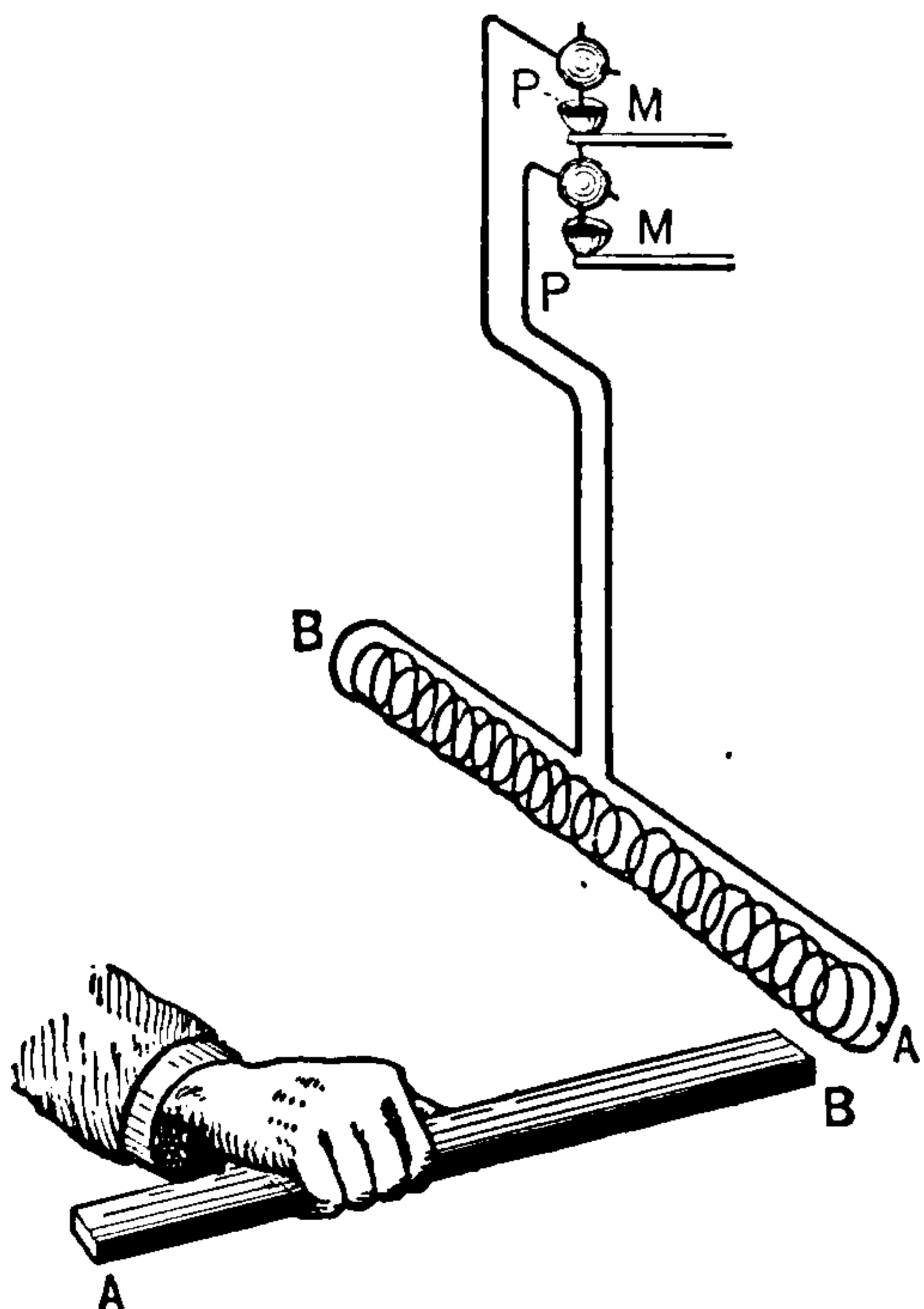

Fig. 505. Practical Solenoid.

it from a solenoidal magnet. (See Magnet, Solenoidal.)

A solenoid, if suspended so as to be free to

move, will come to rest in the plane of the magnetic meridian when traversed by an electric current.

It will also be attracted or repelled by the approach of a dissimilar or similar magnet pole respectively, as shown in Fig. 505.

Solenoid, Left-Handed — — A sinistrorsal solenoid or one in which the winding is left-handed. (See Solenoid, Practical.)

Solenoid, Magnetic — — A spiral coil of wire which acts like a magnet when an electric current passes through it.

The magnetic solenoid must be distinguished from a solenoidal magnet. (See Magnet, Solenoidal. Solenoid, Electro-Magnetic, or Electro-Magnetic Helix.)

Solenoid, Practical — — The name applied to the ordinary solenoid in order to distinguish it from the ideal solenoid. (See Solenoid, Ideal.)

A Practical Solenoid consists, as shown in Figs.

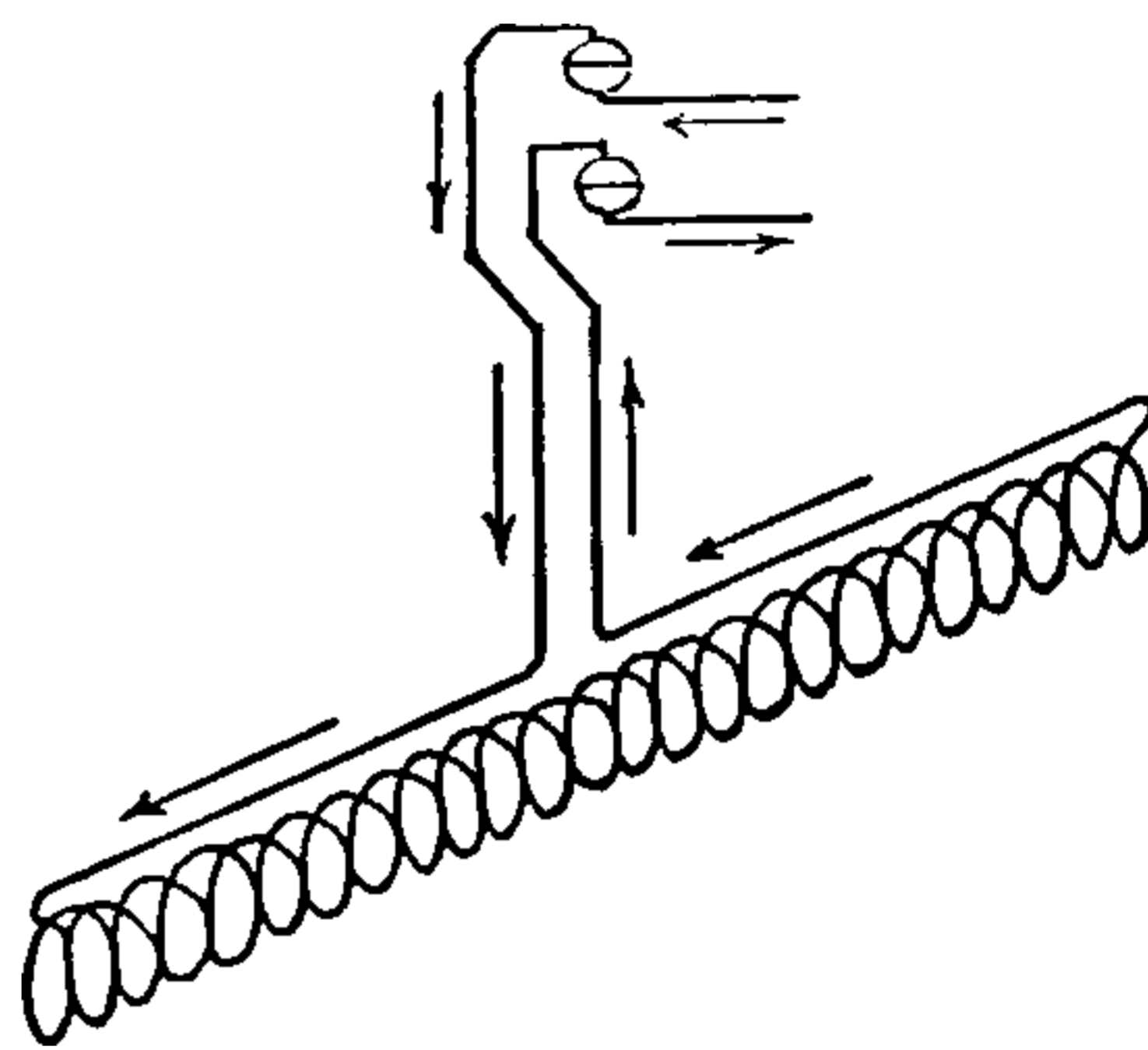

Fig. 506. Practical Solenoid.

505 and 506, of a spiral coil of wire in which the successive circular circuits are connected to one another in series.

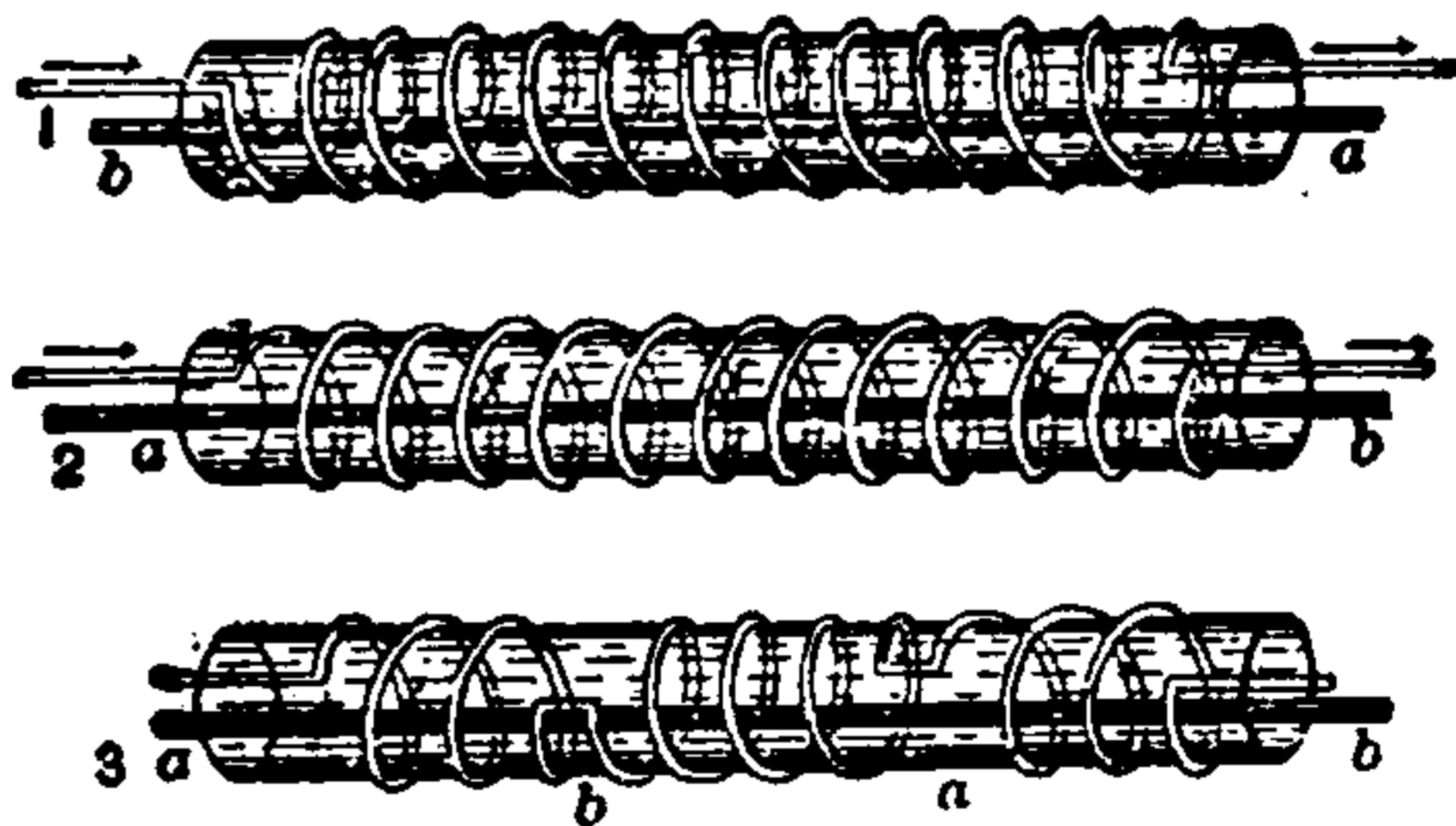

Fig. 507. Right-Handed Helix. Fig. 508. Left-Handed Helix. Fig. 509. Helix, with Consequent Poles.

The polarity of the solenoid depends on the direction of the current, and therefore on the direction of winding. In any solenoid, however, the polarity may be reversed by reversing the direction of the current. (See Magnet, Electro.)

A Right-Handed, or Dextrorsal Solenoid, is one wound in the direction shown in Fig. 507 at 1.

THIS PAGE IS LOCKED TO FREE MEMBERS

Purchase full membership to immediately unlock this page

Know Your Bible

Forgotten Books' Full Membership provides unlimited access to more than 28,000 volumes of Christian literature for \$8.99/month

HOLY BIBLE

Continue

*Fair use policy applies

that is, the to-and-fro motions are at right angles to the direction in which the light is traveling.

Sound.—(Objectively.) The waves in the air or other medium which produce the sensation of sound.

Sound.—(Subjectively.) The effect produced on the ear by a vibrating body.

Sound, Absorption of — —Acoustic absorption. (See *Absorption, Acoustic.*)

Sound, Characteristics of — —The peculiarities that enable different musical sounds to be distinguished from one another.

The characteristics of musical sounds are:

(1.) The *Tone or Pitch*, according to which a sound is either grave or shrill.

(2.) The *Intensity or Loudness*, according to which a sound is either loud or feeble.

(3.) The *Quality or Timbre*, the peculiarity which enables us to distinguish between two sounds of the same pitch and intensity, but sounded on different instruments, as for example, on a flute and on a piano.

Sound, Quality or Timbre of — —That peculiarity of a musical note which enables us to distinguish it from another musical note of the same tone or pitch, and of the same intensity or loudness, but sounded on another instrument.

The middle C, for example, of a pianoforte, is readily distinguishable from the same note on a flute, or on a violin; that is to say, its quality is different. The differences in the quality of musical sounds are caused by the admixture of additional sounds called *overtones* which are always associated with any musical sound.

Briefly, nearly all so-called simple musical sounds are in reality chords or assemblages of a number of different musical sounds.

In the case of the many different notes that are present in an apparently simple note or tone, one of the notes is far louder than all the others and is called the *fundamental tone* or note, and is what is recognized by the ear as the note proper. The others are called the overtones. The overtones are too feeble to be heard very distinctly, but their presence gives to the fundamental note its own peculiar quality. In the case of a note sounded on the flute, these overtones are different either in number or in their relative intensities from the same note sounded on another instru-

ment. Their fundamental tones, however, are the same.

The peculiarities which enable us to distinguish the voice of one speaker or singer from another are due to the presence of these overtones. The overtones must be correctly reproduced by the diaphragm of the telephone, or phonograph, graphophone, or gramophone, if the articulate speech is to be correctly reproduced with all its characteristic peculiarities.

Sounder, Morse Telegraphic — —An electro-magnet which produces audible sounds by the movements of a lever attached to the armature of the magnet.

The Morse sounder has now almost entirely supplanted the paper recorder or register. On short lines it is placed directly in the telegraphic circuit. On long lines it is operated by a *local battery*, thrown into or out of the action by the *relay*. (See *Relay.*)

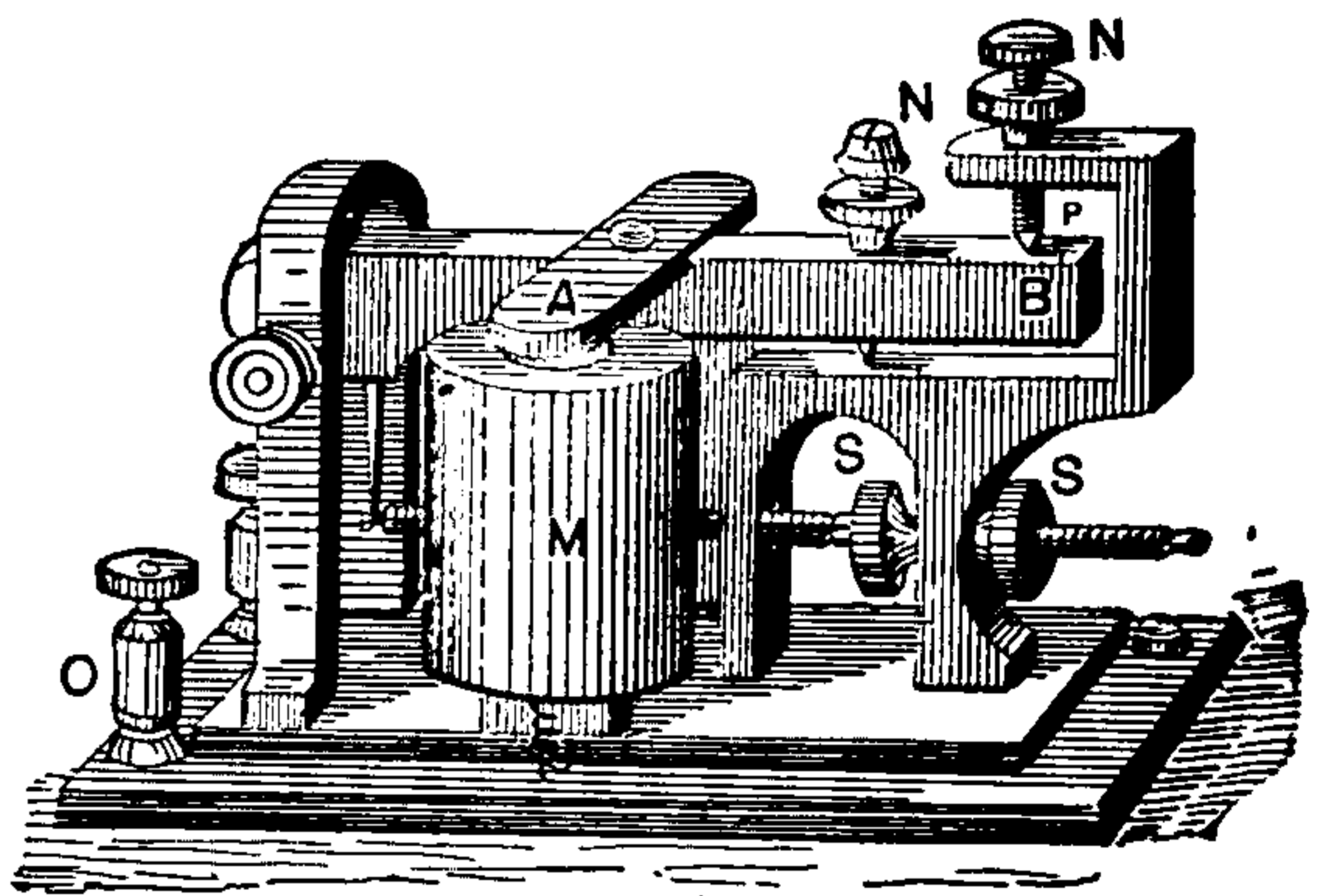

Fig 510. Morse Sounder.

The Morse sounder, shown in Fig. 510, consists of an upright electro-magnet M, whose soft iron armature A, is rigidly attached to the striking lever B, working in adjustable screw pivots as shown. The free end of the lever is limited in its strokes by two set screws N, N. The lower of these screws is set so as to limit the approach of the armature A, to the poles of the electro-magnet; the upper screw is set so as to give the end B, sufficient play to produce a loud sound. A retractile spring, attached to the striking lever near its pivoted end, and provided with regulating screw S S, pulls the lever back when the current ceases to flow through M.

The dots and dashes of the Morse alphabet are reproduced by the sounder, as audible signals, that are distinguished by the operator by means of the different sounds produced by the up and down stroke of the lever as well as by the differ-

ence in the intervals of time between the successive signals.

Another form of telegraphic sounder, similar in its general construction to that already described, is shown in Fig. 511.

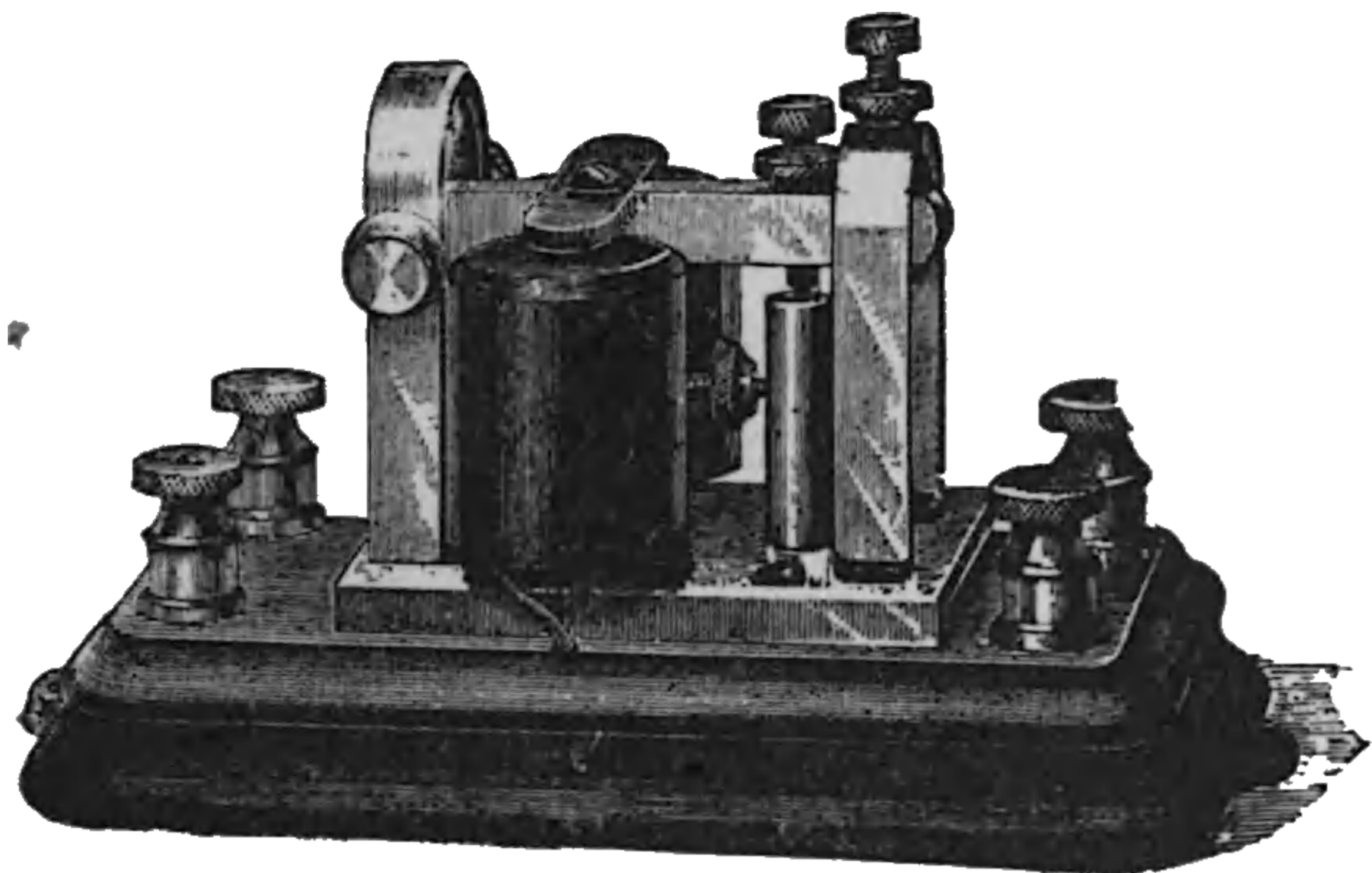

Fig. 511. *Telegraphic Sounder.*

Sounder, Repeating — —A telegraphic sounder which repeats the telegraphic dispatch into another circuit.

Sounds, Magnetic — —Faint clicks heard on the magnetization of a readily magnetizable substance.

One of the earlier forms of Reis' telephone, operated by means of a rapid succession of these faint magnetic sounds.

Source, Electric — —Any arrangement capable of maintaining a difference of potential or an electromotive force.

The following are the more important electric sources, arranged according to the character of the energy which is converted into electric energy.

ELECTRIC SOURCES.

- | | |
|---|-------------------------------|
| 1. Voltaic Cell or Primary Battery. | } Chemical Potential Energy. |
| 2. Charged Storage Cell or Secondary Battery. | |
| 3. Thermo Cell or Thermo Battery. | } Radiant Energy. |
| 4. Selenium Cell or Selenium Battery. | |
| 5. Magneto - Electric Machine. | } Mechanical Energy. |
| 6. Dynamo-Electric Machine. | |
| 7. Frictional Electric Machine. | |
| 8. Electrostatic Induction Machine. | |
| 9. Magneto-Electric Telephone Transmitter. | } Heat and Mechanical Energy. |
| 10. Pyromagnetic Generator. | |
| 11. Animal or Plant..... | Vital Energy. |

Sources, Multiple-Arc-Connected — — A term sometimes applied to sources connected in multiple. (See *Sources, Multiple-Connected.*)

Sources, Multiple-Connected — —The connection of a number of separate sources so as to form a single source by joining the positive poles of all the separate sources to a single positive lead or conductor, and all the negative poles to a single negative lead or conductor.

The multiple connection of sources results in each of the sources discharging its current into the main conductor in a direction parallel to that of the other sources.

The electromotive force in the same is that of any single source, but the resistance of the combined source decreases with each source added. Supposing the resistance of each source be the same, then if ten such sources are connected in multiple-arc, the resistance of the combined source is but one-tenth the resistance of a single source. (See *Circuit, Multiple.*)

Sources are combined in multiple-arc whenever the current furnished by the separate sources is insufficient to properly operate the electro-receptive or translating device with which it is connected.

Sources, Multiple-Series-Connected — —The connection of a number of separate sources so as to form a single source by connecting a number of the sources in groups in series, and joining these groups together in multiple-arc.

The battery of sources obtained by connecting a number of separate sources in multiple-series will have an electromotive force equal to the sum of the separate electromotive forces of the sources connected in any of the separate series-connected groups.

The current produced will be greater in proportion to the number of separate groups in parallel. The internal resistance will be increased in proportion to the number of coils in series, and decreased in proportion to the number of groups in multiple-arc or parallel.

Sources are connected in *multiple-series* when both the electromotive force and the current of any single source are insufficient to operate the electro-receptive or translating device. (See *Circuit, Multiple-Series.*)

Sources, Parallel - Connected — —A term sometimes applied to multiple-connected sources. (See *Sources, Multiple-Connected.*)

Sources, Series-Connected — —The connection of a number of separate electric sources so as to form a single source, in which the separate sources are placed in a single line or circuit by so connecting their opposite poles that the current produced in each passes successively through each of the sources.

The series-connection of sources results in an electromotive force equal to the sum of the separate electromotive forces produced by each source—that is, a rise of potential occurs with each source added. This connection increases the resistance of the circuit by the amount of the resistance of each source introduced into the circuit. The value of the resulting current depends on the total electromotive force and resistance of the series-connected sources.

Sources are connected in series when the electromotive force furnished by a single source is insufficient for the character of work required to be done. (See *Circuit, Series.*)

Sources, Series-Multiple-Connected — —The connection of a number of separate electric sources, so as to form a single source, in which the separate sources are connected in a number of separate multiple groups or circuits, and these groups or circuits separately connected together in series. (See *Circuit, Series-Multiple.*)

Southern Light.—A name sometimes given to the Aurora Australis. (See *Aurora Australis.*)

Space, Clearance — —The space between the revolving armature of a dynamo-electric machine, or electric motor, and the polar faces of the pole pieces.

Space, Dark, Crookes' — —A dark space surrounding the negative electrode in a rarefied space through which electric discharges are passing.

Crookes' dark space lies immediately between the negative electrode and its glow or luminous discharge. It differs, therefore, from Faraday's dark space, which lies between the luminous discharges of the negative and positive electrodes.

The radius of Crookes' dark space increases with the degree of exhaustion. It varies also with the character of the residual gas, with the temperature of the negative electrode, and somewhat with the intensity of the spark. When the vacuum becomes sufficiently high, the dark space fills the entire tube through which the discharges are passing.

Crookes has found that in the case of substances that become phosphorescent under the electric discharge, phosphorescence best takes place when the body is placed on the boundary of the dark space.

Space, Dark, Faraday's — —The gap in the continuity of the luminous discharges that occurs between the glow of the positive and negative electrodes.

Faraday's dark space is seen in a partially exhausted tube through which the discharges of an induction coil are passing. It occurs in as low a vacuum as 6 millimetres of mercury. As the vacuum becomes higher, the length of the dark space increases.

Space, Inter-Air — —A term sometimes employed for the air space between the outer surface of the revolving armature of a dynamo-electric machine and the adjacent faces of the pole pieces. (See *Space, Clearance.*)

Space, Interferric — —A term sometimes used for air gap. (See *Gap, Air.*)

Span Wire.—(See *Wire, Span.*)

Spark Coil.—(See *Coil, Spark.*)

Spark Gap.—(See *Gap, Spark.*)

Spark, Length of — —The length of spark that passes between two charged conductors depends :

(1.) On the difference of potential between them.

(2.) On the character of the gaseous medium that separates the two conductors.

(3.) On the density or pressure of the gaseous medium between the conductors.

Up to a certain pressure, a decrease in the density causes an increase in the length of the distance the spark will pass. When this limit is reached, a further decrease of density decreases the length of spark. A high vacuum prevents the passage of a spark even under great differences of potential.

THIS PAGE IS LOCKED TO FREE MEMBERS

Purchase full membership to immediately unlock this page



HISTORY

Tens of thousands of important historical sources, many previously unobtainable, are now available for the first time with a Forgotten Books Full Membership.

Unlimited Access
\$8.99/month

Continue

*Fair usage policy applies

effects of spark were obtained in these experiments. When a disturbance of the balance exists and a spark is obtained at a, the character of the spark is different from that of the Leyden jar discharge. It appears to be less luminous, the noise less sharp, and its color would indicate a greater power of volatilizing metal and perhaps a greater duration. It is in part, no doubt, due to a current local to the coils in series with one another.

“Another curious effect was the production of T-shaped and Y-shaped sparks, or three-branched sparks (such as are shown in Figs. 513 and 514.)”

“These were obtained by separating the electrodes at A, an inch and a half or thereabouts, and bringing the third electrode from the outer coil to the position shown in Fig. 513. The discharges were now obtained as before from the charged jar. In this case the discharge appears to split and unite in air, producing the curious shaped sparks shown. It would seem that to obtain these effects—particularly the sparks which were three-branched from a common point in the centre between the discharge electrodes—the dielectric air must break down simultaneously between the three electrodes. It would easily explain the T-shapes to assume the straight part above to form first, and the cross or transverse spark to strike from the side of this spark to the third electrode.”

Spark Tube.—(See *Tube, Spark.*)

Spark, Wipe — — In an electric gas-lighting pendant burner, a spark obtained from a spark coil by the wiping contact of a spring, moved by the pulling of the pendant. (See *Burner, Ratchet-Pendant, Electric.*)

Spark, Y-Shaped — — A variety of three-branched spark obtained by the discharge of a Leyden jar through a peculiar form of induction coil. (See *Spark, Three-Branched.*)

Sparking Discharge.—(See *Discharge, Disruptive.*)

Sparking Distance.—(See *Distance, Sparking.*)

Sparking, Line of Least — — The line on a commutator cylinder of a dynamo connecting the points of contact of the collecting brushes where the sparking is a minimum.

In some forms of dynamos the line of least

sparking lies parallel to the lines of magnetic force of the field.

In most forms, however, it is at right angles to such lines. The exact position of all these lines is changed by the angular lead of the brushes. (See *Lead, Angle of.*)

Sparking of Dynamo-Electric Machine.—(See *Machine, Dynamo-Electric, Sparking of.*)

Spar Torpedo.—(See *Torpedo, Spar.*)

Spasmodic Governor.—(See *Governor, Spasmodic.*)

Speaking-Tube Annunciator.—(See *Annunciator, Oral or Speaking-Tube.*)

Speaking-Tube Mouth Piece, Electric Alarm — — A mouth piece for a speaking tube, so arranged, that the movement of a pivoted plate covering the mouth piece automatically rings a bell at the other end of the tube.

Specific Conduction Resistance.—(See *Resistance, Specific Conduction.*)

Specific Conductivity.—(See *Conductivity, Specific.*)

Specific Heat.—(See *Heat, Specific.*)

Specific Heat of Electricity.—(See *Electricity, Specific Heat of.*)

Specific Hysteresial Dissipation.—(See *Dissipation, Specific Hysteresial.*)

Specific Inductive Capacity.—(See *Capacity, Specific Inductive.*)

Specific Magnetic Capacity.—(See *Capacity, Specific Magnetic.*)

Specific Magnetic Conductivity.—(See *Conductivity, Specific Magnetic.*)

Specific Magnetic Inductivity.—(See *Inductivity, Specific Magnetic.*)

Specific Resistance.—(See *Resistance, Specific.*)

Specific Resistance of Liquids.—(See *Resistance, Specific, of Liquids.*)

Speech, Articulate — — The successive tones of the human voice that are necessary to produce intelligible words.

The phrase articulate speech refers to the joining or articulation of the successive sounds involved in speech. The receiving diaphragm of a

telephone is caused to reproduce the articulate speech uttered near the transmitting diaphragm.

Speed, Critical, of Compound-Wound Dynamo — —The speed at which both the series and shunt coils of the machine give the same difference of potential when the full load is on the machine, as the shunt coil would if used alone on open-circuit.

Speed Indicator.—(See *Indicator, Speed.*)

Speeding.—Varying the number of revolutions per minute.

The speeding of a dynamo is for the purpose of obtaining the current requisite to properly operate the electro-receptive device placed in its circuit.

Spent Acid.—(See *Acid, Spent.*)

Spent Liquor.—(See *Liquor, Spent.*)

Spherical Armature.—(See *Armature, Spherical.*)

Sphygmogram.—A record made by a sphygmograph. (See *Sphygmograph.*)

Sphygmograph.—An instrument for recording the peculiarities of the normal or abnormal pulse.

Sphygmograph, Electrical — —An instrument for electrically recording the peculiarities of the pulse.

Sphygmophone.—An apparatus in which a microphone is employed for the medical examination of the pulse. (See *Microphone.*)

Spider, Armature — —A light framework or skeleton consisting of a central sleeve or hub keyed to the armature shaft, and provided with a number of radial spokes or arms for fixing or holding the armature core to the dynamo-electric machine.

Spider, Driving — —Radial arms or spokes connected to the armature of a dynamo-electric machine and keyed to the shaft so as to act as a driving wheel for the armature.

Spin, Magnetic — —A term sometimes employed instead of magnetic field.

The term magnetic spin is sometimes used instead of magnetic field because the magnetism is now generally believed to be due to the effects of a rotary motion or spin in the surrounding universal ether.

Spiral, Primary — —The primary of an induction coil or transformer. (See *Transformer, Coil, Induction.*)

Spiral, Roget's — —A suspended wire spiral conveying a strong electric current and devised to show the attractions produced by parallel currents flowing in the same direction.

The lower end of the wire spiral dips into a mercury cup. On the passage of the current, the attraction of the neighboring turns of the spiral for each other shortens the length of the spiral sufficiently to draw it out of the mercury and thus break the circuit. When this occurs the weight of the spiral causes it to fall and again re-establish the circuit. A rapid automatic-make-and-break is thus established, accompanied by a brilliant spark at the mercury surface due to the extra spark on breaking.

Spiral, Secondary — —The secondary coil of an induction coil or transformer. (See *Transformer, Coil, Induction.*)

Splice Box.—(See *Box, Splice.*)

Split Battery.—(See *Battery, Split.*)

Split Lead Tee.—(See *Tee, Split Lead.*)

Spluttering of Arc.—(See *Arc, Spluttering of.*)

Spots, Sun — —Dark spots, varying in number and position, which appear on the face of the sun and are believed by some to be caused by huge vortex motions in the masses of glowing gas that surround the sun's body.

Sun spots occur in greater number at intervals of about every eleven years.

Their occurrence is generally attended with unusual terrestrial magnetic variations. (See *Storm, Magnetic.*)

In the opinion of most astronomers the sun spots mark depressions in the atmosphere of the sun. Their exact causes are unknown, though they appear to be dependent on a local cooling or condensation of the sun's atmosphere.

When observed through a telescope the sun spot appears as a dark region surrounded by a less dark region. Though darker by contrast with the rest of the sun's face, yet such spots are in reality much brighter than the most brilliant arc light. The outline of the sun spot is quite irregular.

Spreading-Out Magnetic Field.—(See *Field, Magnetic, Spreading-Out.*)

Sprengel Mercury Pump.—(See *Pump, Air, Sprengel's Mercurial.*)

Spring Ammeter. — (See *Ammeter, Spring.*)

Spring Contact.—(See *Contact, Spring.*)

Spring, Hold-Off — —A spring which acts to keep one thing away from another in opposition to some force tending to keep it in contact with such a thing.

Spring, Hold-On — —A spring which acts to keep one thing against another in opposition to some force tending to pull it away.

A hold on spring is sometimes employed in a dynamo-electric machine for the purpose of keeping the collecting brushes in proper pressure against the segments of the commutator.

Spring-Jack.—A device for readily inserting a loop in a main electric circuit. The spring-jack is generally used in connection with a multiple switch board. (See *Board, Multiple Switch.*)

Spring-Jack Cut-Out.—(See *Cut-Out, Spring-Jack.*)

Spurious Hall Effect.—(See *Effect, Hall, Spurious.*)

Spurious Resistance.—(See *Resistance, Spurious.*)

Stabile Galvanization.—(See *Galvanization, Stabile.*)

Staggering.—A term sometimes applied to the position of the brushes on a commutator cylinder, in which one brush is placed slightly in advance of the other brush so as to bridge over a break.

When a break occurs in the circuit of the armature wires, the device of staggering the brushes is adopted for temporarily bridging over the break. When a break occurs, the rewinding of the armature is the only radical cure.

Standard Candle.—(See *Candle, Standard.*)

Standard Carcel Gas Jet.—(See *Jet, Gas, Carcel Standard.*)

Standard, Dynamo — —The supports for the bearings of a dynamo-electric machine.

Standard Earth Quadrant.—(See *Quadrant, Standard.*)

Standard of Self-Induction, Ayrton & Perry's — —(See *Induction, Self, Ayrton & Perry's Standard of.*)

Standard Ohm.—(See *Ohm, Standard.*)

Standard, Pentane — —A standard source of light used in photometric measurements, in place of a Methven screen.

The pentane standard is constructed in general in the same manner as the Methven standard. In place, however, of ordinary coal gas, a mixture of pentane and air is used. Pentane is a variety of coal oil left after several distillations of ordinary crude oil. It distills at a temperature not greater than 50 degrees centigrade.

The mixture for burning consists of about twenty volumes of air to seven volumes of pentane. A burner of the pentane standard is somewhat similar to the Methven standard, but differs in a number of minor details.

Standard Resistance Coil.—(See *Coil, Resistance, Standard.*)

Standard Size of Electrodes, Erb's — —(See *Electrodes, Erb's Standard Size of.*)

Standard Voltaic Cell.—(See *Cell, Voltaic, Standard.*)

Standard Voltaic Cell, Clark's — —(See *Cell, Voltaic, Standard, Clark's.*)

Standard Voltaic Cell, Clark's, Rayleigh's Form of — —(See *Cell, Voltaic, Standard, Rayleigh's Form of Clark's.*)

Standard Voltaic Cell, Fleming's — —(See *Cell, Voltaic, Standard, Fleming's.*)

Standard Voltaic Cell, Lodge's — —(See *Cell, Voltaic, Standard, Lodge's.*)

Standard Voltaic Cell, Sir William Thomson's — —(See *Cell, Voltaic, Standard, Sir William Thomson's.*)

Standard Wire Gauge.—(See *Gauge, Wire, Standard.*)

THIS PAGE IS LOCKED TO FREE MEMBERS

Purchase full membership to immediately unlock this page

Know Your Bible

Forgotten Books' Full Membership provides unlimited access to more than 28,000 volumes of Christian literature for \$8.99/month

HOLY BIBLE

Continue

*Fair use policy applies

voltaic couple is chemically attacked by the electrolyte. (See *Cell, Voltaic. Metals, Electrical Protection of.*)

State, Permanent, of Charge on Telegraph Line — —The condition of the charge on a telegraph wire when the current reaching the distant end has the same strength as at the sending end.

State, Variable, of Charge of Telegraph Line — —The condition of the charge on a telegraph wire while the strength of the current is increasing up to the full strength in all parts.

The duration of the variable state is directly as the length of the line, the electrostatic capacity and the total resistance. It is increased by leakage, by static capacity and by the effects of the extra current. (See *Currents, Extra.*)

Static Breeze.—(See *Breeze, Static.*)

Static Electricity. — (See *Electricity, Static.*)

Static Energy.—(See *Energy, Static.*)

Static Hysteresis. — (See *Hysteresis, Static.*)

Static Insulation. — (See *Insulation, Static.*)

Static Magnetic Induction.—(See *Induction, Magnetic, Static.*)

Static Shock.—(See *Shock, Static.*)

Statics.—The science which treats of the relations that must exist between the points of application of forces and their direction and intensity, in order that equilibrium may result.

Statics, Electro — —That branch of electric science which treats of the phenomena and measurement of electric charges.

Some of the more important principles of electrostatics are embraced in the following laws:

(1.) Charges of like name, *i. e.*, either positive or negative, repel each other. Charges of unlike name attract each other.

(2.) The forces of attraction or repulsion between two charged bodies are directly proportional to the product of the quantities of electricity possessed by the bodies and inversely proportional to the square of the distance between them.

These laws can be demonstrated by the use of Coulomb's torsion balance. (See *Balance, Coulomb's Torsion.*)

Statics, Magneto — —That branch of magnetism which treats of magnetic attractions and repulsions, the distribution of lines of magnetic force and other facts regarding fixed magnets.

Station, Central — —A station, centrally located, from which electricity for light or power is distributed by a series of conductors radiating therefrom.

Station, Distant — —A term applied by an operator to the distant end of the line in order to distinguish it from his own end.

Station, Distributing — —A station from which electricity is distributed.

A central station.

Station, Home — —A term applied by an operator to his end of the line, in order to distinguish it from the other or distant station.

Station, Transforming — —In a system of distribution by transformers or converters a station where a number of transformers are placed, in order to supply a group of houses in the neighborhood. (See *Transformer, Electricity, Distribution of, by Alternating Currents.*)

Stationary Floor Key.—(See *Key, Stationary Floor.*)

Stationary Torpedo.—(See *Torpedo, Stationary.*)

Stay Rods, Telegraphic — —Metal rods attached to a telegraph pole, and securely fastened in the ground in order to counteract the effects of a pull or tension on the poles. (See *Pole, Telegraphic.*)

Stay rods should be used in all exposed situations, or where the poles are exposed to severe strains.

Steady Current.—(See *Current, Steady.*)

Stearns' Relay Shunt.—(See *Shunt, Relay, Stearns.*)

Steel, Qualities of, Requisite for Magnetization — —Qualities which must be

possessed by steel in order to permit it to permanently retain a considerable magnetization.

For the purposes of permanent magnetization steel should possess the following qualities:

It should be hard and fine grained. Hard cast steel answers the purpose very well. Scoresby showed that an intimate relation exists between the quality of the iron from which the steel is made, and the ability of the steel to take and retain considerable magnetism.

The steel should be hardened as high as possible and the temper afterwards drawn by heat to a violet-straw color. Practice is not uniform in this respect, the exact color varying with the quality of the steel.

An admixture with the steel of about $\frac{8}{100}$ of one per cent. of tungsten is said to increase its magnetic powers.

Cast steel is not generally employed for magnets, wrought steel being generally preferred.

Step-by-Step, or Dial Telegraphy.—(See *Telegraphy, Step-by-Step.*)

Step-Down Transformer.—(See *Transformer, Step-Down.*)

Step-Up Transformer.—(See *Transformer, Step-Up.*)

Sterilization, Electric — —Sterilizing a solution by depriving it of whatever germs it may contain by means of electrical currents.

The following experiments were recently made on sterilization by means of electric currents: The fluid, with the culture, was placed in a glass test tube, wound about with a wire coil connected either with a dynamo or accumulator or other electric source. Some increase in temperature was made, but never over 98° Fahr. When a current 1.25 volts, 2.5 ampères passed, a complete sterilization of *Micrococcus Prodigiosus* occurred at the end of twenty-four hours.

Blood and water containing pathogenic germs was sterilized in five to thirty minutes. The above described effects would appear to be magnetic rather than electric.

Sticking.—A word applied by telegraphers to the failure of the positive pole relay armature to leave the magnet pole on the cessation of the current.

In telegraphy, when from any cause a circuit is imperfectly broken by an operator's key, or at

the points of contact of a relay or other instrument, such failure is called sticking. When an arc is formed at the points of a relay where the local circuit is made and broken, the relay "sticks." The arc is caused by burning of the platinum points. *Sticking* may be a result of a too weak retractile spring.

Stone, Hercules — —A name given by the ancients to the lodestone. (See *Lodestone.*)

Stool, Insulating — —A stool provided with insulating supports of vulcanite or other insulator, employed to afford a ready insulating stand or support.

Stop, Limiting — —A stop set so as to limit the motion of an electrically vibrating or oscillating bar to any predetermined extent.

Such limiting stops are common on telegraphic and various other electrical apparatus.

Stopping-Off.—A process employed in electro-plating, in which a metallic article, already electro-plated over its entire surface, is electro-plated with another metal over certain parts only.

The process of stopping-off consists of covering the parts which are to receive the metallic coating, with various stopping-off varnishes. By this means articles can be electro-plated on parts of their surfaces with gold and on the remainder with silver. The whole surface is first silvered and the portions intended to be afterwards gilded are then stopped off and the object placed in the gilding bath.

Stopping-Off Varnish.—(See *Varnish, Stopping-Off.*)

Storage Battery.—(See *Battery, Storage.*)

Storage Capacity of Secondary Cell.—(See *Cell, Secondary or Storage, Capacity of.*)

Storage Cell.—(See *Cell, Storage.*)

Storage of Electricity.—(See *Electricity, Storage of.*)

Storm, Auroral — —A term sometimes employed to express an unusual prevalence of auroras.

Storm, Electric — —An unusual condition of the atmosphere as regards the quantity of its free electricity.

A thunder storm is a variety of electric storm. (See *Storm, Thunder.*)

Storm, Magnetic — — Irregularities occurring in the distribution of the earth's magnetism, affecting the magnetic declination, dip, and intensity.

Magnetic storms have been observed to accompany auroral displays, and to be coincident with the occurrence of *sun spots*, or unusual outbursts of solar activity.

The coincidence of magnetic storms and outbursts of solar activity is unquestioned. Wolf, of Zurich, has shown by a comparison of numerous observations of sun spots, the unquestioned correspondence, in the times of their greatest activity, which occur every 11.1 years, with the time of occurrence of an unusual number of sun spots. He has placed these results in the form of curves. Those shown in Fig. 515 are taken from observations at Paris and Prague. The full lines represent the periods of sun spots. The dotted lines the periods of magnetic storms.

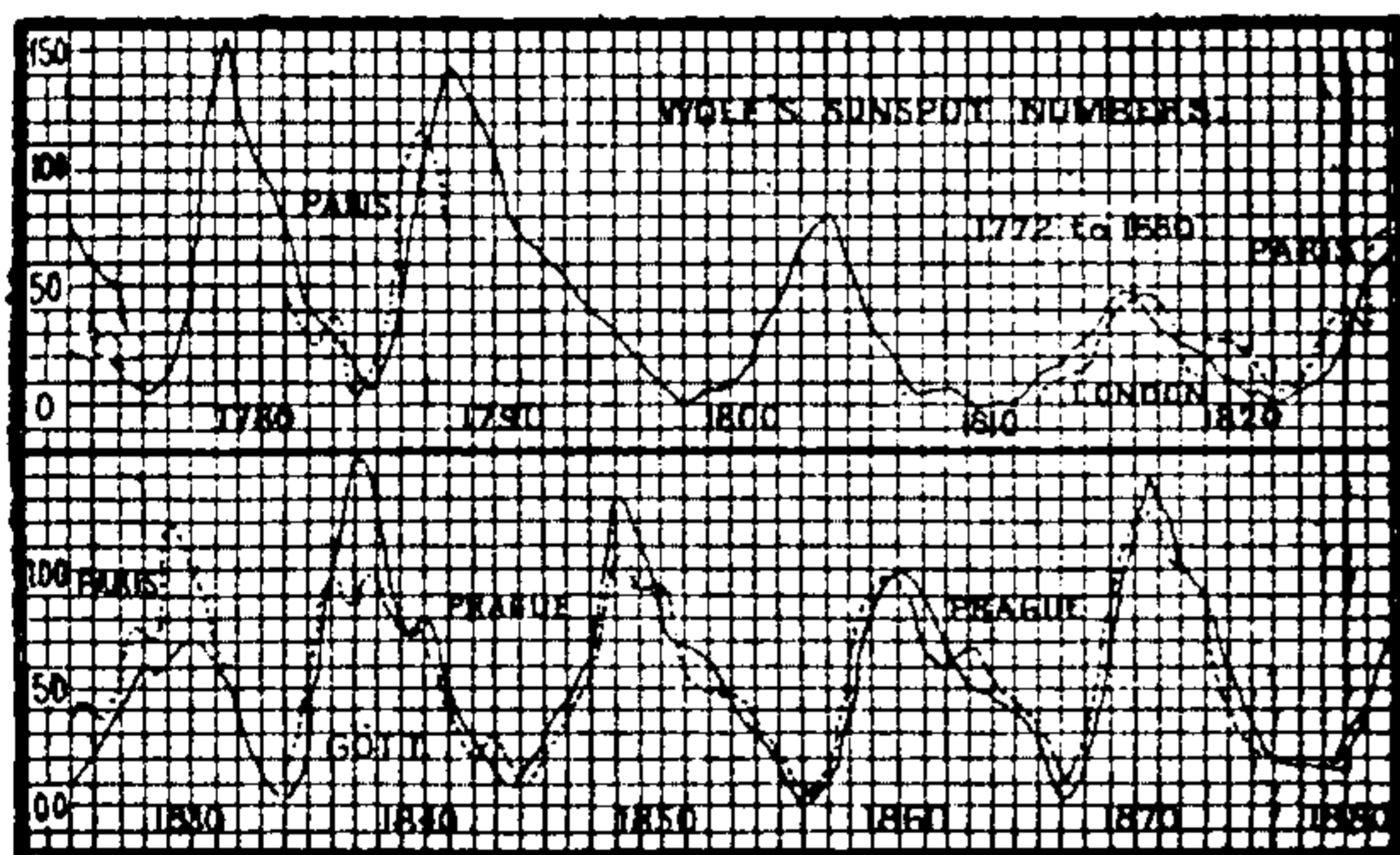

Fig. 515. Wolf's Sun Spot Numbers.

Storm, Thunder — — A storm during which electrical discharges accompanied by thunder take place between two clouds or between a cloud and the earth. (See *Electricity, Atmospheric. Storms, Thunder, Geographical Distribution of.*)

Storms, Thunder, Geographical Distribution of — — The following general facts as to the geographical distribution of thunder storms, show the intimate relation between the frequency of thunder storms and the time and place of the condensation of vapor.

(1.) Thunder storms seldom, if ever, occur in the polar regions.

This is probably because the rainfall in the

polar regions results from the condensation of the vapor that was formed in the equatorial or temperate regions, so that a considerable time elapses between the evaporation and condensation.

(2.) Thunder storms seldom, if ever, occur in rainless districts, owing probably to the absence of the condensation of vapor.

(3.) Thunder storms are most frequent and violent in the equatorial regions, where the rainfall results from the condensation of the vapor by the action of ascending currents, conveying the vapor almost immediately after its formation into the upper and colder regions of the atmosphere.

(4.) Thunder storms occur in regions beyond the tropics, at those seasons of the year when the rainfall results from the condensation of the vapor shortly after the time of its formation, viz., in the temperate zones in the hotter parts of the year.

Straight-Line Trolley Hanger.—(See *Hanger, Straight-Line Trolley.*)

Straightaway Bunched Cable.—(See *Cable, Bunched, Straightaway.*)

Strain, Dielectric — — The strained condition in which the glass, or other dielectric of a condenser, is placed by the charging of the condenser.

The deformation of a body under the influence of a stress. (See *Stress.*)

The *stress* in this case, *i. e.*, the force producing the deformation or *strain*, is the attraction of the opposite charges. This stress, in the case of a Leyden jar, is often sufficiently great to cause a rupture of the glass.

Strain, Electro-Magnetic — — The deformation produced by an electro-magnetic stress. (See *Stress, Electro-Magnetic.*)

Strain, Electrostatic, Optical — — A strain or deformation produced in a plate of glass, or other transparent solid, by subjecting it to the stress of an electrostatic field. (See *Stress, Electrostatic.*)

To obtain the electrostatic stress, holes are drilled in the plate of glass, and wires from a *Holtz machine* or *induction coil* placed therein, the wires being separated by a thin layer of glass.

The glass, on being traversed by a beam of plane polarized light, rotates the plane of polarization of the light in the same direction as the glass would if subjected to a *strain in the direc-*

THIS PAGE IS LOCKED TO FREE MEMBERS

Purchase full membership to immediately unlock this page



HISTORY

Tens of thousands of important historical sources, many previously unobtainable, are now available for the first time with a Forgotten Books Full Membership.

Unlimited Access
\$8.99/month

Continue

*Fair usage policy applies

Stress, Dielectric — —The force producing the deformation or strain in a dielectric.

A dielectric strain, in the case of a Leyden jar or condenser, is sometimes sufficiently great to pierce the dielectric.

Stress, Electro-Magnetic — —The force or pressure in a magnetic field, which produces a strain or deformation in a piece of glass or other similar substance placed therein. (See *Strain, Optical Electro-Magnetic*.)

Stress, Electrostatic — —The force or pressure in an electrostatic field, which produces strain or deformation in a piece of glass or other substance placed therein. (See *Strain, Electrostatic, Optical*.)

Stress, Energy of — —A term sometimes used in place of potential energy. (See *Energy, Potential*.)

Stress, Magnetic — —The force acting to produce a strain in the air-gap between two dissimilar magnet poles by the action of the lines of magnetic force, bridging such air gap.

Striæ, Electric — —Parallel streaked bands, consisting of alternate light and dark spaces, produced in tubes containing low vacua, by the passage of rapidly alternating currents through them. (See *Tube, Stratification*.)

Strip, Safety — —A strip or bar used as a safety fuse. (See *Fuse, Safety*.)

Stripping.—Dissolving the metal coating from a silver-plated or other metal-plated article.

The object of the "stripping" process is to recover silver from imperfectly plated ware, or from old ware which is to be replated.

Stripping of silver is accomplished either in the cold or by aid of heat, by the use of the following solutions, viz.:

Concentrated sulphuric acid,
(Baumé, 66 degrees).....100 parts.
Concentrated nitric acid,
(Baumé, 40 degrees)..... 10 "

The objects are suspended in this liquid, which, provided it be not diluted with water, possesses the property of dissolving the silver without touching the metal underneath.

Stripping Baths.—(See *Bath, Stripping*.)

Stripping Liquid.—(See *Liquid, Stripping*.)

Stroke, Lightning — —A disruptive discharge between two oppositely charged clouds, or between a cloud and the earth. (See *Discharge, Disruptive*.)

Stroke, Lightning, Back or Return — —An electric shock, caused by an induced charge, produced by the discharge of a lightning flash.

The shock is not caused by the lightning flash itself, but by a charge which is induced in neighboring conductors by the discharge. These induced effects are, in fact, effects of electro-dynamic induction. (See *Induction, Electro-Dynamic*.) A similar effect may be noticed by standing near the conductor of a powerful electric machine, when shocks are felt at every discharge.

The effects of the return shock are sometimes quite severe. These effects are often experienced by sensitive people on the occurrence of a lightning discharge at a considerable distance.

In some instances the return stroke has been sufficiently intense to cause death. In general, however, the effects are much less severe than those of the direct lightning discharge.

Struts for Telegraphic Poles.—Inclined wooden or iron poles, applied to telegraph poles in order to support the thrust or pressure acting on them. (See *Pole, Telegraphic*.)

Sturgeon's or Barlow's Wheel.—A wheel capable of rotation on a horizontal axis, which, when placed between the poles of a magnet, rotates when a current is passed through it between the axis and the circumference.

Sub-Aqueous Cable.—(See *Cable, Sub-Aqueous*.)

Sub-Branch.—(See *Branch, Sub*.)

Sub-Main.—(See *Main, Sub*.)

Submarine Boat.—(See *Boat, Submarine, Electric*.)

Submarine Cable.—(See *Cable, Submarine*.)

Submarine Mine.—(See *Mine, Submarine*.)

Submarine Telegraphy.—(See *Telegraphy, Submarine.*)

Substance, Ferro-Magnetic — —A term proposed in place of paramagnetic, for substances that are magnetic after the manner of iron. (See *Paramagnetic.*)

Subterranean Mine. (See *Mine, Subterranean.*)

Subway, Electric — —An accessible underground way or passage provided for the reception of electric wires or cables.

Underground electric conductors, like all electric conductors, are liable to faults, crosses, etc. Unless they are readily accessible, very serious loss and damage may occur before the fault is located and corrected.

Sulphating.—A name applied to one of the sources of loss in the operation of a storage battery, by means of the formation of a coating of inert sulphate of lead on the battery plates.

The addition of a solution of sulphate of soda to the sulphuric acid liquid is claimed to have the effect of decreasing the extent of the sulphating.

Summer Lightning.—(See *Lightning, Summer.*)

Sun Spots.—(See *Spots, Sun.*)

Sunstroke, Electric, or Electric Prostration or Insolation — —Physiological effects, similar to those produced by exposure to the sun, experienced by those exposed for a long while to the intense light and heat of the voltaic arc.

Electric sunstroke is sometimes called electric insolation, or electric prostration.

The effects of electric sunstroke were first noticed by Desprez in his classic experiments on the fusion or volatilization of carbon.

On undue exposure to an intense electric light the eyes are irritated and the skin burned as by the sun. In some cases it is claimed that the effects of sunstroke, or excessive production of heat, as in true *insolation*, are produced. In the applications of electricity to electric furnaces, these same effects have been noticed in an intensified degree.

From some recent investigations it would appear that these effects are to be ascribed to the light rather than to the heat.

The symptoms are as follows: Pain in the throat, face and temples, followed by a coppery red color of the skin, irritation and watering of the eyes, when the symptoms disappear. The skin peels off in about five days.

Superficial Eddy Currents.—(See *Currents, Eddy, Superficial.*)

Super-Saturation of Solution.—(See *Solution, Super-Saturation of.*)

Supplement of Angle.—(See *Angle, Supplement of.*)

Supply, Unit of, Electrical — —A unit, provisionally adopted in England by the Board of Trade, equal to 1,000 ampères flowing for one hour under an electromotive force of one volt.

This would, of course, equal 1,000 watt-hours, and would be the same as 100 ampères flowing for ten hours under one volt.

One unit of electrical supply is equal to 1.34 actual horse-power expended for one hour, and will feed 13.4 Swan lamps of 21 candle-power for one hour. It is equal in illuminating power in Swan lamps to the light produced by 100 cubic feet of gas consumed in twenty 14-candle burners in one hour.

The unit of electrical supply is called a "Board of Trade unit," a B. O. T. unit, or simply a bot. It is equal to one kilo-watt hour.

Support, Tripod Roof — —A support for a housetop telegraphic line.

The tripod roof support, as its name indicates, consists of a three-legged support for any suitable insulator.

A common form is shown in Fig. 516.

Support, Underground Cable — —A support provided for holding a cable where it passes around the side of a man-hole, underground conduit, or other similar location.

Surface, Demarcation — —The surface at which a demarcation current is generated.

The surface which marks the point of injury in a muscle or nerve.

Demarcation currents in electro-therapeutics, are currents produced in injured nerves or muscles. They are probably due to the chemical changes that take place between the injured and the uninjured tissues. The demarcation surface is

the surface separating parts in a normal condition from those in an abnormal condition.

An injury to a muscle or nerve causes or produces at such surface a dying substance which is

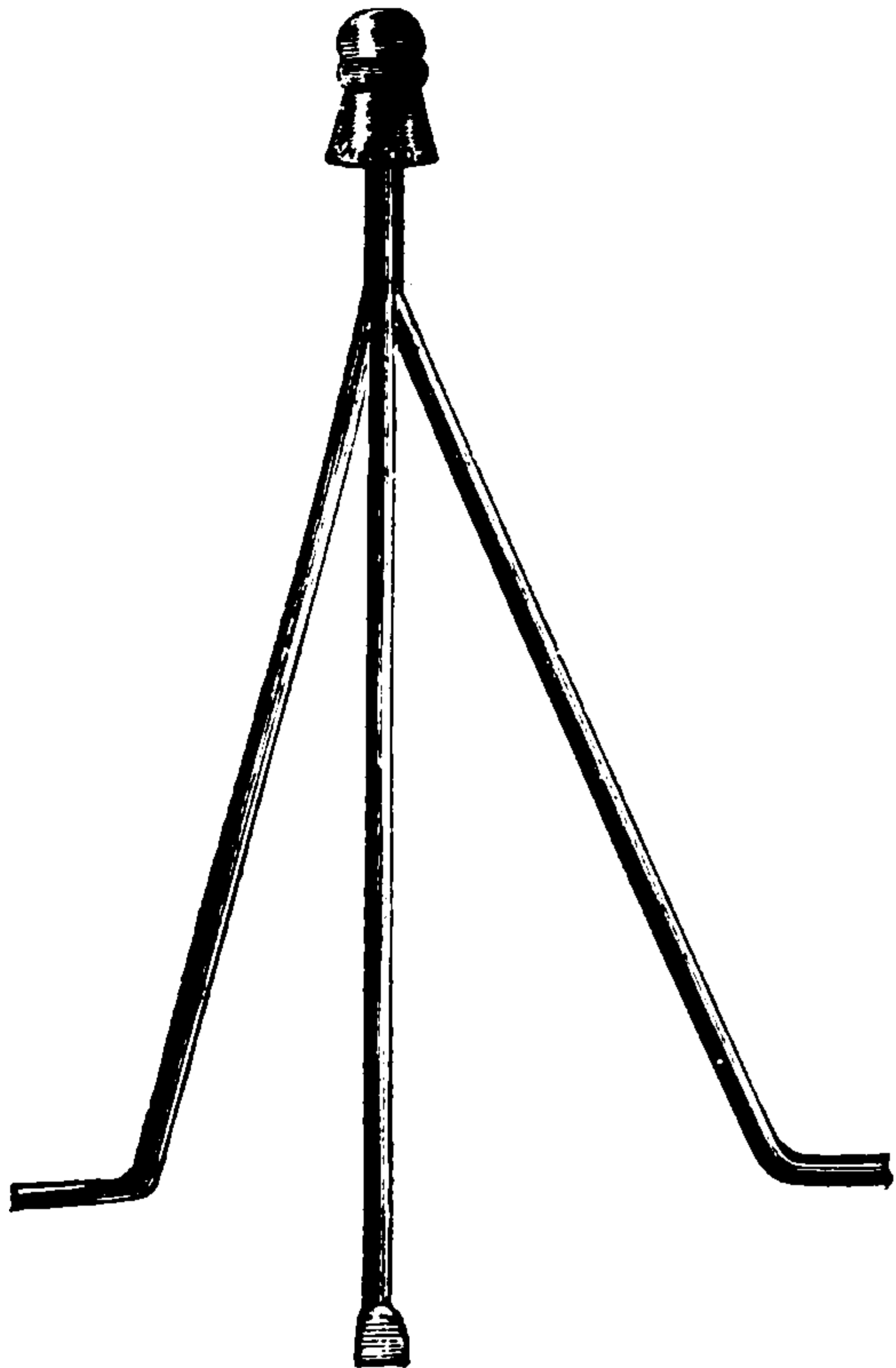

Fig. 516. Tripod Roof Support.

negative to the uninjured, normal or positive substance. Such a surface results in a demarcation current.

Surface Density.—(See *Density, Surface*.)

Surface, Equipotential, of a Conductor Through Which a Current is Flowing —

—A surface described within the mass of a conductor, conveying an electric current, at points perpendicular to the direction of the flow, all possessing the same potential.

Surface, Equipotential, or Level Surface of Escaping Fluid — —A surface described within the mass of a fluid in motion at all places perpendicular to the stream lines passing such surface.

Surface Integral of Magnetic Induction. —(See *Induction, Magnetic, Surface-Integral of*.)

Surfaces, Equipotential, Electrostatic — —Surfaces, all the points of which are at the same electric potential. (See *Potential, Electric*.)

Electric surfaces perpendicular to the lines of electric force over which a quantity of electricity, considered as being concentrated at a point, may be moved without doing work. (See *Field, Electrostatic*.)

Equipotential surfaces correspond with a water level, over which a body may be moved horizontally without doing any work against the force of gravity.

In the case of the charged insulated sphere, shown in Fig. 517, the equipotential surfaces, represented by the circles, are concentric.

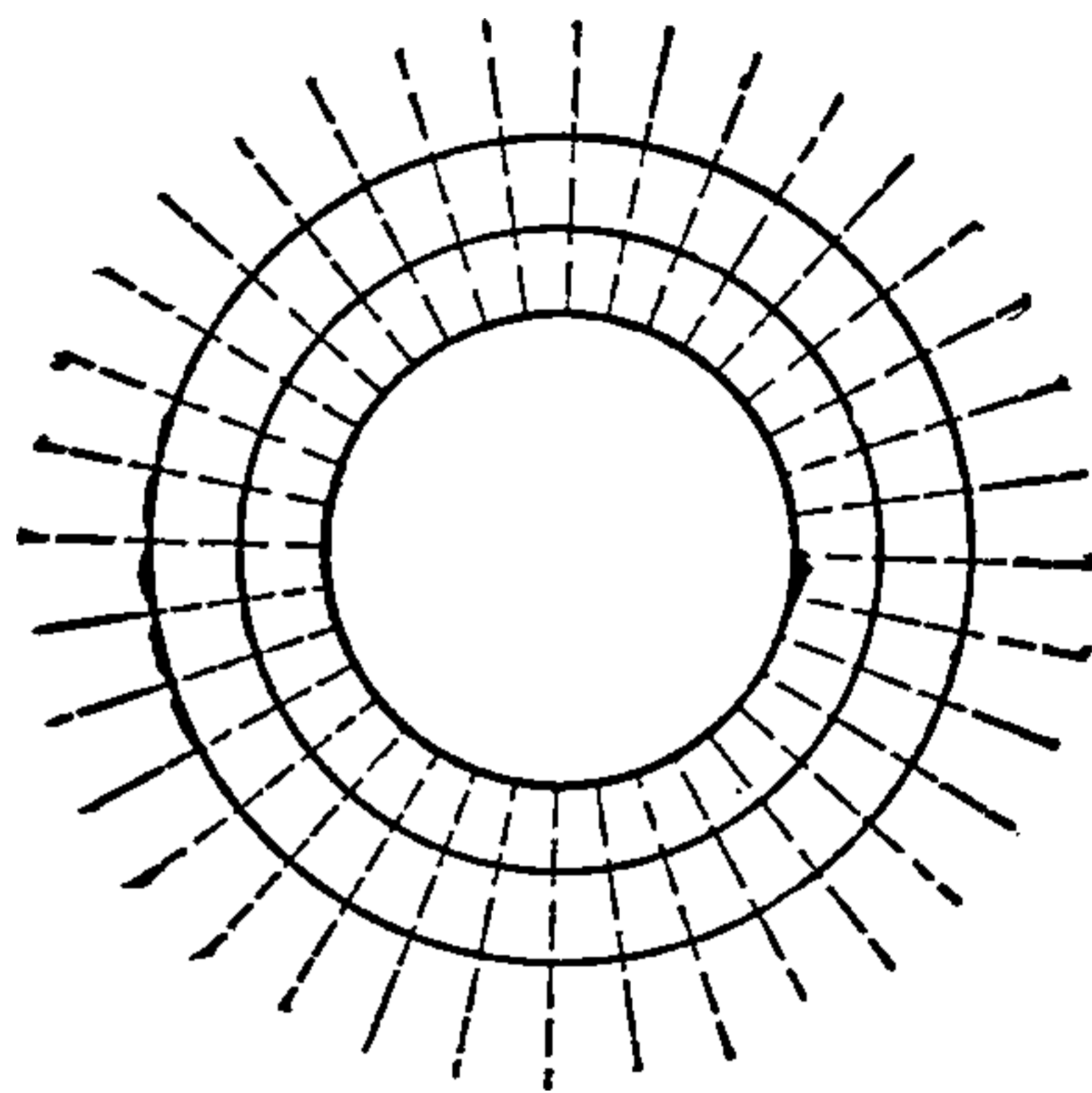

Fig. 517. Equipotential Surfaces.

Surfaces, Equipotential, Magnetic —

—Surfaces surrounding the poles of a magnet, or system of magnets, where the magnetic potential is the same. (See *Potential, Magnetic*.)

Magnetic equipotential surfaces extend in a direction perpendicular to the lines of magnetic force. (See *Field, Magnetic*.)

No work is required in order to move a unit pole over equipotential magnetic surfaces, because in so doing it cuts no lines of magnetic force. Work, however, is done when the motion is from one equal potential surface to another.

Equipotential surfaces, whether electric or magnetic, cannot intersect one another, since their potential is the same at all points.

Surfaces, Isothermal — —Surfaces connecting points in a body which have the same temperature.

Surging Discharge.—(See *Discharge, Surging*.)

Surging, Electric — —Electric oscillations set up in a charged conductor that is undergoing rapid discharge.

These surging produce waves in the surrounding ether that travel outwards with the velocity of

THIS PAGE IS LOCKED TO FREE MEMBERS

Purchase full membership to immediately unlock this page

Know Your Bible

Forgotten Books' Full Membership provides unlimited access to more than 28,000 volumes of Christian literature for \$8.99/month

HOLY BIBLE

Continue

*Fair use policy applies

The jeweled cup is placed above the centre of gravity of the needle, and is supported on a steel point. As a rule, compass needles have this variety of support.

Swage.—A particular form of anvil on which highly heated metallic plates are shaped by hammering them into forms the same as that of the anvil on which they are placed.

Swage.—To fashion heated metallic plates by hammering them into the form of an anvil on which they are supported.

Swaging.—Fashioning highly heated metallic plates into any desired form by hammering while on suitable dies.

Swaging, Electric — — The forming or shaping of metallic plates by hammering them against suitable anvils or dies while softened by electrical heating.

The electro-swaging apparatus consists of a welding transformer provided with a movable clamp. The pressure required for the swaging is attained by the use of steam admitted into a cylinder by a lever which operates a four-way valve.

The rod, bar, or plate of metal to be shaped or swaged, is first heated by the passage of a powerful heating current, obtained preferably from a welding transformer, one of the clamps of which is movable. When the metal is suitably softened by the passage of the current, it is then subjected to swaging.

Swelling Current.—(See *Currents, Swelling*.)

Swelling Faradic Current.—(See *Currents, Swelling Faradic*.)

Swinging Annunciator.—(See *Annunciator, Pendulum or Swinging*.)

Swinging Cross.—(See *Cross, Swinging or Intermittent*.)

Switch, Automatic, for Incandescent Electric Lamps — — A device by which incandescent electric lamps can be lighted or extinguished at a distance by means of push buttons.

The automatic switch for incandescent lamps corresponds in electric lighting to the automatic gaslighting device in systems of electric gaslighting. It consists essentially of two electro-magnets, one for turning the switch which lights

the lamp by cutting them into the circuit of the lighting mains or conductors, and the other for extinguishing them, by cutting them out. These electro-magnets are operated by two push buttons, a black one to extinguish the lamp and a white button to light it.

The details of the automatic switch are shown in Fig. 520. The mains M^1 and M^2 , are connected to one set of contacts, and the branches containing

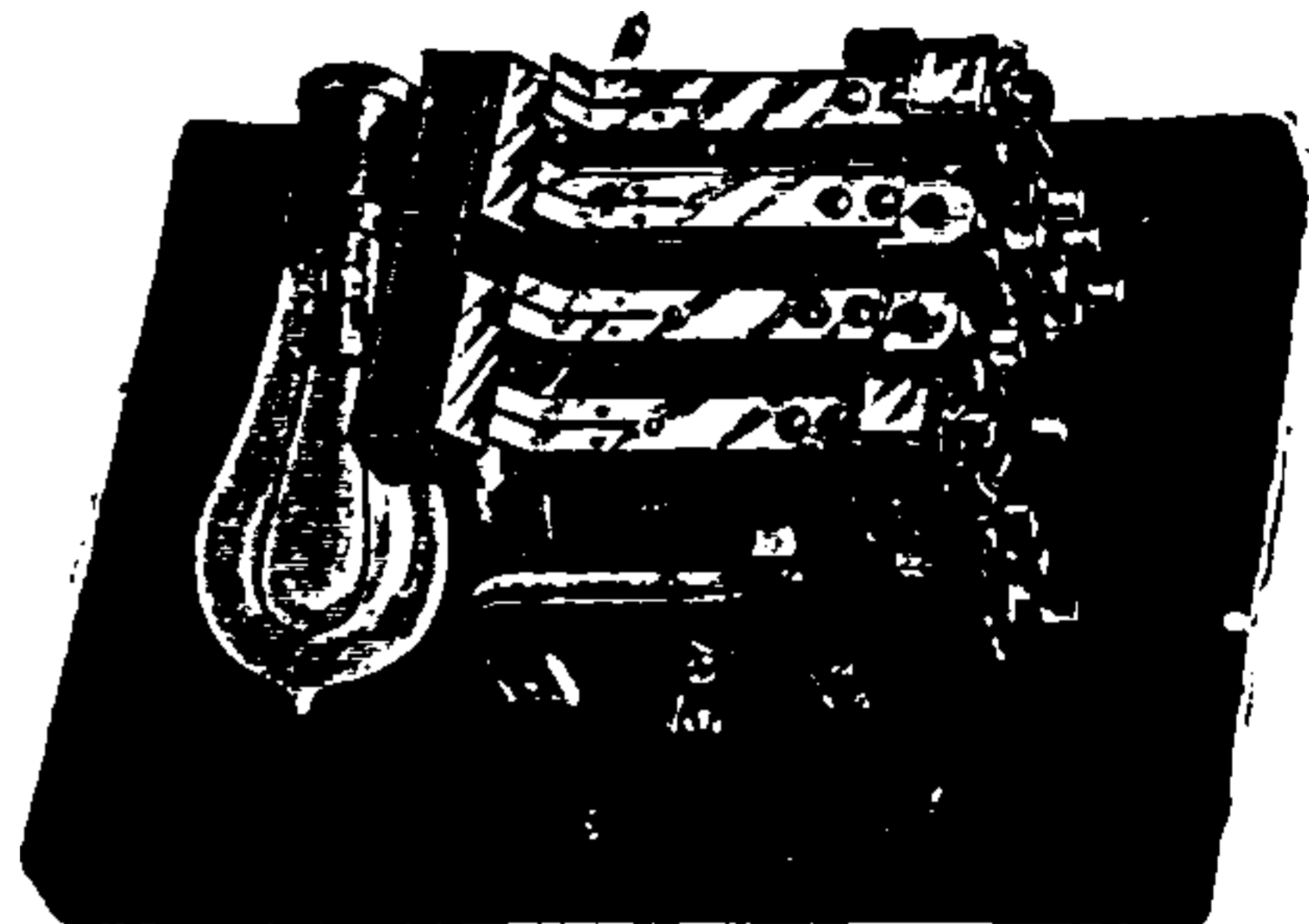

Fig. 519. Automatic Switch.

the lamps to be lighted, to the contacts between them. The push buttons, P^1 and P^2 , are connected by their wires to the main M^1 and the branch P^1 .

These buttons are made respectively positive and negative, and are marked $+$ and $-$. The third wire of the push button is connected as shown to the lamp L , and the switch magnet, $S M$.

When the contact is closed at P^1 , the armature of $S M$, closes the contact through C . When the button is released, connection is estab-

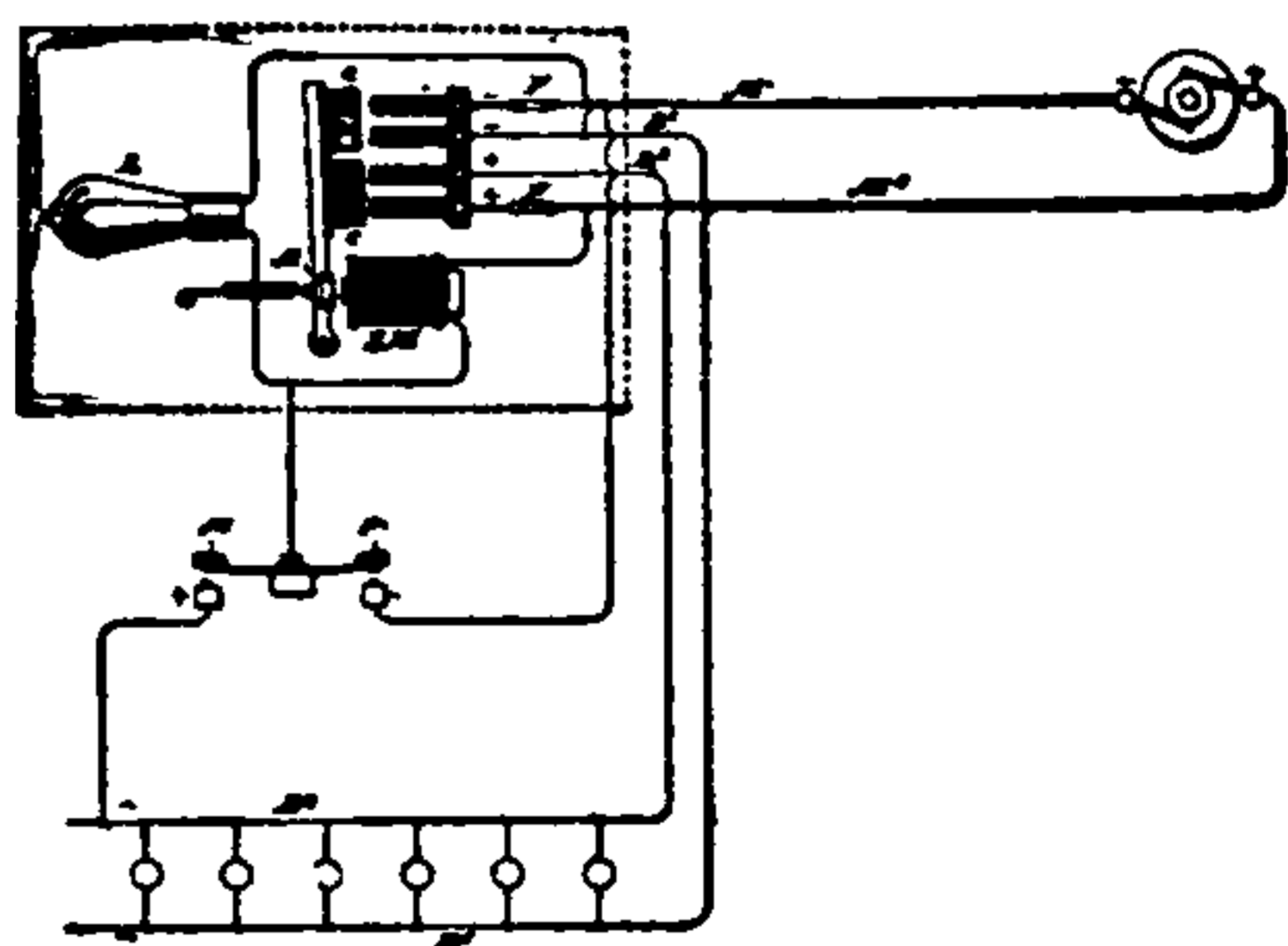

Fig. 520. Automatic Switch.

lished between the magnet and the lamp L , in series. This is for the purpose of cutting down the circuit to the $\frac{1}{10}$ of an ampère, and thus permitting a thin wire to serve between the button and the switch magnet.

When the button, P^2 , is closed the lamps are turned out.

Switch Board.—(See *Board, Switch*.)

Switch Board, Multiple — — (See *Board, Multiple Switch*.)

Switch Board, Telegraphic — — (See *Board, Switch, Telegraphic.*)

Switch Board, Trunking — — (See *Board, Switch, Trunking.*)

Switch, Break-Down — — A special switch, employed in small three-wire systems, for connecting the positive and negative bus-wires in such a manner as to practically convert it into a two-wire system and permit the system to be supplied with current from a single dynamo. (See *Wires, Bus.*)

Switch, Changing — — A switch designed to throw a circuit from one electric source to another.

A changing switch, for example, is of use in disconnecting a circuit from one dynamo and connecting it to another; or, in other words, to suddenly transfer the load from one dynamo to another.

Switch, Changing-Over — — A term sometimes applied to a changing switch. (See *Switch, Changing.*)

Switch, Distributing — — A multiple switch board. (See *Board, Multiple Switch.*)

Switch, Distributing, for Electric Lights — — A switch employed in a system of arc lighting by series-distribution, by means of which any particular dynamo-electric machine or a number of

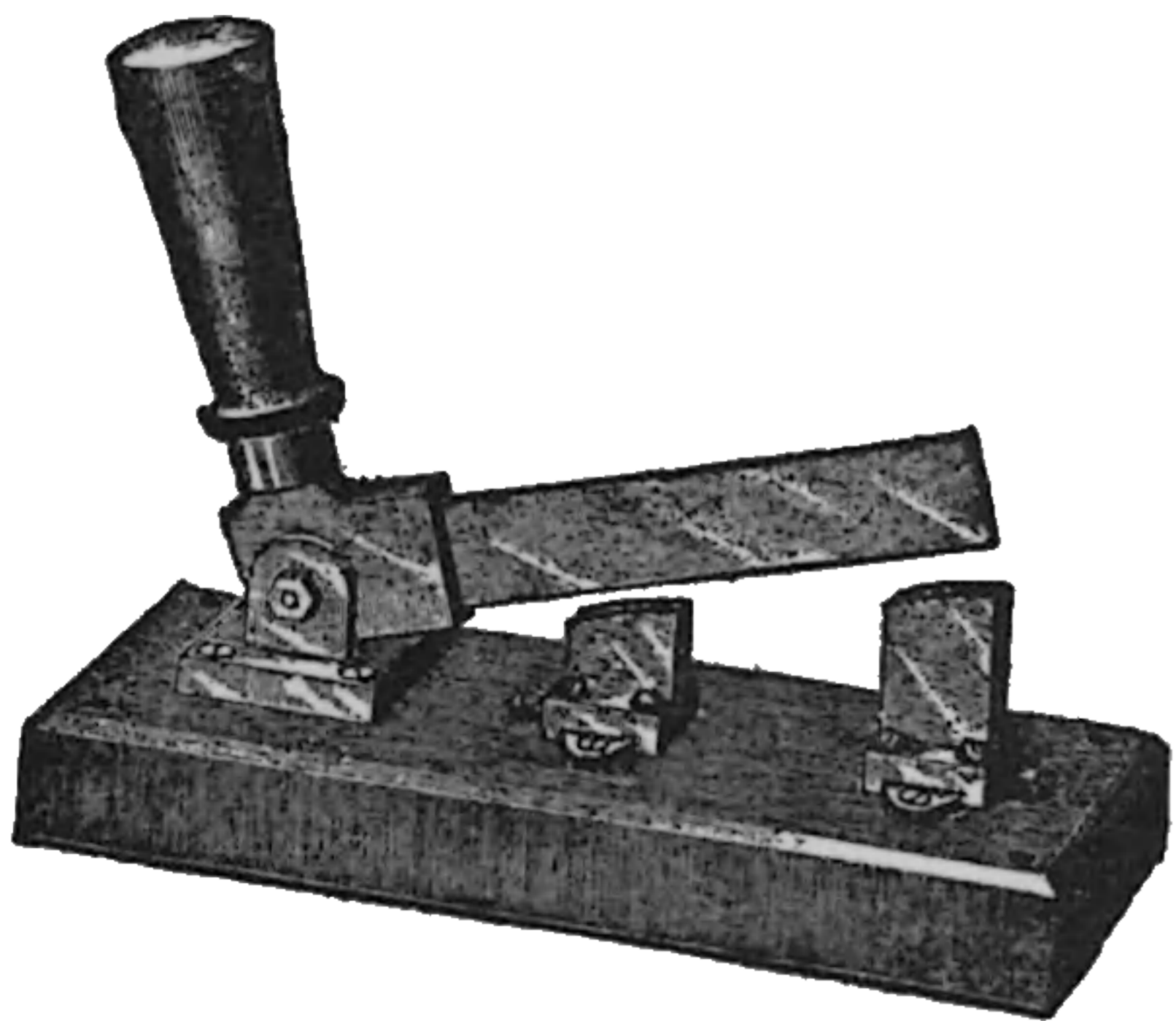

Fig. 521. *Double-Break Knife Switch.*

separate dynamo-electric machines can be connected with the same circuit without interfering with the lights. (See *Board, Multiple Switch.*)

Switch, Double-Break — — A term sometimes used for double-pole switch. (See *Switch, Double-Pole.*)

Switch, Double-Break Knife — — A knife switch provided with double-break contacts.

A double-break knife switch is shown in Fig. 521.

Switch, Double-Pole — — A switch that makes or breaks contact with both poles of the circuit in which it is placed.

A switch consisting of a combination of two separate switches, one connected to the positive lead and the other to the negative lead.

Double-pole switches are used in most systems of incandescent lighting in order to insure the thorough separation of the circuit from the main conductor or leads when cut out and to diminish the spark.

Switch, Feeder — — The switch employed for connecting or disconnecting each conductor of a feeder from the bus-bars in a central station.

Switch, Four-Point — — A switch by which a circuit can be completed through four central points.

Switch, Knife — — A switch which is opened or closed by the motion of a knife

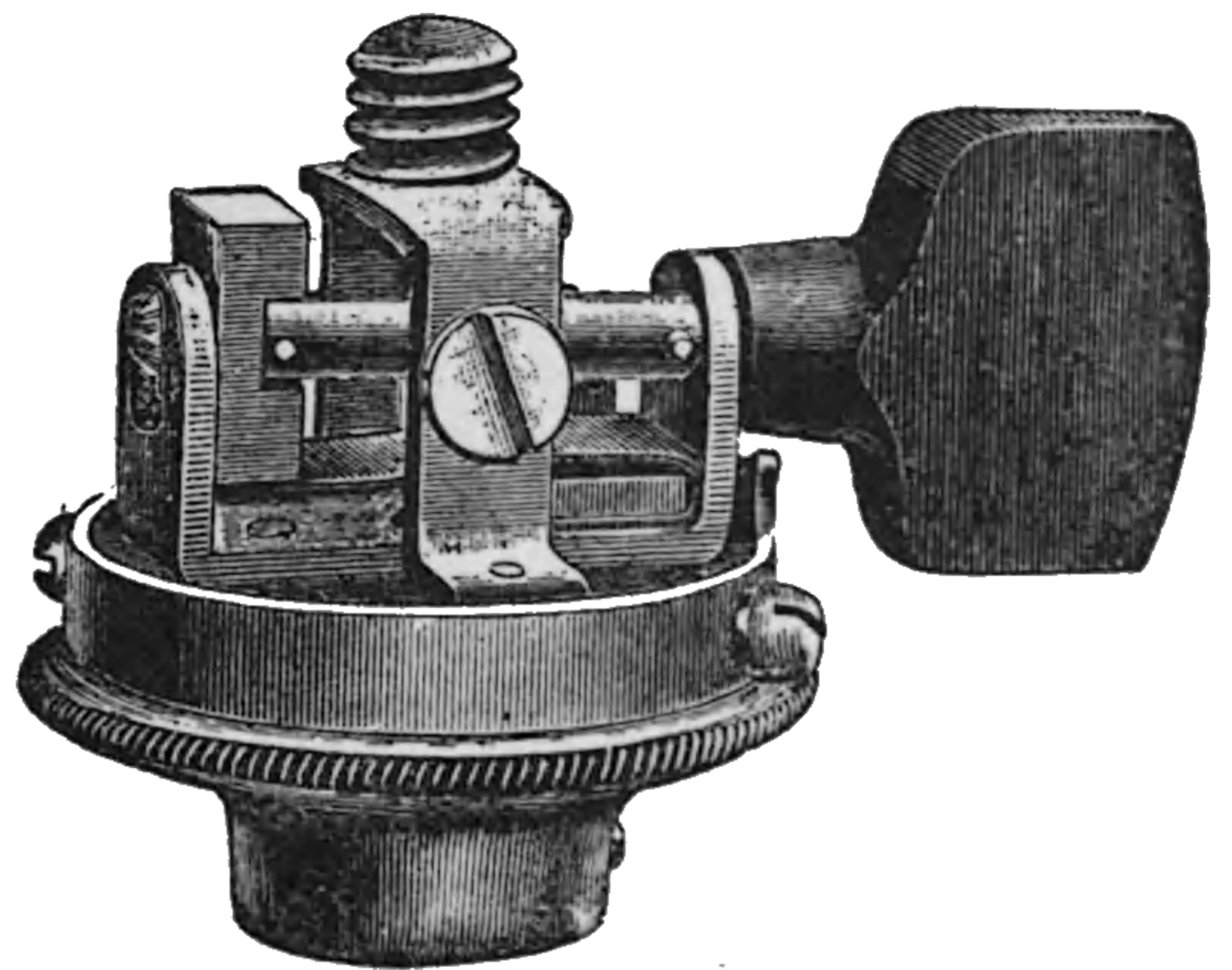

Fig. 522. *Lamp-Socket Switch.*

contact which moves between parallel contact plates.

A knife-edge switch. (See *Switch, Knife-Edge.*)

Switch, Knife-Break — — A knife switch. (See *Switch, Knife.*)

Switch, Knife-Edge — — A term sometimes used in place of knife switch. (See *Switch, Knife.*)

Switch, Lamp-Socket — —A switch placed in the socket of an incandescent lamp and provided for throwing the lamp in and out of the circuit.

A form of lamp socket switch is shown in Fig. 522. Its operation will be understood from an inspection of the drawing.

Switch Pin.—(See *Pin, Switch.*)

Switch, Plug — —A switch in which a metal plug is withdrawn to throw into a circuit a coil or other device, the ends of which are connected to metallic blocks that are sufficiently near together to be joined and short-circuited by the insertion of the plug.

Switch, Pole-Changing — —A switch employed for changing the direction of the current in any circuit.

A form of pole-changing switch is shown in Fig. 523.

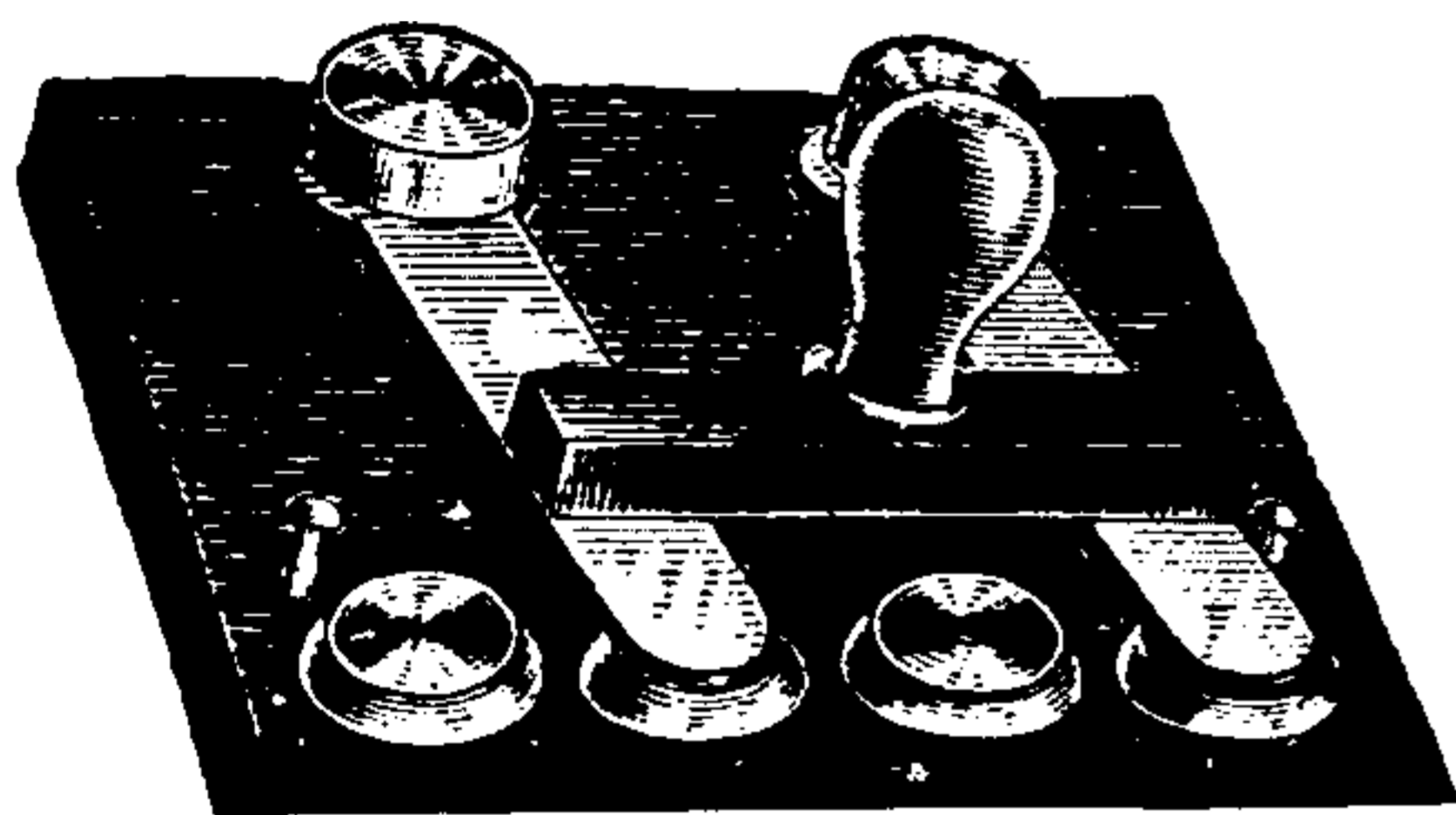

Fig. 523. Pole-Changing Switch.

If the two outer contacts are connected to the same pole as the source, as, for example, the positive, and the two intermediate contacts are connected to the other pole, or to the negative, then in the position shown in the cut, the current will flow through any receptive device connected with the switch, in one direction, but if the switch is moved to the left, it will flow in the opposite direction.

Switch, Removable Key — —A plug switch. (See *Switch, Plug.*)

Switch, Reversing — —A switch for reversing the direction of the battery current through a galvanometer.

A simple reversing switch consists of four insulated brass segments mounted on a plate of ebonite and furnished with openings between them for plug connections.

The battery terminals are connected to two diagonally opposite segments, as B, and D, Fig. 524, and the leading wires of the galvanometer,

or other instrument, to the other segments, as C and A. If, now, the plugs are placed between B and C, and A and D, the battery current flows in one direction. If, however, the plugs are

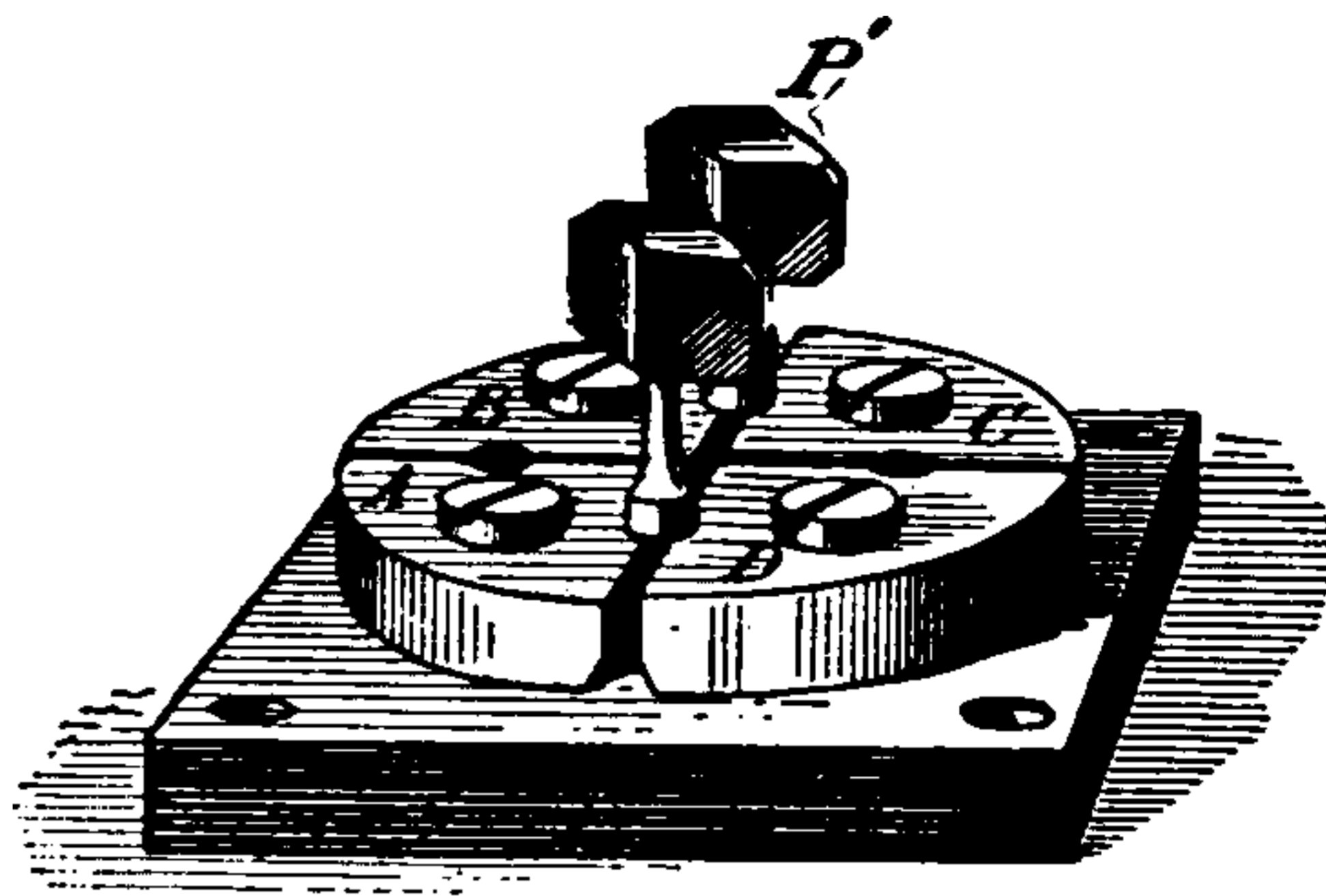

Fig. 524. Reversing Switch.

placed between A and B, and C and D, the battery current will flow in the opposite direction.

The battery current is cut off if one plug is removed. In practice, however, it is preferable to remove both plugs, so as to avoid any current from want of sufficient insulation.

Switch, Snap — —A switch in which the transfer of the contact points from one position to another is accomplished by means of a quick motion obtained by the operation of a spring.

The object of the snap switch is to prevent the switch resting in any half way position, and thus preventing the establishing of an arc.

Switch, Telephone, Automatic — —A device for automatically transferring the connection of the main line from the call bell to the telephone circuit.

In most telephone circuits, as now arranged, the automatic switch, besides transferring the main line from the call bell to the telephone circuit,

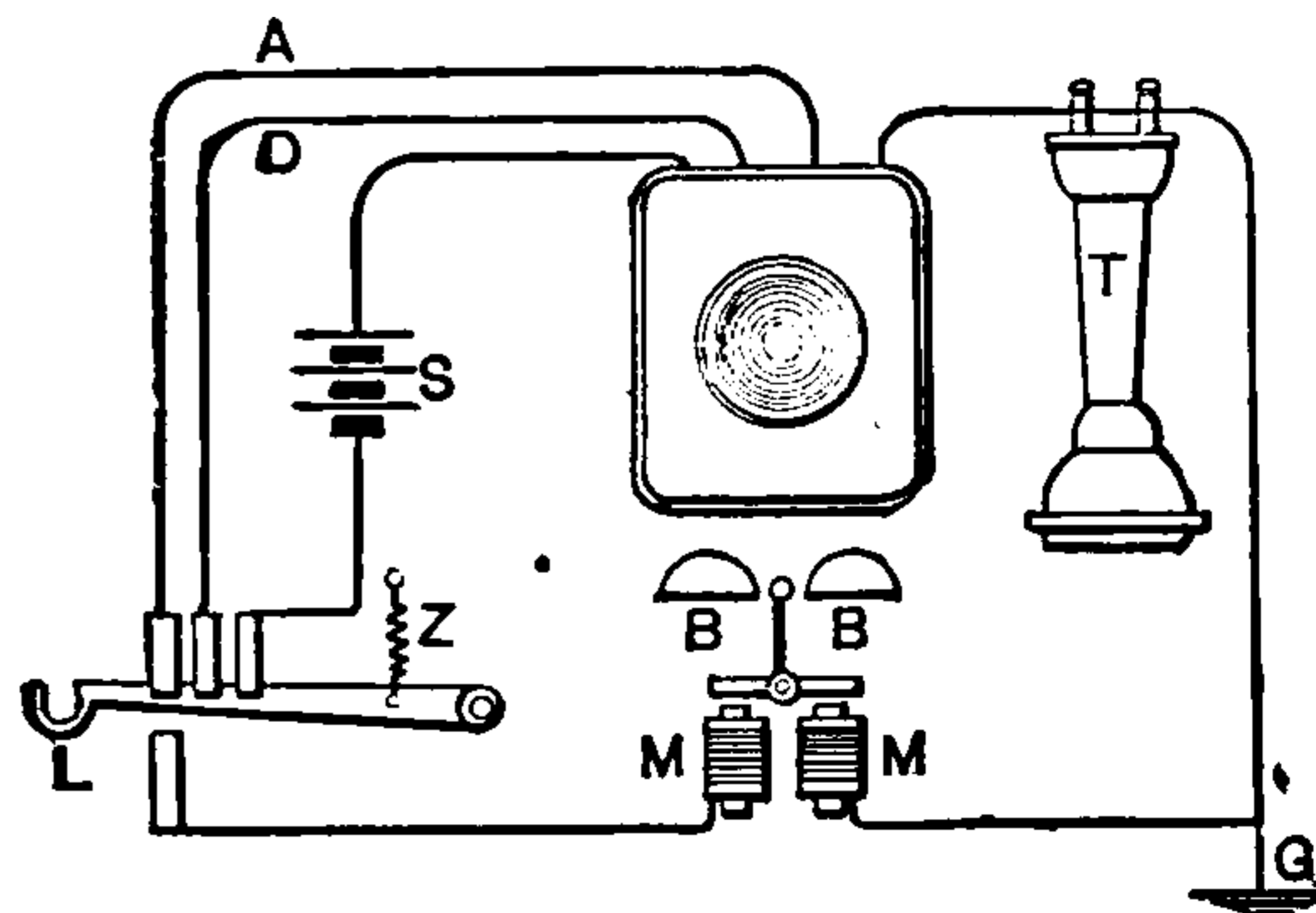

Fig. 525. Automatic Telephone Switch.

closes the local battery circuit of the transmitter on the removal of the telephone from its supporting hook.

THIS PAGE IS LOCKED TO FREE MEMBERS

Purchase full membership to immediately unlock this page



HISTORY

Tens of thousands of important historical sources, many previously unobtainable, are now available for the first time with a Forgotten Books Full Membership.

Unlimited Access
\$8.99/month

Continue

*Fair usage policy applies

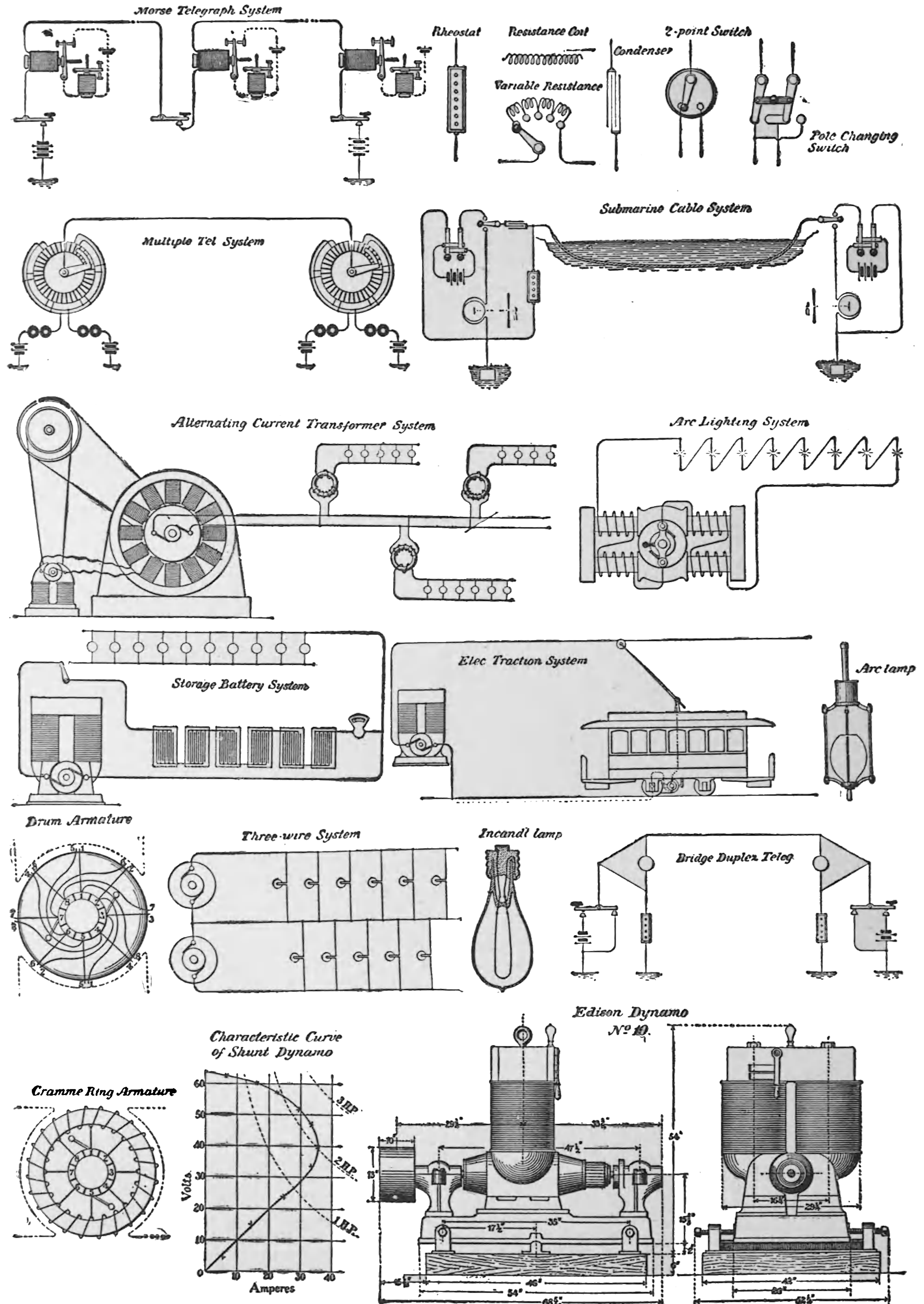

Fig. 526. Crocker's Chart of Standard Electric Symbols and Diagrams.

Symmetrical Induction of Armature.—(See *Induction, Symmetrical, of Armature.*)

Symmetrical Magnetic Field.—(See *Field, Magnetic, Symmetrical.*)

Sympathetic Electrical Vibrations.—(See *Vibrations, Sympathetic Electrical.*)

Sympathetic Vibrations.—(See *Vibrations, Sympathetic.*)

Synchronism.—The simultaneous occurrence of any two events.

A rotating cylinder, or the movement of an index or trailing arm, is brought into synchronism with another rotating cylinder or another index or trailing arm, not only when the two are moving with exactly the same speed, but when in addition they *are simultaneously moving over similar portions of their respective paths.*

In the Breguet *Step-by-Step* or *Dial Telegraph* (See *Telegraphy, Step-by-Step*), the movements of the needle on the indicator are synchronized with the movements of the needle on the *manipulator.*

In systems of *Fac-Simile Telegraphy* the movements of the transmitting apparatus are synchronized with those of the receiving apparatus.

In Delany's *Synchronous Multiplex Telegraph System*, the trailing arm that moves over a circular table of contacts at the transmitting end, is accurately synchronized with a similar trailing arm moving over a similar table at the receiving end.

Delany, who was the first to obtain rigorous synchronism at the two ends of a telegraphic line hundreds of miles in length, accomplishes this by the use of La Cour's phonic wheel, through the agency of correcting electric impulses, automatically sent in either direction over the main line, when one trailing arm gets a short distance in advance or back of the other.

With alternating current dynamos, where one dynamo is feeding incandescent lamps connected to the leads in multiple, and it is desired to couple another alternating current dynamo in parallel with the first, it is necessary to obtain a complete synchronism of the two dynamos before coupling them, since otherwise the lamps will show variations in their light, and the machine may suffer.

Synchronizable.—Capable of being synchronized. (See *Synchronism.*)

Synchronize.—To cause to occur or act simultaneously. (See *Synchronism.*)

Synchronized.—Caused to occur or act simultaneously. (See *Synchronism.*)

Synchronizing Dynamo-Electric Machine.—(See *Machine, Dynamo-Electric, Synchronizing.*)

Synchronous Multiplex Telegraphy.—(See *Telegraphy, Synchronous Multiplex, Delany's System.*)

System, Astatic — — An astatic combination of magnets.

An astatic needle consists of an astatic system of two magnetic needles. The needles are rigidly fixed together with their opposite poles facing each other. The two needles form an astatic pair or couple. (See *Needle, Astatic.*)

System, Block, for Railways — — (See *Railroads, Block System for.*)

System, Centimetre - Gramme - Second — — (See *Units, Centimetre - Gramme - Second.*)

System, Continuous Underground, of Motive Power for Electric Railroads — — (See *Railroads, Electric, Continuous Underground System of Motive Power for.*)

System, Dependent, of Motive Power for Electric Railroads — — (See *Railroads, Electric, Dependent System of Motive Power for.*)

System, Independent, of Motive Power for Railroads — — (See *Railroads, Electric, Independent System of Motive Power for.*)

System, Multiphase — — A term frequently applied to a system of rotating electric currents. (See *Current, Rotating.*)

System of Distribution of Electricity by Commutating Transformers.—(See *Electricity, Distribution of, by Commutating Transformers.*)

System of Distribution of Electricity by Condensers.—(See *Electricity, Distribution of, by Alternating Currents by Means of Condensers. Electricity, Distribution of, by Continuous Current by Means of Condensers.*)

System of Distribution of Electricity by Means of Alternating Currents.—(See *Elec-*

tricity, Distribution of, by Alternating Currents.)

System of Distribution of Electricity by Motor Generators.—(See *Electricity, Distribution of, by Motor Generators.*)

System, Three-Wire — — A system of electric distribution for lamps or other translating devices connected in multiple, in which three wires are used instead of the two usually employed.

In the three-wire system two dynamos are generally employed, which are connected with one another in series.

The three conductors are connected as shown in Fig. 527, the central conductor to the junction of the two dynamos and the two others to their free terminals, and the difference of potential between the central and the two outer conductors is maintained the same. The lamps, or other electro-receptive devices, are placed in multiple-arc between either branch, and so distributed that the current in each branch is the same. When such balance is established no current flows through the central or *neutral* conductor. But when that balance is disturbed, the surplus current in one branch is taken up by the central conductor.

The three-wire system effects considerable

economy in the weight of wire required. Since in the multiple-series-connection of electro-receptive devices whatever difference of potential is impressed on the mains is fed to each device, no higher difference of potential can be employed on the mains than that which the devices are capable of taking. In the case of an incandescent lamp, if such difference be exceeded, too strong a current is passed through the lamps with a consequent decrease in their life.

In the three-wire system of distribution a higher difference of potential can be maintained on the mains than is required for any lamp placed in

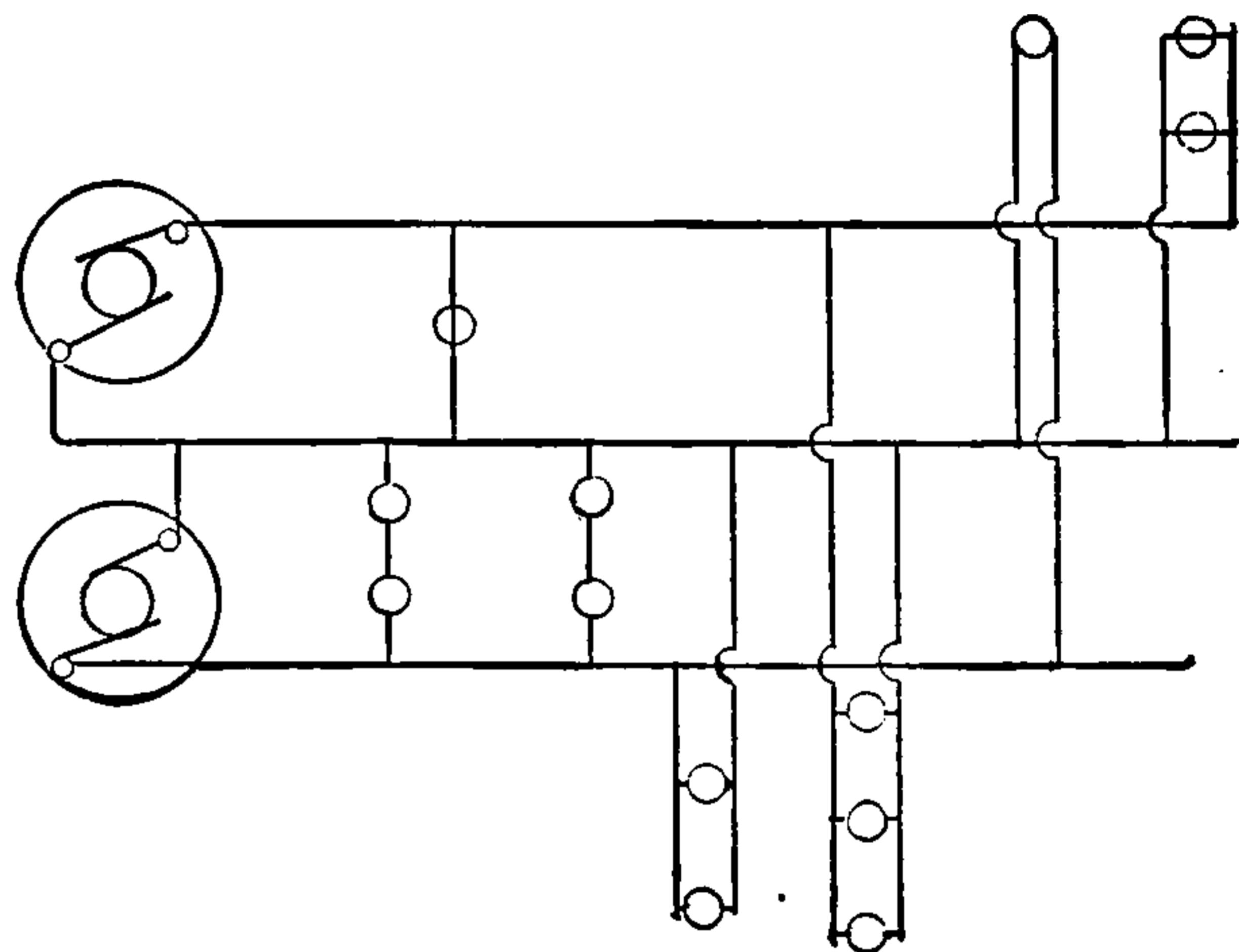

Fig. 527. Three-Wire System

connection therewith, and in this manner a considerable saving is effected in the cost of the leads.

T

T.—A symbol used for time.

T-shaped Spark.—(See *Spark, T-Shaped.*)

Table, Quadruplex, A-Side of — — That side of a quadruplex system which is worked by means of reverse currents. (See *Telegraphy, Quadruplex.*)

Table, Quadruplex, B-Side of — — That side of a quadruplex system which is worked by means of strengthened currents. (See *Telegraphy, Quadruplex.*)

Tables of Conducting Powers.—(See *Powers, Conducting, for Electricity. Resistance, Electric.*)

Tachograph.—An apparatus for recording the number of revolutions per minute of a shaft or machine.

Tachometer.—An apparatus for indicating at any moment on a revolving dial the exact number of revolutions per minute of a shaft or machine.

A tachometer is sometimes called a speed indicator.

Tachyphore.—A term proposed by Wurtz for a system of electric transportation, in which a carriage, formed of magnetic material, is propelled by the sucking action of solenoids placed along the track and energized in succession during the passage of the car.

This is generally called the portelectric system. (See *Portelectric.*)

Tail Light.—(See *Light, Tail.*)

THIS PAGE IS LOCKED TO FREE MEMBERS

Purchase full membership to immediately unlock this page

Know Your Bible

Forgotten Books' Full Membership provides unlimited access to more than 28,000 volumes of Christian literature for \$8.99/month

HOLY BIBLE

Continue

*Fair use policy applies

Teaser.—An electric current teaser. (See *Teaser, Electric Current.*)

Teaser, Electric Current — —A coil of fine wire placed on the field magnets of a dynamo-electric machine, underneath the series coil wound thereon, and connected as a shunt across the main circuit.

The name teaser was applied by Brush to the coil of fine wire used as above described to maintain constant electromotive force under variations of load.

Technics, Electro — —The science which treats of the physical applications of electricity and the general principles applying thereto.

Tee, Lead — —A tee-shaped lead tube provided for the purpose of taking a branch joint from a main cable to a service line.

Tee, Split-Lead — —A tee-shaped lead tube that is split for readily covering a joint at a loop in a cable.

Tel-Autogram.—The recorded message obtained by means of a tel-autograph. (See *Tel-Autograph.*)

Tel-Autograph.—A telegraphic system for the fac-simile reproduction of handwriting.

Teleautograph.—An orthography sometimes employed for tel-autograph. (See *Tel-Autograph.*)

Tele-Barometer, Electric — —An electric recording barometer for indicating and recording barometric or other pressures at a distance.

Telegrapher's Cramp.—(See *Cramp, Telegrapher's.*)

Telegraphic.—Pertaining to telegraphy.

Telegraphic Alarm.—(See *Alarm, Telegraphic.*)

Telegraphic Alphabet.—(See *Alphabet, Telegraphic.*)

Telegraphic Alphabet, Continental Code — —(See *Alphabet, Telegraphic: International Code.*)

Telegraphic Alphabet, Morse's — —(See *Alphabet, Telegraphic: Morse's.*)

Telegraphic Arm.—(See *Arm, Telegraphic.*)

Telegraphic Bracket.—(See *Bracket, Telegraphic.*)

Telegraphic Cable.—(See *Cable, Telegraphic.*)

Telegraphic Code.—(See *Code, Telegraphic.*)

Telegraphic Earth-Circuit.—(See *Circuit, Earth, Telegraphic.*)

Telegraphic Embosser.—(See *Embosser, Telegraphic.*)

Telegraphic Fixtures.—(See *Fixtures, Telegraphic.*)

Telegraphic Fixtures, House-Top — —(See *Fixtures, Telegraphic House-Top.*)

Telegraphic Ground Circuit.—(See *Circuit, Ground, Telegraphic.*)

Telegraphic Joints.—(See *Joint, Telegraphic or Telephonic.*)

Telegraphic Key.—(See *Key, Telegraphic.*)

Telegraphic Line Circuit.—(See *Circuit, Line, Telegraphic.*)

Telegraphic Needle.—(See *Needle, Telegraphic.*)

Telegraphic Paper Winder.—(See *Winders, Telegraphic Paper.*)

Telegraphic Pocket Relay.—(See *Relay, Pocket Telegraphic.*)

Telegraphic Register.—(See *Register, Telegraphic.*)

Telegraphic Switch Board.—(See *Board, Switch, Telegraphic.*)

Telegraphic Translator.—(See *Translator, Telegraphic.*)

Telegraphically. — In a telegraphic manner.

Telegraphing.—Sending a communication by means of telegraphy.

Telegraphy, Acoustic — —A non-recording system of telegraphic communication, in which the dots and dashes of the Morse system, or the deflections of the needle in the needle system, are replaced by sounds

that follow one another at intervals, that represent the dots and dashes, or the deflections of the needle, and thereby the letters of the alphabet.

Morse invented a *souder*, for this purpose, which is used very generally. (See *Souder, Morse Telegraphic.*)

Steinheil and Bright each invented acoustic systems of telegraphy in which electro-magnetic bells are used.

For details of the apparatus and system see *Telegraphy, Morse System of.*

Telegraphy, American System of — — A term sometimes applied to the Morse system of telegraphy. (See *Telegraphy, Morse System of.*)

Telegraphy and Telephony, Simultaneous, Over a Single Wire — — Any system for simultaneous transmission of telegraphic and telephonic messages over a single wire.

These systems are based, in general, on the fact that a gradual make-and-break in a telephone circuit fails to appreciably affect a telephone diaphragm. By the use of gradulators the makes and breaks required for the transmission of the telegraphic dispatch are effected so gradually that they fail to appreciably influence the telephone diaphragm, and thus permit simultaneous telegraphic and telephonic transmission over a single wire. (See *Gradulators.*)

Telegraphy, Autographic — — A name sometimes applied to fac-simile telegraphy. (See *Telegraphy, Fac-Simile.*)

Telegraphy, Automatic — — A system by means of which a telegraphic message is automatically transmitted by the motion of a previously perforated fillet of paper containing perforations of the shape and order required to form the message to be transmitted.

The paper passes between two terminals of the main line, the circuit of which is completed when the terminals come into contact at the perforated parts, and is broken when separated by the unperforated parts of the paper.

In the automatic telegraph some form of registering apparatus is employed.

In the Wheatstone system, the perforations mechanically control the movements of the levers which make contacts between the line and the battery.

The advantage of automatic telegraphy arises from the fact that the rate of transmission or reception of signals does not depend on the expertness of the operators, and the messages may be perforated on the slips preparatory to transmission.

Type-printing telegraphs are often used for registering apparatus, in which case the impulses required for the transmission of the different letters are automatically sent into the line by the depression of corresponding keys on a suitably arranged key-board.

Telegraphy, Chemical — — A system by means of which the closings of the main-line-circuit, corresponding to the dots and dashes of the Morse alphabet, are recorded on a fillet of paper by the electrolytic action of the current on a chemical substance with which the paper fillet is impregnated. (See *Recorder, Chemical, Bain's.*)

Telegraphy, Contraplex — — Duplex telegraphy in which transmissions are simultaneously made from opposite ends of the line.

When the transmissions are simultaneously made from the *same* end of the line, the system is called diplex telegraphy. (See *Telegraphy, Diplex.*)

Telegraphy, Dial — — A system of telegraphy in which the messages are received by the motions of a needle over a dial plate. (See *Telegraphy, Step-by-Step.*)

Telegraphy, Diplex — — A method of simultaneously sending two messages in the same direction over a single wire.

Diplex telegraphy is to be distinguished from duplex telegraphy, where two messages are simultaneously transmitted over a single wire in *opposite* directions.

Telegraphy, Double-Needle — — A system of needle telegraphy in which two separate and independently operated needles are employed.

This system differs from the single-needle system only in the fact that two needles, entirely independent of each other, are mounted side by side, on the same dial, so as to permit their simultaneous operation by the right and left hand of the

operator. Each needle has therefore a separate wire.

The increase in speed of signaling thus obtained is not, however, sufficiently great to balance the increased expense of construction. Single-needle instruments, therefore, are preferred to those with two needles.

Telegraphy, Duplex, Bridge Method of — — — A system whereby two telegraphic messages can be simultaneously transmitted over a single wire in opposite directions.

Various duplex telegraphs have been devised.

The *Bridge Duplex* is shown in Fig. 528. The receiving relay is placed in the cross wire of a *Wheatstone bridge*. (See *Bridge, Electric*.)

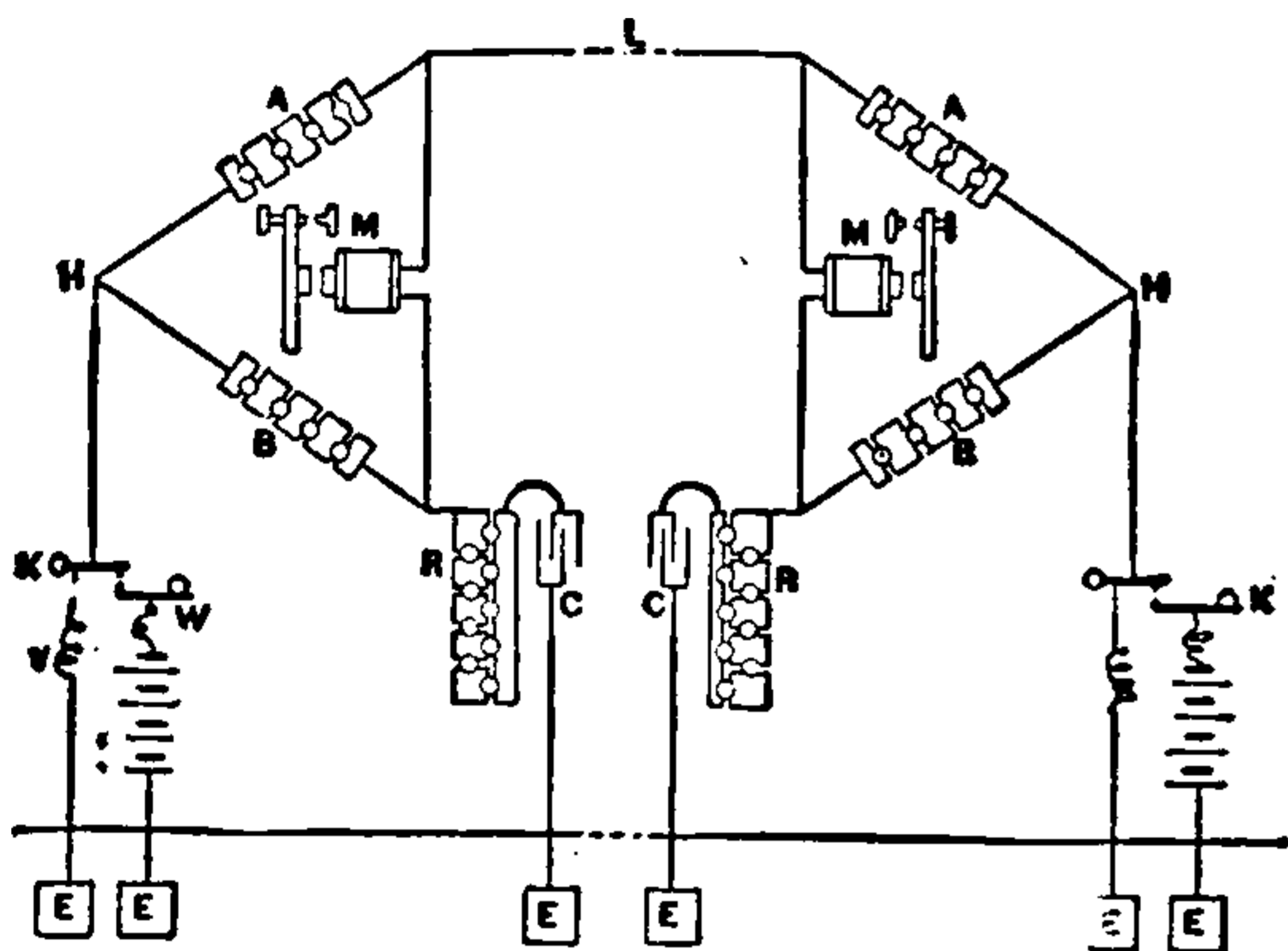

Fig. 528. Duplex Telegraphy, Bridge Method.

When the ends of this cross wire are at the same potential, which will occur when the resistances in the four arms are proportionately equal, no current passes.

The battery is connected through the transmitter *K*, which is arranged so that the battery contact is made before the connection of the line to earth is broken, to *H*, where the circuits branch to form the arms of the bridge. Adjustable resistances *A*, *B*, are placed in the two arms of the bridge.

The line wire *L*, connected as shown, forms the third arm, and a *rheostat* or other adjustable resistance *R*, connected to a condenser *C*, as shown, forms the fourth arm. (See *Rheostat*.)

The relay *M*, is placed in the cross wire of the bridge thus formed. Small resistances *V*, and *W*, are placed in the circuit of the battery to prevent injurious short circuiting.

A similar disposition of apparatus is provided at the other end of the line. If, now, the four resistances at one end are suitably adjusted, the relay will not respond to the outgoing current; but, since an earth circuit is employed, it will

respond to the incoming current. The relay at either end, therefore, will only respond to signals from the other end. The operator may thus signal the distant station while, at the same time, his relay, not being affected by his sending, is in readiness to receive signals from the other end.

Telegraphy, Duplex, Differential Method of — — — A system of duplex telegraphy in which the coils of the receiving and transmitting instruments are differentially wound.

A differential system of duplex telegraphy is shown in Fig. 529. The coils of the receiving and transmitting galvanometers at *A* and *B*, are differentially wound. One of the coils of *A*, is connected to that of *B*, through the line, as shown; and the other, in each to the rheostats at *R*, and *R'*. As these coils are differentially wound, when equal currents flow in opposite directions through either of the instruments at *A*, *B*, no deflection of the galvanometer occurs.

The battery at *A*, has its copper terminal, and that at *B*, its zinc terminal, connected to earth. When the keys at *A* and *B*, are depressed simultaneously, the currents sent into the line flow in the same direction and strengthen each other.

Suppose now that only the key at *A*, be depressed. The current divides equally between rheostat and line, the resistance $e a b b' a' e'$, r' , being made equal to the resistance $e c d R$.

This current passes through both coils of the instrument at *A*, and produces no deflection of the needle; but since it only passes through one coil at *B*, it deflects the galvanometer needle, and produces a signal.

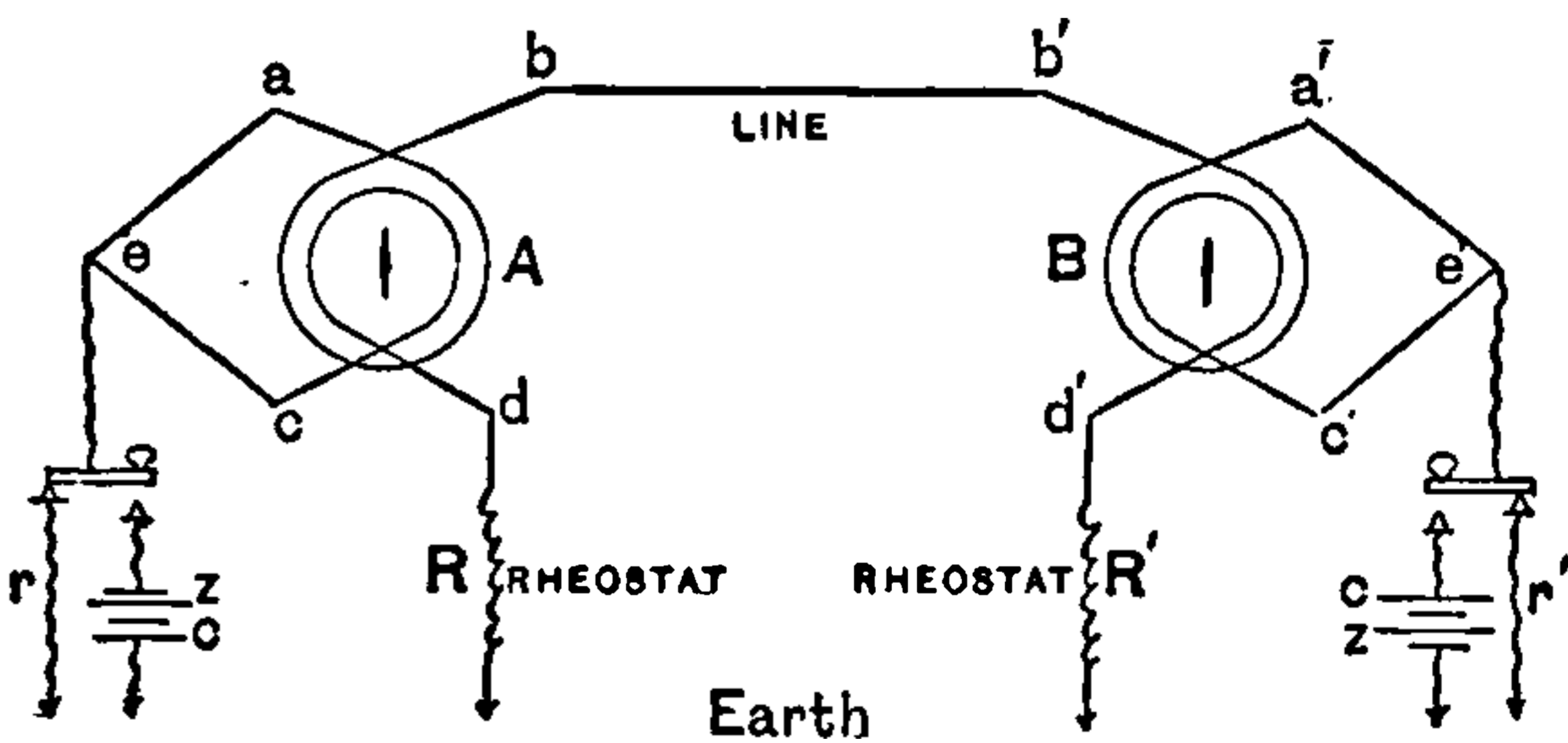

Fig. 529. Duplex Telegraphy, Differential Method.

If the keys at *A*, and *B*, are simultaneously closed, the effect on the line is to add the current of the two batteries, but each rheostat circuit is traversed by its own battery current only.

The line-connected coils of the galvanometer have, therefore, the stronger currents flowing through them, and the needles of both are moved, just as if, with a single battery discharging into the line, its resistance had been decreased. Each

THIS PAGE IS LOCKED TO FREE MEMBERS

Purchase full membership to immediately unlock this page



HISTORY

Tens of thousands of important historical sources, many previously unobtainable, are now available for the first time with a Forgotten Books Full Membership.

Unlimited Access
\$8.99/month

Continue

*Fair usage policy applies

circuit of batteries connected with the main line at the sending end of the line.

The composite tone thus formed, is separated into its component tones by receiving electromagnets called *harmonic receivers*; the armature of each of which consists of a steel ribbon or plate tuned to one of the separate notes sent into the line. As the complex or undulatory current passes through the coils of each harmonic receiver, that note only affects the particular armature that vibrates in unison with its ribbon or reed. The operator, therefore, at this receiver is in communication only with the operator at the key of the circuit that is sending this particular note into the line. The same is true of the other receivers.

The Morse alphabet is used in this system, the dots and dashes being received as musical tones. In practice it was found that there was no difficulty in each operator recognizing the particular sound of his own instrument in receiving, although many instruments were in the same room.

By a subsequent invention the signals received are converted into the regular Morse characters by means of an ingenious device.

Telegraphy, Induction — —A system for telegraphing by induction between moving trains and fixed stations on a railroad, by means of impulses transmitted by induction between the car and a wire parallel with the track.

Two systems of inductive telegraphy are in actual use, viz.,

(1.) The *Static Induction* system of W. W. Smith and Edison, and

(2.) The *Current or Dynamic Induction* system of Willoughby Smith and Lucius J. Phelps.

In the System of Static Induction, one of the condensing surfaces which receives or produces the charge, consists of a wire placed on the road so as to come as near the top of the cars of the moving train as possible. The other condensing surface is composed of the metal roofs of the moving cars.

Each condensing surface is connected to suitable instruments and batteries, and to the earth; the line wire at the fixed station being connected to earth through a ground plate, and the metal roof of the cars to earth through the wheels and track.

Under these circumstances variations in the charge of either of the condensing surfaces pro-

duce inductive impulses that are received by the other surface as telegraphic signals.

The Morse alphabet is employed, but in place of the ordinary receiver or sounder, a telephone is used.

In the System of Current Induction, the line wire is placed near the track, so as to be parallel with a coil of insulated wire placed on the side of the car, and which receives the inductive impulses. The coil of wire on the train is connected with instruments and batteries, and forms a metallic circuit. The line wire is also connected with suitable batteries and receiving and transmitting instruments.

An induction coil is generally employed, since the greater and more rapidly varying difference of potential of its secondary wire renders it better suited for producing effects of induction. A telephone is employed as a receiver, as in the system of static induction. The metallic car roof and the lower truss rods have been successfully used as the secondary conductor of the induction coil.

The automatic make-and break used for operating the induction coil, causes the Morse characters employed in this system to be received in the receiving telephone as shrill buzzing sounds.

The receiving telephones used on the trains have a resistance of about 1,000 ohms.

Telegraphy, Induction, Current System of — —A system of induction telegraphy depending on current induction between a fixed circuit along the road, and a parallel circuit on the moving train.

The circuit on the train generally consists of a coil of wire. (See *Telegraphy, Induction*.)

Telegraphy, Induction, Dynamic System of — —A term sometimes used in place of a system of telegraphic current induction. (See *Telegraphy, Induction*.)

Telegraphy, Induction, Static System of — —A system of inductive telegraphy depending on the static induction between the sending and receiving instrument.

A fixed wire placed along the road so as to come near another wire or metallic surface on the moving train, imparts to the latter a static charge, which is utilized for the transmission of dispatches. The metal roof of the car is generally used for the condensing surface receiving the charge. (See *Telegraphy, Induction*.)

Telegraphy, Machine — — A term sometimes applied instead of automatic telegraphy. (See *Telegraphy, Automatic.*)

A system of telegraphy is properly called machine telegraphy when both the transmission and the receiving of the telegraphic messages are accomplished by machine, instead of by the hand, as usual.

Telegraphy, Morse System of — — A system of telegraphy in which makes and breaks occurring at intervals corresponding to the dots and dashes of the Morse alphabet are received by an electro-magnetic sounder or receiver.

A metallic lever A, Fig. 531, is supported on a pivot at G, between two set screws D, D, so as to have a slight movement in a vertical plane. This motion is limited in one direction by a stop at C, called the *anvil* or *front contact*, and in the other direction by a set screw F, which constitutes its *back stop*.

The front stop C, is provided with a platinum contact or stud, which may be brought into contact with, or separated from, a similar stud placed directly opposite it. These contacts are connected to the ends of the circuit so that on

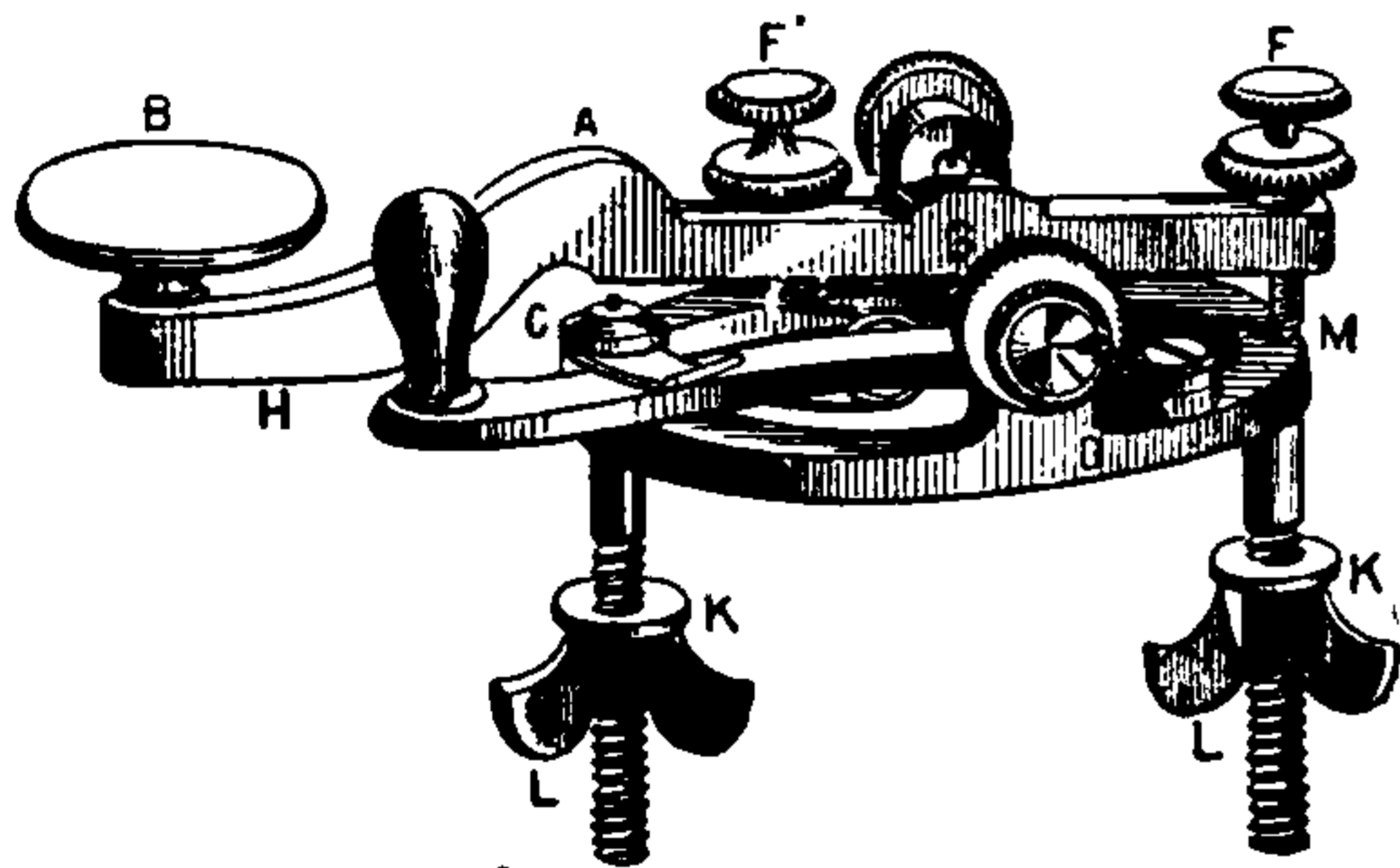

Fig. 531. Telegraphic Key.

the movements of the key, by the hand of the operator placed on the insulated head B, the line is closed and broken in accordance with the dots and dashes of the Morse alphabet. A spring, the pressure of which is regulated by the screw F', is provided for the upward movement of the key. A switch H, is provided for closing the line when the key is not in use.

The system generally used in the United States is known as the "Closed-Circuit System," the battery being connected to line whether the line is in use or not. This battery is generally placed at both ends of the line.

In Europe, the "Open-Circuit System" is gen-

erally used. Alternating currents and polarized relays are employed. One pole is connected to the line at the front of the key, and the other pole to the back of the key. When the line is not in use, it is connected to earth at both ends by switches conveniently placed for the operators. With this system, intermediate stations must each have a main battery, while in the closed-circuit system, the terminal batteries answer for all intermediate offices, which in some cases amount to as many as fifty.

In the Morse system, each station is provided with a key, relay, sounder or register, and local battery. The closed-circuit, connecting one station with another, being broken by the opening of the switch H, or the working of the key, so as to open and close its contacts, the armature of the relay opens or closes the circuit of the local battery and operates the sounder or registering apparatus connected therewith. (See *Sounder, Morse Telegraphic Apparatus, Registering, Telegraphic.*)

Telegraphy, Multiplex — — A system of telegraphy for the simultaneous transmission of more than four separate messages over a single wire. (See *Telegraphy, Synchronous-Multiplex, Delany's System.*)

Telegraphy, Needle System of — — A system of telegraphy in which signals are transmitted by means of the movements of needles under the influence of the electric current. (See *Telegraphy, Single-Needle.*)

Telegraphy, Phonoplex — — A system of telegraphic transmission in which pulsatory currents, superposed on the ordinary Morse currents, actuate a modified telephonic receiver, and thus permit the simultaneous transmission of several separate messages over a single wire without interference.

Telegraphy, Printing — — A system of telegraphy in which the messages received are printed on a paper fillet.

In Callahan's Printing Telegraph, two type wheels are employed, one of which carries letter type and the other numerals on its circumference. These *printing wheels* are placed alongside of each other, as shown in Fig. 532, but on separate and independent axes.

The type wheels are moved by a step-by-step device. The impulses necessary to bring the

desired letters in position for printing are automatically sent by a circuit maker and breaker. These impulses are sent into the line by the depression of keys on a suitably arranged keyboard.

When the proper letter or numeral is reached at the receiving end, the printing wheel is stopped, and a paper fillet is pressed against its surface. The printing wheel is kept covered with ink by means of an inked roller.

The transmitting instrument is similar in its operation to the Breguet *manipulator*. Separate transmitters are used for each of the wires. (See *Telegraphy, Step-by-Step*.)

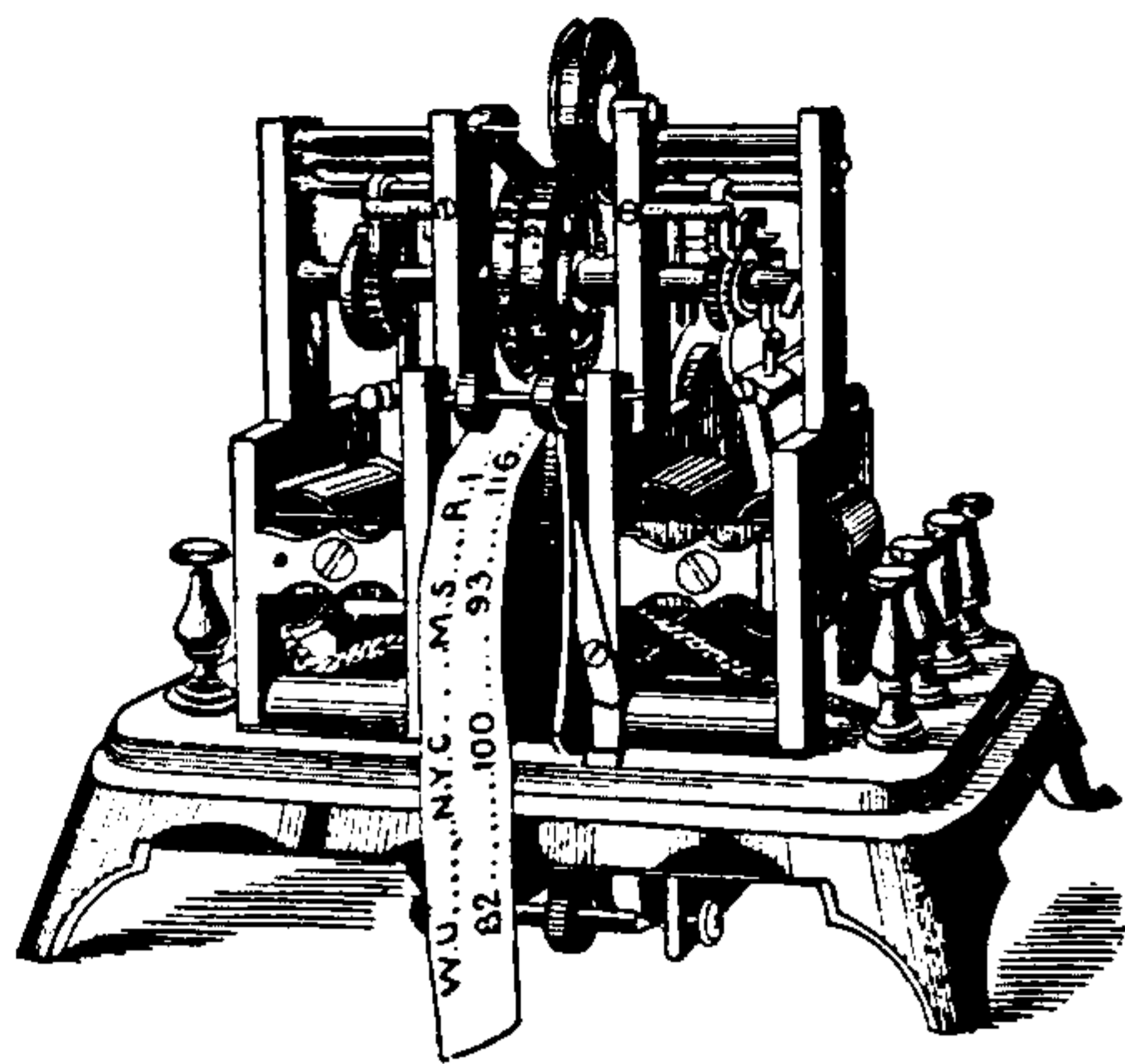

Fig. 532. Callahan's Printing Telegraph.

Telegraphy, Quadruplex — — A system for the simultaneous transmission of four messages over a single wire, two in one direction and the remaining two in the opposite direction.

Quadruplex telegraphy consists in fact of duplex telegraphy duplexed.

There are various systems of quadruplex telegraphy. The most important are the *bridge method* and the *differential method*. (See *Telegraphy, Quadruplex, Bridge Method of*. *Telegraphy, Quadruplex, Differential Method of*.)

Telegraphy, Quadruplex, Bridge Method of — — A system of quadruplex telegraphy by means of a double bridge duplex system. (See *Telegraphy, Quadruplex*.)

In the bridge method of quadruplex telegraphy, as in the differential method, changes in the polarity and strength of the current are utilized to establish a double duplex system of transmission. Fig. 533 from Prescott's "Electricity and Electric Telegraphy," from which the following description

is taken, shows the method first employed by the Western Union Telegraph Company in 1874.

A double current transmitter, or pole changer, is shown at T', with its operating key K' and local battery e'. This instrument interchanges the poles of the main battery E', when K, is depressed, and thus reverses the polarity of current on the line.

The increment transmitter T², is connected to the battery wire 12 of T', in such a way that when K', is depressed, the main battery E', is placed in series with battery E, of say twice the strength of E', thus permitting a current of three-fold the original strength to be sent into the line.

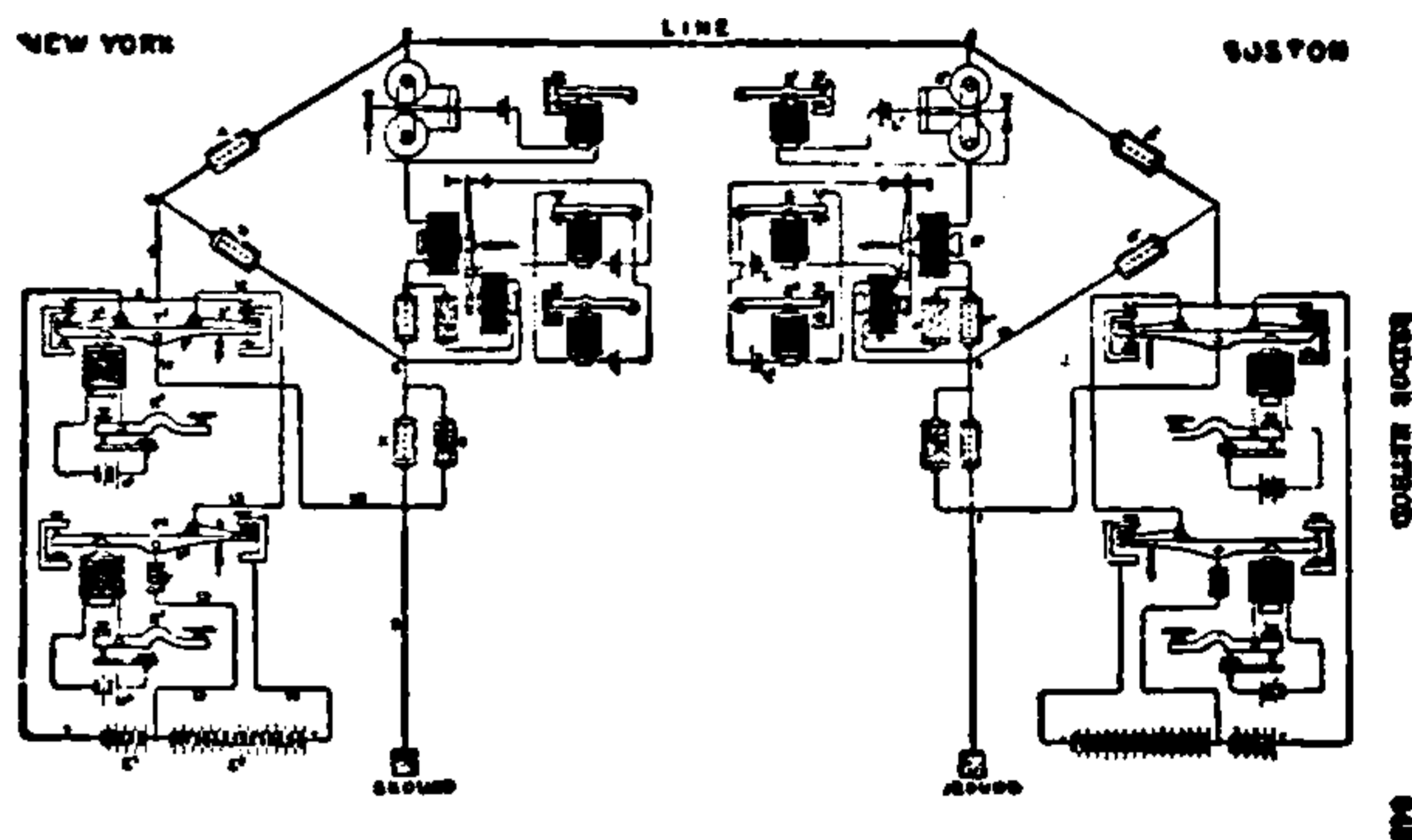

Fig. 533. Quadruplex Telegraphy, Bridge Method.

Two receiving instruments R' and R², are placed at the distant end of the line. R', is a polarized relay whose armature is deflected in one direction by positive currents, and in the opposite direction by negative currents, independently of their strength. That is to say, R', responds to changes in the direction of the currents that pass through its coils, but not to changes in their strength. (See *Relay, Polarized*.)

Relay R², is non-polarized and the movements of its soft iron armature depend on a change in the strength of the current only. That is to say, R², responds to changes in the strength of the current passing through its coils, but not to changes in their direction.

These two relays R and R², are placed in the bridge wire of a Wheatstone bridge. The entire apparatus of transmitting keys and relays is duplicated at each end of the line. Under these conditions, signals transmitted from either end of the line affect the instruments at the other end of the line, but not their own instruments, in the same manner as in the case of the *bridge duplex*. (See *Telegraphy, Duplex, Bridge Method of*.)

Telegraphy, Quadruplex, Differential

THIS PAGE IS LOCKED TO FREE MEMBERS

Purchase full membership to immediately unlock this page

Know Your Bible

Forgotten Books' Full Membership provides unlimited access to more than 28,000 volumes of Christian literature for \$8.99/month

HOLY BIBLE

Continue

*Fair use policy applies

Telegraphy, Simplex — — A system of telegraphy in which a single message only can be sent over the line.

Telegraphy, Single-Needle — — A system of telegraphy by means of which the

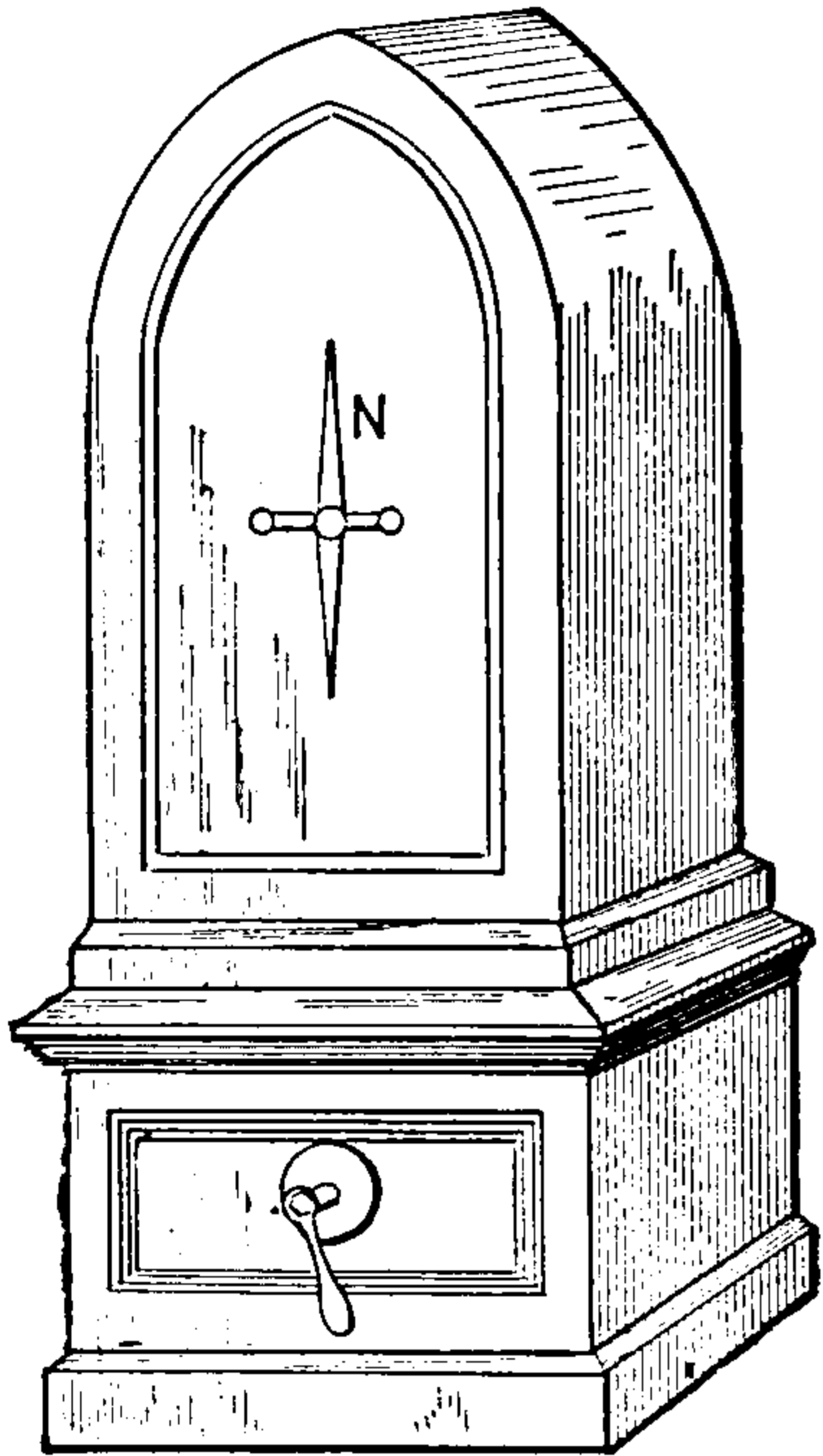

Fig. 535. Single-Needle Telegraphic Apparatus.

signals transmitted are received by observing the movements of a vertical needle over a dial.

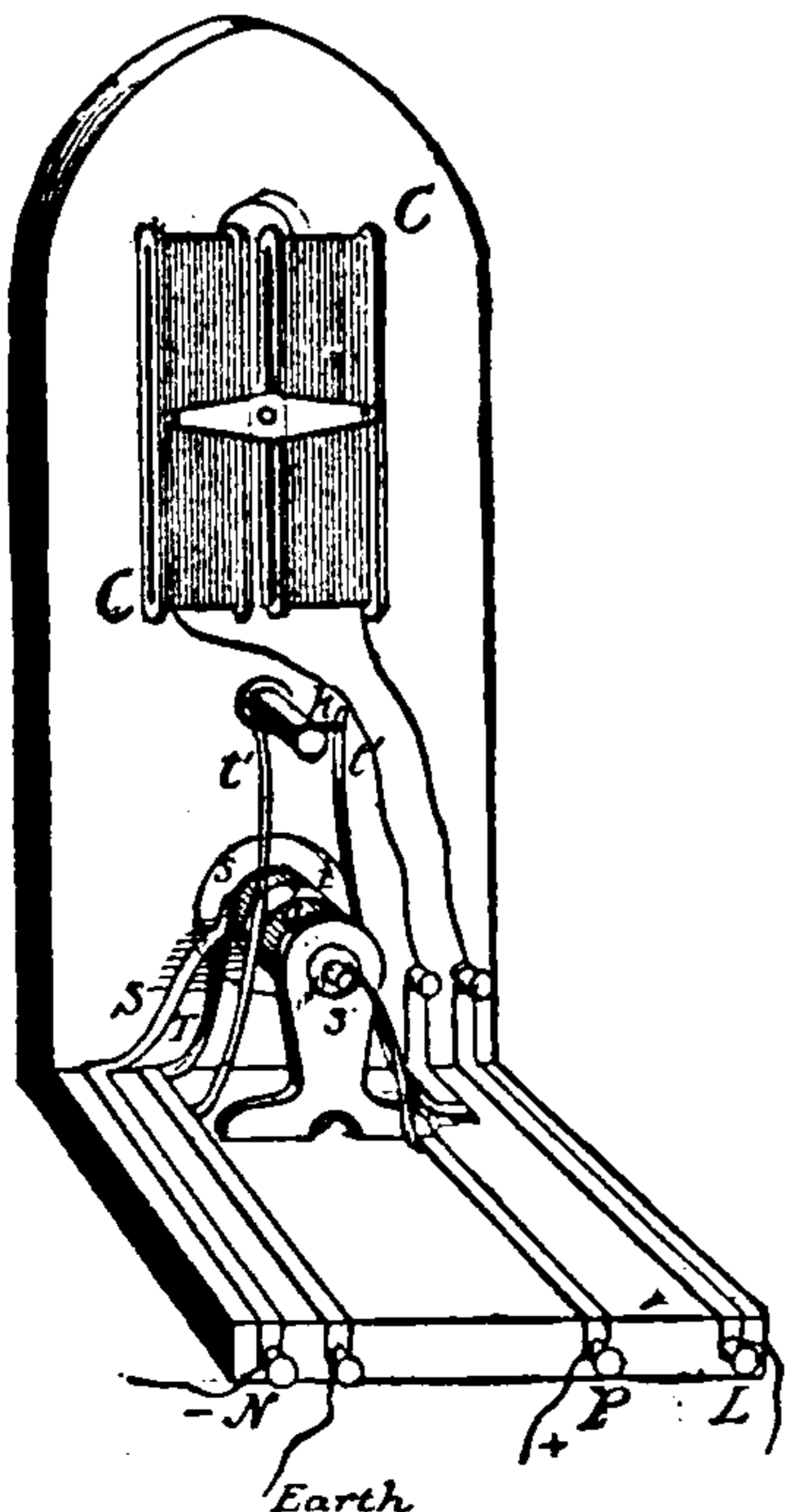

Fig. 536. Wheatstone and Cooke's Single-Needle Apparatus, Internal Arrangement.

Movements of the top of the needle to the right

of the observer represent the dashes, and movements to the left, the dots of the Morse alphabet.

The single-needle apparatus of Wheatstone and Cooke's system is shown in Figs. 535, and 536. Fig. 535, shows the external appearance, and Fig.

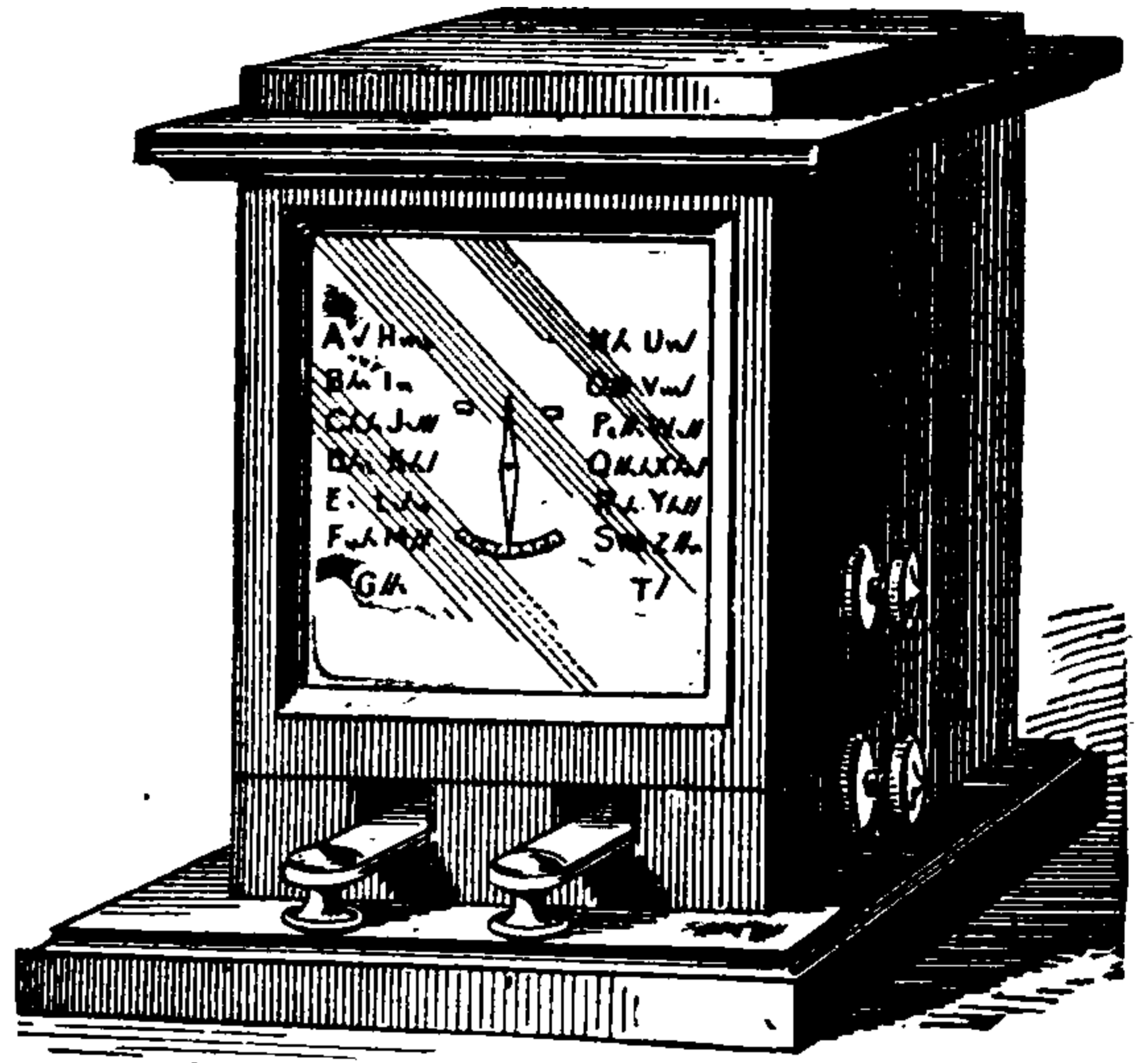

Fig. 537. Wheatstone and Cooke's Single-Needle Apparatus, External View.

536, the internal arrangements as seen from the back. An astatic needle is placed inside two coils of insulated wire C C. Only one of these needles N, is visible on the face of the receiving instrument. The current from the line enters at L, passes through the coil C C, and leaves at N.

The movements of the needle to the right or the left are obtained by changing the direction of the current in the coils C C. This is effected by working the handle when sending, and thus moving the commutator at S, S, and bringing the contact springs resting thereon into different contacts.

In the more modern form of single-needle instrument, shown in Fig. 537, a single magnetic needle N S, Fig. 538, only is placed in the coil.

This needle is rigidly attached to a light needle a, b, used only as a pointer, and is alone visible in the front of the instrument. The relative disposition of these needles is shown in Fig. 538.

The reversals of the current, required to deflect the needle to the right or left, are obtained by

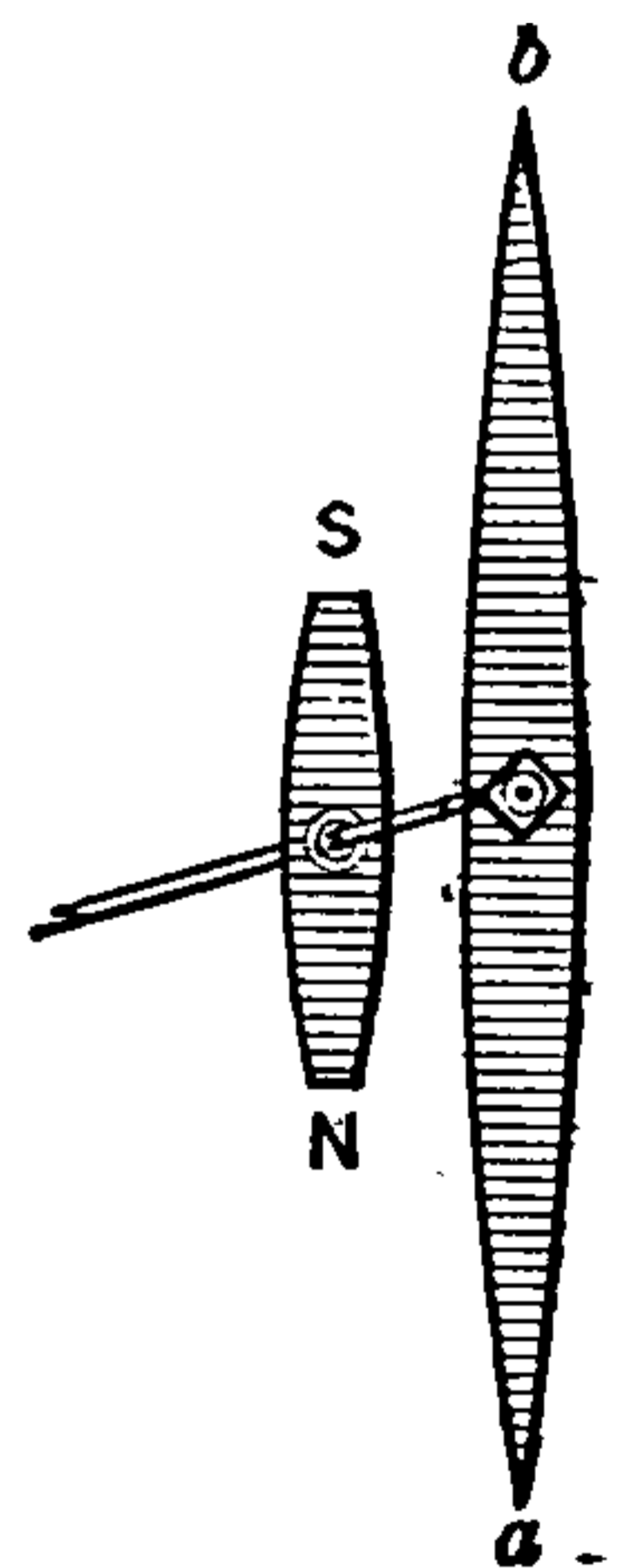
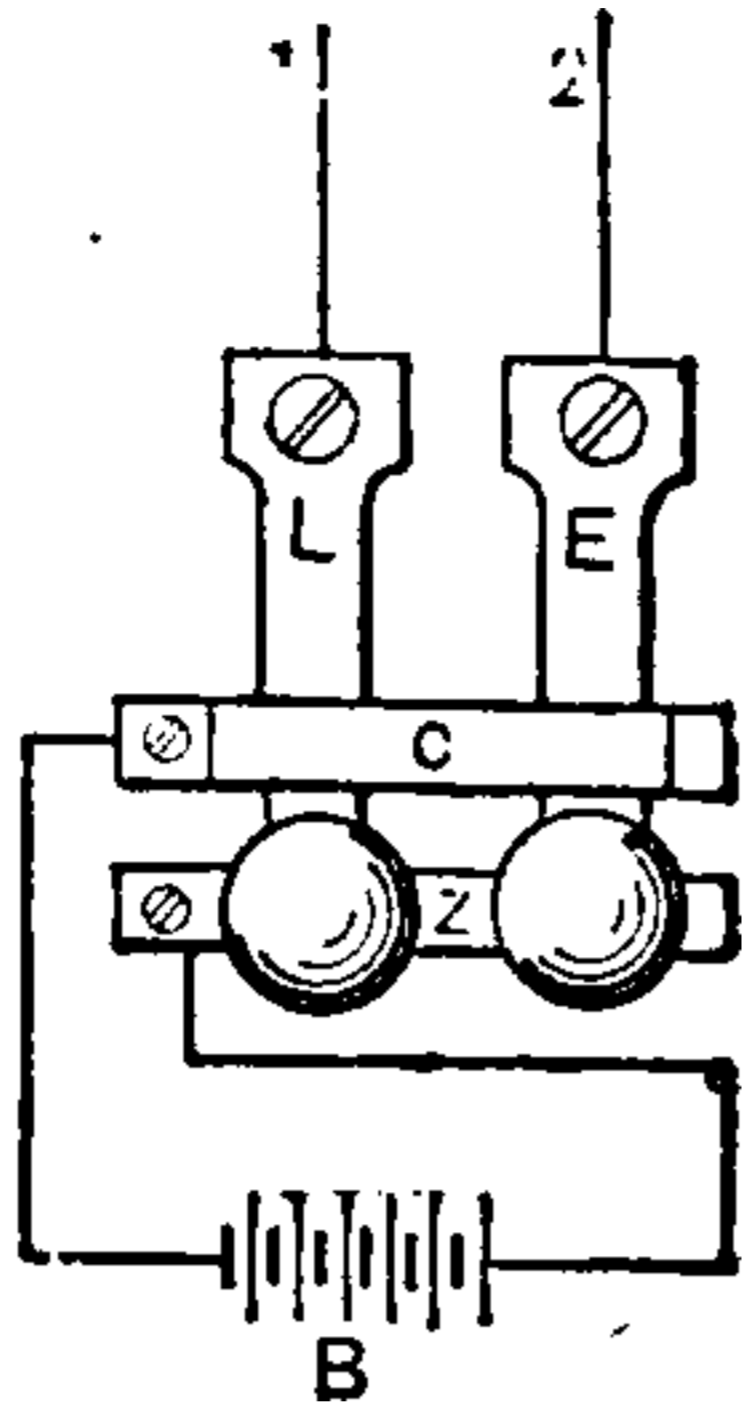

Fig. 538. Needle and Pointer.

means of a *double key* or *tapper*, shown in Fig. 539.

The levers L and E, are connected respectively to line and earth, and, when not in use, rest against C, connected with the positive side of the battery; but when depressed connect with Z, attached to the negative side of the battery.



The depression of L, therefore, sends a negative current into the line and deflects the needle, say, to the left, while the depression of E, sends a positive current into the line and deflects the needle to the right. The terms *positive Key or Tapper*, and *negative currents* are used in telegraphy to indicate currents whose *direction* is positive or negative.

Telegraphy, Speaking — — A system for the telegraphic transmission of articulate speech. (See *Telephone*.)

Telegraphy, Step-by-Step — — A system of telegraphy in which the signals are registered by the movements of a needle over a dial on which the letters of the alphabet, etc., are marked.

Dial telegraphs are especially employed for communication by those who are unable to readily read the Morse characters.

The annexed instrument, devised by Breguet, was formerly used on some of the railway systems of France.

A needle advances over a dial by a step-by-step

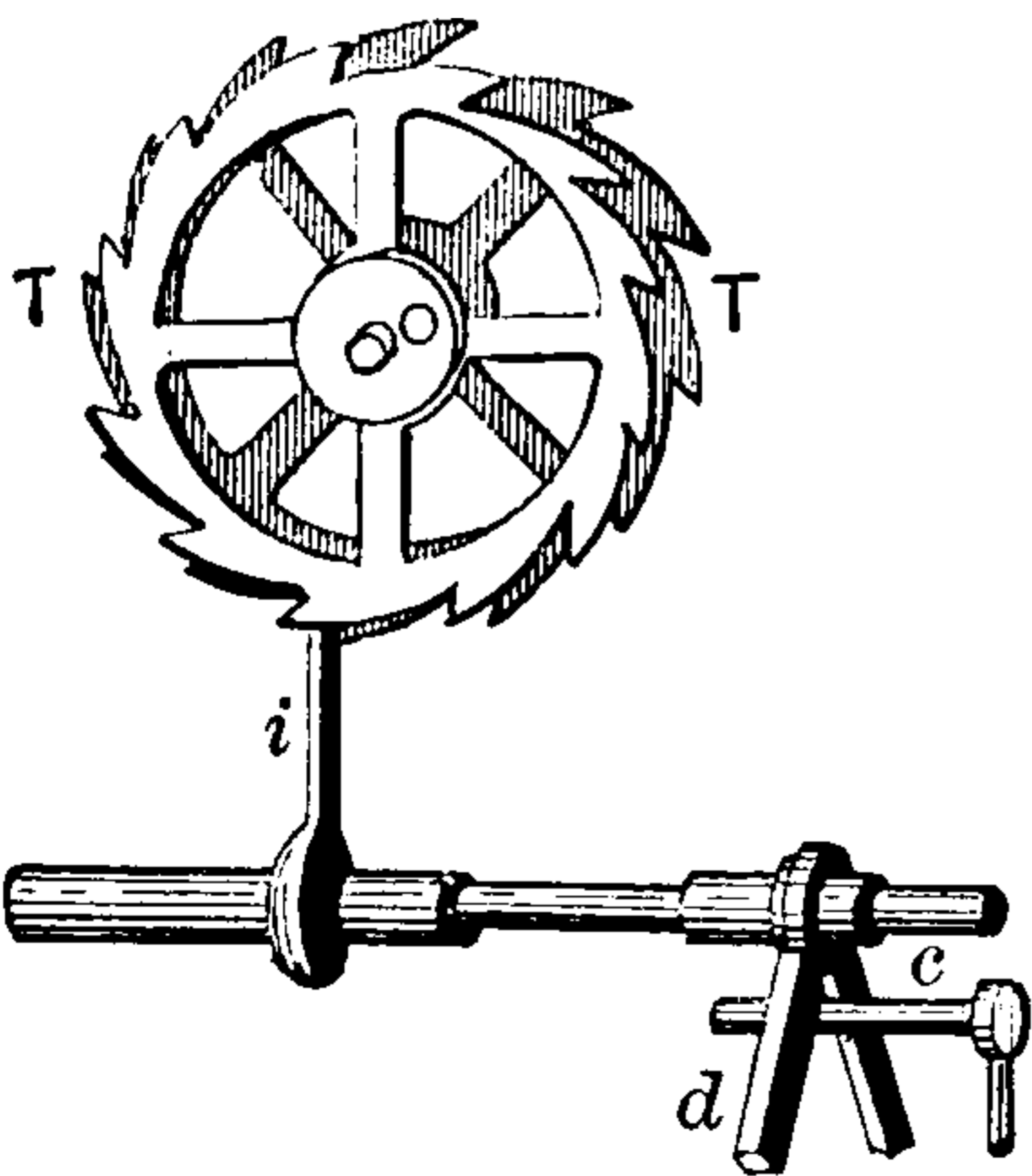

Fig. 540. Step-by-Step Wheel.

movement in one direction only. The alternate to-and-fro motions of the armature of an electromagnet are employed to impart a step-by-step motion to a peculiarly shaped toothed wheel

T, T, Fig. 540, through the action of a horizontal arm c, attached thereto, and moving between the two prongs of a fork d, vibrating on a horizontal axis to which is attached a vertical pallet i.

The receiving instrument is called the *indicator*, and consists of a needle attached to the axis of this wheel. The needle moves over the face of

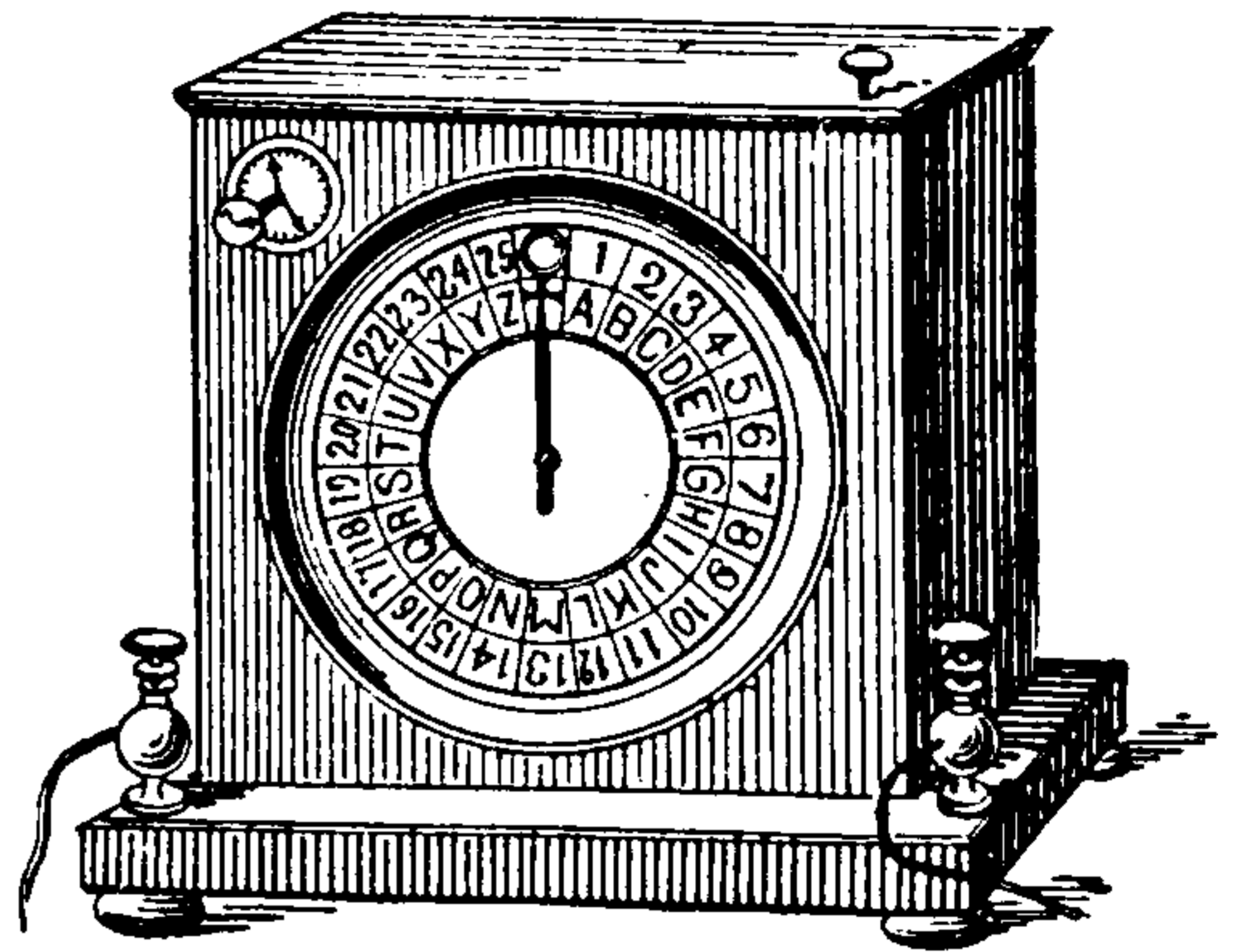

Fig. 541. Breguet's Indicator.

the dial, shown in Fig. 541, on which are marked the letters of the alphabet and the numerals.

The sending instrument is called the *manipulator*. It consists of a device for readily sending over the line the number of successive impulses required to move the needle step-by-step from any letter on the indicator to which it may be pointing, to the next it is desired to send.

The dial, shown in Fig. 542, is marked on its face with the same characters as the indicator. The edge of the wheel is provided with twenty-six notches in which a pin attached to a movable arm engages. The arm is jointed so that it can be placed in any of the notches on the face of the wheel.

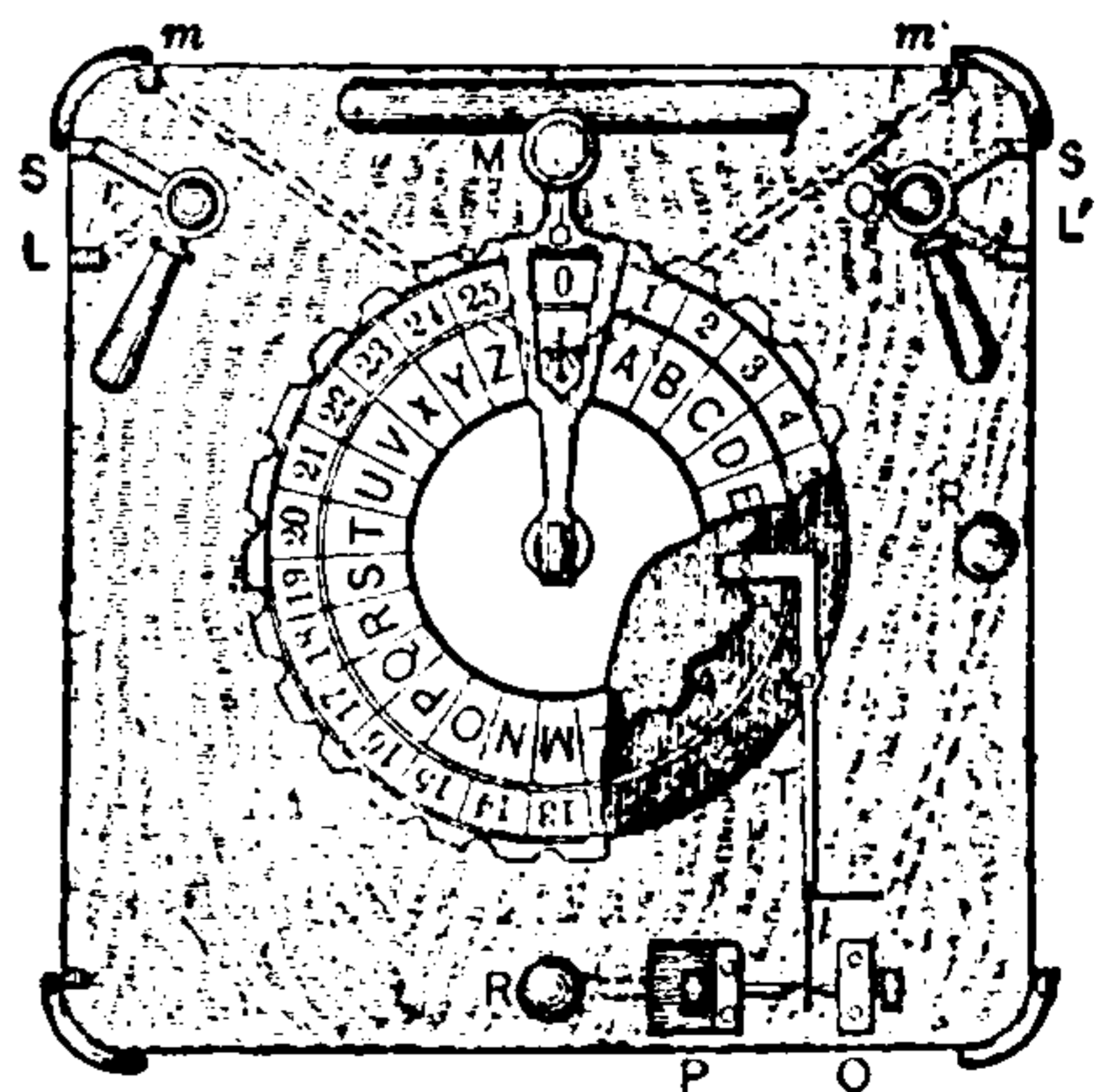

Fig. 542. Breguet's Manipulator.

Below the dial face, and attached to the same axis as the movable arm, is a wheel provided with undulations consisting of thirteen elevations and thirteen depressions.

A lever T, pivoted at a, rests in these undulations at its upper end, and plays between two contact points at P and Q.

If, now, the dials of the indicator and the manipulator both being at O, a movement is given to the arm by the handle M, to any point on the manipulator, there are thus produced the required number of makes and breaks to move the needle of the indicator to the corresponding letter or character.

Telegraphy, Submarine — — A system of telegraphy in which the line wire consists of a submarine cable.

In long submarine cables, in order to avoid *retardation* from the self-induction of the current, and the *static charge* arising from the cable acting as a condenser, very small currents are used. To detect these a very sensitive receiving instrument, such as the *mirror galvanometer*, or the *siphon recorder*, is employed. (See *Galvanometer, Mirror. Recorder, Siphon.*)

According to Culley, the retardation in the case of one of the submarine cables between Newfoundland and Ireland, amounts to *two-tenths of a second* before a signal sent from one end produces any appreciable effect at the other end, while *three-tenths of a second* are required for the current through the cable to gain its full strength.

Telegraphy, Synchronous-Multiplex, Delany's System — — A system devised by Delany for the simultaneous telegraphic transmission of a number of messages either all in the same direction, or part in one direction and the remainder in the opposite direction.

The Delany system embraces the following parts :

(1.) A circular table of alternately insulated and grounded contacts at either end of a telegraphic line.

(2.) A synchronized rotating arm or trailing contact, at each end of the line, driven by a *phonic wheel*, and maintained in synchronous rotation by means of electric impulses automatically sent out over the main line in either direction, on the failure of the wheel at either end to rotate synchronously with that at the other end.

(3.) Transmitting and receiving instruments connecting similar contacts at each end of the main line, and forming practically separate and independent lines for the simultaneous transmis-

sion of dispatches over the main line in either direction.

The main line is simultaneously connected at both of its ends to corresponding operating instruments, and transferred from one set of instruments to another so rapidly that the operators, either sending or receiving, cannot realize that the line has been disconnected from their instruments and given to others, because each of them will always have the line ready for use, even at the highest rate of manipulation, and will, therefore, to all practical intents and purposes, have at his disposal a private wire between himself and the operator with whom he is in communication.

Therefore, although more than one operator may be spoken of as simultaneously using the line at any given time, yet in reality no two operators are absolutely using it at the same time; but they follow one another at such short intervals, and the line is taken from one operator and transferred to another so rapidly, that none of them can at any time tell but that he has the line alone, and that therefore it is practically open for the use of every operator just as if he alone had control of it.

There will, therefore, be established, by the use of a single line, as many private and separate lines as there are transferences of the line from the time it is taken from the first operator, and again given back to him.

This system has been extended to as many as seventy-two distinct and separate printing circuits, maintained and operated on a single connecting line wire.

The speed at which the circuits may be operated is in the inverse order of the number of circuits organized. The best results, practically, are obtained from six divisions of the contacts in the circle, which gives each operator about 36 contacts with the line per second, a speed which admits of the highest rate of transmission on each of the six circuits.

Fig. 543 shows the apparatus at each end of the line, at the stations X and Y. The apparatus at each end is substantially identical. A steel fork a, at each station, is automatically and continuously vibrated by the action of the local battery L, B, and the electro-magnet A, called the *vibrator magnet*.

Platinum contacts x, x¹, placed on the inner faces of the tines of the fork, make and break contact with delicate contact springs y, y¹.

THIS PAGE IS LOCKED TO FREE MEMBERS

Purchase full membership to immediately unlock this page



HISTORY

Tens of thousands of important historical sources, many previously unobtainable, are now available for the first time with a Forgotten Books Full Membership.

Unlimited Access
\$8.99/month

Continue

*Fair usage policy applies

with the wire r , and with the contacts 1 and 5; R^1 is connected by r^1 , with the contacts 2 and 6, R^2 , by the wire r^2 , with the contacts 3 and 7, and R^3 , by the wire r^3 , with the contacts 4 and 8. Similar instruments and circuits are placed at each end of the line.

Without further describing the operation of the instruments shown in the figure, it need only now be borne in mind that the corresponding relays at the distant stations are connected with the correspondingly numbered contacts. When, therefore, the trailing contact finger at each station simultaneously touches the contacts bearing the same number, the corresponding instruments connected

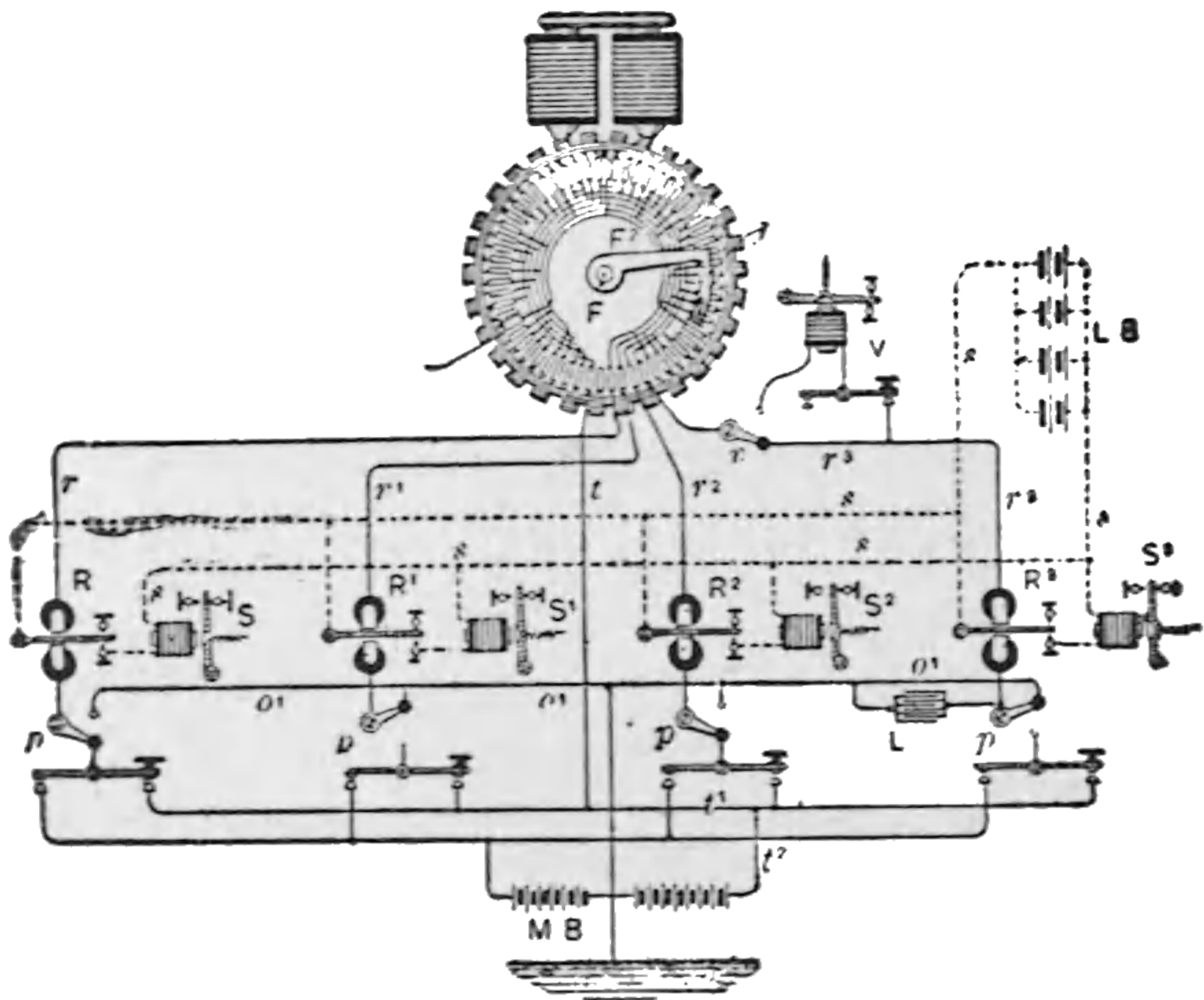

Fig. 546. Working and Receiving Currents.

with these contacts at each station will be placed in communication over the main line, the trailing contact finger f , completing the connection of the main line with the contact arm in the manner already described.

Telegraphy, Time — — A system for the telegraphic transmission of time.

A system of time telegraphy includes a *master clock*, the movements of whose pendulum automatically transmit a number of electric impulses to a number of *secondary clocks* and thus moves them; or self-winding clocks are employed, which are corrected daily by an impulse sent over the line from a master clock. (See *Clock, Electric.*)

Telegraphy, Writing — — A species of fac-simile telegraphy, by means of which the motions of a pen attached to a transmitting instrument so vary the resistance on two lines connected with a receiving instrument as to cause the current received thereby to reproduce the motions, on a pen or stylus, which transfers them to a sheet of paper.

A system of writing telegraphy consists essentially of transmitting and receiving instruments connected by a double line wire.

The transmitting instrument is shown in Fig. 547.

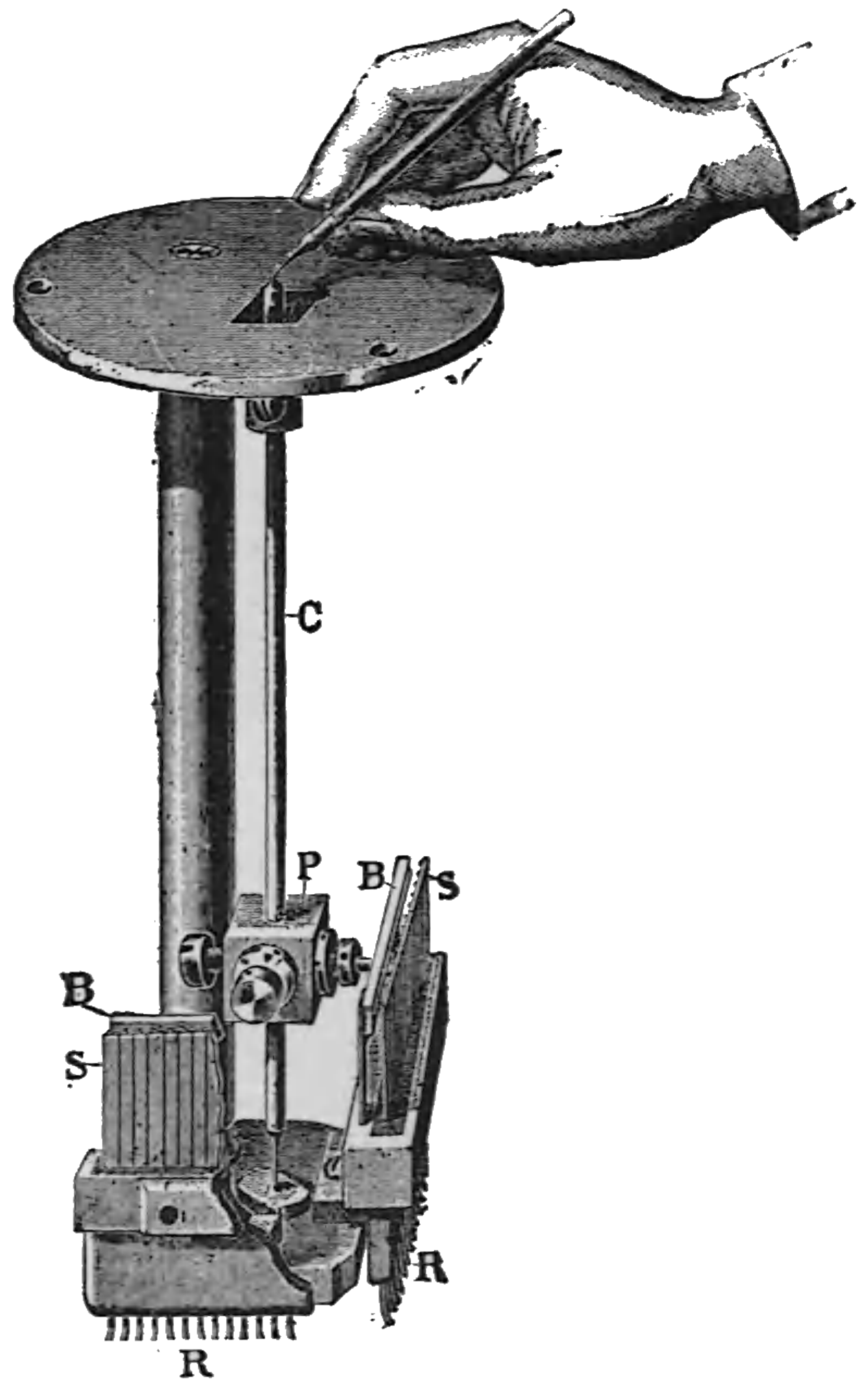

Fig. 547. Transmitter of Writing Telegraphy.

A stylus or pen resting on a top plate, is connected by the rod C , with a series of steel contact springs S, S , secured to the base and placed at right angles to one another. A series of resistances R, R , are connected with the lower ends of these contact springs. Two contact bars, B, B , are provided on the side facing the springs with platinum contacts opposite the contacts on the springs. The stylus rod C , is securely fixed to the base, but a spring at the lower end permits of its free movement. A pressure block at P , is fastened to the stylus rod, as shown, and in its normal position the pressures are adjusted so that contact is secured with the first spring.

A movement of the stylus, as in writing, presses the contact bar against the spring, varying the position and number of contacts, and thereby cutting in or out the resistance necessary to effect the proper movement of the receiving pen.

The receiving instrument is shown in Fig. 548. It consists of two electro-magnets placed at right angles to each other. A double armature sup-

ports the receiving stylus or pen in the manner shown. The variations in the current sent over the line by the varying resistances introduced into the circuit, or cut out or in by the action of the transmitting stylus, causes variations in the position of the double armature, under the varying magnetic attraction of the receiving electromagnet, and thus causes the receiving pen to correctly reproduce the motions of the transmitting pen.

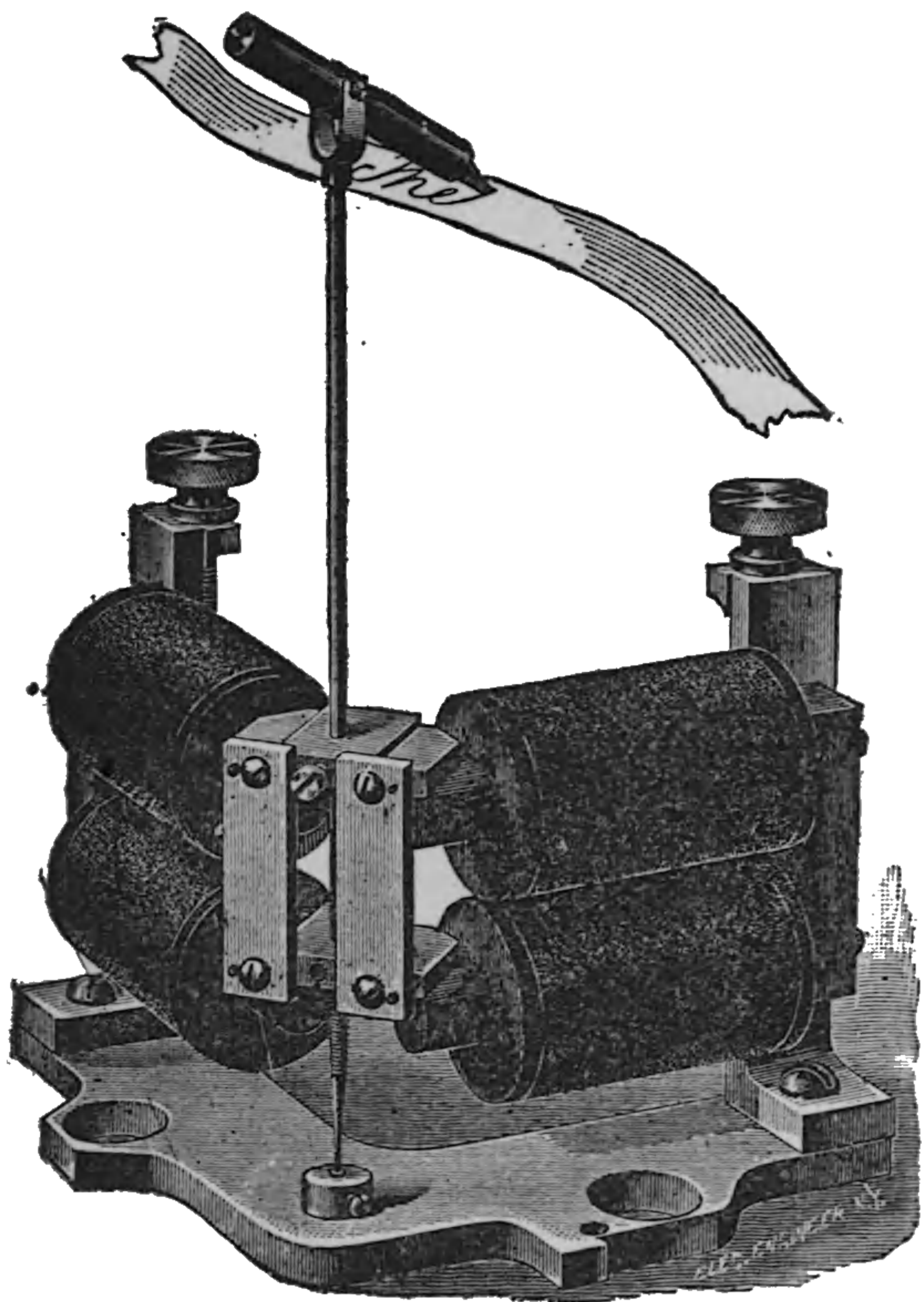

Fig. 548. Receiver of Writing Telegraph.

This system has been operated over a line nearly 500 miles in length, when it successfully reproduced written characters.

The author is indebted for the drawings and the general facts to the *Electrical Engineer* of New York.

Tele-Hydro-Barometer, Electric — —

An apparatus for electrically transmitting to, and recording at a distant station the height of water or other liquid.

Tele-Manometer, Electric — ——A gauge for electrically indicating and recording pressure at a distance.

The tele-manometer includes a pressure gauge furnished with electric contacts operated by the movements of the needle of the steam gauge, for instance, and indicating and recording apparatus. An alarm bell is provided to call attention to any

rise of the pressure above or its fall below the given or predetermined limits for which the hands have been set.

Telemeter.—An apparatus for electrically indicating and recording at a distance the pressure on a gauge, the reading of a thermometer, or the indications of similar instruments. (See *Tele-Hydro-Barometer, Electric. Tele-Manometer, Electric. Tele-Thermometer, Electric.*)

Telephone.—To communicate by means of a telephone.

Telephone.—An apparatus for the electric transmission of articulate speech.

The articulating telephone, though first brought into public use by Bell, was invented by Reis, in Germany, in 1861. In America, after very protracted litigation, Bell has been decided legally to be the first inventor, but scientific men very generally recognize the principles of the invention to be fully anticipated by the earlier instruments of Reis. Bell, however, is justly entitled to the credit of inventing the first really successful telephone.

In Bell's *magneto-electric telephone*, the transmitting and receiving instruments are identical. A coil C, of insulated wire connected with the line, is placed on a core of magnetized steel, mounted opposite the centre of a circular diaphragm of thin sheet iron, rigidly supported at its edges.

In transmitting, the message is spoken into the mouth-piece at one end, as at D, in Fig. 549, and

the to-and-fro motions thus imparted to the metallic diaphragm attached to the mouth-piece P, produce *induction currents* in the coil C, on the magnet M. (See *Induction, Electro-Dynamic.*)

These impulses, passing over the main line E L, Fig. 550, produce similar movements in the diaphragm P', of the receiving instrument, at D', and thus cause it to reproduce the message, in articu-

late sounds, to one listening at the receiving instrument. A ground circuit is shown in the figure, as usually employed in practice, except for long distance and in large cities.

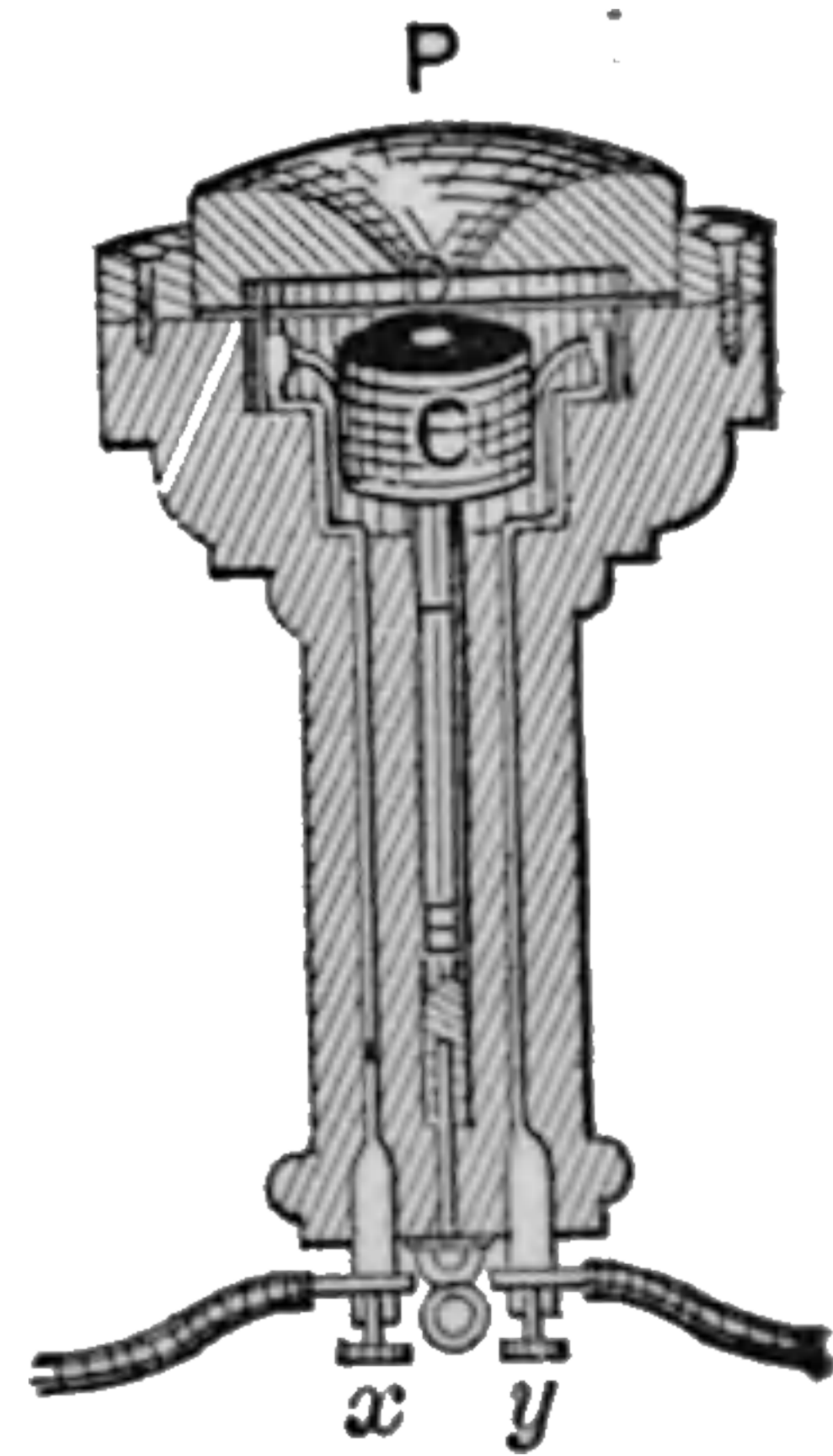

Fig. 549. Telephone.

A magneto-telephone constitutes in reality a magneto-electric machine, driven or propelled by the voice of the speaker, in which the currents so produced instead of being commuted are employed uncommuted to reproduce the uttered speech.

In actual practice the instrument above described is replaced by the *electro-magnetic tele-*

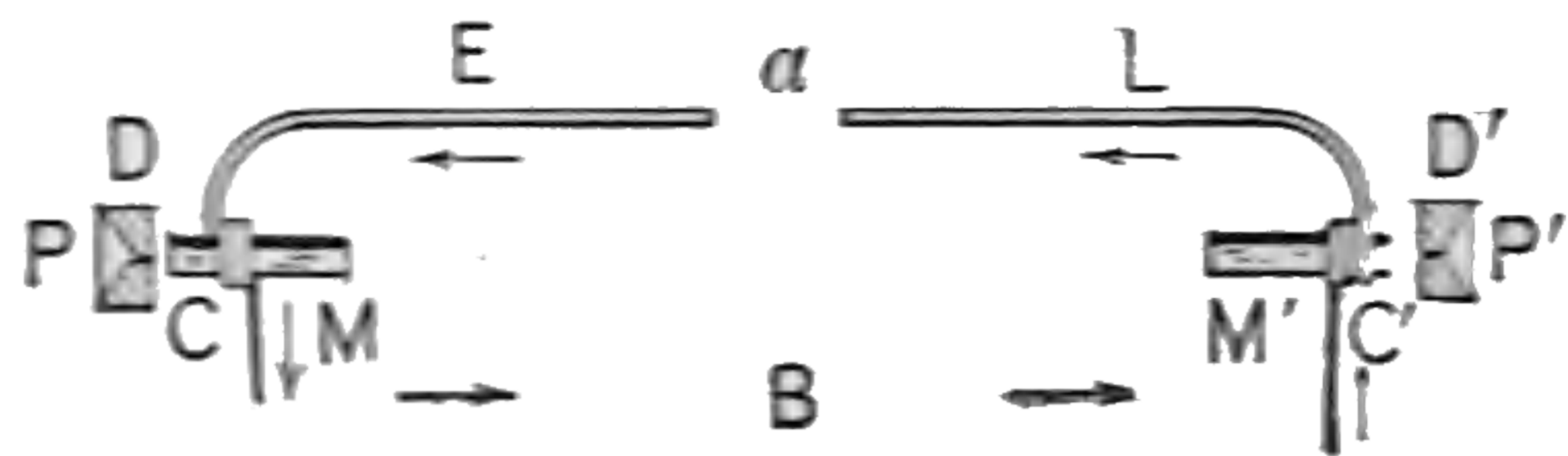
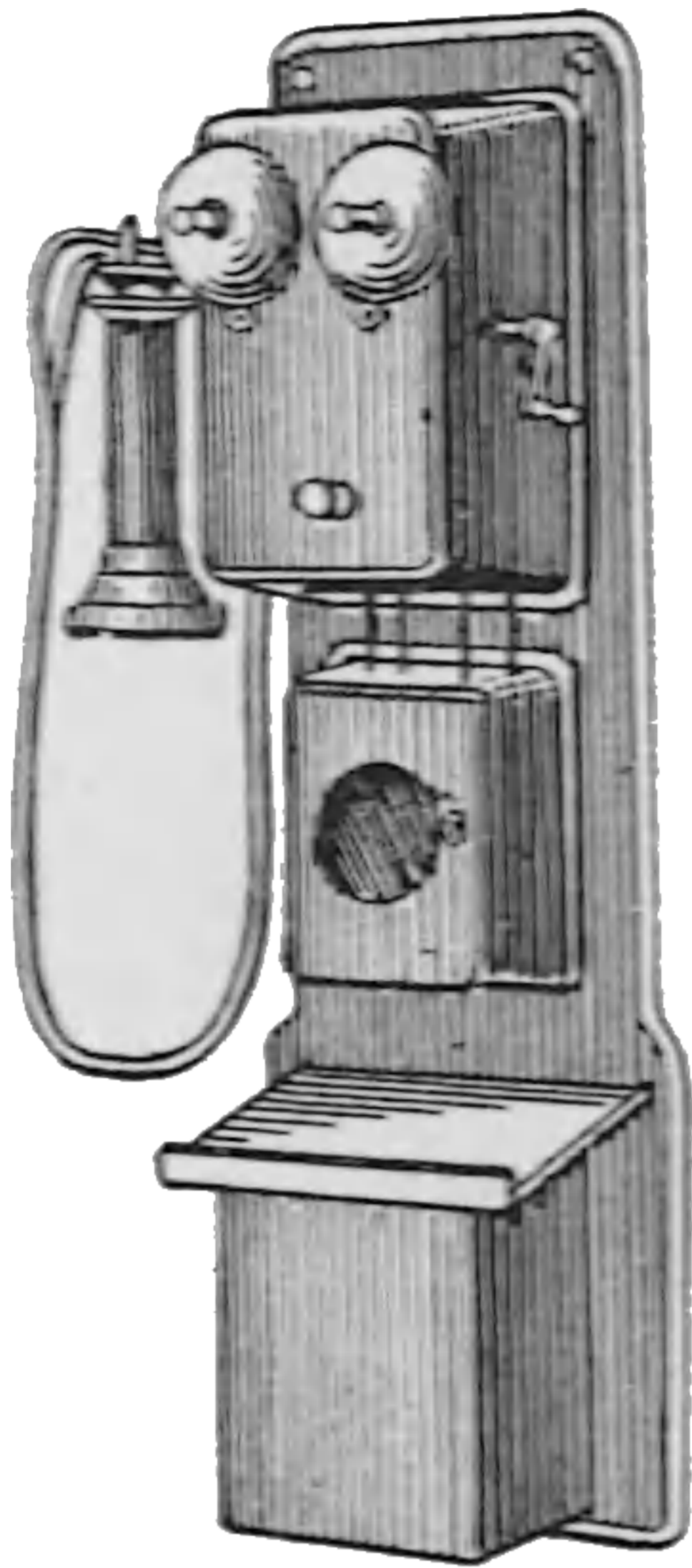

Fig. 550. Telephone Circuit.

phone, in which the to-and-fro motions of the transmitting diaphragm are caused to vary the resistance of a *button of carbon*, or a *variable contact transmitter* similar to that employed by Reis in some of his instruments. The variable resistance is placed in the circuit of a battery, so that on speaking into the transmitter, electric impulses are sent over the line and are received by a telephone with a *magnet core* provided with a coil in the main-line circuit.



The telephone is arranged for actual commercial use in the United States in the manner Fig. 551. Telephone Apparatus.

Telephone, Bi — — A term sometimes applied to a double telephone receiver so arranged as to permit of easy application to both ears of the listener at the receiving instrument.

Telephone Cords.—(See *Cords, Telephone.*)

Telephone, Electro-Capillary — — A telephone in which the movements of the transmitting diaphragm produce currents by means of variations in the electromotive forces of the contact surfaces of liquids in capillary tubes. (See *Phenomena, Electro-Capillary.*)

In Breguet's telephone both the transmitting and the receiving instruments are similar in con-

struction and operate by means of electro-capillary phenomena. A vertical capillary tube communicates at its upper end with an air space below a diaphragm, and at its lower end with a mercury surface on which rests a layer of acidulated water.

A line wire connects the mercury reservoirs of the transmitting and receiving instruments, the remainder of the circuit being formed by another wire connecting the mercury near the upper parts of the two vertical tubes.

The alterations in the contact surfaces at the transmitting end produced by the movements of the diaphragm, cause electric impulses that produce similar movements of the diaphragm at the receiving end.

Telephone, Electro-Chemical — — A name sometimes given to the Edison electromotographic telephone. (See *Telephone, Electro-Motographic.*)

Telephone, Electro-Motographic — — A telephone in which the receiver consists of a diaphragm of mica or other elastic material operated on the principle of the electromotograph.

A straight lever, which forms part of the line circuit, is rigidly attached at one end to the centre of the receiving diaphragm, and rests near its other end on the surface of a chalk cylinder moistened with a solution of caustic potash or potassium iodide, maintained in rotation by suitable mechanical means.

Electric impulses being sent into the line by the voice of a speaker talking at a transmitter of ordinary construction reduce the friction between the lever and the cylinder, and produce slipping movements of the lever that reproduce articulate speech in the receiving diaphragm.

Telephone, Reaction — — An electromagnetic telephone in which the currents induced in a coil of wire attached to the diaphragm are passed through the coils of the electro-magnet, and thus react on and strengthen it.

Telephone Switch, Automatic — — (See *Switch, Telephone, Automatic.*)

Telephonic.—Pertaining to the telephone.

Telephonic Alarm.—(See *Alarm, Telephonic.*)

THIS PAGE IS LOCKED TO FREE MEMBERS

Purchase full membership to immediately unlock this page

Know Your Bible

Forgotten Books' Full Membership provides unlimited access to more than 28,000 volumes of Christian literature for \$8.99/month

HOLY BIBLE

Continue

*Fair use policy applies

Two lines are provided, an *up* and a *down* line, that cross each other at regular intervals. Each line is in segments, and the alternate segments are insulated from each other, but are connected electrically by cross-pieces on the supporting posts. In this way the line shown in Fig. 553 is obtained.

The two lines are maintained at a difference of potential by a dynamo-electric machine at D, Fig. 554. As the train at L T, or L' T', is of such a length as to come into contact with two different segments at the same time, it receives a current sufficient to run the motor connected with it, the current being received through a conductor joining a pair of wheels that are insulated from the truck.

The general arrangement of the line is shown in the annexed Fig. 554

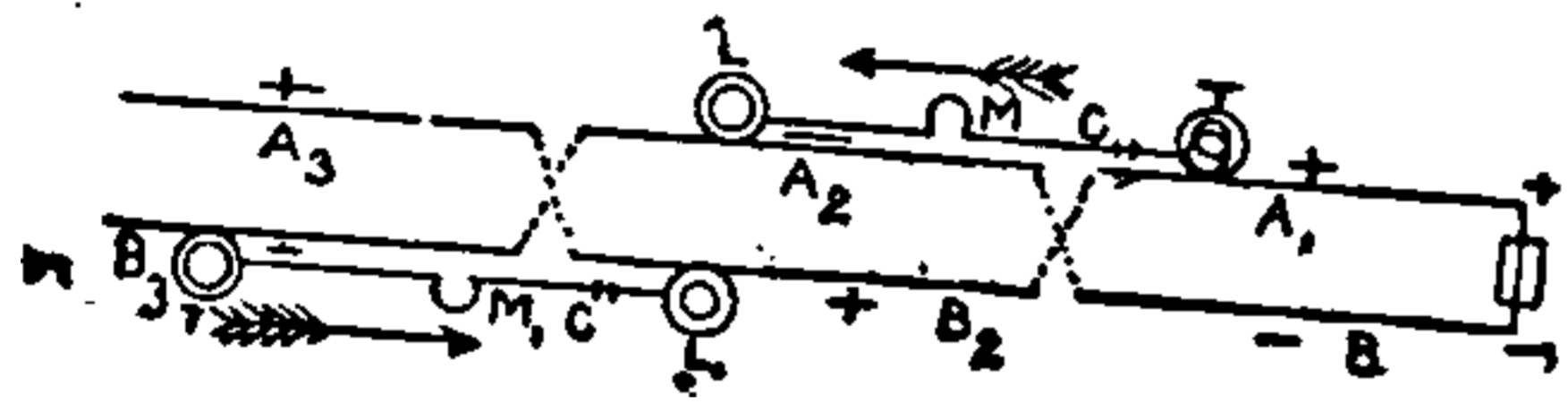

Fig. 554. Circuit for Telpherage System.

Temperature Alarm.—(See *Alarm, Temperature*.)

Temperature, Effects of, on Electric Resistance — —(See *Resistance, Effect of Heat on Electric*.)

Tempering, Electric — —A process for tempering metals in which heat of electric origin is employed instead of ordinary furnace heat.

Temporary Intensity of Magnetization.—(See *Magnetization, Temporary Intensity of*.)

Tension, Electric — —A term often loosely applied to signify indifferently surface density, electromotive force, dielectric stress, or difference of potential.

This term is now very generally abandoned.

Terminal, Cable — —A water-tight covering provided at the end of a cable to prevent injury to the cable insulation by the moisture of the air.

Terminal, Negative — —The negative pole of a battery or other electric source, or the end of the conductor or wire connected with the positive plate.

Terminal, Positive — —The positive pole of a battery or other electric source, or the end of the conductor or wire connected to the negative plate.

Terminals.—A name sometimes applied to the poles of a battery or other electric source, or to the ends of the conductors or wires connected thereto.

The two terminals are distinguished as the *positive* and the *negative*. Their names are unlike those of the battery plates to which they are connected, the positive terminal being connected with the negative plate and the negative terminal with the positive plate.

Terrestrial Magnetism.—(See *Magnetism, Terrestrial*.)

Testing, Methods of — —Various methods for determining the values of the current strength in any circuit, the difference of potential, the resistance, the coulombs, the farads, the joules, the watts, etc. (See *Measurements, Electric*.)

The investigation of an apparatus or circuit for the purpose of determining whether it is in standard or working condition.

Testing of Joints.—(See *Joint, Testing of*.)

Testing Pole.—(See *Pole, Testing*.)

Testing Transformer.—(See *Transformer, Testing*.)

Tetanus.—Continuous, spasmodic contraction of the muscles.

Tetanus, Acoustic — —Tetanus produced in a muscle by means of alternate currents induced in a coil of wire by a magnetized steel spring vibrating near the coil with sufficient rapidity to give a musical note.

The rapidity of the inductive shock can be determined from the pitch of the musical note; hence the use of the term acoustic.

Theatrophone.—A system of telephonic communication between theatres or operas and subscribers, by means of slot machines.

Any person at a café, club, restaurant or other public place, by the theatrophone, is automatically placed in communication with the theatre by means of a receiving telephone so as to hear

the performance by dropping a given piece of money in the slot of the machine.

Theodolite, Magnetic — —An apparatus for measuring the declination or variation of the magnetic needle at any place.

A divided circle, like that on a theodolite, is supported horizontally. The needle is formed of a tubular magnet, having an achromatic lens at one end and a scale at the focus of the lens at the other end.

Theory, Alternation, of Muscular Nerve Current — —A theory proposed by L. Hermann, in which the currents of nerves or muscular fibres are regarded as a result of their alteration from an original condition.

Hermann states:

(1.) That protoplasm undergoing partial death at any part, either while dying or by metamorphosis, becomes negative to the uninjured part.

(2.) Protoplasm, when excited at any part, becomes negative to the unexcited part.

(3.) Protoplasm, when partially heated at any part, becomes positive, and, on cooling, negative to the unchanged part.

(4.) Protoplasm is strongly polarizable on its surface, the polarization constantly diminishing with excitement and while dying.

According to this theory, passive, uninjured and absolutely fresh tissues are devoid of electric currents. This matter must still be regarded as unsettled. (See *Theory, Molecular, of Muscles or Nerve Current.*)

Theory, Contact, of Voltaic Cell — — (See *Cell, Voltaic, Contact Theory of.*)

Theory, Difference — —A theory as to the cause of the electric currents excited between injured and uninjured protoplasm.

Theory, Molecular, of Muscles or Nerve Current — —A theory proposed by Du Bois Reymond, in which every nerve or muscular fibre is regarded as composed of a series of electromotive molecules arranged in series and surrounded by a neutral conducting fluid.

“The molecules are supposed to have a positive equatorial zone directed towards the surface and two negative polar surfaces directed toward the transverse section. Every fresh transverse section exposes new negative surfaces, and every

artificial longitudinal section new positive area.” —(*Landois and Sterling.*)

Theory of Electric Displacement.—(See *Displacement, Electric, Theory of.*)

Therapeutical Electrization.—(See *Electrization, Therapeutical.*)

Therapeutic Bath, Electro — —(See *Bath, Electro-Therapeutic.*)

Therapeutics, Electro, or Electro-Therapy — —The application of electricity to the curing of disease. (See *Biology, Electro.*)

Therapist, Electric — —One skilled in electro-therapy.

An electro-medical practitioner.

Therapy, Electro — —A term sometimes used instead of electro-therapeutics. (See *Therapeutics, Electro, or Electro-Therapy.*)

Therapy, Magneto — —Alleged electro-therapeutic effects produced by the movements of magnets over the body of the patient.

It is asserted by eminent authorities that such effects have an actual existence. They should, however, until more carefully investigated, be accepted with extreme caution.

Therm.—A heat unit proposed by the British Association.

A therm is the amount of heat required to raise the temperature of one gramme of pure water at the temperature of its maximum density one degree centigrade. (See *Calorie.*)

Thermaesthesiometer.—An instrument employed in electro-therapeutics for testing the temperature sense in nervous diseases.

The thermaesthesiometer consists of two thermometers movable on a standard, with flat vessels of mercury in order to readily apply them to the skin. The mercury vessel of one of the two thermometers is surrounded by an insulated platinum wire and may be warmed at pleasure by passing a galvanic current through the wire.

The two vessels, brought to different temperatures, are set on the same part of the skin, one after the other, so as to test the sensibility of the skin for the differences in temperature.

Thermal Absorption.—(See *Absorption, Thermal.*)

Thermal Cautery.—(See *Cautery, Thermal*.)

Thermal Incandescence.—(See *Incandescence, Thermal*.)

Thermic Balance.—(See *Balance, Thermic, or Bolometer*.)

Thermo-Battery.—(See *Battery, Thermo*.)

Thermo Call.—A call operated by means of thermo currents.

Thermo-Cell.—(See *Cell, Thermo-Electric*.)

Thermo-Electric Battery.—(See *Battery, Thermo-Electric*.)

Thermo-Electric Cell.—(See *Cell, Thermo-Electric*.)

Thermo-Electric Couple.—(See *Couple, Thermo-Electric*.)

Thermo-Electric Diagram.—(See *Diagram, Thermo-Electric*.)

Thermo-Electric Effect.—(See *Effect, Thermo-Electric*.)

Thermo-Electric Inversion.—(See *Inversion, Thermo-Electric*.)

Thermo-Electric Pile, Differential —
—(See *Pile, Thermo, Differential*.)

Thermo-Electric Pile or Battery.—(See *Pile, Thermo-Electric*.)

Thermo-Electric Power.—(See *Power, Thermo-Electric*.)

Thermo-Electric Series.—(See *Series, Thermo-Electric*.)

Thermo-Electricity.—(See *Electricity, Thermo*.)

Thermo-Electrometer.—A name sometimes, but not happily, applied to an electric thermometer. (See *Thermometer, Electric*.)

Thermo-Electromotive Force. — (See *Force, Electromotive, Thermo*.)

Thermolysis.—A term applied to the chemical decomposition of a substance by heat.

Thermolysis, or dissociation, is an effect produced by an action of heat somewhat similar to the effect of electrolysis, or chemical decomposition produced by the passage of an electric current. When a chemical substance is heated, the

vibration of its molecules is attended by an interatomic vibration of its constituent atoms so that a decomposition ensues. If the temperature is not excessive, these liberated atoms recombine with others which they meet. At higher temperatures, however, such recombination is impossible, and a permanent decomposition ensues, called thermolysis or dissociation.

Thermometer, Electric — —A device for determining the effects of an electric discharge by the movements of a liquid column on the expansion of a confined mass of air through which the discharge is passed.

Thermometer, Electric Resistance — —A thermometer the action of which is based on the change in the electric resistance of metallic substances with changes in temperature.

The electric resistance thermometer is used, among other purposes, for determining the temperature of the sea at different depths. Its operation is based on the electric resistance of two perfectly similar coils of insulated wire, enclosed in separate water-tight copper cases. One coil is placed where the temperature is to be determined, and the other in a vessel of water, the temperature of which is altered until the two coils show the same resistance, when, of course, the temperature of the distant coil is the same as that of the water surrounding the other coil.

Thermometer Scale, Centigrade — —
(See *Scale, Thermometer, Centigrade*.)

Thermometer Scale, Fahrenheit — —
(See *Scale, Thermometer, Fahrenheit*.)

Thermophone.—Any instrument by means of which sounds are produced by the absorption of radiant energy. (See *Photophone*.)

A telephone has been constructed in which the motions of the receiving diaphragm are effected by the expansions and contractions of a thin metallic wire connected to the diaphragm and placed in the circuit of the main line.

Thermostat.—An instrument for automatically maintaining a given temperature by the closing of an electric circuit through the expansion of a solid or liquid.

Thermostats are often used in systems of automatic fire telegraphy and in systems of automatic temperature regulation in connection with indi-

THIS PAGE IS LOCKED TO FREE MEMBERS

Purchase full membership to immediately unlock this page



HISTORY

Tens of thousands of important historical sources, many previously unobtainable, are now available for the first time with a Forgotten Books Full Membership.

Unlimited Access
\$8.99/month

Continue

*Fair usage policy applies

ber of subscribers, each of whom is furnished with a stock ticker. The transmitter at the central station consists of a keyboard and a cylinder furnished with spiral pins. The spiral pins are connected through a series of pole-changers to separate line wires radiating in all directions from the central office.

The connections are such that, a rapid rotation being given by means of an electric motor to the cylinder, the impulses sent out by the keyboard are transmitted to each of the separate circuits. Since each of these circuits has a number of ticker printers connected with it, reports of fluctuations in prices are simultaneously printed in hundreds of different offices.

Ticker, Stock — —A form of step-by-step telegraphic instrument employed for automatically sending and recording stock quotations to any desired number of subscribers. (See *Telegraphy, Step-by-Step.*)

A form of printing telegraph.

Callahan's Printing Telegraph is used as a stock ticker. (See *Telegraphy, Printing.*)

Phelps' Stock Printer is employed extensively as a stock ticker. This form of printing telegraph requires but a single wire, and has a working speed of almost thirty words a minute.

A double type-wheel, maintained in motion by clockwork, is stopped at the desired characters by the motion of a polarized relay, working between the poles of two electro-magnets, furnished with a soft iron or non-polarized armature. The release of the armature of the printing magnet releases a train, and thus insures the impression of the character it is desired to print.

The type-wheel is driven by a step-by-step movement obtained by means of rapidly alternating pulsations. Although these pass through the coils of the printing magnet, they follow one another too rapidly to charge its coils, so that the armature is unaffected until a pause is made, when, its armature being attracted, it releases the printing mechanism. The message is received on a fillet of paper, fed by a suitable mechanism.

Time-Ball, Electric — —(See *Ball, Electric Time.*)

Time-Constant of Circuit.—(See *Circuit, Time-Constant of.*)

Time-Constant of Condenser.—(See *Condenser, Time-Constant of.*)

Time-Constant of Electro-Magnet.—(See *Constant, Time, of Electro-Magnet.*)

Time Cut-Out, Automatic — —An automatic cut-out arranged on a storage battery so as to cut it in or out of the circuit of the charging source at predetermined times.

Time-Fall of Electromotive Force of Secondary or Storage Cell During Discharge.—(See *Force, Electromotive, of Secondary or Storage Cell, Time-Fall of.*)

Time-Lag of Magnetization.—(See *Magnetization, Time-Lag of.*)

Time, Reaction — —The time required for the effects of an electric current to pass from a nerve to a muscle.

Time-Rise of Electromotive Force of Secondary or Storage Cells During Discharge.—(See *Force, Electromotive, of Secondary or Storage Cell, Time-Rise of.*)

Time-Switch.—(See *Switch, Time.*)

Time, Telegraphic, Register for Railroads — —(See *Register, Time, for Railroads.*)

Time Telegraphy.—(See *Telegraphy, Time.*)

Tinned Wire.—(See *Wire, Tinned.*)

Tinning, Electro — —Covering a surface with a coating of tin by electro-plating. (See *Plating, Electro.*)

Stannic chloride, or the perchloride of tin, dissolved in water in the proportion of 30 parts of the salt to 1,250 of water, makes a good tinning bath.

Tinnitus, Telephone — —A professional neurosis, or abnormal nervous condition of the auditory apparatus, believed to be caused by the continual use of the telephone.

Tips, Polar — —The free ends of the field magnet pole pieces of a dynamo-electric machine.

Tissue, Nerve or Muscular Excitability of — —Electric stimulation of nervous or muscular tissue.

The general effects of electric stimulation of nervous or muscular tissue may be summarized as follows:

(1.) Electric stimulation of a motor nerve, produces a contraction of the muscles to which such nerve is distributed.

(2.) Electric stimulation of a sensory nerve, produces pain in the parts to which the nerve is distributed.

(3.) Electric stimulation of mixed motor and sensory nerves produces both of the effects mentioned under (1) and (2.)

Tongs, Cable Hanger — — Tongs provided with long handles for the purpose of attaching the hangers of an aerial cable to the suspending wire or rope.

Tongs, Discharging — — A term sometimes used for a discharging rod. (See *Rod, Discharging.*)

Tongue, Relay, Bias of — — A term employed to signify such an adjustment of a polarized relay, that on the cessation of the working current, the relay tongue shall always rest against the insulated contact, and not against the other contact, or vice versa.

Sometimes, as in the split-battery duplex, the bias is toward the uninsulated contact. (See *Relay, Polarized.*)

Tool, Lead Scoring — — A tool for readily scoring the surface of the lead of a lead-covered cable, when the same is to be removed preparatory to making joints.

Toothed-Ring Armature.—(See *Armature, Toothed-Ring.*)

Top, Induction — — A top consisting of an iron disc supported on a vertical axis, which, when spun before the poles of a steel magnet, assumes an inclined position, through the influence of the currents induced in the disc.

The top maintains the inclined position so long only as the strength of the induced currents is sufficiently great; that is, while speed of rotation is sufficiently great.

Töppler-Holtz Machine.—(See *Machine, Töppler-Holtz.*)

Torch, Electric Gaslighting — — A gaslighting appliance consisting of the com-

bination of a portable voltaic battery and a spark or induction coil.

The torch is mounted on the end of a rod provided with means for turning on the gas. A key is then touched and the gas lighted by the spark produced by an induction coil or a small electrostatic induction machine.

Torpedo, Automobile — — A torpedo which contains in itself the power for its own motion.

The moving power may be that derived from compressed air or gas, or from a storage battery contained within the torpedo. An automobile torpedo provided with a storage battery and electric motor would then be distinguished from an electrically propelled torpedo, connected by means of cables with a driving dynamo located outside the torpedo on a ship, or on the shore.

Torpedo Boat.—(See *Boat, Torpedo.*)

Torpedo Cable.—(See *Cable, Torpedo.*)

Torpedo, Drifting — — A torpedo suspended from a float, and connected by means of rope with similar torpedoes, allowed to drift with the current, so as to catch against a vessel.

Torpedo, Electric — — A name sometimes given to the electric ray. (See *Ray, Electric.*)

Torpedo, Electric — — An electrically operated torpedo.

This latter usage of the term is the commoner.

Torpedo, Halpine-Savage — — A special form of torpedo, in which electricity is both the propelling and directing power, and in which the electric source furnishing the propelling current is contained within the torpedo.

In the Halpine-Savage torpedo, the propelling power is obtained from a storage battery placed within the torpedo.

Torpedo, Lay — — A moving torpedo, in which the moving power is carbonic acid gas, or compressed air, or other similar power not electric, and the guiding power is electric.

The Lay torpedo has the form of a cylindrical boat furnished with conical ends. The explosive is placed in the fore part of the torpedo. Flags are

attached to the torpedo, showing the operator the exact course taken by it.

The torpedo is started, stopped and steered by means of electric currents sent to the torpedo through an insulated cable connected with the torpedo.

Torpedo Nets.—(See *Nets, Torpedo.*)

Torpedo, Outrigger — —A pole or spar torpedo.

The torpedo is placed in a metallic case and supported on the end of a spar or outrigger. The spar is depressed until the torpedo is sunk below the water line. The torpedo is fired when its end comes in contact with the side of the enemy's vessel.

Torpedo, Sims-Edison — —A special form of torpedo in which electricity is both the propelling and the directing power, but the electric source is situated outside of the torpedo.

The torpedo is propelled by means of an electric motor placed in the torpedo, and driven by means of an electric current transmitted through a cable connected with the sending station.

Torpedo, Spar — —A torpedo, attached to the end of a spar, and designed to be exploded by percussion against the side of an enemy's vessel, when thrust against the side below the water-line.

The spar torpedo is but little used, having been replaced by more efficient forms.

Torpedo, Stationary — —A term sometimes employed instead of a submarine mine. (See *Mine, Submarine.*)

A stationary torpedo is so named in order to distinguish it from a torpedo which is moved through the water by any means. (See *Torpedo, Towing.*)

Torpedo, Towing — —A torpedo arranged to be towed on the surface after a vessel and explode when it strikes the side of an enemy's vessel.

The torpedo is shaped so that it maintains during its motion a certain distance from the sides of the towing boat or vessel.

Torque.—That moment of the force applied to a dynamo or other machine which turns it or causes its rotation.

The mechanical rotary or turning force which acts on the armature of a dynamo-electric machine or motor and causes it to rotate.

In the case of the armature of a dynamo-electric machine the torque is equal to the radius of the armature, multiplied by the pull at the circumference, or the radius of its pulley multiplied by the pull at the circumference of the pulley.

A torque is exerted on the shaft of a motor from the electro-magnetic action, or pull at the periphery of the armature.

The torque is usually measured in pounds of pull at the end of a radius or arm 1 foot in length.

Torricellian Vacuum.—(See *Vacuum, Torricellian.*)

Torsion Balance, Coulomb's — —(See *Balance, Coulomb's Torsion.*)

Torsion Galvanometer.—(See *Galvanometer, Torsion.*)

Total Disconnection.—(See *Disconnection, Total.*)

Total Earth.—(See *Earth, Total.*)

Total Magnetic Induction.—(See *Induction, Total Magnetic.*)

Touch, Double — —A method of magnetization in which two closely approximated magnet poles are simultaneously drawn from one end of the bar to be magnetized to the other and back again, and this repeated a number of times.

Touch, Separate — —A method of magnetization in which two magnetizing poles are simultaneously applied to the bar to be magnetized and drawn over it in opposite directions. (See *Magnetization by Touch.*)

Touch, Single — —A method of magnetization in which a single magnetizing bar is drawn from one end to the other of the bar to be magnetized, and returned through the air for the next stroke. (See *Magnetization, Methods of.*)

Tourmaline.—A mineral consisting of natural silicates and borates of alumina, lime, iron, etc., possessing pyro-electric properties. (See *Electricity, Pyro.*)

THIS PAGE IS LOCKED TO FREE MEMBERS

Purchase full membership to immediately unlock this page

Know Your Bible

Forgotten Books' Full Membership provides unlimited access to more than 28,000 volumes of Christian literature for \$8.99/month

HOLY BIBLE

Continue

*Fair use policy applies

clearly shown in Fig. 558, in which the terminals of the primary and secondary of the converter are readily seen.

When the converter is properly constructed, the loss of conversion at full load is but small; that is to say, the number of watts in the secondary is very nearly equal to the number in the primary. A current of 10 ampères, at 2,000 volts, when passed into a converter the number of whose turns in the primary is twenty times the number in its secondary, will produce in its secondary a current whose strength is about twenty times as great, that is, nearly 200 ampères, but whose voltage is only about one-twentieth, or, 100; the watts in the two cases are nearly the same, or theoretically 20,000 watts.

The ratio between the windings of the primary and the secondary circuits is called the co-efficient of transformation.

In general, the shorter the wire on the secondary, and the smaller its number of turns, the greater is the reduction in the difference of potential, and the greater the current produced. The reduction is nearly proportionate to the ratio of the number of windings of the two coils.

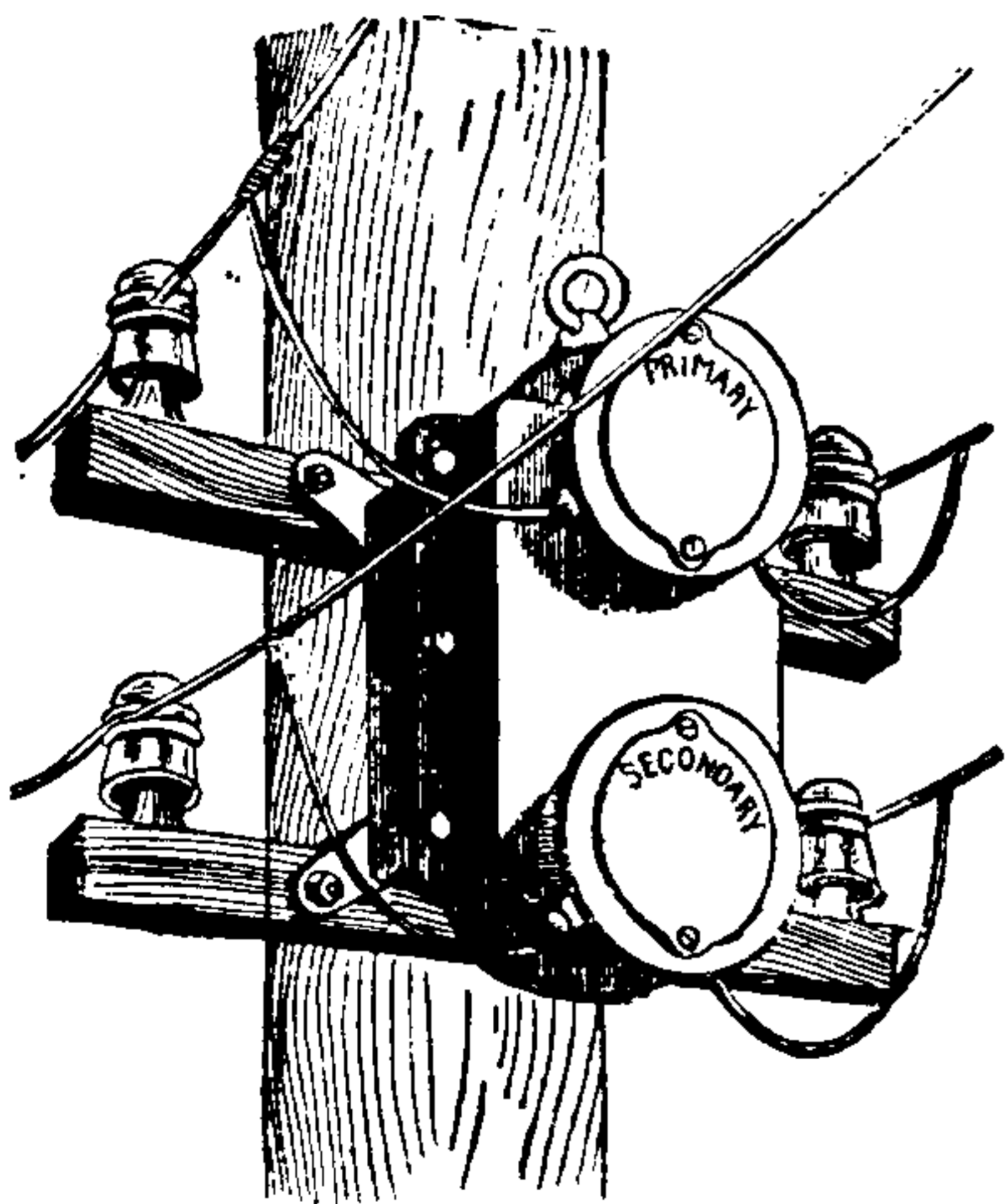

Fig. 558. Transformer Attached to Poles.

Transformer, Closed Iron Circuit — —A transformer the core of which forms a complete magnetic circuit.

These transformers are sometimes called iron-clad transformers.

Transformer, Commuting — —A term sometimes applied to a variety of motor generator in which neither the armature nor the field magnets revolve, the variations in the polarity of the magnetic circuit being obtained by means of special commutators.

Transformer, Constant-Current — —A transformer in which a current of a constant potential in the primary is converted into a current of constant strength in the secondary, despite changes in the load on the secondary.

Transformer, Core — —A transformer in which the primary and secondary wires are wrapped around the outside of a core consisting of a bundle of soft iron wires or plates.

A Ruhmkorff coil is a core transformer.

Transformer, Efficiency of — —The ratio between the whole energy supplied in any given time to the primary circuit of a transformer and that which appears in the form of electric current in the secondary circuit.

The energy applied to the primary circuit of a transformer is dissipated:

- (1.) By eddy currents in the core of the transformer. (See *Currents, Eddy*.)
- (2.) By hysteresis, or magnetic friction. (See *Hysteresis*.)
- (3.) By heating of the primary circuit.
- (4.) By heating of the secondary circuit.

When a transformer is overloaded, its efficiency decreases. There is a certain range of secondary resistance and current, within which a transformer is most advantageously operated.

Transformer Guard.—(See *Guard, Transformer, Lightning*.)

Transformer, Hedgehog — —A name applied to a particular form of open-iron circuit transformer. (See *Transformer*.)

The advantages claimed for the hedgehog transformer are that it can be made to give a higher all-day efficiency, since it insures a smaller loss from hysteresis in the iron. The efficiency for very small loads, or for no loads is greater than in the closed-circuit transformer.

Transformer, Leakage Current of — —A term sometimes used for the current which escapes from the primary through the dielectric of a transformer to the secondary circuit.

The term is a bad one, since the true leakage current would be the current which represents the leakage between the primary or secondary circuit and the ground.

Transformer Lightning Arrester.—(See *Arrester, Lightning, Transformer.*)

Transformer, Multiple — —Any form of transformer which is connected in multiple to the primary circuit.

A multiple or parallel transformer is self-regulating under variable loads, provided the electromotive force in the primary is maintained constant.

Transformer, Oil — —A transformer which is immersed in oil in order to insure a high insulation.

Transformer, Open-Iron Circuit — —A transformer the iron of which does not form a complete magnetic circuit, but is formed instead partly of iron and partly of air.

Transformer, Pilot — —A small transformer, placed at any desired portions of a line in order to determine the drop of potential.

The pilot transformer is used in connection with a lamp or other suitable indicating device. Its use is similar to the use of the pilot incandescent lamp.

Transformer, Rotary-Current — —A transformer operated by means of a rotary current. (See *Current, Rotating.*)

The rotary current transformer for a rotary current of three separate alternating currents combined, transforms all three currents together. There are three cores, connected at one set of ends and at the other to the circumference of an iron ring. Each core contains a primary and secondary wire.

Transformer, Rotary-Phase — —A rotary current transformer. (See *Transformer, Rotary-Current.*)

Transformer, Series — —Transformers which are connected in series with the primary circuit.

A series transformer is not as readily made self-regulating under variations in the load as a multiple transformer. If, however, its core is not saturated, and the electromotive force of its secondary is small, it can be made fairly self-regulating. Series transformers are used in the Jablochhoff system for feeding arc lamps in the shape of Jablochhoff candles.

Transformer, Shell — —A transformer

in which the primary and secondary coils are laid on each other, and the iron core is then wound through and over them so as to enclose all the copper of the primary and secondary circuits within the iron.

The iron shell surrounding the copper may consist of the thin plates of iron, built up so as to leave a rectangular space for the introduction of the primary and secondary.

Transformer, Step-Down — —A transformer in which a small current of comparatively great difference of potential is converted into a large current of comparatively small difference of potential.

An inverted Ruhmkorff induction coil.

Transformer, Step-Up — —A transformer in which a large current of comparatively small difference of potential is converted into a small current of comparatively great difference of potential.

The term step-up transformer is used in contradistinction to the step-down transformer.

The old form of Ruhmkorff coil is an example of a step-up transformer.

Transformer, Testing — —A transformer employed in any system of distribution for the purposes of testing for grounds, condition of line, drop of potential, etc.

Transformer, Welding — —A transformer suitable for changing a small electric current of comparatively high difference of potential, into the heavy currents of low difference of potential required for welding purposes.

Welding transformers have in general a very low resistance in their secondary coils, and almost invariably consist of a single turn or at the most of a few turns of very stout wire.

Transforming Currents.—(See *Current, Transforming a.*)

Transforming Down.—Transforming by means of a step-down transformer. (See *Transformer, Step-Down.*)

Transforming Station.—(See *Station, Transforming.*)

Transforming Up.—Transforming by means of a step-up transformer. (See *Transformer, Step-Up.*)

Transient Currents.—(See *Currents, Transient.*)

Transit, Magnetic Variation — —An apparatus for measuring the declination or variation of the magnetic needle at any place.

The variation transit generally consists of an altitude and azimuth instrument, the telescope of which is so arranged as to be readily converted into a microscope.

Transition Resistance.—(See *Resistance, Transition.*)

Translator, Double-Current — —A telegraphic translator or repeater designed to operate on double current transmission.

Translator, Single-Current — —A telegraphic translator or repeater designed to operate a single-current transmission.

Translator, Telegraphic — —A term sometimes applied to a telegraphic repeater. (See *Repeaters, Telegraphic.*)

Translating Device.—(See *Device, Translating.*)

Translating Devices, Multiple-Arc-Connected — —(See *Devices, Translating, Multiple-Arc-Connected.*)

Translating Devices, Multiple-Connected — —(See *Devices, Translating, Multiple-Connected.*)

Translating Devices, Multiple-Series-Connected — —(See *Devices, Translating, Multiple-Series-Connected.*)

Translating Devices, Series-Connected — —(See *Devices, Translating, Series-Connected.*)

Translating Devices, Series-Multiple-Connected — —(See *Devices, Translating, Series-Multiple-Connected.*)

Translucent-Disc Photometer. — (See *Photometer, Translucent-Disc.*)

Transmission, Double — —The simultaneous sending of two messages over a single wire in opposite directions. (See *Telegraphy, Duplex, Bridge Method of.*)

Transmission, Multiple — —The simultaneous sending of more than two messages over a single line or conductor.

Transmission of Energy.—(See *Energy, Electric, Transmission of.*)

Transmitter, Carbon, for Telephones — —A telephone transmitter consisting of a button of compressible carbon.

The sound waves impart to-and-fro movements to the transmitting diaphragm, and this to the carbon button, thus varying its resistance by pressure. This button is placed in circuit with the battery and induction coil. (See *Telephone.*)

Transmitter, Double-Current — —The transmitting instrument employed in systems of telegraphy, by means of which the direction of the currents on the line is alternately changed, according to whether the key rests on its front or on its back stop.

Double-current transmitters are used in connection with instruments, such as polarized relays, which respond to change in the direction of the current, rather than to changes in its intensity.

Transmitter, Electric — —A name applied to various electric apparatus employed in telegraphy or telephony to transmit or send the electric impulses over a line wire or conductor.

The sending instrument as distinguished from the receiving instrument.

In most telegraphic systems, the transmitting instrument consists of various forms of keys for interrupting or varying the current. In the telephone the transmitter consists of a diaphragm operated by the voice of the speaker. (See *Telephone.*)

Transmitter, Water-Jet Telephone — —A telephone transmitter consisting of a jet of water issuing vertically downwards from a small orifice.

The jet forms a part of the circuit of the receiving telephone. In order to reduce its resistance, the water is rendered acid by the addition of sulphuric acid, and a battery of high electromotive force is employed. Since the jet has a high resistance, a battery of high resistance can be used without inconvenience.

THIS PAGE IS LOCKED TO FREE MEMBERS

Purchase full membership to immediately unlock this page



HISTORY

Tens of thousands of important historical sources, many previously unobtainable, are now available for the first time with a Forgotten Books Full Membership.

Unlimited Access
\$8.99/month

Continue

*Fair usage policy applies

and carrying flanged wheels, extending in over the conductors.

Swinging from the axles of the poles are arms, which form a bail-like draft loop, with insulated material between their lower ends, and furnish means for connection with the car motor. In order to remove this trolley from the conducting wires, these arms are pressed together at points between two points of hangers, which allows them to pass between the inner ends of the wheel axles.

The trolley cannot be removed from the wires except at the end of the track, and it is therefore found in practice to be particularly useful in mines, where, from the nature of the galleries, the trolley wheel is very apt to become detached from the trolley wires.

Trolley, Drop — — The trolley wheel and rod for an electric car which drops away from the wire on slipping from the wire, and is reset upwards through proper elastic pressure.

Trolley Fork.—(See *Fork, Trolley*.)

Trolley Frog.—(See *Frog, Trolley*.)

Trolley Frog, Standard — — (See *Frog, Trolley, Standard*.)

Trolley Hanger.—(See *Hanger, Trolley*.)

Trolley Pole.—(See *Pole, Trolley*.)

Trolley Section.—(See *Section, Trolley*.)

Trolley, Single — — A traveling conductor or wheel which moves over a single conductor in a system of electric railways, and takes off the current for driving the electric motor, in connection with an earth or grounded return conductor.

Trolley Wheel.—(See *Wheel, Trolley*.)

Trolley, Wire — — (See *Wire, Trolley*.)

True Contact Force.—(See *Force, True Contact*.)

True Resistance. — (See *Resistance, True*.)

Trumpet, Electric — — An electromagnetic buzzer, the sound of which is strengthened by means of a resonator in the shape of a trumpet. (See *Buzzer, Electric, Resonator, Electric*.)

The electric trumpet is used to replace electric bells. It gives a louder and more penetrating sound than the electric bell.

Trunking Switch Board.—(See *Board, Switch, Trunking*.)

Tube, Crookes' — — A tube containing a high vacuum and adapted for showing any of the phenomena of the ultra-gaseous state of matter. (See *Matter, Radiant, or Ultra-Gaseous*.)

Tube, Insulating — — A tube of insulating material provided for covering a splice in an insulated conductor.

Tube, Mercury — — Vacuous glass tubes in which a flash of light is produced by the fall of a small quantity of mercury placed inside it.

The light is caused by the electricity produced by the friction of the mercury in falling against the sides of a spiral glass tube placed inside the vacuous tube.

Tube, Plücker — — A modification of a Geissler tube adapted for the study of the stratification of the light, and the peculiarities of the space adjoining the negative electrode. (See *Tubes, Geissler*.)

Tube, Spark — — A high vacuum tube, across which, when the vacuum is sufficiently high, the spark from an induction coil will not pass.

A spark tube, connected with incandescent lamps while undergoing exhaustion, acts as a simple gauge to determine the degree of exhaustion. When an induction coil discharge ceases either to pass, or to pass freely, the vacuum is considered as sufficient, according to circumstances.

Tube, Stratification — — An exhausted glass tube, the residual atmosphere of which displays alternate dark and light striæ, or stratifications, on the passage through it of an induction coil discharge. (See *Discharge, Luminous Effects of*.)

Tubes, Geissler — — Vacuum tubes of glass containing various gases, liquids or solids, provided with platinum electrodes, passed through and fused into the glass, designed to show the various luminous effects

of electric discharges through gases at comparatively low pressures.

Geissler tubes are made of a great variety of shapes, and often include tubes, spirals, spheres, etc., within other tubes. These enclosed tubes are made either of ordinary glass, or of uranium glass in order to obtain the effects of fluorescence.

The vacuum in Geissler tubes is by no means what might be called a high vacuum. Indeed, if the exhaustion of the tube be pushed too far, much of the brilliancy of the luminous effects is lost.

Some of the many forms of Geissler tubes are shown in Fig. 560.

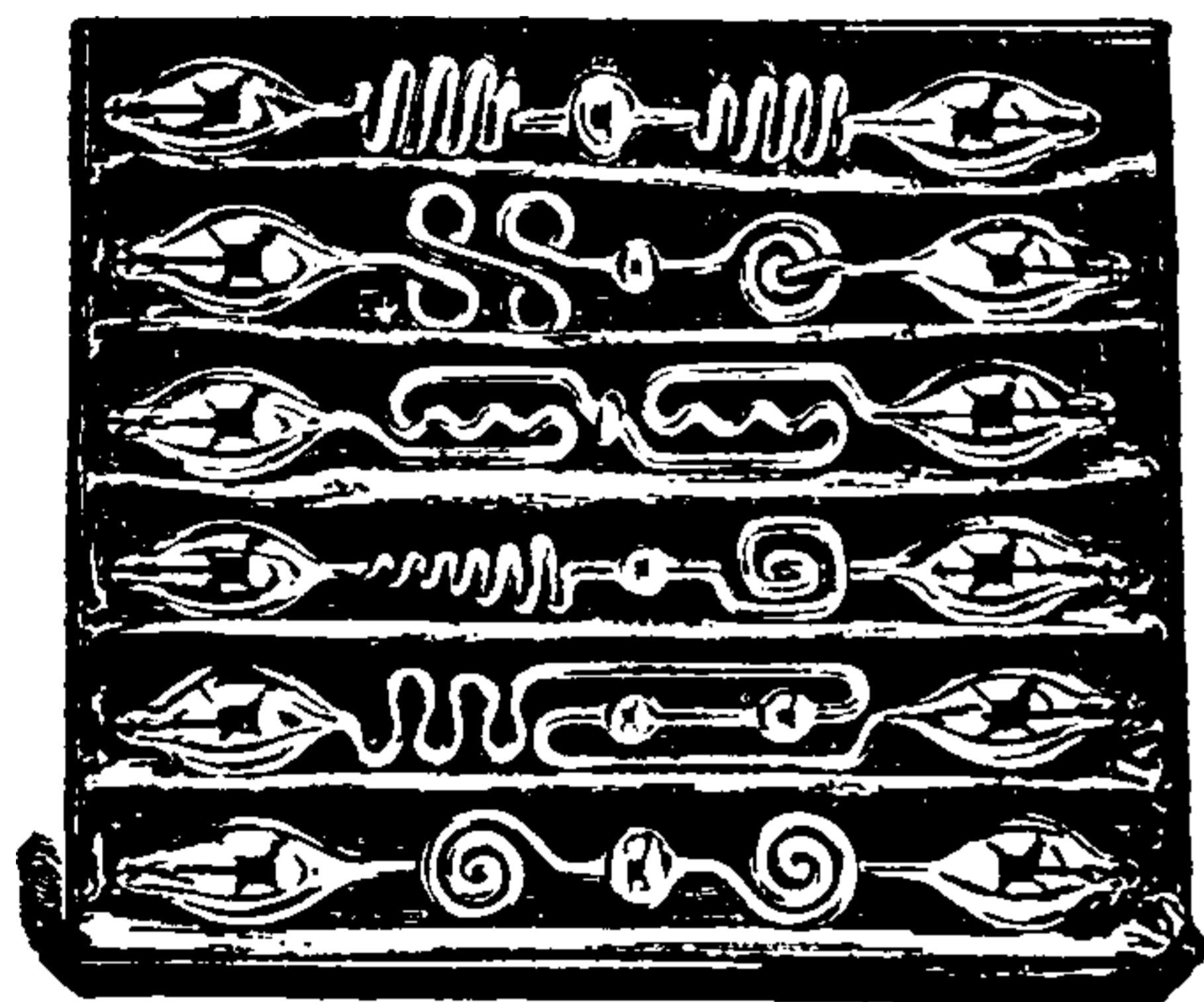

Fig. 560. Geissler Tubes.

Tubes of Force.—(See *Force, Tubes of*.)

Tubes of Induction.—(See *Induction, Tubes of*.)

Tubes, Vacuum — — Glass tubes, from which the air has been partially exhausted and through which electric discharges are passed for the production of luminous effects. (See *Tubes, Geissler*.)

Tubular Braid.—(See *Braid, Tubular*.)

Tumbling Box.—(See *Box, Tumbling*.)

Tuning-Fork or Reed Interrupter.—(See *Interrupter, Tuning-Fork. Interrupter, Reed*.)

Turn, Ampère — — A single turn or winding in a coil of wire through which one ampère passes.

An ampère-turn is sometimes called an ampère-winding. Magneto-motive force in a magnetic circuit is proportioned to the number of ampère-turns linked with it. The practical unit of magneto-motive force is $\frac{1}{4\pi} \times \text{ampère turn} = .0796$ ampère turn. Therefore the magneto-motive

force, m. m. f., is found by multiplying the ampère turns by 4π or 12.57.

The number of ampères multiplied by the number of windings or turns of wire in a coil give the total number of ampère-turns in the coil.

In a coil of fixed dimensions the magnetizing force developed by a given number of ampère-turns remains the same as long as the product of the ampères and the current remains the same. That is to say, the same amount of magnetizing force can be obtained by the use of many windings and a small current, as in shunt dynamos, or by a few turns and a proportionally large current, as in series dynamos. (See *Machine, Dynamo-Electric*.)

Turns, Ampère, Primary — — The ampère-turns of the primary of an induction coil.

Turns, Ampère, Secondary — — The ampère-turns of the secondary of an induction coil.

Turns, Dead — — The number of revolutions a self-exciting dynamo makes before it excites itself.

Turns, Dead, of Armature Wire — — Those turns of the wire on the armature of a dynamo-electric machine which produce no useful electromotive force or resultant current, on the movement of the armature through the magnetic field of the machine.

The wire on the inside of a Gramme or ring armature is dead wire, but not dead turns.

Turns, Series, of Dynamo-Electric Machines — — The ampère-turns in the series circuit of a compound-wound dynamo-electric machine. (See *Machine, Dynamo-Electric, Compound-Wound*.)

Turns, Shunt, of Dynamo-Electric Machine — — The ampère-turns in the shunt circuit of a compound-wound dynamo-electric machine. (See *Machine, Dynamo-Electric, Compound-Wound*.)

Turn-Table, Electric — — A table, suitable for show windows, revolved around a vertical axis by means of an electric motor.

Twig.—A sub-branch. (See *Branch, Sub*.)

Twin Wire.—(See *Wire, Twin*.)

Twist in Leads.—(See *Leads, Armature, Twist in.*)

Twisted Bunched Cable.—(See *Cable, Bunched, Twisted.*)

Twisted-Pair Cable.—(See *Cable, Twisted-Pair.*)

Twisting Force.—(See *Force, Twisting.*)

Two-Fluid Voltaic Cell.—(See *Cell, Voltaic, Two-Fluid.*)

Two-Point Switch.—(See *Switch, Two-Point.*)

Two, Three, Four, etc., Conductor Cable — — (See *Cable, Two, Three, Four, etc., Conductor.*)

Two-Way Splice Box.—(See *Box, Splice, Two-Way.*)

Two-Way Switch.—(See *Switch, Two-Way.*)

Type-Printing Telegraph.—(See *Telegraphy, Printing.*)

Typewriter, Electric — — — A typewriting machine, in which the keys are intended to make the contacts only of circuits of electro-magnets, by the attraction of the armatures of which the movements of the type levers required for the work of printing are effected.

Electric typewriters secure a uniformity of impression that is impossible to obtain with hand-worked machines. They also greatly lessen the mechanical labor of writing. (See *Dynamograph.*)

U

U.—A contraction sometimes used for unit.

Ultra-Gaseous Matter.—(See *Matter, Radiant, or Ultra-Gaseous.*)

Underground Cable.—(See *Cable, Underground.*)

Underground Conductor.—(See *Conductor, Underground.*)

Undulating Currents.—(See *Current, Undulating.*)

Undulatory Currents.—(See *Currents, Undulatory.*)

Undulatory Discharge.—(See *Discharge, Undulatory.*)

Ungilding Bath.—(See *Bath, Ungilding.*)

Unidirectional Discharge. — (See *Discharge, Unidirectional.*)

Unidirectional Leak.—(See *Leak, Unidirectional.*)

Uniform Density of Field.—(See *Field, Uniform Density of.*)

Uniform Magnetic Field.—(See *Field, Magnetic, Uniform.*)

Uniform Magnetic Filament.—(See *Filament, Uniform Magnetic.*)

Uniform Potential. — (See *Potential, Uniform.*)

Uniformly Distributed Current.—(See *Current, Uniformly Distributed.*)

Unipolar Armature.—(See *Armature, Unipolar.*)

Unipolar-Electric Bath.—(See *Bath, Unipolar-Electric.*)

Unipolar Induction.—(See *Induction, Unipolar.*)

Unit Angle.—(See *Angle, Unit. Velocity, Angular.*)

Unit Angular Velocity.—(See *Velocity, Angular.*)

Unit, B. A. — — — A term formerly applied to the British Association unit of resistance, or ohm. (See *Ohm.*)

Unit-Difference of Potential or Electromotive Force — — — (See *Potential, Unit Difference of.*)

Unit, Magnetic, A — — — A term sometimes used for a line of magnetic force, or the amount of magnetism induced in an area of one square centimetre at the centre of a coil having a diameter of 10 centimetres and carrying a current of 7.9578 ampères.

Unit, Natural, of Electricity — — — (See *Electricity, Natural Unit of.*)

THIS PAGE IS LOCKED TO FREE MEMBERS

Purchase full membership to immediately unlock this page

Know Your Bible

Forgotten Books' Full Membership provides unlimited access to more than 28,000 volumes of Christian literature for \$8.99/month

HOLY BIBLE

Continue

*Fair use policy applies

Units, Derived — — Various units obtained or derived from the fundamental units of Length, L., Mass, M., and Time, T.

The derived units and their dimensions are as follows:

Area, L^2 .—The square centimetre.

Volume, L^3 .—The cubic centimetre.

Velocity, V.—Unit distance traversed in unit time, or

$$V = \frac{L}{T}. \quad (1)$$

Acceleration, A.—The rate of change which will produce a change of velocity of one centimetre per second.

$$A = \frac{V}{T}. \quad (2)$$

Substituting in equation (2) the value of V, in equation (1), we have

$$A = \frac{\frac{L}{T}}{T} = \frac{L}{T^2}. \quad (3)$$

Force, F.—The *dyne*, or the force required to act on unit mass in order to impart to it unit velocity.

$$F = M \times A. \quad (4)$$

Substituting the value of A, derived from equation (2), we have

$$F = M \times \frac{V}{T}.$$

Substituting the value of V, derived from equation (1), we have

$$F = \frac{M}{T} \times \frac{L}{T} = \frac{ML}{T^2}. \quad (5)$$

Work or Energy, W.—The *erg*, or the work done in overcoming unit force through unit distance.

$$W = F \times L = \frac{ML}{T^2} \times L = \frac{ML^2}{T^2}.$$

Power, P.—The unit rate of doing work.

$$P = \frac{W}{T} = \frac{\frac{ML^2}{T^2}}{T} = \frac{ML^2}{T^3}. \quad (6)$$

Units, Dimensions of — — The values given to the units of length, L; mass, M, and time, T. (See *Units, Derived*.)

Units, Electro-Magnetic — — A system of units derived from the C. G. S. units, em-

ployed in electro-magnetic measurements. (See *Units, Centimetre-Gramme-Second*.)

Units based on the attractions or repulsions between two unit magnetic poles at unit distance apart. (See *Units, Electrostatic*.)

Units, Electro-Magnetic, Dimensions of

$$\text{Current Strength} = \text{Intensity of Field} \times \text{Length} = \frac{\sqrt{ML}}{T}.$$

$$\text{Quantity} = \text{Current} \times \text{Time} = \sqrt{M \times L}.$$

Potential, Difference of Potential, Electromotive Force =

$$\frac{\text{Work}}{\text{Quantity}} = \frac{\sqrt{M \times L^3}}{T^2}.$$

$$\text{Resistance} = \frac{\text{Electromotive Force}}{\text{Current}} = \frac{L}{T}.$$

$$\text{Capacity} = \frac{\text{Quantity}}{\text{Potential}} = \frac{T^2}{L}.$$

Units, Electrostatic — — Units based on the attractions or repulsions of two unit charges of electricity at unit distance apart.

Two systems of electric units are derived from the C. G. S. system, viz., the *electrostatic* and *electro-magnetic*. These units are based respectively on the force exerted between two quantities of electricity and between two magnet poles.

The electrostatic units embrace the units of *quantity*, *potential* and *capacity*. No particular names have as yet been adopted for these units.

Unit of Quantity.—That quantity of electricity which will repel an equal quantity of the same kind of electricity placed at a distance of one centimetre from it with the force of one dyne.

Electrostatic potential, or power of doing electrostatic work, is measured in units of work, or ergs.

Unit Difference of Potential.—Such a difference of potential between two points as requires the expenditure of one *erg* of work to bring up a unit of positive electricity from one point to the other against the electric force.

Unit of Capacity.—Such a capacity of conductor as will take a charge of one unit of electricity when the potential is unity.

The ratio between the inductive capacity of a substance and that of air, measured under pre-

cisely similar conditions, is called the *specific inductive capacity*.

The specific inductive capacity is obtained by comparing the capacity of a condenser filled with the particular substance and the capacity of the same condenser when filled with air. The specific inductive capacity of air is taken as unity.

Units, Electrostatic, Dimensions of

$$\text{Quantity} = \sqrt{\text{Force} \times (\text{Distance})^2} = \sqrt{F \times L^2} = \frac{M^{\frac{1}{2}} L^{\frac{3}{2}}}{T}$$

$$\text{Current} = \frac{\text{Quantity}}{\text{Time}} = \frac{M^{\frac{1}{2}} L^{\frac{3}{2}}}{T^2} = \frac{\sqrt{M \times L^3}}{T^2}$$

$$\text{Potential} = \frac{\text{Work}}{\text{Quantity}} = \frac{M^{\frac{1}{2}} L^{\frac{1}{2}}}{T} = \frac{\sqrt{M \times L}}{T}$$

$$\text{Resistance} = \frac{\text{Potential}}{\text{Current}} = L^{-1} T = \frac{T}{L}$$

$$\text{Capacity} = \frac{\text{Quantity}}{\text{Potential}} = L.$$

Specific Inductive Capacity =

$\frac{\text{One Quantity}}{\text{Another Quantity}} = \text{A Simple Ratio or Number.}$

Electromotive Intensity =

$$\frac{\text{Force}}{\text{Quantity}} = M^{\frac{1}{2}} L^{\frac{1}{2}} T^{\frac{1}{2}} = \frac{\sqrt{M \times L}}{T}$$

The fractional and negative exponents used above are merely convenient methods of expressing the extraction of roots and division respectively by the quantity represented by these exponents.

Units, Fundamental — — The units of length, time and mass, to which all other quantities can be referred.

The unit of length is now generally taken as the *centimetre*, the unit of time as the *second*, and the unit of mass as the *gramme*. These form a system of measurement known as the *centimetre-gramme-second* system, or the C. G. S. system, or absolute system. (See *Units, Derived*.)

The dimensions of the fundamental units are designated thus:

$$\text{Length} = L.$$

$$\text{Mass} = M.$$

$$\text{Time} = T.$$

Units, Heat — — Units based on the

quantity of heat required to raise a given weight or quantity of a substance, generally water, one degree.

The principal heat units are the English heat unit, the greater and smaller calorie and the joule. (See *Calorie. Foule.*)

The following table gives the values of some of the principal heat units :

1 gram. centigrade,	.001	kilogram centigrade.
1 pound Fahrenheit,	1,047.03	joules.
"	772.	foot-pounds.
"	106.731	kilogram metres.
"	.55556	pound centigrade.
"	.25200	kilogram centigrade.
"	.29084	watt-hours.
"	.0003953	metric horse-power.
"	.0003899	horse-power hours.
1 pound centigrade,	1,884.66	joules.
"	1,389.6	foot-pounds.
"	192.116	kilogram metres.
"	1.800	pound Fahrenheit.
"	.4536	kilogram centigrade.
"	.52352	watt-hour.
"	.0007115	metric horse-power hour.
"	.0007018	horse-power hour.
1 kilogram centigrade,	4,154.95	joules.
"	3,063.5	foot-pounds.
"	423.54	kilogram metres.
"	3.9683	pound Fahrenheit.
"	2.2046	pound centigrade.
"	1.1542	watt-hour.
"	.001569	metric horse-power hour.
"	.0015472	horse-power hour.

—Hering.

Units, Magnetic — — Units based on the force exerted between two magnet poles.

Unit strength of a magnetic pole is such a magnetic strength of pole that repels another magnetic pole of equal strength placed at unit distance with unit force, or with the force of one dyne.

Magnetic Potential.—Is the power of doing work possessed by a magnetic pole.

Magnetic potential is measured like electrostatic potential in units of work or in ergs.

Magnetic Potential, Unit Difference of.—Such a difference of magnetic potential between two points that requires the expenditure of one erg of work to bring a magnetic pole of unit strength from one to the other.

Unit Intensity of Magnetic Field.—Such an intensity of magnetic field as acts on a north or south-seeking pole of unit strength with the force of one dyne.

Units, Magnetic, Dimensions of — —
 Strength of Pole, or }
 Quantity of Magnetism }

$$= \sqrt{\text{Force} \times (\text{Distance})^2} = \sqrt{\frac{ML^3}{T}}$$

Magnetic Potential

$$= \frac{\text{Work}}{\text{Strength of Pole}} = \sqrt{\frac{M \times L}{T}}$$

Intensity of Field = $\frac{\text{Force}}{\text{Strength of Pole}} = \frac{\sqrt{M}}{T \times \sqrt{L}}$

Units, Practical — — Multiples or fractions of the absolute or centimetre-gramme-second units.

The practical units have been introduced because the absolute units are either too small or too large for actual use.

Electromotive Force.—The *Volt* = 100,000,000 C. G. S. or absolute units, that is, 10^8 absolute units of resistance. (See *Volt*.)

Resistance.—The *Ohm* = 1,000,000,000 absolute units of electromotive force, or 10^9 absolute units. (See *Ohm*.)

Current.—The *Ampère* = $\frac{1}{10}$ absolute unit of current. (See *Ampère*.)

Quantity.—The *Coulomb* = $\frac{1}{10}$ absolute unit of quantity, of the electro-magnetic system. (See *Coulomb*.)

Capacity.—The *Farad* = $\frac{1}{1,000,000,000}$ absolute unit of capacity, or 10^{-9} units of capacity. (See *Farad*. *Henry*. *Watt*. *Foule*.)

Units, Proposed New — — The following units and terms have recently been proposed by Oliver Heaviside.

Some of these have been generally adopted.

Conductance.—Capacity for conducting electricity.

Numerically, the ratio, in absolute measure, of the current strength to the total electromotive force in a circuit of uniform flow. A quantity with the nature of a slowness or reciprocal to a velocity. The practical unit is called the mho.

Conductivity.—Conductance per unit volume.

Elastance.—Capacity of a dielectric for opposing electric charge or displacement.

“Numerically, the ratio, in absolute measure, of the difference of potential in an electrostatic circuit to the total charge or displacement therein produced. The reciprocal of permittance and a quantity of the inverse nature of a length.”

“*Elastivity.*—Elastance per unit volume of dielectric.”

Impedance.—Capacity for opposing the variable flow of electricity.

“Numerically, in the absolute measure, the ratio of the total electromotive force to the current strength at any instant in a circuit of a variable flow. A quantity with the nature of a velocity and in any circuit always greater than the resistance.”

“*Inductance.*—Capacity for magnetic induction.”

“Numerically, in absolute measure, the number of unit lines of magnetic force linked with a circuit traversed by the unit current strength. Sometimes alluded to as the co-efficient of self-induction. A quantity of the nature of a length.”

“*Inductivity.*—Specific capacity for magnetic induction.

“The numerical ratio of the induction in a medium to the induction producing it.”

Permittance.—Electrostatic capacity. Capacity of a dielectric for assisting charge or displacement.

“Numerically, the ratio, in absolute measure, of the total charge or displacement in the electrostatic circuit, to the difference of potential producing it. A quantity with the nature of a length.”

“*Permittivity.*—The numerical ratio of the permittance of a dielectric to that of air.

“Also known as specific inductive capacity.”

“*Reluctance.*—Capacity for opposing magnetic induction.

“Numerically, the ratio, in absolute measure, of the magneto-motive force in a magnetic circuit to the total induction therein produced. A quantity with the nature of the reciprocal of a length. Sometimes described as magnetic resistance.”

Reluctancy or Reluctivity.—Reluctance per unit volume.

“Sometimes described as specific magnetic resistance. A numeric, the reciprocal of inductivity.”

“*Resistance.*—Capacity for opposing the steady flow of electricity.

“Numerically, in absolute measure, the ratio of the total electromotive force to the current strength in a circuit of uniform flow. A quantity with the nature of a velocity. The practical unit is called the ohm.”

“*Resistivity.*—Resistance per unit volume; sometimes alluded to as specific resistance.”

Universal Discharger.—(See *Discharger*, *Universal*.)

Upright Galvanometer.—(See *Galvanometer*, *Upright*.)

THIS PAGE IS LOCKED TO FREE MEMBERS

Purchase full membership to immediately unlock this page



HISTORY

Tens of thousands of important historical sources, many previously unobtainable, are now available for the first time with a Forgotten Books Full Membership.

Unlimited Access
\$8.99/month

Continue

*Fair usage policy applies

needle which occurs at different seasons of the year.

Variation Chart or Map.—(See *Map or Chart, Isogonic.*)

Variation, Cyclical Magnetic — —Secular magnetic variations occurring during great cycles of time. (See *Variation, Secular. Variation, Magnetic.*)

Variation, Diurnal — —An approximately regular variation of the magnetic needle, which occurs at different hours of the day. (See *Declination.*)

Variation, Irregular — —A variation of the magnetic needle which occurs at irregular intervals. (See *Declination.*)

Variation, Magnetic — —Variations in the value of the magnetic declination, or inclination, that occur simultaneously over all parts of the earth.

The term is also applied to the magnetic declination itself.

These variations are:

(1.) Secular, or those occurring at great cycles of time.

(2.) Annual, or those occurring at different seasons of the year.

(3.) Diurnal, or those occurring at different hours of the day.

(4.) Irregular, or those accompanying magnetic storms. The first three are periodical; the last is irregular. (See *Declination, Angle of. Chart, Inclination.*)

Variation, Secular — —A variation in the magnetic declination which occurs at great cycles or intervals of time. (See *Declination.*)

Varieties of Circuits.—(See *Circuits, Varieties of.*)

Variometer, Magnetic — —An instrument for comparing the horizontal component of the earth's magnetism in different localities.

Varnish, Electric — —A varnish formed of any good insulating material.

Shellac dissolved in alcohol, applied to a

thoroughly dried surface and afterwards hardened by baking, forms an excellent varnish.

Varnish, Stopping-Off — —A varnish used in electro-plating to cover portions which are not to receive the metallic coating.

A good stopping-off varnish is made by mixing together 10 parts of rosin, 6 parts of beeswax, 4 parts of sealing-wax and 3 parts of rouge, dissolved in turpentine. (See *Stopping-Off.*)

Vat, Depositing — —The vat in which the process of electro-plating is carried on. (See *Plating, Electro.*)

The depositing vat contains the plating liquid, the metallic anode and the object to be plated.

Vegetation, Effects of Electricity on — —Most vegetable fibres contract when an electric current is passed through them while on the living plant.

Some experiments appear to show that electric charges and currents hasten the germination and growth of certain plants. Other experiments seem to show that under certain circumstances electric currents retard plant growth. The direction of the currents is probably of main importance.

Velocimeter.—Any apparatus for measuring the speed of a machine.

Velocity, Angular — —The velocity of a body moving in a circular path, measured, not as usual, by the length of its path divided by the time, but with reference to the angle it subtends and to the length of the radius.

Unit angle is that angle subtended by a part of the circumference equal to the length of the radius, or 57 degrees 17 minutes 44 seconds .8 nearly.—(*Daniell.*)

Unit angular velocity is the velocity under which a particle moving in a circular path, whose radius equals unity, would traverse unit angle in unit time.

Velocity, New Unit of — —The kine. (See *Kine.*)

Velocity of Discharge.—(See *Discharge, Velocity of.*)

Velocity Ratio.—(See *Ratio, Velocity.*)

Ventilation of Armature.—(See *Armature, Ventilation of*.)

Vernier.—A device for the more accurate measurement of small differences of length than can be detected by the eye alone, by means of the direct reading of the position of a mark on a sliding scale.

The sliding scale is called the vernier. There are a variety of vernier scales in use.

Vertical Component of Earth's Magnetism.—(See *Component, Vertical, of Earth's Magnetism*.)

Vertical Electrostatic Voltmeter.—(See *Voltmeter, Vertical, Electrostatic*.)

Verticity, Poles of, Magnetic — —The earth's magnetic poles, as determined by means of the dipping needle.

The point of the north where the angle of dip is 90 degrees. (See *Map or Chart, Inclination*.)

Vibrating.—Moving to-and-fro.

Vibrating Bell.—(See *Bell, Vibrating*.)

Vibrating Contact.—(See *Contact, Vibrating*.)

Vibration.—A to-and-fro motion of the particles of an elastic medium. (See *Wave*.)

Vibration or Wave, Amplitude of — —The ratio that exists in a wave between the degree of condensation and rarefaction of the medium in which the wave is propagated.

The amplitude of a wave is dependent on the amount of energy charged on the medium in which the vibration or wave is produced.

A vibration or wave is a to-and-fro motion produced in an elastic material or medium by the action of energy thereon. Sound, light and heat are subjectively effects produced by the action of vibrations or waves, which in the case of sound are set up in the air, and, in that of light and heat, in a highly tenuous medium called the luminiferous ether. Objectively they are the waves themselves.

As the amplitude of a sound wave increases, the loudness or intensity of the sound increases. As the amplitude of the ether wave increases, the brilliancy of the light or the intensity of the light or heat increases.

Let A C, Fig. 561 represent an elastic cord or string tightly stretched between A and C. If the string be plucked by the finger, it will move to-and-fro, as shown by the dotted lines. Each to-and-fro motion is called a *vibration*. The

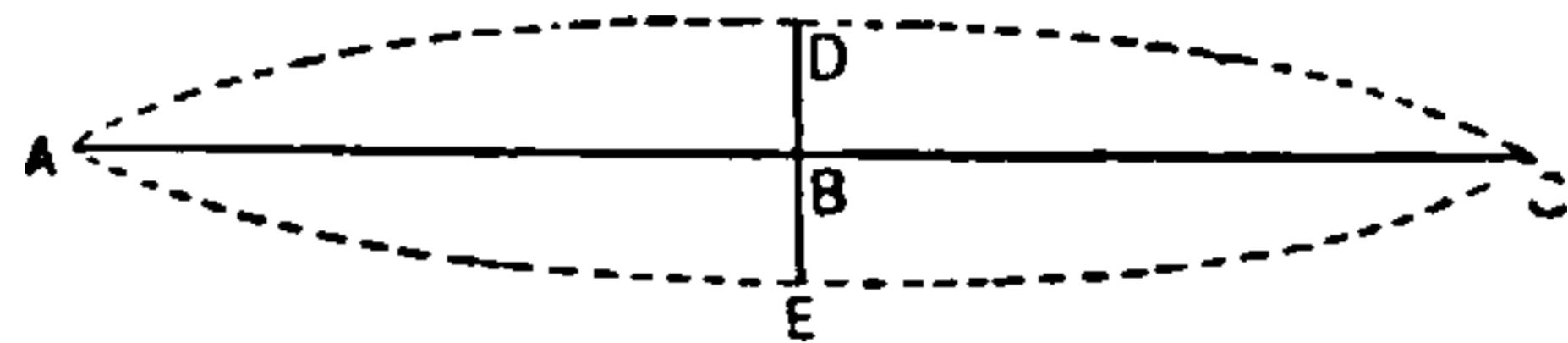

Fig. 561. *Amplitude of Wave.*

vertical distance B D, or B E, represents the *amplitude* of the vibration, and the sound produced is louder, the greater the amount of energy with which the string has been plucked, or, in other words, the greater the value of B D, or B E.

Vibrations assume various forms in solid or fluid media, but in all cases the amplitude will increase with the increase in the energy that causes the vibration.

Vibration Period.—(See *Period, Vibration*.)

Vibration, Period of — —The time occupied in executing one complete vibration or motion to-and-fro.

Vibration, Phase of — —The position of the particles in motion in a wave or vibration at any instant of time during the wave period, as compared with a zero line, or a line passing through their mean or middle position.

Vibrations, Isochronous — —Vibrations which perform their to-and-fro motions on either side of the position of rest in equal times.

The vibrations of a pendulum are practically isochronous, no matter what the amplitude of the swing may be, that is, whether the pendulum swings through a large arc or a small arc, provided this arc be not very great.

All vibrations that produce musical sounds may be regarded as isochronous; that is, in any case, the time required to complete a to-and-fro motion is the same at the beginning when the sound is loud, as at the end, when it is faint.

Vibrations, Sympathetic — —Vibrations set up in bodies by waves of exactly the same wave rate as those produced by the vibrating body.

The pitch or tone of the note produced by the body set into sympathetic vibration, is exactly the

same as the pitch or tone of the exciting waves or vibrations.

Hertz's experiments show that sympathetic vibrations are excited by electro-magnetic waves. (See *Electricity, Hertz's Theory of Electro-Magnetic Radiations or Waves.*)

Vibrations, Sympathetic, Electrical — — — Vibrations set up in circuits, by the effect of pulses in neighboring circuits, that are of exactly the same mean length.

Vibrations, Synchronous — — — Vibrations that are performed not only in the same time as one another, but which pass through the same portions of their to-and-fro movement at the same time.

Vibrator, Electro-Magnetic — — — A lever, or arm, automatically moved to-and-fro by the alternate attractions of an electro-magnet and an opposing spring, or by the successive action of two electro-magnets.

In either case the movement of the lever is utilized to permit the action of first one and then the other device. Automatic or trembling bells are operated by means of an electro magnetic vibrator.

Villari Critical Point.—A term proposed by Sir William Thomson for that strength of magnetic field at which the reversal of the effects of tension occurs.

Both magnetic susceptibility and permeability are affected by mechanical stress, vibration and changes of temperature. In a weak magnetic field the susceptibility of iron wire is increased by longitudinal tension, while in a strong field it may be decreased. The particular strength of field at which the reversal occurs is called the Villari critical point.

Viscosity, Magnetic — — — That property of iron or other paramagnetic substance in virtue of which a certain time is required before a given magnetizing force can produce its effects. (See *Hysteresis, Viscous.*)

Viscous Hysteresis.—(See *Hysteresis, Viscous.*)

Vis-Viva.—The energy stored in a moving body, and therefore the measure of the amount of work that must be performed in order to bring a moving body to rest.

If M, is the mass and V, the velocity

$$\text{The Vis-Viva} = \frac{MV^2}{2}.$$

Vitreous Electricity.—(See *Electricity, Vitreous.*)

Vitrite.—An insulating substance.

Volatilization, Electric — — — A term sometimes used instead of electric evaporation. (See *Evaporation, Electric.*)

Volcanic Lightning.—(See *Lightning, Volcanic.*)

Volt.—The practical unit of electromotive force.

Such an electromotive force as is induced in a conductor which cuts lines of magnetic force at the rate of 100,000,000 per sec.

Such an electromotive force as would cause a current of one ampère to flow against the resistance of one ohm.

Such an electromotive force as would charge a condenser of the capacity of one farad with a quantity of electricity equal to one coulomb.

10^3 absolute electro-magnetic units of electromotive force.

Volt-Ammeter.—A wattmeter.

A variety of galvanometer capable of directly measuring the product of the difference of potential and the ampères. (See *Wattmeter.*)

Volt Ampère.—A watt. (See *Watt.*)

Volt-Coulomb.—The unit of electric work. The joule. (See *Joule.*)

Volt, Mega — — — One million volts.

Volt, Micro — — — The one-millionth of a volt.

Voltage.—This term is now very commonly used for either the electromotive force or difference of potential of any part of a circuit as determined by the reading of a voltmeter placed in that part of the circuit.

Voltage, Terminal — — — The electromotive force expressed in volts of a dynamo or other electric source, as indicated by a voltmeter placed across its terminals.

The terminal voltage is greater than that on the leads or conductors at some distance from

THIS PAGE IS LOCKED TO FREE MEMBERS

Purchase full membership to immediately unlock this page

Know Your Bible

Forgotten Books' Full Membership provides unlimited access to more than 28,000 volumes of Christian literature for \$8.99/month

HOLY BIBLE

Continue

*Fair use policy applies

Voltaic Circuit.—(See *Circuit, Voltaic*.)

Voltaic Couple.—(See *Couple, Voltaic*.)

Voltaic Effect.—(See *Effect, Voltaic*.)

Voltaic Electricity.—(See *Electricity, Voltaic*.)

Voltaic Element.—(See *Element, Voltaic*.)

Voltaic or Current Induction.—(See *Induction, Voltaic*.)

Voltmeter.—An electrolytic cell employed for measuring the quantity of the electric current passing through it by the amount of chemical decomposition effected in a given time.

Various electrolytes are employed in voltmeters, such as aqueous solutions of sulphuric acid, copper sulphate, or other metallic salts.

In the sulphuric acid voltmeter shown in Fig. 562, the battery terminals are connected with platinum electrodes, immersed in water slightly acidulated with sulphuric acid, and placed inside glass tubes, also filled with acidulated water. On the passage of the current hydrogen appears at the kathode, and oxygen at the anode, in nearly the proportion of two volumes to one. (See *Ozone*.)

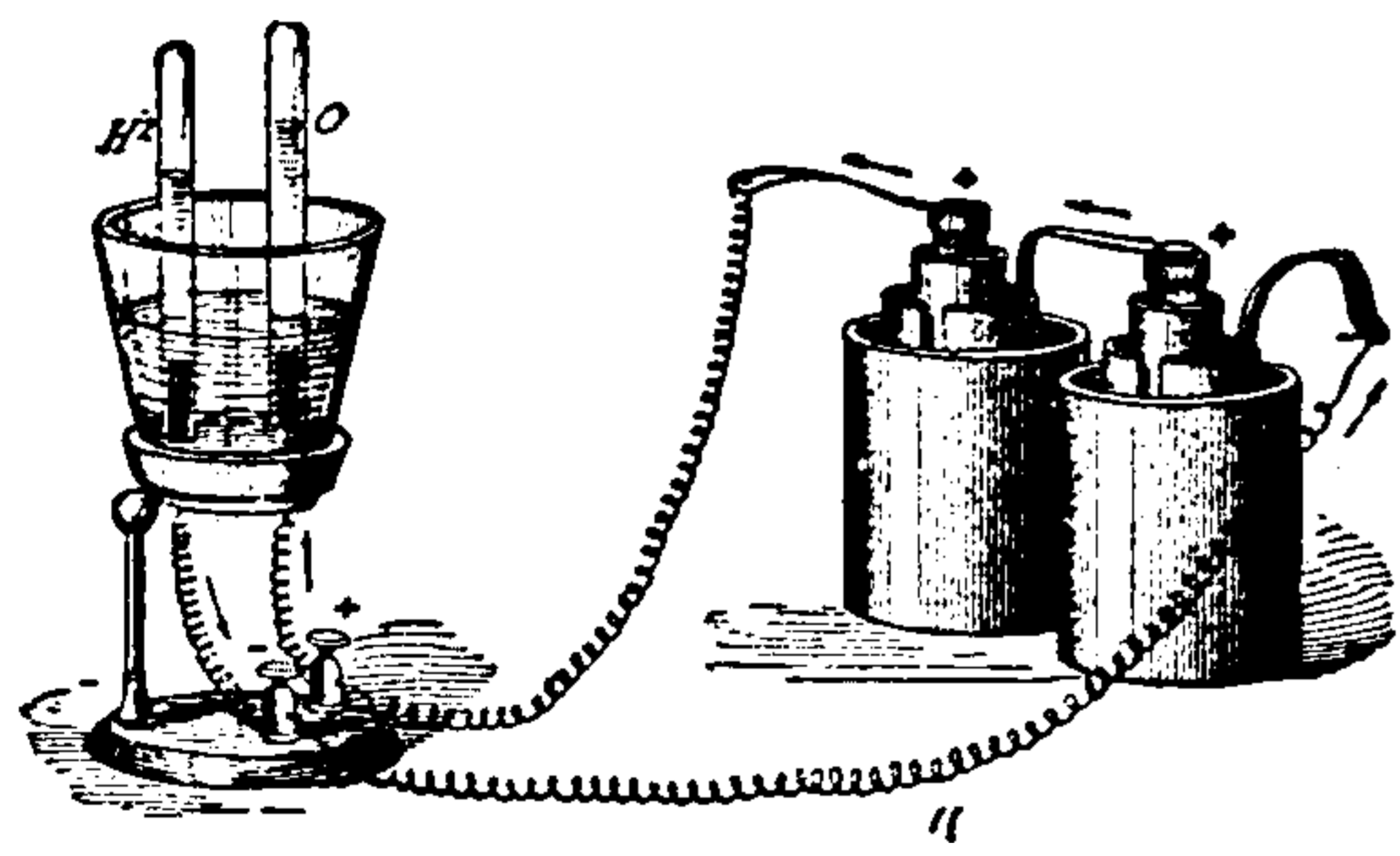
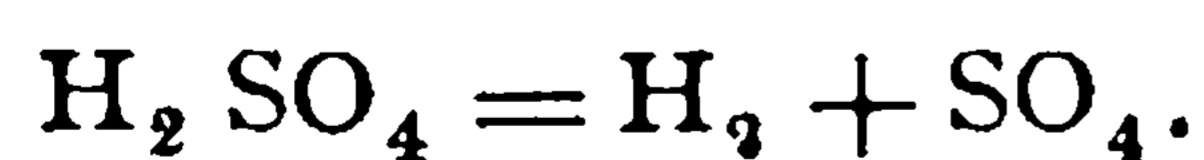

Fig. 562. A Sulphuric Acid Voltmeter.

In the case of water containing sulphuric acid (*hydrogen sulphate*) the decomposition would appear to be that of the sulphuric acid rather than that of the water. The reaction is as follows:



The hydrogen appears at the electro negative terminal or *kathode*. The SO_4 appears at the electro positive terminal or *anode*, but combines with one molecule of water, thus, $\text{SO}_4 + \text{H}_2\text{O} = \text{H}_2\text{SO}_4 + \text{O}$, gaseous oxygen being driven off at the anode.

Voltmeters are not as well suited as galvanometers for the measurement of electric currents, because a certain electromotive force must be reached before electrolysis is effected.

The voltmeter in reality measures the coulombs, and, therefore, is valuable as a current measurer only when the current is constant.

Coulomb-meter would, therefore, be the preferable term.

Then, again, time is required to produce the results, and considerable difficulty is experienced in maintaining the current strength constant, either on account of variations in the electromotive force of the source, or of variations in the resistance of the voltmeter.

Voltmeter, Copper— —A voltmeter in which the quantity of the current passing is determined by the weight of copper deposited.

A current, the strength of which is constant, is passed through the voltmeter for a given time. The kathode, preferably of platinum, is thoroughly cleaned and dried with a current of heated air and accurately weighed before and after. The current strength is then deduced from the increase in weight and the time.

A galvanometer is kept in the circuit of the battery and voltmeter. If a Daniell battery is used, it should be kept on closed-circuit through a resistance for some time before use, in order to insure normal current.

It will be noticed that the indications of this voltmeter are based on the gain in weight of the kathode. The loss in weight of the anode is misleading, owing to secondary chemical action and disintegration.

Voltmeter, Gas — —A term sometimes used for volume voltmeter. (See *Voltmeter, Volume*.)

Voltmeter, Siemens' Differential — — A form of voltmeter employed by Sir William Siemens for determining the resistance of the platinum spiral used in his electric pyrometer. (See *Pyrometer, Siemens' Electric*.)

Two separate voltmeter tubes, provided with platinum electrodes and filled with dilute sulphuric acid, are provided with carefully graduated tubes to determine the volume of the decomposed gases. (See *Voltmeter, Volume*.)

A current from a battery is divided by a suitable commutator into two circuits connected respectively with the two voltmeter tubes. In one of these circuits a known resistance is placed, in the other the resistance to be measured, *i. e.*, the platinum coil used in the electric pyrometer.

Voltmeter, Silver — —A voltmeter in which the quantity of the current passing is determined by the weight of silver deposited.

A solution of silver nitrate is used as the electrolytic liquid. When the current to be measured is strong the strength of the silver nitrate solution is made stronger.

Voltmeter, Volume — —A voltmeter in which the quantity of the current passing is determined by the volume of the gases evolved.

In some forms of volume voltmeter in which dilute sulphuric acid is electrolyzed, both the hydrogen and the oxygen are measured, either separately or together.

In one form of volume voltmeter the hydrogen only is collected, and thus the error in volumetric determinations arising from the decrease in volume from the formation of ozone is avoided. The evolved oxygen is isolated from the hydrogen by placing a porous jar between the electrodes. The negative electrode, is formed of platinum fused in the tube, which, for ease of connection, is partially filled with mercury.

The graduated glass tube, in which the hydrogen is collected, is maintained at a nearly constant temperature by means of a water column. A thermometer is provided for corrections of volume as affected by temperature.

The voltmeter contains dilute sulphuric acid, about 30 per cent. of acid.

Voltmeter, Weight — —A voltmeter in which the quantity of the current passing is determined by the difference in the weight of the instrument after the circuit has passed for a given time.

A weight voltmeter consists essentially of platinum electrodes and some means for thoroughly drying the evolved gases. A vessel filled with pumice stone moistened with sulphuric acid, or a chloride of calcium tube, may be used for this purpose. The voltmeter is carefully weighed before and after the decomposition. The difference in weight gives the weight of the sulphuric acid decomposed.

Voltametric Law.—(See *Law, Voltametric*.)

Voltmeter.—An instrument used for meas-

uring difference of potential. (See *Galvanometer. Potential, Difference of. Volt.*)

A voltmeter may be constructed on the principle of a galvanometer, in which case it differs from an ammeter, or ampère meter, which measures the current, principally in that the resistance of its coils is greater, and that in an ampère meter the coils are placed in the circuit, while in a voltmeter they are placed as a shunt to the circuit.

The difference of potential is determined from the reading of a voltmeter, by the fact that according to Ohm's law, the product of the current and the resistance is equal to the electromotive force, as $C = \frac{E}{R}$ from which we obtain $C \times R = E$.

In the ordinary operation of a voltmeter, the action of the current in passing through a coil of insulated wire is to produce a magnetic field, which causes the deflection of a magnetic needle. Since the resistance of the voltmeter is constant, the current passing, and hence the deflection of the needle, will vary with the value of E . The magnetic field produced by the current deflects the magnetic needle against the action of another field, which may be either the earth's field, or an artificial field produced by a permanent or an electro-magnet. Or, it may deflect it against the action of a spring, or against the force of gravity acting on a weight. There thus arise varieties of voltmeters, such as permanent-magnet voltmeters, spring voltmeters, and gravity voltmeters.

Or, the current produced by a given difference of potential may be used to heat a wire, and the value of the potential difference determined by the movement of a needle by the consequent expansion of a wire. Cardew's voltmeter operates on this principle. (See *Voltmeter, Cardew's*.)

Or, the potential difference to be measured may be utilized to charge a readily movable needle, and thus produce electrostatic attractions and repulsions.

This form of instrument is in reality a form of electrometer. (See *Electrometer, Quadrant. Attraction, Electrostatic*.)

Voltmeter, Cardew's — —A form of voltmeter in which the potential difference is measured by the amount of expansion caused by the heat of a current passing through a fixed resistance.

The current produced by the difference of potential to be measured is passed through a high

resistance wire of platinum silver, the expansion of which is caused to move a needle across a graduated arc. The wire is thin and therefore quickly acquires the temperature due to the current.

The Cardew voltmeter possesses an advantage of being independent of changes of temperature. It is also capable of being used to measure the potential difference of alternating currents.

Voltmeter, Closed-Circuit — —A voltmeter in which the points of the circuit, between which the potential difference is to be measured, are connected with a closed coil or circuit, and which gives indications by means of the current so produced in said circuit.

All galvanometer-voltmeters are of the closed-circuited type.

The Weston standard voltmeter shown in Fig. 563 is a closed-circuit voltmeter.

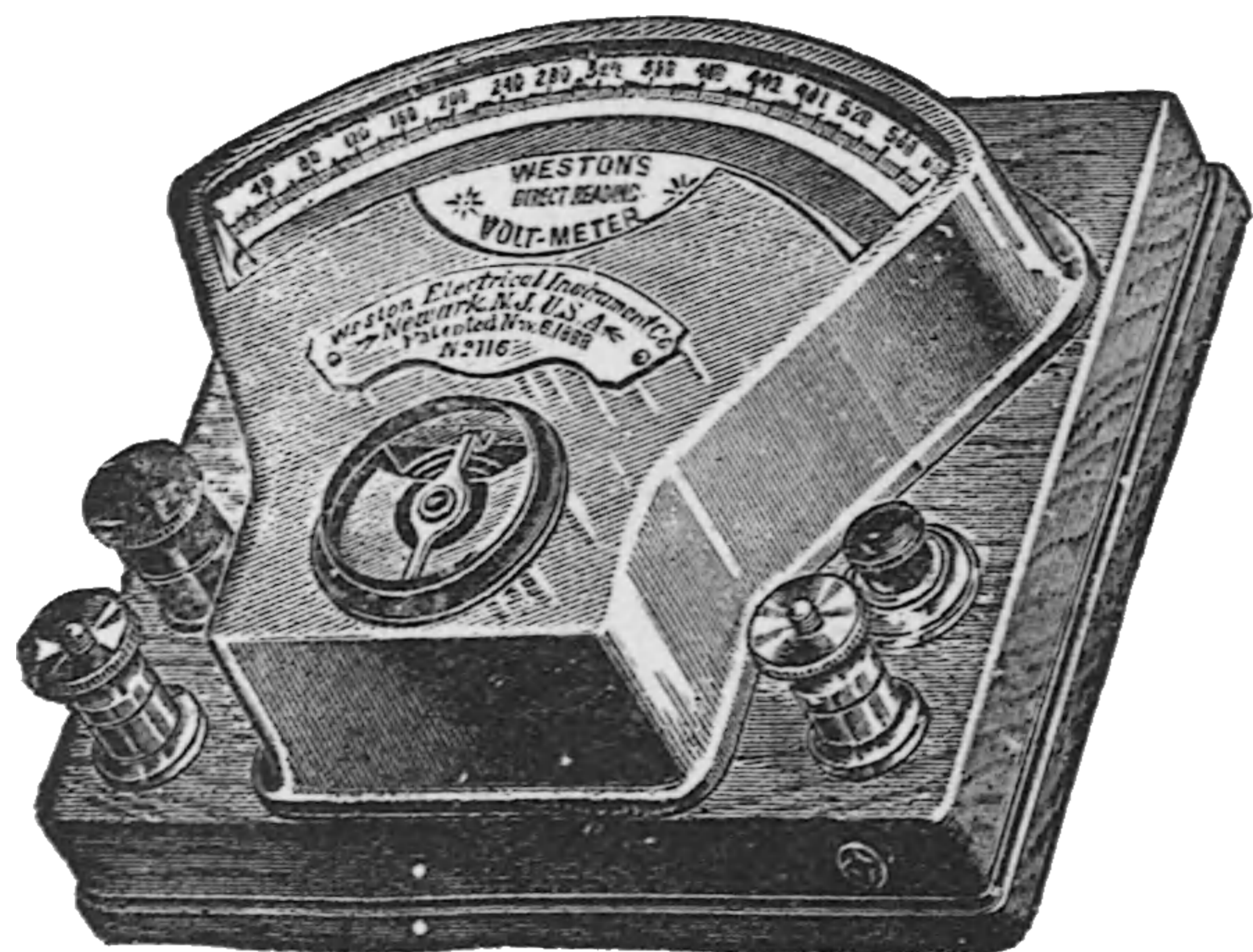

Fig. 563. Weston Standard Voltmeter.

Voltmeter, Electro-Magnetic — —A form of voltmeter in which the difference of potential is measured by the movement of a magnetic needle in the field of an electro-magnet. (See *Voltmeter*.)

Voltmeter, Gravity — —A form of voltmeter in which the potential difference is measured by the movement of a magnetic needle against the pull of a weight.

Sir William Thomson's balance instruments are used as gravity voltmeters. (See *Voltmeter*.)

Voltmeter, Magnetic-Vane — —A voltmeter in which the potential difference is measured by the repulsion exerted between a

fixed and a movable vane of soft iron placed within the field of the magnetizing coil.

A pointer, fixed to the moving vane, serves to measure the amount of the repulsion, and consequently the potential difference producing the magnetizing current. The moving vane moves under the magnetic repulsion against the action of a spring. Discs of copper for damping the movements of the movable vane, are placed before and behind it.

Voltmeter, Multi-Cellular Electrostatic — —An electrostatic voltmeter in which a series of fixed and movable plates are used instead of the single pair employed in the quadrant electrometer.

The movable pairs of plates are connected to a movable axis and placed vertically above one another. To the top of the axis is fixed a light aluminium needle or pointer, which moves over a graduated scale. A series of fixed plates, suitably supported and insulated from the ground, alternate with the needle plates.

Voltmeter, Open-Circuit — —A voltmeter in which the points of the circuit where potential difference is to be measured are connected with an open circuit and give indications by means of the charges so produced.

Electrometer-voltmeters are of the open-circuited type.

Voltmeter, Permanent Magnet — —A form of voltmeter in which the difference of potential is measured by the movement of a magnetic needle under the combined action of a coil and a permanent magnet, against the pull of a spring. (See *Voltmeter*.)

Voltmeter, Reducteur or Resistance for — —(See *Reducteur or Resistance for Voltmeter*.)

Voltmeter, Vertical Electrostatic — —A form of voltmeter the needle of which moves in a vertical instead of in a horizontal plane.

The construction of the vertical electrostatic voltmeter is, in general, similar to that of the quadrant electrometer. (See *Electrometer, Quadrant*.)

THIS PAGE IS LOCKED TO FREE MEMBERS

Purchase full membership to immediately unlock this page



HISTORY

Tens of thousands of important historical sources, many previously unobtainable, are now available for the first time with a Forgotten Books Full Membership.

Unlimited Access
\$8.99/month

Continue

*Fair usage policy applies

The watch is held by its chain and slowly lowered to the bottom of a hollow conical coil of wire, and then slowly withdrawn from the coil.

The wire is wound on the coil, as shown in Fig. 565, in the shape of a cone, viz.: with a single turn at the top, and gradually increasing in number of turns towards the bottom. The conical coil is connected with a source of rapidly alternating currents.

As the watch is lowered into the coil, it gradually becomes more and more powerfully magnetized with alternately opposite polarities, thus completely removing any polarity it previously possessed. As it is now slowly raised from out the hollow cone, this magnetization becomes less and less, until, if removed from the conical coil while high above its apex, all sensible traces of magnetism will have disappeared.

Watchman's Electric Register.—(See *Register, Watchman's Electric.*)

Water Battery.—(See *Battery, Water.*)

Water-Dropping Accumulator.—(See *Accumulator, Water-Dropping.*)

Water, Electrolysis of — — The decomposition of water by the passage through it of an electric current.

Water does not appear to conduct electricity when pure; it is therefore not quite certain that pure water can be electrolytically decomposed. The addition of a small quantity of sulphuric acid, or of a metallic salt, however, renders its electrolysis readily accomplished. (See *Voltameter.*)

In the opinion of most, it is the sulphuric acid that is decomposed rather than the water.

Water Horse-Power.—The Indian Government's term for horse-power developed by falling water.

The estimate is made by the following simple rule: 15 cubic feet of water falling per second through 1 foot equals 1 horse-power.

Water-Jet Telephone Transmitter.—(See *Transmitter, Water-Jet Telephone.*)

Water - Level Alarm.—(See *Alarm, Water or Liquid Level.*)

Water-Proof Wire.—(See *Wire, Water-Proof.*)

Water Pyrometer.—(See *Pyrometer, Siemens' Water.*)

Water Rheostat.—(See *Rheostat, Water.*)

Water Voltaic Cell.—(See *Cell, Voltaic, Water.*)

Watt.—The unit of electric power. The volt-ampère.

The power developed when 44.25 foot-pounds of work are done per minute, or 0.7375 foot-pounds per second.

The $\frac{1}{748}$ of a horse-power.

There are three equations which give the value of the watts, viz.:

$$(1.) C E = \text{The watts.}$$

$$(2.) C^2 R = \text{The watts.}$$

$$(3.) \frac{E^2}{R} = \text{The watts.}$$

Where C = the current in ampères; E = the electromotive force in volts, and R = the resistance in ohms. (See *Energy, Electric.*)

Watt Arc.—(See *Arc, Watt.*)

Watt Generator.—(See *Generator, Watt.*)

Watt-Hour.—A unit of electric work.

A term employed to indicate the expenditure of an electrical power of one watt, for an hour.

Watt-Hour, Kilo — — The Board of Trade unit of work equal to an output of one kilo-watt for one hour.

Watt, Kilo — — One thousand watts.

A unit of power sometimes used in stating the output of a dynamo.

A dynamo of 20 units, or a 20-unit machine, is one capable of giving an output of 20 kilo-watts.

Watt-Meter.—A galvanometer by means of which the simultaneous measurement of the difference of potential and the current passing is rendered possible.

The watt-meter consists of two coils of insulated wire, one coarse and the other fine, placed at right angles to each other as in the ohm-meter, only, instead of the currents acting on a suspended magnetic needle, they act on each other as in the electro-dynamometer.

Watt-Minute.—A unit of electric work.

An expenditure of electric power of one watt for one minute.

Watt-Second.—A unit of electric work.

An expenditure of electric power of one watt for one second.

Wave.—A disturbance in an elastic medium that is periodic both in space and time.

Wave, Electric — —An electric disturbance in an elastic medium that is periodic both in space and time. (See *Oscillations, Electric.*)

Waves, Amplitude of — —The amplitude of a vibration. (See *Vibration or Wave, Amplitude of.*)

Waves, Displacement — —Waves produced in the ether of dielectrics by means of electric displacement.

The electric stress applied to a dielectric to produce electric displacement soon strains it to its utmost and no further displacement can occur until the direction of the electric power is reversed. A rapidly intermittent current therefore can pass through a dielectric and thus produce a series of displacement waves.

Dielectrics, therefore, may be considered as pervious or transparent to rapidly intermittent or reversed periodic currents, but opaque or impervious to continuous currents. A condenser interpolated in a telephone circuit does not prevent telephonic communication, though it does effectually stop all continuous currents.

Waves, Electro-Magnetic — —Waves in the ether that are given off from a circuit through which an oscillating discharge is passing, or from a magnetic circuit undergoing variations in magnetic intensity.

Waves, Electro-Magnetic, Interference of — —Interference effects similar to those produced in the case of waves of light, observed in the case of electro-magnetic radiations, or waves, in which one system of waves, retarded a half wave length behind another system of equal wave length and amplitude, results in a complete loss of motion of the particles of the ether they tend to simultaneously affect.

In order that complete interference may take place, it is necessary

(1.) That the two waves, or system of waves, must meet in opposite phases. That is, that one be retarded back of the other one-half a wave length, or some odd number of half wave lengths.

(2.) That the waves simultaneously affect the

same particles of ether in which they are moving.

(3.) That the energy charged on the ether in the shape of waves of electro-magnetic radiation, must be equal in the case of each system of waves.

(4.) That the two systems of waves must have the same wave length.

These conditions, it will be seen, are exactly the same as in the case of the interference of light.

It will, of course, be readily understood that if electro-magnetic radiations can produce the effect of resonance, they must also necessarily produce interference effects.

Waves, Electro-Magnetic, Reflection of — —Reflection of electro-magnetic waves similar to the reflection of waves of light.

In his experiments on electro-magnetic radiations, Dr. Hertz shows that true reflection of electro-magnetic waves occurs from the surfaces of certain substances placed in the path of the waves.

In some experiments made in a large room, Dr. Hertz obtained undoubted indications of reflection of electro-magnetic waves from the walls of the room.

Waves of Condensation and Rarefaction. —The alternate spheres of condensed and rarefied air by means of which sound is transmitted. (See *Waves, Sound.*)

Waves, Sound — —Waves produced in air or other elastic media by the vibrations of a sonorous body. (See *Sound.*)

Way Line.—(See *Line, Way.*)

Weather Cross.—(See *Cross, Weather.*)

Weber.—A term formerly employed for the unit of electric current, and replaced by ampère. (See *Ampère.*)

The term weber was originally used to express a quantity of electricity equal to what is now called one coulomb, and a current designated by one weber per second. It was, however, used finally as a unit of current.

Weber.—A term proposed by Clausius and Siemens for a magnetic pole of unit strength, but not adopted.

This same term was also employed to designate the unit strength of current, now replaced by the term ampère.

Weber's Theory of Diamagnetism.—
(See *Diamagnetism, Weber's Theory of.*)

Weight, Atomic — —The relative weights of the atoms of elementary substances.

Since the atoms are assumed to be indivisible, they must unite or combine as wholes and not as parts. Although we cannot determine exactly the actual weights of the different elementary atoms, yet we can determine their relative weights by ascertaining the smallest proportions in which any two elements that combine atom for atom will unite with each other. Such numbers will represent the relative weights of the atoms as compared with hydrogen.

Weight Voltmeter.—(See *Voltmeter, Weight.*)

Weights and Measures, Metric System of — —A system of weights and measures adopted by almost all civilized nations except English-speaking, and by the scientific world generally.

For measures of length, the one ten-millionth part of the quadrant of a meridian of the earth is taken as the unit of length. This unit of length is called a metre, and various subdivisions and multiples of its length are made on the decimal system.

For a system of weights, the weight of one cubic centimetre of pure water at 39.2 degrees Fahr., the temperature of the maximum density of water, is taken as the unit of weight. This is called a *gramme*, and various multiples and subdivisions of this unit are made on the decimal system.

The following table of French measures and their corresponding English values are taken from Deschanel's "Elementary Treatise on Natural Philosophy":

Length.

1 millimetre = .03937 inch, or about $\frac{1}{25}$ inch.
1 centimetre = .3937 inch.
1 decimetre = 3.937 inches.
1 metre = 39.37 inches = 3.281 feet = 1.0936 yard.
1 kilometre = 1093.6 yards, or about $\frac{5}{8}$ mile.
Deschanel gives the length of the meter as equal to 39.370432 inches.

U. S. Coast Survey Bull. No. 9 of 1889, gives value of meter = 39.36980 inches. Therefore, 39.37 is probably as accurate as any other figure.

Area.

1 square millimetre = .00155 square inch.
1 square centimetre = .155 square inch.
1 square decimetre = 15.5 square inches.
1 square metre = 1550 square inches = 10.764 square feet = 1.196 square yards.

Volume.

1 cubic millimetre = .000061 cubic inch.
1 cubic centimetre = .061025 cubic inch.
1 decimetre = 61.0254 cubic inches.
Cubic metre = 61025 cubic inches = 35.3156 cubic feet = 1.308 cubic yards.

The litre (used for liquids) is the same as the cubic decimetre, and is equal to 1.7617 pint, or .22021 gallon.

Mass and Weight.

1 milligramme = .01543 grain.
1 gramme = 15.432 grains.
1 kilogramme = 15432.3 grains = 2.205 pounds avoirdupois.

More accurately, the kilogramme is 2.20462125 pounds.

Miscellaneous.

1 gramme per square centimetre = 2.0481 pounds per square foot.

1 kilogramme per square centimetre = 14.223 pounds per square inch.

1 kilogramme = 7.2331 foot-pounds.

1 *force de cheval* = 75 kilogrammetres per second, or 542½ foot pounds per second, nearly, whereas 1 horse-power (English) = 550 foot-pounds per second.

Conversion of English into French measures:

Length.

1 inch = 2.54 centimetres, nearly.
1 foot = 30.48 centimetres, nearly.
1 yard = 91.44 centimetres, nearly.
1 statute mile = 160933 centimetres, nearly.
More accurately, 1 inch = 2.5399772 centimetres.

Area.

1 square inch = 6.45 square centimetres, nearly.
1 square foot = 929 square centimetres, nearly.
1 square yard = 8361 square centimetres, nearly.

1 square mile = 2.59×10^{10} square centimetres, nearly.

Volume.

1 cubic inch = 16.39 cubic centimetres, nearly.
1 cubic foot = 28316 cubic centimetres, nearly.

THIS PAGE IS LOCKED TO FREE MEMBERS

Purchase full membership to immediately unlock this page

Know Your Bible

Forgotten Books' Full Membership provides unlimited access to more than 28,000 volumes of Christian literature for \$8.99/month

HOLY BIBLE

Continue

*Fair use policy applies

lows, viz.: the welding junctions are made slightly convex, so as to touch in but one part of their opposing faces. They are made to touch near their centres and the welding heat is first reached near their points of junction. Pressure is then applied by means of a screw, lever or hydraulic pressure until all the surfaces are at the welding temperature.

This operation requires in practice but a few seconds for small work, and at the most but a

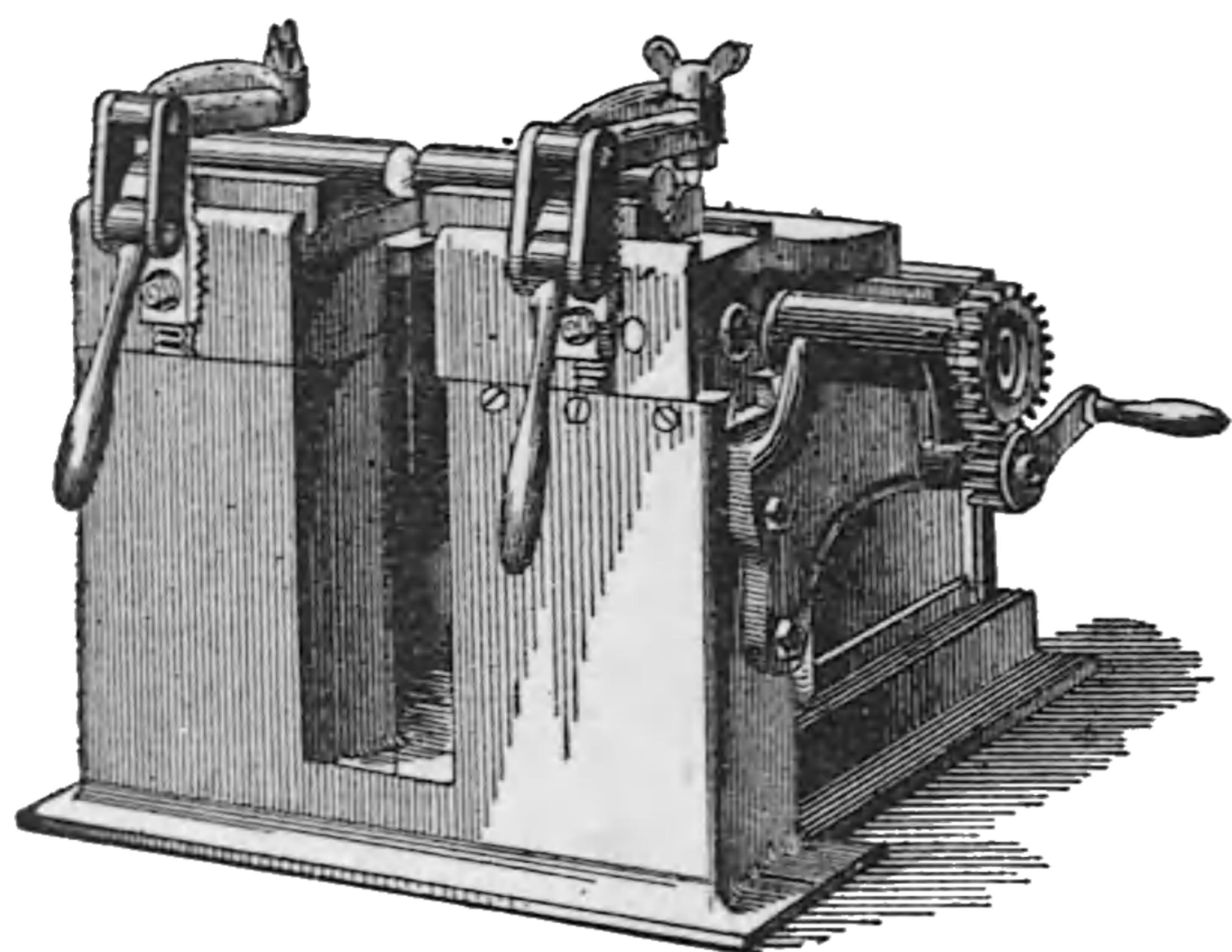

Fig. 567. The Thomson Indirect Welder.

few minutes for larger work. The heating is practically local, extending in most cases a distance equal to about the diameter of the weld.

For the purpose of controlling the electromotive force, and thus adapting the same welder to different classes of work, when a transformer is used, a second transformer provided with a movable core is placed in series with the first. A number of coils of insulated wire are placed in a segment of a split-ring laminated-core. These may be connected in series or in multiple by a switch. An iron armature placed within the split ring encloses the annular core and acts as the low-resistance secondary. When this is placed so as to embrace the primary coils, the difference of potential will be different than if moved to one side or the other of the ring.

Welding Transformer.—(See *Transformer, Welding*.)

Wheatstone's Electric Balance.—(See *Balance, Wheatstone's Electric*.)

Wheatstone's Electric Bridge.—(See *Bridge, Wheatstone's Electric*.)

Wheel, Barlow's or Sturgeon's — — A wheel or disc of metal capable of rotation on a horizontal axis, that is set into rotation when placed between the poles of magnets and

traversed by a current of electricity from the centre to the circumference.

Wheel, Phonic — — A wheel maintained in synchronous rotation by means of timed electric impulses sent over a line, and employed in Delany's synchronous multiplex telegraphic system.

The phonic wheel was invented by La Cour, but was first put into successful operation in multiplex telegraphy by Delany in his system of synchronous multiplex telegraphy. (See *Telegraphy, Synchronous Multiplex, Delany's System*.) Delany obtains the exact synchronism of the phonic wheel by means of a series of correcting electric impulses, automatically sent over the line on the failure of the phonic wheel at either end of the line to exactly synchronize with that at the other end.

Wheel, Reaction, Electric — — A wheel driven by the reaction of a convective discharge. (See *Flyer, Electric*.)

Wheel, Trolley — — A metallic wheel connected with the trolley pole and moved over the trolley wire on the motion of the car over the tracks, for the purpose of taking the current from the trolley wire by means of rolling contact therewith.

Whirl, Electric — — A term employed to indicate the circular direction of the lines of magnetic force surrounding a conductor conveying an electric current. (See *Field, Electro-Magnetic*.)

This is more correctly called a magnetic whirl. (See *Whirl, Magnetic*.)

Whirl, Expanding Magnetic — — One of the magnetic whirls which are sent out from a conductor through which a current of gradually increasing strength is passing, or from a magnet whose magnetism is increasing.

These magnetic whirls, according to Hertz, move outward through free ether with the velocity of light.

Whirl, Magnetic — — The lines of magnetic force which surround the circuit of the conductor conveying an electric current.

Whistle, Steam, Automatic Electric — — A steam whistle, employed on foggy days in some systems of railway signals, when the

visual signals cannot be seen, in which the passage of the steam through the whistle is automatically obtained by the closing of an electric contact, or the passage of the locomotive over a certain part of the track.

White Heat.—(See *Heat, White.*)

White Hot.—(See *Hot, White.*)

Wimshurst Electrical Machine.—(See *Machine, Wimshurst Electrical.*)

Wind, Electric — —The convection stream of air particles produced at the extremities of points attached to the surface of charged, insulated conductors. (See *Convection, Electric. Flyer, Electric.*)

Windage of Dynamo.—A term proposed for the air gap between the armature and the pole pieces of a dynamo.

This term is not much used.

Winders, Telegraphic Paper — —Apparatus for winding or coiling the paper fillets used on telegraphic registers.

When moved by means of a spring they are generally styled automatic winders.

Winding, Ampère — —A single winding or turn through which one ampère passes.

Ampère-winding is used in the same signification as ampère-turn. (See *Turn, Ampère.*)

Winding, Bifilar — —A winding of a coil of wire in which, instead of winding the wire in one continuous length, it is doubled on itself and then wound.

This method is employed in resistance coils, so as to avoid the induction effects. (See *Coil, Resistance.*)

Winding, Compound, of Dynamo-Electric Machine — —A method of winding in which shunt and series coils are placed on the field magnets. (See *Machine, Dynamo-Electric, Compound-Wound.*)

Winding, Series — —A winding of a dynamo-electric machine in which a single set of magnetizing coils are placed on the field magnets, and connected in series with the armature and the external circuit. (See *Machine, Dynamo-Electric, Series-Wound.*)

Window-Tube Insulation.—(See *Insulator, Window-Tube.*)

Wipe Spark.—(See *Spark, Wipe.*)

Wiping Contact.—(See *Contact, Wiping.*)

Wire, Air-Line — —That portion of a circuit which is formed by air-strung wires, in contradistinction to the portion which passes through underground or submarine cables.

Wire, Binding, for Telegraph Lines — —The wire used for securing lines of wire conductors to the insulators.

The line wire rests against the insulators at as small an area of contact as possible, generally only a mere edge. In order to attach the wire to the insulator, and protect the wire from chafing, it is secured to the insulator by binding with wire.

Wire, Block — —A line or wire employed in a block system for railroads, connecting a block tower with the next tower on each side of it. (See *Railroads, Block System for.*)

Wire, Braided — —A conducting wire covered with a braiding, as distinguished from a wire that is merely wrapped with insulating material.

Cotton or silk is used for braiding. The covering is often coated by a layer of some insulating gum or varnish dissolved in a rapidly drying liquid. It is sometimes covered with melted paraffine.



Fig. 568. Braided Wire.

A copper wire covered with insulating material and then braided is shown in Fig. 568.

Wire, Calling — —A wire employed in a telegraphic or telephonic system, by means of which a subscriber communicates with the central office, or one central office communicates with another.

This wire is termed the *calling* wire in order to distinguish from the wire actually used for talking or telegraphing.

Wire, Conductibility and Sizes of — —For tables giving the resistance, size, weight per foot, etc., of wire according to some of the principal wire gauges see pages 254 and 256.

Wire, Copper, Hard-Drawn — —Copper wire that is drawn three or four times after annealing.

The drawing subsequent to annealing renders the wire hard and elastic, with but a trifling decrease in its conductivity. A hard-drawn wire, of course, possesses greater limits of elasticity than soft-drawn wire, and, therefore, in the case of air lines, permits of the use of a longer distance between adjacent poles.

Wire, Copper, Soft-Drawn — —Copper wire that is softened by annealing after drawing. (See *Wire, Copper, Hard-Drawn*.)

Wire, Dead, of Armature — —That part of the wire on the armature of a dynamo which produces no electromotive force or resultant current.

It is called dead because it does not move through the field of the machine.

Wire, Duplex — —An insulated conductor containing two separate parallel wires.

Wire, Earth-Grounded — —A wire one terminal of which is grounded or put to earth, so that the earth forms a part of the circuit in which the wire is placed.

Wire, Feeding — —A term sometimes applied to the wire or lead of a multiple circuit which feeds the main.

In a system of electric railroads the feeding wires feed the trolley wires.

Wire Finder.—(See *Finder, Wire*.)

Wire, Fuse — A readily fusible wire employed in a safety catch to open the circuit when the current is excessive. (See *Catch, Safety*.)

Wire Gauge, Vernier — —(See *Gauge, Wire, Micrometer*.)

Wire, Grounded — —(See *Ground or Earth*.)

Wire, House — —In a system of incandescent electric lighting any conductor that is connected with a service conductor and leads to the meter in the house.

Wire, Insulated — —Wire covered with any insulating material.

Cotton and silk are generally employed for insulating purposes, either alone, or in connection with various gums, resins, or other materials, which are rendered plastic by heat, but which solidify on cooling. India rubber, caoutchouc, and various mixtures and compounds are also employed for the same purpose.

For most of the purposes of line wires, high insulating powers, combined with a low specific inductive capacity, are required in the insulating materials.

For overhead wires a waterproof covering is necessary. In the neighborhood of combustible materials, some fireproof covering is desirable.

Wire, Lead — —A lead fuse wire.

Wire, Line — —In telegraphy the wire that connects the different stations with one another.

In bell and annunciator circuits, the term line wire is sometimes applied to all circuits other than the main line.

In arc-light circuits the term line wire is applied to the entire metallic circuit, to which the lamps are connected in series.

Wire, Main — —The principal wire.

In any system of bell circuits, the main wire is the wire which runs from one pole of the battery to one of the springs of all the pushes, in distinction from the line wires, or the rest of the wires in the battery circuit.

Wire, Message — —A line or wire employed in a block system for railroads, extending along the road and used for local traffic or business. (See *Railroads, Block System for*.)

Wire, Negative — —A term sometimes applied to that wire of a parallel circuit which is connected to the negative pole of a source.

Wire, Neutral — —The middle wire of a three-wire system of electric distribution.

Wire, Omnibus — —An omnibus bar. (See *Bars, Omnibus*.)

A bus bar or wire. (See *Wires, Bus*.)

Wire, Paraffined — —Wire wrapped or braided with some textile material and afterwards coated with paraffine.

The term paraffined wire is sometimes limited to a wrapped wire that is afterwards paraffine coated.

THIS PAGE IS LOCKED TO FREE MEMBERS

Purchase full membership to immediately unlock this page



HISTORY

Tens of thousands of important historical sources, many previously unobtainable, are now available for the first time with a Forgotten Books Full Membership.

Unlimited Access
\$8.99/month

Continue

*Fair usage policy applies

Wire, Wrapped — — Wire that is insulated by placing strands of some insulating material, like cotton, parallel to its length, and then wrapping a number of strands around the wire.

The wrapped wire is afterwards either coated with paraffine or other insulator, or is used without such coating.

Wires, Bus — — A term sometimes used for omnibus bars or wires.

The wires which receive the full current generated by the electric source, and carry it to the feeders.

The bus-wires collect the current from all the sources, hence the name.

Wires, Breaking-Weight of — — The weight required to be hung at the end of a wire in order to break it.

Ordinary copper wire will break at about 17 tons to the square inch of area of cross section. Common wrought iron breaks at 25 tons to the square inch. These figures are to be regarded as approximate only, since almost inappreciable differences in the physical condition of metals, as well as slight variations in their chemical composition, often produce marked differences in their breaking weights.

Wires, Cross — — (See *Cross, Electric*.)

Wires, Crossing — — A device employed in telegraphic circuits whereby a faulty conductor is cut out of the circuit of a telegraph line by crossing over to a neighboring, less used, line.

To cut out a faulty section of wire in any circuit, such as C D, in the circuit A B C D E, Fig. 570, a cross-connection is made to a line X Y, running near it, and which may be temporarily thrown out of use. By this means the interruption of an important circuit may be repaired.

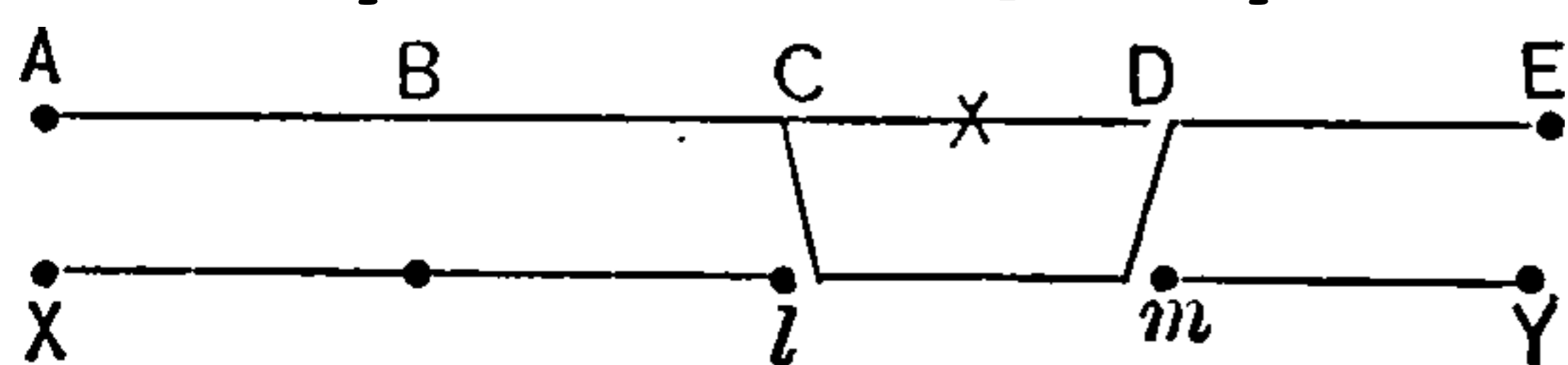

Fig. 570. Crossing Wires.

Wires, Dead — — Disused and abandoned electric wires.

The term *dead* is often applied to a wire through which no current is passing. The term, however, is more properly applied to a wire formerly employed, but subsequently abandoned.

Dead wires in the neighborhood of active wires are a constant menace to life and property, and should invariably be carefully removed.

It is often a matter of considerable importance to be able to determine whether or not a current is passing through a wire. When the wire is not enclosed in a moulding, or fastened against a wall, this can readily be ascertained by bringing a small compass needle near the wire, when it will tend to set itself across the wire.

The term dead wire, as will be seen, is used in two distinct senses.

Wires, Leading-In — — The wires or conductors which lead the current through (into and out of) an electric lamp.

The term leading-in wires is generally applied to incandescent electric lamps, Geissler or Crookes tubes, and to various other apparatus.

Wires, Leading-Up — — Wires employed for raising an aerial cable to the cable hangers.

Wires, Omnibus — — A term sometimes used for bus wires. (See *Wires, Bus*.)

Wires or Conductors, Continuous — — Wires or conductors free from joints.

Wires or conductors without soldered or twisted joints or without any joints whatsoever.

Wires, the entire lengths of which have been taken from the hitherto uncut coil of wire from the draw plate.

Strictly speaking, any metallic circuit consists of a continuous wire, whether in one piece or in several sections or pieces. The preferable term would appear to be unjointed wires or conductors.

Wires, Phantom — — A term applied to the additional circuits or wires obtained in any single wire or conductor by the use of some multiplex telegraphic system. (See *Telegraphy, Multiplex. Telegraphy, Synchronous-Multiplex, Delany's System*.)

Wires, Pilot — — In a system of incandescent lighting, where a comparatively low potential is employed on the mains, thin wires leading directly from the generating station to different parts of the mains, in order to determine the differences of potential at such points.

Pilot wires indicate on a voltmeter the difference of potential at the various points. The pilot wires extend to the various seats of supply, and so give instant warning of any change in the value of the potential.

Wires, Pressure — — — In a system of incandescent electric lighting, wires or conductors, series-connected with the junction boxes, and employed in connection with suitable voltmeters, to indicate the pressure at the junction boxes.

The pressure wires are sometimes called the pilot wires.

Wires, Tap — — — The wires or conductors used to carry the current from the feeders or mains at the pole to a near point on the trolley wire.

Wiring.—Collectively the wires or conducting circuits used in any system of electric distribution.

Wiring.—Placing or establishing the wires or conductors for any electric circuit.

Wiring, Case — — — Placing or establishing electric conductors or wires that are held in place on the walls or ceiling of a room, by means of continuous cleats.

Wiring, Cleat — — — Placing or establishing electric conductors or wires that are held in place on the walls or ceiling of a room by means of suitably shaped insulating cleats.

Wiring, Inside — — — The conductors that, in a system of incandescent electric lighting, lead to the interior of the house or area to be lighted.

Wiring, Moulding — — — Electric conductors or wires that are held in place on the walls or ceiling of a room by means of suitably shaped mouldings.

Work.—The product of the force by the distance through which the force acts.

A force whose intensity is equal to one pound acting through the distance of one foot, does an amount of work equal to one foot-pound.

Work is to be distinguished from the more general term energy.

Work, Electric — — — The joule. (See *Joule*.)

The product of the volts by the coulombs.
 1 joule = 10,000,000 ergs, or .73732 foot-pounds.
 " = 1 volt-coulomb.
 " = 1 watt for 1 second.

Work, Electric, Unit of — — — The volt-coulomb or joule. (See *Volt-Coulomb. Joule*.)

Work, Unit of — — — The erg.
 The amount of work done when a force of one dyne acts through the distance of one centimetre. (See *Erg*.)

Raising one gramme against gravity, through the distance of one centimetre, requires an amount of work equal to 980 ergs.

Work, Units of — — — Various units employed for the measurement of work.

The following table of Units of Work is taken from Hering's work on Dynamo-Electric Machines :

WORK.	
1 erg	= 1 dyne-centimetre.
1 "	= .0000001 joule.
1 gramme-centimetre ..	= 981.00 ergs.
1 " ..	= .00001 kilogr.-metre.
1 foot-grain.....	= 1937 5 ergs.
1 joule, or 1 volt-coulomb, or 1 watt during every second or 1 volt-ampère during every second	= { 10,000,000 ergs, .737324 foot pound, .101937 kilogram-metre, .0013592 metric horse-power for one second.
1 volt ampère during every second.....	= .0013406 horse-power for one second.
"	= .0009551 pound-Fah., heat unit.
"	= .0005306 pound-Centig., heat unit.
"	= .002407 kilogr.-Centig., heat unit.
"	= .0002778 watt-hour.
1 foot-pound.....	= 13562600 ergs.
" ..	= 1.35626 joules.
" ..	= .13825 kilogr. metre.
" ..	= .0018434 metric horse-power for e second.
" ..	= .00181818 horse-power for one second.

1 foot-pound.....	= .0012953 pound-Fah., heat unit.
"	= .0007196 pound-Centig., heat unit.
"	= .0003264 kilogr.-Centig., heat unit.
"	= .0003767 watt-hour.
1 kilogram-metre.....	= 98100000 ergs.
"	= 9.81000 joules.
"	= 7.23314 foot-pounds.
"	= .01333 metric horse-power for one second.
"	= .013151 horse power for one second.
"	= .009369 pound-Fah., heat unit.
"	= .005205 pound-Centig., heat unit.
"	= .002361 kilogr.-Centig., heat unit.
"	= .002725 watt-hour.
1 watt-hour	= 3600 joules.
"	= 2654.4 foot-pounds.
"	= 366.97 kilogram-metres.
"	= 3.4383 pound-Fah., heat units.
"	= 1.9102 pound-Centig., heat units.
"	= .8664 kilogr.-Centig., heat units.
"	= .0013592 metric horse power-hour.
"	= .0013406 horse-power-hour.
1 metric h.-p.-hour	= 2648700 joules.
"	= 1952940 foot-pounds.
"	= 270000 kilogram-metres.
"	= 2529.7 pound-Fah., heat units.
"	= 1405.4 pound-Centig., heat units.
"	= 637.5 kilogr.-Centig., heat units.
"	= 735.75 watt-hours.
"	= .98634 horse-power-hour.
1 horse-power-hour....	= 2685400 joules.
"	= 1980000 foot-pounds.
"	= 273740 kilogram-metres.

1 horse-power-hour....	= 2564.8 pound-Fah., heat units.
"	= 1424.9 pound-Centig., heat units.
"	= 646.31 kilogr.-Centig., heat units.
"	= 745.941 watt-hours.
"	= 1.01385 metric horse-power-hour.

HEAT.

1 gram-Centig.....	= .001 kilogram-Centigrade.
1 pound-Fahr.....	= 1047.03 joules.
"	= 772 foot-pounds.
"	= 106.731 kilogram-metres.
"	= .55556 pound-Centigrade.
"	= .25200 kilogram-Centigrade
"	= .29084 watt-hour.
"	= .0003953 metric horse-power-hour.
"	= .0003899 horse-power-hour.
1 pound-Centig.....	= 1884.66 joules.
"	= 1389.6 foot-pounds.
"	= 192.116 kilogram-metres.
"	= 1.8000 pound-Fahrenheit.
"	= .4536 kilogram-Centigrade.
"	= .52352 watt-hours.
"	= .0007115 metric horse-power-hour.
"	= .0007018 horse-power-hour.
1 kilogram-Centig.....	= 4154.95 joules.
"	= 3063.5 foot-pounds.
"	= 423.54 kilogram-metres.
"	= 3.9683 pound-Fahrenheit.
"	= 2.2046 pound-Centigrade.
"	= 1.1542 watt hours.
"	= .001569 metric horse-power-hour.
"	= .0015472 horse-power-hour.

Working, Direct — —The transmis-

THIS PAGE IS LOCKED TO FREE MEMBERS

Purchase full membership to immediately unlock this page

Know Your Bible

Forgotten Books' Full Membership provides unlimited access to more than 28,000 volumes of Christian literature for \$8.99/month

HOLY BIBLE

Continue

*Fair use policy applies

Yoke, Single-Pair — —A single-brush rocker. (See *Rocker, Single-Brush*.)

Yoke, Single-Pair Brush — —A device for holding a single pair of collecting brushes of a dynamo-electric machine in such a way

that they can be readily moved or rotated on the commutator cylinder.

Yoked-Horseshoe Electro-Magnet.—(See *Magnet, Electro, Yoked-Horseshoe*.)

Z

Z.—A symbol sometimes used in electro-therapeutics for contraction.

The use of Z, is for the purpose of avoiding the letter C, which has already been used for current or ampère in Ohm's law. Increasing strengths of contraction are represented by Z', Z'', Z'''.

Z.—A symbol for electro-chemical equivalent.

Zero, False — —A zero taken midway between any two equal and opposite deflections of a measuring instrument.

Zero, Inferred — —A zero deduced or inferred from the deflection produced by a charge that is to be measured by comparison with the value of the deflection by means of a known charge in an electrical measuring instrument.

An inferred zero is usually completely off the scale, hence its name. It does not actually exist.

Zero Methods.—(See *Method, Null or Zero*.)

Zero Potential.—(See *Potential, Zero*.)

Zero, Shifting — —A zero that changes or shifts in position; a polar zero in a measuring instrument.

Zigzag Electro-Magnet.—(See *Magnet, Electro, Zigzag*.)

Zigzag Electromotive Force.—(See *Force, Electromotive, Zigzag*.)

Zigzag Lightning.—(See *Lightning, Zigzag*.)

Zinc, Amalgamation of — —The covering or amalgamation of zinc with a layer of mercury.

To amalgamate a plate of zinc, its surface is first thoroughly cleaned by immersing the plate in dilute sulphuric acid of about 1 part of acid to

10 or 12 parts of water. A few drops of mercury are then rubbed over its surface, thus coating it with a bright metallic film of zinc amalgam. Care must be taken not to use too much mercury, since the zinc plate would thus be rendered brittle.

Zinc-Carbon Voltaic Cell.—(See *Cell, Voltaic, Zinc-Carbon*.)

Zinc-Copper Voltaic Cell.—(See *Cell, Voltaic, Zinc-Copper*.)

Zinc, Crow-Foot — —A crow-foot-shaped zinc used in the gravity voltaic cell. (See *Cell, Voltaic, Gravity*.)

The term "crow-foot" refers to the shape of the claws. It is hardly a happy term.

Zinc-Lead Voltaic Cell.—(See *Cell, Voltaic, Zinc-Lead*.)

Zinc Sender.—(See *Sender, Zinc*.)

Zincode of Voltaic Cell.—A term formerly employed to indicate the zinc terminal or electrode of a voltaic cell.

The negative electrode or kathode are preferable terms.

Zone, Anelectrotonic — —A name sometimes given to the polar zone. (See *Zone, Polar*.)

Zone, Kathelectrotonic — —A name sometimes given to the peripolar zone. (See *Zone, Peripolar*.)

Zone, Peripolar — —A term proposed by De Watteville for the zone or region surrounding the polar zone on the body of a patient undergoing electro-therapeutic treatment.

Zone, Polar — —A term proposed by De Watteville for the zone or region surrounding the therapeutic electrode applied to the human body for electric treatment.

THE FIRST SYSTEMATIC TREATISE ON THE ELECTRIC RAILWAY.

THE ELECTRIC RAILWAY

IN THEORY AND PRACTICE.

By O. T. CROSBY AND DR. LOUIS BELL.

Covering the General Principles of Design, Construction and Operation.

OCTAVO, 400 PAGES AND 179 ILLUSTRATIONS, PRICE, \$2.50

TABLE OF CONTENTS:

Chapter I. General Electrical Theory. II. Prime Movers. III. Motors and Car Equipment IV. The Line. V. Track, Car Houses, Snow Machines. VI. The Station. VII. The Efficiency of Electric Traction. VIII. Storage Battery Traction. IX. Miscellaneous Methods of Electric Traction. X. High Speed Service. XI. Commercial Considerations. XII. Historical Notes.



O. T. CROSBY.



DR. LOUIS BELL.

APPENDICES:

Appendix A. Electric Railway vs. Telephone Decisions. B. Instructions to Linemen. C. Engineer's Log Book. D. Classification of Expenditures of Electric Street Railways. E. Concerning Lightning Protection, by Prof. Elihu Thomson.

In this important new book just issued will be found a full discussion of the principles, apparatus and methods of construction employed in electric railroading. As will be seen from the table of contents, it treats all departments of the subject as comprehensively as is practicable in a volume of reasonable size. The illustrations have been prepared especially for it, and many of them are entirely new.

To Electric Railway Managers, Superintendents, Electricians and Operators, this volume is invaluable, while no one interested in the modern applications of electricity will want to be without it. The necessity for such a book has been keenly felt.

Copies of **The Electric Railway in Theory and Practice**, or of any other **Electrical work** published, will be mailed to any address, **POSTAGE PREPAID**, on receipt of price. Address

THE W. J. JOHNSTON COMPANY, Ltd.
TIMES BUILDING, NEW YORK.

FIRST AMERICAN BOOK ON ELECTRIC MOTORS.

THE ELECTRIC MOTOR AND ITS APPLICATIONS.

By T. C. MARTIN and JOS. WETZLER.

With an Appendix on the Development of the Electric Motor since 1888.

By DR. LOUIS BELL.

This is the first American Book on Electric Motors, and the only one in any language dealing exclusively and tully with the modern Electric Motor in all its various practical applications.

CONTENTS.

	PAGE.		PAGE.	
Chapter i.	Elementary Considerations.....	1	Chapter ix.	The Industrial Application of Electric Motors in America... 125
" ii.	Early Motors and Experiments in Europe.....	8	" x.	Electric Motors in Marine and Aërial Navigation. 137
" iii.	Early Motors and Experiments in America	13	" xi.	Telpherage. 143
" iv.	The Electrical Transmission of Power.....	29	" xii.	Latest American Motors and Motor Systems 152
" v.	The Modern Electric Railway and Tramway in Europe.....	48	" xiii.	Latest American Motors and Motor Systems Con..... 196
" vi.	The Modern Electric Railway and Street Car Line in America	61	" xiv.	Latest European Motors and Motor Systems. 246
" vii.	The use of Storage Batteries with Electric Motors for Street Rys.	99	" xv.	Alternating Current Motors 255
" viii.	The Industrial Application of Electric Motors in Europe....	114	" xvi.	Thermo-Magnetic Motors..... 272
			Appendix.	The Development of the Electric Motor since 1888..... 279

315 Pages. 353 Illustrations. Price, \$3.00.

The W. J. JOHNSTON CO., LD. 167-176 Times Building, New York.

THE LEADING AMERICAN BOOK ON DYNAMOS.

Principles of Dynamo-Electric Machines, And Practical Directions for Designing and Constructing Dynamos.

*With an Appendix containing several articles on allied subjects and a table
of equivalents of units of measurement.*

By CARL HERING.

CONTENTS.

Chapter I., Review of Electrical Units and Fundamental Laws; Chapter II., Fundamental Principles of Dynamos and Motors; Chapter III., Magnetism and Electromagnetic Induction; Chapter IV., Generation of Electromotive Force in Dynamos; Chapter V., Armatures; Chapter VI., Calculation of Armatures; Chapter VII., Field Magnet Frames; Chapter VIII., Field Magnet Coils; Chapter IX., Regulation of Machines; Chapter X., Examining Machines; Appendix I., Practical Deductions from the Franklin Institute Tests of Dynamos; Appendix II., The So-called "Dead Wire" on Gramme Armatures; Appendix III., Explorations of Magnetic Fields surrounding Dynamos; Appendix IV., Systems of Cylinder-Armature Windings; Appendix IV., Systems of Cylinder-Armature Windings; Appendix V., Equivalents of Units of Measurements (Table).

American electricians have long felt the need of a work of this nature, written in plain and simple language by a man thoroughly familiar with all types of generating apparatus. The book is copiously illustrated, printed on an extra good quality of paper, and substantially bound.

Cloth, 279 Pages. 59 Illustrations. Price, \$2.50

Copies of the above, or of any other electrical book or books published, will be promptly mailed to any address in the world, POSTAGE PREPAID, on receipt of price. Address:

The W. J. JOHNSTON CO., LD., Times Building, New York.

THIS PAGE IS LOCKED TO FREE MEMBERS

Purchase full membership to immediately unlock this page



HISTORY

Tens of thousands of important historical sources, many previously unobtainable, are now available for the first time with a Forgotten Books Full Membership.

Unlimited Access
\$8.99/month

Continue

*Fair usage policy applies

RECORD OF AN ACTIVE FIELD OF DEVELOPMENT.

RECENT PROGRESS
IN
ELECTRIC RAILWAYS.

By Carl Hering.

Compiled and Condensed from Current Electrical Literature.

About 400 pages and 120 Illustrations. Cloth, Price \$1.00.



CARL HERING.

The volume of electrical literature has now assumed such proportions that it is impossible to keep abreast of it, much less to make such records or abstracts as would be of use for future reference. To meet the demand of those interested in the progress of Electric Railways, and who have felt the want of a general index to recently published matter on this subject, this compilation has been prepared. The book contains a classified summary of the recent literature on this active and promising branch of electrical progress and descriptions of new apparatus and devices of interest to the technical reader.

CONTENTS.

Chapter I. Historical. Chapter II. Development and Statistics. Chapter III. Construction and Operation. Chapter IV. Cost of Construction and Operation. Chapter V. Overhead Wire Surface Roads. Chapter VI. Conduit and Surface Conductor Roads. Chapter VII. Storage Battery Roads. Chapter VIII. Underground Tunnel Roads. Chapter IX. High Speed Interurban Railroads. Chapter X. Miscellaneous Systems. Chapter XI. Generators, Motors and Trucks. Chapter XII. Accessories.

TESLA'S LONDON LECTURE.

EXPERIMENTS WITH ALTERNATE CURRENTS

Of High Potential and High Frequency.

By NIKOLA TESLA.

156 Pages, with Portrait and 35 Illustrations. Cloth, \$1.00.

This book gives in full Mr. Tesla's important lecture before the LONDON INSTITUTION OF ELECTRICAL ENGINEERS, which embodies the results of years of patient study and investigation on Mr. Tesla's part of the phenomena of ALTERNATING CURRENTS OF ENORMOUSLY HIGH FREQUENCY AND ELECTROMOTIVE FORCE.

Every Electrician, Electrical Engineer or Student of Electrical Phenomena who makes any pretensions to thorough acquaintance with recent progress in this important field of research which Mr. Tesla has so ably developed must read and reread this lecture.

The book is well illustrated with 35 cuts of Mr. Tesla's experimental apparatus, and contains in addition a biographical sketch, accompanied by a full-page portrait, which forms a fitting frontispiece to a lecture which created such widespread interest.

Copies of the above or of any other Electrical Books published, will be promptly mailed to ANY ADDRESS on receipt of price. Address

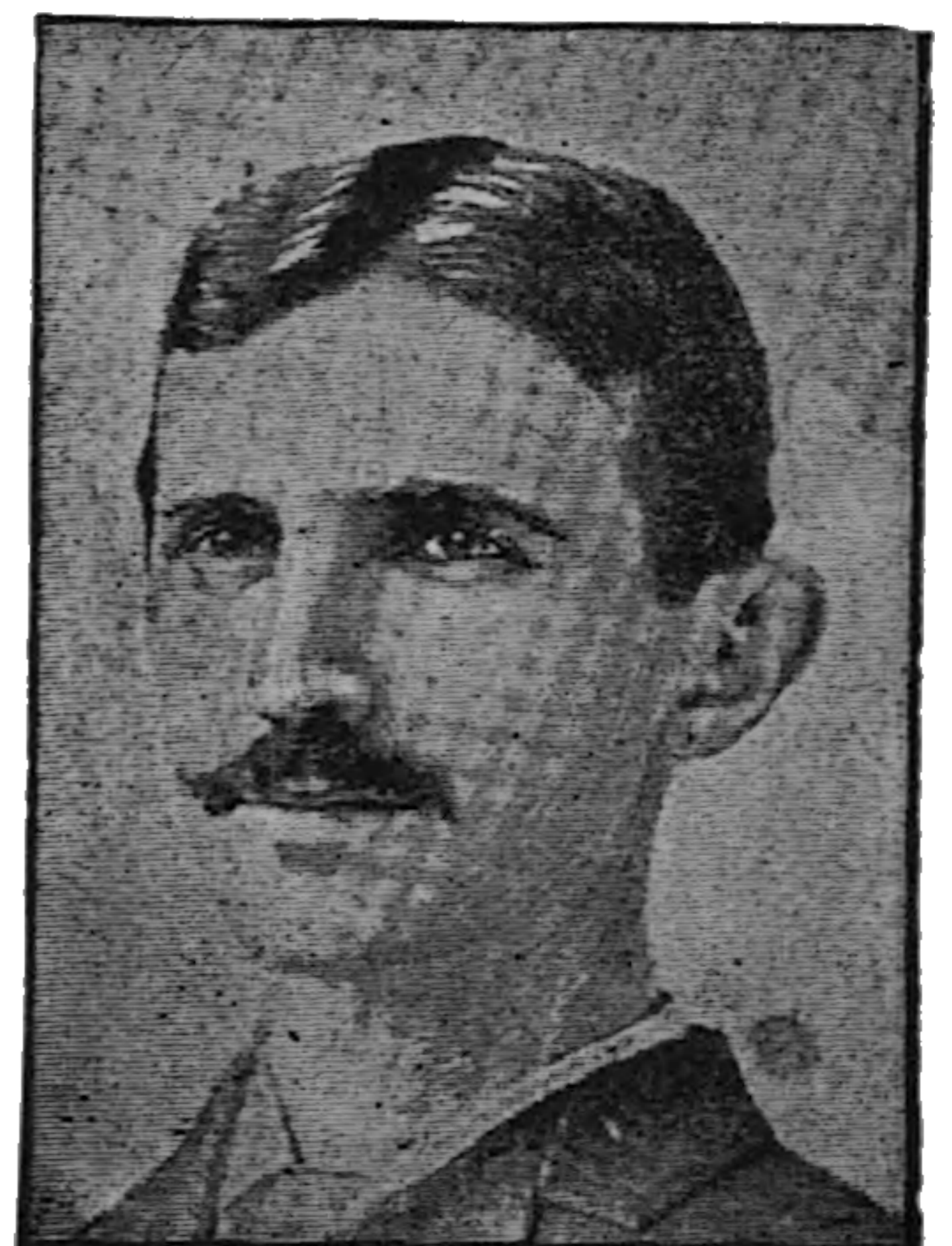

NIKOLA TESLA.

The W. J. JOHNSTON CO., Limited. Times Building, New York.

A BOOK FOR EVERY DEALER AND EVERY BUYER.

JOHNSTON'S
ELECTRICAL AND STREET RAILWAY
DIRECTORY.

Published Annually. :- *Price, in Cloth, (including postage to any address in the world) \$5.00.*

THIS BOOK CONTAINS:

A LIST OF CENTRAL ELECTRIC LIGHT AND POWER STATIONS,

with the Number of Lights in Use, Electric Power Supplied, Capital Paid in, Name of System, Name of Managing Official, Superintendent, Purchasing Agent, Electrician, and other particulars.

A LIST OF ISOLATED ELECTRIC LIGHT PLANTS,

with Name of Electrician, Purchasing Agent, Engineer, System and Size of Plant, and other particulars.

A LIST OF STREET RAILWAY COMPANIES,

with Length of Road, Number of Cars, Car Miles Run, Capital Paid in, Managing Official, Superintendent, Purchasing Agent, System—Electric, Horse or Cable—and other particulars.

A LIST OF EVERY MANUFACTURER AND SUPPLY DEALER

connected with the Electrical or Street Railway Industry.

A special effort is made to have this Directory the **most complete**, the **most reliable** and the **most valuable** of any work of the kind issued. Its pages are full of interest not only to every **dealer** in Electrical and Street Railway Apparatus, Machinery and Supplies, and every **manufacturer** who wishes to reach those engaged in this **large, important and growing** industry, but to the **purchasers** of Electrical Apparatus and Supplies and to all in any way interested in the progress and development of either the Electrical or the Street Railway business.

Copies of **Johnston's Electrical and Street Railway Directory**, or of any other Electrical or Street Railway books, will be mailed to any address in the world, postage prepaid, on receipt of the price. Address:

THE W. J. JOHNSTON COMPANY, Ltd.,

167-176 Times Building,

NEW YORK.

AUTHORIZED AMERICAN EDITION.

THE ELECTROMAGNET.

By PROF. SILVANUS P. THOMPSON, D.S.C., B.A., M.I.E.E.

A full theoretical and practical account of the properties and peculiarities of electromagnets; together with complete Instructions for designing magnets to serve any specific purpose. Published with the express consent and careful revision of the author.

Cloth, 280 Pages. 75 Illustrations. Price \$1.00.

CONTENTS.

LECTURE I.—Introductory ; Historical Sketch ; Generalities Concerning Electromagnets ; Typical Forms ; Polarity ; Uses in General ; The properties of Iron ; Methods of Measuring Permeability ; Traction Methods ; Curves of Magnetisation and Permeability ; The Law of the Electromagnet ; Hysteresis ; Fallacies and Facts about Electromagnets.

LECTURE II.—General Principles of Design and Construction ; Principle of the Magnetic Circuit.

LECTURE III.—Special Designs ; Winding of the Copper ; Windings for Constant Pressure and for Constant Current ; Miscellaneous Rules about Winding ; Specifications for Electromagnets ; Amateur Rules about Resistance of Electromagnet and Battery ; Forms of Electromagnets ; Effect of Size of Coils ; Effect of Position of Coils ; Effect of Shape of Section ; Effect of Distance between Poles ; Researches of Prof. Hughes ; Position and Form of Armature ; Pole-Pieces on Horseshoe Magnets ; Contrast between Electromagnets and Permanent Magnets ; Electromagnets for Maximum Traction ; Electromagnets for Maximum Range of Attraction ; Electromagnets of Minimum Weight ; A useful Guiding Principle ; Electromagnets for Use with Alternating Currents ; Electromagnets for Quickest Action ; Connecting Coils for Quickest Action ; Battery Grouping for Quickest Action ; Short Cores vs. Long Cores.

LECTURE IV.—Electromagnetism and Electromagnetic Mechanism.



PROF. SILVANUS P. THOMPSON.

THE ONLY BOOK TREATING OF THIS SUBJECT EXCLUSIVELY.

THE QUADRUPLEX.

By WM. MAVER, Jr., and MINOR M. DAVIS.

With Chapters on The Dynamo-Electric Machine in Relation to the Quadruplex. The Practical Working of the Quadruplex. Telegraph Repeaters and the Wheatstone Automatic Telegraph. By WM. MAVER, Jr.

CONTENTS.

Development of the Quadruplex.
Introduction and Explanatory.
The Transmitter, Rheostat and the Condenser.
Stearns Duplex.
Instruments of the Polar Duplex.
The Polar Duplex.

The Quadruplex.
The Dynamo-Electric Machine in relation to the Quadruplex.
The Practical Working of the Quadruplex.
Telegraph Repeaters.
The Wheatstone Automatic Telegraph.

This book is written in plain, simple and explicit language, and is within the ready comprehension of all. The illustrations are numerous, and with their aid the readers can at once grasp, mentally, the operation of the Quadruplex. The book is handsomely printed on fine paper and substantially bound. Every Telegrapher and every Electrician should have a copy.

Cloth, 126 Pages. 63 Illustrations. Price, \$1.50.

THE TELEPHONE MAN'S TEXT BOOK.

PRACTICAL INFORMATION FOR TELEPHONISTS.

By T. D. LOCKWOOD, Electrician, American Bell Telephone Company.

CONTENTS.

Historical Sketch of Electricity from 600 B. C. to 1882 A. D.
Facts and Figures about the Speaking Telephone.
How to Build a Short Telegraph or Telephone Line.
The Earth and Its Relation to Telephonic Systems of Communication.
The Magneto-Telephone—What it is, How it is Made, and How it Should be Handled.
The Blake Transmitter.
Disturbances Experienced on Telephone Lines.
The Telephone Switch-Board.
A Chronological Sketch of the Magneto-Bell, and How to Become Acquainted with it.
Telephone Transmitter Batteries.
Lightning—Its Action upon Telephone Apparatus—How to Prevent or Reduce Troubles Arising Therefrom.
The Telephone Inspector.
The Telephone Inspector—His Daily Work.
The Inspector on Detective Duty.
The Daily Routine of the Telephone Inspector
Individual Calls for Telephone Lines.
Telephone Wires versus Electric Light Wires.
Electric Bell Construction, Part I.
Electric Bell Construction, Part II.
Housetop Lines, Pole Lines and Aërial Cables.
Anticipations of Great Discoveries and Inventions.



T. D. LOCKWOOD.

12mo. 192 Pages ; Cloth. Price, \$1.00.

Copies of the above books, or of any other electrical book or books published, will be promptly mailed to any address in the world, postage prepaid, on receipt of price. Address :—

THE W. J. JOHNSTON CO., Lim., TIMES BUILDING, N. Y.

THIS PAGE IS LOCKED TO FREE MEMBERS

Purchase full membership to immediately unlock this page

Know Your Bible

Forgotten Books' Full Membership provides unlimited access to more than 28,000 volumes of Christian literature for \$8.99/month

HOLY BIBLE

Continue

*Fair use policy applies

(2.) **Special Treatises.**

(a.) *Electric Lighting.*

PRICE.

Alglave & Boulard's Electric Light: Its History, Production and Application.....	5.00
Atkinson's Elements of Electric Lighting.....	1.50
Day's Electric Light Arithmetic	0.40
Desmond's Electricity for Engineers.....	2.50
Dredge's Electric Illumination. Vol. I., \$15., Vol. II.....	7.50
Gordon's Decorative Electricity.....	3.75
Houston's Dictionary of Electrical Words, Terms and Phrases, second edition, entirely re-written, containing about 5,000 distinct titles, 570 illustrations and 562 double column pages. 8vo...	5.00
Latimer's Incandescent Electric Lighting	0.50
Merrill's Electric Lighting Specifications, for the use of Engineers and Architects.....	1.50
Russell's Electric Light Cables.....	1.50
Urquhart's Electric Light : Its Production and use....	3.00
Urquhart's Electric Light Fitting.....	2.00

(b.) *The Electric Motor.*

Badt's Electric Transmission Hand-book.....	1.00
Bottone's Electro-motors ; How Made and How Used.....	.50
Crosby & Bell's Electric Railway in Theory and Practice....	2.50
Hering's Recent Progress in Electric Railways.....	1.00
Houston's Dictionary of Electric Words, Terms and Phrases, second edition, entirely re-written, containing about 5,000 distinct titles, 570 illustrations and 562 double column pages. 8vo.....	5.00
Kapp's Electric Transmission of Energy ...	3.00
Martin & Wetzler's Electric Motor and Its Applications ; with an Appendix by Dr. Louis Bell.	3.00
Urquhart's Electro-motors.....	3.00

(c.) *Telegraphy.*

Abernethy's Commercial and Railway Telegraphy.....	2.00
Houston's Dictionary of Electrical Words, Terms and Phrases, second edition, entirely re-written, containing about 5,000 distinct titles, 570 illustrations and 562 double column pages. 8vo.....	5.00
Lockwood's Electricity, Magnetism, and Electric Telegraphy.....	2.50
Maver & Davis' Quadruplex , with Chapters on Telegraph Repeaters and the Wheatstone Automatic Telegraph.....	1.50
Pope's Modern Practice of the Electric Telegraph.....	1.50
Preece & Siverwright's Telegraphy.....	1.75
Prescott's Electricity and the Electric Telegraph. Two vols.....	7.00
Plum's Military Telegraph During Our Civil War. Two vols.....	5.00
Reid's Telegraph in America.....	5.00

(d.) *The Telephone.*

Du Moncel's Telephone, The Microphone and the Phonograph.....	1.25
Houston's Dictionary of Electrical Words, Terms and Phrases, second edition, entirely re-written containing about 5,000 distinct titles, 570 illustrations and 562 double column pages. 8vo.....	5.00
Lockwood's Practical Information for Telephonists.....	1.00
Poole's Practical Telephone Hand-book.....	1.25
Preece & Maier's Telephone.....	4.00
Prescott's Bell's Electric Speaking Telephone.....	6.00

(e.) *Electro-Metallurgy*

Bonney's Electro-platers' Hand-book..	1.20
Gore's Art of Electrolytic Separation of Metals, etc.....	3.50
Gore's Theory and Practice of Electro-deposition.....	0.80
Houston's Dictionary of Electrical Words, Terms and Phrases, second edition, entirely re-written, containing about 5,000 distinct titles, 570 illustrations and 562 double column pages. 8vo.....	5.00
Urquhart's Electrotyping	2.00
Wahl's Galvanoplastic Manipulation.....	7.50
Watt's Electro-deposition.....	3.50

(f.) *Batteries.*

Carhart's Primary Batteries....	1.50
Gladstone & Tribe's Chemistry of Secondary Batteries of Plante and Faure.....	1.00
Houston's Dictionary of Electrical Words, Terms and Phrases, second edition, entirely re-written, containing about 5,000 distinct titles, 570 illustrations and 562 double column pages. 8vo.....	5.00
Niaudet's Elementary Treatise on Electric Batteries.....	2.50

	PRICE.
Niblett's Secondary Batteries	1.50
Reynier's Voltaic Accumulator	3.00
Salomons' Electric Light Installation and the Management of Accumulators	2.00

(g.) *The Dynamo.*

Badt's Dynamo Tenders' Hand-book	\$1.00
Bottone's Dynamo : How Made and How Used	1.00
Croft's How to Make a Dynamo80
Hering's Principles of Dynamo Electric Machines	2.50
Thompson's Dynamo Electric Machinery. New. Fourth edition. Revised. Re-written	9.00
Walker's Practical Dynamo Building for Amateurs80

(h.) *Alternating Currents.*

Blakesley's Papers on Alternating Currents of Electricity. Reprinting	
Desmond's Electricity for Engineers	2.50
Fleming's Alternate Current Transformer in Theory and Practice	3.00
Houston's Dictionary of Electrical Words, Terms and Phrases, second edition, entirely re-written, containing about 5,000 distinct titles, 570 illustrations and 562 double-column pages. 8vo	5.00

(C.) ELECTRICAL TESTING AND MEASUREMENT.

Ayrton's Practical Electricity	\$2.50
Gray's Absolute Measurement in Electricity and Magnetism	1.25
Hering's Table of Equivalents of Units of Measurement	0.50
Houston's Dictionary of Electrical Words, Terms and Phrases, second edition, entirely re-written, containing about 5,000 distinct titles, 570 illustrations and 562 double-column pages. 8vo	5.00
Kempe's Hand-book of Electrical Testing	5.00
Lockwood's Electrical Measurement and the Galvanometer	1.50
Swinburne's Practical Electrical Measurement	1.75
Webb's Testing of Insulated Wires and Cables	1.00

(D.) MISCELLANEOUS.

Allsop's Practical Electric Bell Fitting	\$1.25
Atkinson's Elements of Static Electricity	1.50
Gray's Electrical Influence Machines	1.75
Houston's Dictionary of Electrical Words, Terms and Phrases, second edition, entirely re-written, containing about 5,000 distinct titles, 570 illustrations and 562 double column pages. 8vo	5.00
Hering's Universal Wiring Computer	1.00
Tesla's Experiments with Alternate Currents of High Potential and High Frequency	1.00

(E.) BOOKS FOR THE NON-TECHNICAL READER.

Benjamin's Age of Electricity	\$2.00
Guillemin's Electricity and Magnetism	8.00
Hospitalier's Modern Applications of Electricity. Two vols	8.00
Houston's Dictionary of Electrical Words, Terms and Phrases, second edition, entirely re-written, containing about 5,000 distinct titles, 570 illustrations and 562 double column pages. 8vo	5.00
Reid's Telegraph in America	5.00
Wormell's Electricity in the Service of Man	6.00

(F.) HISTORICAL WORKS.

Alglave & Boulard's Electric Light	\$5.00
Dredge's Electric Illumination. Vol. I, \$15.00, vol. II	7.50
Fahie's History of Telegraphy to 1837	3.00
Martin & Wetzler's Electric Motor and Its Applications	3.00
Pope's Evolution of the Electric Incandescent Lamp	1.00
Prescott's Telephone	6.00
Reid's Telegraph in America	5.00
Thompson's Dynamo Electric Machinery. New. Fourth edition. Revised. Re-written	9.00
Thompson's Philipp Reis, Inventor of the Telephone	3.00

Copies of any of the books mentioned above, or of any other electrical books published, will be mailed, POSTAGE PREPAID, to any address in the world on receipt of the price.

Address:—

THE W. J. JOHNSTON COMPANY, LIMITED
167-176 TIMES BUILDING, NEW YORK.

THE PIONEER ELECTRICAL JOURNAL OF AMERICA.



HANDSOMELY AND PROFUSELY ILLUSTRATED,

IS PUBLISHED EVERY SATURDAY BY

THE W. J. JOHNSTON COMPANY, Ltd.

ESTABLISHED 1874. INCORPORATED 1889.

Telephone Call: CORTLANDT 924.

Cable Address: "ELECTRICAL," NEW YORK.

Publication Offices: 167-176 TIMES BUILDING, NEW YORK.

New England Office: 620 Atlantic Avenue, Boston. | Western Office: 465 "The Rookery," Chicago.
Philadelphia Office: 927 Chestnut Street.

THE ELECTRICAL WORLD is noted for its ability, enterprise, independence and honesty. For thoroughness, candor and progressive spirit it stands in the foremost rank of special journalism.

DURING 1893

more money will be spent than in any previous year to enable it to keep its readers abreast of electrical progress and to sustain its reputation, not only as the pioneer electrical weekly of America, but as the leading journal of its class, and the periodical with the largest circulation of any electrical journal published.

AS EVERY ONE ACQUAINTED WITH THE SUBJECT KNOWS, THE ELECTRICAL WORLD is the largest, most original and most handsomely and profusely illustrated of all the journals in the world devoted to Electricity. No one in any way interested in electrical progress and development can afford to miss reading it for a single issue.

SUBSCRIPTIONS, including postage to any part of the United States, Canada or Mexico, \$3.00 a year. This is a merely nominal price for such a journal. Addresses are changed as often as desired without extra charge. Foreign countries in the U. P. U., \$6.00 a year.

ANY NEWSDEALER will supply THE ELECTRICAL WORLD regularly at 10c. a week. Newsdealers, Postmasters and Electrical Supply Houses receive subscriptions, or remit \$3.00 for one year, direct to the Publishers,

THE W. J. JOHNSTON COMPANY, Ltd., Times Building, New York,

OR ANY OF THE BRANCH OFFICES AS ABOVE.